

stryker[®]

Maintenance Manual

Medical

**Important
Information**

File in your
maintenance
records

Zoom Critical Care Bed
Model 2040

For parts or technical
assistance call
800 327 0770 (option 2)



Table of Contents

Introduction	
Specifications	4
Warning/Caution/Note Definition	4
Safety Tips and Guidelines	5–7
Set-Up Procedures	8
Symbols	9 – 16
Preventive Maintenance	
Cleaning	17
Preventive Maintenance Checklist	18
Nurse Call Battery	19
Circuit Breakers	19
Static Discharge Precautions	20
Troubleshooting Guide	21 – 26
Electrical System Information	
Bed Wiring Diagram	27
CPU Board Diagram	28, 29
Software Configuration	30 – 32
Power Supply Diagram	33
Inverter/Charger Board Diagram	34
Display/CPU Diagram	35
AC Crossover Board Diagram	36
Power Board Diagram	37
Inverter Protection Features	38
Optional Bed Communications Tester	39
Head Wall Output Configuration	40
Quick Reference Replacement Parts List	41, 42
Service Information	
Brake Pedal Replacement	43
Lift Motor and Capacitor Removal and Replacement	44
Lift Housing Removal and Replacement	45, 46
Lift Potentiometer Replacement and Adjustment	47, 48
Lift Potentiometer “Burn In” Procedure	48
Lift Motor Coupler Replacement	49
Power and Sensor Coil Cord Replacement	50, 51
Battery Removal and Replacement	52, 53
DC Motor Board Removal and Replacement	53
Drive Motor Removal and Replacement	54
Drive Wheel Removal and Replacement	54

Table of Contents

Service Information (Continued)

Scale System Diagnostics and Calibration	55 – 57
Load Cell Replacement	58
Head Motor Removal and Replacement	58
Knee Motor Removal and Replacement	59
Power Supply Removal and Replacement	60
CPU Board Removal and Replacement	60
Fowler Potentiometer Replacement	61
Fowler Potentiometer “Burn-In” Procedure	62
AC Crossover Board Replacement	63
Display/CPU Board Replacement	63
Control Bar Potentiometer Replacement	64, 65
Control Bar Potentiometer “Burn-In” Procedure	66
Optional Smart TV Interface “Burn-In” Procedure	67
Head and Foot End Siderail Cover Removal	68
Head and Foot Molded Siderail Replacement	69
Head End Siderail Cable Replacement	70, 71
Foot Board Hinge Removal	72
Foot Board Module Replacement	73
Foot Board Interface Plug Replacement	74

Assembly Drawings And Parts Lists

Base Assembly	75 – 82
Lift Assembly	83 – 86
Isolation Plate Assembly	87
Brake Shaft Assembly	88
Brake Crank Assembly	89
Brake Bar Assembly	90
6” Caster Assembly	91
6” Wheel Assembly	92
8” Caster Assembly	93
8” Wheel Assembly	94
Zoom® Base Assembly	95 – 102
Drive Wheel Lift Lever Assembly	103
Bottom Cover Assembly	104
Zoom® Drive Train Assembly	105
Battery Tray Assembly	106
Zoom® Base Power Assembly	107
Litter Assembly	108 – 120

Table of Contents

Assembly Drawings And Parts Lists (Continued)

Actuator Box Cover Assembly	121
Fowler Brake Kit Assembly	122
Zoom® Litter Assembly	123 – 130
110V Outlet Assembly	131 – 133
110V Box Assembly	134, 135
No 110V Outlet	136, 137
Head End Siderail Assembly	138 – 144
Head End Siderail Latch Assembly	145, 146
Head End Siderail Bypass Detent Clip Assembly	147
Head End Siderail Inner Panel Assembly	148
Head End Siderail Outer Panel Assembly	149
Foot End Siderail Assembly	150 – 153
Siderail Release Lever Assembly	154, 155
Head Board Assembly	153
Foot Board Assembly	157 – 163
Foot Board Main Module Assembly	164
Foot Board CPR Drop/Cardiac Chair Module Assembly	165
Foot Board Bed Exit Module Assembly	166, 167
Foot Board Scale Module Assembly	168
Removable IV Pole Assembly	169
2-Stage IV Mounting Assembly, Foot End	170 – 172
2-Stage IV Pole Assembly	173, 174
Fowler X-Ray Cassette Holder Assembly	175
Transducer Mounts	176, 177
Defibrillator Tray Assembly	178
Foot End Pump Rack Assembly	179
Pleur-Evac Rack with Defibrillator Tray Assembly	180, 181
Pleur-Evac Rack Assembly	182
Siderail Pleur-Evac Rack Assembly	183
Upright Oxygen Bottle Holder Assembly	184
Optional Bed Extender Pad	185
Optional Siderail Pad Set	186
Limited Warranty	
Obtaining Parts and Service	187
Supplemental Warranty Coverage	187
Return Authorization	188
Freight Damage Claims	188

Introduction

INTRODUCTION

This manual is designed to assist you with the maintenance of the Stryker Model 2040 Zoom® Patient Transport Frame. Read it thoroughly before using the equipment or beginning any maintenance on it.

SPECIFICATIONS

Safe Working Load	500 pounds (227 kilograms) 
Scale System Capacity (optional equipment)	Loads weighing up to 500 pounds (227 kilograms)
Scale System Accuracy (optional equipment)	± 1 pound of total patient weight at any bed position ¹ (patients weighing 100 pounds or less) ± 1% of total patient weight at any bed position ¹ (patients weighing greater than 100 pounds)
Overall Length/Width	L-93" /W-42.5" or L-238 cm /W-108 cm
Minimum/Maximum Height (Standard) Minimum/Maximum Height (Enhanced)	18" to 32.5" ± 0.5 / 46 cm. to 82.5 cm. 19.5" to 34.5" ± 0.5 / 49.5 cm. to 88 cm. (Add 2 inches if the bed has 8" casters.)
Fluoro Access	16"
Knee Gatch Angle	0° to 30°
Back Angle	0° to 90°
Trendelenburg/Reverse Trendelenburg	+10° to -12° ± 1°
Electrical Requirements	115 VAC, 60 Hz, 7.0 Amps
Battery Voltage	24 V, 31 Ah
Outlet Option	125 VAC, 5A, 60 Hz

¹ If the bed is equipped with the enhanced height option, the scale accuracy is as described above for litter angles from 0° to ± 5° Trend.

Stryker reserves the right to change specifications without notice.

WARNING / CAUTION / NOTE DEFINITION

WARNING

Alerts the reader about a situation, which if not avoided, could result in death or serious injury. It may also describe potential serious adverse reactions and safety hazards.

CAUTION

Alerts the reader of a potentially hazardous situation, which if not avoided, may result in minor or moderate injury to the user or patient or damage to the equipment or other property. This includes special care necessary for the safe and effective use of the device and the care necessary to avoid damage to a device that may occur as a result of use or misuse.

NOTE

This provides special information to make maintenance easier or important instructions clearer.

Introduction

SAFETY TIPS AND GUIDELINES

Before operating the 2040 Patient Transport Frame, it is important to read and understand all information in this manual. Carefully read and strictly follow the safety guidelines listed on this page. To ensure safe operation of the transport frame, methods and procedures must be established for educating and training hospital staff on the intrinsic risks associated with the usage of motorized electric units.



WARNING

- The 2040 Patient Transport Frame is equipped with a hospital grade plug for protection against shock hazard. It must be plugged directly into a properly grounded three-prong receptacle. Grounding reliability can be achieved only when a hospital grade receptacle is used.
 - Serious injury can result if caution is not used when operating the unit. Operate the unit only when all persons are clear of the electrical and mechanical systems.
 - Leave the frame in the lowest position when the patient is unattended. Leaving the frame in a raised position could increase the chance of patient falls and injury.
 - When raising the siderails, listen for the "click" that indicates the siderail has locked in the up position. Pull firmly on the siderail to ensure it is locked into position. Siderails are not intended to be a patient restraint device. It is the responsibility of attending medical personnel to determine the degree of restraint and the siderail positioning necessary to ensure a patient will remain safely in bed.
 - Always apply the caster brakes when a patient is getting on or off the bed. Always keep the caster brakes applied when a patient is on the bed (except during transport). Injury could result if the bed moves while a patient is getting in or out of bed.
 - Ensure the brakes are completely released prior to attempting to move the unit. Attempting to move the unit with the brakes actuated could result in injury to the user and/or patient.
 - Put the drive wheel in the neutral position and release the brakes before pushing the unit manually. Do not attempt to push the unit manually with the drive wheel engaged. The unit will be difficult to push and injury could result.
 - The CPR emergency release requires assistance to lower the Back if the angle of the Back is above 80°. Attempting to lower the Back in this position without assistance may result in injury to the operator.
 - The power save mode is activated after one hour on battery power with no motion release switch activation. Functions including Bed Exit, scale and motion will cease to operate when the unit enters the power save mode. Injury to the patient could occur if proper patient monitoring protocol is not observed.
 - The Bed Exit System is intended only to aid in the detection of a patient exiting the unit. It is NOT intended to replace patient monitoring protocol. The bed exit system signals when a patient is about to exit. Adding or subtracting objects from the frame after arming the bed exit system may cause a reduction in the sensitivity of the bed exit system.
 - To avoid pinching your fingers, place the IV pole in the upright position before using the drive handle.
 - Always unplug the power cord and push the battery power on/off switch to the "OFF" position before service or cleaning. When working under the frame, always place blocks under the litter frame to prevent injury in case the Bed Down switch is accidentally activated.
 - Battery posts, terminals and related accessories contain lead and lead compounds, chemicals known to the State of California to cause cancer and birth defects or other reproductive harm. **Wash hands after handling.**
 - The 2040 Patient Transport Frame is intended for use by trained hospital personnel only.
 - Warning: Service only by qualified personnel. Refer to maintenance manual.
 - Do not modify the 2040 Patient Transport Frame. Modifying the unit can cause unpredictable operation resulting in injury to the patient or operator. Modifying the unit will also void its warranty.
-

Introduction

SAFETY TIPS AND GUIDELINES (CONTINUED)

WARNING

To avoid possible injury and to assure proper operation when using a powered mattress replacement system such as XPRT:

- Confirm proper scale system operation following mattress installation. For best results, secure the therapy mattress power cord to prevent damage to the cord or interference with the bed frame and the scale system.
 - Do not zero bed scales or weigh patient with Percussion, Vibration, Rotation or Turn-Assist active. Patient motion and position resulting from the dynamic therapy mattress may adversely affect scale system performance.
 - Do not initialize (“arm”) bed exit with Percussion, Vibration, Rotation or Turn-Assist active. The patient motion and position resulting from the dynamic therapy mattress may adversely affect bed exit system performance.
-

CAUTION

- Use caution while maneuvering the unit with the drive wheel activated. Always ensure there are no obstacles near the unit while the drive wheel is activated. Injury to the patient, user or bystanders or damage to the frame or surrounding equipment could occur if the unit collides with an obstacle.
- Use caution when transporting the unit down halls, through doors, in and out of elevators, etc. Damage to the siderails or other parts of the unit could occur if the unit comes in contact with walls or door frames.
- If unanticipated motion occurs, unplug the power cord from the wall socket, push the battery power on/off switch to the “OFF” position (the LED will not be illuminated) and actuate the drive wheel pedal to the neutral position.
- The siderails are not intended to be used as a pushing device. Damage to the siderails could occur.
- The use of a mattress overlay may reduce the effectiveness of the siderail.
- When attaching equipment to the frame, ensure it will not impede normal operation. I.E.: hooks on hanging equipment must not actuate control buttons, equipment must not hide the nurse call button, etc.
- Use caution when lowering the bed with items attached to the optional accessory rail. If caution is not used, items may contact the floor resulting in damage to the items and/or injury to the patient or user.
- The lockout buttons on the foot board lock the Fowler, Gatch and Bed Up/Down functions and prevent motion of the bed. It is the responsibility of attending medical personnel to determine whether these functions should be locked and to use the buttons accordingly.
- Scale function may be affected by siderail/caster interference. With the litter fully lowered or lowered in Reverse Trendelenburg, the siderails tucked under the litter in the storage position and the casters turned, there is the potential for interference between the siderail and the caster. Raise the siderails when lowering the litter to the full down position to prevent the interference from causing the bed’s scale system to weigh inaccurately.
- If large fluid spills occur in the area of the circuit boards or motors, immediately unplug the power cord from the wall socket and push the battery power on/off switch to the “OFF” position. Remove the patient from the unit and clean up the fluid. Have maintenance completely check the unit. Fluids can short out controls and may cause the unit to operate erratically or make some functions completely inoperable. Component failure caused by fluids could even cause the unit to operate unpredictably and could cause injury to the patient. DO NOT put the unit back into service until it is completely dry and has been thoroughly tested for safe operation.

Introduction

SAFETY TIPS AND GUIDELINES (CONTINUED)

CAUTION

- Preventative maintenance should be performed at a minimum of annually to ensure all features are functioning as designed. Close attention should be given to safety features including, but not limited to:
 - Safety side latching mechanisms
 - Caster braking systems
 - Leakage current 300 microamps max.
 - No controls or cabling entangled in frame mechanisms
 - Frayed electrical cords and components
 - All controls return to off or neutral position when released
- The battery tray assembly weighs 50 pounds. Take care when removing the two hex head screws securing it to the base frame or personal injury could result.
- The 2040 Patient Transport Frame is not intended for pediatric use or for patients under 50 pounds.
- Because individual beds may have different options, foot boards should not be moved from one bed to another. Interchanging foot boards between beds could result in unpredictable bed operation.
- The weight of the IV bags should not exceed 40 pounds.

The following Caution statements apply to the optional 110V outlet:

- Maximum total load 5A receptacle rating: 125VAC, 5A, 60Hz.
- The total system chassis risk current should not exceed 300uA
- Grounding continuity should be checked periodically.
- Do not use for life-sustaining equipment.
- Use only hospital-grade equipment with electrical outlet.
- Unplug free-standing equipment before transporting the bed.

WARNING

Potential pinch points



Introduction

SET-UP PROCEDURES

It is important that the 2040 Patient Transport Frame is working properly before it is put into service. The following list will help ensure that each part of the transport frame is checked.

- Plug the power cord into a properly grounded, hospital grade wall receptacle.



WARNING

The 2040 Patient Transport Frame is equipped with a hospital grade plug for protection against shock hazard. It must be plugged directly into a properly grounded three-prong receptacle. Grounding reliability can be achieved only when a hospital grade receptacle is used.

-
- Depress the pedal at either side of the transport frame fully to set the four wheel brakes and ensure all four casters lock. Depress the pedal again to release the brakes.
 - Ensure the siderails raise and lower smoothly and lock in the up and intermediate positions.
 - Run through each function on the foot board control panel and ensure that each is working properly.
 - Ensure all functions are working properly on the siderail controls.
 - Ensure all motion functions are working properly at the head end of the transport frame.
 - Raise the Back up to approximately 60°. Squeeze the CPR release handle and ensure the Back and Knee will drop with minimal effort.
 - Unplug the power cord from the wall socket. Push the battery power switch located on the lower left corner of the head end to the “ON” position. Again, verify each function on the foot board and siderails is operating properly.
 - With the battery power switch in the “ON” position and the brakes engaged, ensure the “Release Brakes” LED on the head end control panel is illuminated.
 - With the battery power switch in the “ON” position and the drive wheel disengaged (not touching the floor), ensure the “Engage Drive Wheel” LED on the head end control panel is illuminated.
 - Run through the operation of the drive wheel to ensure it is operating properly.
 - If the bed is equipped with the Nurse Call option, verify it is functioning properly prior to patient use.

Introduction

BED SYMBOLS



Warning, Refer to Service/Maintenance Manual



Alternating Current



Type B Equipment: equipment providing a particular degree of protection against electric shock, particularly regarding allowable leakage current and reliability of the protective earth connection.

Class 1 Equipment: equipment in which protection against electric shock does not rely on BASIC INSULATION only, but which includes an additional safety precaution in that means are provided for the connection of the EQUIPMENT to the protective earth conductor in the fixed wiring of the installation in such a way that ACCESSIBLE METAL PARTS cannot become live in the event of a failure of the BASIC INSULATION.

Mode of Operation: Continuous

IPX4: Protection from liquid splash



Dangerous Voltage Symbol



Protective Earth Terminal



Potential Equalization Symbol



Medical Equipment Classified by Underwriters Laboratories Inc. with Respect to Electric Shock, Fire, Mechanical and Other Specified Hazards Only in Accordance with UL 2601-1 and CAN/CSA C22.2 No. 601.1

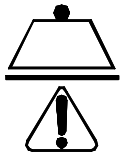

Safe Working Load

Introduction

BED SYMBOLS (CONTINUED)

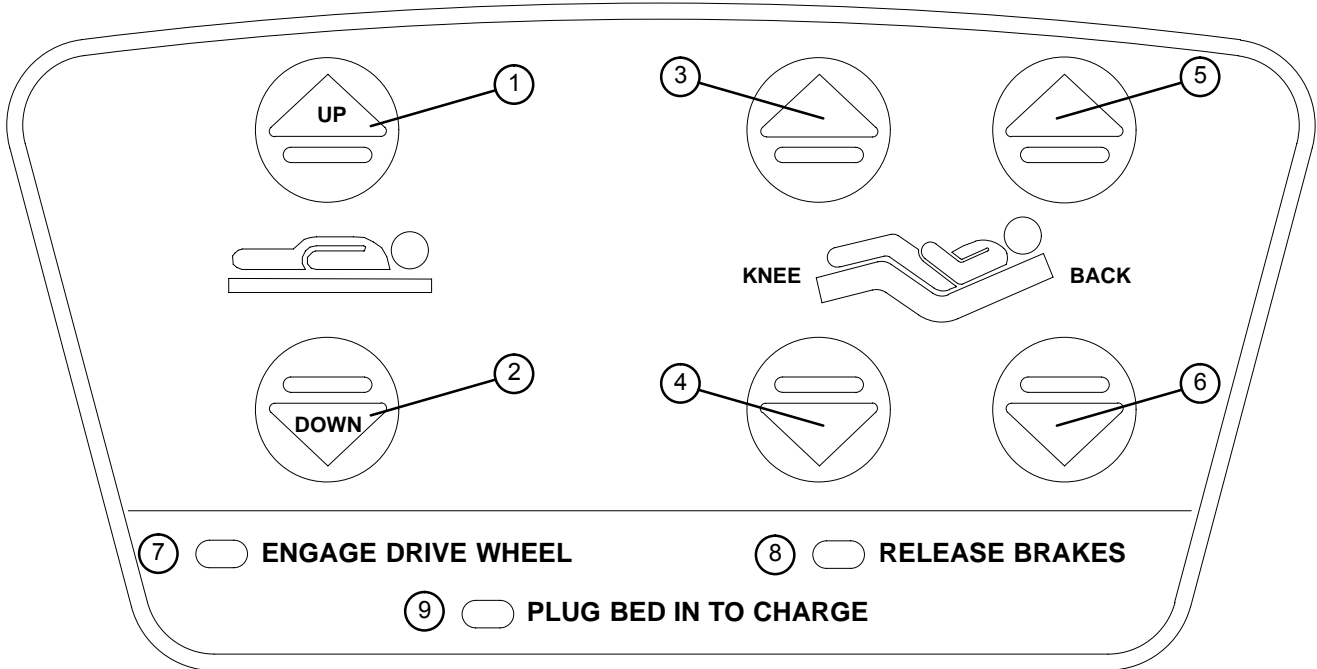

1. Press and hold to raise the litter. If your bed is equipped with the enhanced height option, continue to hold the button an additional 5 seconds after the first stop. The litter will raise an additional 2 inches.
2. Press and hold to lower the litter
3. Press to raise the Knee section.
4. Press to lower the Knee section.
5. Press to raise the Back section.
6. Press to lower the Back section.
7. The "Engage Drive Wheel" LED will be illuminated whenever the battery power switch is on and the drive wheel pedal is in the disengaged position. The light will go off when the drive wheel is engaged.
8. The "Release Brakes" LED will be illuminated whenever the frame's brakes are engaged while the battery power switch is on. The light will go off when the brakes are disengaged.
9. The "Plug Bed In To Charge" LED will be illuminated while the battery power switch is on if the battery level is low. Plug the power cord into the wall socket to charge the batteries.

Introduction

BED SYMBOLS (CONTINUED)

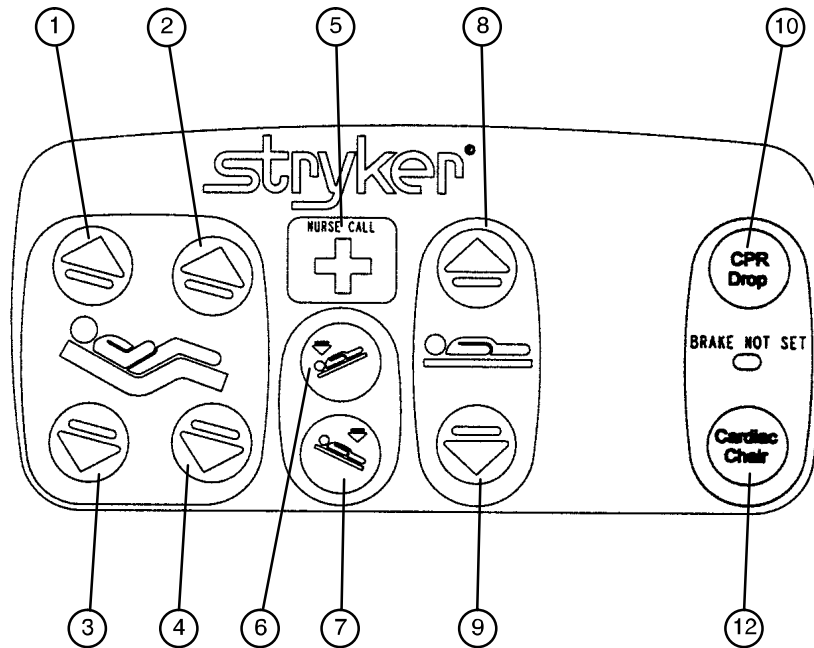

1. Press to raise back section.
2. Press to raise knee section.
3. Press to lower back section.
4. Press to lower knee section.
5. Press to activate nurse call.
6. Press to lower the head end (Trendelenburg).
7. Press to lower the foot end (Reverse Trendelenburg).
8. Press to raise the litter. If your bed is equipped with the enhanced height option, continue to hold the button an additional 5 seconds after the first stop. The litter will raise an additional 2 inches.
9. Press to lower the litter.
10. Press to activate emergency CPR positioning.
11. Press to activate Cardiac Chair positioning.

Introduction

BED SYMBOLS (CONTINUED)

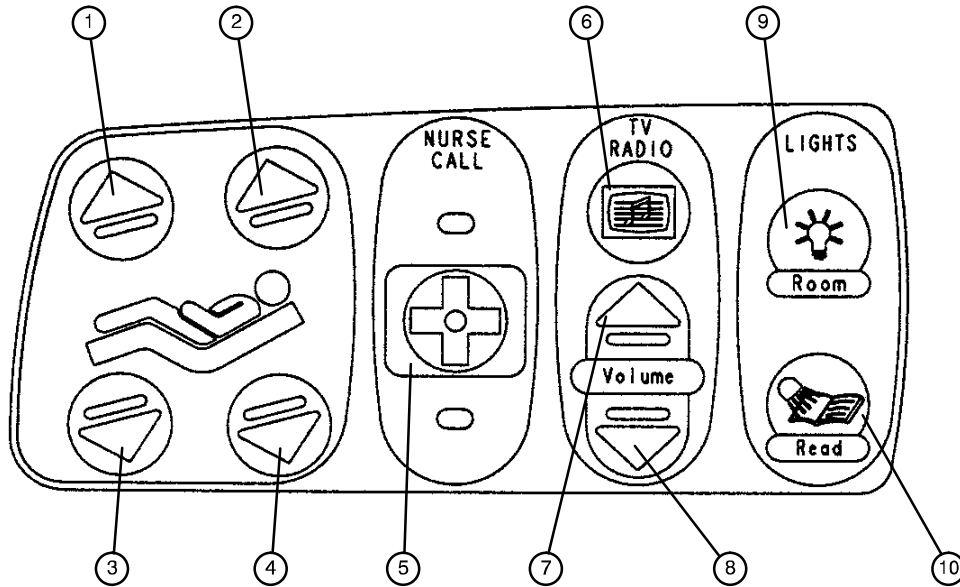

1. Press to raise knee section.
2. Press to raise back section.
3. Press to lower knee section.
4. Press to lower back section.
5. Press to activate the nurse call.
6. Press to turn on the TV or radio. Press again to change TV channels and to turn off the TV.
7. Press to increase the TV or radio volume.
8. Press to decrease the TV or radio volume.
9. Press to turn on the room lights. Press again to turn off.
10. Press to turn on the reading light. Press again to turn off.



WARNING

Because individual beds may have different options, foot boards should not be moved from one bed to another. Mixing foot boards could result in unpredictable bed operation.

Introduction

BED SYMBOLS (CONTINUED)

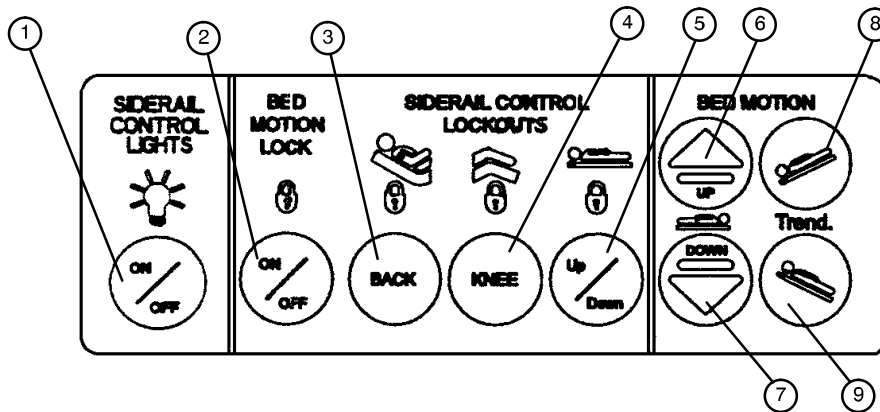

1. Press repeatedly for low, medium and high settings for the siderail control lights. Continue to press this switch to turn off the siderail control lights and the nurse call indicator light.
2. Press to lock out all motion controls on the siderails. Press again to unlock.
3. Press to lock out Back motion control on the siderails. Press again to unlock.
4. Press to lock out Knee motion control on the siderails. Press again to unlock.
5. Press to lock out up/down motion controls on the siderails. Press again to unlock.
6. Press to raise litter. If your bed is equipped with the enhanced height option, continue to hold the button an additional 5 seconds after the first stop. The litter will raise an additional 2 inches.
7. Press to lower litter.
8. Press to lower head end (Trendelenburg).
9. Press to lower foot end (Reverse Trendelenburg).

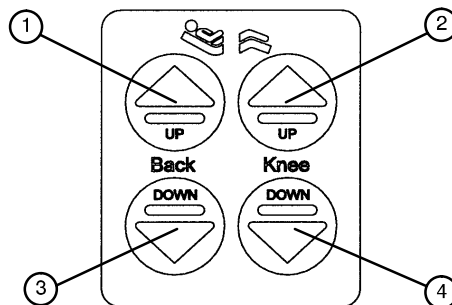

1. Press to raise back section.
2. Press to raise knee section.
3. Press to lower back section.
4. Press to lower knee section.

Introduction

BED SYMBOLS (CONTINUED)

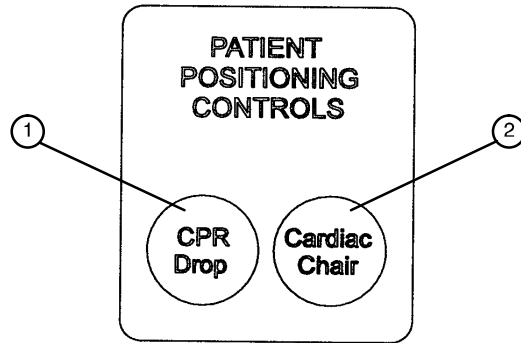

1. Press to activate the emergency CPR function. The Back will lower to flat, the Knee will lower to flat, the litter will level from Trendelenburg/reverse Trendelenburg, and the litter will lower to full down.
2. Press to activate the Cardiac Chair function. The Knee will raise, the Fowler will raise or lower to approximately 52° and the bed will tilt to approximately -12° reverse Trendelenburg (foot end down) or -14° if the bed has the enhanced height option. Release the button to stop bed movement: hold the button until movement stops to complete the function.

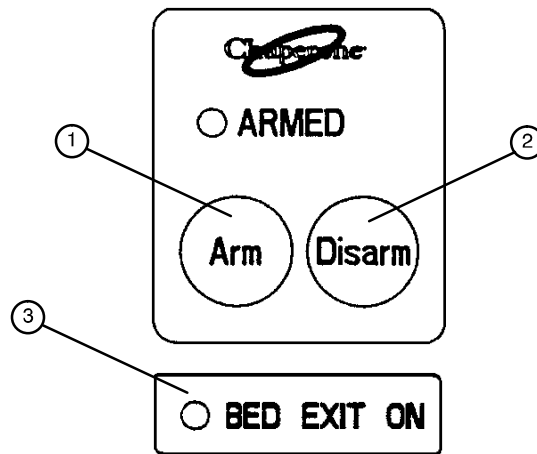

1. Press to arm the Bed Exit function.
2. Press to disarm the Bed Exit function.
3. "BED EXIT ON" LED - will light when the BED EXIT function is armed.

Introduction

BED SYMBOLS (CONTINUED)

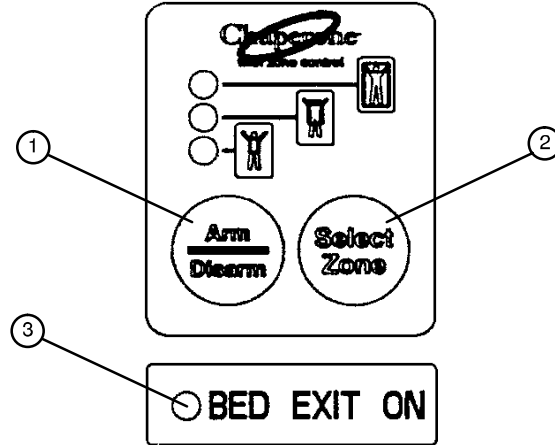

1. Press to arm or disarm the Bed Exit function.
2. Press to select the zone desired for Bed Exit function.
3. "BED EXIT ON" LED – will light when the BED EXIT function is armed.

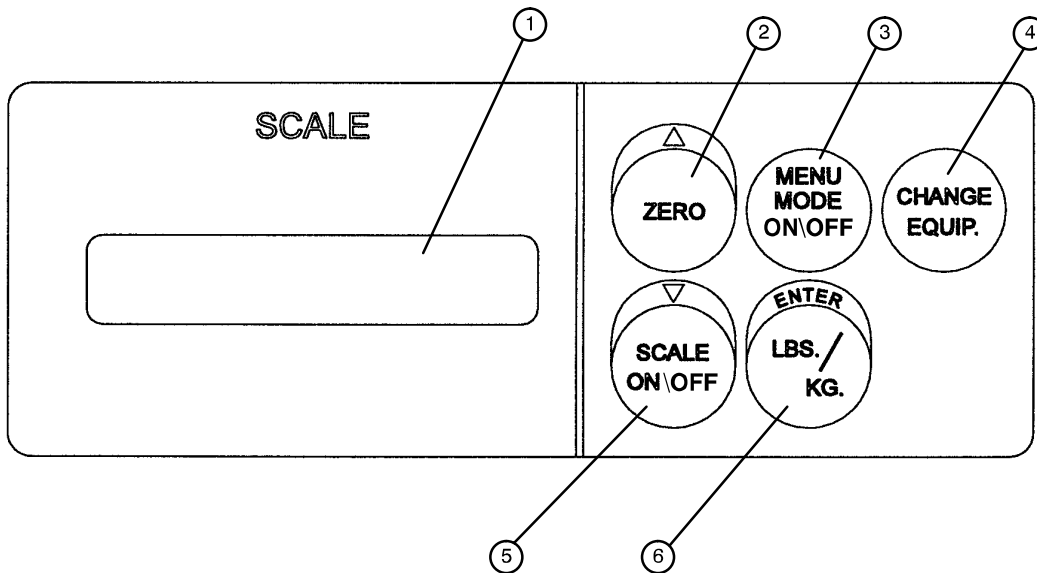

1. LCD – displays patient weight. Trendelenburg angle is displayed when the scale is not active.
2. Press to zero system. Also press to scroll while Menu Mode is active.
3. Press to enter and exit the Menu Mode.
4. Press when adding or removing equipment on the frame.
5. Press to turn weigh system on and off. Also press to scroll while Menu Mode is active.
6. Press to change weight from pounds to kilograms or back. Also press while using the Menu Mode.

Introduction

BED SYMBOLS (CONTINUED)

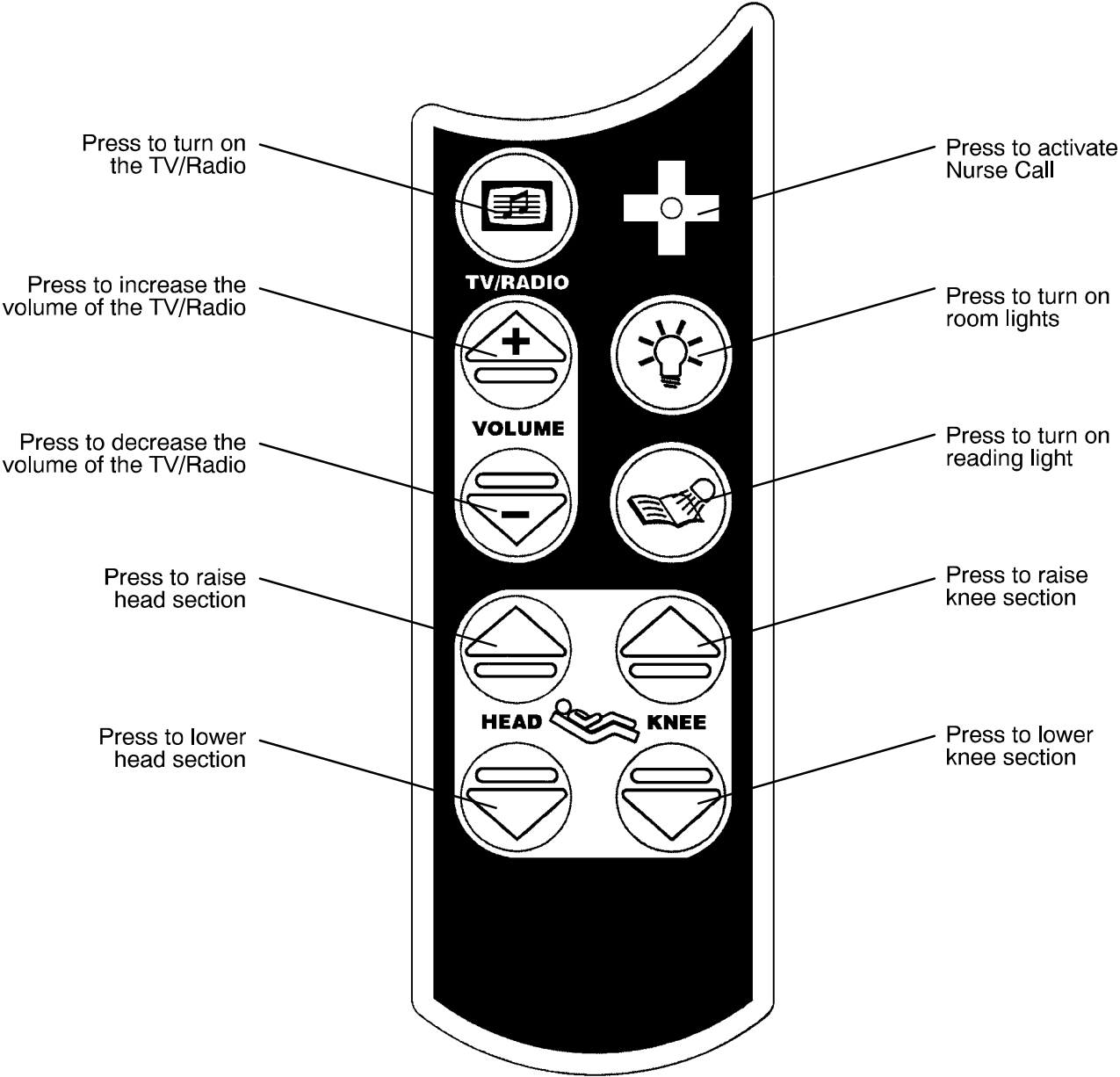

Preventative Maintenance

CLEANING

Hand wash all surfaces of the bed with warm water and mild detergent. DRY THOROUGHLY. Do not steam clean or hose off the Zoom Bed. Do not immerse any part of the bed. Some of the internal parts of the bed are electric and may be damaged by exposure to water.

Suggested cleaners for bed surfaces:

Quaternary Cleaners (active ingredient – ammonium chloride)

Phenolic Cleaners (active ingredient – o-phenyl phenyl)

Chlorinated Bleach Solution (5.25% – less than 1 part bleach to 100 parts water)

Avoid over-saturation and ensure the product does not stay wet longer than the chemical manufacturer's guidelines for proper disinfecting.

CAUTION

SOME CLEANING PRODUCTS ARE CORROSIVE IN NATURE AND MAY CAUSE DAMAGE TO THE PRODUCT IF USED IMPROPERLY. If the products described above are used to clean Stryker patient care equipment, measures must be taken to insure the beds are wiped with clean water and thoroughly dried following cleaning. Failure to properly rinse and dry the beds will leave a corrosive residue on the surface of the bed, possibly causing premature corrosion of critical components. Failure to follow the above directions when using these types of cleaners may void this product's warranty.

For mattress cleaning instructions, please see the tag on the mattress, or contact the mattress manufacturer.

Clean Velcro® AFTER EACH USE. Saturate Velcro® with disinfectant and allow disinfectant to evaporate. (Appropriate disinfectant for nylon Velcro® should be determined by the hospital.)

Preventative Maintenance

CHECKLIST

- _____ All fasteners secure
- _____ Engage brake pedal and push on the frame to ensure all casters lock securely
- _____ Optional locking steer caster engages and disengages properly
- _____ Engage drive wheel and ensure it is operating properly
- _____ Motion release switches working properly
- _____ Confirm Head End Control Panel functionality
- _____ Confirm battery powered functionality
- _____ Siderails move, latch and stow properly
- _____ All functions on siderails working properly (including LED's)
- _____ Manual CPR release working properly
- _____ Foot prop intact and working properly
- _____ I.V. pole working properly
- _____ Foley bag hooks intact
- _____ Chart rack intact and working properly
- _____ CPR board not cracked or damaged and stores properly
- _____ No cracks or splits in head and foot boards
- _____ All functions on footboard working properly (including LED's)
- _____ No rips or cracks in mattress cover
- _____ Scale and Bed Exit system calibrated properly
- _____ Power cord not frayed
- _____ No cables worn or pinched
- _____ All electrical connections tight
- _____ All grounds secure to the frame
- _____ Ground impedance not more than 100 milliohms
- _____ Current leakage not more than 300 microamps
- _____ Apply grease to litter grease points
- _____ Fowler functioning properly

Unit Serial No. _____

Completed By: _____ Date: _____

Preventative Maintenance

WARNING

Service only by qualified personnel. Refer to the maintenance manual.

Ensure the power cord is unplugged and the battery power switch is turned to the off position before servicing.

NURSE CALL BATTERY

To prevent a low battery condition when the power cord is not plugged in, position the cord out switch at the head end to the off position. The switch is identified by the label shown below. If the switch is not positioned as shown below and the power cord and pendant cord are unplugged, the life of the back-up battery will be significantly reduced.

If the foot board POWER LED is flashing, the Nurse Call battery needs to be replaced. The battery is located on the patient's left side under the litter frame. No tools are required to replace the battery. Unplug the power cord from the wall socket and replace the battery. After replacing the battery, verify the foot board POWER LED is no longer flashing. Properly dispose of the old battery in accordance with local regulations.

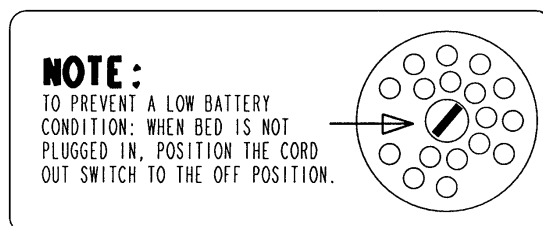

MAIN POWER CIRCUIT BREAKER

In the event of a loss of electric function, unplug the power cord from the wall socket and reset the circuit breaker(s) located under the head end of the litter on the patient's left side. Plug the power cord into a properly grounded wall receptacle and follow the set-up procedures listed on [page 8](#).

BATTERY CHARGER CIRCUIT BREAKER

If the battery charger circuit breaker(s) located under the litter on the patient's head end, left side are tripped, refer to the troubleshooting section of the maintenance manual.

Static Discharge Precautions

The electronic circuits in the 2040 are completely protected from static electricity damage only while the bed is assembled. It is extremely important that all service personnel always use adequate static protection when servicing the electronic systems of the Secure II. *Whenever you are touching wires, you should be using static protection.*

Static Protection Equipment

The necessary equipment for proper static protection is:

- 1 static wrist strap; 3M part number 2214 or equivalent,
- 1 grounding plug; 3M part number 61038 or equivalent,
- 1 test lead with a banana plug on one end and an alligator clip on the other; Smith part number N132B699 or equivalent.

CAUTION

All electronic service parts will be shipped in static shielding bags. Do not open the bags until you have completed steps 2 and 3 of the following procedure. Do not place unprotected circuit boards on the floor. All circuit boards to be returned to Stryker Medical should be shipped in the static shielding bags the new boards were shipped in.

Static Protection Procedure

1. Unplug the power cord from the wall receptacle.
2. Insert the grounding plug into a properly grounded hospital grade wall receptacle. Plug the banana plug of the test lead into the receptacle on the grounding plug. Connect the alligator clip on the other end of the test lead to a ground point on the bed.
3. Place the static control wrist strap on your wrist. Connect the alligator clip at the other end of the wrist strap cord to a ground point on the bed.

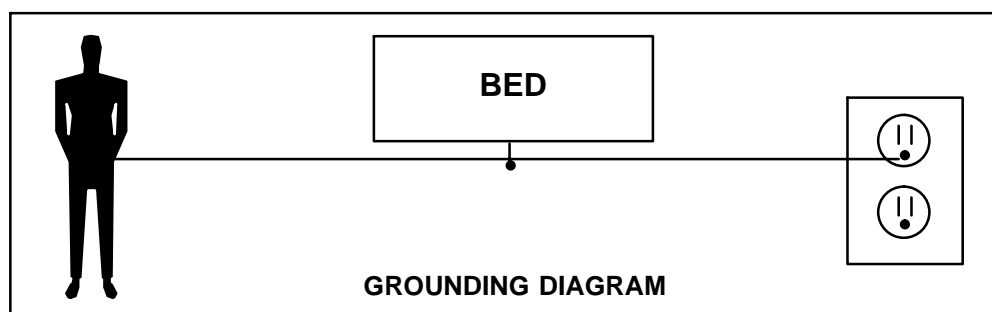

Troubleshooting Guide

NOTE

See [page 29](#) through [page 38](#) for an outline of bed PCB's and voltage test points.

PROBLEM/FAILURE	RECOMMENDED ACTION
No power to bed	<p>A. Verify the power cord connections at the wall and the bed.</p> <p>B. Check circuit breakers, under the litter/gatch section on the patient left side. If the circuit breaker is tripped, reset it by pushing in.</p> <p>C. Check for 120 VAC at J1 on the power supply, Pin 1 and 2.</p> <p>D. Check for DC voltages on J2 (Pins 1, 2, 3 & 6) on power supply. See page 34 for power supply voltage test points.</p> <p>a. If voltage is present, check connector W on the CPU board and check for the same DC voltages. If OK, go to step E.</p> <p>b. If voltage is not present, unplug connector W on the CPU board and recheck for DC voltages at J2 on the power supply.</p> <p>1. If voltages come back, re-connect cable W to the CPU board, and go to step c.</p> <p>2. If DC voltage does not come back, replace the power supply.</p> <p>c. Unplug all connectors except for F, FF, O, and W from the CPU board and recheck voltages on connector W</p> <p>1. If DC voltages come back, plug the cable connections back in until problem comes back, isolate the problem to a component or assembly.</p> <p>2. If DC voltages do not come back, replace the CPU board</p> <p>E. Check for 120 VAC at connector O on the CPU board.</p> <p>a. If voltage is present, replace the CPU board.</p> <p>F. Verify bed function and return to service.</p>
No bed down motion.	<p>A. Enter diagnostics, (see page 57) and press bed down.</p> <p>a. If motion is not present, verify there is a two-pin shunt present on connector Z, closest to the center of the bed, if not, install shunt.</p> <p>1. Test bed down motion, if motion is present then go to step D.</p> <p>b. If motion is present, re-burn lift potentiometer limits, see page 49 for procedure.</p> <p>B. Check for 5 VDC on TP 9 (HL) and TP 7 (FL).</p> <p>a. If 5 VDC is present, go to step C.</p> <p>b. If 5 VDC is not present, replace CPU board.</p> <p>C. Check for 120 VAC power on connector N (HL) and G (FL), pin 1 white and pin 3 black, of the CPU board, while pressing bed motion up.</p> <p>a. If voltage is not present, replace CPU board.</p> <p>b. If voltage is present:</p> <p>1. Verify the motors are running, if so, replace lift couplers.</p> <p>2. If motors are not running, check voltage at motor connection.</p> <p>3. If voltage is present at motor, check capacitors or motors.</p> <p>D. Verify bed function and return to service.</p>

Troubleshooting Guide

PROBLEM/FAILURE	RECOMMENDED ACTION
No bed up motion.	<p>A. Enter diagnostics, (see page 57) and press bed up.</p> <p style="margin-left: 20px;">a. If motion is not present, go to step B.</p> <p style="margin-left: 20px;">b. If motion is present, re-burn lift potentiometer limits, see page 49 for procedure.</p> <p>B. Check for 5VDC on TP 10 (HL) and TP 8 (FL) on the CPU board</p> <p style="margin-left: 20px;">a. If 5 VDC is present, go to step C.</p> <p style="margin-left: 20px;">b. If 5 VDC is not present, replace CPU board.</p> <p>C. Check for 120 VAC power on connector N (HL) and G (FL), pin 1 white and pin 6 red, of the CPU board while pressing bed motion up.</p> <p style="margin-left: 20px;">a. If voltage is not present, replace CPU board.</p> <p style="margin-left: 20px;">b. If voltage is present</p> <p style="margin-left: 40px;">1. Verify the motors are running, if so, replace lift couplers.</p> <p style="margin-left: 40px;">2. If motors are not running, check voltage at motor connection.</p> <p style="margin-left: 40px;">3. If voltage is present at motor, check capacitors or motors.</p> <p>D. Verify bed function and return to service.</p>
No Gatch down motion.	<p>A. Check for 5VDC on TP 5 on the CPU board</p> <p style="margin-left: 20px;">a. If 5 VDC is present, go to step B.</p> <p style="margin-left: 20px;">b. If 5 VDC is not present, replace CPU board.</p> <p>B. Check for 120 VAC power on connector CC, pin 2 (red) and pin 3 (white), of the CPU board while pressing gatch down.</p> <p style="margin-left: 20px;">a. If voltage is not present, replace the CPU board</p> <p style="margin-left: 20px;">b. If 5 VDC is present, check the capacitor and motor.</p> <p>C. Verify bed function and return to service.</p>
No Gatch up motion.	<p>A. Check for 5 VDC on TP 6 on the CPU board</p> <p style="margin-left: 20px;">a. If 5 VDC is present, go to step B.</p> <p style="margin-left: 20px;">b. If 5 VDC is not present, replace CPU board.</p> <p>B. Check for 120 VAC on connector CC, pin 1 (black) and pin 3 (white), of the CPU board while pressing gatch up.</p> <p style="margin-left: 20px;">a. If voltage is not present, replace the CPU board</p> <p style="margin-left: 20px;">b. If 5 VDC is present, check the capacitor and motor.</p> <p>C. Verify bed function and return to service.</p>
No Fowler up/or uneven motion.	<p>A. Check for 5 VDC on TP 3 on the CPU board</p> <p style="margin-left: 20px;">a. If 5 VDC is present, go to step B.</p> <p style="margin-left: 20px;">b. If 5 VDC is not present, replace CPU board.</p> <p>B. Check for 120 VAC on connector GG, Pin 1 (white) and pin 2 (black), of the CPU board while pressing Fowler up.</p> <p style="margin-left: 20px;">a. If voltage is not present, replace the CPU board</p> <p style="margin-left: 20px;">b. If 5 VDC is present, check the capacitor and motor.</p> <p>C. Refer to Fowler Mechanism Customer Guide (2030-009-028)</p> <p>D. Verify bed function and return to service.</p>
No Fowler down/or uneven motion.	<p>A. Check for 5VDC on TP4 on the CPU board</p> <p style="margin-left: 20px;">a. If 5 VDC is present, go to step B.</p> <p style="margin-left: 20px;">b. If 5 VDC is not present, replace CPU board.</p> <p>B. Check for 120 VAC on connector GG, Pin 1 (white) and pin 3 (red), of the CPU board while pressing Fowler up.</p> <p style="margin-left: 20px;">a. If voltage is not present, replace the CPU board</p> <p style="margin-left: 20px;">b. If 5 VDC is present, check the capacitor and motor.</p> <p>C. Refer to Fowler Mechanism Customer Guide (2030-009-028)</p> <p>D. Verify bed function and return to service.</p>

Troubleshooting Guide

This section of the troubleshooting guide includes the Zoom® self-propelled drive and the battery backup functions. When using this guide, assume the bed is functioning properly when powered by the AC line cord with the exception of the battery charging components.

PROBLEM/FAILURE	POSSIBLE CAUSE	RECOMMENDED ACTION
ON/OFF switch is in the on position but the power LED is off and the bed does not function.	No DC voltage from the batteries.	A. Check the fuse (F1) on the power board (see page 38) – replace if necessary (p/n 59-730). B. Verify the battery voltage is greater than 24 VDC. C. Check the battery fuse – replace if necessary (p/n 2040-1-802). D. Check the cable connections from the batteries to the display board. E. Check the ON/OFF switch and cabling.
ON/OFF switch is in the on position, the power LED is on but the bed does not function.	Display board is not functioning or is locking out all functions.	A. Check the safety switches on the drive bar. B. Verify the battery voltage is greater than 24 VDC. C. Verify the display board is functioning (see note below). D. Check all cable connections on the display and power boards.
ON/OFF switch is in the on position, the power LED is on, the Zoom® drive works but the battery backup does not work.	The thermostat on the inverter/charger board has tripped, indicating a temperature above 110° C (230° F).	A. Wait approximately 3-5 minutes to allow the inverter/charger board to cool down.
The Zoom® drive does not work – the bed does not drive – but all other functions are working.	Zoom® drive circuitry is not responding.	A. Verify the display board is functioning (see note below). B. Perform the control bar potentiometer “burn-in” procedure (see page 67). C. Check the control bar potentiometer. When the bar is centered, there should be 2.25VDC – 2.75 VDC between pin 1 and pin 2 on header 1 on the display/CPU board (see page 36) D. Check all cable connections on the display and power boards. E. Verify the power board is functioning. F. Verify the drive wheel is functioning.

NOTE

The display board will display the state of battery charge when the bed is first powered using the ON/OFF switch:
 Three LED's flash = 66% – 100% charged
 Two LED's flash = 33% – 66% charged
 One LED flashes = less than 33% charged
 No LED's flash = no significant charge remaining.

Troubleshooting Guide

PROBLEM/FAILURE	POSSIBLE CAUSE	RECOMMENDED ACTION
The Zoom® drive does work – the bed will drive – but all other bed functions are not working.	No AC power from the Zoom ® base.	A. Check AC voltage coming out of the inverter. It should be 120VAC between pin 1 and pin 4 on header 5 on the AC crossover board (see page 37) B. Check all cable connections from the batteries to the converter. C. Check the AC crossover board.
The bed power cord is plugged in but the battery does not charge.	The battery charger is not functioning.	A. Check the circuit breakers on the Zoom® litter (page 120 , item NA) . B. Check the battery charger. C. Check all cable connections on the charger.

Troubleshooting Guide

INVERTER/CHARGER, BATTERY & ZOOM® TROUBLESHOOTING GUIDE

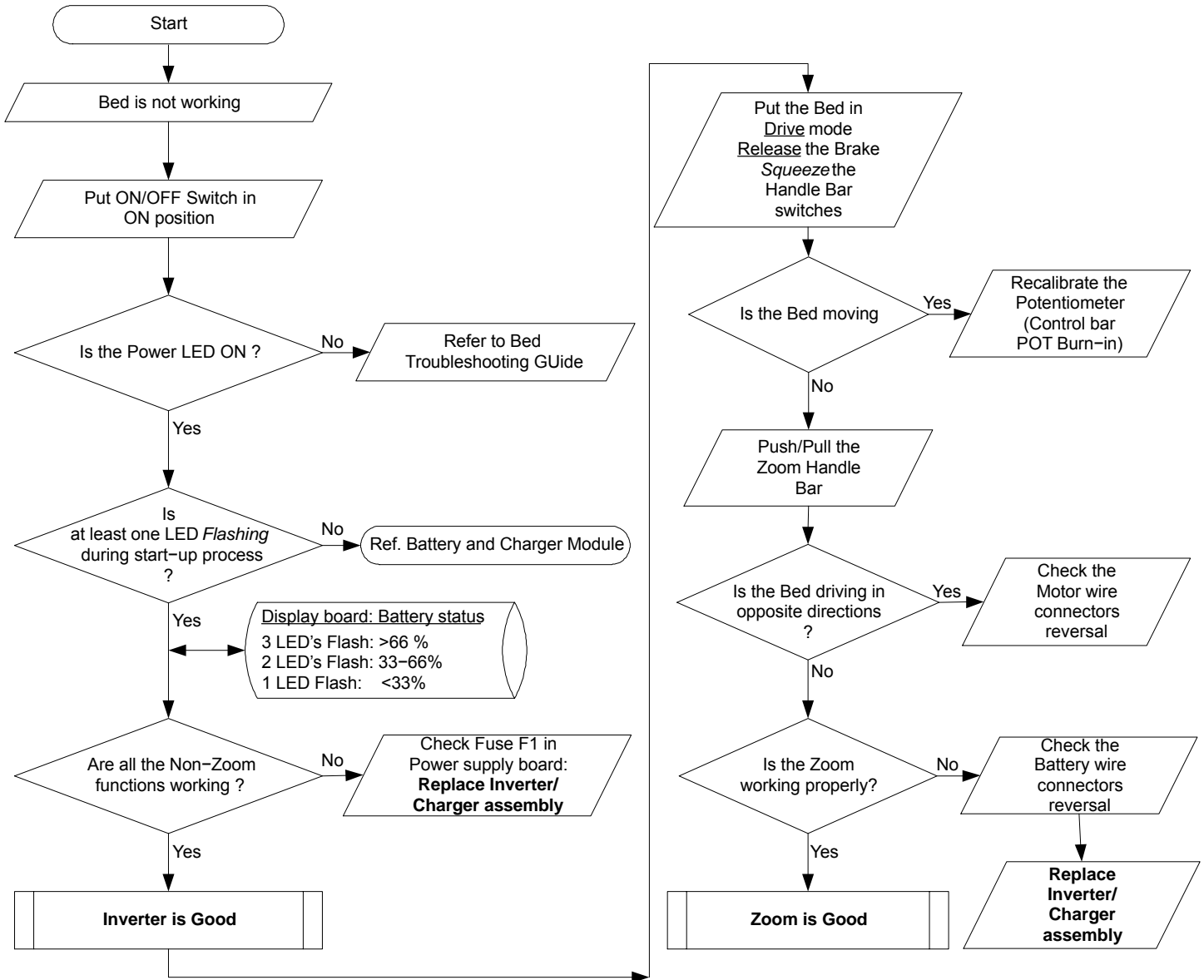

Troubleshooting Guide

INVERTER/CHARGER, BATTERY & ZOOM® TROUBLESHOOTING GUIDE

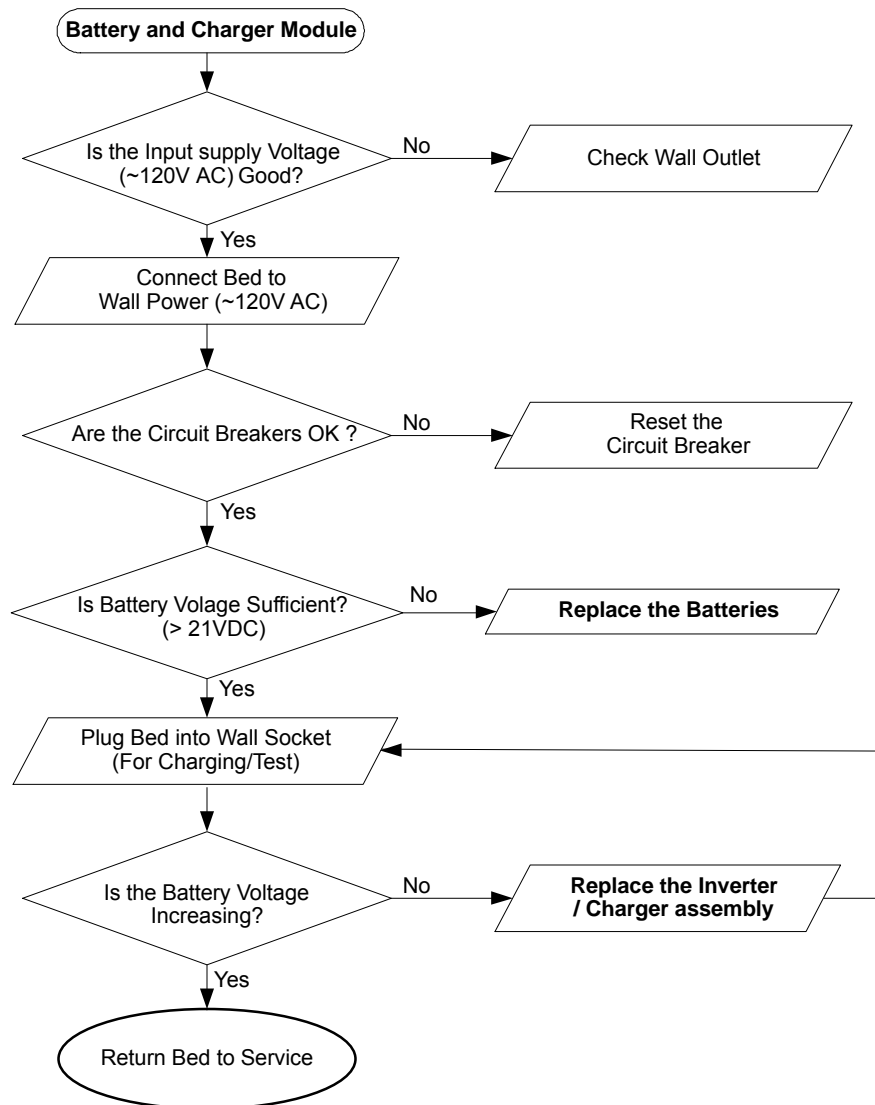

Bed Wiring Diagram

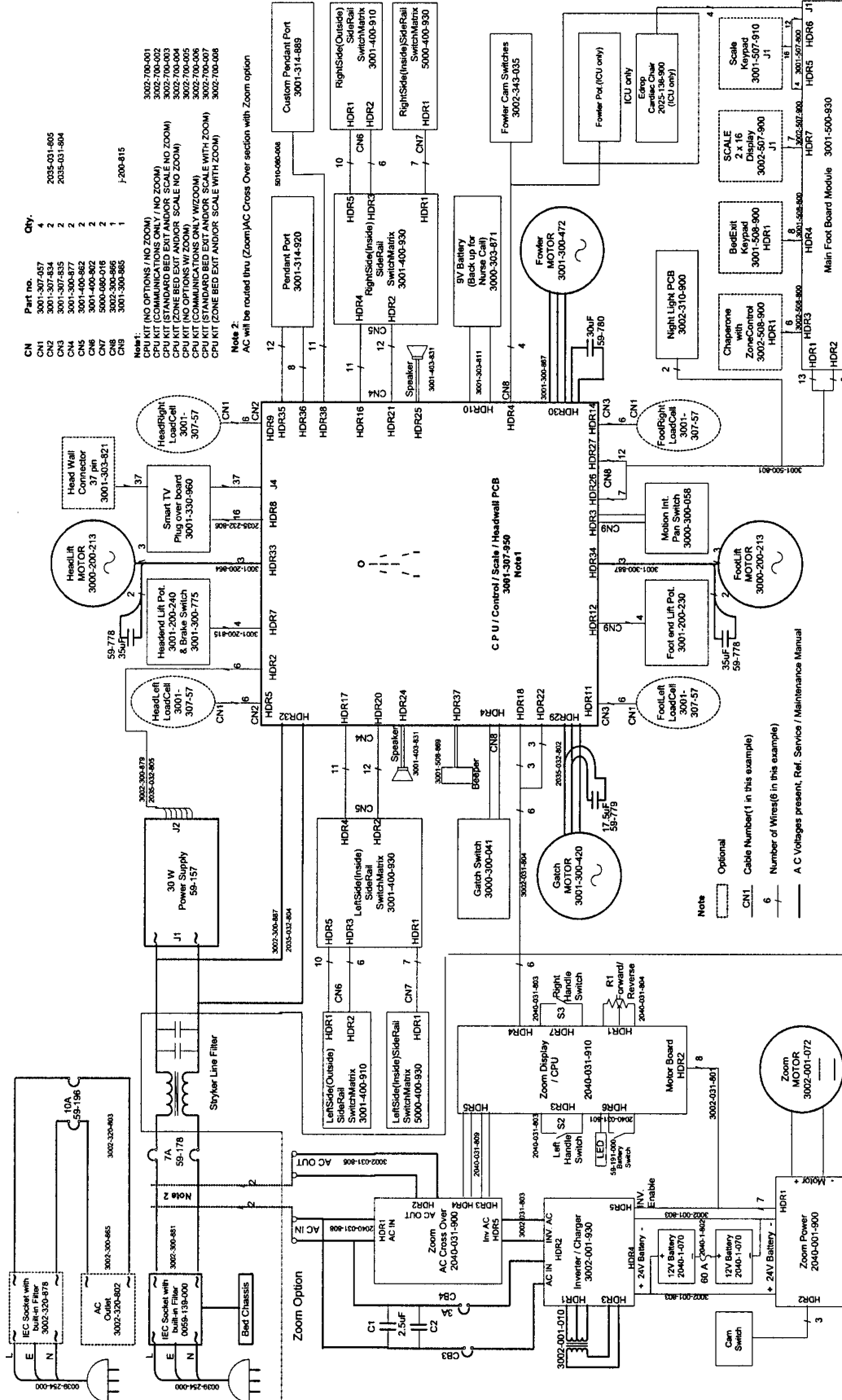

Bed Wiring Diagram

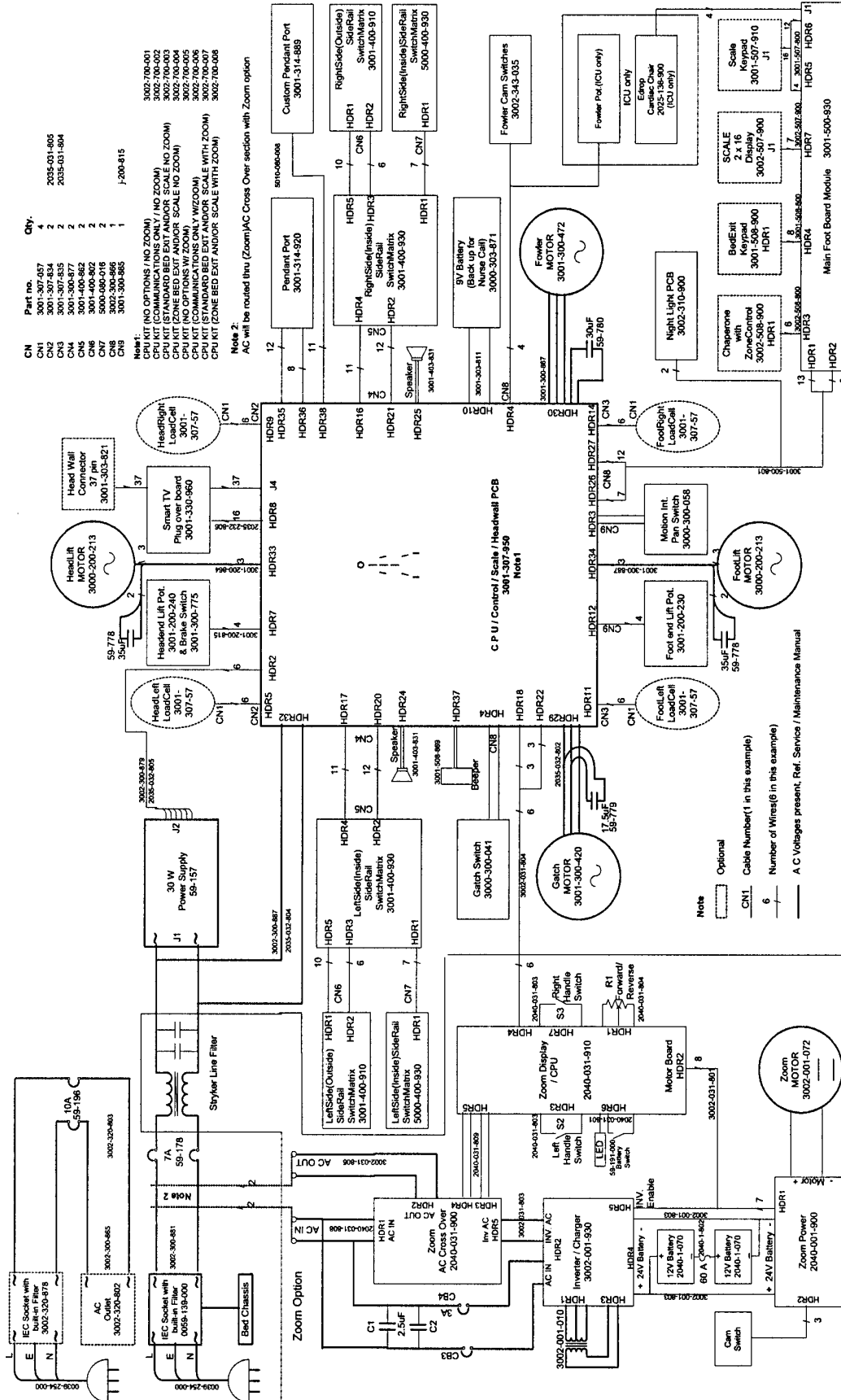

Electrical System Information

CPU BOARD – 3002-407-950

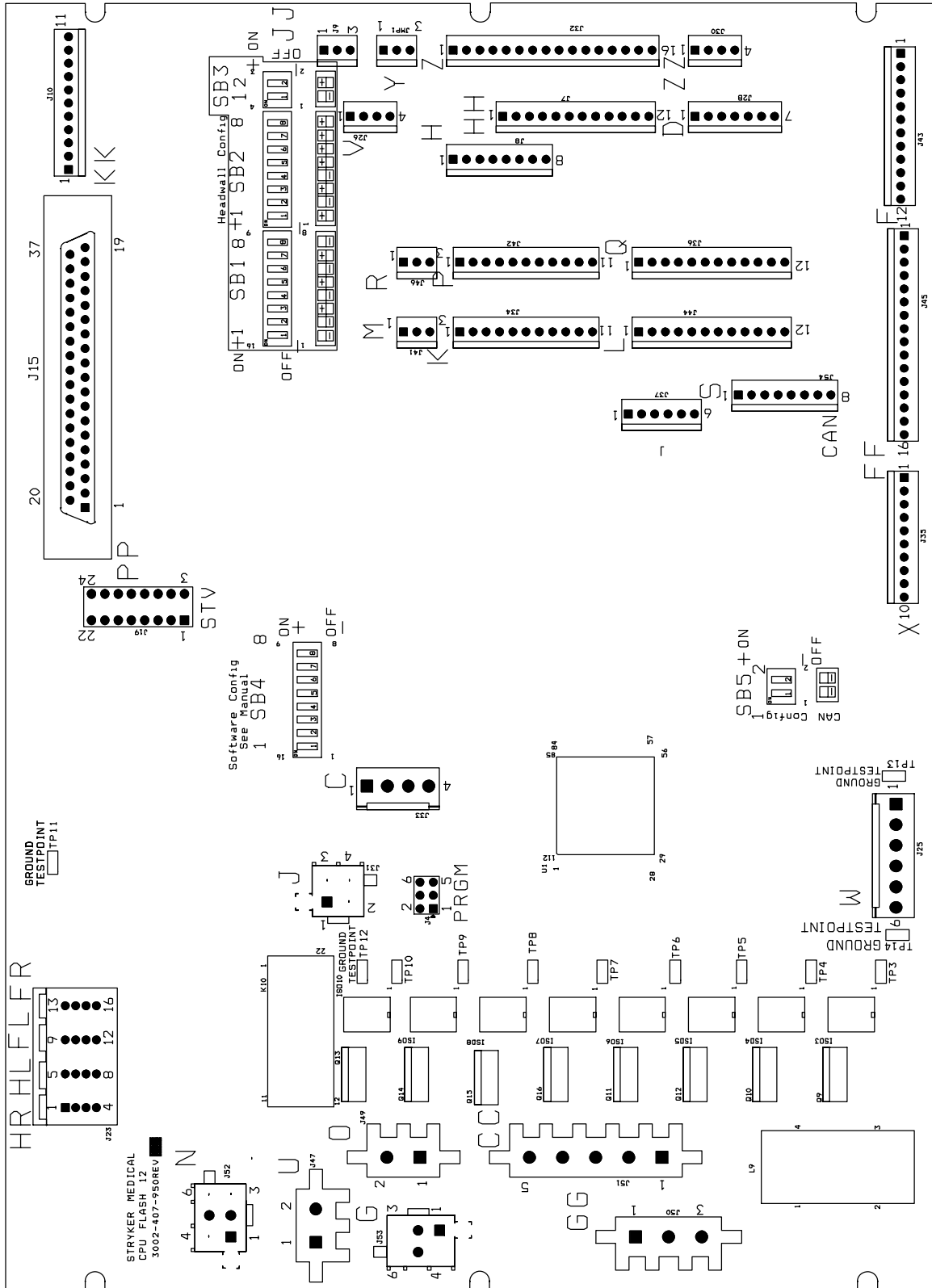

Electrical System Information

CPU BOARD – 3002–407–950

CABLE LOCATION	VOLTAGE	POSITIVE LEAD	NEGATIVE LEAD	DESCRIPTION
W	+12 VDC	Pin 1	Pin 4 or 5	Relays & Siderails Light Voltage
W	+5 VDC	Pin 2 & 3	Pin 4 or 5	+5 VDC from Power Supply
W	-12 VDC	Pin 6	Pin 4 or 5	Relays & Siderails Light Voltage
ZZ	+5 VDC	Pin 1 Red	Pin 4 Black	+5 VDC for Fowler Pot
ZZ	0 – 5 VDC	Pin 1 Red	Pin 3 Green	Fowler Pot Wiper
J	0 – 5 VDC	Pin 3 Red	Pin 2 White	Head Lift Pot Wiper
J	+5 VDC	Pin 4 Green	Pin 2 White	+5 VDC for Head Lift Pot
C	+5 VDC	Pin 1	Pin 2	+5 VDC for Foot Lift Pot
C	0 – 5 VDC	Pin 3	Pin 2	Foot Lift Pot Wiper
CC	0 VAC w/o Switch 120 VAC w/Switch	Pin 3 White	Pin 1 Black	Gatch Up
CC	0 VAC w/o Switch 120 VAC w/Switch	Pin 3 White	Pin 2 Red	Gatch Down
GG	0 VAC w/o Switch 120 VAC w/Switch	Pin 2 Black	Pin 1 White	Fowler Up
GG	0 VAC w/o Switch 120 VAC w/Switch	Pin 3 Red	Pin 1 White	Fowler Down
O	120 VAC	Pin 1	Pin 2	Line Voltage to Bed
N	0 VAC w/o Switch 120 VAC w/Switch	Pin 3 Black	Pin 1 White	Head Lift Down
N	0 VAC w/o Switch 120 VAC w/Switch	Pin 6 Red	Pin 1 White	Head Lift Up
G	0 VAC w/o Switch 120 VAC w/Switch	Pin 3 Black	Pin 1 White	Foot Lift Down
G	0 VAC w/o Switch 120 VAC w/Switch	Pin 6 Red	Pin 1 White	Foot Lift Up

Electrical System Information

SOFTWARE CONFIGURATION

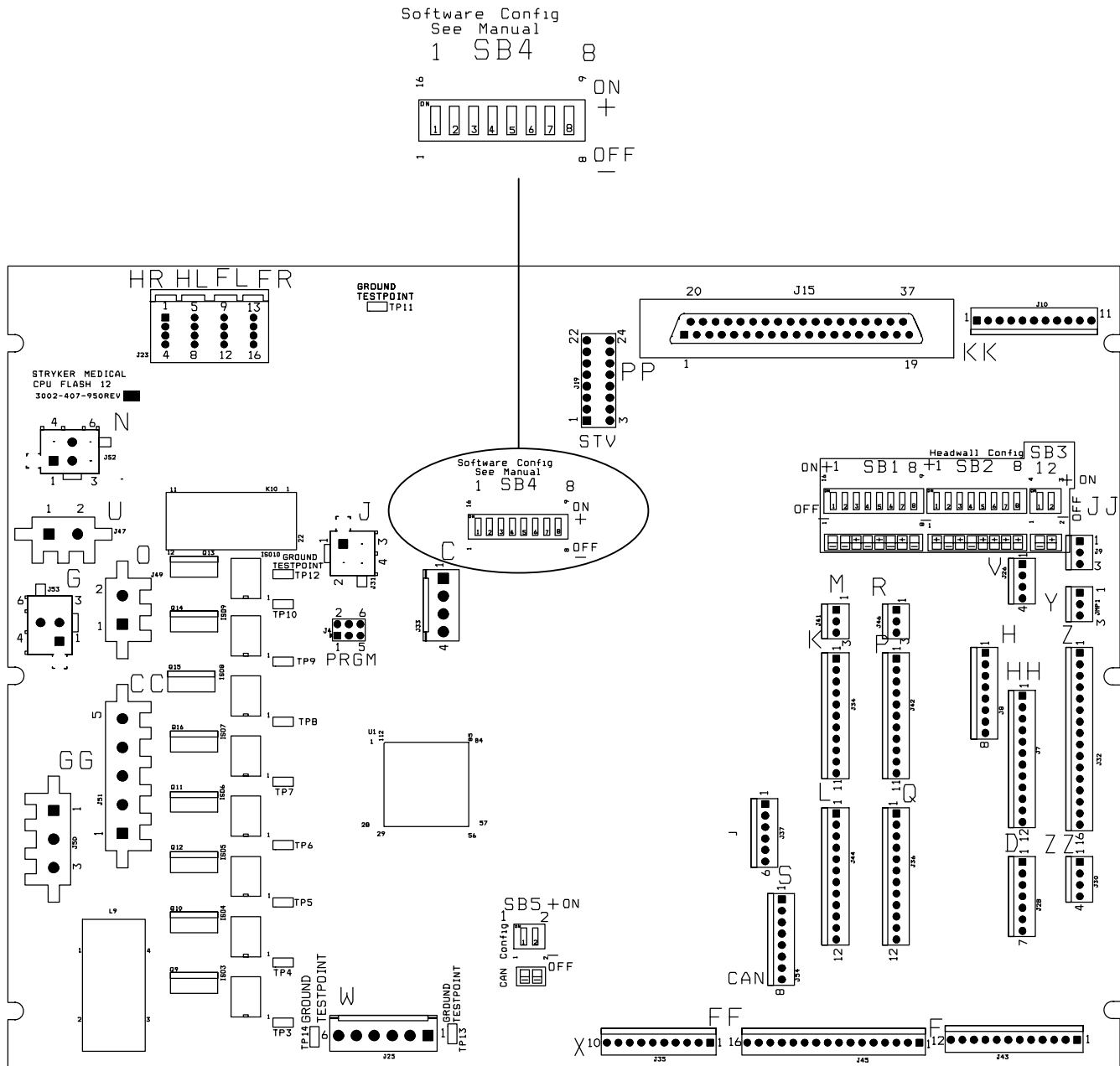

1. Locate switch bank 4, labeled SB4 on the CPU board (see above).
2. Move the switches to the appropriate positions for the specific bed (see page 32 & 33).
3. To verify the switch settings, check what the foot board LCD displays in the burn-in mode. For beds with a scale system, select software config. in the diagnostic mode.











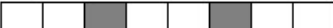

Electrical System Information

SOFTWARE CONFIGURATION (CONTINUED)

<p>ON <input type="checkbox"/> <input type="checkbox"/> <input type="checkbox"/> <input type="checkbox"/> <input type="checkbox"/> <input type="checkbox"/> <input type="checkbox"/> <input type="checkbox"/></p> <p>OFF <input checked="" type="checkbox"/> <input checked="" type="checkbox"/> <input checked="" type="checkbox"/> <input checked="" type="checkbox"/> <input checked="" type="checkbox"/> <input checked="" type="checkbox"/> <input checked="" type="checkbox"/> <input checked="" type="checkbox"/></p> <p style="text-align: center;">1 2 3 4 5 6 7 8</p>	FUNCTIONAL TEST
<p>ON <input checked="" type="checkbox"/> <input type="checkbox"/> <input type="checkbox"/> <input type="checkbox"/> <input type="checkbox"/> <input type="checkbox"/> <input type="checkbox"/> <input type="checkbox"/></p> <p>OFF <input type="checkbox"/> <input checked="" type="checkbox"/> <input checked="" type="checkbox"/> <input checked="" type="checkbox"/> <input checked="" type="checkbox"/> <input checked="" type="checkbox"/> <input checked="" type="checkbox"/> <input checked="" type="checkbox"/></p> <p style="text-align: center;">1 2 3 4 5 6 7 8</p>	ICU-KCI
<p>ON <input type="checkbox"/> <input checked="" type="checkbox"/> <input type="checkbox"/> <input type="checkbox"/> <input type="checkbox"/> <input type="checkbox"/> <input type="checkbox"/> <input type="checkbox"/></p> <p>OFF <input checked="" type="checkbox"/> <input type="checkbox"/> <input checked="" type="checkbox"/> <input checked="" type="checkbox"/> <input checked="" type="checkbox"/> <input checked="" type="checkbox"/> <input checked="" type="checkbox"/> <input checked="" type="checkbox"/></p> <p style="text-align: center;">1 2 3 4 5 6 7 8</p>	MED-SURG-KCI
<p>ON <input type="checkbox"/> <input type="checkbox"/> <input type="checkbox"/> <input checked="" type="checkbox"/> <input type="checkbox"/> <input type="checkbox"/> <input type="checkbox"/> <input type="checkbox"/></p> <p>OFF <input checked="" type="checkbox"/> <input checked="" type="checkbox"/> <input checked="" type="checkbox"/> <input type="checkbox"/> <input checked="" type="checkbox"/> <input checked="" type="checkbox"/> <input checked="" type="checkbox"/> <input checked="" type="checkbox"/></p> <p style="text-align: center;">1 2 3 4 5 6 7 8</p>	ICU-STANDARD BED
<p>ON <input checked="" type="checkbox"/> <input type="checkbox"/> <input type="checkbox"/> <input checked="" type="checkbox"/> <input type="checkbox"/> <input type="checkbox"/> <input type="checkbox"/> <input type="checkbox"/></p> <p>OFF <input type="checkbox"/> <input checked="" type="checkbox"/> <input checked="" type="checkbox"/> <input type="checkbox"/> <input checked="" type="checkbox"/> <input checked="" type="checkbox"/> <input checked="" type="checkbox"/> <input checked="" type="checkbox"/></p> <p style="text-align: center;">1 2 3 4 5 6 7 8</p>	ICU-ZOOM / STANDARD BED
<p>ON <input type="checkbox"/> <input checked="" type="checkbox"/> <input type="checkbox"/> <input checked="" type="checkbox"/> <input type="checkbox"/> <input type="checkbox"/> <input type="checkbox"/> <input type="checkbox"/></p> <p>OFF <input checked="" type="checkbox"/> <input type="checkbox"/> <input checked="" type="checkbox"/> <input type="checkbox"/> <input checked="" type="checkbox"/> <input checked="" type="checkbox"/> <input checked="" type="checkbox"/> <input checked="" type="checkbox"/></p> <p style="text-align: center;">1 2 3 4 5 6 7 8</p>	ICU-ZOOM / SCALE / BEDEXIT
<p>ON <input checked="" type="checkbox"/> <input checked="" type="checkbox"/> <input type="checkbox"/> <input checked="" type="checkbox"/> <input type="checkbox"/> <input type="checkbox"/> <input type="checkbox"/> <input type="checkbox"/></p> <p>OFF <input type="checkbox"/> <input type="checkbox"/> <input checked="" type="checkbox"/> <input type="checkbox"/> <input checked="" type="checkbox"/> <input checked="" type="checkbox"/> <input checked="" type="checkbox"/> <input checked="" type="checkbox"/></p> <p style="text-align: center;">1 2 3 4 5 6 7 8</p>	ICU-ZOOM / SCALE / ZONE CONTROL BEDEXIT
<p>ON <input type="checkbox"/> <input type="checkbox"/> <input checked="" type="checkbox"/> <input checked="" type="checkbox"/> <input type="checkbox"/> <input type="checkbox"/> <input type="checkbox"/> <input type="checkbox"/></p> <p>OFF <input checked="" type="checkbox"/> <input checked="" type="checkbox"/> <input type="checkbox"/> <input type="checkbox"/> <input checked="" type="checkbox"/> <input checked="" type="checkbox"/> <input checked="" type="checkbox"/> <input checked="" type="checkbox"/></p> <p style="text-align: center;">1 2 3 4 5 6 7 8</p>	ICU-SCALE / BEDEXIT
<p>ON <input checked="" type="checkbox"/> <input type="checkbox"/> <input checked="" type="checkbox"/> <input checked="" type="checkbox"/> <input type="checkbox"/> <input type="checkbox"/> <input type="checkbox"/> <input type="checkbox"/></p> <p>OFF <input type="checkbox"/> <input checked="" type="checkbox"/> <input type="checkbox"/> <input type="checkbox"/> <input checked="" type="checkbox"/> <input checked="" type="checkbox"/> <input checked="" type="checkbox"/> <input checked="" type="checkbox"/></p> <p style="text-align: center;">1 2 3 4 5 6 7 8</p>	ICU-SCALE / ZONE CONTROL BEDEXIT
<p>ON <input type="checkbox"/> <input type="checkbox"/> <input type="checkbox"/> <input type="checkbox"/> <input type="checkbox"/> <input checked="" type="checkbox"/> <input type="checkbox"/> <input type="checkbox"/></p> <p>OFF <input checked="" type="checkbox"/> <input checked="" type="checkbox"/> <input checked="" type="checkbox"/> <input checked="" type="checkbox"/> <input type="checkbox"/> <input checked="" type="checkbox"/> <input checked="" type="checkbox"/> <input checked="" type="checkbox"/></p> <p style="text-align: center;">1 2 3 4 5 6 7 8</p>	MED-SURG-STANDARD BED
<p>ON <input checked="" type="checkbox"/> <input type="checkbox"/> <input type="checkbox"/> <input type="checkbox"/> <input type="checkbox"/> <input checked="" type="checkbox"/> <input type="checkbox"/> <input type="checkbox"/></p> <p>OFF <input type="checkbox"/> <input checked="" type="checkbox"/> <input checked="" type="checkbox"/> <input checked="" type="checkbox"/> <input type="checkbox"/> <input type="checkbox"/> <input checked="" type="checkbox"/> <input checked="" type="checkbox"/></p> <p style="text-align: center;">1 2 3 4 5 6 7 8</p>	MED-SURG-ZOOM / STANDARD BED
<p>ON <input type="checkbox"/> <input checked="" type="checkbox"/> <input type="checkbox"/> <input type="checkbox"/> <input type="checkbox"/> <input checked="" type="checkbox"/> <input type="checkbox"/> <input type="checkbox"/></p> <p>OFF <input checked="" type="checkbox"/> <input type="checkbox"/> <input checked="" type="checkbox"/> <input checked="" type="checkbox"/> <input type="checkbox"/> <input type="checkbox"/> <input checked="" type="checkbox"/> <input checked="" type="checkbox"/></p> <p style="text-align: center;">1 2 3 4 5 6 7 8</p>	MED-SURG-ZOOM / SCALE / BEDEXIT

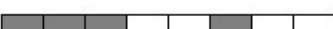
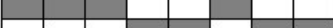
Electrical System Information

SOFTWARE CONFIGURATION (CONTINUED)

<p>ON </p> <p>OFF </p> <p>1 2 3 4 5 6 7 8</p>	MED-SURG-ZOOM / SCALE / ZONE CONTROL BEDEXIT
<p>ON </p> <p>OFF </p> <p>1 2 3 4 5 6 7 8</p>	MED-SURG-SCALE / BEDEXIT
<p>ON </p> <p>OFF </p> <p>1 2 3 4 5 6 7 8</p>	MED-SURG-SCALE / ZONE CONTROL BEDEXIT
<p>ON </p> <p>OFF </p> <p>1 2 3 4 5 6 7 8</p>	MED-SURG-SHORT / ZOOM / STANDARD BED
<p>ON </p> <p>OFF </p> <p>1 2 3 4 5 6 7 8</p>	MED-SURG-SHORT / ZOOM / SCALE / BEDEXIT
<p>ON </p> <p>OFF </p> <p>1 2 3 4 5 6 7 8</p>	MED-SURG-SHORT / ZOOM / SCALE / ZONE CONTROL BEDEXIT
<p>ON </p> <p>OFF </p> <p>1 2 3 4 5 6 7 8</p>	MATERNITY

Electrical System Information

POWER SUPPLY – P/N 59-157

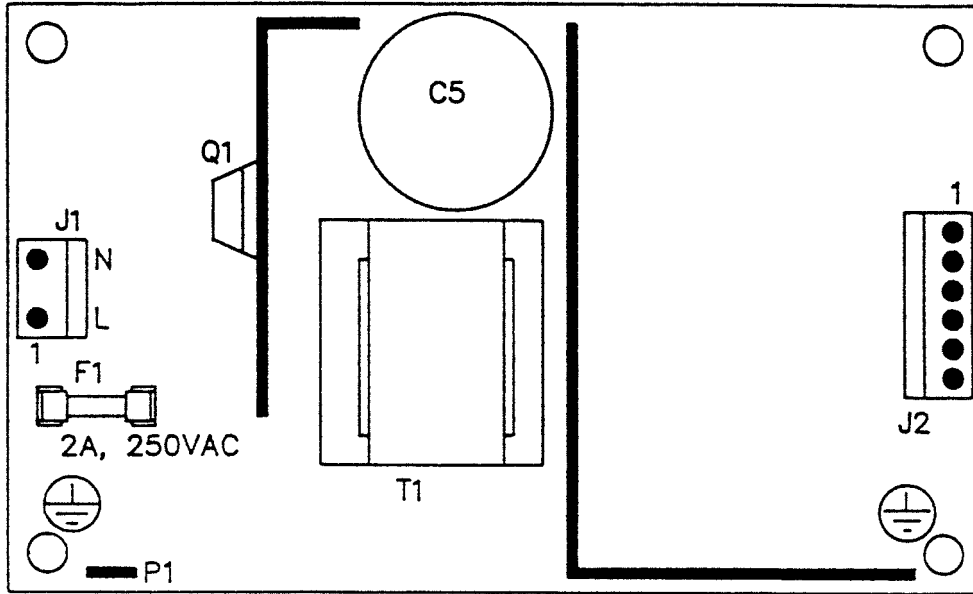

CONNECTOR LOCATION	VOLTAGE	POSITIVE LEAD	NEGATIVE LEAD
J1	110V	Pin 1	Pin 2
J2	12V	Pin 1	Pin 4 or 5
J2	5V	Pin 2	Pin 4 or 5
J2	5V	Pin 3	Pin 4 or 5
J2	GND	Pin 4	Pin 4 or 5
J2	GND	Pin 5	Pin 4 or 5
J2	-12V	Pin 6	Pin 4 or 5

Electrical System Information

INVERTER/CHARGER BOARD – PART NUMBER 3002-1-30

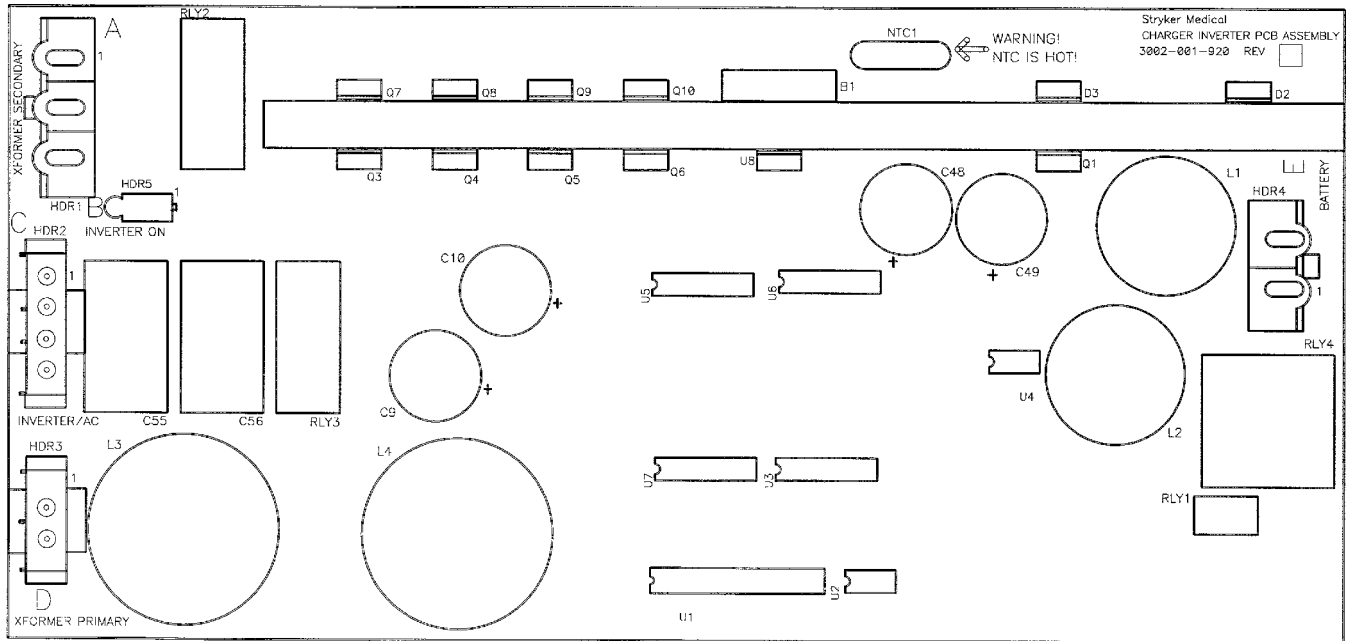

CONNECTOR LOCATION	VOLTAGE	POSITIVE LEAD	NEGATIVE LEAD	DESCRIPTION
HDR 4	26 VDC	Pin 2 Red	Pin 1 Black	From Battery – unplugged
HDR 1	22 VAC	Pin 3 Red	Pin 2	Secondaries from Transformer – plugged in
HDR 1	34 VAC	Pin 1 Green	Pin 2 Brown	Secondaries from Transformer – plugged in
HDR 2	110–140 VAC	Pin 4 Brown	Inverter Module Pin 3 Blue	Unplugged
HDR 2	110 V	Pin 2 Brown	Pin 1 Blue	From Wall – plugged in
HDR 3	120 V	Pin 2	Plug-In Pin 1	Wall Voltage – plugged in

Electrical System Information

DISPLAY/CPU – P/N 2040–31–910

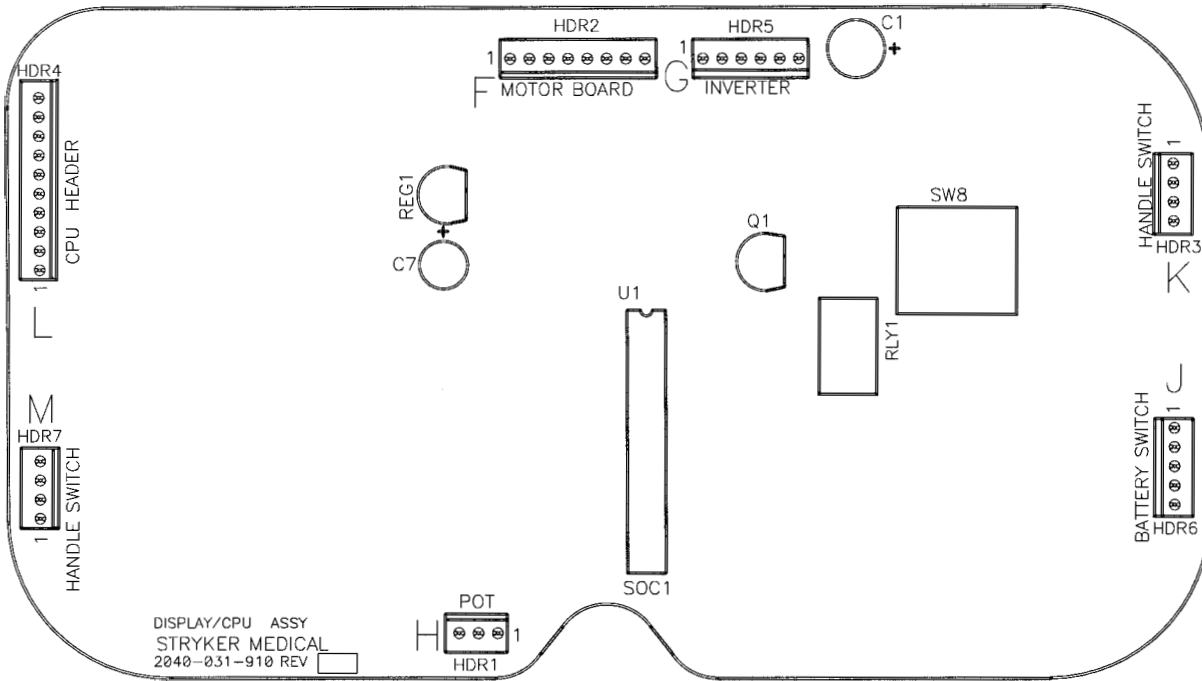

CONNECTOR LOCATION	VOLTAGE	POSITIVE LEAD	NEGATIVE LEAD	DESCRIPTION
HDR 1 (H)	0–5VDC	Pin 1	Pin 2	Control Pot Wiper Voltage (with Switch On)
HDR 6 (J)	Battery voltage around 26VDC	Pin 1	Pin 5	Battery Voltage Return from On/Off Switch (with Switch On)
HDR 4 (L)	5VDC	Pin 9	Pin 1	Voltage from CPU
HDR 1	5VDC	Pin 1	Pin 3	DC Voltage to Pot
HDR 7	Continuity	Pin 1	Pin 4	Right Hand Switch
HDR 3	Continuity	Pin 1	Pin 4	Left Hand Switch
HDR 2	26VDC	Pin 3	Pin 1	Battery Voltage

Electrical System Information

AC CROSSOVER BOARD – P/N 2040–31–900

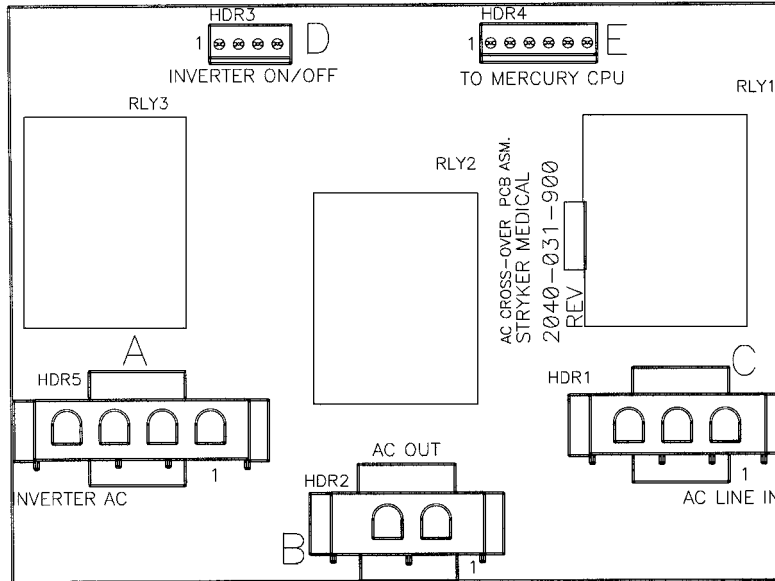

CONNECTOR LOCATION	VOLTAGE	POSITIVE LEAD	NEGATIVE LEAD	DESCRIPTION
HDR 5 (A)	120VAC	Pin 4	Pin 1	AC Input to Board from the Inverter with the Power Cord Unplugged
HDR 1 (C)	120VAC	Pin 3	Pin 1	AC Input to Board from the Wall Receptacle
HDR 2 (B)	120VAC	Pin 2	Pin 1	AC Output of Board to Main Power
HDR 4 (E)	+5VDC	Pin 4	Pin 1	+5VDC when AC is Unplugged from the Wall Receptacle

Electrical System Information

DC MOTOR POWER BOARD – P/N 2040-1-900

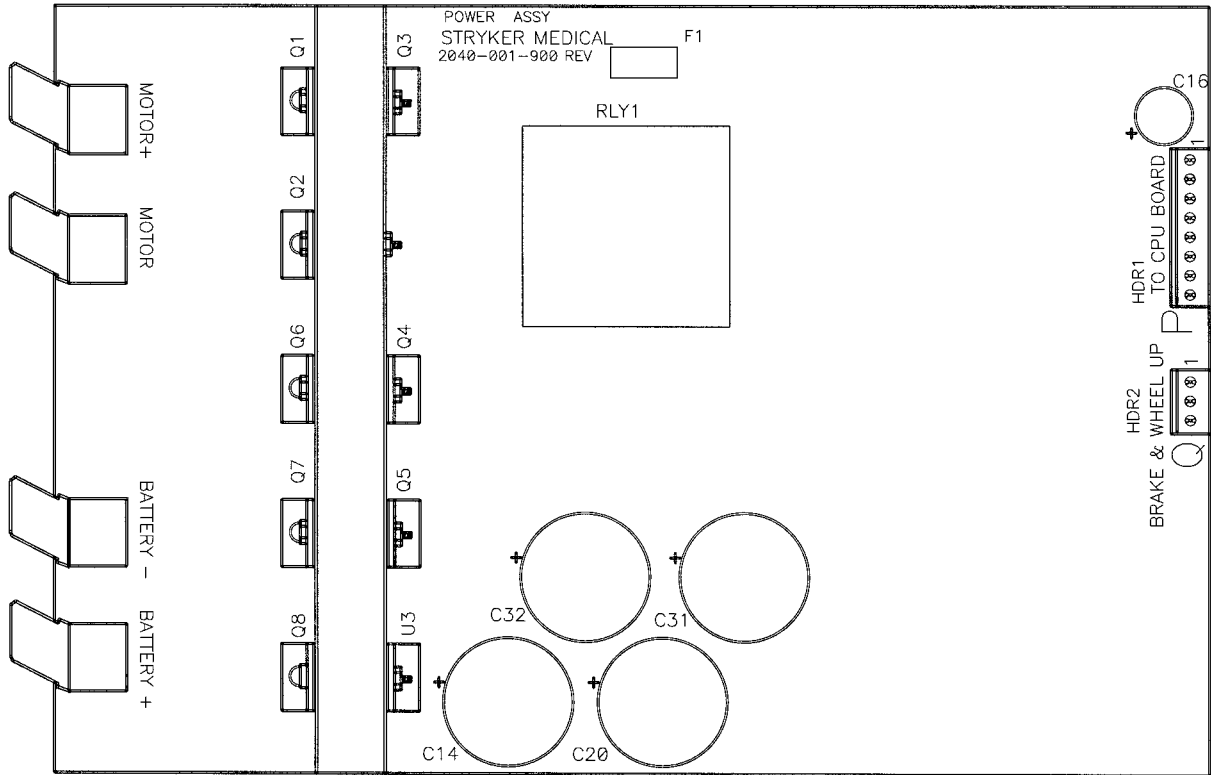

CONNECTOR LOCATION	VOLTAGE	POSITIVE LEAD	NEGATIVE LEAD	DESCRIPTION
HDR 1 (P)	Battery voltage around 26VDC	Pin 3 Red	Pin 1 Black	Battery Voltage out to the Display/CPU Board
HDR 2 (Q)	5VDC Disengaged 0VDC Engaged	Pin 1 Red	Pin 3 Black	Drive Wheel
HDR 2 (Q)	5VDC Disengaged 0VDC Engaged	Pin 2 Red	Pin 3 Black	Brakes

Electrical System Information

INVERTER PROTECTION FEATURES

The inverter has several features to prevent internal damage:

1. Low Battery Voltage – If the battery voltage at the inverter drops below the low voltage cut-off, the inverter will shut off.
2. Over-Temperature – If the inverter gets too hot, it will shut off. The overheating may be caused by high ambient temperature, blocked air flow or an overload condition. When the inverter reaches an acceptable temperature, it will restart.
3. Over-Power – The inverter will source up to its maximum power rating. If the load requires more, the output voltage will shut down. Turning the power switch off and on will reset the inverter. Plugging the bed power cord into the wall socket to charge the battery will reset the inverter.



WARNING

The inverter generates 115VAC, the same as a wall receptacle. To prevent injury, do not put anything into the electrical outlets other than an appliance power cord. Keep the outlets covered when not in use. Do not submerge the unit or subject it to moisture.

Electrical System Information

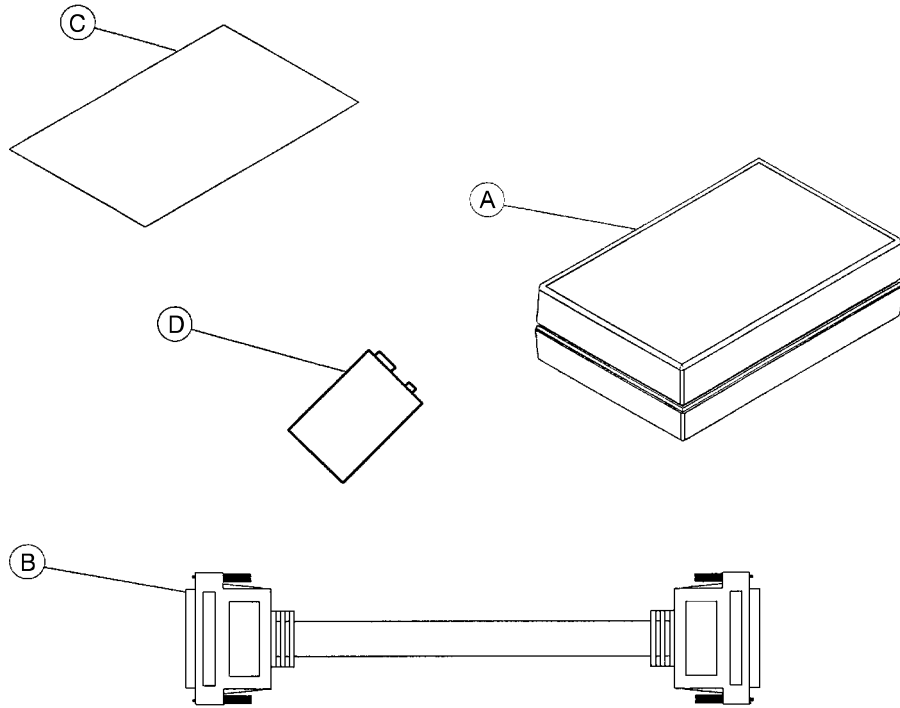

Item	Part No.	Part Name	Qty.
A	3002-45-805	BCT Unit	1
B	3001-303-825	37-Pin Cable	1
C	3002-45-806	Instructions	1
D	3000-303-871	9V Battery	1

Electrical System Information

37-PIN CONNECTOR

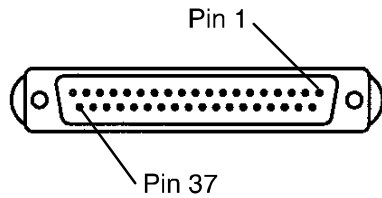

Pin 1	Option 2 Common
Pin 2	Read Light
Pin 3	Room Light
Pin 4	Speaker High
Pin 5	Pot Wiper
Pin 6	Radio Common
Pin 7	Nurse Call Interlock
Pin 8	Audio Transfer -
Pin 9	Audio Transfer +
Pin 10	Interlock +
Pin 11	Interlock -
Pin 12	Spare
Pin 13	Options 3 Common
Pin 14	Pot Low Common
Pin 15	Pot High Common (Std.)/Audio (STV)
Pin 16	Nurse Answer Light +
Pin 17	Option 1 NO/NC
Pin 18	Option 1 Common
Pin 19	Nurse Call Light +
Pin 20	Option 2 NO/NC
Pin 21	Option 3 NO/NC
Pin 22	Option 3A NO/NC
Pin 23	Option 2A Common
Pin 24	Option 2A NO/NC
Pin 25	Nurse Call +
Pin 26	Nurse Call NO/NC
Pin 27	Room/Read Light Common
Pin 28	Nurse Call Light -
Pin 29	Nurse Answer Light -
Pin 30	Priority NO/NC
Pin 31	Priority Common
Pin 32	Option 3A Common
Pin 33	TV - (Std.)/Data (STV)
Pin 34	TV + (Std.)/Common (STV)
Pin 35	Speaker Low Common
Pin 36	Audio Shield
Pin 37	Radio NO/NC

STRYKER PENDANT PORT

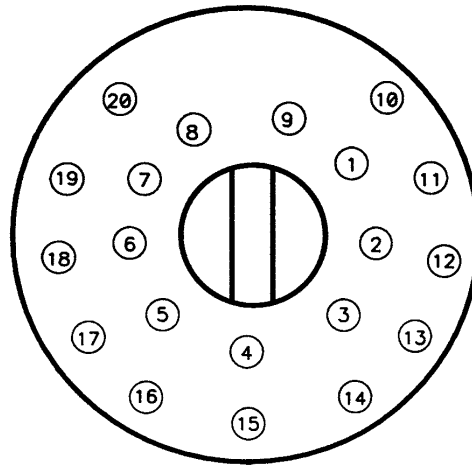

1	Scan Line
2	Audio (-)
3	Nurse Call (+)
4	+5 VDC
5	Scan Line
6	Scan Line
7	Nurse Call (-)
8	TV Channel Up
9	Backlight
10	Audio (+)
11	Gatch Up/Fowler In/Foot Up/DMS Firm
12	Gatch Down/Fowler Out/Foot Out/DMS Soft
13	Fowler Up/Trend In
14	Fowler Down/Trend Out
15	Audio Shield
16	Not Used - Socket Filled
17	Litter Up
18	Ground
19	Read Light/Litter Down
20	Room Light

Quick Reference Replacement Parts List

ELECTRICAL COMPONENTS

AC CROSSOVER BOARD	2040-31-900
FOOT BOARD KEYBOARD (S/R LIGHTS, LOCKOUTS, ETC.)	3001-500-930
FOOT BOARD SCALE DISPLAY	3001-507-900
FOOT BOARD SCALE KEYBOARD	3001-507-910
FOOT BOARD BED EXIT KEYBOARD	3001-508-900
CPU KIT	3002-407-950
DISPLAY/CPU BOARD	2040-31-910
INVERTER/CHARGER BOARD	3002-1-30
POWER BOARD	2040-1-900
POWER SUPPLY	59-157

SIDERAIL BOARDS

INSIDE BOARD	3001-400-930
OUTSIDE BOARD	3001-400-910
SPEAKER W/CABLE	3000-403-831

OTHER COMPONENTS

ADHESIVE, HEAD & FOOT BOARD "C" BUMPERS	72-2-71
BATTERY KIT	2040-700-13
CAPACITOR, FOWLER & GATCH	59-779
CAPACITOR, FOWLER & GATCH, 230V	59-153
CAPACITOR, LIFT	59-778
CAPACITOR, LIFT, 230V	3221-200-243
CASTER, 6"	3001-200-60
CASTER, STEER, 6"	3001-200-50
COIL CORD, LIFT POWER	3001-200-864
COIL CORD, LIFT SENSOR	3001-200-815
COMMUNICATIONS TESTER	3001-303-165
FOOT PROP RETROFIT KIT	2030-700-16
GREASE, SINGLE TUBE	3000-200-700
LOAD CELL	3002-307-57

Quick Reference Replacement Parts List

OTHER COMPONENTS (CONTINUED)

MOTOR COUPLER KIT, LIFT	3000-200-725
MOTOR, DRIVE WHEEL	3002-1-72
MOTOR, FOWLER & GATCH W/CLUTCH	3001-300-560
MOTOR, FOWLER & GATCH W/CLUTCH, 230V	3221-300-705
MOTOR, LIFT (SAME FOR HEAD AND FOOT END)	3000-200-213
MOTOR, LIFT, 230V (SAME FOR HEAD AND FOOT END)	3221-200-213
PAINT, TOUCH-UP, OPAL, BOTTLE W/BRUSH	7000-1-321
PAINT, TOUCH-UP, OPAL, SPRAY CAN	7000-1-318
POTENTIOMETER, CONTROL BAR	2040-31-804
POTENTIOMETER, FOOT END	3001-200-230
POTENTIOMETER, FOWLER	2035-32-803
POTENTIOMETER, HEAD END	3001-200-240
POWER CORD	39-254
RESTRAINT STRAP, 2-PIECE	390-19
SIDERAIL COVER, RIGHT	3000-336-11
SIDERAIL COVER, LEFT	3000-336-12
SIDERAIL COVERS (SET OF FOUR)	2040-130

Service Information

BRAKE PEDAL REPLACEMENT

Required Tools:

5/16" Hex Allen Wrench

Torque Wrench

Loctite 242

Hammer

Punch

#2 Phillips Screwdriver

Bungee Cords (or Equivalent)

Procedure:

1. Raise the litter to the full up position.
2. Unplug the power cord from the wall socket and push the battery power on/off switch to the "OFF" position.
3. Using a #2 Phillips screwdriver, remove the four screws holding the base hood to the frame. If necessary, hold the covers out of the way by using bungee cords (or the equivalent) to secure them to the litter top.
4. Using a 5/16" hex Allen wrench, remove the two bolts holding the brake pedal to the brake rod.
5. Using a hammer and punch, remove the roll pins holding the brake shaft crank to the brake rod on both the head and the foot end.
6. Push the brake rod through the frame until the brake pedal is clear. Remove the brake pedal.
7. Reverse steps 1 – 6 to attach the new brake pedal.

NOTE

Use Loctite 242 when reinstalling the bolts and torque the bolts to 25 foot-pounds.

Service Information

LIFT MOTOR AND CAPACITOR REMOVAL AND REPLACEMENT

Required Tools:

3/8" Socket Wrench w/Extension
Side Cutters

5/16" Socket Wrench
7/16" Open End Wrench

Floor Jack
2 x 4 (or Equivalent)

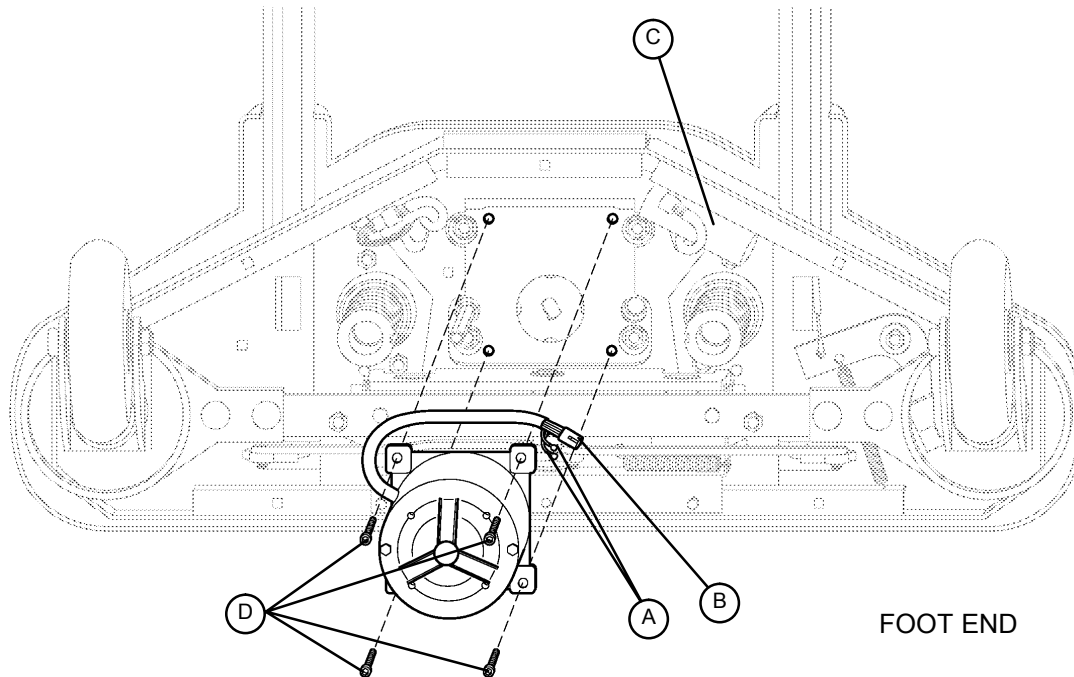

Procedure:

NOTE

If you need more space to work under the base frame, place a 2 x 4 across the base frame rails and use a floor jack to raise the base frame off the floor.

1. Unplug the power cord from the wall socket and push the battery power on/off switch to the "OFF" position.
2. Using a 5/16" socket wrench, remove the five bolts holding the lower lift cover to the base and remove the cover.
3. Disconnect the two connectors (A) at the motor capacitor.
4. Disconnect the white connector (B) from the power cord.
5. Using side cutters, cut the cable ties holding the capacitor (C) to the base and remove the capacitor.
6. Using a 3/8" socket wrench, remove the four screws (D) holding the motor assembly in the lift housing and remove the motor assembly.
7. Reverse steps 1 – 6 to install the new motor.

NOTE

The drive shaft on the new motor might need to be turned with a 7/16" open end wrench to align with the coupler. The procedure for lift motor and capacitor removal and replacement is the same for both ends of the bed.

Service Information

LIFT HOUSING REMOVAL AND REPLACEMENT

Required Tools:

#2 Phillips Screwdriver	Bungee Cord (or Equivalent)	5/16" Socket Wrench
Side Cutters	9/16" Socket Wrench	Floor Jack
7/32" Hex Allen Socket Wrench	Sawhorses (or Equivalent)	2 x 4 (or Equivalent)
3/8" Socket Wrench (w/ 6" extension)		

Procedure:

NOTE

If you need more space to work under the base frame, place a 2 x 4 across the base frame rails and use a floor jack to raise the base frame off the floor.

1. Unplug the power cord from the wall socket and push the battery power on/off switch to the "OFF" position.
2. Using a 5/16" socket wrench, remove the five bolts holding the lower lift cover to the base and remove the cover.
3. Using a #2 Phillips screwdriver, remove the three screws holding the upper lift cover to the base. If necessary, hold the upper and lower covers out of the way by using bungee cords (or the equivalent) to secure them to the litter top.
4. Remove the lift motor and capacitor (refer to the procedure on [page 45](#)).
5. Remove the lift potentiometer (refer to the procedure on [page 48](#)).
6. Using a 5/16" socket wrench, remove the cable clamps holding the power and sensor coil cords on top of the lift housing assembly. Cut the cable ties and disconnect the coil cords from under the lift housing. The power and sensor coil cords are now free of the lift housing assembly. Drape them up out of the way.
7. Using a 7/32" hex Allen socket, remove the two screws holding the lift screws to the header crossbar plate.
8. Lift the litter top up and support it about 6" above the lift screws on sawhorses or the equivalent.

Service Information

LIFT HOUSING REMOVAL AND REPLACEMENT (CONTINUED)

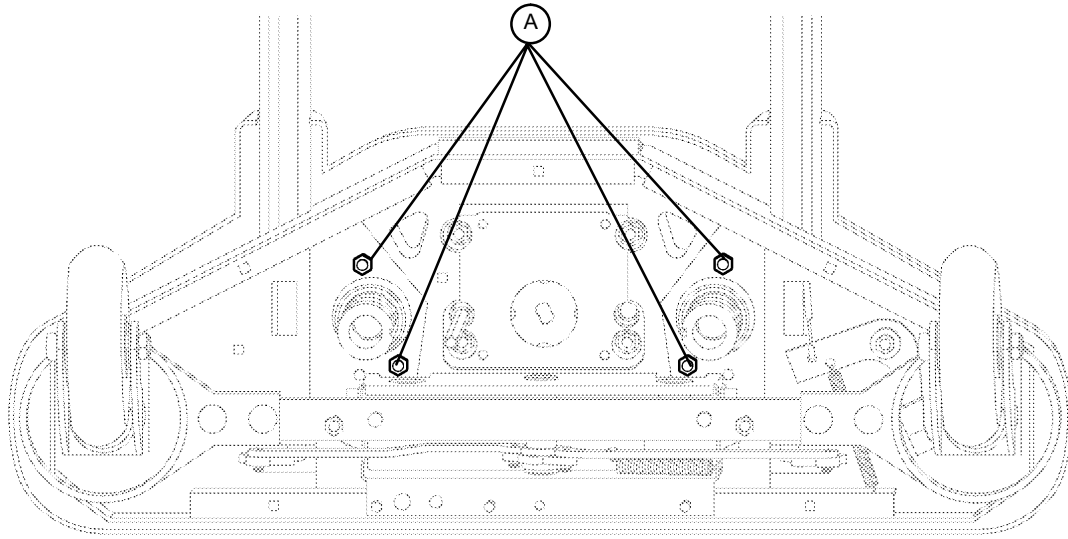

FOOT END – BOTTOM VIEW

9. Under the base, using a 9/16" socket, remove the four nuts (A) holding the lift housing to the base.
10. Lift up and out on the lift housing assembly to remove it from the base.

 **CAUTION**

To ensure proper reattachment of the power and sensor coil cords, refer to the procedure on [page 51](#). Refer to the procedure on [page 48](#) for reattachment of the lift potentiometer.

11. Reverse steps 1 – 10 to reinstall the lift housing assembly after service is completed.

NOTE

The procedure for lift housing removal and replacement is the same for both ends of the bed.

Service Information

LIFT POTENTIOMETER REPLACEMENT AND ADJUSTMENT

Required Tools:

#2 Phillips Screwdriver
3/8" Open End Wrench

Bungee Cord (or equivalent)
Side Cutters

5/16" Socket Wrench

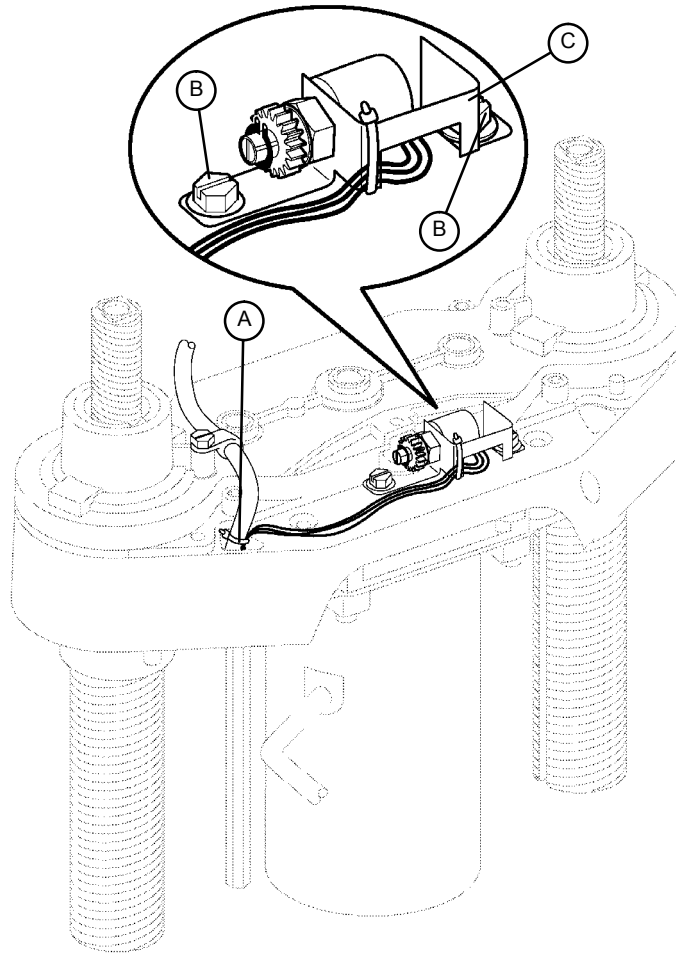

Procedure:

1. Raise the litter to the full up position.
2. Unplug the power cord from the wall socket and push the battery power on/off switch to the "OFF" position.
3. Using a 5/16" socket wrench, remove the five bolts holding the lower lift cover to the base and remove the cover. If necessary, hold the covers out of the way by using bungee cords (or the equivalent) to secure them to the litter top.
4. Using a #2 Phillips screwdriver, remove the three screws holding the upper lift cover to the base. If necessary, hold the covers out of the way by using bungee cords (or the equivalent) to secure them to the litter.
5. Using side cutters, cut the cable tie (A) holding the pot cable to the coil cord.
6. Unplug the pot cable from the sensor coil cord. If replacing a pot at the head end of the bed, unplug the cables attached to the brake sensor switch.
7. Pull the pot cable up through the base.
8. Using a 3/8" open end wrench, remove the two bolts (B) holding the pot housing (C) to the lift housing.

Service Information

LIFT POTENTIOMETER REPLACEMENT AND ADJUSTMENT (CONTINUED)

9. Lift up and out on the pot housing assembly to remove it from the lift housing.
10. Before installing the new pot on the bed, turn it clockwise until it stops. Turn it back counterclockwise two full (360°) revolutions. This allows a "window" position for proper upper and lower limits.
11. Reverse steps 4–9 to install the new pot and pot housing assembly.
12. After installing the new pot, the "burn-in" procedure below must be followed.

NOTE

Be sure to maintain the pot position while installing.

LIFT POTENTIOMETER "BURN-IN" PROCEDURE

NOTE

It requires **two people** to enable the diagnostics mode for the bed.

1. Unplug the bed power cord from the wall socket.
2. On the foot board control panel, hold down the bed motion lock button and the button to lock out the side-rail controls for the knee. While still holding the buttons, plug the bed power cord into the wall socket. Release the foot board buttons. The siderail control lights LED should be flashing to indicate the bed is in diagnostics mode.
3. To "burn in" the Bed Up/Down limits, raise the bed completely up until it can't go any farther. Press and hold the "Bed Motion Lock" button. The "Bed Motion Lock" LED will light. Continue to hold the "Bed Motion Lock" button until the "Bed Motion Lock" LED flashes. The flashing LED indicates the limits have been set. Release the "Bed Motion Lock" button and unplug the power cord from the wall socket to complete the "burn in" mode.
4. Plug the power cord into the wall socket and verify the lift limits are set properly before returning the bed to service.
5. If your bed has an IV Caddy, a lower limit must be burned in. Run the litter down to 19.5 inches. Hold the Bed Up/Down Lock button until the light flashes.



CAUTION

Do not run the litter all the way down while in the diagnostics mode. Damage to the bottom lift covers could result.

Service Information

LIFT MOTOR COUPLER REPLACEMENT

Required Tools:

5/16" Socket Wrench
2 x 4 (or Equivalent)

3/8" Socket Wrench (w/6" Extension)

Floor Jack

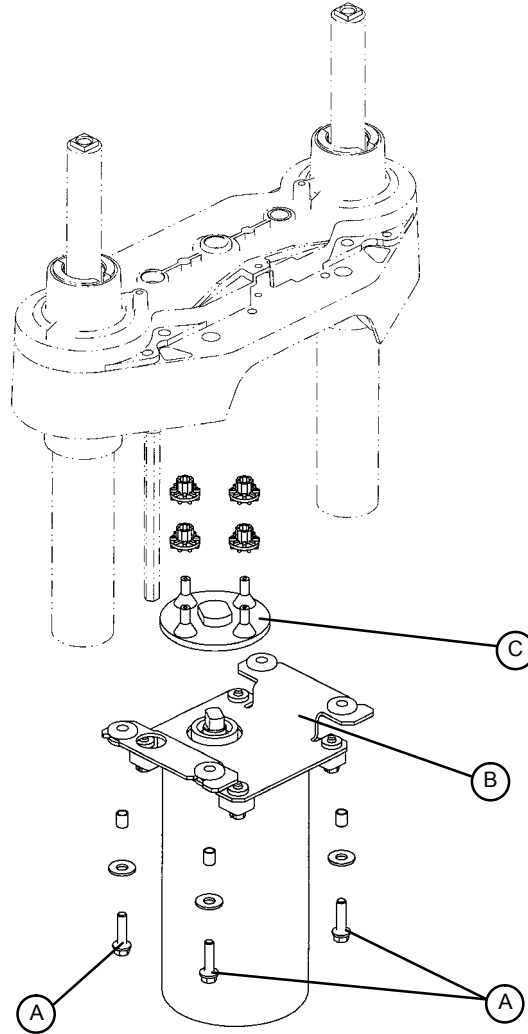

Procedure:

NOTE

If you need more space to work under the base frame, place a 2 x 4 across the base frame rails and use a floor jack to raise the base frame off the floor.

1. Unplug the power cord from the wall socket and push the battery power on/off switch to the "OFF" position.
2. Using a 5/16" socket wrench, remove the five bolts holding the lower lift cover to the base and remove the cover.
3. Using a 3/8" socket with an extension, remove the four bolts (A) holding the isolation plate (B) to the lift housing and lower the lift motor and isolation plate assembly to allow access to the coupler (C).
4. The motor coupler can now be removed from the lift housing.
5. Reverse steps 1 - 4 to install the new motor coupler and bushings.

Service Information

POWER AND SENSOR COIL CORD REPLACEMENT

Required Tools:

#2 Phillips Screwdriver	Side Cutters	5/16" Socket Wrench
Bungee Cord (or equivalent)	5/16" Nut Driver	Floor Jack
2 x 4 (or Equivalent)		

Procedure:

NOTE

If you need more space to work under the base frame, place a 2 x 4 across the base frame rails and use a floor jack to raise the base frame off the floor.

1. Unplug the power cord from the wall socket and push the battery power on/off switch to the "OFF" position.
2. Using a 5/16" socket wrench, remove the five bolts holding the lower lift cover to the base and remove the cover.
3. Using a #2 Phillips screwdriver, remove the three screws holding the upper lift cover to the base. If necessary, hold the covers out of the way by using bungee cords (or the equivalent) to secure them to the litter top.
4. Using side cutters, cut the cable ties holding the power and sensor coil cords to the base. Remove the ground wire coming from the sensor cord that is attached to the base (note the star washer arrangement).
5. Disconnect the cables going to the motor and the lift potentiometer (at the head end, the sensor cord is also attached to the brake switch sensor).
6. Pull both cords up through the frame of the bed and the lift housing.
7. Using a 5/16" socket wrench, remove the two screws (A) holding the cable clamps* to the top of the lift housing.
8. Using a 5/16" socket wrench, remove the two screws (B) securing the cable clamps* to the underside of the header crossbar assembly.
9. Pull both coil cords up through the header crossbar assembly.
10. Disconnect the power and sensor coil cords from the connectors.
11. The cords should now be completely removed from the bed. Reverse the above steps to install the new power and sensor cords.*



CAUTION

* When the power and sensor coil cords are being replaced, secure the cable clamps to the cords at the first coil both on the top and on the bottom to ensure there is not too much slack in the cords between the top of the lift housing assembly and the bottom of the header crossbar. Be sure the clamps are fastened at exactly the correct angle, as shown by the arrows in the illustration on [page 52](#). Arrange the cords exactly as shown in the illustration (left in front of right). **If this is not done correctly, damage to the cords will result.**

Service Information

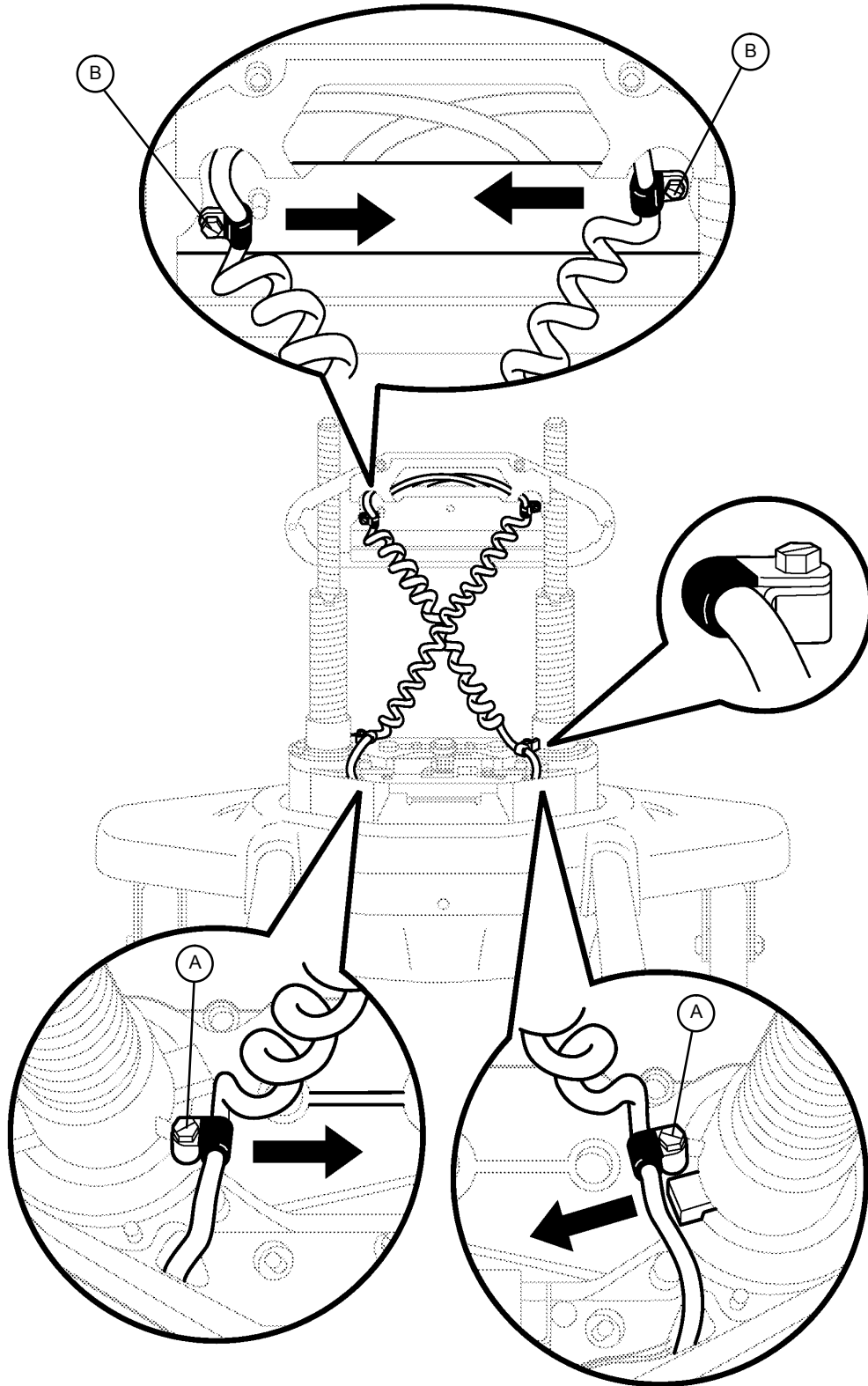

VIEW FROM CENTER OF BED

Service Information

BATTERY REMOVAL AND REPLACEMENT

Required Tools:

Torx T27
1/2" Socket Wrench
Phillips Screwdriver
5/32" Allen Wrench

7/16" Wrench
Bungee Cords

Procedure:

1. Raise the litter to full up. Unplug the power cord from the wall socket and push the battery power on/off switch to the "OFF" position.
2. Using a Phillips screwdriver, remove the four screws holding the base hood to the base frame.
3. Lift the base hood and support it from the litter frame using bungee cords or the equivalent.
4. Properly ground yourself (see [page 20](#) for static discharge precautions).
5. Open the cable clamp at the head end, left side of the base frame and remove the cables from the clamp.
6. Using a Torx T27, remove the four screws (A) holding the electronics box cover and remove the cover.
7. Disconnect the two battery cables (B).



WARNING

The battery tray assembly weighs 50 pounds. Use caution when removing the two hex head screws securing it to the base frame or personal injury could result. Battery posts, terminals and related accessories contain lead and lead compounds, chemicals known to the State of California to cause cancer and birth defects or other reproductive harm. **Wash hands after handling.** Properly dispose of the old battery in accordance with local regulations.

8. Support the battery tray assembly from the bottom. Using a 7/16" hex socket or wrench, remove the two screws (C) supporting the battery tray.

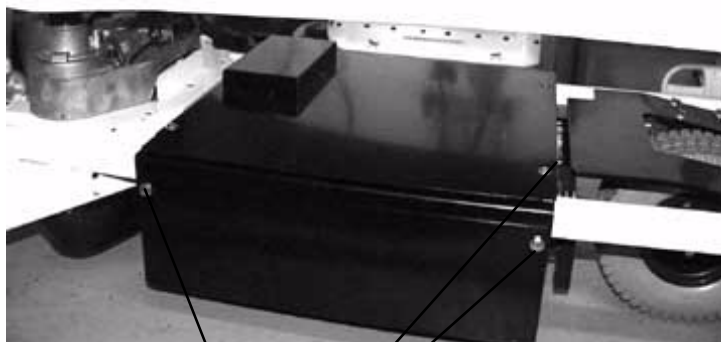

(A)

(B)

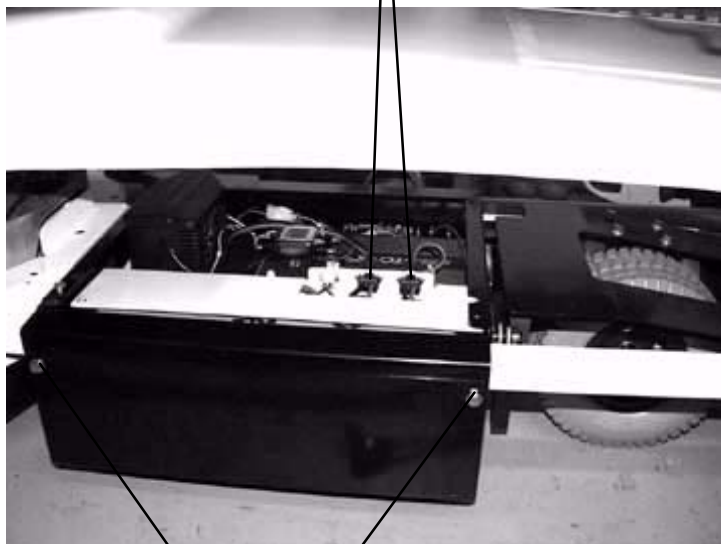

(C)

Service Information

BATTERY REMOVAL AND REPLACEMENT (CONTINUED)

9. The back of the battery tray assembly has a lip which catches on the electronics box. Lift up and out to remove the battery tray assembly.
10. Using a Phillips screwdriver, remove the two screws holding the battery terminal to the battery tray.
11. Using a 5/32" Allen wrench and a 7/16" wrench, remove the four screws and nuts holding the battery harness to the battery terminals.
12. Reverse steps 1 – 11 to install the new batteries. Complete the last four items of the set-up procedures on [page 8](#).

DC MOTOR BOARD REMOVAL AND REPLACEMENT

Required Tools:

Phillips Screwdriver
T27 Torx

1/8" Allen Wrench

Bungee Cords

Procedure:

1. Raise the litter to the full up position.
2. Unplug the power cord from the wall socket and push the battery power on/off switch to the "OFF" position.
3. Using a Phillips screwdriver, remove the four screws holding the base hood to the base frame.
4. Open the cable clamp at the head end, left side of the base frame and remove the cables from the clamp.
5. Lift the base hood and support it from the litter frame using bungee cords or the equivalent.
6. Using a T27 Torx, remove the four screws holding the cover to the side of the electronics box.
7. Properly ground yourself (see [page 20](#) for static discharge precautions).
8. Using a 1/8" Allen wrench, remove the four bolts and standoffs holding the motor board to the electronics box.
9. Remove all cables from the motor board and remove the board.

NOTE

Note the locations of the cables so you can connect them properly to the new motor board.

10. Reverse steps 1 – 8 to install the new motor board.

Service Information

DRIVE MOTOR REMOVAL AND REPLACEMENT

Required Tools:

Phillips Screwdriver	1/2" Socket Wrench	Bungee Cords
Floor Jack	T27 Torx	

Procedure:

1. Raise the litter to the full up position.
2. Unplug the power cord from the wall socket and push the battery power on/off switch to the "OFF" position.
3. Using a Phillips screwdriver, remove the four screws holding the base hood to the base frame.
4. Open the cable clamp at the head end, left side of the base frame and remove the cables from the clamp.
5. Lift the base hood and support it from the litter frame using bungee cords or the equivalent.
6. Using a T27 Torx, remove the four screws holding the power board cover to the side of the electronics box. Remove the two motor wires from the power board and remove the T27 Torx ground screw.
7. Apply the brakes and disengage the drive wheel. Place a floor jack under the leaf spring at the foot end of the bed and raise the wheels approximately three inches off the floor.
8. Using a 1/2" socket wrench, remove the four bolts holding the drive motor to the leaf spring.



CAUTION

Support the drive motor before removing the four bolts to prevent it from falling to the floor and becoming damaged.

9. Reverse steps 1 – 8 to install the new drive motor.
10. Run through the operation of the power drive wheel to ensure it is operating properly before returning the unit to service.

DRIVE WHEEL REMOVAL AND REPLACEMENT

Required Tools:

Phillips Screwdriver	1/2" Socket Wrench	Bungee Cords
Floor Jack	T27 Torx	

Procedure:

1. Remove the drive motor (see procedure above).
2. Using a 1/2" socket wrench, remove the bolt holding the wheel to the drive motor.
3. Slide the wheel off the motor shaft.
4. Reverse steps 1 – 3 to install the new drive wheel and reinstall the drive motor.

Service Information

SCALE SYSTEM DIAGNOSTICS AND CALIBRATION

Diagnostic Mode Functions:

1. ANGLE CALIBRATE – This may be required in the field to recalibrate the scale. Calibrate using 50 pounds.
2. DISP. CORNER LBS – This function displays the individual corner weights in **pounds** for each load cell and can be used to isolate a defective load cell.
3. DISP. CORNER CTS – This function displays the individual corner weights in **counts** for each load cell and can be used to isolate a defective load cell.
4. DISPLAY FACTORS – This function is used to see the scale calibration factors. This can be used to diagnose a bad scale calibration.
5. DISPLAY AVERAGES – This function is used to see the average weight in pounds each load cell has experienced.
6. DISPLAY MAXIMUMS – This function is used to see the maximum weight each load cell has experienced.
7. CLEAR STATISTICS – This function is used to clear the averages and maximums.
8. INIT TO DEFAULTS – This function is used to reset the scale factors back to defaults.
9. VIEW ERROR LOG – This function can be used to see a log of scale errors and the time they occurred.
10. LOCK/UNLOCK LBS/KG – This function can be used to lock out the ability to change weight units.
11. PICK EXIT ALARM – This function can be used to select a different bed exit alarm tone.
12. BRAKE ALARM OFF/ON – This function can be used to enable or disable an audible alarm when the brakes are not set. Not available for beds with Zoom or Battery Backup.
13. DEFAULT ANGLE – This function can be used to select the default angle displayed to either fowler or trend.
14. SOFTWARE CONFIG – This function can be used to see what the bed configuration is.
15. SOFTWARE VERSION – This function can be used to see what software version it is.
16. CALIBRATE SCALE – This is the old scale calibration routine with 200 pounds. Only there for backup purposes.
17. EXIT DIAGNOSTIC – This function will give you the ability to exit the diagnostic mode and go into scale mode.

Diagnostic Mode:

NOTE

It requires **two people** to enable the diagnostic mode for the scale system.

1. To enter diagnostic mode, unplug the bed's power cord from the wall socket.
2. Press and **hold down** the LBS/KGS button.
3. While still holding the LBS/KGS button, plug the bed's power cord into the wall socket.
4. After two seconds, release the LBS/KGS button. The LCD should display "ANGLE CALIBRA TE". The diagnostic mode is now active.

Service Information

Displaying Individual Load Cell Outputs:

A defective load cell can be detected by entering diagnostics and displaying individual load cell outputs.

1. Enter the diagnostic mode. The LCD will display "ANGLE CALIBRATE" when the diagnostic mode is activated.
2. Repeatedly press and release the up or down arrow button (ZERO or SCALE ON/OFF) until the LCD displays "DISPLAY CORNER CTS".
3. Press and release the ENTER button (LBS/KGS). The LCD should display " ^ ∨ SELECT CORNER".

SCALE SYSTEM DIAGNOSTICS AND CALIBRATION (CONTINUED)

Displaying Individual Load Cell Outputs (Continued):

The two buttons listed below function as POSITION buttons to select the four corners of the bed's litter. Whenever the LCD displays " ^ ∨ SELECT CORNER", press one of these buttons to cycle through the corners and to select the load cell assembly at the desired corner.

- A. ZERO = cycle up through the four corners
- B. SCALE ON/OFF = cycle down through the four corners

4. Press and release the position button that corresponds with the load cell to be checked. The LCD should display "X/X=NNN.N". "X/X" represents the initials of the selected corner, i.e. H/R will be displayed for the patient's head end, right side. "NNN.N" represents the resistance of the load cell.
5. Repeat step four for each corner. Head end weight readings will normally be lower than foot end weights. Weight readings should be constant. A drifting 000.0 or 999.9 weight, or a reading that does not change when weight is applied to that corner of the bed indicates a problem with the selected load cell assembly or load cell cable.

Verifying Scale Accuracy:

1. Zero the empty bed. Place a known weight on the center of the bed; the heavier the better and no less than 100 pounds. The displayed weight should be within $\pm 1\%$ of the actual weight.
2. If the displayed weight is not accurate, remove the weight from the bed and proceed to the Scale Calibration section.

Scale Calibration:

NOTE

It requires **two people** to enable the calibration mode for the scale system.

Raise the siderails when calibrating the scale to avoid getting inaccurate scale readings due to possible interference between the siderails and the casters.

Calibrate the scale system with a known 50 pound weight. If exactly 50 pounds is not available, the factory default for calibration will have to be changed as described in step 6.

1. To enter the calibration mode, unplug the bed's power cord from the wall socket.
2. Press and **hold down** the LBS/KGS button.
3. While still holding the LBS/KGS button, plug the bed's power cord into the wall socket.

Service Information

Scale Calibration (Continued):

4. After two seconds, release the LBS/KGS button. The LCD should read "ANGLE CALIBRATE". The calibration mode is now active.
5. Press and hold the ENTER button (LBS/KGS). Zero the bed, following the displayed instructions. When the bed is zeroed, the LCD should display "REF X100=<0>5000". This is the factory default for 50 pounds. If 50 pounds will be used to calibrate the scale, proceed to step 7.

SCALE SYSTEM DIAGNOSTICS AND CALIBRATION (CONTINUED)

6. If exactly 50 pounds is not available, change the display to match the weight you are using. Pressing the CHANGE EQUIP button will move the cursor position to the right. Pressing the up arrow (ZERO) button will increase the numbers. Pressing the down arrow (SCALE ON/OFF) button will decrease the numbers. Scroll through the numbers until they match the weight you will use for calibration.
7. Press and release the ENTER button and the LCD will display "PRESS REV. TREND". Press and hold the button with the Reverse Trendelenburg symbol (feet down/head up) until the bed stops. Release the button and the LCD will display "DO NOT TOUCH BED". Press and hold the Reverse Trendelenburg button again until the bed stops. Release the button and the LCD will display "DO NOT TOUCH BED".
8. The LCD will display "PRESS TREND." Press and hold the button with the Trendelenburg symbol (feet up/head down) until the bed stops. Release the button and the LCD will display "DO NOT TOUCH BED". Press and hold the Trend button again until the bed stops. Release the button and the LCD will display "DO NOT TOUCH BED".
9. Repeat steps 5 – 8 with 200 pounds.
10. The LCD will display the weight. This indicates the calibration procedure is complete.
11. Level the bed at a full up or full down position. Remove the weight and zero the bed.
12. Verify scale accuracy and functionality before returning the bed to service.

Service Information

LOAD CELL REPLACEMENT

Required Tools:

9/16" Socket Wrench 9/16" Open End Wrench Saw Horse (or Equivalent)
Wire Cutters

Replacement Procedure:

1. Raise the Fowler or knee section, depending which end of the litter needs service.
2. Unplug the load cell connector from the load cell cable.
3. Using wire cutters, remove the wire ties holding the cable to the frame.
4. Using a 9/16" socket and a 9/16" open end wrench, remove the two bolts holding the load cell to the litter cross tube and remove the load cell.
5. Using a saw horse or the equivalent, support the litter at the end where the load cell was removed. Reverse the above procedure to install the new load cell.

NOTE

The scale calibration procedure must be performed after the load cell is replaced (see [page 57](#)).

HEAD MOTOR REMOVAL AND REPLACEMENT

Required Tools:

T27 Torx 7/16" Socket Wrench 3/8" Socket Wrench
Wire Cutters

Procedure:

1. Run the litter to the full up position and remove the mattress from the litter.
2. Fold the foot section back toward the head end. Electrically run the knee section to full up. If the knee section will not move electrically, pull the foot section toward the head end while pulling the CPR release handle (located at the head end of the bed). The knee section will raise.
3. Using a T27 torx, remove the four screws holding the cover to the actuator box and remove the cover.
4. Remove the two CPR release cables from the CPR release bracket. Using a 3/8" socket wrench underneath the actuator box, remove the two bolts holding the release bracket to the actuator box and remove the bracket from the actuator box.
5. Disconnect all the electrical connections to the head motor and move aside any wiring that interferes with the removal of the motor.
6. Using a 3/8" socket wrench underneath the actuator box, remove the four bolts holding the motor mounting bracket to the actuator box. Lift up and out on the motor to remove it.
7. Remove the motor mounting bracket from the old motor and install it on the replacement motor.
8. Reverse steps 3 through 6 to install the replacement motor.
9. Verify the unit is working properly before returning it to service.

Service Information

KNEE MOTOR REMOVAL AND REPLACEMENT

Required Tools:

T27 Torx

7/16" Socket Wrench

3/8" Socket Wrench

Wire Cutters

Procedure:

1. Run the litter to the full up position and remove the mattress from the litter .
2. Fold the foot section back toward the head end. Electrically run the knee section to full up. If the knee section will not move electrically, pull the foot section toward the head end while pulling the CPR release handle (located at the head end of the bed). The knee section will raise.
3. Using a 7/16' socket wrench, remove the mounting bolt on the litter for the knee dampening cylinder. This leaves the knee dampener mounted only to the seat panel.
4. Using a T27 torx, remove the four screws holding the cover to the actuator box and remove the cover.
5. Remove the two CPR release cables from the CPR release bracket. Using a 3/8" socket wrench underneath the actuator box, remove the two bolts holding the release bracket to the actuator box and remove the bracket from the actuator box.
6. Disconnect all the electrical connections going to the knee motor and move aside any wiring that could interfere with the removal of the motor.
7. Pull the foot panel toward the head end of the bed. This causes the knee motor linkage to roll past center and allows the motor to be removed without supporting the knee section.
8. Using a 3/8" socket wrench underneath the actuator box, remove the four bolts holding the motor mounting bracket to the actuator box. Lift up and out on the motor to remove it.
9. Remove the motor mounting bracket from the old motor and install it on the replacement motor .
10. Install the replacement motor.
11. Reverse steps 3 – 5 to reinstall the knee dampener, CPR bracket and actuator box cover.
12. Pull the foot panel toward the foot end of the bed. This causes the knee motor linkage to roll back past center.

CAUTION

If step 12 is not done, damage to the motor or linkage will occur.

13. Verify the bed is working properly before returning it to service.

Service Information

POWER SUPPLY REMOVAL AND REPLACEMENT

Required Tools:

T27 Torx

Needle–Nose Pliers

Procedure:

1. Run the litter to the full up position and remove the mattress from the litter .
2. Fold the foot section back toward the head end of the bed. Electrically run the knee section to full up. If the knee section will not move electrically, pull the foot section toward the head end of the bed while pulling the CPR release handle (located at the head end of the bed). The knee section will raise.
3. Using a T27 torx, remove the four screws holding the cover to the actuator box and remove the cover.
4. Properly ground yourself (see [page 20](#) for static discharge precautions).
5. Unplug all electrical connections from the power supply.
6. Using needle–nose pliers, squeeze the four stand–offs supporting the power supply and pull up gently on the power supply to remove it.
7. Reverse steps 2 through 5 to install the new power supply.
8. Verify the unit is working properly before returning it to service.

CPU BOARD REMOVAL AND REPLACEMENT

Required Tools:

T27 Torx

Needle–Nose Pliers

Replacement Procedure:

1. Run the litter to the full up position and remove the mattress from the litter .
2. Fold the foot section back toward the head end of the bed. Electrically run the knee section to full up. If the knee section will not move electrically, pull the foot section toward the head end of the bed while pulling the CPR release handle (located at the head end of the bed). The knee section will raise.
3. Using a T27 torx, remove the four screws holding the cover to the actuator box and remove the cover.
4. Properly ground yourself (see [page 20](#) for static discharge precautions).
5. Unplug all electrical connections from the CPU board.
6. Press the six stand–offs away from the board while gently lifting the board up and out.
7. Install the replacement CPU board.

NOTE

After the replacement CPU board is installed, the “burn–in” procedure must be performed for the Fowler and lift motor potentiometers (see [page 49](#) and [page 63](#))

If the bed is equipped with a scale system, the scale calibration procedure must also be performed after the replacement CPU board is installed (see [page 57](#)).

Service Information

FOWLER POTENTIOMETER REPLACEMENT

Required Tools:

T27 Torx

Wire Cutters

1/2" Open End Wrench

7/64" Allen Wrench

Replacement Procedure:

1. Manually crank the knee section up until it stops.
2. Using a T27 Torx, remove the four screws holding the litter access cover to the litter and remove the cover.
3. Using a 7/64" Allen wrench, loosen the screw holding the linkage to the pot. shaft and remove the linkage from the shaft.
4. Using a 1/2" open end wrench, remove the nut holding the potentiometer to the frame.
5. Using wire cutters, remove the cable ties from the cable. Unplug the cable from the CPU and remove the pot.
6. Reverse the above procedure to install the replacement potentiometer.
7. The new potentiometer must be calibrated after it has been installed.
8. The Fowler pot. should be set at 150 ohms (\pm 10 ohms) in the full down position. This reading must be taken from pins 3 and 4 on the connector with the pot. unplugged from the board. After the correct ohm reading is achieved, tighten the screw on the linkage.
9. Perform the "burn-in" procedure for the Fowler potentiometer (see [page 63](#)).

Service Information

FOWLER POTENTIOMETER “BURN-IN” PROCEDURE

NOTE

It requires **two people** to enable the diagnostics mode for the bed.

1. Unplug the bed power cord from the wall socket.
2. On the foot board control panel, hold down the bed motion lock button and the button to lock out the siderail controls for the knee. While still holding the buttons, plug the bed power cord into the wall socket. Release the foot board buttons. The siderail control lights LED should be flashing to indicate the bed is in diagnostics mode.
3. Using the foot board controls, run the Fowler up to 90°. Press and hold the button on the foot board to lock out the siderail controls for the back until the padlock LED flashes. Release the button.
4. Using the foot board controls, run the Fowler down to 0°. Press and hold the button on the foot board to lock out the siderail controls for the knee until the padlock LED flashes. Release the button..

Service Information

AC CROSSOVER BOARD REPLACEMENT

Required Tools:

T27 Torx	1/2" Box End Wrench	#2 Phillips Screwdriver
Wire Cutters	Small Flat Blade Screwdriver	Needle Nose Pliers
5/16" Nut Driver		

Replacement Procedure:

1. Follow steps 1 – 9 of the control bar potentiometer replacement procedure on [page 66](#).
2. Using a T-27 Torx, remove the 2 bolts holding the AC crossover board cover to the head end frame and remove the cover.
3. Disconnect all wires from the AC crossover board.
4. Using needle nose pliers, release the four mounting stand-offs from the board and remove the board.
5. Reverse steps 1 – 4 to install the new board.
6. Reverse steps 1 – 9 of the control bar potentiometer replacement procedure on [page 66](#) to reassemble the bed.

DISPLAY/CPU BOARD REPLACEMENT

Required Tools:

T27 Torx	1/2" Box End Wrench	#2 Phillips Screwdriver
Wire Cutters	Small Flat Blade Screwdriver	Needle Nose Pliers
5/16" Nut Driver		

Replacement Procedure:

1. Follow steps 1 – 9 of the control bar potentiometer replacement procedure on [page 66](#).
2. Disconnect all wires from the display/CPU board.
3. Using a #2 Phillips screwdriver, remove the six screws holding the display/CPU board to the control bar cover and remove the board.
4. Reverse steps 2 & 3 to install the new board. After the new board has been installed, the potentiometer "burn-in" procedure must be performed (see [page 67](#)).
5. Reverse steps 1 – 9 of the control bar potentiometer replacement procedure on [page 66](#) to reassemble the bed.

Service Information

CONTROL BAR POTENTIOMETER REPLACEMENT

Required Tools:

T27 Torx

1/2" Box End Wrench

#2 Phillips Screwdriver

Wire Cutters

Small Flat Blade Screwdriver

5/16" Nut Driver

Replacement Procedure:

1. Raise the litter and the head end to the full up position.
2. Remove the head board from the bed.
3. Unplug the power cord from the wall socket and push the battery power on/off switch to the "OFF" position.
4. Using a 5/16" nut driver, remove the screw (A) holding the power cord clamp to the bumper weldment and remove the clamp from the bumper.

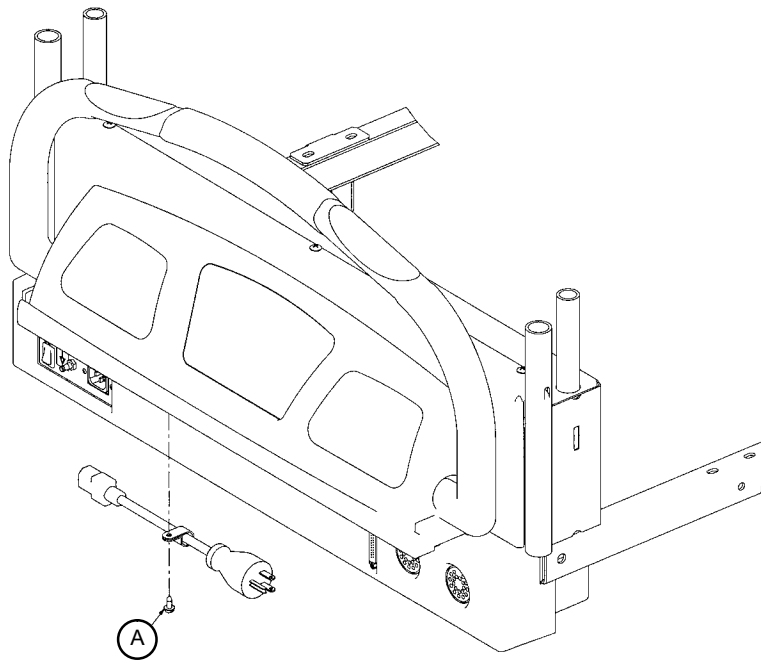

FIGURE 1

Service Information

CONTROL BAR POTENTIOMETER REPLACEMENT (CONTINUED)

5. Using a T27 Torx, remove the four bolts (C) at the head end of the bed holding the control bar mounting bracket to the head end (see Figure 2).
6. Using a #2 Phillips screwdriver, remove the three screws (D) holding the control bar cover to the head end of the bed (see Figure 3).
7. Standing at the head end, pull the control bar toward you and fold down the control bar mounting bracket.
8. Using a 1/2" wrench, remove the nut holding the potentiometer to the mount. Using wire cutters, cut the wire ties. Unplug the pot cable from the CPU display board and remove the pot.
9. Install the new potentiometer. Using a small flat blade screwdriver, turn the pot shaft clockwise until it stops. Turn it back counterclockwise 1/2 turn.
10. After the new pot has been installed, the potentiometer "burn-in" procedure must be performed (see [page 67](#)).
11. After performing the "burn-in" procedure, reverse steps 1 – 9 to reassemble the bed.
12. Test all functions before returning the unit to service.

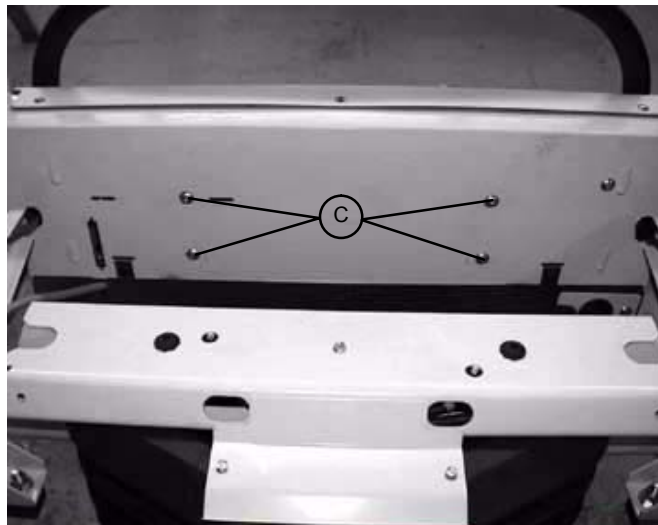

FIGURE 2

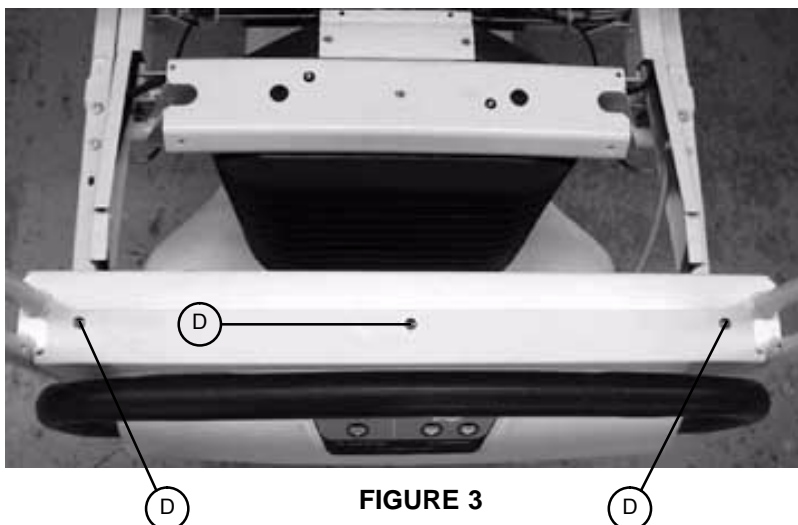

FIGURE 3

Service Information

CONTROL BAR POTENTIOMETER “BURN-IN” PROCEDURE

Required Tools:

T27 Torx	1/2" Box End Wrench	#2 Phillips Screwdriver
Wire Cutters	Small Flat Blade Screwdriver	5/16" Nut Driver

1. If it has not already been done, follow steps 1 – 9 of the control bar potentiometer replacement procedure on [page 66](#).
2. Hold down the switch on the back of the drive CPU board.
3. With the switch depressed, move the battery power on/off switch to the “ON” position.
4. Verify the “ENGAGE DRIVE WHEEL” LED at the head end of the bed is flashing.
5. Move the battery power on/off switch to the “OFF” position, close the drive control box, and move the switch back to the “ON” position.
6. The “ENGAGE DRIVE WHEEL” LED will flash once. The control bar potentiometer is calibrated.
7. Grasp the drive handle and squeeze the motion release switch without moving the drive handle forward or back. Verify the bed does not move.
8. Release the bed brakes and engage the drive wheel. Standing at the head end of the bed, grasp the drive handle and squeeze the motion release switch while moving the drive handle away from you. Verify the bed moves forward.
9. Grasp the drive handle and squeeze the motion release switch while moving the drive handle toward you. Verify the bed moves backward.
10. Reverse steps 1 – 9 of the control bar potentiometer replacement procedure on [page 66](#) to reassemble the bed.

Service Information

OPTIONAL SMART TV INTERFACE “BURN-IN” PROCEDURE

This procedure is used for selecting the style of TV interface desired for your bed. If traditional TV is desired, no calibration is required. If optional Smart TV is available on the bed, select one of the TV manufacturers listed in the table below.

SET-UP

- Ensure the communication cable is connected between the bed and the Db37 wall port or the pillow speaker port of the nurse call system. If available, a bed communication tester can be used instead of the hospital wiring.

PROCEDURE

1. Place the bed in the lift potentiometer burn-in mode (see [page 49](#)).
2. Notice the Nurse Call LED (yellow) is flashing. Notice the Nurse Answer LED (green) is flashing on/off slowly.
3. Press and release the TV ON/OFF switch on the bed’s siderail once. Notice the Nurse Call LED flashes once. This is the first selection of TV manufacturers for the Smart TV mode. Notice the Nurse Answer LED (green) is flashing on/off slowly. The Nurse Answer LED will only light when the Nurse Call LED (yellow) is flashing.
4. Press and release the TV ON/OFF switch on the bed’s siderail to scroll to other TV manufacturers. Notice the number of times the Nurse Call LED flashes matches the number listed in the table below and represents the TV manufacturer selected.
5. When the desired TV manufacturer has been selected, unplug the bed power cord from the wall socket and plug it back in to complete the Smart TV burn-in procedure.

NOTE

If the bed is connected to a television during the burn-in procedure, the television will turn on when the correct setting is selected.

TV MANUFACTURER SELECTION FOR SMART TV BURN-IN PROCEDURE		
Press and release TV ON/OFF switch:	Nurse Call LED (Yellow)	TV Manufacturer
One time	One flash	RCA 1
Two times	Two flashes	RCA 2
Three times	Three flashes	Zenith 1
Four times	Four flashes	Zenith 2
Five times	Five flashes	Phillips/Magnavox
Six times	Six flashes	Magnavox (models 9120, 9220, 9320)
Seven times	Seven flashes	Traditional TV
Eight times	Eight flashes	Traditional Plus
Nine times	Nine flashes	Auto Detect: Smart TV
Ten times	Ten flashes	Auto Detect w/ Digital Volume Smart TV

Service Information

SIDERAIL COVER REMOVAL

Required Tools:

#2 Phillips Screwdriver

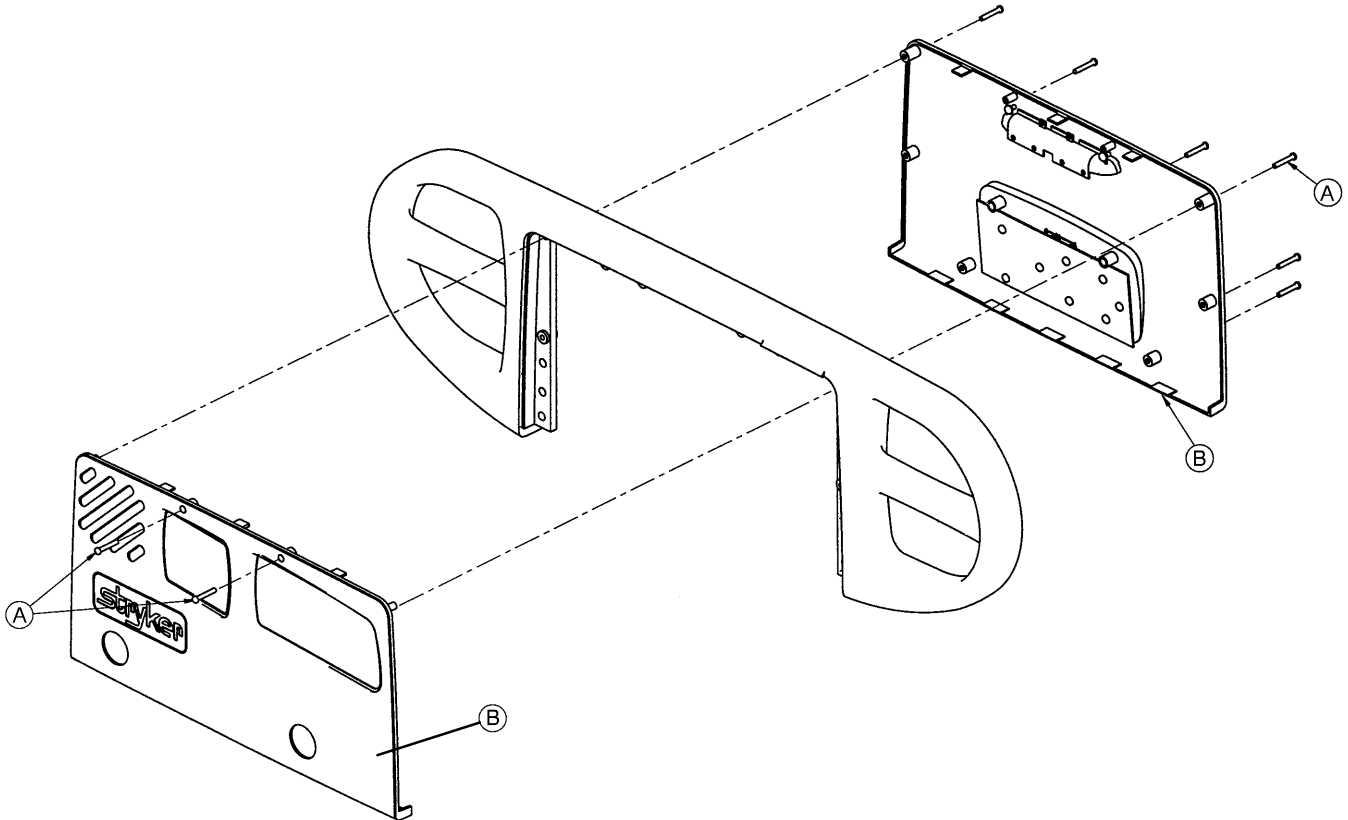

Head End Siderail Cover Removal Procedure:

1. Unplug the bed power cord from the wall receptacle.
2. Using a #2 Phillips screwdriver, remove the 8 Phillips screws (A) holding the covers (B) to the siderail.

 **CAUTION**

There are two cables connecting the head end siderail outside covers to the head end siderails. Be careful not to pull on them when removing the cover or damage could occur.

3. Disconnect the cables from the siderail. Note the proper location for the cables.
4. Reverse the above steps to reattach the cover.

 **CAUTION**

Do not snag or pinch the cables when reinstalling the head end siderail covers or damage could occur.

Service Information

MOLDED SIDERAIL REPLACEMENT

Required Tools:

#2 Phillips Screwdriver

3/8" Nut Driver

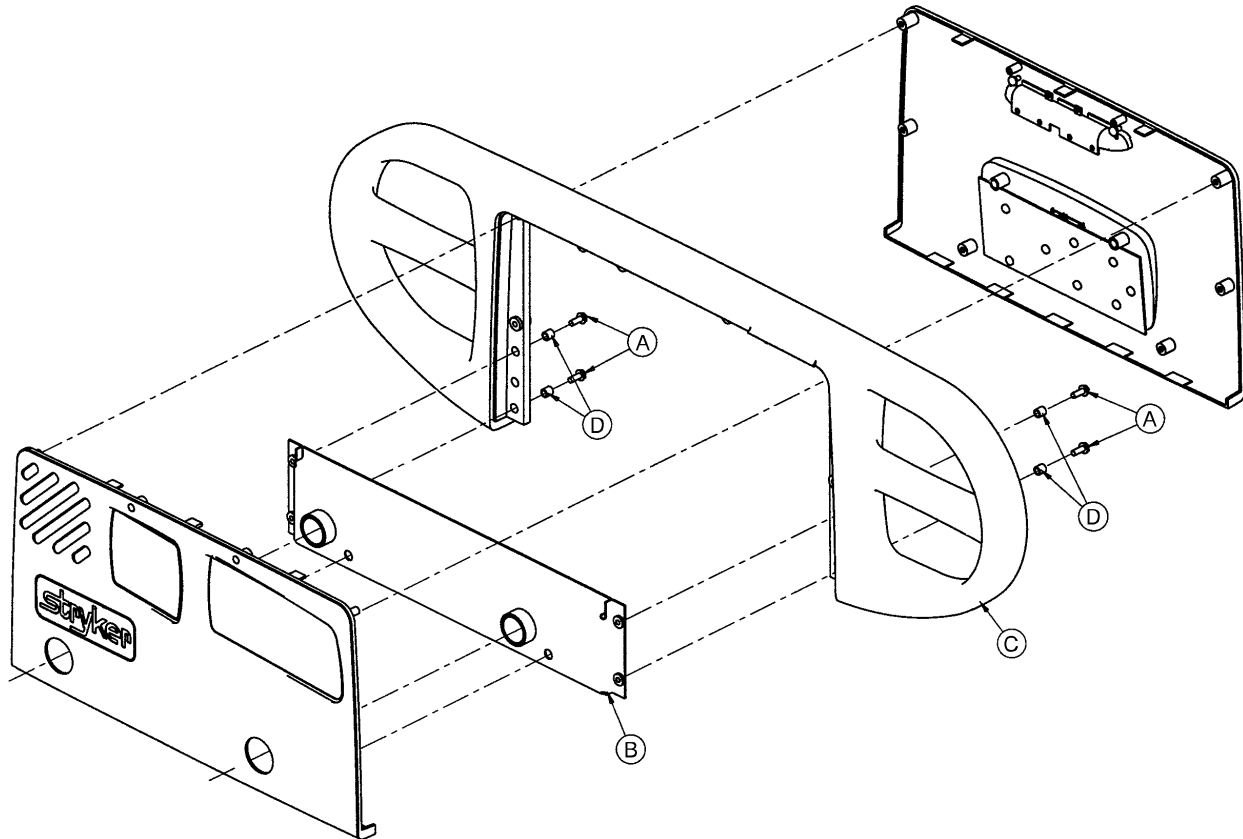

Procedure:

1. Unplug the bed power cord from the wall receptacle.
2. Remove the siderail covers (see [page 69](#)).
3. Using a 3/8" nut driver, remove the four screws (A) holding the molded rail (C) to the siderail support assembly (B).

NOTE

Note the location of the spacers (D) for re-assembly purposes.

4. Pull up on the molded rail (C) to remove it from the siderail assembly.
5. Reverse the above steps to install the new molded rail.

Service Information

HEAD END SIDERAIL CABLE REPLACEMENT

Required Tools:

#2 Phillips Screwdriver

Side Cutters

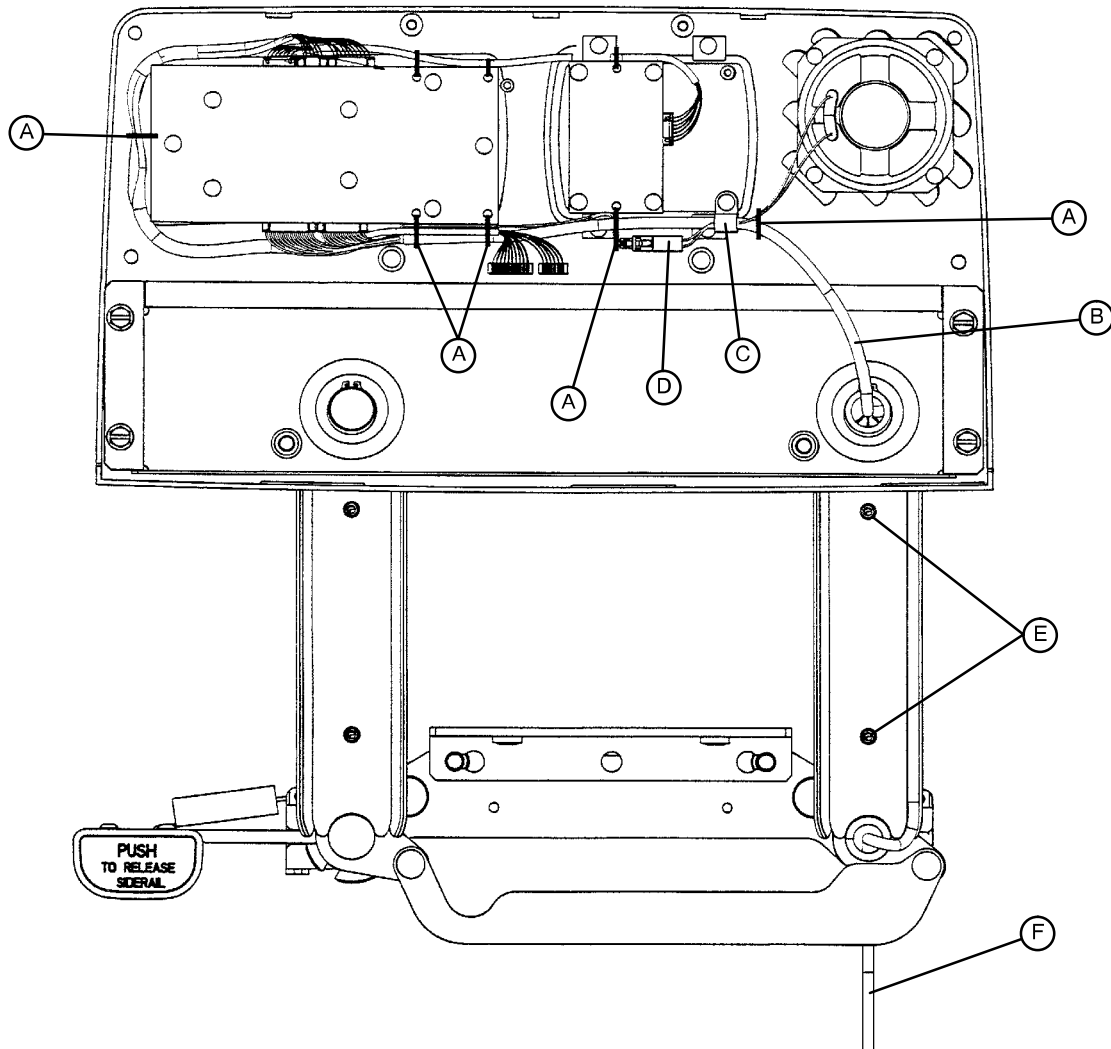

Procedure:

1. Run the head section fully up.
2. Unplug the bed power cord from the wall receptacle.
3. Remove the outside siderail cover (see [page 69](#)).
4. Put the siderail in the down position.
5. Using a #2 Phillips screwdriver, remove the two screws (E) holding the rear siderail pivot arm cover to the pivot arm. Remove the arm cover to expose the siderail cables.

Service Information

HEAD END SIDERAIL CABLE REPLACEMENT (CONTINUED)

6. Using side cutters, clip the cable ties (A) holding the cables together.
7. Using a #2 Phillips screwdriver, remove the cable clamp (C) from the siderail.
8. Disconnect cable (B) from the circuit board and cable (D) from the speaker.

NOTE

The speaker and nurse call are optional equipment and may not be present as shown in the illustration.

9. Pull the cables through the siderail (toward the center of the bed).
10. Unplug the cable assembly (F) underneath the head section.
11. Reverse the above steps to install the new cable.



CAUTION

Be sure to position the cables on both sides of the pivot arm, as shown in the illustration on [page 71](#), before reattaching the pivot arm cover. If the cables are not routed correctly, the arm cover will not fit properly and damage could occur to the cables.

Service Information

FOOT BOARD HINGE REMOVAL

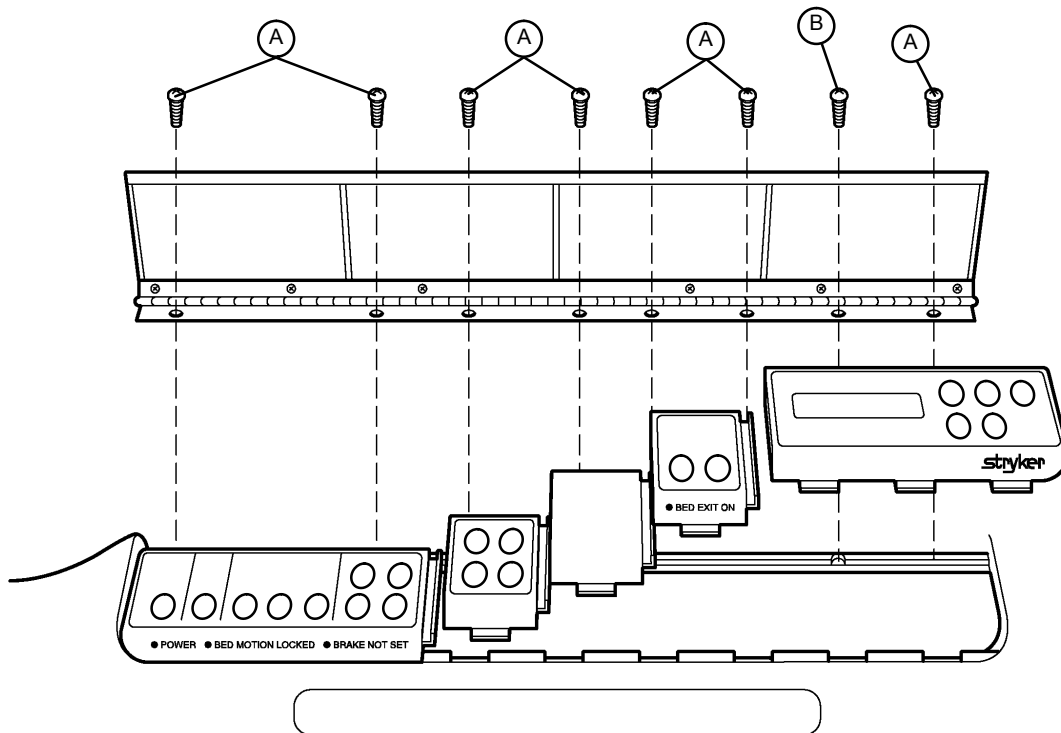

Required Tools:

#2 Phillips Screwdriver

Procedure:

1. Using a #2 Phillips screwdriver, remove the screws (A & B) holding the door and hinge assembly to the foot board.
2. If replacing the hinge only, use a Phillips screwdriver to remove the screws holding the hinge to the door.
3. Reverse the above steps to attach the replacement door and/or hinge.

NOTE

Screw (B) is a machine screw and must be reinstalled in the proper hole.

Service Information

FOOT BOARD MODULE REPLACEMENT

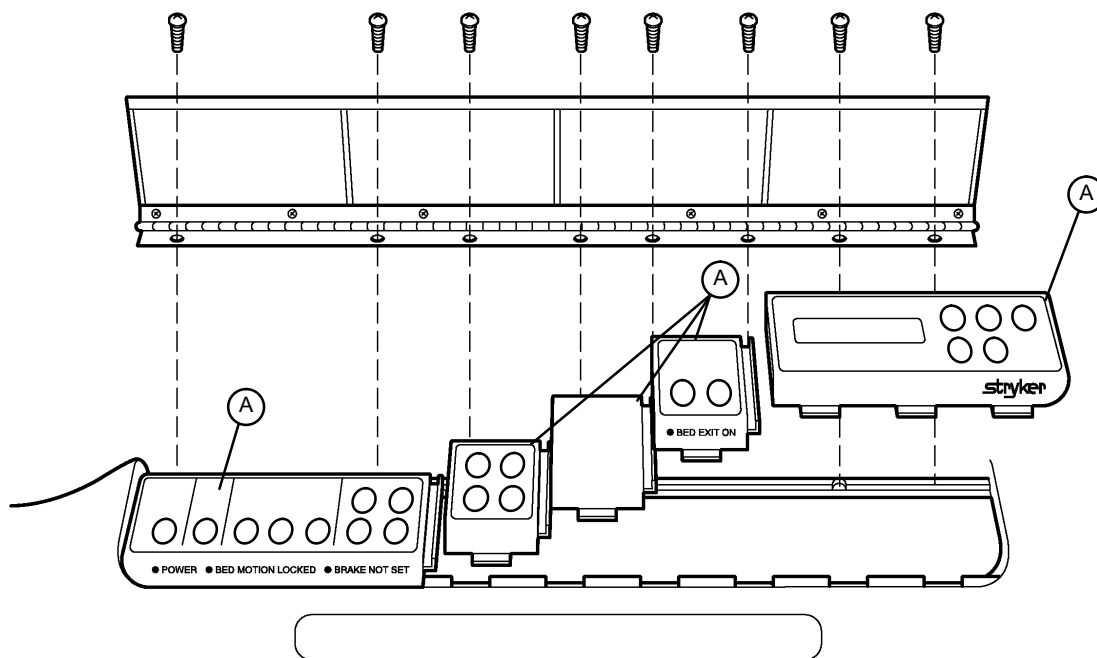

Required Tools:

#2 Phillips Screwdriver

Procedure:

1. Unplug the bed power cord from the wall socket. Remove the foot board hinge (see [page 73](#)).

NOTE

Regardless of which module is being replaced, the farthest module to the right must be removed first.

2. Pull the module out of the foot board and disconnect the cable from the module (A).
3. Reverse the above steps to install the new module.

⚠ CAUTION

The modules must be overlapped as shown in the illustration (right over left) when they are installed to prevent fluids from entering the board cavity and causing damage.

Service Information

FOOT BOARD INTERFACE PLUG REPLACEMENT

Required Tools:

#2 Phillips Screwdriver

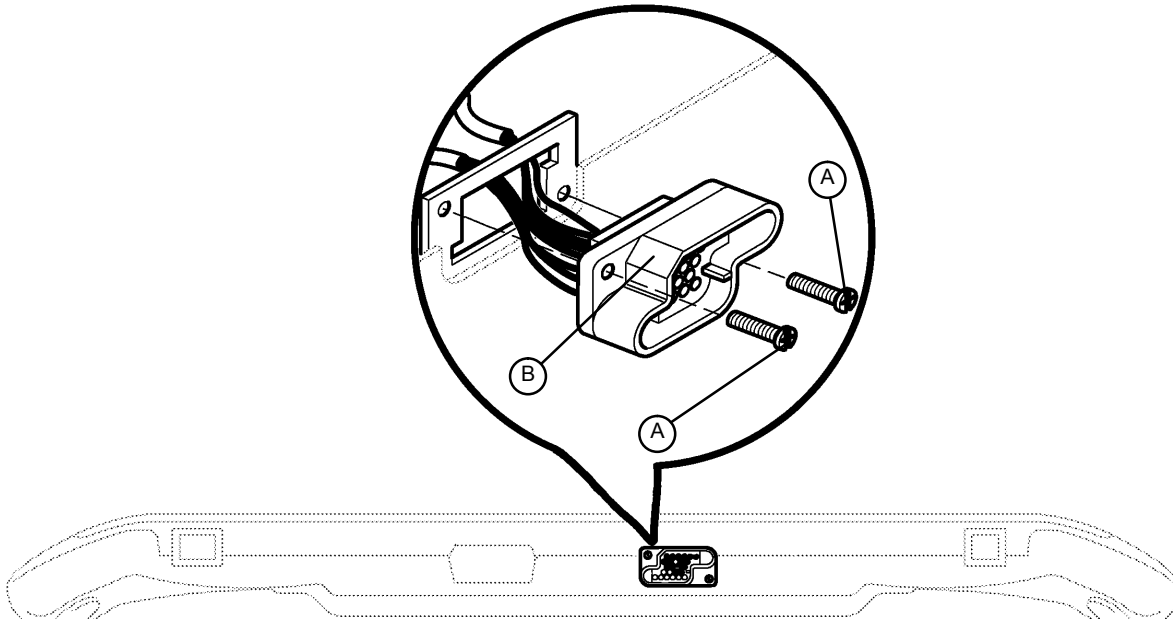

BOTTOM VIEW OF FOOT BOARD

Procedure:

1. Unplug the bed power cord from the wall socket.
2. Remove the foot board from the bed to access the bottom of the board.
3. Properly ground yourself (see [page 20](#) for static discharge precautions).
4. Remove the foot board door (see [page 73](#)).
5. Using a #2 Phillips screwdriver, remove the two screws (A) holding the plug to the foot board.
6. Disconnect the interface cable from the foot board module cable. Note proper placement of the cable so it will be reconnected properly.
7. Reverse the above steps to install the new interface plug.

CAUTION

Be sure to install the new plug with the flat edge (B) at the top left, as shown in the illustration, or the foot board interface plug will not mate properly with the bed and damage to the plug or foot board could result.

Base Assembly and Options

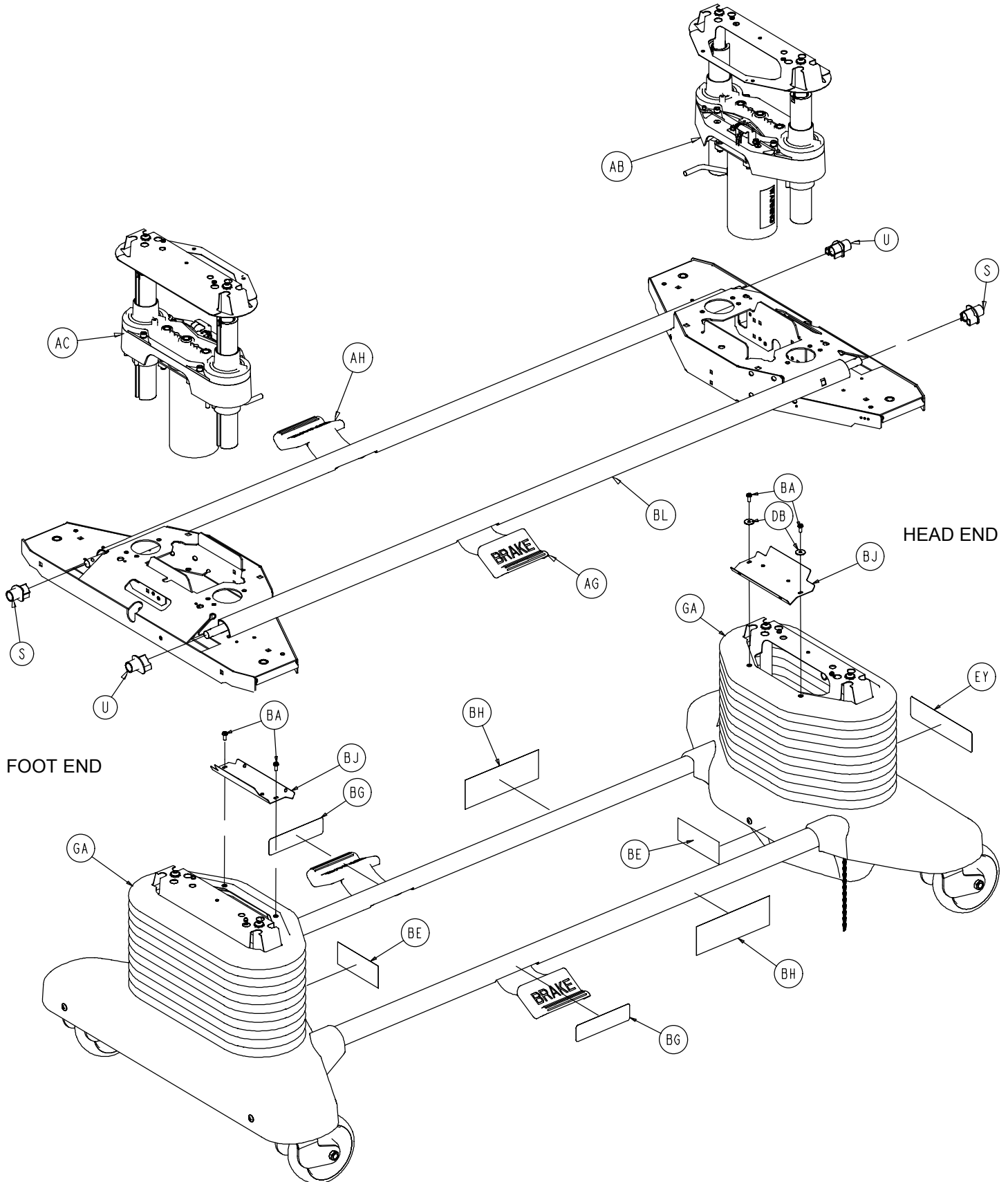

Base Assembly and Options

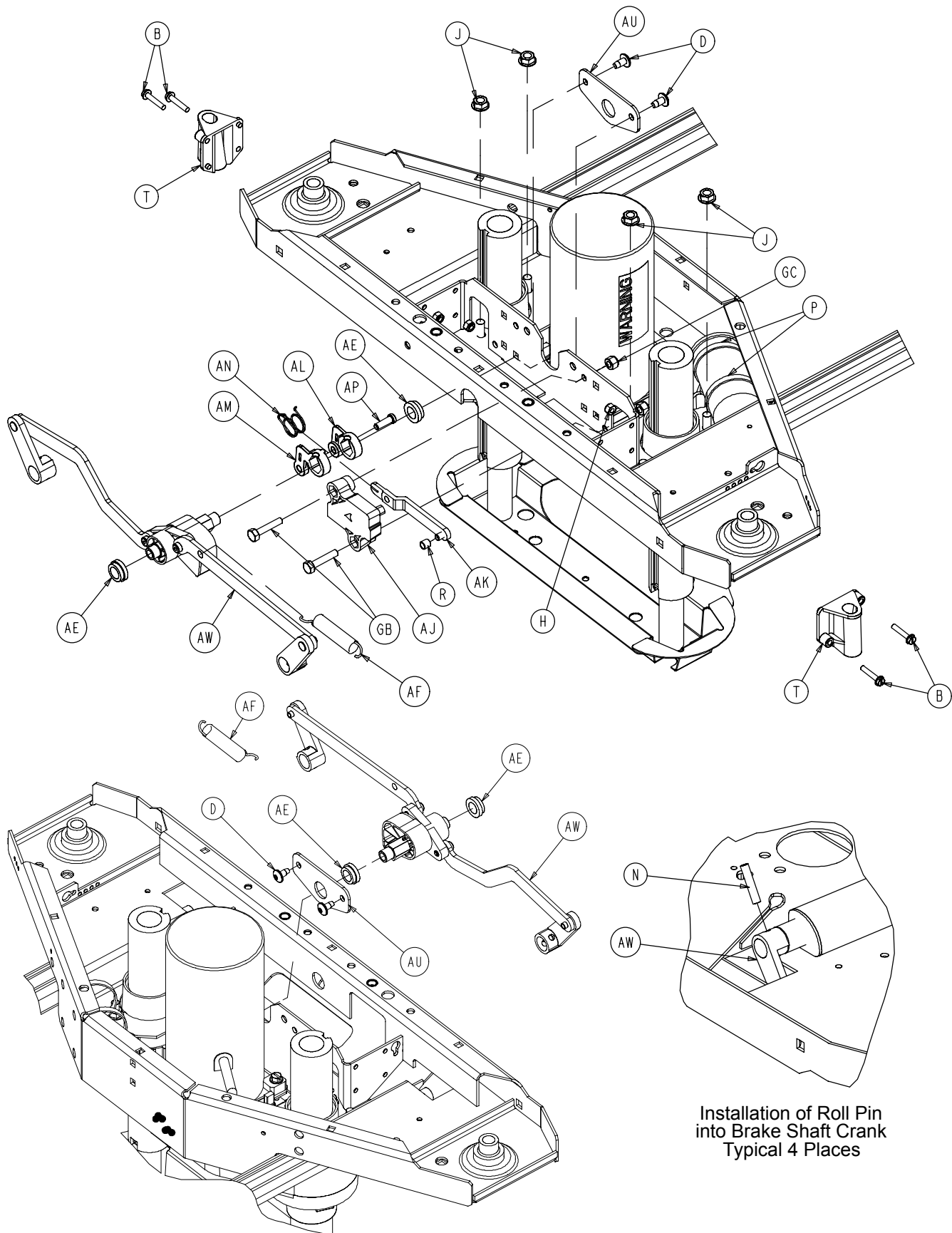

Installation of Roll Pin
into Brake Shaft Crank
Typical 4 Places

Base Assembly and Options

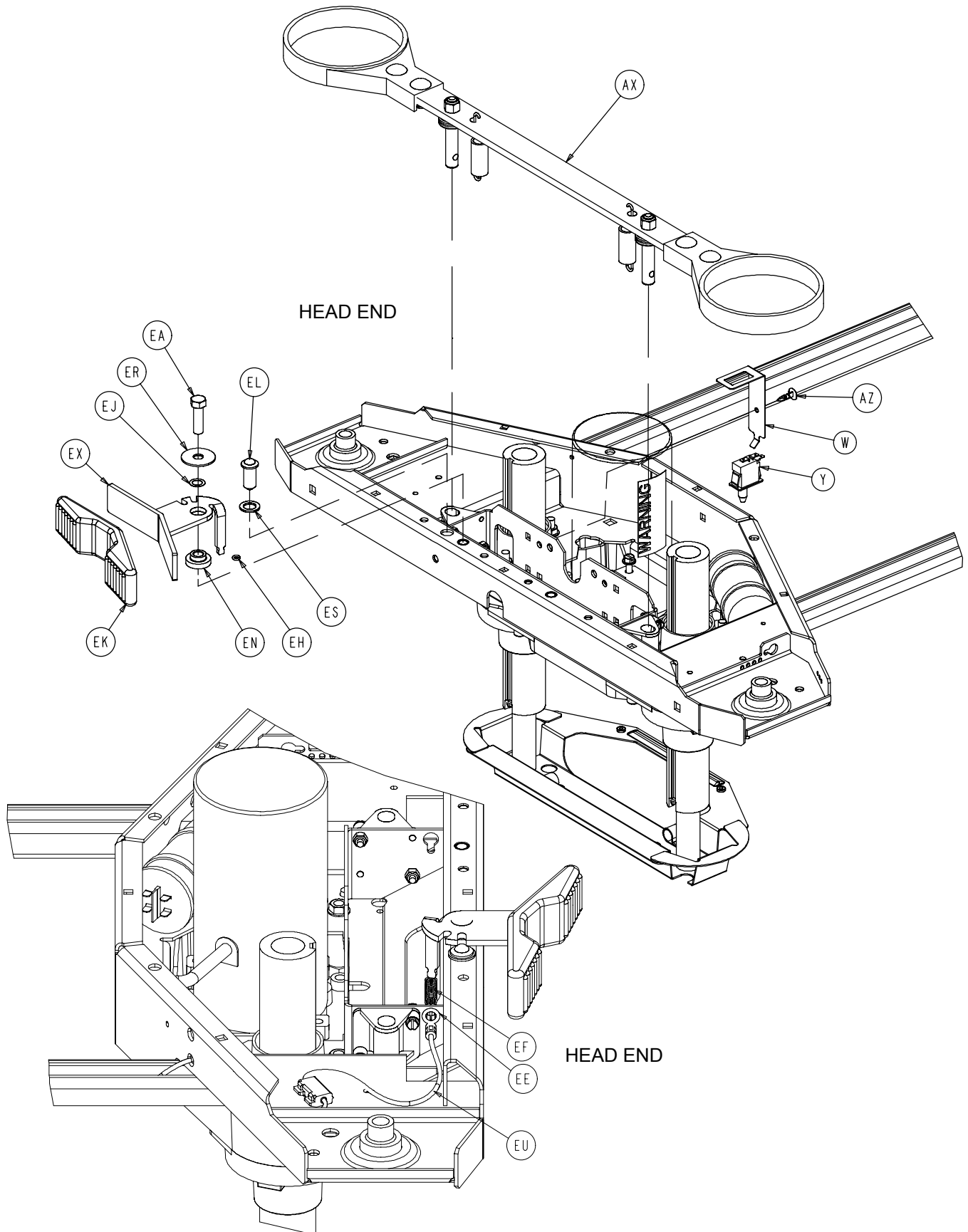

Base Assembly and Options

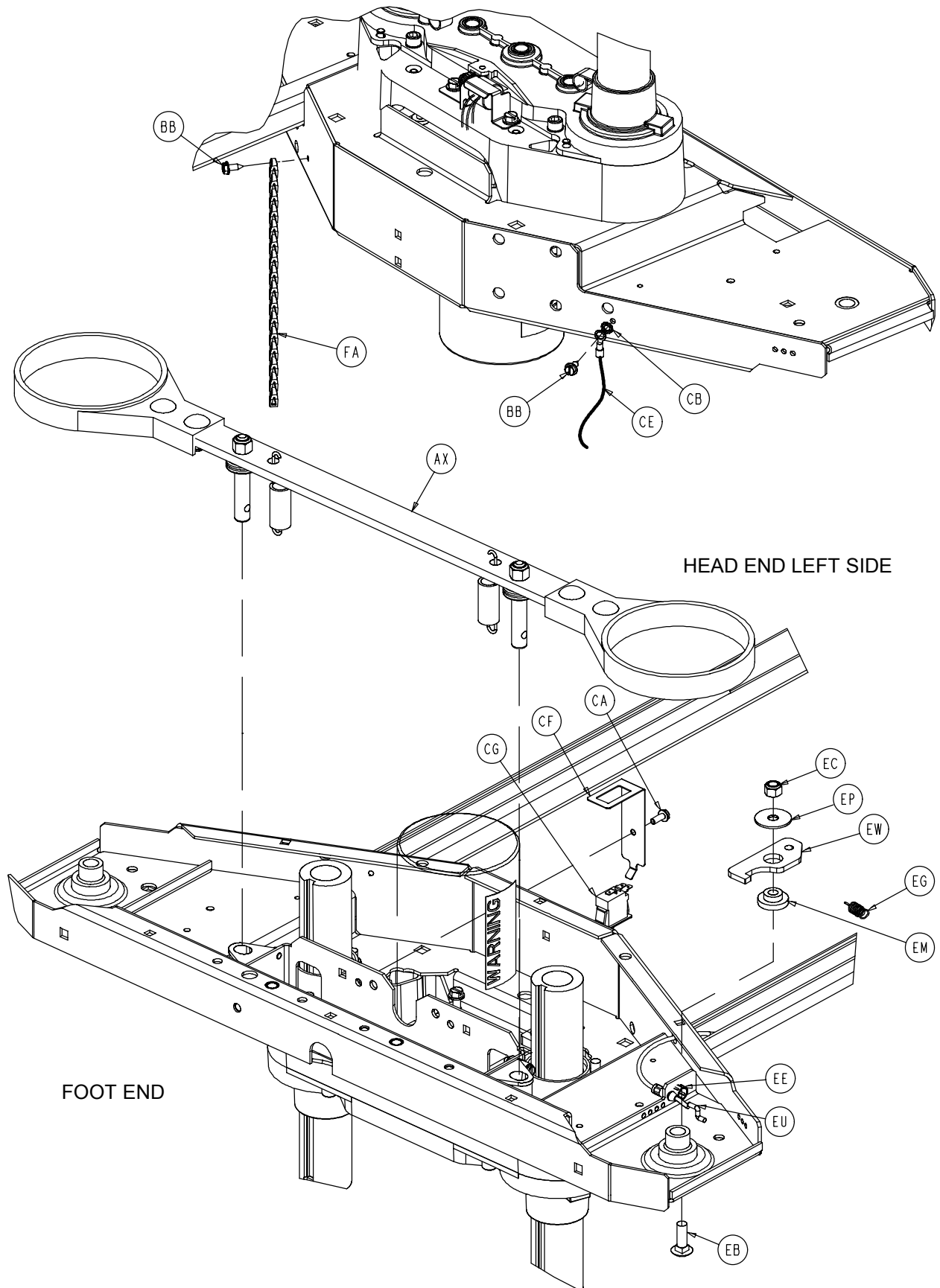

Base Assembly and Options

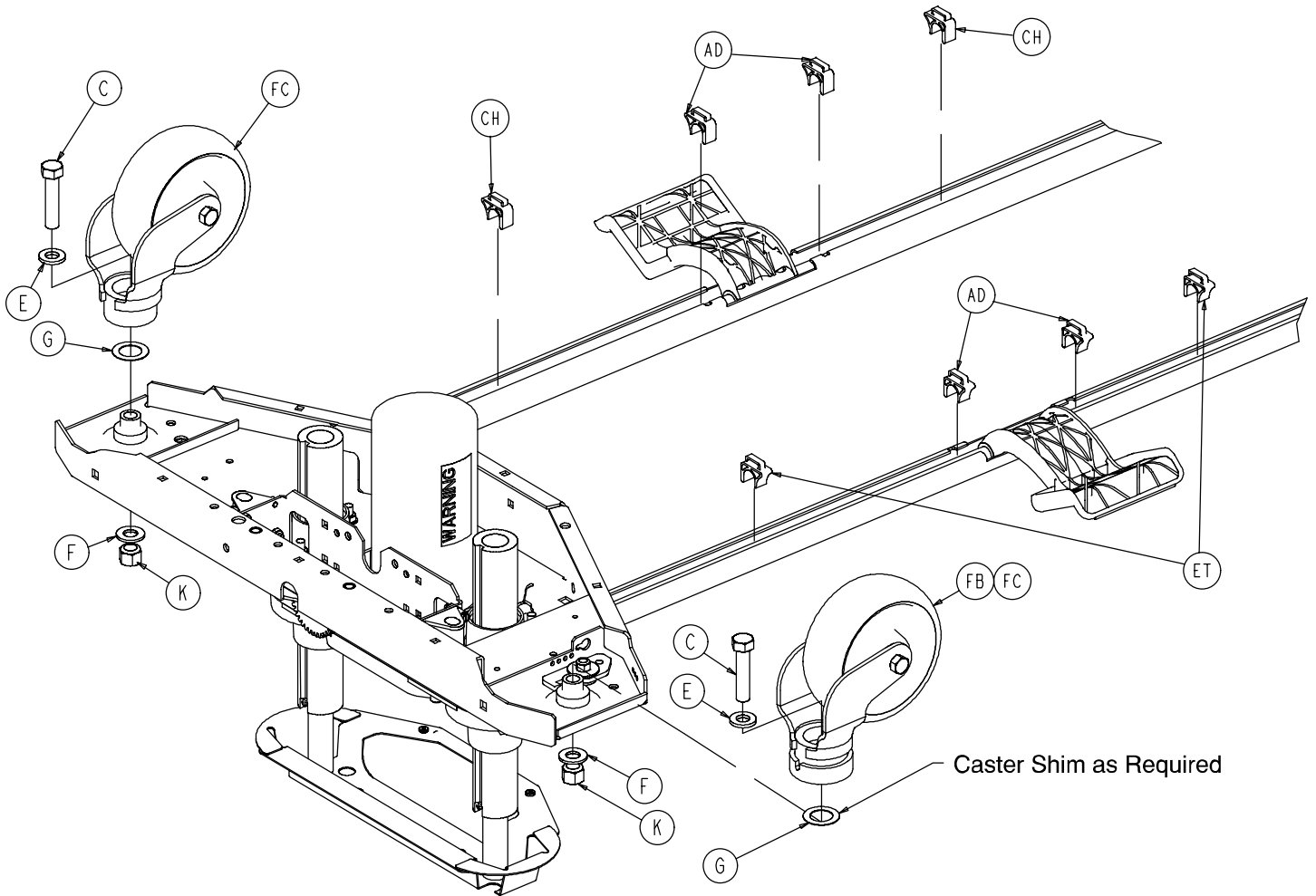

Base Assembly and Options

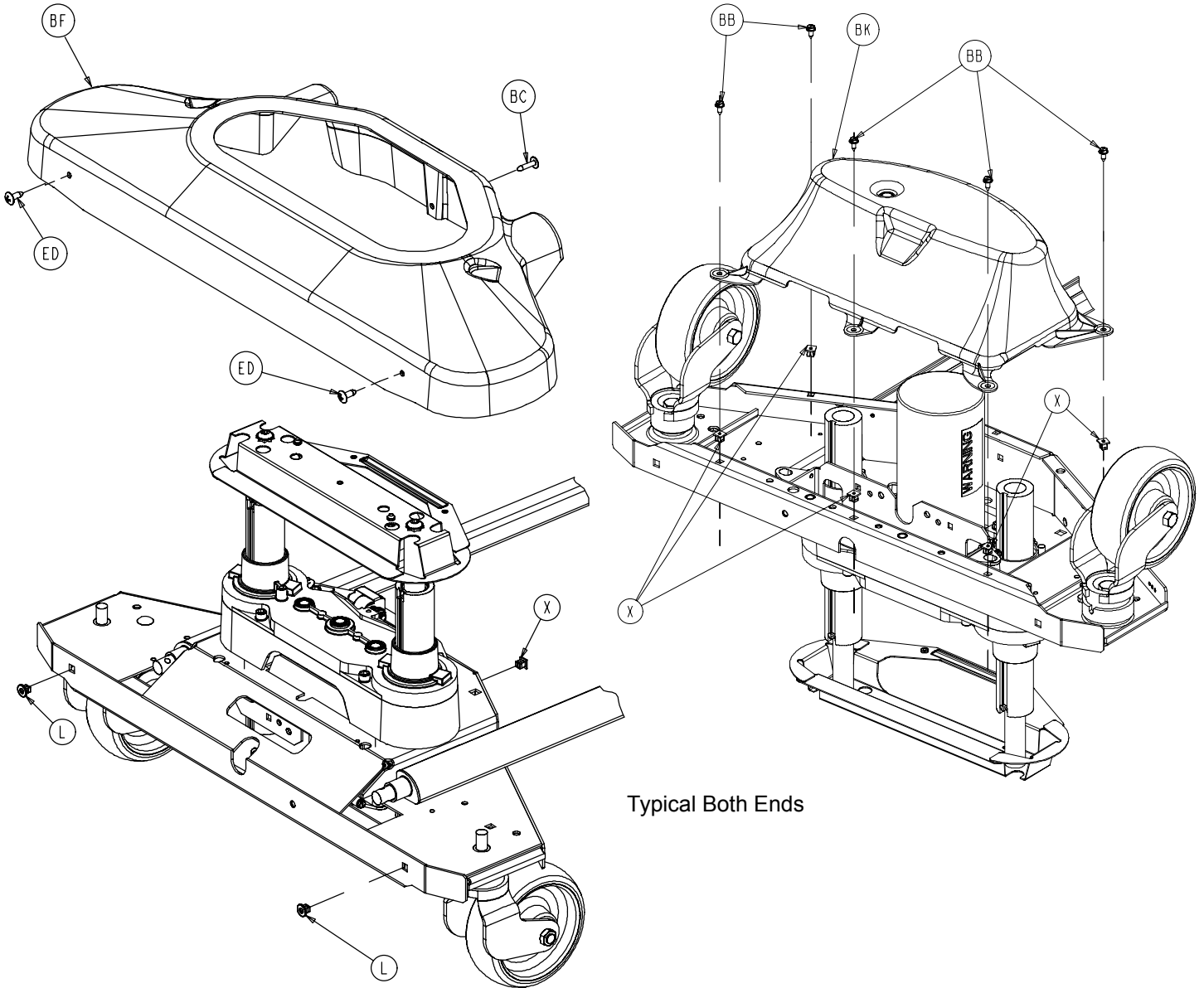

Typical Both Ends

Sensor Coil Cable p/n 3001-200-815 Ground

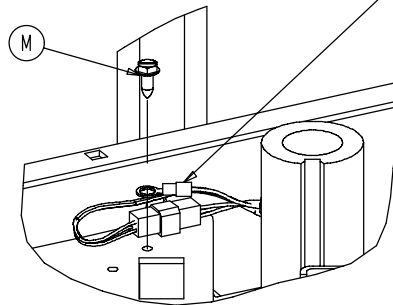

Typical Both Ends

Base Assembly and Options

Base Assembly Common Components – Part Number 3002–200–3 (Reference Only)

Item	Part No.	Part Name	Qty.
B	3-122	Hex Washer Hd. Screw	8
D	7-52	Truss Hd. Torx	4
E	11-310	Washer	4
G	11-343	Washer	4
H	16-2	Nylock Nut	8
J	16-98	Hex Flange Nut	8
K	16-49	Nylock Nut	4
L	18-36	Plastic Clip Nut	4
M	3-224	Hex Washer Hd. Screw	2
N	26-14	Roll Pin	4
P	38-151	Cable Tie	4
R	3000-200-316	Brake Track Roller	1
S	3000-200-305	Brake Shaft Bushing, Right	2
T	3000-200-328	Brake Guide Bushing	4
U	3000-200-331	Brake Shaft Bushing, Left	2
W	3000-200-343	Brake Switch Bracket	1
X	3000-300-2	Plastic Clip Nut	10
Y	3000-300-58	Plunger Switch	1
Z	3000-300-113	8" Cable Tie	6
AB	(page 84)	Head End Lift Assembly	1
AC	(page 84)	Foot End Lift Assembly	1
AD	3001-200-306	Brake Pedal Shaft Bearing	4
AE	3001-200-317	Brake Cam Shaft Bushing	4
AF	3001-200-334	Brake Return Extension Spring	2
AG	(page 89)	Brake Shaft Assembly, Left	1
AH	(page 89)	Brake Shaft Assembly, Right	1
AJ	3002-201-301	Brake Ratchet Track	1
AK	3002-200-302	Brake Ratchet Link Assembly	1
AL	3002-200-305	Brake Ratchet Crank, Left	1
AM	3002-200-306	Brake Ratchet Crank, Right	1
AN	3002-200-307	Brake Latch Spring	1
AP	3002-200-308	Brake Ratchet Crank Pin	1
AU	3002-200-314	Brake Mounting Bracket	2
AW	(page 90)	Brake Crank Assembly	2
AX	(page 91)	Brake Bar Assembly	2
AZ	3000-300-115	Stand-Off	1
GA	2025-000-101	Bellows	2
GB	3-74	Hex Hd. Bolt	2
GC	16-28	Nylock Nut	2

Base Assembly and Options

Base Assembly, Zoom ICU Bed – Part Number 2040–244–3 (Reference Only)

Item	Part No.	Part Name	Qty.
C	3-204	Hex Hd. Cap Screw	4
AB	(page 84)	Head End Lift Assembly	1
AC	(page 84)	Foot End Lift Assembly	1
BL	3002-200-102	Base Weldment	1
CA	3000-300-115	Stand-Off	1
CB	13-18	External Tooth Lock Washer	1
CE	2025-31-805	Ground Strap	1
CF	3000-200-343	Brake Switch Bracket	1
CG	3000-300-58	Switch Plunger	1
CH	3001-200-306	Brake Pedal Shaft Bearing	2
GA	2030-000-101	Bellows	2

6” Caster Option, Zoom – 2040–999–138 (Ref.) 8” Caster Option, Zoom – 2040–999–139 (Ref.)

Item	Part No.	Part Name	Qty.	Item	Part No.	Part Name	Qty.
FA	3001-200-52	6” Ground Chain	1	FA	3001-200-54	8” Ground Chain	1
FC	(page 92)	6” Caster Assembly	4	FC	(page 94)	8” Caster Assembly	4
				FD	2025-1-47	Caster Cover, Right	4
				FE	2025-1-48	Caster Cover, Left	4

Lift Assembly (Head & Foot End)

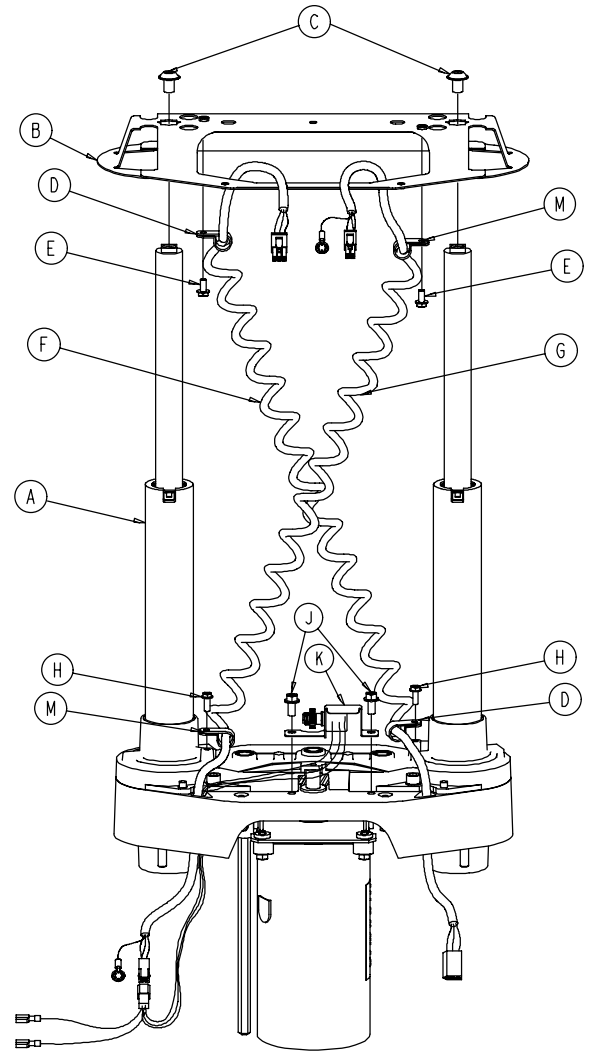
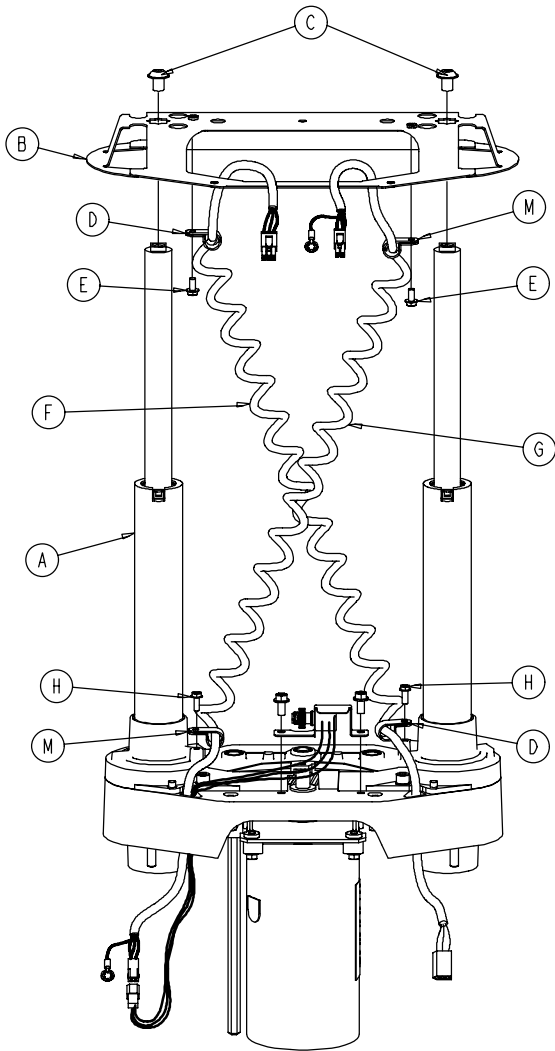
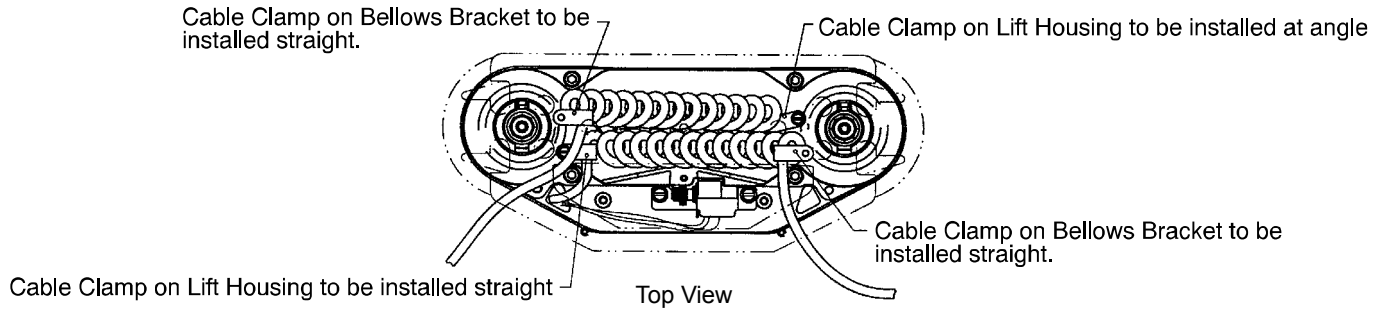

Item	Part No.	Part Name	Qty.	Item	Part No.	Part Name	Qty.
A	(page 85-87)	Common Lift Assembly	1	H	3-128	Hex Washer Hd. Screw	2
B	3000-200-52	Bellows Bracket	1	J	3-121	Hex Washer Hd. Screw	2
D	34-22	Cord Clamp	2	K	3001-200-240	Head End Pot. Ass'y	1
E	3-106	Hex Washer Hd. Screw	2	M	3001-200-230	Foot End Pot. Ass'y	1
F	3001-200-864	Power Coil Cord	1		34-381	Cord Clamp	2
G	3001-200-815	Sensor Coil Cord	1				

Lift Assembly (Common)

Assembly part number 3000-200-275 (reference only)

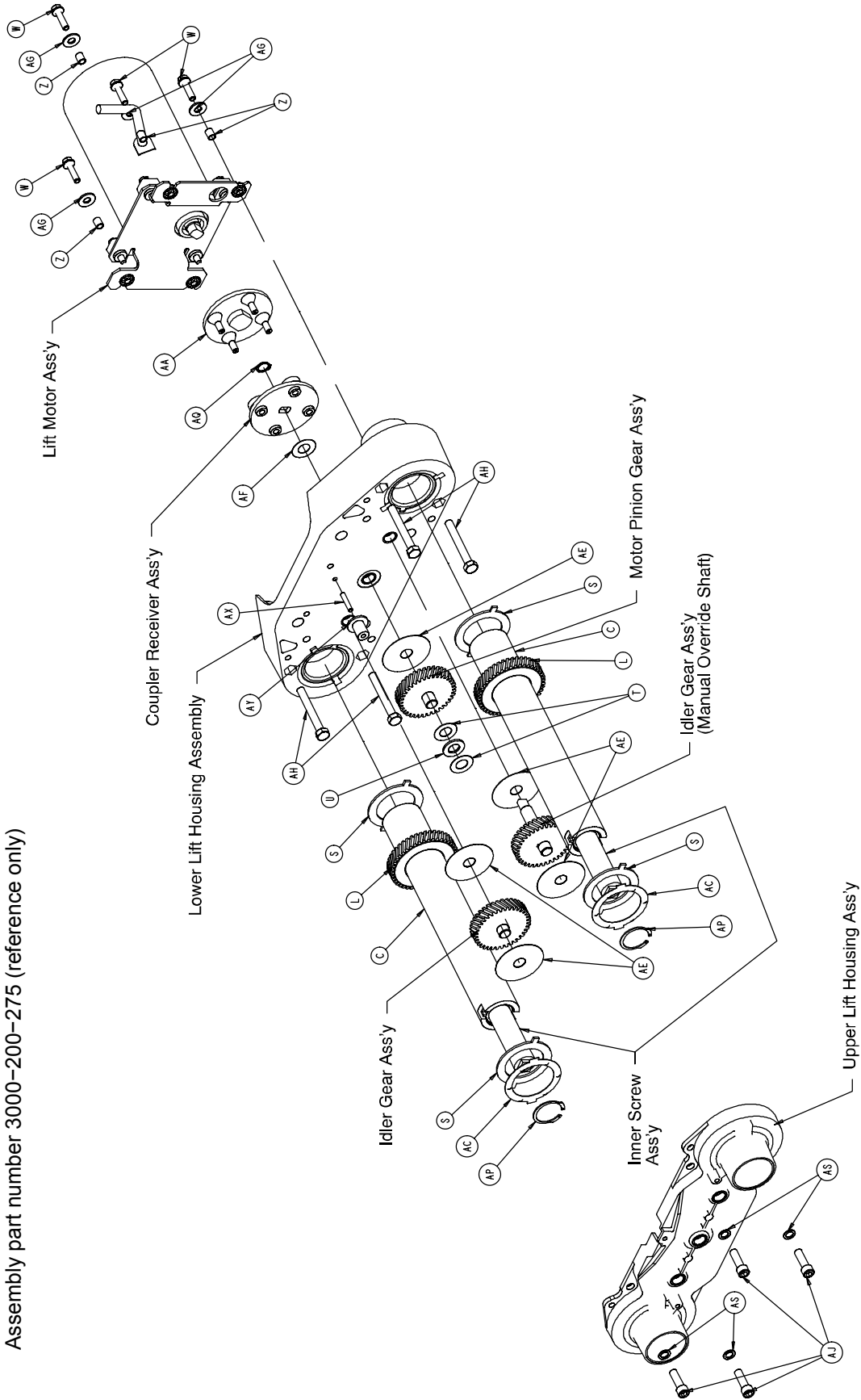

Lift Assembly (Common)

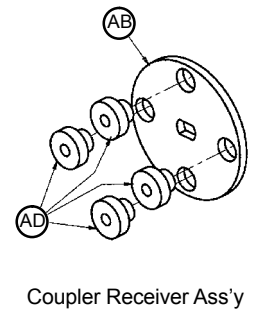
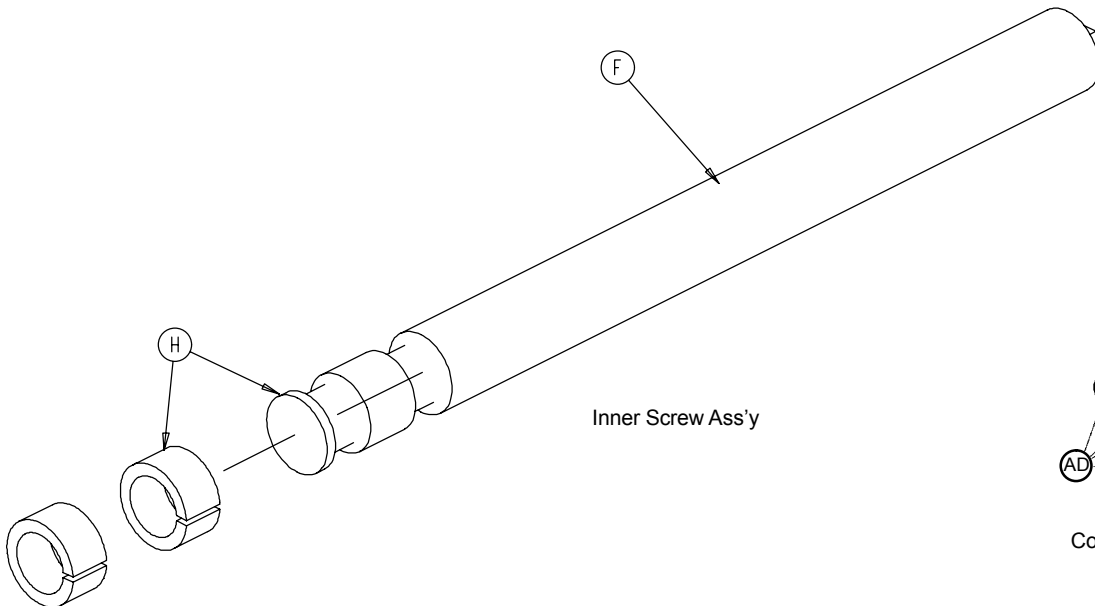
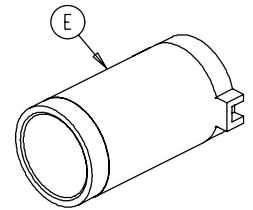
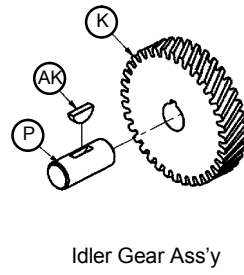
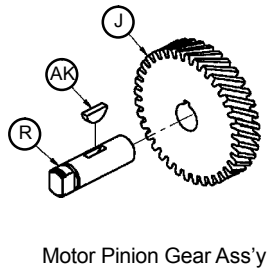
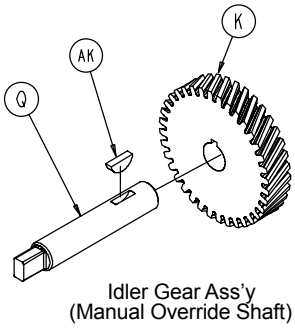
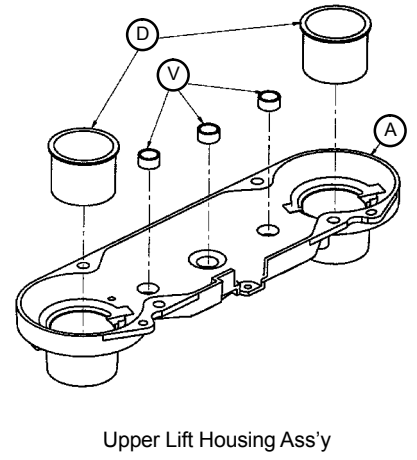
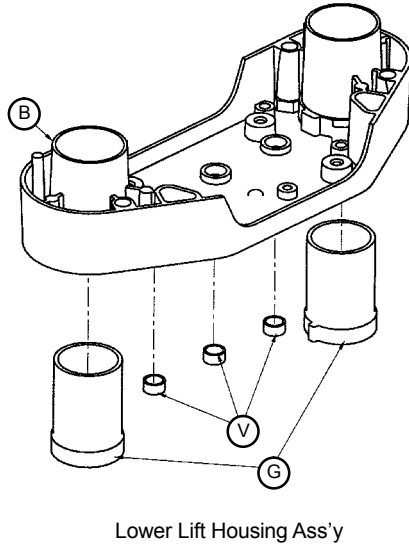
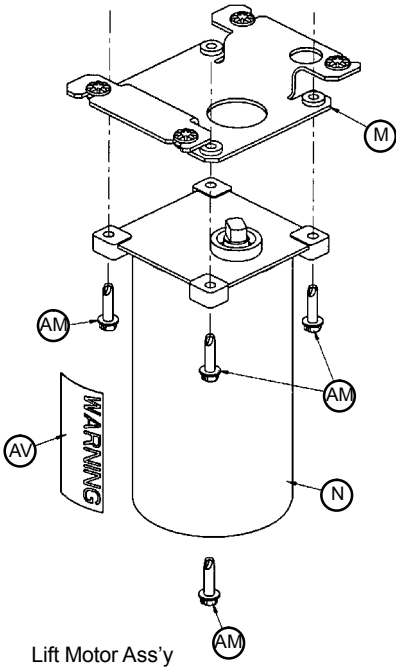

Lift Assembly (Common)

Item	Part No.	Part Name	Qty.
A	3000-200-201	Upper Lift Housing	1
B	3000-200-202	Lower Lift Housing	1
C	3000-200-251	Outer Screw	2
D	3000-200-204	Upper Housing Sleeve	2
E	3000-200-205	Upper Stage Nut	2
F	3000-200-249	Inner Screw	2
G	3000-200-207	Lower Stage Nut	2
H	3000-200-208	Glide Bushing	4
J	3000-200-209	Motor Pinion Gear	1
K	3000-200-210	Idler Gear	2
L	3000-200-252	Output Gear	2
M	(page 88)	Motor Isolation Plate Ass'y	1
N	3000-200-213	Lift Motor	1
	3221-200-213	230V Lift Motor	1
P	3000-200-218	Idler Shaft, Lift	1
Q	3002-200-235	Idler Man. Over. Shaft	1
R	3000-200-220	Input Pinion Shaft	1
S	3000-200-223	Output Gear Thr. Washer	4
T	3000-200-224	Input Gear Thr. Washer	2
U	81-212	Thrust Needle Roller Brg.	1
V	3000-200-226	Pinion Shaft Bushing	6
W	3001-200-228	Mounting Standoff	4
Z	3001-300-19	Isolation Sleeve	4
AA	3000-200-233	Lift Motor Coupler	1
AB	3000-200-234	Coupler Receiver	1
AC	3000-200-241	Crush Washer	2
AD	3000-300-455	Isolation Bushing	4
AE	3000-200-245	Gear Washer	5
AF	3000-200-246	Nylon Washer	1
AG	11-408	Flat Washer	4
AH	3-82	Hex Hd. Cap Screw	4
AJ	4-213	Soc. Hd. Cap Screw	4
AK	58-44	Woodruff Key	3
AM	3-331	Hex Washer Hd. Screw	4
AP	28-121	Retaining Ring	2
AQ	28-97	Retaining Ring	1
AS	11-308	Serrated Belleville Washer	4
AV	3000-300-604	Warning Label	1
AX	3000-200-239	Pot. Drive Gear Shaft	1
AY	3000-200-216	Potentiometer Drive Gear	1

3000-200-723 Motor Isolation Plate Assembly

Assembly part number 3001-200-214 (reference only)

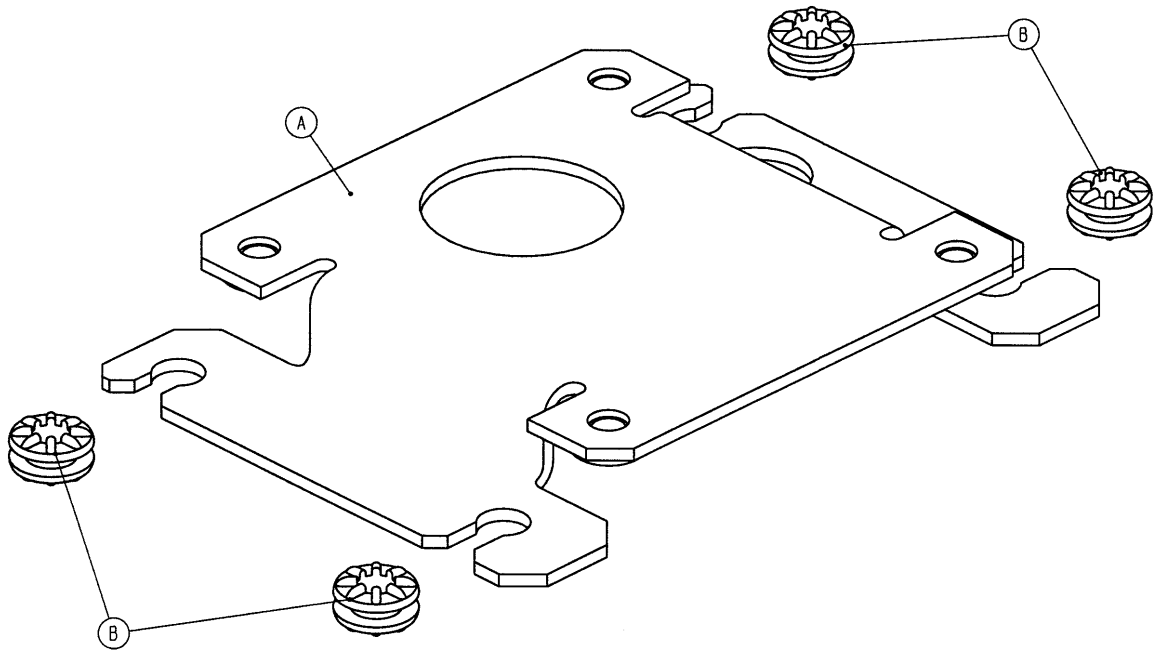

Item	Part No.	Part Name	Qty.
A	3001-200-213	Isolation Plate	1
B	3000-300-442	Grommet	4

Brake Shaft Assembly, Left and Right

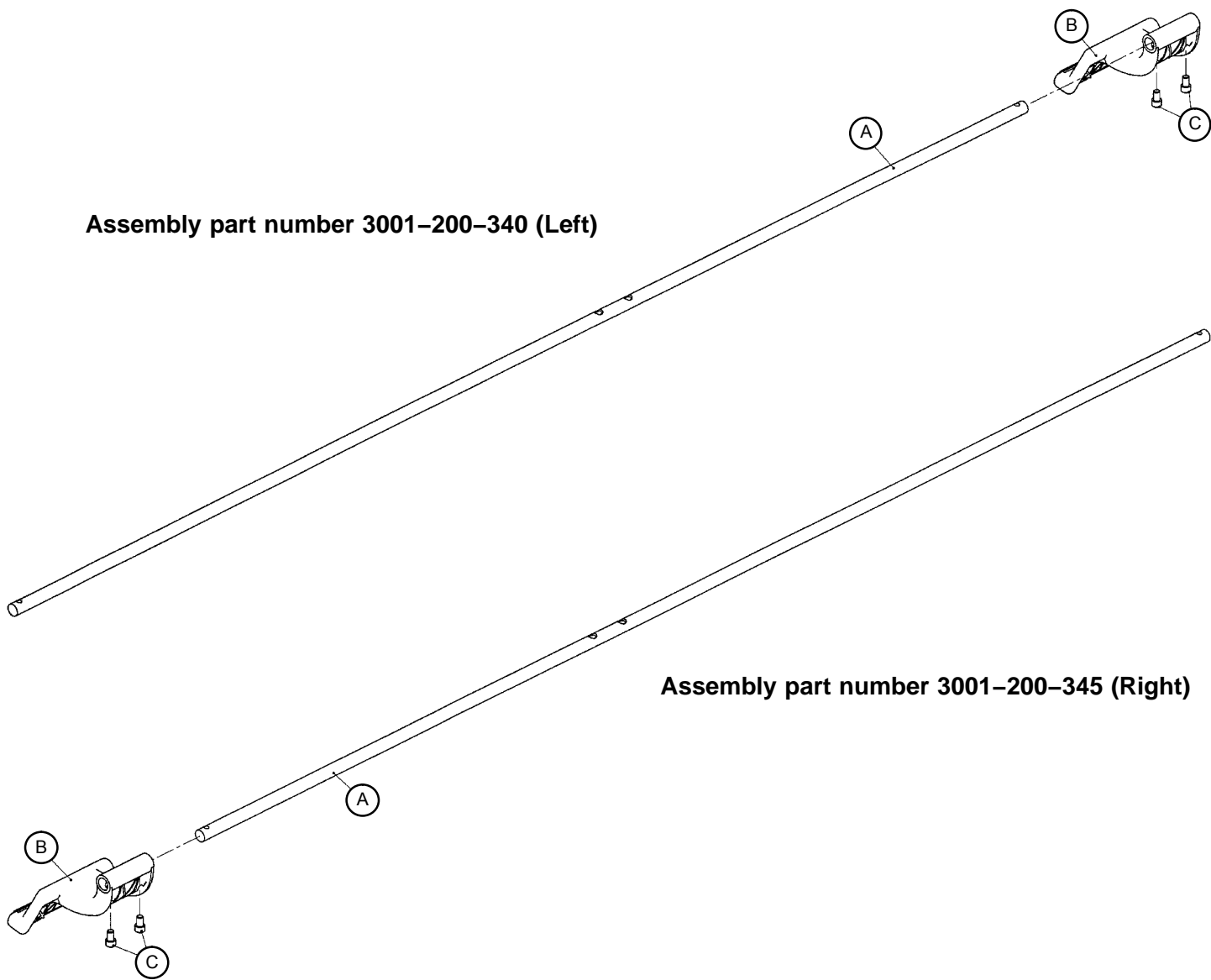

Item	Part No.	Part Name	Qty.
A	3000-200-314	Brake Shaft	1
B	3001-200-325	Brake Pedal	1
C	4-270	Soc. Hd. Cap Screw	2

3002-201-330 Brake Crank Assembly

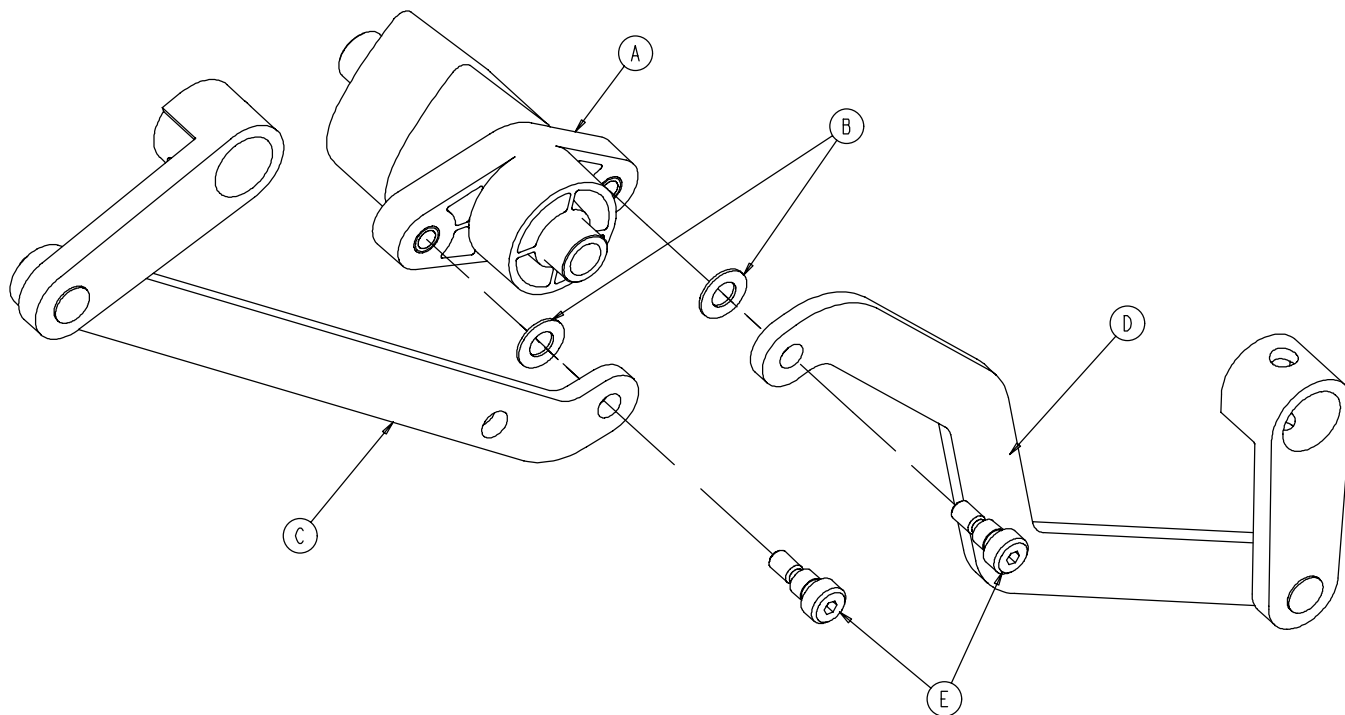

Item	Part No.	Part Name	Qty.
A	3002-201-309	Brake Cam Shaft Crank	1
B	14-4	Washer	2
C	3002-200-331	Brake Link	1
D	3002-200-332	Dog Leg Brake Link	1
E	2-108	Socket Hd. Shoulder Screw	2

3002-200-335 Brake Bar Assembly

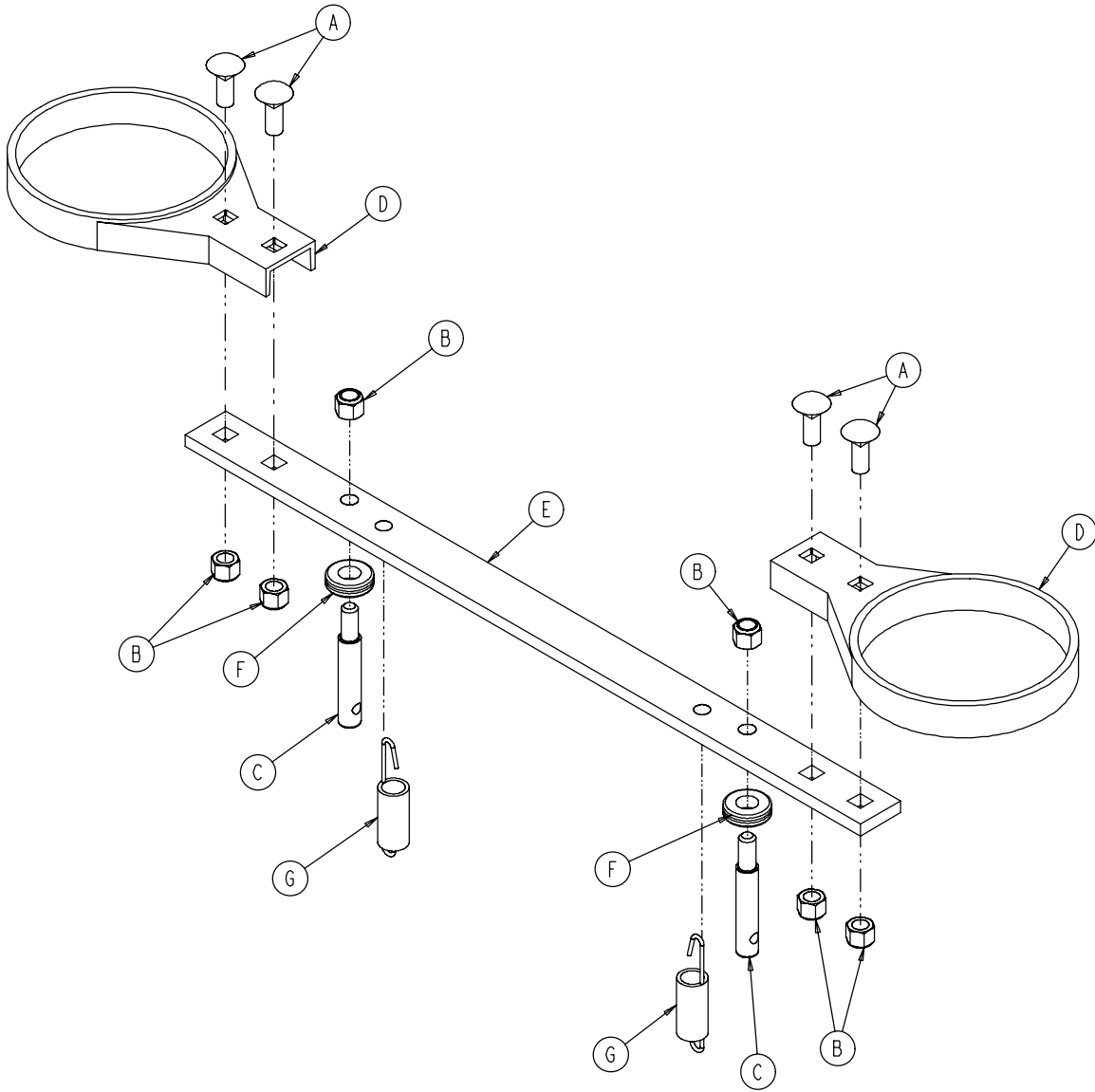

Item	Part No.	Part Name	Qty.
A	5-18	Carriage Bolt	4
B	16-35	Nylock Hex Nut	6
C	3000-200-318	Guide Pin	2
D	3000-200-321	Brake Ring	2
E	3000-200-323	Brake Bar	1
F	3000-200-324	Brake Bar Bumper	2
G	3002-200-310	Brake Bar Return Spring	2

3001-200-60 6" Caster Assembly

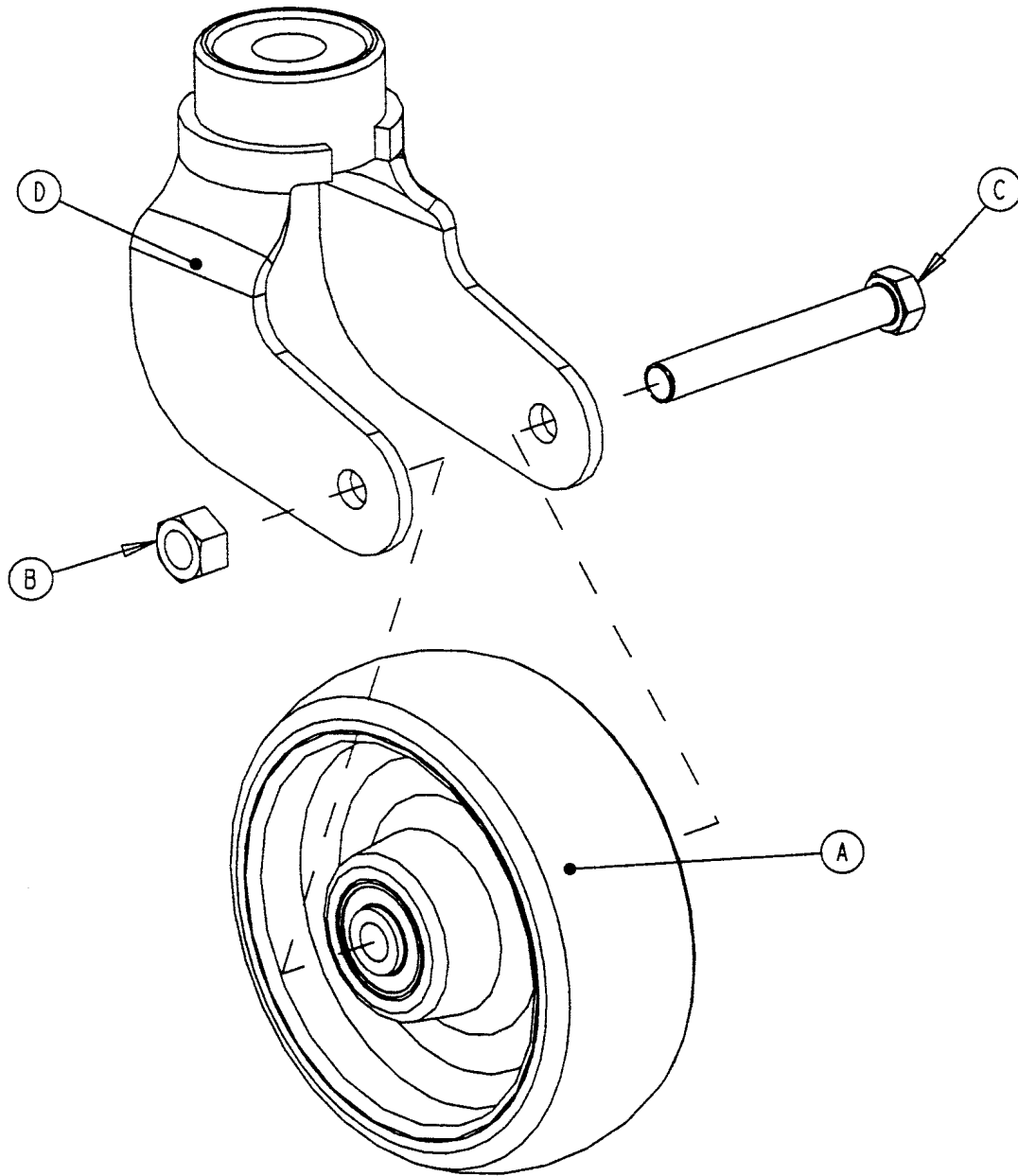

Item	Part No.	Part Name	Qty.
A	(page 93)	Wheel Assembly	1
B	16-60	Lock Nut	1
C	3-342	Hex Hd. Cap Screw	1
D	3001-200-61	Caster Horn w/Bearing	1

5000-2-10 6" Molded Wheel Assembly

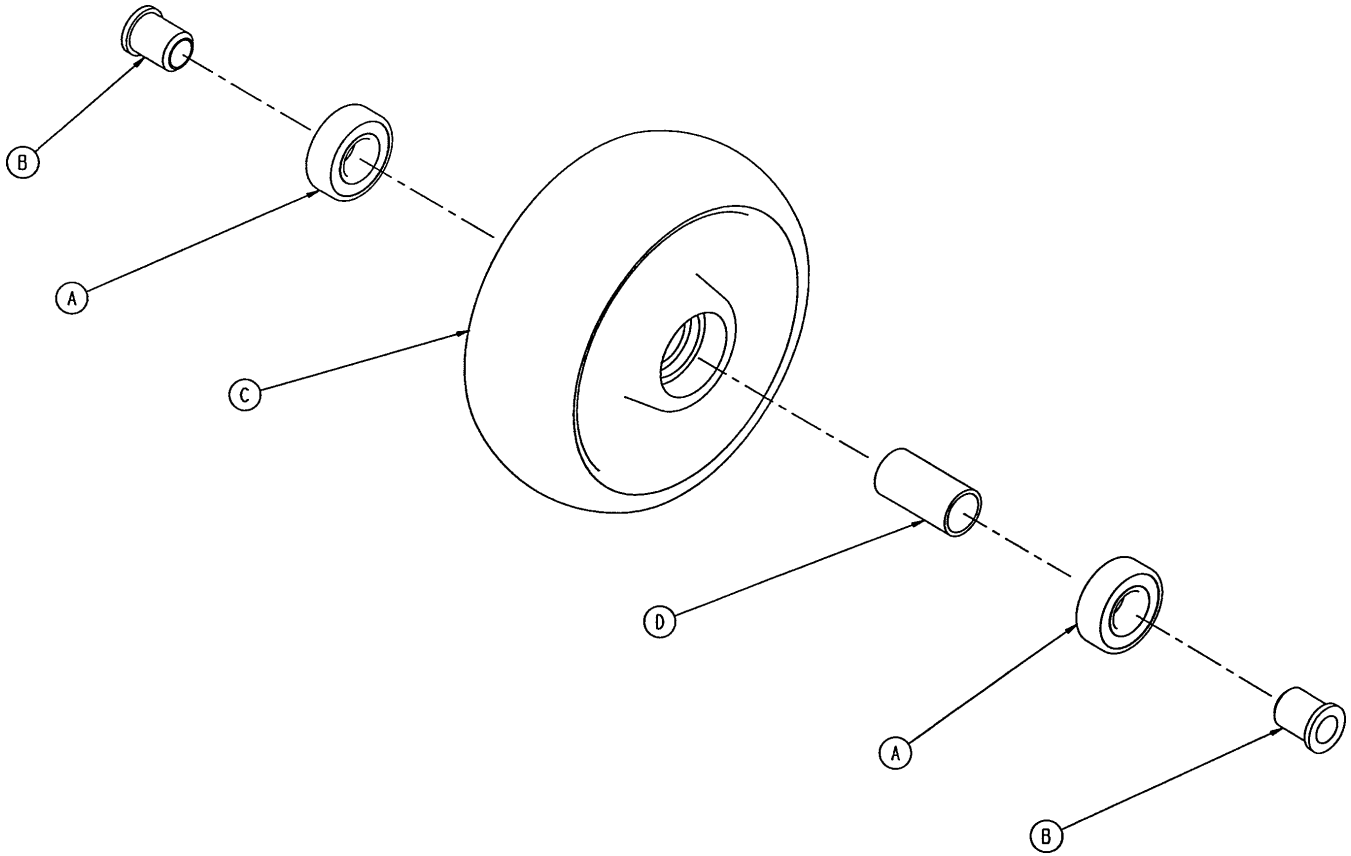

Item	Part No.	Part Name	Qty.
A	81-226	Bearing	2
B	715-1-255	Wheel Bushing	2
C	5000-2-20	Molded Wheel	1
D	6060-2-46	Bearing Spacer	1

3001-200-90 Optional 8" Caster Assembly

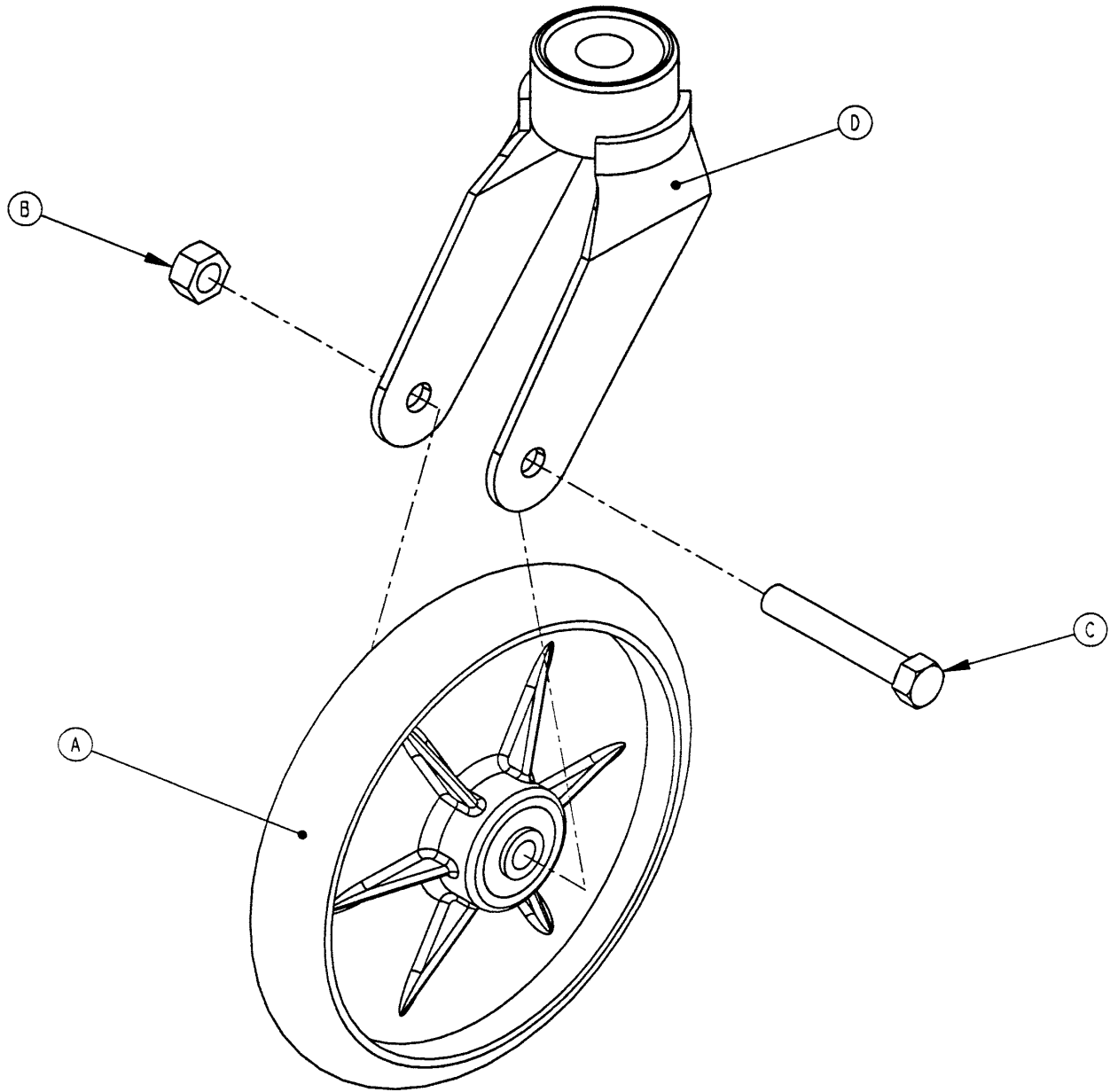

Item	Part No.	Part Name	Qty.
A	(page 96)	Wheel Assembly	1
B	16-60	Hex Nut	1
C	3-99	Hex Hd. Cap Screw	1
D	3001-200-76	Caster Horn	1
E	2025-1-47	Right Siderail Cover (not shown)	1
F	2025-1-48	Left Siderail Cover (not shown)	1

3001-200-90 Optional 8" Caster Assembly

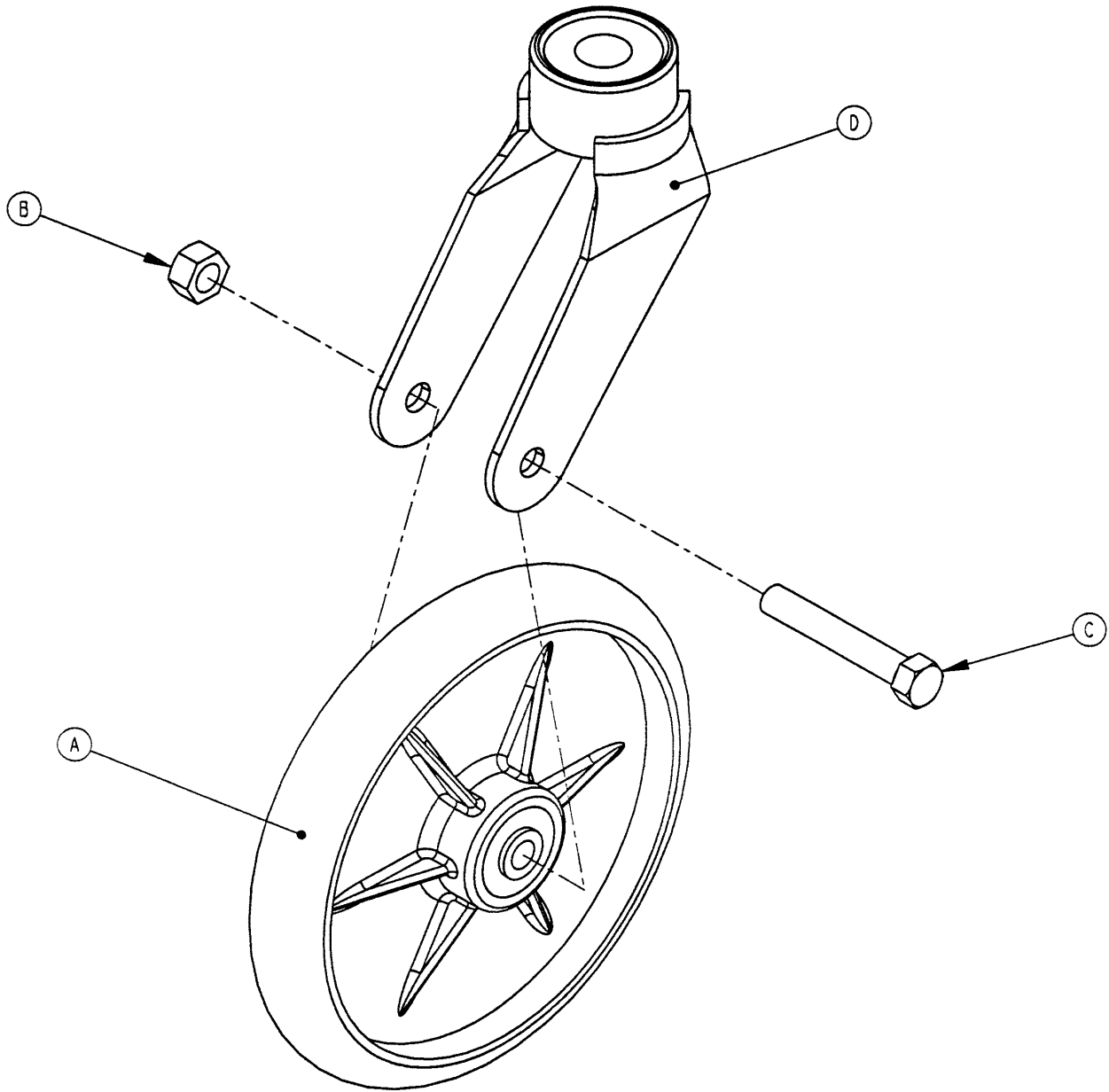

Item	Part No.	Part Name	Qty.
A	(page 96)	Wheel Assembly	1
B	16-60	Hex Nut	1
C	3-99	Hex Hd. Cap Screw	1
D	3001-200-76	Caster Horn	1
E	2025-1-47	Right Siderail Cover (not shown)	1
F	2025-1-48	Left Siderail Cover (not shown)	1

715-2-25 Optional 8" Wheel Assembly

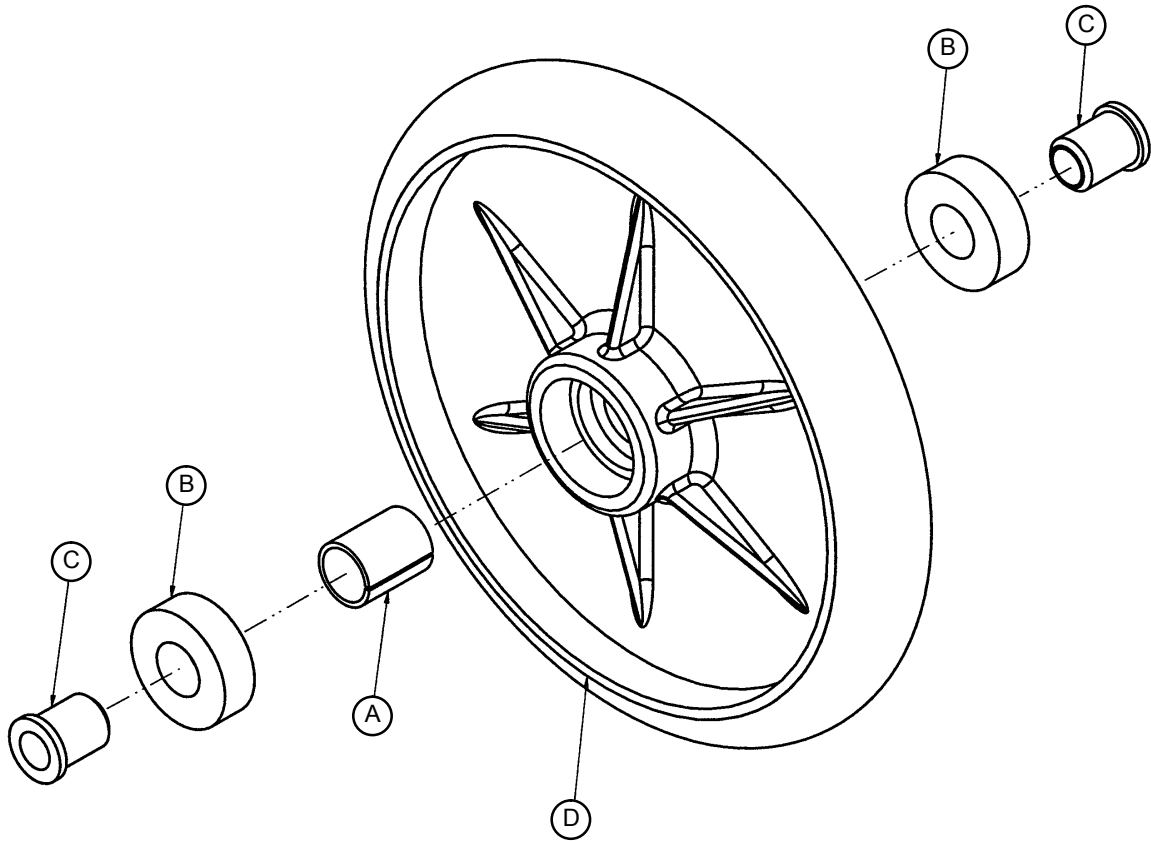

Item	Part No.	Part Name	Qty.
A	52-503	Bearing Spacer	1
B	81-226	Bearing	2
C	715-1-255	Wheel Bearing	2
D	715-2-124	Wheel	1

Zoom® Base Assembly

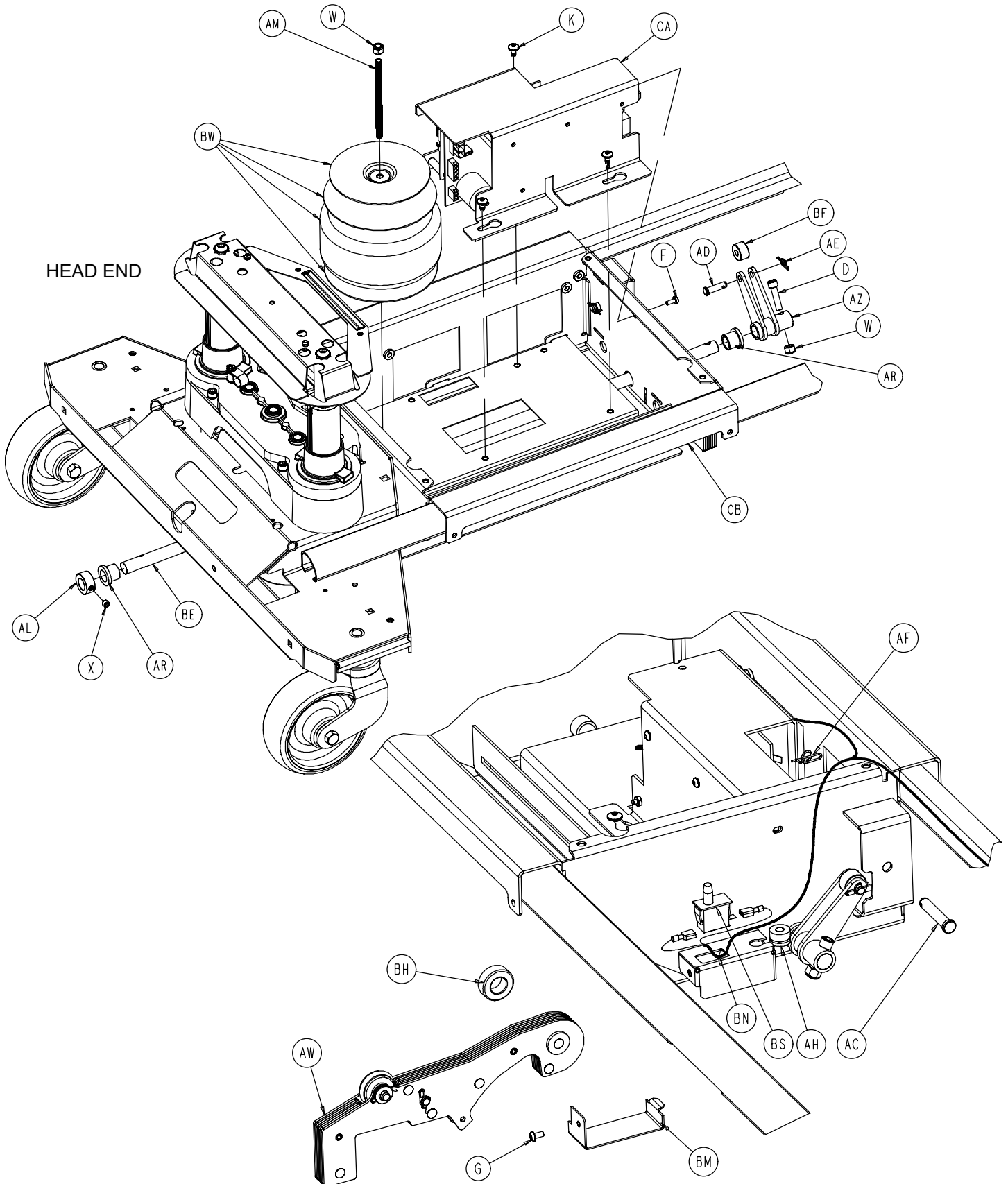

Zoom® Base Assembly

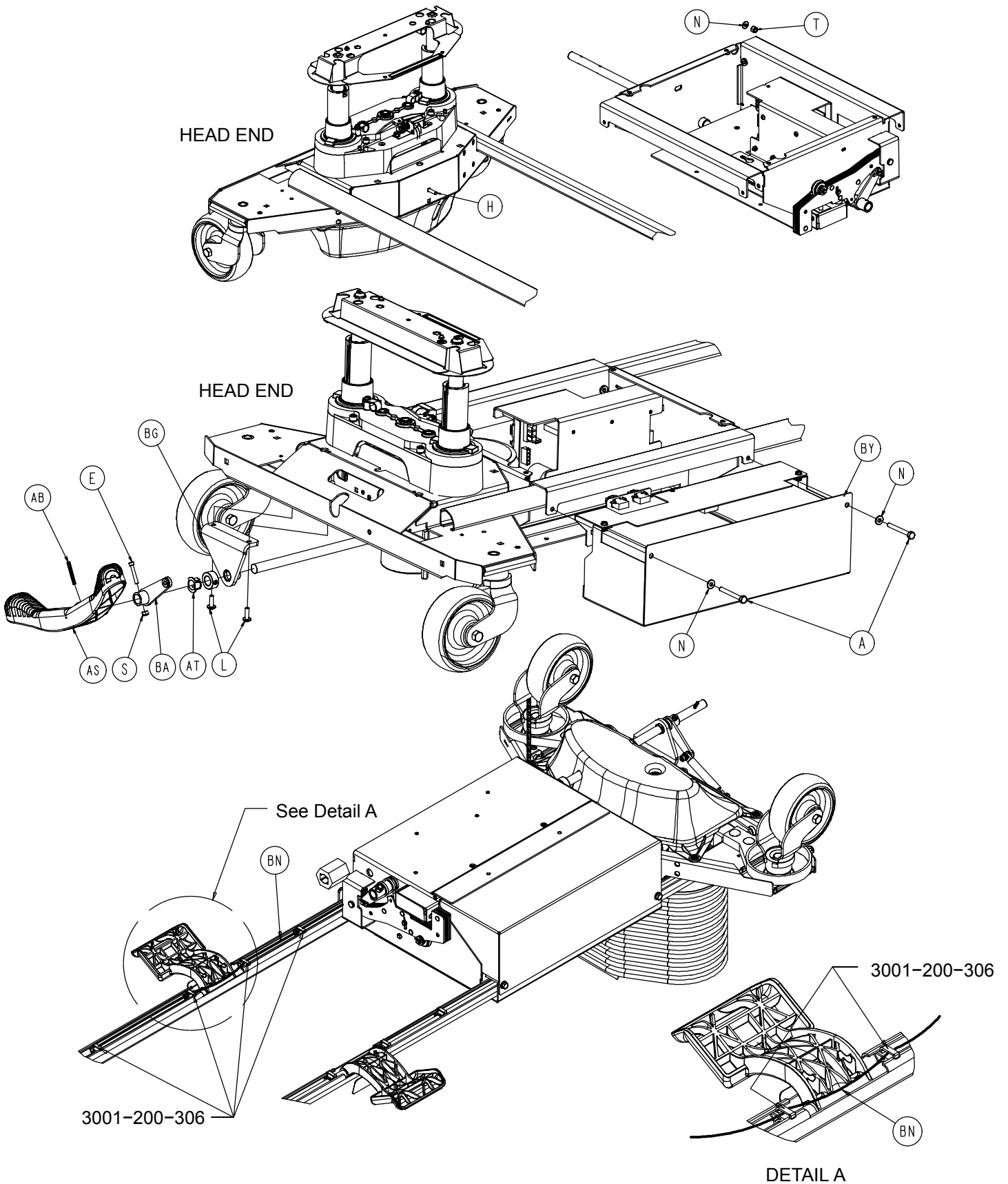

Zoom® Base Assembly

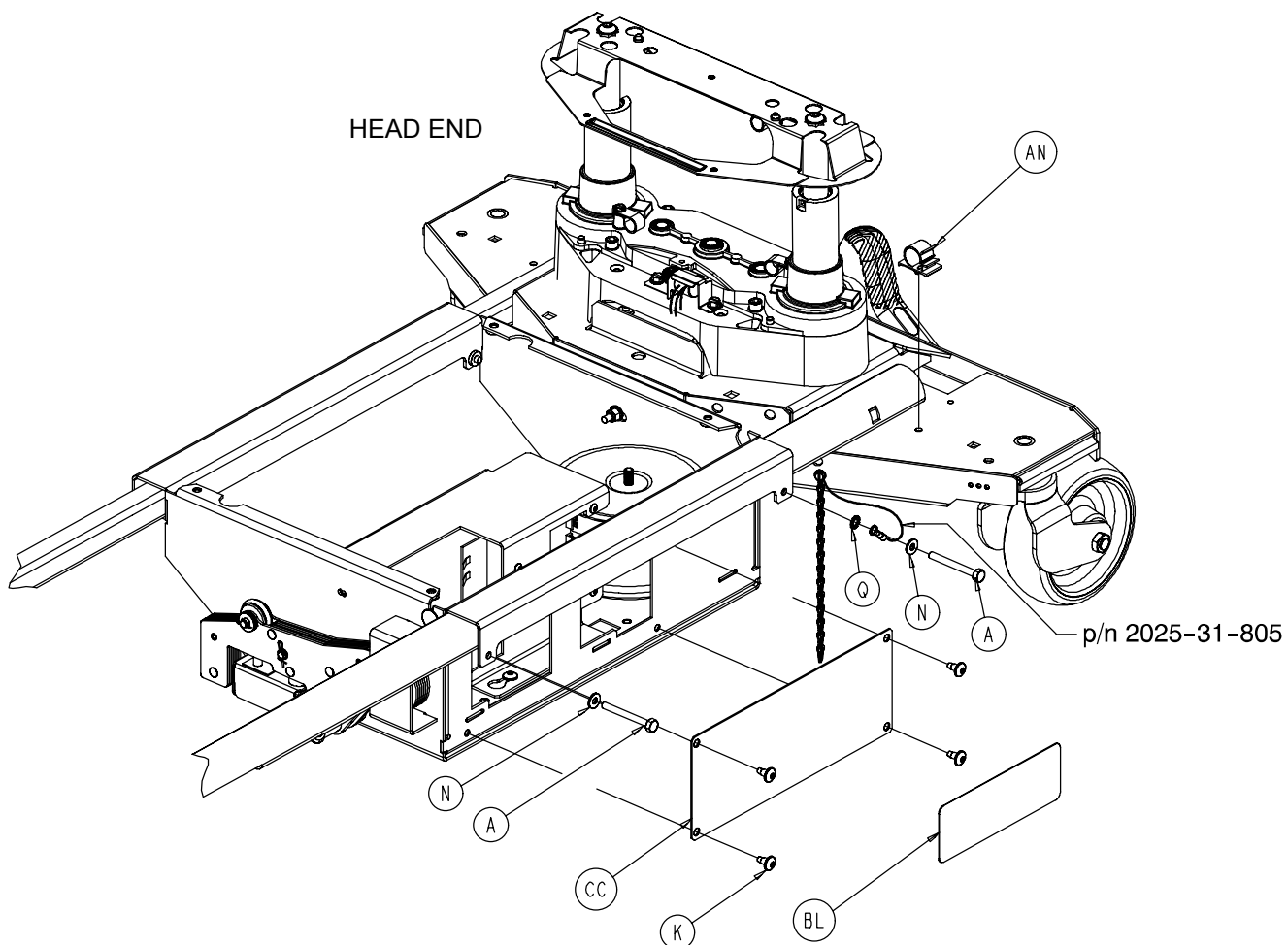
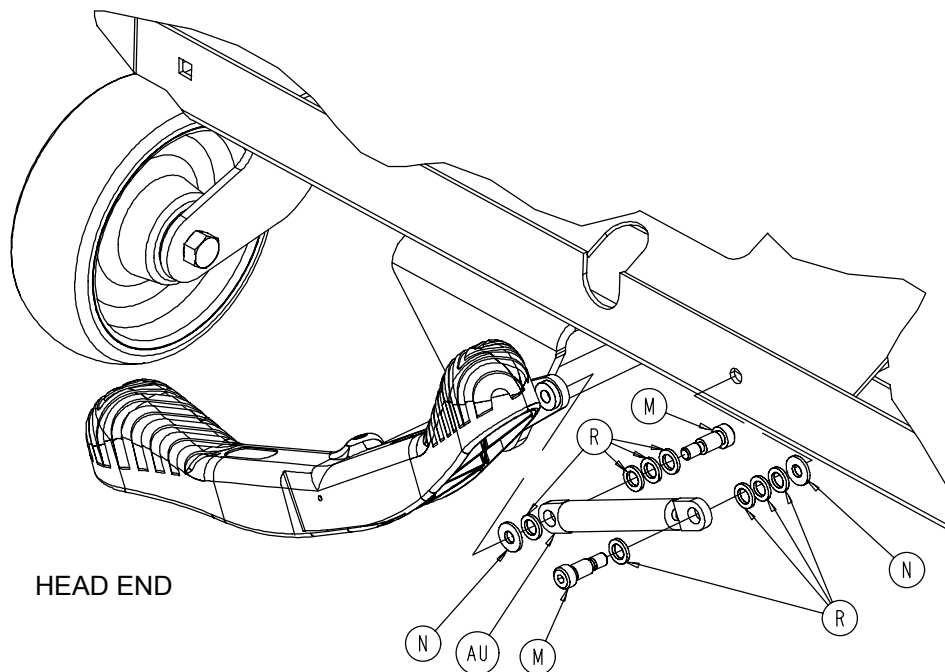

Zoom® Base Assembly

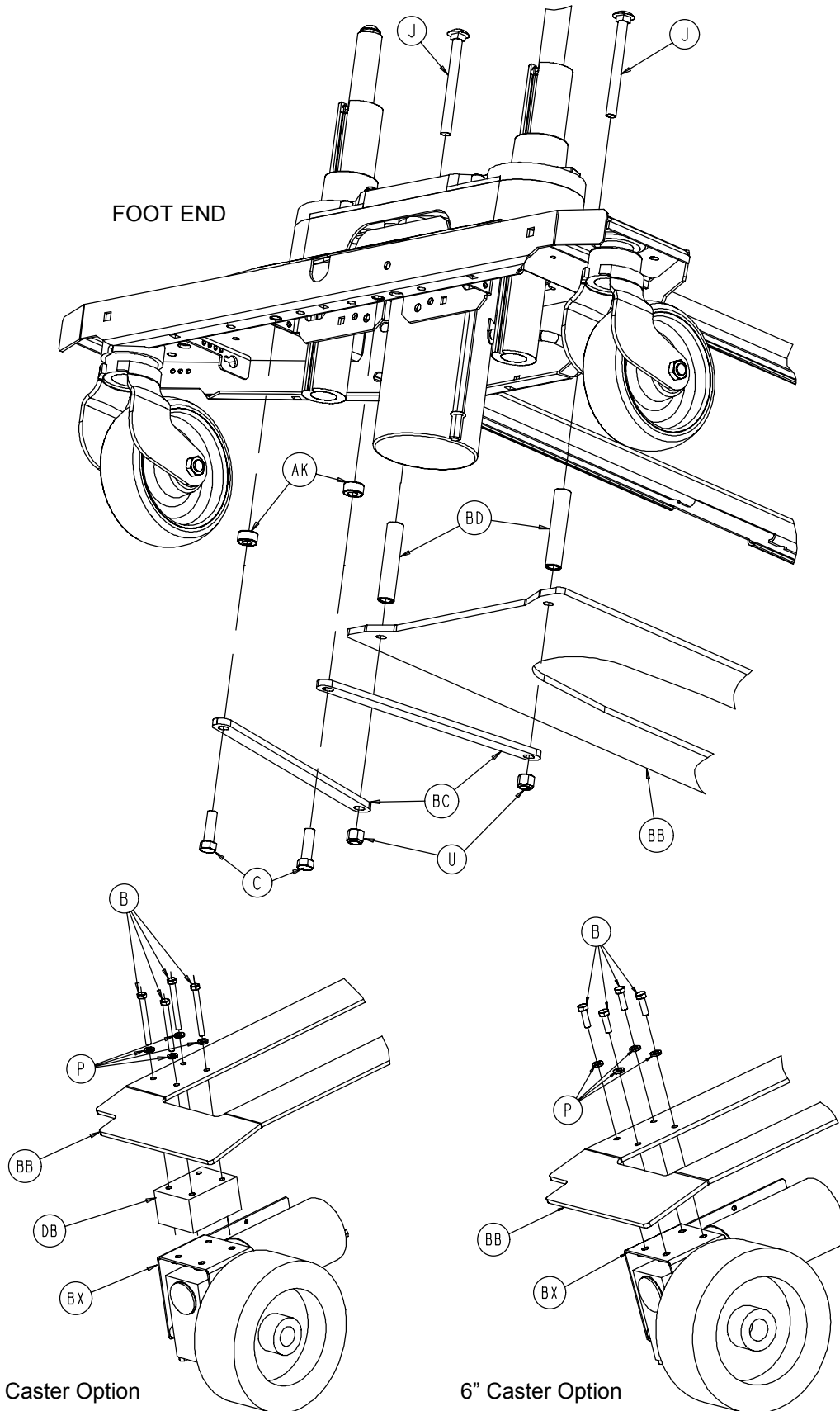

Zoom® Base Assembly

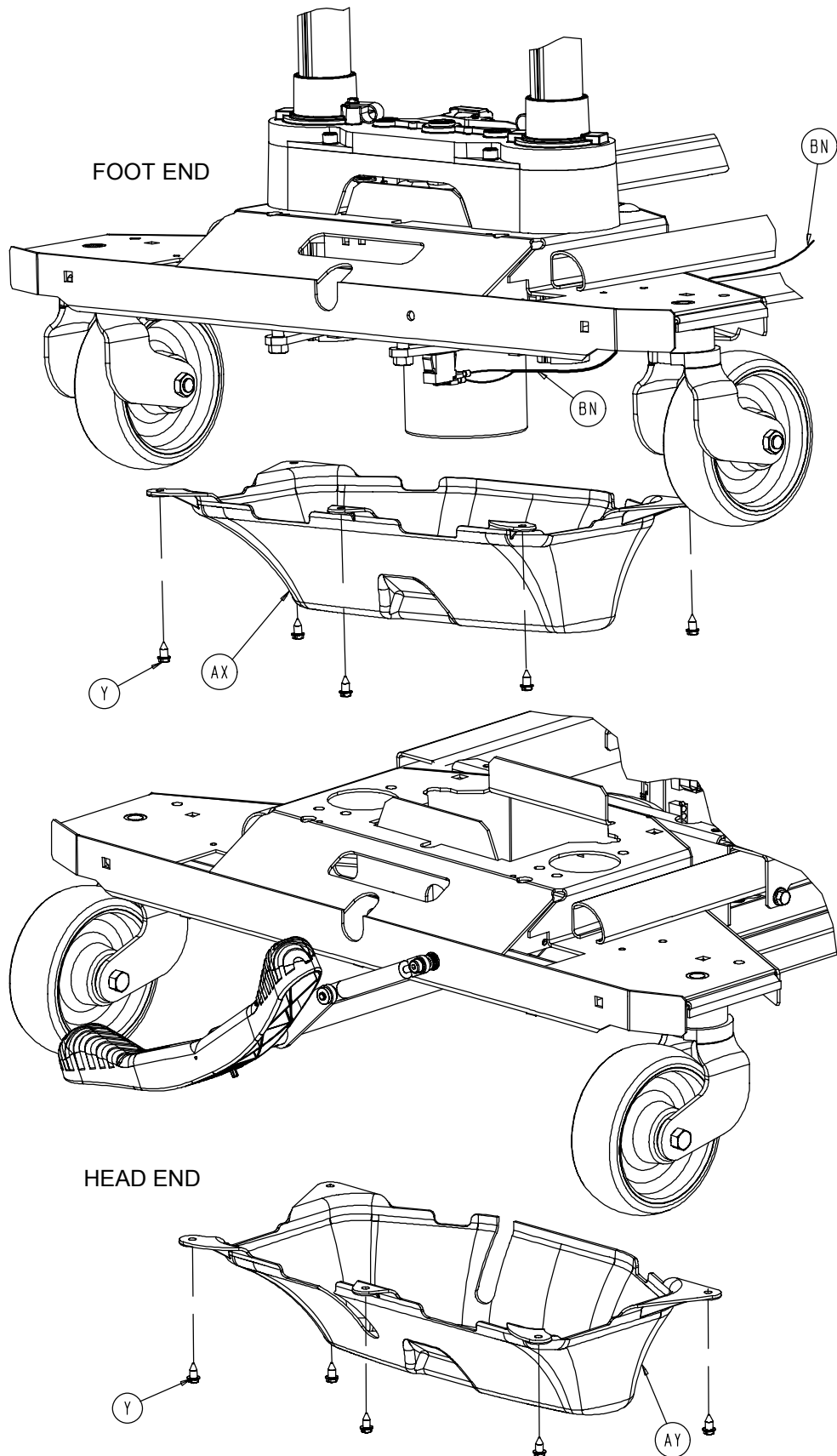

Zoom® Base Assembly

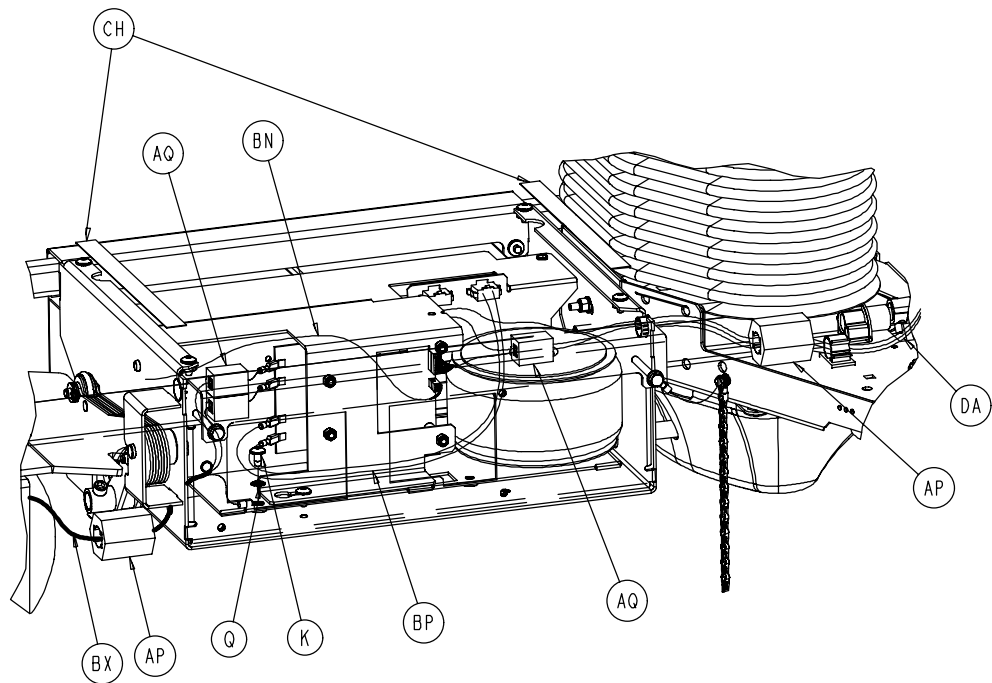
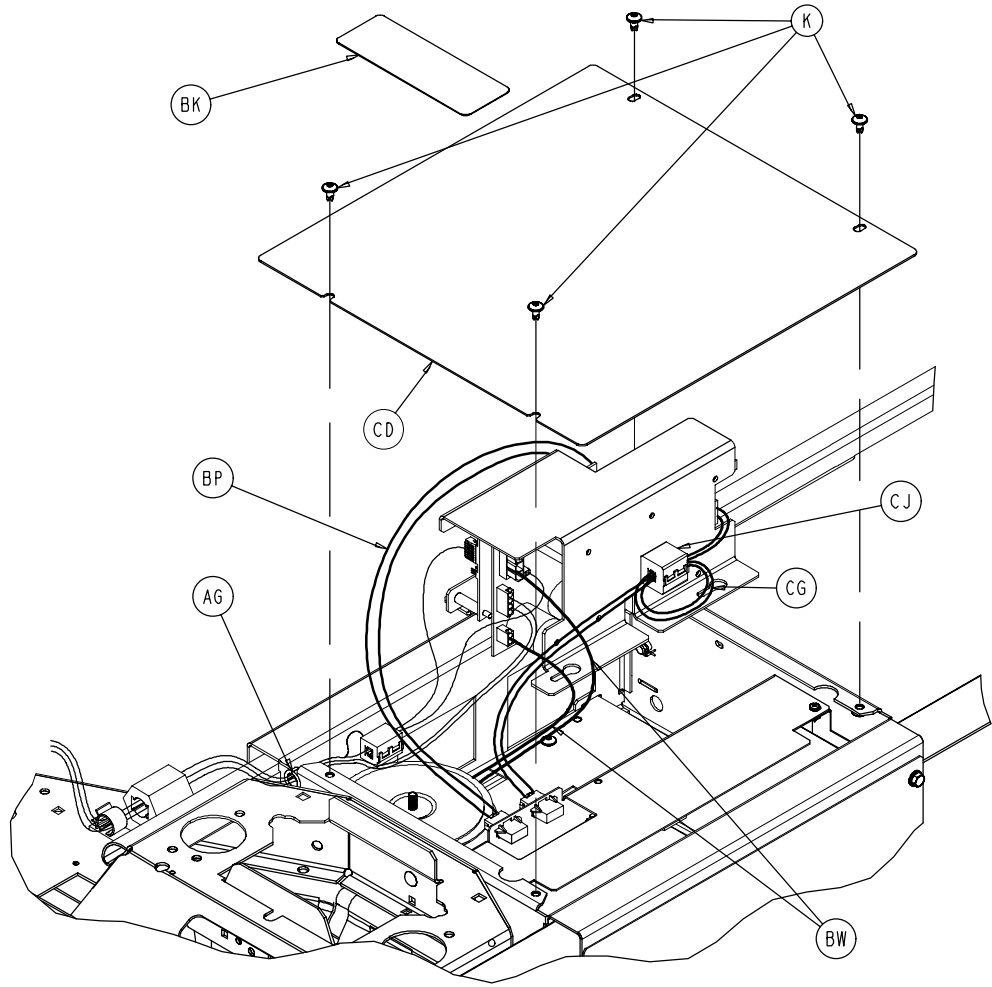

Zoom® Base Assembly

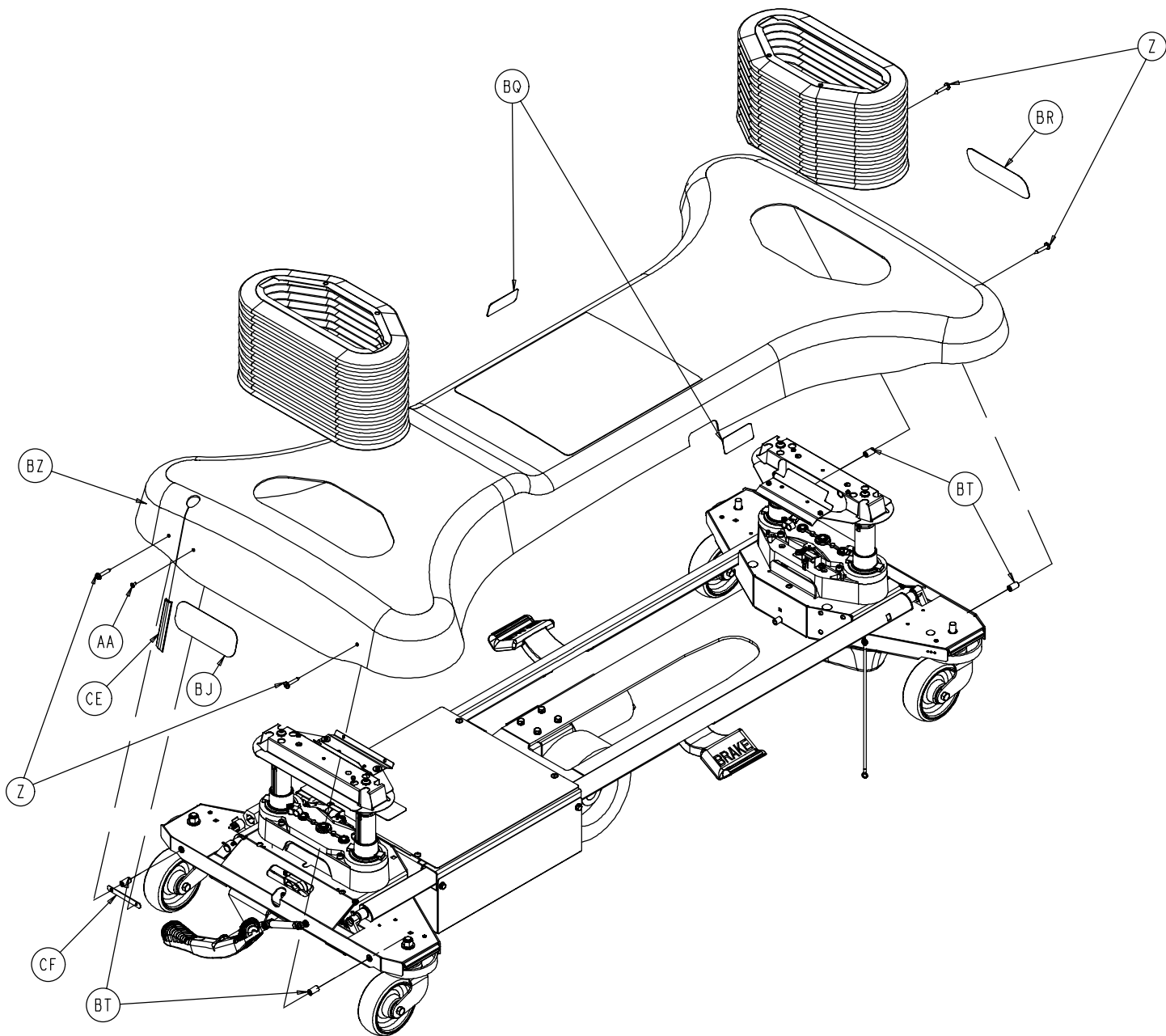

Zoom® Base Assembly

Zoom® Option Common Components – Part Number 3002-1-1 (Reference Only)

Item	Part No.	Part Name	Qty.	Item	Part No.	Part Name	Qty.
A	3-32	Hex Hd. Cap Screw	4	AT	1210-201-251	Insert Bushing	1
C	3-120	Hex Hd. Cap Screw	2	AU	1210-201-671	Damper	1
D	4-39	Soc. Hd. Cap Screw	1	AW	(page 105)	Drive Whl. Lift Lever Ass'y	1
E	4-160	Soc. Hd. Cap Screw	1	AX	(page 106)	Foot End Bottom Cover	1
F	4-301	Pan Hd. Machine Screw	1	AY	(page 106)	Head End Bottom Cover	1
G	4-307	Soc. But. Hd. Cap Screw	1	AZ	2040-1-51	Pedal Crank Weldment	1
H	5-17	Carriage Bolt	1	BA	2040-1-53	Damper Crank Weldment	1
J	5-31	Carriage Bolt	2	BB	2040-1-60	Leaf Spring	1
K	7-52	Truss Hd. Torx	13	BC	2040-1-61	Tie Down Strap	2
L	7-63	Truss Hd. Torx	2	BD	2040-1-62	Reinforcement Tube	2
M	8-49	Soc. Hd. Shoulder Bolt	2	BE	2040-1-82	Pedal Rod	1
N	11-63	Washer	7	BF	2040-1-83	Pedal Crank Roller	1
P	12-20	Lock Washer	4	BG	2040-1-84	Pedal Rod Pivot Bracket	1
Q	13-10	Ext. Tooth Star Washer	5	BH	2040-1-98	Lift Lever Spacer	1
R	14-3	Plastic Washer	8	BJ	2040-1-100	Drive Whl. Position Label	1
S	16-3	Nylock Nut	1	BK	2040-1-101	Charger Box Cover	1
T	16-28	Nylock Nut	1	BL	2040-1-102	Power Bd. Cover Label	1
U	16-35	Nylock Nut	2	BM	2040-1-103	Charger Box Sw. Brkt. Cov.	1
W	16-36	Nylock Nut	2	BN	2040-1-801	Base Switch Cable	1
X	21-22	Set Screw	1	BP	2040-1-804	Pwr. Bd. DC Pwr. Cable	1
Y	23-25	Hex Washer Hd. Screw	10	BQ	3000-200-601	Brake Label	2
Z	23-281	Self-Tapping Screw	4	BR	3000-200-602	Stryker Logo Label	1
AA	25-79	Pop Rivet	1	BS	3000-300-58	Limit Switch	1
AB	26-261	Groove Pin	1	BT	3000-300-428	Gatch Link Sleeve	4
AC	26-277	Clevis Pin	1	BU	3000-300-113	Wire Ties	2
AD	26-197	Clevis Pin	1	BW	3001-1-10	Transformer	1
AE	27-21	Rue Ring Cotter	1	BX	(page 107)	Drive Train Assembly	1
AF	27-22	Rue Ring Cotter	1	BY	(page 108)	Battery Tray Assembly	1
AG	30-38	Split Bushing	1	BZ	3002-1-18	Hood Assembly	1
AH	30-40	E-A-R Grommet	1	CA	(page 109)	Base Power Assembly	1
AK	42-6	Collar	2	CB	3002-1-50	Charger Box Weldment	1
AL	42-20	Lock Collar	1	CC	3002-1-68	Power PCB Cover	1
AM	58-90	Threaded Stud	1	CD	3002-1-71	Charger/Inverter Cover	1
AN	59-133	Push-Mount Wire Clip	1	CE	3002-1-78	Hood Slot Trim	1
AP	59-192	Split Ferrite	1	CF	3002-1-79	Hood Slot Trim Bracket	1
AQ	59-194	Split Ferrite	3	CG	3002-1-802	Inverter/Battery Cable	1
AR	81-245	Bronze Bushing	2	CH	7000-1-326	Foam Tape (10")	2
AS	1210-201-153	Butterfly "V" Pedal	1	CJ	59-144	Split Ferrite	1

Zoom® Base, 6" Casters – 2040-244-10 (Ref.) Zoom® Base, 8" Casters – 2040-244-10 (Ref.)

Item	Part No.	Part Name	Qty.	Item	Part No.	Part Name	Qty.
B	3-85	Hex Hd. Cap Screw	4	B	3-53	Hex Hd. Cap Screw	4
DA	2040-201-809	Umbilical Cable Ass'y	1	DA	2040-201-809	Umbilical Cable Ass'y	1
				DB	2040-1-1	8" Caster Spacer	1

Drive Wheel Lift Lever Assembly

Assembly part number 2040-1-12 (reference only)

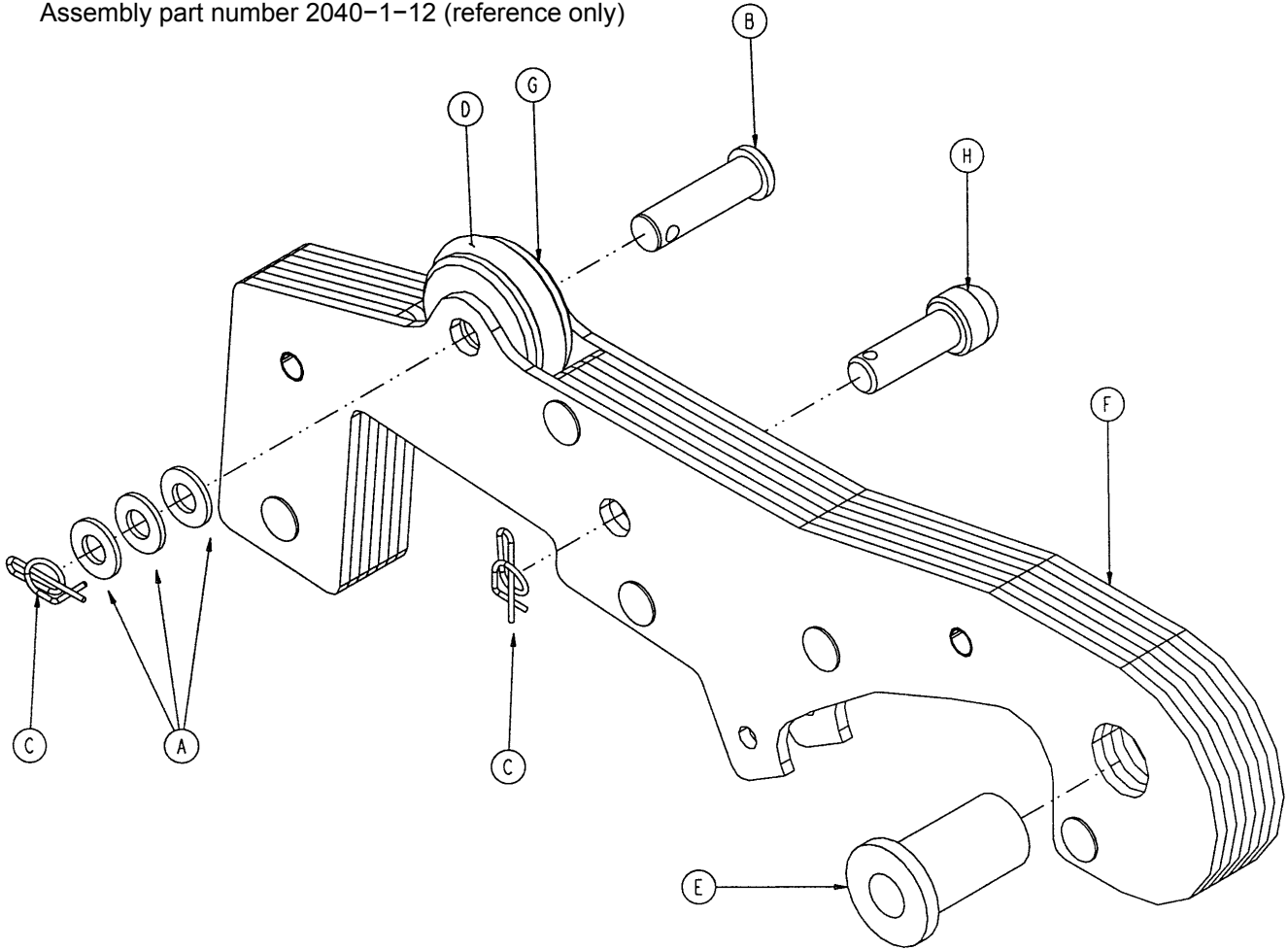

Item	Part No.	Part Name	Qty.
A	11-3	Washer	3
B	26-297	Clevis Pin	1
C	27-21	Rue Ring	2
D	45-232	O-Ring	1
E	81-70	Flange Bearing	1
F	2040-201-13	Drive Wheel Lift Plate Ass'y	1
G	2040-1-87	Lift Lever Roller	1
H	2040-1-99	Lift Lever Guide	1

3001-200-22 Foot End Bottom Cover Assembly

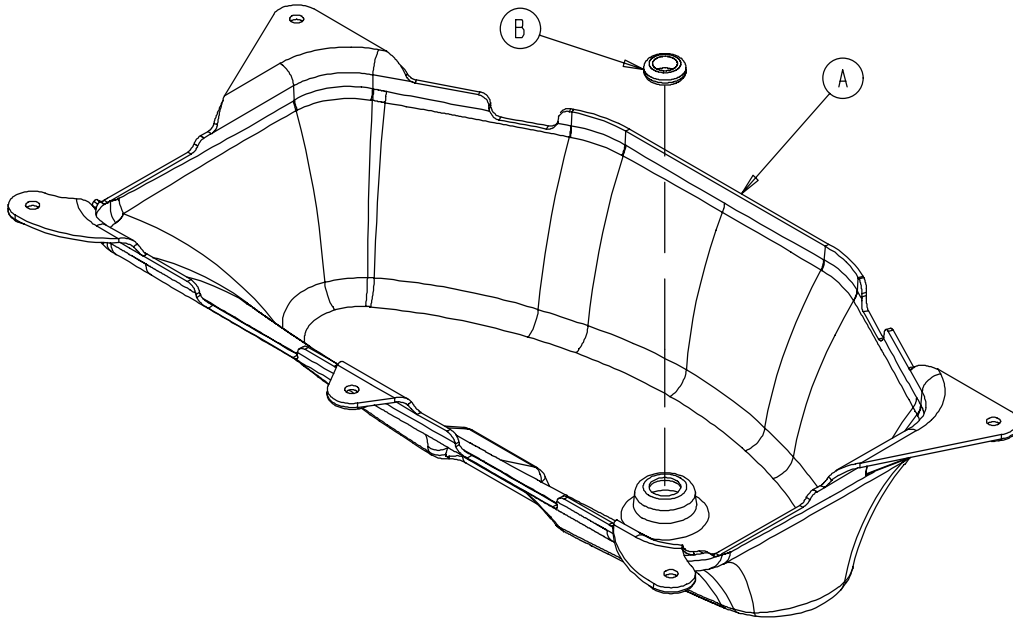

Item	Part No.	Part Name	Qty.
A	3002-1-100	Foot End Bottom Cover	1
B	3000-000-039	Grommet	1

2040-1-17 Head End Bottom Cover

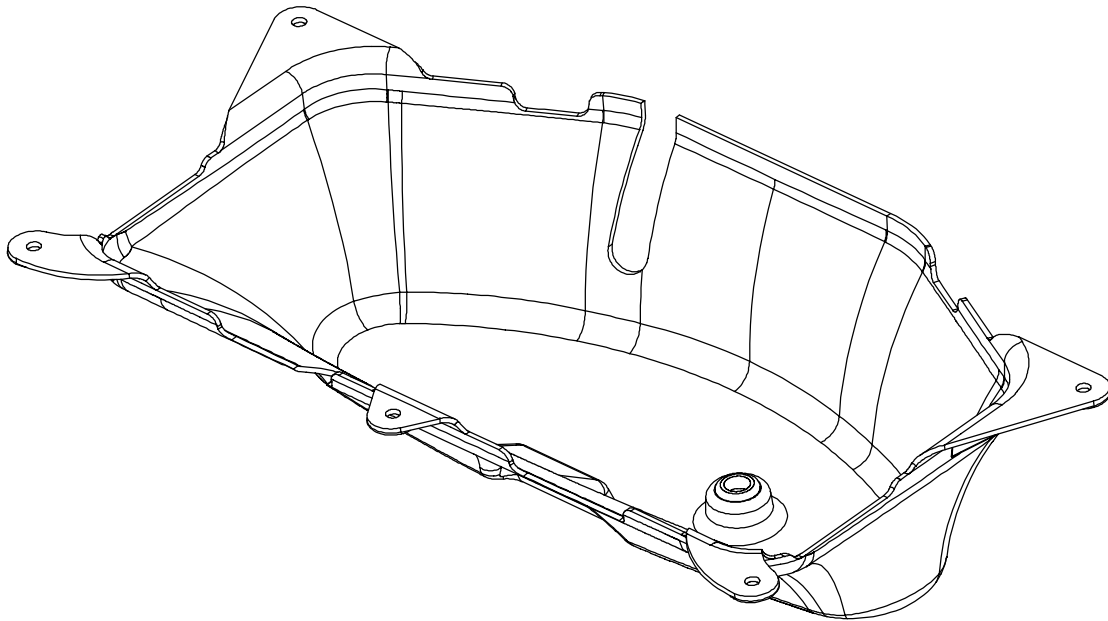

3002-1-14 Zoom® Drive Train Assembly

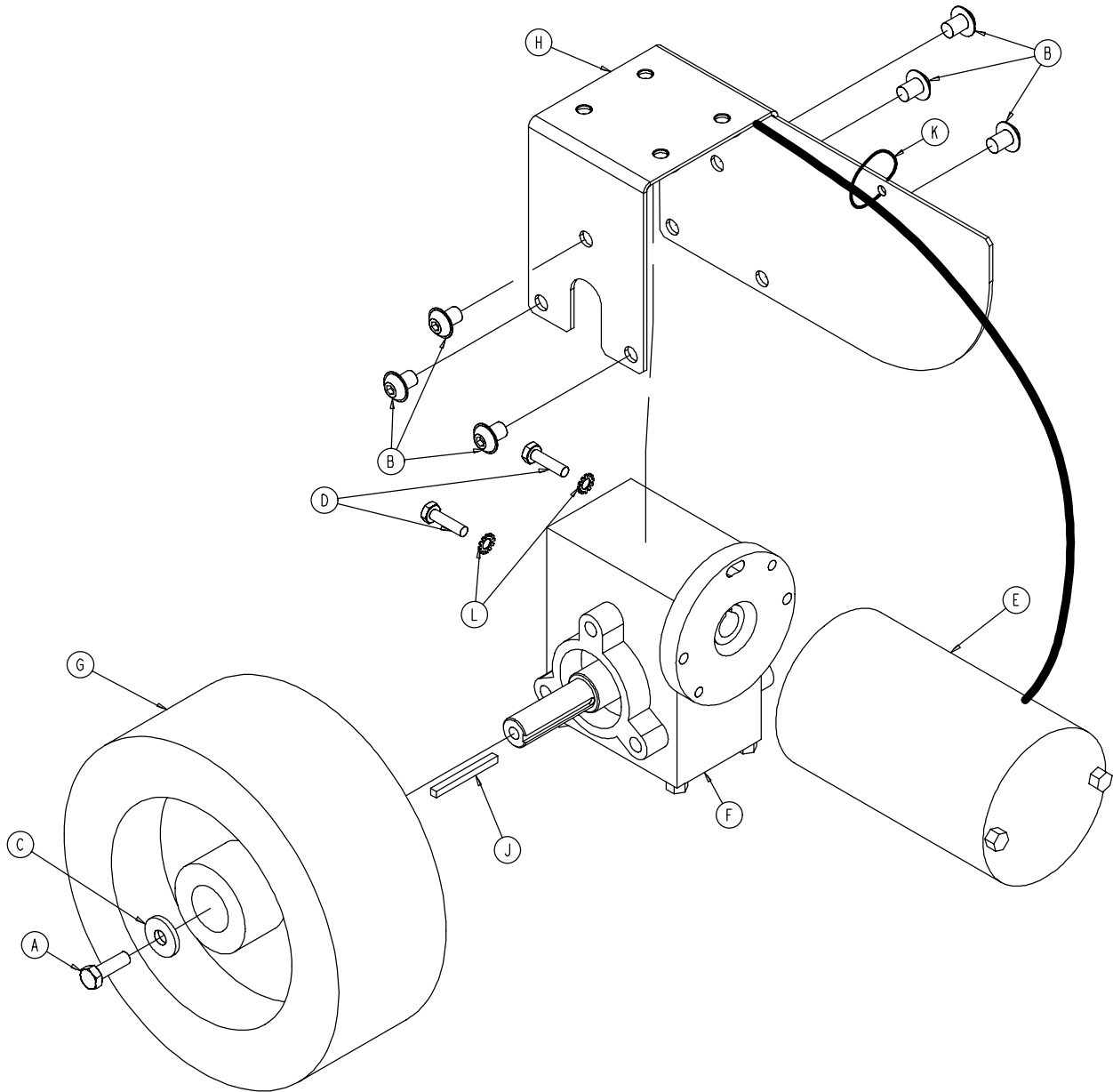

Item	Part No.	Part Name	Qty.
A	8839-793-700	Hex Hd. Cap Screw	1
B	4-245	Flanged But. Hd. Cap Screw	6
C	11-262	Washer	1
D	3-54	Hex Hd. Cap Screw	2
E	3002-1-72	Drive Train Motor	1
F	2040-1-73	Gear Box	1
G	2040-1-74	Drive Train Wheel	1
H	2040-1-75	Motor Mounting Bracket	1
J	2040-1-97	Square Key	1
K	3000-300-113	Wire Tie	1
L	13-10	Star Washer	2

Zoom® Battery Kit

Assembly part number 3002-1-15 (reference only)

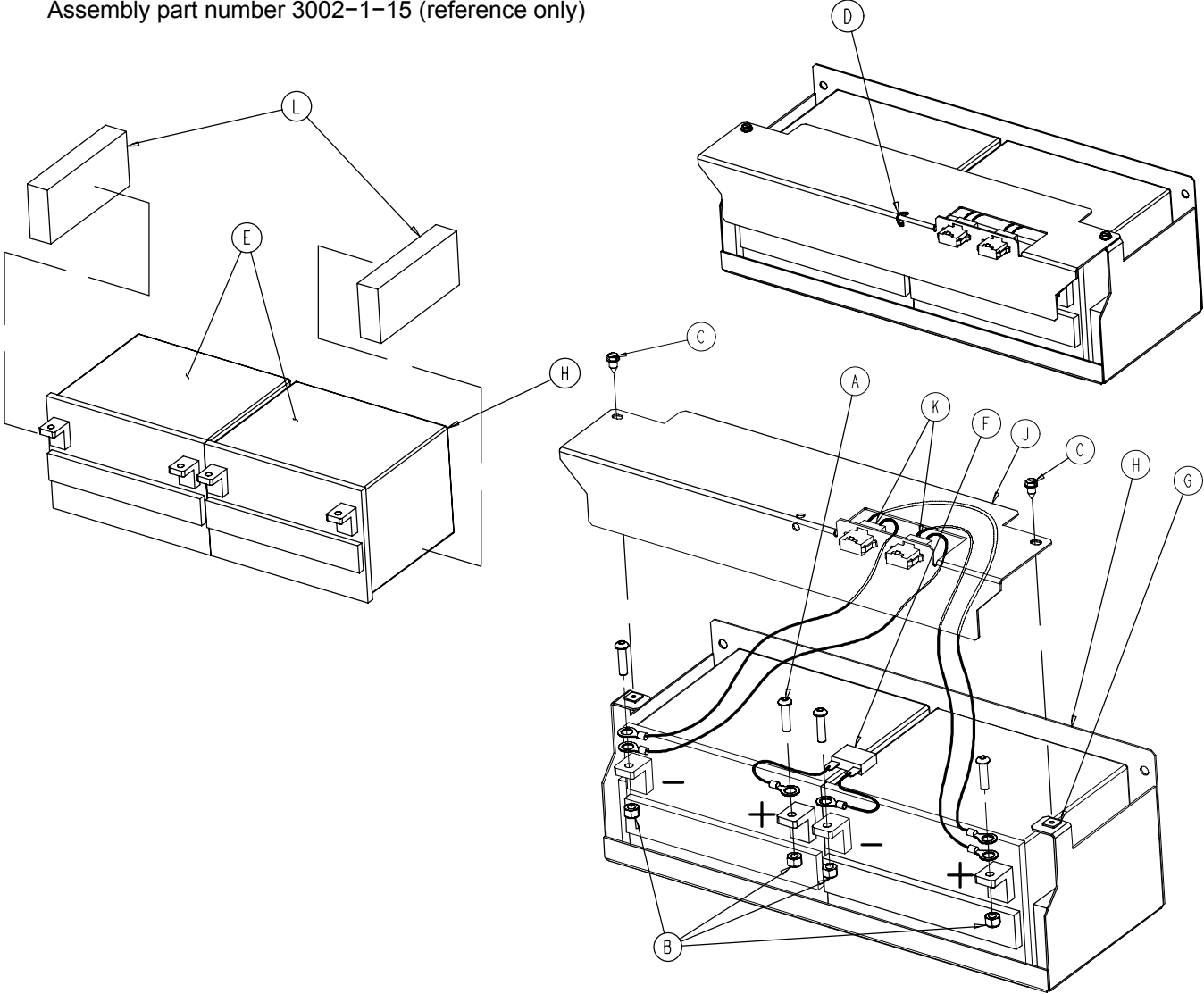

WIRING VIEW

Item	Part No.	Part Name	Qty.
A	4-46	But. Hd. Cap Screw	4
B	16-28	Nylock Nut	4
C	23-256	Pan Hd. Screw	2
D	38-151	Cable Tie	1
E	2040-1-70	Battery	2
F	2040-1-802	Battery Jumper Cable	1
G	3000-300-2	Push Nut	2
H	3002-1-69	Battery Tray	1
J	3002-1-91	Terminal Guard	1
K	3002-1-803	Battery Harness Cable	2
L	3002-101-43	Foam Spacer	2

Replacement Kit Part Number (Batteries Only) – 2040-700-13

3002-1-30 Zoom® Base Power Assembly

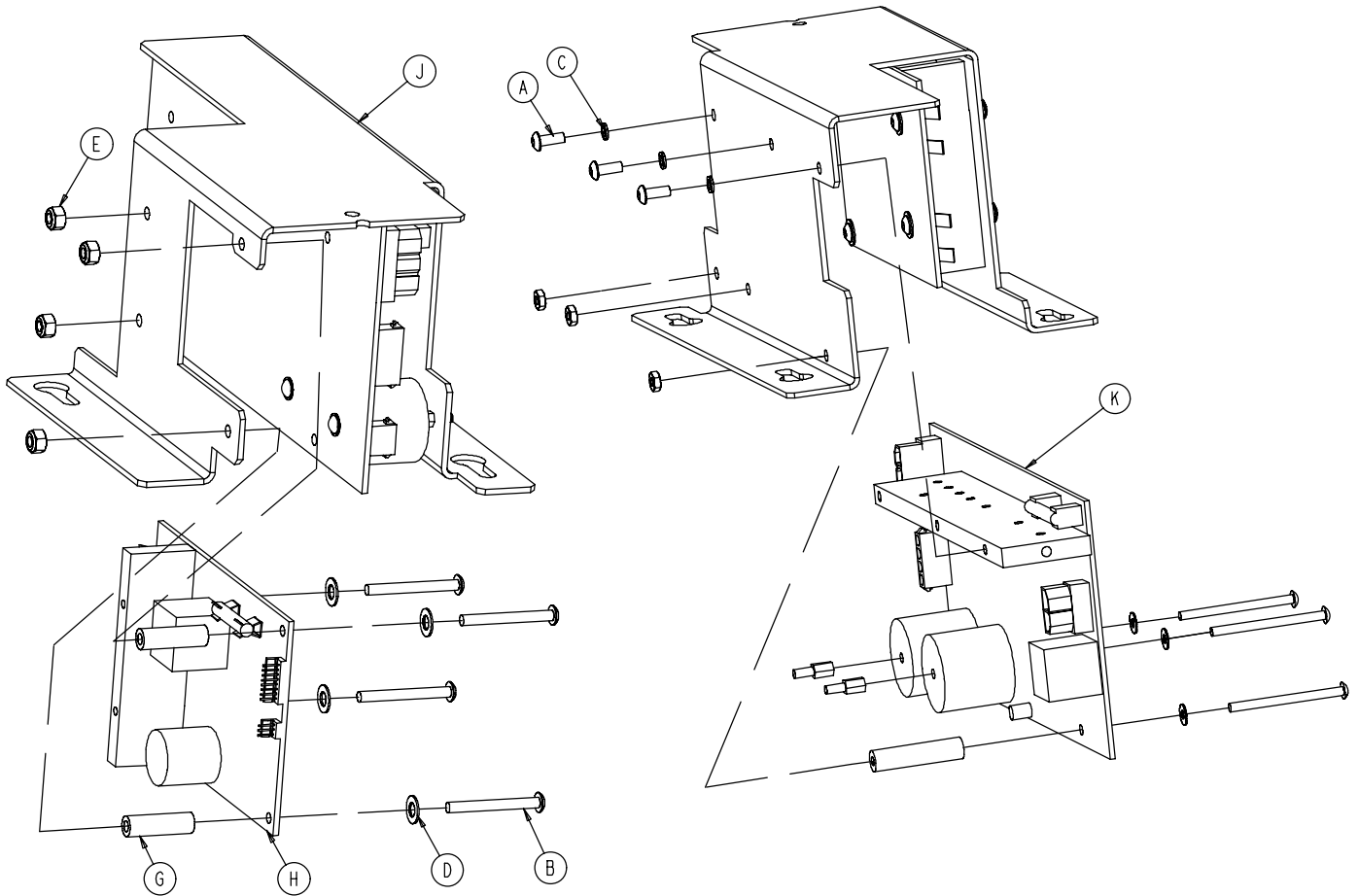

Item	Part No.	Part Name	Qty.
A	4-263	But. Hd. Cap Screw	3
B	4-315	But. Hd. Cap Screw	4
C	12-6	Helical Lock Washer	3
D	14-4	Nylon Washer	4
E	16-2	Fiberlock Nut	4
G	59-187	Spacer	2
H	2040-1-900	Power Board	1
J	3002-1-17	Charger/Inverter Heat Bracket	1
K	3002-1-930	Charger/Inverter Board Ass'y	1

Litter Assembly and Options

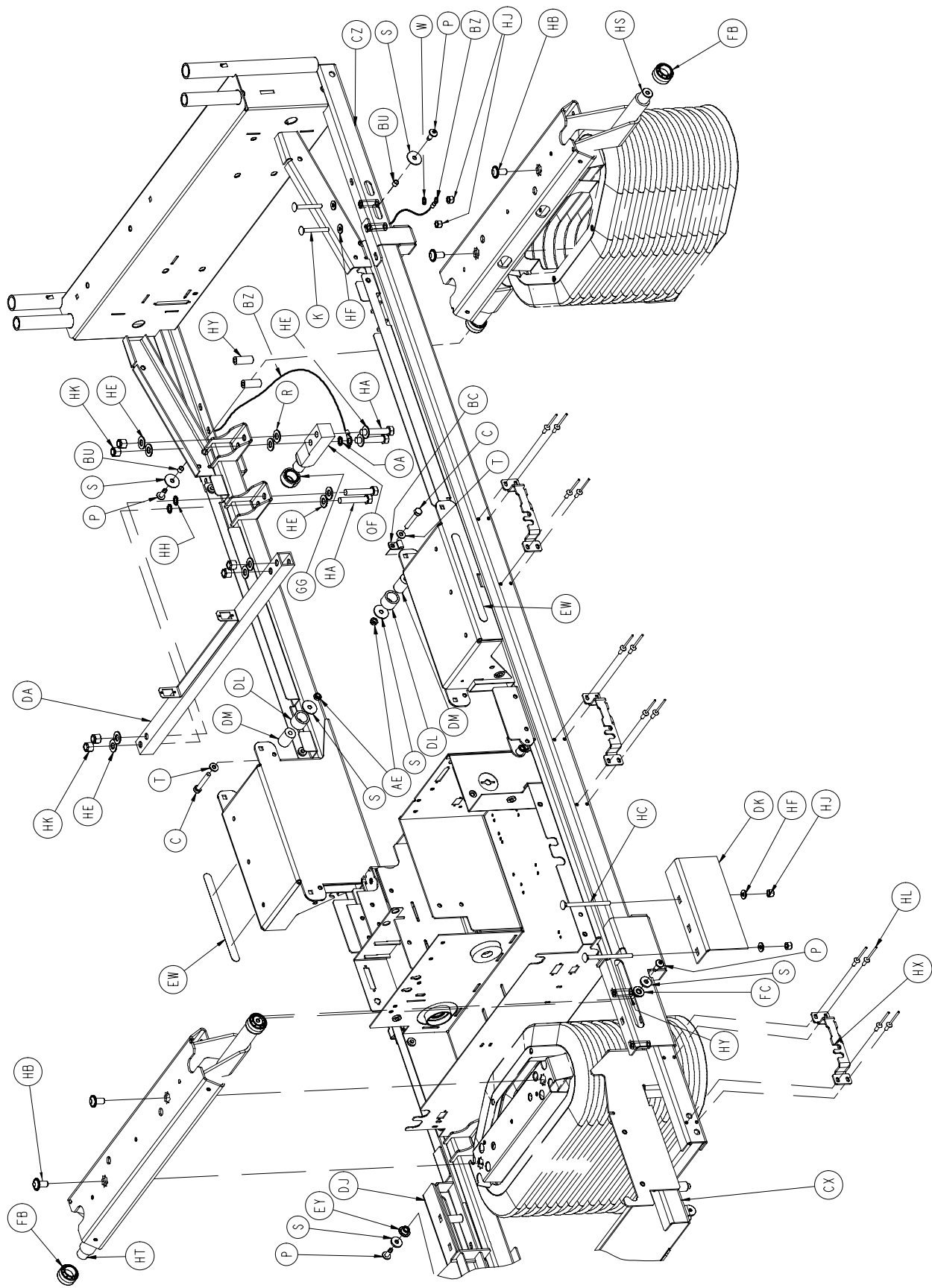

Litter Assembly and Options

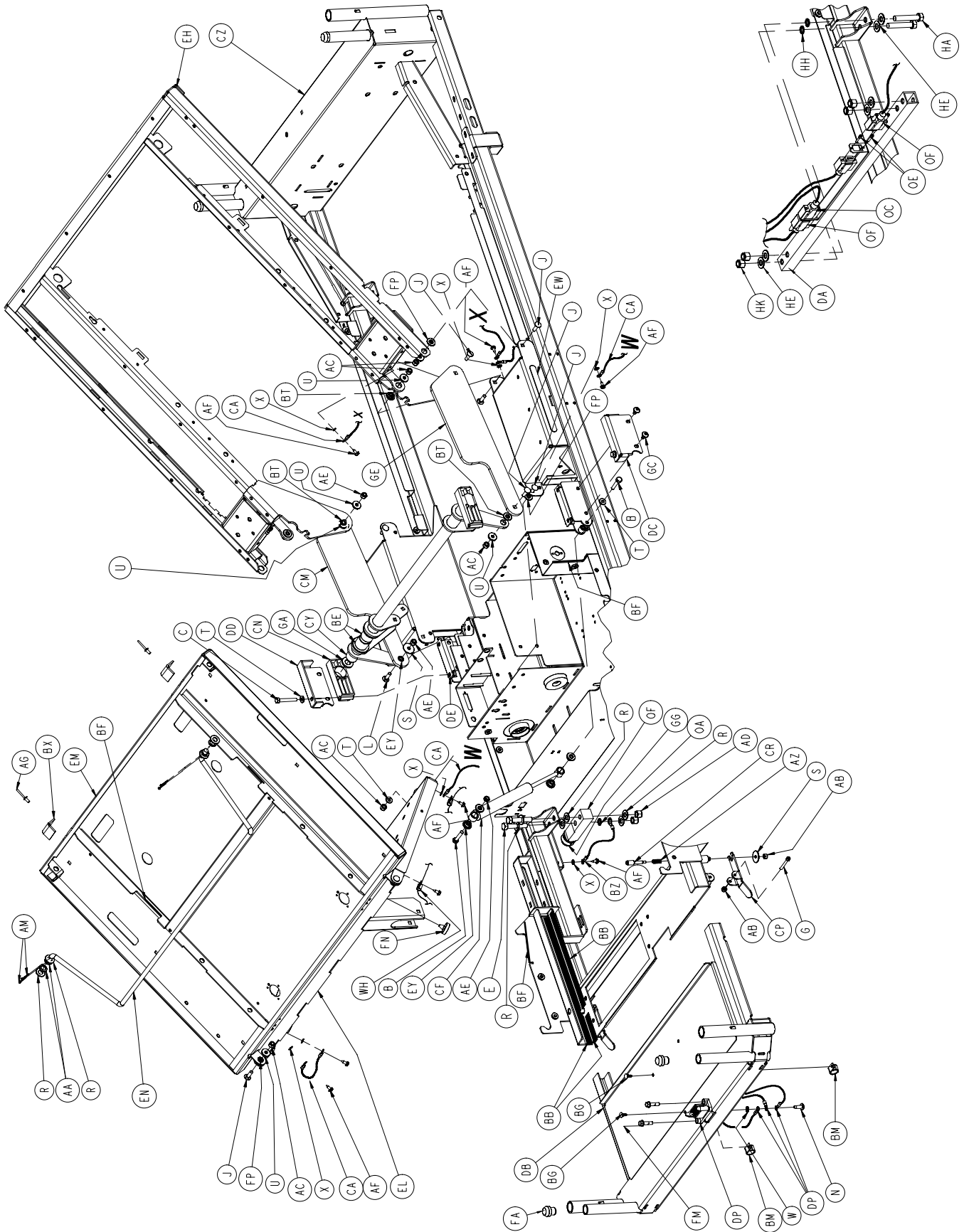

Litter Assembly and Options

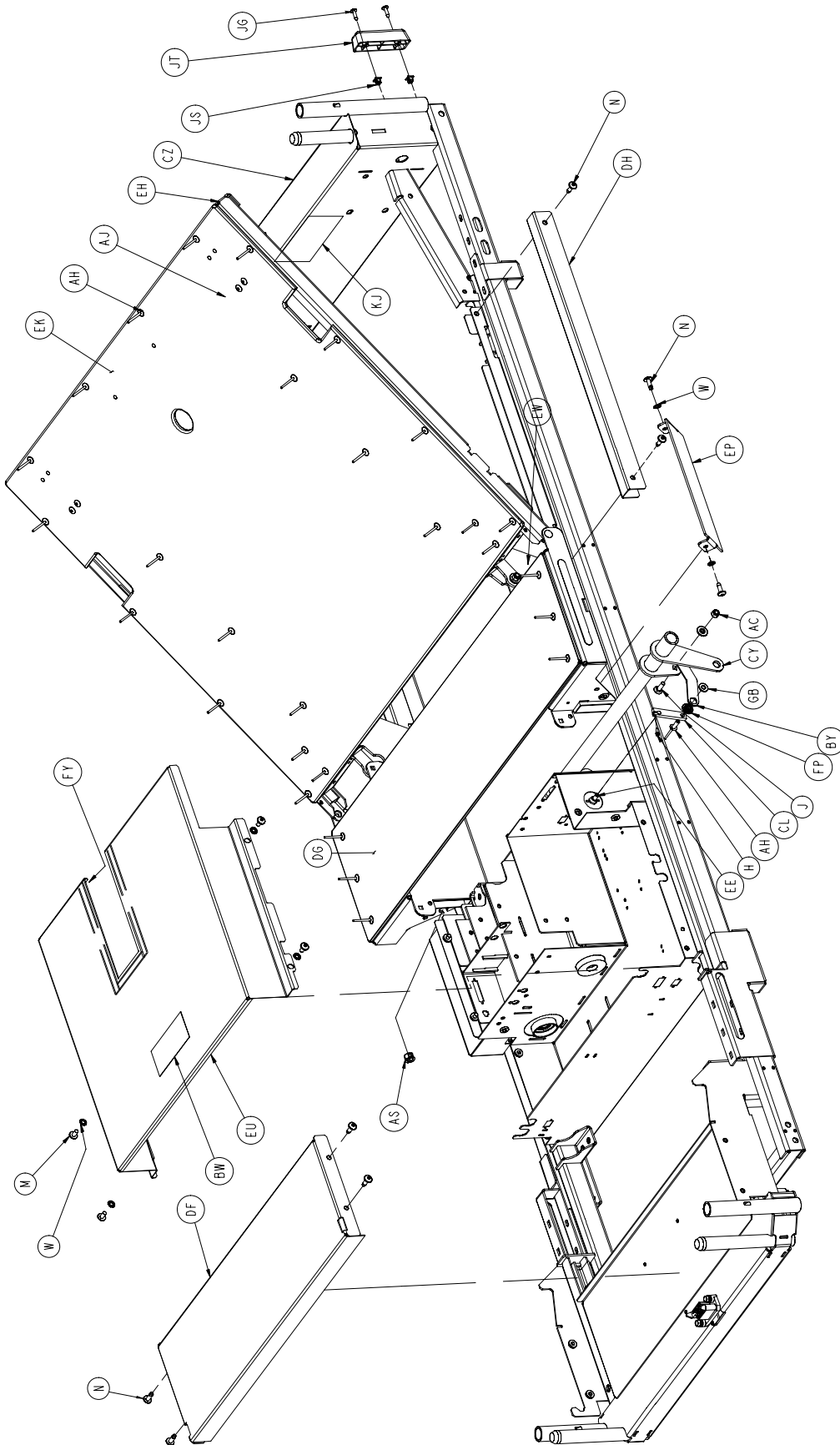

Litter Assembly and Options

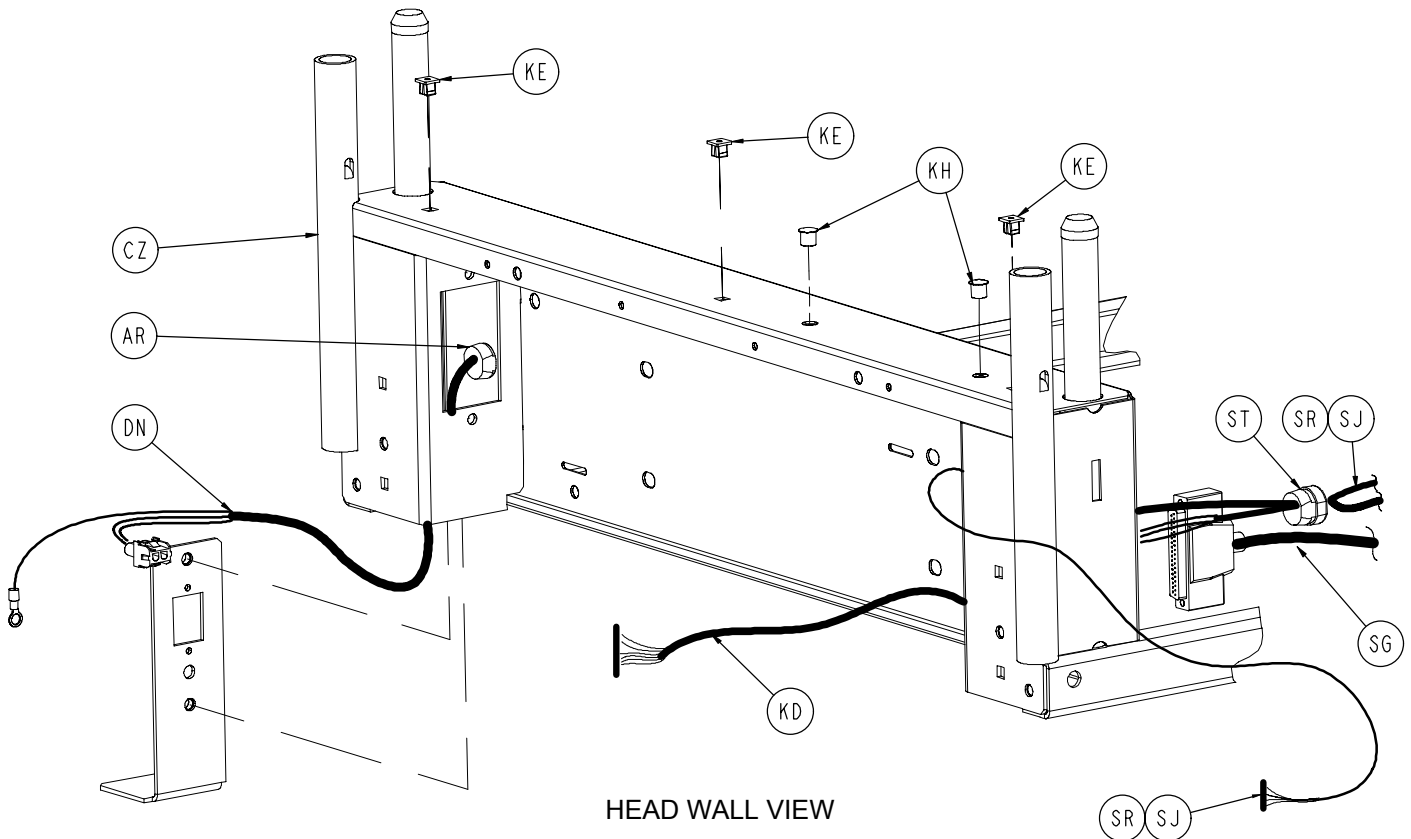
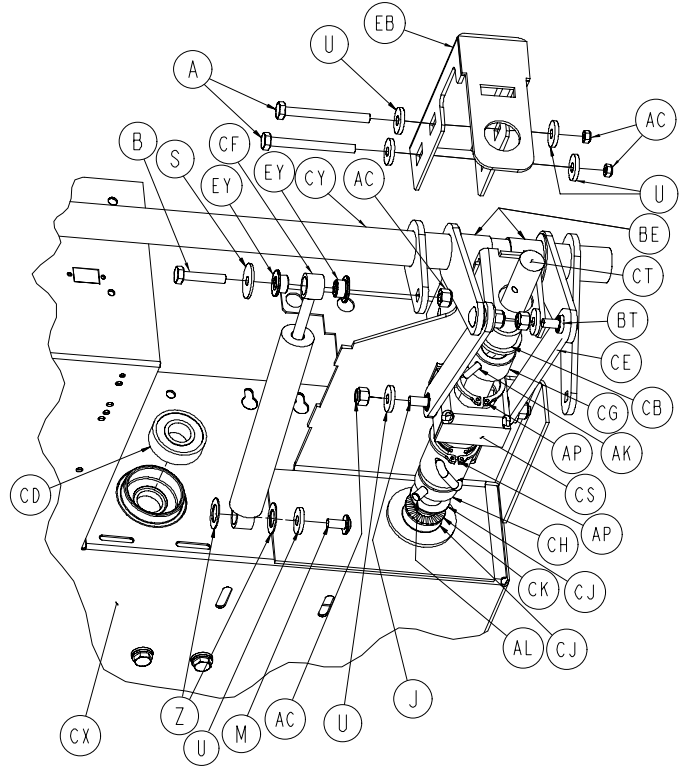
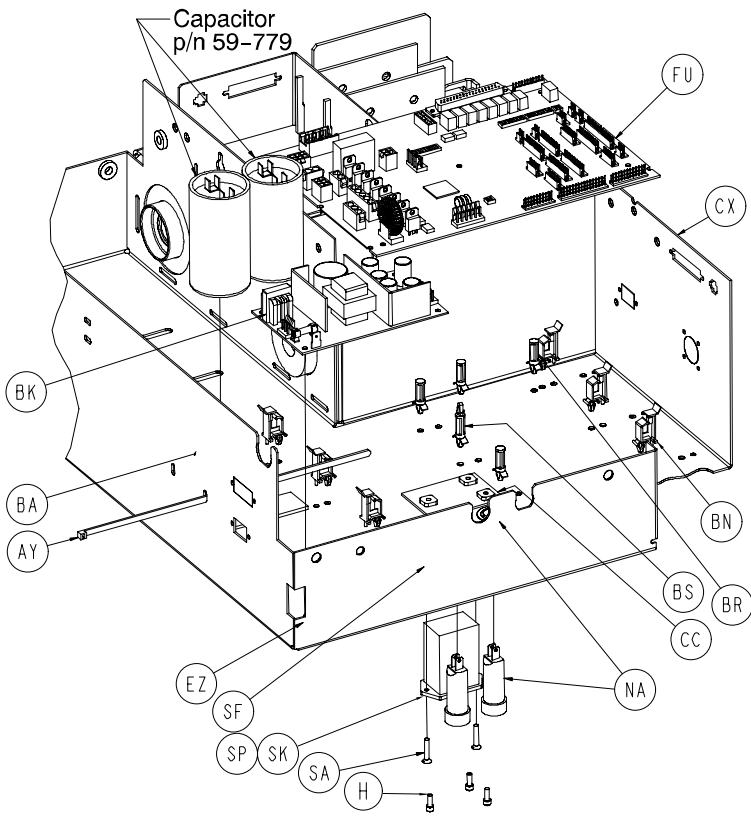

Litter Assembly and Options

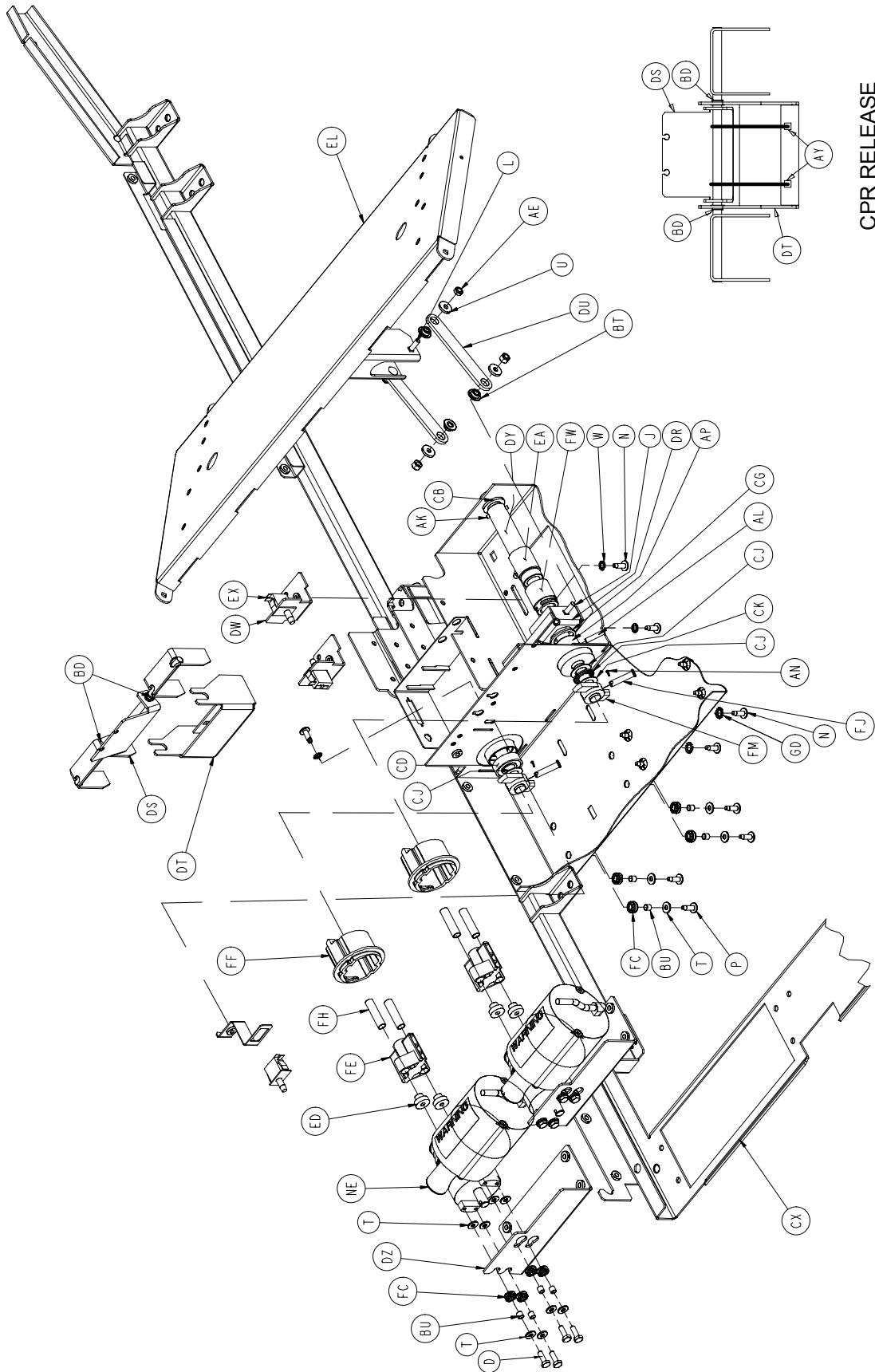

CPR RELEASE

Litter Assembly and Options

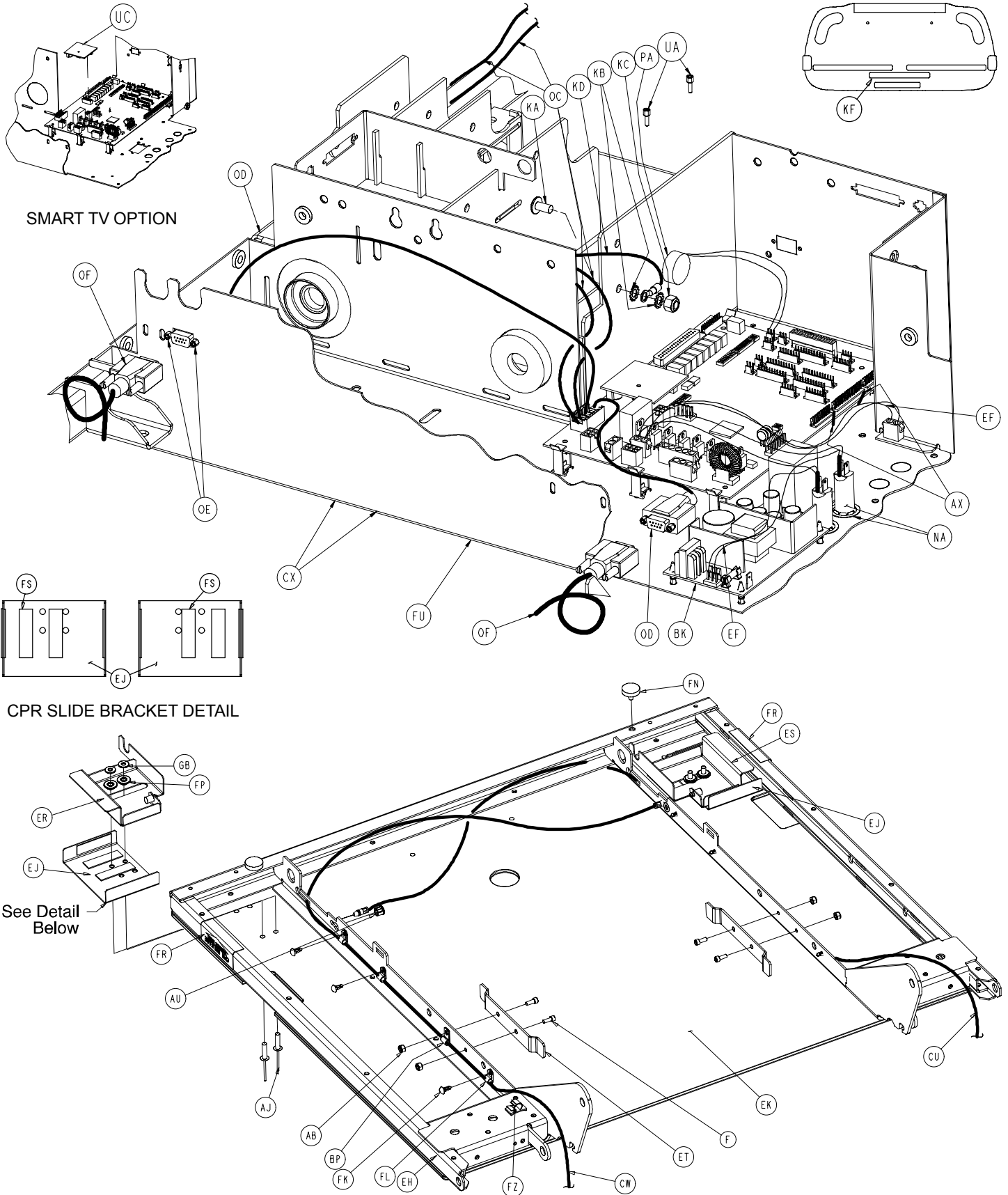

Litter Assembly and Options

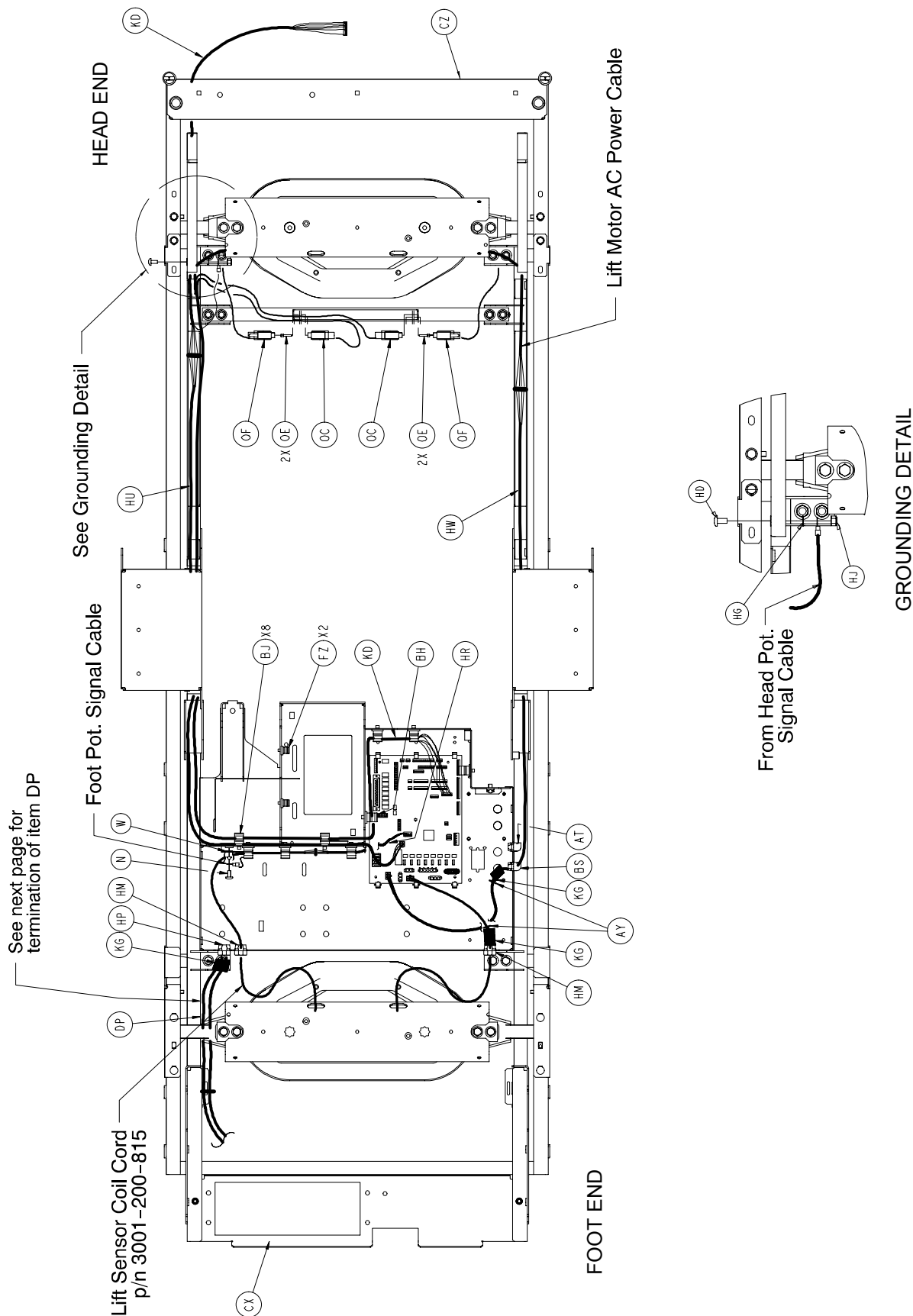

Litter Assembly and Options

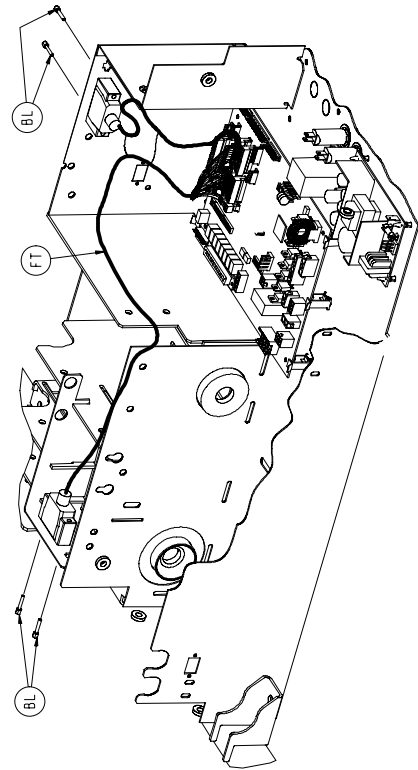
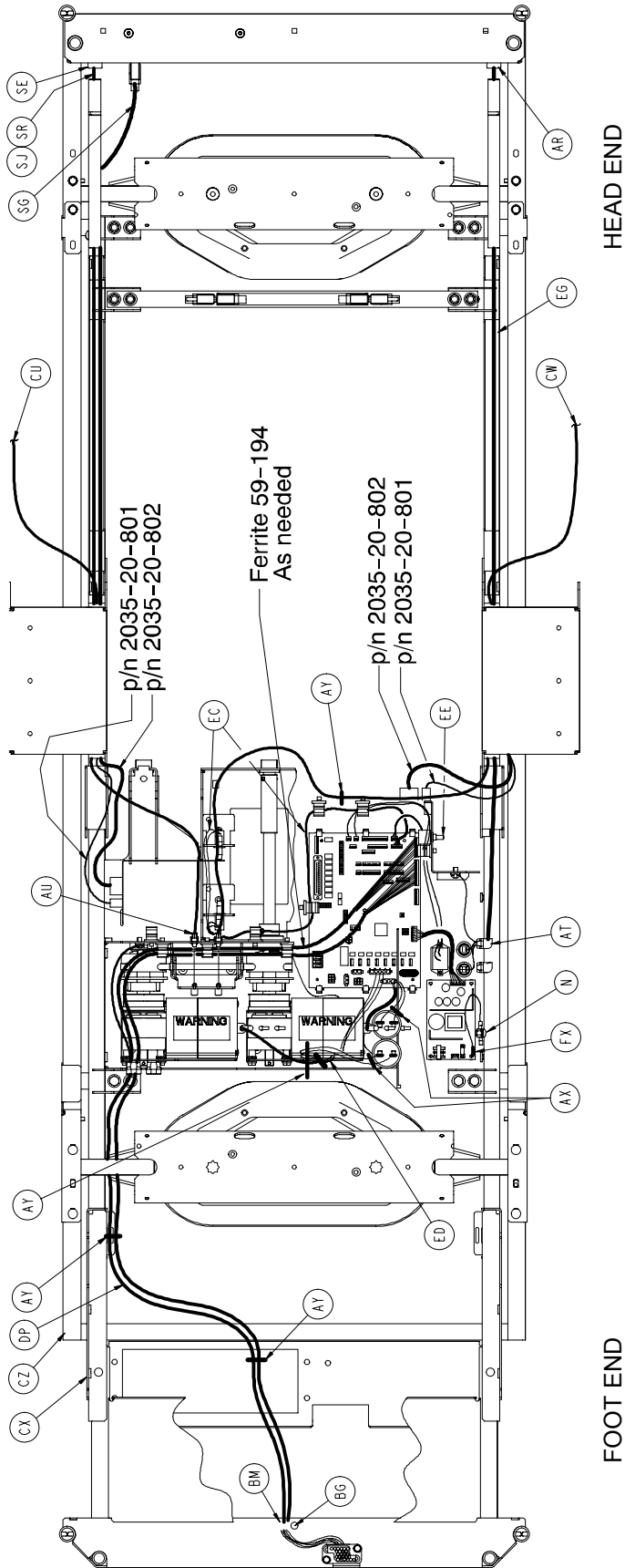

SIDERAIL EXTENSION CABLE ROUTING

Litter Assembly and Options

2030-331-10 Common Litter Components

Item	Part No.	Part Name	Qty.	Item	Part No.	Part Name	Qty.
A	3-23	Hex Hd. Cap Screw	2	BS	59-774	Locking PCB Support	1
B	3-74	Hex Hd. Cap Screw	3	BT	81-268	Flange Bearing	15
C	3-78	Hex Hd. Cap Screw	4	BU	715-1-133	Rel. Valve Stop Sleeve	18
D	3-214	Hex Hd. Cap Screw	8	BW	988-2-708	Shock Caution Label	1
E	3-347	Hex Hd. Cap Screw	4	BY	2025-31-62	Pot. Actuator Link	1
F	4-32	Soc. Hd. Cap Screw	4	BZ	2025-31-880	Ground Jumper	4
G	4-85	Soc. Hd. Cap Screw	2	CA	3002-300-870	Ground Strap	8
H	4-101	Soc. Hd. Cap Screw	1	CB	2025-32-68	Flange Bearing	2
J	5-19	Carriage Bolt	18	CD	2025-32-76	Ball Bearing	2
K	5-24	Carriage Bolt	4	CE	2025-32-77	Fowler Actuator Link	2
L	5-23	Carriage Bolt	3	CF	2025-32-82	Hydraulic Dampener	2
M	7-58	Truss Hd. Torx	5	CG	2025-32-84	Fowler Screw Up Stop	1
N	7-63	Truss Hd. Torx	19	CH	2025-32-85	Fowler Screw Down Stop	1
P	7-65	Truss Hd. Torx	16	CJ	2025-32-86	Thrust Washer	5
R	11-4	Washer	16	CK	2025-32-87	Roller Cage Bearing	2
S	11-53	Washer	10	CL	2025-231-61	Pot. Timing Clamp	1
T	11-63	Washer	37	CM	2025-231-88	Fowler Link	1
U	11-158	Washer	24	CN	2025-231-90	Torque Tube Pivot Brg.	2
W	13-10	Ext. Tooth Lock Washer	16	CP	2025-231-99	Bed Extender Rel. Lever	2
X	13-18	Ext. Tooth Lock Washer	14	CR	2025-231-112	Bed Extender Pin Lock	2
Y	13-32	Ext. Tooth Lock Washer	2	CS	2025-232-89	Fowler Nut Box	1
Z	14-7	Washer	2	CT	2025-232-90	Fowler Ball Screw	1
AB	16-3	Nylock Nut	4	CU	2035-31-48	Short CPR Cable	1
AC	16-28	Nylock Nut	22	CW	2035-31-49	Long CPR Cable	1
AD	16-35	Nylock Nut	8	CX	2035-31-50	Scale Frame Weldment	1
AE	16-102	Nylock Nut	8	CY	2035-31-51	Torque Tube Weldment	1
AF	3-224	Hex Washer Hd. Screw	16	CZ	2035-31-54	Iso. Frame Weldment	1
AH	25-142	Rivet	29	DA	2035-31-55	Head End Crosstube	1
AJ	25-147	Rivet	4	DB	2035-31-57	Bed Extender Weldment	1
AK	26-12	Roll Pin	2	DC	2035-31-64	Torque Tube Ret. Brkt., Lt.	1
AL	26-168	Spiral Pin	2	DD	2035-31-65	Torque Tube Ret. Brkt., Rt.	1
AN	27-17	Cotter Pin	2	DE	2035-31-66	Torque Block Channel	2
AP	28-120	External Retaining Ring	3	DF	2035-31-94	Foot Support Cover	1
AR	30-27	Strain Relief	1	DH	2035-31-100	Wire Channel Cover	2
AS	30-36	Grommet	4	DJ	2035-31-115	Roller Bracket Cover, Rt.	1
AT	30-47	Right Angle Strain Relief	1	DK	2035-31-116	Roller Bracket Cover, Lt.	1
AU	30-52	Snap Bushing	4	DL	2035-31-126	Protective Sleeve	2
AX	38-111	Cable Tie	10	DM	2035-31-127	Nylon Stop	2
AY	38-151	Cable Tie	17	DR	2035-32-52	Gatch Trigger Weldment	1
AZ	38-382	Compression Spring	2	DS	2035-32-54	CPR Release Wldmt. Brkt.	1
BA	44-29	Black Foam Tape	1	DT	2035-32-72	CPR Release Pivot Brkt.	1
BB	44-32	1" Wide Poly Tape	50"	DU	2035-32-77	Gatch Actuator Link	2
BC	52-104	Cable Clamp	2	DW	2035-32-79	Act. Box Cherry Swch. Brkt.	2
BD	52-759	Flange Bearing	2	DX	2035-32-84	Gatch Screw Up Stop	1
BE	52-762	Nyliner Bushing	2	DY	2035-32-85	Gatch Screw Down Stop	1
BF	58-56	Black Edge Trim	18"	DZ	2035-32-88	Act. Box Motor Mtg. Brkt.	2
BG	58-76	Drive Fastener	2	EA	2035-32-90	Gatch Ball Screw Ass'y	1
BH	59-133	Push-Mount Wire Clip	1	EB	2035-32-96	Ball Screw Cover	1
BJ	59-135	Push-Mount Wire Clip	8	EC	2035-32-801	Gatch Limit Switch Cable	1
BK	59-157	Power Supply	1	ED	2035-32-802	Fowler/CPU Jumper Cable	1
BL	59-727	Jack Screw	4	EE	2035-32-803	Fowler Pot. Cable	1
BM	59-743	Wire Harness Clip	2	EF	2035-32-804	Fuse/PCB Cable	1
BN	59-751	Locking Circuit Bd. Supt.	6	EH	2035-33-50	Fowler Frame Weldment	1
BP	59-767	Cable Clamp	2	EJ	2035-33-62	CPR Release Slide Brkt.	2
BR	59-773	Push Spacer	4	EM	2035-35-50	Foot Section Weldment	1

Litter Assembly and Options

2030-331-10 Common Litter Components (Continued)

Item	Part No.	Part Name	Qty.	Item	Part No.	Part Name	Qty.
EP	2035-231-85	Seat Section Cover	2	FM	3001-200-228	Mounting Standoff	2
ET	2035-400-565	Siderail Guide Bracket	2	FN	3001-300-8	Thigh Bumper	2
EU	(page 123)	Actuator Box Cover Ass'y	1	FP	3001-300-99	Flange Bearing	10
EX	3000-300-58	Switch Plunger	2	FR	3001-300-603	CPR Release Label	2
EY	3000-300-99	Modified Bushing	9	FS	3001-300-663	Velcro Strip	10
EZ	3000-300-115	Standoff	4	FT	3001-300-877	Siderail Extension Cable	1
FA	3000-300-349	Head/Foot Board Post Cap	4	FW	5000-30-366	Fowler Nut Adapter	1
FB	3000-300-353	Roller	4	FX	5010-80-7	Power Supply Gd. Cable	1
FC	3000-300-442	Fowler Drive Grommet	16	FY	8800-380-000	Neoprene Sponge	1.5'
FD	3000-300-455	CPR Isolation Bushing	4	FZ	8815-001-100	Wire Mount Clip	4
FE	3000-300-456	CPR Isolator	2	GA	11-310	Washer	2
FF	3000-300-461	CPR Decoupler	2	GB	11-2	Washer	5
FG	3000-300-462	CPR Wing	2	GC	7-52	Truss Hd. Torx	4
FH	3000-300-464	CPR Engagement Spring	4	GD	13-38	Ext. Tooth Lock Washer	2
FJ	3000-300-473	Clevis Pin	2	GE	2025-231-89	Fowler Litter Link	1
FK	3000-300-477	CPR Conduit Stud	6	GF	59-194	Split Ferrite	1
FL	3000-300-478	CPR Conduit Clamp	6	JH	34-22	Cord Clamp	1

2030-132-10 Epic/Epic+ Litter Components

Item	Part No.	Part Name	Qty.	Item	Part No.	Part Name	Qty.
DG	2035-31-97	Seat Section Skin	1	HJ	16-6	Kep Nut	9
DN	2035-31-801	Inlet/Fuse Cable	1	HK	16-35	Nylock Nut	8
EK	2035-33-63	Fowler Skin	1	HL	25-50	Rivet	24
ER	2035-233-64	Quick Drop Rel. Brkt., Lt.	1	HM	30-27	Strain Grommet	2
ES	2035-233-65	Quick Drop Rel. Brkt., Rt.	1	HN	30-47	Right Angle Strain Relief	1
EW	2040-90-100	500 Lb. Label	2	HP	59-106	Strain Relief	1
HA	3-347	Hex Hd. Cap Screw	8	HR	2030-31-801	Foot Pot. Exten. Cable	1
HP	59-106	Strain Relief	1	HU	2030-31-802	Head Pot. Exten. Cable	1
HB	4-338	Flanged But. Hd. Screw	4	HW	2030-31-803	Head Lift Motor Extension	1
HC	5-29	Rd. Hd. Sq. Neck Bolt	4	HX	2040-31-56	Foley Bag Hanger	6
HD	7-58	Truss Hd. Torx	1	HY	3001-300-4	Spacer	8
HE	11-4	Washer	16	JD	16-14	Nylock Nut	1
HF	11-63	Washer	8	JR	2035-31-880	Power Inlet Cable	1
HG	13-10	Ext. Tooth Lock Washer	1	NG	3002-407-950	CPU	1
HH	13-32	Ext. Tooth Lock Washer	4				

2040-32-20 Zoom/Epic/Epic+ Std. Height Option

Item	Part No.	Part Name	Qty.
HS	2030-331-52	Head End Header Wldmt.	1
HT	2030-331-53	Foot End Header Wldmt.	1

2040-32-21 Zoom/Epic/Epic+ Enh. Height Option

Item	Part No.	Part Name	Qty.
HS	2040-31-252	Head End Header Wldmt.	1
HT	2040-31-253	Foot End Header Wldmt.	1

2040-32-15 Zoom® Litter Domestic Components

Item	Part No.	Part Name	Qty.
NA	59-179	Circuit Breaker	2
ND	2040-31-98	Specification Label	1
NE	2035-300-705	Fowler Drive Assembly	2

Litter Assembly and Options

2040-132-11 Epic+/Zoom® Litter Components

Item	Part No.	Part Name	Qty.	Item	Part No.	Part Name	Qty.
KA	7-58	Truss Hd. Torx	1	KE	3000-300-2	Plastic Clip Nut	3
KB	13-10	Ext. Tooth Lock Washer	2	KF	2040-31-100	Manual Push Label	1
KC	16-28	Nylock Nut	1	KG	59-194	Split Ferrite	3
KD	2040-231-807	Bed CPU Cable	1	KH	59-738	Hole Plug	2

2030-30-100 No Scale or Bed Exit Options

Item	Part No.	Part Name	Qty.
	(page 160)	Foot Board, No Scale/BE	1
OF	3001-300-511	"Imitation" Load Cell	4
GG	3000-300-353	Roller	4

2030-140-125 Scale Option Only

Item	Part No.	Part Name	Qty.
OA	13-32	Ext. Tooth Lock Washer	4
	(page 161)	Foot Board, Scale Option	1
OC	2030-317-805	Load Cell Cable, Head	2
OD	2030-317-804	Load Cell Cable, Foot	2
OE	3001-300-7	M/F Screw	8
OF	3002-307-57	Load Cell	4
GG	3002-300-353	Roller	4

2030-140-175 Chaperone® Bed Exit Option

Item	Part No.	Part Name	Qty.
OA	13-32	Ext. Tooth Lock Washer	4
	(page 162)	Ft. Bd., Chaperone Option	1
OC	2030-317-805	Load Cell Cable, Head	2
OD	2030-317-804	Load Cell Cable, Foot	2
OE	3001-300-7	M/F Screw	8
OF	3002-307-57	Load Cell	4
GG	3002-300-353	Roller	4

2030-140-150 Scale & Chaperone® Options

Item	Part No.	Part Name	Qty.
OA	13-32	Ext. Tooth Lock Washer	4
	(page 164)	Ft. Bd., Scale & Chap.	1
OC	2030-317-805	Load Cell Cable, Head	2
OD	2030-317-804	Load Cell Cable, Foot	2
OE	3001-300-7	M/F Screw	8
OF	3002-307-57	Load Cell	4
GG	3002-300-353	Roller	4

2030-140-275 Chaperone II® Bed Exit Option

Item	Part No.	Part Name	Qty.
OA	13-32	Ext. Tooth Lock Washer	4
	(page 163)	Ft. Bd., Chap. II Option	1
OC	2030-317-805	Load Cell Cable, Head	2
OD	2030-317-804	Load Cell Cable, Foot	2
OE	3001-300-7	M/F Screw	8
OF	3002-307-57	Load Cell	4
GG	3000-300-353	Roller	4

2030-140-250 Scale & Chaperone II® B. E. Options

Item	Part No.	Part Name	Qty.
OA	13-32	Ext. Tooth Lock Washer	4
	(page 165)	Foot Board, Scale & BE	1
OC	2030-317-805	Load Cell Cable, Head	2
OD	2030-317-804	Load Cell Cable, Foot	2
OE	3001-300-7	M/F Screw	8
OF	3002-307-57	Load Cell	4
GG	3000-300-353	Roller	4

2030-30-251 High-Sounding Beeper Option

Item	Part No.	Part Name	Qty.
PA	3001-508-870	High-Sound Beeper Cable	1

2035-130-207 Smart TV Option

Item	Part No.	Part Name	Qty.
UA	59-727	Jack Screw	2
UC	3002-39-800	STV Board	1

2030-34-10 Foot Prop Option

Item	Part No.	Part Name	Qty.
R	11-4	Washer	4
AA	14-8	Washer	4
AM	27-15	Cotter Pin	4
EN	2030-35-96	Foot Prop Rod	1
BF	58-56	Black Edge Trim	6"

Litter Assembly and Options

2040-30-200 Head Wall Communication Option

Item	Part No.	Part Name	Qty.
SG	2035-31-806	Head Wall Interface Cable	1
SH	59-710	Static Cap	1
	2040-31-200	Zoom Hd. Wall w/Comm.	1

2040-30-201 Head Wall Comm. w/Nurse Call

Item	Part No.	Part Name	Qty.
SA	1-87	Flat Hd. Mach. Screw	2
SF	52-783	U Clip	2
SG	2035-31-806	Head Wall Interface Cable	1
SH	59-710	Static Cap	1
	2040-31-201	Zoom Hd. Wall w/NC	1
SP	5010-80-20	9V Battery Box w/Cable	1

2040-30-202 HW Comm. w/NC & 1 Stryker Port

Item	Part No.	Part Name	Qty.
SA	1-87	Flat Hd. Mach. Screw	2
SE	30-39	Strain Relief Grommet	1
SF	52-783	U Clip	2
SG	2035-31-806	Head Wall Interface Cable	1
SH	59-710	Static Cap	1
	2040-31-202	Zoom HW w/NC & 1 Port	1
SP	5010-80-20	9V Battery Box w/Cable	1
SR	2035-30-804	Pendant Port Cable	1

2040-30-203 HW Comm. w/NC & 2 Stryker Ports

Item	Part No.	Part Name	Qty.
SA	1-87	Flat Hd. Mach. Screw	2
SE	30-27	Strain Relief Grommet	1
SF	52-783	U Clip	2
SG	2035-31-806	Head Wall Interface Cable	1
SH	59-710	Static Cap	1
SJ	2035-30-805	Dual Pendant Port Cable	1
SP	5010-80-20	9V Battery Box w/Cable	1
	2040-31-203	Zoom HW w/NC & 2 Ports	1

Actuator Box Cover Assembly

Assembly part number 2035-432-75 (reference only)

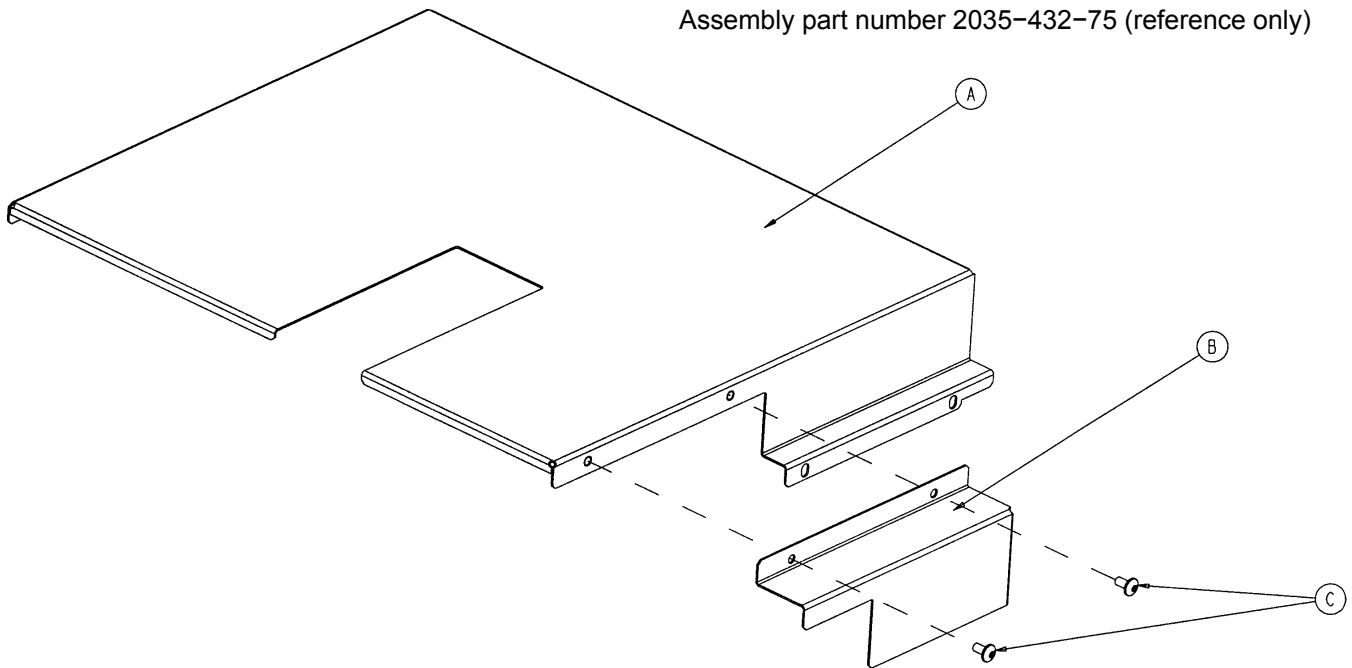

Item	Part No.	Part Name	Qty.
A	2035-332-75	Main Actuator Box Cover	1
B	2035-332-76	Actuator Box Side Cover	1
C	7-58	Truss Hd. Torx	2

3001-300-775 Fowler Brake Kit Assembly

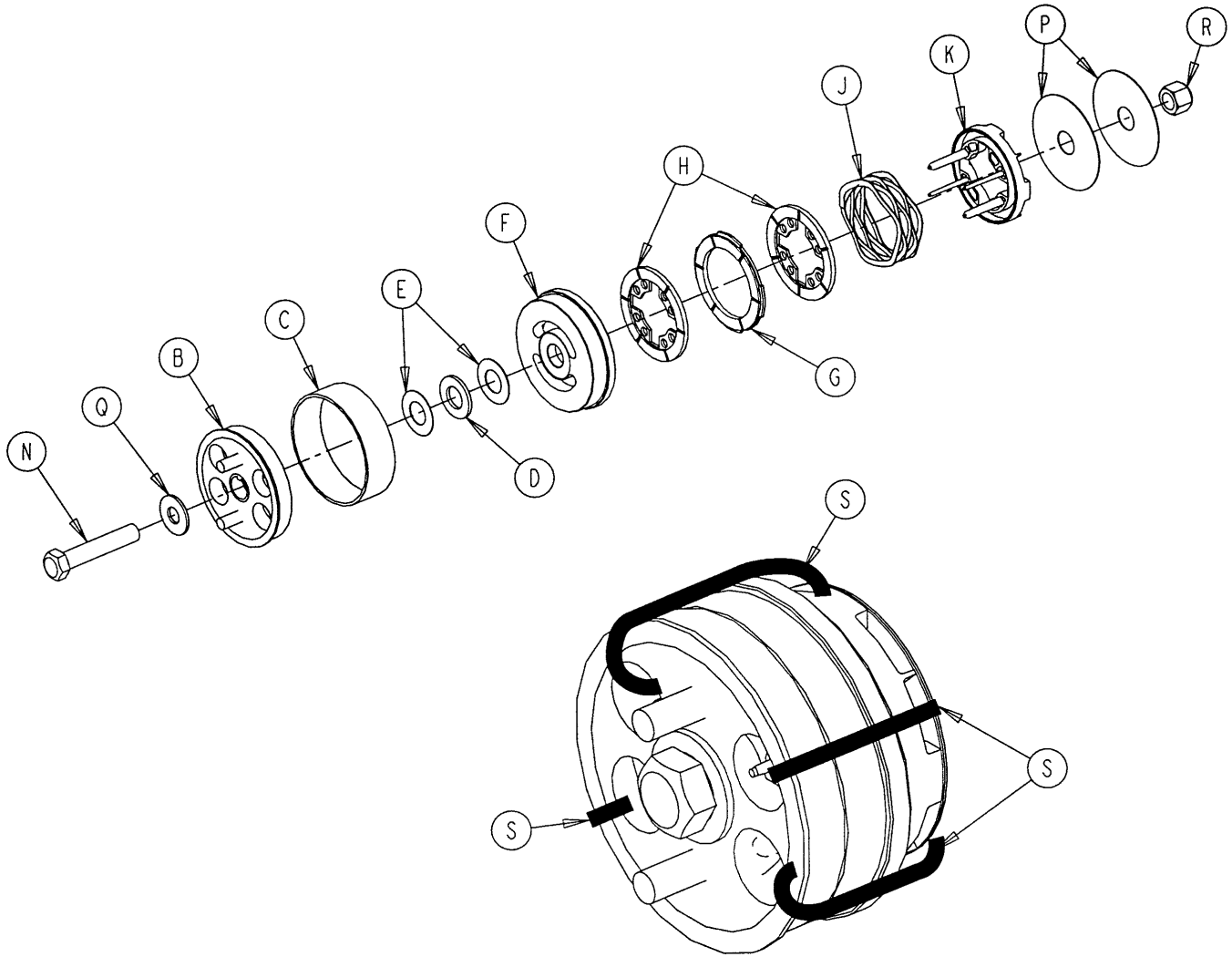

Item	Part No.	Part Name	Qty.
B	3001-300-455	CPR Coupler Assembly	1
C	3000-300-465	CPR Clutch Spring	1
D	81-212	Thrust Needle Roller Brg.	1
E	3000-200-224	Idler Gear Thrust Washer	2
F	3001-300-569	Brake Cup	1
G	3001-300-552	CPR Brake Disc	1
H	3001-300-551	CPR Spring Cup	2
J	3001-300-563	CPR Brake Spring	1
K	3001-300-570	CPR Spring Cup	1
N	3-64	Hex Hd. Cap Screw	1
P	3000-200-245	Flat Washer	2
Q	11-193	Heavy Flat Washer	1
R	16-12	Nylock Nut	1
S	3000-300-113	8" Wire Tie	4

Zoom® Litter Assembly

Assembly part number 2040-31-10 (reference only)

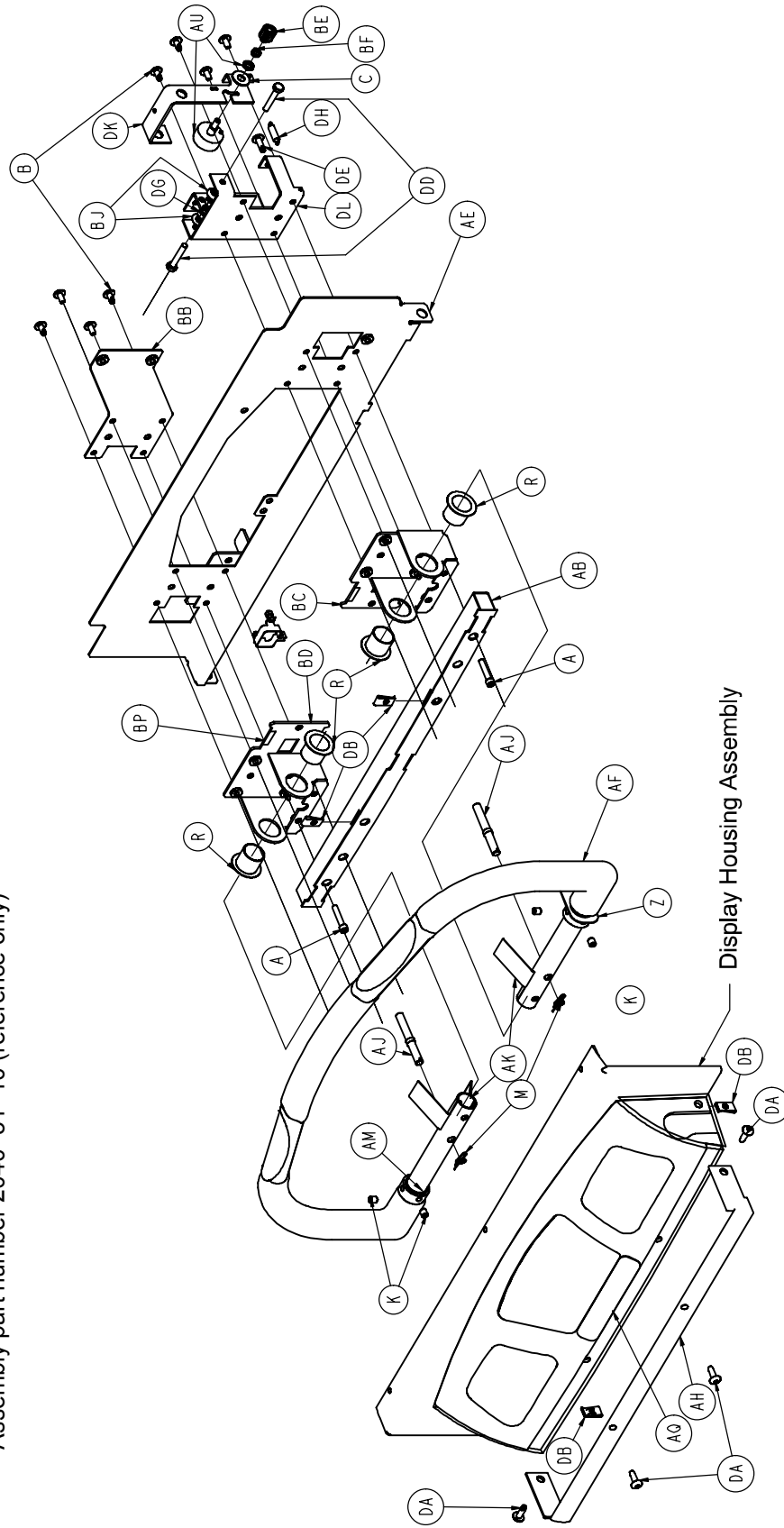

Zoom® Litter Assembly

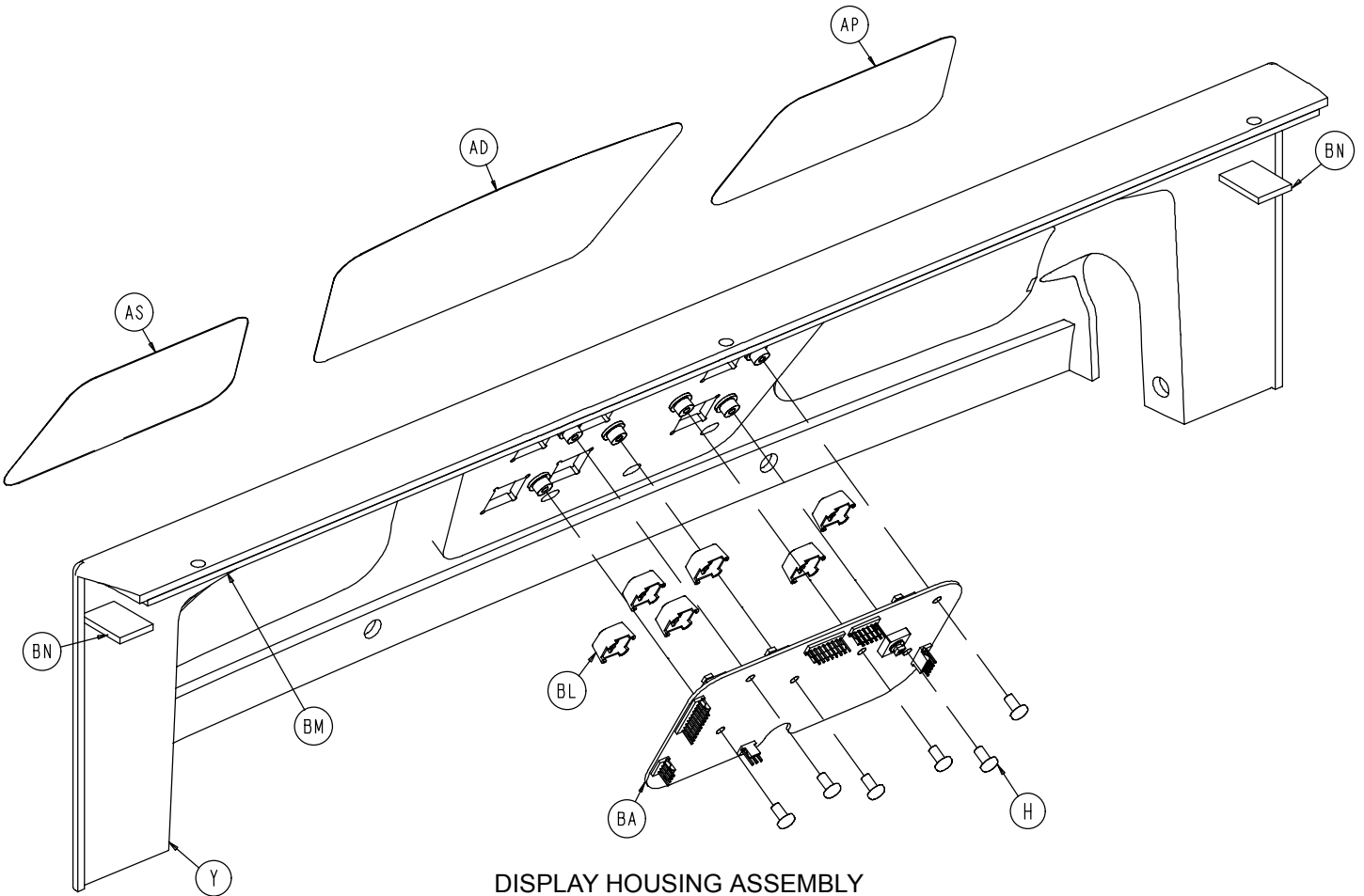
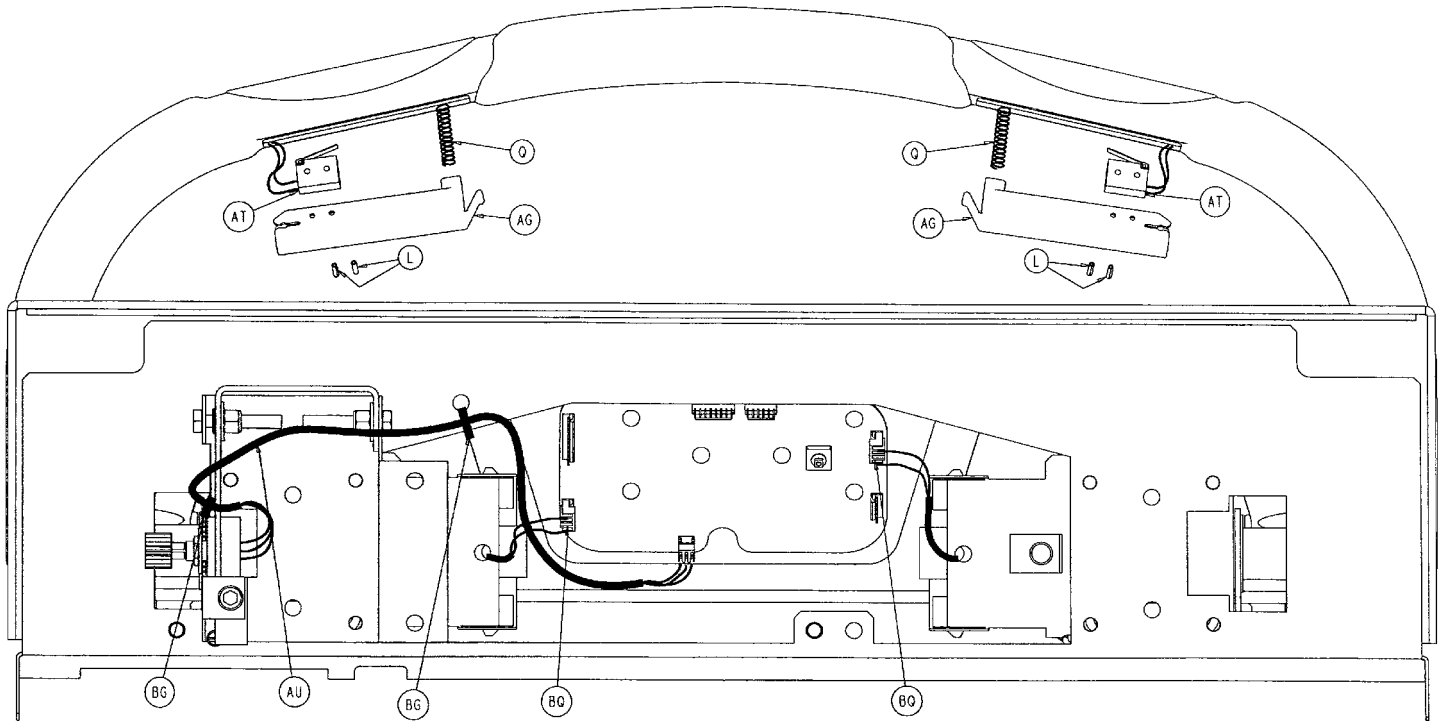

DISPLAY HOUSING ASSEMBLY

Zoom® Litter Assembly

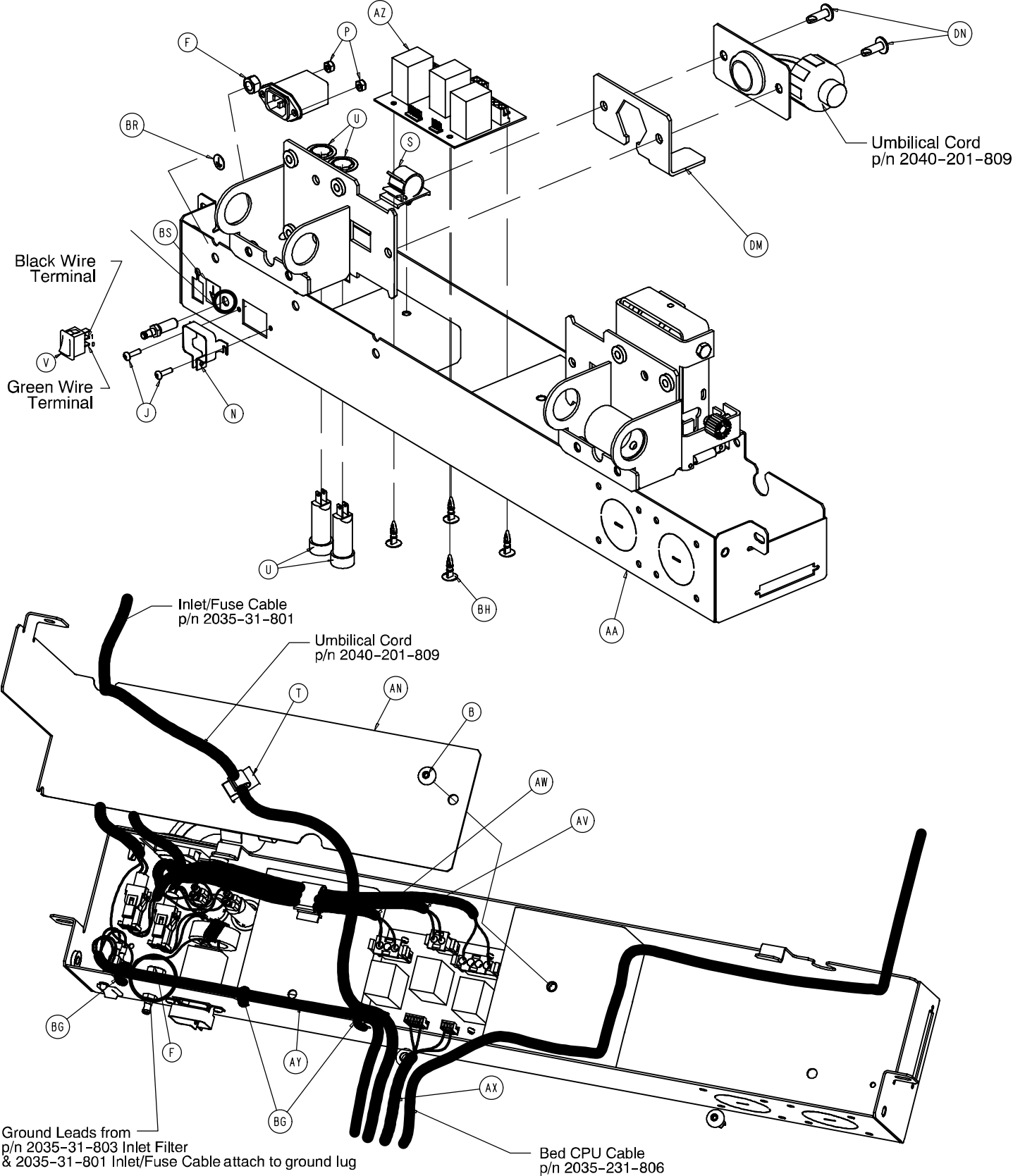

Zoom® Litter Assembly

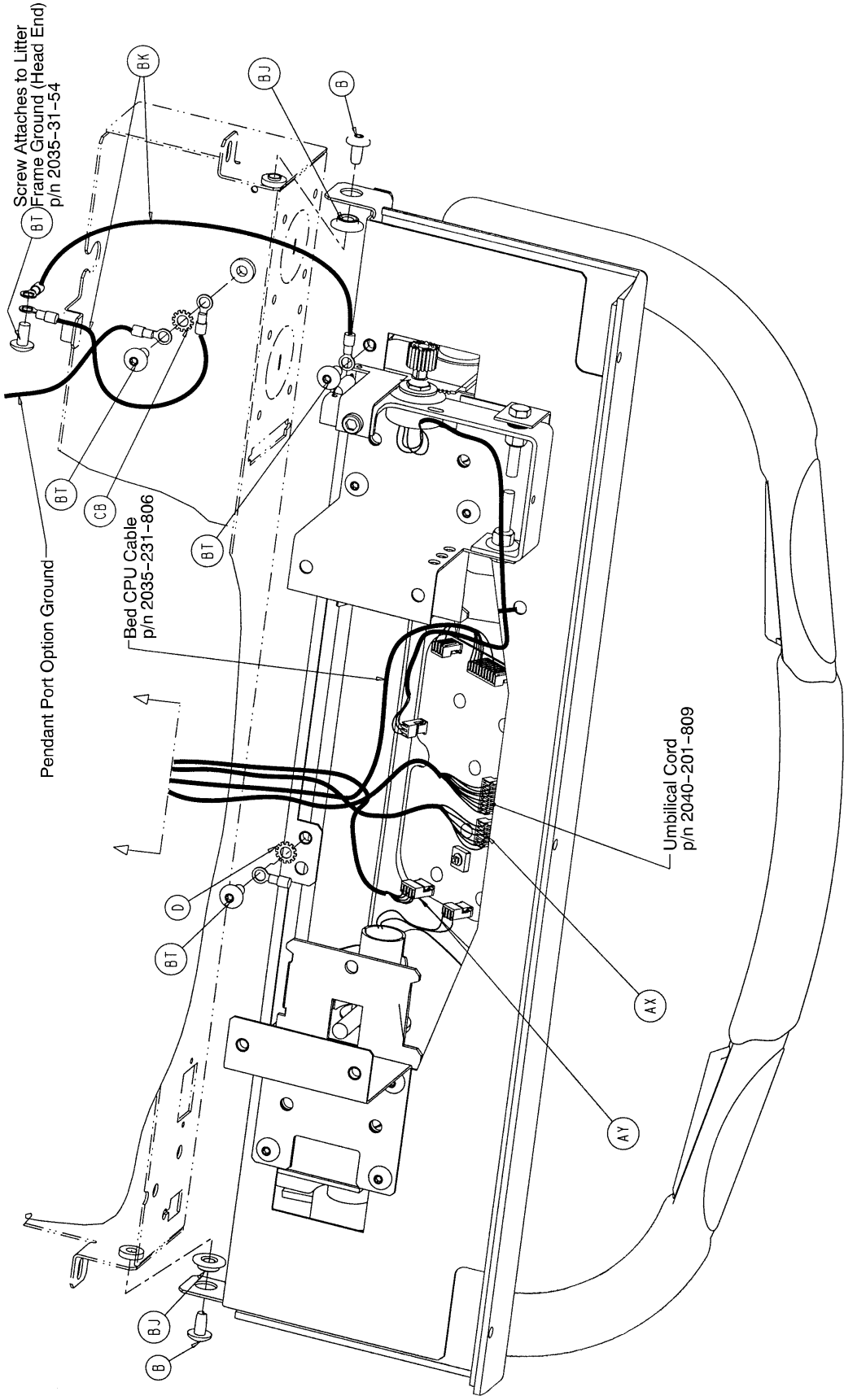

Zoom® Litter Assembly

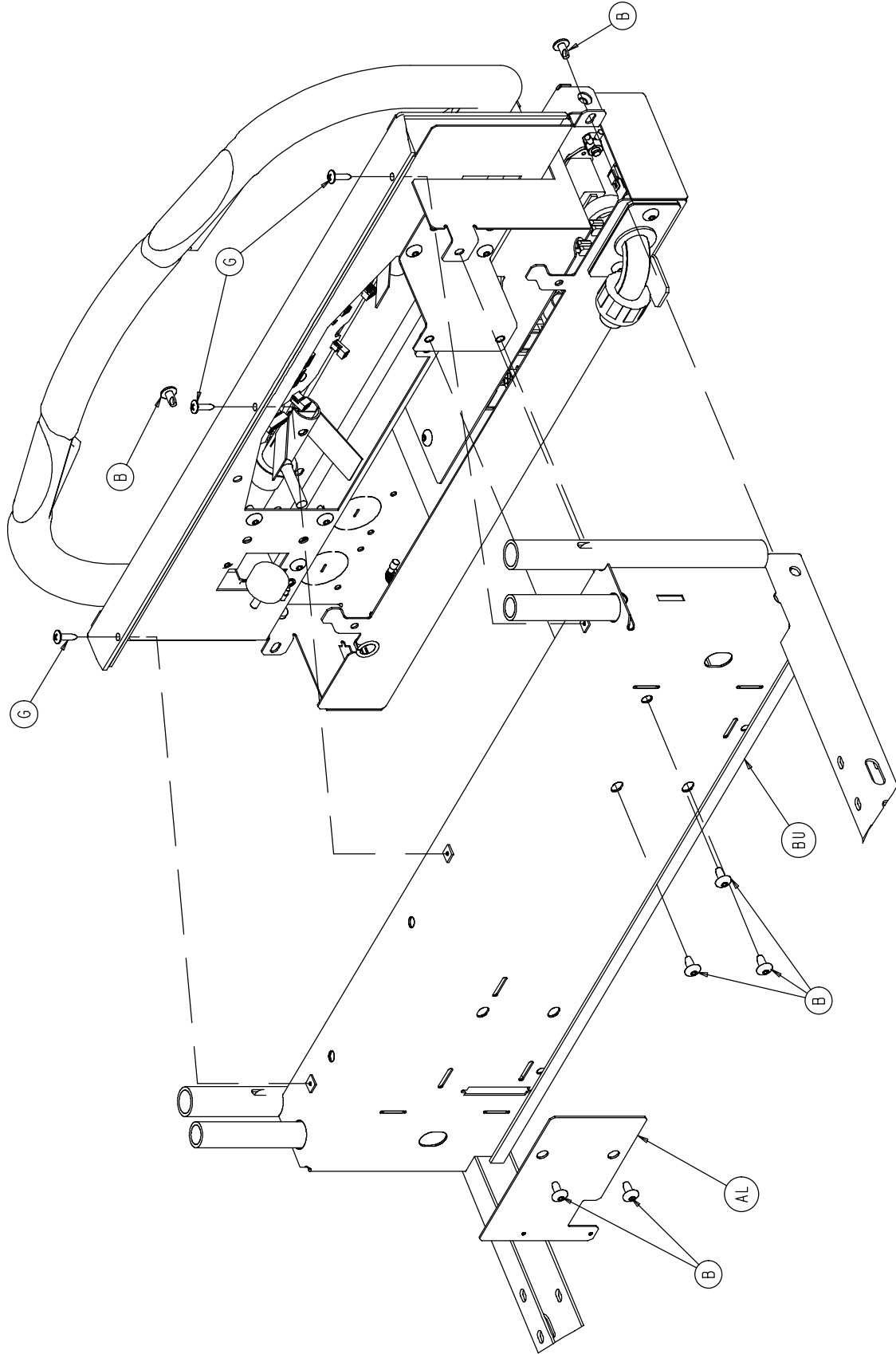

Zoom® Litter Assembly

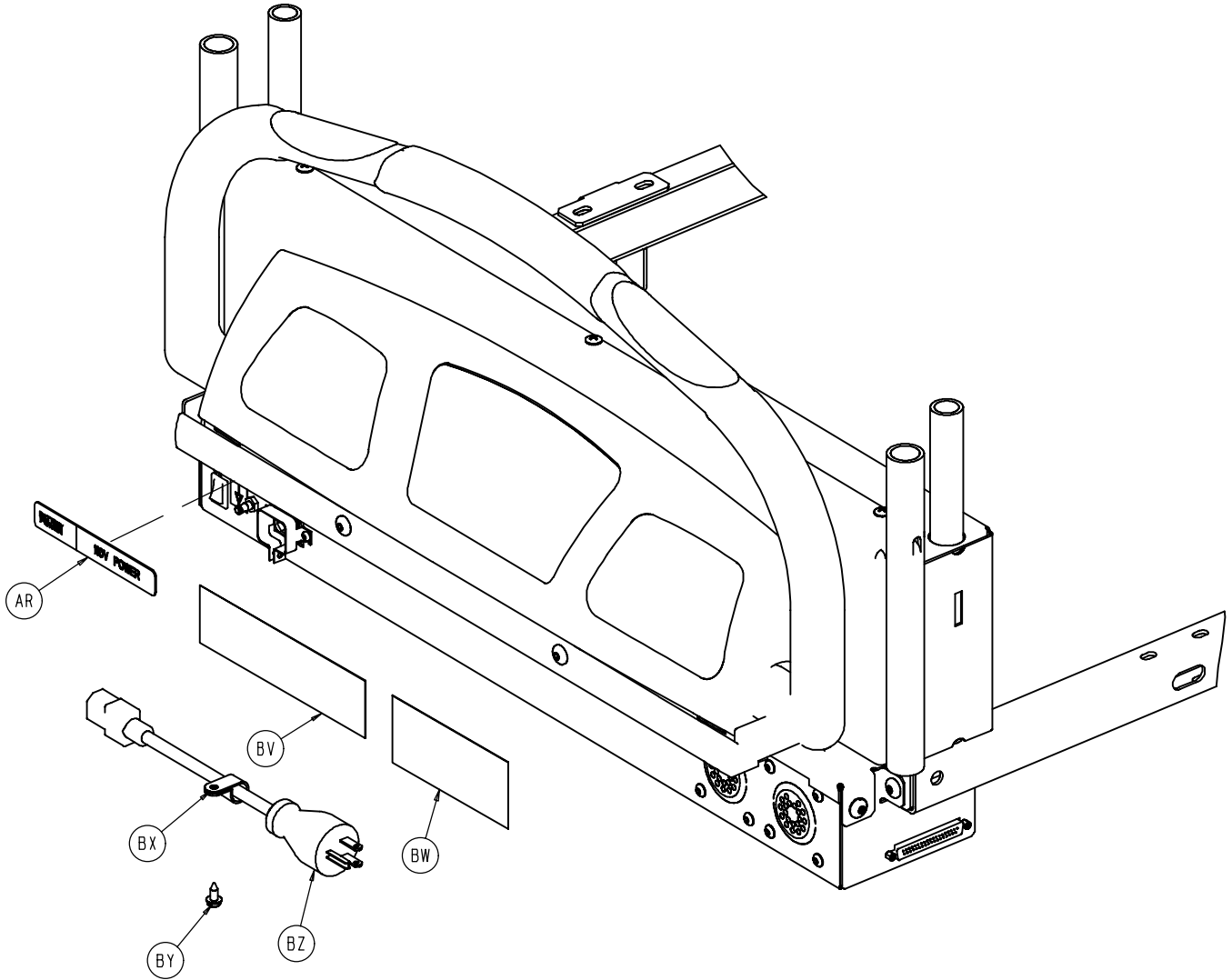

Zoom® Litter Assembly

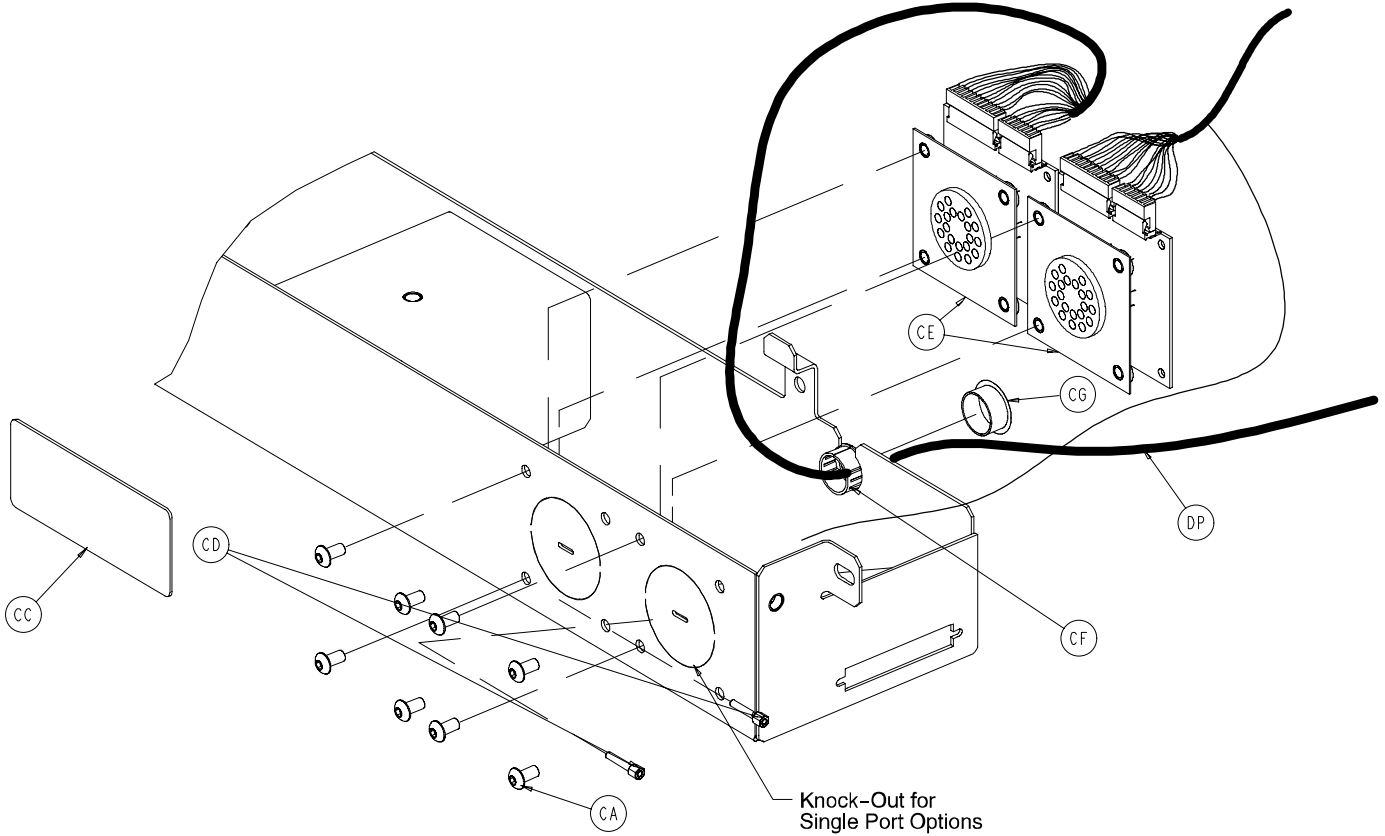

2040-31-200 Head Wall Communication Option

Item	Part No.	Part Name	Qty.
CD	3001-300-7	M/F Screw	2
CF	30-38	Grommet	1

2040-31-201 Head Wall Comm. w/Nurse Call

Item	Part No.	Part Name	Qty.
CD	3001-300-7	M/F Screw	2
CF	30-38	Grommet	1

2040-31-202 HW Comm. w/NC & 1 Stryker Port

Item	Part No.	Part Name	Qty.
CA	4-307	But. Hd. Cap Screw	4
CB	13-10	Ext. Tooth Lock Washer	2
CC	2040-31-104	Cord Out Label	1
CD	3001-300-7	M/F Screw	2
CE	3001-314-920	Head Wall Pend. Port PCB	1
CF	30-38	Grommet	1

2040-31-203 HW Comm. w/NC & 2 Stryker Ports

Item	Part No.	Part Name	Qty.
CA	4-307	But. Hd. Cap Screw	8
CB	13-10	Ext. Tooth Lock Washer	2
CC	2040-31-104	Cord Out Label	1
CD	3001-300-7	M/F Screw	2
CE	3001-314-920	Head Wall Pend. Port PCB	2
CF	30-38	Grommet	1

2040-31-204 No Head Wall Option

Item	Part No.	Part Name	Qty.
CG	37-30	Hole Plug	1

Zoom® Litter Assembly

Item	Part No.	Part Name	Qty.	Item	Part No.	Part Name	Qty.
A	4-142	Soc. Hd. Cap Screw	2	AV	2040-31-807	Bed AC Pwr. Jump. Cbl.	1
B	7-52	Truss Hd. Torx	18	AW	2040-31-808	Charger AC Jumper	1
C	11-193	Flat Washer	1	AX	2040-31-809	CPU/Crossover PCB	1
D	13-10	Ext. Tooth Lock Washer	5	AY	2040-31-810	On/Off Cable	1
F	16-33	Kep Nut	2	AZ	2040-31-900	AC/Switchover PCB	1
G	23-80	Truss Hd. Screw	3	BA	2040-31-910	Display/CPU PCB	1
H	23-112	Hi-Low Tapping Screw	6	BB	2040-231-75	Reinforcement Brkt. Hd.	1
J	50-32	Pan Hd. Mach. Screw	2	BC	2040-31-110	Pivot Bracket, Right	1
K	21-140	Set Screw	4	BD	2040-31-111	Pivot Bracket, Left	1
L	26-303	Roll Pin	4	BE	2040-31-106	Pot. Worm Gear	1
M	27-22	Rue Ring Cotter	2	BF	3000-200-253	Pot. Worm Gear Retainer	1
N	59-205	Connector Lock	1	BG	3000-300-114	Wire Tie	5
P	16-23	Nylock Nut	2	BH	3000-300-115	Standoff	4
Q	38-448	Switch Handle Ret. Spring	2	BJ	3001-300-99	Pivot Bearing	4
R	52-762	Flange Bearing	4	BK	3001-300-870	Ground Strap	2
S	59-133	Push-Mount Wire Clip	1	BL	3001-400-953	Switch Cap	6
T	59-136	Push-Mount Wire Clip	1	BM	8800-380-000	Foam Tape (26.25")	1
U	59-190	1.0 Amp Circuit Breaker	2	BN	8800-380-000	Foam Tape (1.25")	2
V	59-191	On/Off Switch	1	BP	44-32	Press. Sens. Tape (1.5")	4
Y	2040-31-11	Top Display Housing	1	BQ	59-781	4-Position Connector	2
Z	2040-31-51	Pot. Collar Weldment	1	BR	36-46	Ground Label	1
AA	2040-31-53	Hd. End Bottom Encl.	1	BS	36-115	Ground Label	1
AB	2040-31-54	Bumper Attachment Wldmt.	1	BT	7-58	Truss Hd. Torx	4
AD	2040-31-62	Display Label	1	BU	7000-1-326	Foam Tape (26.75")	1
AE	2040-31-63	Hd. End Top Enclosure	1	BV	1550-90-1	Hosp. Grade Plug Label	1
AF	2040-231-64	Control Bar	1	BW	2011-1-104	Anesthetics Danger Label	1
AG	2040-31-68	Handle Switch	2	BX	34-22	Cord Clamp	1
AH	2040-231-69	Display Bumper	1	BY	23-25	Hex Washer Hd. Screw	1
AJ	2040-31-73	Stop Pin	2	BZ	39-254	Power Cord	1
AK	2040-31-74	Control Bar Ret. Spring	2	DA	7-63	Truss Hd. Torx	4
AL	2040-31-77	Cover Plate	1	DB	55-27	"U" Type Nut	4
AM	2040-31-82	Potentiometer Collar	1	DD	3-50	Hex Hd. Cap Screw	2
AN	2040-31-92	Hd. End Electronics Cvr.	1	DE	4-325	Soc. Hd. Cap Screw	1
AP	2040-31-101	Drive Instruction Label	1	DG	16-28	Nylock Nut	2
AQ	2040-31-102	Drive Warning Label	1	DH	38-482	Extension Spring	1
AR	2040-31-103	Power Label	1	DK	2040-31-108	Potentiometer Mount	1
AS	2040-31-105	Logo Label	1	DL	2040-31-109	Reinforcement Bracket	1
AT	2040-31-803	Contact Switch Cable	2	DM	2040-31-85	Umbilical Cord Supt. Plate	1
AU	2040-31-804	Potentiometer Cable	1	DN	7-65	Truss Hd. Torx	2
				DP	2035-31-806	Headwall Interface Cable	1

Optional 110V Outlet Assembly

Assembly part number 2040-320-60
(reference only)

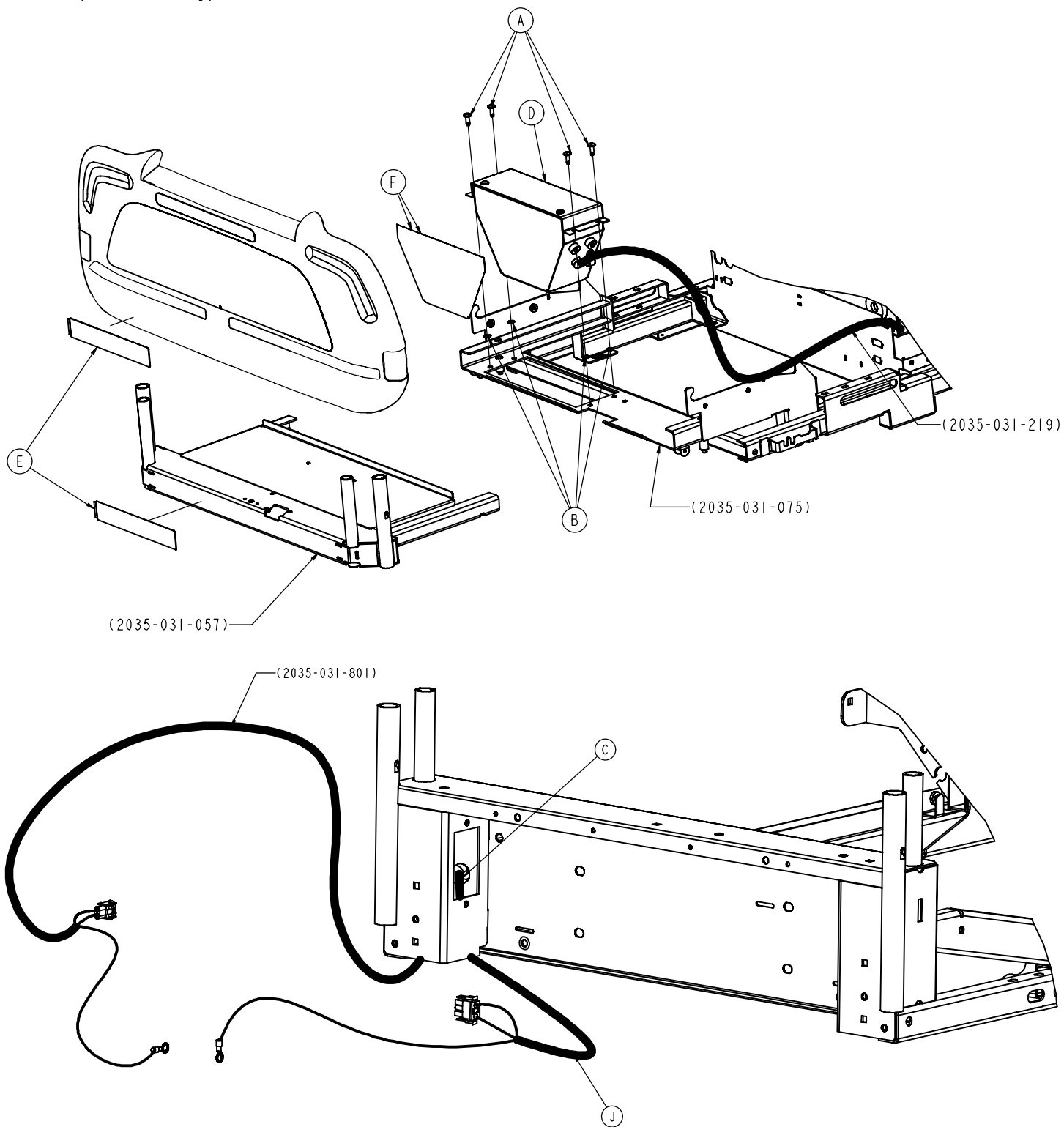

Optional 110V Outlet Assembly

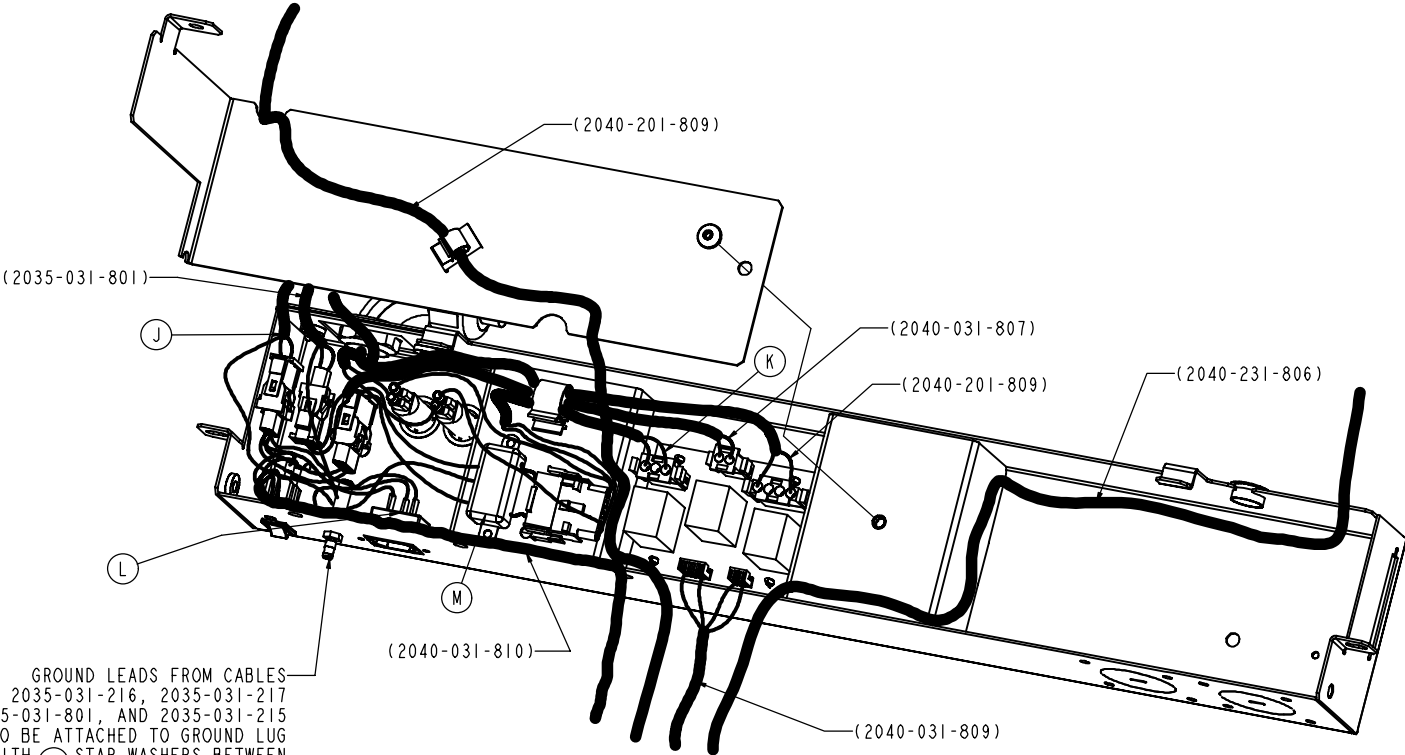
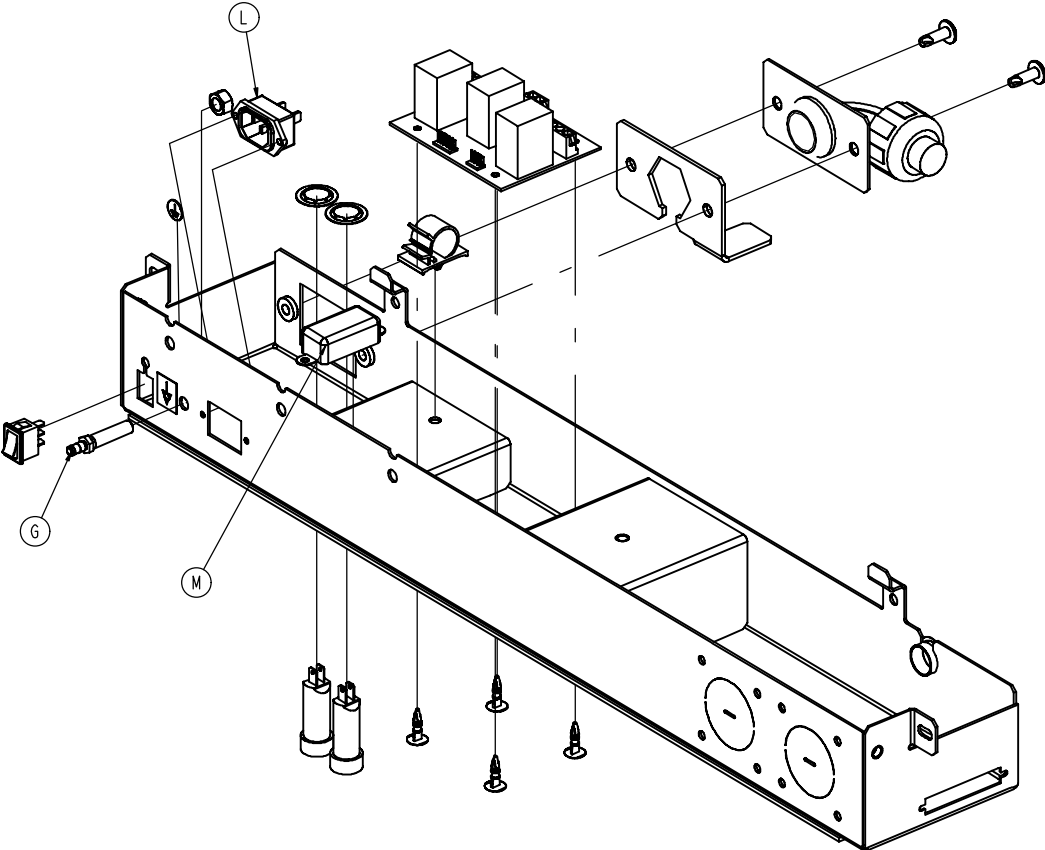

GROUND LEADS FROM CABLES
 2035-031-216, 2035-031-217
 2035-031-801, AND 2035-031-215
 TO BE ATTACHED TO GROUND LUG
 WITH (N) STAR WASHERS BETWEEN
 EACH RING CONNECTOR

Optional 110V Outlet Assembly

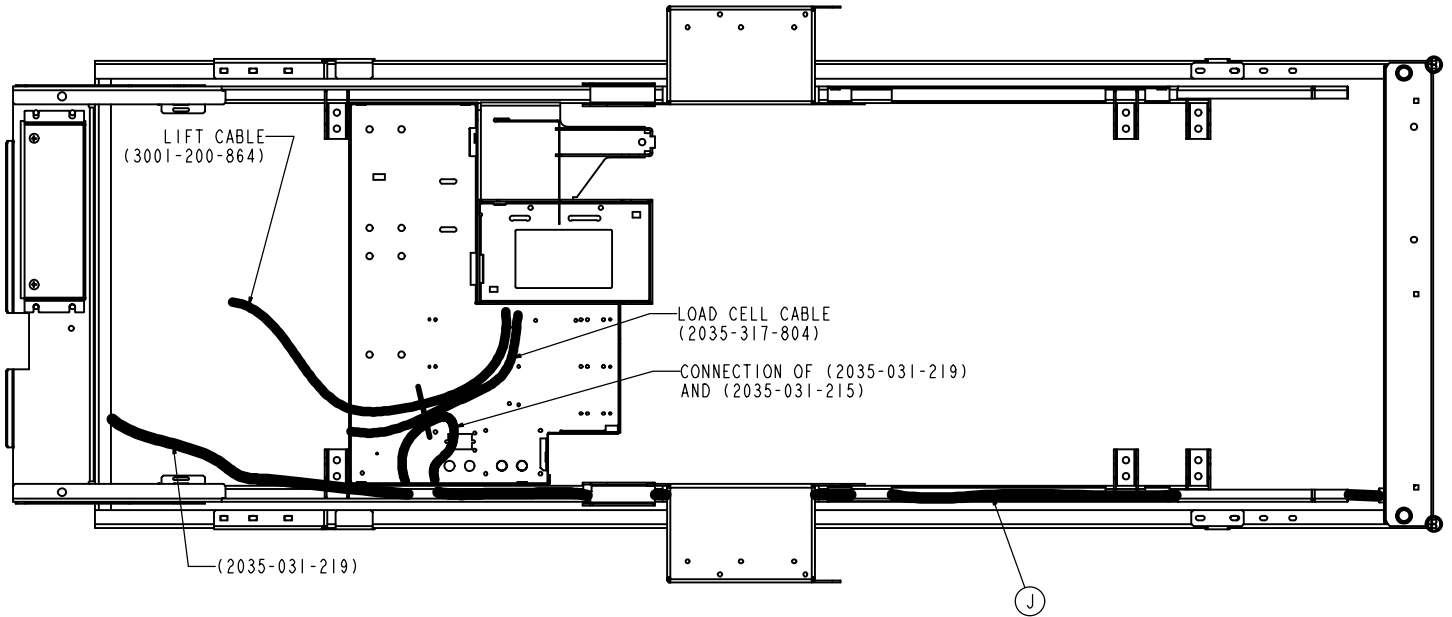

Item	Part No.	Part Name	Qty.
A	7-63	Truss Hd. Screw	4
B	13-10	External Tooth Lock Washer	7
C	59-106	HEYCO	1
D	2035-31-200	110V Box Assembly	1
E	2035-31-204	110V Outlet Caution Label	2
F	2035-31-206	Zoom Box Label	1
G	2030-1-215	Lug	1
H	30-47	HEYCO	2
J	2035-31-215	Cable, 110V Supply	1
K	2040-31-811	AC Jumper Charger	1
L	2035-31-216	Cable, 110V Head End	1
M	2035-31-217	Filter, 110V Zoom	1
N	12-38	Washer	3

2035-31-220 110V Box Assembly

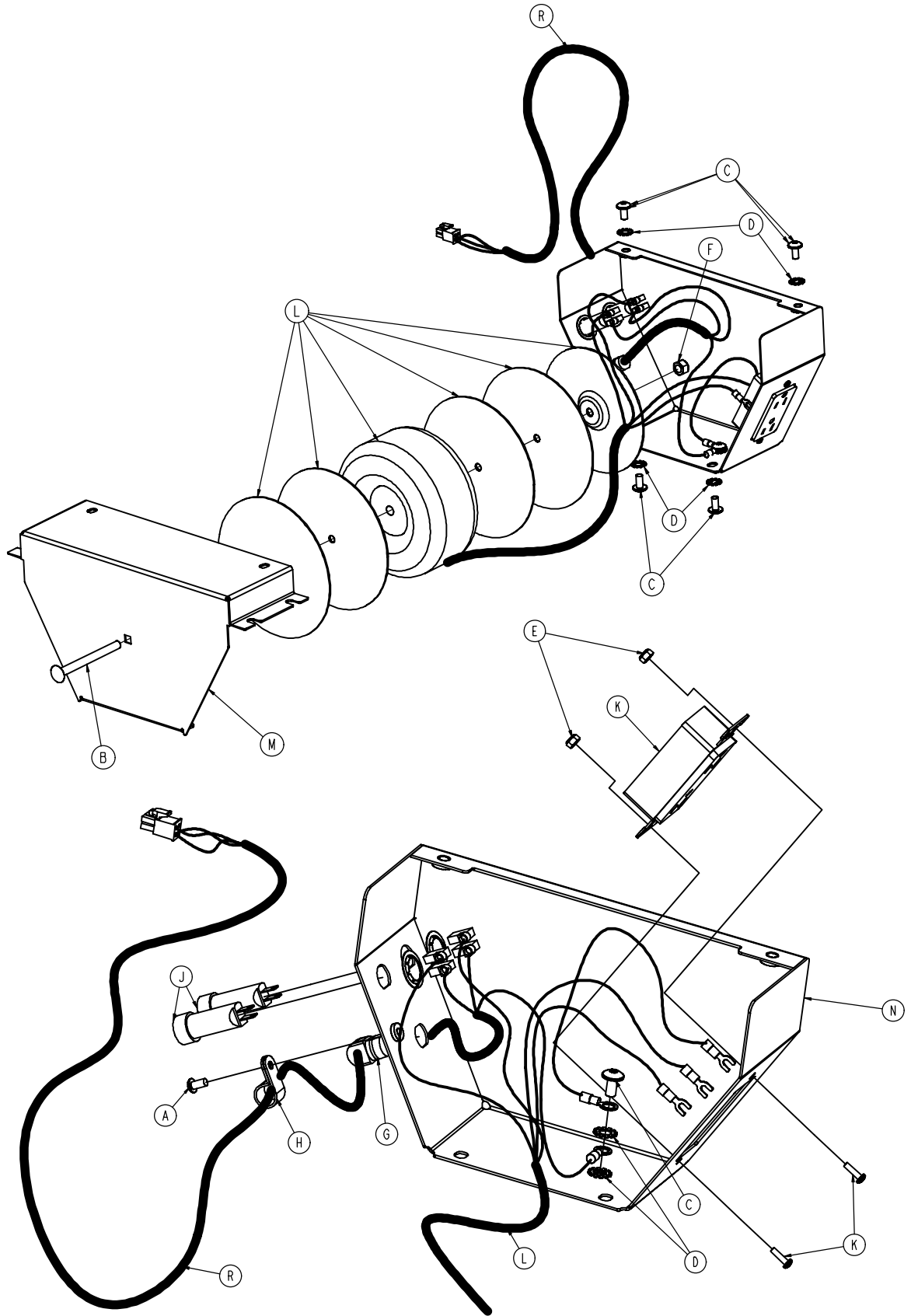

2035-31-220 110V Box Assembly

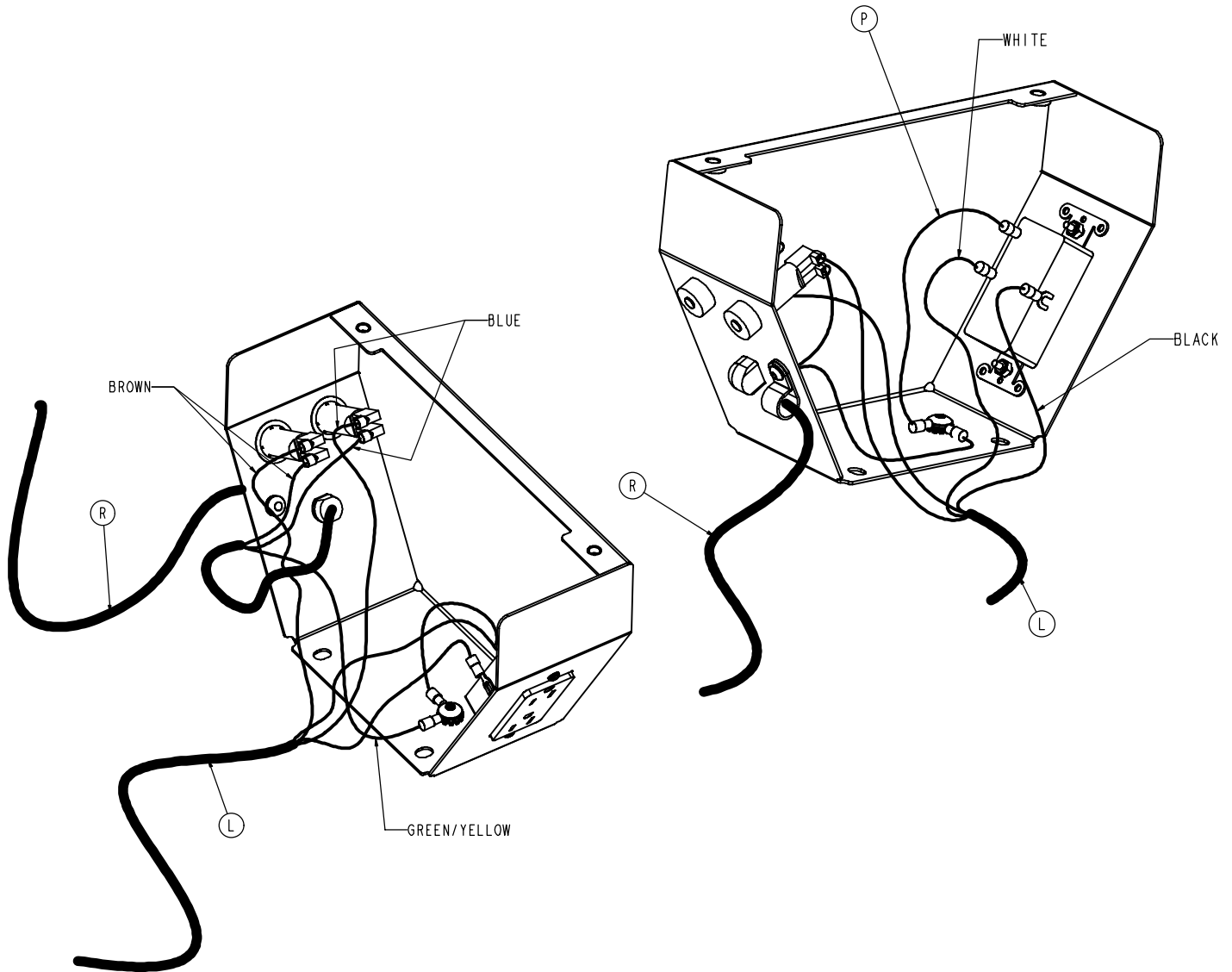

Item	Part No.	Part Name	Qty.	Item	Part No.	Part Name	Qty.
A	4-442	But. Hd. Cap Screw	1	J	59-43	5 Amp. Circuit Breaker	2
B	5-43	Carriage Bolt	1	K	59-732	HG Duplex Receptacle	1
C	7-58	Truss Hd. Mach. Screw	4	L	2030-1-9	Transformer	1
D	13-38	Ext. Tooth Lock Washer	6	M	2035-31-201	110V Box Cover	1
E	16-23	Fiberlock Hex Nut	2	N	2035-31-202	110V Box	1
F	16-36	Nylock Hex Nut	1	P	2035-31-214	110V Ground Cable	1
G	30-47	Strain Relief	1	R	2035-31-219	110V Supply Cable	1
H	34-22	Cord Clamp	1				

No Optional 110V Outlet

Assembly part number 2040-320-61 (reference only)

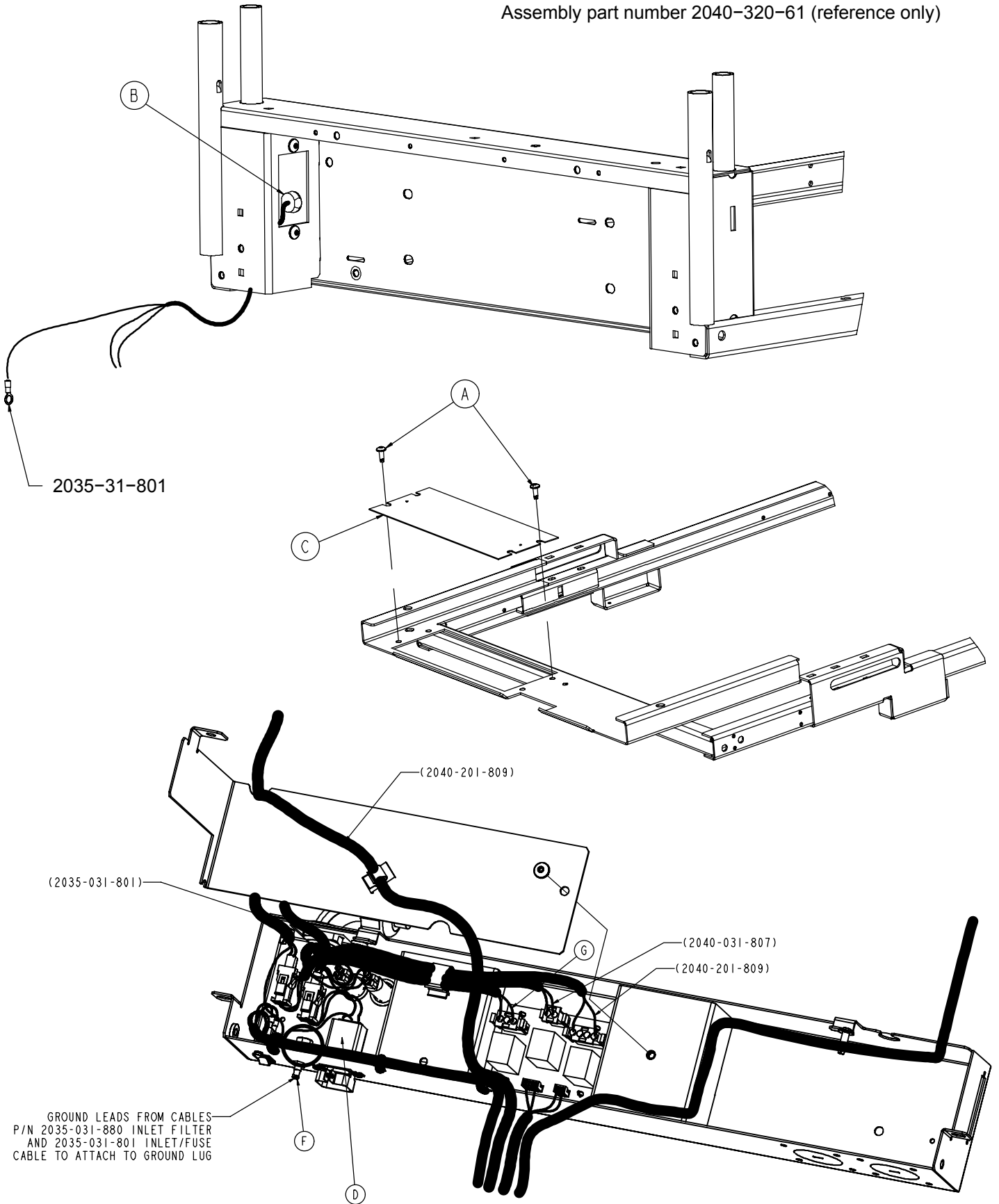

GROUND LEADS FROM CABLES
P/N 2035-031-880 INLET FILTER
AND 2035-031-801 INLET/FUSE
CABLE TO ATTACH TO GROUND LUG

No Optional 110V Outlet

Item	Part No.	Part Name	Qty.
A	7-63	Truss Hd. Screw	2
B	30-27	Strain Relief Bushing	1
C	2035-31-203	Foot Cross Brace Cover	1
D	2035-31-880	Power Inlet Cable	1
E	37-85	Heyco Hole Plug	2
F	2011-1-215	Lug	1
G	2040-31-808	Charger, AC Jumper	1

Head End Siderail Assembly

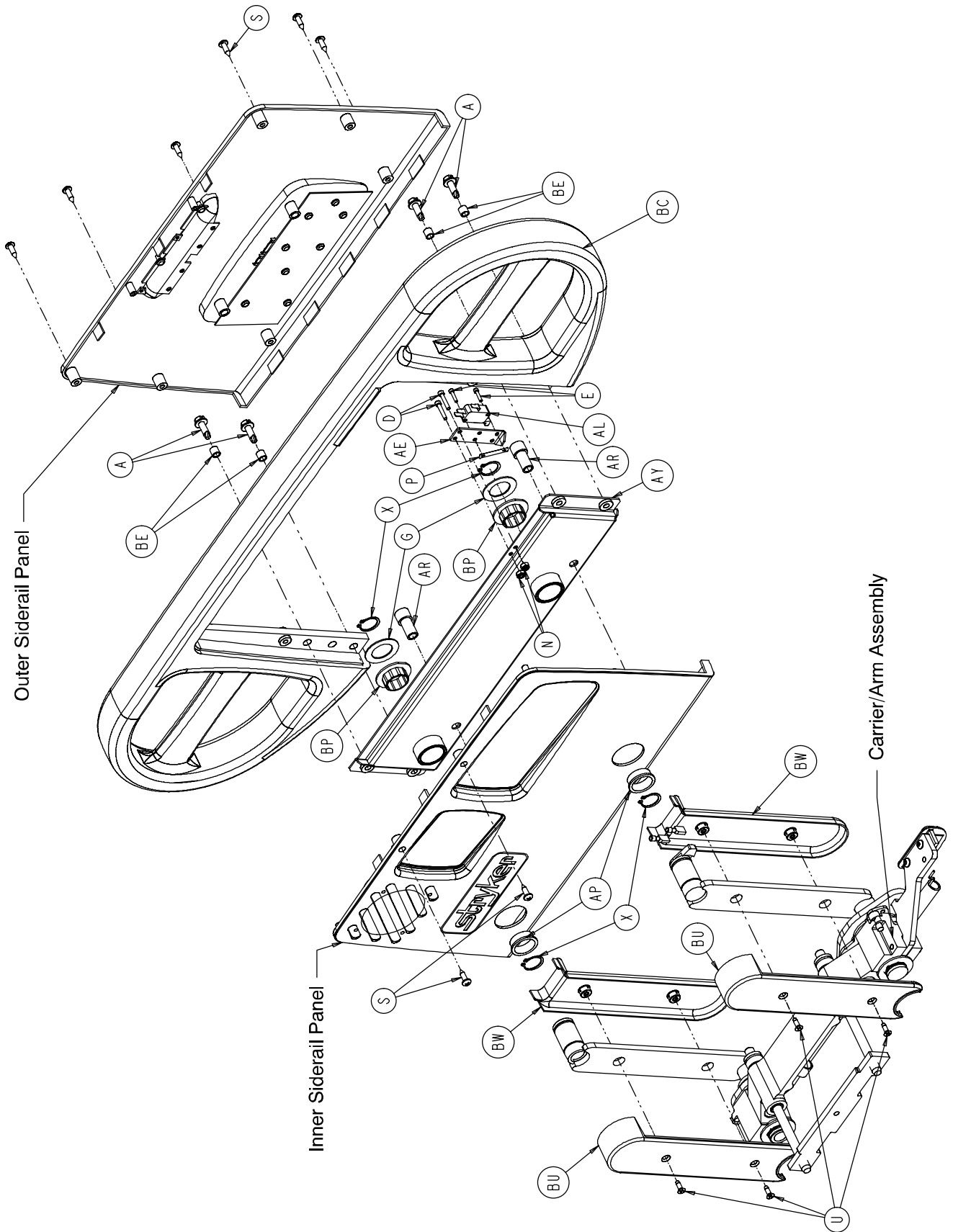

Head End Siderail Assembly

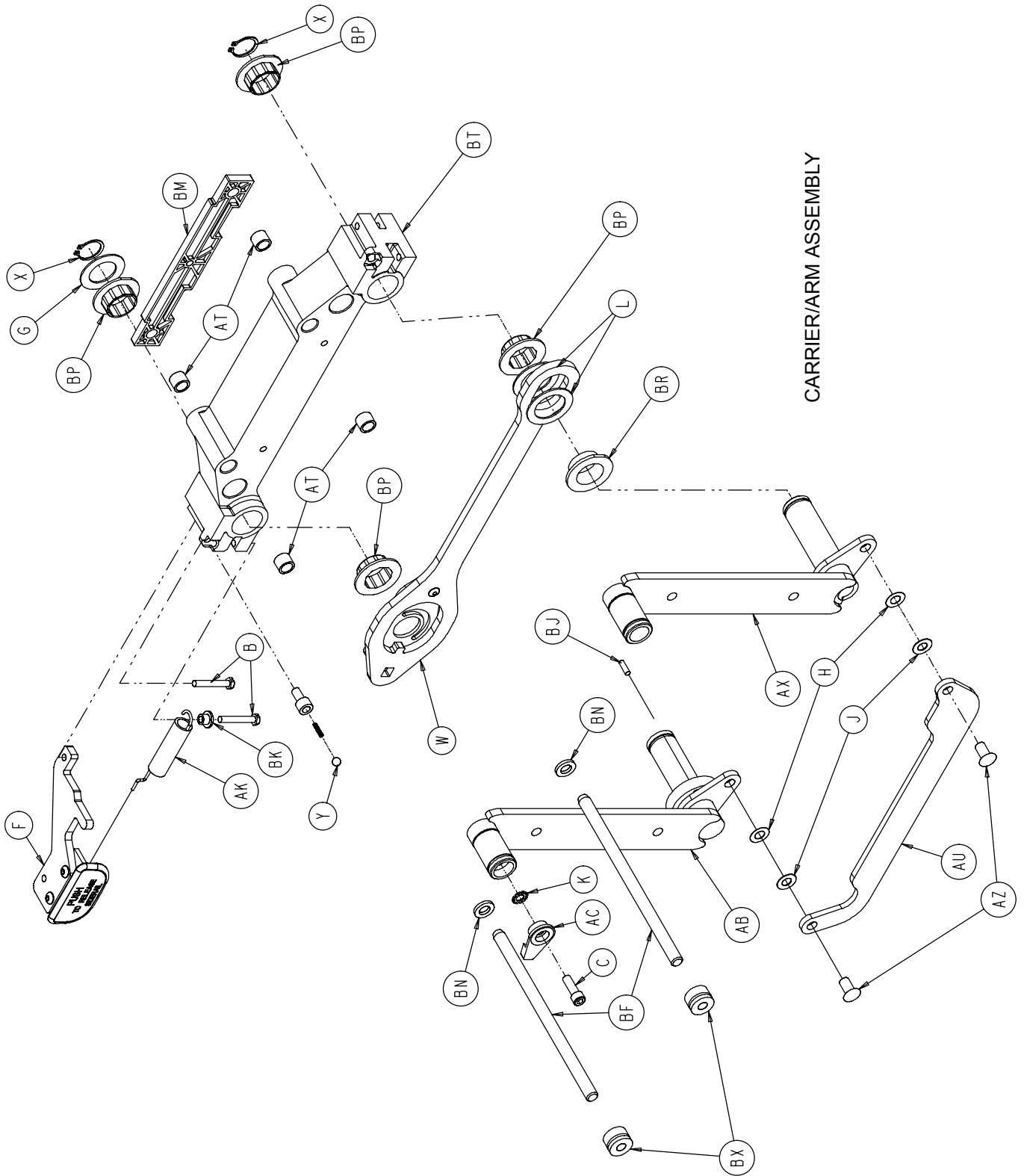

CARRIER/ARM ASSEMBLY

Head End Siderail Assembly

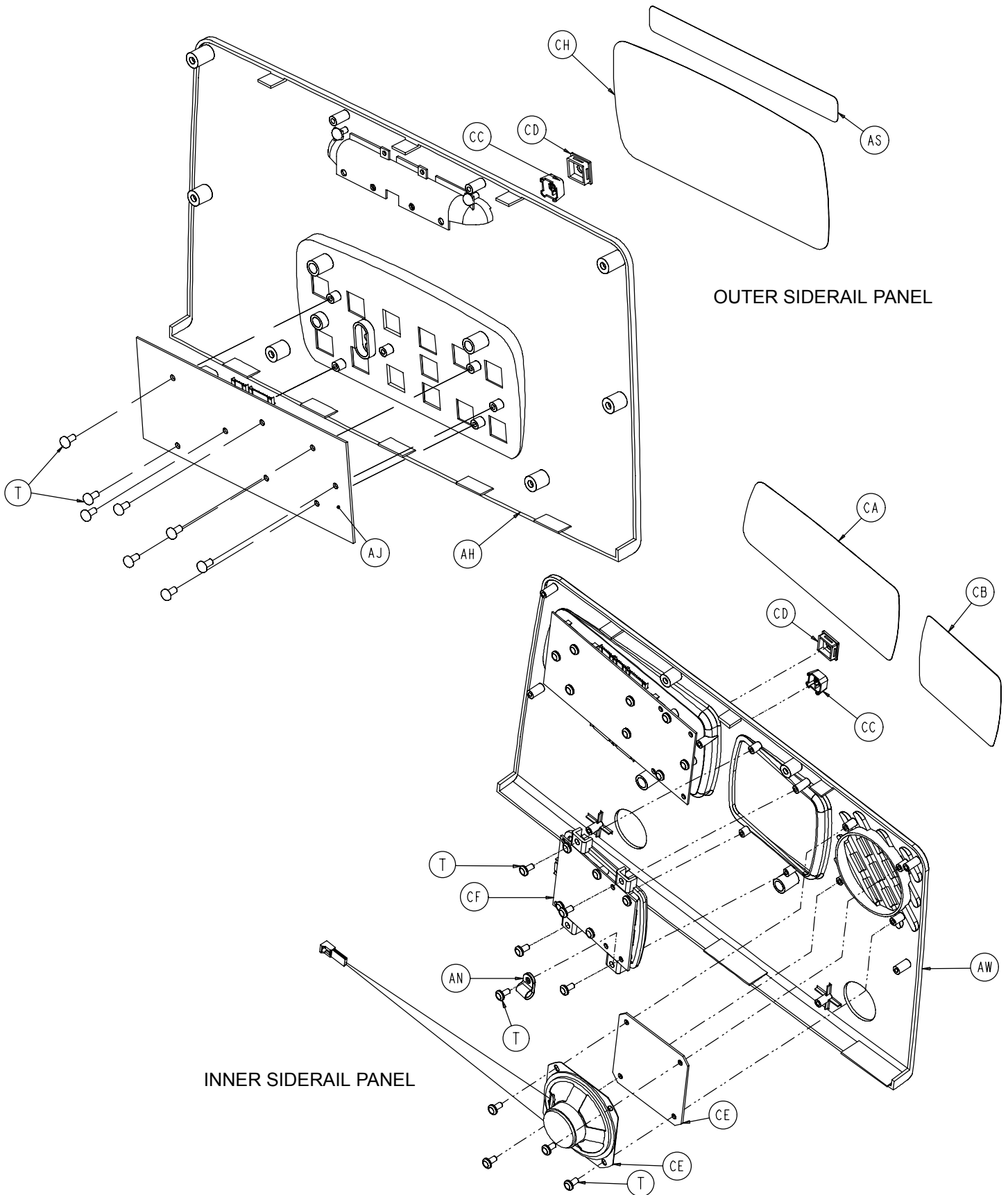

Head End Siderail Assembly

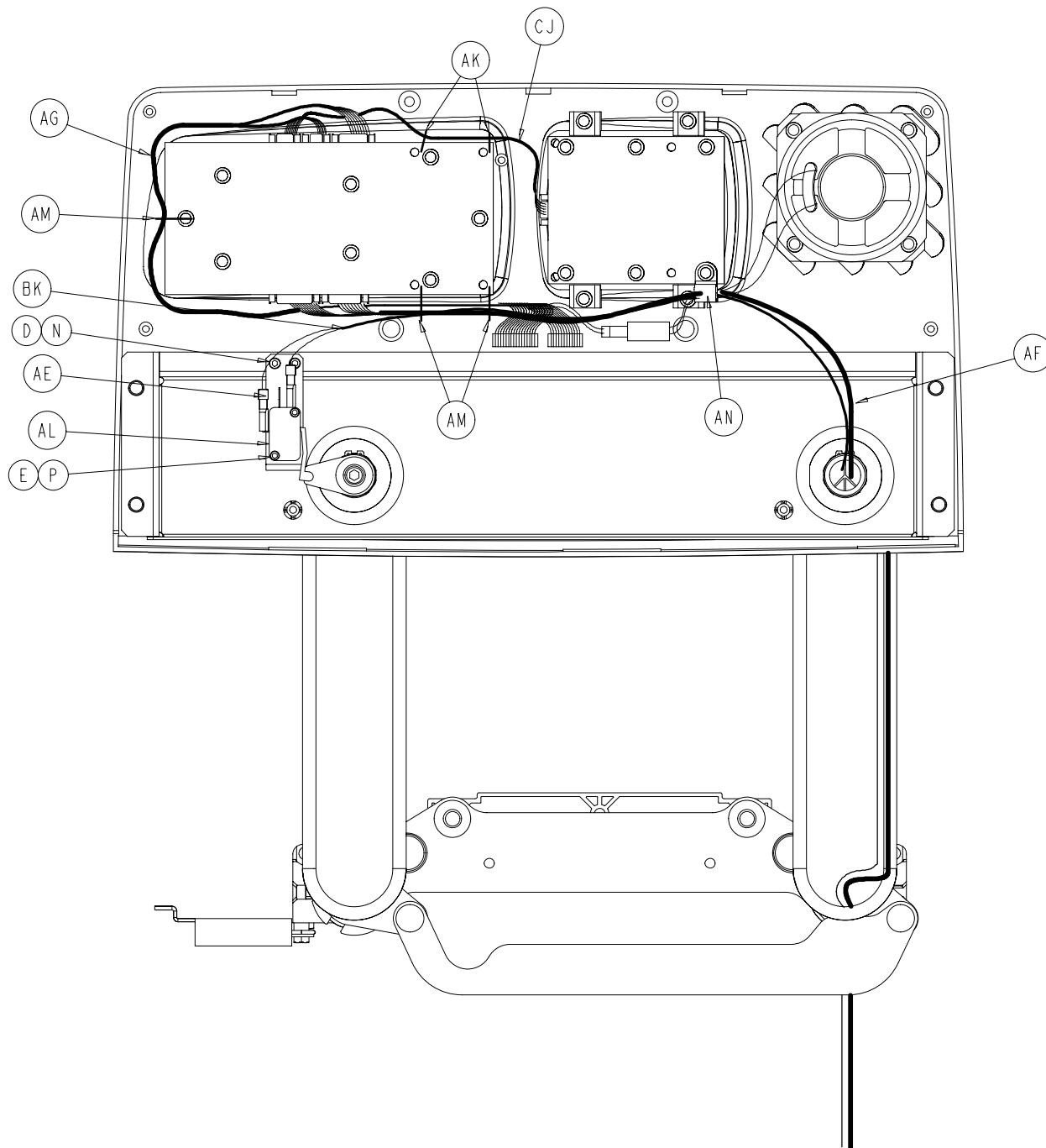

LEFT HEAD END SIDERAIL WIRE ROUTING

Head End Siderail Assembly

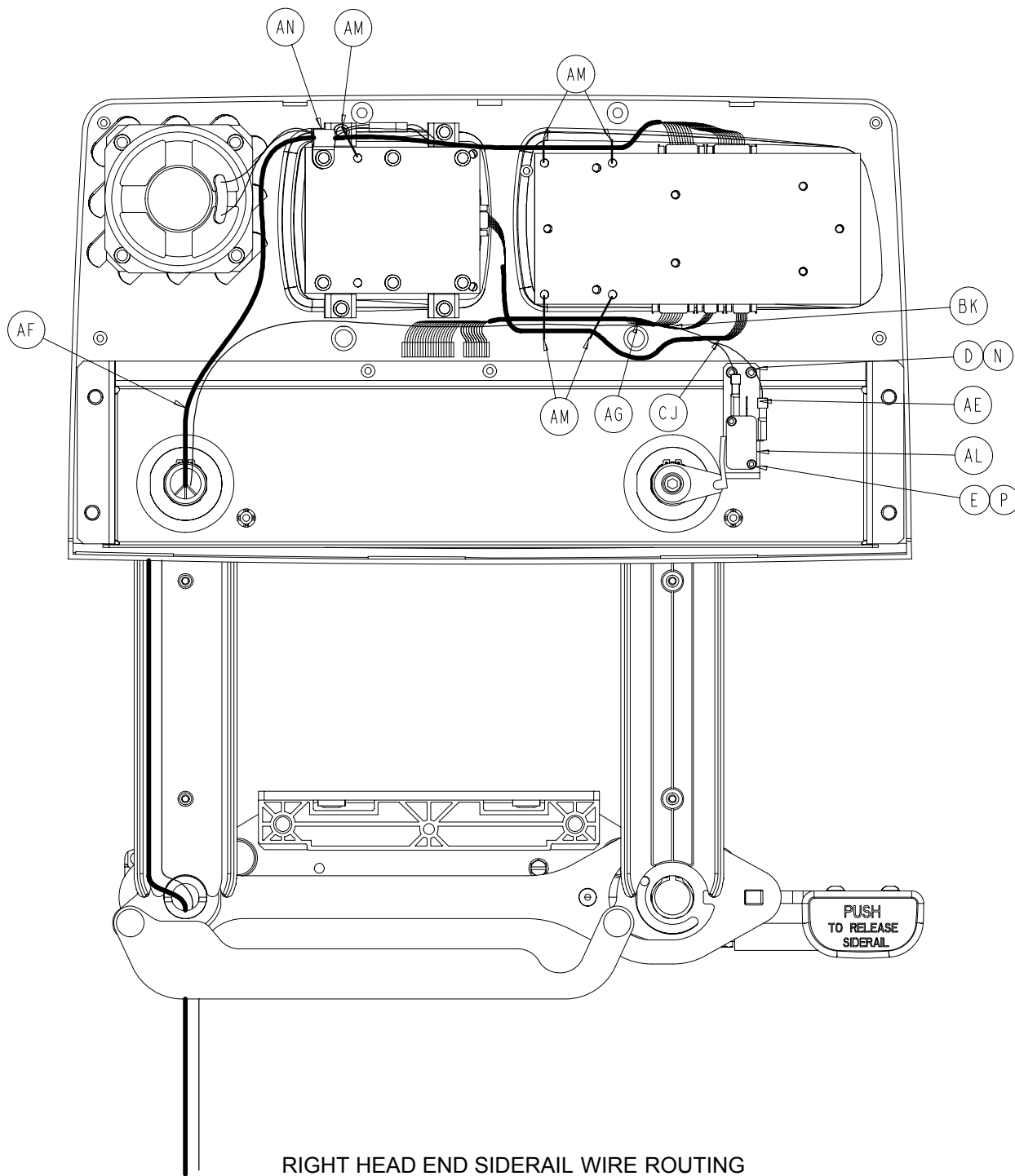

RIGHT HEAD END SIDERAIL WIRE ROUTING

Head End Siderail Assembly

2030-401-105 Left Standard Components

2030-401-205 Right Standard Components

Item	Part No.	Part Name	Qty.	Item	Part No.	Part Name	Qty.
A	3-226	Hex Washer Hd. Screw	4	A	3-226	Hex Washer Hd. Screw	4
B	3-344	Hex Hd. Screw	2	B	3-344	Hex Hd. Screw	2
C	4-9	Soc. Hd. Cap Screw	1	C	4-9	Soc. Hd. Cap Screw	1
D	4-101	Soc. Hd. Cap Screw	2	D	4-101	Soc. Hd. Cap Screw	2
E	4-127	Soc. Hd. Cap Screw	2	E	4-127	Soc. Hd. Cap Screw	2
F	(page 156)	Release Lever Ass'y, Left	1	F	(page 157)	Release Lever Ass'y, Right	1
G	11-343	Shim Washer	3	G	11-343	Shim Washer	3
H	11-377	Washer	2	H	11-377	Washer	2
J	11-491	Steel Shim Washer	2	J	11-491	Steel Shim Washer	2
K	13-10	Ext. Tooth Lock Washer	1	K	13-10	Ext. Tooth Lock Washer	1
L	14-93	Washer	2	L	14-93	Washer	2
N	16-23	Fiberlock Nut	2	N	16-23	Fiberlock Nut	2
P	16-69	Twin Fastener	1	P	16-69	Twin Fastener	1
R	23-88	High-Low Tapping Screw	1	R	23-88	High-Low Tapping Screw	1
S	23-90	High-Low Tapping Screw	8	S	23-90	High-Low Tapping Screw	8
T	23-112	High-Low Tapping Screw	16	T	23-112	High-Low Tapping Screw	16
U	1-72	Ph. Flat Hd. Mach. Screw	4	U	1-72	Ph. Flat Hd. Mach. Screw	4
W	(page 147)	Latch Ass'y, Head, Left	1	W	(page 148)	Latch Ass'y, Head, Right	1
X	28-128	Retaining Ring	6	X	28-128	Retaining Ring	6
Y	(page 149)	Detent Clip Assembly	1	Y	(page 149)	Detent Clip Assembly	1
AB	2030-401-127	Arm Wldmt., Lt., Hd., Ft.	1	AB	2030-401-227	Arm Wldmt., Rt., Hd., Ft.	1
AC	2035-20-60	Limit Switch Cam	1	AC	2035-20-60	Limit Switch Cam	1
AE	2035-20-62	Limit Switch Bracket	1	AE	2035-20-62	Limit Switch Bracket	1
AF	2035-20-802	Siderail Cable	1	AF	2035-20-802	Siderail Cable	1
AG	2035-20-804	Main Outside Cable, Lt.	1	AG	2035-20-803	Main Outside Cable, Rt.	1
AH	(page 151)	Outer Panel Assembly	1	AH	(page 151)	Outer Panel Assembly	1
AJ	2035-400-900	Outside Circuit Board	1	AJ	2035-400-900	Outside Circuit Board	1
AK	3000-200-334	Release Lever Spring	1	AK	3000-200-334	Release Lever Spring	1
AL	3000-300-41	Micro Switch	1	AL	3000-300-41	Micro Switch	1
AM	3000-300-114	Cable Tie	5	AM	3000-300-114	Cable Tie	5
AN	3000-300-478	CPR Conduit Clamp	1	AN	3000-300-478	CPR Conduit Clamp	1
AP	3000-400-513	Wear Bushing	2	AP	3000-400-513	Wear Bushing	2
AR	3000-400-523	Panel Spacer	2	AR	3000-400-523	Panel Spacer	2
AS	3000-400-556	Warning Label	1	AS	3000-400-556	Warning Label	1
AT	3000-400-557	Sleeve Bearing	4	AT	3000-400-557	Sleeve Bearing	4
AU	3001-400-11	Head End Timing Link	1	AU	3001-400-11	Head End Timing Link	1
AW	(page 150)	Inner Panel Assembly, Lt.	1	AW	(page 150)	Inner Panel Assembly, Rt.	1
AX	3001-401-128	Arm Wldmt., Lt., Hd., Hd.	1	AX	3001-401-228	Arm Wldmt., Rt., Hd., Hd.	1
AZ	3001-400-501	Linkage Rivet	2	AZ	3001-400-501	Linkage Rivet	2
BC	3001-400-515	Head Rail	1	BC	3001-400-515	Head Rail	1
BD	3001-400-555	Mounting Bracket	1	BD	3001-400-555	Mounting Bracket	1
BE	3001-400-558	Siderail Spacer	4	BE	3001-400-558	Siderail Spacer	4
BF	2030-400-570	Glide Rod	2	BF	2030-400-570	Glide Rod	2
BJ	3002-400-505	Bypass Pin	1	BJ	3002-400-505	Bypass Pin	1
BM	3002-400-511	Glide Rod Bumper Pad	1	BM	3002-400-511	Glide Rod Bumper Pad	1
BN	3002-400-512	Bumper Washer	2	BN	3002-400-512	Bumper Washer	2
BP	3002-400-513	Pivot Bushing	6	BP	3002-400-513	Pivot Bushing	6
BR	3002-400-519	Latch Bushing	1	BR	3002-400-519	Latch Bushing	1
BT	3002-400-528	Carrier	1	BT	3002-400-528	Carrier	1
BU	5000-20-5	Inner Arm Cover	2	BU	5000-20-5	Inner Arm Cover	2
BW	3001-400-619	Outer Arm Cover	2	BW	3001-400-619	Outer Arm Cover	2
BX	30-40	Grommet	2	BX	30-40	Grommet	2

Head End Siderail Assembly

2030-20-11 Standard Siderail

Item	Part No.	Part Name	Qty.
CA	2035-000-100	Label, Standard, Left	1
CA	2035-000-200	Label, Standard, Right	1
CC	3001-400-953	Switch Cap	28
CD	3001-400-522	Filler Cap	18
CE	3001-400-517	Speaker Seal	2
CF	3001-400-535	Inner Panel Blank Module	2
CH	2030-000-300	Label, Standard, Left	1
CH	2030-000-400	Label, Standard, Right	1

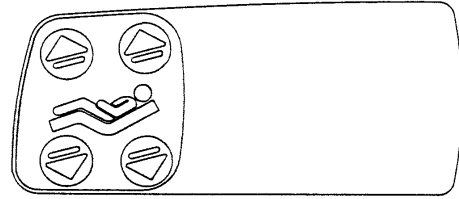

Right Inner Siderail Label

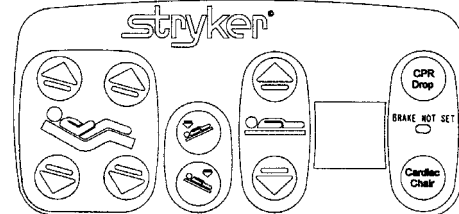

Right Outer Siderail Label

2030-20-12 Standard Siderail with Nurse Call

Item	Part No.	Part Name	Qty.
CA	2035-000-101	Label, Standard, NC, Left	1
CA	2035-000-201	Label, Standard, NC, Right	1
CC	3001-400-953	Switch Cap	32
CD	3001-400-522	Filler Cap	14
CE	3001-403-831	Speaker with Cable	2
CF	3001-400-535	Inner Panel Blank Module	2
CH	2030-000-301	Label, Standard, NC, Left	1
CH	2030-000-401	Label, Standard, NC, Right	1

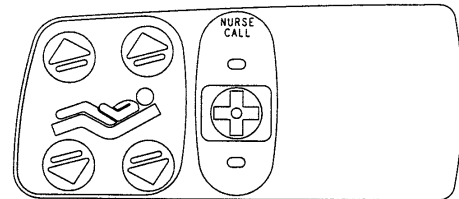

Right Inner Siderail Label

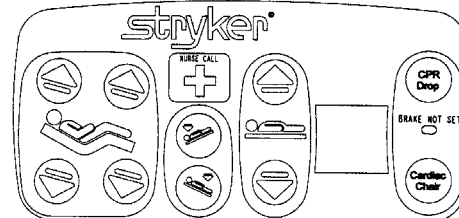

Right Outer Siderail Label

2030-20-15 Standard Siderail w/NC & Comm.

Item	Part No.	Part Name	Qty.
CA	2035-000-102	Label, Standard, Left	1
CA	2035-000-202	Label, Standard, Right	1
CC	3001-400-953	Switch Cap	42
CD	3001-400-522	Filler Cap	4
CE	3001-403-831	Speaker with Cable	2
CF	3001-400-535	Inner Panel Blank Module	2
CH	2030-000-301	Label, Standard, NC, Lt.	1
CH	2030-000-401	Label, Standard, NC, Rt.	1

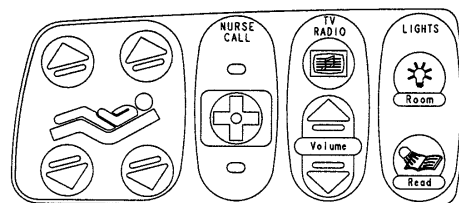

Right Inner Siderail Label

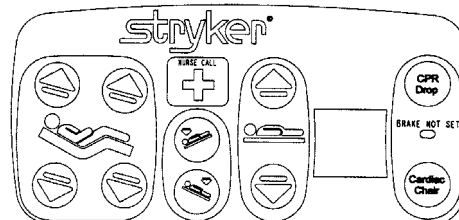

Right Outer Siderail Label

3002-400-70 Head End Siderail Latch Assembly, Left

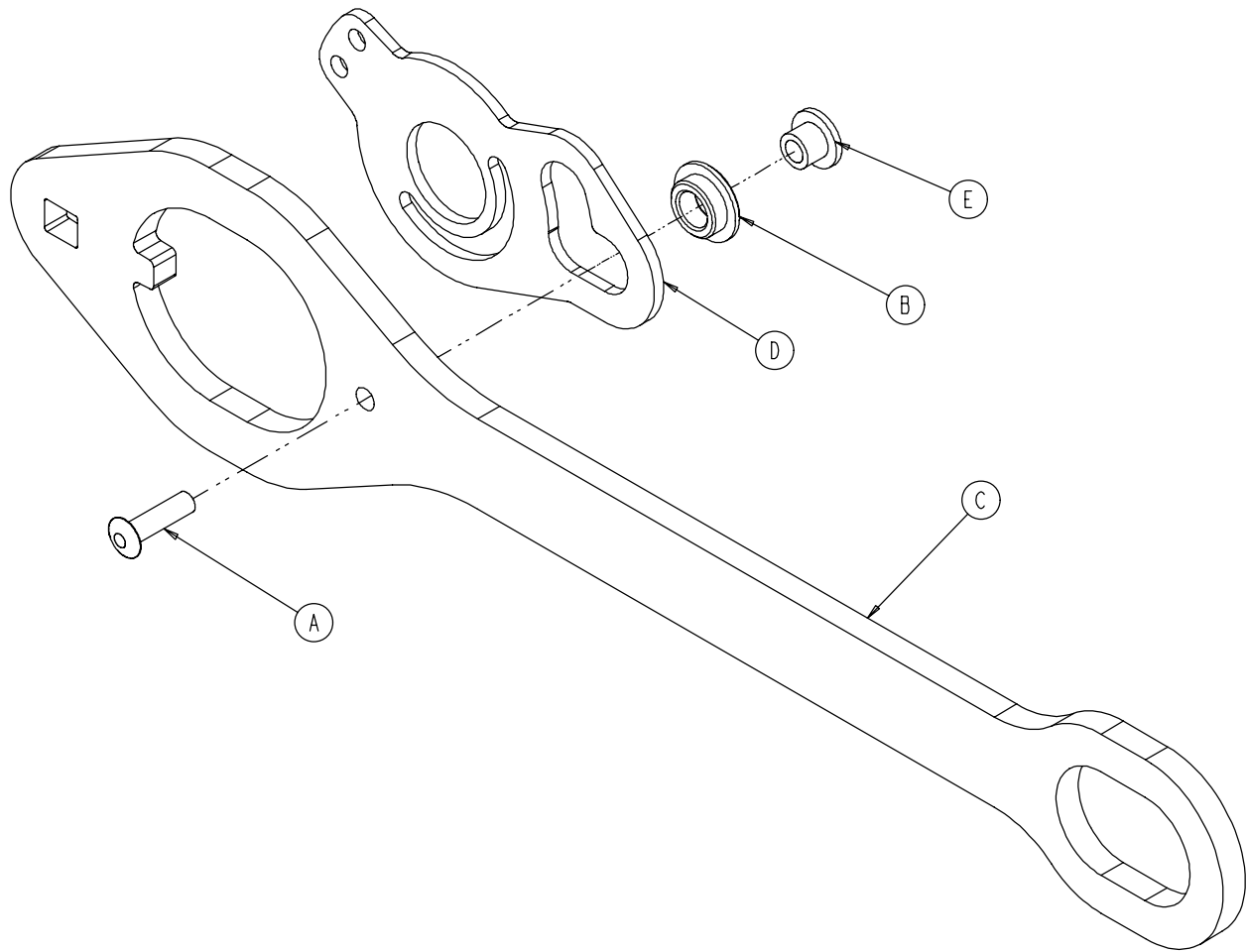

Item	Part No.	Part Name	Qty.
A	25-86	Blind Rivet	1
B	81-317	Bronze Bushing	1
C	3002-400-501	Latch	1
D	3002-400-503	Head End Bypass Plate	1
E	3002-400-509	Bypass Bushing Spacer	1

3002-400-75 Head End Siderail Latch Assembly, Right

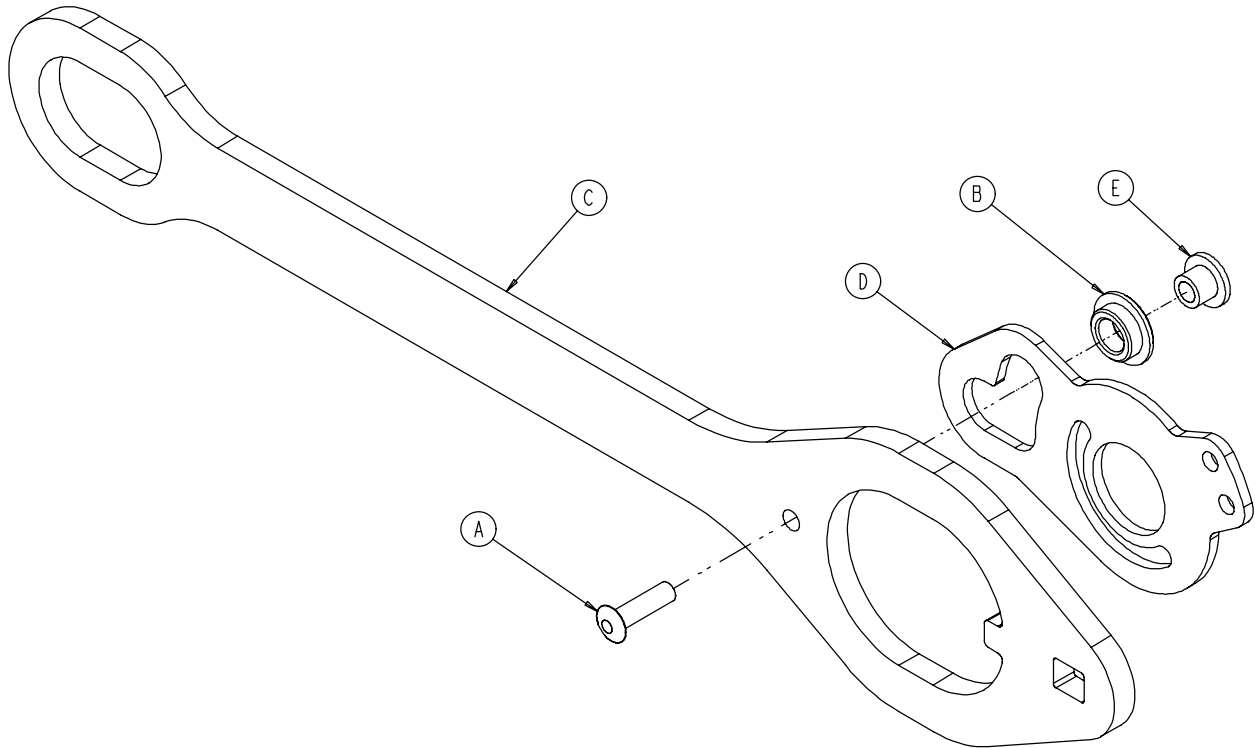

Item	Part No.	Part Name	Qty.
A	25-86	Blind Rivet	1
B	81-317	Bronze Bushing	1
C	3002-400-501	Latch	1
D	3002-400-503	Head End Bypass Plate	1
E	3002-400-509	Bypass Bushing Spacer	1

Siderail Bypass Detent Clip Assembly

Assembly part number 3002-400-90 (reference only)

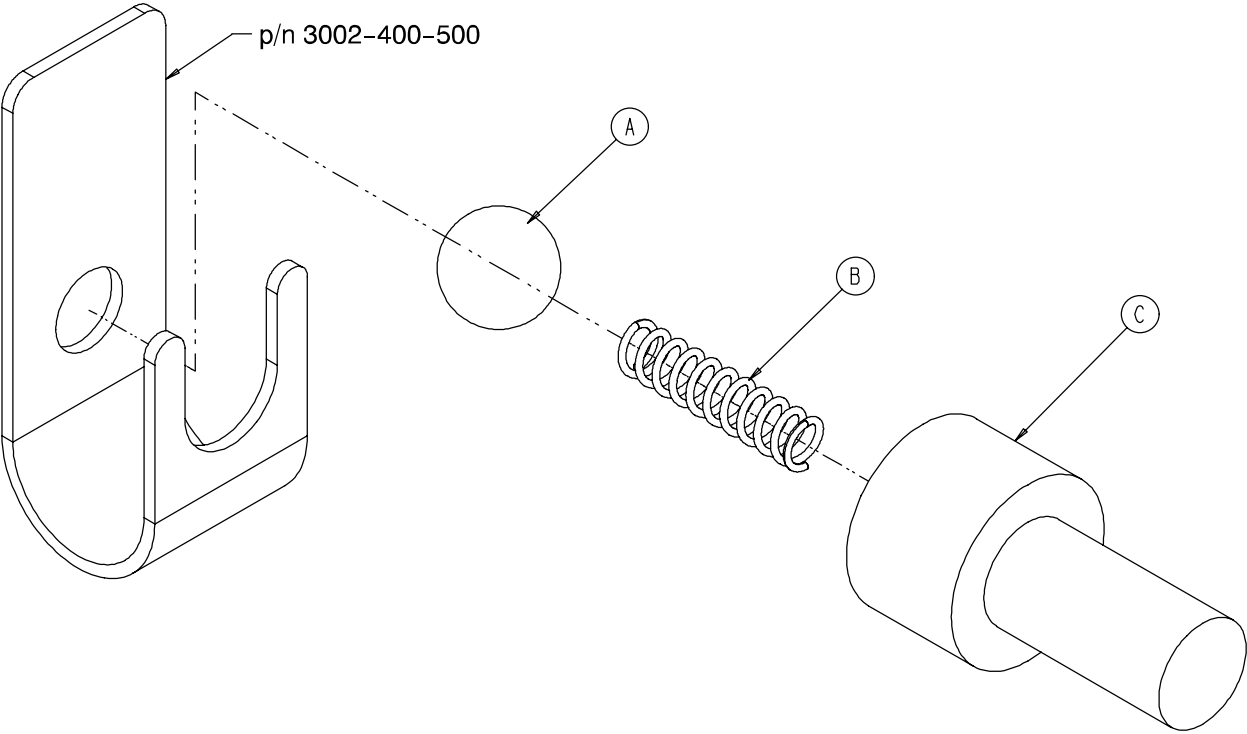

Item	Part No.	Part Name	Qty.
A	31-137	Steel Ball	1
B	38-464	Compression Spring	1
C	3002-400-524	Bypass Detent Housing	1

Head End Siderail Inner Panel Assembly

Assembly part numbers
3001-400-40 (Left) &
3001-400-45 (Right)
(reference only)

(Left Side is Shown)

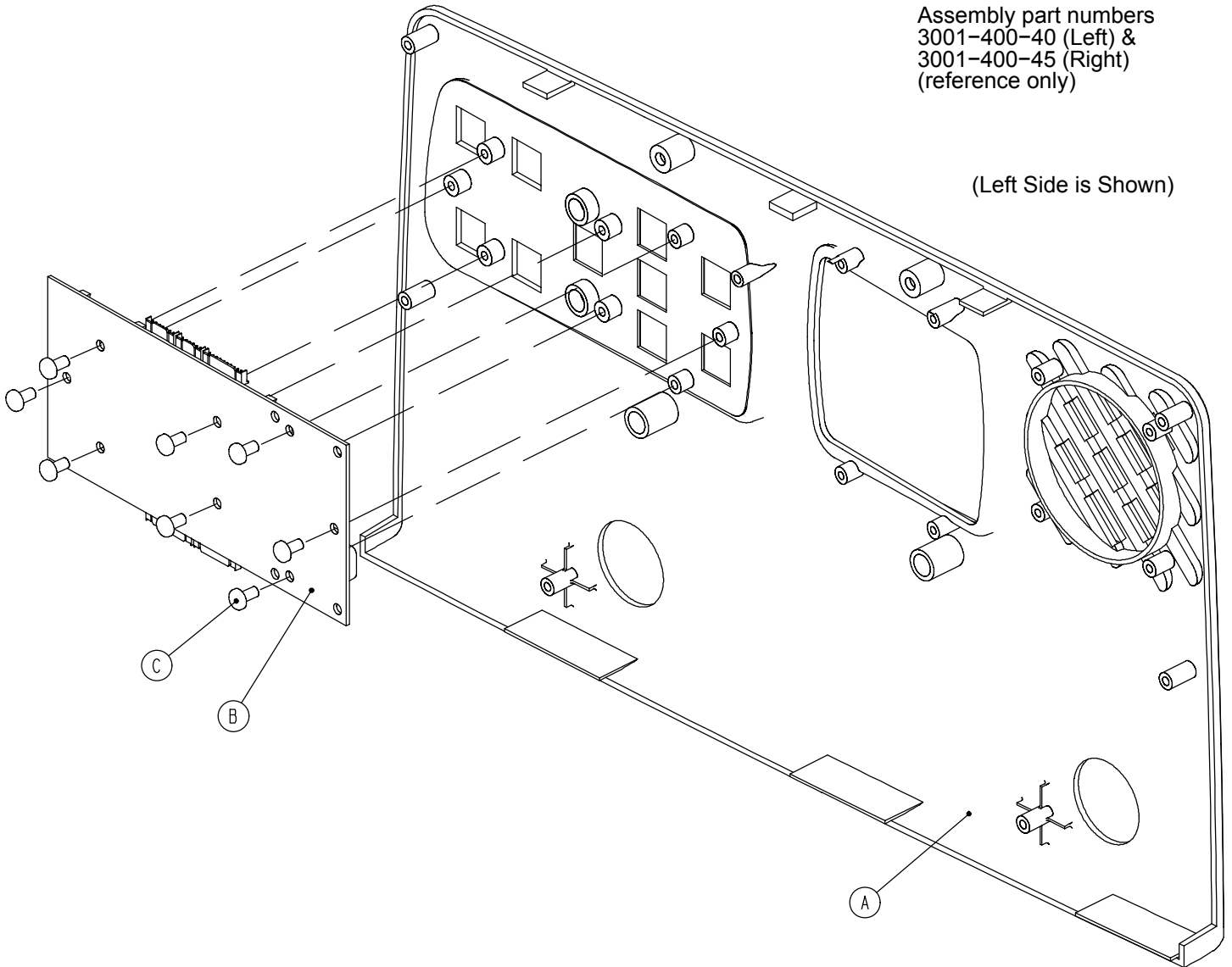

Item	Part No.	Part Name	Qty.
A	3001-400-101	Left Inner Panel	1
	3001-400-201	Right Inner Panel	1
B	3001-400-900	Inner Siderail PCB Assembly	1
C	23-112	Hi-Low Tapping Screw	8

Head End Siderail Outer Panel Assembly

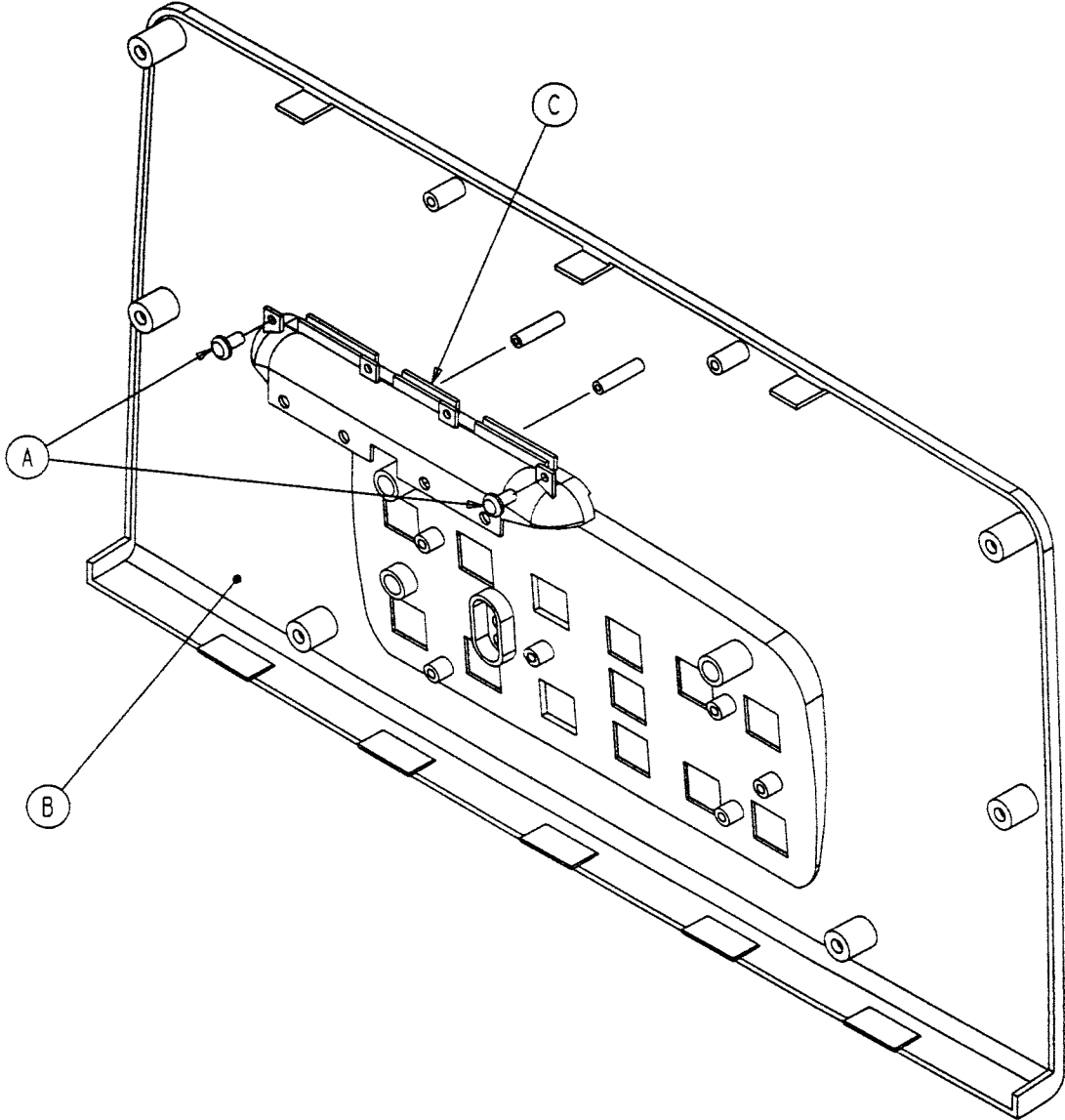

Item	Part No.	Part Name	Qty.
A	23-112	Hi-Low Tapping Screw	2
B	2035-400-102	Outer Panel	1
C	3001-400-599	Handle Insert	1

Foot End Siderail Assembly

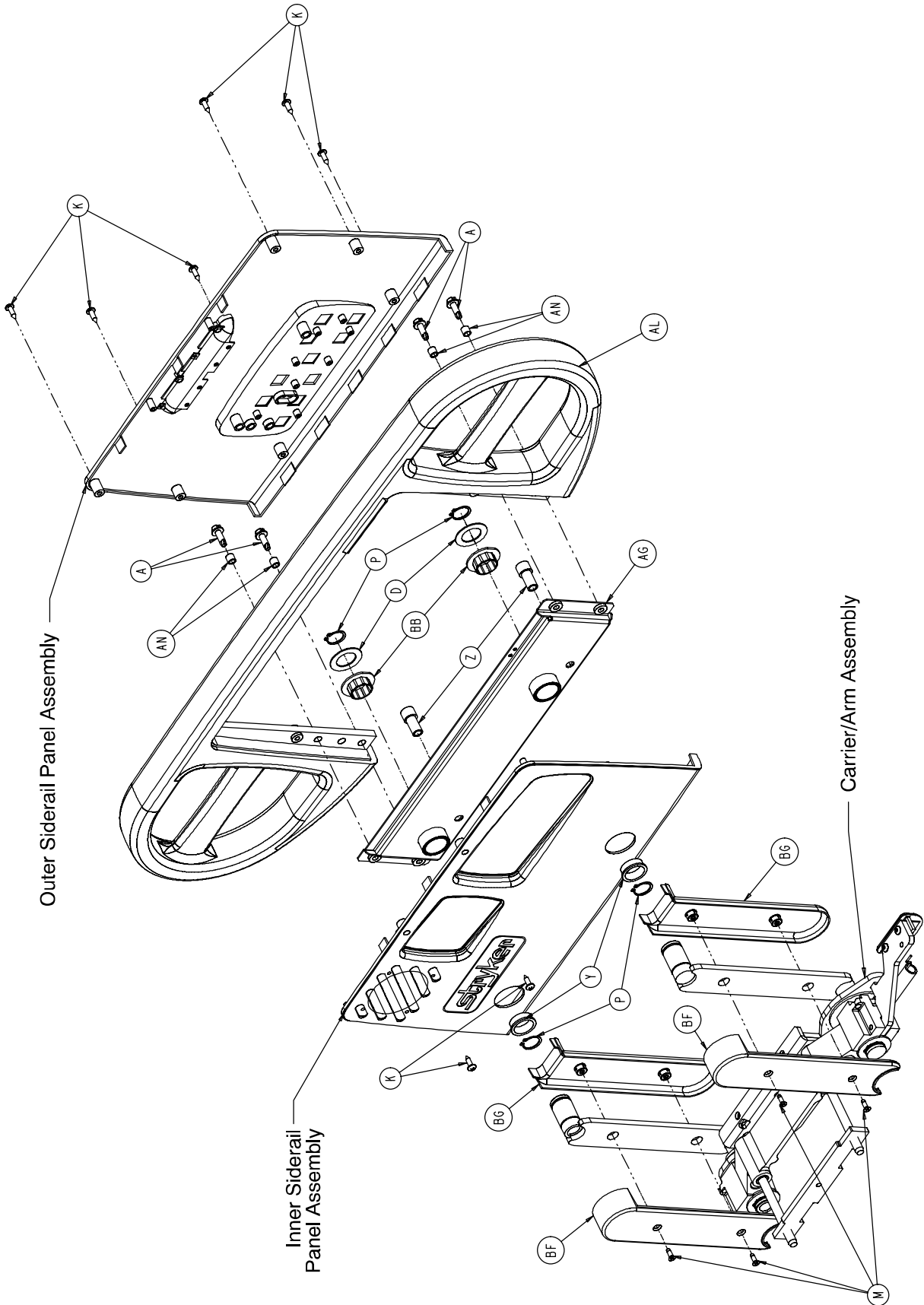

Foot End Siderail Assembly

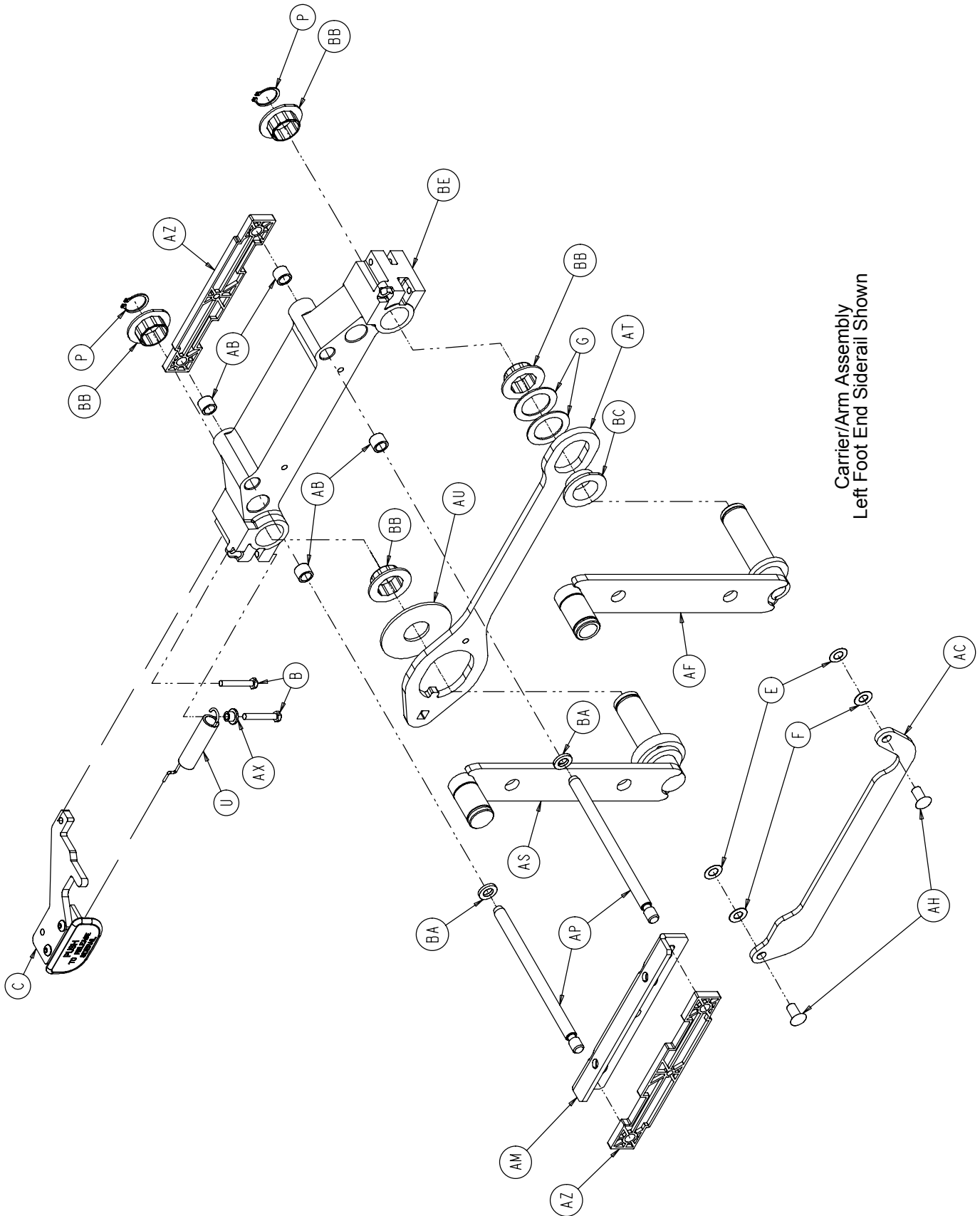

Carrier/Arm Assembly
Left Foot End Siderail Shown

Foot End Siderail Assembly

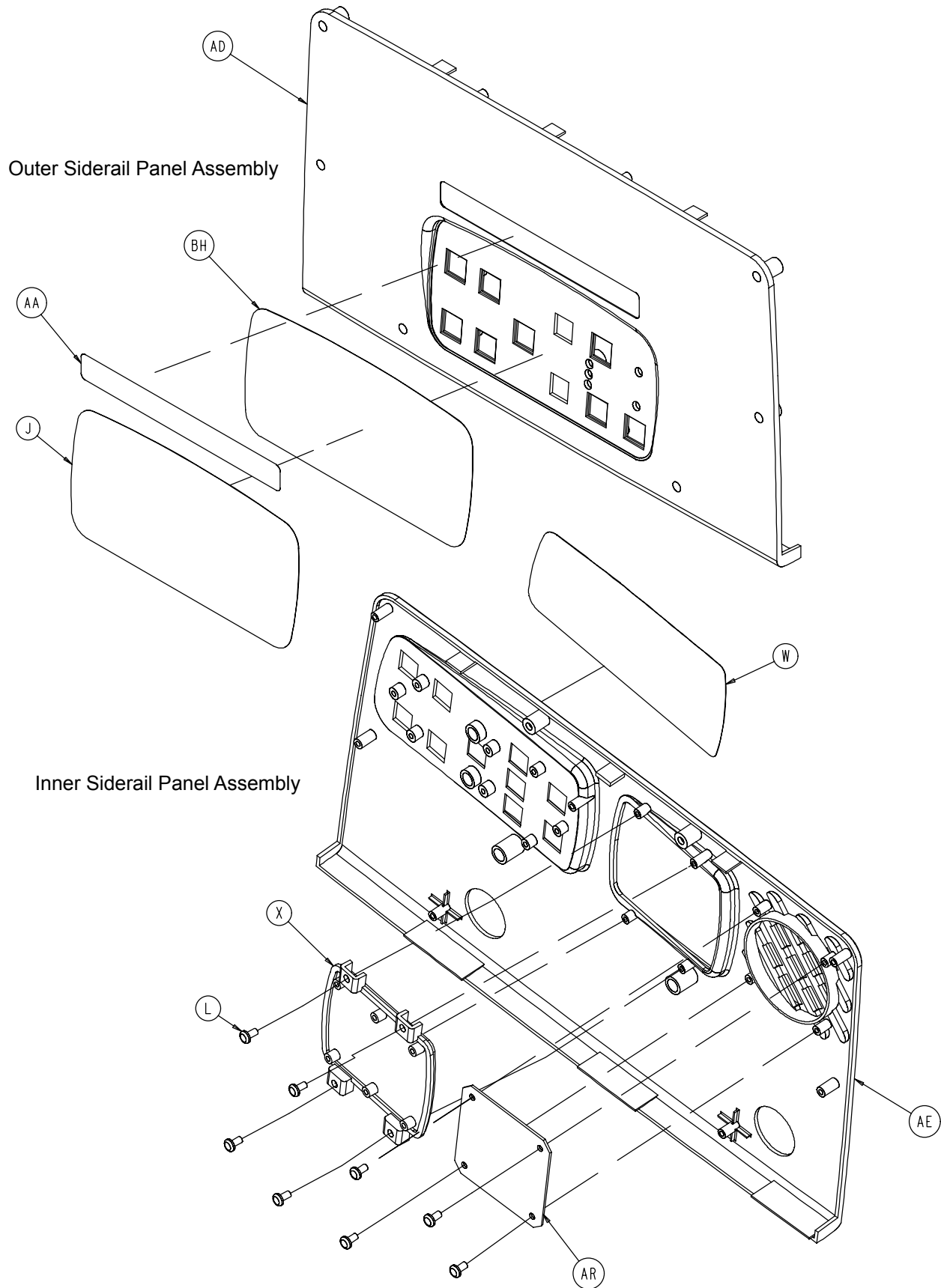

Foot End Siderail Assembly

2030-401-305 Left Common Components

2030-401-405 Right Common Components

Item	Part No.	Part Name	Qty.	Item	Part No.	Part Name	Qty.
A	3-226	Hex Washer Hd. Screw	4	A	3-226	Hex Washer Hd. Screw	4
B	3-344	Hex Hd. Cap Screw	2	B	3-344	Hex Hd. Cap Screw	2
C	(page 156)	Release Lever Ass'y, Lt.	1	C	(page 157)	Release Lever Ass'y, Rt.	1
D	11-343	Shim Washer	2	D	11-343	Shim Washer	2
E	11-377	Washer	2	E	11-377	Washer	2
F	11-491	Steel Shim Washer	2	F	11-491	Steel Shim Washer	2
G	14-93	Washer	2	G	14-93	Washer	2
J	2030-231-8	Outside Label	1	J	2030-231-8	Outside Label	1
K	23-90	Pan Hd. Tapping Screw	8	K	23-90	Pan Hd. Tapping Screw	8
L	23-112	Pan Hd. High-Low Tap. Scr.	8	L	23-112	Pan Hd. High-Low Tap. Scr.	8
M	1-72	Ph. Flat Hd. Mach. Screw	4	M	1-72	Ph. Flat Hd. Mach. Screw	4
P	28-128	Retaining Ring	6	P	28-128	Retaining Ring	6
U	3000-200-334	Extension Spring	1	U	3000-200-334	Extension Spring	1
W	3001-445-621	Blank Label, Left	1	W	3001-445-611	Blank Label, Right	1
X	3001-400-535	Inner Panel Blank Module	1	X	3001-400-535	Inner Panel Blank Module	1
Y	3000-400-513	Wear Bushing	2	Y	3000-400-513	Wear Bushing	2
Z	3000-400-523	Panel Spacer	2	Z	3000-400-523	Panel Spacer	2
AA	3000-400-556	Warning Label	1	AA	3000-400-556	Warning Label	1
AB	3000-400-557	Sleeve Bearing	4	AB	3000-400-557	Sleeve Bearing	4
AC	3001-400-11	Head End Timing Link	1	AC	3001-400-11	Head End Timing Link	1
AD	3001-400-50	Outer Siderail Panel	1	AD	3001-400-50	Outer Siderail Panel	1
AE	3001-400-101	Inner Siderail Panel, Left	1	AE	3001-400-201	Inner Siderail Panel, Right	1
AF	3001-401-228	Arm Weldment, Rt., Hd., Hd.	1	AF	3001-401-128	Arm Weldment, Lt., Hd., Hd.	1
AG	3001-400-130	Supt. Wldmt., Head, Left	1	AG	3001-400-230	Supt. Wldmt., Head, Right	1
AH	3001-400-501	Siderail Linkage Rivet	2	AH	3001-400-501	Siderail Linkage Rivet	2
AL	3001-400-515	Head Rail	1	AL	3001-400-515	Head Rail	1
AM	3001-400-555	Mounting Bracket	1	AM	3001-400-555	Mounting Bracket	1
AN	3001-400-558	Siderail Spacer	4	AN	3001-400-558	Siderail Spacer	4
AP	3001-400-564	Glide Rod	2	AP	3001-400-564	Glide Rod	2
AR	3001-400-517	Speaker Seal	1	AR	3001-400-517	Speaker Seal	1
AS	2030-401-327	Arm Wldmt., Lt., Ft., Ft.	1	AS	2030-401-427	Arm Wldmt., Rt., Ft., Ft.	1
AT	3002-400-501	Latch	1	AT	3002-400-501	Latch	1
AU	11-185	Washer	1	AU	11-185	Washer	1
AW	3002-400-505	Bypass Pin	1	AW	3002-400-505	Bypass Pin	1
AX	3002-400-509	Bypass Bushing Spacer	1	AX	3002-400-509	Bypass Bushing Spacer	1
AZ	3002-400-511	Glide Rod Bumper Pad	2	AZ	3002-400-511	Glide Rod Bumper Pad	2
BA	3002-400-512	Bumper Washer	2	BA	3002-400-512	Bumper Washer	2
BB	3002-400-513	Pivot Bushing	6	BB	3002-400-513	Pivot Bushing	6
BC	3002-400-519	Latch Bushing	1	BC	3002-400-519	Latch Bushing	1
BE	3002-400-528	Siderail Carrier	1	BE	3002-400-528	Siderail Carrier	1
BF	5000-20-5	Inner Arm Cover	2	BF	5000-20-5	Inner Arm Cover	2
BG	3001-400-619	Outer Arm Cover	2	BG	3001-400-619	Outer Arm Cover	2
BH	2030-231-9	Blank Backing Label	1	BH	2030-231-9	Blank Backing Label	1

3002-400-55 Siderail Release Lever Assembly, Left

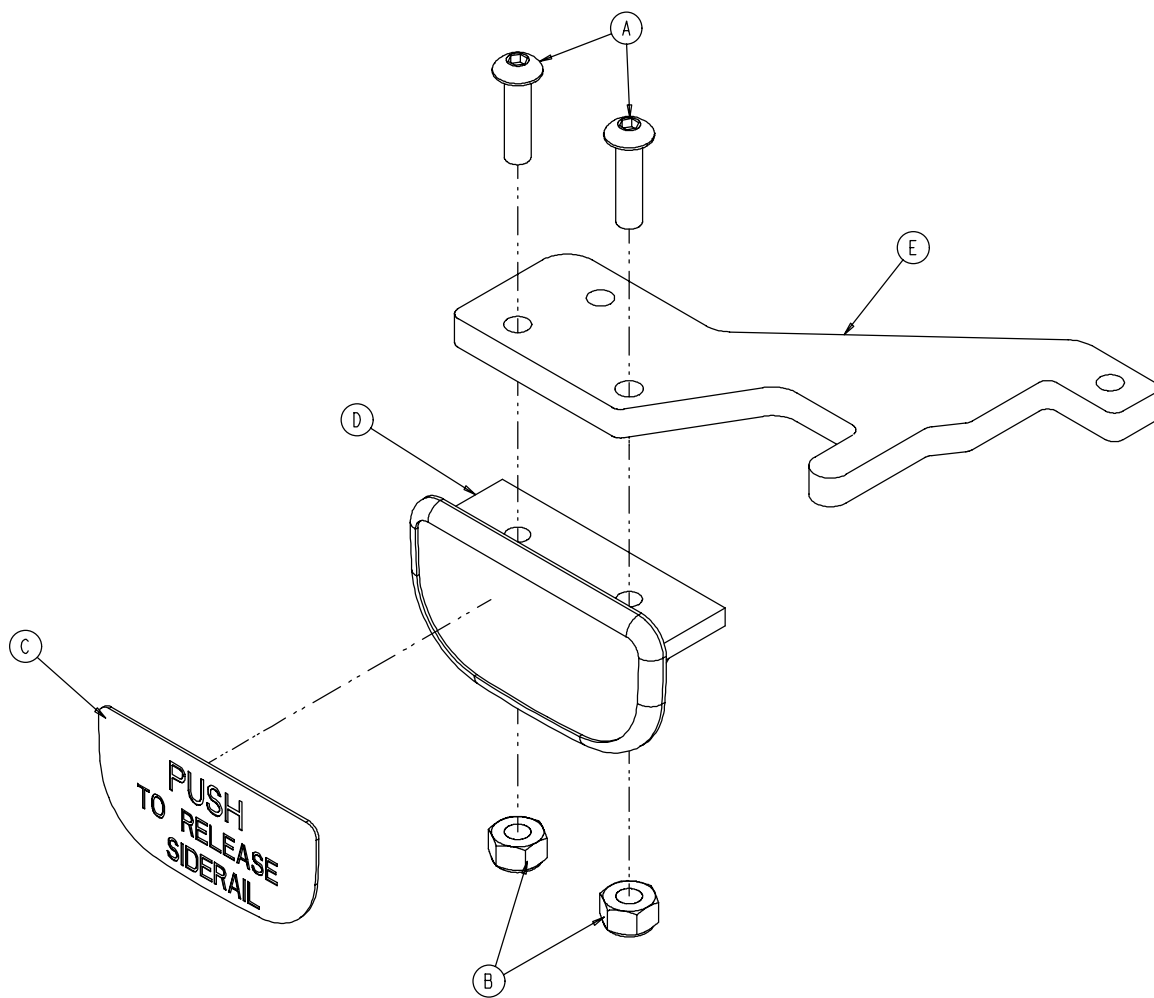

Item	Part No.	Part Name	Qty.
A	4-278	Socket But. Hd. Cap Screw	2
B	16-2	Hex Nut	2
C	3001-400-505	Release Label	1
D	3001-400-514	Release Lever Pad	1
E	3002-400-510	Release Lever	1

3002-400-65 Siderail Release Lever Assembly, Right

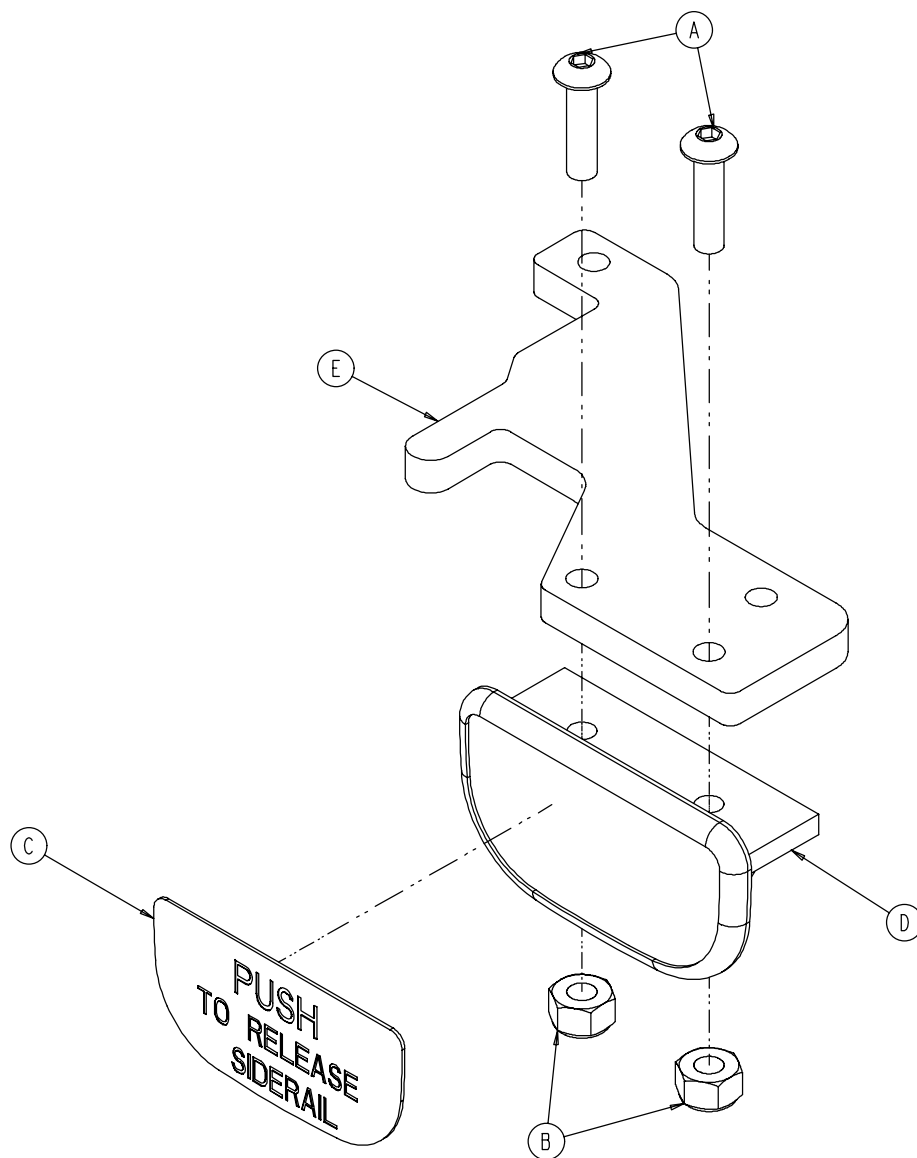

Item	Part No.	Part Name	Qty.
A	4-278	Socket But. Hd. Cap Screw	2
B	16-2	Hex Nut	2
C	3001-400-505	Release Label	1
D	3001-400-514	Release Lever Pad	1
E	3002-400-510	Release Lever	1

2035-130-10 Head Board Assembly

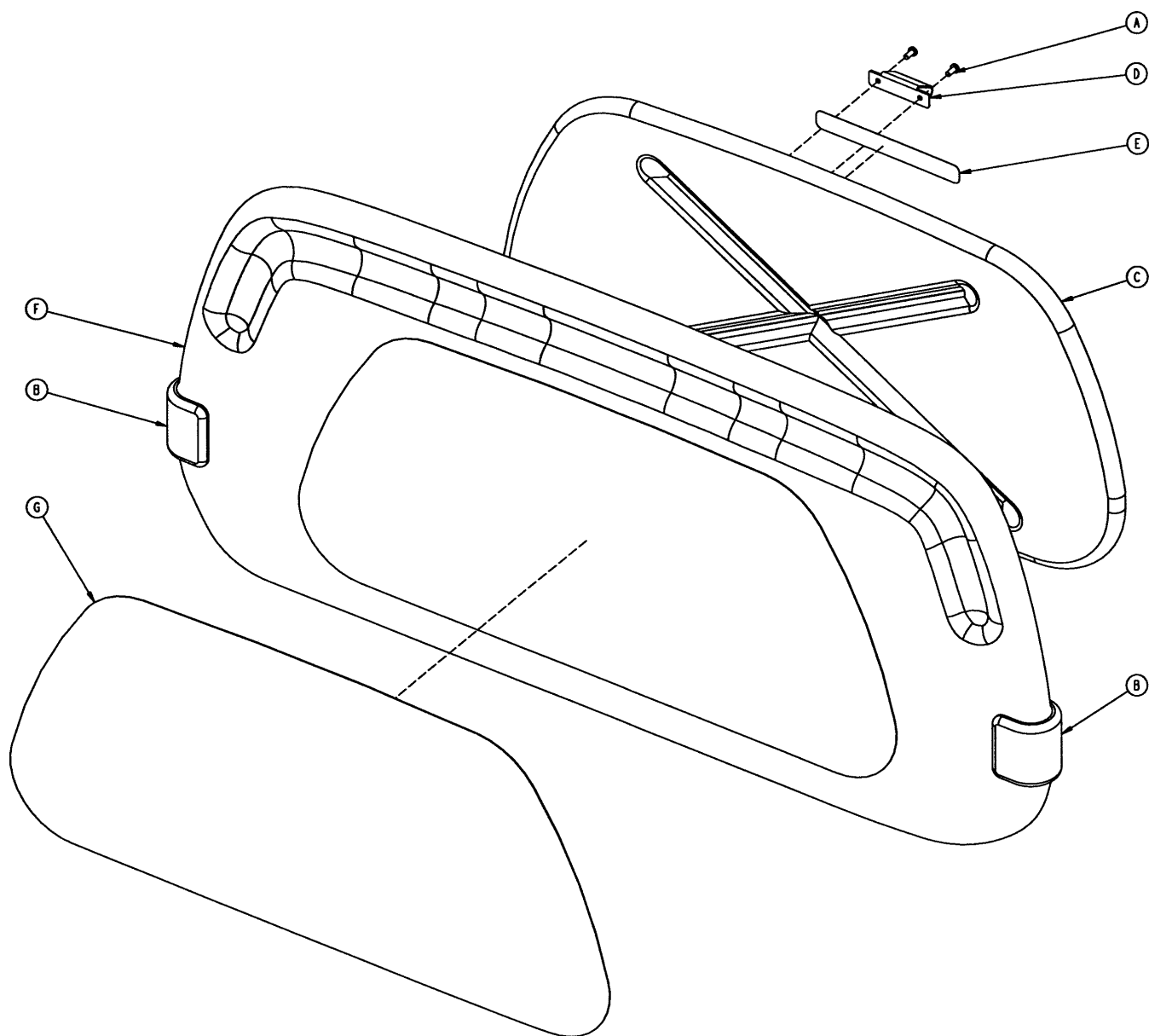

Item	Part No.	Part Name	Qty.
A	23-88	Pan Hd. Screw	2
B	2035-500-7	Dark Blue "C" Bumper	2
C	3000-526-1	CPR Board	1
D	3000-526-2	CPR Board Clip	1
E	3000-526-3	CPR Board Label	1
F	3000-600-10	Head Board Clam Shell Ass'y	1
G	3000-600-56	Beige Head Board Laminate	1
H	72-2-71	"C" Bumper Adhesive	N/A

Foot Board Assembly and Options

part number 2030-000-151

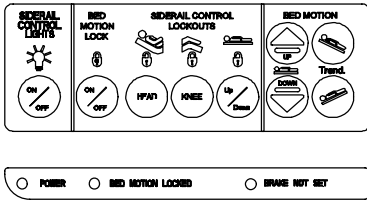

part number 2035-000-153

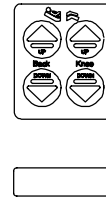

part number 2035-000-155

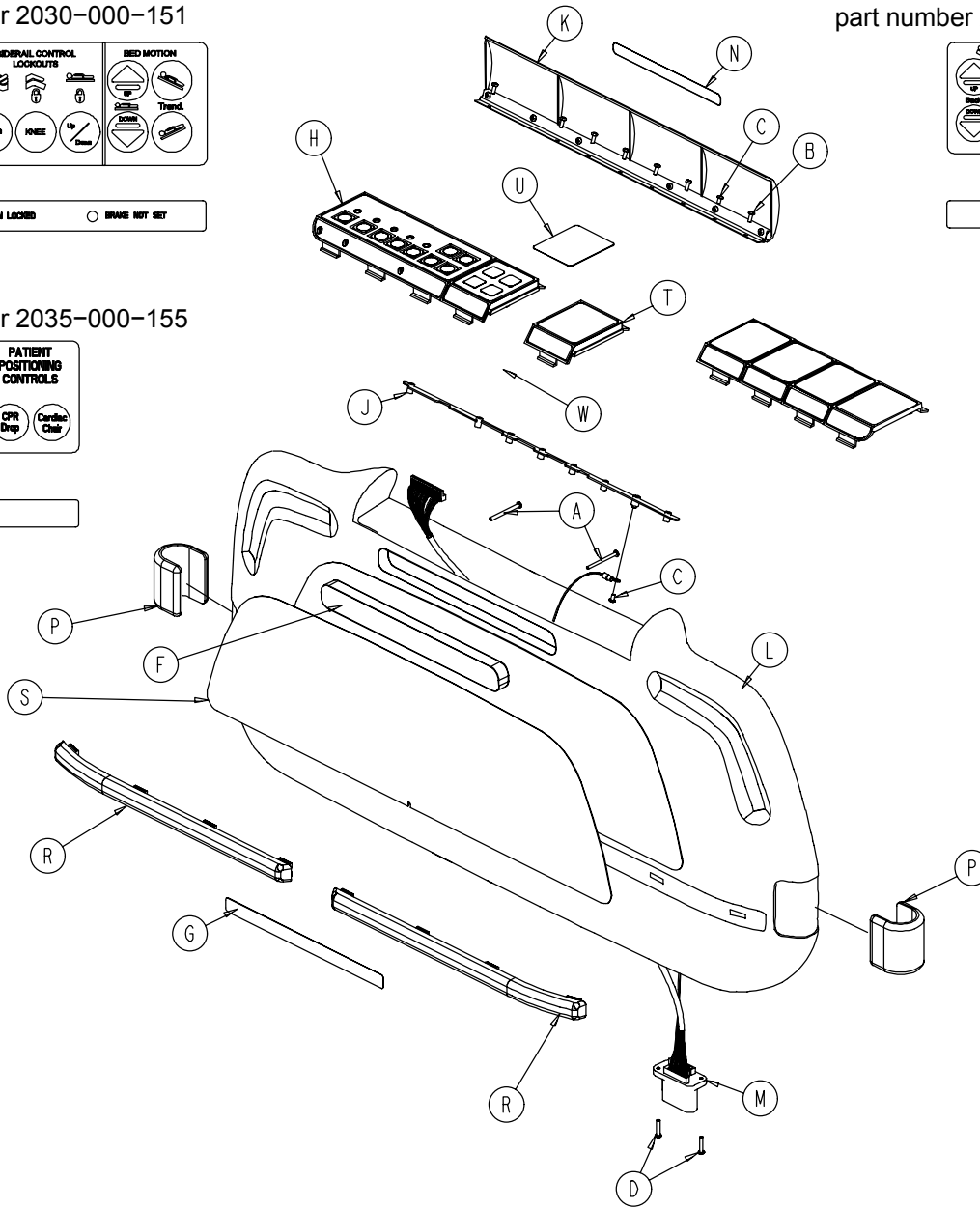
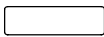
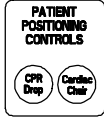

2030-135-10 Foot Board Standard Components

Item	Part No.	Part Name	Qty.	Item	Part No.	Part Name	Qty.
A	23-99	Phil. Pan Hd. Tap. Screw	2	L	3001-500-10	Clamshell Assembly	1
B	23-103	Pan Hd. Hi/Lo Tap. Screw	7	M	3001-500-801	Foot Board Drawer Cable	1
C	50-38	Pan Hd. Mach. Screw	2	N	3000-500-25	Lid Label	1
D	50-39	Pan Hd. Mach. Screw	2	P	2035-500-7	Blue "C" Bumper	2
E	72-2-71	"C" Bumper Adhesive	.30	R	2035-500-8	Strip Bumper	2
F	3000-500-8	Chart Rack Cover	1	S	3000-500-56	Beige Laminate	1
G	3000-500-29	Hazard Label	1	T	(page 167)	E-Drop/Card. Ch. Module	1
H	(page 166)	Main Module	1	U	2035-000-155	E-Drop/Card. Ch. Label	1
J	3001-500-64	Hinge Plate	1	W	2025-136-801	E-Drop/Card. Ch. Cable	1
K	3001-500-1	Lid Assembly	1				

Foot Board Assembly and Options

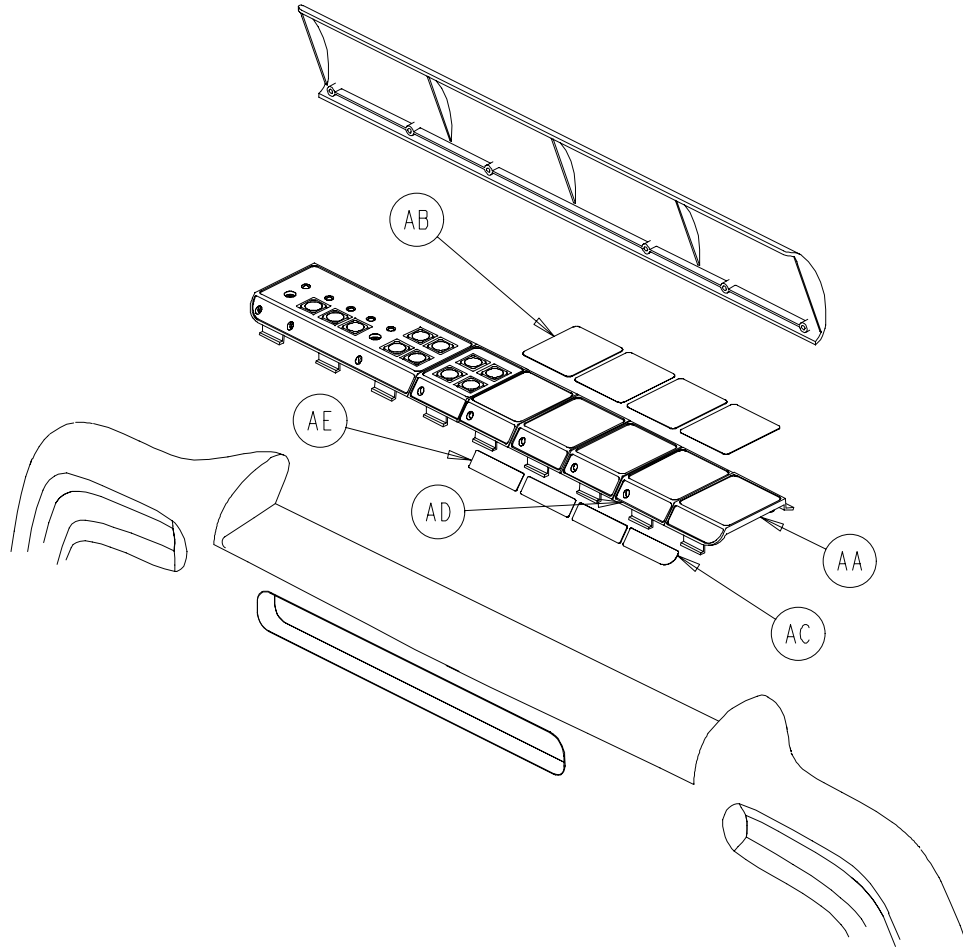

2030-135-11 Foot Board No Scale/No Bed Exit Option

Item	Part No.	Part Name	Qty.
AA	3000-500-4	End Module	1
AB	2035-500-101	Foot Board Blank Label	4
AC	3000-500-27	Blank End Label	1
AD	3001-500-3	Blank Module	3
AE	3000-500-26	Blank Module Label	3

Foot Board Assembly and Options

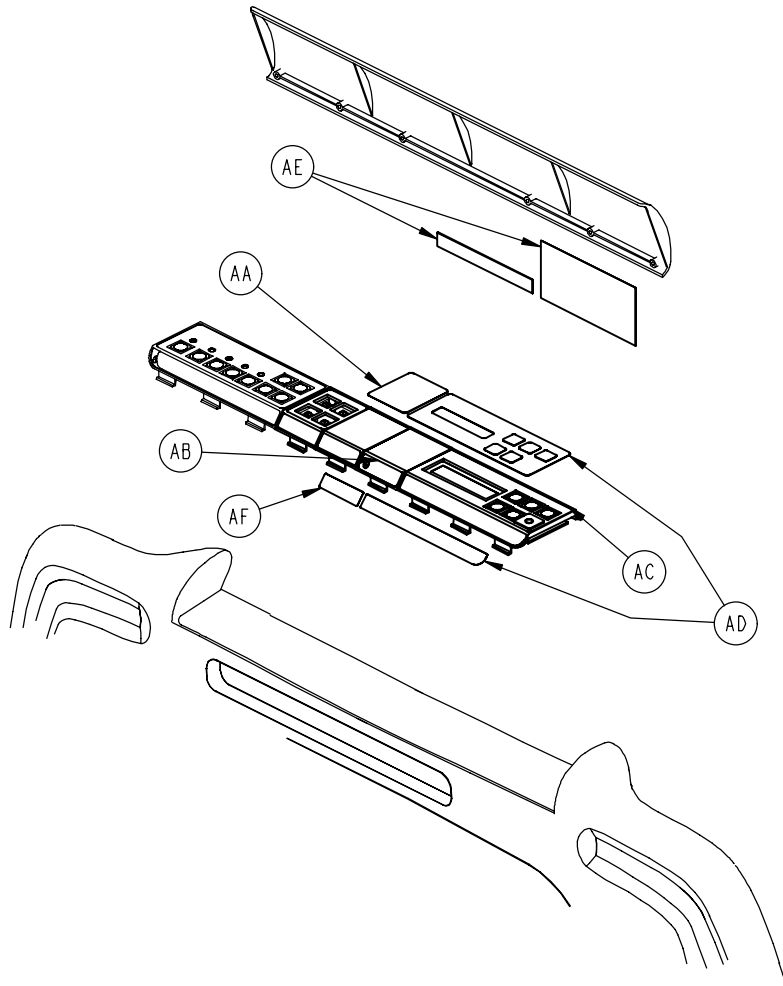

part number 2030-000-902

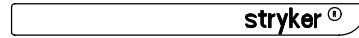
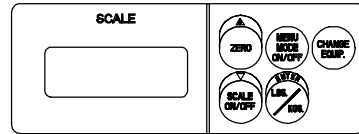

2030-15-13 Foot Board Scale Option

Item	Part No.	Part Name	Qty.
AA	2035-500-101	Foot Board Blank Label	1
AB	3001-500-3	Blank Module	1
AC	(page 170)	Scale Module Assembly	1
AD	2030-000-902	Scale Module Label	1
AE	3002-507-11	Scale Lid Label	1
AF	3000-500-26	Blank Label	1

Foot Board Assembly and Options

part number 2030-000-154

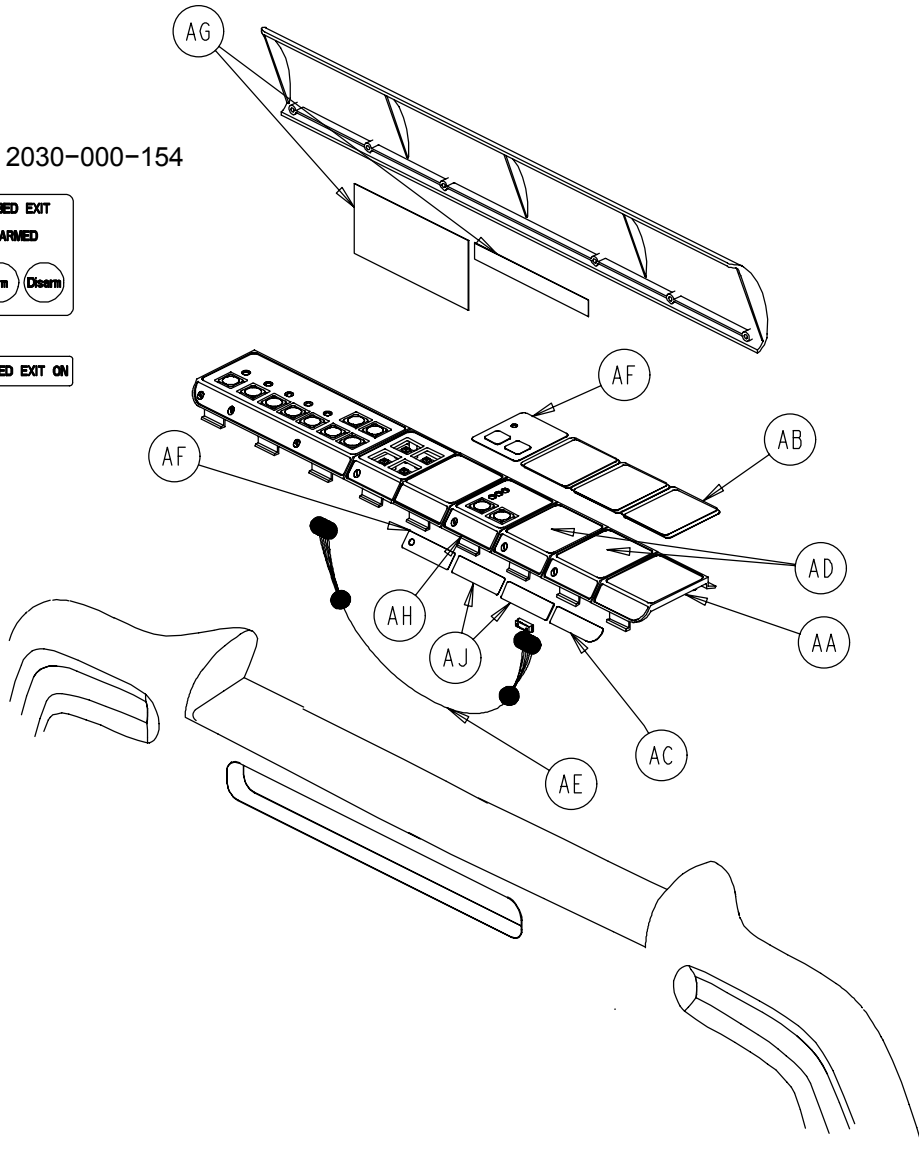

2030-135-12 Foot Board Chaperone™ Option

Item	Part No.	Part Name	Qty.
AA	3000-500-4	End Module	1
AB	2035-500-101	Foot Board Blank Label	3
AC	3000-500-27	Blank End Label	1
AD	3001-500-3	Blank Module	2
AE	3001-508-800	Bed Exit Keypad Cable	1
AF	2030-000-154	Bed Exit Label	1
AG	3002-508-10	Bed Exit Lid Label	1
AH	(page 168)	Bed Exit Module Assembly	1
AJ	3000-500-26	Blank Module Assembly	2

Foot Board Assembly and Options

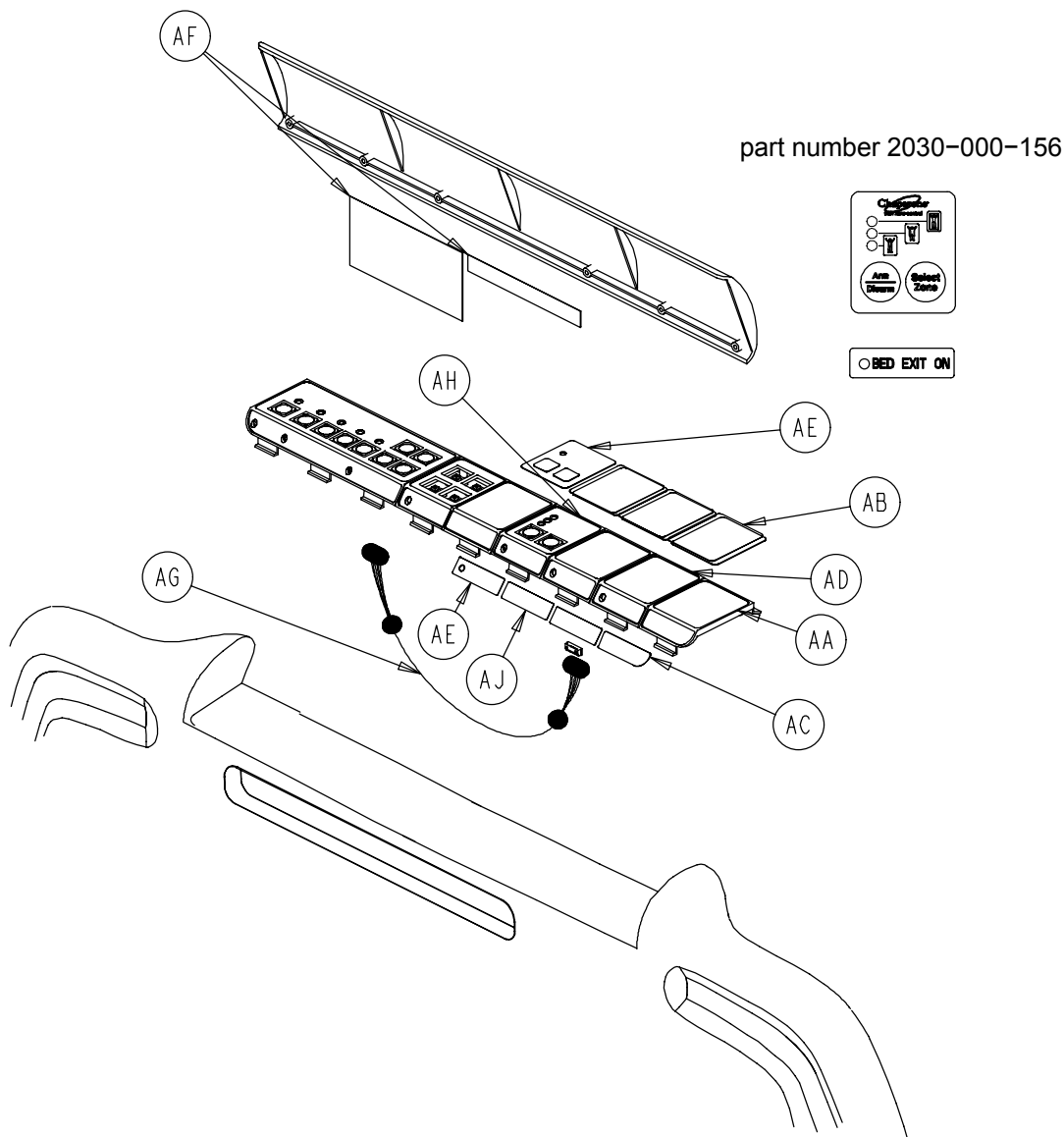

2030-135-15 Foot Board Chaperone™ w/Zone Control Option

Item	Part No.	Part Name	Qty.
AA	3000-500-4	End Module	1
AB	2035-500-101	Foot Board Blank Label	3
AC	3000-500-27	Blank End Label	1
AD	3001-500-3	Blank Module	2
AE	2030-000-156	Chaperone II Module Label	1
AF	3002-508-12	Chaperone II Label	1
AG	3002-508-800	Zone Control Keypad Cable	1
AH	(page 169)	Bed Exit Module Assembly	1
AJ	3000-500-26	Blank Module Label	2

Foot Board Assembly and Options

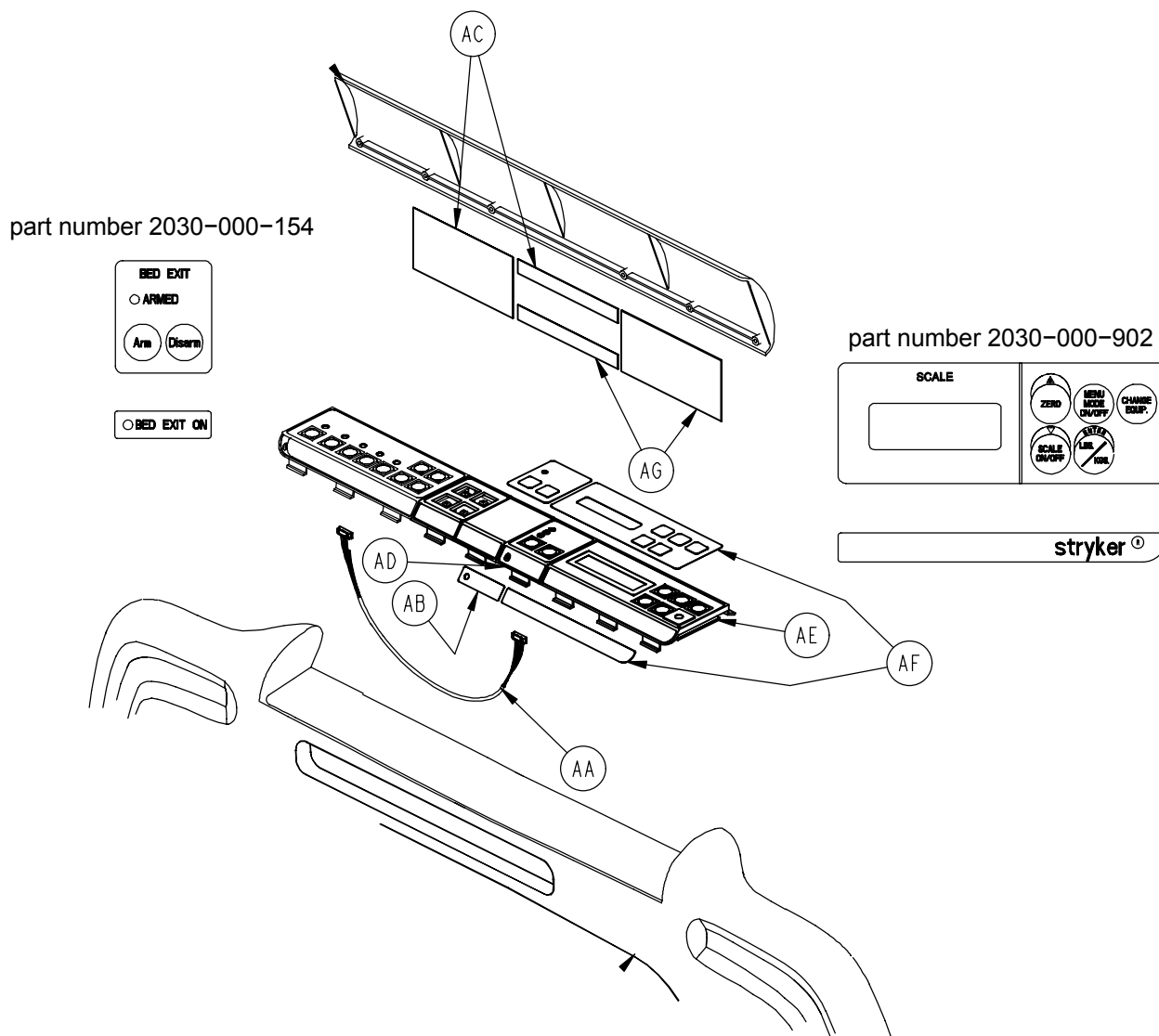

2030-15-14 Foot Board Scale and Chaperone™ Options

Item	Part No.	Part Name	Qty.
AA	3001-508-800	Bed Exit Keypad Cable	1
AB	2030-000-154	Bed Exit Label	1
AC	3002-508-10	Bed Exit Lid Label	1
AD	(page 168)	Bed Exit Module Assembly	1
AH	(page 170)	Scale Module Assembly	1
AJ	2030-000-902	Scale Module Label	1
AL	3002-507-11	Scale Lid Label	1

Foot Board Assembly and Options

part number 2030-000-156

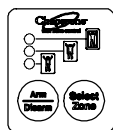

○ BED EXIT ON

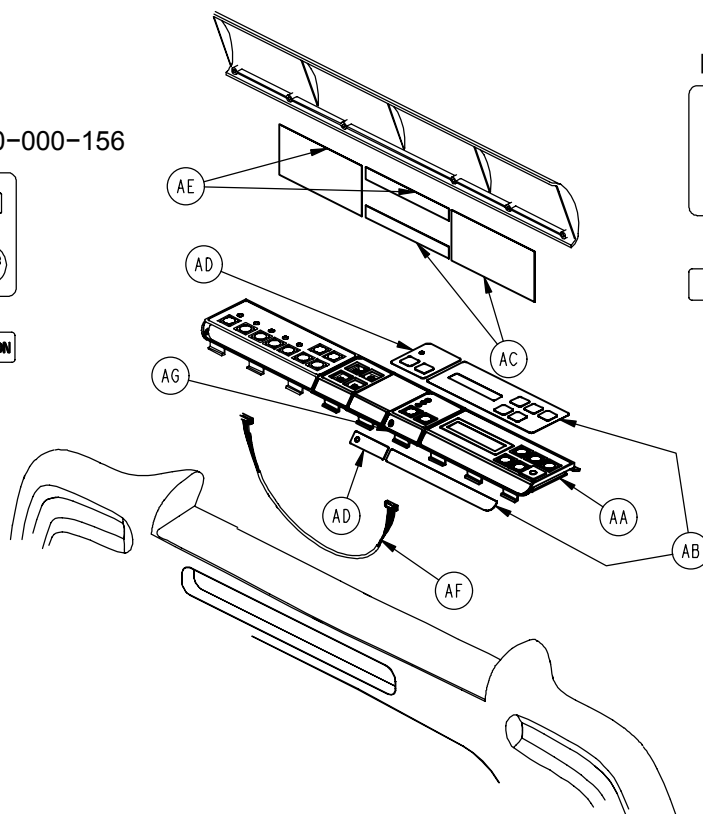

part number 2030-000-902

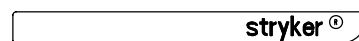
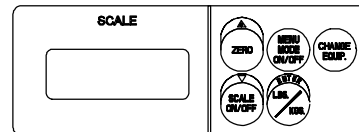

2030-15-16 Foot Board Scale and Chaperone™ w/Zone Control Options

Item	Part No.	Part Name	Qty.
AD	(page 170)	Scale Module Assembly	1
AE	2030-000-902	Scale Module Label	1
AG	3002-507-11	Scale Lid Label	1
AK	2030-000-156	Chaperone II Module Label	1
AL	3002-508-12	Chaperone II Label	1
AM	3002-508-800	Zone Control Keypad Cable	1
AN	(page 169)	Bed Exit Module Assembly	1

2035-235-20 Foot Board Main Module Assembly

part number 2030-000-151

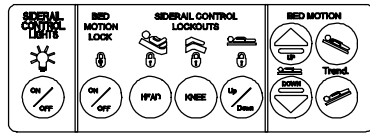

part number 2035-000-153

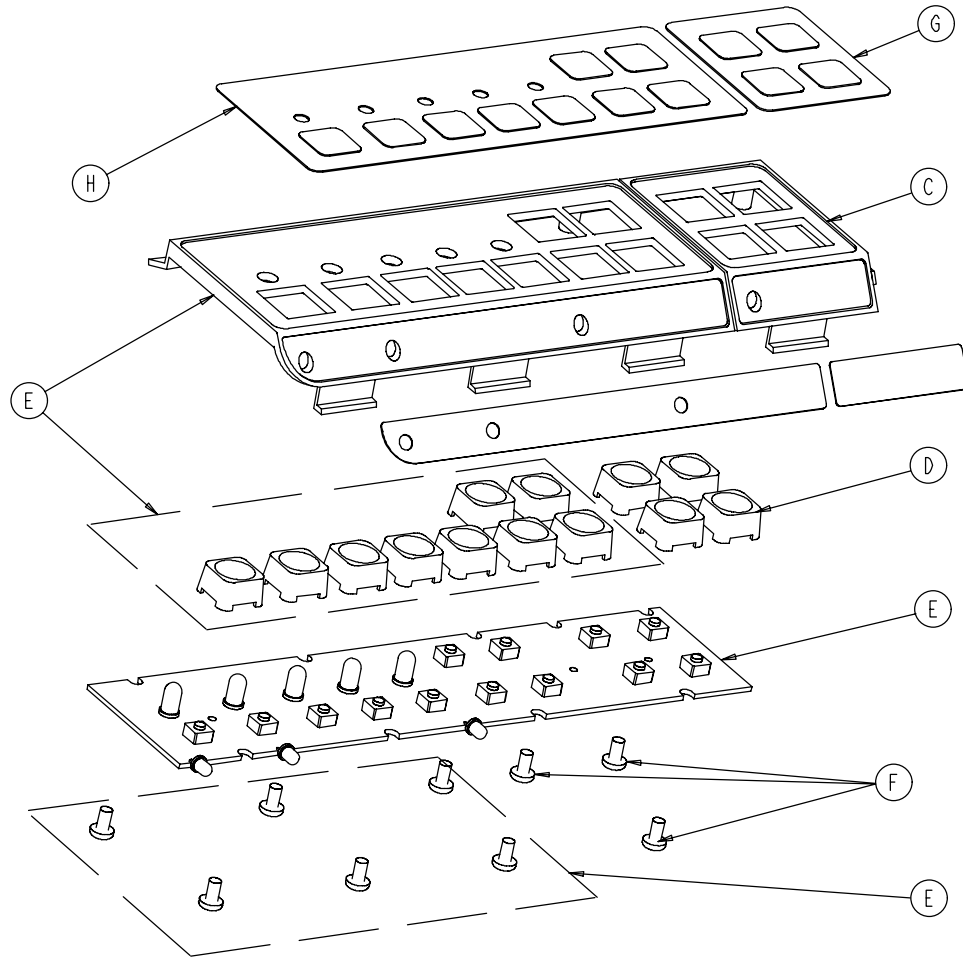
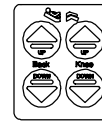

Item	Part No.	Part Name	Qty.
C	3000-501-1	Gatch/Fowler Module	1
D	3001-400-953	Switch Cap	4
E	3001-500-28	Foot Board Std. Module	1
F	23-87	Pan Hd. Tapping Screw	3
G	2035-000-153	Gatch/Fowler Label	1
H	2030-000-151	Foot Board Std. Module Label	1

2025-136-21 Foot Board E. Drop/Card. Chair Module

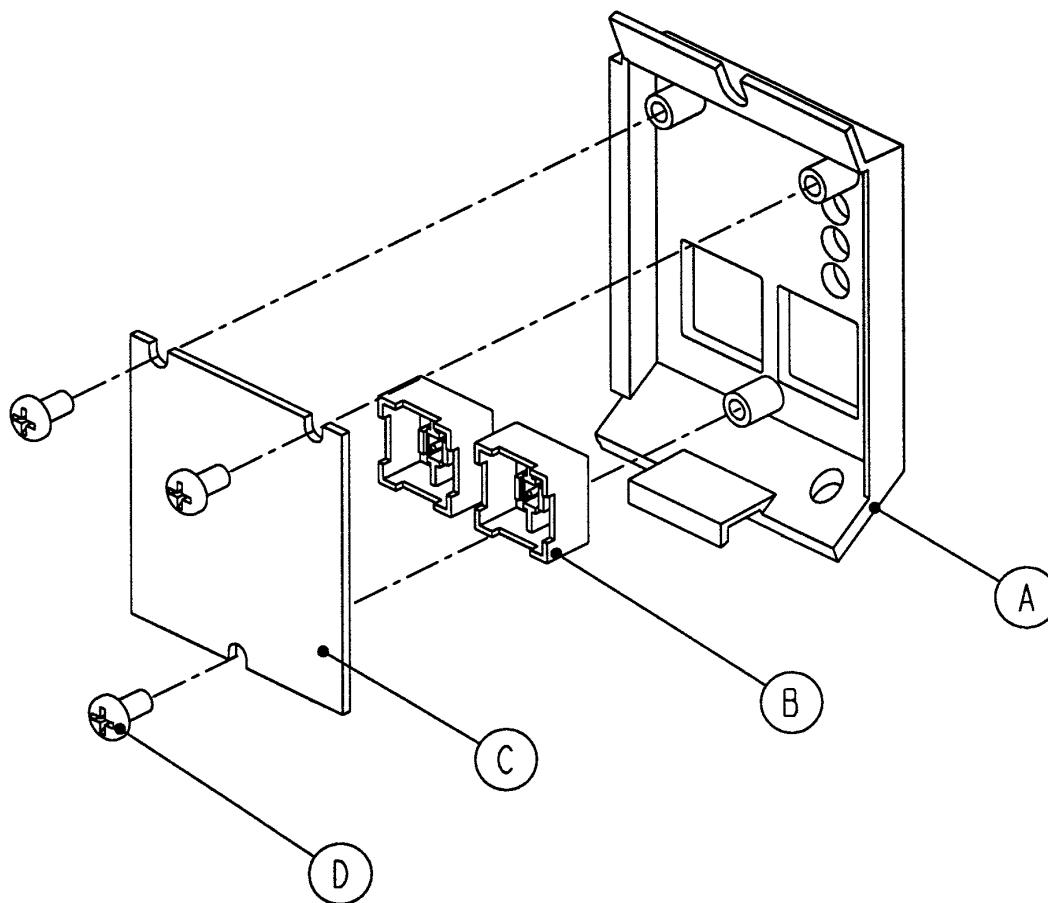

Item	Part No.	Part Name	Qty.
A	3000-508-1	Bed Exit Module Panel	1
B	3001-400-953	Switch Cap	2
C	2025-136-900	CPR Drop/Card. Ch. Keypad	1
D	23-87	Hi-Low Tapping Screw	3

3001-508-030 Foot Board Bed Exit Module

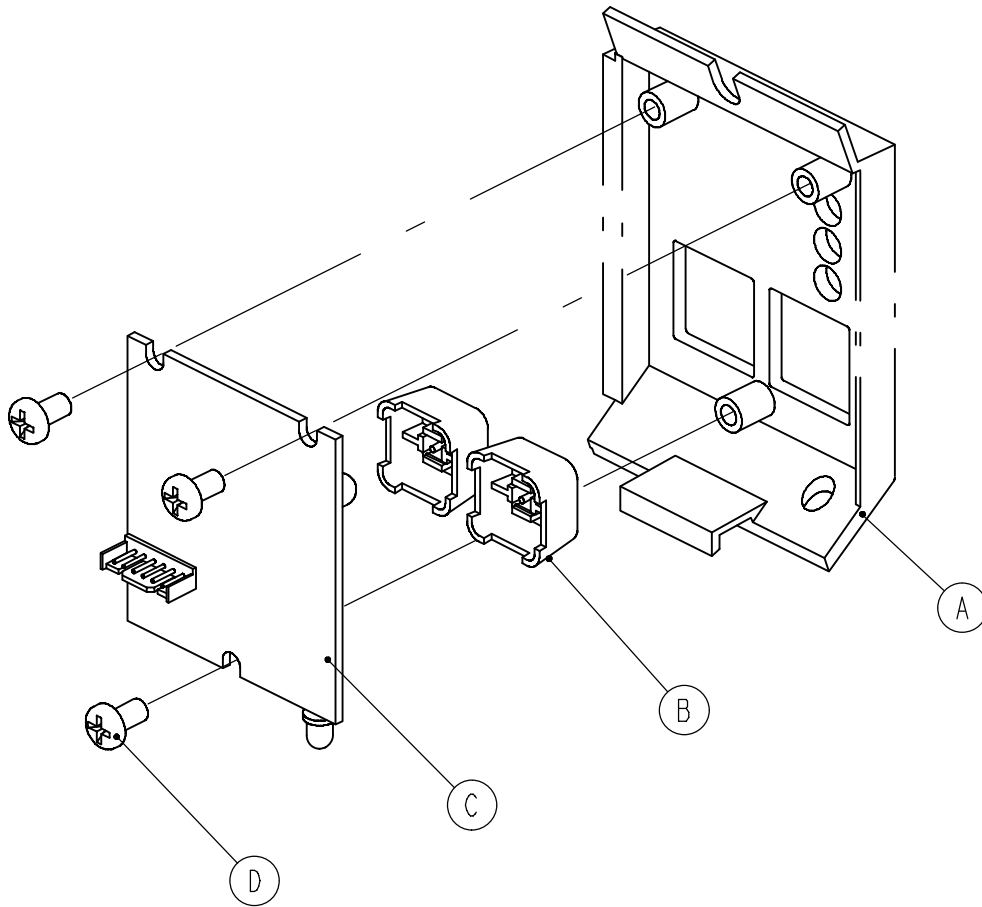

Item	Part No.	Part Name	Qty.
A	3000-508-1	Bed Exit Module Panel	1
B	3001-400-953	Switch Cap	2
C	3001-508-910	Bed Exit Keypad Ass'y	1
D	23-87	Hi-Low Tapping Screw	3

3002-508-30 Foot Board Zone Bed Exit Module

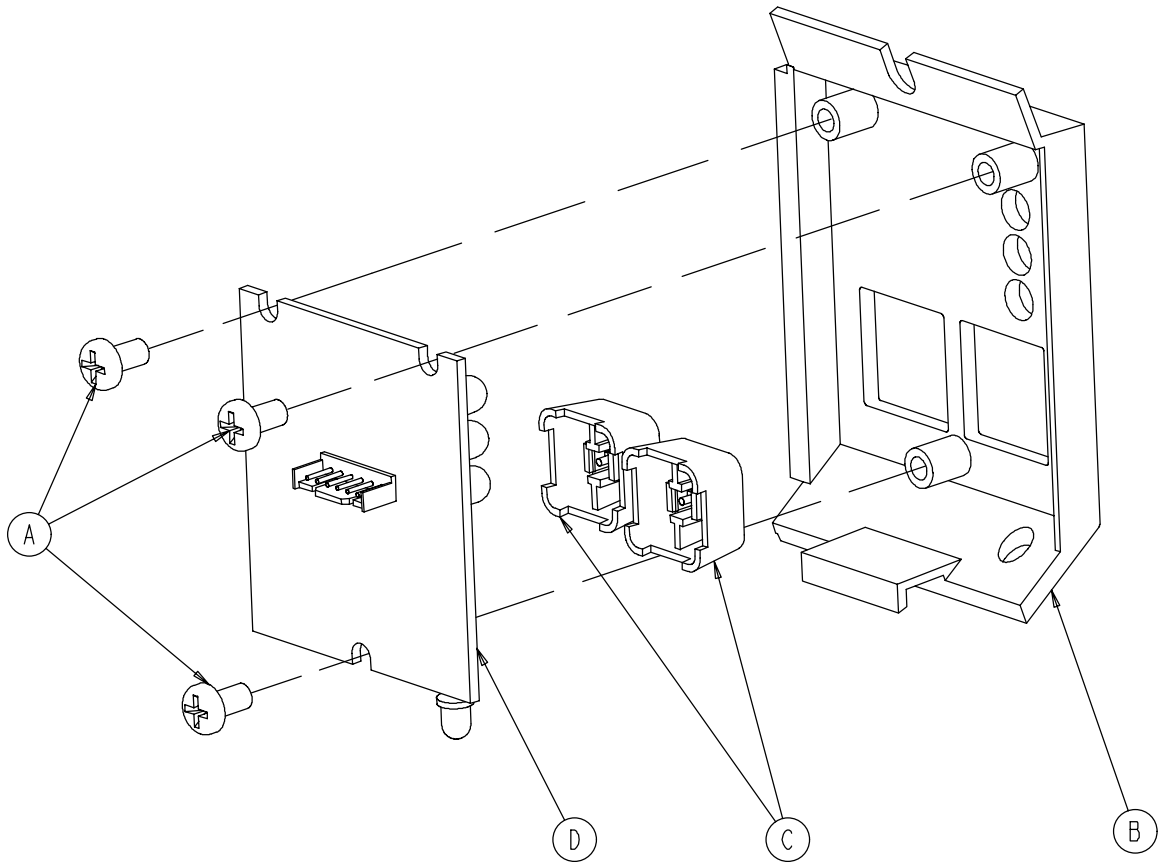

Item	Part No.	Part Name	Qty.
A	23-87	Hi-Low Tapping Screw	3
B	3000-508-1	End Exit Module Panel	1
C	3001-400-953	Switch Cap	2
D	3002-508-900	Bed Exit Board	1

3002-015-001 Foot Board Scale Module Assembly

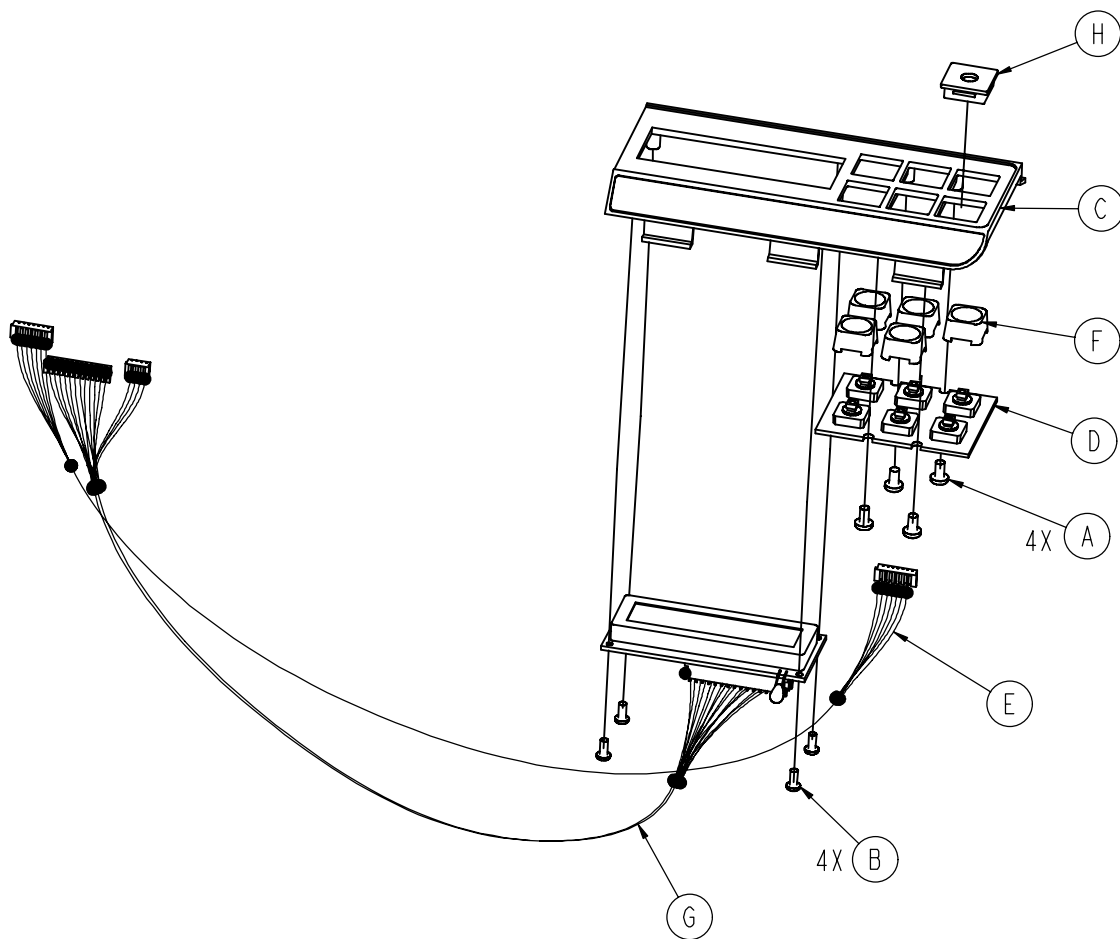

Item	Part No.	Part Name	Qty.
A	23-87	Pan Hd. Hi-Lo Tapping Screw	4
B	23-91	Pan Hd. Hi-Lo Tapping Screw	4
C	3001-507-1	Scale Module	1
D	3001-507-910	Scale Keypad	1
E	3001-507-800	Scale Keypad Cable	1
F	3001-400-953	Switch Cap	5
G	3002-507-900	Scale Display Cable	1
H	3001-400-552	Filler Cap	1

3000-300-80 Removable IV Pole Assembly

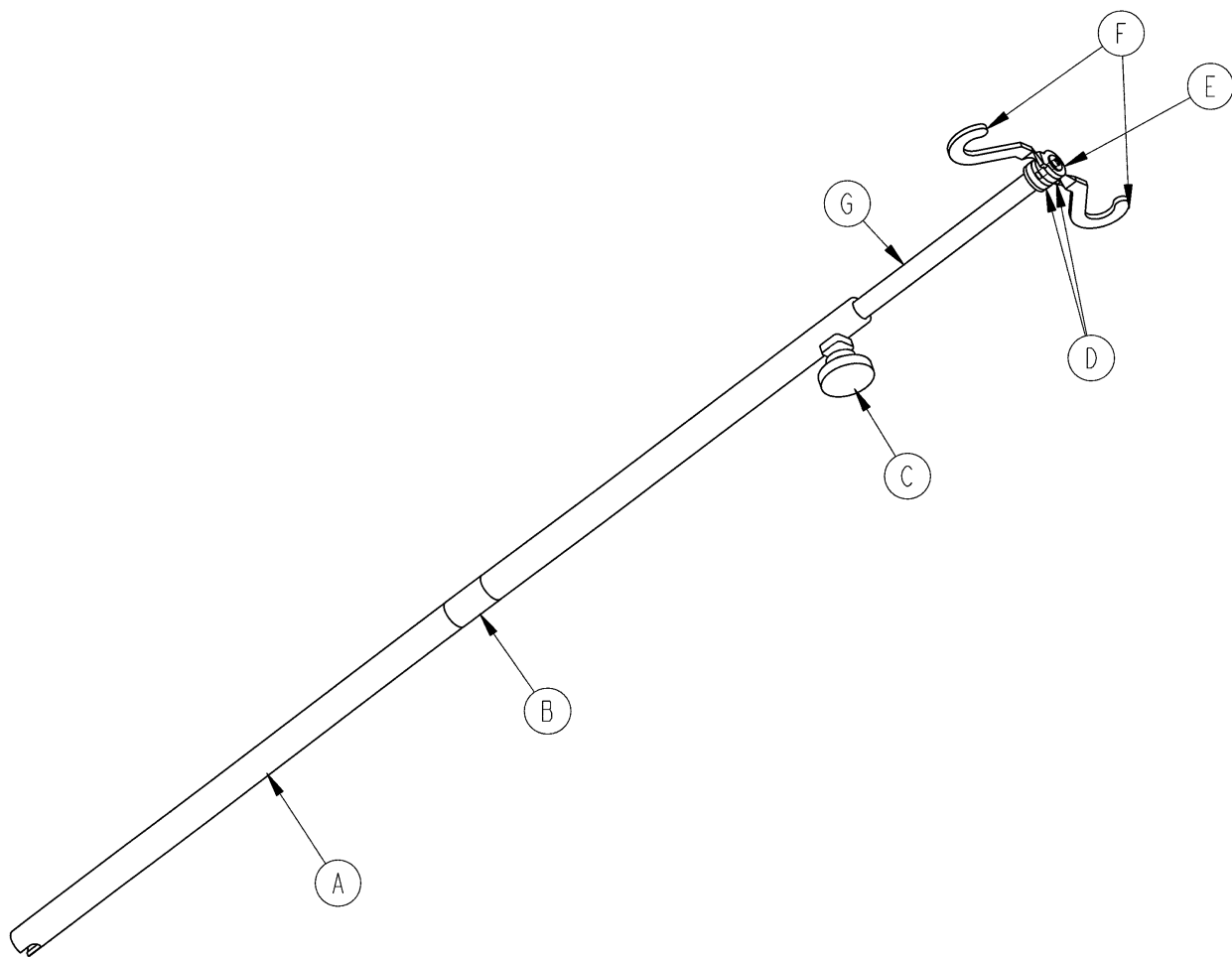

Item	Part No.	Part Name	Qty.
A	3000-300-81	Outer Tube	1
B	3000-300-89	Label	1
C	24-50	Fluted Knob	1
D	52-17	Spacer	2
E	7-40	Phillips Truss Hd. Screw	1
F	1010-59-16	IV Hook	2
G	3000-300-85	Inner Tube Assembly	1

2035-111 2-Stage I.V. Mounting Assembly

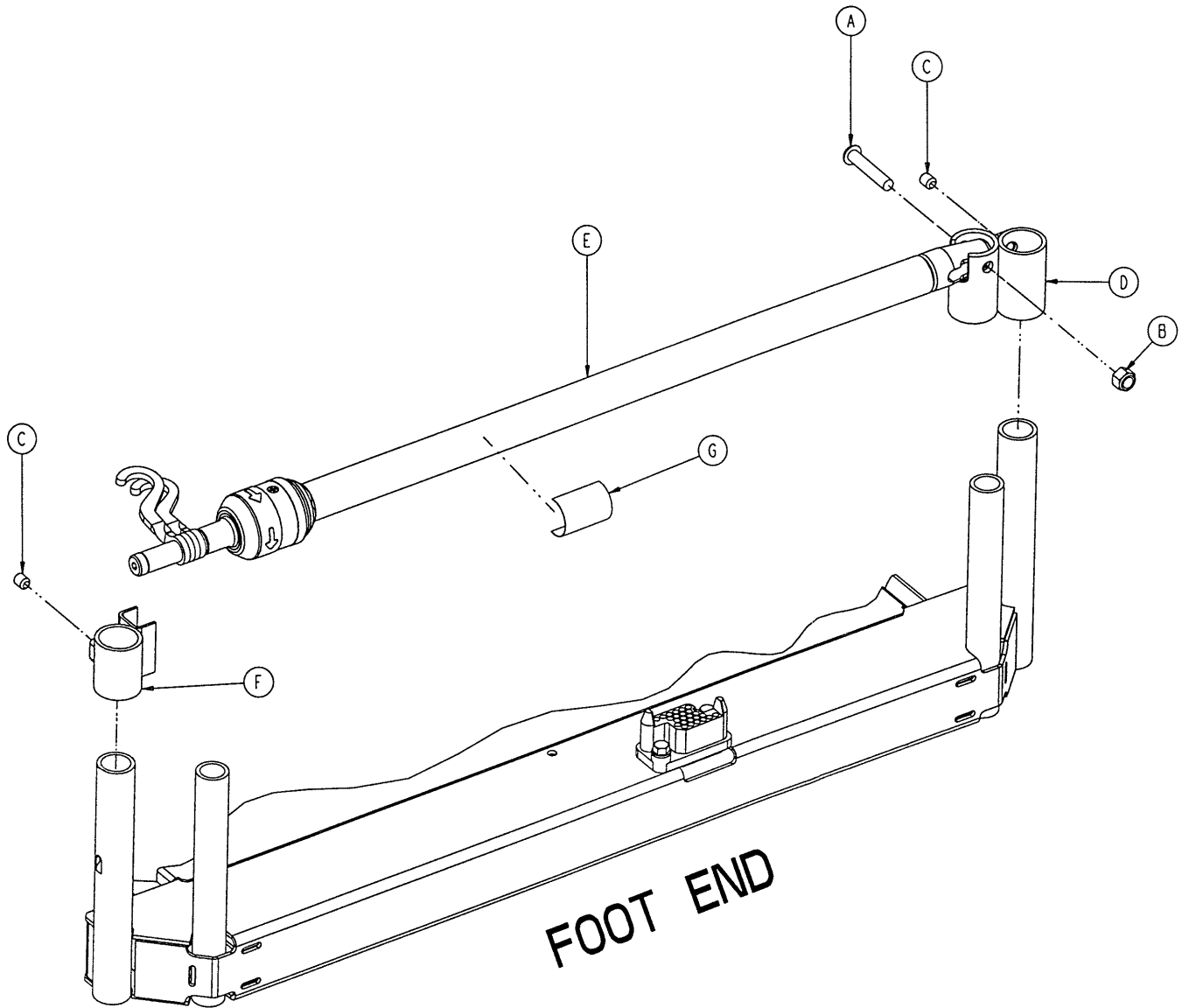

Item	Part No.	Part Name	Qty.
A	4-199	But. Hd. Cap Screw	1
B	16-36	Flexlock Nut	1
C	21-140	Set Screw	2
D	2035-111-1	IV Receptacle, Foot, Left	1
E	(page 175)	IV Pole Assembly, Left	1
F	3000-312-35	IV Cradle	1
G	2035-112-110	Specification Label	1

2035-112 Optional Head End 2-Stage IV Assembly

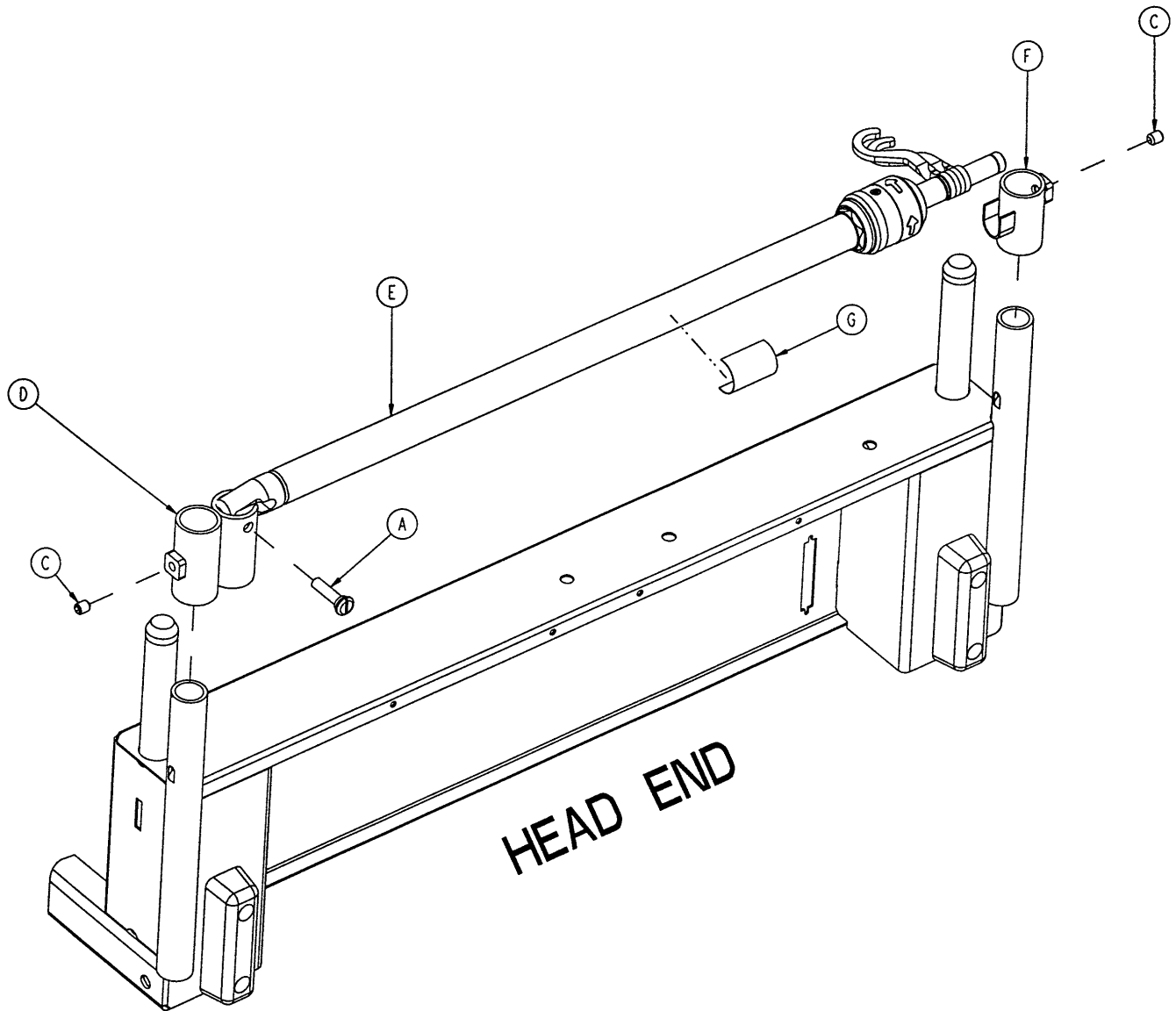

Item	Part No.	Part Name	Qty.
A	1015-24-35	Retaining Pin	1
C	21-140	Set Screw	2
D	2035-112-1	I.V. Receptacle, Head, Left	1
E	(page 175)	I.V. Pole Assembly, Left	1
F	3000-311-16	I.V. Rest	1
G	2035-112-110	Specification Label	1

2040-110-3 Optional Dual Head End IV Assembly

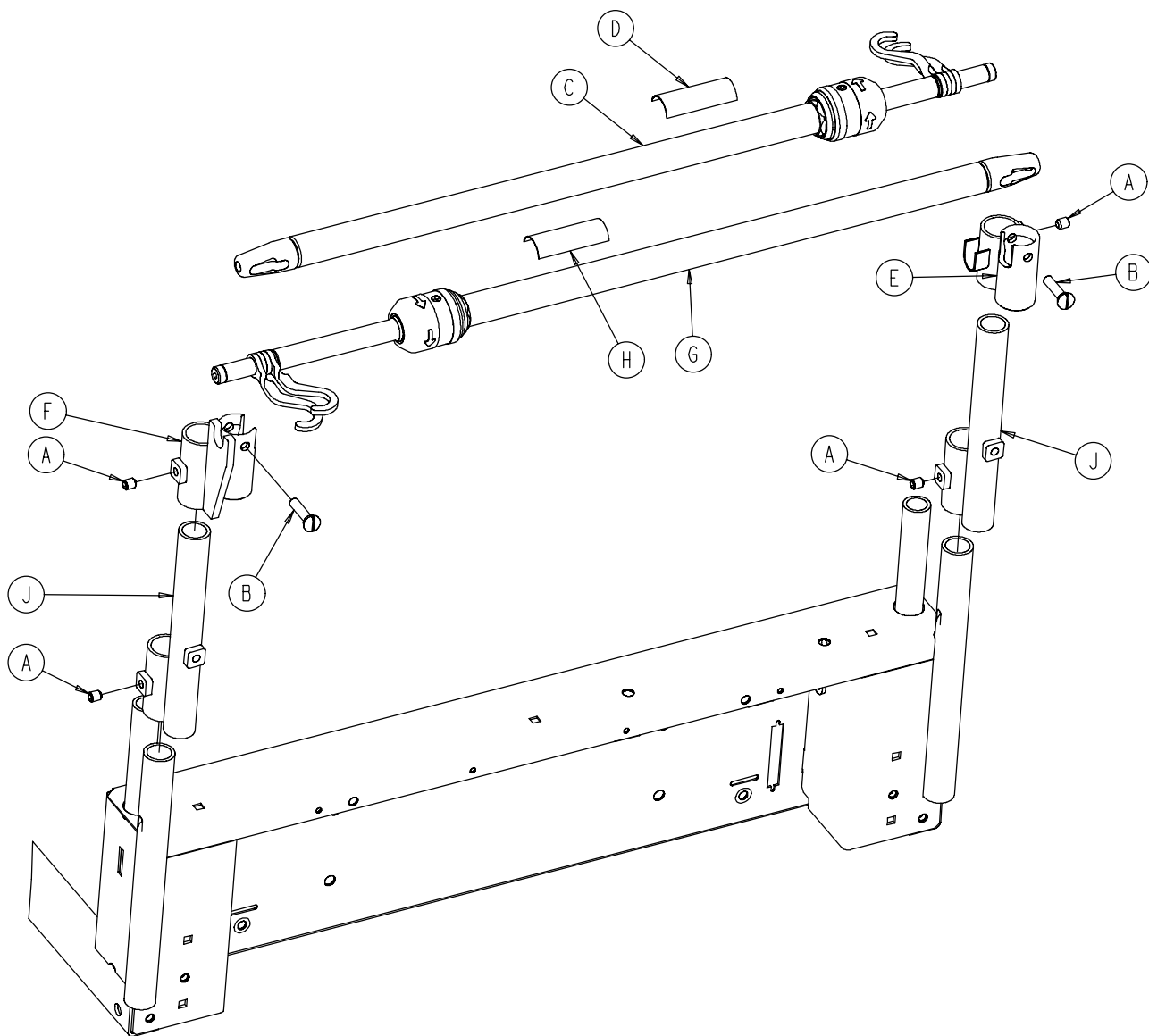

Item	Part No.	Part Name	Qty.
A	21-140	Set Screw	4
B	1015-24-35	Retaining Pin	2
C	(page 175)	IV Pole Assembly, Left	1
D	2035-112-110	Specification Label	1
E	2035-113-2	IV Receptacle, Dual Hd. End, Rt.	1
F	2035-113-1	IV Receptacle, Dual Hd. End, Lt.	1
G	(page 175)	IV Pole Assembly, Right	1
H	2035-113-111	Specification Label	1
J	2040-110-2	IV Pole Extension	2

2035-112-10 & 2035-113-11 2-Stage I.V. Pole

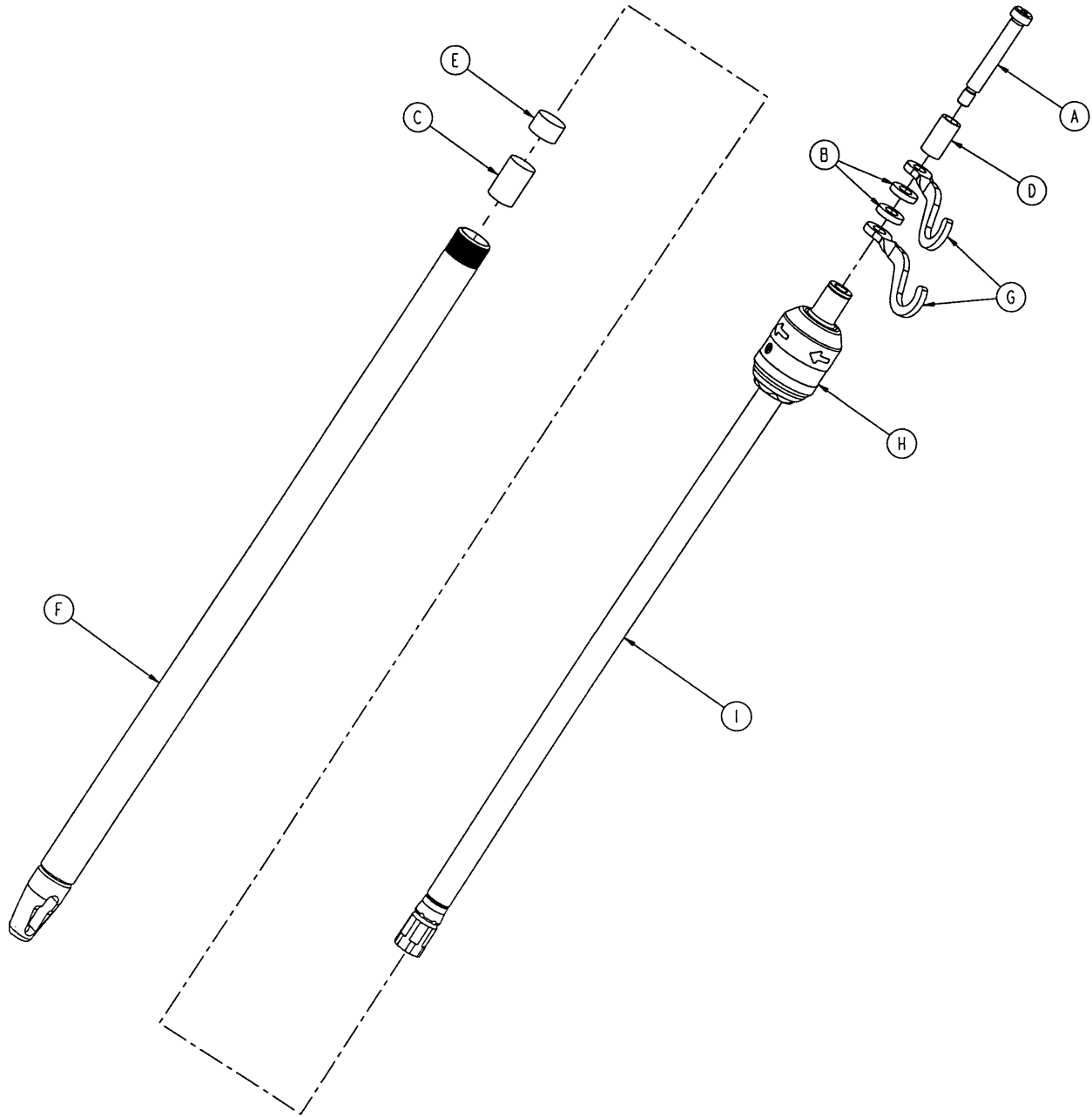

2035-112-10 Head End, Left

2035-113-11 Foot End, Right

Item	Part No.	Part Name	Qty.	Item	Part No.	Part Name	Qty.
A	8-31	Soc. Hd. Shoulder Screw	1	A	8-31	Soc. Hd. Shoulder Screw	1
B	52-17	Washer	2	B	52-17	Washer	2
C	52-310	Spacer	1	C	52-311	Spacer	1
D	926-400-162	Spacer	1	D	926-400-162	Spacer	1
E	1001-259-13	Dampener	1	E	1001-259-13	Dampener	1
F	1001-259-32	Base Tube Weldment	1	F	1001-259-32	Base Tube Weldment	1
G	1010-259-16	IV Hook	2	G	1010-259-16	IV Hook	2
H	(page 176)	IV Pole Latch	1	H	(page 176)	IV Pole Latch	1
I	1211-110-29	2nd Stage Assembly	1	I	1211-110-29	2nd Stage Assembly	1

1211-210-26 IV Pole Latch Assembly

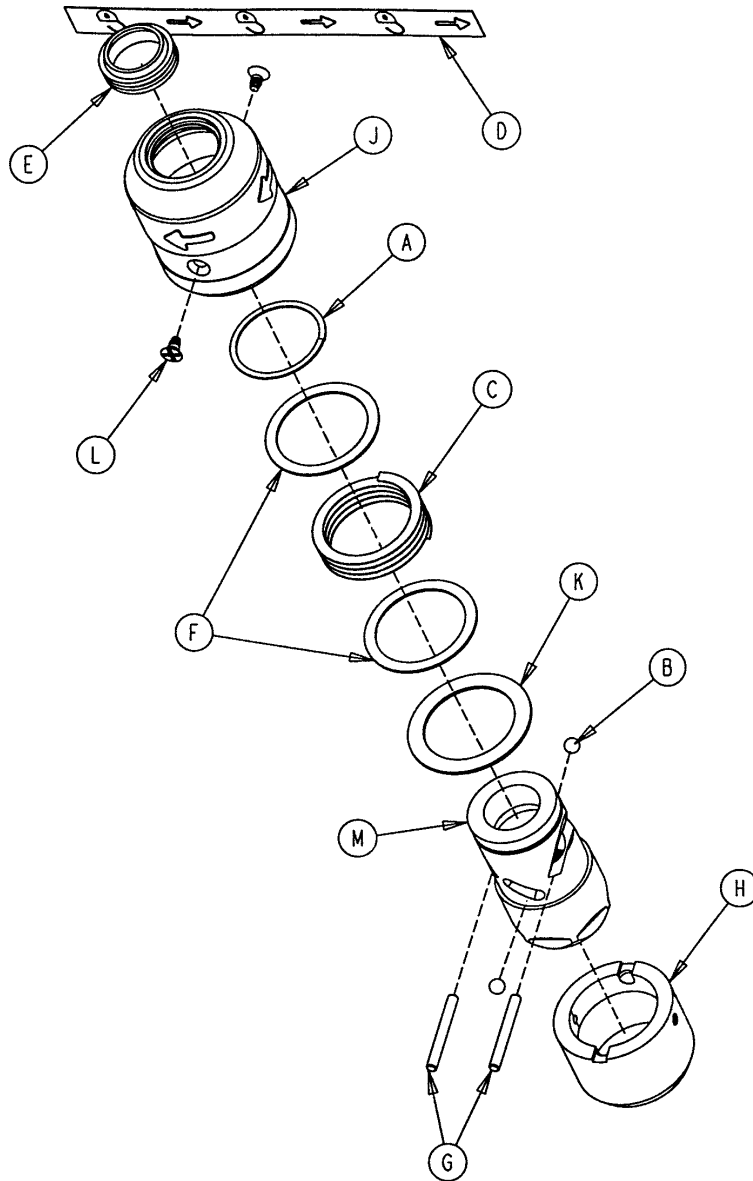

Item	Part No.	Part Name	Qty.
A	28-167	Retaining Ring	1
B	31-4	Steel Ball	2
C	38-392	Crest-to-Crest Spring	1
D	1211-91-34	Release Label	1
E	1211-110-18	IV Latch Seal	1
F	1211-110-20	Washer	2
G	1211-110-21	IV Latch Locking Pin	2
H	1211-110-22	IV Latch Guide	1
J	1211-110-24	IV Latch O.D. Housing	1
K	1211-110-35	Washer	1
L	1211-110-36	Self-Tapping Screw	2
M	1211-210-23	IV Latch I.D. Housing	1

2035-140 X-Ray Cassette Tray Assembly

Assembly part number 2035-140-10 (reference only)

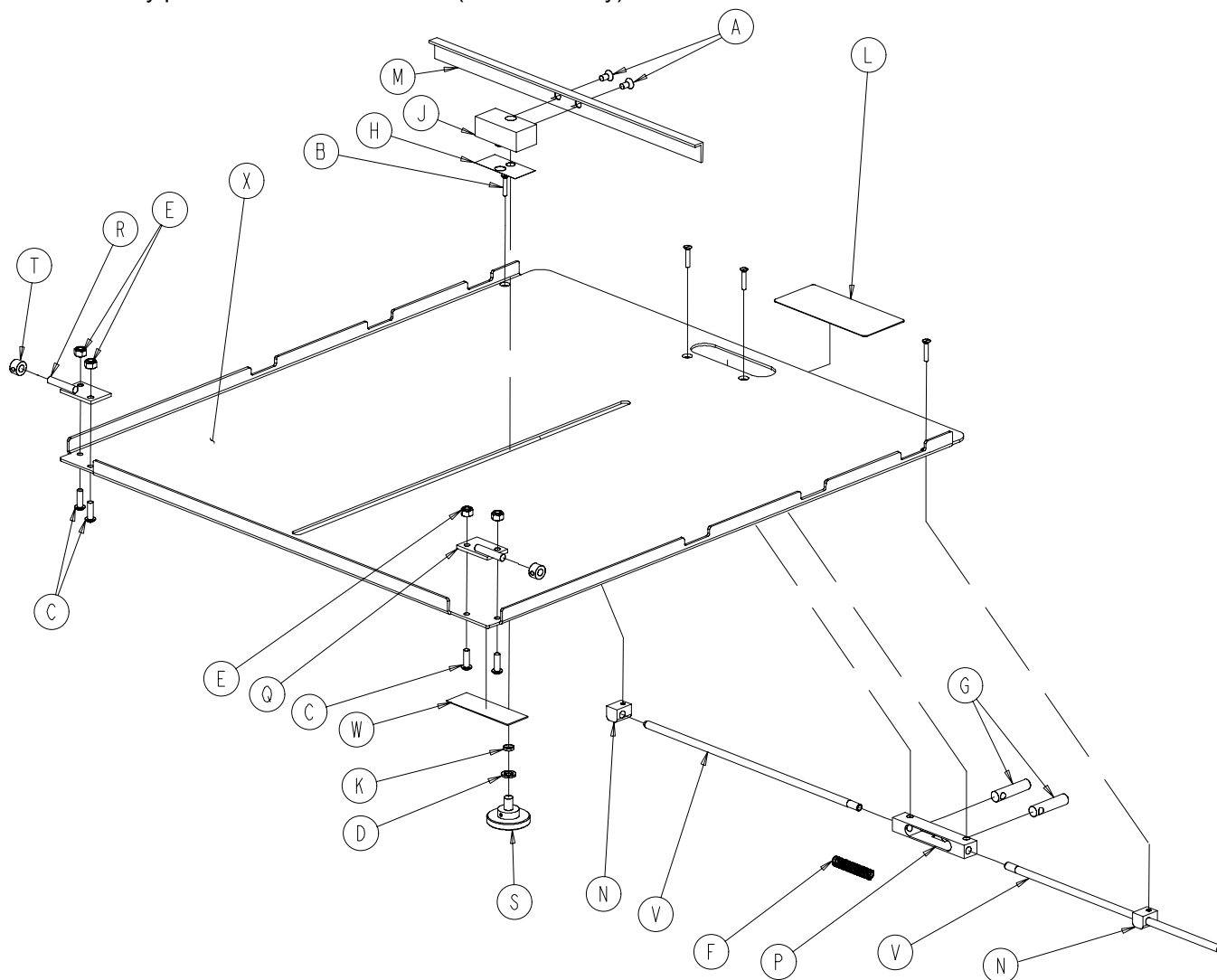

Item	Part No.	Part Name	Qty.	Item	Part No.	Part Name	Qty.
A	1-20	Flat C'sunk Hd. Mach Scr.	2	M	1010-23-28	Tray Angle	1
B	4-49	H. Soc. But. Hd. Cap Scr.	4	N	1010-23-37	Cassette Rod Guide	2
C	4-149	H. Soc. But. Hd. Cap Scr.	4	P	1020-23-16	Cassette Post Housing	1
D	14-3	Washer	1	Q	1020-23-19	Tray Hinge Wldmt., Rt.	1
E	16-3	Hex Nut	4	R	1020-23-20	Tray Hinge Wldmt., Lt.	1
F	38-122	Spring	1	S	1020-23-21	Knob	1
G	926-23-64	Tray Post	2	T	42-13	Collar w/Set Screw	2
H	926-23-69	Cassette Washer	1	V	2025-140-2	Cassette Actuating Rod	2
J	926-23-70	Cassette Block Subassy	1	W	2035-140-25	Specification Label	1
K	926-23-71	Cassette Bushing	1	X	2035-140-99	Cassette Tray	1
L	1010-23-19	Instruction Label	1				

2035-18-10 Optional IV Pole Transducer Mount

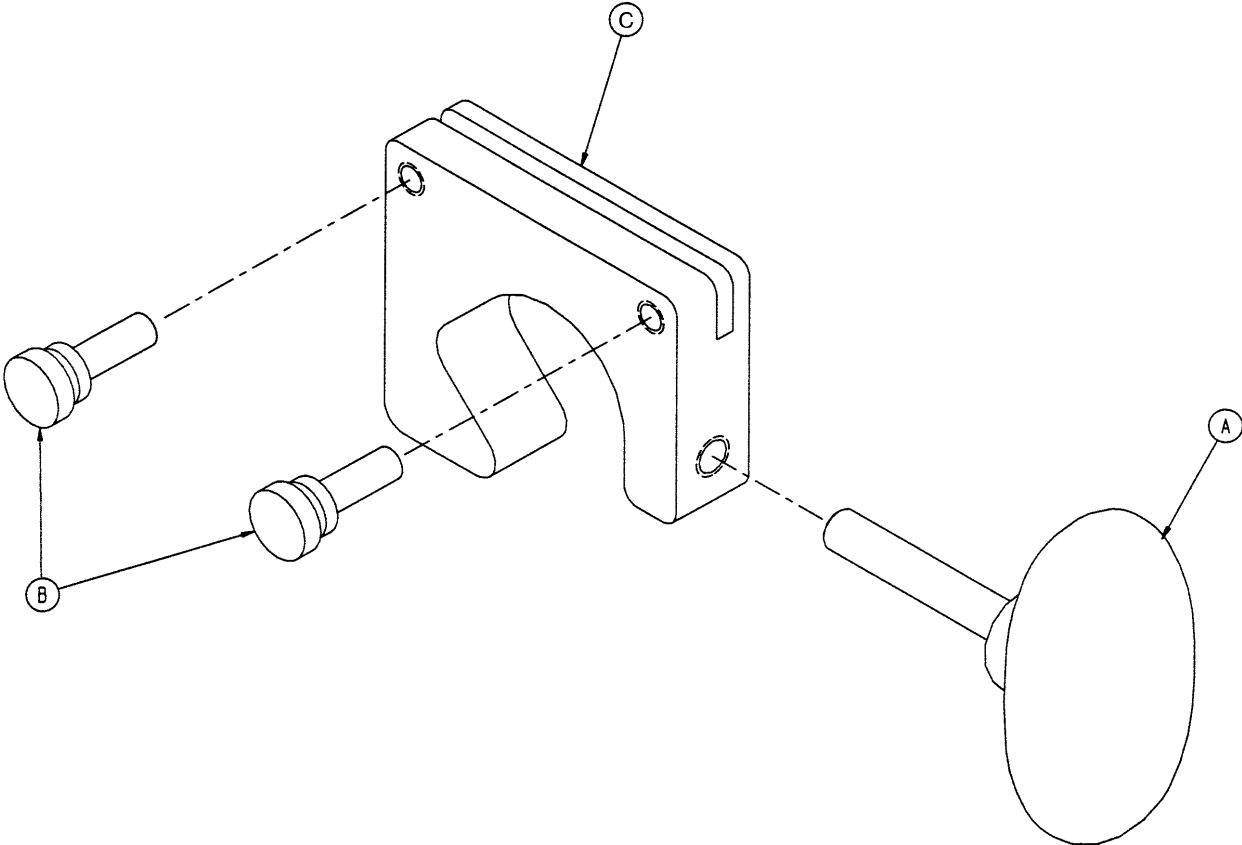

Item	Part No.	Part Name	Qty.
A	24-63	T-Knob	1
B	24-64	Thumb Screw	2
C	2035-18-11	Transducer Mount	1

2035-19-10 Optional Siderail Transducer Mount

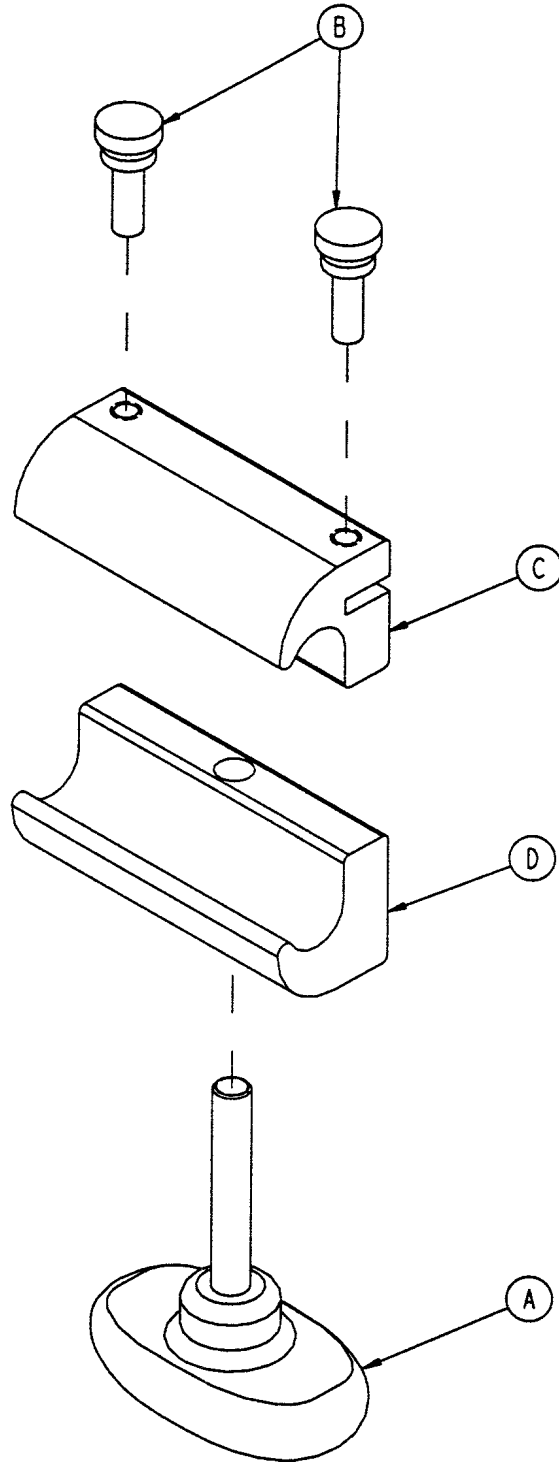

Item	Part No.	Part Name	Qty.
A	24-63	T-Knob	1
B	24-64	Thumb Screw	2
C	2035-19-11	Transducer Mount, Top	1
D	2035-19-12	Transducer Mount, Bottom	1

2025-120 Optional Defibrillator Tray Assembly

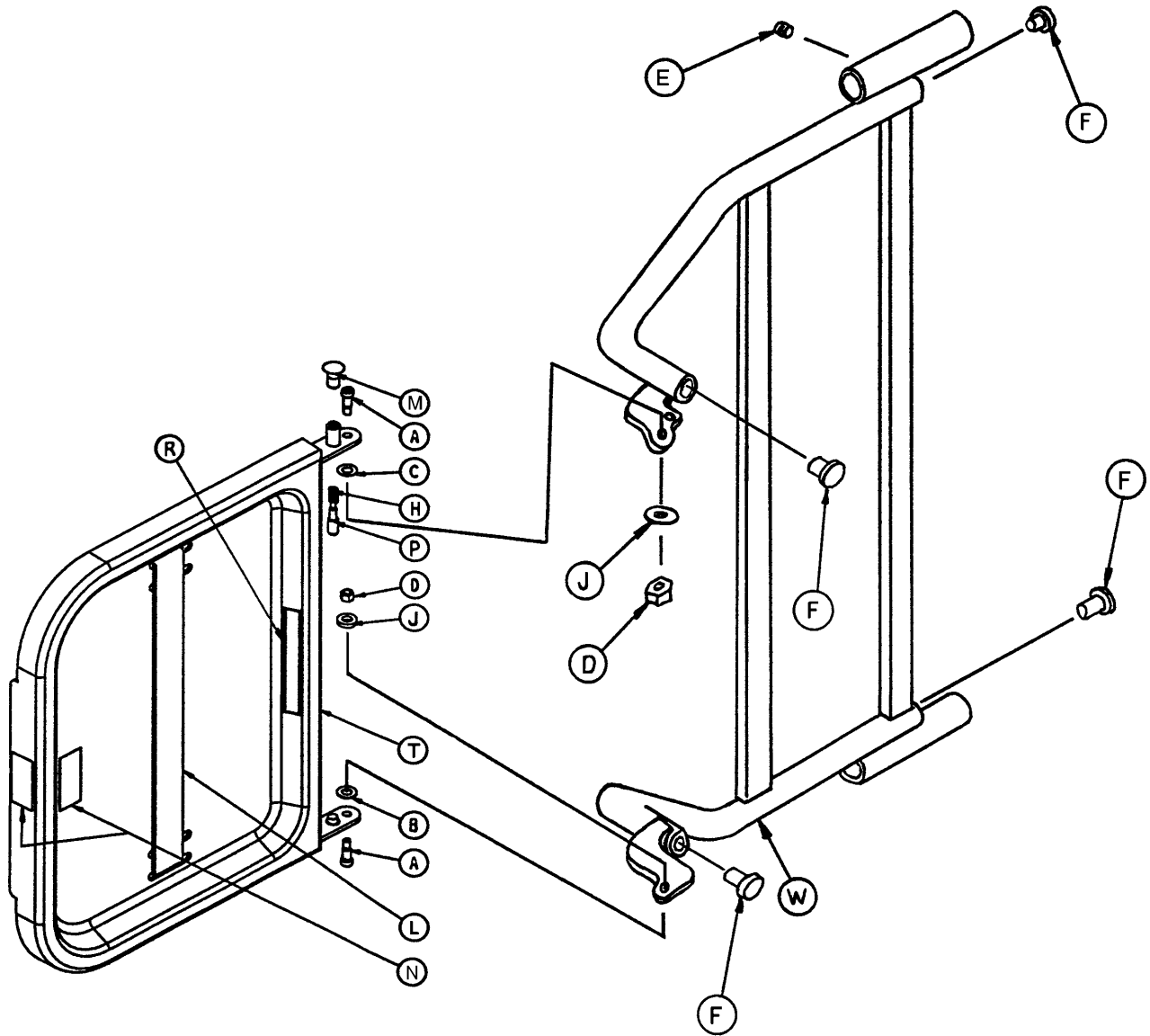

Item	Part No.	Part Name	Qty.	Item	Part No.	Part Name	Qty.
A	8-49	Soc. Hd. Shoulder Bolt	2	L	1010-50-21	Long Strap	1
B	14-20	Thrust Washer	1	M	1010-50-50	Knob	1
C	14-21	Thrust Washer	1	N	1010-50-57	Max. Weight Label	4
D	16-28	Fiberlock Nut	2	P	1010-50-242	Lock Pin	1
E	21-17	Set Screw	4	R	2025-120-5	Equipment Label	1
F	37-214	Hole Plug	4	S	2025-120-6	Specification Label	1
H	38-133	Spring	1	T	2025-120-18	Tray Assembly	1
J	52-17	Spacer	2	W	2025-120-25	Pivot Weldment Frame	1
K	1010-50-19	"Push/Pull" Label	1				

2040-111 Optional Pump Rack Assembly

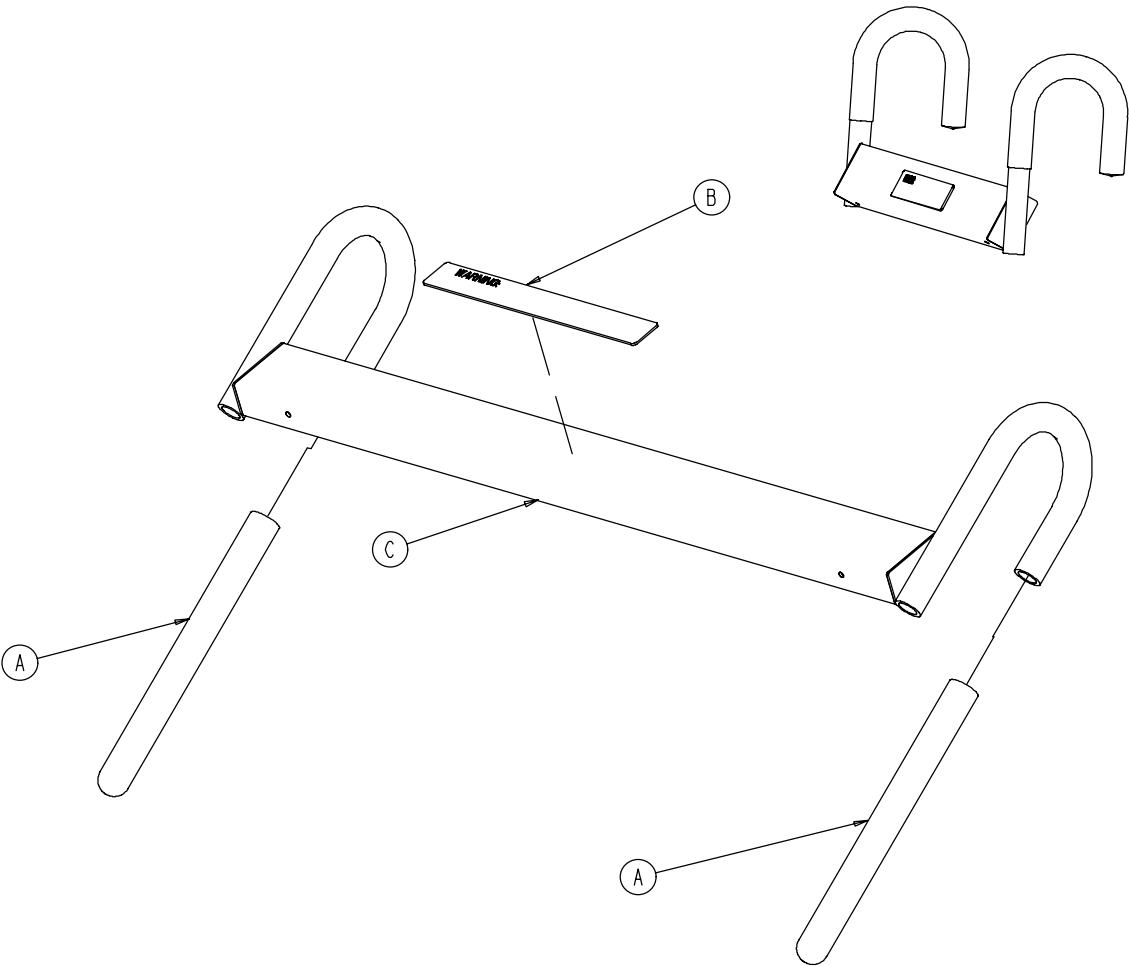

Item	Part No.	Part Name	Qty.
A	58-87	End Cap	2
B	2030-140-2	Pump Rack Label	1
C	2040-111-5	Pump Rack Tube	1

2040-120-4 Optional Pleur-Evac Rack with Defib. Tray

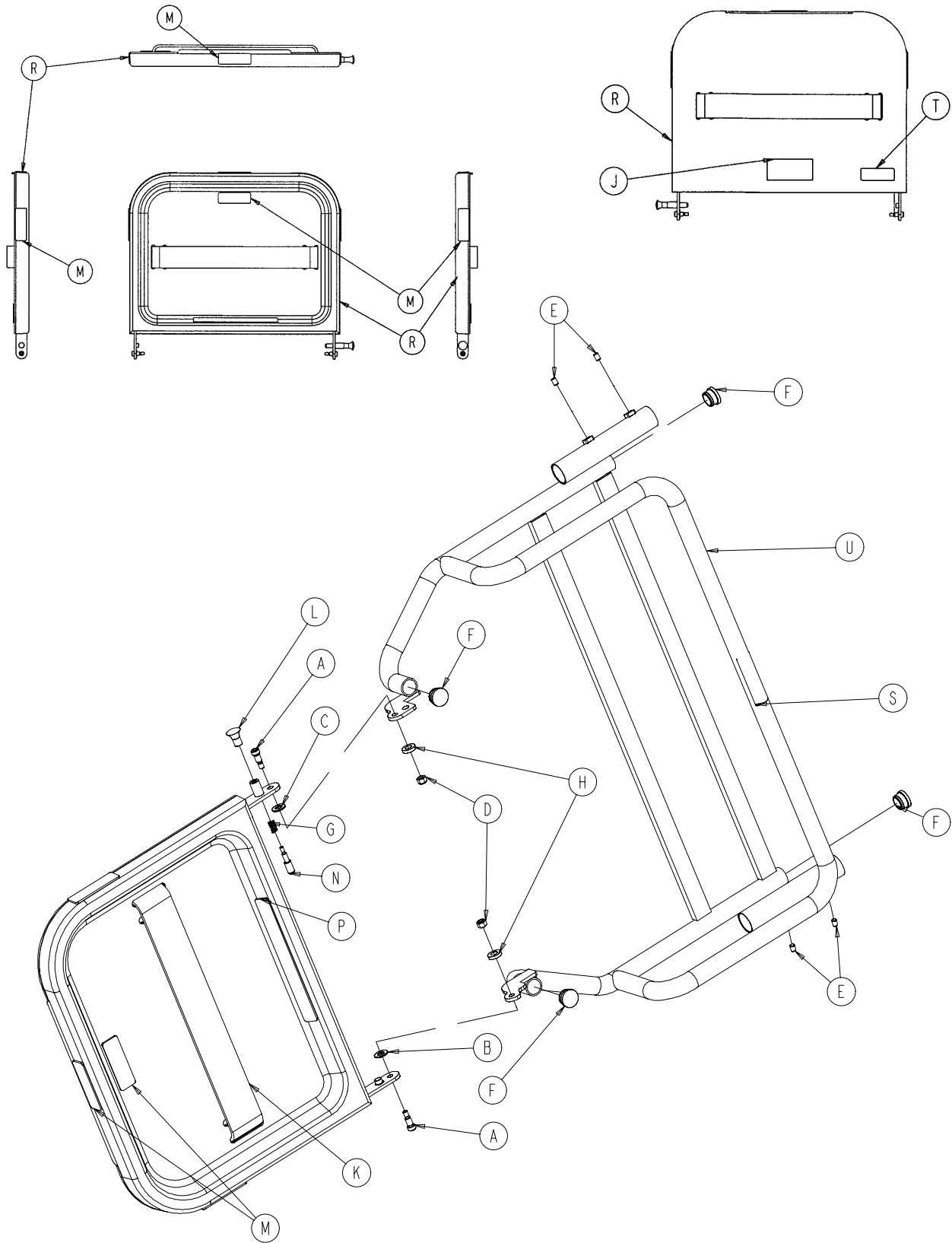

2040-120-4 Optional Pleur-Evac Rack with Defib. Tray

Item	Part No.	Part Name	Qty.
A	8-49	Soc. Hd. Shoulder Bolt	2
B	14-20	Thrust Washer	1
C	14-21	Thrust Washer	1
D	16-28	Fiberlock Nut	2
E	21-17	Set Screw	4
F	37-214	Hole Plug	4
G	38-133	Spring	1
H	52-17	Spacer	2
J	1010-50-19	"Push/Pull" Label	1
K	1010-50-21	Long Strap	1
L	1010-50-50	Knob	1
M	1010-50-57	"Max. Weight" Label	4
N	1010-50-242	Lock Pin	1
P	2025-120-5	Equipment Label	1
R	2025-120-18	Tray Assembly	1
S	2040-90-1	Warning Label	1
T	2040-90-5	Specification Label	1
U	2040-120-3	Rack Weldment	1

2040-120-20 Optional Pleur-Evac Rack Assembly

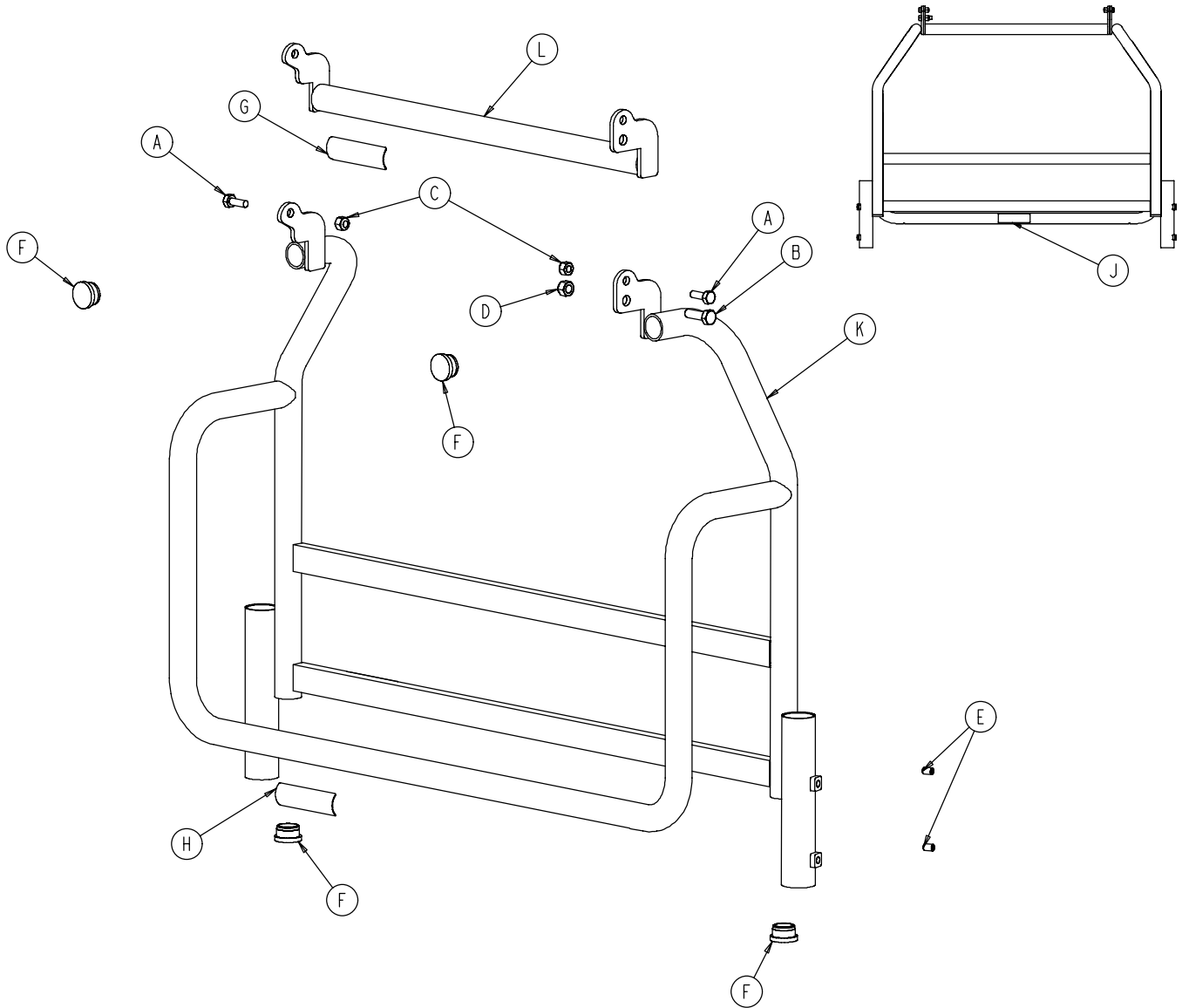

Item	Part No.	Part Name	Qty.
A	3-50	Hex Hd. Cap Screw	2
B	3-85	Hex Hd. Cap Screw	1
C	15-28	Nylock Nut	2
D	16-36	Nylock Nut	1
E	21-17	Set Screw	4
F	37-214	Hole Plug	4
G	1010-50-57	Maximum Weight Label	1
H	2040-90-1	Acc. Rail Warning Label	1
J	2040-90-4	Specification Label	1
K	2040-120-3	Rack Weldment	1
L	2040-120-10	Rack Top Weldment	1

2040-120-9 Optional Siderail Pleur-Evac Rack

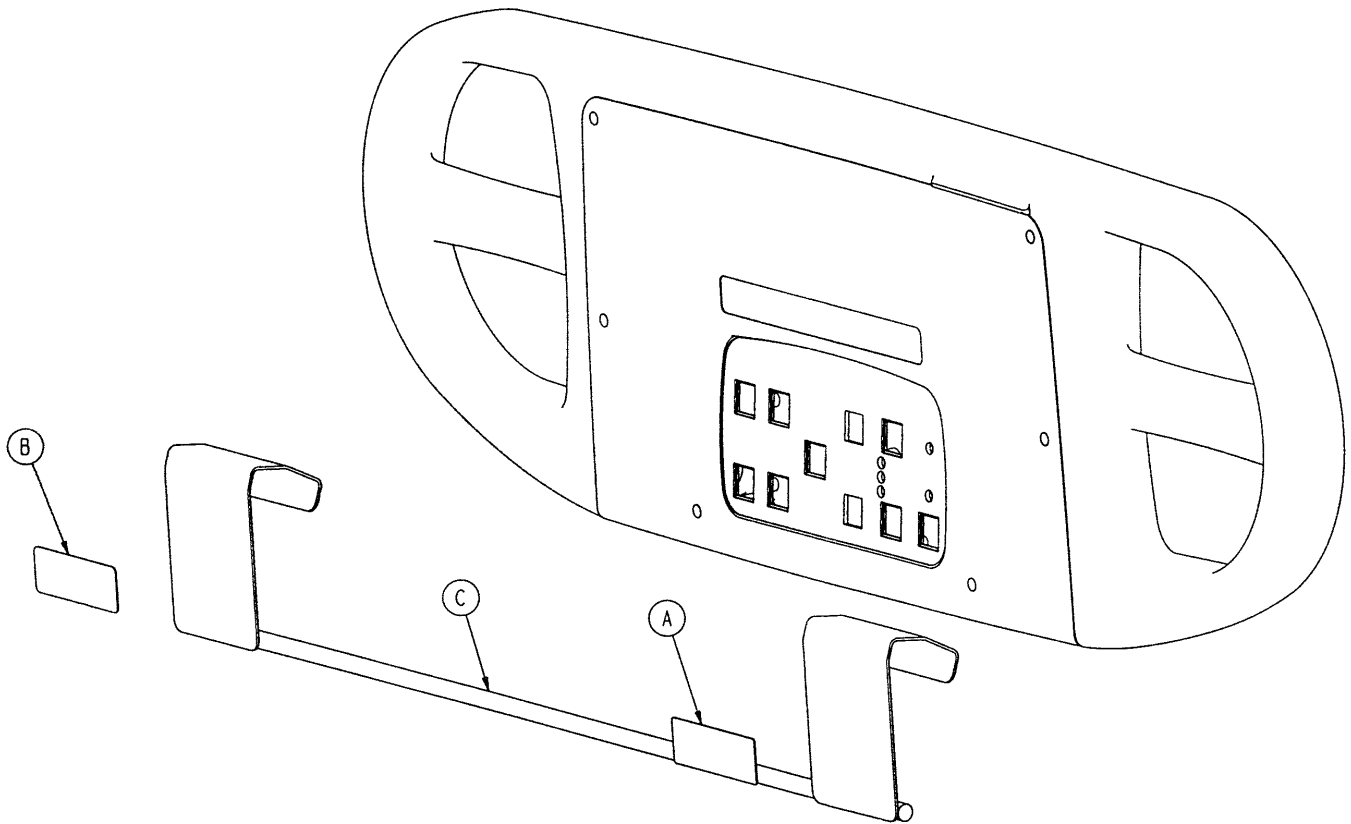

Item	Part No.	Part Name	Qty.
A	2040-90-1	Warning Label	1
B	2040-90-2	Maximum Weight Label	1
C	2040-120-8	Rack Weldment	1

2040-150-10 Optional Upright Oxygen Bottle Holder

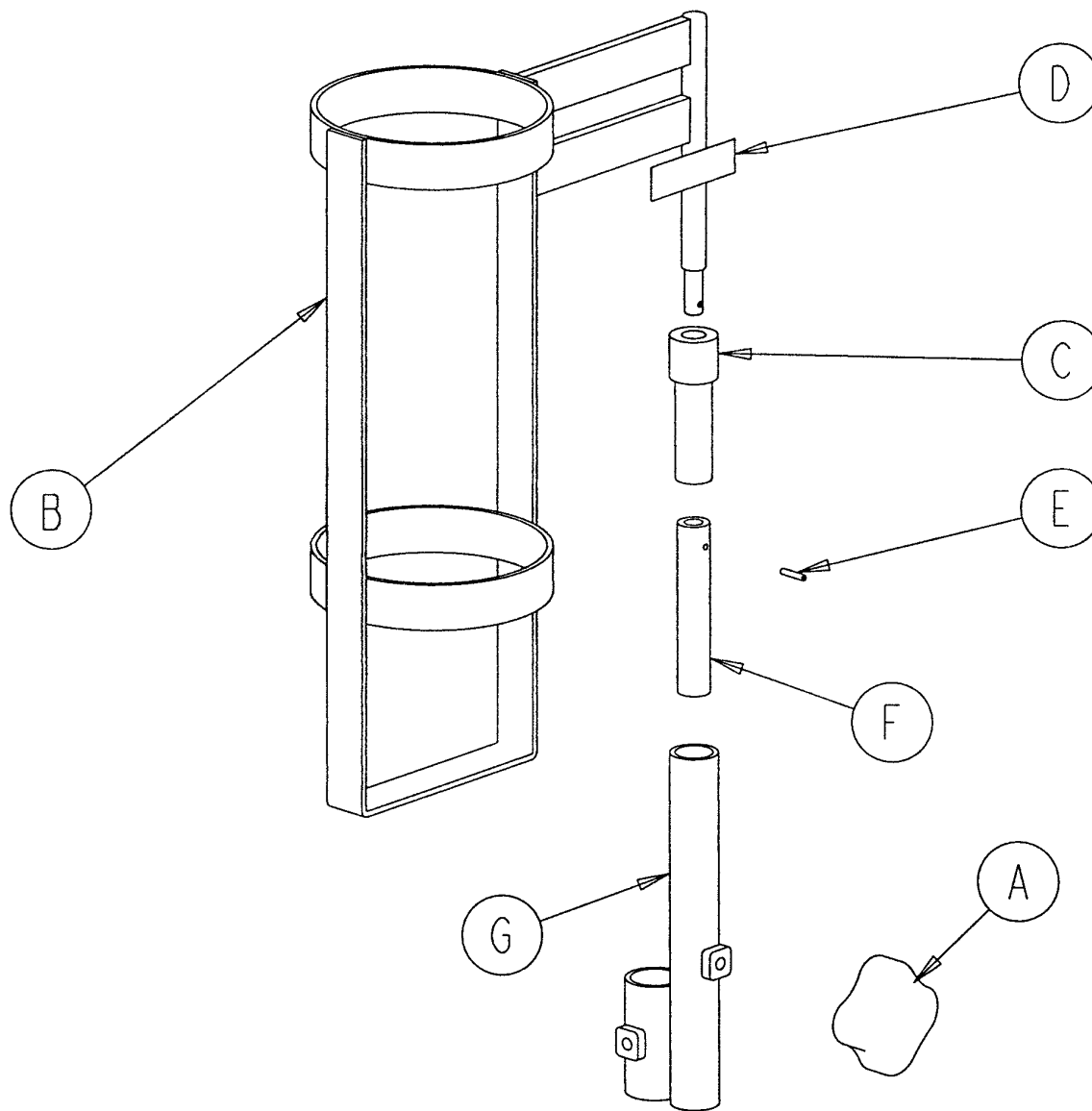

Item	Part No.	Part Name	Qty.
A	24-55	Knob	1
B	1010-30-11	Upright Bottle Holder	1
C	2025-150-1	Adaptor Sleeve	1
D	2025-150-2	Specification Label	1
E	26-5	Spring Pin	1
F	2025-150-3	End Stop Bushing	1
G	2040-110-2	Hd. End Dual I.V. Pole Collar	1

2025-40-10 Optional Bed Extender Pad

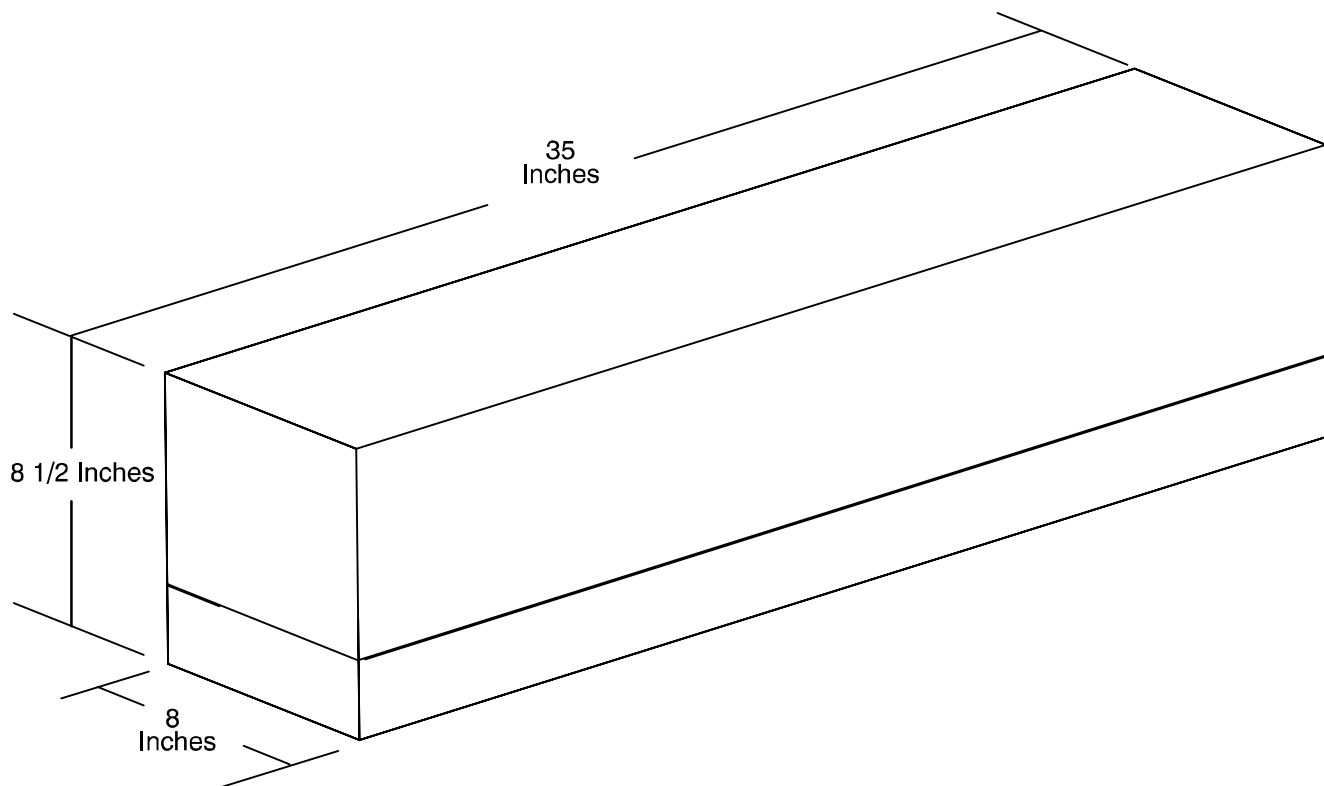

2040-130 Optional Siderail Pad Set

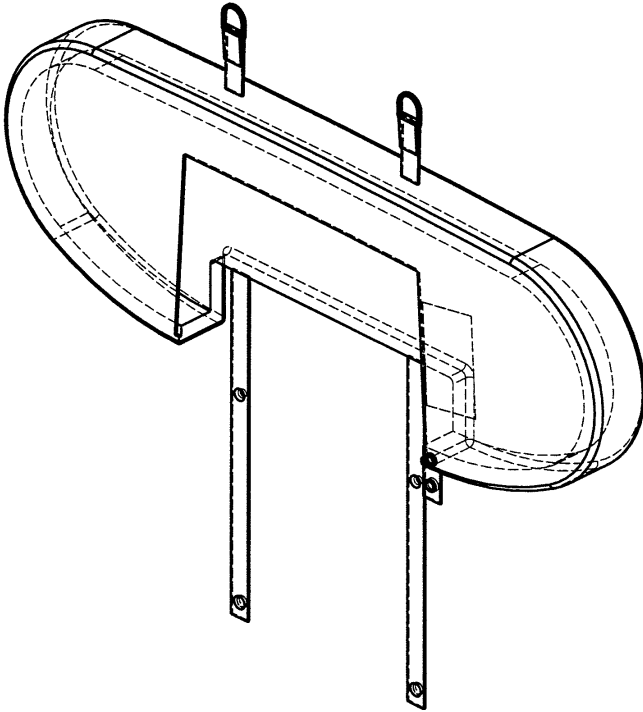

3000-336-11 Right Siderails (2)

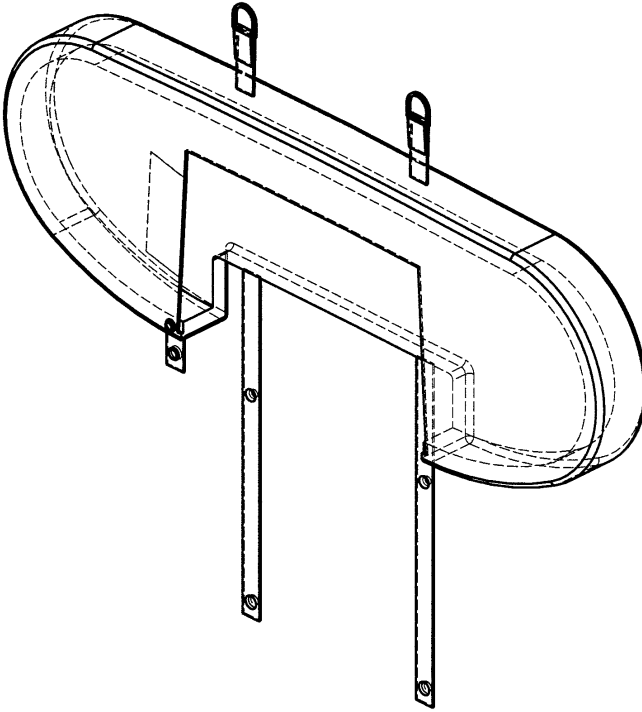

3000-336-12 Left Siderails (2)

Warranty

Limited Warranty:

Stryker Medical Division, a division of Stryker Corporation, warrants to the original purchaser that its products should be free from defects in material and workmanship for a period of one (1) year after date of delivery. Stryker's obligation under this warranty is expressly limited to supplying replacement parts and labor for, or replacing, at its option, any product which is, in the sole discretion of Stryker, found to be defective. Stryker warrants to the original purchaser that the frame and welds on its beds will be free from structural defects for as long as the original purchaser owns the bed. If requested by Stryker, products or parts for which a warranty claim is made shall be returned prepaid to Stryker's factory. Any improper use or any alteration or repair by others in such manner as in Stryker's judgement affects the product materially and adversely shall void this warranty. Any repair of Stryker products using parts not provided or authorized by Stryker shall void this warranty. No employee or representative of Stryker is authorized to change this warranty in any way.

Stryker Medical beds are designed for a 15 year expected life under normal use conditions and appropriate periodic maintenance as described in the maintenance manual for each device.

This statement constitutes Stryker's entire warranty with respect to the aforesaid equipment. STRYKER MAKES NO OTHER WARRANTY OR REPRESENTATION, EITHER EXPRESSED OR IMPLIED, EXCEPT AS SET FORTH HEREIN. THERE IS NO WARRANTY OF MERCHANTABILITY AND THERE ARE NO WARRANTIES OF FITNESS FOR ANY PARTICULAR PURPOSE. IN NO EVENT SHALL STRYKER BE LIABLE HEREUNDER FOR INCIDENTAL OR CONSEQUENTIAL DAMAGES ARISING FROM OR IN ANY MANNER RELATED TO SALES OR USE OF ANY SUCH EQUIPMENT.

To Obtain Parts and Service:

Stryker products are supported by a nationwide network of dedicated Stryker Field Service Representatives. These representatives are factory trained, available locally, and carry a substantial spare parts inventory to minimize repair time. Simply call your local representative, or call Stryker Customer Service at (800) 327-0770.

Service Contract Coverage:

Stryker has developed a comprehensive program of service contract options designed to keep your equipment operating at peak performance at the same time it eliminates unexpected costs. We recommend that these programs be activated *before* the expiration of the new product warranty to eliminate the potential of additional equipment upgrade charges.

A SERVICE CONTRACT HELPS TO:

- Ensure equipment reliability
- Stabilize maintenance budgets
- Diminish downtime
- Establish documentation for JCAHO
- Increase product life
- Enhance trade-in value
- Address risk management and safety

Warranty

Stryker offers the following service contract programs:

SPECIFICATIONS	GOLD	SILVER	PM* ONLY
Annually scheduled preventative maintenance	X		X
All parts,** labor, and travel	X	X	
Unlimited emergency service calls	X	X	
Priority one contact; two hour phone response	X	X	X
Most repairs will be completed within 3 business days	X	X	
JCAHO documentation	X	X	X
On-site log book w/ preventative maintenance & emergency service records	X		
Factory-trained Stryker Service Technicians	X	X	X
Stryker authorized parts	X	X	X
End of year summary	X		
Stryker will perform all service during regular business hours (9-5)	X	X	X

* Replacement parts and labor for products under PM contract will be discounted.

** Does not include any disposable items, I.V. poles (except for Stryker HD permanent poles), mattresses, or damage resulting from abuse.

Stryker Medical also offers *personalized* service contracts.

Pricing is determined by age, location, model and condition of product.

For more information on our service contracts, please call your local representative or call (800) 327-0770 (option #2).

Return Authorization:

Merchandise cannot be returned without approval from the Stryker Customer Service Department. An authorization number will be provided which must be printed on the returned merchandise. Stryker reserves the right to charge shipping and restocking fees on returned items.

SPECIAL, MODIFIED, OR DISCONTINUED ITEMS NOT SUBJECT TO RETURN.

Damaged Merchandise:

ICC Regulations require that claims for damaged merchandise must be made with the carrier within fifteen (15) days of receipt of merchandise. **DO NOT ACCEPT DAMAGED SHIPMENTS UNLESS SUCH DAMAGE IS NOTED ON THE DELIVERY RECEIPT AT THE TIME OF RECEIPT.** Upon prompt notification, Stryker will file a freight claim with the appropriate carrier for damages incurred. Claim will be limited in amount to the actual replacement cost. In the event that this information is not received by Stryker within the fifteen (15) day period following the delivery of the merchandise, or the damage was not noted on the delivery receipt at the time of receipt, the customer will be responsible for payment of the original invoice in full.

Claims for any short shipment must be made within thirty (30) days of invoice.

International Warranty Clause:

This warranty reflects U.S. domestic policy. Warranty outside the U.S. may vary by country. Please contact your local Stryker Medical representative for additional information.

European Representative

Stryker EMEA RA/QA Director
Stryker France
ZAC Satolas Green Pusignan
Av. De Satolas Green
69881 MEYZIEU Cedex
France

stryker[®]

3800 E. Centre Ave., Portage, MI 49002
(800) 327-0770
www.stryker.com



04/2010 2040-009-010 REV C