



**ZOOM®**  
**Critical Care bed**  
Model 2040

# stryker®

## Maintenance Manual



For Parts or Technical Assistance:  
USA: 1-800-327-0770 (option 2)





# Table of Contents

---

Introduction . . . . .	7
Intended Use . . . . .	7
Specifications . . . . .	7
Mattress Specifications . . . . .	7
Warning / Caution / Note Definition. . . . .	8
Symbols . . . . .	9
Summary of Safety Precautions . . . . .	10
Safety Tips and Guidelines. . . . .	10
Setup Procedures. . . . .	13
Operation Guide . . . . .	14
Head End Control Panel. . . . .	14
Outside Siderail Control Panel . . . . .	15
Inside Siderail Control Panel . . . . .	16
Footboard Control Panel . . . . .	17
Chaperone® Bed Exit (Optional Equipment) . . . . .	18
Chaperone® Bed Exit w/Zone Control (Optional Equipment) . . . . .	19
Scale System Control Panel (Optional Equipment) . . . . .	19
Pendant Operation. . . . .	20
Preventative Maintenance . . . . .	21
Nurse Call Battery . . . . .	21
Main Power Circuit Breaker . . . . .	21
Battery Charger Circuit Breaker . . . . .	21
Checklist . . . . .	22
Cleaning. . . . .	23
Troubleshooting Guide . . . . .	24
Quick Reference Replacement Parts List . . . . .	31
Electrical System Information . . . . .	33
Bed Wiring Diagram . . . . .	33
CPU Board - 3002-407-950 . . . . .	34
Software Configuration. . . . .	36
Power Supply - 0000-059-157 . . . . .	38
Inverter - Charger Board - 3002-001-030 . . . . .	39
Display/CPU - 2040-031-910 . . . . .	40
AC Crossover Board - 2040-031-900 . . . . .	41
DC Motor Power Board - 2040-001-900 . . . . .	42
Inverter Protection Features . . . . .	43
Service information. . . . .	46
Static Discharge Precautions . . . . .	46
Static Protection Equipment . . . . .	46
Brake Pedal Replacement . . . . .	47
Lift Motor And Capacitor Removal and Replacement. . . . .	48
Lift Housing Removal And Replacement . . . . .	49
Lift Potentiometer Replacement and Adjustment . . . . .	50

# Table of Contents

---

## Service information (Continued)

Lift Potentiometer “Burn-In” . . . . .	51
Lift Motor Coupler Replacement . . . . .	52
Power and Sensor Coil Cord Replacement . . . . .	53
Battery Removal and Replacement . . . . .	55
DC Motor Board Removal and Replacement . . . . .	56
Drive Motor Removal and Replacement . . . . .	57
Drive Wheel Removal and Replacement . . . . .	58
Load Cell Replacement . . . . .	59
Scale System Diagnostics and Calibration . . . . .	60
Head Motor Removal and Replacement . . . . .	62
Knee Motor Removal and Replacement . . . . .	63
Power Supply Removal and Replacement . . . . .	64
CPU Board Removal and Replacement . . . . .	64
Fowler Potentiometer Replacement . . . . .	65
Fowler Potentiometer “Burn-In” Procedure . . . . .	65
AC Crossover Board Replacement . . . . .	66
Display/CPU Board Replacement . . . . .	66
Control Bar Potentiometer Replacement (Serial # 0702088665 and Earlier) . . . . .	67
Control Bar Potentiometer “Burn-In” Procedure (Serial # 0702088665 and Earlier) . . . . .	68
Control Bar Potentiometer Replacement (Serial # 0702088666 and Later) . . . . .	69
Control Bar Potentiometer “Burn-In” Procedure (Serial # 0702088666 and Later) . . . . .	70
Optional Smart TV Interface “Burn-in” . . . . .	71
Siderail Cover Removal . . . . .	72
Molded Siderail Replacement . . . . .	73
Head End Siderail Cable Replacement . . . . .	74
Foot Board Lid Removal . . . . .	75
Foot Board Module Replacement . . . . .	76
Foot Board Interface Plug Replacement . . . . .	77

## Assembly Drawings

Base Assembly and Options . . . . .	78
Lift Assembly (Head & Foot End) . . . . .	85
Lift Assembly - 2040-243-275 . . . . .	86
Motor Isolation Plate Assembly . . . . .	89
Brake Shaft Assembly, Left - 3001-200-340 . . . . .	90
Brake Shaft Assembly, Right - 3001-200-345 . . . . .	90
Brake Crank Assembly - 3002-201-330 . . . . .	91
Brake Bar Assembly - 3002-200-335 . . . . .	92
6” Caster Assembly - 3001-200-060 . . . . .	93
6” Molded Wheel Assembly - 5000-002-010 . . . . .	94
Optional 8” Caster Assembly - 3001-200-090 . . . . .	95
Optional 8” Wheel Assembly - 0715-002-025 . . . . .	96
ZOOM® Base Assembly . . . . .	97

# Table of Contents

---

## Assembly Drawings (Continued)

Drive Wheel Lift Lever Assembly . . . . .	107
Foot End Bottom Cover - 3001-200-022 . . . . .	108
Head End Bottom Cover - 2040-001-017 . . . . .	108
ZOOM® Option Drive Train Assembly - 3002-001-014 . . . . .	109
ZOOM® Option Battery Tray Assembly . . . . .	110
ZOOM® Option Base Power Assembly - 3002-001-030 . . . . .	111
Litter Assembly and Options. . . . .	112
Actuator Box Cover Assembly . . . . .	125
Fowler Brake Kit Assembly - 3001-300-775. . . . .	126
ZOOM® Litter Assembly 2040-031-010 . . . . .	127
Optional 110V Outlet Assembly. . . . .	135
No Optional 110V Outlet. . . . .	138
110V Box Assembly . . . . .	139
Head End Siderail Assembly. . . . .	146
Timing Link Assembly, Head End, Left - 3003-402-005 . . . . .	147
Timing Link Assembly, Head End, Right - 3003-402-010 . . . . .	148
Siderail Bypass Detent Clip Assembly - 3002-400-090 . . . . .	149
Head End Siderail Inner Panel Assembly . . . . .	150
Head End Siderail Outer Panel Assembly - 2035-400-050. . . . .	151
Foot End Siderail Assembly . . . . .	152
Siderail Release Lever Assembly, Left - 3002-400-055 . . . . .	156
Head Board Assembly - 2035-130-010 . . . . .	158
Foot Board Assembly and Options - 2035-135-010 . . . . .	159
Foot Board No Scale/No Bed Exit - 2030-135-011 . . . . .	160
Optional Foot Board Scale - 2030-015-013. . . . .	161
Optional Foot Board Chaperone™ - 2030-135-012. . . . .	162
Optional Foot Board Chaperone™ w/Zone Control - 2030-135-015. . . . .	163
Optional Foot Board Scale and Chaperone™ - 2030-015-014 . . . . .	164
Opt. Foot Board Scale & Chaperone™ w/Zone Ctrl - 2030-015-016. . . . .	165
Foot Board Main Module Assembly - 2035-235-020 . . . . .	166
Foot Board Emergency Drop/Card. Chair Module - 2025-136-021 . . . . .	167
Optional Foot Board Bed Exit Module - 3001-508-030. . . . .	168
Optional Foot Board Zone Bed Exit Module - 3002-508-030 . . . . .	169
Optional Foot Board Scale Module Assembly - 3002-015-001 . . . . .	170
Optional Removable I.V. Pole Assembly - 3000-300-080 . . . . .	171
Optional 2 Stage I.V. Mounting Assembly - 2035-111-000. . . . .	172
Optional Head End 2-Stage I.V. Assembly - 2035-112-000 . . . . .	173
Optional Dual Head End I.V. Assembly - 2040-110-003 . . . . .	174
2 Stage I.V. Pole - 2035-112-010 & 2035-113-011. . . . .	175
I.V. Pole Latch Assembly - 0785-035-103 . . . . .	176
Optional X-Ray Cassette Tray Assembly - 2035-140-000. . . . .	177
Optional I.V. Pole Transducer Mount Assembly - 2035-018-010 . . . . .	178

# Table of Contents

---

Assembly Drawings (Continued)

- Optional Defibrillator Tray Assembly - 2025-120-010 . . . . . 179
- Optional Pump Rack Assembly - 2040-111-000 . . . . . 180
- Optional Pleur-Evac Rack with Defibrillator Tray - 2040-120-004 . . . . . 181
- Optional Pleur-Evac Rack Assembly - 2040-120-020 . . . . . 182
- Optional Upright Oxygen Bottle Holder - 2040-150-010 . . . . . 183
- Optional Bed Extender Pad - 2025-040-010 . . . . . 184
- Optional Siderail Pad Set - 3003-336-020 . . . . . 185

Warranty . . . . . 186

- Limited Warranty . . . . . 186
- To Obtain Parts and Service . . . . . 186
- Service Contract Coverage . . . . . 186
- Service Contract Programs . . . . . 187
- Return Authorization. . . . . 187
- Damaged Merchandise . . . . . 187
- International Warranty Clause. . . . . 187

# Introduction

## INTENDED USE

This manual is designed to assist you with the maintenance of Stryker Model 2040 ZOOM® Critical Care Bed. Carefully read this manual thoroughly before using the equipment or beginning maintenance on it. To ensure safe operation of this equipment, it is recommended that methods and procedures be established for educating and training staff on the safe operation of this bed.

## SPECIFICATIONS

	<p>Safe Working Load</p> <p><b>Note:</b> Safe Working Load indicates the sum of the patient, mattress, and accessory weight.</p>	500 pounds	227 kg
Scale System Capacity (optional equipment). Loads weighing up to		500 pounds	227 kilogram
Scale System Accuracy (optional equipment)		<p>±1 pound of total patient weight at any bed position<sup>1</sup> (patients weighing 100 pounds or less)</p> <p>±1% of total patient weight at any bed position<sup>1</sup> (patients weighing greater than 100 pounds)</p>	
Overall Length/Width		L-93" / W-42.5"	L-238 cm / W - 108 cm
<p>Minimum/Maximum Height (Standard)</p> <p>Minimum/Maximum Height (Enhanced)</p> <p>(Add 2 inches if the bed has 8" casters.)</p>		18" to 32.5" ±0.5	46 cm. to 82.5 cm.
		19.5" to 34.5" ±0.5	49.5 cm. to 88 cm.
Fluoro Access		16"	
Knee Gatch Angle		0° to 30°	
Back Angle		0° to 90°	
Trendelenburg/Reverse Trendelenburg		+10° to -12° ±1°	
Electrical Requirements		115 VAC, 60 Hz, 7.0 Amps	
Battery Voltage		24V, 31 Ah	
Outlet Option		125 VAC, 5A, 60 Hz	
<p><sup>1</sup> If the bed is equipped with the enhanced height option, the scale accuracy is as described above for litter angles from 0° to ±5° Trend.</p>			
<b>MATTRESS SPECIFICATIONS</b>			
Thickness		6"	
Width		≥ 35"	
Length		≥ 84"	
ILD		80	

**Stryker reserves the right to change specifications without notice.**

Specifications listed are approximate and may vary slightly from unit to unit or by power supply fluctuations.

# Introduction

---

## **WARNING / CAUTION / NOTE DEFINITION**

The words WARNING, CAUTION, and NOTE carry special meanings and should be carefully reviewed.

---

### **WARNING**

Alerts the reader about a situation, which, if not avoided, could result in death or serious injury. It may also describe potential serious adverse reactions and safety hazards.

---

### **CAUTION**

Alerts the reader of a potentially hazardous situation, which, if not avoided, may result in minor or moderate injury to the user or patient or damage to the equipment or other property. This includes special care necessary for the safe and effective use of the device and the care necessary to avoid damage to a device that may occur as a result of use or misuse.

---

### **Note**

This provides special information to make maintenance easier or important instructions clearer.



# Symbols

---



Warning, Refer to Service/Maintenance Manual



Alternating Current



Type B Equipment: Equipment providing a particular degree of protection against electric shock, particularly regarding allowable leakage current and reliability of the protective earth connection.

Class 1 Equipment: Equipment in which protection against electric shock does not rely on **basic insulation** only, but which includes an additional safety precaution in that means are provided for the connection of the **equipment** to the protective earth conductor in the fixed wiring of the installation in such a way that **accessible metal parts** cannot become live in the event of a failure of the **basic insulation**.

**IPX4**

Protection from liquid splash



Dangerous Voltage Symbol



Protective Earth Terminal



Potential Equalization Symbol



Medical Equipment Classified by Underwriters Laboratories Inc. with respect to Electric Shock, Fire, Mechanical and Other Specified Hazards Only in Accordance with UL 60601-1, First Edition (2003) and CAN/CSA C22.2 No. 601.1-M90 with updates 1 and 2.



Safe Working Load Symbol



In accordance with **European Directive 2002/96/EC** on Waste Electrical and Electronic Equipment (**WEEE**), this symbol indicates that the product must not be disposed of as unsorted municipal waste, but should be collected separately. Refer to your local distributor for return and/or collection systems available in your country.

# Summary of Safety Precautions

---

## SAFETY TIPS AND GUIDELINES

Before operating the 2040 Patient Transport Frame, it is important to read and understand all information in this manual. Carefully read and strictly follow the safety guidelines listed on this page. To ensure safe operation of the transport frame, methods and procedures must be established for educating and training hospital staff on the intrinsic risks associated with the usage of motorized electric units

---

### WARNINGS

- The 2040 Patient Transport Frame is equipped with a hospital grade plug for protection against shock hazard. It must be plugged directly into a properly grounded three-prong receptacle. Grounding reliability can be achieved only when a hospital grade receptacle is used.
- Serious injury can result if caution is not used when operating the unit. Operate the unit only when all persons are clear of the electrical and mechanical systems.
- To help reduce the number and severity of falls by patients, always leave the bed in the lowest position when the patient is unattended.
- When raising the siderails, listen for the “click” that indicates the siderail has locked in the up position. Pull firmly on the siderail to ensure it is locked into position. Siderails are not intended to be a patient restraint device. It is the responsibility of attending medical personnel to determine the degree of restraint and the siderail positioning necessary to ensure a patient will remain safely in bed.
- Always apply the caster brakes when a patient is getting on or off the bed. Always keep the caster brakes applied when a patient is on the bed (except during transport). Injury could result if the bed moves while a patient is getting in or out of bed.
- Ensure the brakes are completely released prior to attempting to move the unit. Attempting to move the unit with the brakes actuated could result in injury to the user and/or patient.
- Put the drive wheel in the neutral position and release the brakes before pushing the unit manually. Do not attempt to push the unit manually with the drive wheel engaged. The unit will be difficult to push and injury could result.
- The CPR emergency release requires assistance to lower the Back if the angle of the Back is above 80°. Attempting to lower the Back in this position without assistance may result in injury to the operator.
- The power save mode is activated after one hour on battery power with no motion release switch activation. Functions, including Bed Exit scale and motion, will cease to operate when the unit enters the power save mode. Injury to the patient could occur if proper patient monitoring protocol is not observed.
- The Bed Exit System is intended only to aid in the detection of a patient exiting the unit. It is not intended to replace patient monitoring protocol. The bed exit system signals when a patient is about to exit. Adding or subtracting objects from the frame after arming the bed exit system may cause a reduction in the sensitivity of the bed exit system.
- To avoid pinching your fingers, place the I.V. pole in the upright position before using the drive handle.
- Always unplug the power cord and push the battery power on/off switch to the “Off” position before service or cleaning. When working under the frame, always place blocks under the litter frame to prevent injuries in case the Bed Down switch is accidentally activated.
- Battery posts, terminals and related accessories contain lead and lead compounds, chemicals known to the State of California to cause cancer and birth defects or other reproductive harm. Wash hands after handling.
- The 2040 Patient Transport Frame is intended for use by trained hospital personnel only.

Service only by qualified personnel. Refer to maintenance manual.

- Do not modify the 2040 Patient Transport Frame. Modifying the unit can cause unpredictable operation resulting in injury to the patient or operator. Modifying the unit will also void its warranty.
- When using any mattress and/or mattress overlay that increases the overall height greater than 6” extra caution and/or operator supervision is required to help reduce the likelihood of a patient fall occurring.

# Summary of Safety Precautions

---

## SAFETY TIPS AND GUIDELINES (CONTINUED)

To avoid possible injury and to assure proper operation when using a powered mattress replacement system such as XPRT:

- Confirm proper scale system operation following mattress installation. For best results, secure the therapy mattress power cord to prevent damage to the cord or interference with the bed frame and the scale system.
- Do not zero bed scales or weigh patient with Percussion, Vibration, Rotation or Turn-Assist active. Patient motion and position resulting from the dynamic therapy mattress may adversely affect scale system performance.
- Do not initialize (“Arm”) bed exit with Percussion, Vibration, Rotation or Turn-Assist active. The patient motion and position resulting from the dynamic therapy mattress may adversely affect bed exit system performance.
- When using an XPRT Therapy Mattress extra caution and/or operator supervision is required to help reduce the likelihood of a patient fall occurring.

---

## CAUTIONS

- Use caution while maneuvering the unit with the drive wheel activated. Always ensure there are no obstacles near the unit while the drive wheel is activated. Injury to the patient, user, bystanders or damage to the frame or surrounding equipment could occur if the unit collides with an obstacle.
- Use caution when transporting the unit down halls, through doors, in and out of elevators, etc. Damage to the siderails or other parts of the unit could occur if the unit comes in contact with walls or door frames.
- If unanticipated motion occurs, unplug the power cord from the wall socket, push the battery power on/off switch to the “Off” position (the LED will not be illuminated) and actuate the drive wheel pedal to the neutral position.
- The siderails are not intended to be used as a pushing device. Damage to the siderails could occur.
- The use of a mattress overlay may reduce the effectiveness of the siderail.
- When attaching equipment to the frame, ensure it will not impede normal operation. I.E.: Hooks on hanging equipment must not actuate control buttons, equipment must not hide the nurse call button, etc.
- Use caution when lowering the bed with items attached to the optional accessory rail. If caution is not used, items may contact the floor resulting in damage to the items and/or injury to the patient or user.
- The lockout buttons on the foot board lock the Fowler, Gatch and Bed Up/Down functions and prevent motion of the bed. It is the responsibility of attending medical personnel to determine whether these functions should be locked and to use the buttons accordingly.
- Scale function may be affected by siderail/caster interference. With the litter fully lowered or lowered in Reverse Trendelenburg, the siderails tucked under the litter in the storage position and the casters turned, there is the potential for interference between the siderail and the caster. Raise the siderails when lowering the litter to the full down position to prevent the interference from causing the bed’s scale system to weigh inaccurately.
- If large fluid spills occur in the area of the circuit boards or motors, immediately unplug the power cord from the wall socket and push the battery power on/off switch to the “Off” position. Remove the patient from the unit and clean up the fluid. Have maintenance completely check the unit. Fluids can short out controls and may cause the unit to operate erratically or make some functions completely inoperable. Component failure caused by fluids could even cause the unit to operate unpredictably and could cause injury to the patient. Do not put the unit back into service until it is completely dry and has been thoroughly tested for safe operation.
- Preventative maintenance should be performed at a minimum of annually to ensure all features are functioning as designed. Close attention should be given to safety features including, but not limited to:
  - Safety side latching mechanisms,
  - Caster braking systems,
  - Leakage current 300 microamps max.
  - No controls or cabling entangLED in frame mechanisms.
  - Frayed electrical cords and components.
  - All controls return to off or neutral position when released
- The battery tray assembly weighs 50 pounds. Take care when removing the two hexagonal head screws securing it to the base frame or personal injury could result.
- The 2040 Patient Transport Frame is not intended for pediatric use or for patients under 50 pounds.

# Summary of Safety Precautions

---

## SAFETY TIPS AND GUIDELINES (CONTINUED)

- Because individual beds may have different options, foot boards should not be moved from one bed to another. Interchanging foot boards between beds could result in unpredictable bed operation.
- The weight of the I.V. bags should not exceed 40 pounds.
- Do not add or remove weight when the bed exit system is armed.
- The cleanliness and integrity of both ground chains must be maintained to minimize static build up and discharge.
- I.V. Poles should not be used as a bed push/pull device.

The following Caution statements apply to the optional 110V outlet:

- Maximum total load 5A receptacle rating: 125 VAC, 5A, 60 Hz.
- The total system chassis risk current should not exceed 300  $\mu$ A.
- Grounding continuity should be checked periodically.
- Do not use for life-sustaining equipment.
- Use only hospital-grade equipment with electrical outlet.
- Unplug free-standing equipment before transporting the bed.

---

### **WARNING**

Potential pinch points.



# Setup Procedures

---

It is important that the 2040 Patient Transport Frame is working properly before it is put into service. The following list will help ensure that each part of the transport frame is checked.

- Plug the power cord into a properly grounded, hospital grade wall receptacle.



## **WARNING**

The 2040 Patient Transport Frame is equipped with a hospital grade plug for protection against shock hazard. It must be plugged directly into a properly grounded three-prong receptacle. Grounding reliability can be achieved only when a hospital grade receptacle is used.

- Depress the pedal at either side of the transport frame fully to set the four wheel brakes and ensure all four casters lock. Depress the pedal again to release the brakes.
- Ensure the siderails raise and lower smoothly and lock in the up and intermediate positions.
- Run through each function on the foot board control panel and ensure that each is working properly.
- Ensure all functions are working properly on the siderail controls.
- Ensure all motion functions are working properly at the head end of the transport frame.
- Raise the Back up to approximately 60°. Squeeze the CPR release handle and ensure the Back and Knee will drop with minimal effort.
- Unplug the power cord from the wall socket. Push the battery power switch located on the lower left corner of the head end to the “On” position. Again, verify each function on the foot board and siderails is operating properly.
- With the battery power switch in the “On” position and the brakes engaged, ensure the “Release Brakes” LED on the head end control panel is illuminated.
- With the battery power switch in the “On” position and the drive wheel disengaged (not touching the floor), ensure the “Engage Drive Wheel” LED on the head end control panel is illuminated.
- Run through the operation of the drive wheel to ensure it is operating properly.
- If the bed is equipped with the Nurse Call option, verify it is functioning properly prior to patient use.

# Operation Guide

## HEAD END CONTROL PANEL

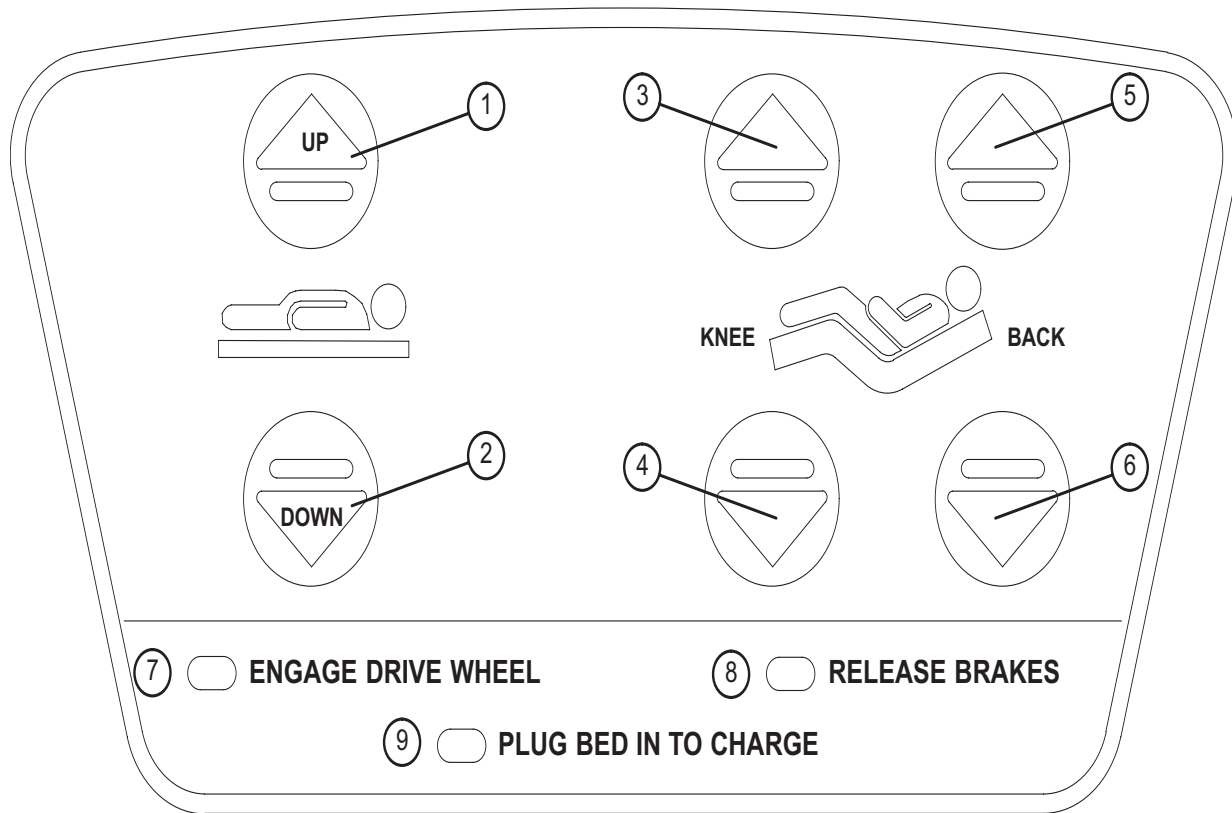

1. Press and hold to raise the litter. If your bed is equipped with the enhanced height option, continue to hold the button an additional 5 seconds after the first stop. The litter will raise an additional 2 inches.
2. Press and hold to lower the litter.
3. Press to raise the knee section.
4. Press to lower the knee section.
5. Press to raise the back section.
6. Press to lower the back section.
7. The "Engage Drive Wheel" LED will be illuminated whenever the battery power switch is on and the drive wheel pedal is in the disengaged position. The light will go off when the drive wheel is engaged.
8. The "Release Brakes" LED will be illuminated whenever the frame's brakes are engaged while the battery power switch is on. The light will go off when the brakes are disengaged.
9. The "Plug Bed In To Charge" LED will be illuminated while the battery power switch is on if the battery level is low. Plug the power cord into the wall socket to charge the batteries.

# Operation Guide

## OUTSIDE SIDERAIL CONTROL PANEL

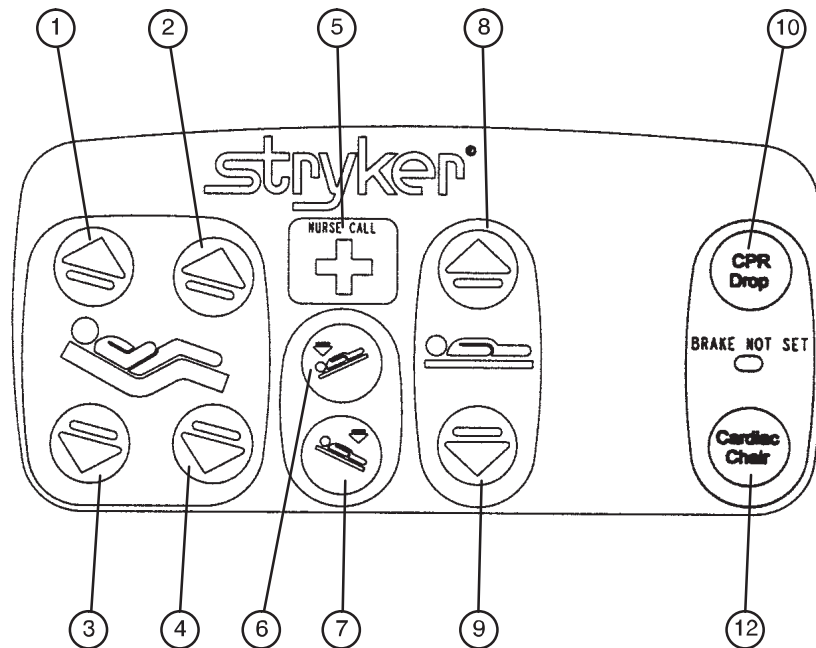

1. Press to raise back section.
2. Press to raise knee section.
3. Press to lower back section.
4. Press to lower knee section.
5. Press to activate nurse call.
6. Press to lower the head end (Trendelenburg).
7. Press to lower the foot end (Reverse Trendelenburg).
8. Press to raise the litter. If your bed is equipped with the enhanced height option, continue to hold the button an additional 5 seconds after the first stop. The litter will raise an additional 2 inches.
9. Press to lower the litter.
10. Press to activate emergency CPR positioning.
11. Press to activate Cardiac Chair positioning.

# Operation Guide

## INSIDE SIDERAIL CONTROL PANEL

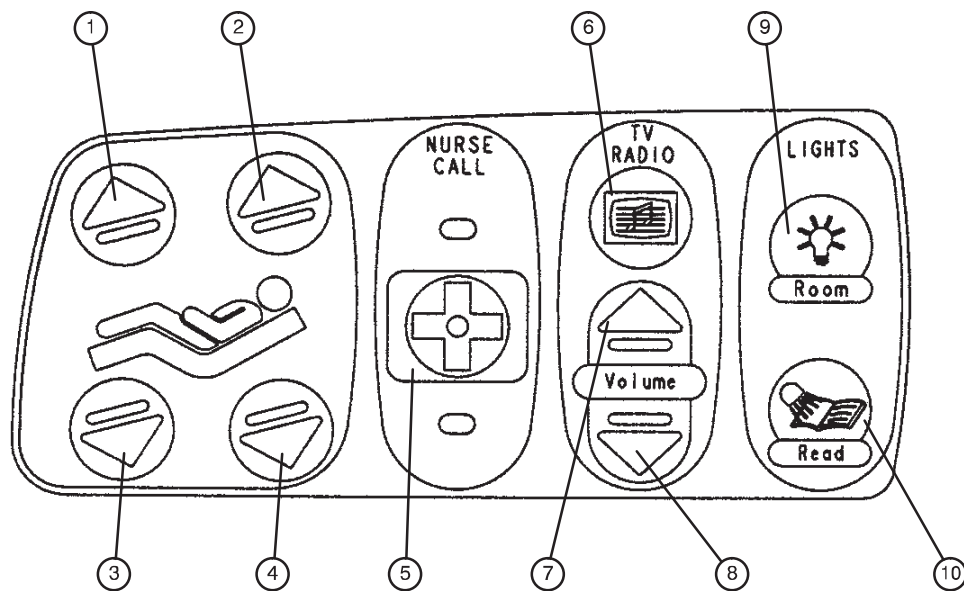

1. Press to raise knee section.
2. Press to raise back section.
3. Press to lower knee section.
4. Press to lower back section.
5. Press to activate the nurse call.
6. Press to turn on the TV or radio. Press again to change TV channels and to turn off the TV.
7. Press to increase the TV or radio volume.
8. Press to decrease the TV or radio volume.
9. Press to turn on the room lights. Press again to turn off.
10. Press to turn on the reading light. Press again to turn off.

### WARNING

Because individual beds may have different options, foot boards should not be moved from one bed to another. Mixing foot boards could result in unpredictable bed operation.



# Operation Guide

## FOOTBOARD CONTROL PANEL

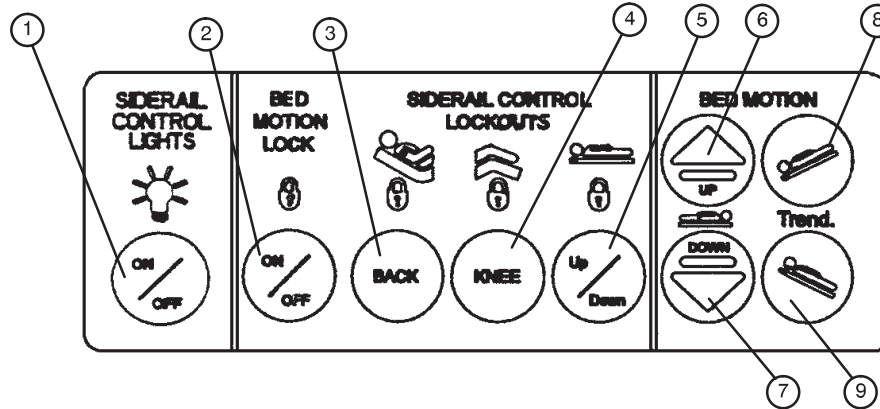

1. Press repeatedly for low, medium and high settings for the siderail control lights. Continue to press this switch to turn off the siderail control lights and the nurse call indicator light.
2. Press to lock out all motion controls on the siderails. Press again to unlock.
3. Press to lock out Back motion control on the siderails. Press again to unlock.
4. Press to lock out Knee motion control on the siderails. Press again to unlock.
5. Press to lock out up/down motion controls on the siderails. Press again to unlock.
6. Press to raise litter. If your bed is equipped with the enhanced height option, continue to hold the button an additional 5 seconds after the first stop. The litter will raise an additional 2 inches.
7. Press to lower litter.
8. Press to lower head end (Trendelenburg).
9. Press to lower foot end (Reverse Trendelenburg).

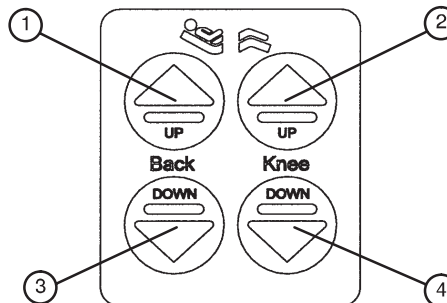

1. Press to raise back section.
2. Press to raise knee section.
3. Press to lower back section.
4. Press to lower knee section.

# Operation Guide

## FOOTBOARD CONTROL PANEL (CONTINUED)

### Foot Panel

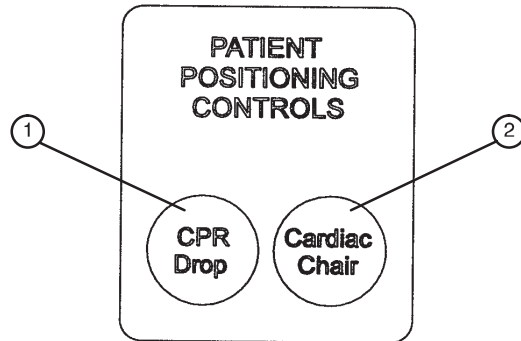

1. Press to activate the emergency CPR function. The back will lower to flat, the knee will lower to flat, the litter will level from Trendelenburg/reverse Trendelenburg, and the litter will lower to full down.
2. Press to activate the Cardiac Chair function. The knee will raise, the Fowler will raise or lower to approximately 52° and the bed will tilt to approximately -12° reverse Trendelenburg (foot end down) or -14° if the bed has the enhanced height option. Release the button to stop bed movement: Hold the button until movement stops to complete the function.

## CHAPERONE® BED EXIT (OPTIONAL EQUIPMENT)

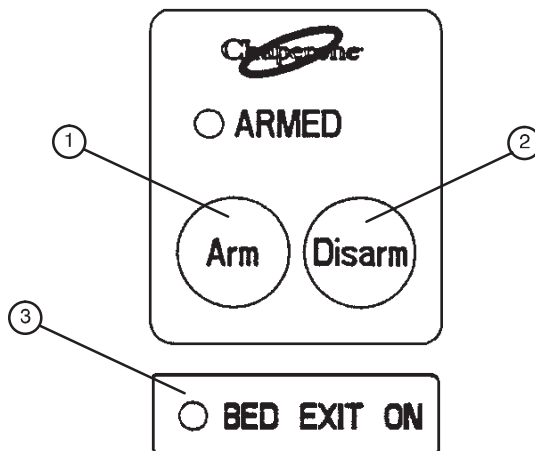

1. Press to arm the Bed Exit function.
2. Press to disarm the Bed Exit function.
3. **"Bed Exit On" LED** - will light when the **bed exit** function is armed.

# Operation Guide

## CHAPERONE® BED EXIT W/ZONE CONTROL (OPTIONAL EQUIPMENT)

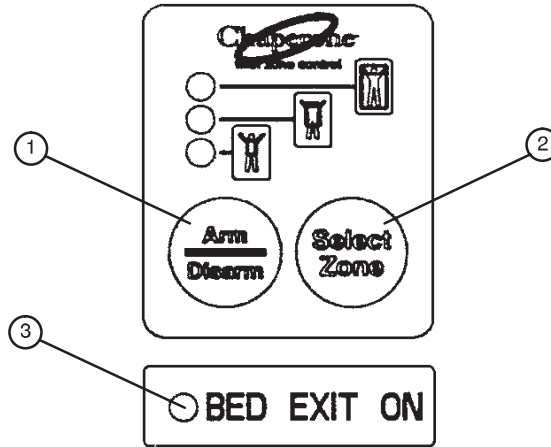

1. Press to arm or disarm the Bed Exit function.
2. Press to select the zone desired for Bed Exit function.
3. "Bed Exit On" LED - will light when the bed exit function is armed.

## SCALE SYSTEM CONTROL PANEL (OPTIONAL EQUIPMENT)

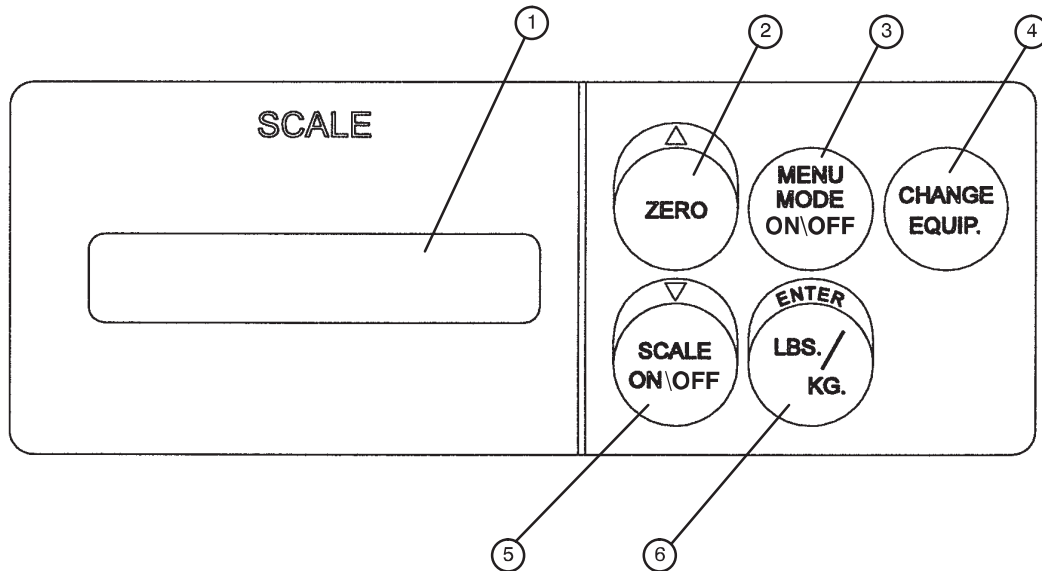

1. LCD - displays patient weight. Trendelenburg angle is displayed when the scale is not active.
2. Press to zero system. Also press to scroll while Menu Mode is active.
3. Press to enter and exit the Menu Mode.
4. Press when adding or removing equipment on the frame.
5. Press to turn weigh system on and off. Also press to scroll while Menu Mode is active.
6. Press to change weight from pounds to kilograms or back. Also press while using the Menu Mode.

# Operation Guide

## PENDANT OPERATION

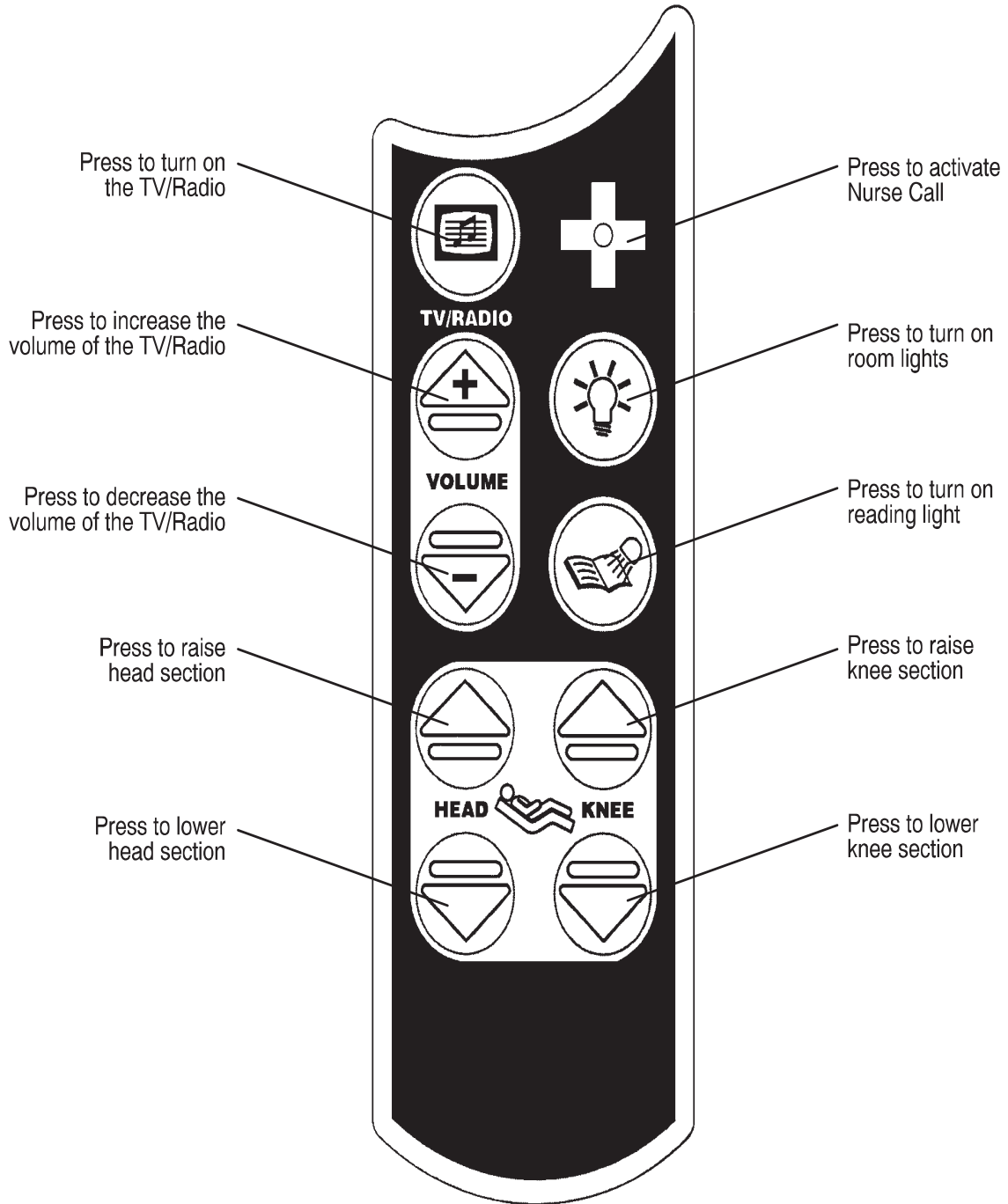

# Preventative Maintenance

---

## WARNING

Service only by qualified personnel. Refer to the maintenance manual. Ensure the power cord is unplugged and the battery power switch is turned to the off position before servicing.

### NURSE CALL BATTERY

To prevent a low battery condition when the power cord is not plugged in, position the cord out switch at the head end to the off position. The switch is identified by the label shown below. If the switch is not positioned as shown below and the power cord and pendant cord are unplugged, the life of the backup battery will be significantly reduced.

If the foot board power LED is flashing, the Nurse Call battery needs to be replaced. The battery is located on the patient's left side under the litter frame. No tools are required to replace the battery. Unplug the power cord from the wall socket and replace the battery. After replacing the battery, verify the foot board power LED is no longer flashing. Properly dispose of the old battery in accordance with local regulations.

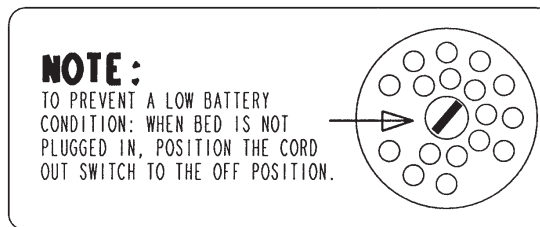

### MAIN POWER CIRCUIT BREAKER

In the event of a loss of electric function, unplug the power cord from the wall socket and reset the circuit breaker(s) located under the head end of the litter on the patient's left side. Plug the power cord into a properly grounded wall receptacle and follow the setup procedures.

### BATTERY CHARGER CIRCUIT BREAKER

If the battery charger circuit breaker(s) located under the litter on the patient's head end, left side are tripped, refer to the troubleshooting section of the maintenance manual.

# Preventative Maintenance

---

**CHECKLIST**

- \_\_\_\_\_ All fasteners secure.
- \_\_\_\_\_ Engage brake pedal and push on the frame to ensure all casters lock securely.
- \_\_\_\_\_ Locking steer caster engages and disengages properly.
- \_\_\_\_\_ Engage drive wheel and ensure it is operating properly.
- \_\_\_\_\_ Motion release switches working properly.
- \_\_\_\_\_ Confirm Head End Control Panel functionality.
- \_\_\_\_\_ Confirm battery powered functionality.
- \_\_\_\_\_ Siderails move, latch and stow properly.
- \_\_\_\_\_ All functions on siderails working properly (including LED's).
- \_\_\_\_\_ Manual CPR release working properly.
- \_\_\_\_\_ Optional Foot prop intact and working properly.
- \_\_\_\_\_ I.V. pole working properly.
- \_\_\_\_\_ Foley bag hooks intact.
- \_\_\_\_\_ Chart rack intact and working properly.
- \_\_\_\_\_ CPR board not cracked or damaged and stores properly.
- \_\_\_\_\_ No cracks or splits in head and foot boards.
- \_\_\_\_\_ All functions on footboard working properly (including LED's).
- \_\_\_\_\_ No rips or cracks in mattress cover.
- \_\_\_\_\_ Scale and Bed Exit system calibrated properly.
- \_\_\_\_\_ Power cord not frayed.
- \_\_\_\_\_ No cables worn or pinched.
- \_\_\_\_\_ All electrical connections tight.
- \_\_\_\_\_ All grounds secure to the frame.
- \_\_\_\_\_ Ground impedance not more than 100 milliohms.
- \_\_\_\_\_ Current leakage not more than 300 microamps.
- \_\_\_\_\_ Apply grease to litter grease points.
- \_\_\_\_\_ Ensure ground chains are clean, intact, and have at least two links touching the floor.
- \_\_\_\_\_ Fowler functioning properly.

Bed Serial Number:		

Completed by: \_\_\_\_\_ Date: \_\_\_\_\_

# Cleaning

---

Hand wash all surfaces of the bed with warm water and mild detergent. Dry thoroughly. Do not steam clean or hose off the ZOOM® Bed. Do not immerse any part of the bed. Some of the internal parts of the bed are electric and may be damaged by exposure to water.

Suggested cleaners for bed surfaces:

- Quaternary Cleaners (active ingredient - ammonium chloride).
- Phenolic Cleaners (active ingredient - o - phenylphenol).
- Chlorinated Bleach Solution (5.25% - less than 1 part bleach to 100 parts water).

Avoid over-saturation and ensure the product does not stay wet longer than the chemical manufacturer's guidelines for proper disinfecting.



## CAUTION

Some cleaning products are corrosive in nature and may cause damage to the product if used improperly. If the products described above are used to clean Stryker patient care equipment, measures must be taken to insure the beds are wiped with clean water and thoroughly dried following cleaning. Failure to properly rinse and dry the beds will leave a corrosive residue on the surface of the bed, possibly causing premature corrosion of critical components. Failure to follow the above directions when using these types of cleaners may void this product's warranty.

For mattress cleaning instructions, please see the tag on the mattress, or contact the mattress manufacturer.

Clean Velcro® after each use. Saturate Velcro® with disinfectant and allow disinfectant to evaporate. (Appropriate disinfectant for nylon Velcro® should be determined by the hospital).

# Troubleshooting Guide

## Note

See Electrical System Information Section for an outline of bed PCB's and voltage test points.

Problem / Failure	Recommended Action
No power to bed.	<ul style="list-style-type: none"> <li>A. Verify the power cord connections at the wall and the bed.</li> <li>B. Check circuit breakers, under the litter/gatch section on the patient left side. If the circuit breaker is tripped, reset it by pushing in.</li> <li>C. Check for 120 VAC at J1 on the power supply, Pin 1 (brown) and Pin 2 (blue).</li> <li>D. Check for DC voltages on J2 (Pins 1, 2, 3 &amp; 6) on power supply. See Software Configuration for power supply voltage test points.               <ul style="list-style-type: none"> <li>a. If voltage is present, check connector W on the CPU board and check for the same DC voltages. If OK, go to step E.</li> <li>b. If voltage is not present, unplug connector W on the CPU board and recheck for DC voltages at J2 on the power supply.                   <ul style="list-style-type: none"> <li>1. If voltages come back, reconnect cable W to the CPU board, and go to step c.</li> <li>2. If DC voltage does not come back, replace the power supply.</li> </ul> </li> <li>c. Unplug all connectors except for F, FF, O, and W from the CPU board and recheck voltages on connector W.                   <ul style="list-style-type: none"> <li>1. If DC voltages come back, plug the cable connections back in until problem comes back, isolate the problem to a component or assembly.</li> <li>2. If DC voltages do not come back, replace the CPU board.</li> </ul> </li> </ul> </li> <li>E. Check for 120 VAC at connector O on the CPU board.               <ul style="list-style-type: none"> <li>a. If voltage is present, replace the CPU board.</li> </ul> </li> <li>F. Verify bed function and return to service.</li> </ul>



# Troubleshooting Guide

Problem / Failure	Recommended Action
No bed down motion.	<p>A. Enter diagnostics (Refer to Scale System Diagnostics and Calibration Section) and press bed down.</p> <p>a. If motion is not present, verify there is a two-pin shunt present on connector Z, closest to the center of the bed, if not, install shunt (0059-137-000).</p> <p>1. Test bed down motion, if motion is present then go to step D.</p> <p>b. If motion is present, re-burn lift potentiometer limits (Refer to Lift Potentiometer “Burn-in” Procedure Section).</p> <p>B. Check for 5 VDC on TP 9 (HL) and TP 7 (FL) referencing ground test point while pressing bed down.</p> <p>a. If 5 VDC is present, go to step C.</p> <p>b. If 5 VDC is not present, replace CPU board.</p> <p>C. Check for 120 VAC power on connector N (HL) and G (FL), pin 1 (white) and pin 3 (black), of the CPU board, while pressing bed motion up.</p> <p>a. If voltage is not present, replace CPU board.</p> <p>b. If voltage is present:</p> <p>1. Verify the motors are running, if so, replace lift couplers.</p> <p>2. If motors are not running, check voltage at motor connection.</p> <p>3. If voltage is present at motor, check capacitors or motors.</p> <p>D. Verify bed function and return to service.</p>
No bed up motion.	<p>A. Enter diagnostics, (Refer to Scale System Diagnostics and Calibration Section) and press bed up.</p> <p>a. If motion is not present, go to step B.</p> <p>b. If motion is present, re-burn lift potentiometer limits, (Refer to Lift Potentiometer “Burn-in” Procedure Section).</p> <p>B. Check for 5 VDC on TP 10 (HL) and TP 8 (FL) on the CPU board referencing ground test point while pressing bed up.</p> <p>a. If 5 VDC is present, go to step C.</p> <p>b. If 5 VDC is not present, replace CPU board.</p> <p>C. Check for 120 VAC power on connector N (HL) and G (FL), pin 1 (white) and pin 6 (red), of the CPU board while pressing bed motion up.</p> <p>a. If voltage is not present, replace CPU board.</p> <p>b. If voltage is present:</p> <p>1. Verify the motors are running, if so, replace lift couplers.</p> <p>2. If motors are not running, check voltage at motor connection.</p> <p>3. If voltage is present at motor, check capacitors or motors.</p> <p>D. Verify bed function and return to service.</p>

# Troubleshooting Guide

Problem / Failure	Recommended Action
No Gatch down motion.	<ul style="list-style-type: none"> <li>A. Check for 5 VDC on TP 5 on the CPU board referencing ground test point while pressing gatch down.               <ul style="list-style-type: none"> <li>a. If 5 VDC is present, go to step B.</li> <li>b. If 5 VDC is not present, replace CPU board.</li> </ul> </li> <li>B. Check for 120 VAC power on connector CC, pin 2 (red) and pin 3 (white), of the CPU board while pressing gatch down.               <ul style="list-style-type: none"> <li>a. If voltage is not present, replace the CPU board.</li> <li>b. If 120 VAC is present, check the capacitor and motor.</li> </ul> </li> <li>C. Verify bed function and return to service.</li> </ul>
No Gatch up motion.	<ul style="list-style-type: none"> <li>A. Check for 5 VDC on TP 6 on the CPU board referencing ground test point while pressing gatch up.               <ul style="list-style-type: none"> <li>a. If 5 VDC is present, go to step B.</li> <li>b. If 5 VDC is not present, replace CPU board.</li> </ul> </li> <li>B. Check for 120 VAC on connector CC, pin 1 (black) and pin 3 (white), of the CPU board while pressing gatch up.               <ul style="list-style-type: none"> <li>a. If voltage is not present, replace the CPU board.</li> <li>b. If 120 VAC is present, check the capacitor and motor.</li> </ul> </li> <li>C. Verify bed function and return to service.</li> </ul>
No Fowler up/or uneven motion.	<ul style="list-style-type: none"> <li>A. Check for 5 VDC on TP 3 on the CPU board referencing ground test point while pressing Fowler up.               <ul style="list-style-type: none"> <li>a. If 5 VDC is present, go to step B.</li> <li>b. If 5 VDC is not present, replace CPU board.</li> </ul> </li> <li>B. Check for 120 VAC on connector GG, Pin 1 (white) and pin 2 (black), of the CPU board while pressing Fowler up.               <ul style="list-style-type: none"> <li>a. If voltage is not present, replace the CPU board.</li> <li>b. If 120 VAC is present, check the capacitor and motor.</li> </ul> </li> <li>C. Refer to Fowler Mechanism Customer Guide (2030-009-028).</li> <li>D. Verify bed function and return to service.</li> </ul>
No Fowler down/or uneven motion.	<ul style="list-style-type: none"> <li>A. Check for 5 VDC on TP 4 on the CPU board referencing ground test point while pressing Fowler down.               <ul style="list-style-type: none"> <li>a. If 5 VDC is present, go to step B.</li> <li>b. If 5 VDC is not present, replace CPU board.</li> </ul> </li> <li>B. Check for 120 VAC on connector GG, Pin 1 (white) and pin 3 (red), of the CPU board while pressing Fowler up.               <ul style="list-style-type: none"> <li>a. If voltage is not present, replace the CPU board.</li> <li>b. If 120 VAC is present, check the capacitor and motor.</li> </ul> </li> <li>C. Refer to Fowler Mechanism Customer Guide (2030-009-028).</li> <li>D. Verify bed function and return to service.</li> </ul>

# Troubleshooting Guide

This section of the troubleshooting guide includes the ZOOM® self-propelled drive and the battery backup functions. When using this guide, assume the bed is functioning properly when powered by the AC line cord with the exception of the battery charging components.

Problem / Failure	Possible Cause	Recommended Action
ON/OFF switch is in the on position but the power LED is off and the bed does not function.	No DC voltage from the batteries.	<ul style="list-style-type: none"> <li>A. Check the fuse (F1) on the power board, (Refer to Ac Crossover Board section) replace if necessary (0000-059-730).</li> <li>B. Verify the battery voltage is greater than 24 VDC.</li> <li>C. Check the battery fuse - replace if necessary (2040-001-802).</li> <li>D. Check the cable connections from the batteries to the display board.</li> <li>E. Check the ON/OFF switch and cabling.</li> </ul>
ON/OFF switch is in the on position, the power LED is on but the bed does not function.	Display board is not functioning or is locking out all functions.	<ul style="list-style-type: none"> <li>A. Check the safety switches on the drive bar.</li> <li>B. Verify the battery voltage is greater than 24 VDC.</li> <li>C. Verify the display board is functioning (see note below).</li> <li>D. Check all cable connections on the display and power boards.</li> </ul>
ON/OFF switch is in the on position, the power LED is on, the ZOOM® drive works but the battery backup does not work.	The thermostat on the inverter/charger board has tripped, indicating a temperature above 110°C (230° F).	<ul style="list-style-type: none"> <li>A. Wait approximately 3 to 5 minutes to allow the inverter, charger board to cool down.</li> </ul>
The ZOOM® drive does not work - The bed does not drive - but all other functions are working.	ZOOM® drive circuitry is not responding.	<ul style="list-style-type: none"> <li>A. Verify the display board is functioning (see note below).</li> <li>B. Perform the control bar potentiometer “burn-in” procedure (Refer to Control Bar Potentiometer “Burn-in” Procedure Section).</li> <li>C. Check the control bar potentiometer. When the bar is centered, there should be 2.25 VDC to 2.75 VDC between pin 1 and pin 2 on header 1 on the display, CPU board (Refer to Inverter/Charger Board section).</li> <li>D. Check all cable connections on the display and power boards.</li> <li>E. Verify the power board is functioning.</li> <li>F. Verify the drive wheel is functioning.</li> </ul>

**Note**

The display board will display the state of battery charge when the bed is first powered using the ON/OFF switch:  
 Three LED's flash = 66% - 100% charged.  
 Two LED's flash = 33% - 66% charged.  
 One LED flashes = Less than 33% charged.  
 No LED's flash = No significant charge remaining.

# Troubleshooting Guide

---

<b>Problem / Failure</b>	<b>Possible Cause</b>	<b>Recommended Action</b>
The ZOOM® drive does work - the bed will drive - but all other bed functions are not working.	No AC power from the ZOOM® base.	A. Check AC voltage coming out of the inverter. It should be 120 VAC between pin 1 and pin 4 on header 5 on the AC crossover board (Refer to Display/CPU section). B. Check all cable connections from the batteries to the converter. C. Check the AC crossover board.
The bed power cord is plugged in but the battery does not charge.	The battery charger is not functioning.	A. Check the circuit breakers on the ZOOM® litter (Refer to NA 0000-059-179 Item) Circuit Breaker 2. B. Check the battery charger. C. Check all cable connections on the charger.

# Troubleshooting Guide

## INVERTER, CHARGER, BATTERY & ZOOM®

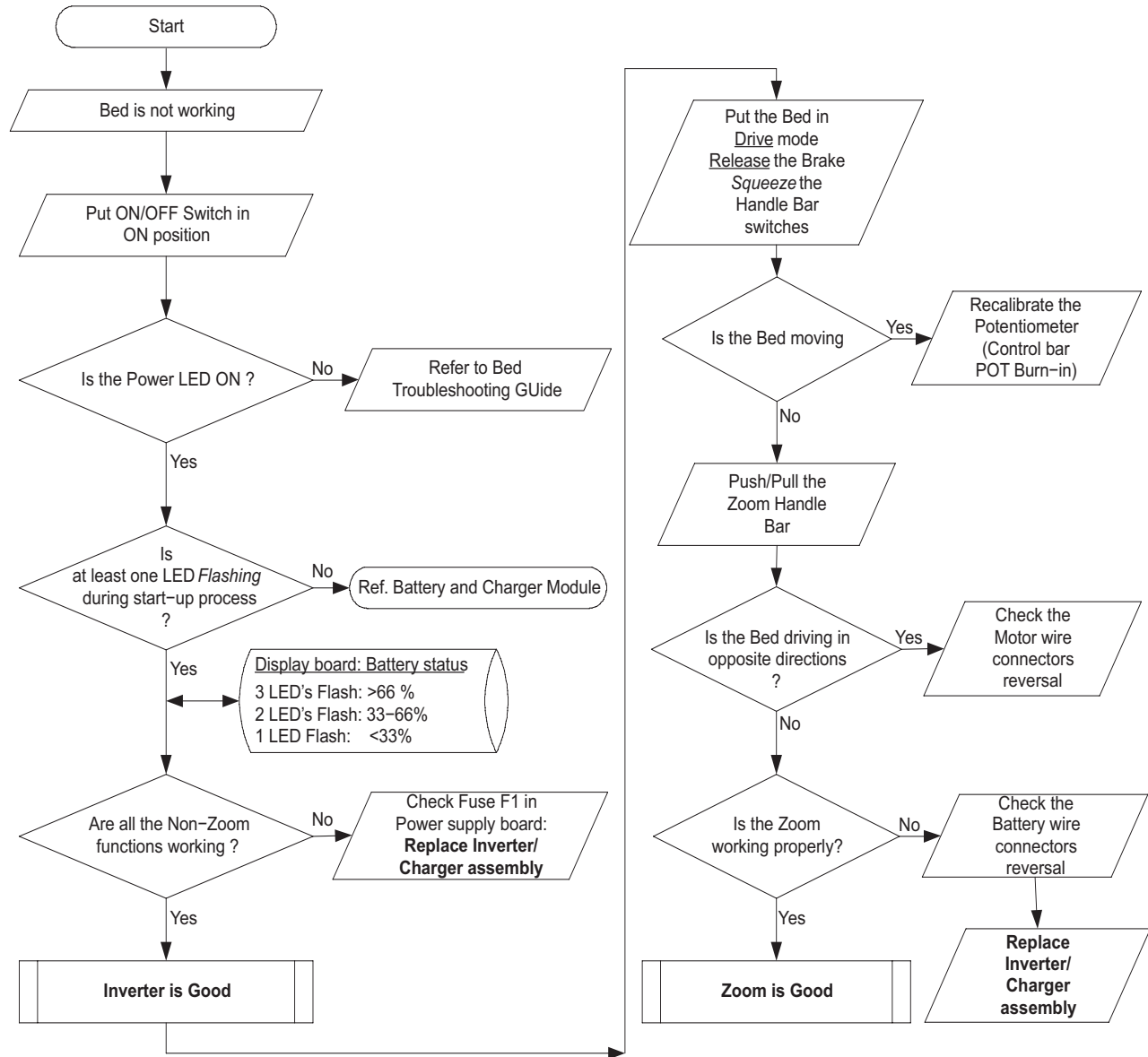

# Troubleshooting Guide

## INVERTER, CHARGER, BATTERY & ZOOM® (CONTINUED)

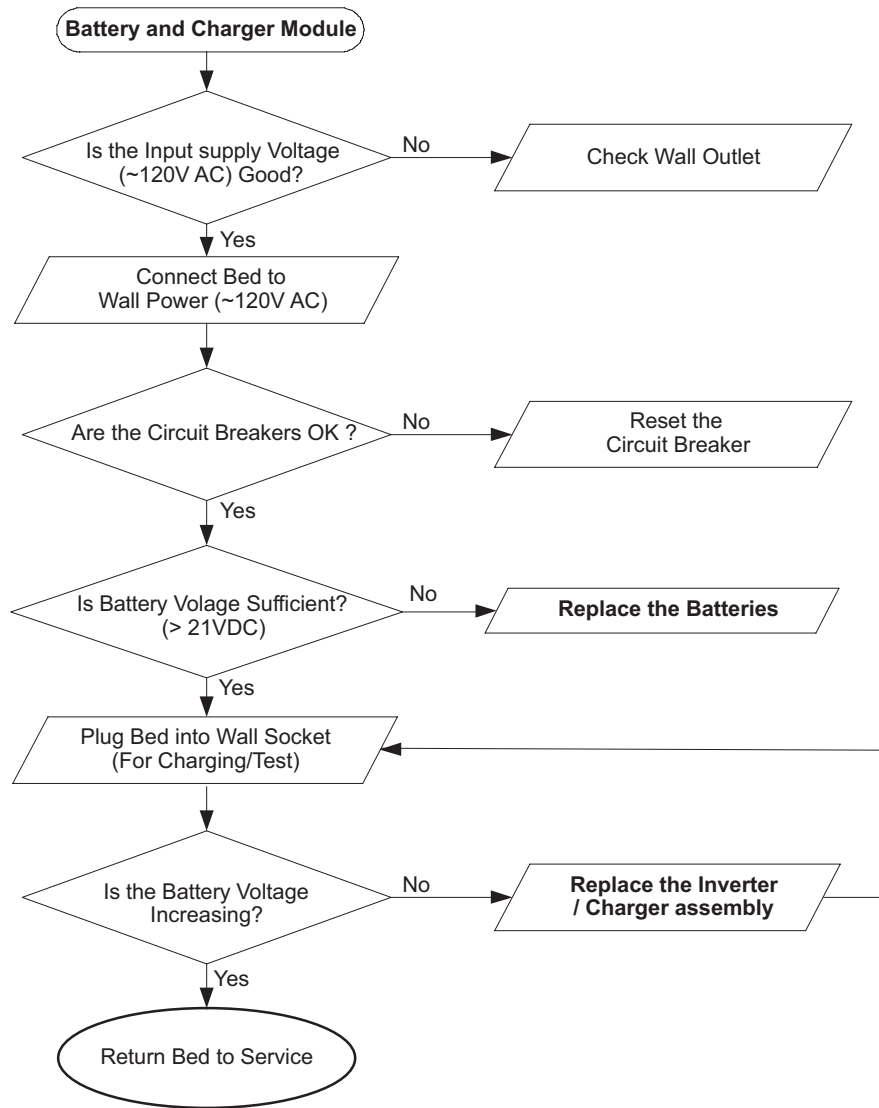

# Quick Reference Replacement Parts List

## Note

The parts and accessories listed on this page are all currently available for purchase. Some of the parts identified on the assembly drawing parts in this manual may not be individually available for purchase. Please call Stryker Customer Service USA: 1-800-327-0770 (Option 2), Canada: 1-888-233-6888 for availability and pricing.

Part Name	Part Number
<b><u>Electrical Components</u></b>	
AC Crossover Board	2040-031-900
Foot Board Keyboard (S/R Lights, Lockouts, etc.)	3001-500-028
Foot Board Scale Display	3001-507-900
Foot Board Scale Keyboard	3001-507-910
Foot Board Bed Exit Keyboard	3001-508-900
CPU Board	3002-407-950
Display/CPU Board	2040-031-910
Inverter/Charger Board (Optional)	2030-001-030
Motor Control Board	2040-001-900
Power Supply	0000-059-157
<b><u>Siderail Boards</u></b>	
Inside Board	3001-400-930
Outside Board	2035-400-900
Speaker W/Cable	3000-403-831
<b><u>Other Components</u></b>	
Adhesive, Head & Foot Board "C" Bumpers.	0072-002-071
Battery Kit	2040-700-013
Capacitor, Fowler & Gatch	0000-059-779
Capacitor, Fowler & Gatch, 230V	0000-059-153
Capacitor, Lift	0000-059-778
Capacitor, Lift, 230V	3221-200-243
Caster, 6"	3001-200-060
Caster, Steer, 6"	3001-200-050
Coil Cord, Lift Power	3001-200-864
Coil Cord, Lift Sensor	3001-200-815
Communications Tester	3002-045-700
Foot Prop Retrofit Kit	2030-700-106
Grease, Single Tube	0300-200-700
Load Cell	3002-307-057
Motor Coupler Kit, Lift	3000-200-725

## Quick Reference Replacement Parts List

---

Part Name	Part Number
<b>Other Components (Continued)</b>	
Motor, Drive Wheel	3002-001-072
Motor, Fowler & Gatch W/Clutch	3001-300-560
Motor, Fowler & Gatch W/Clutch, 230V	3221-300-705
Motor, Lift (Same For Head And Foot End)	3000-200-213
Motor, Lift, 230V (Same For Head And Foot End)	3221-200-213
Paint, Touch-up, Opal, Bottle W/brush	7000-001-321
Paint, Touch-up, Opal, Spray Can	7000-001-318
Potentiometer, Control Bar	2040-031-804
Potentiometer, Foot End	3001-200-230
Potentiometer, Foot End	2035-032-803
Potentiometer, Head End	3001-200-240
Power Cord	3002-700-049
Restraint Strap, 2 pieces	0000-390-019



# Electrical System Information

## BED WIRING DIAGRAM

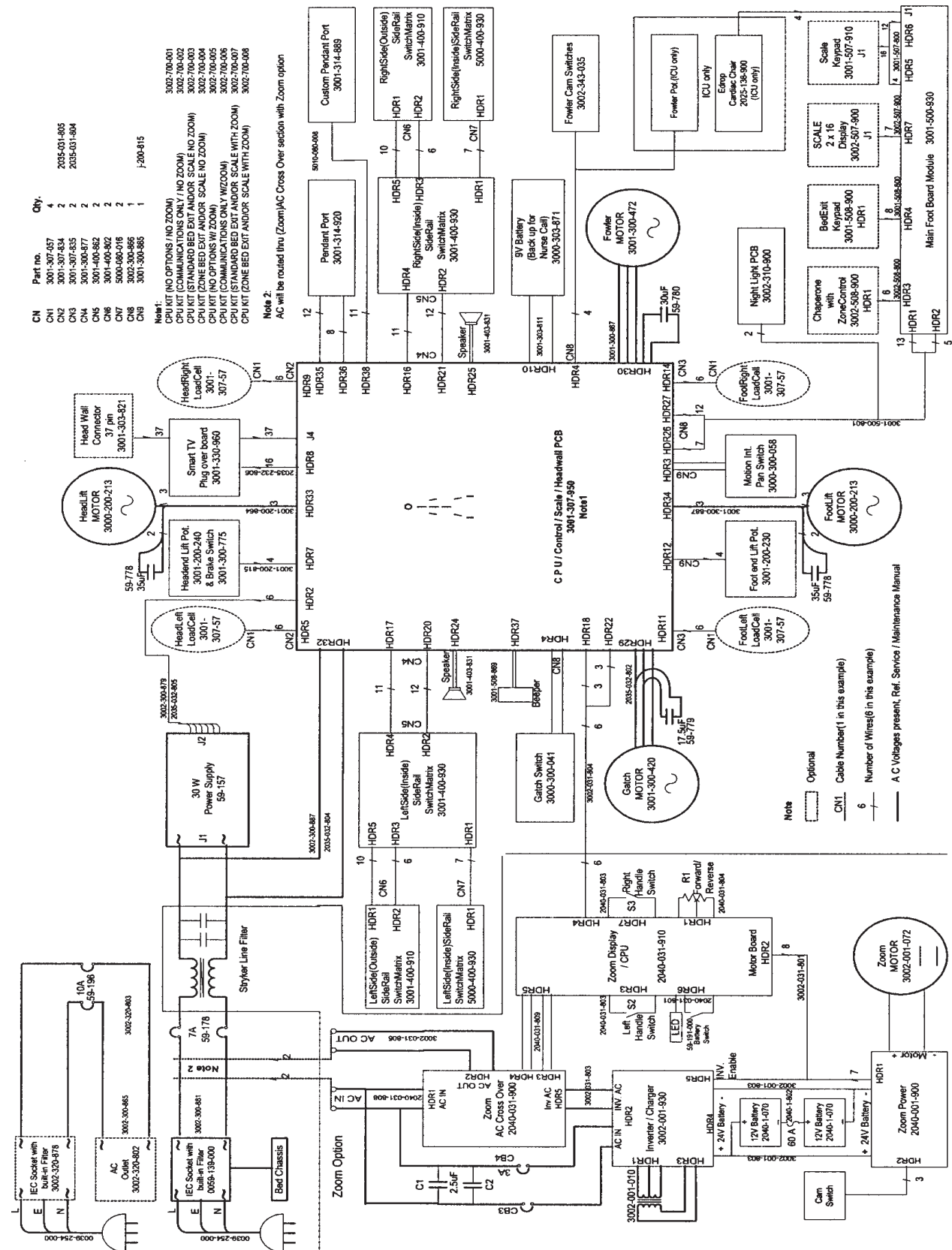

[Return To Table of Contents](#)

# Electrical System Information

## CPU BOARD - 3002-407-950

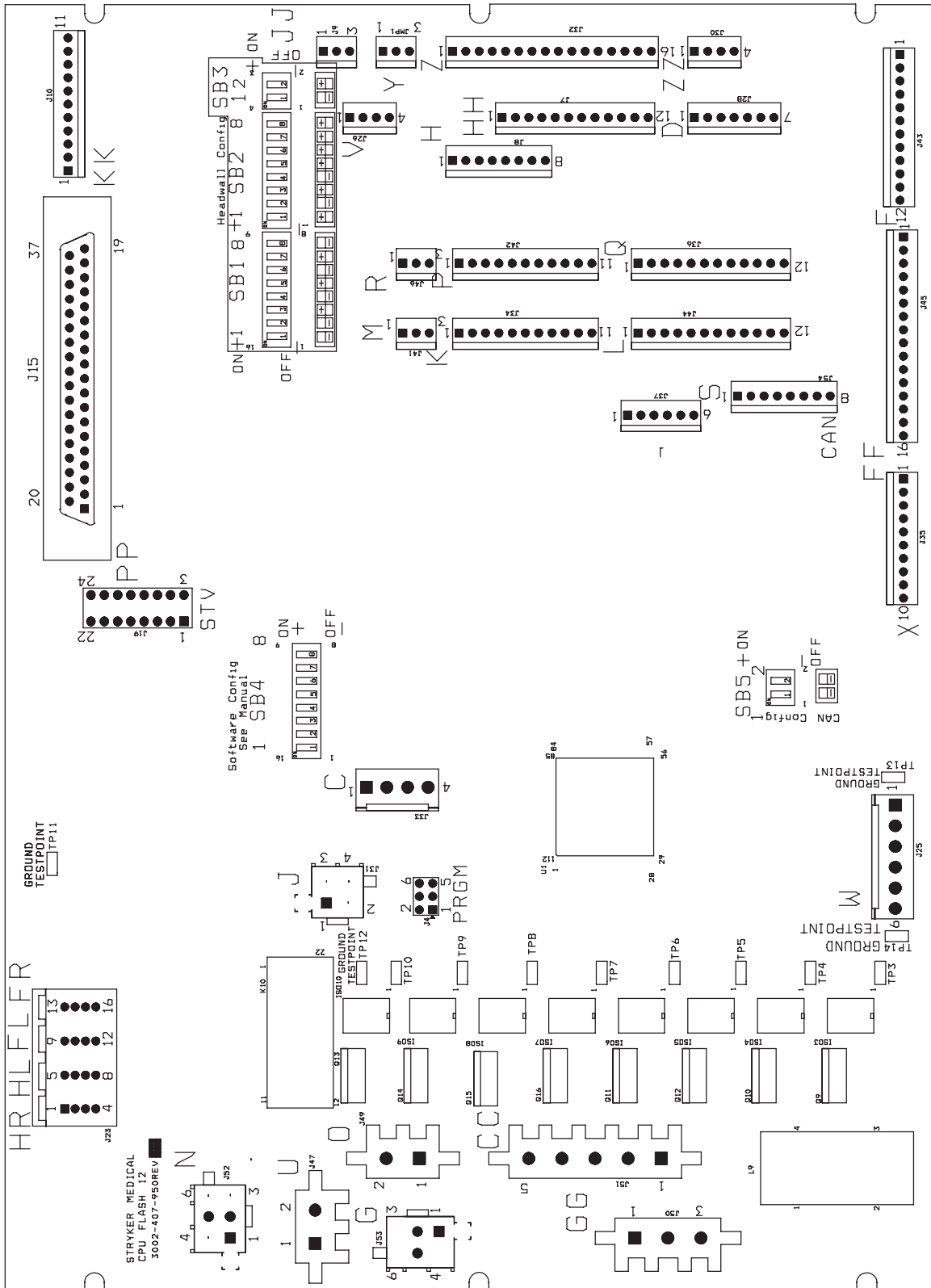

# Electrical System Information

## CPU BOARD - 3002-407-950 (CONTINUED)





Cable Location	Voltage	Positive LED	Negative LED	Description
W	+12 VDC	Pin 1	Pin 4 or 5	Relays & Siderails Light Voltage
W	+5 VDC	Pin 2 & 3	Pin 4 or 5	+5 VDC from Power Supply
W	-12 VDC	Pin 6	Pin 4 or 5	Relays & Siderails Light Voltage
J	+5 VDC	Pin 4 (Green)	Pin 2 (Black)	+5 VDC for Head Lift Pot
J	1-5 VDC	Pin 3 (Red)	Pin 2 (Black)	Head Lift Pot Wiper
C	+5 VDC	Pin 1 (Blue)	Pin 2 (White)	+5 VDC for Foot Lift Pot
C	1-5 VDC	Pin 3 (Black)	Pin 2 (White)	Foot Lift Pot Wiper
GG	0 VAC W/O Switch 120 VAC W/Switch	Pin 1 (Black)	Pin 3 (White)	Fowler Up
GG	0 VAC W/O Switch 120 VAC W/Switch	Pin 2 (Red)	Pin 3 (White)	Fowler Down
CC	0 VAC W/O Switch 120 VAC W/Switch	Pin 2 (Black)	Pin 1 (White)	Gatch Up
CC	0 VAC W/O Switch 120 VAC W/Switch	Pin 3 (Red)	Pin 1 (White)	Gatch Down
O	110 VAC	Pin 1	Pin 2	Line Voltage to Bed
N	0 VAC W/O Switch 120 VAC W/Switch	Pin 3 (Black)	Pin 1 (White)	Head Lift Down
N	0 VAC W/O Switch 120 VAC W/Switch	Pin 6 (Red)	Pin 1 (White)	Head Lift Up
G	0 VAC W/O Switch 120 VAC W/Switch	Pin 3 (Black)	Pin 1 (White)	Foot Lift Down
G	0 VAC W/W Switch 120 VAC W/Switch	Pin 6 (Red)	Pin 1 (White)	Foot Lift Up
ZZ	+5 VDC	Pin 1 (Red)	Pin 4 (Black)	+5 VDC for Fowler Pot
ZZ	1-5 VDC	Pin 3 (Green)	Pin 4 (Black)	Fowler Pot Wiper
V	9 VDC	Pin 2 (Red)	Pin 1 (Black)	Nurse Call Backup Battery
JJ	12 VDC when Bed Exit is Alarming	Pin 1 (Red)	Pin 2 (Black)	Bed Exit Beeper

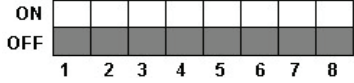

# Electrical System Information

## SOFTWARE CONFIGURATION (CONTINUED)

1. Locate switch bank 4, labeled SB4 on the CPU board (see above).
2. Move the switches to the appropriate positions for the specific bed (See picture below).
3. To verify the switch settings, check what the foot board LCD displays in the burn-in mode. For beds with a scale system, select software config. in the diagnostic mode.

 <p>ON OFF</p> <p>1 2 3 4 5 6 7 8</p>	FUNCTIONAL TEST
 <p>ON OFF</p> <p>1 2 3 4 5 6 7 8</p>	ICU-ZOOM / STANDARD BED
 <p>ON OFF</p> <p>1 2 3 4 5 6 7 8</p>	ICU-ZOOM / SCALE / BED EXIT
 <p>ON OFF</p> <p>1 2 3 4 5 6 7 8</p>	ICU-ZOOM / SCALE / ZONE CONTROL BED EXIT

# Electrical System Information

## POWER SUPPLY - 0000-059-157

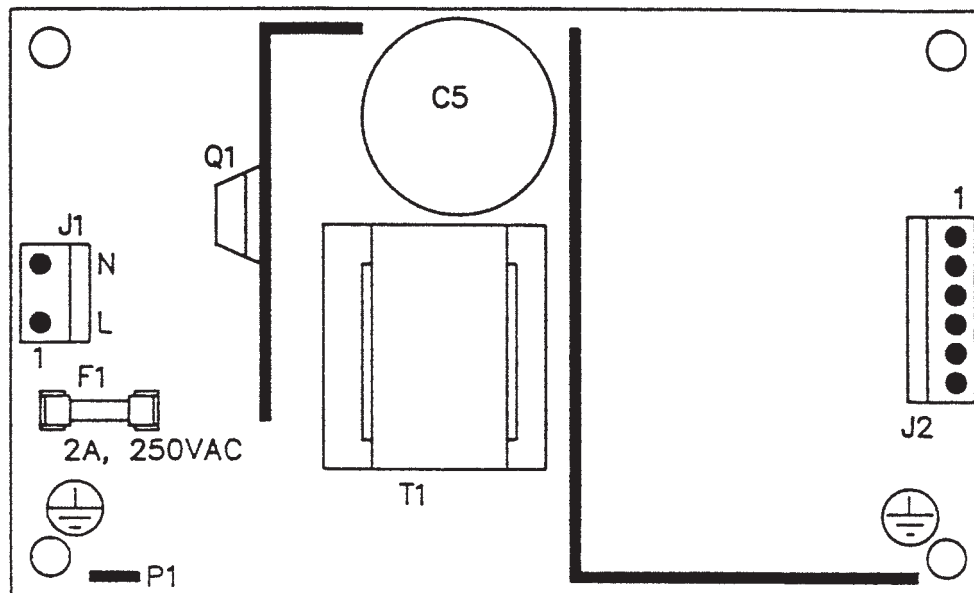

CONNECTOR LOCATION	VOLTAGE	POSITIVE LEAD	NEGATIVE LEAD
J1	110V	Pin 1	Pin 2
J2	12V	Pin 1	Pin 4 or 5
J2	5V	Pin 2	Pin 4 or 5
J2	5V	Pin 3	Pin 4 or 5
J2	GND	Pin 4	Pin 4 or 5
J2	GND	Pin 5	Pin 4 or 5
J2	-12V	Pin 6	Pin 4 or 5

# Electrical System Information

## INVERTER - CHARGER BOARD - 3002-001-030

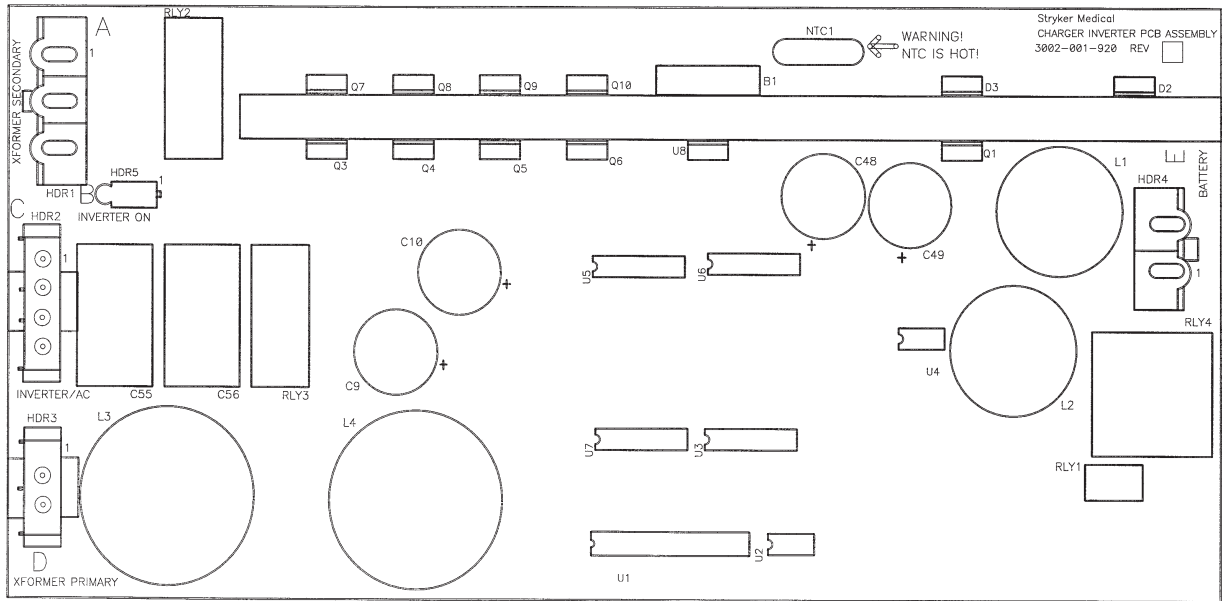

CONNECTOR LOCATION	VOLTAGE	POSITIVE LEAD	NEGATIVE LEAD	DESCRIPTION
HDR 4	26 VDC	Pin 2 Red	Pin 1 Black	From Battery - unplugged
HDR 1	22 VAC	Pin 3 Red	Pin 2	Secondary from Transformer - plugged in
HDR 1	34 VAC	Pin 1 Green	Pin 2 Brown	Secondary from Transformer - plugged in
HDR 2	110-140 VAC	Pin 4 Brown	Inverter Module Pin 3 Blue	Unplugged
HDR 2	110V	Pin 2 Brown	Pin 1 Blue	From Wall - plugged in
HDR 3	120V	Pin 2	Plug-In Pin 1	Wall Voltage - plugged in

# Electrical System Information

## DISPLAY/CPU - 2040-031-910

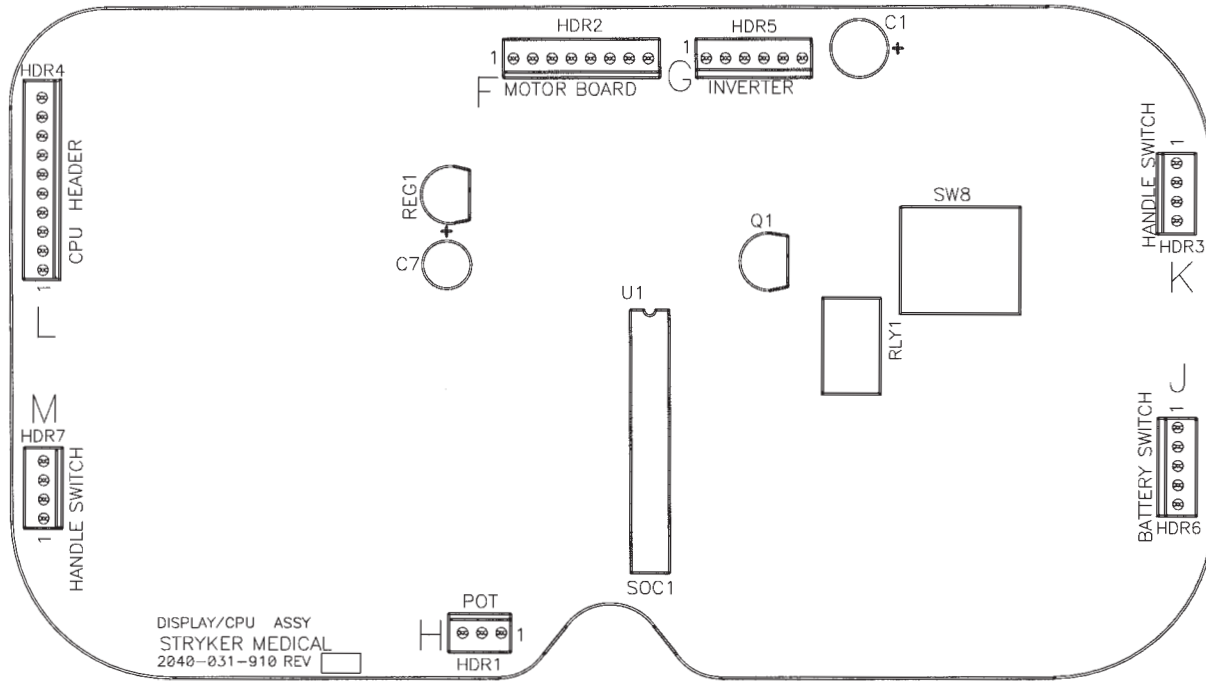

CONNECTOR LOCATION	VOLTAGE	POSITIVE LEAD	NEGATIVE LEAD	DESCRIPTION
HDR 1 (H)	0-5VDC	Pin 1	Pin 2	Control Pot Wiper Voltage (with Switch On)
HDR 6 (J)	Battery voltage around 26 VDC	Pin 1	Pin 5	Battery Voltage Return from On - Off Switch (with Switch On)
HDR 4 (L)	5 VDC	Pin 9	Pin 1	Voltage from CPU
HDR 1	5 VDC	Pin 1	Pin 3	DC Voltage to Pot
HDR 7	Continuity	Pin 1	Pin 4	Right Hand Switch
HDR 3	Continuity	Pin 1	Pin 4	Left Hand Switch
HDR 2	26 VDC	Pin 3	Pin 1	Battery Voltage



# Electrical System Information

## AC CROSSOVER BOARD - 2040-031-900

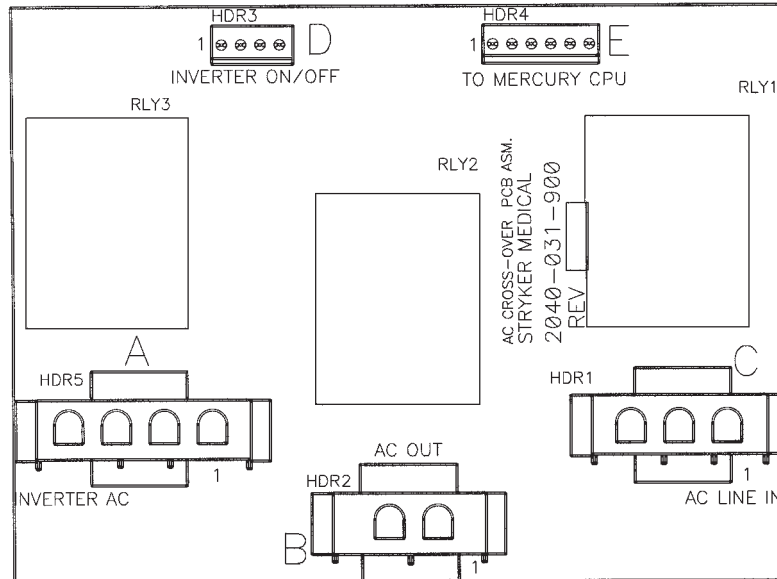

CONNECTOR LOCATION	VOLTAGE	POSITIVE LEAD	NEGATIVE LEAD	DESCRIPTION
HDR 5 (A)	120 VAC	Pin 4	Pin 1	AC Input to Board from the Inverter with the Power Cord Unplugged
HDR 1 (C)	120 VAC	Pin 3	Pin 1	AC Input to Board from the Wall Receptacle
HDR 2 (B)	120 VAC	Pin 2	Pin 1	AC Output of Board to Main Power
HDR 4 (E)	+5 VDC	Pin 4	Pin 1	+5 VDC when AC is Unplugged from the Wall Receptacle

# Electrical System Information

## DC MOTOR POWER BOARD - 2040-001-900

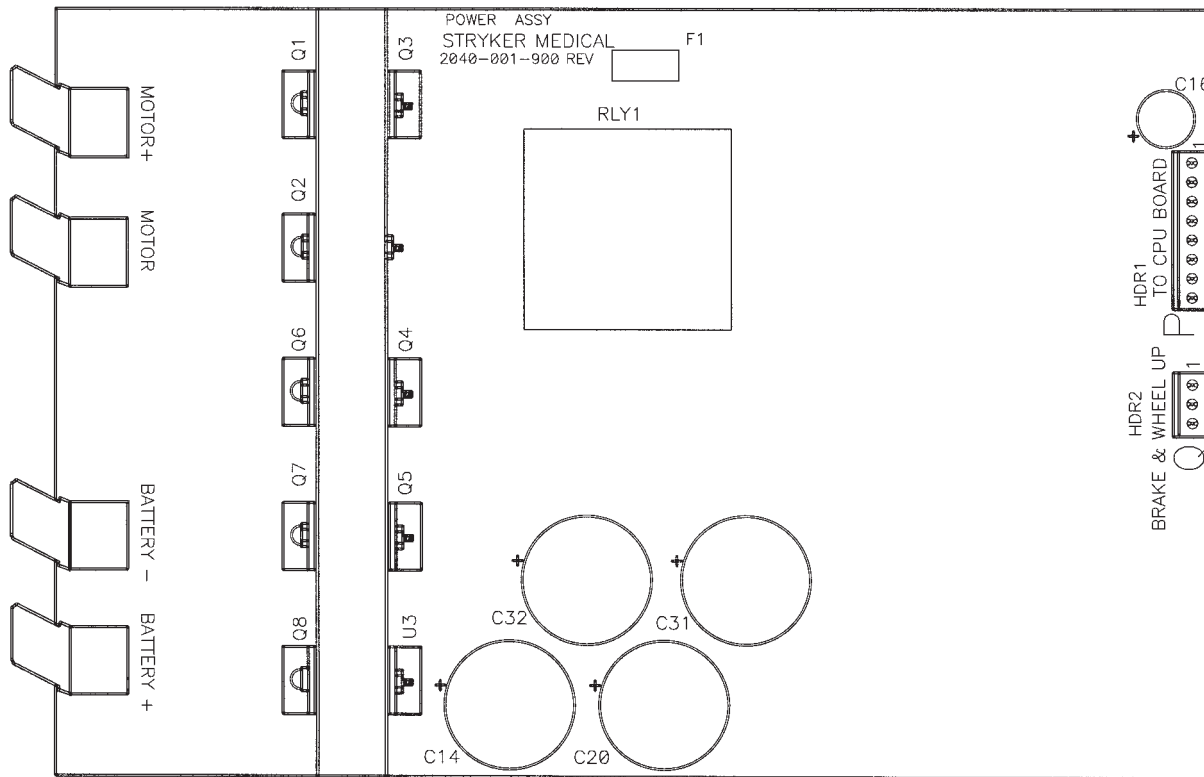

CONNECTOR LOCATION	VOLTAGE	POSITIVE LEAD	NEGATIVE LEAD	DESCRIPTION
HDR 1 (P)	Battery voltage around 26 VDC	Pin 3 Red	Pin 1 Black	Battery Voltage out to the Display/CPU Board
HDR 2 (Q)	5 VDC Disengaged 0 VDC Engaged	Pin 1 Red	Pin 3 Black	Drive Wheel
HDR 2 (Q)	5 VDC Disengaged 0 VDC Engaged	Pin 2 Red	Pin 3 Black	Brakes

# Electrical System Information

---

## INVERTER PROTECTION FEATURES

The inverter has several features to prevent internal damage:

1. Low Battery Voltage - If the battery voltage at the inverter drops below the low voltage cut-off, the inverter will shut off.
2. Over-Temperature - If the inverter gets too hot, it will shut off. The over heating may be caused by high ambient temperature, blocked air flow or an overload condition. When the inverter reaches an acceptable temperature, it will restart.
3. Over-Power - The inverter will source up to its maximum power rating. If the load requires more, the output voltage will shut down. Turning the power switch off and on will reset the inverter. Plugging the bed power cord into the wall socket to charge the battery will reset the inverter.



### **WARNING**

The inverter generates 115 VAC, the same as a wall receptacle. To prevent injury, do not put anything into the electrical outlets other than an appliance power cord. Keep the outlets covered when not in use. Do not submerge the unit or subject into moisture.

# Electrical System Information

## 37-PIN CONNECTOR

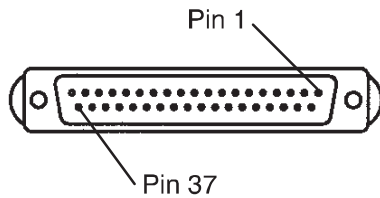

- Pin 1 Option 2 Common
- Pin 2 Read Light
- Pin 3 Room Light
- Pin 4 Speaker High
- Pin 5 Pot Wiper
- Pin 6 Radio Common
- Pin 7 Nurse Call Interlock
- Pin 8 Audio Transfer -
- Pin 9 Audio Transfer +
- Pin 10 Interlock +
- Pin 11 Interlock -
- Pin 12 Spare
- Pin 13 Options 3 Common
- Pin 14 Pot Low Common
- Pin 15 Pot High Common (Std.) - Audio (STV)
- Pin 16 Nurse Answer Light +
- Pin 17 Option 1 NO/NC
- Pin 18 Option 1 Common
- Pin 19 Nurse Call Light +
- Pin 20 Option 2 NO/NC
- Pin 21 Option 3 NO/NC
- Pin 22 Option 3 A NO/NC
- Pin 23 Option 2 A Common
- Pin 24 Option 2 A NO/NC
- Pin 25 Nurse Call +
- Pin 26 Nurse Call NO/NC
- Pin 27 Room/Read Light Common
- Pin 28 Nurse Call Light -
- Pin 29 Nurse Answer Light -
- Pin 30 Priority NO/NC
- Pin 31 Priority Common
- Pin 32 Option 3 A Common
- Pin 33 TV - (Std.) - Data (STV)
- Pin 34 TV + (Std.) - Common (STV)
- Pin 35 Speaker Low Common
- Pin 36 Audio Shield
- Pin 37 Radio NO/NC

## STRYKER PENDANT PORT

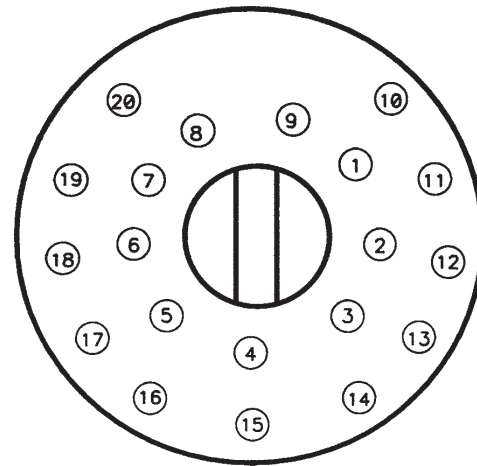

- 1. Scan Line
- 2. Audio (-)
- 3. Nurse Call (+)
- 4. +5 VDC
- 5. Scan Line
- 6. Scan Line
- 7. Nurse Call (-)
- 8. TV Channel Up
- 9. Backlight
- 10. Audio (+)
- 11. Gatch Up - Fowler In - Foot Up - DMS Firm
- 12. Gatch Down - Fowler Out - Foot Out - DMS Soft
- 13. Fowler Up - Trend In
- 14. Fowler Down - Trend Out
- 15. Audio Shield
- 16. Not Used - Socket FILLED
- 17. Litter Up
- 18. Ground
- 19. Read Light - Litter Down
- 20. Room Light

# Electrical System Information

---

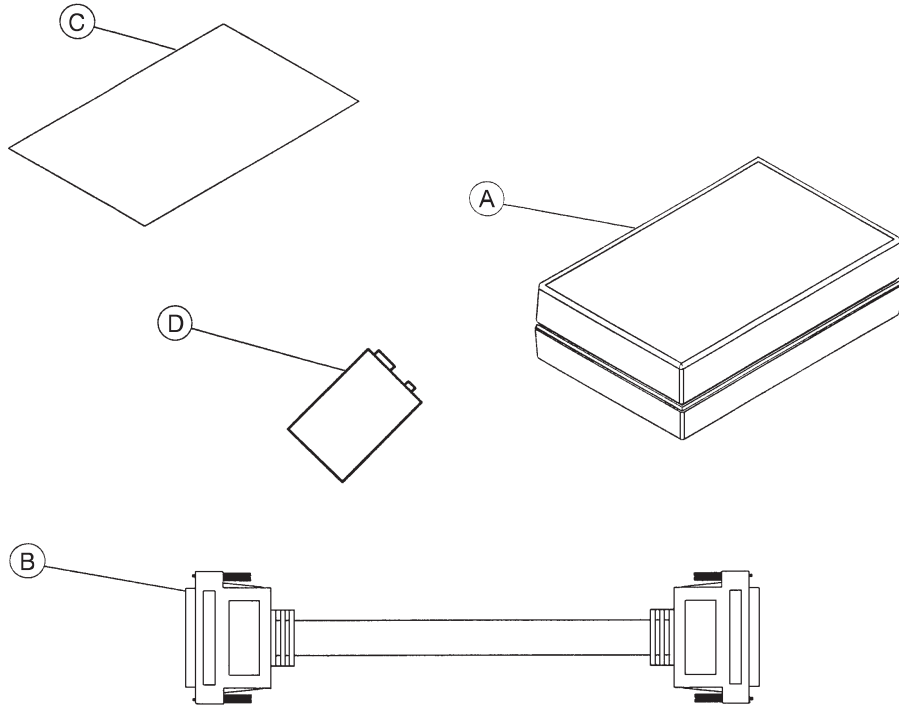

Item	Part No.	Part Name	Qty.
A	3002-045-805	BCT Unit	1
B	3001-303-825	37-Pin Cable	1
C	3002-045-806	Instructions	1
D	3000-303-871	9V Battery	1

# Service information

---

## STATIC DISCHARGE PRECAUTIONS

The electronic circuits in the 2040 are completely protected from static electricity damage only while the bed is assembled. It is extremely important that all service personnel always use adequate static protection when servicing the electronic systems of the Secure II. **Whenever you are touching wires, you should be using static protection.**

## STATIC PROTECTION EQUIPMENT

The necessary equipment for proper static protection is:

- 1 static wrist strap; 3M part number 2214 or equivalent,
- 1 grounding plug; 3M part number 61038 or equivalent,
- 1 test lead with a banana plug on one end and an alligator clip on the other; Smith part number N132B699 or equivalent

---

### CAUTION

All electronic service parts will be shipped in static shielding bags. Do not open the bags until you have completed steps 2 and 3 of the following procedure. Do not place unprotected circuit boards on the floor. All circuit boards to be returned to Stryker Medical should be shipped in the static shielding bags the new boards were shipped in.

### Static Protection Procedure

1. Unplug the power cord from the wall receptacle.
2. Insert the grounding plug into a properly grounded hospital grade wall receptacle. Plug the banana plug of the test lead into the receptacle on the grounding plug. Connect the alligator clip on the other end of the test lead to a ground point on the bed.
3. Place the static control wrist strap on your wrist. Connect the alligator clip at the other end of the wrist strap cord to a ground point on the bed.

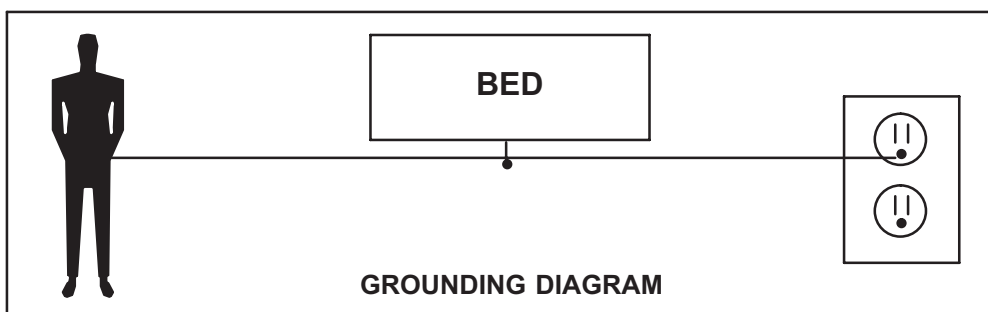

# Service Information

---

## BRAKE PEDAL REPLACEMENT

### Tools Required:

- 5/16" Hex Allen Wrench.
- Torque Wrench.
- Loctite 242.
- Hammer.
- Punch.
- #2 Phillips Screwdriver.
- Bungee Cords (or Equivalent).

### Procedure:

1. Raise the litter to the full up position.
2. Unplug the power cord from the wall socket and push the battery power on/off switch to the "Off" position.
3. Using a #2 Phillips screwdriver, remove the four screws holding the base hood to the frame. If necessary, hold the covers out of the way by using bungee cords (or the equivalent) to secure them to the litter top.
4. Using a 5/16" hex Allen wrench, remove the two bolts holding the brake pedal to the brake rod.
5. Using a hammer and punch, remove the roll pins holding the brake shaft crank to the brake rod on both the head and the foot end.
6. Push the brake rod through the frame until the brake pedal is clear. Remove the brake pedal.
7. Reverse steps 1 - 6 to attach the new brake pedal.

### Note

Use Loctite 242 when reinstalling the bolts and torque the bolts to 25 foot-pounds.

# Service information

## LIFT MOTOR AND CAPACITOR REMOVAL AND REPLACEMENT

### Tools Required:

- 3/8" Socket Wrench W/Extension.
- 5/16" Socket Wrench.
- Floor Jack.
- Side Cutters.
- 7/16" Open End Wrench.
- 2 x 4 (or Equivalent).

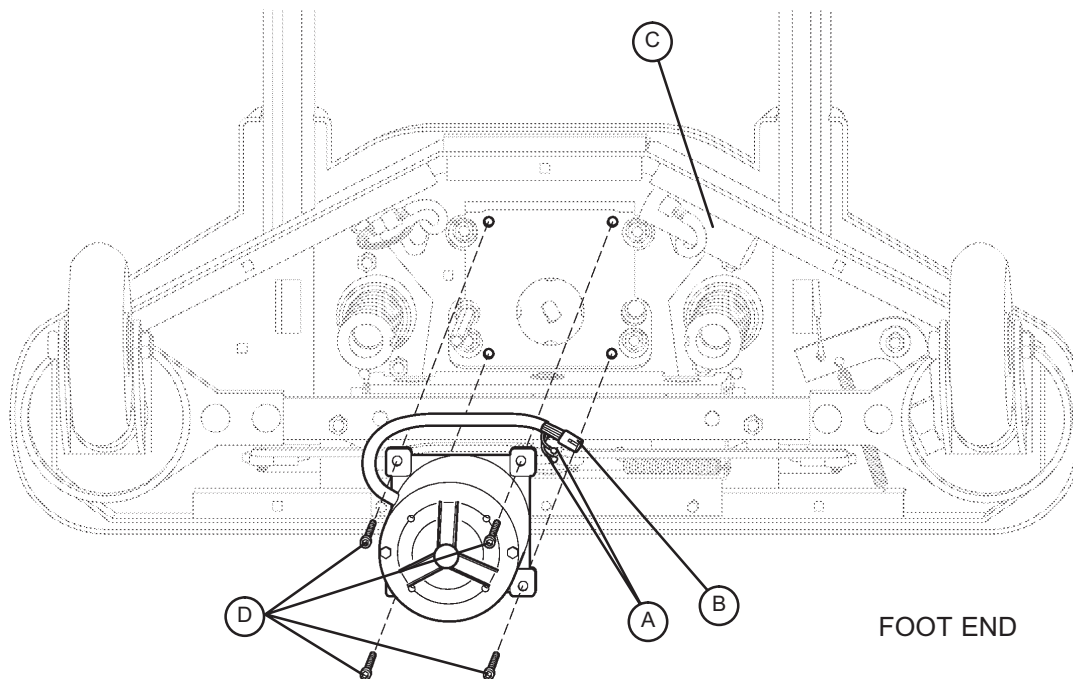

### Procedure:

#### Note

If you need more space to work under the base frame, place a 2 x 4 across the base frame rails and use a floor jack to raise the base frame off the floor.

1. Unplug the power cord from the wall socket and push the battery power on/off switch to the "Off" position.
2. Using a 5/16" socket wrench, remove the five bolts holding the lower lift cover to the base and remove the cover.
3. Disconnect the two connectors (A) at the motor capacitor.
4. Disconnect the white connector (B) from the power cord.
5. Using side cutters, cut the cable ties holding the capacitor (C) to the base and remove the capacitor.
6. Using a 3/8" socket wrench, remove the four screws (D) holding the motor assembly in the lift housing and remove the motor assembly.
7. Reverse steps 1 - 6 to install the new motor.

#### Note

The drive shaft on the new motor might need to be turned with a 7/16" open end wrench to align with the coupler. The procedure for lift motor and capacitor removal and replacement is the same for both ends of the bed.



# Service Information

---

## LIFT HOUSING REMOVAL AND REPLACEMENT

### Tools Required:

- #2 Phillips Screwdriver.
- Bungee Cord (or Equivalent).
- 5/16" Socket Wrench.
- Side Cutters.
- 9/16" Socket Wrench.
- Floor Jack.
- 7/32" Hex Allen Socket Wrench.
- Sawhorses (or Equivalent).
- 2 x 4 (or Equivalent).
- 3/8" Socket Wrench (W/6" extension).

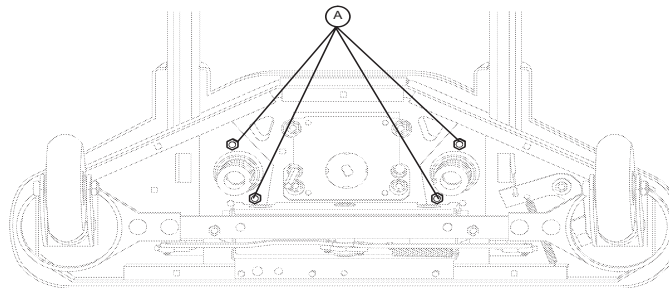

FOOT END - BOTTOM VIEW

### Procedure:

#### Note

If you need more space to work under the base frame, place a 2 x 4 across the base frame rails and use a floor jack to raise the base frame off the floor.

1. Unplug the power cord from the wall socket and push the battery power on/off switch to the "Off" position.
2. Using a 5/16" socket wrench, remove the five bolts holding the lower lift cover to the base and remove the cover.
3. Using a #2 Phillips screwdriver, remove the three screws holding the upper lift cover to the base. If necessary, hold the upper and lower covers out of the way by using bungee cords (or the equivalent) to secure them to the litter top.
4. Remove the lift motor and capacitor (refer to the Brake Pedal Replacement procedure).
5. Remove the lift potentiometer (refer to the Lift Potentiometer Replacement and Adjustment procedure).
6. Using a 5/16" socket wrench, remove the cable clamps holding the power and sensor coil cords on top of the lift housing assembly. Cut the cable ties and disconnect the coil cords from under the lift housing. The power and sensor coil cords are now free of the lift housing assembly. Drape them up out of the way.
7. Using a 7/32" hex Allen socket, remove the two screws holding the lift screws to the header crossbar plate.
8. Lift the litter top up and support it about 6" above the lift screws on sawhorses or the equivalent.
9. Under the base, using a 9/16" socket, remove the four nuts (A) holding the lift housing to the base.
10. Lift up and out on the lift housing assembly to remove it from the base.



### CAUTION

To ensure proper reattachment of the power and sensor coil cords, refer to the Lift Motor Coupler Replacement procedure. Refer to the Lift Potentiometer Replacement and Adjustment procedure for reattachment of the lift potentiometer.

11. Reverse steps 1 - 10 to reinstall the lift housing assembly after service is completed.

#### Note

The procedure for lift housing removal and replacement is the same for both ends of the bed.

# Service information

## LIFT POTENTIOMETER REPLACEMENT AND ADJUSTMENT

### Tools Required:

- #2 Phillips Screwdriver.
- Bungee Cord (or equivalent).
- 5/16" Socket Wrench.
- 3/8" Open End Wrench.
- Side Cutters.

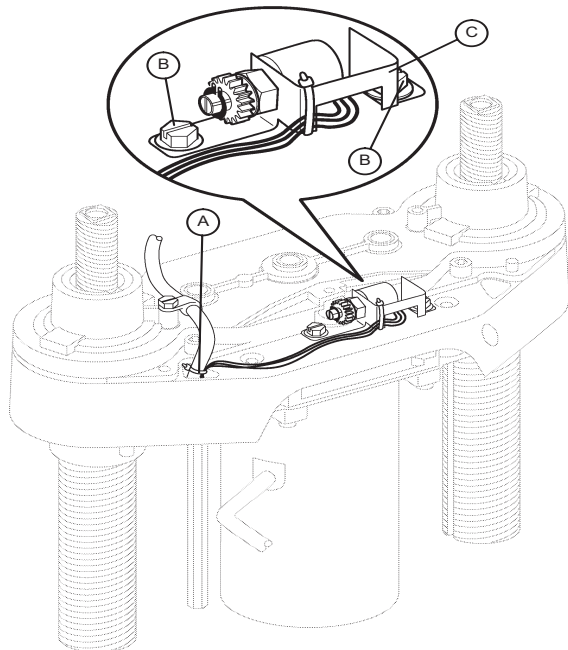

### Procedure:

1. Raise the litter to the full up position.
2. Unplug the power cord from the wall socket and push the battery power on/off switch to the "Off" position.
3. Using a 5/16" socket wrench, remove the five bolts holding the lower lift cover to the base and remove the cover. If necessary, hold the covers out of the way by using bungee cords (or the equivalent) to secure them to the litter top.
4. Using a #2 Phillips screwdriver, remove the three screws holding the upper lift cover to the base. If necessary, hold the covers out of the way by using bungee cords (or the equivalent) to secure them to the litter.
5. Using side cutters, cut the cable tie (A) holding the potentiometer cable to the coil cord.
6. Unplug the potentiometer cable from the sensor coil cord. If replacing a potentiometer at the head end of the bed, unplug the cables attached to the brake sensor switch.
7. Pull the potentiometer cable up through the base.
8. Using a 3/8" open end wrench, remove the two bolts (B) holding the potentiometer housing (C) to the lift housing.
9. Lift up and out on the potentiometer housing assembly to remove it from the lift housing.
10. Before installing the new potentiometer on the bed, turn it clockwise until it stops. Turn it back counterclockwise two full (360°) revolutions. This allows a "window" position for proper upper and lower limits.
11. Reverse steps 4 - 9 to install the new potentiometer and potentiometer housing assembly.
12. After installing the new potentiometer, the "burn-in" procedure below must be followed.

### Note

Be sure to maintain the pot position while installing.

# Service Information

---

## LIFT POTENTIOMETER “BURN-IN”

### Note

It requires **two people** to enable the diagnostics mode for the bed.

1. Unplug the bed power cord from the wall socket.
2. On the foot board control panel, hold down the bed motion lock button and the button to lock out the siderail controls for the knee. While still holding the buttons, plug the bed power cord into the wall socket. Release the foot board buttons. The siderail control lights LED should be flashing to indicate the bed is in diagnostics mode.
3. To “burn in” the Bed Up/Down limits, raise the bed completely up until it can’t go any farther. Press and hold the “Bed Motion Lock” button. The “Bed Motion Lock” LED will light. Continue to hold the “Bed Motion Lock” button until the “Bed Motion Lock” LED flashes. The flashing LED indicates the limits have been set. Release the “Bed Motion Lock” button and unplug the power cord from the wall socket to complete the “burn-in” mode.
4. Plug the power cord into the wall socket and verify the lift limits are set properly before returning the bed to service.
5. If your bed has an I.V. Caddy, a lower limit must be burned in. Run the litter down to 19.5 inches. Hold the Bed Up/Down Lock button until the light flashes.

---

### CAUTION

Do not run the litter all the way down while in the diagnostics mode. Damage to the bottom lift covers could result.

# Service information

## LIFT MOTOR COUPLER REPLACEMENT

### Tools Required:

- 5/16" Socket Wrench.
- 3/8" Socket Wrench (W/6" Extension).
- Floor Jack.
- 2 x 4 (or Equivalent).

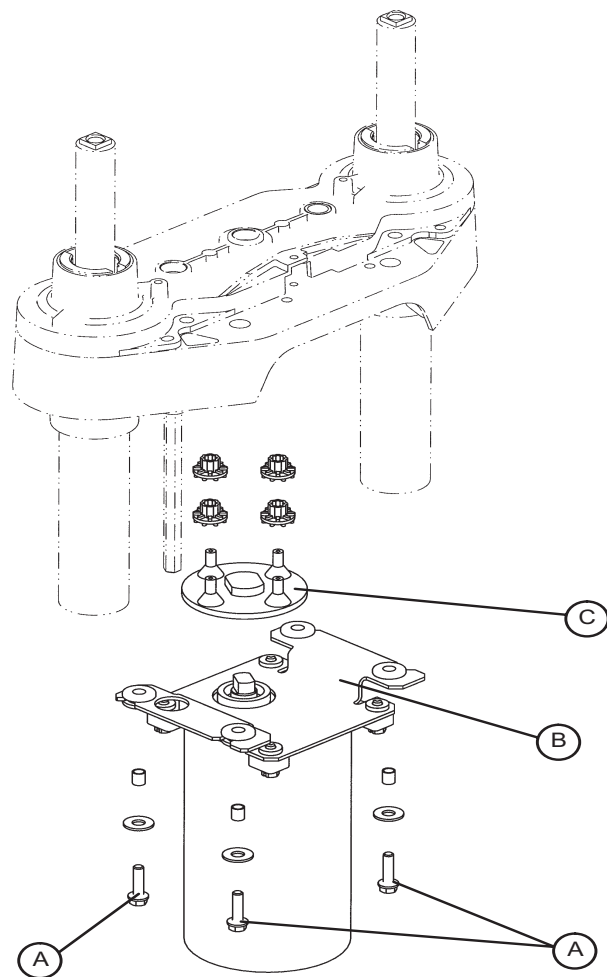

### Procedure:

#### Note

If you need more space to work under the base frame, place a 2 x 4 across the base frame rails and use a floor jack to raise the base frame off the floor.

1. Unplug the power cord from the wall socket and push the battery power on/off switch to the "Off" position.
2. Using a 5/16" socket wrench, remove the five bolts holding the lower lift cover to the base and remove the cover.
3. Using a 3/8" socket with an extension, remove the four bolts (A) holding the isolation plate (B) to the lift housing and lower the lift motor and isolation plate assembly to allow access to the coupler (C).
4. The motor coupler can now be removed from the lift housing.
5. Reverse steps 1 - 4 to install the new motor coupler and bushings.

# Service Information

---

## POWER AND SENSOR COIL CORD REPLACEMENT

### Tools Required:

- #2 Phillips Screwdriver.
- Side Cutters.
- 5/16" Socket Wrench.
- Bungee Cord (or equivalent).
- 5/16" Nut Driver.
- Floor Jack.
- 2 x 4 (or Equivalent).

### Procedure:

#### Note

If you need more space to work under the base frame, place a 2 x 4 across the base frame rails and use a floor jack to raise the base frame off the floor.

1. Unplug the power cord from the wall socket and push the battery power on/off switch to the "Off" position.
2. Using a 5/16" socket wrench, remove the five bolts holding the lower lift cover to the base and remove the cover.
3. Using a #2 Phillips screwdriver, remove the three screws holding the upper lift cover to the base. If necessary, hold the covers out of the way by using bungee cords (or the equivalent) to secure them to the litter top.
4. Using side cutters, cut the cable ties holding the power and sensor coil cords to the base. Remove the ground wire coming from the sensor cord that is attached to the base (note the star washer arrangement).
5. Disconnect the cables going to the motor and the lift potentiometer (at the head end, the sensor cord is also attached to the brake switch sensor).
6. Pull both cords up through the frame of the bed and the lift housing.
7. Using a 5/16" socket wrench, remove the two screws (A) holding the cable clamps to the top of the lift housing.
8. Using a 5/16" socket wrench, remove the two screws (B) securing the cable clamps to the underside of the header crossbar assembly.
9. Pull both coil cords up through the header crossbar assembly.
10. Disconnect the power and sensor coil cords from the connectors.
11. The cords should now be completely removed from the bed. Reverse the above steps to install the new power and sensor cords.



### CAUTION

When the power and sensor coil cords are being replaced, secure the cable clamps to the cords at the first coil both on the top and on the bottom to ensure there is not too much slack in the cords between the top of the lift housing assembly and the bottom of the header crossbar. Be sure the clamps are fastened at exactly the correct angle, as shown by the arrows in the illustration on the next page. Arrange the cords exactly as shown in the illustration (left in front of right). **If this is not done correctly, damage to the cords will result.**

# Service information

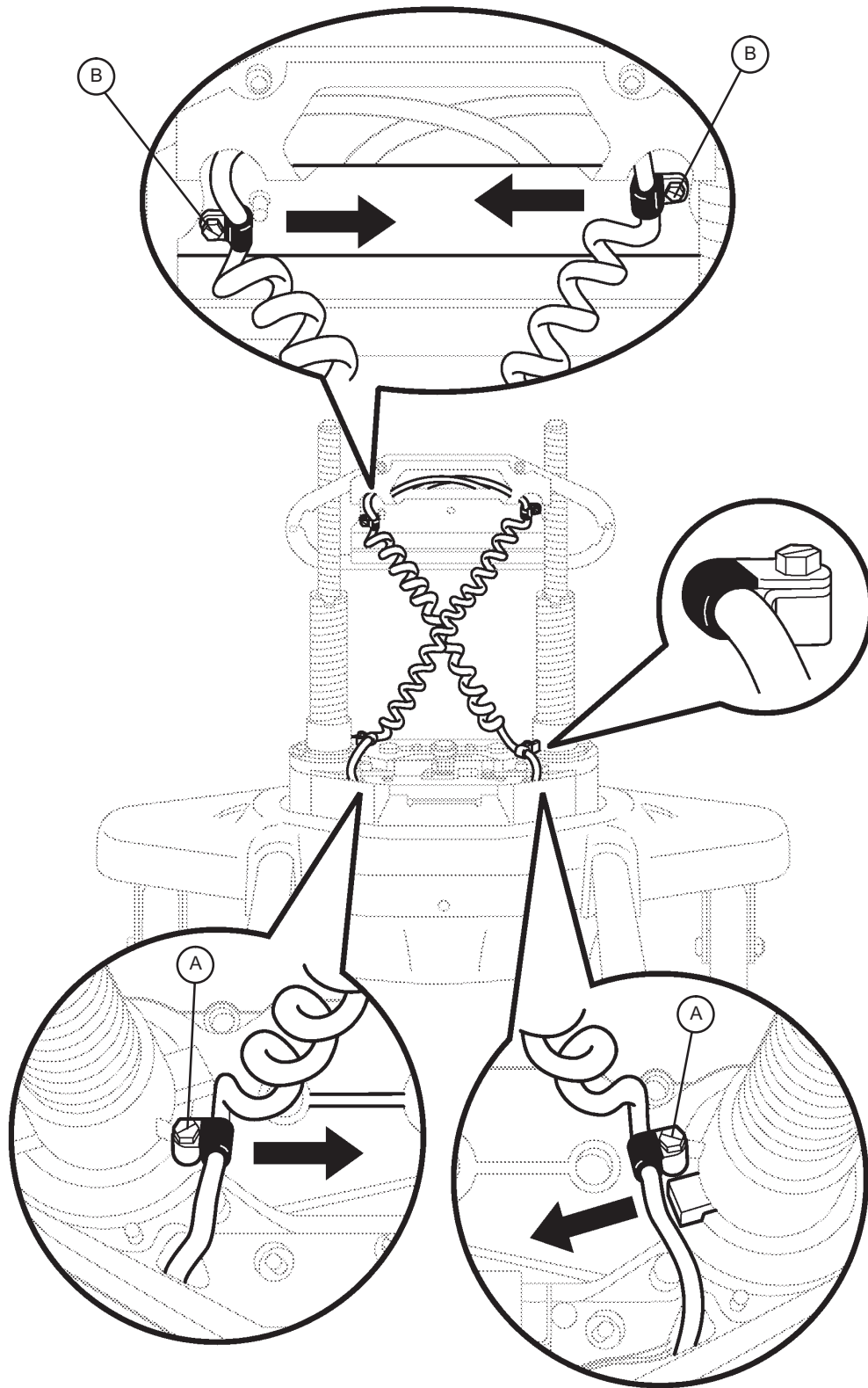

VIEW FROM CENTER OF BED

# Service Information

## BATTERY REMOVAL AND REPLACEMENT

### Required Tools:

- Torx T27.
- 7/16" Wrench.
- 1/2" Socket Wrench.
- Bungee Cords.
- Phillips Screwdriver.
- 5/32" Allen Wrench.

### Procedure:

1. Raise the litter to full up. Unplug the power cord from the wall socket and push the battery power on/off switch to the "Off" position.
2. Using a Phillips screwdriver, remove the four screws holding the base hood to the base frame.
3. Lift the base hood and support it from the litter frame using bungee cords or the equivalent.
4. Properly ground yourself (Refer to Static Discharge Precautions section).
5. Open the cable clamp at the head end, left side of the base frame and remove the cables from the clamp.
6. Using a Torx T27, remove the four screws (A) holding the electronics box cover and remove the cover.
7. Disconnect the two battery cables (B).

### WARNING

The battery tray assembly weighs 50 pounds. Use caution when removing the two hex. head screws securing it to the base frame or personal injury could result. Battery posts, terminals and related accessories contain lead and lead compounds, chemicals known to the State of California to cause cancer and birth defects or other reproductive harm. **Wash hands after handling.** Properly dispose of the old battery in accordance with local regulations.

8. Support the battery tray assembly from the bottom. Using a 7/16" hex socket or wrench, remove the two screws (C) supporting the battery tray.
9. The back of the battery tray assembly has a lip which catches on the electronics box. Lift up and out to remove the battery tray assembly.
10. Using a Phillips screwdriver, remove the two screws holding the battery terminal to the battery tray.
11. Using a 5/32" Allen wrench and a 7/16" wrench, remove the four screws and nuts holding the battery harness to the battery terminals.
12. Reverse steps 1 - 11 to install the new batteries. Complete the last four items of the setup procedures section.



A

B

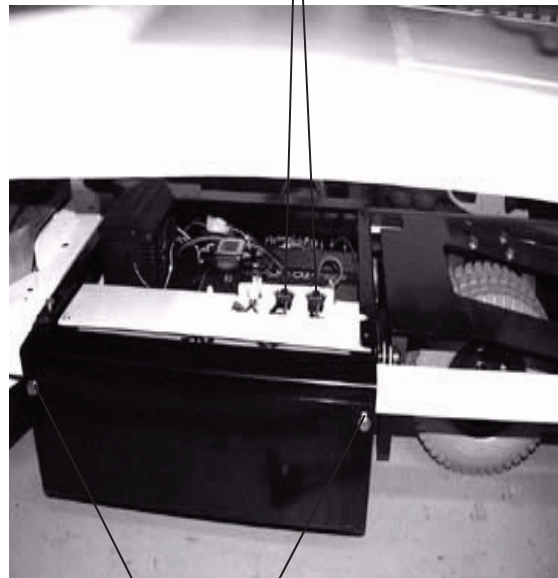

C

# Service Information

---

## DC MOTOR BOARD REMOVAL AND REPLACEMENT

### Tools Required:

- Phillips Screwdriver.
- 1/8" Allen Wrench.
- Bungee Cords.
- T27 Torx.

### Procedure:

1. Raise the litter to the full up position.
2. Unplug the power cord from the wall socket and push the battery power on/off switch to the "Off" position.
3. Using a Phillips screwdriver, remove the four screws holding the base hood to the base frame.
4. Open the cable clamp at the head end, left side of the base frame and remove the cables from the clamp.
5. Lift the base hood and support it from the litter frame using bungee cords or the equivalent.
6. Using a T27 Torx, remove the four screws holding the cover to the side of the electronics box.
7. Properly ground yourself (Refer the Static Discharge Precautions Section).
8. Using a 1/8" Allen wrench, remove the four bolts and standoffs holding the motor board to the electronics box.
9. Remove all cables from the motor board and remove the board.

### Note

Note the locations of the cables so you can connect them properly to the new motor board.

10. Reverse steps 1 - 8 to install the new motor board.



# Service Information

---

## DRIVE MOTOR REMOVAL AND REPLACEMENT

### Required Tools:

- Phillips Screwdriver.
- 1/2" Socket Wrench.
- Bungee Cords.
- Floor Jack.
- T27 Torx.

### Procedure:

1. Raise the litter to the full up position.
2. Unplug the power cord from the wall socket and push the battery power on/off switch to the **"Off"** position.
3. Using a Phillips screwdriver, remove the four screws holding the base hood to the base frame.
4. Open the cable clamp at the head end, left side of the base frame and remove the cables from the clamp.
5. Lift the base hood and support it from the litter frame using bungee cords or the equivalent.
6. Using a T27 Torx, remove the four screws holding the power board cover to the side of the electronics box. Remove the two motor wires from the power board and remove the T27 Torx ground screw.
7. Apply the brakes and disengage the drive wheel. Place a floor jack under the leaf spring at the foot end of the bed and raise the wheels approximately three inches off the floor.
8. Using a 1/2" socket wrench, remove the four bolts holding the drive motor to the leaf spring.



### CAUTION

---

Support the drive motor before removing the four bolts to prevent it from falling to the floor and becoming damaged.

9. Reverse steps 1 - 8 to install the new drive motor.
10. Run through the operation of the power drive wheel to ensure it is operating properly before returning the unit to service.

# Service information

---

## DRIVE WHEEL REMOVAL AND REPLACEMENT

### Required Tools:

- Phillips Screwdriver.
- 1/2" Socket Wrench.
- Bungee Cords.
- Floor Jack.
- T27 Torx.

### Procedure:

1. Remove the drive motor (Refer to Drive Motor Removal and Replacement Section).
2. Using a 1/2" socket wrench, remove the bolt holding the wheel to the drive motor.
3. Slide the wheel off the motor shaft.
4. Reverse steps 1 - 3 to install the new drive wheel and reinstall the drive motor.

# Service Information

---

## LOAD CELL REPLACEMENT

### Tools Required:

- 9/16" Socket Wrench.
- 9/16" Open End Wrench.
- Saw Horse (or Equivalent).
- Wire Cutters.

### Procedure:

1. Raise the Fowler or knee section, depending which end of the litter needs service.
2. Unplug the load cell connector from the load cell cable.
3. Using wire cutters, remove the wire ties holding the cable to the frame.
4. Using a 9/16" socket and a 9/16" open end wrench, remove the two bolts holding the load cell to the litter cross tube and remove the load cell.
5. Using a saw horse or the equivalent, support the litter at the end where the load cell was removed. Reverse the above procedure to install the new load cell.

### Note

The scale calibration procedure must be performed after the load cell is replaced (Refer to Scale System Diagnostics and Calibration section).

# Service information

## SCALE SYSTEM DIAGNOSTICS AND CALIBRATION

### Diagnostic Mode Functions:

ANGLE CALIBRATE	This may be required in the field to recalibrate the scale. Calibrate using 50 pounds.
DISP. CORNER LBS	This function displays the individual corner weights in pounds for each load cell and can be used to isolate a defective load cell.
DISP. CORNER CTS	This function displays the individual corner weights in counts for each load cell and can be used to isolate a defective load cell.
DISPLAY FACTORS	This function is used to see the scale calibration factors. This can be used to diagnose a bad scale calibration.
DISPLAY AVERAGES	This function is used to see the average weight in pounds each load cell has experienced.
DISPLAY MAXIMUMS	This function is used to see the maximum weight each load cell has experienced.
CLEAR STATISTICS	This function is used to clear the averages and maximums.
INIT TO DEFAULTS	This function is used to reset the scale factors back to defaults.
VIEW ERROR LOG	This function can be used to see a log of scale errors and the time they occurred.
LOCK/UNLOCK LBS/KG	This function can be used to lock out the ability to change weight units.
PICK EXIT ALARM	This function can be used to select a different bed exit alarm tone.
BRAKE ALARM OFF/ON	This function can be used to enable or disable an audible alarm when the brakes are not set. Not available for beds with ZOOM® or Battery Backup.
DEFAULT ANGLE	This function can be used to select the default angle displayed to either fowler or trend.
SOFTWARE CONFIG	This function can be used to see what the bed configuration is.
SOFTWARE VERSION	This function can be used to see what software version it is.
CALIBRATE SCALE	This is the old scale calibration routine with 200 pounds. Only there for backup purposes.
EXIT DIAGNOSTIC	This function will give you the ability to exit the diagnostic mode and go into scale mode.

### Diagnostic Mode:

#### Note

It requires **two people** to enable the diagnostic mode for the scale system.

1. To enter diagnostic mode, unplug the bed's power cord from the wall socket.
2. Press and **hold down** the LBS/KGS button.
3. While still holding the LBS/KGS button, plug the bed's power cord into the wall socket.
4. After two seconds, release the LBS/KGS button. The LCD should display "Angle Calibrate". The diagnostic mode is now active.

### Displaying Individual Load Cell Outputs:

A defective load cell can be detected by entering diagnostics and displaying individual load cell outputs.

1. Enter the diagnostic mode. The LCD will display "**Angle Calibrate**" when the diagnostic mode is activated.
2. Repeatedly press and release the up or down arrow button (Zero Or Scale On/Off) until the LCD displays "Display **Corner CTS**".
3. Press and release the Enter button (LBS/KGS). The LCD should display "▲▼Select Corner".

The two buttons listed below function as Position buttons to select the four corners of the bed's litter. Whenever, the LCD displays "▲▼Select Corner", press one of these buttons to cycle through the corners and to select the load cell assembly at the desired corner.

- A. Zero** = Cycle up through the four corners.
- B. Scale On/Off** = Cycle down through the four corners.

[Return To Table of Contents](#)

# Service Information

---

## SCALE SYSTEM DIAGNOSTICS AND CALIBRATION (CONTINUED)

### Displaying Individual Load Cell Outputs (Continued):

4. Press and release the position button that corresponds with the load cell to be checked. The LCD should display “X/X=NNN.N”. “X/X” represents the initials of the selected corner, i.e.: H/R will be displayed for the patient’s head end, right side. “NNN.N” represents the resistance of the load cell.
5. Repeat step four for each corner. Head end weight readings will normally be lower than foot end weights. Weight readings should be constant. A drifting 000.0 or 999.9 weight, or a reading that does not change when weight is applied to that corner of the bed indicates a problem with the selected load cell assembly or load cell cable.

### Verifying Scale Accuracy:

1. Zero the empty bed. Place a known weight on the center of the bed; the heavier the better and no less than 100 pounds. The displayed weight should be within  $\pm 1\%$  of the actual weight.
2. If the displayed weight is not accurate, remove the weight from the bed and proceed to the Scale Calibration section.

### Scale Calibration:

#### Note

It requires **two people** to enable the calibration mode for the scale system. Raise the siderails when calibrating the scale to avoid getting inaccurate scale readings due to possible interference between the siderails and the casters.

Calibrate the scale system with a known 50 pounds weight. If exactly 50 pounds is not available, the factory default for calibration will have to be changed as described in step 6.

1. To enter the calibration mode, unplug the bed’s power cord from the wall socket.
2. Press and **hold down** the LBS/KGS button.
3. While still holding the LBS/KGS button, plug the bed’s power cord into the wall socket.
4. After two seconds, release the LBS/KGS button. The LCD should read “**Angle Calibrate**”. The calibration mode is now active.
5. Press and hold the **Enter** button (LBS/KGS). Zero the bed, following the displayed instructions. When the bed is zeroed, the LCD should display “REF X 100 =<0> 5000”. This is the factory default for 50 pounds. If 50 pounds will be used to calibrate the scale, proceed to step 7.
6. If exactly 50 pounds is not available, change the display to match the weight you are using. Pressing the **Change Equip.** button will move the cursor position to the right. Pressing the up arrow (**Zero**) button will increase the numbers. Pressing the down arrow (**Scale On/Off**) button will decrease the numbers. Scroll through the numbers until they match the weight you will use for calibration.
7. Press and release the **Enter** button and the LCD will display “**Press Rev. Trend**”. Press and hold the button with the Reverse Trendelenburg symbol (feet down/head up) until the bed stops. Release the button and the LCD will display “**Do Not Touch Bed**”. Press and hold the Reverse Trendelenburg button again until the bed stops. Release the button and the LCD will display “**Do Not Touch Bed**”.
8. The LCD will display “**Press Trend.**” Press and hold the button with the Trendelenburg symbol (feet up/head down) until the bed stops. Release the button and the LCD will display “**Do Not Touch Bed**”. Press and hold the Trend button again until the bed stops. Release the button and the LCD will display “**Do Not Touch Bed**”.
9. Repeat steps 5 - 8 with 200 pounds.
10. The LCD will display the weight. This indicates the calibration procedure is complete.
11. Level the bed at a full up or full down position. Remove the weight and zero the bed.
12. Verify scale accuracy and functionality before returning the bed to service.

# Service information

---

## HEAD MOTOR REMOVAL AND REPLACEMENT

### Required Tools:

- T27 Torx.
- 7/16" Socket Wrench.
- 3/8" Socket Wrench.
- Wire Cutters.

### Procedure:

1. Run the litter to the full up position and remove the mattress from the litter.
2. Fold the foot section back toward the head end. Electrically run the knee section to full up. If the knee section will not move electrically, pull the foot section toward the head end while pulling the CPR release handle (located at the head end of the bed). The knee section will raise.
3. Using a T27 Torx, remove the four screws holding the cover to the actuator box and remove the cover.
4. Remove the two CPR release cables from the CPR release bracket. Using a 3/8" socket wrench underneath the actuator box, remove the two bolts holding the release bracket to the actuator box and remove the bracket from the actuator box.
5. Disconnect all the electrical connections to the head motor and move aside any wiring that interferes with the removal of the motor.
6. Using a 3/8" socket wrench underneath the actuator box, remove the four bolts holding the motor mounting bracket to the actuator box. Lift up and out on the motor to remove it.
7. Remove the motor mounting bracket from the old motor and install it on the replacement motor.
8. Reverse steps 3 through 6 to install the replacement motor.
9. Verify the unit is working properly before returning it to service.

# Service Information

---

## KNEE MOTOR REMOVAL AND REPLACEMENT

### Required Tools:

- T27 Torx.
- 7/16" Socket Wrench.
- 3/8" Socket Wrench.
- Wire Cutters.

### Procedure:

1. Run the litter to the full up position and remove the mattress from the litter.
2. Fold the foot section back toward the head end. Electrically run the knee section to full up. If the knee section will not move electrically, pull the foot section toward the head end while pulling the CPR release handle (located at the head end of the bed). The knee section will raise.
3. Using a 7/16" socket wrench, remove the mounting bolt on the litter for the knee dampening cylinder. This leaves the knee dampener mounted only to the seat panel.
4. Using a T27 torx, remove the four screws holding the cover to the actuator box and remove the cover.
5. Remove the two CPR release cables from the CPR release bracket. Using a 3/8" socket wrench underneath the actuator box, remove the two bolts holding the release bracket to the actuator box and remove the bracket from the actuator box.
6. Disconnect all the electrical connections going to the knee motor and move aside any wiring that could interfere with the removal of the motor.
7. Pull the foot panel toward the head end of the bed. This causes the knee motor linkage to roll past center and allows the motor to be removed without supporting the knee section.
8. Using a 3/8" socket wrench underneath the actuator box, remove the four bolts holding the motor mounting bracket to the actuator box. Lift up and out on the motor to remove it.
9. Remove the motor mounting bracket from the old motor and install it on the replacement motor.
10. Install the replacement motor.
11. Reverse steps 3 - 5 to reinstall the knee dampener, CPR bracket and actuator box cover.
12. Pull the foot panel toward the foot end of the bed. This causes the knee motor linkage to roll back past center.



### CAUTION

---

If step 12 is not done, damage to the motor or linkage will occur.

13. Verify the bed is working properly before returning it to service.

# Service information

---

## POWER SUPPLY REMOVAL AND REPLACEMENT

### Required Tools:

- T27 Torx.
- Needle-Nose Pliers.

### Procedure:

1. Run the litter to the full up position and remove the mattress from the litter.
2. Fold the foot section back toward the head end of the bed. Electrically run the knee section to full up. If the knee section will not move electrically, pull the foot section toward the head end of the bed while pulling the CPR release handle (located at the head end of the bed). The knee section will raise.
3. Using a T27 Torx, remove the four screws holding the cover to the actuator box and remove the cover.
4. Properly ground yourself (Refer to Static Discharge Precautions).
5. Unplug all electrical connections from the power supply.
6. Using needle-nose pliers, squeeze the four stand-offs supporting the power supply and pull up gently on the power supply to remove it.
7. Reverse steps 2 through 5 to install the new power supply.
8. Verify the unit is working properly before returning it to service.

## CPU BOARD REMOVAL AND REPLACEMENT

### Required Tools:

- T27 Torx
- Needle-Nose Pliers

### Procedure:

1. Run the litter to the full up position and remove the mattress from the litter.
2. Fold the foot section back toward the head end of the bed. Electrically run the knee section to full up. If the knee section will not move electrically, pull the foot section toward the head end of the bed while pulling the CPR release handle (located at the head end of the bed). The knee section will raise.
3. Using a T27 Torx, remove the four screws holding the cover to the actuator box and remove the cover.
4. Properly ground yourself (Refer to Static Discharge Precautions section).
5. Unplug all electrical connections from the CPU board.
6. Press the six stand-offs away from the board while gently lifting the board up and out.
7. Install the replacement CPU board.

### Note

After replacement of CPU, please set SB1, SB2, SB3, and SB4 dip switches to match original board.

After the replacement CPU board is installed, the “Burn-in” procedure must be performed for the Fowler and lift motor potentiometers (Refer to Lift Potentiometer “Burn-in” Procedure and Fowler Potentiometer “Burn-in” Procedure sections).

If the bed is equipped with a scale system, the scale calibration procedure must also be performed after the replacement CPU board is installed (Refer to Scale System Diagnostics and Calibration section).



# Service Information

---

## FOWLER POTENTIOMETER REPLACEMENT

### Required Tools:

- T27 Torx.
- Wire Cutters.
- 1/2" Open End Wrench.
- 7/64" Allen Wrench.

### Procedure:

1. Manually crank the knee section up until it stops.
2. Using a T27 Torx, remove the four screws holding the litter access cover to the litter and remove the cover.
3. Using a 7/64" Allen wrench, loosen the screw holding the linkage to the potentiometer shaft and remove the linkage from the shaft.
4. Using a 1/2" open end wrench, remove the nut holding the potentiometer to the frame.
5. Using wire cutters, remove the cable ties from the cable. Unplug the cable from the CPU and remove the potentiometer.
6. Reverse the above procedure to install the replacement potentiometer.
7. The new potentiometer must be calibrated after it has been installed.
8. The Fowler potentiometer should be set at 150 ohms ( $\pm 10$  ohms) in the full down position. This reading must be taken from pins 3 and 4 on the connector with the potentiometer unplugged from the board. After the correct ohm reading is achieved, tighten the screw on the linkage.
9. Perform the "Burn-in" procedure for the Fowler potentiometer (Refer to Fowler Potentiometer "Burn-in" Procedure).

## FOWLER POTENTIOMETER "BURN-IN" PROCEDURE

### Note

It requires **two people** to enable the diagnostics mode for the bed.

1. Unplug the bed power cord from the wall socket.
2. On the foot board control panel, hold down the bed motion lock button and the button to lock out the siderail controls for the knee. While still holding the buttons, plug the bed power cord into the wall socket. Release the foot board buttons. The siderail control lights LED should be flashing to indicate the bed is in diagnostics mode.
3. Using the foot board controls, run the Fowler up to 90°. Press and hold the button on the foot board to lock out the siderail controls for the back until the padlock LED flashes. Release the button.
4. Using the foot board controls, run the Fowler down to 0°. Press and hold the button on the foot board to lock out the siderail controls for the knee until the padlock LED flashes. Release the button.

# Service information

---

## AC CROSSOVER BOARD REPLACEMENT

### Required Tools:

- T27 Torx.
- 1/2" Box End Wrench.
- #2 Phillips Screwdriver.
- Wire Cutters.
- Small Flat Blade Screwdriver.
- Needle Nose Pliers.
- 5/16" Nut Driver.

### Procedure:

1. Follow steps 1 - 9 of the control bar potentiometer replacement procedure on Control Bar Potentiometer Replacement Section.
2. Using a T-27 Torx, remove the 2 bolts holding the AC crossover board cover to the head end frame and remove the cover.
3. Disconnect all wires from the AC crossover board.
4. Using needle nose pliers, release the four mounting stand-offs from the board and remove the board.
5. Reverse steps 1 - 4 to install the new board.
6. Reverse steps 1 - 9 of the control bar potentiometer replacement procedure section to reassemble the bed.

## DISPLAY/CPU BOARD REPLACEMENT

### Required Tools:

- T27 Torx.
- 1/2" Box End Wrench.
- #2 Phillips Screwdriver.
- Wire Cutters.
- Small Flat Blade Screwdriver.
- Needle Nose Pliers.
- 5/16" Nut Driver.

### Procedure:

1. Follow steps 1 - 9 of the control bar potentiometer replacement procedure section.
2. Disconnect all wires from the display/CPU board.
3. Using a #2 Phillips screwdriver, remove the six screws holding the display/CPU board to the control bar cover and remove the board.
4. Reverse steps 2 & 3 to install the new board. After the new board has been installed, the potentiometer "Burn-in" procedure must be performed (refer to Control Bar Potentiometer "Burn-in" Procedure Section).
5. Reverse steps 1 - 9 of the Control Bar Potentiometer Replacement Procedure section to reassemble the bed.

# Service Information

## CONTROL BAR POTENTIOMETER REPLACEMENT (SERIAL # 0702088665 AND EARLIER)

### Tools Required:

- T27 Torx
- 1/2" Box End Wrench
- #2 Phillips Screwdriver
- Wire Cutters
- Small Flat Blade Screwdriver
- 5/16" Nut Driver

### Procedure:

1. Raise the litter and the head end to the full up position.
2. Remove the head board from the bed.
3. Unplug the power cord from the wall socket and push the battery power On/Off switch to the "Off" position.
4. Using a 5/16" nut driver, remove the screw holding the power cord clamp to the bumper weldment and remove the clamp from the bumper.
5. Using a T27 Torx, remove the four bolts (A) at the head end of the bed holding the control bar mounting bracket to the head end (see Figure 1).
6. Using a #2 Phillips screwdriver, remove the three screws (B) holding the control bar cover to the head end of the bed (see Figure 2).
7. Standing at the head end, pull the control bar toward you and fold down the control bar mounting bracket.
8. Using a 1/2" wrench, remove the nut holding the potentiometer to the mount. Using wire cutters, cut the wire ties. Unplug the potentiometer cable from the CPU display board and remove the potentiometer.
9. Install the new potentiometer. Using a small flat blade screwdriver, turn the potentiometer shaft clockwise until it stops. Turn it back counterclockwise 1/2 turn.
10. After the new potentiometer has been installed, the potentiometer "burn-in" procedure must be performed (see "Control Bar Potentiometer 'Burn-In' Procedure (Serial #0702088665 and Earlier).
11. After performing the "burn-in" procedure, reverse steps 1 - 7 to reassemble the bed.
12. Test all functions before returning the unit to service.

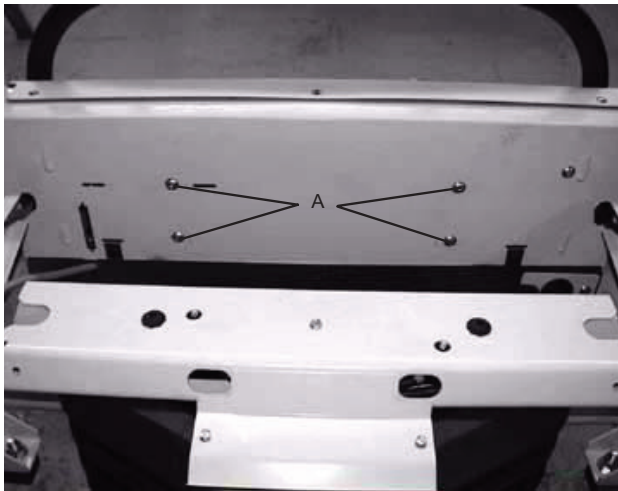

Figure 1

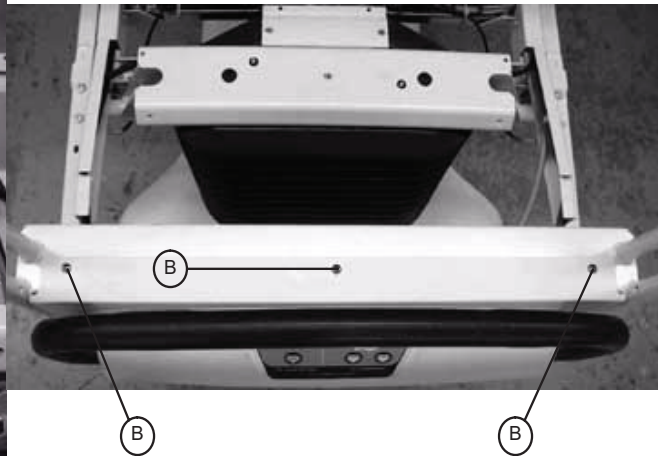

Figure 2

# Service information

---

## CONTROL BAR POTENTIOMETER “BURN-IN” PROCEDURE (SERIAL # 0702088665 AND EARLIER)

### Tools Required:

- T27 Torx
- 1/2” Box End Wrench
- # 2 Phillips Screwdriver
- Wire Cutters
- Small Flat Blade Screwdriver
- 5/16” Nut Driver

### Procedure:

1. If it has not already been done, follow steps 1 - 7 of the Control Bar Potentiometer Replacement Procedure on [previous page](#).
2. Check the control bar potentiometer voltage. When the bar is centered, there should be 2.25VDC – 2.75 VDC between pin 1 and pin 2 on header 1 on the display / CPU board (see page 96).
3. Hold down the switch on the back of the drive CPU board.
4. With the switch depressed, move the battery power on/off switch to the “ON” position.
5. Verify the “ENGAGE DRIVE WHEEL” LED at the head end of the bed is flashing.
6. Move the battery power on/off switch to the “OFF” position, close the drive control box, set the zoom handle to the neutral position, and move the switch back to the “ON” position.
7. The three LEDs on the front of the bed will flash initially to show the battery voltage of the bed by lighting zero, one, two, or three LEDs.
8. After the battery charge has been displayed by the three LEDs, all three LEDs will flash twice. After all three LEDs have flashed twice push the drive handle to the full forward position (within 3 seconds). Hold the drive handle in the full forward position until all three LEDs flash twice again (3 seconds).
9. The “ENGAGE DRIVE WHEEL” LED will flash once. The control bar potentiometer is calibrated.
10. Return the drive handle to the neutral position.
11. Grasp the drive handle and squeeze the motion release trigger switch without moving the drive handle forward or back. Verify the bed does not move.
12. Release the bed brakes and engage the drive wheel. Standing at the head end of the bed, grasp the drive handle and squeeze the motion release trigger switch while moving the drive handle away from you. Verify the bed moves forward.
13. Grasp the drive handle and squeeze the motion trigger release switch while moving the drive handle toward you. Verify the bed moves backward.
14. Reverse steps 1 – 7 of the control bar potentiometer replacement procedure on [previous page](#) to reassemble the bed.

# Service Information

## CONTROL BAR POTENTIOMETER REPLACEMENT (SERIAL # 0702088666 AND LATER)

### Tools Required:

- T27 Torx
- 1/2" Box End Wrench
- #2 Phillips Screwdriver
- Wire Cutters
- Small Flat Blade Screwdriver
- 5/16" Nut Driver
- Multimeter

### Procedure:

1. Raise the litter and the head end to the full up position.
2. Remove the head board from the bed.
3. Unplug the power cord from the wall socket and push the battery power On/Off switch to the "Off" position.
4. Using a 5/16" nut driver, remove the screw holding the power cord clamp to the bumper weldment and remove the clamp from the bumper.
5. Using a T27 Torx, remove the four bolts (A) at the head end of the bed holding the control bar mounting bracket to the head end (see Figure 1).
6. Using a #2 Phillips screwdriver, remove the three screws (B) holding the control bar cover to the head end of the bed (see Figure 2).
7. Standing at the head end, pull the control bar toward you and fold down the control bar mounting bracket.
8. Using a 1/2" wrench, remove the nut holding the potentiometer to the mount. Using wire cutters, cut the wire ties. Unplug the potentiometer cable from the CPU display board and remove the potentiometer.
9. Install the new potentiometer. Using a small flat blade screwdriver, turn the potentiometer shaft clockwise until it stops. Turn it back counterclockwise 1/2 turn until multimeter reads 2.35 to 2.55 using the black and red wires.
10. After the new potentiometer has been installed, the potentiometer "burn-in" procedure must be performed (see "Control Bar Potentiometer 'Burn-In' Procedure (Serial #0702088666 and Later)").
11. After performing the "burn-in" procedure, reverse steps 1 - 7 to reassemble the bed.
12. Test all functions before returning the unit to service.

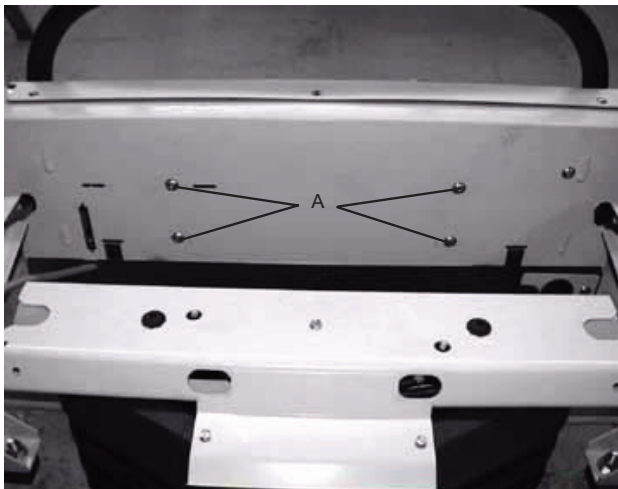

Figure 1

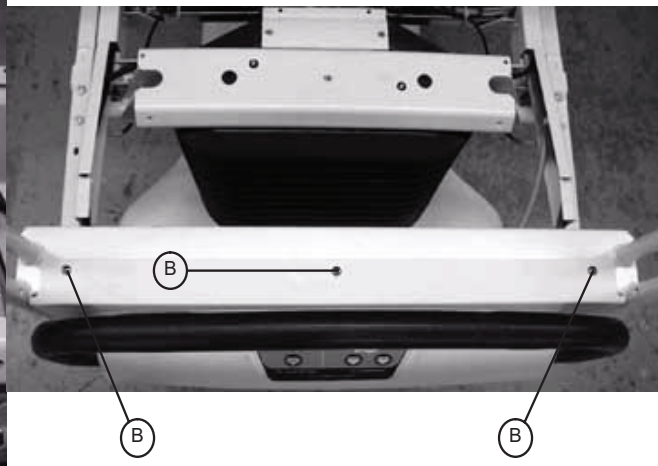

Figure 2

# Service Information

---

## CONTROL BAR POTENTIOMETER “BURN-IN” PROCEDURE (SERIAL # 0702088666 AND LATER)

### Tools Required:

- T27 Torx
- 1/2” Box End Wrench
- # 2 Phillips Screwdriver
- Wire Cutters
- Small Flat Blade Screwdriver
- 5/16” Nut Driver

### Procedure:

1. If it has not already been done, follow steps 1 - 7 of the Control Bar Potentiometer Replacement Procedure on [previous page](#).
2. Ensure the battery on/off switch is in the “Off” position (LED is Off).
3. Hold down the yellow button on the back of the display CPU board.
4. With the switch depressed, move the battery power on/off switch to the “ON” position (LED will light) and continue holding for three seconds.
5. Press and hold the yellow button on the back of the display CPU board.
6. Move the battery power on/off switch to the “on” position (LED will light) and continue holding switch for three seconds.
7. Verify the “Engage Drive Wheel” led at the head end display housing is flashing.
8. Move the battery power on/off switch back to the “Off” position (all LED’s will go out).
9. Close the drive box.
10. Ensure the control bar is in the center of travel by pushing and pulling the bar, then returning the bar to the neutral position.
11. With no objects touching the control bar, turn the battery power on/off switch to the “On” position.
12. The three LED’s on the front of the bed will flash initially to show the battery voltage of the bed by lighting zero, one, two, or three LED’s.
13. After the battery charge has been displayed by the three LED’s, all three LED’s will flash twice.
14. After all three LED’s have flashed twice, push the drive handle to the full forward position. Hold the drive handle in the full forward position until all three LED’s flash twice again (3 seconds).
15. The “ENGAGE DRIVE WHEEL” LED will flash once.
16. The control bar potentiometer is calibrated.
17. Return the control bar to the neutral position.
18. Grasp the control bar and squeeze either motion switch without moving the control bar forward or backward.
19. Verify the bed does not move.
20. Standing at the head end of the bed, grasp the control bar and squeeze either motion switch, then push the control bar forward.
21. Verify the bed moves forward.
22. Standing at the head end of the bed, grasp the control bar and squeeze either motion switch, then pull the control bar backwards.
23. Verify the bed moves backward.
24. Move the battery power on/off switch “Off”, wait a few seconds, then back “On” again.
25. Repeat steps 18-23 to verify that the burn in procedure was performed correctly.

# Service information

## OPTIONAL SMART TV INTERFACE “BURN-IN”

This procedure is used for selecting the style of TV interface desired for your bed. If traditional TV is desired, no calibration is required. If optional Smart TV is available on the bed, select one of the TV manufacturers listed in the table below.

### Setup

- Ensure the communication cable is connected between the bed and the Db37 wall port or the pillow speaker port of the nurse call system. If available, a bed communication tester can be used instead of the hospital wiring.
1. Place the bed in the lift potentiometer “Burn-In” mode Refer to Lift Potentiometer “Burn-In” Procedure section.
  2. Notice the Nurse Call LED (yellow) is flashing. Notice the Nurse Answer LED (green) is flashing on/off slowly.
  3. Press and release the TV **On/Off** switch on the bed’s siderail once. Notice the Nurse Call LED flashes once. This is the first selection of TV manufacturers for the Smart TV mode. Notice the Nurse Answer LED (green) is flashing **On/Off** slowly. The Nurse Answer LED will only light when the Nurse Call LED (yellow) is flashing.
  4. Press and release the TV **On/Off** switch on the bed’s siderail to scroll to other TV manufacturers. Notice the number of times the Nurse Call LED flashes matches the number listed in the table below and represents the TV manufacturer selected.
  5. When the desired TV manufacturer has been selected, unplug the bed power cord from the wall socket and plug it back in to complete the Smart TV “Burn-In” procedure.

### Note

If the bed is connected to a television during the “Burn-In” procedure, the television will turn on when the correct setting is selected.

TV MANUFACTURER SELECTION FOR SMART TV BURN-IN PROCEDURE		
Press and release TV ON/OFF switch	Nurse Call LED (Yellow)	TV Manufacturer
One time	One flash	RCA 1
Two times	Two flashes	RCA 2
Three times	Three flashes	Zenith 1
Four times	Four flashes	Zenith 2
Five times	Five flashes	Philips/Magnavox
Six times	Six flashes	Magnavox (models 9120, 9220, 9320)
Seven times	Seven flashes	Traditional TV
Eight times	Eight flashes	Traditional Plus
Nine times	Nine flashes	Auto Detect: Smart TV
Ten times	Ten flashes	Auto Detect W/Digital Volume Smart TV

# Service Information

---

## SIDERAIL COVER REMOVAL

### Required Tools:

- #2 Phillips Screwdriver.

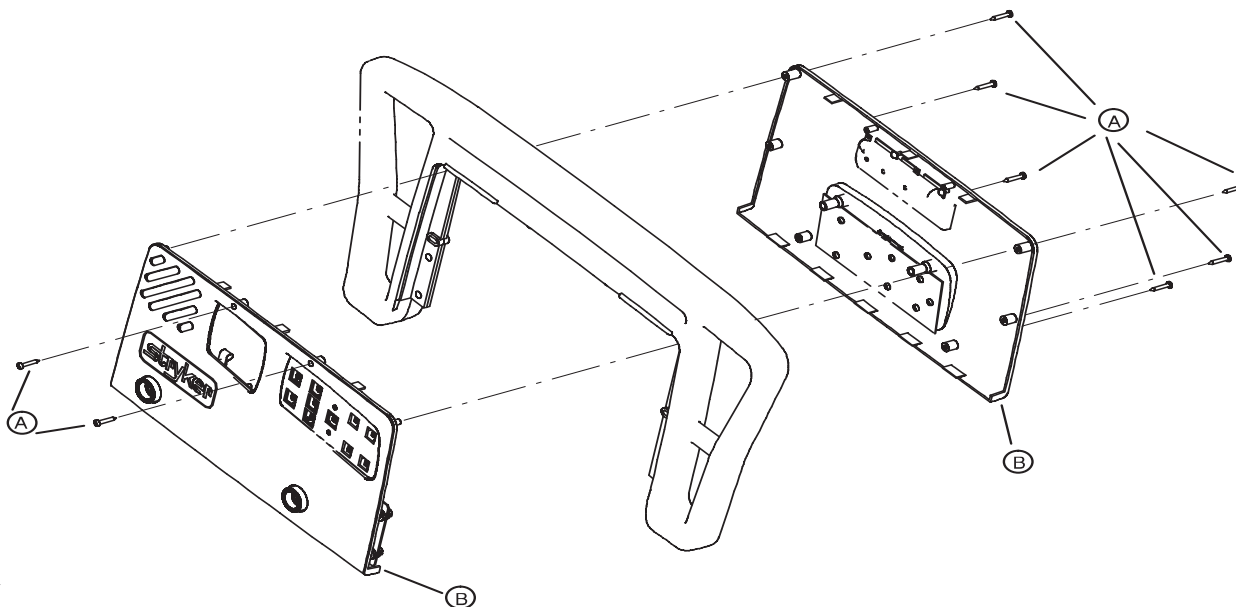

### Head End Siderail Cover Removal:

#### Procedure:

1. Unplug the bed power cord from the wall receptacle.
2. Using a #2 Phillips screwdriver, remove the 8 screws (A) holding the covers (B) to the siderail.

---

### CAUTION

---

There are two cables connecting the head end siderail outside covers to the head end siderails. Be careful not to pull on them when removing the cover or damage could occur.

3. Disconnect the cables from the siderail. Note the proper location for the cables.
4. Reverse the above steps to reattach the cover.

---

### CAUTION

---

Do not snag or pinch the cables when reinstalling the head end siderail covers or damage could occur.



# Service information

## MOLDED SIDERAIL REPLACEMENT

### Required Tools:

- #2 Phillips Screwdriver.
- 3/8" Nut Driver.

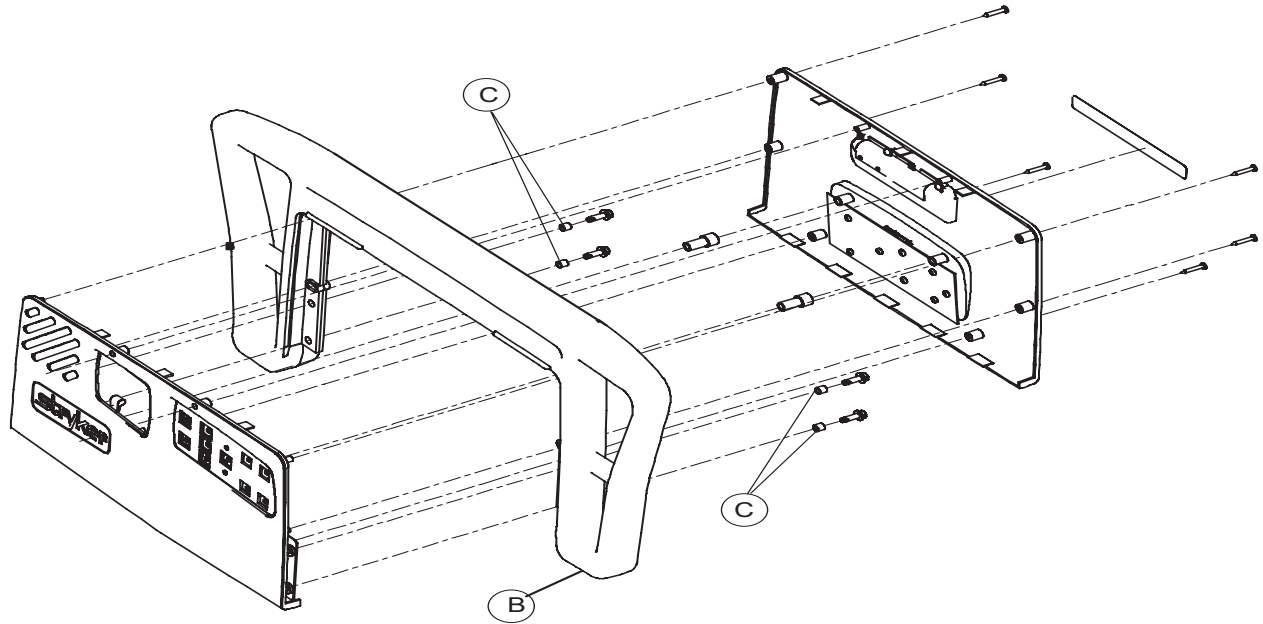

### Procedure:

1. Unplug the bed power cord from the wall receptacle.
2. Remove the siderail covers (Refer to Siderail Cover Removal section).
3. Using a 3/8" nut driver, remove the four screws (A) holding the molded rail (B) to the siderail support assembly

### Note

Note the location of the spacers (C) for reassembly purposes.

4. Pull up on the molded rail (B) to remove it from the siderail assembly.
5. Reverse the above steps to install the new molded rail.

# Service Information

## HEAD END SIDERAIL CABLE REPLACEMENT

### Required Tools:

- #2 Phillips Screwdriver.
- Side Cutters.

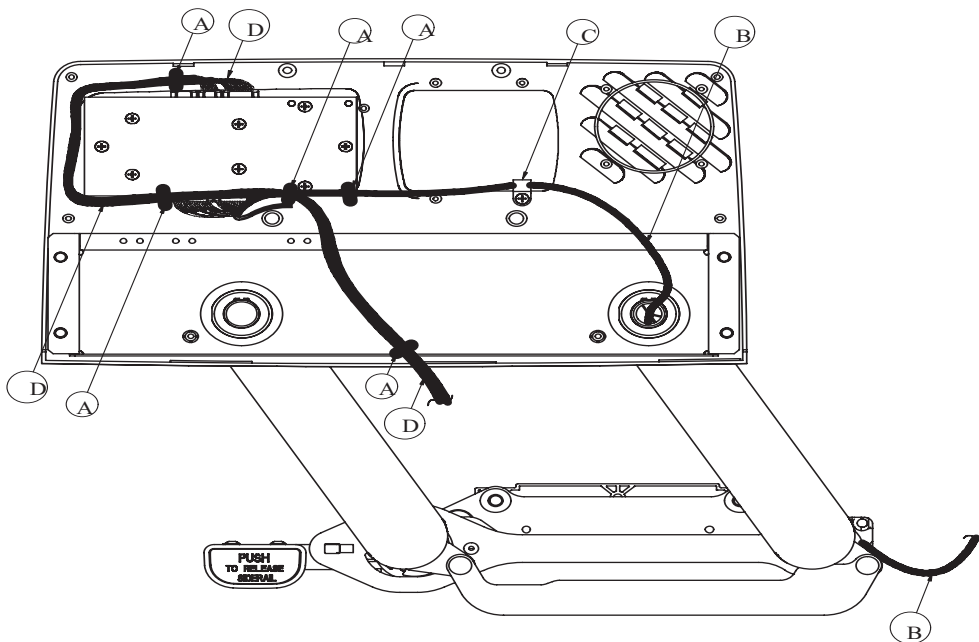

### Procedure:

1. Run the head section fully up.
2. Unplug the bed power cord from the wall receptacle.
3. Remove the outside siderail cover (Refer to Siderail Cover Removal section).
4. Put the siderail in the down position.
5. Remove the arm cover to expose the siderail cables.
6. Using side cutters, clip the cable ties (A) holding the cables together.
7. Using a #2 Phillips screwdriver, remove the cable clamp (C) from the siderail.
8. Disconnect cable (B) from the circuit board and cable (D) from the speaker.

### Note

The speaker and nurse call are optional equipment and may not be present as shown in the illustration.

9. Pull the cables through the siderail (toward the center of the bed).
10. Unplug the cable assembly underneath the head section.
11. Reverse the above steps to install the new cable.

### CAUTION

Be sure to position the cables on both sides of the pivot arm, as shown in the illustration on **Head End Siderail Cable Replacement** section, before reattaching the pivot arm cover. If the cables are not routed correctly, the arm cover will not fit properly and damage could occur to the cables.

# Service information

## FOOT BOARD LID REMOVAL

### Required Tools:

- #2 Phillips Screwdriver.

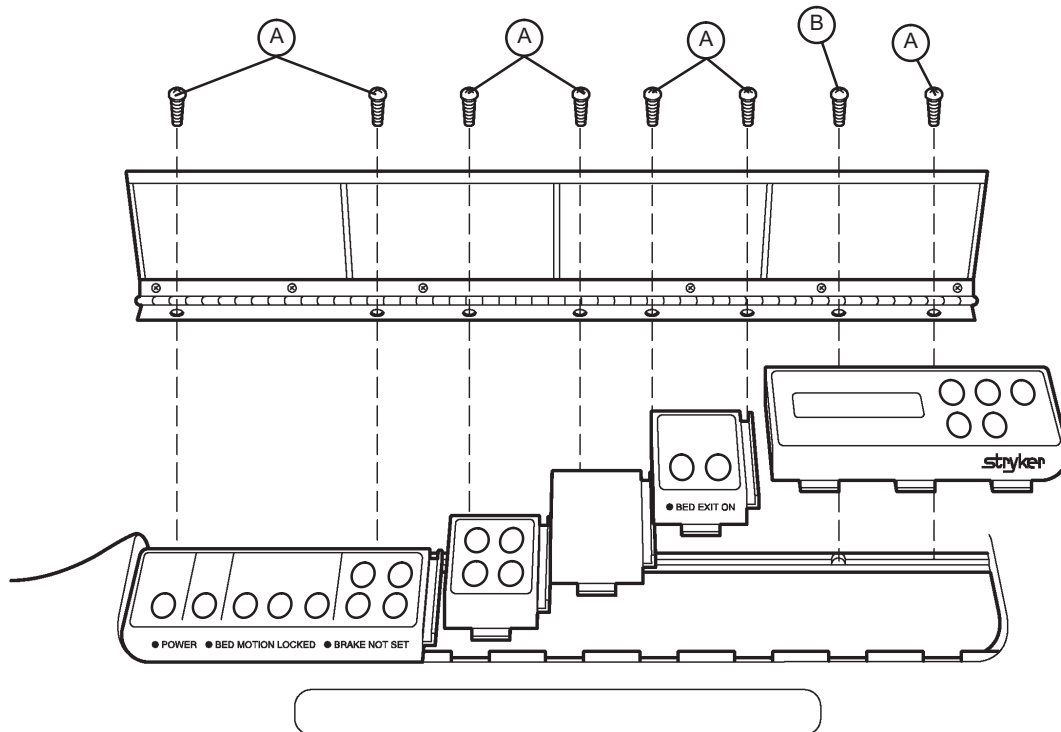

### Procedure:

1. Using a #2 Phillips screwdriver, remove the screws (A & B) holding the door and hinge assembly to the foot board.
2. If replacing the lid only, use a Phillips screwdriver to remove the screws holding the hinge to the door.
3. Reverse the above steps to attach the replacement door and/or hinge.

### Note

Screw (B) is a machine screw and must be reinstalled in the proper hole.

# Service Information

## FOOT BOARD MODULE REPLACEMENT

### Required Tools:

- #2 Phillips Screwdriver.

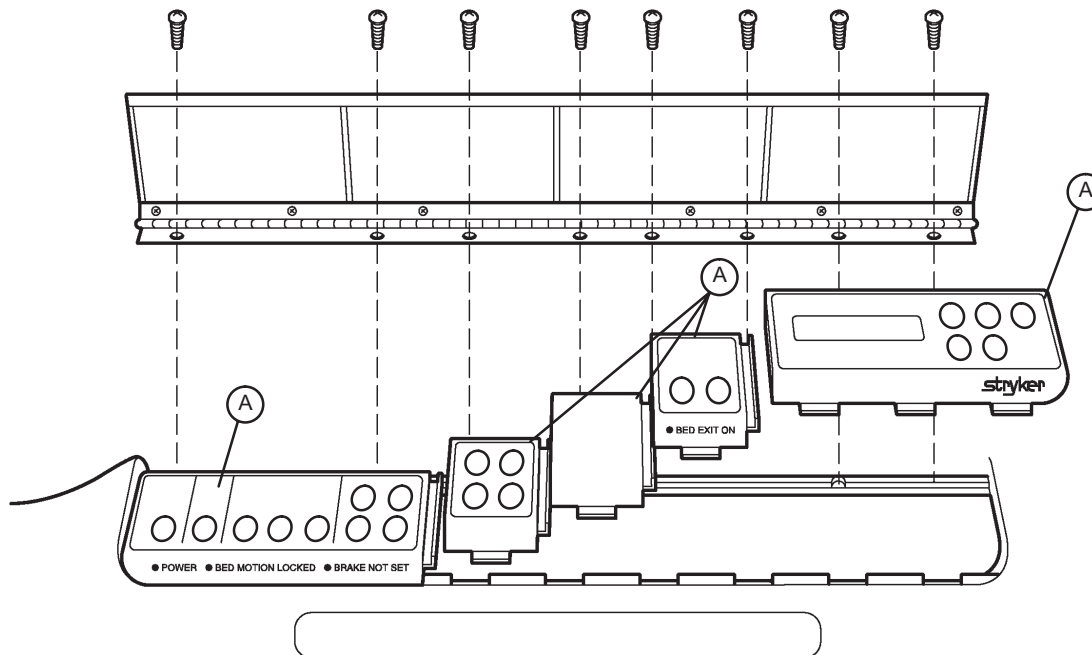

### Procedure:

1. Unplug the bed power cord from the wall socket. Remove the foot board lid (refer to Foot Board Lid Removal procedure).

### Note

Regardless of which module is being replaced, the farthest module to the right must be removed first.

2. Pull the module out of the foot board and disconnect the cable from the module (A).
3. Reverse the above steps to install the new module.

### CAUTION

The modules must be overlapped as shown in the illustration (right over left) when they are installed to prevent fluids from entering the board cavity and causing damage.

# Service information

---

## FOOT BOARD INTERFACE PLUG REPLACEMENT

### Required Tools:

- #2 Phillips Screwdriver.

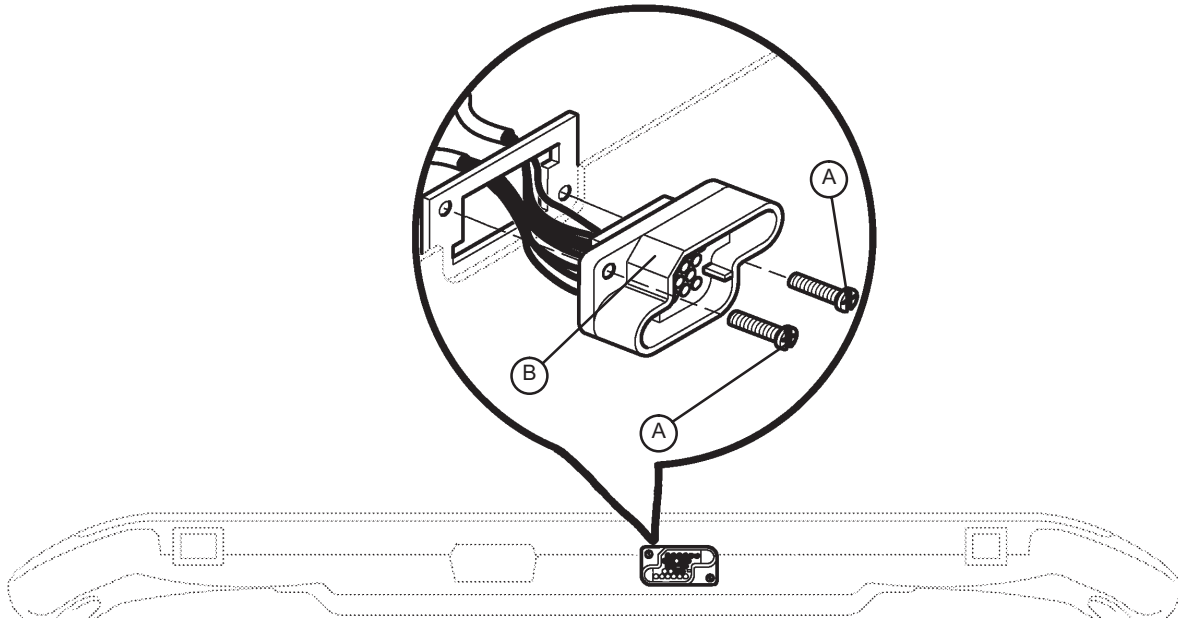

BOTTOM VIEW OF FOOT BOARD

### Procedure:

1. Unplug the bed power cord from the wall socket.
2. Remove the foot board from the bed to access the bottom of the board.
3. Properly ground yourself (Refer to Static Discharge Precautions section).
4. Remove the foot board door (Refer to Foot Board Hinge Removal procedure).
5. Using a #2 Phillips screwdriver, remove the two screws (A) holding the plug to the foot board.
6. Disconnect the interface cable from the foot board module cable. Note the proper placement of the cable so it will be reconnected properly.
7. Reverse the above steps to install the new interface plug.

---

### CAUTION

---

Be sure to install the new plug with the flat edge (B) at the top left, as shown in the illustration, or the foot board interface plug will not mate properly with the bed and damage to the plug or foot board could result.

# Base Assembly and Options

For Reference Only: 3002-200-003

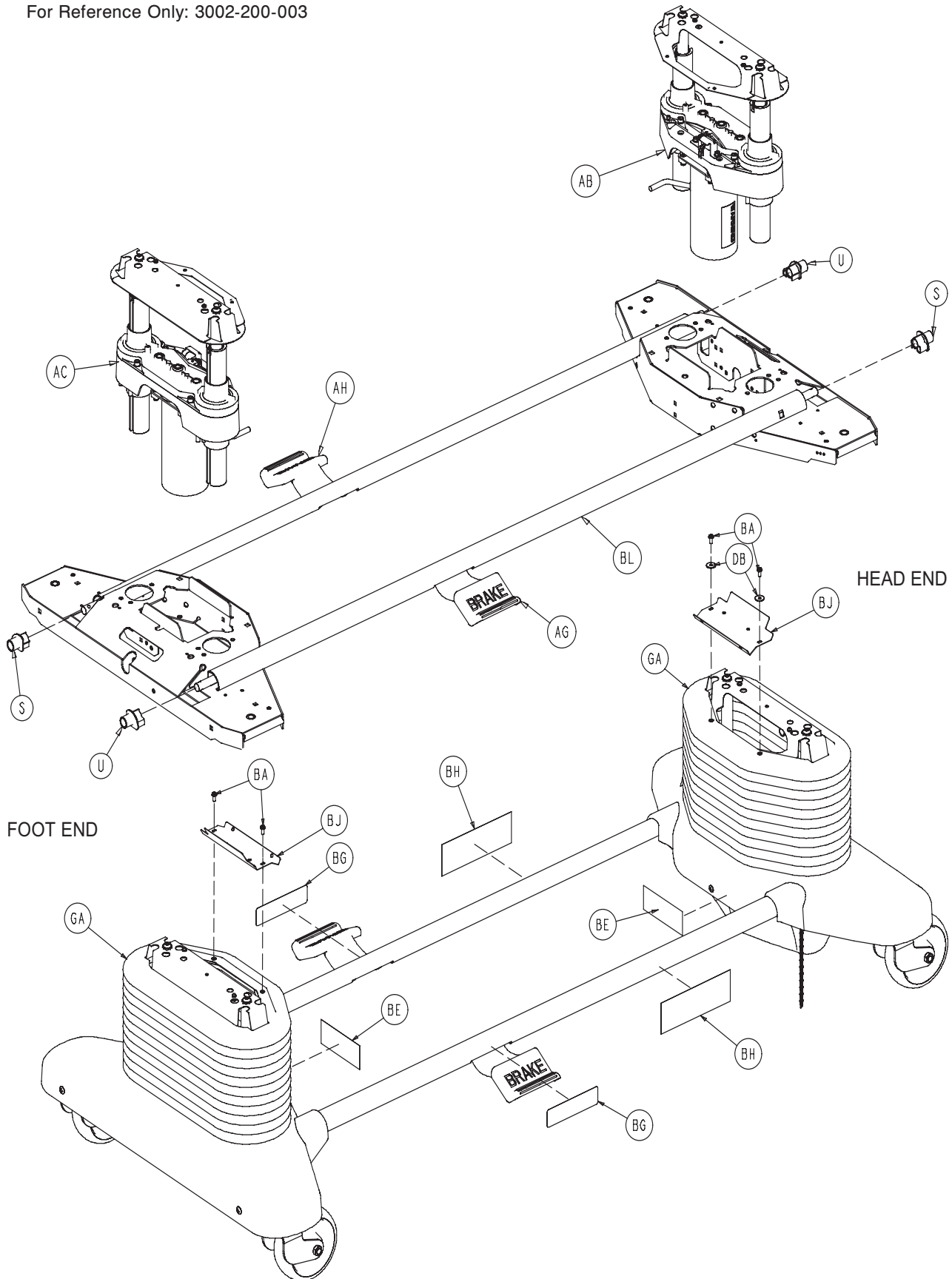

[Return To Table of Contents](#)

# Base Assembly and Options

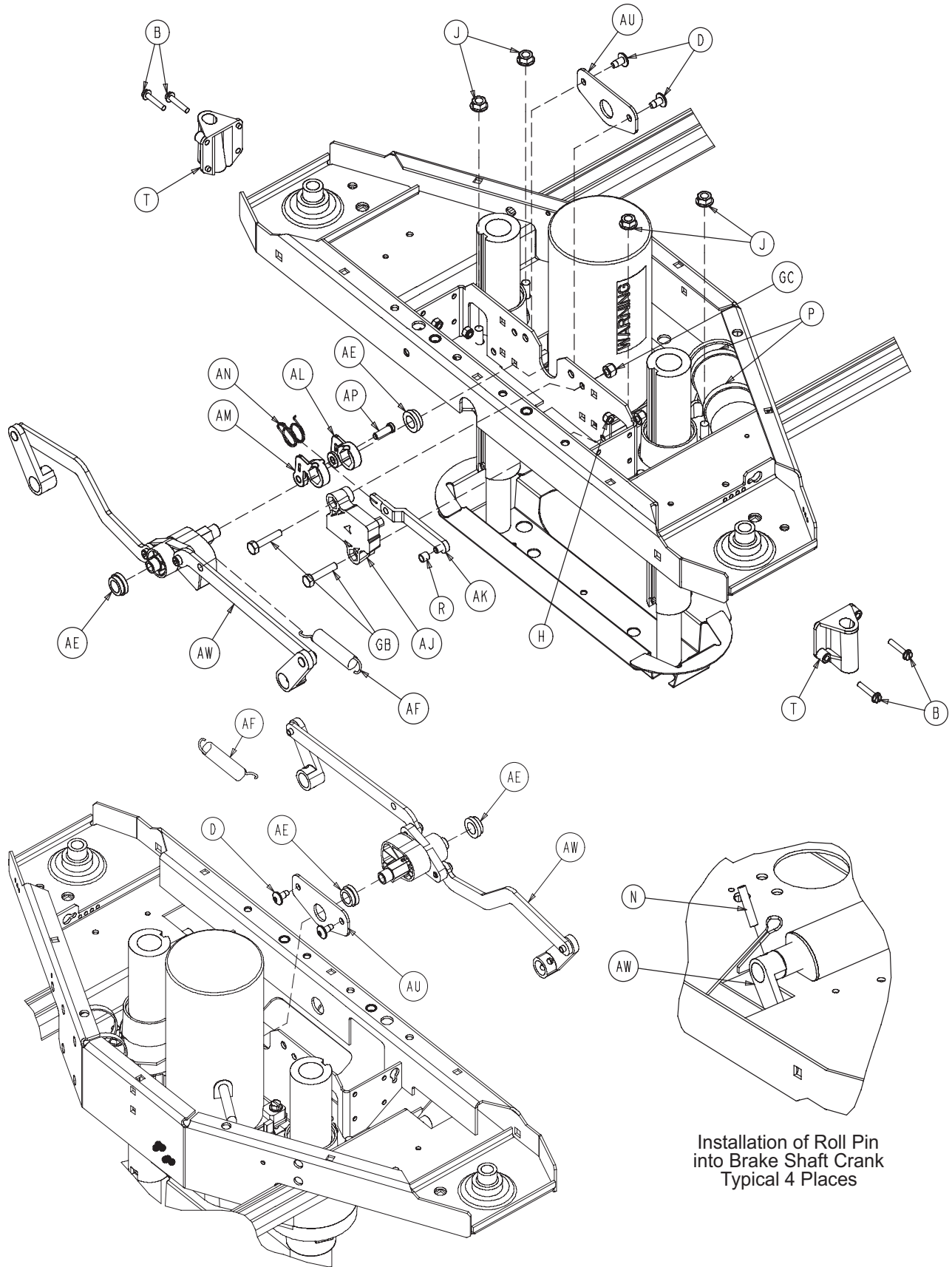

Installation of Roll Pin into Brake Shaft Crank  
Typical 4 Places

# Base Assembly and Options

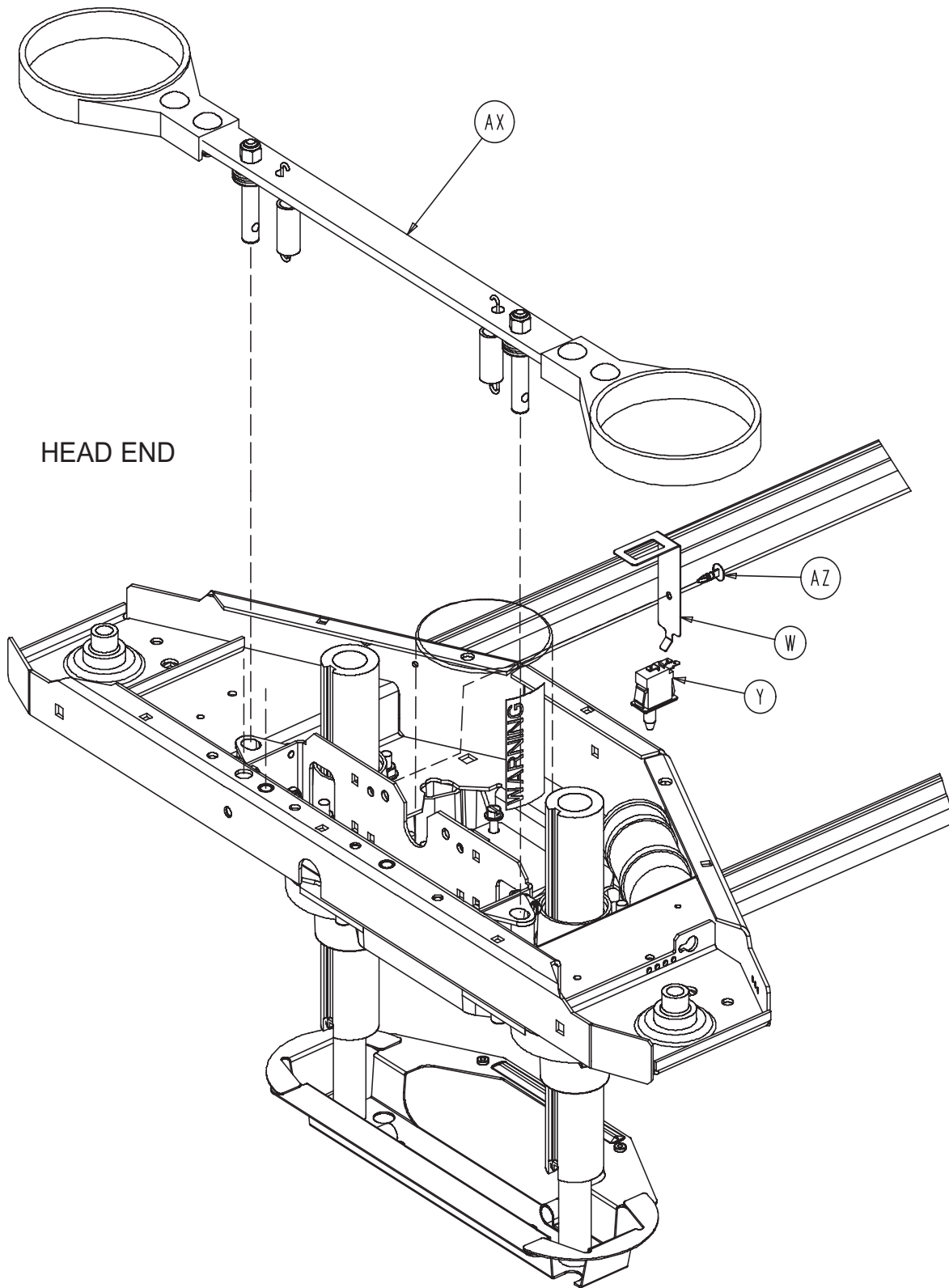



# Base Assembly and Options (Continued)

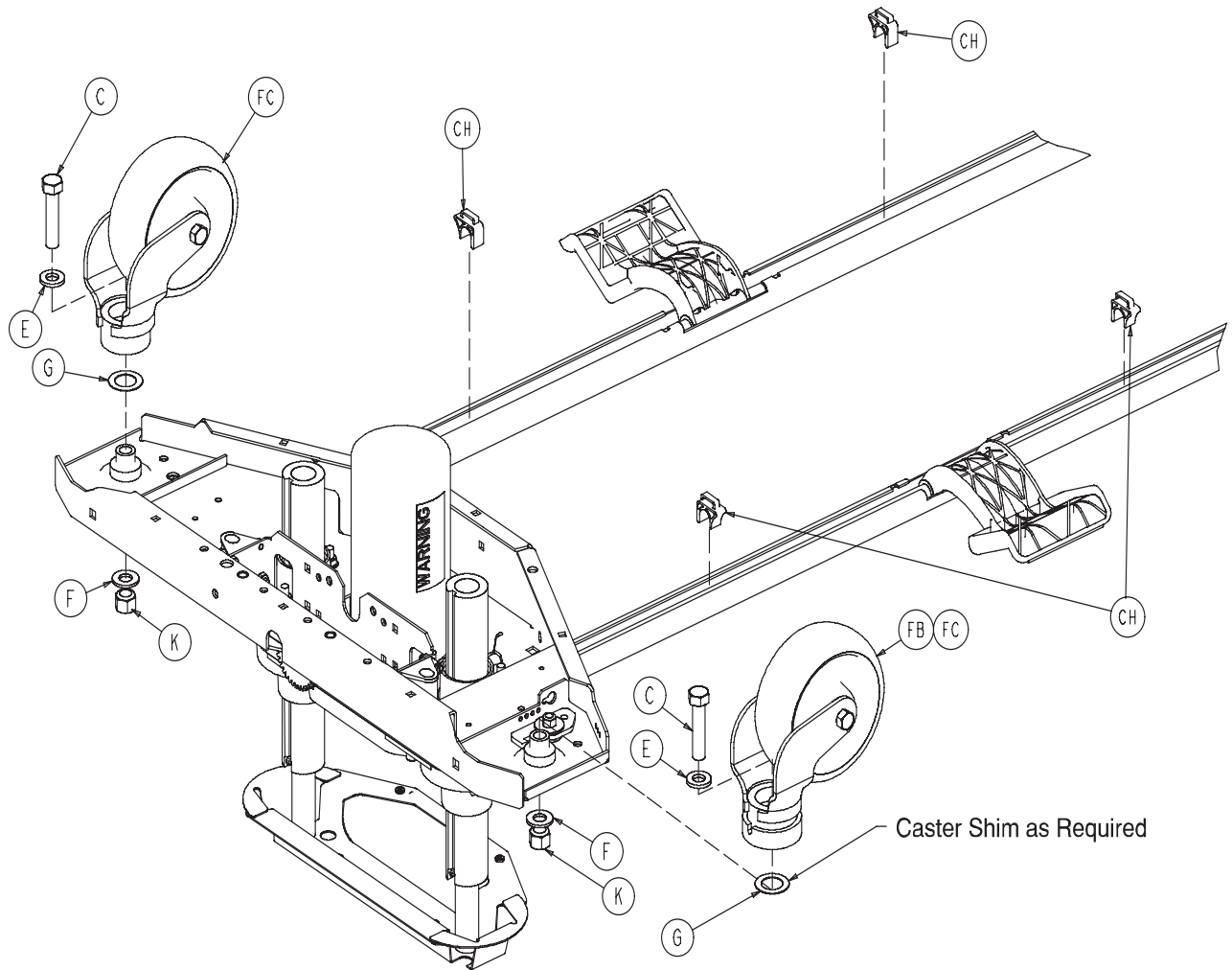

[Return To Table of Contents](#)

# Base Assembly and Options

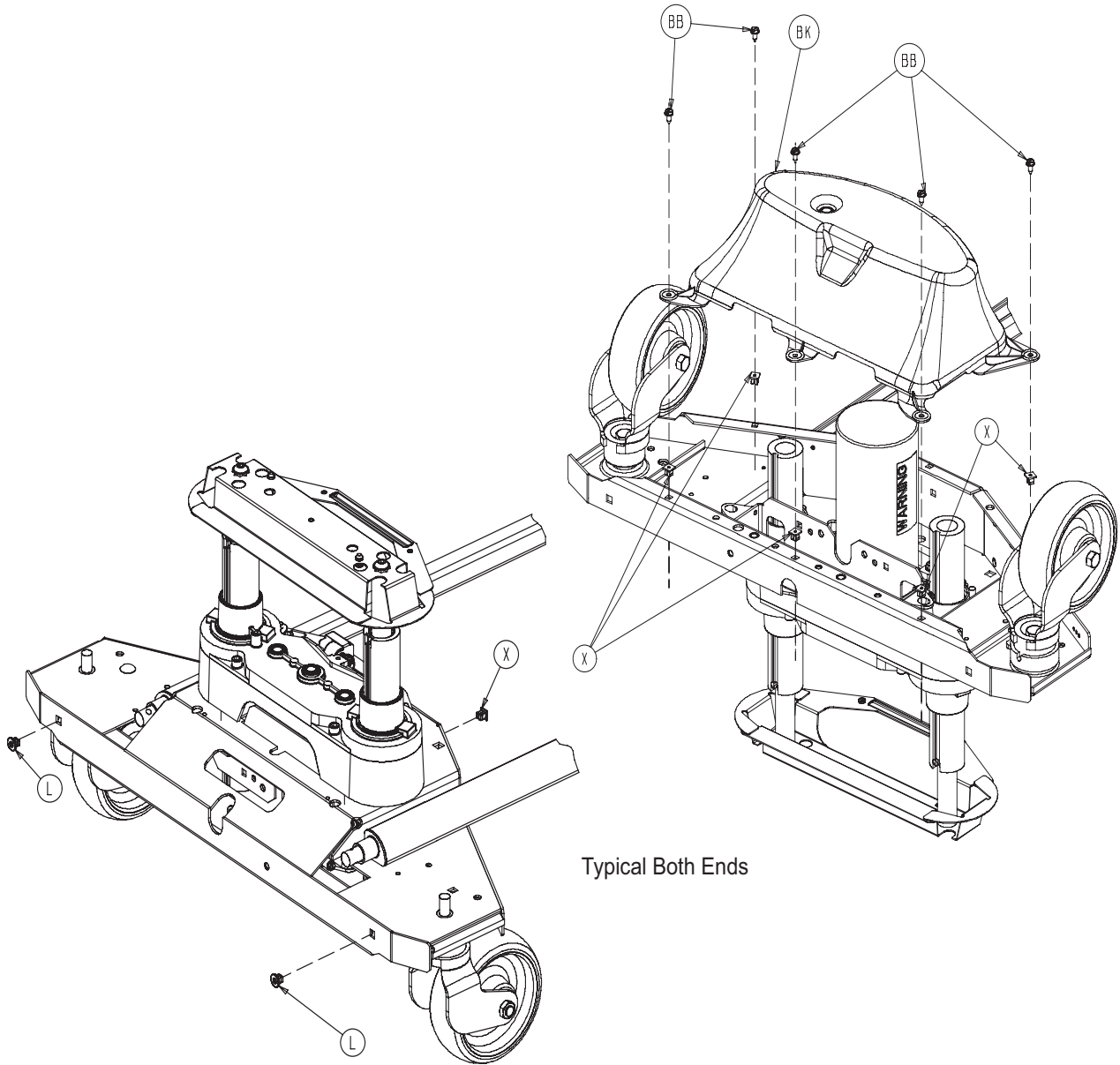

Typical Both Ends

Sensor Coil Cable p/n 3001-200-815 Ground

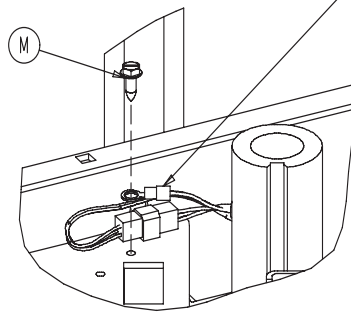

Typical Both Ends

# Base Assembly and Options

---

## Base Assembly Common Components - Part Number 3002-200-003 (Reference Only)

Item	Part No.	Part Name	Qty.
B	0003-122-000	Hex Washer Hd. Screw	8
D	0007-052-000	Truss Hd. Torx	4
E	0011-310-000	Washer	4
G	0011-343-000	Washer	4
H	0016-002-000	Nylock Nut	8
J	0016-098-000	Hex Flange Nut	8
K	0016-049-000	Nylock Nut	4
L	0018-036-000	Plastic Clip Nut	4
M	0003-224-000	Hex Washer Hd. Screw	2
N	0026-014-000	Roll Pin	4
P	0038-151-000	Cable Tie	4
R	3000-200-316	Brake Track Roller	1
S	3000-200-305	Brake Shaft Bushing, Right	2
T	3000-200-328	Brake Guide Bushing	4
U	3000-200-331	Brake Shaft Bushing, Left	2
W	3000-200-343	Brake Switch Bracket	1
X	3000-300-002	Plastic Clip Nut	10
Y	3000-300-058	Plunger Switch	1
Z	3000-300-113	8" Cable Tie	6
AB	3001-200-201	Head End Lift Assembly ( <a href="#">pg.85</a> )	1
AC	3001-200-251	Foot End Lift Assembly ( <a href="#">pg.85</a> )	1
AD	3001-200-306	Brake Pedal Shaft Bearing	4
AE	3001-200-317	Brake Cam Shaft Bushing	4
AF	3001-200-334	Brake Return Extension Spring	2
AG	3001-200-340	Brake Shaft Assembly, Left ( <a href="#">Pg.90</a> )	1
AH	3001-200-345	Brake Shaft Assembly, Right ( <a href="#">Pg.90</a> )	1
AJ	3002-201-301	Brake Ratchet Track	1
AK	3002-200-302	Brake Ratchet Link Assembly	1
AL	3002-200-305	Brake Ratchet Crank, Left	1
AM	3002-200-306	Brake Ratchet Crank, Right	1
AN	3002-200-307	Brake Latch Spring	1
AP	3002-200-308	Brake Ratchet Crank Pin	1
AU	3002-200-314	Brake Mounting Bracket	2
AW	3002-201-330	<a href="#">Brake Crank Assembly (pg.91)</a>	2
AX	3002-200-335	<a href="#">Brake Bar Assembly (pg.92)</a>	2
AZ	3000-300-115	Stand-Off	1
GA	2025-000-101	Bellows	2
GB	0003-074-000	Hex Hd. Bolt	2
GC	0016-028-000	Nylock Nut	2

# Base Assembly and Options

---

## Base Assembly, ZOOM ICU Bed - Part Number 2040-244-003 (Reference Only)

Item	Part No.	Part Name	Qty.
C	0003-204-000	Hex Hd. Cap Screw	4
AB	2040-243-200	Head End Lift Assembly	1
AC	2040-243-250	Foot End Lift Assembly	1
BL	3002-200-102	Base Weldment	1
CA	3000-300-115	Stand-Off	1
CB	0013-018-000	External Tooth Lock Washer	1
CE	2025-031-805	Ground Strap	1
CF	3000-200-343	Brake Switch Bracket	1
CG	3000-300-058	Switch Plunger	1
CH	3001-200-306	Brake Pedal Shaft Bearing	4
GA	2030-000-101	Bellows	2

## 6" Caster Option, ZOOM - 2040-999-138 (Ref.)

Item	Part No.	Part Name	Qty.
FA	3001-200-052	6" Ground Chain	1
FC	3001-200-060	<a href="#">6" Caster Assembly (pg.93)</a>	4

## 8" Caster Option, ZOOM - 2040-999-139 (Ref.)

Item	Part No.	Part Name	Qty.
FA	3001-200-054	8" Ground Chain	1
FC	3001-200-090	<a href="#">8" Caster Assembly (pg.95)</a>	4
FD	2025-001-047	Caster Cover, Right	4
FE	2025-001-048	Caster Cover, Left	4

# Lift Assembly (Head & Foot End)

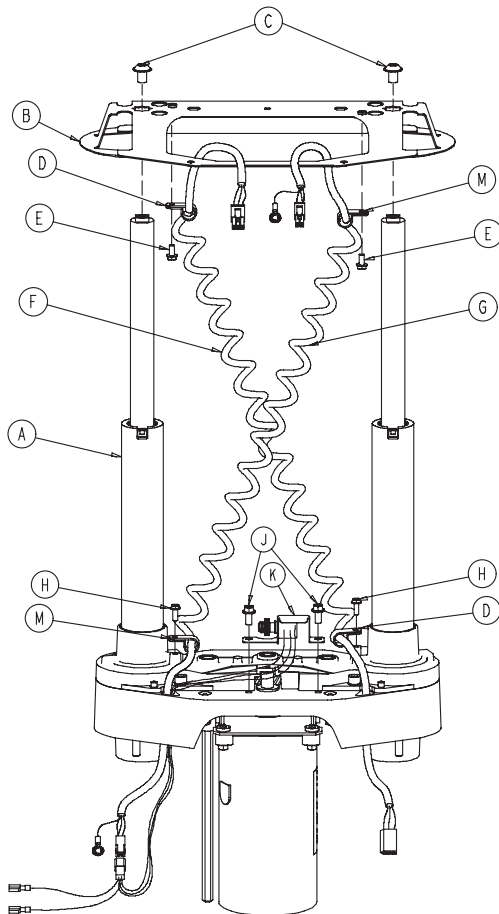
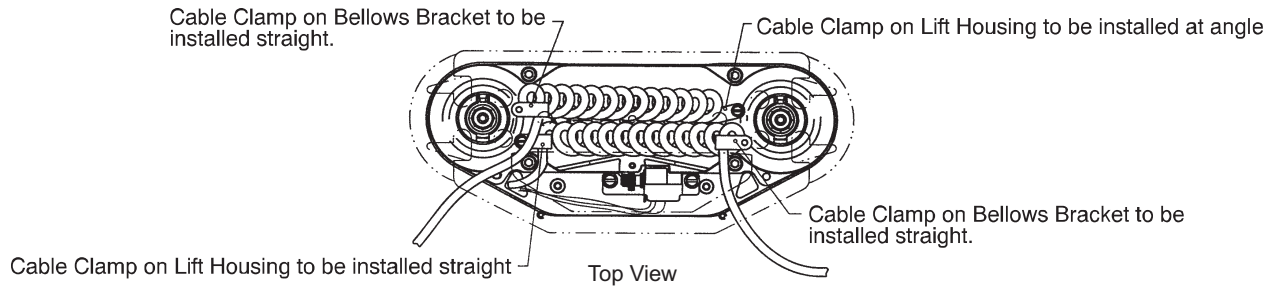

**Lift Assembly, Head End 2040-243-200**

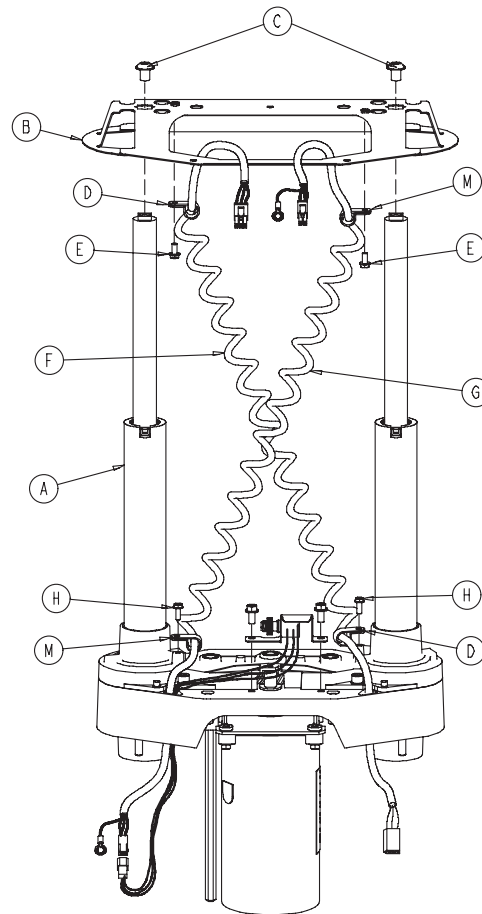

**Lift Assembly, Foot End 2040-243-250**

Item	Part No.	Part No.	Qty.
A	2040-243-275	Lift Assembly	1
B	3000-200-052	Bellows Bracket	1
C	0004-338-000	Button Head Cap Screw	2
D	0034-022-000	Cord Clamp	2
E	0003-123-000	Hex Washer Hd. Screw	2
F	3001-200-864	Power Coil Cord	1
G	3001-200-815	Sensor Coil Cord	1
H	0003-128-000	Hex Washer Hd. Screw	2
J	0003-121-000	Hex Washer Hd. Screw	2
K	3001-200-240	Head End Pot. Ass'y	1
	3001-200-230	Foot End Pot. Ass'y	1
M	0034-381-000	Cord Clamp	2

[Return To Table of Contents](#)



# Lift Assembly

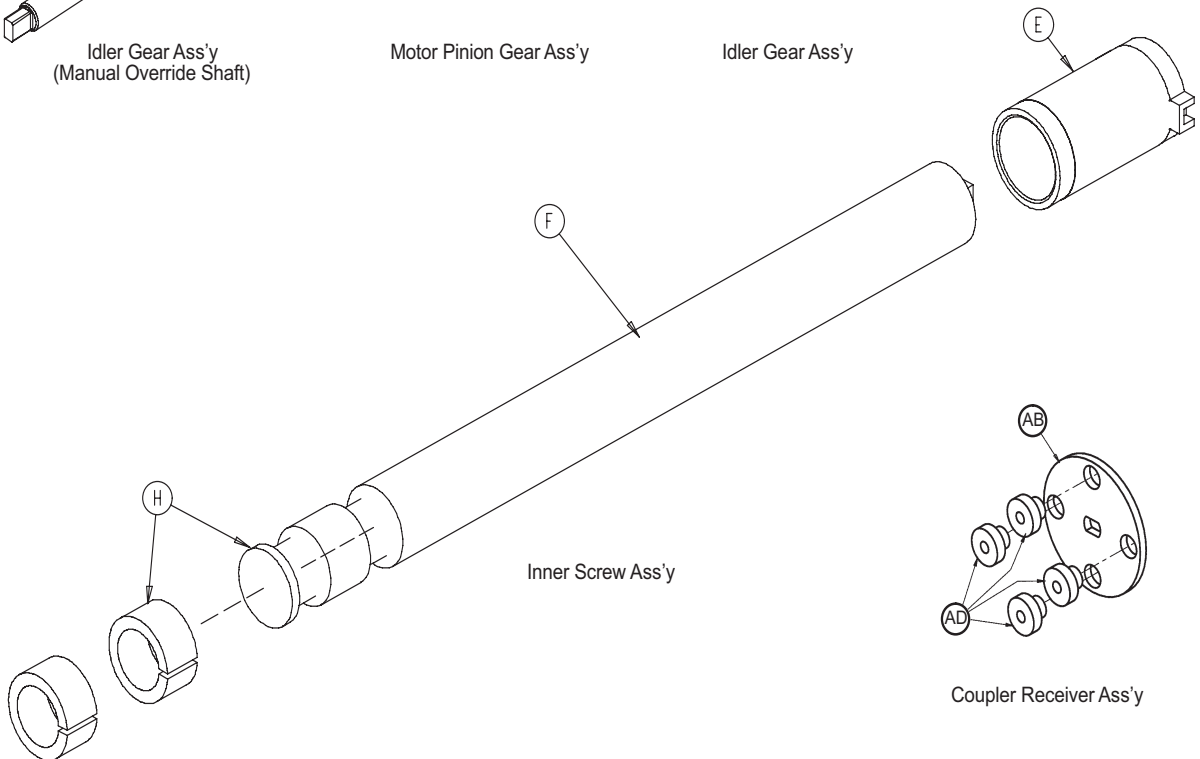
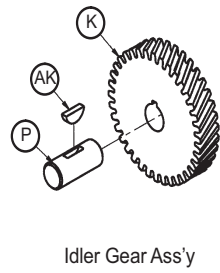
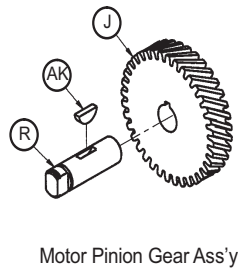
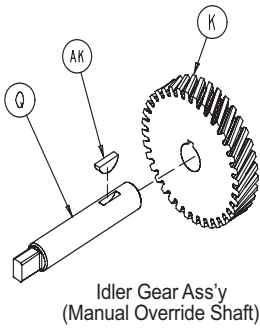
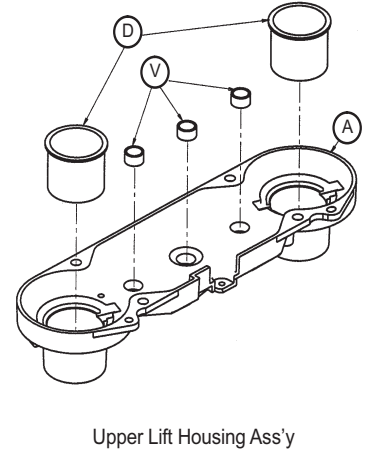
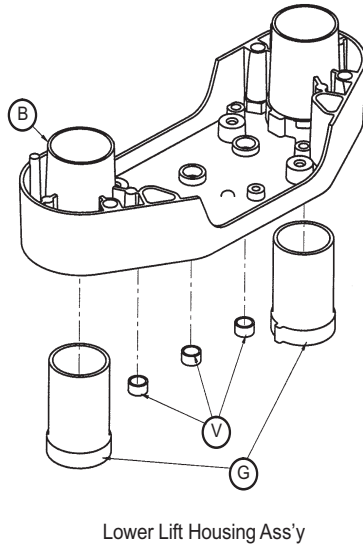
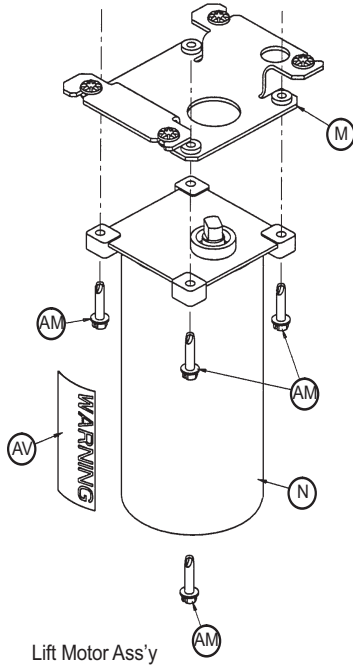

[Return To Table of Contents](#)

# Lift Assembly)

---

Item	Part No.	Part Name	Qty.
A	3000-200-201	Upper Lift Housing	1
B	3000-200-202	Lower Lift Housing	1
C	3000-200-251	Outer Screw	2
D	3000-200-204	Upper Housing Sleeve	2
E	3000-200-205	Upper Stage Nut	2
F	3000-200-249	Inner Screw	2
G	3000-200-207	Lower Stage Nut	2
H	3000-200-208	Glide Bushing	4
J	3000-200-209	Motor Pinion Gear	1
K	3000-200-210	Idler Gear	2
L	3000-200-252	Output Gear	2
M	3001-200-214	<a href="#">Motor Isolation Plate Ass'y (pg.89)</a>	1
N	3000-200-213	Lift Motor	1
	3221-200-213	230V Lift Motor	1
P	3000-200-218	Idler Shaft, Lift	1
Q	3002-200-235	Idler Man. Over. Shaft	1
R	3000-200-220	Input Pinion Shaft	1
S	3000-200-223	Output Gear Thr. Washer	4
T	3000-200-224	Input Gear Thr. Washer	2
U	0081-212-000	Thrust Needle Roller Brg.	1
V	3000-200-226	Pinion Shaft Bushing	6
W	3001-200-228	Mounting Standoff	4
Z	3001-300-019	Isolation Sleeve	4
AA	3000-200-233	Lift Motor Coupler	1
AB	3000-200-234	Coupler Receiver	1
AC	3000-200-241	Crush Washer	2
AD	3000-300-455	Isolation Bushing	4
AE	3000-200-245	Gear Washer	5
AF	3000-200-246	Nylon Washer	1
AG	0011-408-000	Flat Washer	4
AH	0003-082-000	Hex Hd. Cap Screw	4
AJ	0004-213-000	Soc. Hd. Cap Screw	4
AK	0058-044-000	Woodruff Key	3
AM	0003-331-000	Hex Washer Hd. Screw	4
AP	0028-121-000	Retaining Ring	2
AQ	0028-097-000	Retaining Ring	1
AS	0011-308-000	Serrated Belleville Washer	4
AV	3000-300-604	Warning Label	1
AX	3000-200-239	Potentiometer Drive Gear Shaft	1
AY	3000-200-216	Potentiometer Drive Gear	1



# Motor Isolation Plate Assembly

For Reference Only: 3001-200-214

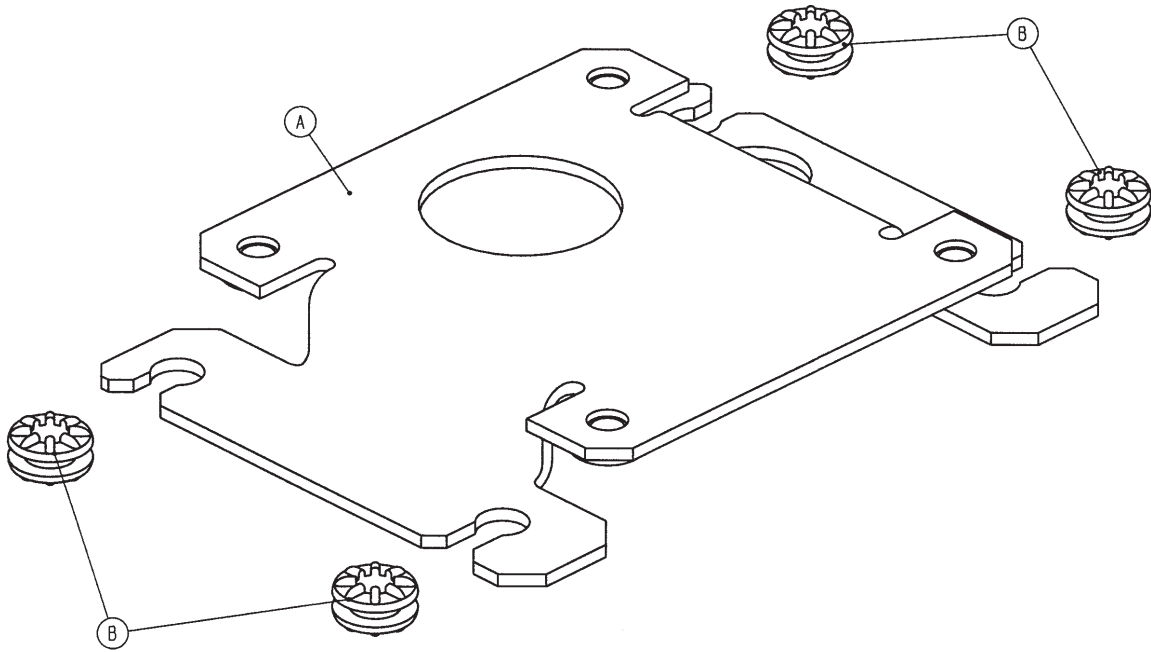

Item	Part No.	Part Name	Qty.
A	3001-200-213	Isolation Plate	1
B	3000-300-442	Grommet	4

[Return To Table of Contents](#)

## Brake Shaft Assembly, Left - 3001-200-340

---

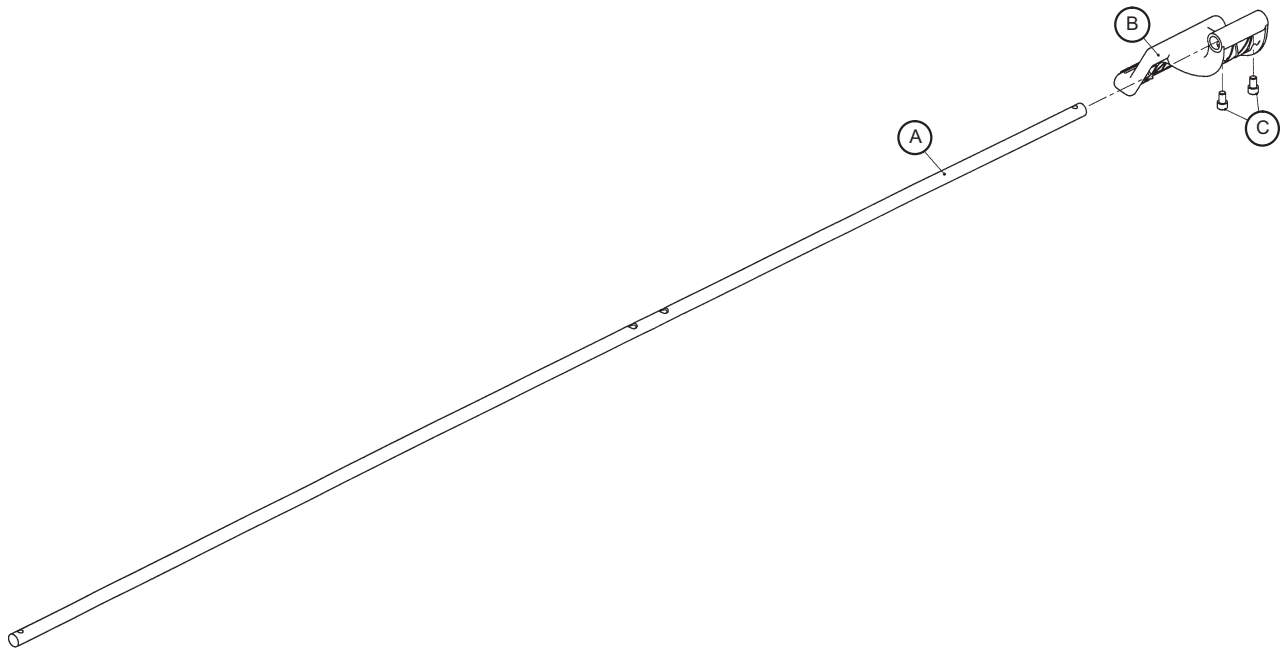

## Brake Shaft Assembly, Right - 3001-200-345

---

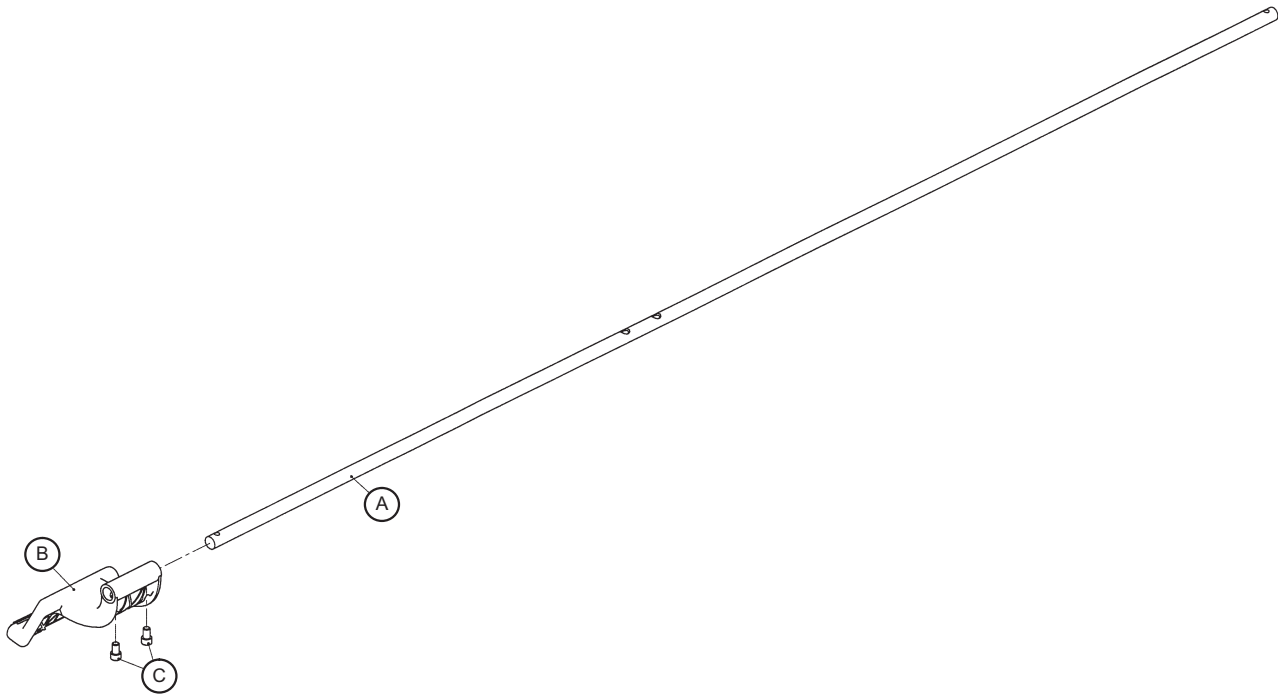

Item	Part No.	Part Name	Qty.
A	3000-200-314	Brake Shaft	1
B	3001-200-325	Brake Pedal	1
C	0004-270-000	Soc. Hd. Cap Screw	2

# Brake Crank Assembly - 3002-201-330

---

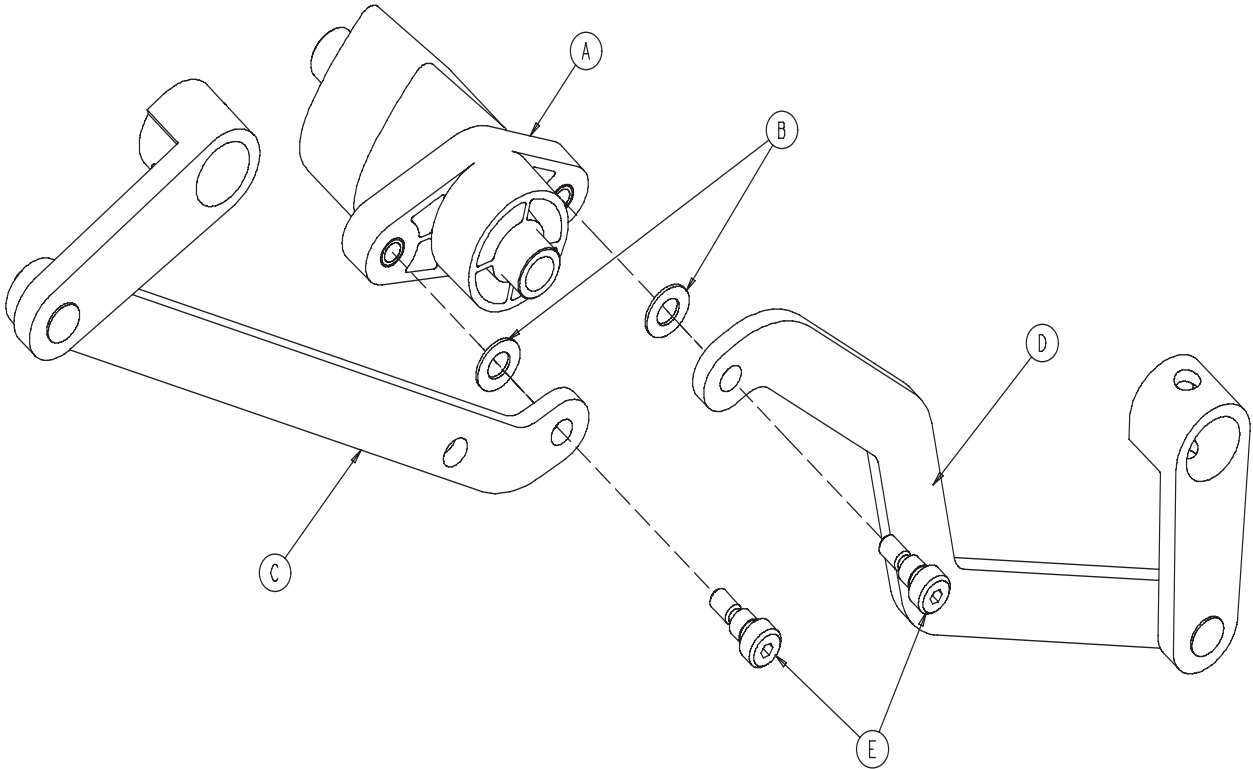

Item	Part No.	Part Name	Qty.
A	3002-201-309	Brake Cam Shaft Crank	1
B	0014-004-000	Washer	2
C	3002-200-331	Brake Link	1
D	3002-200-332	Dog Leg Brake Link	1
E	0002-108-000	Socket Hd. Shoulder Screw	2

# Brake Bar Assembly - 3002-200-335

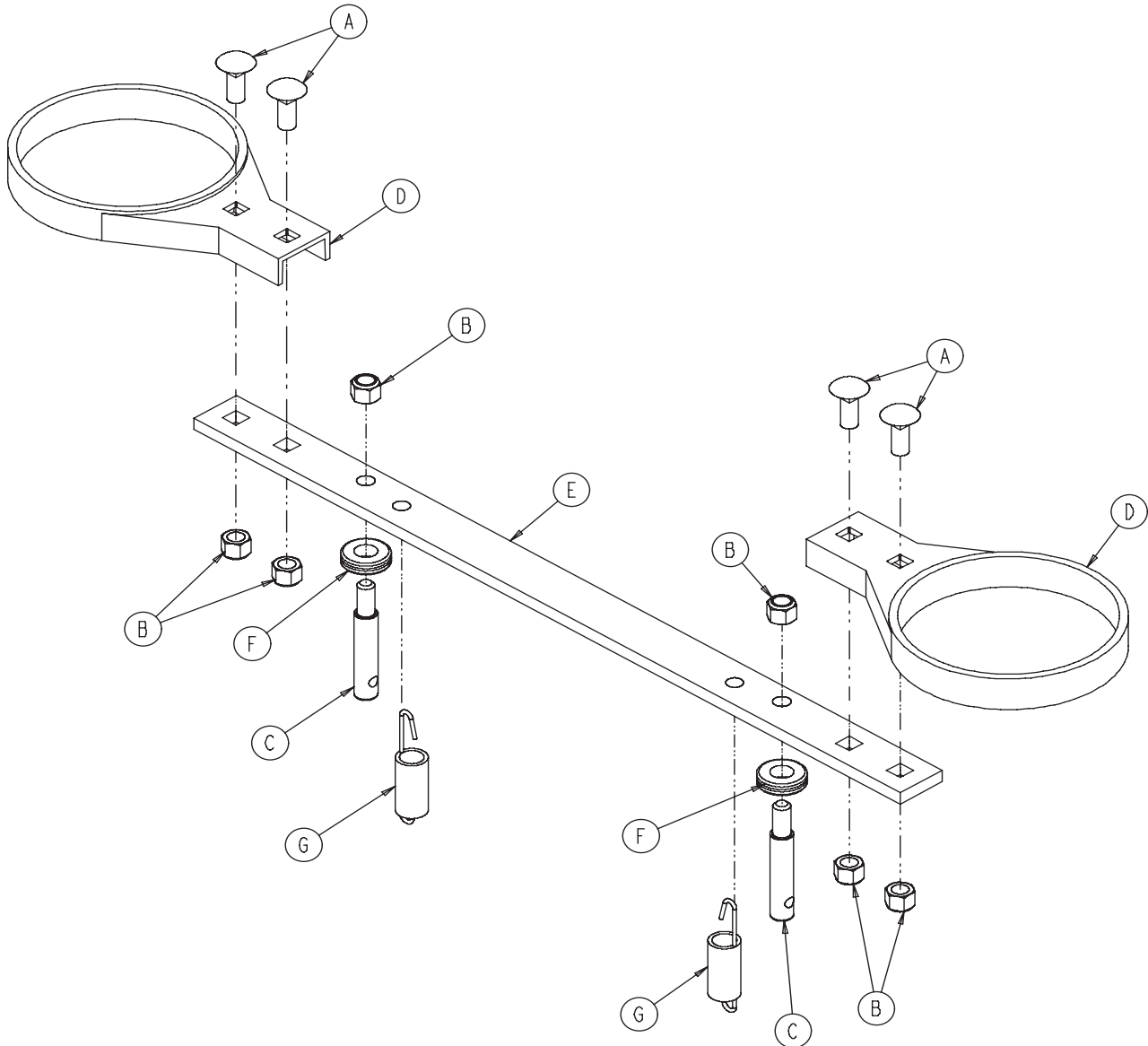

Item	Part No.	Part Name	Qty.
A	0005-018-000	Carriage Bolt	4
B	0016-035-000	Nylock Hex Nut	6
C	3000-200-318	Guide Pin	2
D	3000-200-321	Brake Ring	2
E	3000-200-323	Brake Bar	1
F	3000-200-324	Brake Bar Bumper	2
G	3002-200-310	Brake Bar Return Spring	2

# 6" Caster Assembly - 3001-200-060

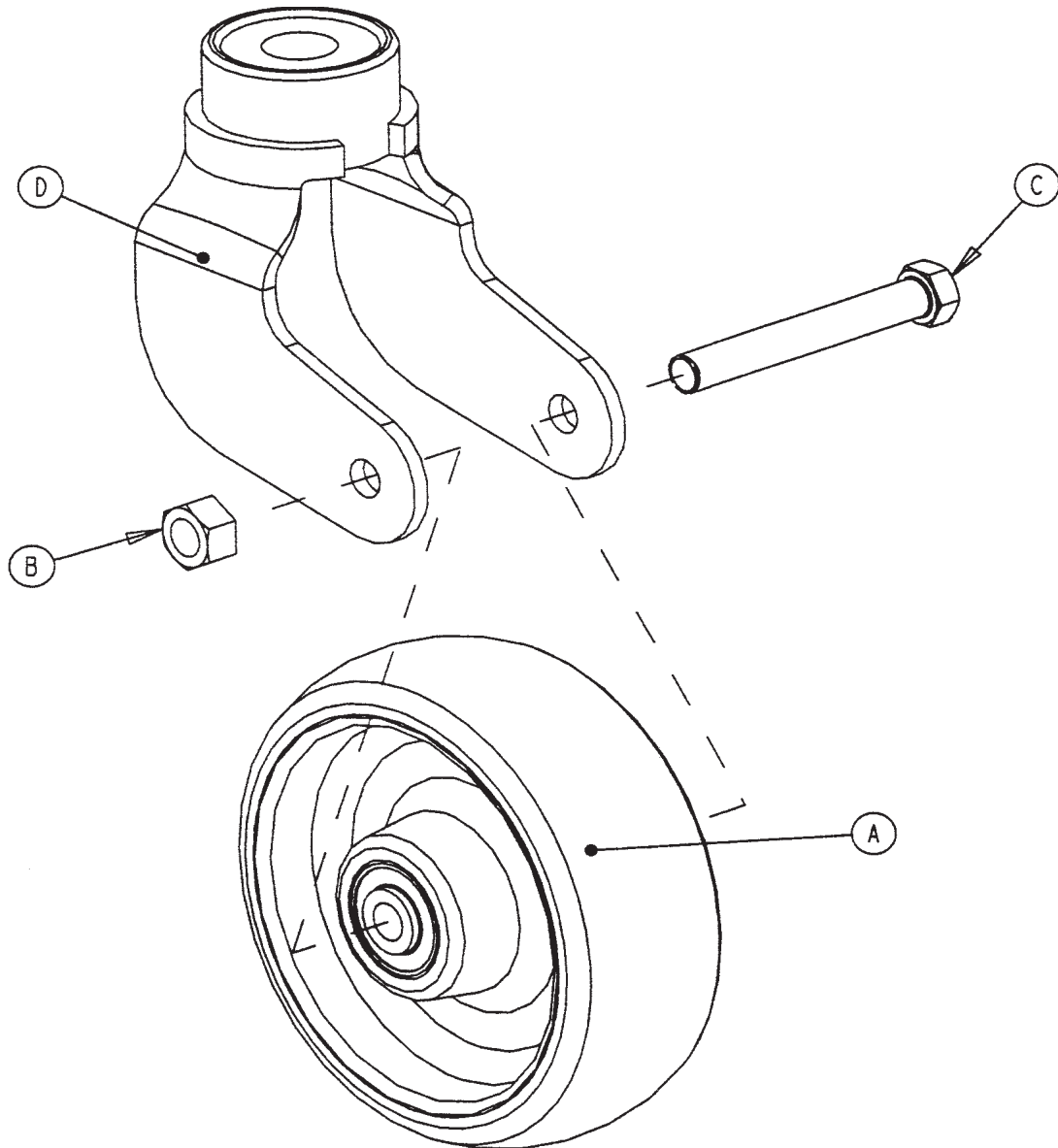

Item	Part No.	Part Name	Qty.
A	5000-002-010	<a href="#">Wheel Assembly (pg.94)</a>	1
B	0016-060-000	Lock Nut	1
C	0003-342-000	Hex Hd. Cap Screw	1
D	3001-200-061	Caster Horn W/Bearing	1

[Return To Table of Contents](#)

# 6" Molded Wheel Assembly - 5000-002-010

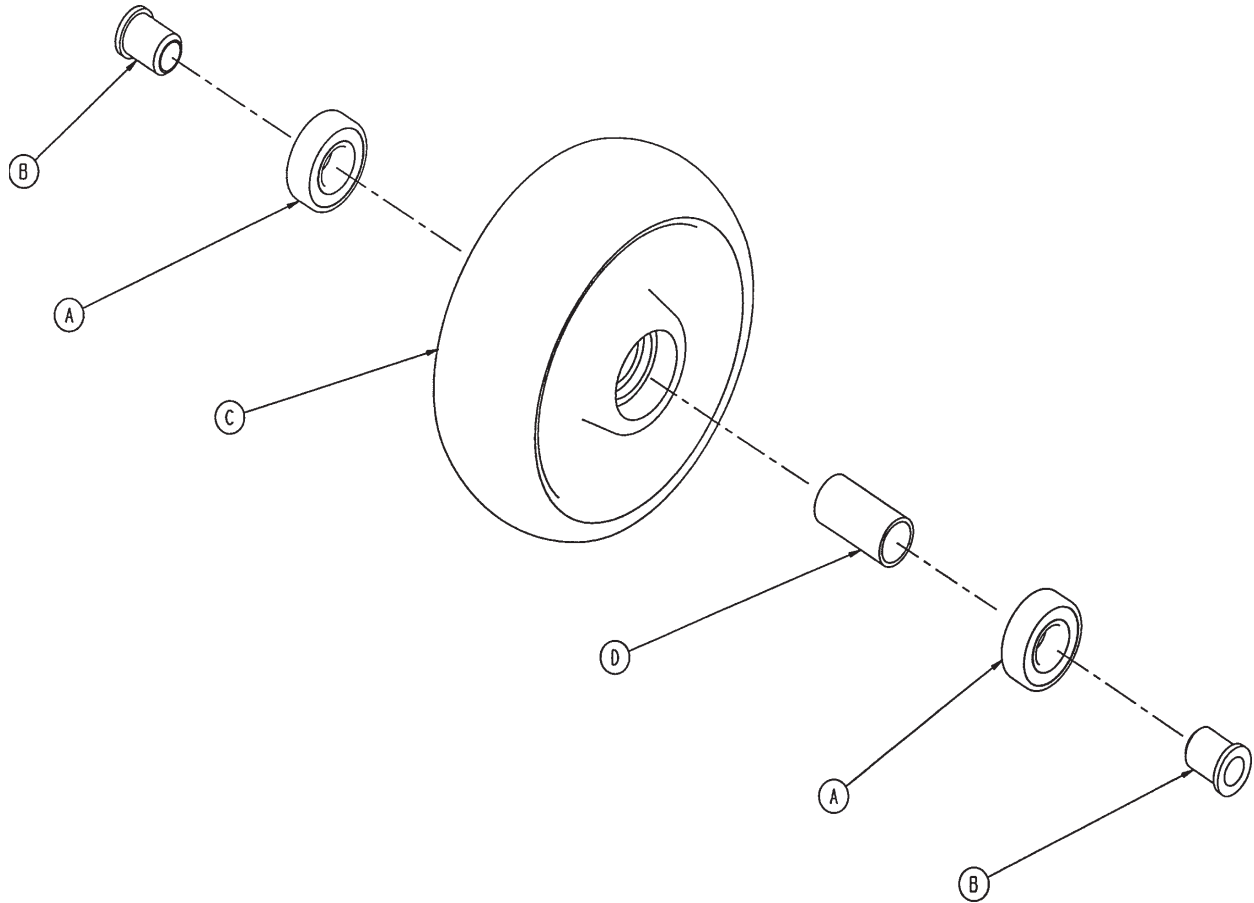

Item	Part No.	Part Name	Qty.
A	0081-226-000	Bearing	2
B	0715-001-255	Wheel Bushing	2
C	5000-002-020	Molded Wheel	1
D	6060-002-046	Bearing Spacer	1

# Optional 8" Caster Assembly - 3001-200-090

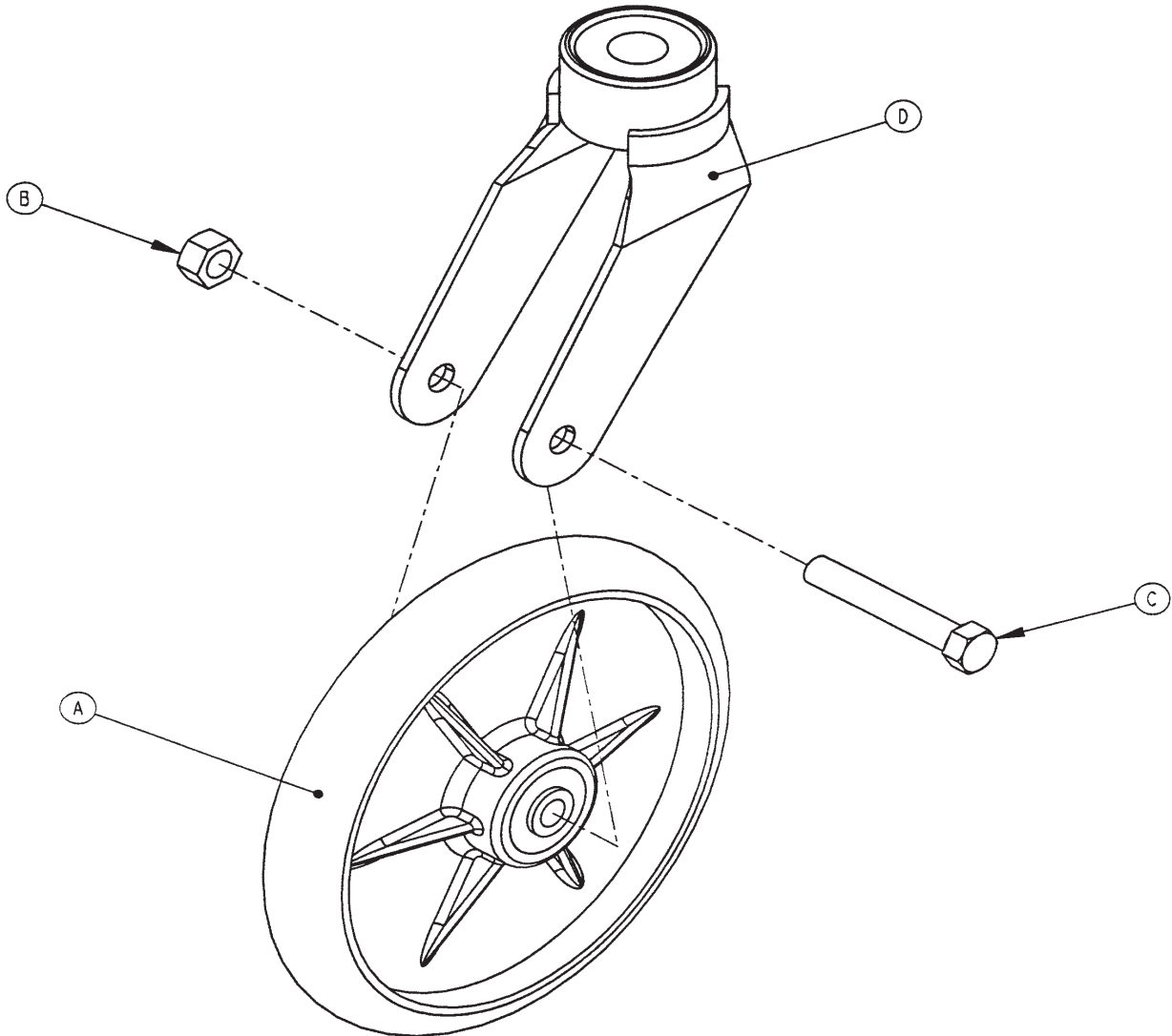

Item	Part No.	Part Name	Qty.
A	0715-002-025	<a href="#">Wheel Assembly (pg.96)</a>	1
B	0016-060-000	Hex Nut	1
C	0003-099-000	Hex Hd. Cap Screw	1
D	3001-200-076	Caster Horn	1
E	2025-001-047	Right Siderail Cover (not shown)	1
F	2025-001-048	Left Siderail Cover (not shown)	1

[Return To Table of Contents](#)

# Optional 8" Wheel Assembly - 0715-002-025

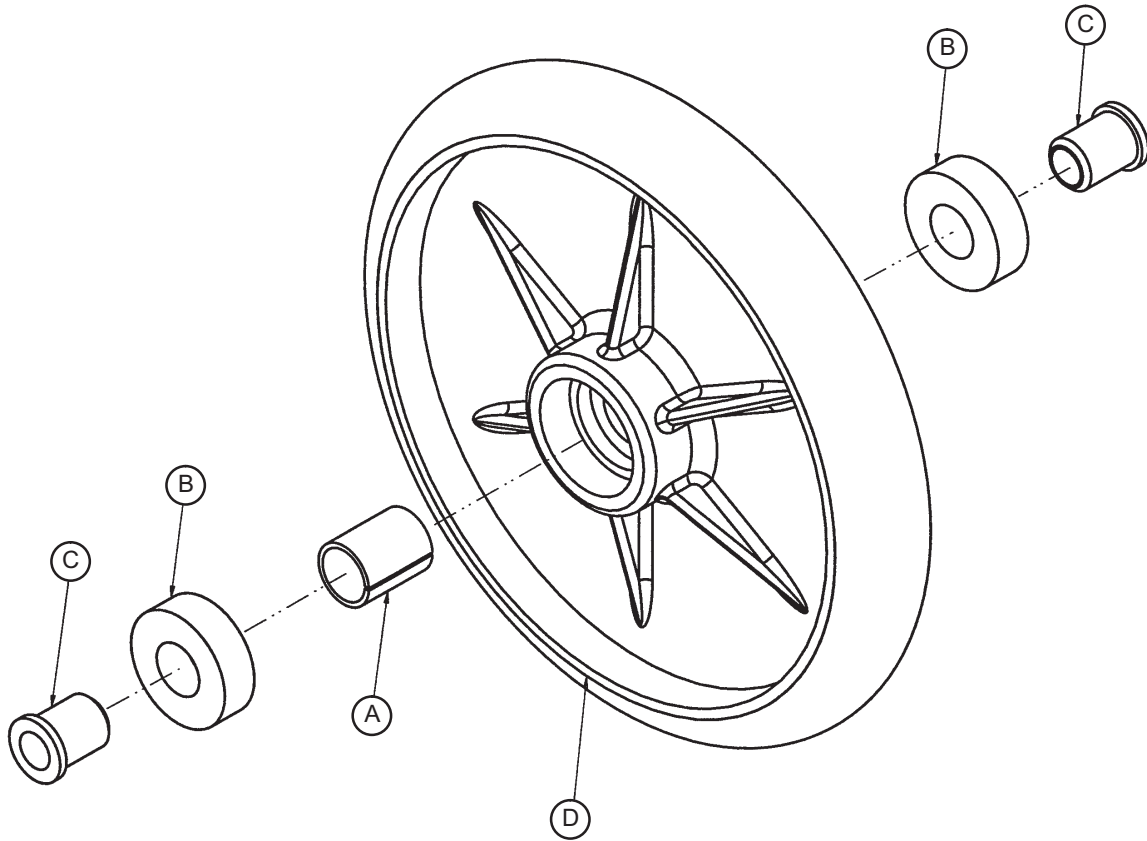

Item	Part No.	Part Name	Qty.
A	0052-503-000	Bearing Spacer	1
B	0081-226-000	Bearing	2
C	0715-001-255	Wheel Bearing	2
D	0715-002-124	Wheel	1



# ZOOM® Base Assembly

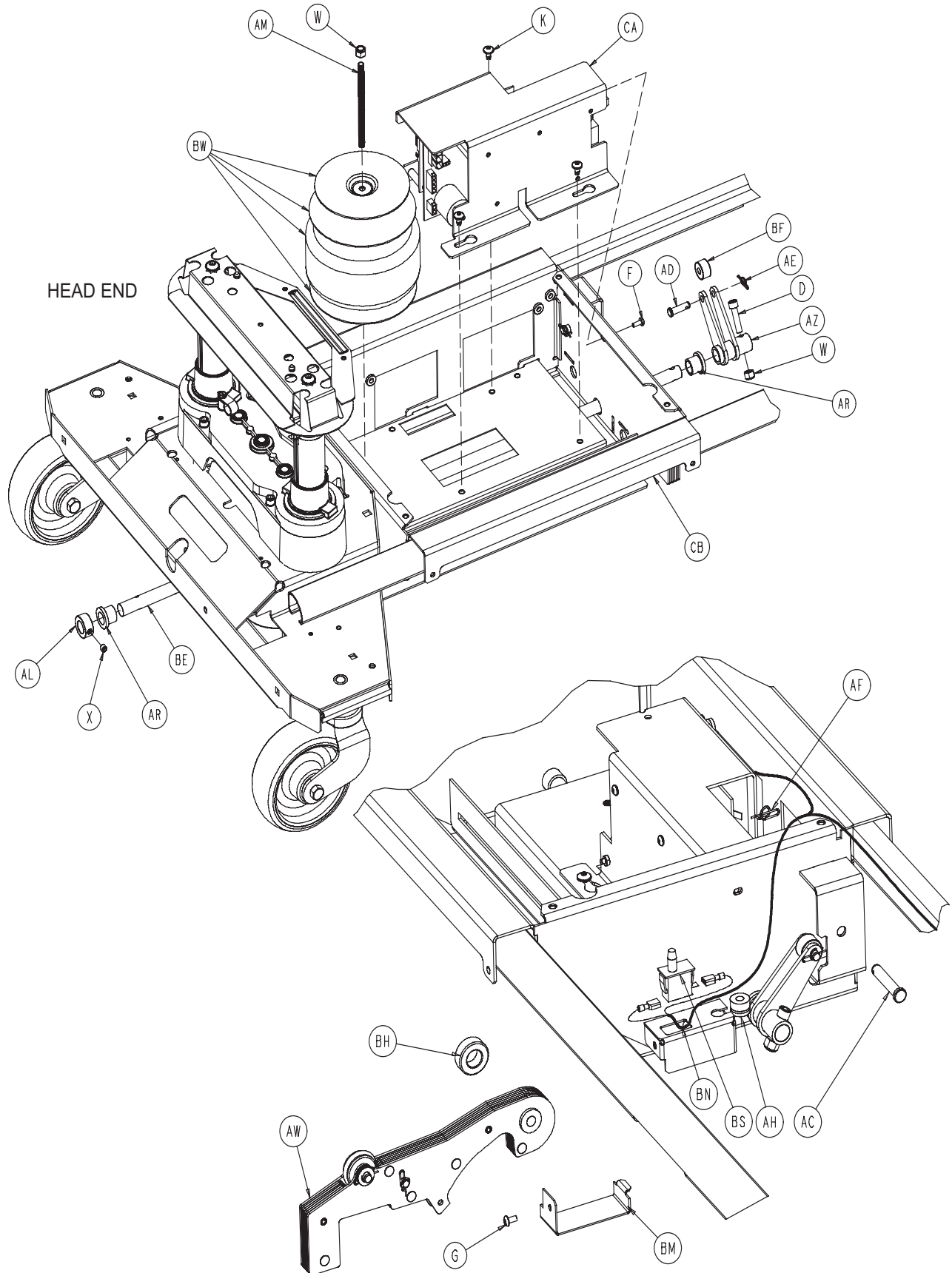

[Return To Table of Contents](#)

# ZOOM® Base Assembly

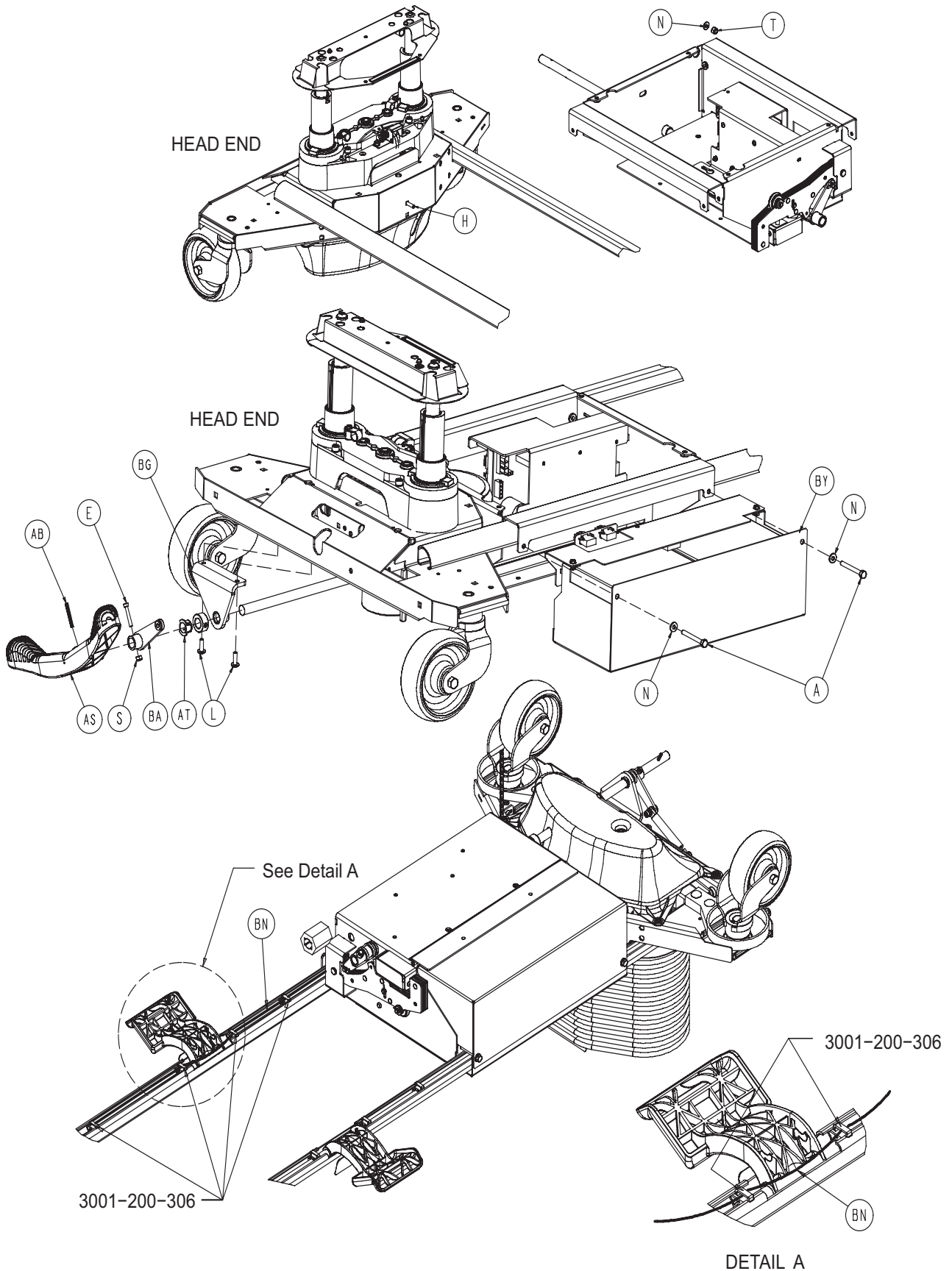

# ZOOM® Base Assembly

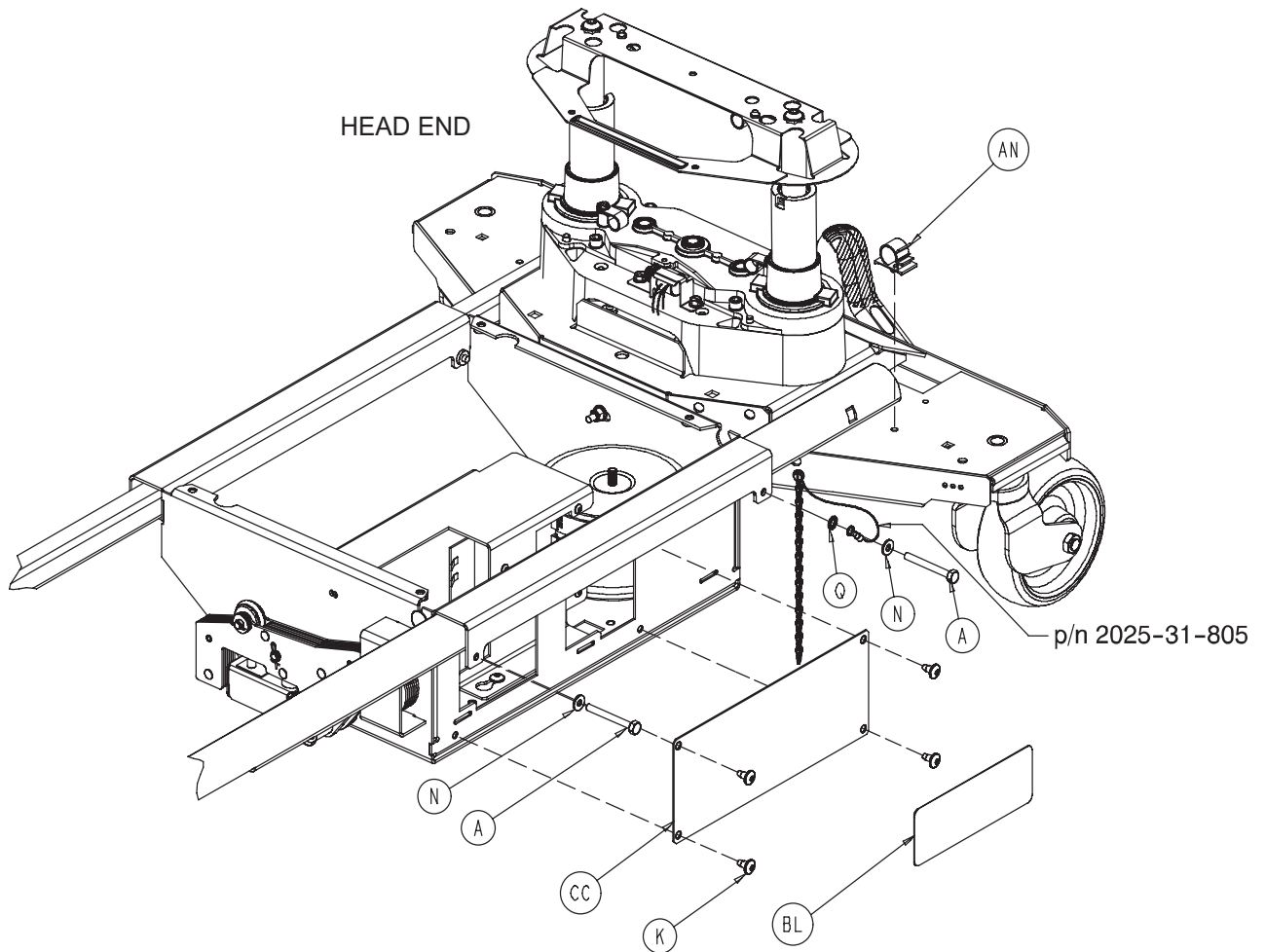
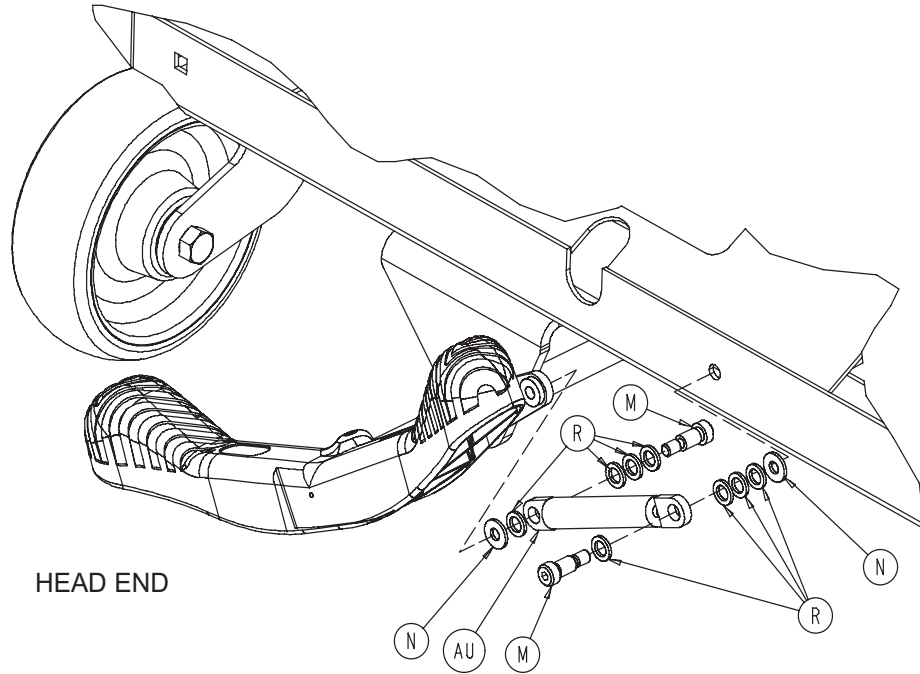

[Return To Table of Contents](#)

# ZOOM® Base Assembly

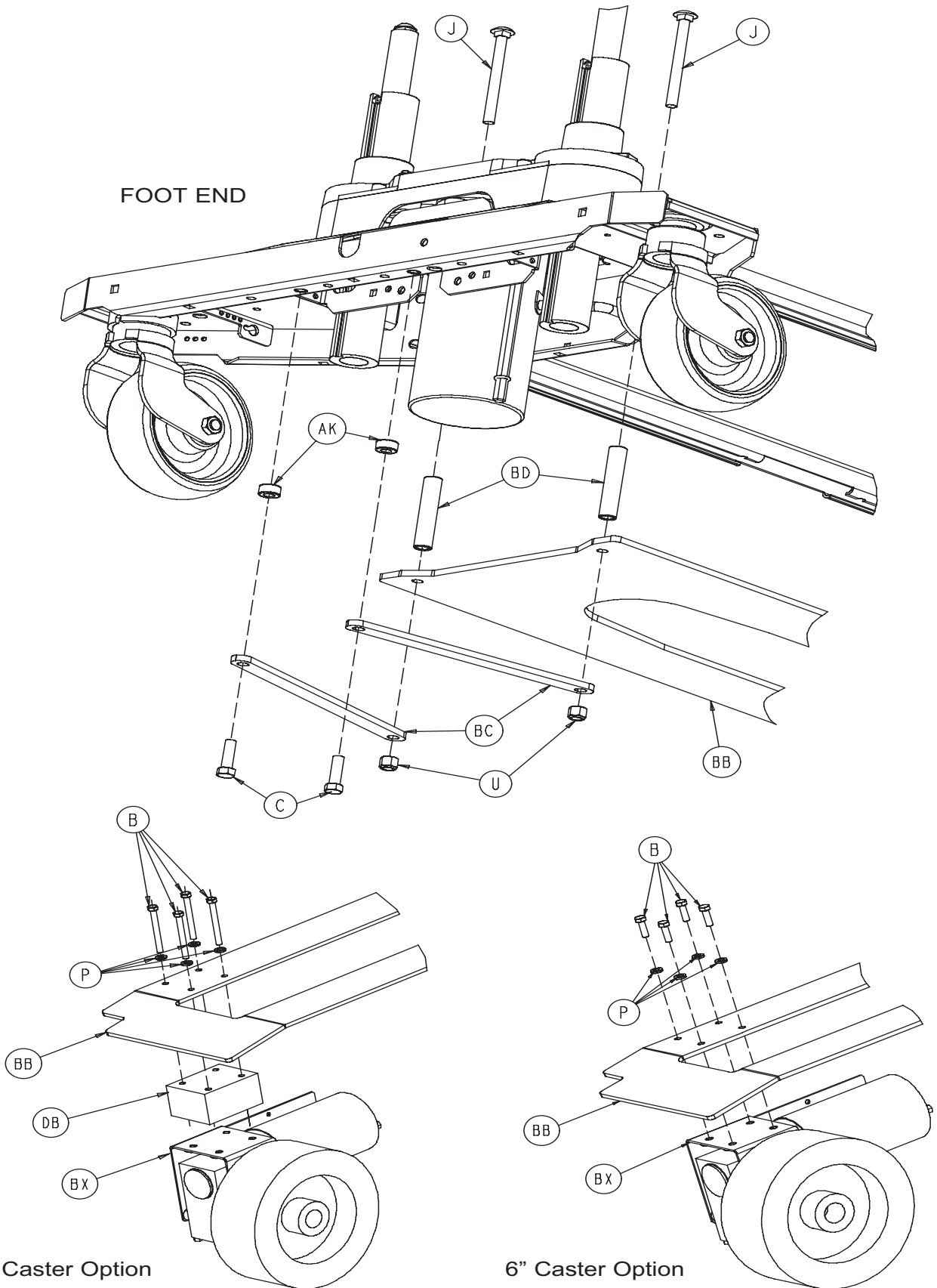

# ZOOM® Base Assembly

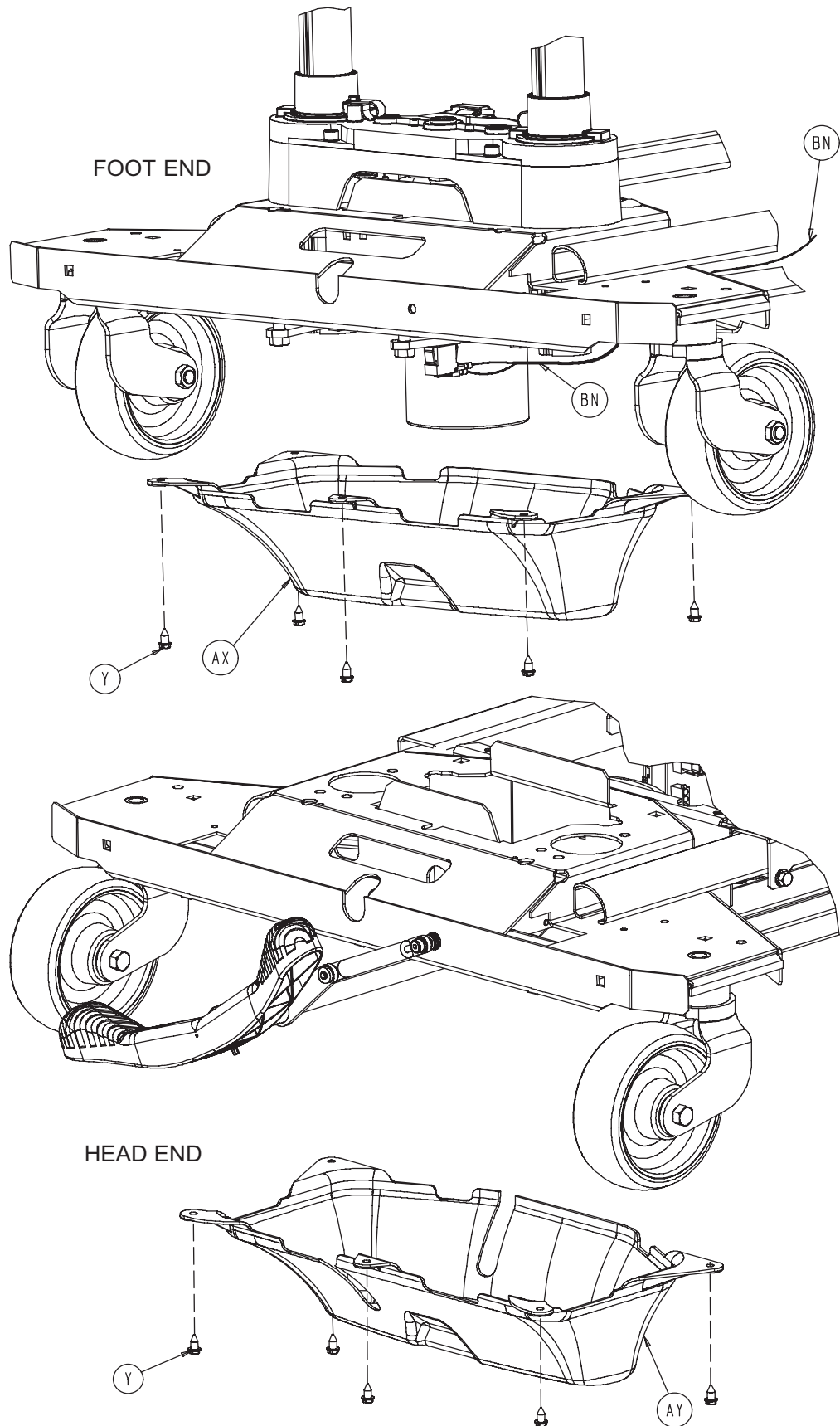

[Return To Table of Contents](#)

# ZOOM® Base Assembly

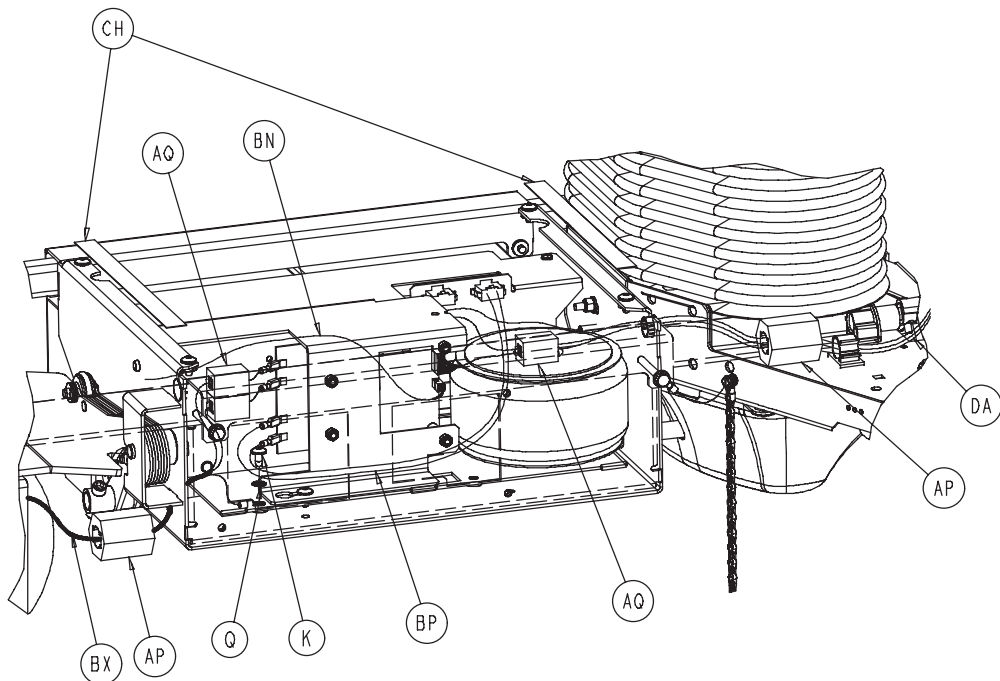
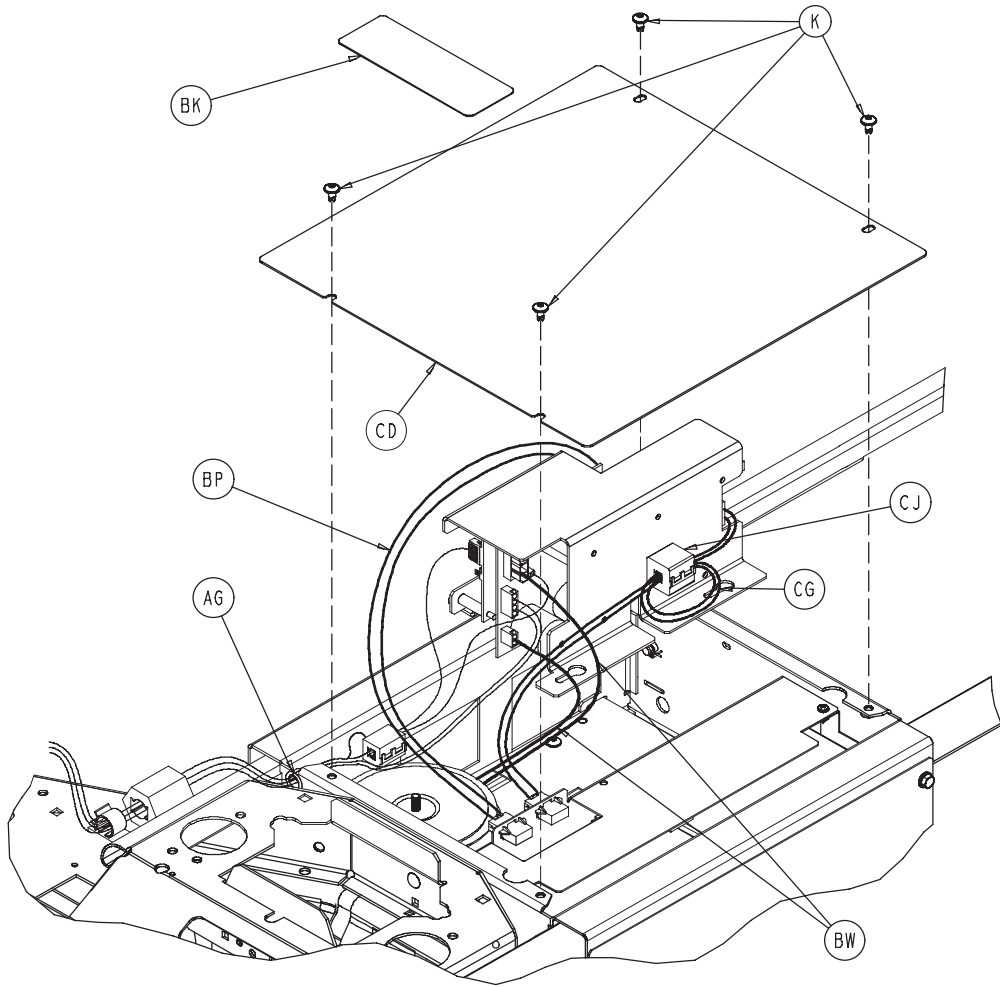

# ZOOM® Base Assembly

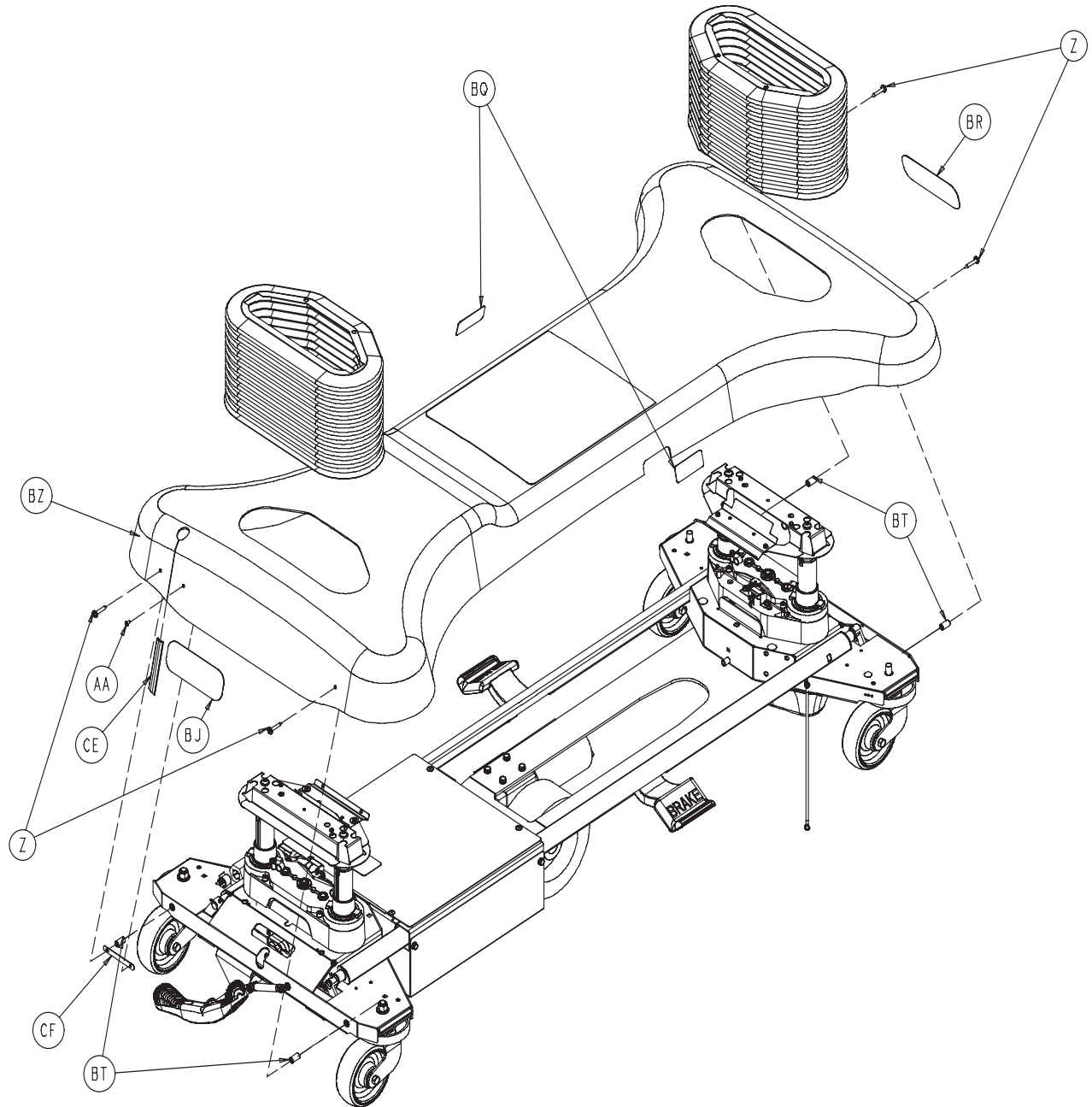

[Return To Table of Contents](#)

# ZOOM® Base Assembly

---

## ZOOM® Option Common Components - Part Number 3002-001-001 (Reference Only)

Item	Part No.	Part Name	Qty.
A	0003-032-000	Hex Hd. Cap Screw	4
C	0003-120-000	Hex Hd. Cap Screw	2
D	0004-039-000	Soc. Hd. Cap Screw	1
E	0004-160-000	Soc. Hd. Cap Screw	1
F	0004-301-000	Pan Hd. Machine Screw	1
G	0004-307-000	Soc. But. Hd. Cap Screw	1
H	0005-017-000	Carriage Bolt	1
J	0005-031-000	Carriage Bolt	2
K	0007-052-000	Truss Hd. Torx	13
L	0007-063-000	Truss Hd. Torx	2
M	0008-049-000	Soc. Hd. Shoulder Bolt	2
N	0011-063-000	Washer	7
P	0012-020-000	Lock Washer	4
Q	0013-010-000	Ext. Tooth Star Washer	5
R	0014-003-000	Plastic Washer	8
S	0016-003-000	Nylock Nut	1
T	0016-028-000	Nylock Nut	1
U	0016-035-000	Nylock Nut	2
W	0016-036-000	Nylock Nut	2
X	0021-022-000	Set Screw	1
Y	0023-025-000	Hex Washer Hd. Screw	10
Z	0023-281-000	Self-Tapping Screw	4
AA	0025-079-000	Pop Rivet	1
AB	0026-261-000	Groove Pin	1
AC	0026-277-000	Clevis Pin	1
AD	0026-197-000	Clevis Pin	1
AE	0027-021-000	Rue Ring Cotter	1
AF	0027-022-000	Rue Ring Cotter	1
AG	0030-038-000	Split Bushing	1
AH	0030-040-000	E-A-R Grommet	1
AK	0042-006-000	Collar	2
AL	0042-020-000	Lock Collar	1
AM	0058-090-000	Threaded Stud	1
AN	0059-133-000	Push-Mount Wire Clip	1
AP	0059-192-000	Split Ferrite	1
AQ	0059-194-000	Split Ferrite	3
AR	0081-245-000	Bronze Bushing	2
AS	1210-201-153	Butterfly "V" Pedal	1



# ZOOM® Base Assembly

---

## ZOOM® Option Common Components - Part Number 3002-001-001 (Reference Only)

Item	Part No.	Part Name	Qty.
AT	1210-201-251	Insert Bushing	1
AU	1210-201-671	Damper	1
AW	2040-001-012	<a href="#">Drive Wheel Lift Lever Ass'y (pg.107)</a>	1
AX	2040-001-022	<a href="#">Foot End Bottom Cover (pg.108)</a>	1
AY	2040-001-017	<a href="#">Head End Bottom Cover (pg.108)</a>	1
AZ	2040-001-051	Pedal Crank Weldment	1
BA	2040-001-053	Damper Crank Weldment	1
BB	2040-001-060	Leaf Spring	1
BC	2040-001-061	Tie Down Strap	2
BD	2040-001-062	Reinforcement Tube	2
BE	2040-001-082	Pedal Rod	1
BF	2040-001-083	Pedal Crank Roller	1
BG	2040-001-084	Pedal Rod Pivot Bracket	1
BH	2040-001-098	Lift Lever Spacer	1
BJ	2040-001-100	Drive Whl. Position Label	1
BK	2040-001-101	Charger Box Cover	1
BL	2040-001-102	Power Bd. Cover Label	1
BM	2040-001-103	Charger Box Sw. Brkt. Cov.	1
BN	2040-001-801	Base Switch Cable	1
BP	2040-001-804	Pwr. Bd. DC Pwr. Cable	1
BQ	3000-200-601	Brake Label	2
BR	3000-200-602	Stryker Logo Label	1
BS	3000-300-058	Limit Switch	1
BT	3000-300-428	Gatch Link Sleeve	4
BU	3000-300-113	Wire Ties	2
BW	3001-001-010	Transformer	1
BX	3002-001-014	<a href="#">Drive Train Assembly (pg.109)</a>	1
BY	3002-001-015	<a href="#">Battery Tray Assembly (pg.110)</a>	1
BZ	3002-001-018	Hood Assembly	1
CA	3002-001-030	Base Power Assembly	1
CB	3002-001-050	Charger Box Weldment	1
CC	3002-001-068	Power PCB Cover	1
CD	3002-001-071	Charger/Inverter Cover	1
CE	3002-001-078	Hood Slot Trim	1
CF	3002-001-079	Hood Slot Trim Bracket	1
CG	3002-001-802	Inverter/Battery Cable	1
CH	7000-001-326	Foam Tape (10")	2
CJ	0059-144-000	Split Ferrite	1

# ZOOM® Base Assembly

---

## ZOOM® Base, 6" Casters - 2040-244-010 (Ref.)

Item	Part No.	Part Name	Qty.
B	0003-085-000	Hex Hd. Cap Screw	4
DA	2040-201-809	Umbilical Cable Ass'y	1

## ZOOM® Base, 8" Casters - 2040-244-010 (Ref.)

Item	Part No.	Part Name	Qty.
B	0003-053-000	Hex Hd. Cap Screw	4
DA	2040-201-809	Umbilical Cable Ass'y	1
DB	2040-001-001	8" Caster Spacer	1

# Drive Wheel Lift Lever Assembly

For Reference Only: 2040-001-012

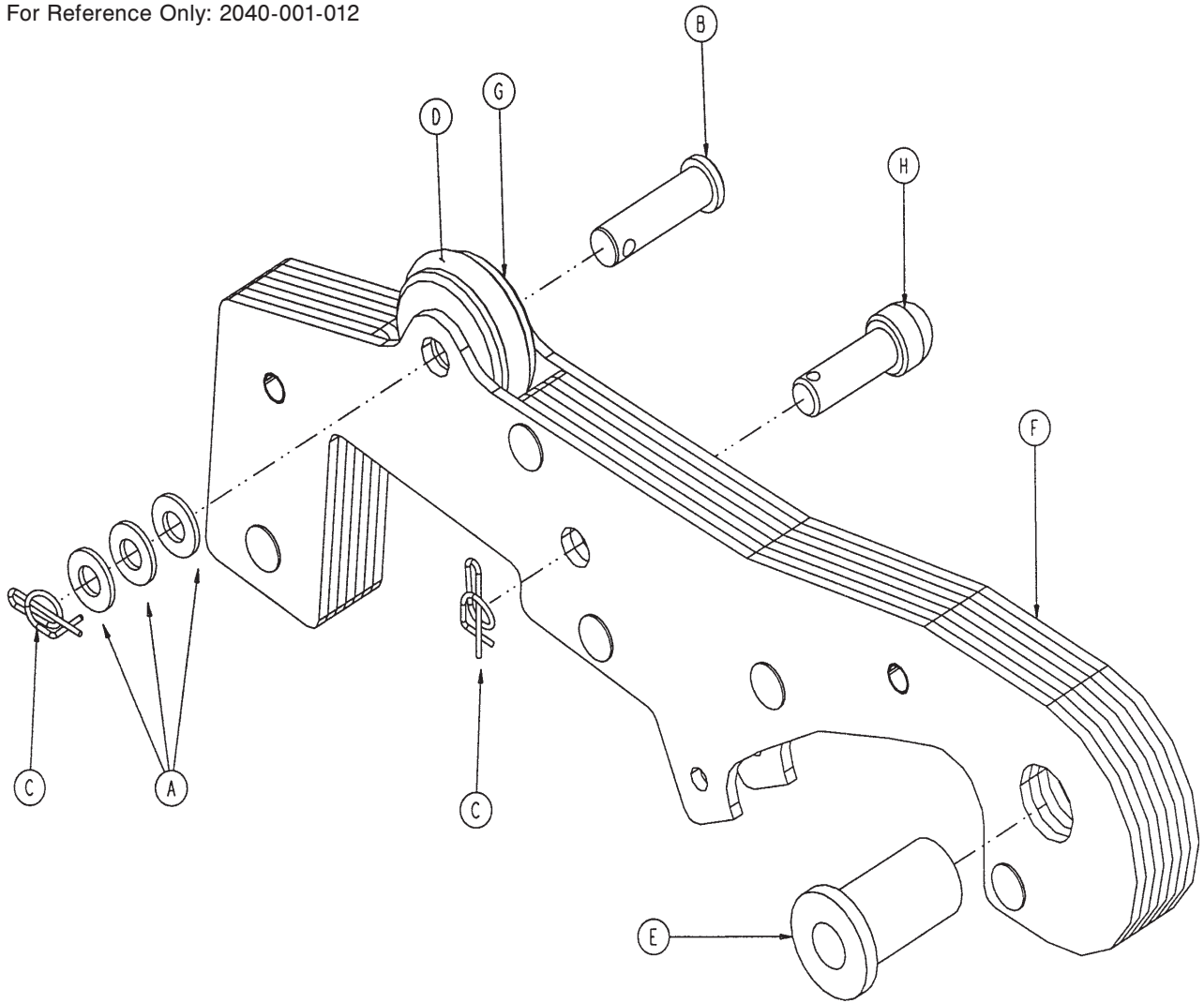

Item	Part No.	Part Name	Qty.
A	0011-003-000	Washer	3
B	0026-297-000	Clevis Pin	1
C	0027-021-000	Rue Ring	2
D	0045-232-000	O-Ring	1
E	0081-070-000	Flange Bearing	1
F	2040-201-013	Drive Wheel Lift Plate Ass'y	1
G	2040-001-087	Lift Lever Roller	1
H	2040-001-099	Lift Lever Guide	1

[Return To Table of Contents](#)

# Foot End Bottom Cover - 3001-200-022

---

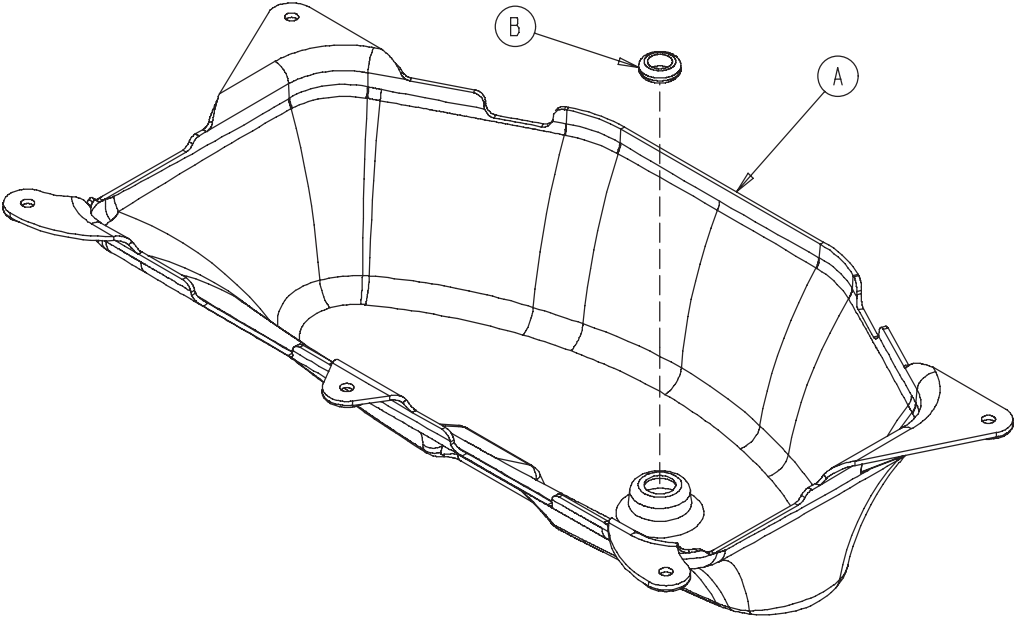

Item	Part No.	Part Name	Qty.
A	3002-001-100	Foot End Bottom Cover	1
B	3000-000-039	Grommet	1

# Head End Bottom Cover - 2040-001-017

---

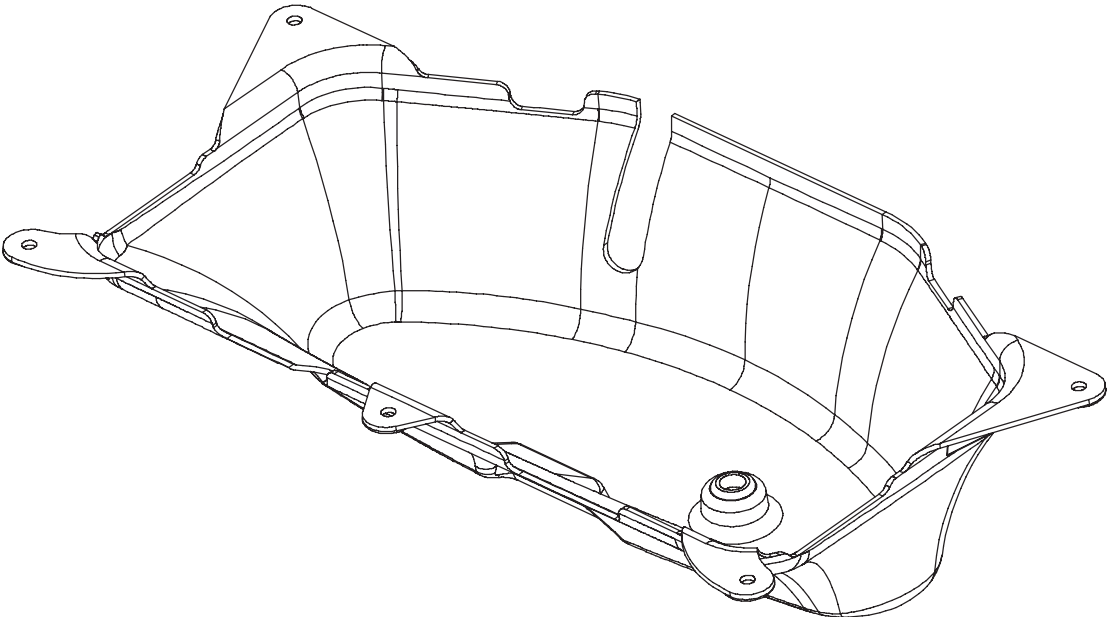

# ZOOM® Option Drive Train Assembly - 3002-001-014

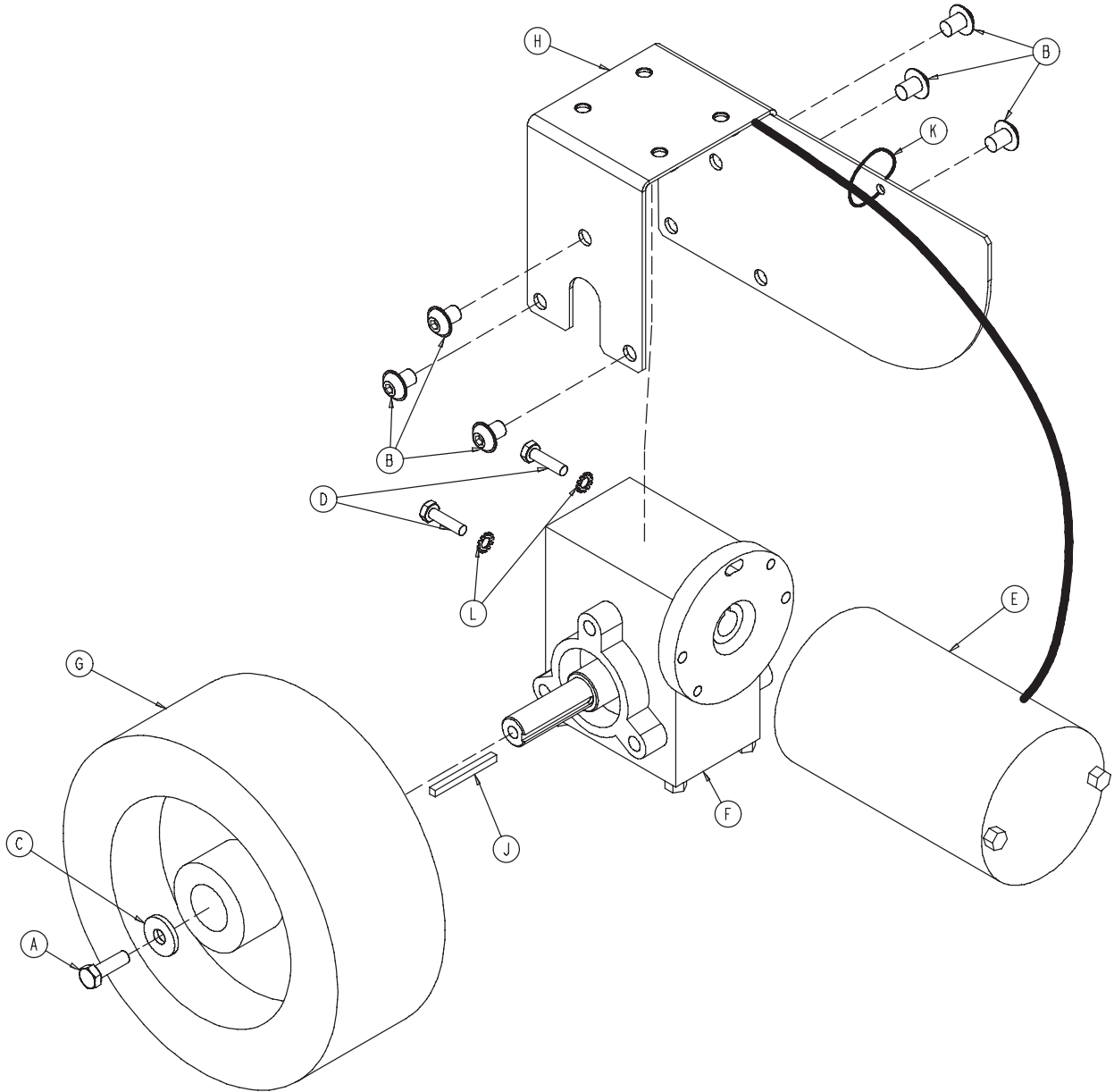

Item	Part No.	Part Name	Qty.
A	8839-793-700	Hex Hd. Cap Screw	1
B	0004-245-000	Flanged But. Hd. Cap Screw	6
C	0011-262-000	Washer	1
D	0003-054-000	Hex Hd. Cap Screw	2
E	3002-001-072	Drive Train Motor	1
F	2040-001-073	Gear Box	1
G	2040-001-074	Drive Train Wheel	1
H	2040-001-075	Motor Mounting Bracket	1
J	2040-001-097	Square Key	1
K	3000-300-113	Wire Tie	1
L	0013-010-000	Star Washer	2

[Return To Table of Contents](#)

# ZOOM® Option Battery Tray Assembly

Replacement Kit Part Number (Batteries Only) - 2040-700-013

For Reference Only: 3002-001-015

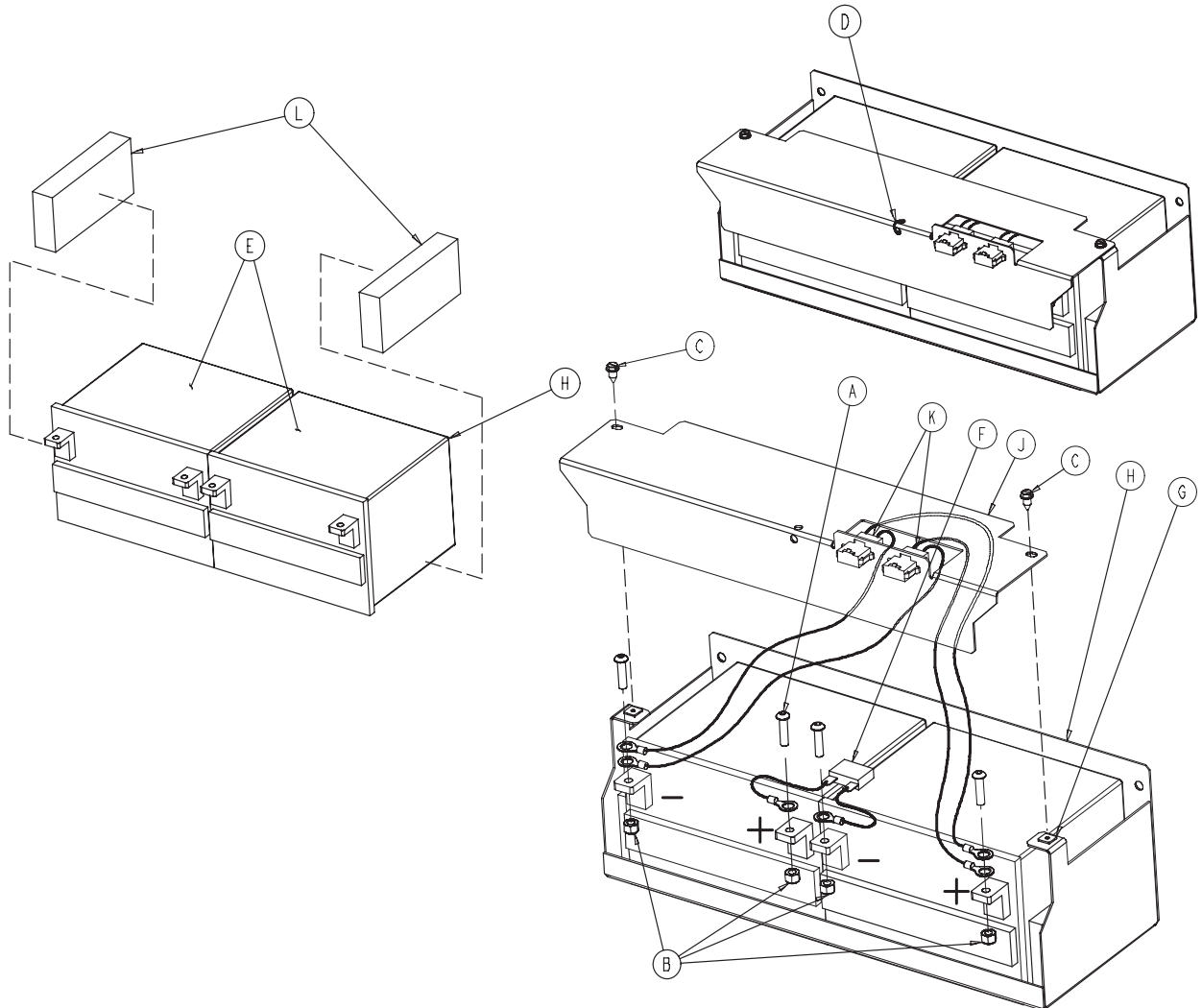

Item	Part No.	Part Name	Qty.
A	0004-046-000	But. Hd. Cap Screw	4
B	0016-028-000	Nylock Nut	4
C	0023-256-000	Pan Hd. Screw	2
D	0038-151-000	Cable Tie	1
E	2040-001-070	Battery	2
F	2040-001-802	Battery Jumper Cable	1
G	3000-300-002	Push Nut	2
H	3002-001-069	Battery Tray	1
J	3002-001-091	Terminal Guard	1
K	3002-001-803	Battery Harness Cable	2
L	3002-101-043	Foam Spacer	2

# ZOOM® Option Base Power Assembly - 3002-001-030

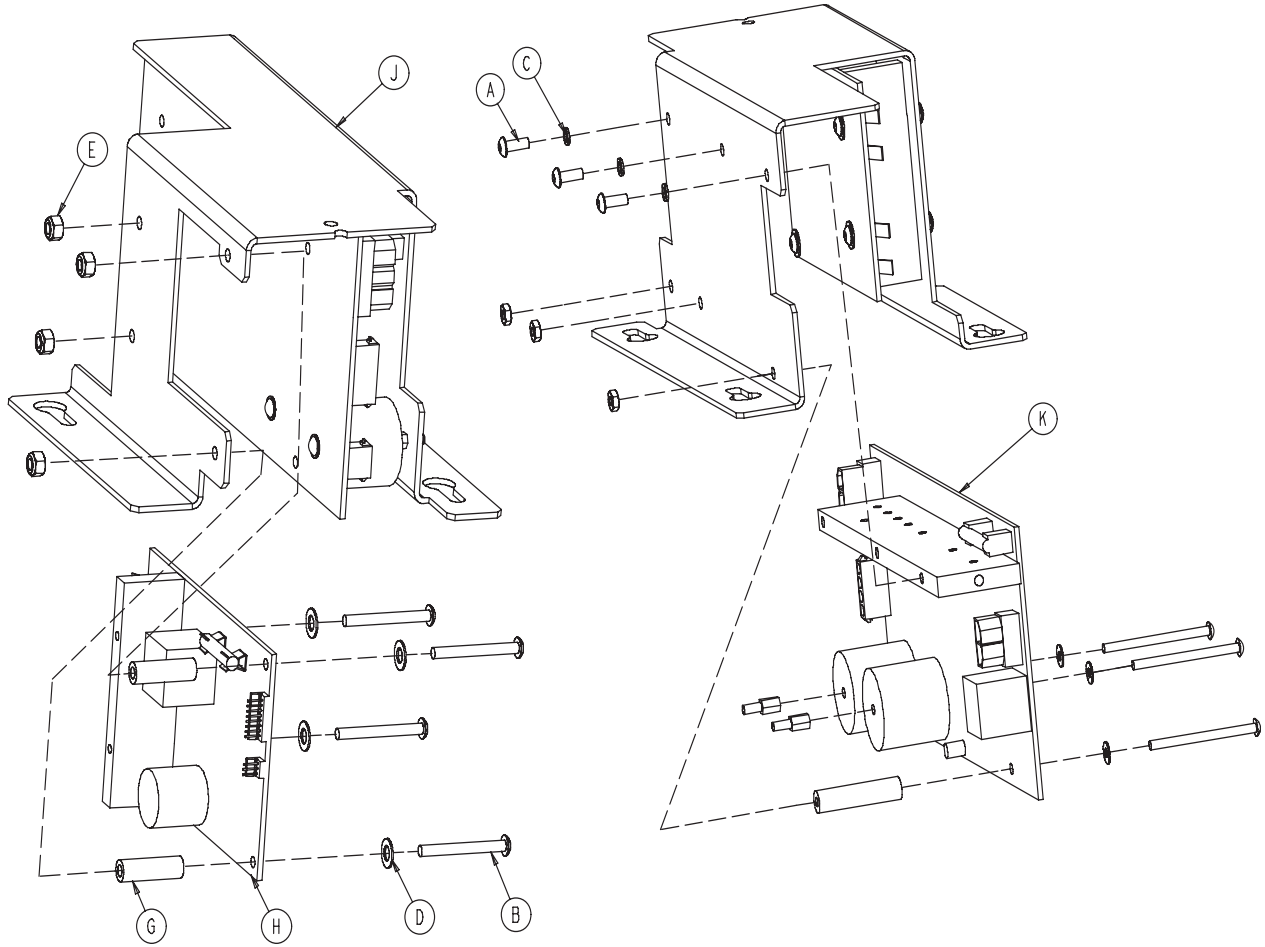

Item	Part No.	Part Name	Qty.
A	0004-263-000	But. Hd. Cap Screw	3
B	0004-315-000	But. Hd. Cap Screw	4
C	0012-006-000	Helical Lock Washer	3
D	0014-004-000	Nylon Washer	4
E	0016-002-000	Fiberlock Nut	4
G	0059-187-000	Spacer	2
H	2040-001-900	Power Board	1
J	3002-001-017	Charger/Inverter Heat Bracket	1
K	3002-001-930	Charger/Inverter Board Ass'y	1

[Return To Table of Contents](#)





# Litter Assembly and Options

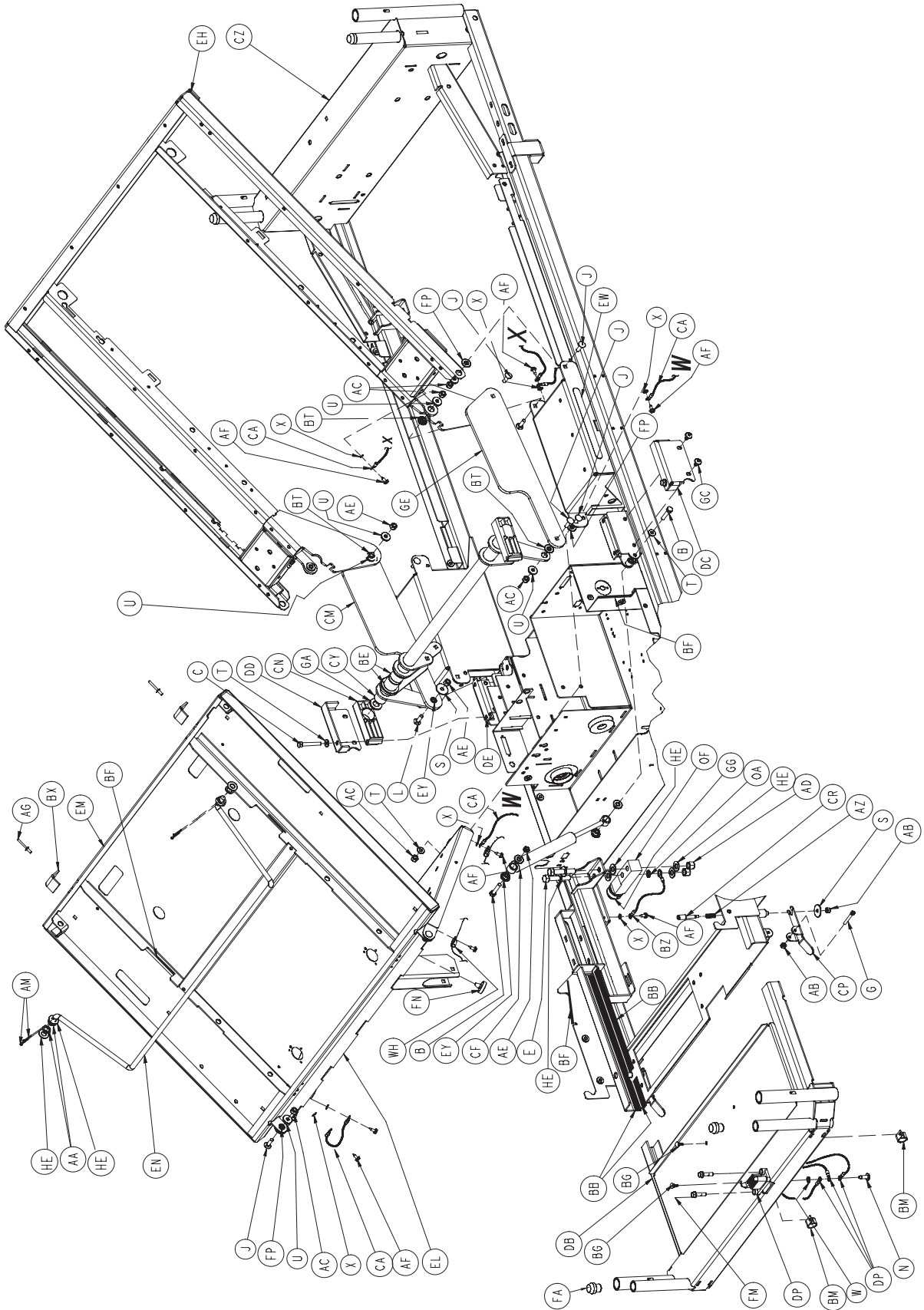

[Return To Table of Contents](#)

# Litter Assembly and Options

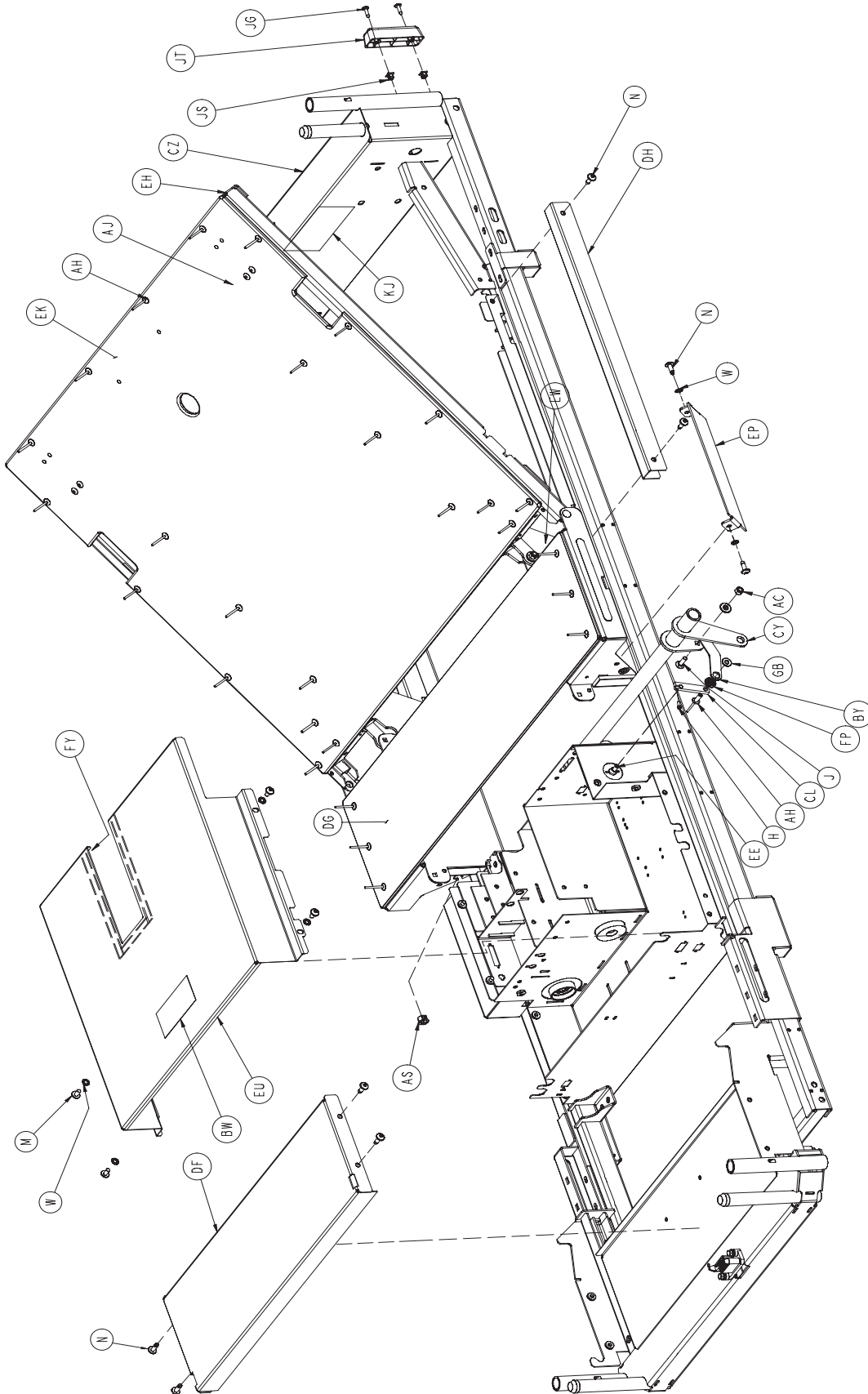

# Litter Assembly and Options

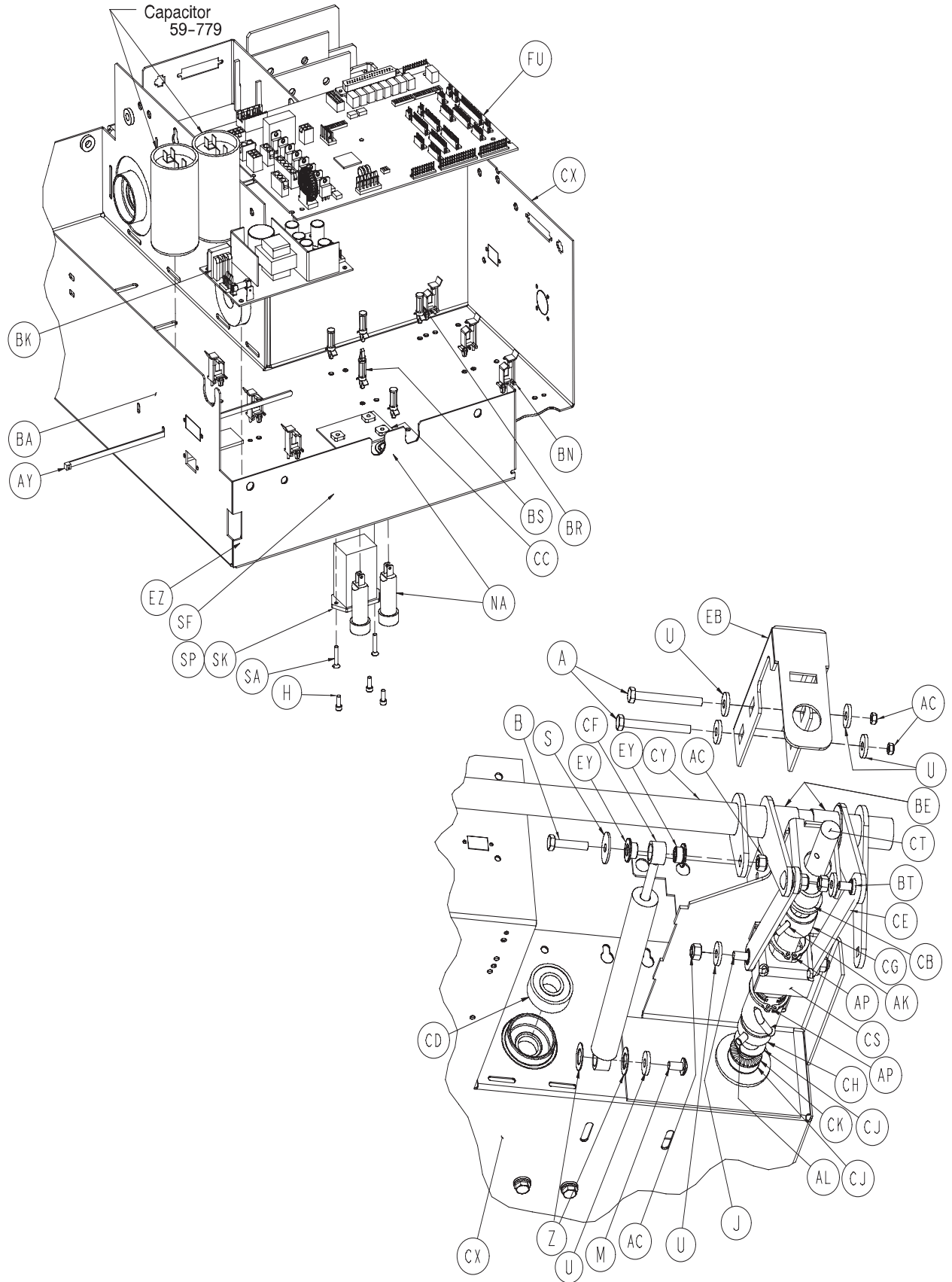

[Return To Table of Contents](#)

# Litter Assembly and Options

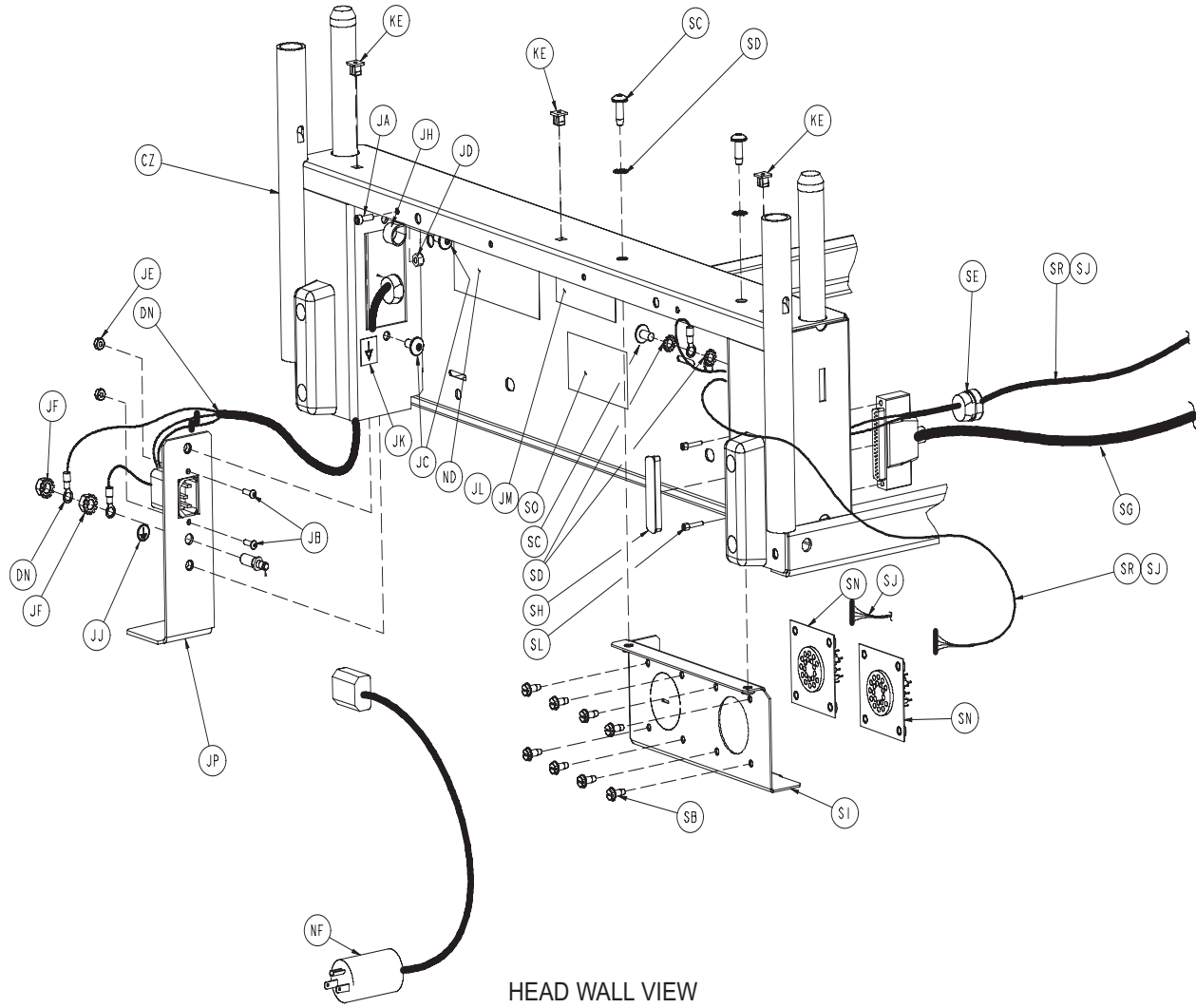



# Litter Assembly and Options

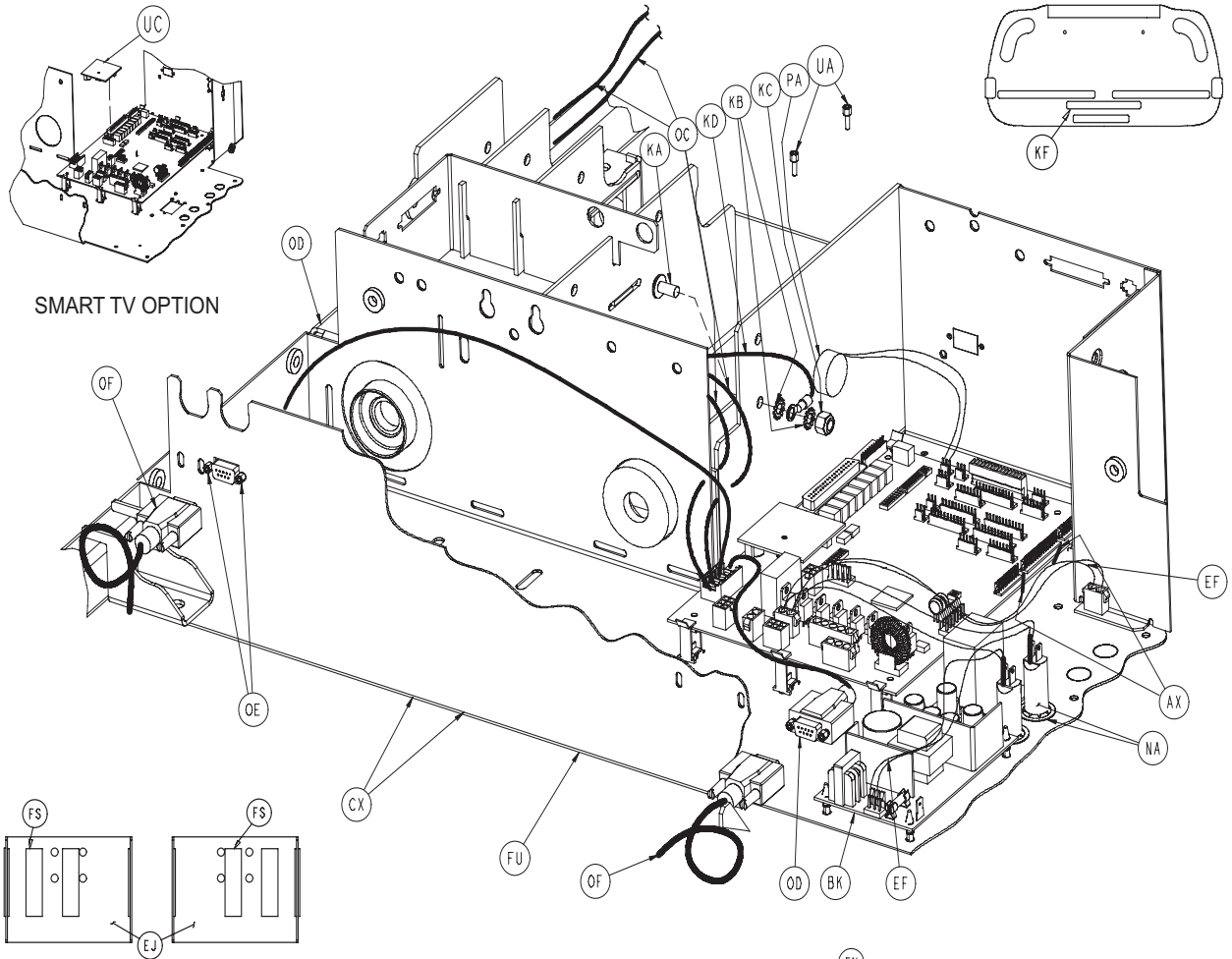

SMART TV OPTION

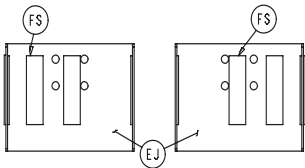

CPR SLIDE BRACKET DETAIL

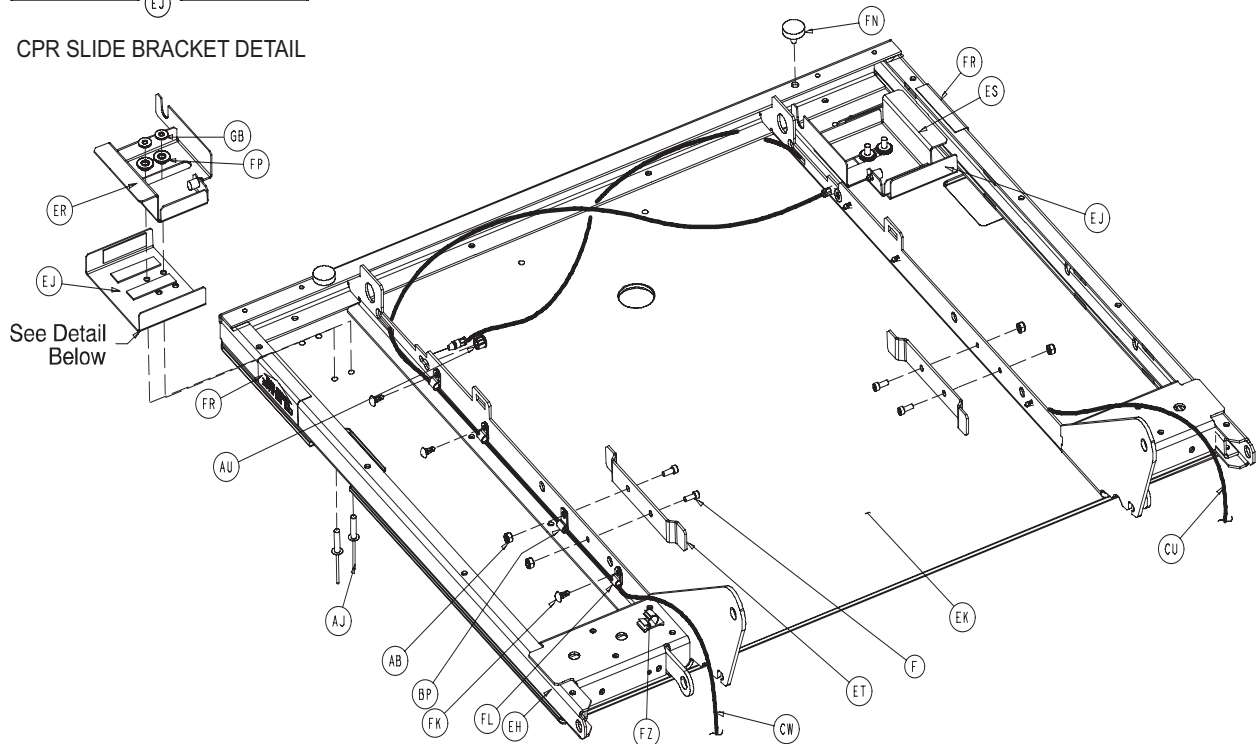

See Detail Below



# Litter Assembly and Options

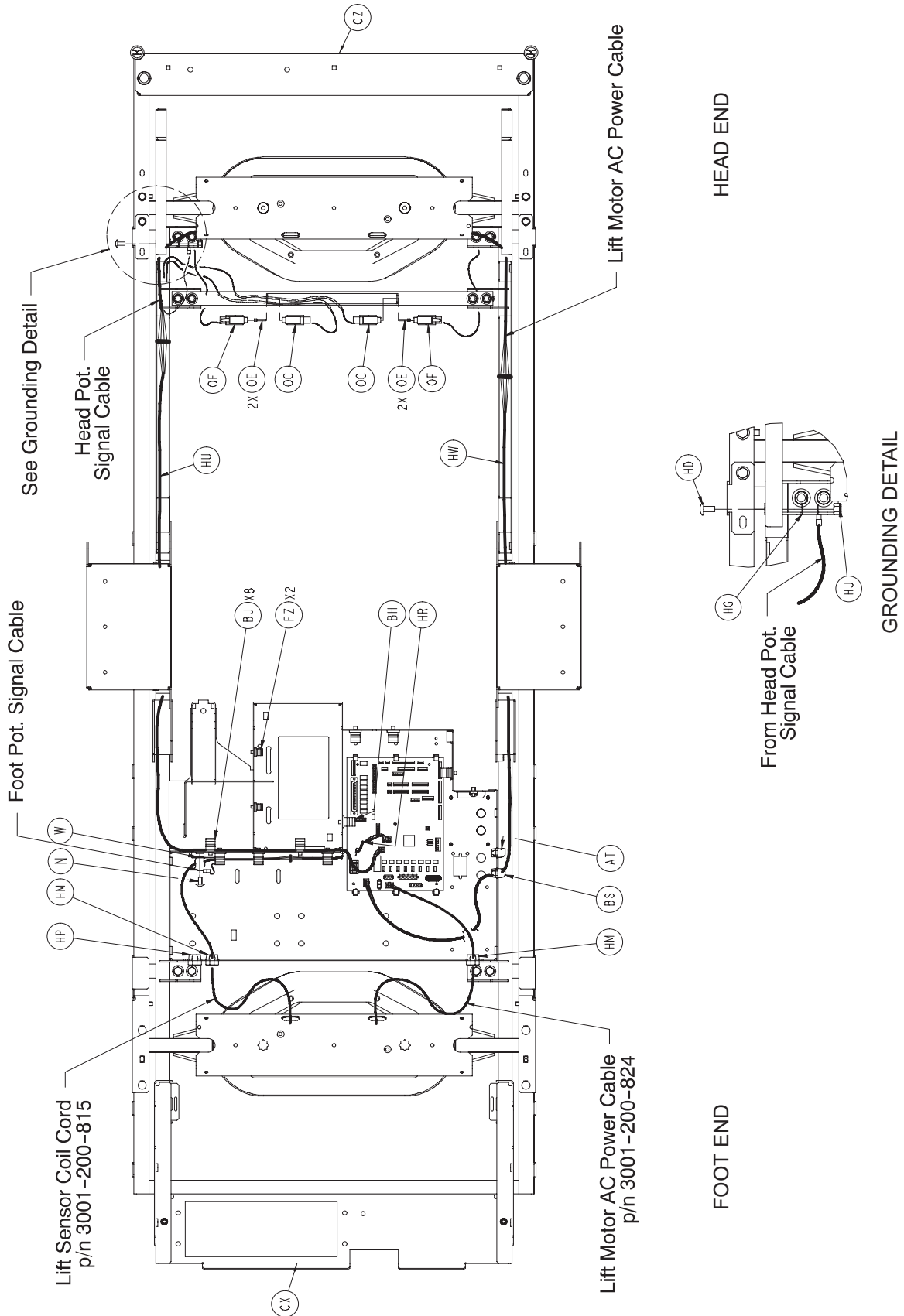



# Litter Assembly and Options

## 2032-231-010 EPIC II® Domestic, EPIC II® +, and ZOOM® Common Litter Components

Item	Part No.	Part Name	Qty.	Item	Part No.	Part Name	Qty.
A	0003-023-000	Hex Hd. Cap Screw	2	BN	0059-751-000	Locking Circuit Bd. Supt.	6
B	0003-074-000	Hex Hd. Cap Screw	3	BP	0059-767-000	Cable Clamp	2
C	0003-078-000	Hex Hd. Cap Screw	4	BR	0059-773-000	Push Spacer	4
D	0003-214-000	Hex Hd. Cap Screw	8	BS	0059-774-000	Locking PCB Support	1
E	0003-347-000	Hex Hd. Cap Screw	4	BT	0081-268-000	Flange Bearing	15
F	0004-032-000	Soc. Hd. Cap Screw	4	BU	0715-001-333	Rel. Valve Stop Sleeve	18
G	0004-085-000	Soc. Hd. Cap Screw	2	BW	0988-002-708	Shock Caution Label	1
H	0004-101-000	Soc. Hd. Cap Screw	1	BX	2020-034-758	Rest-Calf Section	2
J	0005-019-000	Carriage Bolt	18	BY	2025-031-062	Pot. Actuator Link	1
K	0005-024-000	Carriage Bolt	4	BZ	2025-031-088	Ground Jumper	4
L	0005-023-000	Carriage Bolt	3	CA	3002-300-870	Ground Strap	8
M	0007-058-000	Truss Hd. Torx	5	CB	2025-032-068	Flange Bearing	2
N	0007-063-000	Truss Hd. Torx	20	CD	2025-032-076	Ball Bearing	2
P	0007-065-000	Truss Hd. Torx	16	CE	2025-032-077	Fowler Actuator Link	2
S	0011-053-000	Washer	10	CF	2025-032-082	Hydraulic Dampener	2
T	0011-063-000	Washer	37	CG	2025-032-084	Fowler Screw Up Stop	1
U	0011-158-000	Washer	20	CH	2025-032-085	Fowler Screw Down Stop	1
W	0013-010-000	Ext. Tooth Lock Washer	17	CJ	2025-032-086	Thrust Washer	5
X	0013-018-000	Ext. Tooth Lock Washer	14	CK	2025-032-087	Roller Cage Bearing	2
Y	0013-032-000	Ext. Tooth Lock Washer	2	CL	2025-231-061	Pot. Timing Clamp	1
Z	0014-007-000	Washer	2	CM	2025-231-088	Fowler Link	1
AB	0016-003-000	Nylock Nut	4	CN	2025-231-090	Torque Tube Pivot Brg.	2
AC	0016-028-000	Nylock Nut	20	CP	2025-231-099	Bed Extender Rel. Lever	2
AD	0016-035-000	Nylock Nut	8	CR	2025-231-112	Bed Extender Pin Lock	2
AE	0016-102-000	Nylock Nut	8	CS	2025-232-089	Fowler Nut Box	1
AF	0003-224-000	Hex Washer Hd. Screw	16	CT	2025-232-090	Fowler Ball Screw	1
AH	0025-142-000	Rivet	37	CU	2035-031-048	Short CPR Cable	1
AJ	0025-147-000	Rivet	4	CW	2035-031-049	Long CPR Cable	1
AK	0026-012-000	Roll Pin	2	CX	2032-031-050	Scale Frame Weldment	1
AL	0026-168-000	Spiral Pin	2	CY	2035-031-051	Torque Tube Weldment	1
AN	0027-017-000	Cotter Pin	2	CZ	2035-031-054	Iso. Frame Weldment	1
AP	0028-120-000	External Retaining Ring	3	DA	2035-031-055	Head End Crosstube	1
AR	0030-045-000	Strain Relief	3	DB	2035-031-057	Bed Extender Weldment	1
AS	0030-036-000	Grommet	4	DC	2035-031-064	Torque Tube Ret. Brkt., Lt.	1
AT	0030-047-000	Right Angle Strain Relief	2	DD	2035-031-065	Torque Tube Ret. Brkt., Rt.	1
AU	0030-052-000	Snap Bushing	4	DE	2035-031-066	Torque Block Channel	2
AX	0038-111-000	Cable Tie	10	DF	2035-031-094	Foot Support Cover	1
AY	0038-151-000	Cable Tie	17	DG	2032-031-097	Seat Section Skin	1
AZ	0038-382-000	Compression Spring	2	DH	2035-031-100	Wire Channel Cover	2
BA	0044-029-000	Black Foam Tape	1	DJ	2035-031-115	Roller Bracket Cover, Rt.	1
BB	0044-032-000	1" Wide Poly Tape	50"	DK	2035-031-116	Roller Bracket Cover, Lt.	1
BC	0052-104-000	Cable Clamp	1	DL	2035-031-126	Protective Sleeve	2
BD	0052-759-000	Flange Bearing	2	DM	2035-031-127	Nylon Stop	2
BE	0052-762-000	Nyliner Bushing	2	DN	2035-031-801	Inlet/Fuse Cable	1
BF	0058-056-000	Black Edge Trim	1.5'	DP	2035-031-802	Footboard/CPU Cable	1
BG	0058-076-000	Drive Fastener	2	DR	2035-032-052	Gatch Trigger Weldment	1
BH	0059-133-000	Push-Mount Wire Clip	1	DS	2035-032-054	CPR Release Wldmt. Brkt.	1
BJ	0059-135-000	Push-Mount Wire Clip	7	DT	2035-032-072	CPR Release Pivot Brkt	1
BK	0059-157-000	Power Supply	1	DU	2035-032-077	Gatch Actuator Link	2
BL	0059-727-000	Jack Screw	4	DW	2035-032-079	Act. Box Cherry Swch. Brkt.	2
BM	0059-743-000	Wire Harness Clip	2	DX	2035-032-084	Gatch Screw Up Stop	1

[Return To Table of Contents](#)

# Litter Assembly and Options

## 2032-231-010 EPIC II® Domestic, EPIC II® +, and ZOOM® Common Litter Components (Continued)

Item	Part No.	Part Name	Qty.	Item	Part No.	Part Name	Qty.
DY	2035-032-085	Gatch Screw Down Stop	1	FX	5010-080-007	Power Supply Gd. Cable	1
DZ	2035-032-088	Act. Box Motor Mtg. Brkt.	2	FY	8800-380-000	Neoprene Sponge	1.5'
EA	2035-032-090	Gatch Ball Screw Ass'y	1	FZ	8815-001-100	Wire Mount Clip	4
EB	2035-032-096	Ball Screw Cover	1	GA	0011-310-000	Washer	2
EC	2035-032-801	Gatch Limit Switch Cable	1	GB	0011-002-000	Washer	5
ED	2035-032-802	Fowler/CPU Jumper Cable	1	GC	0007-052-000	Truss Hd. Torx	4
EE	2035-032-803	Fowler Pot. Cable	1	GD	0013-038-000	Ext. Tooth Lock Washer	2
EF	2035-032-804	Fuse/PCB Cable	1	GE	2025-231-089	Fowler Litter Link	1
EH	2032-033-050	Fowler Frame Weldment	1	GF	0059-194-000	Split Ferrite	1
EJ	2035-033-062	CPR Release Slide Brkt.	2	HA	0003-347-000	Hex Hd. Cap Screw	8
EK	2035-033-063	Fowler Skin	1	HB	0004-338-000	Flanged But. Hd. Screw	4
EM	2032-035-050	Foot Section Weldment	1	HC	0005-029-000	Rd. Hd. Sq. Neck Bolt	4
EL	2032-034-050	Thigh Section Weldment	1	HD	0007-058-000	Truss Hd. Torx	1
EP	2035-231-085	Seat Section Cover	2	HE	0011-539-000	Washer	32
ER	2035-233-064	Quick Drop Rel. Brkt., Lt.	1	HF	0011-063-000	Washer	8
ES	2035-233-065	Quick Drop Rel. Brkt., Rt.	1	HG	0013-010-000	Ext. Tooth Lock Washer	1
ET	2035-400-565	Siderail Guide Bracket	2	HH	0013-032-000	Ext. Tooth Lock Washer	4
EU	2035-432-075	<a href="#">Actuator Box Cover Ass'y (pg.125)</a>	1	HJ	0016-006-000	Kep Nut	9
EW	2040-090-100	500 Lb. Label	2	HK	0016-035-000	Nylock Nut	8
EX	3000-300-058	Switch Plunger	2	HL	0025-050-000	Rivet	24
EY	3000-300-099	Modified Bushing	9	HP	0059-106-000	Strain Relief	1
EZ	3000-300-115	Standoff	4	HR	2030-031-801	Foot Pot. Exten. Cable	1
FA	3000-300-349	Head/Foot Board Post Cap	4	HU	2030-031-802	Head Pot. Exten. Cable	1
FB	3000-300-353	Roller	4	HW	2030-031-803	Head Lift Motor Extension	1
FC	3000-300-442	Fowler Drive Grommet	16	HX	2040-031-056	Foley Bag Hanger	6
FD	3000-300-455	CPR Isolation Bushing	4	HY	3001-300-004	Spacer	8
FE	3000-300-456	CPR Isolator	2	JD	0016-014-000	Nylock Nut	1
FF	3000-300-461	CPR Decoupler	2	JH	0034-021-000	Cord Clamp	1
FG	3000-300-462	CPR Wing	2	JR	2035-031-880	Power Inlet Cable	1
FH	3000-300-464	CPR Engagement Spring	4	NG	3002-407-950	CPU	1
FJ	3000-300-473	Clevis Pin	2	YA	3003-300-033	Mattress Retainer	4
FK	3000-300-477	CPR Conduit Stud	6	YC	2035-032-805	Cable CPU/Power Supply	1
FL	3000-300-478	CPR Conduit Clamp	6	YD	2035-020-805	Siderail LS Bypass Cable	2
FM	3001-200-228	Mounting Standoff	2				
FM	3001-200-228	Mounting Standoff	2				
FN	3001-300-008	Thigh Bumper	2				
FP	3001-300-099	Flange Bearing	10				
FR	3001-300-603	CPR Release Label	2				
FS	3001-300-663	Velcro Strip	10				
FT	3001-300-877	Siderail Extension Cable	1				
FW	5000-030-366	Fowler Nut Adapter	1				

### 2040-032-020 ZOOM®/EPIC II®/EPIC II®+ Std. Height Option

### 2040-032-021 ZOOM®/EPIC II®/EPIC II®+ Enh. Height Option

Item	Part No.	Part Name	Qty.	Item	Part No.	Part Name	Qty.
HS	2030-331-052	Head End Header Wldmt.	1	HS	2040-031-252	Head End Header Wldmt.	1
HT	2030-331-053	Foot End Header Wldmt.	1	HT	2040-031-253	Foot End Header Wldmt.	1

# Litter Assembly and Options

## 2040-032-015 ZOOM® Litter Domestic Components

## 2030-030-251 High-Sounding Beeper Option

Item	Part No.	Part Name	Qty.	Item	Part No.	Part Name	Qty.
NA	0059-179-000	Circuit Breaker	2	PA	3001-508-870	High-Sound Beeper Cable	1
ND	2040-031-098	Specification Label	1				
NE	2035-300-705	Fowler Drive Assembly	2				

## 2040-132-011 EPIC II®+/ZOOM® Litter Components

Item	Part No.	Part Name	Qty.	Item	Part No.	Part Name	Qty.
KA	0007-058-000	Truss Hd. Torx	1	KE	3000-300-002	Plastic Clip Nut	3
KB	0013-010-000	Ext. Tooth Lock Washer	2	KF	2040-031-100	Manual Push Label	1
KC	0016-028-000	Nylock Nut	1	KG	0059-194-000	Split Ferrite	3
KD	2040-231-807	Bed CPU Cable	1	KH	0059-738-000	Hole Plug	2

## 2030-030-100 No Scale or Bed Exit Options

## 2030-140-125 Scale Option Only

Item	Part No.	Part Name	Qty.	Item	Part No.	Part Name	Qty.
	2030-135-011	Foot Board, No Scale/BE	1	OA	0013-032-000	Ext. Tooth Lock Washer	4
OF	3001-300-511	"Imitation" Load Cell	4		2030-015-013	Foot Board, Scale Option	1
GG	3000-300-353	Roller	4	OC	2030-317-805	Load Cell Cable, Head	2
				OD	2030-317-804	Load Cell Cable, Foot	2
				OE	3001-300-007	M/F Screw	8
				OF	3002-307-057	Load Cell	4
				GG	3002-300-353	Roller	4

## 2030-140-175 Chaperone® Bed Exit Option

## 2030-140-150 Scale & Chaperone® Options

Item	Part No.	Part Name	Qty.	Item	Part No.	Part Name	Qty.
OA	0013-032-000	Ext. Tooth Lock Washer	4	OA	0013-032-000	Ext. Tooth Lock Washer	4
	2030-135-012	Ft. Bd., Chaperone Option	1		2030-015-014	Ft. Bd., Scale & Chap.	1
OC	2030-317-805	Load Cell Cable, Head	2	OC	2030-317-805	Load Cell Cable, Head	2
OD	2030-317-804	Load Cell Cable, Foot	2	OD	2030-317-804	Load Cell Cable, Foot	2
OE	3001-300-007	M/F Screw	8	OE	3001-300-007	M/F Screw	8
OF	3002-307-057	Load Cell	4	OF	3002-307-057	Load Cell	4
GG	3002-300-353	Roller	4	GG	3002-300-353	Roller	4

## 2030-140-275 Chaperone II® Bed Exit Option

## 2030-140-250 Scale & Chaperone II® B. E. Options

Item	Part No.	Part Name	Qty.	Item	Part No.	Part Name	Qty.
OA	0013-032-000	Ext. Tooth Lock Washer	4	OA	0013-032-000	Ext. Tooth Lock Washer	4
	2030-135-015	Ft. Bd., Chap. II Option	1		2030-015-016	Foot Board, Scale & BE	1
OC	2030-317-805	Load Cell Cable, Head	2	OC	2030-317-805	Load Cell Cable, Head	2
OD	2030-317-804	Load Cell Cable, Foot	2	OD	2030-317-804	Load Cell Cable, Foot	2
OE	3001-300-007	M/F Screw	8	OE	3001-300-007	M/F Screw	8
OF	3002-307-057	Load Cell	4	OF	3002-307-057	Load Cell	4
GG	3000-300-353	Roller	4	GG	3000-300-353	Roller	4

[Return To Table of Contents](#)

# Litter Assembly and Options

## 2035-130-207 Smart TV Option

Item	Part No.	Part Name	Qty.
UA	0059-727-000	Jack Screw	2
UC	3002-039-800	STV Board	1

## 2030-034-010 Foot Prop Option

Item	Part No.	Part Name	Qty.
R	0011-004-000	Washer	4
AA	0014-008-000	Washer	4
AM	0027-015-000	Cotter Pin	4
EN	2030-035-096	Foot Prop Rod	1
BF	0058-056-000	Black Edge Trim	6

## 2040-030-200 Head Wall Communication Option

Item	Part No.	Part Name	Qty.
SG	2035-031-806	Head Wall Interface Cable	1
SH	0059-710-000	Static Cap	1
	2040-031-200	ZOOM® Hd. Wall W/Comm.	1

## 2040-030-201 Head Wall Comm. W/Nurse Call

Item	Part No.	Part Name	Qty.
SA	0001-087-000	Flat Hd. Mach. Screw	2
SF	0052-783-000	U Clip	2
SG	2035-031-806	Head Wall Interface Cable	1
SH	0059-710-000	Static Cap	1
	2040-031-201	ZOOM® Hd. Wall W/NC	1
SP	5010-080-020	9V Battery Box W/Cable	1

## 2040-030-202 HW Comm. W/NC & 1 Stryker Port

Item	Part No.	Part Name	Qty.
SA	0001-087-000	Flat Hd. Mach. Screw	2
SE	0030-039-000	Strain Relief Grommet	1
SF	0052-783-000	U Clip	2
SG	2035-031-806	Head Wall Interface Cable	1
SH	0059-710-000	Static Cap	1
	2040-031-202	ZOOM® HW W/NC & 1 Port	1
SP	5010-080-020	9V Battery Box w/Cable	1
SR	2035-030-804	Pendant Port Cable	1

## 2040-030-203 HW Comm. W/NC & 2 Stryker Ports

Item	Part No.	Part Name	Qty.
SA	0001-087-000	Flat Hd. Mach. Screw	2
SE	0030-027-000	Strain Relief Grommet	1
SF	0052-783-000	U Clip	2
SG	2035-031-806	Head Wall Interface Cable	1
SH	0059-710-000	Static Cap	1
SJ	2035-030-805	Dual Pendant Port Cable	1
SP	5010-080-020	9V Battery Box W/Cable	1
	2040-031-203	ZOOM® HW W/NC & 2 Ports	1

## 2030-030-251 High-Sounding Beeper Option

Item	Part No.	Part Name	Qty.
PA	3001-508-870	High-Sound Beeper Cable	1

# Actuator Box Cover Assembly

For Reference Only: 2035-432-075

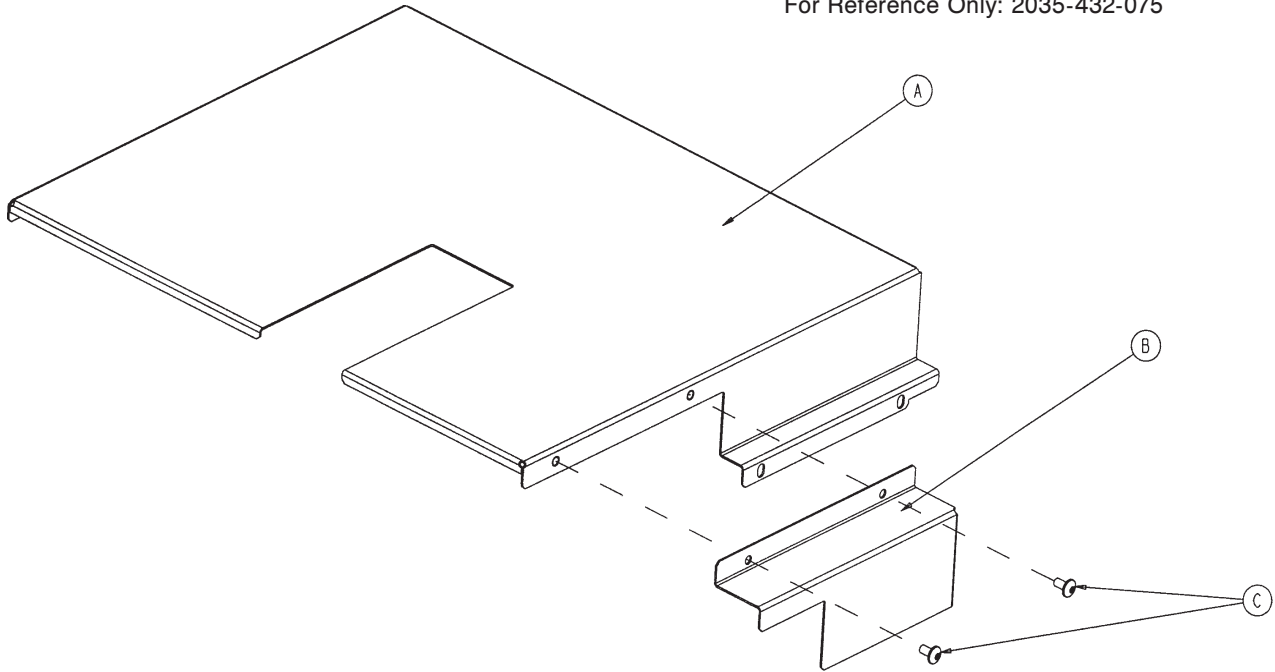

Item	Part No.	Part Name	Qty.
A	2035-332-075	Main Actuator Box Cover	1
B	2035-332-076	Actuator Box Side Cover	1
C	0007-058-000	Truss Hd. Torx	2

[Return To Table of Contents](#)

# Fowler Brake Kit Assembly - 3001-300-775

For Reference Only: 2040-001-012

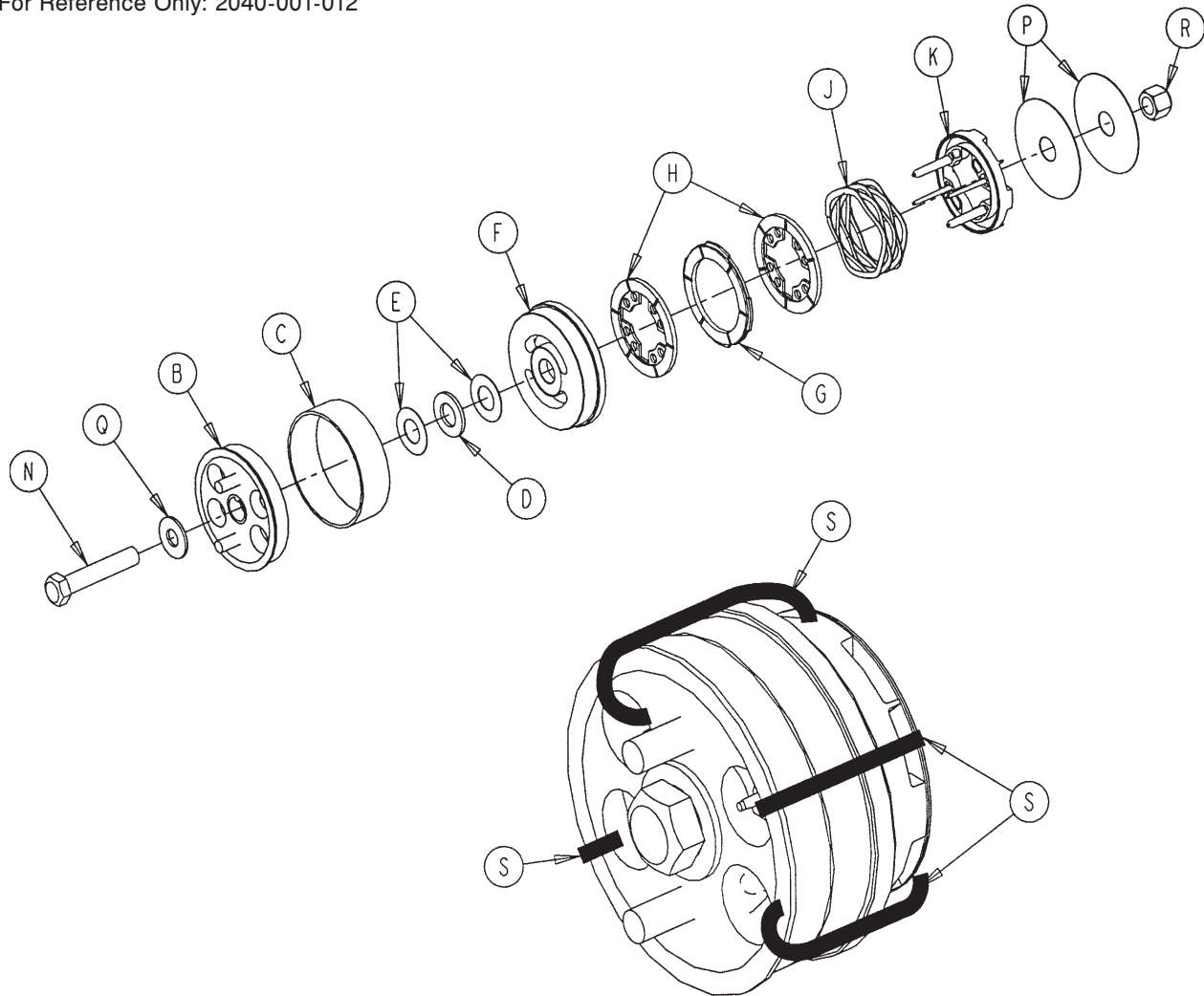

Item	Part No.	Part Name	Qty.
B	3001-300-455	CPR Coupler Assembly	1
C	3000-300-465	CPR Clutch Spring	1
D	0081-212-000	Thrust Needle Roller Bearing	1
E	3000-200-224	Idler Gear Thrust Washer	2
F	3001-300-569	Brake Cup	1
G	3001-300-552	CPR Brake Disc	1
H	3001-300-551	CPR Spring Cup	2
J	3001-300-563	CPR Brake Spring	1
K	3001-300-570	CPR Spring Cup	1
N	0003-064-000	Hex Head Cap Screw	1
P	3000-200-245	Flat Washer	2
Q	0011-193-000	Heavy Flat Washer	1
R	0016-012-000	Nylock Nut	1
S	3000-300-113	8" Wire Tie	4

# ZOOM<sup>®</sup> Litter Assembly 2040-031-010

For Reference Only: 2040-031-012

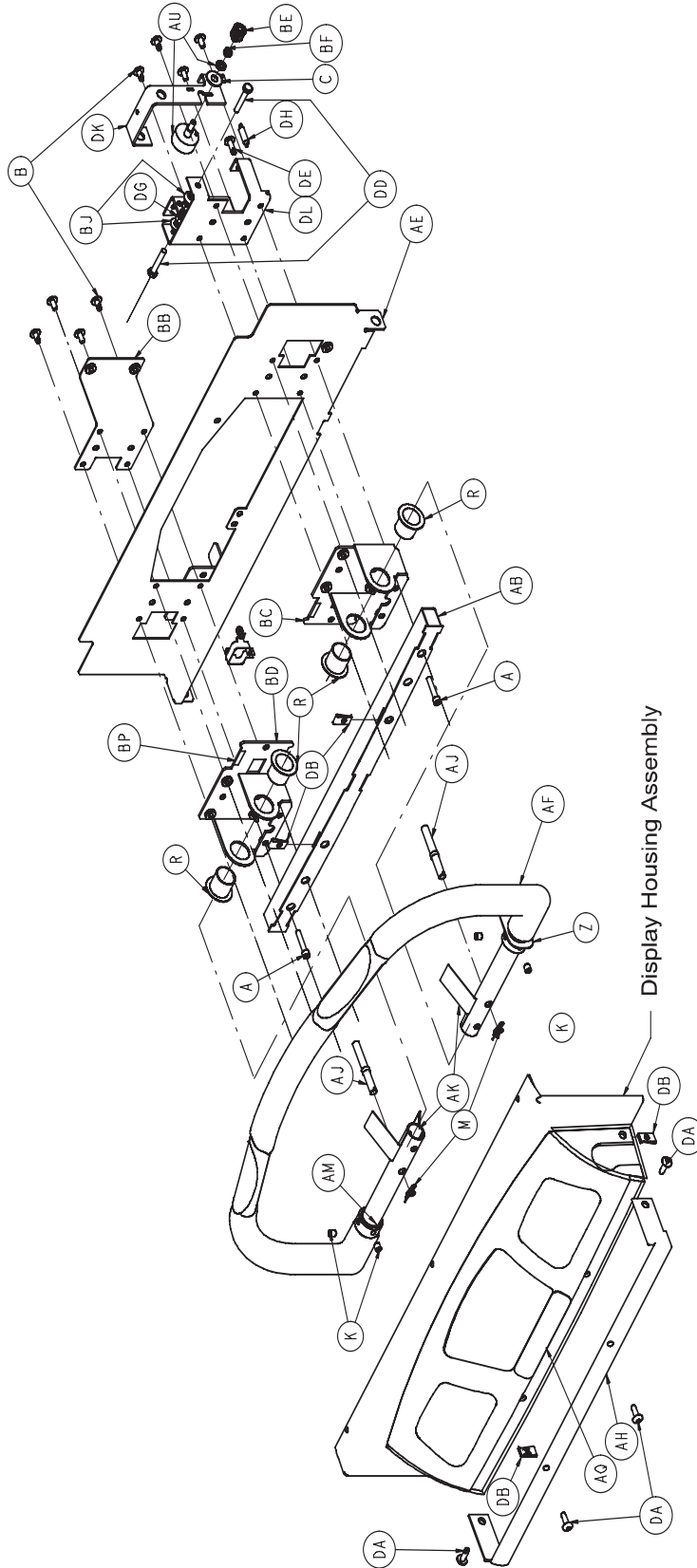

# ZOOM® Litter Assembly

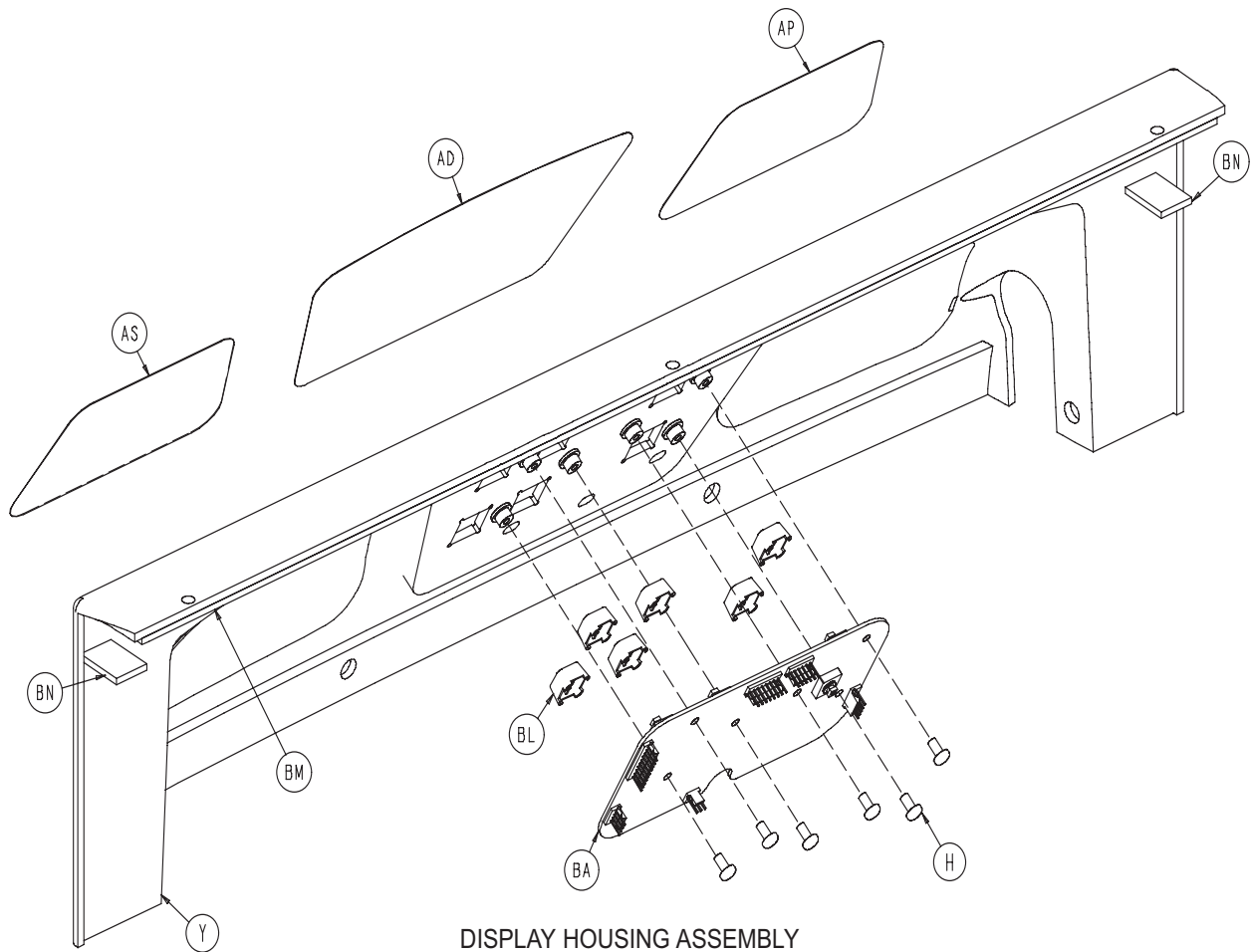
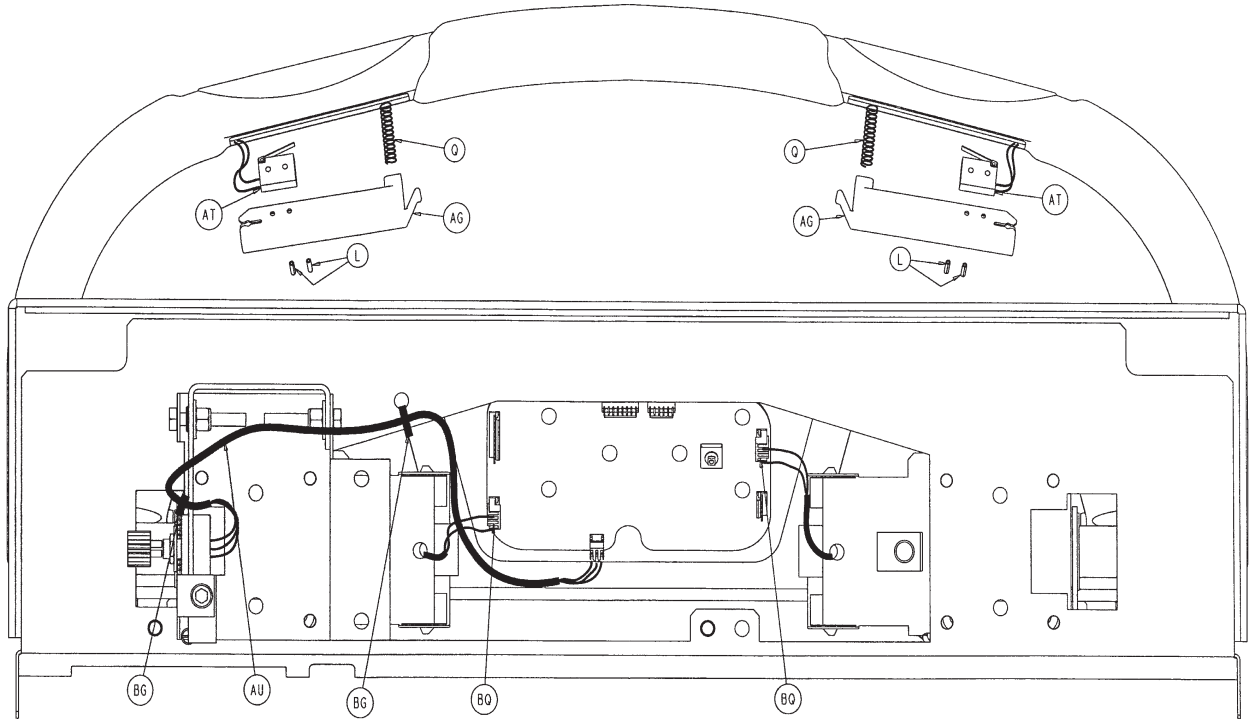

DISPLAY HOUSING ASSEMBLY



# ZOOM® Litter Assembly

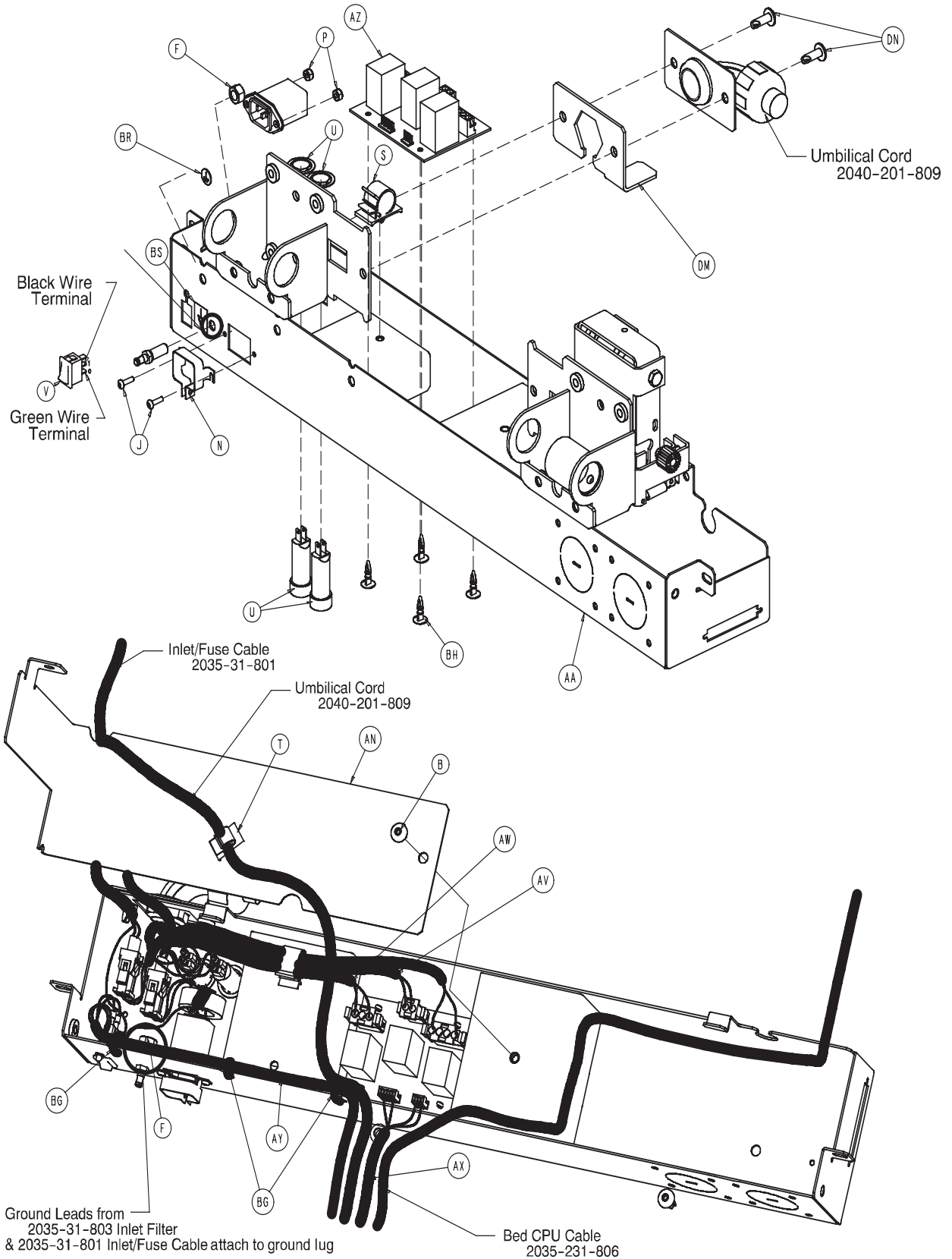

[Return To Table of Contents](#)

# ZOOM® Litter Assembly

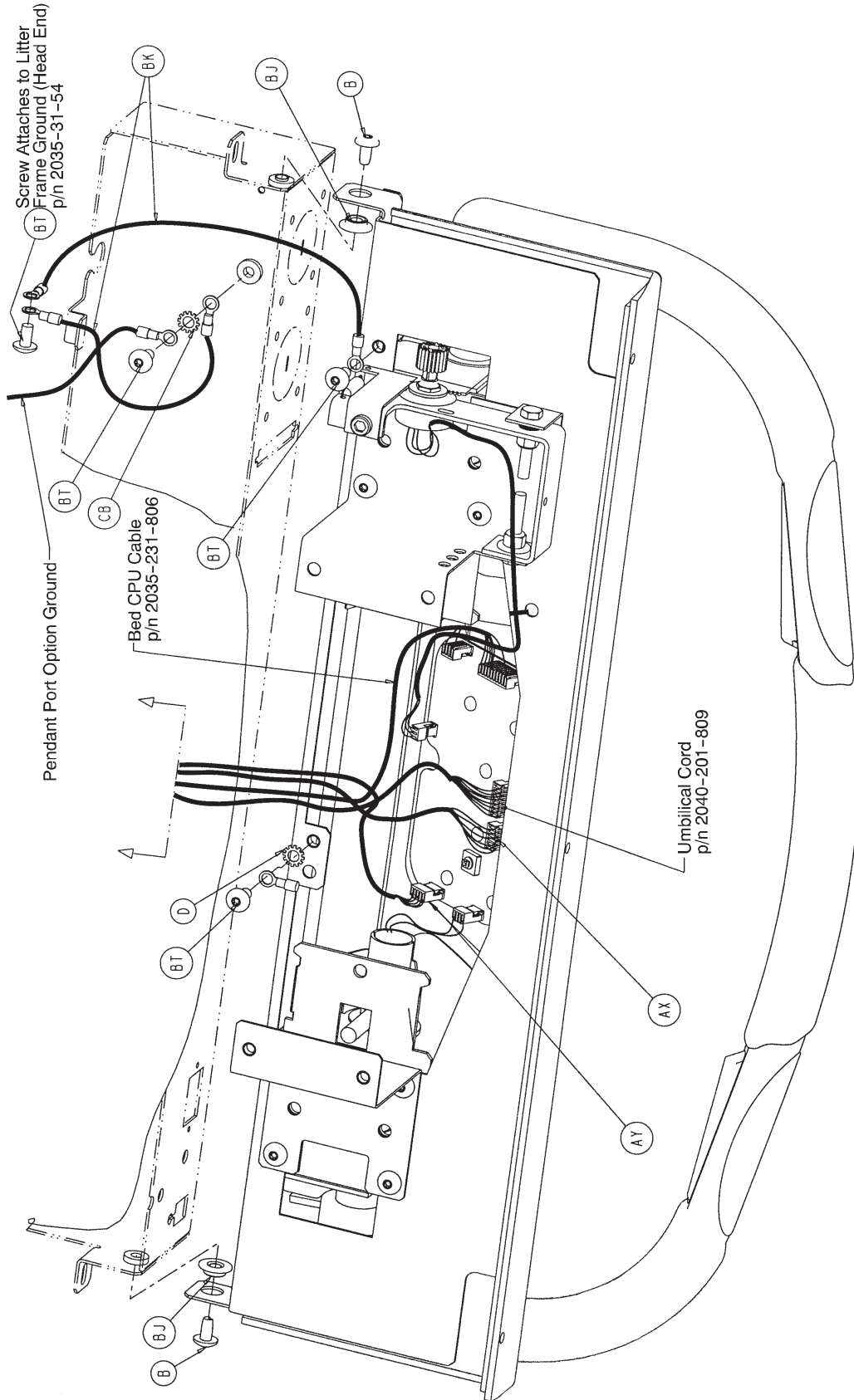

# ZOOM® Litter Assembly

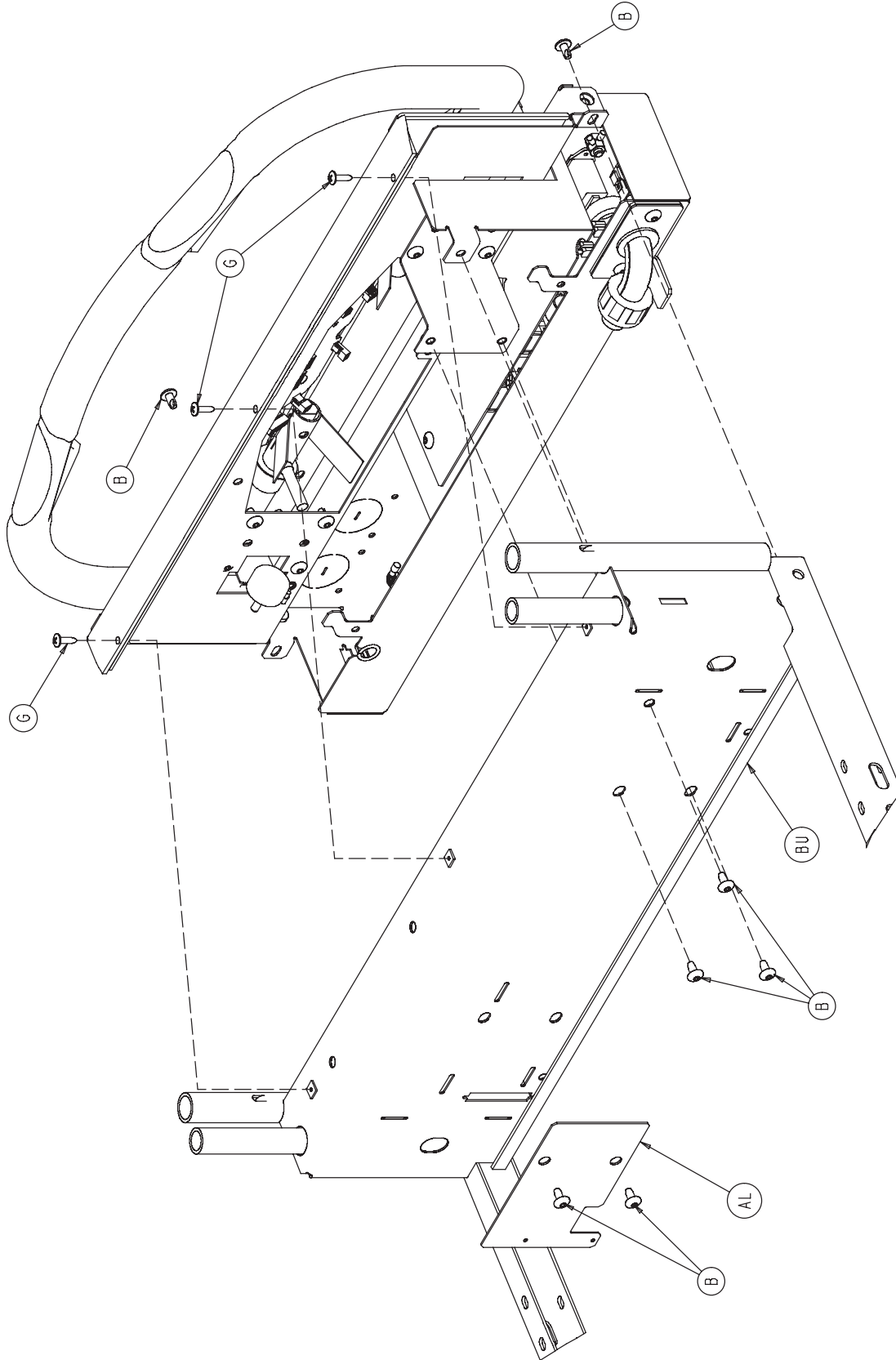

[Return To Table of Contents](#)

# ZOOM® Litter Assembly

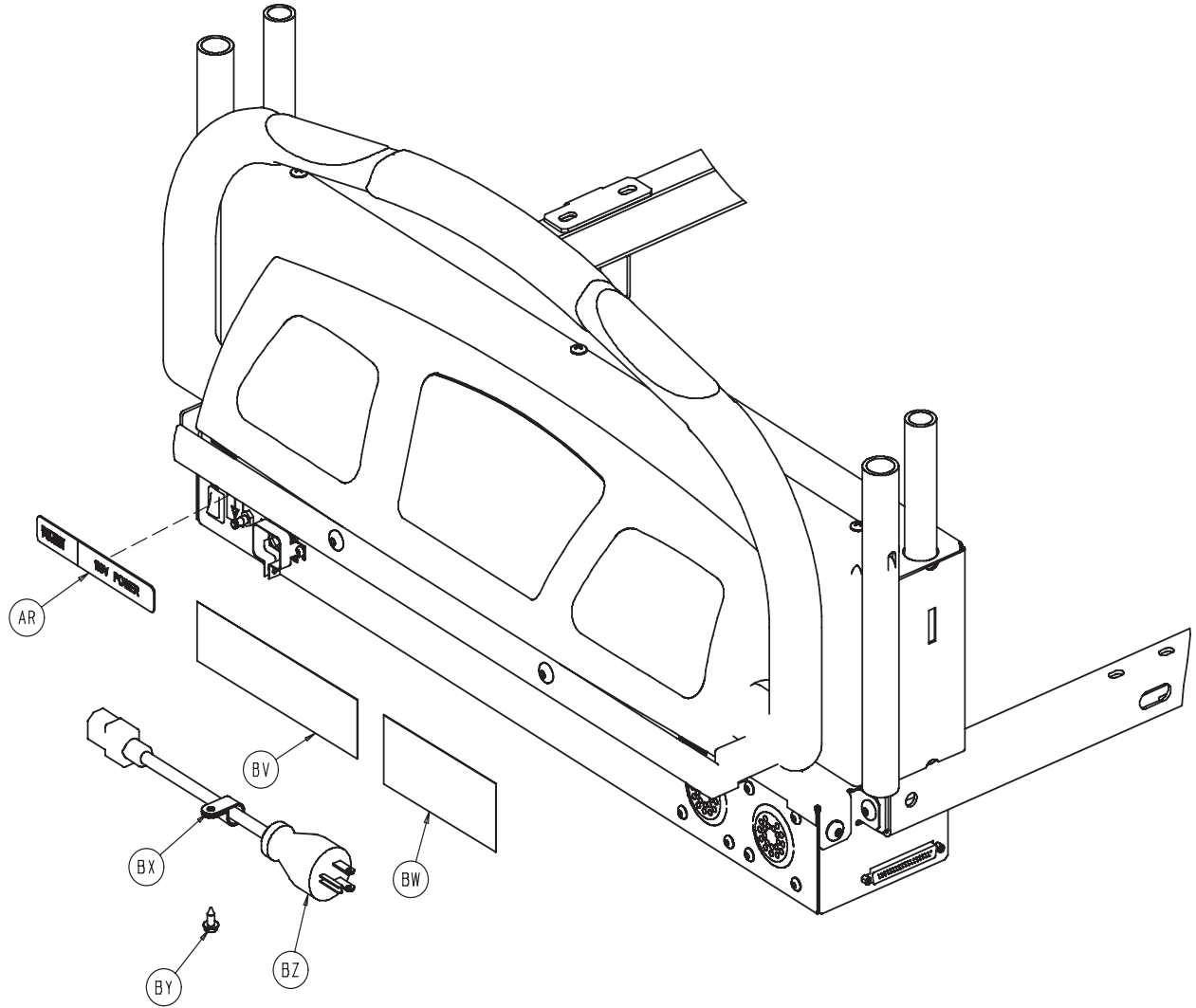

# ZOOM® Litter Assembly

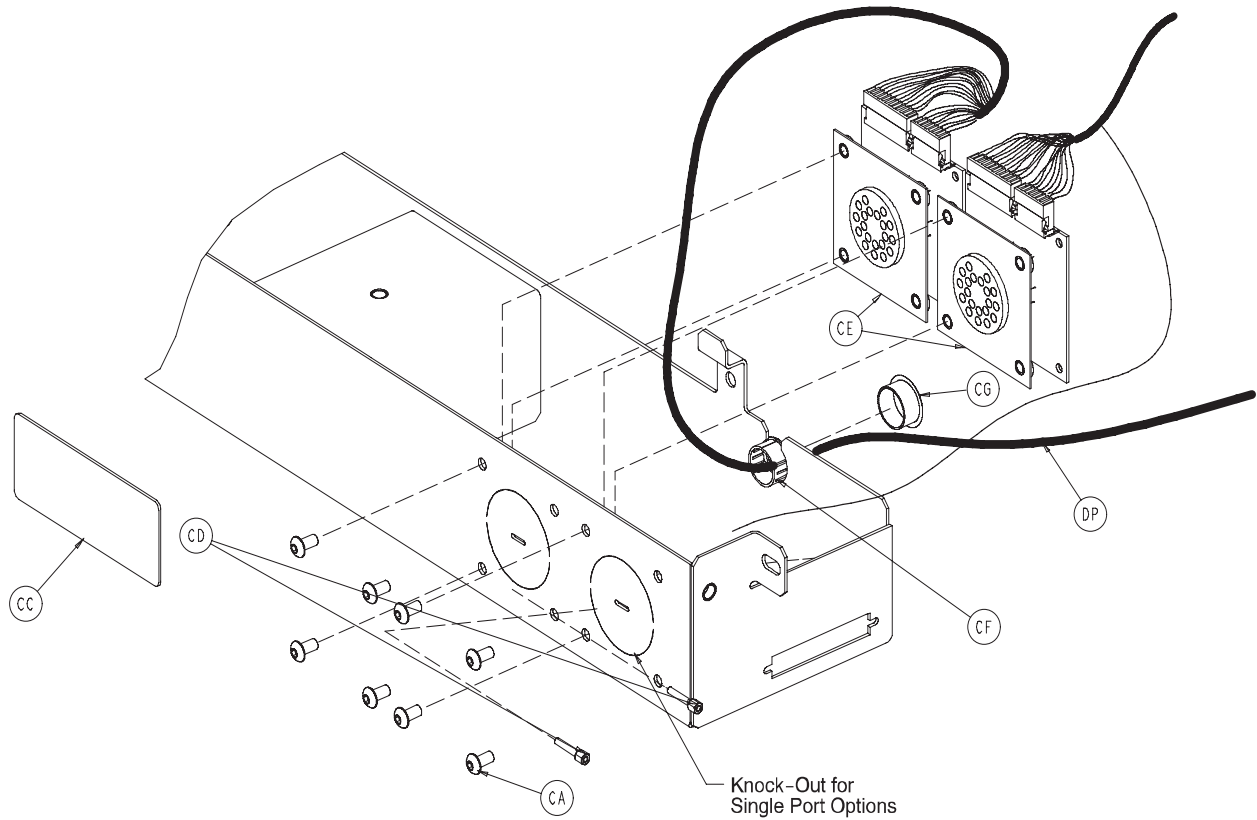

## 2040-031-200 Head Wall Communication Option

Item	Part No.	Part Name	Qty.
CD	3001-300-007	M/F Screw	2
CF	0030-038-000	Grommet	1

## 2040-031-201 Head Wall Comm. W/Nurse Call

Item	Part No.	Part Name	Qty.
CD	3001-300-007	M/F Screw	2
CF	0030-038-000	Grommet	1

## 2040-031-202 HW Comm. W/NC & 1 Stryker Port

Item	Part No.	Part Name	Qty.
CA	0004-307-000	But. Hd. Cap Screw	4
CB	0013-010-000	Ext. Tooth Lock Washer	2
CC	2040-031-104	Cord Out Label	1
CD	3001-300-007	M/F Screw	2
CE	3001-314-920	Head Wall Pend. Port PCB	1
CF	0030-038-000	Grommet	1

## 2040-031-203 W Comm. W/NC & 2 Stryker Ports

Item	Part No.	Part Name	Qty.
CA	0004-307-000	But. Hd. Cap Screw	8
CB	0013-010-000	Ext. Tooth Lock Washer	2
CC	2040-031-104	Cord Out Label	1
CD	3001-300-007	M/F Screw	2
CE	3001-314-920	Head Wall Pend. Port PCB	2
CF	0030-038-000	Grommet	1

## 2040-031-204 No Head Wall Option

Item	Part No.	Part Name	Qty.
CG	0037-030-000	Hole Plug	1

[Return To Table of Contents](#)

# ZOOM® Litter Assembly

Item	Part No.	Part Name	Qty.	Item	Part No.	Part Name	Qty.
A	0004-142-000	Soc. Hd. Cap Screw	2	AV	2040-031-807	Bed AC Pwr. Jump. Cbl.	1
B	0007-052-000	Truss Hd. Torx	18	AW	2040-031-808	Charger AC Jumper	1
C	0011-193-000	Flat Washer	1	AX	2040-031-809	CPU/Crossover PCB	1
D	0013-010-000	Ext. Tooth Lock Washer	5	AY	2040-031-810	On/Off Cable	1
F	0016-033-000	Kep Nut	2	AZ	2040-031-900	AC/Switchover PCB	1
G	0023-080-000	Truss Hd. Screw	3	BA	2040-031-910	Display/CPU PCB	1
H	0023-112-000	Hi-Low Tapping Screw	6	BB	2040-231-075	Reinforcement Brkt. Hd.	1
J	0050-032-000	Pan Hd. Mach. Screw	2	BC	2040-031-110	Pivot Bracket, Right	1
K	0021-140-000	Set Screw	4	BD	2040-031-111	Pivot Bracket, Left	1
L	0026-303-000	Roll Pin	4	BE	2040-031-106	Pot. Worm Gear	1
M	0027-022-000	Rue Ring Cotter	2	BF	3000-200-253	Pot. Worm Gear Retainer	1
N	0059-205-000	Connector Lock	1	BG	3000-300-114	Wire Tie	5
P	0016-023-000	Nylock Nut	2	BH	3000-300-115	Standoff	4
Q	0038-448-000	Switch Handle Ret. Spring	2	BJ	3001-300-099	Pivot Bearing	4
R	0052-762-000	Flange Bearing	4	BK	3001-300-870	Ground Strap	2
S	0059-133-000	Push-Mount Wire Clip	1	BL	3001-400-953	Switch Cap	6
T	0059-136-000	Push-Mount Wire Clip	1	BM	8800-380-000	Foam Tape (26.25")	1
U	0059-190-000	1.0 Amp Circuit Breaker	2	BN	8800-380-000	Foam Tape (1.25")	2
V	0059-191-000	On/Off Switch	1	BP	0044-032-000	Press. Sens. Tape (1.5")	4
Y	2040-031-011	Top Display Housing	1	BQ	0059-781-000	4-Position Connector	2
Z	2040-031-051	Pot. Collar Weldment	1	BR	0036-046-000	Ground Label	1
AA	2040-031-053	Hd. End Bottom Encl.	1	BS	0036-115-000	Ground Label	1
AB	2040-031-054	Bumper Attachment Wldmt.	1	BT	0007-058-000	T Russ Hd. Torx	4
AD	2040-031-062	Display Label	1	BU	7000-001-326	Foam Tape (26.75")	1
AE	2040-031-063	Hd. End Top Enclosure	1	BV	1550-090-001	Hosp. Grade Plug Label	1
AF	2040-231-064	Control Bar	1	BW	2011-001-104	Anesthetics Danger Label	1
AG	2040-031-068	Handle Switch	2	BX	0034-022-000	Cord Clamp	1
AH	2040-231-069	Display Bumper	1	BY	0023-025-000	Hex Washer Hd. Screw	1
AJ	2040-031-073	Stop Pin	2	BZ	0039-254-000	Power Cord	1
AK	2040-031-074	Control Bar Ret. Spring	2	DA	0007-063-000	Truss Hd. Torx	4
AL	2040-031-077	Cover Plate	1	DB	0055-027-000	"U" Type Nut	4
AM	2040-031-082	Potentiometer Collar	1	DD	0003-050-000	Hex Hd. Cap Screw	2
AN	2040-031-092	Hd. End Electronics Cvr.	1	DE	0004-325-000	Soc. Hd. Cap Screw	1
AP	2040-031-101	Drive Instruction Label	1	DG	0016-028-000	Nylock Nut	2
AQ	2040-031-102	Drive Warning Label	1	DH	0038-482-000	Extension Spring	1
AR	2040-031-103	Power Label	1	DK	2040-031-108	Potentiometer Mount	1
AS	2040-031-105	Logo Label	1	DL	2040-031-109	Reinforcement Bracket	1
AT	2040-031-803	Contact Switch Cable	2	DM	2040-031-085	Umbilical Cord Supt. Plate	1
AU	2040-031-804	Potentiometer Cable	1	DN	0007-065-000	Truss Hd. Torx	2
				DP	2035-031-806	Headwall Interface Cable	1

# Optional 110V Outlet Assembly

For Reference Only: 2040-320-060

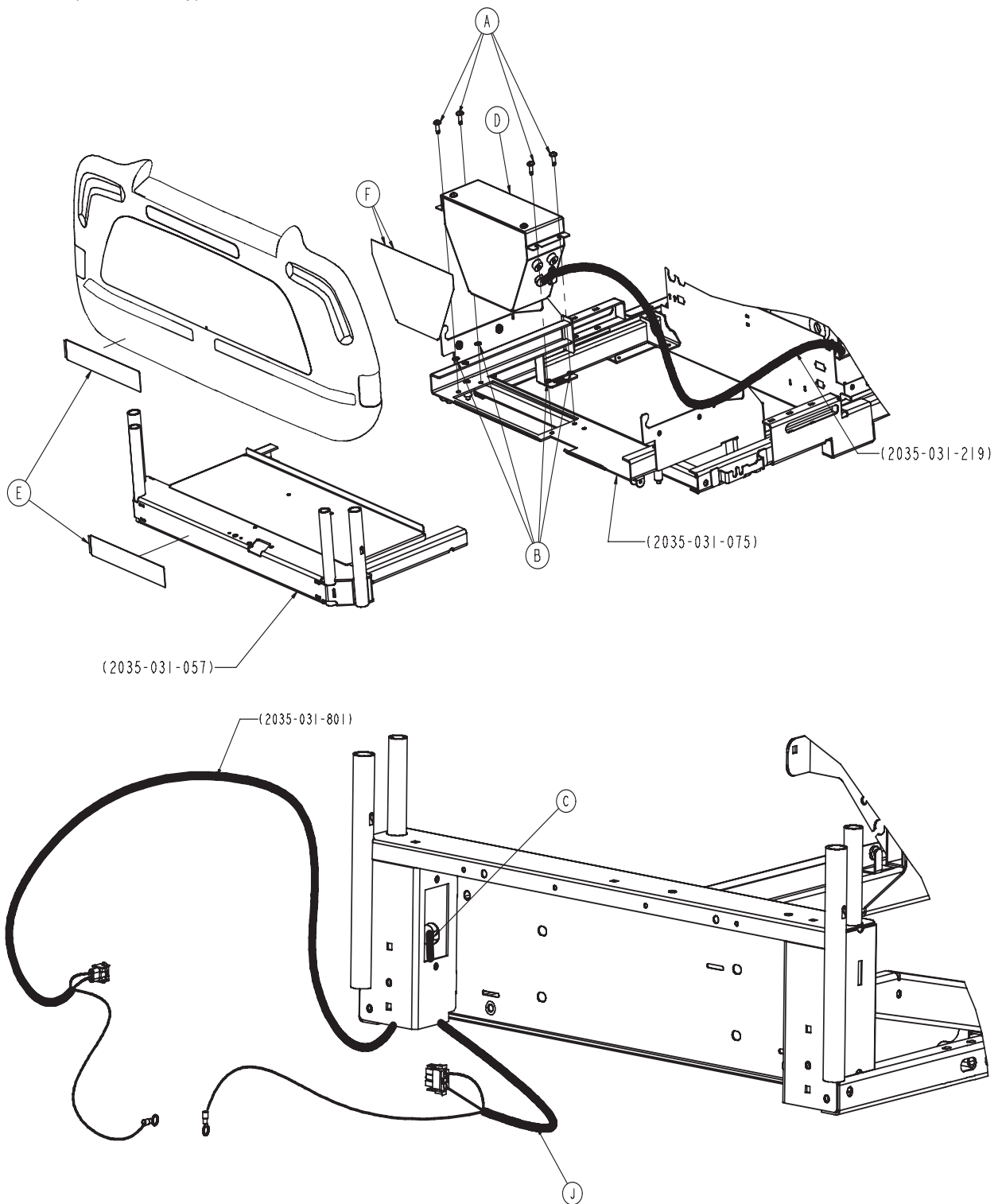

[Return To Table of Contents](#)

# Optional 110V Outlet Assembly

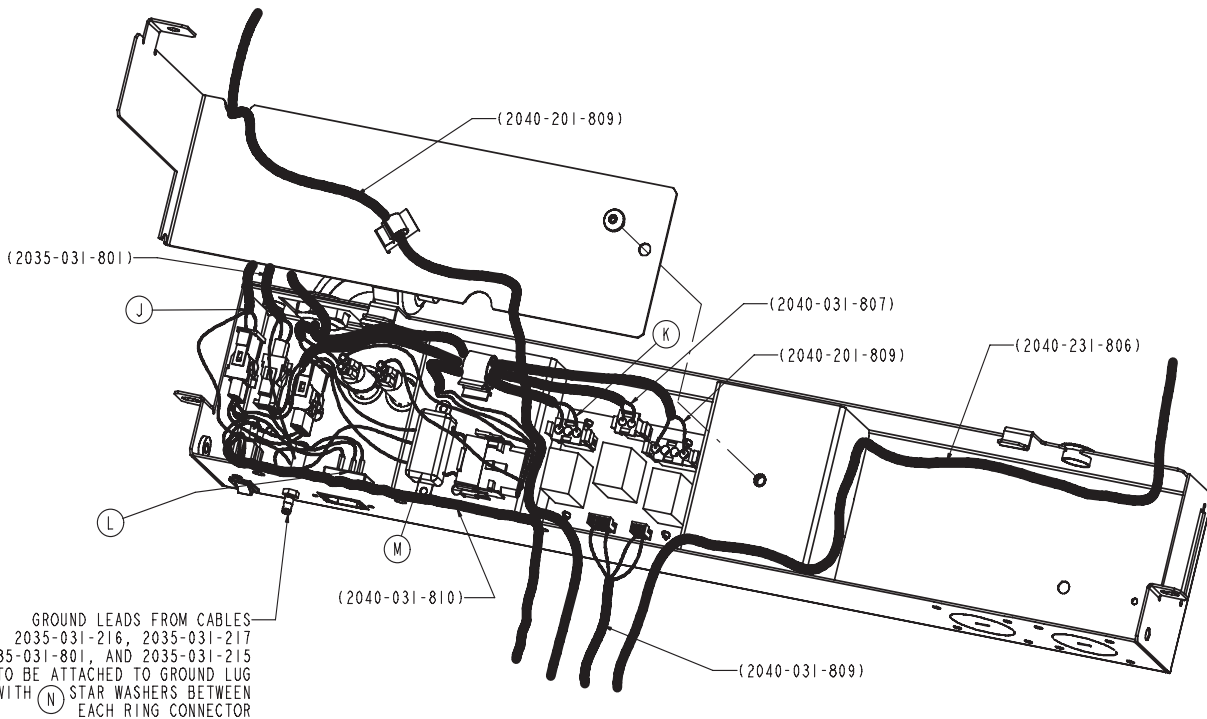
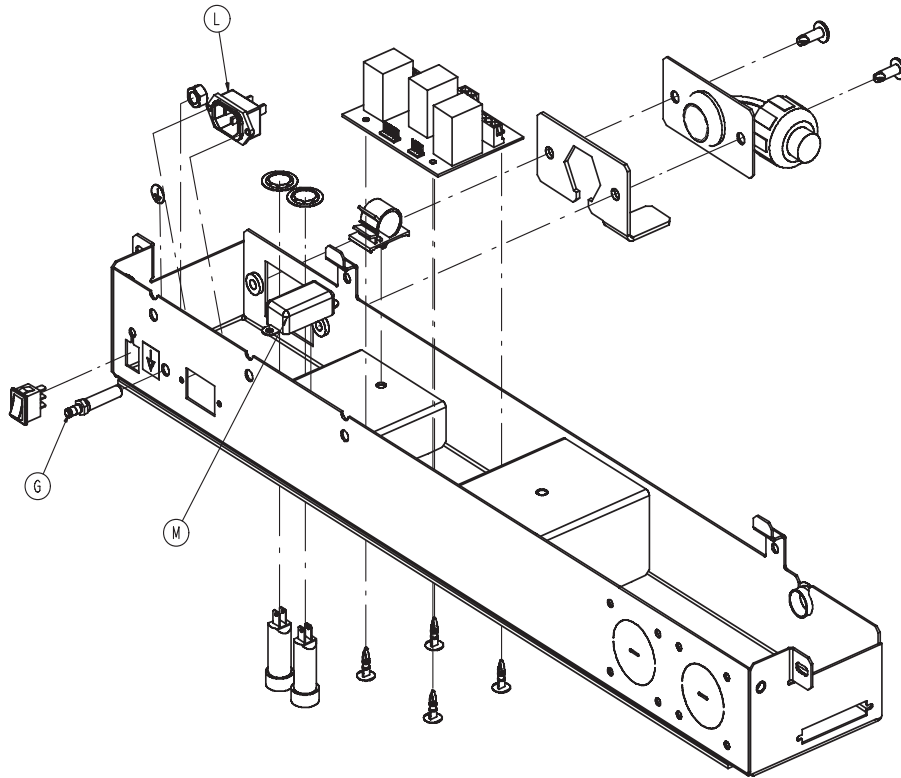



# Optional 110V Outlet Assembly

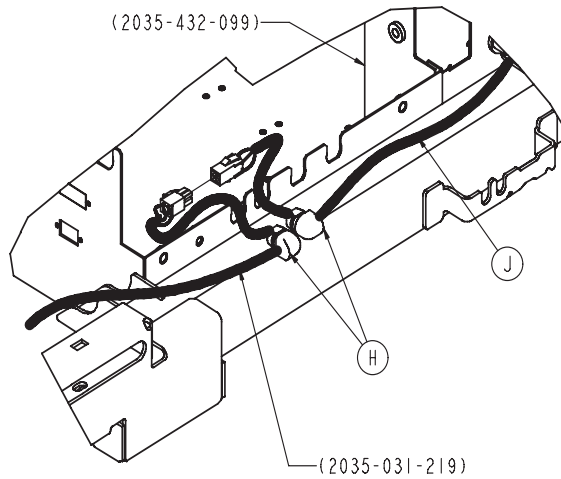
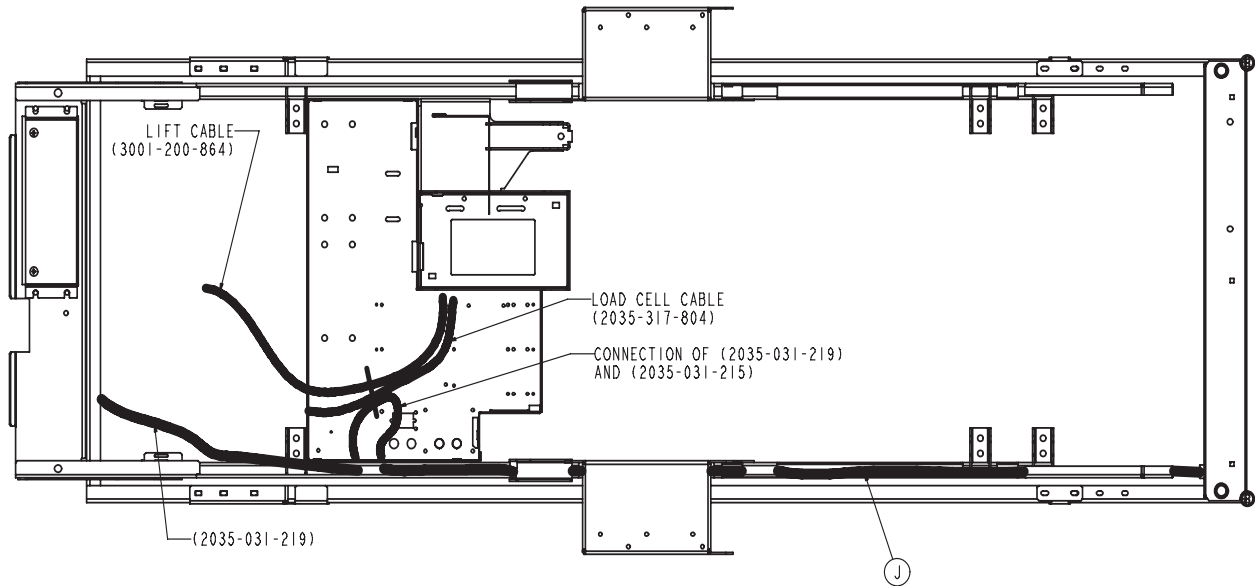

Item	Part No.	Part Name	Qty.
A	0007-063-000	Truss Hd. Screw	4
B	0013-010-000	External Tooth Lock Washer	7
C	0059-106-000	HEYCO	1
D	2035-031-220	<a href="#">110V Box Assembly (pg.139)</a>	1
E	2035-031-204	110V Outlet Caution Label	2
F	2035-031-206	ZOOM® Box Label	1
G	2030-001-215	Lug	1
H	0030-047-000	HEYCO	2
J	2035-031-215	Cable, 110V Supply	1
K	2040-031-811	AC Jumper Charger	1
L	2035-031-216	Cable, 110V Head End	1
M	2035-031-217	Filter, 110V ZOOM®	1
N	0012-038-000	Washer	3

[Return To Table of Contents](#)

# No Optional 110V Outlet

For Reference Only: 2040-320-060

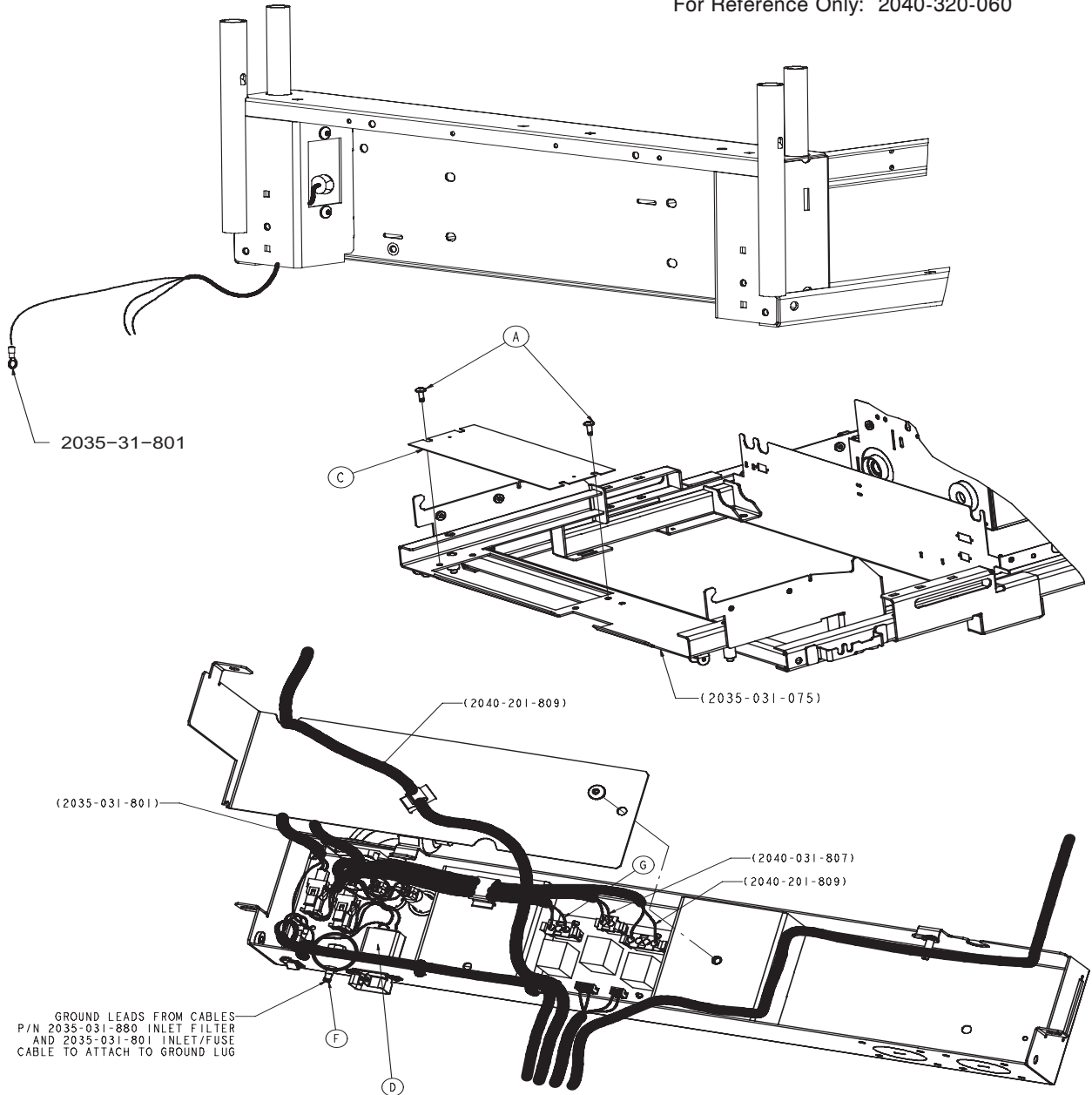

GROUND LEADS FROM CABLES  
P/N 2035-031-880 INLET FILTER  
AND 2035-031-801 INLET/FUSE  
CABLE TO ATTACH TO GROUND LUG

Item	Part No.	Part Name	Qty.
A	0007-063-000	Truss Hd. Screw	2
C	2035-031-203	Foot Cross Brace Cover	1
D	2035-031-880	Power Inlet Cable	1
E	0037-085-000	Heyco Hole Plug	2
F	2011-001-215	Lug	1
G	2040-031-808	Charger, AC Jumper	1

# 110V Box Assembly

For Reference Only: 2035-031-220

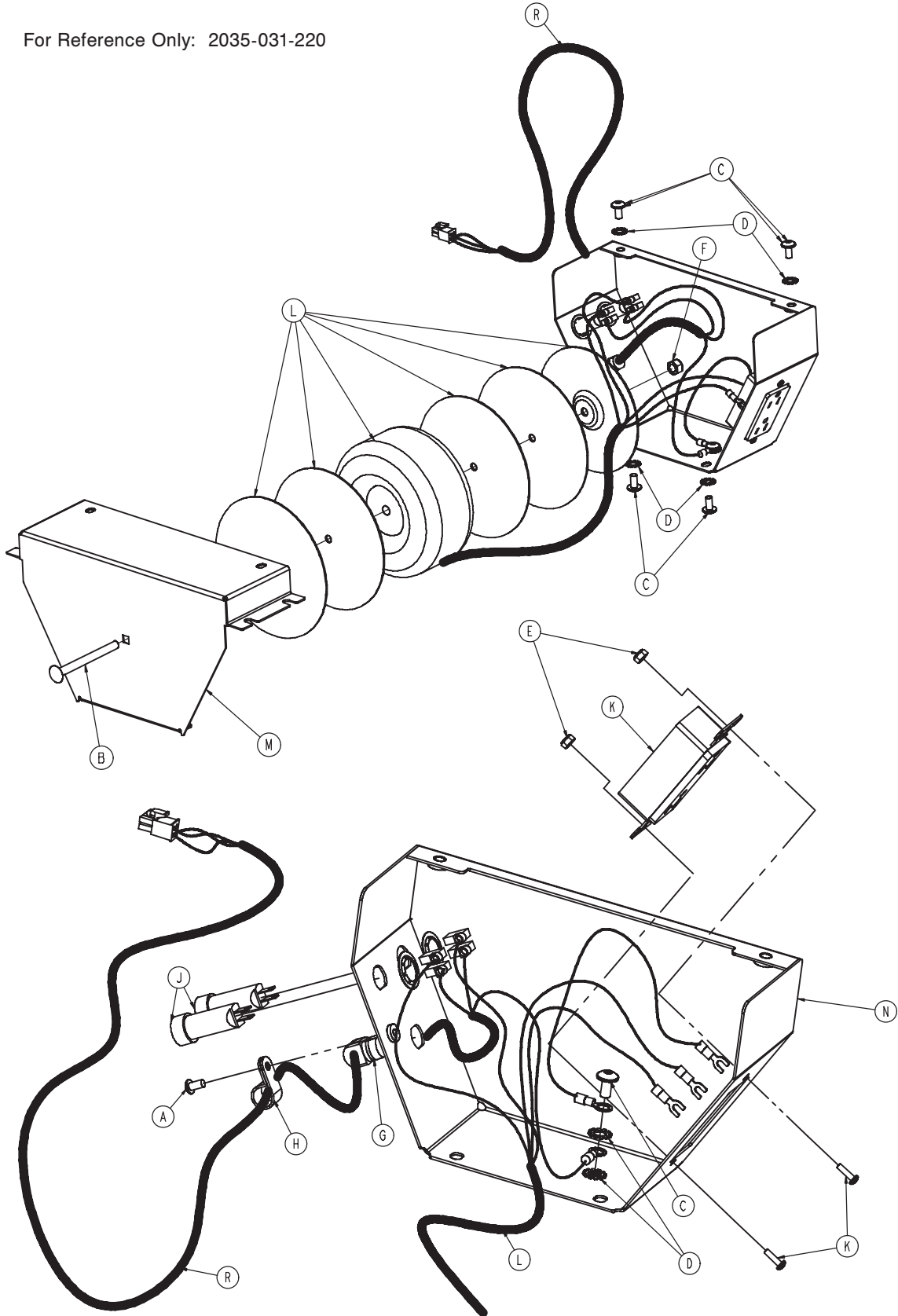

# Head End Siderail Assembly

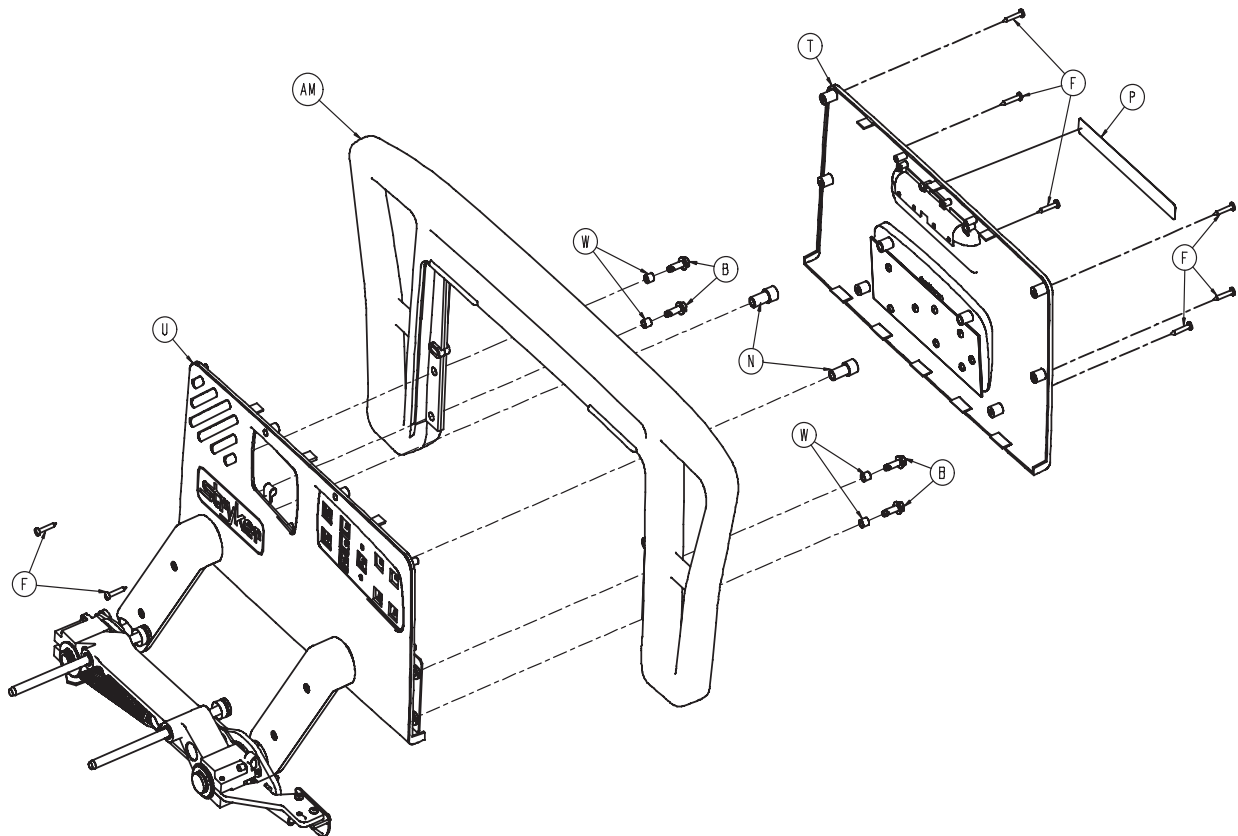
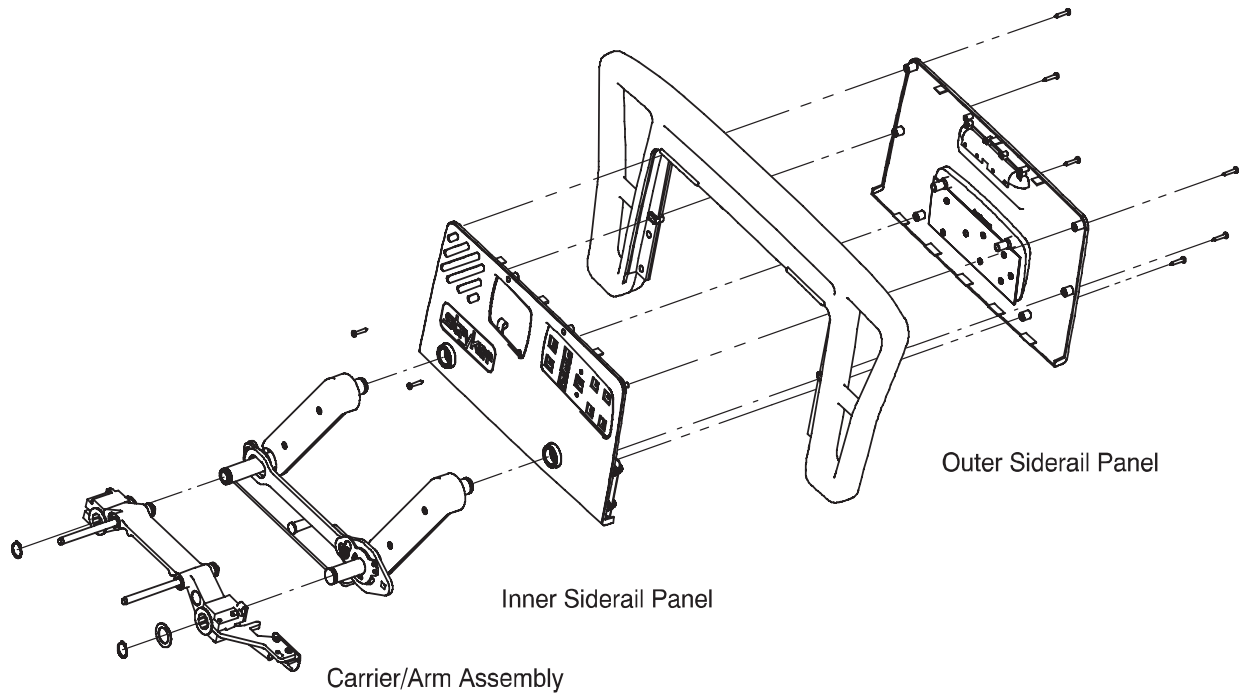

# Head End Siderail Assembly

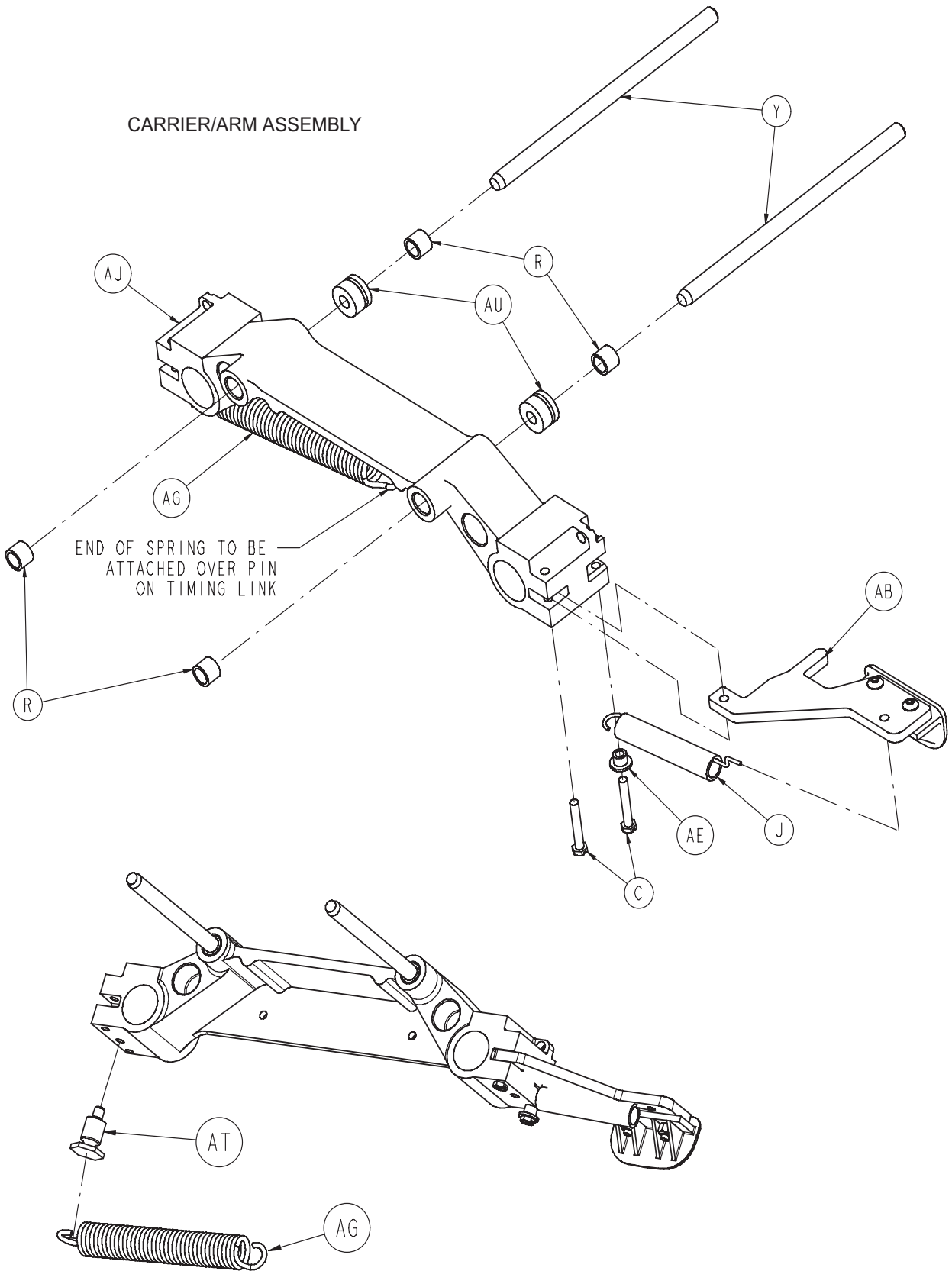

# Head End Siderail Assembly

## CARRIER/ARM ASSEMBLY

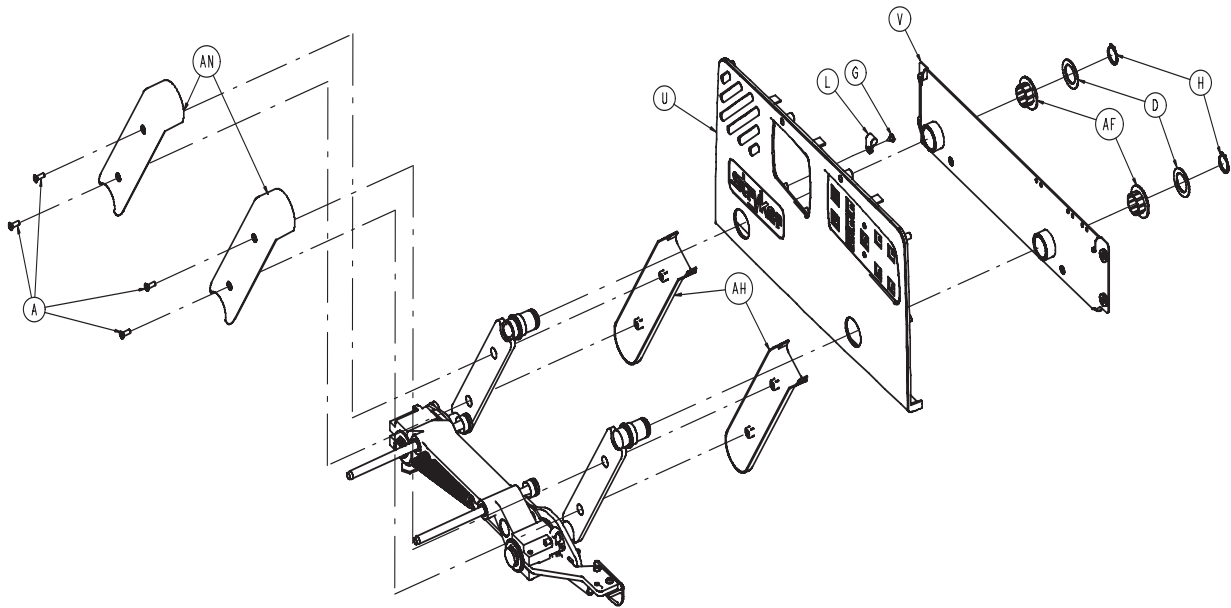
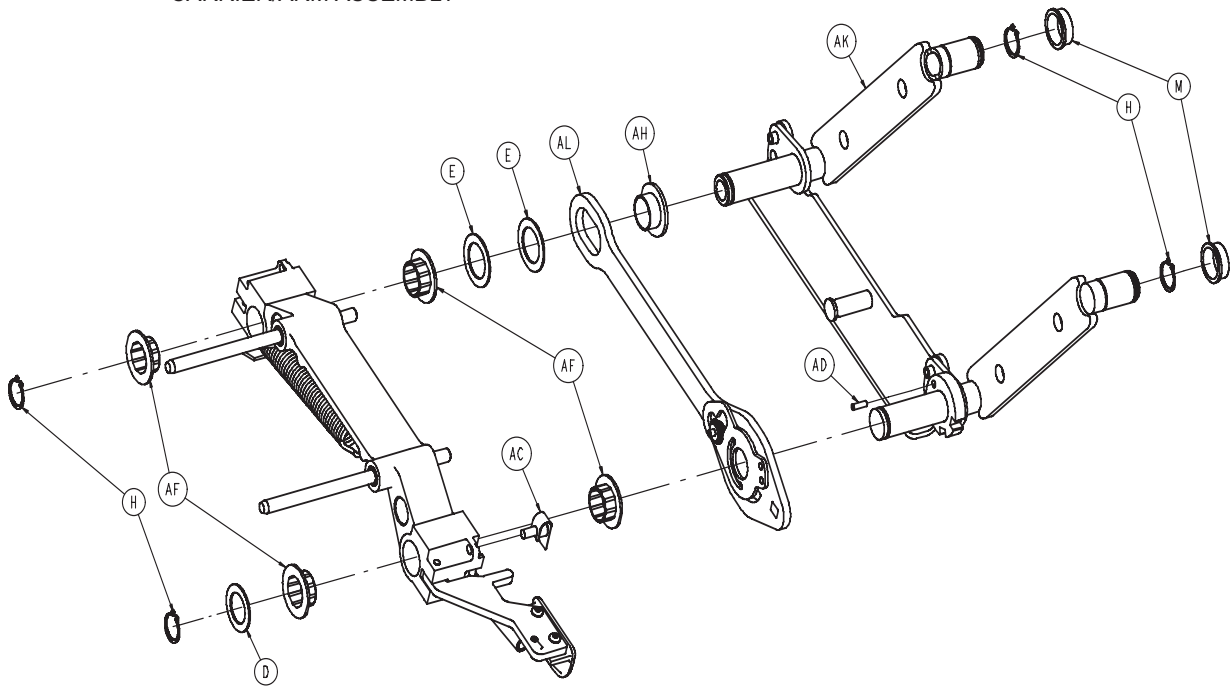

# Head End Siderail Assembly

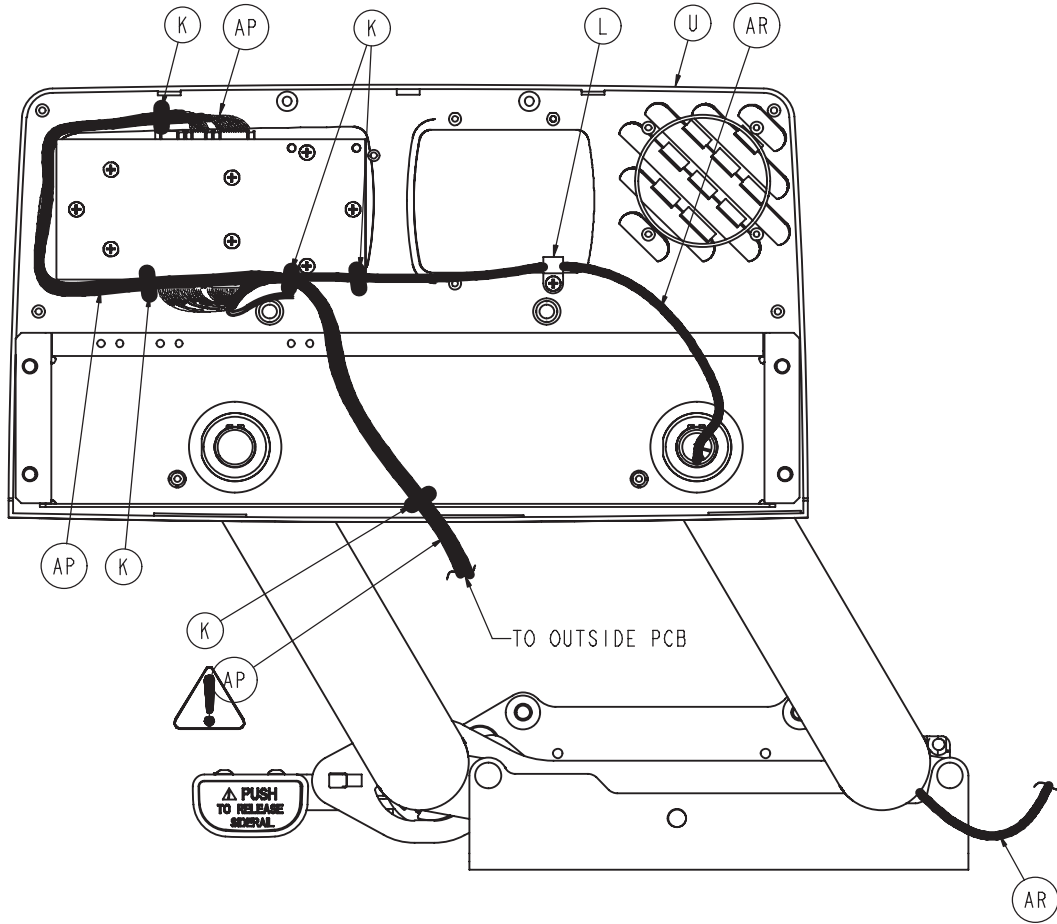

LEFT HEAD END SIDERAIL WIRE ROUTING

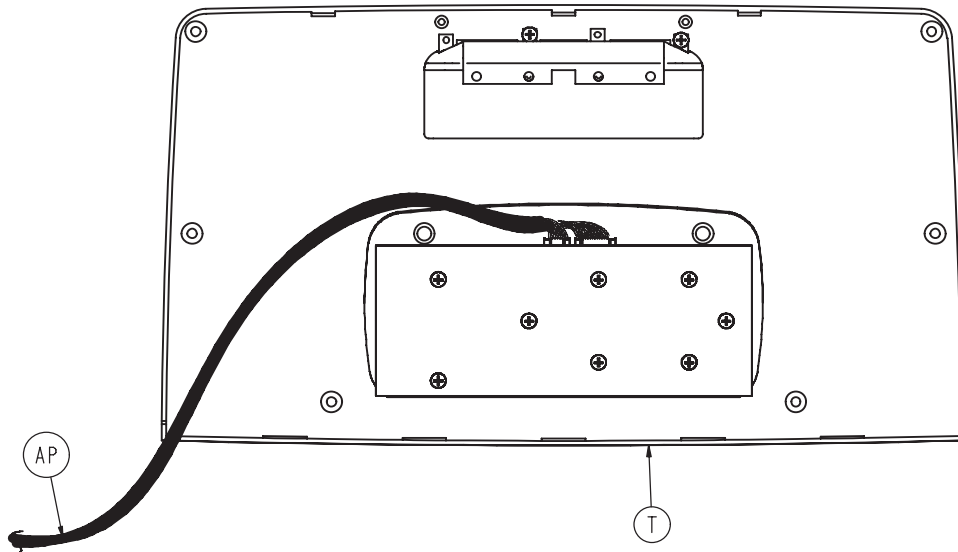

# Head End Siderail Assembly

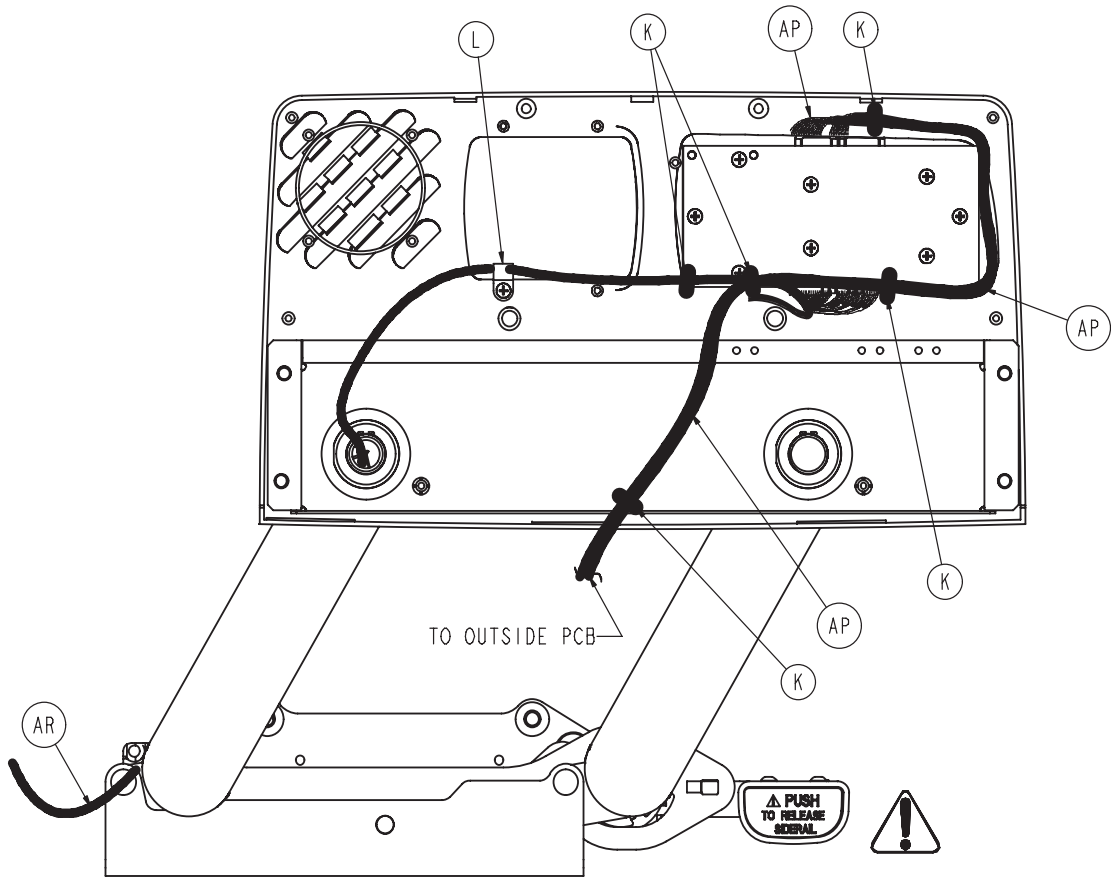

RIGHT HEAD END SIDERAIL WIRE ROUTING

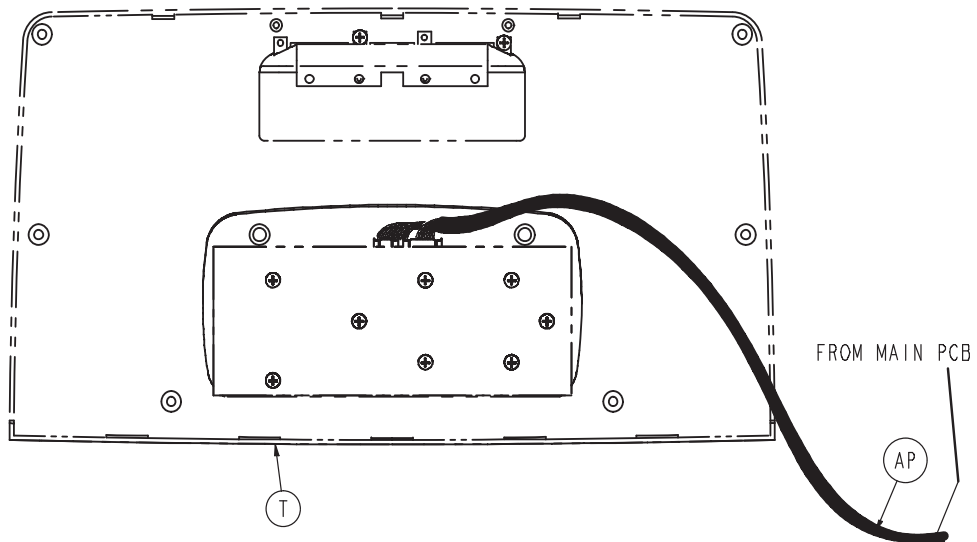



# Head End Siderail Assembly

2032-402-105 Left Standard Components				2032-402-205 Right Standard Components			
Item	Part No.	Part Name	Qty.	Item	Part No.	Part Name	Qty.
A	0001-072-000	Ph. Flat Hd. Mach. Screw	4	A	0001-072-000	Ph. Flat Hd. Mach. Screw	4
B	0003-226-000	Hex Washer Hd. Screw	4	B	0003-226-000	Hex Washer Hd. Screw	4
C	0003-344-000	Hex Hd. Screw	2	C	0003-344-000	Hex Hd. Screw	2
D	0011-343-000	Shim Washer	3	D	0011-343-000	Shim Washer	3
E	0014-093-000	Washer	2	E	0014-093-000	Washer	2
F	0023-090-000	High-Low Tapping Screw	8	F	0023-090-000	High-Low Tapping Screw	8
G	0023-112-000	High-Low Tapping Screw	1	G	0023-112-000	High-Low Tapping Screw	1
H	0028-128-000	Retaining Ring	6	H	0028-128-000	Retaining Ring	6
J	3000-200-334	Release Lever Spring	1	J	3000-200-334	Release Lever Spring	1
K	3000-300-114	Cable Tie	5	K	3000-300-114	Cable Tie	5
L	3000-300-478	CPR Conduit Clamp	1	L	3000-300-478	CPR Conduit Clamp	1
M	3000-400-513	Wear Bushing	2	M	3000-400-513	Wear Bushing	2
N	3000-400-523	Panel Spacer	2	N	3000-400-523	Panel Spacer	2
P	3000-400-556	Warning Label	1	P	3000-400-556	Warning Label	1
R	3000-400-557	Sleeve Bearing	4	R	3000-400-557	Sleeve Bearing	4
T	2035-400-050	<a href="#">Outer Panel Assembly (pg. 151)</a>	1	T	2035-400-050	<a href="#">Outer Panel Assembly (pg. 151)</a>	1
U	3001-400-040	<a href="#">Inner Panel Assembly, Lt. (pg. 150)</a>	1	U	3001-400-045	<a href="#">Inner Panel Assembly, Rt. (pg. 150)</a>	1
V	3003-400-130	Support Weldment HE Lt.	1	V	3003-400-230	Support Weldment HE Rt.	1
W	3001-400-558	Siderail Spacer	4	W	3001-400-558	Siderail Spacer	4
Y	2035-400-570	Glide Rod	2	Y	3001-400-564	Glide Rod	2
AA	3001-400-619	Outer Arm Cover	2	AA	3001-400-619	Outer Arm Cover	2
AB	3002-400-055	<a href="#">Release Lever Ass'y, Left (pg. 156)</a>	1	AB	3002-400-065	<a href="#">Release Lever Ass'y, Right (pg. 156)</a>	1
AC	3002-400-090	<a href="#">Ball Detent Clip Assembly (pg. 149)</a>	1	AC	3002-400-090	<a href="#">Ball Detent Clip Assembly (pg. 149)</a>	1
AD	3002-400-505	Byp ass Pin	1	AD	3002-400-505	Bypass Pin	1
AE	3002-400-509	Spacer	1	AE	3002-400-509	Spacer	1
AF	3002-400-513	Pivot Bushing	6	AF	3002-400-513	Pivot Bushing	6
AG	3003-402-517	Foot Rail Tuck Spring	1	AG	3003-402-517	Foot Rail Tuck Spring	1
AH	3002-400-519	Latch Bushing	1	AH	3002-400-519	Latch Bushing	1
AJ	3002-400-528	Carrier	1	AJ	3002-400-528	Carrier	1
AK	3003-402-005	<a href="#">HE Timing Link Ass'y LH (pg. 147)</a>	1	AK	3003-402-010	<a href="#">HE Timing Link Ass'y RH (pg. 148)</a>	1
AL	3003-402-005	Latch Ass'y, Head, Left	1	AL	3003-402-010	Latch Ass'y, Head, Right	1
AM	3003-400-515	Head Rail	1	AM	3003-400-515	Head Rail	1
AN	5000-020-005	Inner Arm Cover	2	AN	5000-020-005	Inner Arm Cover	2
AP	3001-400-802	Main Outside Cable, Lt.	1	AP	3001-400-801	Main Outside Cable, Rt.	1
AR	3001-400-862	Siderail Cable	1	AR	3001-400-862	Siderail Cable	1
AT	3003-402-114	Spring Attachment Pin	1	AT	3003-402-114	Spring Attachment Pin	1
AU	0030-040-000	Grommet	2	AU	0030-010-000	Grommet	2

# Head End Siderail Assembly

## 2030-020-011 Standard Siderail

Item	Part No.	Part Name	Qty.
CA	2035-000-100	Label, Standard, Left	1
CA	2035-000-200	Label, Standard, Right	1
CC	3001-400-953	Switch Cap	28
CD	3001-400-522	Filler Cap	18
CE	3001-400-517	Speaker Seal	2
CF	3001-400-535	Inner Panel Blank Module	2
CH	2030-000-300	Label, Standard, Left	1
CH	2030-000-400	Label, Standard, Right	1

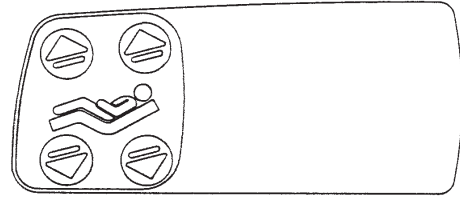

Right Inner Siderail Label

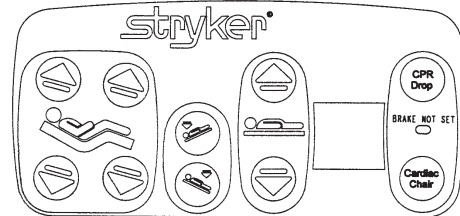

Right Outer Siderail Label

## 2030-020-012 Standard Siderail with Nurse Call

Item	Part No.	Part Name	Qty.
CA	2035-000-101	Label, Standard, NC, Left	1
CA	2035-000-201	Label, Standard, NC, Right	1
CC	3001-400-953	Switch Cap	32
CD	3001-400-522	Filler Cap	14
CE	3001-403-831	Speaker with Cable	2
CF	3001-400-535	Inner Panel Blank Module	2
CH	2030-000-301	Label, Standard, NC, Left	1
CH	2030-000-401	Label, Standard, NC, Right	1

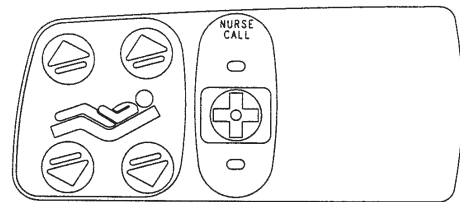

Right Inner Siderail Label

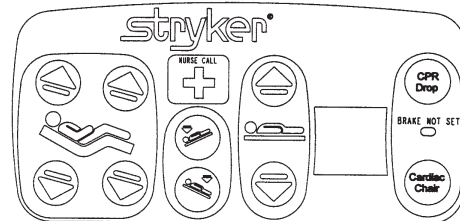

Right Outer Siderail Label

## 2030-020-015 Standard Siderail W/NC & Comm.

Item	Part No.	Part Name	Qty.
CA	2035-000-102	Label, Standard, Left	1
CA	2035-000-202	Label, Standard, Right	1
CC	3001-400-953	Switch Cap	42
CD	3001-400-522	Filler Cap	4
CE	3001-403-831	Speaker with Cable	2
CF	3001-400-535	Inner Panel Blank Module	2
CH	2030-000-301	Label, Standard, NC, Lt.	1
CH	2030-000-401	Label, Standard, NC, Rt.	1

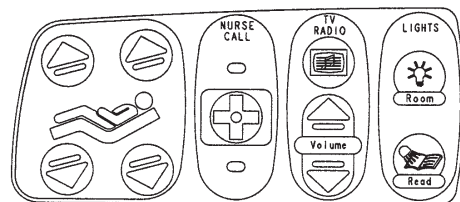

Right Inner Siderail Label

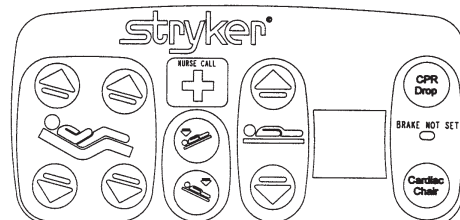

Right Outer Siderail Label

# Timing Link Assembly, Head End, Left - 3003-402-005

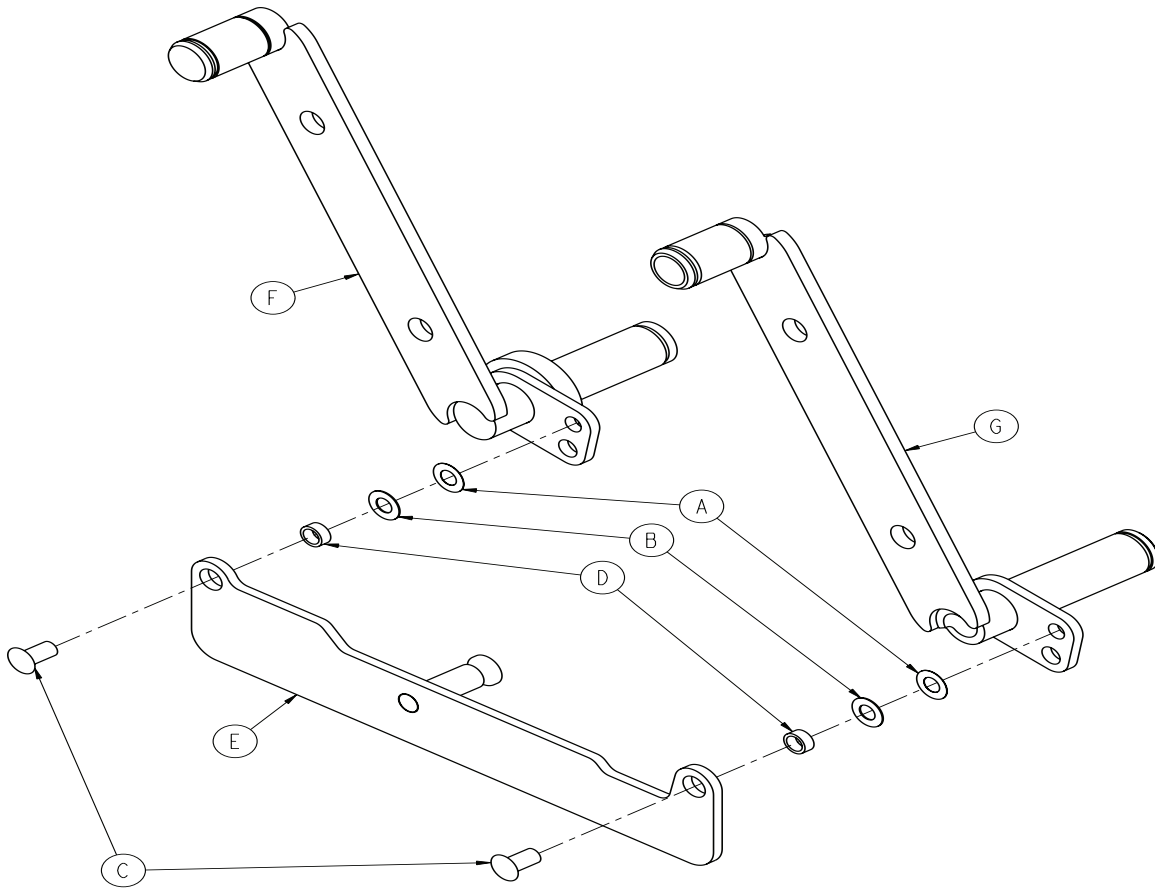

Item	Part No.	Part Name	Qty.
A	0011-377-000	Washer	2
B	0011-491-000	Washer	2
C	3001-400-501	Siderail Linkage Rivot	2
D	3003-401-001	Bushing	2
E	3003-402-112	Timing Link	1
F	3003-402-127	Arm Weldment - LHF	1
G	3003-402-128	Arm Weldment - LHH	1

# Timing Link Assembly, Head End, Right - 3003-402-010

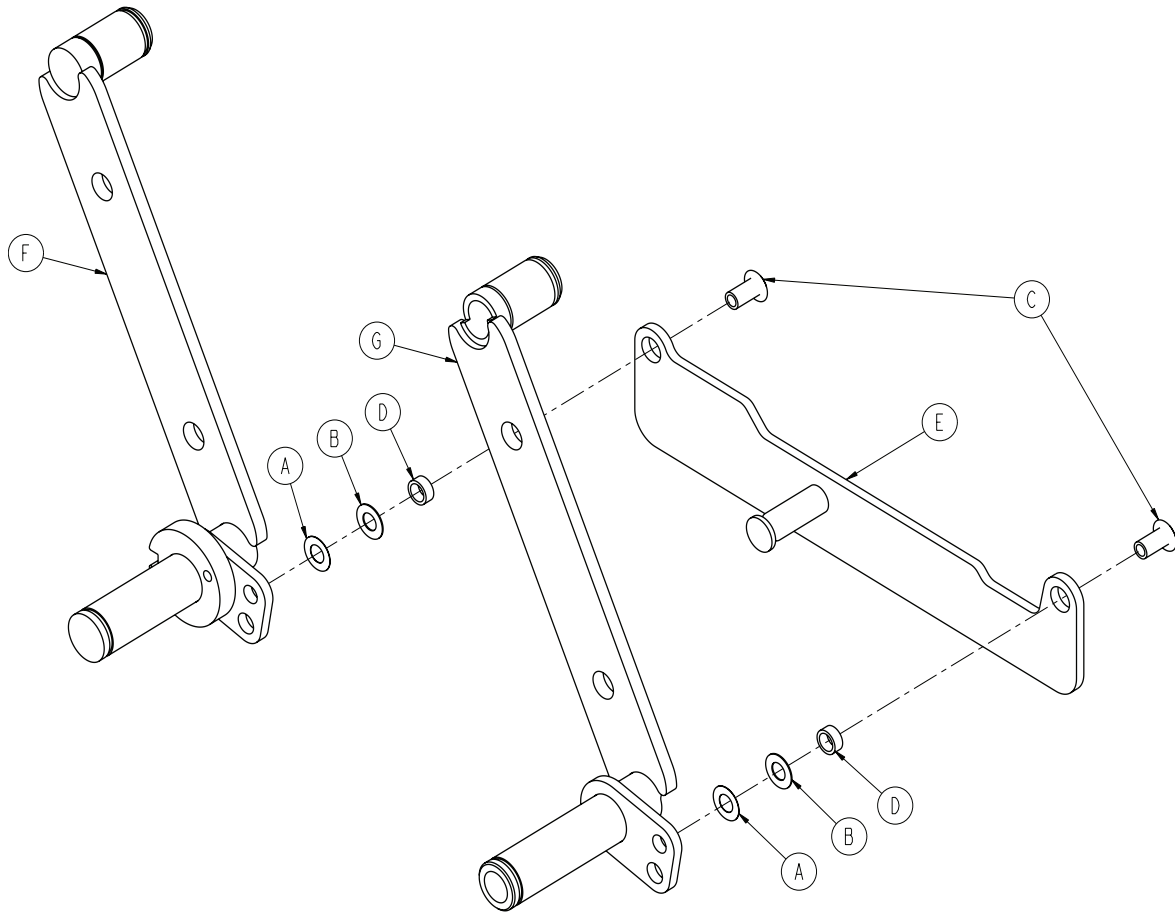

Item	Part No.	Part Name	Qty.
A	0011-377-000	Washer	2
B	0011-491-000	Washer	2
C	3001-400-501	Siderail Linkage Rivot	2
D	3003-401-001	Bushing	2
E	3003-402-117	Timing Link	1
F	3003-402-227	Arm Weldment - LHF	1
G	3003-402-228	Arm Weldment - LHH	1

# Siderail Bypass Detent Clip Assembly - 3002-400-090

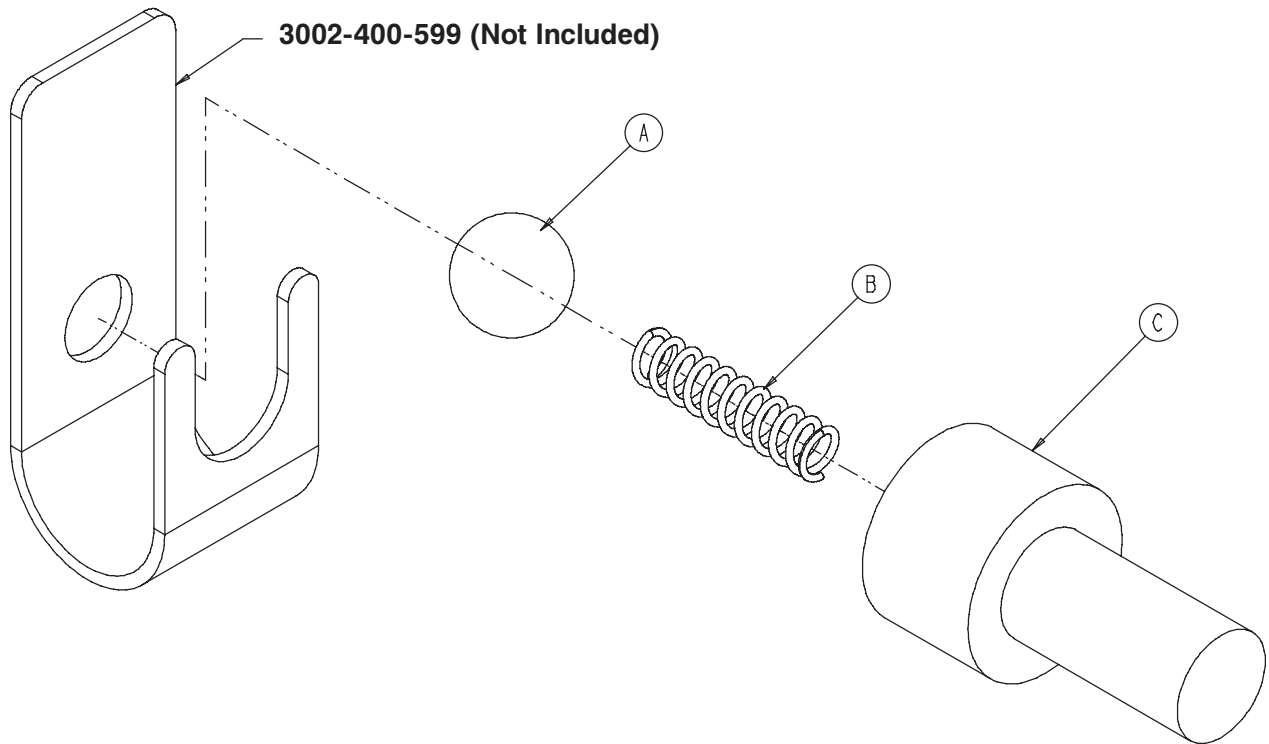

Item	Part No.	Part Name	Qty.
A	0031-137-000	Steel Ball	1
B	0038-464-000	Compression Spring	1
C	3002-400-524	Bypass Detent Housing	1

# Head End Siderail Inner Panel Assembly

For Reference Only: 3001-400-040 (Left)  
& 3001-400-045 (Right)

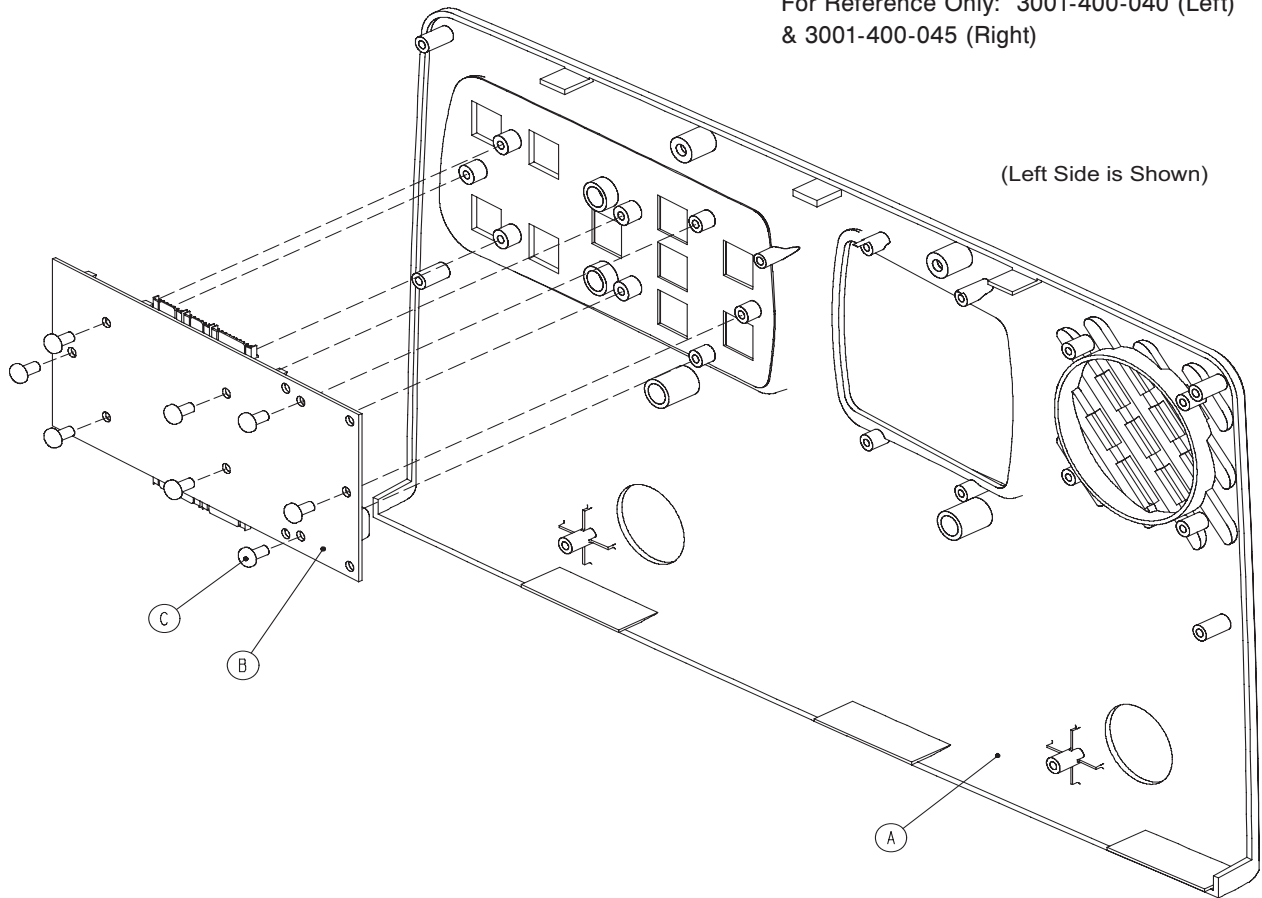

Item	Part No.	Part Name	Qty.
A	3001-400-101	Left Inner Panel	1
	3001-400-201	Right Inner Panel	1
B	3001-400-900	Inner Siderail PCB Assembly	1
C	0023-112-000	Hi-Low Tapping Screw	8

# Head End Siderail Outer Panel Assembly - 2035-400-050

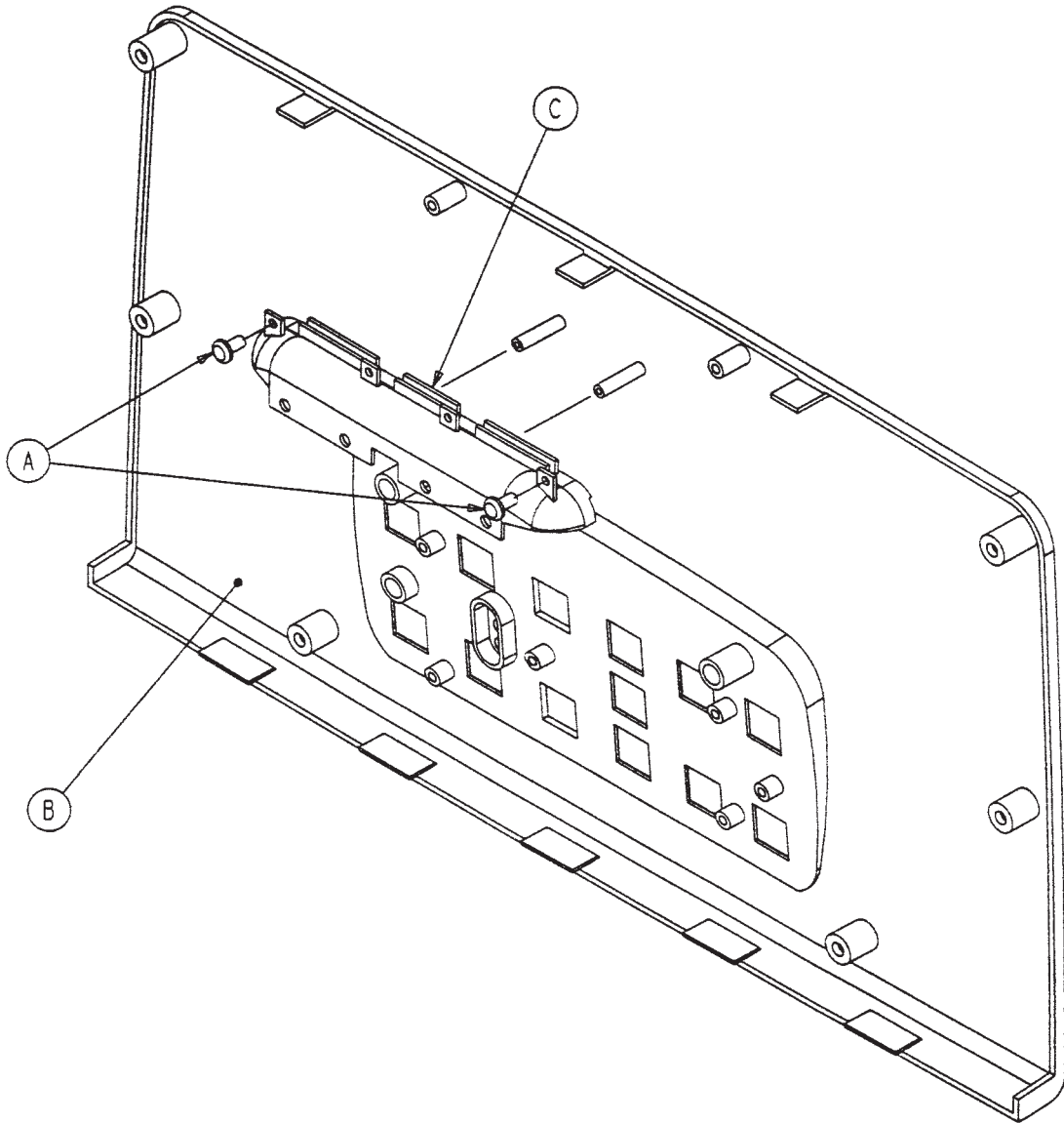

Item	Part No.	Part Name	Qty.
A	0023-112-000	Hi-Low Tapping Screw	2
B	2035-400-102	Outer Panel	1
C	3001-400-599	Handle Insert	1

[Return To Table of Contents](#)

# Foot End Siderail Assembly

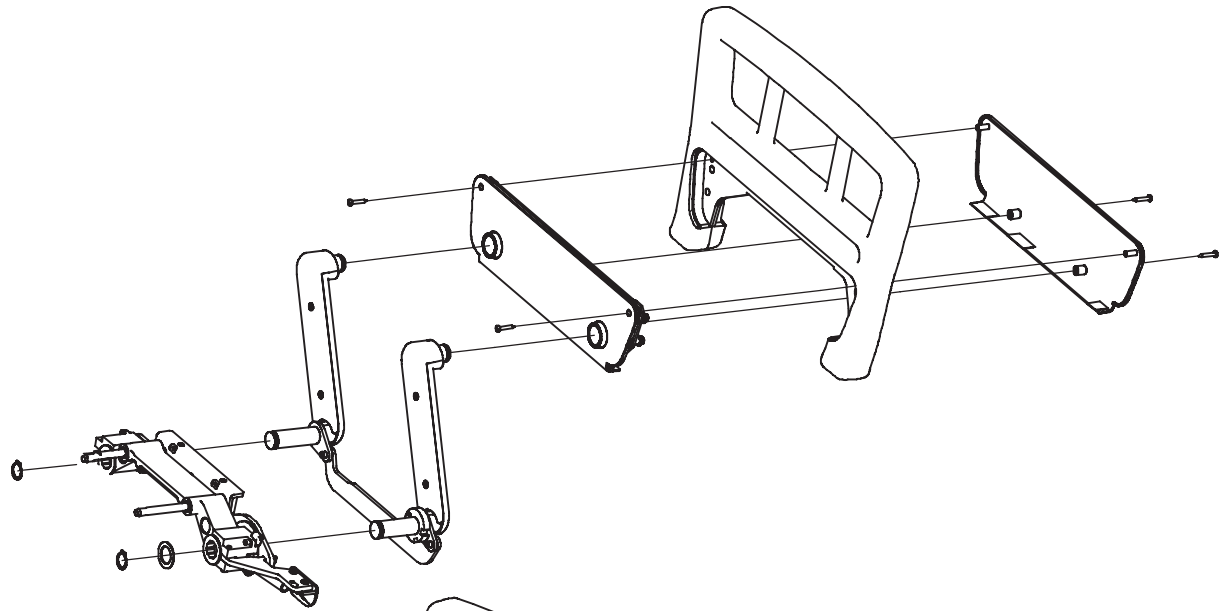

Carrier/Arm Assembly

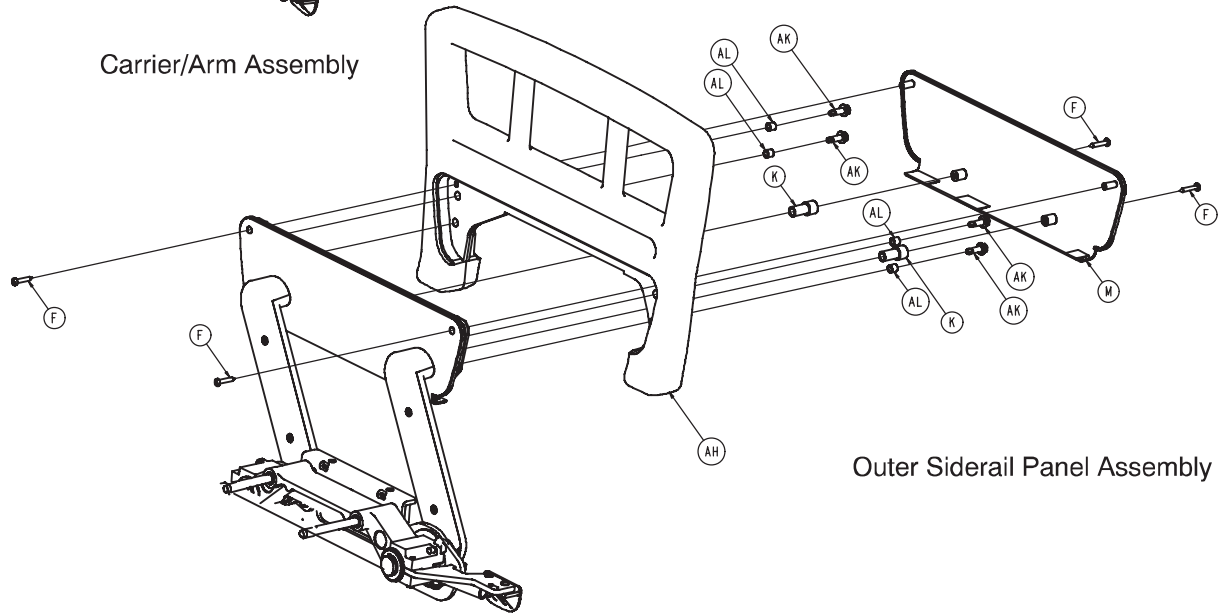

Outer Siderail Panel Assembly



# Foot End Siderail Assembly

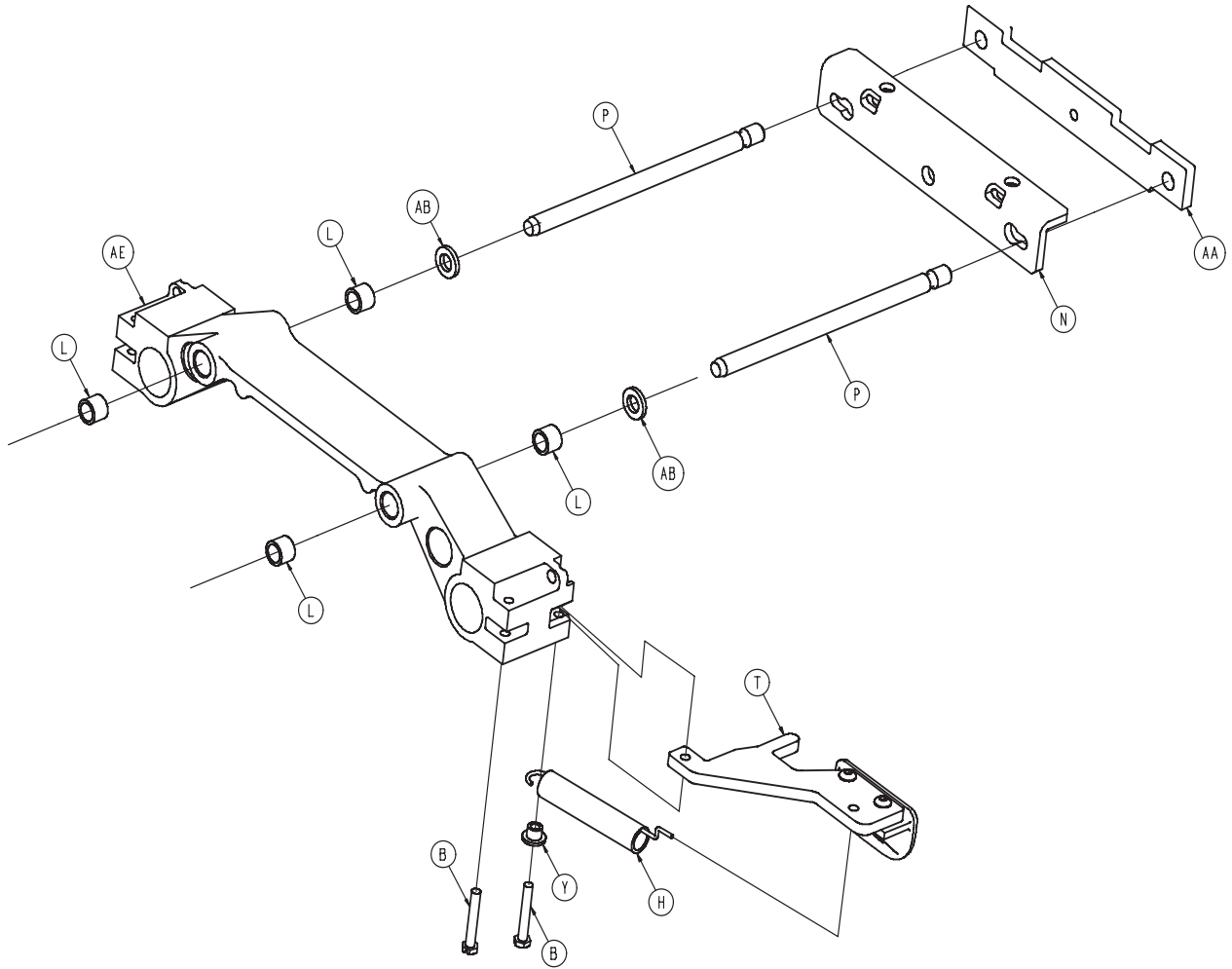

Carrier/Arm Assembly Left Foot End Siderail Shown



# Foot End Siderail Assembly

2032-401-305 Left Common Components				2032-401-405 Right Common Components			
Item	Part No.	Part Name	Qty.	Item	Part No.	Part Name	Qty.
A	0001-072-000	Ph. Flat Hd. Mach. Screw	4	A	0001-072-000	Ph. Flat Hd. Mach. Screw	4
B	0003-344-000	Hex Hd. Cap Screw	2	B	0003-344-000	Hex Hd. Cap Screw	2
C	0011-185-000	Washer	1	C	0011-185-000	Washer	1
D	0011-343-000	Shim Washer	3	D	0011-343-000	Shim Washer	3
E	0014-093-000	Washer	2	E1	0004-093-000	Washer	2
F	0023-090-000	Pan Hd. Tapping Screw	4	F	0023-090-000	Pan Hd. Tapping Screw	4
G	0028-128-000	Retaining Ring	6	G	0028-128-000	Retaining Ring	6
H	3000-200-334	Extension Spring	1	H	3000-200-334	Extension Spring	1
J	3000-400-513	Wear Bushing	2	J	3000-400-513	Wear Bushing	2
K	3000-400-523	Panel Spacer	2	K	3000-400-523	Panel Spacer	2
L	3000-400-557	Sleeve Bearing	4	L	3000-400-557	Sleeve Bearing	4
M	3001-400-527	Outer Rail	1	M	3001-400-527	Outer Rail	1
N	3001-400-555	Mounting Bracket	1	N	3001-400-555	Mounting Bracket	1
P	3001-400-564	Glide Rod	2	P	3001-400-564	Glide Rod	2
R	3001-400-619	Outer Arm Cover	2	R	3001-400-619	Outer Arm Cover	2
T	3002-400-055	Release Lever Ass'y, Lt.	1	T	3002-400-065	Release Lever Ass'y, Rt.	1
U	3002-400-090	Ball Detent Clip Ass'y	1	U	3002-400-090	Ball Detent Clip Ass'y	1
V	3002-400-501	Latch	1	V	3002-400-501	Latch	1
W	3002-400-505	Bypass Pin	1	W	3002-400-505	Bypass Pin	1
Y	3002-400-509	Bypass Bushing Spacer	1	Y	3002-400-509	Bypass Bushing Spacer	1
AA	3002-400-511	Glide Rod Bumper Pad	1	AA	3002-400-511	Glide Rod Bumper Pad	1
AB	3002-400-512	Bumper Washer	2	AB	3002-400-512	Bumper Washer	2
AC	3002-400-513	Pivot Bushing	6	AC	3002-400-513	Pivot Bushing	6
AD	3002-400-519	Latch Bushing	1	AD	3002-400-519	Latch Bushing	1
AE	3002-400-528	Siderail Carrier	1	AE	3002-400-528	Siderail Carrier	1
AF	3003-400-526	Inner Panel	1	AF	3003-400-526	Inner Panel	1
AG	2032-401-030	FE Timing Link Ass'y, LH	1	AG	2032-401-030	FE Timing Link Ass'y, LH	1
AH	3003-400-520	Foot Rail	1	AH	3003-400-520	Foot Rail	1
AJ	5000-020-005	Inner Arm Cover	2	AJ	5000-020-005	Inner Arm Cover	2
AK	0003-226-000	Hex Washer Head Screw	4	AK	0003-226-000	Hex Washer Head Screw	4
AL	3001-400-558	Spacer	4	AL	3001-400-558	Spacer	4
AM	3003-400-580	Weldment, FE Support Plate	1	AM	3003-400-580	Weldment, FE Support Plate	1

# Siderail Release Lever Assembly, Left - 3002-400-055

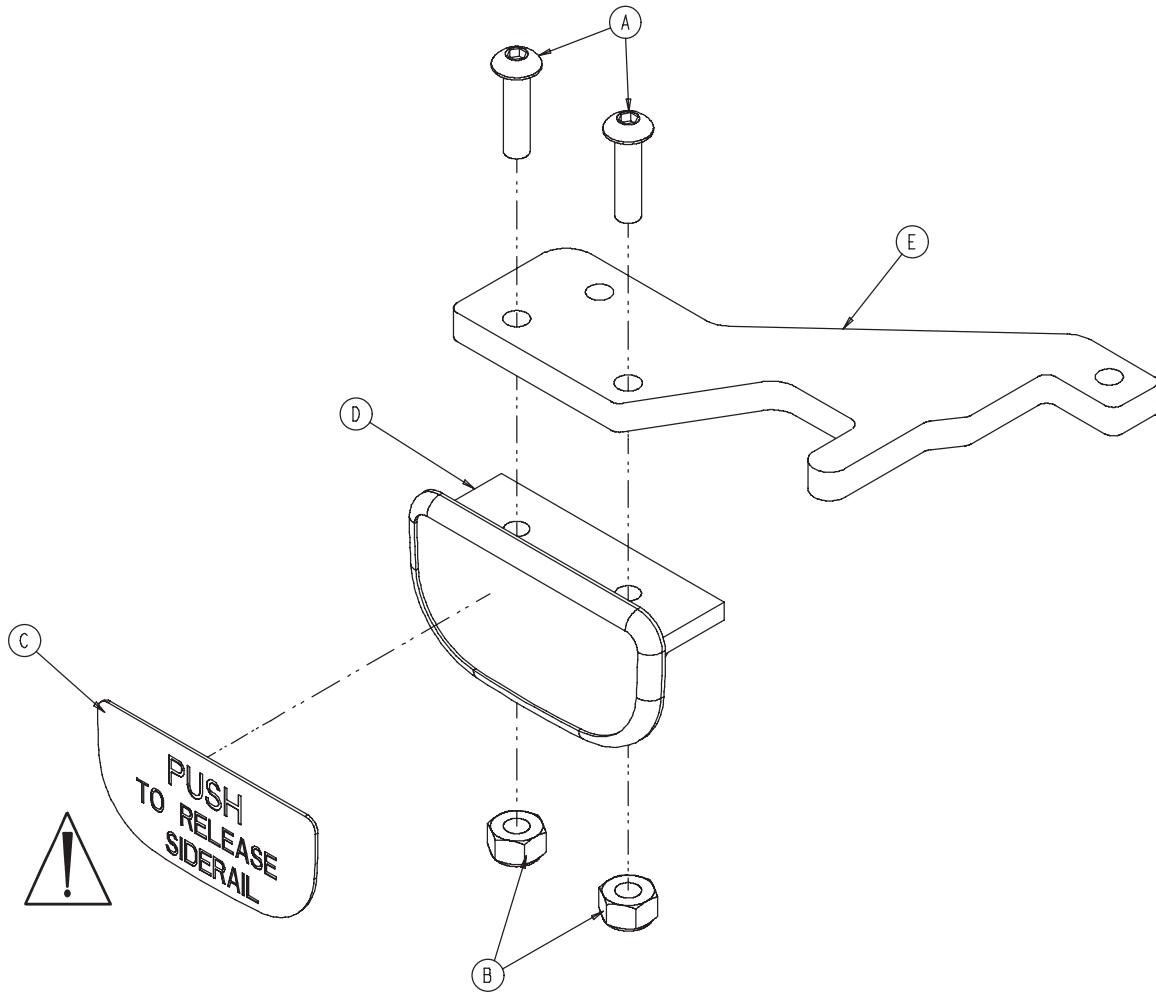

Item	Part No.	Part Name	Qty.
A	0004-278-000	Socket But. Hd. Cap Screw	2
B	0016-002-000	Hex Nut	2
C	3003-503-901	Release Label	1
D	3001-400-514	Release Lever Pad	1
E	3002-400-510	Release Lever	1

# Siderail Release Lever Assembly, Right - 3002-400-065

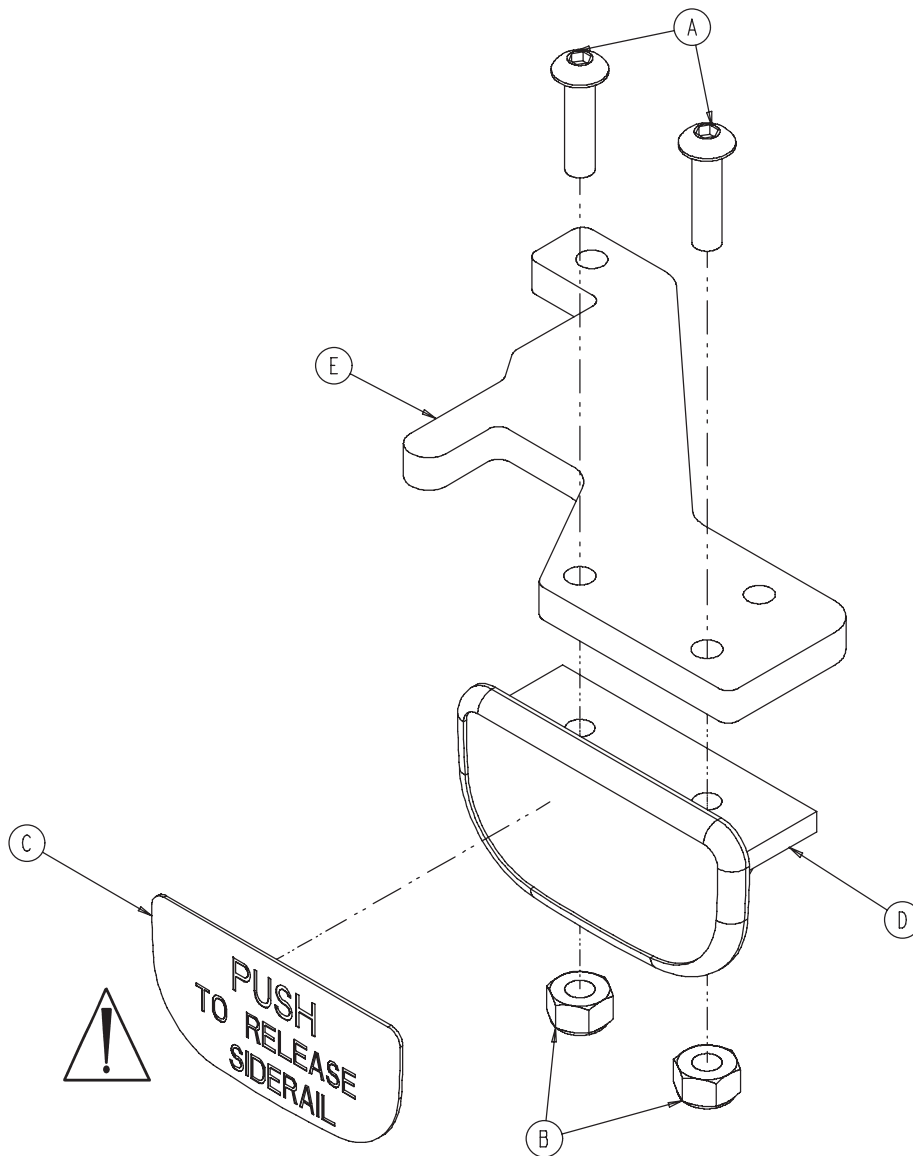

Item	Part No.	Part Name	Qty.
A	0004-278-000	Socket But. Hd. Cap Screw	2
B	0016-002-000	Hex Nut	2
C	3003-503-901	Release Label	1
D	3001-400-514	Release Lever Pad	1
E	3002-400-510	Release Lever	1

# Head Board Assembly - 2035-130-010

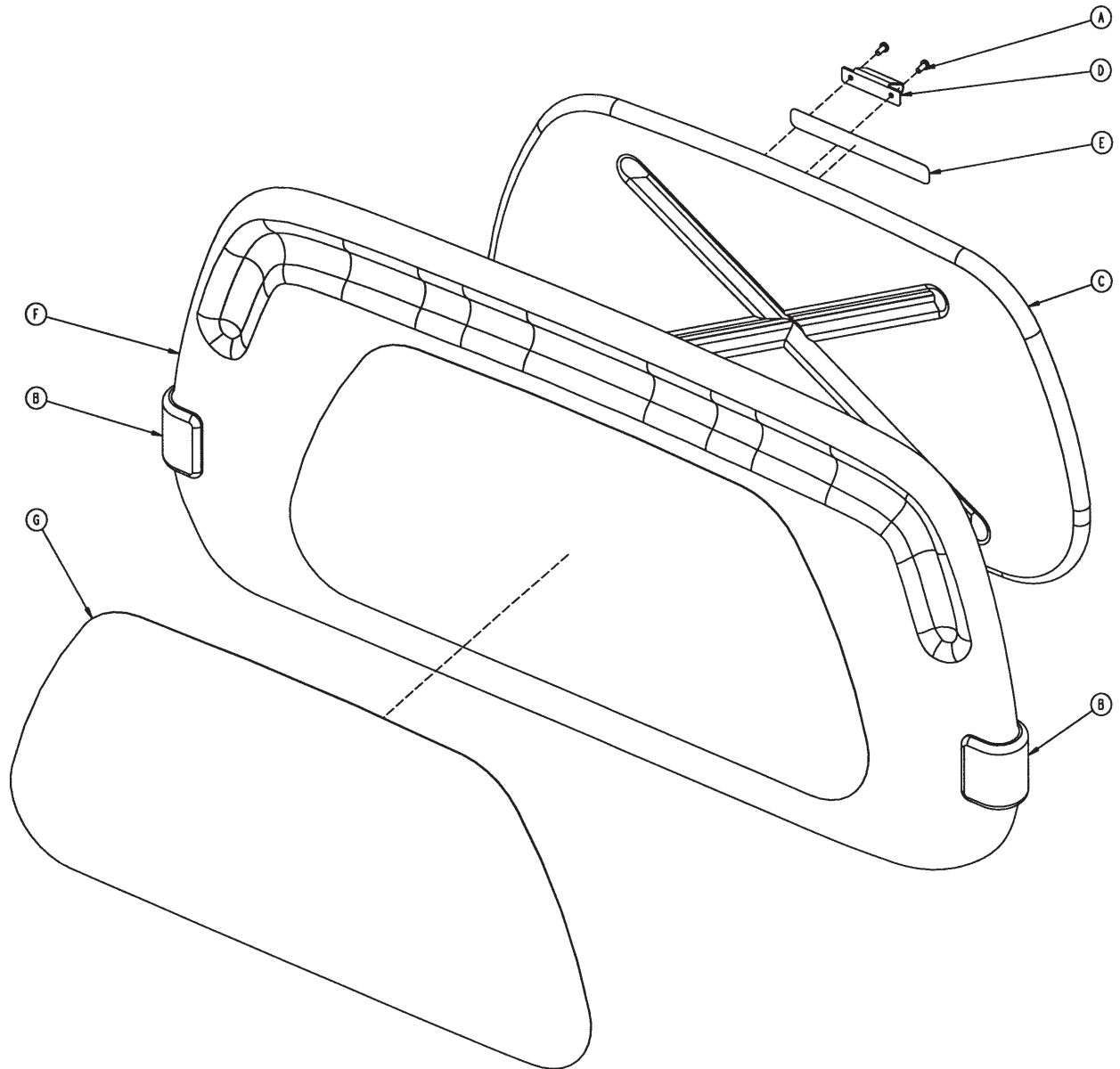

Item	Part No.	Part Name	Qty.
A	0023-088-000	Pan Hd. Screw	2
B	2035-500-007	Dark Blue "C" Bumper	2
C	3000-526-001	CPR Board	1
D	3000-526-002	CPR Board Clip	1
E	3000-526-003	CPR Board Label	1
F	3000-600-010	Head Board Clam Shell Ass'y	1
G	3000-600-056	Beige Head Board Laminate	1
H	0072-002-071	"C" Bumper Adhesive	N/A

# Foot Board Assembly and Options - 2035-135-010

part number 2030-000-151

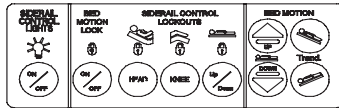

part number 2035-000-153



part number 2035-000-155

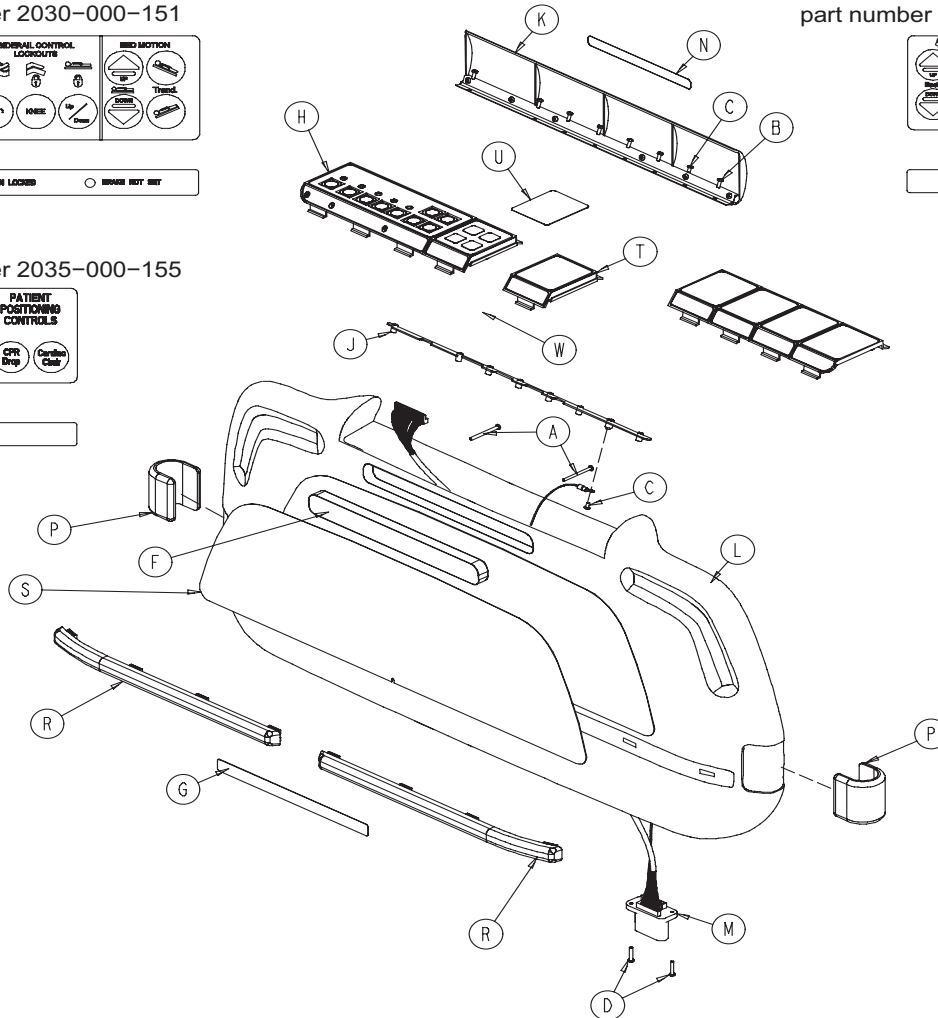

Item	Part No.	Part Name	Qty.
A	0023-099-000	Phil. Pan Hd. Tap. Screw	2
B	0023-103-000	Pan Hd. Hi/Lo Tap. Screw	7
C	0050-038-000	Pan Hd. Mach. Screw	2
D	0050-039-000	Pan Hd. Mach. Screw	2
E	0072-002-071	"C" Bumper Adhesive	.30
F	3000-500-008	Chart Rack Cover	1
G	3000-500-029	Hazard Label	1
H	2035-235-020	<a href="#">Main Module (pg.166)</a>	1
J	3001-500-064	Hinge Plate	1
K	3001-500-001	Lid Assembly	1
L	3001-500-010	Clamshell Assembly	1
M	3001-500-801	Foot Board Drawer Cable	1
N	3000-500-025	Lid Label	1
P	2035-500-007	Blue "C" Bumper	2
R	2035-500-008	Strip Bumper	2
S	3000-500-056	Beige Laminate	1
T	2025-136-021	<a href="#">E-Drop/Card. Ch. Module (pg.167)</a>	1
U	2035-000-155	E-Drop/Card. Ch. Label	1
W	2025-136-801	E-Drop/Card. Ch. Cable	1

[Return To Table of Contents](#)

# Foot Board No Scale/No Bed Exit - 2030-135-011

---

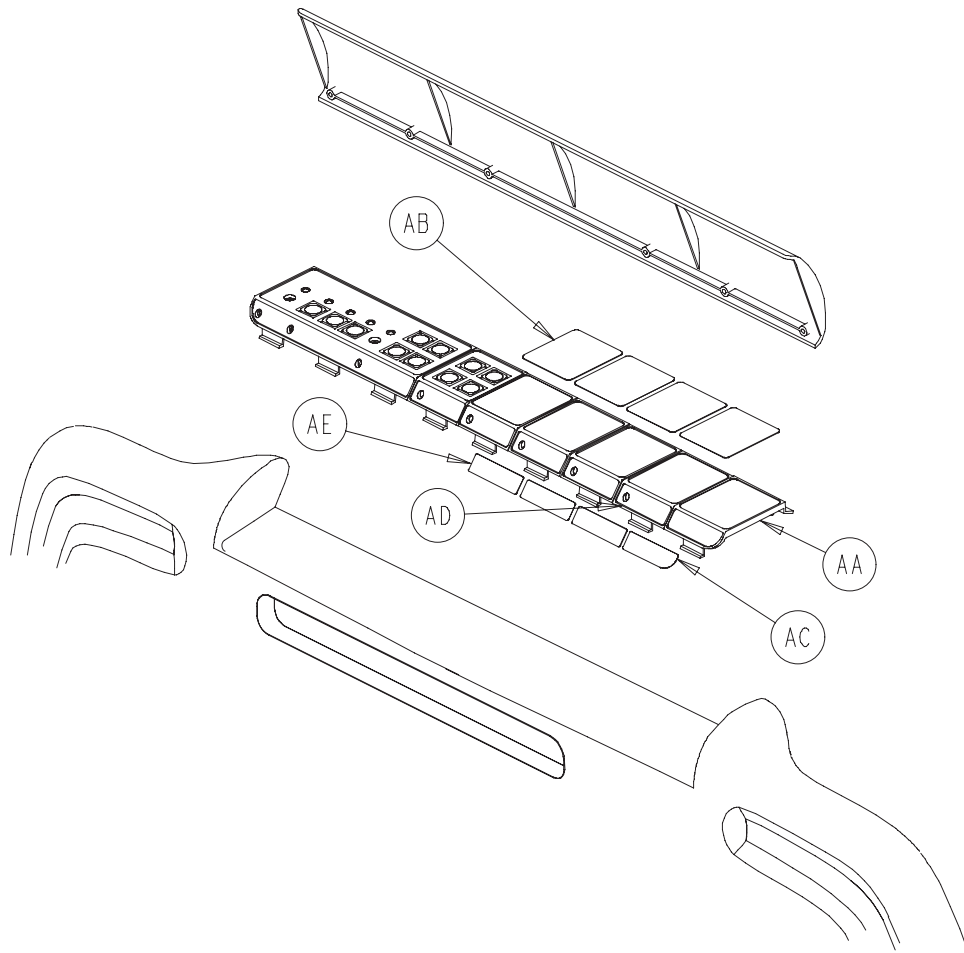

Item	Part No.	Part Name	Qty.
AA	3000-500-004	End Module	1
AB	2035-500-101	Foot Board Blank Label	4
AC	3000-500-027	Blank End Label	1
AD	3001-500-003	Blank Module	3
AE	3000-500-026	Blank Module Label	3



# Optional Foot Board Scale - 2030-015-013

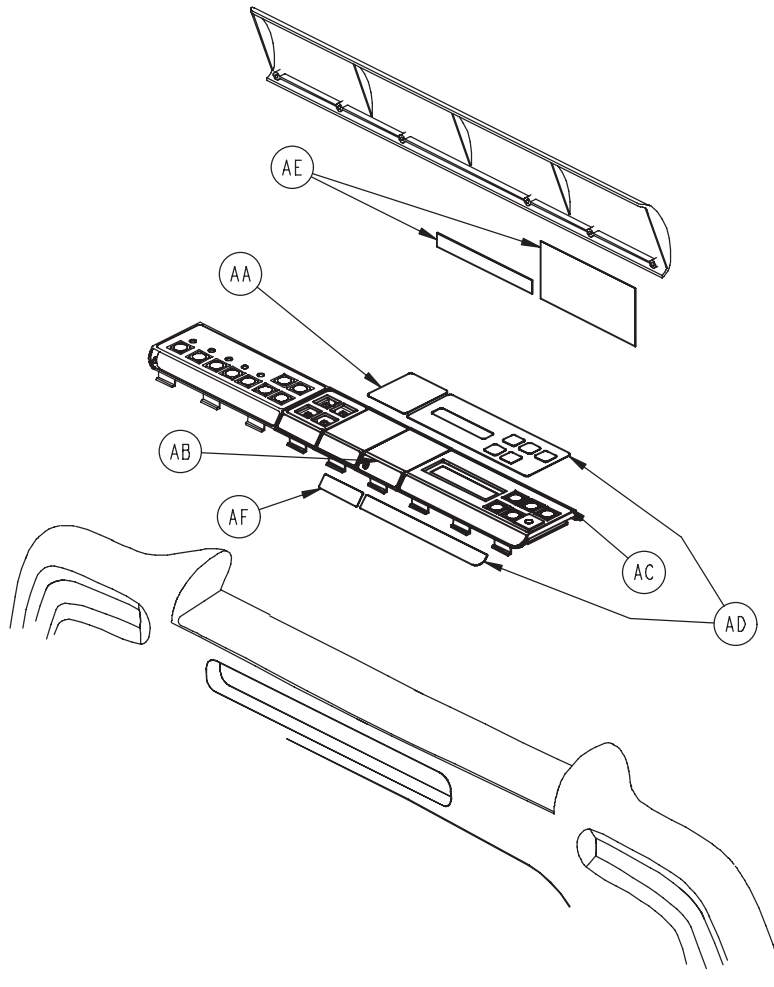

part number 2030-000-902

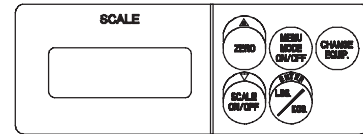

Item	Part No.	Part Name	Qty.
AA	2035-500-101	Foot Board Blank Label	1
AB	3001-500-003	Blank Module	1
AC	3002-015-001	Scale Module Assembly	1
AD	2030-000-902	Scale Module Label	1
AE	3002-507-011	Scale Lid Label	1
AF	3000-500-026	Blank Label	1

[Return To Table of Contents](#)

# Optional Foot Board Chaperone™ - 2030-135-012

part number 2030-000-154

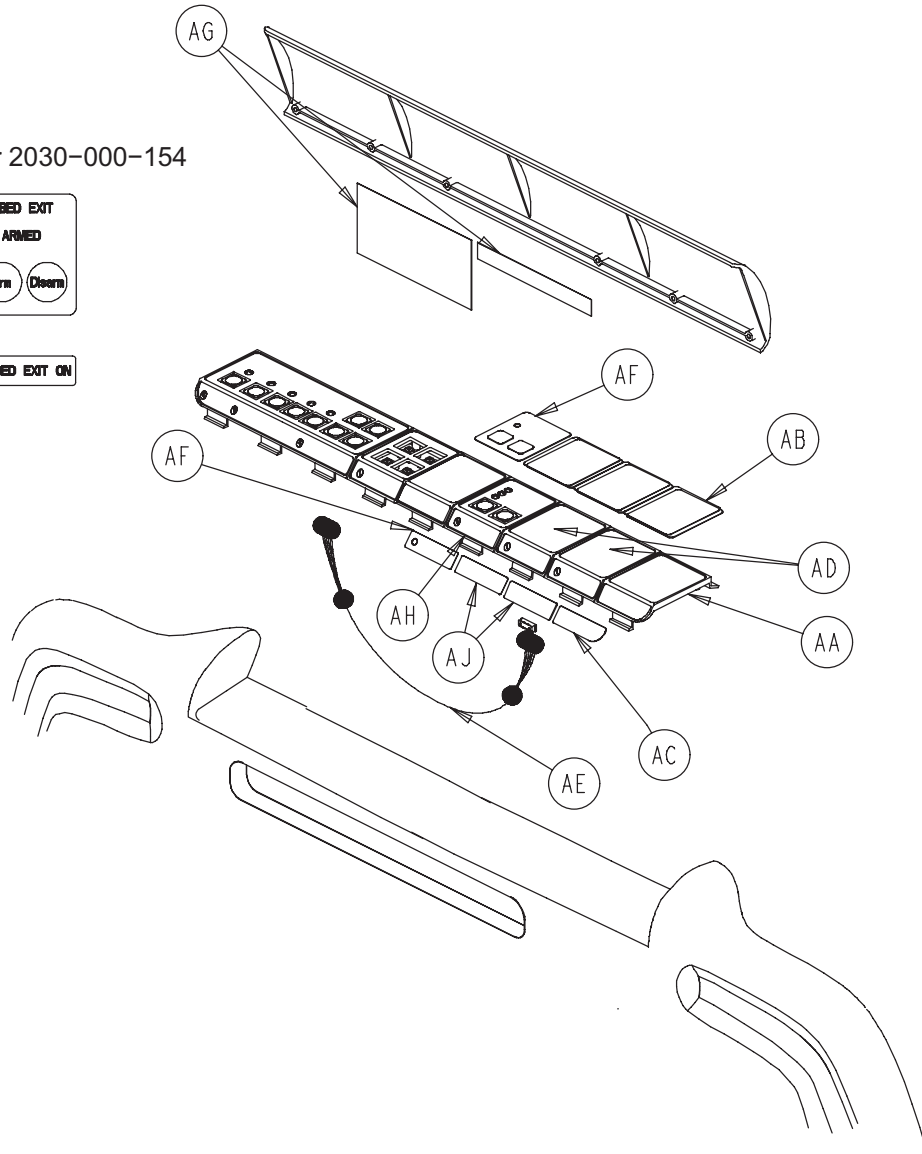

Item	Part No.	Part Name	Qty.
AA	3000-500-004	End Module	1
AB	2035-500-101	Foot Board Blank Label	3
AC	3000-500-027	Blank End Label	1
AD	3001-500-003	Blank Module	2
AE	3001-508-800	Bed Exit Keypad Cable	1
AF	2030-000-154	Bed Exit Label	1
AG	3002-508-010	Bed Exit Lid Label	1
AH	3001-508-030	<a href="#">Bed Exit Module Assembly (pg.168)</a>	1
AJ	3000-500-026	Blank Module Assembly	2

# Optional Foot Board Chaperone™ w/Zone Control - 2030-135-015

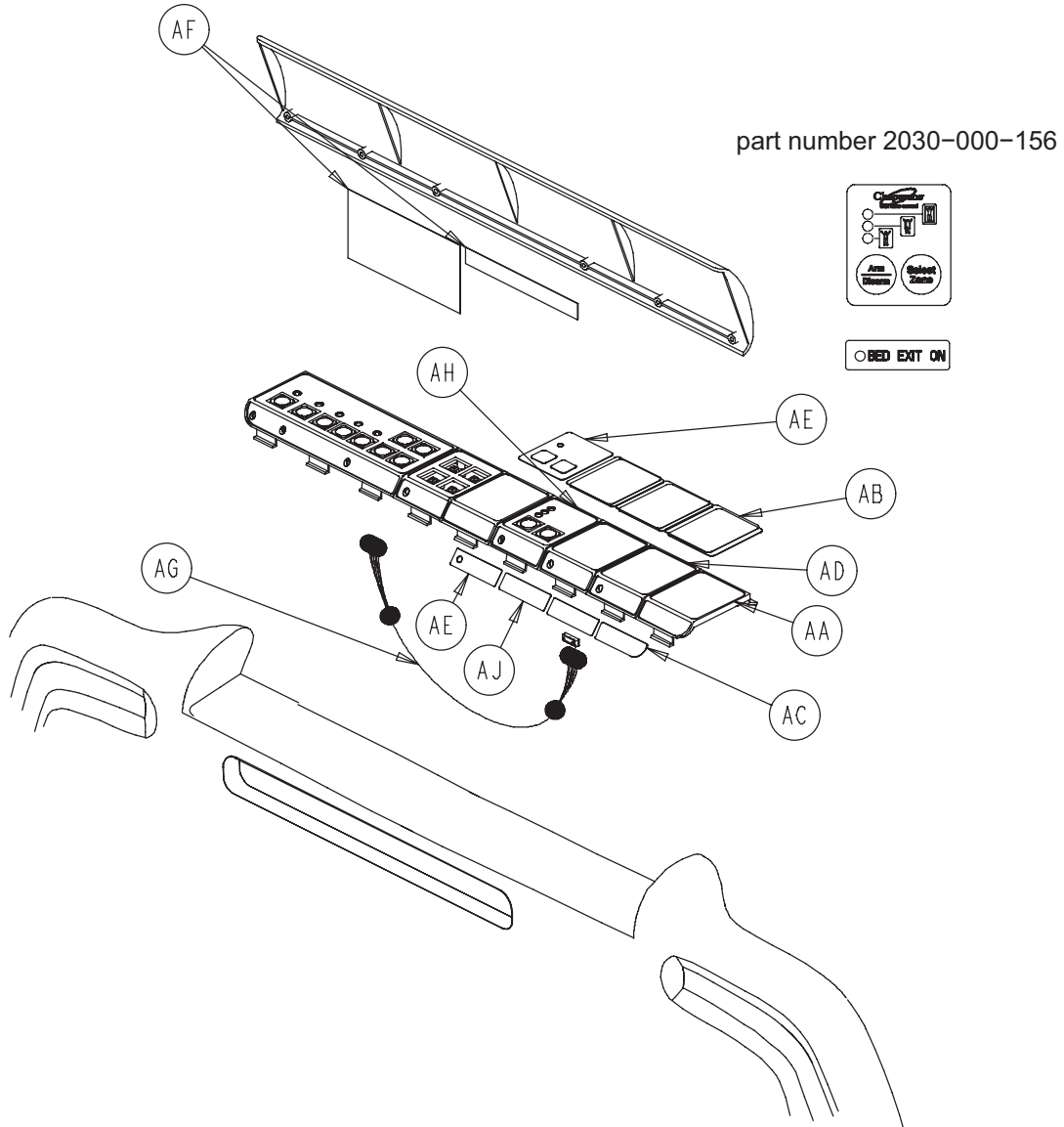

Item	Part No.	Part Name	Qty.
AA	3000-500-004	End Module	1
AB	2035-500-101	Foot Board Blank Label	3
AC	3000-500-027	Blank End Label	1
AD	3001-500-003	Blank Module	2
AE	2030-000-156	Chaperone II Module Label	1
AF	3002-508-012	Chaperone II Label	1
AG	3002-508-800	Zone Control Keypad Cable	1
AH	2035-111-000	<a href="#">Bed Exit Module Assembly (pg.169)</a>	1
AJ	3000-500-026	Blank Module Label	2

[Return To Table of Contents](#)

# Optional Foot Board Scale and Chaperone™ - 2030-015-014

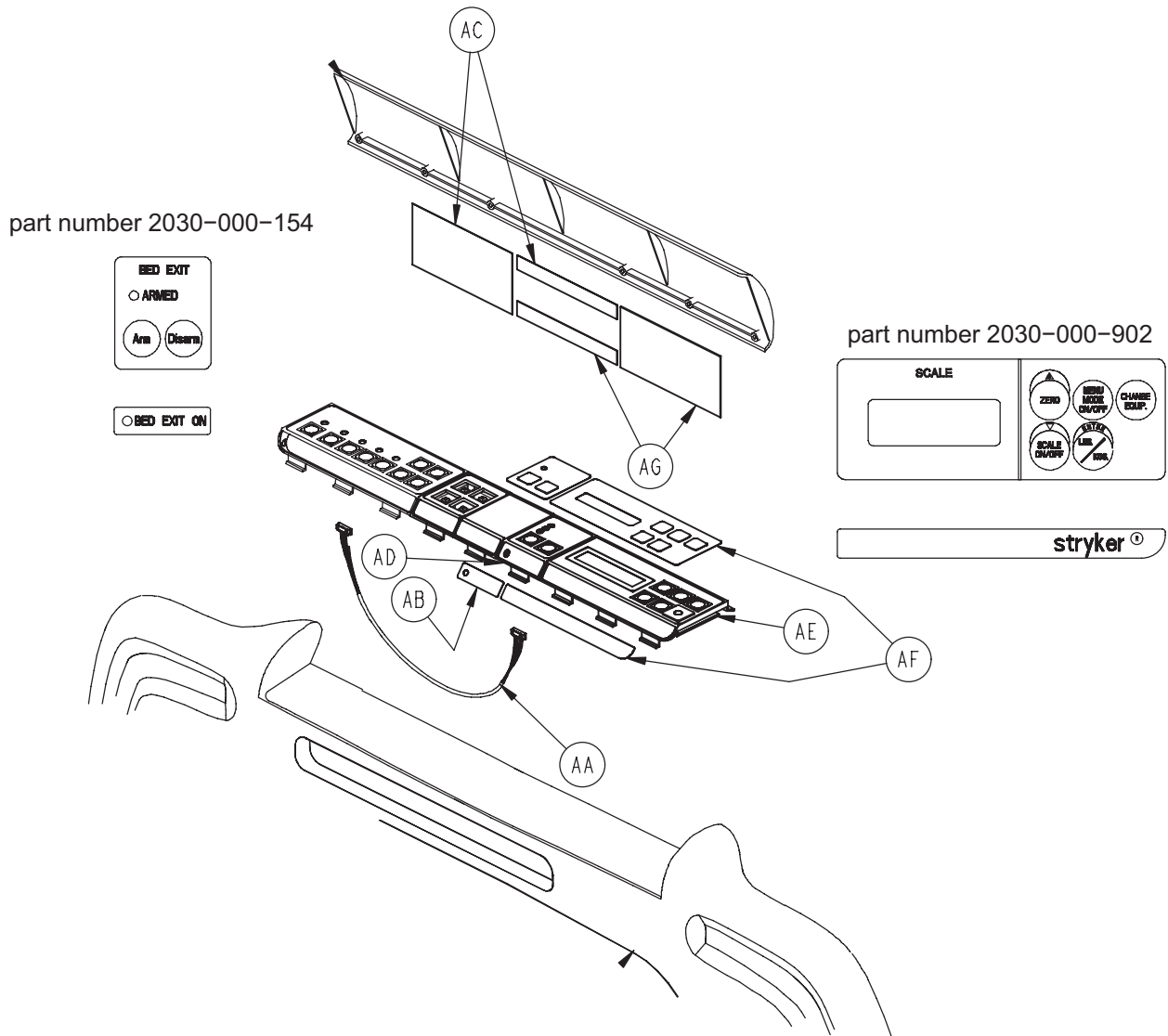

Item	Part No.	Part Name	Qty.
AA	3001-508-800	Bed Exit Keypad Cable	1
AB	2030-000-154	Bed Exit Label	1
AC	3002-508-010	Bed Exit Lid Label	1
AD	3001-508-030	<a href="#">Bed Exit Module Assembly (pg.168)</a>	1
AE	3002-015-001	<a href="#">Scale Module Assembly (pg.170)</a>	1
AF	2030-000-902	Scale Module Label	1
AG	3002-507-011	Scale Lid Label	1

# Opt. Foot Board Scale & Chaperone™ w/Zone Ctrl - 2030-015-016

part number 2030-000-156



○BED EXIT ON

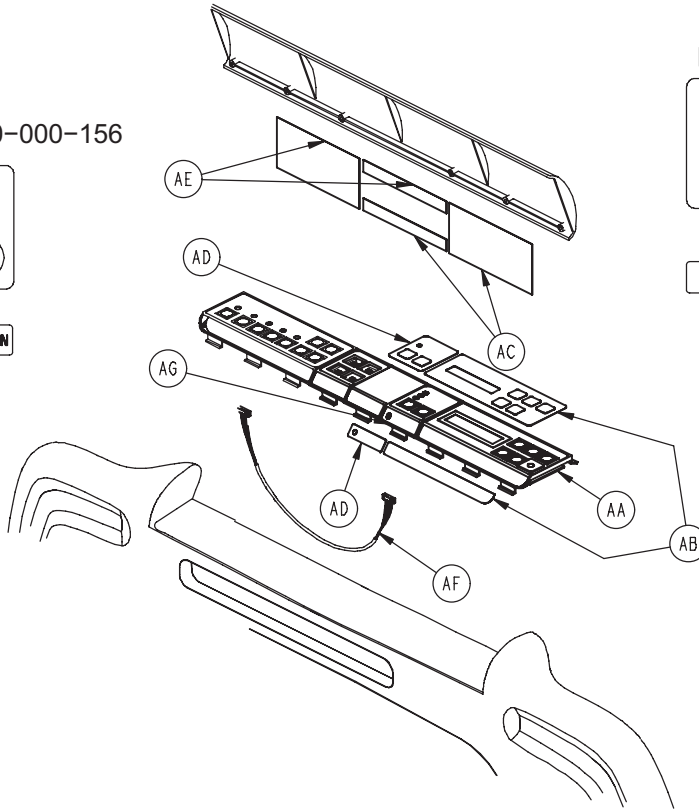

part number 2030-000-902

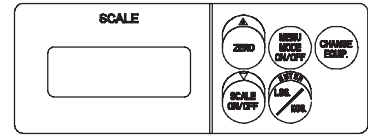

stryker®

Item	Part No.	Part Name	Qty.
AA	3002-015-001	<a href="#">Scale Module Assembly (pg.170)</a>	1
AB	2030-000-902	Scale Module Label	1
AC	3002-507-011	Scale Lid Label	1
AD	2030-000-156	Chaperone II Module Label	1
AE	3002-508-012	Chaperone II Label Lid	1
AF	3002-508-800	Zone Control Keypad Cable	1
AG	3001-508-030	<a href="#">Bed Exit Module Assembly (pg.169)</a>	1

[Return To Table of Contents](#)

# Foot Board Main Module Assembly - 2035-235-020

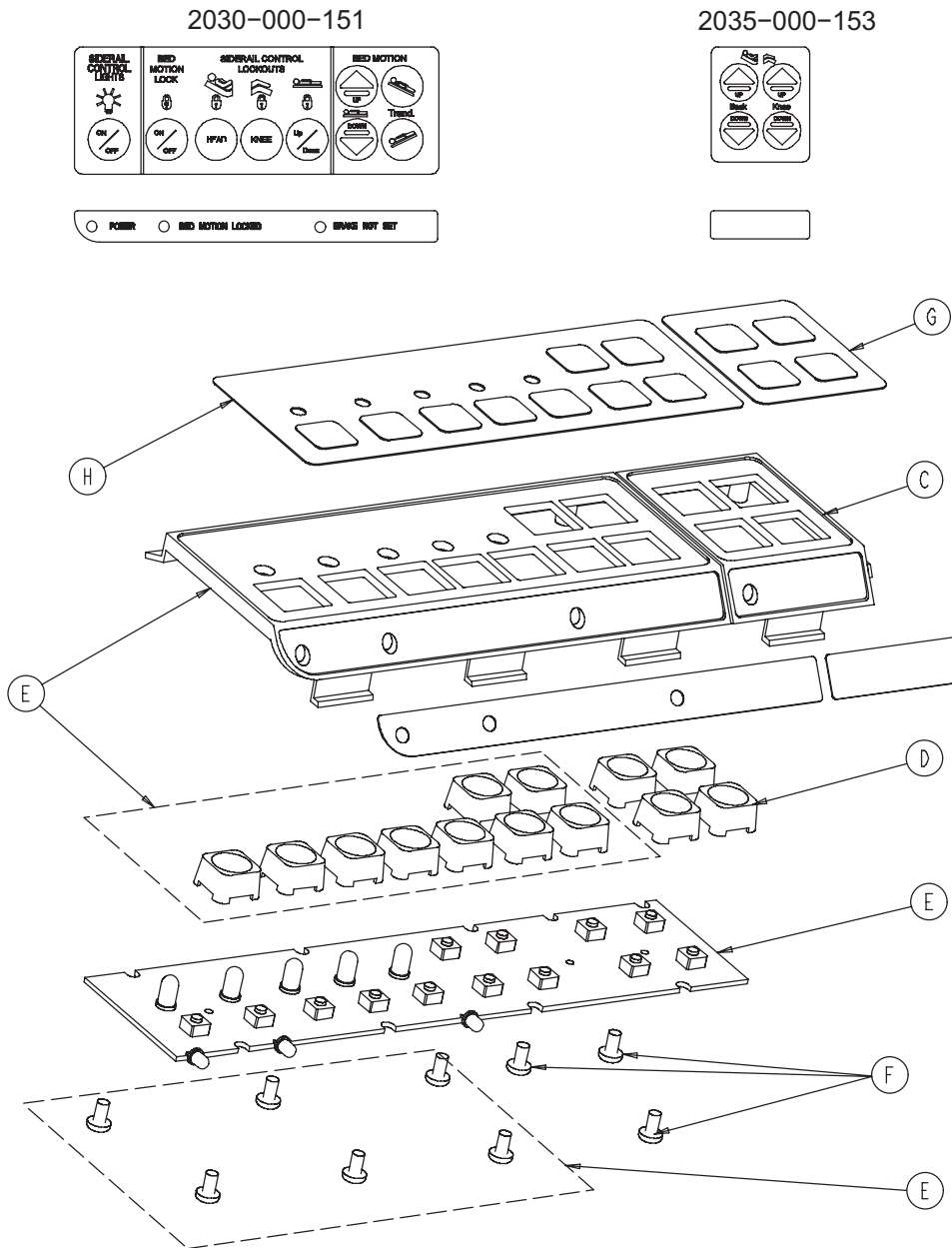

Item	Part No.	Part Name	Qty.
C	3000-501-001	Gatch/Fowler Module	1
D	3001-400-953	Switch Cap	4
E	3001-500-028	Foot Board Std. Module	1
F	0023-087-000	Pan Hd. Tapping Screw	3
G	2035-000-153	Gatch/Fowler Label	1
H	2030-000-151	Foot Board Std. Module Label	1

# Foot Board Emergency Drop/Card. Chair Module - 2025-136-021

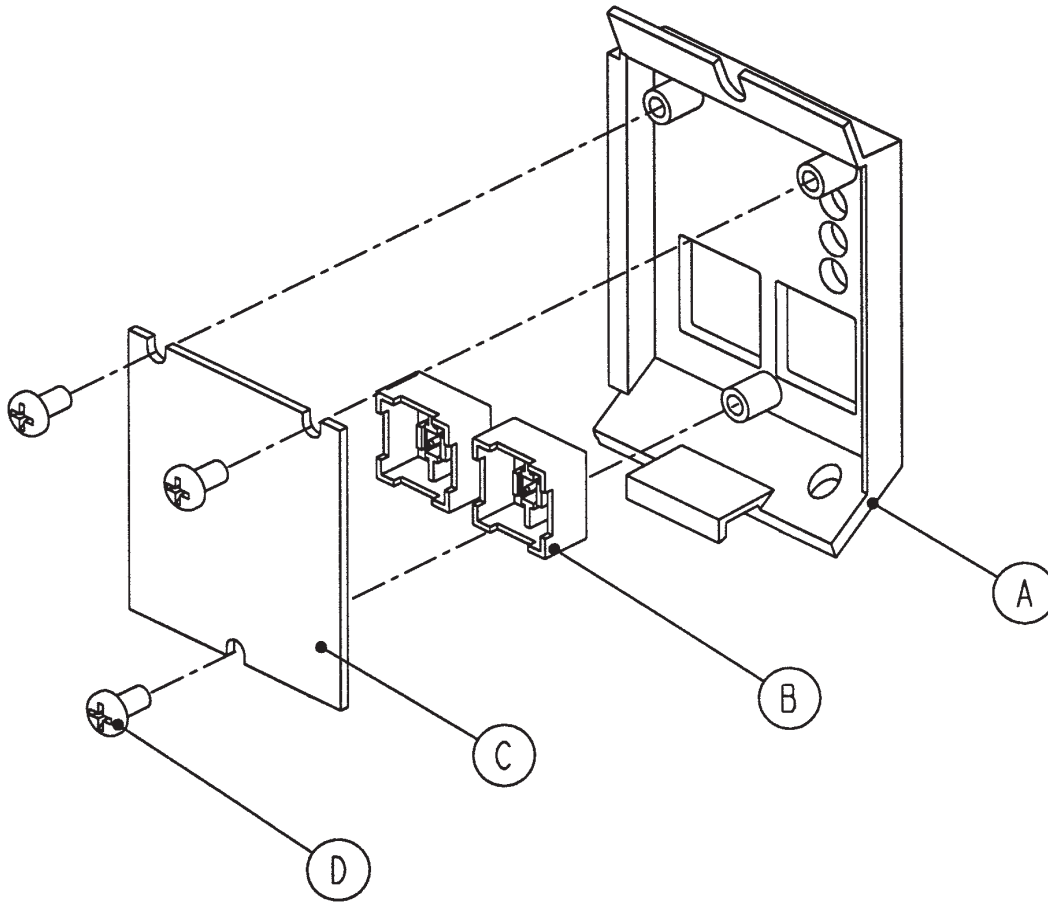

Item	Part No.	Part Name	Qty.
A	3000-508-001	Bed Exit Module Panel	1
B	3001-400-953	Switch Cap	2
C	2025-136-900	CPR Drop/Card. Ch. Keypad	1
D	0023-087-000	Hi-Low Tapping Screw	3

[Return To Table of Contents](#)

# Optional Foot Board Bed Exit Module - 3001-508-030

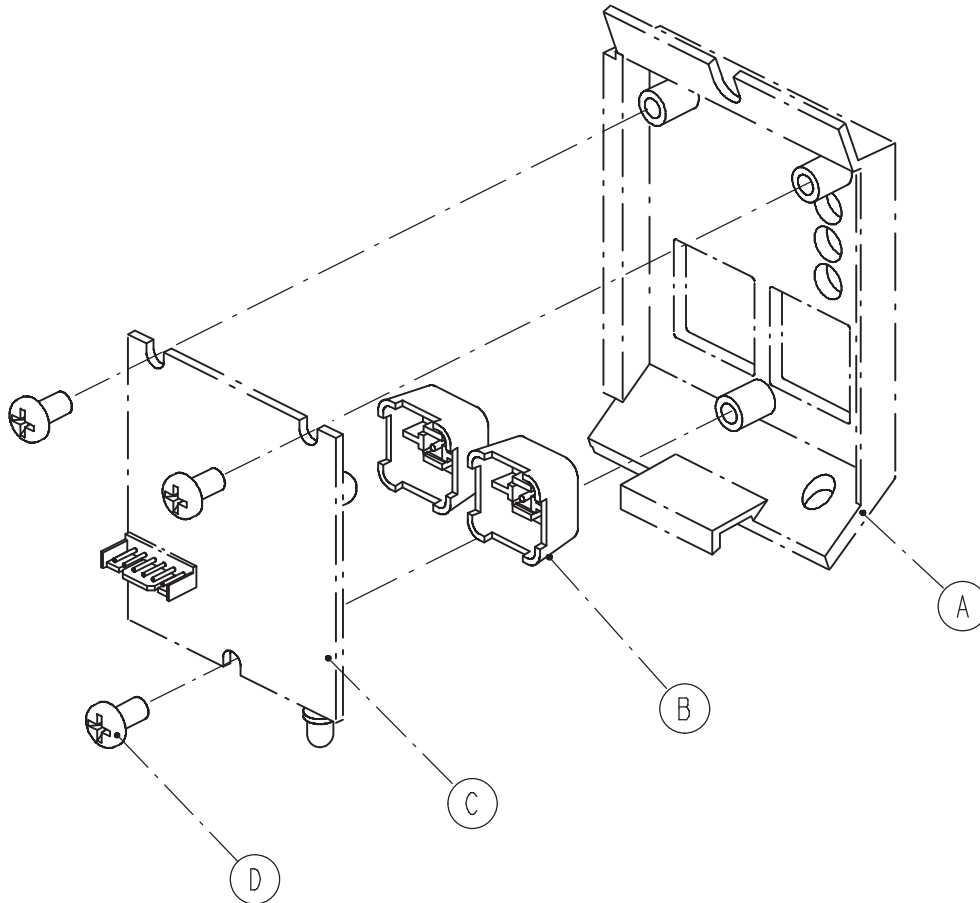

Item	Part No.	Part Name	Qty.
A	3000-508-001	Bed Exit Module Panel	1
B	3001-400-953	Switch Cap	2
C	3001-508-910	Bed Exit Keypad Ass'y	1
D	0023-087-000	Hi-Low Tapping Screw	3



# Optional Foot Board Zone Bed Exit Module - 3002-508-030

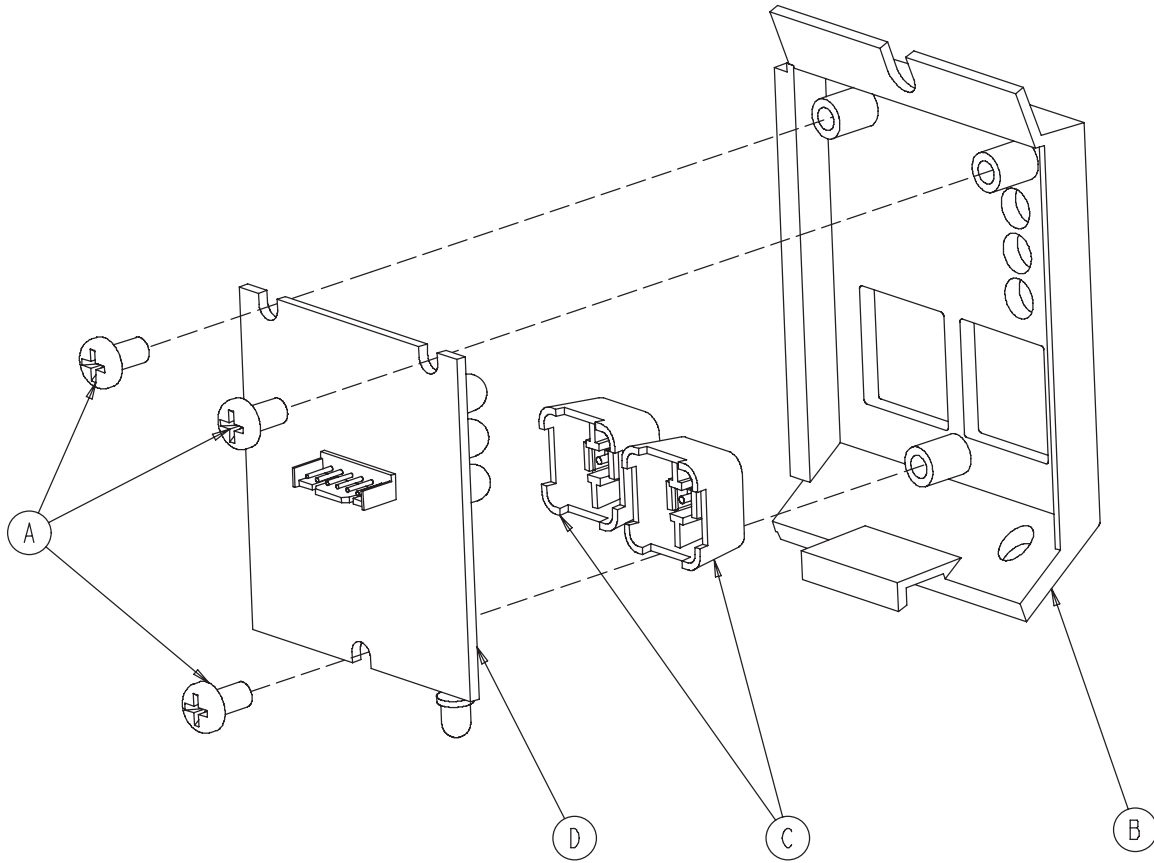

Item	Part No.	Part Name	Qty.
A	0023-087-000	Hi-Low Tapping Screw	3
B	3000-508-001	End Exit Module Panel	1
C	3001-400-953	Switch Cap	2
D	3002-508-900	Bed Exit Board	1

[Return To Table of Contents](#)

# Optional Foot Board Scale Module Assembly - 3002-015-001

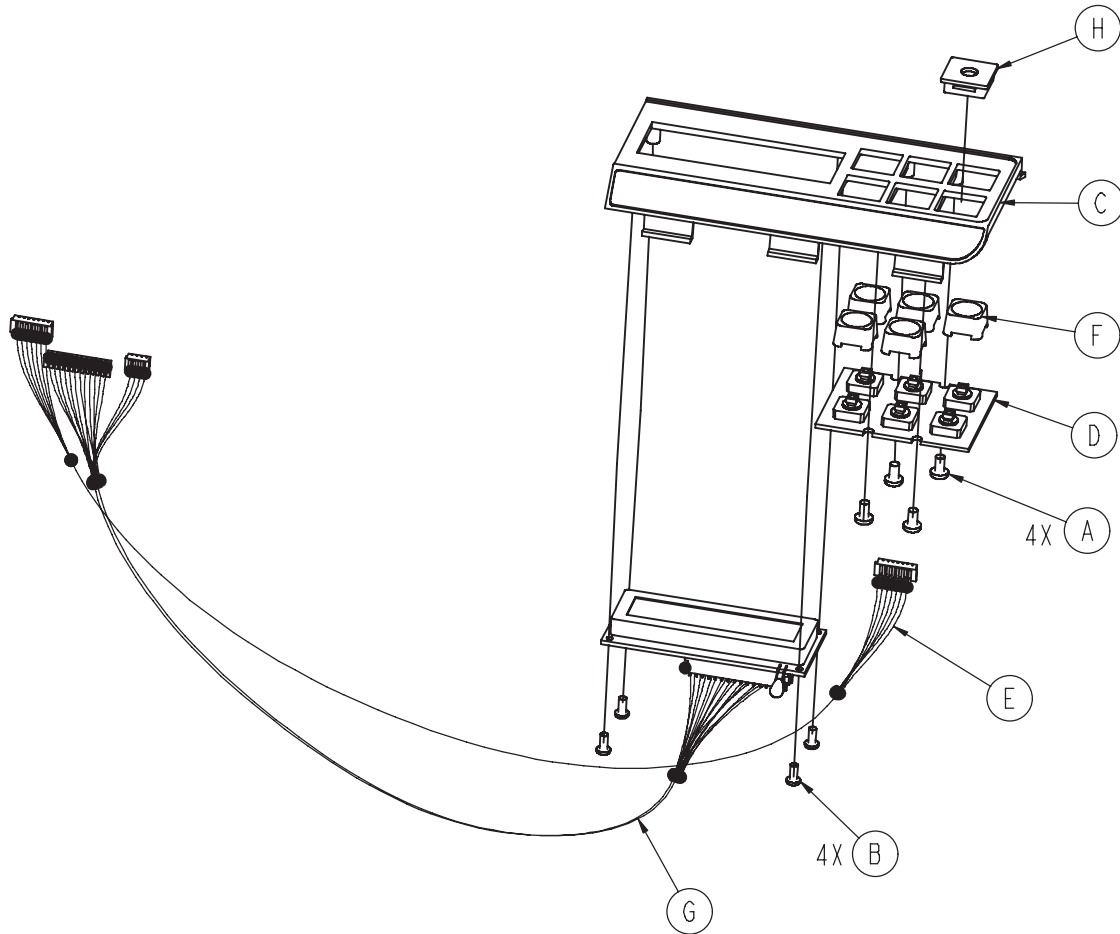

Item	Part No.	Part Name	Qty.
A	0023-087-000	Pan Hd. Hi-Lo Tapping Screw	4
B	0023-091-000	Pan Hd. Hi-Lo Tapping Screw	4
C	3001-507-001	Scale Module	1
D	3001-507-910	Scale Keypad	1
E	3001-507-800	Scale Keypad Cable	1
F	3001-400-953	Switch Cap	5
G	3002-507-900	Scale Display Cable	1
H	3001-400-552	Filler Cap	1

# Optional Removable I.V. Pole Assembly - 3000-300-080

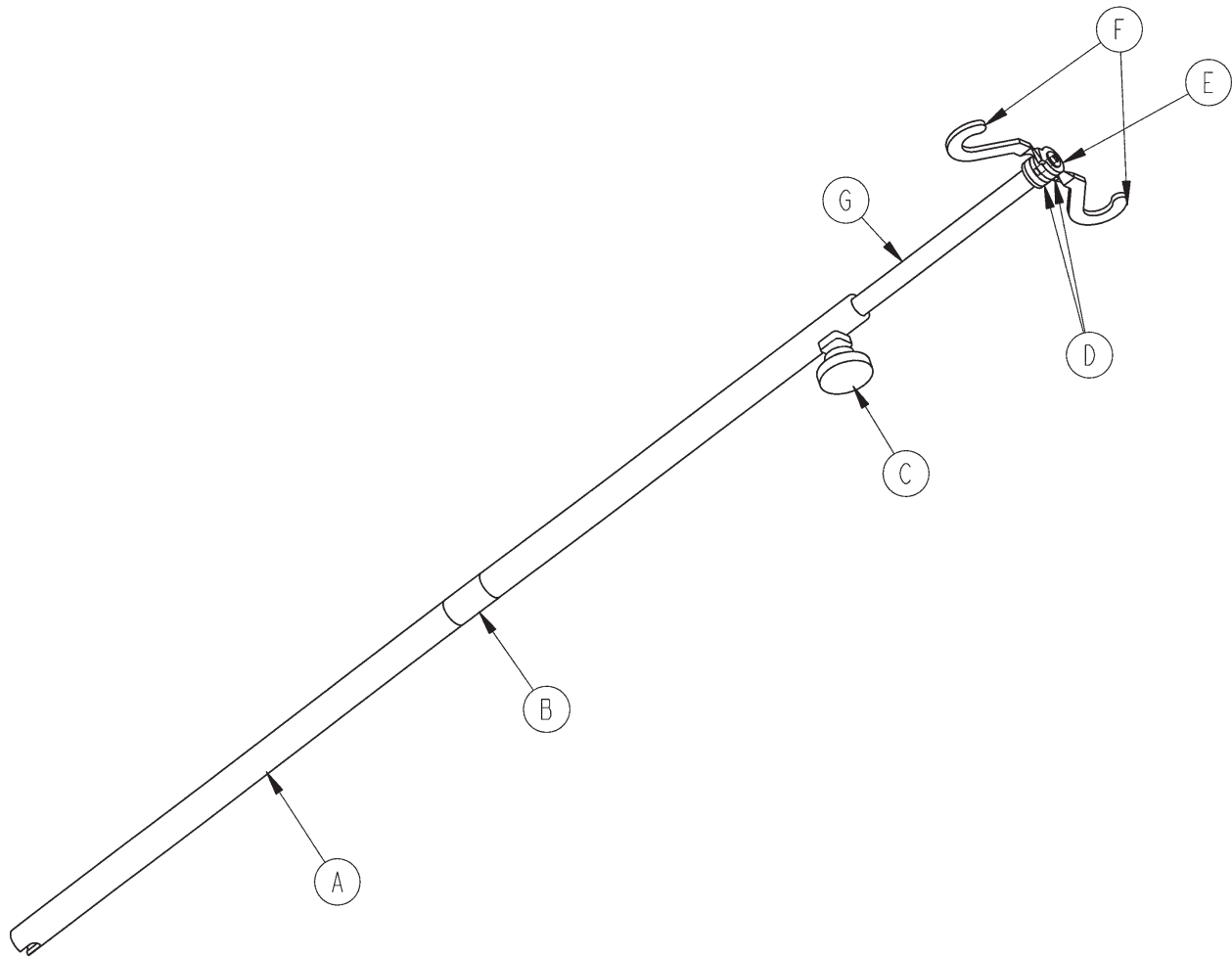

Item	Part No.	Part Name	Qty.
A	3000-300-081	Outer Tube	1
B	3000-300-089	Label	1
C	0024-050-000	Fluted Knob	1
D	0052-017-000	Spacer	2
E	0007-040-000	Phillips Truss Hd. Screw	1
F	1010-059-016	I.V. Hook	2
G	3000-300-085	Inner Tube Assembly	1

[Return To Table of Contents](#)

# Optional 2 Stage I.V. Mounting Assembly - 2035-111-000

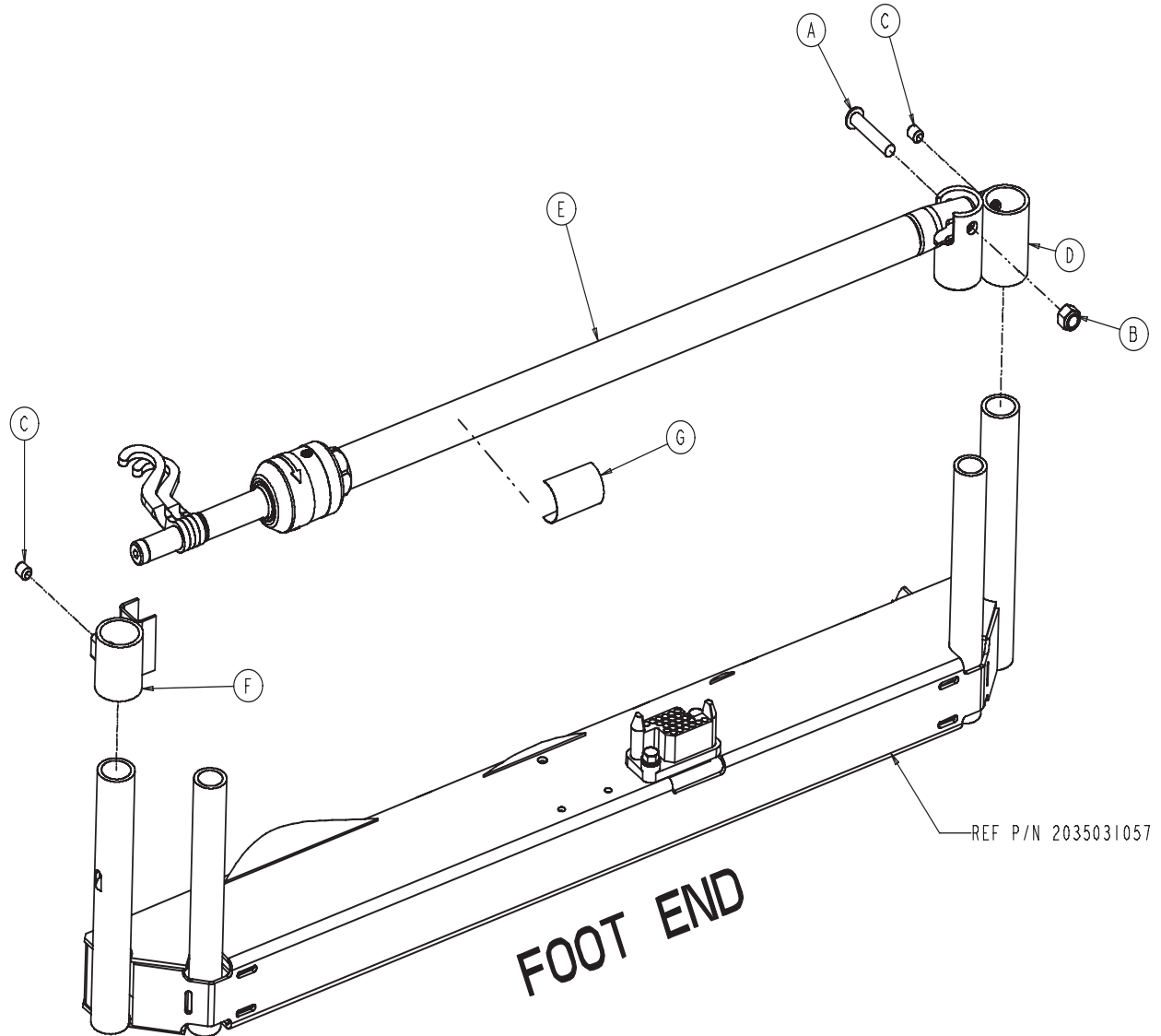

Item	Part No.	Part Name	Qty.
A	0004-199-000	But. Hd. Cap Screw	1
B	0016-036-000	Flexlock Nut	1
C	0021-140-000	Set Screw	2
D	2035-111-001	I.V. Receptacle, Foot, Left	1
E	2035-112-010	I.V. Pole Assembly, Left	1
F	3000-312-035	I.V. Cradle	1
G	2035-112-110	Specification Label	1

# Optional Head End 2-Stage I.V. Assembly - 2035-112-000

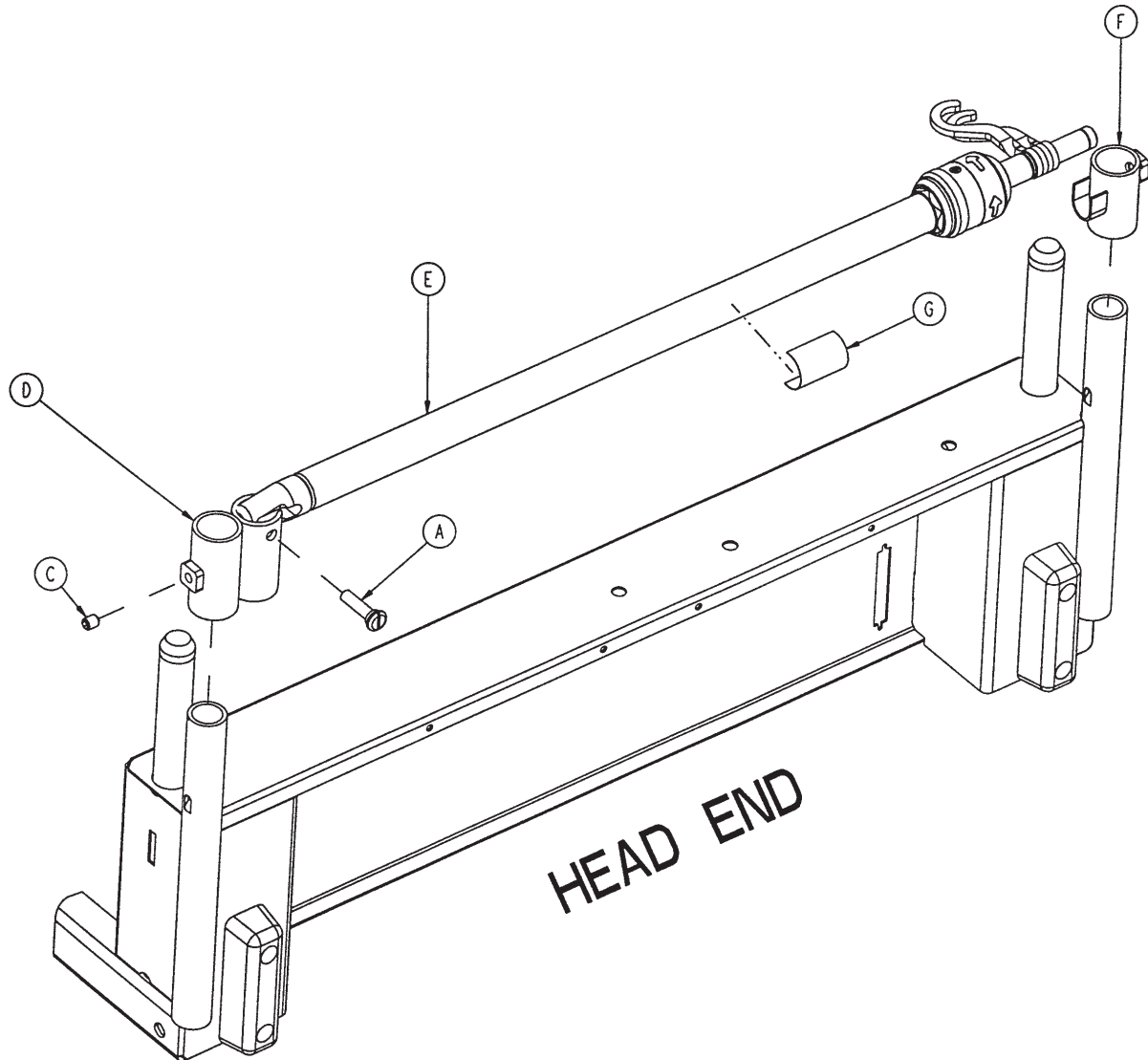

Item	Part No.	Part Name	Qty.
A	1015-024-035	Retaining Pin	1
C	0021-140-000	Set Screw	2
D	2035-112-001	I.V. Receptacle, Head, Left	1
E	2035-112-010	I.V. Pole Assembly, Left	1
F	3000-311-016	I.V. Rest	1
G	2035-112-110	Specification Label	1

# Optional Dual Head End I.V. Assembly - 2040-110-003

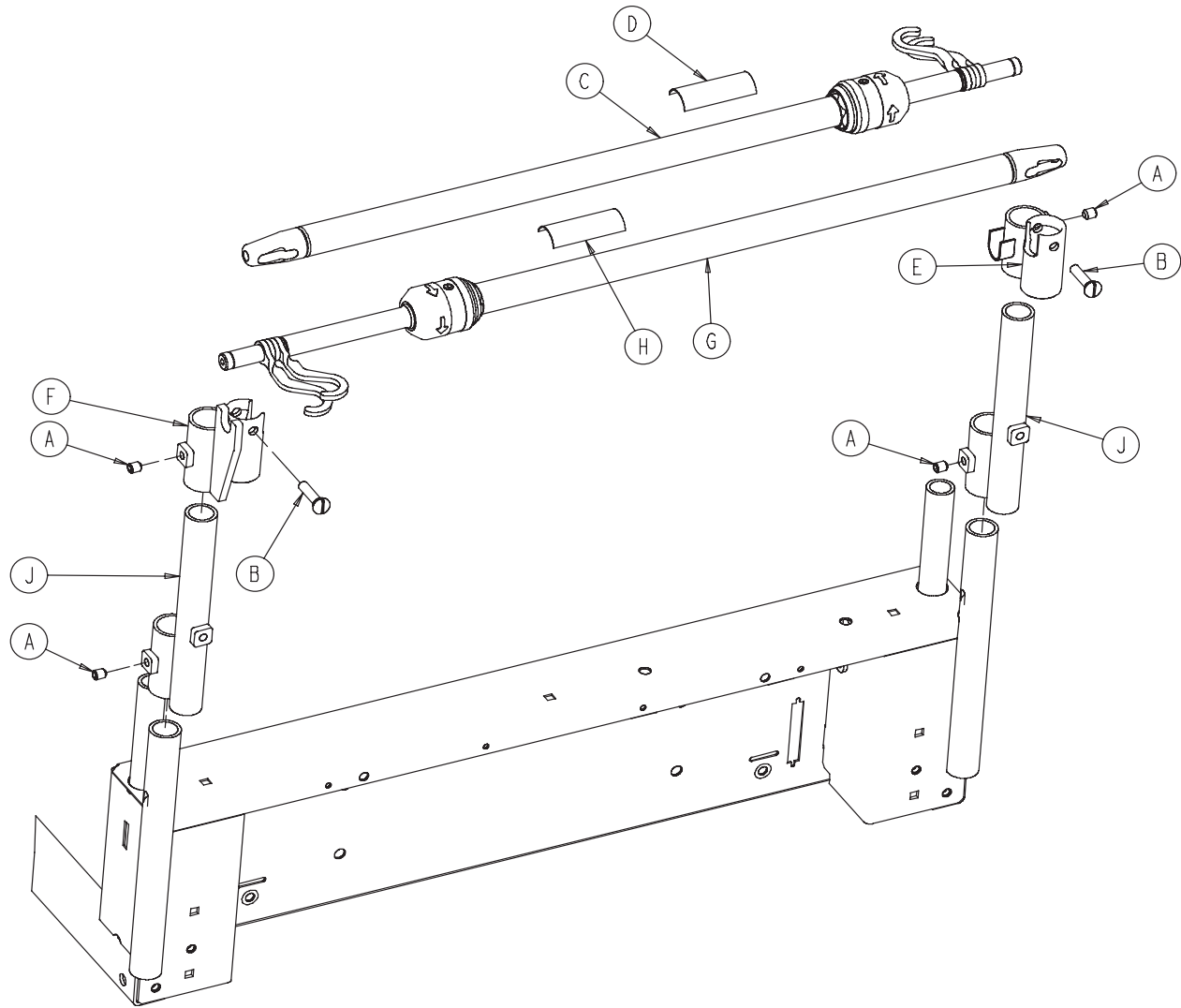

Item	Part No.	Part Name	Qty.
A	0021-140-000	Set Screw	4
B	1015-024-035	Retaining Pin	2
C	2035-112-010	I.V. Pole Assembly, Left	1
D	2035-112-110	Specification Label	1
E	2035-113-002	I.V. Receptacle, Dual Hd. End, Rt.	1
F	2035-113-001	I.V. Receptacle, Dual Hd. End, Lt.	1
G	2035-113-011	I.V. Pole Assembly, Right	1
H	2035-113-111	Specification Label	1
J	2040-110-002	I.V. Pole Extension	2

## 2 Stage I.V. Pole - 2035-112-010 & 2035-113-011

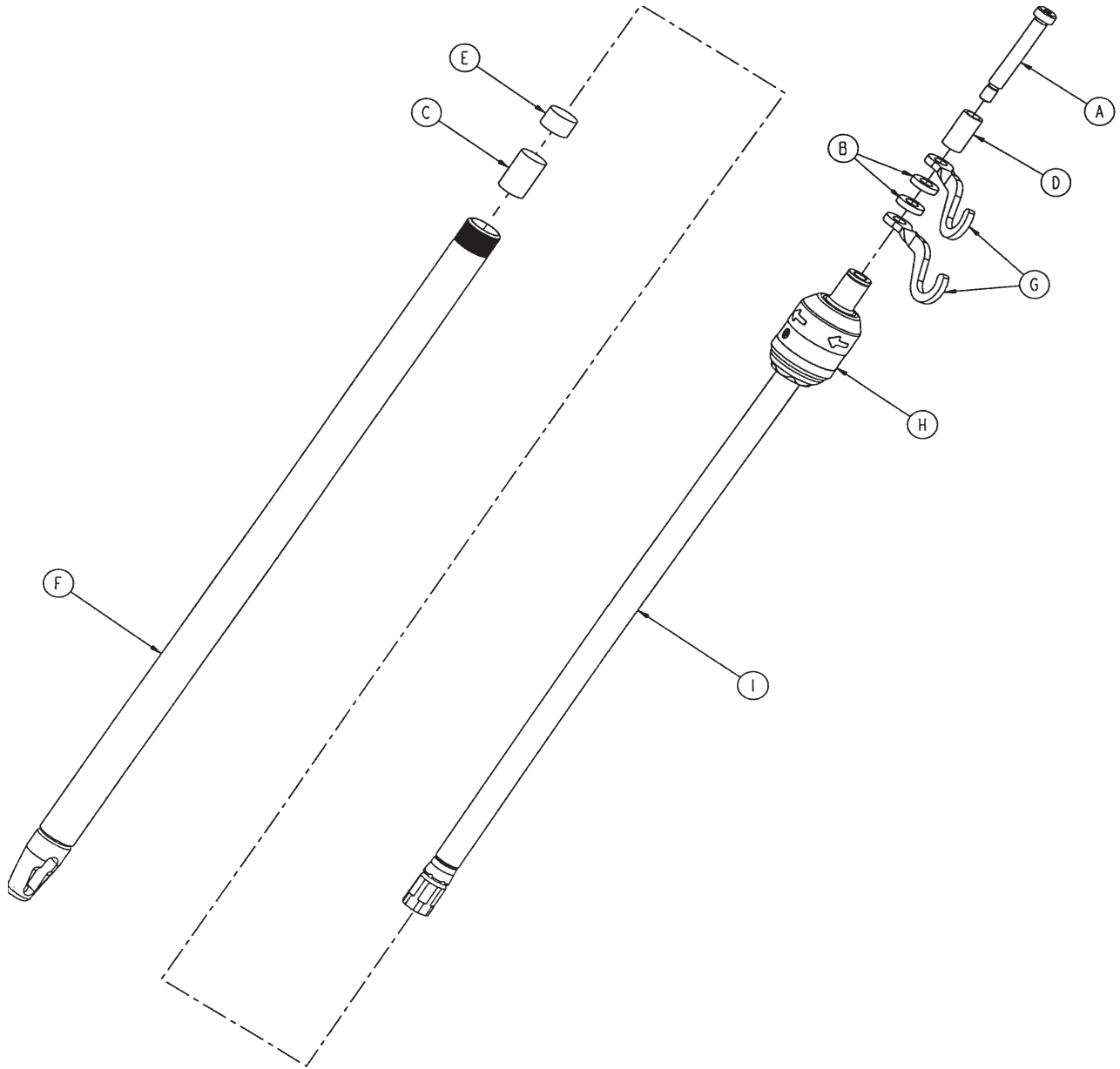

**2035-112-010 Head End, Left**

**2035-113-011 Foot End, Right**

Item	Part No.	Part Name	Qty.	Item	Part No.	Part Name	Qty.
A	0008-031-000	Soc. Hd. Shoulder Screw	1	A	0008-031-000	Soc. Hd. Shoulder Screw	1
B	0052-017-000	Washer	2	B	0052-017-000	Washer	2
C	0052-310-000	Spacer	1	C	0052-311-000	Spacer	1
D	0926-400-162	Spacer	1	D	0926-400-162	Spacer	1
E	1001-259-013	Dampener	1	E	1001-259-013	Dampener	1
F	1001-259-032	Base Tube Weldment	1	F	1001-259-032	Base Tube Weldment	1
G	1010-259-016	I.V. Hook	2	G	1010-259-106	I.V. Hook	2
H	0785-035-103	I.V. Pole Latch	1	H	0785-035-103	I.V. Pole Latch	1
I	1211-110-029	2nd Stage Assembly	1	I	1211-110-029	2nd Stage Assembly	1

[Return To Table of Contents](#)

# I.V. Pole Latch Assembly - 0785-035-103

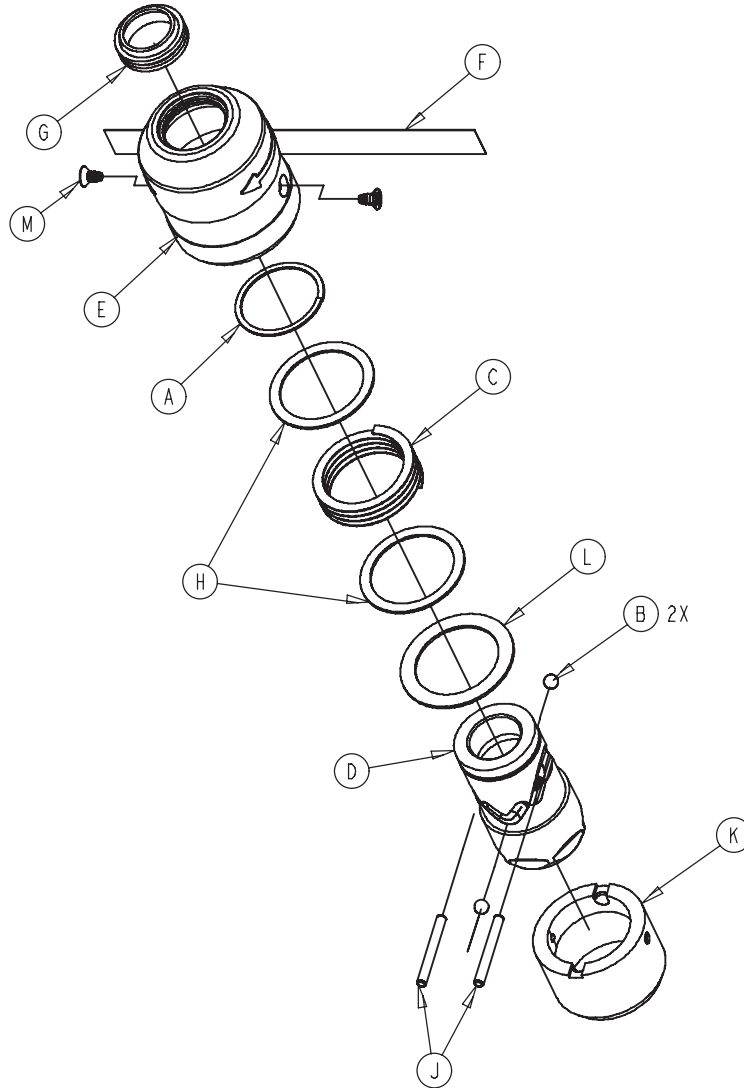

Item	Part No.	Part Name	Qty.
A	0028-167-000	Retaining Ring	1
B	0031-004-000	Steel Ball	2
C	0038-392-000	Wave Spring	1
D	0785-035-023	I.V. Latch ID Housing	1
E	0785-035-024	I.V. Latch OD Housing	1
F	0785-035-029	I.V. Release Label	2
G	1211-011-018	I.V. Latch Seal	2
H	1211-110-020	Washer	2
J	1211-110-021	I.V. Latch Locking Pin	2
K	1211-110-022	I.V. Latch Guide	1
L	1211-110-035	Washer	1
M	1211-110-036	Self-Tapping Screw	2



# Optional X-Ray Cassette Tray Assembly - 2035-140-000

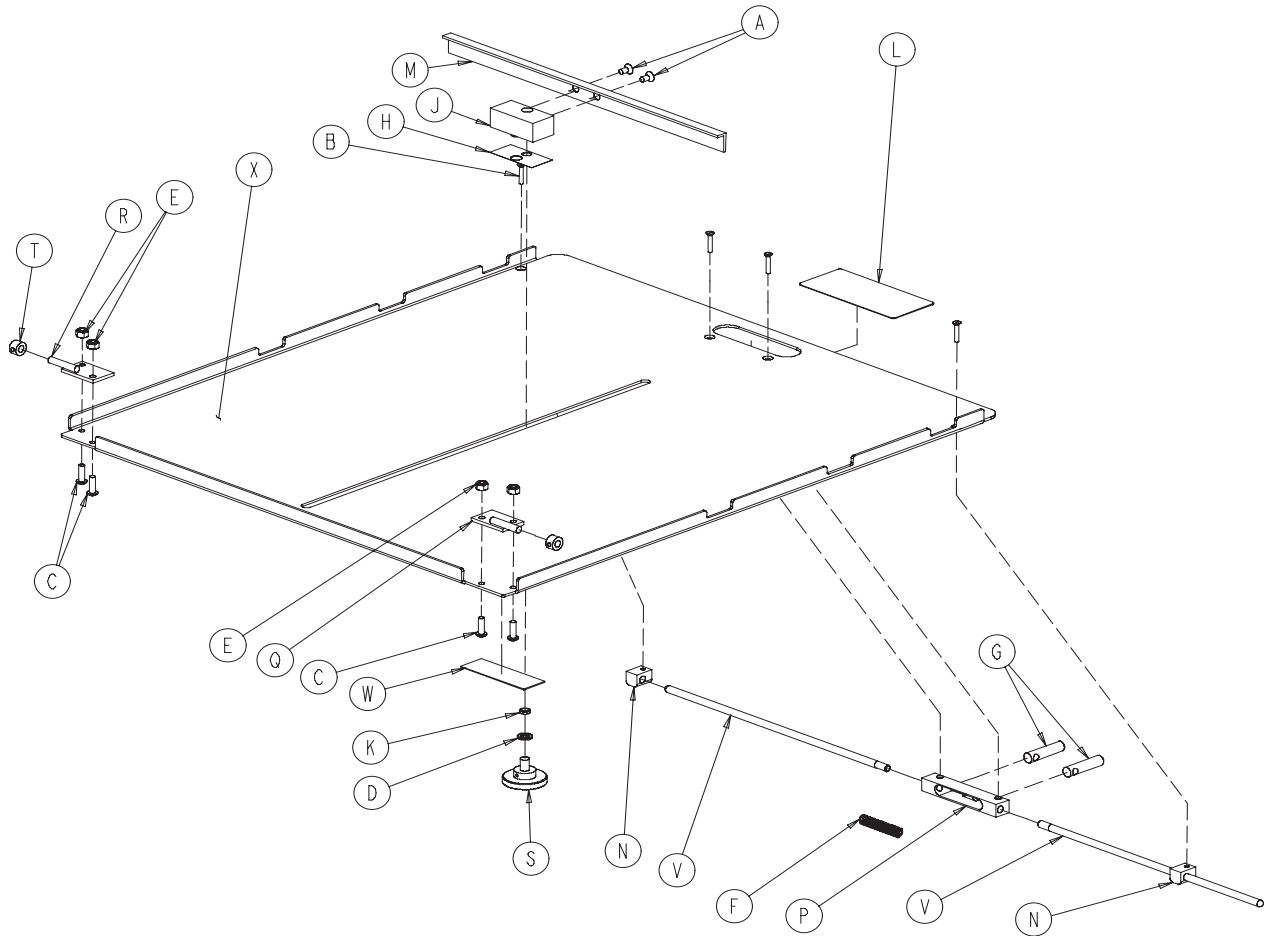

Item	Part No.	Part Name	Qty.
A	0001-020-000	Flat C'sunk Hd. Mach Scr.	2
B	0004-049-000	H. Soc. But. Hd. Cap Scr.	4
C	0004-149-000	H. Soc. But. Hd. Cap Scr.	4
D	0014-003-000	Washer	1
E	0016-003-000	Hex Nut	4
F	0038-122-000	Spring 1S1020-23-21 Knob	1
G	0926-023-064	Tray Post	2
H	0926-023-069	Cassette Washer	1
J	0926-023-070	Cassette Block Subass'y	1
L	1010-023-019	Instruction Label	1
M	1010-023-028	Tray Angle	1
N	1010-023-037	Cassette Rod Guide	2
P	1020-023-016	Cassette Post Housing	1
Q	1020-023-019	Tray Hinge Wldmt., Rt.	1
R	0020-023-020	Tray Hinge Wldmt., Lt.	1
T	0000-042-013	Collar W/Set Screw	2
V	2025-140-002	Cassette Actuating Rod	2
W	2035-140-025	Specification Label	1
K	0926-023-071	Cassette Bushing	1
X	2032-140-099	Cassette Tray	1

[Return To Table of Contents](#)

# Optional I.V. Pole Transducer Mount Assembly - 2035-018-010

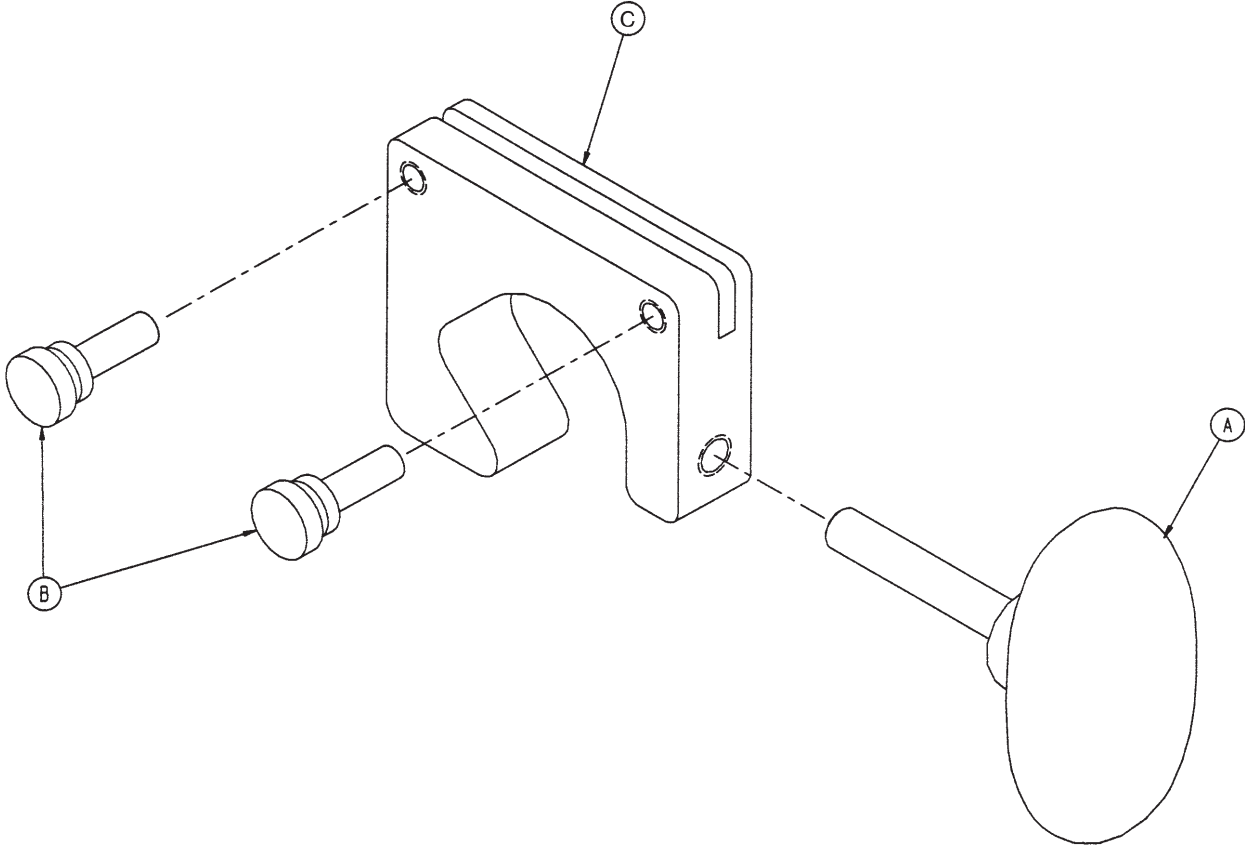

Item	Part No.	Part Name	Qty.
A	0024-063-000	T-Knob	1
B	0024-064-000	Thumb Screw	2
C	2035-018-011	Transducer Mount	1

# Optional Defibrillator Tray Assembly - 2025-120-010

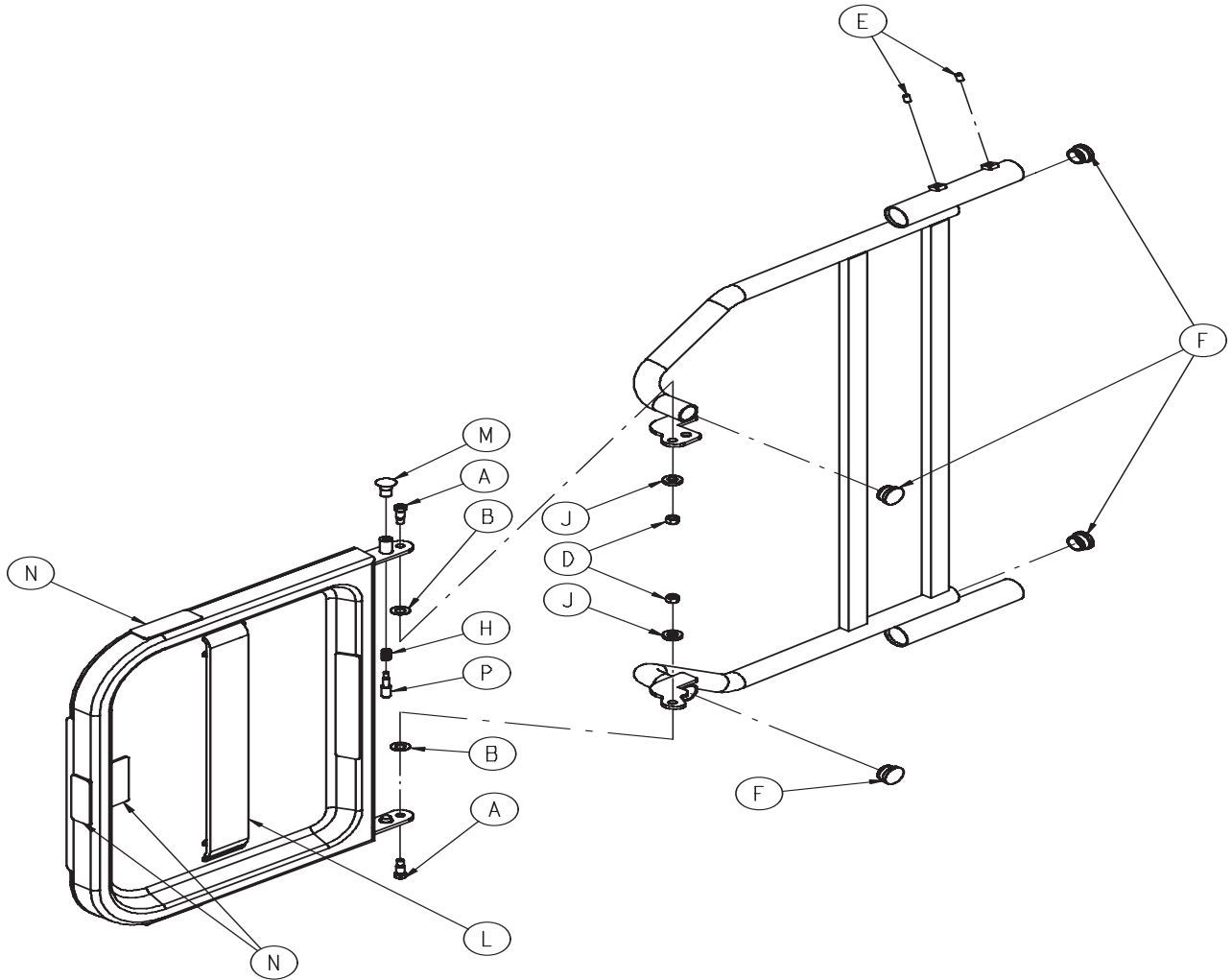

Item	Part No.	Part Name	Qty.
A	0008-049-000	Soc. Hd. Shoulder Bolt	2
B	0014-020-000	Thrust Washer	2
D	0016-028-000	Fiberlock Nut	2
E	0021-017-000	Set Screw	4
F	0037-214-000	Hole Plug	4
H	0038-133-000	Spring	1
J	0052-017-000	Spacer	2
K	1010-050-019	"Push/Pull" Label	1
L	1010-050-021	Long Strap	1
M	1010-050-050	Knob	1
N	1010-050-057	Max. Weight Label	4
P	1010-050-242	Lock Pin	1
R	2025-120-005	Equipment Label	1
S	2025-120-006	Specification Label	1
T	2025-120-018	Tray Assembly	1
W	2025-120-025	Pivot Weldment Frame	1

[Return To Table of Contents](#)

# Optional Pump Rack Assembly - 2040-111-000

---

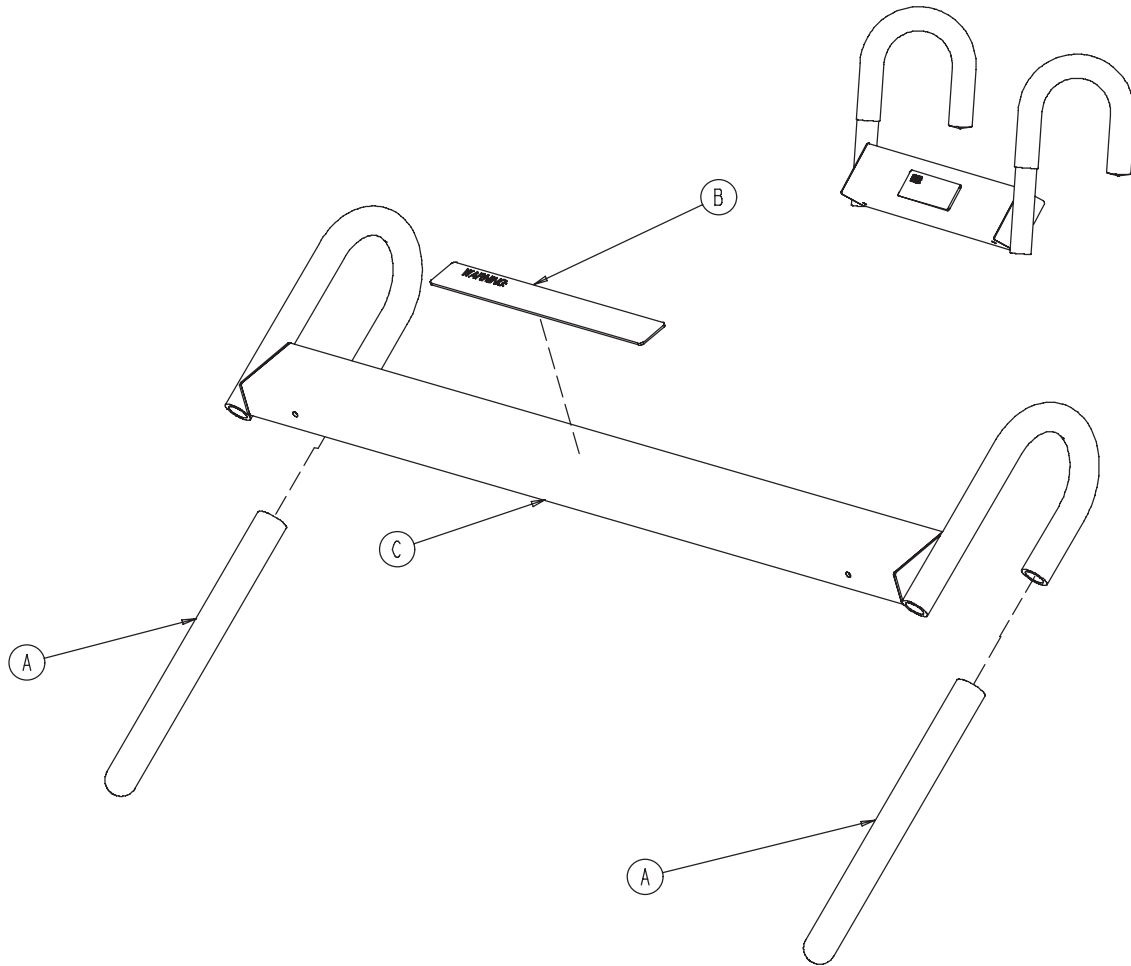

Item	Part No.	Part Name	Qty.
A	0058-087-000	End Cap	2
B	2030-140-002	Pump Rack Label	1
C	2040-111-005	Pump Rack Tube	1

# Optional Pleur-Evac Rack with Defibrillator Tray - 2040-120-004

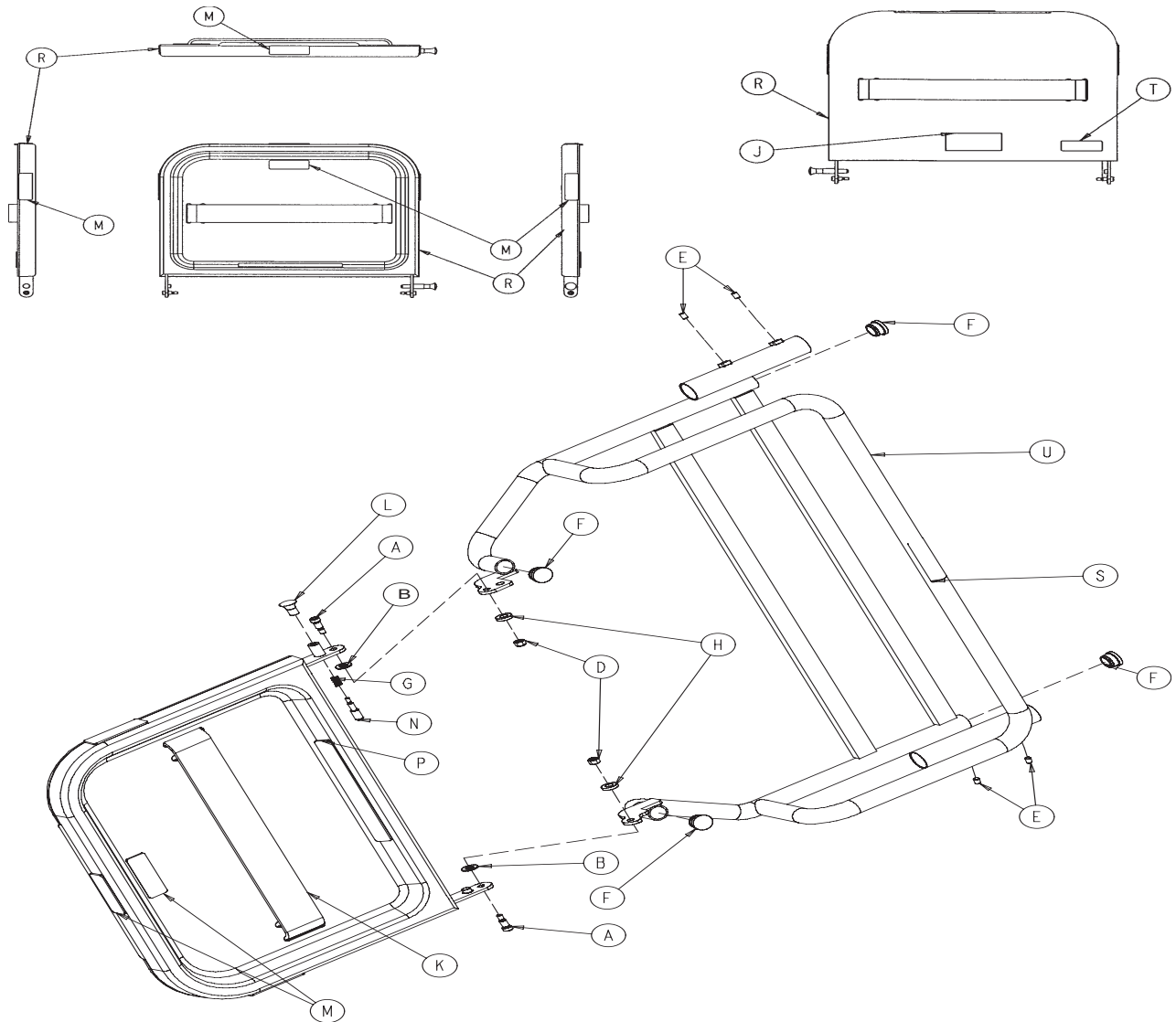

Item	Part No.	Part Name	Qty.
A	0008-049-000	Soc. Hd. Shoulder Bolt	2
B	0014-020-000	Thrust Washer	2
D	0016-028-000	Fiberlock Nut	2
E	0021-017-000	Set Screw	4
F	0037-214-000	Hole Plug	4
G	0038-133-000	Spring	1
H	0052-017-000	Spacer	2
J	1010-050-019	"Push/Pull" Label	1
K	1010-050-021	Long Strap	1
L	1010-050-050	Knob	1
M	1010-050-057	"Max. Weight" Label	4
N	1010-050-242	Lock Pin	1
P	2025-120-005	Equipment Label	1
R	2025-120-018	Tray Assembly	1
S	2040-090-001	Warning Label	1
T	2040-090-005	Specification Label	1
U	2040-120-003	Rack Weldment	1

[Return To Table of Contents](#)

# Optional Pleur-Evac Rack Assembly - 2040-120-020

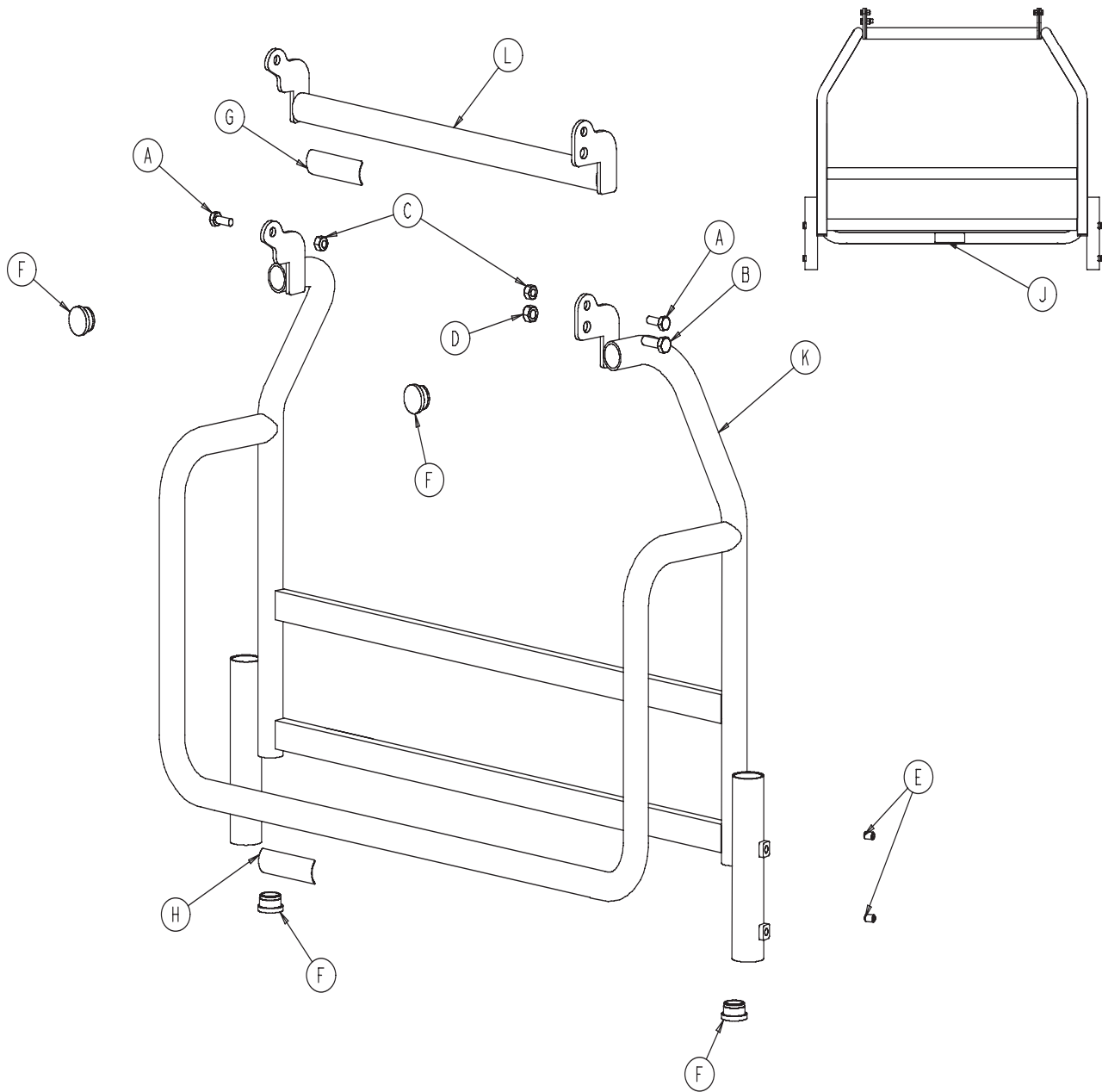

Item	Part No.	Part Name	Qty.
A	0003-050-000	Hex Hd. Cap Screw	2
B	0003-085-000	Hex Hd. Cap Screw	1
C	0015-028-000	Nylock Nut	2
D	0016-036-000	Nylock Nut	1
E	0021-017-000	Set Screw	4
F	0037-214-000	Hole Plug	4
G	1010-050-057	Maximum Weight Label	1
H	2040-090-001	Acc. Rail Warning Label	1
J	2040-090-004	Specification Label	1
K	2040-120-003	Rack Weldment	1
L	2040-120-010	Rack Top Weldment	1

# Optional Upright Oxygen Bottle Holder - 2040-150-010

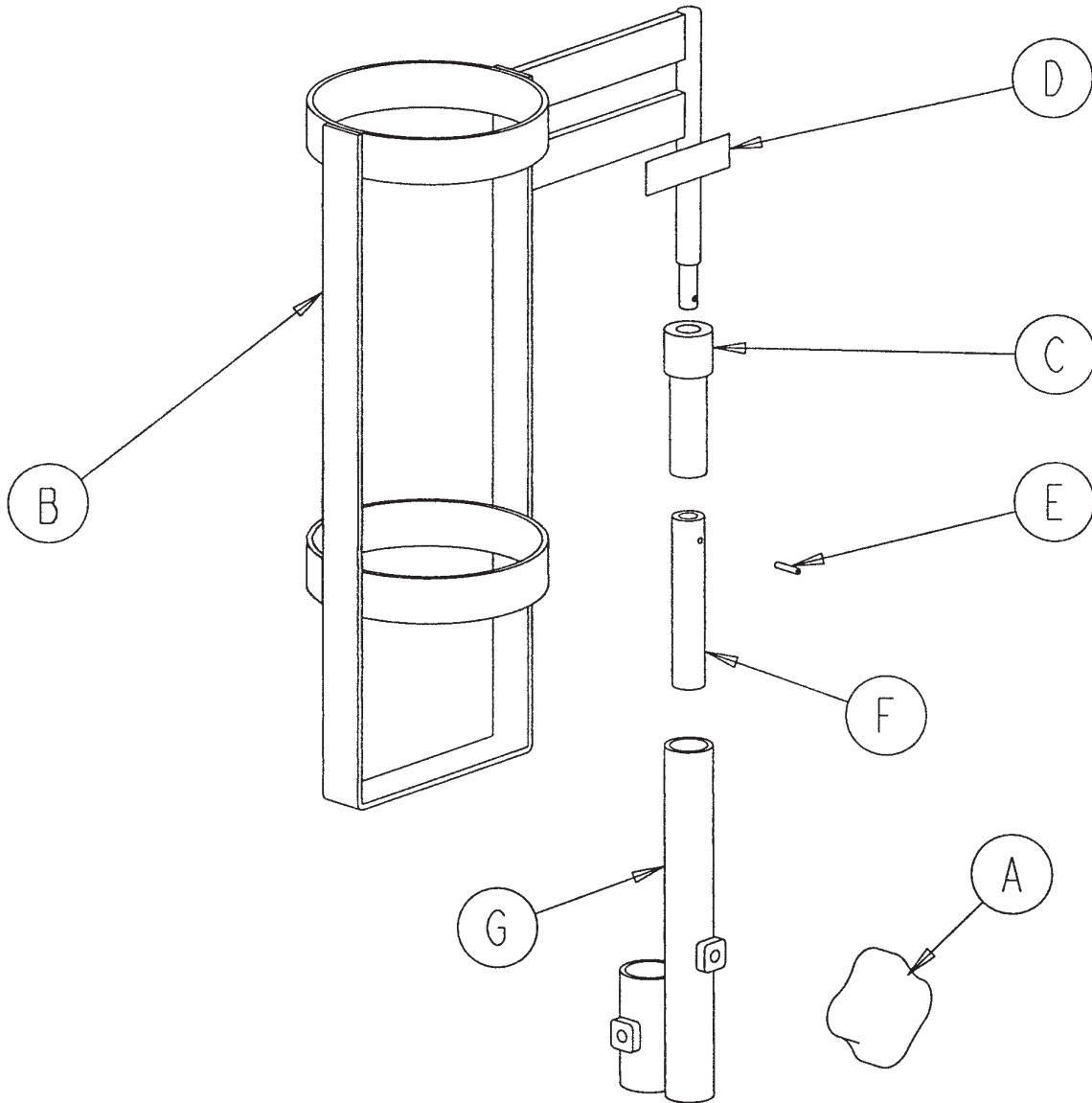

Item	Part No.	Part Name	Qty.
A	0024-055-000	Knob	1
B	1010-030-011	Upright Bottle Holder	1
C	2025-150-001	Adaptor Sleeve	1
D	2025-150-002	Specification Label	1
E	0026-005-000	Spring Pin	1
F	2025-150-003	End Stop Bushing	1
G	2040-110-002	Hd. End Dual I.V. Pole Collar	1

[Return To Table of Contents](#)

# Optional Bed Extender Pad - 2025-040-010

---

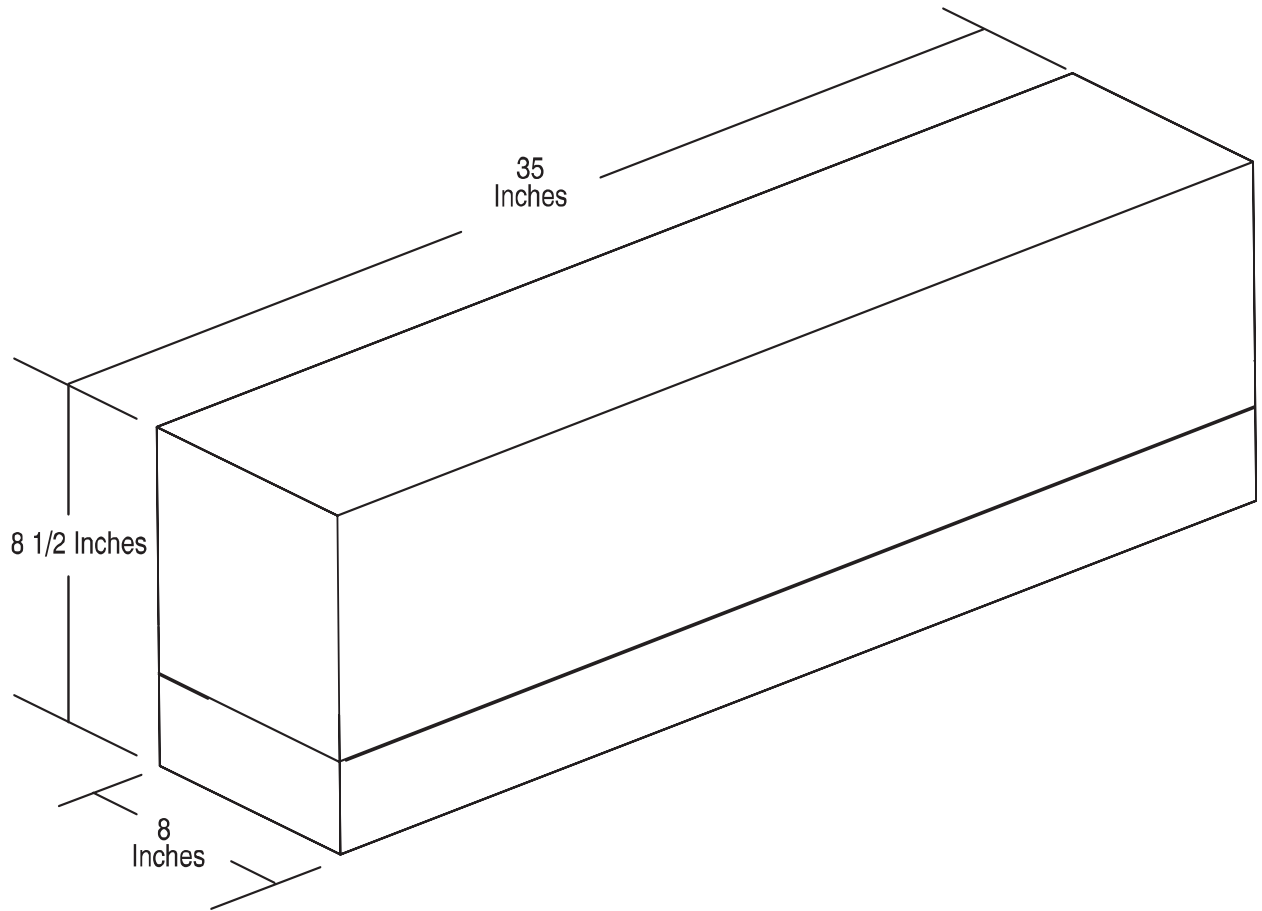



## Optional Siderail Pad Set - 3003-336-020

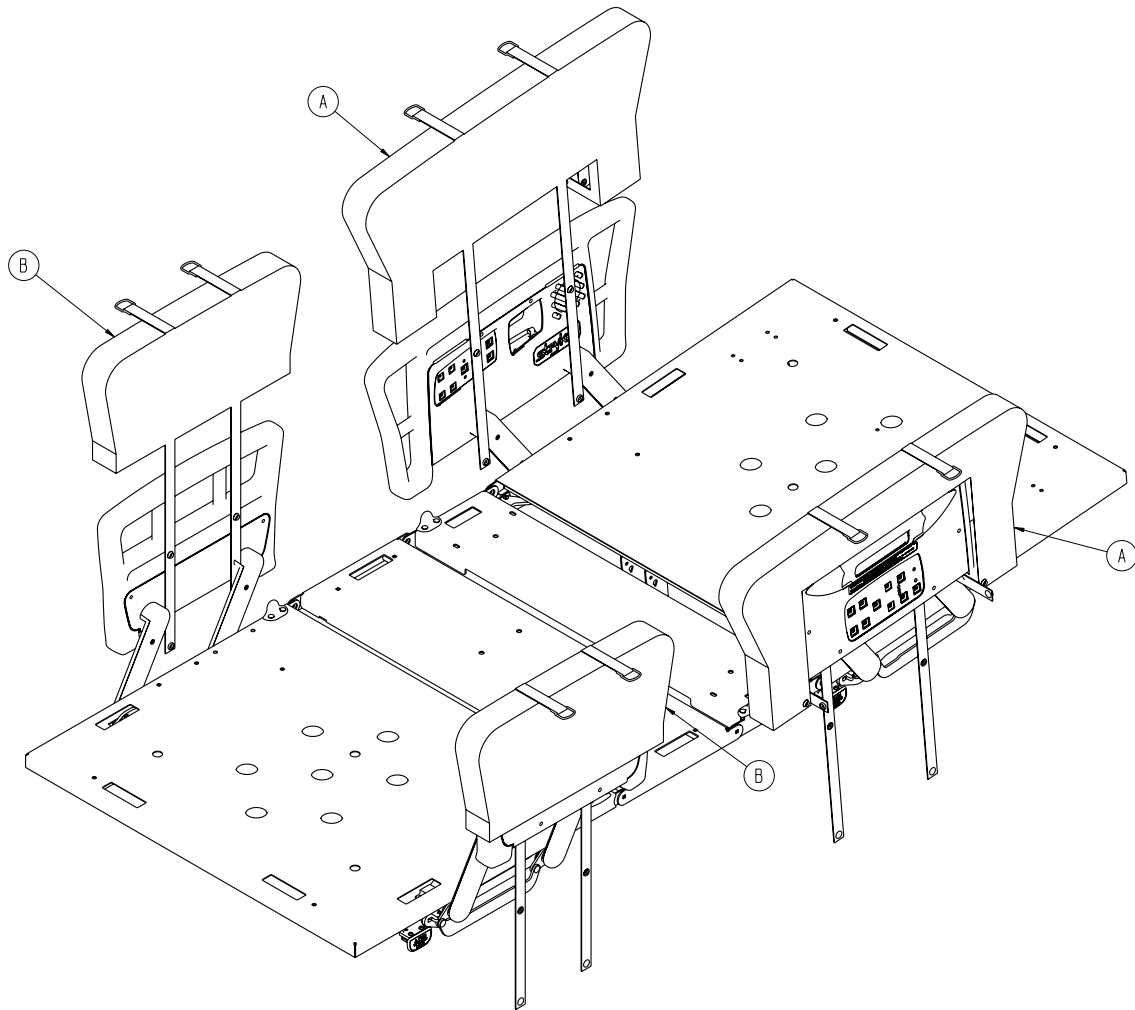

Item	Part No.	Part Name	Qty.
A	3003-336-011	Siderail Padded Cover, Head End	1
B	3003-336-013	Siderail Padded Cover, Foot End	1

# Warranty

---

## LIMITED WARRANTY

Stryker Medical Division, a division of Stryker Corporation, warrants to the original purchaser the ZOOM® Critical Care Beds to be free from defects in material and workmanship for a period of One (1) years after date of delivery. Stryker's obligation under this warranty is expressly limited to supplying replacement parts and labor for, or replacing, at its option, any product which is, in the sole discretion of Stryker, found to be defective. If requested by Stryker, products or parts for which a warranty claim is made shall be returned prepaid to the factory. Any improper use or any alteration or repair by others in such manner as in Stryker's judgment affects the product materially and adversely shall void this warranty. Any repair of Stryker products using parts not provided or authorized by Stryker shall void this warranty. No employee or representative of Stryker is authorized to change this warranty in any way.

Stryker Medical Bed products are designed for a 15 year expected service life under normal use, conditions, and with appropriate periodic maintenance as described in the maintenance manual for each device. Stryker warrants to the original purchaser that the welds on its Bed products will be free from structural defects for the expected 15 years life of the Bed product as long as the original purchaser owns the product.

This statement constitutes Stryker's entire warranty with respect to the aforesaid equipment. **Stryker makes no other warranty or representation, either expressed or implied, except as set forth herein. There is no warranty of merchantability and there are no warranties of fitness for any particular purpose. In no event shall Stryker be liable here under for incidental or consequential damages arising from or in any manner related to sales or use of any such equipment.**

## TO OBTAIN PARTS AND SERVICE

Stryker products are supported by a nationwide network of dedicated Stryker Field Service Representatives. These representatives are factory trained, available locally, and carry a substantial spare parts inventory to minimize repair time. Simply call your local representative, or call Stryker Customer Service USA at 1-800-327-0770, Canada 1-888-233-6888.

## SERVICE CONTRACT COVERAGE

Stryker has developed a comprehensive program of service contract options designed to keep your equipment operating at peak performance at the same time it eliminates unexpected costs. We recommend that these programs be activated before the expiration of the new product warranty to eliminate the potential of additional equipment upgrade charges.

### A Service Contract helps to:

- Ensure equipment reliability.
- Stabilize maintenance budgets.
- Diminish downtime.
- Establish documentation for JCAHO.
- Increase product life.
- Enhance trade-in value.
- Address risk management and safety.

# Warranty

## SERVICE CONTRACT PROGRAMS

Stryker offers the following service contract programs:

Service Agreement Options *	Gold	Silver	Parts	Labor	PM
Annually scheduled preventative maintenance.	X				X
All parts.	X	X	X		
All labor and travel.	X	X		X	
Unlimited emergency service calls.	X	X		X	
Priority one contact: two hour phone response.	X	X	X	X	
Most repairs completed within 3 days.	X	X		X	
JCAHO documentation.	X	X		X	X
On-site record of PM & emergency service.	X				X
Factory-trained Stryker service technician.	X	X		X	X
Stryker authorized parts used.	X	X	X	X	X
Service during regular business hours (8–5).	X	X	X	X	X

\* Does not include maintenance due to abuse or for any disposable items. Stryker reserves the right to change options without notice.

Stryker Medical also offers personalized service contracts.  
Pricing is determined by age, location, model and condition of product.

**For more information on our service contracts,  
please call your local representative.**

## RETURN AUTHORIZATION

Merchandise cannot be returned without approval from the Stryker Customer Service Department. An authorization number will be provided which must be printed on the returned merchandise. Stryker reserves the right to charge shipping and restocking fees on returned items. **Special, modified, or discontinued, items not subject to return.**

## DAMAGED MERCHANDISE

ICC Regulations require that claims for damaged merchandise must be made with the carrier within fifteen (15) days of receipt of merchandise. **Do not accept damaged shipments unless such damage is noted on the delivery receipt at the time of receipt.** Upon prompt notification, Stryker will file a freight claim with the appropriate carrier for damages incurred. Claim will be limited in amount to the actual replacement cost. In the event that this information is not received by Stryker within the fifteen (15) day period following the delivery of the merchandise, or the damage was not noted on the delivery receipt at the time of receipt, the customer will be responsible for payment of the original invoice in full. Claims for any short shipment must be made within thirty (30) days of invoice.

## INTERNATIONAL WARRANTY CLAUSE

This warranty reflects U.S. domestic policy. Warranty outside the U.S. may vary by country. Please contact your local Stryker Medical representative for additional information.

[Return To Table of Contents](#)





UNITED STATES  
Stryker Medical  
3800 E. Centre Ave.,  
Portage, Michigan USA  
49002

CANADA  
Stryker Canada  
45 Innovation Drive  
Hamilton, Ontario Canada  
L9H 7L8

EC	REP
----	-----

**European Representative**  
Stryker France  
ZAC Satolas Green Pusignan  
Av. De Satolas Green  
69881 MEYZIEU Cedex  
France

**stryker**<sup>®</sup>