

# InTouch® Critical Care Bed

**REF** FL27 (2131/2141)

*Version 5.0 with Wi-Fi /  
Isolibrium™ (2971/2972) support surface*

# stryker®















## Maintenance Manual















# Symbols

	General warning
	Caution
	Consult instructions for use
	Catalogue number
	Serial number
	Manufacturer
	Date of manufacture
	Safe working load
~	Alternating current
	Dangerous voltage
	Fuse rating for beds with the 100V~ or 120V~ electric system
	Potential Equalization
	Protective Earth terminal
<b>IPX4</b>	Protection from liquid splash
	Type B applied part
	Medical Equipment Classified by Underwriters Laboratories Inc. With Respect to Electric Shock, Fire, and Mechanical Hazards Only in Accordance with ANSI/AAMI ES60601-1: 2005 and CAN/CSA-C22.2 No. 60601-1:08.

# Symbols

	<p>In accordance with European Directive 2012/19/EU on Waste Electrical and Electronic Equipment (WEEE) as amended, this symbol indicates that the product should be collected separately for recycling. Do not dispose of as unsorted municipal waste. Contact local distributor for disposal information. Ensure infected equipment is decontaminated prior to recycling.</p>
	<p>Non-ionizing radiation; i.e. RF transmitter (Wi-Fi)</p>
	<p>iBed Locator is connected</p>
	<p>iBed Locator is not connected</p>
	<p>Wireless Network is connected</p>
	<p>Wireless Network is trying to connect/not connected</p>
	<p>Wireless module not detected</p>
	<p>Call maintenance</p>
	<p>Support surface call maintenance</p>

# Table of Contents

---

Warning / Caution / Note Definition . . . . .	<a href="#">9</a>
Summary of Safety Precautions . . . . .	<a href="#">10</a>
Introduction . . . . .	<a href="#">11</a>
Product Description . . . . .	<a href="#">11</a>
Intended Use: InTouch Critical Care Bed . . . . .	<a href="#">11</a>
Intended Use – iBed® Wireless with iBed Awareness . . . . .	<a href="#">12</a>
Expected service life . . . . .	<a href="#">12</a>
Contraindications . . . . .	<a href="#">12</a>
Specifications . . . . .	<a href="#">13</a>
Environmental Conditions . . . . .	<a href="#">15</a>
Product Illustration . . . . .	<a href="#">19</a>
Contact Information . . . . .	<a href="#">20</a>
Serial Number Location . . . . .	<a href="#">20</a>
Specification Label Location . . . . .	<a href="#">20</a>
Static Discharge Precautions . . . . .	<a href="#">21</a>
Protecting against Electrostatic Discharge (ESD) . . . . .	<a href="#">21</a>
Maintenance Menu Guide . . . . .	<a href="#">22</a>
InTouch Configuration Screen . . . . .	<a href="#">23</a>
A. Bed Calibration . . . . .	<a href="#">23</a>
B. Full Diagnostic . . . . .	<a href="#">34</a>
C. Touch Screen Calibration . . . . .	<a href="#">35</a>
D. Wi-Fi Reset . . . . .	<a href="#">36</a>
E. Bed Options Configuration . . . . .	<a href="#">37</a>
F. Serial Number Configuration . . . . .	<a href="#">38</a>
Accessing the Isolibrium diagnostic menu . . . . .	<a href="#">39</a>
Reviewing active Isolibrium errors . . . . .	<a href="#">40</a>
Reviewing and Clearing Isolibrium Error History . . . . .	<a href="#">40</a>
Viewing Advanced Signal Values for Isolibrium . . . . .	<a href="#">41</a>
Running a Diagnostic Test for Isolibrium . . . . .	<a href="#">42</a>
Preventive Maintenance . . . . .	<a href="#">44</a>
Troubleshooting . . . . .	<a href="#">46</a>
Bed Troubleshooting . . . . .	<a href="#">46</a>
Scale Troubleshooting . . . . .	<a href="#">52</a>
Error Codes . . . . .	<a href="#">53</a>
Error Handling . . . . .	<a href="#">53</a>
Error Messages . . . . .	<a href="#">53</a>
CPU/Power Board - QDF75-0440 . . . . .	<a href="#">58</a>
Fuse Specification . . . . .	<a href="#">59</a>
Bed Electrical Diagram . . . . .	<a href="#">60</a>
Quick Reference Replacement Parts . . . . .	<a href="#">79</a>
Service Information . . . . .	<a href="#">81</a>
Bed lift Actuator (Head) Removal and Replacement - (Base) . . . . .	<a href="#">81</a>
Bed lift Actuator (Foot) Removal and Replacement - (Base) . . . . .	<a href="#">82</a>
Fowler Actuator Removal and Replacement - (Litter) . . . . .	<a href="#">83</a>
Gatch Actuator Removal and Replacement - (Litter) . . . . .	<a href="#">84</a>
Foot Actuator Removal and Replacement - (Litter) . . . . .	<a href="#">85</a>

# Table of Contents

---

Zoom® Drive Actuator Removal and Replacement (2141 Model Only) - (Base) . . . . .	<a href="#">86</a>
CPU / Power Board Removal and Replacement - (Litter) . . . . .	<a href="#">87</a>
Load Cell (Head End) Removal and Replacement - (Litter) . . . . .	<a href="#">88</a>
Load Cell (Foot End) Removal and Replacement - (Litter) . . . . .	<a href="#">89</a>
Display Removal and Replacement - (Footboard) . . . . .	<a href="#">90</a>
Brake Control Board Removal and Replacement - (Footboard) . . . . .	<a href="#">91</a>
Function Selection/LED Board Removal and Replacement - (Footboard) . . . . .	<a href="#">92</a>
Touch Screen Removal and Replacement - (Footboard) . . . . .	<a href="#">93</a>
Battery Removal and Replacement - (Footboard) . . . . .	<a href="#">94</a>
Brake / Neutral / Drive Potentiometer Removal and Replacement - QDF27-2024 . . . . .	<a href="#">95</a>
Battery Removal and Replacement - (Litter) . . . . .	<a href="#">96</a>
Fowler Angle Sensor Removal and Replacement - (Litter) . . . . .	<a href="#">97</a>
Gatch Angle Sensor Removal and Replacement - (Litter) . . . . .	<a href="#">98</a>
Foot Angle Sensor Removal and Replacement - (Litter) . . . . .	<a href="#">99</a>
Base Angle Sensor Removal and Replacement - (Base) . . . . .	<a href="#">100</a>
Trend Angle Sensor Removal and Replacement - (Litter) . . . . .	<a href="#">101</a>
Headwall Communication Board Removal and Replacement - (Litter) . . . . .	<a href="#">102</a>
IR Module Removal and Replacement - (Litter) (Optional) . . . . .	<a href="#">103</a>
Wi-Fi Board Removal and Replacement - (Footboard) (Optional) . . . . .	<a href="#">104</a>
Base Assembly, Hood . . . . .	<a href="#">106</a>
Base Assembly, Brake . . . . .	<a href="#">108</a>
Base Assembly, Caster Lock (Model 2131 Only) . . . . .	<a href="#">111</a>
Base Assembly, Caster Non-Lock (Model 2141 Only) . . . . .	<a href="#">112</a>
Angle Sensor Assembly . . . . .	<a href="#">113</a>
Base Assembly, Electrical . . . . .	<a href="#">114</a>
Base Assembly, Zoom® . . . . .	<a href="#">120</a>
Base Assembly, Zoom® Drive (Model 2141 Only) . . . . .	<a href="#">122</a>
Bed Labeling . . . . .	<a href="#">124</a>
Lift Assembly . . . . .	<a href="#">128</a>
Spring Assembly . . . . .	<a href="#">132</a>
Litter Assembly . . . . .	<a href="#">133</a>
Litter Assembly, Interior Frame . . . . .	<a href="#">137</a>
Litter Assembly with Serial Port . . . . .	<a href="#">140</a>
Litter Assembly, Upper Frame . . . . .	<a href="#">141</a>
Litter Assembly, Foot End . . . . .	<a href="#">143</a>
Litter Assembly, Standard Cabling . . . . .	<a href="#">147</a>
Litter Assembly, Electrical . . . . .	<a href="#">148</a>
120V Electric System . . . . .	<a href="#">154</a>
Coiled Power Cord . . . . .	<a href="#">155</a>
Litter Assembly, Foot End, with Mattress Connector . . . . .	<a href="#">156</a>
Standard Outlet . . . . .	<a href="#">157</a>
Litter Assembly, Optional Dual 120V Outlet . . . . .	<a href="#">158</a>
CPR Assembly, Mechanical . . . . .	<a href="#">160</a>
Handle Assembly (Model 2131 Only) . . . . .	<a href="#">165</a>

# Table of Contents

---

Assembly Drawings (Continued)	
Zoom® Handle Assembly (Model 2141 Only) . . . . .	<a href="#">166</a>
Zoom® Assembly. . . . .	<a href="#">168</a>
Optional No Head End Control Panel. . . . .	<a href="#">169</a>
Optional Head End Control Panel Assembly . . . . .	<a href="#">170</a>
Siderail Mounting Assembly, Head End . . . . .	<a href="#">172</a>
Standard Siderail Assembly, Head End, Right . . . . .	<a href="#">173</a>
Standard Siderail Assembly, Head End, Left . . . . .	<a href="#">177</a>
Standard Siderail Assembly, Labeling . . . . .	<a href="#">181</a>
Optional Siderail Assembly, Head End, with Speaker/ <i>i</i> Audio . . . . .	<a href="#">182</a>
Optional Siderail Assembly, Head End, with Speaker/with NC/with <i>i</i> Audio . . . . .	<a href="#">183</a>
Optional Siderail Assembly, Head End, with Speaker/ <i>i</i> Audio/IR . . . . .	<a href="#">185</a>
Optional Siderail Assembly, Head End, with Speaker/with NC/with <i>i</i> Audio/with <i>i</i> Bed® Wireless . . . . .	<a href="#">186</a>
Siderail Mounting Assembly, Foot End . . . . .	<a href="#">190</a>
Standard Siderail Assembly, Foot End, Right . . . . .	<a href="#">191</a>
Standard Siderail Assembly, Foot End, Left . . . . .	<a href="#">194</a>
Standard Siderail Assembly without <i>i</i> Bed. . . . .	<a href="#">197</a>
Optional Siderail Assembly with <i>i</i> Bed . . . . .	<a href="#">198</a>
Headboard and Footboard Assembly. . . . .	<a href="#">199</a>
Standard Footboard Assembly . . . . .	<a href="#">200</a>
Standard Footboard Assembly . . . . .	<a href="#">202</a>
Footboard Assembly with <i>i</i> Bed . . . . .	<a href="#">205</a>
Footboard Assembly with <i>i</i> Bed and Wi-Fi. . . . .	<a href="#">208</a>
Wireless Option - 27-2866 . . . . .	<a href="#">211</a>
Bed Extender - FA64234-XXX. . . . .	<a href="#">212</a>
Bed Extender Pad with Position Pro Mattress - DM64196-XXX. . . . .	<a href="#">213</a>
Bed Extender Pad with XPRT™ Mattress - DM64197-XXX . . . . .	<a href="#">213</a>
Line Management Clip - FA64210-XXX . . . . .	<a href="#">214</a>
IV Pole Assembly, Permanent - FA64221-XXX/FA64238-XXX. . . . .	<a href="#">215</a>
IV Pole Ass'y, Dual Head End, Permanent - FA64202-XXX. . . . .	<a href="#">216</a>
Monitor Tray Assembly - FA64214-XXX . . . . .	<a href="#">218</a>
Upright Oxygen Bottle Holder Assembly - FA64187-XXX. . . . .	<a href="#">219</a>
Right-Fit Oxygen Bottle Holder Assembly - FA64203 . . . . .	<a href="#">220</a>
Pendant Assembly with Motion Control - FA64228-XXX . . . . .	<a href="#">221</a>
Pendant Assembly with Motion Control/NC - FA64226 . . . . .	<a href="#">222</a>
Pendant Assembly with Motion Control/Smart TV - FA64227. . . . .	<a href="#">223</a>
Pendant Assembly with Motion Control/NC/Smart TV - FA64225. . . . .	<a href="#">224</a>
Pendant Clip Assembly - FA64186-XXX . . . . .	<a href="#">224</a>
Roller Bumpers. . . . .	<a href="#">225</a>
Traction Sleeve Assembly, 4 in. x 1/2 in. - FA64215-XXX . . . . .	<a href="#">226</a>
Traction Sleeve Assembly, 4 in. x 3/4 in. - FA64216-XXX . . . . .	<a href="#">227</a>
Traction Sleeve Assembly, 8 in. x 1/2 in. - FA64217-XXX . . . . .	<a href="#">228</a>
Traction Sleeve Assembly, 8 in. x 3/4 in. - FA64218-XXX . . . . .	<a href="#">229</a>
Traction Sleeve Assembly, 6-1/2 in. x 3/4 in. - FA64219-XXX . . . . .	<a href="#">230</a>
Wall Saver Cable Assembly - FA64208 . . . . .	<a href="#">231</a>

# Table of Contents

---

X-ray Cassette Holder Assembly - FA64205-XXX. . . . . [232](#)  
Tube Support . . . . . [234](#)  
FCC Notification . . . . . [235](#)  
Recycling Passports . . . . . [236](#)

# Warning / Caution / Note Definition

---

The words **WARNING**, **CAUTION**, and **NOTE** carry special meanings and should be carefully reviewed.

---

## **WARNING**

Alerts the reader about a situation, which if not avoided, could result in death or serious injury. It may also describe potential serious adverse reactions and safety hazards.

---

## **CAUTION**

Alerts the reader of a potentially hazardous situation, which if not avoided, may result in minor or moderate injury to the user or patient or damage to the equipment or other property. This includes special care necessary for the safe and effective use of the device and the care necessary to avoid damage to a device that may occur as a result of use or misuse.

---

## **Note**

This provides special information to make maintenance easier or important instructions clearer.

# Summary of Safety Precautions

---

Always read and strictly follow the warnings and cautions listed on this page. Service only by qualified personnel.

---

## **WARNING**

- Improper usage of the product can cause injury to the patient or operator. Operate the product only as described in this manual.
  - Do not modify the product or any components of the product. Modifying the product can cause unpredictable operation resulting in injury to patient or operator. Modifying the product also voids its warranty.
  - Please ensure patient is not in the bed prior to starting bed calibration. In calibration mode, the software does not control the interferences between the mechanical parts of the bed. Mechanical damage could occur without supervision. Only qualified personnel should perform the calibration.
  - Electrical shock risk. Refer all servicing to qualified personnel.
  - Do not perform diagnostic test with a patient or other weight on the support surface.
- 

## **CAUTION**

- Always use ESD protective equipment before opening antistatic bags and servicing electronic parts.
- Do not place unprotected circuit boards on the floor.
- All electronic service parts will be shipped in static shielding bags. Do not open the bags until you have completed steps 2 and 3 of the Static Protection Procedure.
- These settings should only be modified by trained personnel. Changing these settings may disable the wireless feature. These settings should only be changed or updated with the aid of the hospital's IT department or the appropriate maintenance personnel.
- Do not touch the support surface while performing diagnostics test. Failure to do so could lead to inaccurate diagnostic results.
- Do not remove the clevis pins.
- Make sure that prior to jacking, the 2 x 4 is perpendicular to the floor.
- Ensure cables do not get pinched when securing the head end frame cover together.
- Do not pinch the cable when installing the load cell.



# Introduction

---

This manual assists you with the operation or maintenance of the Stryker Model FL27 (2131/2141) **InTouch**® Critical Care bed. Read this manual thoroughly before operating or maintaining this product. Set methods and procedures to educate and train your staff on the safe operation or maintenance of this product.

---

## WARNING

- Improper usage of the product can cause injury to the patient or operator. Operate the product only as described in this manual.
  - Do not modify the product or any components of the product. Modifying the product can cause unpredictable operation resulting in injury to patient or operator. Modifying the product also voids its warranty.
- 

## Notes

- This manual is a permanent part of the product and should remain with the product even if the product is sold.
- Stryker continually seeks advancements in product design and quality. This manual contains the most current product information available at the time of printing. There may be minor discrepancies between your product and this manual. If you have any questions, contact Stryker Customer Service or Technical Support at 1-800-327-0770.

## PRODUCT DESCRIPTION

**InTouch** is an AC-powered, adjustable hospital bed designed to position human patients for procedures, therapy, and recovery in a healthcare environment, and transport patients between bays and procedural rooms. **InTouch** measures and displays patient weight. The scale output is not intended to be used to determine diagnosis or treatment. The nurse call allows patients to alert an operator when the patient requires assistance. There is a 30-degree head of bed (HOB) button that puts the patient at a 30-degree angle that is calculated relative to the base to assist in ventilator-associated pneumonia (VAP) prevention. When the Chaperone bed exit system is active, it monitors a chosen zone, and alerts the operator of a deliberate or non-deliberate bed exit. The bed has 39 prerecorded clinical phrases in 24 languages and a sound feature that offers various environmental and musical selections.

## INTENDED USE: INTOUCH CRITICAL CARE BED

**InTouch** is intended for use by patients in an acute care setting. The safe working load (the sum of the patient, the mattress, and accessory weight) for **InTouch** is 550 lb (249 kg).

**InTouch** is intended to support a human patient. The frame can come in contact with human skin, but a patient should never be on the frame without a support surface in use.

**InTouch** is intended for use in acute care. These settings may include critical care, step down, progressive care, med/surg, sub-acute care, and post anesthesia care unit (PACU), or other locations, as prescribed. Intended operators are healthcare professionals (nurses, nurse aids, doctors) that can use all bed operations (such as bed motion functions, nurse call, siderail communications, bed exit, therapy options), patient and bystander that can use bed motion functions, nurse call and siderail communications, and trained professionals for installation, service, and calibration.

The product is intended for use in a healthcare environment, including hospitals, surgery centers, long term acute care centers, and rehabilitation centers.

The product is compatible with 35 in. x 84 in. support surfaces, the facility nurse call system, standard med/surg equipment, and the facility infrastructure. **InTouch** is intended for use with a 6 in. to 8.5 in. support surface. You may use a support surface or overlay greater than 6 in. that offers therapeutic value with added patient supervision.

The Chaperone bed exit system is intended only to aid in the detection of a patient exiting the unit. It is not intended to replace patient monitoring protocol.

# Introduction

---

## **INTENDED USE – /BED® WIRELESS WITH /BED AWARENESS**

The intended use for the /Bed® Wireless (with /Bed® Awareness) is to assist clinical staff to monitor bed parameters on specific Stryker beds. The desired bed parameters will be set by clinicians at the bedside. The /Bed® Wireless software is intended to be used only with specifically enabled Stryker beds that have been verified and validated with the /Bed® Wireless software, and is not intended to provide bed status information for non-Stryker beds. The /Bed® Wireless software is not intended to communicate any patient status information, nor to permanently store any type of data. The /Bed® Wireless with /Bed® Awareness System is not intended to provide automated treatment decisions or as a substitute for professional healthcare judgment. The /Bed® Wireless with /Bed® Awareness System is not a replacement or substitute for vital signs monitoring or alert equipment. All patient medical diagnosis and treatment are to be performed under direct supervision and oversight of an appropriate health care professional.

## **EXPECTED SERVICE LIFE**

InTouch has a 10 year expected service life under normal use conditions and with appropriate periodic maintenance.

## **CONTRAINDICATIONS**

InTouch is not intended to:

- be used without a support surface
- use the scale output to determine diagnosis or treatment
- be used with an oxygen tent
- support more than one individual at a time
- be used with patients that are 35 in. or less
- be used with patients that weigh 50 lb or less
- be used on patient less than two years old
- be used in a home healthcare environment
- be used in the presence of flammable anesthetics

# Introduction

## SPECIFICATIONS

	<b>Safe Working Load</b>  <b>Note:</b> Safe Working Load indicates the sum of the patient, mattress and accessory weight.	550 lbs	249 kg
	Bed Weight	750 lbs	340.2 kg
Overall Bed Length		90 in.	228,6 cm
Overall Bed Width	Siderails Up	42 in.	106,7 cm
	Siderails Down	40 in.	102,9 cm
Base	Underbed Clearance	5 in.	12,7 cm
Litter	Patient Surface <ul style="list-style-type: none"> <li>Width</li> <li>Length</li> <li>Length (with Optional Bed Extender)</li> </ul>	35 in. 84 in. 90 in.	88,9 cm 213,4 cm 228,6 cm
	Seat Section <ul style="list-style-type: none"> <li>Depth</li> </ul>	18.5 in.	47 cm
	Foot Section <ul style="list-style-type: none"> <li>Length</li> <li>Angle</li> </ul>	29 in. 0° to 50° (± 5°)	73,7 cm 0° to 50° (± 5°)
	Fowler Section <ul style="list-style-type: none"> <li>Length</li> <li>Width</li> <li>Angle</li> </ul>	36 in. 34 in. to 35 in. 0° to 70° (0°-40° and 50°-70° ± 3°) (40°-50° ± 5°)	91,4 cm 86,4 cm - 88,9 cm 0° to 70° (0°-40° and 50°-70° ± 3°) (40°-50° ± 5°)
	Gatch Section <ul style="list-style-type: none"> <li>Length</li> <li>Width</li> <li>Angle</li> </ul>	18 in. 34 in. to 35 in. 0° to 15° (± 3°)	45,7 cm 86,4 cm - 88,9 cm 0° to 15° (± 3°)
	Cardiac Chair <ul style="list-style-type: none"> <li>Standard Cardiac Chair Position</li> <li>Enhanced Cardiac Chair Position</li> </ul>	Head: 65°, Seat: 17°, Foot: 30°, Trend: 3° Head: 70°, Seat: 19°, Foot: 47°, Trend: 3°	
	Bed Lift System <ul style="list-style-type: none"> <li>Height (high) to top of litter</li> <li>Height (low) to top of litter</li> <li>Trendelenburg/Reverse Trendelenburg</li> <li>Bed Lift Time</li> </ul>	33 in. 16 in. 12° (± 2°) 35 seconds maximum from lowest to highest position	83,8 cm 40,6 cm
Scale System	Capacity	550 lbs	249 kg
	Accuracy: <ul style="list-style-type: none"> <li>For weight from 100 lb to 550 lb</li> <li>For weight from 100 lb to 550 lb</li> <li>For weight under 100 lb</li> <li>For weight under 100 lb</li> </ul>	± 2% when in Trendelenburg or Reverse Trendelenburg ± 2% when Flat ± 2 lb when in Trendelenburg or Reverse Trendelenburg ± 2 lb when Flat	
CPR System	Speed to level bed from any position <ul style="list-style-type: none"> <li>Fowler</li> <li>Foot and Seat</li> </ul>	15 seconds 60 seconds	
<b>Zoom®</b> motorized drive (Model 2141) (option)	Speed <ul style="list-style-type: none"> <li>Forward</li> <li>Backwards</li> </ul>	2.98 mph 1.79 mph	4.8 km/h 2.88 km/h

[Return To Table of Contents](#)

# Introduction

## SPECIFICATIONS (CONTINUED)

Maximum Current Consumption	Without Optional Auxiliary Outlet (120VAC Only)	4.0 Amps
	With Optional Auxiliary Outlet(s) (120VAC Only)	9.8 Amps
Electrical Requirements	All electrical requirements meet CSA C22.2 No. 601.1, UL 60601-1 and IEC 60601-1.60601-2-38 specifications.	120 ± 10% Vac, 50/60Hz - Two 250V, 10A Fuses 120V~, 50-60Hz, 4.0A (9.8A with 120V Optional Auxiliary Outlet) - Two 250V, 10A Fuses
Battery	12 V, 17.2 Ahr, Sealed Lead-Acid Battery (Part Number QDF9188) 3.0 V 220mAh Lithium Battery, Size 20mm - Varta Int. CR2032 Coin Cell PC Battery Holder, Size 20mm - MDP Int. BA2032	



**Note:** For **Isolibrium** specifications, see the **Isolibrium** operations/maintenance manual.

Recommended Support Surface Size	35 in. x 84 in. x 6 in.	88,9 cm x 213,4 cm x 15,2 cm
• With Bed Extender DM64196 (35 in. x 6 in. x 4 in.)	35 in. x 90 in. x 4 in.	88,9 cm x 228,6 cm x 10,1 cm
• With Bed Extender DM64197 (35 in. x 6 in. x 5.5 in.)	35 in. x 90 in. x 5.5 in.	88,9 cm x 228,6 cm x 13,9 cm

Recommended Air Mattress Size	35 in. x 84 in. x 6 in. - 8.5 in.	88,9 cm x 213,4 cm x 15,2 cm - 21,6 cm
• With Bed Extender DM64196 ( <b>PositionPRO</b> <sup>®</sup> and <b>Isolibrium</b> <sup>™</sup> ) (35 in. x 6 in. x 4 in.)	35 in. x 90 in. x 4 in.	88,9 cm x 228,6 cm x 10,1 cm
• With Bed Extender DM64197 ( <b>XPRT</b> <sup>™</sup> ) (35 in. x 6 in. x 5.5 in.)	35 in. x 90 in. x 5.5 in.	88,9 cm x 228,6 cm x 13,9 cm

# Introduction

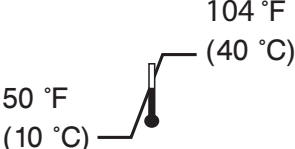
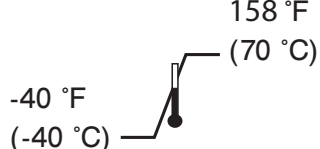
## ENVIRONMENTAL CONDITIONS

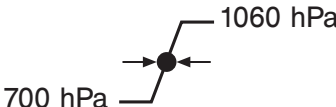
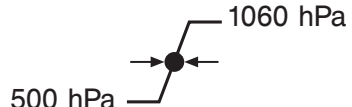
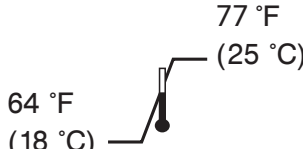
Environmental Conditions	Operation	Storage and Transportation
Ambient Temperature		
Relative Humidity (Non-Condensing)		
Atmospheric Pressure		
Scale Accuracy		

Specifications listed are approximate and may vary slightly from product to product or by power supply fluctuations.  
**Stryker reserves the right to change specifications without notice.**

# Introduction

## SYSTEM REQUIREMENTS AND RECOMMENDATIONS FOR /BED WIRELESS (OPTION)

To implement **iBed** Wireless, follow these requirements for hardware, software, and communication, product specifications, required settings and recommendations.

**Note:** If minimum system requirements are not met, system performance will be impacted.

## STRYKER /BED WIRELESS CLIENT RADIO SPECIFICATIONS

Manufacturer model	Silex SX-SDMAC-2830S
Chipset	Qualcomm Atheros QCA9377
IEEE 802.11	a/b/g/n/ac
RF bands	2.4 GHz, 5 GHz
Encryption	AES and TKIP (TKIP is not supported with WPA2)
Authentication	WPA Personal / Enterprise and WPA2 Personal / Enterprise
802.1X	PEAP-MSCHAP - V2
Client certificates	Stryker <b>iBed</b> Wireless client(s) cannot accept or upload certificates
Supported data rates	802.11b/g: 1-54 Mbps 802.11a: 6-54 Mbps 802.11n: MCS0-7 802.11ac: Compatible ONLY
Channel plan	2.4 GHz: All Channels Supported 5 GHz: All Channels Supported (Recommend against using DFS and ISM Channels)
Other	Stryker <b>iBed</b> Wireless Client is able to connect to an existing SSID

### ADDITIONAL ROAMING SETTINGS

Security	Fast Transition compatibility (enable and adaptive)	CCKM compatibility
WPA Enterprise	Yes	Yes (see note below)
WPA2 Enterprise	Yes	Yes
WPA	Yes	N/A
WPA2	Yes	N/a

**Note:** CCKM is not compatible if Fast Transition and CCKM are both enabled.

# Introduction

## SYSTEM REQUIREMENTS AND RECOMMENDATIONS FOR /BED WIRELESS (OPTION) (CONTINUED)

### CLIENT DEVICE DATA USAGE

- The client uses 10-15 KB per connected device every 40 seconds.
- The client uses an additional 5-21 KB per device for each subscription that is created by a third-party vendor like Connexall, Capsule, Epic, and Cerner.

**Note:** Based on network conditions, device messages are typically sent in near real time or in up to five minutes while connected. This depends on device activity like applying the brakes, adjusting the rails, alarms, and how the third-party defines subscription times.

### CUSTOMER NETWORK COMMUNICATION REQUIREMENTS FOR /BED WIRELESS OPTION

**Note:** Stryker recommends that you install iBed products on a separate VLAN to confirm network security access to other hospital systems.

LAN ENVIRONMENT		
Client/server communication	IPv4 only	Not applicable
Client device IP allocation	Static	If Static - Unique IP address will be required for each client MAC address
	DHCP	<ul style="list-style-type: none"> <li>• If DHCP and not using a DNS name - Each client MAC address will need a reserved IP address</li> <li>• If DHCP and using a DNS name - It is required to create a unique name for each client MAC address for client management</li> </ul> <p>– Stryker recommends using the Stryker client host name when the Stryker device connects to the wireless network - Example: SYK-00197b12365 so it may look like http://SYK-00197b12365.hosp.org</p>
Server IP allocation	Static IP required	Not applicable
VLAN	New, existing	Install <b>iBed</b> Wireless on a separate VLAN

# Introduction

## SYSTEM REQUIREMENTS AND RECOMMENDATIONS FOR /BED WIRELESS (OPTION) (CONTINUED)

IP TRAFFIC ENVIRONMENT		
Source	Protocol / Port number	Destination
iBed Server	TCP/21	Stryker iBed Wireless Client
iBed Server	TCP/80/443	Third party / Stryker back office
iBed Server	TCP/1639	Stryker iBed Wireless Client
Third party / Stryker iBed Wireless Client	TCP/80/443	iBed Server

CUSTOMER WLAN ENVIRONMENT		
Supported wireless vendors	Cisco, Aruba	Required
Access point (AP) types	Controller based or autonomous	Required
Channel width	2.4 GHz: 20 MHz 5 GHz: 20/40 MHz	Required
Channel utilization	Consistently less than 30%	Recommended
Signal strength range (minimum)	2.4 GHz: -67dBm +/-8dBm 5 GHz: -67dBm +/-8dBm	Required
Minimum SNR	Minimum 20dB	Required
Priority queuing	Prioritized over best effort traffic	Recommended
Client exclusion	Disabled	Recommended
Client load balancing	Disabled	Recommended
Max number of SSIDs	5	Recommended
Authentication timeouts	Add session timeout of at least 24 hours	Recommended

**Note:** A transmit power asymmetry problem may arise at the edges of virtual cell coverage if an APs transmit power is higher than the Stryker Wireless Client device (6 mW 2.4 GHz or 12 mW 5 GHz). The received signal strength indicator (RSSI) of the Stryker iBed Wireless Client on the AP must be verified. The device should never drop below an RSSI of -75 dBm on the AP.



# Introduction

## PRODUCT ILLUSTRATION

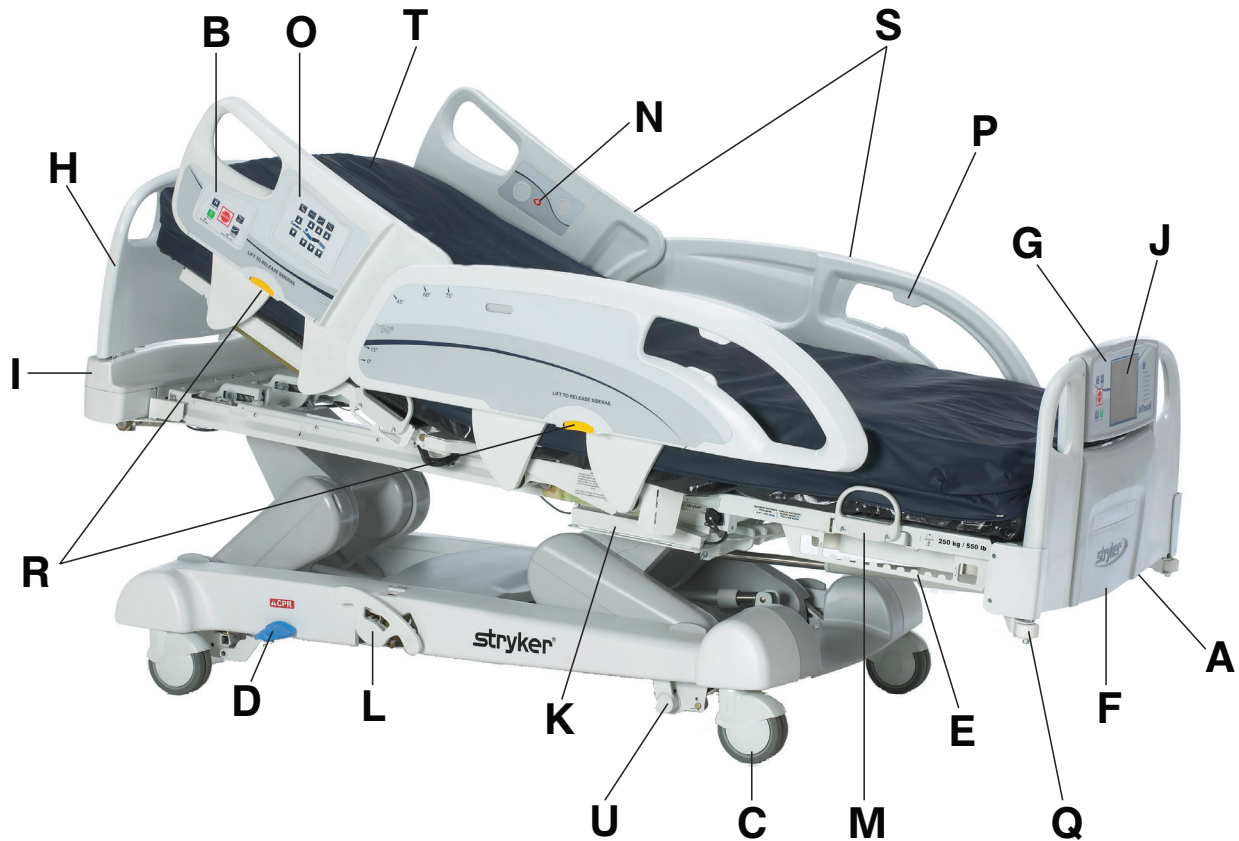

<b>A</b>	120V outlet (optional)
<b>B</b>	Brake control panel (outside siderail)
<b>C</b>	Caster
<b>D</b>	CPR release pedal
<b>E</b>	Foley bag hooks
<b>F</b>	Footboard
<b>G</b>	Footboard control panel
<b>H</b>	Headboard
<b>I</b>	Head end control panel (optional)
<b>J</b>	InTouch touch screen
<b>K</b>	Isolated foley bag hooks

<b>L</b>	Manual backup brake
<b>M</b>	Mattress retainer
<b>N</b>	Nurse call (inside siderail) (optional)
<b>O</b>	Motion control panel (outside siderail)
<b>P</b>	Pendant holder
<b>Q</b>	Roller bumpers
<b>R</b>	Siderail release levers
<b>S</b>	Siderails
<b>T</b>	Support surface (optional)
<b>U</b>	Zoom drive system (model 2141) (optional)

# Introduction

## CONTACT INFORMATION

Contact Stryker Customer Service or Technical Support at 1-800-327-0770.

Stryker Medical  
3800 E. Centre Avenue  
Portage, Michigan 49002  
USA

To view your operations or maintenance manual online, see <https://techweb.stryker.com/>.

Have the serial number (A) of your Stryker product available when calling Stryker Customer Service or Technical Support. Include the serial number in all written communication.

## SERIAL NUMBER LOCATION

You can find the serial number plate behind the patient right siderail near the foot end of the product.



## SPECIFICATION LABEL LOCATION

You can find the specification label behind the head end cover on the patient right side of the product.

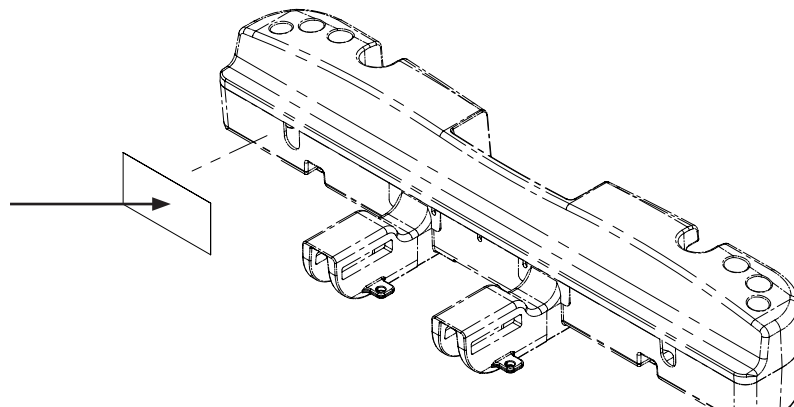

# Static Discharge Precautions

## PROTECTING AGAINST ELECTROSTATIC DISCHARGE (ESD)

### CAUTION

- Always use ESD protective equipment before opening antistatic bags and servicing electronic parts.
- Do not place unprotected circuit boards on the floor.
- All electronic service parts will be shipped in static shielding bags. Do not open the bags until you have completed steps 2 and 3 of the Static Protection Procedure.

**Note:** Always ship back circuit boards to Stryker in the same antistatic bags that the new boards were originally shipped in.

The electronic circuits in the product are completely protected from static electricity damage when factory assembled. Always use adequate static protection when servicing the electronic systems of the product. All service personnel must use static protection whenever they are touching wires.

### Static Antistatic Protection Equipment Includes:

- 1 antistatic wrist strap
- 1 grounding plug
- 1 test lead with a banana plug on one end and an alligator clip on the other end

### Static Protection Procedure

1. Unplug the power cord from the power source.
2. Insert the grounding plug into a properly grounded hospital grade wall receptacle. Plug the banana plug of the test lead into the receptacle on the grounding plug. Connect the alligator clip on the other end of the test lead to a ground point on the bed.
3. Place the static control wrist strap on your wrist. Connect the alligator clip at the other end of the wrist strap cord to a ground point on the bed.

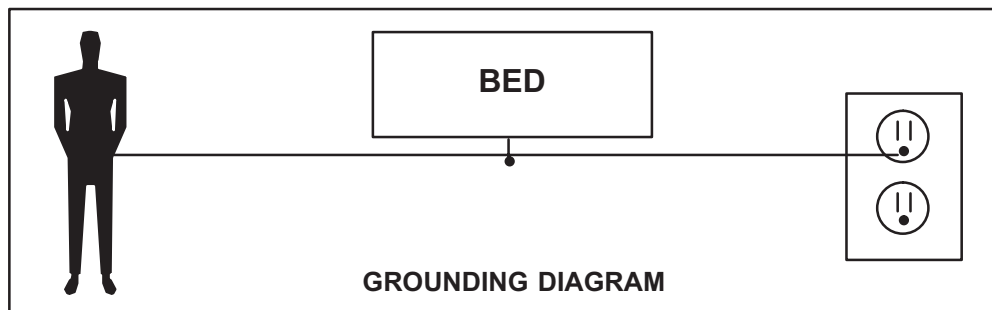

# Maintenance Menu Guide

The Maintenance Menu is accessed through the Touch Screen and contains additional features of the product. This menu provides an interface to the user and/or service personnel in order to provide the ability to control and access maintenance features.

## ACCESSING THE CONFIGURATION SCREEN

### WARNING

Please ensure patient is not in the bed prior to starting bed calibration. In calibration mode, the software does not control the interferences between the mechanical parts of the bed. Mechanical damage could occur without supervision. Only qualified personnel should perform the calibration.

### Note

Verify that the bed is on a level surface which does not have any slopes or inclines prior to entering into the calibration mode.

1. Unseat and reseat the footboard and wait until the main control screen is displayed.
2. Push and hold the Main Menu button located in the upper right corner of the footboard control panel (see Figure 1 below). Continue pressing on the Main Menu button while executing steps 3-5.
3. Push and hold the **Brake** button for 5 seconds and then release.
4. Push the **HOB 30°+** button once and release.
5. Push the **Drive** button once and release.
6. Release the Main Menu button and you will be taken into the Configuration Screen shown in Figure 3.

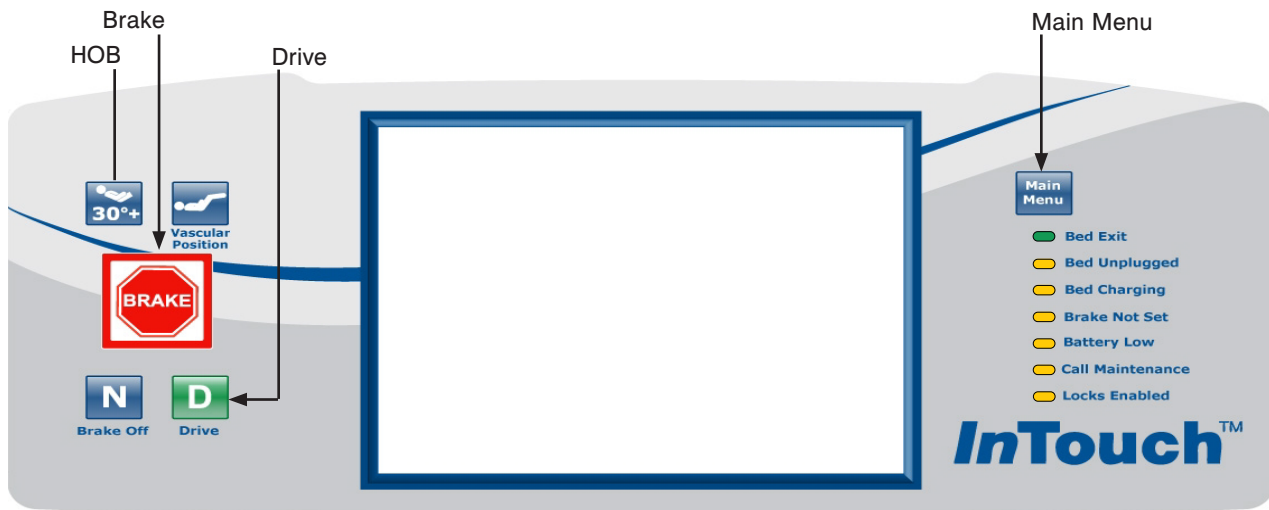

Figure 1: Footboard Control Panel

# Maintenance Menu Guide

## INTOUCH CONFIGURATION SCREEN

The following items A, B, and C are configuration buttons available and displayed on the Configuration screen (Figure 3).

- A. Bed Calibration
- B. Full Diagnostic ([see page 34](#))
- C. Touch Screen Calibration ([see page 35](#))
- D. Wi-Fi Reset ([see page 38](#))

The following items D and E are configuration options available but are **not displayed** on the Configuration screen. To access these configuration options, follow the procedures identified on page listed below.

- E. Bed Options Configuration ([see page 37](#))
- F. Serial Number Configuration ([see page 38](#))



Figure 3: Configuration Screen Menu Items

### A. Bed Calibration

**Note:** During calibration, if the backlight shuts off touch the screen to continue.

1. Connect the bed to an A/C outlet.
2. Place the mattress onto the frame.
3. Press the Bed Calibration button on the Configuration Screen (refer to Figure 3).
4. After pressing the Bed Calibration button, Figure 4 will be displayed. Press "NEXT" to continue with calibration.

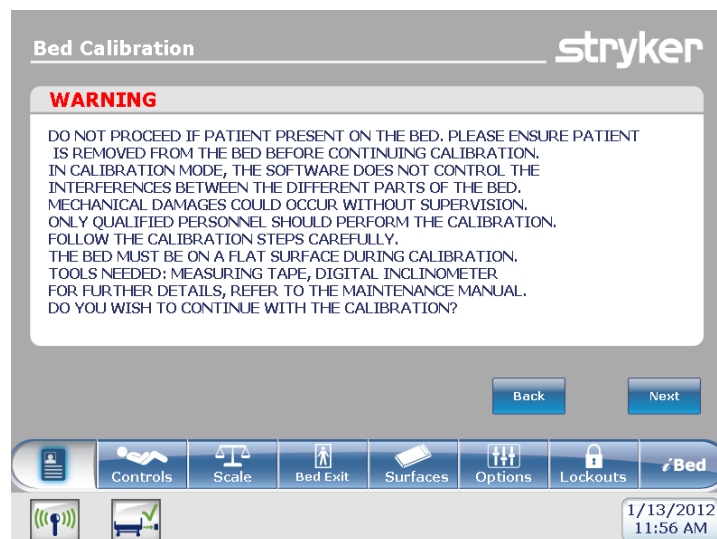

Figure 4: Bed Calibration - WARNING

# Maintenance Menu Guide

## INTOUCH CONFIGURATION SCREEN (CONTINUED)

### A. Bed Calibration (Continued)

- 5. After pressing **Next** to continue calibration, Figure 5 will appear.



Figure 5: Bed Calibration - Step #1 of 6

- 6. Place the Litter surface to a flat position by pressing simultaneously the **Foot Up**, **Fowler Down** and **Gatch Down** buttons as shown in Figure 6.

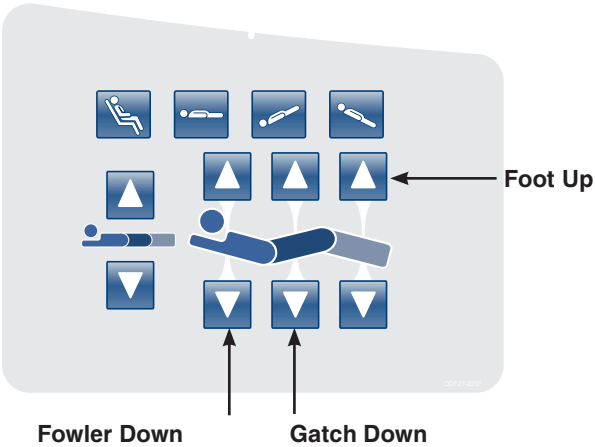

Figure 6: HE Siderail Control Panel - (Right Side Shown)

- 7. Lower the bed to the lowest position. Press the **Bed Height Down (Head Lift Down)** and **Reverse Trendelenburg (Foot Lift Down)** buttons simultaneously as shown in Figure 7.

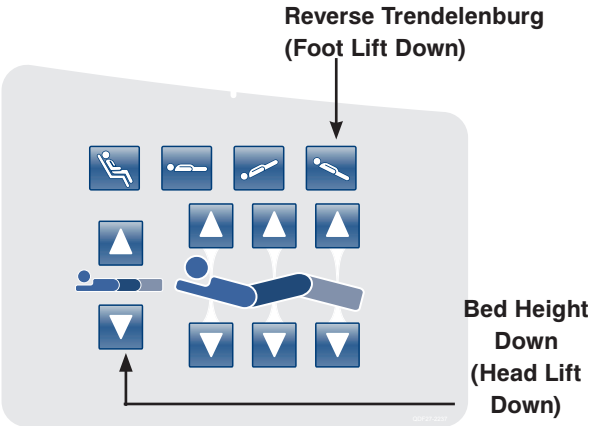

Figure 7: HE Siderail Control Panel - (Right Side Shown)

# Maintenance Menu Guide

## INTOUCH CONFIGURATION SCREEN (CONTINUED)

### A. Bed Calibration (Continued)

8. Press the **Next** button when done. The “Do Not Touch Bed” screen will appear as shown in Figure 8.

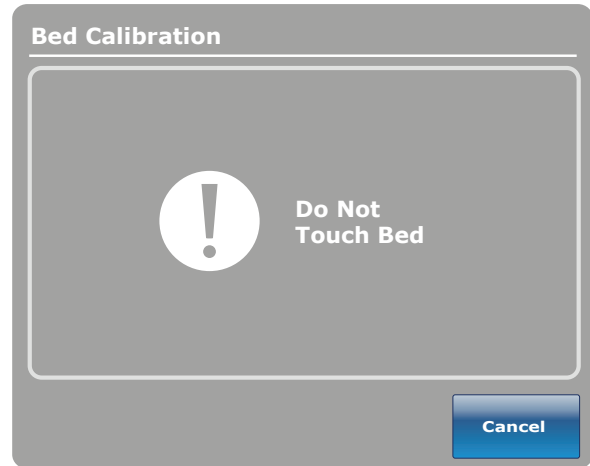

Figure 8

9. When step 1 of the calibration procedure has completed, step 2 of the calibration procedure will begin and Figure 9 will be displayed.



Figure 9: Bed Calibration - Step 2

# Maintenance Menu Guide

## INTOUCH CONFIGURATION SCREEN (CONTINUED)

### A. Bed Calibration (Continued)

10. Raise the bed height to 20 inches measuring from the top of the seat section to the floor. Press the **Bed Height Up (Head Lift Up)** and **Trendelenburg (Foot Lift Up)** buttons as shown in Figure 10.

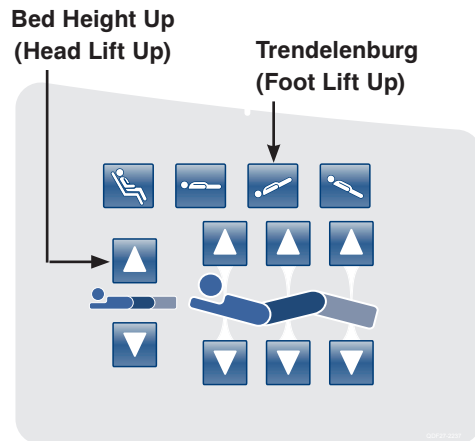

Figure 10: Head Siderail Control Panel (Right Side Shown)

11. Standing on either side of the bed at the fowler section, raise the foot siderail and then position the digital level/inclinometer on the bottom of the litter below the mattress retainer (refer to Figure 11). Using the digital level/inclinometer, verify the bed is level (0.0 +/- 0.1).

**Note: Cycle power on the digital level/inclinometer prior to placing it on the bottom of the litter frame and do not zero/calibrate the digital level/inclinometer.**



Placement on Litter

Figure 11: Inclinometer placement

12. Press the **Next** button when done. The “Do Not Touch Bed” screen will appear as shown in Figure 12.

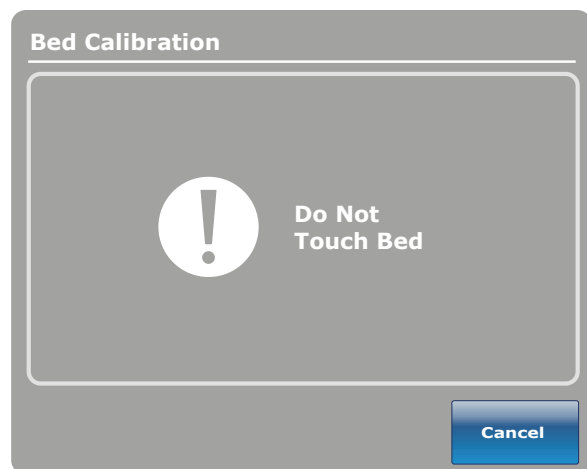

Figure 12: Do Not Touch Bed Screen



# Maintenance Menu Guide

## INTOUCH CONFIGURATION SCREEN (CONTINUED)

### A. Bed Calibration (Continued)

13. When step 2 of the calibration procedure has completed, step 3 of the calibration procedure will begin and Figure 13 as shown below will appear on the screen.



Figure 13: Bed Calibration - Step 3

14. Place the bed at +12 degrees Trendelenburg by pressing the **Trendelenburg (Foot Lift Up)** button as shown in Figure 14. Verify +12 degrees +/- 0.1 with the inclinometer you previously placed on the litter frame in step 11.

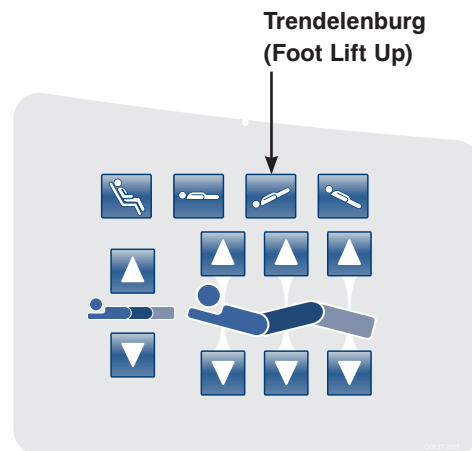

Figure 14: Head Siderail Control Panel

# Maintenance Menu Guide

## INTOUCH CONFIGURATION SCREEN (CONTINUED)

### A. Bed Calibration (Continued)

15. Press the **Next** button when done.

16. The “Do Not Touch Bed” screen will appear as shown in Figure 15.

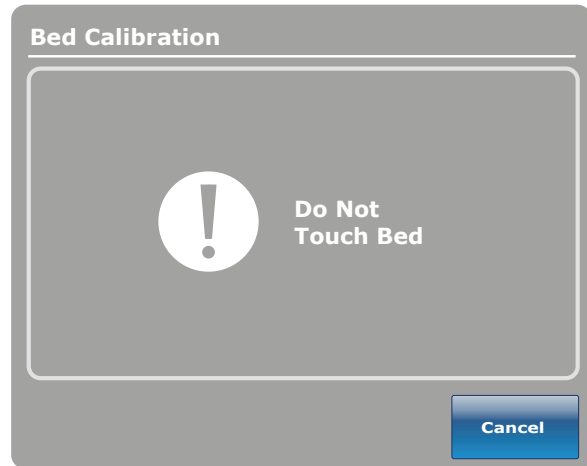

Figure 15: Do Not Touch Bed Screen

17. When step 3 of the calibration procedure has completed, step 4 of the calibration procedure will begin and Figure 16 will be displayed as shown below.



Figure 16: Bed Calibration - Step 4

# Maintenance Menu Guide

## INTOUCH CONFIGURATION SCREEN (CONTINUED)

### A. Bed Calibration (Continued)

18. Level the bed back out to zero degrees by pushing the Reverse Trendelenburg button until the litter is level while referencing the inclinometer. Note: Confirm inclinometer reads zero degrees.
19. Place the bed at -12 degrees Reverse Trendelenburg by pressing the **Bed Height Up (Head Lift Up)** button as shown in Figure 17 below. Verify -12 degrees +/- 0.1 with the inclinometer you previously placed on the bottom of the litter frame in step 11.

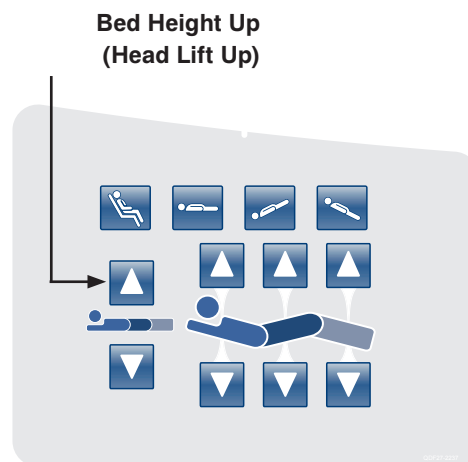

Figure 17: Head Siderail Control Panel - (Right Side Shown)

20. Press the **Next** button when done.

21. The “Do Not Touch Bed” screen will appear as shown in Figure 18.

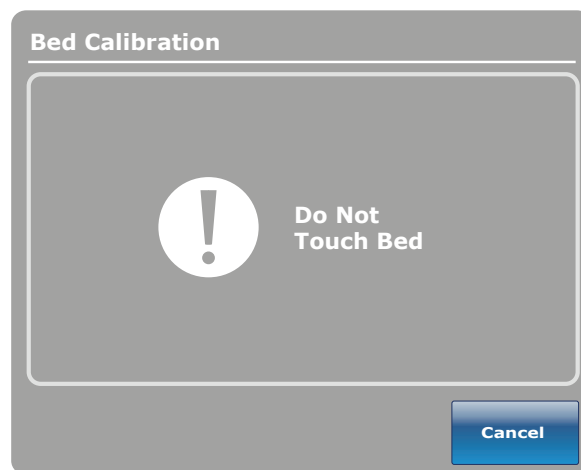

Figure 18: Do Not Touch Bed Screen

# Maintenance Menu Guide

## INTOUCH CONFIGURATION SCREEN (CONTINUED)

### A. Bed Calibration (Continued)

22. When step 4 of the calibration procedure has completed, step 5 of the calibration procedure will begin and Figure 19 will appear on the screen as shown below.



Figure 19: Bed Calibration - Step 5

23. Place the bed at the highest height by pressing simultaneously the **Trendelenburg (Foot Lift Up)** button and **Bed Height Up (Head Lift Up)** button as shown in Figure 20.

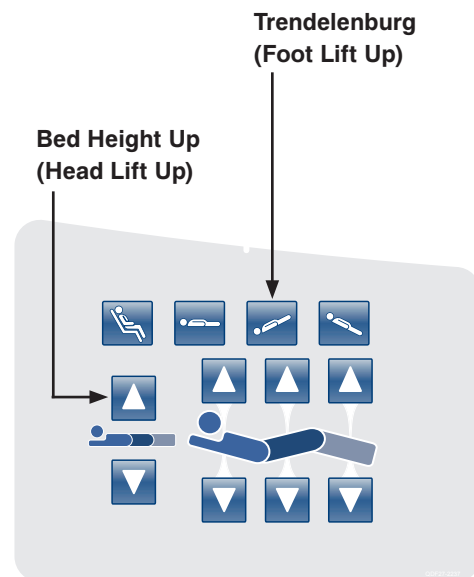

Figure 20: Head Siderail Control Panel - (Right Side Shown)

# Maintenance Menu Guide

## INTOUCH CONFIGURATION SCREEN (CONTINUED)

### A. Bed Calibration (Continued)

24. Press the **Fowler Up** button until the Fowler reaches the highest height, next press the **Gatch Up** button until the Gatch reaches its highest height, lastly press the **Foot Up** button until the foot section reaches its highest height (refer to Figure 21 below). The foot section should be at a flat position.

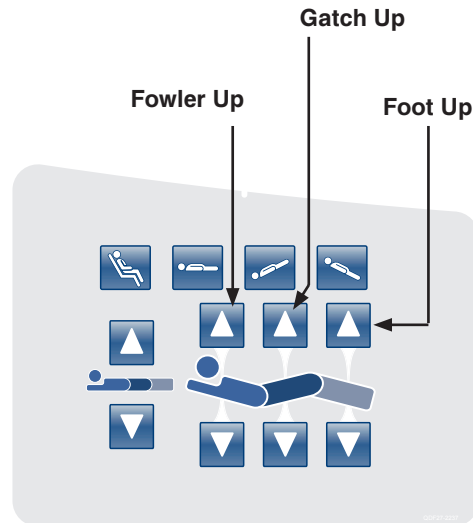

Figure 21: Head Siderail Control Panel - (Right Side Shown)

25. Press the **Next** button when done.

26. The “Do Not Touch Bed” screen will appear as shown in Figure 22.

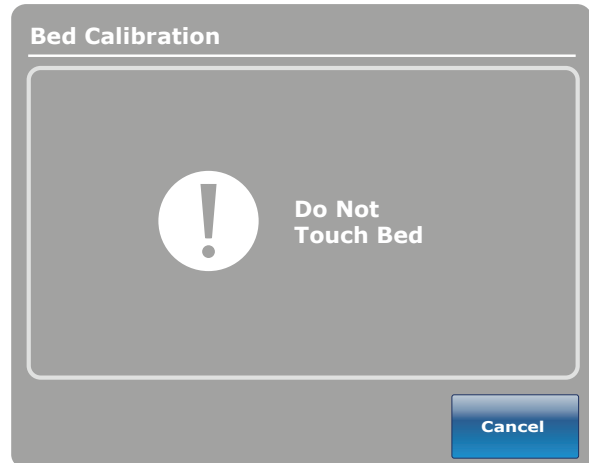

Figure 22: Do Not Touch Bed Screen

# Maintenance Menu Guide

## INTOUCH CONFIGURATION SCREEN (CONTINUED)

### A. Bed Calibration (Continued)

27. When step 5 of the calibration procedure has completed, step 6 of the calibration procedure will begin and Figure 23 will be displayed as shown below.



Figure 23: Bed Calibration - Step 6

28. Place the bed at the highest height by pressing simultaneously the **Trendelenburg (Foot Lift Up)** button and **Bed Height Up (Head Lift Up)** button (see Figure 24).
29. Place the Fowler and Gatch section of the bed at the highest height by first pressing the **Fowler Up** button then the **Gatch Up** button (See Figure 24).
30. Place the foot at the lowest position by pushing the **Foot Down** button until limit is met (see Figure 24) . **CAUTION: The Gatch must be raised to the highest height prior to running the Foot Down or damage could occur.**

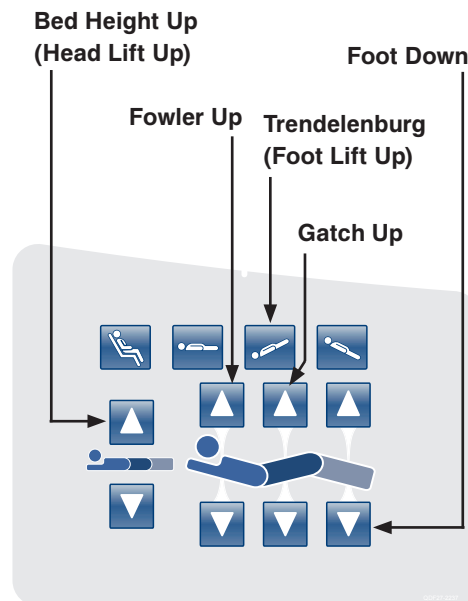

Figure 24: Calibration Complete

# Maintenance Menu Guide

## INTOUCH CONFIGURATION SCREEN (CONTINUED)

### A. Bed Calibration (Continued)

31. When the calibration procedure is completed, Figure 25 will be displayed as shown below.
32. Press the Close button to exit the Calibration Procedure Menu.
33. Level the litter flat using the CPR pedal. Verify all display readings are zero degrees while the bed is at 33" (84 cm) (highest height). Lower the bed to 16" (41 cm) (lowest height) and verify the display readings maintain a constant reading of zero degrees with no fluctuations. When the bed reaches it lowest height at 16", verify the display readings are still at zero degrees.

**Note:** If readings are not all zero, you will need to recalibrate the bed by repeating steps 1-30.

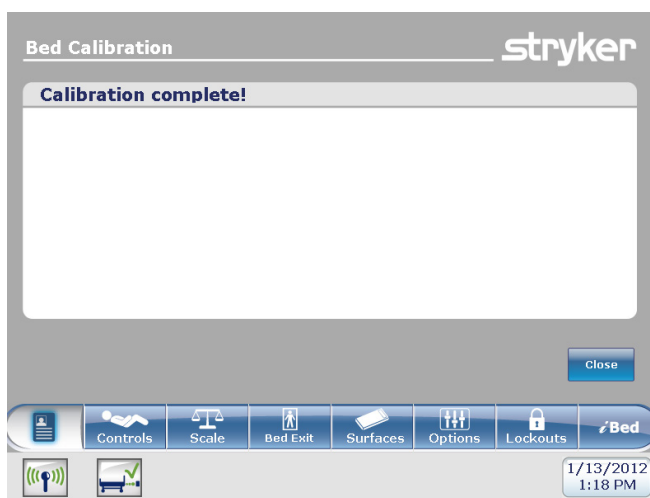

**Figure 25: Calibration Complete**

# Maintenance Menu Guide

## INTOUCH CONFIGURATION SCREEN (CONTINUED)

### B. Full Diagnostic

1. From the Configuration Screen, press the Full Diagnostic button. Figure 26 will appear.
2. The following menu items may be selected by pressing their button.
  - a. **BOARDS** (Figure 27a)  
Provides information on the switch boards and the touch screen's software version.
  - b. **ERROR CODES** (Figure 27b)  
Provides information on errors which the CPU board has identified.
  - c. **INPUT STATES** (Figure 27c)  
Provides information on the status of all switches and jumpers on the bed.
  - d. **MOTORS** (Figure 27d)  
Provides information on what a motor is doing when a function button is pushed.  
**Note:** This requires assistance to press the buttons on the head siderails or at the head end control.
  - e. **BUTTONS PRESSED** (Figure 27e)  
Provides information on when the CPU has detected a button being pressed.  
**Note:** This requires assistance to press the buttons on the head siderails or at the head end control.
  - f. **SIGNAL VALUES** (Figure 27f)  
Provides information on CPU voltages, load cell values, and angle sensor values.

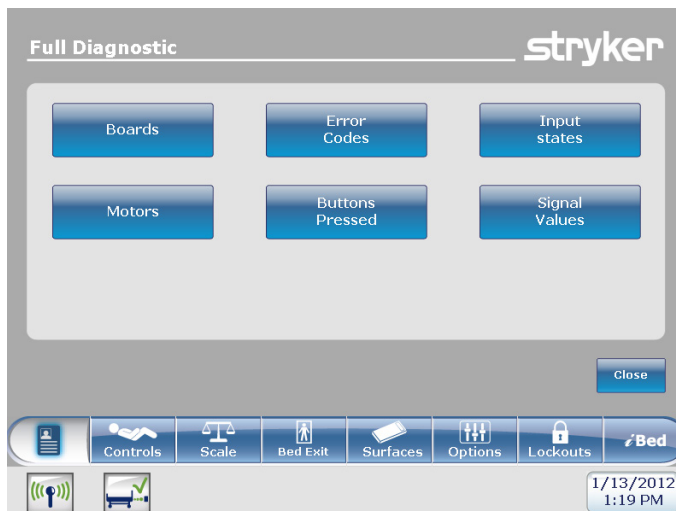

Figure 26: Full Diagnostic Screen

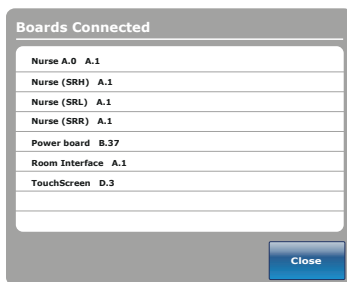

Figure 27a: Board

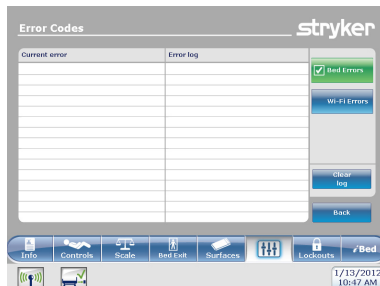

Figure 27b: Error Codes

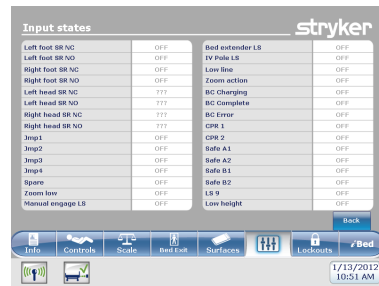

Figure 27c: Input States

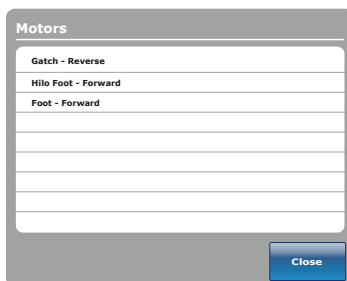

Figure 27d: Motor

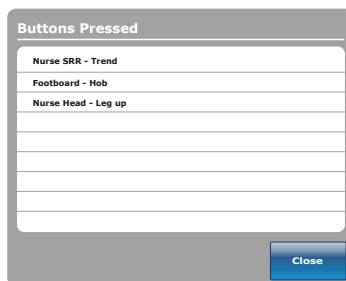

Figure 27e: Pressed Buttons

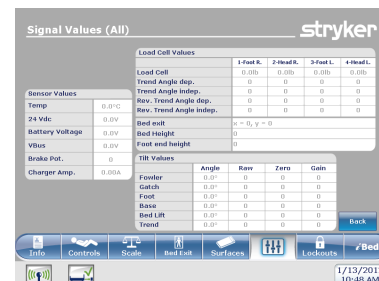

Figure 27f: Signal Values



# Maintenance Menu Guide

## INTOUCH CONFIGURATION SCREEN (CONTINUED)

### C. Touch Screen Calibration

Ensure patient is not present on the bed before performing the Touch Screen Calibration.

1. From the Configuration Screen, press the Touch Screen Calibration button. Figure 28 will appear.  
**NOTE: If the touch screen will not respond, you will need to push the HOB 30<sup>o</sup>+, Brake and Drive buttons on the footboard at the same time (this will enable you to get directly into the touch screen calibration).**  
**CAUTION: When pushing the buttons above the fowler, brakes, or drive, actuators may activate.**
2. Carefully press and briefly hold a stylus or your finger on the center of the cross hair shown on the screen.
3. Repeat as the target moves around the screen. There will be five different locations to press: center, lower right, upper right, upper left, and lower left.
4. When the last cross hair has been touched, Figure 29 displays 'New calibration settings have been measured'.
5. Tap the screen to register saved data.
6. If you do not want to save the new data, wait for 30 seconds to cancel saved data and keep the current setting.

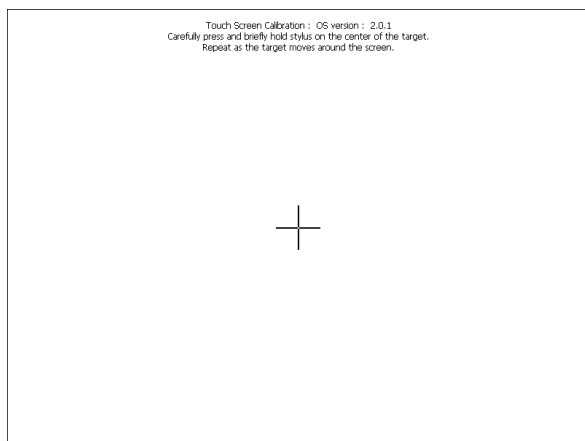

Figure 28: Touch Screen Calibration: Start



Figure 29: Touch Screen Calibration: Completed

**NOTE: The TOUCH SCREEN CALIBRATION SCREEN is a validation of the touch screen's calibration. When the user presses anywhere on the screen, the coordinates x and y are displayed on the lower part of the screen.**

# Maintenance Menu Guide

---

## INTOUCH CONFIGURATION SCREEN (CONTINUED)

### D. Wi-Fi Reset

---

#### CAUTION

These settings should only be modified by trained personnel. Changing these settings may disable the wireless feature. These settings should only be changed or updated with the aid of the hospital's IT department or the appropriate maintenance personnel.

---

1. From the Configuration Screen, tap **Wi-Fi Reset** to reset the wireless radio of the bed.



**Figure 30: Wi-Fi Reset**

# Maintenance Menu Guide

## INTOUCH CONFIGURATION SCREEN (CONTINUED)

### E. Bed Options Configuration

Access the configuration screen as shown on [page 22](#). Once in the configuration screen, follow the steps below to access the options screen or the serial number screen.

#### To access the Bed Options screen:

1. Press and hold the **HOB 30** button and the **BRAKE** button at the same time for 5 seconds, then release both buttons. The Bed Options screen (Figure 34) will be displayed.

**NOTE: When the European Community message window displays, push the Close button to close out of the message. That is not applicable in this configuration.**

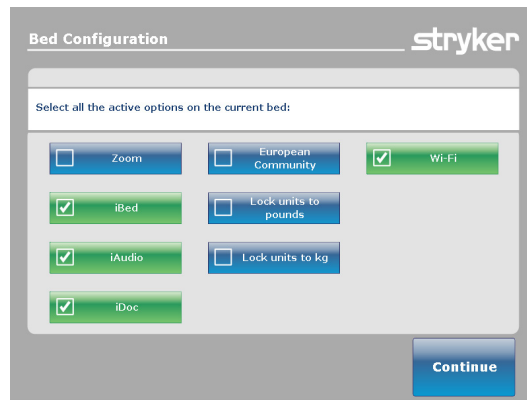

Figure 34: Bed Options screen

2. Select all of the options shown on the Bed Options screen that apply to the bed configuration then, press **Continue**.  
**NOTE: In Figure 34, the options selected are iBed, iAudio, iDoc and Wi-Fi. All of the options selected will turn green.**
3. After pressing **Continue** in step 2, a confirmation screen as shown in Figure 35 will be displayed verifying the options you selected.
  - a. If the options on the confirmation screen do not match the options on the bed, press the **Back** button.
  - b. If the options on the confirmation screen match the options on the bed, press the **OK** button.
4. After pressing the **OK** button, the options will be saved and the screen will return to the configuration screen. Press the **Close** button to close the configuration screen.
5. After pressing the **Close** button, a cycle power screen (Figure 38) will be displayed stating to cycle power on the bed.
6. To cycle power on the bed, turn the battery disconnect switch to **OFF** (O) then unplug the power cord from the wall outlet. Plug the power cord back into the wall outlet then turn the battery disconnect switch back **ON** (I).
7. Test bed functionality prior to returning the bed into service.

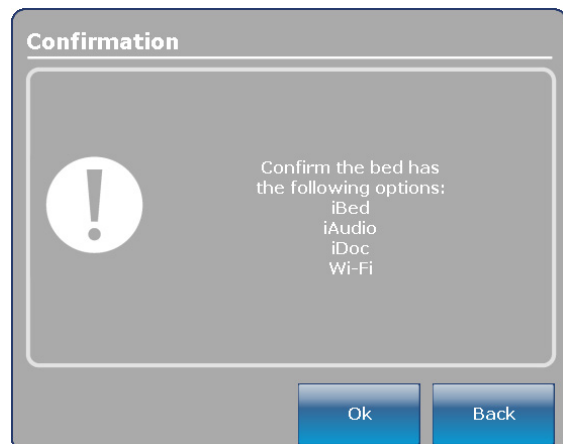

Figure 35: Bed Options Confirmation Screen

# Maintenance Menu Guide

## INTOUCH CONFIGURATION SCREEN (CONTINUED)

### F. Serial Number Configuration

#### To access the Serial Number screen:

1. Press and hold the **HOB 30** button and the **Vascular Position** button at the same time for 5 seconds then release both buttons. The Bed Configuration - Serial Number screen (Figure 36) will be displayed.

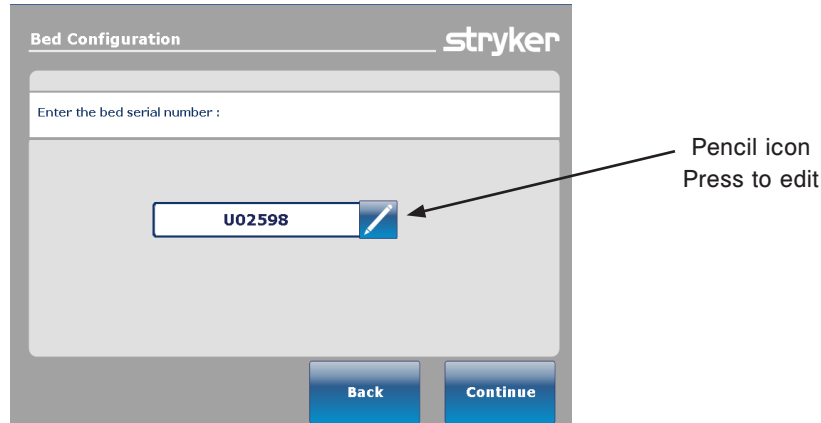

Figure 36: Bed Configuration Serial Number Screen

2. Enter or confirm the serial number of the bed (Figure 36).
  - a. **To enter the serial number:**
    - i. Press the pencil button located to the right of the serial number field. The Edit screen will be displayed.
    - ii. Enter the serial number of the bed in the serial number field, then press the **OK** button. You will be returned to the serial number main screen as shown in Figure 36.
    - iii. Press the **Continue** button and proceed to step 3.
  - b. **To confirm the serial number:**
    - i. Review the serial number displayed in the serial number field.
    - ii. If serial number is correct, press the **Back** button and proceed to step 6.
    - iii. If the serial number is incorrect, press the pencil icon button to open the Edit screen then enter the correct serial number.
    - iv. Press the **OK** button and you will be returned to the serial number main screen.
    - v. Press the **Continue** button and proceed to step 3.
3. After pressing the **Continue** button, the serial number will be saved and the serial number confirmation screen (Figure 37) will be displayed. Press the **OK** button.
4. After pressing the **OK** button, a cycle power screen (Figure 38) will be displayed stating to cycle power on the bed.
5. To cycle power on the bed, turn the battery disconnect switch to **OFF** (O) then unplug the power cord from the wall outlet. Plug the power cord back into the wall outlet then turn the battery disconnect switch back **ON** (I).
6. Test bed functionality prior to returning the bed into service.

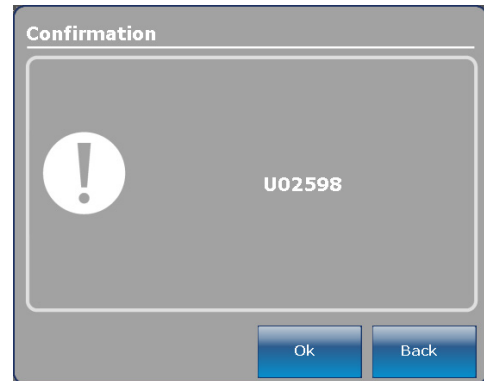

Figure 37: Serial Number Confirmation Screen

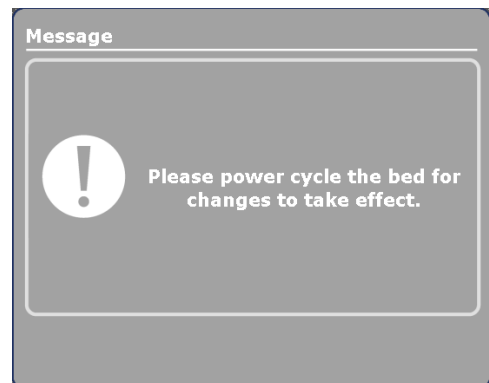

Figure 38: Cycle Power Screen

# Maintenance Menu Guide

## ACCESSING THE ISOLIBRIUM DIAGNOSTIC MENU

### WARNING

- Electrical shock risk. Refer all servicing to qualified personnel.
- Do not perform diagnostic test with a patient or other weight on the support surface.

### CAUTION

Do not touch the support surface while performing diagnostics test. Failure to do so could lead to inaccurate diagnostic results.

**Note:** Make sure that you plug the support surface power cord into the **InTouch** auxiliary mattress outlet (A) and the integration cable to the mattress connector (B) (Figure 39).

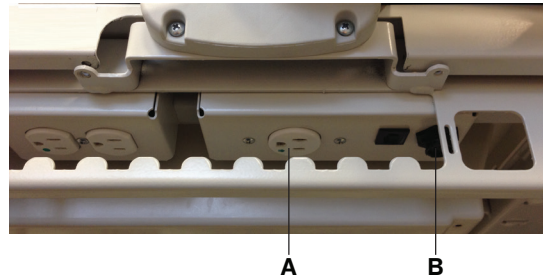

Figure 39: InTouch auxiliary mattress outlet and integration cable

The service display and its functions are for use by authorized service personnel only to avoid the risk of equipment malfunction. The entry to this menu is through a key combination in the **Support Surface** menu.

To access the diagnostic menu:

1. Unplug the InTouch bed and turn the battery switch to off and wait one minute.
2. Turn the battery switch to on and plug the InTouch bed into a wall outlet.
3. Tap Support Surfaces.
4. Enter the following key combination within 5 minutes of the support surface connection (Figure 40):
  - a. Lock (A) (lock is activated)
  - b. Low Air Loss (B) (press and hold for a minimum of 5 seconds)
  - c. Therapy History (C) (press and hold for a minimum of 5 seconds)



Figure 40: Diagnostic Entry Combination

5. If you have entered into the diagnostic menu and need to exit, tap X (Figure 41).

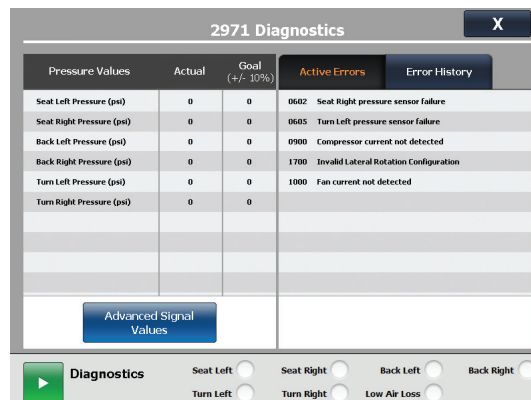

Figure 41: Diagnostic Main Screen Sample

# Maintenance Menu Guide

## REVIEWING ACTIVE ISOLIBRIUM ERRORS

**Note:** For **Isolibrium** error codes, see the **Isolibrium** operations/maintenance manual.

To enter the **Active Errors** screen, tap the **Active Errors** tab on the Service Diagnostic screen (Figure 42).

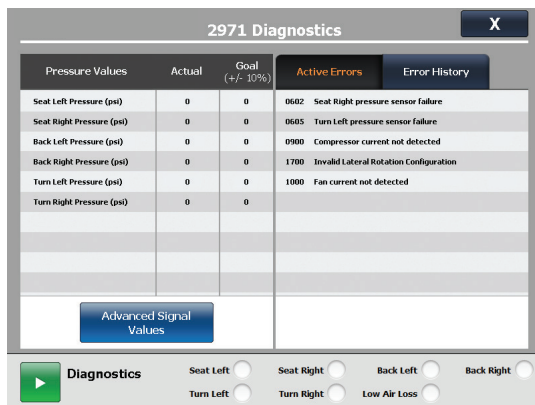

Figure 42: Active Errors

A list of the active errors are displayed (Figure 42). A maximum of five active errors are displayed simultaneously, and are ordered by priority.

## REVIEWING AND CLEARING ISOLIBRIUM ERROR HISTORY

To enter the **Error History** screen, tap the **Error History** tab on the Diagnostic Screen (Figure 43).

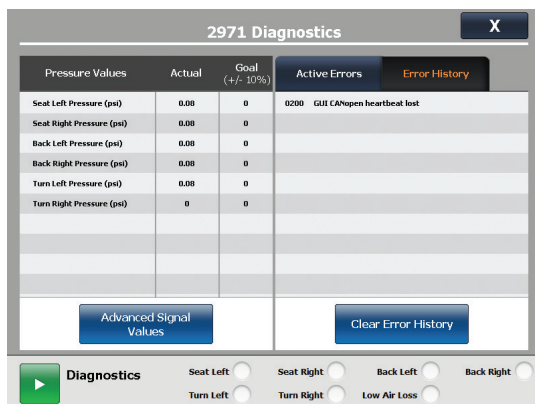

Figure 43: Diagnostic Screen

The error list is ordered from the oldest entry to the newest, with a maximum of 10 errors.

To clear the **Error History** screen, tap **Clear Error History** on the Diagnostic screen (Figure 43).

### Notes

- Always tap **Clear Error History** after troubleshooting is complete
- If you clear the error history while there is an active error, the active error does not show in the **Error History** tab until the active error is fixed.

# Maintenance Menu Guide

## VIEWING ADVANCED SIGNAL VALUES FOR ISOLIBRIUM

The Advanced Signal Values screen displays the complete list of signal values of the support surface. The screen displays the actual and goal pressure values. For other non-pressure signals, only the actual values are displayed.

To enter the **Advanced Signal Values** screen, tap **Advanced Signal Values** on the Diagnostics screen (Figure 44).

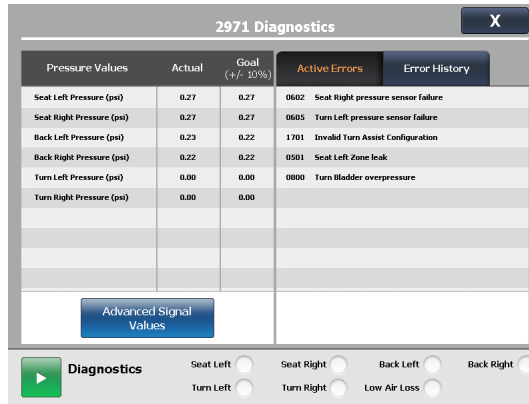

Figure 44: Diagnostic Main Screen - Sample

To exit the **Advanced Signal Values** screen, tap **Back** to return to the Diagnostics screen (Figure 45).

Signal Values	Actual	Goal (+/- 10%)	Signal Values	Actual	Goal (+/- 10%)
Seat Left Pressure (psi)	0.27	0.27	Turn Right Def I (mA)	0.00	-
Seat Right Pressure (psi)	0.27	0.27	Intake	0.00	-
Back Left Pressure (psi)	0.24	0.24	Exhaust	0.00	-
Back Right Pressure (psi)	0.24	0.24	Compressor Control I (mA)	0.00	-
Turn Left Pressure (psi)	0.00	0.00	Compressor I (mA)	0.09	-
Turn Right Pressure (psi)	0.01	0.01	Fan 1 I (mA)	0.00	-
Seat Left Inf I (mA)	0.00	-	Fan 2 I (mA)	0.00	-
Seat Left Def I (mA)	0.00	-	Ambient Temp (deg. C)	27.00	-
Seat Right Inf I (mA)	0.00	-			
Seat Right Def I (mA)	0.00	-			
Back Left Inf I (mA)	0.00	-			
Back Left Def I (mA)	0.00	-			
Back Right Inf I (mA)	0.00	-			
Back Right Def I (mA)	0.00	-			
Turn Left Inf I (mA)	0.00	-			
Turn Left Def I (mA)	0.00	-			
Turn Right Inf I (mA)	0.00	-			

Figure 45: Advanced Signal Values

# Maintenance Menu Guide

## RUNNING A DIAGNOSTIC TEST FOR ISOLIBRIUM

**⚠ WARNING**

Do not perform diagnostic test with a patient or other weight on the support surface.

**⚠ CAUTION**

Do not touch the support surface while performing diagnostics test. Failure to do so could lead to inaccurate diagnostic results.

**Notes**

- The results of the test will not be displayed until all tests have been completed.
- No results will be displayed if the tests are canceled.
- Other diagnostic functions are disabled while the diagnostic test is running.

The diagnostic test runs seven tests at one time on the support surface and take approximately 45 minutes to complete. They include the following:

- Seat Left
- Seat Right
- Back Left
- Back Right
- Turn Left
- Turn Right
- Low Air Loss

To run diagnostics, tap **start** on the lower portion of the Diagnostics screen (Figure 46).

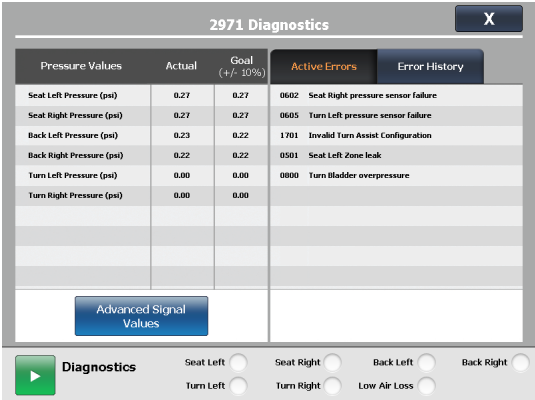

**Figure 46: Diagnostic Main Screen - Sample**



# Maintenance Menu Guide

## RUNNING A DIAGNOSTIC TEST FOR ISOLIBRIUM (CONTINUED)

**Note: Diagnostics running** (Figure 47) appears to indicate that the diagnostic test is in progress.

To cancel diagnostics, tap **stop** on the lower portion of the Diagnostics screen (Figure 47).

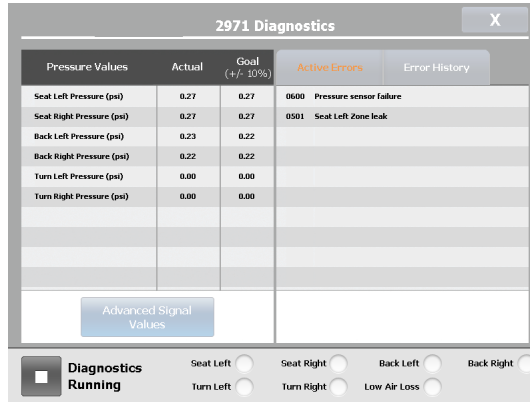

Figure 47: Diagnostic Main Screen - Sample

When the test is complete, the results of each test section is indicated by a red cross when there is a failure or a green check mark when successful (Figure 48).

**Note:** When a failure is first detected, all following pressure tests will be marked as a failure.

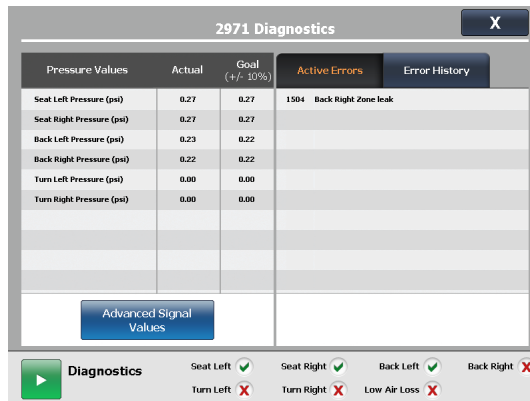

Figure 48: Diagnostic Test Result - Sample

# Preventive Maintenance

---

At a minimum, check all items listed during annual preventive maintenance for all Stryker Medical products. You may need to perform preventive maintenance checks more frequently based on your level of product usage.

Remove product from service before performing preventive maintenance. Preventive maintenance should only be performed by trained or certified personnel.

## Notes

- Clean and disinfect the exterior of the support surface before inspection, if applicable.
- For **Isolibrium** preventive maintenance items, see the **Isolibrium** operations/maintenance manual.

Inspect the following items:

- All welds and all fasteners are secure
- Tubing or sheet metal for bends or breaks
- Casters are free of debris
- Casters are secure and swivel properly
- Casters lock securely by depressing the brake pedal
- Manual and electric brakes apply and release properly
- Brake Not Set LED on the footboard and head end siderails when brakes are not engaged
- Locking steer caster engages and disengages properly (model 2131)
- Steer caster latches properly
- Fowler operates properly
- Litter up/down operates properly
- Trend operates properly
- IV pole is intact and operating properly (optional)
- Support surface cover after each use
- Support surface cover for rips or cracks
- Headboard, footboard, and siderail panels for cracks or splits
- All covers are not damaged and are not producing sharp edges
- Night light operating properly
- CPR release operating properly
- All siderail motion functionality
- Siderails move, latch, and stow properly
- Siderail switches working properly (iBed Awareness option)
- iBed Awareness light bars on footboard and siderails are working properly (iBed Awareness option)
- All functions on head end siderails working properly (including LEDs)
- All functions on footboard working properly (buttons, touch screen display, and LEDs)
- Touch screen is accurately calibrated
- Product is accurately calibrated
- Scale and bed exit system operating properly
- Drive wheel to make sure it is operating properly (model 2141 — Zoom option)
- Motion release switches working properly (model 2141 — Zoom option)
- Head end Zoom handle functionality operates properly (2141 model only)
- Batteries for replacement (every two years) (use only QDF9188 for battery replacement)
- Batteries for corrosion at the terminals, cracking, expanded or bulging at the sides, or can no longer maintain a full charge
- Nurse call functionality (optional)
- Lubricate where required
- Pendant for any physical damage
- Power cord not frayed
- Cables not worn or pinched
- All electrical connections tight

# Preventive Maintenance

---

- \_\_\_\_\_ All grounds secure to the frame
- \_\_\_\_\_ Ground impedance not more than 100 mΩ (milliohms)
- \_\_\_\_\_ Current leakage not more than 300 μA (microamps)
- \_\_\_\_\_ Ground chains are clean, intact, and have at least two links touching the floor
- \_\_\_\_\_ Enclosure is free from wear, tear, stresses and mechanical damage
- \_\_\_\_\_ No rust or corrosion of parts
- \_\_\_\_\_ Labels for legibility, proper adherence, and integrity
- \_\_\_\_\_ Apply relevant software patches
- \_\_\_\_\_ iBed Wireless Module and IR Module are intact and footboard icons are displaying (iBed Wireless option)

Serial Number:		

Completed by: \_\_\_\_\_ Date: \_\_\_\_\_

# Troubleshooting

## Notes:

- See the **Bed Circuit Boards** section for an outline of InTouch PCBs and voltage test points.
- For **Isolibrium** troubleshooting, see the **Isolibrium** operations/maintenance manual.

## BED TROUBLESHOOTING

Problem / Failure		Recommended Action
No Power to Bed. (On wall voltage 120VAC)		<ol style="list-style-type: none"> <li>1. Verify the bed is plugged into a functional wall outlet.               <ol style="list-style-type: none"> <li>A. Check your country voltage option at wall outlet.                   <ol style="list-style-type: none"> <li>I. If your country voltage option is present, go to step 2.</li> <li>II. If your country voltage option is not present, contact hospital maintenance staff and try another outlet.</li> </ol> </li> </ol> </li> <li>2. Verify the Bed main power fuses are good, located in drawer where power cord plugs into the bed.               <ol style="list-style-type: none"> <li>A. Check for continuity of each 10A fuse.                   <ol style="list-style-type: none"> <li>I. If each fuse (see CV Table) is good, go to step 3.</li> <li>II. If either fuse (see CV Table) does not have continuity, replace the fuse.</li> </ol> </li> </ol> </li> <li>3. Verify there is power at the transformer connection (J11) on the CPU/Power board at the foot end.               <ol style="list-style-type: none"> <li>A. Check for 24VAC at J11 between the blue and red wires.                   <ol style="list-style-type: none"> <li>I. If 24VAC is present, go to step 4.</li> <li>II. If 24VAC is not present, check the 25 Amp fuse in the fuse holder on the red wire from the transformer. If bad, replace the fuse.</li> <li>III. If 24VAC is not present, check the power cable quick connection going to the transformer for (see CV Table) VAC. If no voltage, follow the cable and repair or replace the damaged component.</li> <li>IV. If (see CV Table) VAC is present, replace the transformer assembly.</li> </ol> </li> </ol> </li> <li>4. A. Check for 30VAC at J11 between the yellow and orange wires for the transformer.               <ol style="list-style-type: none"> <li>I. If 30VAC is present, go to step 5.</li> <li>II. If 30VAC is not present, check the power cable quick connection going to the transformer for (see CV Table) VAC. If no voltage, follow the cable and repair or replace the damaged component.</li> <li>III. If (see CV Table) VAC is present, replace the transformer assembly.</li> </ol> </li> <li>5. A. Check fuse F1 on the CPU/Power board.               <ol style="list-style-type: none"> <li>I. If fuse is good, replace CPU/Power board.</li> <li>II. If fuse does not have continuity, replace the fuse (littelfuse 215008.P).</li> </ol> </li> </ol>
<b>COUNTRY VOLTAGE (CV) TABLE</b>		
<b>VOLTAGE</b>	<b>FUSE</b>	
<b>100V</b>	<b>10A</b>	
<b>110V</b>	<b>10A</b>	
<b>120V</b>	<b>10A</b>	
<b>200V</b>	<b>10A</b>	
<b>220V</b>	<b>10A</b>	
<b>230V</b>	<b>10A</b>	
<b>240V</b>	<b>10A</b>	

# Troubleshooting

## BED TROUBLESHOOTING

Problem / Failure		Recommended Action
No Bed Up Motion.	FOOT	<ol style="list-style-type: none"> <li>1. Put the bed into the Bed Calibration menu.               <ol style="list-style-type: none"> <li>A. Using one of the head siderails, push the trend button.                   <ol style="list-style-type: none"> <li>I. If the foot lift motor runs up, recalibrate the bed (refer to the Bed Calibration procedures located on <a href="#">page 23</a>).                       <ol style="list-style-type: none"> <li>a. If recalibration does not work, replace the litter angle sensor and recalibrate.</li> </ol> </li> <li>II. If the foot lift motor does not run up, check for 24VDC at connector J6 while pressing the trend button. Black lead to pin 1, red lead to pin 2.                       <ol style="list-style-type: none"> <li>a. If voltage is present, replace the motor.</li> <li>b. If voltage is not present, replace the CPU/Power board.</li> </ol> </li> </ol> </li> </ol> </li> </ol>
	HEAD	<ol style="list-style-type: none"> <li>1. Put the bed into the Bed Calibration menu.               <ol style="list-style-type: none"> <li>A. Using one of the head siderails, push the bed up button.                   <ol style="list-style-type: none"> <li>I. If the head lift motor runs up, recalibrate the bed (refer to the Bed Calibration procedures located on <a href="#">page 23</a>).                       <ol style="list-style-type: none"> <li>a. If recalibration does not work, replace the litter angle sensor and recalibrate.</li> </ol> </li> <li>II. If the head lift motor does not run up, check for 24VDC at connector J4 while pressing the trend button. Black lead to pin 1, red lead to pin 2.                       <ol style="list-style-type: none"> <li>a. If voltage is present, replace the motor.</li> <li>b. If voltage is not present, replace the CPU/Power board.</li> </ol> </li> </ol> </li> </ol> </li> </ol>
No Bed Down Motion.	FOOT	<ol style="list-style-type: none"> <li>1. Put the bed into the Bed Calibration menu.               <ol style="list-style-type: none"> <li>A. Using one of the head siderails, push the reverse trend button.                   <ol style="list-style-type: none"> <li>I. If the foot lift motor runs down, recalibrate the bed (refer to the Bed Calibration procedures located on <a href="#">page 23</a>).                       <ol style="list-style-type: none"> <li>a. If recalibration does not work, replace the litter angle sensor and recalibrate.</li> </ol> </li> <li>II. If the foot lift motor does not run down, check for 24VDC at connector J6 while pressing the reverse trend button. Red lead to pin 1, black lead to pin 2.                       <ol style="list-style-type: none"> <li>a. If voltage is present, replace the motor.</li> <li>b. If voltage is not present, replace the CPU/Power board.</li> </ol> </li> </ol> </li> </ol> </li> </ol>
	HEAD	<ol style="list-style-type: none"> <li>1. Put the bed into the Bed Calibration menu.               <ol style="list-style-type: none"> <li>A. Using one of the head siderails, push the bed down button.                   <ol style="list-style-type: none"> <li>I. If the head lift motor runs down, recalibrate the bed (refer to the Bed Calibration procedures located on <a href="#">page 23</a>).                       <ol style="list-style-type: none"> <li>a. If recalibration does not work, replace the litter angle sensor and recalibrate.</li> </ol> </li> <li>II. If the head lift motor does not run down, check for 24VDC at connector J4 while pressing the trend button. Red lead to pin 1, black lead to pin 2.                       <ol style="list-style-type: none"> <li>a. If voltage is present, replace the motor.</li> <li>b. If voltage is not present, replace the CPU/Power board.</li> </ol> </li> </ol> </li> </ol> </li> </ol>

# Troubleshooting

## BED TROUBLESHOOTING

Problem / Failure	Recommended Action
No Fowler Up Motion.	<ol style="list-style-type: none"> <li>1. Put the bed into the Bed Calibration menu.               <ol style="list-style-type: none"> <li>A. Using one of the head siderails, push the fowler up button.                   <ol style="list-style-type: none"> <li>I. If the fowler motor runs up, recalibrate the bed (refer to the Bed Calibration procedures located on <a href="#">page 23</a>).                       <ol style="list-style-type: none"> <li>a. If recalibration does not work, replace the fowler angle sensor and recalibrate.</li> </ol> </li> <li>II. If the fowler motor does not run up, check for 24VDC at connector J5 while pressing the fowler up button. Black lead to pin 1, red lead to pin 2.                       <ol style="list-style-type: none"> <li>a. If voltage is present, replace the motor.</li> <li>b. If voltage is not present, replace the CPU/Power board.</li> </ol> </li> </ol> </li> </ol> </li> </ol>
No Fowler Down Motion.	<ol style="list-style-type: none"> <li>1. Put the bed into the Bed Calibration menu.               <ol style="list-style-type: none"> <li>A. Using one of the head siderails, push the fowler down button.                   <ol style="list-style-type: none"> <li>I. If the fowler motor runs down, recalibrate the bed (refer to the Bed Calibration procedures located on <a href="#">page 23</a>).                       <ol style="list-style-type: none"> <li>a. If recalibration does not work, replace the fowler angle sensor and recalibrate.</li> </ol> </li> <li>II. If the fowler motor does not run down, check for 24VDC at connector J5 while pressing the fowler down button. Red lead to pin 1, black lead to pin 2.                       <ol style="list-style-type: none"> <li>a. If voltage is present, replace the motor.</li> <li>b. If voltage is not present, replace the CPU/Power board.</li> </ol> </li> </ol> </li> </ol> </li> </ol>
No Gatch Up Motion.	<ol style="list-style-type: none"> <li>1. Put the bed into the Bed Calibration menu.               <ol style="list-style-type: none"> <li>A. Using one of the head siderails, push the gatch up button.                   <ol style="list-style-type: none"> <li>I. If the gatch motor runs up, recalibrate the bed (refer to the Bed Calibration procedures located on <a href="#">page 23</a>).                       <ol style="list-style-type: none"> <li>a. If recalibration does not work, replace the gatch angle sensor and recalibrate.</li> </ol> </li> <li>II. If the gatch motor does not run up, check for 24VDC at connector J3 while pressing the gatch up button. Red lead to pin 1, black lead to pin 2.                       <ol style="list-style-type: none"> <li>a. If voltage is present, replace the motor.</li> <li>b. If voltage is not present, replace the CPU/Power board.</li> </ol> </li> </ol> </li> </ol> </li> </ol>

# Troubleshooting

## BED TROUBLESHOOTING

Problem / Failure	Recommended Action
No Gatch Down Motion.	<ol style="list-style-type: none"> <li>1. Go to the Bed Calibration menu.               <ol style="list-style-type: none"> <li>A. Using one of the head siderails, push the gatch down button.                   <ol style="list-style-type: none"> <li>I. If the gatch motor runs down, recalibrate the bed (refer to the Bed Calibration procedures located on <a href="#">page 23</a>).                       <ol style="list-style-type: none"> <li>a. If recalibration does not work, replace the gatch angle sensor and recalibrate.</li> </ol> </li> <li>II. If the gatch motor does not run down, check for 24VDC at connector J3 while pressing the gatch down button. Black lead to pin 1, red lead to pin 2.                       <ol style="list-style-type: none"> <li>a. If voltage is present, replace the motor.</li> <li>b. If voltage is not present, replace the CPU/Power board.</li> </ol> </li> </ol> </li> </ol> </li> </ol>
No Foot Up Motion.	<ol style="list-style-type: none"> <li>1. Put the bed into the Bed Calibration menu.               <ol style="list-style-type: none"> <li>A. Using one of the head siderails, push the foot up button.                   <ol style="list-style-type: none"> <li>I. If the foot motor runs up, recalibrate the bed (refer to the Bed Calibration procedures located on <a href="#">page 23</a>).                       <ol style="list-style-type: none"> <li>a. If recalibration does not work, replace the foot angle sensor and recalibrate.</li> </ol> </li> <li>II. If the foot motor does not run up, check for 24VDC at connector J1 while pressing the foot up button. Red lead to pin 1, black lead to pin 2.                       <ol style="list-style-type: none"> <li>a. If voltage is present, replace the motor.</li> <li>b. If voltage is not present, replace the CPU/Power board.</li> </ol> </li> </ol> </li> </ol> </li> </ol>
No Foot Down Motion.	<ol style="list-style-type: none"> <li>1. Ensure there is no debris in the foot end traction sockets. If debris exists, remove it and press the foot down button. If the foot motor still does not run down, proceed to step 2.</li> <li>2. Put the bed into the Bed Calibration menu.               <ol style="list-style-type: none"> <li>A. Using one of the head siderails, push the foot down button.                   <ol style="list-style-type: none"> <li>I. If the foot motor runs down, recalibrate the bed (refer to the Bed Calibration procedures located on <a href="#">page 23</a>).                       <ol style="list-style-type: none"> <li>a. If recalibration does not work, replace the foot angle sensor and recalibrate.</li> </ol> </li> <li>II. If the foot motor does not run down, check for 24VDC at connector J1 while pressing the foot down button. Black lead to pin 1, red lead to pin 2.                       <ol style="list-style-type: none"> <li>a. If voltage is present, replace the motor.</li> <li>b. If voltage is not present, replace the CPU/Power board.</li> </ol> </li> </ol> </li> </ol> </li> </ol>

# Troubleshooting

## BED TROUBLESHOOTING

Problem / Failure	Recommended Action
No Trendelenburg Motion.	<ol style="list-style-type: none"> <li>1. Check the touch screen trend angle display for accuracy of the level of the litter.               <ol style="list-style-type: none"> <li>I. If not accurate, recalibrate the bed (refer to the Bed Calibration procedures located on <a href="#">page 23</a>).                   <ol style="list-style-type: none"> <li>a. If recalibration does not work, replace the trend angle sensor and recalibrate.</li> <li>b. If replacement of the trend angle sensor did not resolve the problem, replace the CPU/Power board.</li> </ol> </li> </ol> </li> </ol>
No Reverse Trendelenburg Motion.	<ol style="list-style-type: none"> <li>1. Check the touch screen trend angle display for accuracy of the level of the litter.               <ol style="list-style-type: none"> <li>I. If not accurate, recalibrate the bed (refer to the Bed Calibration procedures located on <a href="#">page 23</a>).                   <ol style="list-style-type: none"> <li>a. If recalibration does not work, replace the trend angle sensor and recalibrate.</li> <li>b. If replacement of the trend angle sensor did not resolve the problem, replace the CPU/Power board.</li> </ol> </li> </ol> </li> </ol>
No Cardiac Chair Motion.	<ol style="list-style-type: none"> <li>1. Check the touch screen fowler and foot section angle display for accuracy of the angle of the fowler and foot section.               <ol style="list-style-type: none"> <li>I. If not accurate, recalibrate the bed (refer to the Bed Calibration procedures located on <a href="#">page 23</a>).                   <ol style="list-style-type: none"> <li>a. If recalibration does not work, replace the fowler or foot section angle sensor depending on the one which was not accurate, then recalibrate.</li> <li>b. If replacement of the fowler or foot section angle sensor did not resolve the problem, replace the CPU/Power board.</li> </ol> </li> </ol> </li> </ol>
HOB 30 <sup>o</sup> .	<ol style="list-style-type: none"> <li>1. Check the touch screen fowler angle display for accuracy of the angle of the fowler.               <ol style="list-style-type: none"> <li>I. If not accurate, recalibrate the bed (refer to the Bed Calibration procedures located on <a href="#">page 23</a>).                   <ol style="list-style-type: none"> <li>a. If recalibration does not work, replace the fowler angle sensor and recalibrate.</li> <li>b. If replacement of the fowler angle sensor did not resolve the problem, replace the CPU/Power board.</li> </ol> </li> </ol> </li> </ol>



# Troubleshooting

## BED TROUBLESHOOTING

Problem / Failure	Recommended Action
No Vascular Motion.	<ol style="list-style-type: none"><li>1. Check the touch screen fowler, gatch, foot, and trend/rev. trend display for accuracy of the angle of all.<ol style="list-style-type: none"><li>I. If not accurate, recalibrate the bed (refer to the Bed Calibration procedures located on <a href="#">page 23</a>).<ol style="list-style-type: none"><li>a. If recalibration does not work, replace the angle sensor of the section that is not accurate and then recalibrate the bed (refer to the Bed Calibration procedures located on <a href="#">page 23</a>).</li><li>b. If replacement of the fowler angle sensor did not resolve the problem, replace the CPU/Power board.</li></ol></li></ol></li></ol>
No Electric Brake Motion.	<ol style="list-style-type: none"><li>1. Verify the Brake Not Set LED is flashing and the Brake Set LED is OFF.<ol style="list-style-type: none"><li>I. If the Brake Set LED is ON, check manual brake position.<ol style="list-style-type: none"><li>a. If manual brake pedal is in the brake position, the bed should not move and is okay; go to step 2.</li><li>b. If manual brake is not in the brake position, check the switch on the patients left side in the middle below the base hood.</li></ol></li></ol></li><li>2. If the brake motor does not run down when the brake button is pushed, check for 24VDC at connector J7 while pressing the brake button. Black lead to pin 1, red lead to pin 2.</li></ol>

# Troubleshooting

## SCALE TROUBLESHOOTING

When the Scale system is unable to correctly weigh the patient weight due to a problem with the electronics, Figure 49 appears. It also appears when there is a problem with the Trendelenberg angle sensor. Because of this, the value for the weight and the angle cannot be displayed.

When the weight exceeds 550 lbs., Figure 50 appears. If the weight is less than 2 lbs., the screen displays “0 lb.”

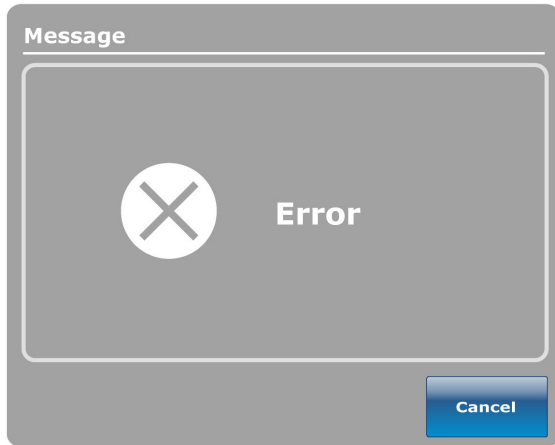

Figure 49

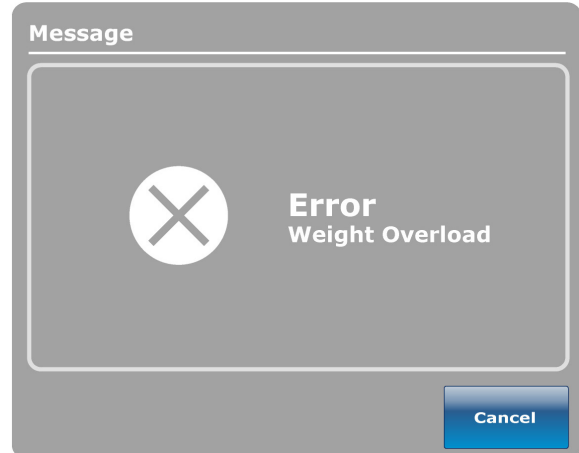

Figure 50

When the Trendelenburg or Reverse Trendelenburg angle is above  $12^{\circ}$  or below  $-12^{\circ}$ , Figure 51 appears.

When the scale system is unstable due to a problem with scale electronics or excessive patient movement, the weight reading is orange (Figure 52).

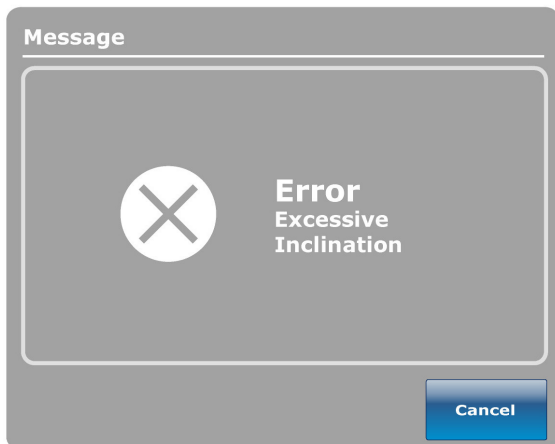

Figure 51

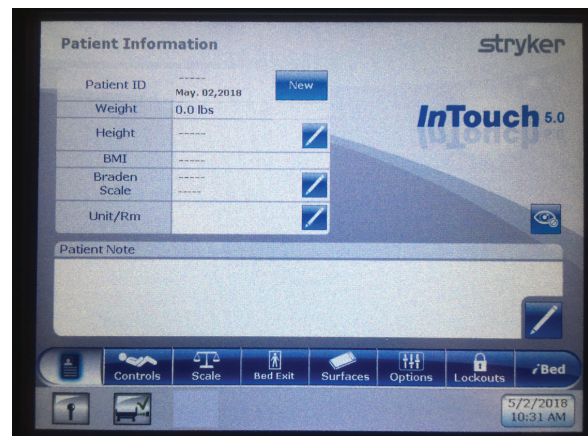

Figure 52

# Error Codes

---

## ERROR HANDLING

- There are two different CAN networks; each of the networks is divided into two connectors.
- A safe error without command can be obtained when a bad connection is carried out on the Power Sensor Board when the control panel is defective (there is no message sent on the network when a button is pressed) or when the network is defective (short-circuit between the signals, open circuit or defective network circuit).
- A command error without safe is obtained when a bad connection is done on the Power Sensor board, when the control panel is defective (a message is sent over the network but not the safe signal) or when the safe signal is defective (short-circuit panel or open circuit or safe circuit on the Power Sensor board is broken).
- These errors can be present when a button is pressed, or at any time, and will thus cause the Call Maintenance LED to light up.
- There is a LED on the Power Sensor Board (DS2 SAFE) which is active when there is at least one safe signal which is active. There are also four LEDs on the Power Sensor board, which shows the activity of the network. Every time a message is sent on the network, the LEDs will flash. If the network is defective, the LEDs will remain on or remain off. If there is nothing connected to the network, the LEDs will remain on or off.
- A safe error can be obtained if a command button is pressed without having the Power Sensor Board receiving a safe signal or if a safe signal is received by the Power Sensor board without having any command button pressed.
- The control panel for the weighing scale of the Power Sensor board can also send errors to the micro-controller which will display them. An error of the weighing scale control panel will light on the Call Maintenance LED.

## ERROR MESSAGES

Touch Screen Error Messages Name	Definition
Atd Invalid Values	Digital to analog converter is damaged (Replace the Control Board).
Brake pot bad range	Verify if potentiometer is still in place.
Brake unable to elec ctl	Verify wiring to Brake motor and limit switch for manual engage.
Brake pot Disconnected or short	Verify wiring to potentiometer and replace potentiometer. Ensure potentiometer is still in place.
Brake motor time out	Verify wiring to brake motor.
Calibration Error	Previous calibration step performed incorrectly, redo calibration procedure.
Cmd WO safe from nurse SRR	Right siderail outside board has a network communication error (Check network connections, dip-switch configuration of board or if a button is stuck).
Cmd WO safe from nurse SRL	Left siderail outside board has a network communication error (Check network connections, dip-switch configuration of board or if a button is stuck).
Cmd WO safe from nurse SRH	Head end board has a network communication error (Check network connections).
Cmd WO safe from pat pend R	Optional pendant control has a network communication error (Check network connections).
Cmd WO safe from pat pend L	Optional pendant control has a network communication error (Check network connections).
Cmd WO safe from pat pend H	Optional pendant control has a network communication error (Check network connections).
Cmd WO safe from TS	Touch screen has a network communication error (Check network connections).

## Error Codes

Touch Screen Error Messages Name	Definition
Cmd WO safe from room	Communication board has a network communication error (Check network connections).
Cmd WO safe from room	Communication board has a network communication error (Check network connections).
GPIO Failure Init	Initialization of the PCA9555 (GPIO expansion chip) failed (Replace control board).
GPIO Failure Read	Reading from the PCA9555 (GPIO expansion chip) failed (Replace control board).
GPIO Failure Write	Writing to the PCA9555 (GPIO expansion chip) failed (Replace control board).
Limit switch head side rail right	Verify wiring to limit switch and replace limit switch.
Limit switch head side rail left	Verify wiring to limit switch and replace limit switch.
Limit switch foot side rail right	Verify wiring to limit switch and replace limit switch.
Limit switch foot side rail left	Verify wiring to limit switch and replace limit switch.
Foot Right Load cell over range	Foot Right load cell or cabling is damaged (Replace load cell).
Head Right cell over range	Head Right load cell or cabling is damaged (Replace load cell).
Foot Left Load cell over range	Foot Left load cell or cabling is damaged (Replace load cell).
Head Left Load cell over range	Head Left load cell or cabling is damaged (Replace load cell).
Motor Brake Overheat	Brake motor has ran too long (Leave motor stationary for 54 minutes).
Motor Brake Overload	Brake motor is drawing too many AMPS (remove restriction or replace motor).
Motor Foot Overheat	Foot motor has ran too long (Leave motor stationary for 54 minutes).
Motor Foot Overload	Foot motor is drawing too many AMPS (remove restriction or replace motor).
Motor Gatch Overheat	Gatch motor has ran too long (Leave motor stationary for 54 minutes).
Motor Gatch Overload	Gatch motor is drawing too many AMPS (remove restriction or replace motor).
Motor Head Overheat	Fowler motor has ran too long (Leave motor stationary for 54 minutes).
Motor Head Overload	Fowler motor is drawing too many AMPS (remove restriction or replace motor).
Motor HL Foot Overheat	Foot lift motor has ran too long (Leave motor stationary for 54 minutes).
Motor HL Foot Overload	Foot lift motor is drawing too many AMPS (remove restriction or replace motor).
Motor HL Head Overheat	Head lift motor has ran too long (Leave motor stationary for 54 minutes).
Motor HL Head Overload	Head lift motor is drawing too many AMPS (remove restriction or replace motor).
Motor Zoom® Overheat	Zoom® motor has ran too long (Leave motor stationary for 54 minutes).
Motor Zoom® Overload	Zoom® motor is drawing too many AMPS (remove restriction or replace motor).
No Error	Angle sensor failure or calibration issue.
One Motor Drive Short	Short on drive motor detected.
Safe WO Cmd from A1	Network A1 has a wiring issue (Check cabling).
Safe WO Cmd from A2	Network A2 has a wiring issue (Check cabling).
Safe WO Cmd from B1	Network B1 has a wiring issue (Check cabling).
Safe WO Cmd from B2	Network B2 has a wiring issue (Check cabling).
Scale ADC Error	Scale chip not calibrated. DC Control Board needs to be replaced.

# Error Codes

<b>Touch Screen Error Messages Name</b>	<b>Definition</b>
Scale Chip Failure	Control board is bad (Replace Control Board).
Tilt base over range	Verify if tilt sensor is still in place. Inspect for a damaged or improperly assembled tilt sensor or recalibrate bed.
Tilt Error Base	Angle sensor is damaged (Replace sensor).
Tilt Error Foot	Angle sensor is damaged (Replace sensor).
Tilt Error Gatch	Angle sensor is damaged (Replace sensor).
Tilt Error Head	Angle sensor is damaged (Replace sensor).
Tilt Error HiLo Foot	Angle sensor is damaged (Replace sensor).
Tilt Error Trend	Angle sensor is damaged (Replace sensor).
Tilt foot over range	Verify if tilt sensor is still in place. Inspect for a damaged or improperly assembled tilt sensor or recalibrate bed.
Tilt gatch over range	Verify if tilt sensor is still in place. Inspect for a damaged or improperly assembled tilt sensor or recalibrate bed.
Tilt head over range	Verify if tilt sensor is still in place. Inspect for a damaged or improperly assembled tilt sensor or recalibrate bed.
Tilt hiLo foot over range	Verify if tilt sensor is still in place. Inspect for a damaged or improperly assembled tilt sensor or recalibrate bed.
Tilt trend over range	Verify if tilt sensor is still in place. Inspect for a damaged or improperly assembled tilt sensor or recalibrate bed.
Zoom® time out for switch	Verify wiring to Zoom® motor.
<b>Wi-Fi / IR Communication Error</b>	<b>Definition</b>
Wireless Adapter Failure	Unable to detect or communicate with Wi-Fi radio. Check assembly or cabling of Wi-Fi card in footboard or replace Wi-Fi card or footboard.
DHCP Error: Unable to obtain IP Address	Bed is not able to connect to the wireless network. Check wireless network settings and Wi-Fi configuration of bed.
Unable to connect to network	Bed is not able to connect to the wireless network. Check wireless network settings and Wi-Fi configuration of bed.
Internal Communication Error	Internal software failure. Software corruption may have occurred. Re-upload software or replace footboard.
Wi-Fi Settings corrupted	Reconfigure Wi-Fi settings in bed.
Bed Serial Number not available	Configure bed serial number.
Left IR Module not detected	Unable to detect IR module. Check cabling or replace the IR module.
Right IR Module not detected	Unable to detect IR module. Check cabling or replace the IR module.
IR Interface Board not detected	Unable to detect the Room interface board. Check cabling or replace the Room interface board.
IR Crosstalk detected	Crosstalk detected with iBed Locator Wall module. Verify placement of IR modules on bed or wall modules.
<b>Isolibrium Error Code</b>	<b>Definition</b>
0100	Sensor Board communication failure
0101	Sensor Board EEPROM corruption
0102	Sensor Board not calibrated
0200	GUI CANopen Heartbeat Lost
0400	EEPROM corruption
0500	Ambient temperature sensor failure
0501	Ambient temperature out of range
0600	Pressure sensor failure
0601	Seat Left pressure sensor failure

# Error Codes

Isolibrium Error Code	Definition
0602	Seat Right pressure sensor failure
0603	Back Left pressure sensor failure
0604	Back Right pressure sensor failure
0605	Turn Left pressure sensor failure
0606	Turn Right pressure sensor failure
0700	Mattress zone overpressure
0701	Seat Left zone overpressure
0702	Seat Right zone overpressure
0703	Back Left zone overpressure
0704	Back Right zone overpressure
0800	Turn bladder overpressure
0801	Turn Left bladder overpressure
0802	Turn Right bladder overpressure
0900	Compressor current not detected
1000	Fan current not detected
1001	Fan 1 current not detected
1002	Fan 2 current not detected
1100	Valve not detected
1101	Seat Left inflate valve not detected
1102	Seat Left deflate valve not detected
1103	Seat Right inflate valve not detected
1104	Seat Right deflate valve not detected
1105	Back Left inflate valve not detected
1106	Back Left deflate valve not detected
1107	Back Right inflate valve not detected
1108	Back Right deflate valve not detected
1109	Turn Left inflate valve not detected
1110	Turn Left deflate valve not detected
1111	Turn Right inflate valve not detected
1112	Turn Right deflate valve not detected
1113	Intake valve not detected
1114	Exhaust valve not detected
1200	Compressor current when OFF
1300	Fan current when OFF
1301	Fan 1 current when OFF
1302	Fan 2 current when OFF
1400	Valve current when OFF
1401	Seat Left inflate valve current when OFF
1402	Seat Left deflate valve current when OFF
1403	Seat Right inflate valve current when OFF
1404	Seat Right deflate valve current when OFF
1405	Back Left inflate valve current when OFF
1406	Back Left deflate valve current when OFF
1407	Back Right inflate valve current when OFF
1408	Back Right deflate valve current when OFF

# Error Codes

Isolibrium Error Code	Definition
1409	Turn Left inflate valve current when OFF
1410	Turn Left deflate valve current when OFF
1411	Turn Right inflate valve current when OFF
1412	Turn Right deflate valve current when OFF
1413	Intake valve current when OFF
1414	Exhaust valve current when OFF
1500	Mattress leak
1501	Seat Left zone leak
1502	Seat Right zone leak
1503	Back Left zone leak
1504	Back Right zone leak
1505	Turn Left bladder leak
1506	Turn Right bladder leak
1600	Mattress deflate timeout
1601	Seat Left deflate timeout
1602	Seat Right deflate timeout
1603	Back Left deflate timeout
1604	Back Right deflate timeout
1605	Turn Left deflate timeout
1606	Turn Right deflate timeout
1700	Reference voltage hardware failure
1800	Weight input out of range
1900	HOB angle out of range for Lateral Rotation
1901	HOB angle out of range for Turn Assist

# CPU/Power Board - QDF75-0440

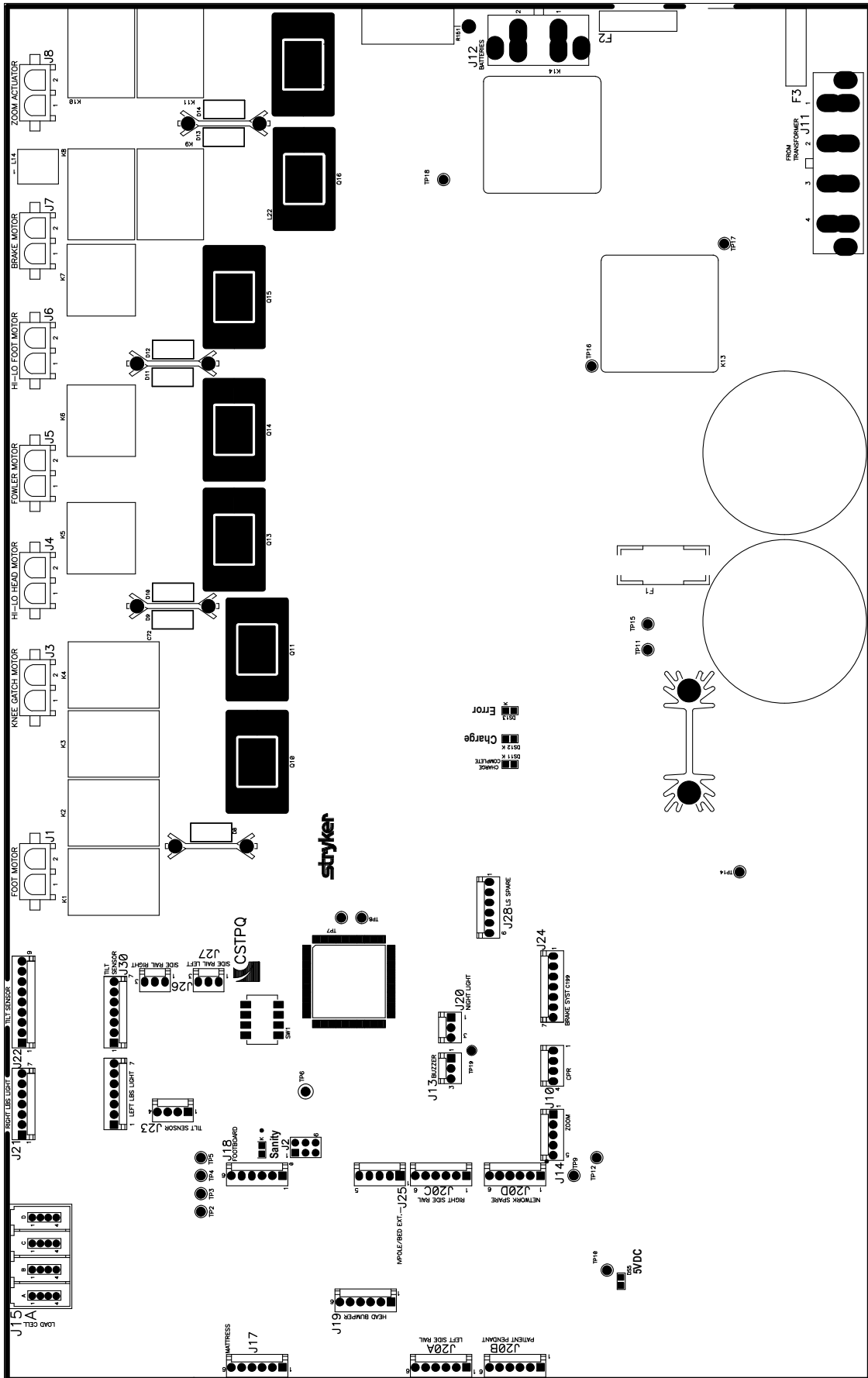



# CPU/Power Board - QDF75-0440

## FUSE SPECIFICATION

Location	Description	Amp
F1	30VAC from transformer for the battery charger and the 5VDC / 12VDC supply	10 Amp - 215008.P
F2	24 VDC from batteries for power supply	40 Amp - 142.6185.5402
F3	24 VAC from transformer for power supply	40 Amp - 142.6185.5402

Cable Location	Voltage	Positive Lead	Negative Lead	Description
J11	24-31VAC	Blue	Red	Stepped down voltage from transformer for power supply
J11	30-39VAC	Yellow	Orange	Stepped down voltage from transformer for battery charger and power supply
J12	24-29DC	Pin 1 - Red	Pin 2 - Black	Battery/Charger
J1	24-28VDC	Pin 1 - Black	Pin 2 - Brown	Foot Actuator Up
J1	24-28VDC	Pin 2 - Brown	Pin 1 - Blue	Foot Actuator Down
J3	24-28VDC	Pin 1 - White	Pin 2 - Black	Gatch Actuator Up
J3	24-28VDC	Pin 2 - Black	Pin 1 - White	Gatch Actuator Down
J6	24-28VDC	Pin 2 - White	Pin 1 - Black	Bed Lift-Foot Up
J6	24-28VDC	Pin 1 - Black	Pin 2 - White	Bed Lift-Foot Down
J4	24-28VDC	Pin 2 - White	Pin 1 - Black	Bed Lift-Head Up
J4	24-28VDC	Pin 1 - Black	Pin 2 - White	Bed Lift-Head Down
J5	24-28VDC	Pin 2 - White	Pin 1 - Black	Fowler Actuator Up
J5	24-28VDC	Pin 1 - Black	Pin 2 - White	Fowler Actuator Down
J7	24-28VDC 24-28VDC 24-28VDC	Pin 1 - Black Pin 1 - Black Pin 1 - Black	Pin 2 - White Pin 2 - White Pin 2 - White	Brake/Brake Off/Drive Actuator • Brake • Brake Off • Drive
J8	Bed Unplugged 25VDC 25VDC	Pin 2 - White Pin 1 - Black	Pin 1 - Black Pin 2 - White	Zoom® Drive Actuator (Model 2141 Only)

# Bed Electrical Diagram

27-1136 Rev R (Reference Only)

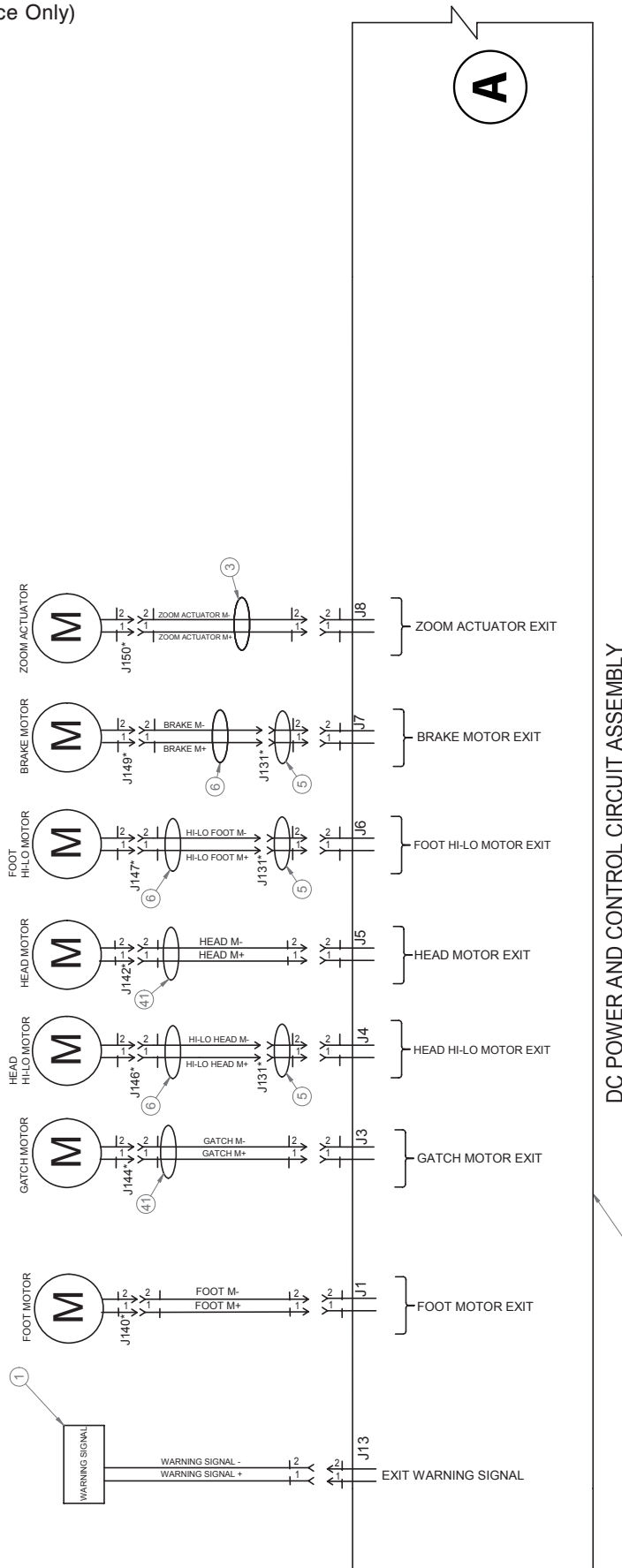

ALL MODELS

# Bed Electrical Diagram

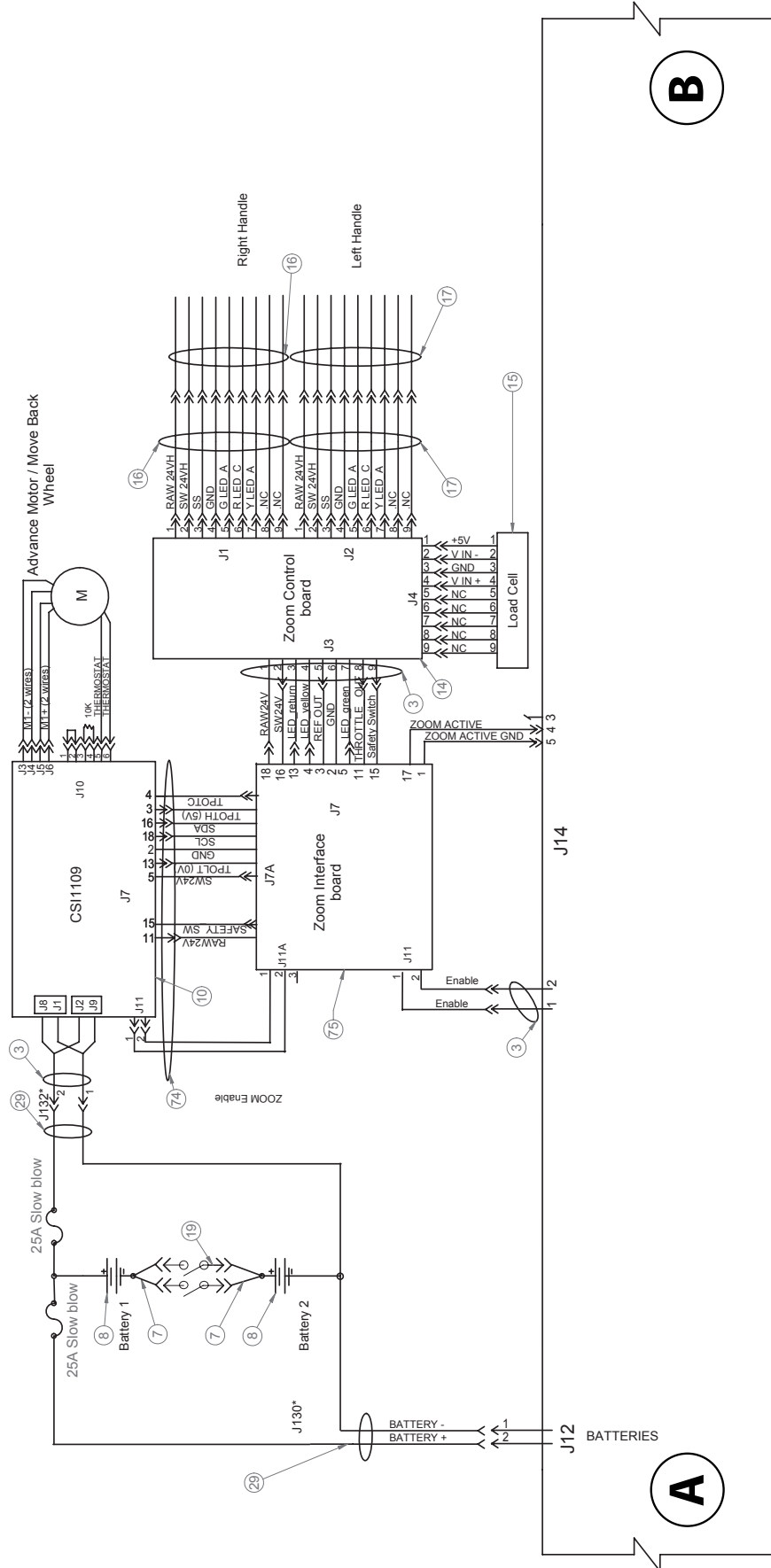

DC POWER AND CONTROL CIRCUIT ASSEMBLY

2131 to 2156

**B**

**A**

# Bed Electrical Diagram

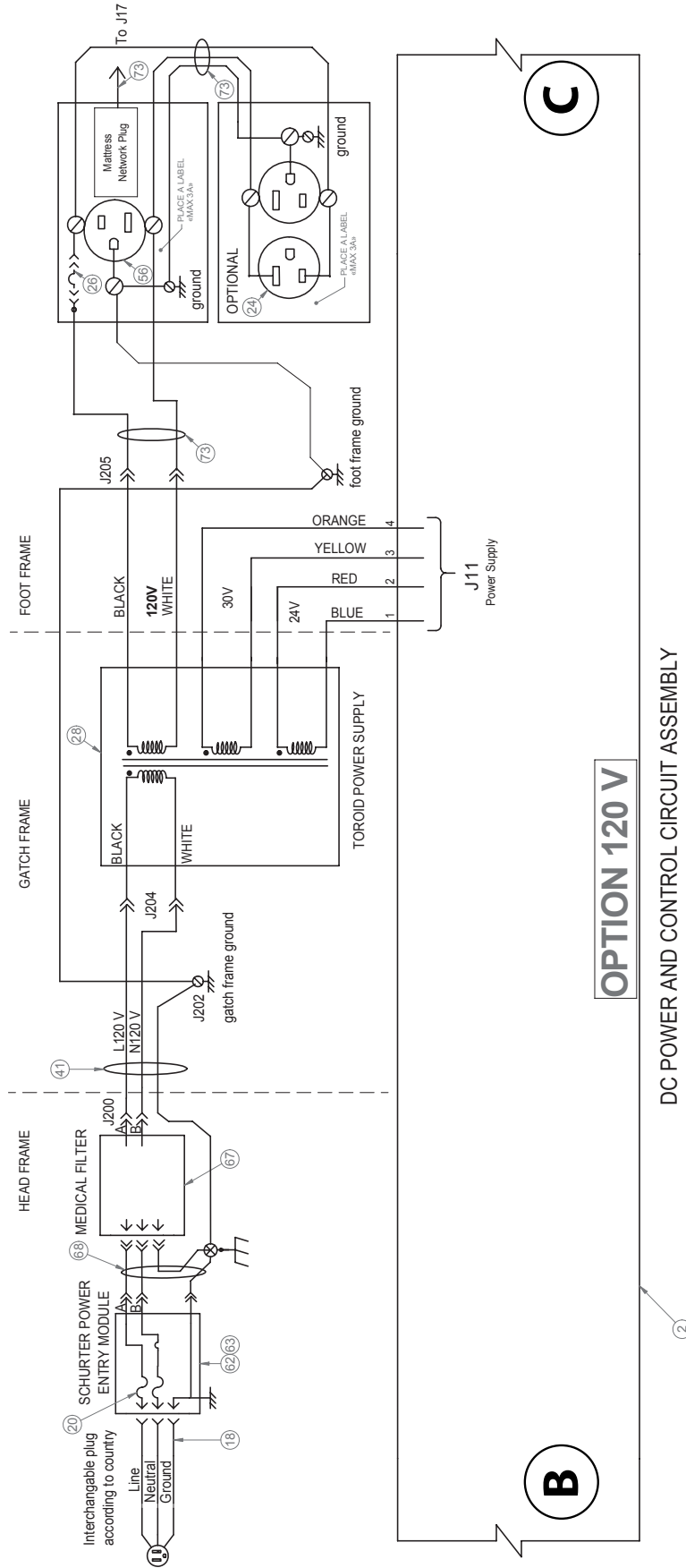

**ALL MODELS**

# Bed Electrical Diagram

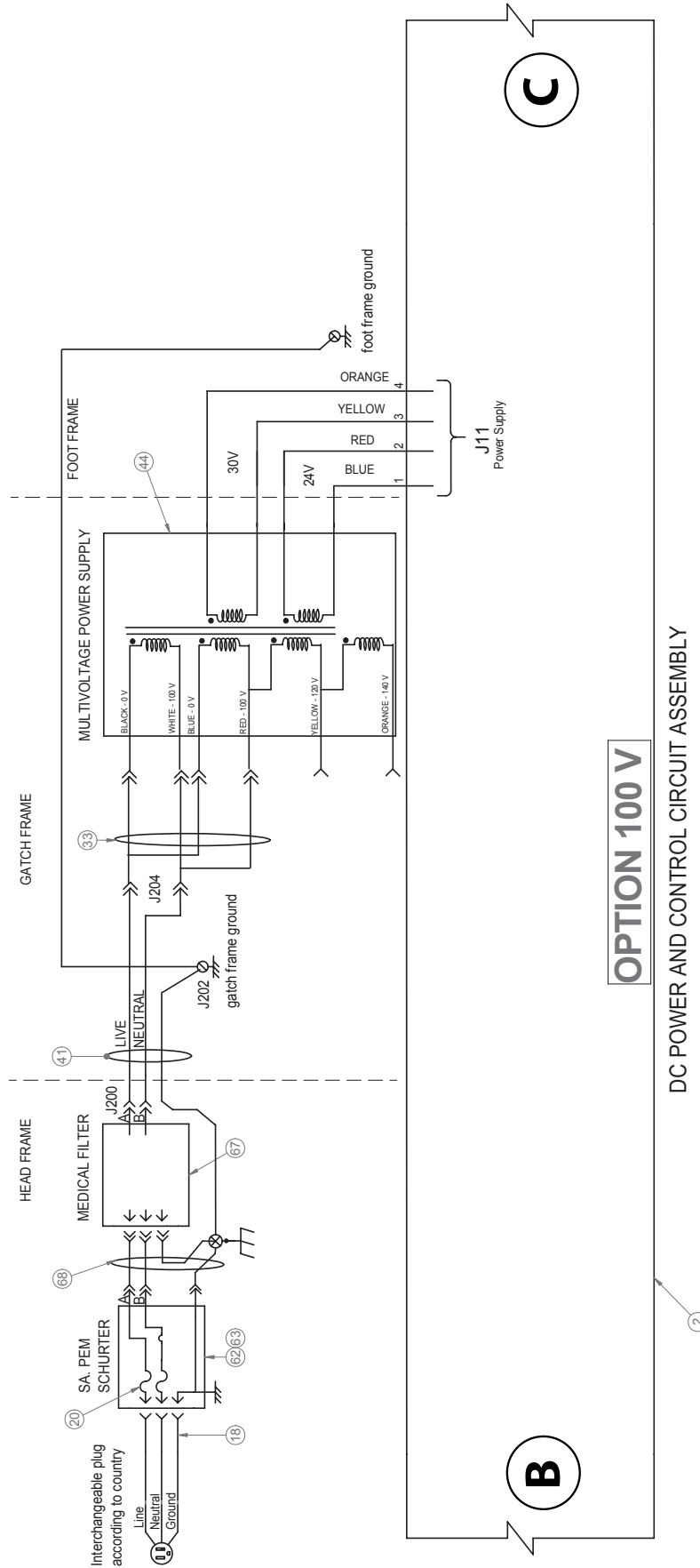

ALL MODELS

# Bed Electrical Diagram

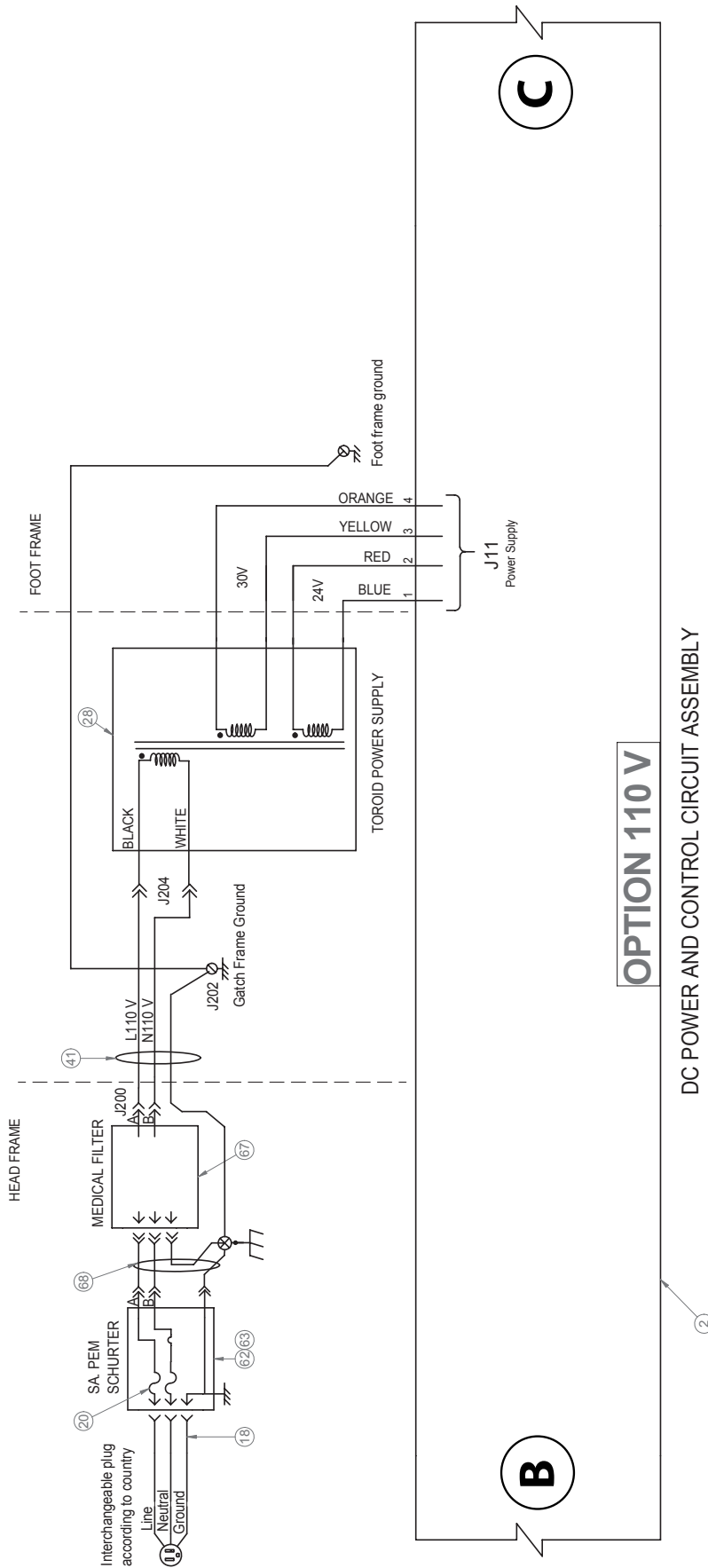

2131 to 2141

# Bed Electrical Diagram

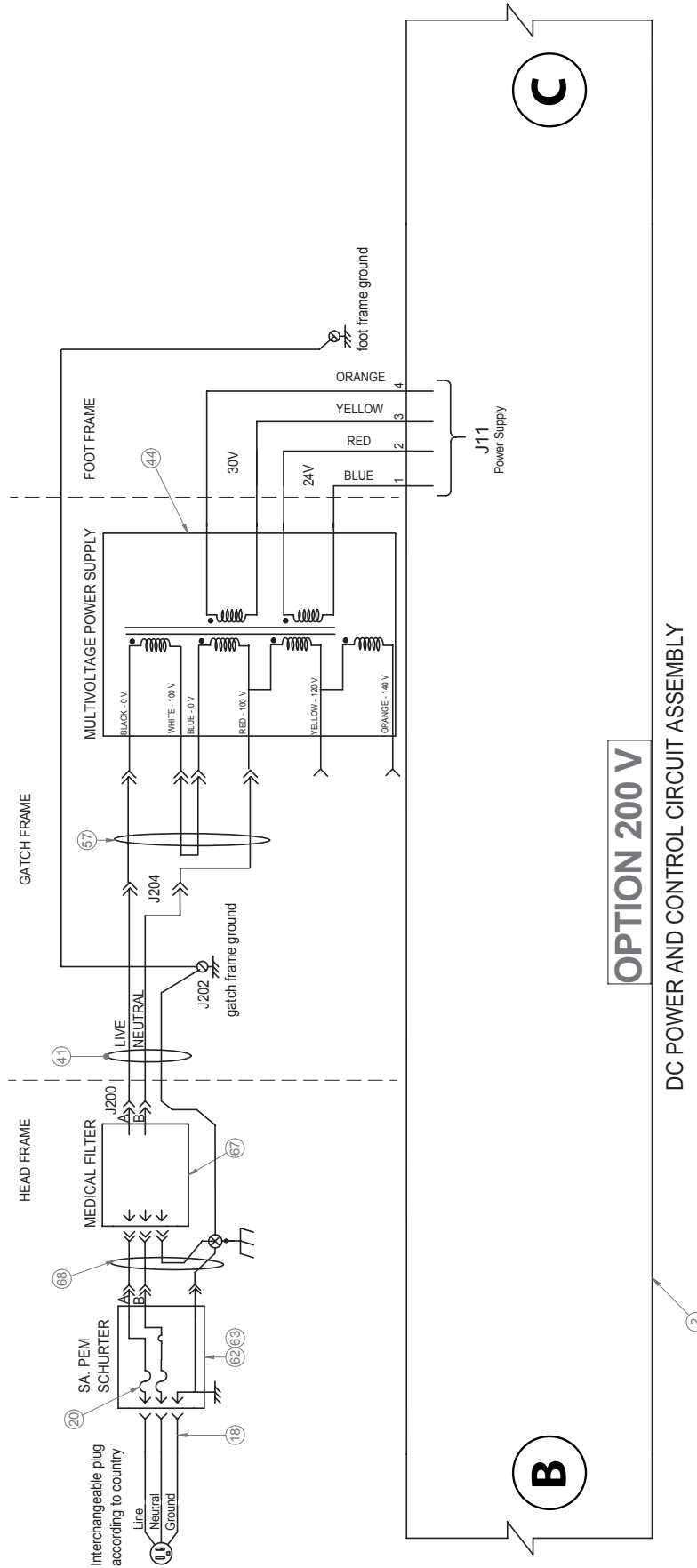

**ALL MODELS**

# Bed Electrical Diagram

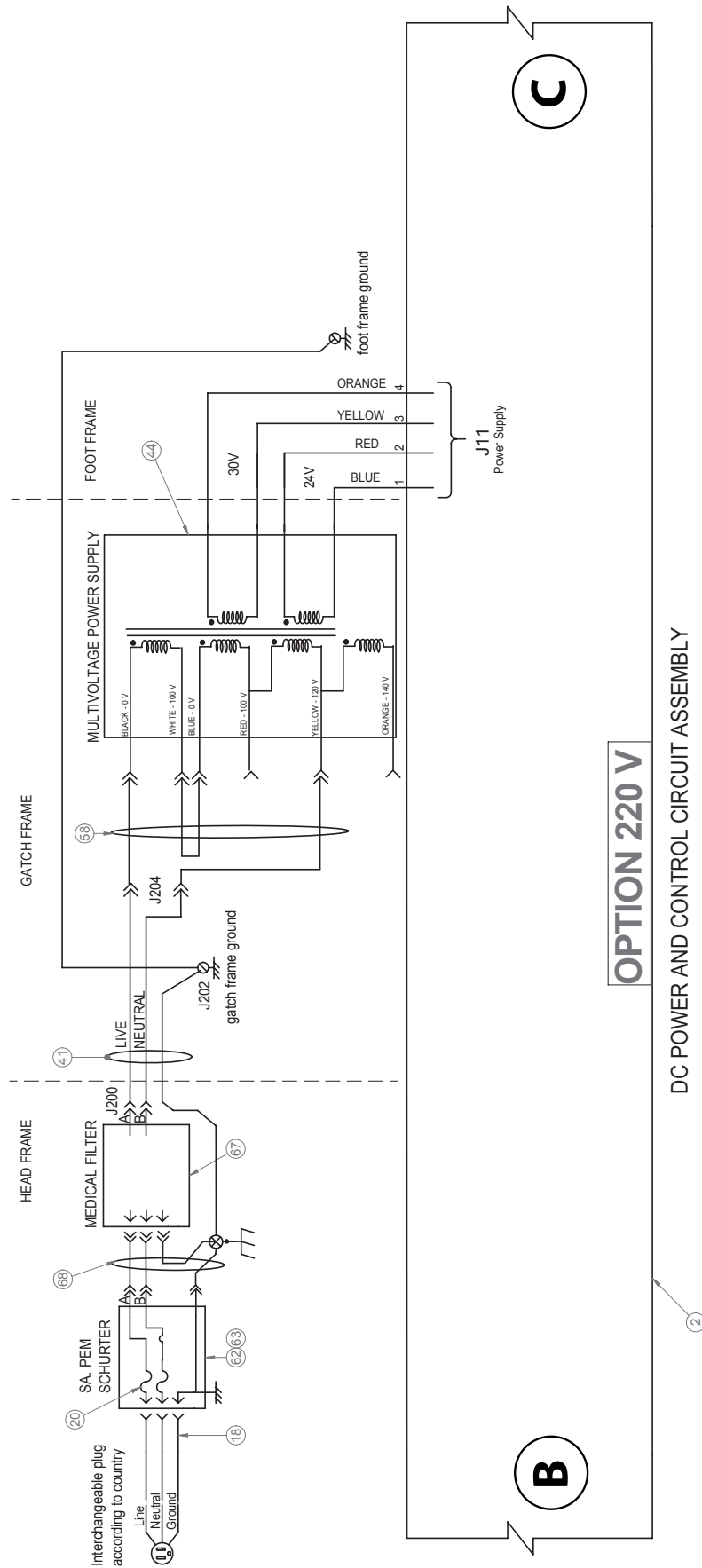

**OPTION 220 V**

DC POWER AND CONTROL CIRCUIT ASSEMBLY

**ALL MODELS**



# Bed Electrical Diagram

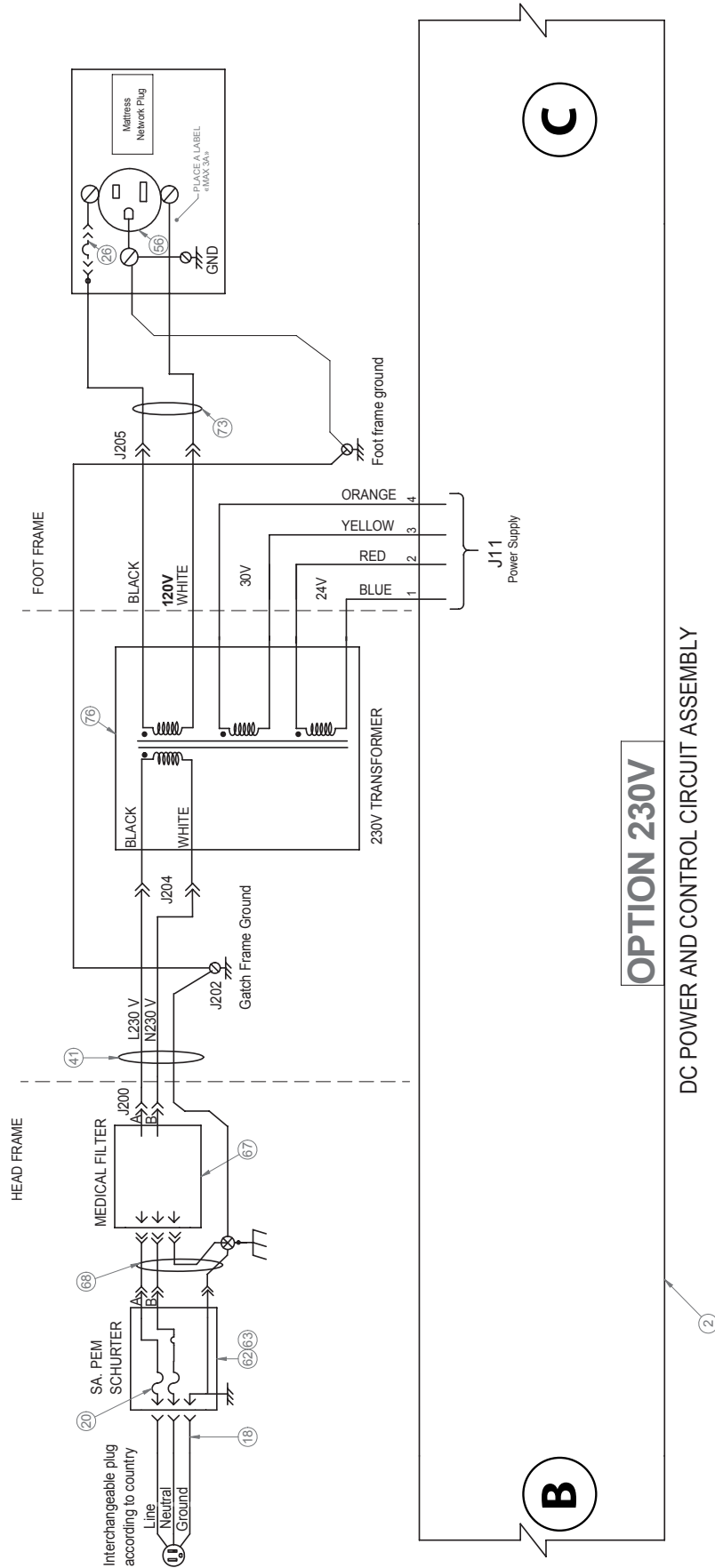

2131 to 2156

# Bed Electrical Diagram

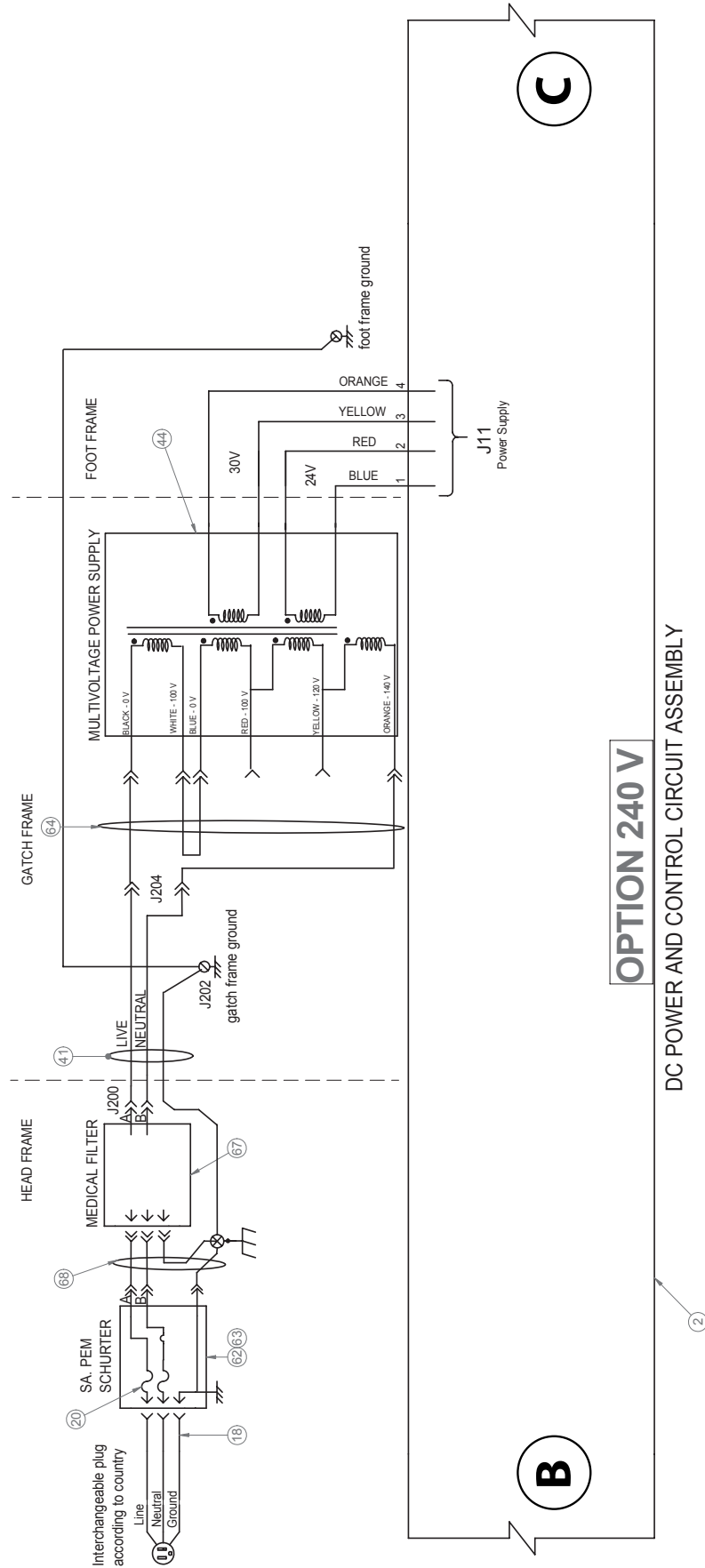

**ALL MODELS**

# Bed Electrical Diagram

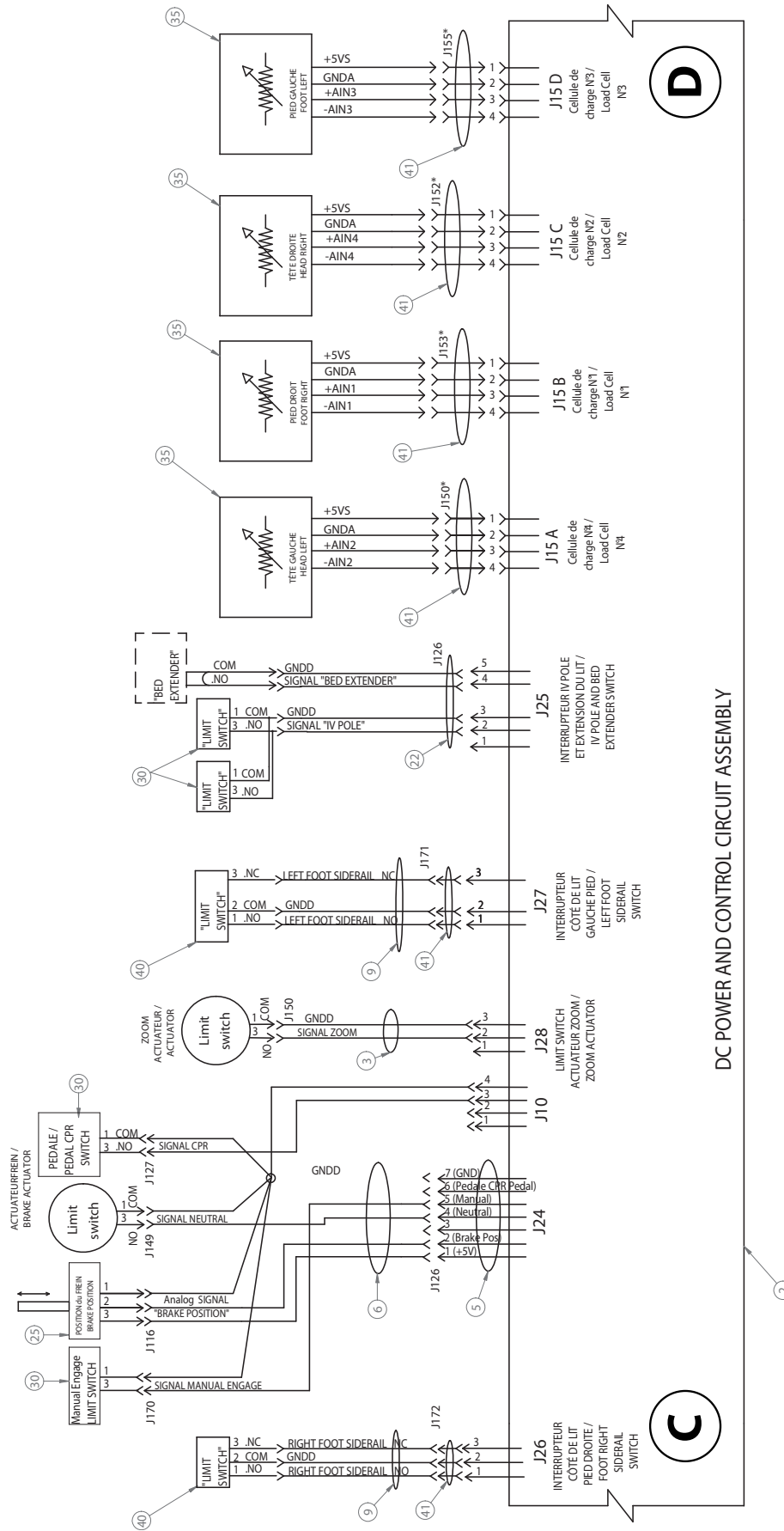

2131 to 2156

# Bed Electrical Diagram

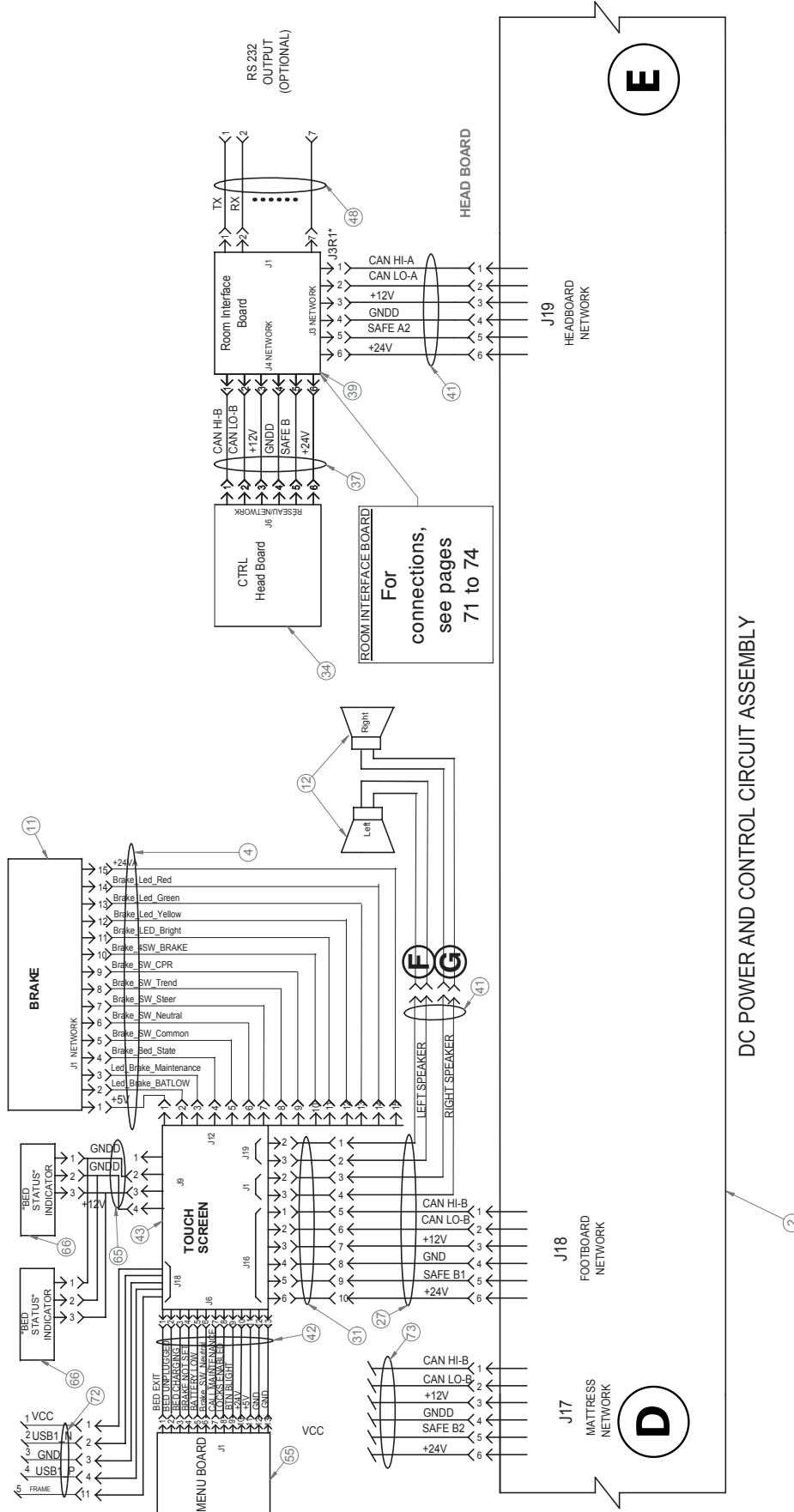

DC POWER AND CONTROL CIRCUIT ASSEMBLY

2131 to 2156

# Bed Electrical Diagram

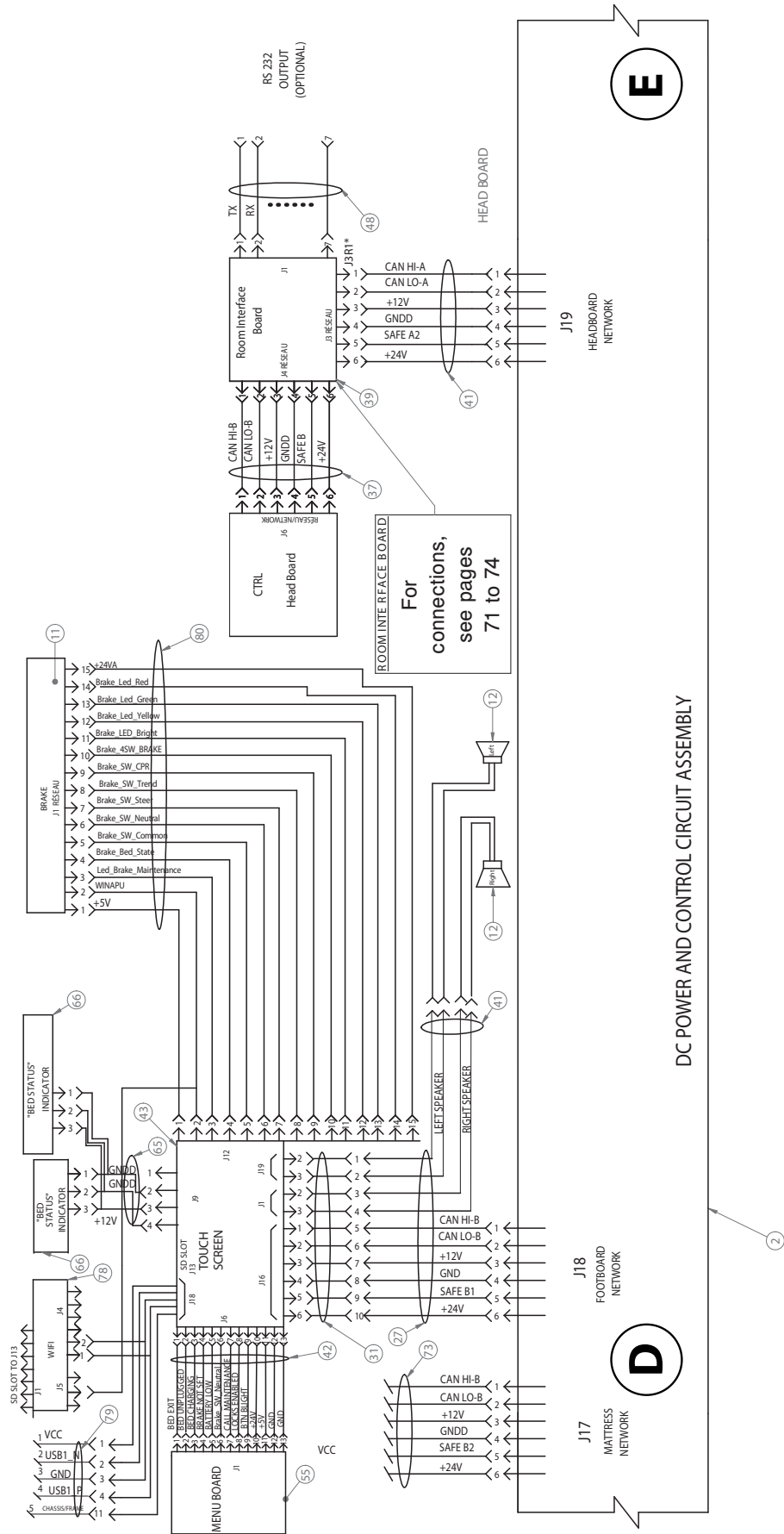

2131 / 2141 WITH WI-FI OPTION

# Bed Electrical Diagram

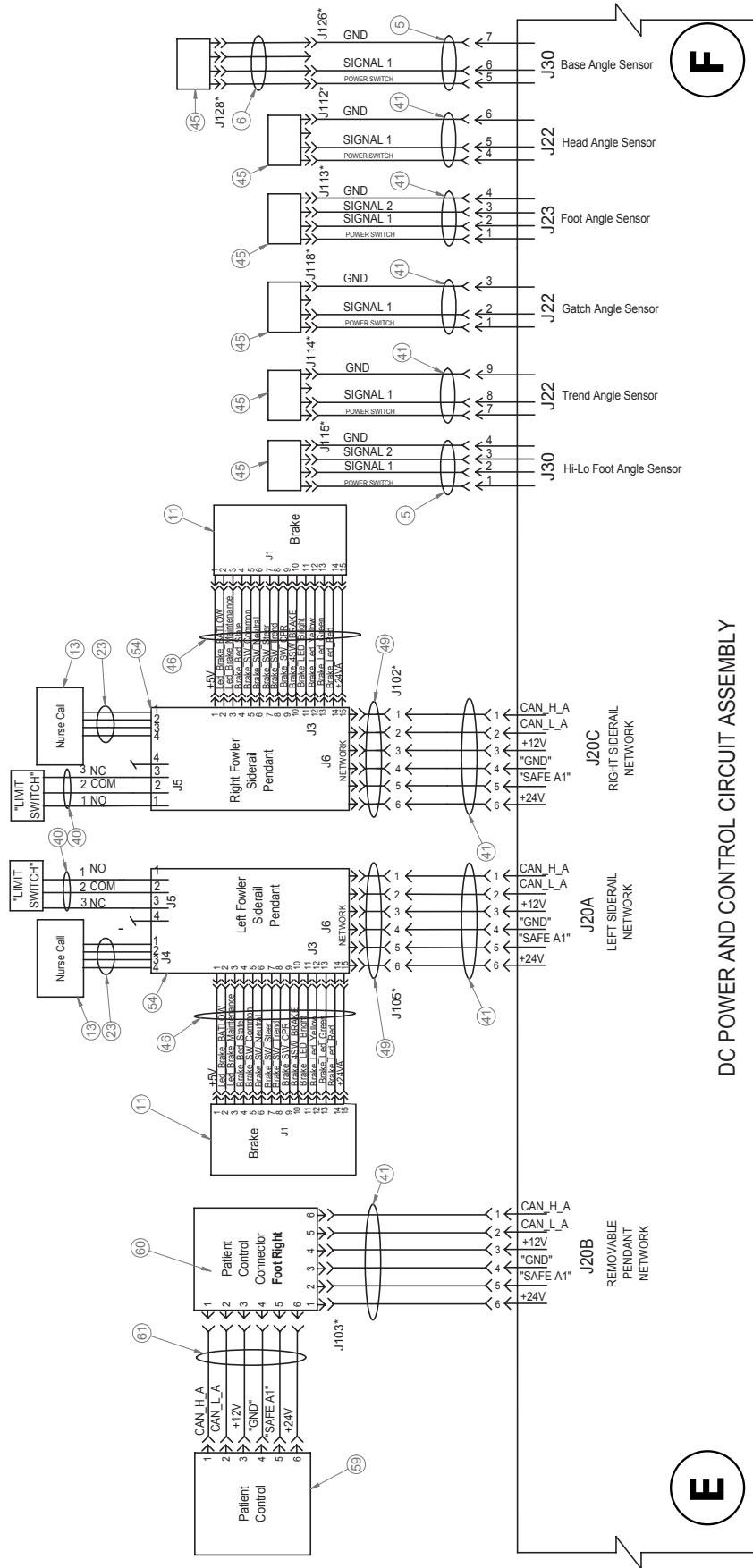

DC POWER AND CONTROL CIRCUIT ASSEMBLY

**ALL MODELS**

DIP SWITCH CONFIGURATION ON SIDERAIL & HEAD-NURSE CTRL BOARD			
RIGHT	ON	ON	ON
LEFT	OFF	ON	ON
HEAD	ON	OFF	ON

# Bed Electrical Diagram

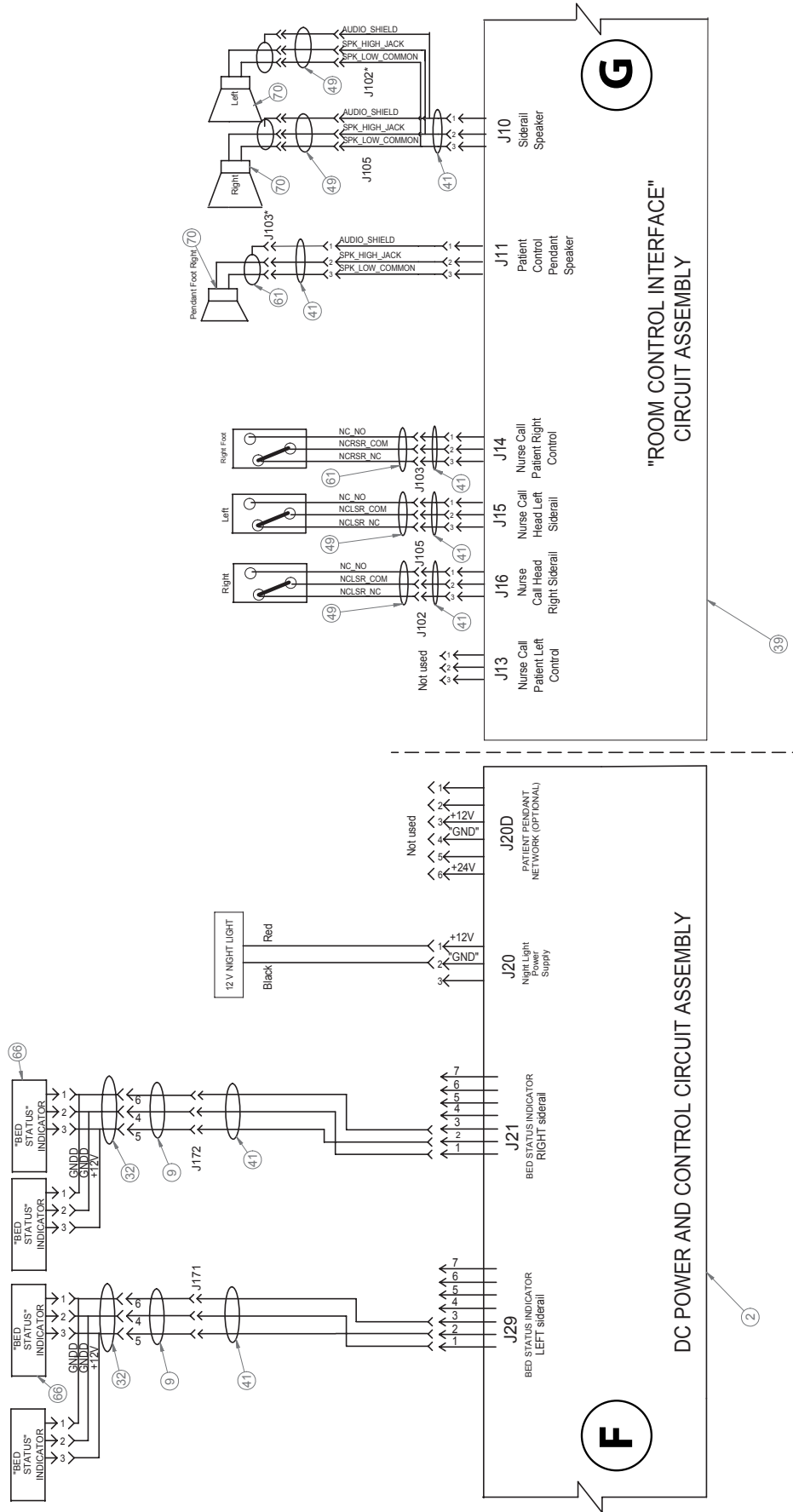

ALL MODELS

# Bed Electrical Diagram

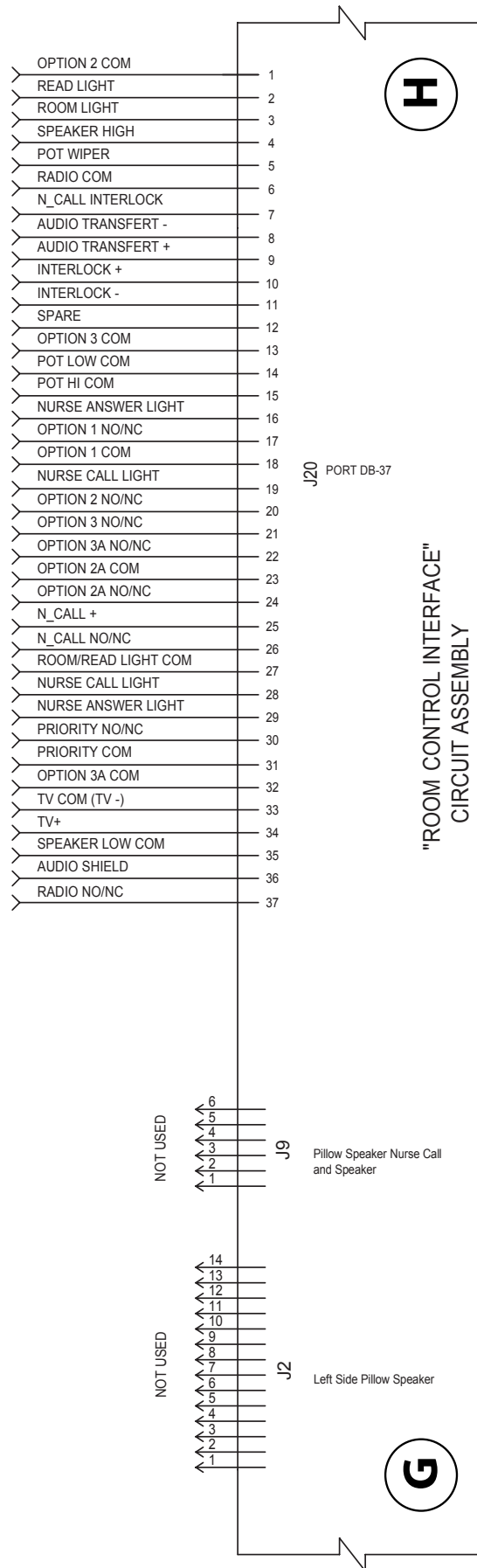

ALL MODELS PRIOR TO 3.1



# Bed Electrical Diagram

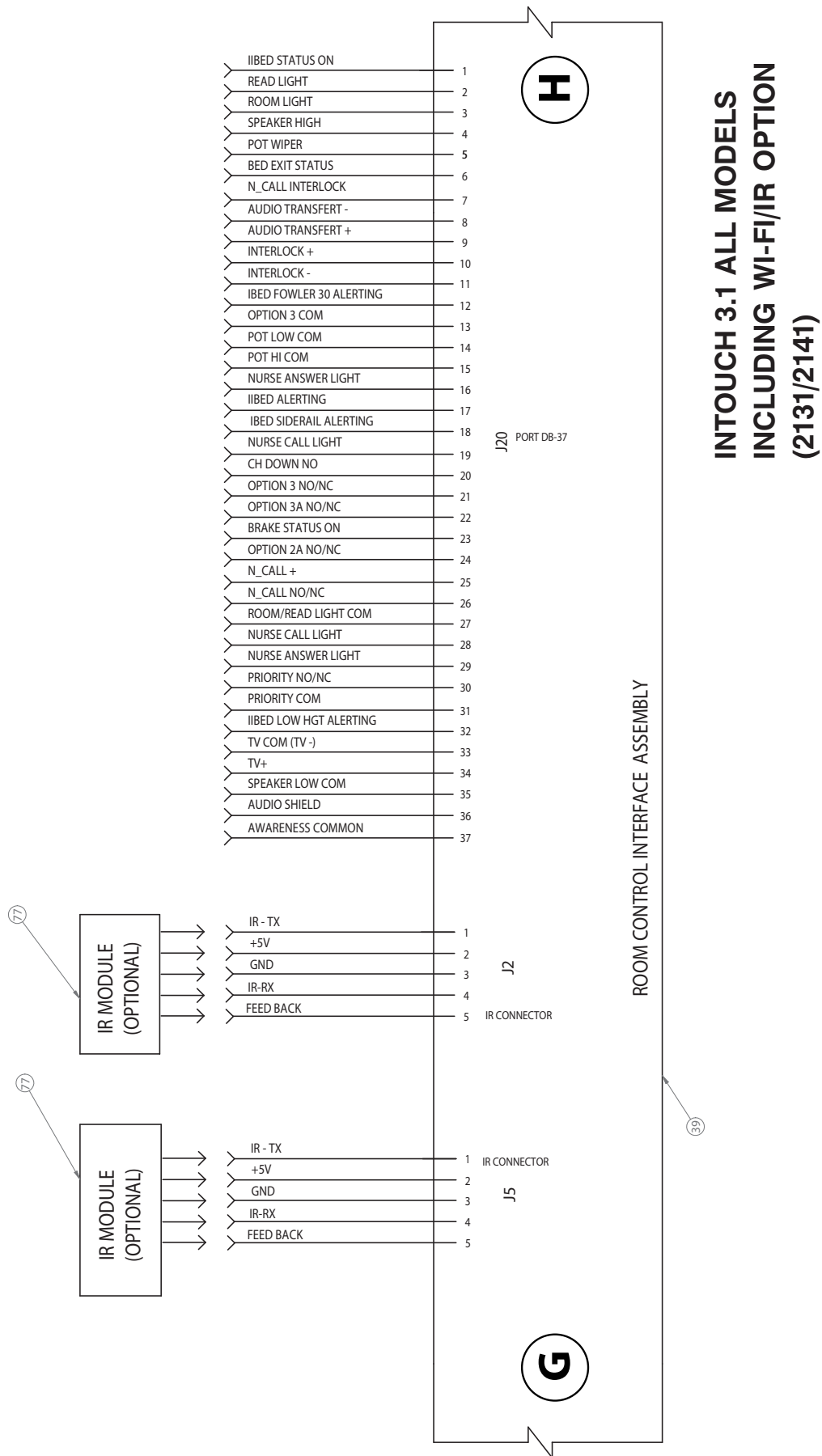

# Bed Electrical Diagram

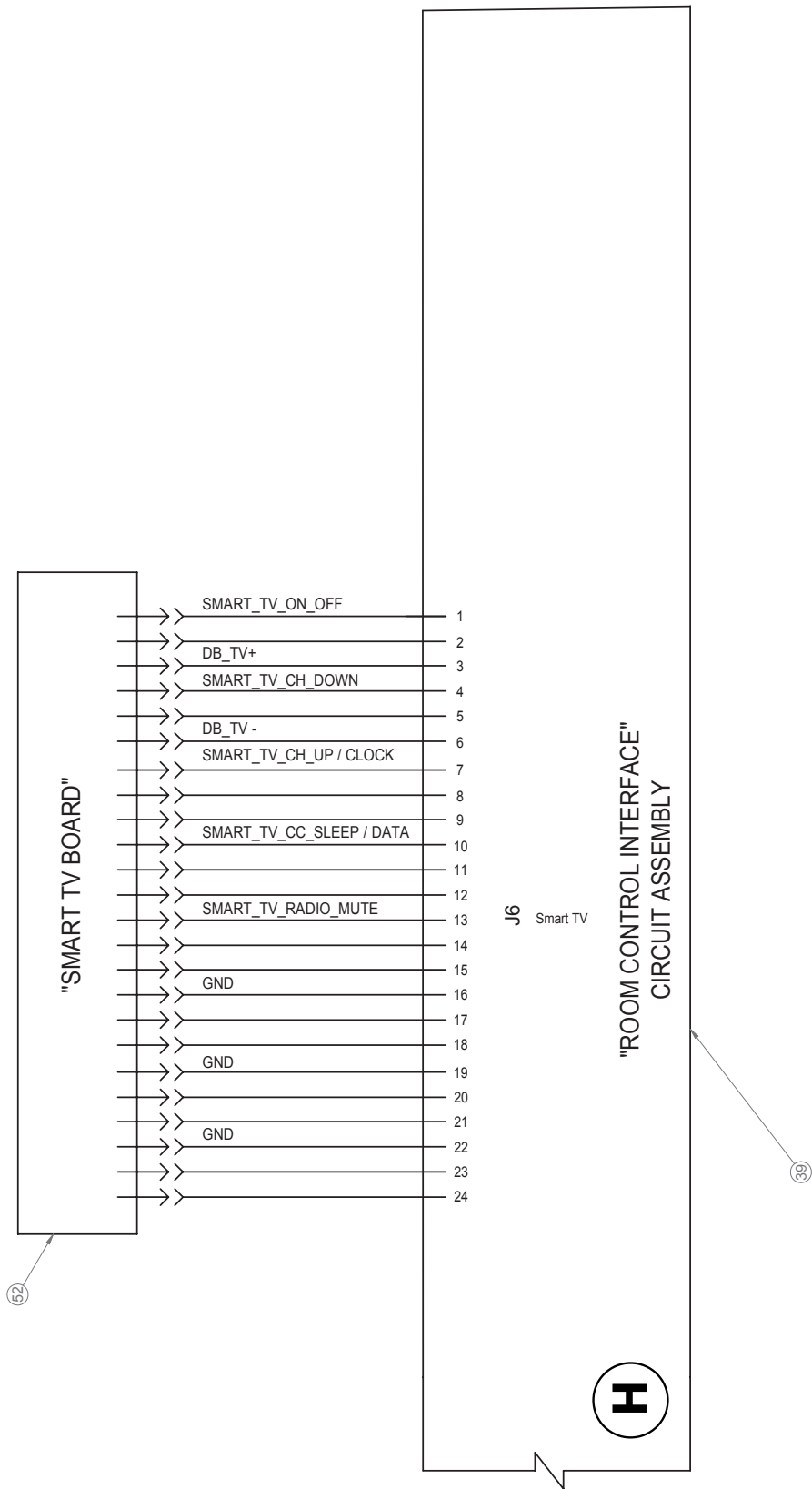

**ALL MODELS**

# Bed Electrical Diagram

## Bed Electrical Diagram - 27-1136 Rev R (Reference Only)

Item	Part No.	Part Name	Qty.
1	QDF5095	Sound Alarm	1
2	QDF75-0440	DC Power Control	1
3	QDF27-1185	Number 3 Harness	1
4	QDF27-2229	Footboard Brake Cable	1
5	QDF27-2181	Number 2 Harness	1
6	QDF27-2182	Base Structure Extension	1
7	QDF27-1381	Battery Switch Cable	2
8	QDF9188	12V, 17.9 Ah Battery	2
9	QDF27-1208	Limit Switch Siderail Cable	2
10	QDF27-1430	CSI 1109 Board	1
11	QDF27-1097	Brake / Neutral / Drive Board	3
12	QDF27-2196	Speaker	2
13	QDF27-1429	Nurse Call Board	2
14	QDF75-0230	Zoom® Control Board	1
15	QDF9136	Load Cell Handle	1
16	QDF9130	Right Handle	1
17	QDF9131	Left Handle	1
18	QDF8066	Power Cord	2
19	QDF2087	Toggle Switch	1
20	QDF8078	10A Fuse	2
22	QDF27-1607	I.V. Pole and Bed Extender Cable	1
23	QDF27-1682	Nurse Call Board Cable	2
24	QDF8024	120V Auxiliary Outlet	1
25	QDF27-2024	Linear Position Sensor	1
26	QDF9025	Breaker	1
27	QDF27-2214	Footboard Control Board Cable	1
28	QDF27-2038	Toroid Power Supply	1
29	QDF27-1646	Battery Cable	2
30	QDF9004	Micro-Switch	2
31	QDF27-2232	Footboard Cable	1
32	QDF27-1834	Footboard LBS Cable	2
33	QDF27-1841	100V Adapter	1
35	QDF27-1372	Load Cell	4
36	QDF21-1151	CAN Head Control Board	3
37	QDF21-2895	12" Network Cable	2
39	QDF75-0270	CAN Room Interface Board w/o GEN III	1
40	QDF27-1521	Siderail Limit Switch	2
41	QDF27-2213	Number 1 Harness Wire	1
42	QDF27-2230	Touch Screen Cable	2
43	QDF75-0290	Touch Screen Board	1
44	QDF27-2049	Multivoltage Power Supply	1
45	QDF75-0140	Angle Sensor	6
46	QDF27-1156	Brake Board Cable	2
47	QDF27-2025	12V 3 LEDs Night Light	1
48	QDF27-2432	Serial Interface Connector Cable	1
49	QDF27-2212	Head Siderail Cable	2
52	QDF2060	Smart TV Board	1
53	QDF21-2901	SIP-N-PUFF Cable	2
54	QDF27-1099	Siderail & Head Nurse Control Board	3
55	QDF75-0010	Menu Touch Screen Board	1
56	QDF9573	XPRT™ Mattress Plug	-

# Bed Electrical Diagram

---

## Bed Electrical Diagram - 27-1136 Rev R (Reference Only) (Continued)

Item	Part No.	Part Name	Qty.
57	QDF27-1842	200V Adaptor	1
58	QDF27-1843	220V Adaptor	1
59	QDF27-1102	Patient Pendant Control	2
60	–	Patient Pendant Connector	1
61	QDF27-1525	Patient Pendant Cable	2
62	27-2848	Inlet Filter Assembly	1
63	QDF9575	Schurter #4303.2901	1
64	QDF27-1840	240V Adaptor	1
65	QDF27-2253	LBS Cable	1
66	QDF27-1562	Local Bed Status Board	2
67	QDF9571	Medical Filter	1
68	QDF27-1524	Filter and Receptacle Connector	1
69	QDF27-1681	Interior Siderail Cable	2
70	QDF27-1526	Speaker	4
72	QDF27-2231	USB Cable	1
73	QDF27-1976	Auxiliary Plug + Mattress Cable	1
74	QDF27-2542	Zoom® Interface Board Harness	1
75	QDF75-0240	Zoom® Interface Board	1
76	QDF27-2658	230V Transformer	1
77	QDF75-0310	IR Module	2
78	QDF75-0630	Wi-Fi Board	1
79	QDF27-2573	USB Y Cable to Interface Board	1
80	QDF27-2594	Brake Card to Interface Cable	1

# Quick Reference Replacement Parts

These parts are currently available for purchase. Call Stryker Customer Service: 1-800-327-0770 for availability and pricing.

Part Name	Part Number
<b>Electrical Components</b>	
Actuator, Brake	QDF27-1227
Actuator, Foot	QDF27-1216
Actuator, Fowler	QDF27-1214
Actuator, Gatch	QDF27-1215
Actuator, Lift, Foot End	QDF27-1251
Actuator, Lift, Head End	QDF27-1252
Angle Sensor, Foot, Fowler, Base, Gatch, Lift	27-2477
Batteries (Replace both at same time)	QDF9188
Board, CPU/Power	QDF75-0440
Board, Drive (2141 Zoom® Only)	QDF27-1430
Board, Headwall	QDF75-0270
Board, Brake Control	QDF27-1097
Board, Footboard, Function Section/LED's	QDF75-0010
Board, Siderail, Outside (Bed Motion)	QDF27-1099
Board, Wi-Fi	27-2863
Fuse, 8Amp Ceramic	QDF2120
Fuse, 10Amp, Main Power	QDF8078
Fuse, 25Amp Cartridge	QDF2119
Load Cell	QDF27-1372
Motor, Drive (2141 Zoom® Only)	QDF27-1445
Motor, Drive Actuator (2141 Zoom® Only)	27-2593
Position Sensor, Brake/Brake Off/Drive	QDF27-2024
Power Cord	27-2782
Speaker, Right Siderail	QDF27-2216
Speaker, Left Siderail	QDF27-2175
Touch Screen, Footboard	27-2757
Transformer (120VAC)	QDF27-2038

## Quick Reference Replacement Parts

---

Part Name	Part Number
<b>Other Components</b>	
Caster (2141 Model - all four casters) (2131 Model - both head end casters)	RD27-1970
Caster, Steer (2131 Model Only - both foot end casters)	RD27-1971
Headboard Assembly	27-2583K
Footboard Assembly without <i>i</i> Bed	27-2891K
Footboard Assembly with <i>i</i> Bed and <i>i</i> Audio	27-2893K
Footboard Assembly with <i>i</i> Bed and Wi-Fi	27-2894K
Footboard Assembly with <i>i</i> Bed, without <i>i</i> Audio	27-2892K

# Service Information

---

## BED LIFT ACTUATOR (HEAD) REMOVAL AND REPLACEMENT - (BASE)

### Tools Required:

- Needle-Nose Pliers
- Diagonal Pliers
- Jack (if needed)
- 2 x 4 (20" recommended)

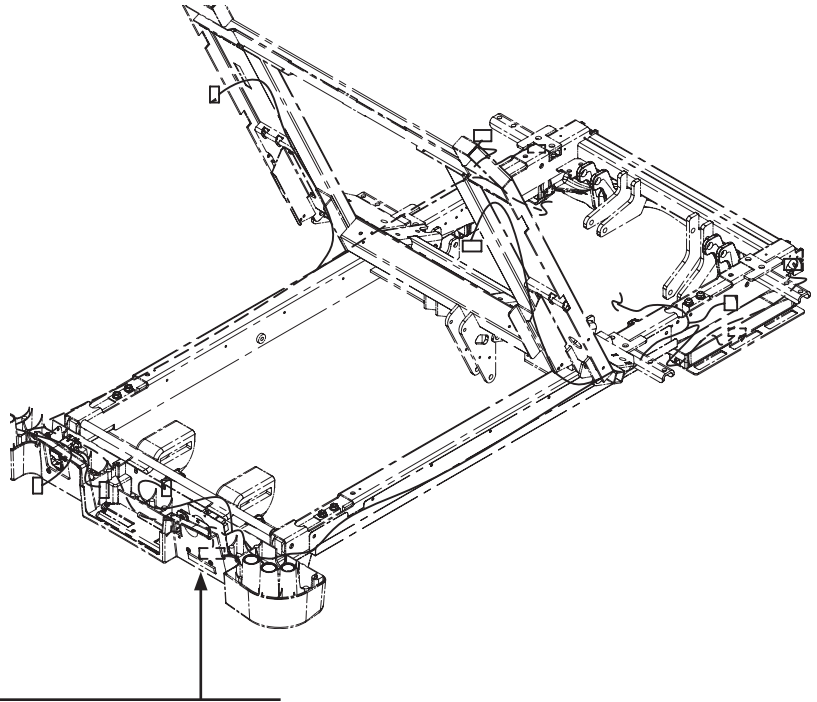

### Step #8:

Locate Jack Stand between floor and underside of Foot Frame.

**Floor**

---

### Procedure:

1. Plug bed into wall outlet.
2. Raise the head end siderails to the full up position and set the brakes using one of the brake control locations or by using the manual brake pedal.
3. Remove head end base cover by pulling up and out.
4. Remove center base cover by pulling up and out.
5. Using diagonal pliers, cut the zip tie securing the actuator cable to the base frame.
6. Using Needle-nose pliers, remove the rue clips from the clevis pins securing the actuator.

---

### CAUTION

Do not remove the clevis pins.

---

7. If the bed will lower down, run it all the way down so the litter is supported by the base litter stop.
8. If the bed will not lower all the way down; using a jack and a 2 x 4, take tension off of the actuator clevis pins by placing the jack and 2 x 4 between the bottom of the right side of the litter and the floor and jack up just enough to take the litter weight off of the base frame (reference picture above).

---

### CAUTION

Make sure that prior to jacking, the 2 x 4 is perpendicular to the floor.

---

9. Using the bed up/down controls, tap the up or down button to remove tension on the clevis pins and remove clevis pins.
10. Unplug the cable quick connect and remove the actuator.
11. Reverse the steps to install the new actuator.
12. Test all bed functionality prior to putting bed back in service.

[Return To Table of Contents](#)

# Service Information

---

## BED LIFT ACTUATOR (FOOT) REMOVAL AND REPLACEMENT - (BASE)

### Tools Required:

- Needle-Nose Pliers
- Diagonal Pliers

### Procedure:

1. Plug bed into wall outlet.
2. Raise head end siderails to full up position and ensure brakes are activated.
3. Remove head end base cover by pulling up and out.
4. Remove center base cover by pulling up and out.
5. Using diagonal pliers, cut the zip tie securing the actuator cable to the base frame.
6. Using Needle-nose pliers, remove the ruc clips from the clevis pins securing the actuator.

---

### CAUTION

Do not remove the clevis pins.

---

7. Lower the bed all of the way down so the litter is supported by the base litter stops.
8. Using the bed up/down controls, tap the up or down button to remove tension on the clevis pins and remove clevis pins.
9. Unplug the cable quick connect and remove the actuator.
10. Reverse the steps to install the new actuator.
11. Test all bed functionality prior to putting bed back in service.



# Service Information

## FOWLER ACTUATOR REMOVAL AND REPLACEMENT - (LITTER)

### Tools Required:

- Diagonal Pliers
- Regular Screwdriver
- Phillips Screwdriver #2
- 3/8" Combination Wrench

### Procedure:

1. Plug bed into wall outlet.
2. Raise bed to the full up position.
3. Raise the head end siderails to the full up position and set the brakes using one of the brake control locations or by using the manual brake pedal.
4. Working from the right side of the bed, step on the CPR pedal to lower the fowler all the way down.
5. Raise the gatch to the full up position.
6. Remove the three center base hoods (head, center, foot), then remove the right base hood.
7. Using Needle-nose pliers, remove the two rue clips from the clevis pins holding the actuator.
8. Using diagonal pliers, cut the zip ties securing the CPR cable to the actuator and the litter frame. Also cut the zip ties securing the actuator cable to the wire harness.
9. Unplug the actuator from the quick connect.
10. Holding the actuator with one hand remove the clevis pins from the actuator and carefully lower the actuator down.
11. Using a Phillips screwdriver and a 3/8" combination wrench, remove the CPR cable retaining screw from the right CPR pedal.
12. Using a regular screwdriver, loosen the CPR cable retainer on the actuator just enough so it will move.
13. Slide the gray cable retainer lock towards the CPR cable retainer and unclip the CPR cable from the red actuator release activator.
14. Remove actuator.
15. Reverse these steps to reinstall.
16. When re-adjusting the cable retainer lock set, set it to  $1.00 \pm 0.06$  as shown (right). When the actuator is back in place, use needle-nose pliers to reattach the spring to the center of the clevis pin.
17. Test all bed functionality prior to putting bed back into service.

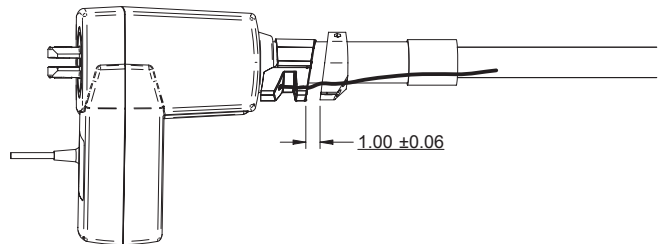

# Service Information

---

## GATCH ACTUATOR REMOVAL AND REPLACEMENT - (LITTER)

### Tools Required:

- Needle-Nose Pliers

### Procedure:

1. Plug bed into wall outlet.
2. Set the brakes using one of the brake control locations or by using the manual brake pedal.
3. Remove the mattress and set aside.
4. Raise bed to the full up position.
5. If the actuator will run, lower the gatch down to take the tension off of the actuator mounting pins. If the actuator will not run, support the gatch section to take tension off of the actuator mounting pins.
6. Unplug the actuator cable from the quick connect near the actuator.
7. Using Needle-nose pliers, remove the two rue clips from the clevis pins holding the actuator in place.
8. Holding the actuator with one hand, remove the clevis pins securing the actuator to the bed then remove the actuator.
9. Reverse these steps to reinstall  
**Note: If new actuator shaft does not line up with mounting holes, mount the base of the actuator then plug the actuator in and run it electrically in or out until lined up.**
10. Test all bed functionality prior to putting bed back in service.

# Service Information

## FOOT ACTUATOR REMOVAL AND REPLACEMENT - (LITTER)

### Tools Required:

- Needle-Nose pliers
- Diagonal Pliers
- Phillips Screwdriver #2
- Jack Stand

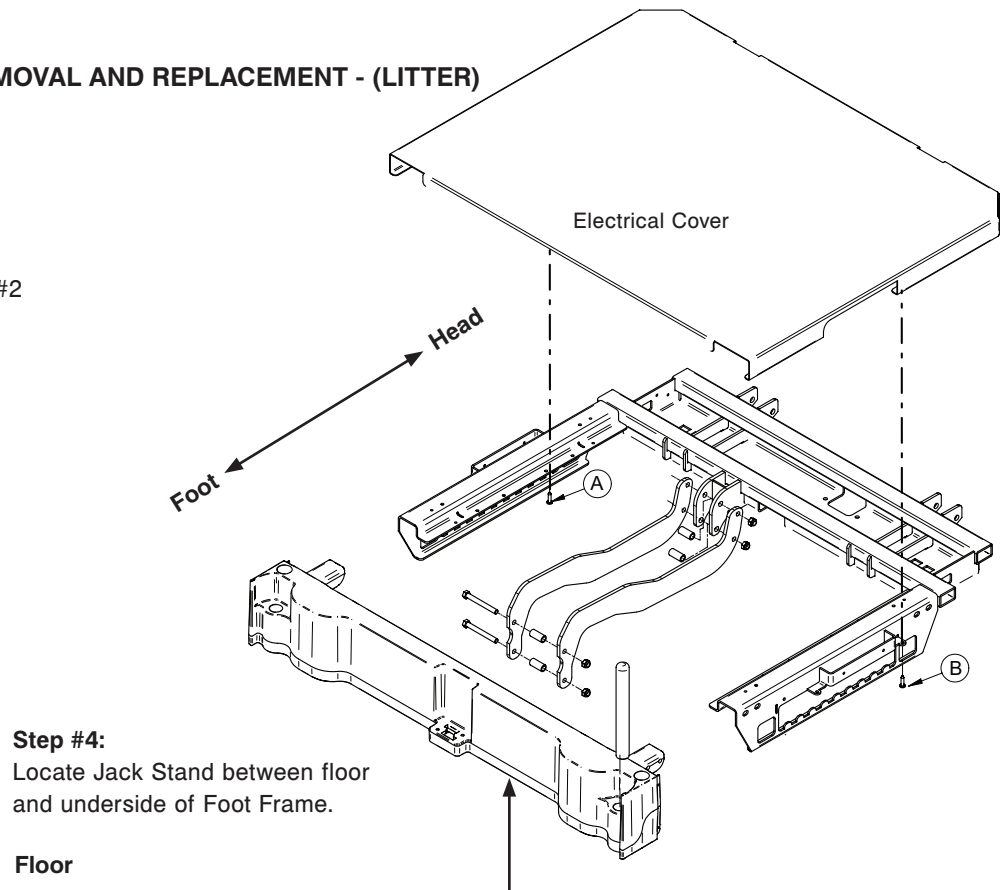

**Step #4:**  
Locate Jack Stand between floor  
and underside of Foot Frame.

**Floor**

### Procedure:

1. Plug bed into wall outlet.
2. Set the brakes by using one of the brake control locations or the manual brake pedal.
3. Remove the mattress and set aside.
4. Using a jack stand, support the foot section by lowering the bed height down enough to take the tension off the actuator mounting pins (reference drawing above).
5. Using diagonal pliers, cut the zip ties securing the actuator cable to the bed.
6. Remove the mattress assembly or fold back to expose the foot section.
7. Using a Phillips screwdriver, remove the two screws (reference drawing above, item A and B) securing the electrical cover from the foot section and remove the cover.

**Note: Use caution as the cover is large and heavy.**

8. Unplug the actuator from J1 and feed cable down to actuator.
9. Using needle-nose pliers, remove the two ruc clips from the clevis pins holding the actuator in place.
10. Holding the actuator with one hand, remove the clevis pins securing the actuator to the bed then remove the actuator.
11. Reverse these steps to reinstall.

**Note: If new motor shaft does not line up with mounting holes, mount the base of the actuator then plug the actuator in and run it electrically in or out until lined up.**

12. Test all bed functionality prior to putting bed back in service.

# Service Information

---

## ZOOM® DRIVE ACTUATOR REMOVAL AND REPLACEMENT (2141 MODEL ONLY) - (BASE)

### Tools Required:

- Needle-Nose Pliers
- Pry Bar or 2 x 4
- Diagonal Pliers

### Procedure:

1. Plug bed into wall outlet.
2. Position the bed height in the middle range.
3. Remove the center base cover then remove the Zoom® drive actuator cover and set aside.
4. Using Needle-nose pliers, remove the two ruc clips from the clevis pins securing the actuator to the base frame.
5. Using diagonal pliers, cut the zip ties securing the actuator cable and then unplug the actuator from the quick connect.
6. Using a pry bar or a 2 x 4, pry upward on the Zoom® drive actuator frame and push the actuator clevis pins out.
7. Remove actuator.
8. Reverse steps to install new actuator.
9. Test all bed functionality prior to putting bed back into service.

# Service Information

## CPU / POWER BOARD REMOVAL AND REPLACEMENT - (LITTER)

### Tools Required:

- Phillips Screwdriver #2
- ESD System
- 3/8" Nutdriver

### Procedure:

1. Plug bed into wall outlet.
2. Set the brakes using one of the brake control locations or by using the manual brake pedal.
3. Raise the bed to the full upright position.
4. Remove the mattress assembly or fold back to expose the foot section.
5. Using a Phillips screwdriver, remove the two screws (reference drawing, item A and B) securing the electrical cover and remove the cover.

**Note: Use caution as the cover is large and heavy.**

6. Unplug the bed from the wall outlet and turn battery switch OFF. The bed should now have no power.
7. Using an ESD system, properly ground yourself.
8. Unplug all cable connections from the CPU/Power board.
9. Using a 3/8" nutdriver and a Phillips screwdriver, unscrew the four screws (C) securing the metal CPU/Power board mounting plate to the electrical tray (reference drawing above).
10. Remove CPU/Power board and discard.
11. Reverse steps 9-4 to install the new CPU/Power board (QDF75-0440).
12. Plug bed back into wall outlet and turn the battery switch back ON.
13. Configure bed options (refer to the Bed Options Configuration procedure on [page 37](#)).
14. Configure the bed serial number (refer to the Serial Number Configuration procedure on [page 38](#)).
15. Recalibrate the bed by referring to the Bed Calibration procedure on [page 23](#).
16. Test all bed functionality prior to putting the bed back into service.

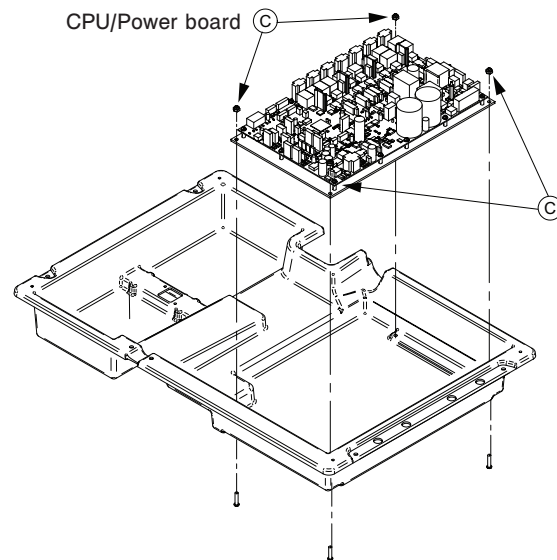
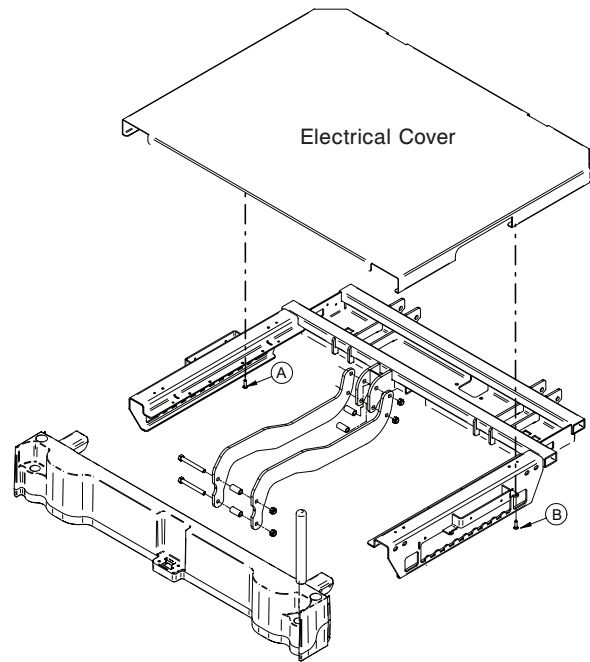

# Service Information

## LOAD CELL (HEAD END) REMOVAL AND REPLACEMENT - (LITTER)

### Tools Required:

- Phillips Screwdriver #2
- Needle-Nose Pliers
- 3/8" Drive Ratchet
- 1/2" Socket
- 1/2" Combination Wrench

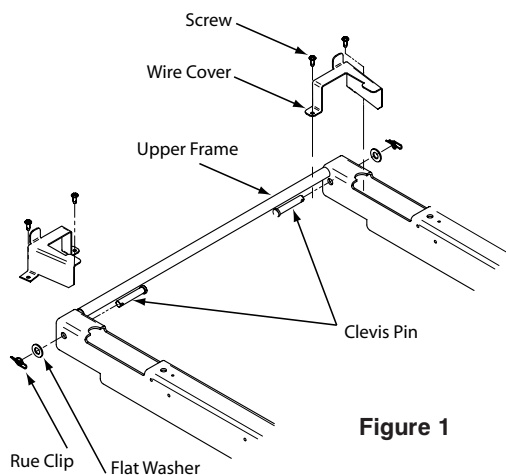

Figure 1

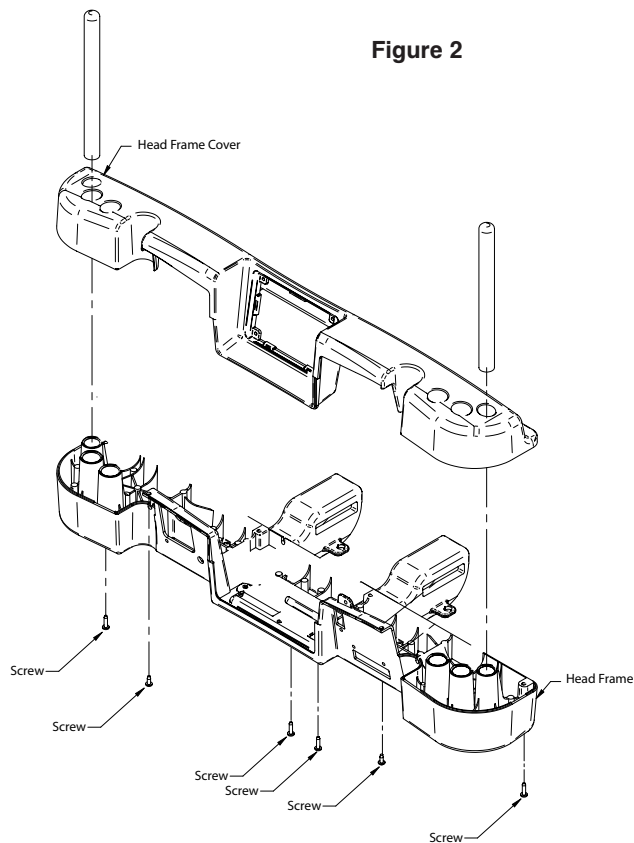

Figure 2

### Procedure: (procedure the same for left and right sides)

1. Plug bed into wall outlet.
2. Raise bed and fowler to full up position, gatch down and foot up.
3. Raise head end siderails.
4. Using a Phillips screwdriver, remove the two screws securing the wire cover to the head frame (Figure 1).
5. Using a Phillips screwdriver, remove the six screws from the head frame cover, lift up on the cover and lay it on the litter (Figure 2)
6. Unscrew the load cell connection and feed the connection back towards the cell.
7. Using Needle-nose pliers, remove the rue clip and the flat washer.
8. Using one hand, grab the upper frame cross bar to remove tension on the litter then push the clevis pin out.
9. Using a ratchet with a 1/2" socket and a 1/2 combination wrench, remove the two bolts securing the load cell then remove the load cell.
10. Reverse procedures to install the new load cell.

### CAUTION

Ensure cables do not get pinched when securing the head end frame cover together.

11. Recalibrate the bed (refer to Bed Calibration procedures on [page 23](#)).
12. Test all bed functionality prior to putting bed back into service.

# Service Information

---

## LOAD CELL (FOOT END) REMOVAL AND REPLACEMENT - (LITTER)

### Tools Required:

- Phillips Screwdriver #2
- Needle-Nose Pliers
- 1/2" Combination Wrench
- 3/8" Ratchet
- 1/2" Shallow Well Socket
- Diagonal Pliers
- Jack
- 2 x 4 (20" recommended)

### Procedure: (procedure the same for left and right sides)

1. Plug bed into wall outlet.
2. Raise bed to around 24" (reference the footboard display) and gatch to full up position.
3. Remove the mattress assembly.
4. Using a 1/2" combination wrench, remove the four bolts securing the gatch section cover and remove by lifting up on the foot end and then pushing backwards on the cover.
5. Raise the foot end siderails up.
6. Using needle-nose pliers, remove the ratchet clip and flat washer.
7. Remove the foot end base cover.
8. Using a Phillips screwdriver, remove the four screws securing the foley bag bracket.
9. Using a jack and 2 x 4, take the tension off of the load cells and remove the clevis pins from both foot end load cells.
10. Unscrew load cell cable connector.
11. Using diagonal pliers, cut the two cable ties securing the main wire harness and the siderail cable located just behind the load cell.
12. Using a ratchet and 1/2" socket, remove the two nuts and bolts securing the load cell to the litter frame.
13. Remove the load cell by pulling back and upward towards the middle of the bed while feeding the cable through the litter frame.
14. Reverse procedures to install the new load cell.

---

### CAUTION

Do not pinch the cable when installing the load cell.

---

15. Recalibrate the bed (refer to Bed Calibration procedures on [page 23](#)).
16. Test all bed functionality prior to putting bed back into service.

# Service Information

## DISPLAY REMOVAL AND REPLACEMENT - (FOOTBOARD)

### Tools Required:

- Phillips Screwdriver #2
- Stubby Phillips Screwdriver #2
- Small Slotted Screwdriver
- Utility Knife
- ESD System

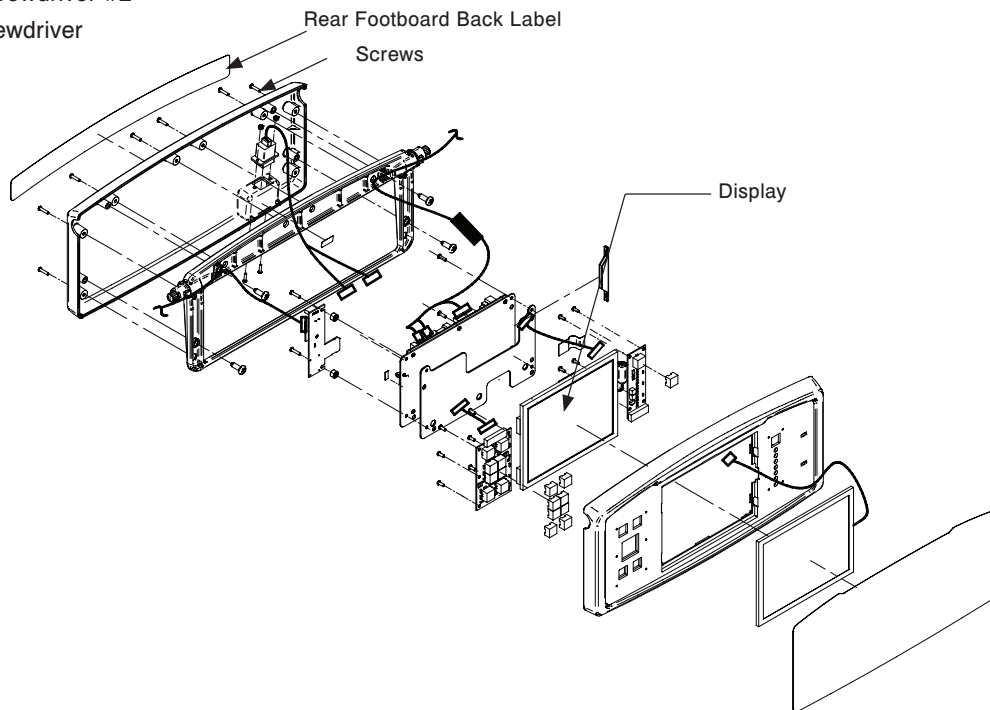

### Procedure:

**Note: ESD protection is required for this procedure.**

1. Remove the footboard assembly and place onto a nearby work surface, face down.
2. Using a small slotted screwdriver or a utility knife, remove the rear footboard label.  
**Note: This label will need to be replaced with a new label (QDF27-2756).**
3. Using a Phillips screwdriver, remove the six screws securing the footboard display panel to the footboard.
4. Pivot the display panel up.
5. Using a stubby Phillips screwdriver, remove the two screws from the bottom of the display panel.
6. Hold the display panel and footboard assembly together and flip the footboard assembly over, with the display panel facing up.
7. Carefully remove the display panel from the footboard assembly. Rotate over to display the circuit boards.
8. Disconnect the two ribbon cables from J3 and J7 by pulling outward on the locking tabs, then pulling the ribbon cable.
9. Disconnect the menu board cable from connector J6.
10. Using a Phillips screwdriver, remove the two screws that secure the Wi-Fi board to the LCD interface board.
11. Using a Phillips screwdriver, remove the two screws that secure the LCD interface board to the display housing.
12. Remove the two spacer shims between the LCD interface board and the display housing.
13. Carefully remove the LCD interface board from the display.  
**Note: The components are secured together with double-sided foam tape. Slight upward force will be necessary to separate.**
14. Using a small slotted screwdriver, separate the locking tabs from the display and remove the display.
15. Reverse the procedure to install the new display.
16. Recalibrate the touch screen, by referencing the Touch Screen Calibration procedure on [page 23](#).
17. Test all bed functionality before returning the bed to service.



# Service Information

## BRAKE CONTROL BOARD REMOVAL AND REPLACEMENT - (FOOTBOARD)

### Tools Required:

- Phillips Screwdriver #2
- Stubby Phillips Screwdriver #2
- Small Slotted Screwdriver
- Utility Knife
- ESD System

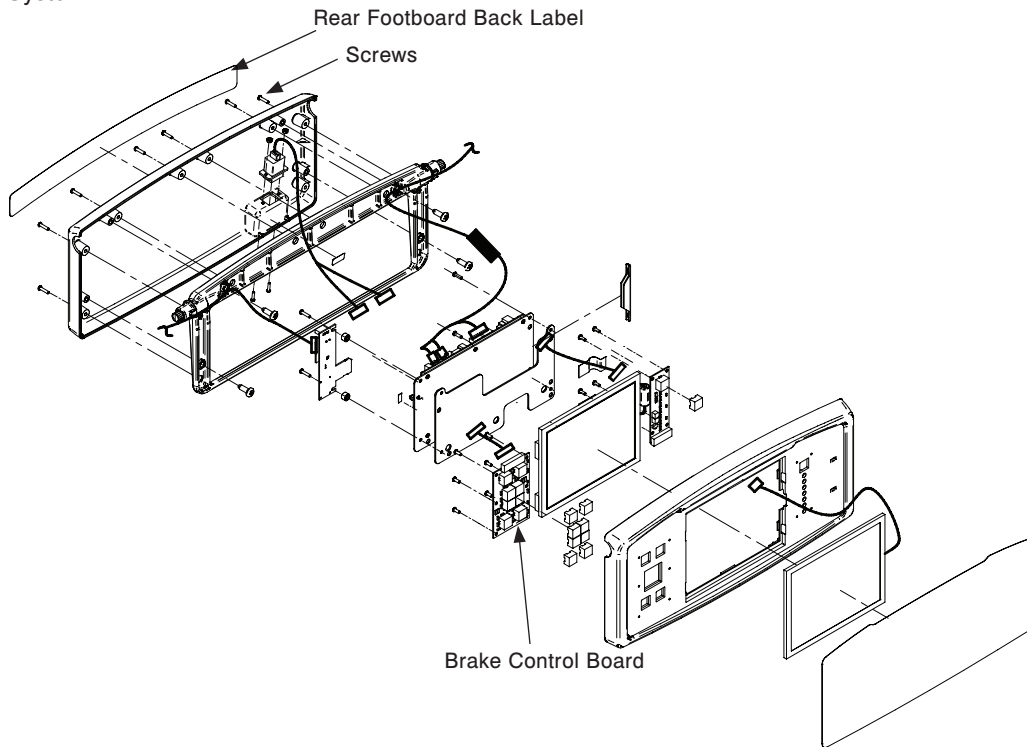

### Procedure:

**Note: ESD protection is required for this procedure.**

1. Remove the footboard assembly and place onto a nearby work surface, face down.
2. Using a small slotted screwdriver or a utility knife, remove the rear footboard label.  
**Note: This label will need to be replaced with a new label (QDF27-2756).**
3. Using a Phillips screwdriver, remove the six screws securing the footboard display panel to the footboard.
4. Pivot the display panel up.
5. Using a stubby Phillips screwdriver, remove the two screws from the bottom of the display panel.
6. Hold the display panel and footboard assembly together and flip the footboard assembly over, with the display panel facing up.
7. Carefully remove the display panel from the footboard assembly. Rotate over to display the circuit boards.
8. Using a Phillips screwdriver, remove the two screws that secure the Wi-Fi antenna P-clamps to the brake control board.
9. Using a Phillips screwdriver, remove the remaining four screws that secure the brake control board to the footboard display housing.
10. Disconnect the brake control cable from the brake control board.
11. Remove the brake control board.
12. Reverse the procedure to install the new brake control board.
13. Test all bed functionality before returning the bed to service.

# Service Information

## FUNCTION SELECTION/LED BOARD REMOVAL AND REPLACEMENT - (FOOTBOARD)

### Tools Required:

- Phillips Screwdriver #2
- Stubby Phillips Screwdriver #2
- Small Slotted Screwdriver
- Utility Knife
- ESD System

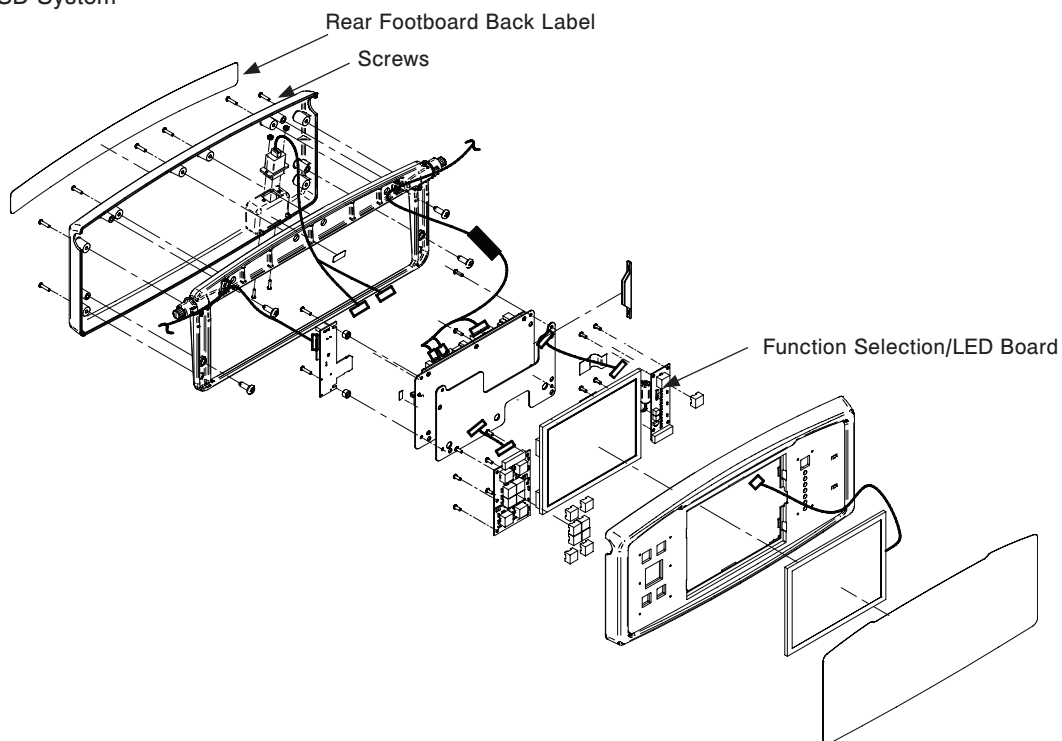

### Procedure:

1. Plug the bed into a wall outlet.
2. Raise the bed to the full up position and level.
3. Unplug the bed and turn the battery disconnect "OFF" (0).
4. Using a small slotted screwdriver or a utility knife, remove the rear footboard label.  
**Note: This label will need to be replaced with a new label (QDF27-2756).**
5. Using a Phillips screwdriver, remove the six screws from the top of the control panel which the label was covering.
6. Raise the display up and using a stubby Phillips screwdriver, remove the three screws on the bottom.
7. Remove the display housing and unplug the two cables from the function control board and set the display assembly on a bench to work on.
8. Using a Phillips screwdriver, remove the four screws securing the function selection/LED board.
9. Unplug the cable going to the function selection/LED board.
10. Reverse the procedures to install the new function selection/LED board.
11. Test all bed functionality prior to putting the bed back into service.

# Service Information

## TOUCH SCREEN REMOVAL AND REPLACEMENT - (FOOTBOARD)

### Tools Required:

- Phillips Screwdriver #2
- Stubby Phillips Screwdriver #2
- Small Slotted Screwdriver
- Utility Knife
- ESD System

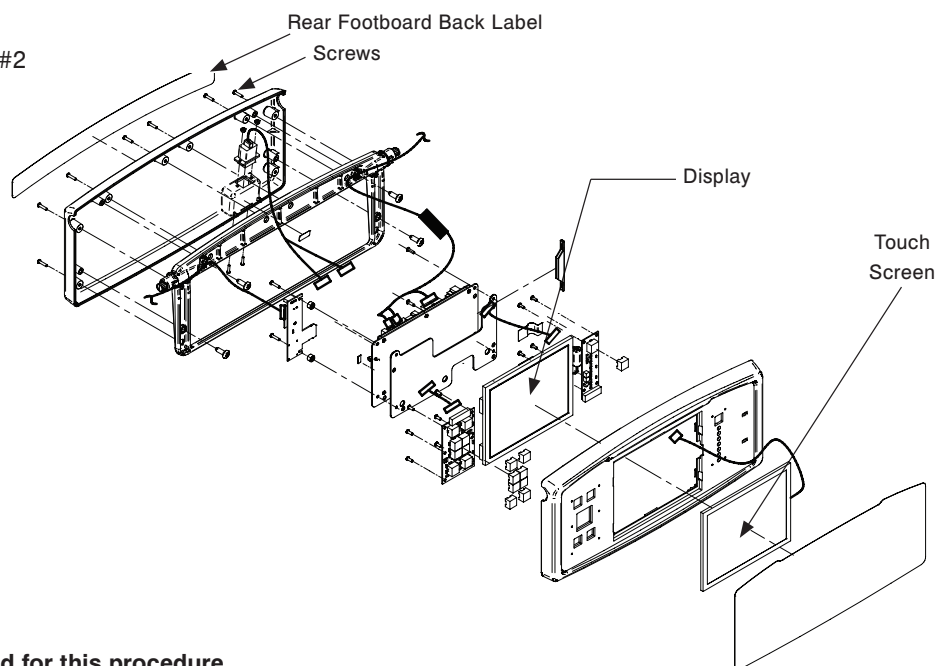

### Procedure:

**Note: ESD protection is required for this procedure.**

1. Remove the footboard assembly and place onto a nearby work surface, face down.
2. Using a small slotted screwdriver or a utility knife, remove the rear footboard label.  
**Note: This label will need to be replaced with a new label (QDF27-2756).**
3. Using a Phillips screwdriver, remove the six screws securing the footboard display panel to the footboard.
4. Pivot the display panel up.
5. Using a stubby Phillips screwdriver, remove the two screws from the bottom of the display panel.
6. Hold the display panel and footboard assembly together and flip the footboard assembly over, with the display panel facing up.
7. Carefully remove the display panel from the footboard assembly and rotate over to display the circuit boards.
8. Disconnect the two ribbon cables from J3 and J7 by pulling outward on the locking tabs, then pulling the ribbon cable.
9. Disconnect the menu board cable from connector J6.
10. Using a Phillips screwdriver, remove the two screws that secure the Wi-Fi board to the LCD interface board.
11. Using a Phillips screwdriver, remove the two screws that secure the LCD interface board to the display housing.
12. Remove the two spacer shims between the LCD interface board and the display housing.
13. Carefully remove the LCD interface board from the display.  
**Note: The components are secured together with double-sided foam tape. Slight upward force will be necessary to separate.**
14. Using a small slotted screwdriver, separate the locking tabs from the display and remove the display.
15. Using a small slotted screwdriver or utility knife, remove the foot control overlay label.  
**Note: This overlay label will need to be replaced with a new overlay label (QDF27-2188-ENG) and patent pending label (QE71-1094-ENG).**
16. Carefully separate the touch screen from the display housing.
17. Reverse the procedure to install the new touch screen.
18. Recalibrate the touch screen, by referencing the Touch Screen Calibration procedure on [page 23](#).
19. Test all bed functionality before returning the bed to service.

# Service Information

## BATTERY REMOVAL AND REPLACEMENT - (FOOTBOARD)

### Tools Required:

- Phillips Screwdriver #2
- Stubby Phillips Screwdriver #2
- Small Slotted screwdriver
- Utility Knife
- ESD System

### Procedure:

1. Plug the bed into a wall outlet.
2. Raise the bed to the full up position and level.
3. Unplug the bed and turn the battery disconnect switch to the "OFF" (0) position.
4. Using a small slotted screwdriver or a utility knife, remove the rear footboard label.  
**Note: This label will need to be replaced with a new label (QDF27-2756).**
5. Using a Phillips screwdriver remove the six screws from the top of the control panel which the label was covering.
6. Raise the display up and using a stubby Phillips screwdriver, remove the three screws on the bottom.
7. Remove the display housing and unplug the two cables from the function control board and set the display assembly on a bench to work on.
8. Remove the battery and replace with new battery (see figure below).
9. Reverse the above steps to reassemble.
10. Referencing the operation manual complete the Time / Date Setup procedure.



Battery

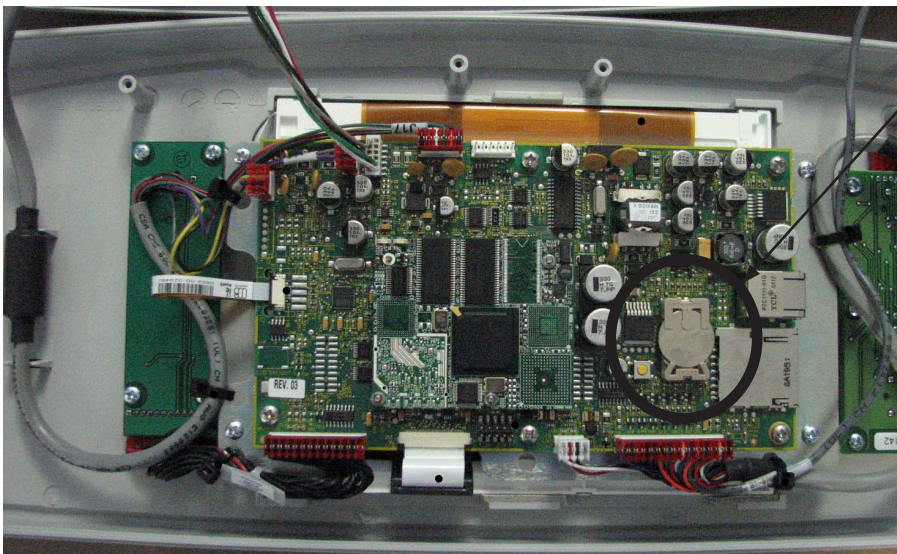

# Service Information

## BRAKE / NEUTRAL / DRIVE POTENTIOMETER REMOVAL AND REPLACEMENT - QDF27-2024

### Tools Required:

- Diagonal Pliers

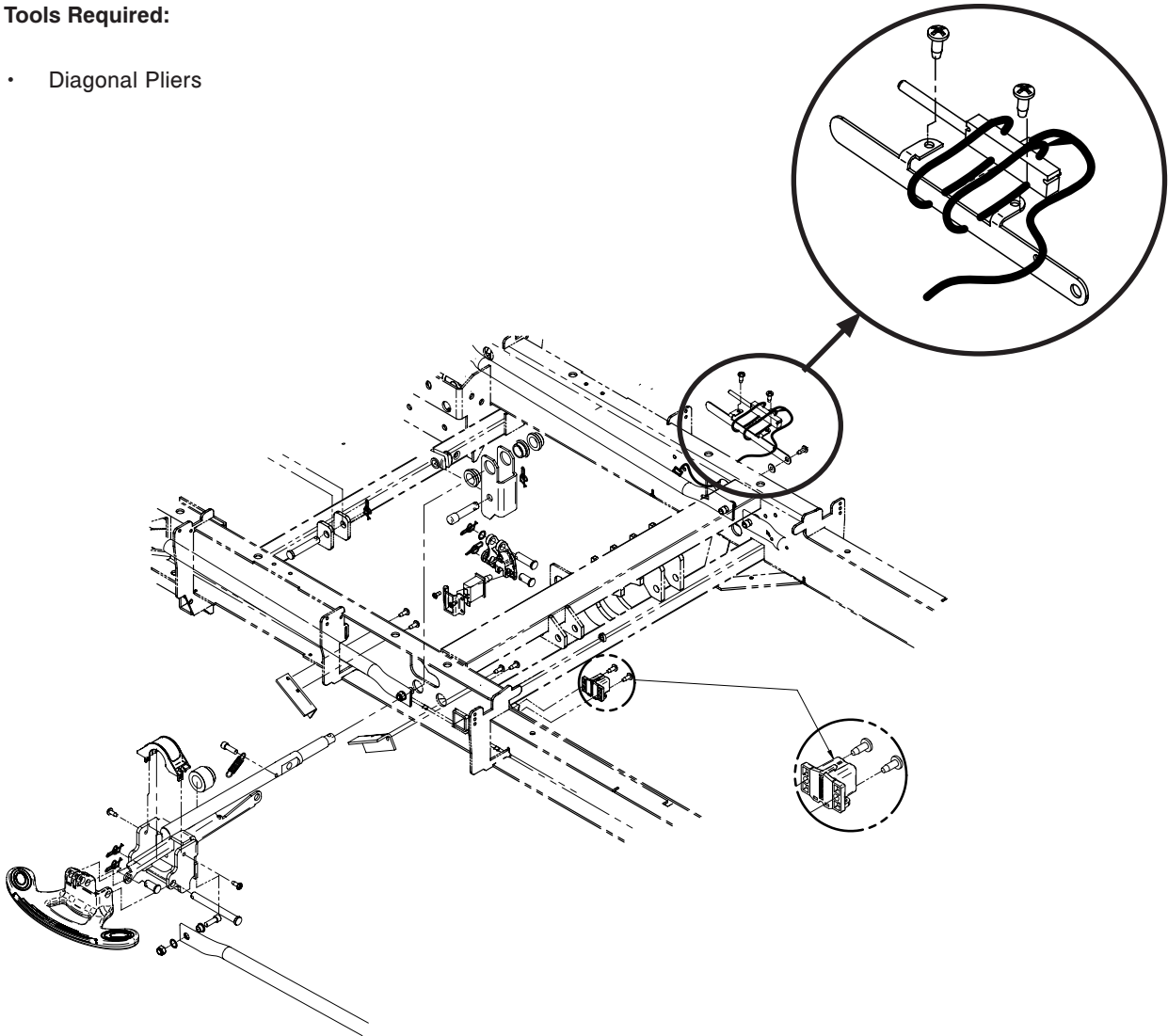

### Procedure:

1. Plug bed into wall outlet.
2. Raise the bed lift and patient's left siderails all the way up.
3. Remove the base center covers (foot, center, and head).
4. Remove the patient's left base frame cover.
5. Cut the two wire ties securing the potentiometer to the potentiometer bracket; then cut the two wire ties securing the potentiometer wires to the frame.
6. Remove the electrical tape holding the quick connection together.
7. Reverse the above procedures for installation of the new potentiometer.  
**Note: Make sure to install new wire ties in the same location.**
8. Recalibrate the bed (refer to Bed Calibration procedures on [page 23](#)).
9. Test all bed functionality prior to putting the bed back into service.

# Service Information

## BATTERY REMOVAL AND REPLACEMENT - (LITTER)

### Tools Required:

- Phillips Screwdriver #2
- 5/16" Nutdriver
- 5/16" Combination Wrench

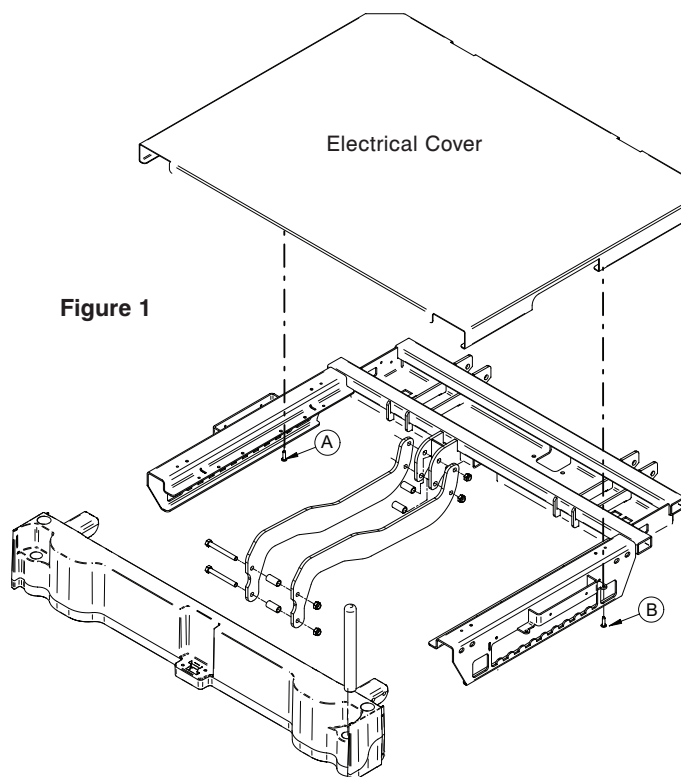
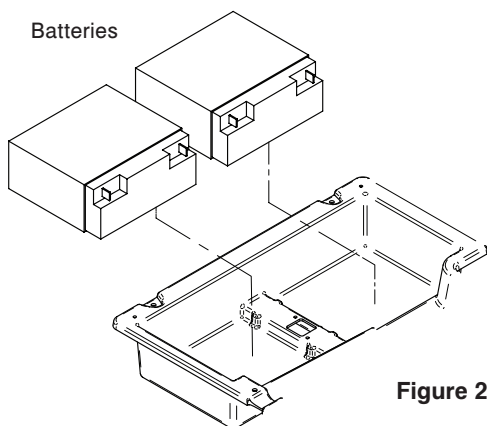

### Procedure:

#### Note

Batteries should always be replaced in pairs.

1. Plug bed into wall outlet.
2. Set the brakes using one of the brake control locations or by using the manual brake pedal.
3. Raise the bed to the full up position.
4. Remove the mattress assembly or fold back to expose the foot section.
5. Using a Phillips screwdriver, remove the two screws securing the electrical cover and remove the cover (reference Figure 1 above, item A and B).

**Note: Use caution as the cover is large and heavy.**

6. Unplug the bed from the wall outlet and turn battery switch "OFF" (0). The bed should now have no power.
7. Unplug J12 connector from the CPU/Power board.
8. Lift up on both batteries and stand them upright (reference Figure 2 above).
9. Using a 5/16" nutdriver and a 5/16" combination wrench, unbolt the wires from the battery posts.
10. Reverse the steps to install new batteries.

**Note: New battery information should be facing the right side when installing and upright when installed.**

11. Test all bed functionality while plugged into wall outlet and when unplugged prior to putting back into service.

# Service Information

## FOWLER ANGLE SENSOR REMOVAL AND REPLACEMENT - (LITTER)

### Tools Required:

- Stubby Phillips Screwdriver #2
- ESD System

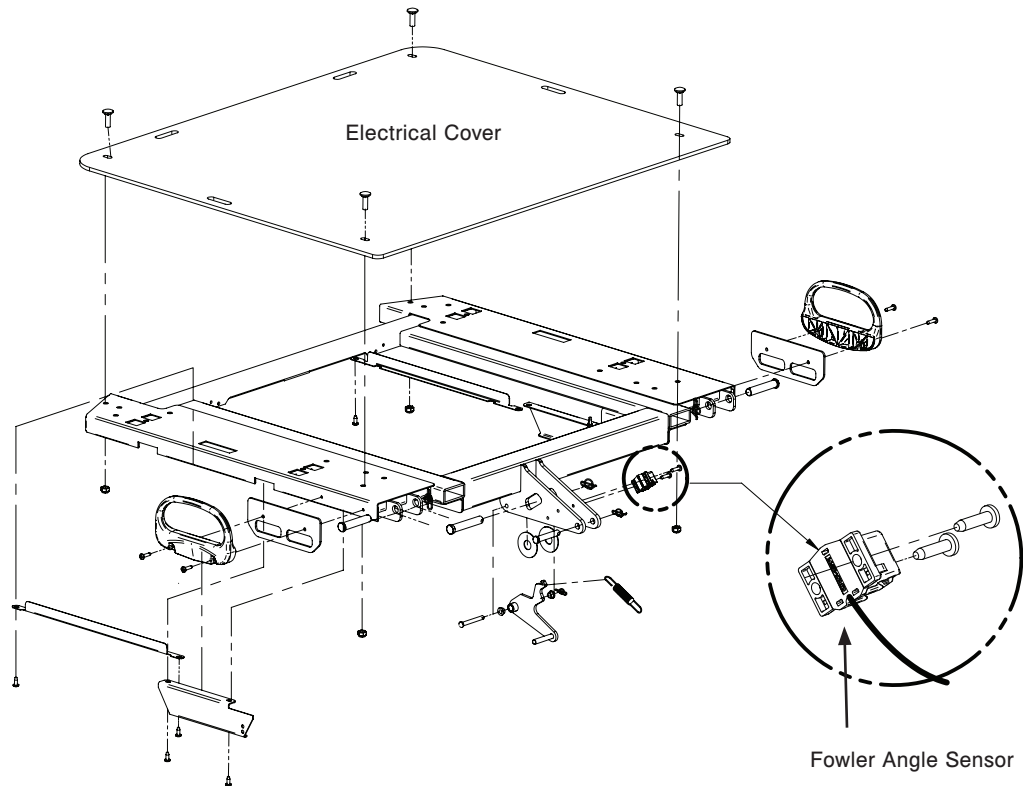

### Procedure:

1. Plug bed into wall outlet.
  2. Set the brakes using one of the brake control locations or by using the manual brake pedal.
  3. Raise the bed to the full up position and raise the patient left siderails (head end and foot end).
  4. If fowler motor will run, raise fowler up to approximately 20 degrees. If the fowler motor will not run, put the bed into the calibration mode step one as shown on [page 23](#). Run the Fowler up to approximately 20 degrees.
  5. Working from the left side of the bed, use a stubby Phillips screwdriver and remove the two screws securing the fowler angle sensor to the bottom of the fowler frame.
  6. Using an ESD system, properly ground yourself.
  7. Unclip the three clips holding the board cover on.
  8. Unplug the cable from the board.
  9. Reverse the steps to install the new fowler angle sensor.
- Note: Do not over-tighten the two screws.**
10. Recalibrate the bed (refer to Bed Calibration procedures on [page 23](#)).
  11. Test all bed functionality prior to putting the bed back into service.



# Service Information

## GATCH ANGLE SENSOR REMOVAL AND REPLACEMENT - (LITTER)

### Tools Required:

- Stubby Phillips Screwdriver #2
- ESD System

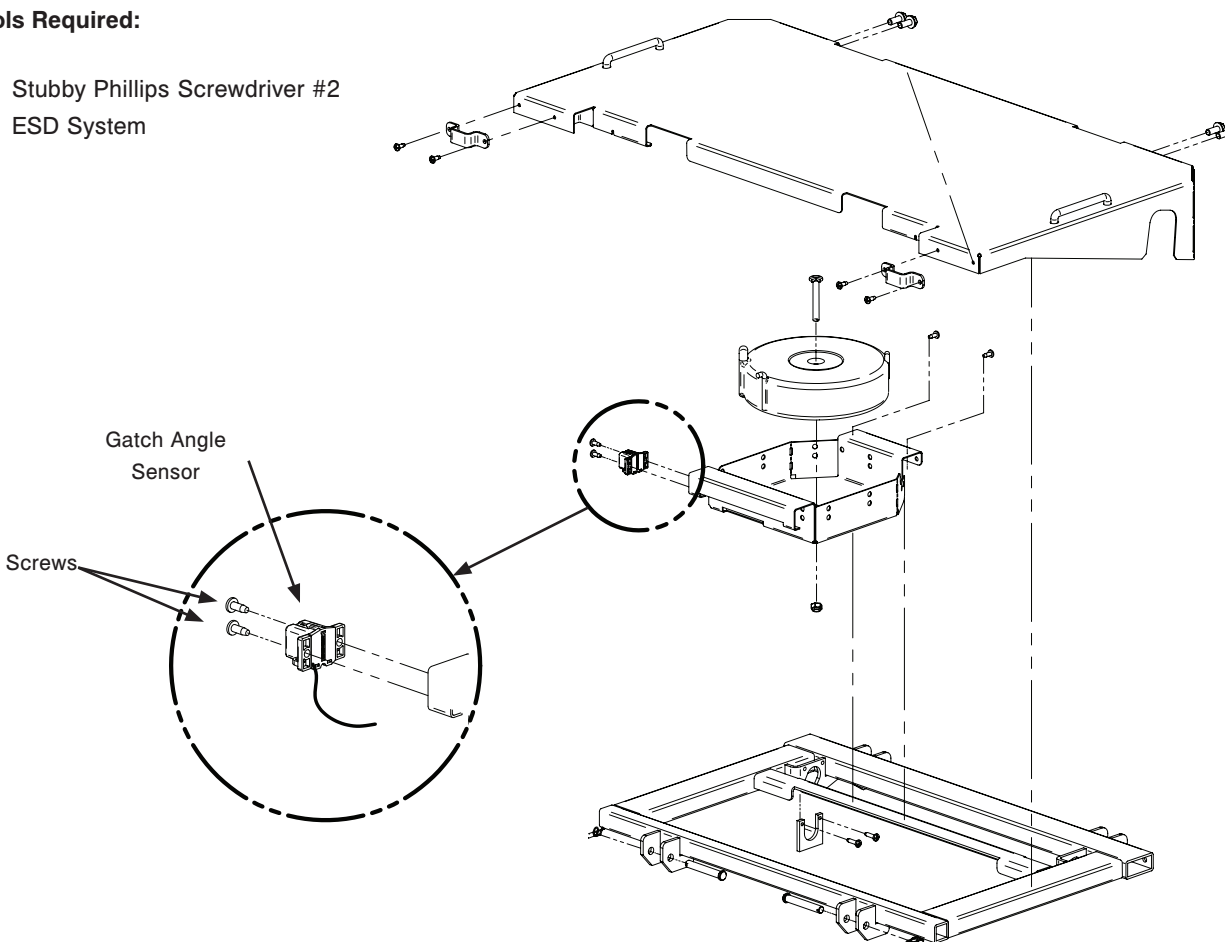

### Procedure:

1. Plug bed into wall outlet.
  2. Set the brakes using one of the brake control locations or by using the manual brake pedal.
  3. Raise the bed to the full up position.
  4. If gatch motor will run, raise gatch up to approximately 20 degrees. If the gatch motor will not run, then put the bed into the calibration mode step one as shown on [page 23](#).
  5. Working from the bottom left side of the litter, under the gatch section, use a stubby Phillips screwdriver and remove the two screws securing the gatch angle sensor to the bottom of the gatch frame.
  6. Using an ESD system, properly ground yourself.
  7. Unclip the three clips holding the board cover on.
  8. Unplug the cable from the board.
  9. Reverse the steps to install new gatch angle sensor.
- Note: Do not over tighten the two screws.**
10. Recalibrate the bed (refer to Bed Calibration procedures on [page 23](#)).
  11. Test all bed functionality prior to putting the bed back into service.



# Service Information

## FOOT ANGLE SENSOR REMOVAL AND REPLACEMENT - (LITTER)

### Tools Required:

- Phillips Screwdriver #2
- ESD System

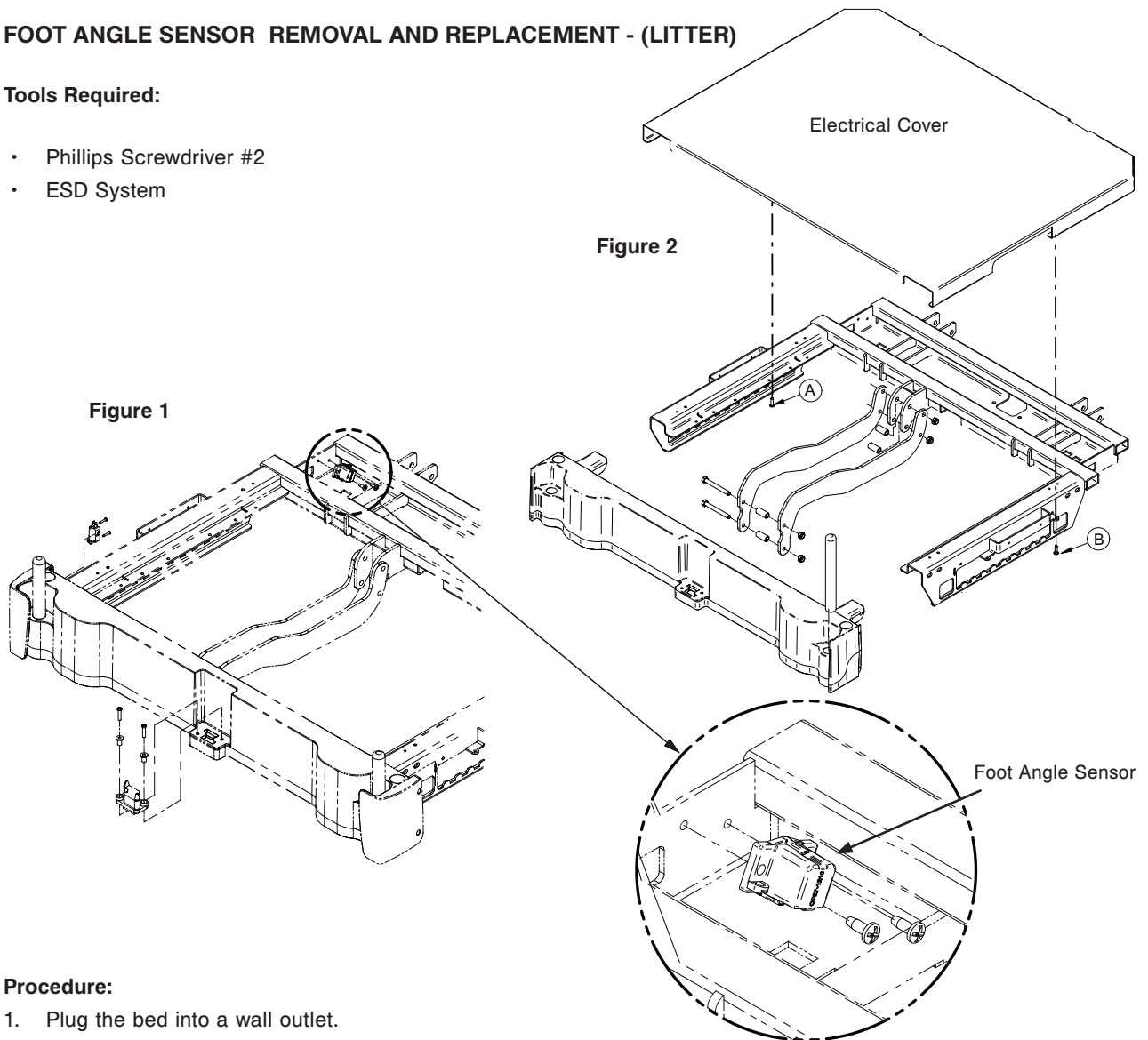

### Procedure:

1. Plug the bed into a wall outlet.
2. Raise the bed to the full up position and level the litter surface.
3. Remove or fold back the mattress, exposing the foot section.
4. Using a Phillips screwdriver, remove the two screws securing the electrical cover and then remove the cover (refer to Figure 1 above, item A and B).
5. Using a Phillips screwdriver, remove the two screws securing the angle sensor to the foot frame (refer to Figure 2 above). **Note: Use caution as the cover is large and heavy.**
6. Using an ESD system, properly ground yourself.
7. Unclip the three clips holding the board cover on.
8. Unplug the cable from the board.
9. Reverse the steps to install the new foot angle sensor.  
**Note: Do not over-tighten the two screws.**
10. Recalibrate the bed (refer to Bed Calibration procedures on [page 23](#)).
11. Test all bed functionality prior to putting the bed back into service.

# Service Information

## BASE ANGLE SENSOR REMOVAL AND REPLACEMENT - (BASE)

### Tools Required:

- Stubby Phillips Screwdriver
- ESD System

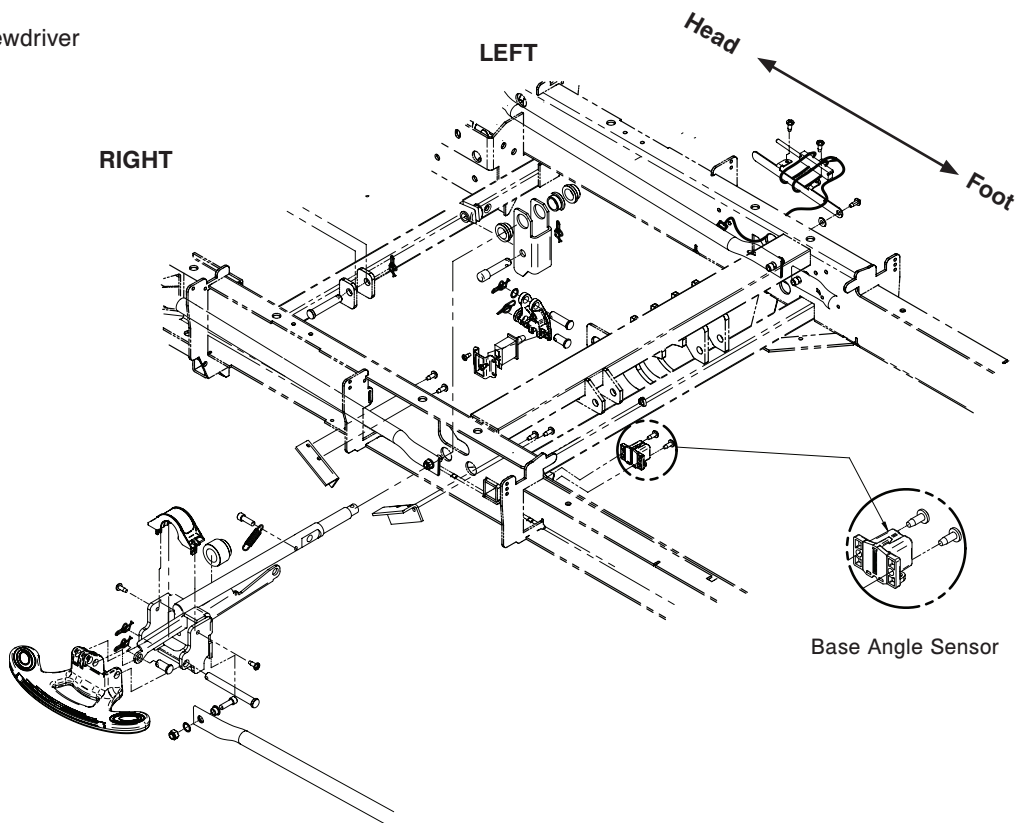

### Procedure:

1. Plug the bed into a wall outlet.
2. Set the brakes using one of the brake control locations or by using the manual brake pedal.
3. Raise the bed to the full up position and raise the patient right siderails (foot end and head end).
4. Remove the head end, enter, foot end, and right base cover.
5. Using a Phillips screwdriver, remove the two screws securing the base angle sensor to the base frame (reference Figure above).
6. Using an ESD system, properly ground yourself.
7. Unclip the three clips holding the board cover on.
8. Unplug the cable from the board.
9. Reverse the steps to install new base angle sensor.

**Note: Do not over-tighten the two screws.**

10. Recalibrate the bed (refer to Bed Calibration procedures on [page 23](#)).
11. Test all bed functionality prior to putting the bed back into service.

# Service Information

## TREND ANGLE SENSOR REMOVAL AND REPLACEMENT - (LITTER)

### Tools Required:

- Phillips Screwdriver #2
- ESD System

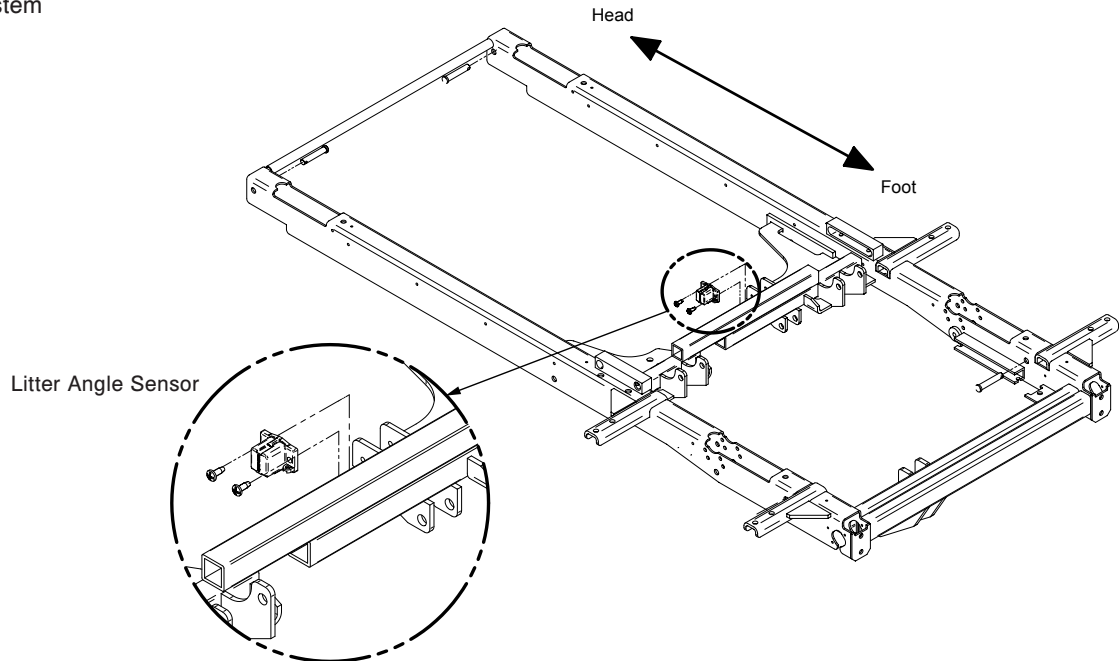

### Procedure:

1. Plug the bed into a wall outlet.
2. Raise the bed to the full up position and raise the patient right siderail.
3. Working from the patient's right side, use a Phillips screwdriver and remove the two screws securing the trend angle sensor to the litter frame (refer to Figure above),
4. Using an ESD system, properly ground yourself.
5. Unclip the three clips holding the board cover on.
6. Unplug the cable from the board.
7. Reverse the steps to install new trend angle sensor.

**Note: Do not over-tighten the two screws.**

8. Recalibrate the bed (refer to Bed Calibration procedures on [page 23](#)).
9. Test all bed functionality prior to putting the bed back into service.

# Service Information

## HEADWALL COMMUNICATION BOARD REMOVAL AND REPLACEMENT - (LITTER)

### Tools Required:

- Phillips Screwdriver #2
- ESD System

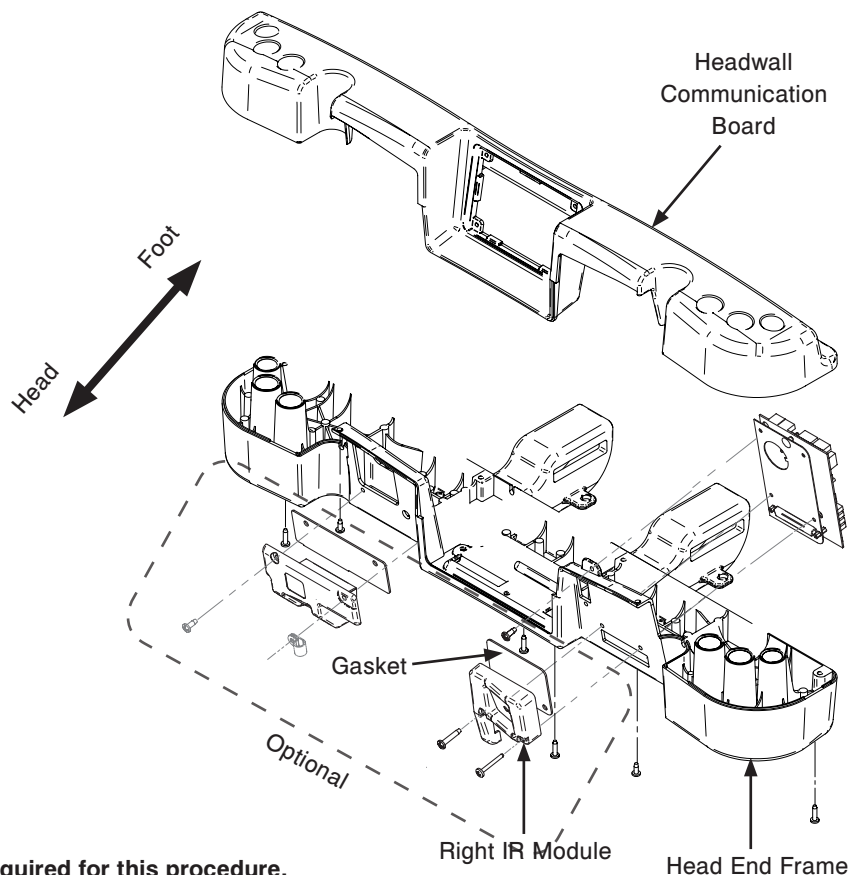

### Procedure:

**Note: ESD protection is required for this procedure.**

1. Plug the bed into a wall outlet.
2. Raise the bed to the full up position.
3. Raise the fowler to the full up position.
4. Unplug the bed power cord from the wall outlet.
5. Turn the battery disconnect switch off.
6. Remove the headboard from the bed.
7. If the optional head end IV pole is present, use a 1/2" socket and 3/8" drive ratchet to remove the IV pole.
8. Using a Phillips screwdriver, remove the six screws that secure the head end frame cover to the head end frame.
9. Remove the head end frame cover and set aside.

10. Using a Phillips screwdriver, remove the two screws that secure the right IR module and gasket to the head end frame.

**Note: Ensure the IR module cable is routed in the wire track before reinstallation.**

11. Using a Phillips screwdriver, remove the screw that secures the headwall communication board to the head end frame.
12. Disconnect all of the cables going to the headwall communication board.

**Note: Make note of all cable connections and dip switch settings on the headwall communication board.**

13. Configure the new headwall communication board to match the dip switch settings from the old headwall communication board.
14. If the bed is equipped with the optional Smart TV, transfer the Smart TV board from the old headwall communication board to the new headwall communication board.
15. Reverse steps 12 through 1 to install the new headwall communication board.
16. Test all bed functionality before returning the bed to service.

# Service Information

## IR MODULE REMOVAL AND REPLACEMENT - (LITTER) (OPTIONAL)

### Tools Required:

- Phillips Screwdriver #2
- Diagonal Pliers
- ESD System

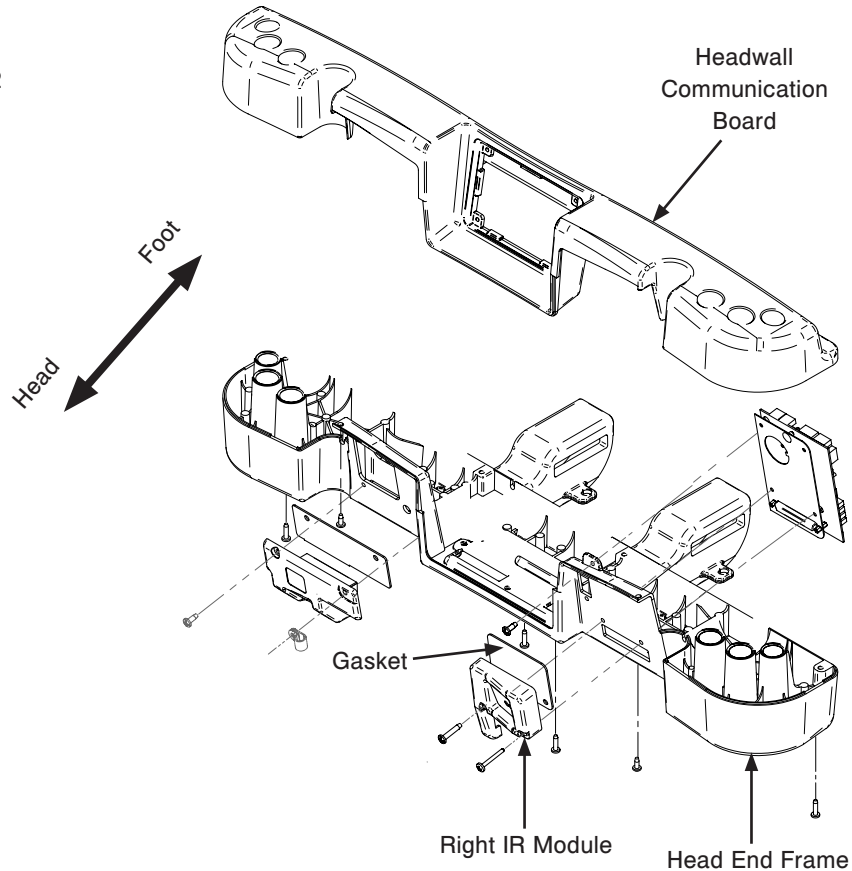

### Procedure:

**Note: ESD protection is required for this procedure.**

1. Plug the bed into a wall outlet.
2. Raise the bed to the full up position.
3. Raise the fowler to the full up position.
4. Unplug the bed power cord from the wall outlet.
5. Turn the battery disconnect switch off.
6. Remove the headboard from the bed.
7. If the optional head end IV pole is present, use a 1/2" socket and 3/8" drive ratchet to remove the IV pole.
8. Using a Phillips screwdriver, remove the six screws that secure the head end frame cover to the head end frame.
9. Remove the head end frame cover and set aside.
10. Using a Phillips screwdriver, remove the two screws that secure the right IR module and gasket to the head end frame.

**Note: Ensure the IR module cable is routed in the wire track before reinstallation.**

11. Using a Phillips screwdriver, remove the two screws that secure the left IR module and gasket to the head end frame.
12. Using diagonal pliers, cut the cable tie that secures the IR module cables below the head end frame.
13. Disconnect the right IR module cable from connector J5 on the headwall communication board.
14. Disconnect the left IR module cable from connector J2 on the headwall communication board.
15. Reverse the procedure to install the new IR modules.

**Note: Route both right and left IR module cables into the head end frame through the matching right and left Zoom® handle cable cutouts in the head end frame.**

16. Test all bed functionality before returning the bed to service.

# Service Information

## WI-FI BOARD REMOVAL AND REPLACEMENT - (FOOTBOARD) (OPTIONAL)

### Tools Required:

- Phillips Screwdriver #3
- Small pick
- Small Slotted Screwdriver
- ESD System
- iBed Wireless Configuration Tool
- Router

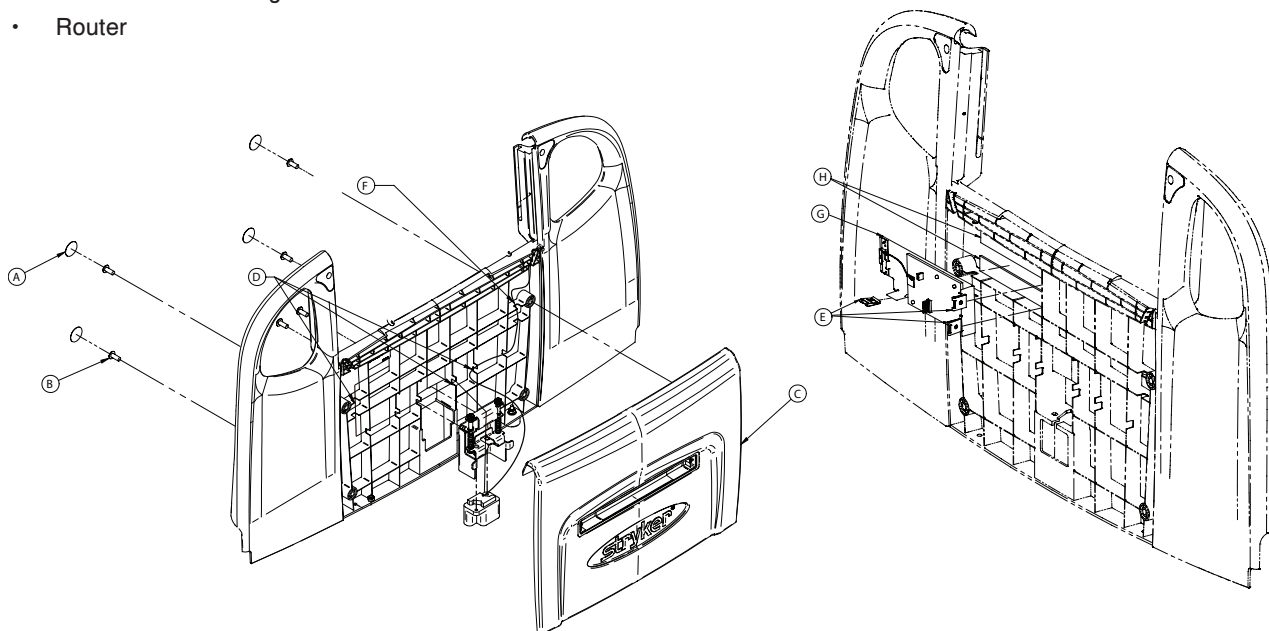

### Procedure:

**Note:** The facility's IT department must be contacted to update the IP/DNS record for the affected product. The MAC address for the record will need to be updated from the old Wi-Fi board MAC address to the new Wi-Fi board MAC address. Failing to do so will prevent the unit from connecting to the facility's wireless network.

**Note:** ESD protection is required for this procedure.

1. Remove the footboard assembly and place onto a nearby work surface, face down.
2. Use a small pick to remove and save the four screw covers (A) from the back of the footboard.
3. Use a #3 Phillips screwdriver to remove and save the four screws (B) that secure the footboard cover (C) to the footboard.
4. Lift the footboard up so the display faces you. Lift the footboard cover (C) out and up to remove. Disconnect the local bed status board (D). Save the footboard cover (C).
5. Place the footboard onto a work surface with the display up and pivot the nurse control panel upward.
6. Use a small slotted screwdriver to remove and save the three clip nuts (E).
7. Disconnect the footboard cable (F) from the Gateway heat stake board assembly (G).
8. Pull on all four corners of the Gateway heat stake board assembly (G) to remove the board from the double sided tape (H) holding it to the footboard. Discard the board.
9. Remove all doublesided tape (H) from the footboard.

# Service Information

## WI-FI BOARD REMOVAL AND REPLACEMENT - (FOOTBOARD) (OPTIONAL) (CONTINUED)

10. Reverse steps to reinstall.

**Note: To configure the wireless network connection settings, you must have a laptop and a router configured for Stryker defaults.**

11. Plug in the router configured for Stryker defaults.

12. Plug the power cord of the bed into the wall outlet and make sure that the wireless option is turned on.

13. Connect the laptop to the syk\_med\_install SSID which the configured router is broadcasting.

14. Open the **iBed** Wireless Configuration Tool.

15. On the bed, enter the **Connectivity Info** menu by accessing the service menu on the footboard.

16. Scroll down to the IP address which the router provided for the bed.

17. Enter the bed IP address in the **Wireless Device URL/IP** box.

18. Click the **Get Wireless Device Configuration** button. This will retrieve the bed wireless default settings and connect to the bed, which is shown in the left column of the tool.

19. Click the **OK** button of the retrieval confirmation.

20. Enter the facility network information and make sure that you fill in all of the appropriate blanks in the right column of the tool.

21. Select the **Radio Mode** for the facility requirements.

22. Click the **Upload Configuration to Device** button.

**Note: If the radio does not connect, make sure that you check the settings entered into the column on the right. If they are incorrect, the radio will need to be reset to defaults and then repeat the configuration process.**

23. Test all bed functionality before returning the bed to service.

The screenshot displays the 'Wireless Configuration Tool' interface. At the top, there is a 'Wireless Device URL / IP' field containing '192.168.1.118', a dropdown menu set to 'GW3 or greater', and a 'Port' field set to '1639'. A 'Get Wireless Device Configuration' button is located below these fields. The interface is divided into two main columns: 'Current Device Configuration' on the left and 'New Device Configuration' on the right. The 'Current Device Configuration' panel includes sections for 'Radio Settings' (Country Code, Radio Mode), 'Connection Status' (DHCP checkbox, IP Address, Subnet Mask, Default Gateway), 'Network name (SSID)', 'Security' (Authentication, Encryption, Network key, Show Key checkbox, 802.1X), 'User Authentication' (User Name, Password, Show Password checkbox, Domain), and 'Device Identification' (Model Number, Serial Number, with 'GW1 Only' labels). A 'View Device Log' button is at the bottom. The 'New Device Configuration' panel includes 'Radio Settings' (Country Code: UNITED STATES(USA), Radio Mode: 11a/b/g/n/ac), 'Connection Status' (DHCP checked, IP Address, Subnet Mask, Default Gateway), 'Network name (SSID)', 'Security' (Authentication, Encryption, Network key, Show Key checkbox, 802.1X), 'User Authentication' (User Name, Password, Show Password checkbox, Domain), and 'Configuration Profile' (Load Profile, Save Profile, Save Profile (set as default), Delete Profile buttons). An 'Upload Configuration to Device' button is at the bottom. A double arrow '>>' button is positioned between the two columns.

# Base Assembly, Hood

L27-026 Rev J (Reference Only)

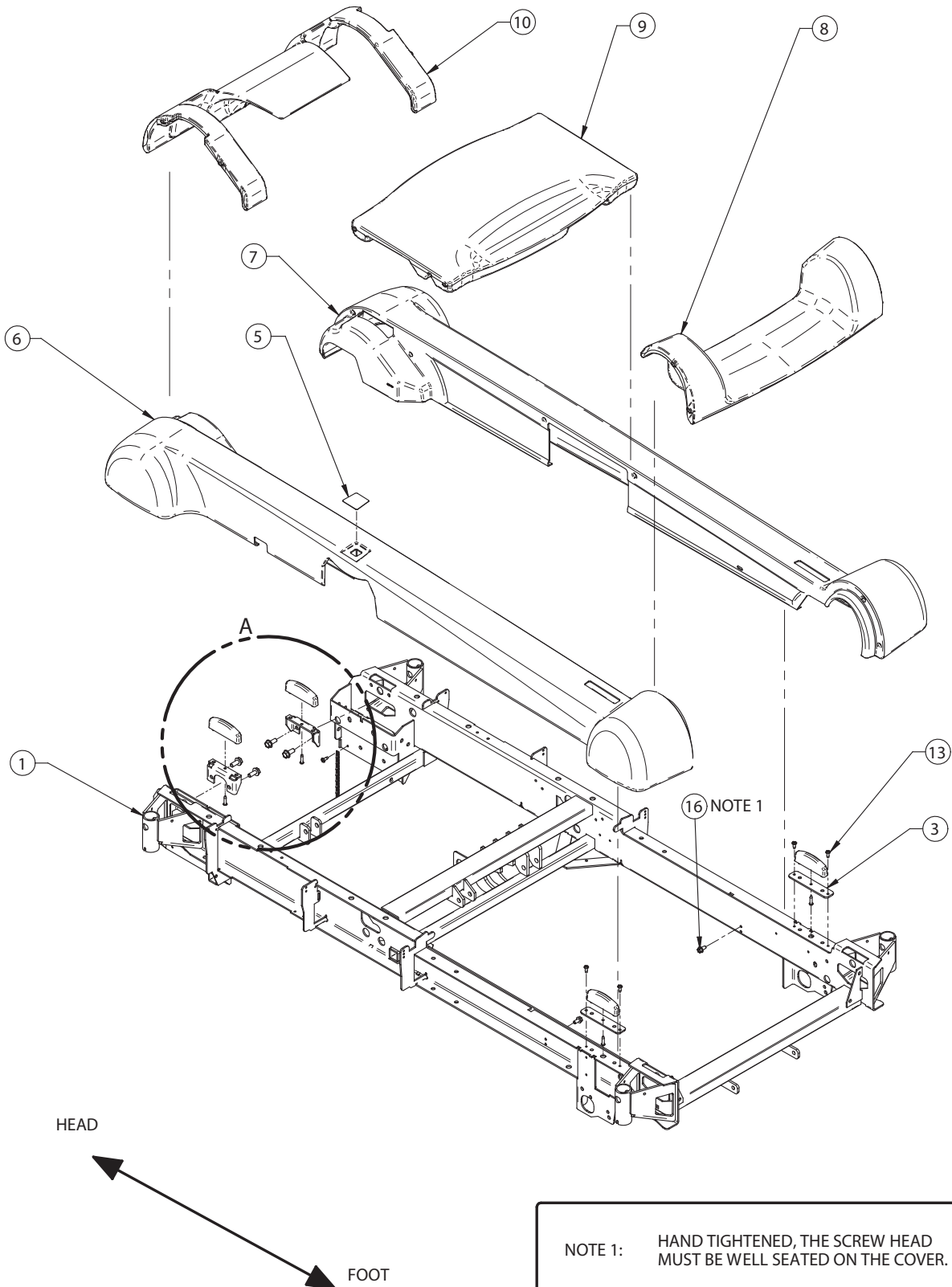



# Base Assembly, Hood

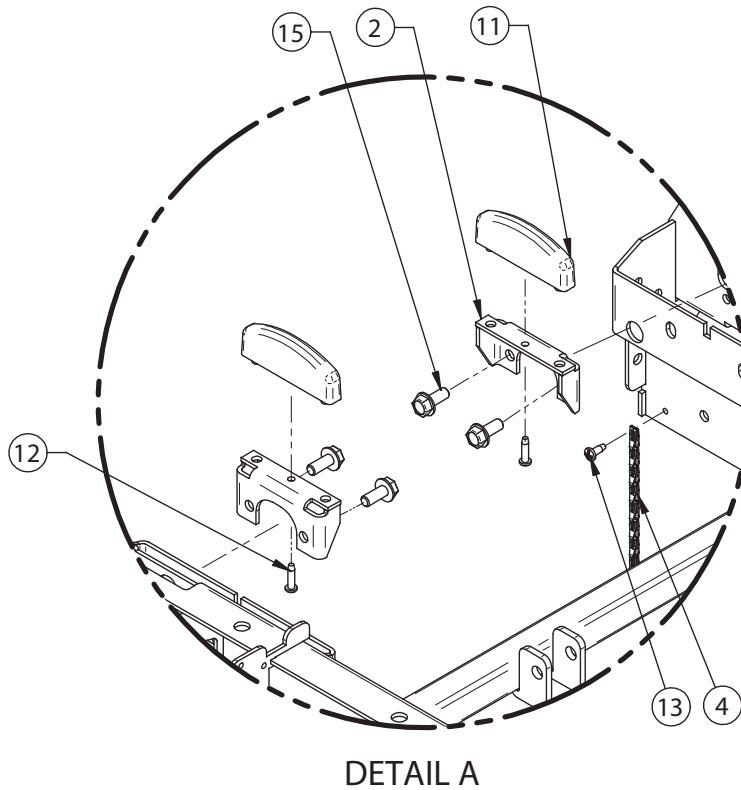

## Base Assembly, Hood - L27-026 Rev J (Reference Only)

Item	Part No.	Part Name	Qty.
1	27-0758P	Base Assembly	1
2	27-1462P	Support Stopper	2
3	27-1628P	Foot Stopper Support	2
4	27-2123	Ground Chain	1
5	QDF27-1419	Base Transparent Plate	1
6	QP27-1008	Right Base Cover	1
7	QP27-1009	Left Base Cover	1
8	QP27-1087	Foot Base Cover	1
9	QP27-1093	Center Base Cover	1
10	QP27-1105	Head Base Cover	1
11	QP27-1461	Stopper in Base	4
12	VV23A1G24HL	Tapping Screw	4
13	VV83A9G16	Tapping Screw	5
15	VVB4A1O24	Thread Rolling Bolt	4
16	VV84A1I16	Flanged Hex Head Tapping Screw	2

# Base Assembly, Brake

L27-043 Rev-02 (Reference Only)

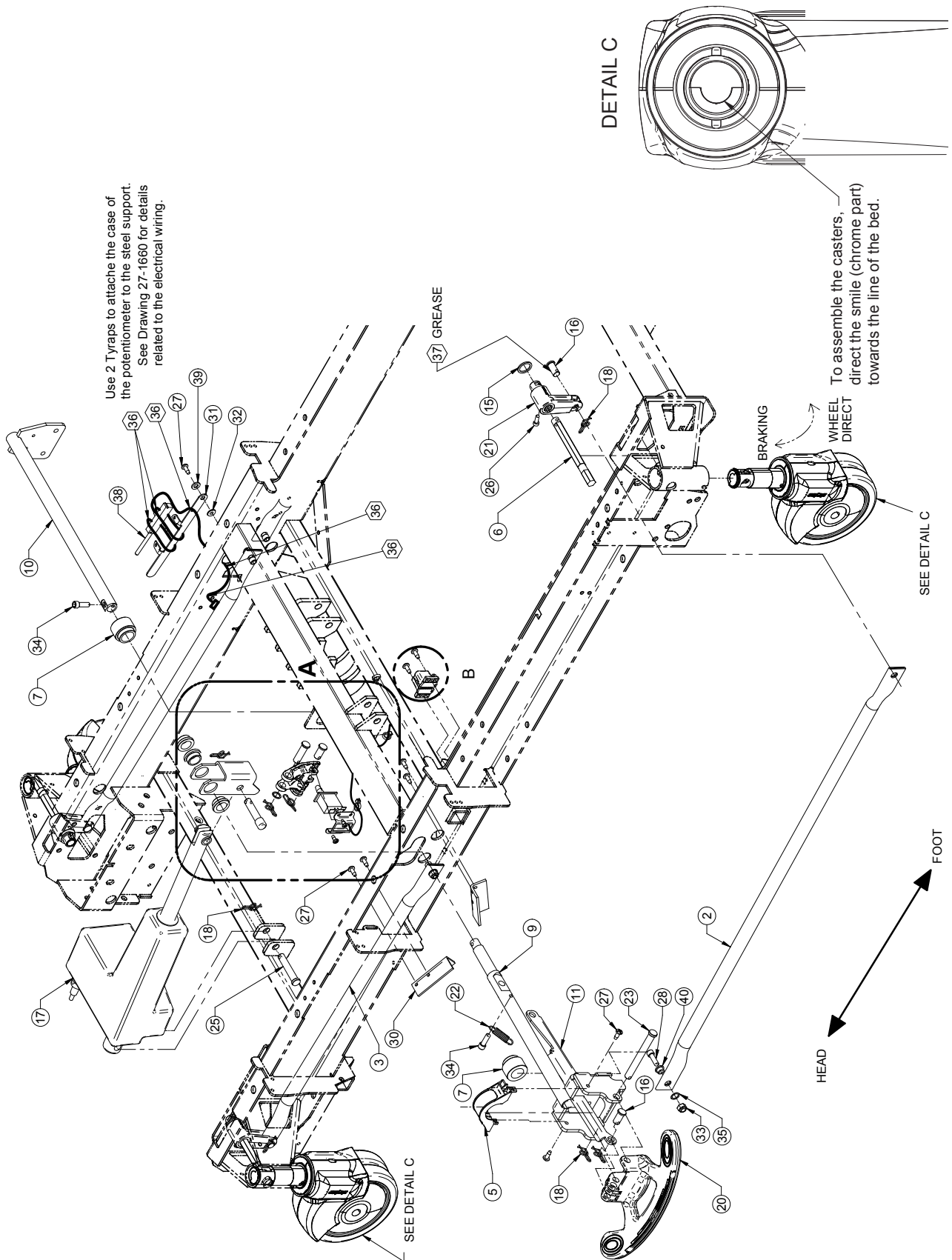

# Base Assembly, Brake

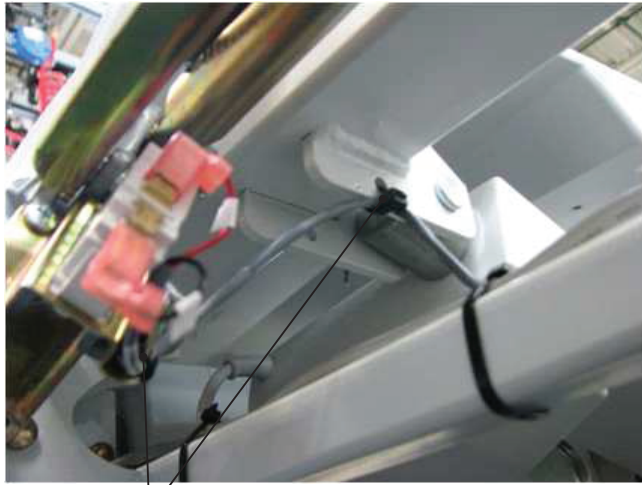

The angle sensor orientation is very important. Wire should exit towards the bottom.

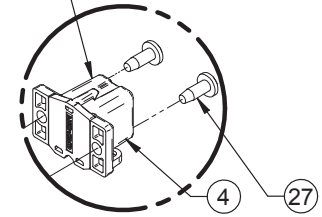

DETAIL B

Tyrap positioning

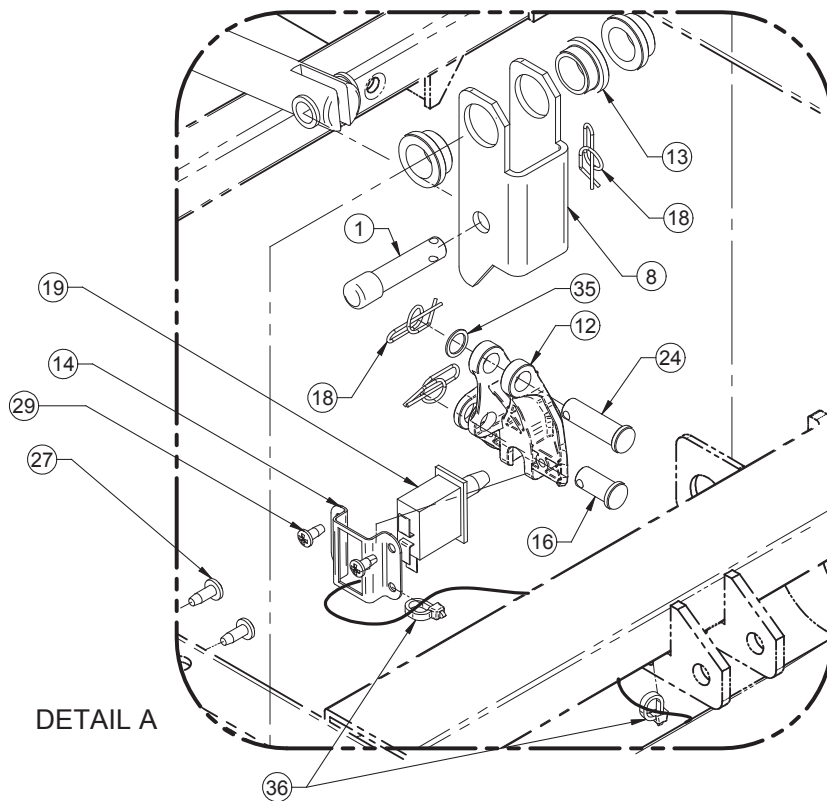

DETAIL A

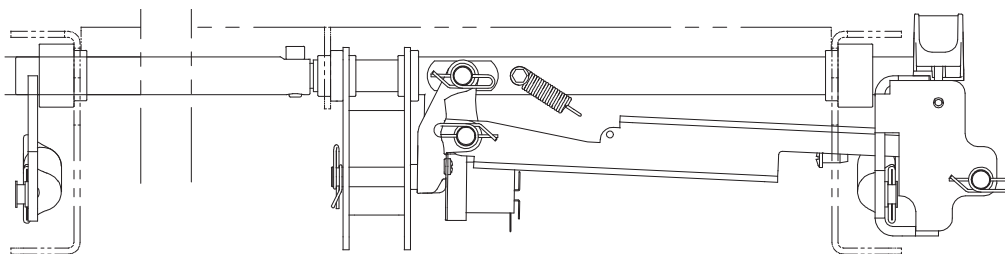

View of Assembled Brake System

[Return To Table of Contents](#)

# Base Assembly, Brake

---

## Base Assembly, Brake - L27-043 Rev-02 (Reference Only)

Item	Part No.	Part Name	Qty.
1	27-1402Z	Brake Clevis pin	1
2	27-0772Z	Foot Brake Tube	2
3	27-0773Z	Head Brake Tube	2
4	27-2477	Angle Sensor Assembly	1
5	QP27-1255	Brake Indicator	1
6	27-1336Z	Casters Activation Roller Strike	4
7	27-1354	Brake Bearing	2
8	27-1391Z	Brake Actuator Pivot	1
9	27-1405Z	Right Brake Cross Member	1
10	27-1406Z	Left Brake Cross Member	1
11	27-1411Z	Brake Shift Control Stem	1
12	QPA27-1448	Brake Trigger	1
13	27-1449	Braking Bearing	3
14	27-1452Z	Microswitch Bracket	1
15	VW10C202802	Washer	4
16	VG50A1224	Clevis Pin	6
17	QDF27-1227	Brake Actuator	1
18	QDF7878	Fastener Pin	10
19	QDF9159	Cherry Limit Switch	1
20	27-2519P	Emergency Pedal	1
21	QPA27-1335	Brake Lever	4
22	QRE27-1844	Extension Spring	1
23	VG50A1259	Clevis Pin	1
24	VG50B1236	Clevis Pin	1
25	VG50B1248	Clevis Pin	1
26	VV10A0G16-S	Hexagon Cylinder Head	4
27	VV83A9G16	Tapping Screw	9
28	VV10A1N24	Hexagon Cylinder Head	4
29	VV83A9E12	Tapping Screw	2
30	27-1745Z	Head Brake Microswitch Stop	2
31	27-1946Z	Potentiometer Support	1
32	27-1948	Copper Sleeve Spacer	1
33	VE30A1N	Nylon Locknut	4
34	VV10A1N24-S	Cylinder Head Hex Screw	2
35	VW10C121601	Nylon Washer	5
36	QDF9518	Cable Tie	3
37	M0019	Grease	1
38	QDF27-2024	Position Sensor	1
39	VW10C081602	Nylon Washer	1
40	QB2938T1	Sleeve	4

# Base Assembly, Caster Lock (Model 2131 Only)

OL270006 Rev D (Reference Only)

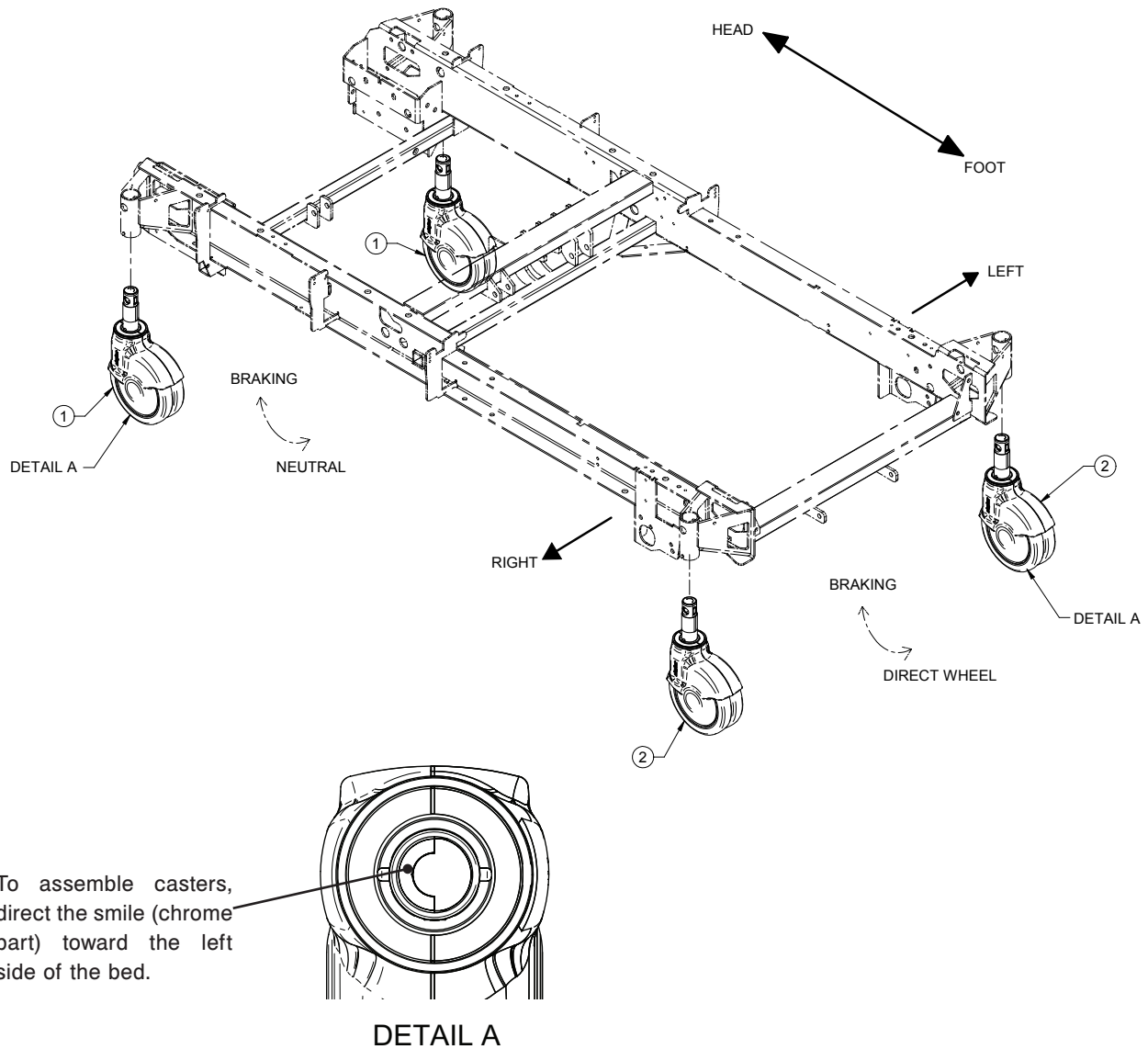

Item	Part No.	Part Name	Qty.
1	RD27-2787	5.5" Caster Brake/Neutral/Neutral	2
2	RD27-2788	5.5" Caster Brake/Neutral/Drive	2

# Base Assembly, Caster Non-Lock (Model 2141 Only)

OL270005 Rev D (Reference Only)

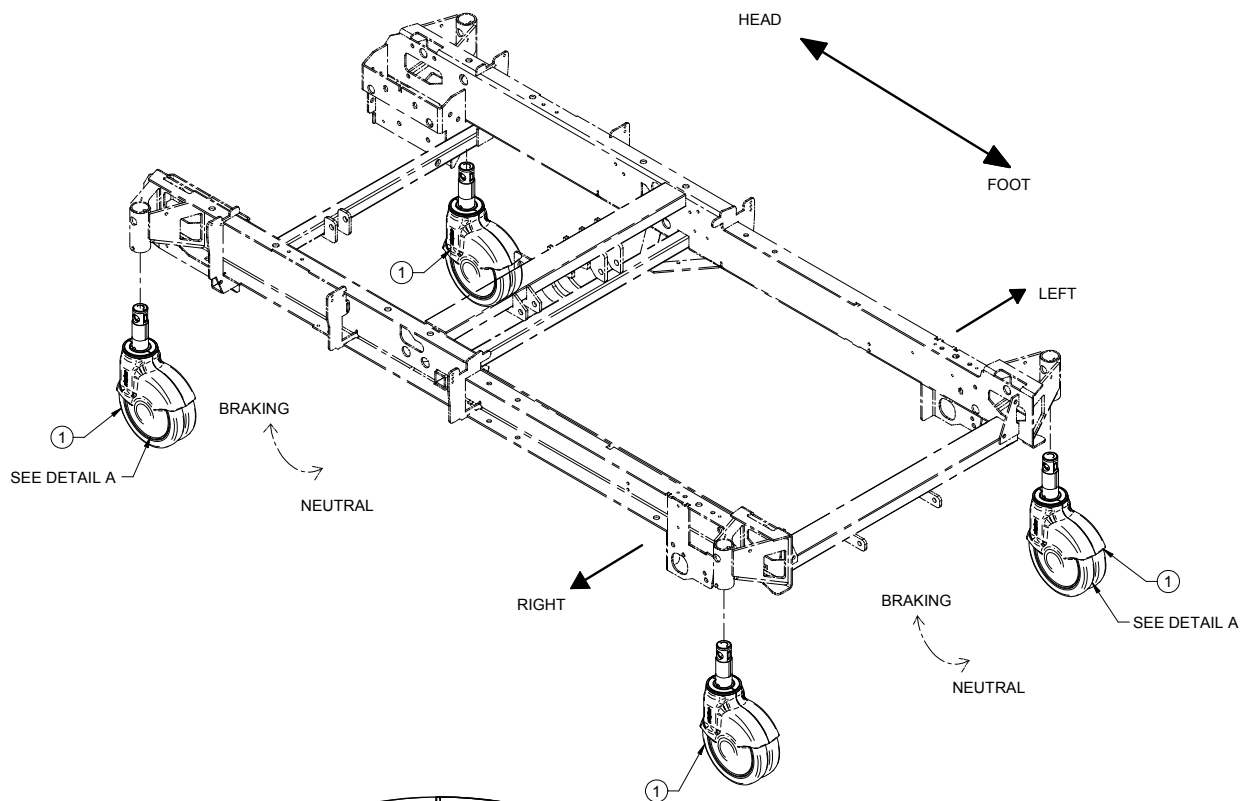

To assemble casters, direct the smile (chromed part) toward the left side of the bed.

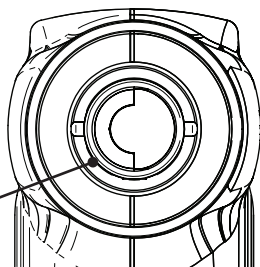

DETAIL A

Item	Part No.	Part Name	Qty.
1	RD27-2787	5.5" Caster Brake/Neutral/Neutral	4

# Angle Sensor Assembly

27-2477 Rev 0 (Reference Only)

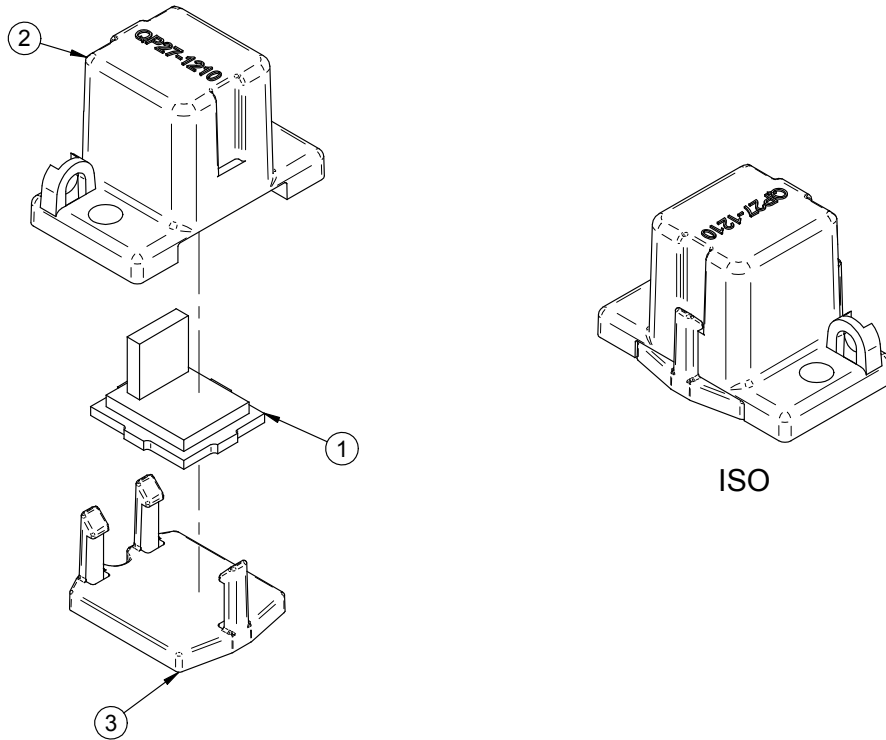

Item	Part No.	Part Name	Qty.
1	QDF75-0140	Angle Sensor	1
2	QP27-1210	Angle Sensor Case	1
3	QP27-1211	Bottom Lid for Tilt Sensor	1

# Base Assembly, Electrical

27-2687 Rev B (Reference Only)

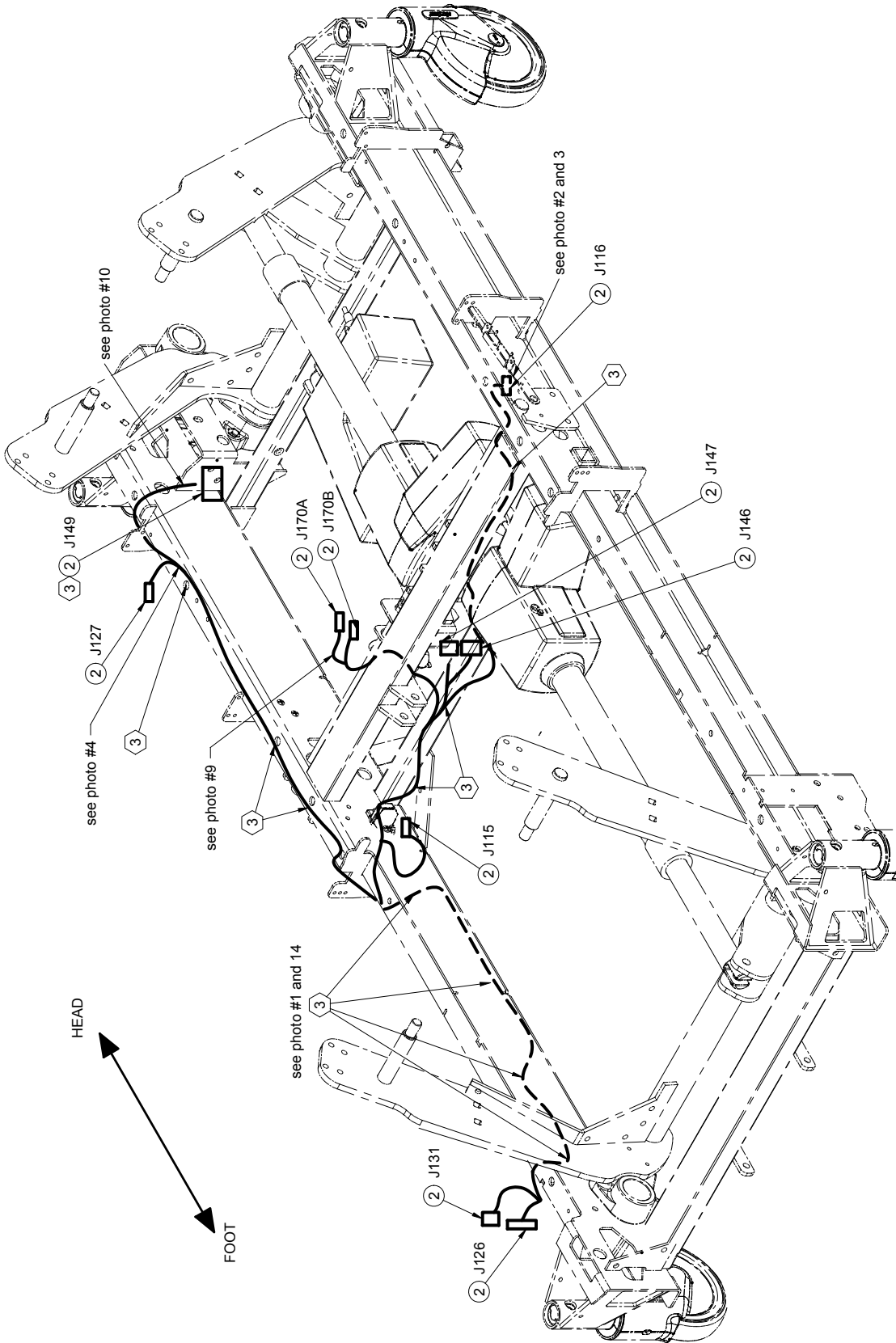



# Base Assembly, Electrical

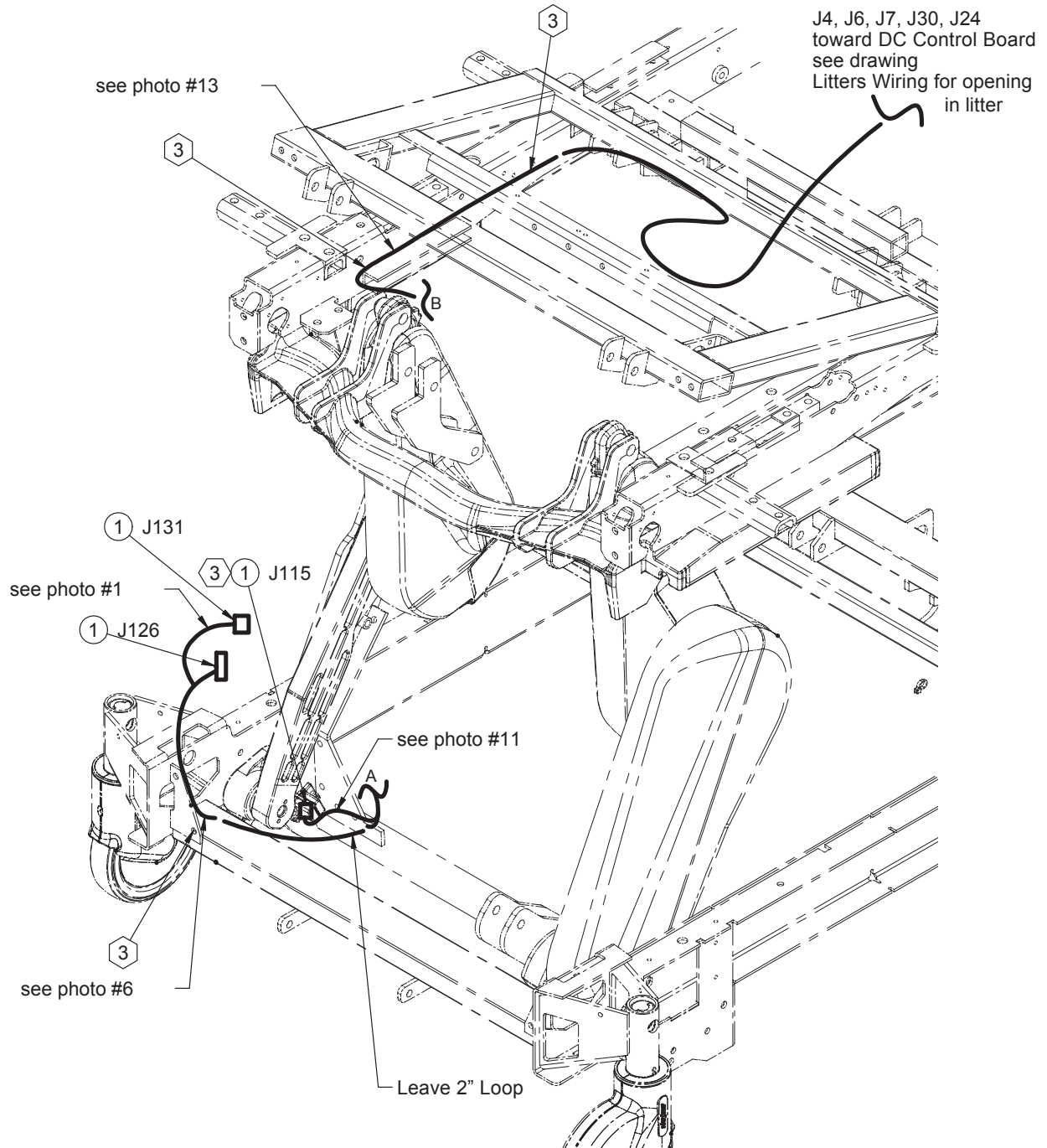

# Base Assembly, Electrical

## Note

To avoid any risk of pinching when assembling these cables:

- Bed must be in high position
- Gatch must be at 15 degrees
- Foot Litter must be at 45 degrees

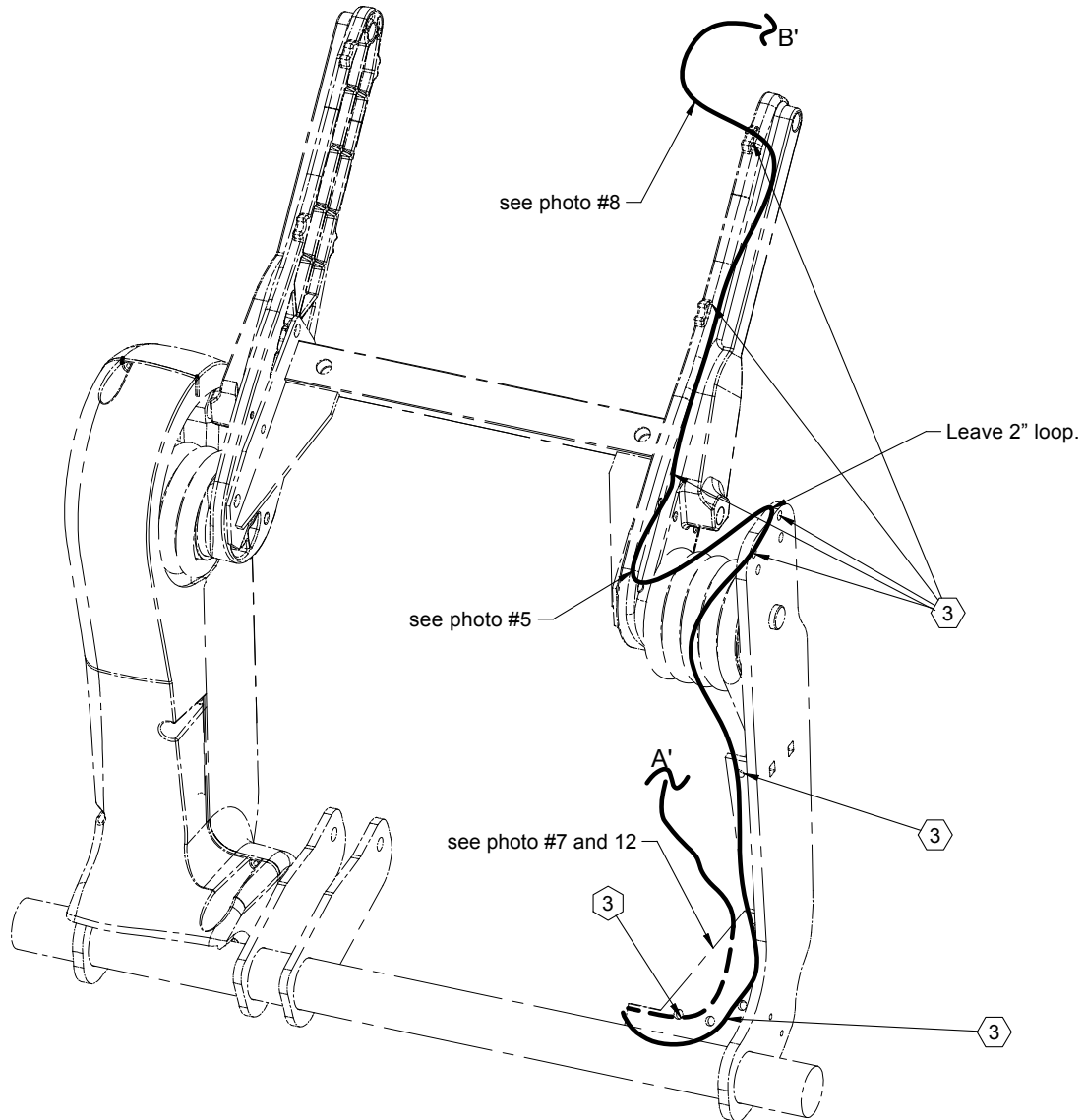

# Base Assembly, Electrical

Be sure to place the connectors one beside the other and in a flat position.

PHOTO #1

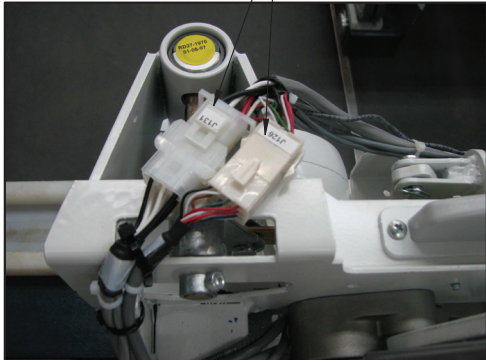

PHOTO #2



PHOTO #3



PHOTO #4



PHOTO #5

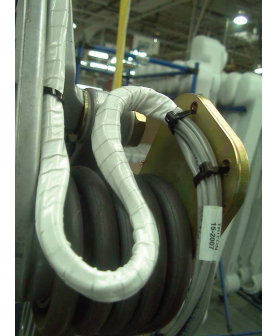

PHOTO #6



PHOTO #7



PHOTO #8

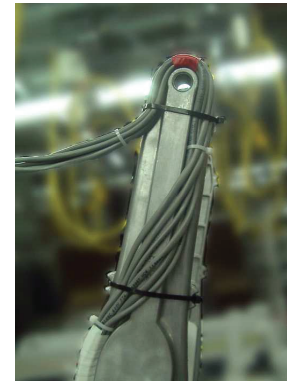

PHOTO #9



PHOTO #10



# Base Assembly, Electrical

PHOTO #11



PHOTO #12



PHOTO #13

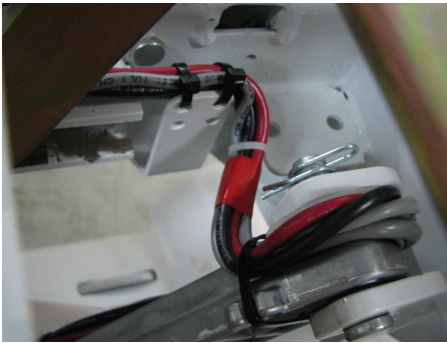

PHOTO #14



CABLE QDF27-2182 CONNECTION TABLE				
Cable No.	Connector No.	To	Cable No.	Connector No.
QDF27-2182	J126	To	27-1181	J126 Hi-lo Harness
QDF27-2182	J131	To	27-1181	J131 Hi-lo Harness
QDF27-2182	J115	To	27-2277	Sensor Base
QDF27-2182	J127	To	QDF2083	CPR Switch
QDF27-2182	J116	To	QDF27-2724	Brake Potentiometer
QDF27-2182	Bornes J170A	To	QDF9159	No Manual Switch
QDF27-2182	Bornes J170B	To	QDF9159	COM Manual Switch
QDF27-2182	J146	To	QDF27-1252	Hi-lo Head Motor
QDF27-2182	J147	To	QDF27-1251	Hi-lo Foot Motor
QDF27-2182	J149	To	QDF27-1227	Brake Motor

# Base Assembly, Electrical

CABLE QDF27-2181 CONNECTION TABLE				
Cable No.	Connector No.	To	Cable No.	Connector No.
QDF27-2181	J126	To	QDF27-2182	J126 Hi-lo Harness
QDF27-2181	J131	To	QDF27-2182	J131 Hi-lo Harness
QDF27-2181	J115	To	27-2477	Sensor Base
QDF27-2181	J7	To	QDF75-0440	J7 DC Control Board
QDF27-2181	J6	To	QDF75-0440	J6 DC Control Board
QDF27-2181	J4	To	QDF75-0440	J4 DC Control Board
QDF27-2181	J30	To	QDF75-0440	J30 DC Control Board
QDF27-2181	J24	To	QDF75-0440	J24 DC Control Board

## Base Assembly, Electrical - 27-2687 Rev B (Reference only)

Item	Part No.	Part Name	Qty.
1	QDF27-2181	Wires Harness #2	1
2	QDF27-2182	Base Structure Extender	1
3	QDF9518	Wire Tie	51
4	QDF9523	Wire Tie	2



# Base Assembly, Zoom®

OL270232 Rev C (Reference Only)

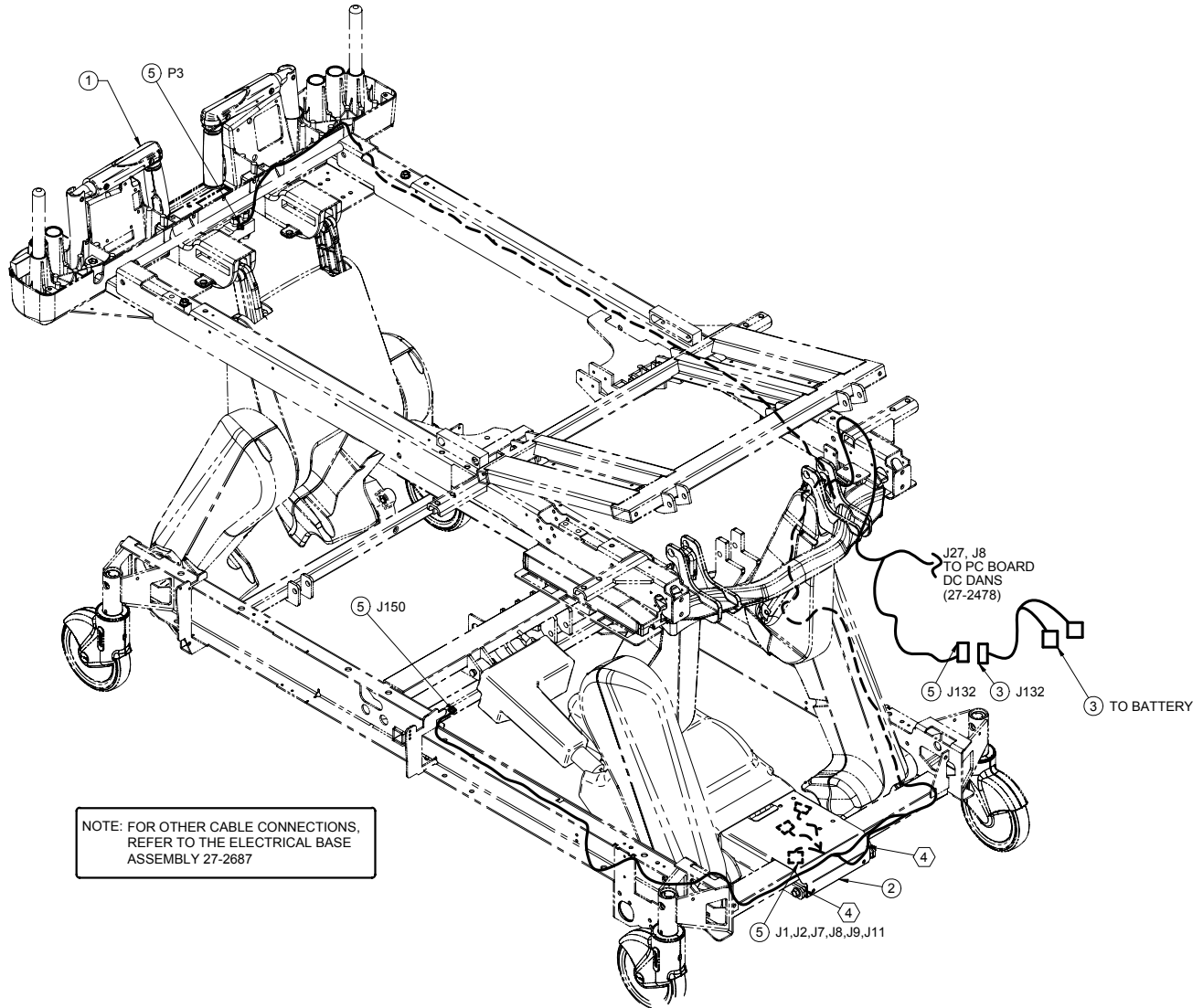

NOTE: FOR OTHER CABLE CONNECTIONS,  
REFER TO THE ELECTRICAL BASE  
ASSEMBLY 27-2687

CABLE CONNECTION QDF27-1646 TABLE				
Cable No.	Connector No.	To	Cable No.	Connector No.
QDF27-1646	Mini Fit	To	QDF27-1185	J132
QDF27-1646	Black Eyelets	To	QDF9188	BAT #2 POLE -
QDF27-1646	White Eyelets	To	QDF9188	BAT #1 POLE +

# Base Assembly, Zoom®

QDF27-1185 CONNECTIONS				
Cable No.	Connector No.	To	Cable No.	Connector No.
QDF27-1185	J27	To	QDF21-1174	DC Card J27
QDF27-1185	J8	To	QDF21-1174	DC Card J8
QDF27-1185	J132	To	QDF27-1646	Mini Fit
QDF27-1185	P3	To	QDF27-1430	P3 (27-2547-XXX)
QDF27-1185	J150	To	QDF27-1445	Zoom (27-2546)
QDF27-1185	J1	To	QDF27-2548	J1 (27-2546)
QDF27-1185	J9	To	QDF27-2548	J9 (27-2546)
QDF27-1185	J2	To	QDF27-2548	J2 (27-2546)
QDF27-1185	J8	To	QDF27-2548	J8 (27-2546)
QDF27-1185	J7	To	QDF75-0240	J7
QDF27-1185	J11	To	QDF75-0240	J11

## Base Assembly, Zoom® - OL270232 Rev C (Reference Only)

Item	Part No.	Part Name	Qty.
1	27-2547	Zoom® Handle Assembly	1
2	27-2546	Zoom® Drive Base Assembly	1
3	QDF27-1646	Battery Wire	1
4	QDF9518	Cable Attachment	1
5	QDF27-1185	Wire Harness	1

# Base Assembly, Zoom® Drive (Model 2141 Only)

27-2546 Rev-02 (Reference Only)

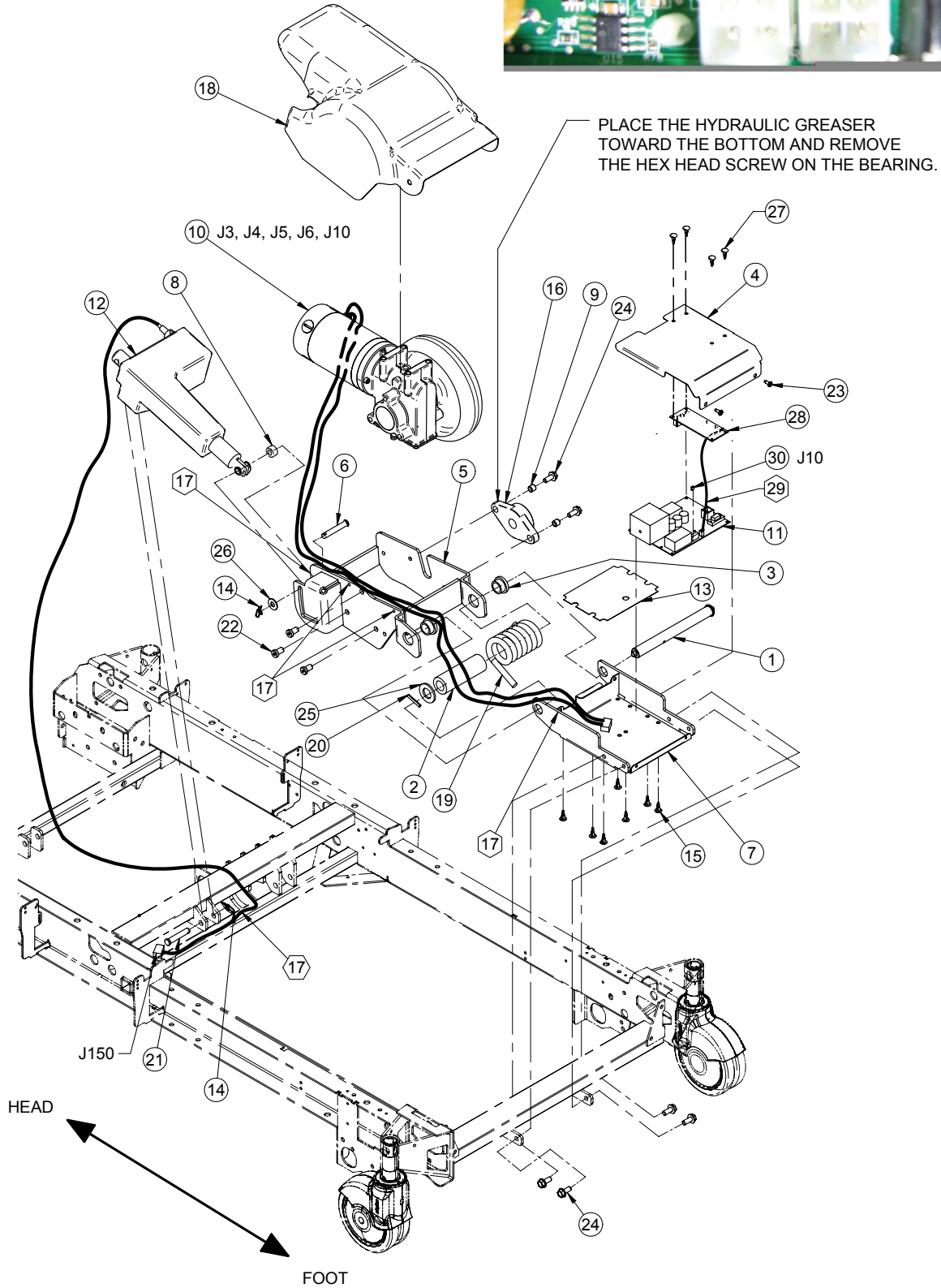
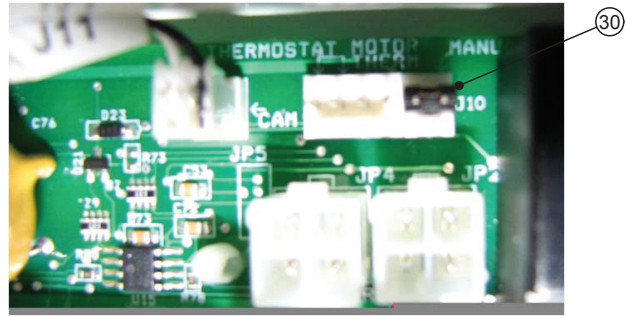



# Base Assembly, Zoom® Drive (Model 2141 Only)

ACTUATOR CONNECTION QDF27-1445 TABLE				
Cable No.	Connector No.	To	Cable No.	Connector No.
QDF27-1445	2-Positions Con.	To	QDF27-1185	J150 (OL270002)

MOTOR REDUCER CONNECTION 27-2593 TABLE				
Cable No.	Connector No.	To	Cable No.	Connector No.
QDF27-2523	Red 2-Positions Con.	To	QDF27-1430	J3, J4
QDF27-2523	Black 2-Pos. Con.	To	QDF27-1430	J5, J6 (CSI 1109)
QDF27-2523	4-Positions MTA	To	QDF27-1430	J10 (CSI 1109)

CABLE CONNECTIONS 27-2542 TABLE				
Cable No.	Connector No.	To	Cable No.	Connector No.
QDF27-2542	J7, 18-Position Mini Fit	To	QDF27-1430	J7 (CSI 1109)
QDF27-2542	J11, 2-Positions MTA	To	QDF27-1430	J11 (CSI 1109)
QDF27-2542	J7A, 9-Positions MTA	To	QDF75-0240	J7A, 9-Positions MTA
QDF27-2542	J11A, 3-Positions MTA	To	QDF75-0240	J11A, 3-Positions MTA

## Base Assembly, Zoom® Drive (2141 Model Only) - 27-2546 Rev-02 (Reference Only)

Item	Part No.	Part Name	Qty.
1	27-0804Z	Fifth Wheel Long Shaft	1
2	QP27-2556	Motorized Fifth Wheel Spring Pivot	1
3	27-0915	Fifth Wheel Thread Spacer	2
4	27-2545P	CSI1109 Box Cover	1
5	27-1059P	Motorized Wheel Structure	1
6	27-1138	Fifth Wheel Actuator Axis	1
7	27-1140P	Fifth Wheel Structure Box	1
8	27-1150	Fifth Wheel Actuator Spacer	1
9	27-1636	Motorized Fifth Wheel Sleeve	2
10	27-2593	Fifth Wheel	1
11	QDF27-1430	CSI1109 Zoom® Board	1
12	QDF27-1445	Fifth Wheel Actuator	1
13	QE71-1019	Fifth Wheel Board Protector	1
14	QDF7878	Clevis Pin	2
15	QDF8011	Board Support	7
16	QDF9162	Fifth Wheel Flange Bearing	1
17	QDF9518	Cable Tie	5
18	QP27-1916	Motorized Wheel Cover	1
19	QRT27-0796	Fifth Wheel Torsion Spring	1
20	VG10B0636	Spring Pin	1
21	VG50B1248	Clevis Pin Diameter	1
22	VV10A1P20-S	Cylindric Head Screw	3
23	VV83A9G16	Pan Head Tapping Screw	2
24	VVB4A1024	Thread Rolling Bolt	6
25	VW10B264004	Steel Washer	1
26	VW10C122802	Nylon Washer	1
27	QDF2134	Board Support	4
28	QDF75-0240	Zoom® Interface Board	1
29	QDF27-2542	Zoom® Interface Board Harness	1
30	QDF8047	Jumper	1

# Bed Labeling

OL270016-XXX Rev P (Reference Only)

## RIGHT SIDE OF THE BED

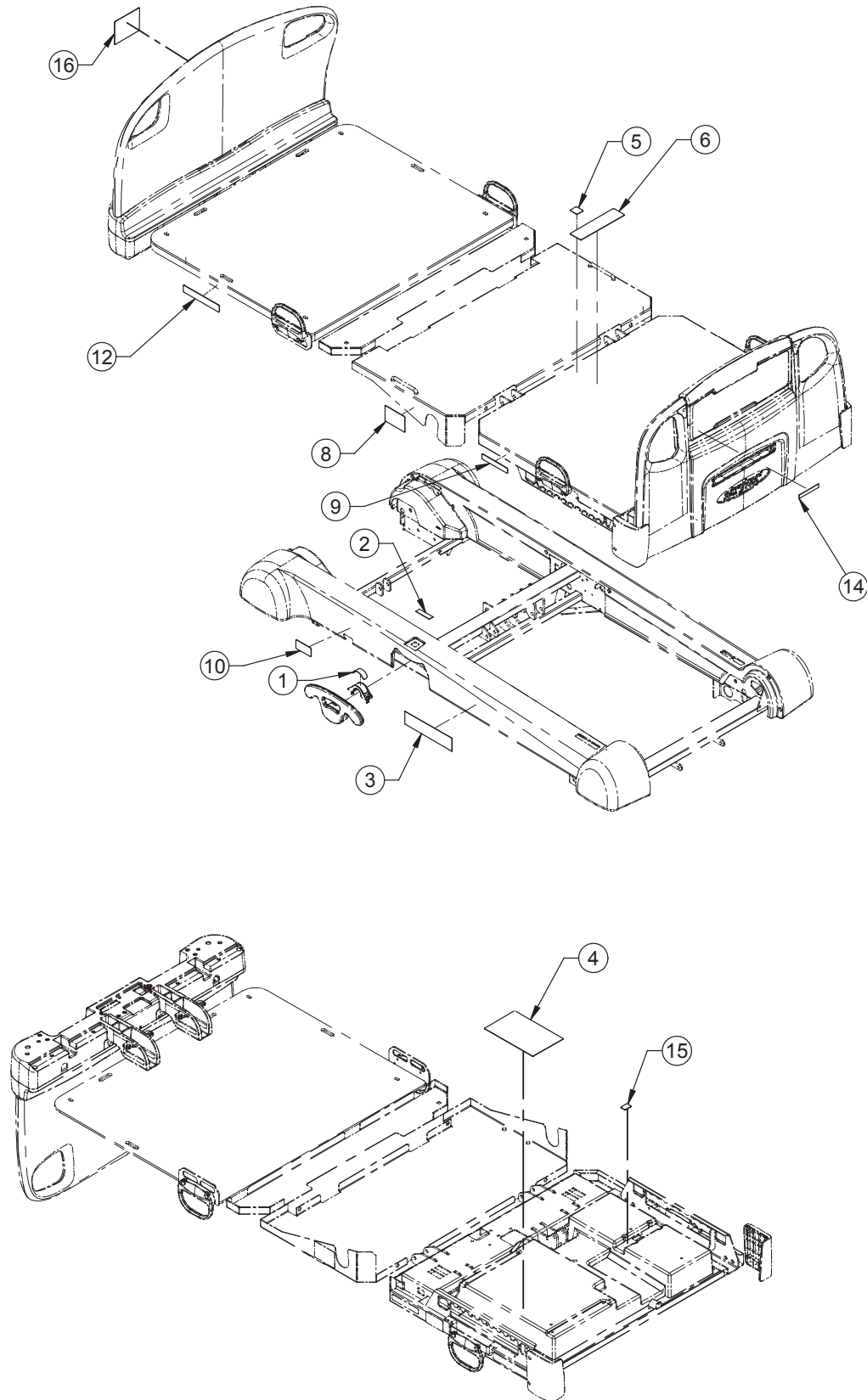

# Bed Labeling

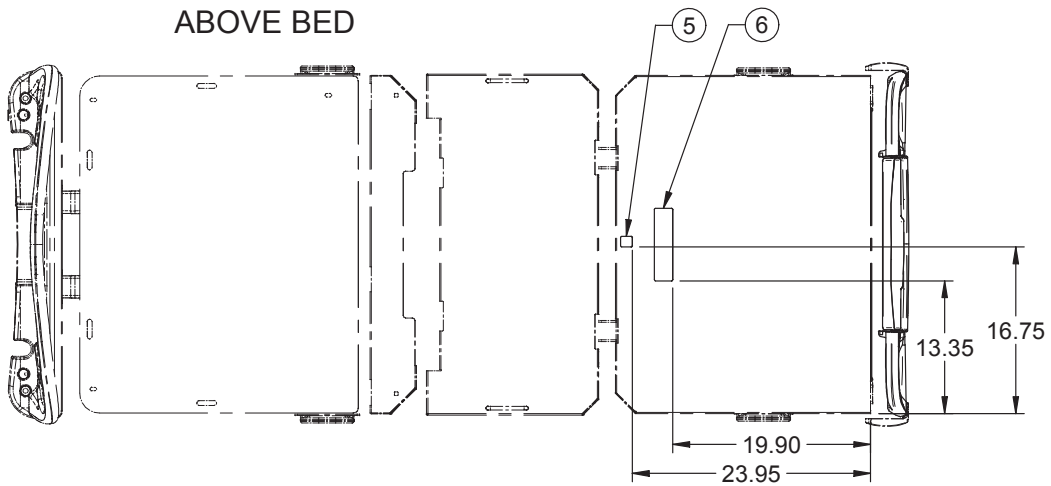
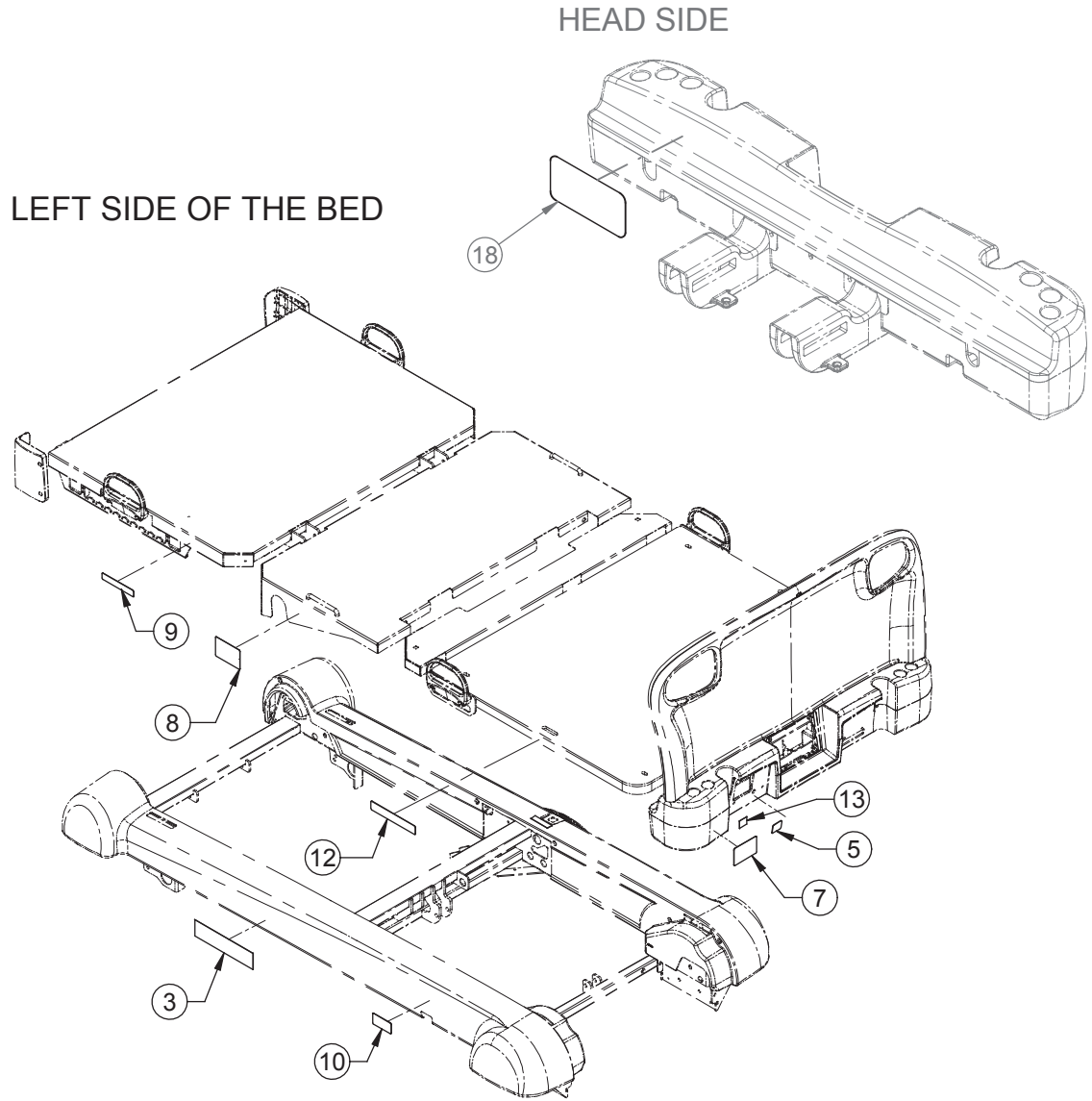

# Bed Labeling

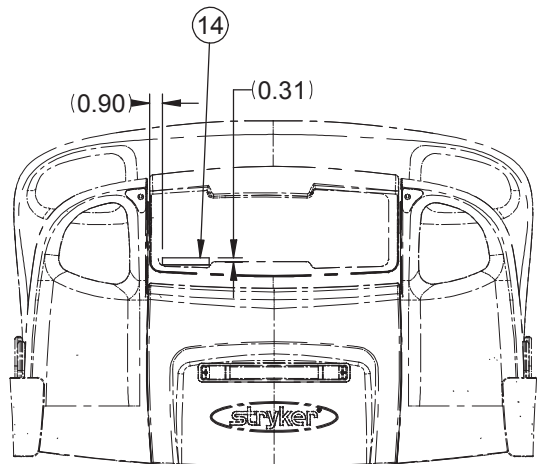
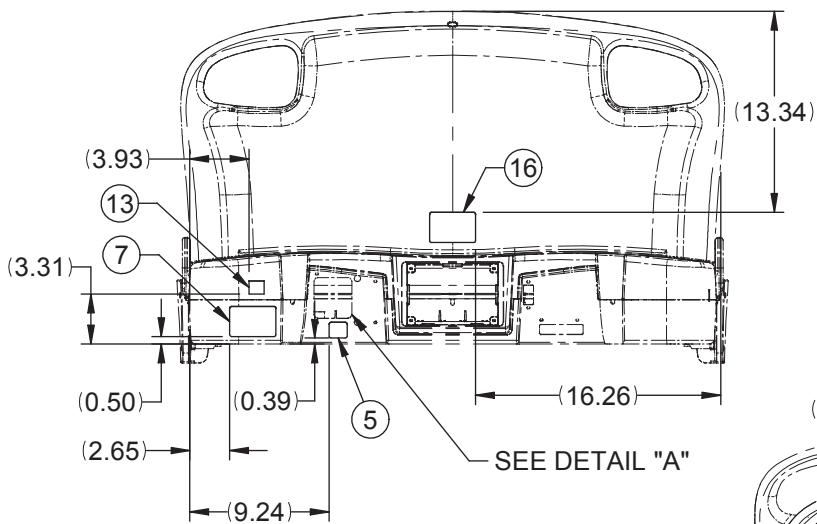
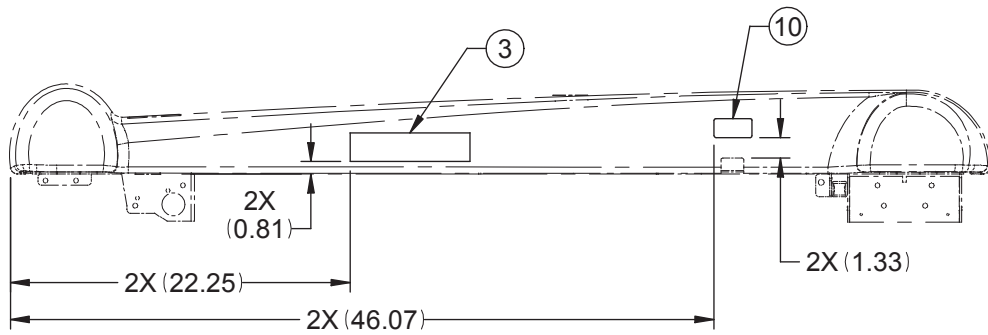
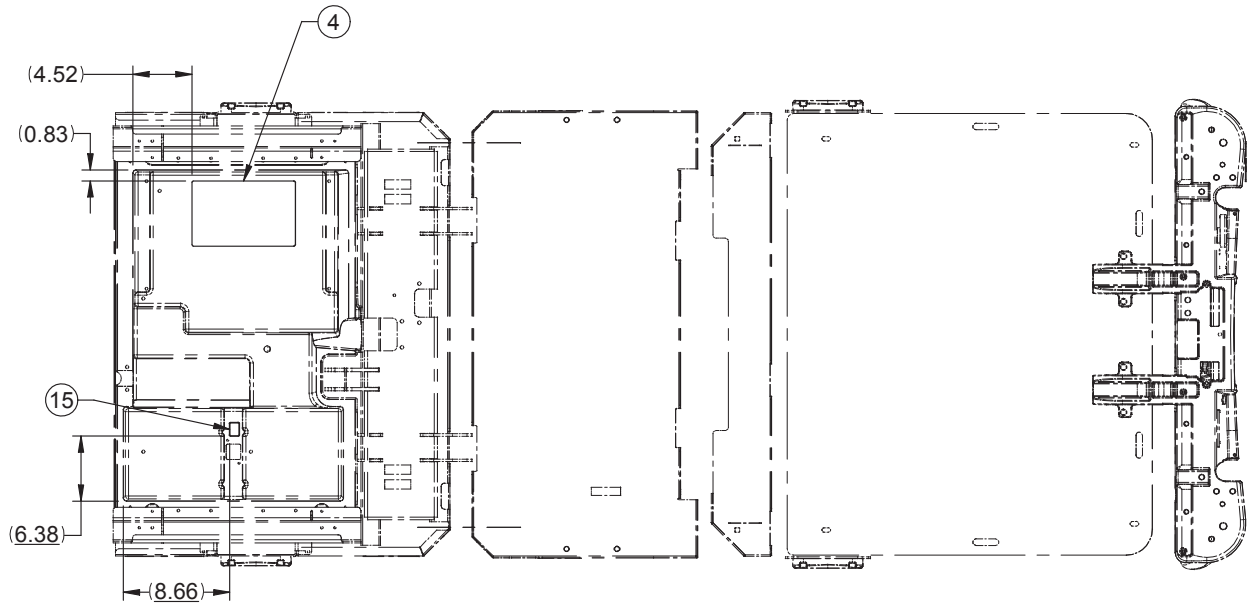

# Bed Labeling

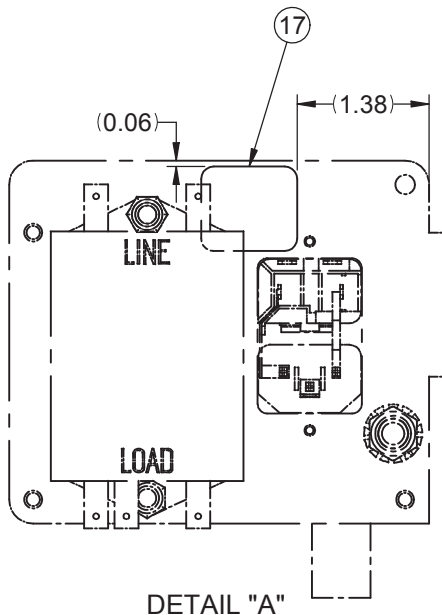
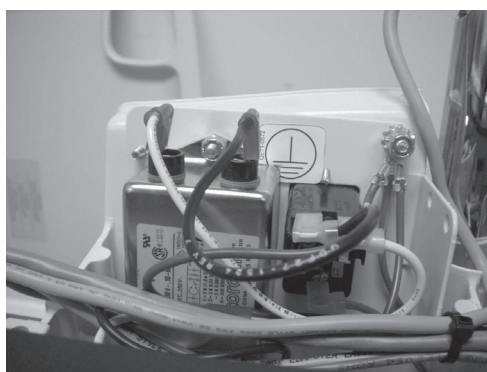
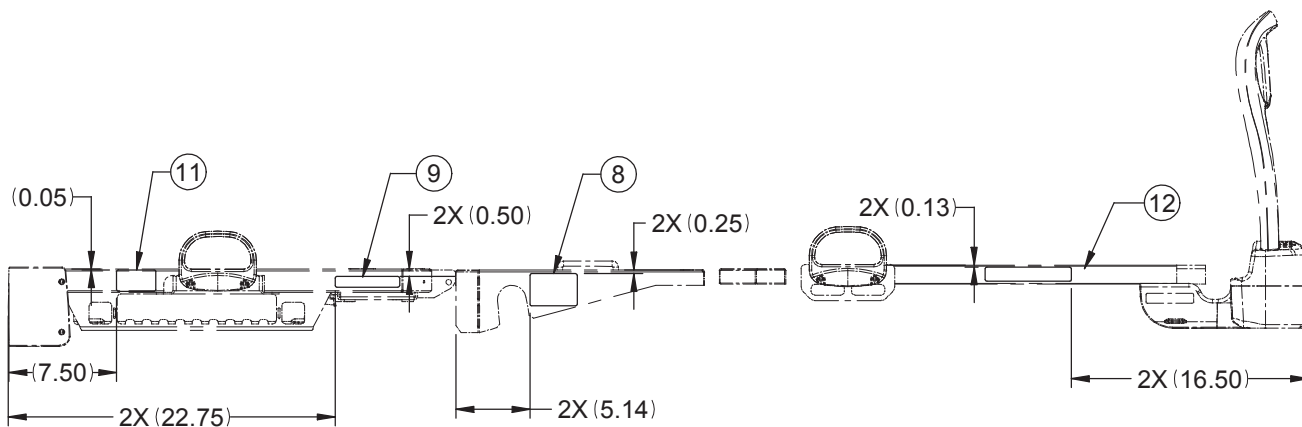

VIEW FROM INSIDE

**NOTE:** XXX - indicates language choice (tri = English/French/Spanish; bil = English/French)

## Base Labeling - OL270016-XXX Rev P (Reference Only)

Item	Part No.	Part Name	Qty.
1	QDF27-1256-XXX	Brake Pedal Label	1
2	QE71-0947-XXX	Manual Backup Label	1
3	QE71-1046	Stryker Label	2
4	QE14400	Result of Isolation Room Label	1
5	QE18545	Reference Customer Manual Label	2
6	QE71-1207-XXX	Electric Shock Hazard Label	1
7	QE71-0943-XXX	Grounding Reliability Label	1
8	QE71-0944-XXX	Oxygen Tent Label	2
9	QE71-0949-XXX	Maximum Mattress Thickness Label	2
10	QE71-0963-XXX	CPR Label	2
12	QE71-1010	550 lbs Safe Working Load label	2
13	QE71-0571	Fuse 10A 250V Label	1
14	QE71-1094-XXX	Patent Pending Label	1
15	QE71-1042-XXX	On-Off Label	1
16	QE71-1257-XXX	Orientation Label	1
17	QE71-0572	Ground Label	1
18	QE71-1368	CSA Label	1

[Return To Table of Contents](#)

# Lift Assembly

L27-044 Rev C (Reference Only)

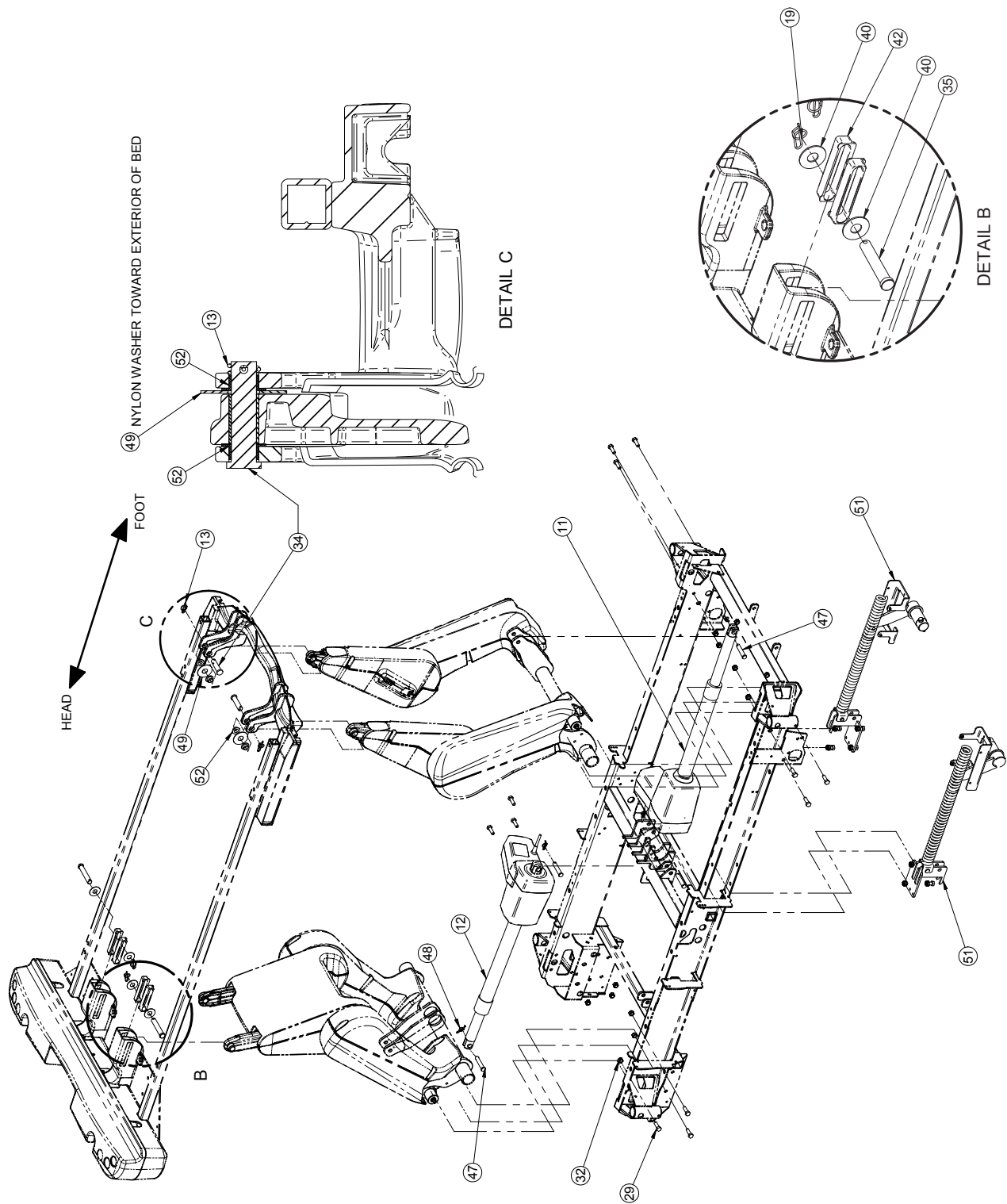

# Lift Assembly

## Head End

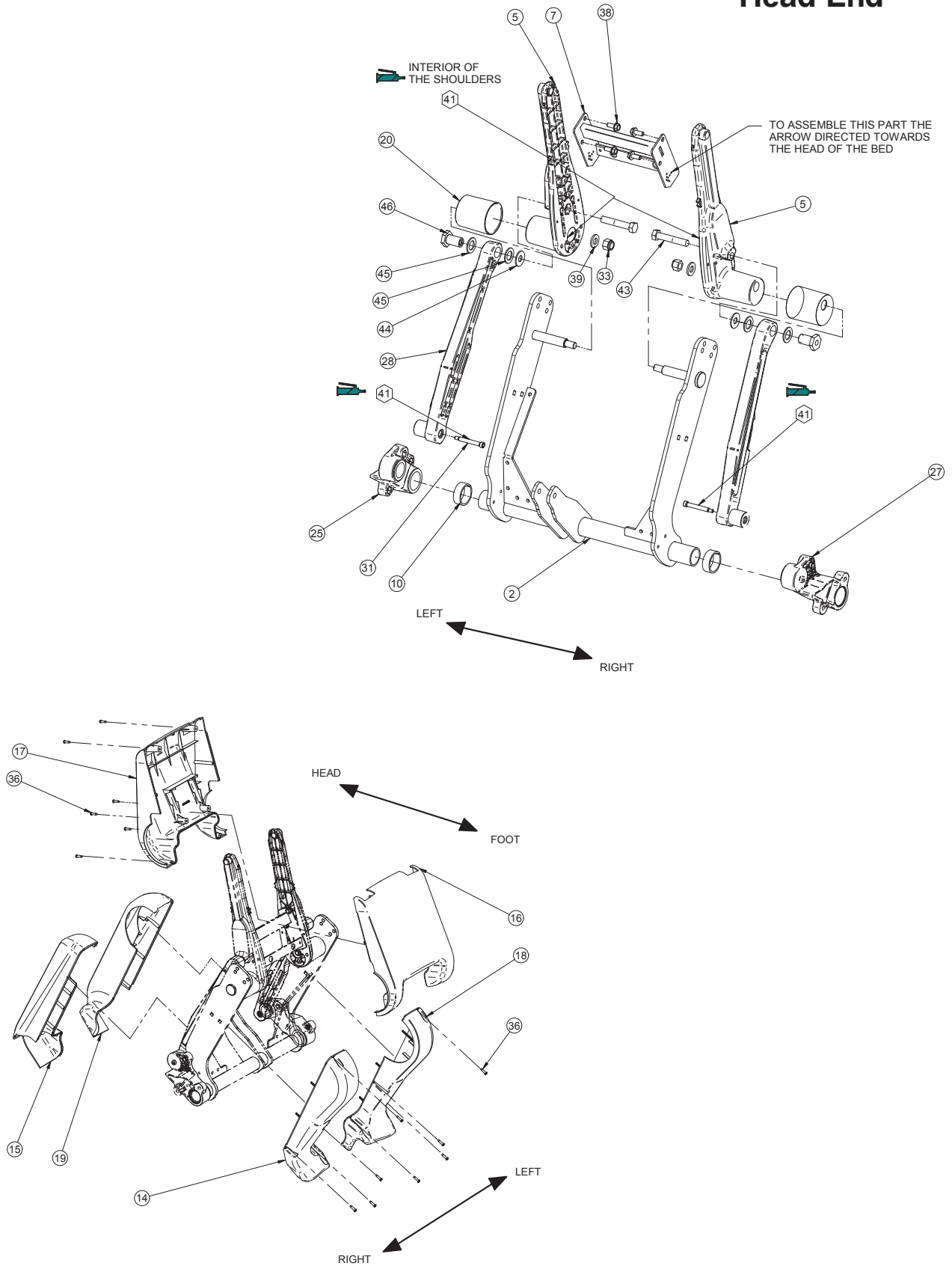



# Lift Assembly

## Foot End

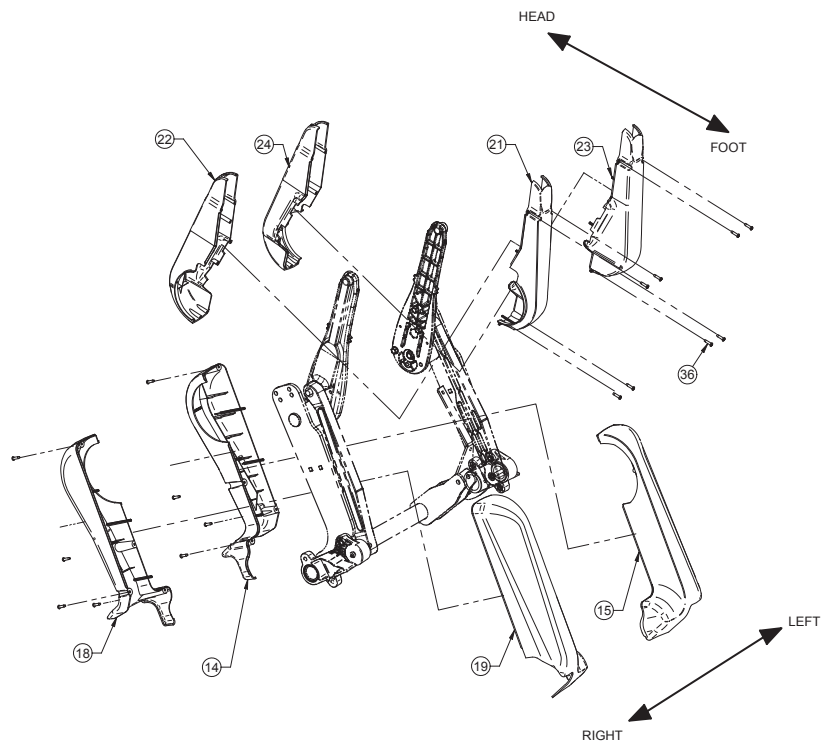
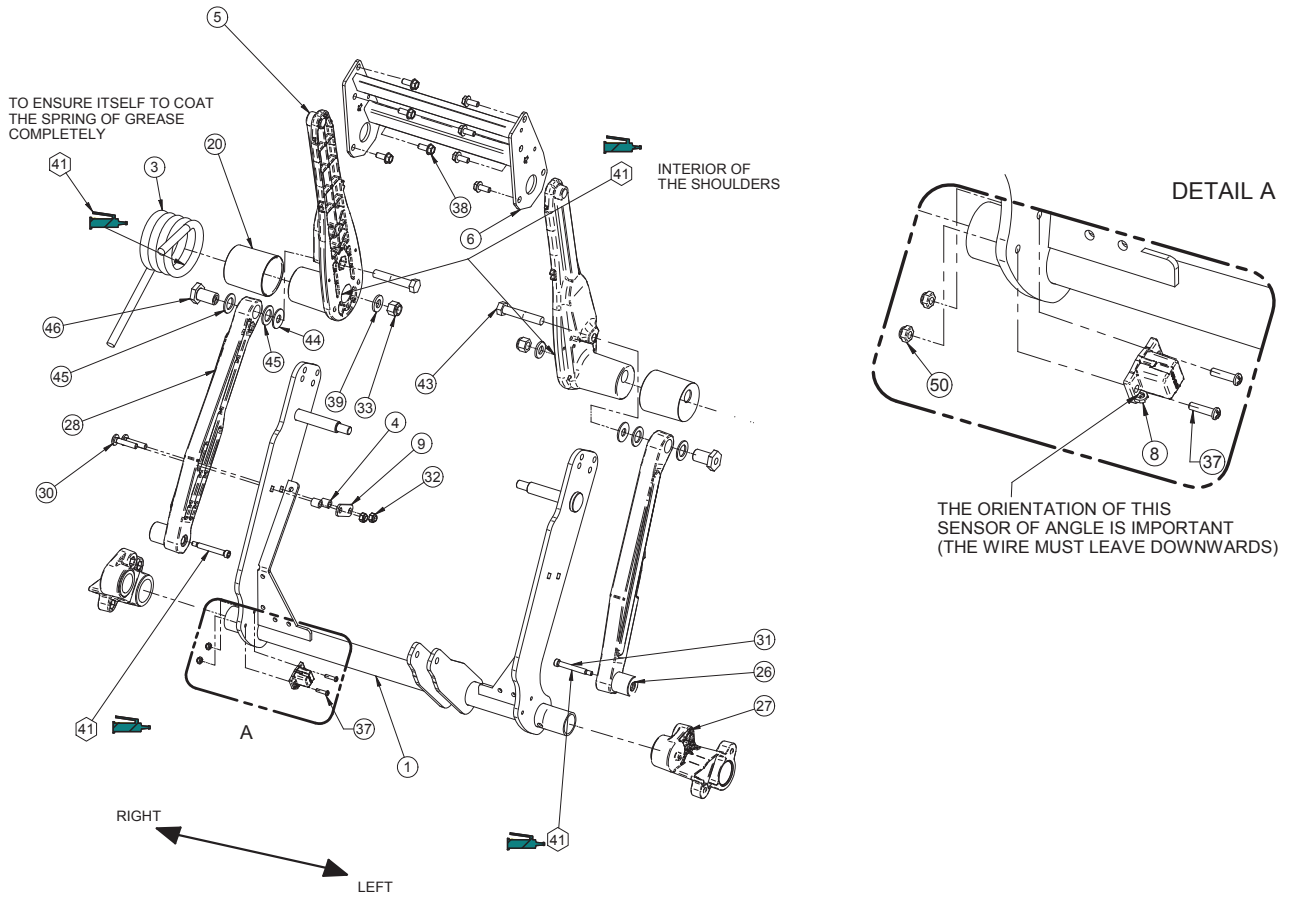



# Lift Assembly

## Lift Assembly - L27-044 Rev C (Reference only)

Item	Part No.	Part Name	Qty.
1	27-0992W	Foot Main Lift	1
2	27-0993W	Head Main Lift	1
3	QRT27-1011	Bed Lift System Right Spring	1
4	27-1012	Spring Stop	2
5	QPA27-1013	Molded Bed Lift System Arm	4
6	27-1977W	Foot Reinforcement	1
7	27-1089W	Head Transverse Reinforcement	1
8	27-2477	Angle Sensor Assembly	1
9	27-1243Z	Spring Retention Plate	1
10	27-1623	Lift Spacer	2
11	QDF27-1251	Foot Lift Actuator	1
12	QDF27-1252	Head Lift Actuator	1
13	QDF7899	Hitch Pin Diameter 1/2"	4
14	QP27-0982-10	Exterior Right Low Lift Cover	2
15	QP27-0983-10	Interior Right Low Lift Cover	2
16	QP27-0984-10	Interior Head High Lift Cover	1
17	QP27-0985-10	Exterior Head High Lift Cover	1
18	QP27-0986-10	Exterior Left Low Lift Cover	2
19	QP27-0987-10	Interior Left Low Lift Cover	2
20	QP27-1065	Spring Sleeve	4
21	QP27-1236-10	Exterior Right Foot High Lift Cover	1
22	QP27-1237-10	Interior Right Foot High Lift Cover	1
23	QP27-1238-10	Exterior Left Foot High Lift Cover	1
24	QP27-1239-10	Interior Left Foot High Lift Cover	1
25	QPA27-1024	Right Lever Support	2
26	QPA27-1030	Right Stiffener Arm	2
27	QPA27-1036	Left Lever Support	2
28	QPA27-1040	Left Stiffener Arm	2
29	VB18A1O32	Bolt	12
30	VB35A1O40	Carriage Bolt	2
31	VD60B1O48	Shoulder Screw	4
32	VE30A1O	Nylon Locknut	14
33	VE30A1R	Nylon Locknut Diameter	4
34	VG50A1648	Clevis Pin Diameter	2
35	VG50A1654	Clevis Pin Diameter	2
36	VV23A1G24HL	Pan Head Tapping Screw	32
37	VV33A0G24	Pan Head Tapping Screw	2
38	VVB4A1024	Thread Rolling Bolt	12
39	VW10A173308	Flat Washer	4
40	VW10C173602	Nylon Washer	4
41	M0019	Grease	1
42	QP27-1830-01	Glider	4
43	VB18A1R54-S	Hexagon Bolt	4
44	27-2022Z	Stiffener Arm Steel Washer	4
45	QP27-2019	Stiffener Arm Acetal Washer	8
46	27-2018Z	Stiffener Arm Bearing	4
47	27-2053Z	Clevis Pin Diameter	4
48	QDF7878	Hitch Pin Diameter	4
49	VW10C432002	Nylon Washer	2
50	VE30A0G	Nylon Locknut	2
51	27-2117	Spring in Base	1
52	QDF2100	Round	4

# Spring Assembly

27-2117 Rev-06 (Reference Only)

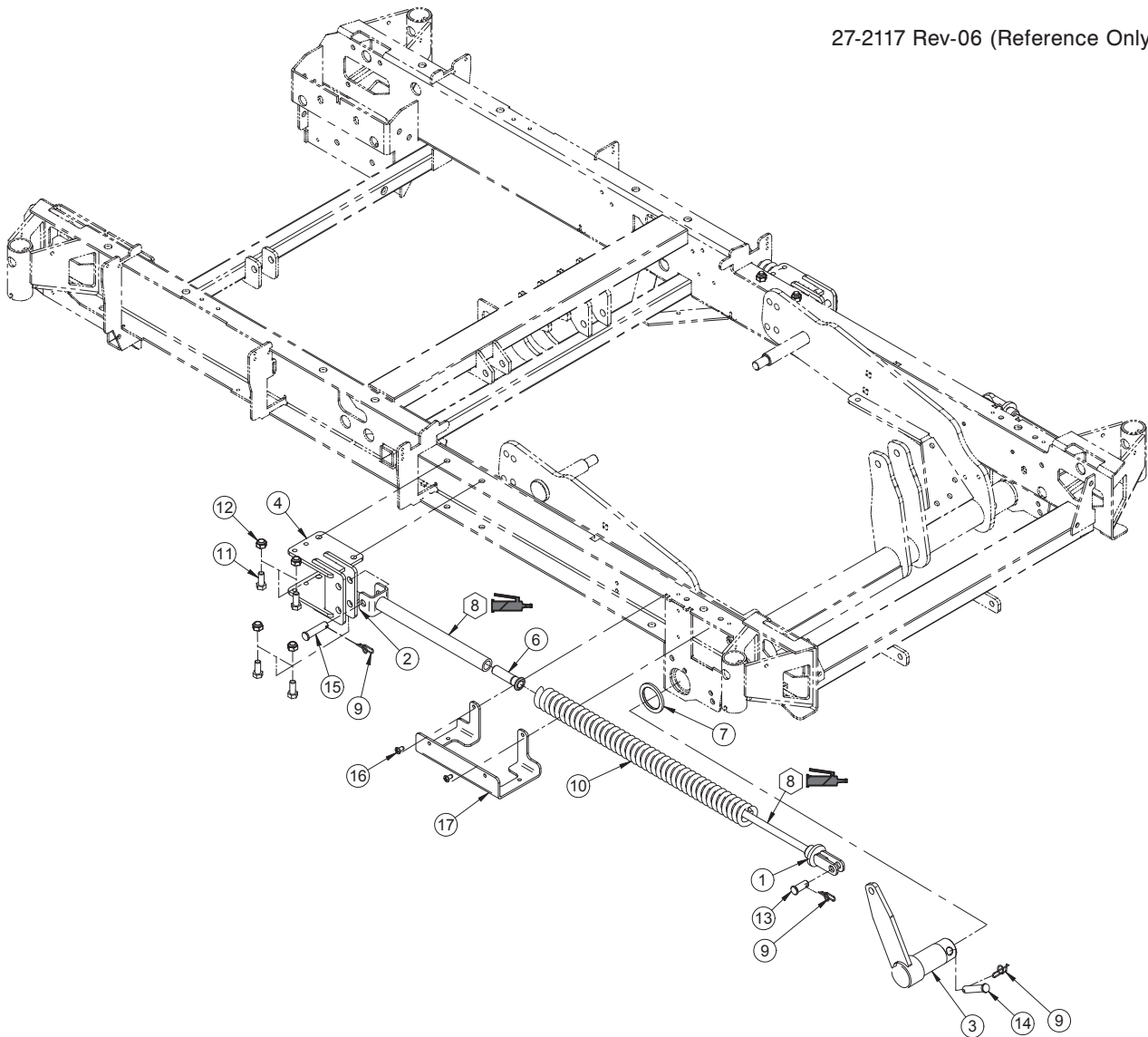

Spring Assembly - 27-2117 Rev-06 (Reference Only)

Item	Part No.	Part Name	Qty.
1	27-2096P	Hi-Lo Spring Support	2
2	27-2099P	Hi-Lo Spring Support Tube	2
3	27-2102P	Spring Tie	2
4	27-2107P	Spring Support Assembly	2
6	27-2115	Hi-Lo Spring Support Glider	2
7	27-2116	Acetal Washer	2
8	M0019	Grease	1
9	QDF7878	Clevis Pin Diameter	6
10	QRC27-2114	Base Compression Spring	2
11	VB15A1O24	Bolt	8
12	VE30A1O	Nylon Locknut	8
13	VG50A1228	Clevis Pin	2
14	VG50A1244	Clevis Pin	2
15	VG50A1240	Clevis Pin	2
16	VV83A9G12	Phillips Head Tapping Screw	4
17	27-2139P	Base Wiring Routing	2

# Litter Assembly

L27-056 Rev E (Reference Only)

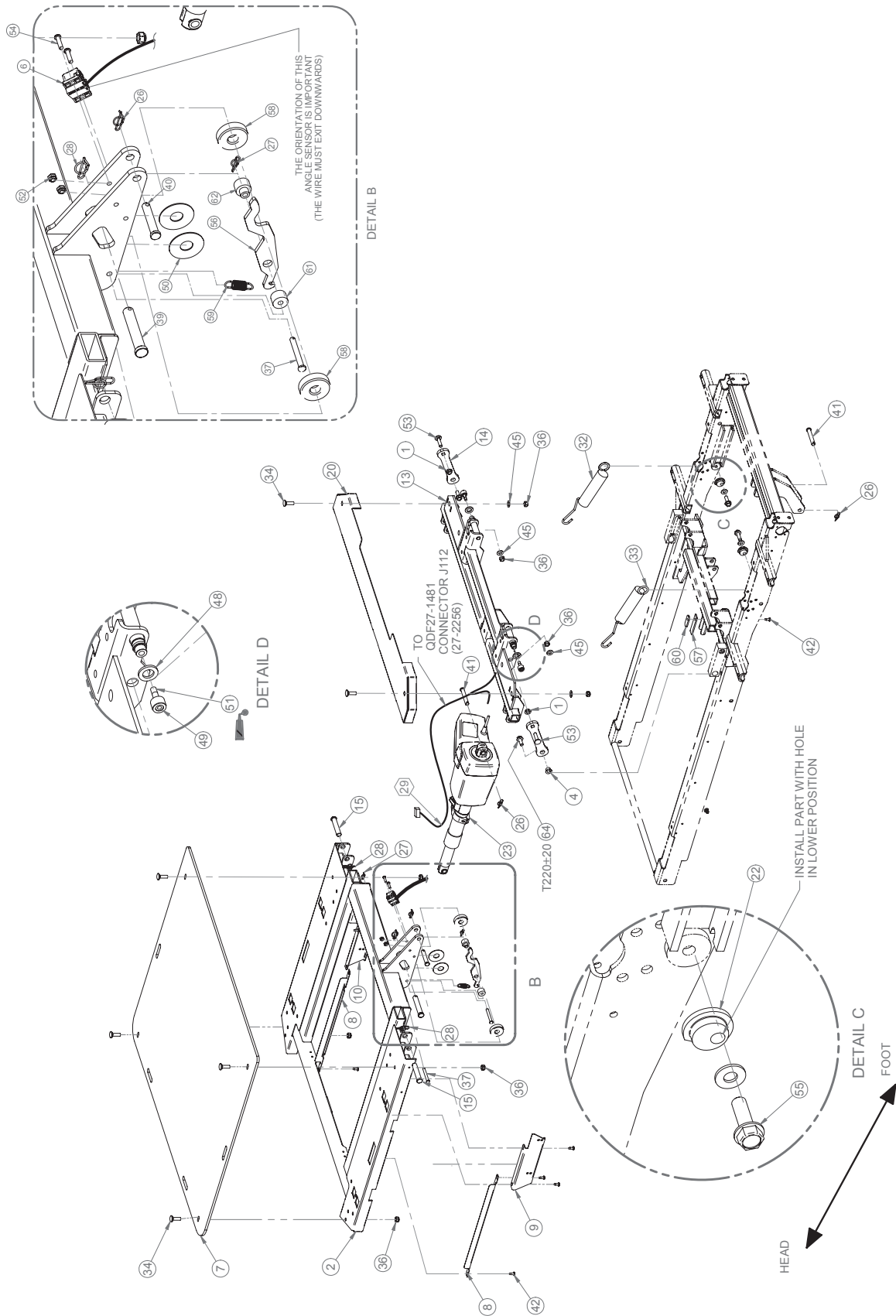

# Litter Assembly

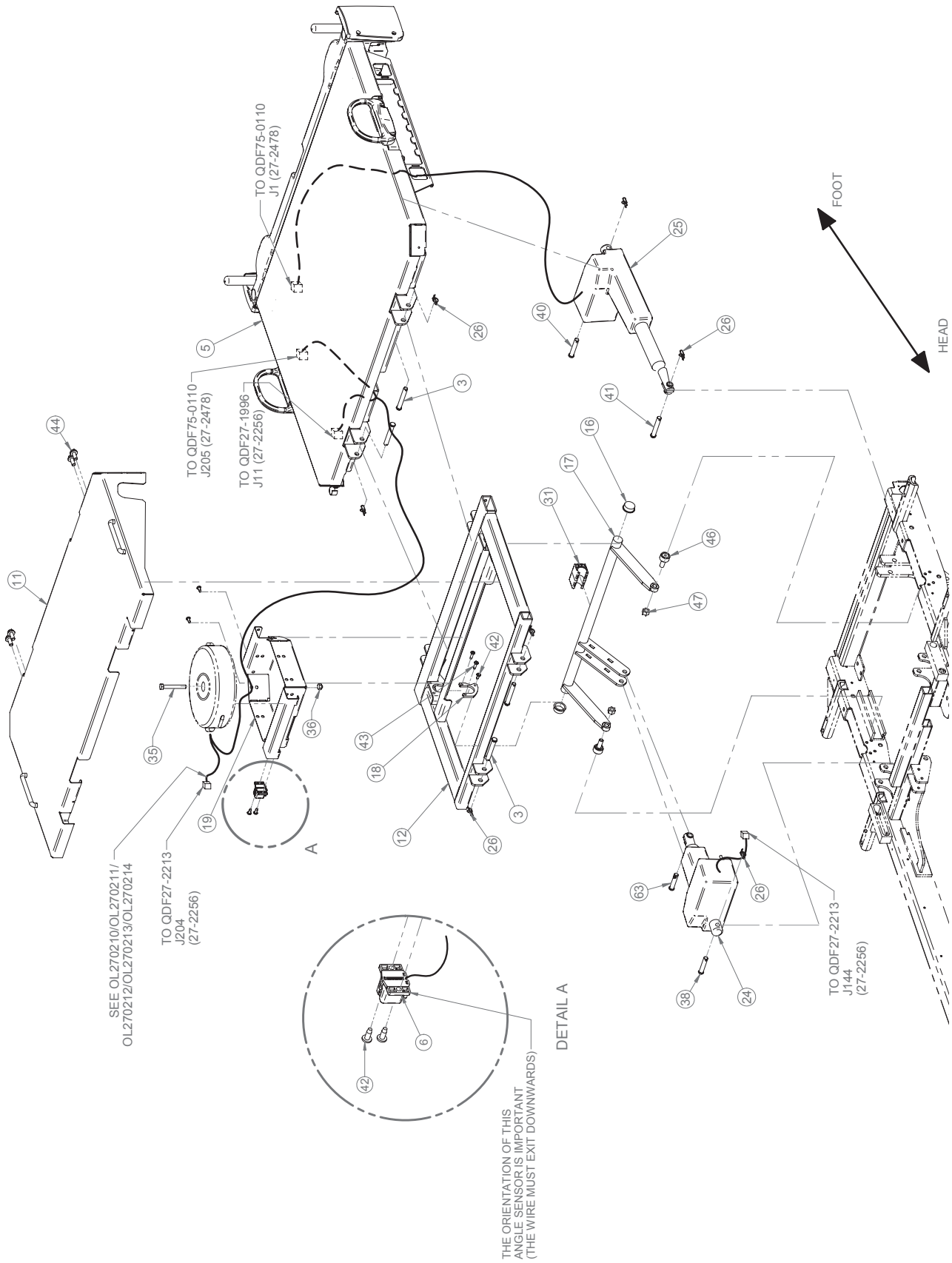

# Litter Assembly

## Litter Assembly - L27-056 Rev E (Reference Only)

Item	Part No.	Part Name	Qty.
1	21-3613	5/16" Sleeve for 3/16	2
2	27-2269P	Fowler S.A.	1
3	27-0485	Clevis Pin -	4
4	27-0919	5/16" Sleeve for 5/16	2
5	27-2688	Bolted Foot Litter	1
6	27-2477	Angle Sensor Assembly	2
7	QDF27-1397	Fowler	1
8	27-1634P	Cable Protector	2
9	27-1652P	Right Cable Protector	1
10	27-1667P	Left Cable Protector	1
11	27-1825P	Welded Center Section Cover	1
12	27-1862P	Gatch	1
13	27-1888P	Intermediary Fowler	1
14	27-1919Z	Lever Arm	2
15	27-1920	Clevis Pin	2
16	27-1925	Gatch Bushing	2
17	27-1932Z	Gatch Pivot	1
18	27-1935Z	Upper Pivot Support	1
19	27-1940P	Transformer Box	1
20	27-1973P	Intermediary Section Cover	1
22	27-2141	Unbalanced Spring Support Rod	2
23	QDF27-1214	Fowler Actuator	1
24	QDF27-1215	Gatch Actuator	1
25	QDF27-1216	Foot Actuator	1
26	QDF7878	Cotter Pin	9
27	QDF7898	Cotter Pin	2
28	QDF7899	Cotter Pin	3
29	QDF9518	Cable Tie	1
31	QP27-1958	Gatch Pivot Stopper	1
32	QRT27-2020	Torsion Spring	1
33	QRT27-2026	Right Upper Frame Spring Base Rod	1
34	VB35A1O32	Carriage Bolt	6
35	VB15A1O50	Carriage Bolt	1
36	VE30A1O	Nylon Locknut 5/16-18	9
37	VG50A0848	Clevis Pin	2
38	VG50A1244	Clevis Pin	1
39	VG50A1654	Clevis	1
40	VG50B1248	Clevis Pin	2
41	VG50A1250	Clevis Pin	2
42	VV83A9G16	Phillips Screw	14
43	VV83A9G24	Phillips Screw	2
44	VVB4A1O24	Thread Rolling Bolt	4
45	VW10A10	Flat Washer	6
46	QDF2098	CAM Follower	2
47	VE59A0P	Nylon Locknut 3/8-24	2
48	27-2063	Intermediary Pivot Washer	2
49	QDF2110	Needle Bearing	2
50	VW10C432002	Nylon Washer	2
51	M0008	Threadlocker (Blue)	-

# Litter Assembly

---

## Litter Assembly (Continued) - L27-056 Rev E (Reference Only) (Continued)

<b>Item</b>	<b>Part No.</b>	<b>Part Name</b>	<b>Qty.</b>
52	VE30A0G	Nylon Locknut	2
53	VB35A1O36	Carriage Bolt	2
54	VV33A0G24	Phillips Screw	2
55	VVB4A1O32	Hex Head Thread Rolling Bolt	2
56	27-2223Z	Finger	1
57	27-2217	PVC Slide	1
58	27-2227	Bushing Latch Finger	2
59	QRE27-2218	Finger Bracket Spring	1
60	27-2219Z	Plate of Tightening	1
61	27-2221	Female Bushing Latch Finger	1
62	27-2220	Male Bushing Latch Finger	1
63	QDF2132	Clevis Pin	1
64	VVB4A1O28	Thread Rolling Bolt	2

# Litter Assembly, Interior Frame

L27-055 Rev D (Reference Only)

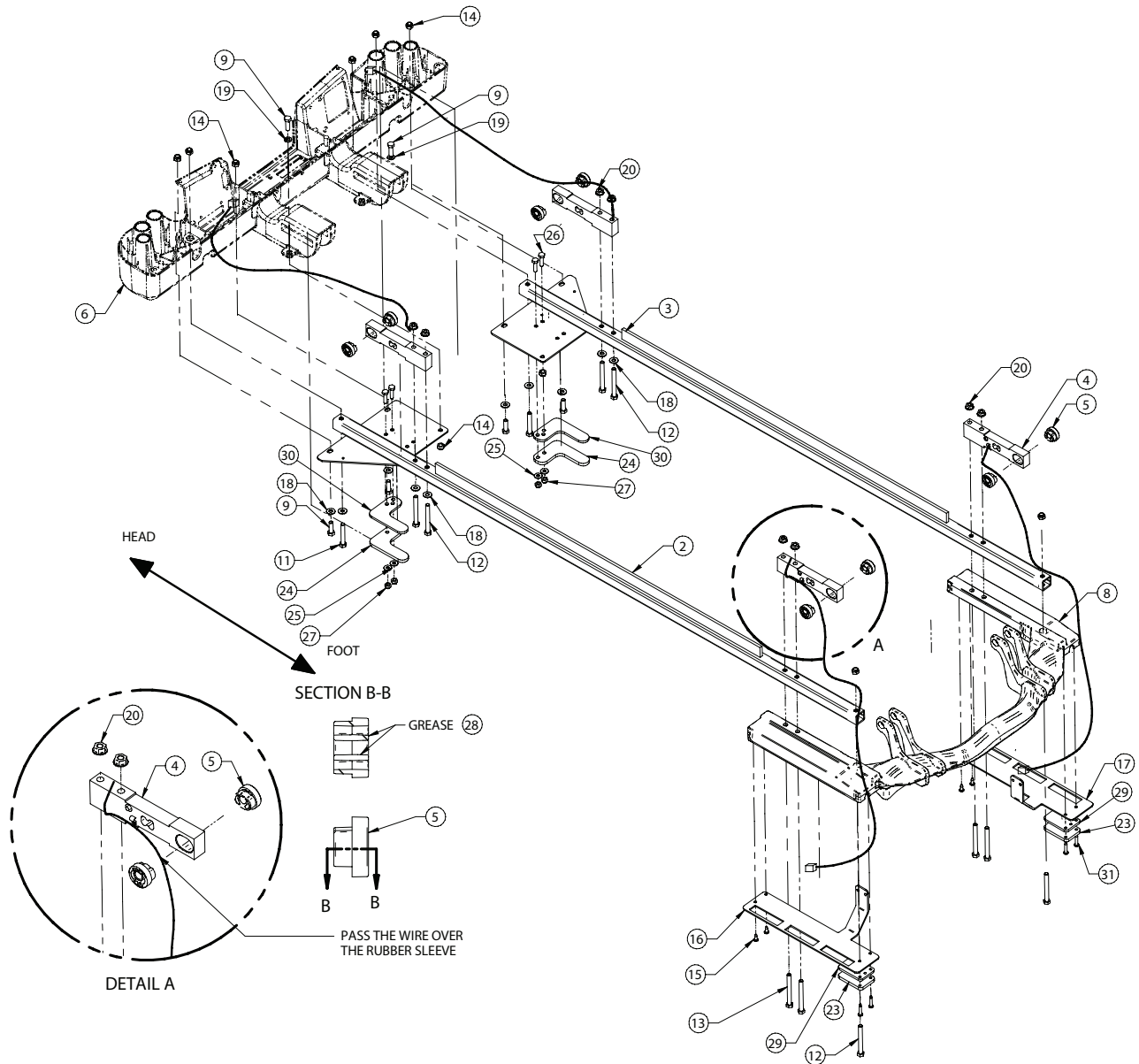

# Litter Assembly, Interior Frame

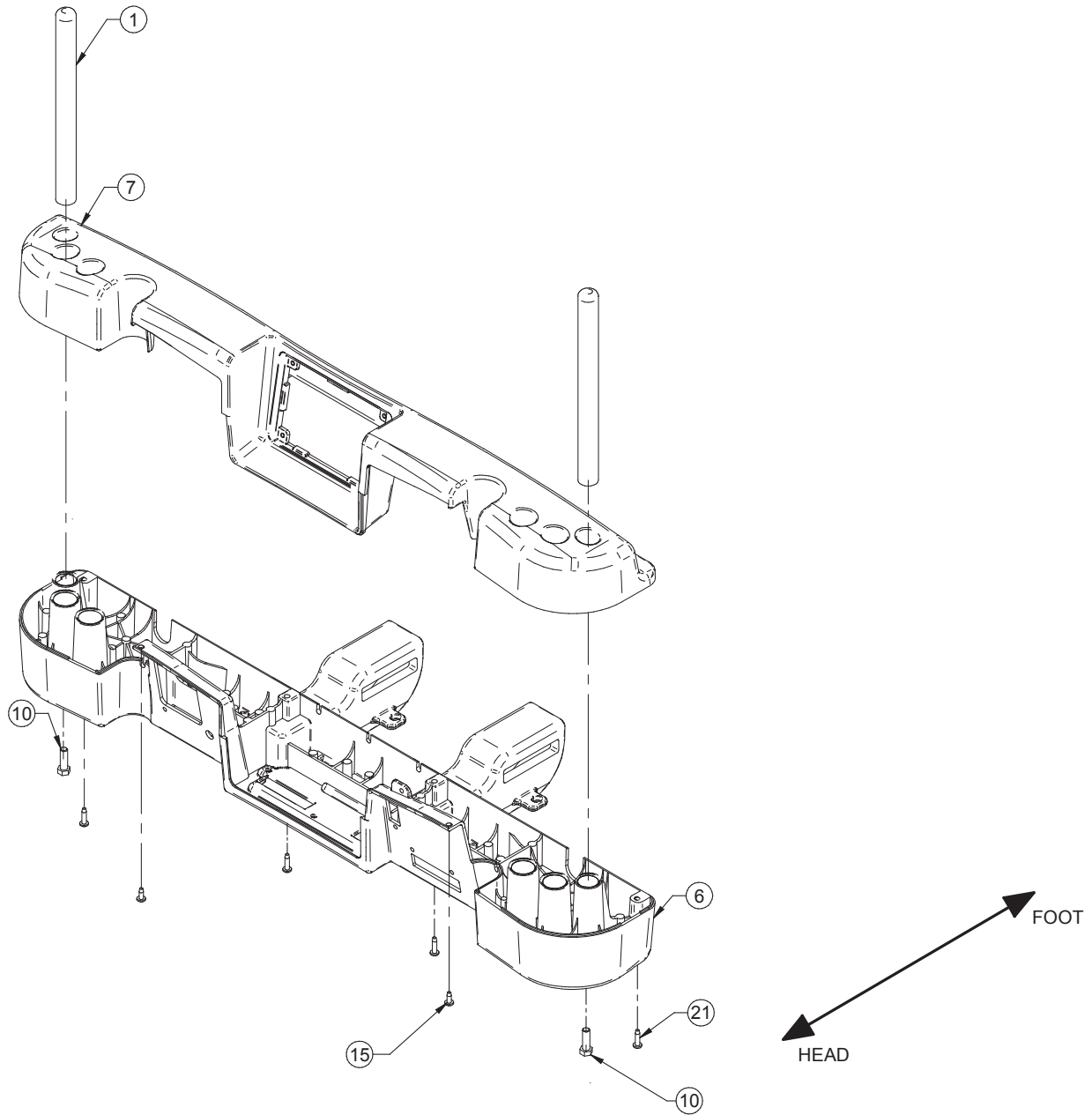



# Litter Assembly, Interior Frame

---

## Litter Assembly, Interior Frame - L27-055 Rev D (Reference Only)

Item	Part No.	Part Name	Qty.
1	27-1180C	Head Board Anchoring	2
2	27-1310P	Right Lower Frame Support	1
3	27-1368P	Left Lower Frame Support	1
4	QDF27-1372	Symmetrical Load Cell	4
5	QP27-1469	Elastimer Sleeve	8
6	QPA27-1290	Head Chassis	1
7	QPA27-1291	Frame Head Cover	1
8	27-1426P	Foot Frame Support	1
9	VB15A1O32	Bolt	6
10	VB15A1O32-S	Bolt	2
11	VB15A1O48	Bolt	2
12	VB15A1O54	Bolt	6
13	VB15A1O56	Hex Bolt	4
14	VE30A1O	Nylon Hex Locknut	10
15	VV83A9G16	Pan Head Tapping Screw	6
16	27-1806P	Right Frame Support Cover	1
17	27-1385P	Left Frame Support Cover	1
18	VW10A10	Flat Washer	10
19	VW20A10	Spring Washer	2
20	VE78A1O	Flanged Locknut	8
21	VV83A9G24	Pan Head Tapping Screw	4
23	27-2143P	Spacer Foot	2
24	27-2144P	Spacer Head	2
25	VW10A08	Flat Washer	4
26	VB15A1N32	Bolt	4
27	VE30A1N	Nylon Hex Locknut	4
28	M0019	Grease	1
29	27-2880	Foot end hardstop additional spacer	2
30	27-2881	Head end hardstop additional spacer	2
31	VV83A9G32	Pan head tapping screw	4

# Litter Assembly with Serial Port

OL270278 Rev A (Reference Only)

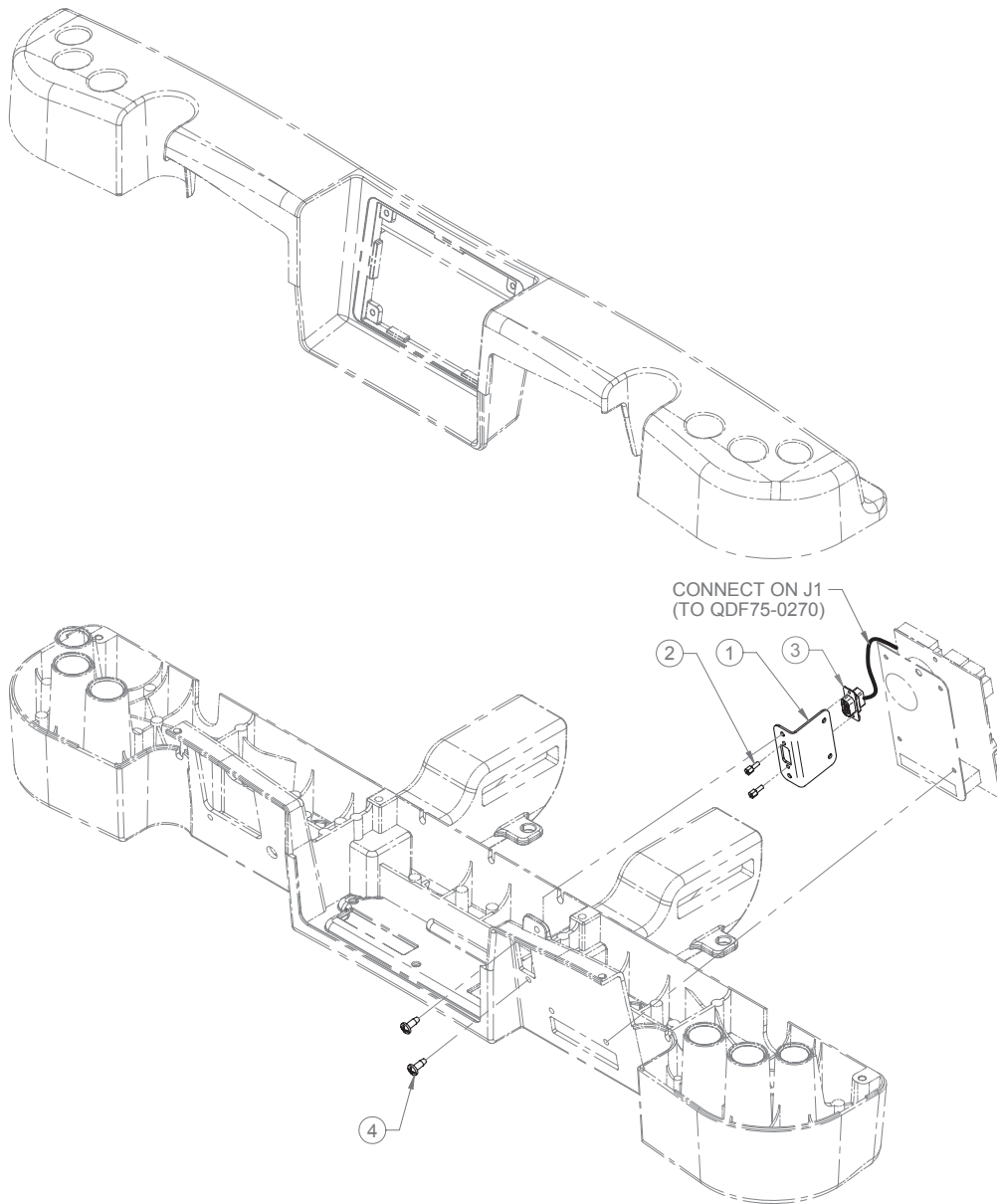

## Litter Assembly with Serial Port - OL270278 Rev A (Reference Only)

Item	Part No.	Part Name	Qty.
1	27-1520P	Support Connector	1
2	QDF2056	Standoff	2
3	QDF27-2432	Serial Interconnection Cable	1
4	VV83A9G16	Pan Head Phillips Screw	2

# Litter Assembly, Upper Frame

L27-046 Rev-01 (Reference Only)

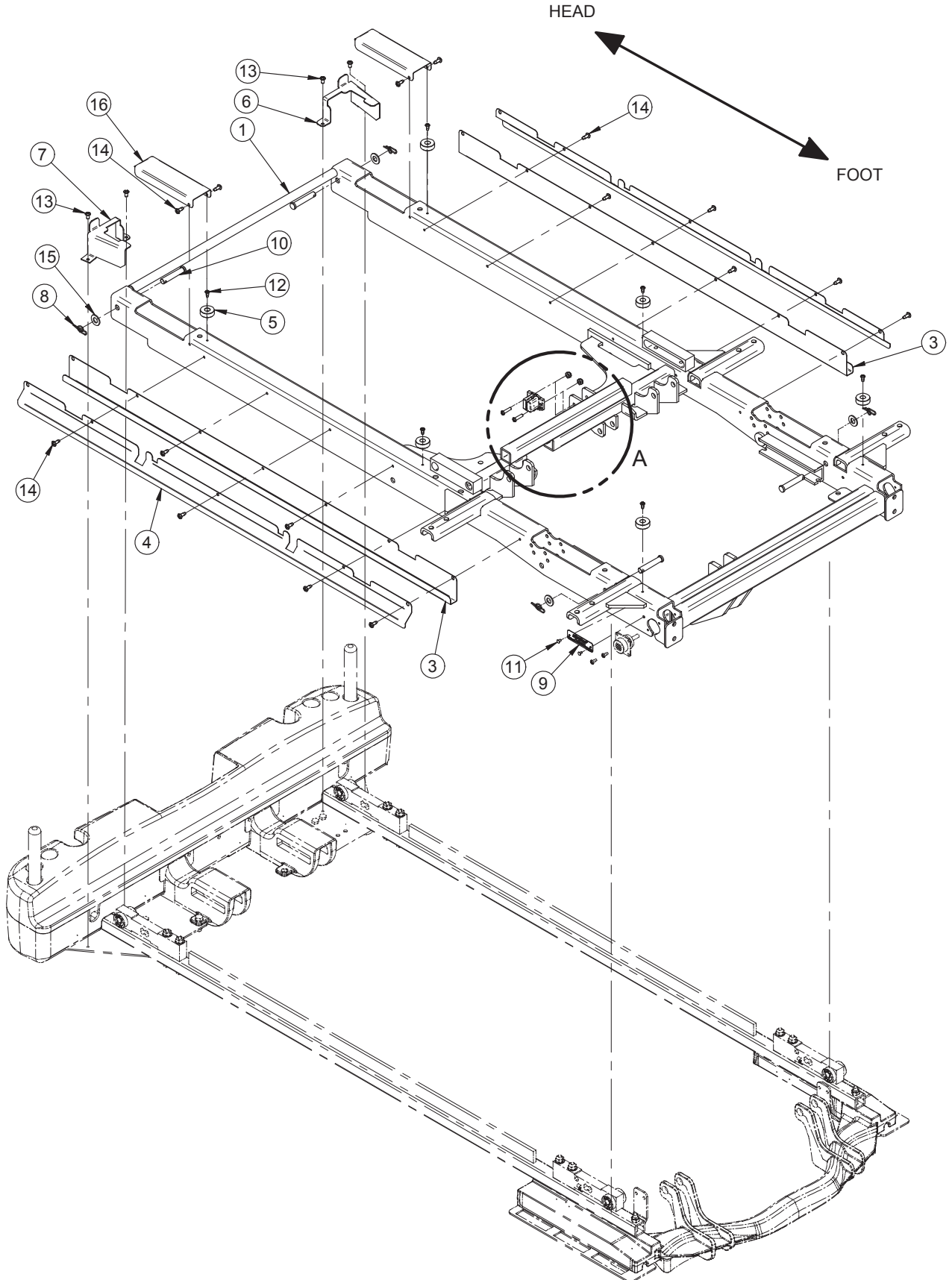

[Return To Table of Contents](#)

# Litter Assembly, Upper Frame

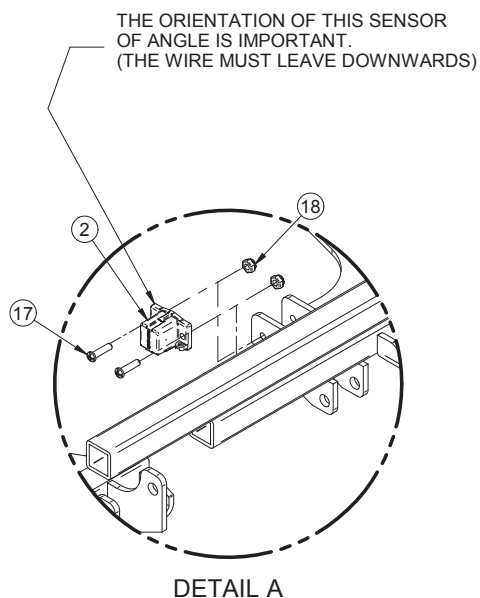

## Litter Assembly, Upper Frame - L27-046 Rev-01 (Reference Only)

Item	Part No.	Part Name	Qty.
1	27-2598P	Upper Frame	1
2	27-2477	Angle Sensor Assembly	1
3	27-1433P	Wire Channel	2
4	27-1434P	Wire Cover	2
5	QP27-1760	Stopper	6
6	27-1850P	Left Head Frame Wire Cover	1
7	27-1851P	Right Head Frame Wire Cover	1
8	QDF7878	Coupling Pin	4
9	QE71-1181	Serial Number Plate	1
10	VG50B1248	Clevis Pin	4
11	VR11H43	Pop Rivet	2
12	VV83A9E12	Pan Head Tapping Screw	6
13	VV83A9G12	Pan Head Tapping Screw	4
14	VV83A9G16	Pan Head Tapping Screw	16
15	VW10A12	Washer	4
16	27-2005P	Hiding place cell	2
17	VV33A0G24	Phillips Head Screw	2
18	VE30A0G	Nylon Nut	2

# Litter Assembly, Foot End

27-2688 Rev B (Reference Only)

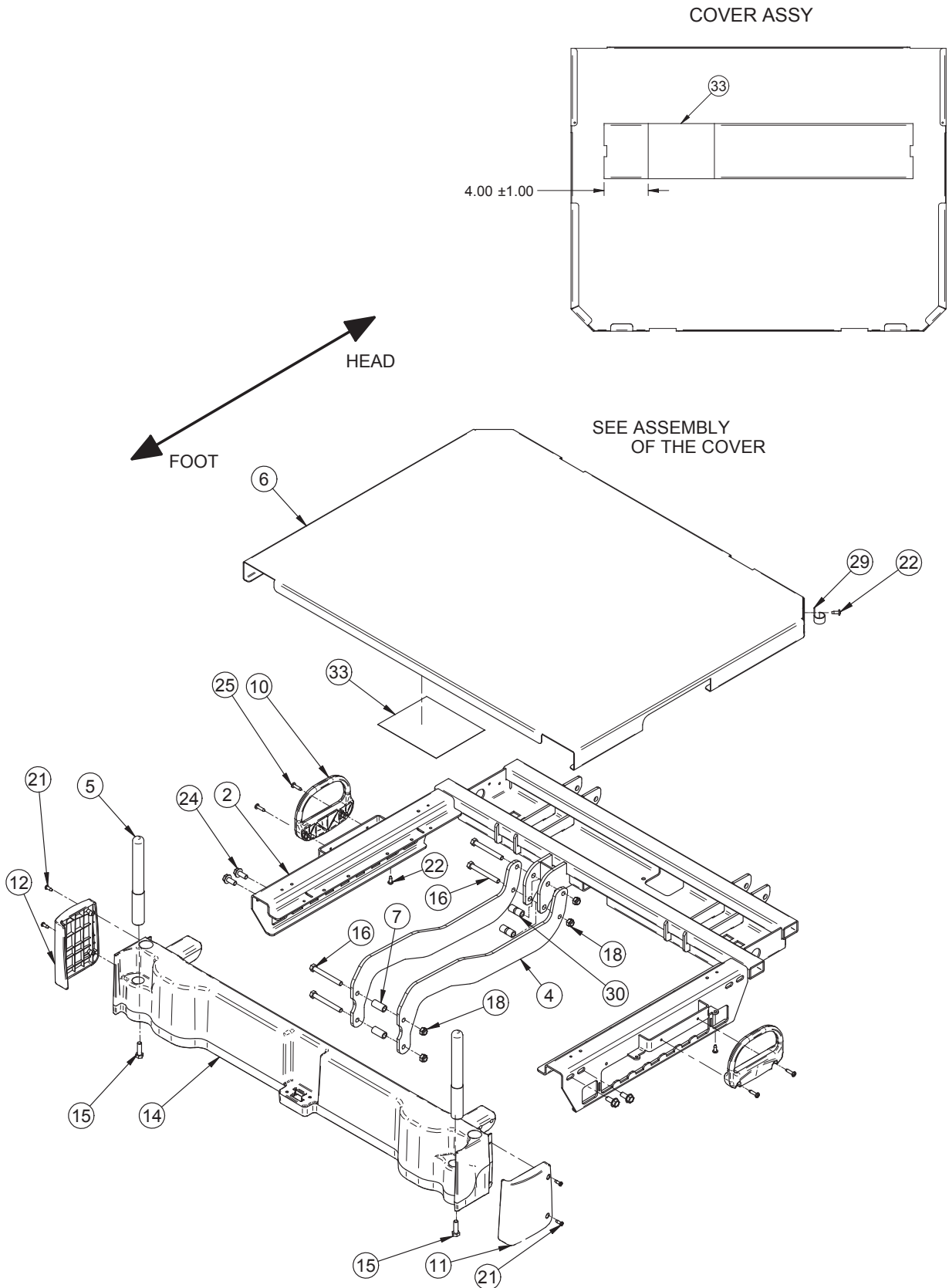

[Return To Table of Contents](#)

# Litter Assembly, Foot End

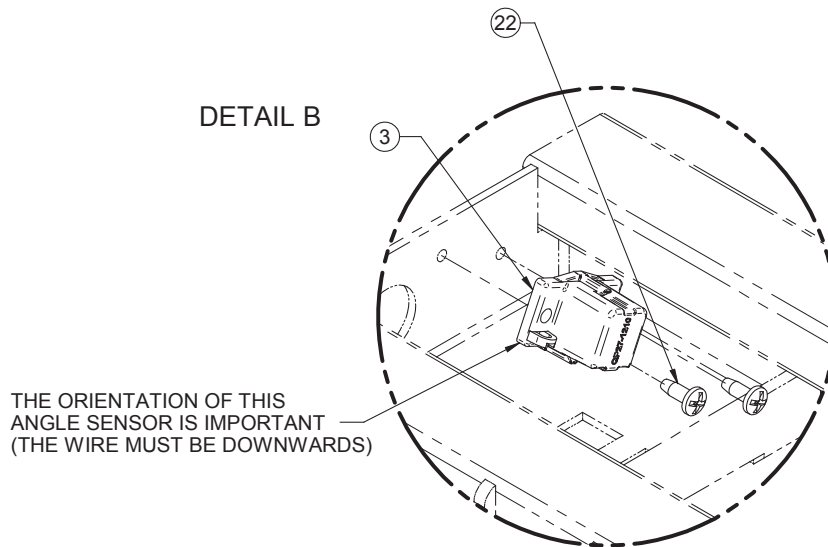
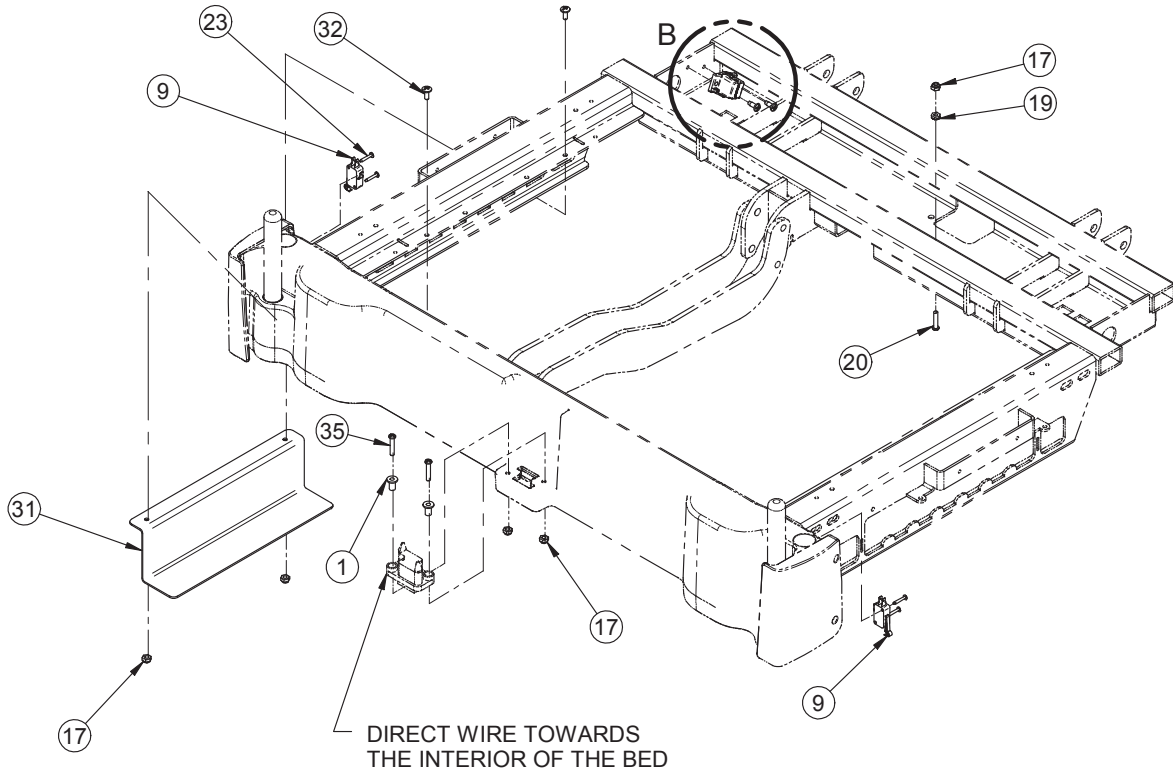

# Litter Assembly, Foot End

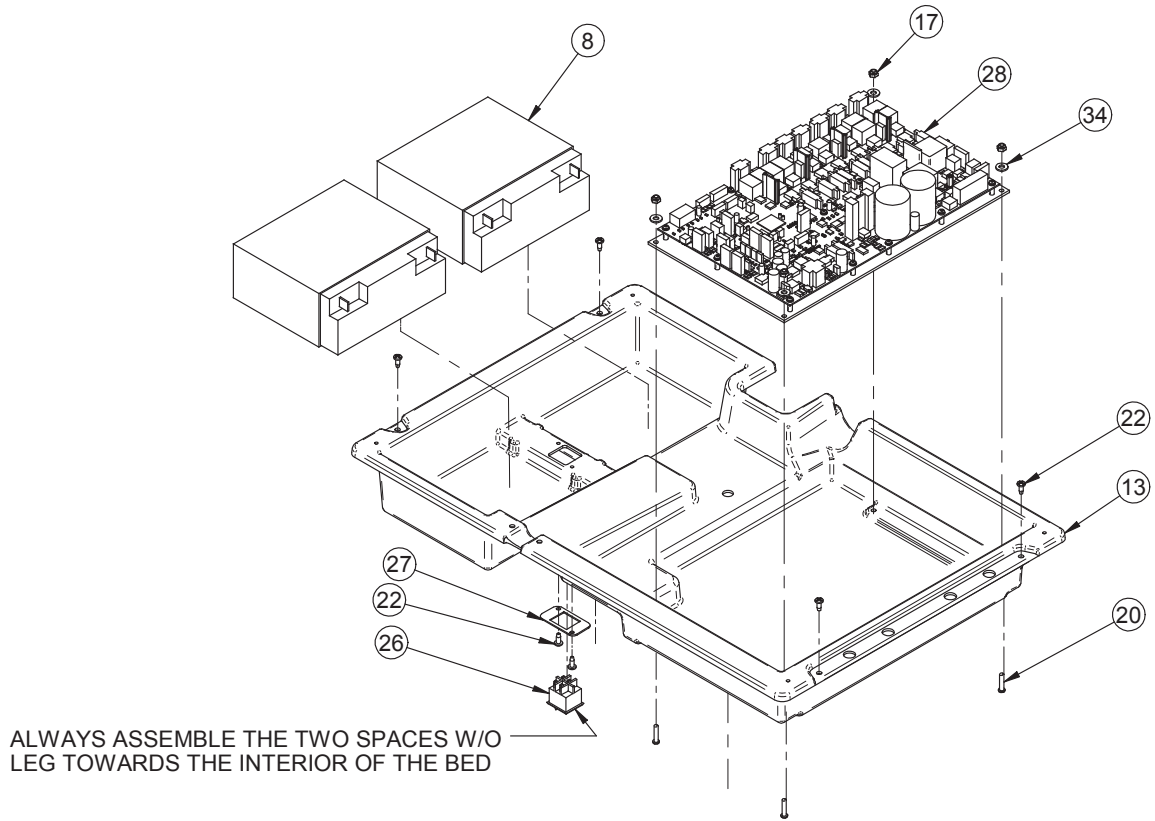

# Litter Assembly, Foot End

---

## Litter Assembly, Foot End - Common Components - 27-2688 Rev B (Reference Only)

Item	Part No.	Part Name	Qty.
1	25-0527Z	Connector's Sleeve	2
2	27-0112P	Foot Section	1
3	27-2477	Angle Sensor	1
4	27-1579W	Foot Litter Center Plate	2
5	27-1833C	Footboard Rod	2
6	27-1606W	Mattress Support	1
7	27-1710Z	Spacer	2
8	QDF9188	12V 18AH Battery	2
9	QDF9535	Micro Switch	2
10	QP27-1435-10	Mattress Stopper	2
11	QP27-2644	Left Foot Bumper	1
12	QP27-2645	Right Foot Bumper	1
13	QP27-1597	Molded Electronic Box	1
14	QPA27-1576-W	Molded Foot Litter End	1
15	VB15A1O32-S	Scotch Grip Bolt	2
16	VB15A1O54	"Full Thread" Bolt	4
17	VE30A0G	Nylon Locknut	9
18	VE30A1O	Nylon Locknut	4
19	VE80A0G	Locknut	1
20	VV33A0G28	Phillips Machine Screw	5
21	VV83A9E16	Phillips Screw	4
22	VV83A9G16	Phillips Screw	11
23	VV87A9A24	Phillips Tapping Screw	4
24	VVB4A1024	Thread Rolling Bolt	4
25	VV83A9G24	Phillips Tapping Screw	4
26	QDF2089	Battery Switch	1
27	27-1972Z	Switch Support Plate	1
28	QDF75-0440	DC Control Board	1
29	QDF2091	Wiring Clip	1
30	27-2058Z	Spacer	2
31	27-1858W	Electronic Box Reinforcement	1
32	VV37A0G16	Phillips Machine Screw	2
33	QE71-1061	Battery Protection Sticker	1
34	VW10C081802	Nylon Washer	4
35	VV31A0G32	Phillips Machine Screw	2



# Litter Assembly, Standard Cabling

L27-059 Rev B (Reference Only)

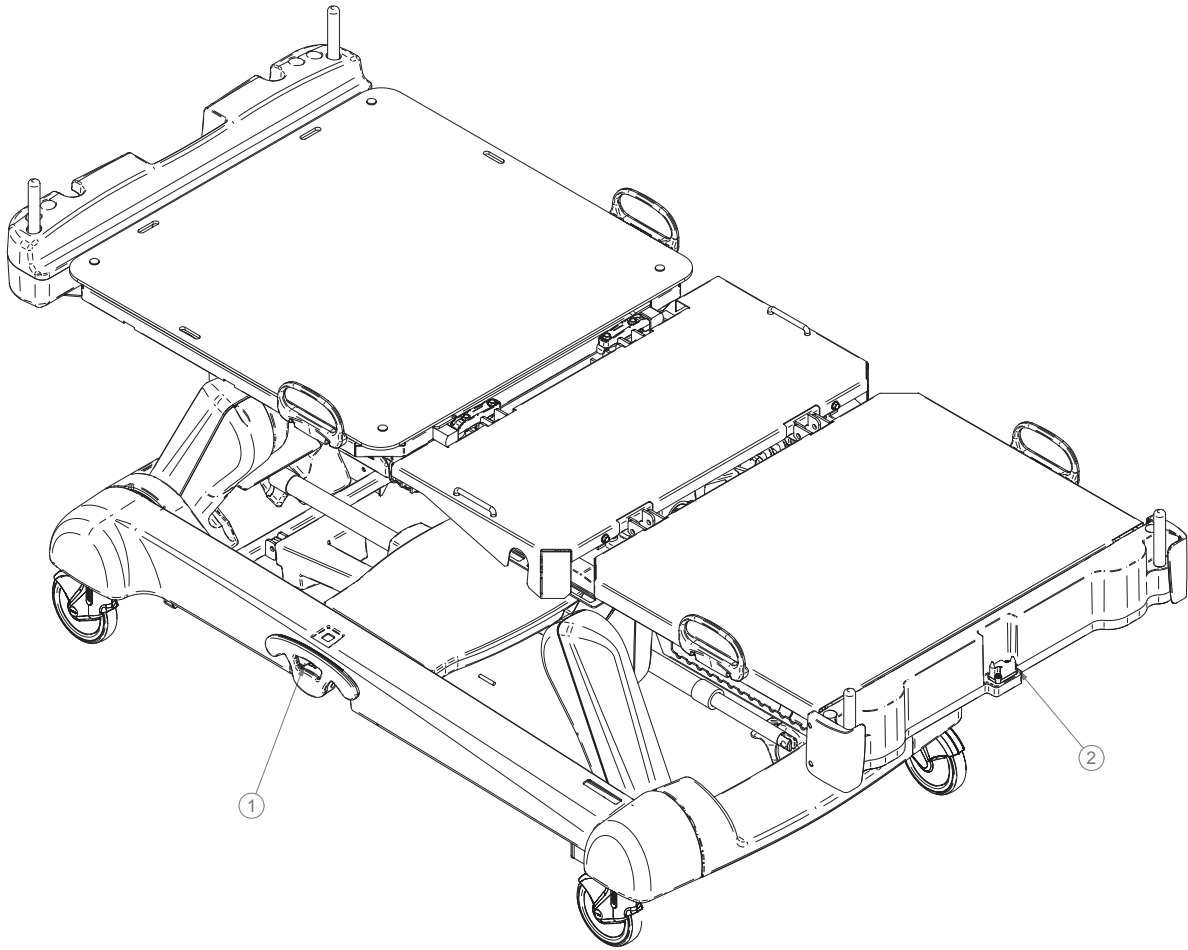

Item	Part No.	Part Name	Qty.
1	27-2687	Base and Lever Wiring	1
2	27-2695	Litter Wiring	1

# Litter Assembly, Electrical

27-2695 Rev B (Reference Only)

**Note:** To avoid any binding risk when assembling these cables, the bed must be in high position.

- Fowler at 70 degrees
- Knee Gatch at 15 degrees
- Foot Litter at 45 degrees

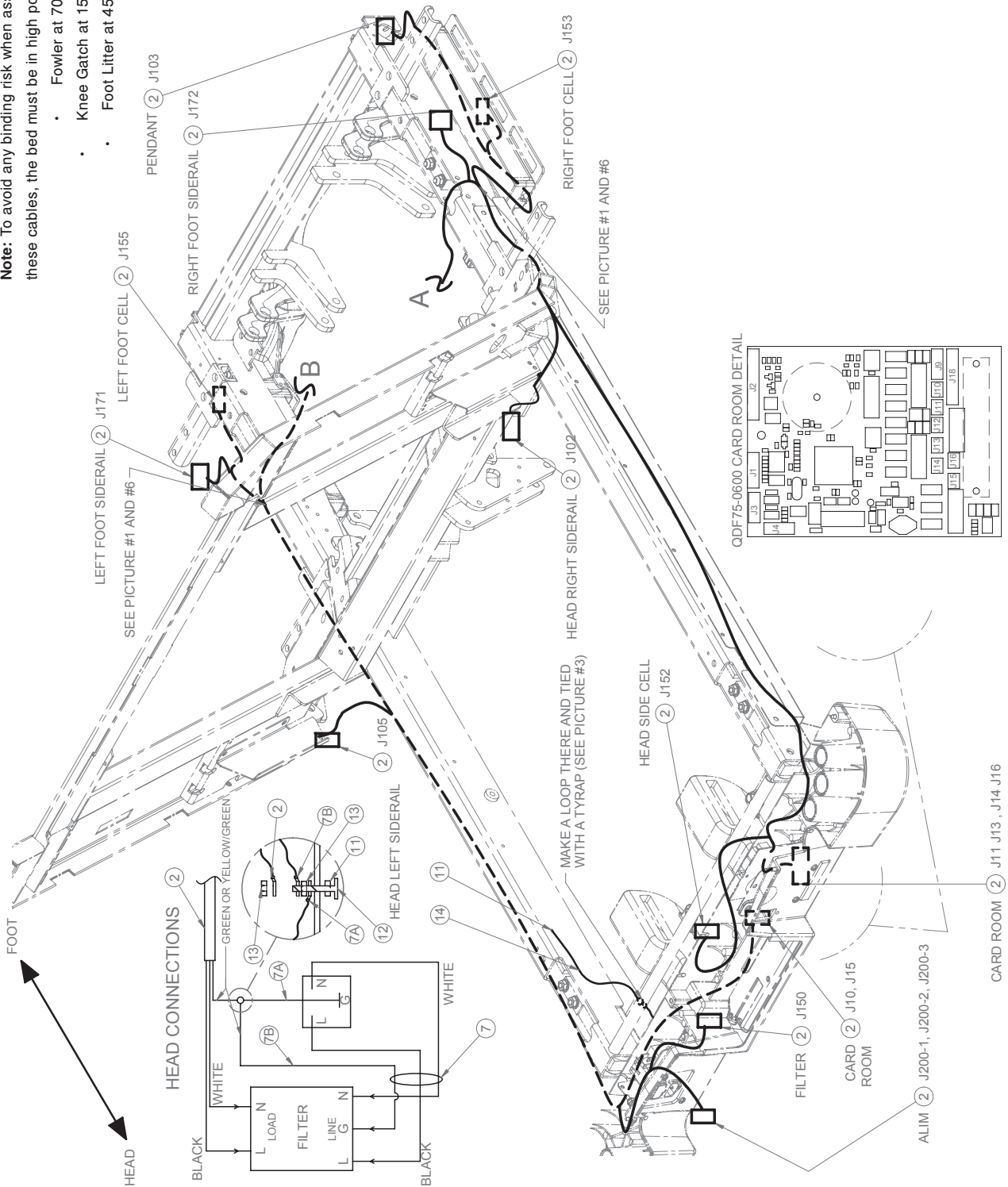

# Litter Assembly, Electrical

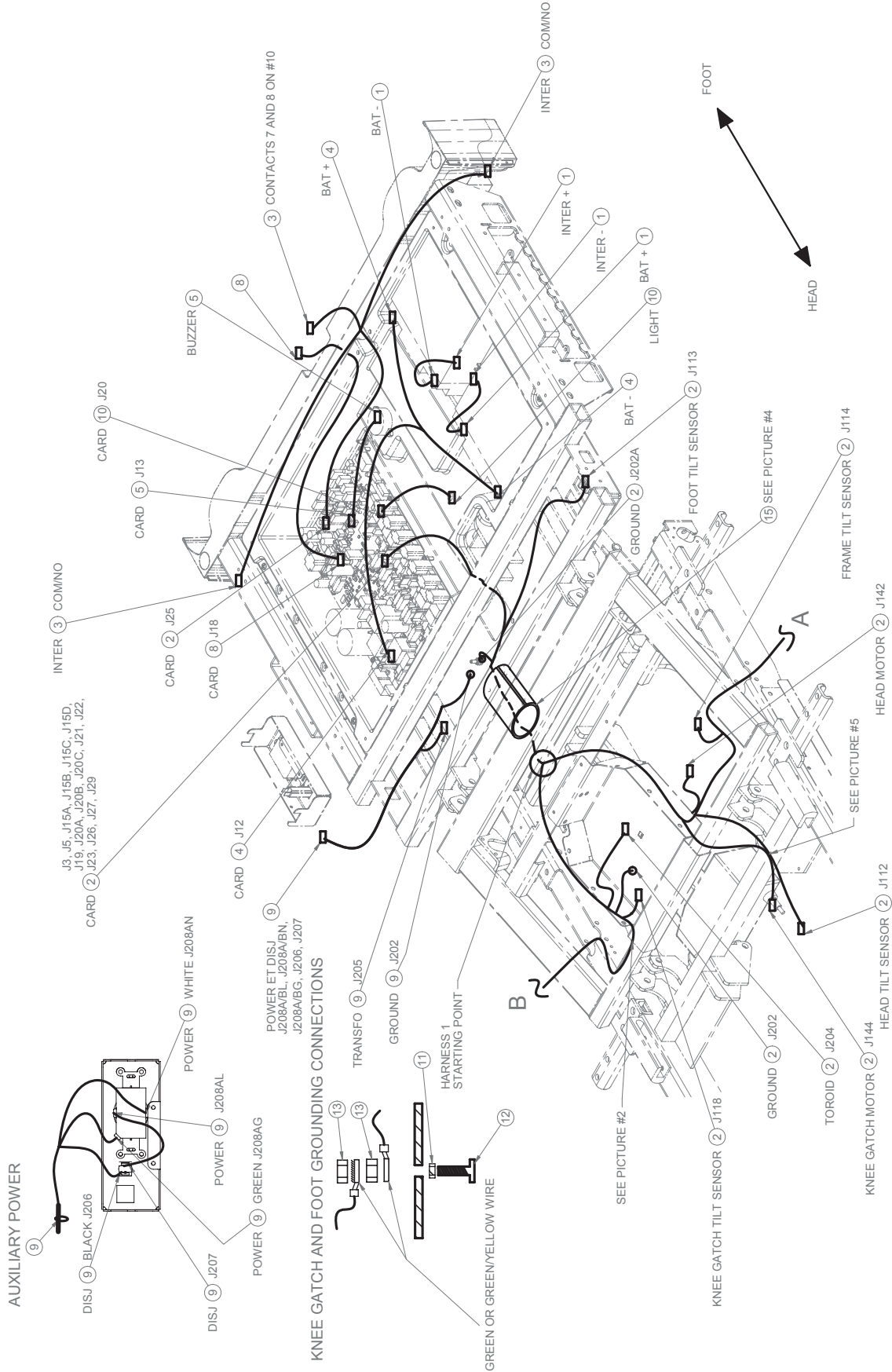

# Litter Assembly, Electrical

Photo #1



Photo #2



Photo #3



Photo #4



Photo #5



Photo #5



19

**QDF27-1381 CABLES #1 CONNECTION TABLE**

Cable No.	Connector No.	To	Cable No.	Connector No.
QDF27-1381	Grommet	To	QDF9188	Battery
QDF27-1381	Terminal	To	QDF2089	Interrupter
QDF27-1381	Terminal	To	QDF2089	Interrupter

**QDF27-1646 CABLES #4 CONNECTION TABLE**

Cable No.	Connector No.	To	Cable No.	Connector No.
QDF27-1646	Mini Fit	To	QDF75-0440	J12 DC Board
QDF27-1646	Black Grommet	To	QDF9188	Battery #2 Pole -
QDF27-1646	White Grommet	To	QDF9188	Battery #1 Pole +

# Litter Assembly, Electrical

QDF27-2213 CABLES #2 CONNECTION TABLE				
Cable No.	Connector No.	To	Cable No.	Connector No.
QDF27-2213	J22	To	QDF75-0440	J22 DC Board
QDF27-2213	J21	To	QDF75-0440	J21 DC Board
QDF27-2213	J20A	To	QDF75-0440	J20A DC Board
QDF27-2213	J20B	To	QDF75-0440	J20B DC Board
QDF27-2213	J20C	To	QDF75-0440	J20C DC Board
QDF27-2213	J19	To	QDF75-0440	J19 DC Board
QDF27-2213	J29	To	QDF75-0440	J29 DC Board
QDF27-2213	J15A	To	QDF75-0440	J15A DC Board
QDF27-2213	J15B	To	QDF75-0440	J15B DC Board
QDF27-2213	J15C	To	QDF75-0440	J15C DC Board
QDF27-2213	J15D	To	QDF75-0440	J15D DC Board
QDF27-2213	J204	To	QDF27-2038	Transformer J204
QDF27-2213	J27	To	QDF75-0440	J27 DC Board
QDF27-2213	J3	To	QDF75-0440	J3 DC Board
QDF27-2213	J5	To	QDF75-0440	J5 DC Board
QDF27-2213	J113	To	QDF75-0140	Foot Sensor
QDF27-2213	J202	To	-	Gatch Ground
QDF27-2213	J114	To	QDF75-0140	Trend Sensor
QDF27-2213	J153	To	QDF27-1372	Right Foot Cell
QDF27-2213	J103	To	27-2598	Removable Control
QDF27-2213	J172	To	QDF27-1208	Right Foot Siderail
QDF27-2213	J102	To	QDF27-2212	Right Head Siderail
QDF27-2213	J152	To	QDF27-1372	Right Head Cell
QDF27-2213	J202A	To	-	Foot Ground
QDF27-2213	J16	To	QDF75-0270	J16
QDF27-2213	J15	To	QDF75-0270	J15
QDF27-2213	J14	To	QDF75-0270	J14
QDF27-2213	J13	To	QDF75-0270	J13
QDF27-2213	J10	To	QDF75-0270	J10
QDF27-2213	J11	To	QDF75-0270	J11
QDF27-2213	J144	To	QDF27-1215	Gatch Motor
QDF27-2213	J142	To	QDF27-1214	Fowler Motor
QDF27-2213	J112	To	QDF75-0140	Fowler Sensor
QDF27-2213	J118	To	QDF75-0140	Gatch Sensor
QDF27-2213	J155	To	QDF27-1372	Left Foot Cell
QDF27-2213	J171	To	QDF27-1208	Left Foot Siderail
QDF27-2213	J105	To	QDF27-2212	Left Head Siderail
QDF27-2213	J150	To	QDF27-1372	Left Head Cell
QDF27-2213	J23	To	QDF75-0440	J23 DC Board
QDF27-2213	J26	To	QDF75-0440	J26 DC Board
QDF27-2213	J200A Black	To	QDF9571	Line "L"
QDF27-2213	J200B White	To	QDF9571	Line "N"
QDF27-2213	J200C Green/Yellow	To	Ground	Head Screw

# Litter Assembly, Electrical

**QDF27-1607 CABLES #3 CONNECTION TABLE**

Cable No.	Connector No.	To	Cable No.	Connector No.
QDF27-1607	Con. MTA 5 Pos.	To	QDF75-0440	J25 DC Board
QDF27-1607	Contact	To	QDF27-1213	Contact 7 or 8
QDF27-1607	Contact	To	QDF27-1213	Contact 7 or 8
QDF27-1607	Terminal	To	QDF9535	Right Limit Switch No/Com
QDF27-1607	Terminal	To	QDF9535	Right Limit Switch Com/No
QDF27-1607	Terminal	To	QDF9535	Left Limit Switch No/Com
QDF27-1607	Terminal	To	QDF9535	Left Limit Switch Com/No

**QDF5095 CABLES #5 CONNECTION TABLE**

Cable No.	Connector No.	To	Cable No.	Connector No.
QDF5095	Con. MTA	To	QDF75-0440	J13 DC Board
QDF5095	Buzzer	To	Electrical Box	See Position on Drawing

**QDF27-1524 CABLES #7 CONNECTION TABLE**

Cable No.	Connector No.	To	Cable No.	Connector No.
QDF27-1524	Black 90° Terminal	To	QDF9571	Line "L"
QDF27-1524	White 90° Terminal	To	QDF9571	Line "L"
QDF27-1524	Green 90° Terminal	To	QDF9571	Line "L"
QDF27-1524	Black Right Terminal	To	27-2848	"L" (Power Supply)
QDF27-1524	White Right Terminal	To	27-2848	"N" (Power Supply)
QDF27-1524	Green Right Terminal	To	27-2848	"E" (Power Supply)
QDF27-1524	Cross Grommet	To	Head Ground	Screw
QDF27-1524	Cross Grommet	To	Head Ground	Screw

**QDF27-2214 CABLES #10 CONNECTION TABLE**

Cable No.	Connector No.	To	Cable No.	Connector No.
QDF27-2214	Con. MTA 6 Pos.	To	QDF75-0440	J18 DC Board
QDF27-2214	Con. Metrimate	To	27-1547	Panel (27-1547)

**QDF27-2025 CABLES #12 CONNECTION TABLE**

Cable No.	Connector No.	To	Cable No.	Connector No.
QDF27-2025	Light	To	QDF75-0440	J20 DC Board

# Litter Assembly, Electrical

QDF27-2228 CABLES #11 CONNECTION TABLE				
Cable No.	Connector No.	To	Cable No.	Connector No.
QDF27-2228	J205	To	QDF27-2038	Transformer
QDF27-2228	J202 Grommet	To	-	Foot Litter Ground
QDF27-2228	J208AL (Black)	To	QDF9573	Single Outlet
QDF27-2228	J207 Terminal	To	QDF9025	Breaker
QDF27-2228	J206 Terminal	To	QDF9025	Breaker
QDF27-2228	J208AN (White)	To	QDF9573	Right Limit Switch No/Com
QDF27-2228	J208AG (Green/Yellow)	To	QDF9573	Ground

## Litter Assembly, Electrical - 27-2695 Rev B (Reference Only)

Item	Part No.	Part Name	Qty.
1*	QDF27-1381	Battery Switch Wire	2
2*	QDF27-2213	#1 Wire Harness	1
3*	QDF27-1607	I.V. Pole and Bed Extender Cable	1
4*	QDF27-1646	Battery Wires	1
5*	QDF5095	Buzzer	1
6*	QDF9518	Cable Tie	51
7*	QDF27-1524	Filter and Receiver Connector	1
8*	QDF27-2214	Panel – Control Board Cable	1
9*	QDF27-2228	Auxiliary 120V Outlet Cable without Mattress Connector	1
10*	QDF27-2025	12V Night Light	1
11*	VW20A76	Locking Washer	4
12*	VV33A0G28	Phillips Machine Screw #10-32 x 7/8"	3
13*	VE30A0G	Nylon Locknut #10-32	6
14*	QDF27-2284	Electronic Board Ground Wire	1
15	QDF2115	1.25 Split Loom Polyethylene	1
16	QDF9523	Wire Tie	2



# 120V Electric System

OL270206-XXX Rev E (Model 2131 Only) (For Reference Only)

OL270211-XXX Rev E (Model 2141 Only)

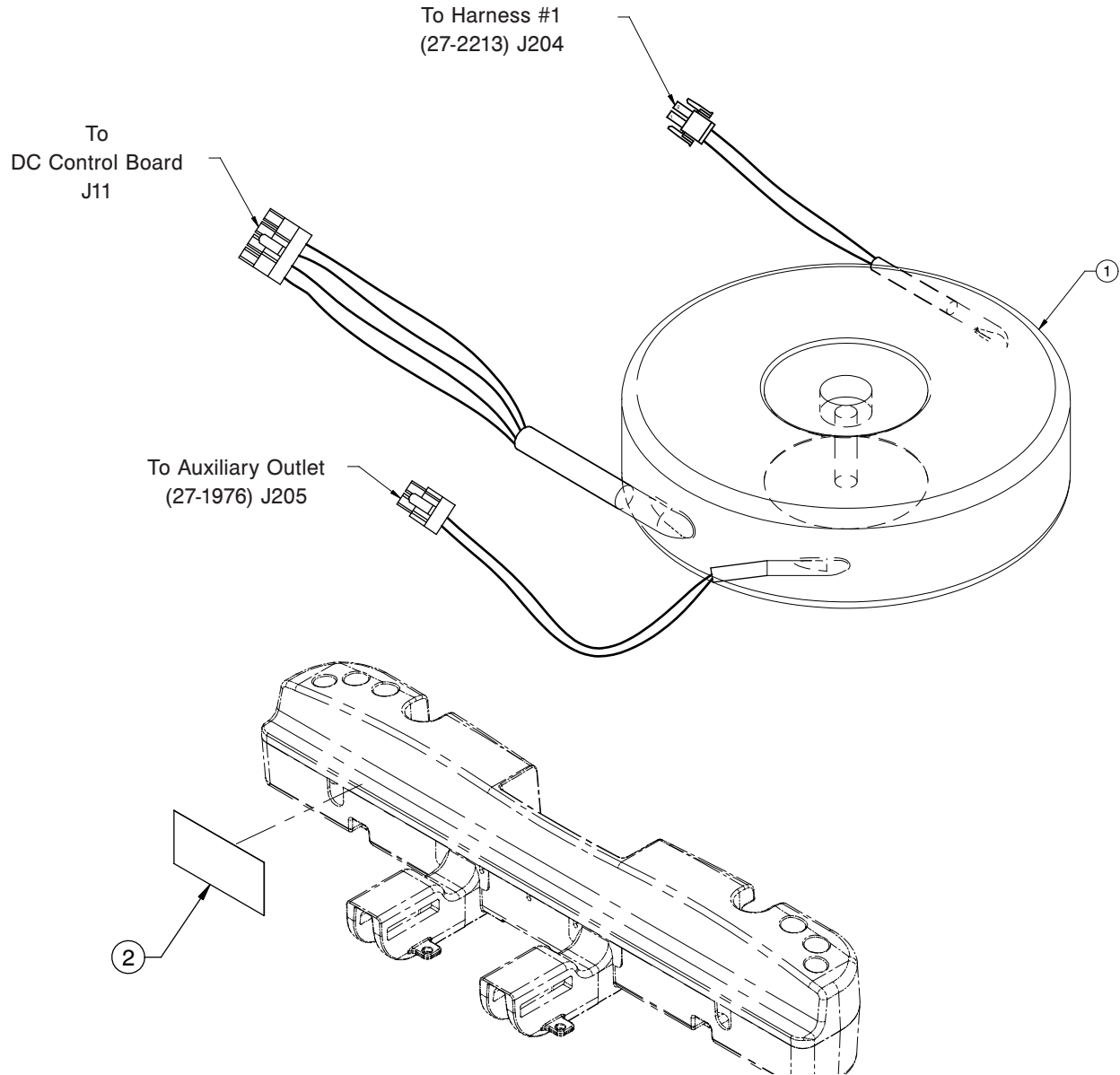

**NOTE:** XXX - indicates language choice (tri = English/French/Spanish; bil = English/French)

Item	Part No.	Part Name	Qty.
1	QDF27-2038	Medical Toroidal Transformer	1
2	QE71-1183-XXX	120V CSA Label (2131 Models Only)	1 or
	QE71-1188-XXX	120V CSA Label (2141 Models Only)	1



# Coiled Power Cord

---

27-2782 Rev A (Reference Only)



# Litter Assembly, Foot End, with Mattress Connector

OL270166 Rev 2 (Reference Only)

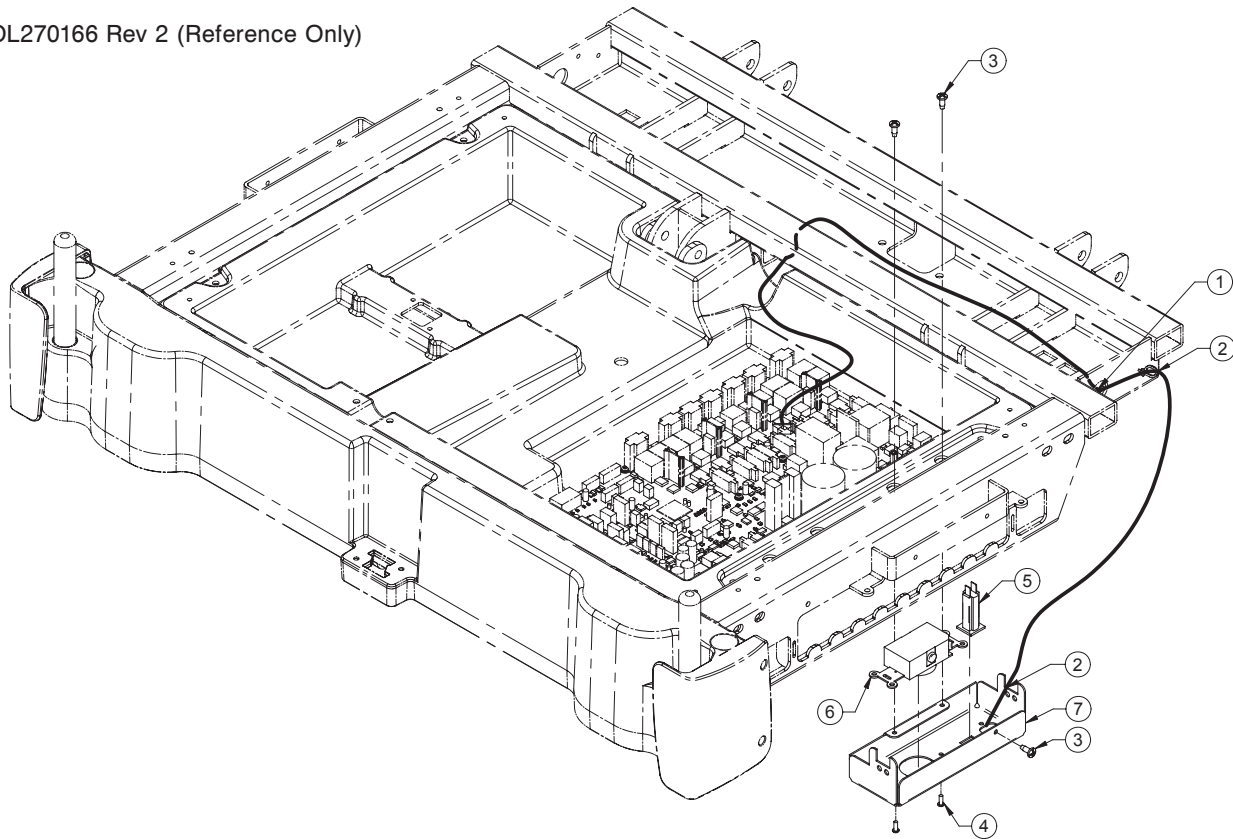

**QDF27-2248 CABLES #1 CONNECTION TABLE**

Cable No.	Connector No.	To	Cable No.	Connector No.
QDF27-2248	J17	To	QDF27-1960	J17 DC Board
QDF27-2248	J17A	To	Hole	(27-1200)

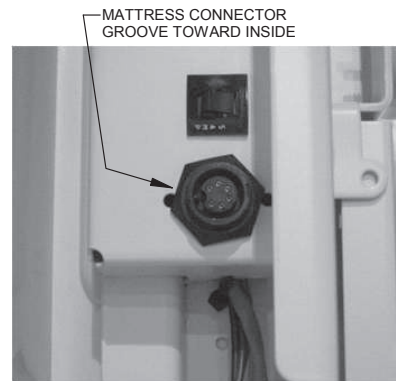
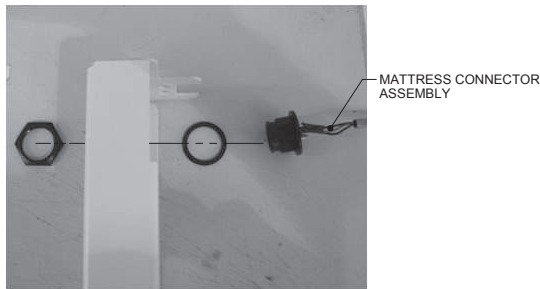

**BOTTOM VIEW**

Item	Part No.	Part Name	Qty.
1	QDF27-2248	Mattress Connector Cable	1
2	QDF9518	Cable Tie	2
3	VV83A9G16	Tapping Screw	3
4	VV37A1C12	Machine Screw	2
5	QDF9025	5A Breaker	1
6	QDF9573	Single Leviton 8310-G Outlet	1
7	27-1967P	Auxiliary Outlet Box	1

# Standard Outlet

OL270247 Rev D (Reference Only)

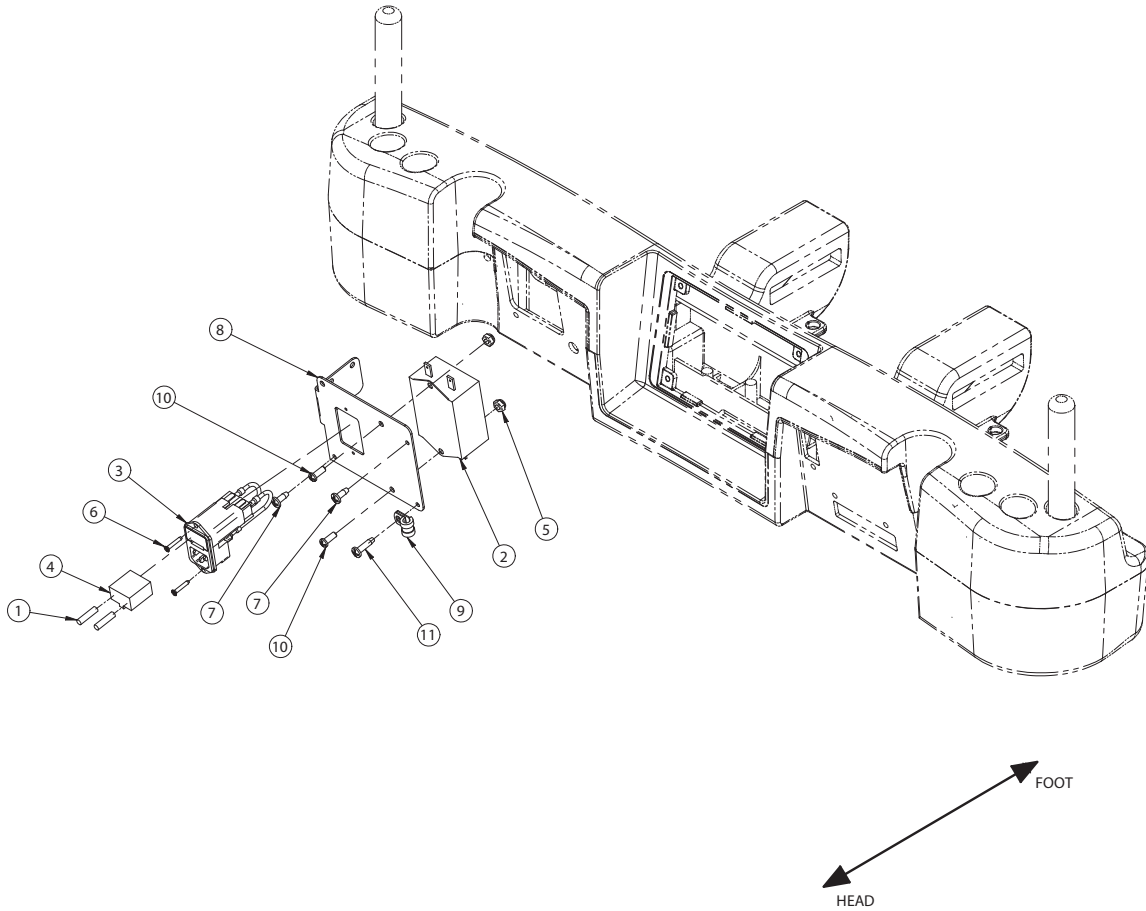

Item	Part No.	Part Name	Qty.
1	QDF8078	10A 250V Fuse	2
2	QDF9571	Medical Filter	1
3	27-2848	Inlet Filter Assembly	1
4	QDF9575	Fuse Holder	1
5	VE30A0G	Nylon Hex. Locknut	2
6	VV41A1A20	Tapping Screw Flat Head Phillips	2
7	VV83A9G16	Tapping Screw Pan Head Phillips	2
8	27-1723P	Head Plate without Auxiliary Outlet	1
9	QDF2155	Steel Cable Clamp	1
10	VV33A0G16	Machine Screw Pan Head Phillips	2
11	VV83A9G24	Pan Head Tapping Screw	1

# Litter Assembly, Optional Dual 120V Outlet

OL270013-XXX Rev-04 (Reference Only)

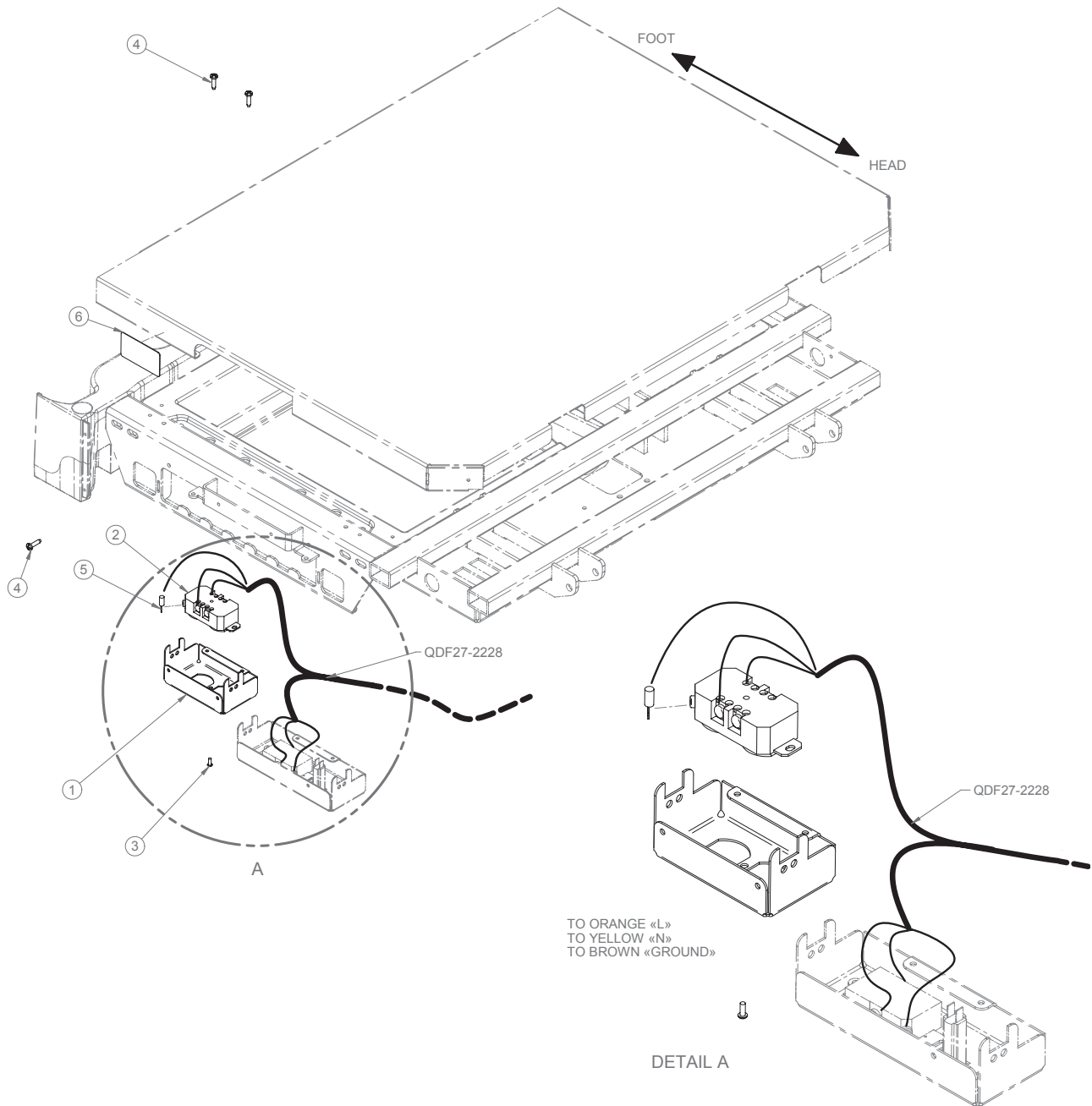

**QDF27-2228 CABLE CONNECTION TABLE**

Cable No	Connector No.	Cable No	Connector No.
QDF27-2228	J108A-L (Black)	QDF9573	“L”
QDF27-2228	J108A-N (White)	QDF9573	“N”
QDF27-2228	J108A-G (Green)	QDF9573	“GROUND”
QDF27-2228	J108B-L (Orange)	QDF8024	“L”
QDF27-2228	J108B-N (Yellow)	QDF8024	“N”
QDF27-2228	J108B-G (Brown)	QDF8024	“GROUND”

# Litter Assembly, Optional Dual 120V Outlet

---

## Litter Assembly, Optional Dual 120V Outlet - OL270013-XXX Rev-04 (Reference Only)

**NOTE:** XXX - indicates language choice (tri = English/French/Spanish; bil = English/French)

<b>Item</b>	<b>Part No.</b>	<b>Part Name</b>	<b>Qty.</b>
1	27-1978P	Optional Auxiliary Outlet Box	1
2	QDF8024	Leviton 8200-w Double Outlet	1
3	VV37A1C12	Truss Head Machine Screw	1
4	VV83A9G24	Tapping Screw	3
5	QDF2124	Terminal #10 for 16-14 AWG	1
6	QE71-0964-XXX	Auxiliary Plug Label-XXX	1

# CPR Assembly, Mechanical

L27-033 Rev-09 (Reference Only)

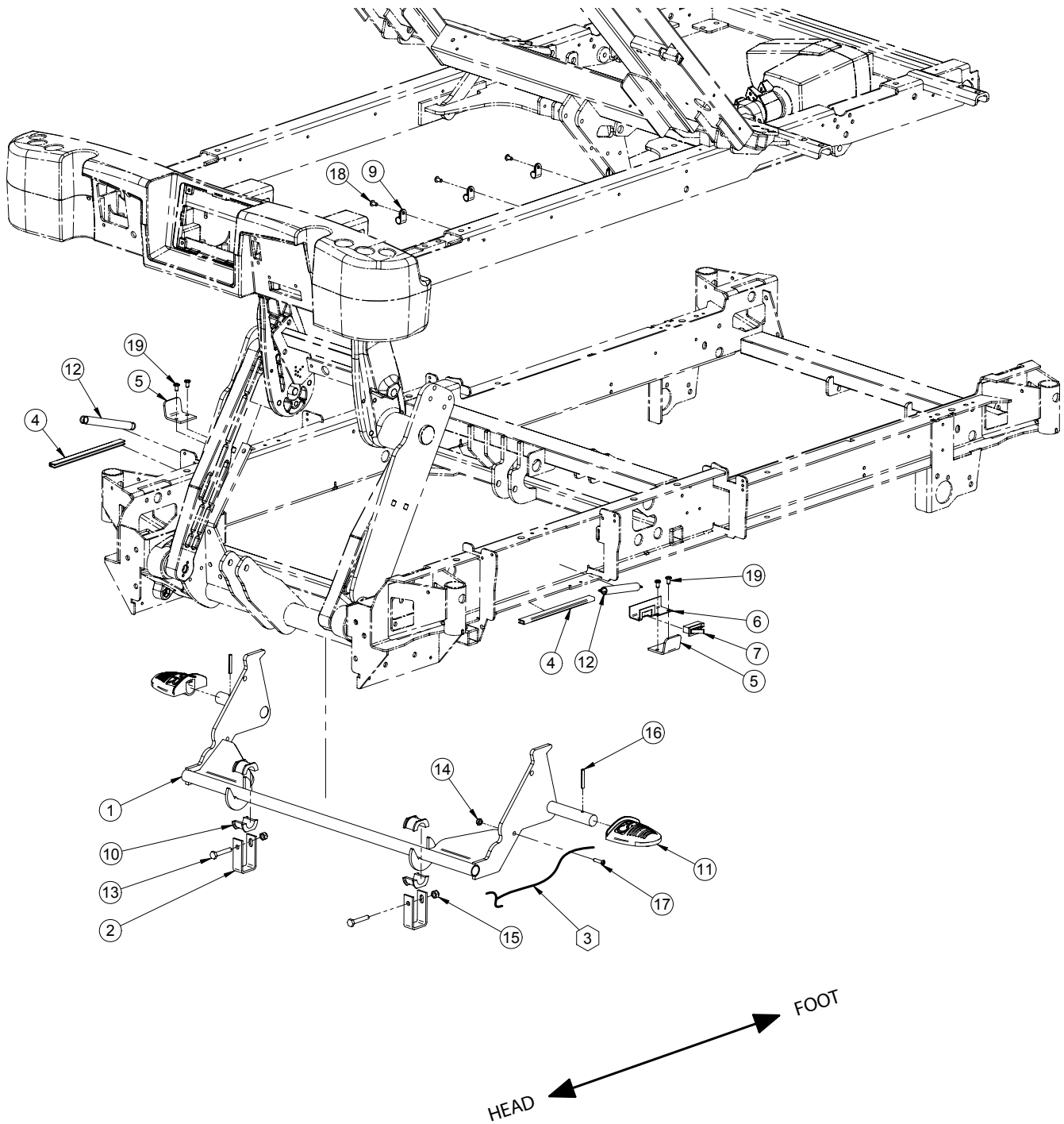

# CPR Assembly, Mechanical

## NOTE: For Cable Routing

- The Fowler must at 30° when installing the cable.
- There must be no tie installed on the actuator

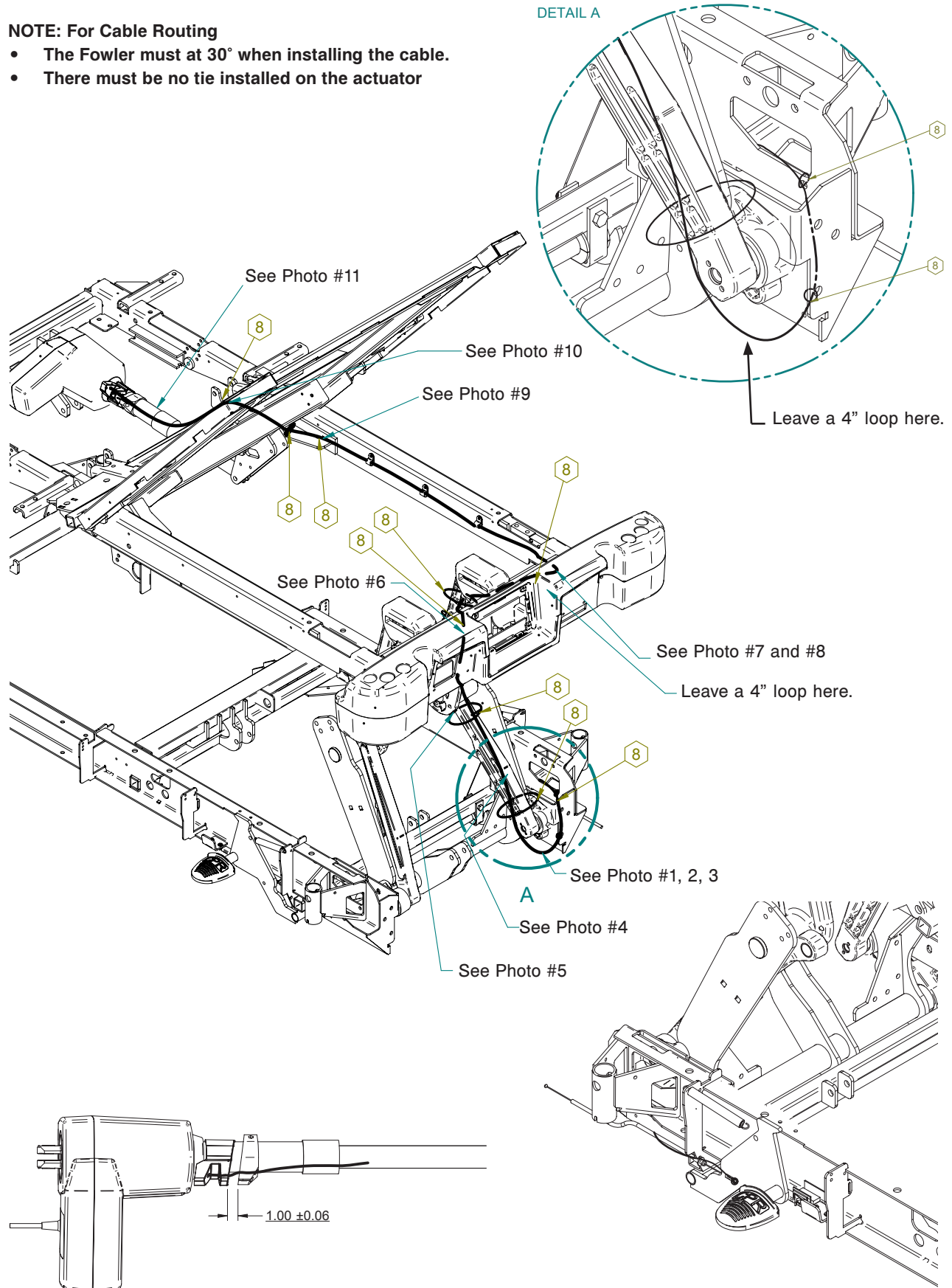



# CPR Assembly, Mechanical

---

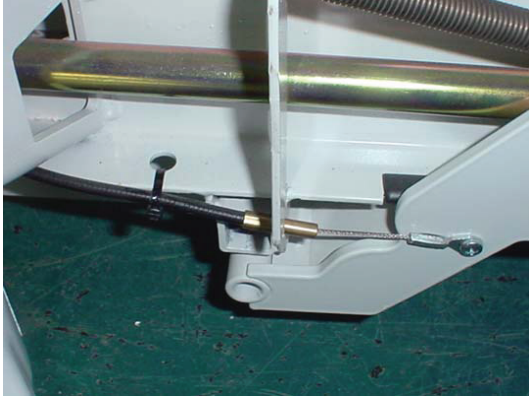

Photo #1



Photo #2



Photo #3



Photo #4

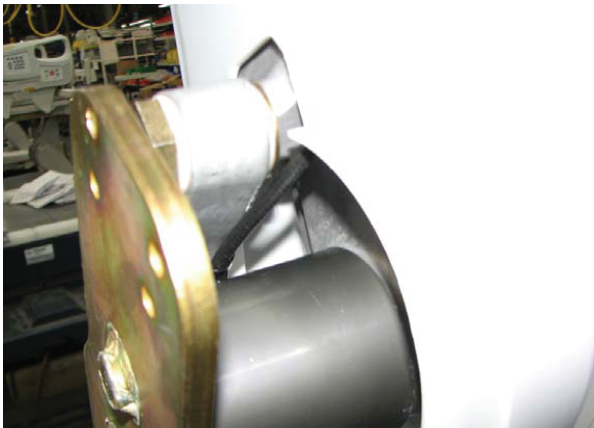

Photo #5



Photo #6



# CPR Assembly, Mechanical



Photo #7



Photo #8



Photo #9

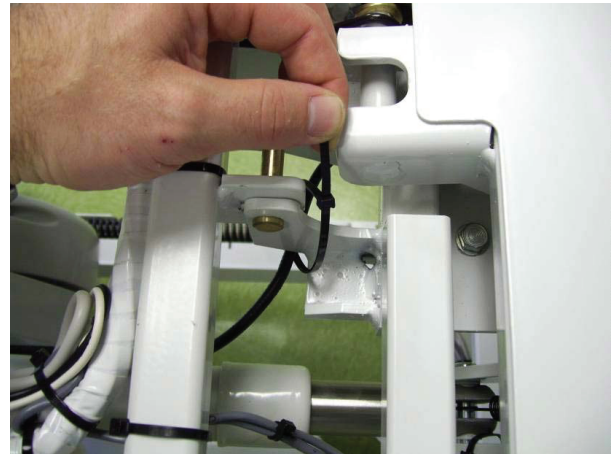

Photo #10



Photo #11

# CPR Assembly, Mechanical

CABLE CONNECTION TABLE			
Cable No.	Connector No.	Cable No.	Connector No.
QDF2083	CPR Switch	QDF27-1204	J127

## CPR Assembly, Mechanical - L27-033 Rev-09 (Reference Only)

Item	Part No.	Part Name	Qty.
1	27-1897P	CPR Pedal	1
2	27-1917Z	CPR Support	2
3	27-1966	CPR Cable	1
4	27-2036	CPR Lateral Stop	2
5	27-2062Z	CPR Pedal Stopper	2
6	27-2086Z	CPR Switch Support	1
7	QDF2083	Lever Switch	1
8	QDF9518	Cable Tie	12
9	QDF2155	Steel Cable Clamp	3
10	QP19-0270	Shaft Support Bearing	4
11	QP27-2065	CPR Pedal	2
12	QRE23-0438	Siderail Spring	2
13	VB15A1N44	Bolt	2
14	VE30A0G	Nylon Locknut	1
15	VE30A1N	Nylon Locknut	2
16	VG10B0636	Spring Pin	2
17	VV33A0G24	Pan Head Machine Screw	1
18	VV83A9G12	Pan Head Tapping Screw	3
19	VV83A9G16	Pan Head	4

# Handle Assembly (Model 2131 Only)

OL270058 Rev G (Reference Only)

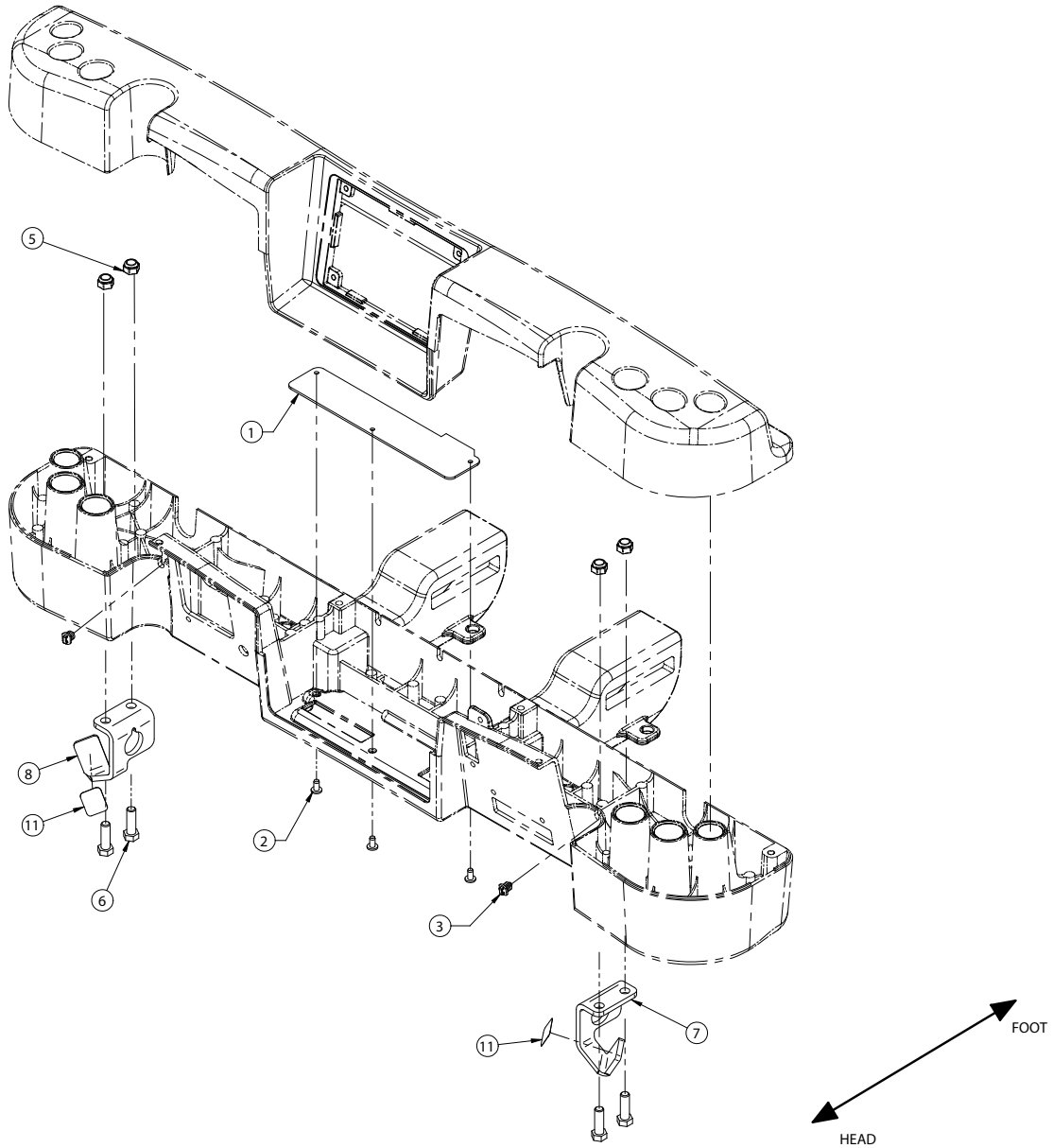

Item	Part No.	Part Name	Qty.
1	27-1651P	Without 5th Wheel Plate	1
2	VV83A9G12	Pan Head Tapping Screw	3
3	QDF5096	Plastic Tie	2
5	VE30A1O	Nylon Hex Locknut	4
6	VB15A1O32	Bolt	4
7	27-2790P	Zoom® Handle Bracket, Right	1
8	27-2789P	Zoom® Handle Bracket, Left	1
11	QE71-1373	Coiled Power Cord Label	2

# Zoom® Handle Assembly (Model 2141 Only)

27-2547-XXX Rev B (Reference Only)

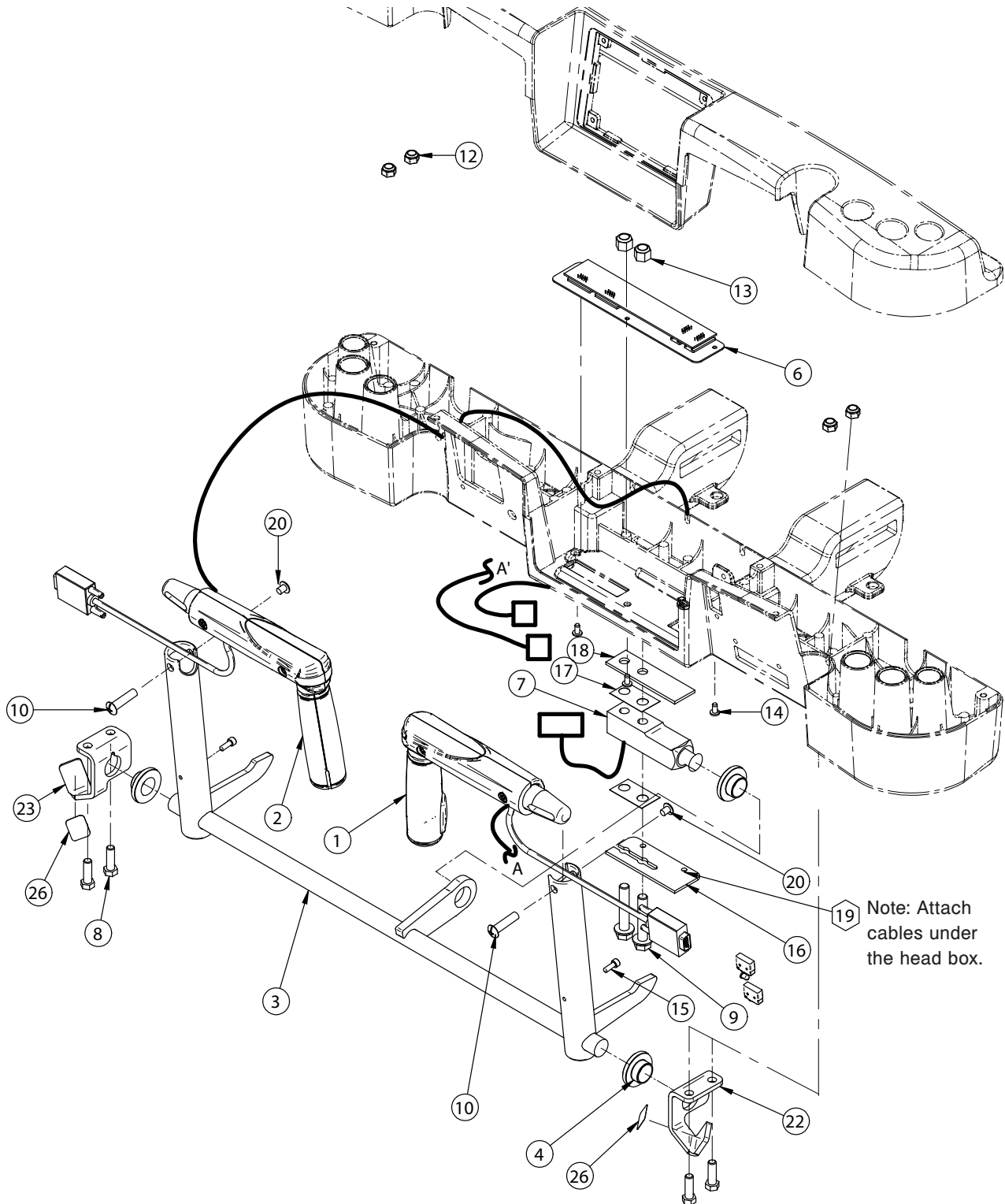

# Zoom® Handle Assembly (Model 2141 Only)

## 27-2548 BOARD CONNECTION

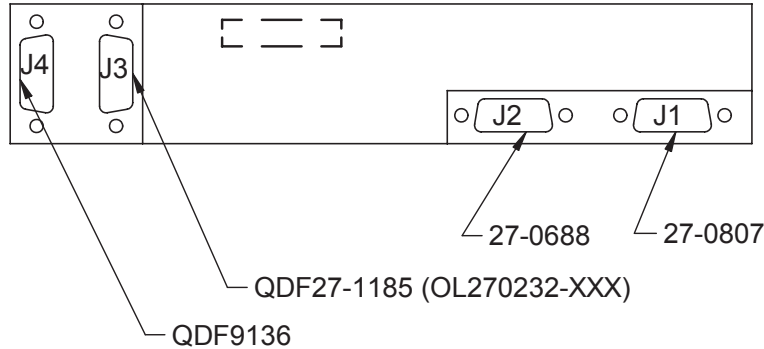

### Zoom® Handle Assembly - 27-2547-XXX Rev B (Reference Only)

**NOTE:** XXX - indicates language choice (tri = English/French/Spanish; bil = English/French)

Item	Part No.	Part Name	Qty.
1	27-0688	Right Zoom® Handle	1
2	27-0807	Left Zoom® Handle	1
3	27-0880C	Tie Bus	1
4	27-1181	Zoom® Handle Sleeve	3
6	27-2548	Zoom® Control Board Assembly	1
7	QDF9136	250 lbs Load Cell	1
8	VB15A1O32	Bolt	4
9	VB95A1P48	Hex Neck Bolt	2
10	VE42A9036	Combination Barrel Nut	2
12	VE30A1O	Nylon Locknut	4
13	VE30A1P	Nylon Locknut	2
14	VV83A9G12	Phillips Head Tapping Screw	3
15	VV10A0G16-S	Hex Head Screw	2
16	27-1857Z	Bottom Zoom® Load Cell Stopper	1
17	QDF27-1780	Load Cell Spacer	2
18	27-1775Z	Zoom® Load Cell Stopper	1
19	QDF9518	Nylon Tie-Wrap	1
20	VV33A1N10-S	Machine Screw	2
22	27-2790P	Zoom® Handle Bracket, Right	1
23	27-2789P	Zoom® Handle Bracket, Left	1
26	QE71-1373	Coiled Power Cord Label	2

# Zoom® Assembly

OL270077-XXX Rev D (Reference Only)

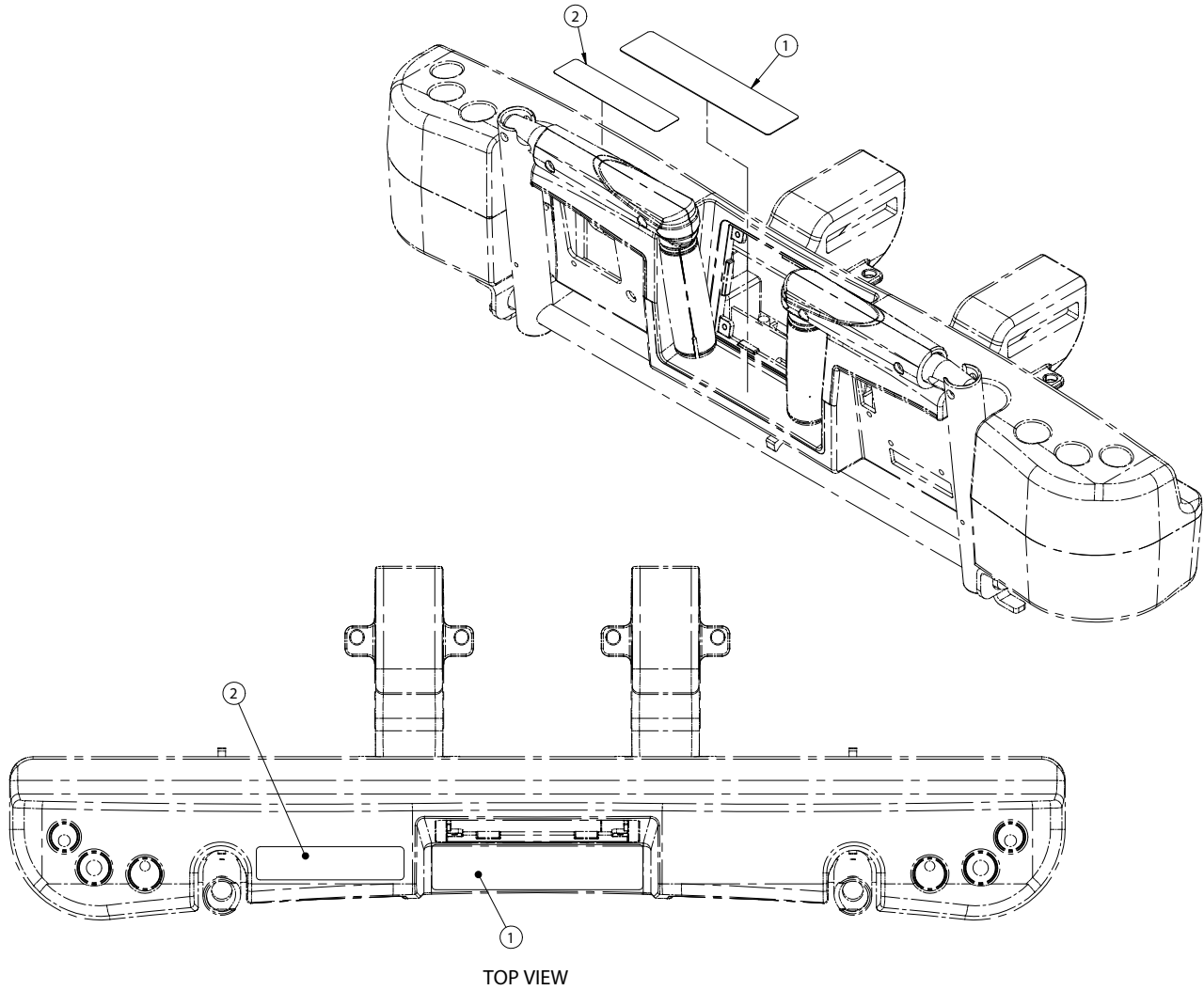

**NOTE:** XXX - indicates language choice (tri = English/French/Spanish; bil = English/French)

Item	Part No.	Part Name	Qty.
1	QE71-0946-XXX	Zoom® Label	1
2	QE71-1372	Zoom® Handle Label	1

# Optional No Head End Control Panel

OL270019 Rev-01 (Reference Only)

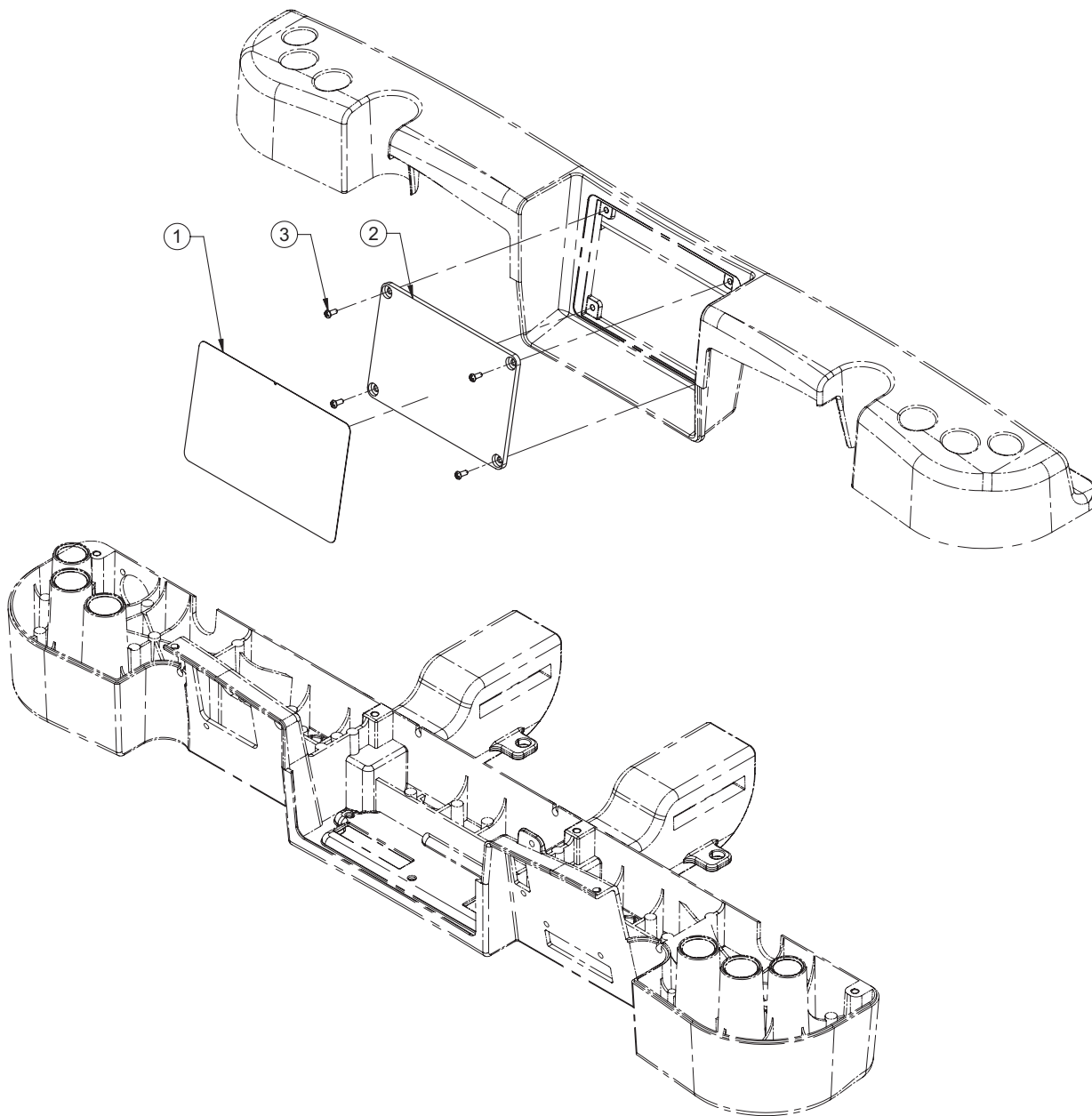

## No Head End Control Panel Assembly - OL270019 Rev-01 (Reference Only)

Item	Part No.	Part Name	Qty.
1	QDF27-1649	Head End Control Fascia without Motorized Zoom® Drive	1
2	QP27-1650	Head Frame Plate	1
3	VV23A9C12HL	Pan Head Screw	4



# Optional Head End Control Panel Assembly

OL270263-XXX Rev C (Reference Only)

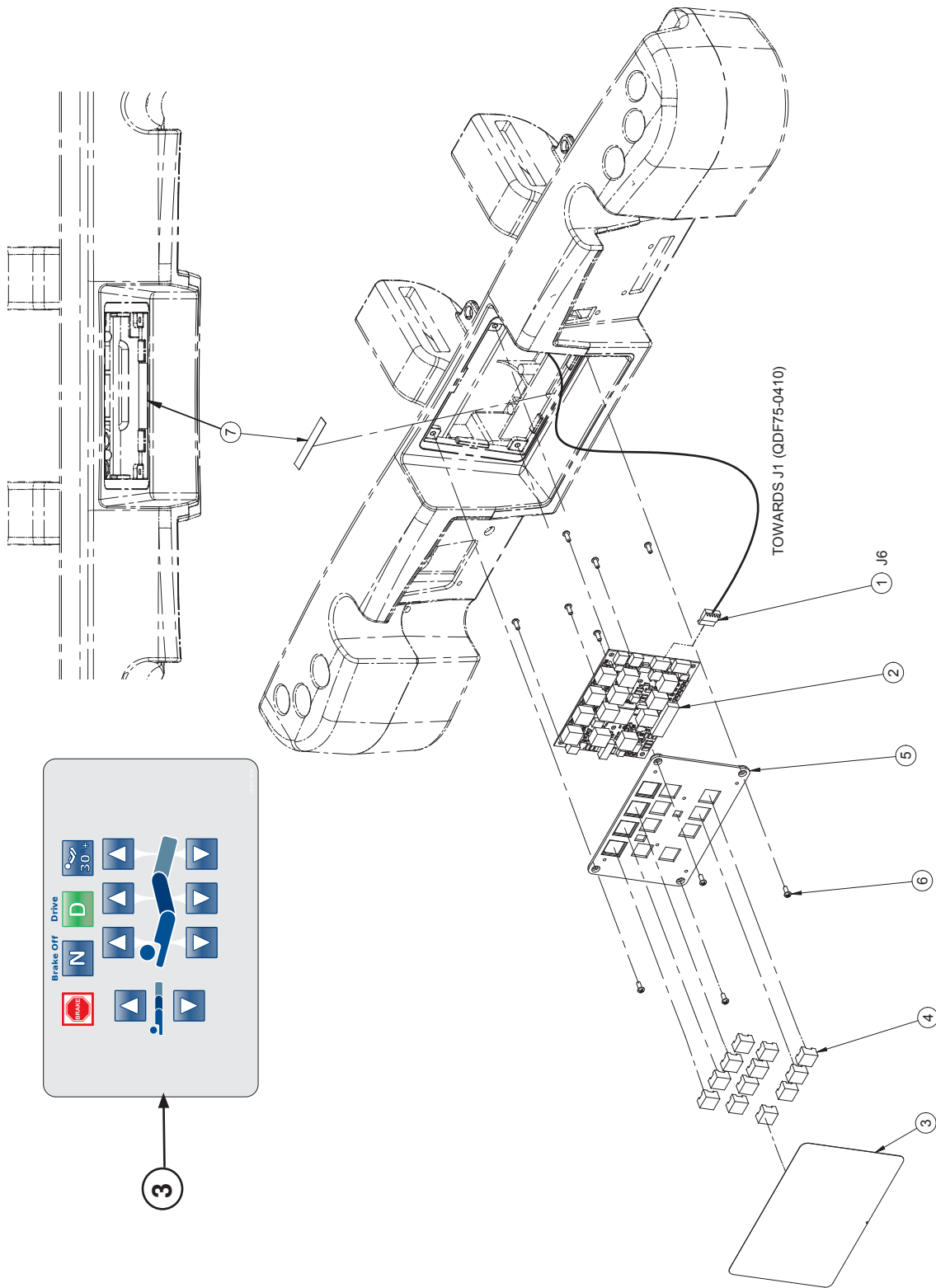



# Optional Head End Control Panel Assembly

QDF21-2895 CONNECTION TABLE			
Cable No	Connector No.	Cable No	Connector No.
QDF21-2895	MTA6	QDF27-1099	J6
QDF21-2895	MTA6	QDF75-0270	J1

DIP SWITCH CONFIGURATION ON QDF27-1099			
SW13	ON	OFF	ON
SW14	OFF	OFF	-

## Optional Head End Control Panel Assembly - OL270263-XXX Rev C (Reference Only)

**NOTE:** XXX - indicates language choice (tri = English/French/Spanish; bil = English/French)

Item	Part No.	Part Name	Qty.
1	QDF21-2895	12" Network Cable	1
2	QDF27-1099	Siderail Nurse Control Board	1
3	QF27-2236-XXX	Fascia, Head of Bed Control	1
4	QDF9183	Electronic Board Button	12
5	QP27-1111	Nurse Control Board Support	1
6	VV23A9C12HL	Pan Head Screw	10
7	QE71-1340	Connection Isolation Sticker	1

# Siderail Mounting Assembly, Head End

L27-039 Rev-01 (Reference Only)

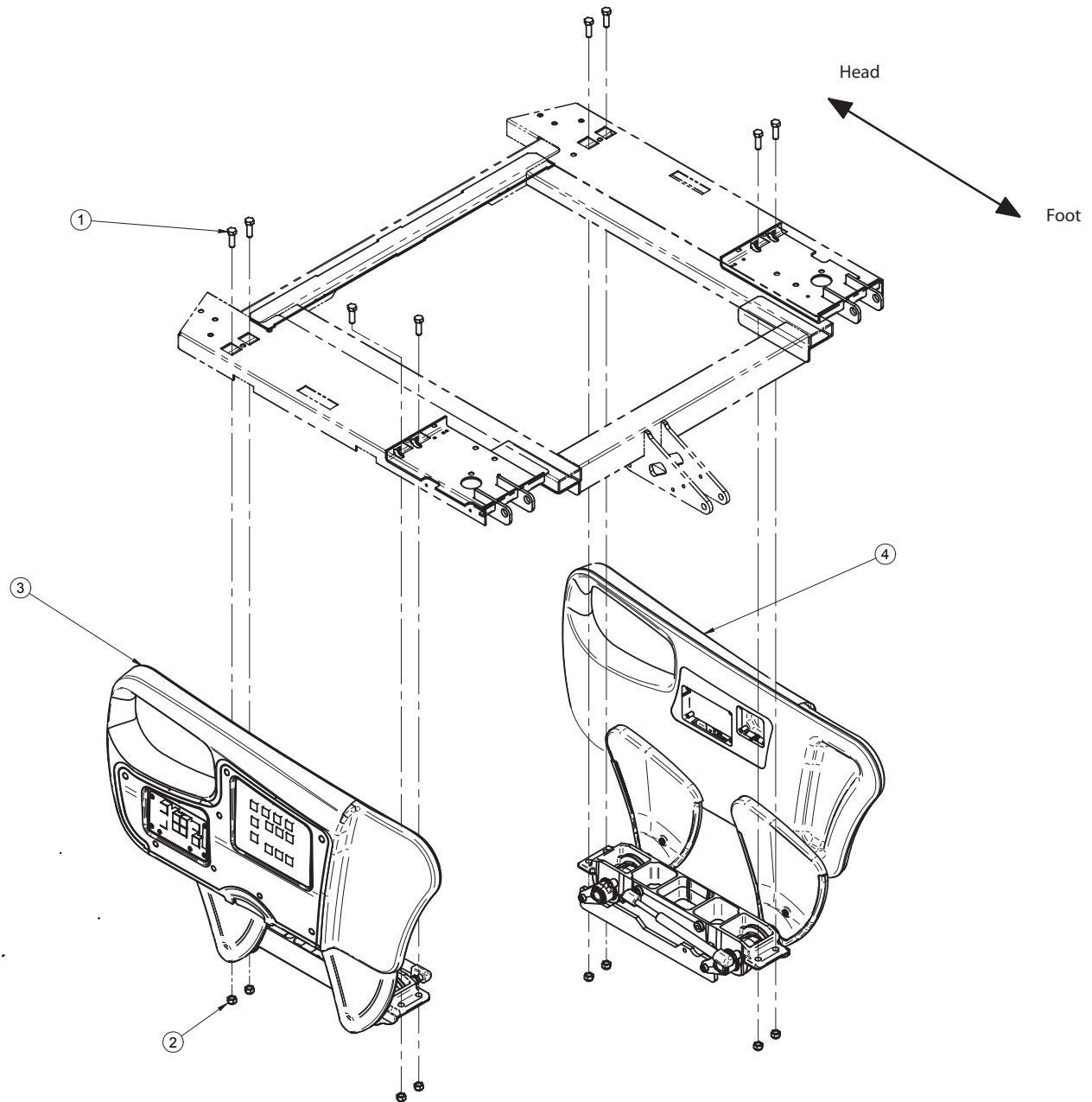

Item	Part No.	Part Name	Qty.
1	VB18A1O32	Bolt	8
2	VE30A1O	Nylon Locknut	8
3	27-2287	Head End Siderail, Right	1
4	27-2288	Head End Siderail, Left	1

# Standard Siderail Assembly, Head End, Right

27-2287 Rev-04 (Reference Only)

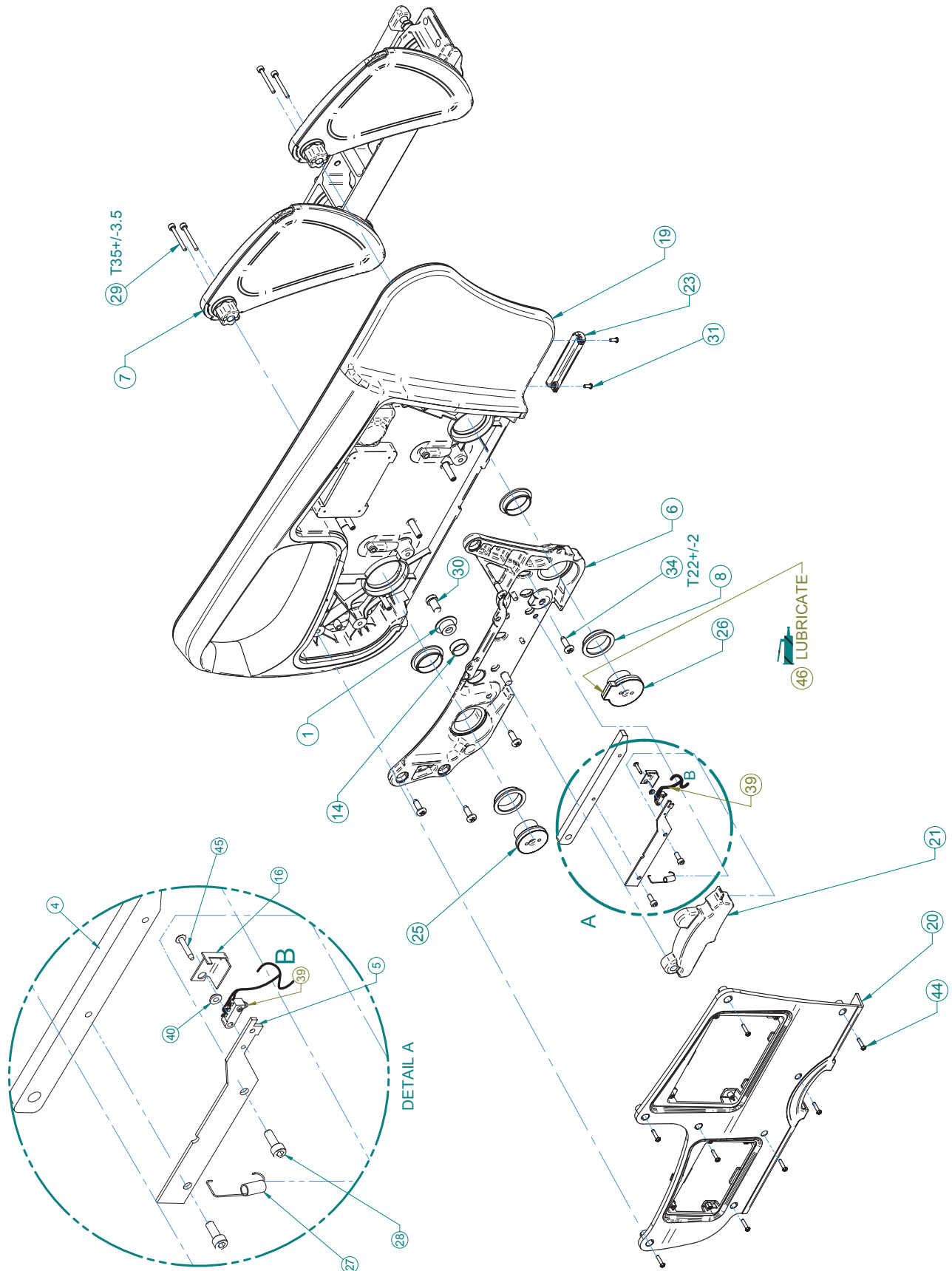

[Return To Table of Contents](#)

# Standard Siderail Assembly, Head End, Right

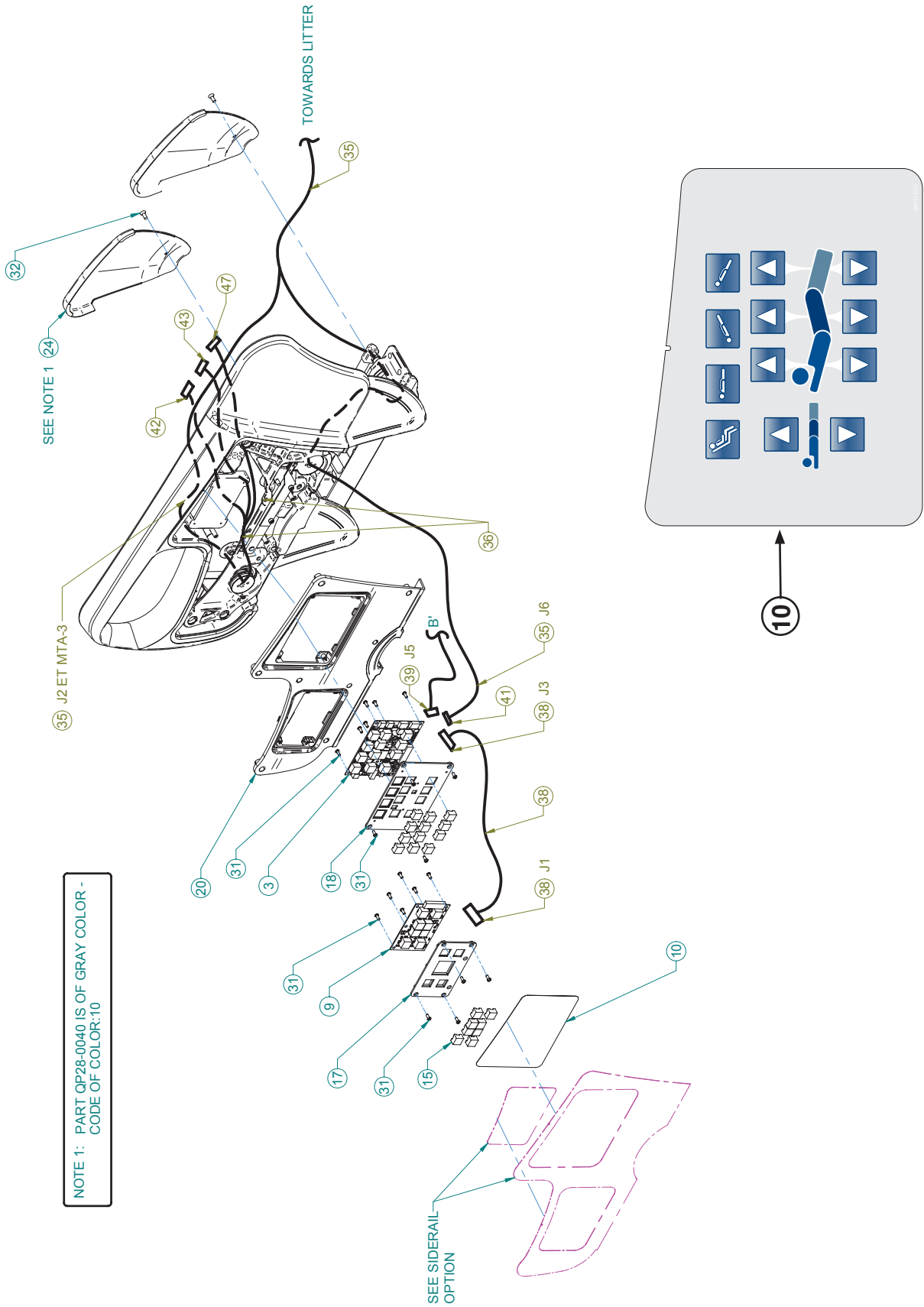

# Standard Siderail Assembly, Head End, Right

POSITION ON CONNECTOR						
Cable	Position on Connector	Position on Connector	Position on Connector	Position on Connector	Signal	Color
36	47	41	43	42		
1	-	1	-	-	"CAN H"	Black / Red
2	-	2	-	-	"CAN L"	Red
3	-	3	-	-	+12V	Black / White
4	-	4	-	-	"GND"	White
5	-	5	-	-	"SAFE"	Black / Green
6	-	6	-	-	+24V	Green
-	-	-	-	-	Audioshield	-
1	-	-	1	-	"SPK HIGH"	Black
2	-	-	2	-	"SPK COM"	White
1	-	-	-	1	N.O.	Red
2	-	-	-	2	COM	Green
3	-	-	-	3	N.C.	Brown
1	1	-	-	-	Speaker	Blue
2	2	-	-	-	Speaker	Orange

DIP SWITCH SETUP ON QDF27-1099			
SW13	ON	ON	ON
SW14	ON	ON	-

CABLES CONNECTION TABLE				
Cable No.	Connector No.	To	Cable No.	Connector No.
QDF27-1681	MTA – 3 Positions	To	QDF27-1099	J5
QDF27-1156	MTA – 6 Positions	To	QDF27-1099	J3
QDF27-1156	MTA – 6 Positions	To	QDF27-1097	J1
QDF27-1784	MTA – 3 Positions	To	QDF27-2212	MTA-2 Positions
QDF27-2212	Mate N Lock 12 Positions	To	QDF27-2213	J105 (L27-038)
QDF27-2212	MTA – 6 Positions	To	QDF27-1099	J6
QDF27-2212	MTA – 3 Positions	To	See OL270162, OL270163, OL270164, OL270173, OL270174, OL270175	
QDF27-2212	MTA – 2 Positions	To		
QDF27-2212	Connector 2 Pins	To		
QDF27-2212	Connector 2 Pins	To		

# Standard Siderail Assembly, Head End, Right

## Standard Siderail Assembly, Head End, Right - 27-2287 Rev-04 (Reference Only)

Item	Part No.	Part Name	Qty.
1	QPA28-0493	Siderail Sleeve	1
3	QDF27-1099	Siderail Nurse Control Board	1
4	QDF27-2574Z	Siderail Lock	1
5	27-2575Z	Siderail Switch Support	1
6	QPA27-2295	Right Head Siderail Structure	1
7	27-2061W	Reversed Siderail Mechanism S.A.	1
8	QDF2049	Shoulder Spacer	4
9	QDF27-1097	Brake Control Board	1
10	QDF27-2237	Right Head Nurse Control Fascia	1
14	QDF28-0491	Machined Spacer QDF9191	1
15	QDF9183	Electronic Board Button	20
16	27-2292Z	Switch Guide 2	1
17	QP27-1109-10	Brake Board Support	1
18	QP27-1111	Nurse Control Board Support	1
19	QP27-2225-05	Right Head Siderail	1
20	QP27-1265-05	Right Head Siderail Cover	1
21	QP27-1273-08	Right Siderail Handle	1
23	QP27-1496-05	Head Siderail Cap	1
24	QP28-0040-10	Reversed Siderail Arm Cover	2
25	QPA28-0015	Siderail Sleeve	1
26	QPA28-0016	Sleeve with Lock	1
27	QRE27-1736	Return Spring	1
28	VV10A0G16-S	Cylinder Head Screw	2
29	VV10B0G40-S	Cylinder Head Screw	4
30	VV10A1P20-S	Cylinder Head Screw	1
31	VV23A9C12HL	Phillips Screw	22
32	VV31A0G16	Phillips Machine Screw	2
34	VVB3A9N24PF	Bosscrew Screw	5
35*	QDF27-2212	Head Siderail Wire	1
36*	QDF9518	Cable Tie	2
38*	QDF27-1156	Brake Board Cable	1
39*	QDF27-1521	Siderail Limit Switch	1
40	27-1839	Spacer Washer	1
41*	QDF2088	6 Positions Polarized Connector	1
42*	QDF9028	3 Positions Connector	1
43*	QDF2087	2 Positions Connector	1
44	VV23A9C20HL	Phillips Screw	8
45	VV87A9A20	Phillips Screw	1
46*	M0019	OG 2 Grade Grease	1
47*	QDF2127	2 Pins Connector	1

# Standard Siderail Assembly, Head End, Left

27-2288 Rev-04 (Reference Only)

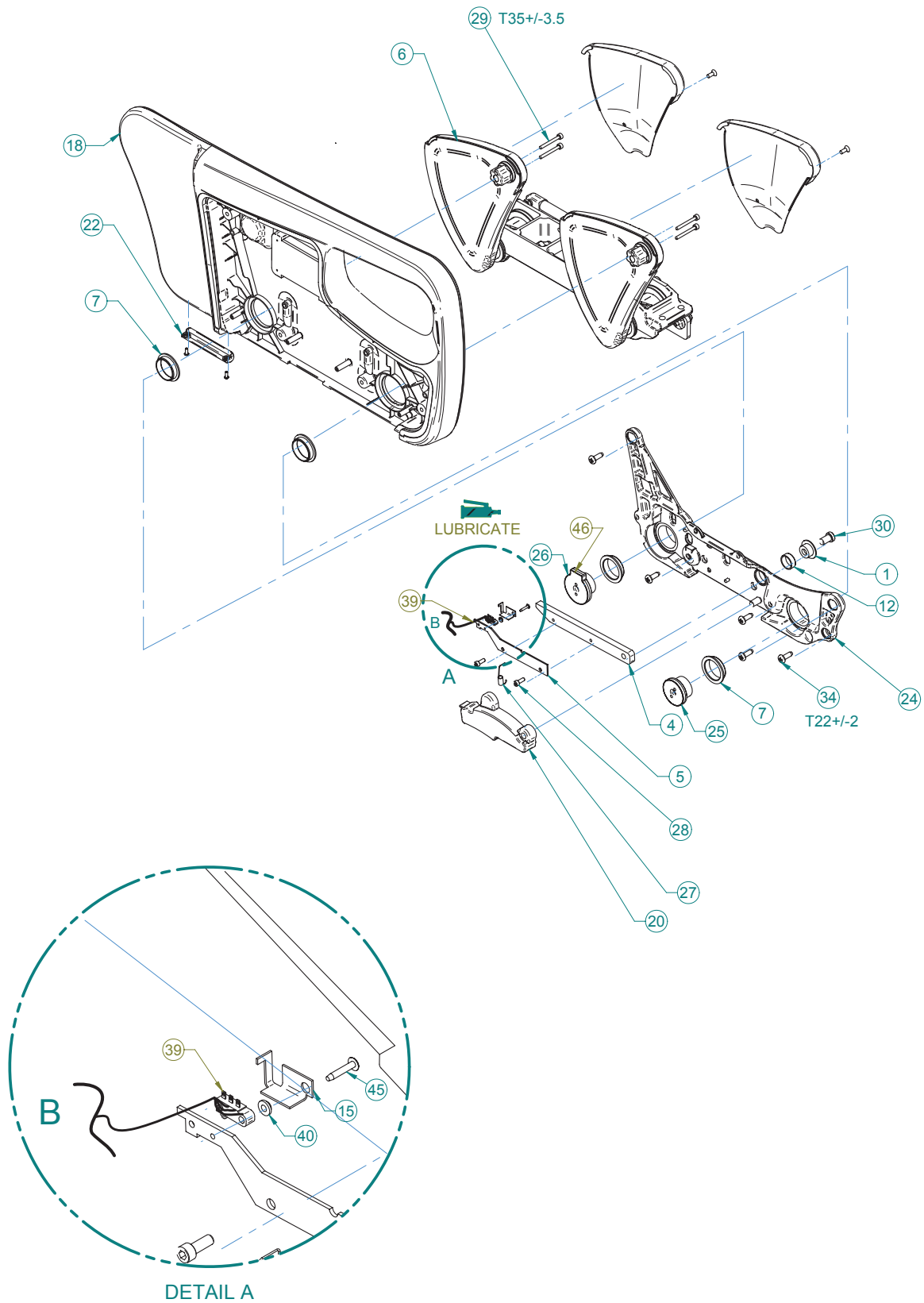

[Return To Table of Contents](#)

# Standard Siderail Assembly, Head End, Left

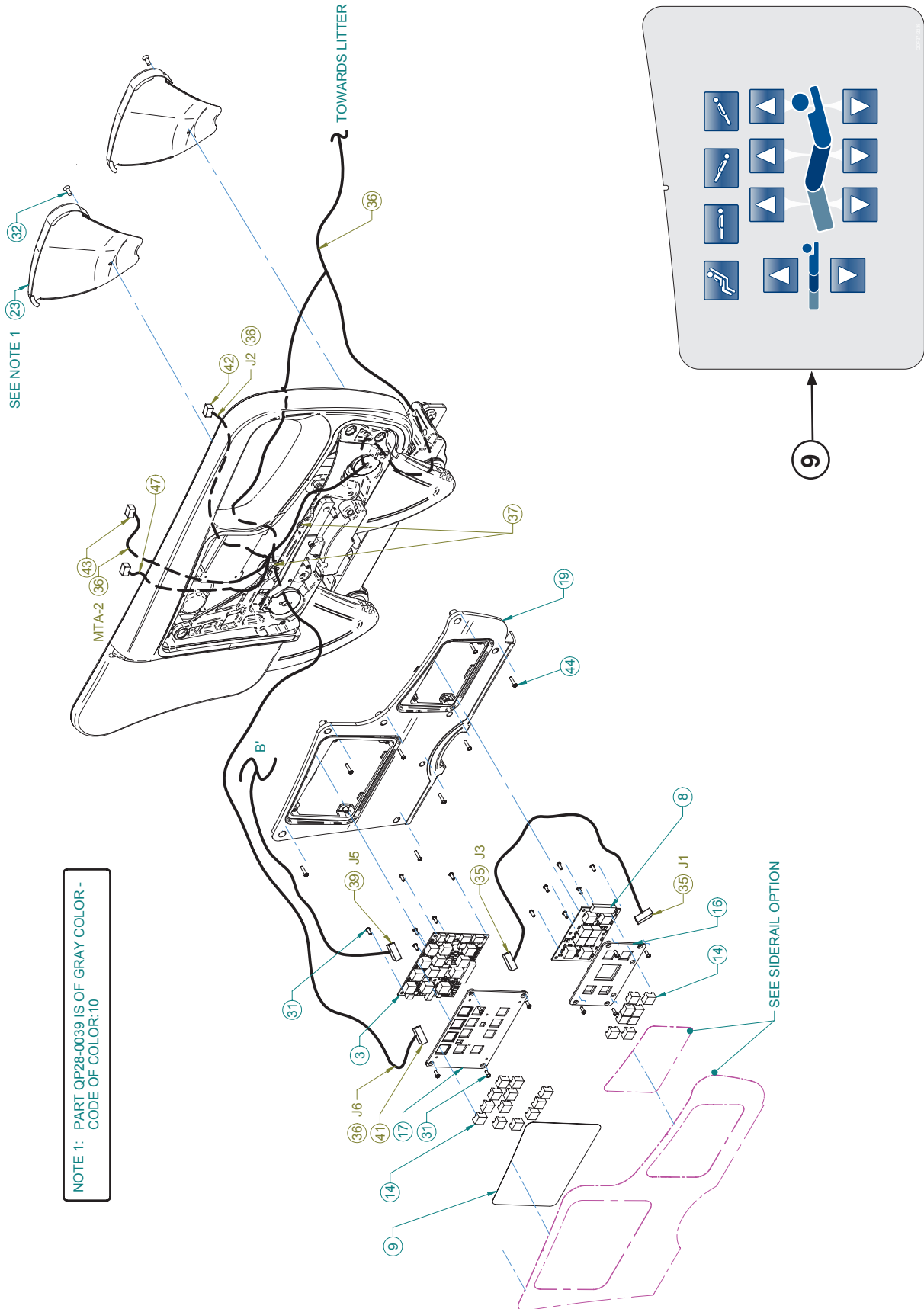



# Standard Siderail Assembly, Head End, Left

POSITION ON CONNECTOR						
Cable	Position on Connector	Position on Connector	Position on Connector	Position on Connector	Signal	Color
36	47	41	43	42		
1	-	1	-	-	"CAN H"	Black / Red
2	-	2	-	-	"CAN L"	Red
3	-	3	-	-	+12V	Black / White
4	-	4	-	-	"GND"	White
5	-	5	-	-	"SAFE"	Black / Green
6	-	6	-	-	+24V	Green
-	-	-	-	-	Audioshield	-
1	-	-	1	-	"SPK HIGH"	Black
2	-	-	2	-	"SPK COM"	White
1	-	-	-	1	N.O.	Red
2	-	-	-	2	COM	Green
3	-	-	-	3	N.C.	Brown
1	1	-	-	-	Speaker	Blue
2	2	-	-	-	Speaker	Orange

DIP SWITCH SETUP ON QDF27-1099			
SW13	OFF	ON	ON
SW14	OFF	OFF	-

CABLES CONNECTION TABLE				
Cable No.	Connector No.	To	Cable No.	Connector No.
QDF27-1681	MTA – 3 Positions	To	QDF27-1099	J5
QDF27-1156	MTA – 6 Positions	To	QDF27-1099	J3
QDF27-1156	MTA – 6 Positions	To	QDF27-1097	J1
QDF27-1784	MTA – 3 Positions	To	QDF27-2212	MTA-2 Positions
QDF27-2212	Mate N Lock 12 Positions	To	QDF27-2213	J105 (L27-038)
QDF27-2212	MTA – 6 Positions	To	QDF27-1099	J6
QDF27-2212	MTA – 3 Positions	To	See OL270162 OL270163, OL270164, OL270173, OL270174, OL270175	
QDF27-2212	MTA – 2 Positions	To		
QDF27-2212	Connector 2 Pins	To		

# Standard Siderail Assembly, Head End, Left

---

## Standard Siderail Assembly, Head End, Left - 27-2288 Rev-04 (Reference Only)

Item	Part No.	Part Name	Qty.
1	QPA28-0493	Siderail Sleeve	1
3	QDF27-1099	Siderail Nurse Control Board	1
4	QDF27-2574Z	Siderail Lock	1
5	27-2575Z	Switch Support	1
6	27-2060W	Siderail Mechanics S.A.	1
7	QDF2049	Spacer	4
8	QDF27-1097	Brake Control Board	1
9	QDF27-2238	Left Head Nurse Control Fascia	1
12	QDF28-0491	Machining Spacer QDF9191	1
14	QDF9183	Electronic Board Button	20
15	27-2293Z	Switch Guide 1	1
16	QP27-1109-10	Brake Board Support	1
17	QP27-1111	Nurse Control Board Support	1
18	QP27-2226-05	Left Head Siderail	1
19	QP27-1266 -05	Left Head Siderail Cover	1
20	QP27-1274-08	Left Siderail Handle	1
22	QP27-1496-05	Head Siderail Cap	1
23	QP28-0039-10	Siderail Rotation Lever Cover	2
24	QPA27-2296	Left Head Siderail Structure	1
25	QPA28-0015	Siderail Sleeve	1
26	QPA28-0016	Sleeve with Lock	1
27	QRE27-1736	Spring Balance	1
28	VV10A0G16-S	Hexagon Socket Head Screw	2
29	VV10B0G40-S	Hexagon Socket Head Screw	4
30	VV10A1P20-S	Hexagon Socket Head Screw	1
31	VV23A9C12HL	Pan Hd. Screw Type Hi-Lo	22
32	VV31A0G16	Flat Hd. Machine Screw	2
34	VVB3A9N24PF	Bosscrew Screw	5
35*	QDF27-1156	Brake Board Cable	1
36*	QDF27-2212	Head Siderail Wire	1
37*	QDF9518	Cable Tie	1
39*	QDF27-1521	Siderail Limit Switch S.A.	1
40	27-1839	Side Ring	1
41*	QDF2088	Polarized 6-Position Connector	1
42*	QDF9028	3-Position Connector	1
43*	QDF2087	2-Position Connector	1
44	VV23A9C20HL	Pan Head hi-Low Screw	8
45	VV87A9A20	Truss Head Tapping Screw	1
46*	M0019	OG2 Grade Grease	1
47*	QDF2127	2 Pins Connector	1

# Standard Siderail Assembly, Labeling

OL270180-XXX Rev-02 (Reference Only)

Head End Right

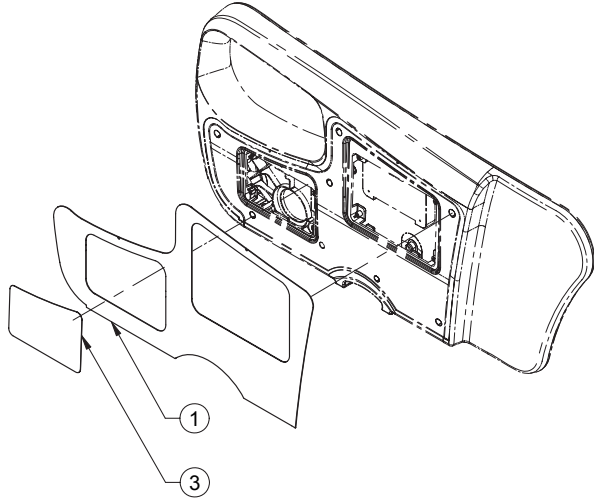

Head End Left

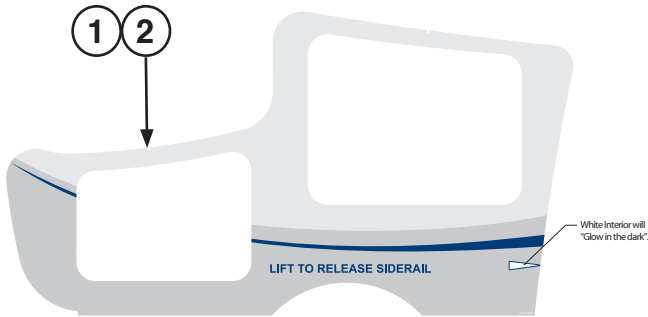
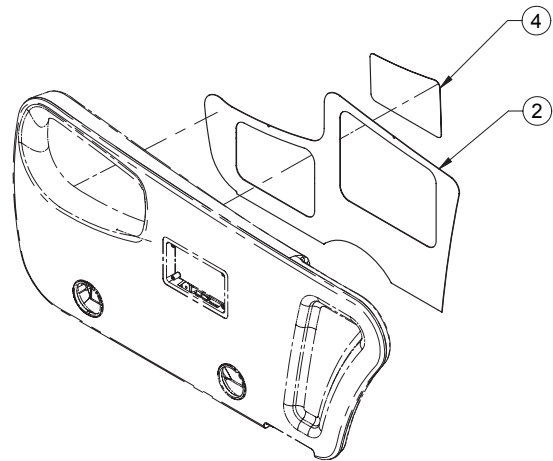

Right label shown (QDF27-0906)

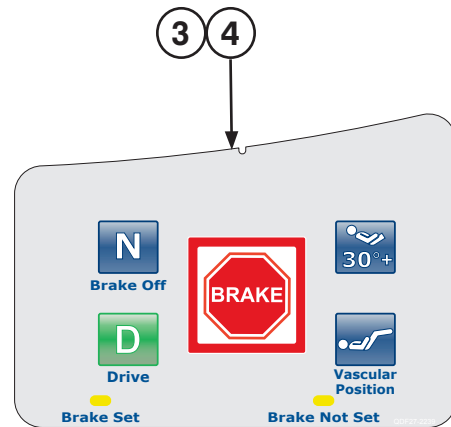

Right label shown (QDF27-2239)

**NOTE:** XXX - indicates language choice (tri = English/French/Spanish; bil = English/French)

Item	Part No.	Part Name	Qty.
1	QDF27-0906-XXX	Nurse Control Label, HE, Right	1
2	QDF27-0907-XXX	Nurse Control Label, HE, Left	1
3	QDF27-2239-XXX	Brake Control Label, HE, Right	1
4	QDF27-2240-XXX	Brake Control Label, HE, Left	1

# Optional Siderail Assembly, Head End, with Speaker/iAudio

OL270308 Rev B (Reference Only)

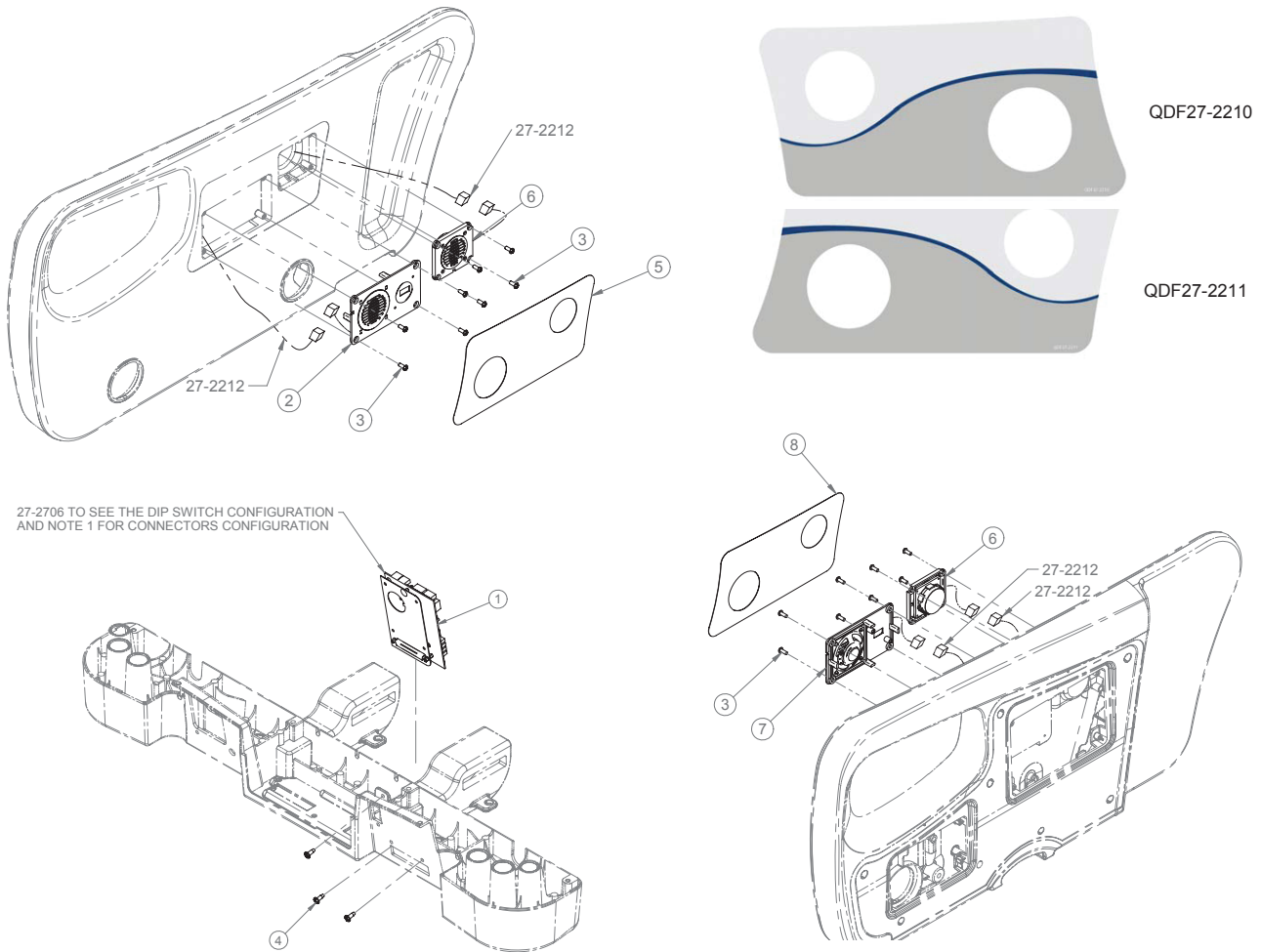

Cable No.	Cable Connection	To	Cable No.	Cable Connection
QDF27-2175	MTA-2 Positions	To	QDF27-2212	MTA-2 Positions (Standard Siderail Assembly, Head End, Left)
QDF27-2216	MTA-2 Positions	To	QDF27-2212	MTA-2 Positions (Standard Siderail Assembly, Head End, Right)
QDF27-2196	2 Position Conn.	To	QDF27-2212	(Standard Siderail Assembly, Head End, Left) and (Standard Siderail Assembly, Head End, Right)

## Optional Siderail Assembly, Head End, with Speaker/iAudio - OL270308 Rev B (Reference Only)

Item	Part No.	Part Name	Qty.
1	QDF75-0270	Room Interface Board	1
2	QDF27-2175	Siderail Speaker, Left	1
3	VV23A9C12HL	Pan Head Tapping Screw	16
4	VV83A9G16	Pan Head Tapping Screw	3
5	QDF27-2211	Label, Left Communications	1
6	QDF27-2196	Head Speaker	2
7	QDF27-2216	Siderail Speaker, Right	1
8	QDF27-2210	Label, Right Communications	1

# Optional Siderail Assembly, Head End, with Speaker/with NC/with iAudio

OL270311 Rev A (Reference Only)

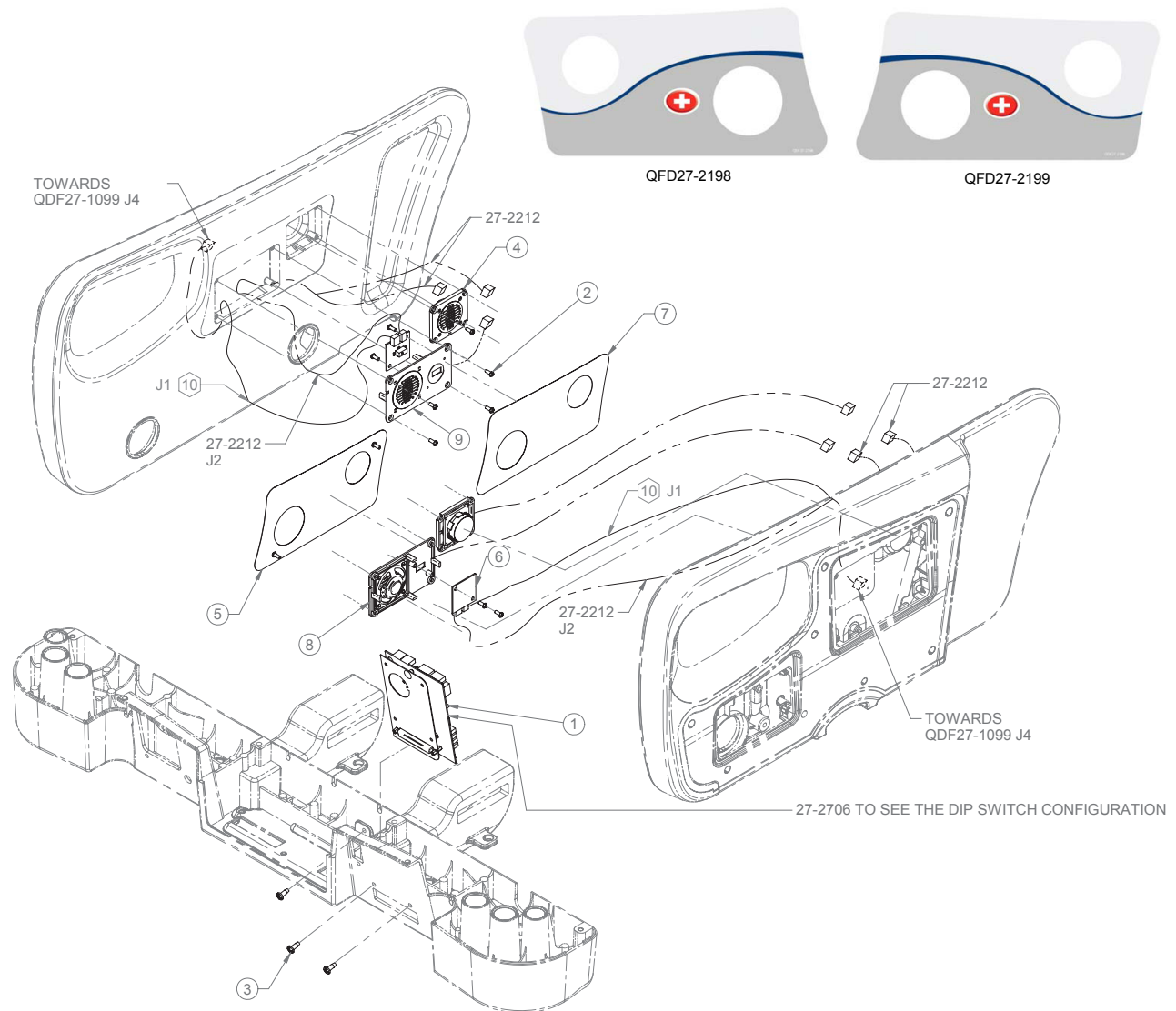

Cable No.	Cable Connection	To	Cable No.	Cable Connection
QDF27-2175	MTA-2 Positions	To	QDF27-2212	MTA-2 Positions (Standard Siderail Assembly, Head End, Left)
QDF27-1429	J1	To	QDF27-1682	MTA-3 Positions
QDF27-1429	J2	To	QDF27-1206	MTA-3 Positions (Standard Siderail Assembly, Head End, Left) and (Standard Siderail Assembly, Head End, Right)
QDF27-1682	MTA-3 Positions	To	QDF27-1429	J1
QDF27-1682	MTA-3 Positions	To	QDF27-1099	J4 (Standard Siderail Assembly, Head End, Left) and (Standard Siderail Assembly, Head End, Right)
QDF27-2216	MTA-2 Positions	To	QDF27-2212	MTA-2 Positions (Standard Siderail Assembly, Head End, Right)
QDF27-2196	2 Positions Conn.	To	QDF27-2212	(Standard Siderail Assembly, Head End, Left) and (Standard Siderail Assembly, Head End, Right)

[Return To Table of Contents](#)

## Optional Siderail Assembly, Head End, with Speaker/with NC/with iAudio

---

### Optional Siderail Assembly, HE, with Speaker/with NC/with iAudio - OL270311 Rev A (Reference Only)

Item	Part No.	Part Name	Qty.
1	QDF75-0270	Room Interface Board	1
2	VV23A9C12HL	Pan Head Tapping Screw	20
3	VV83A9G16	Pan Head Tapping Screw	3
4	QDF27-2196	Head Speaker	2
5	QDF27-2198	Nurse Call and Speaker Fascia, Right	1
6	QDF27-1429	Nurse Call Board	2
7	QDF27-2199	Nurse Call and Speaker Fascia, Left	1
8	QDF27-2216	Siderail Speaker, Right	1
9	QDF27-2175	Siderail Speaker, Left	1
10*	QDF27-1682	Siderail Nurse Call Wires	2

# Optional Siderail Assembly, Head End, with Speaker/*i*Audio/IR

OL270322 Rev B (Reference Only)

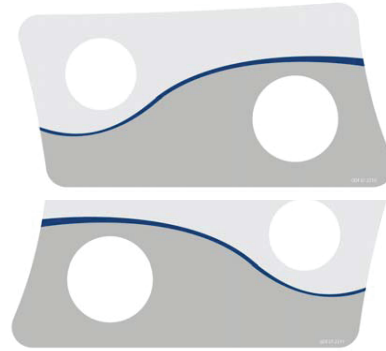
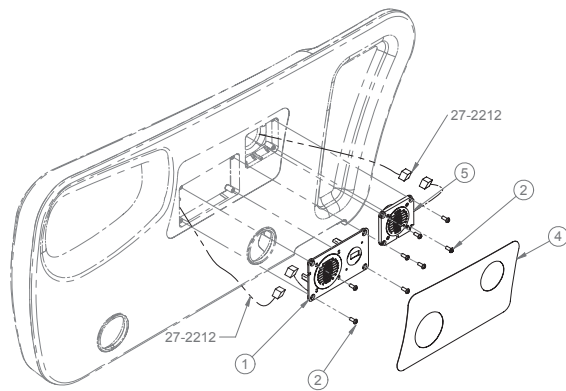

NOTE 1: MAKE SURE THAT A JUMPER OR A CONNECTOR IS PLUGGED ON J14 TO J16 OF QDF75-0270 BOARD. IF NO CONNECTOR IS PLUGGED, PUT A JUMPER ON PINS 2 AND 3 FOR J14 TO J16 OF QDF75-0600 BOARD.

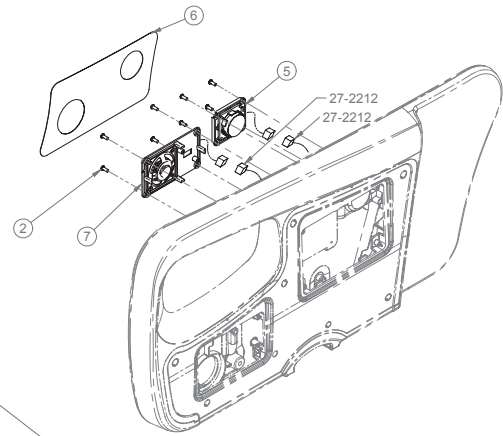
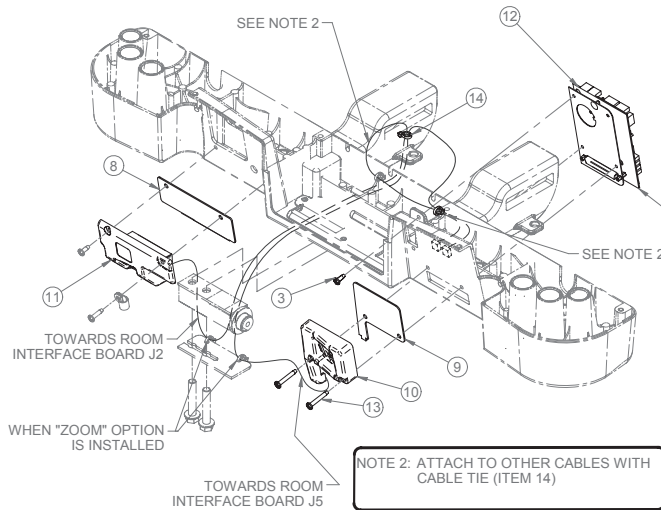

SEE 27-2706 FOR DIP SWITCH CONFIGURATION AND NOTE 1 FOR CONNECTORS CONFIGURATION

NOTE 2: ATTACH TO OTHER CABLES WITH CABLE TIE (ITEM 14)

Cable No.	Cable Connection	To	Cable No.	Cable Connection
QDF27-2175	MTA-2 Positions	To	QDF27-2212	MTA-2 Positions (Standard Siderail Assembly, Head End, Left)
QDF27-2216	MTA-2 Positions	To	QDF27-2212	MTA-2 Positions (Standard Siderail Assembly, Head End, Right)
QDF27-2196	2 Position Conn.	To	QDF27-2212	(Standard Siderail Assembly, Head End, Left) and (Standard Siderail Assembly, Head End, Right)

## Optional Siderail Assembly, Head End, with Speaker/*i*Audio/IR - OL270322 Rev B (Reference Only)

Item	Part No.	Part Name	Qty.	Item	Part No.	Part Name	Qty.
1	QDF27-2175	Siderail Speaker, Left	1	8	QP27-2735	IR Support Gasket, Left	1
2	VV23A9C12HL	Pan Head Tapping Screw	16	9	QP27-2734	IR Support Gasket, Right	1
3	VV83A9G16	Pan Head Tapping Screw	2	10	27-2662	IR Module, Right	1
4	QDF27-2211	Label, <i>i</i> Audio/Comm., Left	1	11	27-2661	IR Module, Left	1
5	QDF27-2196	Head Speaker	2	12	QDF75-0270	Room Interface Board	1
6	QDF27-2210	Label, <i>i</i> Audio/Comm., Right	1	13	VV83A9G36	Pan Head Phillips	2
7	QDF27-2216	Siderail Speaker, Right	1	14	QDF9518	Cable Tie	3

[Return To Table of Contents](#)



# Optional Siderail Assembly, Head End, with Speaker/with NC/ with *i*Audio/with *i*Bed® Wireless

OL270302 Rev B (Reference Only)

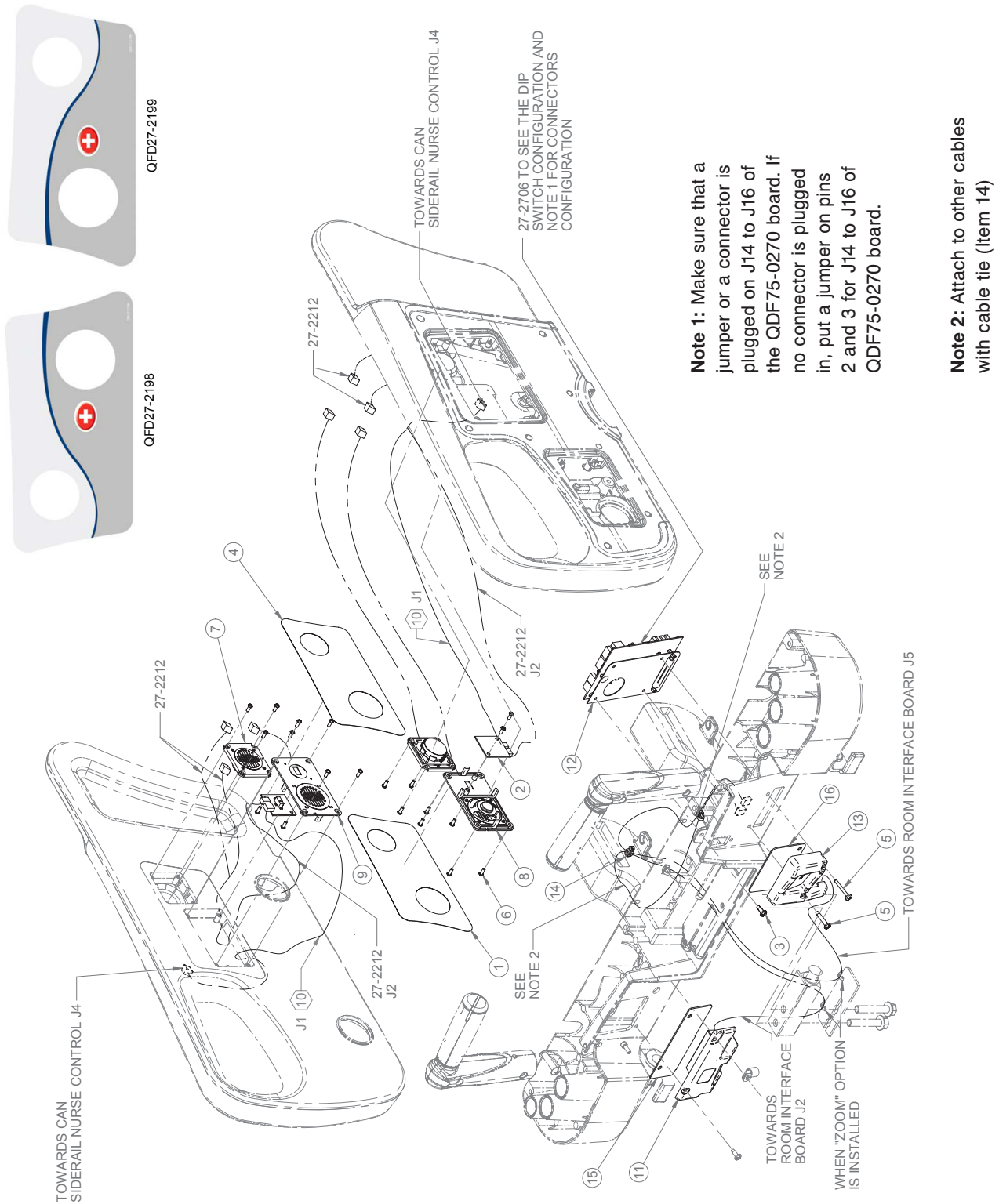



# Optional Siderail Assembly, Head End, with Speaker/with NC/ with *i*Audio/with *i*Bed® Wireless

## Path of IR Module Cables to the Room Interface Board

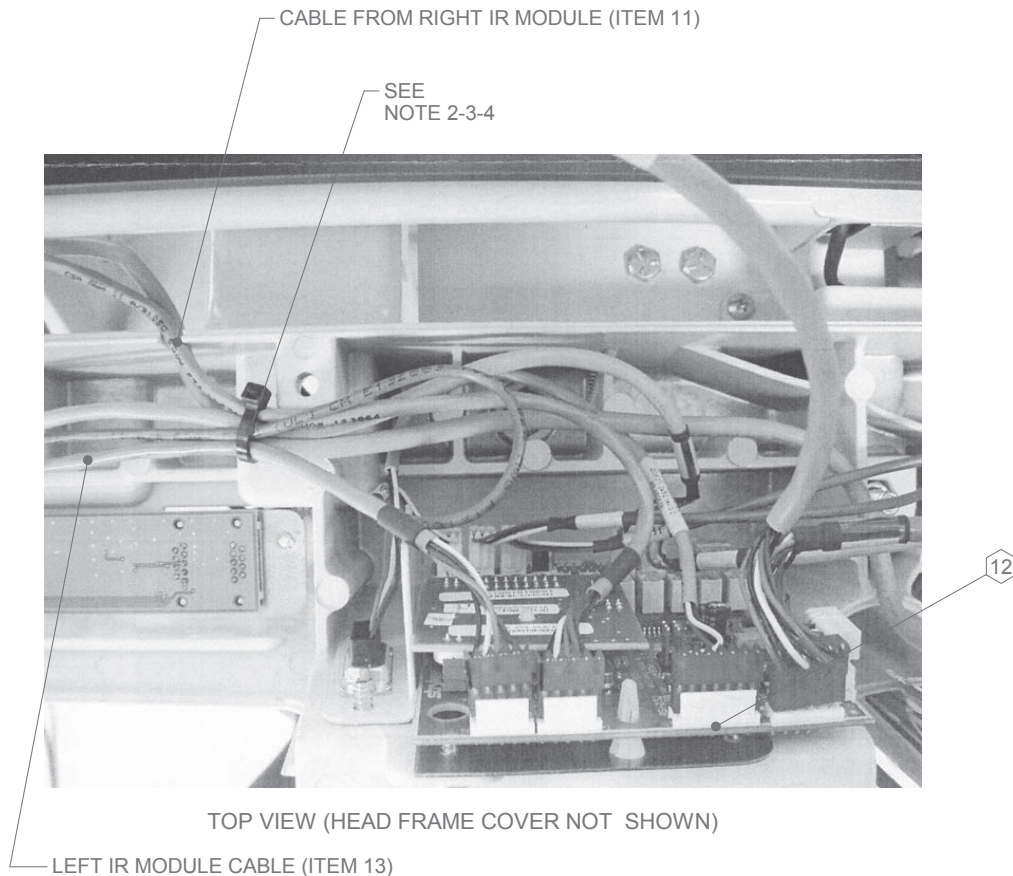
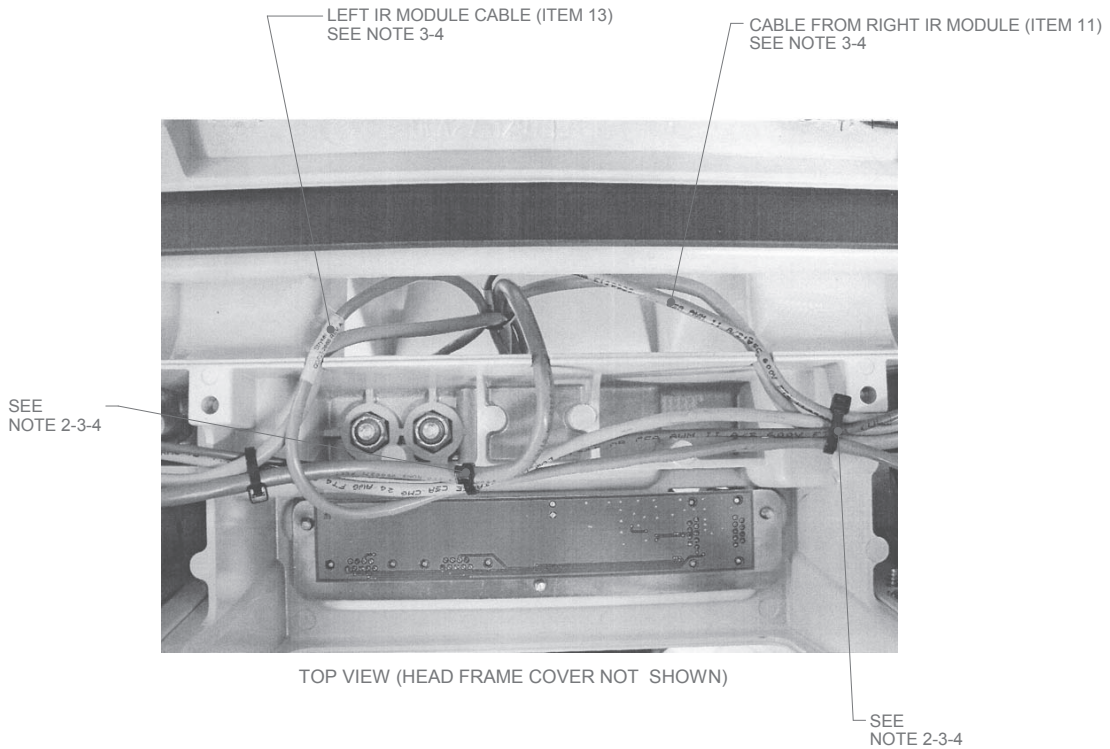

# Optional Siderail Assembly, Head End, with Speaker/with NC/ with *i*Audio/with *i*Bed® Wireless

## Path of IR Module Cables to the Room Interface Board

SEE  
NOTE 3

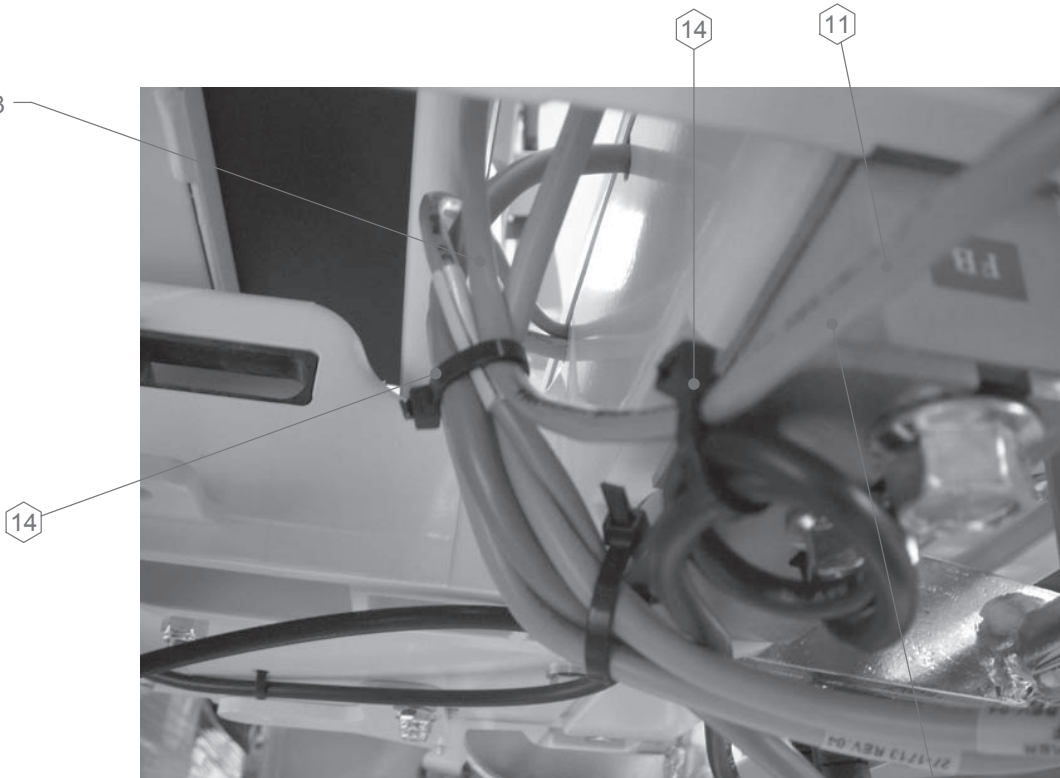

UNDER BED VIEW

SEE  
NOTE 3



UNDER BED VIEW

## Optional Siderail Assembly, Head End, with Speaker/with NC/ with *i*Audio/with *i*Bed® Wireless

Cable No.	Connector No.	To	Cable No.	Connector No.
QDF27-2175	MTA-2 Positions	To	QDF27-2212	MTA-2 Positions (Standard Siderail Assembly, Head End, Left)
QDF27-1429	J1	To	QDF27-1682	MTA-3 Positions
QDF27-1429	J2	To	QDF27-1206	MTA-3 Positions (Standard Siderail Assembly, Head End, Left) and (Standard Siderail Assembly, Head End, Right)
QDF27-1682	MTA-3 Positions	To	QDF27-1429	J1
QDF27-1682	MTA-3 Positions	To	QDF27-1099	J4 (Standard Siderail Assembly, Head End, Left) and (Standard Siderail Assembly, Head End, Right)
QDF27-2216	MTA-2 Positions	To	QDF27-2212	MTA-2 Positions (Standard Siderail Assembly, Head End, Right)
QDF27-2196	2 Positions Conn.	To	QDF27-2212	(Standard Siderail Assembly, Head End, Left) and (Standard Siderail Assembly, Head End, Right)

### Optional Siderail Assembly, Head End, with Speaker/with NC /with *i*Audio/with *i*Bed® Wireless - OL270302 Rev B (Reference Only)

Item	Part No.	Part Name	Qty.
1	QDF27-2198	<i>i</i> Audio Speaker and Nurse Call Overlay, Right	1
2	QDF27-1429	Nurse Call Board	2
3	VV83A9G16	Pan Head Tapping Screw	1
4	QDF27-2199	<i>i</i> Audio Speaker and Nurse Call Overlay, Left	1
5	VV83A9G36	Round Head Tapping Screw	2
6	VV23A9C12HL	Pan Head Tapping Screw	20
7	QDF27-2196	Head Speaker Cover	2
8	QDF27-2216	Right Siderail Speaker	1
9	QDF27-2175	Left Siderail Speaker	1
10	QDF27-1682	Siderail Nurse Call Wires	2
11	27-2661	IR Module, Left	1
12	QDF75-0270	Room Interface Board	1
13	27-2662	IR Module, Right	1
14	QDF9518	Cable Tie	3
15	QP27-2735	IR Support Gasket, Left	1
16	QP27-2734	IR Support Gasket, Right	1

# Siderail Mounting Assembly, Foot End

L27-032 Rev-02 (Reference Only)

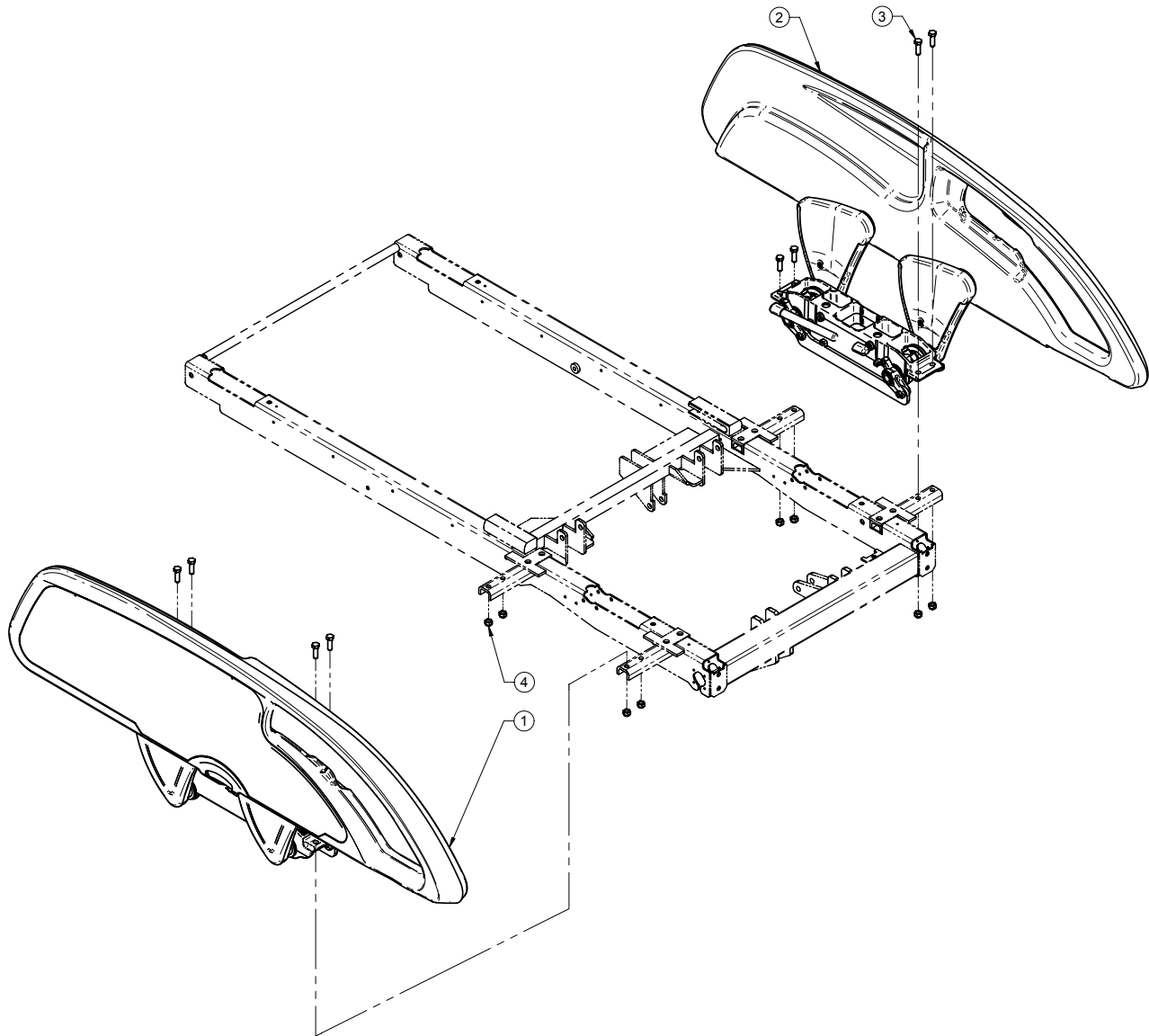

Item	Part No.	Part Name	Qty.
1	27-2289	Right Foot Siderail Assembly	1
2	27-2290	Left Foot Siderail Assembly	1
3	VB18A1O32	Bolt	8
4	VE30A1O	Nylon Locknut	8

# Standard Siderail Assembly, Foot End, Right

27-2289 Rev-03 (Reference Only)

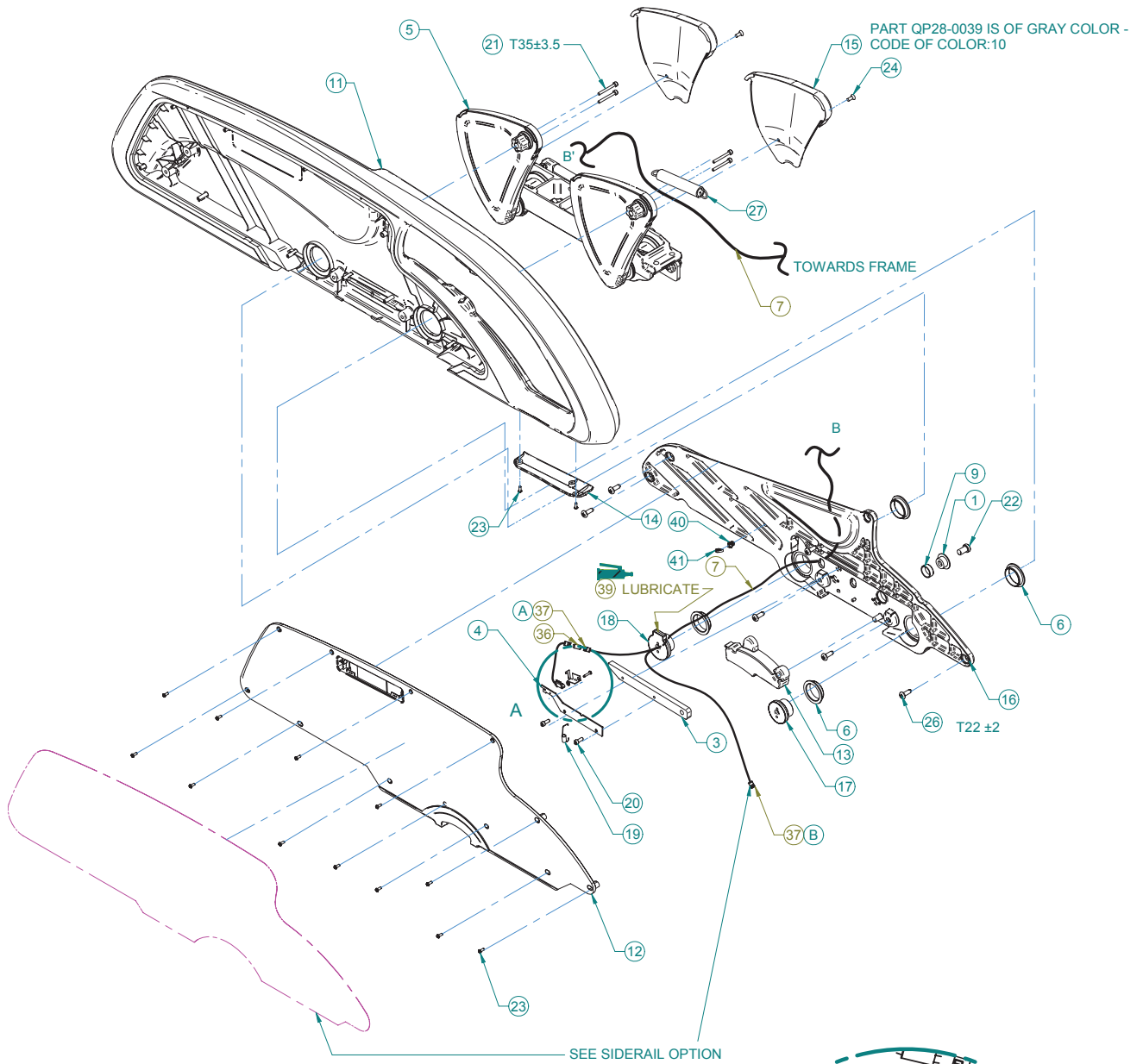

## RACEWAY

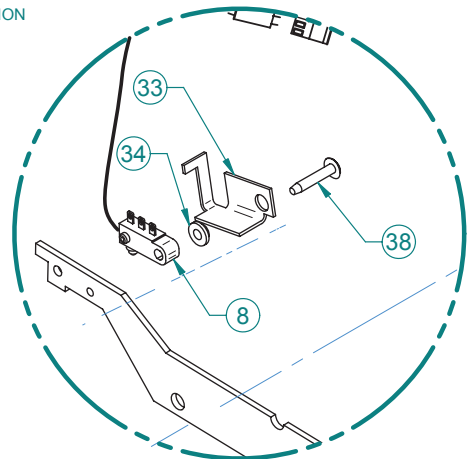
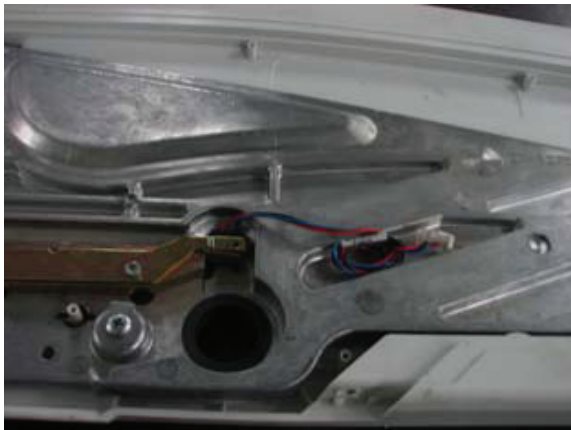

DETAIL A

[Return To Table of Contents](#)

## Standard Siderail Assembly, Foot End, Right

POSITION ON CONNECTOR			
Cable No.	Connector No.	Cable No.	Connector No.
QDF27-1521	MTA-100 3 Positions	QDF27-1208	MTA-100 3 Positions
QDF27-1208	MTA-100 3 Positions	QDF27-1521	MTA-100 3 Positions
QDF27-1208	Mate N Lock 3 Positions	QDF27-1481	J172 (L27-029)

POSITION ON CONNECTOR				
Cable QDF27-1208 ⑦	Signal	Color	Position on Connector ③⑦ A	Position on Connector ③⑦ B
1	NO SWITCH	White	1	-
2	COM SWITCH	Black	2	-
3	NC SWITCH	Green	3	-
4	LED1 LBS	Orange	-	1
5	+12V	Red	-	3
6	LED2 LBS	Blue	-	2

**Note 1:**

Siderail **without iBed** option - See OL270059-XXX ([page 197](#)).

Siderail **with iBed** option - See OL270060-XXX ([page 198](#)).



# Standard Siderail Assembly, Foot End, Right

## Standard Siderail Assembly, Foot End, Right - 27-2289 Rev-03 (Reference Only)

Item	Part No.	Part Name	Qty.
1	QPA28-0493	Siderail Sleeve	1
3	QDF27-2574Z	Siderail Lock	1
4	27-2575Z	Switch Support	1
5	27-2060	S.A. Siderail Mechanism	1
6	QDF2049	Shoulder Spacing	4
7	QDF27-1208	Foot Siderail Limit Switch Cable	1
8	QDF27-1521	S.A. Siderail Switch	1
9	28-0491	Machined Spacer QDF9191	1
11	QP27-1263	Right Foot Siderail	1
12	QP27-1267	Right Foot Siderail Cover	1
13	QP27-1274	Left Siderail Handle	1
14	QP27-1508	Right Foot Siderail Cap	1
15	QP28-0039	Siderail Rotation Arm Cover	2
16	QPA27-2297	Right Foot Siderail Structure	1
17	QPA28-0015	Siderail Sleeve	1
18	QPA28-0016	Sleeve with Lock	1
19	QRE27-1736	Return Spring	1
20	VV10A0G16-S	Hexagon Cylindric Head Screw	2
21	VV10B0G40-S	Hexagon Cylindric Head Screw	4
22	VV10A1P20-S	Hexagon Cylindric Head Screw	1
23	VV23A9C12HL	Phillips Pan Head Screw	15
24	VV31A0G16	Phillips Flat Head Screw	2
26	VVB3A9N24PF	Bosscrew Screw	6
27	QRE28-0293	Siderail Tension Spring,	1
33	27-2293Z	Switch Guide 1	1
34	27-1839	Shoulder Washer	1
36	QDF2080	Inline Splice	1
37	QDF2099	Female Connector MTA-100 3 Positions	2
38	VV87A9A20	Phillips Truss Head Tapping Screw	1
39	M0019	Grease	1
40	QDF5096	Plastic Tie Support	1
41	QDF9518	Cable Tie	1

# Standard Siderail Assembly, Foot End, Left

27-2290 Rev-03 (Reference Only)

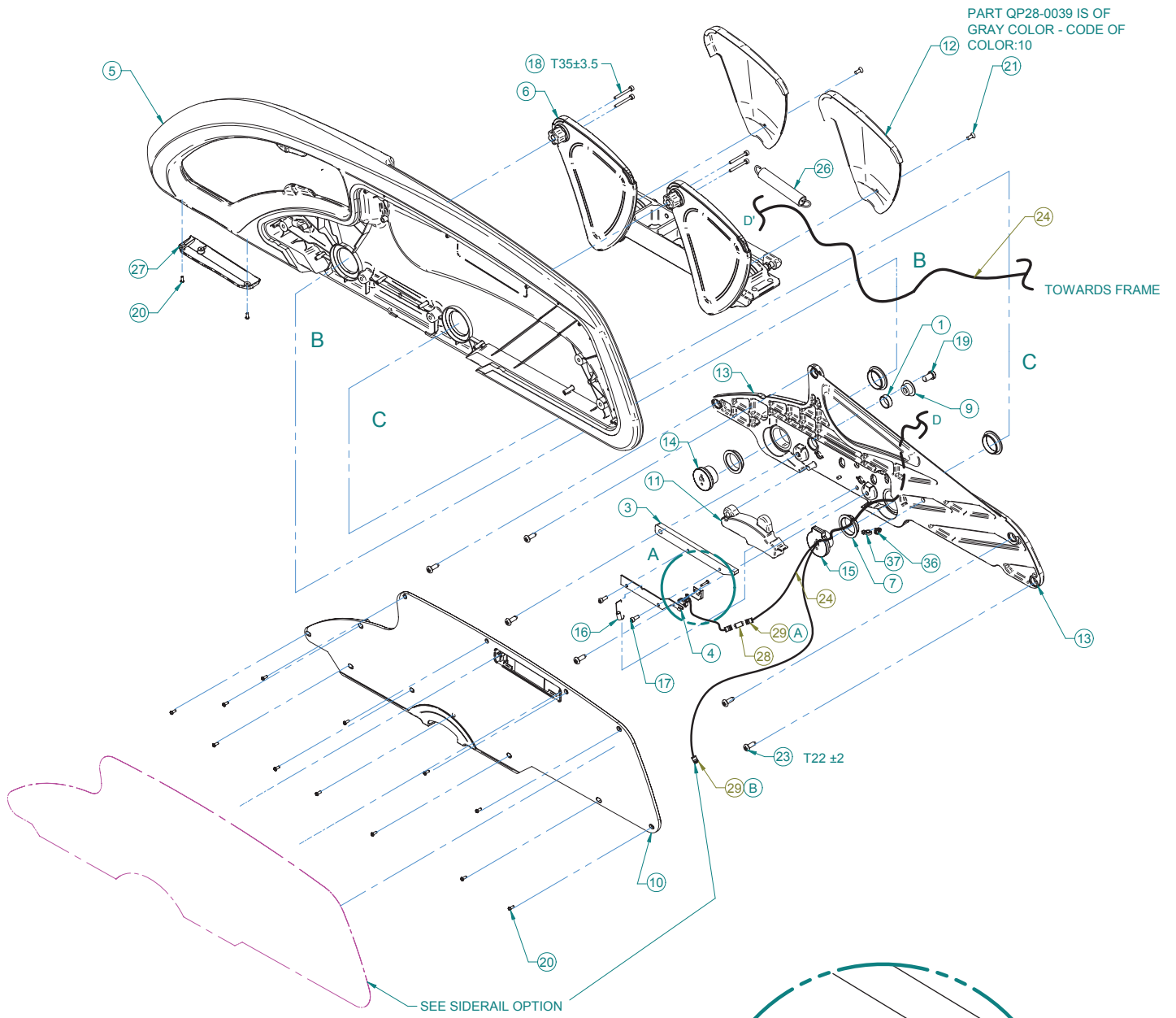

## RACEWAY

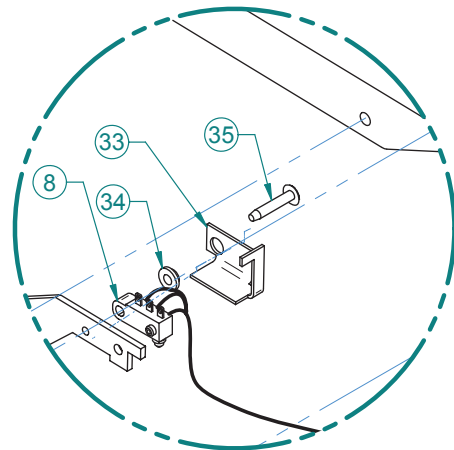

DETAIL A



## Standard Siderail Assembly, Foot End, Left

POSITION ON CONNECTOR			
Cable No.	Connector No.	Cable No.	Connector No.
QDF27-1521	MTA-100 3 Positions	QDF27-1208	MTA-100 3 Positions
QDF27-1208	MTA-100 3 Positions	QDF27-1521	MTA-100 3 Positions
QDF27-1208	Mate N Lock 3 Positions	QDF27-1481	J171 (L27-029)

POSITION ON CONNECTOR				
Cable QDF27-1208 <b>(24)</b>	Signal	Color	Position on Connector <b>(29) (A)</b>	Position on Connector <b>(29) (B)</b>
1	NO SWITCH	White	1	-
2	COM SWITCH	Black	2	-
3	NC SWITCH	Green	3	-
4	LED1 LBS	Orange	-	1
5	+12V	Red	-	3
6	LED2 LBS	Blue	-	2

**Note 1:**

Siderail **without iBed** option - See OL270059-XXX ([page 197](#)).

Siderail **with iBed** option - See OL270060-XXX ([page 198](#)).

# Standard Siderail Assembly, Foot End, Left

---

## Standard Siderail Assembly, Foot End, Left - 27-2290 Rev-03 (Reference Only)

Item	Part No.	Part Name	Qty.
1	QDF28-0491	Machined Spacer QDF9191	1
3	QDF27-2574Z	Siderail Lock	1
4	27-2575Z	Switch Support	1
5	QP27-1264	Left Foot Siderail	1
6	27-2061	S.A. Reversed Siderail Mechanism	1
7	QDF2049	Shoulder Spacer	4
8	QDF27-1521	S.A. Siderail Switch	1
9	QPA28-0493	Siderail Sleeve	1
10	QP27-1268	Left Foot Siderail Cover	1
11	QP27-1273	Right Siderail Handle	1
12	QP28-0040	Reversed Siderail Arm Cover	2
13	QPA27-2298	Foot Left Siderail Casting	1
14	QPA28-0015	Siderail Sleeve	1
15	QPA28-0016	Sleeve with Lock	1
16	QRE27-1736	Return Spring	1
17	VV10A0G16-S	Hexagon Cylindric Head Screw	2
18	VV10B0G40-S	Hexagon Cylindric Head Screw	4
19	VV10A1P20-S	Hexagon Cylindric Head Screw	1
20	VV23A9C12HL	Phillips Pan Head Screw	15
21	VV31A0G16	Phillips Flat Head Screw	2
23	VVB3A9N24PF	Bosscrew Screw	6
24	QDF27-1208	Foot Siderail Limit Switch Cable	1
26	QRE28-0293	Siderail Tension Spring, K11	1
27	QP27-1509-05	Left Foot Siderail Cap	1
28	QDF2080	Inline Splice	1
29	QDF2099	Female Connector MTA-100	
		3 Positions	2
33	27-2292Z	Switch Guide 2	1
34	27-1839	Shoulder Washer	1
35	VV87A9A20	Phillips Tapping Screw	1
36	QDF5096	Plastic Tie Support	1
37	QDF9518	Cable Tie	1

# Standard Siderail Assembly without iBed

OL270059-XXX Rev-05 (Reference Only)

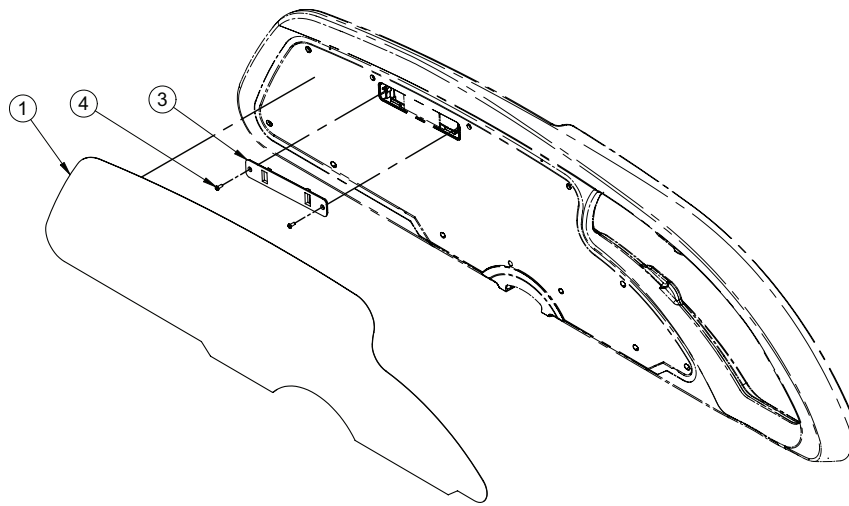

**Right Siderail Shown**

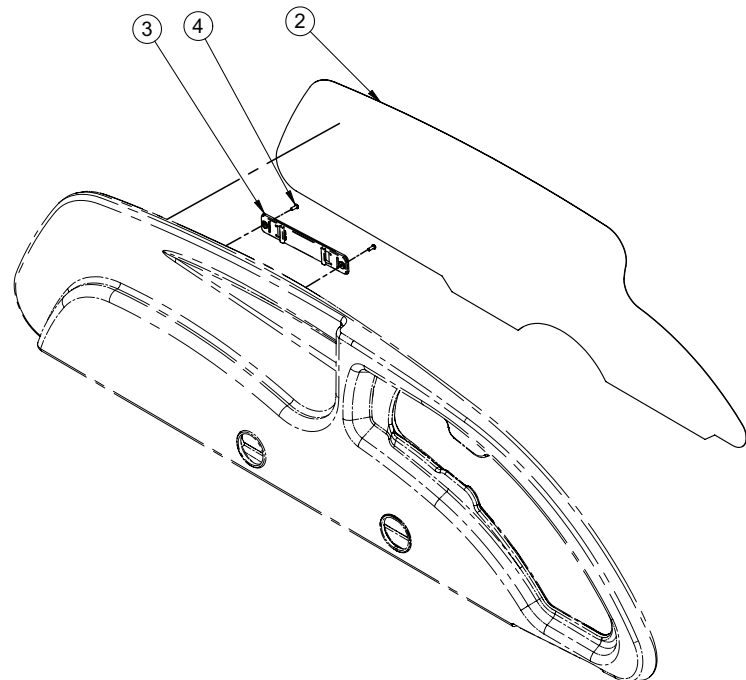

**Left Siderail Shown**

**NOTE:** XXX - indicates language choice (tri = English/French/Spanish; bil = English/French)

Item	Part No.	Part Name	Qty.
1	QDF27-0909-XXX	Right Foot Siderail Cover Fascia	1
2	QDF27-0910-XXX	Left Foot Siderail Cover Fascia	1
3	QP27-1831	LBS Lens Foot Siderail	2
4	VV23A9C12HL	Pan Head Tapping Screw	4

[Return To Table of Contents](#)

# Optional Siderail Assembly with *i*Bed

OL270060-XXX Rev-04 (Reference Only)

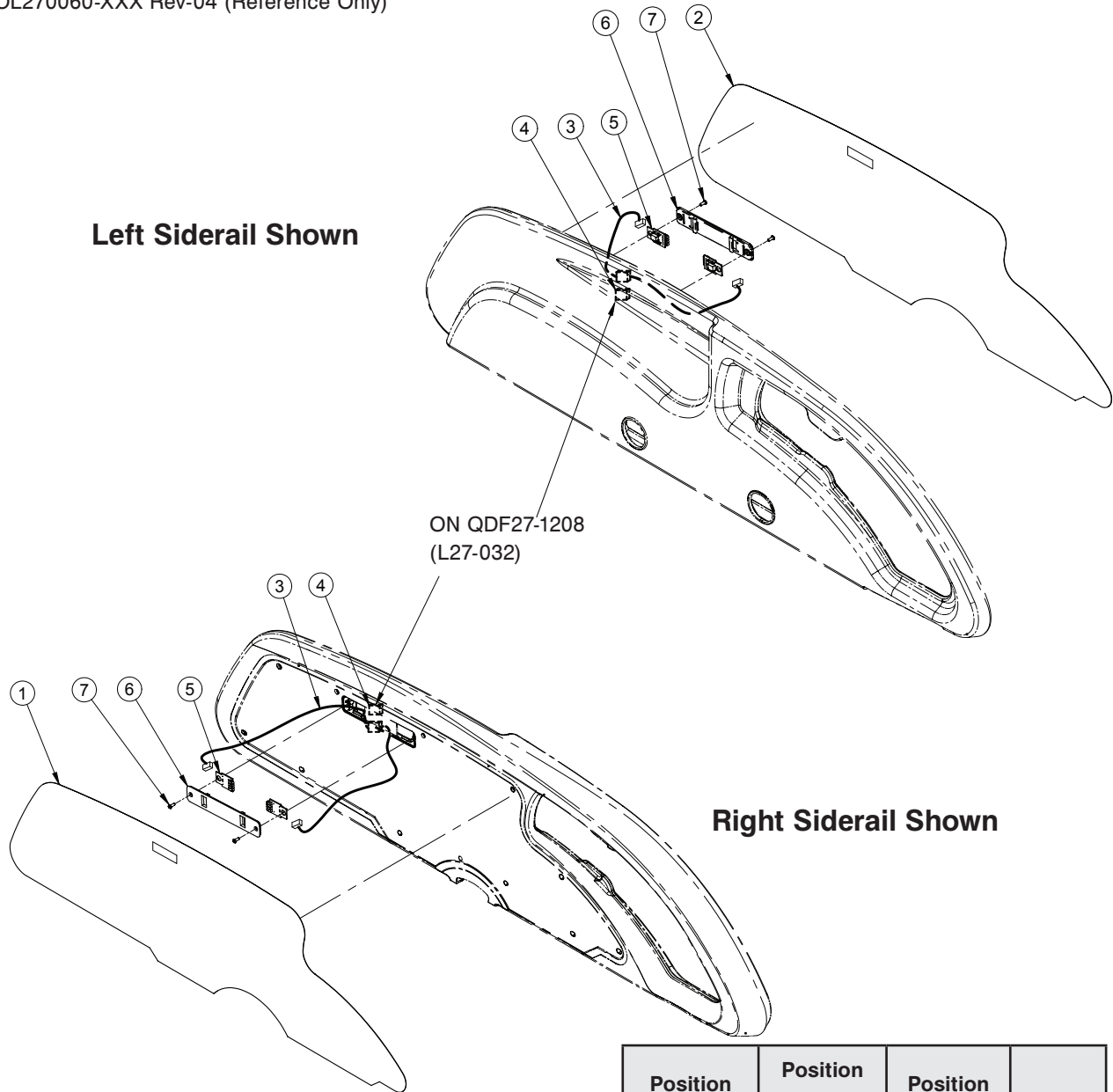

Position on Wire 27-1834	Position on Connector 4	Position on Wire 27-1208	Signal
1	1	1	LED 1
2	2	2	LED 2
3	3	3	+12V

**NOTE:** XXX - indicates language choice  
(tri = English/French/Spanish; bil = English/French)

Item	Part No.	Part Name	Qty.
1	QDF27-2030-XXX	Right Foot Siderail Fascia with <i>i</i> Bed	1
2	QDF27-2031-XXX	Left Foot Siderail Fascia with <i>i</i> Bed	1
3	QDF27-1834	LBS Cable Foot Siderail	2
4	QDF2080	Inline Splice	2
5	QDF27-1562	<i>i</i> BED Electronic Board Lens	4
6	QP27-1831	LBS Foot Siderail Lens	2
7	VV23A9C12HL	Pan Head Tapping Screw	4

# Headboard and Footboard Assembly

L27-028 Rev E (Reference Only)

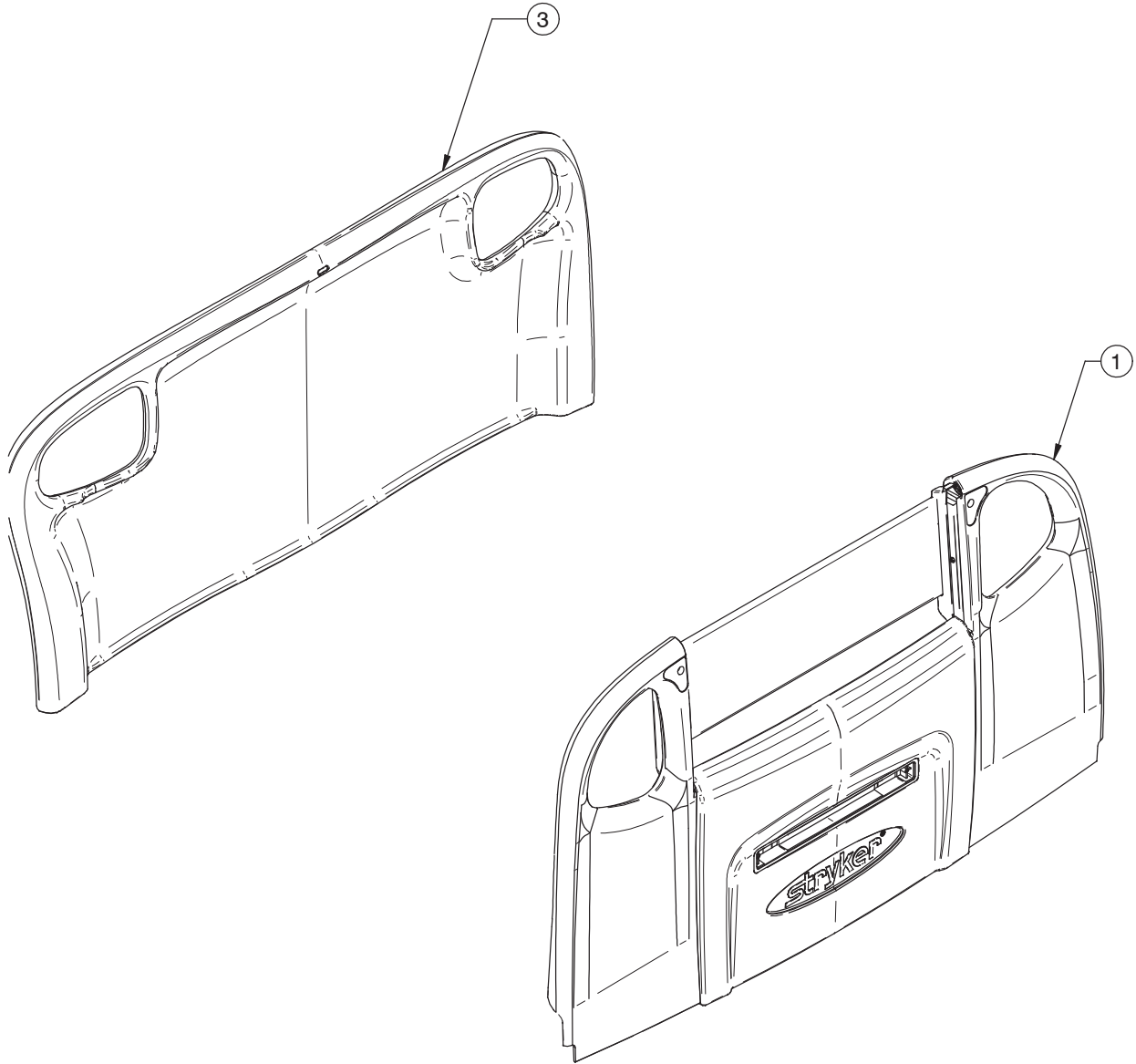

Item	Part No.	Part Name	Qty.
1	27-1547	Footboard Assembly	1
3	QP27-1077	Head Panel	1

# Standard Footboard Assembly

27-1547 Rev U (Reference Only)

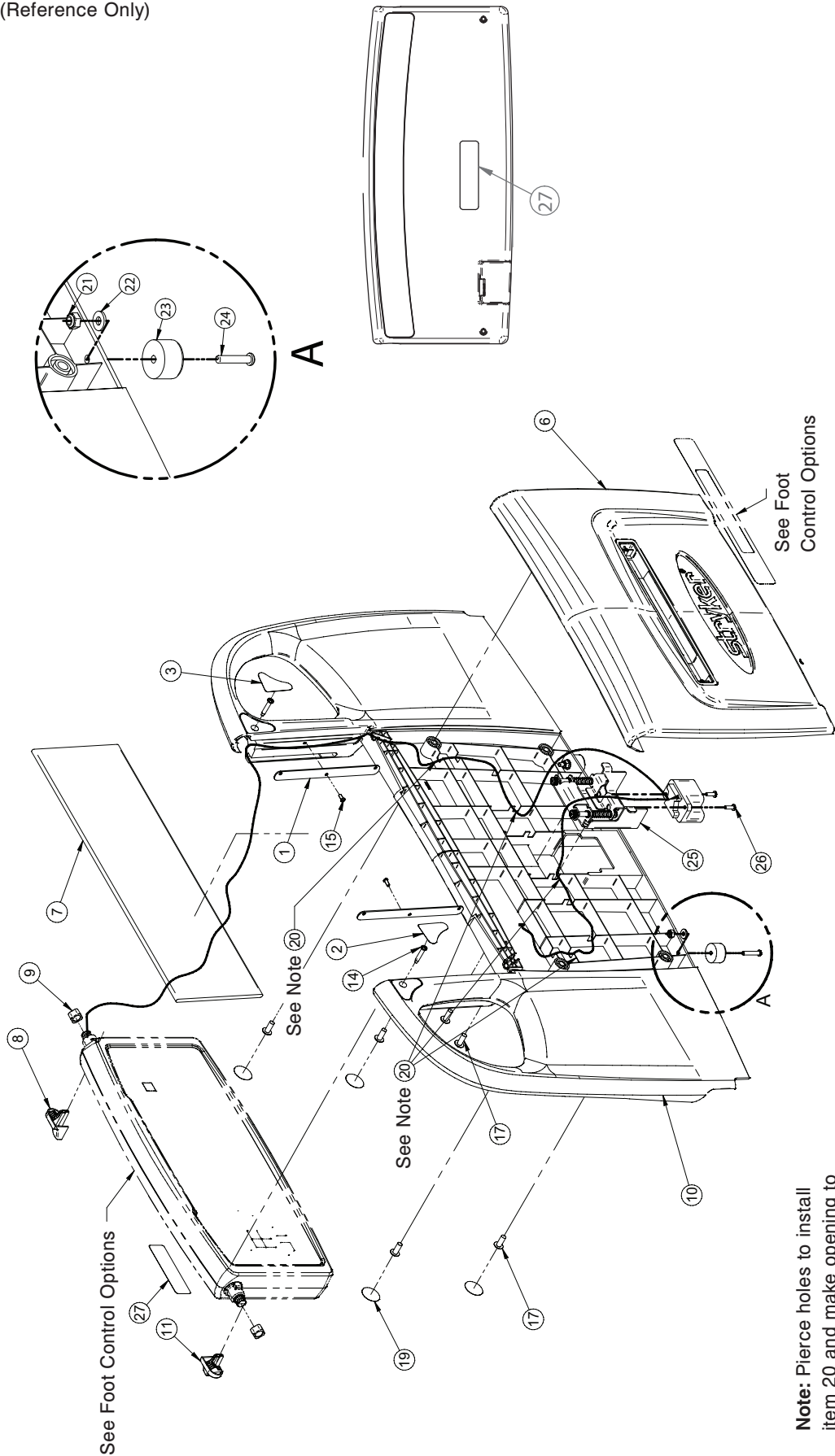

**Note:** Pierce holes to install item 20 and make opening to route the cables, if necessary

# Standard Footboard Assembly

---

## Footboard Assembly - 27-1547 Rev U (Reference Only)

Item	Part No.	Part Name	Qty.
1	27-2274P	Board Wire Cover	2
2	QDF27-1601	Footboard Screw Cover Sticker, Right	1
3	QDF27-1602	Footboard Screw Cover Sticker, Left	1
6	QP27-1026	Footboard Cover	1
7	QP27-1359	Foot Support	1
8	QP27-1493	Right Foot Control Support	1
9	QP27-1511	Foot Control Pivot Bushing	2
10	27-2785	Main Footboard	1
11	QP27-1569	Left Foot Control Support	1
14	VV23A1G32HL	Pan Head Tapping Screw	2
15	VV23A9C12HL	Pan Head Tapping Screw	2
17	VV37A1N20-S	Truss Head Machine Screw	6
19	QDF21-3943	Screw Cover	4
20	QDF9518	Cable Tie	4
21	VE30A1G	Nylon Hex Locknut	2
22	VW10A06	Flat Washer	2
23	0056-028-000	Black TPR Bumper	2
24	VV33A1G32	Pan Head Machine Screw	2
25	27-2770	Spring Load Connector	1
26	VV33A1E16	Pan Head Machine Screw	2
27	QE71-1367-T	Label, Footboard Serial Number	1

# Standard Footboard Assembly

OL270344-XXX Rev A (Reference Only)

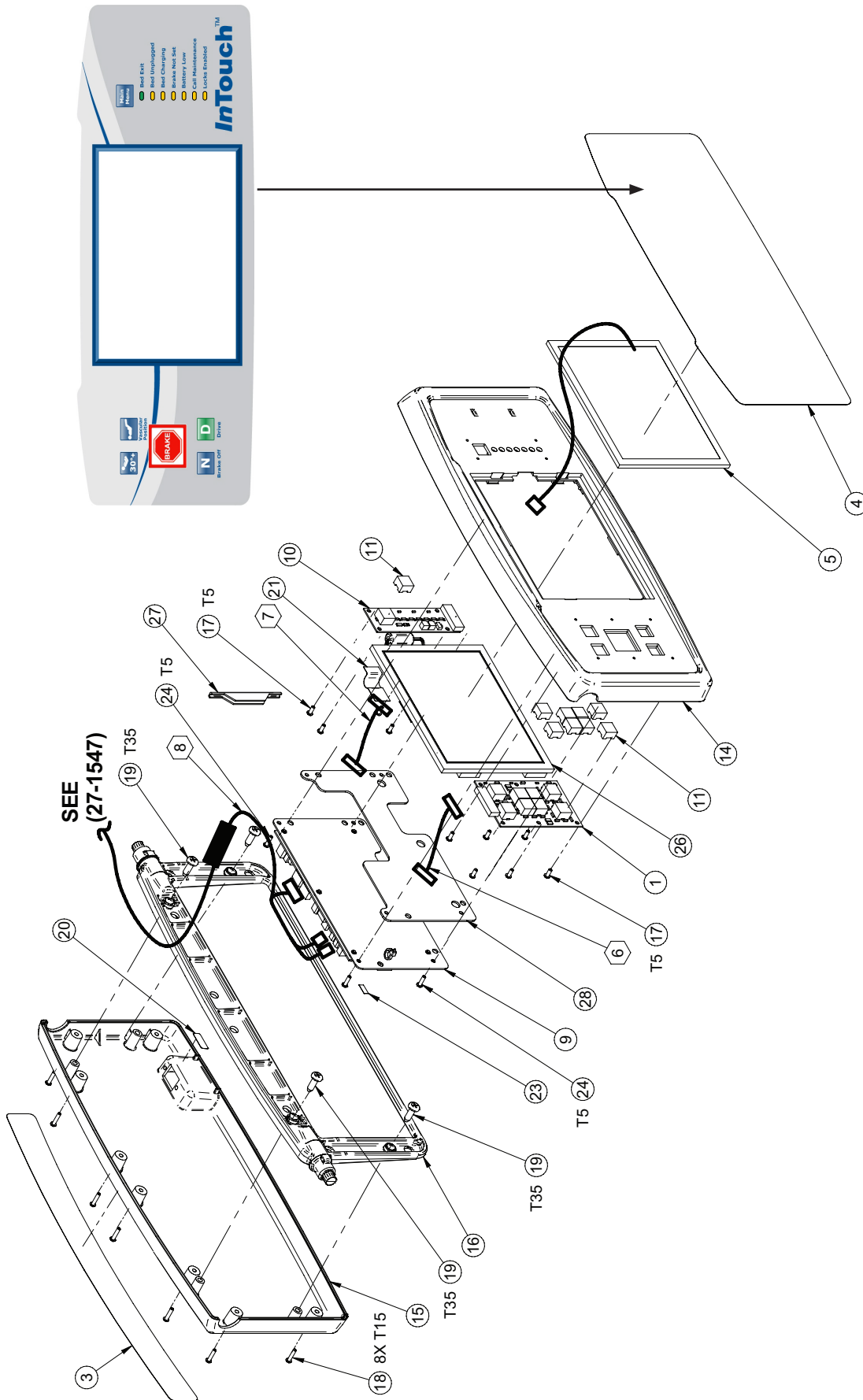



# Standard Footboard Assembly

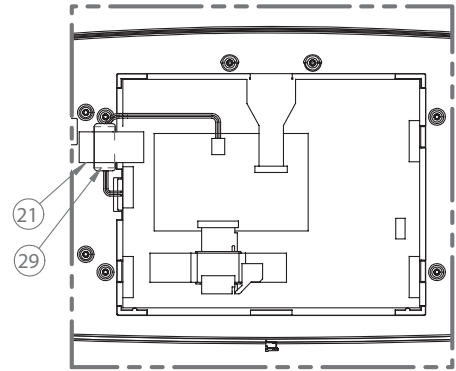
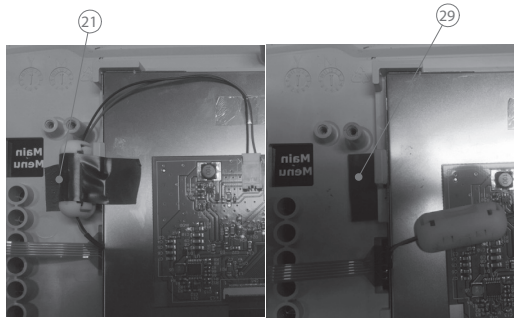
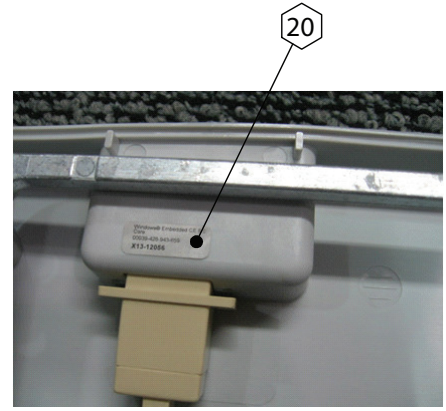
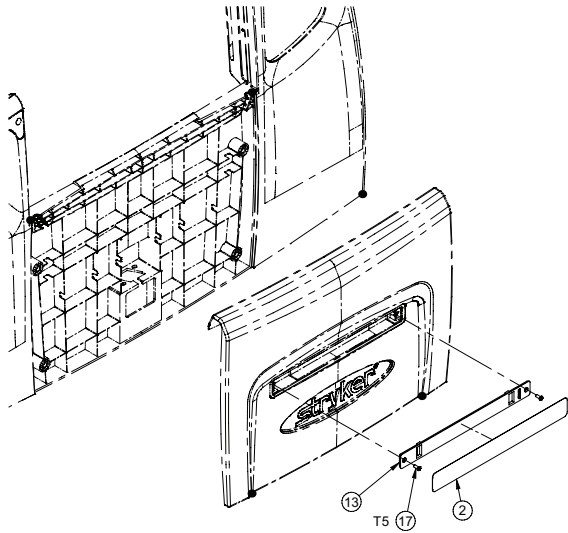

CONNECTION OF THE TOUCHSCREEN ON J3 BOARD

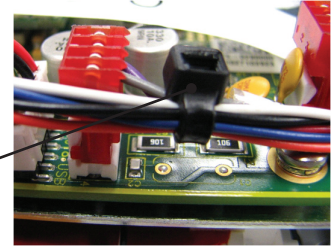

POSITION THE SCREEN TO HAVE THE YELLOW CABLES UPWARD

## QDF75-0290 BOARD ASSEMBLY

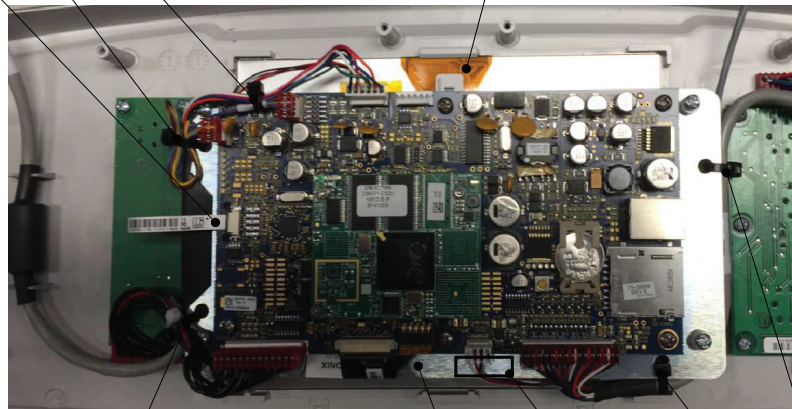

BOARD ORIENTED TO HAVE THE WRITING ON THE RIGHT SIDE VISIBLE

# Standard Footboard Assembly

CABLE CONNECTION TABLE				
Cable No.	Connector No.	To	Cable No.	Connector No.
QDF27-2229	Connector MTA 15 Positions	To	QDF75-0290	J12 (Interface Board)
QDF27-2229	Connector MTA 15 Positions	To	QDF27-1097	J1 (Brake Board)
QDF27-2230	Connector MTA 13 Positions	To	QDF75-0290	J6 (Interface Board)
QDF27-2230	Connector MTA 13 Positions	To	QDF75-0010	J1 (Menu Board)
QDF27-2864	Connector Metrimate 19 Pos.	To	QDF27-1213	Con. Metrimate (27-1661)
QDF27-2864	Connector MTA 4 Positions J1	To	QDF75-0290	J1 (Interface Board)
QDF27-2864	Connector MTA 4 Positions J19	To	QDF75-0290	J19 (Interface Board)
QDF27-2864	Connector MTA 6 Positions	To	QDF75-0290	J17 (Interface Board)
QDF27-2864	Connector MTA 6 Positions	To	Not Connected	See 27-1547
QDF27-2193	Touch Screen	To	QDF75-0290	J3 (Interface Board)
QDF27-2838	PCB Flex	To	QDF75-0290	J7 (Interface Board)

**NOTE:** XXX - indicates language choice (tri = English/French/Spanish; bil = English/French)

## Standard Footboard Assembly - OL270344-XXX Rev A (Reference Only)

Item	Part No.	Part Name	Qty.	Item	Part No.	Part Name	Qty.
1	QDF27-1097	Brake Control Board	1	28	27-2841	Shim	1
2	QDF27-2054	iBed Label w/o Lens	1	29	QDF2147	Double Face Tape	1
3	QDF27-2756	Back Foot Control Fascia	1				
4	QDF27-2188-XXX	Foot Control Overlay	1				
5	QDF27-2193	8" Touch Screen	1				
6*	QDF27-2229	Brake to Interface Cable	1				
7*	QDF27-2230	Menu to Interface Cable	1				
8*	27-2864	InTouch/Gateway 3.0 Cable	1				
9	QDF75-0290	Touch Board Assembly	1				
10	QDF75-0010	Main Menu Board	1				
11	QDF9183	Control Board Button	9				
12*	QDF9518	Cable Tie	5				
13	QP27-1609	iBed Lens	1				
14	QP27-2185	Nurse Control Panel					
		Foot End	1				
15	QP27-2186	Rear Footboard Control	1				
16	QPA27-1494	Foot Control Frame	1				
17	VV23A9C12HL	Pan Head Tapping Screw	12				
18	VV23A9C20HL	Pan Head Tapping Screw	8				
19	VVB3A9N24PF	Bosscrew Screw	4				
20	QDF27-2279	Windows License CE Label	1				
21	QDF2053	Red Electric Tape	1				
22*	75-0665	InTouch 5.0 Touchscreen					
		Software	1				
23	QE71-1396	InTouch 5.0 Software Label	2				
24	VV33A0A16HL	Pan Head Machine Screw	4				
26	27-2840	LCD Screen	2				
27	27-2698	Protection Tape	1				

# Footboard Assembly with iBed

OL270343-XXXX Rev A (Reference Only)

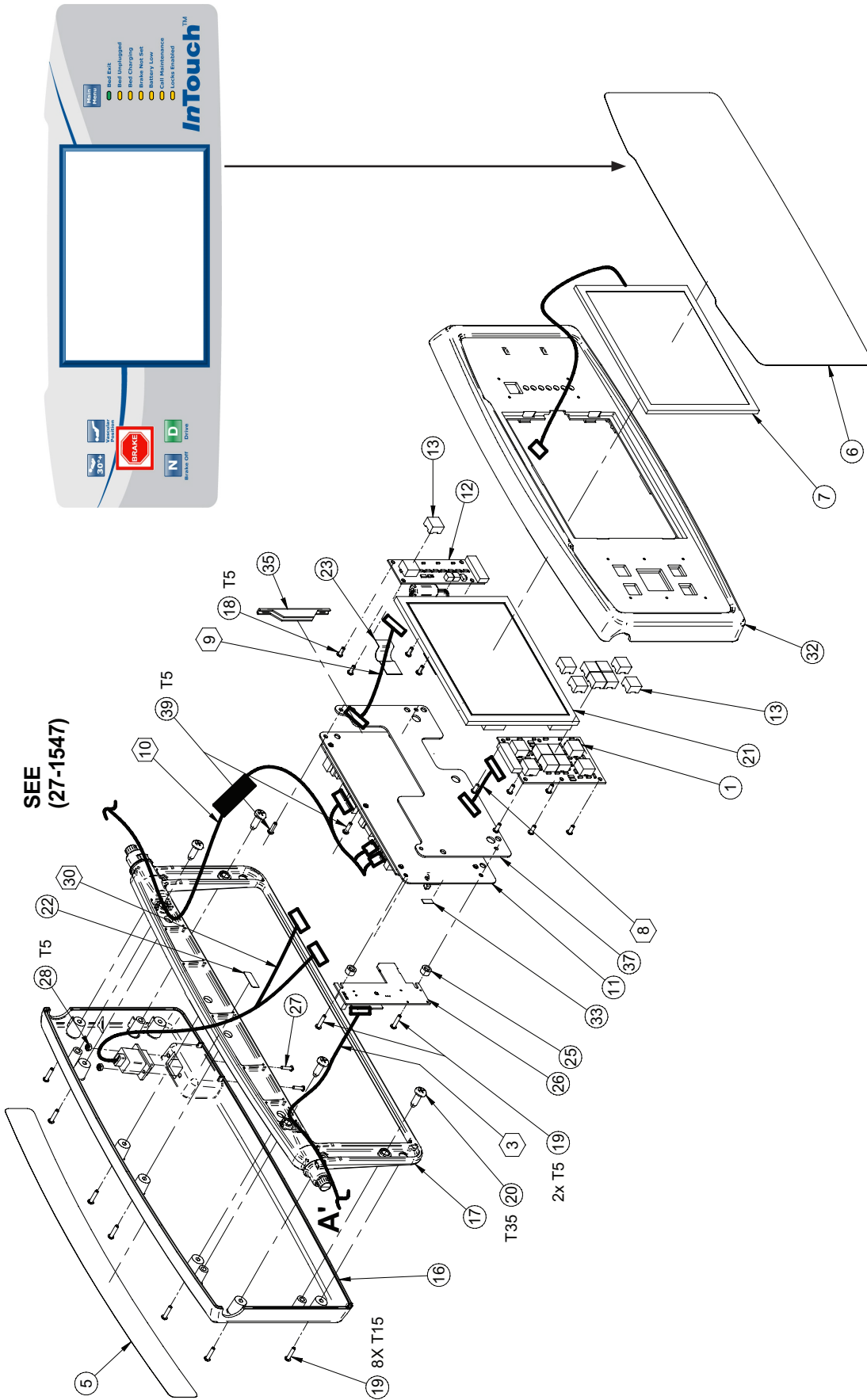

[Return To Table of Contents](#)

# Footboard Assembly with iBed

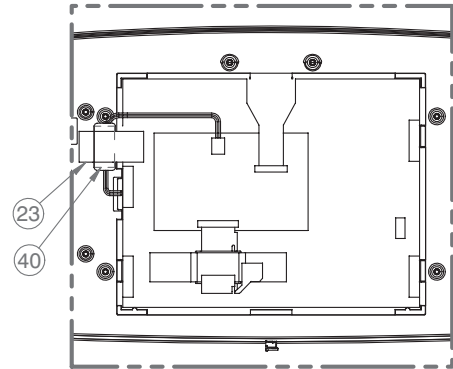
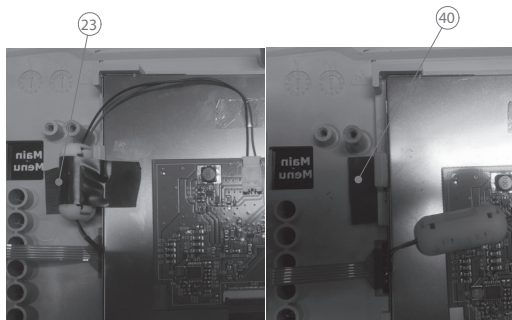
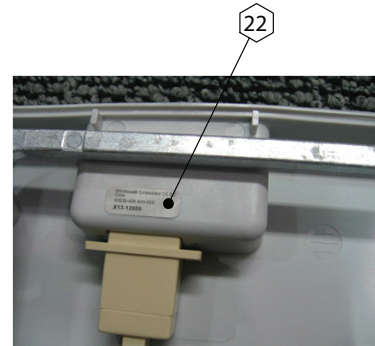
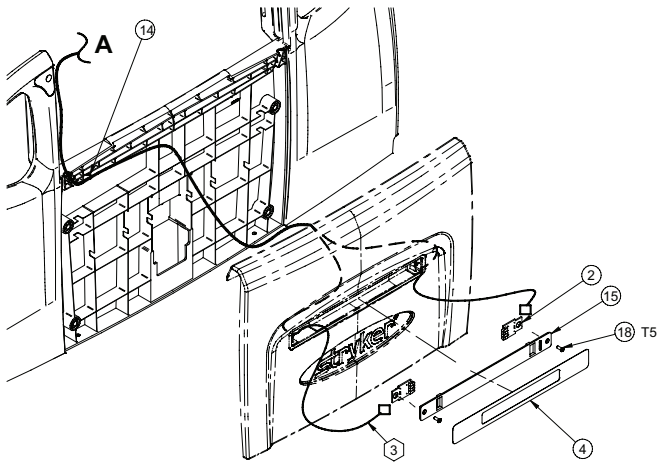

CONNECTION OF THE TOUCHSCREEN ON J3 BOARD

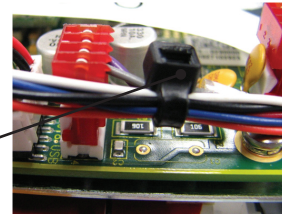

POSITION THE SCREEN TO HAVE THE YELLOW CABLES UPWARD

## QDF75-0290 BOARD ASSEMBLY

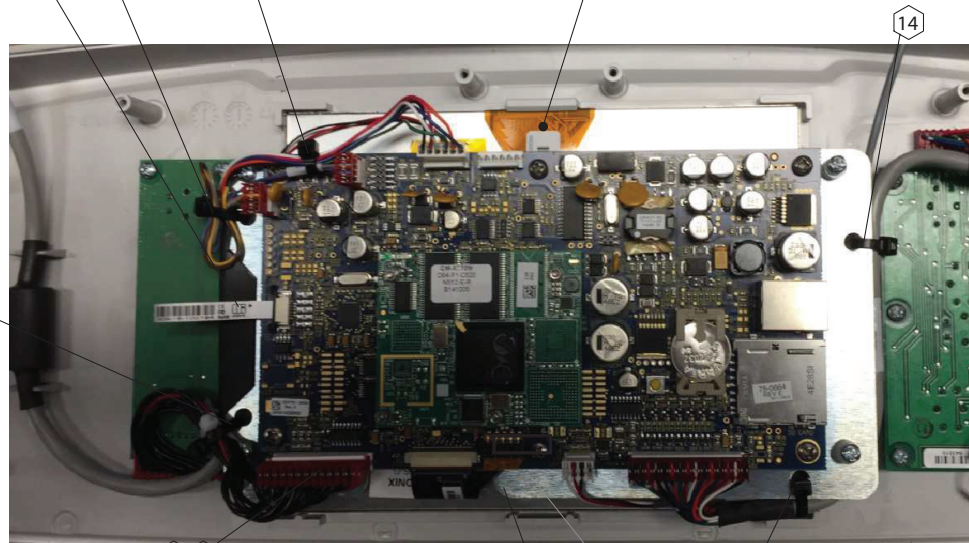

BOARD ORIENTED TO HAVE THE WRITING ON THE RIGHT SIDE VISIBLE



# Footboard Assembly with iBed

CABLE CONNECTION TABLE				
Cable No.	Connector No.	To	Cable No.	Connector No.
QDF27-2253	Connector MTA	To	QDF27-1562	Left Side
QDF27-2253	Connector MTA	To	QDF27-1562	Right Side
QDF27-2253	Connector MTA 4 Positions	To	QDF75-0290	J9 (Interface Board)
QDF27-2229	Connector MTA 15 Positions	To	QDF75-0290	J12 (Interface Board)
QDF27-2229	Connector MTA 15 Positions	To	QDF27-1097	J1 (Brake Board)
QDF27-2230	Connector MTA 13 Positions	To	QDF75-0290	J6 (Interface Board)
QDF27-2230	Connector MTA 13 Positions	To	QDF75-0010	J1 (Menu Board)
QDF27-2864	Connector Metrimate 19 Pos.	To	QDF27-1213	Con. Metrimate (27-1661)
QDF27-2864	Connector MTA 4 Positions J1	To	QDF75-0290	J1 (Interface Board)
QDF27-2864	Connector MTA 4 Positions J19	To	QDF75-0290	J19 (Interface Board)
QDF27-2864	Connector MTA 6 Positions	To	QDF75-0290	J17 (Interface Board)
QDF27-2864	Connector MTA 6 Positions	To	Not Connected	See 27-1547
QDF27-2193	Touch Screen	To	QDF75-0290	J3 (Interface Board)
QDF27-2838	PCB Flex	To	QDF75-0290	J7 (Interface Board)
QDF27-2573	Connector 12 Positions	To	QDF75-0290	J18 (Touch Board)
QDF27-2573	Connector 12 Positions	To	QDF75-0634	J4 (USB Memory Board)

**NOTE:** XXX - indicates language choice (tri = English/French/Spanish; bil = English/French)

## Footboard Assembly with iBed - OL270343-XXX Rev A (Reference Only)

Item	Part No.	Part Name	Qty.	Item	Part No.	Part Name	Qty.
1	QDF27-1097	Brake Control Board	1	21	27-2840	LCD Screen	1
2	QDF27-1562	Local Bed Status Board	2	22	QDF27-2279	Windows License CE Label	1
3*	QDF27-2253	LBS Cable Foot Panel	1	23	QDF2053	Red Electric Tape	1
4	QDF27-1610	iBed Lens Label	1	24*	75-0665	InTouch	
5	QDF27-2756	Back Foot Control Fascia	1			5.0 Touchscreen Software	1
6	QDF27-2188-XXX	Foot Control Overlay	1	25	QDF2157	Collar Spacer	2
7	QDF27-2193	8" Touch Screen	1	26*	QDF75-0634	Memory Board Assembly	1
8*	QDF27-2229	Brake to Interface Cable	1	27	VV33A0A16	Pan Head Machine Screw	2
9*	QDF27-2230	Menu to Interface Cable	1	28	VE39A0A	Nylon Hex Locknut	2
10*	27-2864	InTouch/Gateway 3.0 Cable	1	30*	QDF27-2573	Interface Board	
11	QDF75-0290	Touch Board Assembly	1			"Y" USB Cable	1
12	QDF75-0010	Main Menu Board	1	32	QP27-2185	Nurse Control Panel, Foot End	1
13	QDF9183	Control Board Button	9	33	QE71-1396	InTouch 5.0 Software Label	1
14*	QDF9518	Cable Tie	6	35	27-2698	Protection Tape	1
15	QP27-1609	iBed Lens	1	37	27-2841	Shim	1
16	QP27-2186	Rear Footboard Control	1	39	VV23A9C16HL	Pan Head Tapping Screw	2
17	QPA27-1494	Foot Control Frame	1	40	QDF2147	Double Face Tape	1
18	VV23A9C12HL	Pan Head Tapping Screw	12				
19	VV23A9C20HL	Pan Head Tapping Screw	10				
20	VVB3A9N24PF	Bosscrew Screw	4				

[Return To Table of Contents](#)

# Footboard Assembly with iBed and Wi-Fi

OL270342-XXX Rev A (Reference Only)

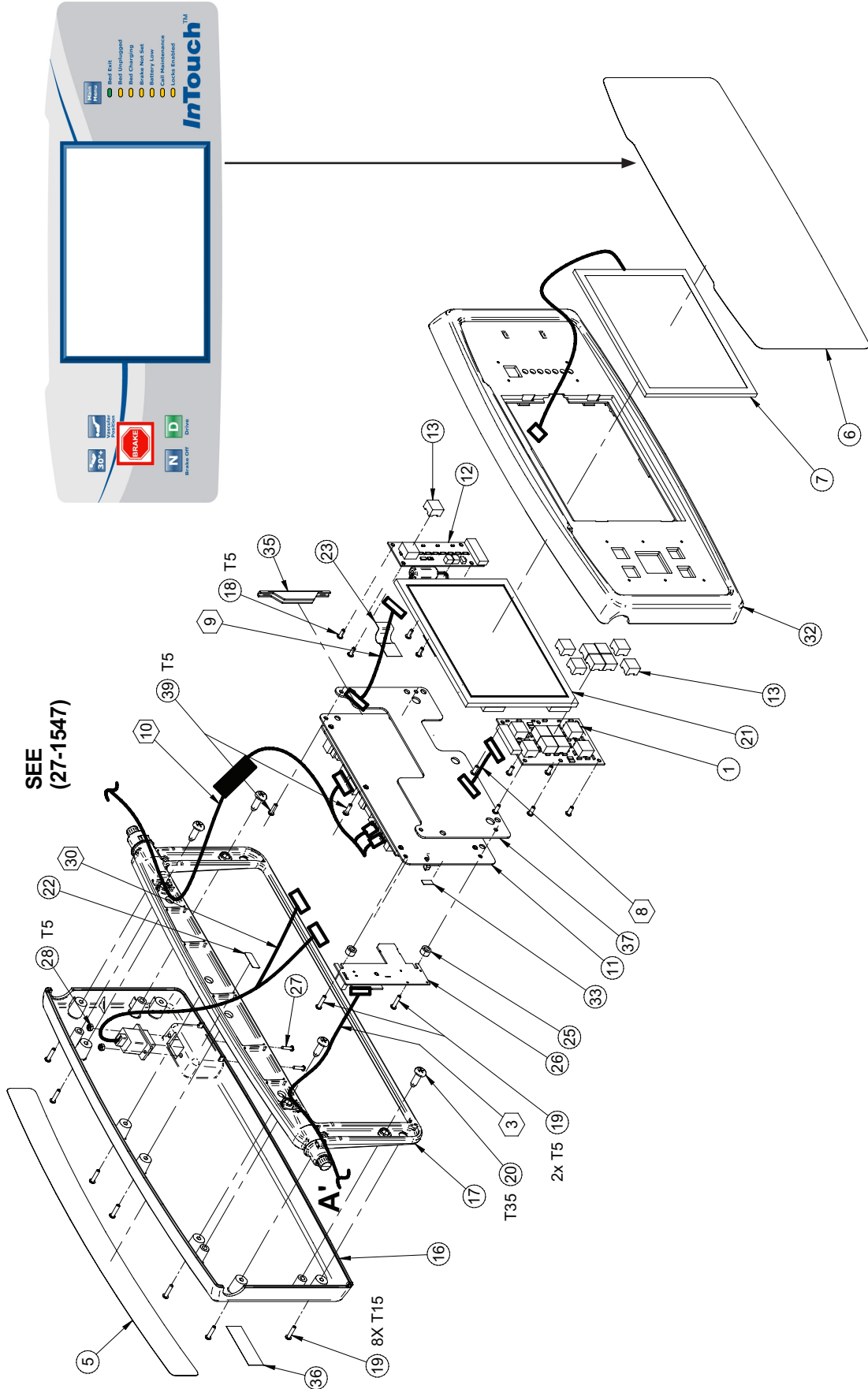

# Footboard Assembly with iBed and Wi-Fi

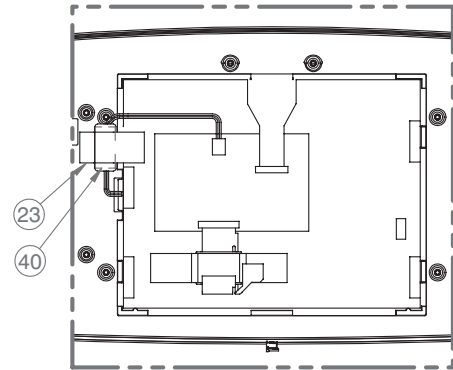
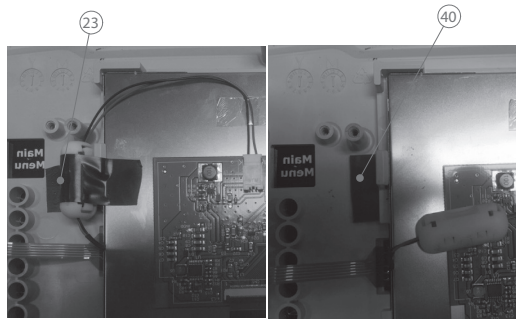
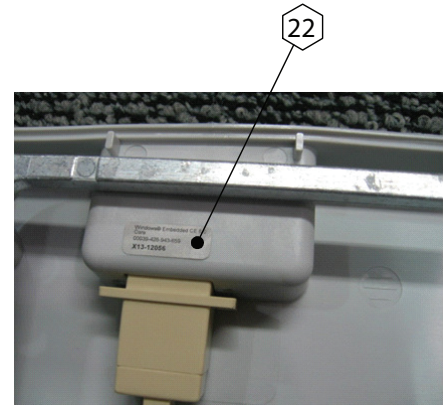
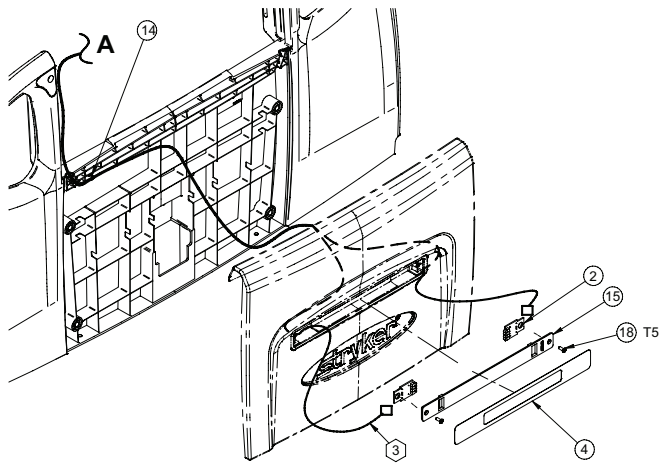

CONNECTION OF THE TOUCHSCREEN ON J3 BOARD

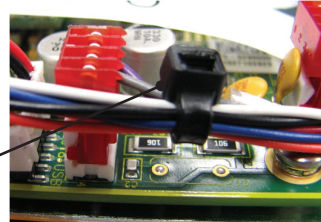

POSITION THE SCREEN TO HAVE THE YELLOW CABLES UPWARD

## QDF75-0290 BOARD ASSEMBLY

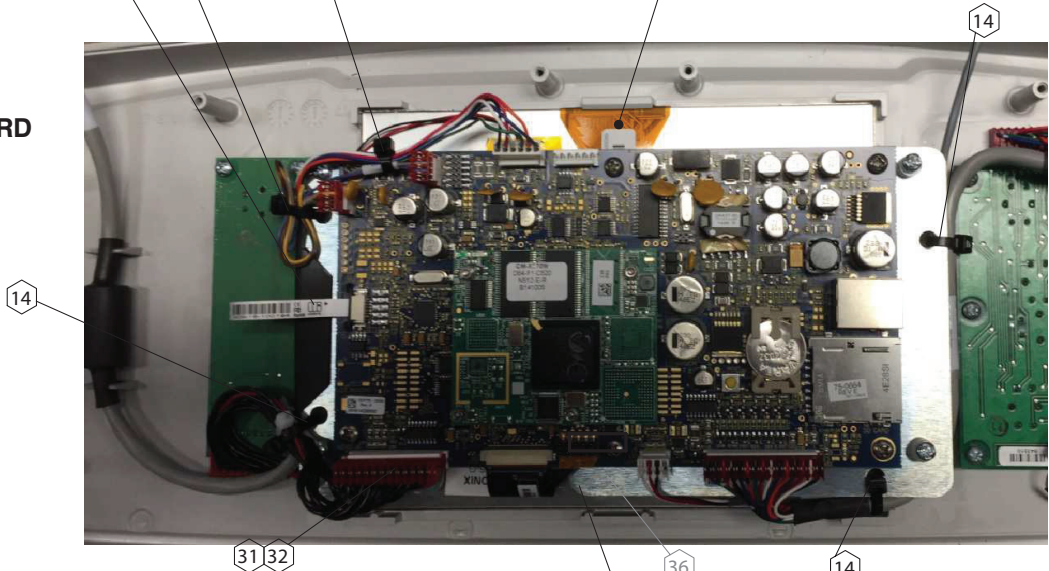

BOARD ORIENTED TO HAVE THE WRITING ON THE RIGHT SIDE VISIBLE

# Footboard Assembly with iBed and Wi-Fi

CABLE CONNECTION TABLE				
Cable No.	Connector No.	To	Cable No.	Connector No.
QDF27-2253	Connector MTA	To	QDF27-1562	Left Side
QDF27-2253	Connector MTA	To	QDF27-1562	Right Side
QDF27-2253	Connector MTA 4 Positions	To	QDF75-0290	J9 (Interface Board)
QDF27-2229	Connector MTA 15 Positions	To	QDF75-0290	J12 (Interface Board)
QDF27-2229	Connector MTA 15 Positions	To	QDF27-1097	J1 (Brake Board)
QDF27-2230	Connector MTA 13 Positions	To	QDF75-0290	J6 (Interface Board)
QDF27-2230	Connector MTA 13 Positions	To	QDF75-0010	J1 (Menu Board)
QDF27-2864	Connector Metrimate 19 Pos.	To	QDF27-1213	Con. Metrimate (27-1661)
QDF27-2864	Connector MTA 4 Positions J1	To	QDF75-0290	J1 (Interface Board)
QDF27-2864	Connector MTA 4 Positions J19	To	QDF75-0290	J19 (Interface Board)
QDF27-2864	Connector MTA 6 Positions	To	QDF75-0290	J17 (Interface Board)
QDF27-2864	Connector MTA 6 Positions	To	5212-500-910	J8 (27-2866)
QDF27-2193	Touch Screen	To	QDF75-0290	J3 (Interface Board)
QDF27-2838	PCB Flex	To	QDF75-0290	J7 (Interface Board)
QDF27-2573	Connector 12 Positions	To	QDF75-0290	J18 (Touch Board)
QDF27-2573	Connector 12 Positions	To	QDF75-0634	J4 (USB Memory Board)

**NOTE:** XXX - indicates language choice (tri = English/French/Spanish; bil = English/French)

## Footboard Assembly with iBed and Wi-Fi - OL270342-XXX Rev A (Reference Only)

Item	Part No.	Part Name	Qty.	Item	Part No.	Part Name	Qty.
1	QDF27-1097	Brake Control Board	1	21	27-2840	LCD Screen	1
2	QDF27-1562	Local Bed Status Board	2	22	QDF27-2279	Windows License CE Label	1
3*	QDF27-2253	LBS Cable Foot Panel	1	23	QDF2053	Red Electric Tape	1
4	QDF27-1610	iBed Lens Label	1	24*	75-0665	InTouch	
5	QDF27-2756	Back Foot Control Fascia	1			5.0 Touchscreen Software	1
6	QDF27-2188-XXX	Foot Control Overlay	1	25	QDF2157	Collar Spacer	2
7	QDF27-2193	8" Touch Screen	1	26*	QDF75-0634	Memory Board Assembly	1
8*	QDF27-2229	Brake to Interface Cable	1	27	VV33A0A16	Pan Head Machine Screw	2
9*	QDF27-2230	Menu to Interface Cable	1	28	VE39A0A	Nylon Hex Locknut	2
10*	27-2864	InTouch/Gateway 3.0 Cable	1	30*	QDF27-2573	Interface Board	
11	QDF75-0290	Touch Board Assembly	1			"Y" USB Cable	1
12	QDF75-0010	Main Menu Board	1	32	QP27-2185	Nurse Control Panel, Foot End	1
13	QDF9183	Control Board Button	9	33	QE71-1396	InTouch 5.0 Software Label	1
14*	QDF9518	Cable Tie	6	35	27-2698	Protection Tape	1
15	QP27-1609	iBed Lens	1	36	5212-500-802	FCC Label Gateway 3.0	1
16	QP27-2186	Rear Footboard Control	1	37	27-2841	Shim	1
17	QPA27-1494	Foot Control Frame	1	39	VV23A9C16HL	Pan Head Tapping Screw	2
18	VV23A9C12HL	Pan Head Tapping Screw	12	40	QDF2147	Double Face Tape	1
19	VV23A9C20HL	Pan Head Tapping Screw	10				
20	VVB3A9N24PF	Bosscrew Screw	4				



# Wireless Option - 27-2866

27-2866 Rev A (Reference Only)

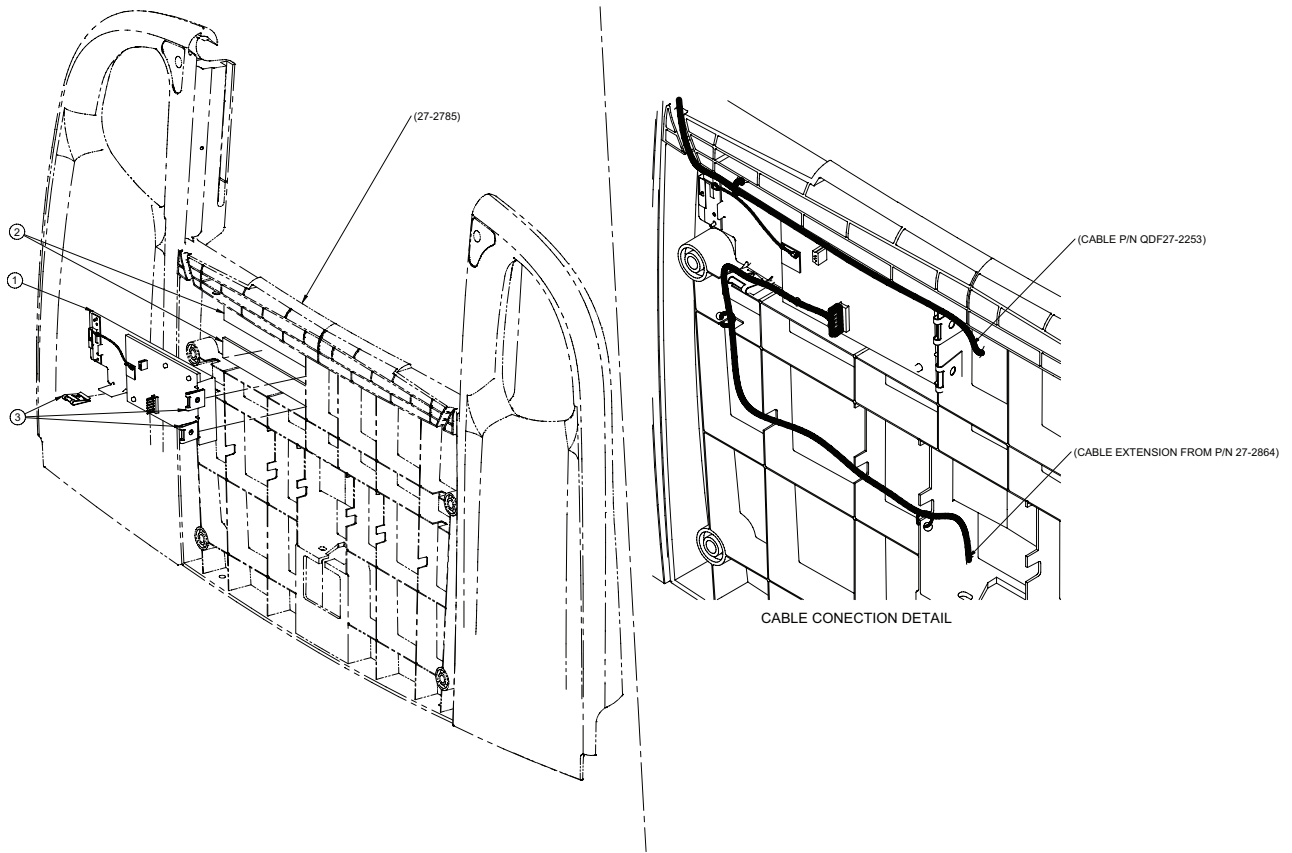

Item	Part No.	Part Name	Qty.
1	27-2863	Gateway Board Assembly	1
2	QDF2147	Double Face Tape	1
3	0016-136-000	Clip	3

# Bed Extender - FA64234-XXX

L64-150-XXX Rev A (Reference Only)

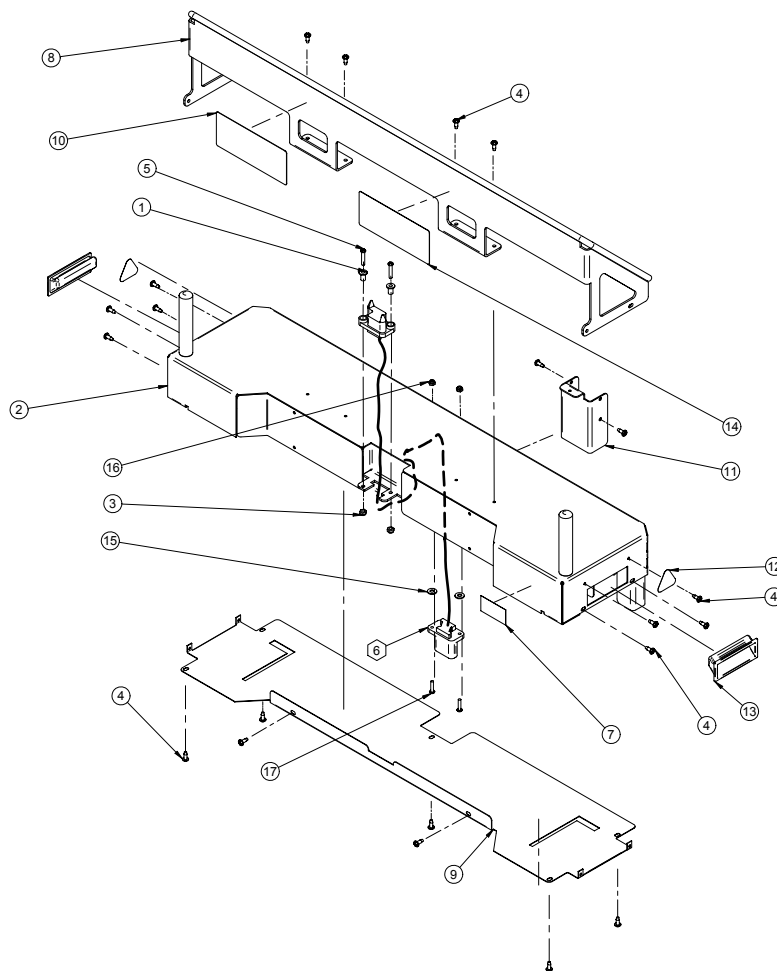

Item	Part No.	Part Name	Qty.
1	25-0527Z	Connector Sleeve	2
2	64-1158P	Bed Extender	1
3	VE30A0G	Nylon Hex Locknut	2
4	VV83A9G16	Pan Head Tapping Screw	21
5	VV31A0G32	Pan Head Machine Screw	2
6	QDF64-1358	Bed Extender Cable	1
7	QE71-1350-XXX	Manufacturer Sticker	1
8	64-1271P	Bed Extender Protective Device	1
9	64-1278P	Bed Extender Cover	1
10	QE71-1112-XXX	Bed Extender Warning Label	1
11	64-1284P	Bed Extender Connector	1
12	QE71-0533	Protective Top Sticker	2
13	QDF6029	ABS Handle	2
14	QE71-1132-XXX	Appropriate Cushion Label	1
15	VW10C081802	Nylon Washer	2
16	VE30A1E	Nylon Hex Locknut	2
17	VV33A1E24	Pan Head Machine Screw	2

## Bed Extender Pad with Position Pro Mattress - DM64196-XXX

---

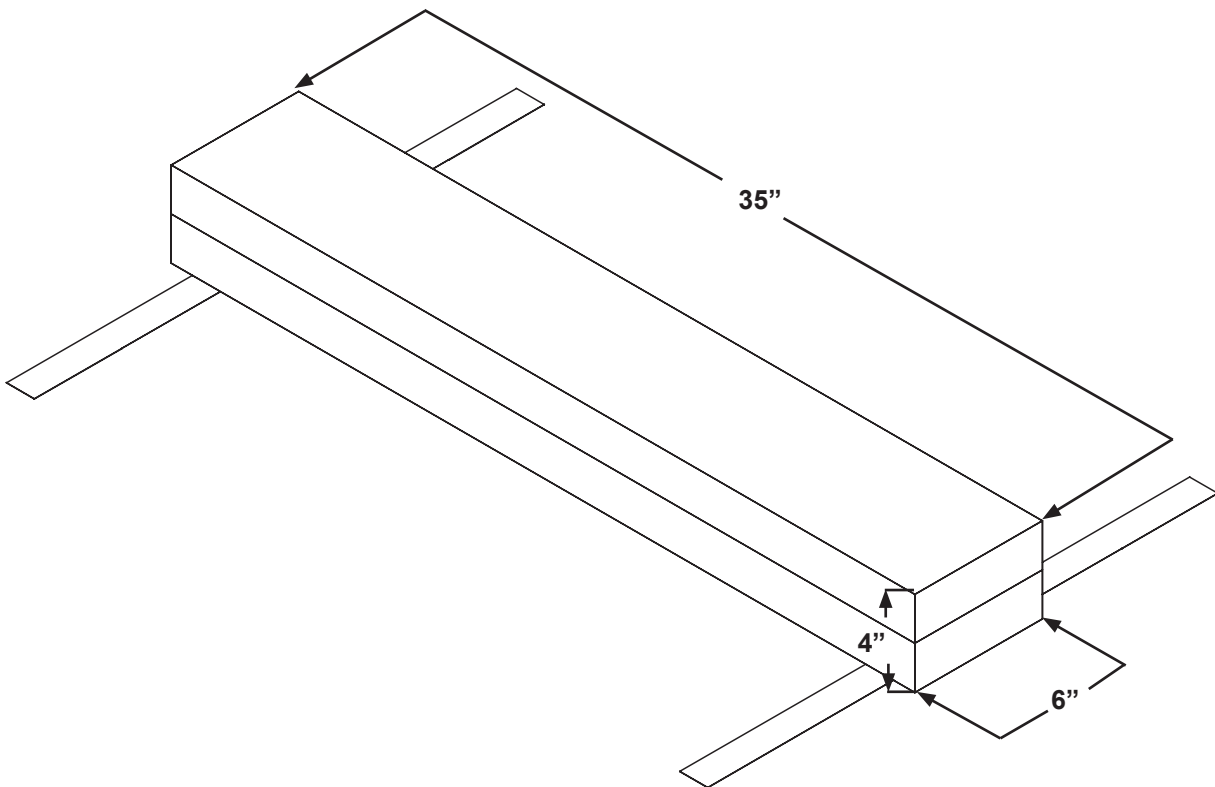

## Bed Extender Pad with XPRT™ Mattress - DM64197-XXX

---

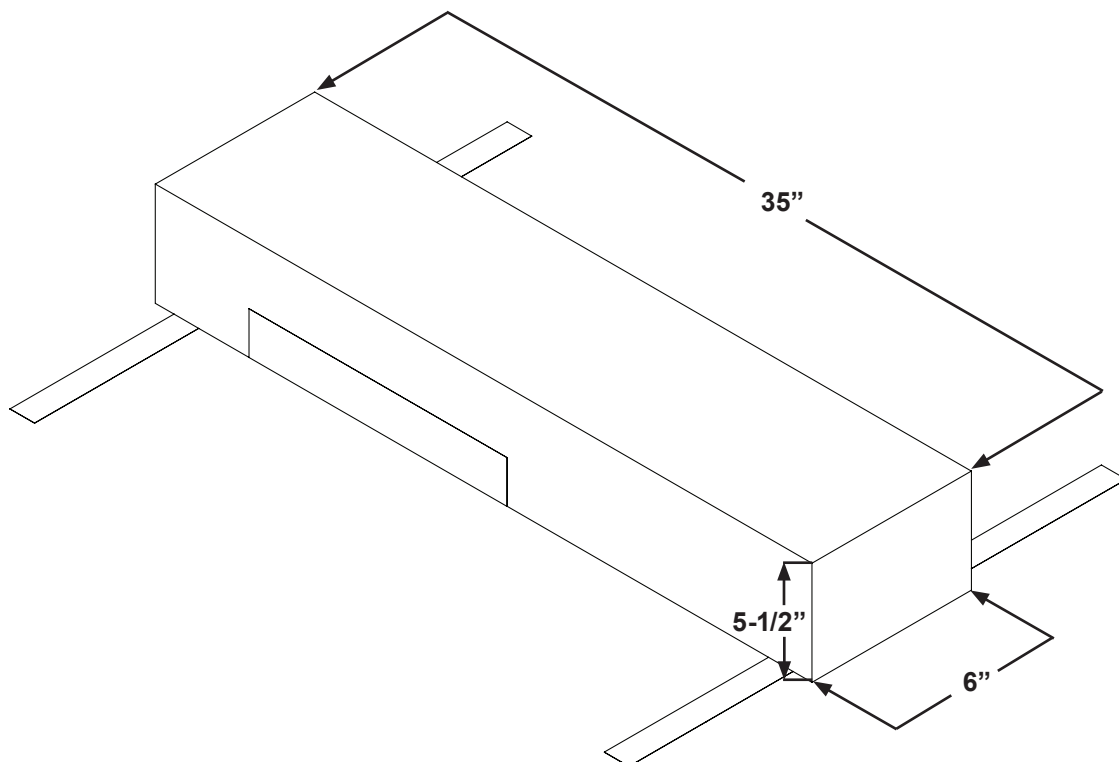

# Line Management Clip - FA64210-XXX

---

L64-130-XXX Rev A (Reference Only)

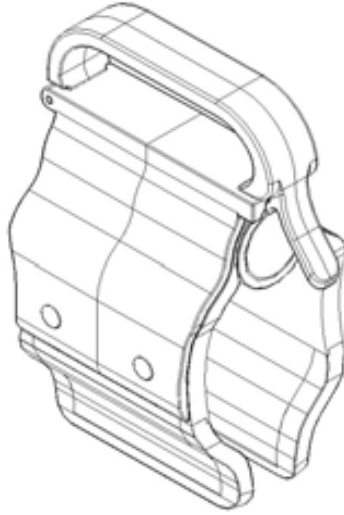

# IV Pole Assembly, Permanent - FA64221-XXX/FA64238-XXX

L64-139-XXX Rev A (Reference Only)

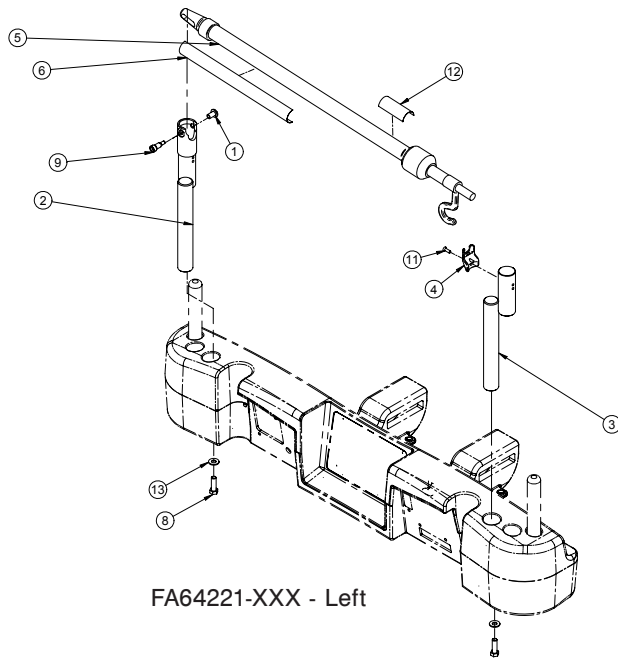

FA64221-XXX - Left

L64-153-XXX Rev A (Reference Only)

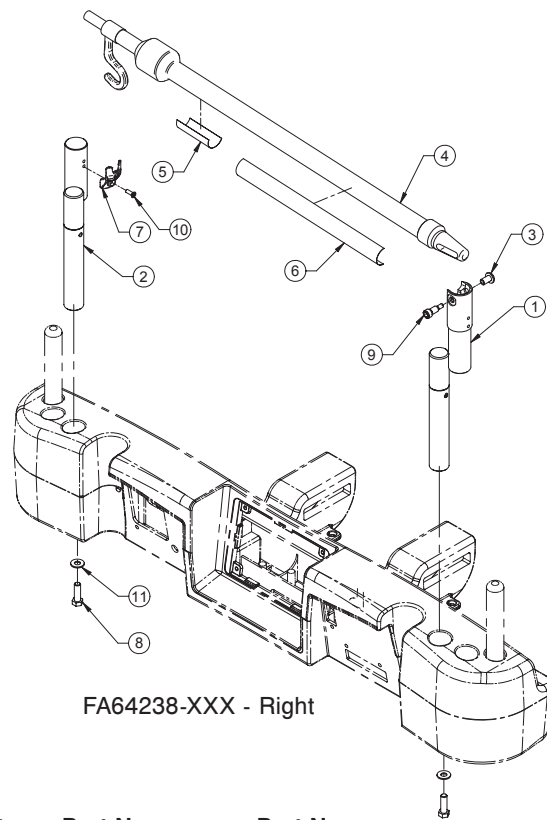

FA64238-XXX - Right

Item	Part No.	Part Name	Qty.	Item	Part No.	Part Name	Qty.
1	QDF2121	Sleeve Nut	1	1	QDF64-1366	I.V. Pole Support, Right	1
2	QDF64-1362	I.V. Pole Support, Left	1	2	QDF64-1367	Simple Stop I.V. Pole, Left	1
3	QDF64-1365	Simple Stop I.V. Pole, Right	1	3	QDF2121	Sleeve Nut	1
4	QP64-1225	I.V. Pole Plastic Support	1	4	QDF5073	2-Stage I.V. Pole	1
5	QDF5073	2-Stage I.V. Pole	1	5	QE71-1350-XXX	Manufacturer Sticker	1
6	QE71-1306-XXX	Warning Sticker	1	6	QE71-1306-XXX	Warning Sticker	1
8	VB15A1O32-S	Bolt	2	7	QP64-1225	I.V. Pole Plastic Support	1
9	VD60A1N1016-S	Shoulder Screw	1	8	VB15A1O32-S	Bolt	2
11	VV81A9E16-10	Flat Head Tapping Screw	1	9	VD60A1N1016-S	Shoulder Screw	1
12	QE71-1350-XXX	Manufacturer Sticker	1	10	VV81A9E16-10	Flat Head Tapping Screw	1
13	VW10A10	Flat Washer	2	11	VW10A10	Flat Washer	2

[Return To Table of Contents](#)

# IV Pole Ass'y, Dual Head End, Permanent - FA64202-XXX

L64-107-XXX Rev A (Reference Only)

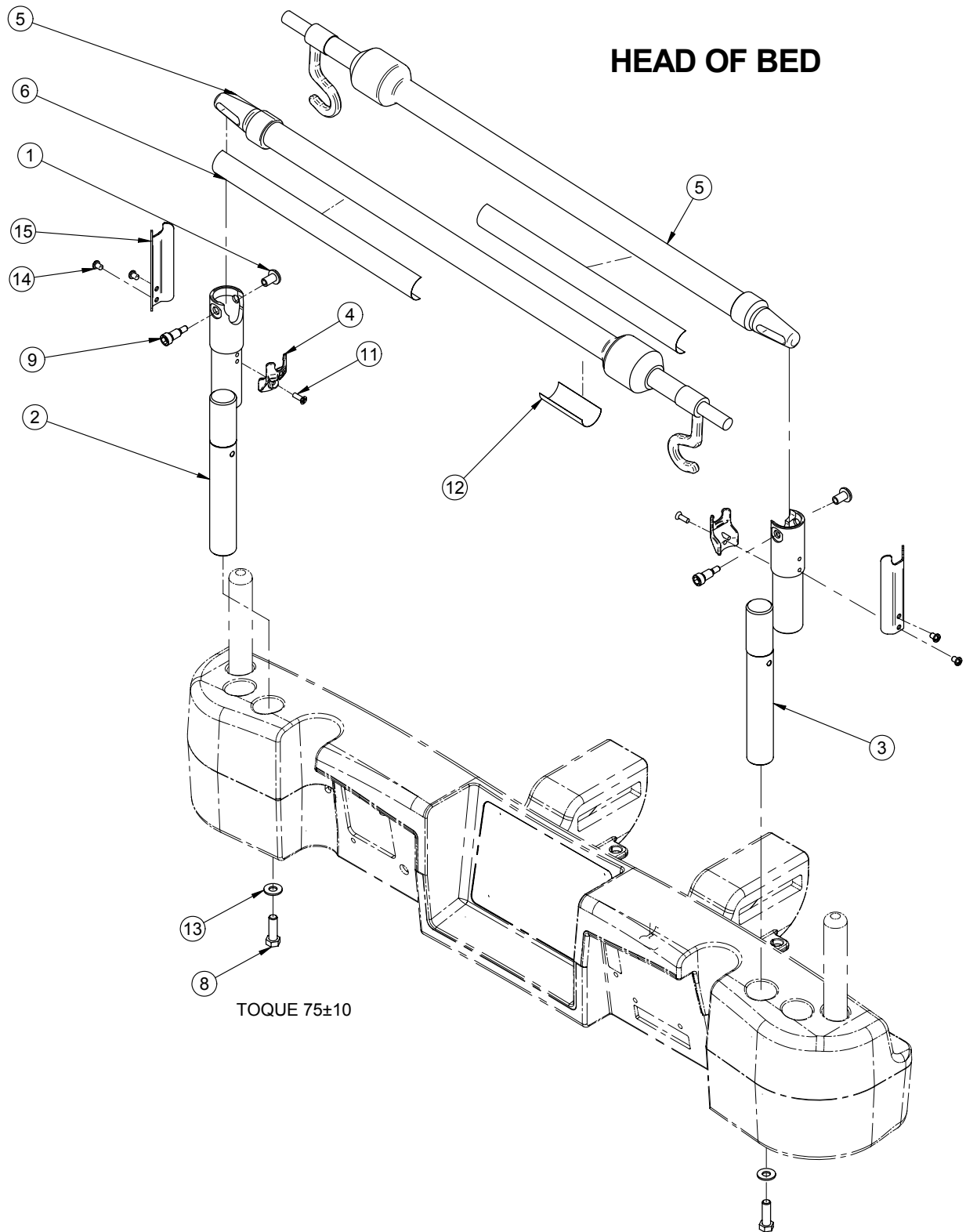

# IV Pole Ass'y, Dual Head End, Permanent (Continued) - FA64202-XXX

---

## IV Pole Assembly, Dual Head End, Permanent - L64-107-XXX Rev A (Reference Only)

Item	Part No.	Part Name	Qty.
1	QDF2121	Sleeve Nut	2
2	QDF64-1362	I.V. Pole Support, Left	1
3	QDF64-1366	I.V. Pole Support, Right	1
4	QP64-1225	I.V. Pole Plastic Support	2
5	QDF5073	2-Stage I.V. Pole	2
6	QE71-1306-XXX	Warning Sticker	2
8	VB15A1O32-S	Bolt	2
9	VD60A1N1016-S	Shoulder Screw	2
11	VV81A9E16-10	Flat Head Tapping Screw	2
12	QE71-1350-XXX	Manufacturer Sticker	1
13	VW10A10	Flat Washer	2
14	VV33A1G08-S	Pan Head Machine Screw	4
15	64-1269C	Double I.V. Pole Support	2

# Monitor Tray Assembly - FA64214-XXX

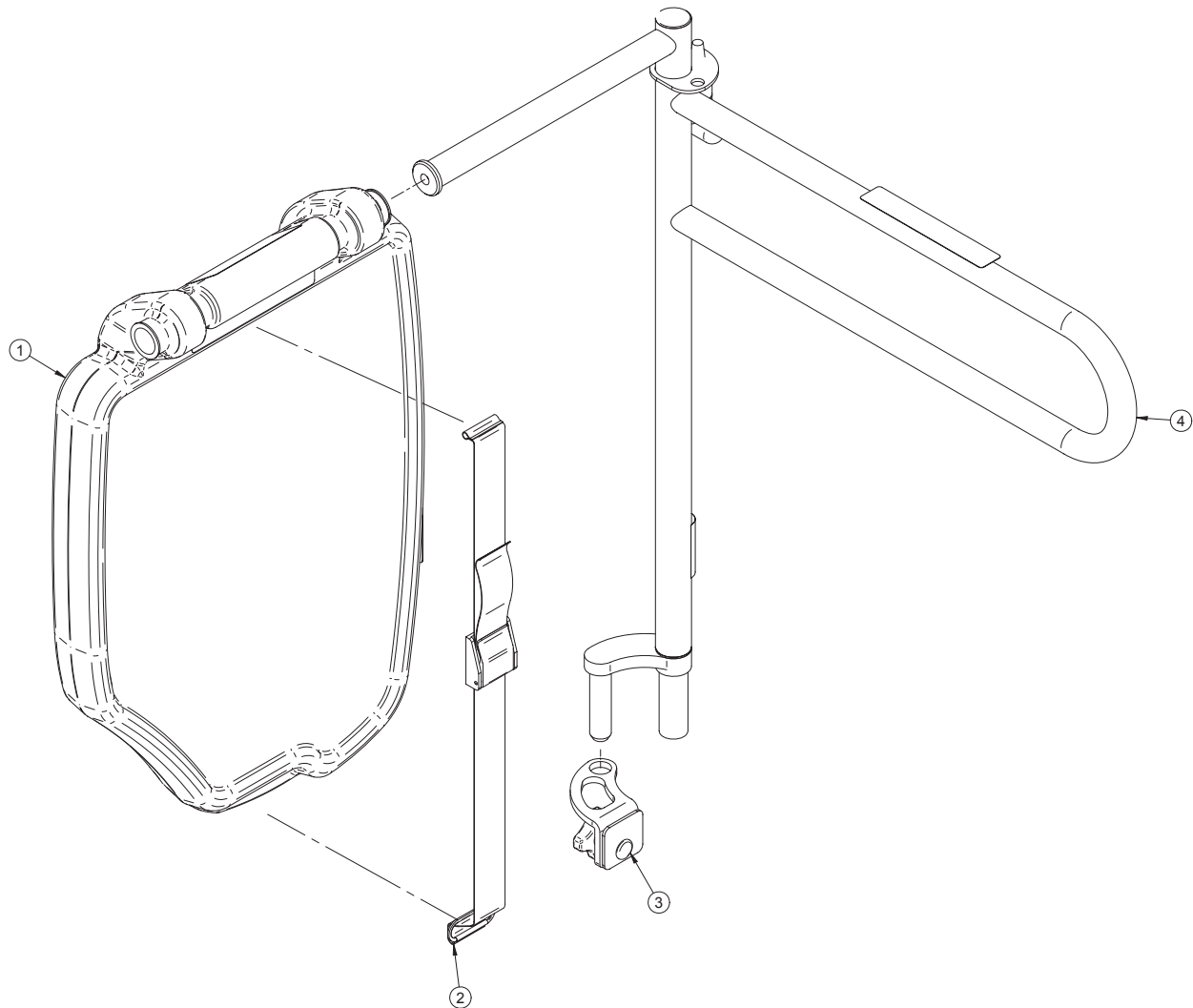

Item	Part No.	Part Name	Qty.
1	QDF64-1300	Tray	1
2	QDF64-1301	Transport Strap	1
3	QDF64-1302	Fastener Sleeve	1
4	QDF64-1303T	Tray Support Pole	1



# Upright Oxygen Bottle Holder Assembly - FA64187-XXX

L64-112-XXX Rev A (Reference Only)

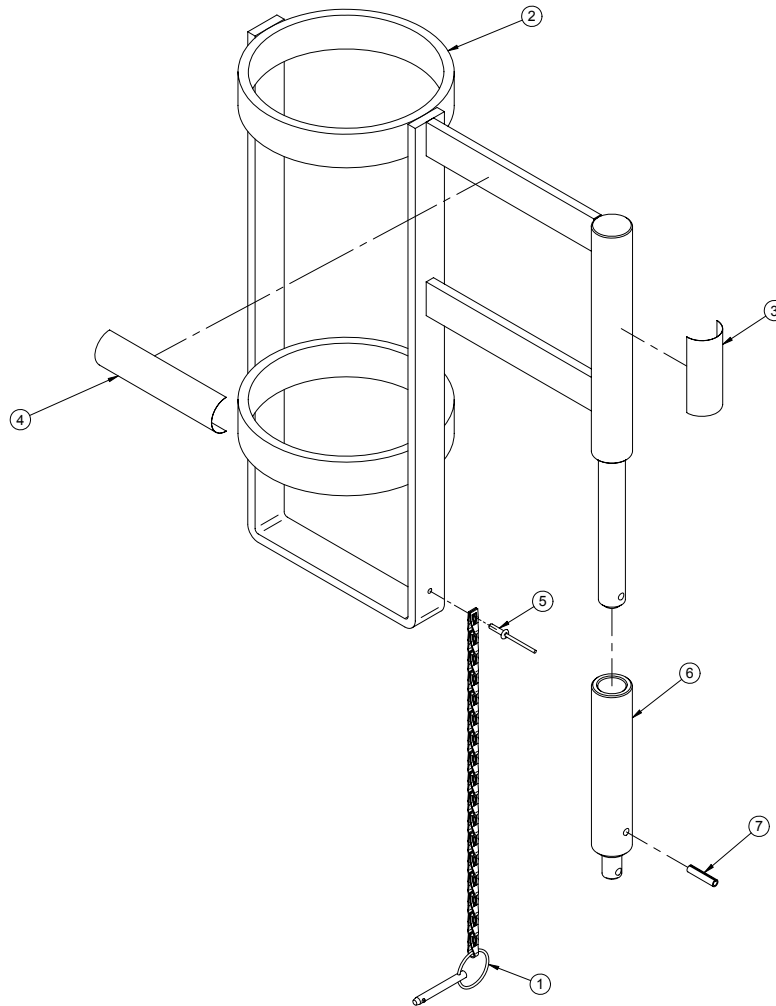

Item	Part No.	Part Name	Qty.
1	64-0647	Security Chain	1
2	QDF64-1059	Bottle Holder	1
3	QE71-1350-XXX	Manufacturer Sticker	1
4	QE71-0601	Maximum Load Sticker	1
5	VR11H46	Dome Head Pop Rivet	1
6	64-1285	Oxygen Bottle Holder Socket	1
7	VG10B0628	Spring Pin	1

# Right-Fit Oxygen Bottle Holder Assembly - FA64203

---

L64-124 Rev-00 (Reference Only)

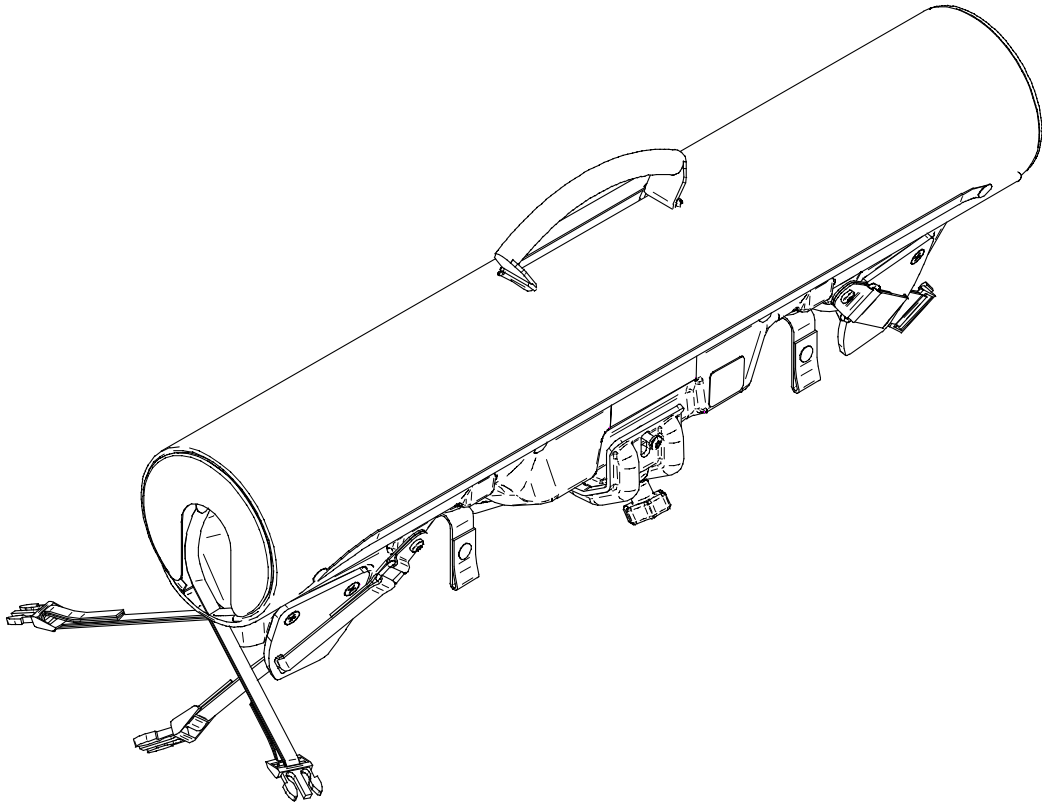

# Pendant Assembly with Motion Control - FA64228-XXX

L64-146-XXX Rev A (Reference Only)

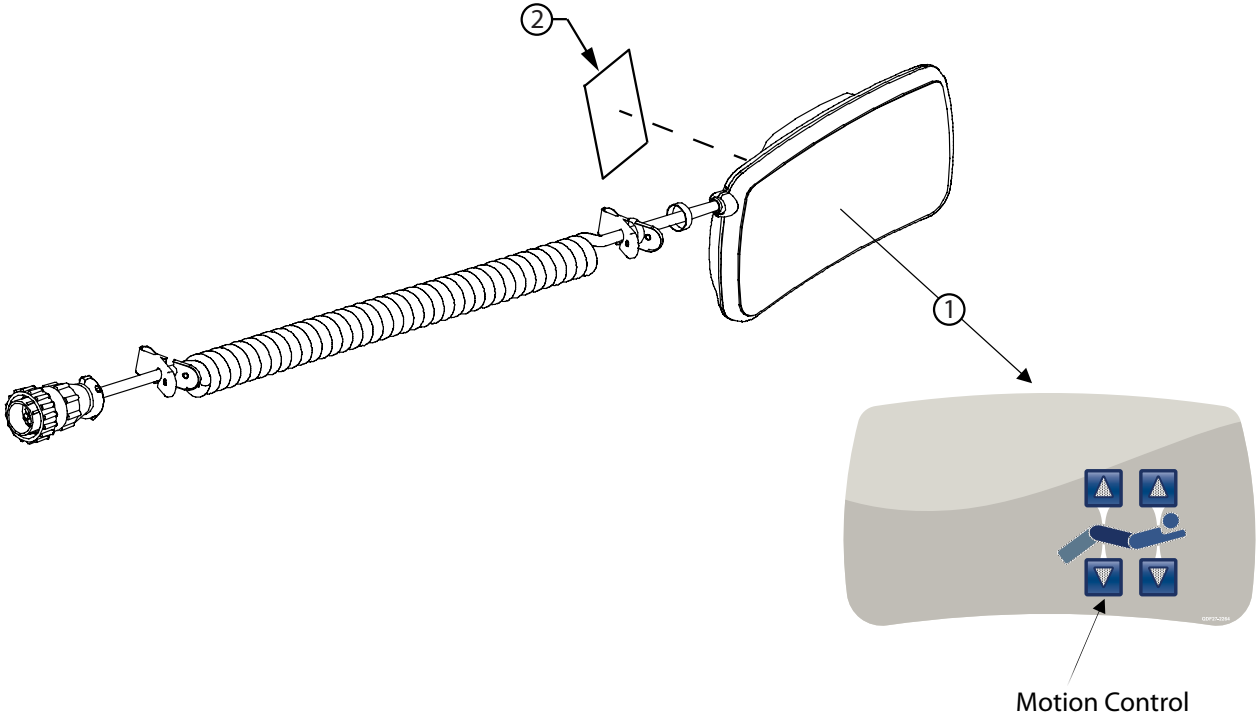

Item	Part No.	Part Name	Qty.
1	QDF64-1240	Removable Pendant with Motion Control	1
2	QE14399-T	Manufacturer Sticker	1

# Pendant Assembly with Motion Control/NC - FA64226

L64-118 Rev 2 (Reference Only)

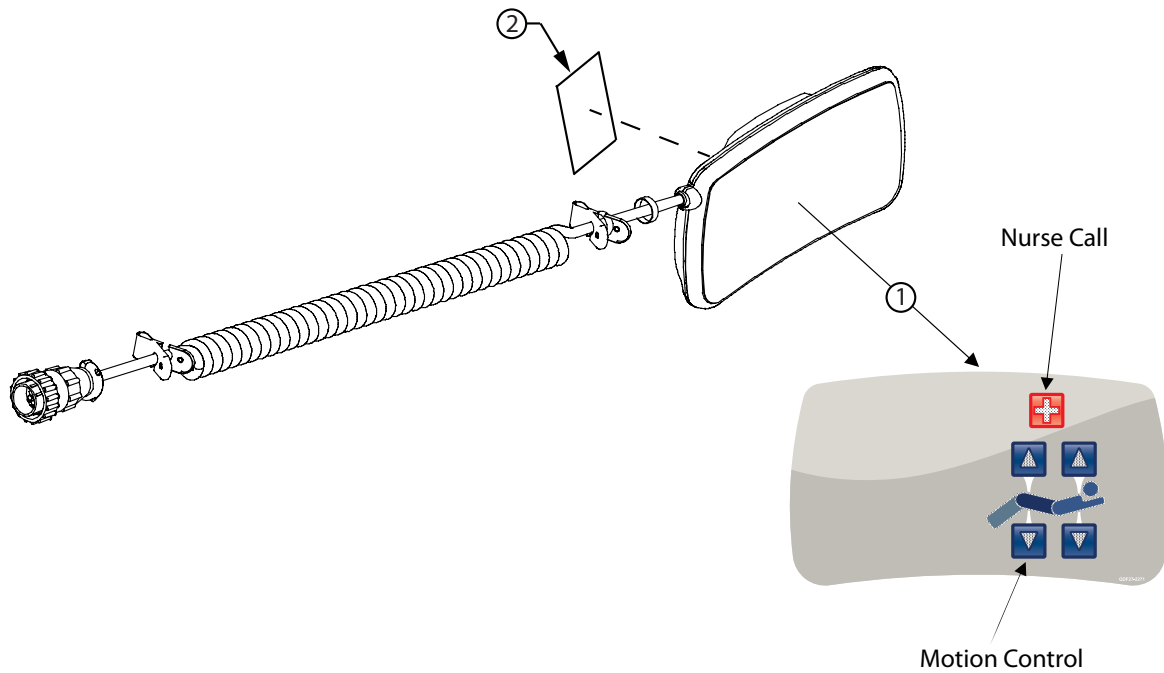

Item	Part No.	Part Name	Qty.
1	QDF64-1238	Removable Pendant with Nurse Call and Motion Control	1
2	QE14399-T	Manufacturer Sticker	1

# Pendant Assembly with Motion Control/Smart TV - FA64227

L64-119 Rev 3 (Reference Only)

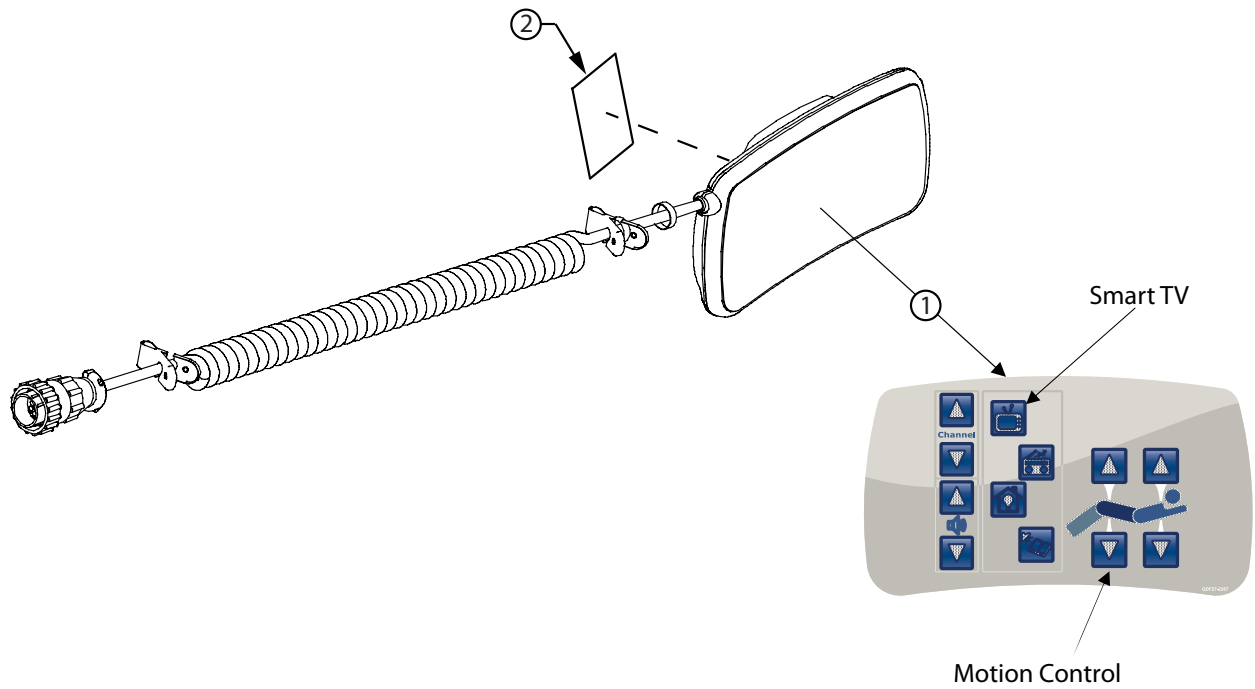

Item	Part No.	Part Name	Qty.
1	QDF64-1239	Removable Pendant with Motion Control and Smart TV	1
2	QE14399-T	Manufacturer Sticker	1

# Pendant Assembly with Motion Control/NC/Smart TV - FA64225

L64-117 Rev 2 (Reference Only)

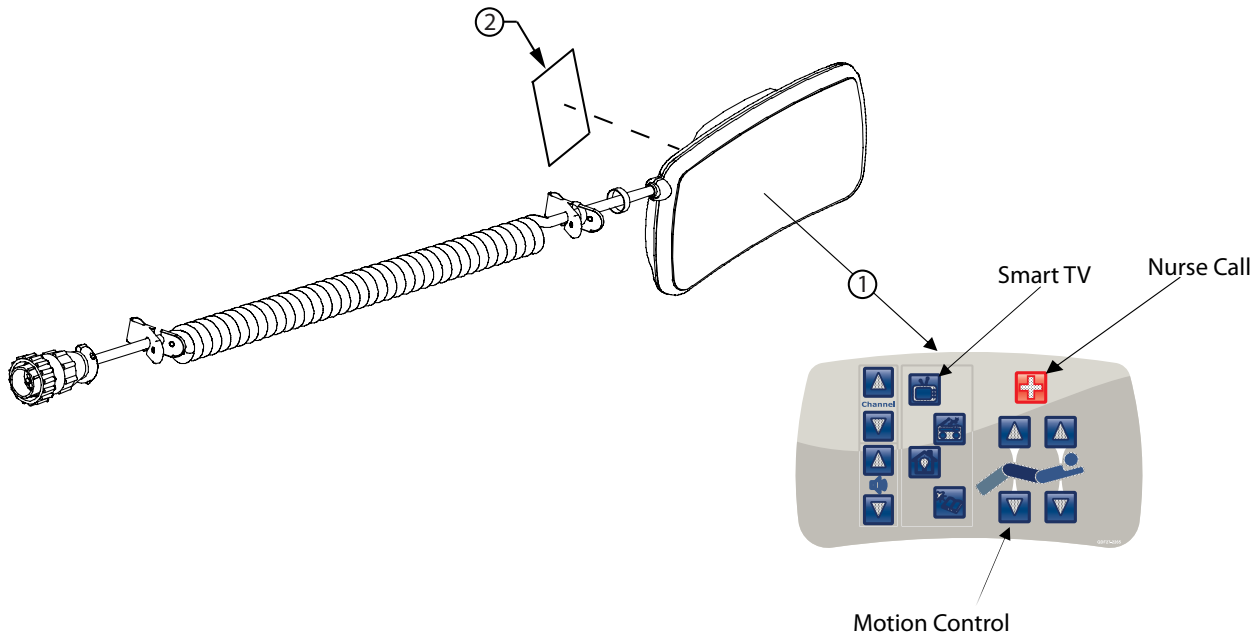

Item	Part No.	Part Name	Qty.
1	QDF64-1237	Removable Pendant with Nurse Call, Motion Control and Smart TV	1
2	QE14399-T	Manufacturer Sticker	1

# Pendant Clip Assembly - FA64186-XXX

L64-111-XXX Rev A (Reference Only)

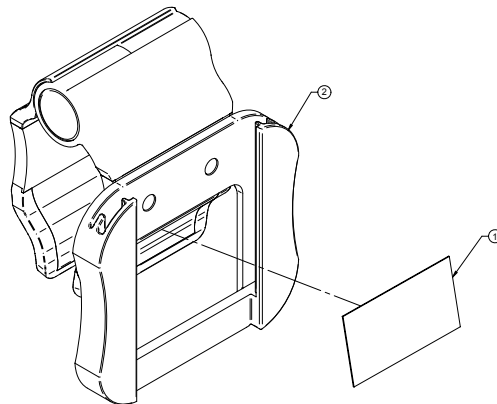

Item	Part No.	Part Name	Qty.
1	QE71-1350-XXX	Manufacturer Sticker	1
2	QDF64-1282	Additional Removable Grip	1

# Roller Bumpers

OL270050 Rev 04 (Reference Only)

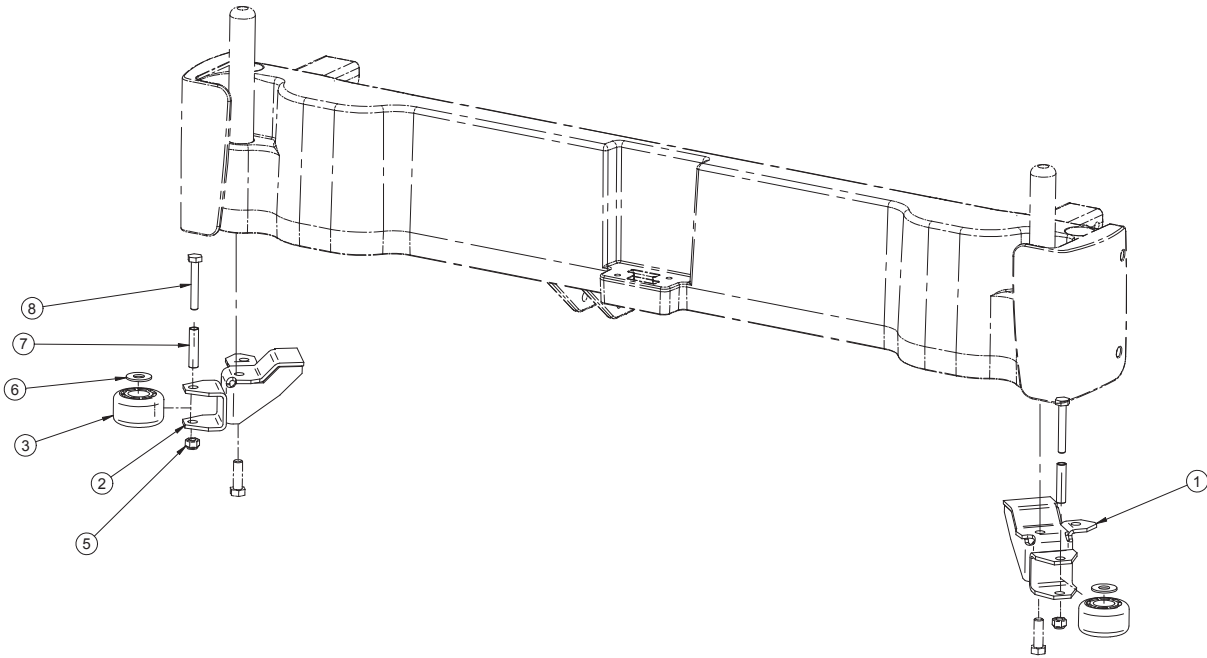

Item	Part No.	Part Name	Qty.
1	27-2046P	Left Bumper Support	1
2	27-2056P	Right Bumper Support	1
3	QPC27-2059	Wheel, 1 3/4" Diameter	2
5	VE30A1N	Nylon Locknut	2
6	VW10C122802	Nylon Washer	2
7	27-2235Z	Bumper Spacer	2
8	VB15A1N44	Bolt	2

# Traction Sleeve Assembly, 4 in. x 1/2 in. - FA64215-XXX

L64-134-XXX Rev A (Reference Only)

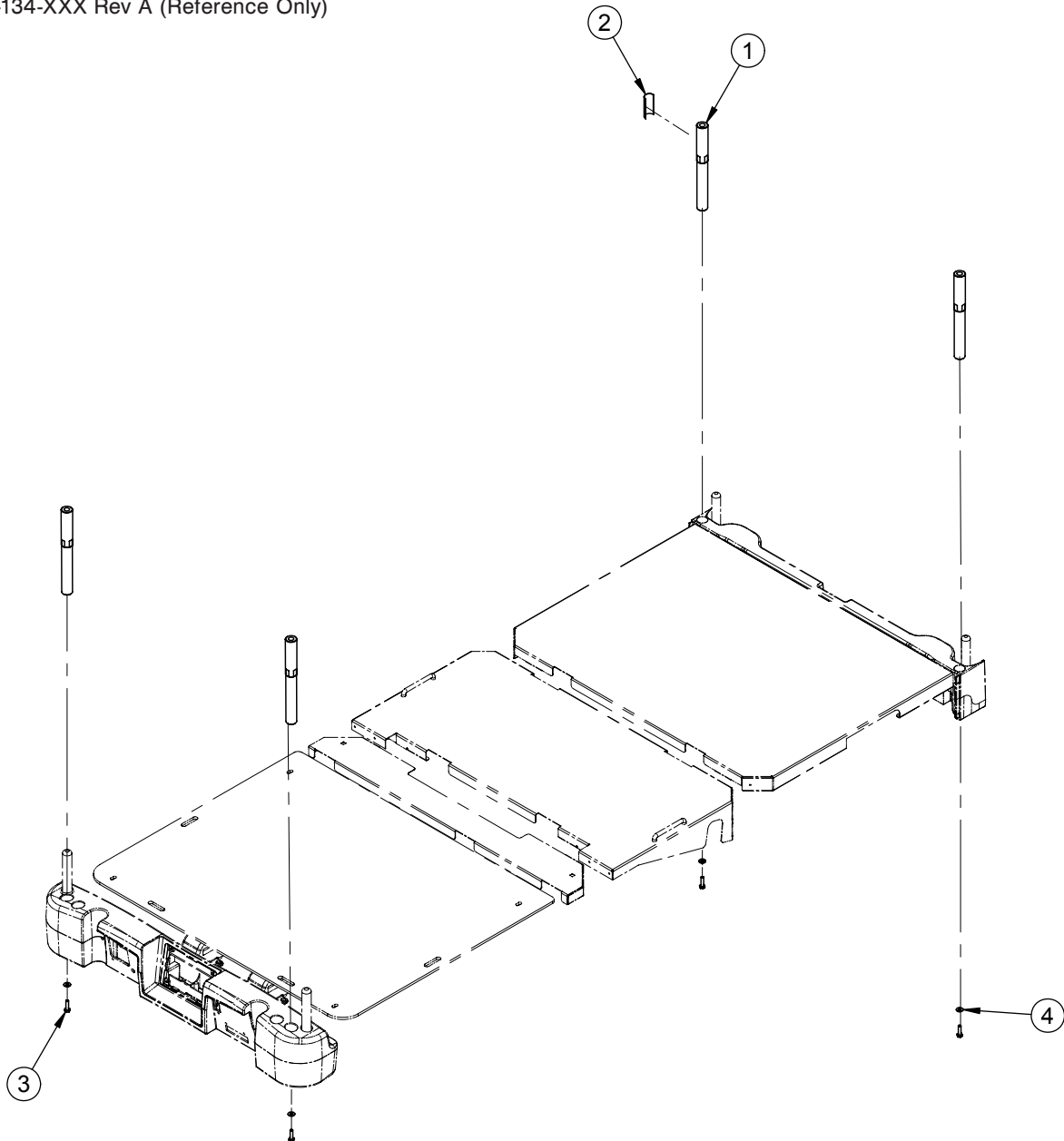

Item	Part No.	Part Name	Qty.
1	64-1262C	Traction Sleeve 4" x 1/2"	4
2	QE71-1350-XXX	Manufacturer Sticker	1
3	VB15A1N32-S	Hex Bolt	4
4	VW10A08	Flat Washer	4



# Traction Sleeve Assembly, 4 in. x 3/4 in. - FA64216-XXX

L64-135-XXX Rev A (Reference Only)

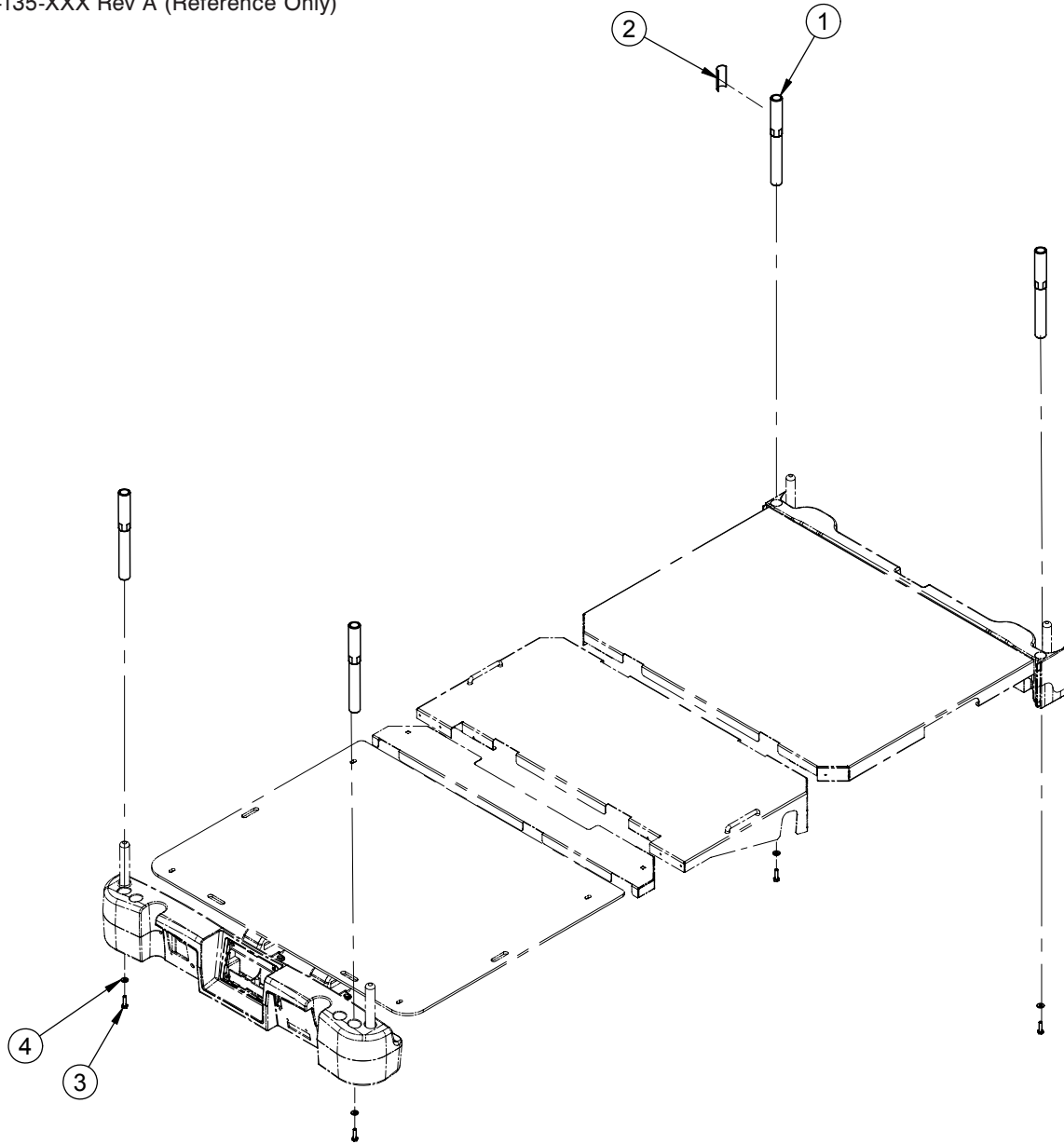

Item	Part No.	Part Name	Qty.
1	64-1263C	Traction Sleeve 4" x 3/4"	4
2	QE71-1350-XXX	Manufacturer Sticker	1
3	VB15A1N32-S	Hex Bolt	4
4	VW10A08	Flat Washer	4

# Traction Sleeve Assembly, 8 in. x 1/2 in. - FA64217-XXX

L64-136-XXX Rev A (Reference Only)

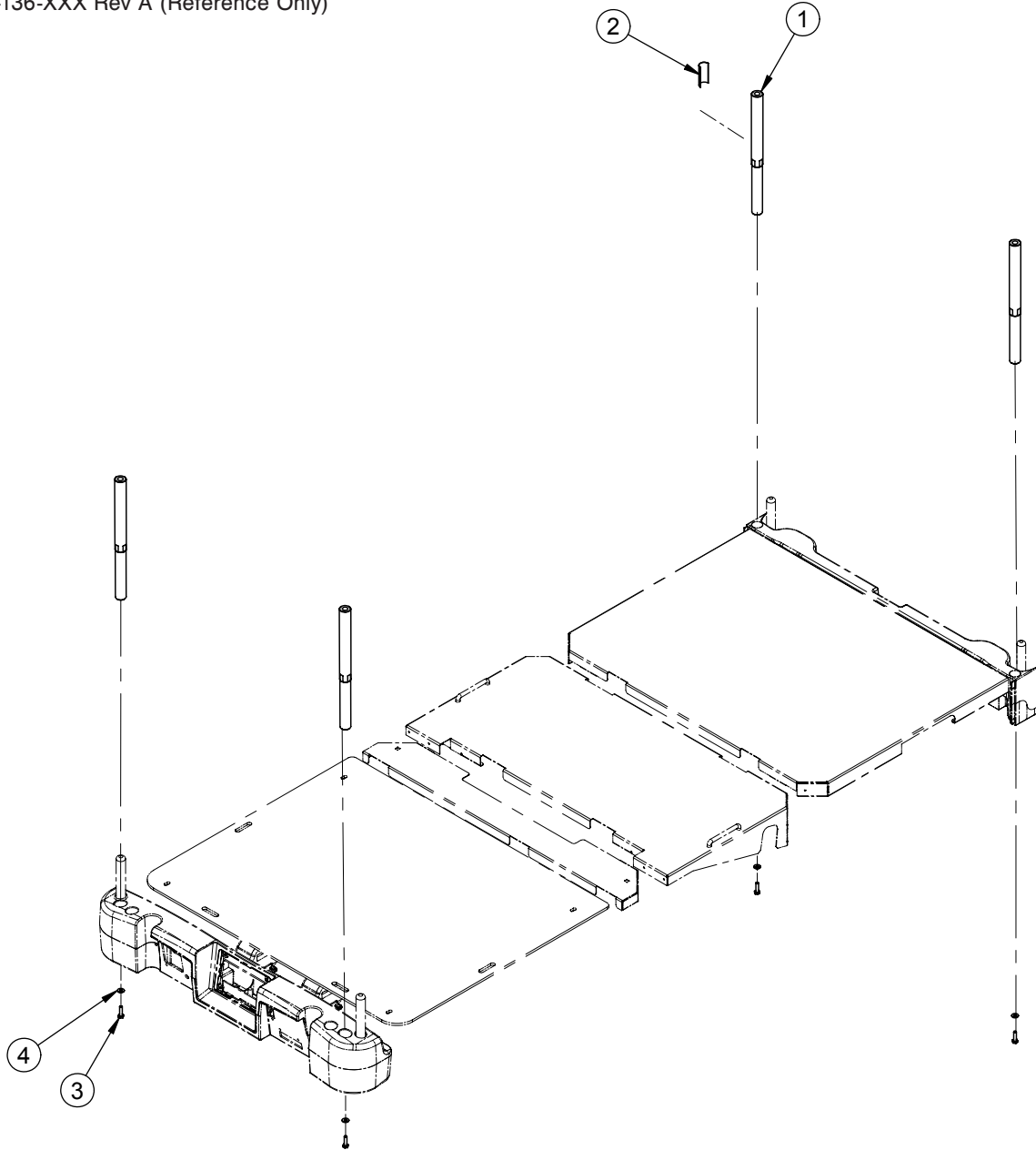

Item	Part No.	Part Name	Qty.
1	64-1264C	Traction Sleeve 8" x 1/2"	4
2	QE71-1350-XXX	Manufacturer Sticker	1
3	VB15A1N32-S	Hex Bolt	4
4	VW10A08	Flat Washer	4

# Traction Sleeve Assembly, 8 in. x 3/4 in. - FA64218-XXX

L64-137-XXX Rev A (Reference Only)

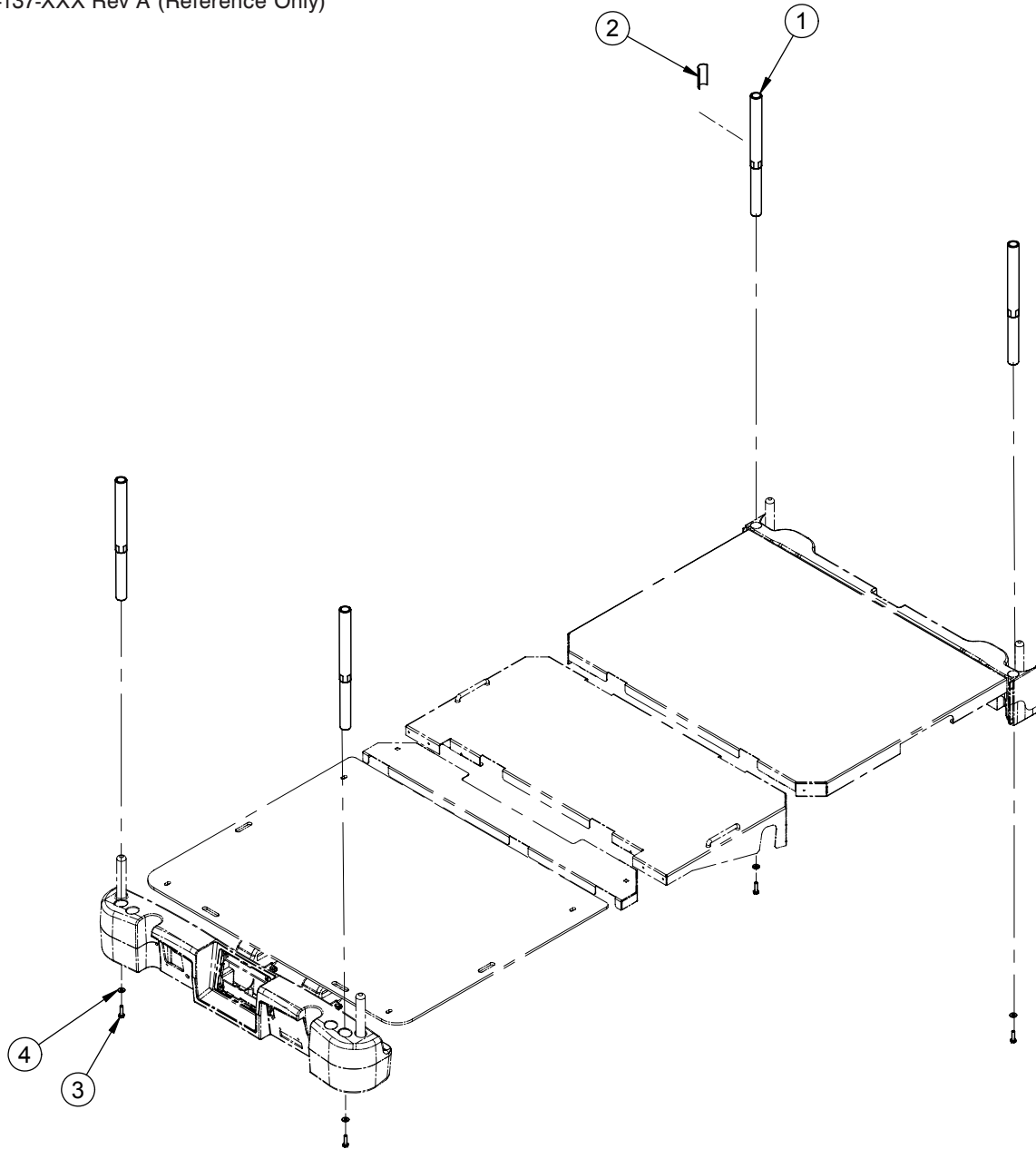

Item	Part No.	Part Name	Qty.
1	64-1265C	Traction Sleeve 8" x 3/4"	4
2	QE71-1350-XXX	Manufacturer Sticker	1
3	VB15A1N32-S	Hex Bolt	4
4	VW10A08	Flat Washer	4

# Traction Sleeve Assembly, 6-1/2 in. x 3/4 in. - FA64219-XXX

L64-138-XXX Rev A (Reference Only)

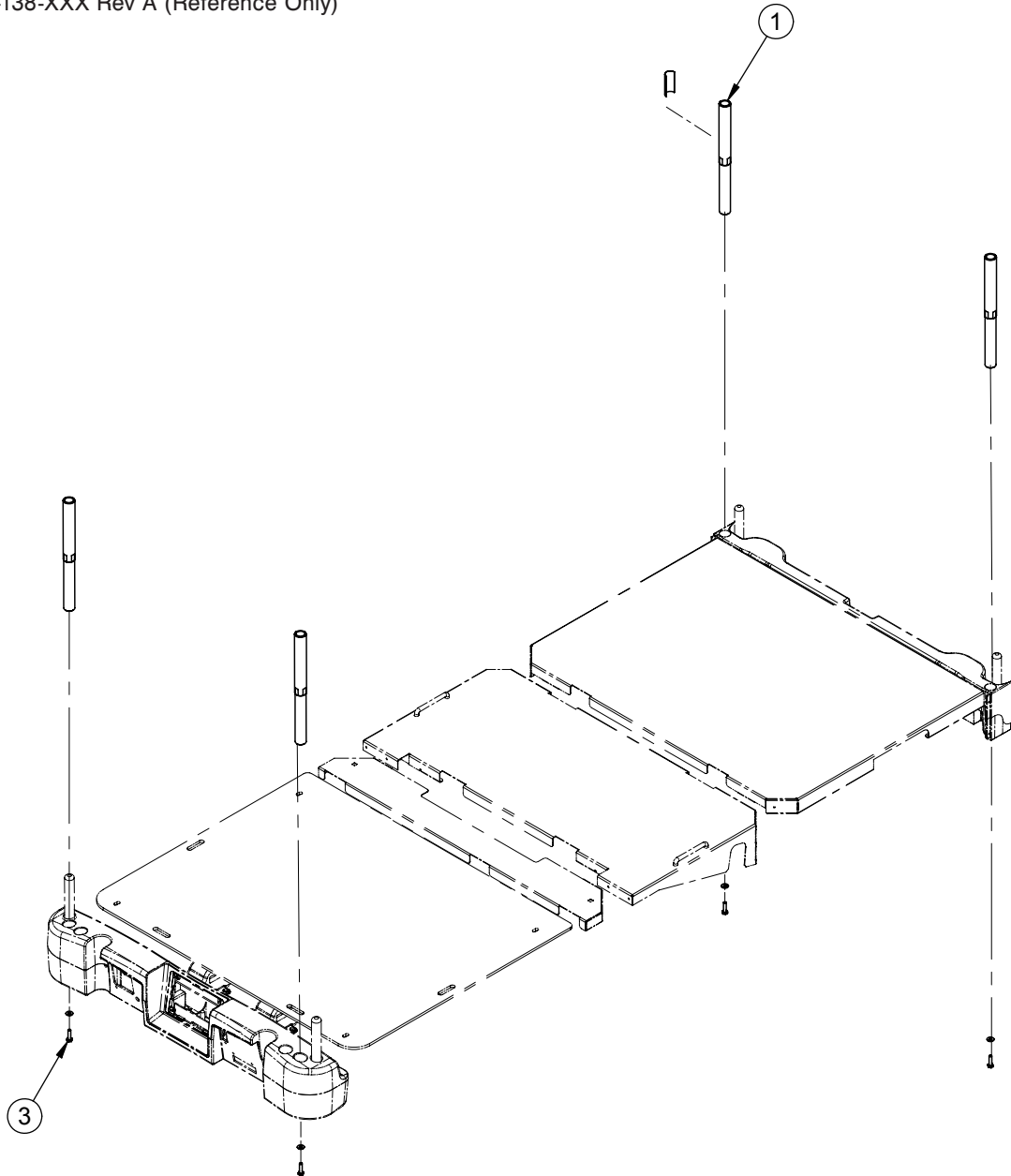

Item	Part No.	Part Name	Qty.
1	64-1266C	Traction Sleeve 6-1/2" x 3/4"	4
2	QE71-1350-XXX	Manufacturer Sticker	1
3	VB15A1N32-S	Hex Bolt	4
4	VW10A08	Flat Washer	4

# Wall Saver Cable Assembly - FA64208

---

L64-129 Rev-03 (Reference Only)

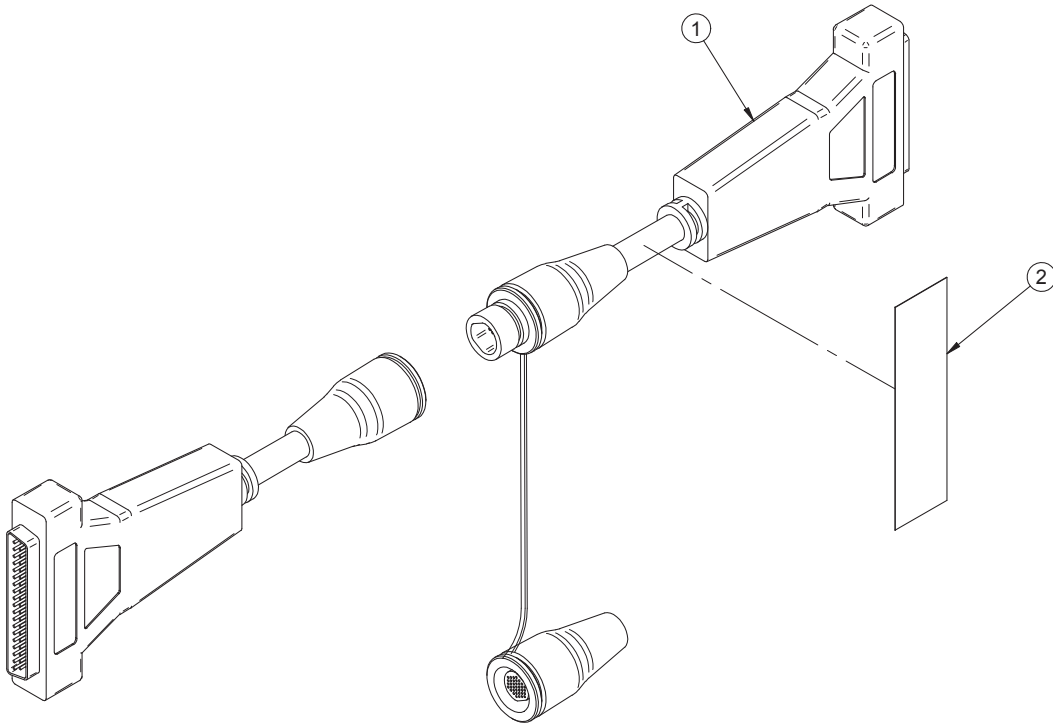

Item	Part No.	Part Name	Qty.
1	QDF64-1371	Wall Saver	1
2	QE71-1313-T	Sticker Manufacturing	1

# X-ray Cassette Holder Assembly - FA64205-XXX

L64-123-XXX Rev A (Reference Only)

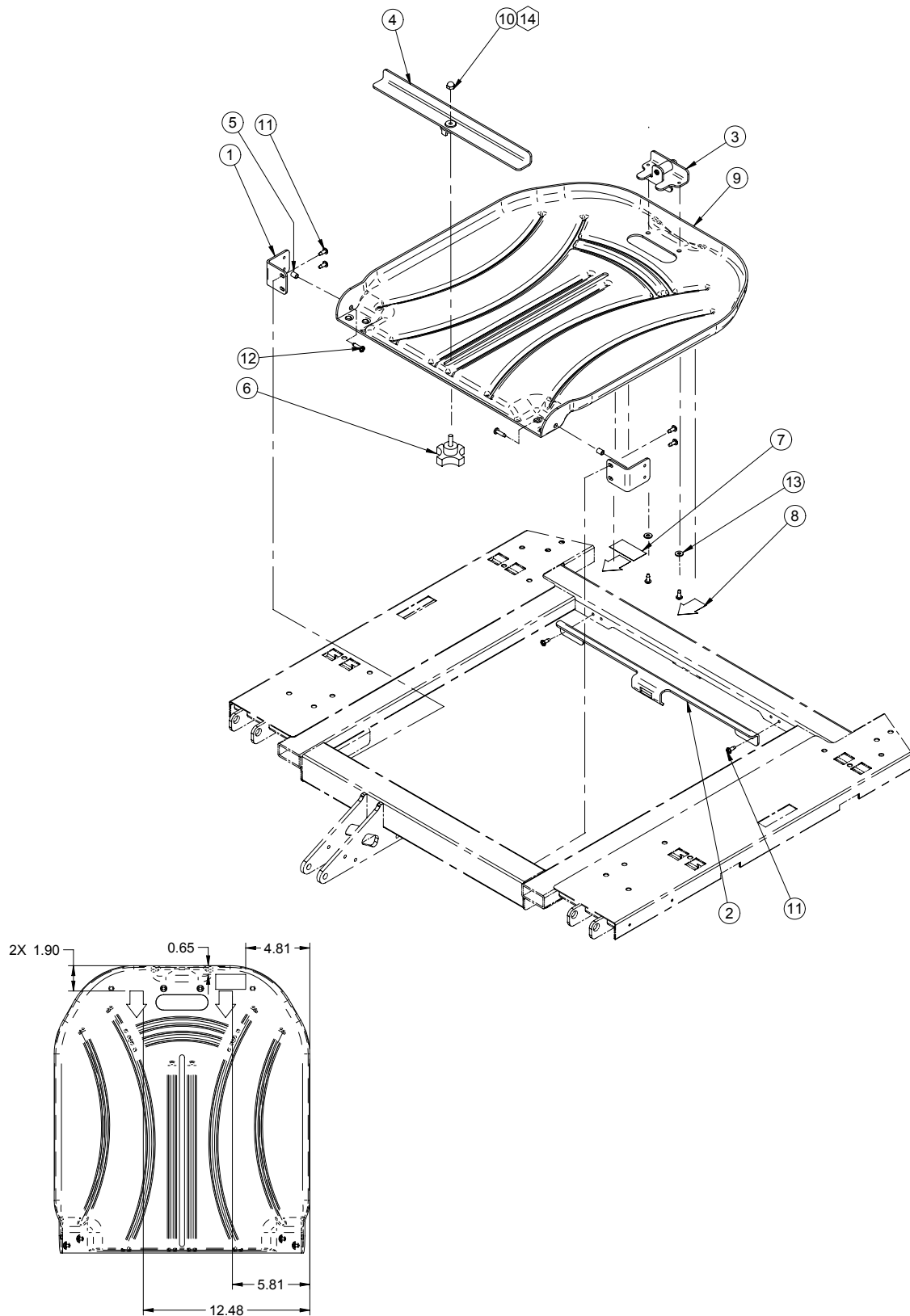

# X-ray Cassette Holder Assembly - FA64205-XXX

---

## X-Ray Cassette Holder Assembly - L64-123-XXX Rev A (Reference Only)

Item	Part No.	Part Name	Qty.
1	64-1199Z	Right Cassette Holder Pivot Point	2
2	64-1372P	Fastener	1
3	64-1255	Plunger	1
4	64-1260Z	Cassette Support	1
5	64-1276	X-Ray Cassette Support Spacer	2
6	QDF2093	X-Ray Cassette	
		Manual Tightening Screw	1
7	QE71-1350-XXX	Manufacturer Sticker	1
8	QE71-1080	X-Ray Cassette Handle Sticker	2
9	QP64-1185	X-Ray Cassette for Plate	1
10	VE40A1N	Cap Nut	1
11	VV83A9G16	Phillips Head Tapping Screw	8
12	VV83A9G24	Phillips Head Tapping Screw	2
13	VW10A06	Flat Washer	2
14	M0008	Threadlocker	
		Medium Strength (Blue)	-

# Tube Support

OL270224-XXX Rev 01 (Reference Only)

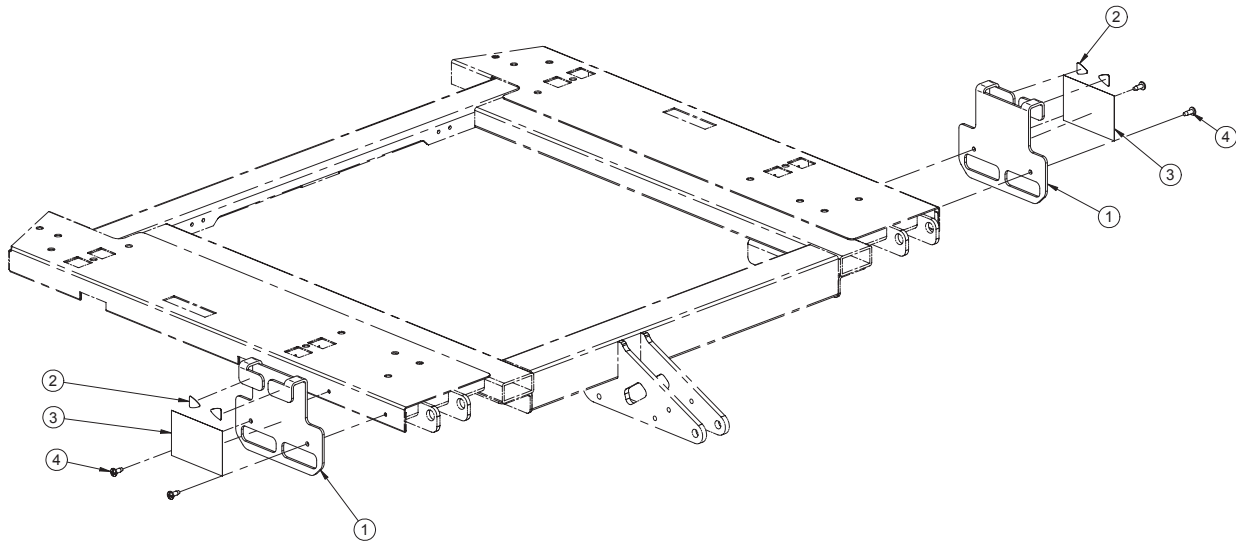

Item	Part No.	Part Name	Qty.
1	27-2518P	Tube Support	2
2	QE71-0498	Triangular Sticker	4
3	QE71-1248-XXX	Sticker to Drainage Tube	2
4	VV83A9G24	Pan Phillips Head Screw	4



# FCC Notification

## NOTIFICATIONS

- FCC ID: Z7A-SDMAC
- IC NO. : 4919E-SDMAC

## Notice

### Federal Communication Interference Statement (United States Only)

This equipment has been tested and found to comply with the limits for a class B digital device, pursuant to Part 15 of the FCC rules. These limits are designed to provide reasonable protection against harmful interference in a residential installation. This equipment generates, uses, and can radiate radio frequency energy and, if not installed and used in accordance with the instructions, may cause harmful interference to radio communications. However, there is no guarantee that interference will not occur in a particular installation. If this equipment does cause harmful interference to radio or television reception, which can be determined by turning the equipment off and on, the user is encouraged to try to correct the interference by one or more of the following measures:

- Re-orient or relocate the receiving antenna
- Increase the separation between the equipment and receiver
- Connect the equipment to an outlet on a circuit different from that to which the receiver is connected
- Consult the dealer or an experienced radio/TV technician for help

This device and its antenna(s) must not be co-located or operation in conjunction with any other antenna or transmitter.

For product available in the USA/Canada market, only channels 1-11 can be operated. Selection of other channels is not possible.

If this device is to be operated in the 5.15~5.25GHz frequency range, it is restricted to indoor environments only.

Antenna: Proprietary

Antenna gain information: Embedded Antenna: 2.5dBi (2.4 GHz), 3.5dBi (5 GHz)

Frequency Tolerance +/-20ppm

# Recycling Passports

Assembly Part number: 27-2287/27-2288 (Reference Only)

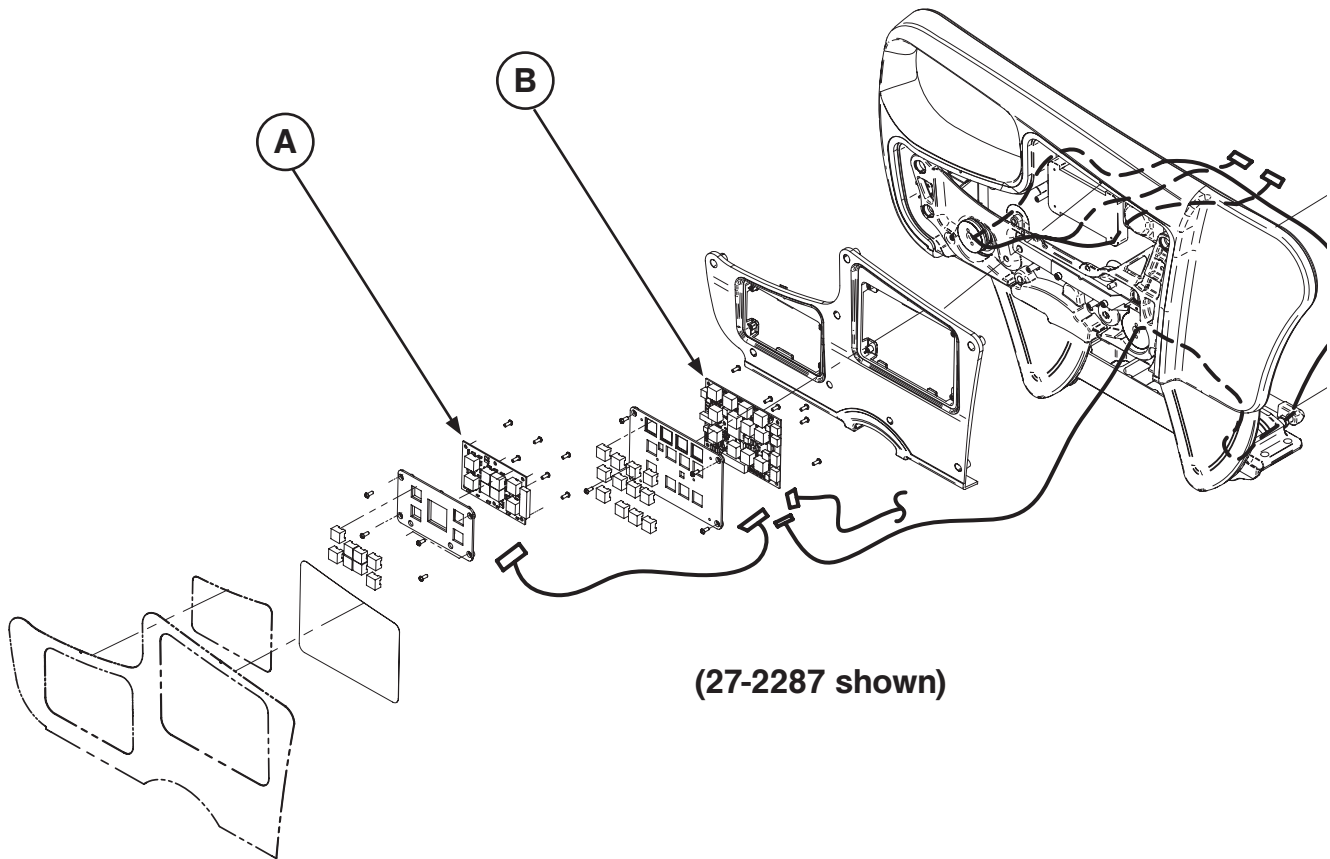

(27-2287 shown)

Item	Recycling/Material Code	Important Information	Qty
A	(QDF27-1097) Brake Control Board		2
B	(QDF27-1099) Siderail Nurse Control Board		2

# Recycling Passports

Assembly Part number: OL270311 (Reference Only)

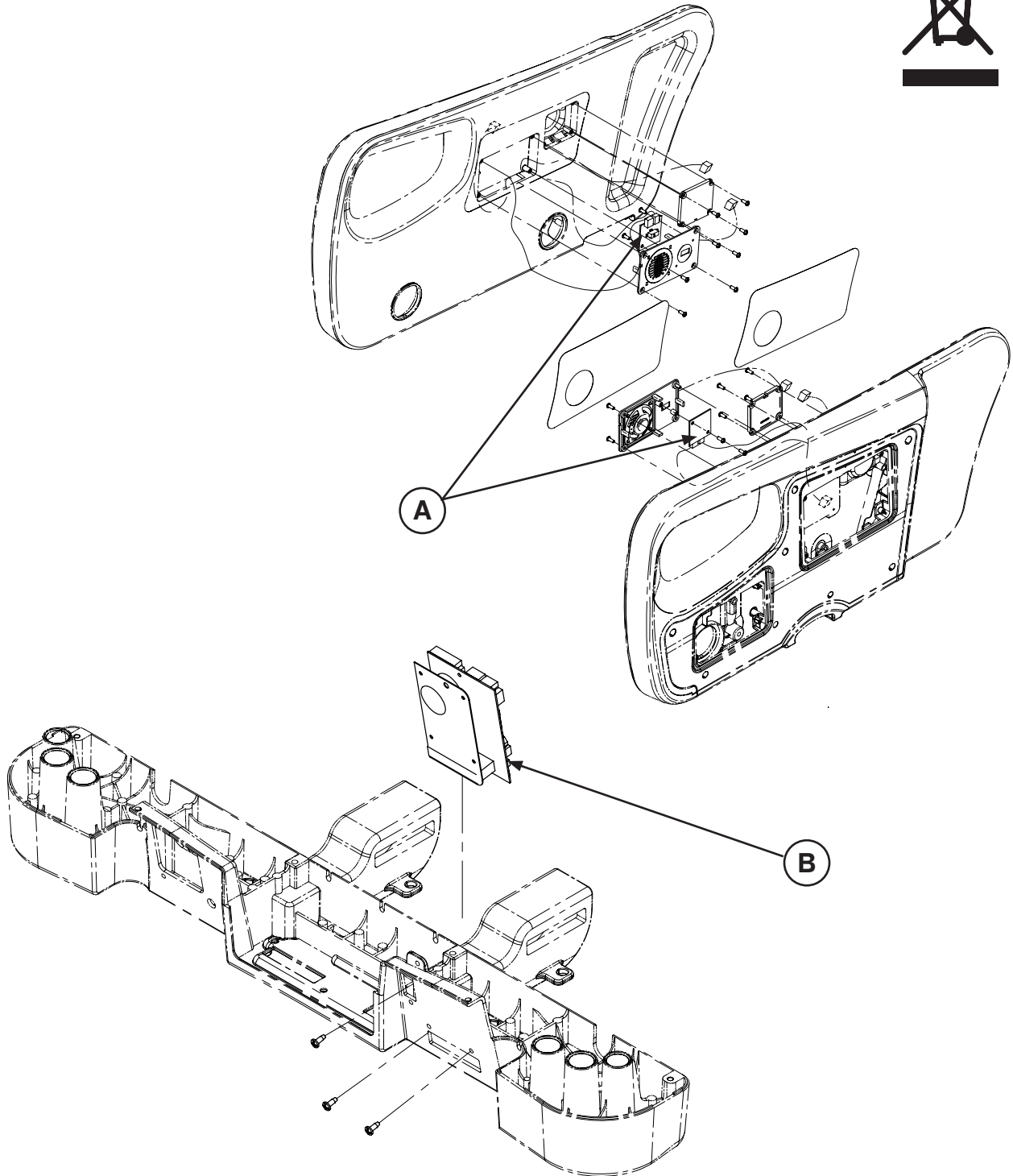

Item	Recycling/Material Code	Important Information	Qty
A	(QDF27-1429) Nurse Call Board		2
B	(QDF75-0270) Room Interface Board		1

[Return To Table of Contents](#)

# Recycling Passports

Assembly Part number: OL270302 (Reference Only)

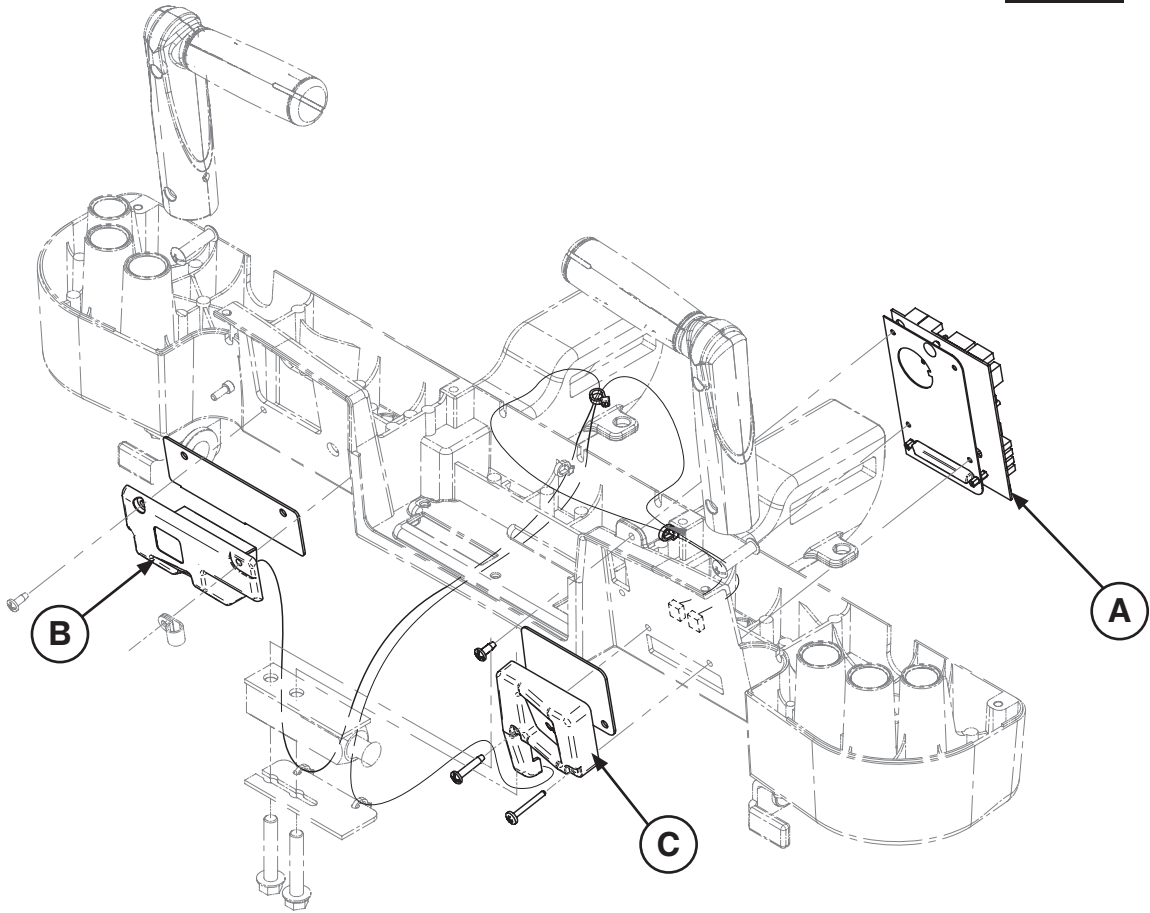

Item	Recycling/Material Code	Important Information	Qty
A	(QDF75-0270) Room Interface Board		1
B	(27-2661) Left IR Module	See page 247	1
C	(27-2662) Right IR Module	See page 248	1

# Recycling Passports

Assembly Part number: OL270032 (Reference Only)

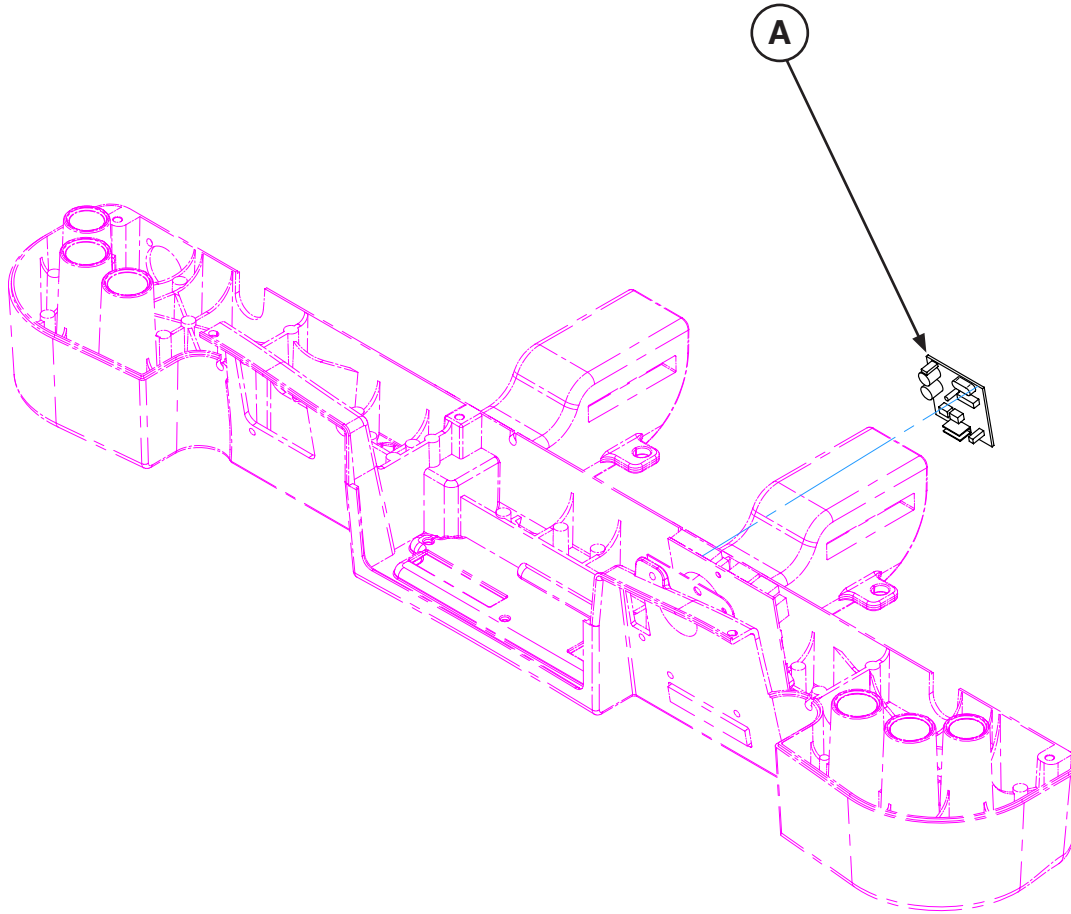

Item	Recycling/Material Code	Important Information	Qty
A	(QDF2060) Smart TV Board		1

# Recycling Passports

Assembly Part number: OL270263-XXX (Reference Only)

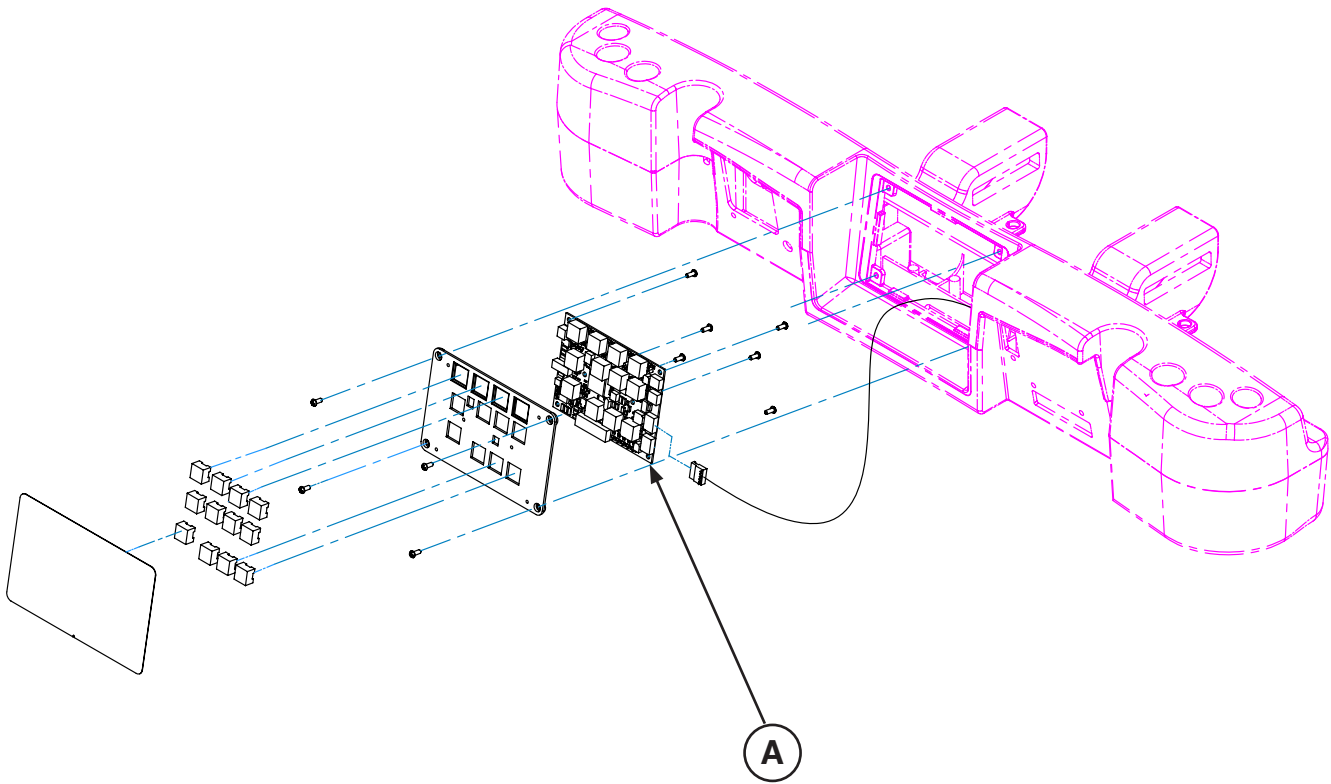

Item	Recycling/Material Code	Important Information	Qty
A	(QDF27-1099) Siderail Nurse Control Board		3

# Recycling Passports

Assembly Part number: 27-2547-XXX (Reference Only)

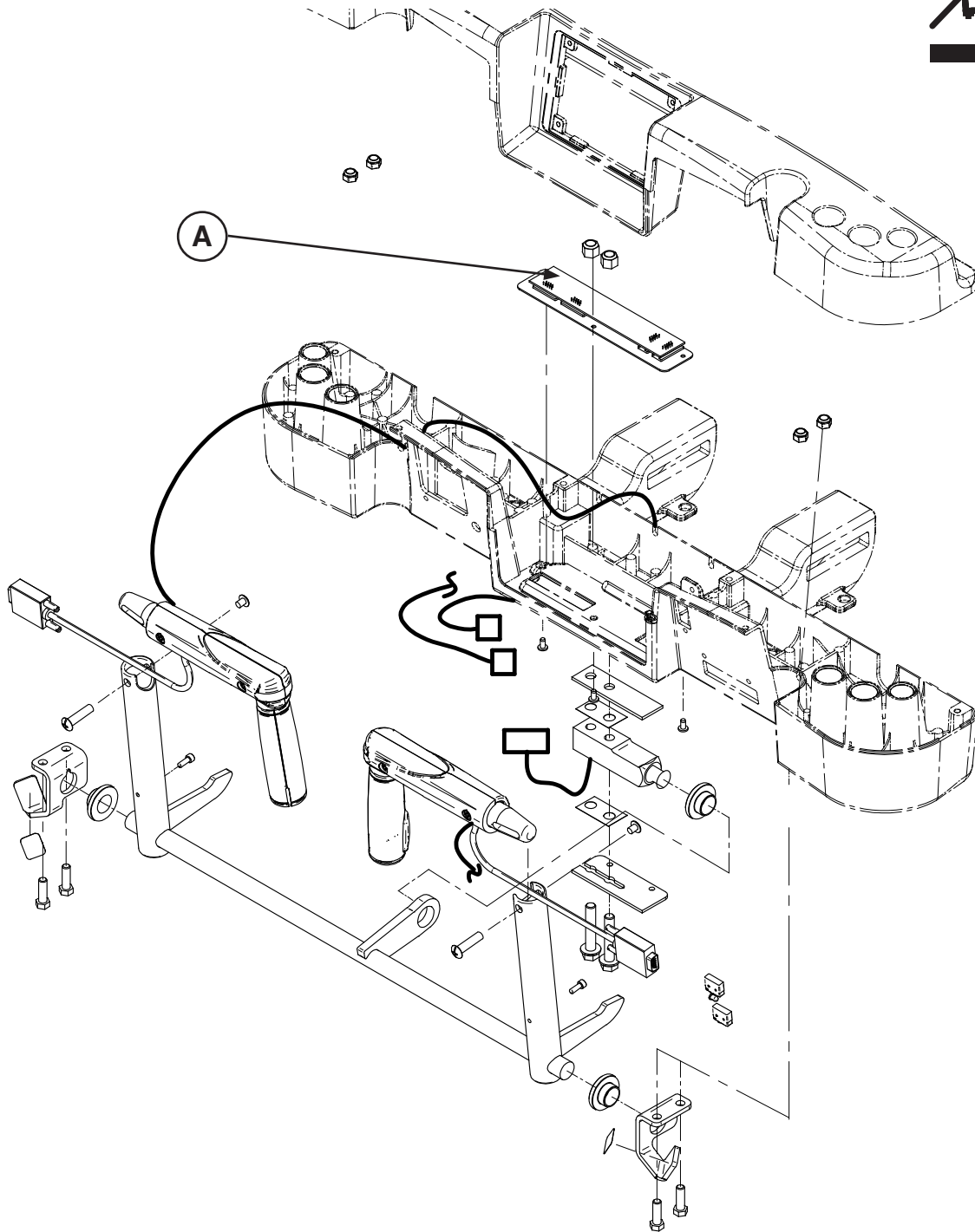

Item	Recycling/Material Code	Important Information	Qty
A	(27-2548) Zoom® Control Board		1

# Recycling Passports

Assembly Part number: OL270327-XXX

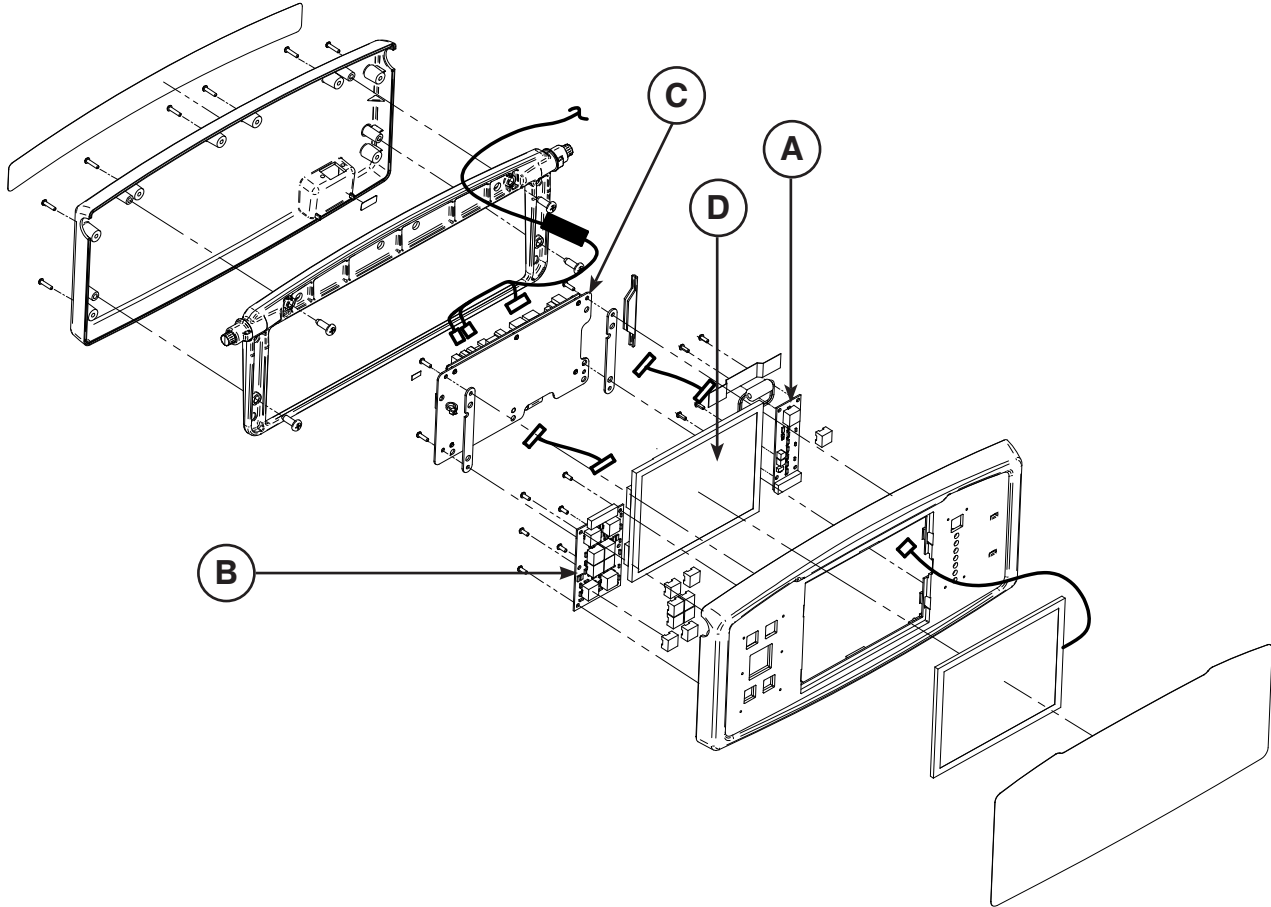

Item	Recycling/Material Code	Important Information	Qty
A	(QDF75-0010) Main Menu Board		1
B	(QDF27-1097) Brake Control Board		1
C	(QDF75-0290) Touch Board Assembly		1
D	(27-2480) LCD Display		1



# Recycling Passports

Assembly Part number: OL270342-XXX (Reference Only)

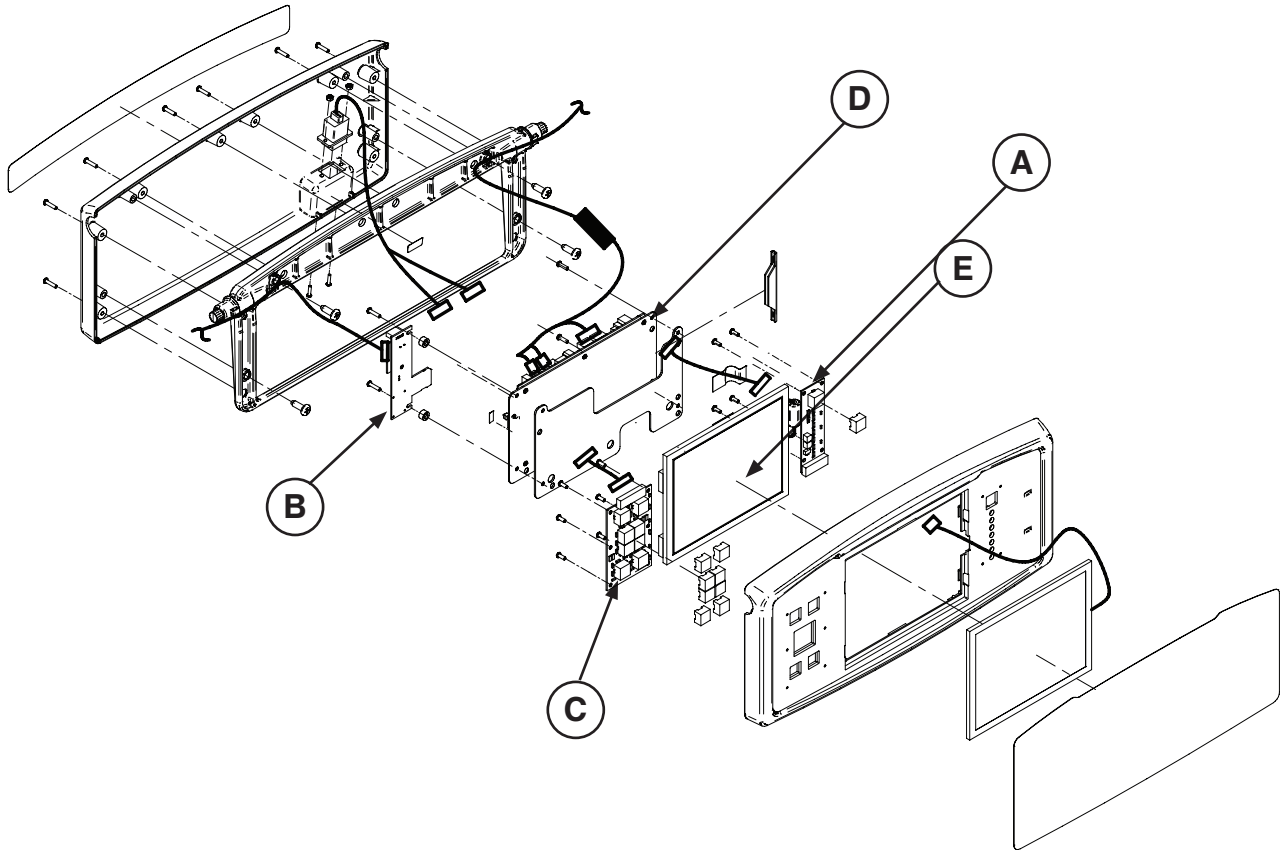

Item	Recycling/Material Code	Important Information	Qty
A	(QDF75-0010) Main Menu Board		1
B	(QDF75-0634) Memory Board Assembly		1
C	(QDF27-1097) Brake Control Board		1
D	(QDF75-0290) Touch Board Assembly		1
E	(27-2480) LCD Display		1

# Recycling Passports

Assembly Part number: 27-2866 (Reference Only)

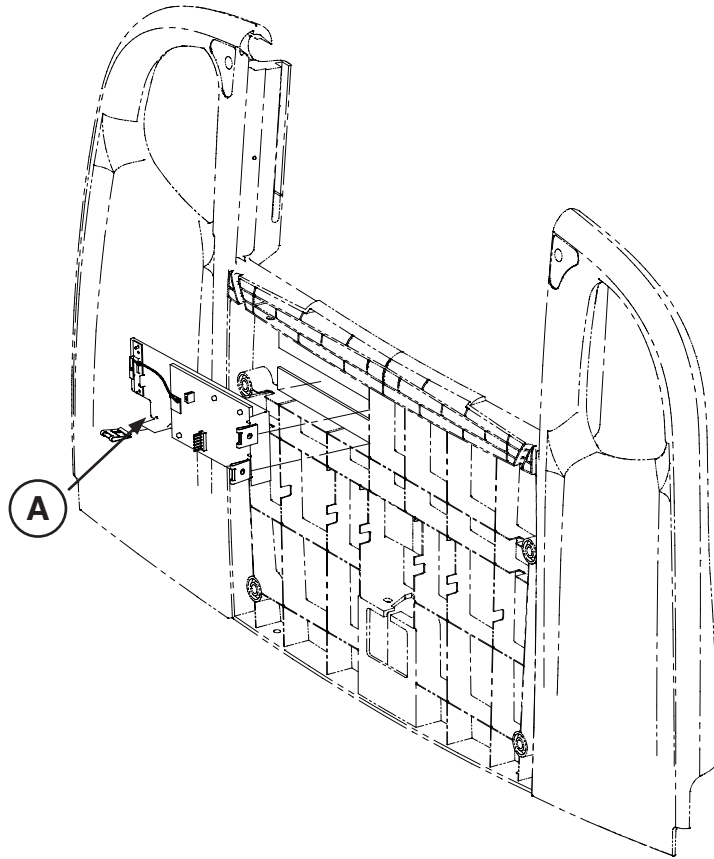

Item	Recycling/Material Code	Important Information	Qty
A	(27-2863) Gateway Board Assembly		1

# Recycling Passports

Assembly Part Number: 27-2688 (Reference Only)

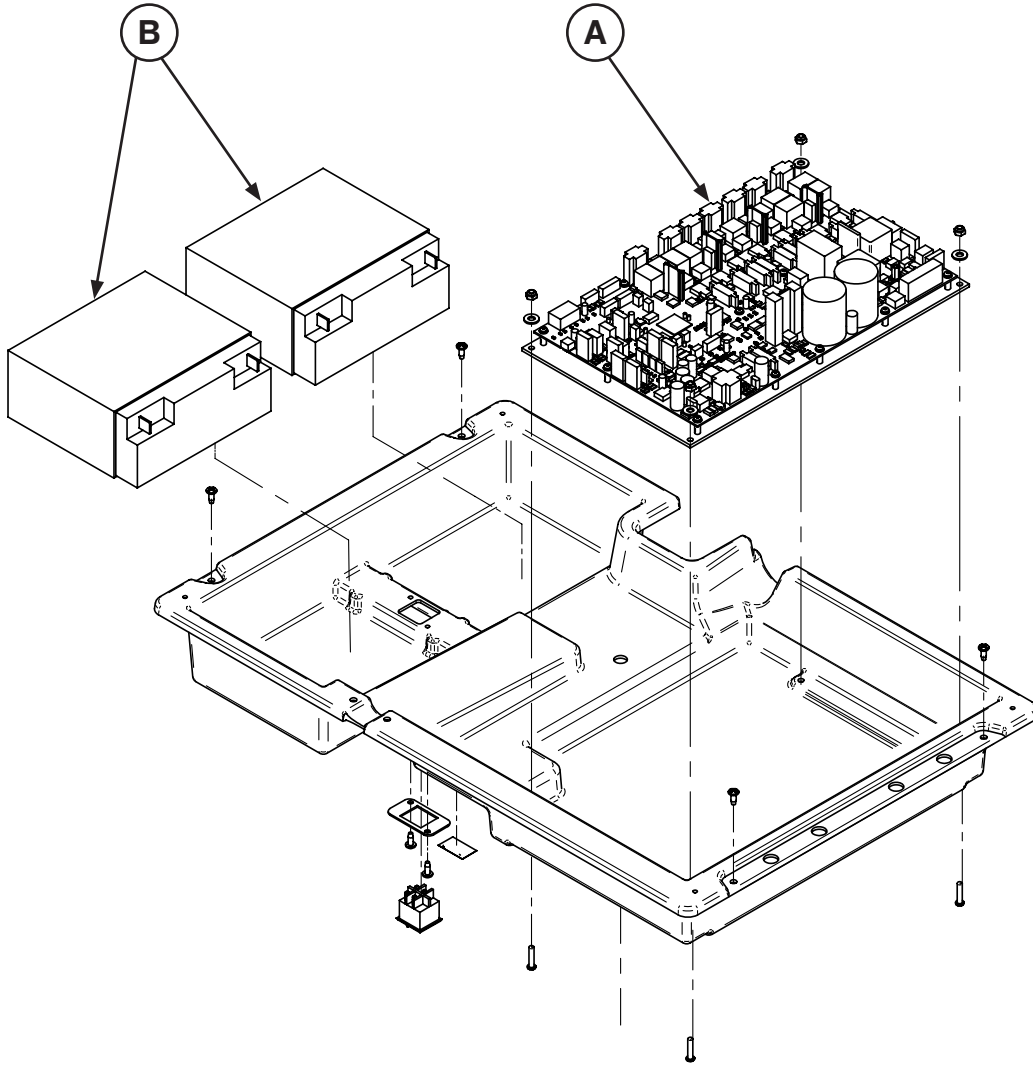

Item	Recycling/Material Code	Important Information	Qty
A	(QDF75-0440) DC Power Control Board		1
B	(QDF9188) 12V 18Ah Battery		2

[Return To Table of Contents](#)

# Recycling Passports

Assembly Part number: 27-2546 (Reference Only)

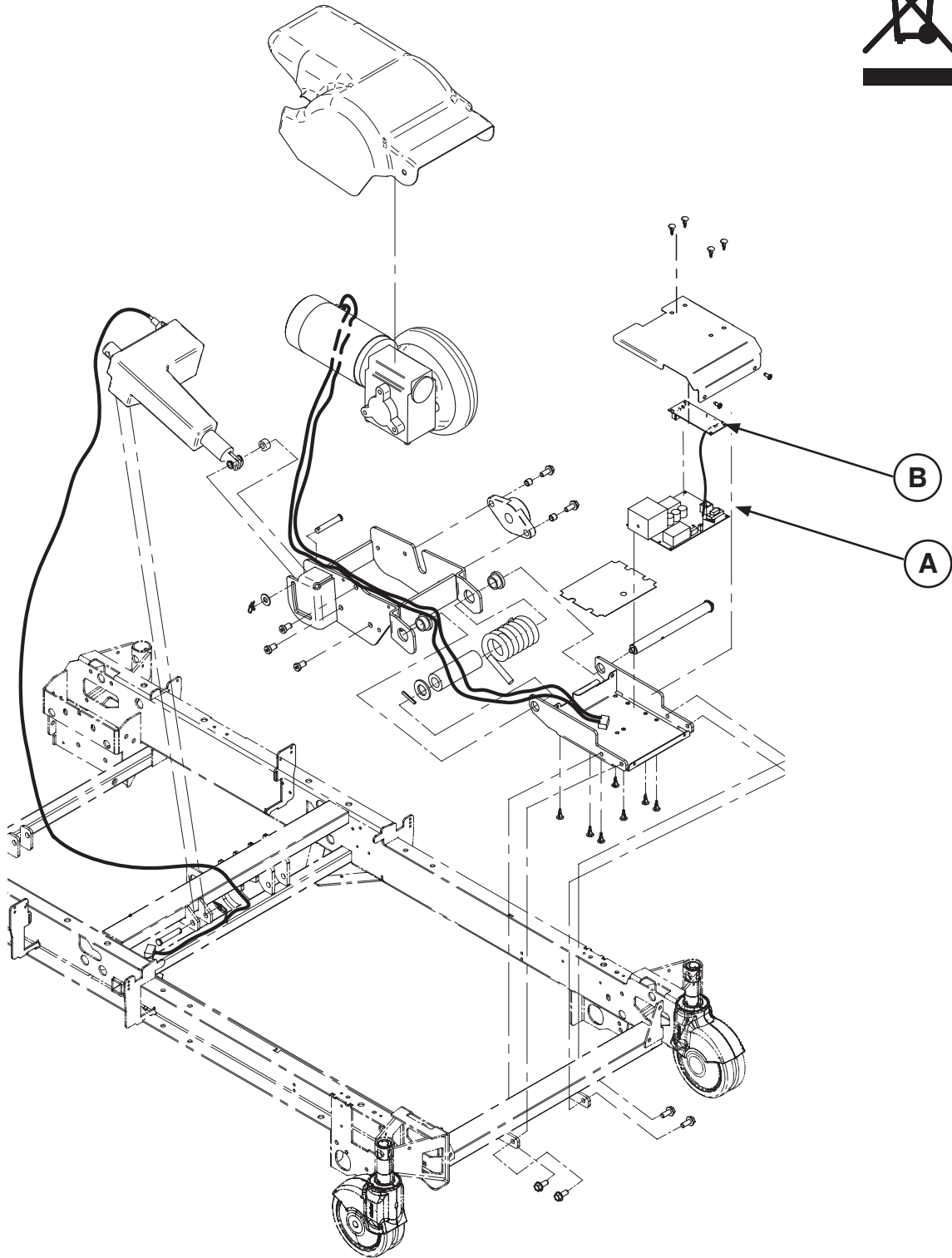

Item	Recycling/Material Code	Important Information	Qty
A	(QDF27-1430) Zoom® Board		1
B	(QDF75-0240) Zoom® Interface Board		1

# Recycling Passports

Assembly Part number: 27-2661 (Reference Only)

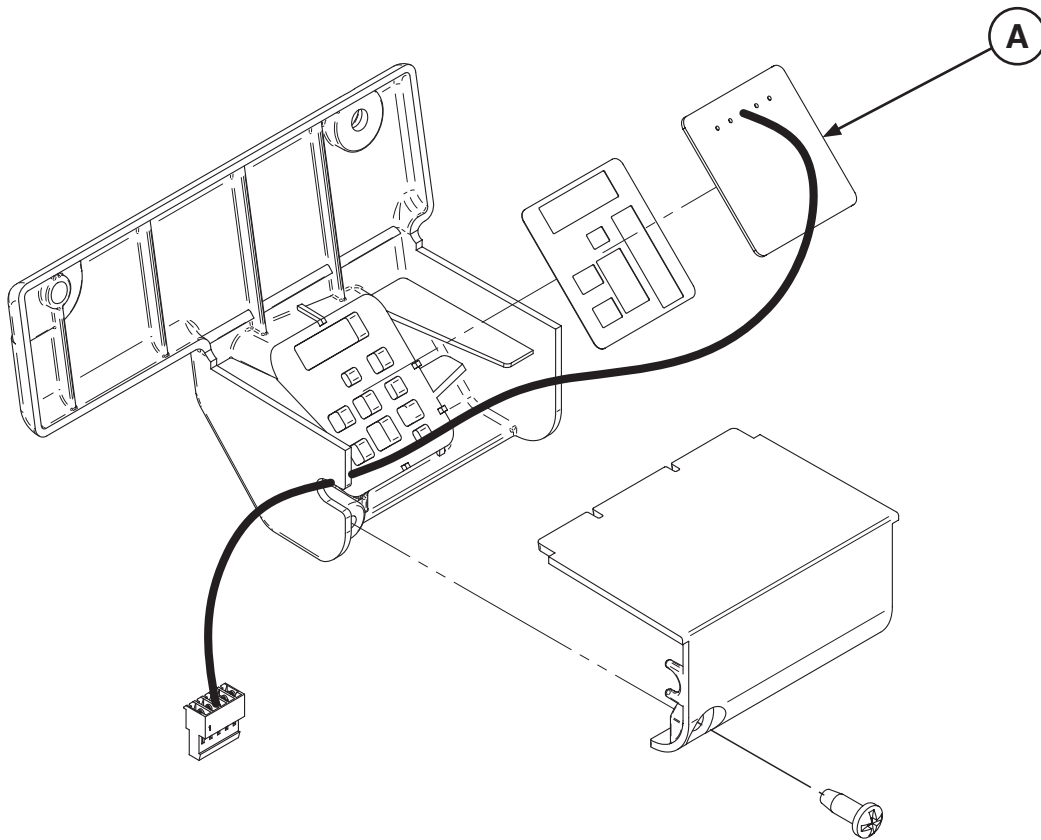

Item	Recycling/Material Code	Important Information	Qty
A	(QDF75-0310) IR Board		1

# Recycling Passports

Assembly Part number: 27-2662 (Reference Only)

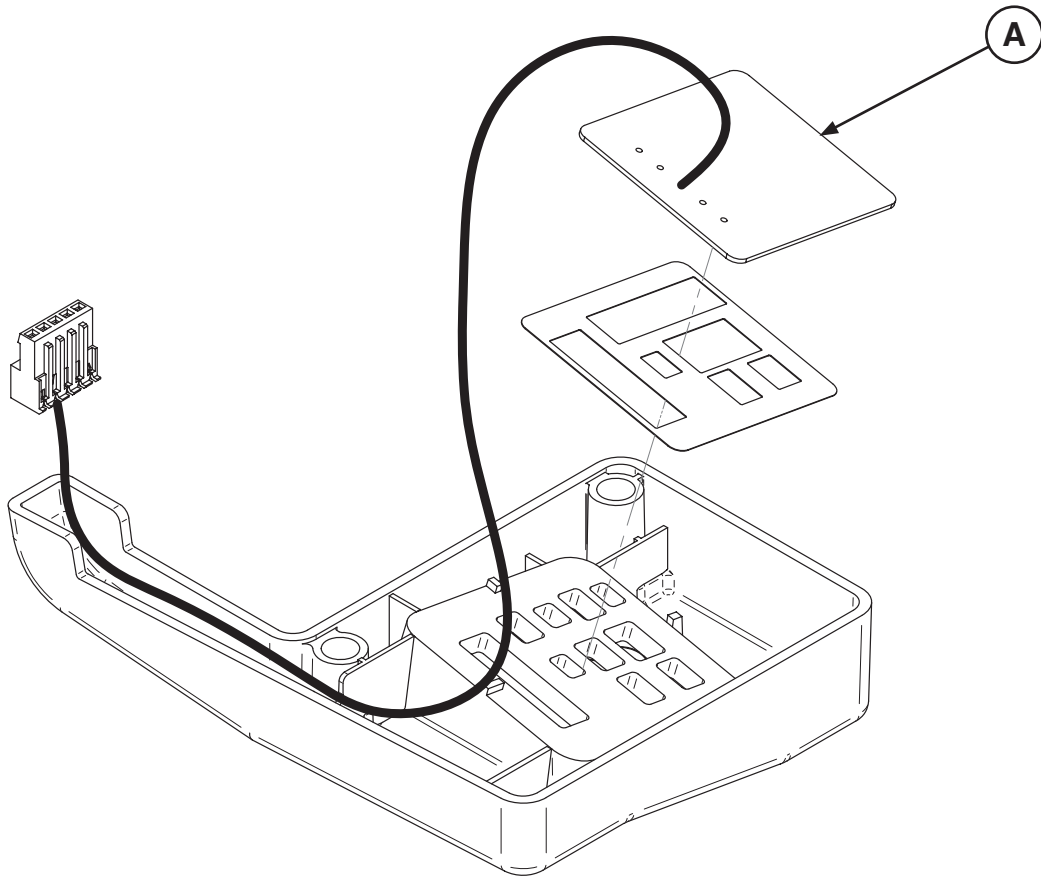

Item	Recycling/Material Code	Important Information	Qty
A	(QDF75-0310) IR Board		1









Manufactured For  
Stryker Medical  
3800 E. Centre Avenue  
Portage, MI 49002  
USA

**stryker**<sup>®</sup>