IMPORTANT
Keep manual
on file at all
times.

stryker[®]
Medical



Model 6080 MX-PRO[™]

▲RUGGED▲[™] **Ambulance Cot**

OPERATIONS/MAINTENANCE MANUAL

For cots with serial numbers of 000939122 and higher

For Parts or Technical Assistance

1-800-327-0770

Table of Contents

Introduction	
Specifications	2
Warning / Caution / Note Definition	2
Warranty	3
Obtaining Parts and Service	3
Supplemental Warranty Coverage	3
Return Authorization	4
Freight Damage Claims	4
Summary of Safety Precautions	5
Set-Up Procedures	6
Component Identification	7
Vehicle Safety Hook Installation	8
Cot Positions	9
Using Restraint Straps	10, 11
Transferring the Patient to the Cot	12
Rolling the Cot	12
Loading the Cot into a Vehicle	13
Unloading the Cot from a Vehicle	14
Operating Optional Wheel Lock	14.1
Changing Cot Height	15
Adjusting Leg Rest	16
Operating Backrest	17
Operating Siderails	17
Operating Break-away Head Section	18
Operating 3-Stage I.V. Pole	19
Preventative Maintenance	
Cleaning	20
Preventative Maintenance Schedule & Checklist	21
Pneumatic Fowler Adjustment	22
Maintenance Record	23
Training Record	24
Assembly Drawings and Parts Lists	
Cot Assembly	25-27
Base Assembly	28 - 29.1
Wheel Lock Assembly	29.2
Wheel Assembly	30
Lock Bar Assembly	31
Litter Assembly	32-35
Breakaway Head Assembly	36, 37
Siderail Assembly	38
Upper Lift Tube Assembly	39
Lower Lift Tube Assembly	40
Release Handle Assembly	41
I.V. Pole Mounting Assembly, Right	42
2-Stage I.V. Assembly, Right	44
3-Stage I.V. Assembly, Right	44
I.V. Pole Mounting Assembly, Left	45
2-Stage I.V. Assembly, Left	46
3-Stage I.V. Assembly, Left	47
2-Stage I.V. Pole Assembly	48
3-Stage I.V. Pole Assembly	49
3rd Stage Assembly	50
Oxygen Bottle Holder Assembly	51, 52
Bottle Holder Tray Assembly	53
Pull Handle Assembly	54
Quick Reference Parts List	55

Introduction

INTRODUCTION

This manual is designed to assist you with the operation and maintenance of the 6080 **ARUGGED™** MX-PRO Ambulance Cot. Read it thoroughly before using the equipment or beginning any maintenance on it.

SPECIFICATIONS

Overall Length/Minimum Length/Width	80"/62"/23"
Height ¹ – Position 1	12"
Position 2	19.5"
Position 3	23.5"
Position 4	26.5"
Position 5	29.5"
Position 6	32.0"
Position 7	34.5"
Position 8	37"
Backrest Articulation/Shock Position	0° to 75°/+14°
Weight ²	84 pounds
Maximum Weight Capacity	500 pounds
Caster Diameter/Width	6"/2"
Minimum Operators Required for Loading/Unloading	2
Recommended Fastener Systems	Model 6370 Floor Mount Type Model 6371 Wall Mount Type
Recommended Floor Height	Up to 33"
Roll-In Style	Yes
Wheel Lock	Optional

¹ Height measured from bottom of mattress at seat section to ground level.

² Cot is weighed without mattress and restraints.

Stryker reserves the right to change specifications without notice.

The MX-PRO is designed to conform to the Federal Specification for the Star-of-Life Ambulance KKK-A-1822-D.

WARNING / CAUTION / NOTE DEFINITION

The words WARNING, CAUTION and NOTE carry special meanings and should be carefully reviewed.

WARNING

The personal safety of the patient or user may be involved. Disregarding this information could result in injury to the patient or user.

CAUTION

These instructions point out special procedures or precautions that must be followed to avoid damaging the equipment.

NOTE

This provides special information to make maintenance easier or important instructions clearer.

Warranty

Limited Warranty:

Stryker Medical Division, a division of Stryker Corporation, warrants to the original purchaser that its products should be free from defects in material and workmanship for a period of one (1) year after date of delivery. Stryker's obligation under this warranty is expressly limited to supplying replacement parts and labor for, or replacing, at its option, any product which is, in the sole discretion of Stryker, found to be defective. Stryker warrants to the original purchaser that the frame and welds on its beds will be free from structural defects for as long as the original purchaser owns the bed. If requested by Stryker, products or parts for which a warranty claim is made shall be returned prepaid to Stryker's factory. Any improper use or any alteration or repair by others in such manner as in Stryker's judgement affects the product materially and adversely shall void this warranty. No employee or representative of Stryker is authorized to change this warranty in any way.

Stryker Medical ambulance cots are designed for a 5 year expected life under normal use conditions and appropriate periodic maintenance as described in the maintenance manual for each device.

This statement constitutes Stryker's entire warranty with respect to the aforesaid equipment. STRYKER MAKES NO OTHER WARRANTY OR REPRESENTATION, EITHER EXPRESSED OR IMPLIED, EXCEPT AS SET FORTH HEREIN. THERE IS NO WARRANTY OF MERCHANTABILITY AND THERE ARE NO WARRANTIES OF FITNESS FOR ANY PARTICULAR PURPOSE. IN NO EVENT SHALL STRYKER BE LIABLE HEREUNDER FOR INCIDENTAL OR CONSEQUENTIAL DAMAGES ARISING FROM OR IN ANY MANNER RELATED TO SALES OR USE OF ANY SUCH EQUIPMENT.

To Obtain Parts and Service:

Stryker products are supported by a nationwide network of dedicated Stryker Field Service Representatives. These representatives are factory trained, available locally, and carry a substantial spare parts inventory to minimize repair time. Simply call your local representative, or call Stryker Customer Service at (800) 327-0770.

Supplemental Warranty Coverage:

Stryker has developed a comprehensive program of extended warranty options designed to keep your equipment operating at peak performance at the same time it eliminates unexpected costs. We recommend that these programs be activated *before* the expiration of the new product warranty to eliminate the potential of additional equipment upgrade charges. Stryker offers the following Supplemental Warranties:

Extended (Parts and Labor)

- All replacement parts (excluding mattresses and consumable items)
- Labor and travel for *all* scheduled and unscheduled calls
- Annual Preventive Maintenance Inspections and repairs
- JCAHO paperwork for preventive maintenance
- Priority Emergency Service

Standard (Labor Only):

- Labor and travel for *all* scheduled and unscheduled calls
- Annual Preventive Maintenance Inspections and repairs
- JCAHO paperwork for preventive maintenance
- Priority Emergency Service

Basic (Parts Only):

- All replacement parts (excluding mattresses and consumable items)
- Priority Emergency Service

Please call your local representative, or call (800) 327-0770 for further information

Warranty

Return Authorization:

Merchandise cannot be returned without approval from the Stryker Customer Service Department. An authorization number will be provided which must be printed on the returned merchandise. Stryker reserves the right to charge shipping and restocking fees on returned items.

SPECIAL, MODIFIED, OR DISCONTINUED ITEMS NOT SUBJECT TO RETURN.

Damaged Merchandise:

ICC Regulations require that claims for damaged merchandise must be made with the carrier within fifteen (15) days of receipt of merchandise. **DO NOT ACCEPT DAMAGED SHIPMENTS UNLESS SUCH DAMAGE IS NOTED ON THE DELIVERY RECEIPT AT THE TIME OF RECEIPT.** Upon prompt notification, Stryker will file a freight claim with the appropriate carrier for damages incurred. Claim will be limited in amount to the actual replacement cost. In the event that this information is not received by Stryker within the fifteen (15) day period following the delivery of the merchandise, or the damage was not noted on the delivery receipt at the time of receipt, the customer will be responsible for payment of the original invoice in full.

Claims for any short shipment must be made within thirty (30) days of invoice.

International Warranty Clause:

This warranty reflects U.S. domestic policy. Warranty outside the U.S. may vary by country. Please contact your local Stryker Medical representative for additional information.

Patent Information

Rugged Products are manufactured under the following patents:

United States 5,575,026
 5,537,700

Other Patents Pending

Summary of Safety Precautions

The following is a list of safety precautions that must be observed when operating or servicing this unit. The precautions are repeated throughout the manual, where applicable. Carefully read this list before using or servicing the unit.

WARNING

- Improper usage of the **▲RUGGED™** Cot can cause injury to the patient or operator. Operate the cot only as described in this manual.
- Always use all restraint straps to secure the patient on the cot. An unrestrained patient may fall from the cot and be injured.
- Never leave a patient unattended on the cot or injury could result. Hold the cot securely while a patient is on the cot.
- Never apply the optional wheel lock while a patient is on the cot. Tipping could occur if the cot is moved while the wheel lock is applied, resulting in injury to the patient or operator and/or damage to the cot.
- The wheel lock is only intended to help prevent the cot from rolling while unattended. The wheel lock may not provide sufficient resistance on all surfaces or under loads.
- Never install or use the wheel lock on a cot with excessively worn wheels. Installing or using the wheel lock on a wheel with less than a 6" diameter could compromise the holding ability of the wheel lock, resulting in injury to the patient or operator and/or damage to the cot or other equipment.
- Be sure the undercarriage has engaged and locked before removing the loading wheels from the patient compartment floor of the vehicle. An unlocked undercarriage will not support the cot and injury to the patient and/or operator could result.
- Do not allow untrained helpers to assist in the operation of the cot. Untrained technicians/helpers can cause injury to the patient or themselves.
- Grasping the **▲RUGGED™** Cot improperly can cause injury. Grasp only the lifting bars to lift the cot. Keep hands, fingers and feet away from moving parts. To avoid injury, use extreme caution when placing your feet near the base tubes while raising and lowering the cot.
- Do not modify the **▲RUGGED™** Cot. Modifying the cot can cause unpredictable operation resulting in injury to the patient or operator. Modifying the cot will also void its warranty (see page 3).
- Have the vehicle safety hook installed by a certified mechanic. Improper safety hook installation can cause injury to the patient or operator or damage to the unit.
- Failure to use the vehicle safety hook can cause injury to the patient or operator. Install and use the safety hook as described in this manual.
- When the optional head end storage pouch is being used, ensure it does not interfere with the operation of the safety bar and safety hook. Injury to the patient or operator could occur.
- Do not pull or lift on the safety bar when unloading the cot. Damage to the safety bar could result and injury to the patient or operator could occur.
- Improper maintenance can cause injury or damage to the unit. Maintain the cot as described in this manual. Use only Stryker approved parts and maintenance procedures. Using unapproved parts and procedures could cause unpredictable operation and/or injury and will void the product warranty.
- Do not step or ride on the base of the **▲RUGGED™** cot. Damage to the cot could occur, resulting in injury to the patient or operator.
- Failure to properly clean or dispose of contaminated mattress or cot components will increase the risk of exposure to bloodborne pathogens and may cause injury to the patient or the operator.

CAUTION

- Damage to the cot can occur if the cot is lowered in the shortened position. Use only positions 5–8 (see page 9) when the cot is shortened.
- Lifting the cot by the safety bar can cause damage to the cot. Lift the cot only by the lifting bars.
- Do not allow the cot undercarriage to drop unassisted (commonly known as a “hot drop”) when removing the cot from the vehicle. Repeated hot dropping will cause premature wear or damage to the cot.

Set-Up Procedures

Unpack the cartons and check all items for proper operation. It is important that the **▲RUGGED™** Cot is working properly before it is put into service. Have a qualified service person use the following list and the operation instructions to check the cot before it is put into service.

- All fasteners secure (reference all assembly prints)
- All welds intact, not cracked or broken
- No bent or broken tubing or sheet metal
- No debris in wheels
- All wheels secure, rolling and swivelling properly
- Siderails move and latch properly
- Backrest operating properly
- Optional accessories intact and operating properly
- Height positioning latch functioning properly
- Cot secure in each height position
- Undercarriage folds properly
- Break-away head section operating properly
- Safety bar operating properly
- Foot rest operating properly
- No rips or cracks in mattress cover
- Body restraints intact and working properly
- Wheel lock operating properly (optional equipment)
- Does the vehicle safety hook engage the safety bar so that the cot loads and unloads easily from the vehicle?
- Is there an approved crash-stable fastener (Stryker part number 6370 or 6371 – not included) installed in the vehicle?

The patient compartment of the vehicle in which the **▲RUGGED™** Cot will be used must have:

- A smooth rear edge for cot loading.
- A level floor large enough for the folded cot.
- Stryker 6370 or 6371 crash stable cot fastener (not included).
- 33" (84 cm.) maximum loading height.
- Space to install the safety hook.

When necessary, modify the vehicle to fit the cot. Do not modify the cot.

WARNING

Do not modify the **▲RUGGED™** Cot. Modifying the cot can cause unpredictable operation resulting in injury to the patient or operator. Modifying the cot will also void its warranty (see page 3).

Component Identification

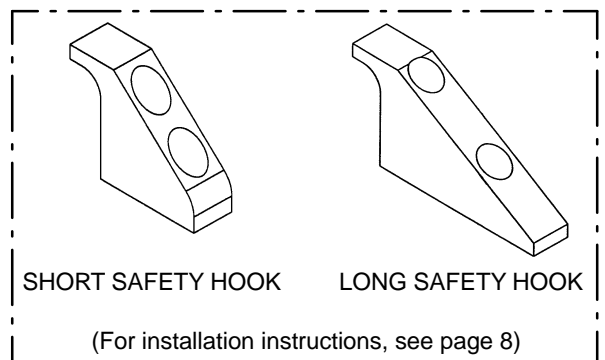
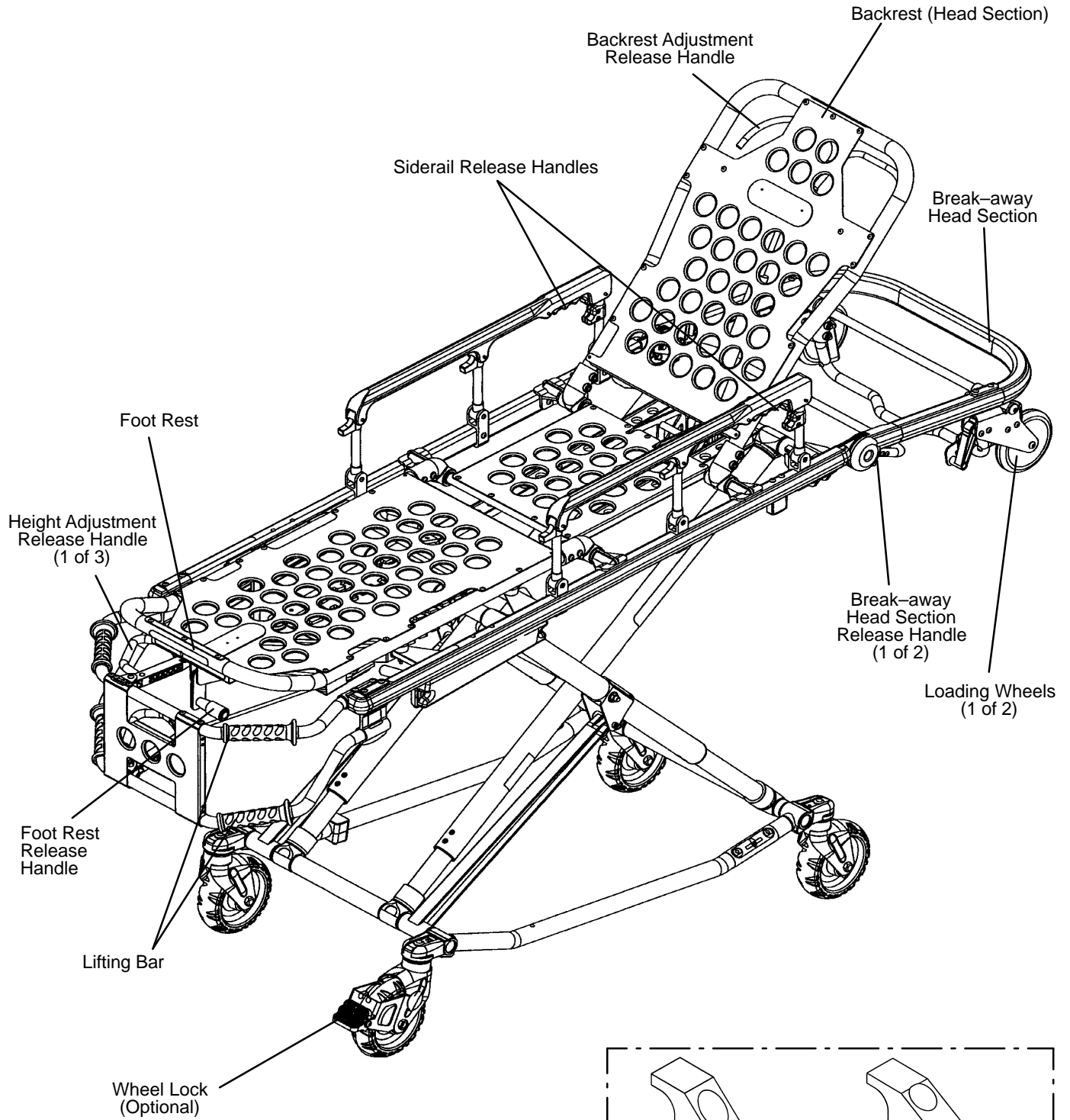

Vehicle Safety Hook Installation

The vehicle safety hook is a device shipped with the cot. The safety hook activates the safety bar and prevents the cot from being removed from the vehicle accidentally.

Installation of the safety hook should be done by a certified mechanic familiar with ambulance construction. Consult the vehicle manufacturer before installing the safety hook and be sure the installation of the safety hook does not damage or interfere with the brake lines, oxygen lines, fuel lines, fuel tank or the electrical wiring of the vehicle.

Required Hardware for Installation of the Safety Hook (Not Supplied)

- (2) Grade 5, 1/4"–20 Socket Head Cap Screws*
- (2) Flat Washers
- (2) Lock Washers
- (2) 1/4"–20 Nuts

* The length of the socket head cap screws depends on the thickness of the vehicle floor. Use screws long enough to go completely through the patient compartment floor, washer and nut by at least two full threads.

Place the cot in the cot fastener. Remove the cot from the fastener and unload it from the vehicle. While the cot is being removed from the vehicle, note the position of the unloading wheels and the safety bar.

NOTE 1. Center the safety hook on the cot safety bar with the hook facing the front of the vehicle. Be sure the safety hook will always engage the safety bar when the cot is unloaded from the vehicle.

NOTE 2. The safety hook should be installed as close to the rear of the vehicle as possible while allowing the vehicle doors to close (see Figures 1 & 2). Be sure the bumper and the bumper step do not interfere with the folding and unfolding of the cot's undercarriage.

Mark the desired position of the safety hook on the patient compartment floor. Drill the holes for the socket head cap screws. Attach the safety hook to the patient compartment floor.

WARNING

Improper safety hook installation can cause injury to the patient and/or operator or damage to the cot. Have a certified mechanic install the safety hook. Failure to install the safety hook can cause injury to the patient or operator. Install and use the safety hook as described in this manual.

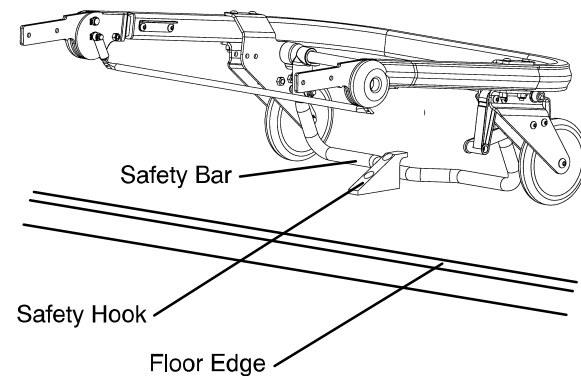
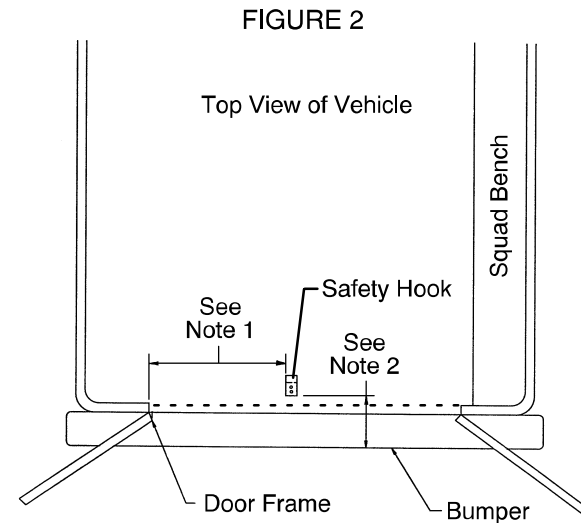
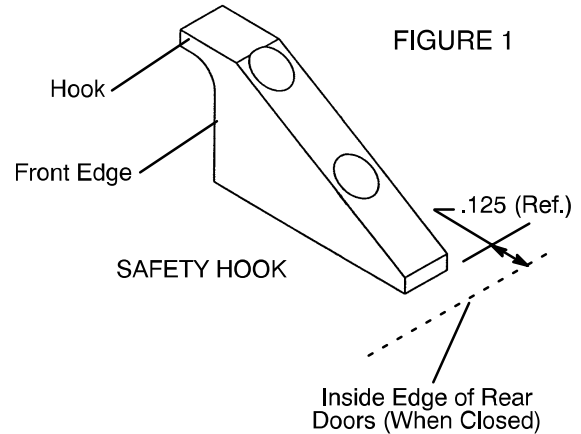

Cot Fastener Installation

The Stryker Model 6370 and 6371 Cot Fastener systems are designed to be compatible only with cots which conform to the installation specifications listed on page 8.2. Ambulance cots which currently meet these specifications are:

Stryker

Model 6060 DX Emergency Transport

Model 6070 LX Emergency Transport

Model 6080 MX-PRO

Model 6081 MX-PRO Incubator Transporter

Model 6090 EZ-PRO

Model 6091 EZ-PRO2

Ferno-Washington

Model 29-M Three Level Roll-In Cot*

Model 93 ES Squadmate™ *

Model 93 EX Squadmate™ *

Model 35-A Mobile Transporter™ *

Model 35 A+ Mobile Transporter Plus™

Model 35-IT Incubator Transporter*

WARNING

It is the responsibility of the cot operator to ensure that the cot being used in the Stryker Model 6370 or 6371 Cot Fastener Systems meets the installation specifications listed on page 8.2. Injury may result if a non-compatible cot is used in the Stryker Model 6370 or 6371 Fastener System.

NOTE

Adjustment of the rail clamp assembly may be required in order to compensate for any variation in cot retaining post position depending on the ambulance cot manufacturer and model number.

For more detailed installation and operation instructions for the Stryker Model 6370 and 6371 Cot Fastener systems, refer to part number 6370-90-10 Rugged™ Cot Fastener Installation/Operation Instructions.

* 1999 model year or earlier. Stryker is not responsible for changes in specifications to other manufacturer's cots.

Cot Fastener Installation

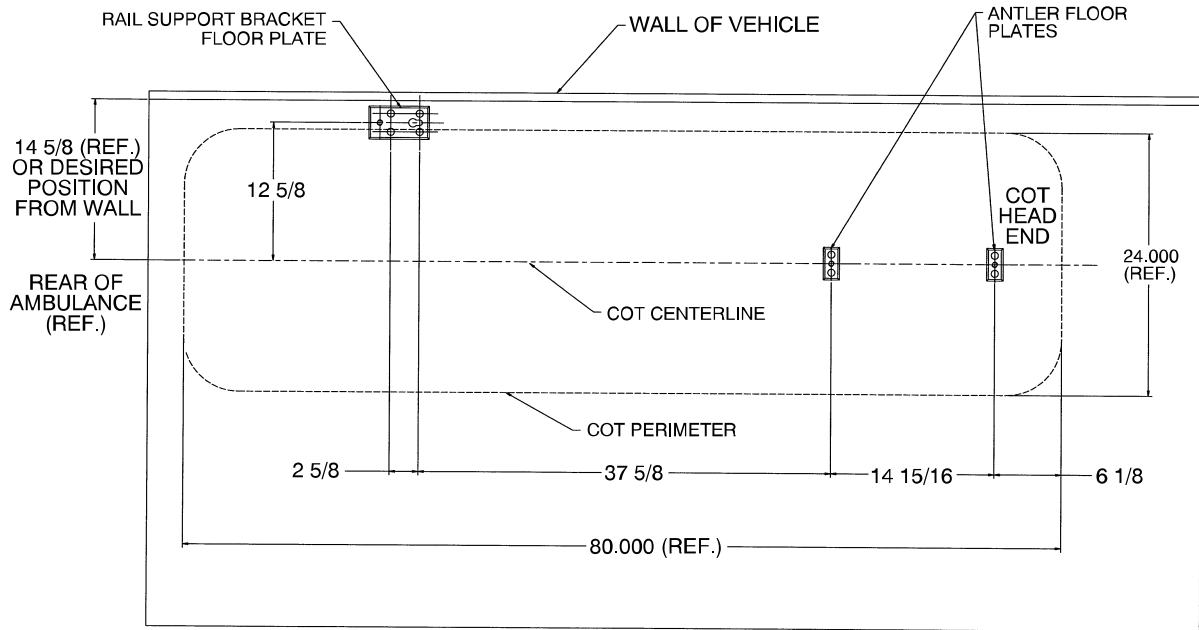

INSTALLATION SPECIFICATIONS – FLOOR MOUNT FASTENER (MODEL 6370)

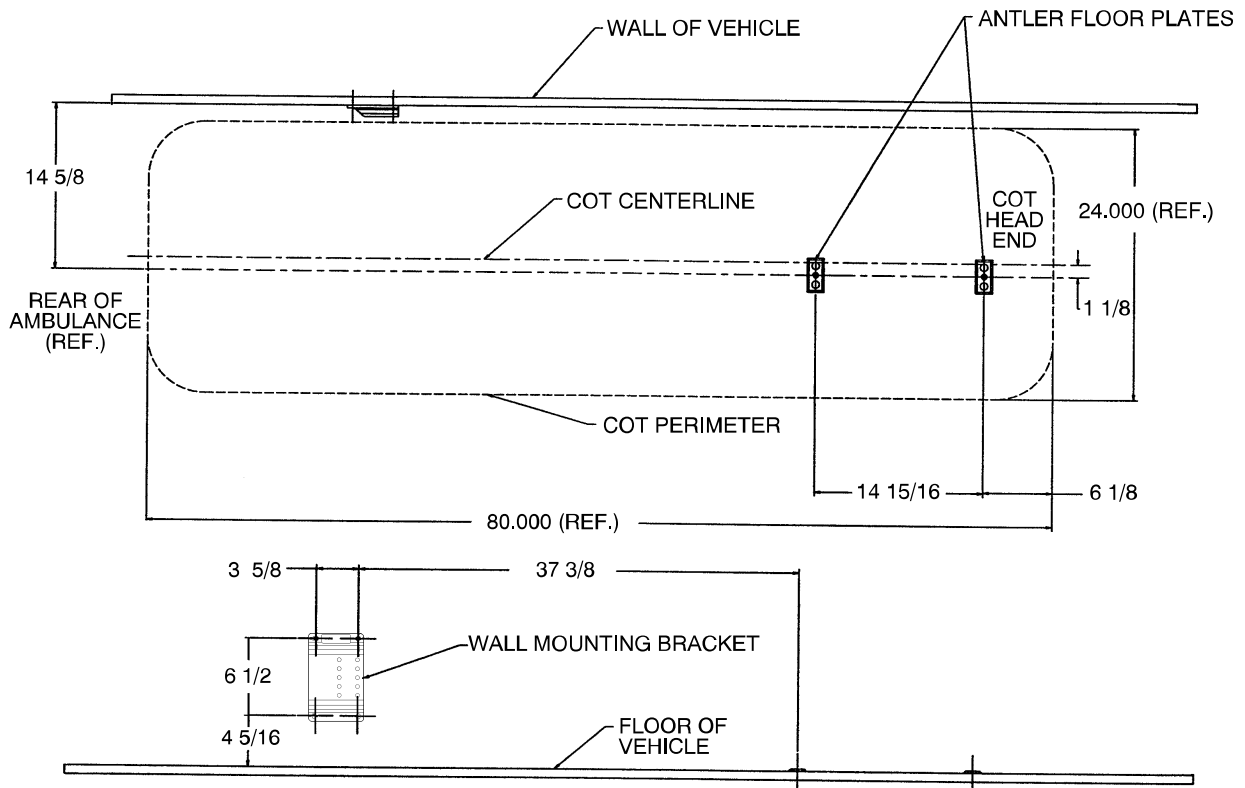

INSTALLATION SPECIFICATIONS – WALL MOUNT FASTENER (MODEL 6371)

Cot Positions

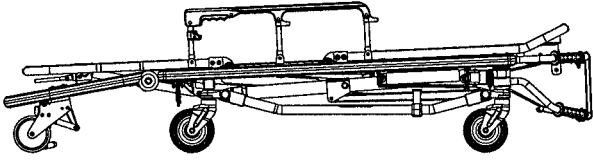

Position 1 – Use for patient transfer.

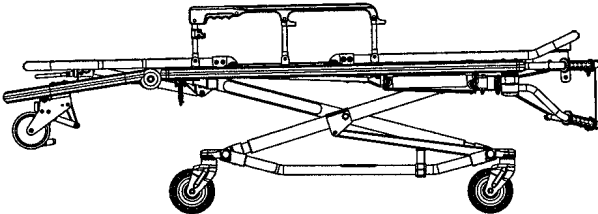

Position 2 – Use for patient transfer/cot rolling.

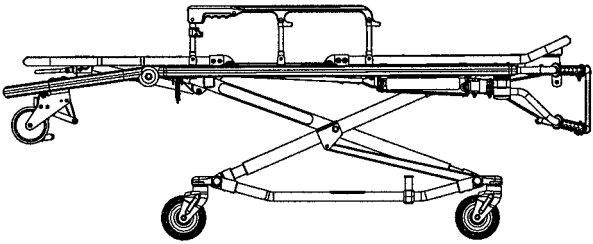

Position 3 – Use for patient transfer/cot rolling.

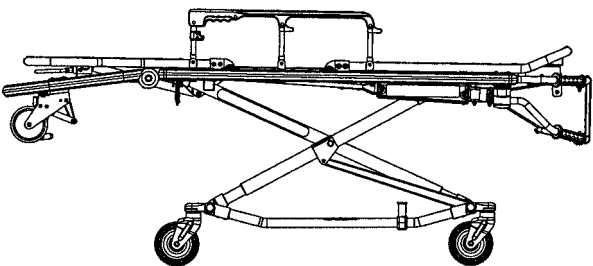

Position 4 – use for patient transfer/cot rolling.

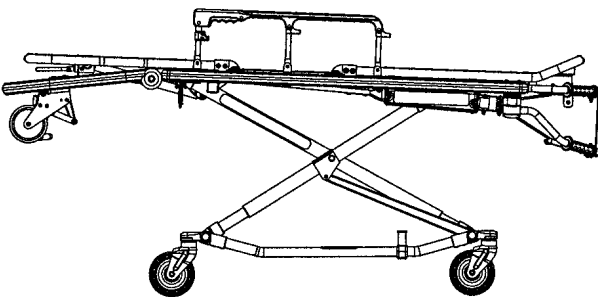

Position 5 – use for patient transfer/cot rolling.

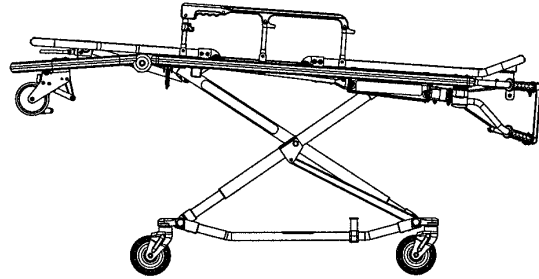

Position 6 – Use for patient transfer/cot rolling.

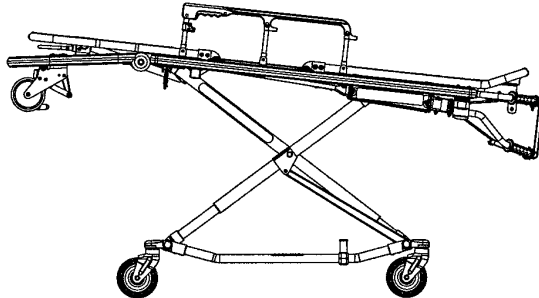

Position 7 – Use for patient transfer/cot rolling/
vehicle loading.

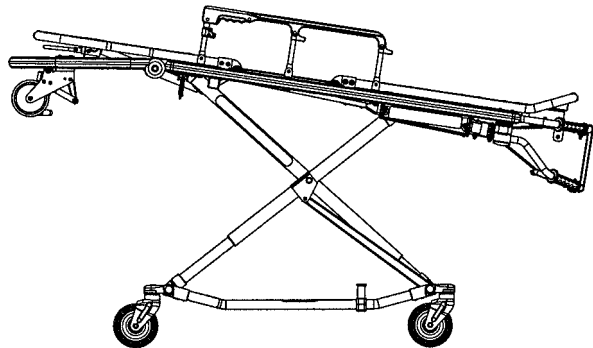

Position 8 – Use for patient transfer/cot rolling/
vehicle loading.

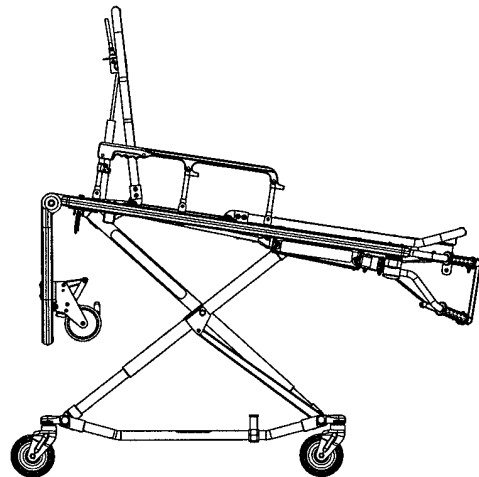

Use for cot rolling in position 5–8 when space is limited.

Cot Operation

Using Restraint Straps

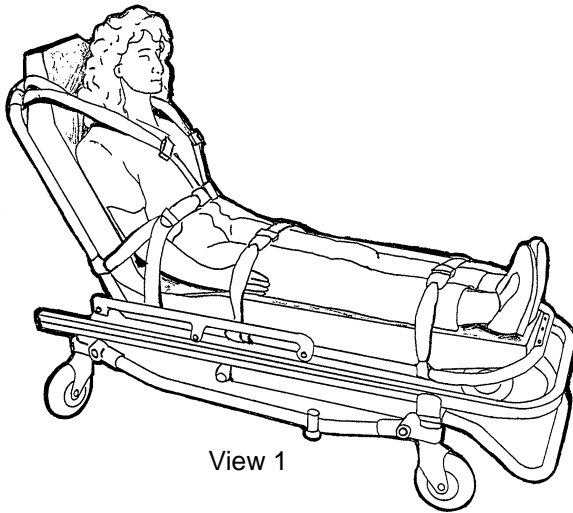

View 1

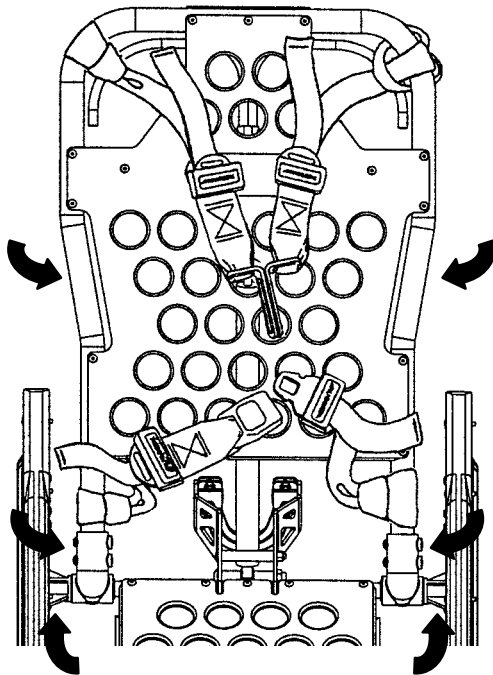

View 2 (Head Section)

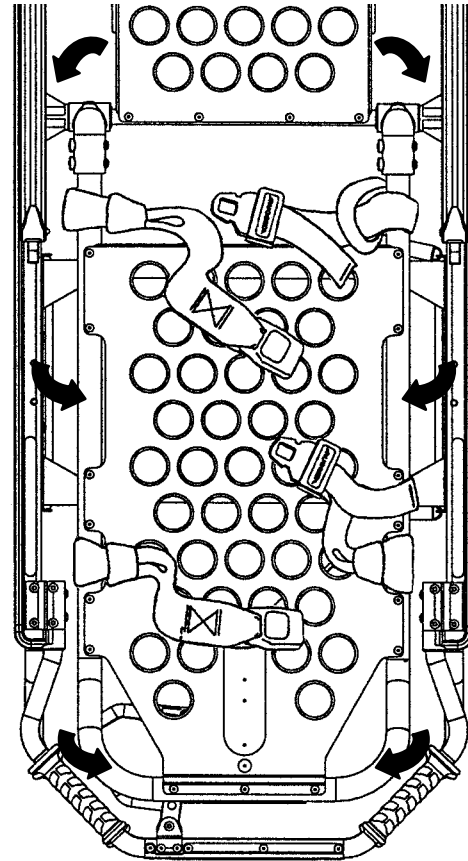

View 3 (Foot Section)

WARNING

Always use all restraint straps to secure the patient on the cot. An unrestrained patient may fall from the cot and be injured.

Always secure the patient on the cot with all the restraint straps. Buckle the restraints across the patient's chest/shoulders, waist and legs (View 1). Keep the restraint straps buckled when the cot is not being used with a patient to avoid damage to the buckles and straps.

When attaching the restraint straps to the cot, keep in mind the attachment points should provide strong anchorage and proper restraint position while not interfering with equipment and accessories. Wrap the strap around the cot frame and back through the loop on the end of the strap as shown in views 2 and 3. The arrows indicate alternate attachment areas.

Cot Operation

Using Restraint Straps (Continued)

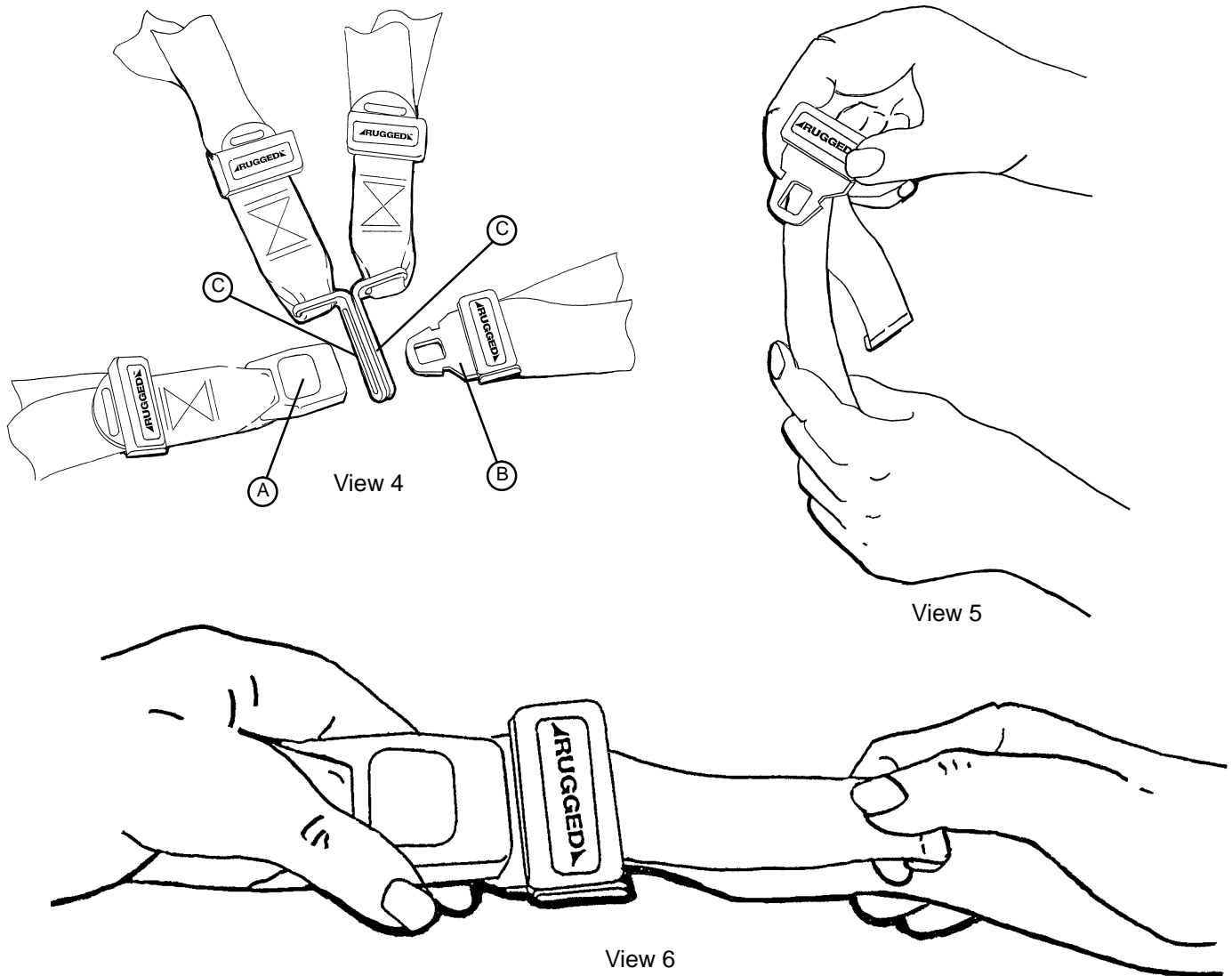

When the cot is put into service, the restraints are opened and placed to either side of the cot until the patient is positioned on the cot mattress. The restraint is lengthened, buckled around the patient and shortened until the required tightness is achieved.

To open the restraint, press the red button (A) on the front of the buckle "receiver". This releases the buckle "tang" (B) which can then be pulled out of the receiver (View 4).

To close the restraint, push the tang into the receiver until a "click" is heard. When fastening the chest restraint be sure the tang passes through both links (C) on the shoulder strap (View 4).

To lengthen the restraint, grasp the buckle tang, turn it at an angle to the webbing, then pull out (View 5). A hemmed tab at the end of the webbing prevents the tang from coming off the strap.

To shorten the restraint, grasp the hemmed tab and pull the webbing back through the tang until the required tightness is achieved (View 6).

Whenever a restraint is buckled on a patient, the attendant should check to be sure the tang is fully engaged and that the extra webbing is not tangled in the cot or hanging loose.

Inspection of the restraints should be done at least once a month (more frequently if used heavily). Inspection should include checking for a bent or broken receiver or tang, torn or frayed webbing, etc. Any restraint showing wear or not operating properly must be replaced immediately.

Cot Operation

Operating Guidelines

- Use the **▲RUGGED™** Cot only as described in this manual.
- Read all labels and instructions on the cot before using the cot.
- Use a minimum of two operators to manipulate the cot.
- Do not adjust, roll or load the cot without advising the patient. Stay with the patient and control the cot at all times.
- Never apply the optional wheel lock while a patient is on the cot.
- Always use the restraint straps and keep the siderails up when a patient is on the cot.
- Use properly trained helpers when necessary to control the cot and patient.

Transferring the Patient to the **▲RUGGED™** Cot

Roll the cot to the patient. Place the cot beside the patient and raise/lower the cot to the patient's level. Lower the siderails and open the restraint straps. Transfer the patient to the cot using accepted EMS procedures. Use all the restraints to secure the patient to the cot (see page 10 for restraint strap usage instructions). Raise the siderails and adjust the backrest and leg rest as necessary.

WARNING

Always use all restraint straps to secure the patient on the cot. An unrestrained patient may fall from the cot and be injured.

Never apply the optional wheel lock while a patient is on the cot. Tipping could occur if the cot is moved while the wheel lock is applied, resulting in injury to the patient or operator and/or damage to the cot.

Rolling the **▲RUGGED™** Cot

Make sure all the restraint straps are securely buckled around the patient (see page 10 & 11 for restraint strap usage instructions). Place the cot in positions 2–8 for rolling (see page 9 for cot positions). When rolling the cot, position an operator at the foot end and one at the head end at all times.

Cot Operation

Loading the **ARUGGED™** Cot into a Vehicle

When loading the cot into a vehicle, an operator should remember the following important issues:

- There must be a safety hook properly installed in the vehicle so that the bumper does not interfere with the front legs of the base frame. (See page 8 for safety hook installation instructions.)
- The operator(s) must be able to lift the total weight of the patient, cot and any other items on the cot.
- The higher the operator must lift the cot, the more difficult it becomes to hold the weight. The operator may need help loading the cot into a vehicle if he/she is too short or if the patient is too heavy for the operator to lift safely.

The operator must be able to lift the cot high enough for the cot's legs to unfold completely and lock when the cot is unloaded. A shorter operator will have to raise his/her arms higher to enable the undercarriage to unfold.

Place the cot in a loading position (position 7 or 8 – see page 9). Roll the cot to the open door of the patient compartment. Fold vehicle bumper to raised position (if available).

Push the cot forward until the loading wheels are on the patient compartment floor and the safety bar passes the safety hook.

WARNING

Failure to use the safety hook can cause injury to the patient or operator. Install and use the safety hook as described in this manual.

Operator 1 – Grasp the cot frame at the foot end. Lift the foot end of the cot until the weight is off the latching mechanism. Squeeze and hold the release handle (location A or B).

Operator 2 – Grasp the base frame where indicated (location C). Raise and hold the undercarriage until it stops in its uppermost position.

Both operators – Push the cot into the patient compartment, engaging the cot fastener (not included).

NOTE

Loose items or debris on the patient compartment floor can interfere with the operation of the safety hook and cot fastener. Keep the patient compartment floor clear.

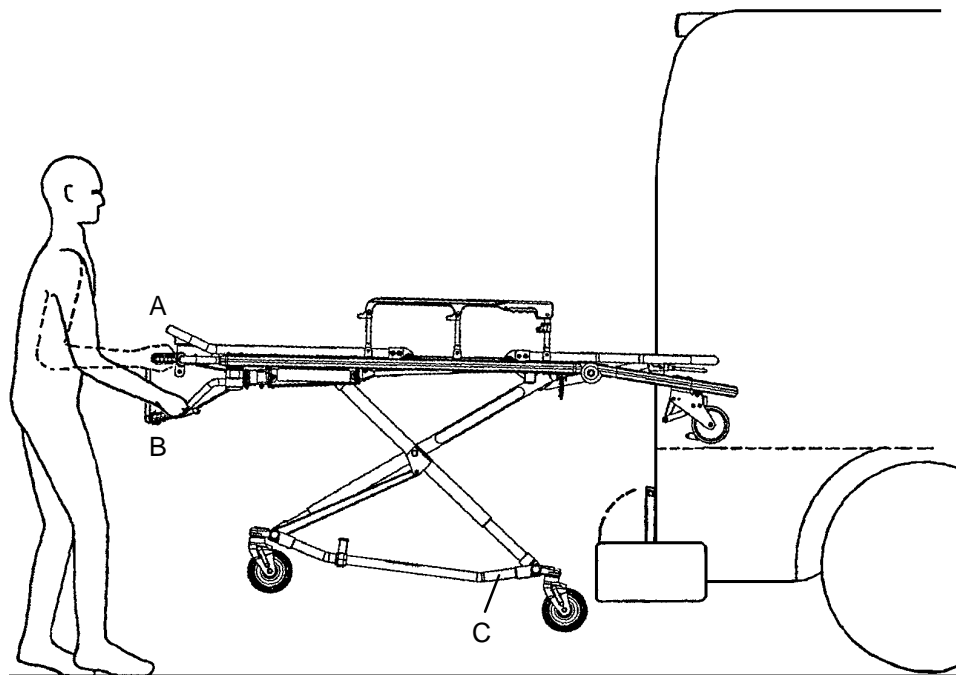

Cot Operation

Unloading the Cot from a Vehicle

Disengage the cot from the cot fastener. (For more detailed instructions, reference the cot fastener installation/operation instruction manual – Stryker part number 6370–90–10.)

Operator 1 – Grasp the cot frame. Pull the cot from the patient compartment until the safety bar engages the safety hook.

WARNING

Failure to use the safety hook can cause injury to the patient or operator. Install and use the safety hook as described in this manual.

Operator 2 – Grasp the base frame where indicated, lift slightly, and lower the base frame to its fully extended position while operator 1 squeezes and holds the release handle.

Operator 1 – Let go of the release handle and be sure the undercarriage locks into place.

Operator 2 – Disengage the safety bar from the safety hook by pushing the safety release lever forward.

WARNING

Do not pull or lift on the safety bar when unloading the cot. Damage to the safety bar could result and injury to the patient or operator could occur.

Remove the cot from the vehicle. Place the cot in a rolling position (positions 2–8 – see page 9).

CAUTION

Do not allow the cot undercarriage to drop unassisted (commonly known as a “hot drop”) when removing the cot from the vehicle. Repeated hot dropping will cause premature wear or damage to the cot.

WARNING

Be sure the undercarriage has engaged before removing the loading wheels from the patient compartment floor of the vehicle. An unlocked undercarriage will not support the cot and injury to the patient or operator could result.

Cot Operation

OPERATING WHEEL LOCK (OPTIONAL)

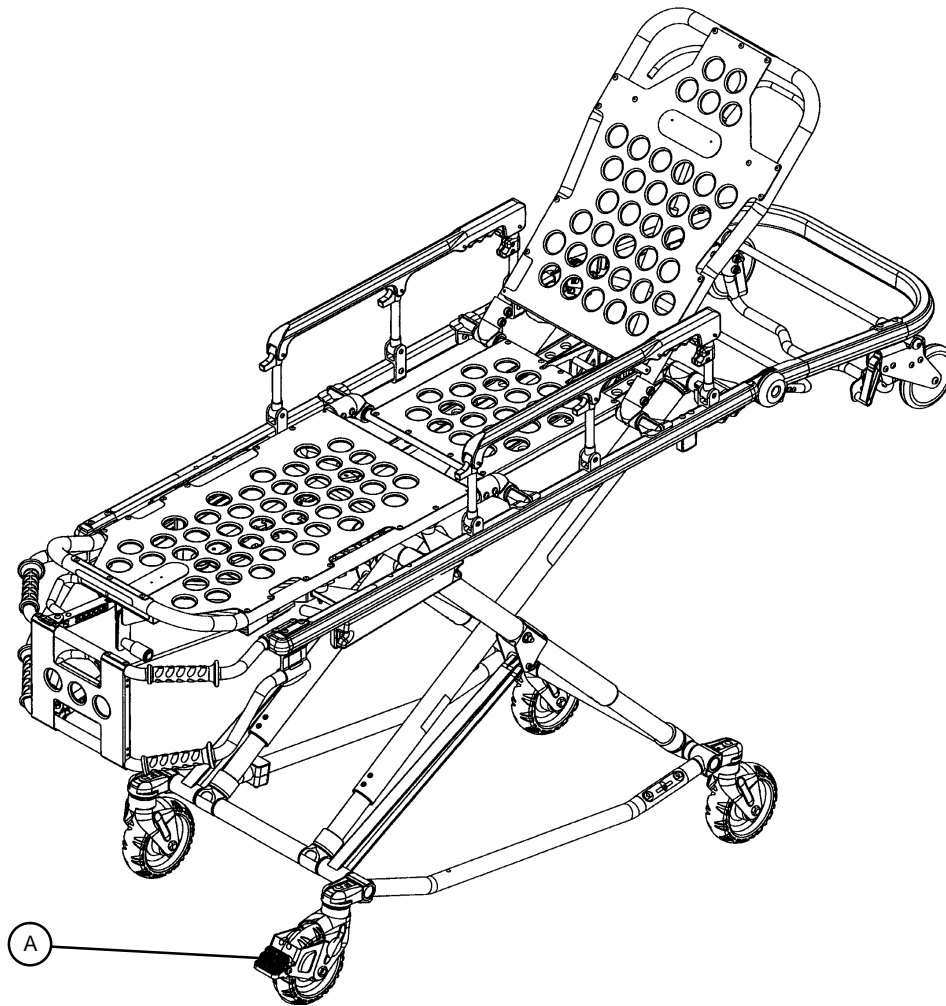

1. To activate the optional wheel lock, press fully down on the pedal (A) until it stops.
2. To release the optional wheel lock, depress the upper face of the pedal with your foot or lift up with your toe under the pedal. The upper portion of the pedal will rest against the caster frame when the wheel lock is released.

WARNING

Never apply the optional wheel lock while a patient is on the cot. Tipping could occur if the cot is moved while the wheel lock is applied, resulting in injury to the patient or operator and/or damage to the cot.

The wheel lock is only intended to help prevent the cot from rolling while unattended. The wheel lock may not provide sufficient resistance on all surfaces or under loads.

Never leave a patient unattended on the cot or injury could result. Hold the cot securely while a patient is on the cot.

Never install or use the wheel lock on a cot with excessively worn wheels. Installing or using the wheel lock on a wheel with less than a 6" diameter could compromise the holding ability of the wheel lock, resulting in injury to the patient or operator and/or damage to the cot or other equipment.

Notes

Cot Operation

Changing Cot Height

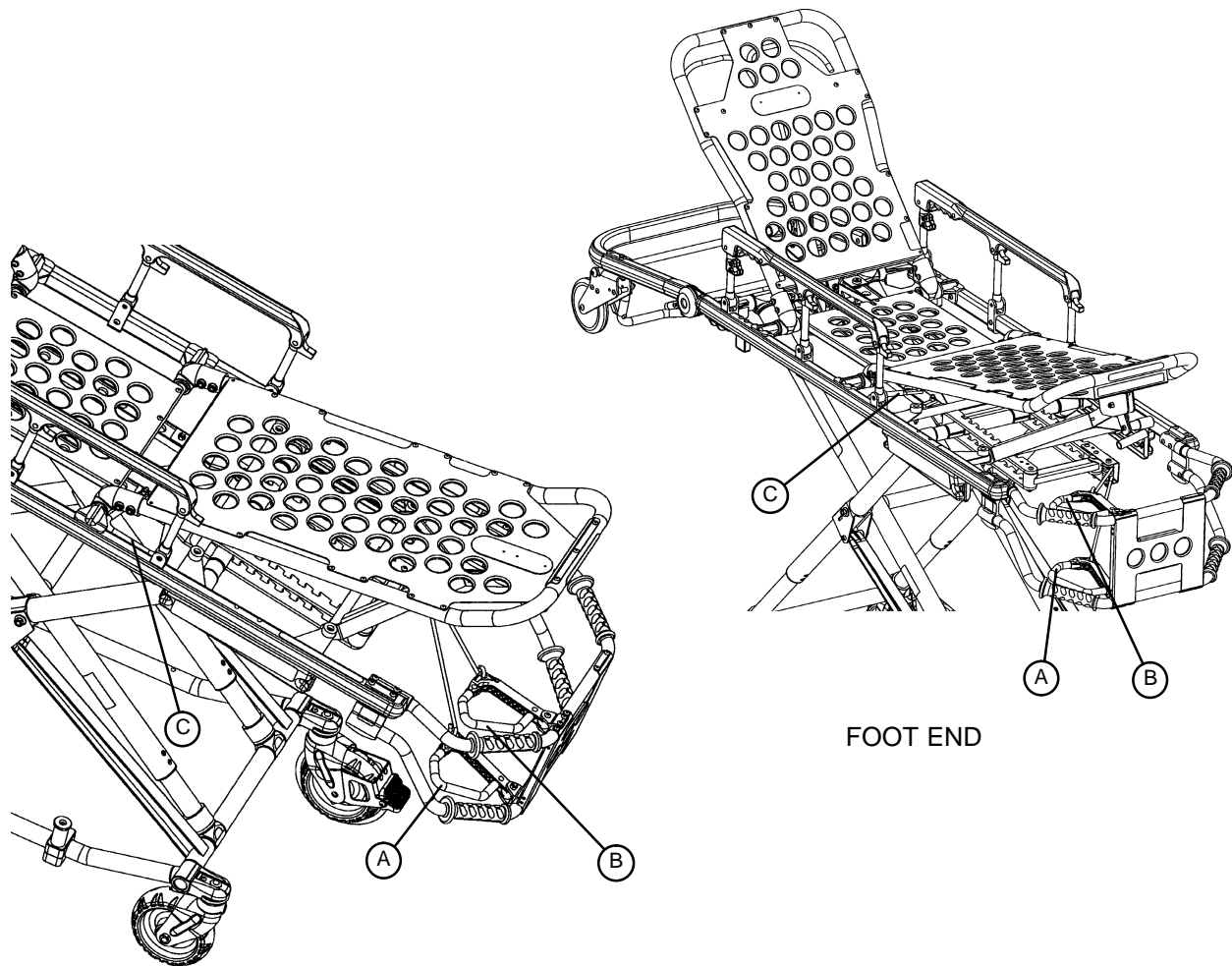

NOTE

Changing the cot height requires a minimum of two operators, positioned at both ends or on each side of the cot. Each operator must grasp the cot frame securely.

To lower the cot from the ends, the operator at the foot end of the cot positions his/her hands so the release handle (A or B) can be squeezed while a secure grip is maintained on the lifting bars. Both operators must lift the cot until the weight is off the latching mechanism (approximately 1/4"). The operator at the foot end squeezes and holds the release handle and both operators then raise or lower the cot together. The handle is released when the desired position is reached. Both operators should maintain a secure grip on the litter frame until the latching mechanism is securely locked into position.

To lower the cot from the sides, the operator on the patient's right positions his/her hands so he/she can reach the release handle at the midpoint of the litter (C). Both operators must lift the cot until the weight is off the latching mechanism (approximately 1/4"). The operator at the patient's right squeezes and holds the release handle. Both operators then raise or lower the cot together. The handle is released when the desired position is reached. Both operators should maintain a secure grip on the litter frame until the latching mechanism is securely locked into position.

WARNING

Grasping the **ARUGGED™** Cot improperly can cause injury. Grasp only the litter frame or the lifting bar to lift the cot. Keep hands, fingers and feet away from moving parts. To avoid injury, use extreme caution when placing your feet near the base tubes while raising and lowering the cot.

Cot Operation

Adjusting Leg Rest

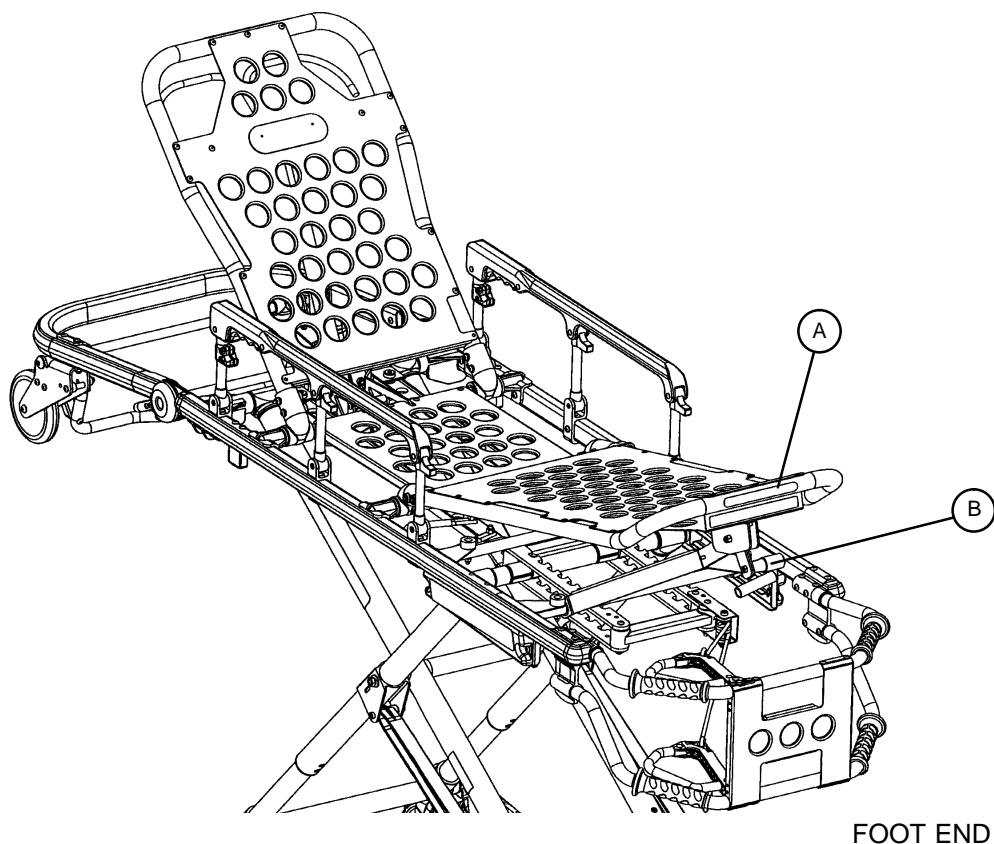

The leg rest is adjustable to allow for elevation of the patient's legs.

To raise the leg rest, lift the leg rest frame (A) as high as possible. The support bracket will engage automatically. Release the frame after the support bracket has engaged.

To lower the leg rest, lift the leg rest frame (A) and, while holding the frame, lift up on the release handle (B) until the bracket disengages. Lower the leg rest until flat.

Cot Operation

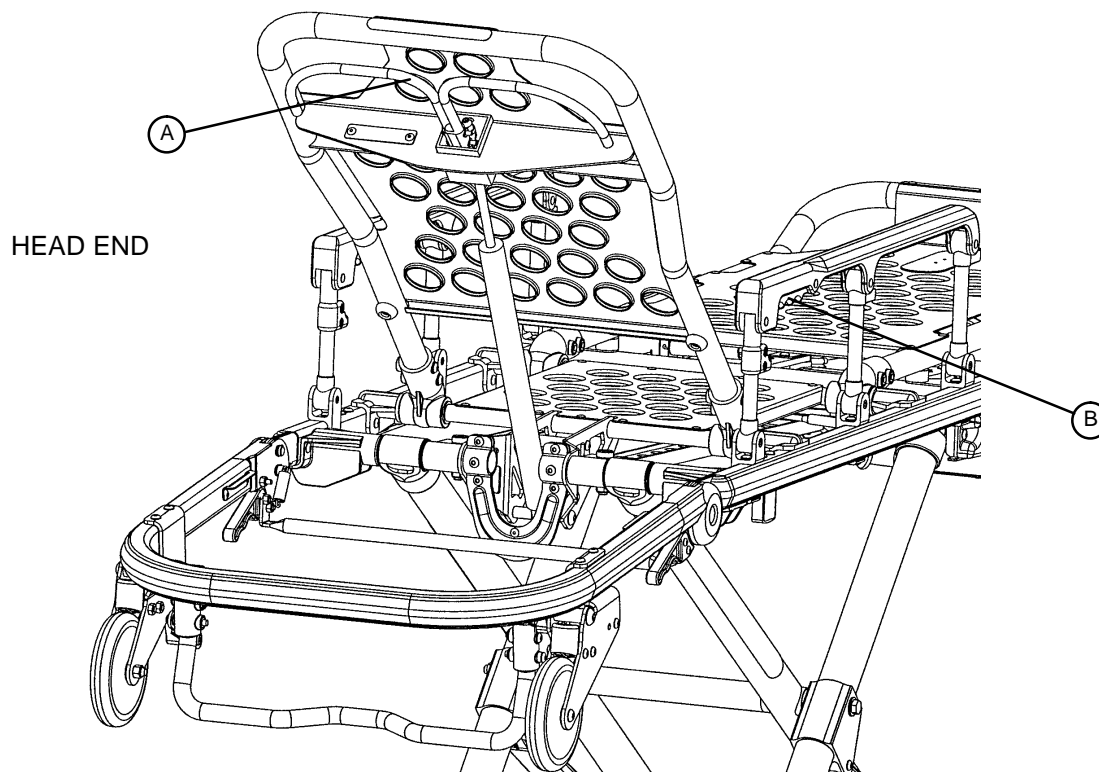

Operating Backrest

To raise, squeeze handle (A) for pneumatic assist in lifting the Backrest to the desired height. Remove hand(s) from handle when desired height is achieved.

To lower, squeeze handle (A) and push down on the Backrest frame until the Backrest has reached the desired height. Remove hand(s) from handle when desired height is achieved.

Operating Siderails

To raise, lift up until the latch clicks and the siderail locks into place. When a patient is on the cot, always keep the siderails in the raised position unless the patient is being transferred.

To lower, squeeze handle (B) to release the siderail latch. Guide the siderail down toward the foot end until flat.

Cot Operation

Operating Break-away Head Section

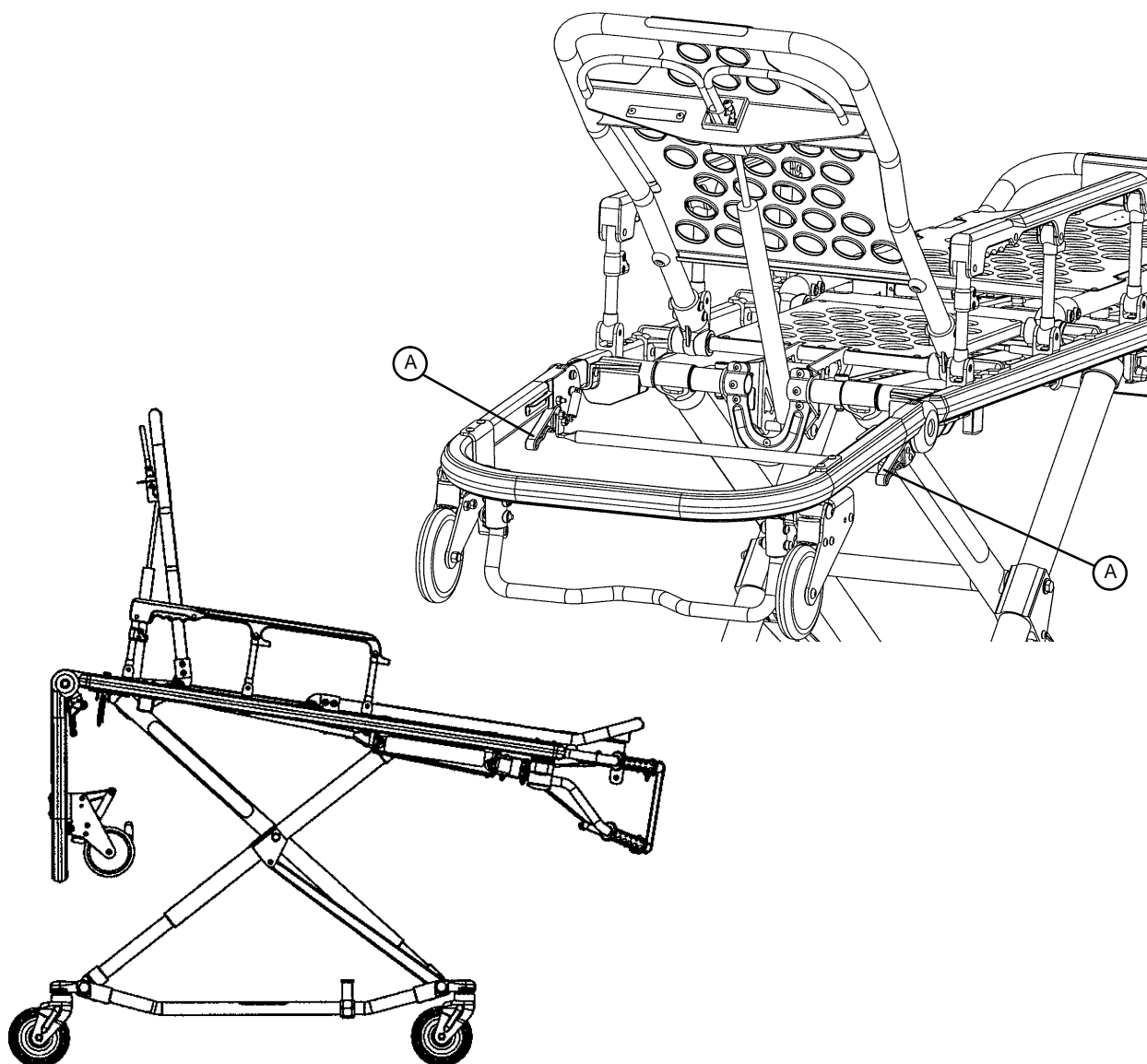

The head end of the cot litter folds down to shorten the length of the cot and allow for maneuvering when space is limited in elevators, halls, etc.

The break-away head section should only be used when the cot is in positions 5–8 (see page 9).

To lower the break-away head section, raise the backrest to its uppermost position (see page 17 for backrest operation instructions). Squeeze either red release handle (A) at the head end of the cot with one hand while supporting the head section with the other hand. Lower the head section.

To raise the break-away head section, lift the break-away head section until the release handles click and the head section locks into place.

CAUTION

Damage to the cot can occur if the cot is lowered in the shortened position. Use only positions 5–8 (see page 9) when the cot is shortened.

Cot Operation

Operating 2-Stage I.V. Pole

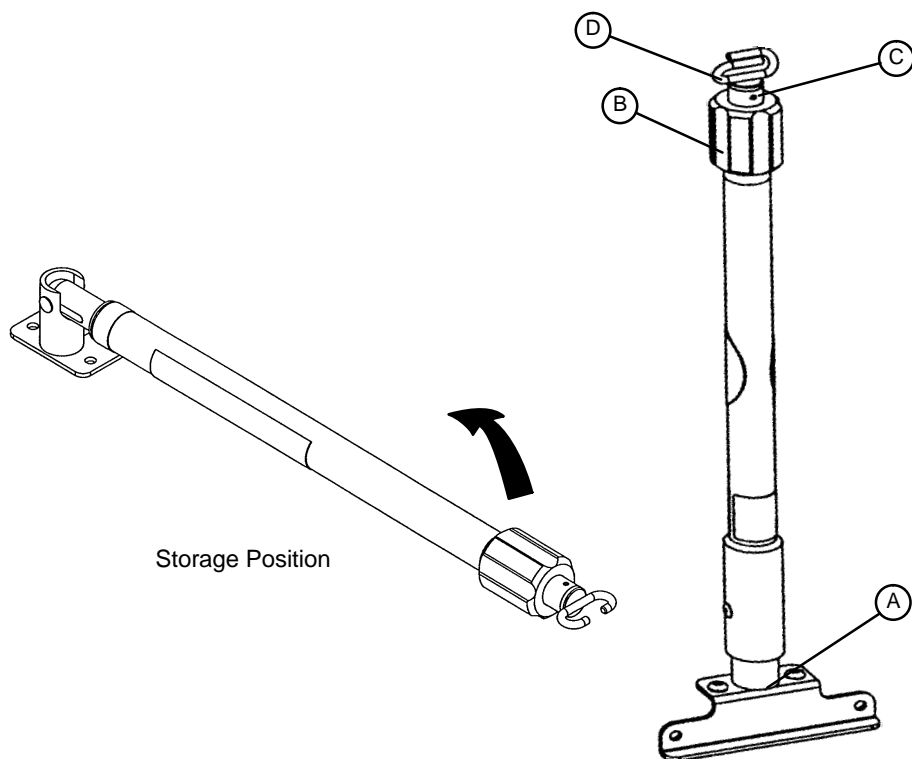

1. Lift and pivot the pole from the storage position and push down until it is locked into receptacle (A).
2. To raise the height of the pole, turn the lock actuator (B) counterclockwise and pull up on the telescoping portion (C) of the pole to raise it to the desired height.
3. Turn the lock actuator (B) clockwise to lock the telescoping portion in place.
4. Hang I.V. bags on the I.V. hook (D).

CAUTION

The weight of the I.V. bags should not exceed 40 pounds.

Cot Operation

Operating 3-Stage I.V. Pole (Optional Equipment)

1. Lift and pivot the pole from the storage position and push down until it is locked into receptacle (A).
2. To raise the height of the pole, turn the lock actuator (B) counterclockwise and pull up on the bottom telescoping portion (C) of the pole to raise it to the desired height.
3. Turn the lock actuator (B) clockwise to lock the bottom telescoping portion in place.
4. For a higher I.V. pole, pull up on section (D) until the spring clip (E) engages.
5. Hang I.V. bags on the I.V. hook (F).

CAUTION

The weight of the I.V. bags should not exceed 40 pounds.

6. To lower the I.V. pole, push in on the spring clip (E) and slide section (D) down into section (C). Turn the lock actuator (B) counterclockwise and slide section (C) into the bottom tube.
7. Lift up and pivot the pole down into the storage position.

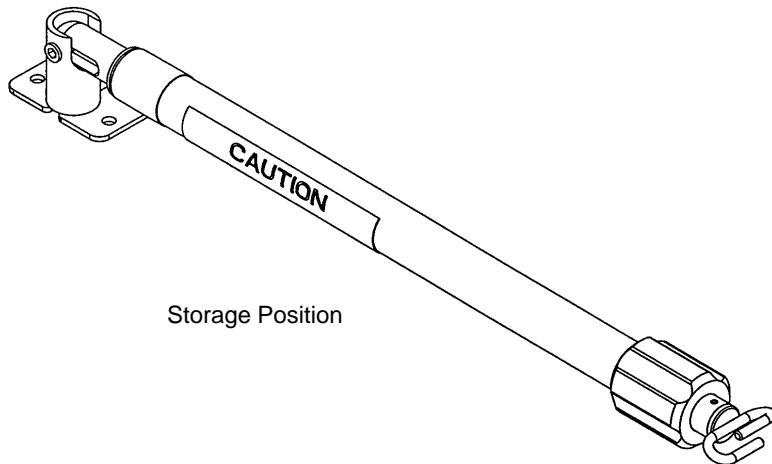

Storage Position

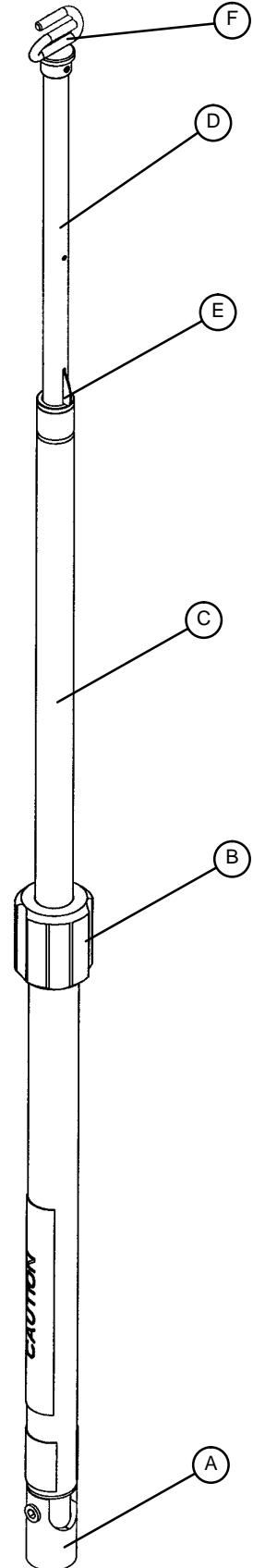

Notes

Cleaning

Hand wash all surfaces of the cot with warm water and mild detergent. Dry thoroughly. **DO NOT STEAM CLEAN, PRESSURE WASH, HOSE OFF OR ULTRASONICALLY CLEAN.** Using these methods of cleaning is **not** recommended and may void this product's warranty.

Clean Velcro **AFTER EACH USE**. Saturate Velcro with disinfectant and allow disinfectant to evaporate. (Appropriate disinfectant for nylon Velcro should be determined by the hospital.)

In general, when used in those concentrations recommended by the manufacturer, either phenolic type or quaternary type disinfectants can be used. Iodophor type disinfectants are not recommended for use because staining may result. The following products have been tested and have been found not to have a harmful effect **WHEN USED IN ACCORDANCE WITH MANUFACTURERS RECOMMENDED DILUTION.***

TRADE NAME	DISINFECTANT TYPE	MANUFACTURER	*MANUFACTURER'S RECOMMENDED DILUTION
A33	Quaternary	Airwick (Professional Products Division)	2 ounces/gallon
A33 (dry)	Quaternary	Airwick (Professional Products Division)	1/2 ounce/gallon
Beaucoup	Phenolic	Huntington Laboratories	1 ounce/gallon
Blue Chip	Quaternary	S.C. Johnson	2 ounces/gallon
Elimstaph	Quaternary	Walter G. Legge	1 ounce/gallon
Franklin Phenomysan F2500	Phenolic	Purex Corporation	1 1/4 ounce/gallon
Franklin Sentinel	Quaternary	Purex Corporation	2 ounces/gallon
Galahad	Phenolic	Puritan Churchill Chemical Company	1 ounce/gallon
Hi-Tor	Quaternary	Huntington Laboratories	1/2 ounce/gallon
LPH	Phenolic	Vestal Laboratories	1/2 ounce/gallon
Matar	Phenolic	Huntington Laboratories	1/2 ounce/gallon
Omega	Quaternary	Airwick (Professional Products Division)	1/2 ounce/gallon
Quanto	Quaternary	Huntington Laboratories	1 ounce/gallon
Sanikleen	Quaternary	West Chemical Products	2 ounces/ gallon
Sanimaster II	Quaternary	Service Master	1 ounce/gallon
Vesphene	Phenolic	Vestal Laboratories	1 1/4 ounce/ gallon

Quaternary Germicidal Disinfectants, used as directed, and/or Chlorine Bleach products, typically 5.25% Sodium Hypochlorite in **dilutions ranging between 1 part bleach to 100 parts water, and 2 parts bleach to 100 parts water are not considered mild detergents.** These products are corrosive in nature and may cause damage to your stretcher if used improperly. If these types of products are used to clean Stryker patient handling equipment, measures must be taken to insure the stretchers are rinsed with clean water and thoroughly dried following cleaning. Failure to properly rinse and dry the stretchers will leave a corrosive residue on the surface of the stretcher, possibly causing premature corrosion of critical components.

NOTE

Failure to follow the above directions when using these types of cleaners may void this product's warranty.

REMOVAL OF IODINE COMPOUNDS

1. Use a solution of 1–2 tablespoons Sodium Thiosulfate in a pint of warm water to clean the stained area. Clean as soon as possible after staining occurs. If stains are not immediately removed, allow solution to soak or stand on the surface. Rinse surfaces which have been exposed to the solution in clear water before returning unit to service.

WARNING

Failure to properly clean or dispose of contaminated mattress or cot components will increase the risk of exposure to bloodborne pathogens and may cause injury to the patient or the operator.

Preventative Maintenance

Operation	Schedule	Procedure
Cleaning & Disinfecting	Each use.	See page 20.
Inspection	For 1–25 calls per month, inspect cot every 6 months. For 26–200 calls per month, inspect cot every 3 months. For 201+ calls per month, inspect cot monthly.	See below for checklist.

NOTE

Keep up-to-date maintenance records using the form on page 23.

Parts, Service or Technical Assistance:

Contact Stryker Customer Service at 1-800-327-0770 or

Stryker Medical
 3800 E. Centre Ave.
 Portage, MI 49002
 ATTN: Customer Service

CHECKLIST

- _____ All fasteners secure (reference all assembly prints)
- _____ All welds intact, not cracked or broken
- _____ No bent or broken tubing or sheet metal
- _____ No debris in wheels
- _____ All wheels secure, rolling and swivelling properly
- _____ Optional wheel lock holds wheel securely when on and clears wheel when off
- _____ Siderails move and latch properly
- _____ Backrest operating properly
- _____ Optional accessories intact and operating properly
- _____ Height positioning latch functioning properly
- _____ Cot secure in each height position
- _____ Undercarriage folds properly
- _____ Breakaway head section operating properly
- _____ Safety bar operating properly
- _____ Foot rest operating properly
- _____ No rips or cracks in mattress cover
- _____ Body restraints intact and working properly

Serial No. _____

Completed By: _____

Date: _____

Preventative Maintenance

PNEUMATIC BACKREST ADJUSTMENT

Required Tools:

1/2" Wrench

5/32" Allen Wrench

Loctite

3/32" Allen Wrench

7/32" Allen Wrench

9/16" Wrench

Adjustment Procedure:

3. For easier access, move Backrest to 75 degrees.

NOTE

Before continuing with the Backrest adjustment procedure, be sure the pneumatic cylinder (item A) is completely threaded into the yoke (item B) so no threads are showing on the shaft of the cylinder. If threads are showing, use a 3/32" Allen wrench to remove the set screw (item C) in the center of the yoke and a 7/32" Allen wrench and 9/16" wrench to remove the nut and bolt (items D & E) holding the bottom of the pneumatic cylinder. Thread cylinder shaft (item A) completely into yoke (item B). Replace the nut and bolt (items D & E) and replace the set screw (item C) using Loctite.

4. Using a 1/2" wrench, loosen the hex nut (item F) on the Backrest pivot (item J) while holding the set screw (item H) fixed in the pivot.

5. Using a 5/32" Allen wrench, turn the set screw (item H) until there is no play between the Backrest release handle (item K) and the pneumatic cylinder release button.

6. Be sure the Backrest will travel from flat to at least 75 degrees. If it doesn't, turn the set screw (item H) clockwise 1/2 turn. Repeat until at least 75 degrees of travel is achieved.

7. Lower the Backrest to a 5–10 degree angle and release the handle. Apply approximately 50 pounds downward force to the end of the Backrest. If the Backrest drifts down, turn the set screw (item H) counterclockwise. Repeat until the Backrest does not drift downward.

8. Using the 1/2" wrench, tighten the hex nut (item F) while holding the set screw (item H) fixed in the pivot.

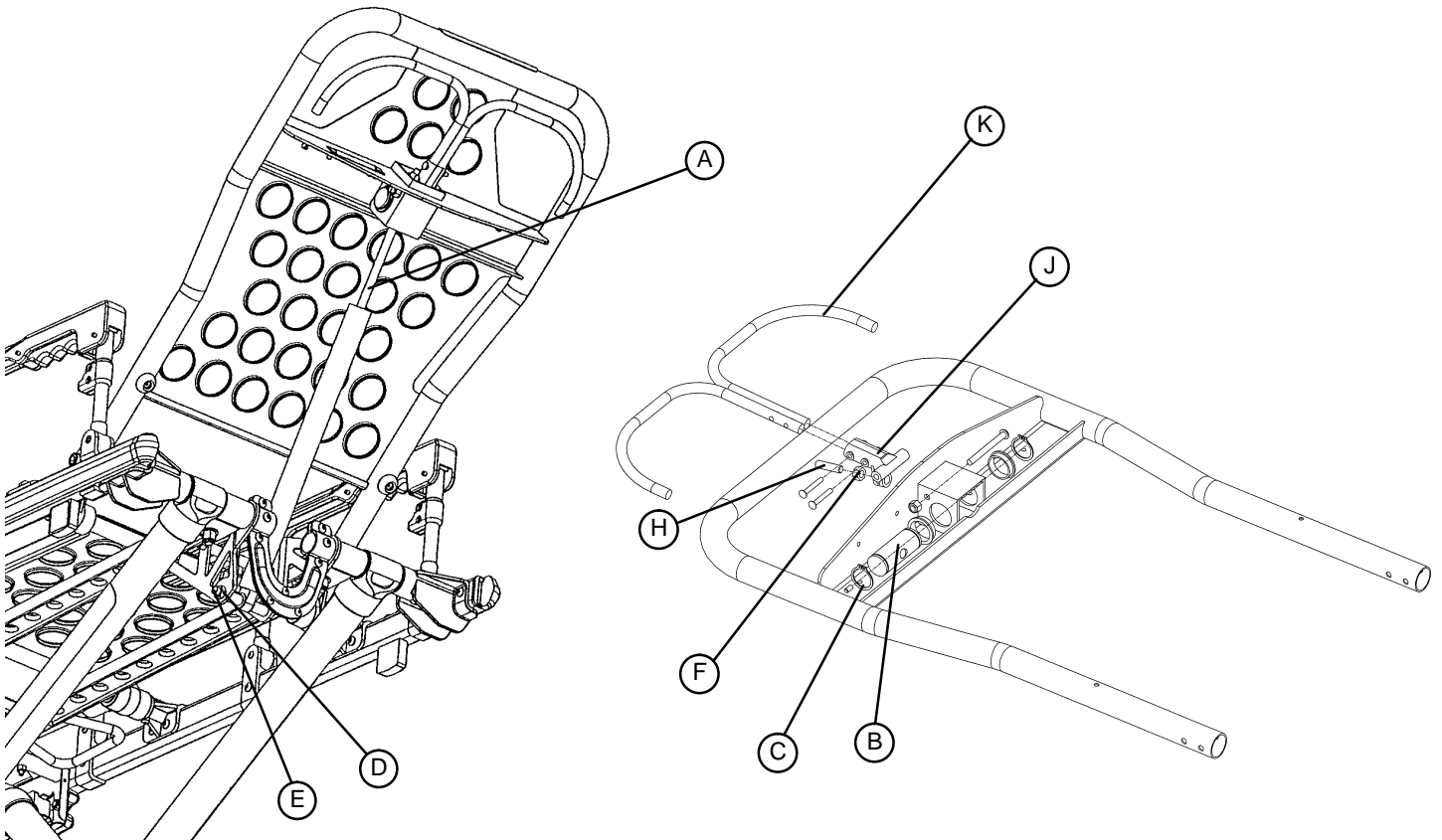

Maintenance Record

Date	Maintenance Operation Performed	By

Assembly part number
6080-50-11
(reference only)

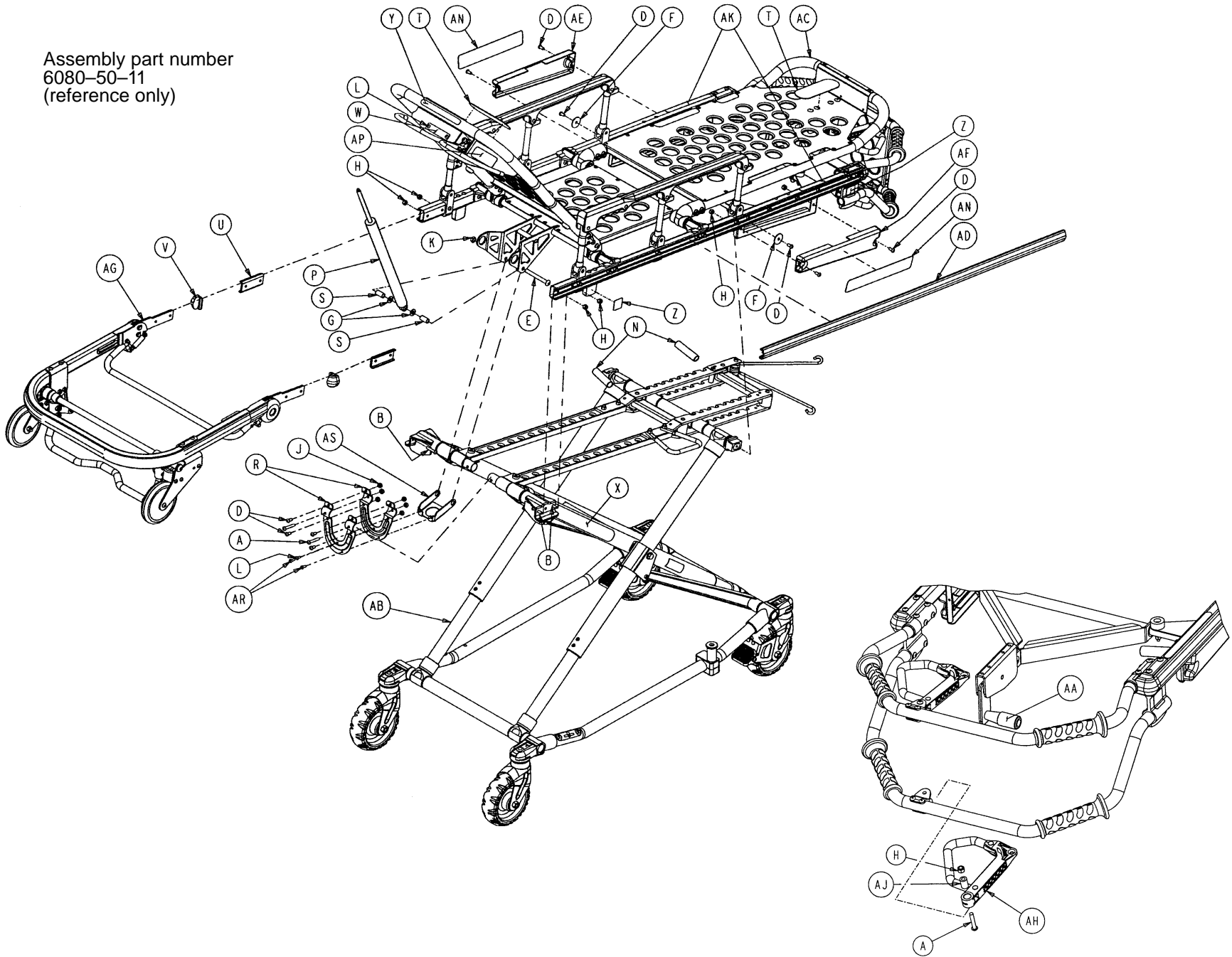

Cot Assembly

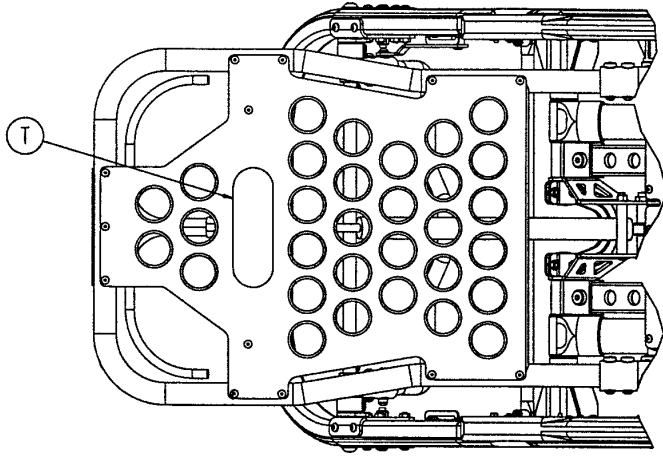

Fowler Section Top View

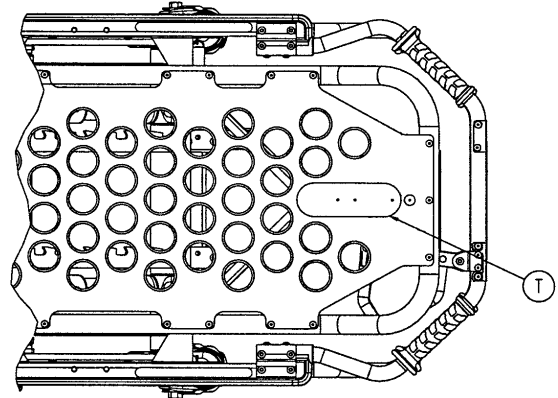
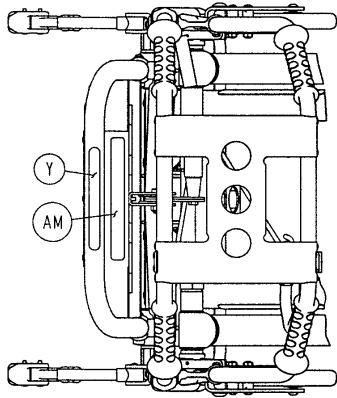
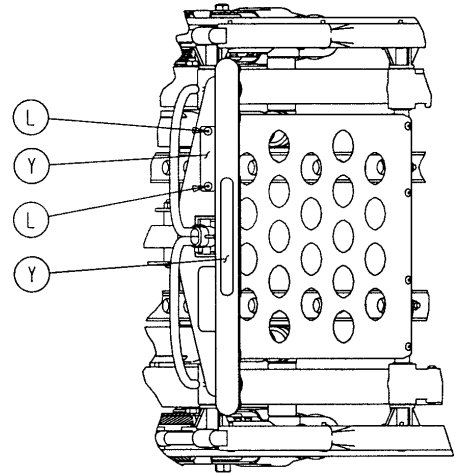

Foot Section Top View

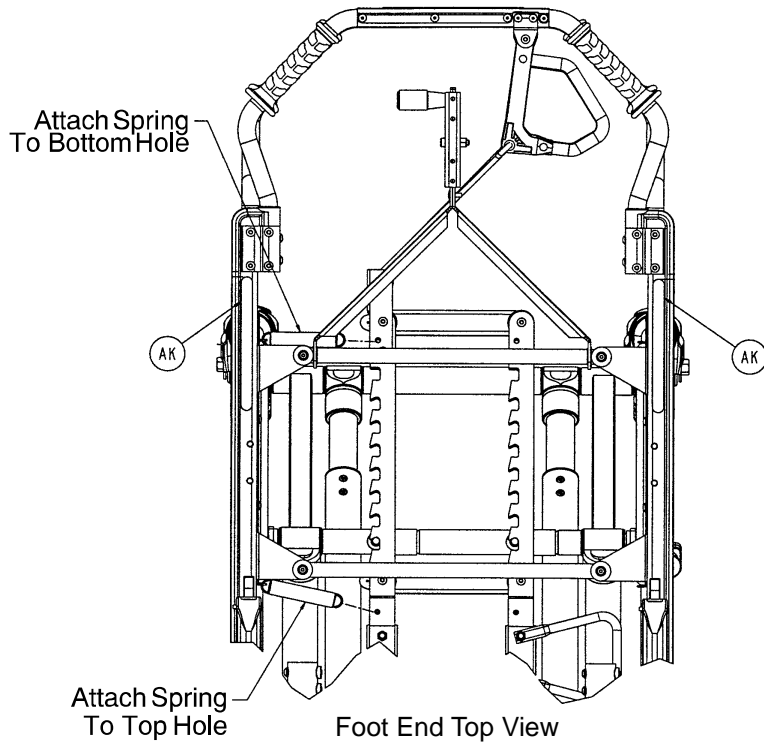

Foot End Top View

Cot Assembly

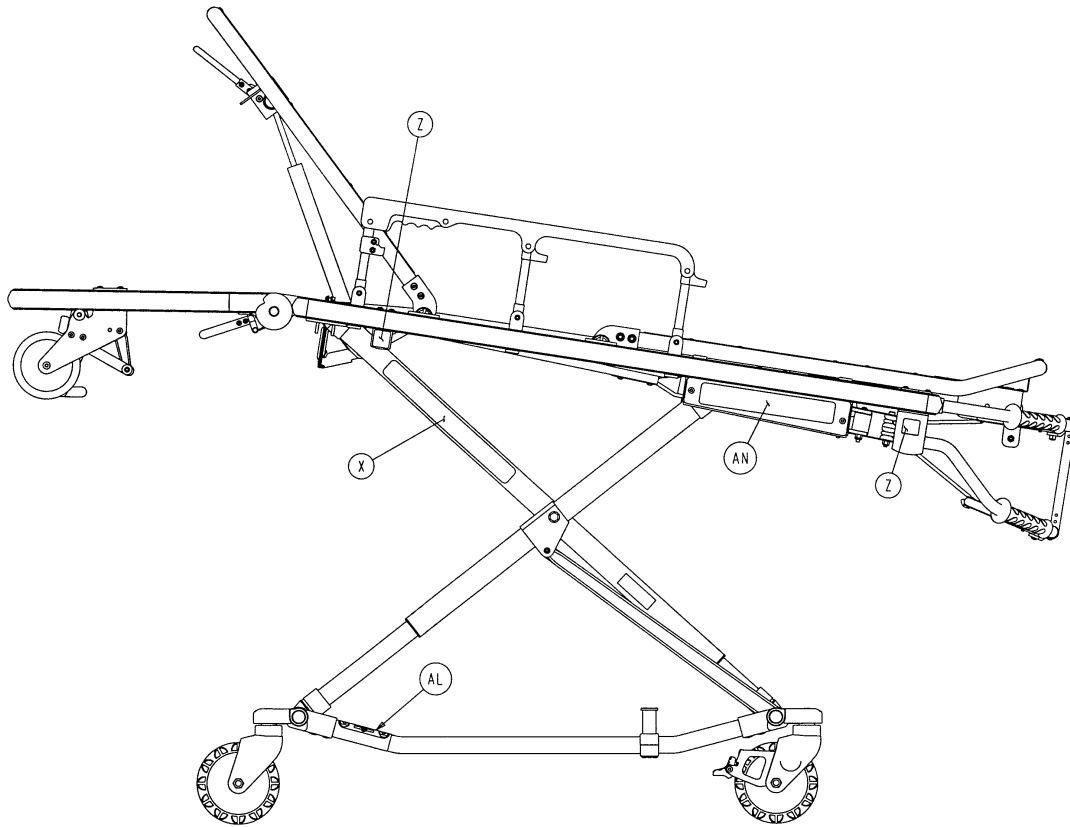

Item	Part No.	Part Name	Qty.	Item	Part No.	Part Name	Qty.
A	4-135	H. Soc. But. Hd. Cap Scr.	4	Y	6060-90-4	Small "Rugged" Label	2
B	4-198	H. Soc. But. Hd. Cap Scr.	4	Z	6060-90-114	"Hands Clear" Label	4
D	4-232	H. Soc. But. Hd. Cap Scr.	10	AA	6070-90-107	"Lift to Release" Label	1
E	4-240	H. Soc. But. Hd. Cap Scr.	1	AB	(page 28 & 29)	Base Assembly	1
F	11-355	Flat Washer	2	AC	(page 32-35)	Litter Assembly	1
G	14-21	Nylon Washer	2	AD	6080-30-43	Litter Frame Bumper	2
H	16-28	Fiberlock Nut	10	AE	6080-33-36	Retainer Plate Cover, Lt.	1
J	16-78	Centerlock Hex Nut	6	AF	6080-33-37	Retainer Plate Cover, Rt.	1
K	16-89	Centerlock Nut	1	AG	(page 36 & 37)	Breakaway Head Ass'y	1
L	25-79	Dome Hd. Rivet	3	AH	(page 41)	Release Handle Ass'y	2
N	38-348	Extension Spring	2	AJ	6080-40-44	Link Release Spacer	2
P	1010-31-77	Gas Cylinder	1	AK	6080-90-106	"500 Lb. Max." Label	2
R	6060-231-39	Lit./Base Interface End Plate	2	AL	6080-90-108	"Lift Here" Label	2
S	6060-31-46	Lit./Base Interface Piv. Spcr.	2	AM	6080-90-9	"Damage Warning" Label	1
T	6060-32-46	Adhesive Loop Pile	2	AN	6080-90-110	"MX-Pro" Label	2
U	6060-37-26	Spacer Plate	2	AP	6080-90-37	Specification Label	1
V	6060-37-35	End Cap	2	AR	25-133	Dome Head Rivet	2
W	6060-90-2	Serial Number Tag	1	AS	6060-31-25	End Plate Supt. Bracket	1
X	6060-90-3	Large "Rugged" Label	2				

Base Assembly

Assembly part number 6080-1-11 (reference only)

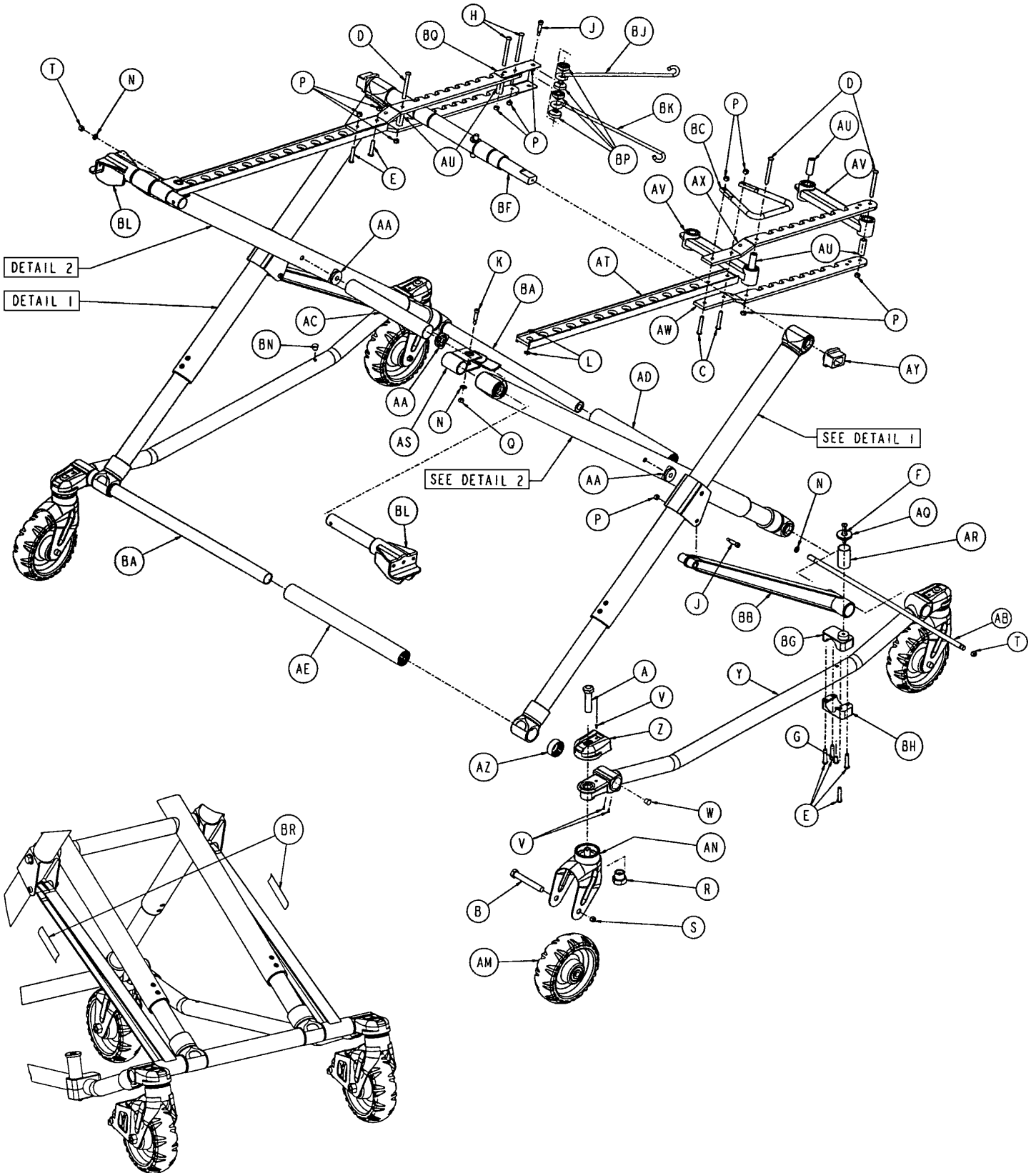

Base Assembly

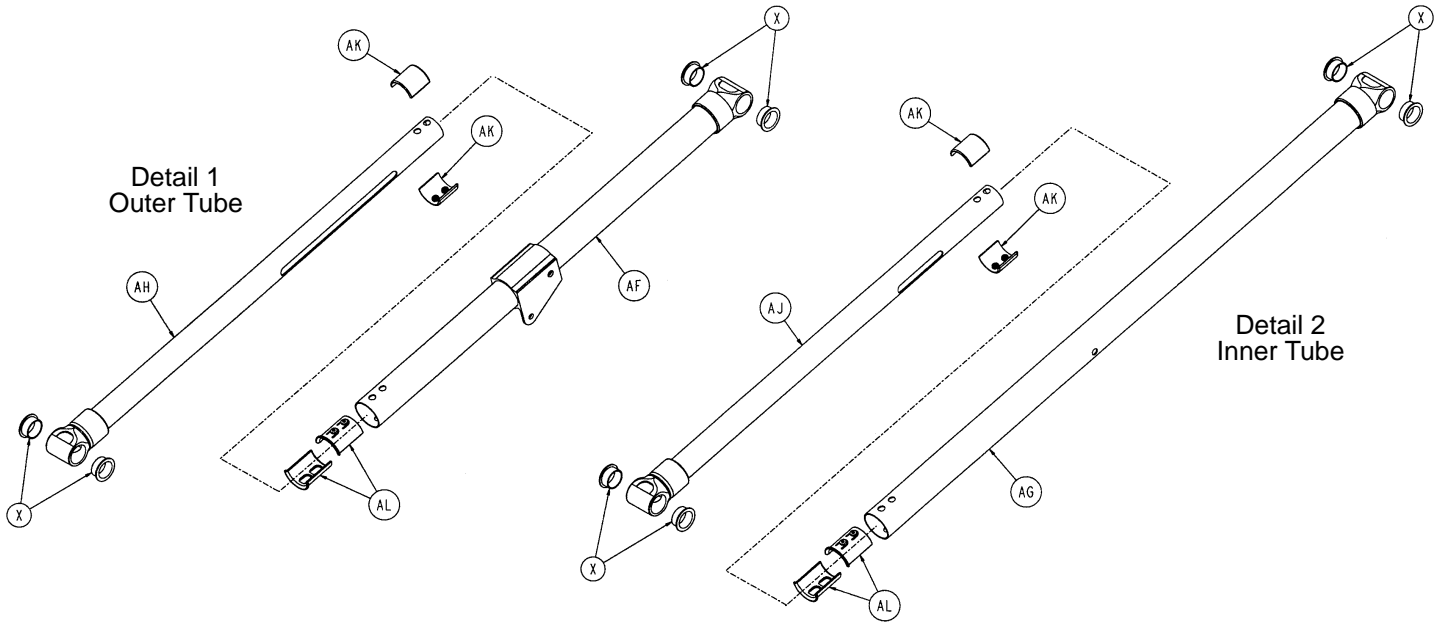

Item	Part No.	Part Name	Qty.	Item	Part No.	Part Name	Qty.
A	3-353	Hex Hd. Cap Screw	4	AH	6060-1-57	B. Piv. Out. Lift Tube Wldmt.	2
B	3-205	Hex Hd. Cap Screw	4	AJ	6060-1-59	B. Piv. In. Lift Tube Wldmt.	2
C	4-135	H. Soc. But. Hd. Cap Scr.	2	AK	6060-1-70	Upper Frame Tube Bearing	8
D	4-163	H. Soc. But. Hd. Cap Scr.	3	AL	6060-1-71	Lower Frame Tube Bearing	8
E	4-198	H. Soc. But. Hd. Cap Scr.	6	AM	(page 30)	Wheel Assembly	4
F	4-204	H. Soc. But. Hd. Cap Scr.	1	AN	6060-2-12	Caster Horn Assembly	*
G	4-232	H. Soc. But. Hd. Cap Scr.	1	AQ	6060-4-43	Retaining Post Cap	1
H	4-234	H. Soc. But. Hd. Cap Scr.	2	AR	6060-4-44	Retaining Post Tube	1
J	8-28	Soc. Hd. Shoulder Bolt	3	AS	6060-5-29	Ht. Adj. Rack Mtg. Pivot	2
K	8-45	Hex Soc. Shoulder Bolt	2	AT	6060-5-32	Height Adjustment Bar	2
L	11-350	Nylon Washer	4	AU	6060-5-37	Spacer Link Spacer	5
N	11-4	Flat Washer	4	AV	6060-5-38	Spacer Link	2
P	16-28	Fiberlock Hex Nut	12	AW	6060-5-42	Lower Ht. Adjustment Rack	2
Q	16-35	Nylock Hex Nut	2	AX	6060-5-43	Upper Ht. Adjustment Rack	2
R	6090-1-9	Caster Nut	4	AY	6060-5-44	Lock Bar Slide Bearing	2
S	16-60	Centerlock Nut	4	AZ	6080-1-29	Outer Base Spacer, Hd. End	2
T	16-89	Centerlock Nut	2	BA	6080-1-43	Base Tube	2
V	25-133	Dome Hd. Rivet	12	BB	6080-1-46	Support Link	2
W	37-204	End Cap	4	BC	6080-5-26	Side Release Handle	1
X	81-244	Flange Bearing	16	BF	(page 31)	Lock Bar Assembly	1
Y	6060-101-15	Outer Base Tube Ass'y	2	BG	6080-4-45	Ret. Post Casting, Top	1
Z	6060-1-21	Caster Mount Cover	4	BH	6080-4-46	Ret. Post Casting, Bottom	1
AA	6060-1-27	Connecting Rod Bearing	4	BJ	6080-40-22	Upper Link	1
AB	6060-101-28	Connecting Rod	1	BK	6080-40-23	Lower Link	1
AC	6060-1-30	Center Base Spacer	1	BL	(page 31.1)	Litter/Base Adapter Ass'y	2
AD	6060-1-31	Inner Base Spcr., Ft. End	1	BN	721-31-65	Hole Plug	1
AE	6060-1-32	Inner Base Spcr., Hd. End	1	BP	6080-40-25	Link Bushing	4
AF	6060-201-53	Lit. Piv. Out. Lift T. Wldmt.	2	BQ	6080-40-88	Link Bracket	1
AG	6060-101-55	Lit. Piv. In. Lift Tube Wldmt.	2	BR	946-1-73	Stryker Logo Label	2

* If the cot is not equipped with a wheel lock option, item AN, Caster Horn is quantity of 4. If the cot is equipped with the wheel lock option, item AN, Caster Horn is quantity of 3.

Base Assembly

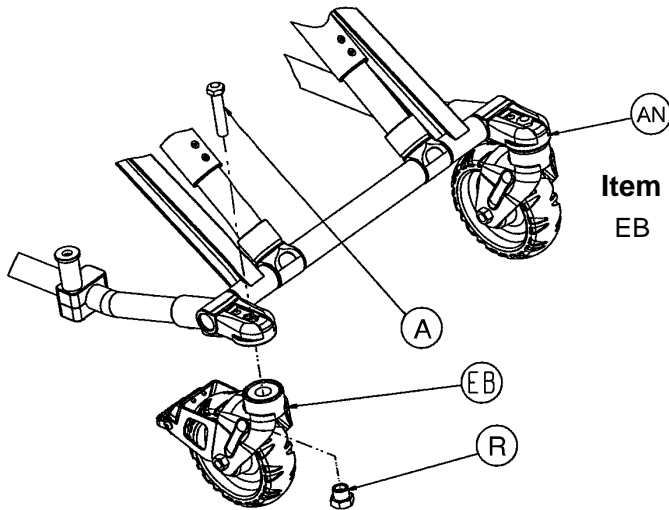

Item	Part No.	Part Name	Qty.
EB	(page 29.2)	Wheel Lock Assembly	1

FOOT END

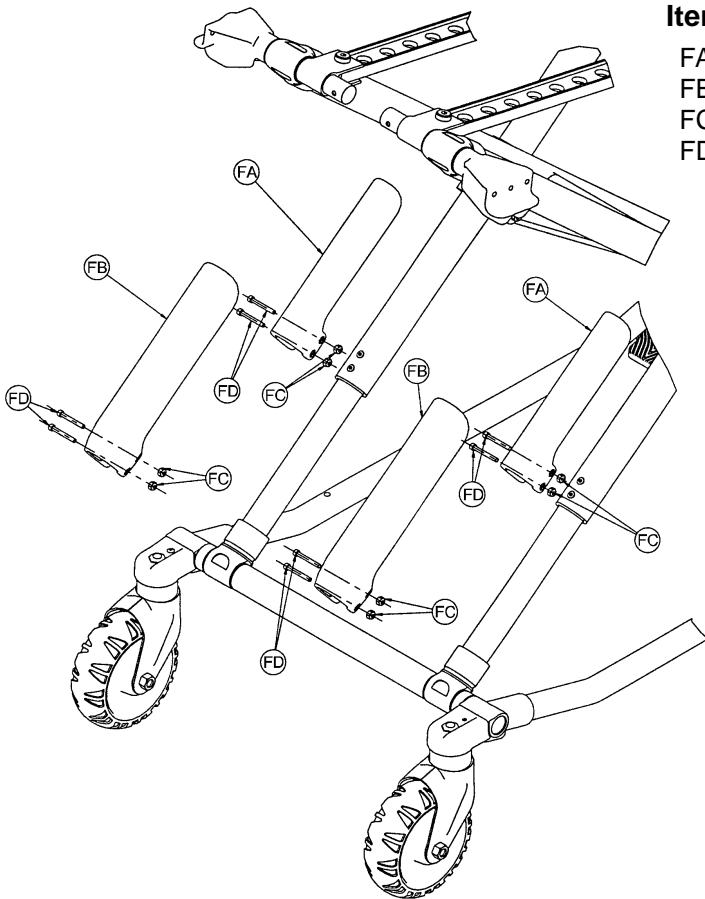

Item	Part No.	Part Name	Qty.
FA	6080-145-1	Upper Frame Guard	2
FB	6080-145-2	Lower Frame Guard	2
FC	16-111	Hex Nut	8
FD	4-215	Hex But. Hd. Cap Scr.	8

Wheel Lock Assembly

Assembly part number 6080-100-10 (reference only)

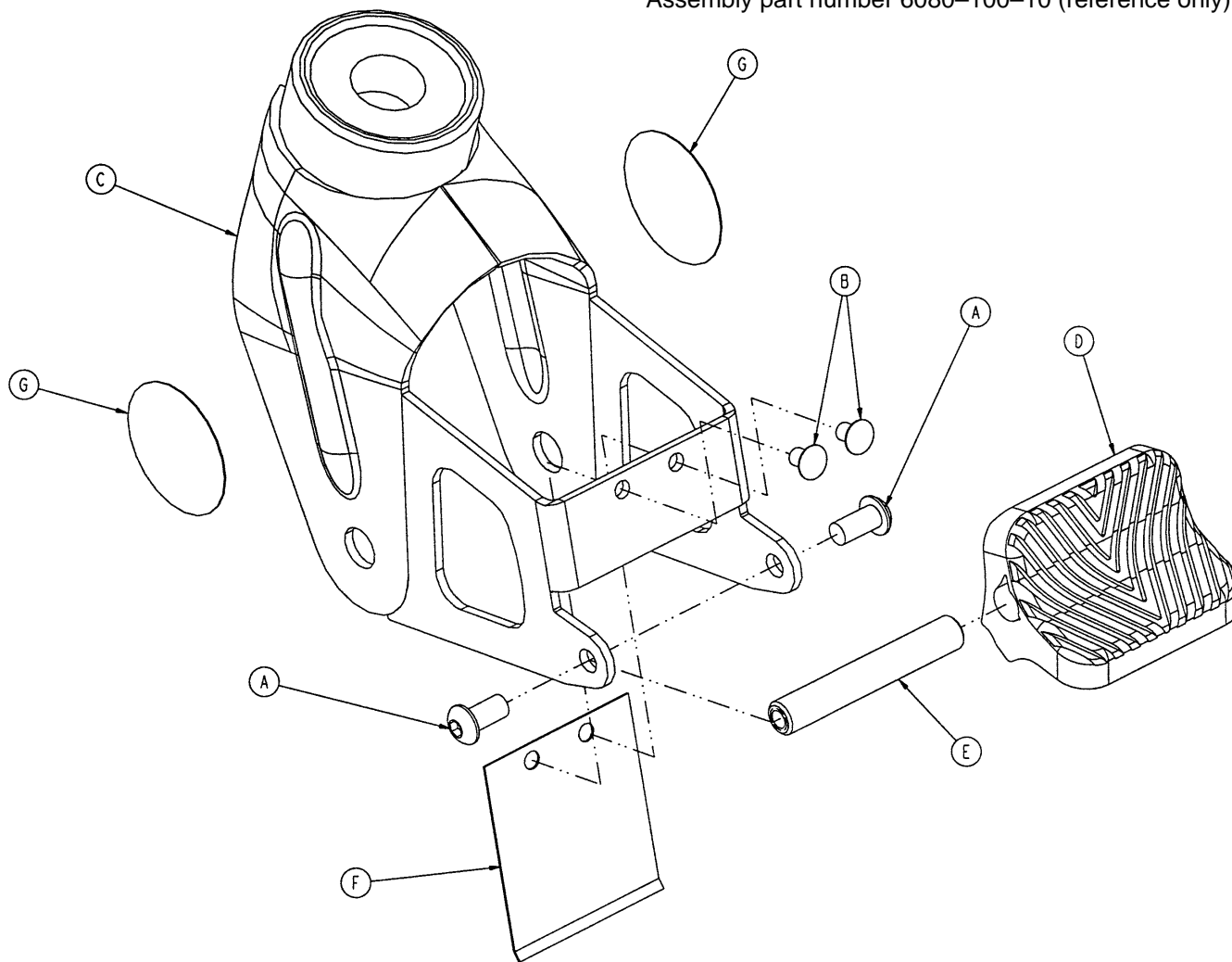

Item	Part No.	Part Name	Qty.
A	4-325	Hex Soc. But. Hd. Screw	2
B	25-153	Rivet	2
C	6080-100-12	Caster Horn Ass'y	1
D	6080-100-30	Pedal	1
E	6080-100-31	Sleeve	1
F	6080-100-32	Spring	1
G	6080-90-101	Warning Label	2

6060-2-10 Wheel Assembly

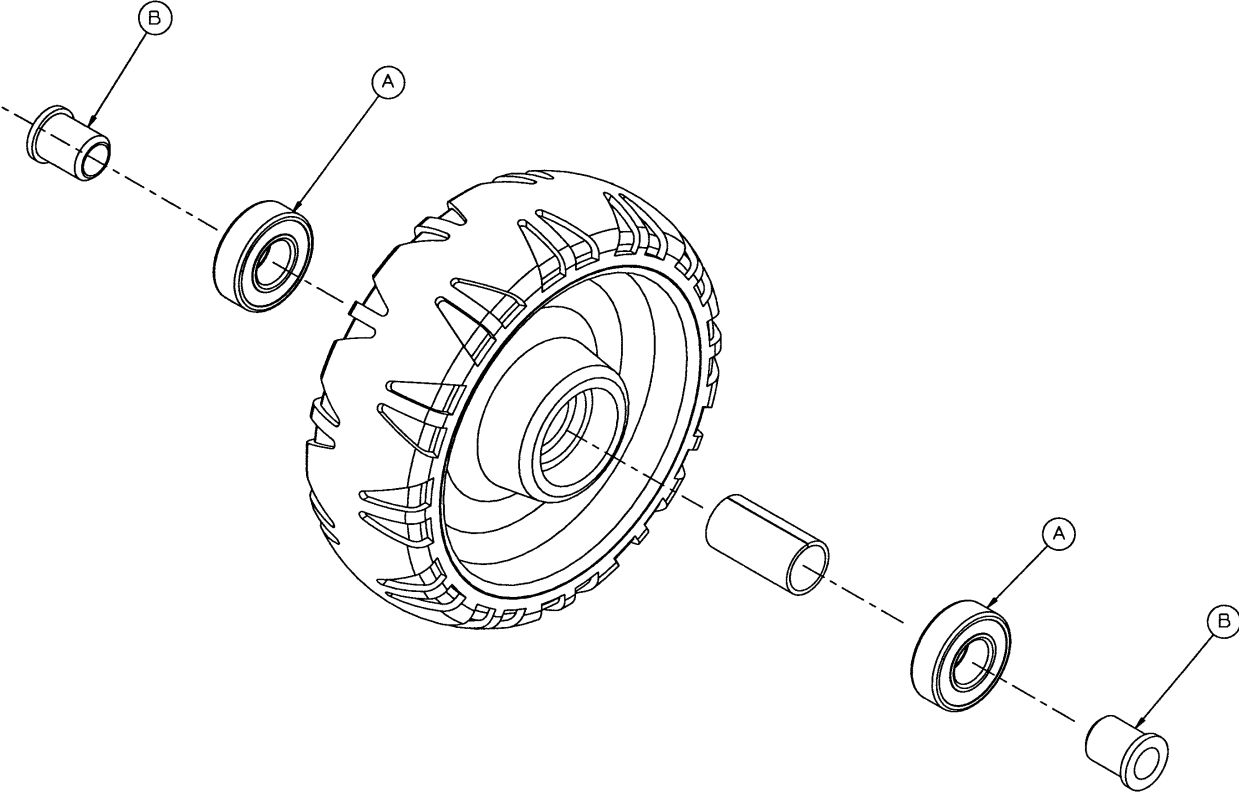

Item	Part No.	Part Name	Qty.
A	81-226	Bearing	2
B	715-1-255	Wheel Bushing	2

6080-5-56 Lock Bar Assembly

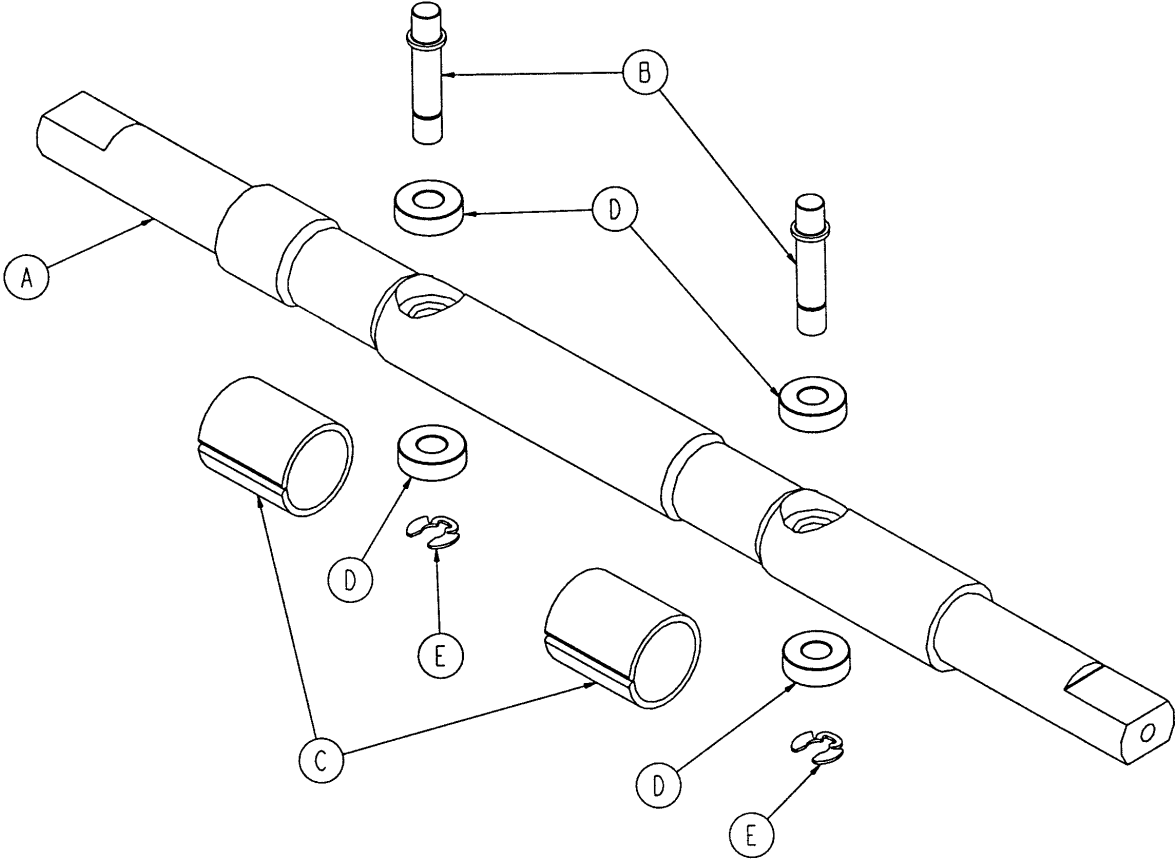

Item	Part No.	Part Name	Qty.
A	6080-5-55	Lock Bar	1
B	6060-5-96	Latch Pin	2
C	6080-5-36	Wear Ring	2
D	81-248	Bearing	4
E	28-181	Retaining Ring	2

6080-5-50 Litter/Base Adapter Assembly

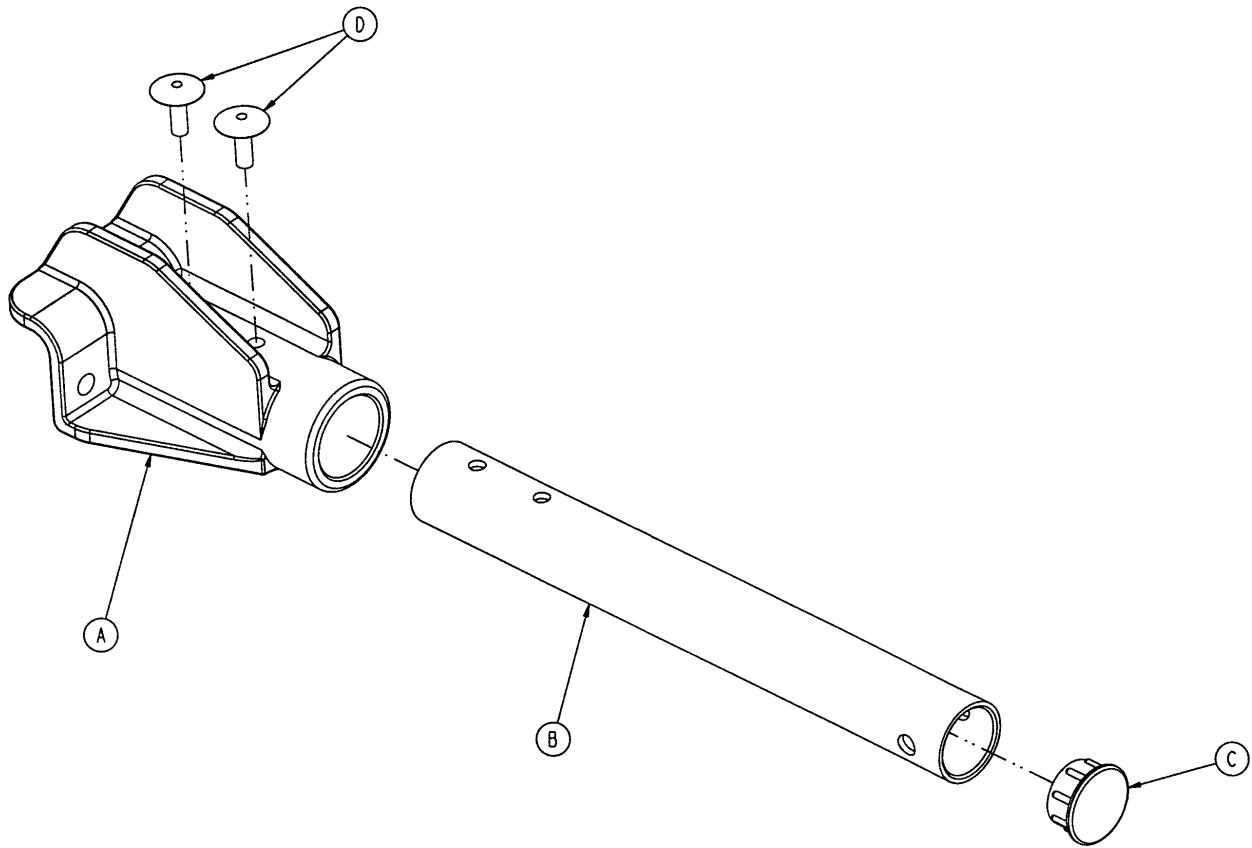

Item	Part No.	Part Name	Qty.
A	6080-5-34	Adapter Mounting Bracket	1
B	6080-5-51	Adapter Pivot Tube	1
C	37-204	Hole Plug	1
D	25-128	Flange Rivet	2

6080-157 Optional Base Lift Bar Assembly

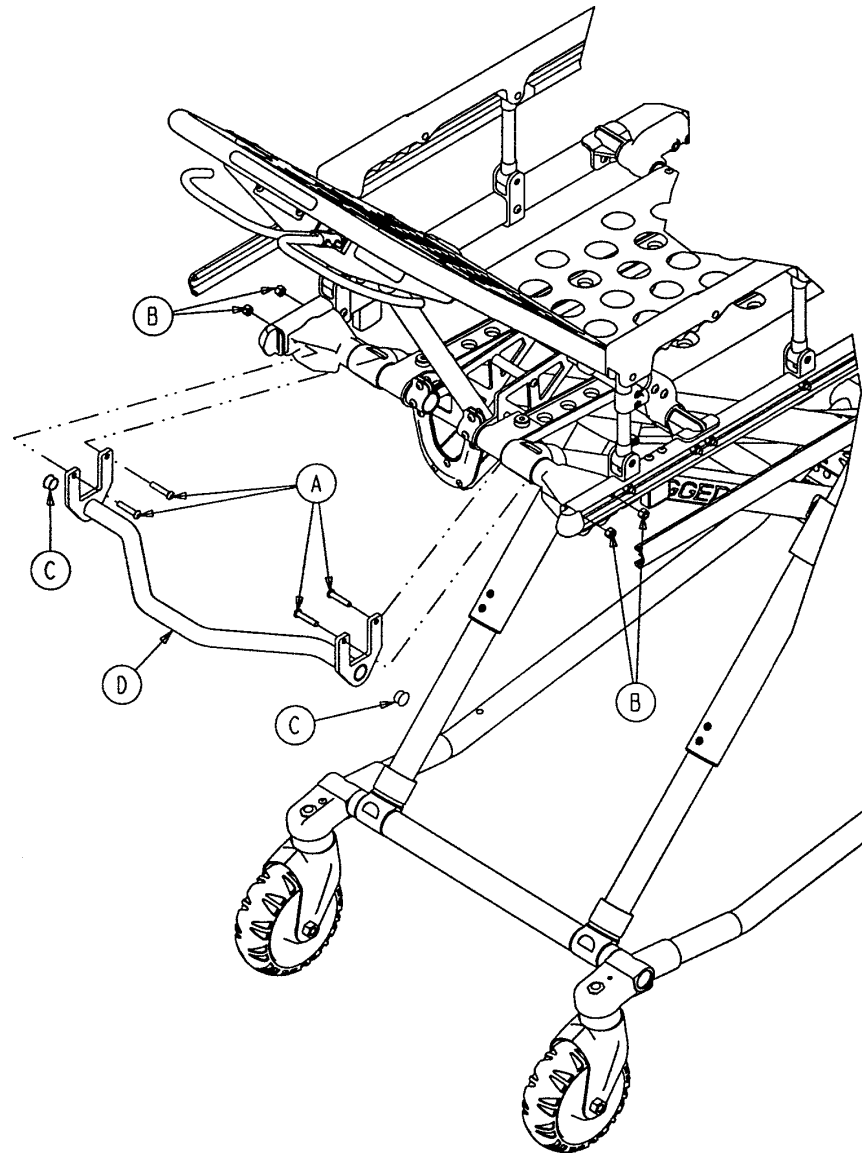

Item	Part No.	Part Name	Qty.
A	4-135	Hex Soc. But. Hd. Cap Screw	4
B	16-28	Nylock Hex Nut	4
C	37-202	Tube Plug	2
D	6080-157-13	Breakaway Lift Bar Weldment	1

Litter Assembly

Assembly part number 6080-30-11 (reference only)

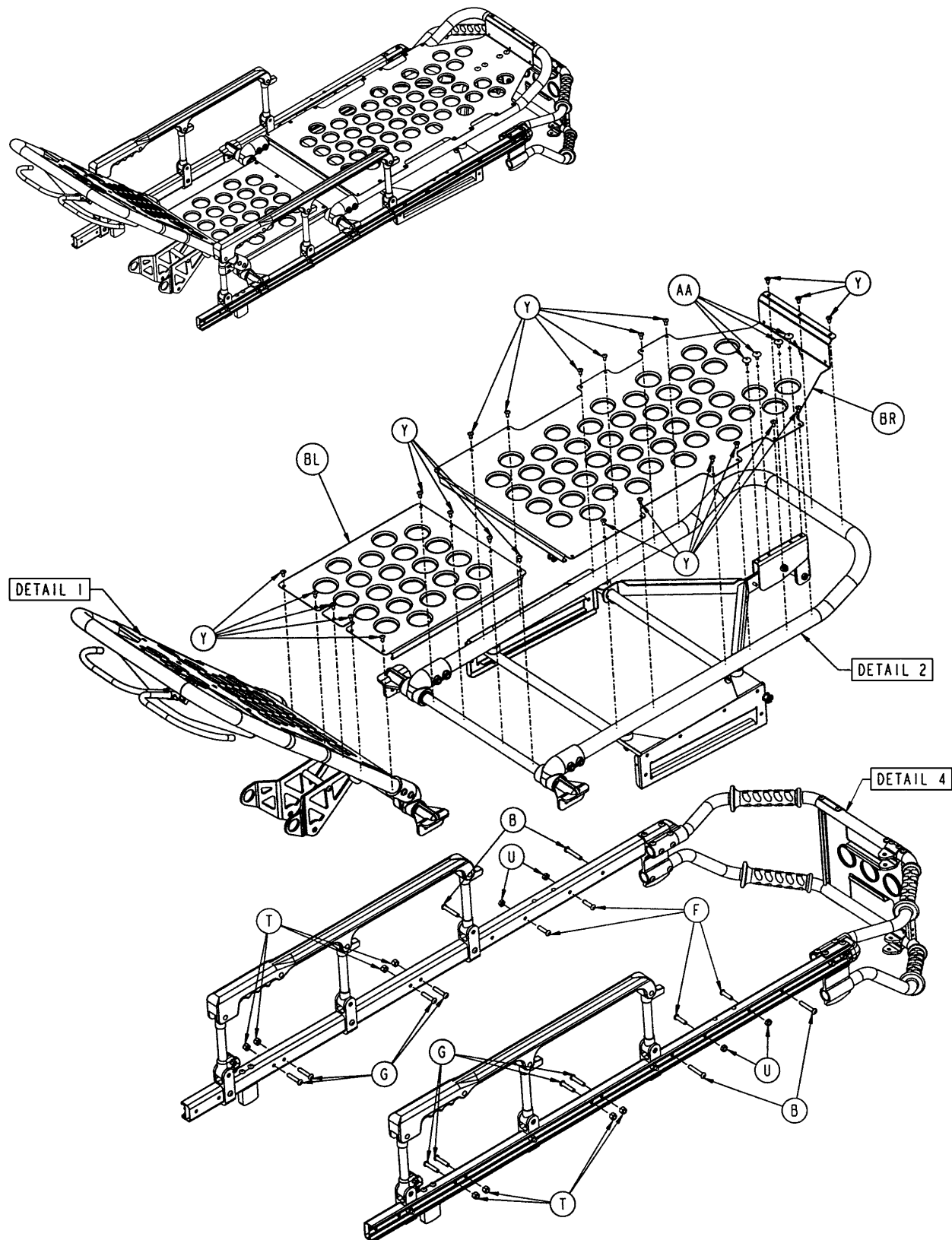

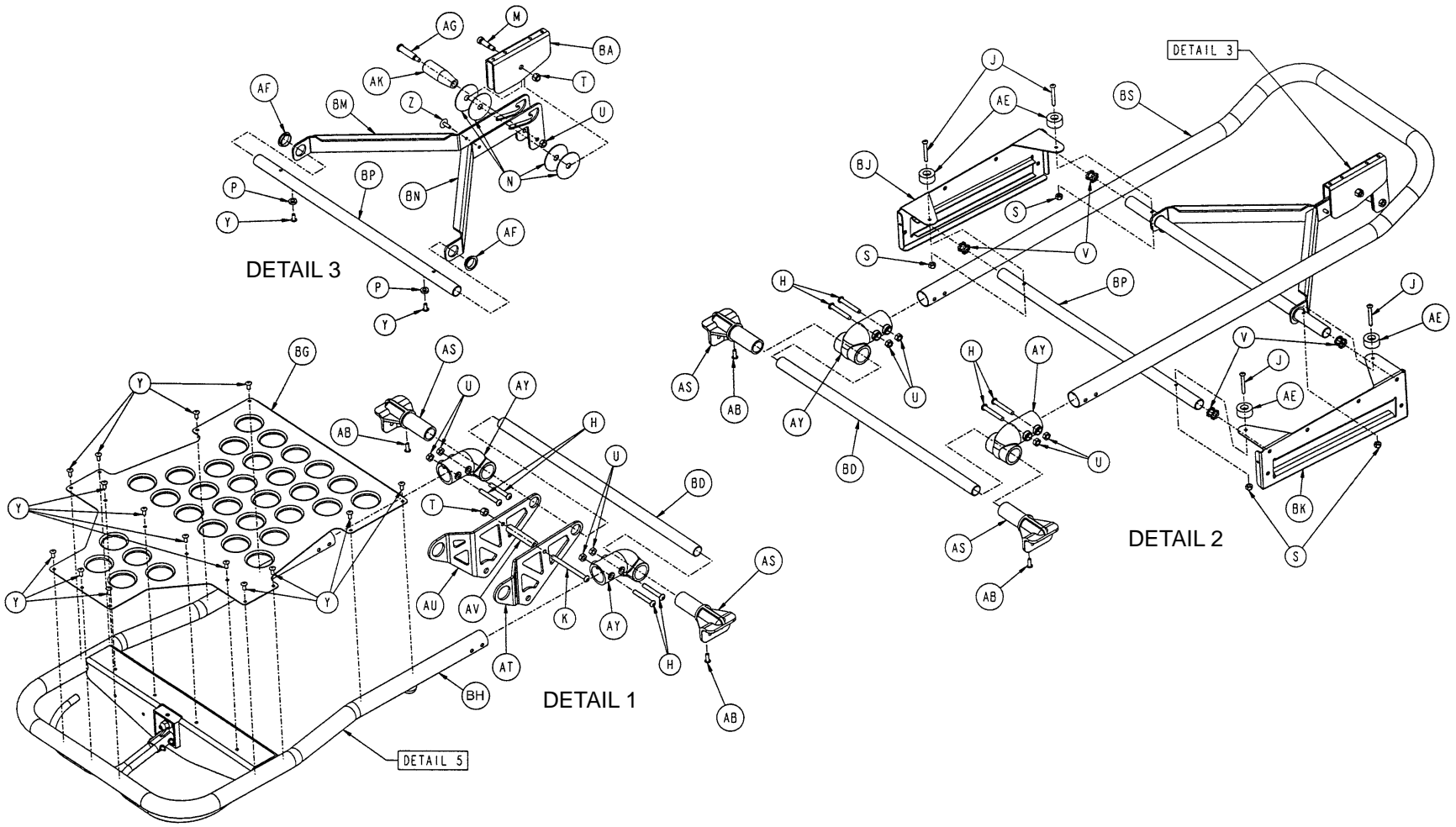

Litter Assembly

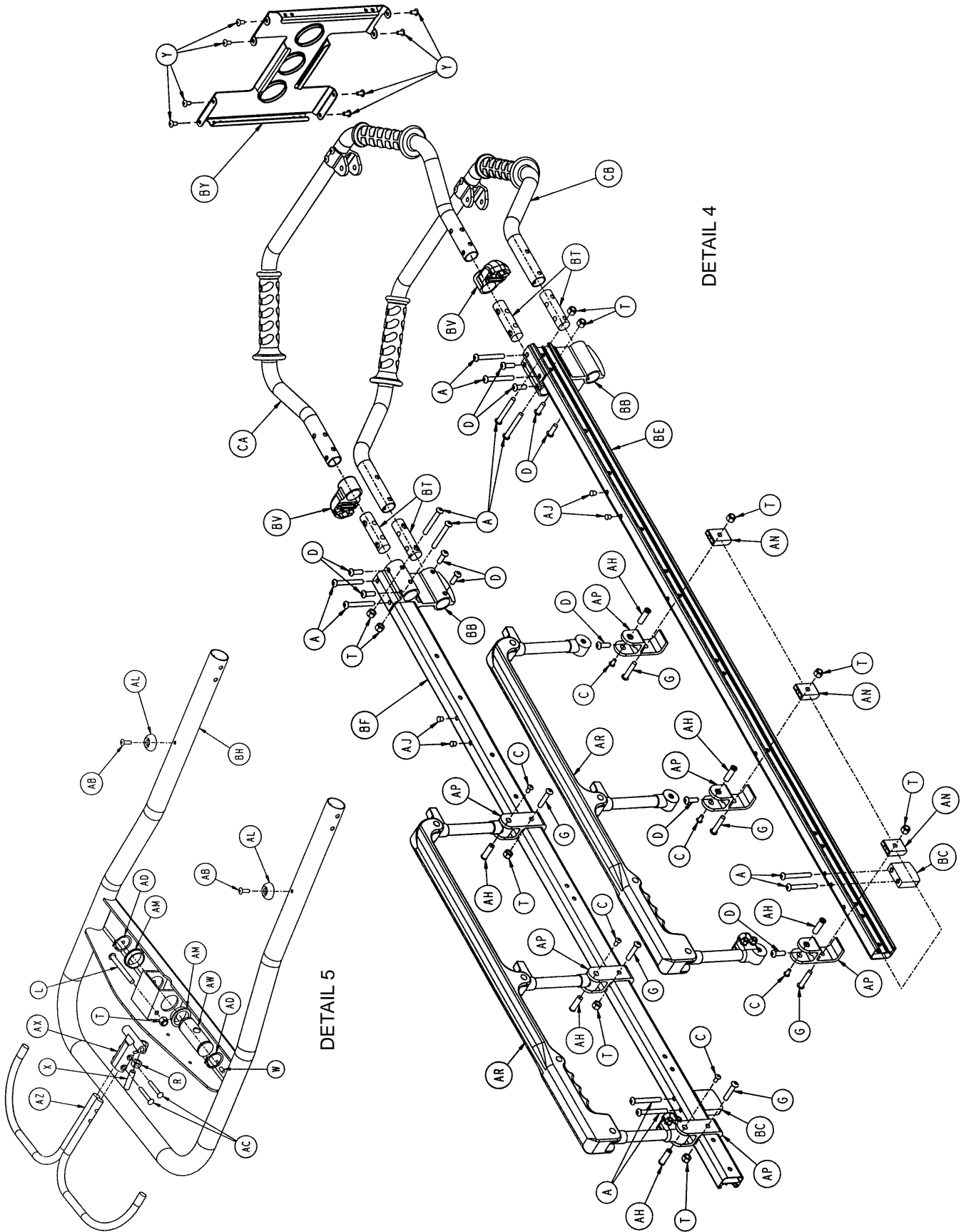

Litter Assembly

Item	Part No.	Part Name	Qty.	Item	Part No.	Part Name	Qty.
A	4-97	Hex Soc. But. Hd. Cap Scr.	12	AM	946-35-25	Liner	2
B	4-135	Hex Soc. But. Hd. Cap Scr.	4	AN	6060-25-33	Pivot Mount Spacer	6
C	4-136	Pan Hd. Mach. Screw	6	AP	6060-25-55	Pivot Mount	6
D	4-161	Hex Soc. But. Hd. Cap Scr.	14	AR	(page 38)	Folddown Siderail Ass'y	2
F	4-197	Hex Soc. But. Hd. Cap Scr.	4	AS	6060-30-31	Support Mount	4
G	4-198	Hex Soc. But. Hd. Cap Scr.	14	AT	6060-31-35	Outer Plate, Right	1
H	4-204	Hex Soc. But. Hd. Cap Scr.	8	AU	6060-31-36	Outer Plate, Left	1
J	4-215	Hex Soc. But. Hd. Cap Scr.	4	AV	6060-31-47	Litter/Base Interface Spcr.	1
K	4-218	Hex Soc. But. Hd. Cap Scr.	1	AW	6060-32-38	Yoke	1
L	4-234	Hex Soc. But. Hd. Cap Scr.	1	AX	6060-32-40	Pivot	1
M	8-27	Shoulder Bolt	1	AY	6060-32-42	Adapter Pivot	4
N	14-73	Nylon Flat Washer	2	AZ	6060-32-52	Release Handle Wldmnt.	1
P	14-67	Nylon Flat Washer	2	BA	6070-38-33	Calf Stand Retainer	1
R	15-50	Hex Nut	1	BB	6080-30-38	Foot End Litter Stop	2
S	16-3	Fiberlock Hex Nut	4	BC	6080-30-40	Litter Stop	2
T	16-28	Fiberlock Hex Nut	21	BD	6080-30-42	Litter Crossbrace	2
U	16-78	Centerlock Hex Nut	13	BE	6080-30-46	Outer Support Rail, Rt.	1
V	18-38	Umbrella Nut	4	BF	6080-30-47	Outer Support Rail, Lt.	1
W	21-119	Hex Soc. Set Screw	1	BG	6080-32-45	Fowler Skin	1
X	21-138	Hex Soc. Set Screw	1	BH	6080-32-50	Fowler Weldment	1
Y	25-79	Dome Head Rivet	49	BJ	6080-33-32	Slide Plate, Left	1
Z	25-128	Flange Rivet	1	BK	6080-33-33	Slide Plate, Right	1
AA	25-132	Flange Rivet	4	BL	6080-34-46	Midsection Skin	1
AB	25-133	Dome Head Rivet	6	BM	6080-38-31	Calf Stand Support, Lt.	1
AC	25-131	Semi-Tubular Rivet	2	BN	6080-38-32	Calf Stand Support, Rt.	1
AD	28-76	External Retaining Ring	2	BP	6080-38-35	Trend Cross Tube	2
AE	56-16	Bumper	4	BR	6080-38-45	Foot Section Skin	1
AF	81-255	Split Bearing	2	BS	6080-38-46	Foot Section Tube	1
AG	378-24-29	Shoulder Bolt	1	BT	6080-39-43	Lift Bar Plug	4
AH	721-26-66	Pivot Screw	6	BV	6080-40-12	Outer Rail End Cap, Ft.	2
AJ	721-31-65	Hole Plug	4	BY	6080-240-30	Lift Bar Brace	1
AK	938-1-177	Knob	1	CA	6080-40-53	Upper Lift Tube w/Grips	1
AL	946-1-155	Bumper	2	CB	6080-40-54	Lower Lift Tube w/Grips	1

Breakaway Head Assembly

Assembly part number 6080-37-55 (reference only)

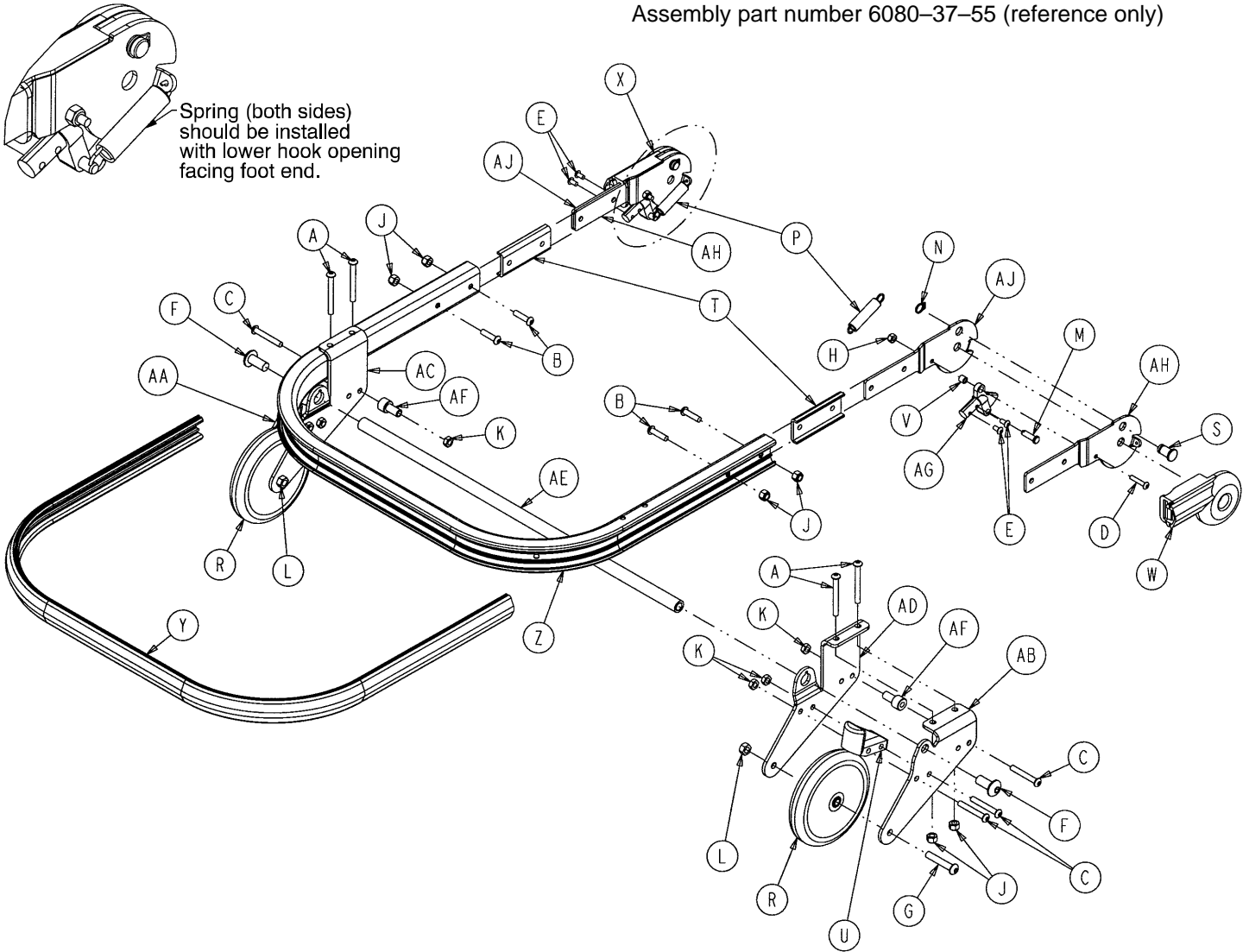

Item	Part No.	Part Name	Qty.	Item	Part No.	Part Name	Qty.
A	4-163	H. Soc. But. Hd. Cap Scr.	4	T	6060-37-26	Pivot Spacer Plate	2
B	4-197	H. Soc. But. Hd. Cap Scr.	4	U	6060-37-33	Horn Stop Block	2
C	4-204	H. Soc. But. Hd. Cap Scr.	9	V	6060-37-36	Trigger Lock Spacer	2
D	4-222	H. Soc. But. Hd. Cap Scr.	2	W	6060-37-37	Pivot Cover, Right	1
E	4-231	H. Soc. But. Hd. Cap Scr.	4	X	6060-37-38	Pivot Cover, Left	1
F	4-310	But. Hd. Cap Screw	2	Y	6080-36-44	Bumper	1
G	4-54	But. Hd. Cap Screw	2	Z	6080-36-45	Outer Rail	1
H	16-3	Fiberlock Hex Nut	2	AA	6080-37-27	Outer Caster Horn, Left	1
J	16-28	Fiberlock Hex Nut	12	AB	6080-37-28	Outer Caster Horn, Right	1
K	16-78	Centerlock Hex Nut	7	AC	6080-37-29	Inner Caster Horn, Left	1
L	16-114	Centerlock Hex Nut	2	AD	6080-37-30	Inner Caster Horn, Right	1
M	26-269	Clevis Pin	2	AE	6080-37-34	Safety Hook Pivot Tube	1
N	28-138	Retaining Ring	4	AF	6080-37-49	Release Handle Spacer	2
P	38-410	Extension Spring	2	AG	6090-37-39	Trigger Lock	2
R	6060-36-20	Five Inch Wheel Ass'y	2	AH	6090-37-42	Pivot Form, Right	2
S	6060-36-24	Pivot Stop Pin	2	AJ	6090-37-43	Pivot Form, Left	2

Breakaway Head Assembly

Assembly part number 6080-37-10 (reference only)

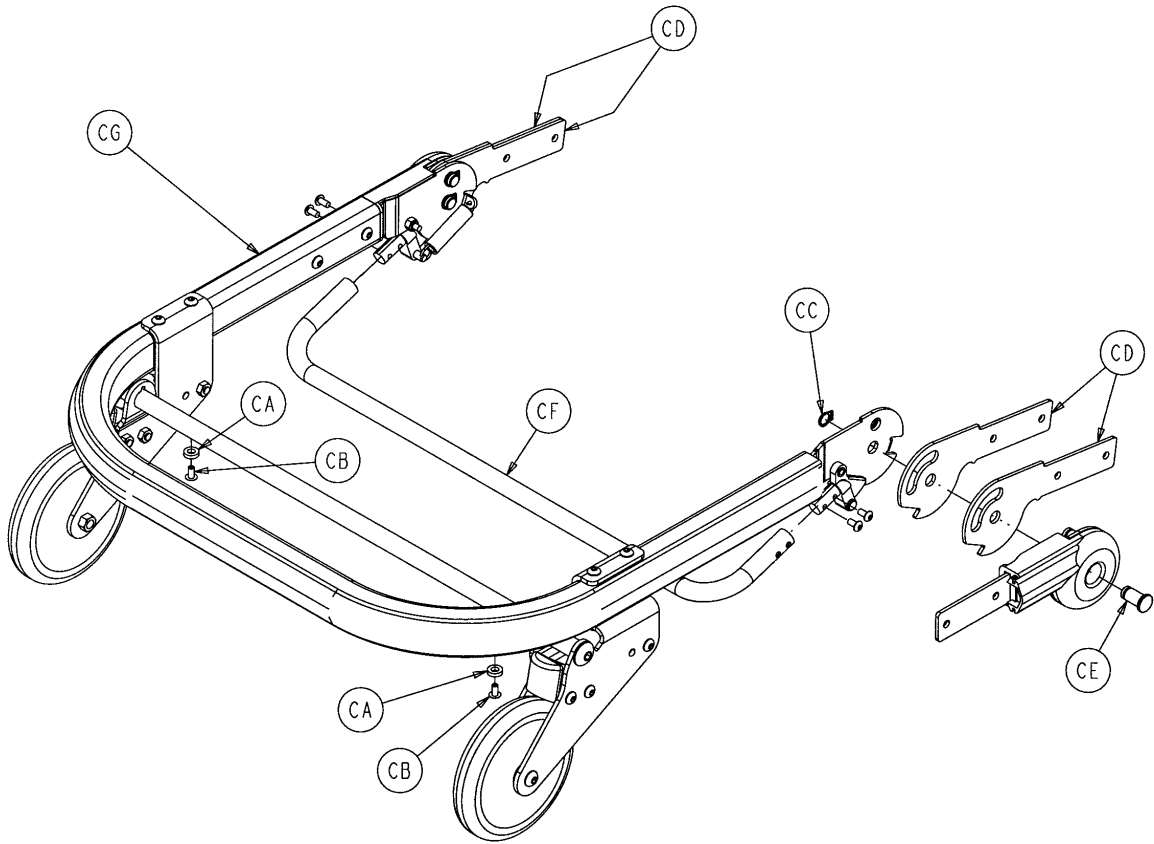

Item	Part No.	Part Name	Qty.
CA	14-67	Nylon Flat Washer	2
CB	25-79	Rivet	2
CC	28-138	Retaining Ring	2
CD	6060-37-40	Center Pivot	4
CE	6080-36-25	Pivot Pin	2
CF	6080-36-47	Bent Release Crossbar	1
CG	(page 36)	Breakaway Head Section	1

Breakaway Head Section Assembly

Assembly part number 6091-156-10 – Safety Hook Option
 Assembly part number 6091-156-16 – Lift Option
 Assembly part number 6091-156-15 – No Lift Option
 (reference only)

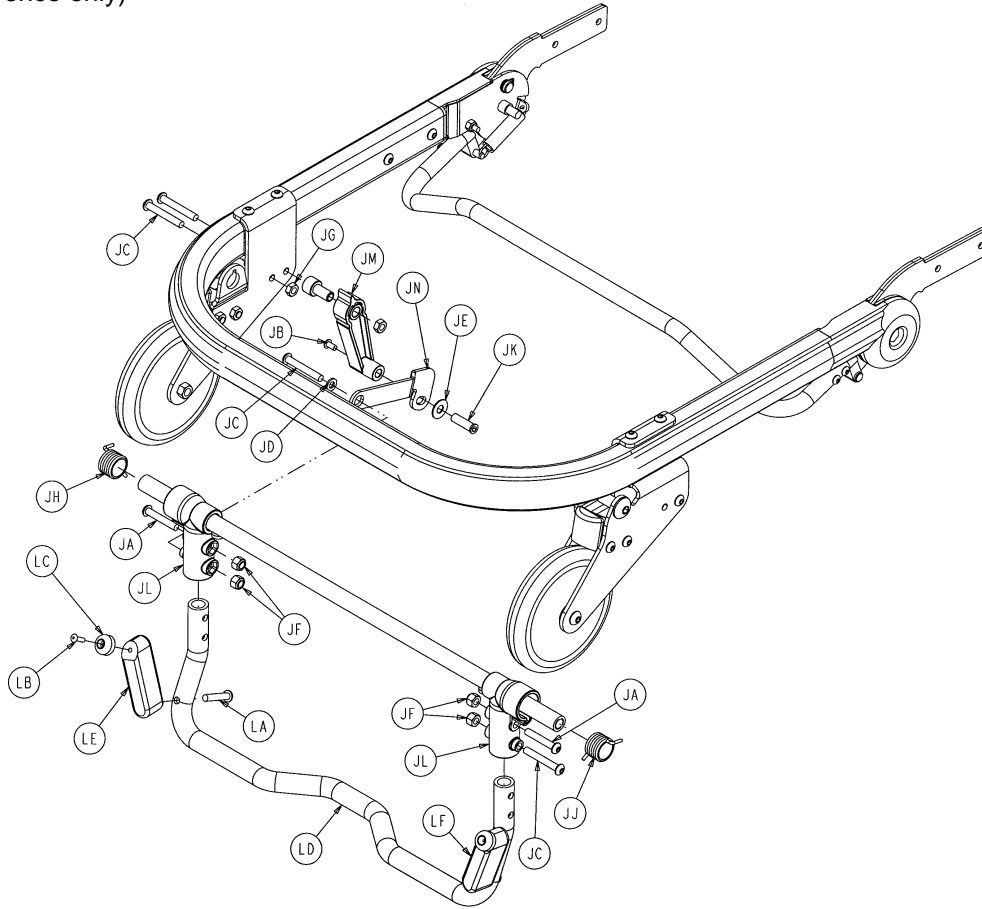

Item	Part No.	Part Name	Qty.	Item	Part No.	Part Name	Qty.
JA	4-135	H. Soc. But. Hd. Cap Scr.	2	JL	6060-37-21	Safety Hook Pivot	2
JB	4-136	Pan Hd. Mach. Screw	1	JM	6060-37-47	Safety Hook Rel. Handle	1
JC	4-204	Hex Soc. But. Hd. Cap Scr.	3	JN	6080-237-48	Safety Hook Release Arm	1
JD	11-65	Flat Washer	1	LA	4-440	But. Hd. Cap Screw	2
JE	11-179	Flat Washer	1	LB	25-157	Dome Head Rivet	2
JF	16-28	Fiberlock Hex Nut	4	LC	56-19	Bumper	2
JG	16-78	Centerlock Hex Nut	1	LD	6080-37-22	Hook Tube	1
JH	38-408	Torsion Spring	1	LD	6080-37-23	Lift Capable Hook Tube	1
JJ	38-409	Torsion Spring	1	LE	6091-160-21	Lift Nub, Left	1
JK	721-26-66	Pivot Screw	1	LF	6091-160-22	Lift Nub, Right	1

Notes

6060-26-10 Siderail Assembly

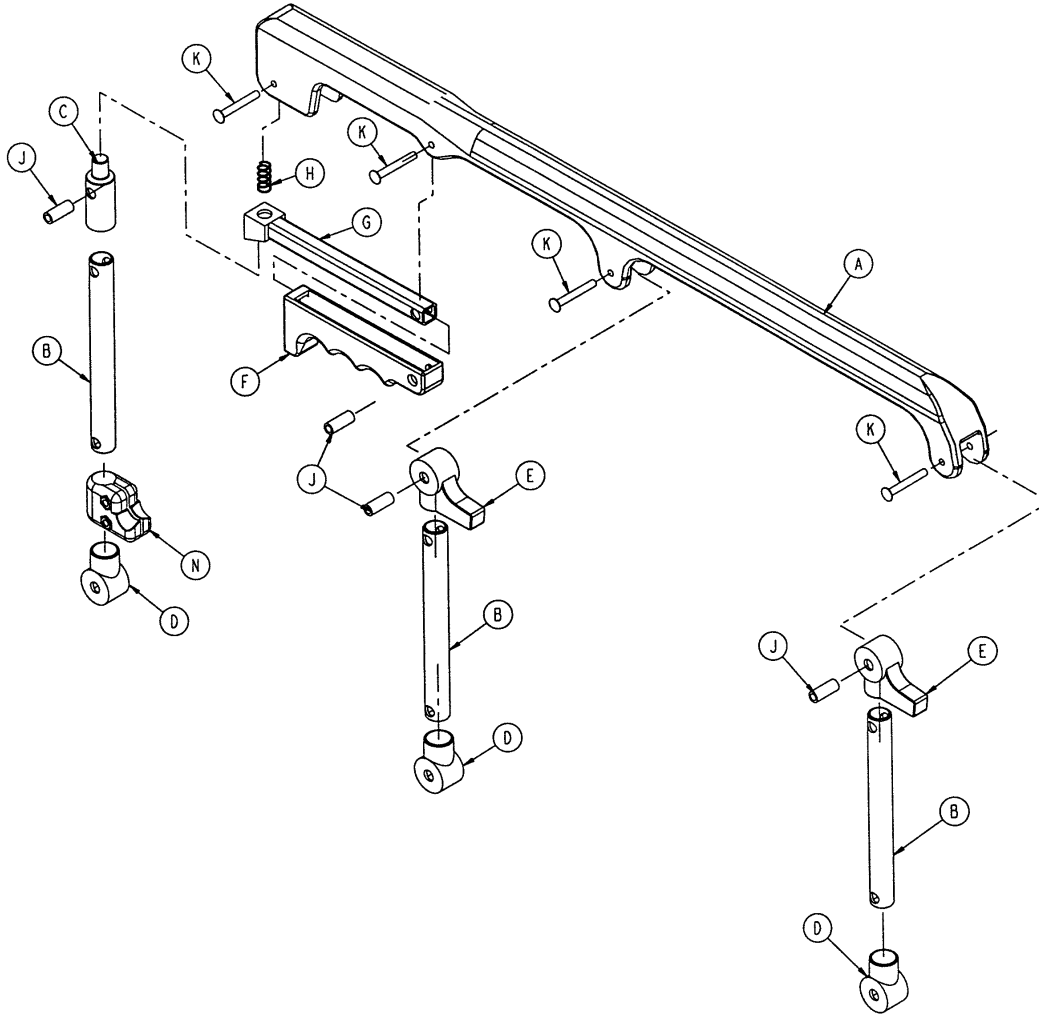

Item	Part No.	Part Name	Qty.
A	6060-25-24	Top Rail	1
B	6060-25-43	Spindle	3
C	6060-25-47	Spindle Lock	1
D	6060-25-41	Spindle Pivot	3
E	6060-25-40	Spindle Pivot Stop	2
F	6060-25-29	Lock Release Grip	1
G	6060-25-30	Lock Bar Weldment	1
H	38-344	Compression Spring	1
J	6060-25-35	Pivot Bushing	4
K	25-131	Rivet	4
N	1001-26-39	Ring Spacer Assembly	1

6080-40-51 Upper Lift Tube Assembly

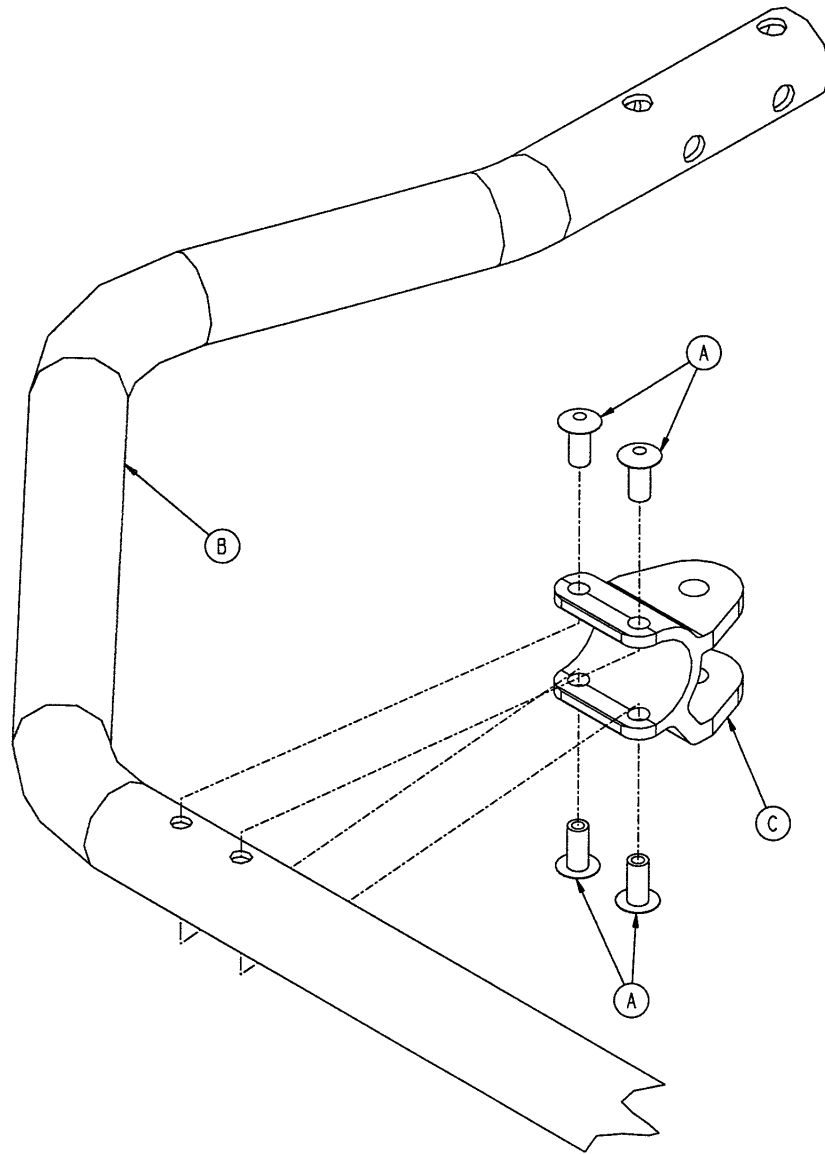

Item	Part No.	Part Name	Qty.
A	25-79	Rivet	4
B	6080-40-18	Upper Lifting Bar	1
C	6080-40-38	Release Handle Pivot	1

6080-40-52 Lower Lift Tube Assembly

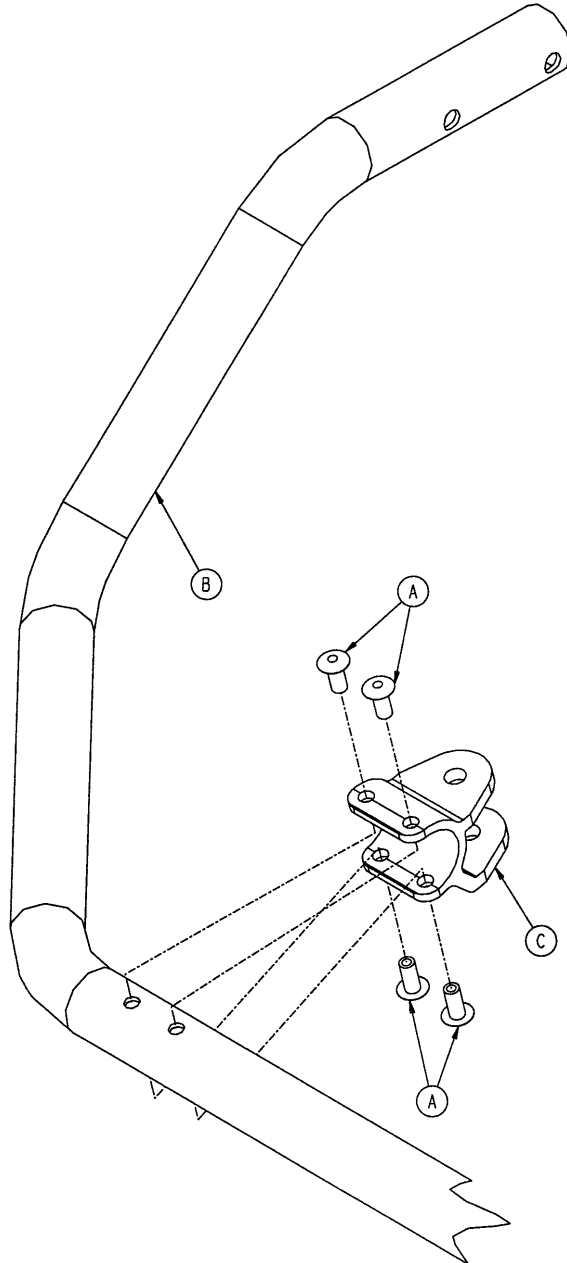

Item	Part No.	Part Name	Qty.
A	25-79	Rivet	4
B	6080-40-19	Lower Lifting Bar	1
C	6080-40-38	Release Handle Pivot	1

6080-40-40 Release Handle Assembly

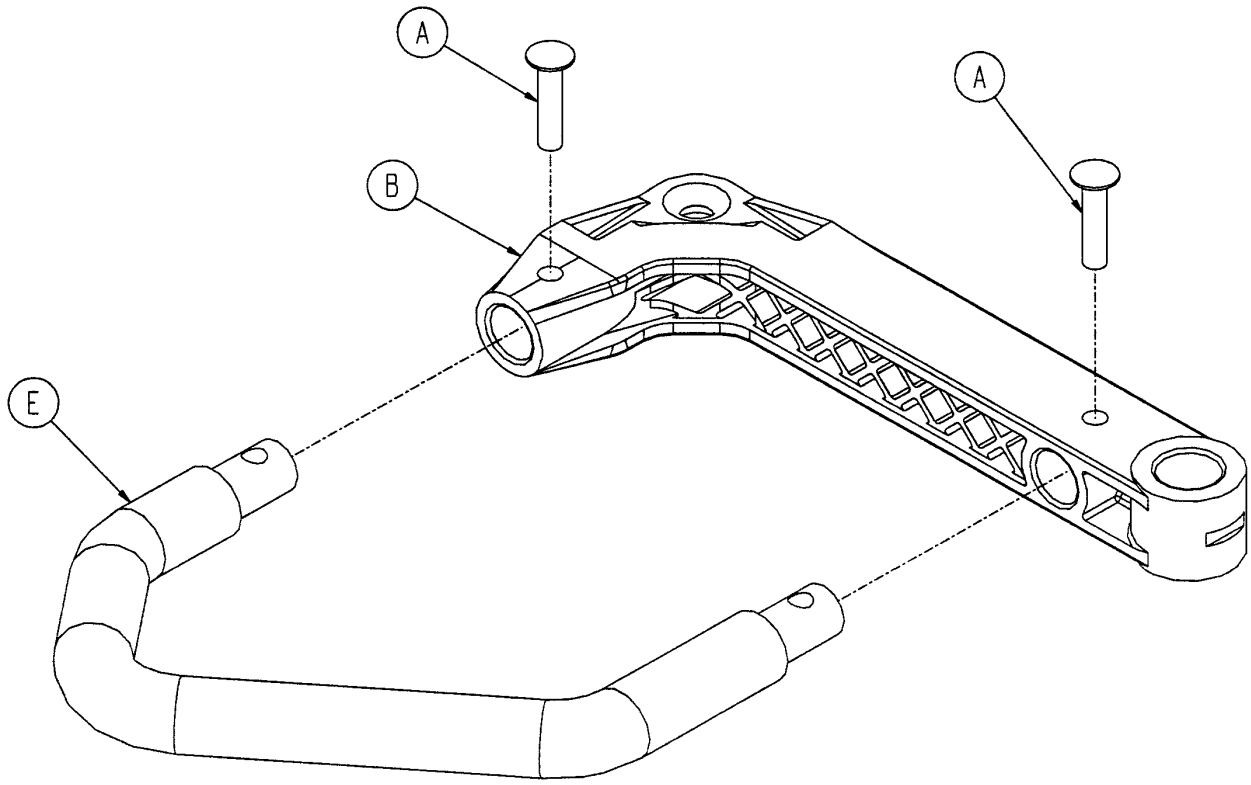

Item	Part No.	Part Name	Qty.
A	25-125	Rivet	2
B	6080-40-41	Release Handle Link	1
E	6080-40-50	Side Release Handle Ass'y	1

6080-210-10 Optional 2-Stage I.V. Mounting Ass'y, Rt.

6080-215-10 Optional 3-Stage I.V. Mounting Ass'y, Rt.

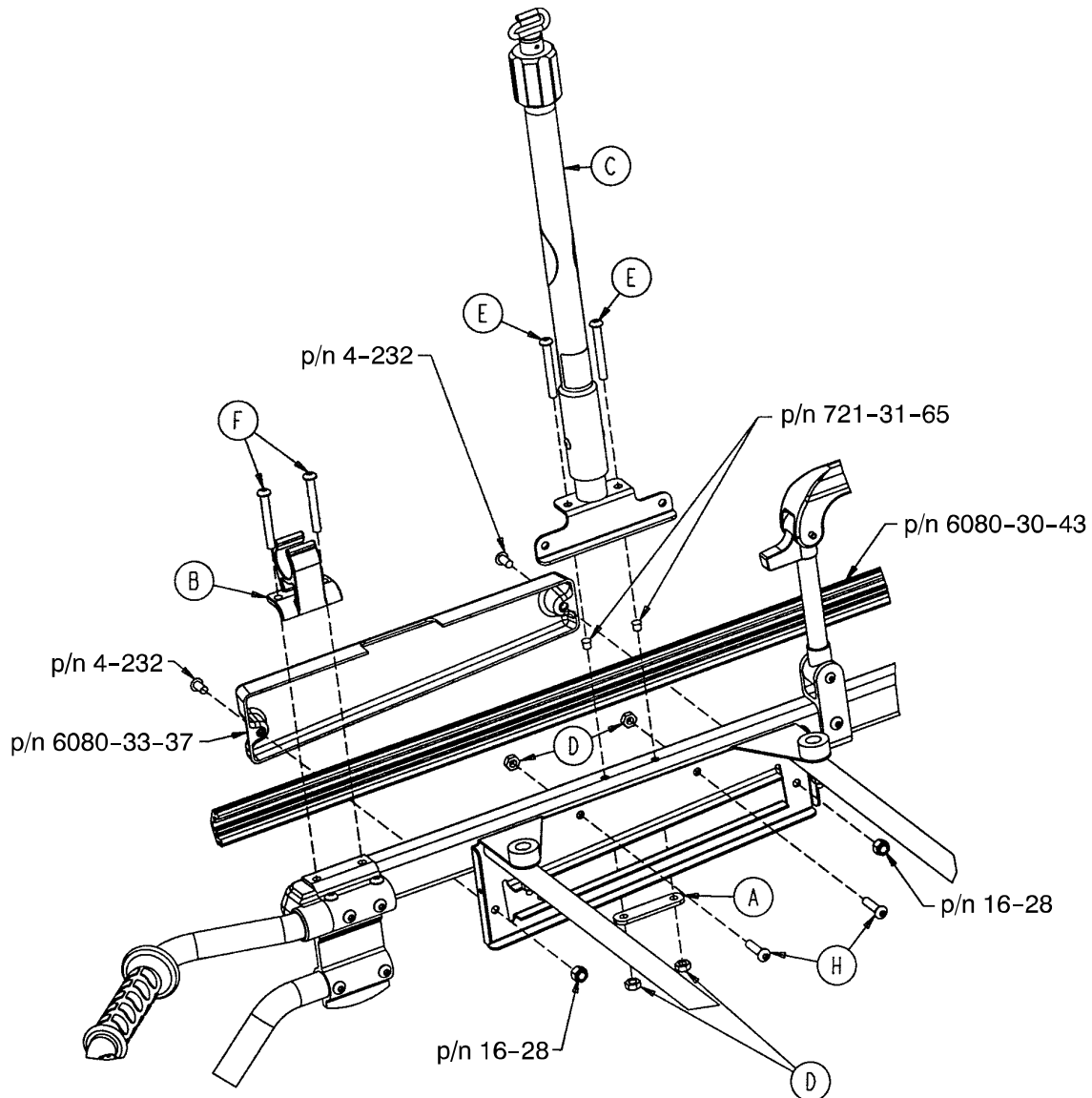

6080-210-10

6080-215-10

Item	Part No.	Part Name	Qty.	Item	Part No.	Part Name	Qty.
A	6070-110-32	I.V. Retainer Plate	1	A	6070-110-32	I.V. Retainer Plate	1
B	6080-110-35	I.V. Clip	1	B	6080-110-35	I.V. Clip	1
C	(page 43)	2-Stage I.V. Pole, Right	1	C	(page 44)	3-Stage I.V. Pole, Right	1
D	16-78	Centerlock Hex Nut	4	D	16-78	Centerlock Hex Nut	4
E	4-97	Hex Soc. But. Hd. Cap Scr.	2	E	4-97	Hex Soc. But. Hd. Cap Scr.	2
F	4-163	Hex Soc. But. Hd. Cap Scr.	2	F	4-163	Hex Soc. But. Hd. Cap Scr.	2
G	4-197	Hex Soc. But. Hd. Cap Scr.	2	G	4-197	Hex Soc. But. Hd. Cap Scr.	2

6080-210-20 2-Stage I.V. Assembly, Patient Right

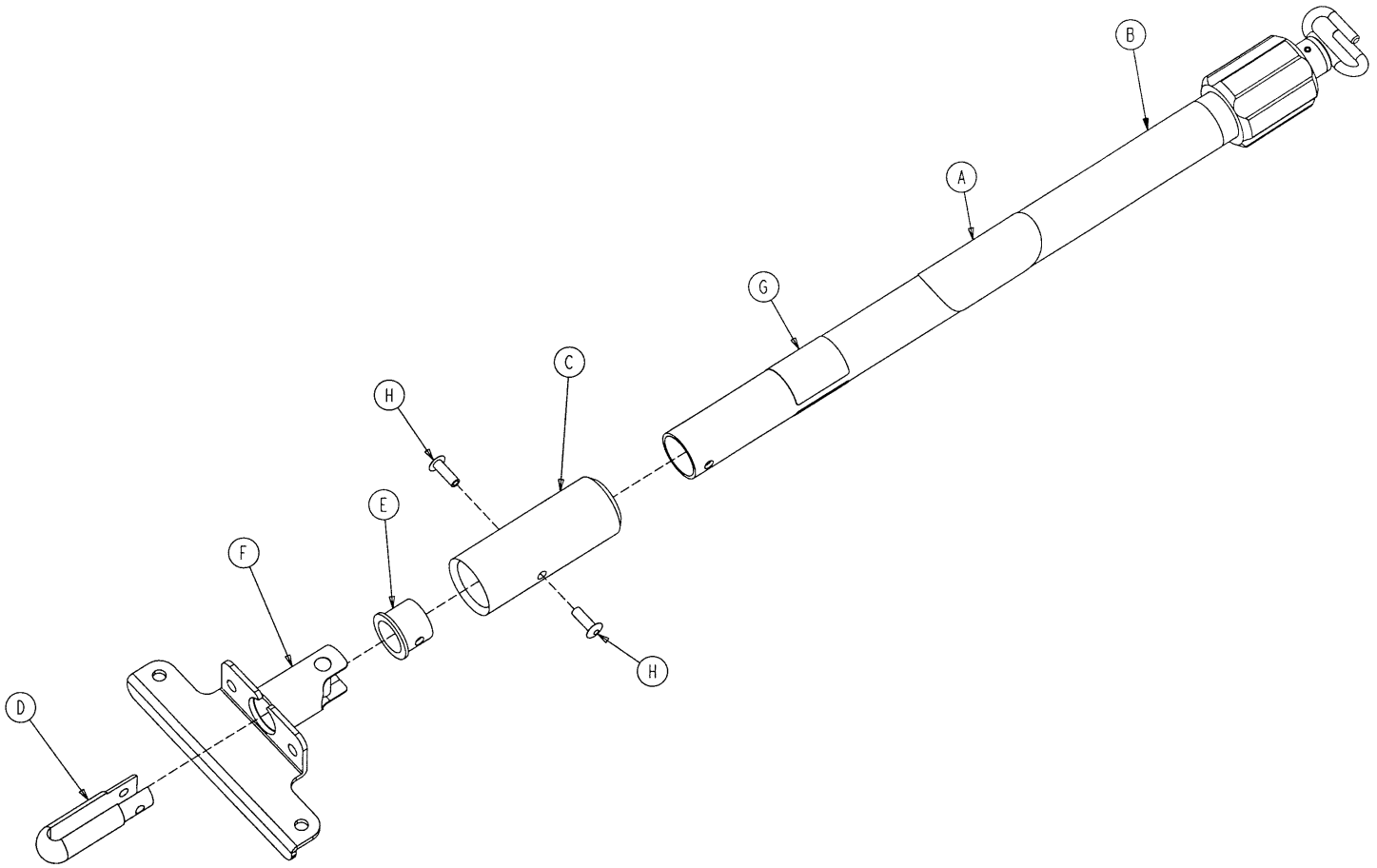

Item	Part No.	Part Name	Qty.
A	6070-90-105	Caution Label	1
B	(page 48)	2-Stage I.V. Pole Assembly	1
C	6070-210-45	I.V. Pole Sleeve	1
D	6070-210-46	I.V. Pivot	1
E	6070-210-49	I.V. Pivot Ring	1
F	6080-210-52	I.V. Socket Weldment, Right	1
G	6090-90-31	Specification Label	1
H	25-133	Blind Rivet	2

6080-215-20 3-Stage I.V. Assembly, Patient Right

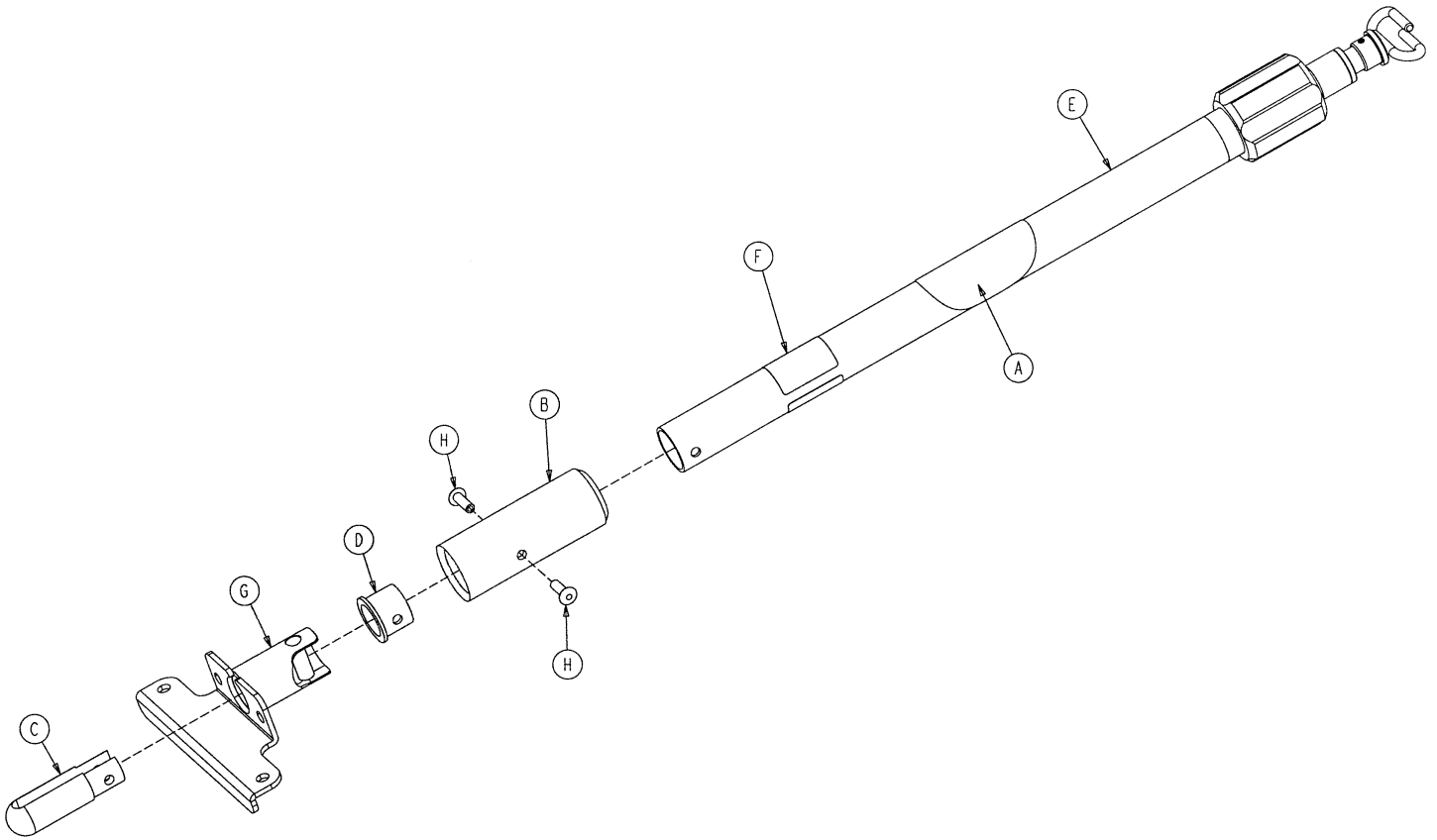

Item	Part No.	Part Name	Qty.
A	6070-90-105	Caution Label	1
B	6070-210-45	I.V. Pole Sleeve	1
C	6070-210-46	I.V. Pivot	1
D	6070-210-49	I.V. Pivot Ring	1
E	(page 49)	3-Stage I.V. Pole Assembly	1
F	6080-90-33	Specification Label	1
G	6080-210-52	I.V. Socket Weldment, Right	1
H	25-133	Blind Rivet	2

6080-211-10 Optional 2-Stage I.V. Mounting Ass'y, Left

6080-216-10 Optional 3-Stage I.V. Mounting Ass'y, Left

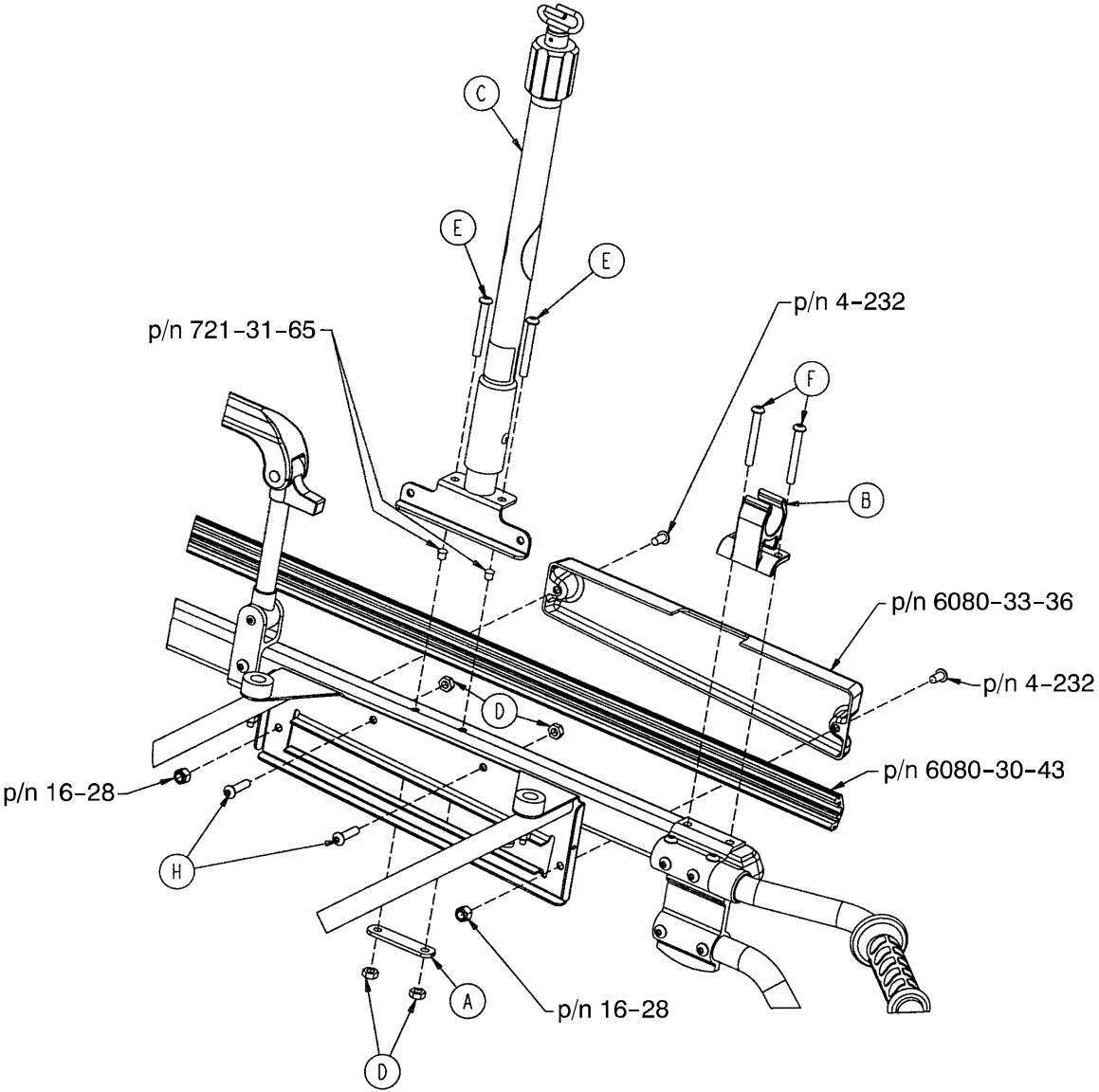

6080-211-10

6080-216-10

Item	Part No.	Part Name	Qty.	Item	Part No.	Part Name	Qty.
A	6070-110-32	I.V. Retainer Plate	1	A	6070-110-32	I.V. Retainer Plate	1
B	6080-110-35	I.V. Clip	1	B	6080-110-35	I.V. Clip	1
C	(page 46)	2-Stage I.V. Pole, Left	1	C	(page 47)	3-Stage I.V. Pole, Left	1
D	16-78	Centerlock Hex Nut	4	D	16-78	Centerlock Hex Nut	4
E	4-97	H. Soc. But. Hd. Cap Scr.	2	E	4-97	H. Soc. But. Hd. Cap Scr.	2
F	4-163	H. Soc. But. Hd. Cap Scr.	2	F	4-163	H. Soc. But. Hd. Cap Scr.	2
G	4-197	H. Soc. But. Hd. Cap Scr.	2	G	4-197	H. Soc. But. Hd. Cap Scr.	2

6080-211-20 2-Stage I.V. Assembly, Patient Left

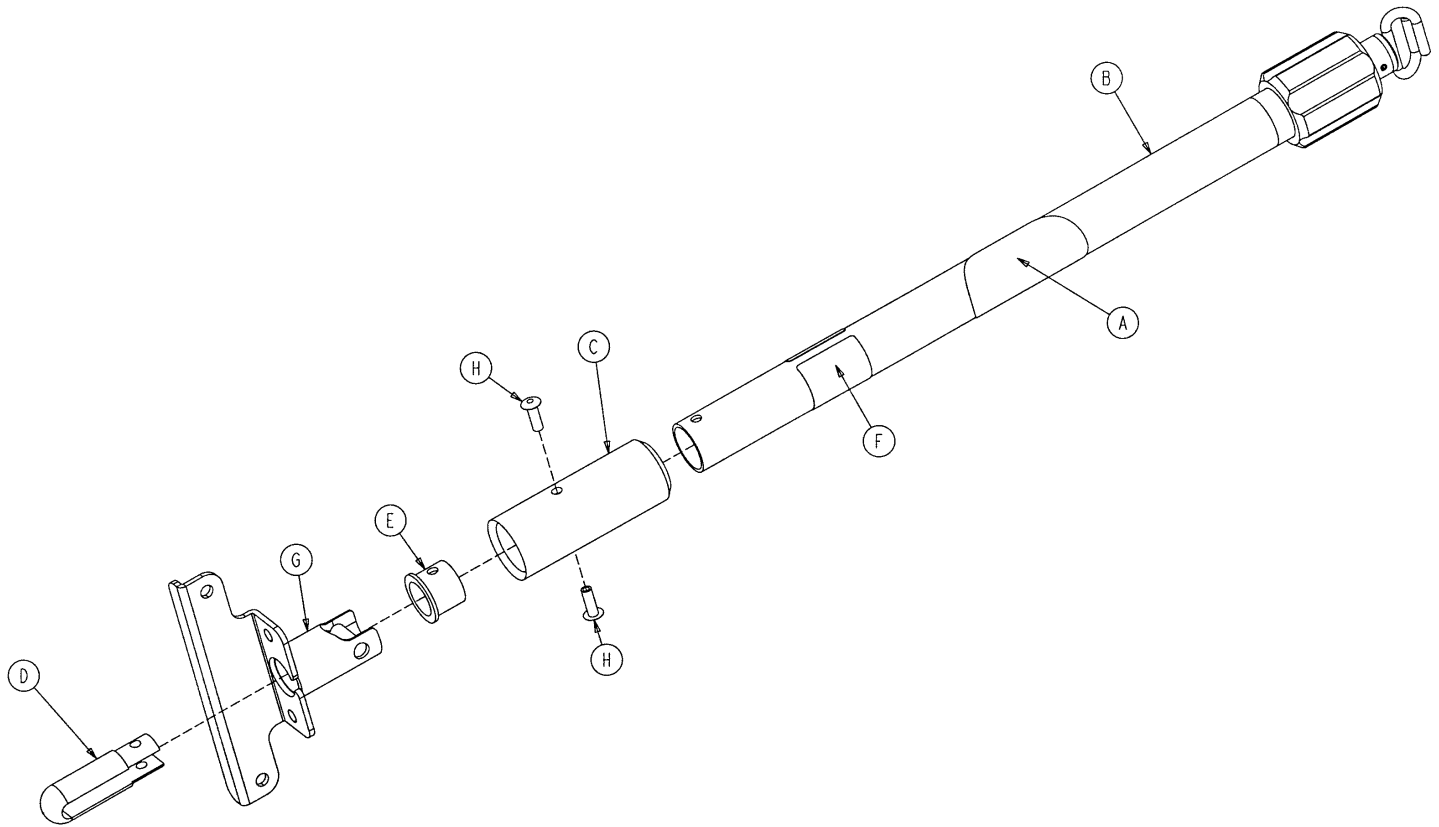

Item	Part No.	Part Name	Qty.
A	6070-90-105	Caution Label	1
B	(page 48)	2-Stage I.V. Pole Assembly	1
C	6070-210-45	I.V. Pole Sleeve	1
D	6070-210-46	I.V. Pivot	1
E	6070-210-49	I.V. Pivot Ring	1
F	6080-90-32	Specification Label	1
G	6080-211-52	I.V. Socket Weldment, Left	1
H	25-133	Blind Rivet	2

6080-216-20 3-Stage I.V. Assembly, Patient Left

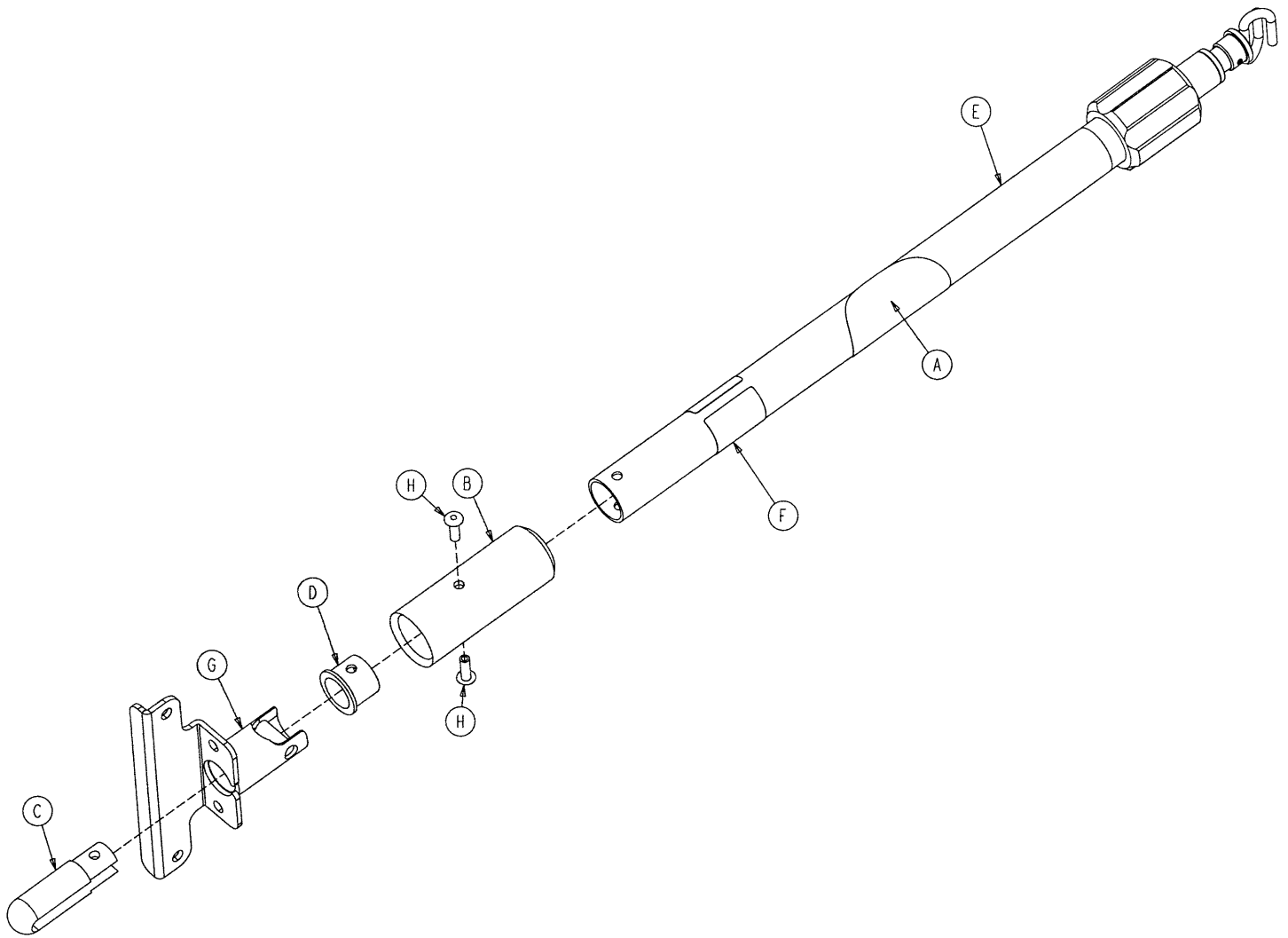

Item	Part No.	Part Name	Qty.
A	6070-90-105	Caution Label	1
B	6070-210-45	I.V. Pole Sleeve	1
C	6070-210-46	I.V. Pivot	1
D	6070-210-49	I.V. Pivot Ring	1
E	(page 49)	3-Stage I.V. Pole Assembly	1
F	6080-90-34	Specification Label	1
G	6080-211-52	I.V. Socket Weldment, Left	1
H	25-133	Blind Rivet	2

6070-210-40 2-Stage I.V. Pole Assembly

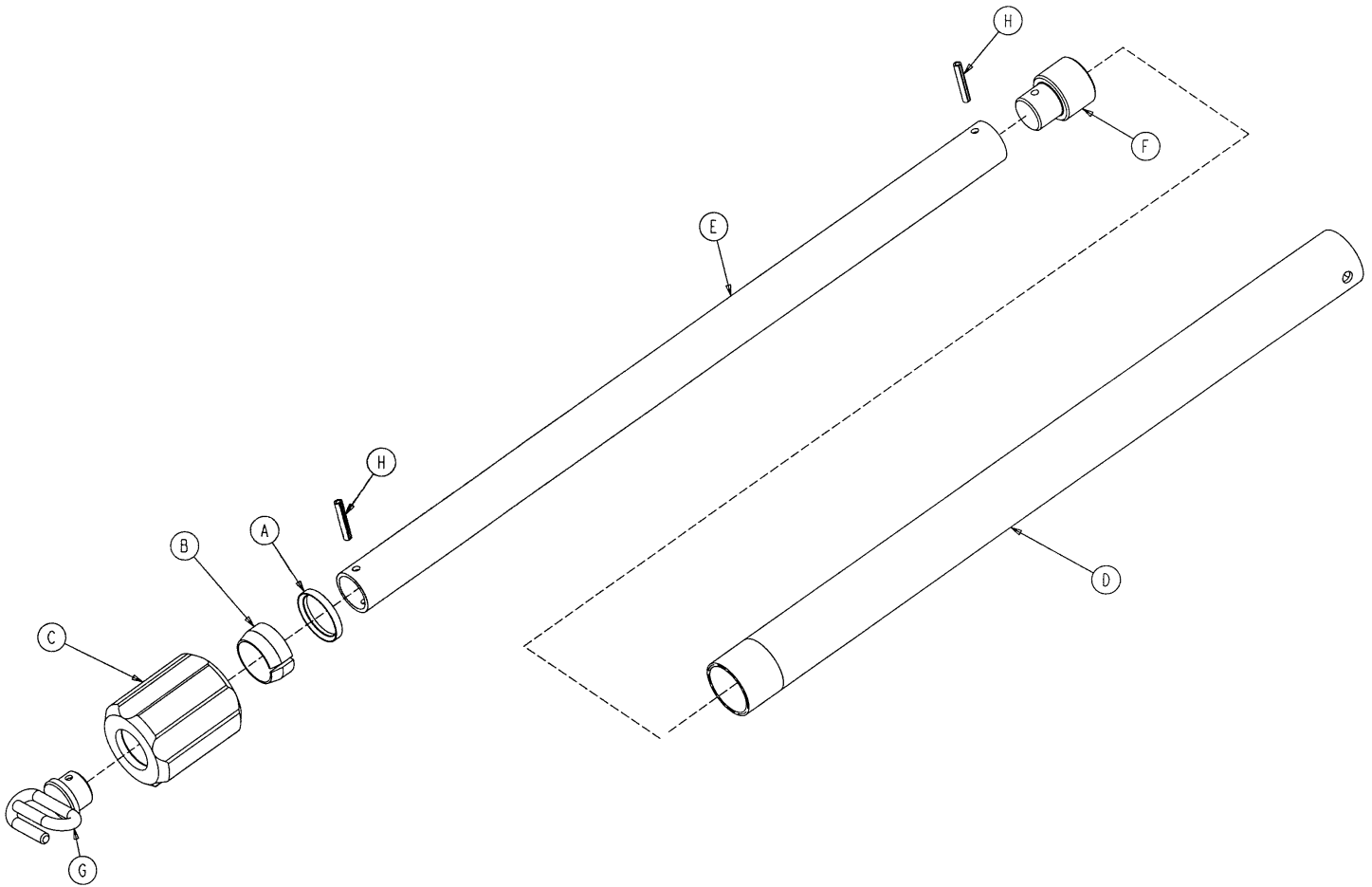

Item	Part No.	Part Name	Qty.
A	1210-110-46	Back-Up Ring	1
B	1210-110-47	Lock Ring	1
C	1210-110-49	Molded Actuator	1
D	6070-210-41	Base Tube	1
E	6070-110-42	2nd Stage Tube	1
F	6070-110-44	2nd Stage Slide Plug	1
G	6070-110-50	Hook Weldment	1
H	26-6	Roll Pin	2

6070-215-40 3-Stage I.V. Pole Assembly

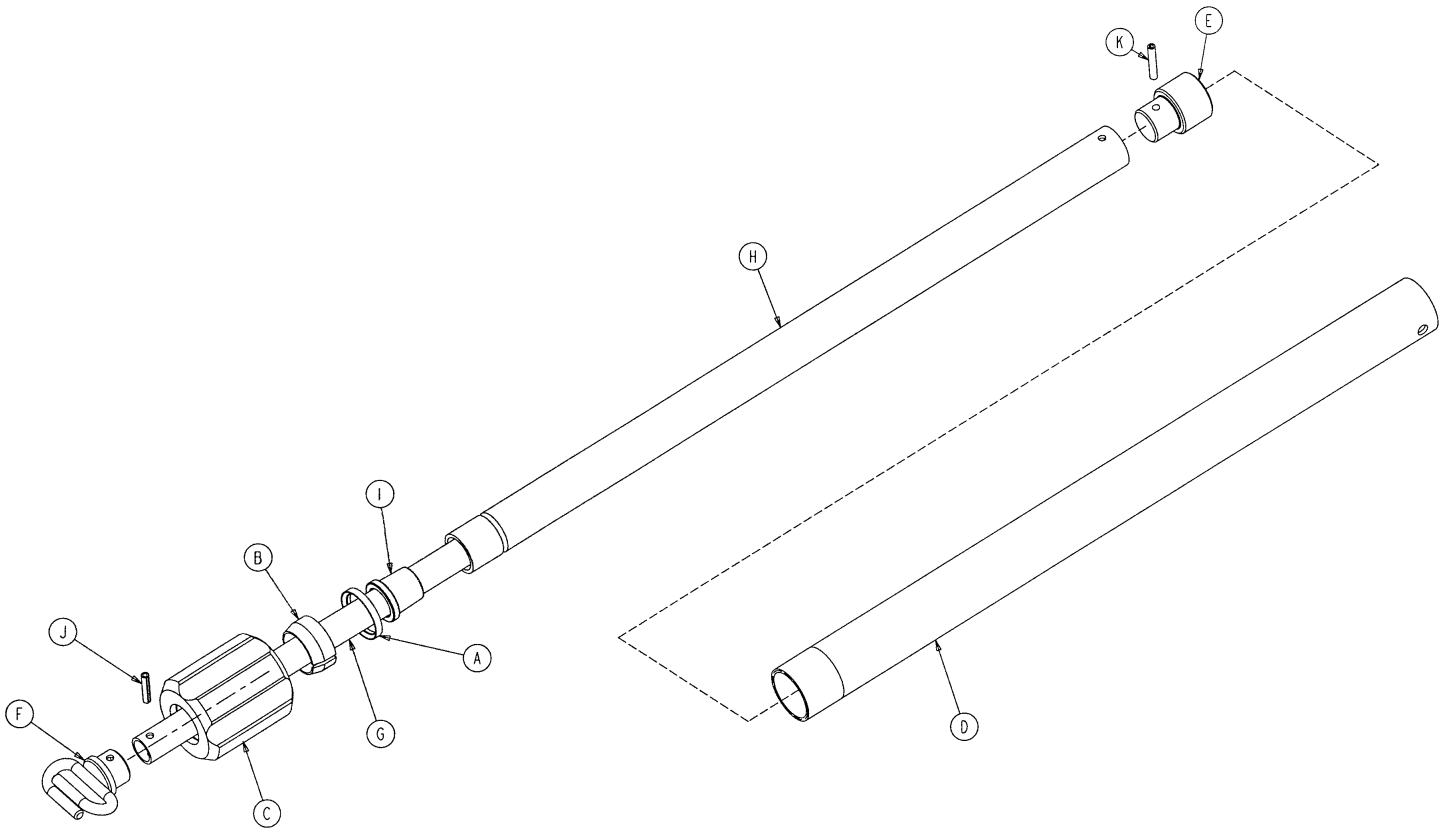

Item	Part No.	Part Name	Qty.
A	1210-110-46	Back-Up Ring	1
B	1210-110-47	Lock Ring	1
C	1210-110-49	Molded Actuator	1
D	6070-210-41	Base Tube	1
E	6070-110-44	2nd Stage Slide Plug	1
F	6070-110-50	Hook Weldment	1
G	(page 50)	3rd Stage Assembly	1
H	6070-115-42	2nd Stage Tube	1
I	6070-115-45	Bearing Plug	1
J	26-5	Spring Pin	1
K	26-6	Spring Pin	1

6070-115-30 3rd Stage Ass'y – Optional 3-Stage I.V. Pole

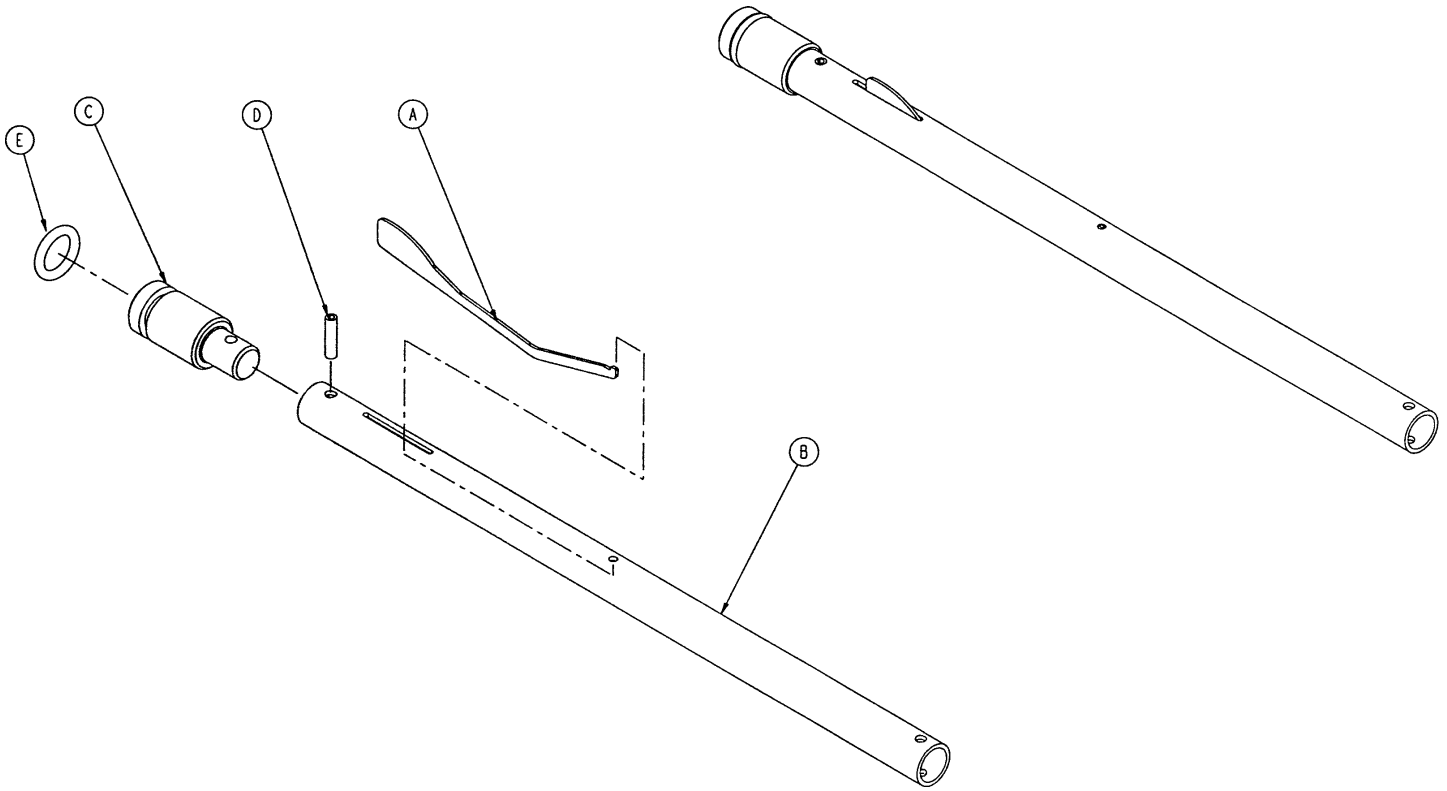

Item	Part No.	Part Name	Qty.
A	6070-115-141	Spring Clip	1
B	6070-115-143	3rd Stage Tube	1
C	6070-115-44	3rd Stage Slide Plug	1
D	26-4	Roll Pin	1
E	45-139	O-Ring	1

6080-140 Optional Hanging Oxygen Bottle Holder Ass'y

Assembly part number 6080-140-10 (reference only)

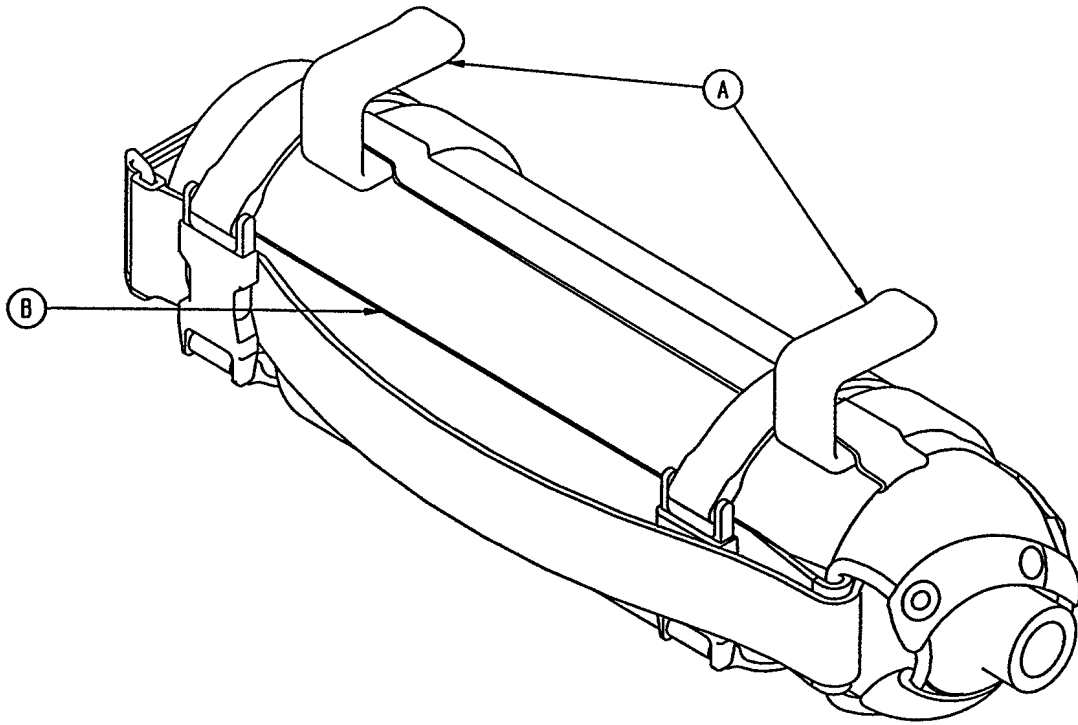

Item	Part No.	Part Name	Qty.
A	6080-140-11	Bottle Holder Hanger	2
B	6080-140-12	Oxygen Bottler Holder	1

6070-140 Optional Oxygen Bottle Holder Assembly

Assembly part number 6070-140-10 (reference only)

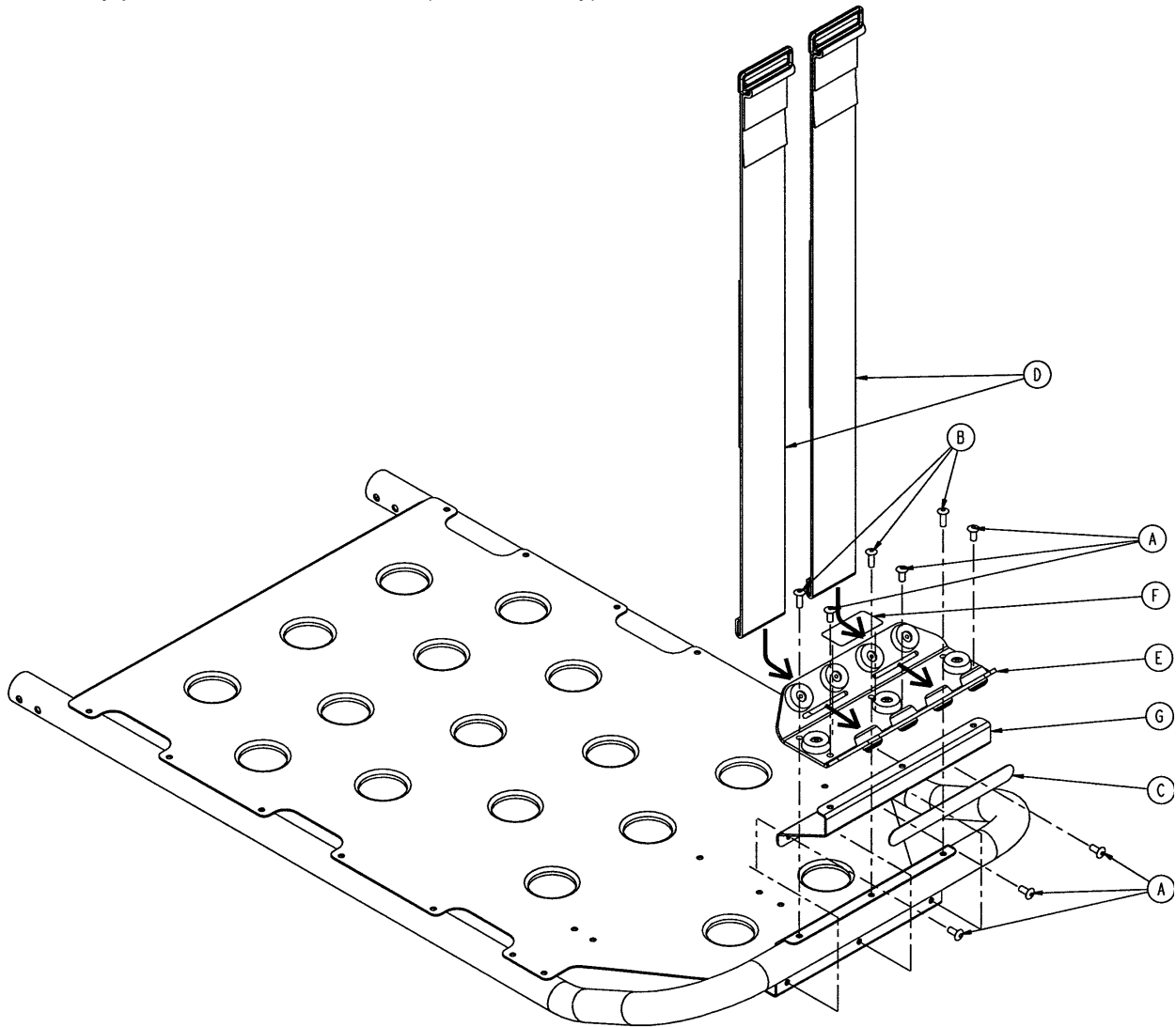

Item	Part No.	Part Name	Qty.
A	25-79	Rivet	6
B	25-133	Rivet	3
C	6060-90-4	"Rugged" Label	1
D	6060-140-13	Strap Assembly	2
E	(page 53)	Bottle Holder Tray Ass'y	1
F	6070-90-14	Specification Label	1
G	6070-140-17	Support Bracket	1

6060-140-20 Optional Oxygen Bottle Hldr. Tray Ass'y

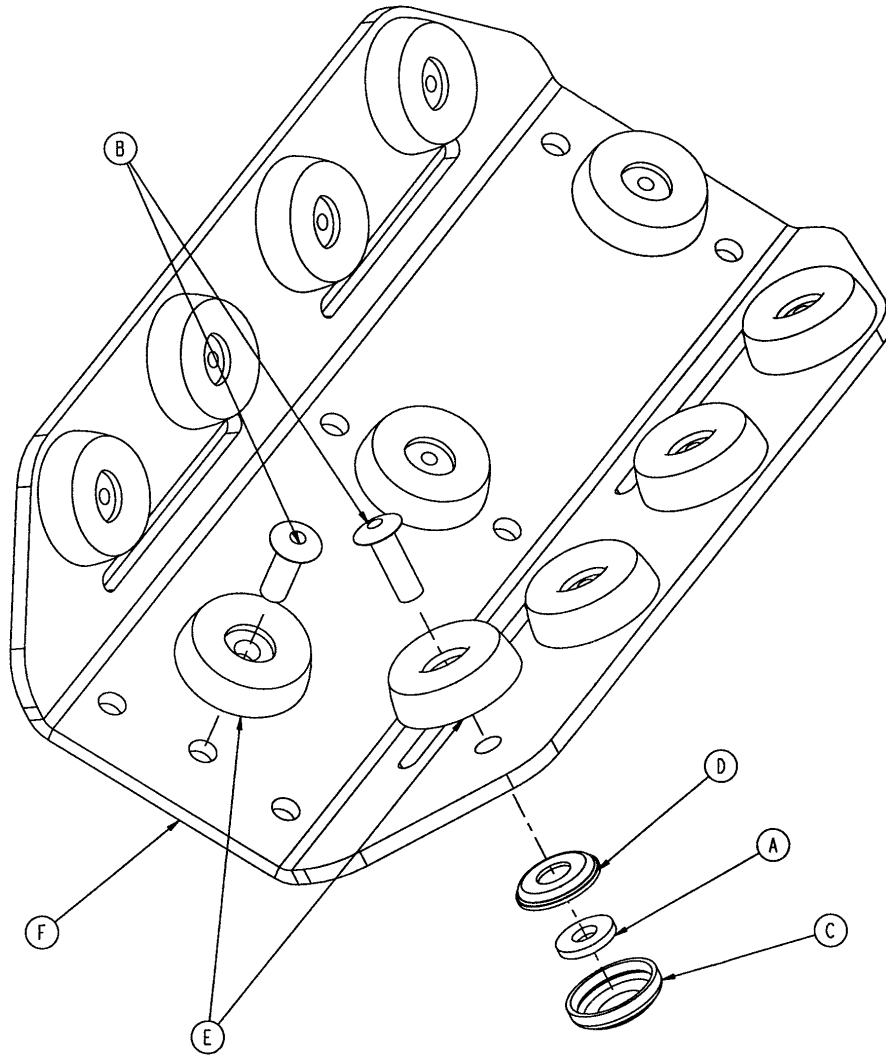

Item	Part No.	Part Name	Qty.
A	11-436	Flat Washer	8
B	25-133	Rivet	11
C	37-55	Cap	8
D	37-56	Washer	8
E	946-1-155	Bumper	11
F	6060-140-15	Bottle Holder Tray	1

6080-155-20 Optional Pull Handle Assembly

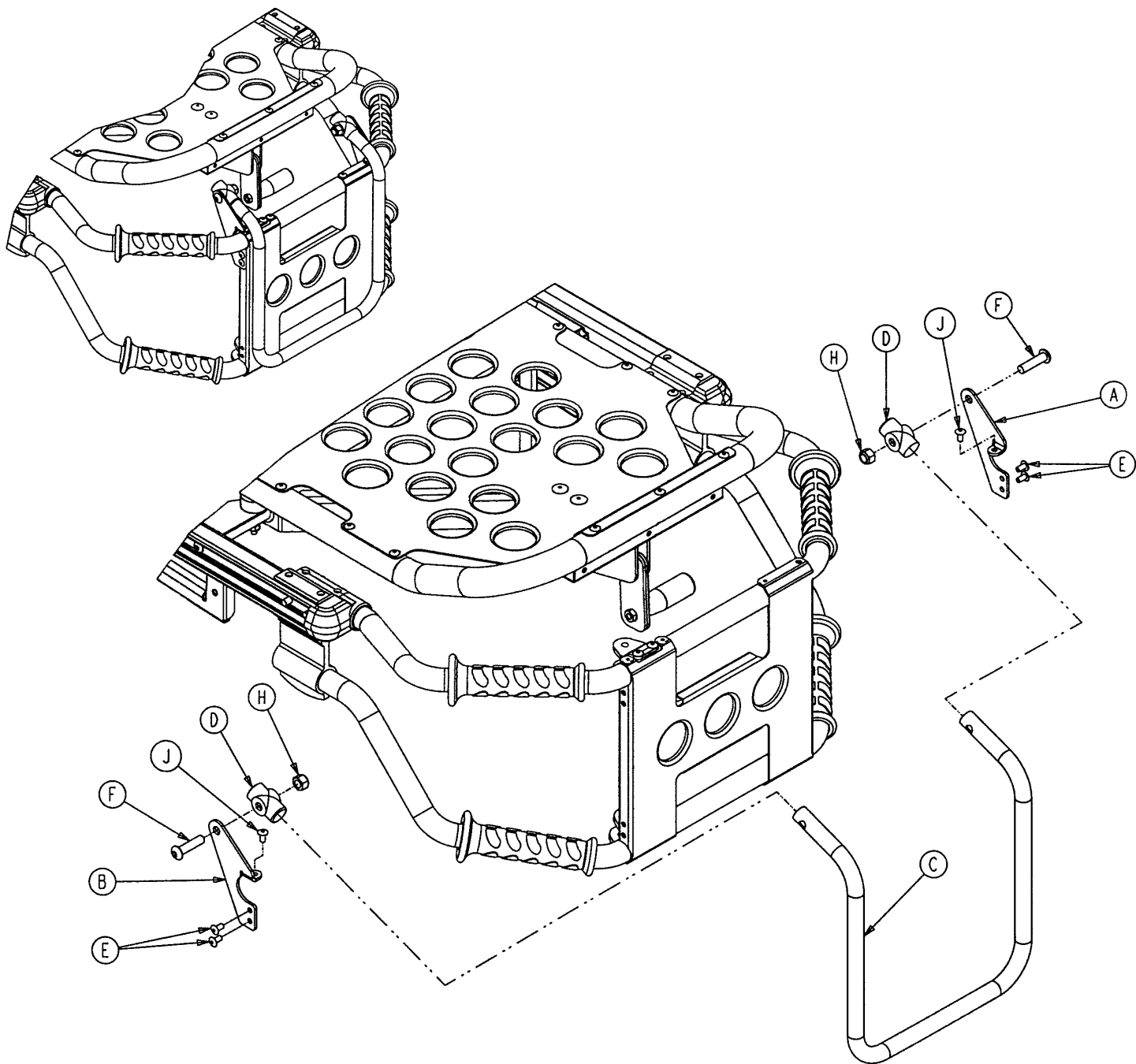

Item	Part No	Part Name	Qty.
A	6080-155-1	Pull Handle Bracket, Left	1
B	6080-155-2	Pull Handle Bracket, Right	1
C	6080-155-3	Pull Handle	1
D	721-26-69	Upright Sleeve	2
E	25-79	Dome Hd. Rivet	4
F	4-130	Hex Soc. But. Hd. Cap Screw	2
H	16-36	Nylock Hex Nut	2
J	23-133	Rivet	2

Quick Reference Part Numbers

<u>ITEM</u>	<u>PART NUMBER</u>
Breakaway Head Torsion Spring Kit	6080-700-1
Bumper, Fowler	946-1-155
Bumper, Litter Foot Section	6080-30-43
Bumper, Litter Break-Away Head Section	6080-36-44
Extension Spring, Height Adjustment	38-348
Gas Cylinder, Fowler	1010-31-77
Handle, Break-Away Head Lock Release	6060-36-37
Handle, Pull	6080-155
Height Limit Kit	6060-202
Label, Cot Base "Lift Here"	6080-90-8
Label, Cot I.V. Pole Caution	6070-90-5
Label, Damage Warning	6080-90-9
Manual, Maintenance/Operations, Cot	6080-90-11
Manual, Installation/Operation, Cot Fastener	6370-90-10
Mattress, Vinyl Covered	6080-41-10
Oxygen Bottle Holder	6070-140
Oxygen Bottle Holder (Hanging)	6080-140
Restraint, Lap Belt (2 Used per Unit)	6060-160-44
Restraint, Shoulder Harness	6060-160-45
Permanent I.V. Pole Kit, 2-Stage, Right	6080-210
Permanent I.V. Pole Kit, 2-Stage, Left	6080-211
Permanent I.V. Pole Kit, 3-Stage, Right	6080-215
Permanent I.V. Pole Kit, 3-Stage, Left	6080-216
Safety Hook, Long	6060-36-18
Safety Hook, Short	6060-36-17
Siderail Assembly (Complete)	6060-26-10
Storage Net, Base	6080-150-10
Storage Pouch, Head End (MX-PRO)	6080-128-10
Touch-Up Paint (Yellow)	6060-199-10
Touch-Up Paint (Black)	6060-199-11
Velcro Adhesive Loop Pile, Litter	6060-32-46
Video, In-Service	6080-90-2
Wheel Assembly, Base	6060-2-10
Wheel Bearing	81-226
Wheel Lock Kit, Domestic	6080-201
Wheel Lock Kit, International	6080-202
Wheel Mount Cover	6060-1-21
Wheel Mount Cover Rivet	25-133
X-Frame Guard Option	6080-145

European Representative

Stryker EMEA RA/QA Director
Stryker France
ZAC Satolas Green Pusignan
Av. De Satolas Green
69881 MEYZIEU Cedex
France

stryker[®]

3800 E. Centre Ave., Portage, MI 49002
(800) 327-0770
www.stryker.com



JH 1/06 6080-090-011 REV Y