



Power Pro Cot

Model 6500 RUGGED®

stryker®

Parts Manual

Manuel relatif aux pièces
Manuale delle schematizzazioni dei componenti
Teilekatalog
Onderdelenhandleiding
Komponenthandbok

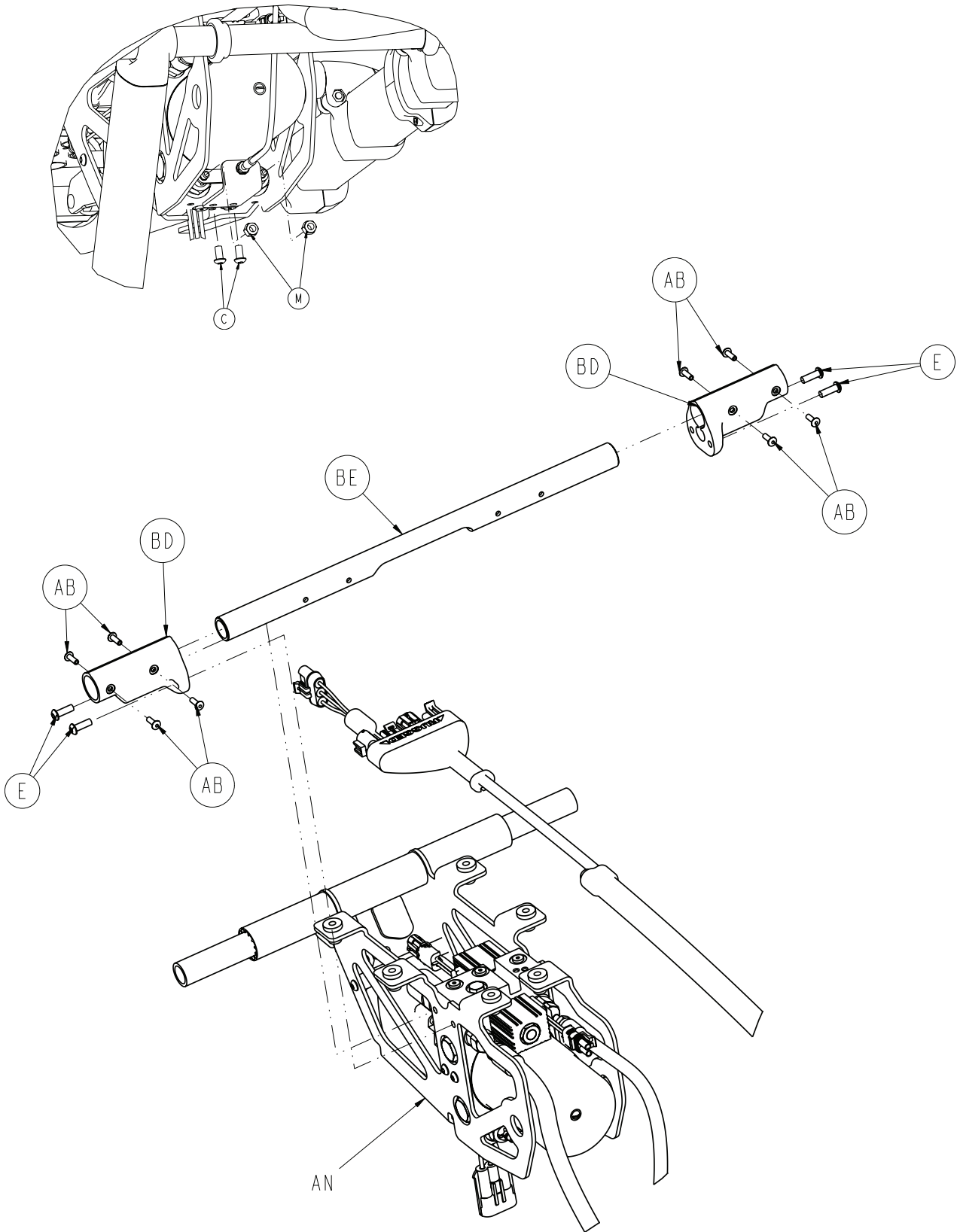


For parts or technical
assistance call
(800) 327-0770 (option 2)
or (269) 324-6500

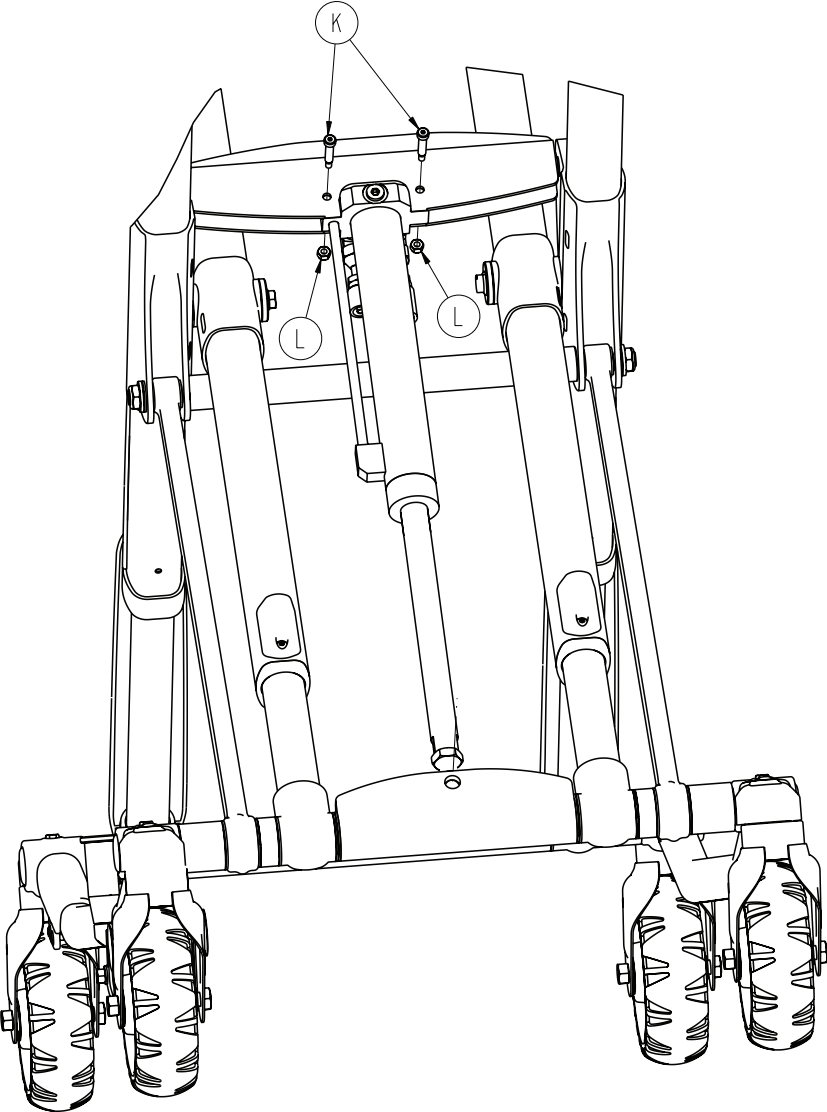
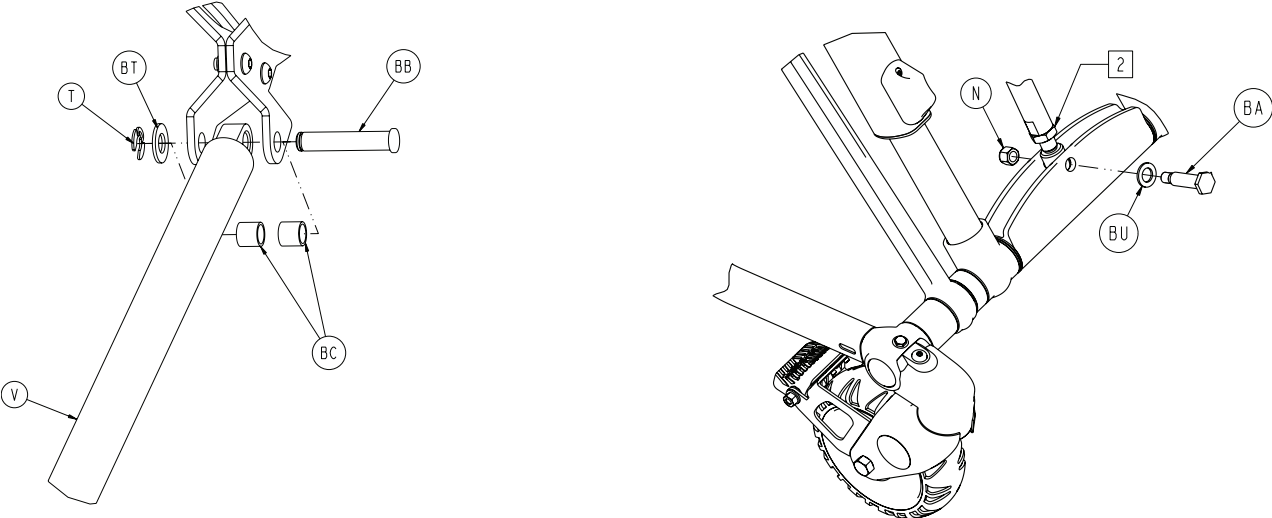


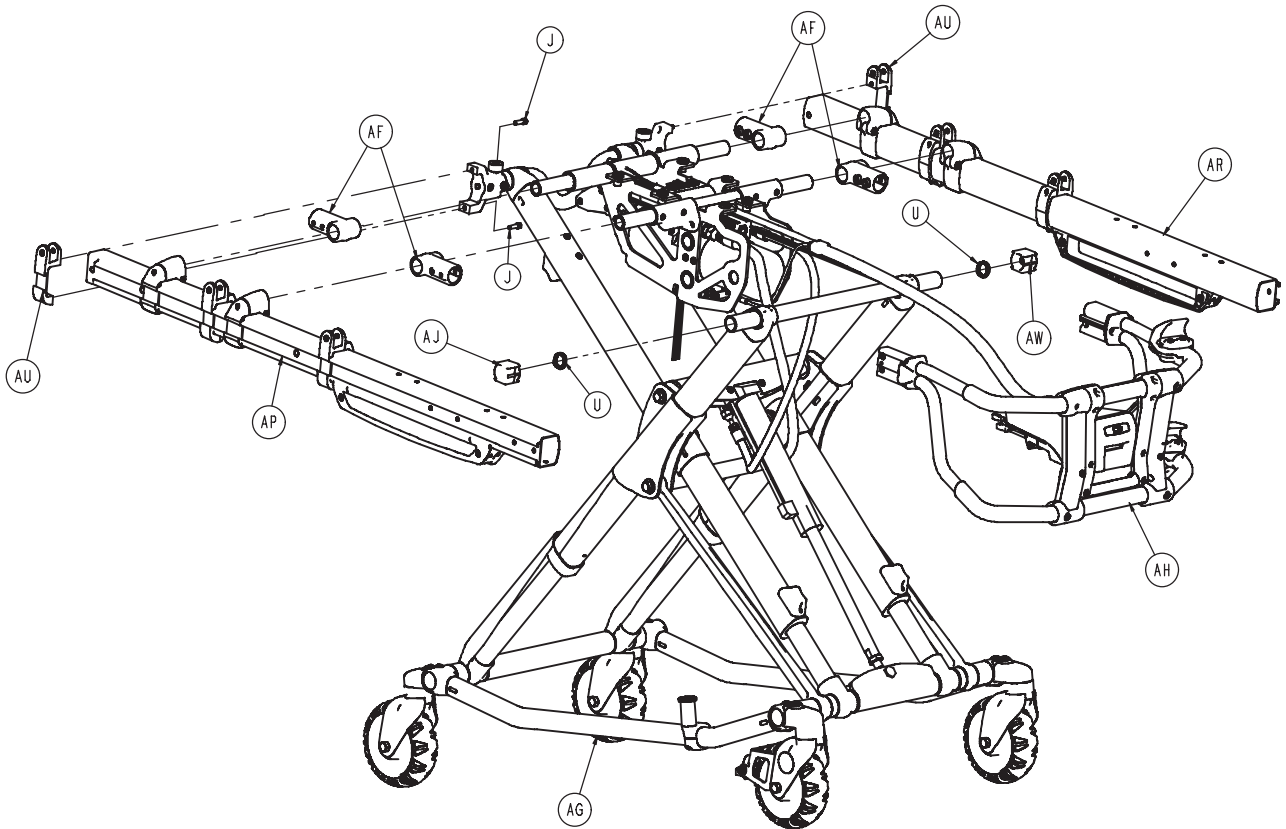
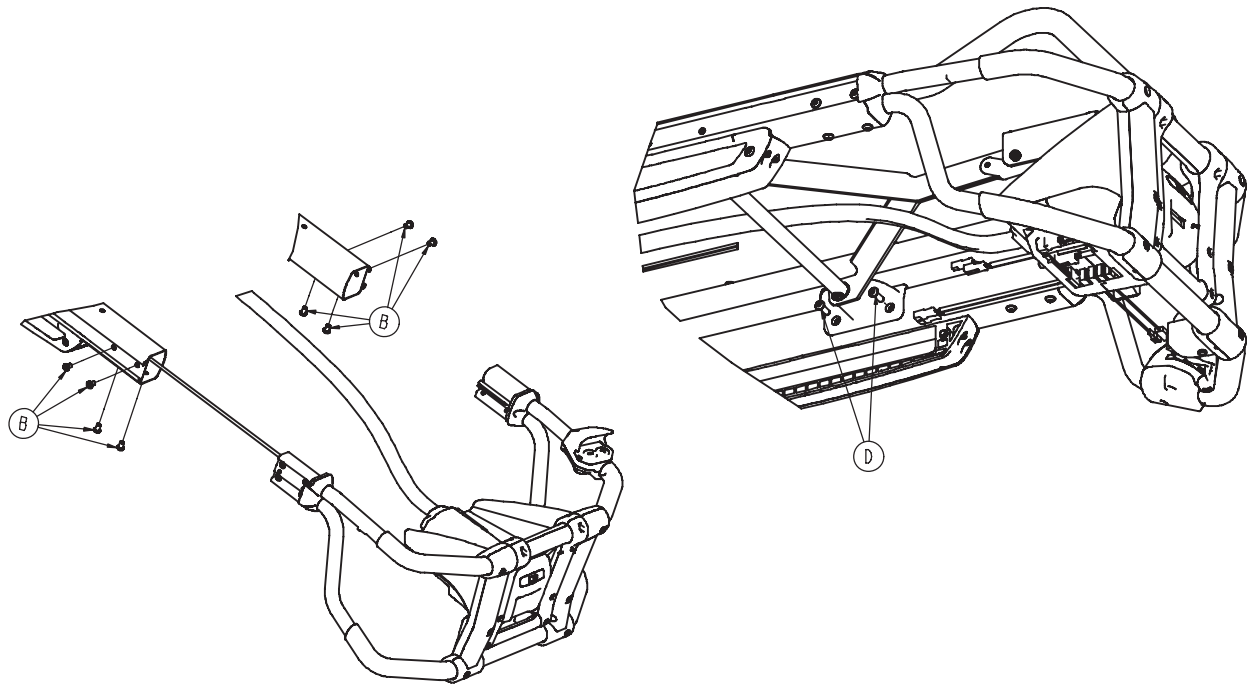
Table of Contents

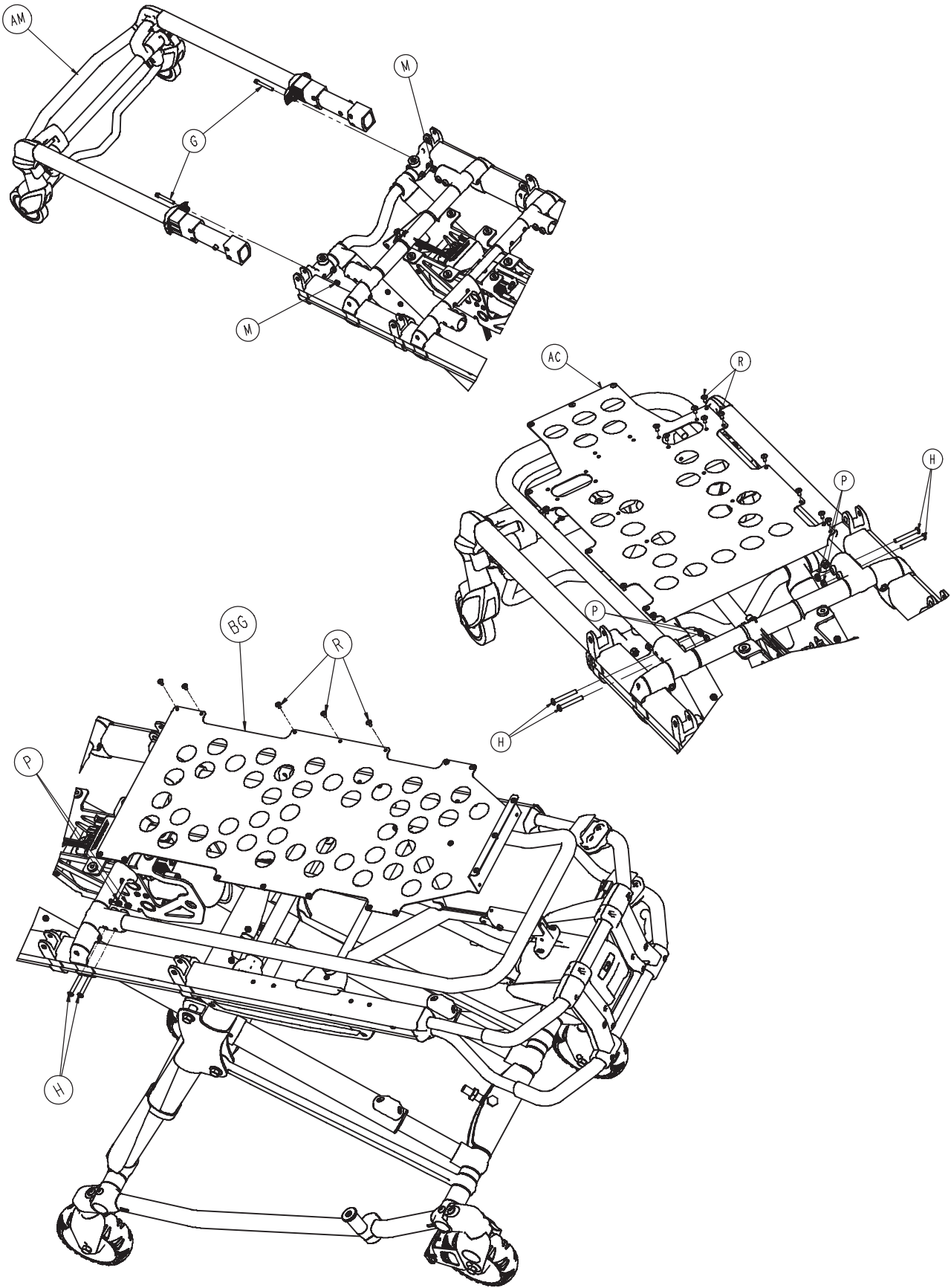
6500-001-010.....	4	6500-001-026.....	38
6500-001-012.....	12	6500-001-027.....	39
6500-001-021.....	16	6500-140-000.....	40
6500-001-022.....	17	6500-001-040.....	41
6500-001-034.....	18	6500-141-000.....	42
6500-001-035.....	19	6080-140-010.....	43
6500-001-032.....	20	6500-210-000 / 6500-215-000.....	44
6500-001-033.....	22	6500-001-041.....	45
6500-001-028.....	24	6500-001-043.....	46
6500-001-029.....	25	6500-211-000 / 6500-216-000.....	47
6500-001-031.....	26	6500-001-042.....	48
6500-001-030.....	28	6500-001-044.....	49
6500-001-015.....	29	6500-212-000 / 6500-217-000.....	50
6500-001-016.....	33	6500-170-000.....	51
6500-001-018.....	34	6100-044-000.....	52
6500-001-019.....	35	6100-044-012.....	53
6500-001-020.....	36		

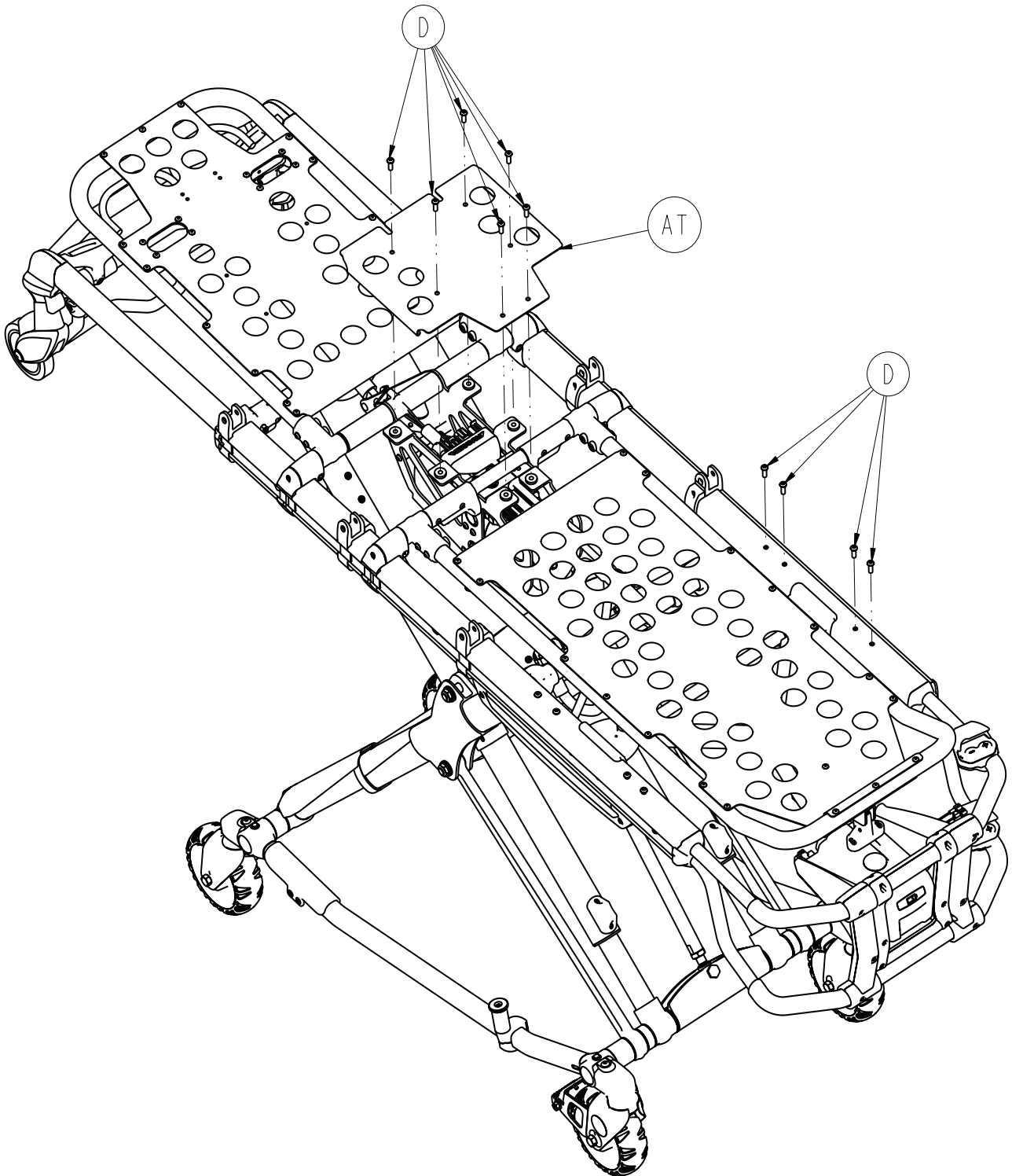


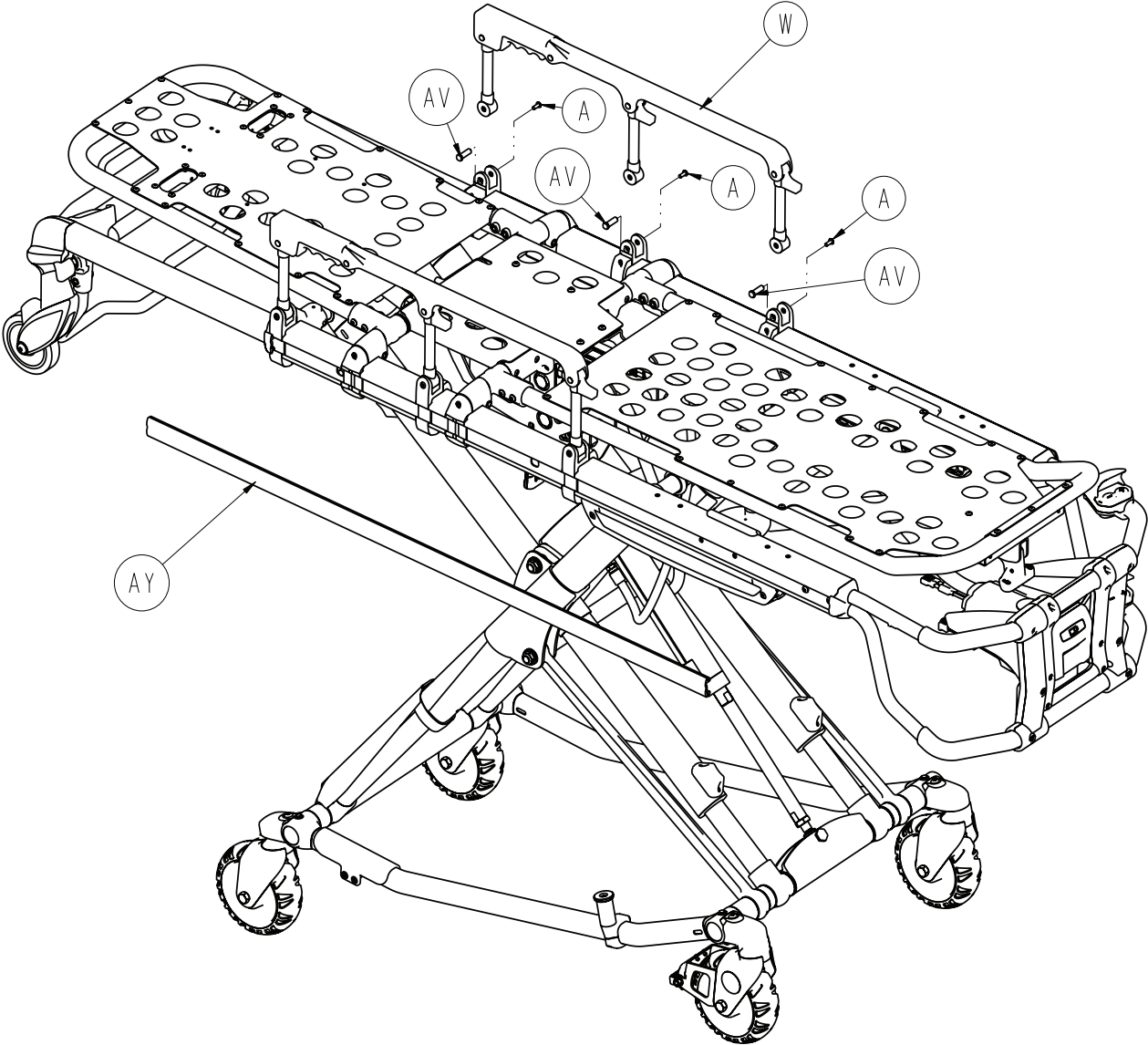
6500-001-010

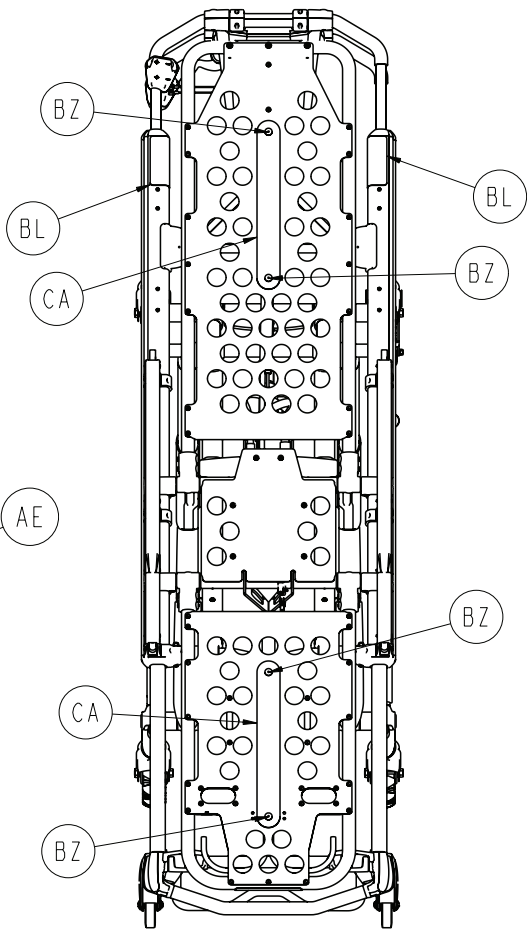
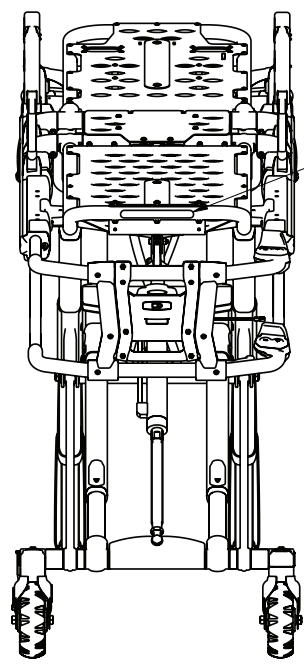
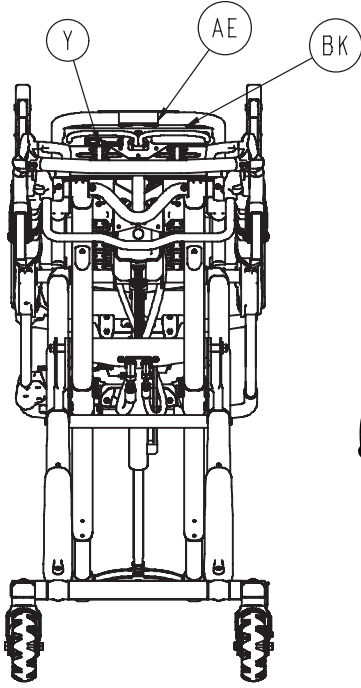
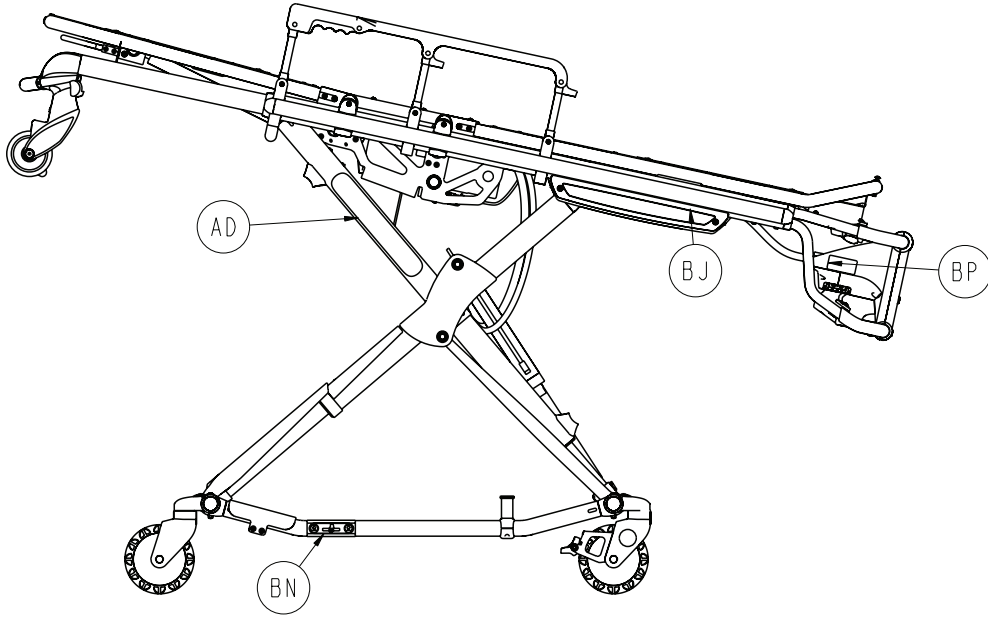






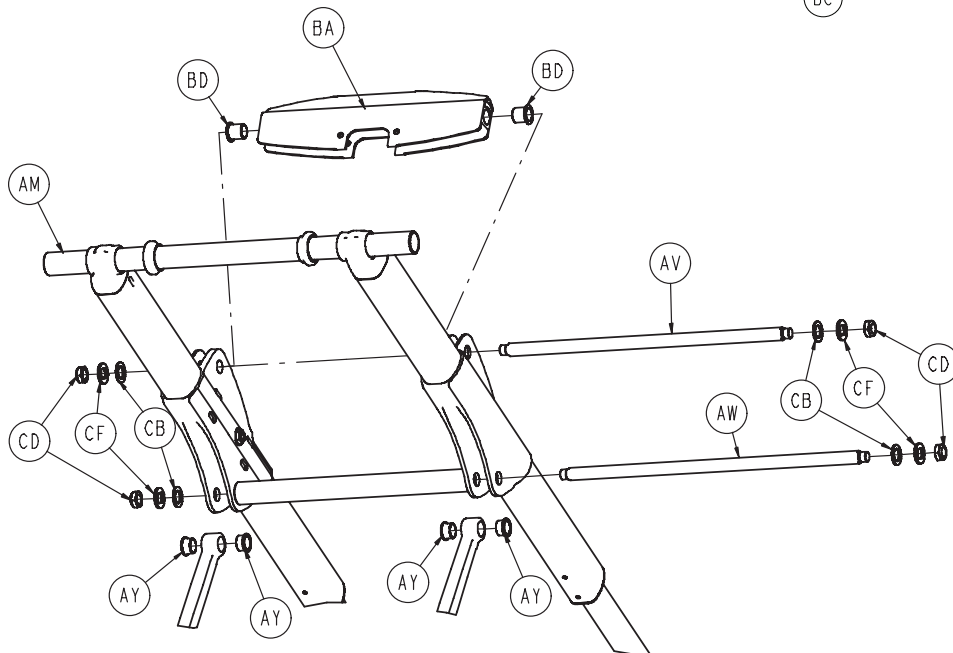
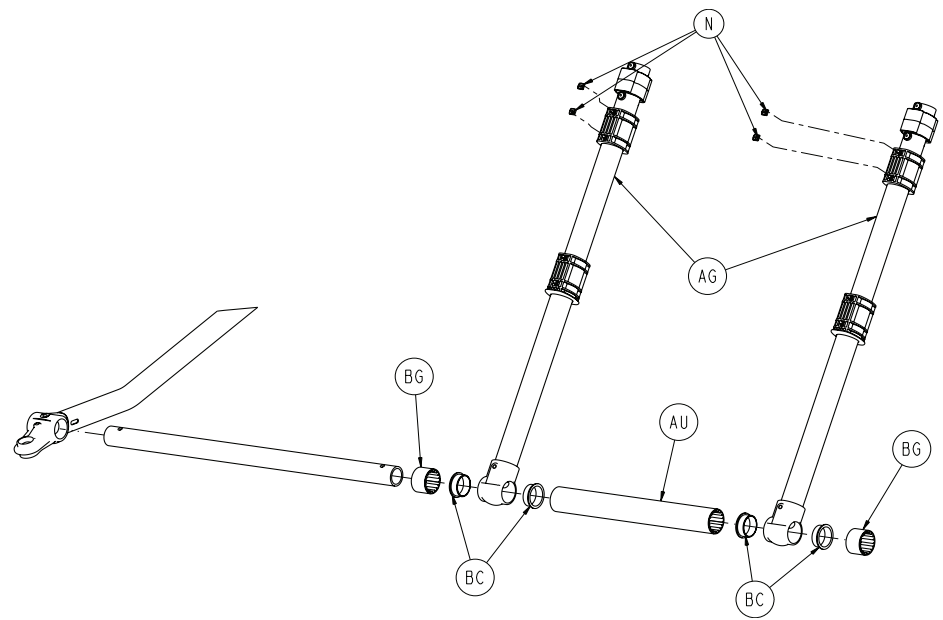
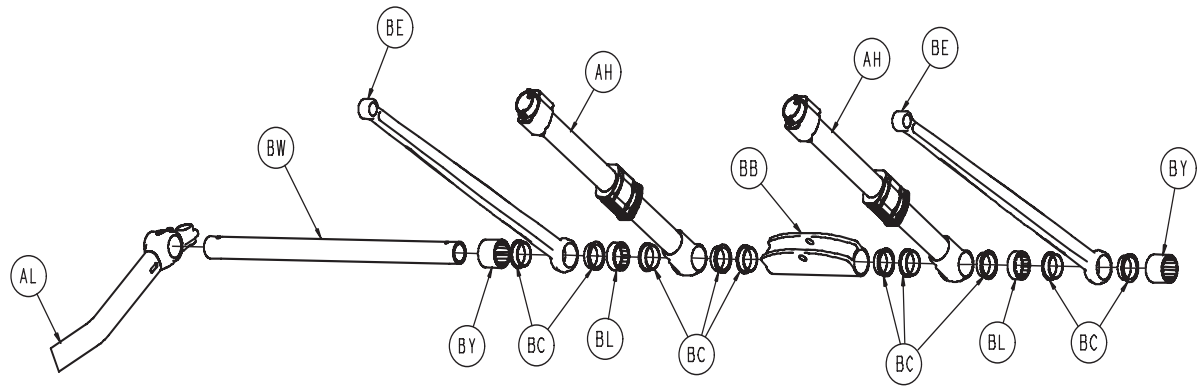


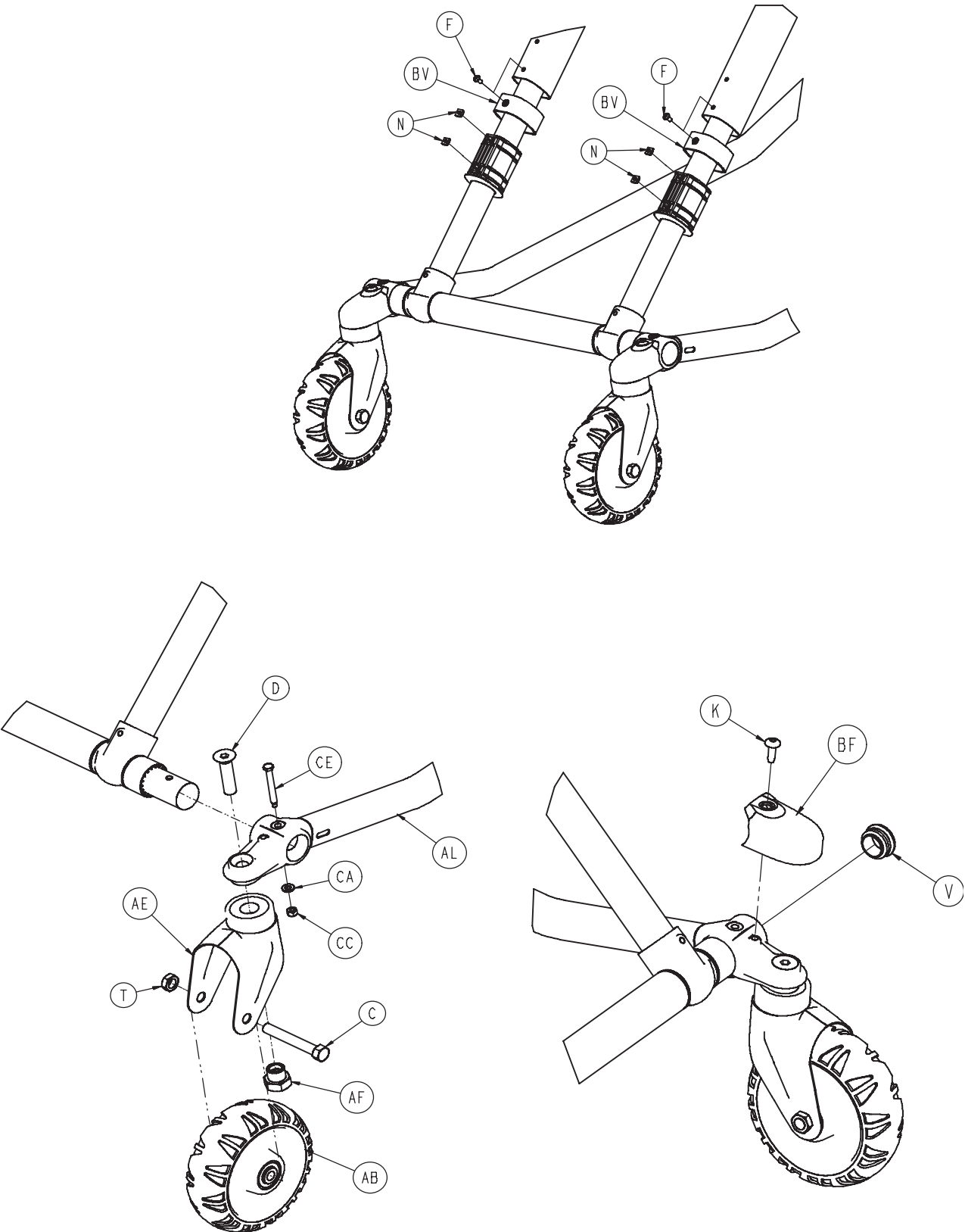


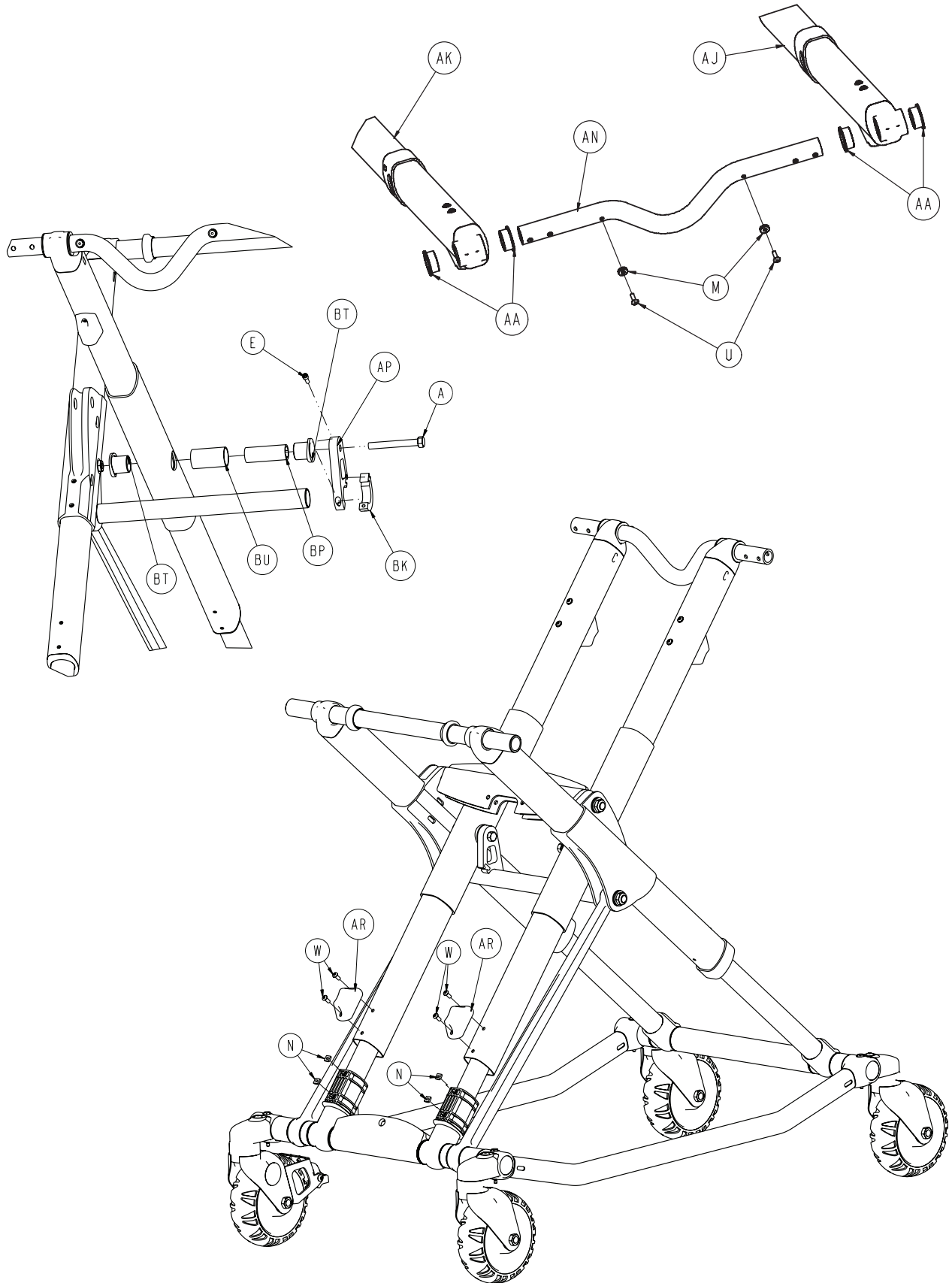


6500-001-010

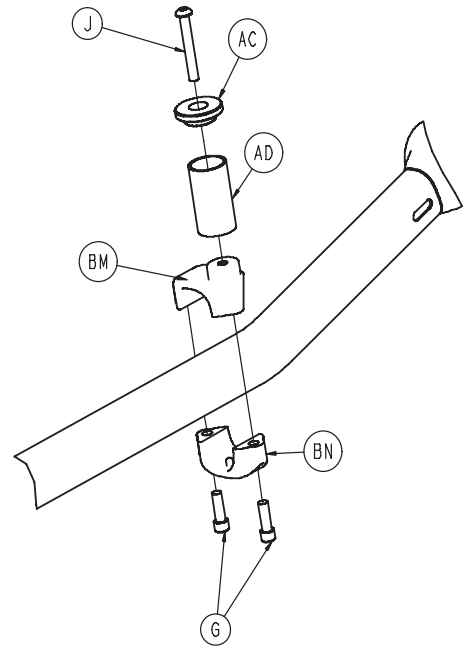
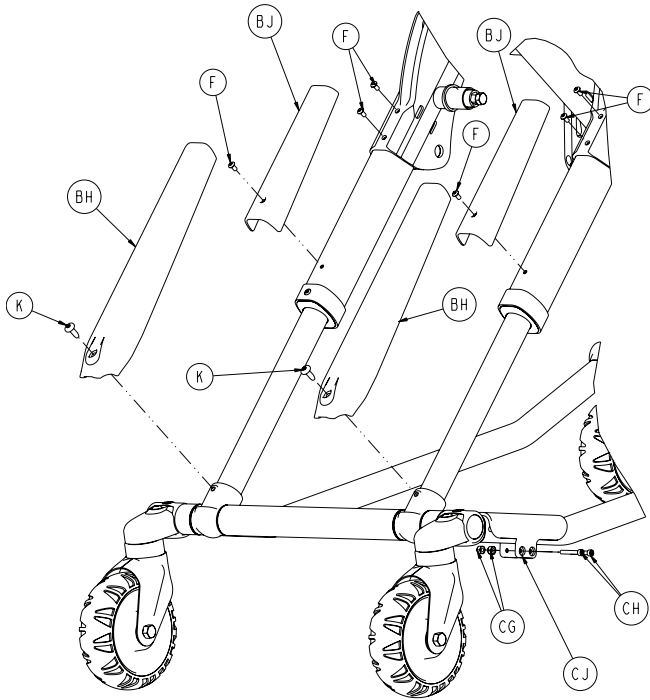
Item	Part No.	Qty.	Item	Part No.	Qty.
A	0004-585-000	6	AM	6500-001-020	1
B	2030-009-901	1	AN	6500-001-031	1
C	0004-589-000	10	AP	6500-001-032	1
D	0004-592-000	18	AR	6500-001-033	1
E	0004-593-000	4	AT	6500-001-111	1
G	0004-595-000	4	AV	6500-001-118	6
H	0004-596-000	8	AW	6500-001-123	1
K	0008-030-000	2	AY	6500-001-127	2
L	0016-002-000	2	BA	6500-001-168	1
M	0016-028-000	6	BB	6500-001-170	1
N	0016-035-000	2	BC	6500-001-191	2
P	0016-102-000	8	BD	6500-001-195	2
R	0025-079-000	46	BE	6500-001-196	1
T	0028-181-000	1	BF	6500-001-197	1
U	0038-574-000	2	BG	6500-001-198	1
V	1010-031-077	1	BJ	6500-001-233	2
W	6082-026-010	2	BK	6500-001-234	1
Y	6060-090-002	1	BL	6500-001-259	2
AB	0025-133-000	8	BM	0059-211-000	2
AC	6082-032-045	1	BN	6080-090-108	2
AD	6082-090-043	2	BP	6500-001-258	2
AE	6060-090-004	2	BR	0004-614-000	2
AF	6100-003-125	4	BT	0011-004-000	1
AG	6500-001-012	1	BU	0011-013-000	1
AH	6500-001-015	1	BV	0946-001-155	2
AJ	6500-001-017	1	BW	6500-001-128	2
AK	6500-001-018	1	BY	6500-001-185	2
AL	6500-001-019	1	BZ	0025-132-000	4
			CA	6082-001-085	2







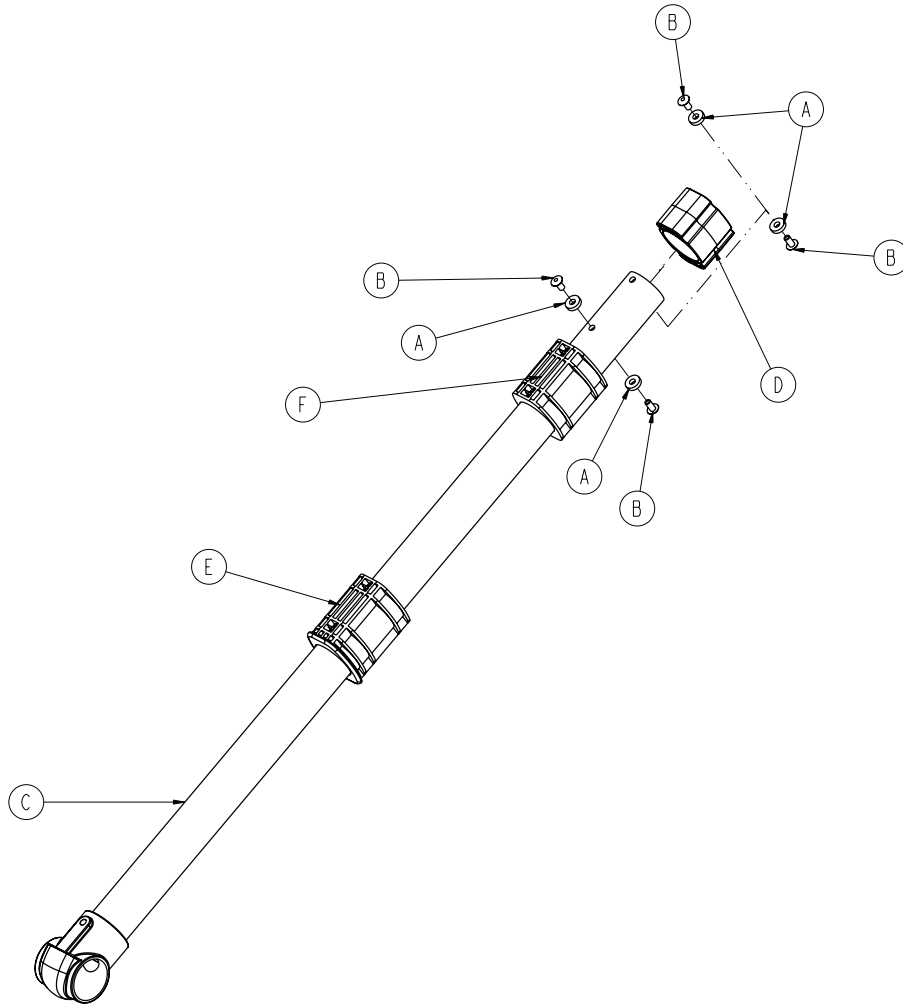
6500-001-012



Item	Part No.	Qty.
A	0003-107-000	2
C	0003-205-000	4
D	0004-319-000	4
F	0004-587-000	4
G	0004-591-000	2
J	0004-631-000	1
K	0007-086-000	6
M	0014-115-000	2
N	0015-051-000	8
T	0016-060-000	4
U	0025-133-000	10
V	0037-083-000	4
W	0004-634-000	4
AA	0081-244-000	4
AB	6060-002-010	4
AC	6060-004-043	1
AD	6060-004-044	1
AE	6082-002-012	2
AF	6090-001-009	4
AG	6500-001-021	2
AH	6500-001-022	2
AJ	6500-001-034	1
AK	6500-001-035	1
AL	6500-001-054	2
AM	6500-001-056	1
AN	6500-001-090	1
AR	6500-001-125	2
AU	6500-001-129	1
AV	6500-001-171	1

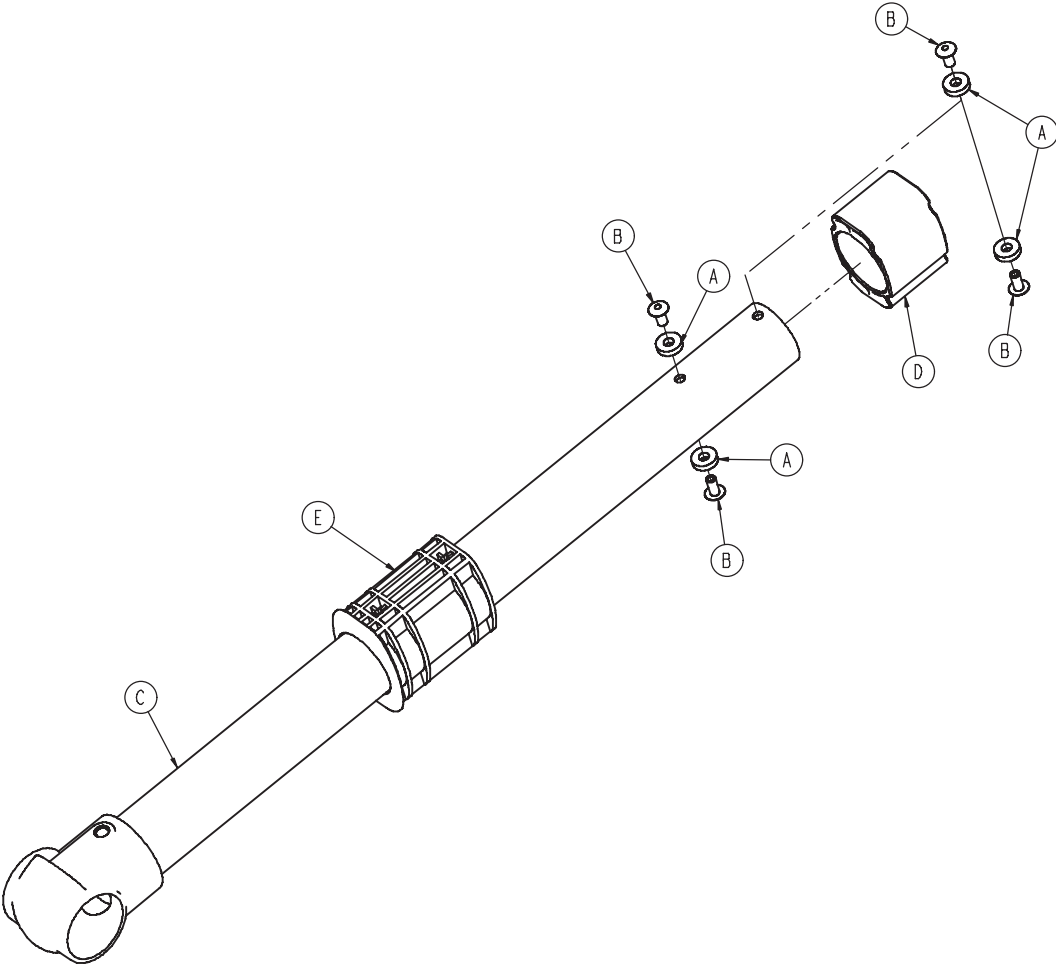
Item	Part No.	Qty.
AW	6500-001-182	1
AY	6500-001-162	4
BA	6500-001-164	1
BB	6500-001-165	1
BC	6500-001-166	14
BD	6500-001-157	2
BE	6500-001-172	2
BF	6500-001-177	4
BG	6500-001-178	2
BH	6500-001-179	2
BJ	6500-001-180	2
BL	6500-001-183	2
BM	6500-001-189	1
BN	6500-001-190	1
BP	6500-001-217	2
BR	6500-001-218	2
BT	6500-001-226	4
BU	6500-001-227	2
BV	6500-001-228	2
BW	6500-001-229	1
BY	6500-001-230	2
CA	0014-002-000	4
CB	0014-040-000	4
CC	0016-002-000	4
CD	0016-049-000	4
CE	6500-001-145	4
CF	6500-001-225	4

6500-001-021



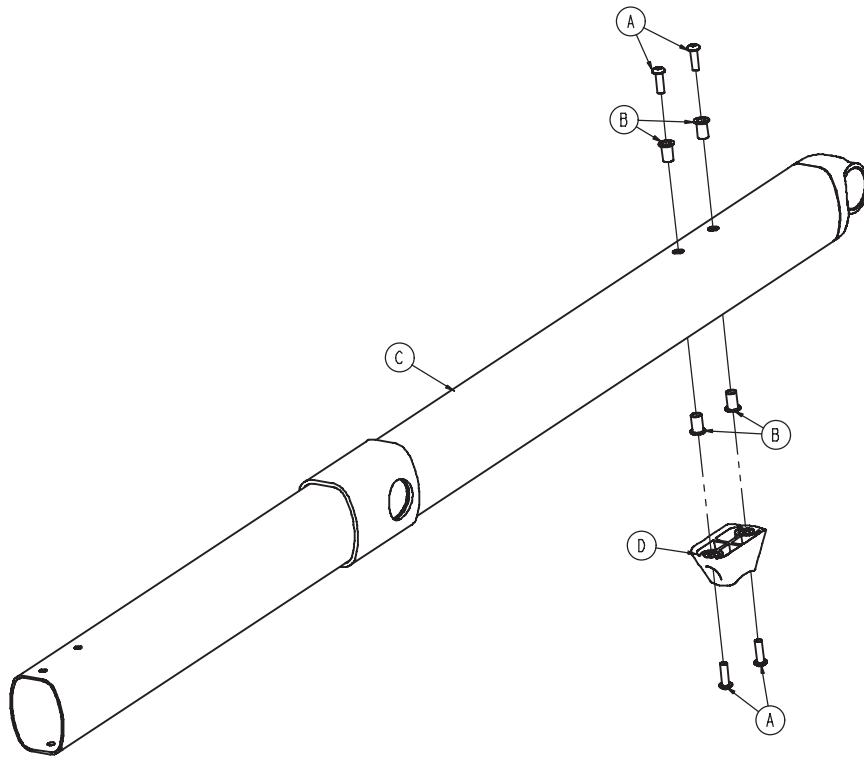
Item	Part No.	Qty.
A	014-115-000	4
B	0025-079-000	4
C	6500-001-050	1
D	6500-001-186	1
E	6500-001-187	1
F	6500-001-311	1

6500-001-022



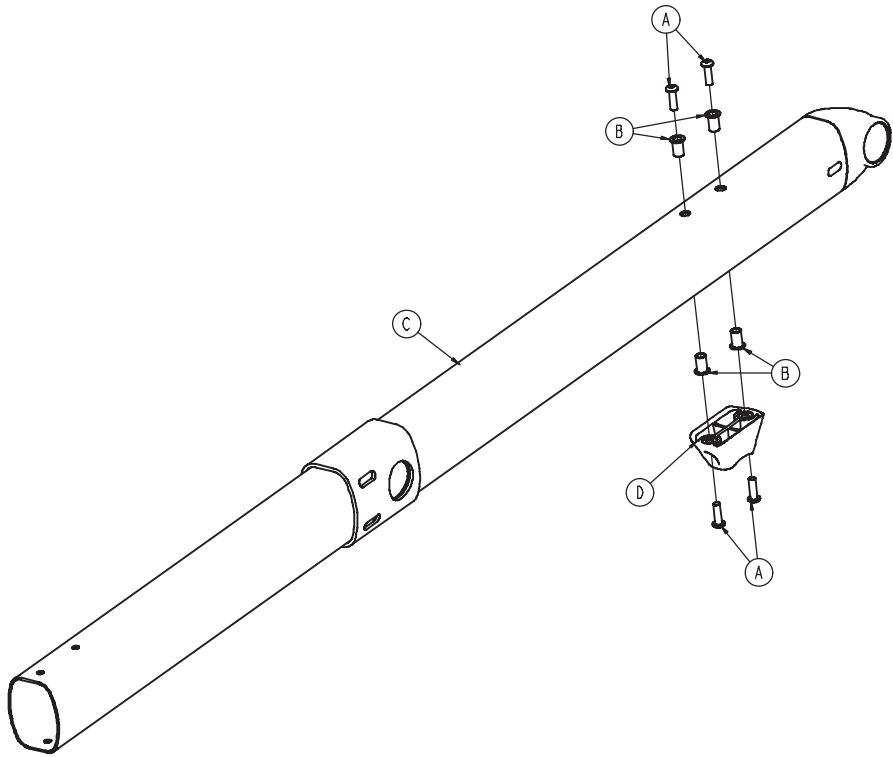
Item	Part No.	Qty.
A	0014-115-000	4
B	0025-079-000	4
C	6500-001-051	1
D	6500-001-186	1
E	6500-001-187	1

6500-001-034

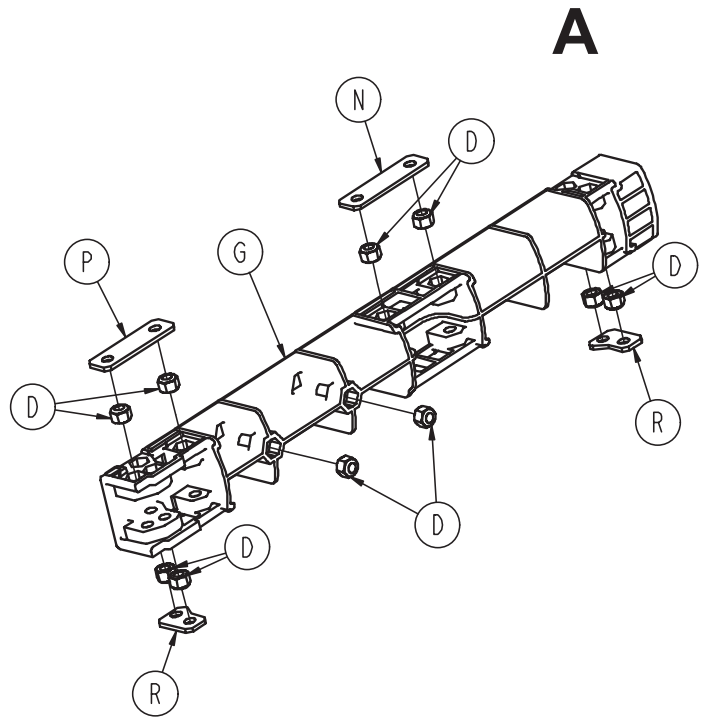
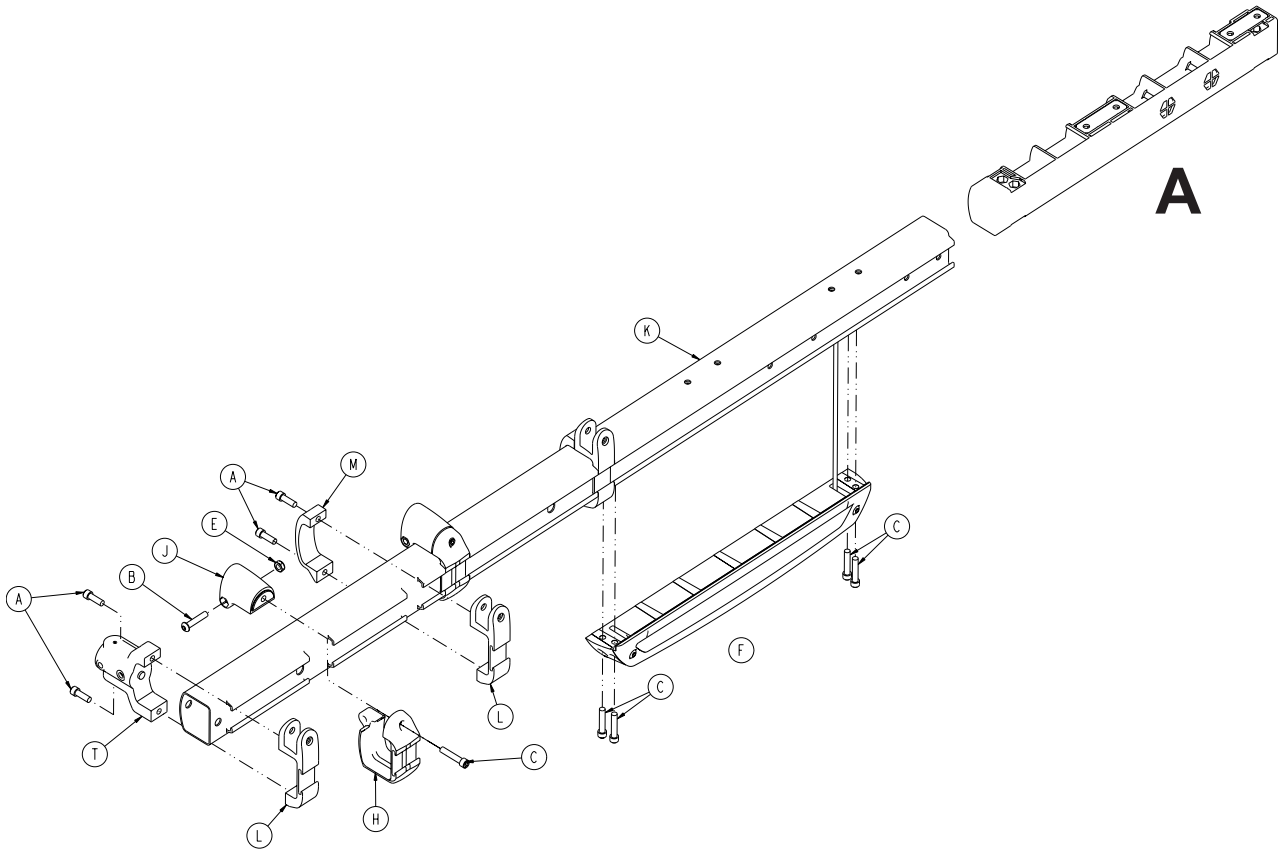


Item	Part No.	Qty.
A	4-590-0	4
B	55-100-75	4
C	6500-1-53	1
D	6500-1-125	1

6500-001-035

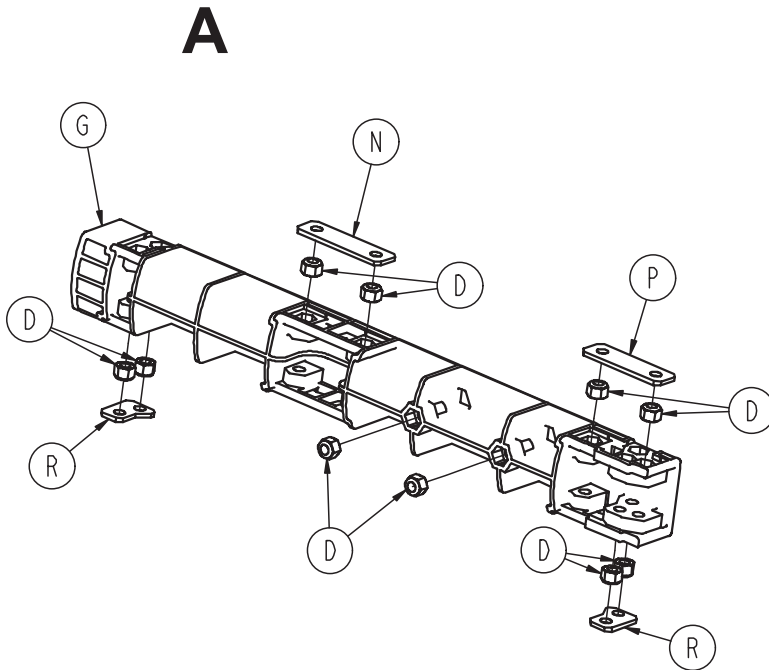
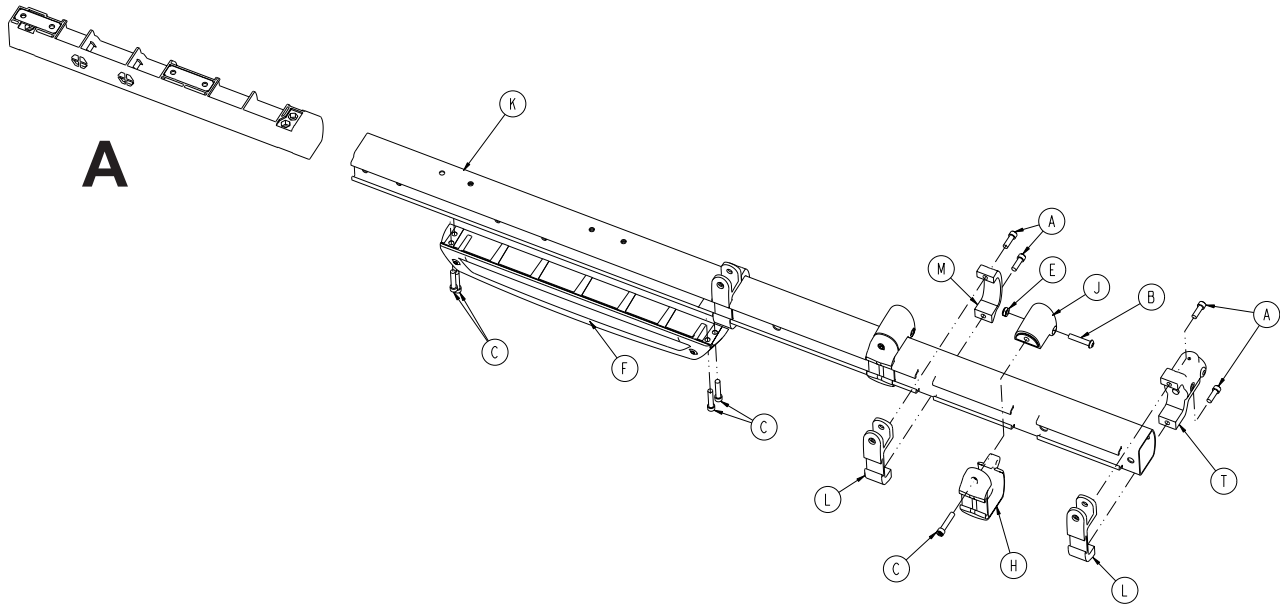


Item	Part No.	Qty.
A	0004-590-000	4
B	0055-100-075	4
C	6500-001-053	1
D	6500-001-125	1



6500-001-032

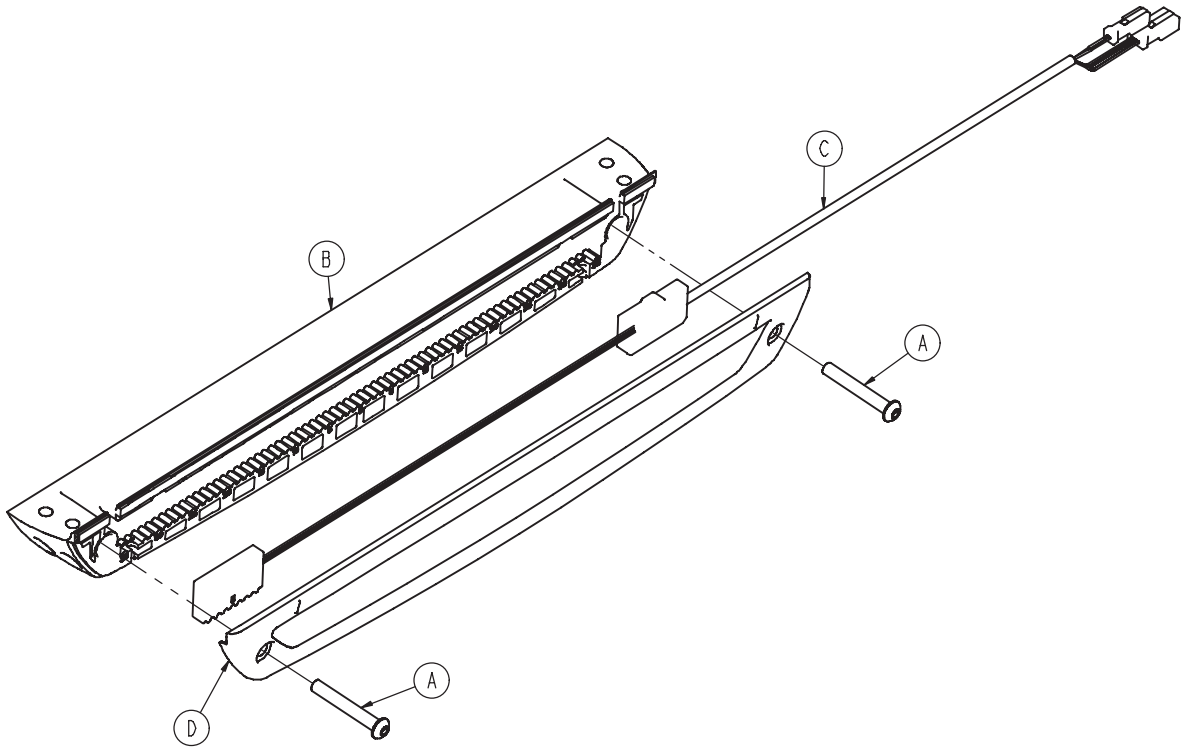
Item	Part No.	Qty.
A	0004-591-000	6
B	0004-612-000	2
C	0004-613-000	6
D	0016-028-000	10
E	0016-102-000	2
F	6500-001-028	1
G	6500-001-098	1
H	6500-001-104	2
J	6500-001-106	2
K	6500-001-114	1
L	6500-001-116	3
M	6500-001-117	2
N	6500-001-243	1
P	6500-001-244	1
R	6500-001-245	2
T	6500-001-102	1



6500-001-033

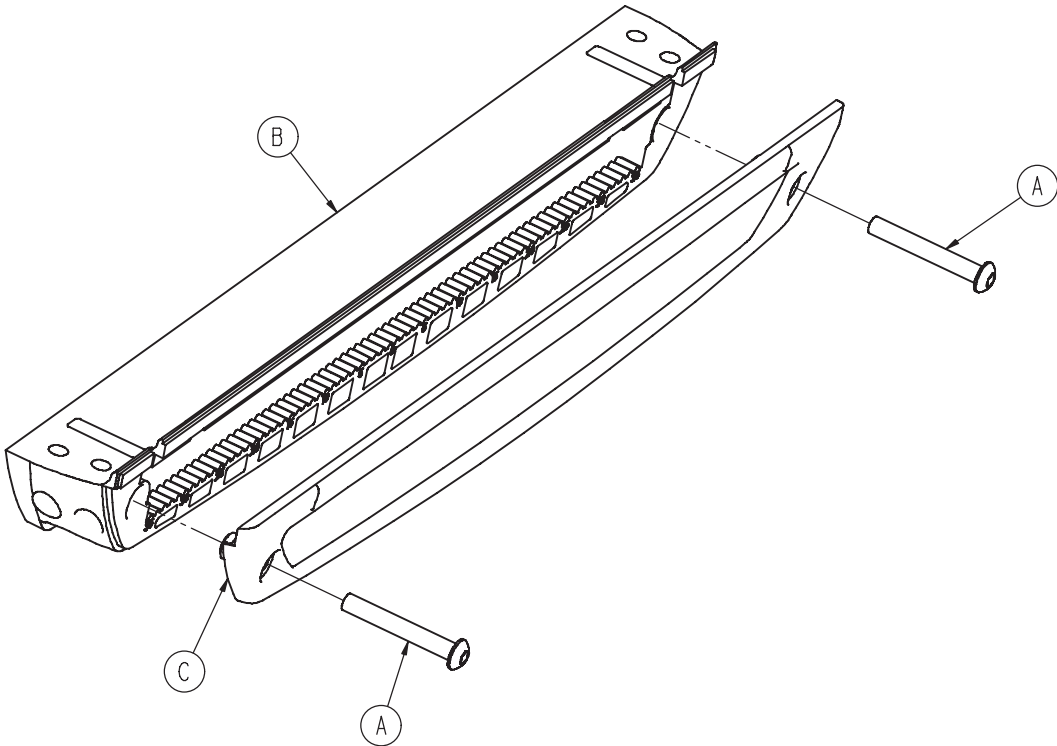
Item	Part No.	Qty.
A	0004-591-000	6
B	0004-612-000	2
C	0004-613-000	6
D	0016-028-000	10
E	0016-102-000	2
F	6500-001-029	1
G	6500-001-098	1
H	6500-001-104	2
J	6500-001-106	2
K	6500-001-115	1
L	6500-001-116	3
M	6500-001-117	2
N	6500-001-243	1
P	6500-001-244	1
R	6500-001-245	2
T	6500-001-102	1

6500-001-028

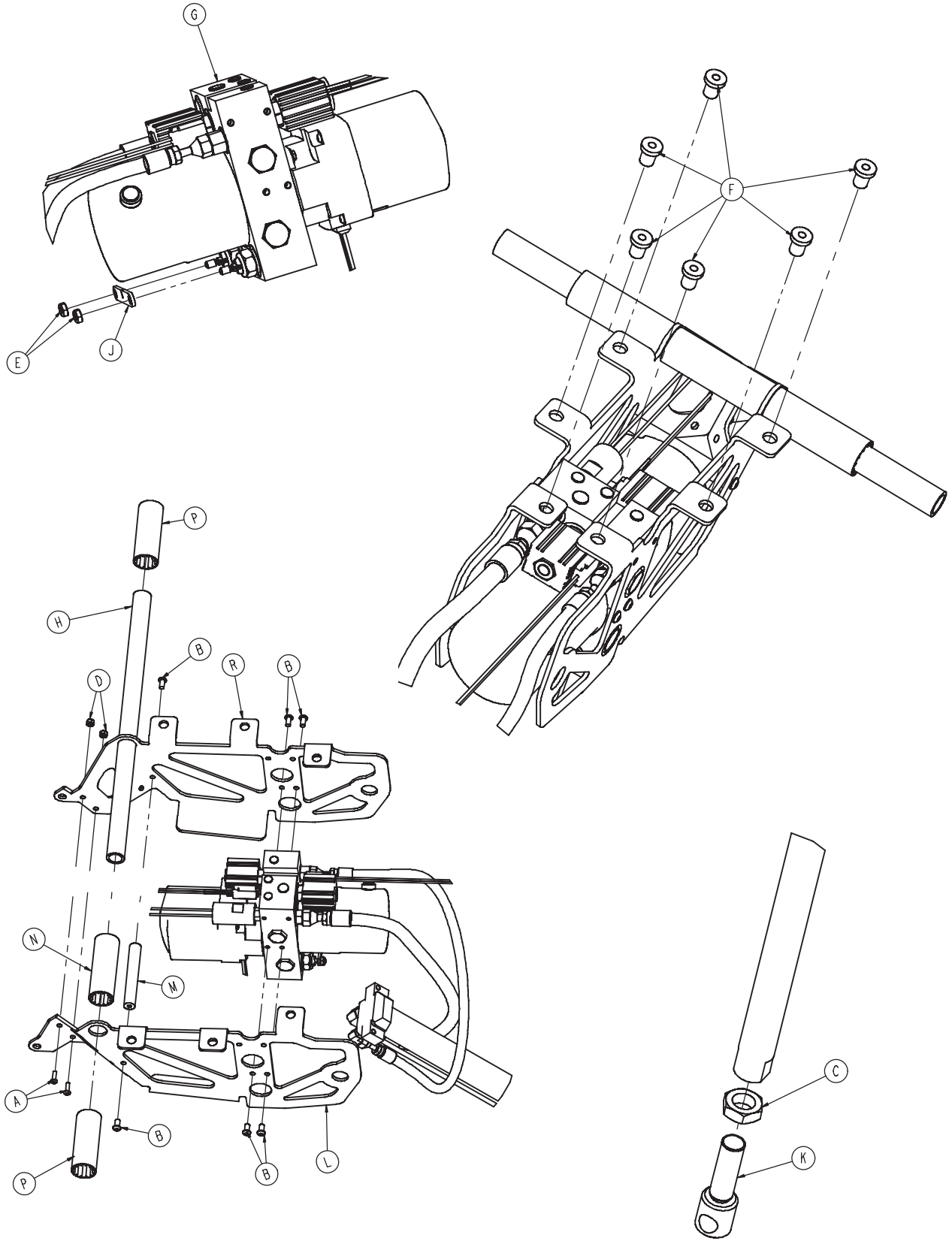


Item	Part No.	Qty.
A	0004-596-000	2
B	6500-001-124	1
C	6500-001-160	1
D	6500-001-199	1

6500-001-029



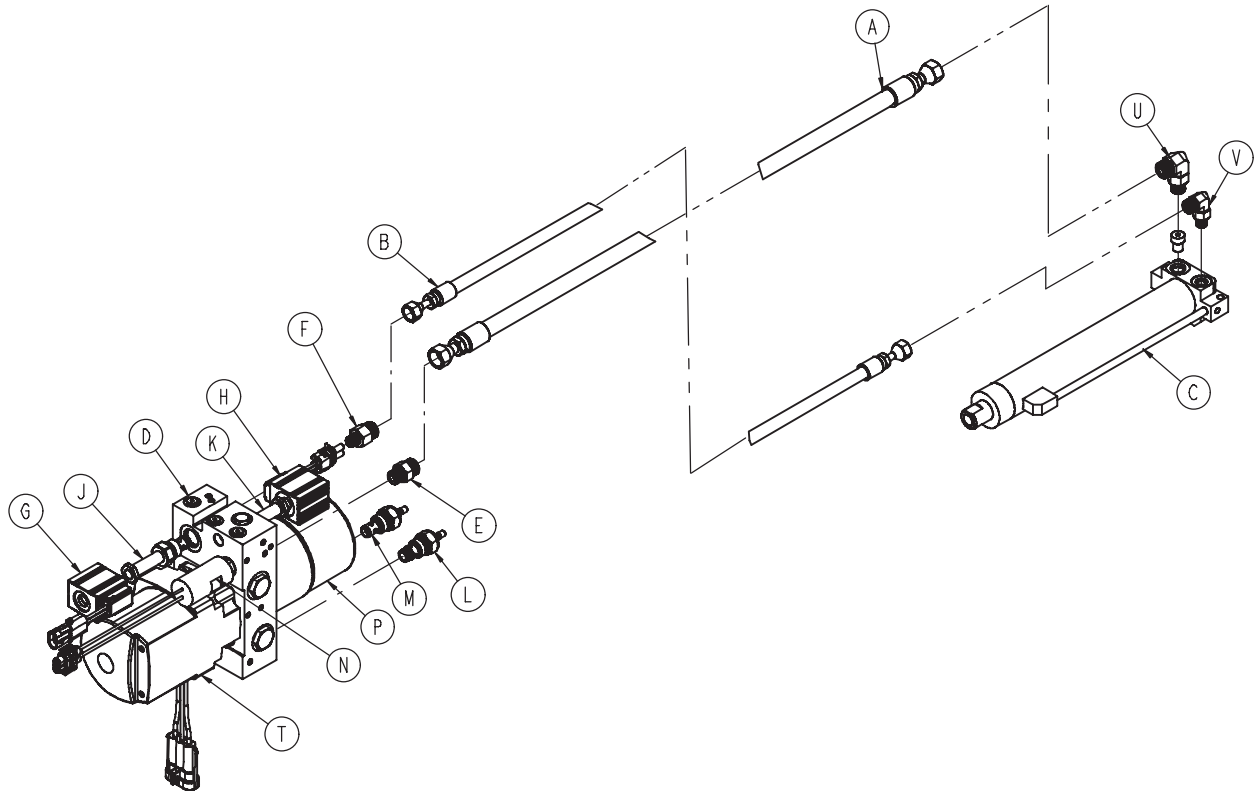
Item	Part No.	Qty.
A	0004-596-000	2
B	6500-001-124	1
C	6500-001-199	1



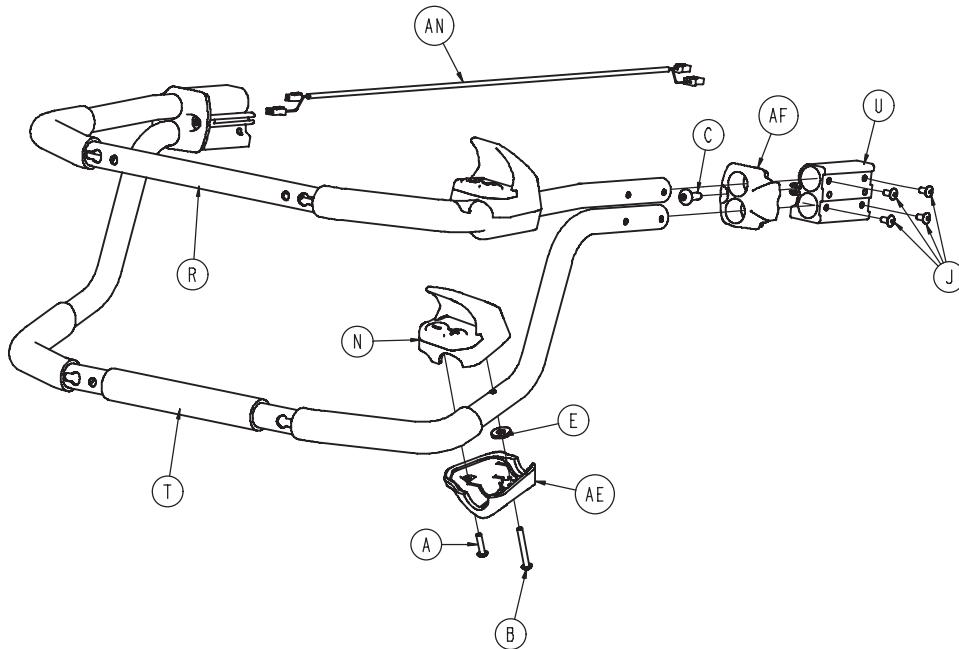
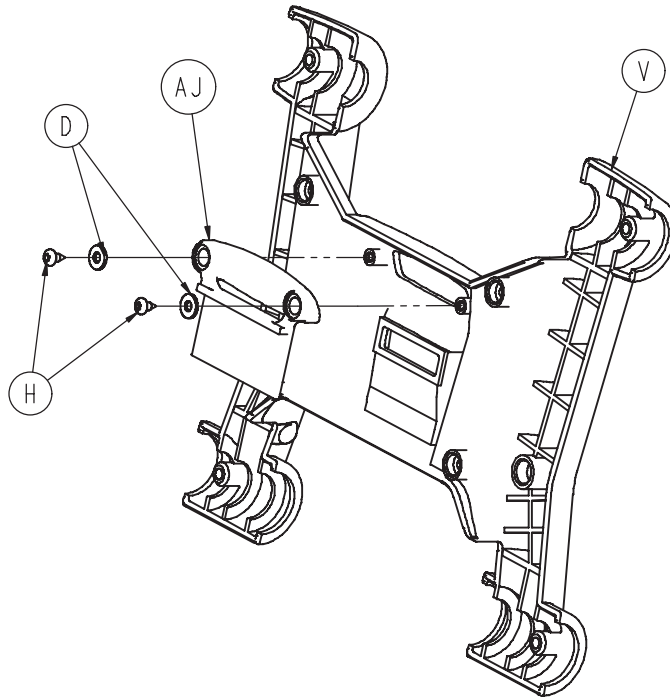
6500-001-031

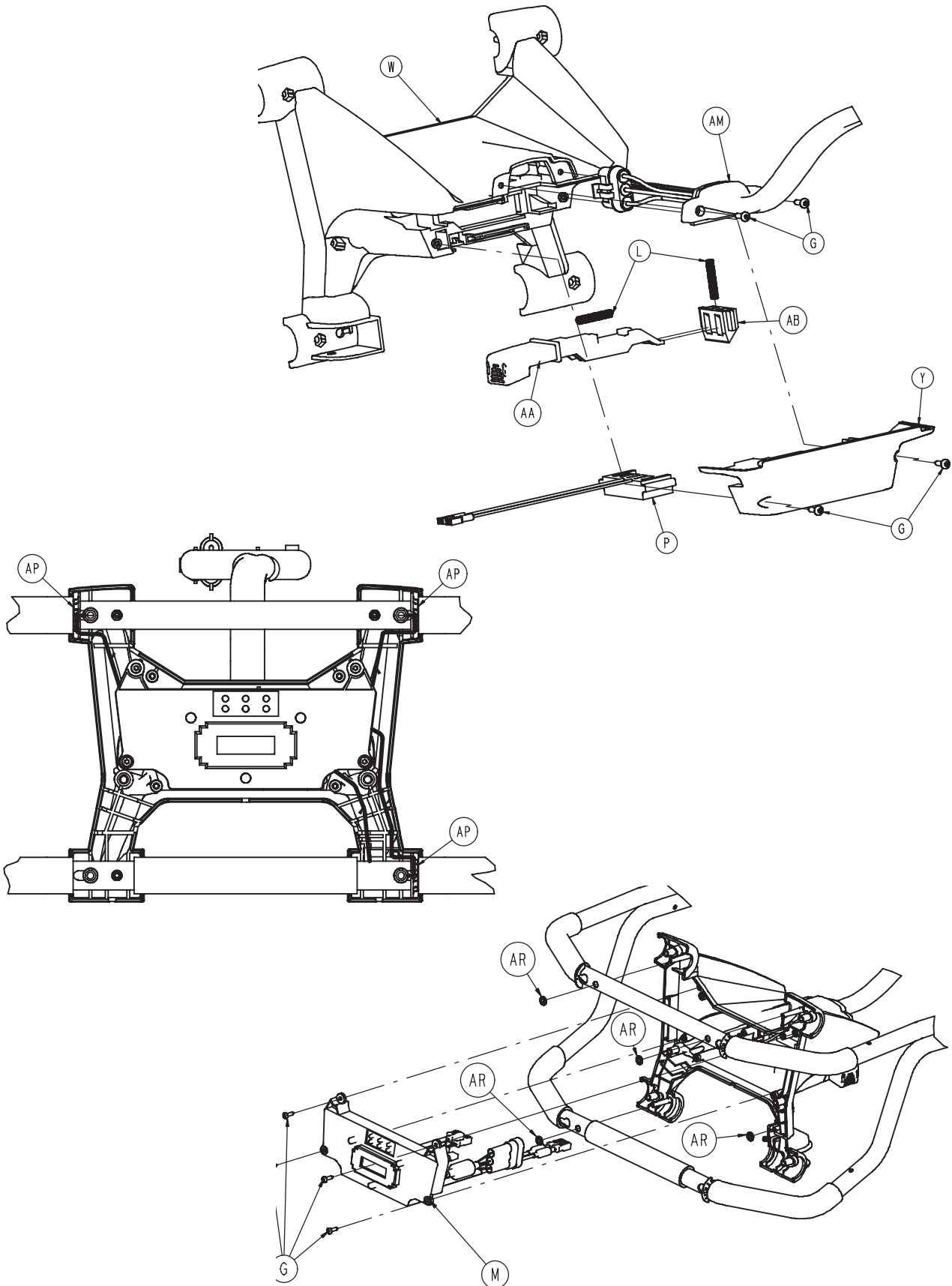
Item	Part No.	Qty.
A	0004-586-000	2
B	0004-589-000	6
C	0015-052-000	1
D	0016-002-000	2
E	0016-102-000	2
F	0055-100-074	6
G	6500-001-030	1
H	6500-001-105	1
J	6500-001-152	1
K	6500-001-169	1
L	6500-001-194	1
M	6500-001-212	1
N	6500-001-249	1
P	6500-001-250	2
R	6500-001-294	1

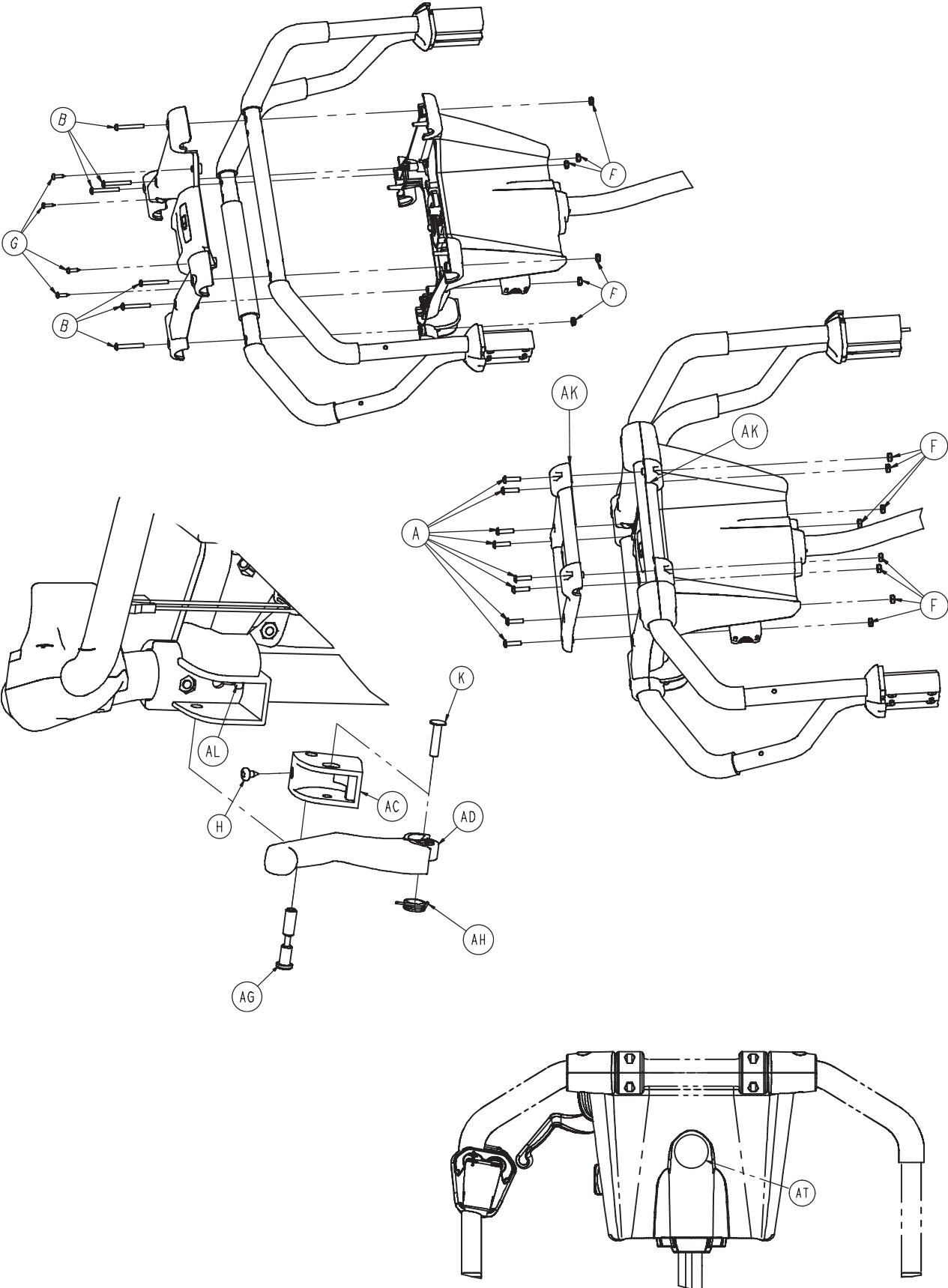
6500-001-030



Item	Part No.	Qty.
A	6500-001-210	1
B	6500-001-211	1
C	6500-001-213	1
D	6500-001-214	1
E	6500-001-282	1
F	6500-001-283	1
G	6500-001-284	1
H	6500-001-285	1
J	6500-001-286	1
K	6500-001-287	1
L	6500-001-288	1
M	6500-001-289	1
N	6500-001-290	1
P	6500-001-291	1
R	6500-001-293	1
T	6500-001-295	1
U	6500-001-296	1
V	6500-001-297	1



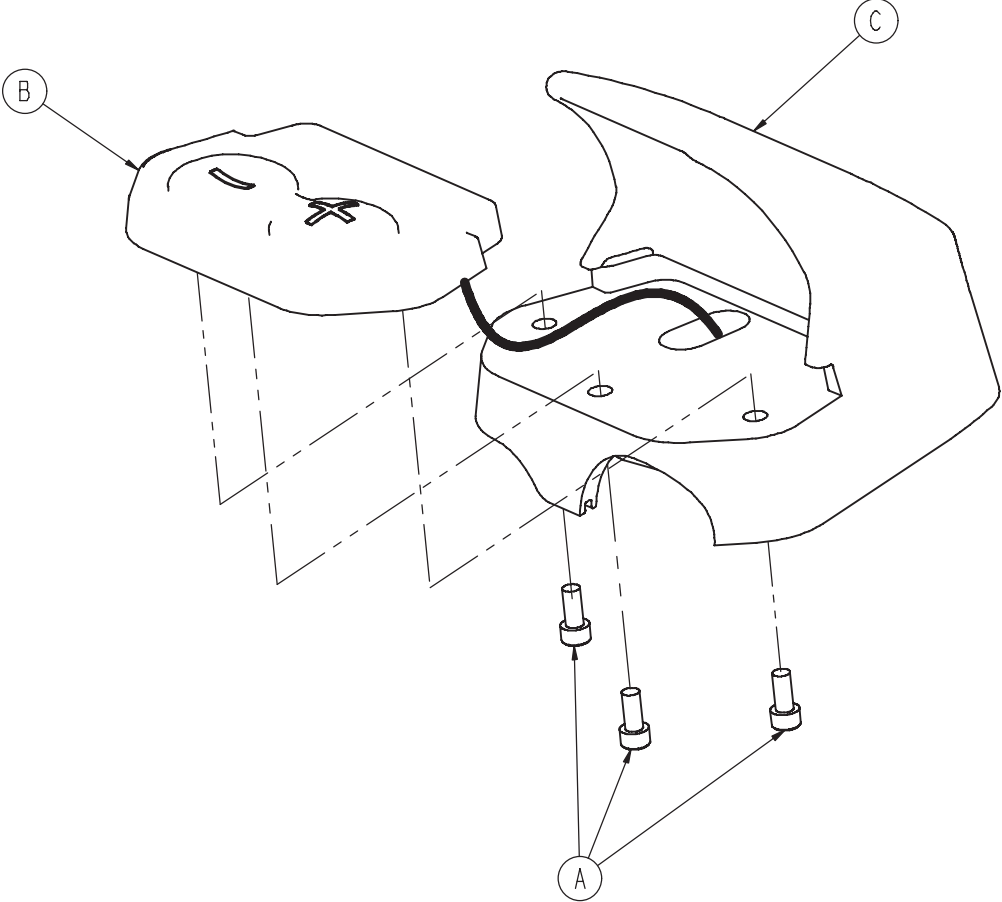




6500-001-015

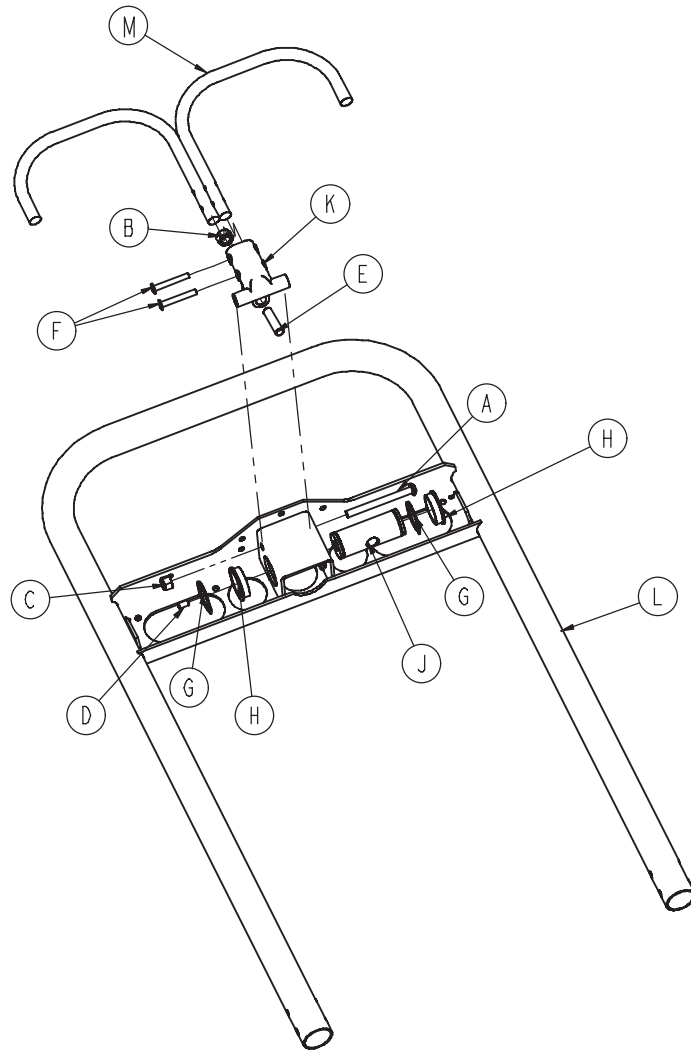
Item	Part No.	Qty.
A	0004-614-000	10
B	0004-615-000	8
C	0007-065-000	2
D	0011-062-000	2
E	0011-543-000	2
F	0016-131-000	2
G	0023-162-000	12
H	0023-163-000	3
J	0025-079-000	8
K	0025-187-000	1
L	0038-572-000	2
M	6500-001-014	1
N	6500-001-016	2
P	6500-001-101	1
R	6500-001-131	1
T	6500-001-132	1
U	6500-001-133	2
V	6500-001-134	1
W	6500-001-135	1
Y	6500-001-136	1
AA	6500-001-138	1
AB	6500-001-139	1
AC	6500-001-140	1
AD	6500-001-141	1
AE	6500-001-142	2
AF	6500-001-144	2
AG	6500-001-146	1
AH	6500-001-147	1
AJ	6500-001-153	1
AK	6500-001-154	2
AL	6500-001-156	1
AM	6500-001-159	1
AN	6500-001-161	1
AP	6500-001-275	3
AR	0028-116-000	4
AT	6080-090-101	1

6500-001-016



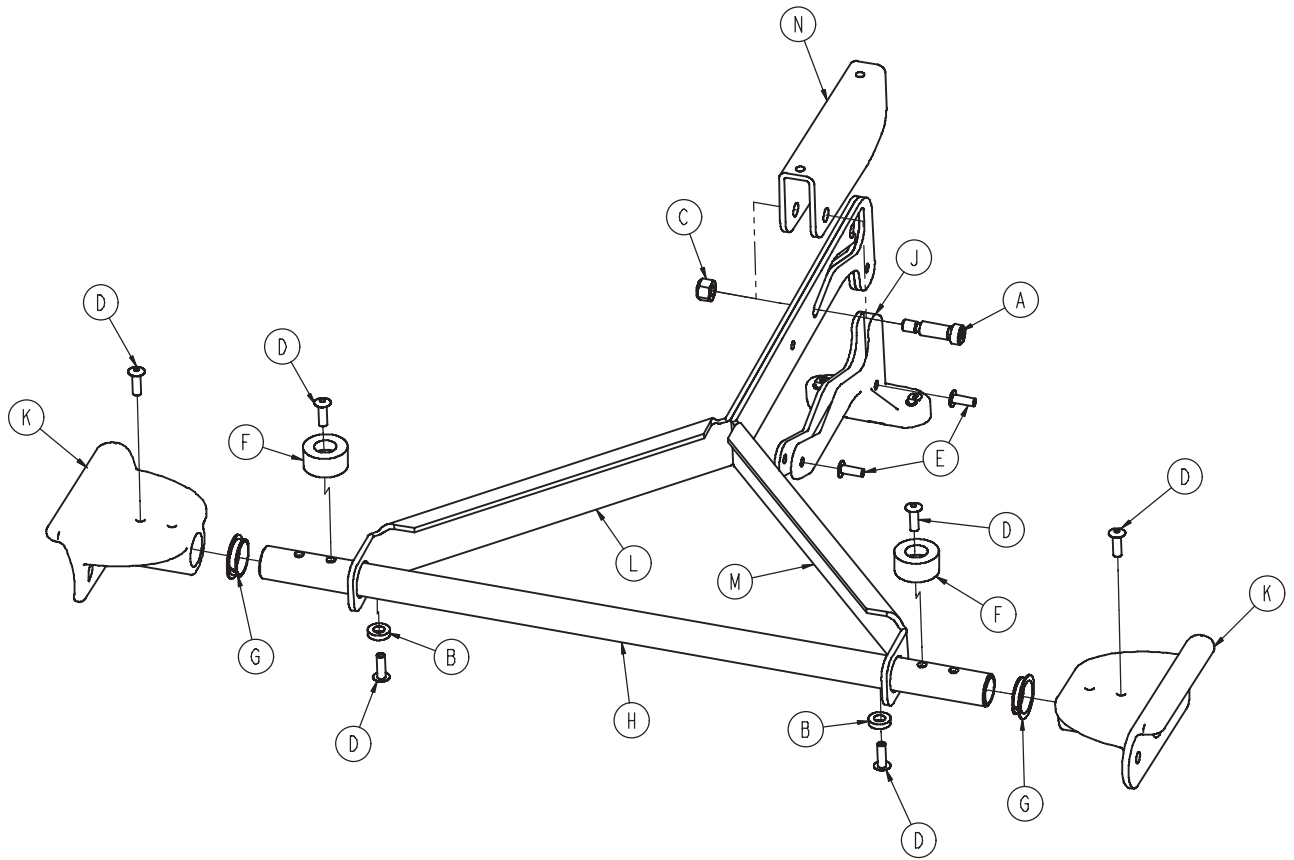
Item	Part No.	Qty.
A	0004-616-000	3
B	6500-001-130	1
C	6500-001-143	1

6500-001-018

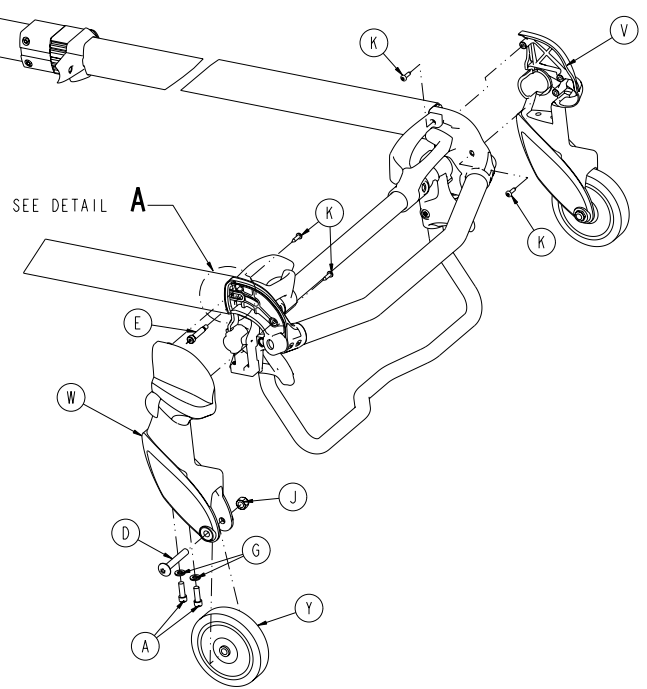
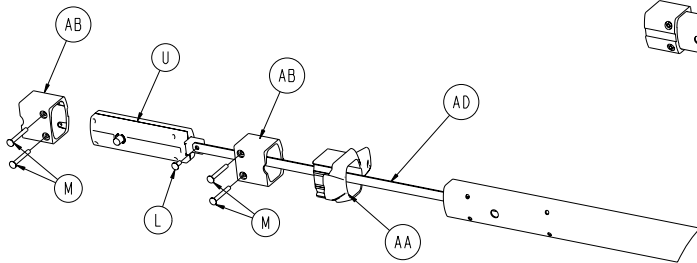
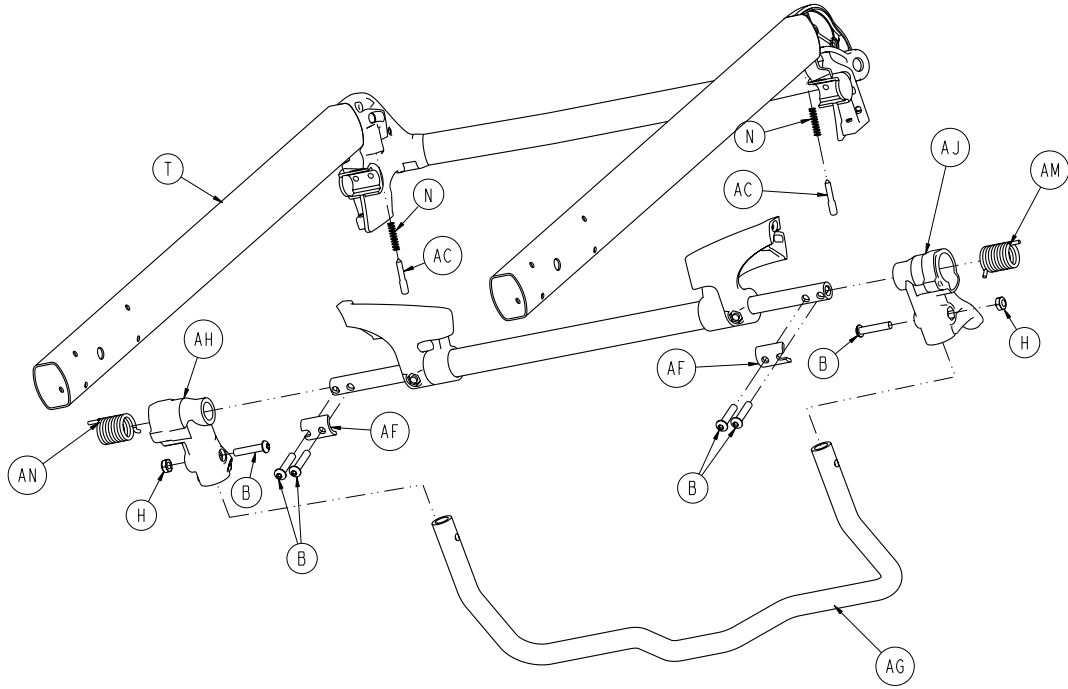


Item	Part No.	Qty.
A	0004-234-000	1
B	0015-050-000	1
C	0016-028-000	1
D	0021-119-000	1
E	0021-138-000	1
F	0025-131-000	2
G	0028-076-000	2
H	0946-035-025	2
J	6060-032-038	1
K	6060-032-040	1
L	6082-032-050	1
M	6082-032-052	1

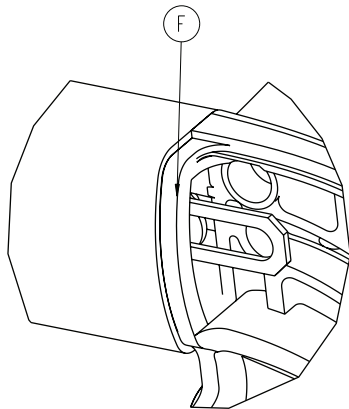
6500-001-019



Item	Part No.	Qty.
A	0008-027-000	1
B	0014-067-000	2
C	0016-028-000	1
D	0025-133-000	6
E	0025-186-000	2
F	0056-016-000	2
G	0081-255-000	2
H	6500-001-107	1
J	6500-001-108	1
K	6500-001-109	2
L	6500-001-203	1
M	6500-001-204	1
N	6500-001-205	1

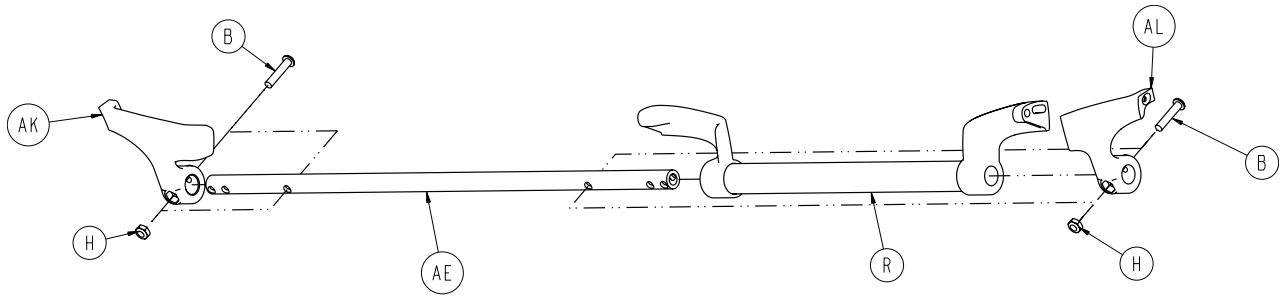


SEE DETAIL A



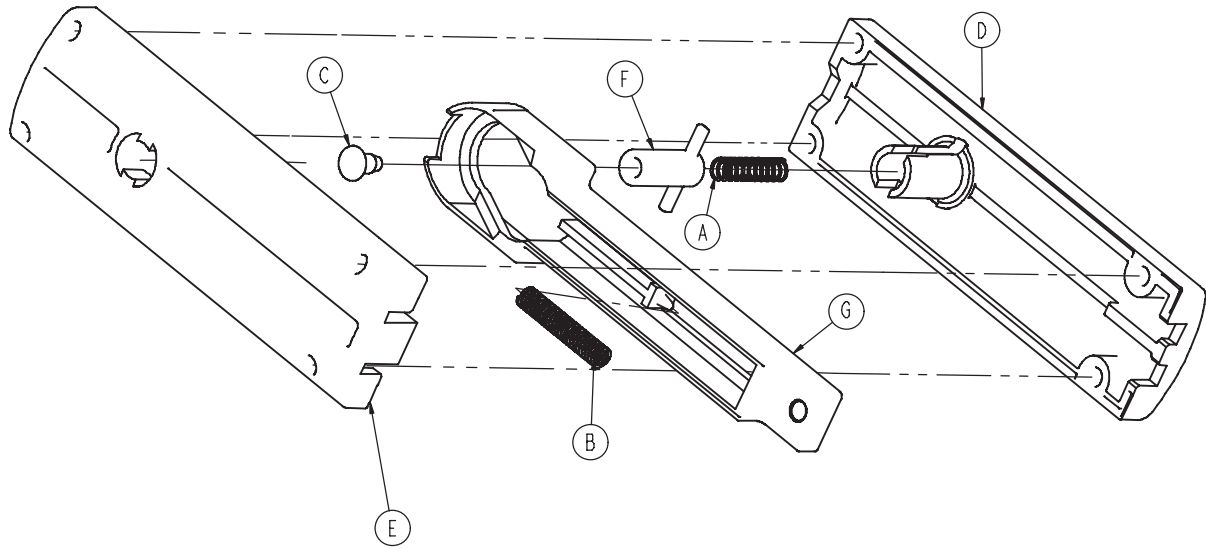
A

6500-001-020



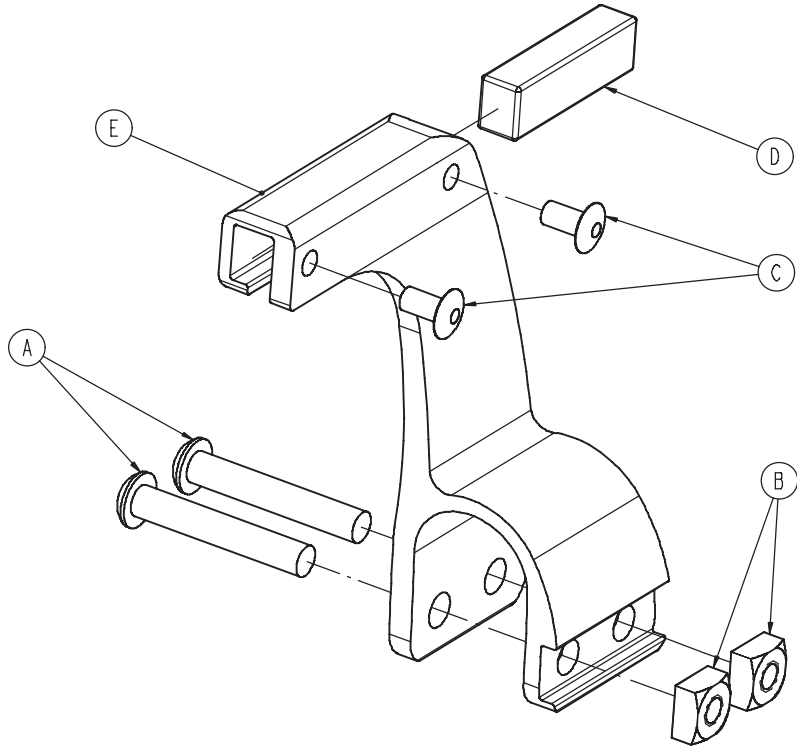
Item	Part No.	Qty.
A	0004-591-000	4
B	0004-612-000	8
D	0007-036-000	2
E	0008-030-000	2
F	0014-002-000	2
G	0011-065-000	4
H	0016-102-000	4
J	0016-123-000	2
K	0023-162-000	4
L	0025-126-000	2
M	0025-185-000	8
N	0038-570-000	2
R	6500-001-023	1
T	6500-001-024	1
U	6500-001-026	2
V	6500-001-082	1
W	6500-001-083	1
Y	6500-001-086	2
AA	6500-001-087	2
AB	6500-001-088	4
AC	6500-001-093	2
AD	6500-001-096	2
AE	6500-001-220	1
AF	6500-001-221	2
AG	6500-001-322	1
AH	6500-001-323	1
AJ	6500-001-324	1
AK	6500-001-280	1
AL	6500-001-281	1
AM	6500-001-325	1
AN	6500-001-326	1

6500-001-026



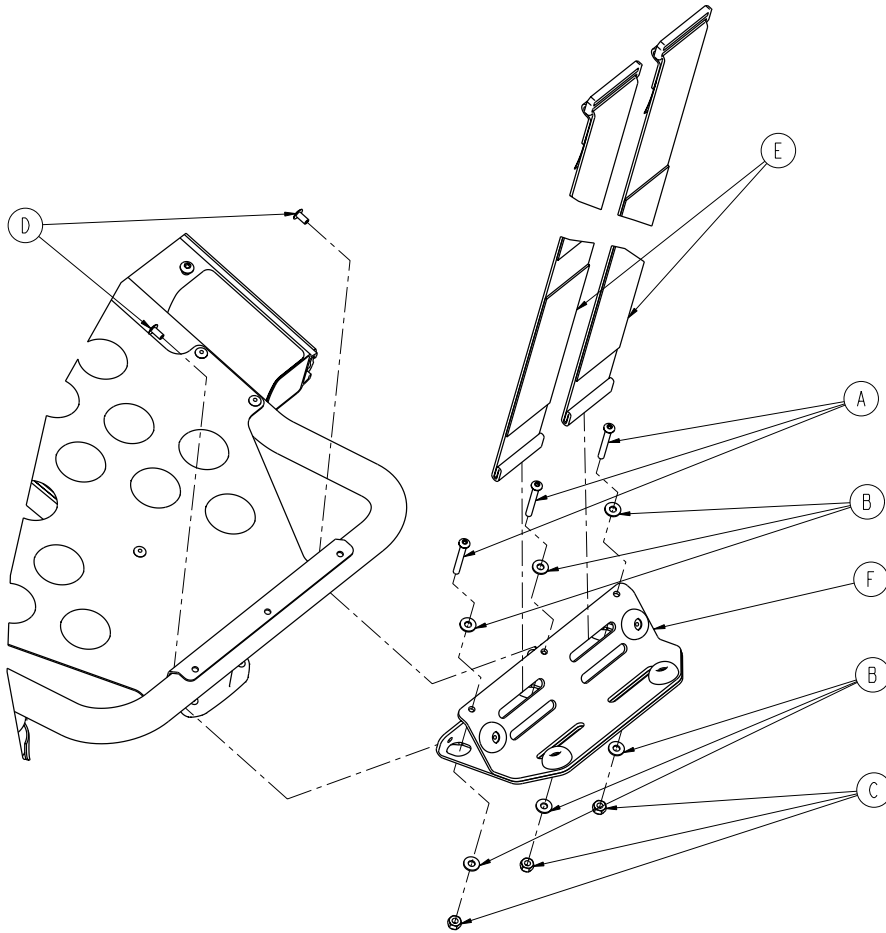
Item	Part No.	Qty.
A	038-570-000	1
B	038-572-000	1
C	6500-001-089	1
D	6500-001-091	1
E	6500-001-092	1
F	6500-001-094	1
G	6500-001-095	1

6500-001-027



Item	Part No.	Qty.
A	0004-135-000	2
B	0015-016-000	2
C	0025-079-000	2
D	6500-001-271	1
E	6500-001-272	1

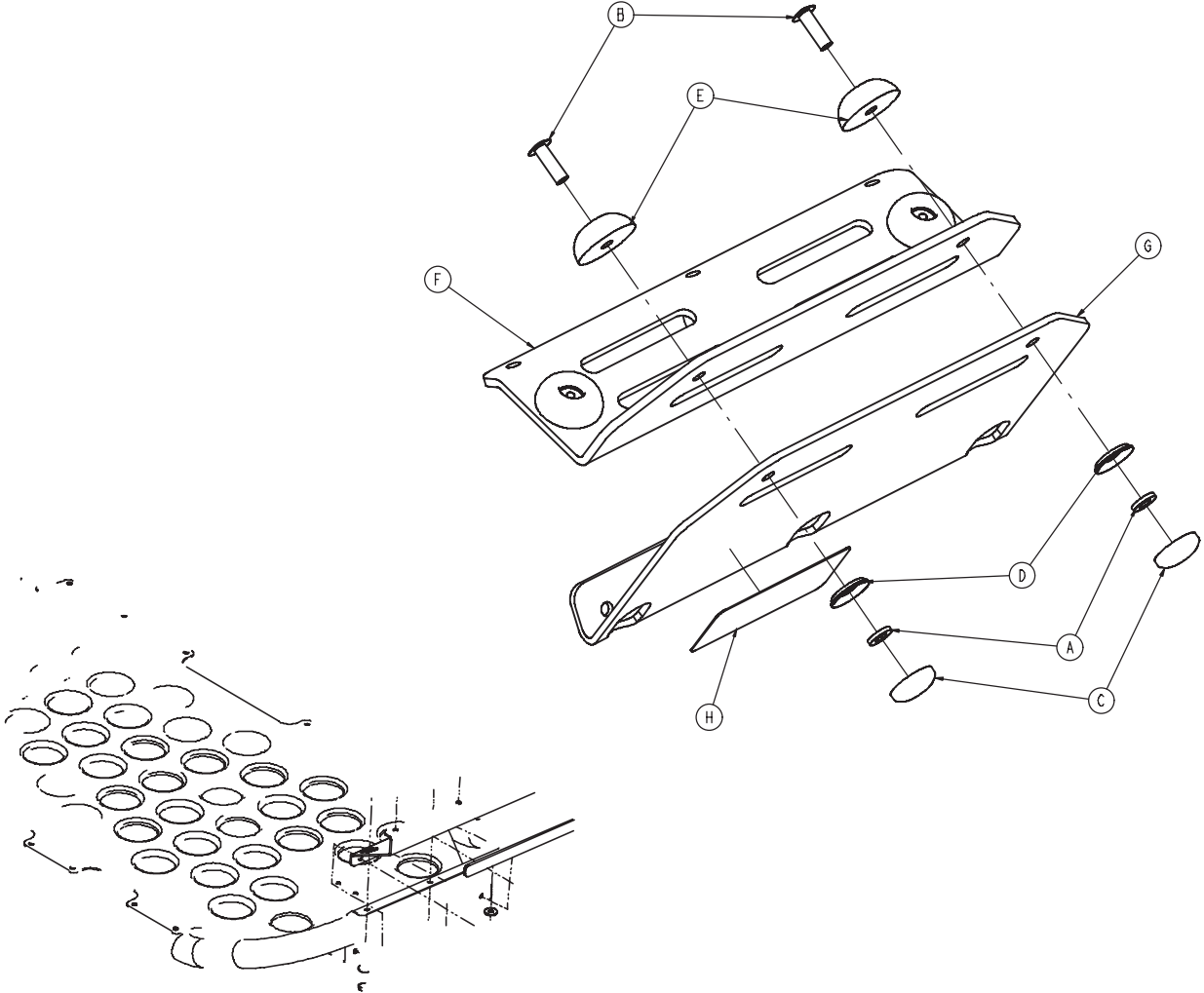
6500-140-000



Item	Part No.	Qty.
A	0004-508-000	3
B	0011-001-000	6
C	0016-003-000	3
D	0025-079-000	2
E	6060-140-013	2
F	6500-001-040	1

NOTE: Max Load = 40 lbs.

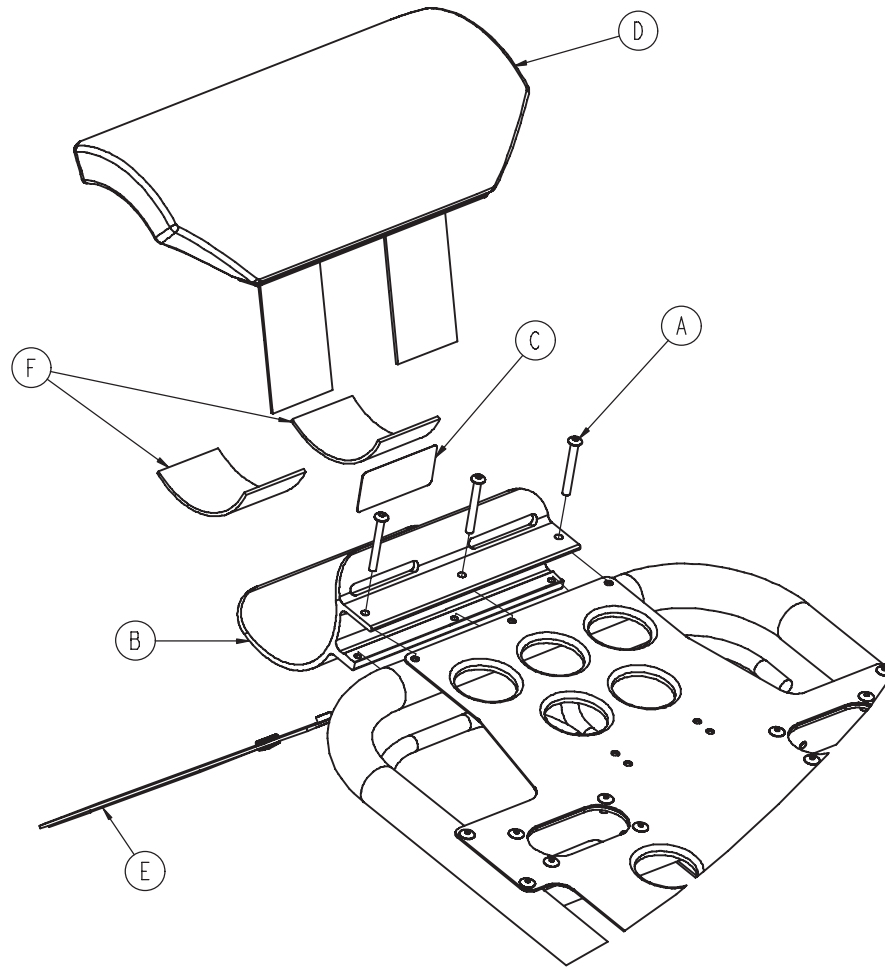
6500-001-040



Item	Part No.	Qty.
A	0011-436-000	4
B	0025-133-000	4
C	0037-055-000	4
D	0037-056-000	4
E	0946-001-155	4
F	6500-001-239	1
G	6500-001-240	1
H	6500-001-257	1

NOTE: Max Load = 40 lbs.

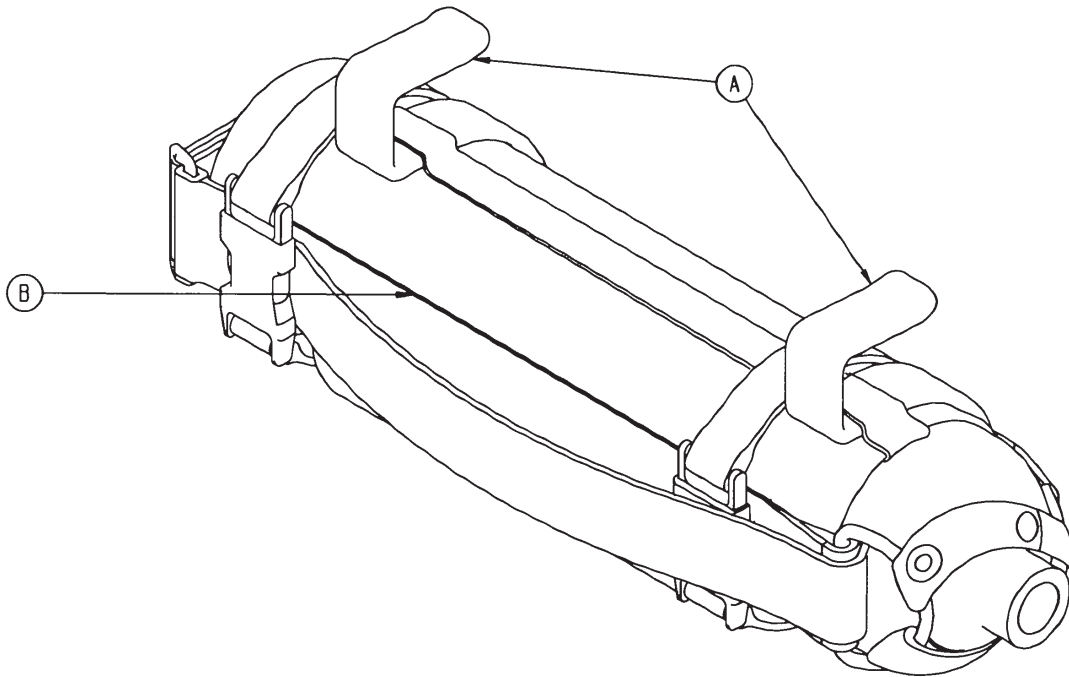
6500-141-000



Item	Part No.	Qty.
A	0004-636-000	3
B	6500-001-119	1
C	6500-001-231	1
D	6500-001-260	1
E	6500-001-261	1
F	6500-001-262	1
G	0025-079-000	2

NOTE: Max Load = 40 lbs.

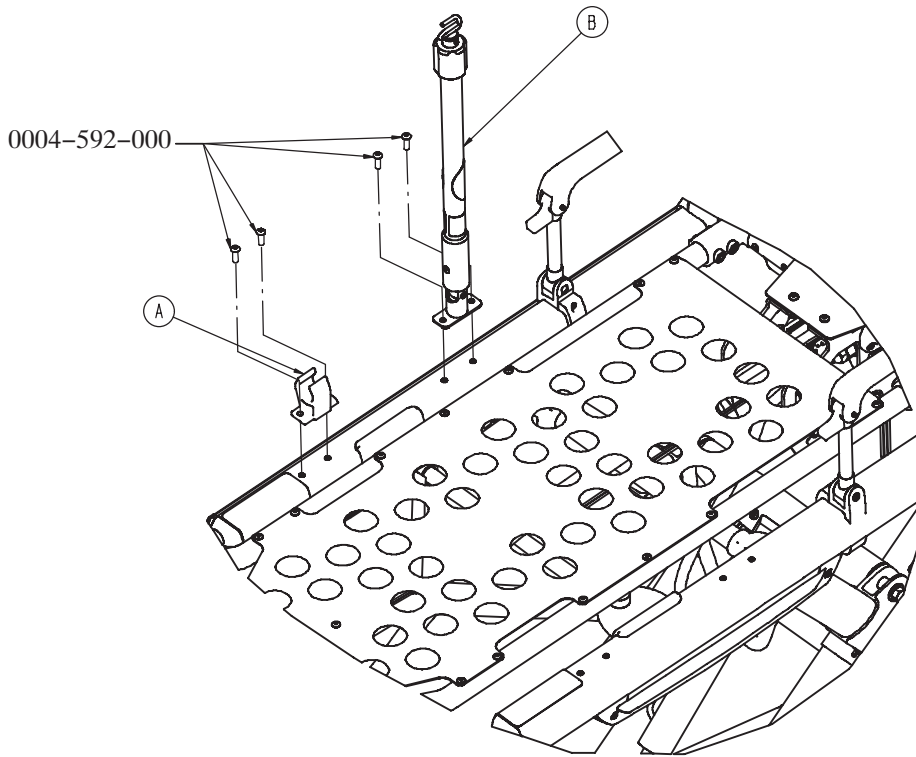
6080-140-010



Item	Part No.	Qty.
A	6080-140-011	2
B	6080-140-012	1

NOTE: Max Load = 25 lbs.

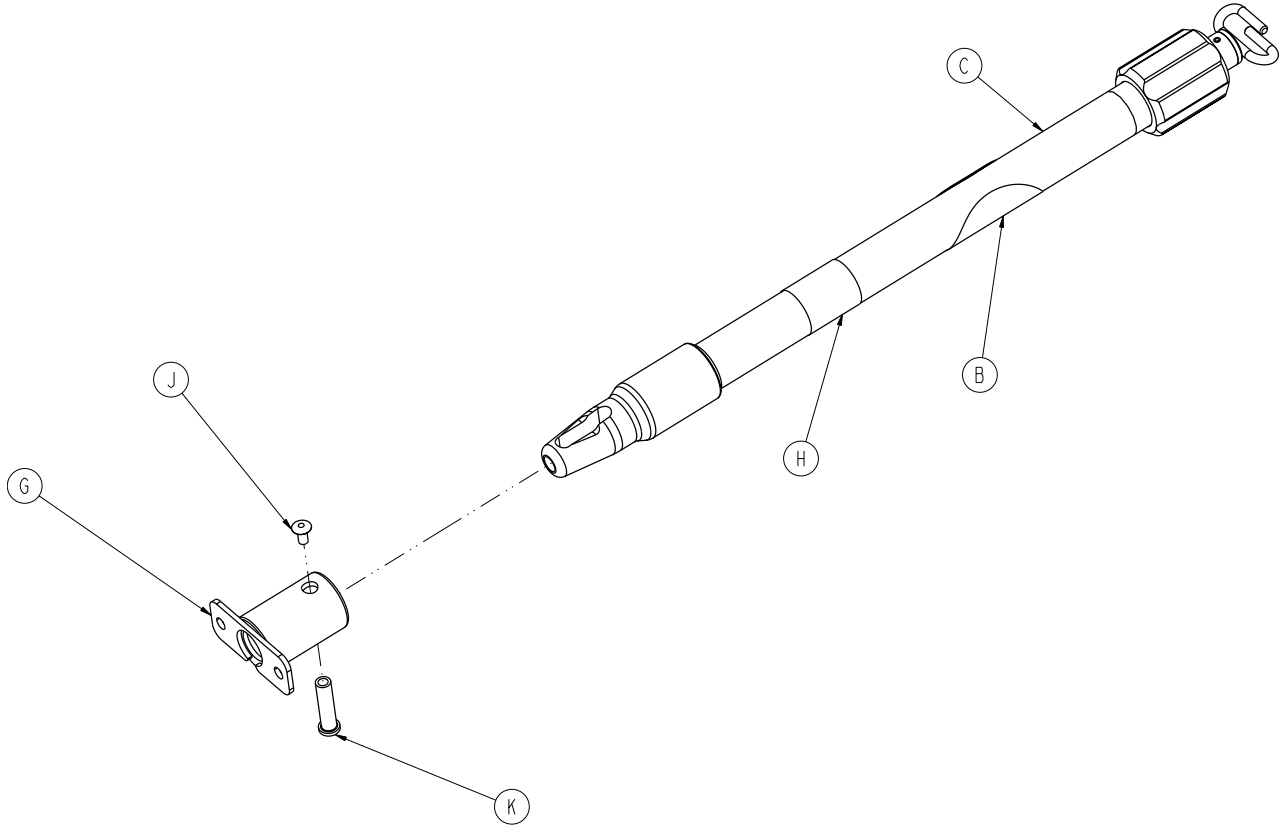
6500-210-000 / 6500-215-000



6500-210-000		
Item	Part No.	Qty.
A	6100-115-060	1
B	6500-001-041	1

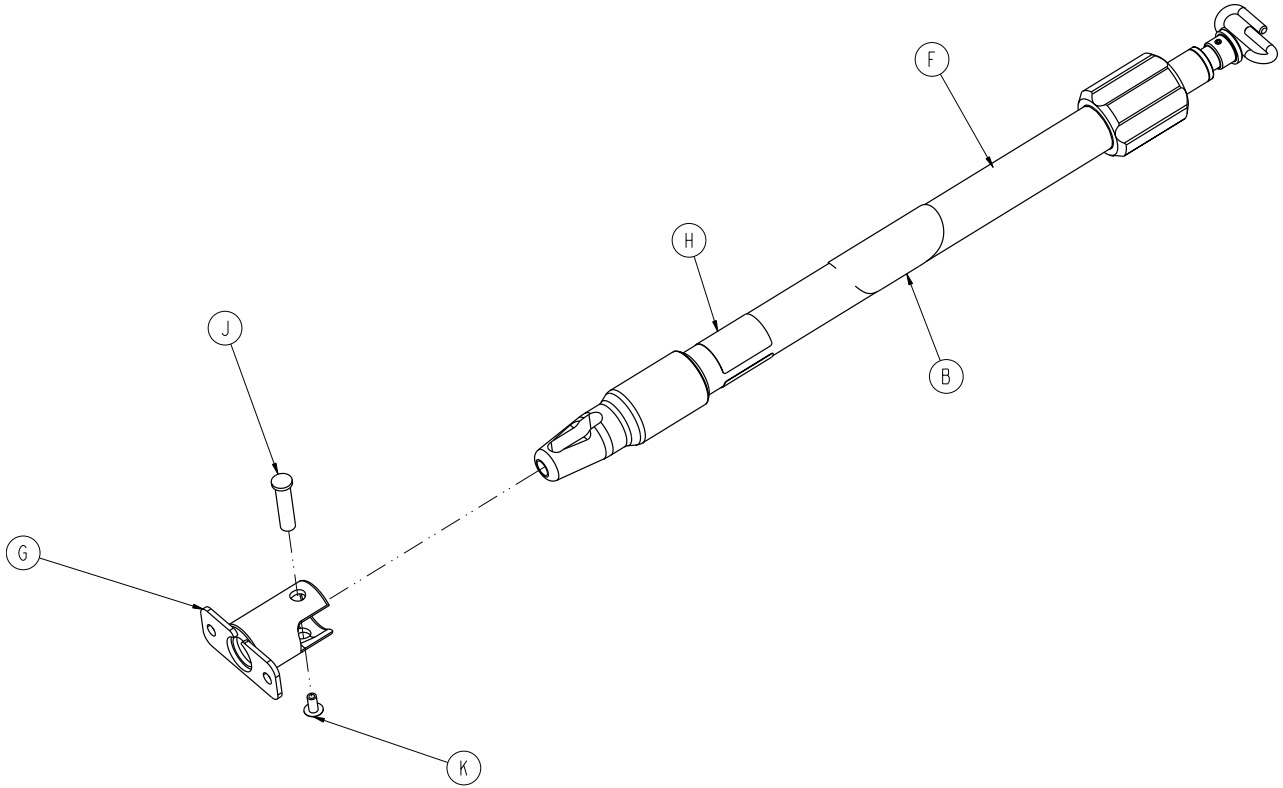
6500-215-000		
Item	Part No.	Qty.
A	6100-115-060	1
B	6500-001-043	1

6500-001-041



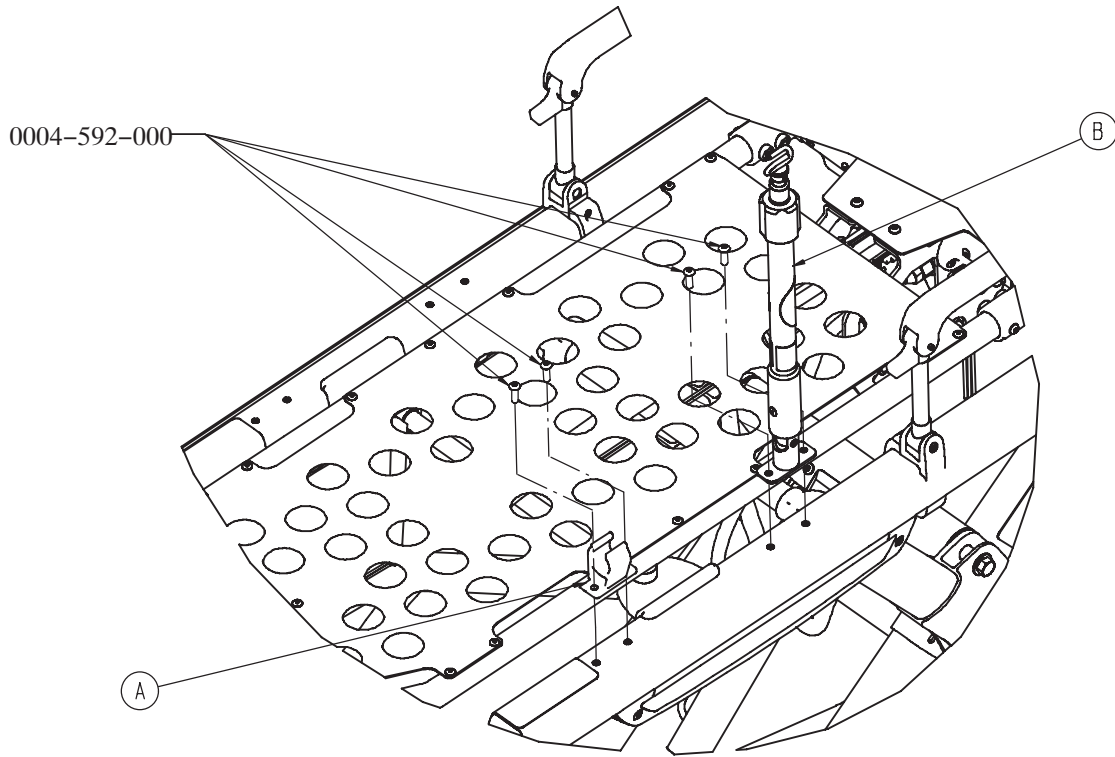
Item	Part No.	Qty.
B	6070-090-105	1
C	6070-210-070	1
G	6100-115-051	1
H	6500-001-253	1
J	0025-079-000	1
K	6070-110-037	1

6500-001-043



Item	Part No.	Qty.
B	6070-090-105	1
F	6070-210-070	1
G	6100-115-051	1
H	6500-001-255	1
J	6070-110-037	1
K	0025-079-000	1

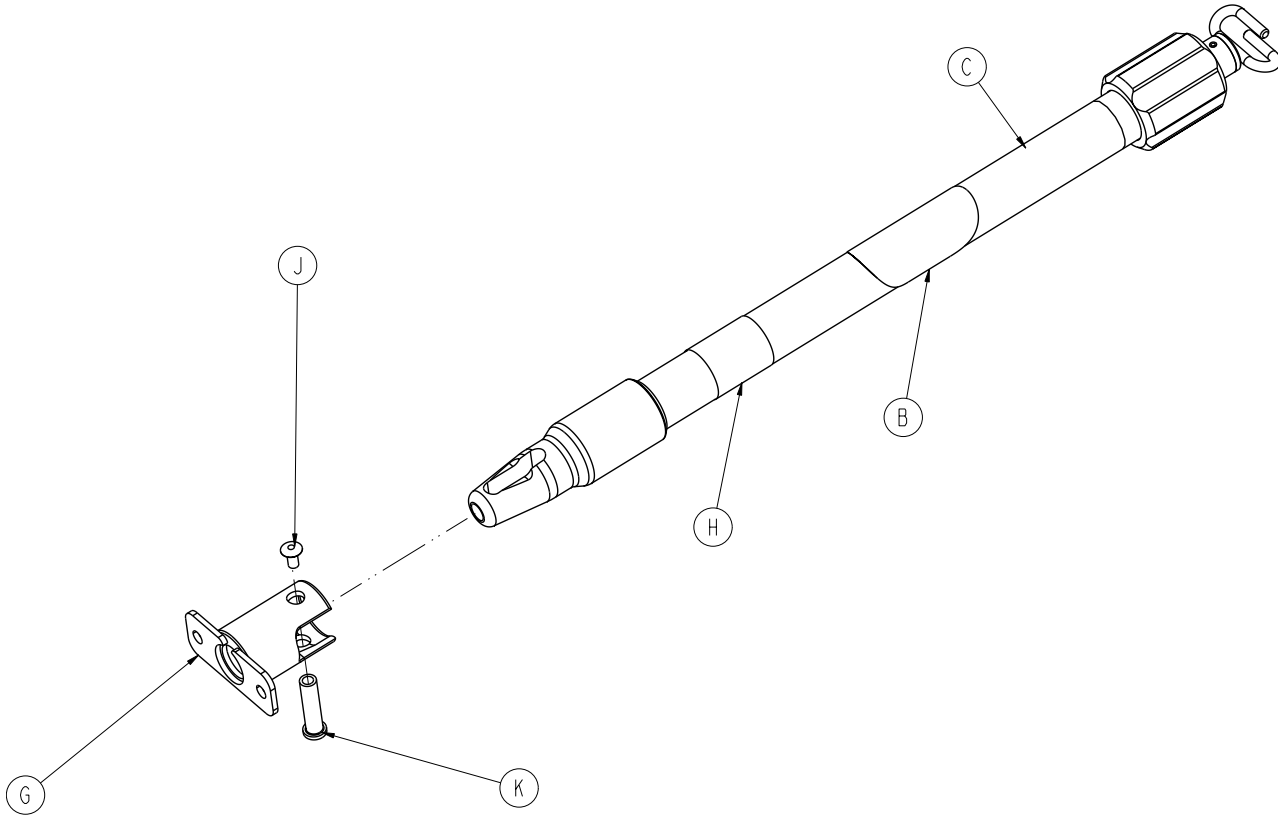
6500-211-000 / 6500-216-000



6500-211-000		
Item	Part No.	Qty.
A	6100-115-060	1
B	6500-001-042	1

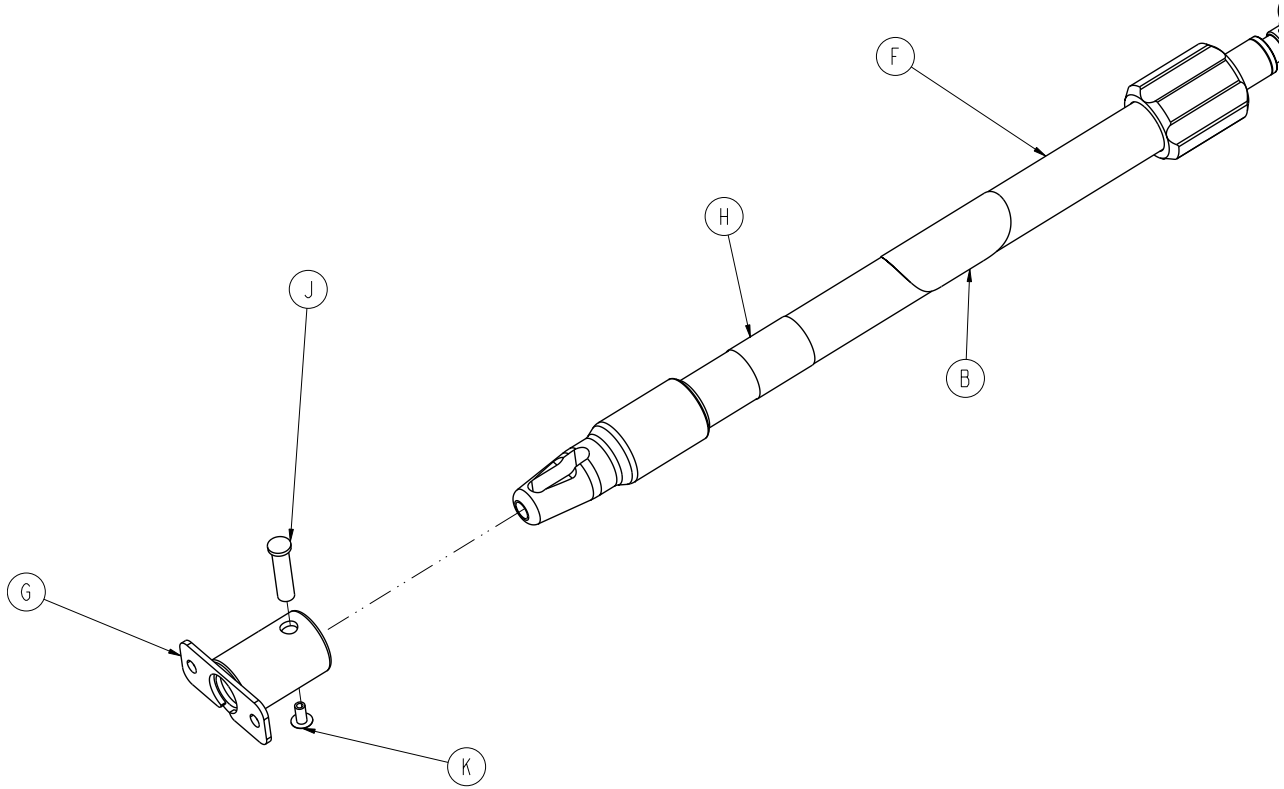
6500-216-000		
Item	Part No.	Qty.
A	6100-115-060	1
B	6500-001-044	1

6500-001-042



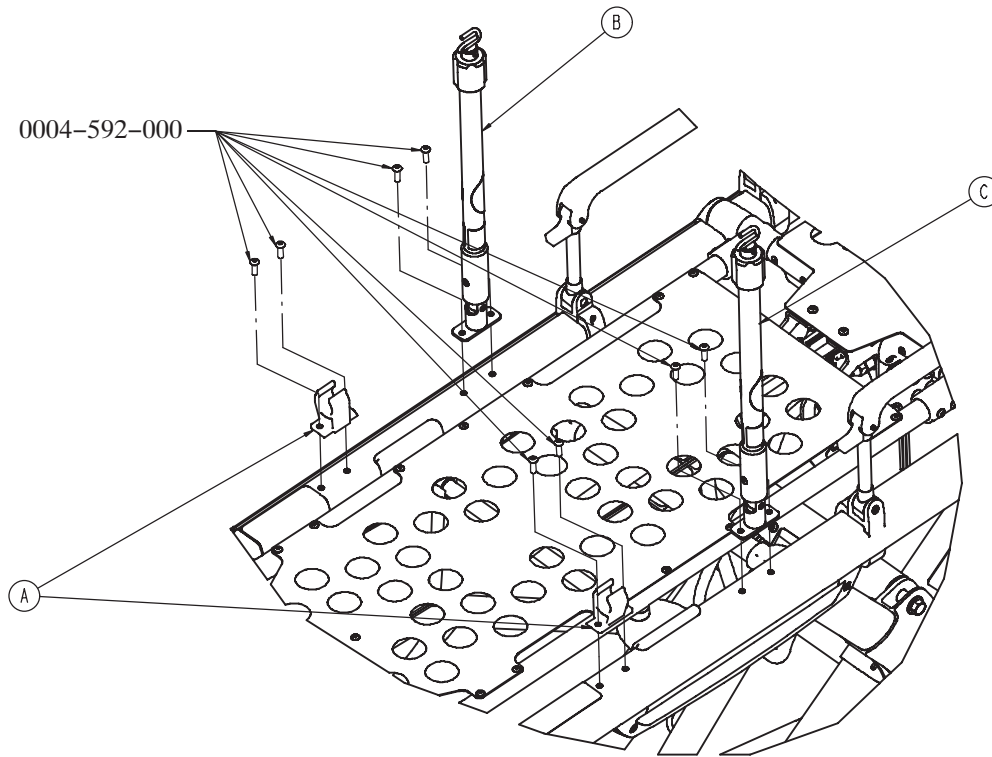
Item	Part No.	Qty.
B	6070-090-105	1
C	6070-210-070	1
G	6100-115-051	1
H	6500-001-254	1
J	0025-079-000	1
K	6070-110-037	1

6500-001-044



Item	Part No.	Qty.
B	6070-090-105	1
F	6070-210-070	1
G	6100-115-051	1
H	6500-001-256	1
J	6070-110-037	1
K	0025-079-000	1

6500-212-000 / 6500-217-000



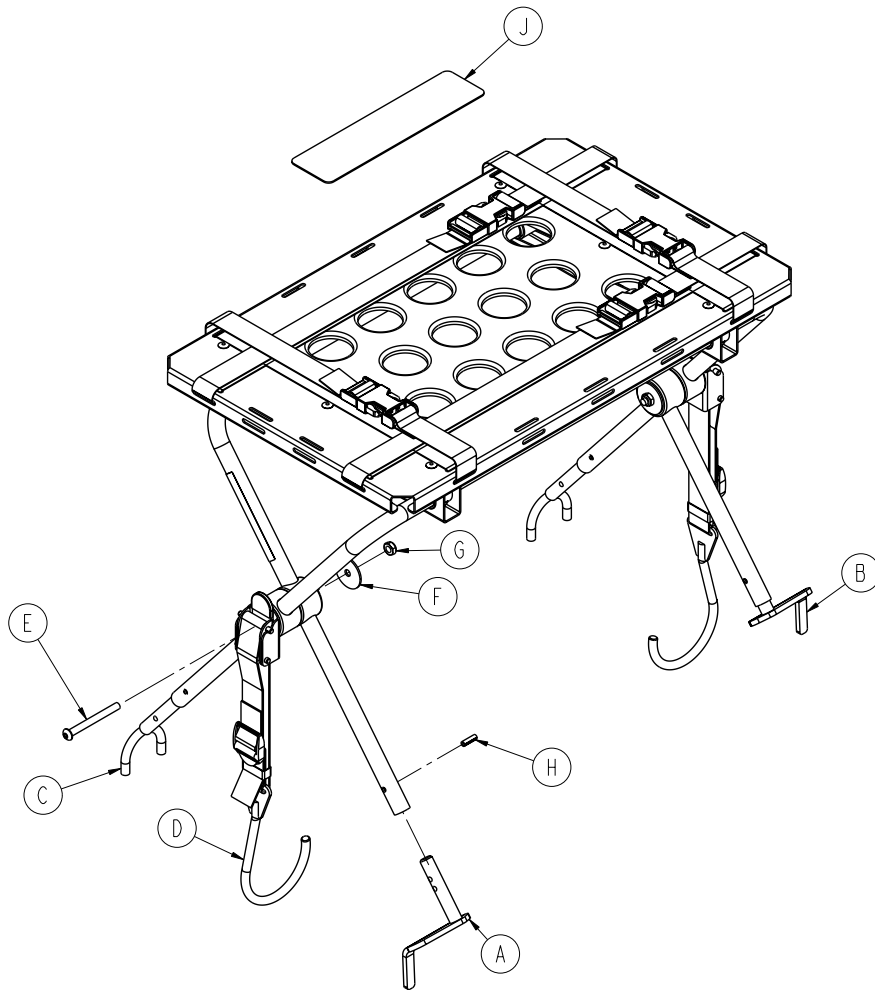
6500-212-000

Item	Part No.	Qty.
A	6100-115-060	1
B	6500-001-041	1
C	6500-001-042	1

6500-217-000

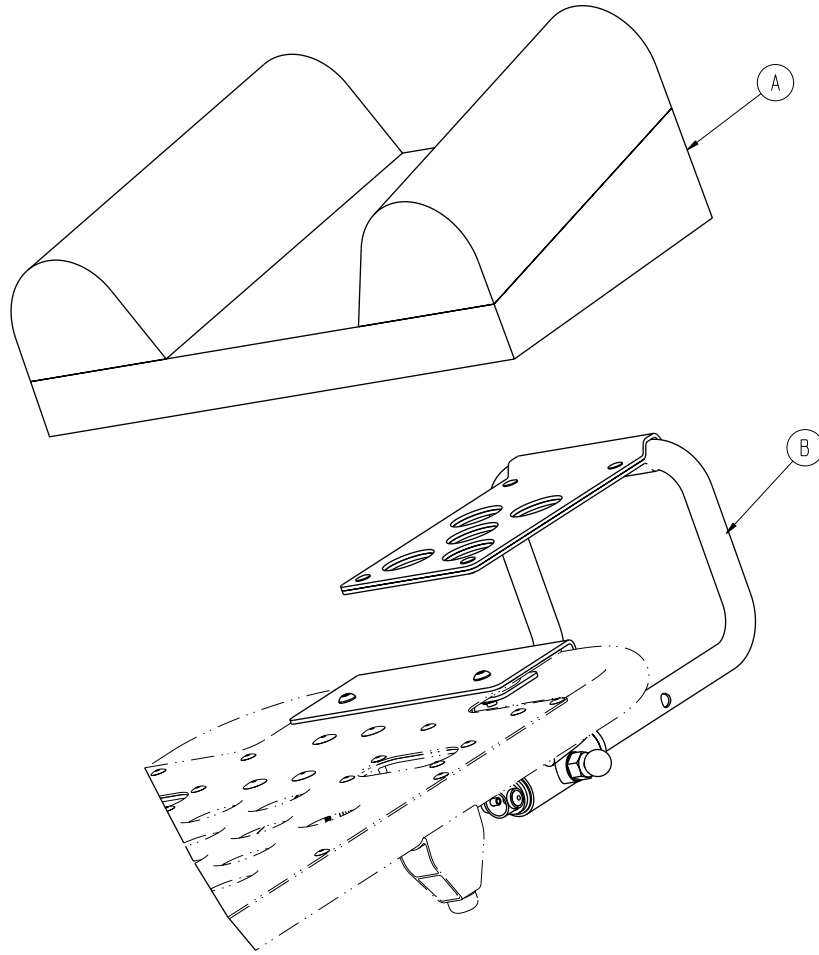
Item	Part No.	Qty.
A	6100-115-060	1
B	6500-001-043	1
C	6500-001-044	1

6500-170-000



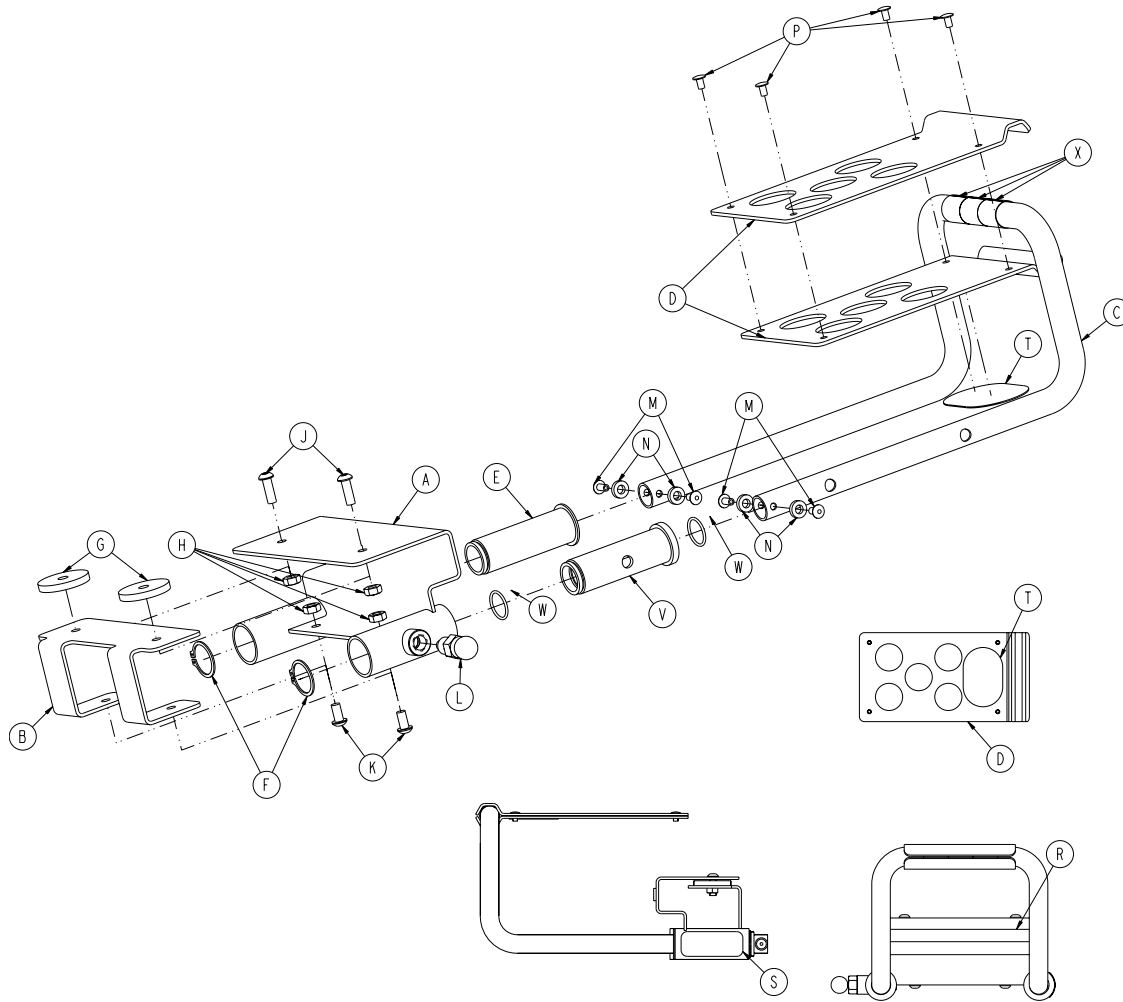
Item	Part No.	Qty.
A	6100-170-050	1
B	6100-170-051	2
C	6082-170-050	2
D	6100-170-020	2
E	0004-234-000	2
F	0011-355-000	2
G	0016-102-000	2
H	0026-172-000	4
J	6500-001-298	1

6100-044-000



Item	Part No.	Qty.
A	6100-041-030	1
B	6100-044-012	1

6100-044-012



Item	Part No.	Part Name	Qty.
A	6100-044-010		1
B	6100-044-007		1
C	6100-044-011		1
D	6100-044-008		2
E	6100-044-005		1
F	0028-076-000		2
G	6100-044-006		2
H	0016-028-000		4
J	0004-161-000		2
K	0004-232-000		2
L	6372-010-016		1
M	0025-079-000		4
N	0014-067-000		4
P	0025-031-000		4
R	6060-090-004		1
S	6100-090-013		1
T	6100-044-013		1
V	6100-044-004		1
W	0045-999-603		2
X	6100-044-014		3

English Equivalence Part Number: 6500-209-001 REV A

UNITED STATES
Stryker Medical
3800 E. Centre Ave.,
Portage, Michigan USA
49002

EC	REP
----	-----

European Representative
Stryker France
ZAC Satolas Green Pusignan
Av. De Satolas Green
69881 MEYZIEU Cedex
France

stryker[®]