

Power-PRO™ XT

Model 6500

# stryker®

## Operations/Maintenance Manual



For parts or technical assistance:  
USA: 1-800-327-0770 (option 2)

CE



# Table of Contents

---

Symbols and Definitions . . . . .	7
Symbols . . . . .	7
Warning/Caution/Note Definition . . . . .	8
Introduction . . . . .	9
Product Description . . . . .	9
Intended Use of Product. . . . .	9
Specifications . . . . .	10
Contact Information . . . . .	12
Serial Number Location . . . . .	12
Product Illustration . . . . .	13
Summary of Safety Precautions . . . . .	14
Pinch Points . . . . .	19
Setup Procedures. . . . .	20
Setting Cot Load Height and “Jog” Function . . . . .	21
Product Inspection . . . . .	22
Cot Fastener Installation . . . . .	24
Installing the In-Fastener Shut-Off . . . . .	26
Vehicle Safety Hook Selection . . . . .	27
Vehicle Safety Hook Installation . . . . .	28
Vehicle Configuration . . . . .	28
Required Hardware for Installation of the Safety Hook (Not Supplied) . . . . .	28
Front to Back Positioning of the Safety Hook . . . . .	29
Side to Side Positioning of the Safety Hook . . . . .	30
Installing the Safety Hook. . . . .	30
Operation Guide . . . . .	31
Operating Guidelines . . . . .	31
Proper Lifting Techniques. . . . .	31
Transferring the Patient to the Cot . . . . .	32
Rolling the Cot. . . . .	32
Adjusting The Height of the Cot with Two Operators . . . . .	33
Loading the Cot into a Vehicle with Two Operators - Powered Method. . . . .	34
Loading the Cot into a Vehicle with Two Operators at the Foot End - Powered Method. . . . .	35
High Speed Retract/Extend . . . . .	35
Loading an Empty Cot into a Vehicle with One Operator - Powered Method. . . . .	36
Unloading the Cot from a Vehicle with Two Operators - Powered Method . . . . .	37
Unloading an Empty Cot from a Vehicle with One Operator - Powered Method . . . . .	38
Using the Manual Override. . . . .	39
Loading the Cot into a Vehicle with Two Operators - Manual Method. . . . .	40
Unloading the Cot from a Vehicle with Two Operators - Manual Method . . . . .	41
Unloading an Empty Cot from a Vehicle with One Operator - Manual Method . . . . .	42
Using Additional Assistance . . . . .	43
Removing and Replacing the Battery . . . . .	44
Removing and Replacing a SMRT Pak . . . . .	44
Removing and Replacing a DEWALT® BATTERY . . . . .	45

# Table of Contents

---

Using the Battery Power Indicator . . . . .	<a href="#">46</a>
Using the Hour Meter . . . . .	<a href="#">47</a>
Using Restraint Straps . . . . .	<a href="#">48</a>
Using the Optional Restraint Belt Extension . . . . .	<a href="#">50</a>
Operating the Siderails. . . . .	<a href="#">51</a>
Operating the Backrest . . . . .	<a href="#">51</a>
Operating the Retractable Head Section . . . . .	<a href="#">52</a>
Adjusting the Footrest . . . . .	<a href="#">53</a>
Raising and Lowering the Optional Gatch . . . . .	<a href="#">54</a>
Operating the Optional Wheel Lock(s) . . . . .	<a href="#">55</a>
Operating the Optional 2-Stage I.V. Pole . . . . .	<a href="#">56</a>
Operating the Optional 3-Stage I.V. Pole . . . . .	<a href="#">57</a>
Optional Accessories . . . . .	<a href="#">58</a>
Using the Equipment Hook . . . . .	<a href="#">59</a>
Using the Retractable Head Section Oxygen Bottle Holder . . . . .	<a href="#">60</a>
Attaching the Pedi-Mate® Infant Restraint System . . . . .	<a href="#">61</a>
Using the Transfer Flat. . . . .	<a href="#">63</a>
Installing the Backrest Storage Pouch. . . . .	<a href="#">63</a>
Installing the Head End Storage Flat. . . . .	<a href="#">64</a>
Cleaning. . . . .	<a href="#">65</a>
Washing Procedure . . . . .	<a href="#">65</a>
Washing Limitations . . . . .	<a href="#">65</a>
Removal of Iodine Compounds . . . . .	<a href="#">66</a>
Preventative Maintenance . . . . .	<a href="#">67</a>
Lubrication. . . . .	<a href="#">67</a>
Regular Inspection and Adjustments . . . . .	<a href="#">68</a>
Maintenance Record . . . . .	<a href="#">71</a>
Training Record . . . . .	<a href="#">72</a>
Troubleshooting Guide . . . . .	<a href="#">73</a>
Electronics and Hydraulics Locator . . . . .	<a href="#">73</a>
Hydraulic Manifold Components Locator . . . . .	<a href="#">74</a>
Electrical System Block Diagram . . . . .	<a href="#">75</a>
Troubleshooting Guide . . . . .	<a href="#">77</a>
Main Cable Assembly . . . . .	<a href="#">80</a>
Electronics Assembly . . . . .	<a href="#">80</a>
Electronics Assembly Wiring Schematics . . . . .	<a href="#">81</a>
Quick Reference Replacement Parts List . . . . .	<a href="#">82</a>
Service Information. . . . .	<a href="#">85</a>
Manual Release Cable Adjustment . . . . .	<a href="#">85</a>
Filling the Reservoir . . . . .	<a href="#">85</a>
Wheel Locking Force Adjustment . . . . .	<a href="#">86</a>
Cot Retaining Post Adjustment . . . . .	<a href="#">86</a>
Cot Assembly . . . . .	<a href="#">87</a>
Base Assembly . . . . .	<a href="#">94</a>

# Table of Contents

---

Outer Lift Tube Assembly, Base Pivot - 6500-301-021 . . . . .	<a href="#">99</a>
Inner Lift Tube Assembly, Base Pivot - 6500-301-022 . . . . .	<a href="#">100</a>
Inner Lift Tube, Litter Pivot - 6500-001-034 . . . . .	<a href="#">101</a>
Inner Lift Tube, Litter Pivot - 6500-001-035 . . . . .	<a href="#">102</a>
Outer Rail, Patient Right Assembly . . . . .	<a href="#">104</a>
Outer Rail, Patient Left Assembly . . . . .	<a href="#">106</a>
Hall Sensor Assembly. . . . .	<a href="#">108</a>
Sensor Housing Assembly. . . . .	<a href="#">109</a>
Powerplant Assembly . . . . .	<a href="#">110</a>
Hydraulic Sub-Assembly - 6500-001-030. . . . .	<a href="#">112</a>
Foot End Assembly. . . . .	<a href="#">113</a>
Trend - 6085-031-000. . . . .	<a href="#">117</a>
Trend Assembly . . . . .	<a href="#">118</a>
Optional Gatch - 6500-082-000 . . . . .	<a href="#">119</a>
Optional Gatch Assembly . . . . .	<a href="#">120</a>
Optional Gatch Support Assembly. . . . .	<a href="#">123</a>
Switch Assembly - 6500-001-016 . . . . .	<a href="#">124</a>
Fowler Assembly . . . . .	<a href="#">125</a>
Head Section Assembly - 6085-001-037 . . . . .	<a href="#">126</a>
Head Section Lock Assembly - 6500-001-026 . . . . .	<a href="#">128</a>
In-Fastener Shut-Off Assembly - 6500-001-027. . . . .	<a href="#">129</a>
Optional Retract. Head Sect. Oxygen Bottle Holder - 6085-046-000 . . . . .	<a href="#">130</a>
Optional Oxygen Bottle Holder Assembly - 6500-001-040 . . . . .	<a href="#">131</a>
Optional Head End Oxygen Bottle Holder - 6500-141-000 . . . . .	<a href="#">132</a>
Two-Stage I.V. Pole Assembly Patient Right - 6500-210-000. . . . .	<a href="#">133</a>
Three-Stage I.V. Pole Assembly Patient Right - 6500-215-000 . . . . .	<a href="#">133</a>
Two-Stage I.V. Pole Assembly Patient Right - 6500-001-041. . . . .	<a href="#">134</a>
Three-Stage I.V. Pole Assembly Patient Right - 6500-001-043 . . . . .	<a href="#">135</a>
Two-Stage I.V. Pole Assembly Patient Left - 6500-211-000 . . . . .	<a href="#">136</a>
Three-Stage I.V. Pole Assembly Patient Left - 6500-216-000 . . . . .	<a href="#">136</a>
Two-Stage I.V. Pole Assembly Patient Left - 6500-001-042. . . . .	<a href="#">137</a>
Three-Stage I.V. Pole Assembly Patient Left - 6500-001-044 . . . . .	<a href="#">138</a>
Two-Stage I.V. Pole Assembly, Dual - 6500-212-000 . . . . .	<a href="#">139</a>
Three Stage I.V. Pole Assembly, Dual - 6500-217-000 . . . . .	<a href="#">139</a>
Optional Head Extension Assembly - 6100-044-012. . . . .	<a href="#">140</a>
Label, SMRT Power . . . . .	<a href="#">141</a>
Label, DeWALT® . . . . .	<a href="#">142</a>
Optional Accessories . . . . .	<a href="#">143</a>
Equipment Hook - 6500-147-000 . . . . .	<a href="#">144</a>
Oxygen Bottle Holder - 6500-140-000 . . . . .	<a href="#">145</a>
Removable Oxygen Bottle Holder - 6080-140-000 . . . . .	<a href="#">146</a>
Head Extension - 6100-044-000 . . . . .	<a href="#">147</a>
Transfer Flat - 6083-001-200 . . . . .	<a href="#">148</a>
Optional Defibrillator Platform - 6500-170-000. . . . .	<a href="#">149</a>

# Table of Contents

---

Backrest Pouch - 6500-130-000 . . . . . [150](#)

Head End Storage Flat - 6500-128-000 . . . . . [151](#)

Recycling Passport. . . . . [152](#)

EMC Information. . . . . [159](#)

Warranty . . . . . [163](#)

    Stryker EMS Return Policy . . . . . [164](#)

    Return Authorization. . . . . [164](#)









    Damaged Merchandise . . . . . [164](#)

    International Warranty Clause. . . . . [164](#)

    Patent Information . . . . . [164](#)

# Symbols and Definitions

## SYMBOLS

	Warning, consult accompanying documentation
	Safe Working Load Symbol
	Dangerous Voltage Symbol
	Pinch Point
	Extend
	Retract
	Type B Equipment: equipment providing a particular degree of protection against electric shock, particularly regarding allowable leakage current and reliability of the protective earth connection.  Internally Powered Equipment: Equipment able to operate from an internal (removable) electric power source.  Mode of Operation: 16.7% (1 Min. On / 5 Min. Off)
<b>IPX6</b>	Protection from powerful jets of water
	Medical Equipment Classified by Underwriters Laboratories Inc. With Respect to Electric Shock, Fire, and Mechanical Hazards Only in Accordance with UL 60601-1, and CAN/CSA C22.2 No. 601.1.
	In accordance with European Directive 2002/96/EC on Waste Electrical and Electronic Equipment, this symbol indicates that the product must not be disposed of as unsorted municipal waste, but should be collected separately. Refer to your local distributor for return and/or collection systems available in your country.

# Symbols and Definitions

---

## WARNING/CAUTION/NOTE DEFINITION

The words **WARNING**, **CAUTION** and **NOTE** carry special meanings and should be carefully reviewed.

---

### **WARNING**

Alerts the reader about a situation, which if not avoided, could result in death or serious injury. It may also describe potential serious adverse reactions and safety hazards.

---

### **CAUTION**

Alerts the reader of a potentially hazardous situation, which if not avoided, may result in minor or moderate injury to the user or patient or damage to the equipment or other property. This includes special care necessary for the safe and effective use of the device and the care necessary to avoid damage to a device that may occur as a result of use or misuse.

---

### **NOTE**

This provides special information to make maintenance easier or important instructions clearer.



# Introduction

---

This manual is designed to assist you with the operation and maintenance of the Power-PRO™ XT Cot. Carefully read this manual thoroughly before using the equipment or beginning maintenance on it. To ensure safe operation of this equipment, it is recommended that methods and procedures be established for educating and training staff on the safe operation of this cot.

## **PRODUCT DESCRIPTION**

The model 6500 Power-PRO™ XT powered cot reduces manual lifting. The battery-powered hydraulic system raises and lowers the patient with the touch of a button and the retractable head section shortens the cot for 360-degree mobility in any height position.

## **INTENDED USE OF PRODUCT**

The model 6500 Power-PRO™ XT powered cot is intended to be used as a powered emergency cot.

# Introduction

## SPECIFICATIONS

	<p>Safe Working Load  <b>Note:</b> Safe Working Load indicates the sum of the patient, mattress and accessory weight.</p>	700 pounds	318 kg
Maximum Unassisted Lift Capacity		500 pounds	225 kg
Backrest Articulation/Shock Position		0° to 73° / +15°	
Overall Length/Minimum Length/Width		81" / 63" / 23"	206 cm / 160 cm / 58 cm
Height <sup>1</sup>		Adjustable from 14" to 41.5"	Adjustable from 36 cm to 105 cm
Weight <sup>2</sup>		125 pounds	57 kg
Caster Diameter/Width		6" / 2"	15 cm / 5 cm
Minimum Operators Required for Loading/ Unloading an Occupied Cot		2	
Minimum Operators Required for Loading/ Unloading an Unoccupied Cot		1	
Recommended Fastener Systems		Model 6370 or 6377 Floor Mount Type Model 6371 Wall Mount Type	
Recommended Loading Height <sup>3</sup>		Up to 36"	Up to 91 cm
Roll-In Style		Yes	
Single Wheel Lock / Double Wheel Lock		Optional	
Hydraulic Oil		Stryker Part Number 6500-001-293	
Power System <sup>4</sup>			
- Battery		24V DC NiCd - SMRT™ Power System 24V DC NiCd - DeWALT® Battery System	
- Charger		120V/240Vac or 12V DC - SMRT™ Power System 110V/220Vac or 12V DC - DeWALT® Battery System	
Standards (Cots and Chargers)		IEC 60601-1 CAN/CSA-C22.2 No. 601.1-M90 UL 60601-1 IEC 60601-1-2:2001 KKK-A-1822	

<sup>1</sup> Height measured from bottom of mattress at seat section to ground level.

<sup>2</sup> Cot is weighed with 1 battery and without mattress and restraints.

<sup>3</sup> Cot may be set to any ambulance deck height ranging from 26" to 36" (66 cm to 91 cm).

<sup>4</sup> Cot is compatible with the SMRT™ Power System and DeWALT® Battery System.

Stryker reserves the right to change specifications without notice.

The Power-PRO™ XT is designed to conform to the Federal Specification for the Star-of-Life Ambulance (KKK-A-1822).

The Power-PRO™ XT is designed to be compatible with competitive cot fastener systems.

DeWALT® is a registered trademark of Black & Decker Inc.



Patents pending.

**The yellow and black color scheme is a proprietary trademark of Stryker Corporation.**

# Introduction

---

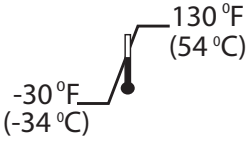
## SPECIFICATIONS (CONTINUED)

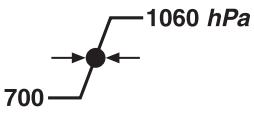
Environmental Conditions	Operation
Temperature	 A diagram showing a temperature range from -30°F (-34°C) to 130°F (54°C). The values are connected by a jagged line, with a thermometer icon in the center.
Relative Humidity	 A diagram showing a relative humidity range from 0% to 100%. The values are connected by a jagged line, with a water droplet icon in the center.
Atmospheric Pressure	 A diagram showing an atmospheric pressure range from 700 to 1060 hPa. The values are connected by a jagged line, with a central dot and arrows pointing outwards.

# Introduction

## CONTACT INFORMATION

Contact Stryker Customer Service or Technical Support at: (800) 327-0770 or (269) 324-6500.

Stryker Medical  
3800 E. Centre Avenue  
Portage, MI 49002  
USA

Please have the serial number (A) of your Stryker product available (as shown in Figure 1) when calling Stryker Customer Service or Technical Support. Include the serial number in all written communication.

## SERIAL NUMBER LOCATION

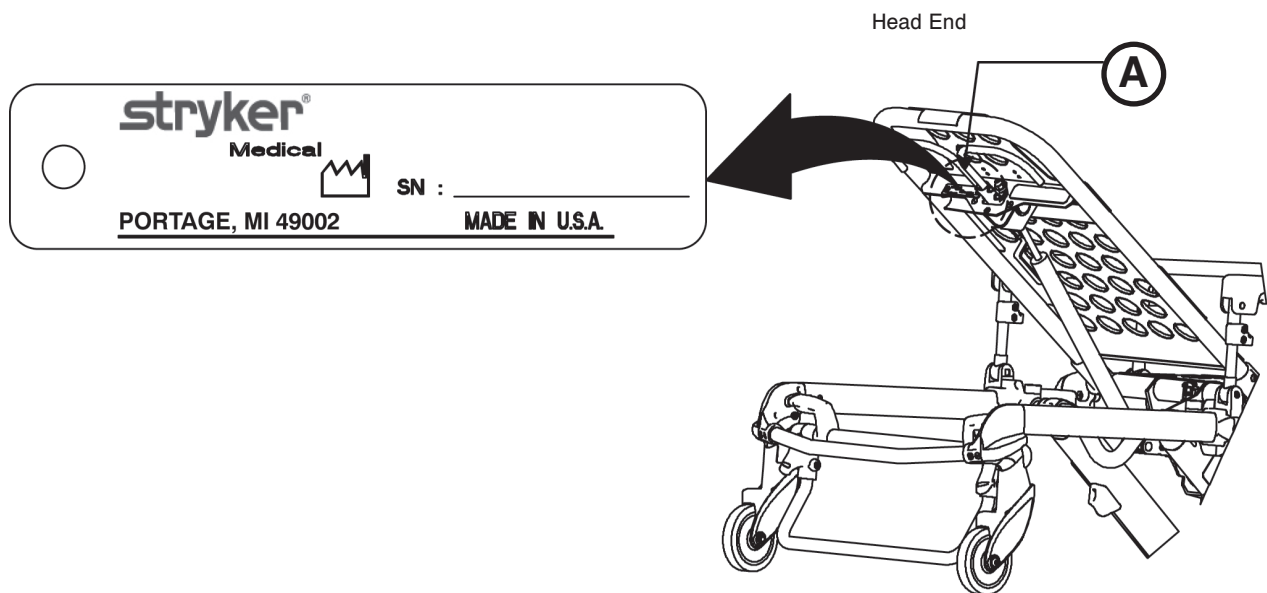
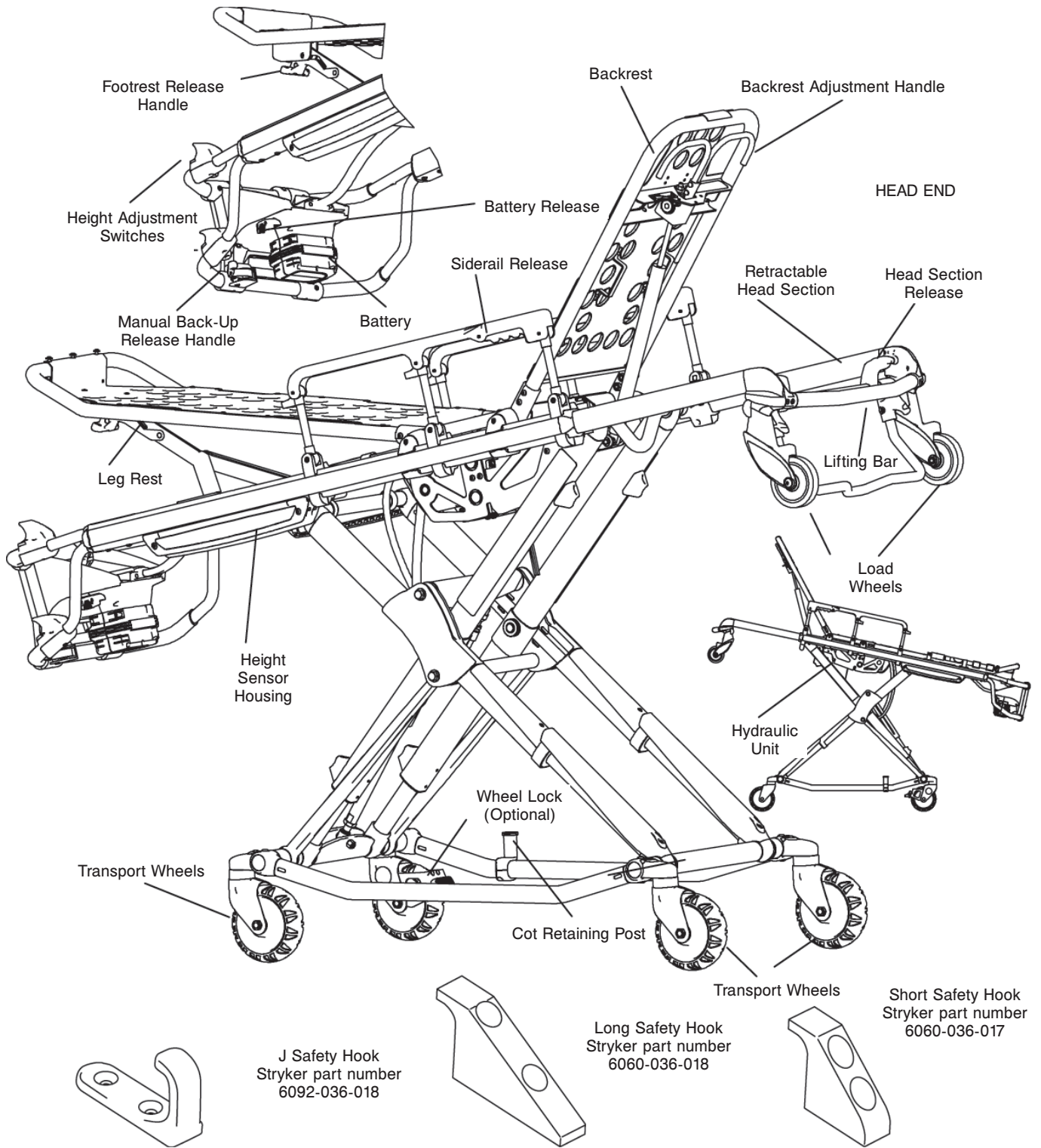

Figure 1: Cot Serial Number & Location

# Introduction

## PRODUCT ILLUSTRATION



**Figure 2: Cot Components**

[Return To Table of Contents](#)

# Summary of Safety Precautions

---

Carefully read and strictly follow the warnings and cautions listed on these pages. Service only by qualified personnel.

---

## WARNING

- Improper usage of the cot can cause injury to the patient or operator. Operate the cot only as described in this manual.
  - Do not modify the cot or any components of the cot. Modifying the product can cause unpredictable operation resulting in injury to the patient or operator. Modifying the product also voids its warranty (see [page 163](#)).
  - Any emergency vehicle to be used with this cot **must** have the in-fastener shut-off system installed (see [page 26](#)).
  - It is the responsibility of the cot operator to ensure that the cot being used in the Stryker Cot Fastener Systems meets the installation specifications listed on [page 25](#). Injury may result if a non-compatible cot is used in the Stryker Fastener System.
  - The in-fastener shut-off must be positioned properly before placing the cot into service. Failure to install the in-fastener shut-off may cause injury to the patient or operator and/or damage to the vehicle.
  - Do not attempt to operate the cot when it is loaded into a cot fastener.
  - The in-fastener shut-off is **only** a means for disabling the electronic functionality. Damage to the product and/or injury to the patient and/or operator may occur if used for any other purpose.
  - Have the vehicle safety hook installed by a certified mechanic. Improper safety hook installation can cause injury to the patient or operator and/or damage to the cot.
  - Failure to install the safety hook can cause injury to the patient or operator. Install and use the safety hook as described on [page 28](#).
  - The face of the safety hook that engages the safety bar should be located at least 3-3/4" from the leading edge of the door sill. After installation, verify that the cot legs lock into the load position without contacting the vehicle bumper.
  - To avoid injury, verify that the safety bar has engaged the safety hook before removing the cot from the patient compartment.
  - Verify that the safety hook always engages the cot safety bar regardless of how the cot is unloaded from the vehicle or injury to the patient or operator and/or damage to the cot may occur.
  - The cot must have at least 5/8" of clearance between the vehicle bumper and the cot to disengage the safety bar when unloading the cot from the vehicle. Verify that the cot legs lock into the load position before disengaging the safety bar from the safety hook. Failure to properly lock the cot into position can cause injury to the patient or operator and/or damage to the cot.
  - Entanglement in powered cot mechanisms can cause serious injury. Operate the cot only when all persons are clear of the mechanisms.
  - Practice changing height positions and loading the cot until operation of the product is fully understood. Improper use can cause injury.
  - Do not allow untrained assistants to assist in the operation of the cot. Untrained technicians/assistants can cause injury to the patient or themselves.
  - Ensure proper hand placement on hand grips. Hands should be clear of red safety bar pivots while loading and unloading the cot.
  - Do not ride on the base of the cot. Damage to the product could occur, resulting in injury to the patient or operator.
  - Transporting the cot sideways can cause the cot to tip, resulting in possible damage to the product and/or injury to the patient or operator. Transporting the cot in a lowered position, head or foot end first, minimizes the potential of a cot tip.
  - Grasping the cot improperly can cause injury. Keep hands, fingers and feet away from moving parts. To avoid injury, use extreme caution when placing your hands and feet near the base tubes while raising and lowering the cot.
  - Always use all restraint straps to secure the patient on the cot. An unrestrained patient may fall from the cot and be injured.
  - Never leave a patient unattended on the cot or injury could result. Hold the cot securely while a patient is on the product.
  - Never apply the optional wheel lock(s) while a patient is on the cot. Tipping could occur if the cot is moved while the wheel lock is applied, resulting in injury to the patient or operator and/or damage to the cot.
  - Siderails are not intended to serve as a patient restraint device. See [page 48](#) for proper restraint strap usage. Failure to utilize the siderails properly could result in patient injury.
-

# Summary of Safety Precautions

---

## WARNING (CONTINUED)

- Hydraulically raising or lowering the cot may temporarily affect electronic patient monitoring equipment. For best results, patient monitoring should be conducted when the cot is idle. High obstacles such as curbing, steps or rough terrain can cause the cot to tip, possibly causing injury to the patient or operator.
- Transporting the cot in lower positions reduces the potential of a cot tip. If possible, obtain additional assistance or take an alternate route.
- Two operators must be present when the cot is occupied.
- Operators must be able to lift the total weight of the patient, cot and any items on the cot.
- The higher an operator must lift the cot, the more difficult it becomes to hold the weight. An operator may need help loading the cot if he/she is too short or if the patient is too heavy to lift safely. The operator must be able to lift the cot high enough for the cot legs to unfold completely and lock when the cot is unloaded. A shorter operator needs to raise their arms higher to enable the undercarriage to unfold.
- There must be a safety hook properly installed in the vehicle so that the bumper does not interfere with the front legs of the base frame.
- When using a standard cot fastener, do not load the cot into the vehicle with the head section retracted. Loading the cot with the head section retracted may cause the product to tip or not engage properly in the cot fastener, possibly causing injury to the patient or operator and/or damage to the cot.
- Whenever the weight of the cot and patient is off of the wheels, the cot will **automatically** enter the high speed retract mode if the retract (-) button is pressed.
- Once the weight is off of the ground, the operator(s) must support the load of the patient, cot and any accessories. Failure to support the load properly may cause injury to the patient or operator.
- The one person loading and unloading procedures are for use only with an empty cot. Do not use the procedures when loading/unloading a patient. Injury to the patient or operator could result.
- Do not pull or lift on the safety bar when unloading the cot. Damage to the safety bar could result and injury to the patient or operator could occur.
- Do not press the extend (+) button until the safety bar has engaged the safety hook.
- To avoid risk of electric shock, never attempt to open the battery pack for any reason. If the battery pack case is cracked or damaged, do not insert it into the charger. Return damaged battery packs to a service center for recycling.
- Do not remove the battery when the cot is activated.
- Avoid direct contact with a wet battery or battery enclosure. Contact may cause injury to the patient or operator.
- Do not attach restraints to the base or cross tubes, improper restraint attachment could result in damage to the cot further resulting in injury to the patient or operator.
- Siderails are not intended to serve as a patient restraint device. See [page 48](#) for proper restraint strap usage. Failure to utilize the siderails properly could result in patient injury.
- To avoid injury, always verify that the head section is locked into place prior to operating the cot.
- Never install or use a wheel lock on a cot with excessively worn wheels. Installing or using a wheel lock on a wheel with less than a 6" diameter could compromise the holding ability of the wheel lock, possibly resulting in injury to the patient or operator and/or damage to the cot or other equipment.
- If the cot is equipped with the optional retractable head section oxygen bottle holder, use caution while the oxygen bottle holder is installed to avoid pinching your fingers between the fowler bracket and the oxygen bottle.
- To avoid accidental release of the Pedi-Mate®, and possible injury to the infant, ensure that the restraint buckle is located away from obstructions on the cot or accessories.
- When the optional head end storage flat is being used, ensure that it does not interfere with the operation of the retractable head section, safety bar and safety hook. Injury to the patient or operator could result.
- Use any appropriate personal safety equipment (goggles, respirator, etc.) to avoid the risk of inhaling contagion. Use of power washing equipment can aerate contamination collected during the use of the cot.
- **SOME CLEANING PRODUCTS ARE CORROSIVE IN NATURE AND MAY CAUSE DAMAGE TO THE PRODUCT IF USED IMPROPERLY.** If the products described above are used to clean Stryker EMS equipment, measures must be taken to insure the cots are wiped with clean water and thoroughly dried following cleaning. Failure to properly rinse and dry the cots will leave a corrosive residue on the surface of the cots, possibly causing premature corrosion of critical components.

# Summary of Safety Precautions

---

## WARNING (CONTINUED)

- Failure to properly clean or dispose of contaminated mattress or other cot components will increase the risk of bloodborne pathogens and may cause injury to the patient or operator.
  - Escaping fluid under pressure can penetrate the skin causing serious injury. Avoid the hazard by relieving pressure before disconnecting hydraulic or other lines. Tighten all connections before applying pressure. If an accident occurs, see a doctor immediately. Any fluid injected into the skin must be surgically removed within a few hours or gangrene may result. Doctors unfamiliar with this type of injury should reference a knowledgeable medical source.
  - To avoid the risk of injury, do not use bare hands to check for hydraulic leaks.
- 

## CAUTION

- The cot can be set at any cot load height position. Establish the required cot load height before placing the cot into service.
  - When charging a battery in an ambulance, locate the charger in an enclosed cabinet and out of patient reach during transport.
  - Set the cot load height to the proper stop height prior to operation.
  - Installation of the safety hook should be done by a certified mechanic familiar with ambulance vehicle construction. Consult the vehicle manufacturer before installing the safety hook and be sure that the installation of the safety hook does not damage or interfere with the brake lines, oxygen lines, fuel lines, fuel tank or electrical wiring of the vehicle.
  - Before operating the cot, clear any obstacles that may interfere and cause injury to the operator or patient.
  - Do not “jog” the cot past the established cot load height of the product when the safety bar engages the vehicle safety hook or damage may occur to the product.
  - When unloading the cot from the patient compartment, ensure that the caster wheels are safely set on the ground or damage to the product may occur.
  - Do not “jog” the cot past the load height while the safety bar is engaged.
  - Remove the battery if the cot is not going to be used for an extended period of time (more than 24 hours).
  - Only use the battery and charger as specified.
  - The cot is not for use with an AC adapter.
  - Ensure that the battery is fully charged prior to placing into service. An uncharged or depleted battery may cause poor cot performance.
  - Ensure that the restraints are not entangled in the base frame when raising and lowering the cot.
  - Wheel lock(s) are only intended to help prevent the cot from rolling while unattended and to aid in patient transfer. A wheel lock may not provide sufficient resistance on all surfaces or under loads.
  - To avoid damage to the I.V. pole, the weight of the I.V. bags or equipment must not exceed 40 pounds (18 kg).
  - To avoid damage to the equipment hook, the weight of the accessories or equipment must not exceed 35 pounds (15.9 kg).
  - To avoid damage to the retractable head section oxygen bottle holder (if equipped), the weight of the equipment must not exceed 40 pounds (18 kg).
  - Do not use two head end oxygen bottle holders at the same time.
  - Do not store items under the cot mattress. Storing items under the mattress can interfere with the operation of the cot.
  - The weight of the equipment in the pocketed backrest storage pouch (if equipped) must not exceed 20 pounds (9 kg).
  - The weight of the equipment in the head end storage flat (if equipped) must not exceed 40 pounds (18 kg).
  - DO NOT STEAM CLEAN OR ULTRASONICALLY CLEAN THE UNIT.
  - Maximum water temperature should not exceed 180°F/82°C.
  - Maximum air dry temperature (cart washers) should not exceed 240°F/115°C.
  - Maximum water pressure should not exceed 1500 psi/130.5 bar. If a hand held wand is being used to wash the unit, the pressure nozzle must be kept a minimum of 24 inches (61 cm) from the unit.
  - Towel dry all casters and interface points.
  - Failure to comply with these instructions may invalidate any/all warranties.
  - Always remove the battery before washing the cot.
-



# Summary of Safety Precautions

---

## CAUTION (CONTINUED)

- A preventative maintenance program should be established for all Stryker EMS equipment. Preventative maintenance may need to be performed more frequently based on the usage level of the product. Close attention should be given to safety features including, but not limited to:
    - Hydraulic power mechanism
    - All electrical controls return to off or neutral position when released.For additional maintenance information, see the preventative maintenance information.
  - Improper maintenance can cause injury or damage to the product. Maintain the cot as described in this manual. Use only Stryker approved parts and maintenance procedures. Using unapproved parts and procedures could cause unpredictable operation and/or injury and will void the product warranty (see [page 163](#)).
  - Failure to use authorized parts, lubricants, etc. could cause damage to the cot and will void the warranty of the product.
  - Hydraulic lines, hoses, and connections can fail or loosen due to physical damage, kinks, age, and exposure. Check hoses and lines regularly to avoid damage to the cot. Check and tighten loose connections.
  - Do not tip the cot onto its load wheels and actuate the product as this will allow air to enter the hydraulic system.
  - Do not lubricate the bearings in the X-frame as it will degrade the performance of the cot and may void its warranty (see [page 163](#)).
  - The cot retaining post comes preconfigured for an X-frame cot, if the fastener has been configured for an H-frame style cot, the cot retaining post must be adjusted to accommodate the fastener.
-

# Summary of Safety Precautions

---

## NOTE

- Loose items or debris on the patient compartment floor can interfere with the operation of the safety hook and cot fastener. Keep the patient compartment floor clear.
- This manual should be considered a permanent part of the cot and should remain with the product even if the cot is subsequently sold.
- Stryker continually seeks advancements in product design and quality. Therefore, while this manual contains the most current product information available at the time of printing, there may be minor discrepancies between your cot and this manual. If you have any questions, please contact Stryker Customer Service or Technical Support at (800) 327-0770 or (269) 324-6500.
- Adjustment of the rail clamp assembly may be required in order to compensate for any variation in the cot retaining post position depending on the cot manufacturer and model number.
- When replacing an existing safety hook with a new style, adjust the mounting location to maintain the proper position of the safety hook face.
- Stryker recommends that, prior to installation, the certified mechanic plan the placement of the safety hook in the rear of the vehicle.
- If the extend (+) button on the control switch remains activated after reaching the set load height, the motor will remain halted until the operator releases the button. Once the button is released, press the extend (+) button again to “jog” the cot height up further.
- The operators must lift the cot weight slightly off of the wheels to use the manual extend or retract while a patient is on the cot.
- Activation of the manual back-up release handle may cause the cot to lower slowly if less than 40 pounds (18 kg) are on the cot.
- Hydraulic fluid will become more viscous when the cot is used for extended periods in cold temperatures. When using the manual back-up release function to extend the base during unloading in cold weather conditions, hold the release handle for approximately one second after the cot wheels touch the ground to minimize sagging of the litter as the cot is removed from the ambulance.
- When operating the manual back-up release handle, avoid rapid lifting or lowering of the base or movement may appear sluggish; lift with a slow constant motion.
- Batteries slowly lose power when not on the charger.
- Inspect the straps and clips for wear between use and replace the strap if it is no longer holding the oxygen bottle.
- These are general instructions for installation of the Pedi-Mate®. Safe and proper use of the Pedi-Mate® is solely at the discretion of the user. Stryker recommends that all users be trained on the proper use of the Pedi-Mate® before using it in an actual situation. Retain these instructions for future reference. Include them with the product in the event of transfer to new users.
- Failure to follow the cleaning directions when using the specified types of cleaners may void this product’s warranty (see [page 163](#)).
- If the arrow on the bottom bracket of the retaining post points toward the head end of the cot, the retaining post is set for an X-frame style cot. If the arrow points toward the foot end of the cot the post is set for an H-frame style cot.

# Summary of Safety Precautions

## PINCH POINTS

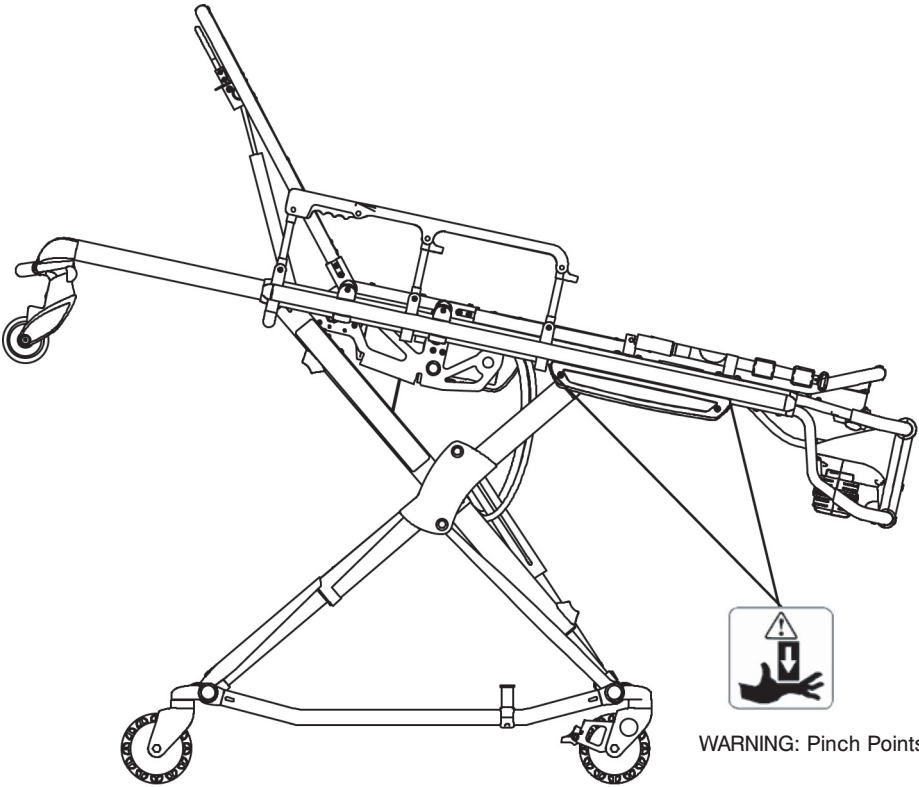

Figure 3: Potential Pinch Points

# Setup Procedures

---

**Ensure that all shipping and packaging materials have been removed from the product(s) prior to use.**

Unpack the cartons and check all items for proper operation. It is important that the cot is working properly before it is put into service. Have a qualified service technician use the Product Inspection checklist on [page 22](#) and the operation instructions to check the cot before it is put into service. See Figure 2 on [page 13](#) to identify all of the cot components.

The patient compartment of the vehicle in which the cot will be used must have a:

- Smooth rear edge for cot loading.
- Level floor large enough for the folded cot.
- Stryker Model 6370/6377/6378/6379 or 6371 Cot Fastener System (not included).
- In-fastener shut-off module installed and positioned properly (see [page 26](#)).
- Space to properly install the safety hook.

**Note:** Loose items or debris on the patient compartment floor can interfere with the operation of the safety hook and cot fastener. Keep the patient compartment floor clear.

When necessary, modify the vehicle to fit the cot. Do not modify the cot.

---

## **WARNING**

- Improper usage of the cot can cause injury to the patient or operator. Operate the cot only as described in this manual.
- Do not modify the cot or any components of the cot. Modifying the product can cause unpredictable operation resulting in injury to the patient or operator. Modifying the product also voids its warranty (see [page 163](#)).
- Any emergency vehicle to be used with this cot **must** have the in-fastener shut-off system installed (see [page 26](#)).

---

## **Note:**

- This manual should be considered a permanent part of the cot and should remain with the product even if the cot is subsequently sold.
- Stryker continually seeks advancements in product design and quality. Therefore, while this manual contains the most current product information available at the time of printing, there may be minor discrepancies between your cot and this manual. If you have any questions, please contact Stryker Customer Service or Technical Support at (800) 327-0770 or (269) 324-6500.

# Setup Procedures

## SETTING COT LOAD HEIGHT AND “JOG” FUNCTION

The cot control mechanism uses height sensors to set the load height stop for the cot. These height sensors match the load wheel height for a specific ambulance deck height.

The cot load height can be set from 26" to 36" (66 cm to 91,4 cm), measured from the ground to the bottom of the load wheel. Determine the cot load height before placing the cot into service. You can modify the cot load height at any time, but you must determine and set the cot load height before the cot is placed into service.

### To set the cot load height:

1. Locate the sensor housing on the patient right side of the cot as shown in Figure 4.1.
2. Using a T27 Torx wrench, remove the sensor housing cover by loosening the two (2) screws (one on each end) as shown in Figure 4.2.
3. Adjust the left height sensor only as shown in Figure 4.3.
  - a. Move the sensor to the left to increase the set load height or move the sensor to the right to decrease the set load height.
  - b. Press the retract (-) button to lower the cot to its lowest position, then press the extend (+) button to raise the cot to its highest position.
  - c. Measure the cot height from the bottom of the load wheels to the floor.  
**Note:** Add an additional 1/2" (1,3 cm) to your deck height measurement to allow for variations with patient height and other equipment added to the cot.
  - d. Repeat steps 3a and 3b until the desired cot load height is reached.
4. After the proper load wheel height is set, ensure that all of the height sensor cables are secure and lying flat inside of the housing between the sensors as shown in Figure 4.4.
5. Using a T27 Torx wrench, replace the sensor housing cover by reinstalling the two screws that were removed in step 2.
6. Following completion of the sensor height adjustment, verify that the cot properly engages the safety hook.



Figure 4.1: Sensor Housing



Figure 4.2: Loosening Screws



Figure 4.3: Adjusting Height



Figure 4.4: Securing Cables

### CAUTION

The cot can be set at any cot load height position. Establish the required cot load height before placing the cot into service.

[Return To Table of Contents](#)

# Product Inspection

The condition of the cot is the responsibility of the owner. It is important that the cot is working properly before the product is put into service. Have a qualified service technician use the following list and the operation instructions to check the cot before the product is put into service.

The battery must be charged prior to checking the features and condition of the cot.

Item	Routine
Battery	Unpack batteries and charger
	Charge battery according to SMRT Power System instructions (6500-009-101) or DeWALT® Battery System instructions

The power indicator LED, located at the foot end control enclosure of the cot, is solid green when the battery is fully charged or has adequately charged battery power.

## CAUTION

When charging a battery in an ambulance, locate the charger in an enclosed cabinet and out of patient reach during transport.

After the battery is fully charged, inspect the cot for the following points:

Item	Routine	Page
Battery	Charge spare battery (if necessary) according to SMRT Pak or DeWALT® battery instructions	
	Install battery into foot end enclosure - power indicator LED operates	<a href="#">44</a>
	Ensure that the battery remains firmly secured	<a href="#">44</a>
	Release and remove battery from foot end enclosure	<a href="#">44</a>
	Reinstall battery into foot end enclosure	<a href="#">44</a>
Hydraulics	Inspect motor mount - all fasteners secure	<a href="#">73</a>
	Check cylinder attachments at both ends - all fasteners secure	<a href="#">73</a>
	Inspect main cable - all connections secure	<a href="#">73</a>
	Inspect hoses and cylinder seal for leaks	<a href="#">73</a>
Electronic Controls	Check power indicator LED - charged	<a href="#">46</a>
	Extend cot to raised position	<a href="#">33</a>
	Verify "jog" function operates smoothly	<a href="#">33</a>
	Lower to retracted position - cot secures in a mid-height position (motor does not operate)	<a href="#">33</a>
	Determine and set ambulance vehicle load height	<a href="#">21</a>
	Check high speed retract	<a href="#">35</a>
	Extend cot to full height - no drift	<a href="#">33</a>
Manual Back-up Release	Verify the manual back-up release handle functions properly - adjust accordingly	<a href="#">39</a>
	With the cot empty, check the raise/lower function	<a href="#">39</a>
	With the cot loaded with a minimum of 99 pounds (45 kg), check the raise/lower function	<a href="#">39</a>
	With the cot loaded with a minimum of 99 pounds (45 kg), check the load/unload function	<a href="#">39</a>

# Product Inspection

Item	Routine	Page
Litter	All fasteners secure (reference all assembly drawings)	
	All welds intact - not cracked or broken	
	No bent, broken, or damaged components	
	Inspect hand grips - no defects or tears	
	Verify siderails operate and latch properly	<a href="#">51</a>
	Verify backrest cylinder operates properly through range of motion	<a href="#">51</a>
	Verify the leg rest operates properly	<a href="#">53</a>
	Install body restraints. Restraints intact and operating properly.	<a href="#">48</a>
	No rips or tears in mattress cover	
Head Section	All fasteners secure (reference all assembly drawings)	
	No bent or broken tubing or sheet metal	
	Verify the head section extends and retracts properly	<a href="#">52</a>
	Inspect grip on lift bar - no defects or tears	
	Load wheels are secure and roll freely	
	Verify the safety bar operates properly	<a href="#">34</a>
Base	All fasteners secure (reference all assembly drawings)	
	All welds intact - not cracked or broken	
	No bent, broken, or damaged components	
Wheels and Tires	No debris in wheels	
	All wheels secure, rolling and swiveling properly	
	Operate wheel locks (if equipped) - wheel secure when engaged, rolls freely when disengaged	<a href="#">55</a>
Cot Fastener	Inspect the cot retaining post - fasteners secure	<a href="#">86</a>
	Install in-fastener shut-off module. Determine and set in-fastener shut-off position. Verify the cot and cot fastener fit and function properly.	<a href="#">26</a>
	Install vehicle safety hook	<a href="#">28</a>
	Verify the safety bar engages the vehicle safety hook properly	<a href="#">34</a>
Accessories	Verify I.V. pole (if equipped) operates properly	<a href="#">56</a>
	Verify foot end oxygen bottle holder (if equipped) operates properly	
	Verify removable oxygen bottle holder (if equipped) operates properly	
	Verify Pedi-Mate® restraint package (if equipped) is installed properly	<a href="#">61</a>
	Verify accessory hook (if equipped) is installed properly	<a href="#">59</a>
	Verify head extension with pillow (if equipped) is installed properly	
	Verify pocketed backrest storage pouch (if equipped) is installed properly	<a href="#">63</a>
	Verify head end storage flat (if equipped) is installed properly	<a href="#">64</a>
	Verify pillow (if equipped) included	
	Verify 36" restraint extender (if equipped) is included	<a href="#">50</a>
	Verify the bariatric transfer flat (if equipped) is included	<a href="#">63</a>

# Cot Fastener Installation

---

The Stryker Cot Fastener Systems are designed to be compatible only with cots which conform to the installation specifications listed on [page 25](#).

---

 **WARNING**

It is the responsibility of the cot operator to ensure that the cot being used in the Stryker Cot Fastener Systems meets the installation specifications listed on [page 25](#). Injury may result if a non-compatible cot is used in the Stryker Fastener System.

---

**Note:** Adjustment of the rail clamp assembly may be required in order to compensate for any variation in the cot retaining post position depending on the cot manufacturer and model number.

For more information about the Stryker Cot Fastener Systems, see the Cot Fastener Operations/Maintenance Manual (6370-009-001).



# Cot Fastener Installation

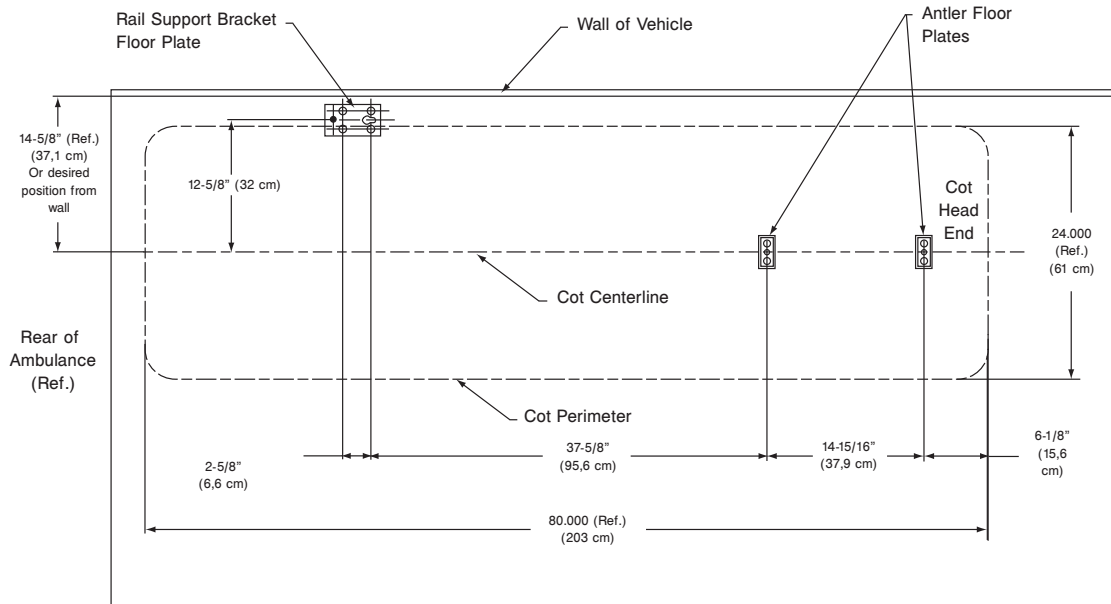

Figure 5: Installation Specifications - Floor Mount Fastener

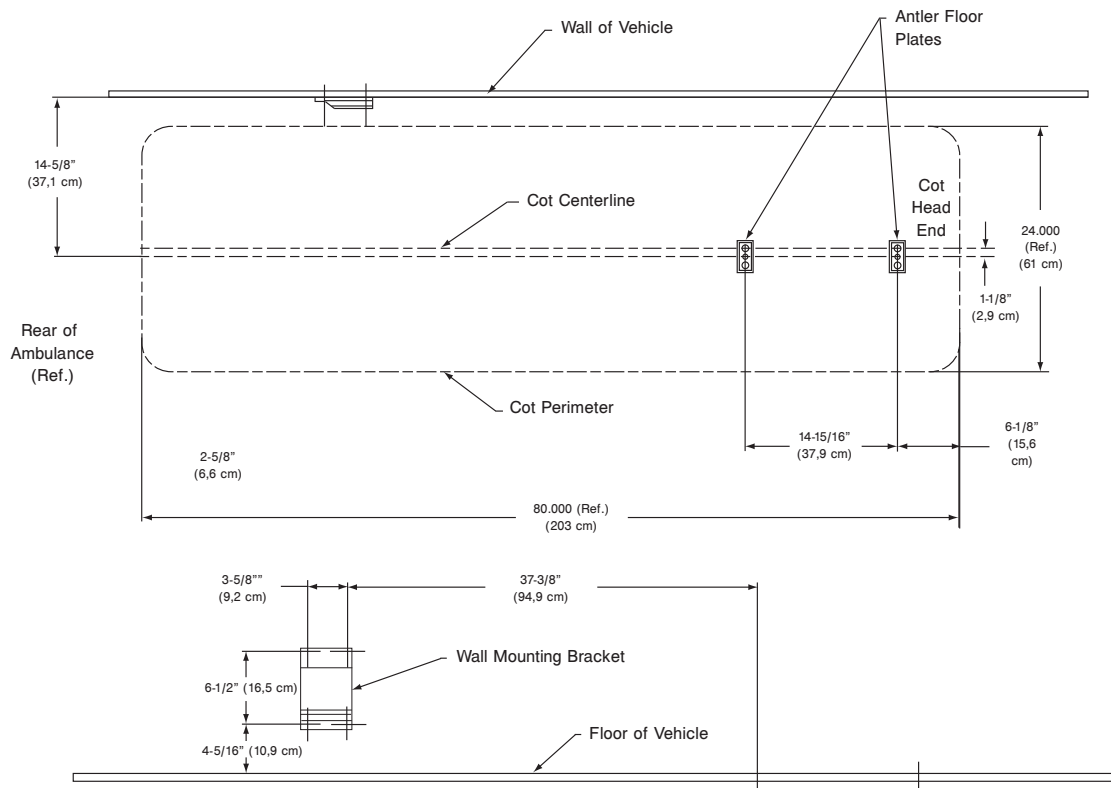

Figure 6: Installation Specifications - Wall Mount Fastener

# Cot Fastener Installation

## INSTALLING THE IN-FASTENER SHUT-OFF

### WARNING

The in-fastener shut-off must be positioned properly before placing the cot into service. Failure to install the in-fastener shut-off may cause injury to the patient or operator and/or damage to the vehicle.

The cot and fastener system have an integrated in-fastener shut-off function that disables the cot motor when the cot is secured into the cot fastener. Securely tighten the bolts on the fastener before installing the shut-off bracket. Install the shut-off bracket onto the rail clamp assembly before putting the cot into service.

1. Place the cot into a loading position (any position where the load wheels of the head section meet the vehicle floor height).
2. Lift the vehicle bumper to the raised position (if equipped).
3. Roll the cot to the open door of the patient compartment.
4. Push the cot forward until the load wheels are on the compartment floor and the safety bar passes the safety hook.
3. For maximum clearance to lift the base, pull the cot back until the safety bar engages the safety hook.
4. Raise the base and push the cot into the patient compartment following the appropriate loading instructions.
5. Engage the **extended** head section of the cot into the cot fastener antler and secure the cot post into the fastener rail clamp.
6. Adjust the shut-off bracket along the rail clamp until the “diamond” on the sensor housing is lined up with the pop rivet head as shown in Figure 7.
7. Using a T27 Torx wrench, securely fasten the bolts to attach the shut-off bracket to the rail clamp assembly.
8. Press the retract (–) button to ensure that the motor does not turn on while the cot is in the fastener. The battery indicator will still illuminate. If the motor turns on, readjust the shut-off bracket.

### WARNING

- Do not attempt to operate the cot when it is loaded into a cot fastener.
- The in-fastener shut-off is **only** a means for disabling the electronic functionality. Damage to the product and/or injury to the patient and/or operator may occur if used for any other purpose.
- Any emergency vehicle to be used with this cot **must** have the in-fastener shut-off system installed.

**Note:** Align the ‘diamond’ (A) on the sensor housing cover with the pop rivet head (B) on the in-ambulance shut-off.

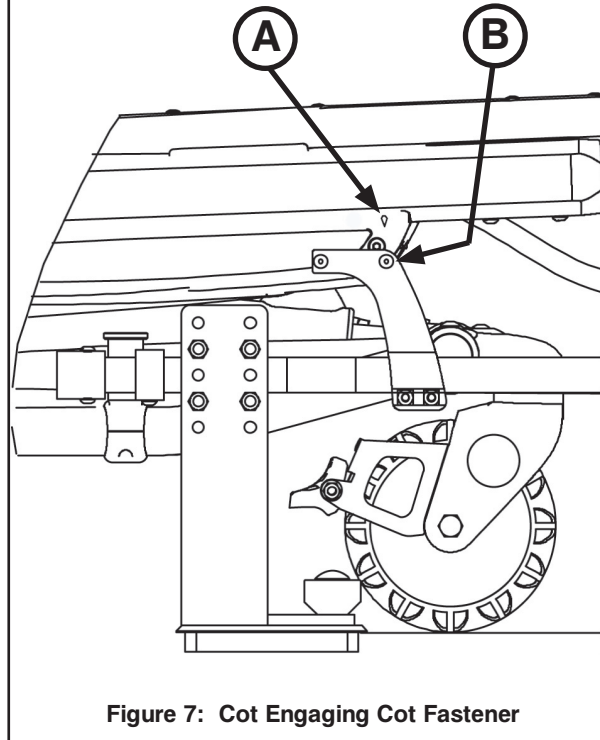

Figure 7: Cot Engaging Cot Fastener

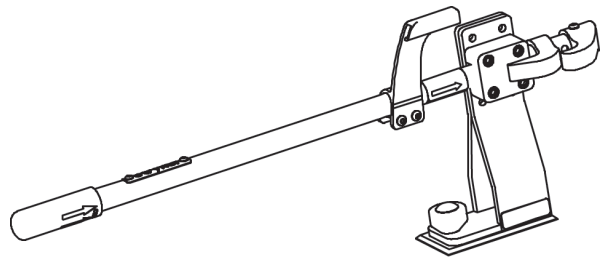

Figure 8: In-Fastener Shut-Off Module

# Vehicle Safety Hook Selection

The vehicle safety hook is a device that ships with the cot. The cot safety bar and vehicle safety hook are designed to keep the cot from being accidentally removed from the vehicle and to provide increased operator assurance and confidence when loading and unloading. The safety hook was designed for compatibility and proper operation when loading and unloading the cot from a vehicle that is compliant with Federal Regulation KKK-A-1822.

Stryker offers three different types of safety hooks that are ordered and shipped with your cot. These safety hook types are designed to meet the needs of various emergency vehicle configurations, specifically the length and location of the floor structure support that is located in the rear of the vehicle.

Consider the following information when selecting which safety hook is appropriate for your vehicle configuration:

- Determine the location of the floor structure support where there is adequate room to mount the safety hook.
- Ensure that the safety hook can be securely mounted into the back of the vehicle while providing adequate bumper clearance to allow the cot to be loaded and unloaded from the vehicle.
- Note the differences in vehicle design. Each safety hook provides a different mounting location option to maintain the appropriate distance between the face of the safety hook and the edge of the door sill.

Due to the differences in vehicle dimensions and the floor structure support locations, each safety hook requires a different mounting location. See "Vehicle Safety Hook Installation" to determine the correct positioning for safety hook installation.

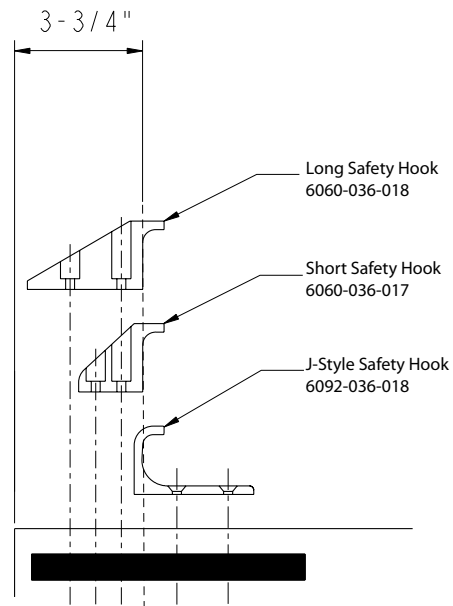

Figure 9: Safety Hook Types

**Note:** When replacing an existing safety hook with a new style, adjust the mounting location to maintain the proper position of the safety hook face.

# Vehicle Safety Hook Installation

## VEHICLE CONFIGURATION

According to federal regulations (reference KKK-A-1822), the bumper height of the vehicle shall be installed equidistant  $\pm 5$  cm (2 inches) from the vehicle floor to the ground level, which is defined as the vehicle deck height. The bumper step shall have a minimum depth of 13 cm (5 inches) and a maximum depth of 25 cm (10 inches). If the bumper depth is greater than 18 cm (7 inches), then the bumper must be able to fold. Installation of the safety hook into any vehicle compliant with this federal specification provides adequate clearance for the cot base to lower to its fully extended position. The cot is compatible with all vehicle deck heights (see specifications for maximum load height) as long as the vehicle meets the federal specifications that are outlined in KKK-A-1822.

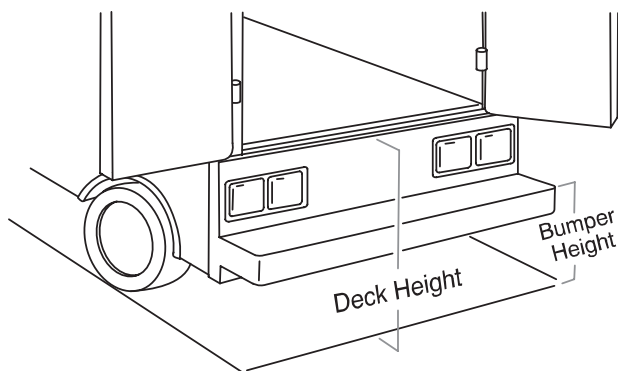

Figure 10.1: Vehicle Deck Height

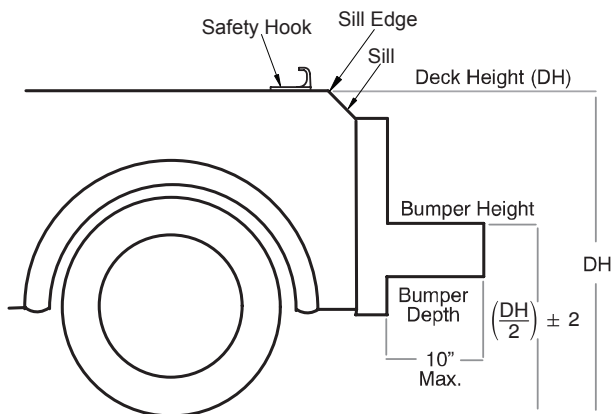

Figure 10.2: Vehicle Deck Height

### CAUTION

- Set the cot load height to the proper stop height prior to operation.
- Installation of the safety hook should be done by a certified mechanic familiar with ambulance vehicle construction. Consult the vehicle manufacturer before installing the safety hook and be sure that the installation of the safety hook does not damage or interfere with the brake lines, oxygen lines, fuel lines, fuel tank or electrical wiring of the vehicle.

## REQUIRED HARDWARE FOR INSTALLATION OF THE SAFETY HOOK (NOT SUPPLIED)

- (2) Grade 5, 1/4"-20 Socket Head Cap Screws\*
- (2) Grade 5, 1/4"-20 Flat Socket Head Cap Screws\*
- (2) Flat Washers
- (2) Lock Washers
- (2) 1/4"-20 Nuts

\* The length of the socket head cap screws depends on the thickness of the vehicle floor. Use screws that are long enough to go completely through the patient compartment floor, washer and nut by at least two full threads.

# Vehicle Safety Hook Installation

## WARNING

- Have the vehicle safety hook installed by a certified mechanic. Improper safety hook installation can cause injury to the patient or operator and/or damage to the cot.
- Failure to install the safety hook can cause injury to the patient or operator.
- The face of the safety hook that engages the safety bar should be located at least 3-3/4" from the leading edge of the door sill. After installation, verify that the cot legs lock into the load position without contacting the vehicle bumper.
- To avoid injury, verify that the safety bar has engaged the safety hook before removing the cot from the patient compartment.

**Note:** Stryker recommends that, prior to installation, the certified mechanic plan the placement of the safety hook in the rear of the vehicle.

Before installing the safety hook into your vehicle, check the front to back and side to side positioning when unloading and loading the cot to ensure that the safety hook will be installed properly. The cot safety bar must engage the safety hook every time, regardless of cot position.

## FRONT TO BACK POSITIONING OF THE SAFETY HOOK

1. Select the appropriate safety hook for your vehicle configuration.
2. Position the safety hook at least 3-3/4" from the leading edge of the door sill.
3. Ensure that the safety hook can be securely mounted into the back of the vehicle while providing adequate bumper clearance to allow the cot to be loaded and unloaded from the vehicle.
4. See "Side to Side Positioning of the Safety Hook" to confirm the side to side placement.

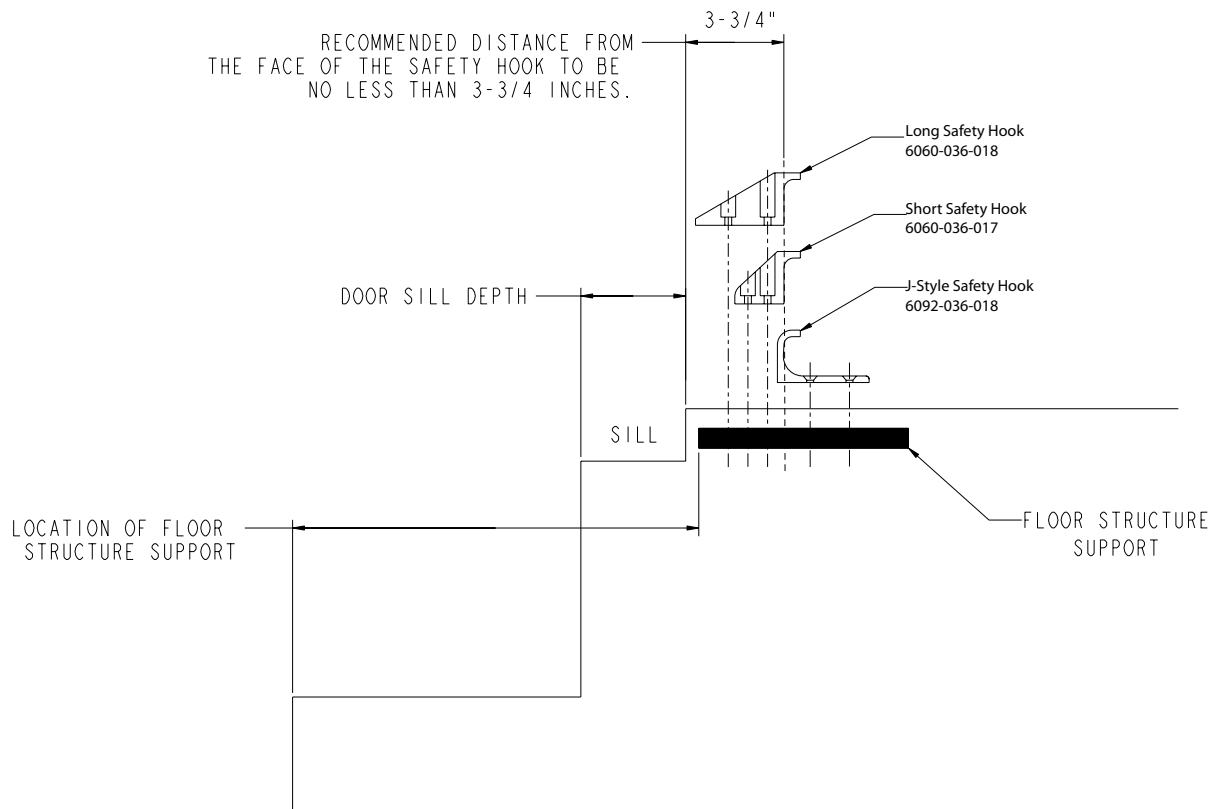

**Figure 11: Safety Hook Placement**

[Return To Table of Contents](#)

# Vehicle Safety Hook Installation

## SIDE TO SIDE POSITIONING OF THE SAFETY HOOK

1. Remove the cot from the fastener and unload it from the vehicle.
2. While the cot is being removed, note the position of the load wheels and the safety bar.
3. Mark the center of the cot safety bar on the vehicle floor.
4. Verify that the position marked in Step 3 is where the safety bar engages the safety hook every time when unloading the cot in a variety of positions (all the way to the left and all the way to the right), regardless of cot position.
  - If the cot safety bar does not engage the safety hook in any of these positions (left, center, or right), modify the vehicle, not the cot or safety hook.
  - If the cot safety bar engages the safety hook every time, install the safety hook.

## INSTALLING THE SAFETY HOOK

1. Determine the correct safety hook front to back and side to side positioning, so the cot safety bar engages the safety hook every time.
2. Drill the holes for the socket head cap screws.
3. Fasten the safety hook to the patient compartment floor and verify that the safety hook always engages the cot safety bar regardless of how the cot is unloaded from the vehicle.

### WARNING

Verify that the safety hook always engages the cot safety bar regardless of how the cot is unloaded from the vehicle or injury to the patient or operator and/or damage to the cot may occur.

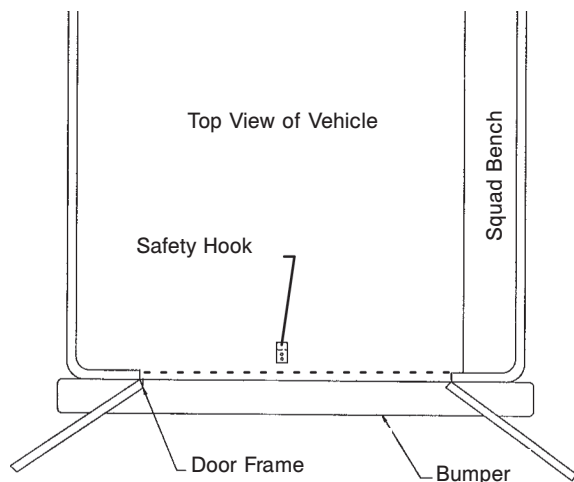

**Figure 12: Safety Hook Placement  
(For Reference Only)**

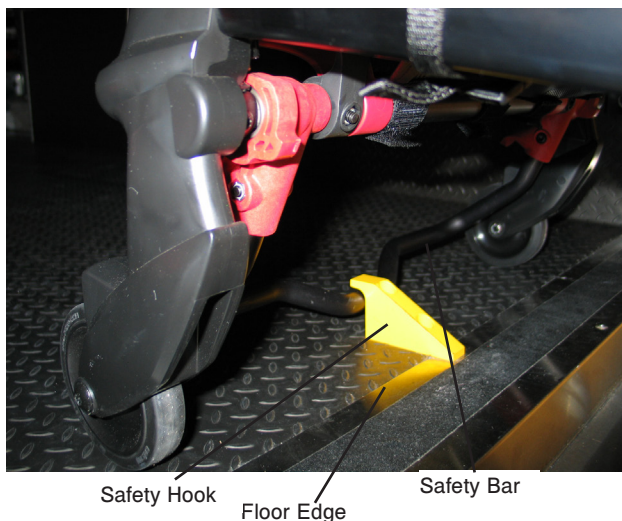

**Figure 13: Safety Bar Engaging Safety Hook**

### WARNING

The cot must have at least 5/8" of clearance between the vehicle bumper and the cot to disengage the safety bar when unloading the cot from the vehicle. Verify that the cot legs lock into the load position before disengaging the safety bar from the safety hook. Failure to properly lock the cot into position can cause injury to the patient or operator and/or damage to the cot.

# Operation Guide

---

## OPERATING GUIDELINES

- Use the cot only as described in this manual.
- Read all labels and instructions on the cot before using the cot.
- Use a minimum of two (2) trained operators to operate the cot while a patient is on the cot. If additional assistance is needed, see “Using Additional Assistance” on [page 43](#).
- Do not adjust, roll or load the cot into a vehicle without advising the patient. Stay with the patient and control the cot at all times.
- The cot can be transported in any position. Stryker recommends that the operators transport the patient in the lowest comfortable position to maneuver the cot.
- Only use the wheel lock(s) during patient transfer or without a patient on the cot.
- Always use the restraint straps.
- Use properly trained helpers, when necessary, to control the cot.

---

### WARNING

- Improper usage of the cot can cause injury to the patient or operator. Operate the cot only as described in this manual.
- Entanglement in powered cot mechanisms can cause serious injury. Operate the cot only when all persons are clear of the mechanisms.
- Practice changing height positions and loading the cot until operation of the product is fully understood. Improper use can cause injury.
- Do not allow untrained assistants to assist in the operation of the cot. Untrained technicians/assistants can cause injury to the patient or themselves.
- Ensure proper hand placement on hand grips. Hands should be clear of red safety bar pivots while loading and unloading the cot.
- Do not ride on the base of the cot. Damage to the product could occur, resulting in injury to the patient or operator.
- Transporting the cot sideways can cause the cot to tip, resulting in possible damage to the product and/or injury to the patient or operator. Transporting the cot in a lowered position, head or foot end first, minimizes the potential of a cot tip.
- Grasping the cot improperly can cause injury. Keep hands, fingers and feet away from moving parts. To avoid injury, use extreme caution when placing your hands and feet near the base tubes while raising and lowering the cot.
- Any emergency vehicle to be used with this cot **must** have the in-fastener shut-off system installed (see [page 26](#)).

---

### CAUTION

Before operating the cot, clear any obstacles that may interfere and cause injury to the operator or patient.

---

## PROPER LIFTING TECHNIQUES

When lifting the cot and patient, there are five basic guidelines to help you avoid injury:

- Keep your hands close to your body.
- Keep your back straight.
- Coordinate your movements with your partner and lift with your legs.
- Avoid twisting.
- Always operate the cot as described in this manual.

# Operation Guide

---

## TRANSFERRING THE PATIENT TO THE COT

### To transfer the patient to the cot:

1. Roll the cot to the patient.
2. Place the cot beside the patient and raise or lower the cot to the level of the patient.
3. Lower the siderails and open the restraint straps.
4. Transfer the patient to the cot using accepted EMS procedures.
5. Use all the restraint straps to secure the patient to the cot (see [page 48](#)).
6. Raise the siderails and adjust the backrest and leg rest as necessary.

---

### **WARNING**

- Always use all restraint straps to secure the patient on the cot. An unrestrained patient may fall from the cot and be injured.
  - Never leave a patient unattended on the cot or injury could result. Hold the cot securely while a patient is on the product.
  - Never apply the optional wheel lock(s) while a patient is on the cot. Tipping could occur if the cot is moved while the wheel lock is applied, resulting in injury to the patient or operator and/or damage to the cot.
  - Siderails are not intended to serve as a patient restraint device. See [page 48](#) for proper restraint strap usage. Failure to utilize the siderails properly could result in patient injury.
  - Hydraulically raising or lowering the cot may temporarily affect electronic patient monitoring equipment. For best results, patient monitoring should be conducted when the cot is idle.
- 

## ROLLING THE COT

### When rolling the cot:

- Make sure that all of the restraint straps are securely buckled around the patient (see [page 48](#)).
- Place the cot in any position for rolling.
- Position an operator at the foot end and one at the head end of the cot **at all times** when rolling the cot with a patient on it.
- Approach door sills and/or other low obstacles squarely and lift each set of wheels over the obstacle separately.

---

### **WARNING**

- High obstacles such as curbing, steps or rough terrain can cause the cot to tip, possibly causing injury to the patient or operator.
  - Transporting the cot in lower positions reduces the potential of a cot tip. If possible, obtain additional assistance or take an alternate route.
-



# Operation Guide

---

## ADJUSTING THE HEIGHT OF THE COT WITH TWO OPERATORS

Changing the height of the cot while a patient is on the cot requires a minimum of **two (2) trained operators** who are positioned at each end of the cot.

### To raise or lower the cot:

1. **Operator 1 (Foot End)** – Grasp the cot frame at the foot end and press either the extend (+) button on the control switch to raise the litter or the retract (-) button on the control switch to lower the litter to the desired position.
2. **Operator 2 (Head End)** – Maintain a firm grip on the outer rail until the cot is securely in the desired position.

---

### **WARNING**

Grasping the cot improperly can cause injury. Keep hands, fingers and feet away from moving parts. To avoid injury, use extreme caution when placing your hands and feet near the base tubes while raising and lowering the cot.

---

**Note:** If the extend (+) button on the control switch remains activated after reaching the set load height, the motor will remain halted until the operator releases the button. Once the button is released, press the extend (+) button again to “jog” the cot height up further.

---

### **CAUTION**

Do not “jog” the cot past the established cot load height of the product when the safety bar engages the vehicle safety hook or damage may occur to the product.

---

# Operation Guide

## LOADING THE COT INTO A VEHICLE WITH TWO OPERATORS - POWERED METHOD

Loading an occupied cot into a vehicle requires a minimum of **two (2) trained operators**.

### WARNING

- Two operators must be present when the cot is occupied.
- Operators must be able to lift the total weight of the patient, cot and any items on the cot.
- The higher an operator must lift the cot, the more difficult it becomes to hold the weight. An operator may need help loading the cot if he/she is too short or if the patient is too heavy to lift safely. The operator must be able to lift the cot high enough for the cot legs to unfold completely and lock when the cot is unloaded. A shorter operator needs to raise their arms higher to enable the undercarriage to unfold.
- Ensure proper hand placement on hand grips. Hands should be clear of red safety bar pivots while loading and unloading the cot.
- There must be a safety hook properly installed in the vehicle so that the bumper does not interfere with the front legs of the base frame.
- Failure to install the safety hook can cause injury to the patient or operator. Install and use the safety hook as described on [page 28](#).

### To load the cot into a vehicle with two operators:

1. Place the cot in a loading position (any position where the load wheels meet the vehicle floor height).
2. Lift the vehicle bumper to the raised position (if equipped).
3. Roll the cot to the open door of the patient compartment.
4. Push the cot forward until the load wheels are on the compartment floor and the safety bar passes the safety hook as shown in Figure 14.
5. For maximum clearance to lift the base, pull the cot back until the safety bar engages the safety hook.
6. **Operator 2** – Verify that the bar engages the safety hook.
7. **Operator 1** – Grasp the cot frame at the foot end and press the retract (–) button until the undercarriage of the cot retracts fully as shown in Figure 15.
8. **Operator 2** – Securely grasp the cot outer rail to stabilize the cot during retraction.
9. **Both Operators** – Push the cot into the patient compartment as shown in Figure 16, engaging the cot fastener (not included).



Figure 14: Safety Bar Engaging Safety Hook



Figure 15: 2 Operators - One Pressing the Retract Button



Figure 16: 2 Operators Loading the Cot

### WARNING

When using a standard cot fastener, do not load the cot into the vehicle with the head section retracted. Loading the cot with the head section retracted may cause the product to tip or not engage properly in the cot fastener, possibly causing injury to the patient or operator and/or damage to the cot.

[Return To Table of Contents](#)

# Operation Guide

---

## LOADING THE COT INTO A VEHICLE WITH TWO OPERATORS AT THE FOOT END - POWERED METHOD

---

### WARNING

Ensure proper hand placement on hand grips. Hands should be clear of red safety bar pivots while loading and unloading the cot.

---

1. Place the cot in a loading position (any position where the load wheels meet the vehicle floor height).
2. Lift the vehicle bumper to the raised position (if equipped).
3. Roll the cot to the open door of the patient compartment.
4. Push the cot forward until the load wheels are on the compartment floor and the safety bar passes the safety hook.
5. For maximum clearance to lift the base, pull the cot back until the safety bar engages the safety hook.
6. **Operator 1** – Grasp the cot frame at the foot end.
7. **Operator 2** – Verify that the bar engages the safety hook and return to the foot end.
8. **Both Operators** – Lift the cot together, while Operator 1 presses the retract (-) button until the undercarriage of the cot retracts fully.
9. **Both Operators** – Push the cot into the patient compartment, until the cot engages the cot fastener (not included).

## HIGH SPEED RETRACT/EXTEND

The cot is equipped with a high-speed retract mode to expedite loading/unloading the cot into and out of a vehicle.

- The undercarriage **rapidly** retracts toward the highest position once the weight of the cot and patient is off of the wheels. Press the retract (-) button to actuate the control switch.
- The undercarriage **rapidly** extends toward the lowest position once the weight of the cot and patient is off of the wheels. Press the extend (+) button to actuate the control switch.

### WARNING

- Whenever the weight of the cot and patient is off of the wheels, the cot will **automatically** enter the high speed retract mode if the retract (-) button is pressed.
  - Once the weight is off of the ground, the operator(s) must support the load of the patient, cot and any accessories. Failure to support the load properly may cause injury to the patient or operator.
-

# Operation Guide

## LOADING AN EMPTY COT INTO A VEHICLE WITH ONE OPERATOR - POWERED METHOD

Loading an **unoccupied** cot into the emergency vehicle can be accomplished by a single operator.

### WARNING

- The one person loading and unloading procedures are for use only with an empty cot. Do not use the procedures when loading/unloading a patient. Injury to the patient or operator could result.
- Ensure proper hand placement on hand grips. Hands should be clear of red safety bar pivots while loading and unloading the cot.

### To load an empty cot into a vehicle with one operator:

1. Place the cot into a loading position (any position where the load wheels of the head section meet the vehicle floor height).
2. Lift the vehicle bumper to the raised position (if equipped).
3. Roll the cot to the open door of the patient compartment.
4. Push the cot forward until the load wheels are on the patient compartment floor (Figure 17) and the safety bar passes the safety hook.
5. For maximum clearance to lift the base, pull the cot back until the safety bar engages the safety hook.
6. Grasp the cot frame at the foot end and press the retract (-) button, until the undercarriage of the cot retracts into its highest position as shown in Figure 18).
7. Push the cot into the patient compartment until the cot engages the cot fastener (not included) as shown in Figure 19.

### WARNING

When using a standard cot fastener, do not load the cot into the vehicle with the head section retracted. Loading the cot with the head section retracted may cause the product to tip or not engage properly in the cot fastener, possibly causing injury to the patient or operator and/or damage to the cot.



Figure 17: Load Wheels on the Vehicle Floor



Figure 18: Press the Retract Button



Figure 19: Push the Cot into the Vehicle

# Operation Guide

## UNLOADING THE COT FROM A VEHICLE WITH TWO OPERATORS - POWERED METHOD

Unloading the cot from the vehicle while a patient is on the cot requires a minimum of **two (2) trained operators**, positioned at each end of the cot. Each operator must grasp the cot frame securely.

### WARNING

- To avoid injury, verify that the safety bar has engaged the safety hook before removing the cot from the patient compartment.
- Do not pull or lift on the safety bar when unloading the cot. Damage to the safety bar could result and injury to the patient or operator could occur.
- Ensure proper hand placement on hand grips. Hands should be clear of red safety bar pivots while loading and unloading the cot.
- Do not press the extend (+) button until the safety bar has engaged the safety hook.

### To unload the cot from a vehicle with two operators:

1. Lift the vehicle bumper to the raised position (if equipped).
2. Disengage the cot from the cot fastener. (For more information about the cot fastener, see [page 25](#)).
3. **Operator 1** – Grasp the cot frame at the foot end. Pull the cot out of the patient compartment until the safety bar engages the safety hook as shown in Figure 20.
4. **Operator 2** - Verify that the bar engages the safety hook.
5. **Operator 2** – Stabilize the cot during the unloading operation by securely grasping the outer rail.
6. **Operator 1** – Depress the extend (+) button to lower the undercarriage to its fully extended position as shown in Figure 21.
7. **Operator 2** – Pull the safety bar release lever forward to disengage the safety bar from the safety hook in the patient compartment as shown in Figure 22.
8. Remove the load wheels from the patient compartment of the vehicle.

### CAUTION

- When unloading the cot from the patient compartment, ensure that the caster wheels are safely set on the ground or damage to the product may occur.
- Do not “jog” the cot past the load height while the safety bar is engaged.



Figure 20: 2 Operators Unloading the Cot



Figure 21: 2 Operators - One Pressing the Extend Button

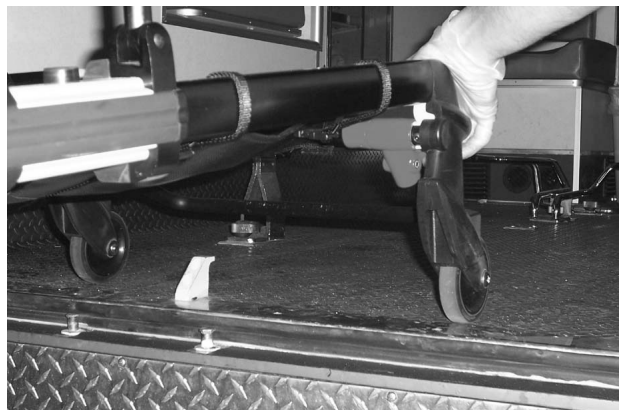

Figure 22: Disengaging the Safety Bar

# Operation Guide

## UNLOADING AN EMPTY COT FROM A VEHICLE WITH ONE OPERATOR - POWERED METHOD

Unloading an **unoccupied** cot from a vehicle can be accomplished by a single operator.

### WARNING

- The one person loading and unloading procedures are for use only with an empty cot. Do not use the procedures when loading or unloading a patient. Injury to the patient or operator could result.
- Do not pull or lift on the safety bar when unloading the cot. Damage to the safety bar could result and injury to the patient or operator could occur.
- Ensure proper hand placement on hand grips. Hands should be clear of red safety bar pivots while loading and unloading the cot.

### To unload an empty cot from a vehicle with one operator:

1. Lift the vehicle bumper to the raised position (if equipped).
2. Disengage the cot from the cot fastener. (For more information about the cot fastener, see [page 25](#)).
3. Grasp the cot frame at the foot end.
4. Pull the cot from the vehicle until the safety bar engages the safety hook as shown in Figure 23.
5. Depress the extend (+) button to lower the undercarriage to its fully extended position as shown in Figure 24.
6. Disengage the safety bar from the safety hook by pulling the safety bar release lever forward and roll the cot out of the vehicle as shown in Figure 25.
7. Remove the load wheels from the patient compartment of the vehicle.

### CAUTION

- When unloading the cot from the patient compartment, ensure that the caster wheels are safely set on the ground or damage to the product may occur.
- Do not “jog” the cot past the load height while the safety bar is engaged.



Figure 23: Pull the Cot out of the Vehicle



Figure 24: Press the Extend Button



Figure 25: Roll the Cot out of the Vehicle

# Operation Guide

## USING THE MANUAL OVERRIDE

In the event of loss of electrical function, the cot is equipped with a manual override to allow manual operation of the product until electrical functionality is restored. You can use the red manual back-up release handle to raise or lower the cot.

The **red** manual back-up release handle (A) is located along the patient left side of the lower lift bar at the foot end of the cot as shown in Figure 26.

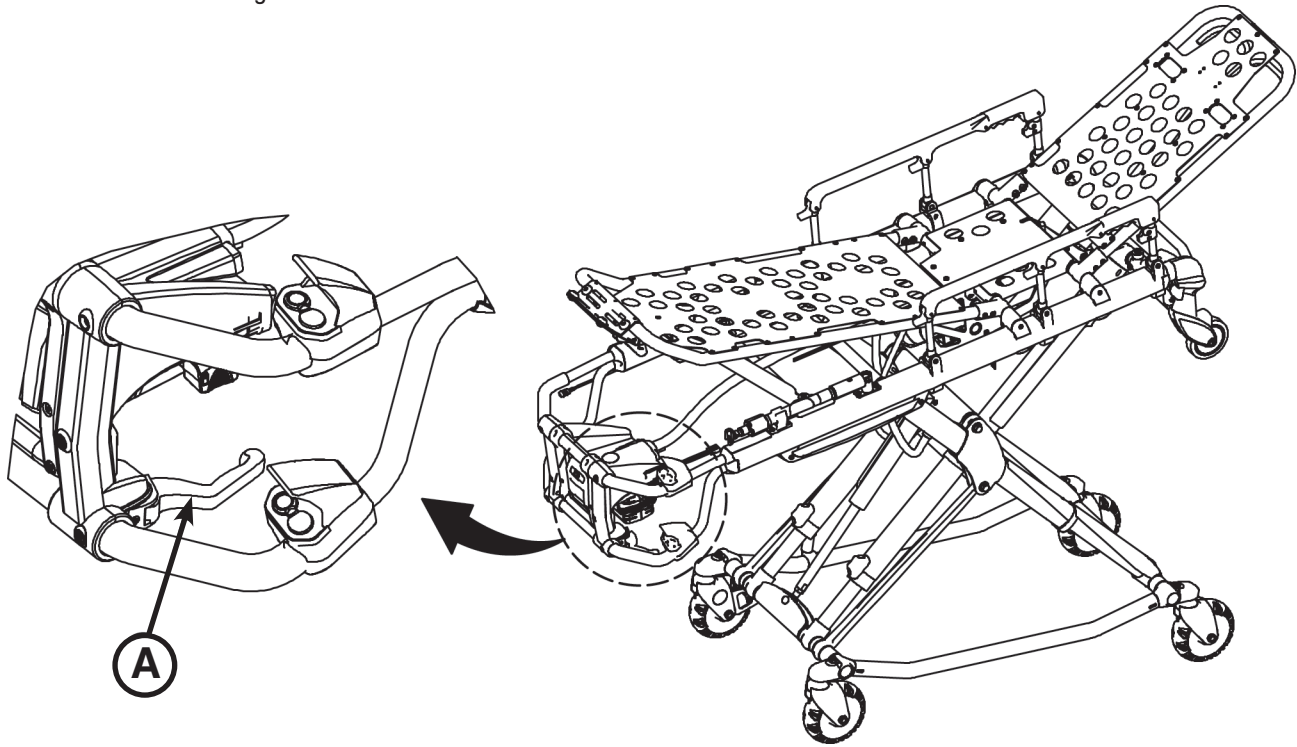

Figure 26: Manual Back-Up Release Handle

### To raise or lower the cot with the manual back-up release handle:

1. **Both Operators** – Lift the cot during the raise/lower operation to support the weight of the cot at each end.
2. **Operator 1 (Foot End)** – Pull the manual back-up release handle toward the lift bar. While the manual back-up release handle is pulled, raise or lower the cot to the desired position and then release the handle to lock the cot into position.

### Note:

- The operators must lift the cot weight slightly off of the wheels to use the manual extend or retract while a patient is on the cot.
- Activation of the manual back-up release handle may cause the cot to lower slowly if less than 40 pounds (18 kg) are on the cot.
- Hydraulic fluid will become more viscous when the cot is used for extended periods in cold temperatures. When using the manual back-up release function to extend the base during unloading in cold weather conditions, hold the release handle for approximately one second after the cot wheels touch the ground to minimize sagging of the litter as the cot is removed from the ambulance.

# Operation Guide

## LOADING THE COT INTO A VEHICLE WITH TWO OPERATORS - MANUAL METHOD

Loading an occupied cot into a vehicle requires a minimum of **two (2) trained operators**.

### **WARNING**

- Two operators must be present when the cot is occupied.
- Operators must be able to lift the total weight of the patient, cot and any items on the cot.
- The higher an operator must lift the cot, the more difficult it becomes to hold the weight. An operator may need help loading the cot if he/she is too short or if the patient is too heavy to lift safely. The operator must be able to lift the cot high enough for the cot legs to unfold completely and lock when the cot is unloaded. A shorter operator needs to raise their arms higher to enable the undercarriage to unfold.
- Ensure proper hand placement on hand grips. Hands should be clear of red safety bar pivots while loading and unloading the cot.
- There must be a safety hook properly installed in the vehicle so that the bumper does not interfere with the front legs of the base frame.
- Failure to install the safety hook can cause injury to the patient or operator. Install and use the safety hook as described on [page 28](#).

### To load the cot into a vehicle with two operators using the manual back-up release handle:

1. Place the cot in a loading position (any position where the load wheels meet the vehicle floor height).
2. Lift the vehicle bumper to the raised position (if equipped).
3. Roll the cot to the open door of the patient compartment.
4. Push the cot forward until the load wheels are on the patient compartment floor and the safety bar passes the safety hook.
5. For maximum clearance to lift the base, pull the cot back until the safety bar engages the safety hook.
6. **Operator 2** – Verify that the bar engages the safety hook.
7. **Operator 1** – Grasp the cot frame at the foot end. Lift the foot end of the cot until the weight is off of the cot base. Squeeze and hold the release handle as shown in Figure 27.
8. **Operator 2** – Stabilize the cot by placing your hand on the outer rail. Grasp the base frame. After the foot end operator has lifted the cot and squeezed the release handle, raise the undercarriage until it stops in the highest position and hold it there as shown in Figure 28.
9. **Both Operators** – Push the cot into the patient compartment, engaging the cot fastener (not included) as shown in Figure 29.

**Note:** When operating the manual back-up release handle, avoid rapid lifting or lowering of the base or movement may appear sluggish; lift with a slow constant motion.

[Return To Table of Contents](#)



Figure 27: Manual Back-up Release Handle



Figure 28: 2 Operators - One Lifting Base



Figure 29: Push the Cot Into the Vehicle



# Operation Guide

## UNLOADING THE COT FROM A VEHICLE WITH TWO OPERATORS - MANUAL METHOD

Unloading the cot from the vehicle while a patient is on the cot requires a minimum of **two (2) trained operators**, positioned at each end of the cot as shown in Figure 30. Each operator must grasp the cot frame securely.

### WARNING

- To avoid injury, verify that the safety bar has engaged the safety hook before removing the cot from the patient compartment.
- Do not pull or lift on the safety bar when unloading the cot. Damage to the safety bar could result and injury to the patient or operator could occur.
- Ensure proper hand placement on hand grips. Hands should be clear of red safety bar pivots while loading and unloading the cot.

### To unload the cot from a vehicle with two operators:

1. Lift the vehicle bumper to the raised position (if equipped).
2. Disengage the cot from the cot fastener. (For more information about the cot fastener, see [page 25](#)).
3. **Operator 1** – Grasp the cot frame at the foot end. Pull the manual back-up release handle to lower the undercarriage to its fully extended position (Figure 31). Pull the cot out of the patient compartment until the safety bar engages the safety hook.
4. **Operator 2** - Verify that the bar engages the safety hook.
5. **Operator 2** – Stabilize the cot during the unloading operation by securely grasping the outer rail.
6. **Operator 2** – Pull the safety bar release lever forward to disengage the safety bar from the safety hook in the patient compartment (Figure 32).
7. Remove the load wheels from the patient compartment of the vehicle.

### CAUTION

When unloading the cot from the patient compartment, ensure that the caster wheels are safely set on the ground or damage to the product may occur.



Figure 30: 2 Operators Unloading the Cot



Figure 31: 2 Operators - One Pressing the Extend Button

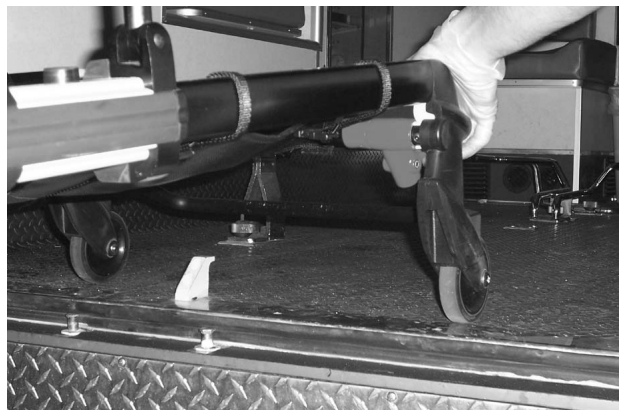

Figure 32: Disengaging the Safety Bar

# Operation Guide

## UNLOADING AN EMPTY COT FROM A VEHICLE WITH ONE OPERATOR - MANUAL METHOD

Unloading an **unoccupied** cot from a vehicle can be accomplished by a single operator.

### WARNING

- The one person loading and unloading procedures are for use only with an empty cot. Do not use the procedures when loading or unloading a patient. Injury to the patient or operator could result.
- Do not pull or lift on the safety bar when unloading the cot. Damage to the safety bar could result and injury to the patient or operator could occur.
- Ensure proper hand placement on hand grips. Hands should be clear of red safety bar pivots while loading and unloading the cot.

**To unload an empty cot from a vehicle with one operator:**

1. Lift the vehicle bumper to the raised position (if equipped).
2. Disengage the cot from the cot fastener. (For more information about the cot fastener, see [page 25](#)).
3. Grasp the cot frame at the foot end.
4. Pull the cot from the vehicle until the safety bar engages the safety hook as shown in Figure 33.
5. Pull the manual back-up release handle to lower the undercarriage to its fully extended position as shown in Figure 34.
6. Disengage the safety bar from the safety hook by pulling the safety bar release lever forward and roll the cot out of the vehicle as shown in Figure 35.
7. Remove the load wheels from the patient compartment of the vehicle.

### CAUTION

When unloading the cot from the patient compartment, ensure that the caster wheels are safely set on the ground or damage to the product may occur.



Figure 33: Pull the Cot out of the Vehicle



Figure 34: Pull the Manual Back-up Release Handle



Figure 35: Roll the Cot out of the Vehicle

# Operation Guide

## USING ADDITIONAL ASSISTANCE

	Changing Levels	Rolling	Loading/Unloading
Two Operators Two Helpers			
Two Operators Four Helpers			

# Operation Guide

---

## REMOVING AND REPLACING THE BATTERY

The cot is supplied with two removable 24V SMRT Paks or 24V DeWALT® batteries as the power source.

See the SMRT Power System Operations/Maintenance manual (6500-009-101) for additional SMRT Pak and SMRT Charger information. See the DeWALT® Battery System manual for battery and charger information.

## REMOVING AND REPLACING A SMRT PAK

---

### **WARNING**

- To avoid risk of electric shock, never attempt to open the battery pack for any reason. If the battery pack case is cracked or damaged, do not insert it into the charger. Return damaged battery packs to a service center for recycling.
  - Do not remove the battery when the cot is activated.
  - Avoid direct contact with a wet battery or battery enclosure. Contact may cause injury to the patient or operator.
- 

### To remove the SMRT Pak:

1. Press the RED one hand release button (C) or press the battery release button (A) to release the SMRT Pak (B) from the cot as shown in Figure 36.
2. Slide the released SMRT Pak out of the enclosure.

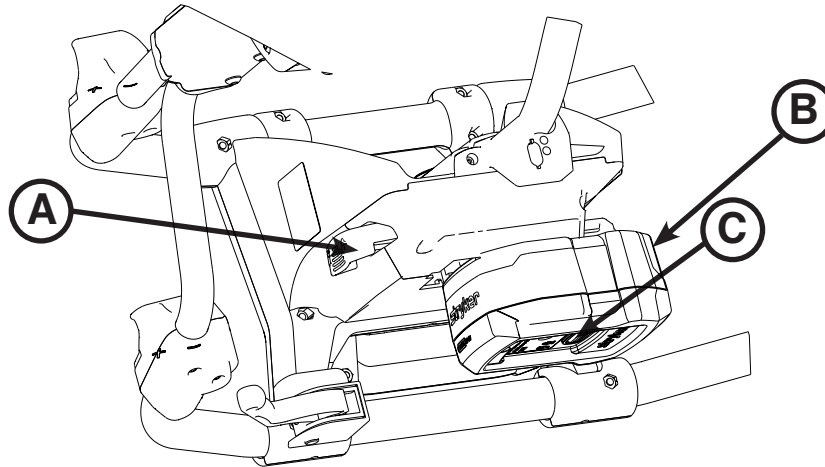

**Figure 36: SMRT Pak Removal and Replacement**

### To reinstall or replace the SMRT Pak:

1. Align the tabs in the battery enclosure.
2. Push the SMRT Pak into the enclosure until the latch clicks into place.
  - The cot power indicator LED is solid GREEN if the SMRT Pak is fully charged and ready.
  - The cot power indicator LED flashes RED if the SMRT Pak needs to be recharged or replaced.

**Note:** Batteries slowly lose power when not on the charger.

---

### **CAUTION**

Remove the battery if the cot is not going to be used for an extended period of time (more than 24 hours).

---

# Operation Guide

---

## REMOVING AND REPLACING A D<sub>E</sub>WALT<sup>®</sup> BATTERY

---

### WARNING

- To avoid risk of electric shock, never attempt to open the battery pack for any reason. If the battery pack case is cracked or damaged, do not insert it into the charger. Return damaged battery packs to a service center for recycling.
  - Do not remove the battery when the cot is activated.
  - Avoid direct contact with a wet battery or battery enclosure. Contact may cause injury to the patient or operator.
- 

### To remove the battery:

1. Press the red battery release button (A), located on the patient left side of the foot end control enclosure, to release the battery (B) from the cot as shown in Figure 37.
2. Slide the released battery out of the enclosure.

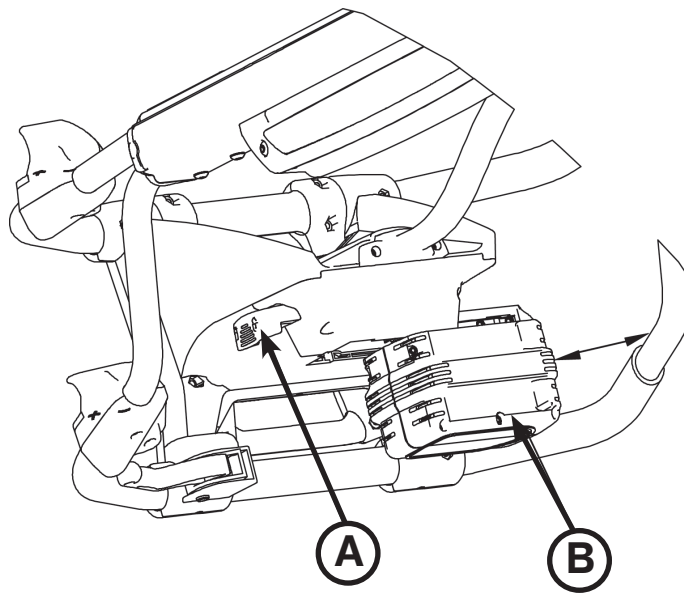

Figure 37: D<sub>E</sub>WALT<sup>®</sup> Battery Removal & Replacement

### To reinstall or replace the battery:

1. Align the tabs in the battery enclosure.
2. Push the battery into the enclosure until the latch clicks into place.
  - The cot power indicator LED is solid GREEN if the battery is fully charged and ready.
  - The cot power indicator LED flashes RED if the battery needs to be recharged or replaced.

**Note:** Batteries slowly lose power when not on the charger.

---

### CAUTION

Remove the battery if the cot is not going to be used for an extended period of time (more than 24 hours).

---

# Operation Guide

---

## USING THE BATTERY POWER INDICATOR

To check the battery power level, depress **lightly** on the retract (-) switch (A) to activate the power indicator LED (B) as shown in Figures 38.1 and 38.2.

The power indicator LED is located at the foot end control enclosure as shown in Figure 38.2, represented by a battery icon.

- The indicator LED is solid green when the battery is fully charged or has adequately charged battery power.
- The indicator LED flashes red when the battery needs to be recharged or replaced.

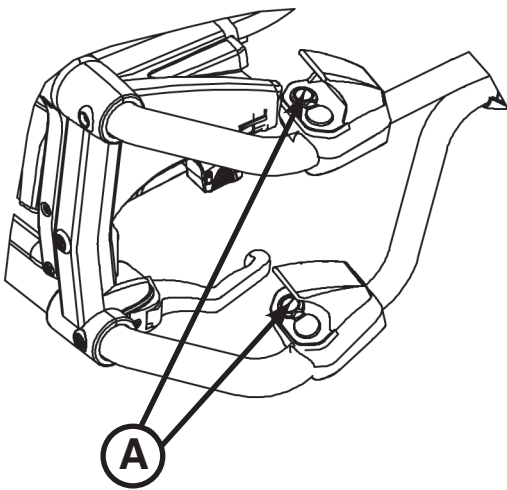

Figure 38.1: Retract Switches

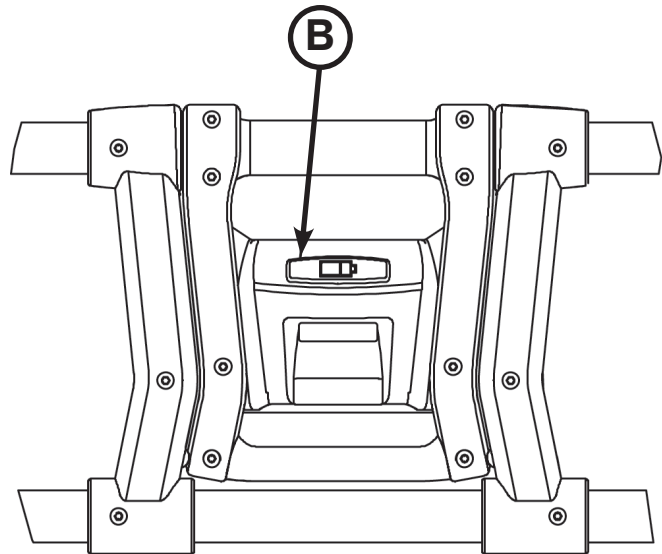

Figure 38.2: Power Indicator LED

---

### WARNING

- To avoid risk of electric shock, never attempt to open the battery pack for any reason. If the battery pack case is cracked or damaged, do not insert it into the charger. Return damaged battery packs to a service center for recycling.
- Do not remove the battery when the cot is activated.
- Avoid direct contact with a wet battery or battery enclosure. Contact may cause injury to the patient or operator.

---

### CAUTION

- Only use the battery and charger as specified.
- The cot is not for use with an AC adapter.
- When charging a battery in an ambulance, locate the charger in an enclosed cabinet and out of patient reach during transport.
- Ensure that the battery is fully charged prior to placing into service. An uncharged or depleted battery may cause poor cot performance.

---

See the SMRT Power System Operations/Maintenance manual (6500-009-101) for additional SMRT Pak and SMRT Charger information. See the DeWALT® Battery System manual for battery and charger information.

# Operation Guide

---

## USING THE HOUR METER

The hour meter, located on the foot end control enclosure as shown in Figure 39, indicates the amount of time (HHH.H hours) that the hydraulics have been activated. You can use the hour meter to determine the frequency for preventative maintenance procedures as listed on [page 67](#).

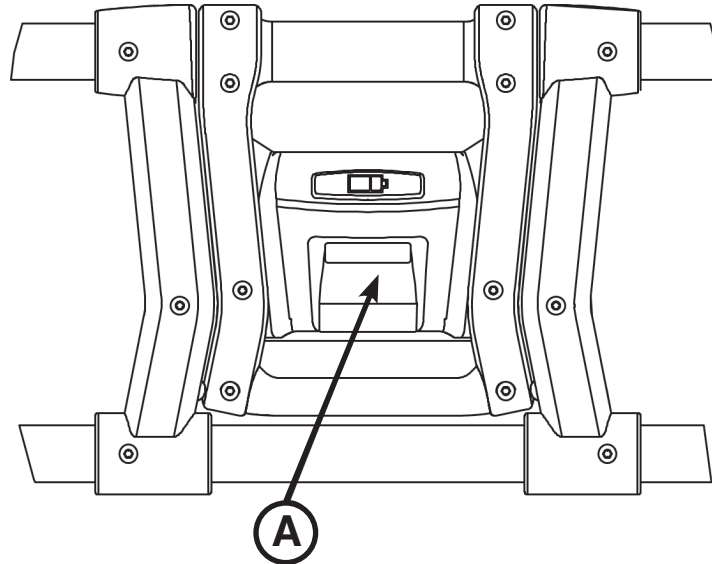

**Figure 39: Hour Meter**

# Operation Guide

## USING RESTRAINT STRAPS

### WARNING

Always use all restraint straps to secure the patient on the cot. An unrestrained patient may fall from the cot and be injured.

Always secure the patient on the cot with all of the restraint straps. Buckle the restraints across the patient's chest/shoulders, waist and legs as shown in Figure 40.1. Keep the restraint straps buckled when the cot is not being used with a patient to avoid damage to the buckles and straps.

### WARNING

Do not attach restraints to the base or cross tubes, improper restraint attachment could result in damage to the cot further resulting in injury to the patient or operator.

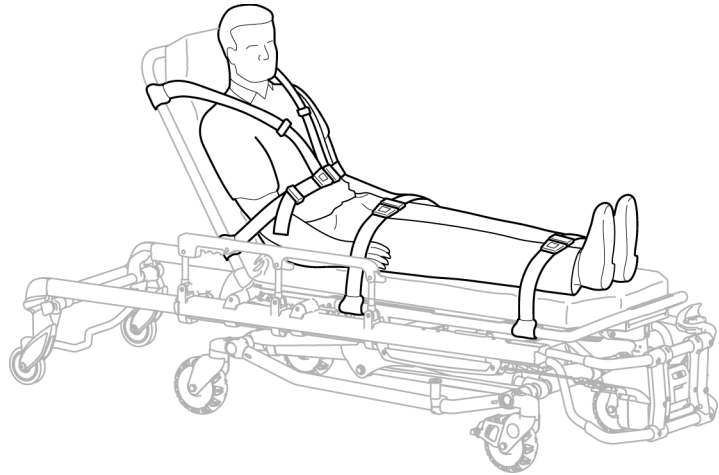

Figure 40.1: Safety Restraints

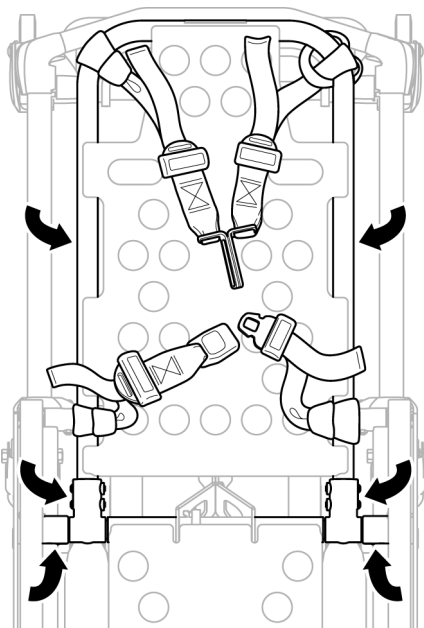

Figure 40.2: Head Section Restraints

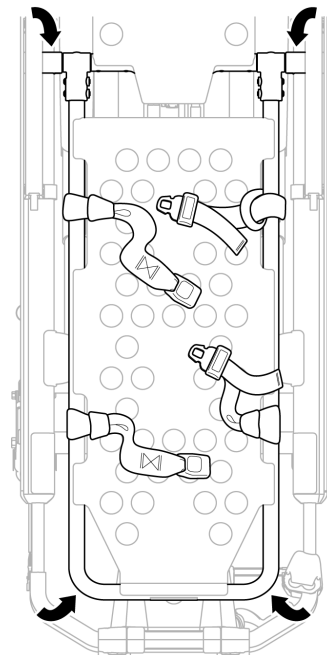

Figure 40.3: Foot Section Restraints

Wrap the strap around the cot frame and back through the loop on the end of the strap as shown in Figures 40.2 and 40.3. The arrows indicate alternate attachment areas.

When attaching the restraint straps to the cot, the attachment points should provide both strong anchorage and proper restraint position while not interfering with equipment and accessories.



# Operation Guide

## USING RESTRAINT STRAPS (CONTINUED)

### CAUTION

Ensure that the restraints are not entangled in the base frame when raising and lowering the cot.

When the cot is put into service, open the restraints and place them at either side of the cot until the patient is positioned on the cot mattress. Lengthen the restraints, buckle them around the patient and shorten them until the required tightness is achieved.

- **To open the restraint**, press the red button (A) on the front of the buckle “receiver”. This releases the buckle latch plate (B) which can then be pulled out of the receiver (Figure 41.1).
- **To close the restraint**, push the latch plate into the receiver until a “click” is heard. When fastening the chest restraint ensure that the latch plate passes through both links (C) on the shoulder strap (Figure 41.1).
- **To lengthen the restraint**, grasp the buckle latch plate, turn it at an angle to the webbing, then pull it out (Figure 41.2). A hemmed tab at the end of the webbing prevents the latch plate from coming off of the strap.
- **To shorten the restraint**, grasp the hemmed tab and pull the webbing back through the latch plate until the required tightness is achieved (Figure 41.3).

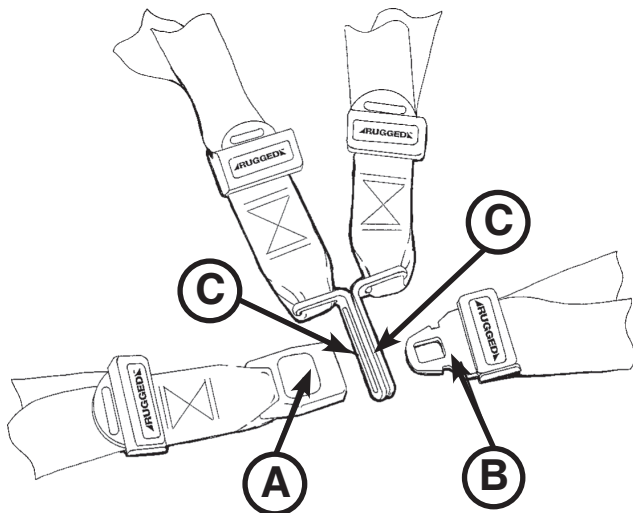

Figure 41.1: Buckling the Safety Restraints

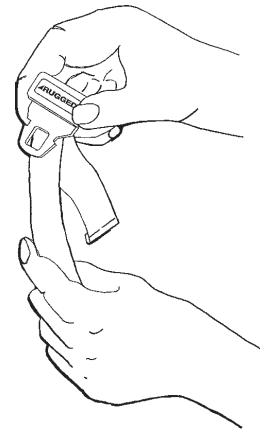

Figure 41.2: Lengthening the Safety Restraint

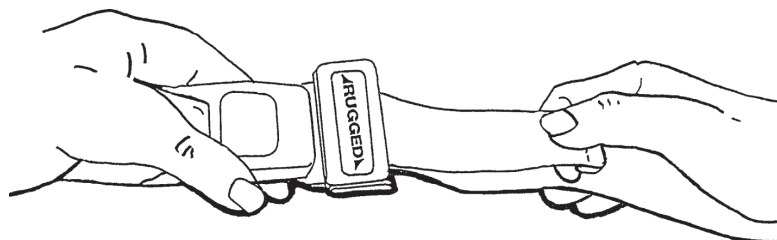

Figure 41.3: Shortening the Safety Restraint

Whenever a restraint is buckled on a patient, verify that the latch plate is fully engaged and any extra webbing is not tangled in the cot or hanging loose.

Inspect the restraints **at least** once a month (more frequently if used heavily). Inspection should include checking for a bent or broken receiver or latch plate, torn or frayed webbing, etc. Any restraint showing wear or not operating properly **must** be replaced immediately.

[Return To Table of Contents](#)

# Operation Guide

---

## USING THE OPTIONAL RESTRAINT BELT EXTENSION

Use the restraint belt extension, as shown in Figure 42, for extra length when buckling the lap belt around large patients.

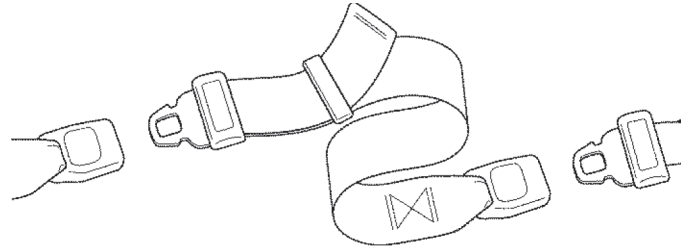

**Figure 42: Attaching the Restraint Belt Extension**

# Operation Guide

---

## OPERATING THE SIDERAILS

**To raise the siderails**, as shown in Figure 43, lift up on the siderail until the latch clicks and the siderail locks into place. When a patient is on the cot, always keep the siderails in the raised position unless the patient is being transferred.

**To lower the siderails**, squeeze handle (B) to release the siderail latch. Guide the siderail down toward the foot end until flat.

---

### WARNING

Siderails are not intended to serve as a patient restraint device. See [page 48](#) for proper restraint strap usage. Failure to utilize the siderails properly could result in patient injury.

---

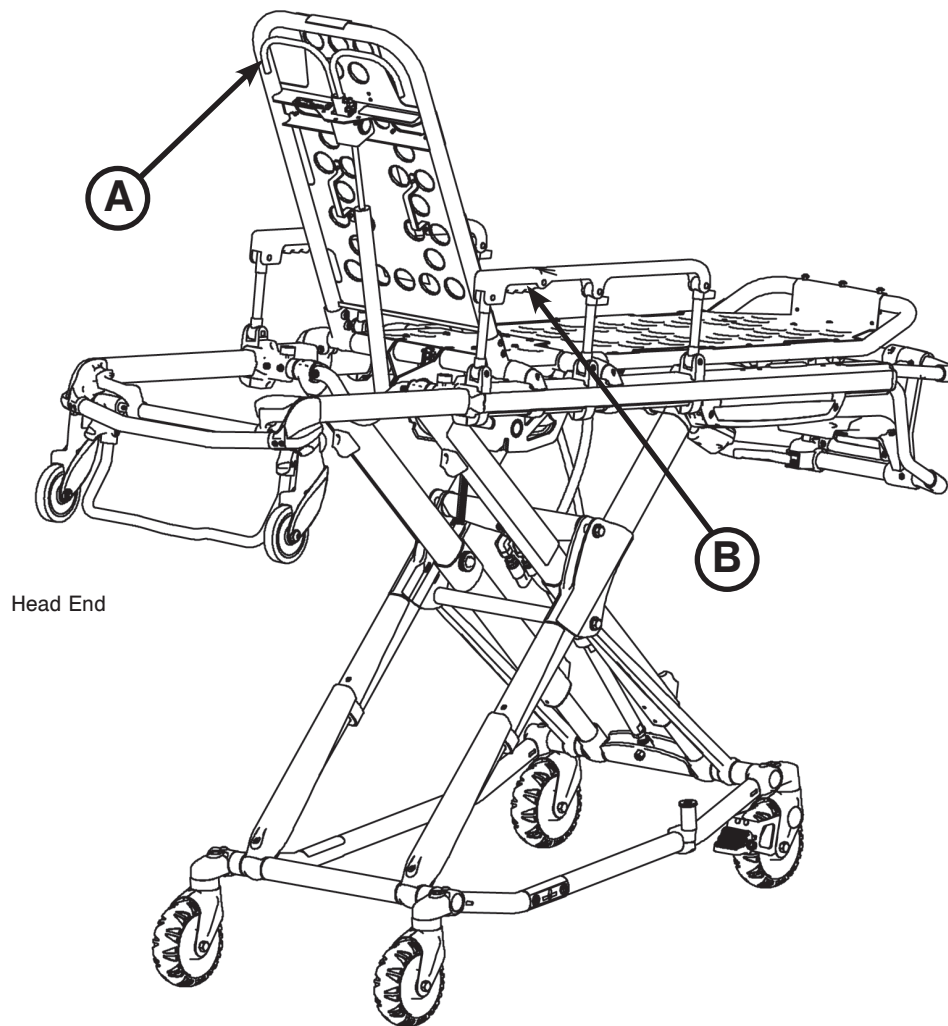

Figure 43: Backrest Elevated and Siderails Raised

## OPERATING THE BACKREST

**To raise the backrest**, as shown in Figure 43, squeeze handle (A) for pneumatic assist in lifting the backrest to the desired height.

**To lower the backrest**, squeeze handle (A) and push down on the backrest frame until the backrest has reached the desired height.

[Return To Table of Contents](#)

# Operation Guide

## OPERATING THE RETRACTABLE HEAD SECTION

The head section telescopes from a first position suitable for loading the cot into an emergency vehicle to a second position retracted within the litter frame. When retracted, the cot can roll in any direction on the caster wheels even in the lowest position, allowing for improved mobility and maneuverability.

### To extend the head section:

1. Grasp the outer rail with one hand for support and pull the lever (A), rotating the lever toward the head end of the cot to release the head section from the locked position.
2. While holding the handle (A) in the released position, pull the head section away from the litter frame, lengthening the head section until it engages in the fully extended position.
3. Release lever (A) to lock the head section in the extended position.

### To retract the head section:

1. Grasp the outer rail with one hand for support and release the lever (A), rotate the lever toward the head end of the cot to release the head section from the locked position.
2. While holding the handle (A) in the released position, push the head section toward the litter frame, retracting the head section until it engages in the retracted position.
3. Release lever (A) to lock the head section in the retracted position.

### WARNING

- To avoid injury, always verify that the head section is locked into place prior to operating the cot.
- When using a standard cot fastener, do not attempt to load the cot into the patient compartment with the head section retracted. Loading the cot with the head section retracted may cause the product to tip or not engage properly in the cot fastener, possibly causing injury to the patient or operator and/or damage to the product.

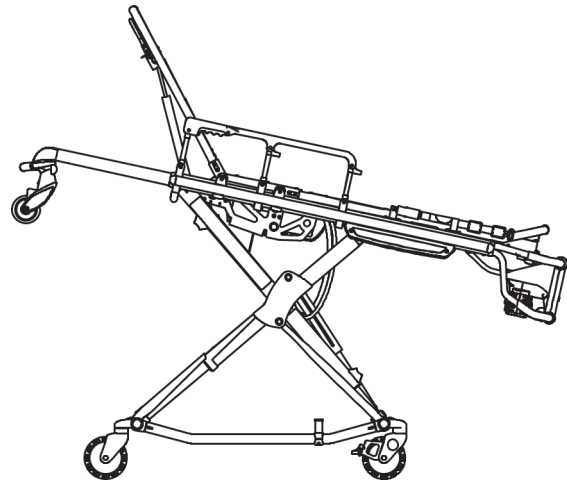

Figure 44.1: Head Section Extended

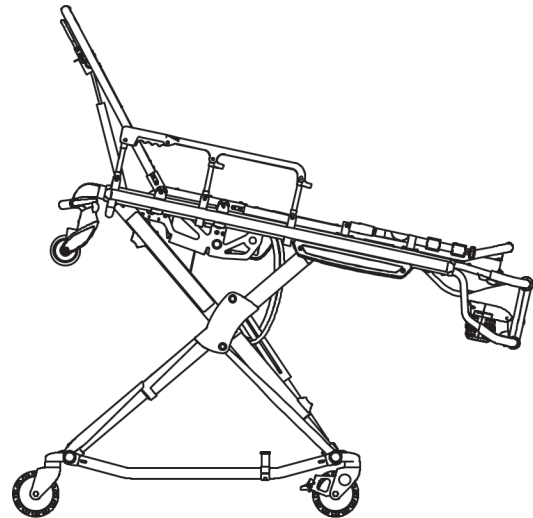

Figure 44.2: Head Section Retracted

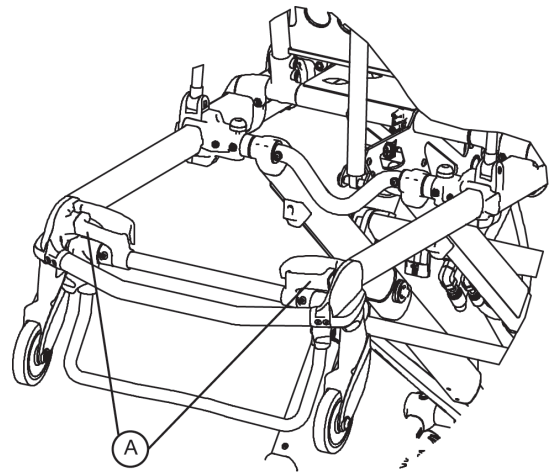

Figure 44.3: Head Section Release Handles

# Operation Guide

## ADJUSTING THE FOOTREST

The footrest is adjustable to elevate the patient's legs (see Figure 45).

**To raise the footrest**, lift the footrest frame (A) as high as possible. The support bracket engages automatically when released.

**To lower the footrest**, lift the footrest frame (A) and while holding the frame, lift up on the release handle (B) until the bracket disengages. Lower the footrest until flat.

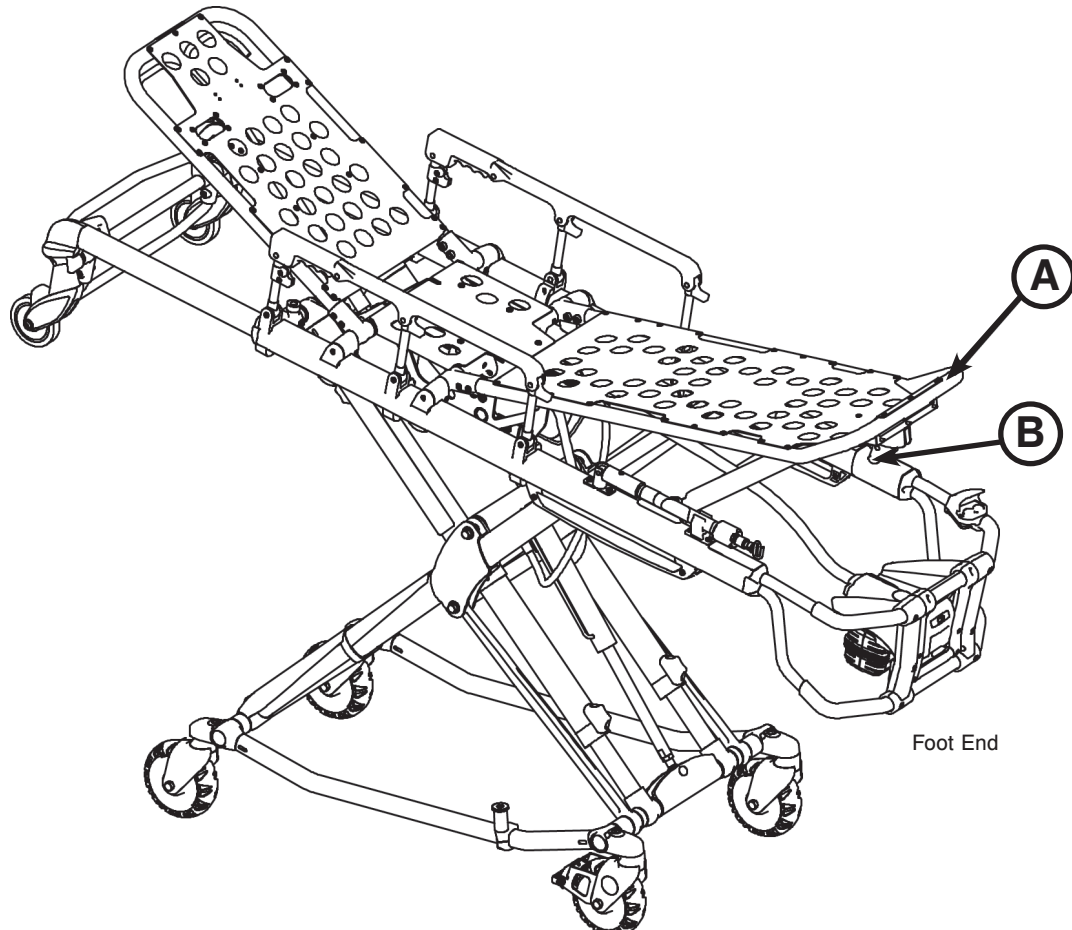

Figure 45: Footrest Elevated

# Operation Guide

## RAISING AND LOWERING THE OPTIONAL GATCH

**To raise the gatch,** lift either of the red lifting loops (A) until the gatch is in its fully raised position, then slowly lower the gatch to allow the support bracket to engage into the locking mechanism. Make sure that the lock is fully engaged before releasing the lifting loop.

**To lower the gatch,** lift either of the red lifting loops (A) to relieve pressure on the locking mechanism and while holding the loop, lift up on the red release handle (B) until the bracket disengages. Lower the gatch to the flat position.

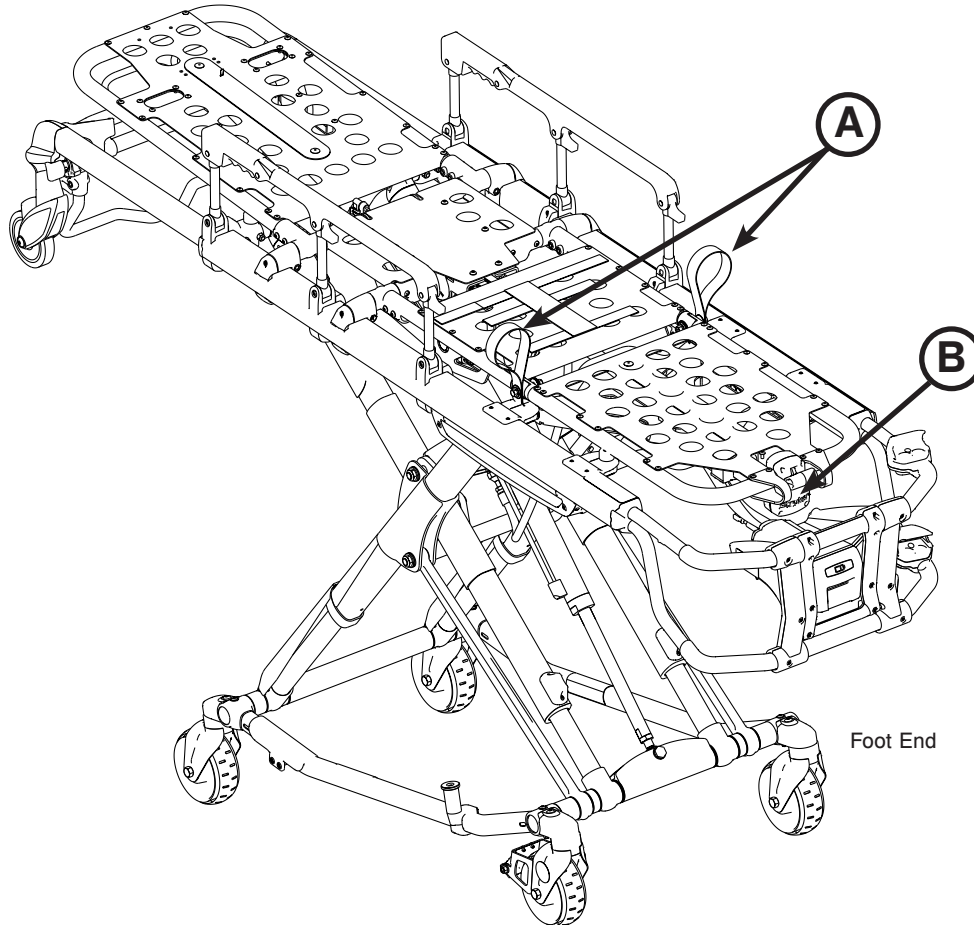

Figure 46: Gatch

# Operation Guide

---

## OPERATING THE OPTIONAL WHEEL LOCK(S)

To activate the optional wheel lock(s), press fully down on the pedal (A) as shown in Figure 47 until it stops and is resting firmly against the surface of the wheel.

To release the optional wheel lock(s), depress the upper face of the pedal with your foot or lift up with your toe under the pedal. The upper portion of the pedal will rest against the caster frame when the wheel lock is released.

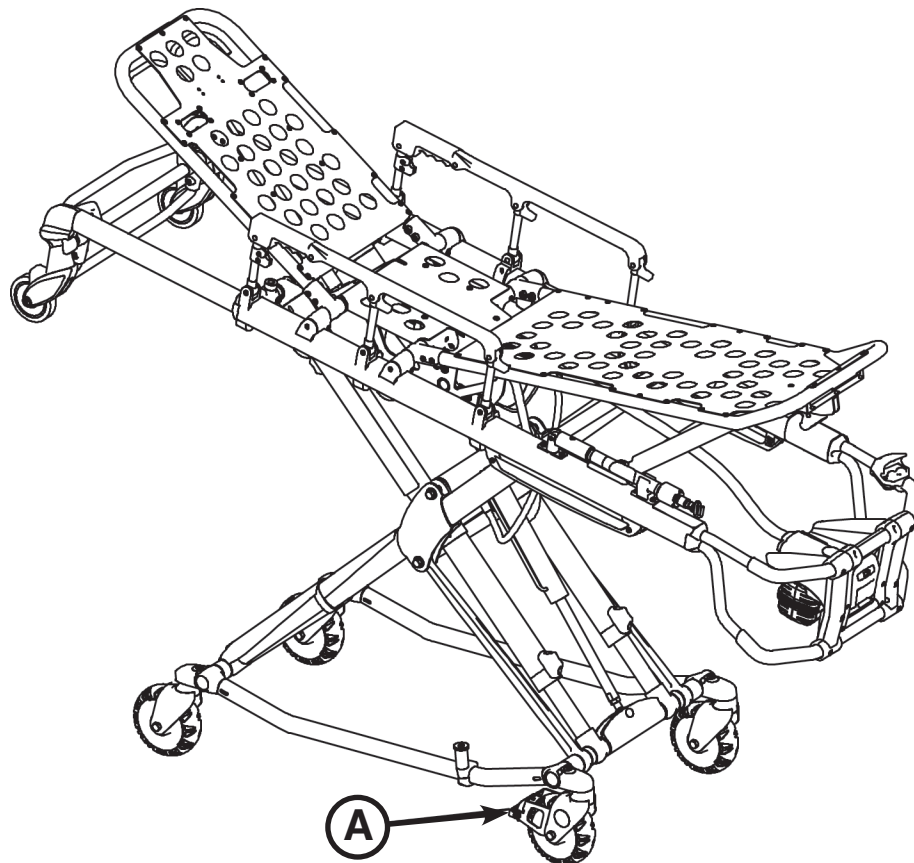

Figure 47: Wheel Lock

---

### WARNING

- Never apply the optional wheel lock(s) while a patient is on the cot. Tipping could occur if the cot is moved while a wheel lock is applied, resulting in injury to the patient or operator and/or damage to the cot.
- Never leave a patient unattended on the cot or injury could result. Hold the cot securely while a patient is on the cot.
- Never install or use a wheel lock on a cot with excessively worn wheels. Installing or using a wheel lock on a wheel with less than a 6" diameter could compromise the holding ability of the wheel lock, possibly resulting in injury to the patient or operator and/or damage to the cot or other equipment.

---

### CAUTION

Wheel lock(s) are only intended to help prevent the cot from rolling while unattended and to aid in patient transfer. A wheel lock may not provide sufficient resistance on all surfaces or under loads.

---

[Return To Table of Contents](#)

# Operation Guide

## OPERATING THE OPTIONAL 2-STAGE I.V. POLE

### To use the 2-stage I.V. pole (see Figure 48.2):

1. Lift and pivot the pole from the storage position and push down until it is locked into the receptacle (A).
2. To raise the height of the pole, turn the lock actuator (B) counterclockwise and pull up on the telescoping portion (C) of the pole to raise it to the desired height.
3. Turn the lock actuator (B) clockwise to lock the telescoping portion in place.
4. Hang the I.V. bags on the I.V. hook (D).
5. Turn the lock actuator (B) counterclockwise and slide section (C) into the bottom tube.
6. Turn the lock actuator (B) clockwise to tighten.
7. Lift up and pivot the pole down into the storage position (see Figure 48.1).

### CAUTION

To avoid damage to the I.V. pole, the weight of the I.V. bags or equipment must not exceed 40 pounds (18 kg).

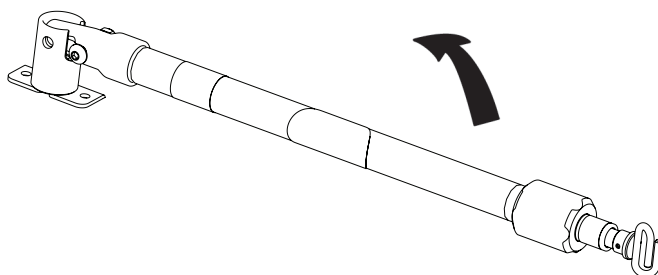

Figure 48.1: 2-Stage I.V. Pole Storage Position

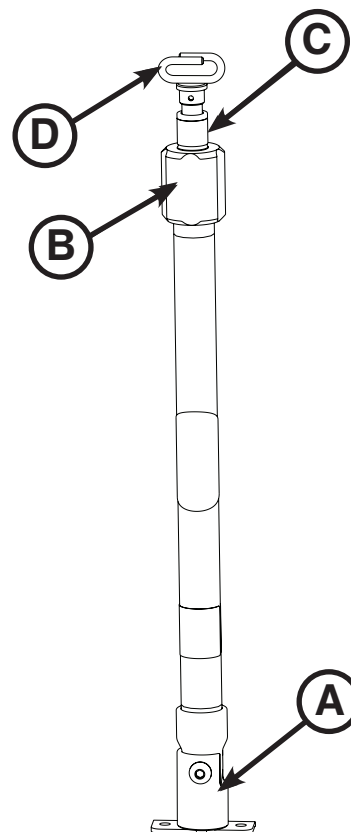

Figure 48.2: 2-Stage I.V. Pole



# Operation Guide

## OPERATING THE OPTIONAL 3-STAGE I.V. POLE

### To use the 3-stage I.V. pole (see Figure 49.2):

1. Lift and pivot the pole from the storage position and push down until it is locked into the receptacle (A).
2. To raise the height of the pole, turn the lock actuator (B) counterclockwise and pull up on the bottom telescoping portion (C) of the pole to raise it to the desired height.
3. Turn the lock actuator (B) clockwise to lock the bottom telescoping portion in place.
4. For a higher I.V. pole, pull up on section (D) until the spring clip (E) engages.
5. Hang I.V. bags on the I.V. hook (F).
6. To lower the I.V. pole, push in on the spring clip (E) and slide section (D) down into section (C). Turn the lock actuator (B) counterclockwise and slide section (C) into the bottom tube.
7. Turn the lock actuator (B) clockwise to tighten.
8. Lift up and pivot the pole down into the storage position (see Figure 49.1).

### CAUTION

To avoid damage to the I.V. pole, the weight of the I.V. bags or equipment must not exceed 40 pounds (18 kg).

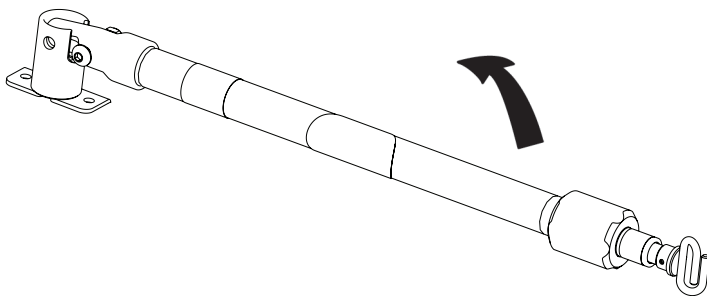

Figure 49.1: 3-Stage I.V. Pole Storage Position

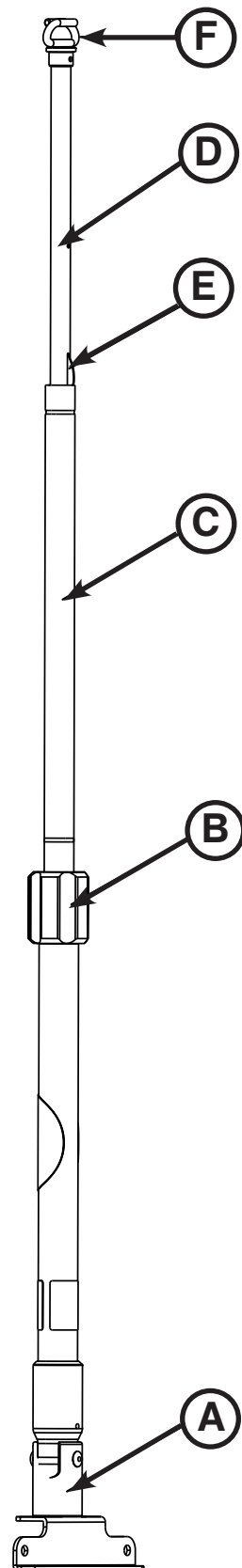

Figure 49.2: 3-Stage I.V. Pole

# Optional Accessories

---

The accessories listed below can be purchased and installed on the Power-PRO XT cot.

<b>Accessory</b>	<b>Part Number</b>	<b>Operation Guide Page Number</b>
Equipment Hook	6500-147-000	<a href="#">59</a>
Oxygen Bottle Holder, Removable	6080-140-000	<a href="#">60</a>
Pedi-Mate® Restraint Package	6091-300-010	<a href="#">61</a>
Bariatric Transfer Flat	6083-001-200	<a href="#">63</a>
Pocketed Back Rest Pouch	6500-130-000	<a href="#">63</a>
Head End Storage Flat	6500-128-000	<a href="#">64</a>

# Optional Accessories

---

## USING THE EQUIPMENT HOOK

Use the equipment hook (A) (see Figure 50) to hang additional accessories or equipment, such as defibrillators or monitors.

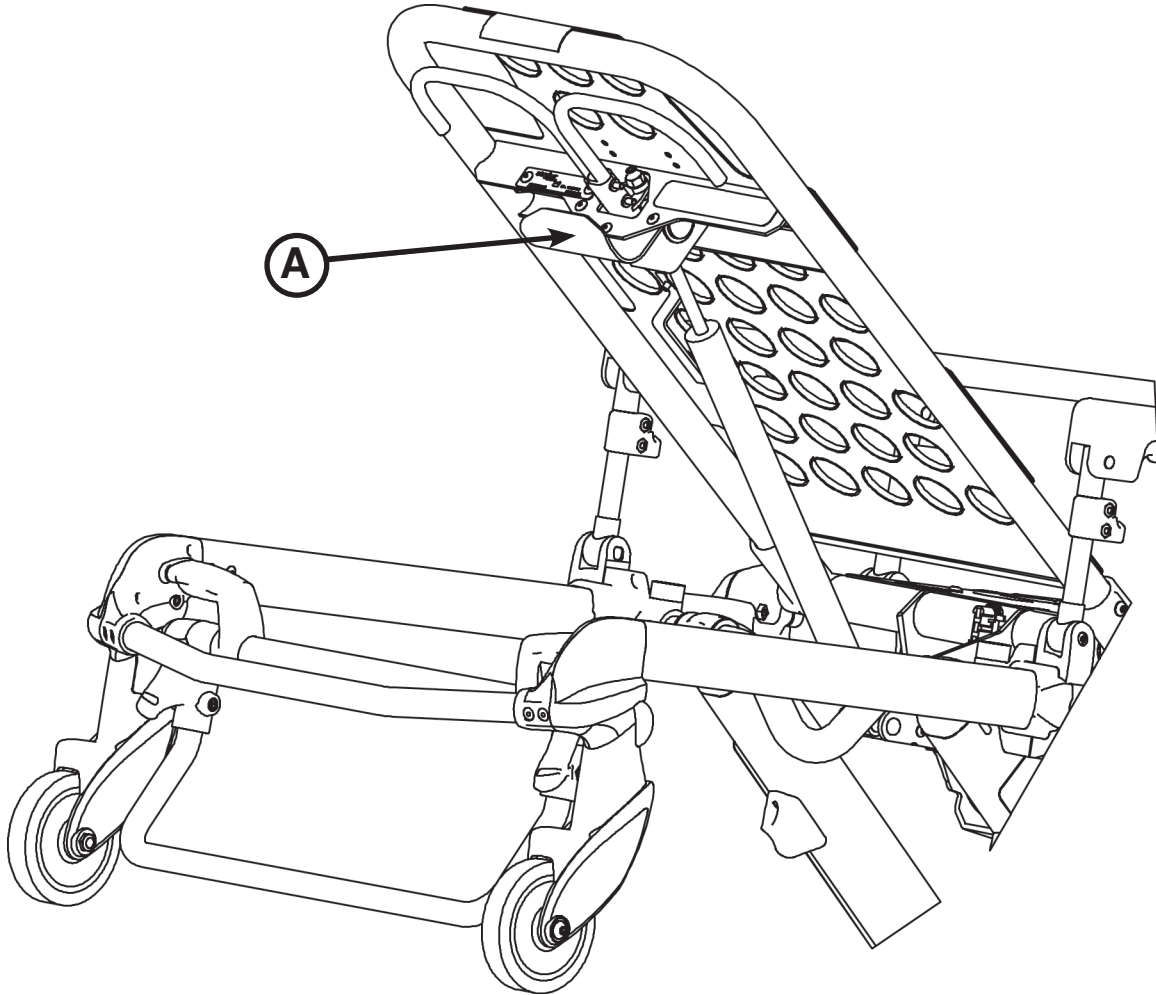

Figure 50: Equipment Hook

---

**⚠ CAUTION**

To avoid damage to the equipment hook, the weight of the accessories or equipment must not exceed 35 pounds (15.9 kg).

---

# Optional Accessories

---

## USING THE RETRACTABLE HEAD SECTION OXYGEN BOTTLE HOLDER

To attach an oxygen bottle to the retractable head section oxygen bottle holder:

1. Center the oxygen bottle on the cradled surface of item (A) as shown in Figure 51.
2. Tighten both straps (B) around the oxygen bottle.
3. Secure the slack on the straps to the Velcro® on the straps.

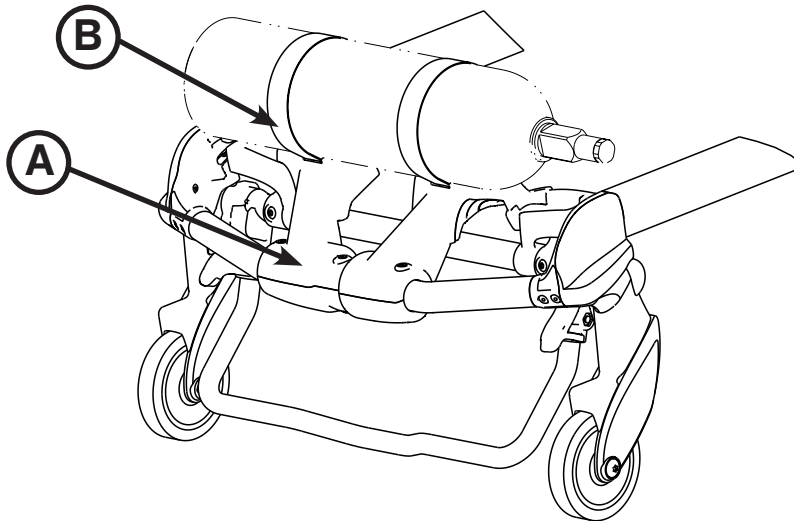

**Figure 51: Retractable Head Section Oxygen Bottle Holder**

**Note:** Inspect the straps and clips for wear between use and replace the strap if it is no longer holding the oxygen bottle.

---

**⚠ WARNING**

If the cot is equipped with the optional retractable head section oxygen bottle holder, use caution while the oxygen bottle holder is installed to avoid pinching your fingers between the fowler bracket and the oxygen bottle.

---

**⚠ CAUTION**

- To avoid damage to the retractable head section oxygen bottle holder (if equipped), the weight of the equipment must not exceed 40 pounds (18 kg).
  - Do not use two head end oxygen bottle holders at the same time.
-

# Optional Accessories

---

## ATTACHING THE PEDI-MATE® INFANT RESTRAINT SYSTEM

See the Pedi-Mate® users manual for the manufacturer's recommendations for the use, operation and care of the Pedi-Mate® Infant Restraint System.

### To secure the Pedi-Mate® to the cot:

1. Remove any restraints that are already attached to the cot.
2. Raise the cot backrest to the full upright position.
3. Position the Pedi-Mate® pad flat on the backrest with the black backrest straps out (see Figure 52.1).



Figure 52.1: Positioning the Pedi-Mate®

4. Wrap the straps around the backrest and insert the ends of the straps through the brackets. Securely fasten the buckle (see Figure 52.2).

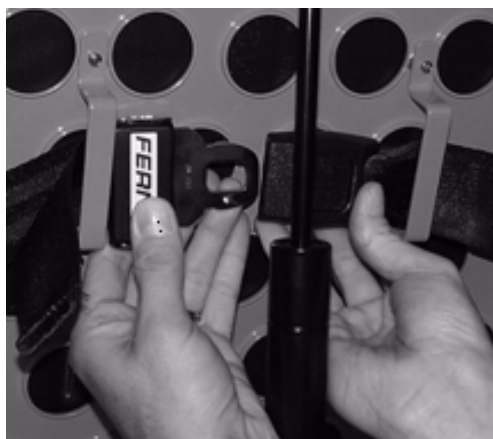

Figure 52.2: Fastening the Pedi-Mate® Buckle

---

### **WARNING**

To avoid accidental release of the Pedi-Mate®, and possible injury to the infant, ensure that the buckle is located away from obstructions on the cot or accessories.

---

# Optional Accessories

---

## ATTACHING THE PEDI-MATE® INFANT RESTRAINT SYSTEM (CONTINUED)

5. Pull firmly on the end of the adjustable backrest strap and tighten it securely.
6. Insert the mainframe straps between the cot frame and the mattress. To ensure that the release button is located toward the foot end of the cot, insert the buckle behind the litter cross brace and bring it up in front of the cross brace. Secure the buckle around the cross brace, leaving a little slack in the strap for final adjustment (see Figure 52.3).



Figure 52.3: Securing the Safety Restraints on a Cot

---

### **WARNING**

To avoid accidental release of the Pedi-Mate®, and possible injury to the infant, ensure that the buckle is located away from obstructions on the cot or accessories.

---

7. Verify that all of the straps are snug and fastened securely (see Figure 52.4).



Figure 51.4: Pedi-Mate® Strapped to a Cot

**Note:** These are general instructions for installation of the Pedi-Mate®. Safe and proper use of the Pedi-Mate® is solely at the discretion of the user. Stryker recommends that all users be trained on the proper use of the Pedi-Mate® before using it in an actual situation. Retain these instructions for future reference. Include them with the product in the event of transfer to new users.

Pedi-Mate® is a registered trademark of Ferno-Washington, Inc.

# Optional Accessories

---

## USING THE TRANSFER FLAT

When transferring larger patients, use of the Transfer Flat (6083-001-200) is recommended.

## INSTALLING THE BACKREST STORAGE POUCH

Install the optional backrest storage pouch using the Velcro® straps as shown in Figure 53. Insert each strap through a hole in the backrest skin and mount the pouch flat against the backrest.

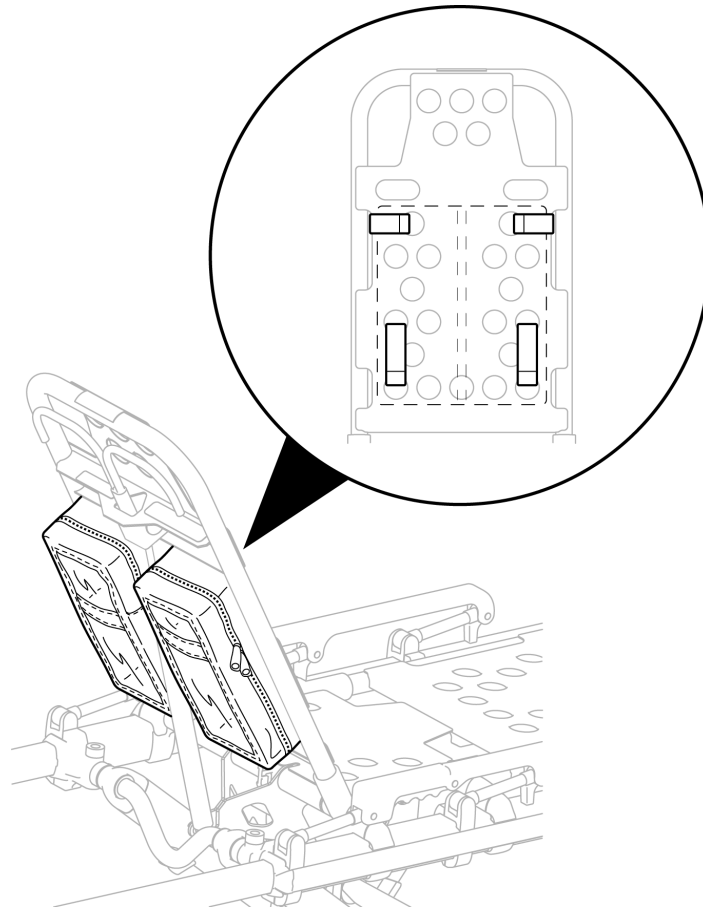

**Figure 53: Backrest Storage Pouch**

---

### CAUTION

- Do not store items under the cot mattress. Storing items under the mattress can interfere with the operation of the cot.
  - The weight of the equipment in the pocketed backrest storage pouch (if equipped) must not exceed 20 pounds (9 kg).
-

# Optional Accessories

## INSTALLING THE HEAD END STORAGE FLAT

To install the optional head end storage flat (see Figure 54):

1. Install the Velcro® straps (A) near the pneumatic cylinder and around the cross bar of the retractable head section.
2. Buckle the restraint straps (B) around the outer rails of the retractable head section.

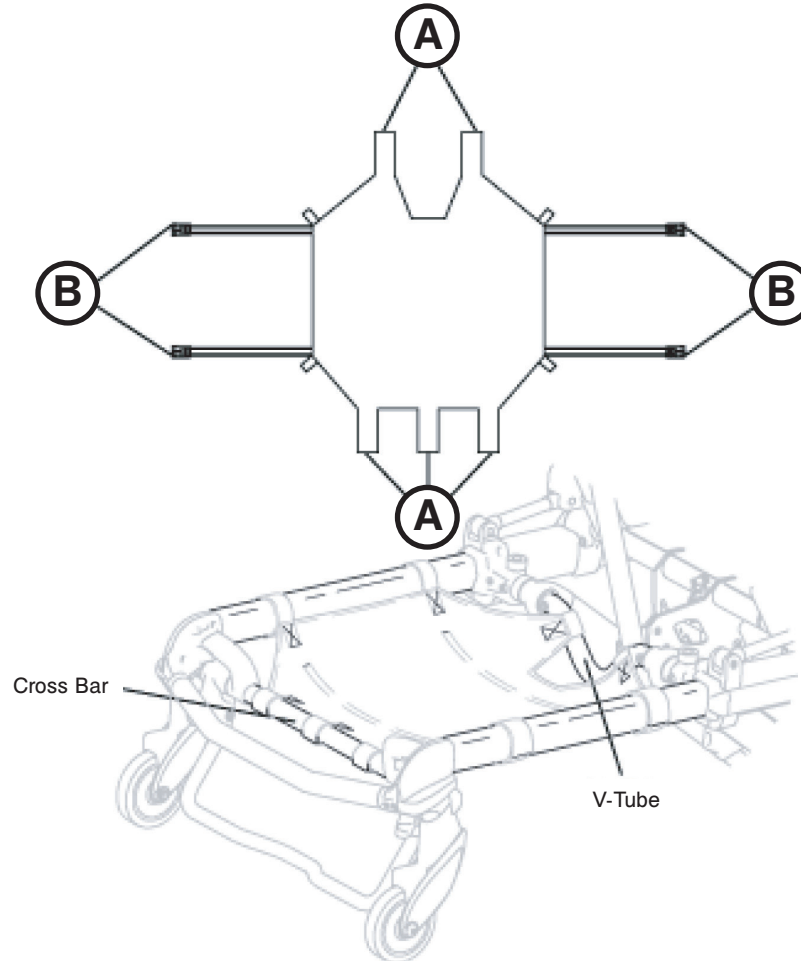

Figure 54: Head End Storage Flat

### WARNING

When the optional head end storage flat is being used, ensure that it does not interfere with the operation of the retractable head section, safety bar and safety hook. Injury to the patient or operator could result.

### CAUTION

- Do not store items under the cot mattress. Storing items under the mattress can interfere with the operation of the cot.
- The weight of the equipment in the head end storage flat (if equipped) must not exceed 40 pounds (18 kg).



# Cleaning

---

The Power-PRO™ XT cot is designed to be power washable. The unit may show some signs of oxidation or discoloration from continuous washing, however, no degradation of the cot's performance characteristics or functionality will occur due to power washing as long as the proper procedures are followed.

Thoroughly clean the cot once a month. Clean Velcro® AFTER EACH USE. Saturate Velcro® with disinfectant and allow disinfectant to evaporate. (Appropriate disinfectant for nylon Velcro® should be determined by the service.)

## WASHING PROCEDURE

- **Always remove the battery!** Never wash the cot with the battery installed.
- Follow the cleaning solution manufacturer's dilution recommendations exactly.
- The preferred method Stryker Medical recommends for power washing the cot is with the standard hospital surgical cart washer or hand held wand unit.

## WASHING LIMITATIONS

---

### WARNING

Use any appropriate personal safety equipment (goggles, respirator, etc.) to avoid the risk of inhaling contagion. Use of power washing equipment can aerate contamination collected during the use of the cot.

---

### CAUTION

- DO NOT STEAM CLEAN OR ULTRASONICALLY CLEAN THE UNIT.
  - Maximum water temperature should not exceed 180°F/82°C.
  - Maximum air dry temperature (cart washers) should not exceed 240°F/115°C.
  - Maximum water pressure should not exceed 1500 psi/130.5 bar. If a hand held wand is being used to wash the unit, the pressure nozzle must be kept a minimum of 24 inches (61 cm) from the unit.
  - Towel dry all casters and interface points.
  - Failure to comply with these instructions may invalidate any/all warranties.
  - Always remove the battery before washing the cot.
-

# Cleaning

---

In general, when used in those concentrations recommended by the manufacturer, either phenolic type or quaternary (excluding Virex® TB) type disinfectants can be used. Iodophor type disinfectants are not recommended for use because staining may result.

Suggested cleaners for the cot surfaces:

- Quaternary Cleaners (active ingredient - ammonium chloride)
- Phenolic Cleaners (active ingredient - o-phenylphenol)
- Chlorinated Bleach Solution (5.25% - less than 1 part bleach to 100 parts water)

Avoid over saturation and ensure that the product does not stay wet longer than the chemical manufacturer's guidelines for proper disinfecting.

---

## WARNING

SOME CLEANING PRODUCTS ARE CORROSIVE IN NATURE AND MAY CAUSE DAMAGE TO THE PRODUCT IF USED IMPROPERLY. If the products described above are used to clean Stryker EMS equipment, measures must be taken to insure the cots are wiped with clean water and thoroughly dried following cleaning. Failure to properly rinse and dry the cots will leave a corrosive residue on the surface of the cots, possibly causing premature corrosion of critical components.

---

**Note:** Failure to follow the above directions when using these types of cleaners may void this product's warranty (see [page 163](#)).

## REMOVAL OF IODINE COMPOUNDS

Use a solution of 1/2 Tablespoon Sodium Thiosulfate in a pint of warm water to clean the stained area. Clean as soon as possible after staining occurs. If stains are not immediately removed, allow solution to soak or stand on the surface. Rinse surfaces which have been exposed to the solution in clear water before returning unit to service.

---

## WARNING

Failure to properly clean or dispose of contaminated mattress or cot components will increase the risk of exposure to bloodborne pathogens and may cause injury to the patient or the operator.

---

# Preventative Maintenance

---

Preventative maintenance should be performed at a minimum of annually. A preventative maintenance program should be established for all Stryker Medical equipment. Preventative maintenance may need to be performed more frequently based on the usage level of the product. The cot requires regular maintenance. Establish and follow a maintenance schedule and keep records of maintenance activity (see [page 71](#) for a form).

---

## CAUTION

A preventative maintenance program should be established for all Stryker EMS equipment. Preventative maintenance may need to be performed more frequently based on the usage level of the product. Close attention should be given to safety features including, but not limited to:

- Hydraulic power mechanism
- All electrical controls return to off or neutral position when released

For additional maintenance information, see the preventative maintenance information on [page 71](#).

---

## WARNING

- Do not modify the cot or any components of the cot. Modifying the product can cause unpredictable operation resulting in injury to the patient or operator. Modifying the product will also void its warranty (see [page 163](#)).
  - Escaping fluid under pressure can penetrate the skin causing serious injury. Avoid the hazard by relieving pressure before disconnecting hydraulic or other lines. Tighten all connections before applying pressure. If an accident occurs, see a doctor immediately. Any fluid injected into the skin must be surgically removed within a few hours or gangrene may result. Doctors unfamiliar with this type of injury should reference a knowledgeable medical source.
  - To avoid the risk of injury, do not use bare hands to check for hydraulic leaks.
- 

When using maintenance products, follow the directions of the manufacturer and reference all material safety data sheets.

---

## CAUTION

- Improper maintenance can cause injury or damage to the product. Maintain the cot as described in this manual. Use only Stryker approved parts and maintenance procedures. Using unapproved parts and procedures could cause unpredictable operation and/or injury and will void the product warranty (see [page 163](#)).
  - Failure to use authorized parts, lubricants, etc. could cause damage to the cot and will void the warranty of the product.
  - Hydraulic lines, hoses, and connections can fail or loosen due to physical damage, kinks, age, and exposure. Check hoses and lines regularly to avoid damage to the cot. Check and tighten loose connections.
  - Do not tip the cot onto its load wheels and actuate the product as this will allow air to enter the hydraulic system.
- 

## LUBRICATION

The cot has been designed to operate without the need for lubrication.

---

## CAUTION

Do not lubricate the bearings in the X-frame as it will degrade the performance of the cot and may void its warranty (see [page 163](#)).

---

# Preventative Maintenance

## REGULAR INSPECTION AND ADJUSTMENTS

### Maintenance Intervals

The following schedule is intended as a general guide to maintenance. Bear in mind that such factors as weather, terrain, geographical location, and individual usage will alter the required maintenance schedule. If you are unsure as to how to perform these checks please contact your Stryker service technician. If you are in doubt as to what intervals to follow in maintaining your product, consult your Stryker service technician. Use the hour meter (see [page 47](#)) to determine the frequency for preventative maintenance procedures.

Item	Routine	Every (whichever comes first)			
		1 Month or 2 hours	3 Months or 6 hours	6 Months or 12 hours	12 Months or 24 hours
Settings	Verify the in-fastener shut-off is configured properly	X			
	Verify the cot and fastener fit and function properly				X
	Verify the safety bar engages the vehicle safety hook properly				X
Cylinder	All fasteners are secure (reference all assembly drawings)		X		
	Verify the cylinder is adjusted so the lock nut is tight and the cot stops moving when it hits the dead stops				X
	Inspect for and verify that there are no hydraulic fluid (red) leaks; inspect the fittings and tighten as necessary		X		
	Extend cylinder rod completely and wipe down rod with soft cloth and household cleaner	X			
Hydraulics	Inspect motor mount and verify that all fasteners are secure		X		
	Verify that there are no hydraulic fluid leaks		X		
	Inspect the reservoir and verify that there are no leaks		X		
	Inspect hoses and fittings for damage or wear; replace as necessary			X	
	Verify the hydraulic velocity fuse - Place a weight of approximately 50 pounds on the cot, raise the cot, lift the cot with two operators, pull the manual back-up release handle, rapidly set the cot down, verify that the cot does not drop				X
Electronic Controls	Extend cot to raised position, measure and check load height			X	
	Verify "jog" function is operating			X	
	Verify high speed retract is working			X	
Switches	Verify there is no damage or wear to either switch			X	
	Verify both switches operate correctly - Replace if necessary			X	
Cables/Wires	Verify there is no damage or pinching of wiring harness, cables or lines		X		
	Check routing(s) and connection(s), verify there are no hanging wires	X			
	Verify there are no damaged connectors, replace if necessary		X		

# Preventative Maintenance

Item	Routine	Every (whichever comes first)			
		1 Month or 2 hours	3 Months or 6 hours	6 Months or 12 hours	12 Months or 24 hours
Manual Back-up Release Handle	Verify that the manual back-up release handle functions properly	X			
	Verify the manual back-up release handle returns to the stowed position		X		X
	Verify the base extends/retracts smoothly when the manual back-up release handle is engaged				
	With 100 pounds or more on the cot, verify the cot does not lower when the manual backup release handle is pulled		X		
Litter	Inspect the cot frame/litter	X			
	Verify all welds intact, not cracked or broken				X
	Verify no bent, broken or damaged components			X	
	Verify all fasteners secure (reference all assembly drawings)		X		
	Verify warning labels present, legible (reference assembly drawings)				X
	Verify no damage or tears on cot grips			X	
	Verify the siderails operate and latch properly			X	
	Verify the backrest cylinder operates properly		X		
Mattress	Adjust pneumatic cylinder for full range of motion, if required		X		
	Verify the footrest operates properly			X	
Restraints	Verify no cracks or tears on cot mattress			X	
	Inspect patient restraints for proper function and no excessive wear	X			
Base	Inspect the cot frame/base	X			
	Verify all welds intact, not cracked or broken				X
	Verify no bent, broken, or damaged components			X	
	Verify all fasteners secure		X		
	Verify no excessive damage to X-frame guards, replace if necessary			X	
Wheels	Verify wheels are free of debris			X	
	Verify tires in good condition				X
	Verify all wheels secure, rolling and swiveling properly	X			
	Check and adjust optional wheel locks as necessary				X

[Return To Table of Contents](#)

# Preventative Maintenance

Item	Routine	Every (whichever comes first)			
		1 Month or 2 hours	3 Months or 6 hours	6 Months or 12 hours	12 Months or 24 hours
X-Frame	Verify smooth operation of X-frame		X		
Head Section	Verify all fasteners secure		X		
	Verify no bent, broken, or damaged components			X	
	Verify the head section extends and locks properly		X		
	Verify the grip bar has no excessive damage or tears			X	
	Verify load wheels are secure and roll properly			X	
Accessories	Verify the safety bar operates properly	X			
	Inspect the straps and clips on the retractable head section oxygen bottle holder (optional) for wear				X
	Verify the I.V. pole (optional) operates properly		X		
	Verify the head extension & pillow (optional) operates properly		X		
	Verify the restraint extender (optional) operates properly		X		

# Maintenance Record

Date	Maintenance Operation Performed	By	Hours





# Troubleshooting Guide

## ELECTRONICS AND HYDRAULICS LOCATOR

**Note:** Some components have been removed for clarity.

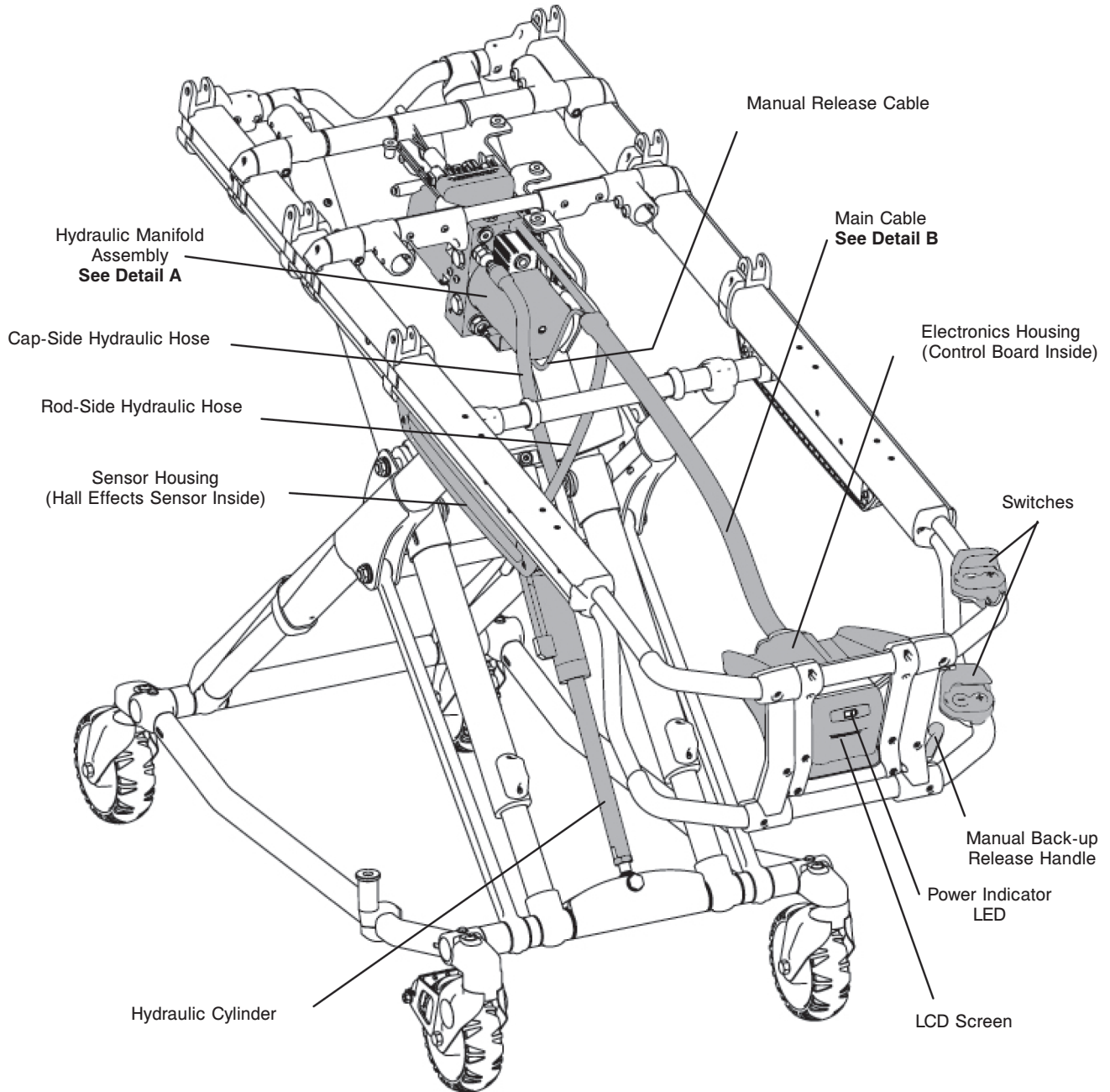

[Return To Table of Contents](#)

# Troubleshooting Guide

## HYDRAULIC MANIFOLD COMPONENTS LOCATOR

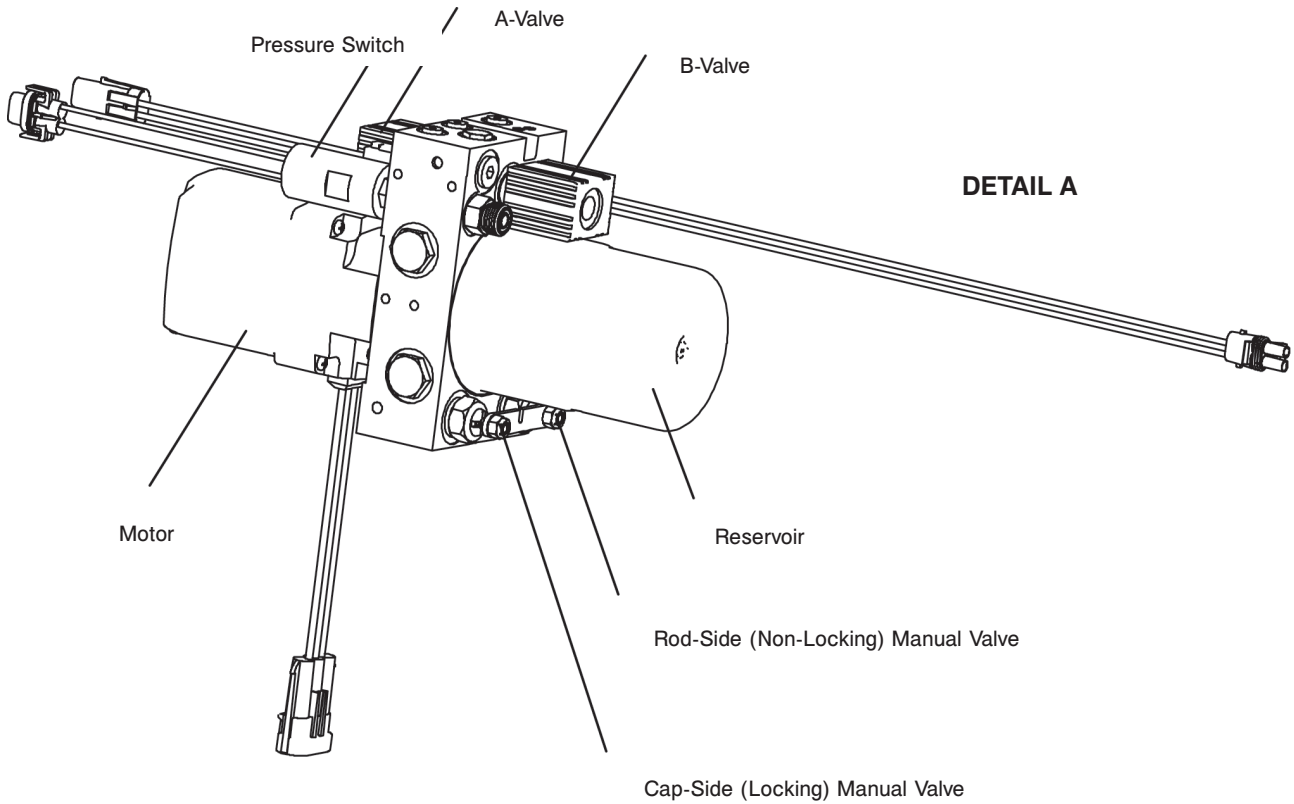

### DETAIL B

**Wiring Schematics**  
Main Cable 8-Pin Connector

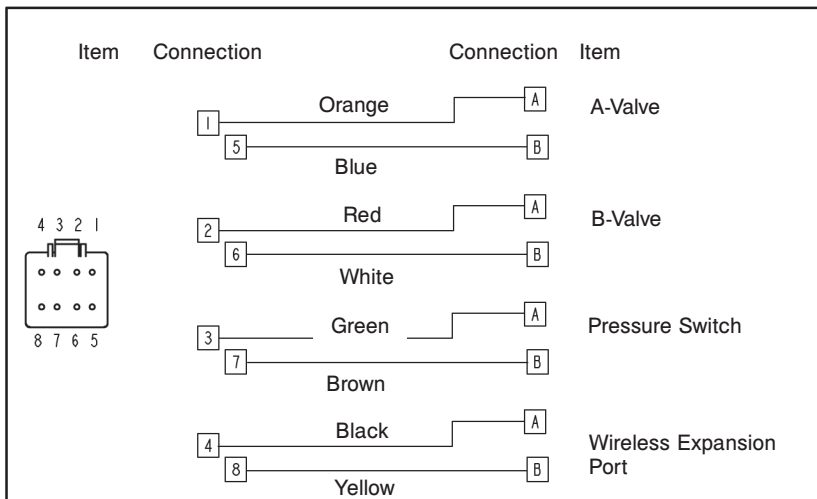

# Troubleshooting Guide

## ELECTRICAL SYSTEM BLOCK DIAGRAM

Lift and Extend (Unload) Functions

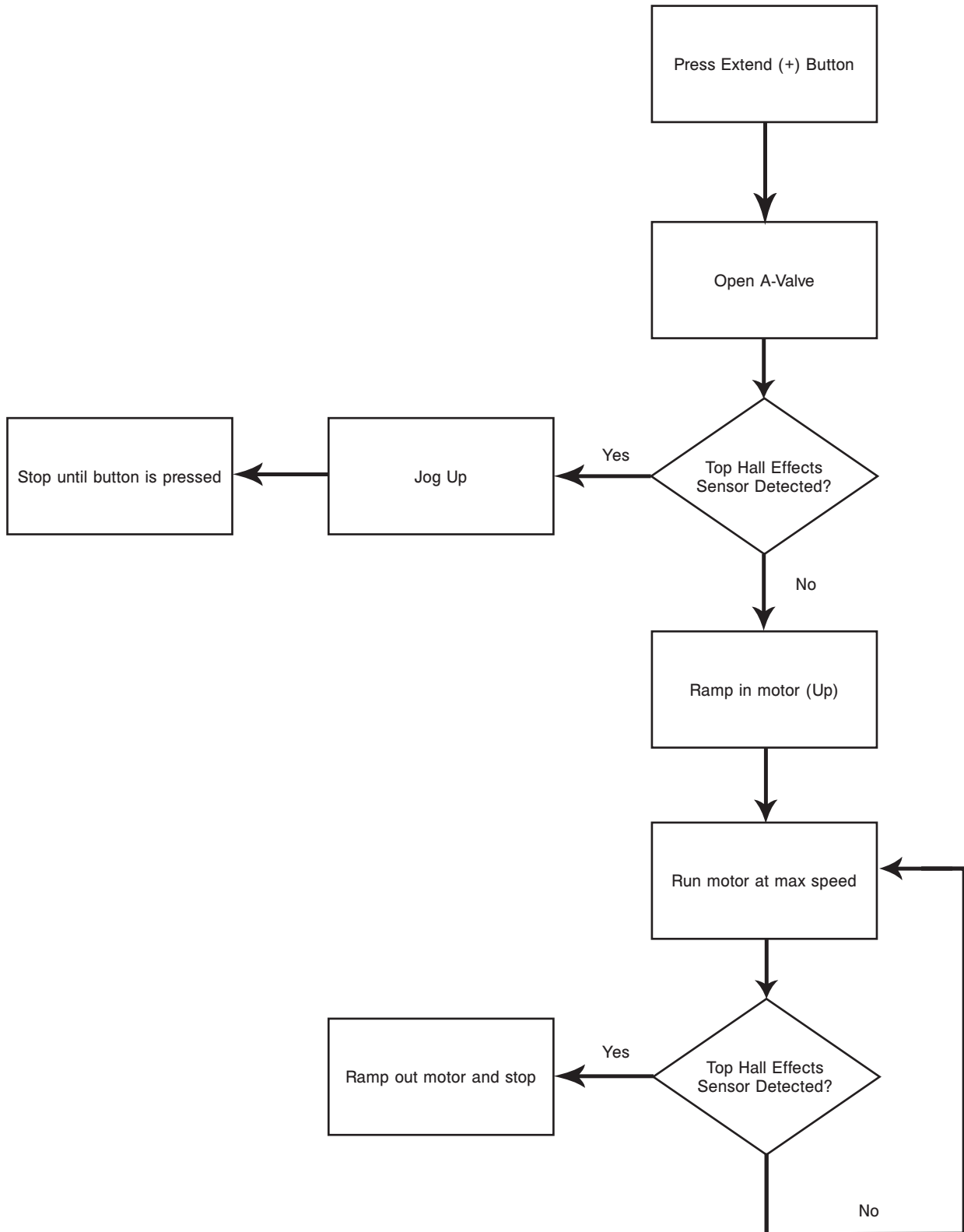

[Return To Table of Contents](#)

# Troubleshooting Guide

## Electrical System Block Diagram

### Lower and Retract (Load) Functions

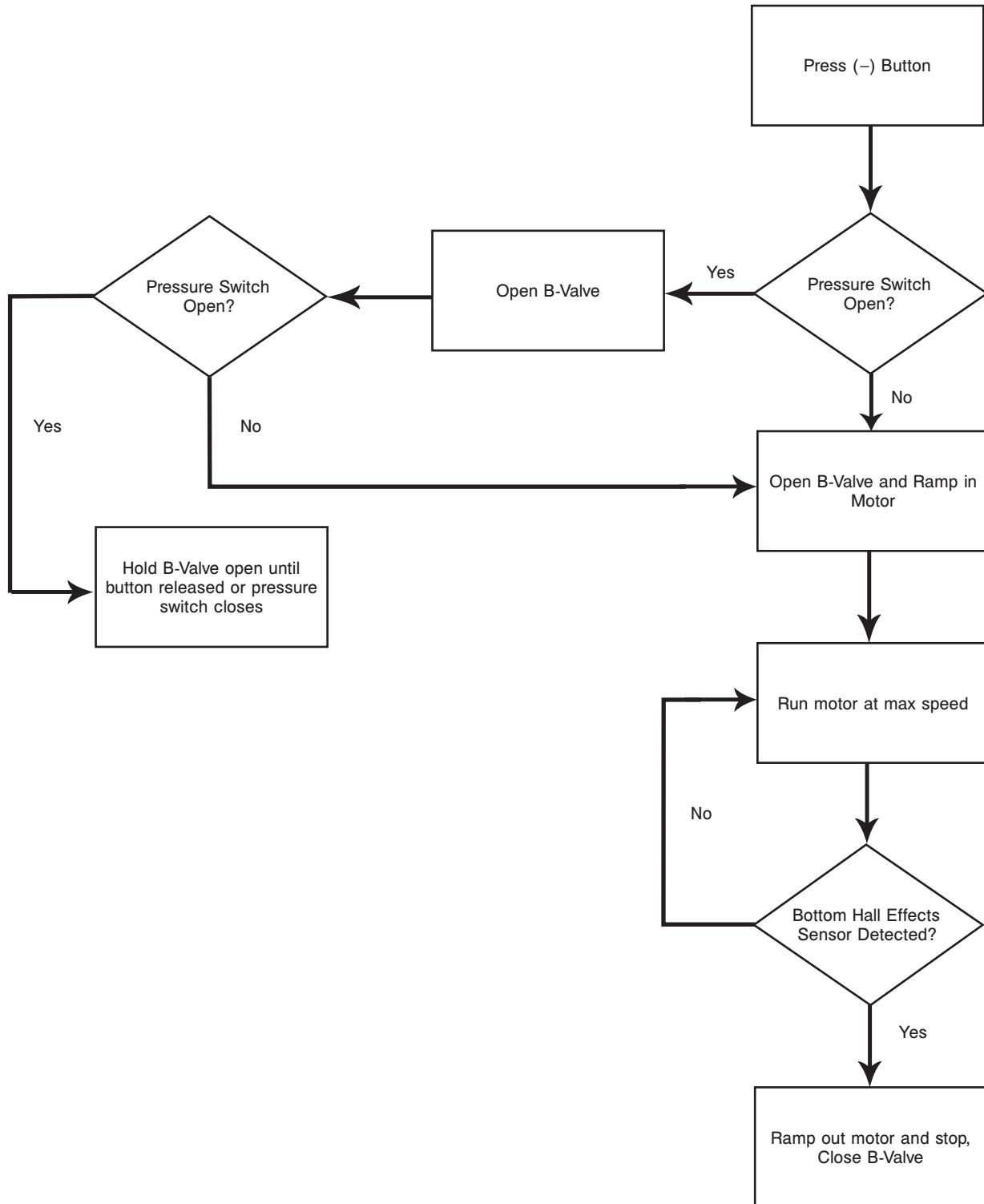

# Troubleshooting Guide

## TROUBLESHOOTING GUIDE

Check for proper operation after each step. When the problem is fixed, return the cot to service. If assistance is needed at any time during troubleshooting, please contact a service technician at (800) 327-0770 or (269) 324-6500.

PROBLEM	SOLUTION	PAGE(S)
Litter drifts (without patient weight).	<ol style="list-style-type: none"> <li>1. Flush the hydraulic system by squeezing the manual release handle while simultaneously pressing the (+) power button for approximately 15 seconds. Repeat if necessary.</li> <li>2. Check manual release cable adjustment.</li> <li>3. Change 'locking' manual valve.</li> <li>4. Change 'B' valve.</li> </ol>	
Base drifts (without patient weight).	<ol style="list-style-type: none"> <li>1. Flush the hydraulic system by squeezing the manual release handle while simultaneously pressing the (+) power button for approximately 15 seconds. Repeat if necessary.</li> <li>2. Check manual release cable adjustment.</li> <li>3. Change 'non-locking' manual valve.</li> <li>4. Change 'A' valve.</li> </ol>	
Litter does not lower in the powered mode.	<ol style="list-style-type: none"> <li>1. Check power indicator LED.               <ol style="list-style-type: none"> <li>A. If blinking constant RED, change battery.</li> <li>B. If blinking a patterned RED short, short, long flash:                   <ol style="list-style-type: none"> <li>i. Check for broken or disconnected wires.</li> <li>ii. Check for 24 VDC at connector (C) on the main cable by the motor while pressing the retract (-) button. If voltage is present, replace (in order) the hall effect sensor, solenoid, and or 'B' valve. If voltage is not present, go to step iii.</li> <li>iii. Check for 24 VDC on electronics assembly pins 1 blue and 5 orange on (F) while pressing the retract (-) button. If voltage is not present, replace the electronics assembly. If voltage is present, replace the wire harness.</li> </ol> </li> <li>C. If the GREEN light turns on, but does not lower, try the other switch. If the other switch works, replace the bad switch.</li> </ol> </li> </ol>	80, 81

# Troubleshooting Guide

## TROUBLESHOOTING GUIDE (CONTINUED)

PROBLEM	SOLUTION	PAGE(S)
<p>Litter does not extend in the powered mode.</p>	<ol style="list-style-type: none"> <li>1. Check power indicator LED.               <ol style="list-style-type: none"> <li>A. If blinking constant RED, change battery.</li> <li>B. If blinking a patterned RED short, short, long flash:                   <ol style="list-style-type: none"> <li>i. Check for broken or disconnected wires.</li> <li>ii. Check for 24 VDC at connector (B) on the main cable by the motor while pressing the extend (+) button. If voltage is present, replace (in order) the hall effect sensor, solenoid, and or 'A' valve. If voltage is not present, go to step iii.</li> <li>iii. Check for 24 VDC on electronics assembly pins 2 white and 6 red on (F) while pressing the extend (+) button. If voltage is not present, replace the electronics assembly. If voltage is present, replace the wire harness.</li> </ol> </li> <li>C. If the GREEN light turns on, but does not lower, try the other switch. If the other switch works, replace the bad switch.</li> </ol> </li> <li>2. Check motor.               <ol style="list-style-type: none"> <li>A. If the motor runs, but does not raise the cot:                   <ol style="list-style-type: none"> <li>i. Check the manual release cable for too much tension.</li> <li>ii. Lightly tap the manual locking valve.</li> <li>iii. Replace the manual locking valve.</li> </ol> </li> <li>B. If the motor is stalled, replace the 'A' valve.</li> <li>C. If the light is GREEN, but the motor does not run                   <ol style="list-style-type: none"> <li>i. Check for 24 VDC at connector (E) on the main cable. If voltage is present, replace the hall effect sensor. If the hall effect sensor is replaced, and the motor still does not run, replace the hydraulic sub assembly. If voltage is not present, go to step ii.</li> <li>ii. Check for 24 VDC on electronics assembly connection (H) (-) lead on black (+) lead on green while pressing the extend (+) button. If voltage is not present, replace the electronics assembly. If voltage is present, replace the main cable.</li> </ol> </li> </ol> </li> </ol>	<p>80, 81</p>

# Troubleshooting Guide

## TROUBLESHOOTING GUIDE (CONTINUED)

PROBLEM	SOLUTION	PAGE(S)
Base does not retract in the powered mode.	<ol style="list-style-type: none"> <li>1. Check power indicator LED.               <ol style="list-style-type: none"> <li>A. If blinking constant RED, change battery.</li> <li>B. If blinking a patterned RED short, short, long flash:                   <ol style="list-style-type: none"> <li>i. Check for broken or disconnected wires.</li> <li>ii. Check for 24 VDC at connector (B) on the main cable by the motor while pressing the extend (+) button. If voltage is present, replace (in order) the hall effect sensor, solenoid, and or 'A' valve. If voltage is not present, go to step iii.</li> <li>iii. Check for 24 VDC on electronics assembly pins 2 white and 6 red on (F) while pressing the (+a) button. If voltage is not present, replace the electronics assembly. If voltage is present, replace the wire harness.</li> </ol> </li> </ol> </li> </ol>	80, 81
Base does not extend in the manual mode.	<ol style="list-style-type: none"> <li>1. Check manual cable adjustment.</li> <li>2. Change 'non-locking' manual valve.</li> </ol>	
Base does not retract in the manual mode.	<ol style="list-style-type: none"> <li>1. Check manual release cable adjustment.</li> <li>2. Change 'locking' manual valve.</li> </ol>	
Litter does not retract in the manual mode (with patient weight).	<ol style="list-style-type: none"> <li>1. Make sure that the weight is off of the casters before lowering the cot.</li> <li>2. Check manual cable adjustment.</li> <li>3. Replace 'locking' manual valve.</li> </ol>	
Litter does not extend in the manual mode.	<ol style="list-style-type: none"> <li>1. Check manual cable adjustment.</li> <li>2. Change 'non-locking' manual valve.</li> </ol>	
High Speed retract does not engage.	<ol style="list-style-type: none"> <li>1. Check that weight is off of the casters.</li> <li>2. Change pressure switch.</li> <li>3. Change hall effect cable.</li> </ol>	

# Troubleshooting Guide

## MAIN CABLE ASSEMBLY

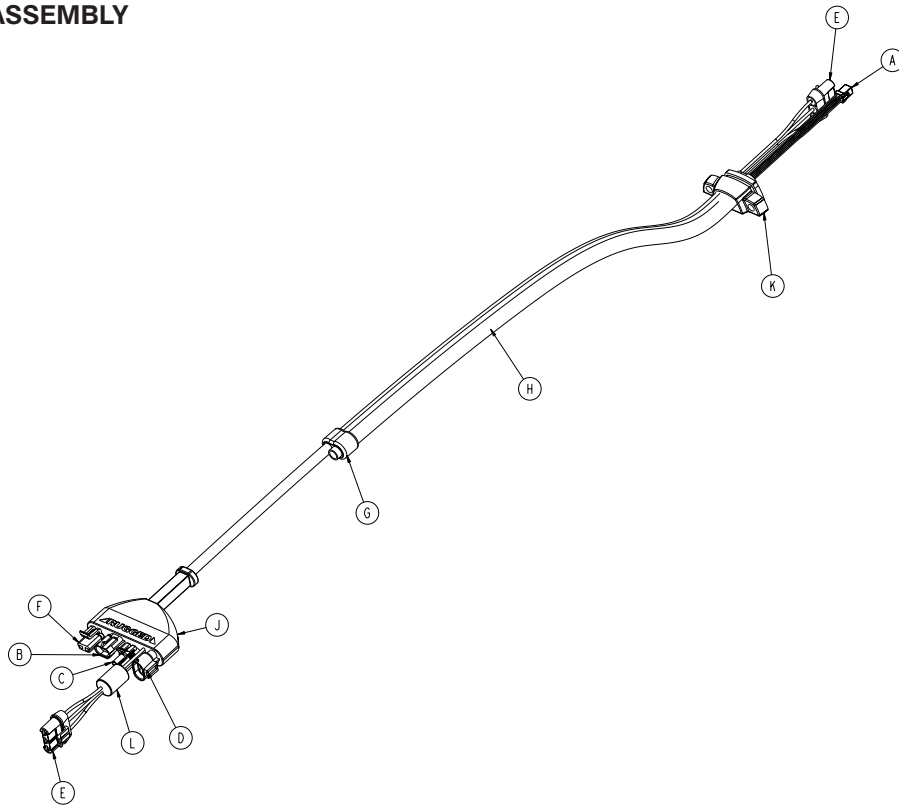

## ELECTRONICS ASSEMBLY

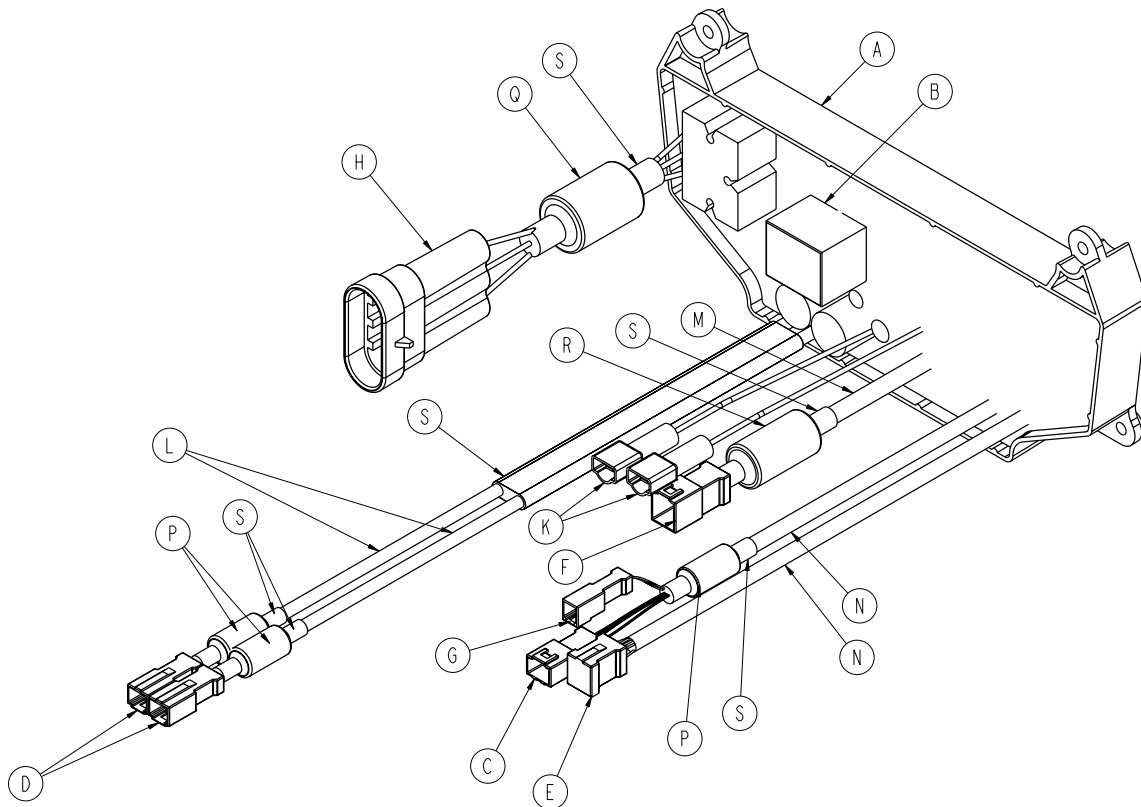



# Troubleshooting Guide

## ELECTRONICS ASSEMBLY WIRING SCHEMATICS

ITEM	CONNECTION	CONNECTION	ITEM
------	------------	------------	------

### HYDRAULICS - 22 AWG

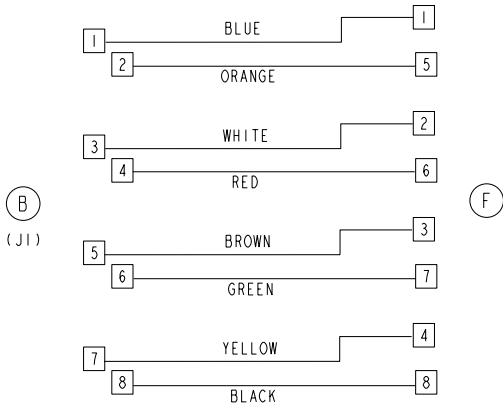

### SWITCH - 22 AWG



ITEM	CONNECTION	CONNECTION	ITEM
------	------------	------------	------

### HAND HELD PROGRAMMER - 22 AWG

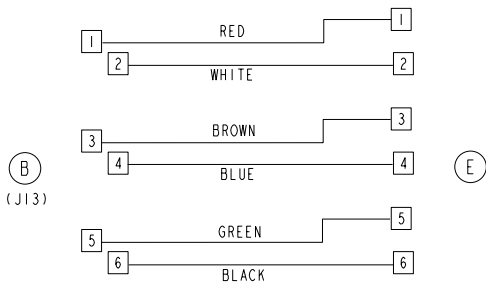

### HALL-EFFECT SENSOR - 22 AWG

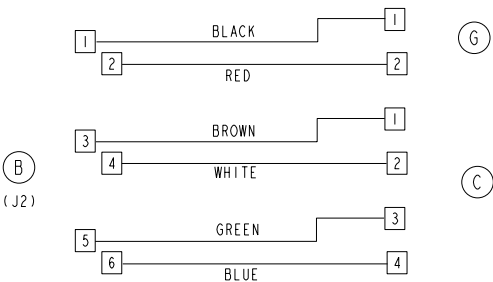

ITEM	CONNECTION	CONNECTION	ITEM
------	------------	------------	------

### MOTOR CABLE - 14 AWG



### BATTERY POSITIVE - 14 AWG



### BATTERY NEGATIVE - 14 AWG

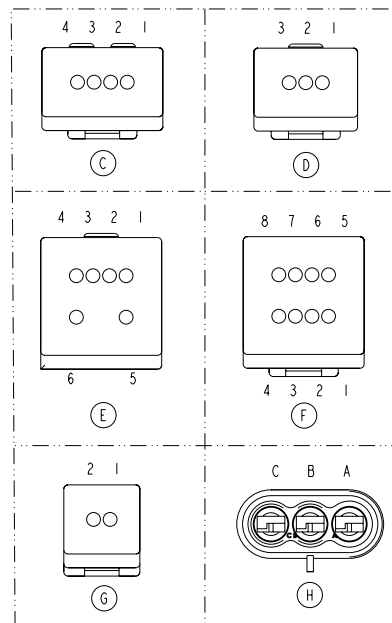

[Return To Table of Contents](#)

## Quick Reference Replacement Parts List

---

The parts and accessories listed on these pages are all currently available for purchase. Some of the parts identified on the assembly drawing parts in this manual may not be individually available for purchase. Please call Stryker Customer Service USA: 1-800-327-0770 (Option 2) for availability and pricing.

Part Name	Part Number
Backrest Pouch Option	6500-130-000
Base Storage Flat	6500-160-000
Cable, Hall Effect Sensor	6500-001-160
Cylinder	6500-001-213
DC Battery Charger, 110V, Domestic	6500-070-000
DC Battery Charger 12V/24V, In-Ambulance	6500-072-000
Defibrillator Tray Option	6500-170-000
Electronics Assembly	6500-001-014
Equipment Hook Option	6500-147-000
Equipment Hook	6500-700-003
Gas Cylinder, Fowler	1010-031-077
Head Extension Kit	6100-700-012
Head Extension Pillow Only Option	6100-045-000
Head Section Assembly	6085-001-037
Hydraulic Oil	6500-001-293
In-Fastener Shut-Off Assembly	6500-001-027
I.V. Pole, 2-Stage, Right	6500-210-000
I.V. Pole, 2-Stage, Left	6500-211-000
I.V. Pole, 2-Stage, Dual	6500-212-000
I.V. Pole, 3-Stage, Right	6500-215-000
I.V. Pole, 3-Stage, Left	6500-216-000
I.V. Pole, 3-Stage, Dual	6500-217-000
Kit, Base Tube Protector	6500-700-015
Kit, Battery Pack, SMRT Pak	6500-700-046
Kit, SMRT Power System 12 VDC (Car Charger), includes charger, 2 paks, and power cord	6500-700-040
Kit, SMRT Power System 120 Vac (Wall Charger), includes charger, 2 paks, and power cord	6500-700-041
Kit, Battery Pack, DeWALT® 24V NiCd	6500-700-006
Kit, Battery Charger, DeWALT® 12 VDC (Car Charger)	6500-700-009
Kit, Battery Charger, DeWALT® 120 Vac (Wall Charger)	6500-700-007

# Quick Reference Replacement Parts List

Part Name	Part Number
Kit, Battery Charger, DeWALT® 240 Vac (International Wall Charger)	6500-700-008
Kit, Brake Adjuster	6080-700-018
Kit, Brake - Single Wheel, Foot End Right	6080-201-000
Kit, Brake - Dual Wheel, Foot End Left and Right	6082-202-000
Kit, Base Tube Protector	6500-700-015
Kit, Equipment Hook	6500-700-003
Kit, Lift Capable Safety Bar	6082-700-031
Kit, Oxygen Bottle Holder, Foot End	6500-700-017
Kit, Oxygen Bottle Holder, Fowler	6500-700-011
Kit, Oxygen Bottle Holder, Retractable Head Section	6085-700-003
Label, Base, "Lift Here"	6080-090-008
Label, I.V. Pole Caution	6070-090-005
Label, Damage Warning	6080-090-009
Manual, Installation/Operation, Cot Fastener	6370-090-010
Mattress, Bolster	6090-041-010
Mattress, Flat	6090-042-010
Mounting Bracket, SMRT Charger	6500-201-100
Oxygen Bottle Holder, Foot End	6500-140-000
Oxygen Bottle Holder, Head End	6500-141-000
Oxygen Bottle Holder, Removable	6080-140-000
Oxygen Bottle Holder, Retractable Head Section	6085-046-000
Restraint Belt Extension	6082-160-050
Restraint, Chest	6060-260-046
Restraint, Lap Belt (2 Used per Unit)	6060-160-044
Restraint Package, Domestic	6082-260-010
Restraint, Shoulder Harness	6060-260-045
Restraint Strap Plastic Cap (Short)	6082-160-051
Restraint Strap Plastic Cap (Tall)	6082-160-055
Safety Hook, Long	6060-036-017
Safety Hook, Short	6092-036-018
Siderail Assembly	6060-026-010
Storage Flat Option	6500-128-000

[Return To Table of Contents](#)

## Quick Reference Replacement Parts List

---

<b>Part Name</b>	<b>Part Number</b>
Switch, Control	6500-001-016
Touch-Up Paint (Yellow)	6060-199-010
Touch-Up Paint (Black)	7000-001-322
Valve, "A"	6500-001-286
Valve, "B"	6500-001-287
Valve, Locking	6500-001-288
Valve, Non-Locking	6500-001-289
Velcro® 4.6" Adhesive Loop Pile, Litter	6060-032-046
Velcro® 10"	6082-001-082
Wheel Lock	6082-200-010

# Service Information

---

## MANUAL RELEASE CABLE ADJUSTMENT

### Tools Required:

- 8mm Combination Wrench
- 10mm Wrench

### Procedure:

1. Support the litter so no weight is on the base.
2. Ensure that the cable is intact.
3. Using a 10mm wrench, loosen the cable lock nut.
4. Using a 8mm hex wrench, adjust the tension on the manual release cable.
5. Tighten cable lock nut.

## FILLING THE RESERVOIR

**Use only Mobil Mercon® V Synthetic Blend Oil (6500-001-293)**

**Note:** Any time you work with the hydraulics you may lose some oil.

### Tools Required:

- 3/16" Allen Wrench

### Procedure:

1. Raise the cot to the full up position.
2. Ensure that the fill port is horizontal and lined up with the hole in the motor mount.
3. Remove the port plug using a 3/16" Allen wrench.
4. Fill the reservoir up to the bottom of the fill port.
5. Replace the plug and run the cot up and down a few times.

# Service Information

## WHEEL LOCKING FORCE ADJUSTMENT

### Tools Required:

- 5/32" Allen Wrench
- 7/16" Combination Wrench or Socket

### Procedure:

1. Using the 5/32" Allen wrench and 7/16" combination wrench or socket, remove the socket screw from the center of the lock pedal. The wheel lock is initially assembled with the pedal set at the minimum locking force. The marker on the pedal (A) is aligned with the marker on the octagonal sleeve (B).
2. Remove the sleeve (B). Rotate the sleeve counterclockwise to increase the pedal locking force and clockwise to decrease the locking force. Insert the sleeve into the pedal.
3. Using the 5/32" Allen wrench and 7/16" combination wrench or socket, reinstall the socket screw.
4. Test the pedal locking force and verify that the pedal holds properly before returning the cot to service.



Figure 55: Wheel Locking Force Adjustment

## COT RETAINING POST ADJUSTMENT

### Tools Required:

- 3/16" Allen Wrench

### CAUTION

The cot retaining post comes preconfigured for an X-frame cot, if the fastener has been configured for an H-frame style cot, the cot retaining post must be adjusted to accommodate the fastener.

### Procedure:

1. Using a 3/16" Allen wrench, remove the bolts that hold the two retaining post brackets to the base frame.
2. Turn the bottom bracket 180°.
3. Using a 3/16" Allen wrench, reinstall the bolts that were removed in step 1.

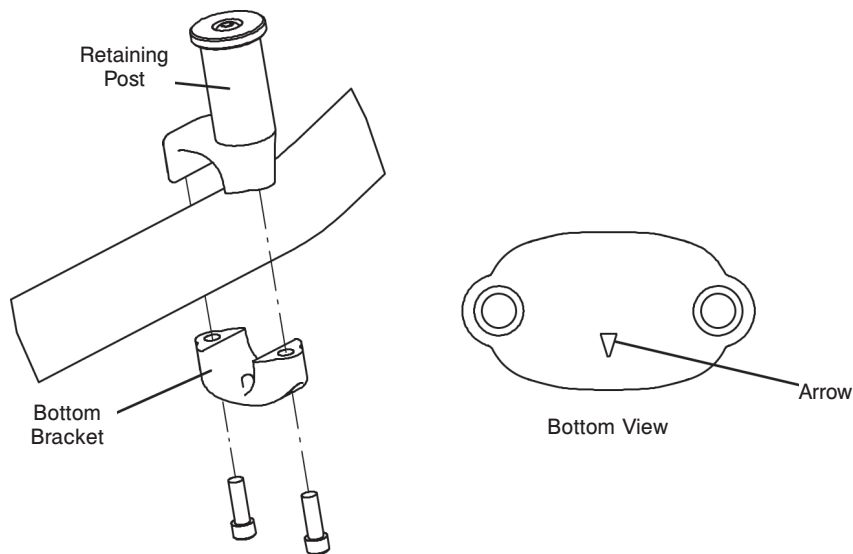
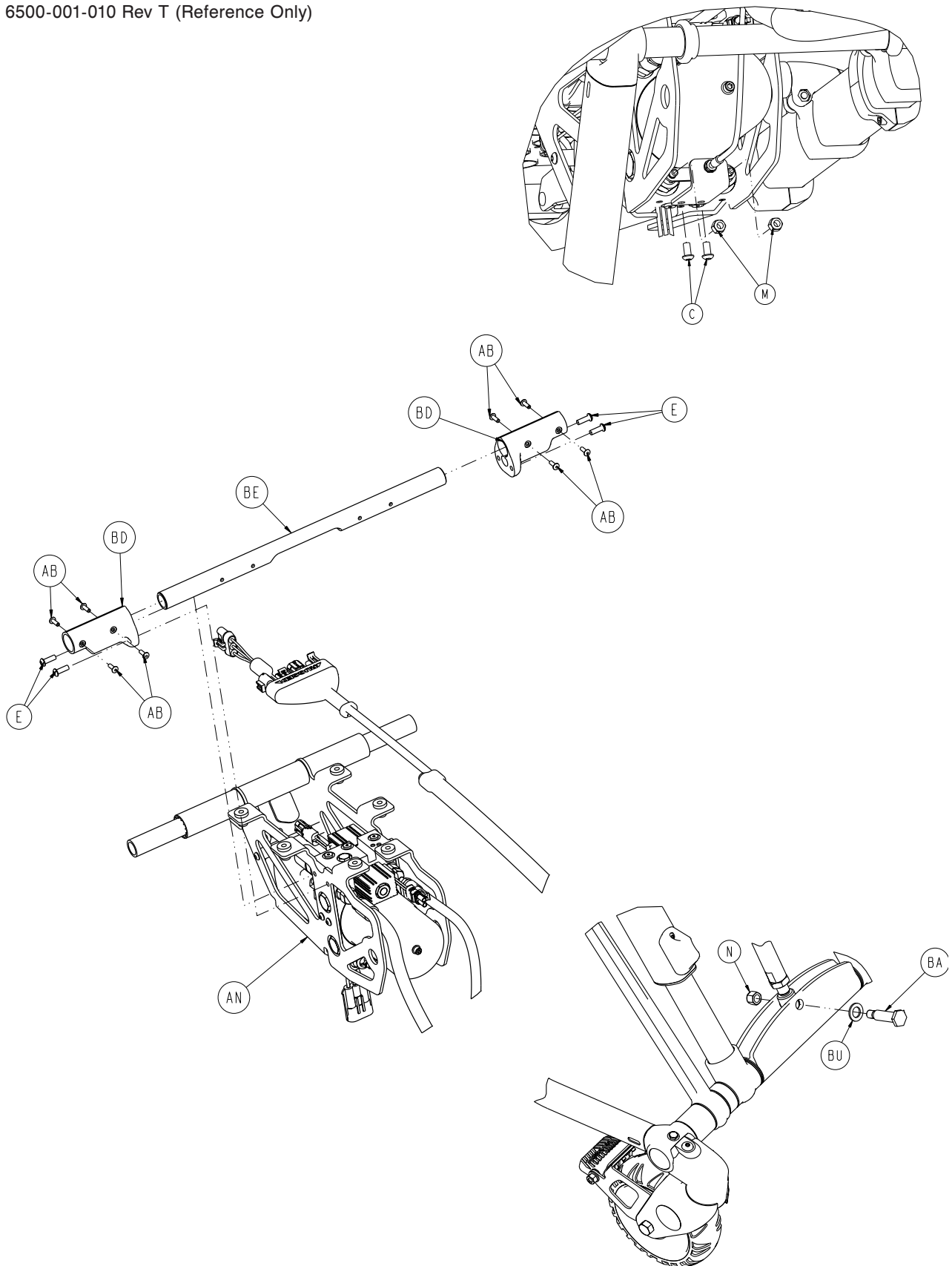

Figure 56: Cot Retaining Post

**Note:** If the arrow on the bottom bracket of the retaining post points toward the head end of the cot, the retaining post is set for an X-frame style cot. If the arrow points toward the foot end of the cot the post is set for an H-frame style cot.

# Cot Assembly

6500-001-010 Rev T (Reference Only)



[Return To Table of Contents](#)

# Cot Assembly

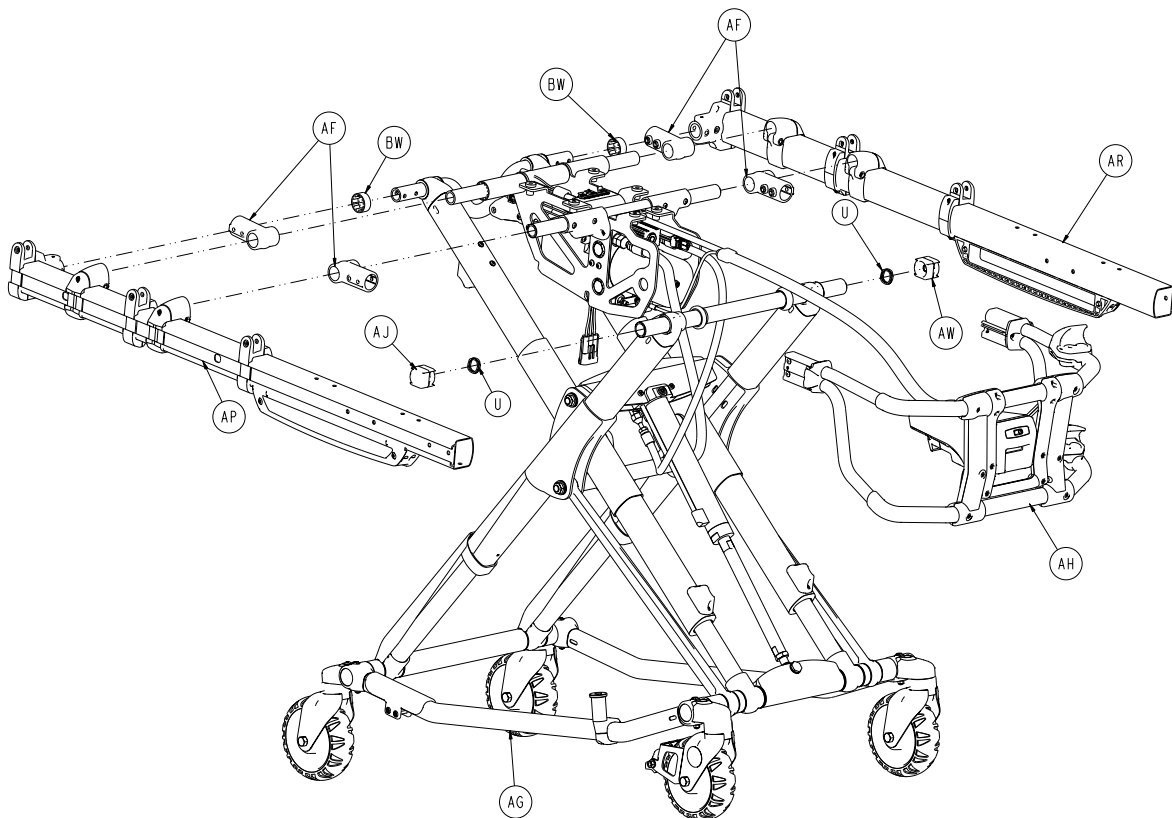
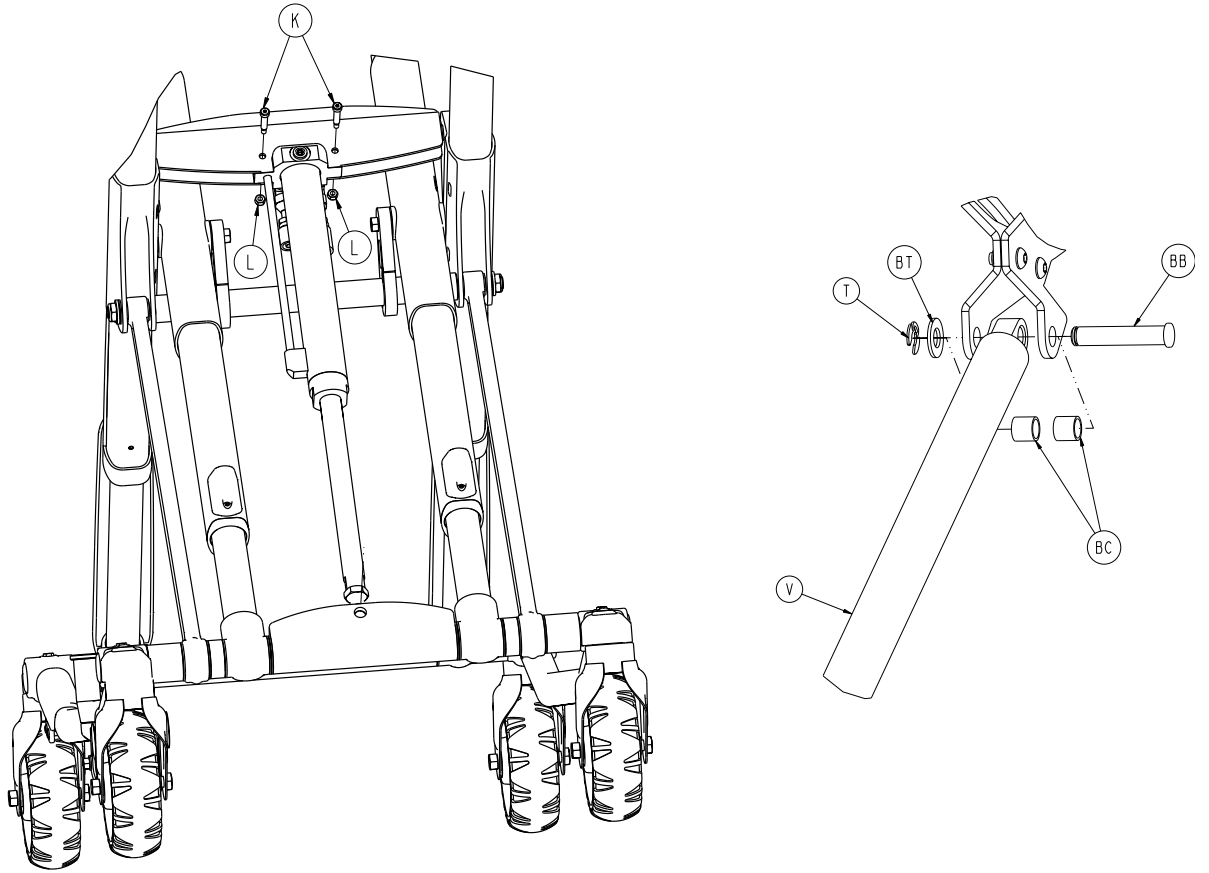



# Cot Assembly

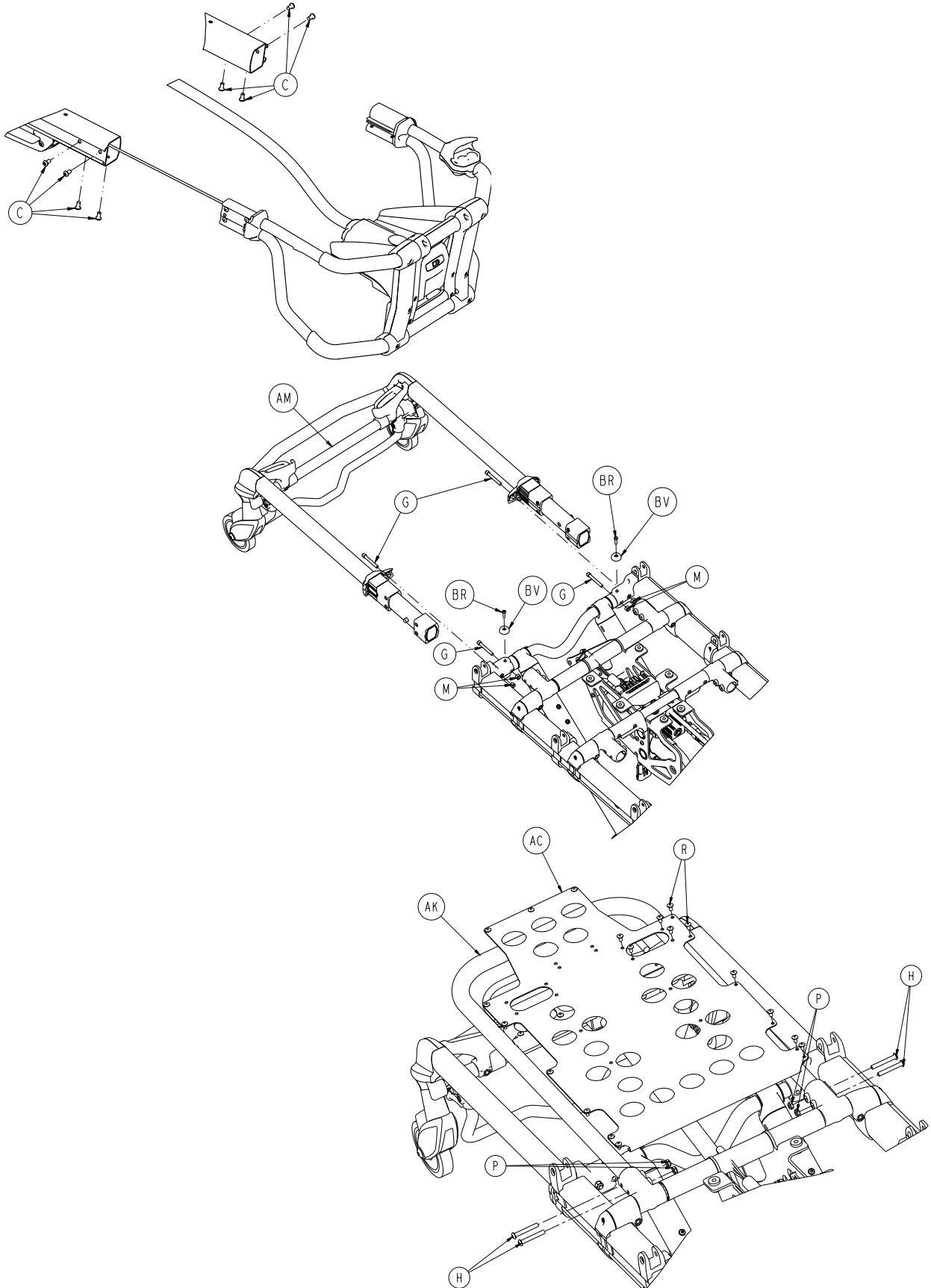

[Return To Table of Contents](#)

# Cot Assembly

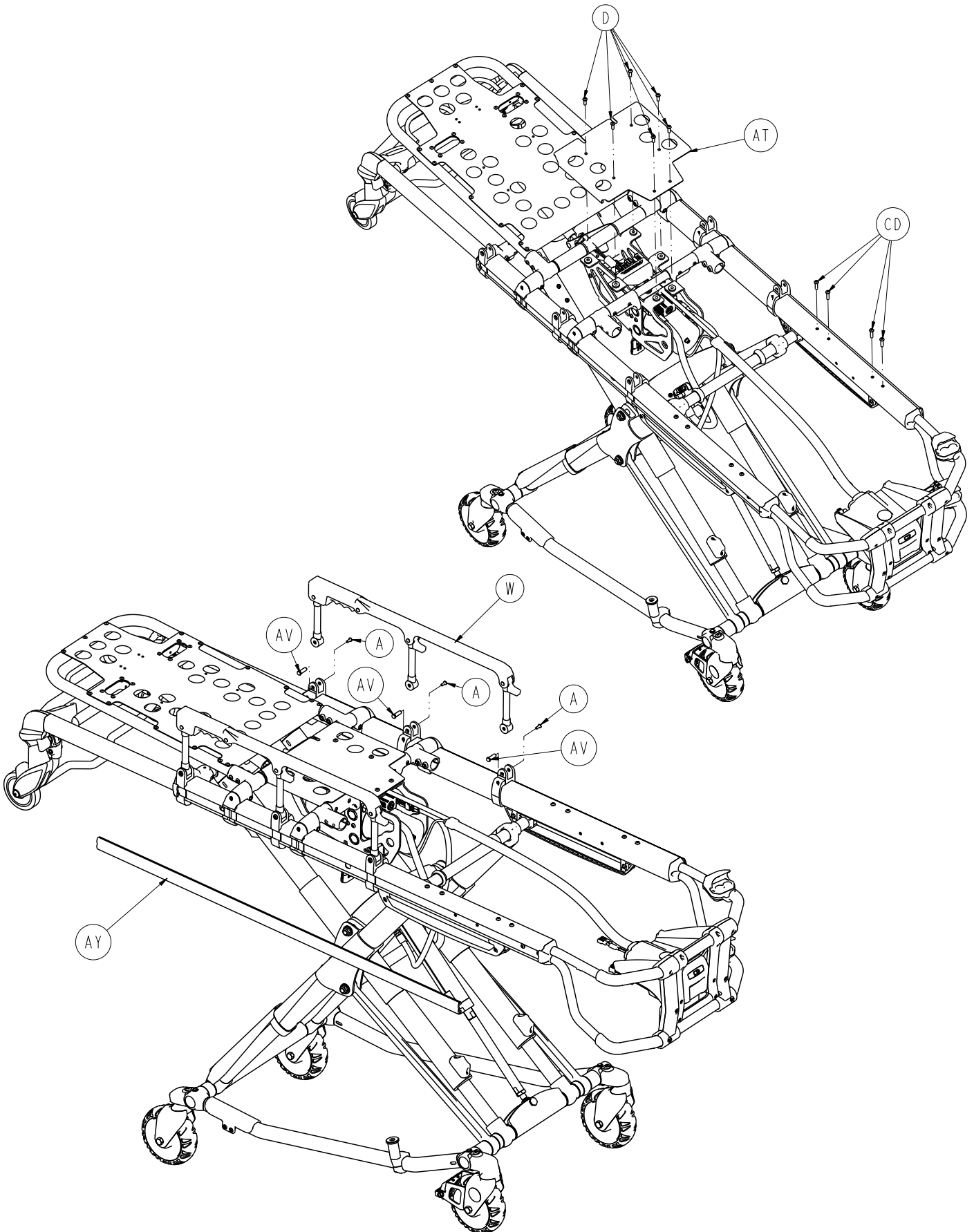

# Cot Assembly

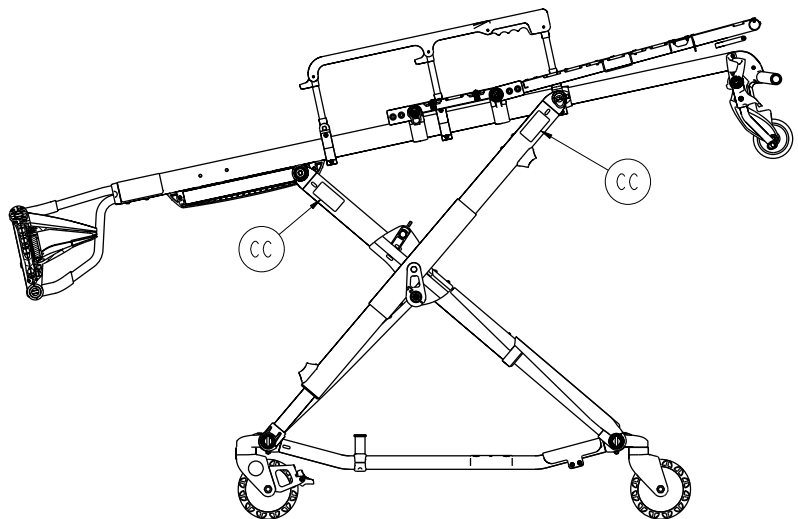
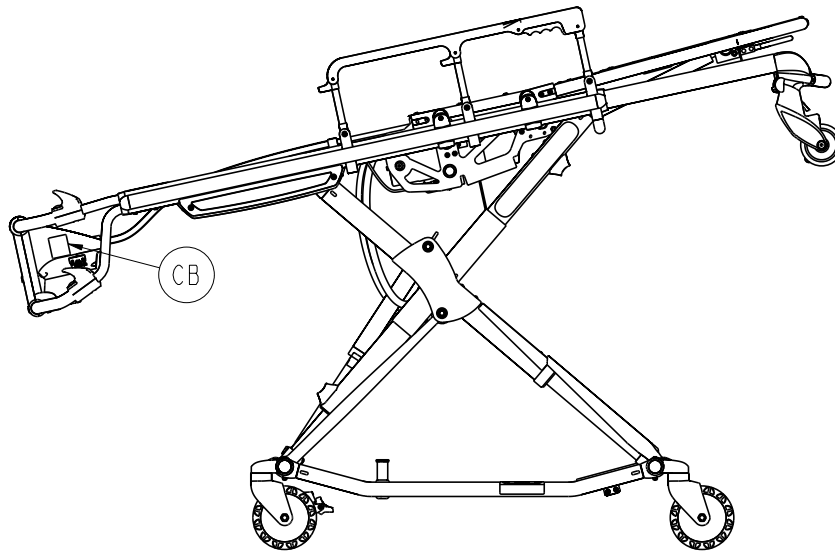
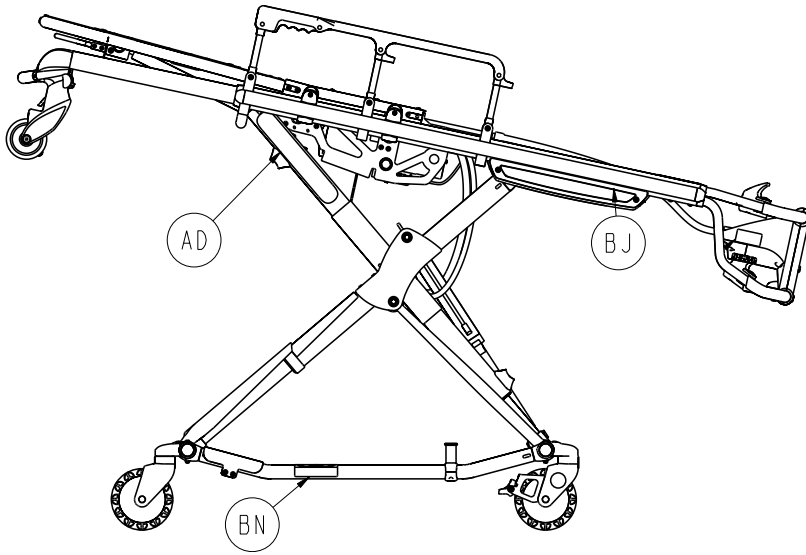

SECTION **A - A**

[Return To Table of Contents](#)

# Cot Assembly

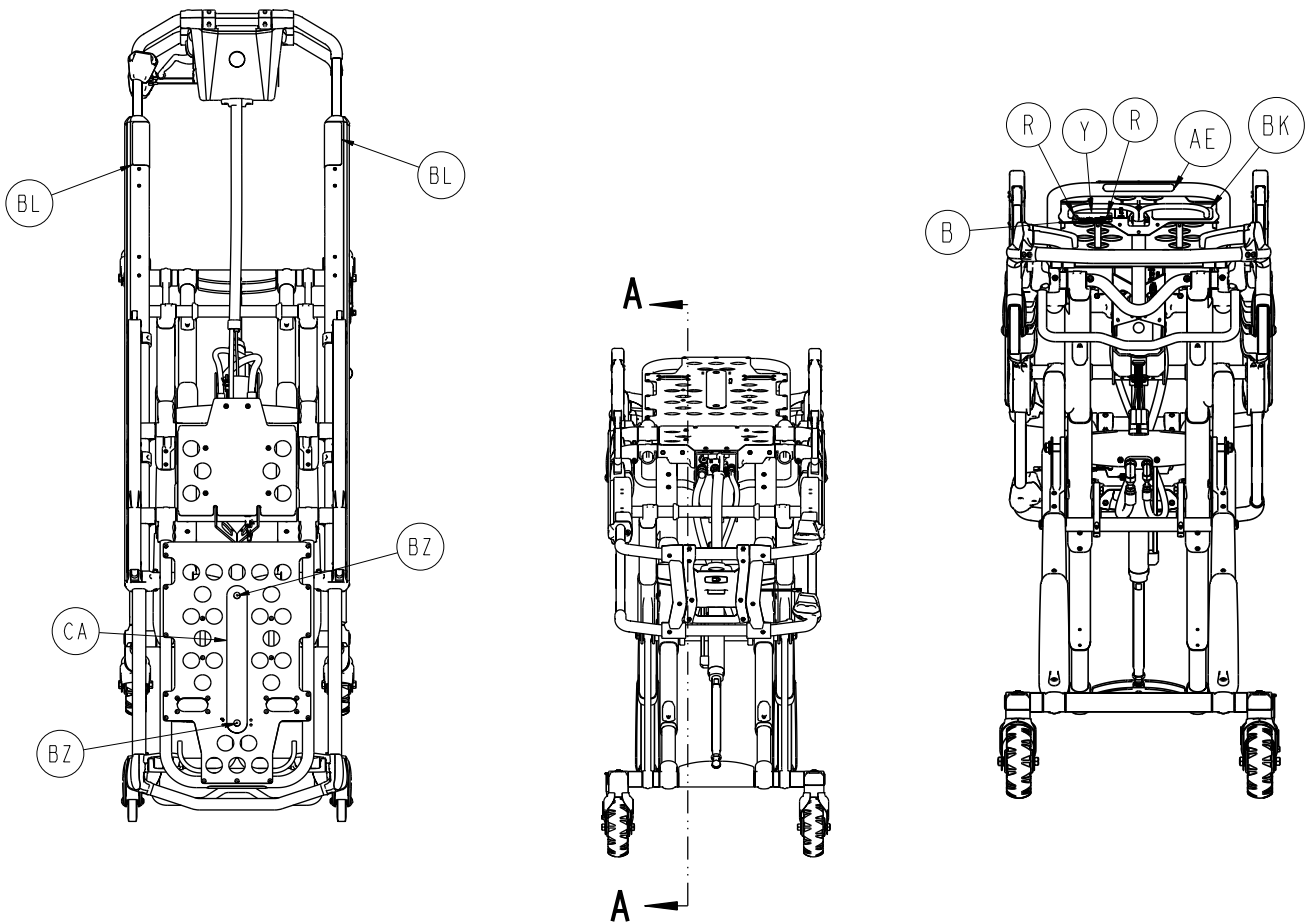

Cot Assembly - 6500-001-010 Rev T (Reference Only)

Item	Part No.	Part Name	Qty.
A	0004-585-000	Button Head Cap Screw	6
B	2030-009-901	WEEE Label	1
C	0004-589-000	Button Head Cap Screw	10
D	0004-592-000	Button Head Cap Screw	6
E	0004-593-000	Button Head Cap Screw	4
G	0004-595-000	Socket Head Cap Screw	4
H	0004-596-000	Button Head Cap Screw	4
K	0008-030-000	Socket Head Set Screw	2
L	0016-002-000	Nylock Hex Nut	2
M	0016-028-000	Nylock Hex Nut	6
N	0016-035-000	Nylock Hex Nut	2
P	0016-102-000	Nylock Hex Nut	4
R	0025-079-000	Dome Head Rivet	27
T	0028-181-000	Truarc Ring	1
U	0038-574-000	Spring	2
V	1010-031-077	Gas Spring	1
W	6082-026-010	Siderail Assembly	2

# Cot Assembly

---

## Cot Assembly - 6500-001-010 Rev T (Reference Only) - Continued

Item	Part No.	Part Name	Qty.
Y	6060-090-002	Serial Number Tag	1
AB	0025-133-000	Dome Head Rivet	8
AC	6082-032-045	Fowler Skin	1
AD	6082-090-043	Stryker Label	2
AE	6060-090-004	Label	1
AF	6100-003-125	Straight T Pivot	4
AG	6500-001-012	Base Assembly	1
AH	6500-001-015	Foot End Assembly ( <a href="#">page 113</a> )	1
AJ	6500-001-017	Slider Magnet	1
AK	6500-001-018	Fowler Assembly ( <a href="#">page 125</a> )	1
AM	6085-001-037	Head Section Assembly ( <a href="#">page 126</a> )	1
AN	6500-001-031	Powerplant Assembly ( <a href="#">page 110</a> )	1
AP	6500-001-032	Outer Rail, Right ( <a href="#">page 104</a> )	1
AR	6500-001-033	Outer Rail Left ( <a href="#">page 106</a> )	1
AT	6500-001-111	Mid-Section Skin	1
AV	6500-001-118	Siderail Nut	6
AW	6500-001-123	Slider	1
AY	6500-001-127	Outer Rail Bumper	2
BA	6500-001-168	Pin, Rod Attachment	1
BB	6500-001-170	Pin, Fowler Cylinder	1
BC	6500-001-191	Spacer, Fowler Cylinder	2
BD	6500-001-195	Motor Mount Casting	2
BE	6500-001-196	Cross Brace	1
BJ	6500-001-233	Sensor Housing Label	2
BK	6500-001-234	Power-PRO™ XT Label	1
BL	6085-001-155	Weight Capacity Label	2
BM	0059-211-000	Cable Tie	2
BN	6080-090-108	Lift Here Label	2
BR	0004-614-000	Button Head Cap Screw	2
BT	0011-004-000	Flat Washer	1
BU	0011-013-000	Flat Washer	1
BV	0946-001-155	Bumper	2
BW	6500-001-128	Spacer	2
BZ	0025-132-000	Rivet	2
CA	6082-001-085	2" Adhesive Loop Pile	1
CB	6550-001-201	Oxygen Caution Label	1
CC	6252-001-139	Do Not Lubricate Label	4
CD	0004-594-000	Button Head Cap Screw	8

# Base Assembly

6500-001-012 Rev P (Reference Only)

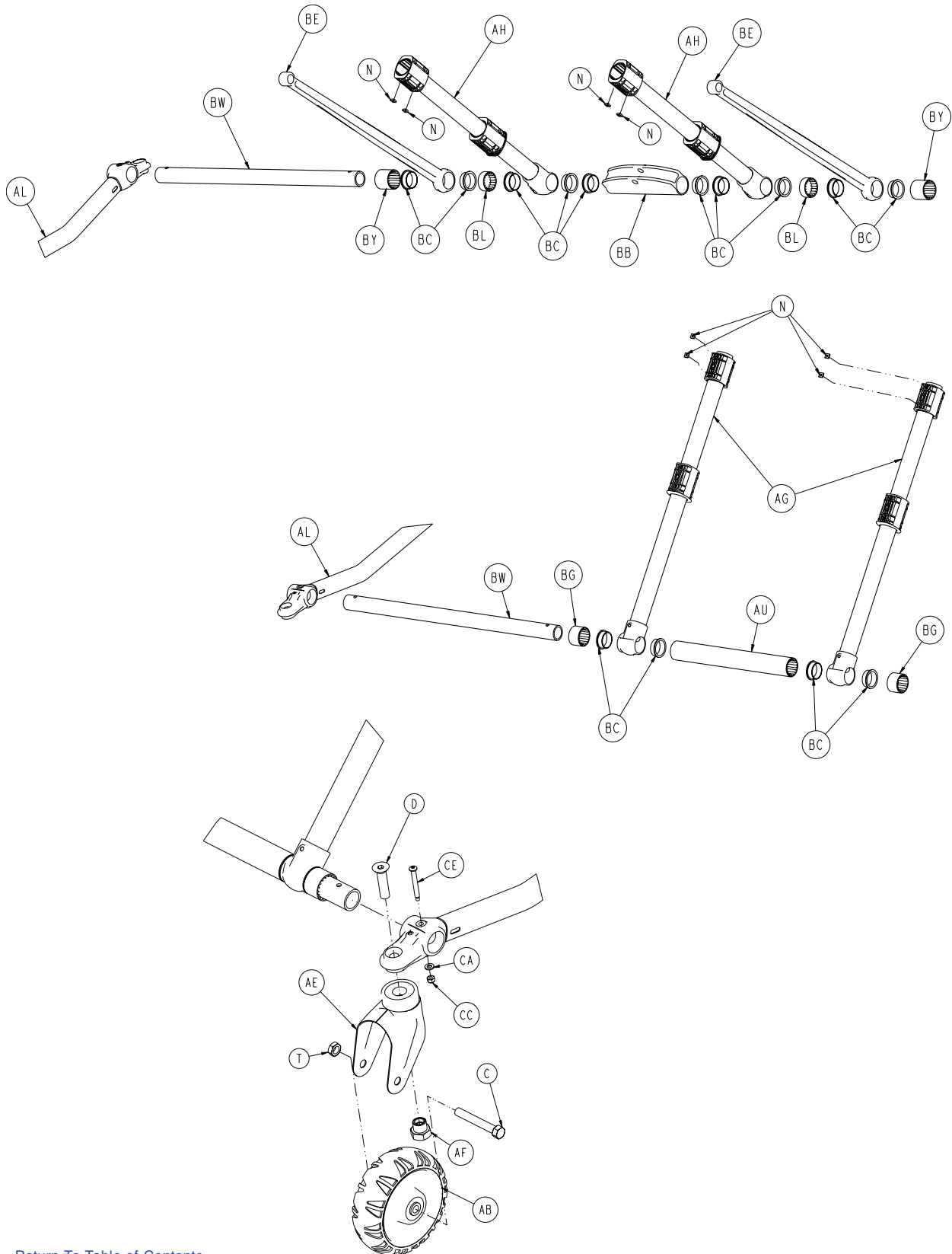

[Return To Table of Contents](#)

# Base Assembly

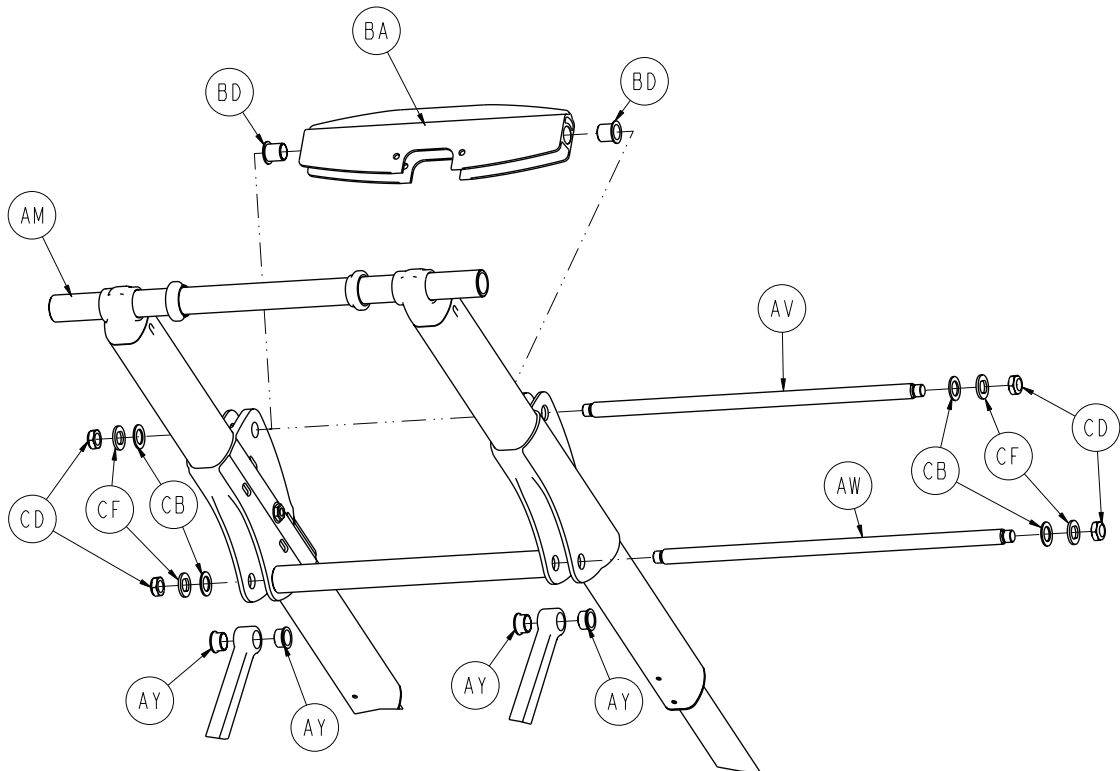
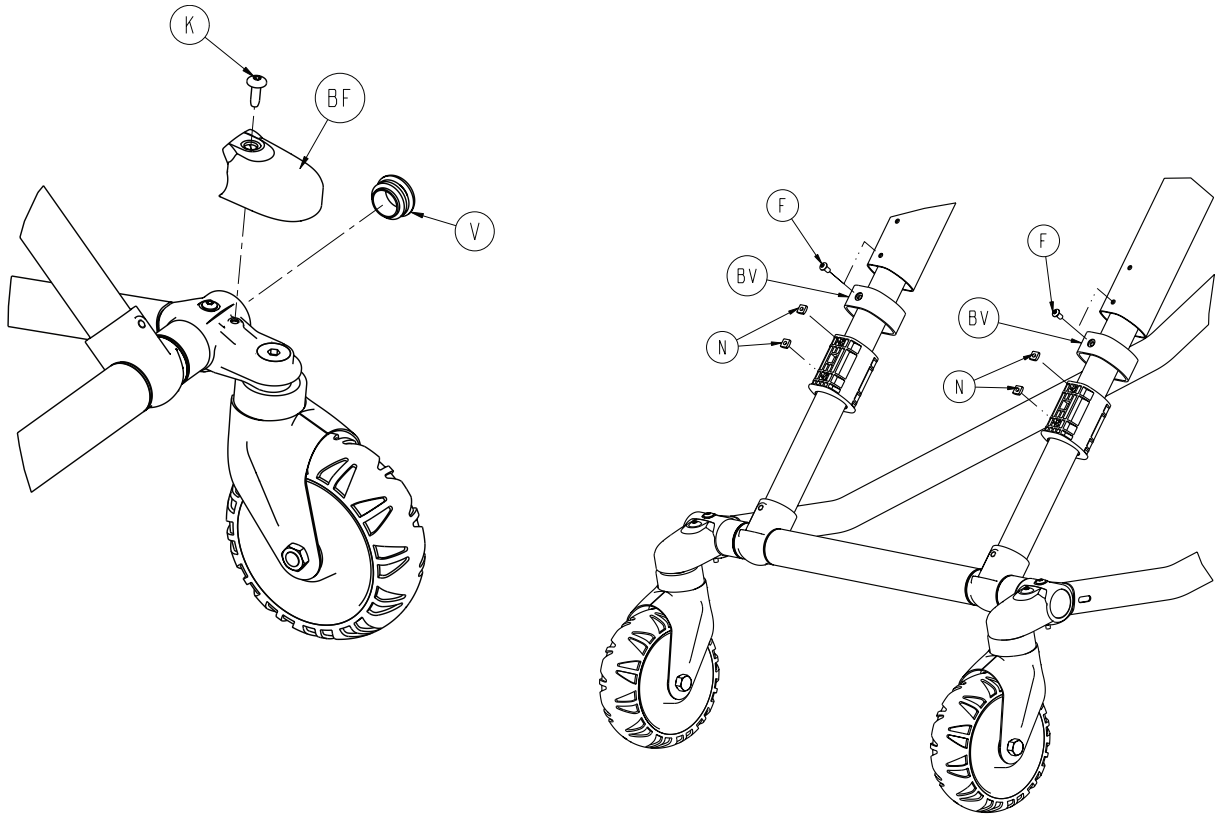

[Return To Table of Contents](#)

# Base Assembly

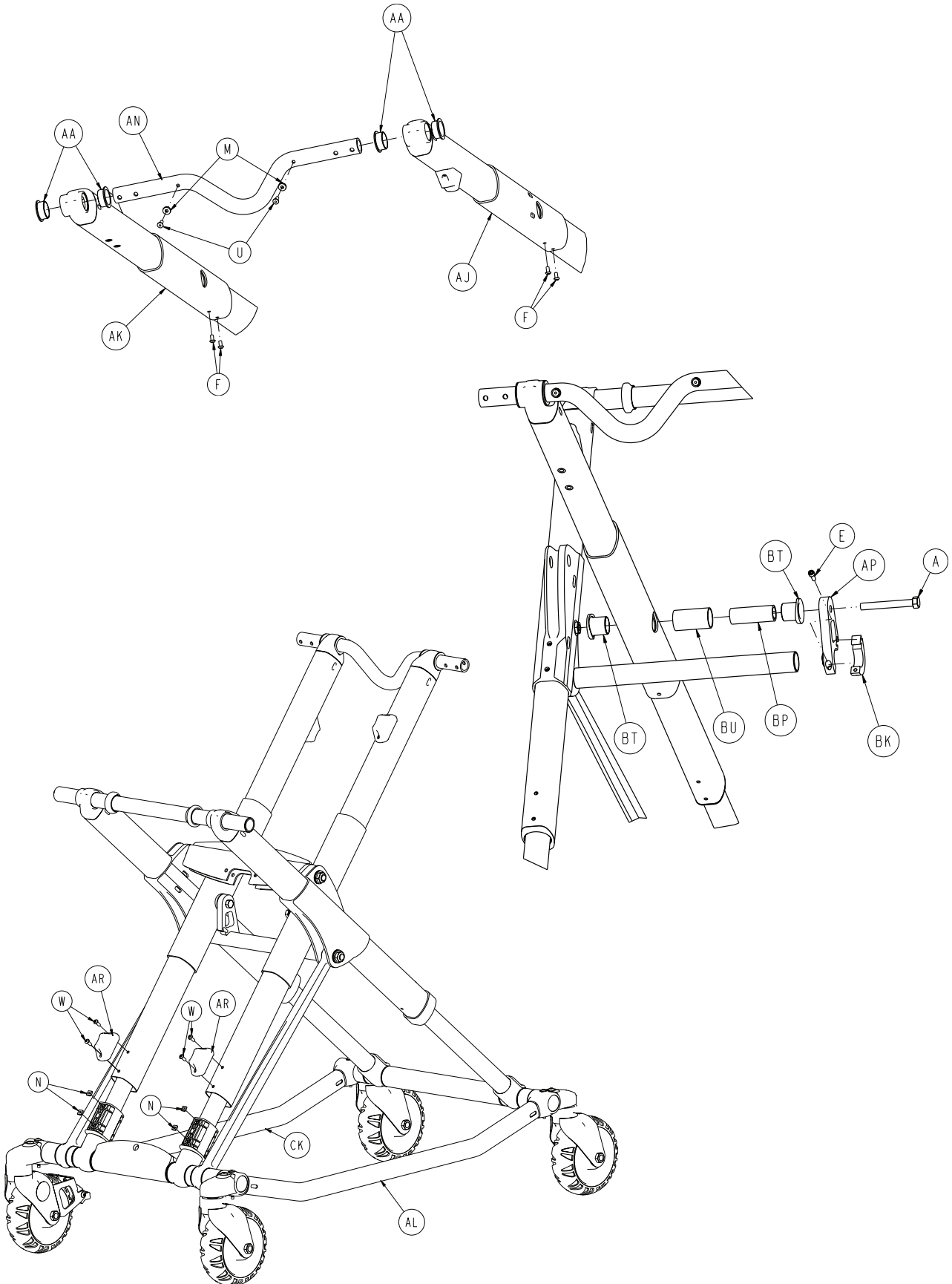



# Base Assembly

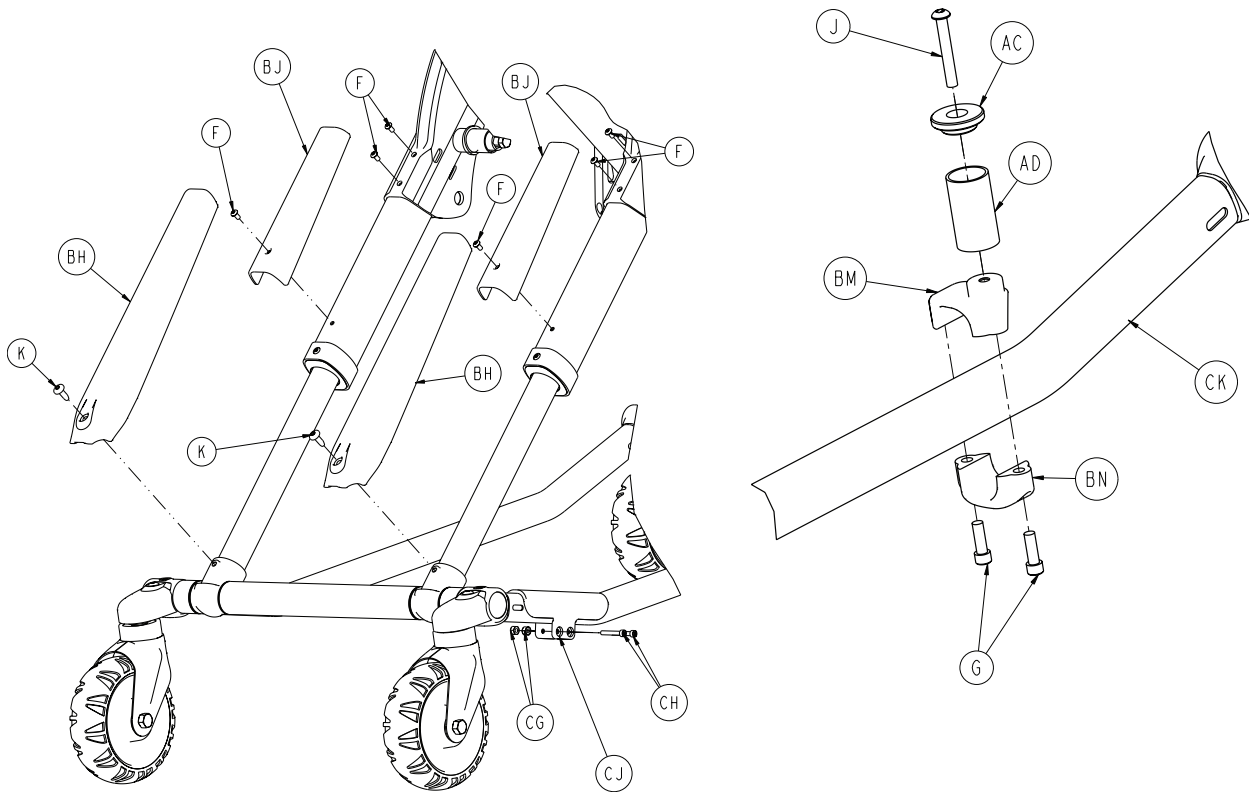

Base Assembly - 6500-001-012 Rev P (Reference Only)

Item	Part No.	Part Name	Qty.
A	0003-388-000	Hex Head Cap Screw	2
C	0003-205-000	Hex Head Cap Screw	4
D	0004-319-000	Flat Head/ Hex Socket Bolt	4
E	0004-348-000	Socket Head Cap Screw	2
F	0004-587-000	Button Head Cap Screw	12
G	0004-591-000	Socket Head Cap Screw	2
J	0004-631-000	Hex Head Cap Screw	1
K	0007-086-000	Truss Head Screw	6
M	0014-115-000	Washer	2
N	0015-051-000	Square Nut	16
T	0016-060-000	Toplock Hex Nut	4
U	0025-133-000	Rivet	10
V	0037-083-000	Tube Plug	4
W	0004-634-000	Button Head Cap Screw	4
AA	0081-244-000	Bearing-Flange	4
AB	6060-002-010	Molded Wheel Assembly	4
AC	6060-004-043	Retaining Post Cap	1
AD	6060-004-044	Post Tube	1
AE	6082-002-012	Caster Assembly	2
AF	6090-001-009	Caster Nut	4
AG	6500-301-021	Outer Lift Tube Assembly ( <a href="#">page 99</a> )	2
AH	6500-301-022	Inner Lift Tube Assembly ( <a href="#">page 100</a> )	2

[Return To Table of Contents](#)

# Base Assembly - 6500-001-012

---

## Base Assembly - 6500-001-012 Rev P (Reference Only) - Continued

Item	Part No.	Part Name	Qty.
AJ	6500-001-034	Inner Lift Tube, Right ( <a href="#">page 101</a> )	1
AK	6500-001-035	Inner Lift Tube, Left ( <a href="#">page 102</a> )	1
AL	6085-001-056	Outer Base Tube Weldment	1
AM	6500-001-056	Frame, Base, Tube	1
AN	6500-001-090	Head End Cross Tube	1
AP	6500-001-308	Strap	1
AR	6500-001-125	Dead Stop	2
AT	6500-001-309	Strap	1
AU	6500-001-129	Plastic Extrusion - Spacer	1
AV	6500-001-171	Cross Tube Cylinder Mount	1
AW	6500-001-182	Cross Tube, Stiffener Bar	1
AY	6500-001-162	Flange Bearing	4
BA	6500-001-164	Pivot, Cylinder Mount, Top	1
BB	6500-001-165	Pivot, Cylinder Mount, Bottom	1
BC	6500-001-166	Bearing, Flange	14
BD	6500-001-157	Bearing, Flange	2
BE	6500-001-172	Support Link	2
BF	6500-001-177	Cover, Caster Mount	4
BG	6500-001-178	Plastic Extrusion - Spacer	2
BH	6500-001-179	X-Frame Lower Guard	2
BJ	6500-001-180	X-Frame Upper Guard	2
BK	6500-001-310	Strap Clamp	2
BL	6500-001-183	Plastic Extrusion - Spacer	2
BM	6500-001-189	Top Pin Bracket	1
BN	6500-001-190	Bottom Pin Bracket	1
BP	6500-001-341	Post, Pivot, Base Tube	2
BT	6500-001-226	Bearing, Pivot, Base Tube	4
BU	6500-001-227	Post, Pivot, Base tube	2
BV	6500-001-228	Sleeve, Inner Lift Tube	2
BW	6500-001-229	Base Tube Foot	2
BY	6500-001-230	Plastic Extrusion - Spacer	2
CA	0014-002-000	Flat Washer	4
CB	0014-040-000	Flat Washer	4
CC	0016-002-000	Fiberlock Nut	4
CD	0016-049-000	Nylon Hex Nut	4
CE	6085-001-097	Spacer	4
CF	6500-001-225	"D" Washer	4
CG	0016-003-000	Nylock Hex Nut	2
CH	0004-160-000	Socket Head Cap Screw	2
CJ	6500-001-302	Base Tube Protector	1
CK	6085-001-057	Outer Base Tube Weldment	1

# Outer Lift Tube Assembly, Base Pivot - 6500-301-021

Rev A

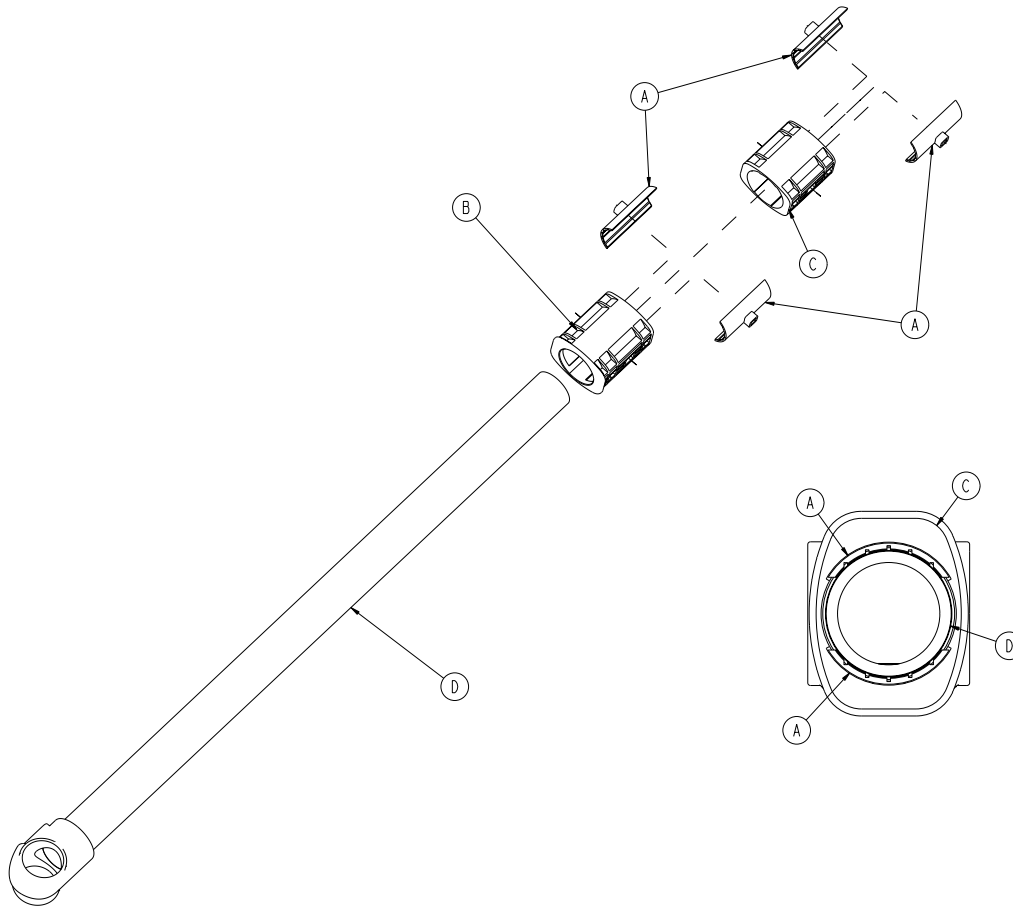

Item	Part No.	Part Name	Qty.
A	6500-001-327	Half Shell Bearing	4
B	6500-001-328	Bearing Carrier, Lower	1
C	6500-001-329	Bearing Carrier, Middle	1
D	6500-301-050	Outer Lift Tube Weldment	1

# Inner Lift Tube Assembly, Base Pivot - 6500-301-022

Rev B

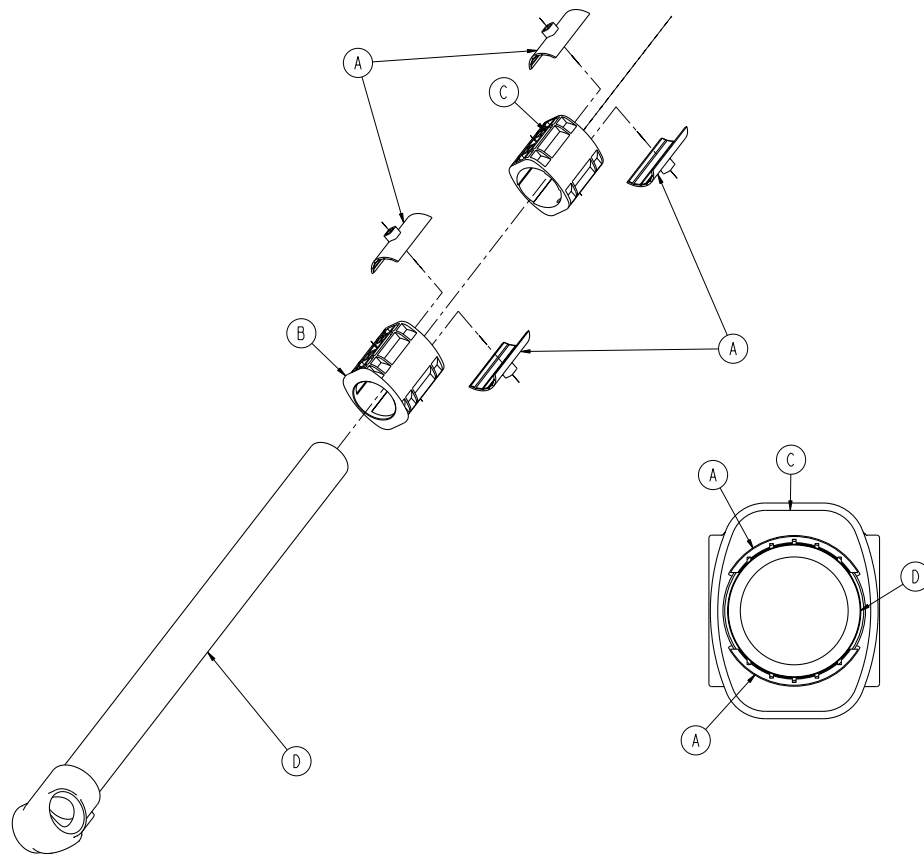

Item	Part No.	Part Name	Qty.
A	6500-001-327	Half Shell Bearing	4
B	6500-001-328	Bearing Carrier, Lower	1
C	6500-001-329	Bearing Carrier, Middle	1
D	6500-301-051	Lift Tube Weldment, Base Pivot	1

# Inner Lift Tube, Litter Pivot - 6500-001-034

## Patient Right Assembly

Rev F

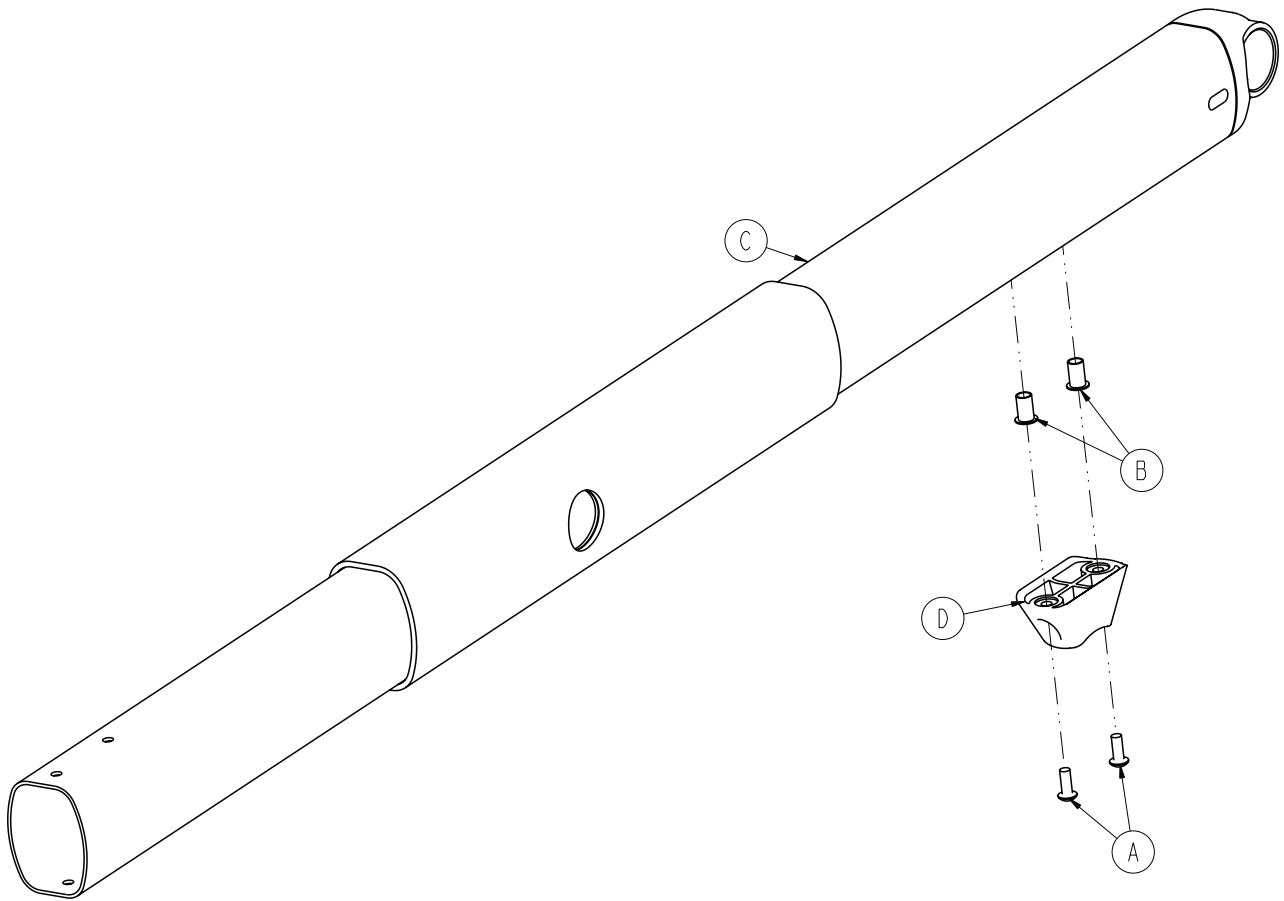

Item	Part No.	Part Name	Qty.
A	0004-634-000	Button Head Cap Screw	2
B	0055-100-075	Nut	2
C	6500-001-355	Inner Lift Tube Weldment	1
D	6500-001-125	Dead Stop	1

[Return To Table of Contents](#)

# Inner Lift Tube, Litter Pivot - 6500-001-035

## Patient Left Assembly

Rev F

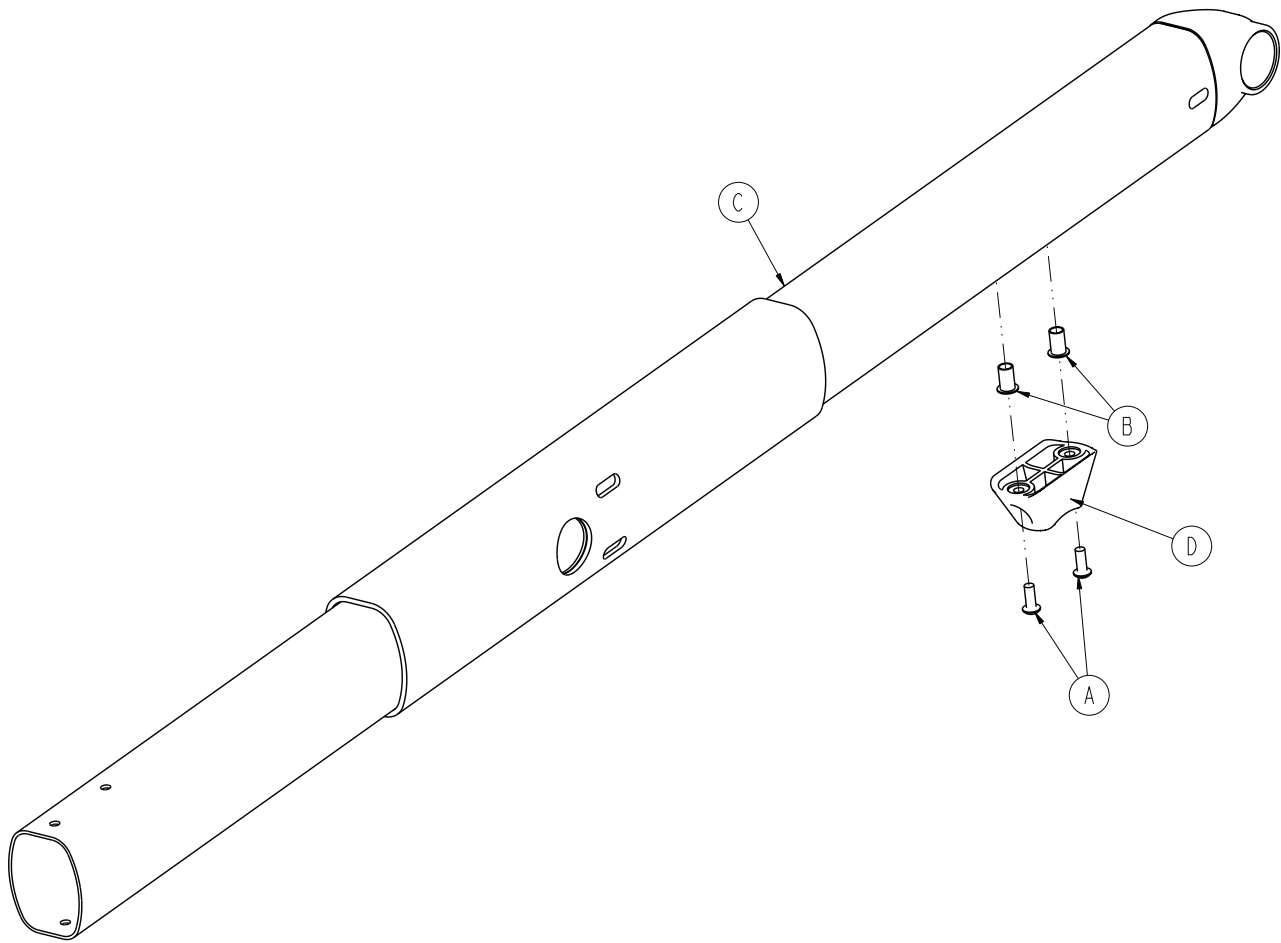

Item	Part No.	Part Name	Qty.
A	0004-634-000	Button Head Cap Screw	2
B	0055-100-075	Nut	2
C	6500-301-053	Inner Lift Tube Weldment	1
D	6500-001-125	Dead Stop	1

# Notes

---

# Outer Rail, Patient Right Assembly

6500-001-032 Rev B (Reference Only)

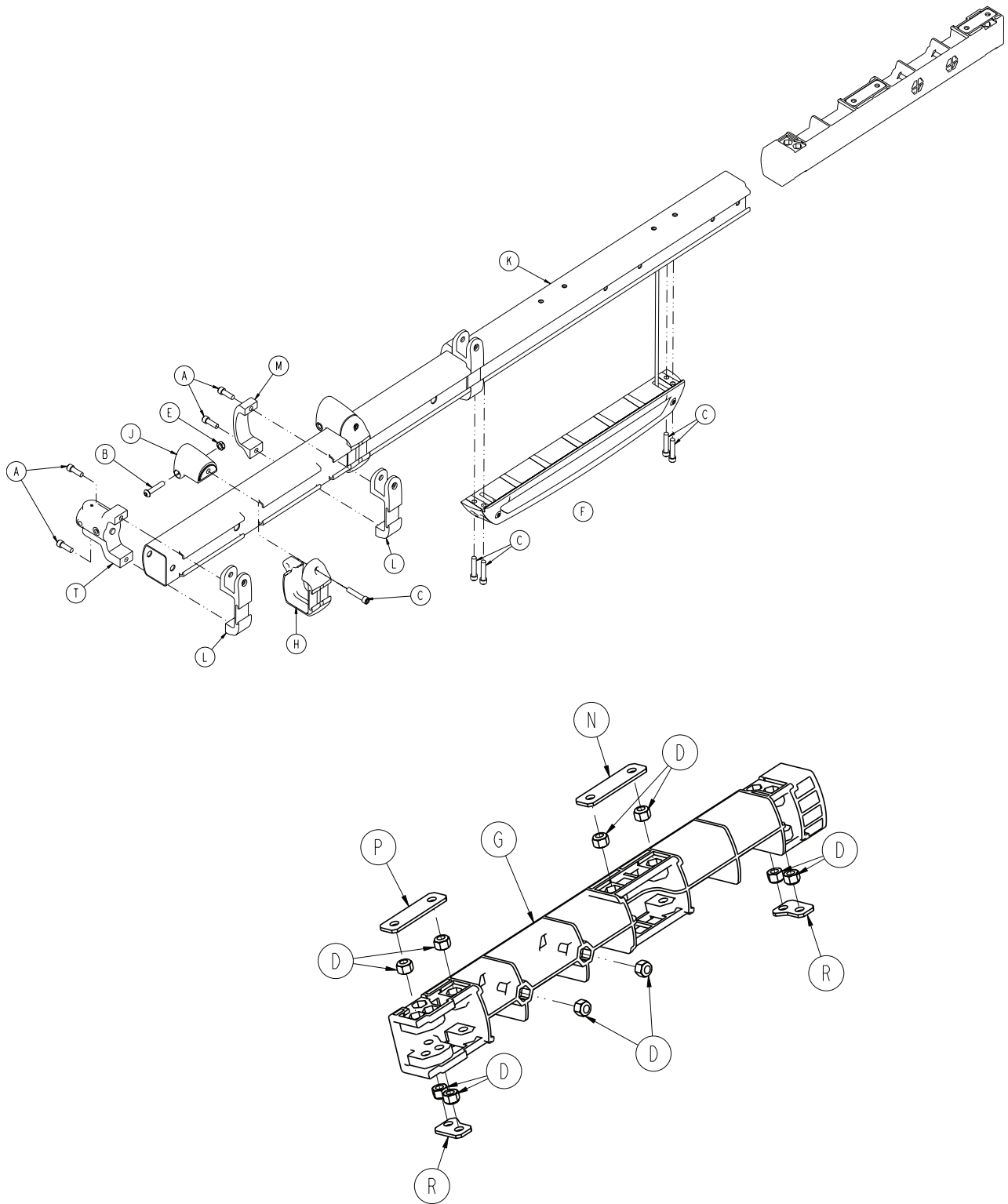



# Outer Rail, Patient Right Assembly

---

## Outer Rail, Patient Right Assembly Rev B - 6500-001-032 (Reference Only)

Item	Part No.	Part Name	Qty.
A	0004-591-000	Socket Head Cap Screw	6
B	0004-612-000	Button Head Cap Screw	2
C	0004-613-000	Socket Head Cap Screw	6
D	0016-028-000	Nut	10
E	0016-102-000	Nut	2
F	6500-001-028	Hall Sensor Assembly ( <a href="#">page 108</a> )	1
G	6500-001-098	Dead Stop	1
H	6500-001-104	Support Bracket	2
J	6500-001-106	Support Bracket	2
K	6500-001-114	Outer Rail	1
L	6500-001-116	Siderail Bracket	3
M	6500-001-117	Siderail Clamp	2
N	6500-001-243	I.V. Pole Backer Plate	1
P	6500-001-244	I.V. Clip Backer Plate	1
R	6500-001-245	Sensor Housing Backer Plate	2
T	6500-001-102	Base/Litter Interface Bracket	1

# Outer Rail, Patient Left Assembly

6500-001-033 Rev B (Reference Only)

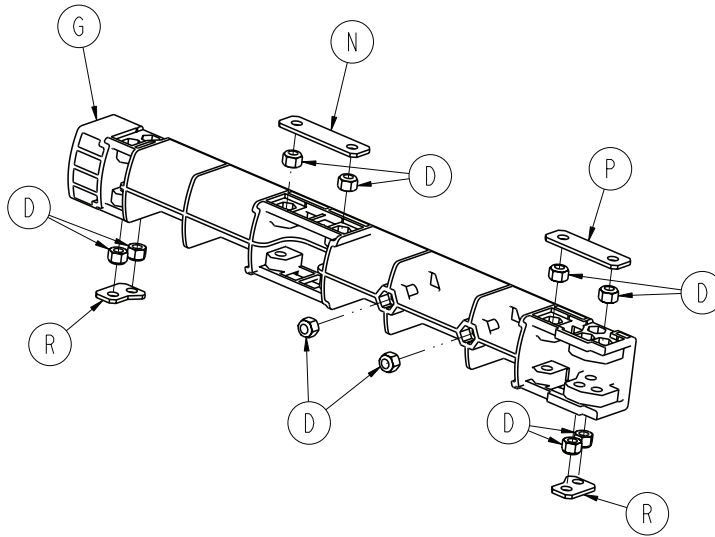
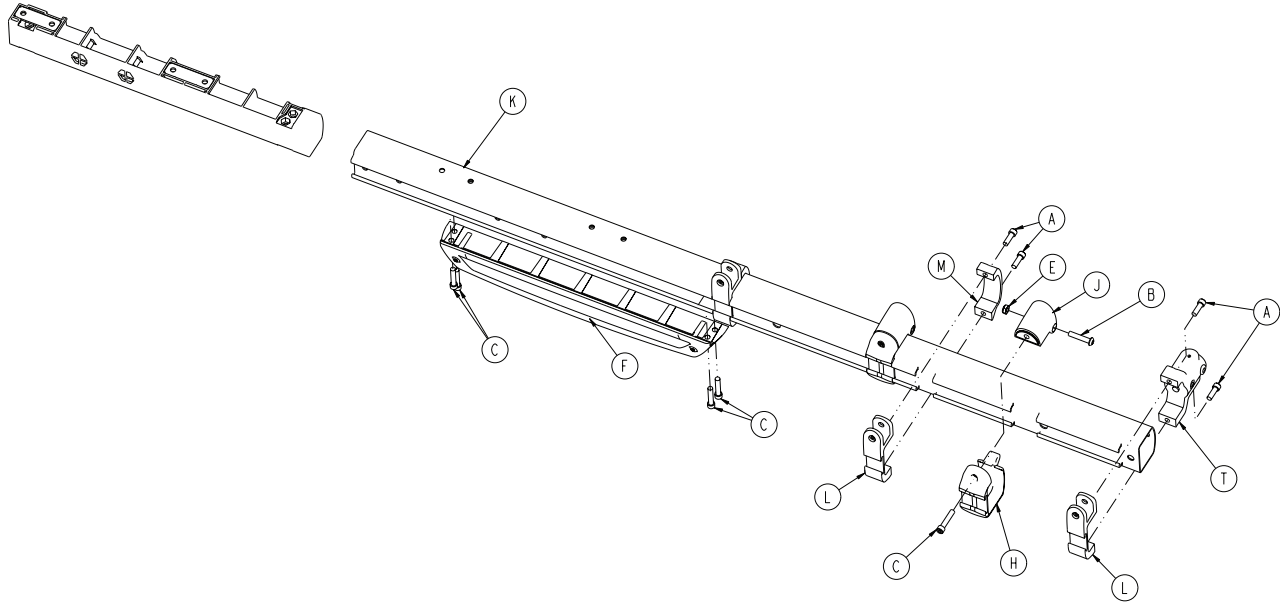

# Outer Rail, Patient Left Assembly

---

## Outer Rail, Patient Left Assembly - 6500-001-033 Rev B (Reference Only)

Item	Part No.	Part Name	Qty.
A	0004-591-000	Socket Head Cap Screw	6
B	0004-612-000	Button Head Cap Screw	2
C	0004-613-000	Socket Head Cap Screw	6
D	0016-028-000	Nut	10
E	0016-102-000	Nut	2
F	6500-001-029	Sensor Housing Assembly ( <a href="#">page 109</a> )	1
G	6500-001-098	Dead Stop	1
H	6500-001-104	Support Bracket	2
J	6500-001-106	Support Bracket	2
K	6500-001-115	Outer Rail	1
L	6500-001-116	Siderail Bracket	3
M	6500-001-117	Siderail Clamp	2
N	6500-001-243	I.V. Pole Backer Plate	1
P	6500-001-244	I.V. Clip Backer Plate	1
R	6500-001-245	Sensor Housing Backer Plate	2
T	6500-001-102	Base/Litter Interface Bracket	1

# Hall Sensor Assembly

6500-001-028 Rev A (Reference Only)

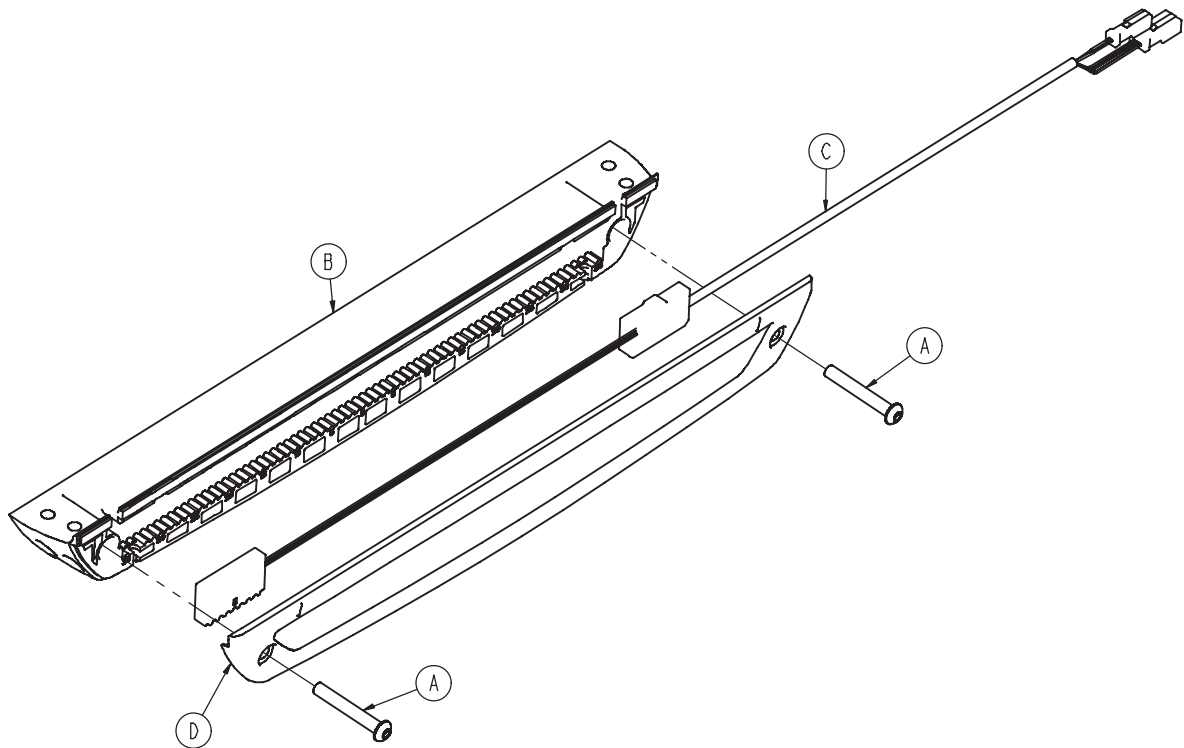

Item	Part No.	Part Name	Qty.
A	0004-596-000	Button Head Cap Screw	2
B	6500-001-124	Sensor Housing	1
C	6500-001-160	Hall Effects Sensor	1
D	6500-001-199	Housing Cover	1

# Sensor Housing Assembly

6500-001-029 Rev A (Reference Only)

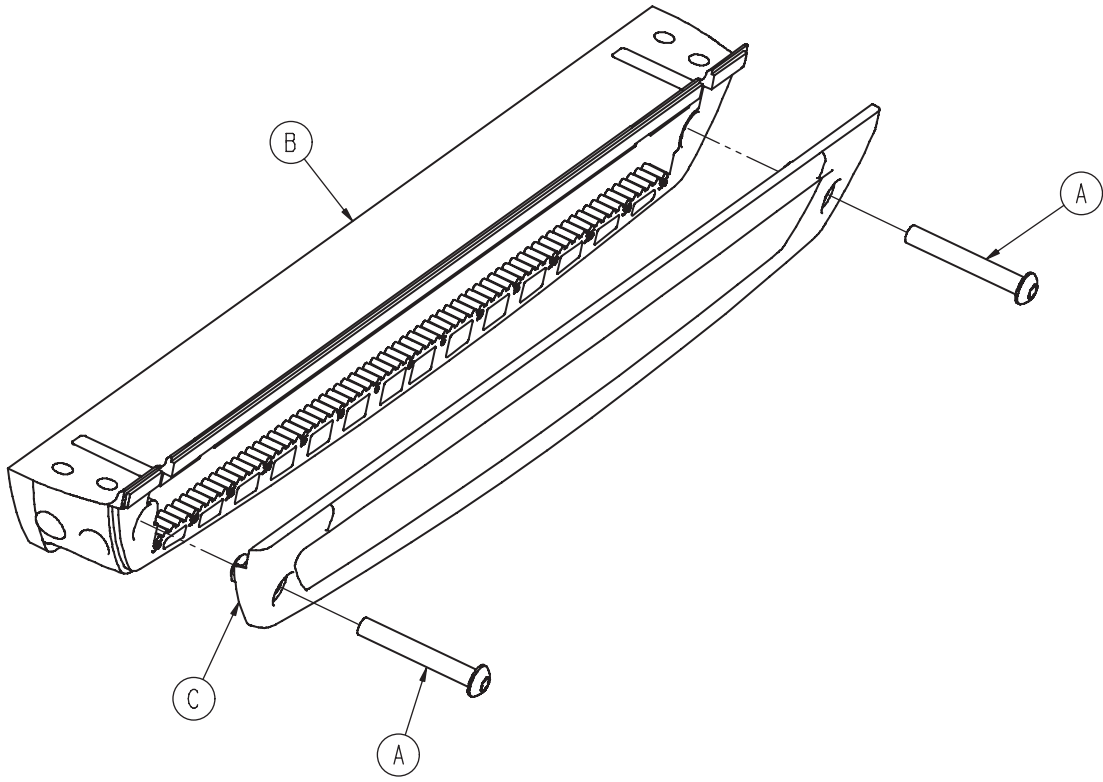

Item	Part No.	Part Name	Qty.
A	0004-596-000	Button Head Cap Screw	2
B	6500-001-124	Sensor Housing	1
C	6500-001-199	Housing Cover	1

[Return To Table of Contents](#)

# Powerplant Assembly

6500-001-031 Rev B (Reference Only)

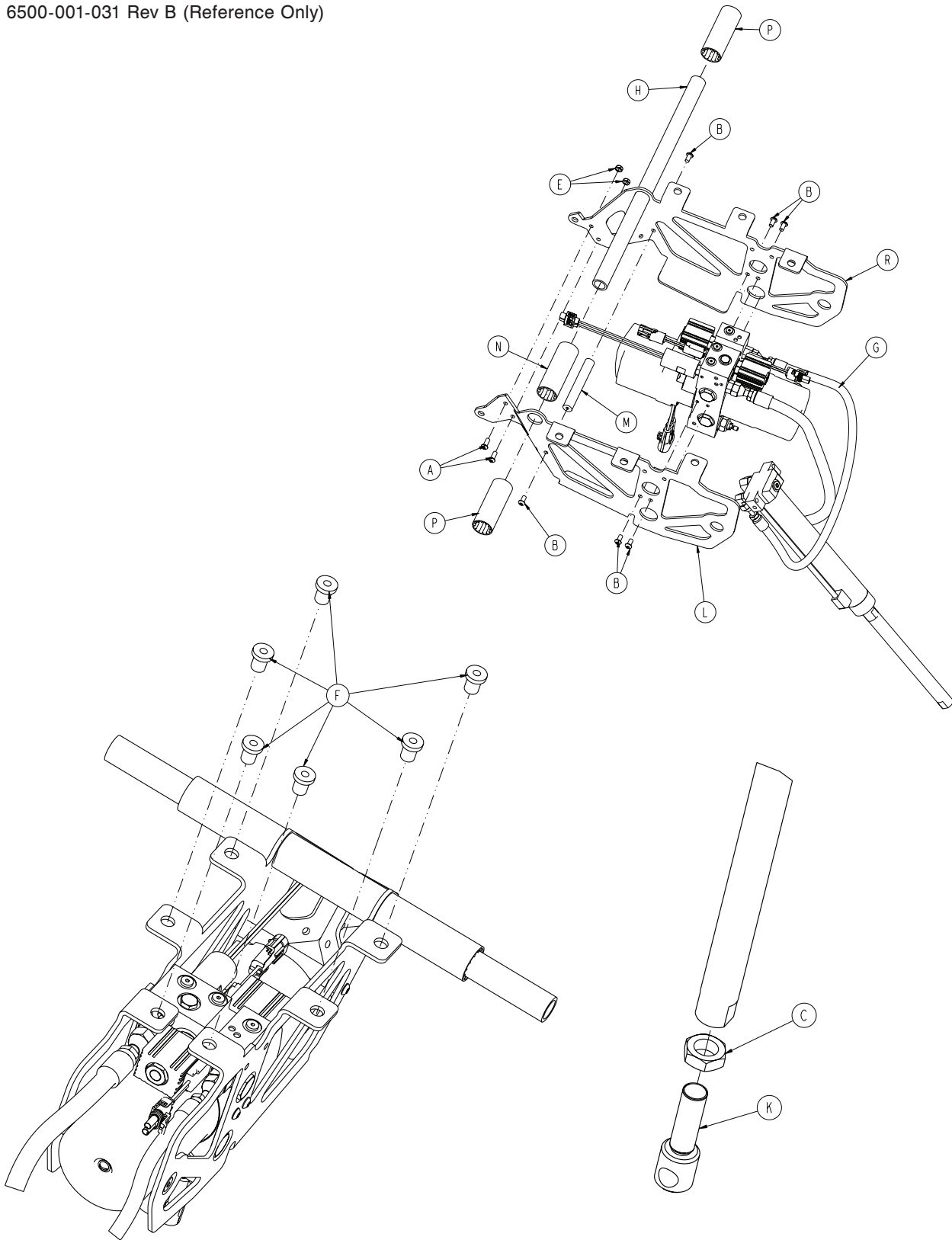

# Powerplant Assembly

---

## Powerplant Assembly - 6500-001-031 Rev B (Reference Only)

Item	Part No.	Part Name	Qty.
A	0004-577-000	Button Head Cap Screw	2
B	0004-589-000	Button Head Cap Screw	6
C	0015-052-000	Jam Hex Nut	1
E	0016-102-000	Nylock Hex Nut	2
F	0055-100-074	Well Nut	6
G	6500-001-030	Hydraulics Assembly ( <a href="#">page 112</a> )	1
H	6500-001-105	Litter Support Cross Tube	1
K	6500-001-169	Cylinder Rod End	1
L	6500-001-194	Motor Mount	1
M	6500-001-212	Motor Mount Cross Bar	1
N	6500-001-249	Plastic Extrusion Spacer	1
P	6500-001-250	Plastic Extrusion Spacer	2
R	6500-001-294	Motor Mount	1

# Hydraulic Sub-Assembly - 6500-001-030

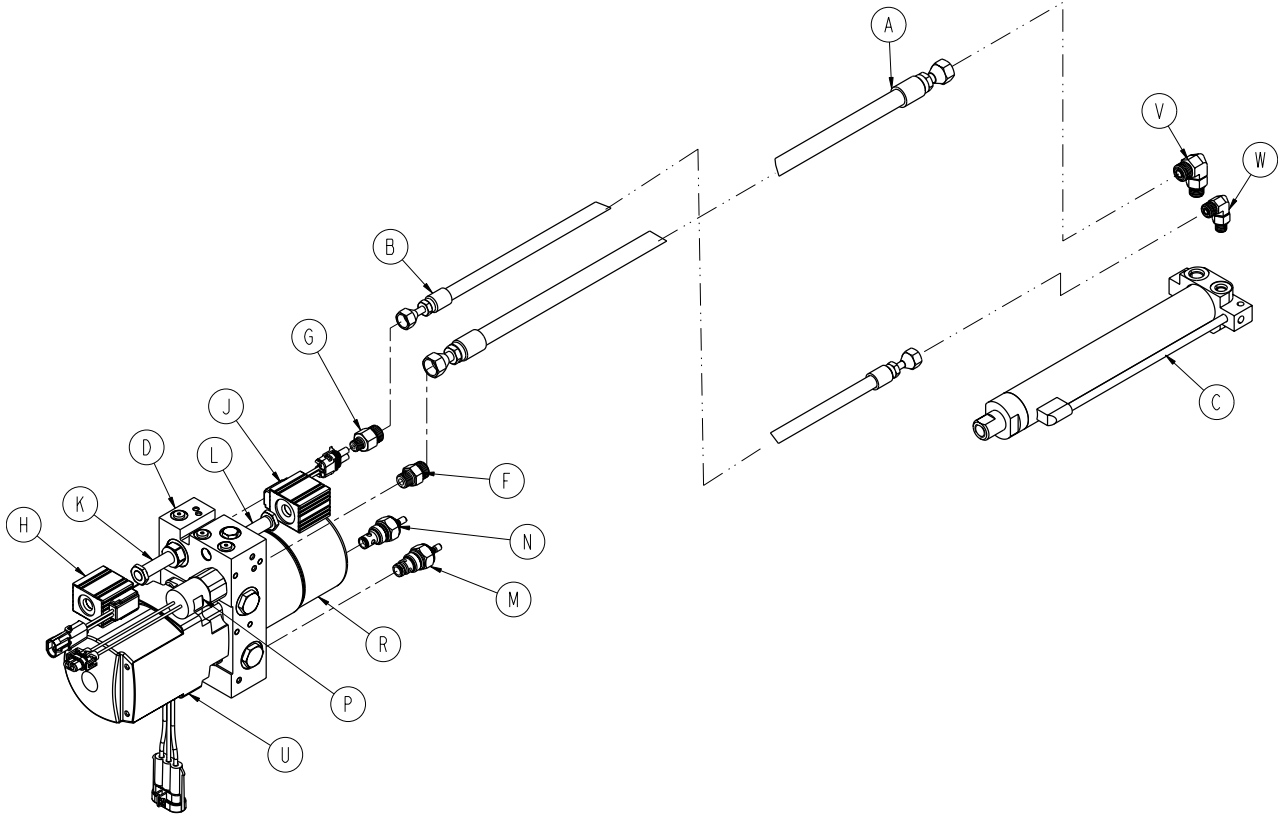

Item	Part No.	Part Name	Qty.
A	6500-001-210	Cap Side Hose	1
B	6500-001-211	Rod Side Hose	1
C	6500-001-213	Cylinder	1
D	6500-001-214	Manifold Assembly	1
E	6500-001-270	Pressure Compensated Flow Control	1
F	6500-001-282	Manifold Cap Side Hose Fitting	1
G	6500-001-283	Manifold Rod Side Hose Fitting	1
H	6500-001-284	A Value Solenoid	1
J	6500-001-285	B Value Solenoid	1
K	6500-001-286	A Valve	1
L	6500-001-287	B Valve	1
M	6500-001-288	Locking Manual Valve	1
N	6500-001-289	Non-Locking Manual Valve	1
P	6500-001-290	Pressure Switch	1
R	6500-001-291	Reservoir	1
T	6500-001-293	Hydraulic Fluid	1
U	6500-001-295	Motor	1
V	6500-001-296	Cylinder Cap Side Hose Fitting	1
W	6500-001-297	Cylinder Rod Side Hose Fitting	1
Y	6500-001-299	Hydraulic Fill Plug	1



# Foot End Assembly

6500-001-015 Rev D (Reference Only)

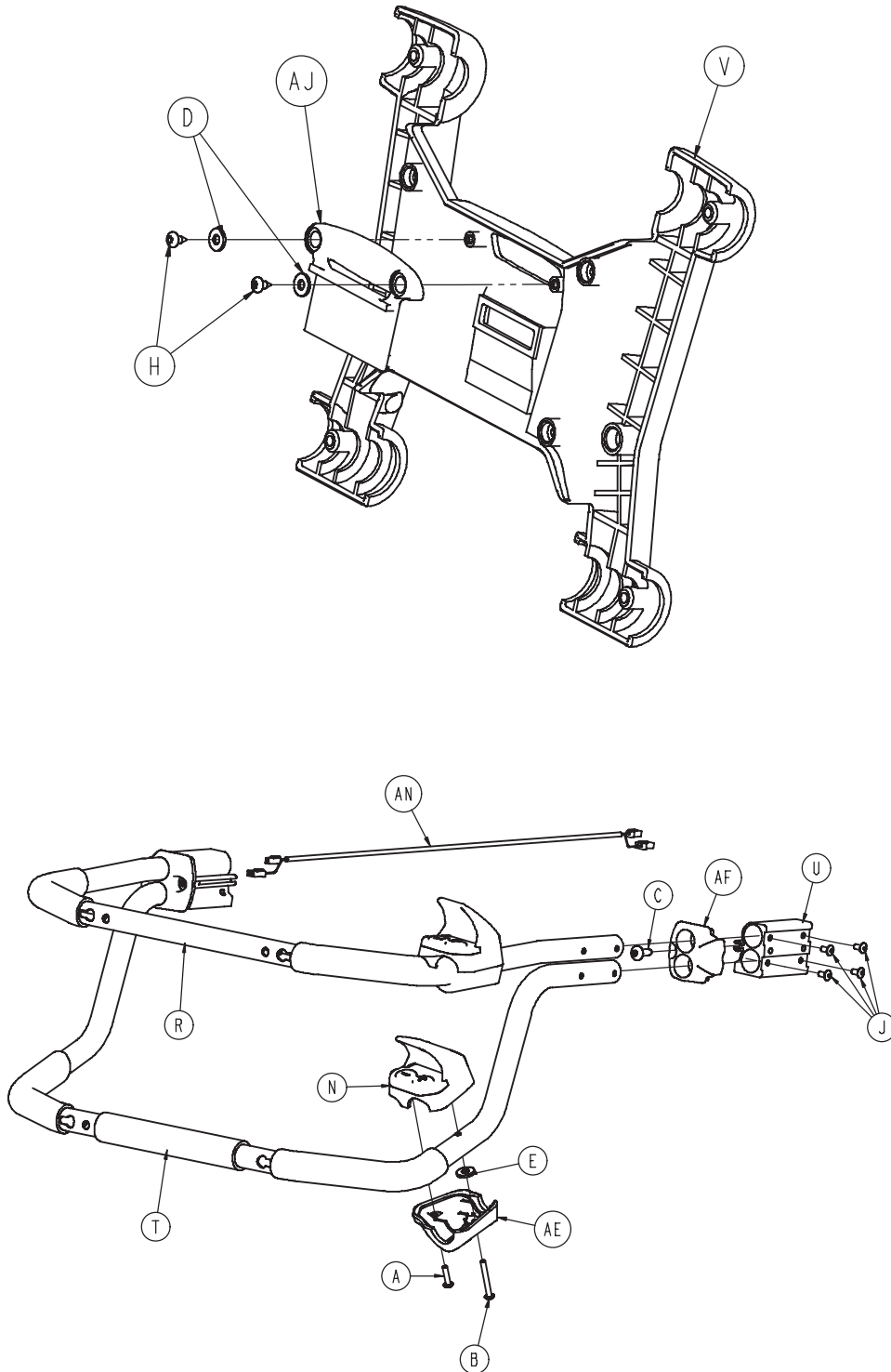

[Return To Table of Contents](#)

# Foot End Assembly

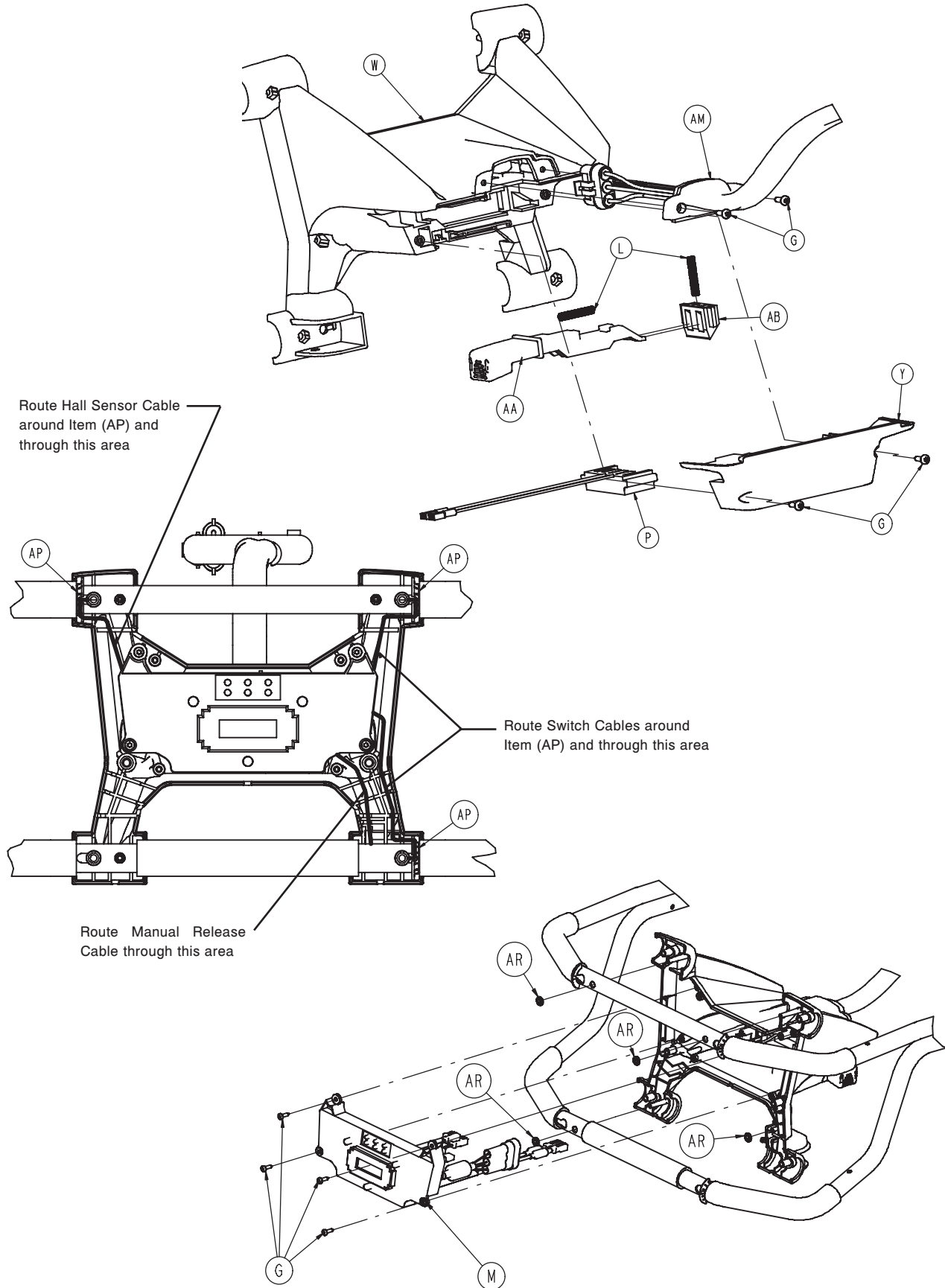

[Return To Table of Contents](#)

# Foot End Assembly

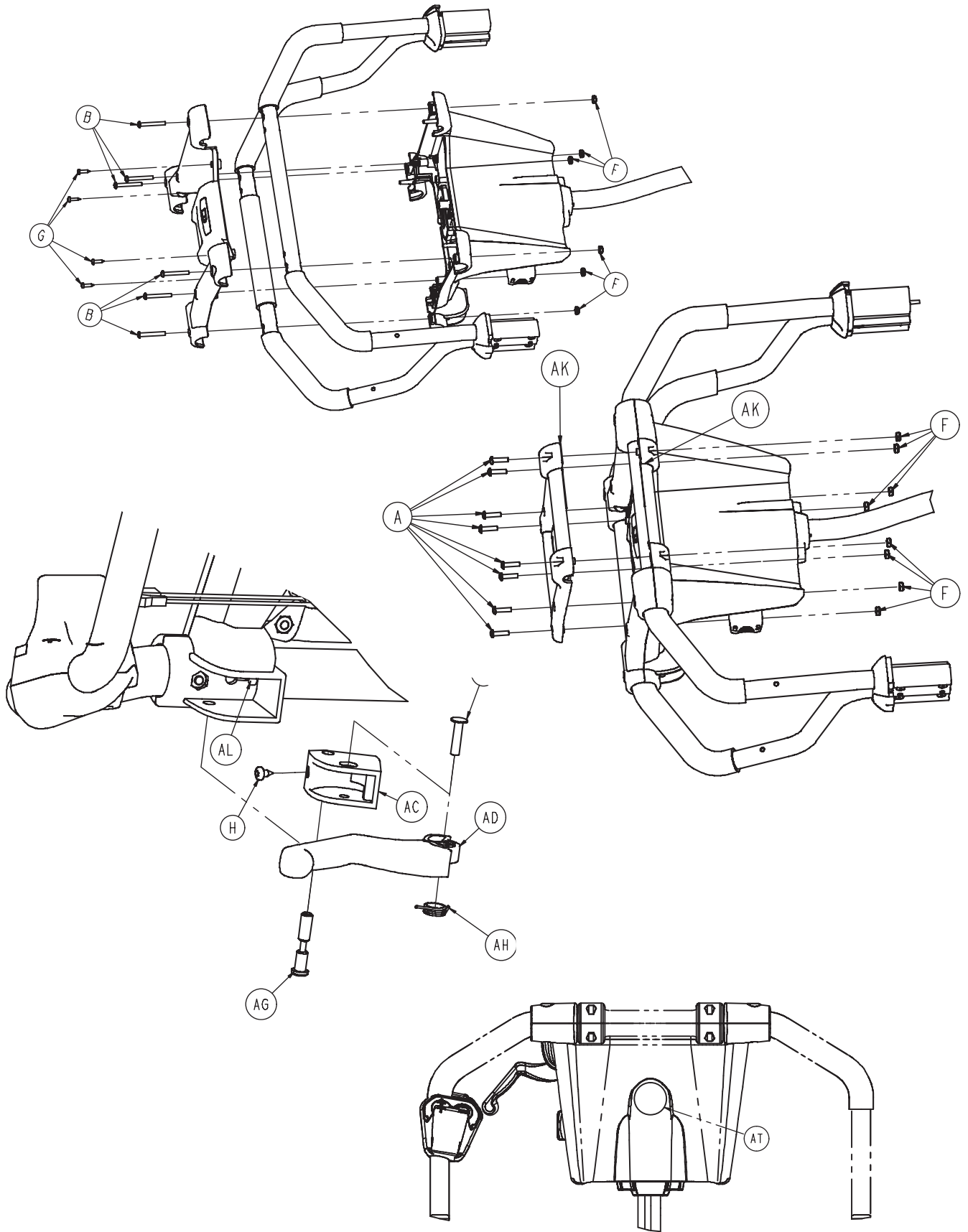

[Return To Table of Contents](#)

# Foot End Assembly

---

## Foot End Assembly - 6500-001-015 Rev D (Reference Only)

Item	Part No.	Part Name	Qty.
A	0004-614-000	Button Head Cap Screw	10
B	0004-615-000	Button Head Cap Screw	8
C	0007-086-000	Truss Head Screw	2
D	0011-062-000	Washer	2
E	0011-543-000	Washer	2
F	0016-131-000	Nut - Nylock Hex	14
G	0023-162-000	Pan Head Thread Forming Screw	12
H	0023-163-000	Pan Head Thread Forming Screw	3
J	0025-079-000	Rivet	8
K	0025-187-000	Semi-Tubular Rivet	1
L	0038-572-000	Compression Spring	2
M	6500-001-014	Electronics Assembly	1
N	6500-001-016	Switch Assembly ( <a href="#">page 124</a> )	2
P	6500-001-216	Terminal Block	1
R	6500-001-131	Upper Lifting Bar	1
T	6500-001-132	Lower Lifting Bar	1
U	6500-001-133	Machined Extruded Bracket	2
V	6500-001-134	Battery Enclosure - Face Plate	1
W	6500-001-135	Top Plate, Foot End Enclosure	1
Y	6500-001-136	Bottom Plate, Foot End Enclosure	1
AA	6500-001-138	Button, Battery Release	1
AB	6500-001-139	Lock, Battery Release	1
AC	6500-001-140	Pivot, Manual Release Actuator	1
AD	6500-001-141	Lever, Manual Release Actuator	1
AE	6500-001-142	Housing, Lower, Button, Foot End	2
AF	6500-001-144	Transition Cap, Right	2
AG	6500-001-146	Pivot Pin, Manual Release	1
AH	6500-001-147	Torsion Spring	1
AJ	6500-001-153	ORB, Light Panel	1
AK	6500-001-154	Pull Handle	2
AL	6500-001-156	Cable, Manual Release	1
AM	6500-001-159	Cable Assembly	1
AN	6500-001-161	Cable, Hall Effects	1
AP	6500-001-275	Wire Route Clip	3
AR	0028-116-000	Push Nut	4
AT	6080-090-101	Warning Label	1

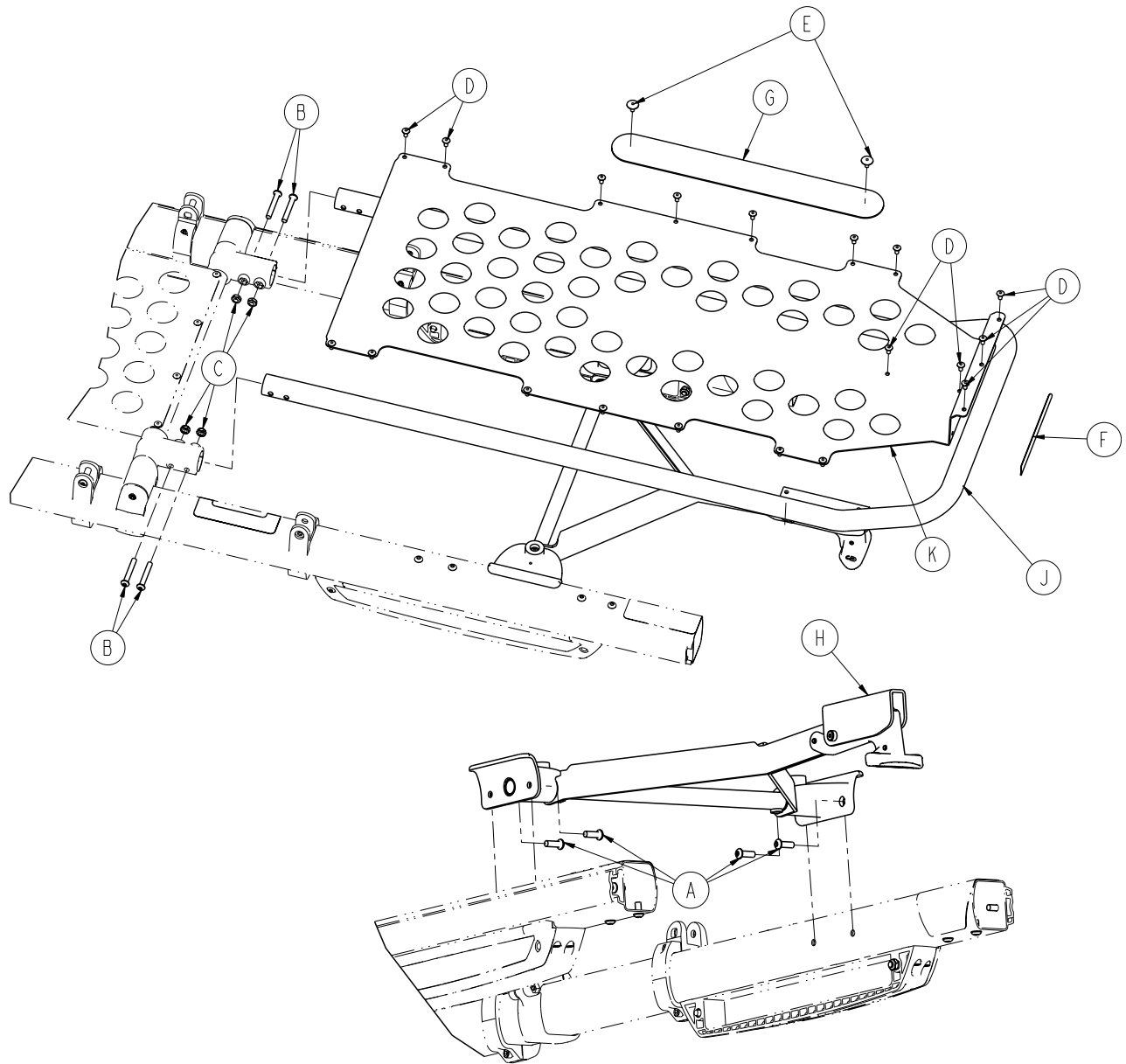

Item	Part No.	Part Name	Qty.
A	0004-592-000	Button Head Cap Screw	4
B	0004-596-000	Button Head Cap Screw	4
C	0016-102-000	Nylock Hex Nut	4
D	0025-079-000	Dome Head Rivet	19
E	0025-132-000	Dome Head Rivet	2
F	6060-090-004	Small Label	1
G	6082-001-085	2" Adhesive Loop Pole	1
H	6500-001-019	Trend Assembly ( <a href="#">page 118</a> )	1
J	6500-001-197	Foot Section Tube	1
K	6500-001-198	Foot Section Skin	1

# Trend Assembly

6500-001-019 Rev C (Reference Only)

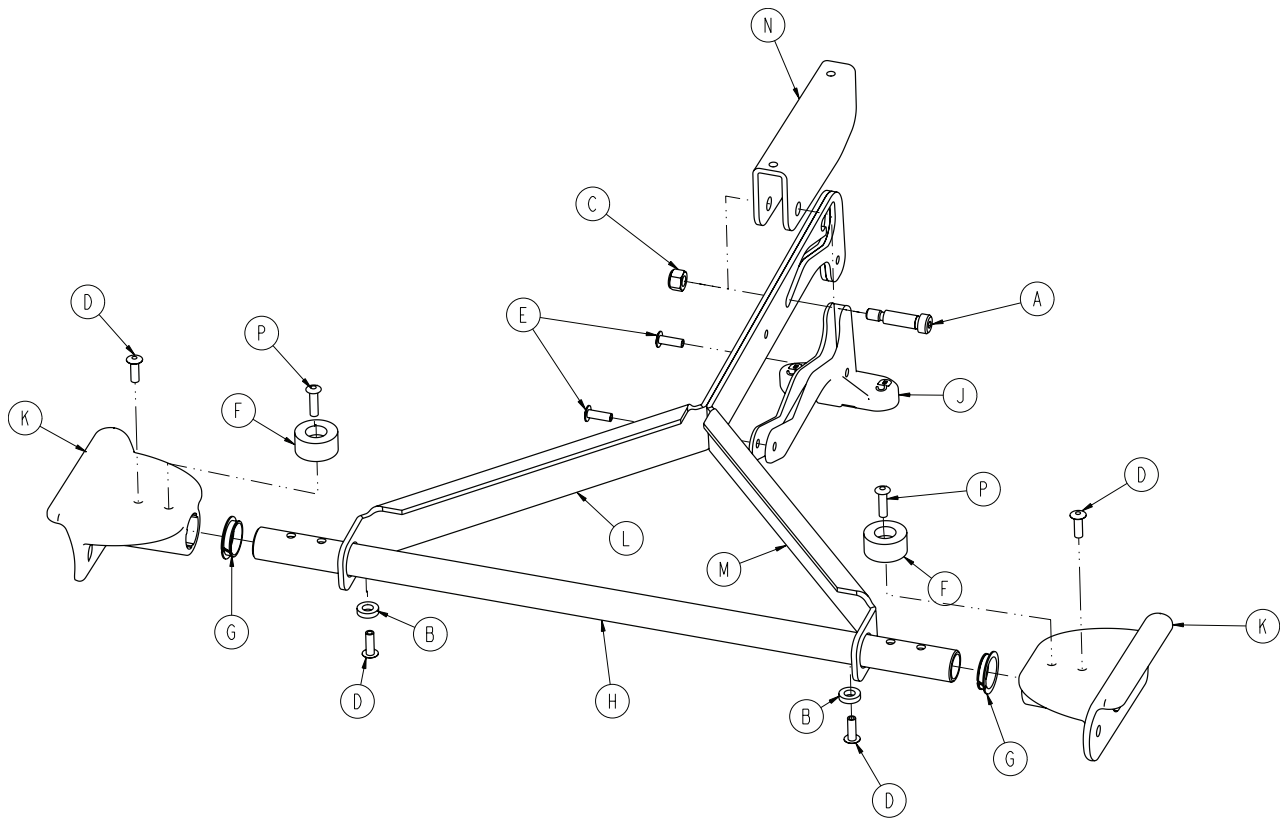

Item	Part No.	Part Name	Qty.
A	0008-074-000	Socket Head Shoulder Screw	1
B	0014-067-000	Washer	2
C	0016-028-000	Nut	1
D	0025-133-000	Rivet	4
E	0025-186-000	Rivet	2
F	0056-016-000	Bumper	2
G	0081-255-000	Split Bearing	2
H	6500-001-107	Litter Cross Tube	1
J	6500-001-108	Trend Release	1
K	6500-001-109	Trend Bracket	2
L	6500-001-203	Calf Stand Support, Right	1
M	6500-001-204	Calf Stand Support, Left	1
N	6500-001-205	Retainer, Calf Stand	1
P	0025-086-000	Rivet	2

# Optional Gatch - 6500-082-000

Rev A

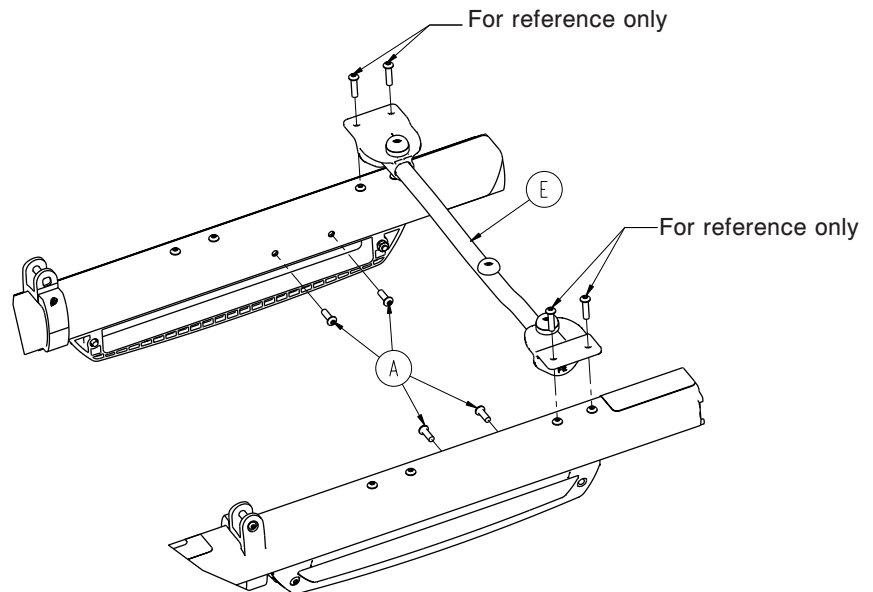
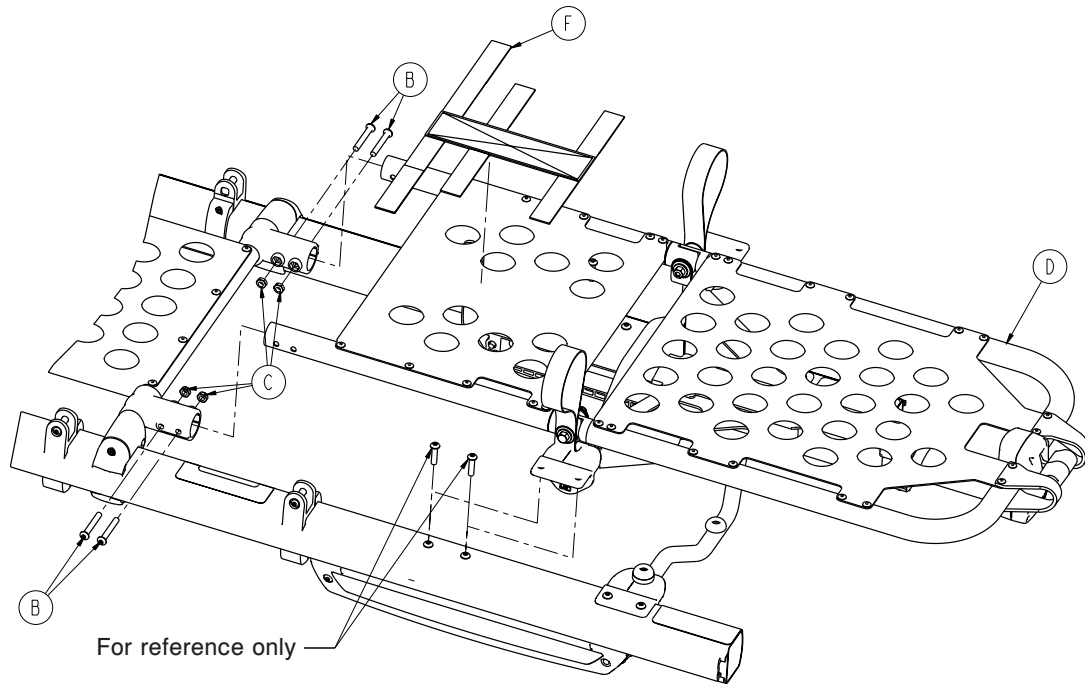

Item	Part No.	Part Name	Qty.
A	0004-592-000	Button Head Cap Screw	4
B	0004-596-000	Button Head Cap Screw	4
C	0016-102-000	Nylock Hex Nut	4
D	6500-001-048	Gatch Assembly ( <a href="#">page 120</a> )	1
E	6085-001-031	Gatch Support Assembly ( <a href="#">page 123</a> )	1
F	6550-001-197	Velcro® Strap	1

[Return To Table of Contents](#)

# Optional Gatch Assembly

6500-001-048 Rev A (Reference Only)

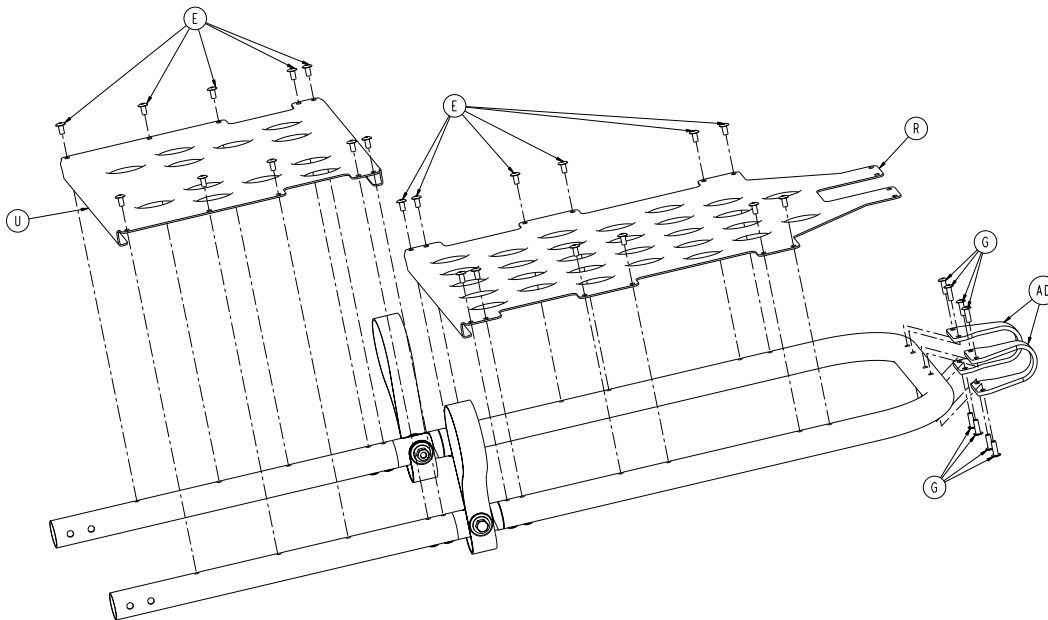
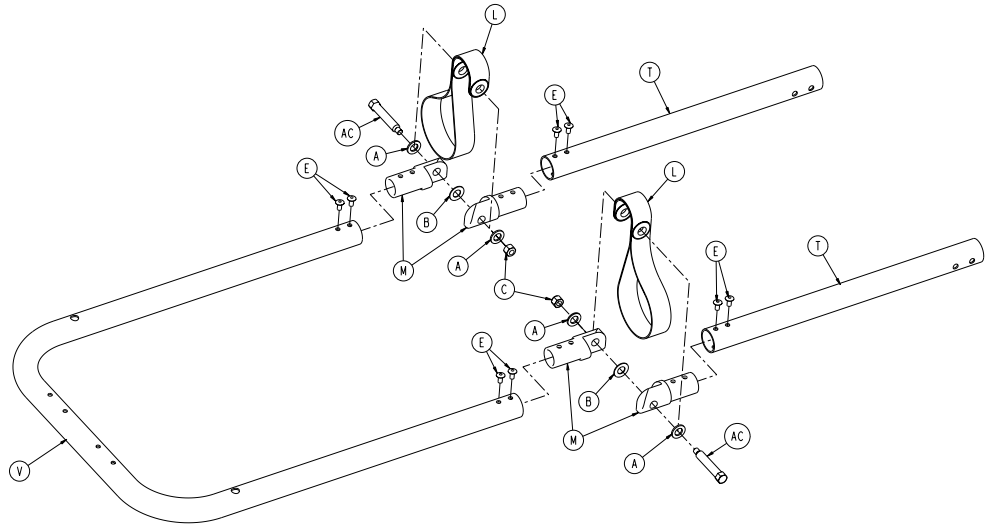



# Optional Gatch Assembly

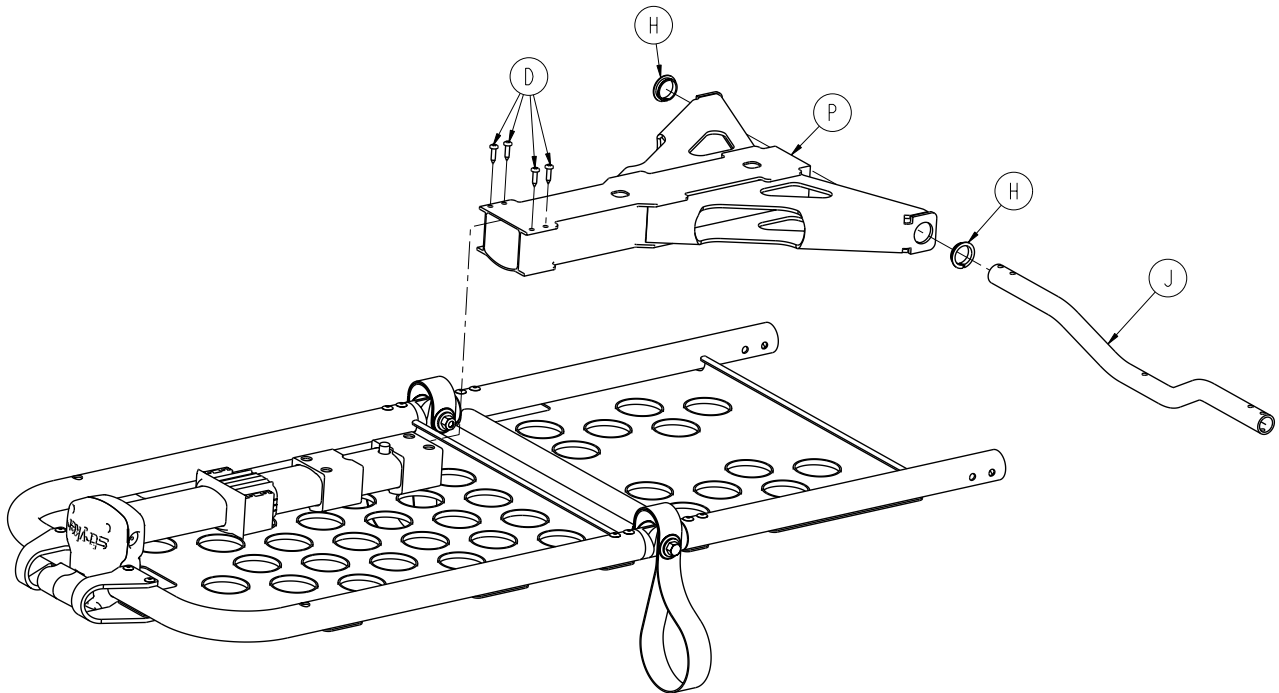
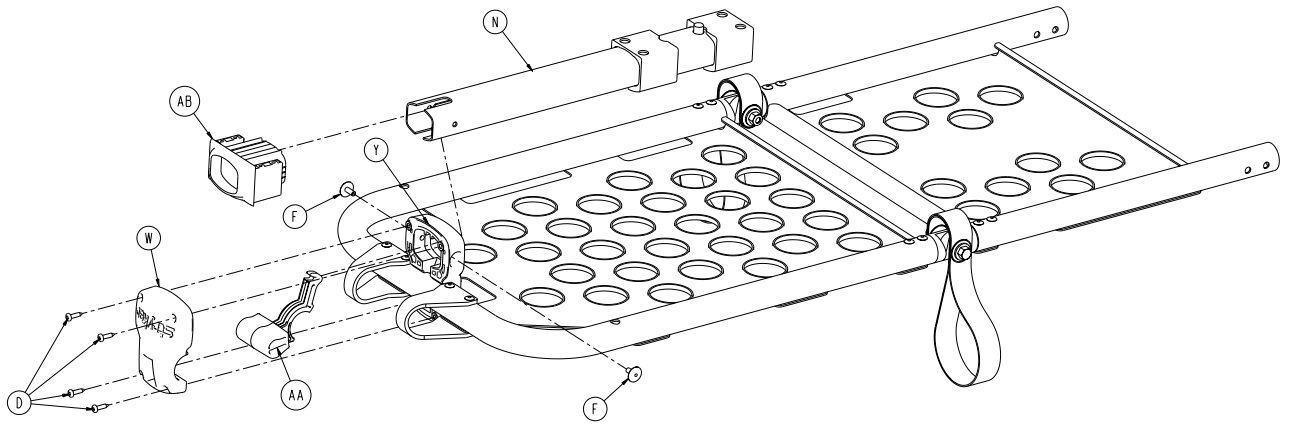

[Return To Table of Contents](#)

# Optional Gatch Assembly

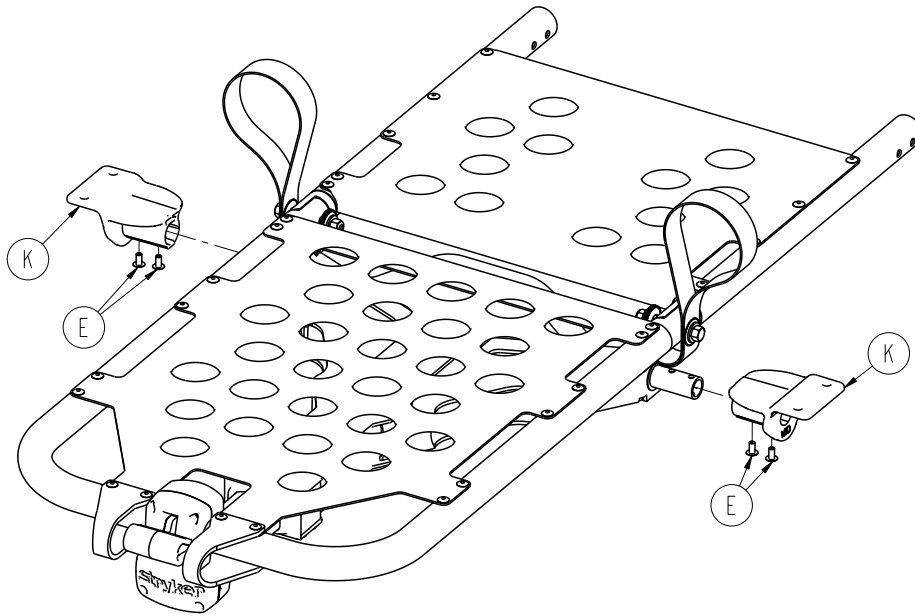

## Optional Gatch Assembly - 6500-001-048 Rev A (Reference Only)

Item	Part No.	Part Name	Qty.
A	0011-448-000	Washer	4
B	0014-020-000	Washer	2
C	0016-028-000	Fiberlock Hex Nut	2
D	0023-162-000	Delta Screw	8
E	0025-079-000	Dome Head Rivet	34
F	0025-132-000	Dome Head Rivet	2
G	0025-133-000	Dome Head Rivet	8
H	0081-255-000	Split Bearing	2
J	6500-001-346	Gatch Cross Tube	1
K	6085-001-125	Gatch Support, Mid	2
L	6100-031-096	Trend Lift Strap	2
M	6100-031-108	Gatch Pivot	4
N	6550-001-017	Gatch Telescoping Assembly	1
P	6550-001-057	Gatch Lock Tube Weldment	1
R	6550-001-110	Foot Section Skin	1
T	6550-001-111	Thigh Section Tube	2
U	6550-001-112	Thigh Section Skin	1
V	6550-001-116	Foot Section U-Tube	1
W	6550-001-124	Front Gatch Release	1
Y	6550-001-125	Back Gatch Release	1
AA	6550-001-126	Gatch Release Lever	1
AB	6550-001-131	Gatch Bearing End Cap	1
AC	6550-001-186	Gatch Pivot Pin	2
AD	6550-001-193	Gatch Handle Guard	2

# Optional Gatch Support Assembly

6085-001-031 Rev C (Reference Only)

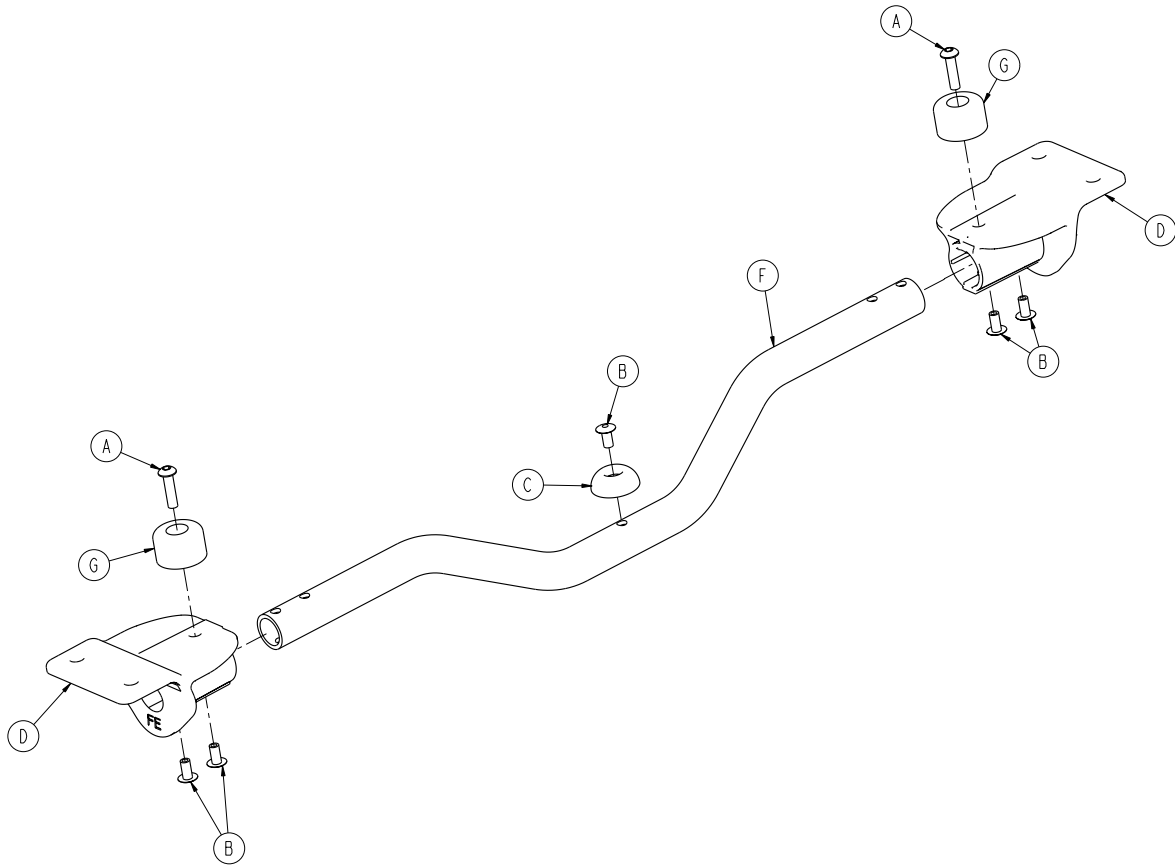

Item	Part No.	Part Name	Qty.
A	0004-614-000	Button Head Cap Screw	2
B	0025-079-000	Dome Head Rivet	5
C	0946-001-155	Bumper	1
D	6085-001-135	Gatch Support, Foot End	2
F	6500-001-346	Gatch Crosstube	1
G	0056-028-000	Black TPR Bumper	2

[Return To Table of Contents](#)

# Switch Assembly - 6500-001-016

Rev D

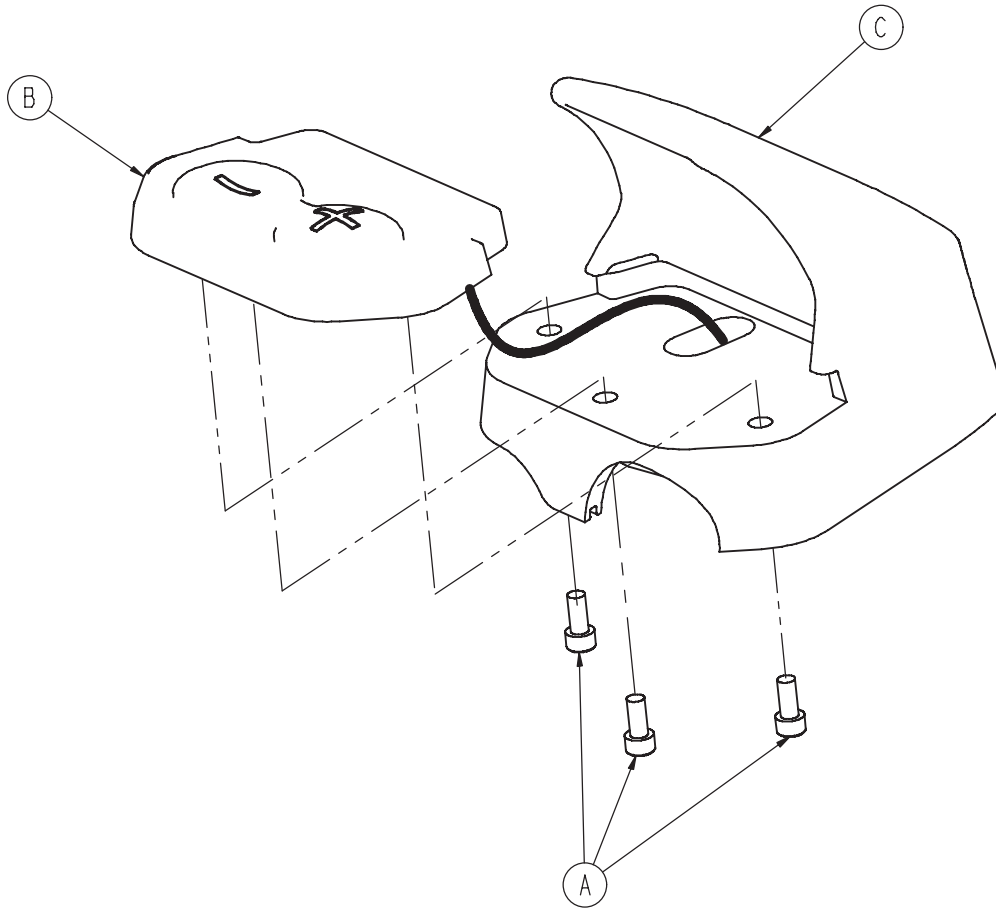

Item	Part No.	Part Name	Qty.
A	0004-616-000	Socket Head Cap Screw	3
B	6500-001-130	Activation Switch	1
C	6500-001-143	Housing, Upper, Button, Foot End	1

# Fowler Assembly

6500-001-018 Rev B (Reference Only)

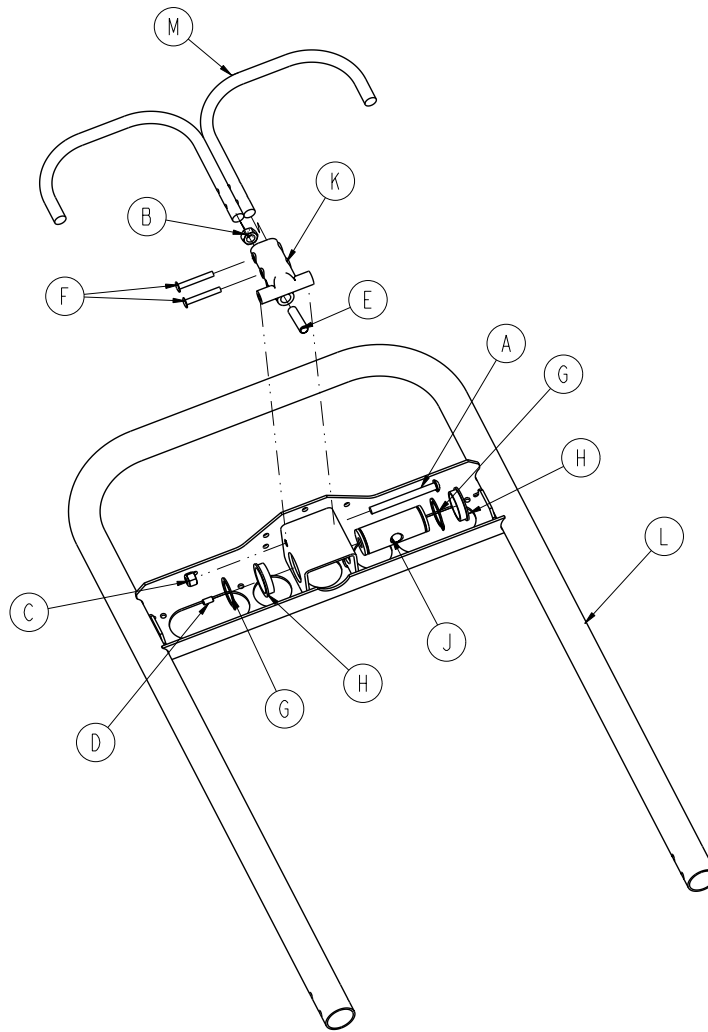

Item	Part No.	Part Name	Qty.
A	0004-597-000	Button Head Cap Screw	1
B	0015-050-000	Nut	1
C	0016-028-000	Nut	1
D	0021-119-000	Set Screw	1
E	0021-138-000	Set Screw	1
F	0025-131-000	Rivet	2
G	0028-076-000	External Retaining Ring	2
H	0946-035-025	Liner	2
J	6060-032-038	Yoke	1
K	6060-032-040	Pivot	1
L	6082-032-050	Fowler Weldment	1
M	6082-032-052	Release Handle Weldment	1

[Return To Table of Contents](#)

# Head Section Assembly - 6085-001-037

Rev B

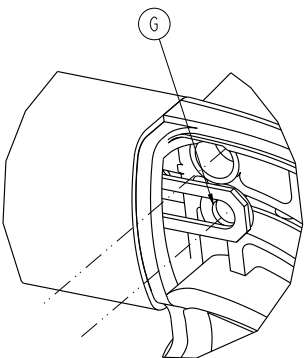
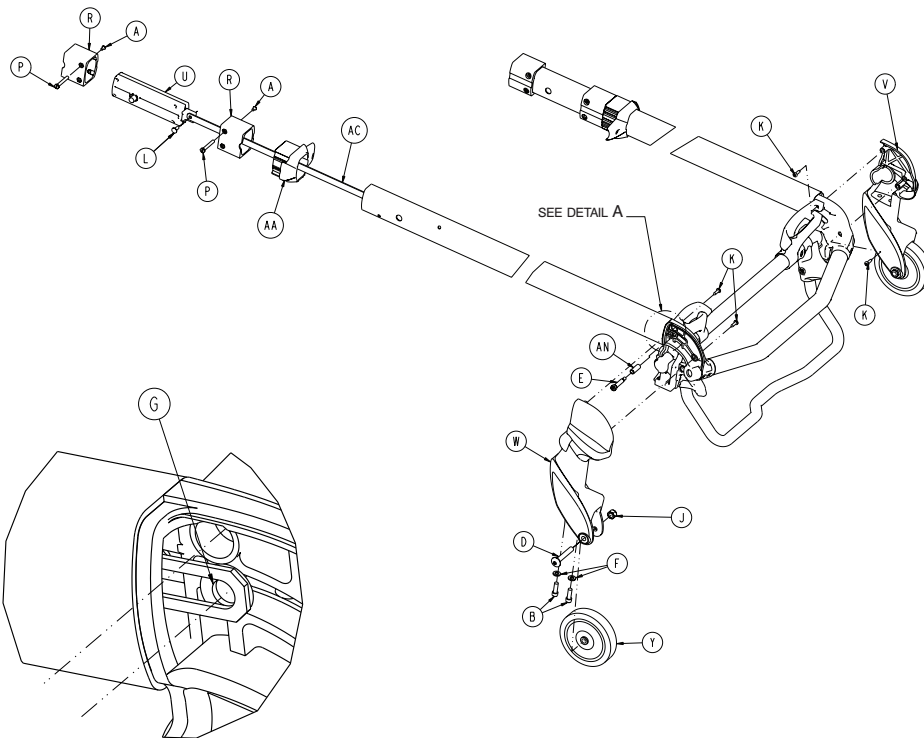
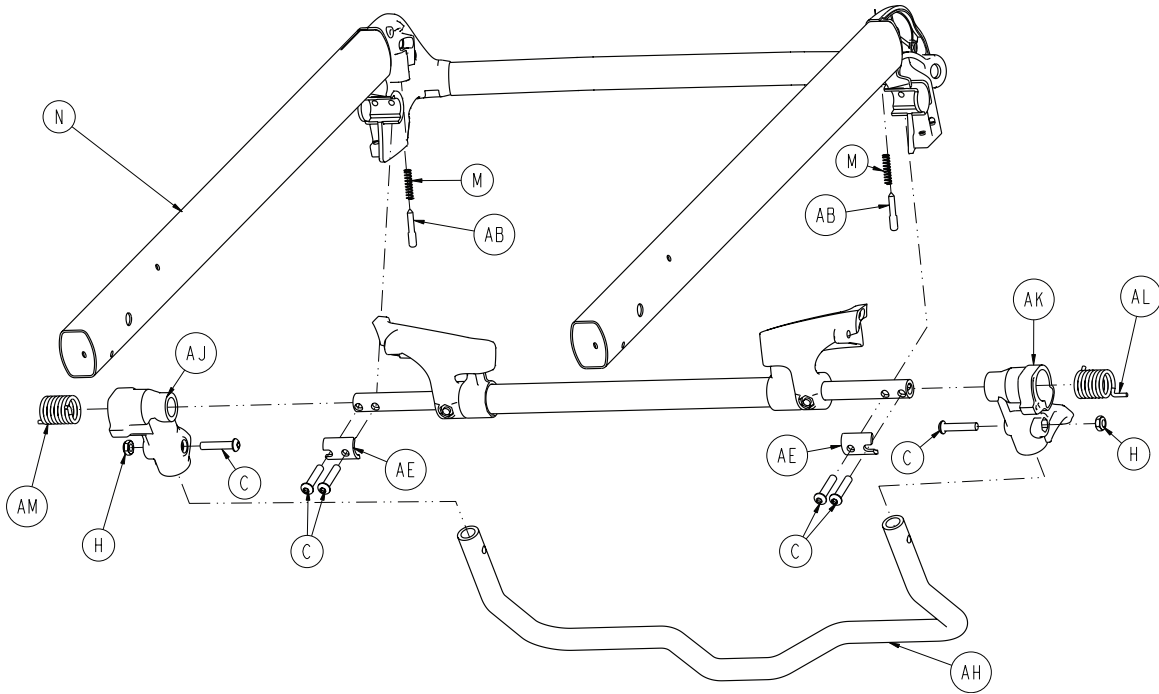

# Head Section Assembly - 6085-001-037

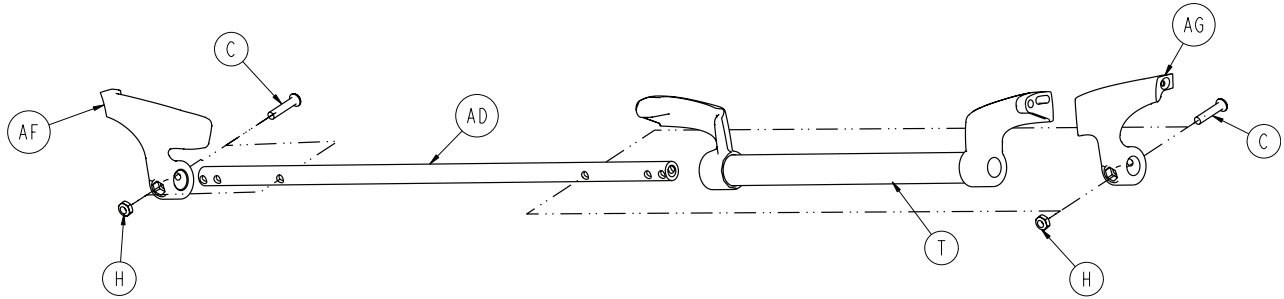

Item	Part No.	Part Name	Qty.
A	0004-168-000	Button Head Cap Screw	4
B	0004-591-000	Socket Head Cap Screw	4
C	0004-612-000	Button Head Cap Screw	8
D	0007-036-000	Truss Head Machine Screw	2
E	0008-030-000	Socket Head Shoulder Screw	2
F	0011-065-000	Washer	4
G	0014-002-000	Washer	2
H	0016-102-000	Nylock Hex Nut	4
J	0016-123-000	Nylock Hex Nut	2
K	0023-162-000	Delta Screw	4
L	0025-126-000	Rivet	2
M	0038-570-000	Compression Spring	2
N	6085-001-036	Telescoping Tube Assembly	1
P	6085-001-169	Head Section Nut	4
R	6085-001-170	Internal Bearing	4
T	6500-001-023	Head Trigger Assembly	1
U	6500-001-026	Head Section Lock Assy ( <a href="#">page 128</a> )	2
V	6500-001-082	Load Wheel Horn	1
W	6500-001-083	Load Wheel Casting	1
Y	6500-001-086	Front Wheel	2
AA	6500-001-087	Cap Bearing	2
AB	6500-001-093	Safety Bar Lock Pin	2
AC	6500-001-096	Head Section Release Link	2
AD	6500-001-220	Head Section Pivot Cross Tube	1
AE	6500-001-221	Cross Tube Clamp	2
AF	6500-001-280	Head Section Guard, Right	1
AG	6500-001-281	Head Section Guard, Left	1
AH	6500-001-322	Sliding Head Section Safety Bar	1
AJ	6500-001-323	Safety Hook Pivot, Right	1
AK	6500-001-324	Safety Hook Pivot, Left	1
AL	6500-001-325	Safety Bar Torsion Spring, Left	1
AM	6500-001-326	Safety Bar Torsion Spring, Right	1
AN	6500-001-360	Head Section Sleeve	2

[Return To Table of Contents](#)

# Head Section Lock Assembly - 6500-001-026

Rev C

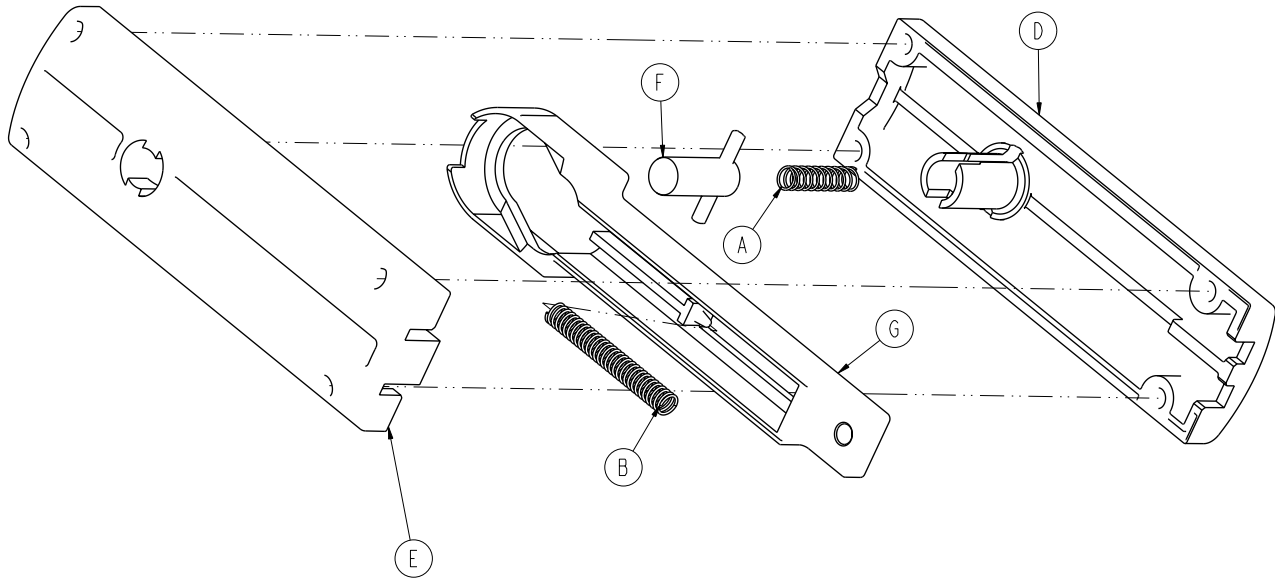

Item	Part No.	Part Name	Qty.
A	0038-570-000	Compression Spring	1
B	0038-134-000	Compression Spring	1
D	6500-001-091	Top Latch Housing	1
E	6500-001-092	Bottom Latch Housing	1
F	6500-001-025	Latch Assembly	1
G	6500-001-095	Actuation Slide	1



# In-Fastener Shut-Off Assembly - 6500-001-027

Rev C

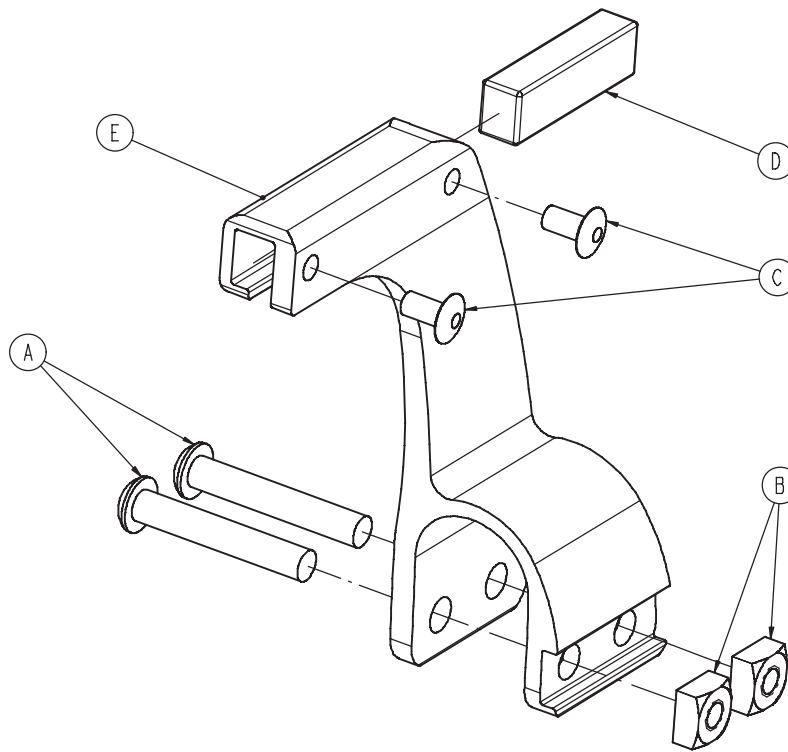

Item	Part No.	Part Name	Qty.
A	0004-376-000	Button Head Cap Screw	2
B	0015-016-000	Square Nut	2
C	0025-079-000	Rivet	2
D	6500-001-271	Magnet	1
E	6500-001-272	Holder	1

[Return To Table of Contents](#)

# Optional Retractable Head Sect. Oxygen Bottle Holder - 6085-046-000

Rev B

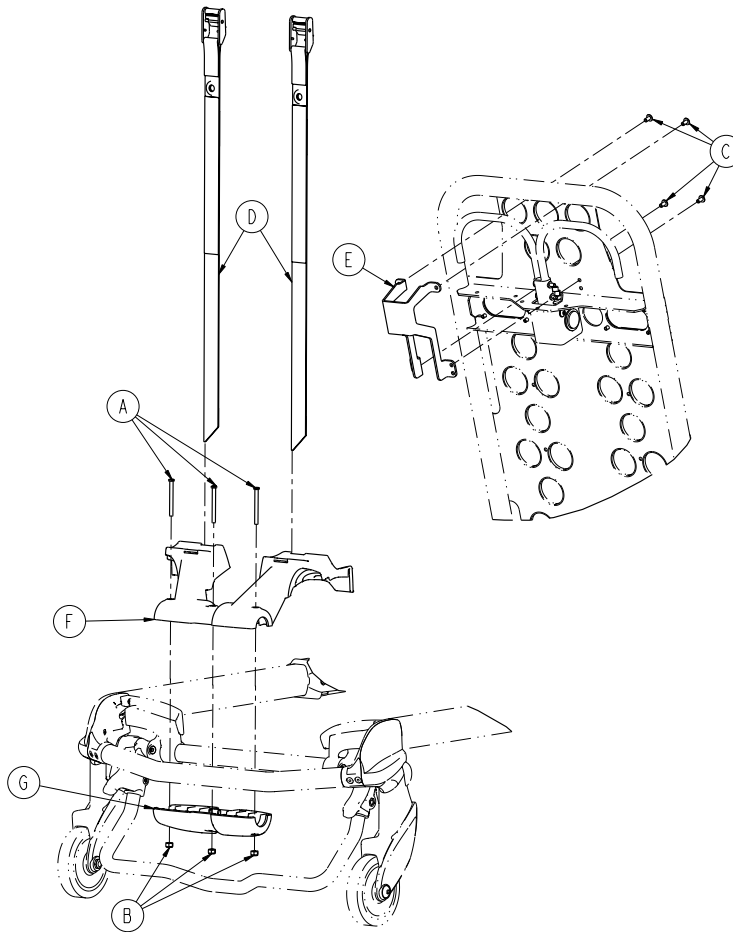

Item	Part No.	Part Name	Qty.
A	0004-656-000	Socket Head Cap Screw	3
B	0016-002-000	Fiberlock Hex Nut	3
C	0025-079-000	Dome Head Rivet	4
D	6085-001-171	Oxygen Strap, Head End	2
E	6085-001-172	Oxygen Fowler Guard	1
F	6085-001-173	Oxygen Bottle Holder, Top	1
G	6085-001-174	Oxygen Bottle Holder, Bottom	1

**Note:** Max Load = 40 pounds

# Optional Oxygen Bottle Holder Assembly - 6500-001-040

Rev B

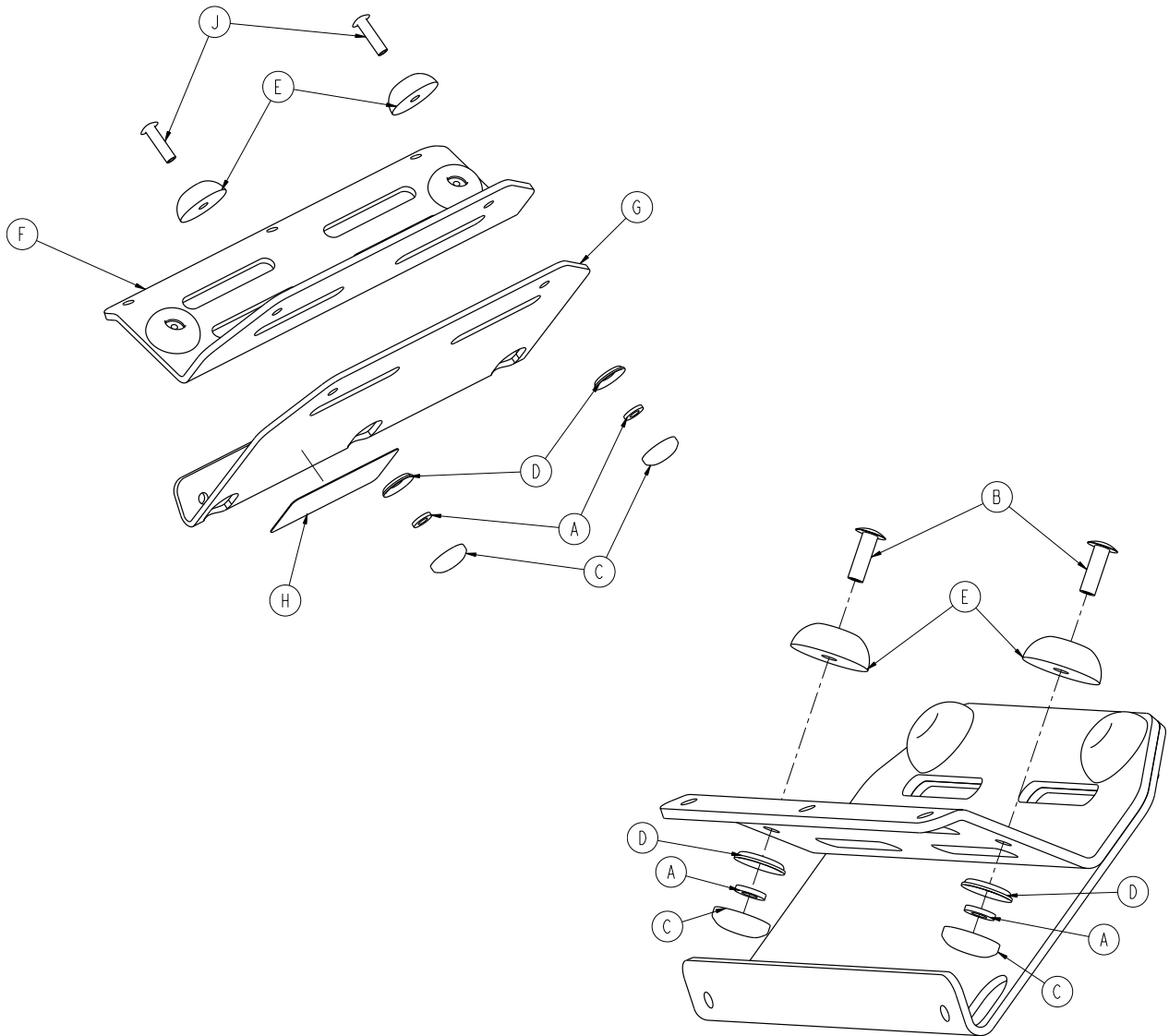

Item	Part No.	Part Name	Qty.
A	0011-436-000	Washer	4
B	0025-133-000	Rivet	2
C	0037-055-000	Cap	4
D	0037-056-000	Washer	4
E	0946-001-155	Bumper	4
F	6500-001-239	Tray	1
G	6500-001-240	Bracket	1
H	6500-001-257	Label	1
J	0025-086-000	Blind Rivet	2

**Note:** Max Load = 40 pounds

[Return To Table of Contents](#)

# Optional Head End Oxygen Bottle Holder - 6500-141-000

Rev C

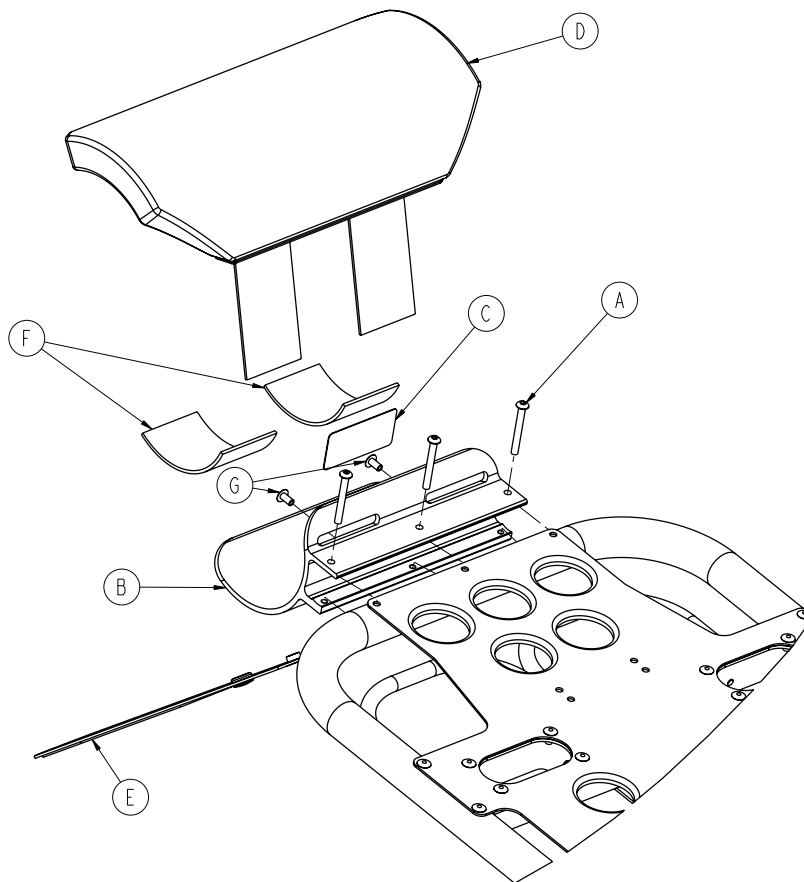

Item	Part No.	Part Name	Qty.
A	0004-636-000	Button Head Cap Screw	3
B	6500-001-119	Backrest Oxygen Holder Bracket	1
C	6500-001-231	Fowler Oxygen Bottle Holder Label	1
D	6500-001-260	Fowler Oxygen Bottle Holder Cover	1
E	6500-001-261	Fowler Oxygen Bottle Holder Strap	1
F	6500-001-262	Neoprene Pad	2
G	0025-079-000	Dome Head Pop Rivet	2

**Note:** Max Load = 40 pounds

# Two-Stage I.V. Pole Assembly Patient Right - 6500-210-000

# Three-Stage I.V. Pole Assembly Patient Right - 6500-215-000

Rev A

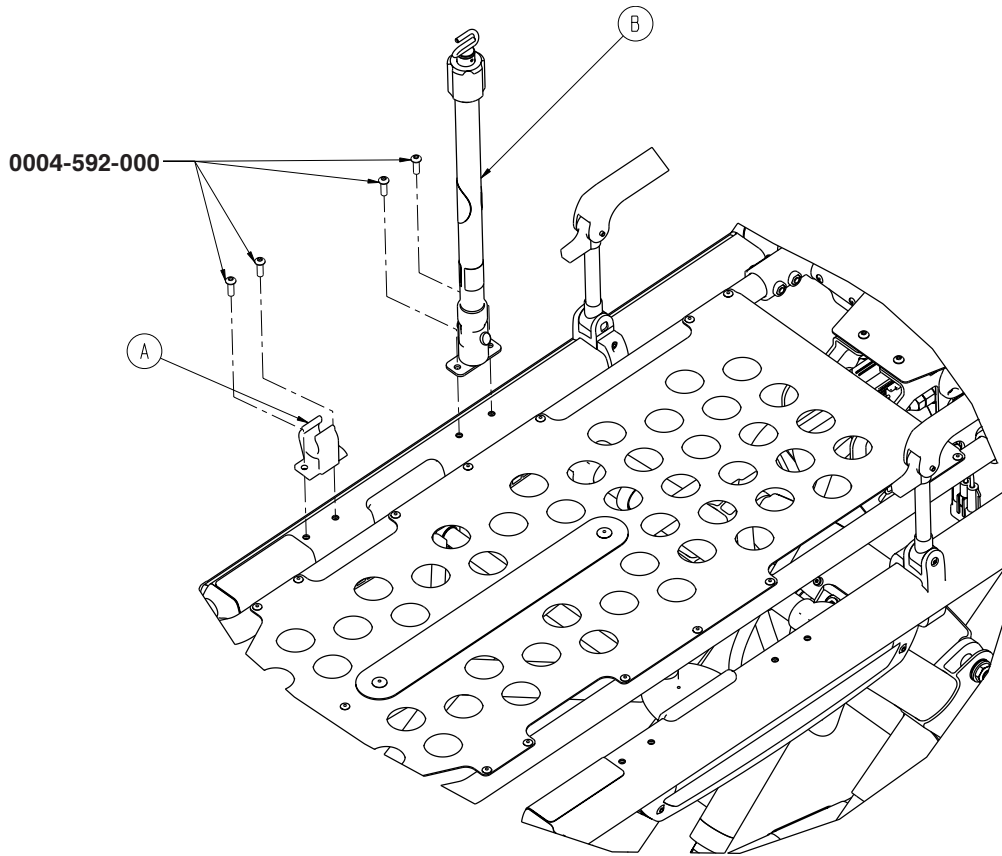

### Optional Two-Stage I.V. Pole Assembly, Right - 6500-210-000

Item	Part No.	Part Name	Qty.
A	6100-115-060	Clip, I.V. Pole	1
B	6500-001-041	I.V. Pole Assembly, 2-Stage, Right (page 134)	1

Item	Part No.	Part Name	Qty.
A	6100-115-060	Clip, I.V. Pole	1
B	6500-001-043	I.V. Pole Assembly, 3-Stage, Right (page 135)	1

[Return To Table of Contents](#)

# Two-Stage I.V. Pole Assembly Patient Right - 6500-001-041

Rev C

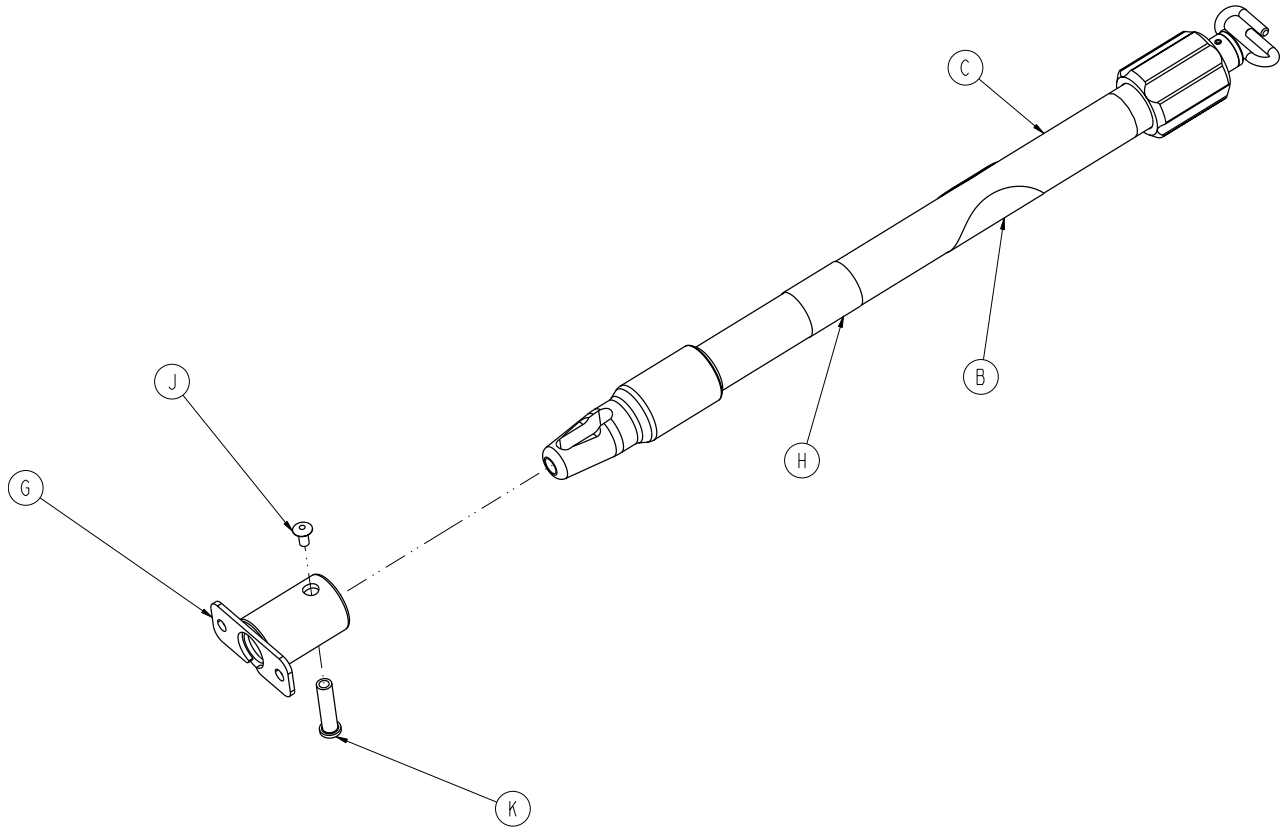

Item	Part No.	Part Name	Qty.
B	6070-090-105	Caution Label	1
C	6070-210-070	Pole Assembly	1
G	6100-115-051	Socket Weldment	1
H	6500-001-253	Label	1
J	0025-079-000	Dome Head Rivet	1
K	6070-110-037	I.V. Pivot Pin	1

# Three-Stage I.V. Pole Assembly Patient Right - 6500-001-043

Rev D

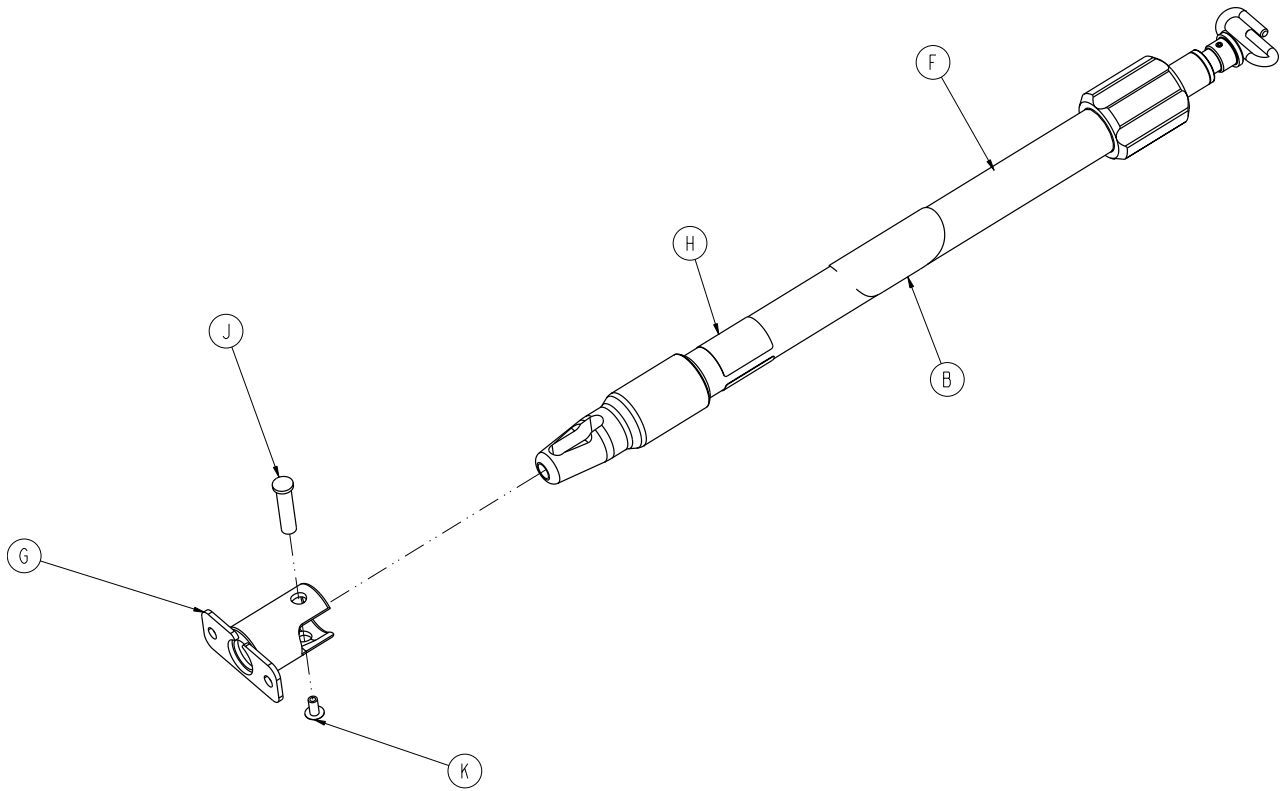

Item	Part No.	Part Name	Qty.
B	6070-090-105	Caution Label	1
F	6070-215-070	Pole Assembly	1
G	6100-115-051	Socket Weldment	1
H	6500-001-255	Label	1
J	6070-110-037	I.V. Pivot Pin	1
K	0025-079-000	Dome Head Rivet	1

[Return To Table of Contents](#)

# Two-Stage I.V. Pole Assembly Patient Left - 6500-211-000

# Three-Stage I.V. Pole Assembly Patient Left - 6500-216-000

Rev A

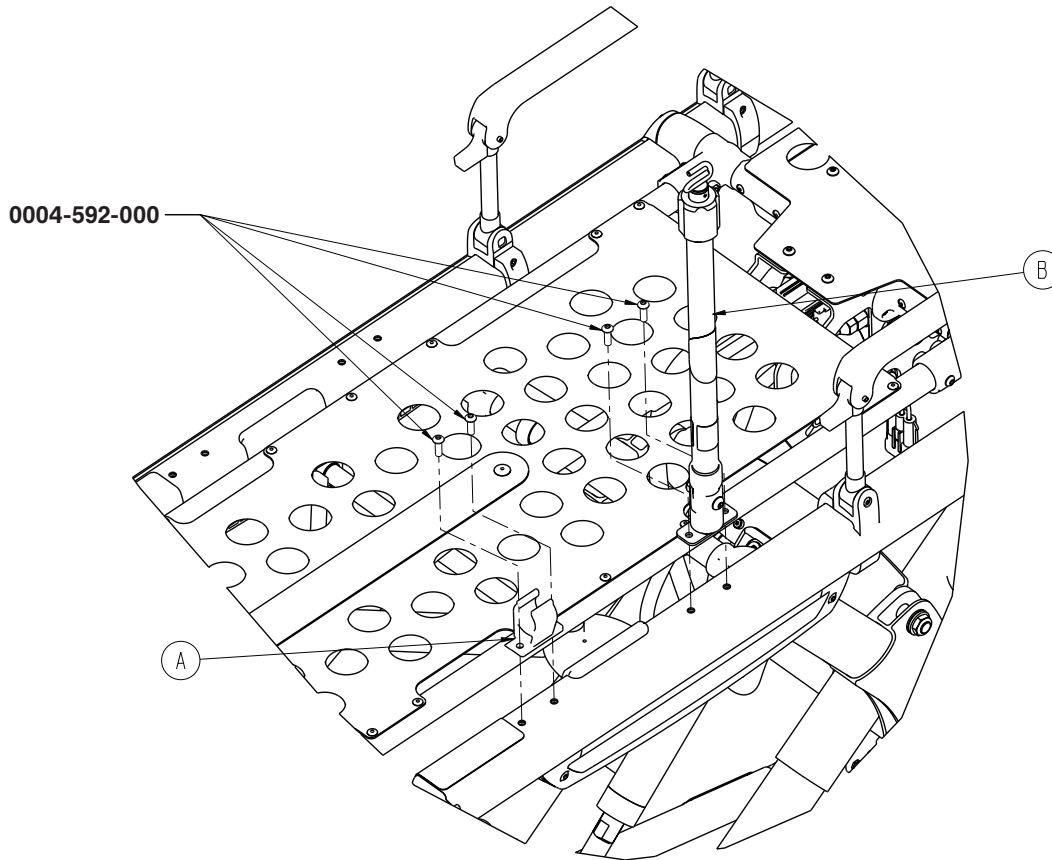

## Optional 2-Stage I.V. Pole Assembly, Left - 6500-211-000

Item	Part No.	Part Name	Qty.
A	6100-115-060	Clip, I.V. Pole	1
B	6500-001-042	I.V. Pole Assembly, 2-Stage, Left (page 137)	1

## Optional 3-Stage I.V. Pole Assembly, Left - 6500-216-000

Item	Part No.	Part Name	Qty.
A	6100-115-060	Clip, I.V. Pole	1
B	6500-001-044	I.V. Pole Assembly, 3-Stage, Left (page 138)	1



# Two-Stage I.V. Pole Assembly Patient Left - 6500-001-042

Rev C

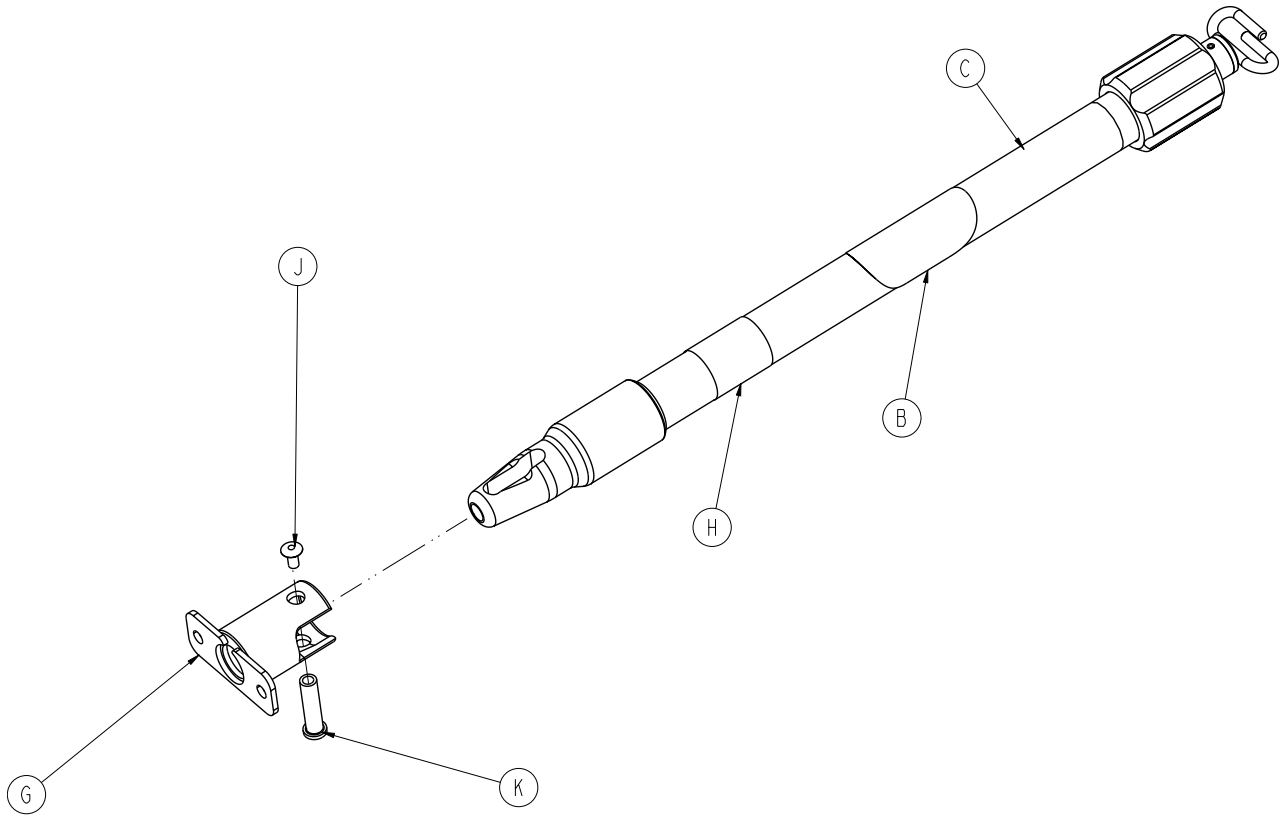

Item	Part No.	Part Name	Qty.
B	6070-090-105	Caution Label	1
C	6070-210-070	Pole Assembly	1
G	6100-115-051	Socket Weldment	1
H	6500-001-254	Label	1
J	0025-079-000	Dome Head Rivet	1
K	6070-110-037	I.V. Pivot Pin	1

[Return To Table of Contents](#)

# Three-Stage I.V. Pole Assembly Patient Left - 6500-001-044

Rev D

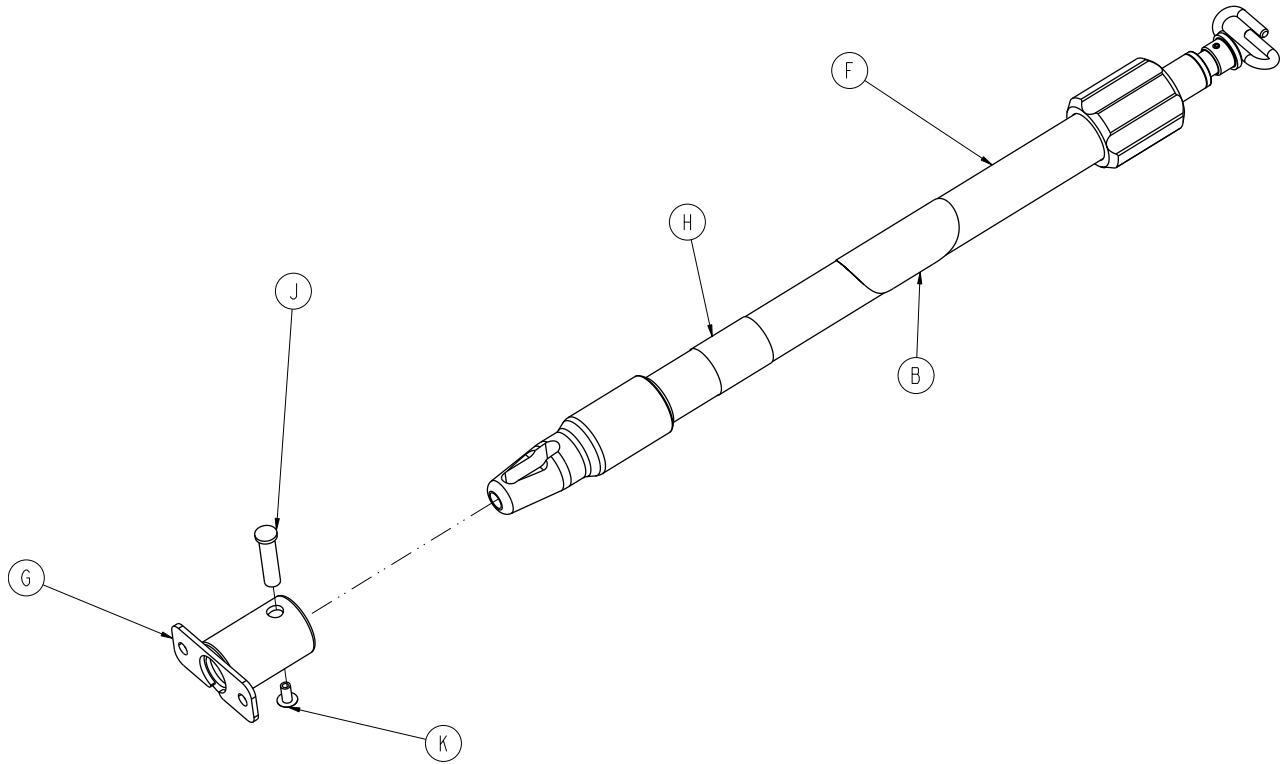

Item	Part No.	Part Name	Qty.
B	6070-090-105	Caution Label	1
F	6070-215-070	Pole Assembly	1
G	6100-115-051	Socket Weldment	1
H	6500-001-256	Label	1
J	6070-110-037	I.V. Pivot Pin	1
K	0025-079-000	Dome Head Rivet	1

# Two-Stage I.V. Pole Assembly, Dual - 6500-212-000

# Three Stage I.V. Pole Assembly, Dual - 6500-217-000

Rev A

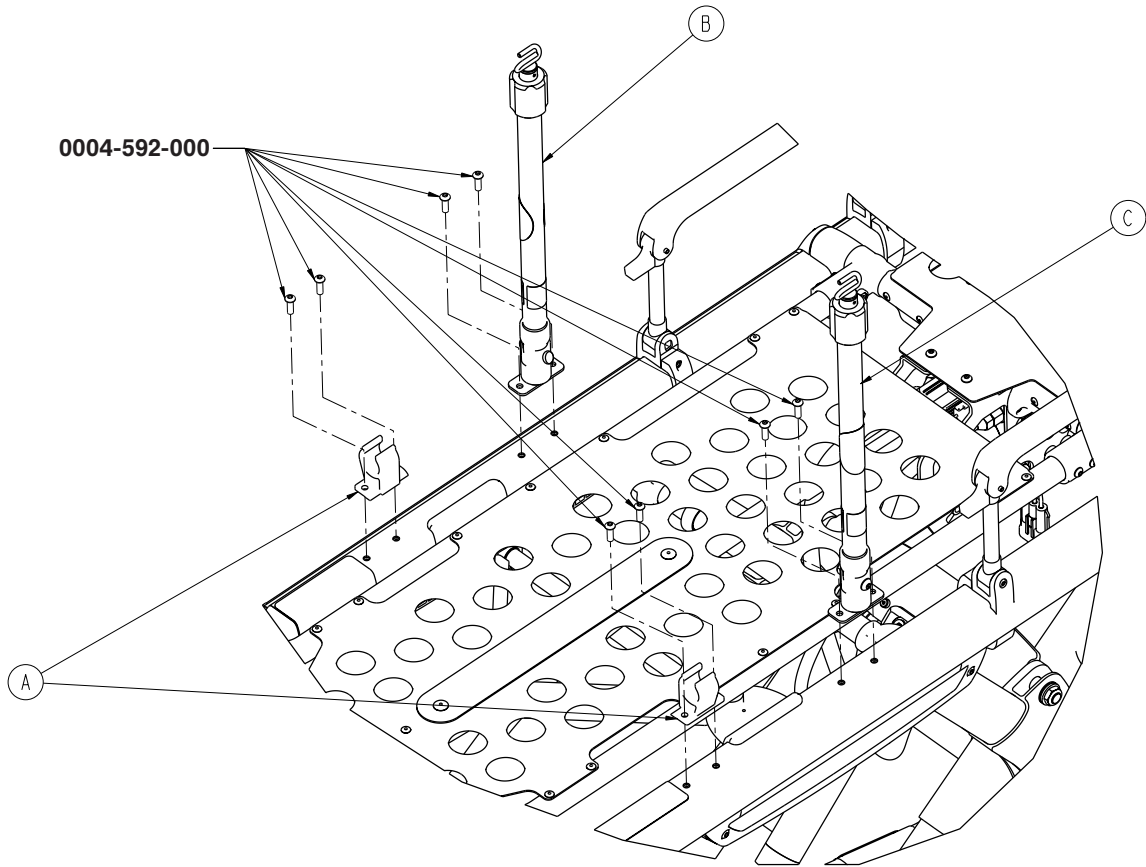

### Optional Two-Stage I.V. Pole Assembly, Dual - 6500-212-000

Item	Part No.	Part Name	Qty.
A	6100-115-060	Clip, I.V. Pole	2
B	6500-001-041	I.V. Pole Assembly, 2-Stage, Right (page 134)	1
C	6500-001-042	I.V. Pole Assembly, 2-Stage, Left (page 137)	1

### Optional Three-Stage I.V. Pole Assembly, Dual - 6500-217-000

Item	Part No.	Part Name	Qty.
A	6100-115-060	Clip, I.V. Pole	2
B	6500-001-043	I.V. Pole Assembly, 3-Stage, Right (page 135)	1
C	6500-001-044	I.V. Pole Assembly, 3-Stage, Left (page 138)	1

[Return To Table of Contents](#)

# Optional Head Extension Assembly - 6100-044-012

Rev F

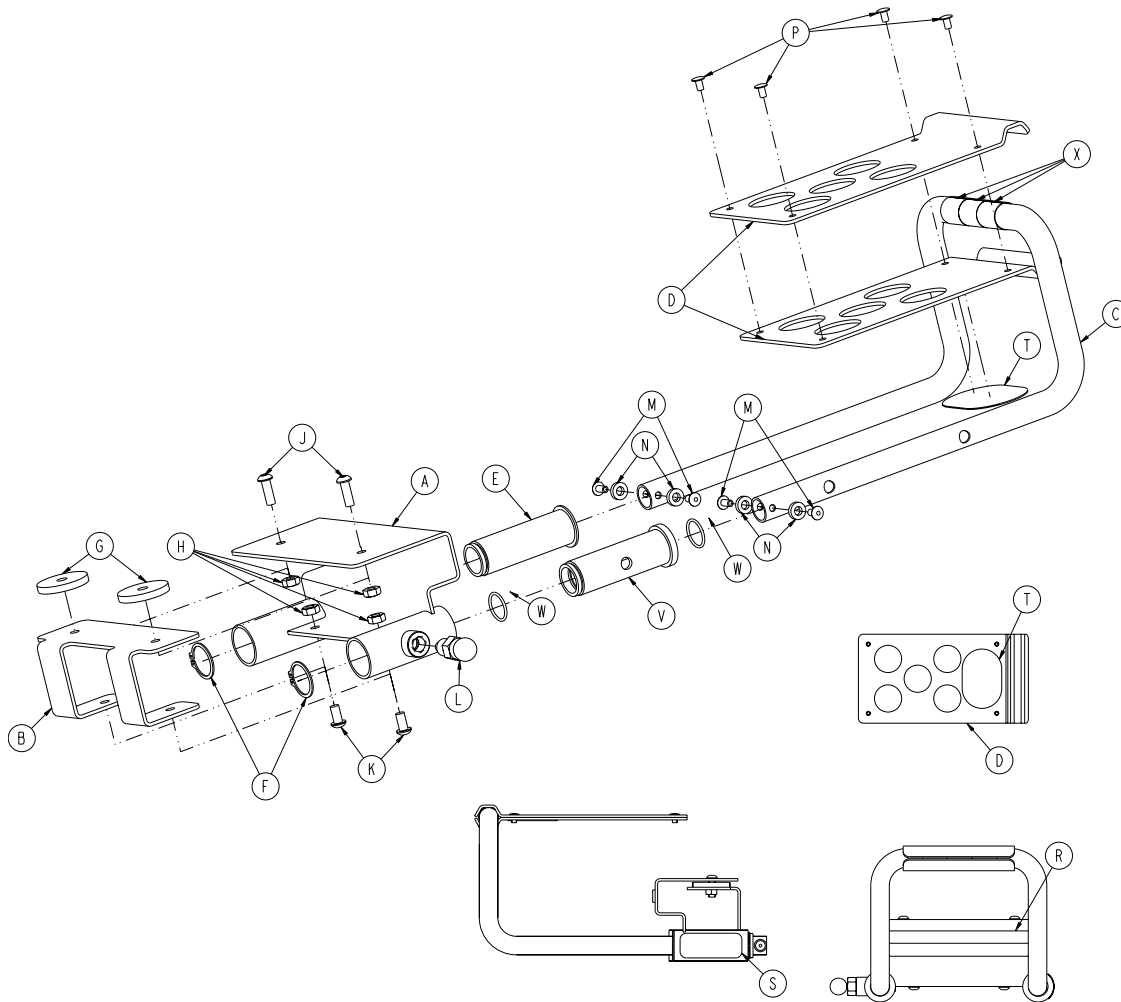

Item	Part No.	Part Name	Qty.
A	6100-044-010	Bracket Weldment	1
B	6100-044-007	Support	1
C	6100-044-011	Extension Tube	1
D	6100-044-008	Pillow Support	2
E	6100-044-005	Insert	1
F	0028-076-000	Clip	2
G	6100-044-006	Spacer	2
H	0016-028-000	Nylock Nut	4
J	0004-161-000	Button Head Cap Screw	2
K	0004-232-000	Button Head Cap Screw	2
L	6372-010-016	Pull Pin Assembly	1
M	0025-079-000	Rivet	4
N	0014-067-000	Washer	4
P	0025-031-000	Semi-Tubular Rivet	4
R	6060-090-004	Small Label	1
S	6100-090-013	Spec Label	1
T	6100-044-013	Velcro® (Hook)	1
V	6100-044-004	Insert	1
W	0045-999-603	O-Ring	2
X	6100-044-014	Head Extension Tape	3

[Return To Table of Contents](#)

# Label, SMRT Power

---

6500-027-000 Rev A (Reference Only)

6500-028-000 Rev A (Reference Only)

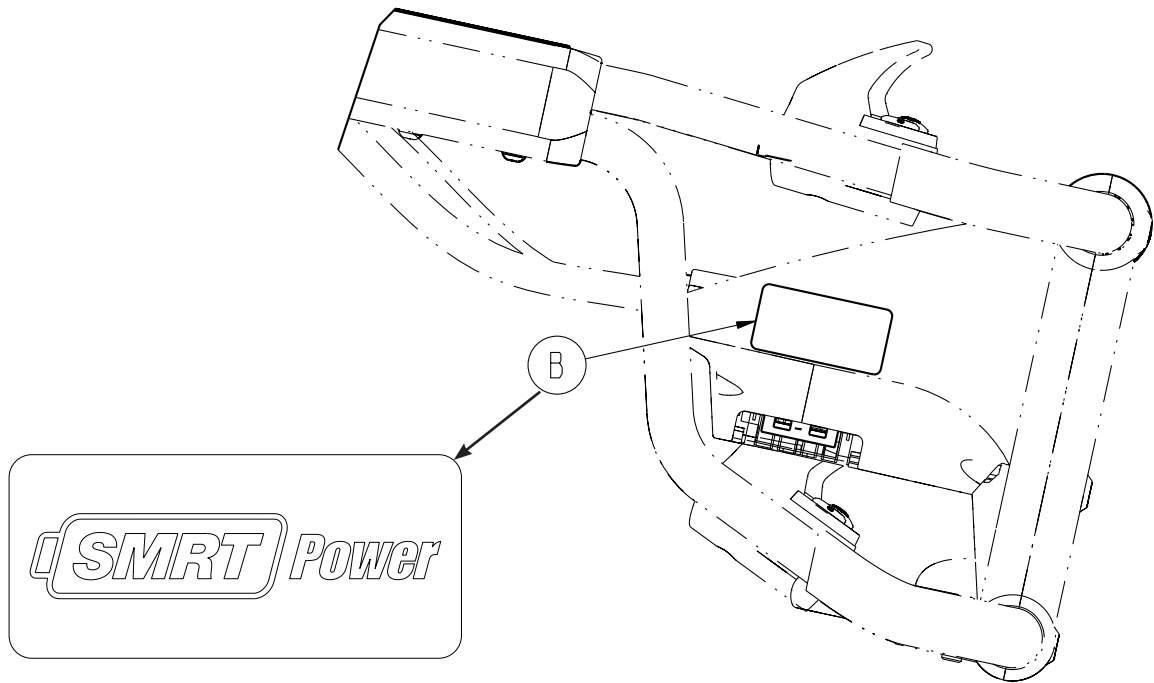

Item	Part No.	Part Name	Qty.
B	6500-001-356	Label, SMRT Power	1

# Label, DeWALT®

---

6500-270-000 Rev A (Reference Only)

6500-272-000 Rev A (Reference Only)

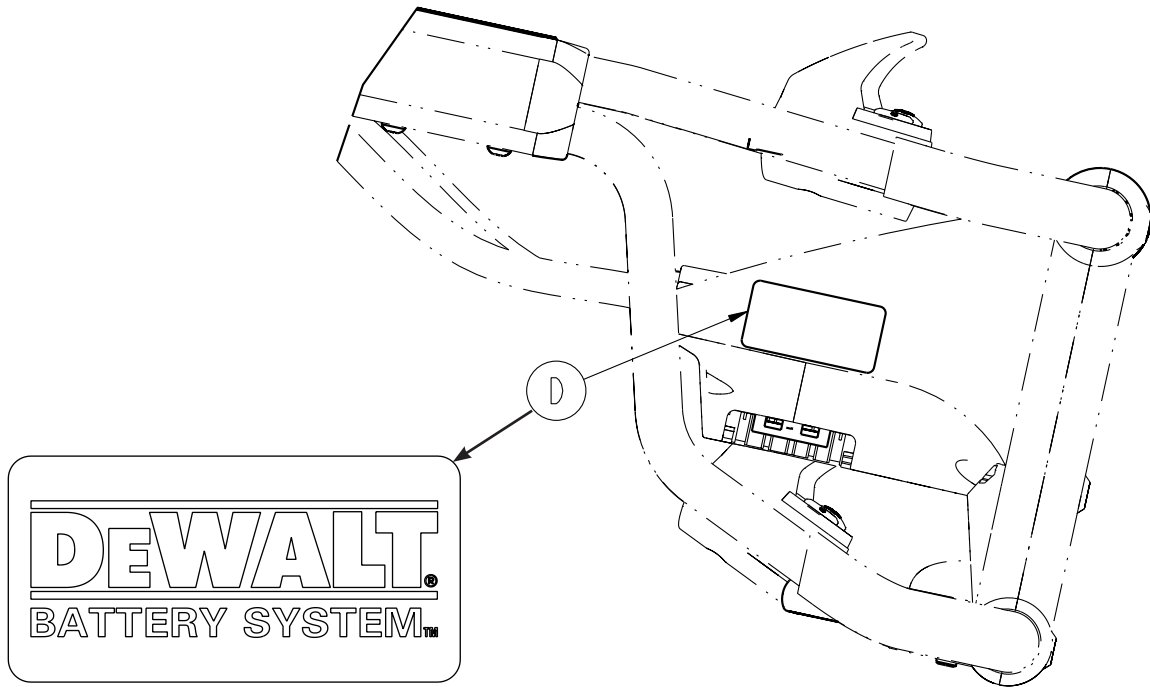

Item	Part No.	Part Name	Qty.
D	6500-001-258	Label, DeWALT®	1

# Optional Accessories

---

The accessories listed below can be purchased and installed on the Power-PRO XT cot.

Accessory	Part Number	Assembly Page Number
Equipment Hook	6500-147-000	<a href="#">144</a>
Oxygen Bottle Holder, Foot End	6500-140-000	<a href="#">145</a>
Oxygen Bottle Holder, Removable	6080-140-000	<a href="#">146</a>
Head Extension with Pillow	6100-044-000	<a href="#">147</a>
Bariatric Transfer Flat	6083-001-200	<a href="#">148</a>
Defibrillator Platform	6500-170-000	<a href="#">149</a>
Pocketed Back Rest Pouch	6500-130-000	<a href="#">150</a>
Head End Storage Flat	6500-128-000	<a href="#">151</a>

# Equipment Hook - 6500-147-000

Rev B

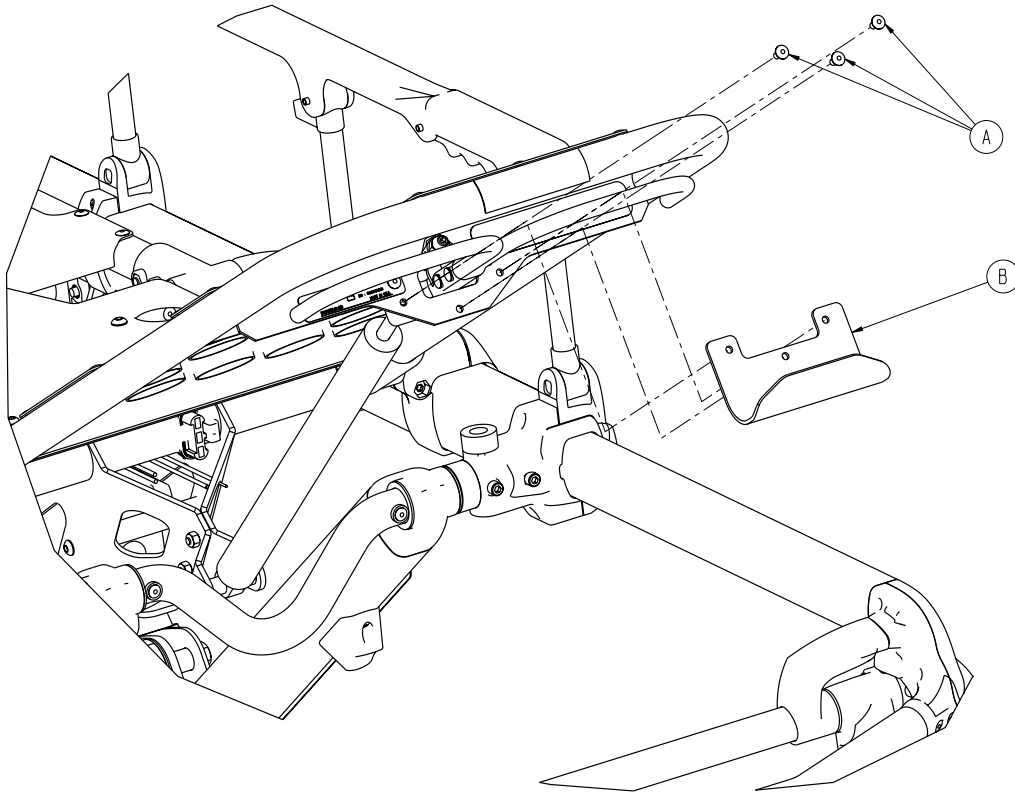

Item	Part No.	Part Name	Qty.
A	0025-079-000	Rivet Dome Head	3
B	6500-001-237	Equipment Hook	1



# Oxygen Bottle Holder - 6500-140-000

Rev B

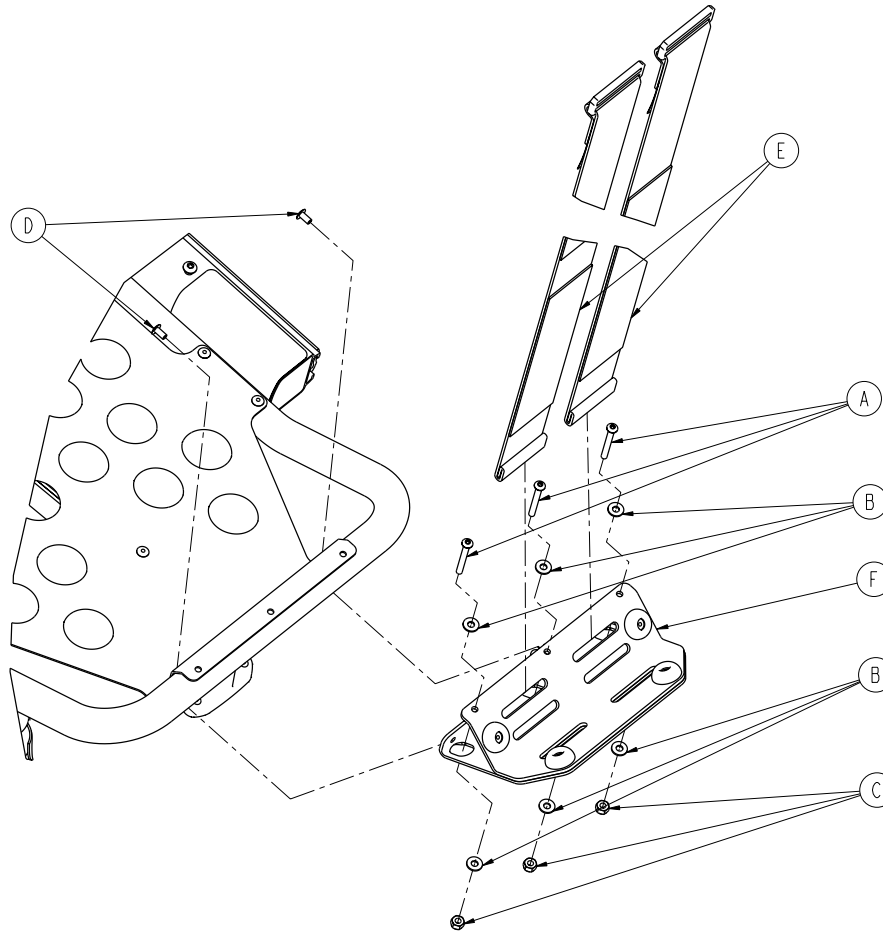

Item	Part No.	Part Name	Qty.
A	0004-508-000	Button Head Cap Screw	3
B	0011-001-000	Washer	6
C	0016-003-000	Nylock Nut	3
D	0025-079-000	Dome Head Rivet	2
E	6060-140-013	Strap Assembly	2
F	6500-001-040	Oxygen Bottle Holder ( <a href="#">page 131</a> )	1

**Note:** Max Load = 40 pounds

[Return To Table of Contents](#)

# Removable Oxygen Bottle Holder - 6080-140-000

6080-140-010 Rev A (Reference Only)

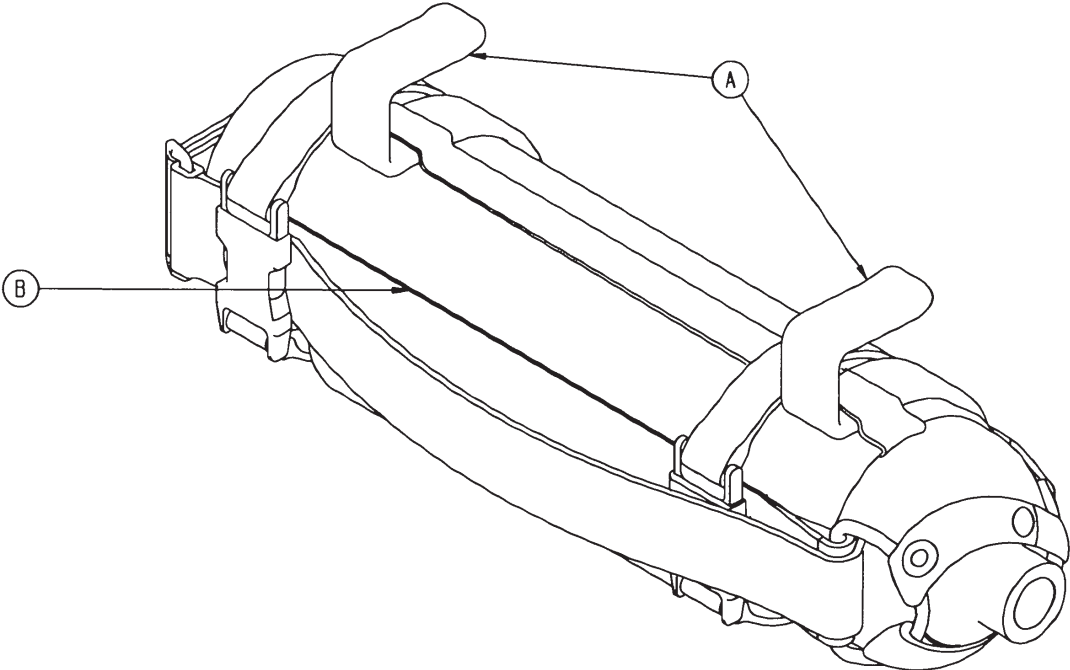

Item	Part No.	Part Name	Qty.
A	6080-140-011	Oxygen Bottle Holder Hanger	2
B	6080-140-012	Oxygen Bottle Holder	1

**Note:** Max Load = 25 pounds

# Head Extension - 6100-044-000

Rev B

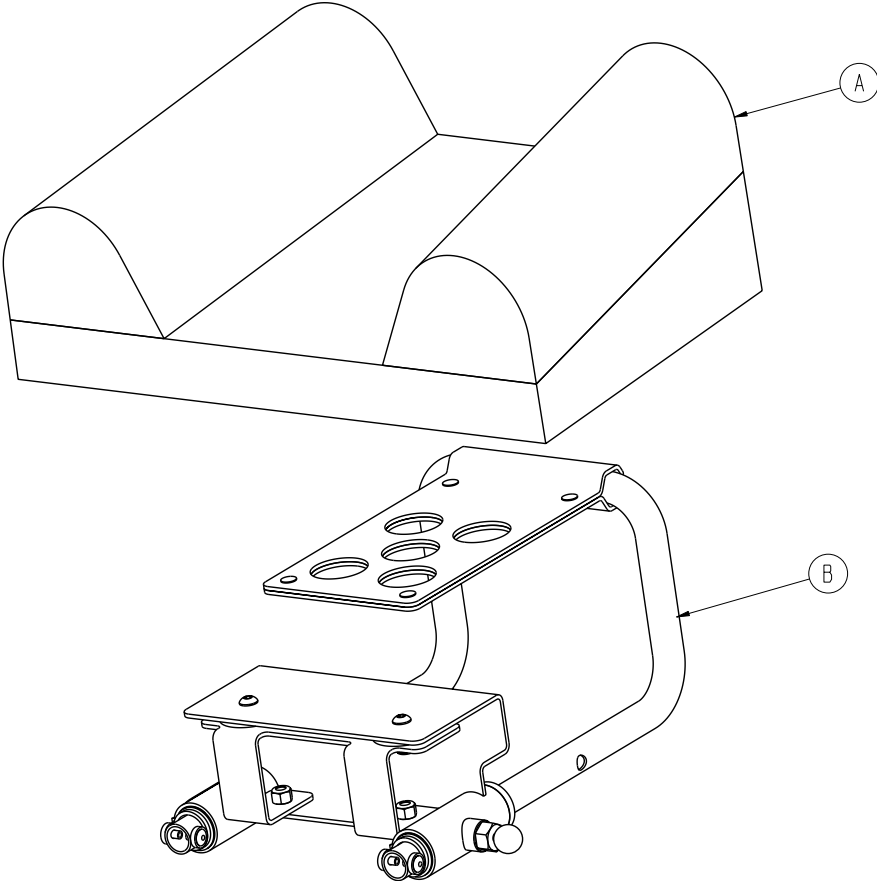

Item	Part No.	Part Name	Qty.
A	6100-041-030	Pillow	1
B	6100-044-012	Head Extension Assembly ( <a href="#">page 140</a> )	1

[Return To Table of Contents](#)

# Transfer Flat - 6083-001-200

---

Rev C

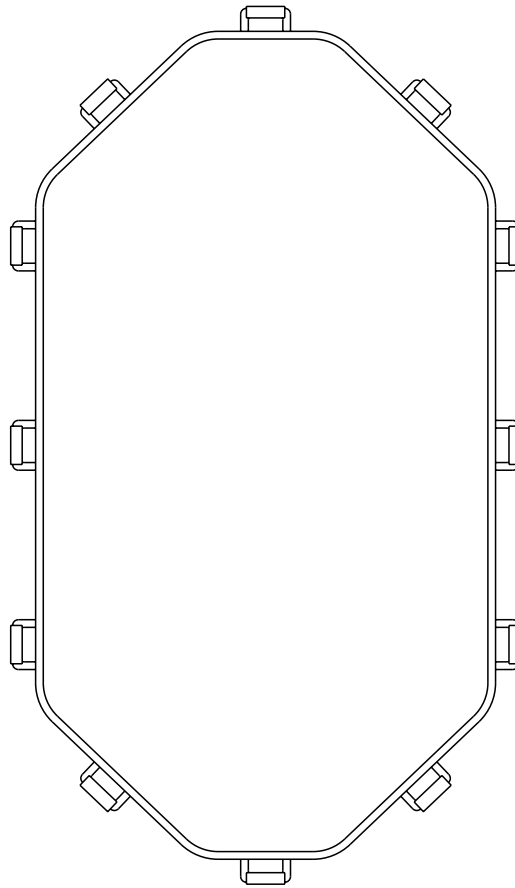

Item	Part No.	Part Name	Qty.
A	6083-000-001	Transfer Flat Standard Components	1

# Optional Defibrillator Platform - 6500-170-000

6500-001-046 Rev E (Reference Only)

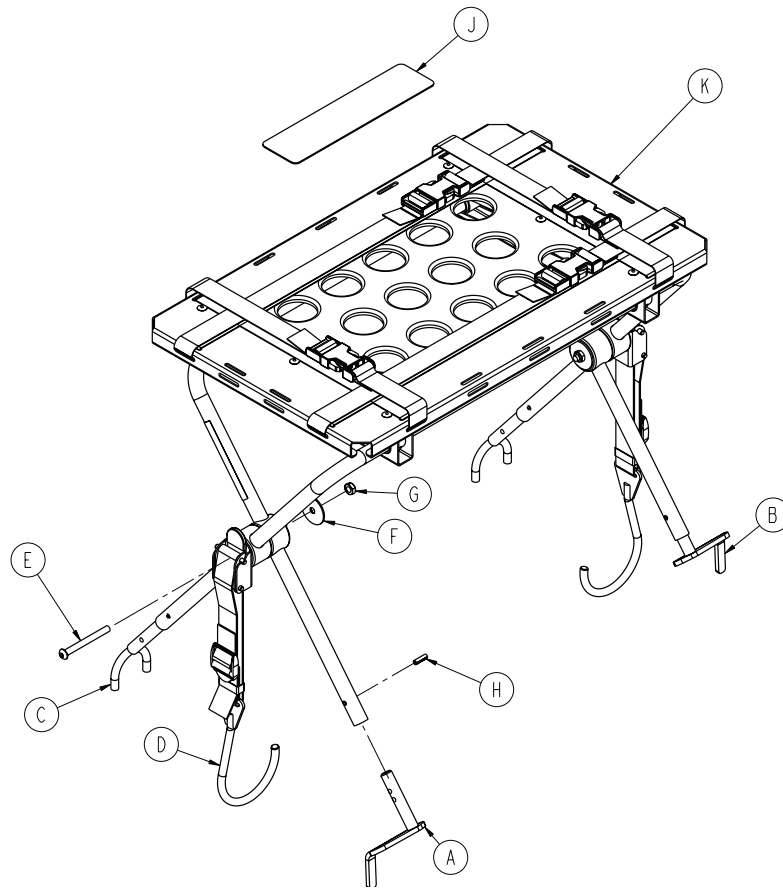

Item	Part No.	Part Name	Qty.
A	6100-170-050	Head End Bracket Weldment, Left	1
B	6100-170-051	Head End Bracket Weldment, Right	1
C	6082-170-050	Defib U-Foot Weldment	2
D	6100-170-020	Defib Latch Strap Assembly	2
E	0004-234-000	Button Head Cap Screw	2
F	0011-355-000	Washer	2
G	0016-102-000	Nylock Nut	2
H	0026-172-000	Slotted Spring Pin	4
J	6500-001-298	Defib Platform Label	1
K	6082-170-020	Defib Platform Common Components	1

[Return To Table of Contents](#)

# Backrest Pouch - 6500-130-000

Rev A

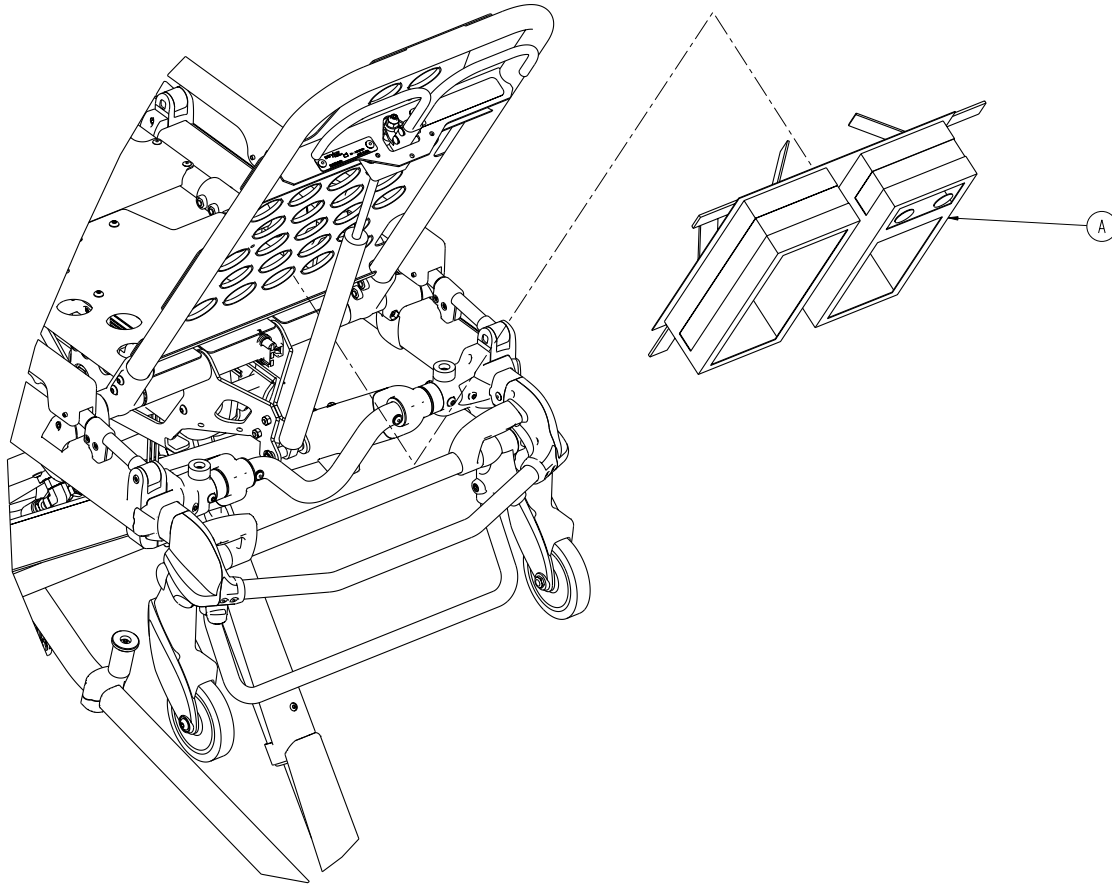

Item	Part No.	Part Name	Qty.
A	6500-001-241	Pocketed Backrest Storage Pouch	1

# Head End Storage Flat - 6500-128-000

Rev A

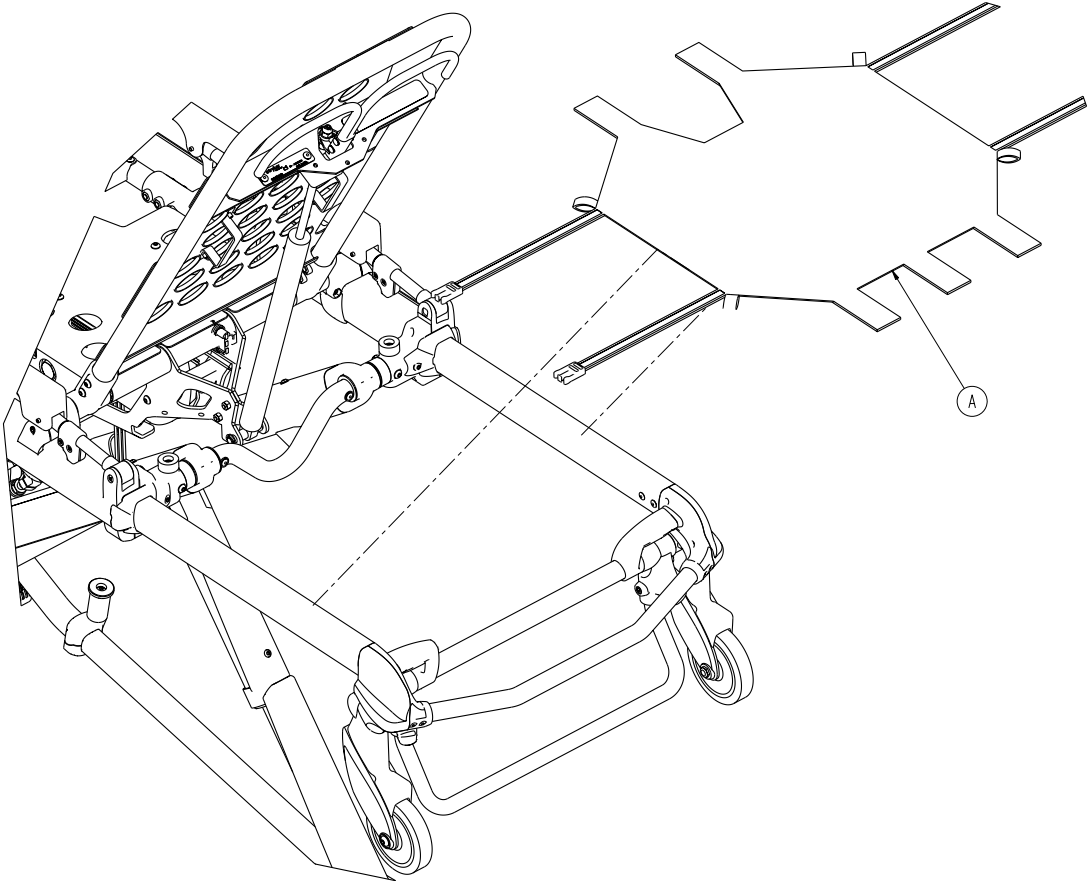

Item	Part No.	Part Name	Qty.
A	6500-001-232	Head End Storage Flat	1

[Return To Table of Contents](#)

# Recycling Passport

Assembly Part Number: 6500-101-010 (Reference Only)



View of battery

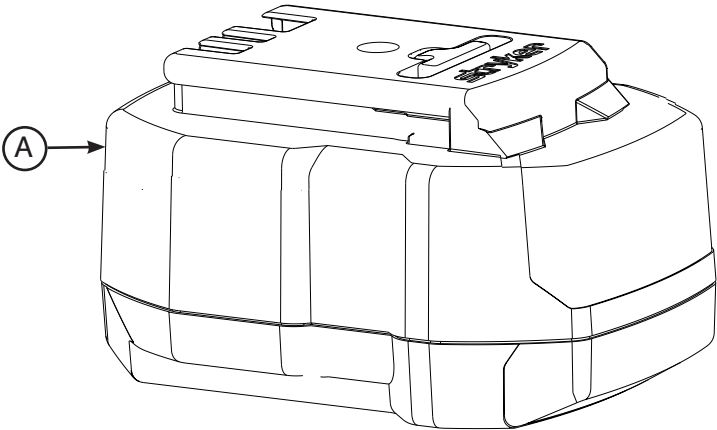

Item	Recycling/Material Code	Important Information	Qty
A	SMRT Pak (6500-101-010)	NiCd	2



The Rechargeable Battery Recycling Corporation (RBRC) is a non-profit, public service organization that promotes the recycling of portable rechargeable batteries. Batteries must be delivered to a battery collection site. Visit the RBRC website ([www.rbrc.org](http://www.rbrc.org)) to find a nearby collection site or call the phone number shown on the recycling symbol.



# Recycling Passport

Assembly Part Number: 6500-700-006 (Reference Only)



View of battery

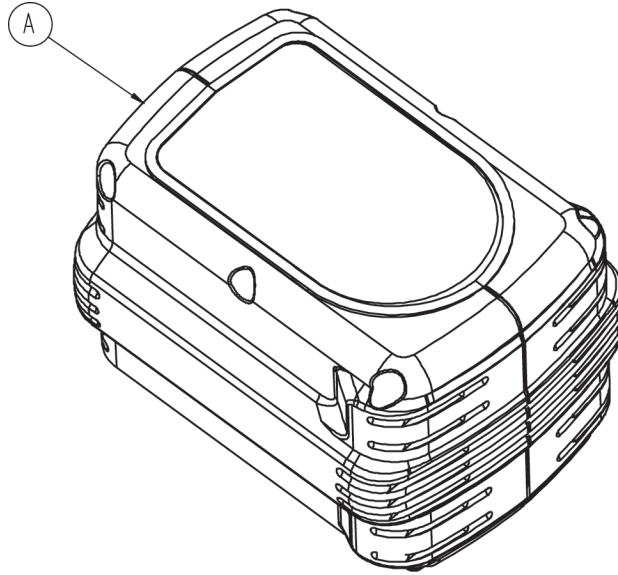

Item	Recycling/Material Code	Important Information	Qty
A	Battery Pack	NiCd	2

**Note:** See the DeWALT® Manual for battery recycling information.



The Rechargeable Battery Recycling Corporation (RBRC) is a non-profit, public service organization that promotes the recycling of portable rechargeable batteries. Batteries must be delivered to a battery collection site. Visit the RBRC website ([www.rbrc.org](http://www.rbrc.org)) to find a nearby collection site or call the phone number shown on the recycling symbol.

[Return To Table of Contents](#)

# Recycling Passport

Assembly Part Number: 6500-001-016 (Reference Only)



Exploded view of switch assembly

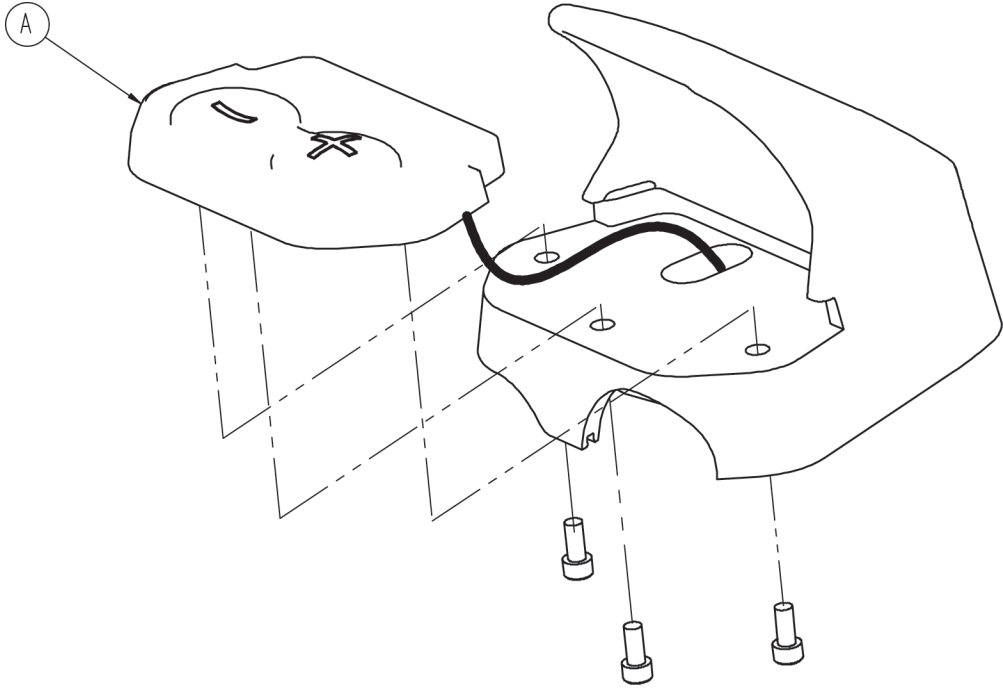

Item	Recycling/Material Code	Important Information	Qty
A	Printed Circuit Board		2

# Recycling Passport

Assembly Part Number: 6500-001-028 (Reference Only)



Exploded view of hall sensor assembly

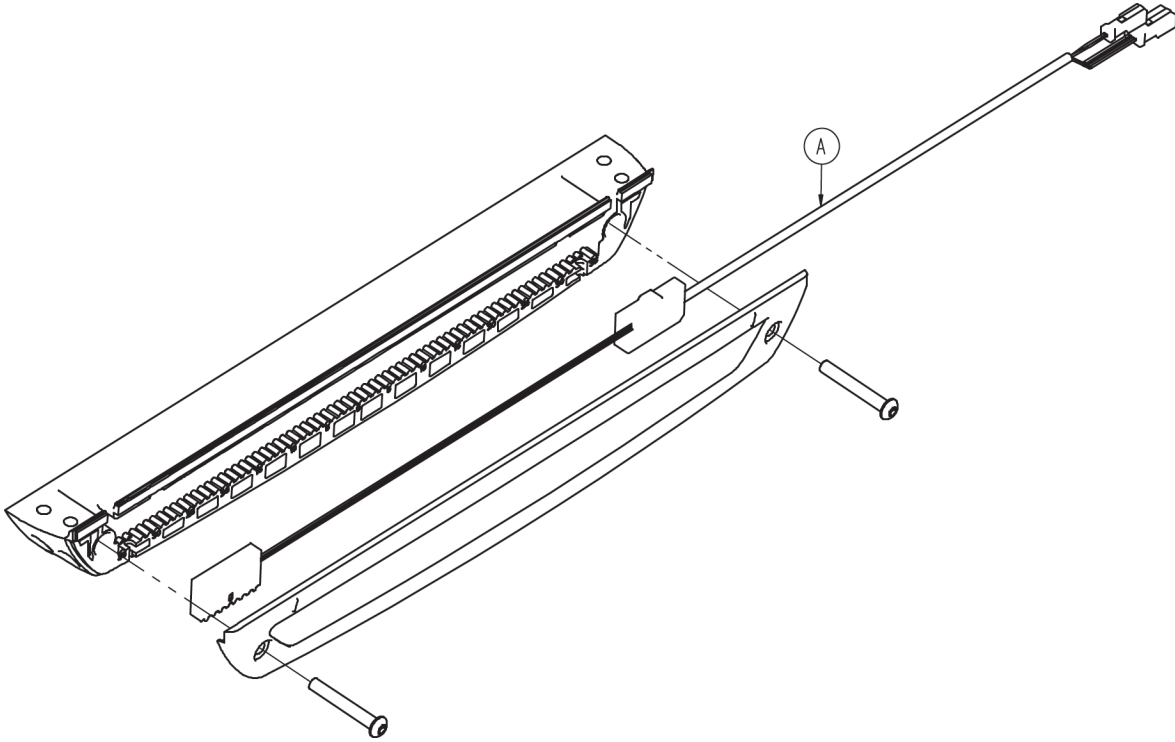

Item	Recycling/Material Code	Important Information	Qty
A	Printed Circuit Board		1

# Recycling Passport



Assembly Part Number: 6500-001-015 (Reference Only)

Exploded view of foot end assembly

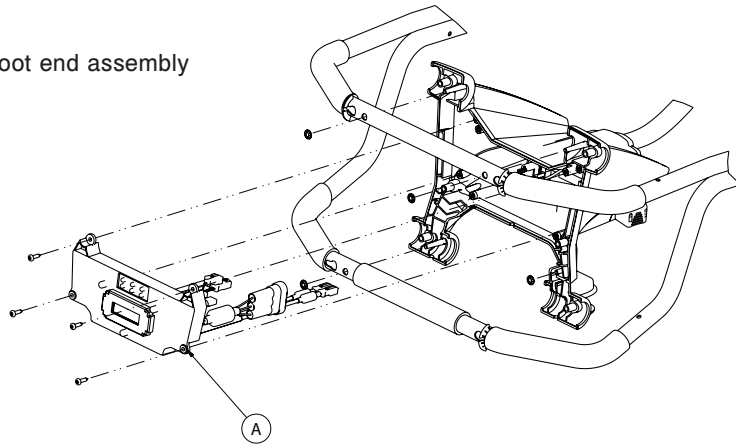

Assembly Part Number: 6500-001-014 (Reference Only)

Exploded view of electronics control board

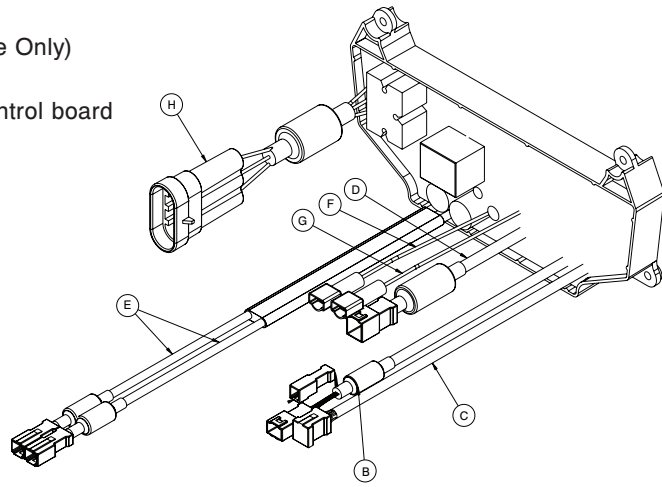

Item	Recycling/Material Code	Important Information	Qty
A	Printed Circuit Board	Contains Liquid Crystal Display	1
B	External Electrical Cable		1
C	External Electrical Cable		1
D	External Electrical Cable		1
E	External Electrical Cable		1
F	External Electrical Cable		1
G	External Electrical Cable		1
H	External Electrical Cable		1

# Recycling Passport

Assembly Part Number: 6500-001-030 (Reference Only)



Exploded view of hydraulics assembly

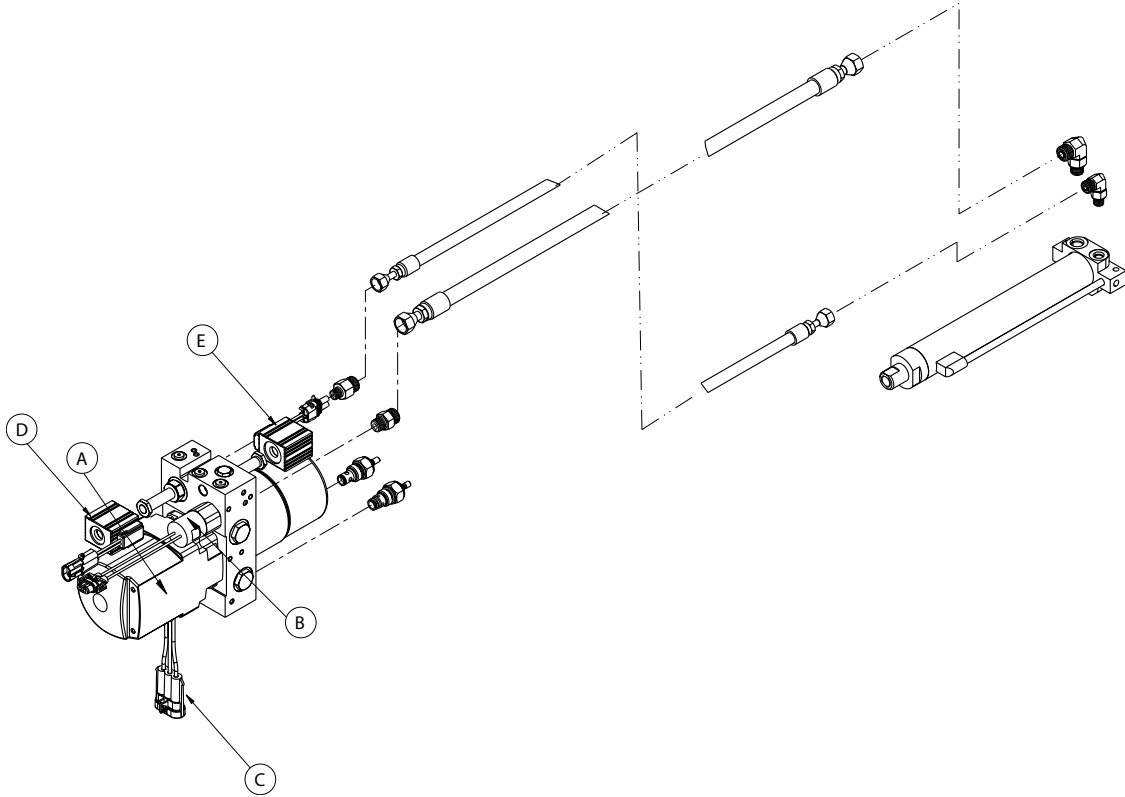

Item	Recycling/Material Code	Important Information	Qty
A	Motor	Contains Automatic Transmission Fluid*	1
B	External Electrical Cable		1
C	External Electrical Cable		1
D	External Electrical Cable		1
E	External Electrical Cable		1

\* Mobil Mercon® V Synthetic Blend or equivalent

[Return To Table of Contents](#)

# Recycling Passport

Assembly Part Number: 6500-001-159 (Reference Only)

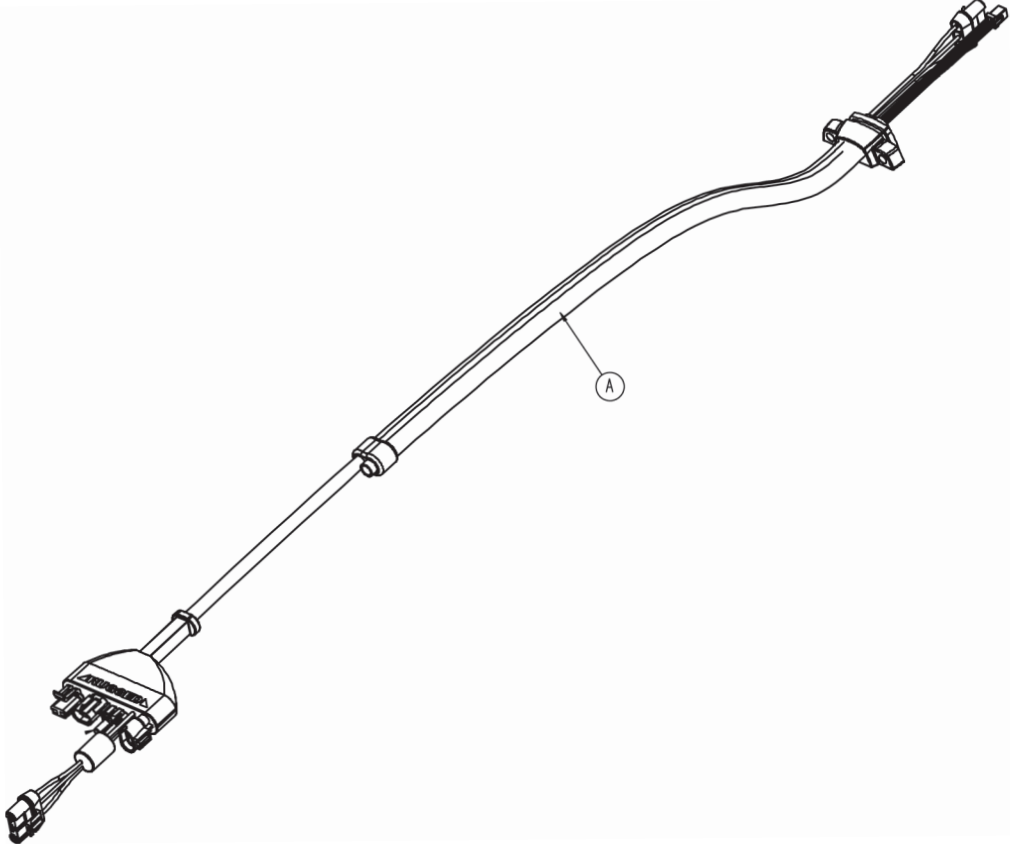

Item	Recycling/Material Code	Important Information	Qty
A	External Electrical Cable		1

# EMC Information

## POWER-PRO™ XT

<b>Guidance and Manufacturer's declaration - Electromagnetic Immunity</b>			
The model 6500 Power-PRO™ XT cot is suitable for use in the electromagnetic environment specified below. The customer or the user of the model 6500 Power-PRO™ XT cot should assure that it is used in such an environment.			
Immunity Test	IEC 60601 Test Level	Compliance Level	Electromagnetic Environment Guidance
Electrostatic Discharge (ESD) IEC 61000-4-2	±6 kV contact  ±8 kV air	±6 kV contact  ±8 kV air	Floors should be wood, concrete, or ceramic tile. If floors are covered with synthetic material, the relative humidity should be at least 30%. Applies to: <ul style="list-style-type: none"> <li>• Cot,</li> <li>• SMRT Charger (6500-201-010),</li> <li>• DEWALT® AC/DC Charger (6500-070-000),</li> <li>• DEWALT® DC/DC Charger (6500-072-000).</li> </ul>
Electrostatic fast Transient/burst IEC 61000-4-4	±2 kV for power supply lines  ±1 kV for input/output lines	±2 kV for power supply lines  ±1 kV for input/output lines	Main power quality should be that of a typical commercial or hospital environment. Applies to: <ul style="list-style-type: none"> <li>• SMRT Charger (6500-201-010),</li> <li>• DEWALT® AC/DC Charger (6500-070-000).</li> </ul>
Surge IEC 61000-4-5	±8 kV differential mode  ±2 kV common mode	±8 kV differential mode  ±2 kV common mode	Main power quality is that of a typical commercial and/or hospital environment. Applies to: <ul style="list-style-type: none"> <li>• SMRT Charger (6500-201-010),</li> <li>• DEWALT® AC/DC Charger (6500-070-000).</li> </ul>
Voltage dips, voltage variations and short interruptions on power supply input lines IEC 61000-4-11	<5% $U_T$ (>95% dip in $U_T$ ) for 0,5 cycle 40% $U_T$ (60% dip in $U_T$ ) for 5 cycles 70% $U_T$ (30% dip in $U_T$ ) for 25 cycles <5% $U_T$ (>95% dip in $U_T$ ) for 5 seconds	<5% $U_T$ (>95% dip in $U_T$ ) for 0,5 cycle 40% $U_T$ (60% dip in $U_T$ ) for 5 cycles 70% $U_T$ (30% dip in $U_T$ ) for 25 cycles <5% $U_T$ (>95% dip in $U_T$ ) for 5 seconds	Main power quality should be that of a typical commercial and/or hospital environment. If the user of the charger requires continued operation during power main interruptions, it is recommended that the device be powered from an uninterrupted power supply or a battery.
Power frequency (50/60 Hz) magnetic field IEC 61000-4-8	3 A/m	3 A/m	Power frequency magnetic fields should be at levels characteristic of a typical location in a typical commercial and/or hospital environment. Applies to: <ul style="list-style-type: none"> <li>• Cot,</li> <li>• SMRT Charger (6500-201-010),</li> <li>• DEWALT® AC/DC Charger (6500-070-000),</li> <li>• DEWALT® DC/DC Charger (6500-072-000).</li> </ul>
<b>Note:</b> $U_T$ is the alternating current mains voltage prior to application of the test level.			

[Return To Table of Contents](#)

# EMC Information

## POWER-PRO™ XT (CONTINUED)

<b>Recommended separation distances between portable and mobile RF communications equipment and the Power-PRO™ XT.</b>			
<p>The model 6500 Power-PRO™ XT cot is intended for use in an electromagnetic environment in which radiated RF disturbances are controlled. The customer or the user of the model 6500 Power-PRO™ XT cot can help prevent electromagnetic interferences by maintaining a minimum distance between portable and mobile RF communications equipment (transmitters) and the model 6500 Power-PRO™ XT cot as recommended below, according to the maximum output power of the communications equipment.</p>			
Rated maximum output power of transmitter <b>W</b>	Separation distance according to frequency of transmitter		
	m		
	150 kHz to 80 MHz	80 MHz to 800 MHz	800 MHz to 2.5 GHz
	$d=1.17\sqrt{P}$	$d=1.17\sqrt{P}$	$d=2.33\sqrt{P}$
0,01	0,12	0,12	0,23
0,1	0,38	0,38	0,73
1	1,2	1,2	2,3
10	3,8	3,8	7,3
100	12	12	23
<p>For transmitters rated at a maximum output power not listed above, the recommended separation distance <math>d</math> in meters (m) can be estimated using the equation applicable to the frequency of the transmitter, where <math>P</math> is the maximum output power rating of the transmitter in watts (W) according to the transmitter manufacturer.</p> <p><b>Note 1:</b> At 80 MHz and 800 MHz, the separation distance for the higher frequency range applies.</p> <p><b>Note 2:</b> These guidelines may not apply in all situations. Electromagnetic propagation is affected by absorption and reflection from structures, objects and people.</p>			



# EMC Information

## POWER-PRO™ XT (CONTINUED)

The model 6500 Power-PRO™ XT cot is suited for use in the electromagnetic environment specified below. The customer or the user of the model 6500 Power-PRO™ XT cot should assure that it is used in such an environment.			
Immunity Test	IEC 60601 Test Level	Compliance Level	Electromagnetic Environment - Guidance
Conducted RF IEC 61000-4-6	3 Vrms 150 kHz to 80 MHz	3 Vrms	<p>Portable and mobile RF communications equipment should be used no closer to any part of the model 6500 Power-PRO™ XT cot, including cables, than the recommended separation distance calculated from the equation appropriate for the frequency of the transmitter.</p> <p style="text-align: center;">Recommended separation distance <math>d=1.2\sqrt{P}</math></p> <p>Applies to:</p> <ul style="list-style-type: none"> <li>• SMRT Charger (6500-201-010),</li> <li>• DeWALT® AC/DC Charger (6500-070-000)</li> </ul>
Radiated RF IEC 61000-4-3	3 V/m 80 MHz to 2,5 GHz	3 V/m	<p style="text-align: center;"><math>d=1.2\sqrt{P}</math> 80 MHz to 800 MHz</p> <p style="text-align: center;"><math>d=2.3\sqrt{P}</math> 800 MHz to 2.5 GHz</p> <p>where <math>P</math> is the maximum output power rating of the transmitter in watts (W) according to the transmitter manufacturer and <math>d</math> is the recommended separation distance in metres (m).</p> <p>Field strengths from fixed RF transmitters, as determined by an electromagnetic site survey, <sup>a</sup> should be less than the compliance level in each frequency range. <sup>b</sup></p> <p>Interference may occur in the vicinity of equipment marked with the following symbol:</p> <div style="text-align: center;">  </div>
<p><b>Note 1:</b> At 80 MHz and 800 MHz, the higher frequency range applies.</p> <p><b>Note 2:</b> These guidelines may not apply in all situations. Electromagnetic propagation is affected by absorption and reflection from structures, objects and people.</p>			
<p><sup>a</sup> Field strengths from fixed transmitters, such as base stations for radio (cellular/cordless) telephones and land mobile radios, amateur radio, AM and FM radio broadcast, and TV broadcast cannot be predicted theoretically with accuracy. To assess the electromagnetic environment due to fixed RF transmitters, an electromagnetic site survey should be considered. If the measured field strength in the location in which the model 6500 Power-PRO™ XT cot is used exceeds the applicable RF compliance level above, the model 6500 Power-PRO™ XT cot should be observed to verify normal operation. If abnormal performance is observed, additional measures may be necessary, such as reorienting or relocating the model 6500 Power-PRO™ XT cot.</p> <p><sup>b</sup> Over the frequency range 150 kHz to 80 MHz, field strengths are less than 3 V/m.</p>			

[Return To Table of Contents](#)

# EMC Information

## POWER-PRO™ XT (CONTINUED)

<b>Guidance and Manufacturer's declaration - Electromagnetic Emissions</b>		
The model 6500 Power-PRO™ XT cot is intended for use in an electromagnetic environment specified below. The customer or the user of the model 6500 Power-PRO™ XT cot should assure that it is used in such an environment.		
Emissions Test	Compliance	Electromagnetic Environment
RF Emissions CISPR 11	Group 1	The model 6500 Power-PRO™ XT cot uses RF energy only for its internal function. Therefore, its RF emissions are very low and are not likely to cause any interference in nearby electronic equipment.
RF Emissions CISPR 11	Cot: Class A	The model 6500 Power-PRO™ XT cot is suitable for use in all establishments other than domestic and those directly connected to the public low-voltage power supply network that supplies buildings used for domestic purposes.
	SMRT Charger (6500-201-010): Class A	The SMRT Charger is suitable for use in all establishments other than domestic establishments other than domestic and those directly connected to the public low-voltage power supply network that supplies buildings used for domestic purposes.
	DeWALT® AC/DC Charger (6500-070-000): Class B	The DeWALT® AC/DC Charger and DeWALT® DC/DC Charger are suitable for use in all establishments including domestic establishments and those directly connected to the public low-voltage power supply network that supplies buildings used for domestic purposes.
	DeWALT® DC/DC Charger (6500-072-000): Class B	
Harmonic Emissions IEC 61000-3-2	Cot: N/A	
	SMRT Charger (6500-201-010): Class A	
	DeWALT® AC/DC Charger (6500-070-000): Class A	
	DeWALT® DC/DC Charger (6500-072-000): N/A	
Voltage Fluctuations Flicker Emissions IEC 61000-3-3	Cot: N/A	
	SMRT Charger (6500-201-010): Complies	
	DeWALT® AC/DC Charger (6500-070-000): Complies	
	DeWALT® DC/DC Charger (6500-072-000): N/A	

# Warranty

---

Stryker EMS, a division of the Stryker Corporation, offers one warranty option in the United States:

**Two (2) year parts and labor.** Stryker EMS warrants to the original purchaser that its products should be free from manufacturing non-conformances that affect product performance and customer satisfaction for a period of two (2) years after date of delivery. Stryker's obligation under this warranty is expressly limited to supplying replacement parts and labor for, or replacing, at its option, any product that is, in the sole discretion of Stryker, found to be defective. Expendable components, i.e. mattresses, restraints, I.V. poles, storage nets, storage pouches, oxygen straps, and other soft goods, have a one (1) year limited warranty.

The Stryker Power-PRO XT is designed for a 7 year expected service life under normal use conditions, and with appropriate periodic maintenance as described in the maintenance manual. Stryker warrants to the original purchaser that the welds on the Power-PRO XT will be free from structural defects for the expected 7 year life of the product as long as the original purchaser owns the product. Original purchasers will also obtain a three (3) year limited parts warranty for the X-frame components of the Power-PRO cot and a three (3) year limited power train warranty covering the motor pump assembly and hydraulic cylinder assembly. Stryker's obligation under this three (3) year limited warranty is expressly limited to supplying replacement parts and labor for, or replacing, at its option, any part that is, in the sole discretion of Stryker, found to be defective.

**SMRT Power Warranties.** Stryker EMS warrants the SMRT Charger for the same duration as the Stryker product for which it is furnished. All SMRT Paks are warranted to be free from manufacturing non-conformances that affect product performance and customer satisfaction for a period of one (1) year.

Upon Stryker's request, purchaser shall return to Stryker's factory any product or part (freight prepaid by Stryker) for which an original purchaser makes a warranty claim.

Any improper use or alteration or repair by unauthorized service providers in such a manner as in Stryker's judgment affects the product materially and adversely, shall void this warranty. Any repair of Stryker products using parts not provided or authorized by Stryker shall void this warranty. No employee or representative of Stryker is authorized to change this warranty in any way.

This statement constitutes Stryker EMS's entire warranty with respect to the aforesaid equipment. STRYKER MAKES NO OTHER WARRANTY OR REPRESENTATION EITHER EXPRESSED OR IMPLIED, EXCEPT AS SET FORTH HEREIN. THERE IS NO WARRANTY OF MERCHANTABILITY AND THERE ARE NO WARRANTIES OF FITNESS FOR ANY PARTICULAR PURPOSE. IN NO EVENT SHALL STRYKER BE LIABLE HEREUNDER FOR INCIDENTAL OR CONSEQUENTIAL DAMAGES ARISING FROM OR IN ANY MANNER RELATED TO SALES OR USE OF ANY SUCH EQUIPMENT.

## **DeWALT® Product Warranty**

Any DeWALT® product purchased from Stryker EMS is covered for a period of one (1) year after date of delivery. Stryker's obligation under this warranty is expressly limited to supplying replacement parts and labor for, or replacing, at its option, any product that is, in the sole discretion of Stryker, found to be defective.

# Warranty

---

## STRYKER EMS RETURN POLICY

Cots, Stair Chairs, Evacuation Chairs, Cot Fasteners and Aftermarket Accessories may be returned up to 180 days of receipt if they meet the following guidelines:

### Prior to 30 Days

- 30 day money back guarantee in effect
- Stryker EMS is responsible for all charges
- Returns will not be approved on modified items

### Prior to 90 Days

- Product must be **unused, undamaged** and in the original packaging
- Customer is responsible for a 10% restocking fee

### Prior to 180 Days

- Product must be **unused, undamaged** and in the original packaging
- Customer is responsible for a 25% restocking fee

## RETURN AUTHORIZATION

Stryker customer service department must approve any merchandise return and will provide an authorization number to be printed on any returned merchandise. Stryker reserves the right to charge shipping and restocking fees on returned items. SPECIAL, MODIFIED, OR DISCONTINUED ITEMS NOT SUBJECT TO RETURN.

## DAMAGED MERCHANDISE

ICC Regulations require that claims for damaged merchandise must be made with the carrier within fifteen (15) days of receipt of merchandise. DO NOT ACCEPT DAMAGED SHIPMENTS UNLESS SUCH DAMAGE IS NOTED ON THE DELIVERY RECEIPT AT THE TIME OF RECEIPT. Upon prompt notification, Stryker will file a freight claim with the appropriate carrier for damages incurred. Claim will be limited in amount to the actual replacement cost. In the event that this information is not received by Stryker within the fifteen (15) day period following the delivery of the merchandise, or the damage was not noted on the delivery receipt at the time of receipt, the customer will be responsible for payment of the original invoice in full.

Claims for any short shipment must be made within thirty (30) days of invoice.

## INTERNATIONAL WARRANTY CLAUSE

This warranty reflects U.S. domestic policy. Warranty outside the U.S. may vary by country. Please contact your local Stryker Medical representative for additional information.

## PATENT INFORMATION

The Stryker Power-PRO XT cot is covered by one or more of the following patents:

United States	5,537,700	5,575,026	6,908,133	7,398,571	7,540,047
---------------	-----------	-----------	-----------	-----------	-----------

Other patents pending

The Stryker SMRT Power System is covered by one or more of the following patents:

United States	5,977,746	6,018,227
---------------	-----------	-----------

Other patents pending



UNITED STATES  
Stryker Medical  
3800 E. Centre Ave.,  
Portage, Michigan USA  
49002

EC	REP
----	-----

**European Representative**  
Stryker France  
ZAC Satolas Green Pusignan  
Av. De Satolas Green  
69881 MEYZIEU Cedex  
France

**stryker**<sup>®</sup>