

Power-PRO™ XT















REF 6506

stryker®

















Operations/Maintenance Manual

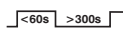

Symbols

	Refer to instruction manual/booklet
	Operating instructions
	CE Mark
	Manufacturer
	Safe working load
	Dangerous voltage
	General warning
	Caution
	Warning; crushing of hands
	No pushing
	Do not lubricate
	SMRT™ Power System
	Extend
	Retract
	Warning; non-ionizing radiation
IPX6	Protection from powerful water jets

Symbols

	Type B Applied Part
	Medical Equipment Classified by Underwriters Laboratories Inc. With Respect to Electric Shock, Fire, and Mechanical Hazards Only in Accordance with ANSI/AAMI ES60601-1: 2005 and CAN/CSA-C22.2 No. 60601-1:08.
	In accordance with European Directive 2012/19/EU on Waste Electrical and Electronic Equipment, this symbol indicates that the product must not be disposed of as unsorted municipal waste, but should be collected separately. Refer to your local distributor for return and/or collection systems available in your country.
	Keep dry
	450 lb/205 kg weight capacity
	Do not stack more than three high
	Dangerous voltage
	This device complies with Part 15 of the FCC rules
	Date of manufacture
	Serial number
	Lot (batch) code
	Catalog/model number
	Cot duty cycle: 16.7% (less than 60 seconds on, more than 300 seconds off)
	Lift here
	This way up
	Fragile

Symbols







	Two person lift
	Direct current
	European authorized representative
	English text below this symbol is intended for USA audiences only
	Approved by independent communications authority of South Africa
	Registered in United Arab Emirates by the Telecommunications Regulatory Authority
	Product complies with applicable EMC standards in Australia/New Zealand
	Box manufacturer's certificate - this packaging box has minimum bursting test value of 500 lbs per sq inch

Table of Contents

Symbols	3
Warning/Caution/Note Definition	10
Introduction	11
Product Description	11
Intended Use of Product.	11
Expected Service Life	11
Contraindications	11
Specifications	12
Contact Information	14
Serial Number Location	14
Serial Number Key	14
Product Illustration	15
Summary of Safety Precautions	16
Pinch Points	21
Mechanical Stability.	22
Setup Procedures.	23
Setting Cot Load Height and “Jog” Function	24
Cot Fastener Installation	25
Installing the In-Fastener Shut-Off	27
Vehicle Safety Hook Selection	28
Vehicle Safety Hook Installation	29
Vehicle Configuration	29
Required Hardware for Installation of the Safety Hook (Not Supplied)	29
Front to Back Positioning of the Safety Hook	30
Side to Side Positioning of the Safety Hook	31
Installing the Safety Hook.	31
Power-PRO™ Cot User Controls	32
Using the Cot Control Switches	32
Checking the Cot Battery Power Level	33
Checking the Hour Meter/LCD Error Display	34
Operation Guide	35
Operating Guidelines	35
Proper Lifting Techniques.	35
Transferring the Patient to the Cot	36
Rolling the Cot.	36
Adjusting The Height of the Cot	37
Loading or Unloading the Cot.	38
Loading or Unloading the Cot with the Power-LOAD Option	38
High Speed Retract/Extend	38
Loading the Cot into a Vehicle with Two Operators - Powered Method.	39
Loading an Empty Cot into a Vehicle with One Operator - Powered Method.	41
Unloading the Cot from a Vehicle with Two Operators - Powered Method	42
Unloading an Empty Cot from a Vehicle with One Operator - Powered Method	44
Using the Manual Override.	45

Table of Contents

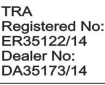
Loading the Cot into a Vehicle with Two Operators - Manual Method	46
Unloading the Cot from a Vehicle with Two Operators - Manual Method	48
Unloading an Empty Cot from a Vehicle with One Operator - Manual Method	50
Using Additional Assistance	51
Operating the Backrest	52
Raising and Lowering the Siderails (Standard)	52
Raising and Lowering the Siderails (XPS Option)	53
Operating the Retractable Head Section	54
Adjusting the Footrest	55
Raising and Lowering the Optional Knee Gatch	56
Operating the Optional Wheel Locks	57
Operating the Optional Steer-Lock	58
Using the Optional Kickstand for Dialysis Scale	59
Using Restraint Straps	60
Using X-Restraint Straps	62
Adjusting Restraint Straps	64
Using the Restraint Extender	65
Attaching the Pedi-Mate® Infant Restraint System	66
Removing and Replacing a SMRT™ Pak	68
Using the Defibrillator Platform	69
Using the Equipment Hook	71
Using the Head Extension with Pillow	71
Operating the Optional Two-Stage I.V. Pole	72
Operating the Optional Three-Stage I.V. Pole	73
Attaching an Oxygen Bottle to an Oxygen Bottle Holder	74
Using the Retractable Head Section Oxygen Bottle Holder	75
Installing the Base Storage Net	76
Installing the Backrest Storage Pouch	77
Installing the Head End Storage Flat	78
Using the Transfer Flat	78
Attaching the Mattress	79
Cleaning	80
Washing Procedure	80
Washing Limitations	80
Removal of Iodine Compounds	81
Preventive Maintenance	82
Lubrication	82
Regular Inspection and Adjustments	83
Maintenance Record	86
Training Record	87
Troubleshooting Guide	88
Electronics and Hydraulics Locator	88
Hydraulic Assembly	89
Hydraulic Assembly Wiring Schematics	89

Table of Contents

Electrical System Block Diagram	90
Troubleshooting Guide	92
LCD Error Codes	95
Main Cable Assembly	96
Main Cable Assembly Wiring Schematics	96
Control Board Assembly	97
Control Board Wiring Schematics	97
Quick Reference Replacement Parts List	98
Accessories	100
Service Information	101
Backrest Adjustment	101
Headsection Replacement	102
Backrest Gas Cylinder Replacement	102
Manual Release Cable Adjustment	103
Filling the Hydraulics Assembly Reservoir	104
Wheel Locking Force Adjustment	105
Steer-Lock Mechanism Adjustment	106
Cot Retaining Post Adjustment	107
Cot Retaining Post Replacement	108
Cot Retaining Post Screw Replacement	108
Hydraulic A Valve or B Valve Replacement	109
Hydraulic Manual Release Valve Replacement	110
Hydraulic Cylinder Replacement	111
Hydraulic Hose Replacement	112
Terminal Block Replacement	113
Siderail Assembly Replacement (Standard)	114
Siderail Assembly Replacement (XPS Option)	115
Ratchet Assembly Replacement (XPS Option)	116
Release Handle Assembly Replacement (XPS Option)	117
Spring Handle Assembly Replacement (XPS Option)	117
Warranty	118
Stryker EMS Return Policy	119
Return Authorization	119
Damaged Merchandise	119
International Warranty Clause	119
Patent Information	119
EMC Information	120

Warning/Caution/Note Definition

The words **WARNING**, **CAUTION** and **NOTE** carry special meanings and should be carefully reviewed.

WARNING

Alerts the reader about a situation which, if not avoided, could result in death or serious injury. It may also describe potential serious adverse reactions and safety hazards.

CAUTION

Alerts the reader of a potentially hazardous situation which, if not avoided, may result in minor or moderate injury to the user or patient or damage to the equipment or other property. This includes special care necessary for the safe and effective use of the device and the care necessary to avoid damage to a device that may occur as a result of use or misuse.

NOTE

Provides special information to make maintenance easier or important instructions clearer.

Introduction

This manual is designed to assist you with the operation and maintenance of the Stryker **Power-PRO™** XT cot. Read this manual thoroughly before using the equipment or beginning maintenance on it. To ensure safe operation of this equipment, it is recommended that methods and procedures be established for educating and training staff on the safe operation of this cot.

PRODUCT DESCRIPTION

The Stryker Model 6506 **Power-PRO™** XT is a powered ambulance cot that consists of a platform mounted on a wheeled X-frame designed to support and transport a maximum weight of 700 lb (318 kg) in pre-hospital and hospital environments. The device is collapsible for use in emergency vehicles and has an adjustable load height feature to allow the device to be set to different ambulance deck heights for proper body mechanics during loading and unloading. The NiCd battery-powered hydraulic lift system allows operators to raise and lower the cot using the powered controls, while duplicate foot-end controls on the upper and lower lift bars accommodate different operator positions or sizes. The cot is equipped with a manual back-up release handle to allow the operation of cot functions in the event of power loss. The device is equipped with the following: a retractable head section for 360-degree mobility in any height position, side rails, patient securement straps, an adjustable pneumatic backrest and various optional accessories that assist with transport of the patient. Maximum patient comfort is attainable with the three different litter positions of shock, flat leg and optional knee gatch positioning.

INTENDED USE OF PRODUCT

The Stryker **Power-PRO™** is a powered wheeled stretcher, which is intended to support and transport the entire body of a traumatized, ambulatory or non-ambulatory human patient (includes infants and adults). The battery-powered hydraulic lift system is intended to help reduce the effort required by the operator to raise and lower the cot. The device is designed to support patients in a supine (horizontal) or sitting position and facilitate the transportation of associated medical equipment (i.e. oxygen bottles, monitors, and/or pumps) in emergency/transport vehicles. This ambulance cot is intended to be used in pre-hospital and hospital environments, in emergency and non-emergency applications. It is rated to a maximum capacity of 700 lb (318 kg) (sum of the patient, mattress and accessory weight) and the intended operators of the device are trained professionals including emergency medical service and medical care center personnel, as well as medical first responders.

EXPECTED SERVICE LIFE

- 7 years for **Power-PRO™** XT cot
- 7 years for **SMRT™** charger
- 2 years for **SMRT™** Pak battery

CONTRAINDICATIONS

- **Power-PRO™** XT is not intended for extended stay or to be used as a hospital bed.
- **Power-PRO™** XT is not intended to be used in devices which modify air pressure, such as hyperbaric chambers.

Introduction

SPECIFICATIONS

	<p>Safe Working Load Note: Safe Working Load indicates the sum of the patient, mattress and accessory weight.</p>	700 lb	318 kg
Maximum Unassisted Lift Capacity ¹		500 lb	227 kg
Backrest Articulation/Shock Position (Standard Fowler - 6506-012-003)		0° to 73° / +15°	
Backrest Articulation/Shock Position (1865 Fowler Option - 6506-012-004)		0° to 75° / +15°	
Overall Length/Minimum Length/Width		81 in. / 63 in. / 23 in.	206 cm / 160 cm / 58 cm
Height ²		Adjustable from 14 in. to 41.5 in.	Adjustable from 36 cm to 105 cm
Weight ³		125 lb	57 kg
Caster Diameter/Width		6 in. / 2 in.	15 cm / 5 cm
Minimum Operators Required for Loading/ Unloading an Occupied Cot		2	
Minimum Operators Required for Loading/ Unloading an Unoccupied Cot		1	
Recommended Fastener Systems		Model 6370 or 6377 Floor Mount Type Model 6371 Wall Mount Type Model 6390 Power-LOAD	
Recommended Loading Height ⁴		Up to 36 in.	Up to 91 cm
Recommended Working Height (excluding mattress)		15.75 in.	40 cm
Single Adjustable Wheel Lock/ Double Adjustable Wheel Lock		Optional	
Hydraulic Oil		Stryker Part Number 6500-001-293	
Power System			
Battery		24V \equiv NiCd - SMRT™ Power System	
Charger		100-240V - 1.20 A, 50/60Hz or 12V \equiv 4.16 A - SMRT™ Power System	
Cot Duty Cycle		16.7% (1 Min. On / 5 Min. Off)	
Standards (Cots and Chargers) ⁵		ANSI/AAMI ES60601-1: 2005, CAN/CSA-C22.2 No. 60601-1:08, BS EN 1789:2007+A2:2014, AS/NZS-4535, KKK-A-1822, SAE J3027, BS EN 1865-2:2010 (for 1865 fowler option), BS EN 1865-3:2012 (for XPS option)	

¹ Cot loads over 300 lb (136 kg) may require additional assistance to meet the set cot load height.

² Height measured from bottom of mattress at seat section to ground level.

³ Cot is weighed with one battery and without mattress and restraints.

⁴ Cot may be set to any ambulance deck height ranging from 26 in. to 36 in. (66 cm to 91 cm).

⁵ To meet SAE J3027 and AS/NZS-4535 crash-test standards with the use of a crash-rated fastener, such as Power-LOAD (Model 6390), you must install the X-restraint package (6500-001-430) and either a knee gatch bolster mattress (6500-002-150/6506-002-150) or XPS mattress (6500-003-130) (depending on cot siderail). To meet BS EN 1789:2007+A2:2014 crash-test standards with the use of a crash rated fastener, such as Power-LOAD (Model 6390), you must install the G-rated restraint package (6500-002-030) and knee gatch bolster mattress (6500-002-150/6506-001-150) or XPS mattress (6500-003-130) (depending on cot siderail). Cot is compliant to the BS EN 1865-3:2012+A1:2015 standard with the XPS option (6506-040-000). Cot is compliant to the BS EN 1865-2:2010+A1:2015 standard with the 1865 fowler option (6506-012-004).

Introduction

SPECIFICATIONS (CONTINUED)

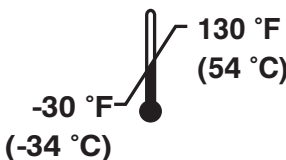
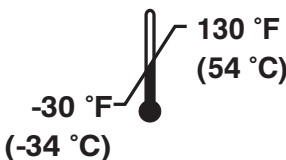
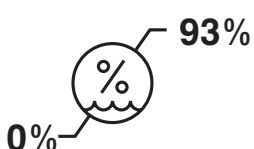
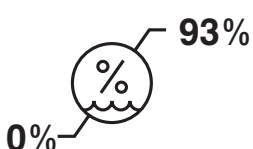
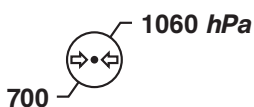
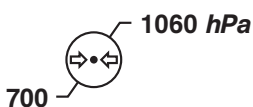
Environmental Conditions	Operation	Storage and Transportation
Temperature		
Relative Humidity		
Atmospheric Pressure		

Stryker reserves the right to change specifications without notice.

The **Power-PRO™** XT is designed to conform to the Federal Specification for the Star-of-Life Ambulance (KKK-A-1822).

The **Power-PRO™** XT is designed to be compatible with competitive cot fastener systems.

Patents pending.

The yellow and black color scheme is a proprietary trademark of Stryker Corporation.

Stryker hereby declares that this **Power-PRO™** XT ambulance cot (model 6506) is in compliance with the essential requirements and other relevant provisions of Directive 1999/5/EC. A copy of the original declaration of conformity can be obtained by contacting Stryker Medical at 3800 E. Centre Ave. Portage, MI 49002 Attn. Regulatory Affairs.

CAUTION

- Changes or modifications to the unit not expressly approved by Stryker could void the user's authority to operate the system.
- This equipment has been tested and found to comply with the limits for a Class A digital device, pursuant to part 15 of the FCC Rules. These limits are designed to provide reasonable protection against harmful interference when the equipment is operated in a commercial environment. This equipment generates, uses, and can radiate radio frequency energy and, if not installed and used in accordance with the instruction manual, may cause harmful interference to radio communications. Operation of this equipment in a residential area is likely to cause harmful interference in which case the user will be required to correct the interference at their expense.

[Return To Table of Contents](#)

Introduction

CONTACT INFORMATION

Contact Stryker Customer Service or Technical Support at: (800) 327-0770.

Stryker Medical
3800 E. Centre Avenue
Portage, MI 49002
USA

Please have the serial number (A) of your Stryker product available (as shown in Figure 1) when calling Stryker Customer Service or Technical Support. Include the serial number in all written communication.

SERIAL NUMBER LOCATION

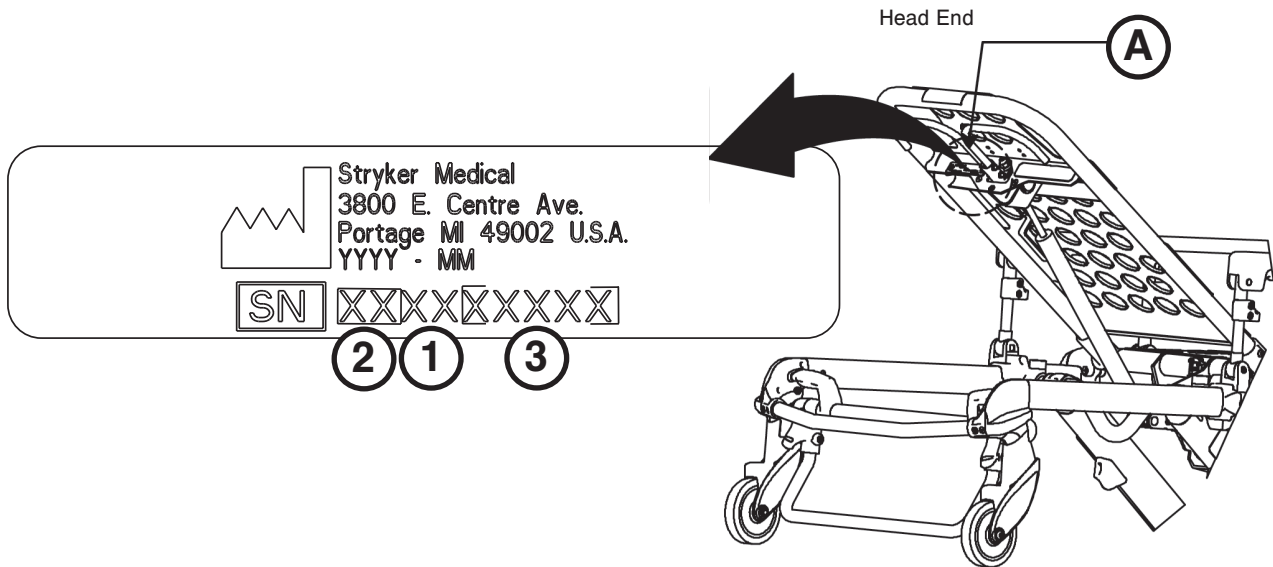

Figure 1

SERIAL NUMBER KEY

See Figure 1 and the following key for additional serial number information:

①	2 digit month
②	2 digit year
③	5 digit sequence that starts with 39000 each month

Introduction

PRODUCT ILLUSTRATION

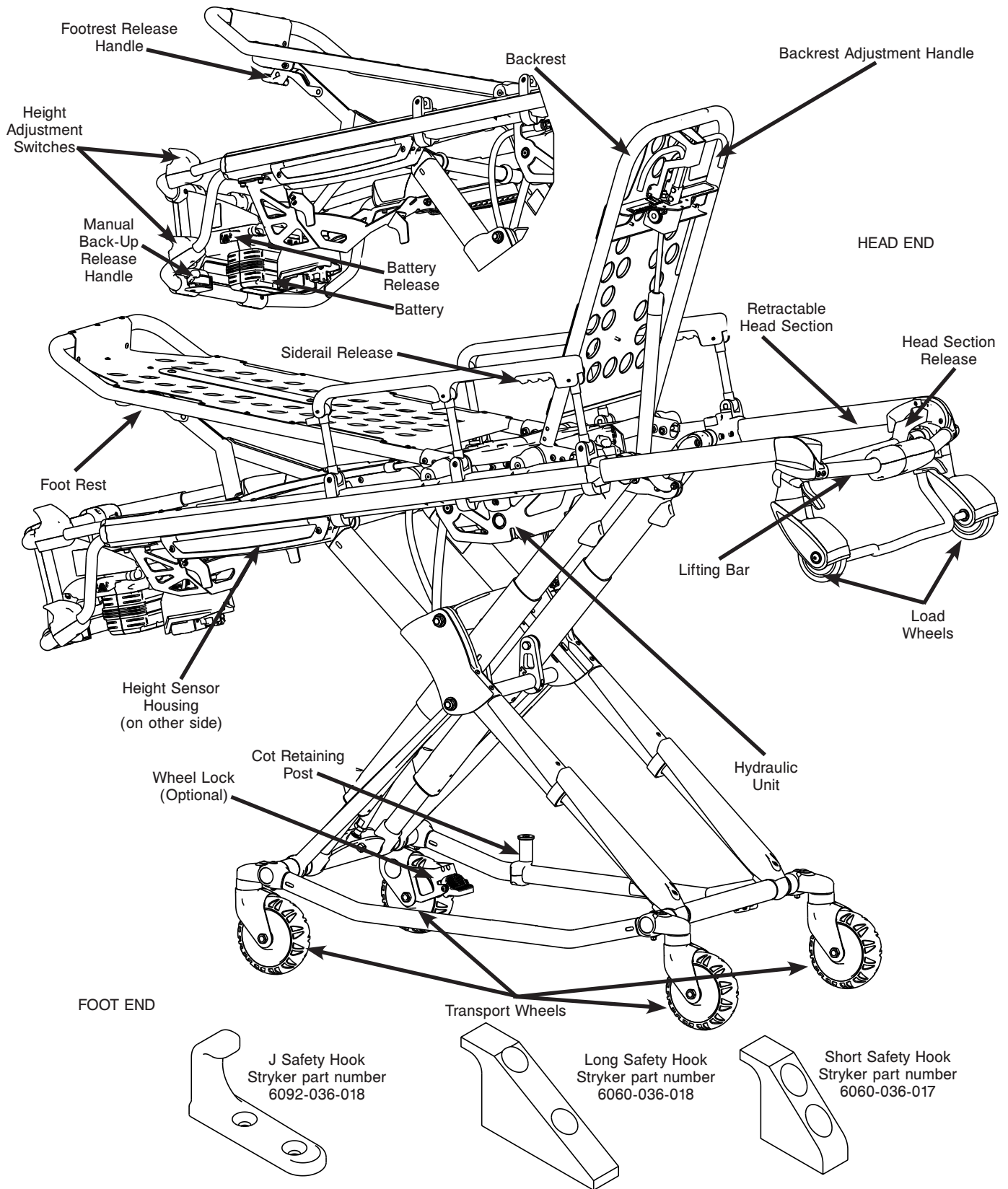

Figure 2

[Return To Table of Contents](#)

Summary of Safety Precautions

Carefully read and strictly follow the warnings and cautions listed on these pages. Service only by qualified personnel.

WARNING

- Ensure proper hand placement on hand grips. Hands should be clear of red safety bar pivots while loading and unloading the cot or whenever changing height position of the cot with two or more operators.
 - To avoid the risk of patient or operator injury, use both hands when transporting the cot.
 - Improper usage of the cot can cause injury to the patient or operator. Operate the cot only as described in this manual.
 - Do not modify the cot or any components of the cot. Modifying the product can cause unpredictable operation resulting in injury to the patient or operator. Modifying the product also voids its warranty (see [page 118](#)).
 - Any emergency vehicle to be used with this cot **must** have the in-fastener shut-off system installed (if not using Power-LOAD) (see [page 27](#)).
 - It is the responsibility of the cot operator to ensure that the cot being used in the Stryker Cot Fastener Systems meets the installation specifications listed on [page 26](#). Injury may result if a non-compatible cot is used in the Stryker Fastener System.
 - The in-fastener shut-off must be positioned properly before placing the cot into service. Failure to install the in-fastener shut-off may cause injury to the patient or operator and/or damage to the vehicle.
 - Do not attempt to operate the cot when it is loaded into a cot fastener.
 - The in-fastener shut-off is **only** a means for disabling the electronic functionality. Damage to the product and/or injury to the patient and/or operator may occur if used for any other purpose.
 - Have the vehicle safety hook installed by a certified mechanic. Improper safety hook installation can cause injury to the patient or operator and/or damage to the cot.
 - Failure to install the safety hook can cause injury to the patient or operator. Install and use the safety hook as described on [page 29](#).
 - The face of the safety hook that engages the safety bar should be located at least 3-3/4" from the leading edge of the door sill. After installation, verify that the cot legs lock into the load position without contacting the vehicle bumper.
 - To avoid injury, verify that the safety bar has engaged the safety hook before removing the cot from the patient compartment.
 - Verify that the safety hook always engages the cot safety bar regardless of how the cot is unloaded from the vehicle or injury to the patient or operator and/or damage to the cot may occur.
 - The cot must have at least 5/8" of clearance between the vehicle bumper and the cot to disengage the safety bar when unloading the cot from the vehicle. Verify that the cot legs lock into the load position before disengaging the safety bar from the safety hook. Failure to properly lock the cot height into position can cause injury to the patient or operator and/or damage to the cot.
 - To avoid risk of electric shock, never attempt to open the battery pack for any reason. If the battery pack case is cracked or damaged, do not insert it into the charger. Return damaged battery packs to a service center for recycling.
 - Do not remove the battery when the cot is activated.
 - Avoid direct contact with a wet battery or battery enclosure. Contact may cause injury to the patient or operator.
 - Entanglement in powered cot mechanisms can cause serious injury. Operate the cot only when all persons are clear of the mechanisms.
 - Inspect **SMRT™** Paks for damage before every use.
 - Practice changing height positions and loading the cot until operation of the product is fully understood. Improper use can cause injury.
 - Do not allow untrained assistants to assist in the operation of the cot. Untrained technicians/assistants can cause injury to the patient or themselves.
 - Do not ride on the base of the cot. Damage to the product could occur, resulting in injury to the patient or operator.
 - Transporting the cot sideways can cause the cot to tip, resulting in possible damage to the product and/or injury to the patient or operator. Transporting the cot in a lowered position, head or foot end first, minimizes the potential of a cot tip.
 - Grasping the cot improperly can cause injury. Keep hands, fingers and feet away from moving parts. To avoid injury, use extreme caution when placing your hands and feet near the base tubes while raising and lowering the cot.
-

Summary of Safety Precautions

WARNING (CONTINUED)

- Always use all restraint straps to secure the patient on the cot. An unrestrained patient may fall from the cot and be injured.
- Never leave a patient unattended on the cot or injury could result. Hold the cot securely while a patient is on the product.
- Never apply the optional wheel locks while a patient is on the cot. Tipping could occur if the cot is moved while the wheel lock is applied, resulting in injury to the patient or operator and/or damage to the cot.
- Siderails are not intended to serve as a patient restraint device. See [page 60](#) for proper restraint strap usage. Failure to use the restraint straps properly could result in patient injury.
- Hydraulically raising or lowering the cot may temporarily affect electronic patient monitoring equipment. For best results, patient monitoring should be conducted when the cot is idle.
- High obstacles such as curbing, steps or rough terrain can cause the cot to tip, possibly causing injury to the patient or operator.
- If the cot is equipped with the optional kickstand, make sure that the kickstand remains in the retracted position and does not engage during transport.
- Transporting the cot in lower positions reduces the potential of a cot tip. If possible, obtain additional assistance or take an alternate route.
- Power-LOAD is designed to be compatible with the 6085/6086 Performance-PRO XT, 6500/6506 **Power-PRO™** XT, and 6510/6516 **Power-PRO™** IT cots with the Power-LOAD option only. In certain situations, you can use Power-LOAD as a standard antler for most X-frame cots, but a rail clamp assembly is required for all cots without the Power-LOAD option.
- It is the responsibility of the cot operator to ensure that the cot being used in the Stryker Model 6390 Power-LOAD system is a Power-LOAD compatible cot. Injury may result if a non-compatible cot is used in the Stryker Model 6390 Power-LOAD system.
- Two operators must be present when the cot is occupied.
- Operators must be able to lift the total weight of the patient, cot and any items on the cot.
- The higher an operator must lift the cot, the more difficult it becomes to hold the weight. An operator may need help loading the cot if he/she is too short or if the patient is too heavy to lift safely. The operator must be able to lift the cot high enough for the cot legs to unfold completely and lock when the cot is unloaded. A shorter operator needs to raise their arms higher to enable the undercarriage to unfold.
- There must be a safety hook properly installed in the vehicle so that the bumper does not interfere with the front legs of the base frame.
- When using a cot fastener, do not load the cot into the vehicle with the head section retracted. Loading the cot with the head section retracted may cause the product to tip or not engage properly in the cot fastener, possibly causing injury to the patient or operator and/or damage to the cot.
- Whenever the weight of the cot and patient is no longer supported by the wheels, the cot will **automatically** enter the high speed retract mode if the retract (-) button is pressed.
- After the weight is off of the ground, the operators must support the load of the patient, cot and any accessories. Failure to support the load properly may cause injury to the patient or operator.
- The one person loading and unloading procedures are for use only with an empty cot. Do not use the procedures when loading/unloading a patient. Injury to the patient or operator could result.
- Do not pull or lift on the safety bar when unloading the cot. Damage to the safety bar could result and injury to the patient or operator could occur.
- Do not press the extend (+) button until the safety bar has engaged the safety hook.
- To avoid injury, always verify that the head section is locked into place prior to operating the cot.
- Do not attempt to load the cot into the patient compartment with the head section retracted. Loading the cot with the head section retracted may cause the product to tip or not engage properly in the cot fastener, possibly causing injury to the patient or operator and/or damage to the product.
- Never install or use a wheel lock on a cot with excessively worn wheels. Installing or using a wheel lock on a wheel with less than a 6" diameter could compromise the holding ability of the wheel lock, possibly resulting in injury to the patient or operator and/or damage to the cot or other equipment.
- Do not attach restraints to the base tubes, cross tubes, or fowler skin. Improper restraint attachment could result in damage to the cot further resulting in injury to the patient or operator.

[Return To Table of Contents](#)

Summary of Safety Precautions

WARNING (CONTINUED)

- To avoid the risk of patient injury or equipment damage, ensure that you properly mount and secure the defibrillator platform to the cot.
- To avoid the risk of patient injury or equipment damage, you must use the provided straps to secure the defibrillator to the defibrillator platform.
- Due to the difference in sizes and shapes of available defibrillators, you may have to change the location and adjustment of the straps that secure the defibrillator to the defibrillator platform. To avoid the risk of patient injury or equipment damage, use and adjust all straps properly to ensure the security of the defibrillator.
- To avoid the risk of patient injury or equipment damage, the weight placed on the defibrillator platform must not exceed 30 lb (13.6 kg).
- Stryker recommends a two person operation when using the kickstand.
- Make sure that the patient weight is centered on the cot before using the kickstand.
- Engage the kickstand with your foot only.
- Lower cot height prior to engaging kickstand for increased stability.
- Make sure that the kickstand remains in the retracted position and does not engage during transport.
- Do not use the kickstand as a brake.
- Do not engage kickstand on a sloped surface.
- If the cot is equipped with the optional retractable head section oxygen bottle holder, use caution while the oxygen bottle holder is installed to avoid pinching your fingers between the fowler bracket and the oxygen bottle.
- To avoid accidental release of the Pedi-Mate®, and possible injury to the infant, ensure that the restraint buckle is located away from obstructions on the cot or accessories.
- When the optional head end storage flat is being used, ensure that it does not interfere with the operation of the retractable head section, safety bar and safety hook. Injury to the patient or operator could result.
- When cleaning, use any appropriate personal safety equipment (goggles, respirator, etc.) to avoid the risk of inhaling contagion. Use of power washing equipment can aerate contamination collected during the use of the cot.
- **SOME CLEANING PRODUCTS ARE CORROSIVE IN NATURE AND MAY CAUSE DAMAGE TO THE PRODUCT IF USED IMPROPERLY.** If the products described above are used to clean Stryker EMS equipment, measures must be taken to ensure the cots are wiped with clean water and thoroughly dried following cleaning. Failure to properly rinse and dry the cots will leave a corrosive residue on the surface of the cots, possibly causing premature corrosion of critical components.
- Failure to properly clean or dispose of contaminated mattress or other cot components will increase the risk of bloodborne pathogens and may cause injury to the patient or operator.
- Escaping fluid under pressure can penetrate the skin causing serious injury. Avoid the hazard by relieving pressure before disconnecting hydraulic or other lines. Tighten all connections before applying pressure. If an accident occurs, see a doctor immediately. Any fluid injected into the skin must be surgically removed within a few hours or gangrene may result. Doctors unfamiliar with this type of injury should reference a knowledgeable medical source.
- To avoid the risk of injury, do not use bare hands to check for hydraulic leaks.
- Take special precautions regarding electromagnetic compatibility (EMC) when using medical electrical equipment like **Power-PRO™**. Install and place **Power-PRO™** into service according to the EMC information in this manual. Portable and mobile RF communications equipment can affect the function of **Power-PRO™**.
- The use of accessories, transducers and cables other than those specified, with the exception of transducers and cables sold by Stryker as replacement parts for internal components may result in increased emissions or decreased immunity of the **Power-PRO™** cot.
- The Power-LOAD system and the **Power-PRO™** cot should not be used adjacent to or stacked with other equipment. If adjacent or stacked use is necessary, observe the **Power-PRO™** cot to verify normal operation in the configuration in which it will be used.
- **Power-PRO™** operates at the following frequencies: 70 - 125 kHz for inductive charging and 13.56 MHz±7 kHz, Amplitude Modulated (OOK), ERP: -79.57 dBm. The **Power-PRO™** cot may be interfered with by other equipment, even if that other equipment complies with CISPR emission requirements.

Summary of Safety Precautions

CAUTION

- Changes or modifications to the unit not expressly approved by Stryker could void the user's authority to operate the system.
 - This equipment has been tested and found to comply with the limits for a Class A digital device, pursuant to part 15 of the FCC Rules. These limits are designed to provide reasonable protection against harmful interference when the equipment is operated in a commercial environment. This equipment generates, uses, and can radiate radio frequency energy and, if not installed and used in accordance with the instruction manual, may cause harmful interference to radio communications. Operation of this equipment in a residential area is likely to cause harmful interference in which case the user will be required to correct the interference at their expense.
 - The cot can be set at any cot load height position. Establish the required cot load height before placing the cot into service.
 - Set the cot load height to the proper stop height prior to operation.
 - Installation of the safety hook should be done by a certified mechanic familiar with ambulance vehicle construction. Consult the vehicle manufacturer before installing the safety hook and be sure that the installation of the safety hook does not damage or interfere with the brake lines, oxygen lines, fuel lines, fuel tank or electrical wiring of the vehicle.
 - Only use the battery and charger as specified in the **SMRT™** Power System Operations/Maintenance Manual.
 - The cot is not for use with an AC adapter.
 - When charging a battery in an ambulance, locate the charger in an enclosed cabinet and out of patient reach during transport.
 - Ensure that the battery is fully charged prior to placing into service. An uncharged or depleted battery may cause poor cot performance.
 - Before operating the cot, clear any obstacles that may interfere and cause injury to the operator or patient.
 - Do not "jog" the cot past the established cot load height of the product when the safety bar engages the vehicle safety hook or damage may occur to the product.
 - When unloading the cot from the patient compartment, ensure that the caster wheels are safely set on the ground or damage to the product may occur.
 - Do not use the XPS option with a standard mattress. Use the wider gatch bolster mattress (6500-003-130) with the XPS option.
 - Do not sit or stand on the siderails (XPS option).
 - Do not use the siderails (XPS option) as a patient transfer device or surface (for example, to slide a patient from the cot to another surface).
 - Do not position patients with full weight on the siderails (XPS option).
 - Do not use the siderails (XPS option) as a push/pull device or to steer the unit.
 - Remove the battery if the cot is not going to be used for an extended period of time (more than 24 hours).
 - Wheel locks are only intended to help prevent the cot from rolling while unattended and to aid in patient transfer. A wheel lock may not provide sufficient resistance on all surfaces or under loads.
 - Ensure that the restraints are not entangled in the base frame when raising and lowering the cot.
 - The weight of the equipment in the base storage net (if equipped) must not exceed 20 lb (9 kg).
 - Be careful when retracting the base to avoid damaging items stored in the base storage net.
 - To avoid damage to the equipment hook, the weight of the accessories or equipment must not exceed 35 lb (15.8 kg).
 - To avoid damage to the I.V. pole, the weight of the I.V. bags or equipment must not exceed 25 lb (11.3 kg).
 - To avoid damage to the oxygen bottle holder (if equipped), the weight of the equipment must not exceed 15 lb (6.8 kg).
 - Do not use two head end oxygen bottle holders at the same time.
 - Do not store items under the cot mattress. Storing items under the mattress can interfere with the operation of the cot.
 - The weight of the equipment in the pocketed backrest storage pouch (if equipped) must not exceed 20 lb (9 kg).
 - The weight of the equipment in the head end storage flat (if equipped) must not exceed 40 lb (18 kg).
-

Summary of Safety Precautions

CAUTION (CONTINUED)

- DO NOT STEAM CLEAN OR ULTRASONICALLY CLEAN THE UNIT.
 - Maximum water temperature should not exceed 180°F/82°C.
 - Maximum water pressure should not exceed 1500 psi/130.5 bar. If a hand held wand is being used to wash the unit, the pressure nozzle must be kept a minimum of 24 inches (61 cm) from the unit.
 - Allow cot to air dry.
 - Towel dry all casters and interface points.
 - Failure to comply with these instructions may invalidate any/all warranties.
 - Always remove the battery before washing the cot.
 - A preventive maintenance program should be established for all Stryker EMS equipment. Preventive maintenance may need to be performed more frequently based on the usage level of the product. Close attention should be given to safety features including, but not limited to:
 - Hydraulic power mechanism
 - All electrical controls return to off or neutral position when released.
- For additional maintenance information, see the preventive maintenance information.
- Improper maintenance can cause injury or damage to the product. Maintain the cot as described in this manual. Use only Stryker approved parts and maintenance procedures. Using unapproved parts and procedures could cause unpredictable operation and/or injury and will void the product warranty (see [page 118](#)).
 - Failure to use authorized parts, lubricants, etc. could cause damage to the cot and will void the warranty of the product.
 - Hydraulic lines, hoses, and connections can fail or loosen due to physical damage, kinks, age, and environment exposure. Check hoses and lines regularly to avoid damage to the cot. Check and tighten loose connections.
 - Do not tip the cot onto its load wheels and actuate the product as this will allow air to enter the hydraulic system.
 - Do not lubricate the bearings in the X-frame as it will degrade the performance of the cot and may void its warranty (see [page 118](#)).
 - The cot retaining post is shipped preconfigured for an X-frame cot. If the cot fastener has been configured for an H-frame cot, you must adjust the cot retaining post to accommodate the cot fastener.
-

Summary of Safety Precautions

PINCH POINTS

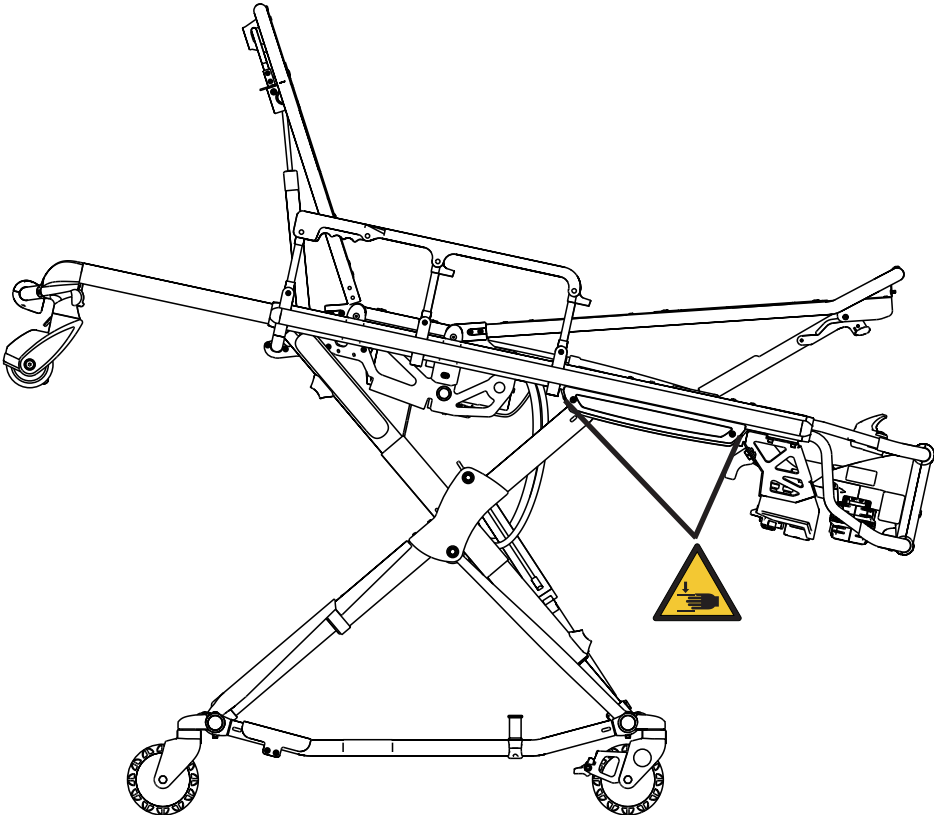

Figure 3

 **WARNING**

Ensure proper hand placement on hand grips. Hands should be clear of red safety bar pivots while loading and unloading the cot or whenever changing height position of the cot with two or more operators.

Summary of Safety Precautions

MECHANICAL STABILITY

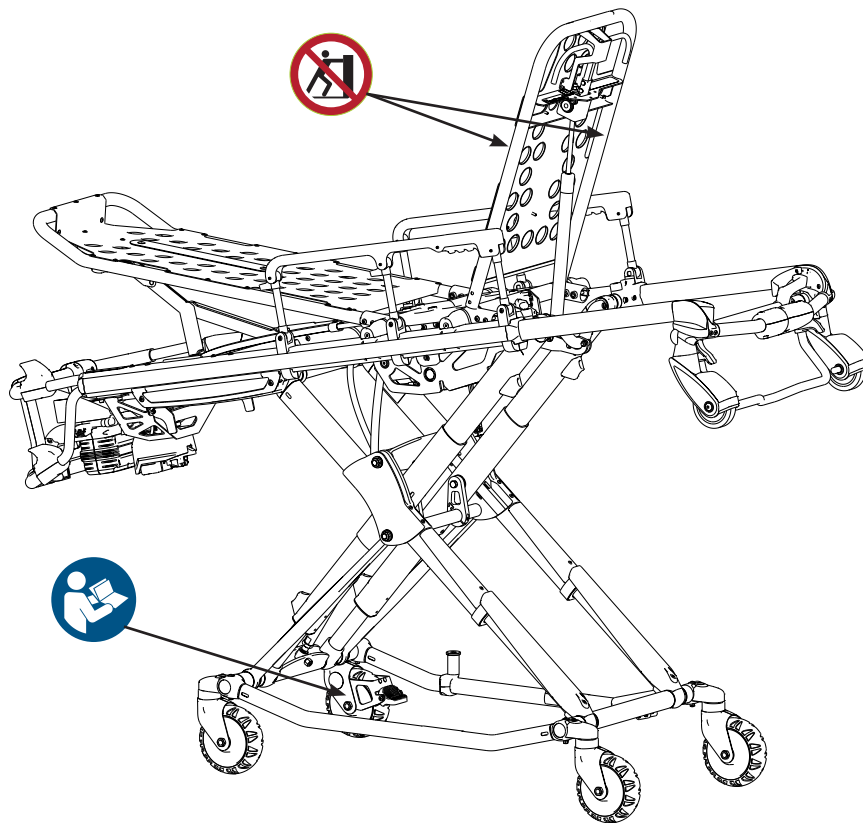

Figure 4

WARNING

To avoid the risk of patient or operator injury, use both hands when transporting the cot.

Notes:

- If the cot is on a plane steeper than five degrees, place the cot in the fully lowered position.
- The defibrillator option and the foot end oxygen bottle holder option can not be used at the same time.

Setup Procedures

Ensure that all shipping and packaging materials have been removed from the products prior to use.

Unpack the cartons and check all items for proper operation. It is important that the cot is working properly before it is put into service. See Figure 2 on [page 15](#) to identify all of the cot components.

The patient compartment of the vehicle in which the cot will be used must have a:

- Smooth rear edge for cot loading
- Level floor large enough for the folded cot
- Stryker Model 6370/6377/6378/6379 or 6371 Cot Fastener System or Stryker Model 6390 Power-LOAD (not included)
- In-fastener shut-off module installed and positioned properly (if not using Power-LOAD) (see [page 27](#))
- Space to properly install the safety hook

Note: Loose items or debris on the patient compartment floor can interfere with the operation of the safety hook and cot fastener. Keep the patient compartment floor clear.

When necessary, modify the vehicle to fit the cot. Do not modify the cot.

WARNING

- Improper usage of the cot can cause injury to the patient or operator. Operate the cot only as described in this manual.
- Do not modify the cot or any components of the cot. Modifying the product can cause unpredictable operation resulting in injury to the patient or operator. Modifying the product also voids its warranty (see [page 118](#)).
- Any emergency vehicle to be used with this cot **must** have the in-fastener shut-off system installed (if not using Power-LOAD) (see [page 27](#)).

Note:

- This manual should be considered a permanent part of the cot and should remain with the product even if the cot is subsequently sold.
- Stryker continually seeks advancements in product design and quality. Therefore, while this manual contains the most current product information available at the time of printing, there may be minor discrepancies between your cot and this manual. If you have any questions, please contact Stryker Customer Service or Technical Support at (800) 327-0770.

Setup Procedures

SETTING COT LOAD HEIGHT AND “JOG” FUNCTION

The cot control mechanism uses height sensors to set the load height stop for the cot. These height sensors match the load wheel height for a specific ambulance deck height.

The cot load height can be set from 26” to 36” (66 cm to 91 cm) as measured from the ground to the bottom of the load wheel. Determine the cot load height before placing the cot into service. You can modify the cot load height at any time, but you must determine and set the cot load height before the cot is placed into service.

To set the cot load height:

1. Locate the sensor housing on the patient right side of the cot as shown in Figure 5.
2. Using a T27 Torx driver, remove the sensor housing cover by loosening the two (2) screws (one on each end) as shown in Figure 6.
3. Adjust the left height sensor only as shown in Figure 7.
 - a. Move the sensor to the left to increase the set load height or move the sensor to the right to decrease the set load height.
 - b. Press the retract (-) button to lower the cot to its lowest position, then press the extend (+) button to raise the cot to its highest set load height.
 - c. Measure the cot height from the bottom of the load wheels to the floor.

Note: Add an additional 1/2" (1,3 cm) to your deck height measurement to allow for variations with patient height and other equipment added to the cot.

- d. Repeat steps 3a and 3b until the desired cot load height is reached.
4. After the proper load wheel height is set, ensure that all of the height sensor cables are secure and lying flat inside of the housing between the sensors as shown in Figure 8.
 5. Using a T27 Torx driver, replace the sensor housing cover by reinstalling the two screws that were removed in step 2.
 6. Following completion of the sensor height adjustment, verify that the cot properly engages the safety hook.



Figure 5



Figure 6



Figure 7



Figure 8

CAUTION

The cot can be set at any cot load height position. Establish the required cot load height before placing the cot into service.

Cot Fastener Installation

Note: The Cot Fastener Installation instructions on [page 25](#) through [page 27](#) are intended for cots that you will NOT use with Power-LOAD. For Model 6506 cots with the Power-LOAD option, see the Power-LOAD Operations/Maintenance Manual for installation instructions.

The Stryker Cot Fastener Systems are designed to be compatible only with cots which conform to the installation specifications listed on [page 26](#).

 **WARNING**

It is the responsibility of the cot operator to ensure that the cot being used in the Stryker Cot Fastener Systems meets the installation specifications listed on [page 26](#). Injury may result if a non-compatible cot is used in the Stryker Fastener System.

Note: Adjustment of the rail clamp assembly may be required in order to compensate for any variation in the cot retaining post position depending on the cot manufacturer and model number.

For more information about the Stryker Cot Fastener Systems, see the Cot Fastener Operations/Maintenance Manual.

Cot Fastener Installation

Note: These installation instructions are intended for cots with cot fastener systems (NOT Power-LOAD). For Model 6506 cots with the Power-LOAD option, see the Power-LOAD Operations/Maintenance Manual for installation instructions.

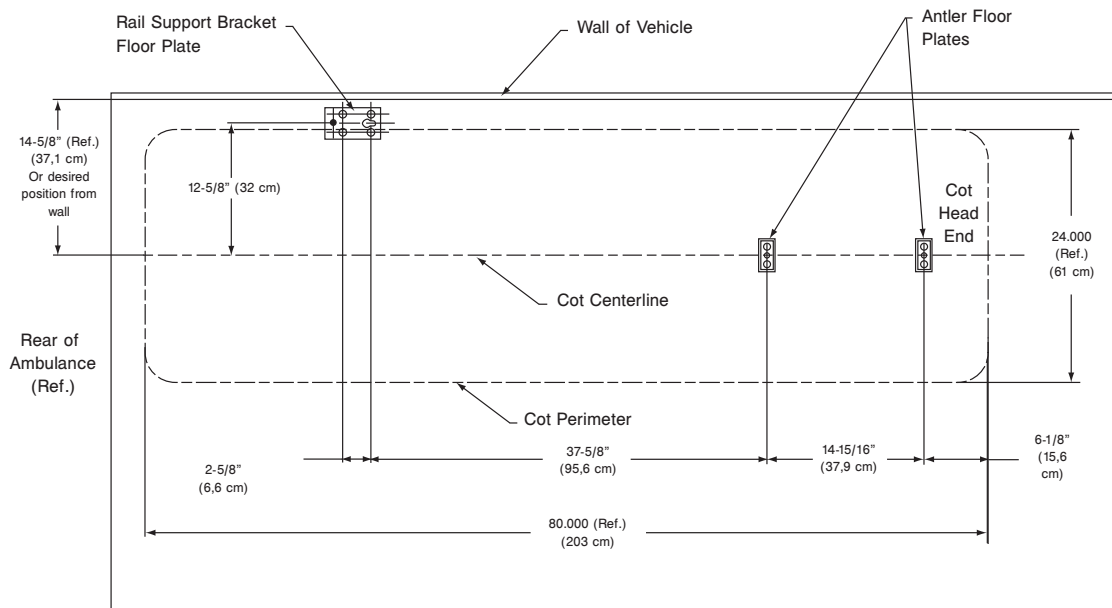

Figure 9

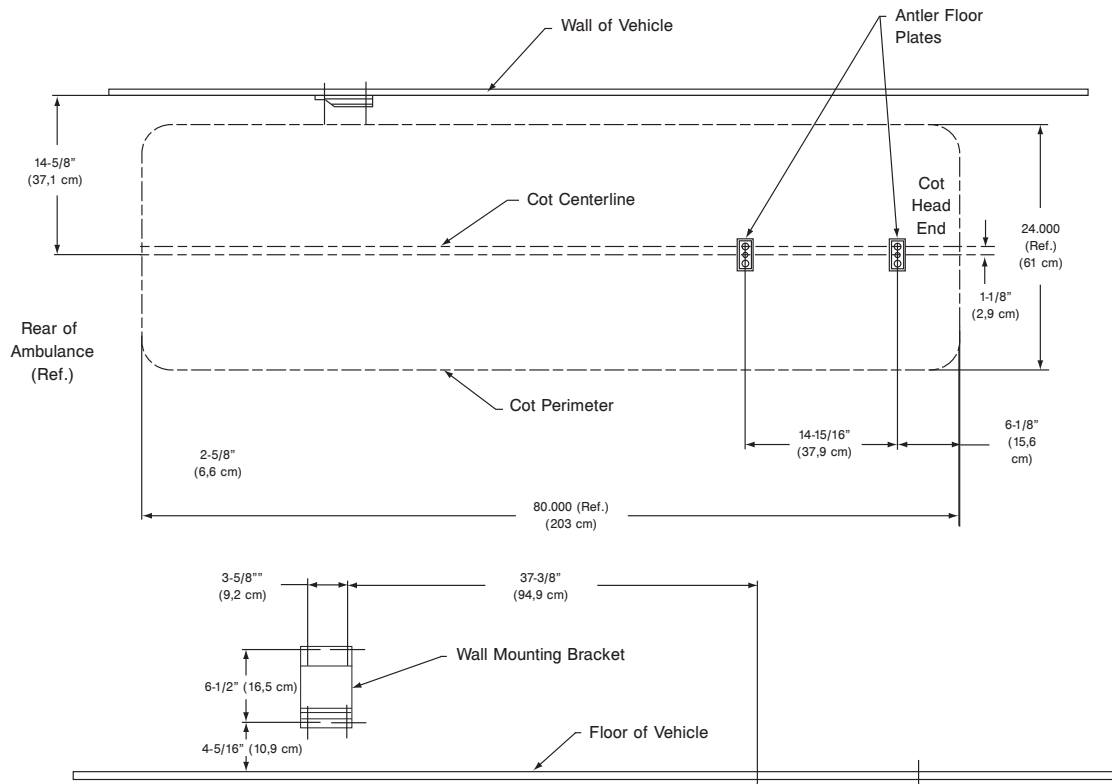

Figure 10

Cot Fastener Installation

INSTALLING THE IN-FASTENER SHUT-OFF

Note: These installation instructions are intended for cots that you will NOT use with Power-LOAD. For Model 6506 cots with the Power-LOAD option, see the Power-LOAD Operations/Maintenance Manual for installation instructions.

WARNING

The in-fastener shut-off must be positioned properly before placing the cot into service. Failure to install the in-fastener shut-off may cause injury to the patient or operator and/or damage to the vehicle.

The cot and fastener system have an integrated in-fastener shut-off function that disables the cot motor when the cot is secured into the cot fastener. Securely tighten the bolts on the fastener before installing the shut-off bracket. Install the shut-off bracket onto the rail clamp assembly before putting the cot into service.

1. Place the cot into a loading position (any position where the load wheels of the head section meet the vehicle floor height).
2. Lift the vehicle bumper to the raised position (if equipped).
3. Roll the cot to the open door of the patient compartment.
4. Push the cot forward until the load wheels are on the compartment floor and the safety bar passes the safety hook.
5. For maximum clearance to lift the base, pull the cot back until the safety bar engages the safety hook.
6. Raise the base and push the cot into the patient compartment following the appropriate loading instructions.
7. Engage the extended head section of the cot into the cot fastener antler and secure the cot post into the fastener rail clamp.
8. Adjust the shut-off bracket along the rail clamp until the “diamond” (A) on the sensor housing is lined up with the pop rivet head (B) as shown in Figure 11.
9. Using a T27 Torx driver, securely fasten the bolts to attach the shut-off bracket to the rail clamp assembly.
10. Press the retract (–) button to ensure that the motor does not turn on while the cot is in the fastener. The battery indicator will still illuminate. If the motor turns on, readjust the shut-off bracket.

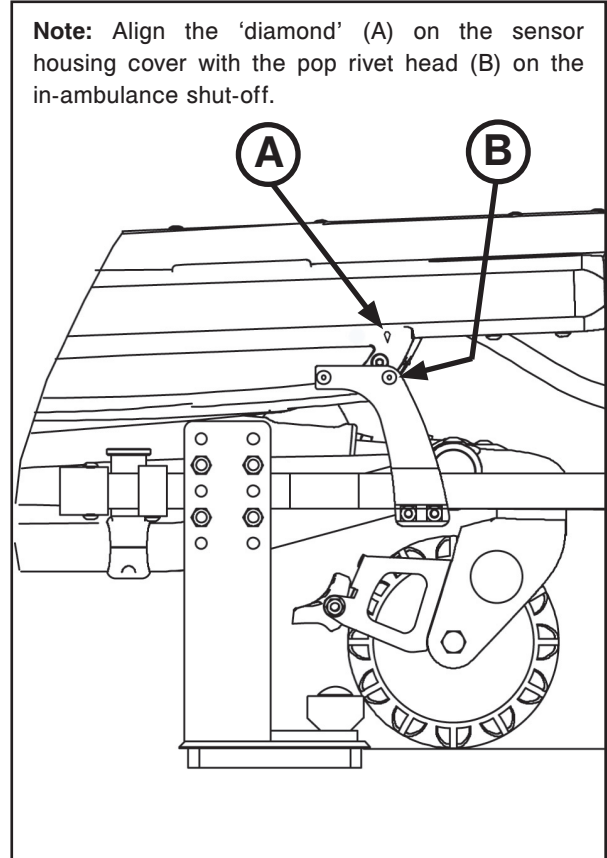

Figure 11

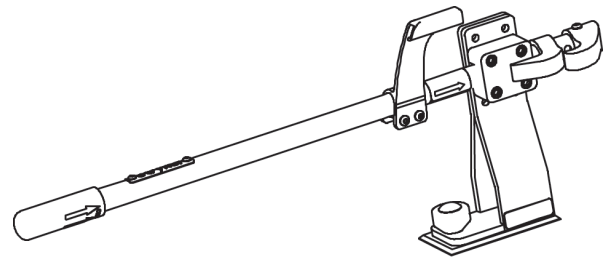

Figure 12

WARNING

- Do not attempt to operate the cot when it is loaded into a cot fastener.
- The in-fastener shut-off is **only** a means for disabling the electronic functionality. Damage to the product and/or injury to the patient and/or operator may occur if used for any other purpose.
- Any emergency vehicle to be used with this cot **must** have the in-fastener shut-off system installed (if not using Power-LOAD).

[Return To Table of Contents](#)

Vehicle Safety Hook Selection

Note: The Vehicle Safety Hook Selection and Installation instructions on [page 28](#) through [page 31](#) are intended for cots that you will NOT use with Power-LOAD. For Model 6506 cots with the Power-LOAD option, see the Power-LOAD Operations/Maintenance Manual for installation instructions. Power-LOAD ships and is installed with its own safety hook, thus no additional hook is needed.

The vehicle safety hook is a device that ships with the cot. The cot safety bar and vehicle safety hook are designed to keep the cot from being accidentally removed from the vehicle and to provide increased operator assurance and confidence when loading and unloading. The safety hook was designed for compatibility and proper operation when loading and unloading the cot from a vehicle that is compliant with Federal Regulation KKK-A-1822.

Stryker offers three different types of safety hooks that are ordered and shipped with your cot. These safety hook types are designed to meet the needs of various emergency vehicle configurations, specifically the length and location of the floor structure support that is located in the rear of the vehicle.

Consider the following information when selecting which safety hook is appropriate for your vehicle configuration:

- Determine the location of the floor structure support where there is adequate room to mount the safety hook.
- Ensure that the safety hook can be securely mounted into the back of the vehicle while providing adequate bumper clearance to allow the cot to be loaded and unloaded from the vehicle.
- Note the differences in vehicle design. Each safety hook provides a different mounting location option to maintain the appropriate distance between the face of the safety hook and the edge of the door sill.

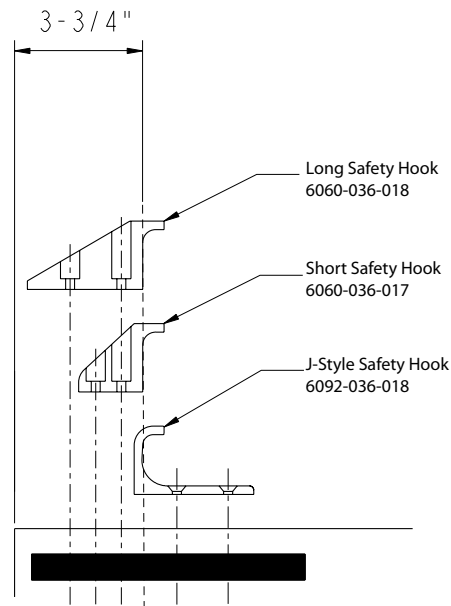

Figure 13

Due to the differences in vehicle dimensions and the floor structure support locations, each safety hook requires a different mounting location. See "Vehicle Safety Hook Installation" to determine the correct positioning for safety hook installation.

Note: When replacing an existing safety hook with a new style, adjust the mounting location to maintain the proper position of the safety hook face.

Vehicle Safety Hook Installation

Note: These installation instructions are intended for cots that you will NOT use with Power-LOAD. For Model 6506 cots with the Power-LOAD option, see the Power-LOAD Operations/Maintenance Manual for installation instructions.

VEHICLE CONFIGURATION

According to federal regulations (reference KKK-A-1822), the bumper height of the vehicle shall be installed equidistant ± 5 cm (2 inches) from the vehicle floor to the ground level, which is defined as the vehicle deck height. The bumper step shall have a minimum depth of 13 cm (5 inches) and a maximum depth of 25 cm (10 inches). If the bumper depth is greater than 18 cm (7 inches), then the bumper must be able to fold. Installation of the safety hook into any vehicle compliant with this federal specification provides adequate clearance for the cot base to lower to its fully extended position. The cot is compatible with all vehicle deck heights (see specifications for maximum load height) as long as the vehicle meets the federal specifications that are outlined in KKK-A-1822.

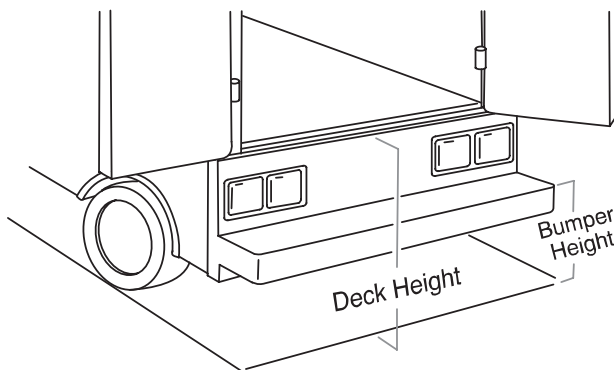

Figure 14

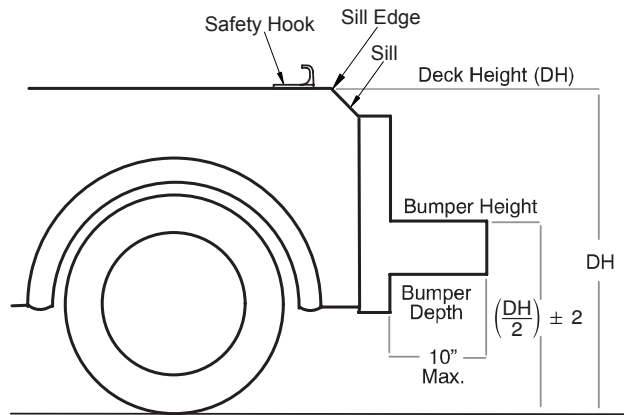

Figure 15

CAUTION

- Set the cot load height to the proper stop height prior to operation.
- Installation of the safety hook should be done by a certified mechanic familiar with ambulance vehicle construction. Consult the vehicle manufacturer before installing the safety hook and be sure that the installation of the safety hook does not damage or interfere with the brake lines, oxygen lines, fuel lines, fuel tank or electrical wiring of the vehicle.

REQUIRED HARDWARE FOR INSTALLATION OF THE SAFETY HOOK (NOT SUPPLIED)

- (2) Grade 5, Minimum 1/4"-20 Socket Head Cap Screws* for the short or long safety hook
- (2) Grade 5, Minimum 1/4"-20 Flat Socket Head Cap Screws* for the J hook
- (2) Flat Washers
- (2) Lock Washers
- (2) 1/4"-20 Nuts

* The length of the socket head cap screws depends on the thickness of the vehicle floor. Use screws that are long enough to go completely through the patient compartment floor, washer and nut by at least two full threads.

[Return To Table of Contents](#)

Vehicle Safety Hook Installation

Note: These installation instructions are intended for cots that you will NOT use with Power-LOAD. For Model 6506 cots with the Power-LOAD option, see the Power-LOAD Operations/Maintenance Manual for installation instructions.

WARNING

- Have the vehicle safety hook installed by a certified mechanic. Improper safety hook installation can cause injury to the patient or operator and/or damage to the cot.
- Failure to install the safety hook can cause injury to the patient or operator.
- The face of the safety hook that engages the safety bar should be located at least 3-3/4" from the leading edge of the door sill. After installation, verify that the cot legs lock into the load position without contacting the vehicle bumper.
- To avoid injury, verify that the safety bar has engaged the safety hook before removing the cot from the patient compartment.

Note: Stryker recommends that, prior to installation, the certified mechanic plan the placement of the safety hook in the rear of the vehicle.

Before installing the safety hook into your vehicle, check the front to back and side to side positioning when unloading and loading the cot to ensure that the safety hook will be installed properly. The cot safety bar must engage the safety hook every time, regardless of cot position.

FRONT TO BACK POSITIONING OF THE SAFETY HOOK

1. Select the appropriate safety hook for your vehicle configuration.
2. Position the safety hook at least 3-3/4" from the leading edge of the door sill.
3. Ensure that the safety hook can be securely mounted into the back of the vehicle while providing adequate bumper clearance to allow the cot to be loaded and unloaded from the vehicle.
4. See "Side to Side Positioning of the Safety Hook" to confirm the side to side placement.

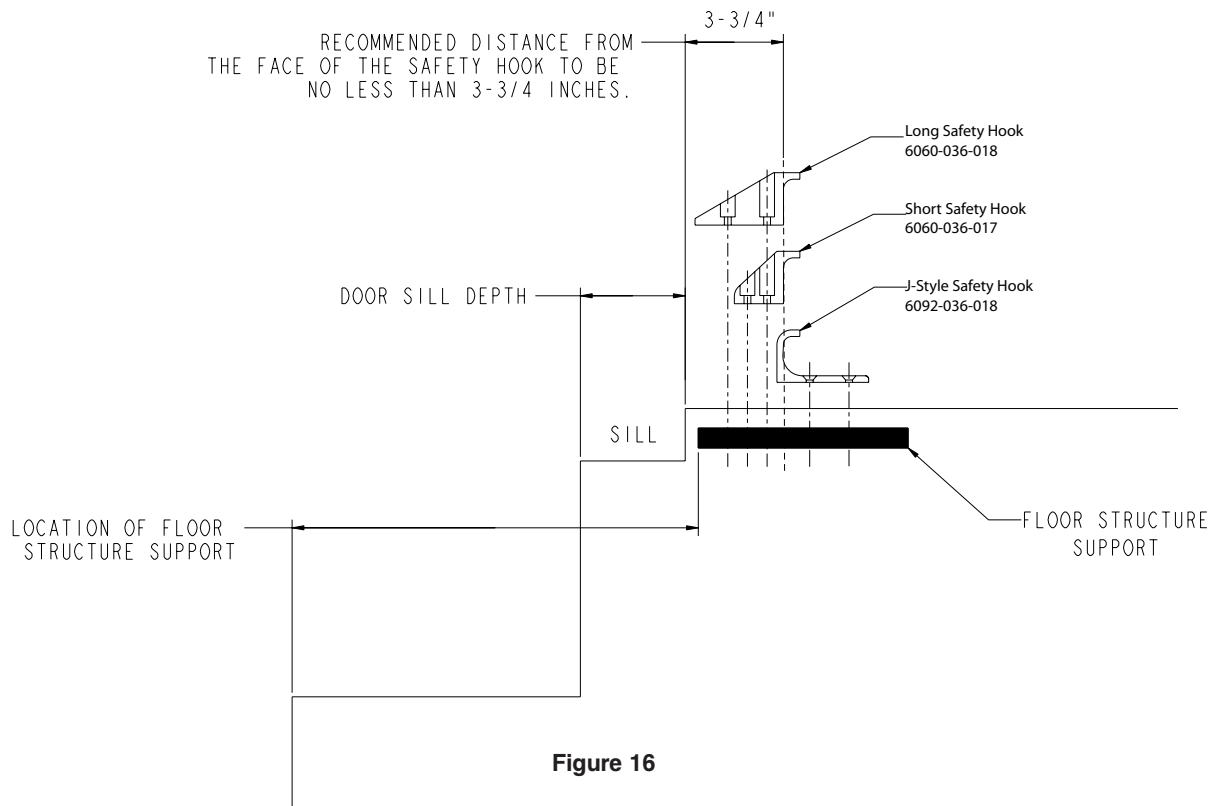

Figure 16

Vehicle Safety Hook Installation

Note: These installation instructions are intended for cots that you will NOT use with Power-LOAD. For Model 6506 cots with the Power-LOAD option, see the Power-LOAD Operations/Maintenance Manual for installation instructions.

SIDE TO SIDE POSITIONING OF THE SAFETY HOOK

1. Remove the cot from the fastener and unload it from the vehicle.
2. While the cot is being removed, note the position of the load wheels and the safety bar.
3. Mark the center of the cot safety bar on the vehicle floor.
4. Verify that the position marked in Step 3 is where the safety bar engages the safety hook every time when unloading the cot in a variety of positions (all the way to the left and all the way to the right), regardless of cot position.
 - If the cot safety bar does not engage the safety hook in any of these positions (left, center, or right), modify the vehicle, not the cot or safety hook.
 - If the cot safety bar engages the safety hook every time, install the safety hook.

INSTALLING THE SAFETY HOOK

1. Determine the correct safety hook front to back and side to side positioning, so the cot safety bar engages the safety hook every time.
2. Drill the holes for the screws.
3. Fasten the safety hook to the patient compartment floor and verify that the safety hook always engages the cot safety bar regardless of how the cot is unloaded from the vehicle.

WARNING

- Verify that the safety hook always engages the cot safety bar regardless of how the cot is unloaded from the vehicle or injury to the patient or operator and/or damage to the cot may occur.
- The cot must have at least 5/8" of clearance between the vehicle bumper and the cot to disengage the safety bar when unloading the cot from the vehicle. Verify that the cot legs lock into the load position before disengaging the safety bar from the safety hook. Failure to properly lock the cot height into position can cause injury to the patient or operator and/or damage to the cot.

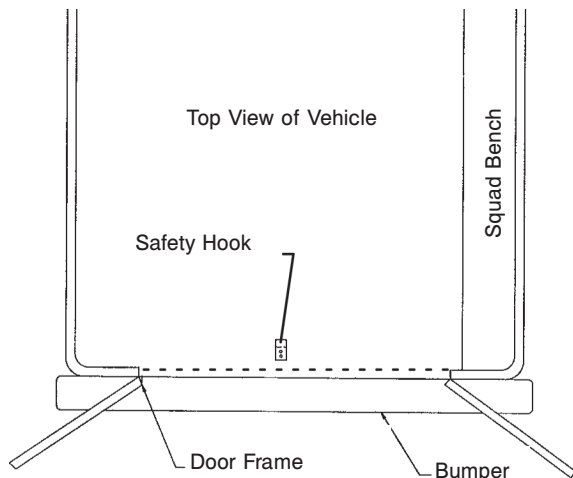

Figure 17

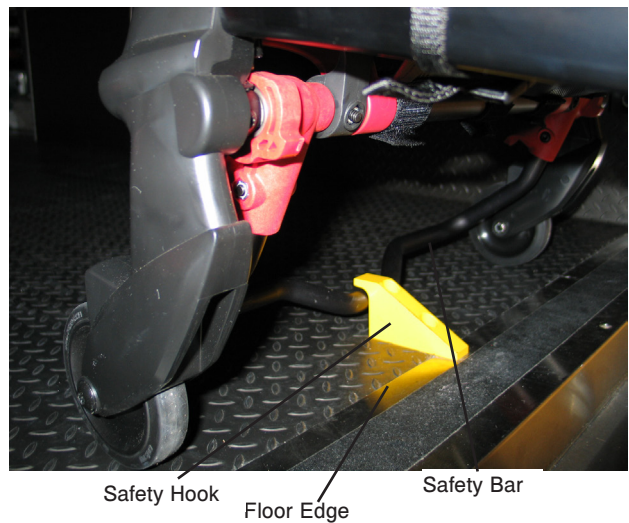

Figure 18

[Return To Table of Contents](#)

Power-PRO™ Cot User Controls

USING THE COT CONTROL SWITCHES

There are two identical cot control switches located on the **Power-PRO™** cots. Press the buttons on either of these switches to extend the cot, retract the cot, or release the cot from Power-LOAD (if applicable).

This Figure 19 and table highlight the three buttons located on the cot control switch.

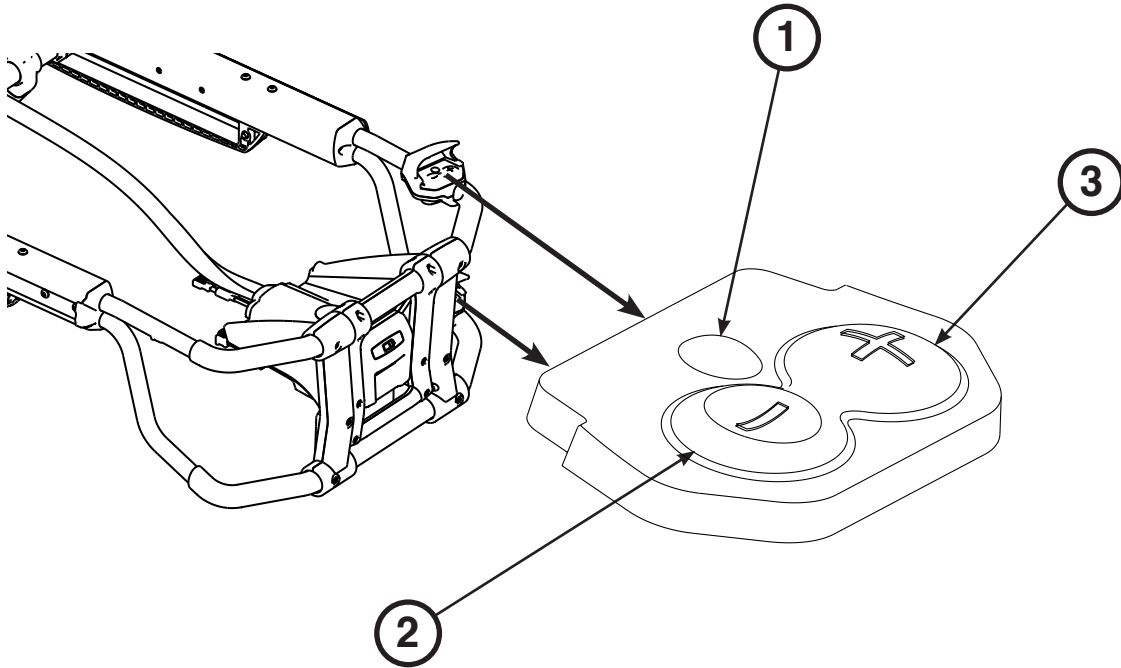

Figure 19

Ref	Name	Description	Description (with use of Power-LOAD)
1	Release	Not applicable	Press to unlock the cot from Power-LOAD
2	Retract (-)	Press and hold to lower the litter or retract the cot undercarriage when loading	Press and hold to fully retract the cot undercarriage
3	Extend (+)	Press and hold to raise the litter or extend the cot undercarriage when loading	Press and hold to fully extend the cot undercarriage

Power-PRO™ Cot User Controls

CHECKING THE COT BATTERY POWER LEVEL

To check the battery power level, press the retract (–) button (A) as shown in Figure 20 on the cot control switch to activate the cot battery LED indicator (B) as shown in Figure 21 on [page 34](#).

The cot battery LED indicator is located at the **Power-PRO™** foot end control enclosure (shown as a battery symbol).

- The LED is solid green when the battery is fully charged or has adequately charged battery power.
- The LED flashes amber when the battery needs to be recharged or replaced.
- The LED is solid amber to indicate a battery error.

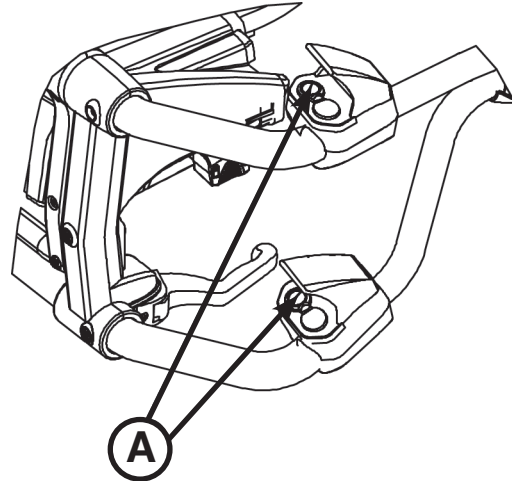

Figure 20

See the **SMRT™** Power System Operations/Maintenance Manual for additional **SMRT™** Pak and **SMRT™** Charger information.

Notes:

- Automatic charging will only occur with **SMRT™** Pak batteries.
- Only use Stryker-approved batteries with **Power-PRO™**.
- If applicable, Power-LOAD automatically charges the **Power-PRO™ SMRT™** Pak battery when the cot is locked into Power-LOAD in the transport position (no cable or connectors required). The cot battery LED indicator momentarily flashes green to signify that it is charging.

WARNING

- To avoid risk of electric shock, never attempt to open the battery pack for any reason. If the battery pack case is cracked or damaged, do not insert it into the charger. Return damaged battery packs to a service center for recycling.
- Do not remove the battery when the cot is activated.
- Avoid direct contact with a wet battery or battery enclosure. Contact may cause injury to the patient or operator.

CAUTION

- Only use the battery and charger as specified in the **SMRT™** Power System Operations/Maintenance Manual.
 - The cot is not for use with an AC adapter.
 - When charging a battery in an ambulance, locate the charger in an enclosed cabinet and out of patient reach during transport.
 - Ensure that the battery is fully charged prior to placing into service. An uncharged or depleted battery may cause poor cot performance.
-

Power-PRO™ Cot User Controls

CHECKING THE HOUR METER/LCD ERROR DISPLAY

The hour meter (C), located on the foot end control enclosure, indicates the amount of time (HHH.H hours) that the hydraulics have been activated as shown in Figure 21. You can use the hour meter to determine the frequency for preventive maintenance procedures as listed on [page 82](#).

The error display (C), located on the foot end control enclosure, provides error code information for troubleshooting. See “LCD Error Codes” on [page 95](#).

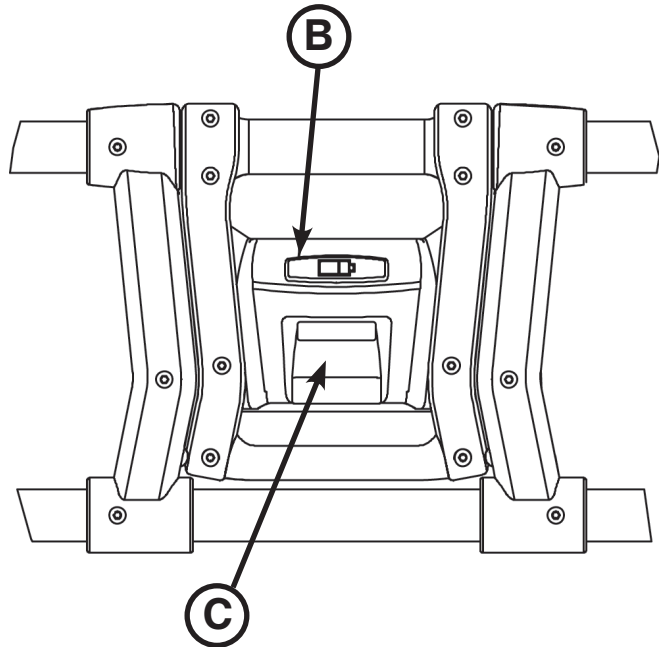

Figure 21

Operation Guide

OPERATING GUIDELINES

- Use the cot only as described in this manual.
- Read all labels and instructions on the cot before using the cot.
- Before first and every use, inspect the **SMRT™** Pak housing and terminal area for cracks and/or damage.
- Loading or unloading an occupied cot into a vehicle requires a minimum of **two (2) trained operators**. One or two operators can lift from the foot end of the cot. Stryker recommends that both operators are at the foot end to reduce the load on each operator. If additional assistance is needed, see “Using Additional Assistance” on [page 51](#).
- Do not adjust, roll or load the cot into a vehicle without advising the patient. Stay with the patient and control the cot at all times.
- The cot can be transported in any position. Stryker recommends that the operators transport the patient in the lowest comfortable position to maneuver the cot.
- Only use the wheel locks during patient transfer or without a patient on the cot.
- Do not leave wheel locks engaged while transporting the cot. Failure to do so may cause wheel damage.
- Always use the restraint straps.
- Use properly trained helpers, when necessary, to control the cot.

WARNING

- Improper usage of the cot can cause injury to the patient or operator. Operate the cot only as described in this manual.
- Entanglement in powered cot mechanisms can cause serious injury. Operate the cot only when all persons are clear of the mechanisms.
- Inspect **SMRT™** Paks for damage before every use.
- Practice changing height positions and loading the cot until operation of the product is fully understood. Improper use can cause injury.
- Do not allow untrained assistants to assist in the operation of the cot. Untrained technicians/assistants can cause injury to the patient or themselves.
- Ensure proper hand placement on hand grips. Hands should be clear of red safety bar pivots while loading and unloading the cot or whenever changing height position of the cot with two or more operators.
- Do not ride on the base of the cot. Damage to the product could occur, resulting in injury to the patient or operator.
- Transporting the cot sideways can cause the cot to tip, resulting in possible damage to the product and/or injury to the patient or operator. Transporting the cot in a lowered position, head or foot end first, minimizes the potential of a cot tip.
- Grasping the cot improperly can cause injury. Keep hands, fingers and feet away from moving parts. To avoid injury, use extreme caution when placing your hands and feet near the base tubes while raising and lowering the cot.
- Any emergency vehicle to be used with this cot **must** have the in-fastener shut-off system installed (if not using Power-LOAD) (see [page 27](#)).

CAUTION

Before operating the cot, clear any obstacles that may interfere and cause injury to the operator or patient.

PROPER LIFTING TECHNIQUES

When lifting the cot and patient, there are five basic guidelines to help you avoid injury:

- Keep your hands close to your body.
- Keep your back straight.
- Coordinate your movements with your partner and lift with your legs.
- Avoid twisting.
- Always operate the cot as described in this manual.

Operation Guide

TRANSFERRING THE PATIENT TO THE COT

To transfer the patient to the cot:

1. Roll the cot to the patient.
2. Place the cot beside the patient and raise or lower the cot to the level of the patient.
3. Lower the siderails and open the restraint straps.
4. Transfer the patient to the cot using accepted EMS procedures.
5. Use all the restraint straps to secure the patient to the cot (see [page 60](#)).
6. Adjust the backrest and foot rest as necessary.

Note: When transferring larger patients, use of the Transfer Flat (6005-001-001) is recommended.

WARNING

- Always use all restraint straps to secure the patient on the cot. An unrestrained patient may fall from the cot and be injured.
 - Never leave a patient unattended on the cot or injury could result. Hold the cot securely while a patient is on the product.
 - Never apply the optional wheel locks while a patient is on the cot. Tipping could occur if the cot is moved while the wheel lock is applied, resulting in injury to the patient or operator and/or damage to the cot.
 - Siderails are not intended to serve as a patient restraint device. See [page 60](#) for proper restraint strap usage. Failure to use the restraint straps properly could result in patient injury.
 - Hydraulically raising or lowering the cot may temporarily affect electronic patient monitoring equipment. For best results, patient monitoring should be conducted when the cot is idle.
-

ROLLING THE COT

When rolling the cot:

- Make sure that all of the restraint straps are securely buckled around the patient (see [page 60](#)).
- Position an operator at the foot end and one at the head end of the cot **at all times** when rolling the cot with a patient on it.
- Approach door sills and/or other low obstacles squarely and lift each set of wheels over the obstacle separately.

WARNING

- High obstacles such as curbing, steps or rough terrain can cause the cot to tip, possibly causing injury to the patient or operator.
 - If the cot is equipped with the optional kickstand, make sure that the kickstand remains in the retracted position and does not engage during transport.
 - Transporting the cot in lower positions reduces the potential of a cot tip. If possible, obtain additional assistance or take an alternate route.
-

Operation Guide

ADJUSTING THE HEIGHT OF THE COT

WARNING

- Grasping the cot improperly can cause injury. Keep hands, fingers and feet away from moving parts. To avoid injury, use extreme caution when placing your hands and feet near the base tubes while raising and lowering the cot.
 - Ensure proper hand placement on hand grips. Hands should be clear of red safety bar pivots while loading and unloading the cot or whenever changing height position of the cot with two or more operators.
-

You can raise or lower an unoccupied cot with one operator. If a patient is on the cot, a minimum of **two (2) trained operators** (one located at each end of the cot) are required to raise or lower the cot.

To raise or lower an unoccupied cot:

1. **Operator 1 (Foot End)** – Grasp the cot frame at the foot end and press either the extend (+) button on the control switch to raise the litter or the retract (-) button on the control switch to lower the litter to the desired position.

To raise or lower the cot with a patient:

1. **Operator 1 (Foot End)** – Grasp the cot frame at the foot end and press either the extend (+) button on the control switch to raise the litter or the retract (-) button on the control switch to lower the litter to the desired position.
2. **Operator 2 (Head End)** – Maintain a firm grip on the outer rail until the cot is securely in the desired position.

Note: If the extend (+) button on the control switch remains activated after reaching the set load height, the motor will remain halted until the operator releases the button. After the button is released, press the extend (+) button again to “jog” the cot height up further.

CAUTION

Do not “jog” the cot past the established cot load height of the product when the safety bar engages the vehicle safety hook or damage may occur to the product.

Operation Guide

LOADING OR UNLOADING THE COT

The cot loading and unloading instructions on [page 38](#) through [page 51](#) are intended for cots that you will NOT use with Power-LOAD. For Model 6506 cots with the Power-LOAD option, see the Power-LOAD Operations/Maintenance Manual for loading and unloading instructions.

LOADING OR UNLOADING THE COT WITH THE POWER-LOAD OPTION

The Model 6506 **Power-PRO™** XT cot is fully compatible with the Model 6390 Power-LOAD system if it is ordered with the Power-LOAD option or compatibility kit (6506-700-001).

For more information about using your Power-LOAD compatible cot, see the Power-LOAD Operations/Maintenance Manual.

WARNING

- Power-LOAD is designed to be compatible with the 6085/6086 Performance-PRO XT, 6500/6506 **Power-PRO™** XT, and 6510/6516 **Power-PRO™** IT cots with the Power-LOAD option only. In certain situations, you can use Power-LOAD as a standard antler for most X-frame cots, but a rail clamp assembly is required for all cots without the Power-LOAD option.
 - It is the responsibility of the cot operator to ensure that the cot being used in the Stryker Model 6390 Power-LOAD system is a Power-LOAD compatible cot. Injury may result if a non-compatible cot is used in the Stryker Model 6390 Power-LOAD system.
-

HIGH SPEED RETRACT/EXTEND

The cot is equipped with a high-speed retract mode to expedite loading/unloading the cot into and out of a vehicle.

- The undercarriage **rapidly** retracts toward the highest position once the weight of the cot and patient is no longer supported by the wheels. Press the retract (–) button to actuate the control switch.
 - The undercarriage **rapidly** extends toward the lowest position once the weight of the cot and patient is no longer supported by the wheels. Press the extend (+) button to actuate the control switch.
-

WARNING

- Whenever the weight of the cot and patient is no longer supported by the wheels, the cot will **automatically** enter the high speed retract mode if the retract (–) button is pressed.
 - After the weight is off of the ground, the operators must support the load of the patient, cot and any accessories. Failure to support the load properly may cause injury to the patient or operator.
-

Operation Guide

LOADING THE COT INTO A VEHICLE WITH TWO OPERATORS - POWERED METHOD

Loading an occupied cot into a vehicle requires a minimum of **two (2) trained operators**. One or two operators can lift from the foot end of the cot. Stryker recommends that both operators are at the foot end to reduce the load on each operator.

WARNING

- Two operators must be present when the cot is occupied.
- Operators must be able to lift the total weight of the patient, cot and any items on the cot.
- The higher an operator must lift the cot, the more difficult it becomes to hold the weight. An operator may need help loading the cot if he/she is too short or if the patient is too heavy to lift safely. The operator must be able to lift the cot high enough for the cot legs to unfold completely and lock when the cot is unloaded. A shorter operator needs to raise their arms higher to enable the undercarriage to unfold.
- Ensure proper hand placement on hand grips. Hands should be clear of red safety bar pivots while loading and unloading the cot or whenever changing height position of the cot with two or more operators.
- There must be a safety hook properly installed in the vehicle so that the bumper does not interfere with the front legs of the base frame.
- Failure to install the safety hook can cause injury to the patient or operator. Install and use the safety hook as described on [page 29](#).

To load the cot into a vehicle with two operators:

1. Ensure that the retractable head section is fully extended and locked.
2. Place the cot in a loading position (any position where the load wheels meet the vehicle floor height).
3. Lift the vehicle bumper to the raised position (if equipped).
4. Roll the cot to the open door of the patient compartment.
5. Push the cot forward until the load wheels are on the compartment floor and the safety bar passes the safety hook as shown in Figure 22.
6. For maximum clearance to lift the base, pull the cot back until the safety bar engages the safety hook.
7. **Operator 2** – Verify that the safety bar engages the safety hook.



Figure 22

Operation Guide

LOADING THE COT INTO A VEHICLE WITH TWO OPERATORS - POWERED METHOD (CONTINUED)

8. Load the cot either from the foot end or with one operator at the foot end and one on the side:

With both operators at the foot end (preferred method):

- **Both Operators** – Grasp the cot frame at the foot end (Figure 23).
- **Operator 1** – Press the retract (-) button until the undercarriage of the cot retracts fully (Figure 24).



Figure 23



Figure 24

With one operator at the foot end and one on the side:

- **Operator 1** – Grasp the cot frame at the foot end and press the retract (-) button (Figure 25) until the undercarriage of the cot retracts fully (Figure 25).



Figure 25



Figure 26

- **Operator 2** – Securely grasp the cot outer rail to stabilize the cot during retraction.

9. **Both Operators** – Push the cot into the patient compartment as shown in Figure 24 or Figure 26 until the cot engages the cot fastener (not included).

WARNING

When using a cot fastener, do not load the cot into the vehicle with the head section retracted. Loading the cot with the head section retracted may cause the product to tip or not engage properly in the cot fastener, possibly causing injury to the patient or operator and/or damage to the cot.

[Return To Table of Contents](#)

Operation Guide

LOADING AN EMPTY COT INTO A VEHICLE WITH ONE OPERATOR - POWERED METHOD

Loading an **unoccupied** cot into the emergency vehicle can be accomplished by a single operator.

WARNING

- The one person loading and unloading procedures are for use only with an empty cot. Do not use the procedures when loading/unloading a patient. Injury to the patient or operator could result.
- Ensure proper hand placement on hand grips. Hands should be clear of red safety bar pivots while loading and unloading the cot or whenever changing height position of the cot with two or more operators.

To load an empty cot into a vehicle with one operator:

1. Place the cot into a loading position (any position where the load wheels of the head section meet the vehicle floor height).
2. Lift the vehicle bumper to the raised position (if equipped).
3. Roll the cot to the open door of the patient compartment.
4. Push the cot forward until the load wheels are on the patient compartment floor (Figure 27) and the safety bar passes the safety hook.
5. For maximum clearance to lift the base, pull the cot back until the safety bar engages the safety hook.
6. Grasp the cot frame at the foot end and press the retract (–) button, until the undercarriage of the cot retracts into its highest position as shown in Figure 28.
7. Push the cot into the patient compartment until the cot engages the cot fastener (not included) as shown in Figure 29.

WARNING

When using a cot fastener, do not load the cot into the vehicle with the head section retracted. Loading the cot with the head section retracted may cause the product to tip or not engage properly in the cot fastener, possibly causing injury to the patient or operator and/or damage to the cot.



Figure 27



Figure 28



Figure 29

Operation Guide

UNLOADING THE COT FROM A VEHICLE WITH TWO OPERATORS - POWERED METHOD

Unloading an occupied cot from a vehicle requires a minimum of **two (2) trained operators**. One or two operators can lift from the foot end of the cot. Stryker recommends that both operators are at the foot end to reduce the load on each operator.

WARNING

- Two operators must be present when the cot is occupied.
- Operators must be able to lift the total weight of the patient, cot and any items on the cot.
- The higher an operator must lift the cot, the more difficult it becomes to hold the weight. An operator may need help loading the cot if he/she is too short or if the patient is too heavy to lift safely. The operator must be able to lift the cot high enough for the cot legs to unfold completely and lock when the cot is unloaded. A shorter operator needs to raise their arms higher to enable the undercarriage to unfold.
- Ensure proper hand placement on hand grips. Hands should be clear of red safety bar pivots while loading and unloading the cot or whenever changing height position of the cot with two or more operators.
- There must be a safety hook properly installed in the vehicle so that the bumper does not interfere with the front legs of the base frame.
- Failure to install the safety hook can cause injury to the patient or operator. Install and use the safety hook as described on [page 29](#).
- To avoid injury, verify that the safety bar has engaged the safety hook before removing the cot from the patient compartment.
- Do not pull or lift on the safety bar when unloading the cot. Damage to the safety bar could result and injury to the patient or operator could occur.
- Do not press the extend (+) button until the safety bar has engaged the safety hook.

To unload the cot from a vehicle with two operators:

1. Lift the vehicle bumper to the raised position (if equipped).
2. Disengage the cot from the cot fastener. (For more information about the cot fastener, see [page 26](#)).
3. Unload the cot either from the foot end or with one operator at the foot end and one on the side:

With both operators at the foot end (preferred method):

- **Both Operators** – Grasp the cot frame at the foot end. Pull the cot out of the patient compartment until the safety bar engages the safety hook as shown in Figure 30.
- **Both Operators** – Verify that the safety bar engages the safety hook.
- **Operator 1** – Depress the extend (+) button to lower the undercarriage to its fully extended position (Figure 31).

Note: You can use the manual release or a combination of the manual release followed by the extend (+) button. If the extend (+) button is used, you must ensure that the manual release is fully engaged before pressing the extend (+) button.



Figure 30



Figure 31

Operation Guide

UNLOADING THE COT FROM A VEHICLE WITH TWO OPERATORS - POWERED METHOD (CONTINUED)

With one operator at the foot end and one on the side (Figure 32):

- **Operator 1** – Grasp the cot frame at the foot end. Pull the cot out of the patient compartment until the safety bar engages the safety hook.
- **Operator 2** – Verify that the safety bar engages the safety hook.
- **Operator 2** – Stabilize the cot during the unloading operation by securely grasping the outer rail.
- **Operator 1** – Depress the extend (+) button to lower the undercarriage to its fully extended position as shown in Figure 33.

Note: You can use the manual release or a combination of the manual release followed by the extend (+) button. If the extend (+) button is used, you must ensure that the manual release is fully engaged before pressing the extend (+) button.



Figure 32



Figure 33

4. **Operator 2** – Pull the safety bar release lever forward to disengage the safety bar from the safety hook in the patient compartment as shown in Figure 34.
5. Remove the load wheels from the patient compartment of the vehicle.

CAUTION

- When unloading the cot from the patient compartment, ensure that the caster wheels are safely set on the ground or damage to the product may occur.
- Do not “jog” the cot past the established cot load height of the product when the safety bar engages the vehicle safety hook or damage may occur to the product.

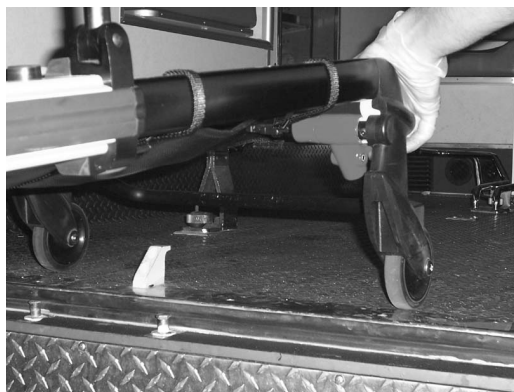

Figure 34

Operation Guide

UNLOADING AN EMPTY COT FROM A VEHICLE WITH ONE OPERATOR - POWERED METHOD

Unloading an **unoccupied** cot from a vehicle can be accomplished by a single operator.

WARNING

- The one person loading and unloading procedures are for use only with an empty cot. Do not use the procedures when loading or unloading a patient. Injury to the patient or operator could result.
- Do not pull or lift on the safety bar when unloading the cot. Damage to the safety bar could result and injury to the patient or operator could occur.
- Ensure proper hand placement on hand grips. Hands should be clear of red safety bar pivots while loading and unloading the cot or whenever changing height position of the cot with two or more operators.

To unload an empty cot from a vehicle with one operator:

1. Lift the vehicle bumper to the raised position (if equipped).
2. Disengage the cot from the cot fastener. (For more information about the cot fastener, see [page 26](#)).
3. Grasp the cot frame at the foot end.
4. Pull the cot from the vehicle until the safety bar engages the safety hook as shown in Figure 35.
5. Depress the extend (+) button to lower the undercarriage to its fully extended position as shown in Figure 36.
6. Disengage the safety bar from the safety hook by pulling the safety bar release lever forward and roll the cot out of the vehicle as shown in Figure 37.
7. Remove the load wheels from the patient compartment of the vehicle.

CAUTION

- When unloading the cot from the patient compartment, ensure that the caster wheels are safely set on the ground or damage to the product may occur.
- Do not “jog” the cot past the established cot load height of the product when the safety bar engages the vehicle safety hook or damage may occur to the product.



Figure 35



Figure 36



Figure 37

Operation Guide

USING THE MANUAL OVERRIDE

In the event of loss of electrical function, the cot is equipped with a manual override to allow manual operation of the product until electrical functionality is restored. You can use the red manual back-up release handle to raise or lower the cot.

The **red** manual back-up release handle (A) is located along the patient left side of the lower lift bar at the foot end of the cot as shown in Figure 38.

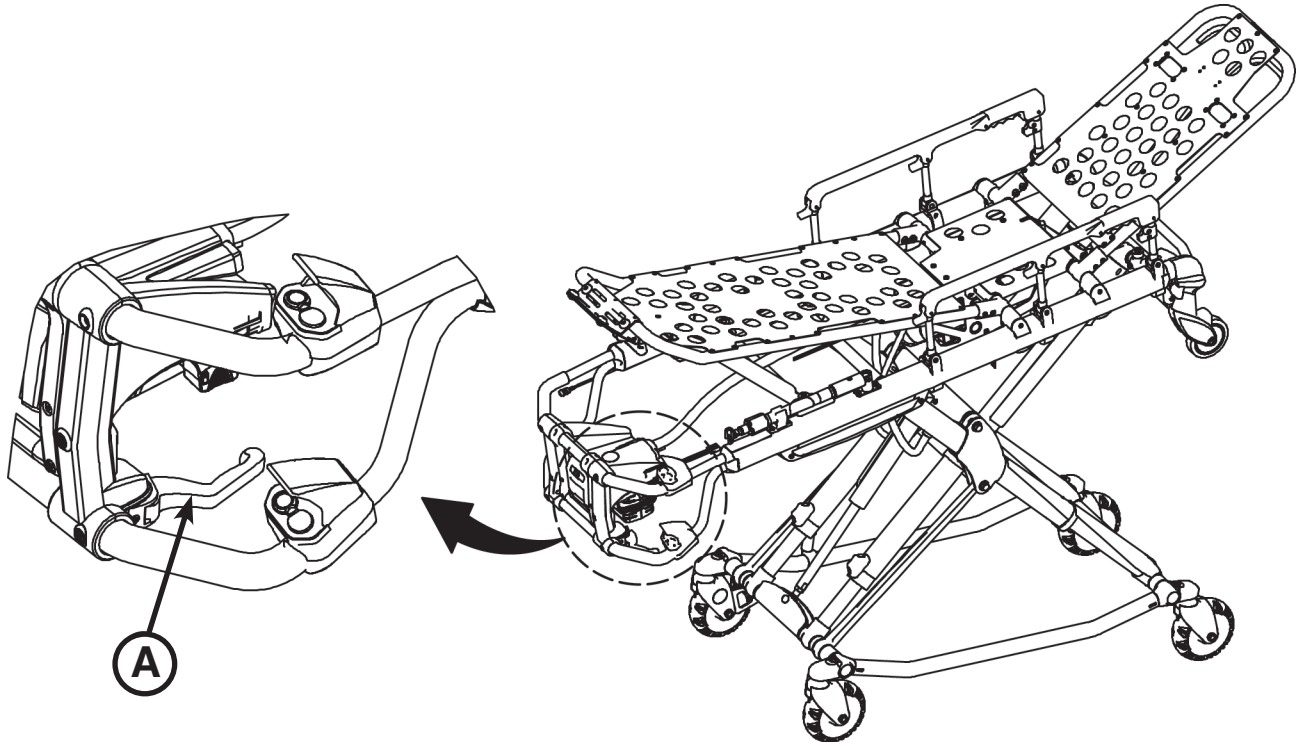

Figure 38

To raise or lower the cot with the manual back-up release handle:

1. **Both Operators** – Lift the cot during the raise/lower operation to support the weight of the cot at each end.
2. **Operator 1 (Foot End)** – Pull the manual back-up release handle toward the lift bar. While the manual back-up release handle is pulled, raise or lower the cot to the desired position and then release the handle to lock the cot into position.

Notes:

- The operators must lift the cot weight slightly off of the wheels to use the manual extend or retract while a patient is on the cot.
- Activation of the manual back-up release handle may cause the cot to lower slowly if less than 50 lb (23 kg) are on the cot.
- Hydraulic fluid will become more viscous when the cot is used for extended periods in cold temperatures. When using the manual back-up release function to extend the base during unloading in cold weather conditions, hold the release handle for approximately one second after the cot wheels touch the ground to minimize sagging of the litter as the cot is removed from the ambulance.

Operation Guide

LOADING THE COT INTO A VEHICLE WITH TWO OPERATORS - MANUAL METHOD

Loading an occupied cot into a vehicle requires a minimum of **two (2) trained operators**. One or two operators can lift from the foot end of the cot. Stryker recommends that both operators are at the foot end to reduce the load on each operator.

WARNING

- Two operators must be present when the cot is occupied.
- Operators must be able to lift the total weight of the patient, cot and any items on the cot.
- The higher an operator must lift the cot, the more difficult it becomes to hold the weight. An operator may need help loading the cot if he/she is too short or if the patient is too heavy to lift safely. The operator must be able to lift the cot high enough for the cot legs to unfold completely and lock when the cot is unloaded. A shorter operator needs to raise their arms higher to enable the undercarriage to unfold.
- Ensure proper hand placement on hand grips. Hands should be clear of red safety bar pivots while loading and unloading the cot or whenever changing height position of the cot with two or more operators.
- There must be a safety hook properly installed in the vehicle so that the bumper does not interfere with the front legs of the base frame.
- Failure to install the safety hook can cause injury to the patient or operator. Install and use the safety hook as described on [page 29](#).

To load the cot into a vehicle with two operators using the manual back-up release handle:

1. Place the cot in a loading position (any position where the load wheels meet the vehicle floor height).
2. Lift the vehicle bumper to the raised position (if equipped).
3. Roll the cot to the open door of the patient compartment.
4. Push the cot forward until the load wheels are on the patient compartment floor and the safety bar passes the safety hook.
5. For maximum clearance to lift the base, pull the cot back until the safety bar engages the safety hook.

Operation Guide

LOADING THE COT INTO A VEHICLE WITH TWO OPERATORS - MANUAL METHOD (CONTINUED)

6. **Operator 2** – Verify that the safety bar engages the safety hook.
7. **Operator 1** – Grasp the cot frame at the foot end. Lift the foot end of the cot until the weight is off of the cot base. Squeeze and hold the release handle as shown in Figure 39.
8. **Operator 2** – Stabilize the cot by placing your hand on the outer rail. Grasp the base frame as shown in Figure 40. After the foot end operator has lifted the cot and squeezed the release handle, raise the undercarriage until it stops in the highest position and hold it there.
9. **Both Operators** – Push the cot into the patient compartment, engaging the cot fastener (not included) as shown in Figure 41.

Note: When operating the manual back-up release handle, avoid rapid lifting or lowering of the base or movement may appear sluggish; lift with a slow constant motion.



Figure 39



Figure 40



Figure 41

Operation Guide

UNLOADING THE COT FROM A VEHICLE WITH TWO OPERATORS - MANUAL METHOD

Unloading an occupied cot from a vehicle requires a minimum of **two (2) trained operators**. One or two operators can lift from the foot end of the cot. Stryker recommends that both operators are at the foot end to reduce the load on each operator.

WARNING

- Two operators must be present when the cot is occupied.
- Operators must be able to lift the total weight of the patient, cot and any items on the cot.
- The higher an operator must lift the cot, the more difficult it becomes to hold the weight. An operator may need help loading the cot if he/she is too short or if the patient is too heavy to lift safely. The operator must be able to lift the cot high enough for the cot legs to unfold completely and lock when the cot is unloaded. A shorter operator needs to raise their arms higher to enable the undercarriage to unfold.
- Ensure proper hand placement on hand grips. Hands should be clear of red safety bar pivots while loading and unloading the cot or whenever changing height position of the cot with two or more operators.
- There must be a safety hook properly installed in the vehicle so that the bumper does not interfere with the front legs of the base frame.
- Failure to install the safety hook can cause injury to the patient or operator. Install and use the safety hook as described on [page 29](#).
- To avoid injury, verify that the safety bar has engaged the safety hook before removing the cot from the patient compartment.
- Do not pull or lift on the safety bar when unloading the cot. Damage to the safety bar could result and injury to the patient or operator could occur.
- Do not press the extend (+) button until the safety bar has engaged the safety hook.

To unload the cot from a vehicle with two operators:

1. Lift the vehicle bumper to the raised position (if equipped).
2. Disengage the cot from the cot fastener. (For more information about the cot fastener, see [page 26](#)).
3. Unload the cot either from the foot end or with one operator at the foot end and one on the side:

With both operators at the foot end (preferred method):

- **Both Operators** – Grasp the cot frame at the foot end as shown in Figure 42.
- **Operator 1** – Pull the manual back-up release handle to lower the undercarriage to its fully extended position (Figure 43). Pull the cot out of the patient compartment until the safety bar engages the safety hook.
- **Operator 2** – Verify that the safety bar engages the safety hook.



Figure 42



Figure 43

Operation Guide

UNLOADING THE COT FROM A VEHICLE WITH TWO OPERATORS - MANUAL METHOD (CONTINUED)

With one operator at the foot end and one on the side (Figure 44):

- **Operator 1** – Grasp the cot frame at the foot end. Pull the manual back-up release handle to lower the undercarriage to its fully extended position (Figure 45). Pull the cot out of the patient compartment until the safety bar engages the safety hook.
- **Operator 2** – Verify that the safety bar engages the safety hook.
- **Operator 2** – Stabilize the cot during the unloading operation by securely grasping the outer rail.



Figure 44



Figure 45

4. **Operator 2** – Pull the safety bar release lever forward to disengage the safety bar from the safety hook in the patient compartment (Figure 46).
5. Remove the load wheels from the patient compartment of the vehicle.

CAUTION

When unloading the cot from the patient compartment, ensure that the caster wheels are safely set on the ground or damage to the product may occur.

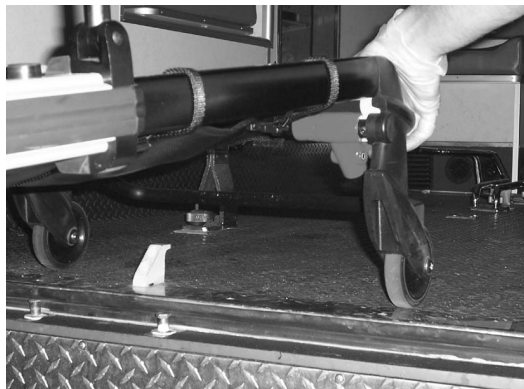

Figure 46

Operation Guide

UNLOADING AN EMPTY COT FROM A VEHICLE WITH ONE OPERATOR - MANUAL METHOD

Unloading an **unoccupied** cot from a vehicle can be accomplished by a single operator.

WARNING

- The one person loading and unloading procedures are for use only with an empty cot. Do not use the procedures when loading or unloading a patient. Injury to the patient or operator could result.
- Do not pull or lift on the safety bar when unloading the cot. Damage to the safety bar could result and injury to the patient or operator could occur.
- Ensure proper hand placement on hand grips. Hands should be clear of red safety bar pivots while loading and unloading the cot or whenever changing height position of the cot with two or more operators.

To unload an empty cot from a vehicle with one operator:

1. Lift the vehicle bumper to the raised position (if equipped).
2. Disengage the cot from the cot fastener. (For more information about the cot fastener, see [page 26](#)).
3. Grasp the cot frame at the foot end.
4. Pull the cot from the vehicle until the safety bar engages the safety hook as shown in Figure 47.
5. Pull the manual back-up release handle to lower the undercarriage to its fully extended position as shown in Figure 48.
6. Disengage the safety bar from the safety hook by pulling the safety bar release lever forward and roll the cot out of the vehicle.
7. Remove the load wheels from the patient compartment of the vehicle.



Figure 47



Figure 48

CAUTION

When unloading the cot from the patient compartment, ensure that the caster wheels are safely set on the ground or damage to the product may occur.

Operation Guide

USING ADDITIONAL ASSISTANCE

	Changing Levels	Rolling	Loading/Unloading
Two Operators Two Helpers			
Two Operators Four Helpers			

Figure 49

⚠ WARNING

Ensure proper hand placement on hand grips. Hands should be clear of red safety bar pivots while loading and unloading the cot or whenever changing height position of the cot with two or more operators.

Operation Guide

OPERATING THE BACKREST

To raise the backrest, as shown in Figure 50, squeeze handle (A) for pneumatic assist in lifting the backrest to the desired height.

To lower the backrest, squeeze handle (A) and push down on the backrest frame until the backrest has reached the desired height.

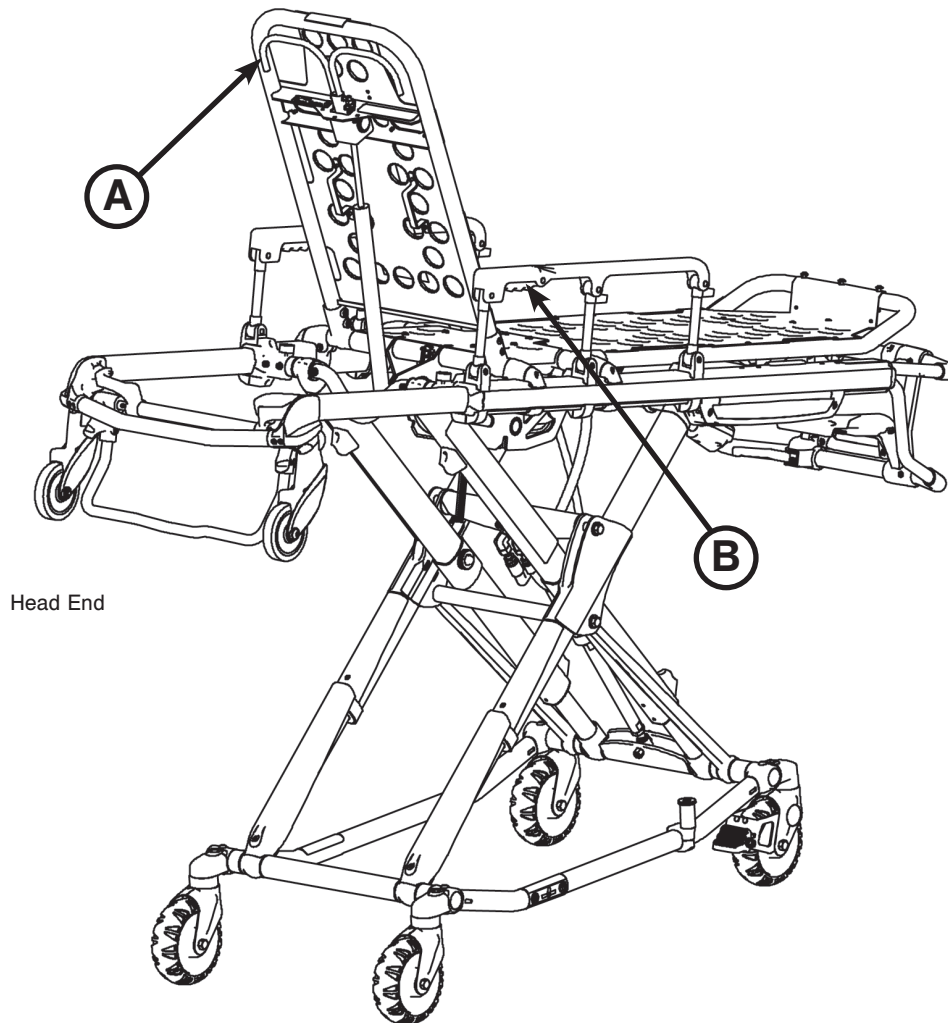

Figure 50

RAISING AND LOWERING THE SIDERAILS (STANDARD)

To raise the siderails, as shown in Figure 50, lift up on the siderail until the latch clicks and the siderail locks into place.

To lower the siderails, squeeze handle (B) to release the siderail latch. Guide the siderail down toward the foot end until flat. Ensure that the siderails are lowered when a patient is being transferred to or from the cot.

WARNING

Siderails are not intended to serve as a patient restraint device. See [page 60](#) for proper restraint strap usage. Failure to use the restraint straps properly could result in patient injury.

[Return To Table of Contents](#)

Operation Guide

RAISING AND LOWERING THE SIDERAILS (XPS OPTION)

WARNING

Siderails are not intended to serve as a patient restraint device. See [page 60](#) for proper restraint strap usage. Failure to use the restraint straps properly could result in patient injury.

You can order your cot with the eXpandable patient surface (XPS) option or upgrade your cot to add the XPS option. Siderails (XPS option) are attached to the cot and are always available for your use. The siderails (XPS option) adjust according to patient size and lock into seven positions. The siderails also adjust to fit through standard doorways or elevators.

To raise the siderails, lift up on the siderail until it locks into the desired position.

To lower the siderails, lift up to relieve the weight, then pull the red lever (A) (Figure 51).

The XPS option is not a primary patient support surface. It includes a wider mattress and is intended to enhance patient comfort.

CAUTION

- Do not use the XPS option with a standard mattress. Use the wider gatch bolster mattress (6500-003-130) with the XPS option.
- Do not sit or stand on the siderails (XPS option).
- Do not use the siderails (XPS option) as a patient transfer device or surface (for example, to slide a patient from the cot to another surface).
- Do not position patients with full weight on the siderails (XPS option).
- Do not use the siderails (XPS option) as a push/pull device or to steer the unit.

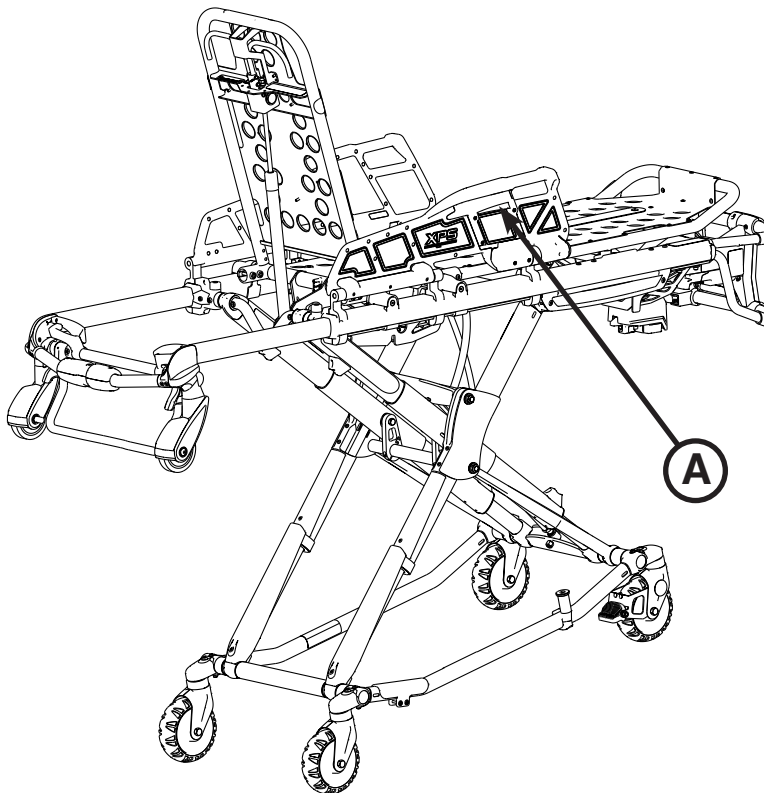

Figure 51

Operation Guide

OPERATING THE RETRACTABLE HEAD SECTION

The head section telescopes from a first position suitable for loading the cot into an emergency vehicle to a second position retracted within the litter frame. When retracted, the cot can roll in any direction on the caster wheels even in the lowest position, allowing for improved mobility and maneuverability.

To extend the head section:

1. Grasp the outer rail with one hand for support and pull the handle (A), rotating the handle toward the head end of the cot to release the head section from the locked position.
2. While holding the handle (A) in the released position, pull the head section away from the litter frame, lengthening the head section until it engages in the fully extended position.
3. Release handle (A) to lock the head section in the extended position.

To retract the head section:

1. Grasp the outer rail with one hand for support and release the handle (A), rotate the handle toward the head end of the cot to release the head section from the locked position.
2. While holding the handle (A) in the released position, push the head section toward the litter frame, retracting the head section until it engages in the retracted position.
3. Release handle (A) to lock the head section in the retracted position.

WARNING

- To avoid injury, always verify that the head section is locked into place prior to operating the cot.
- Do not attempt to load the cot into the patient compartment with the head section retracted. Loading the cot with the head section retracted may cause the product to tip or not engage properly in the cot fastener, possibly causing injury to the patient or operator and/or damage to the product.

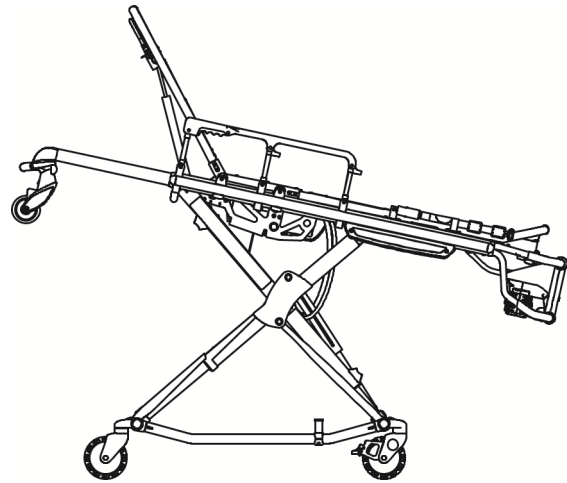

Figure 52

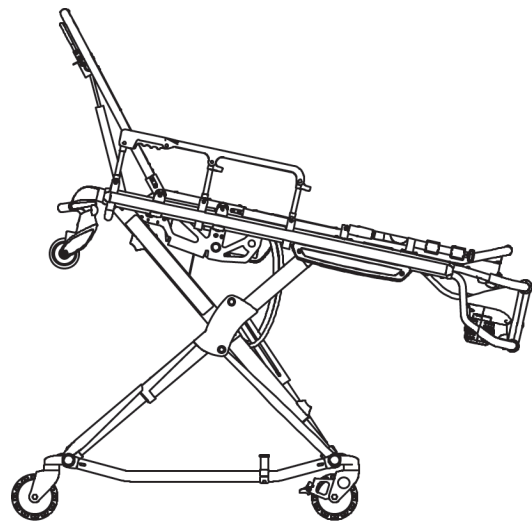

Figure 53

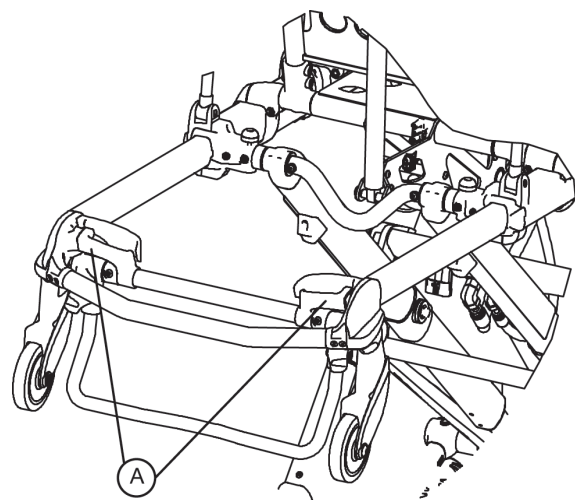

Figure 54

Operation Guide

ADJUSTING THE FOOTREST

The footrest is adjustable to elevate the patient's legs (see Figure 55).

To raise the footrest, lift the footrest frame (A) as high as possible. The support bracket engages automatically when released.

To lower the footrest, lift the footrest frame (A) and while holding the frame, lift up on the release handle (B) until the bracket disengages. Carefully lower the footrest until flat.

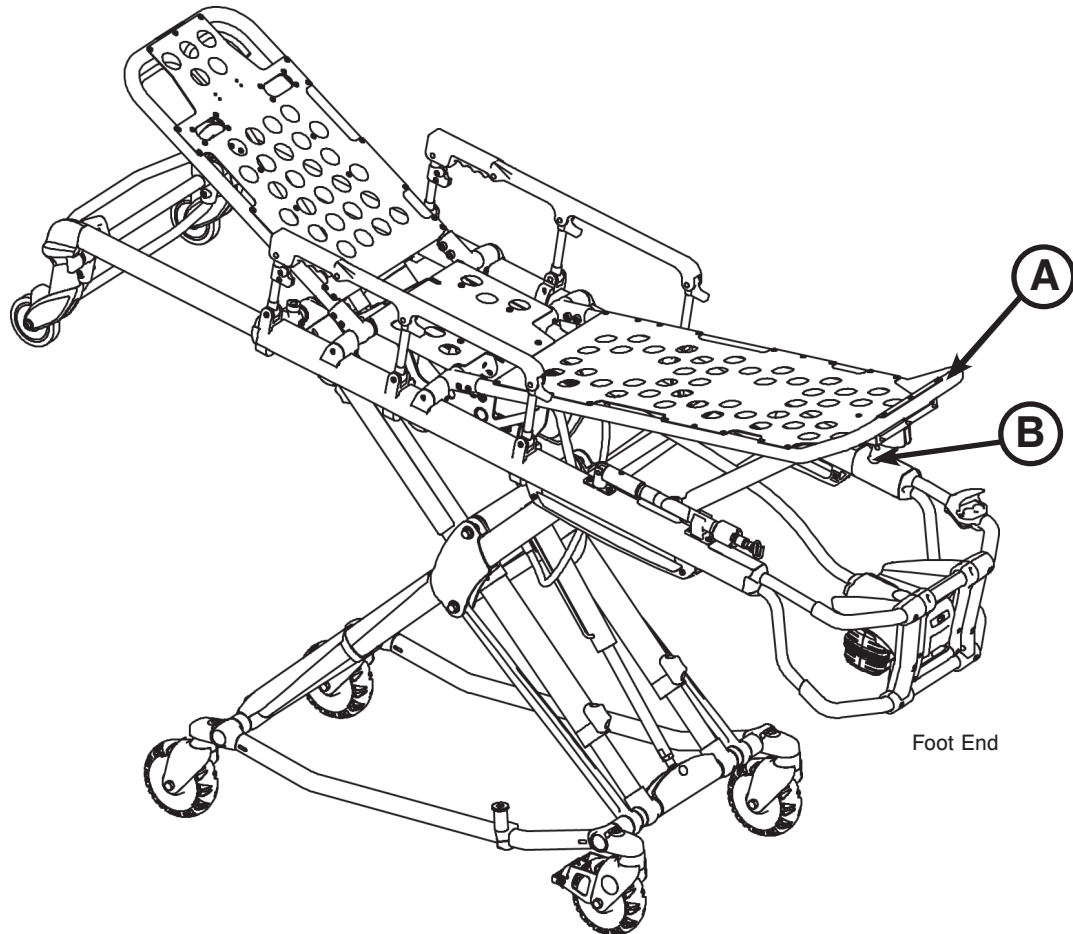

Figure 55

Operation Guide

RAISING AND LOWERING THE OPTIONAL KNEE GATCH

To raise the knee gatch (see Figure 56):

1. Lift either of the red lifting loops (A) until the knee gatch is in its fully raised position.
2. Slowly lower the knee gatch to allow the support bracket to engage in the locking mechanism.
3. Check to be sure the lock is fully engaged before releasing the lifting loop.

To lower the knee gatch:

1. Lift either of the red lifting loops to relieve pressure on the locking mechanism and while holding the loop, push on the red release handle (B) until the bracket disengages.
2. Carefully lower the knee gatch to the flat position.

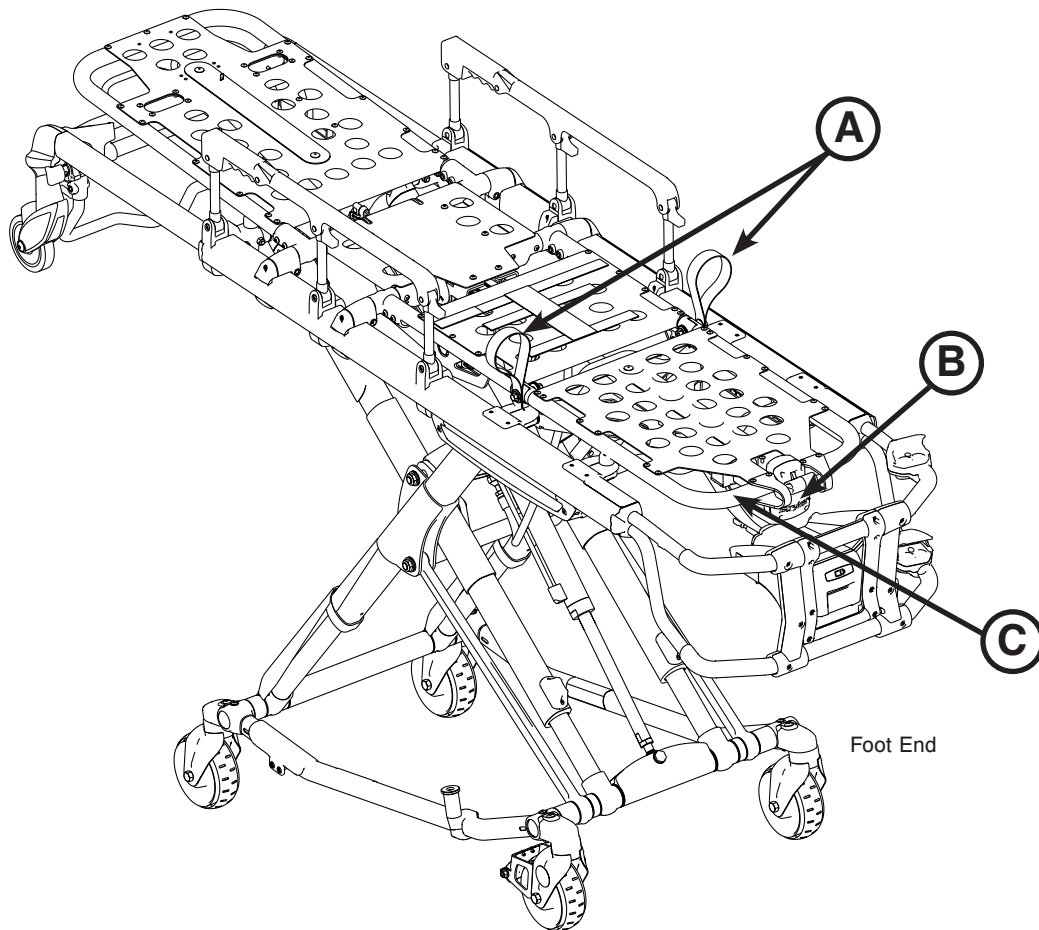

Figure 56

To raise the knee gatch in trend (see Figure 56):

1. Lift the foot rest frame (C) as high as possible until it locks into place.
2. The support bracket engages automatically when released.

To lower the knee gatch in trend:

1. Lift the foot rest frame (C) and, while holding the frame, lift up on the release handle (B) until the bracket disengages.
2. Carefully lower the footrest until it rests flat.

Operation Guide

OPERATING THE OPTIONAL WHEEL LOCKS

To activate the optional wheel locks, press fully down on the pedal (A) as shown in Figure 57 until it stops and is resting firmly against the surface of the wheel.

To release the optional wheel locks, depress the upper face of the pedal with your foot or lift up with your toe under the pedal. The upper portion of the pedal will rest against the caster frame when the wheel lock is released.

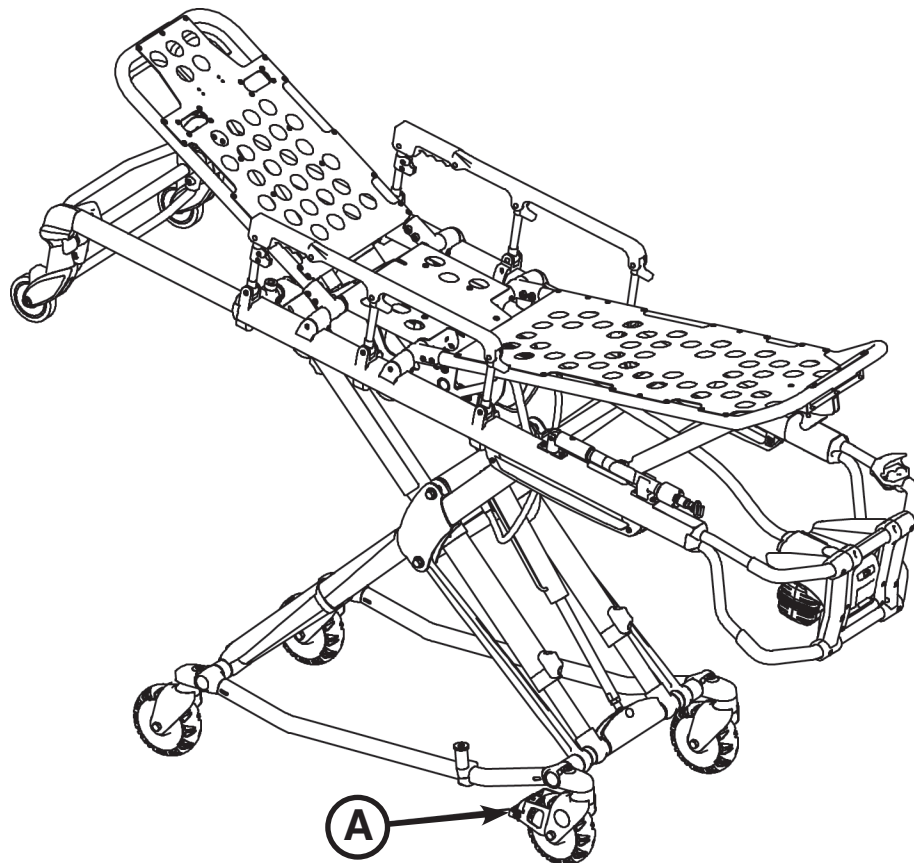

Figure 57

WARNING

- Never apply the optional wheel locks while a patient is on the cot. Tipping could occur if the cot is moved while a wheel lock is applied, resulting in injury to the patient or operator and/or damage to the cot.
- Never leave a patient unattended on the cot or injury could result. Hold the cot securely while a patient is on the cot.
- Never install or use a wheel lock on a cot with excessively worn wheels. Installing or using a wheel lock on a wheel with less than a 6" diameter could compromise the holding ability of the wheel lock, possibly resulting in injury to the patient or operator and/or damage to the cot or other equipment.

CAUTION

Wheel locks are only intended to help prevent the cot from rolling while unattended and to aid in patient transfer. A wheel lock may not provide sufficient resistance on all surfaces or under loads.

[Return To Table of Contents](#)

Operation Guide

OPERATING THE OPTIONAL STEER-LOCK

To activate steer-lock from the cot foot or head end:

- From the cot foot end, press the red (lock) side of the foot pedal as shown in Figure 58 or from the cot head end, press down on either red pedal as shown in Figure 59.
- Rotate the cot until at least one head end caster is locked.



Figure 58



Figure 59

To deactivate steer-lock from the cot foot or head end:

- From the cot foot end, press the green (unlock) side of the foot pedal as shown in Figure 60 or from the cot head end, lift up on either red pedal at the head end as shown in Figure 61.



Figure 60



Figure 61

Operation Guide

USING THE OPTIONAL KICKSTAND FOR DIALYSIS SCALE

The kickstand is intended for weighing patients on a scale.

Note:

- The optional kickstand assembly is configured for an X-frame cot retention system only.
- The optional kickstand (6085-102-000) is not compatible with the optional base storage net (6500-160-000).

WARNING

- Stryker recommends a two person operation when using the kickstand.
- Make sure that the patient weight is centered on the cot before using the kickstand.
- Engage the kickstand with your foot only.
- Lower cot height prior to engaging kickstand for increased stability.
- Make sure that the kickstand remains in the retracted position and does not engage during transport.
- Do not use the kickstand as a brake.
- Do not engage kickstand on a sloped surface.

To use the kickstand:

1. Operator 1 engages the kickstand with their foot as shown in Figure 62.
2. Operator 2 lifts the foot end of the cot at a height sufficient to actuate the kickstand.
3. Both operators must make sure that the kickstand is in the forward locked position as shown in Figure 63.



Figure 62



Figure 63

To release the kickstand:

1. Operator 1 lifts the foot end of the cot until both wheels are off of the floor.
2. Operator 2 rolls the cot slightly forward to make sure that the kickstand retracts on its own as shown in Figure 64.

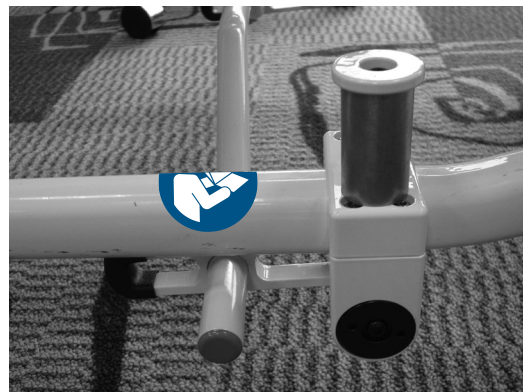

Figure 64

Operation Guide

USING RESTRAINT STRAPS

WARNING

Always use all restraint straps to secure the patient on the cot. An unrestrained patient may fall from the cot and be injured.

Always secure the patient on the cot with all of the restraint straps.

To attach the restraint strap to the cot:

1. Wrap the restraint strap around the cot frame as shown in Figure 65.
2. Push the restraint strap buckle through the loop as shown in Figure 66.
3. Pull the buckle through the loop to secure the restraint strap to the cot as shown in Figure 67.
4. Repeat steps 1-3 until all restraint straps are securely attached to the cot in the required attachment locations as shown in Figure 68.



Figure 65



Figure 66



Figure 67

Buckle the restraints across the patient's chest/shoulders, waist and legs. Note the attachment locations in Figure 68.

Keep the restraint straps buckled (as shown in Figure 68) when the cot is not being used with a patient to avoid damage to the buckles and straps.

Note: Restraint straps are a Type B applied part.



Figure 68

Operation Guide

USING RESTRAINT STRAPS (CONTINUED)

When attaching the restraint straps to the cot, the attachment points should provide both strong anchorage and proper restraint position while not interfering with equipment and accessories.

⚠ WARNING

Do not attach restraints to the base tubes, cross tubes, or fowler skin. Improper restraint attachment could result in damage to the cot further resulting in injury to the patient or operator.

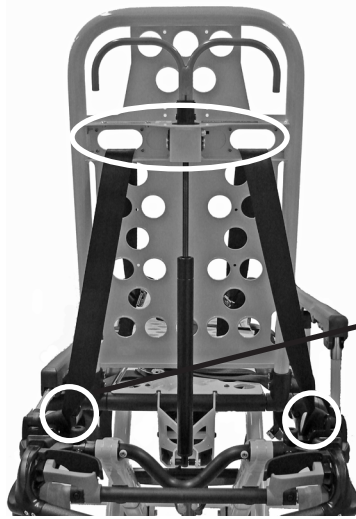

(Back View)

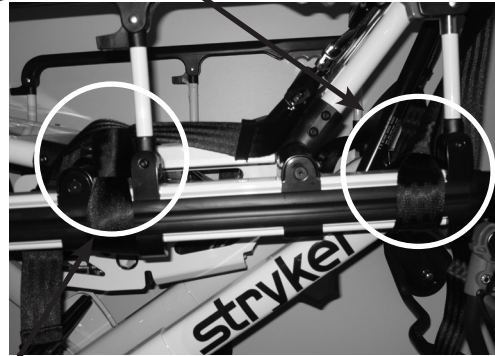

Shoulder/Chest Restraint Straps



Knee Restraint Straps



Foot Restraint Straps

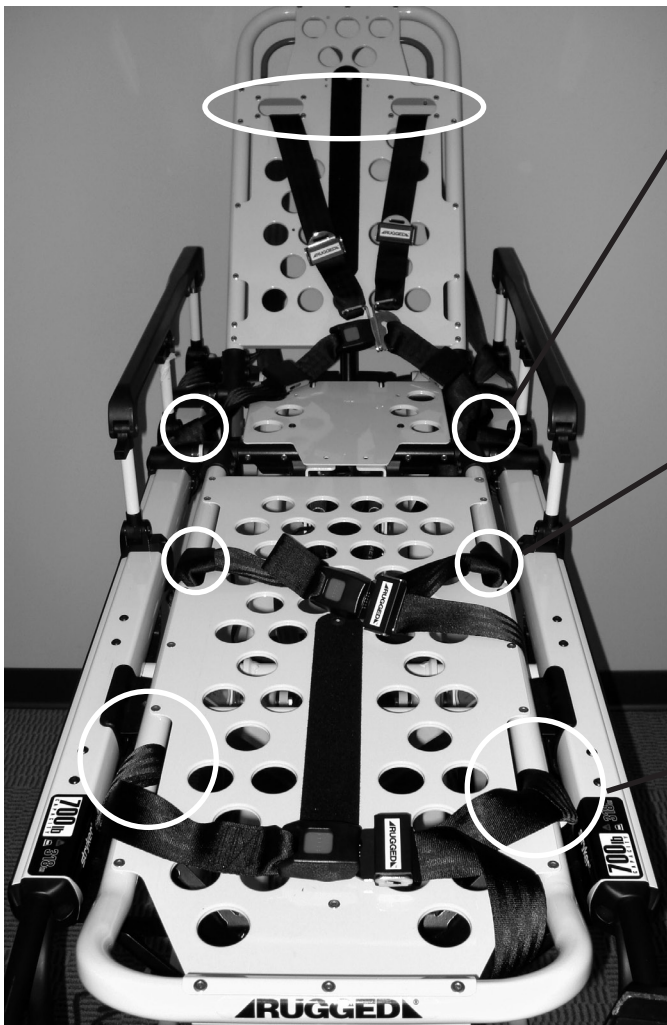

Figure 69

[Return To Table of Contents](#)

Operation Guide

USING X-RESTRAINT STRAPS

WARNING

Always use all restraint straps to secure the patient on the cot. An unrestrained patient may fall from the cot.

To attach the restraint strap at the shoulder, thigh, or ankle:

1. Wrap the restraint strap around the cot frame (Figure A).
2. Push the restraint strap buckle through the loop (Figure B).
3. Pull the buckle through the loop to secure the restraint strap to the cot (Figure C).



Figure A: Wrap strap around cot



Figure B: Push buckle through loop



Figure C: Pull strap to tighten

To attach the restraint strap at the waist:

1. Wrap the restraint strap around the cot frame.
2. Push both buckles through the loop for the double buckle strap (Figure D).
3. Push the buckle and the tongue through the loop for the tongue and buckle strap (Figure E).
4. Pull the buckle through the loop to secure the restraint strap to the cot.



Figure D



Figure E

Note: The restraint strap at the waist must form an X with the restraint strap at the shoulder (Figure F).

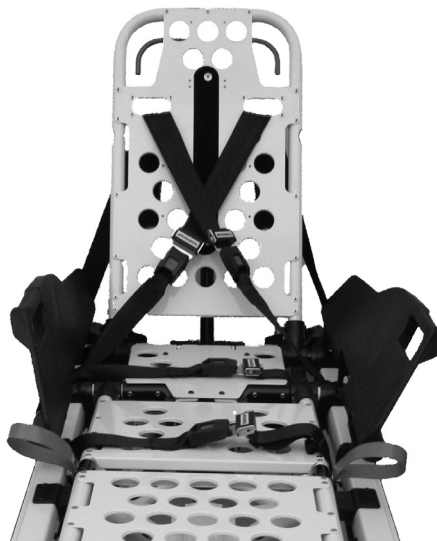

Figure F: Front view



Figure G: Back view

Operation Guide

USING X-RESTRAINT STRAPS (CONTINUED)

Secure restraint straps to the cot in the required attachment locations (Figure H). Restraint strap attachment locations should provide strong anchorage and proper restraint position. Do not allow restraint straps to interfere with equipment or accessories. Buckle the restraints across the patient's shoulders, waist, thighs, and ankles. Buckle restraint straps when the cot is not in use.

WARNING

Do not attach restraint straps to the base tubes or cross tubes.

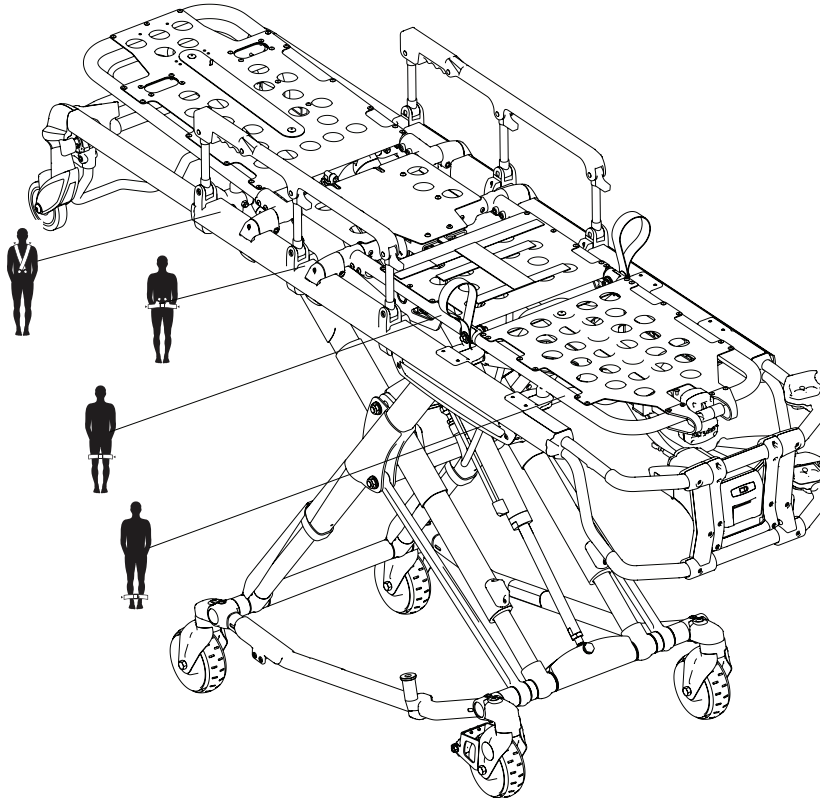

Figure H: Attachment locations

Operation Guide

ADJUSTING RESTRAINT STRAPS

CAUTION

Ensure that the restraints are not entangled in the base frame when raising and lowering the cot.

When the cot is put into service, open the restraints and place them at either side of the cot until the patient is positioned on the cot mattress. Lengthen the restraints, buckle them around the patient and shorten them until the required tightness is achieved.

- **To open the restraint**, press the red button (A) on the front of the buckle “receiver”. This releases the buckle latch plate (B) which can then be pulled out of the receiver (Figure 70).
- **To close the restraint**, push the latch plate into the receiver until a “click” is heard. For G-restraint straps only, ensure that the latch plate passes through both links (C) on the shoulder strap when fastening the chest restraint (Figure 70).
- **To lengthen the restraint**, grasp the buckle latch plate, turn it at an angle to the webbing, then pull it out (Figure 71). A hemmed tab at the end of the webbing prevents the latch plate from coming off of the strap.
- **To shorten the restraint**, grasp the hemmed tab and pull the webbing back through the latch plate until the required tightness is achieved (Figure 72).

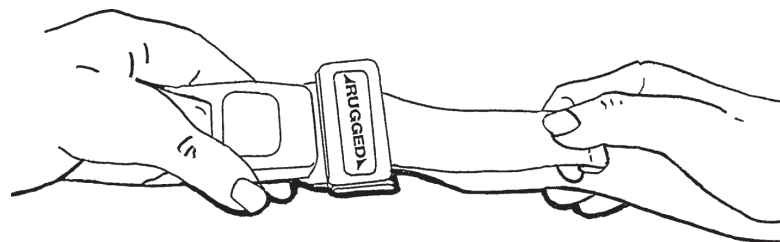
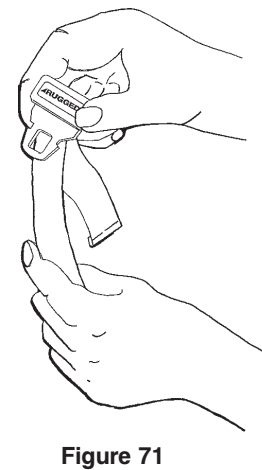
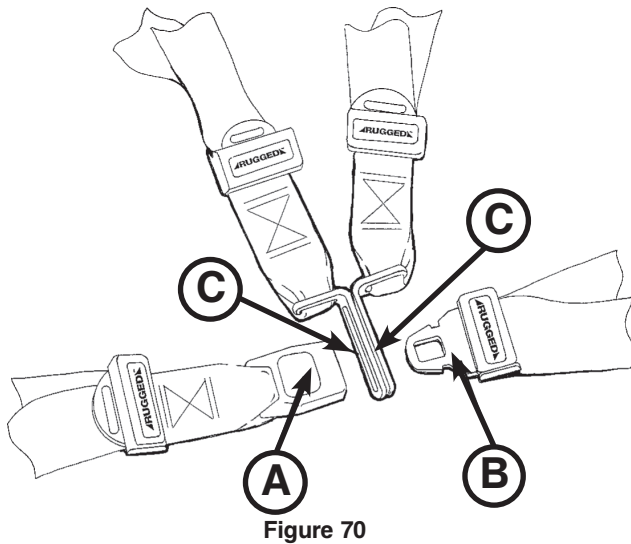

Whenever a restraint is buckled on a patient, verify that the latch plate is fully engaged and any extra webbing is not tangled in the cot or hanging loose.

Inspect the restraints **at least** once a month (more frequently if used heavily). Inspection should include checking for a bent or broken receiver or latch plate, torn or frayed webbing, etc. Any restraint showing wear or not operating properly **must** be replaced immediately.

Operation Guide

USING THE RESTRAINT EXTENDER

Use the restraint extender, as shown in Figure 73, for extra length when buckling the lap belt around large patients.

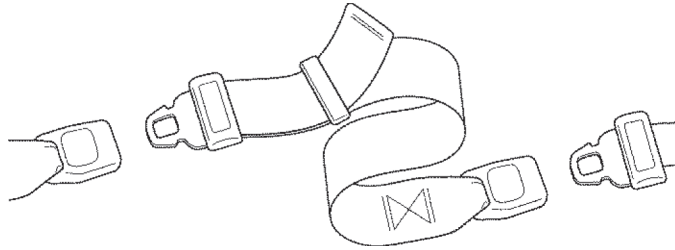

Figure 73

Operation Guide

ATTACHING THE PEDI-MATE® INFANT RESTRAINT SYSTEM

See the Pedi-Mate® users manual for the manufacturer's recommendations for the use, operation and care of the Pedi-Mate® Infant Restraint System.



Note: The Pedi-Mate® Infant Restraint System is a Type B applied part.

To secure the Pedi-Mate® to the cot:

1. Remove any restraints that are already attached to the cot.
2. Raise the cot backrest to the full upright position.
3. Position the Pedi-Mate® pad flat on the backrest with the black backrest straps out (see Figure 74).



Figure 74

4. Wrap the straps around the backrest and insert the ends of the straps through the brackets. Securely fasten the buckle (see Figure 75).

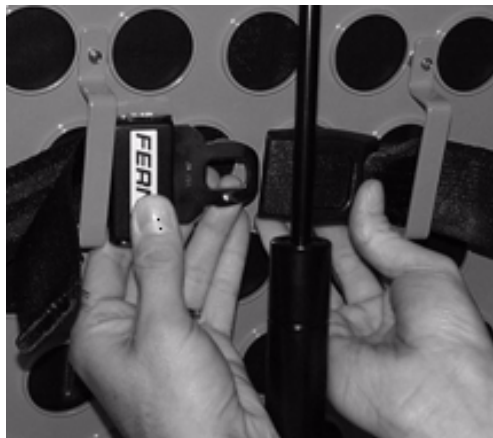

Figure 75

WARNING

To avoid accidental release of the Pedi-Mate®, and possible injury to the infant, ensure that the buckle is located away from obstructions on the cot or accessories.

[Return To Table of Contents](#)

Operation Guide

ATTACHING THE PEDI-MATE® INFANT RESTRAINT SYSTEM (CONTINUED)

5. Pull firmly on the end of the adjustable backrest strap and tighten it securely.
6. Insert the mainframe straps between the cot frame and the mattress. To ensure that the release button is located toward the foot end of the cot, insert the buckle behind the litter cross brace and bring it up in front of the cross brace. Secure the buckle around the cross brace, leaving a little slack in the strap for final adjustment (see Figure 76).



Figure 76

WARNING

To avoid accidental release of the Pedi-Mate®, and possible injury to the infant, ensure that the buckle is located away from obstructions on the cot or accessories.

7. Verify that all of the straps are snug and fastened securely (see Figure 77).



Figure 77

Note: These are general instructions for installation of the Pedi-Mate®. Safe and proper use of the Pedi-Mate® is solely at the discretion of the user. Stryker recommends that all users be trained on the proper use of the Pedi-Mate® before using it in an actual situation. Retain these instructions for future reference. Include them with the product in the event of transfer to new users.

Pedi-Mate® is a registered trademark of Ferno-Washington, Inc.

[Return To Table of Contents](#)

Operation Guide

REMOVING AND REPLACING A SMRT™ PAK

The cot is supplied with two removable 24V **SMRT™** Paks as the power source.

See the **SMRT™** Power System Operations/Maintenance Manual for additional **SMRT™** Pak and **SMRT™** Charger information.

WARNING

- To avoid risk of electric shock, never attempt to open the battery pack for any reason. If the battery pack case is cracked or damaged, do not insert it into the charger. Return damaged battery packs to a service center for recycling.
- Do not remove the battery when the cot is activated.
- Avoid direct contact with a wet battery or battery enclosure. Contact may cause injury to the patient or operator.

To remove the **SMRT™** Pak:

1. Press the red one hand release button (C) or press the battery release button (A) to release the **SMRT™** Pak (B) from the cot as shown in Figure 78.
2. Slide the released **SMRT™** Pak out of the enclosure.

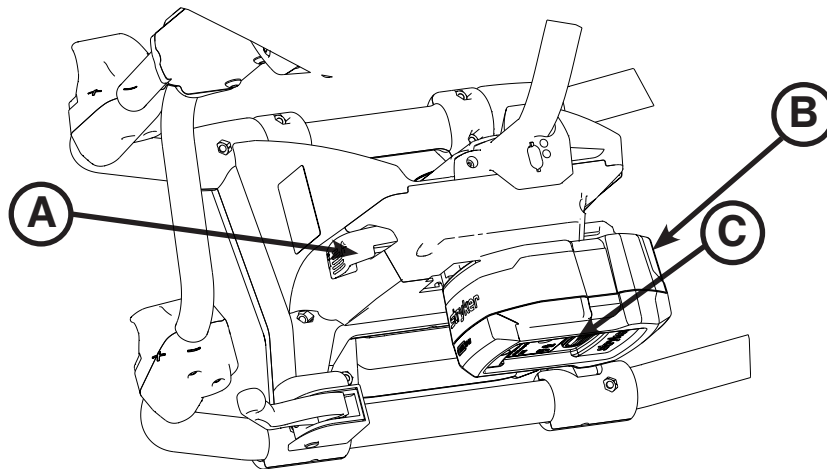

Figure 78

To reinstall or replace the **SMRT™** Pak:

1. Align the tabs in the battery enclosure.
2. Push the **SMRT™** Pak into the enclosure until the latch clicks into place.
 - The cot power indicator LED is solid green if the **SMRT™** Pak is charged and ready.
 - The cot power indicator LED flashes amber if the **SMRT™** Pak needs to be recharged or replaced.

Note: Batteries slowly lose power when not on the charger.

CAUTION

Remove the battery if the cot is not going to be used for an extended period of time (more than 24 hours).

Operation Guide

USING THE DEFIBRILLATOR PLATFORM

To install the defibrillator platform:

1. Place the defibrillator platform in the stored position as shown in Figure 79.
2. Open and expand the defibrillator platform legs as shown in Figure 80.

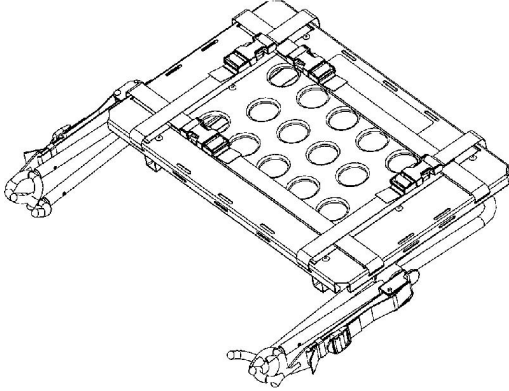

Figure 79

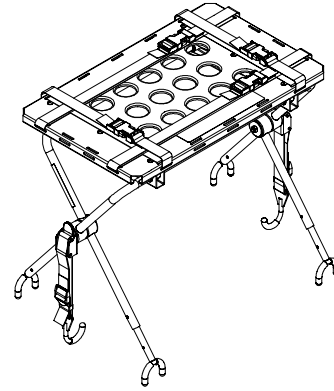

Figure 80

3. If the cot is equipped with an I.V. pole, raise the I.V. pole (A) to the up position as shown in Figure 81.
4. Place the defibrillator platform on the cot frame as shown in Figure 81. Position the inside legs (B) of the defibrillator platform toward the head end of the cot to properly fit the defibrillator platform on the cot frame.

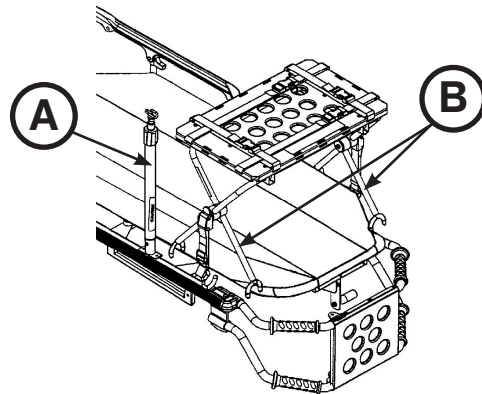

Figure 81

Operation Guide

USING THE DEFIBRILLATOR PLATFORM (CONTINUED)

- Place the latch hook (C) under the cot litter frame or foot end fastener and push the tab (D) up until it locks into place with an audible click as shown in Figure 82. Repeat on the other side of the defibrillator platform.

Notes:

- For Power-LOAD compatible cots, you must lengthen and attach the straps to the foot end fastener as indicated in Figure 83.
- If the defibrillator platform is not securely attached to the cot when both latch hooks are engaged or if you cannot secure the latch hooks around the cot litter frame, unlatch the tab (E), loosen or tighten the strap (F) until the proper adjustment is achieved, and then push the tab (E) up until it locks into place with an audible click (Figure 84).

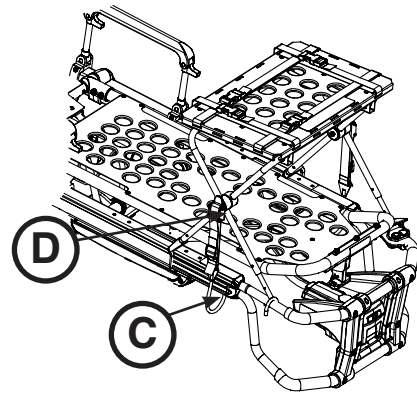

Figure 82

WARNING

To avoid the risk of patient injury or equipment damage, ensure that you properly mount and secure the defibrillator platform to the cot.

- Ensure that the defibrillator platform is properly secured to the cot.
- Place the defibrillator on the defibrillator platform and secure the straps.

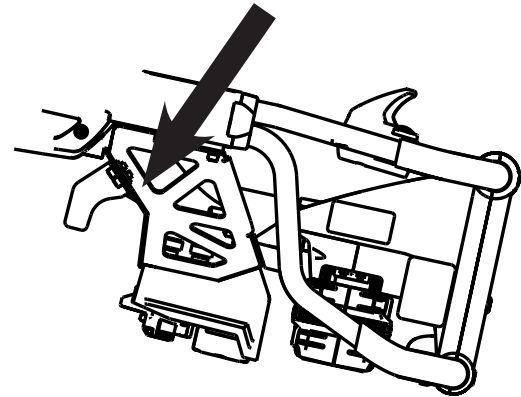

Figure 83

WARNING

- To avoid the risk of patient injury or equipment damage, you must use the provided straps to secure the defibrillator to the defibrillator platform.
- Due to the difference in sizes and shapes of available defibrillators, you may have to change the location and adjustment of the straps that secure the defibrillator to the defibrillator platform. To avoid the risk of patient injury or equipment damage, use and adjust all straps properly to ensure the security of the defibrillator.
- To avoid the risk of patient injury or equipment damage, the weight placed on the defibrillator platform must not exceed 30 lb (13.6 kg).

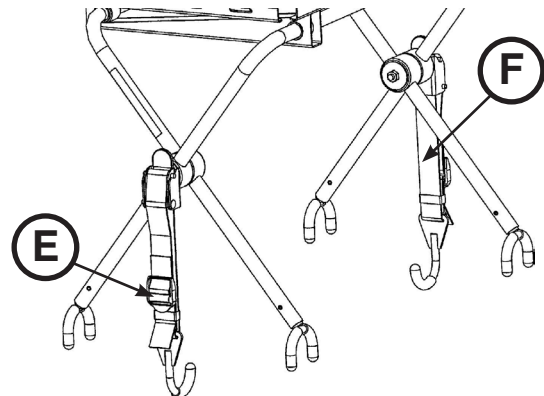

Figure 84

Operation Guide

USING THE EQUIPMENT HOOK

Use the equipment hook (A) (see Figure 85) to hang additional accessories or equipment, such as defibrillators or monitors.

CAUTION

To avoid damage to the equipment hook, the weight of the accessories or equipment must not exceed 35 lb (15.8 kg).

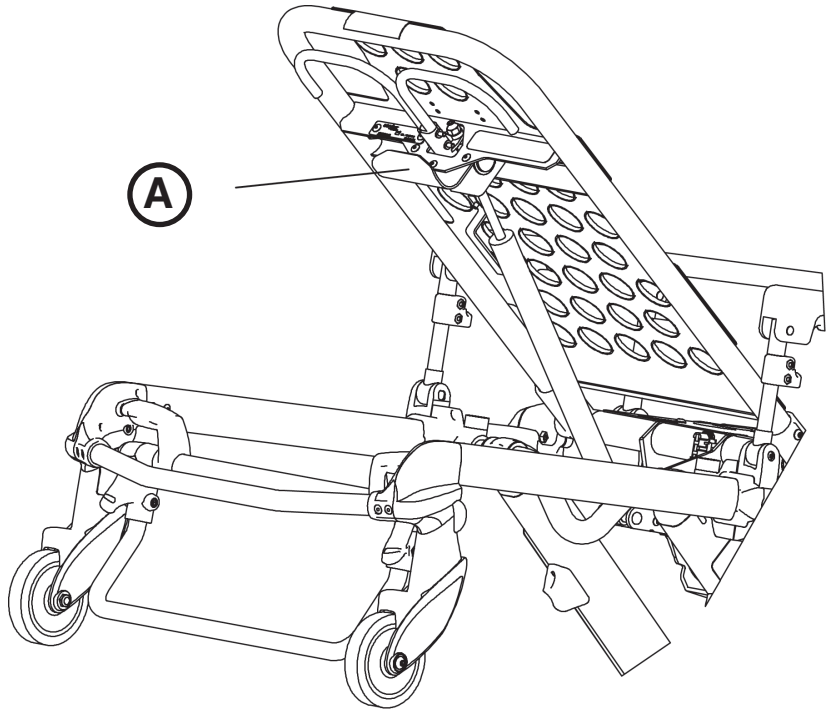

Figure 85

USING THE HEAD EXTENSION WITH PILLOW

You can install the head extension assembly over the fowler to provide head end support.

Attach the pillow to the head extension by placing the support into the flap on the bottom of the pillow. Secure the pillow to the Velcro® on the bottom of the support.

Note: The head extension with pillow (6100-044-000) is not compatible with the optional equipment hook (6500-147-000) or optional fowler oxygen bottle holder (6500-241-000).

Note: The head extension pillow is a Type B applied part.

Operation Guide

OPERATING THE OPTIONAL TWO-STAGE I.V. POLE

To use the two-stage I.V. pole (see Figure 87):

1. Lift and pivot the pole from the storage position and push down until it is locked into the receptacle (A).
2. To raise the height of the pole, turn the lock actuator (B) counterclockwise and pull up on the telescoping portion (C) of the pole to raise it to the desired height.
3. Turn the lock actuator (B) clockwise to lock the telescoping portion in place.
4. Hang the I.V. bags on the I.V. hook (D).
5. Turn the lock actuator (B) counterclockwise and slide section (C) into the bottom tube.
6. Turn the lock actuator (B) clockwise to tighten.
7. Lift up and pivot the pole down into the storage position (see Figure 86).

CAUTION

To avoid damage to the I.V. pole, the weight of the I.V. bags or equipment must not exceed 25 lb (11.3 kg).

Note: The dual two-stage I.V. poles (6500-312-000) are not compatible with either the patient right (6500-310-000) or patient left (6500-311-000) two-stage I.V. pole options.

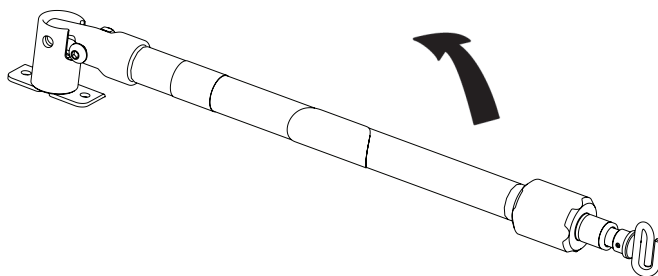

Figure 86

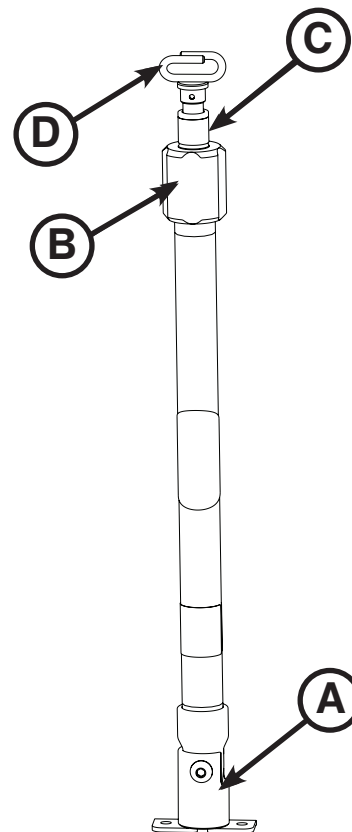

Figure 87

Operation Guide

OPERATING THE OPTIONAL THREE-STAGE I.V. POLE

To use the three-stage I.V. pole (see Figure 89):

1. Lift and pivot the pole from the storage position and push down until it is locked into the receptacle (A).
2. To raise the height of the pole, turn the lock actuator (B) counterclockwise and pull up on the bottom telescoping portion (C) of the pole to raise it to the desired height.
3. Turn the lock actuator (B) clockwise to lock the bottom telescoping portion in place.
4. For a higher I.V. pole, pull up on section (D) until the spring clip (E) engages.
5. Hang I.V. bags on the I.V. hook (F).
6. To lower the I.V. pole, push in on the spring clip (E) and slide section (D) down into section (C). Turn the lock actuator (B) counterclockwise and slide section (C) into the bottom tube.
7. Turn the lock actuator (B) clockwise to tighten.
8. Lift up and pivot the pole down into the storage position (Figure 88).

CAUTION

To avoid damage to the I.V. pole, the weight of the I.V. bags or equipment must not exceed 25 lb (11.3 kg).

Note: The dual three-stage I.V. poles (6500-317-000) are not compatible with either the patient right (6500-315-000) or patient left (6500-316-000) two-stage I.V. pole options.

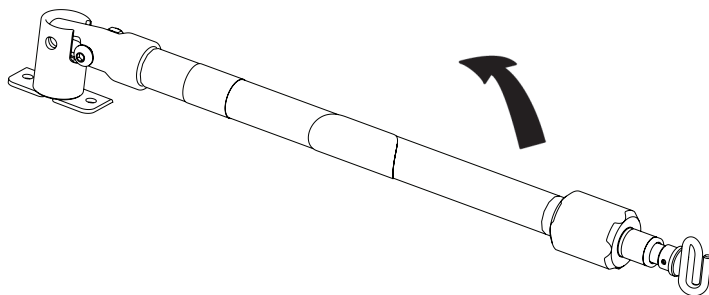

Figure 88

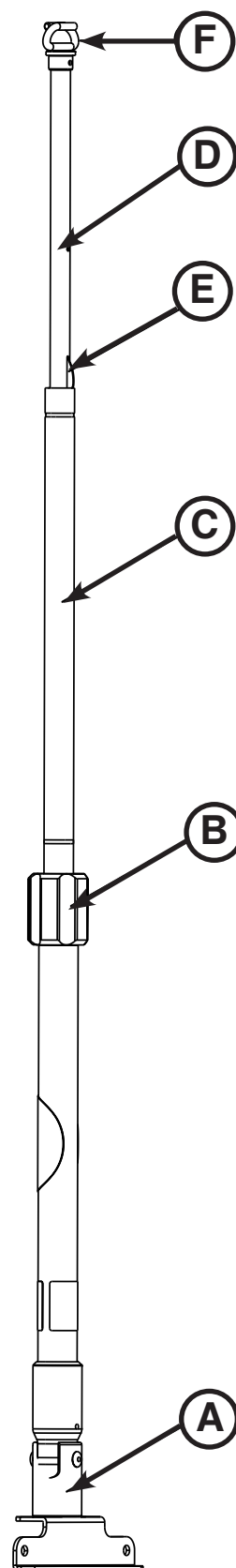

Figure 89

Operation Guide

ATTACHING AN OXYGEN BOTTLE TO AN OXYGEN BOTTLE HOLDER

To attach an oxygen bottle:

1. Place an oxygen bottle in the holder.
2. Insert the lower strap through the buckle and affix the strap onto itself to secure the oxygen bottle to the holder.

Note: Inspect the straps and clips for wear between use and replace the strap if it is no longer holding the oxygen bottle.

 **CAUTION**

- To avoid damage to the oxygen bottle holder (if equipped), the weight of the equipment must not exceed 15 lb (6.8 kg).
- Do not use two head end oxygen bottle holders at the same time.

Note: The optional fowler oxygen bottle holder (6500-241-000) is not compatible with the optional retractable head section oxygen bottle holder (6085-046-000).

Operation Guide

USING THE RETRACTABLE HEAD SECTION OXYGEN BOTTLE HOLDER

To attach an oxygen bottle to the retractable head section oxygen bottle holder:

1. Center the oxygen bottle on the cradled surface of item (A) as shown in Figure 90.
2. Tighten both straps (B) around the oxygen bottle.
3. Secure the slack on the straps to the Velcro® on the straps.

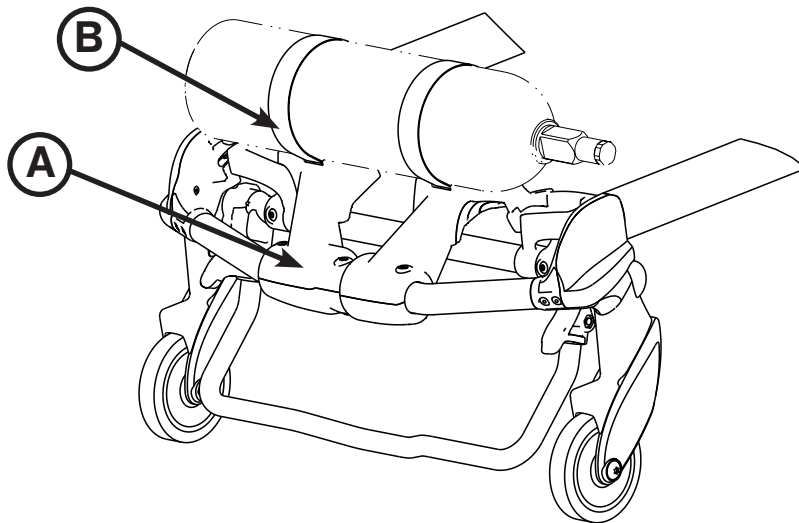

Figure 90

Note: Inspect the straps and clips for wear between use and replace the strap if it is no longer holding the oxygen bottle.

⚠ WARNING

If the cot is equipped with the optional retractable head section oxygen bottle holder, use caution while the oxygen bottle holder is installed to avoid pinching your fingers between the fowler bracket and the oxygen bottle.

⚠ CAUTION

- To avoid damage to the oxygen bottle holder (if equipped), the weight of the equipment must not exceed 15 lb (6.8 kg).
 - Do not use two head end oxygen bottle holders at the same time.
-

Operation Guide

INSTALLING THE BASE STORAGE NET

To install the base storage net, wrap the Velcro® straps around the base tubes.

CAUTION

- The weight of the equipment in the base storage net (if equipped) must not exceed 20 lb (9 kg).
 - Be careful when retracting the base to avoid damaging items stored in the base storage net.
-

Note: The optional kickstand (6085-102-000) is not compatible with the optional base storage net (6500-160-000).



Operation Guide

INSTALLING THE BACKREST STORAGE POUCH

Install the optional backrest storage pouch using the Velcro® straps as shown in Figure 91. Insert each strap through a hole in the backrest skin and mount the pouch flat against the backrest.

CAUTION

- Do not store items under the cot mattress. Storing items under the mattress can interfere with the operation of the cot.
 - The weight of the equipment in the pocketed backrest storage pouch (if equipped) must not exceed 20 lb (9 kg).
-

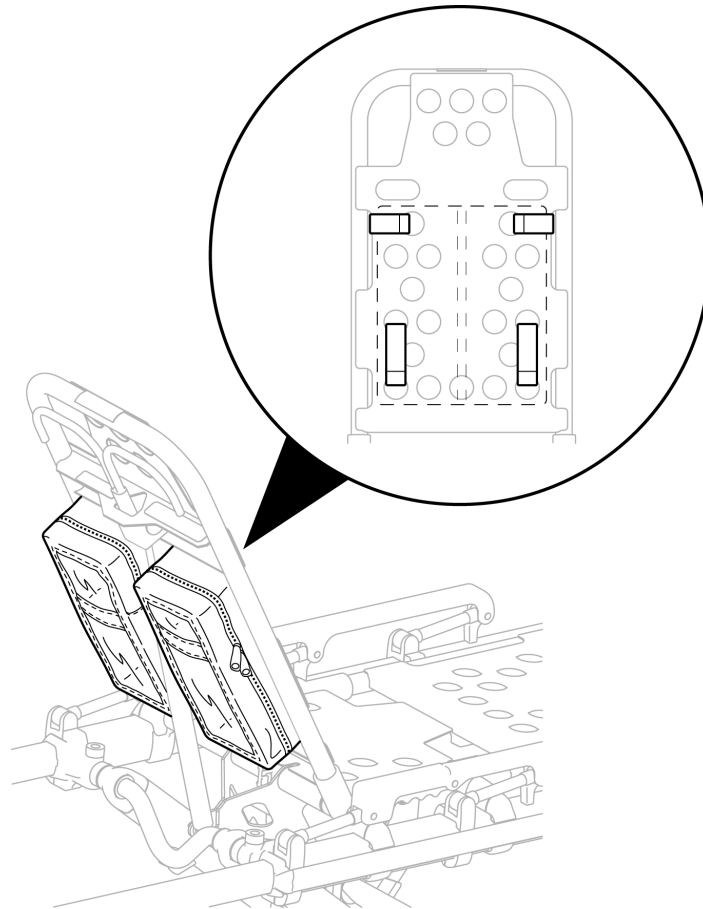

Figure 91

Operation Guide

INSTALLING THE HEAD END STORAGE FLAT

WARNING

When the optional head end storage flat is being used, ensure that it does not interfere with the operation of the retractable head section, safety bar and safety hook. Injury to the patient or operator could result.

To install the optional head end storage flat (see Figure 92):

1. Install the Velcro® straps (A) near the pneumatic cylinder and around the cross bar of the retractable head section.
2. Buckle the restraint straps (B) around the outer rails of the retractable head section.

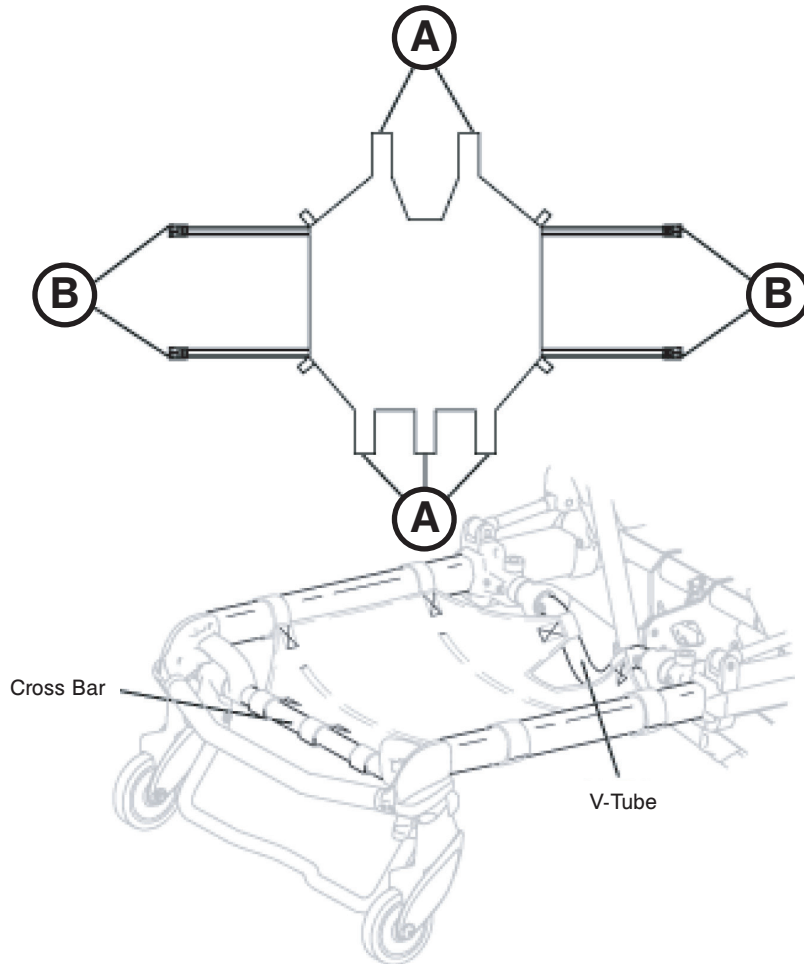

Figure 92

CAUTION

The weight of the equipment in the head end storage flat (if equipped) must not exceed 40 lb (18 kg).

USING THE TRANSFER FLAT

When transferring larger patients, use of the Transfer Flat (6005-001-001) is recommended.

Operation Guide

ATTACHING THE MATTRESS

Use the standard gatch bolster mattress (6500-002-150/6506-002-150) with the standard siderail. Use the wider gatch bolster mattress (6500-003-130) with the optional eXpandable patient system (XPS).

To attach the mattress to the cot:

1. Align the Velcro® on the back of the mattress with the Velcro® on the cot litter.
2. Attach the strap at the foot end of the mattress through the two holes in the foot end skin on the cot litter.
3. Pull the strap through the buckle and attach the Velcro® to secure the strap.

Note: The optional gatch bolster mattress for XPS (6500-003-130) is not compatible with the standard siderail (6506-031-000).

Note: The mattress is a Type B applied part.

CAUTION

Do not store items under the cot mattress. Storing items under the mattress can interfere with the operation of the cot.

Cleaning

The **Power-PRO™** XT cot is designed to be power washable. The unit may show some signs of oxidation or discoloration from continuous washing, however, no degradation of the cot's performance characteristics or functionality will occur due to power washing as long as the proper procedures are followed.

Thoroughly clean the cot once a month. Clean Velcro® **AFTER EACH USE**. Saturate Velcro® with disinfectant and allow disinfectant to evaporate. Appropriate disinfectant for nylon Velcro® should be determined by the service.

WASHING PROCEDURE

- **Always remove the battery!** Never wash the cot with the battery installed.
- Follow the cleaning solution manufacturer's dilution recommendations exactly.
- The preferred method Stryker Medical recommends for power washing the cot is with the standard hospital surgical cart washer or hand held wand unit.

WASHING LIMITATIONS

WARNING

When cleaning, use any appropriate personal safety equipment (goggles, respirator, etc.) to avoid the risk of inhaling contagion. Use of power washing equipment can aerate contamination collected during the use of the cot.

CAUTION

- **DO NOT STEAM CLEAN OR ULTRASONICALLY CLEAN THE UNIT.**
 - Maximum water temperature should not exceed 180°F/82°C.
 - Maximum water pressure should not exceed 1500 psi/130.5 bar. If a hand held wand is being used to wash the unit, the pressure nozzle must be kept a minimum of 24 inches (61 cm) from the unit.
 - Allow cot to air dry.
 - Towel dry all casters and interface points.
 - Failure to comply with these instructions may invalidate any/all warranties.
 - Always remove the battery before washing the cot.
-

Cleaning

In general, when used in those concentrations recommended by the manufacturer, either phenolic type or quaternary (**excluding Virex® TB**) type disinfectants can be used. Iodophor type disinfectants are not recommended for use because staining may result.

Suggested cleaners for the cot surfaces and restraint straps:

- Quaternary Cleaners (active ingredient - ammonium chloride)
- Phenolic Cleaners (active ingredient - o-phenylphenol)
- Chlorinated Bleach Solution (5.25% - less than 1 part bleach to 100 parts water)

Note: Do not immerse the restraint strap metal buckle components in water. Rinse with clean water. Allow to air dry.

Avoid over saturation and ensure that the product does not stay wet longer than the chemical manufacturer's guidelines for proper disinfecting.

WARNING

SOME CLEANING PRODUCTS ARE CORROSIVE IN NATURE AND MAY CAUSE DAMAGE TO THE PRODUCT IF USED IMPROPERLY. If the products described above are used to clean Stryker EMS equipment, measures must be taken to ensure the cots are wiped with clean water and thoroughly dried following cleaning. Failure to properly rinse and dry the cots will leave a corrosive residue on the surface of the cots, possibly causing premature corrosion of critical components.

Note: Failure to follow the above directions when using these types of cleaners may void this product's warranty (see [page 118](#)).

REMOVAL OF IODINE COMPOUNDS

Use a solution of 1/2 Tablespoon Sodium Thiosulfate in a pint of warm water to clean the stained area. Clean as soon as possible after staining occurs. If stains are not immediately removed, allow solution to soak or stand on the surface. Rinse surfaces which have been exposed to the solution in clear water before returning unit to service.

WARNING

Failure to properly clean or dispose of contaminated mattress or cot components will increase the risk of exposure to bloodborne pathogens and may cause injury to the patient or the operator.

Preventive Maintenance

A preventive maintenance program should be established for all Stryker Medical equipment. Preventive maintenance may need to be performed more frequently based on the usage level of the product. The cot requires regular maintenance. Establish and follow a maintenance schedule and keep records of maintenance activity (see [page 86](#) for a form).

CAUTION

A preventive maintenance program should be established for all Stryker EMS equipment. Preventive maintenance may need to be performed more frequently based on the usage level of the product. Close attention should be given to safety features including, but not limited to:

- Hydraulic power mechanism
- All electrical controls return to off or neutral position when released

For additional maintenance information, see the preventive maintenance information on [page 86](#).

WARNING

- Do not modify the cot or any components of the cot. Modifying the product can cause unpredictable operation resulting in injury to the patient or operator. Modifying the product will also void its warranty (see [page 118](#)).
 - Escaping fluid under pressure can penetrate the skin causing serious injury. Avoid the hazard by relieving pressure before disconnecting hydraulic or other lines. Tighten all connections before applying pressure. If an accident occurs, see a doctor immediately. Any fluid injected into the skin must be surgically removed within a few hours or gangrene may result. Doctors unfamiliar with this type of injury should reference a knowledgeable medical source.
 - To avoid the risk of injury, do not use bare hands to check for hydraulic leaks.
-

When using maintenance products, follow the directions of the manufacturer and reference all material safety data sheets.

CAUTION

- Improper maintenance can cause injury or damage to the product. Maintain the cot as described in this manual. Use only Stryker approved parts and maintenance procedures. Using unapproved parts and procedures could cause unpredictable operation and/or injury and will void the product warranty (see [page 118](#)).
 - Failure to use authorized parts, lubricants, etc. could cause damage to the cot and will void the warranty of the product.
 - Hydraulic lines, hoses, and connections can fail or loosen due to physical damage, kinks, age, and environment exposure. Check hoses and lines regularly to avoid damage to the cot. Check and tighten loose connections.
 - Do not tip the cot onto its load wheels and actuate the product as this will allow air to enter the hydraulic system.
-

LUBRICATION

The cot has been designed to operate without the need for lubrication.

CAUTION

Do not lubricate the bearings in the X-frame as it will degrade the performance of the cot and may void its warranty (see [page 118](#)).

You can apply Tri-Flow® lubrication to the optional kickstand during periodic maintenance (see [page 83](#)).

Preventive Maintenance

REGULAR INSPECTION AND ADJUSTMENTS

Maintenance Intervals

The following schedule is intended as a general guide to maintenance. Bear in mind that such factors as weather, terrain, geographical location, and individual usage will alter the required maintenance schedule. If you are unsure as to how to perform these checks please contact your Stryker service technician. If you are in doubt as to what intervals to follow in maintaining your product, consult your Stryker service technician. Use the hour meter (page 34) to determine the frequency for preventive maintenance procedures. Check each routine and replace damaged or worn parts if necessary.

Item	Routine	Every (whichever comes first)			
		1 Month or 2 hours	3 Months or 6 hours	6 Months or 12 hours	12 Months or 24 hours
Settings	Verify the in-fastener shut-off is configured properly	X			
	Verify the cot and fastener fit and function properly				X
	Verify the safety bar engages the vehicle safety hook properly				X
Cylinder	All fasteners are secure (reference all assembly drawings)		X		
	Verify the cylinder is adjusted so the lock nut is tight and the cot stops moving when it hits the dead stops				X
	Inspect for and verify that there are no hydraulic fluid (red) leaks; inspect the fittings and tighten as necessary		X		
Hydraulics	Extend cylinder rod completely and wipe down rod with soft cloth and household cleaner	X			
	Inspect motor mount and verify that all fasteners are secure		X		
	Verify that there are no hydraulic fluid leaks		X		
Electronic Controls	Inspect the reservoir and verify that there are no leaks		X		
	Inspect hoses and fittings for damage or wear			X	
	Verify the hydraulic velocity fuse - Place a weight of approximately 50 lb on the cot, raise the cot, lift the cot with two operators, pull the manual back-up release handle, rapidly set the cot down, verify that the cot does not drop				X
Switches	Extend cot to raised position, measure and check load height			X	
	Verify "jog" function is operating			X	
	Verify high speed retract is working			X	
Cables/Wires	Verify there is no damage or wear to either switch			X	
	Verify both switches operate correctly			X	
	Verify there is no damage or pinching of wiring harness, cables or lines		X		
	Check routings and connections, verify there are no hanging wires	X			
	Verify there are no damaged connectors		X		

Preventive Maintenance

Item	Routine	Every (whichever comes first)				
		1 Month or 2 hours	3 Months or 6 hours	6 Months or 12 hours	12 Months or 24 hours	
Manual Back-up Release Handle	Verify that the manual back-up release handle functions properly	X				
	Verify the manual back-up release handle returns to the stowed position				X	
	Verify the base extends/retracts smoothly when the manual back-up release handle is engaged		X			
	With 100 lb or more on the cot, verify the cot does not lower when the manual back-up release handle is pulled		X			
	Inspect the cot frame/litter	X				
	Verify all welds intact, not cracked or broken				X	
	Verify no bent, broken or damaged components			X		
	Verify all fasteners secure (reference all assembly drawings)		X			
	Verify warning labels present, legible (reference assembly drawings)				X	
	Verify no damage or tears on cot grips			X		
Litter	Verify the siderails operate and latch properly			X		
	Verify the backrest cylinder operates properly		X			
	Adjust pneumatic cylinder for full range of motion, if required		X			
	Verify the footrest operates properly			X		
	Verify no cracks or tears on cot mattress			X		
	Mattress	Inspect patient restraints for proper function and no excessive wear (bent or broken receiver or latch plate, torn or frayed webbing, etc.)	X			
		Inspect the cot frame/base	X			
		Verify all welds intact, not cracked or broken				X
		Verify no bent, broken, or damaged components			X	
		Verify all fasteners secure		X		
Verify that the cot retaining post is secure. If not secure, then the screw must be replaced. See "Cot Retaining Post Screw Replacement" on page 108.				X		
Verify no excessive damage to X-frame guards				X		
Verify wheels are free of debris				X		
Verify all wheels secure, rolling and swiveling properly		X				
Check and adjust optional wheel locks as necessary						
Wheels	Verify smooth operation of X-frame		X			
					X	
X-Frame						

Preventive Maintenance

Item	Routine	Every (whichever comes first)			
		1 Month or 2 hours	3 Months or 6 hours	6 Months or 12 hours	12 Months or 24 hours
Head Section	Verify all fasteners secure		X		
	Verify no bent, broken, or damaged components			X	
	Verify the head section extends and locks properly		X		
	Verify the grip bar has no excessive damage or tears			X	
	Verify load wheels are secure and roll properly			X	
	Verify the safety bar operates properly. Pull toward the head section to ensure that it swings and rotates freely and pulls back to home position.	X			
Battery	Inspect the SMART™ Pak housing and terminal area for cracks or damage	X			
Accessories	Inspect the straps and clips on the retractable head section oxygen bottle holder (optional) for wear				X
	Verify the I.V. pole (optional) operates properly		X		
	Verify the head extension & pillow (optional) operates properly		X		
	Verify the restraint extender (optional) operates properly		X		
	Verify that the defibrillator platform straps (optional) are intact - not frayed or torn				X
	Verify that both defibrillator platform (optional) latch hooks are intact and secure				X
	Verify the kickstand (optional) retracts fully to the transport position		X		
	Verify that the kickstand (optional) bolts are tightened properly		X		
	Lubricate the kickstand spring and internal spring housing (optional) using Tri-Flow® lubrication			X	

Troubleshooting Guide

ELECTRONICS AND HYDRAULICS LOCATOR

Note: Some components have been removed for clarity.

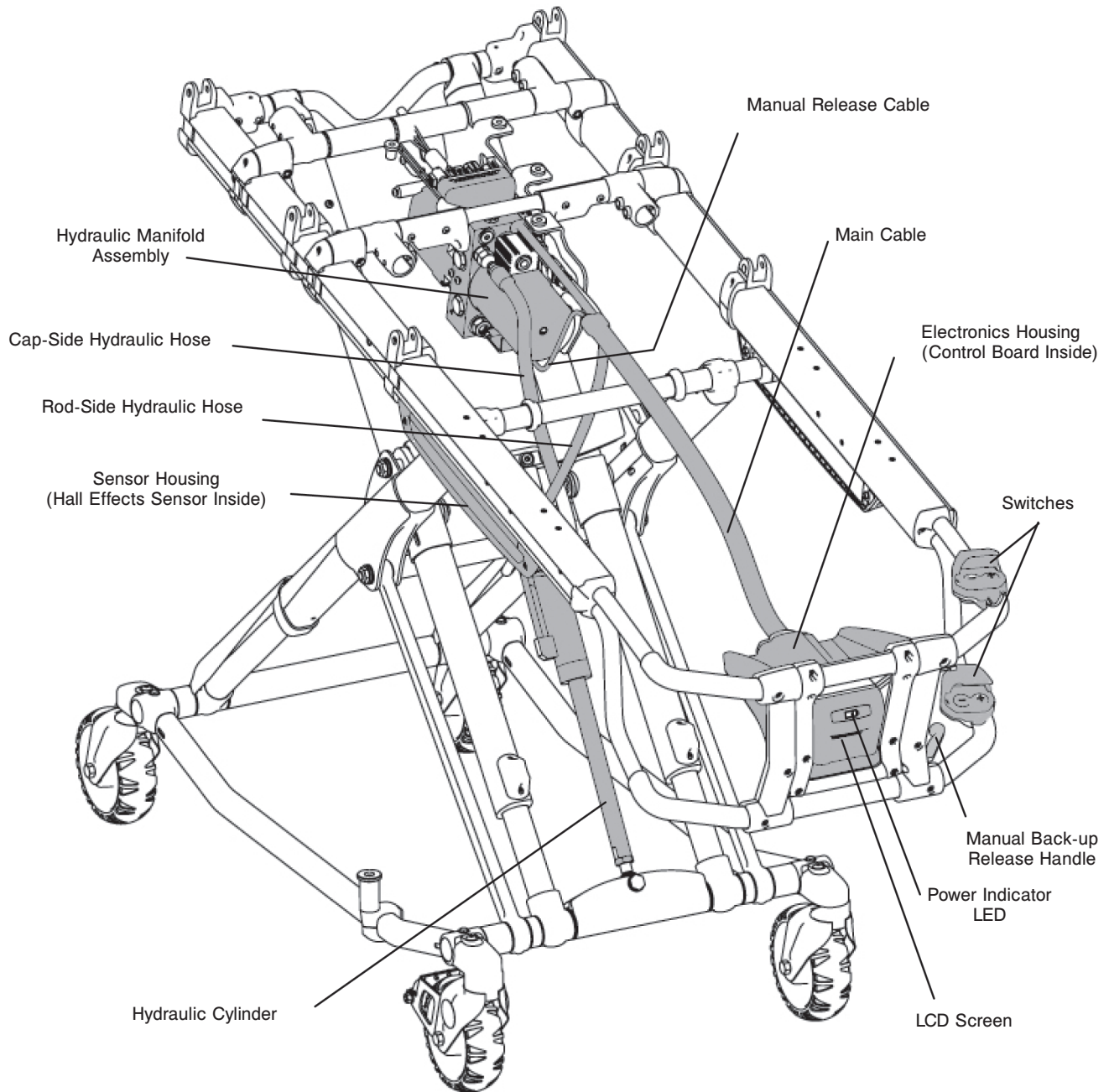

Figure 93

Troubleshooting Guide

HYDRAULIC ASSEMBLY

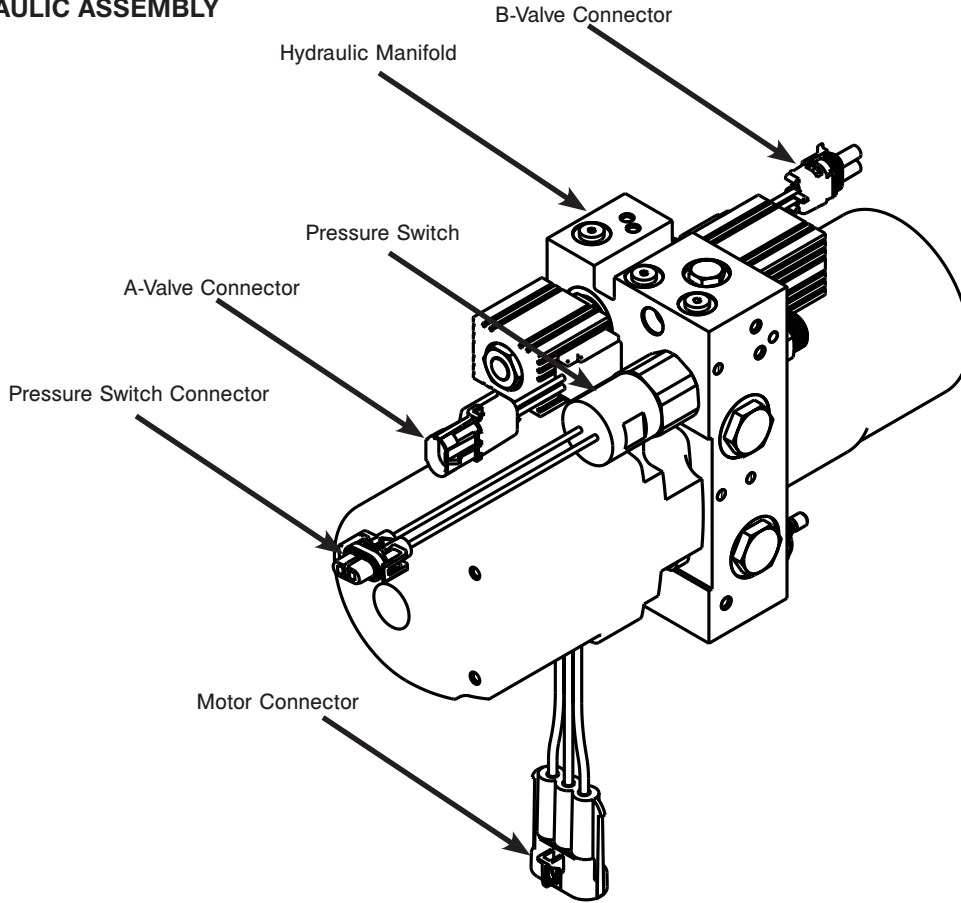
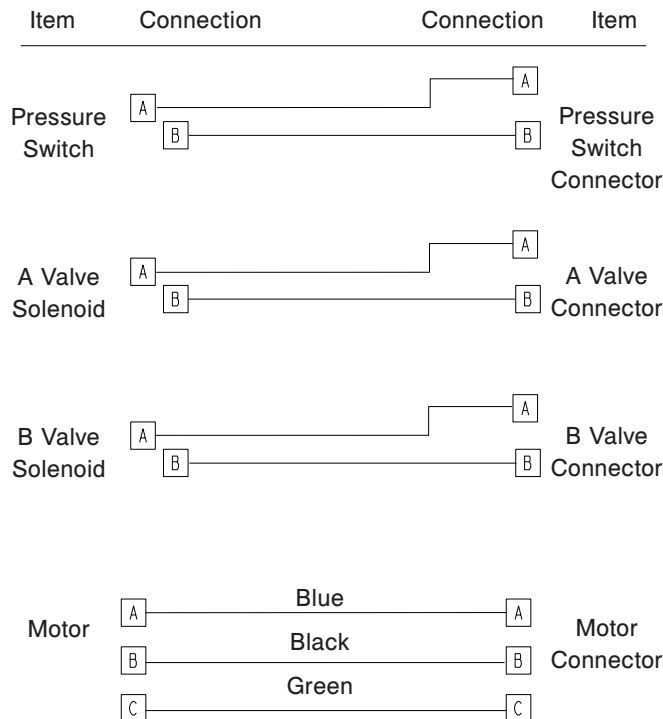

Figure 94

HYDRAULIC ASSEMBLY WIRING SCHEMATICS



[Return To Table of Contents](#)

Troubleshooting Guide

ELECTRICAL SYSTEM BLOCK DIAGRAM

Lift and Extend (Unload) Functions

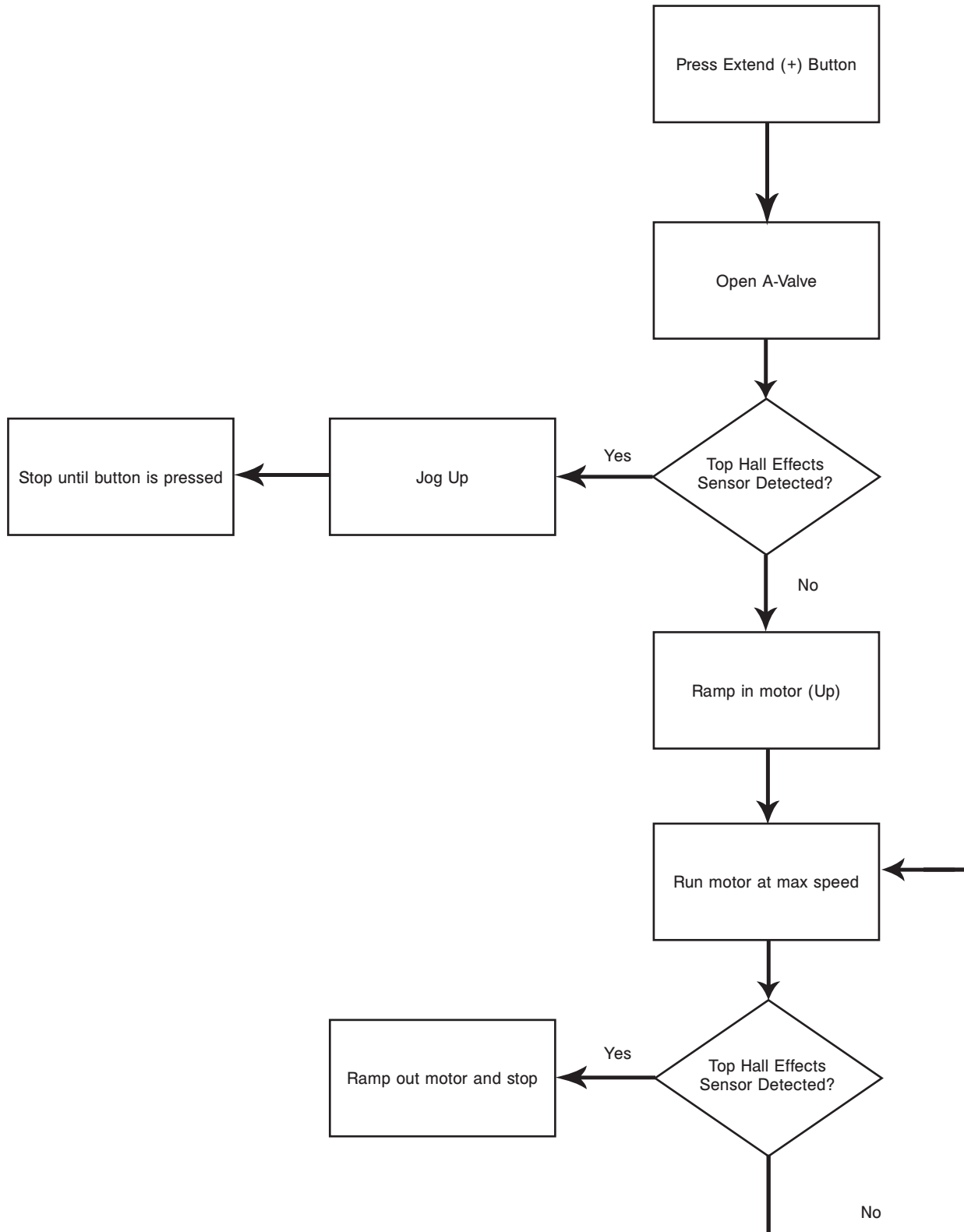

Troubleshooting Guide

Electrical System Block Diagram

Lower and Retract (Load) Functions

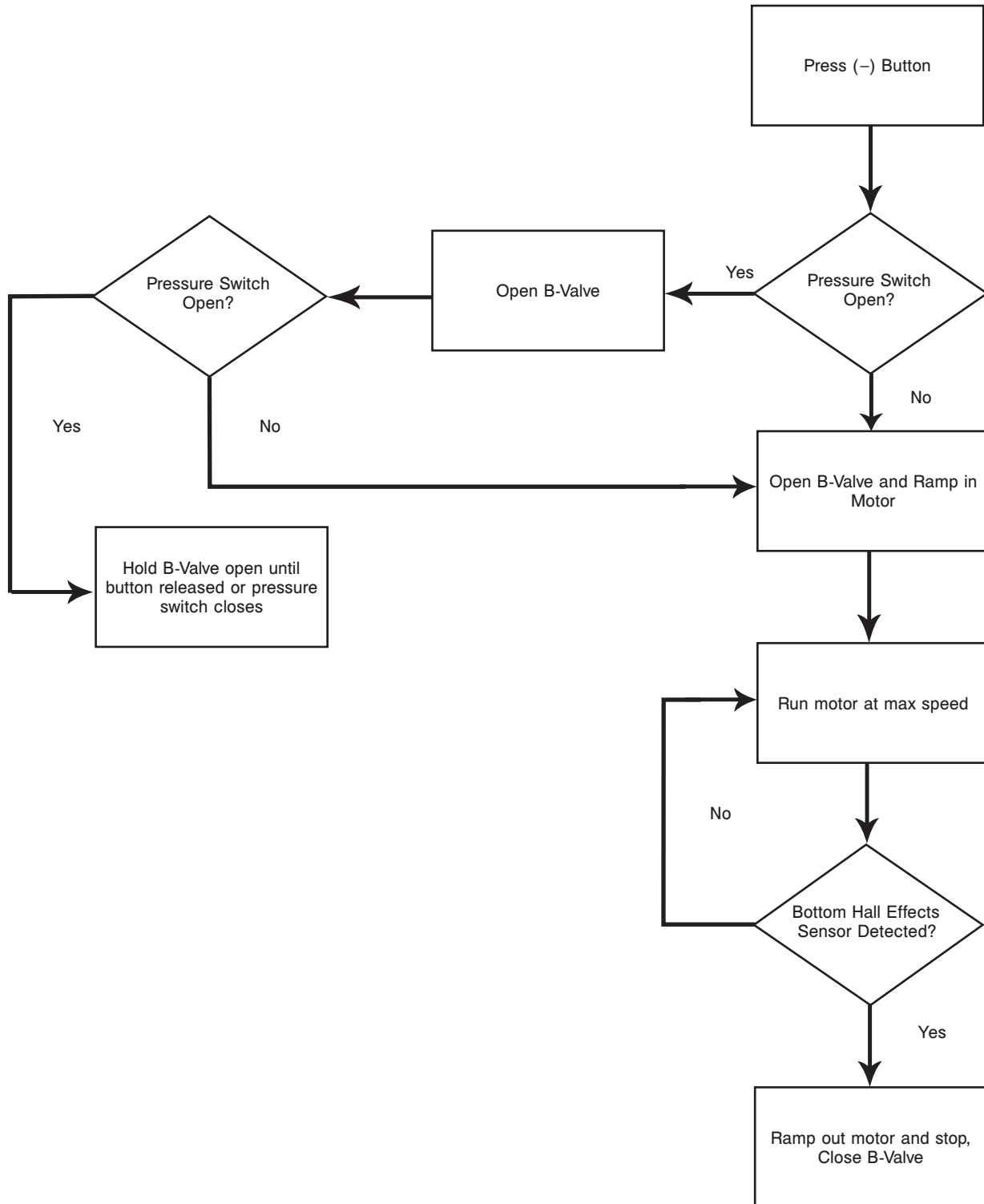

Troubleshooting Guide

TROUBLESHOOTING GUIDE

Check for proper operation after each step. When the problem is fixed, return the cot to service. If assistance is needed at any time during troubleshooting, please contact a service technician at (800) 327-0770 or (269) 324-6500.

PROBLEM	SOLUTION	PAGES
Litter drifts (without patient weight)	<ol style="list-style-type: none"> 1. Flush the hydraulic system by squeezing the manual release handle while simultaneously pressing the (+) power button for approximately 15 seconds. Repeat if necessary. 2. Check the manual release cable adjustment. 3. Change the 'locking' manual valve. 4. Change the 'B' valve. 	
Base drifts (without patient weight)	<ol style="list-style-type: none"> 1. Flush the hydraulic system by squeezing the manual release handle while simultaneously pressing the (+) power button for approximately 15 seconds. Repeat if necessary. 2. Check the manual release cable adjustment. 3. Change the 'non-locking' manual valve. 4. Change the 'A' valve. 	
Litter does not lower in the powered mode	<ol style="list-style-type: none"> 1. Check the power indicator LED. <ol style="list-style-type: none"> a. If blinking constant amber, change the battery. 2. Check for error on LCD. 3. Check for broken or disconnected wires. 4. Check for 24V DC at connector (C) on the main cable by the motor while pressing the retract (-) button. If voltage is present, replace (in order) the hall effects sensor, solenoid, and or 'B' valve. If voltage is not present, go to step 5. 5. Check for 24V DC on electronics assembly pins 1 blue and 5 orange on (F) while pressing the retract (-) button. If voltage is not present, replace the electronics assembly. If voltage is present, replace the wire harness. <ol style="list-style-type: none"> a. If the green light turns on, but does not lower, try the other switch. If the other switch works, replace the bad switch. 	<p style="text-align: right;"> page 96 page 97 </p>

Troubleshooting Guide

TROUBLESHOOTING GUIDE (CONTINUED)

PROBLEM	SOLUTION	PAGES
Litter does not extend in the powered mode	<ol style="list-style-type: none"> 1. Check the power indicator LED. <ol style="list-style-type: none"> a. If blinking constant amber, change the battery. 2. Check for error on LCD. 3. Check for broken or disconnected wires. 4. Check for 24V DC at connector (C) on the main cable by the motor while pressing the retract (-) button. If voltage is present, replace (in order) the hall effects sensor, solenoid, and or 'B' valve. If voltage is not present, go to step 5. 5. Check for 24V DC on electronics assembly pins 1 blue and 5 orange on (F) while pressing the retract (-) button. If voltage is not present, replace the electronics assembly. If voltage is present, replace the wire harness. <ol style="list-style-type: none"> a. If the green light turns on, but does not lower, try the other switch. If the other switch works, replace the bad switch. 6. Check the motor. <ol style="list-style-type: none"> a. If the motor runs, but does not raise the cot: <ol style="list-style-type: none"> i. Check the manual release cable for too much tension. ii. Lightly tap the manual locking valve. iii. Replace the manual locking valve. b. If the motor is stalled, replace the 'A' valve. c. If the light is green, but the motor does not run: <ol style="list-style-type: none"> i. Check for 24V DC at connector (E) on the main cable. If voltage is present, replace the hall effects sensor. If the hall effects sensor is replaced, and the motor still does not run, replace the hydraulic sub assembly. If voltage is not present, go to step ii. ii. Check for 24V DC on electronics assembly connection (H) (-) lead on black (+) lead on green while pressing the extend (+) button. If voltage is not present, replace the electronics assembly. If voltage is present, replace the main cable. 	<p>page 96 page 97</p>

Troubleshooting Guide

TROUBLESHOOTING GUIDE (CONTINUED)

PROBLEM	SOLUTION	PAGES
Base does not retract in the powered mode	<ol style="list-style-type: none"> 1. Check the power indicator LED. <ol style="list-style-type: none"> a. If blinking constant amber, change the battery. 2. Check for error on LCD. 3. Check for broken or disconnected wires. 4. Check for 24V DC at connector (C) on the main cable by the motor while pressing the retract (-) button. If voltage is present, replace (in order) the hall effects sensor, solenoid, and or 'B' valve. If voltage is not present, go to step 5. 5. Check for 24V DC on electronics assembly pins 1 blue and 5 orange on (F) while pressing the retract (-) button. If voltage is not present, replace the electronics assembly. If voltage is present, replace the wire harness. 	page 96 page 97
Base does not extend in the manual mode	<ol style="list-style-type: none"> 1. Check the manual cable adjustment. 2. Change the 'non-locking' manual valve. 	
Base does not retract in the manual mode	<ol style="list-style-type: none"> 1. Check the manual release cable adjustment. 2. Change 'locking' manual valve. 	
Litter does not retract in the manual mode (with patient weight)	<ol style="list-style-type: none"> 1. Make sure that the weight is off of the casters before lowering the cot. 2. Check the manual cable adjustment. 3. Replace the 'locking' manual valve. 	
Litter does not extend in the manual mode	<ol style="list-style-type: none"> 1. Check the manual cable adjustment. 2. Change the 'non-locking' manual valve. 	
High speed retract does not engage	<ol style="list-style-type: none"> 1. Check that the weight is off of the casters. 2. Change the pressure switch. 3. Change the hall effect cable. 	

Troubleshooting Guide

LCD ERROR CODES

MAIN MICRO

LCD DISPLAY	ERROR DESCRIPTION	DETECTION PERIOD
ERR 01	RAM diagnostic failure	Initialization
ERR 02	Program memory failure	Initialization
ERR 03	EE diagnostic failure	Initialization
ERR 04	EEPROM type and hardware type incompatible	Initialization
ERR 10	Valves diagnostic failure	Initialization
ERR 61	EEPROM rev and firmware rev incompatible	Initialization
ERR 21	Motor shorted	Initialization
ERR 22	Motor open	Initialization
ERR 23	High power gating relay shorted	Initialization
ERR 51	Motor drive FET shorted - Q15	Initialization
ERR 52	Motor drive FET shorted - Q11	Initialization
ERR 55	Motor drive FET shorted - Q16	Initialization
ERR 56	Motor drive FET shorted - Q12	Initialization
ERR 62	Main Micro and ASIC current limit mismatch	Initialization
ERR 80	Extend (+) or retract (-) button detected without key	Run Time
ERR 31	Electronics board over temp (280.22 °F +/- 5%)	Run Time
ERR 81	Bad hall effect sensor combination	Run Time
ERR 93	Safety Micro non-responsive	Run Time

SAFETY MICRO

LCD DISPLAY	ERROR DESCRIPTION	DETECTION PERIOD
ERR 05	RAM diagnostic failure	Initialization
ERR 06	Program memory diagnostic failure	Initialization
ERR 08	EEPROM type and hardware type incompatible	Initialization
ERR 40	Data error	Run Time
ERR 41	Charging failed battery voltage	Run Time
ERR 42	Charging failed read battery	Run Time
ERR 43	Charging failed battery charging time or over voltage limit	Run Time
ERR 44	Charging failed charging current	Run Time
ERR 45	Charging failed delta temp	Run Time
ERR 63	EEPROM rev and firmware rev incompatible	Initialization
ERR 83	Extend (+) or retract (-) button detected without key	Run Time
ERR 90	ASIC driving without microprocessor instruction	Run Time

[Return To Table of Contents](#)

Troubleshooting Guide

MAIN CABLE ASSEMBLY

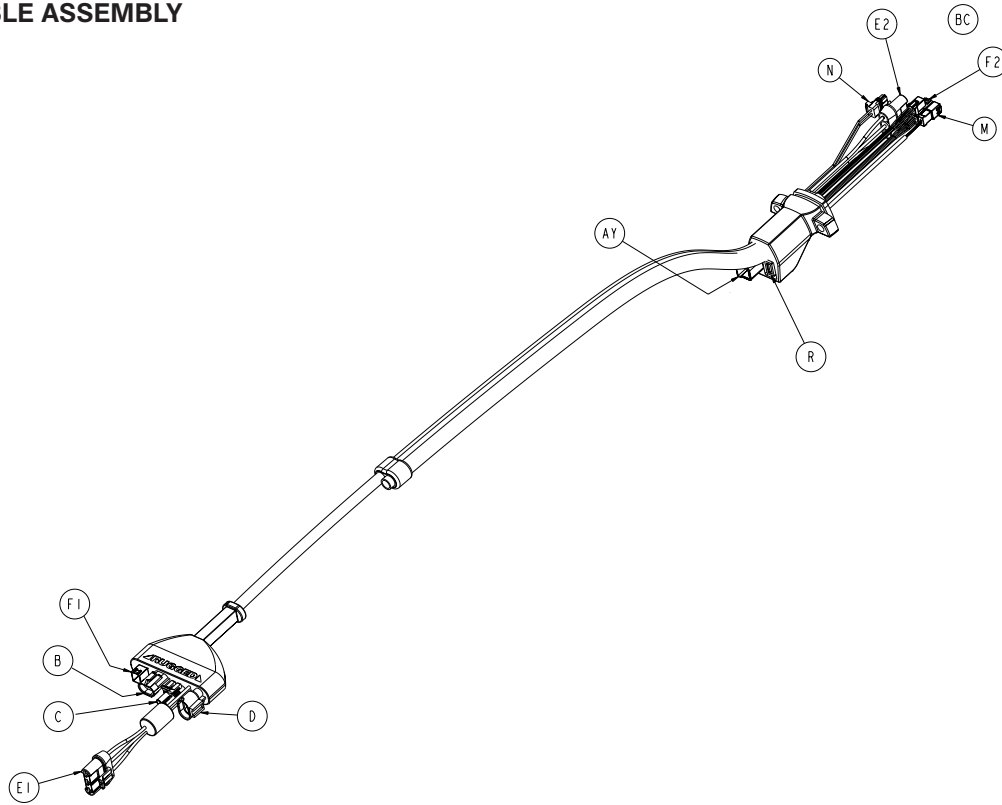
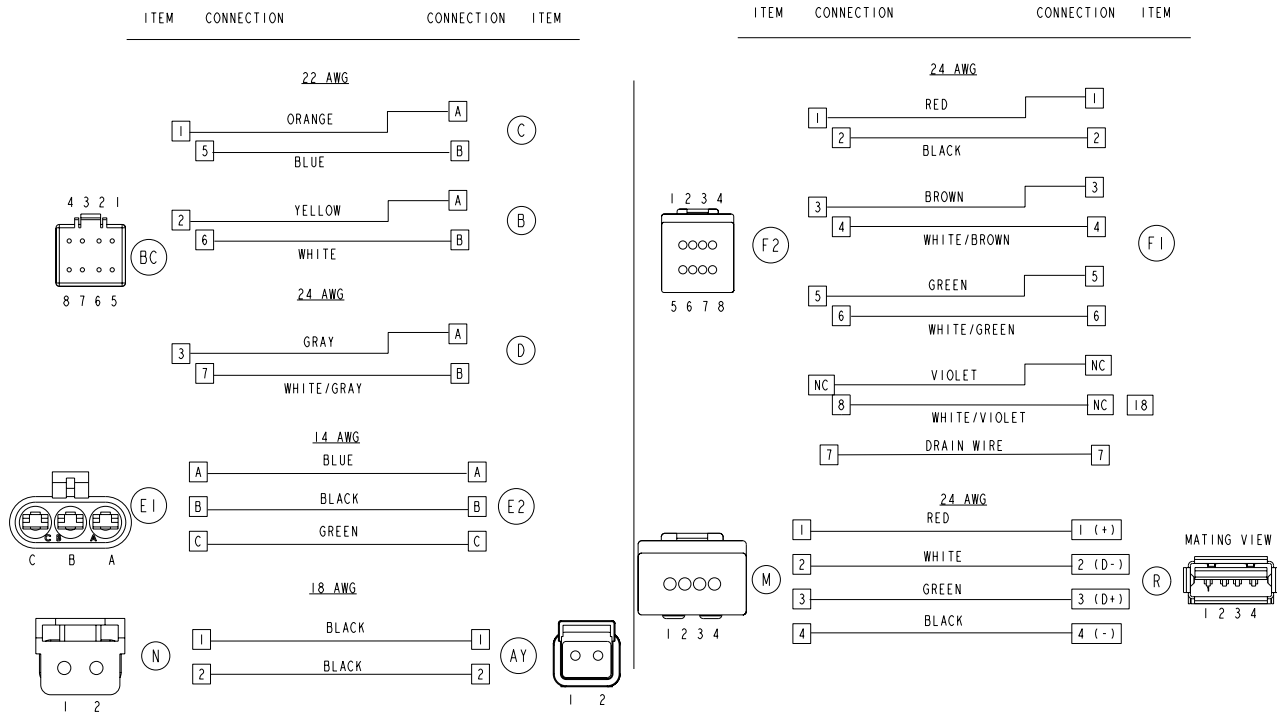

Figure 95

MAIN CABLE ASSEMBLY WIRING SCHEMATICS



Troubleshooting Guide

CONTROL BOARD ASSEMBLY

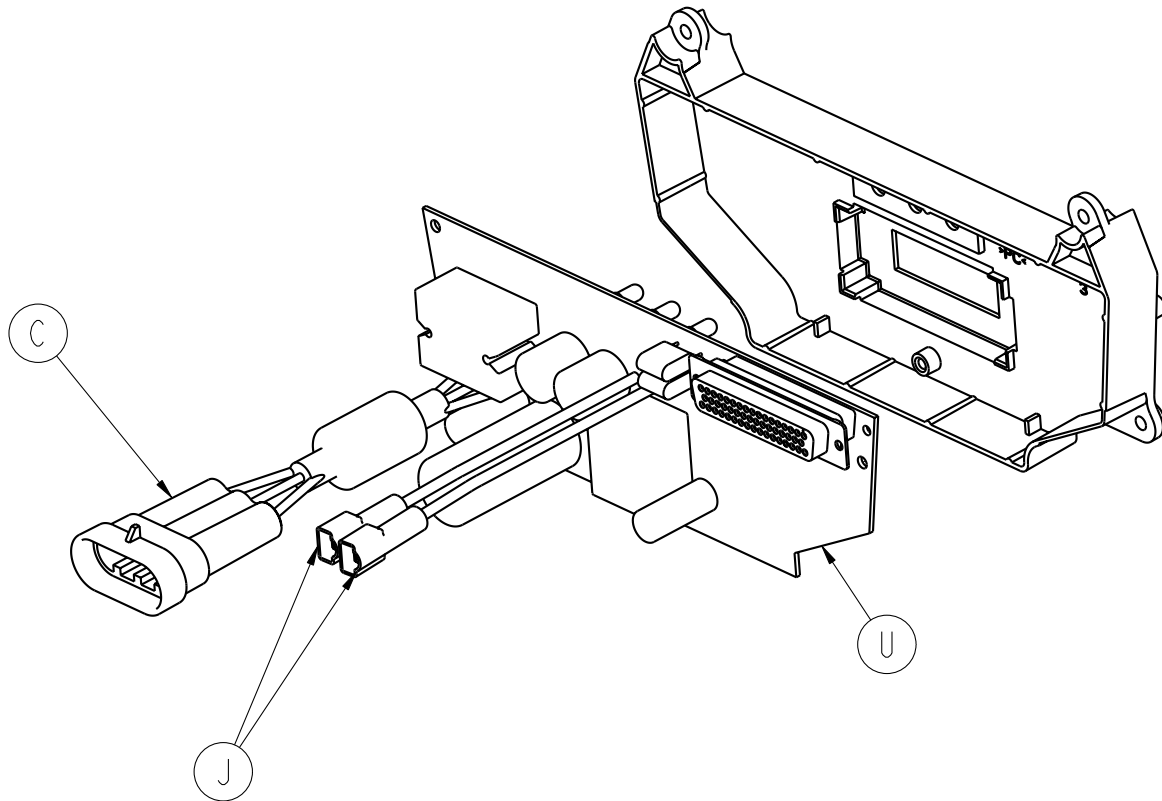
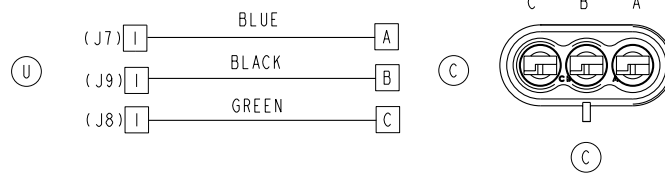

Figure 96

CONTROL BOARD WIRING SCHEMATICS

ITEM	CONNECTION	CONNECTION	ITEM
------	------------	------------	------

MOTOR CABLE



BATTERY POSITIVE



BATTERY NEGATIVE



[Return To Table of Contents](#)

Quick Reference Replacement Parts List

The parts listed on these pages are all currently available for purchase. Some of the parts identified on the assembly drawing parts in this manual may not be individually available for purchase. Please call Stryker Customer Service USA: 1-800-327-0770 for availability and pricing.

Part Name	Part Number
Cable, Hall Effect Sensor	6500-001-160
DC Battery Charger, 110V, Domestic	6500-070-000
DC Battery Charger 12V/24V, In-Ambulance	6500-072-000
Electronics Assembly	6500-002-014
Gas Cylinder, Backrest	1010-031-077
Headsection (not Power-LOAD compatible)	6506-001-020
Headsection (Power-LOAD compatible)	6506-001-021
Hydraulic Oil	6500-001-293
Kit, Base Tube Protector	6500-700-015
Kit, Battery Pack, SMRT™ Pak	6500-700-046
Kit, SMRT™ Power System 12V DC (Car Charger), includes charger, 2 paks, and power cord	6500-700-040
Kit, SMRT™ Power System 120V AC (Wall Charger), includes charger, 2 paks, and power cord	6500-700-041
Kit, Brake Adjuster	6080-700-018
Kit, Brake - Single Wheel, Foot End Right	6080-201-000
Kit, Brake - Dual Wheel, Foot End Left and Right	6080-202-000
Kit, Equipment Hook	6500-700-003
Kit, Head Extension	6100-700-012
Kit, Lift Capable Safety Bar	6082-700-031
Kit, Oxygen Bottle Holder, Foot End	6500-700-017
Kit, Oxygen Bottle Holder, Fowler	6500-700-011
Kit, Oxygen Bottle Holder, Retractable Head Section	6085-700-003
Mounting Bracket, SMRT™ Charger	6500-201-100
Restraint Belt Extension	6082-160-050
Restraint, Leg	6500-001-395
Restraint, Waist	6500-001-393
Restraint Package, Domestic	6500-002-030
Restraint, Shoulder Harness	6500-001-391
Restraint Strap Plastic Cap (Short)	6082-160-051
Restraint Strap Plastic Cap (Tall)	6082-160-055

Quick Reference Replacement Parts List

Part Name	Part Number
Safety Hook, J	6092-036-018
Safety Hook, Long	6060-036-017
Safety Hook, Short	6060-036-018
Siderail, Standard	6082-026-010
Siderail, XPS Option (XPS Siderail and XPS Mattress Kit)	6506-700-004
Touch-Up Paint (Yellow)	6060-199-010
Touch-Up Paint (Black)	7000-001-322
Valve, "A"	6500-001-286
Valve, "B"	6500-001-287
Valve, Locking	6500-001-288
Valve, Non-Locking	6500-001-289
Velcro® 4.6" Adhesive Loop Pile, Litter	6060-032-046
Velcro® 10"	6082-001-082
Wheel Lock	6086-200-010

[Return To Table of Contents](#)

Accessories

These accessories may be available for use with your product. Confirm availability for your configuration or region. Call Stryker Customer Service: 1-800-327-0770.

Part Name	Part Number
Defibrillator platform	6506-170-000
Equipment hook	6500-147-000
Head extension with pillow	6100-044-000
I.V. pole, two-stage, right	6500-310-000
I.V. pole, two-stage, left	6500-311-000
I.V. pole, two-stage, dual	6500-312-000
I.V. pole, three-stage, right	6500-315-000
I.V. pole, three-stage, left	6500-316-000
I.V. pole, three-stage, dual	6500-317-000
Mattress, knee gatch bolster	6500-002-150
Mattress, knee gatch bolster, grey	6506-002-150
Mattress, knee gatch bolster, XPS	6500-003-130
Oxygen bottle holder, foot end	6500-240-000
Oxygen bottle holder, head end	6500-241-000
Oxygen bottle holder, removable	6080-140-000
Oxygen bottle holder, retractable head section	6085-046-000
Pedi-Mate restraint package	6091-300-010
Storage flat, head end	6500-128-000
Storage net, base	6500-160-000
Storage pouch, back rest	6500-130-000

Service Information

BACKREST ADJUSTMENT

Tools Required:

- 1/2" Combination Wrench
- 5/32" Hex Wrench
- 3/32" Hex Wrench
- Small Slotted Screwdriver

Procedure:

1. For easier access, move the backrest to 73 degrees.

Note: Before continuing with the backrest adjustment procedure, be sure that the cylinder (A) is completely threaded into the yoke (B) so no threads are showing on the shaft of the cylinder. If threads are showing, use a 3/32" hex wrench to remove the set screw (C) in the center of the yoke. Using a small slotted screwdriver, remove the E-clip and pin (D & E) that holds the bottom of the pneumatic cylinder. Thread the cylinder shaft (A) completely into the yoke (B). Replace the E-clip and pin (D & E) and replace the set screw (C) using Loctite®. (Figure 97 and Figure 98)

2. Using a 1/2" combination wrench, loosen the hex nut (F) on the backrest pivot (J) while holding the set screw (H) fixed in the pivot Figure 98).
3. Using a 5/32" hex wrench, turn the set screw (H) until there is no play between the backrest release handle (K) and the pneumatic cylinder release button (Figure 98).

Note: Make sure that the backrest travels from flat to at least 73 degrees. If it does not, turn the set screw clockwise 1/2 turn. Repeat until at least 73 degrees of travel is achieved.

4. Lower the backrest to a 5–10 degree angle and release the handle. Apply approximately 50 lb of downward force to the end of the backrest. If the backrest drifts down, turn the set screw counterclockwise. Repeat until the backrest does not drift downward.
5. Using the 1/2" combination wrench, tighten the hex nut (F) while holding the set screw fixed in the pivot (Figure 98).
6. Verify proper operation of the unit before returning it to service.

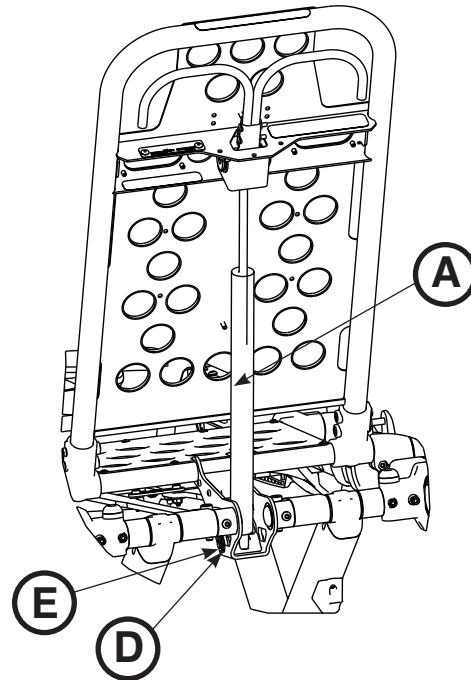

Figure 97

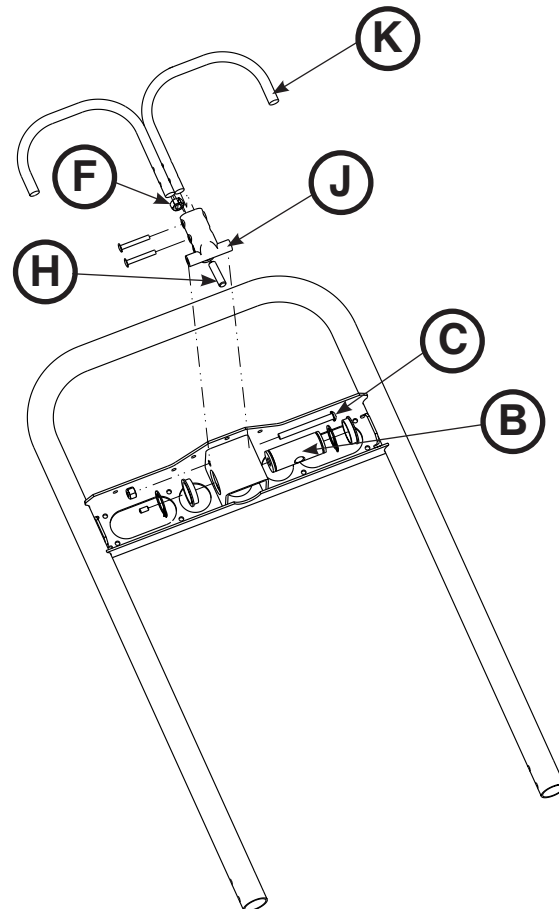

Figure 98

Service Information

HEADSECTION REPLACEMENT

Tools Required:

- 7/16" Combination Wrench
- 3/16" Hex Wrench

Procedure:

1. Raise the cot and the backrest to the full upright position.
2. Using a 7/16" combination wrench and a 3/16" hex wrench, remove the two screws (A) that secure the cap bearings to the base litter interface bracket (one on each side) (Figure 99).
3. Squeeze the head release handles and slowly remove the head section assembly.
4. Reverse steps to reinstall.
5. Verify proper operation of the unit before returning it to service.

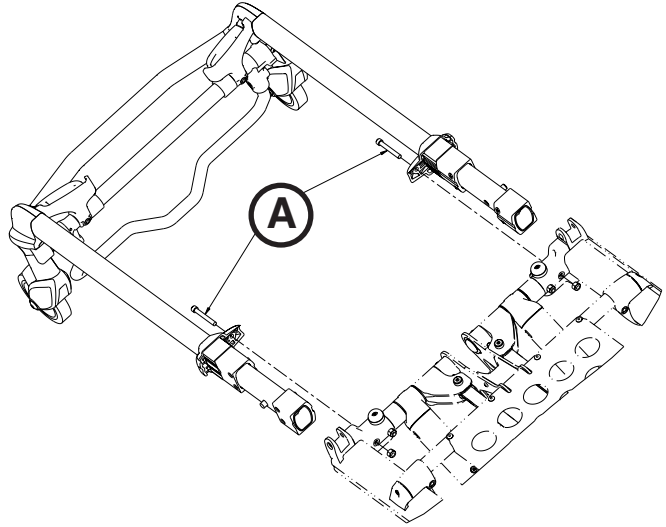

Figure 99

BACKREST GAS CYLINDER REPLACEMENT

Tools Required:

- 3/32" Hex Wrench
- Slotted Screwdriver

Procedure:

1. Raise the cot and the backrest to the full upright position.
2. Using a 3/32" hex wrench, loosen the set screw (A) that holds the gas shaft to the yoke (Figure 100).
3. Using a slotted screwdriver, remove the e-clip from the clevis pin that secures the bottom of the gas cylinder.
4. Unscrew the gas cylinder shaft from the yoke.
5. Reverse the above procedures to install the new gas cylinder. See "Backrest Adjustment" on [page 101](#).
6. Verify proper operation of the unit before returning it to service.

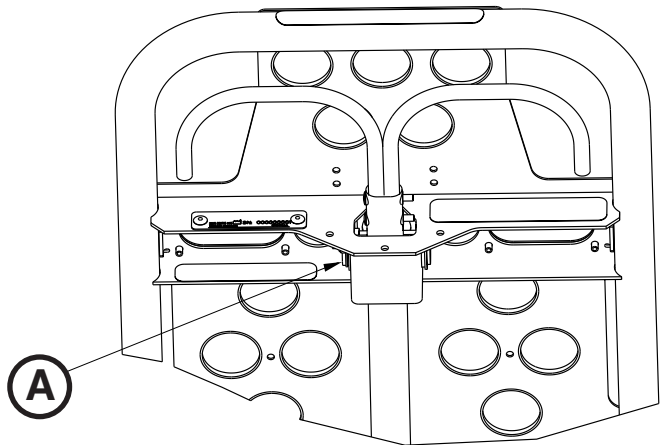

Figure 100

Service Information

MANUAL RELEASE CABLE ADJUSTMENT

Tools Required:

- 8 mm Combination Wrench
- 10 mm Combination Wrench
- (2) Weight (50 lb each)

Procedure:

1. Support the litter so no weight is on the base.
2. Ensure that the manual release cable is intact (A) (Figure 101).
3. Using a 10 mm combination wrench, loosen the cable lock nut (B) (Figure 101).
4. Using a 8 mm combination wrench, adjust the tension on the manual release cable so it just starts to touch the manual release dual pull bracket (C) (Figure 101).

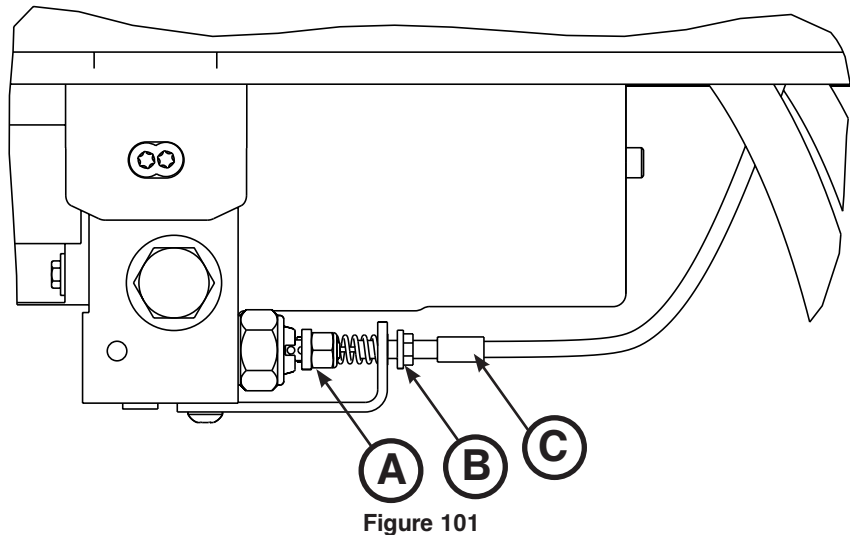

Note: The manual release dual pull bracket should not be tight against the manual valve nuts.

5. Tighten the cable lock nut.
6. Test for proper adjustment by following steps A-D:
 - A. Place 50 lb of weight on the hydraulic skin.
 - B. Load height must read 34-1/2" to 35-1/2".
 - C. Place 100 lb of weight on the hydraulic skin, raise cot to full height, pull the manual release handle and ensure that the cot does not drop.
 - D. Remove 100 lb of weight, raise cot to full height, pull the manual release handle, and ensure that the cot drops.

Note: If steps A-D do not work properly, repeat steps 3-6.

7. Verify proper operation of the unit before returning it to service.

Service Information

FILLING THE HYDRAULICS ASSEMBLY RESERVOIR

Use only Mobil Mercon® V Synthetic Blend Oil (6500-001-293)

Note: Any time you work with the hydraulics you may lose some oil.

Tools Required:

- 3/16" Hex Wrench

Procedure:

1. Raise the cot to the full up position.
2. Ensure that the fill port is horizontal and lined up with the hole in the motor mount.
3. Remove the port plug (A) using a 3/16" hex wrench (Figure 102).
4. Fill the reservoir up to the bottom of the fill port.
5. Replace the plug and run the cot up and down a few times.
6. Verify proper operation of the unit before returning it to service.

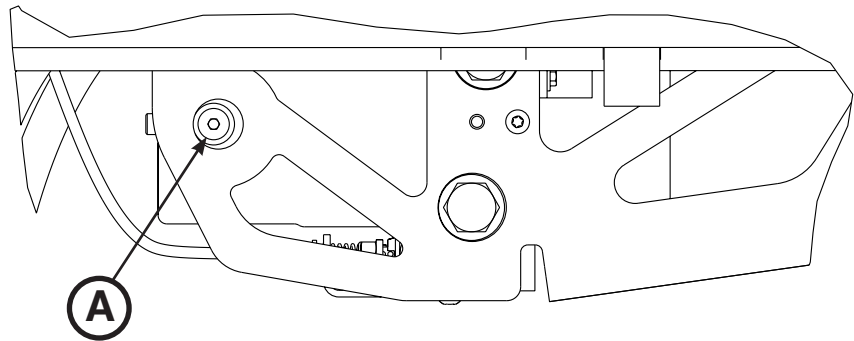

Figure 102

Service Information

WHEEL LOCKING FORCE ADJUSTMENT

Tools Required:

- 5/32" Hex Wrench
- 7/16" Combination Wrench or Socket

Procedure:

1. Using the 5/32" hex wrench and 7/16" combination wrench or socket, remove the socket screw from the center of the lock pedal. The wheel lock is initially assembled with the pedal set at the minimum locking force. The marker on the pedal (A) is aligned with the marker on the octagonal sleeve (B) (Figure 103).
2. Remove the sleeve (B). Rotate the sleeve counterclockwise to increase the pedal locking force and clockwise to decrease the locking force. Insert the sleeve into the pedal (Figure 103).
3. Using the 5/32" hex wrench and 7/16" combination wrench or socket, reinstall the socket screw.
4. Test the pedal locking force and verify that the pedal holds properly before returning it to service.

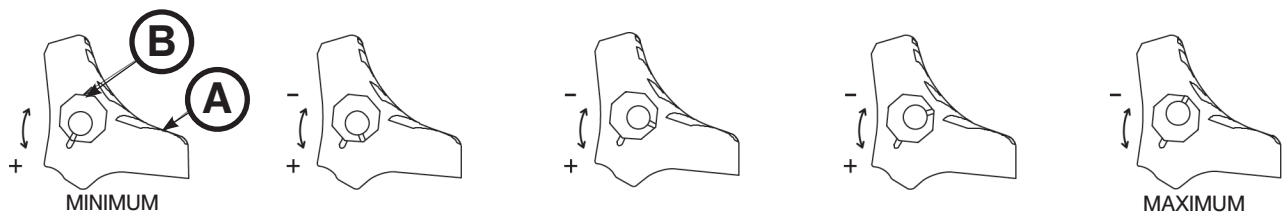

Figure 103

Service Information

STEER-LOCK MECHANISM ADJUSTMENT

Tools Required:

- 9/16" Combination Wrench

Procedure:

If your steer-lock mechanism will not engage:

- Using a 9/16" combination wrench, adjust the barrel nuts toward the foot end of the cot (Figure 104).

Note: After adjustment, make sure that a minimum of one full thread is exposed on each side of the barrel nut.

If your steer-lock mechanism will not disengage:

- Using a 9/16" combination wrench, adjust the barrel nuts toward the head end of the cot (Figure 105).

Note: After adjustment, make sure that a minimum of one full thread is exposed on each side of the barrel nut.



Figure 104



Figure 105

Service Information

COT RETAINING POST ADJUSTMENT

Tools Required:

- T30 Torx Driver

CAUTION

The cot retaining post is shipped preconfigured for an X-frame cot. If the cot fastener has been configured for an H-frame cot, you must adjust the cot retaining post to accommodate the cot fastener.

Procedure:

1. Using a T30 Torx driver, remove the two socket head cap screws (A) that hold the brackets (B) to the base frame (C) (Figure 106). Save both screws for reinstallation.
2. Turn the bottom bracket 180°.
3. Using a T30 Torx driver, reinstall the two socket head cap screws that were removed in step 1.
4. Verify proper operation of the unit before returning it to service.

To determine if your cot is an X-frame or H-frame cot, look for an arrow or groove on the bottom bracket of the cot retaining post.

- The cot retaining post is set for an X-frame cot if the arrow on the bottom bracket of the retaining post points toward the head end of the cot or if the groove in the bottom bracket is located on the inside of the patient left side of the base tube.
- The cot retaining post is set for an H-frame cot if the arrow on the bottom bracket of the retaining post points toward the foot end of the cot or if the groove in the bottom bracket is located on the outside of the patient left side of the base tube.

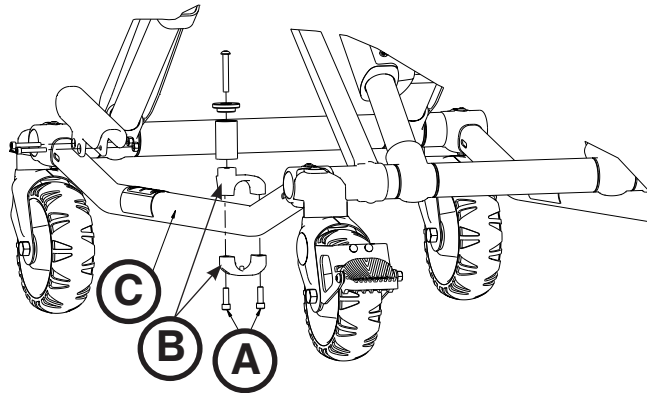

Figure 106

Service Information

COT RETAINING POST REPLACEMENT

Tools Required:

- T30 Torx Driver
- 5/32" Hex Wrench
- Torque Wrench (in-lb)

Procedure:

1. Raise the cot to the full upright position.
2. Turn the cot onto the patient left side.

Note: Locate the arrow or groove on the bottom bracket. The replacement retaining post bracket will need to be assembled in the same orientation.

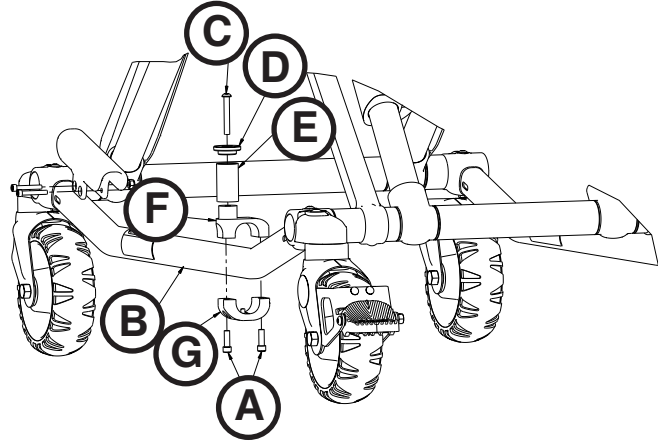

Figure 107

3. Using a T30 Torx driver, remove the two socket head cap screws (A) that secure the current cot retaining post to the base tube (B) (Figure 107). Discard the screws and cot retaining post.
4. Insert the button head cap screw (C) through the retaining post cap (D) and post tube (E), and then into the top pin bracket (F) (Figure 107).
5. Using a 5/32" hex wrench, tighten the button head cap screw (C) completely to secure the retaining post cap (D) and post tube (E) to the top pin bracket (F) (Figure 107). Using a torque wrench, torque the screw to 100-140 in-lb.
6. Assemble the cot retaining post across the base tube. Align the holes of the brackets and insert two socket head cap screws (A) into the threaded holes of the bottom pin bracket (G) (Figure 107).
7. Using a T30 Torx driver, tighten the two socket head cap screws completely.
8. Verify proper operation of the unit before returning it to service.

Note: Adjustment of the rail clamp assembly may be required in order to compensate for any variation in cot retaining post position depending on the ambulance cot manufacturer and model number.

COT RETAINING POST SCREW REPLACEMENT

Tools Required:

- T25 Torx Driver
- 5/32" Hex Wrench
- Torque Wrench (in-lb)

Procedure:

1. Using a T25 Torx driver or 5/32" hex wrench, remove the button head cap screw that secures the retaining post cap and post tube to the top pin bracket. Discard the screw.
2. Using a 5/32" hex wrench, install and tighten the button head cap screw (0004-503-000) completely to secure the retaining post cap and tube to the top portion of the retaining post assembly. Using a torque wrench, torque the screw to 100-140 in-lb.

Note: If you cannot torque the screw to 100-140 in-lb, then you must replace the entire cot retaining post. See "Cot Retaining Post Replacement".

3. Verify proper operation of the unit before returning it to service.

Service Information

HYDRAULIC A VALVE OR B VALVE REPLACEMENT

Tools Required:

- T25 Torx Driver
- 3/4" Combination Wrench
- 7/8" Combination Wrench
- (2) Saw Horse

Procedure:

1. Raise the cot to the full upright position.
2. Using two saw horses, support the litter and activate the manual release handle to relieve any hydraulic oil pressure.
3. Using a T25 Torx driver, remove the seat pan from the litter to access the hydraulic assembly.
4. Disconnect all connections to the main cable assembly.
5. Using a 3/4" combination wrench, remove the nut that secures the solenoid to the A valve (A) or B valve (B) (Figure 108). Save the nut for reinstallation.
6. Remove the solenoid from the valve. Save the solenoid for reinstallation.
7. Using a 7/8" combination wrench, remove the A valve or B valve from the hydraulic subassembly.

Note: Hydraulic oil will leak from the valve and manifold. Lay down towels to catch the oil.

8. Reverse steps to reinstall.
9. Check functionality by running the cot up and down several times. If necessary, add hydraulic oil. See "Filling the Hydraulics Assembly Reservoir" on [page 104](#).
10. Verify proper operation of the unit before returning it to service.

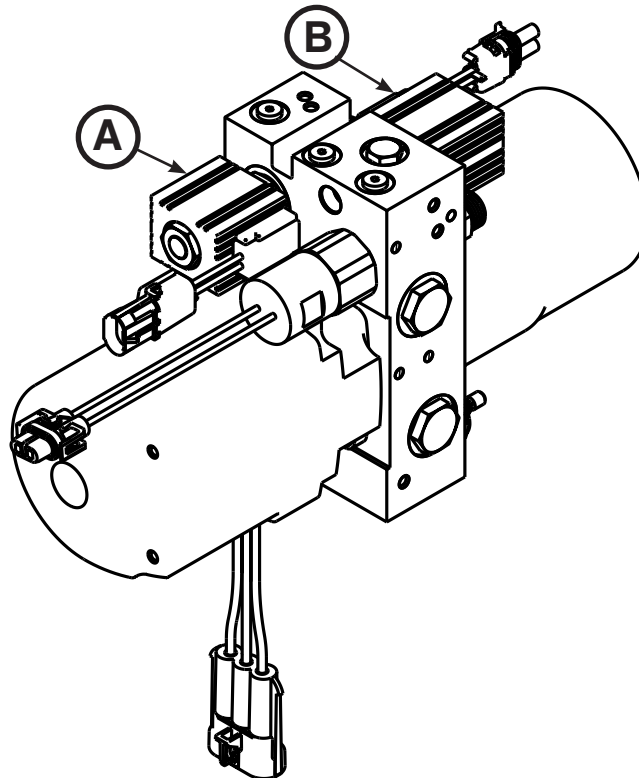

Figure 108

Service Information

HYDRAULIC MANUAL RELEASE VALVE REPLACEMENT

Tools Required:

- T27 Torx Driver
- 7/16" Combination Wrench
- 1/8" Hex Wrench
- 7/8" Hex Wrench
- (2) Saw Horse

Procedure:

1. Raise the cot to the full upright position.
2. Using two saw horses, support the litter and activate the manual release handle to relieve any hydraulic oil pressure.
3. Using a T27 Torx driver, remove the two button head cap screws (A) that secure the manual release cable bracket to the bottom of the hydraulic subassembly (Figure 109).
4. Using a 1/8" hex wrench, place the hex wrench through the stem at the groove in the valve body to hold the valve stem in position.
5. Using a 7/16" combination wrench, remove the Nylock hex nut (B) from each of the valve stems (Figure 109).
6. Using a 7/8" combination wrench, remove the valve (C or D) to be replaced (Figure 110).
7. Reverse steps to reinstall.
8. Check functionality by running the cot up and down several times. If necessary, add hydraulic oil. See "Filling the Hydraulics Assembly Reservoir" on [page 104](#).
9. Verify proper operation of the unit before returning it to service.

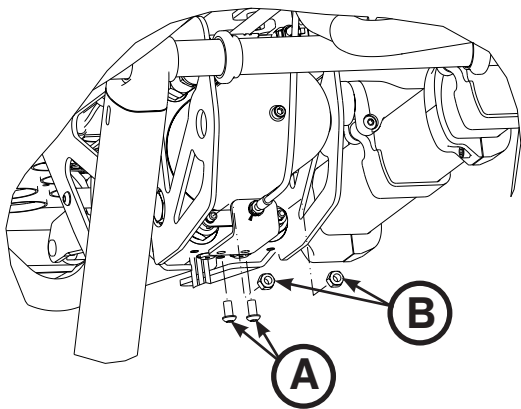

Figure 109

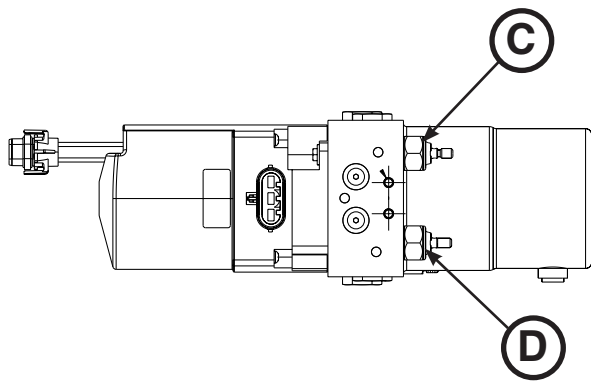

Figure 110

Service Information

HYDRAULIC CYLINDER REPLACEMENT

Tools Required:

- 9/16" Combination Wrench
- 3/4" Combination Wrench
- 11/16" Combination Wrench
- 13/16" Combination Wrench
- 3/8" Combination Wrench
- 1/8" Hex Wrench
- (2) Saw Horse

Procedure:

1. Raise the cot to the full upright position.
2. Using two saw horses, support the litter and activate the manual release handle and manually compress ram to remove the tension on the base cross tube connecting bolt.
3. Using a 3/4" and 9/16" combination wrench, remove the rod attachment pin (A), washer (B), and Nylock hex nut (C) that secure the hydraulic cylinder to the base (Figure 111).
4. Activate the manual release handle and fully compress the hydraulic cylinder.
5. Using a 11/16" and 13/16" combination wrench, remove both hoses (D) from the hydraulic cylinder (E) (Figure 112).

Note: Hydraulic oil will leak from the hoses and cylinder. Lay down towels to catch the oil.

6. Keep the hose ends high and upright to minimize the amount of fluid lost.
7. Using a 1/8" hex wrench and 3/8" combination wrench, remove the two socket head set screws (F) and Fiberlock hex nuts (G) that secure the hydraulic cylinder to the base (Figure 113).
8. Reverse steps to reinstall.
9. Check functionality by running the cot up and down several times. If necessary, add hydraulic oil. See "Filling the Hydraulics Assembly Reservoir" on [page 104](#).
10. Verify proper operation of the unit before returning it to service.

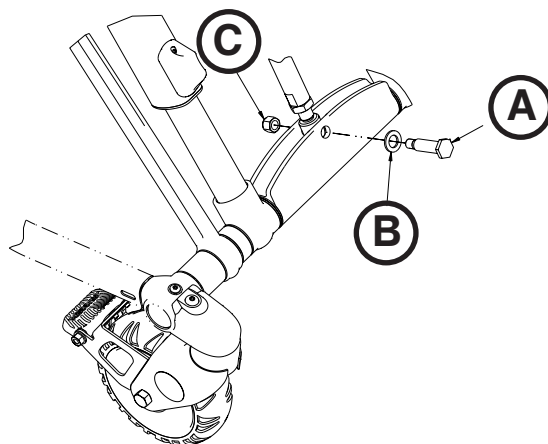

Figure 111

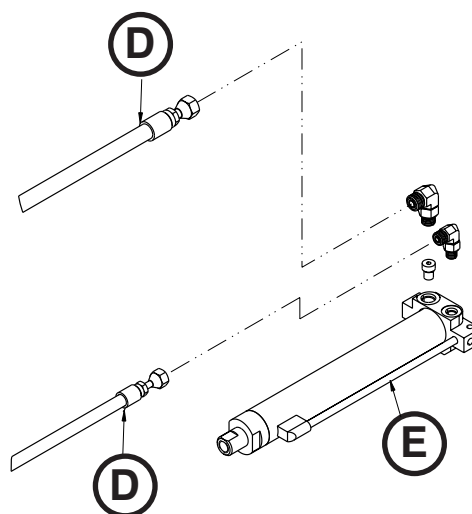

Figure 112

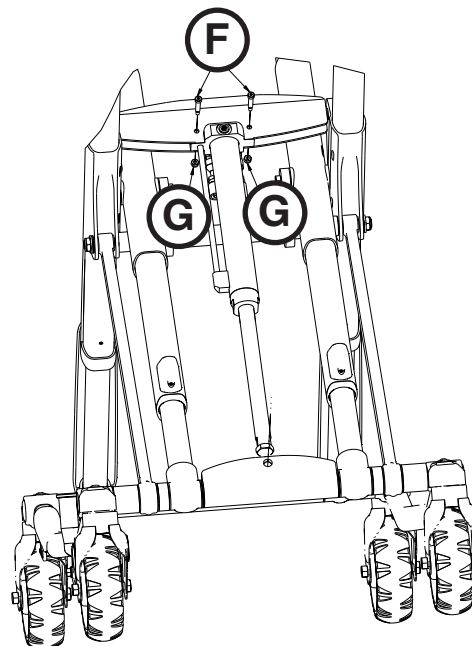

Figure 113

[Return To Table of Contents](#)

Service Information

HYDRAULIC HOSE REPLACEMENT

Tools Required:

- 13/16" Combination Wrench
- 11/16" Combination Wrench
- (2) Saw Horse

Procedure:

1. Raise the cot to the full upright position.
2. Using two saw horses, support the litter and activate the manual release handle to relieve any hydraulic oil pressure.
3. Using 11/16" and 13/16" combination wrenches, remove the damaged hose (A or B) (Figure 114).

Notes:

- Pay attention to the routing of the hydraulic hose for reinstallation.
 - Hydraulic oil will leak from the hoses and cylinder. Lay down towels to catch the oil.
4. Reverse steps to reinstall.
 5. Check functionality by running the cot up and down several times. If necessary, add hydraulic oil. See "Filling the Hydraulics Assembly Reservoir" on [page 104](#).
 6. Verify proper operation of the unit before returning it to service.

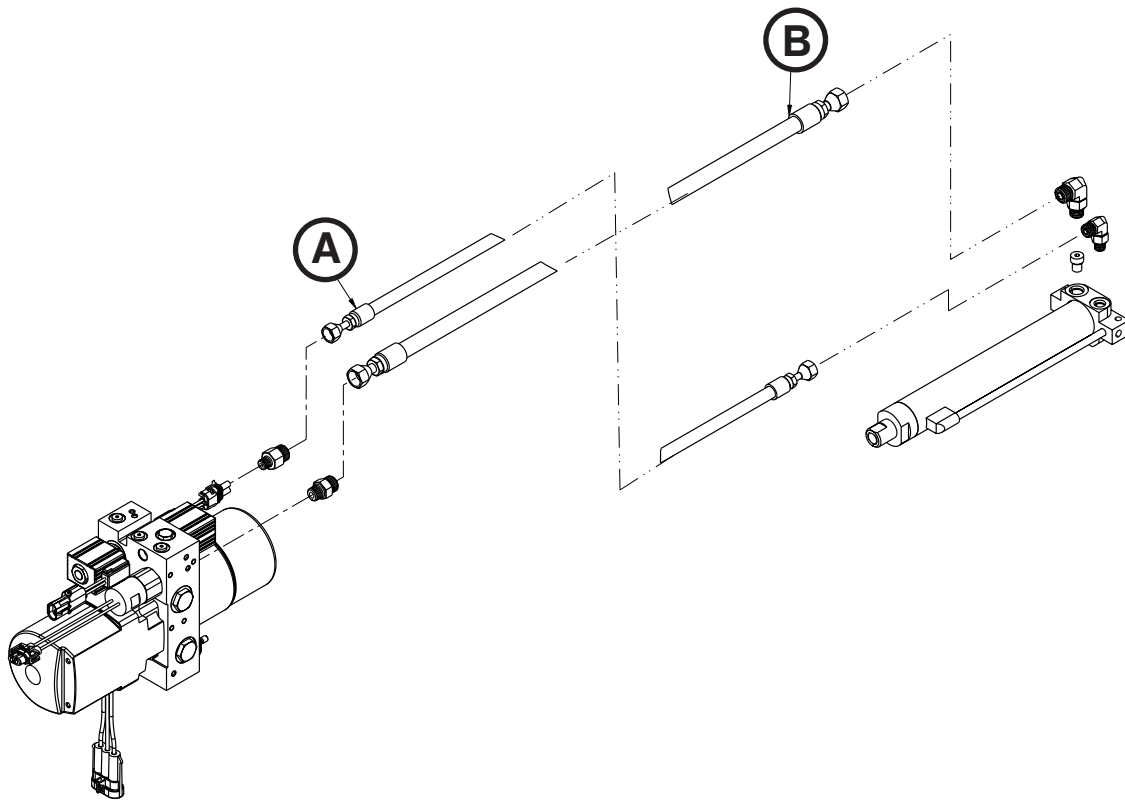

Figure 114

Service Information

TERMINAL BLOCK REPLACEMENT

Tools Required:

- T20 Torx Driver
- T25 Torx Driver

Procedure:

1. Raise the cot to full up position.
2. Remove the battery and save for reinstallation.
3. Using a T25 Torx driver, remove the six outer button head cap screws (A) from the face plate (Figure 115). Save all screws for reinstallation.
4. Using a T20 Torx driver, remove the four inner delta screws (B) from the face plate to remove the face plate (Figure 115). Save all screws and the face plate for reinstallation.
5. Using a T20 Torx driver, remove the four delta screws (C) that secure the electronics assembly to the foot end enclosure and pull the electronics assembly out (Figure 116). Save all parts for reinstallation.
6. Unplug the black and red wires that connect the cot connector cable assembly (D) to the control board (E) (Figure 117).
7. Using a T20 Torx driver, remove the two delta screws (F) from the bottom plate of the foot end enclosure (G) to remove the enclosure (Figure 117). Save all parts for reinstallation.
8. Remove the terminal block and discard.
9. Reverse steps to reinstall.
10. Check functionality by running the cot up and down several times.
11. Verify proper operation of the unit before returning it to service.

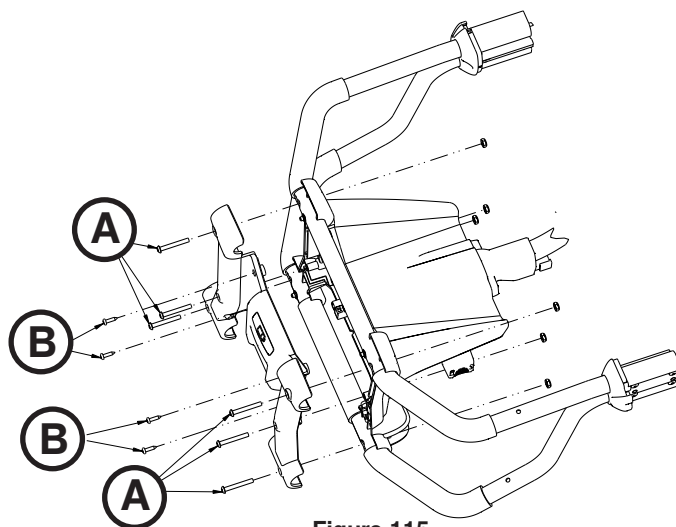

Figure 115

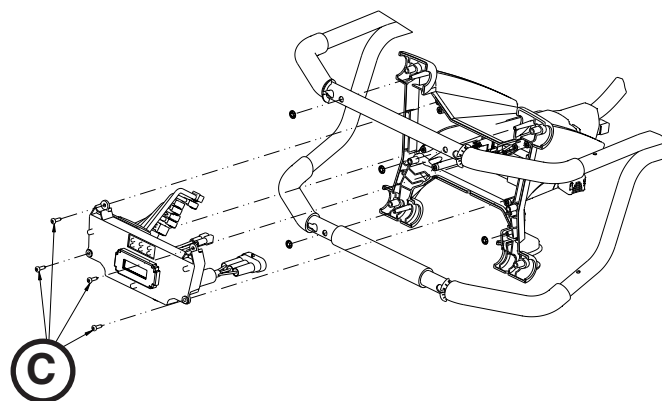

Figure 116

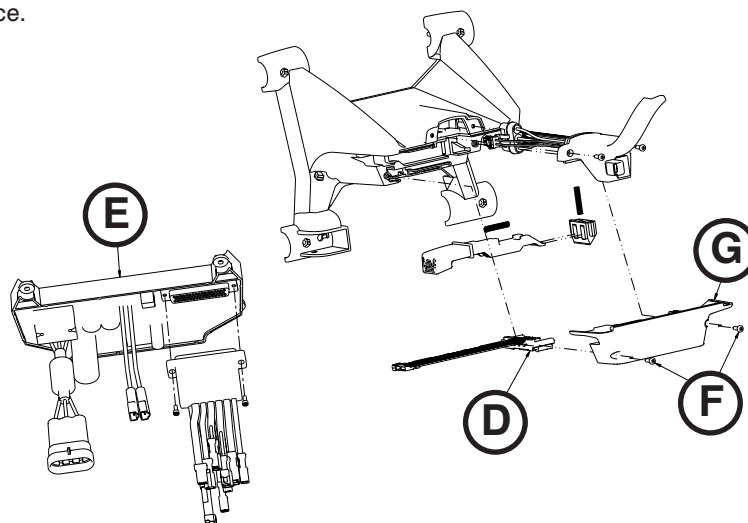

Figure 117

Service Information

SIDERAIL ASSEMBLY REPLACEMENT (STANDARD)

Tools Required:

- T25 Torx Driver

Procedure:

1. Raise the cot to the full upright position.
2. Raise the siderail to the up and locked position.
3. Using a T25 driver, remove the three spindle screws that secure the siderail assembly.
4. Remove the siderail.
5. Reverse the above procedures to install the new siderail assembly.
6. Verify proper operation of the unit before returning it to service.

Service Information

SIDERAIL ASSEMBLY REPLACEMENT (XPS OPTION)

Tools Required:

- T25 Torx Driver
- 1/4" Hex Wrench
- 3/16" Hex Wrench
- Slotted Screwdriver
- Deadblow Hammer
- Torque Wrench (ft-lb)

Procedure:

1. Raise the cot and the fowler to the full upright position.
2. Remove the mattress.
3. Using a T25 Torx driver, remove the button head cap screw (A) and black bumper (B) on the side where you are replacing the siderail (Figure 118). Save the screw and bumper for reinstallation.
4. Using a slotted screwdriver, remove the outer rail bumper.

Note: When removing the outer rail bumper, hold on to the siderail main assembly, so it does not fall off. Also, note that the head end and middle siderail pivots may be loose and could fall off of the main assembly.

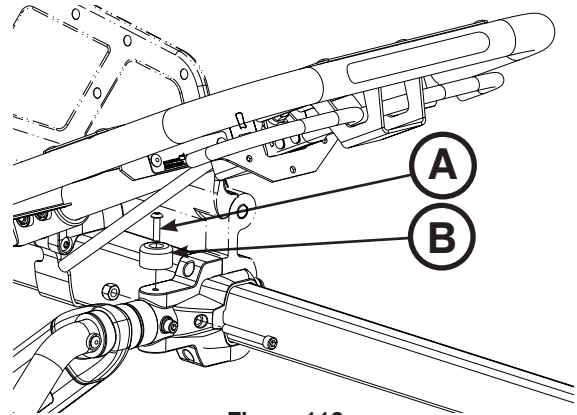

Figure 118

5. Using a 1/4" hex wrench, remove the socket head cap screws (C) that secure the siderail clamp (D) to the ratchet assembly at the foot end of the main assembly (Figure 119). During installation, torque both new screws to 22 ± 3.3 ft-lb.

Note: The siderail will be loose, so do not operate or pull on the siderail.

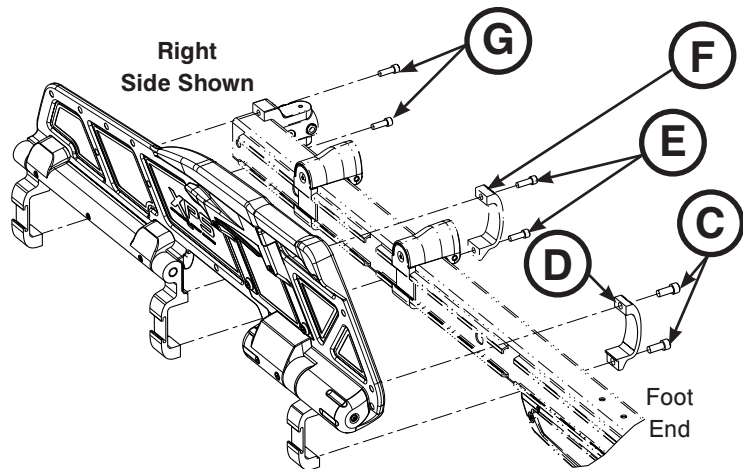

Figure 119

6. Using a 3/16" hex wrench, remove the two socket head cap screws (E) that secure the middle siderail clamp (F) to the outer rail assembly (Figure 119).
7. Using a 3/16" hex wrench, remove the two socket head cap screws (G) that secure the top and bottom of the base/litter interface bracket to the outer rail assembly (Figure 119).
8. Reverse steps to reinstall. Use a deadblow hammer to reinstall the outer rail bumper.
9. Verify proper operation of the unit before returning it to service.

Service Information

RATCHET ASSEMBLY REPLACEMENT (XPS OPTION)

Tools Required:

- 3/32" Hex Wrench
- 1/4" Hex Wrench
- 3/16" Hex Wrench
- Torque Wrench (ft-lb)

Procedure:

1. Raise the cot and the fowler to the full upright position.
2. Raise the siderail to the up and locked position.
3. Using a 3/32" hex wrench, remove the two screws (A) that secure the ratchet cover (B) to the ratchet assembly. Remove the cover (Figure 120).
4. Using a 1/4" hex wrench, remove the socket head cap screws (C) that secure the siderail clamp (D) to the ratchet assembly at the foot end of the main assembly (Figure 120). During installation, torque both new screws to 22 ± 3.3 ft-lb.
5. Using a 3/16" hex wrench, remove the four screws (E) that secure the ratchet assembly (F) to the overmold assembly and discard, then remove the ratchet assembly (Figure 120). During installation, torque the four new screws to 9.5 ± 1.5 ft-lb.
6. Grasp the ratchet assembly and pull it toward the head end of the cot to remove.
7. Reverse steps to reinstall.
8. Verify proper operation of the unit before returning it to service.

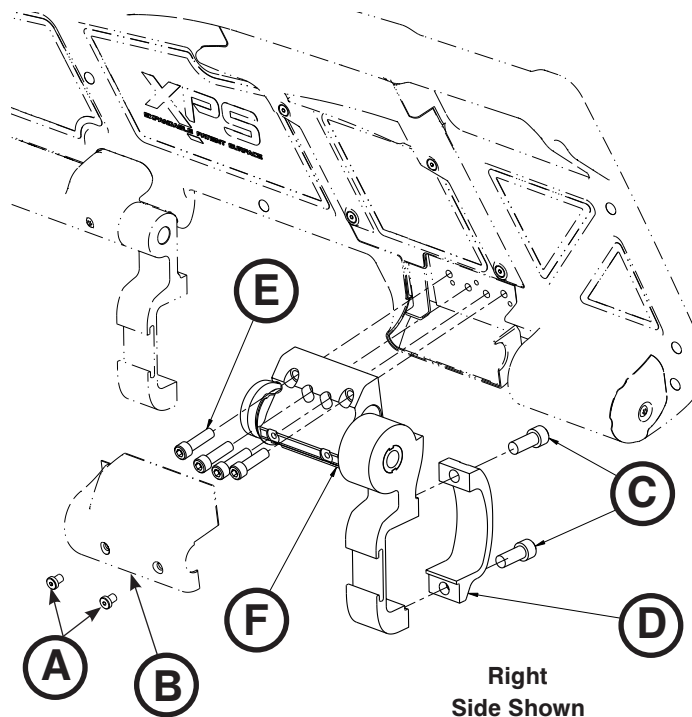

Figure 120

Service Information

RELEASE HANDLE ASSEMBLY REPLACEMENT (XPS OPTION)

Tools Required:

- 3/32" Hex Wrench
- Small Slotted Screwdriver

Procedure:

1. Raise the cot and the fowler to the full upright position.
2. Raise the siderail to the up and locked position.
3. Using a 3/32" hex wrench, remove the four screws (A) that secure the release cover (B) to the overmold assembly to remove the release cover (Figure 121).
4. Using a small slotted screwdriver, pry the release handle return spring (C) up to remove the spring (Figure 121).
5. Grasp the release handle assembly (D), and hinge it upward on the spring side to remove it from the cover (Figure 121).
6. Reverse steps to reinstall.
7. Verify proper operation of the unit before returning it to service.

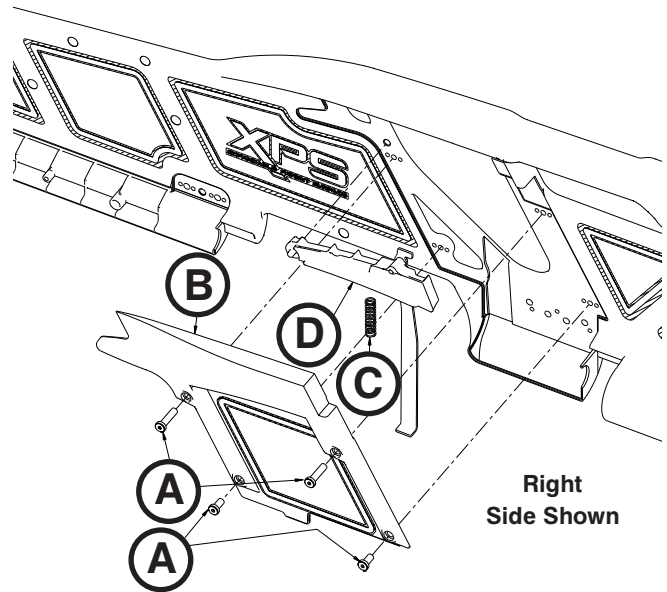

Figure 121

SPRING HANDLE ASSEMBLY REPLACEMENT (XPS OPTION)

Tools Required:

- 3/32" Hex Wrench
- Small Slotted Screwdriver

Procedure:

1. Raise the cot and the fowler to the full upright position.
2. Raise the siderail to the up and locked position.
3. Using a 3/32" hex wrench, remove the four screws (A) that secure the release cover (B) to the overmold assembly to remove the release cover (Figure 121).
4. Using a small slotted screwdriver, pry the release handle return spring (C) up to remove the spring (Figure 121).
5. Reverse steps to reinstall.
6. Verify proper operation of the unit before returning it to service.

Warranty

Stryker EMS, a division of the Stryker Corporation, offers one warranty option in the United States:

Two (2) year parts and labor. Stryker EMS warrants to the original purchaser that its products should be free from manufacturing non-conformances that affect product performance and customer satisfaction for a period of two (2) years after date of delivery. Stryker's obligation under this warranty is expressly limited to supplying replacement parts and labor for, or replacing, at its option, any product that is, in the sole discretion of Stryker, found to be defective. Expendable components, i.e. mattresses, restraints, I.V. poles, storage nets, storage pouches, oxygen straps, and other soft goods, have a one (1) year limited warranty.

The Stryker **Power-PRO™** XT is designed for a 7 year expected service life under normal use conditions, and with appropriate periodic maintenance as described in the maintenance manual. Stryker warrants to the original purchaser that the welds on the **Power-PRO™** XT will be free from structural defects for the expected 7 year life of the product as long as the original purchaser owns the product. Original purchasers will also obtain a three (3) year limited parts warranty for the X-frame components of the **Power-PRO™** cot and a three (3) year limited power train warranty covering the motor pump assembly and hydraulic cylinder assembly. Stryker's obligation under this three (3) year limited warranty is expressly limited to supplying replacement parts and labor for, or replacing, at its option, any part that is, in the sole discretion of Stryker, found to be defective.

SMRT™ Power Warranties. Stryker EMS warrants the **SMRT™** Charger for the same duration as the Stryker product for which it is furnished. All **SMRT™** Paks are warranted to be free from manufacturing non-conformances that affect product performance and customer satisfaction for a period of one (1) year.

Upon Stryker's request, purchaser shall return to Stryker's factory any product or part (freight prepaid by Stryker) for which an original purchaser makes a warranty claim.

WARRANTY EXCLUSIONS AND OTHER CONDITIONS

- Any improper use or alteration or repair by unauthorized service providers in such a manner as in Stryker's judgment affects the product materially and adversely, shall void this warranty.
- Any repair of Stryker products using parts not provided or authorized by Stryker shall void this warranty.
- There are extenuating circumstances and events that may alter the performance of the products such as an ambulance accident. In Stryker's discretion, certain circumstances may allow for evaluation of the product post ambulance accident which could allow for continued use of the product. If products recommended to be removed from service are put back into service, Stryker will consider the product as being subject to unusual stress and improperly maintained. Products which are subject to unusual stress and improper maintenance are not subject to Stryker's warranty as noted above. In addition, Stryker will not indemnify any customer for any third-party claims related to injuries caused by products that have been involved in accidents.
- This warranty is void if the label bearing the serial number of the product has been removed or defaced.
- This warranty is void if the product is not purchased from an authorized Stryker dealer.

This statement constitutes Stryker EMS's entire warranty with respect to the aforesaid equipment. STRYKER MAKES NO OTHER WARRANTY OR REPRESENTATION EITHER EXPRESSED OR IMPLIED, EXCEPT AS SET FORTH HEREIN. THERE IS NO WARRANTY OF MERCHANTABILITY AND THERE ARE NO WARRANTIES OF FITNESS FOR ANY PARTICULAR PURPOSE. IN NO EVENT SHALL STRYKER BE LIABLE HEREUNDER FOR INCIDENTAL OR CONSEQUENTIAL DAMAGES ARISING FROM OR IN ANY MANNER RELATED TO SALES OR USE OF ANY SUCH EQUIPMENT.

No employee or representative of Stryker is authorized to change this warranty in any way.

Warranty

STRYKER EMS RETURN POLICY

Cots, Stair Chairs, Evacuation Chairs, Cot Fasteners and Aftermarket Accessories may be returned up to 180 days of receipt if they meet the following guidelines:

Prior to 30 Days

- 30 day money back guarantee in effect
- Stryker EMS is responsible for all charges
- Returns will not be approved on modified items

Prior to 90 Days

- Product must be **unused, undamaged** and in the original packaging
- Customer is responsible for a 10% restocking fee

Prior to 180 Days

- Product must be **unused, undamaged** and in the original packaging
- Customer is responsible for a 25% restocking fee

RETURN AUTHORIZATION

Stryker customer service department must approve any merchandise return and will provide an authorization number to be printed on any returned merchandise. Stryker reserves the right to charge shipping and restocking fees on returned items. **SPECIAL, MODIFIED, OR DISCONTINUED ITEMS NOT SUBJECT TO RETURN.**

DAMAGED MERCHANDISE

ICC Regulations require that claims for damaged merchandise must be made with the carrier within fifteen (15) days of receipt of merchandise. **DO NOT ACCEPT DAMAGED SHIPMENTS UNLESS SUCH DAMAGE IS NOTED ON THE DELIVERY RECEIPT AT THE TIME OF RECEIPT.** Upon prompt notification, Stryker will file a freight claim with the appropriate carrier for damages incurred. Claim will be limited in amount to the actual replacement cost. In the event that this information is not received by Stryker within the fifteen (15) day period following the delivery of the merchandise, or the damage was not noted on the delivery receipt at the time of receipt, the customer will be responsible for payment of the original invoice in full.

Claims for any short shipment must be made within thirty (30) days of invoice.

INTERNATIONAL WARRANTY CLAUSE

This warranty reflects U.S. domestic policy. Warranty outside the U.S. may vary by country. Please contact your local Stryker Medical representative for additional information.

PATENT INFORMATION

The Stryker **Power-PRO™** XT cot is covered by one or more of the following patents:

United States	5,537,700	5,575,026	6,908,133	7,398,571	7,540,047
---------------	-----------	-----------	-----------	-----------	-----------

Other patents pending

The Stryker **SMRT™** Power System is covered by one or more of the following patents:

United States	5,977,746	6,018,227
---------------	-----------	-----------

Other patents pending

EMC Information

POWER-PRO XT

Guidance and manufacturer's declaration - electromagnetic emissions		
The Model 6506 Power-PRO™ XT cot is intended for use in the electromagnetic environment specified below. The customer or the user of the Model 6506 Power-PRO™ XT cot should assure that it is used in such an environment.		
Emissions test	Compliance	Electromagnetic environment - guidance
RF emissions CISPR 11	Group 1	The Model 6506 Power-PRO™ XT cot uses RF energy only for its internal function. Therefore, its RF emissions are very low and are not likely to cause any interference in nearby electronic equipment.
RF emissions CISPR 11	Group 2	The Model 6506 Power-PRO™ XT cot must emit electromagnetic energy in order to perform its intended function. Nearby electronic equipment may be affected.
RF emissions CISPR 11	Cot: Class A	The Model 6506 Power-PRO™ XT cot is suitable for use in all establishments other than domestic and those directly connected to the public low-voltage power supply network that supplies buildings used for domestic purposes.
	SMRT™ Charger (6500-201-010): Class A	The SMRT™ Charger is suitable for use in all establishments other than domestic establishments other than domestic and those directly connected to the public low-voltage power supply network that supplies buildings used for domestic purposes.
Harmonic emissions IEC 61000-3-2	Cot: N/A	Not applicable
	SMRT™ Charger (6500-201-010): Class A	
Voltage fluctuations flicker emissions IEC 61000-3-3	Cot: N/A	Not applicable
	SMRT™ Charger (6500-201-010): Complies	

EMC Information

POWER-PRO™ XT (CONTINUED)

Guidance and manufacturer's declaration - electromagnetic immunity			
The Model 6506 Power-PRO™ XT cot is intended for use in the electromagnetic environment specified below. The customer or user of the Model 6506 Power-PRO™ XT cot should assure that it is used in such an environment.			
IMMUNITY test	EN/IEC 60601 test level	Compliance level	Electromagnetic environment - guidance
Electrostatic discharge (ESD) EN/IEC 61000-4-2	±6 kV contact ±8 kV air	±6 kV contact ±8 kV air	Floors should be wood, concrete or ceramic tile. If floors are covered with synthetic material, the relative humidity should be at least 30%. Applies to: • Cot • SMRT™ Charger (6500-201-010)
Electrostatic fast transient/burst IEC 61000-4-4	±2 kV for power supply lines ±1 kV for input/output lines	±2 kV for power supply lines ±1 kV for input/output lines	Mains power quality should be that of a typical commercial or hospital environment. Applies to: • SMRT™ Charger (6500-201-010)
Surge IEC 61000-4-5	±8 kV differential mode ±2 kV common mode	±8 kV differential mode ±2 kV common mode	Mains power quality should be that of a typical commercial or hospital environment. Applies to: • SMRT™ Charger (6500-201-010)
Voltage dips, short interruptions, and voltage variations on power supply input lines IEC 61000-4-11	<5% U_T (>95% dip in U_T) for 0,5 cycle 40% U_T (60% dip in U_T) for 5 cycles 70% U_T (30% dip in U_T) for 25 cycles <5% U_T (>95% dip in U_T) for 5 seconds	<5% U_T (>95% dip in U_T) for 0,5 cycle 40% U_T (60% dip in U_T) for 5 cycles 70% U_T (30% dip in U_T) for 25 cycles <5% U_T (>95% dip in U_T) for 5 seconds	Mains power quality should be that of a typical commercial or hospital environment. If the user of the charger requires continued operation during power main interruptions, it is recommended that the device be powered from an uninterrupted power supply or a battery.
Power frequency (50/60Hz) magnetic field EN/IEC 61000-4-8	3A/m	3A/m	Power frequency magnetic fields should be at levels characteristic of a typical location in a typical commercial or hospital environment. Applies to: • Cot • SMRT™ Charger (6500-201-010)
Note: U_T is the alternating current mains voltage prior to application of the test level.			

[Return To Table of Contents](#)

EMC Information

POWER-PRO XT (CONTINUED)

Guidance and manufacturer's declaration - electromagnetic immunity			
The Model 6506 Power-PRO™ XT cot is intended for use in the electromagnetic environment specified below. The customer or user of the Model 6506 Power-PRO™ XT cot should assure that it is used in such an environment.			
IMMUNITY test	EN/IEC 60601 test level	Compliance level	Electromagnetic environment - guidance
Conducted RF EN/IEC 61000-4-6	3 Vrms 150 kHz to 80 MHz	3 Vrms	<p>Portable and mobile RF communications equipment should be used no closer to any part of the model 6506 Power-PRO™ XT cot, including cables, than the recommended separation distance calculated from the equation appropriate for the frequency of the transmitter.</p> <p>Recommended separation distance $d=1.2\sqrt{P}$</p> <p>Applies to:</p> <ul style="list-style-type: none"> • SMRT™ Charger (6500-201-010)

EMC Information

POWER-PRO™ XT (CONTINUED)

Guidance and manufacturer's declaration - electromagnetic immunity			
The Model 6506 Power-PRO™ XT cot is intended for use in the electromagnetic environment specified below. The customer or user of the Model 6506 Power-PRO™ XT cot should assure that it is used in such an environment.			
IMMUNITY test	EN/IEC 60601 test level	Compliance level	Electromagnetic environment - guidance
Radiated RF EN/IEC 61000-4-3	20 V/m 80 MHz to 2,5 GHz	20 V/m	<p>Portable and mobile RF communications equipment should be used no closer to any part of the Model 6506 Power-PRO™ XT cot, including cables, than the recommended separation distance calculated from the equation applicable to the frequency of the transmitter.</p> <p>Recommended separation distance:</p> <p>$D=(1.2)(\sqrt{P})$</p> <p>$D=(0.18)(\sqrt{P})$ 80 MHz to 800 MHz</p> <p>$D=(0.35)(\sqrt{P})$ 800 MHz to 2,5 GHz</p> <p>where P is the maximum output power rating of the transmitter in watts (W) according to the transmitter manufacturer and d is the recommended separation distance in metres (m).</p> <p>Field strengths from fixed RF transmitters, as determined by an electromagnetic site survey, ^a should be less than the compliance level in each frequency range. ^b</p> <p>Interference may occur in the vicinity of equipment with the following symbol:</p> <div style="text-align: center;">  </div>
<p>NOTE 1: At 80 MHz and 800 MHz, the higher frequency range applies.</p> <p>NOTE 2: These guidelines may not apply in all situations. Electromagnetic propagation is affected by absorption and reflection from structures, objects and people.</p>			
<p>^a Field strengths from fixed transmitters, such as base stations for radio (cellular/cordless) telephones and land mobile radios, amateur radio, AM and FM radio broadcast, and TV broadcast cannot be predicted theoretically with accuracy. To assess the electromagnetic environment due to fixed RF transmitters, an electromagnetic site survey should be considered. If the measured field strength in the location in which the Model 6506 Power-PRO™ XT cot is used exceeds the applicable RF compliance level above, the Model 6506 Power-PRO™ XT cot should be observed to verify normal operation. If abnormal performance is observed, additional measures may be necessary, such as re-orienting or relocating the Model 6506 Power-PRO™ XT cot.</p> <p>^b Over the frequency range 150 kHz to 80 MHz, field strengths are less than 20 V/m.</p>			

[Return To Table of Contents](#)

EMC Information

POWER-PRO™ XT (CONTINUED)

Recommended separations distances between portable and mobile RF communication equipment and the Model 6506 Power-PRO™ XT cot			
<p>The Model 6506 Power-PRO™ XT cot is intended for use in an electromagnetic environment in which radiated RF disturbances are controlled. The customer or the user of the Model 6506 Power-PRO™ XT cot can help prevent electromagnetic interference by maintaining a minimum distance between portable and mobile RF communications equipment (transmitters) and the Model 6506 Power-PRO™ XT cot as recommended below, according to the maximum output power of the communications equipment.</p>			
Rated maximum output power of transmitter W	Separation distance according to frequency of transmitter m		
	150 kHz to 80 MHz $D=(1.2)(\sqrt{P})$	80 MHz to 800 MHz $D=(0.18)(\sqrt{P})$	800 MHz to 2,5 GHz $D=(0.35)(\sqrt{P})$
0.01	0.12	0.018	0.035
0.1	0.38	0.57	0.11
1	1.2	0.18	0.35
10	3.8	0.57	1.1
100	12	1.8	3.5
<p>For transmitters rated at a maximum output power not listed above, the recommended separation distance d in meters (m) can be estimated using the equation applicable to the frequency of the transmitter, where P is the maximum output power rating of the transmitter in watts (W) according to the transmitter manufacturer.</p>			
<p>NOTE 1: At 80 MHz and 800 MHz, the separation distance for the higher frequency range applies.</p>			
<p>NOTE 2: These guidelines may not apply in all situations. Electromagnetic propagation is affected by absorption and reflection from structures, objects and people.</p>			

Cot assembly

6506-001-010 Rev G (Reference only)

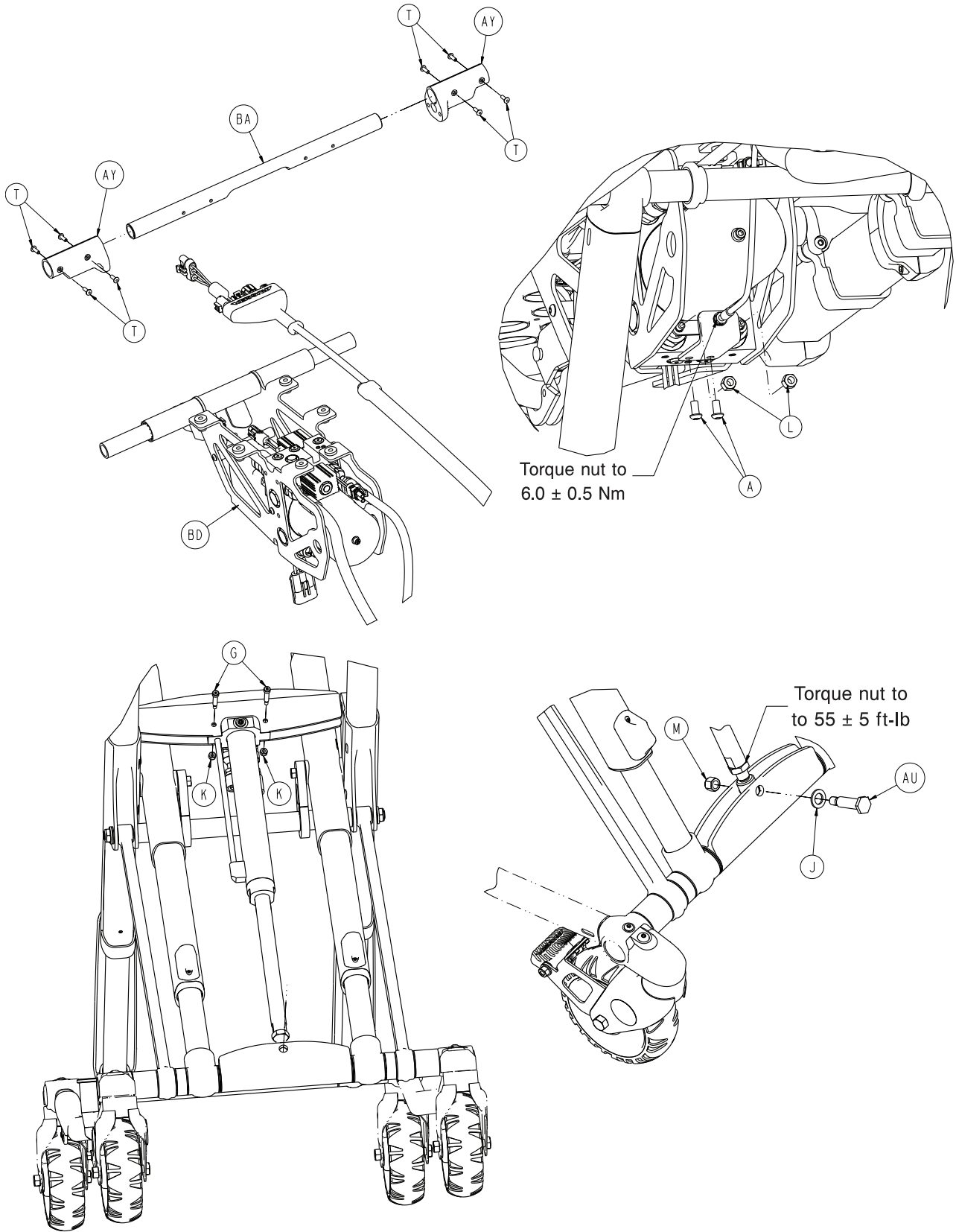

Cot assembly

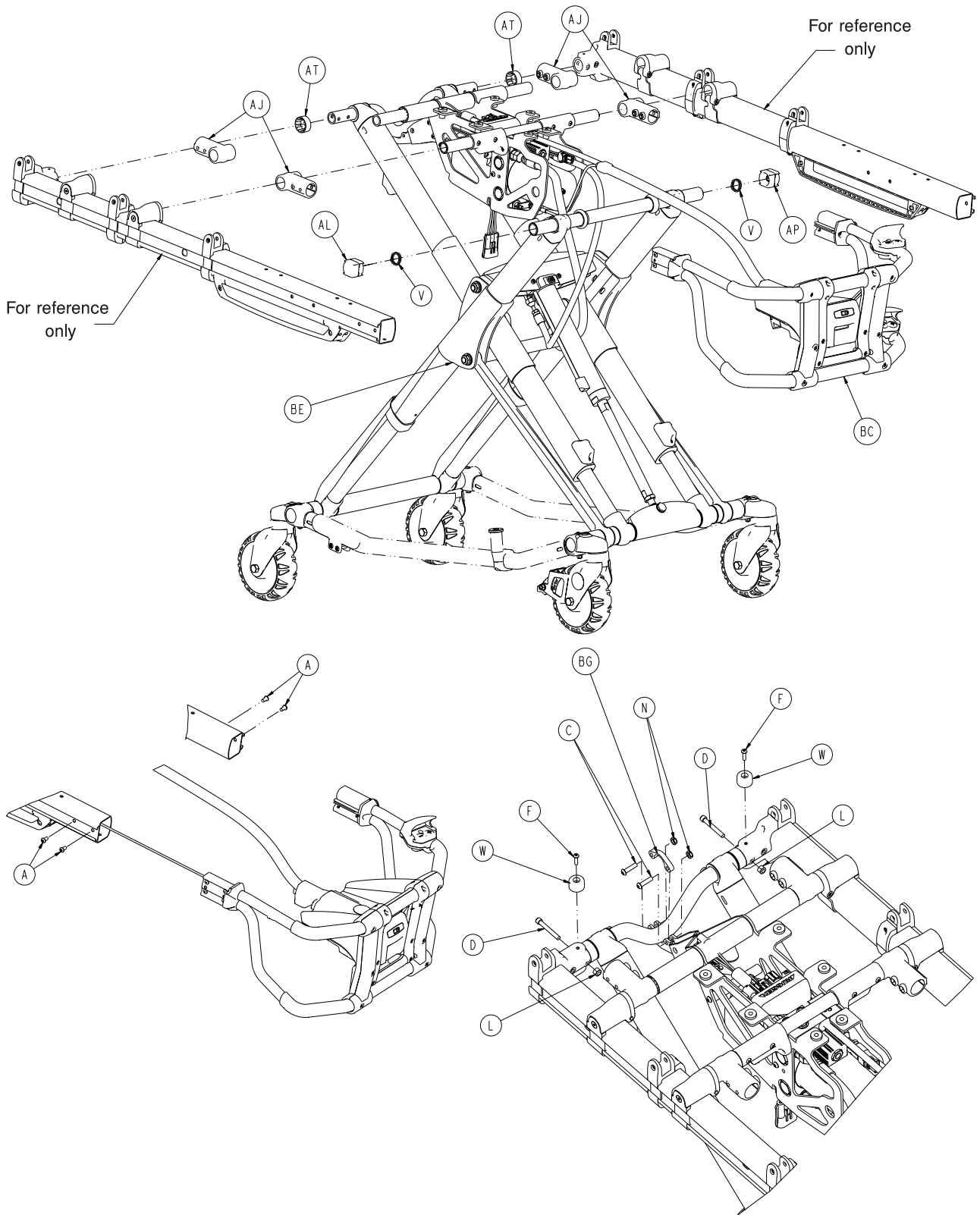

Cot assembly

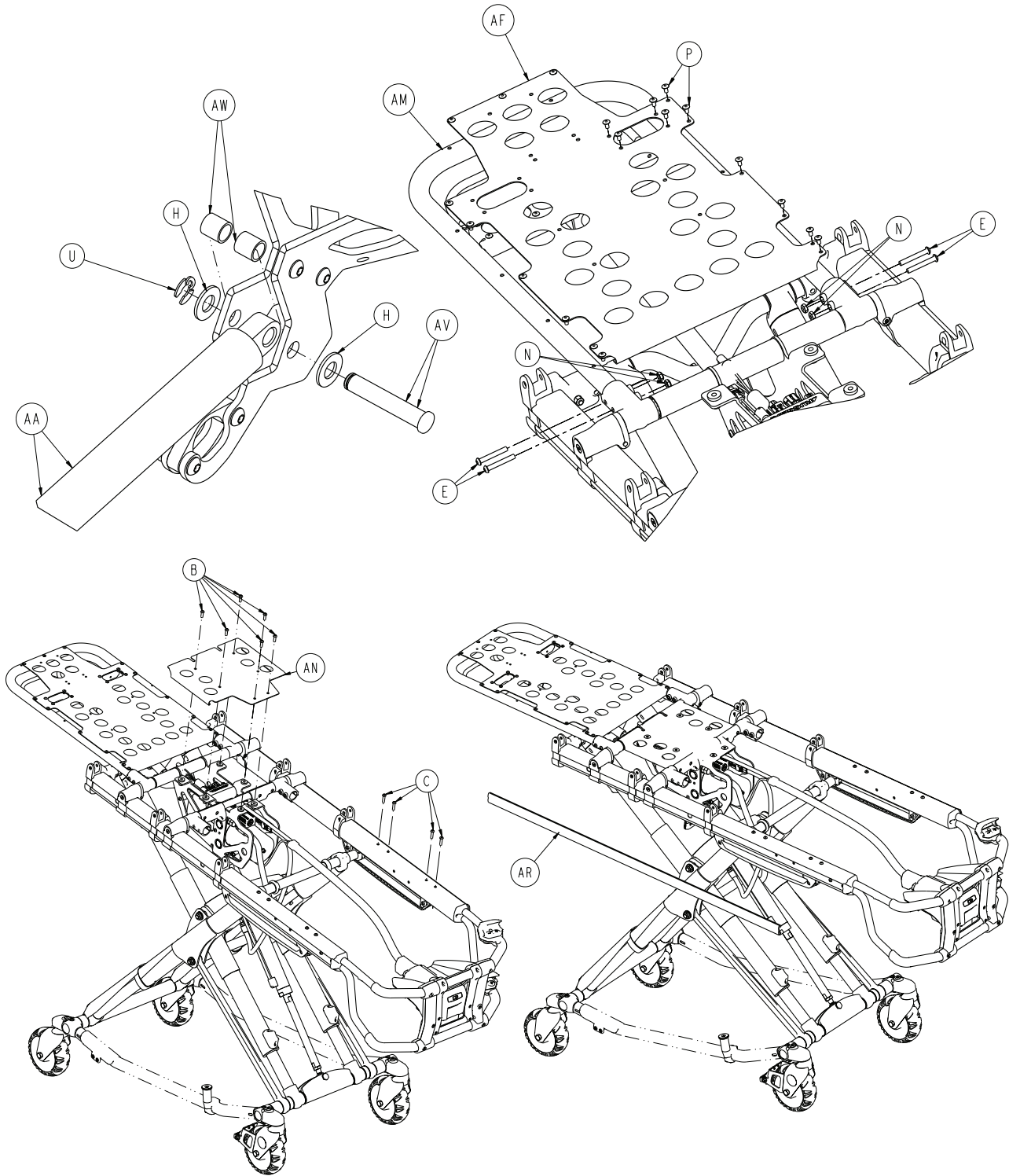

Cot assembly

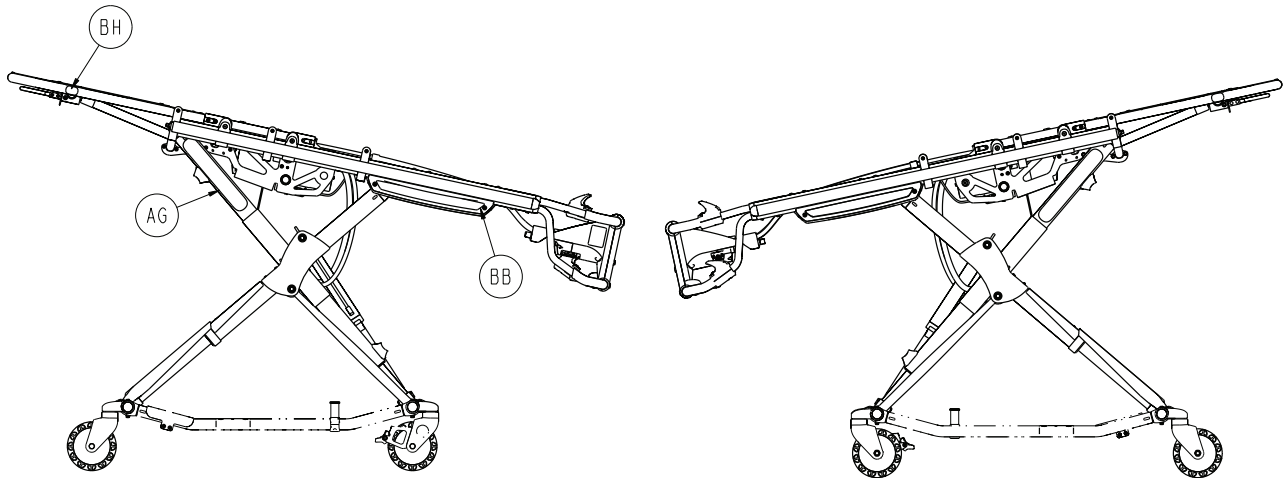
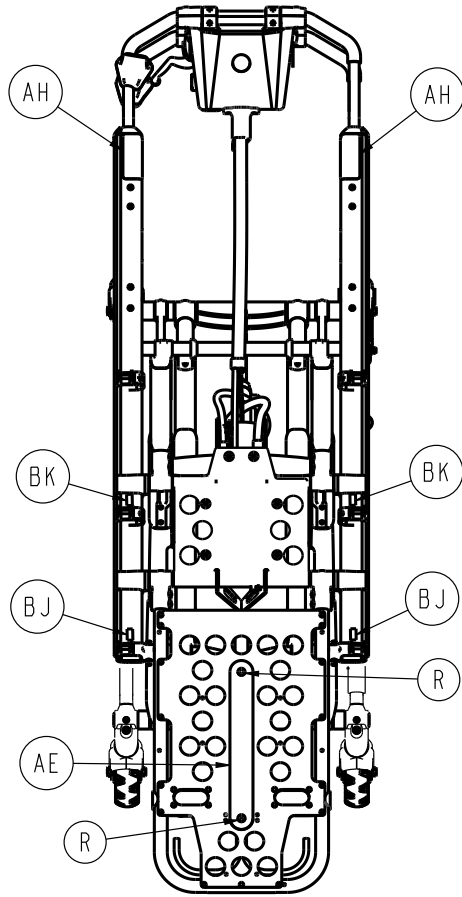

Cot assembly

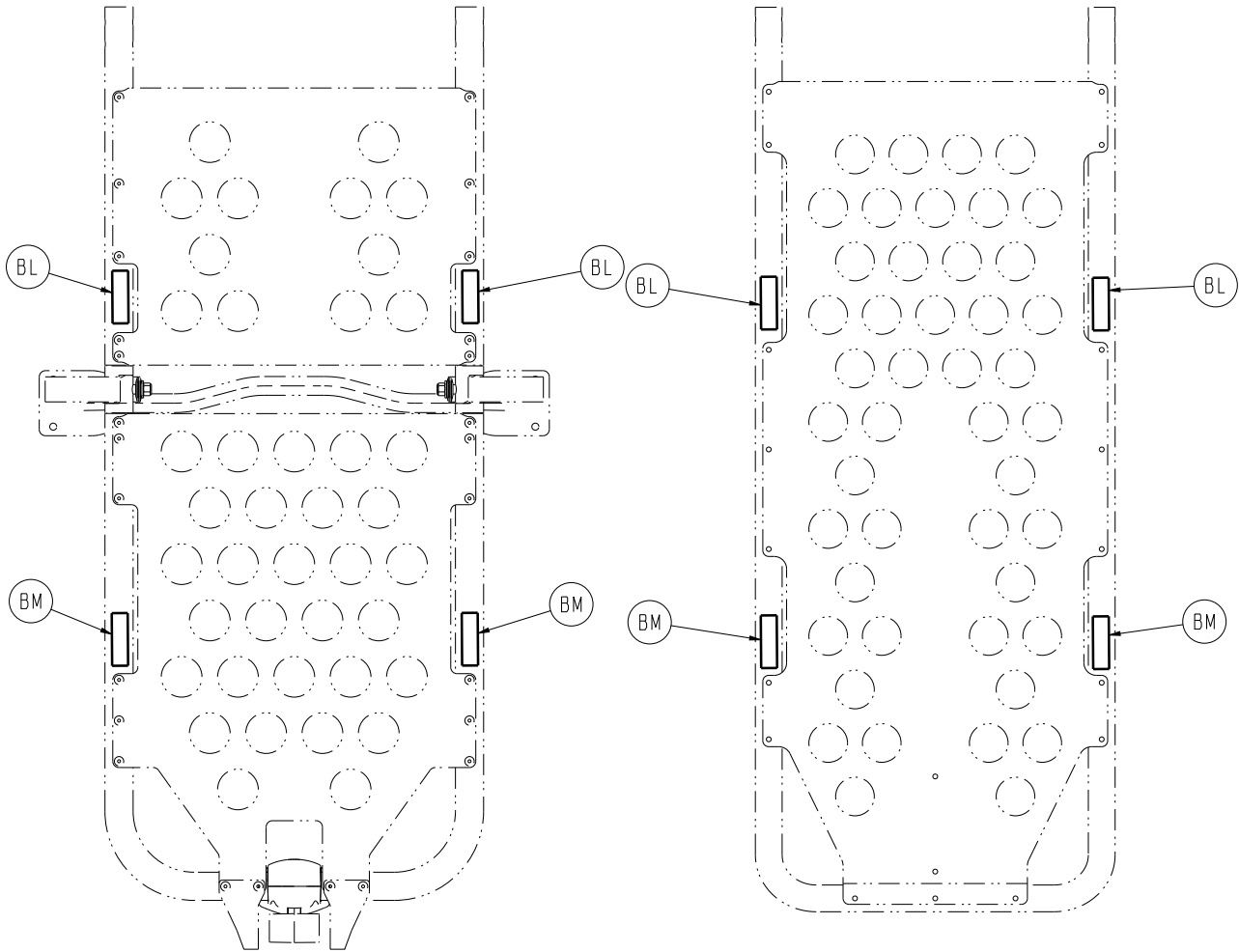
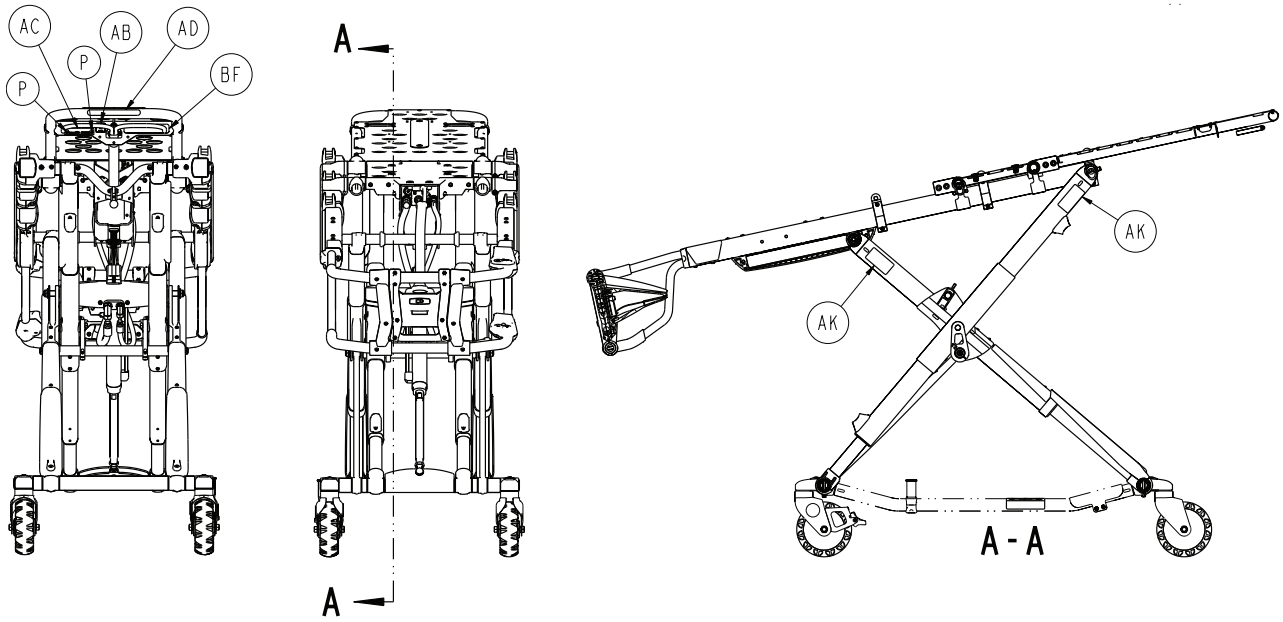

Cot assembly

Item	Part No.	Part Name	Qty
A	0004-589-000	Button head cap screw	6
B	0004-592-000	Button head cap screw	6
C	0004-594-000	Button head cap screw	10
D	0004-595-000	Button head cap screw	2
E	0004-596-000	Button head cap screw	4
F	0004-614-000	Button head cap screw	2
G	0008-030-000	Socket head cap screw	2
H	0011-004-000	Washer	2
J	0011-013-000	Washer	1
K	0016-002-000	Fiberlock hex nut	2
L	0016-028-000	Fiberlock hex nut	4
M	0016-035-000	Nylock hex nut	1
N	0016-102-000	Nylock hex nut	6
P	0025-079-000	Dome head rivet	25
R	0025-132-000	Dome head rivet	2
T	0025-133-000	Dome head rivet	8
U	0028-181-000	Truarc ring	1
V	0038-574-000	Crest-to-crest spring	2
W	0056-028-000	Black bumper, TPR	2
Y	0059-211-000	Nylon cable tie, 11"	2
AA	6500-031-077	Gas spring	1
AB	2030-009-901	Label, WEEE	1
AC	6060-090-002	Serial number tag	1
AD	6060-090-004	Label, small	1
AE	6082-001-085	2" Adhesive loop pile	1
AF	6082-032-045	Fowler skin	1
AG	6082-090-043	Label, Stryker, 11"	2
AH	6085-101-155	Label, weight capacity	2
AJ	6100-003-125	Straight "T" pivot	4
AK	6252-101-139	Label, do not lubricate	4
AL	6500-001-017	Magnet slider	1
AM	6500-001-018	Fowler assembly on page 178	1
AN	6500-001-111	Mid-section skin	1
AP	6500-001-123	Hall effects slider	1
AR	6500-001-127	Outer rail bumper	2
AT	6500-001-128	Plastic extrusion spacer	2
AU	6500-001-168	Rod attachment pin	1
AV	6085-101-143	Fowler cylinder pin	1
AW	6500-001-191	Fowler cylinder spacer	2
AY	6500-001-195	Casting motor mount	2
BA	6500-001-196	Litter cross brace	1
BB	6500-101-233	Label, sensor housing	2
BC	6500-102-015	Foot end assembly on page 166	1
BD	6500-002-031	Power assembly on page 163	1
BE	6506-001-012	Base assembly on page 132	1

Cot assembly

Item	Part No.	Part Name	Qty
BF	6506-101-100	Label, Power-PRO™ XT spec	1
BG	6500-002-195	Collar	1
BH	6506-001-901	Label, no pushing	2
BJ	6506-001-916	Label, restraint location, shoulder	2
BK	6506-001-917	Label, restraint location, waist	2
BL	6506-001-918	Label, restraint location, thigh	2
BM	6506-001-919	Label, restraint location, ankle	2

Base assembly

6506-001-012 Rev B (Reference only)

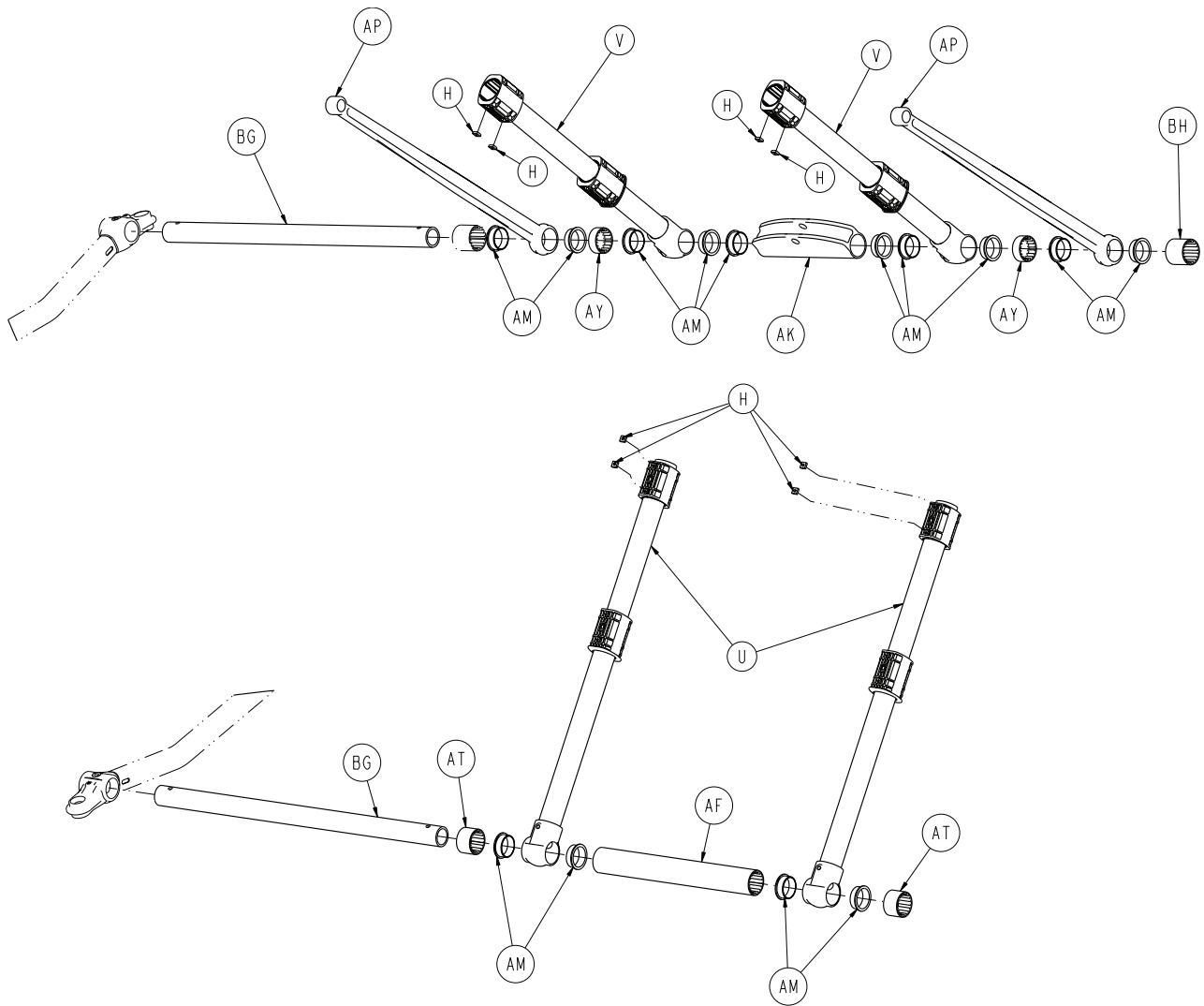

Base assembly

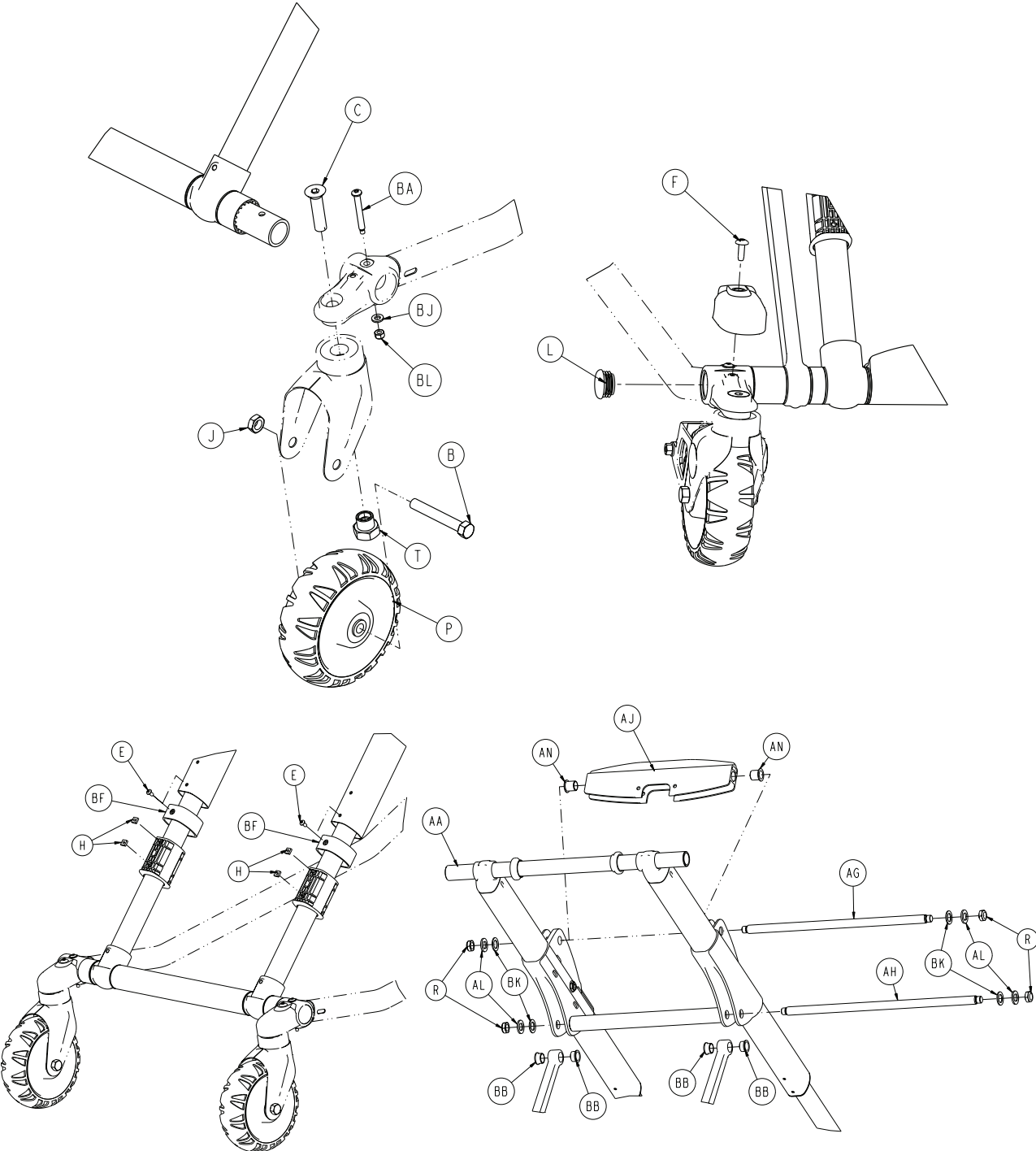

Base assembly

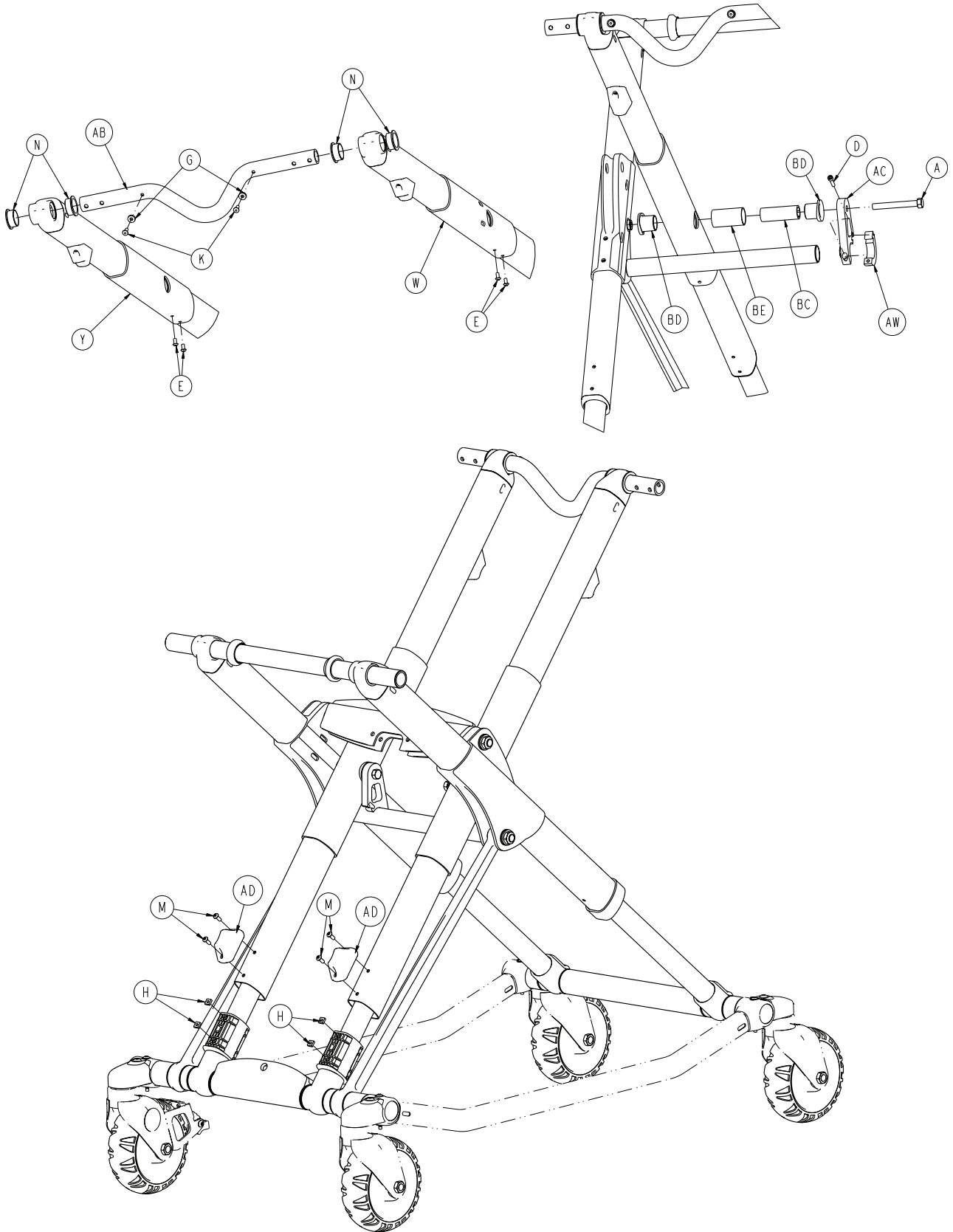

Base assembly

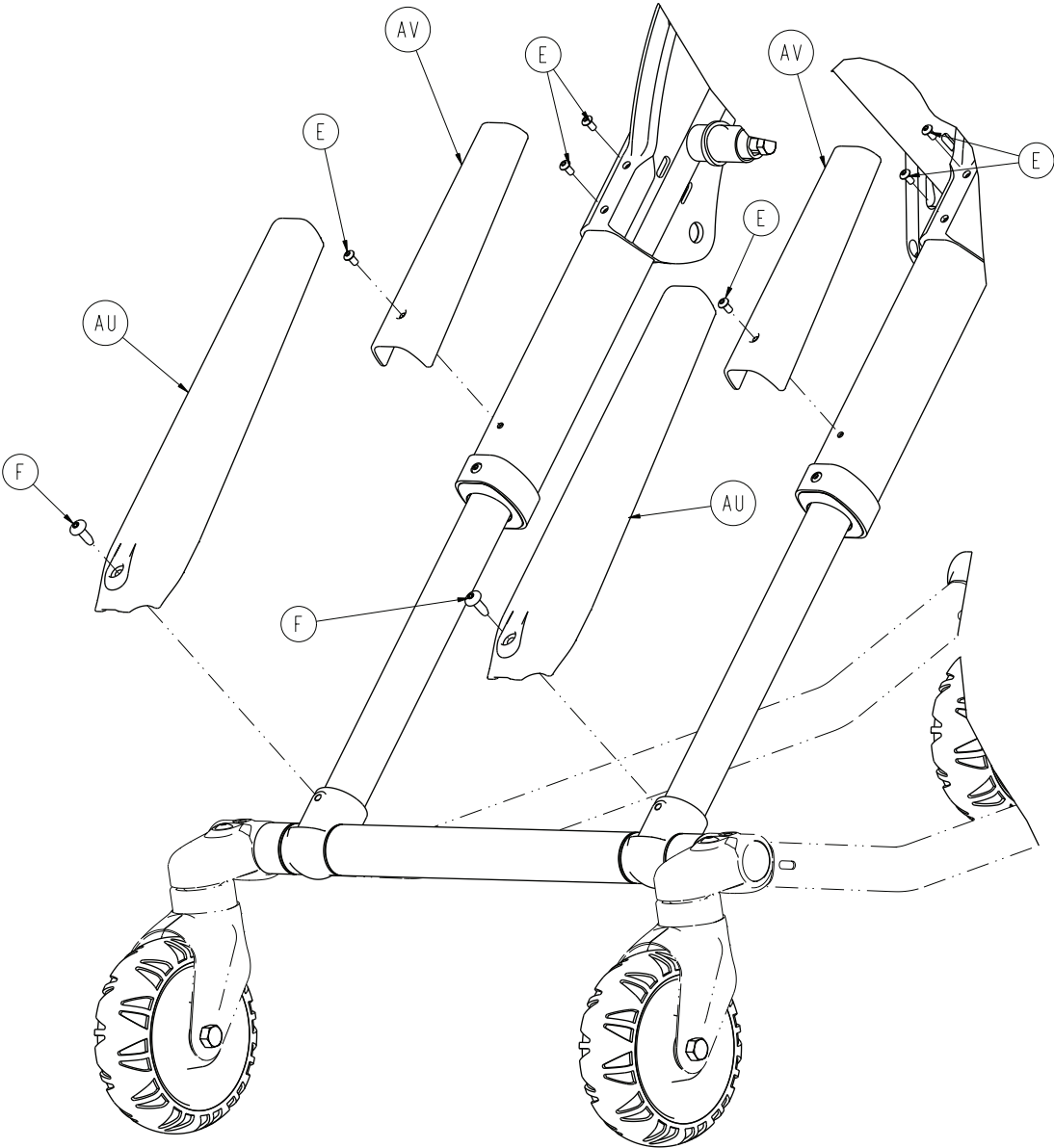

Base assembly

Item	Part no.	Part name	Qty
A	0003-388-000	Hex head cap screw	2
B	0003-205-000	Hex head cap screw	4
C	0004-319-000	Flat head socket screw	4
D	0004-659-000	Socket head cap screw	2
E	0004-587-000	Button head cap screw	12
F	0007-086-000	Truss head screw	6
G	0014-115-000	Washer	2
H	0015-051-000	Square nut	16
J	0016-060-000	Toplock hex jam nut	4
K	0025-133-000	Dome head rivet	2
L	0037-083-000	Tube plug	4
M	0004-634-000	Button head cap screw	4
N	0081-244-000	Flange bearing	4
P	6060-002-010	Wheel assembly - 6060-002-010 on page 146	4
R	0016-049-000	Nylock hex nut	4
T	6090-001-009	Caster nut	4
U	6500-301-021	Outer lift tube assembly, base pivot - 6500-301-021 on page 150	2
V	6500-301-022	Inner lift tube assembly, base pivot - 6500-301-022 on page 151	2
W	6500-001-034	Inner lift tube, litter pivot, patient right assembly - 6500-001-034 on page 152	1
Y	6500-001-035	Inner lift tube, litter pivot, patient left assembly - 6500-001-035 on page 153	1
AA	6500-001-056	Inner tube base frame	1
AB	6500-001-090	Cross tube, head end	1
AC	6500-001-308	Base strap, right	1
AD	6500-001-125	Base dead stop	2
AE	6500-001-309	Base strap, left	1
AF	6500-001-129	Plastic extrusion spacer	1
AG	6500-001-171	Cross tube cylinder mount	1
AH	6500-001-182	Cross tube stiffener bar	1
AJ	6500-001-164	Cylinder mount pivot, top	1
AK	6500-001-165	Cylinder mount pivot, bottom	1
AL	6500-001-225	D washer	4
AM	6500-001-166	Flange bearing	14
AN	6500-001-157	Flange bearing	2
AP	6500-001-172	Support link	2
AT	6500-001-178	Plastic extrusion spacer	2
AU	6500-001-179	Top x-frame guard, lower	2
AV	6500-001-180	Top x-frame guard, upper	2
AW	6500-001-310	Base strap clamp	2
AY	6500-001-183	Plastic extrusion spacer	2
BA	6085-001-097	Caster mount bolt	4
BB	6500-001-162	Flange bearing	4
BC	6500-001-341	Base tube pivot post	2

Base assembly

Item	Part no.	Part name	Qty
BD	6500-001-226	Base tube pivot bearing	4
BE	6500-001-227	Base tube pivot post	2
BF	6500-001-228	Inner lift tube sleeve	2
BG	6500-001-229	Foot base tube	2
BH	6500-001-230	Plastic extrusion spacer	1
BJ	0014-002-000	Flat washer	4
BK	0014-040-000	Flat washer	4
BL	0016-002-000	Fiberlock nut	4

No wheel lock option

6086-500-010 Rev A (Reference only)

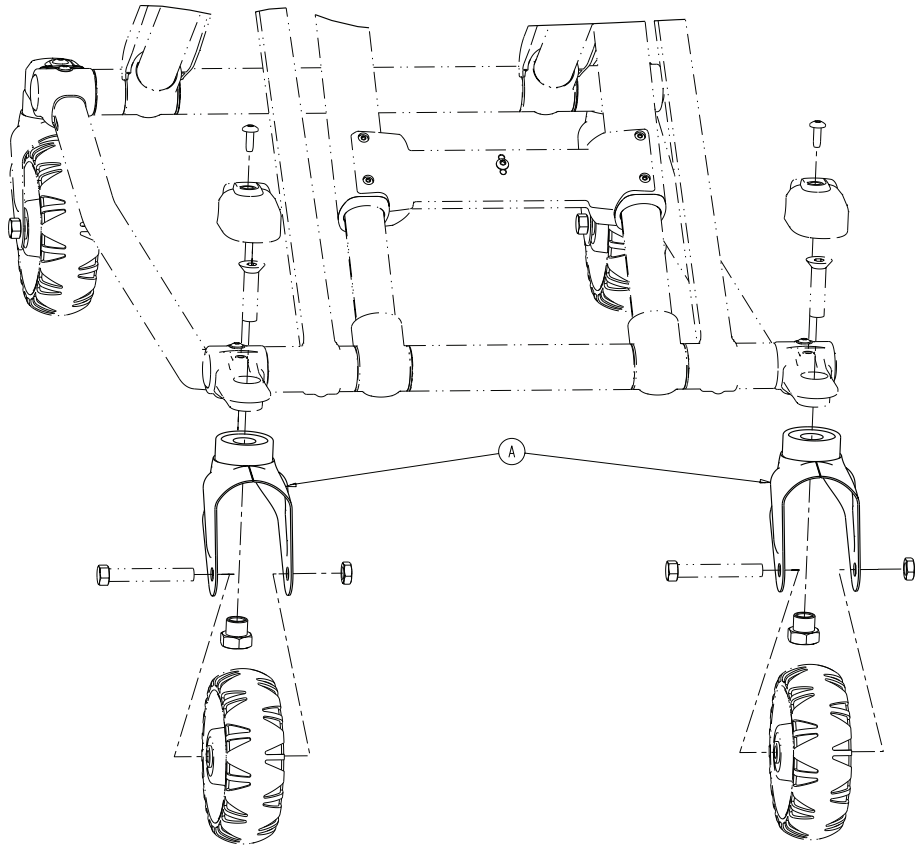

Item	Part no.	Part name	Qty
A	6082-002-012	Caster horn assembly on page 141	2

Single wheel lock option

6086-601-010 Rev A (Reference only)

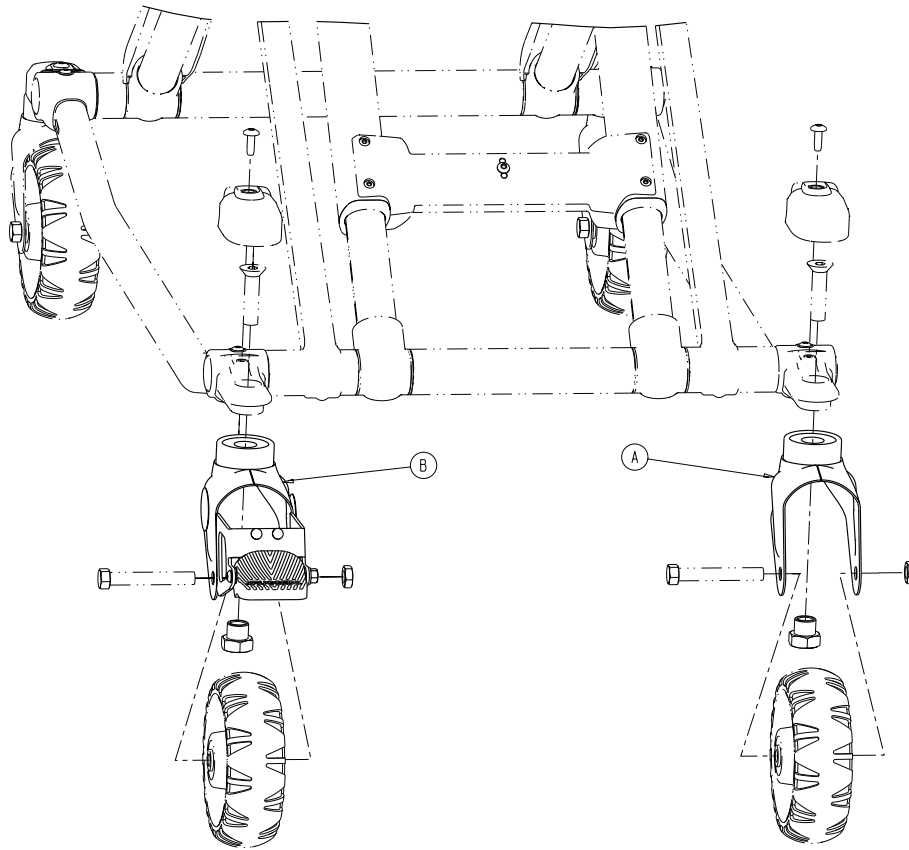

Item	Part no.	Part name	Qty
A	6082-002-012	Caster horn assembly on page 141	1
B	6086-200-010	Adjustable caster lock assembly on page 142	1

Dual wheel lock option

6086-602-010 Rev A (Reference only)

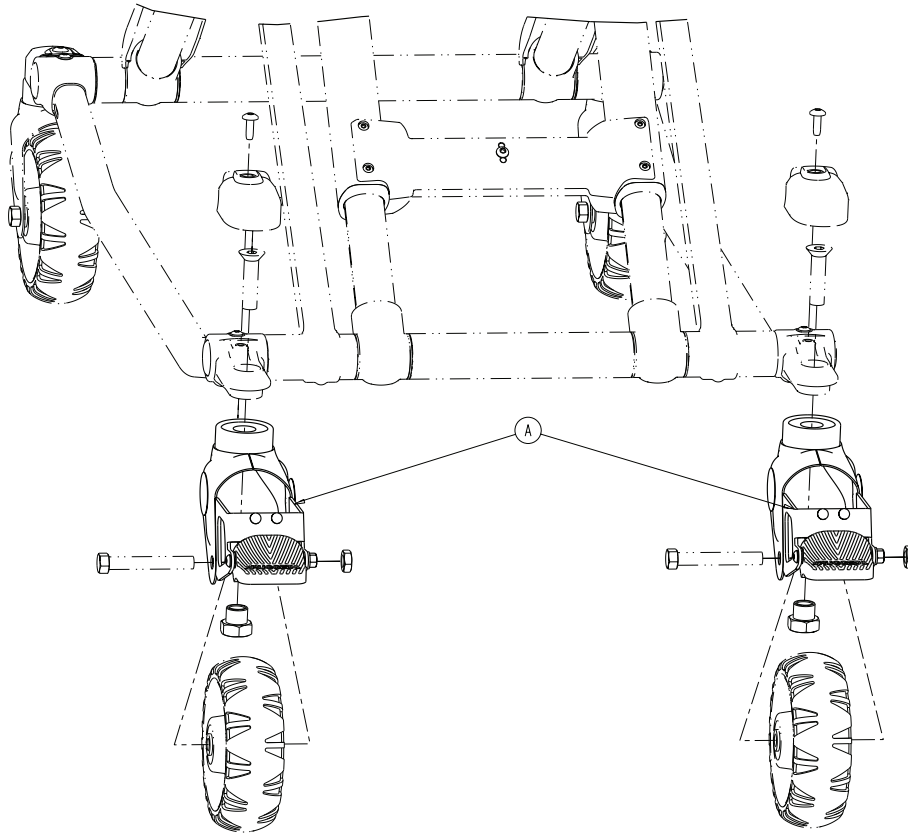

Item	Part no.	Part name	Qty
A	6086-200-010	Adjustable caster lock assembly on page 142	2

Caster horn assembly

6082-002-012 Rev C (Reference only)

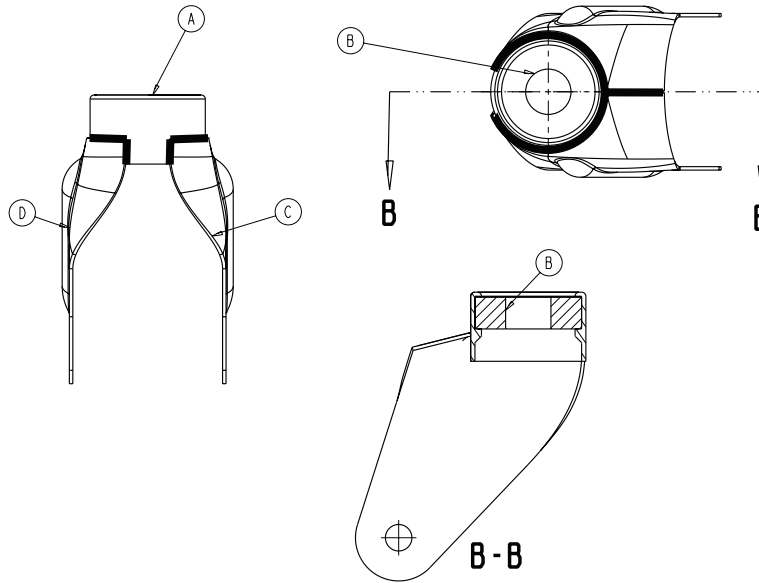

Item	Part no.	Part name	Qty
A	6082-002-039	Bearing retainer	1
B	0081-227-000	Bearing	1
C	6082-002-042	Caster horn plate, left	1
D	6082-002-043	Caster horn plate, right	1

Adjustable caster lock assembly

6086-200-010 Rev A (Reference only)

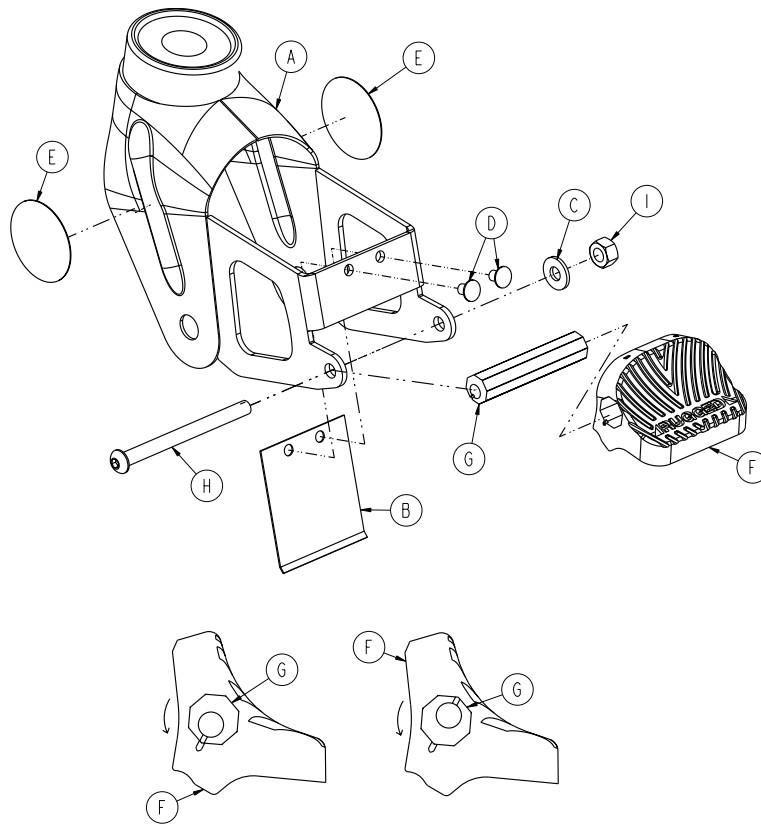

Item	Part no.	Part name	Qty
A	6082-100-012	Caster horn	1
B	6080-100-032	Spring	1
C	0011-456-000	Washer	1
D	0025-153-000	Semi-tubular rivet	2
E	6506-001-900	Label	2
F	6080-300-030	Pedal, adjustable caster lock	1
G	6080-200-041	Octagonal sleeve, adjustable caster lock	1
H	0004-098-000	Hex socket button head cap screw	1
I	0016-118-000	Centerlock nut	1

No Steer-Lock option

6506-037-000 Rev A (Reference only)

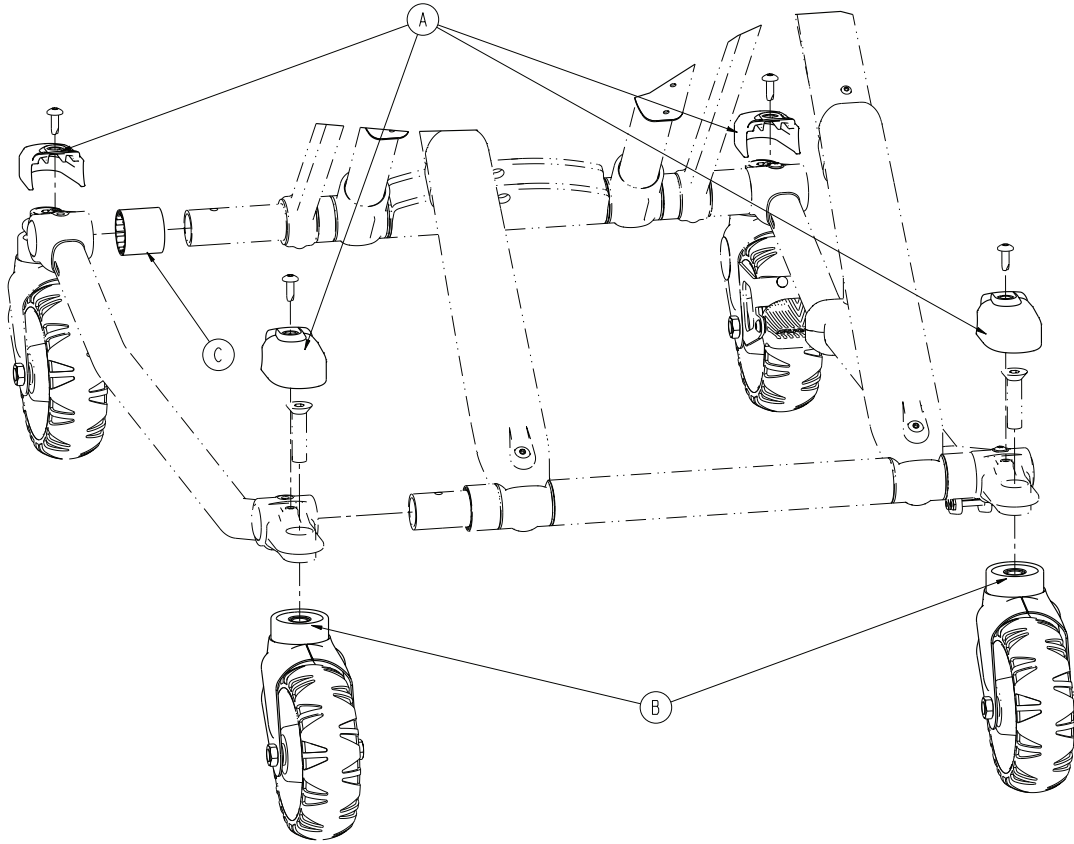

Item	Part no.	Part name	Qty
A	6500-001-177	Caster mount cover	4
B	6082-002-012	Caster horn assembly on page 141	2
C	6500-001-230	Plastic extrusion - spacer	1

Steer-Lock, optional - 6506-038-000

Rev A (Reference only)

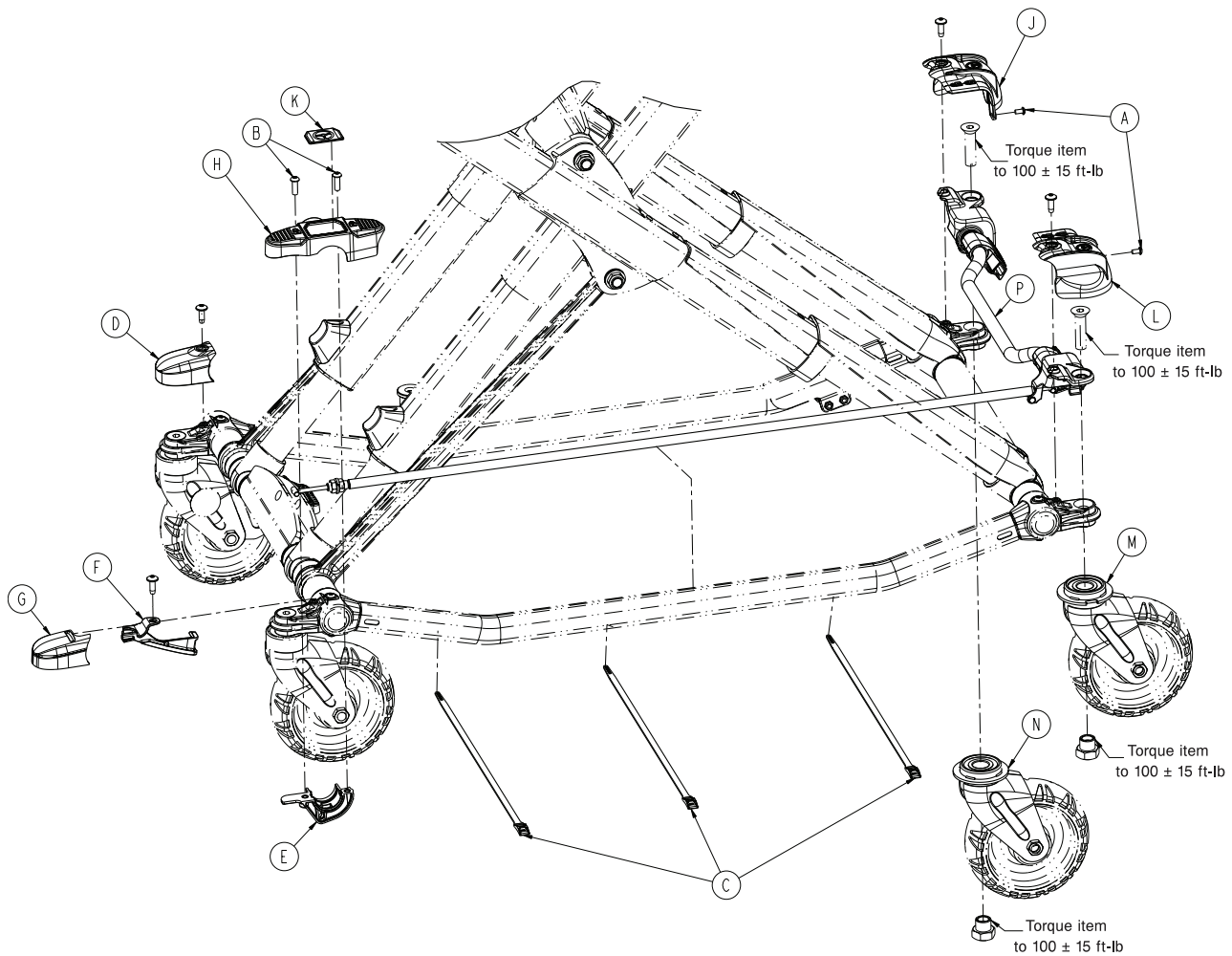

Item	Part no.	Part name	Qty
A	0004-587-000	Button head cap screw	2
B	0004-592-000	Button head cap screw	2
C	0059-211-000	Cable tie	3
D	6500-001-177	Caster mount cover	1
E	6500-002-243	Steer-Lock pedal collar, foot end	1
F	6500-002-244	Steer-Lock cable support bracket	1
G	6500-002-245	Caster mount cover	1
H	6500-002-246	Steer-Lock overmolded pedal, foot end	1
J	6500-002-247	Steer-Lock housing cover, head end	1
K	6500-002-248	Label, Steer-Lock pedal, foot end	1
L	6500-002-249	Steer-Lock housing cover, head end	1
M	6500-002-255	Steer-Lock caster horn weldment, left	1
N	6500-002-260	Steer-Lock caster horn weldment, right	1
P	6506-002-265	Steer-Lock sub assembly, head end on page 145	1

Steer-Lock sub assembly, head end

6506-002-265 Rev A (Reference only)

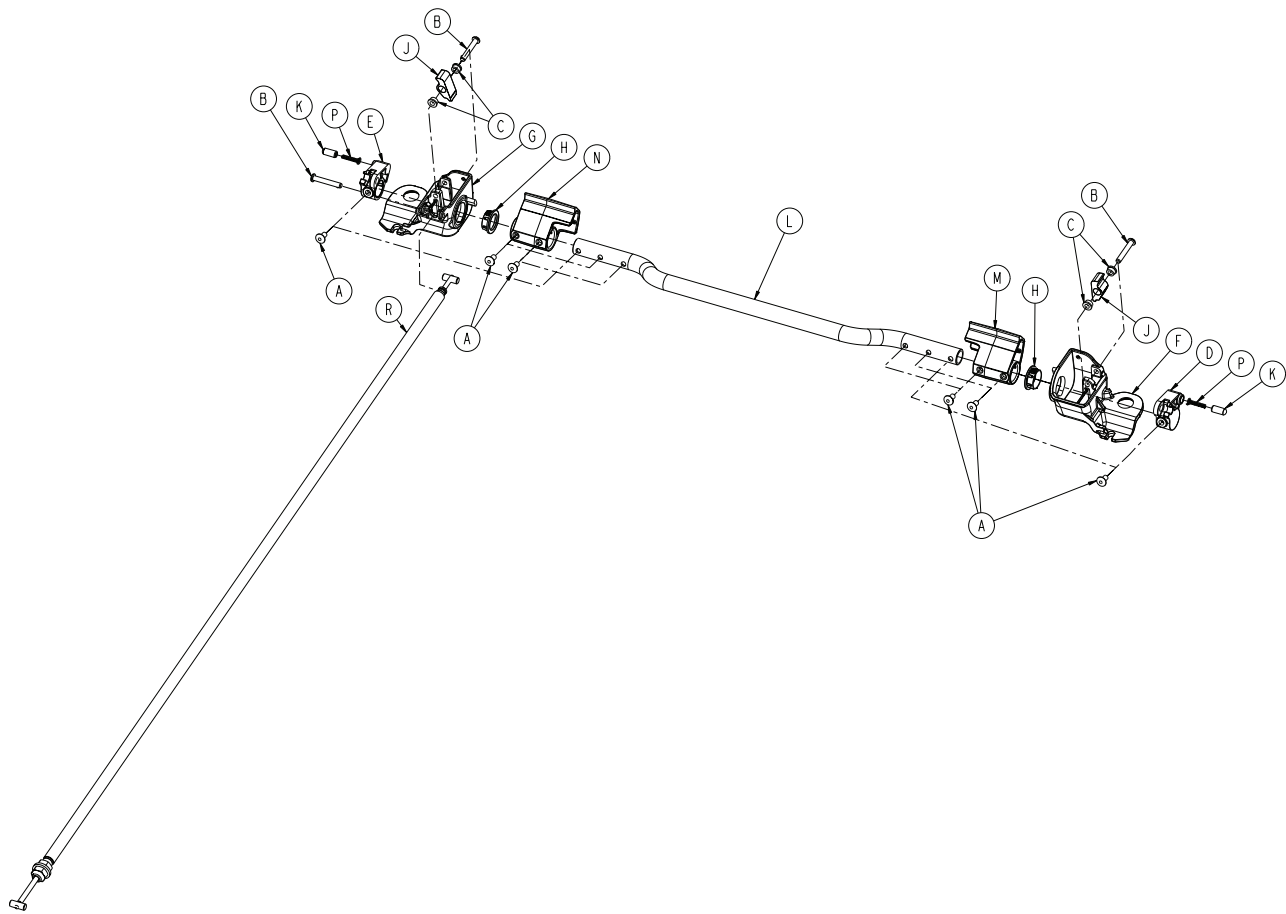

Item	Part no.	Part name	Qty
A	0025-079-000	Dome head rivet	6
B	0027-036-000	Slic pin	3
C	0081-347-000	Flange bearing	4
D	6500-002-230	Steer-Lock plunger housing	1
E	6500-002-231	Steer-Lock plunger housing	1
F	6500-002-234	Steer-Lock mechanism housing	1
G	6500-002-235	Steer-Lock mechanism housing	1
H	6500-002-236	Steer-Lock custom flange bushing	2
J	6500-002-237	Steer-Lock lock pawl	2
K	6500-002-238	Steer-Lock plunger button	2
L	6500-002-240	Steer-Lock cross tube	1
M	6500-002-241	Steer-Lock pedal, head end	1
N	6500-002-251	Steer-Lock pedal, head end	1
P	6500-002-252	Compression spring	2
R	6500-002-250	Steer-Lock push-pull flex rod assembly	1

Wheel assembly - 6060-002-010

Rev C (Reference only)

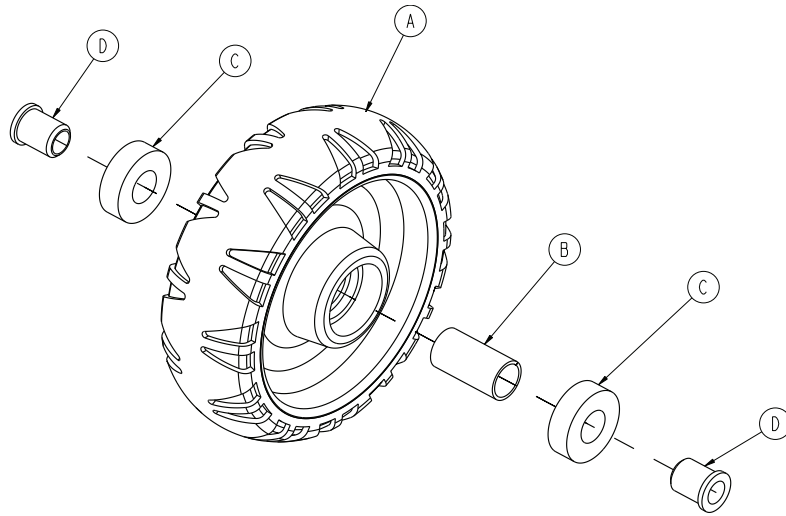

Item	Number	Name	Quantity
A	6060-002-045	6" molded wheel	1
B	6060-002-046	Bearing spacer	1
C	0081-226-000	Bearing	2
D	0715-001-255	Wheel bushing	2

Cot retaining post, right - 6085-033-000

Rev E (Reference only)

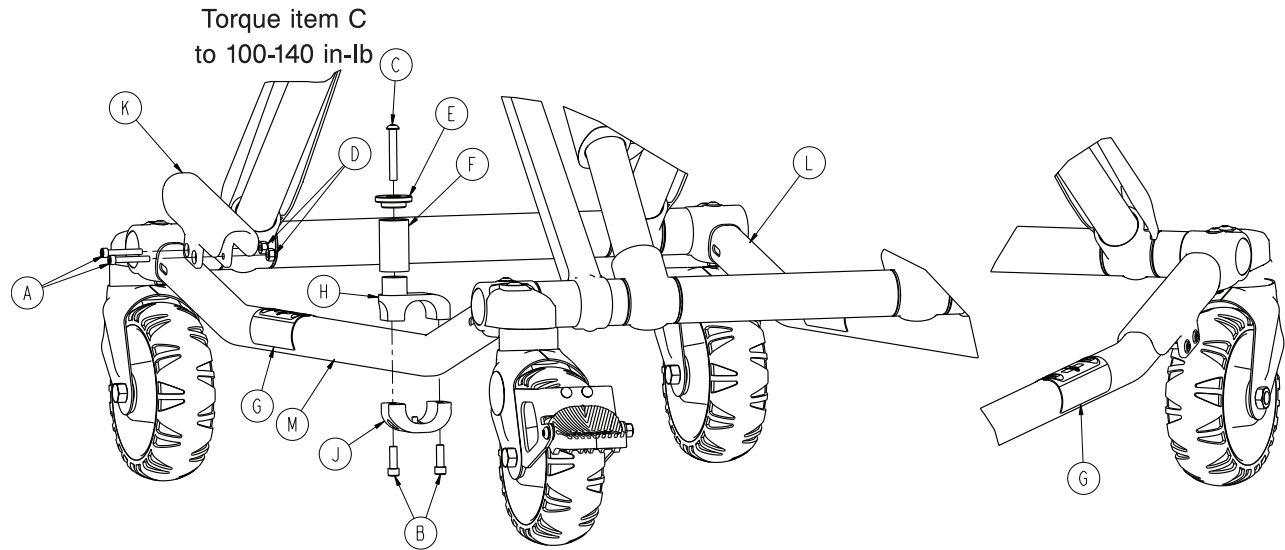

Item	Part no.	Part name	Qty
A	0004-160-000	Socket head cap screw	2
B	0004-591-000	Socket head cap screw	2
C	0004-503-000	Button head cap screw	1
D	0016-003-000	Nylock hex nut	2
E	6060-004-043	Retaining post cap	1
F	6060-004-044	Post tube	1
G	6080-090-108	Label, lift here	2
H	6500-101-189	Top pin bracket	1
J	6500-101-190	Bottom pin bracket	1
K	6500-001-302	Base tube protector	1
L	6085-001-056	Outer base tube weldment	1
M	6085-001-057	Outer base tube weldment	1

Kickstand assembly, optional - 6085-102-000

Rev A (Reference only)

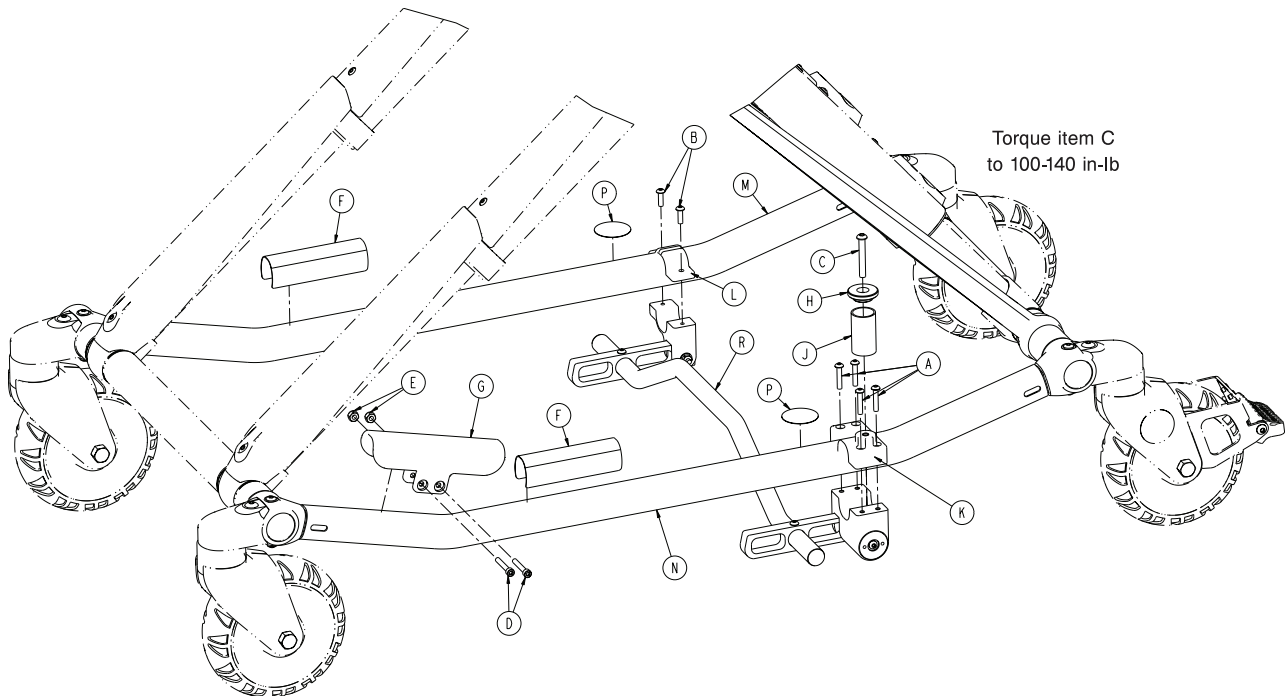

Item	Part no.	Part name	Qty
A	0004-460-000	Button head socket screw	4
B	0004-515-000	Button head cap screw	2
C	0004-503-000	Button head cap screw	1
D	0004-160-000	Socket head cap screw	2
E	0016-003-000	Nylock hex nut	2
F	6080-090-108	Label, lift here	2
G	6500-001-302	Base tube protector	1
H	6060-004-043	Retaining post cap	1
J	6060-004-044	Post tube	1
K	6085-002-001	Kickstand cot retaining post bracket	1
L	6085-002-002	Kickstand top pin bracket	1
M	6085-001-056	Outer base tube weldment	1
N	6085-001-057	Outer base tube weldment	1
P	6506-001-900	Label, refer to instruction manual	2
R	6085-002-016	Kickstand sub assembly - 6085-002-016 on page 149	1

Kickstand sub assembly - 6085-002-016

Rev A (Reference only)

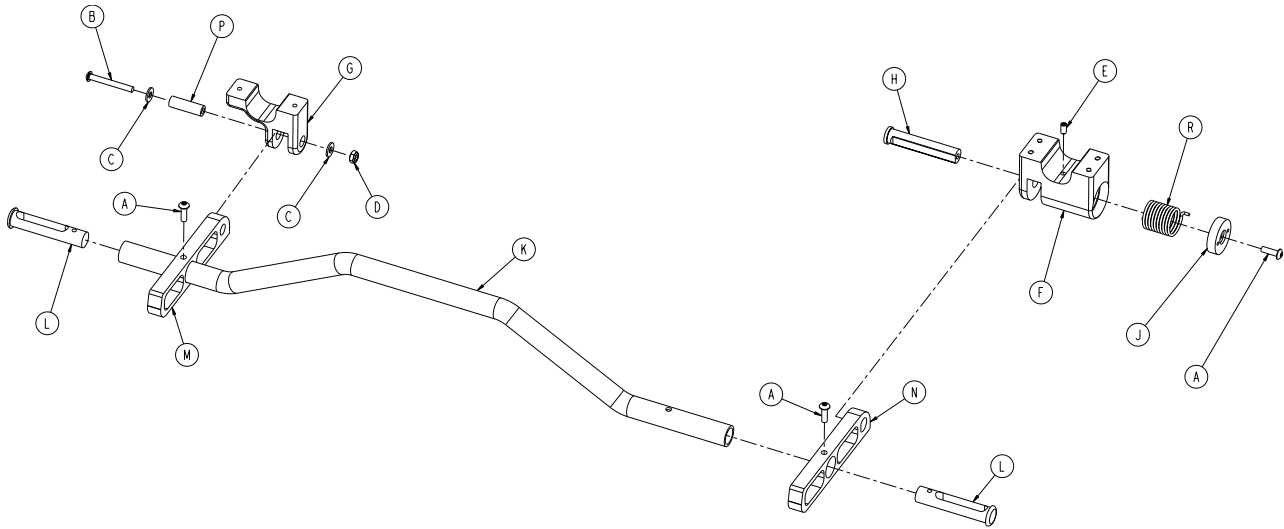

Item	Part no.	Part name	Qty
A	0004-515-000	Button head cap screw	3
B	0004-636-000	Button head cap screw	1
C	0011-302-000	Plain washer	2
D	0016-131-000	Nylock hex nut	1
E	0021-180-000	Set screw	1
F	6085-002-003	Kickstand spring housing	1
G	6085-002-004	Kickstand bottom bracket	1
H	6085-002-006	Kick bolt	1
J	6085-002-007	Kick bolt head	1
K	6085-002-008	Kick tube	1
L	6085-002-009	Kick tube cap	2
M	6085-002-011	Rocker strut, left	1
N	6085-002-012	Rocker strut, right	1
P	6085-002-013	Kickstand spacer	1
R	6085-002-014	Kickstand torsion spring	1

Outer lift tube assembly, base pivot - 6500-301-021

Rev B (Reference only)

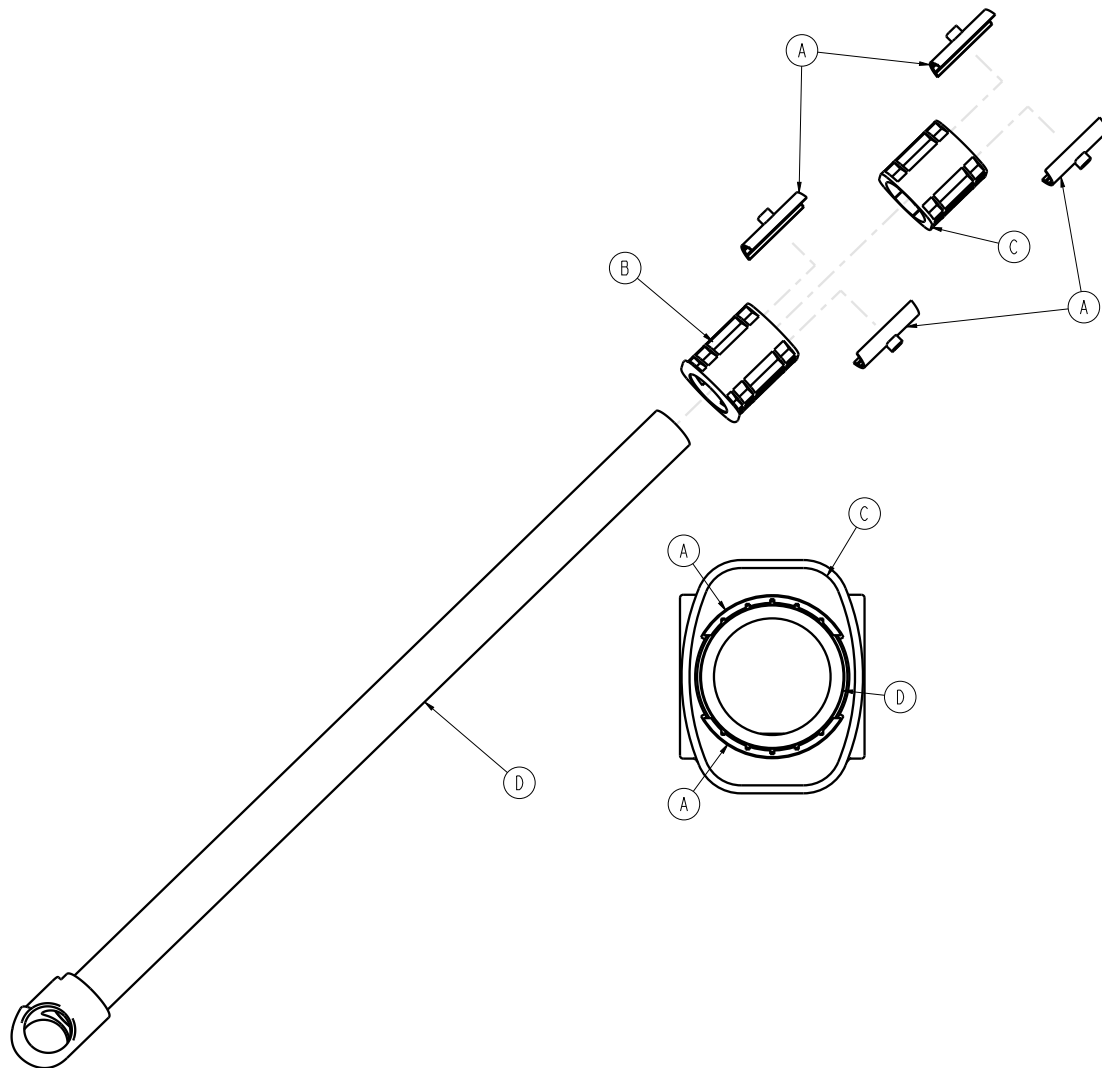

Item	Part no.	Part name	Qty
A	6500-101-327	Half shell bearing	4
B	6500-001-328	Bearing carrier, lower	1
C	6500-001-329	Bearing carrier, middle	1
D	6500-301-050	Outer lift tube weldment	1

Inner lift tube assembly, base pivot - 6500-301-022

Rev C (Reference only)

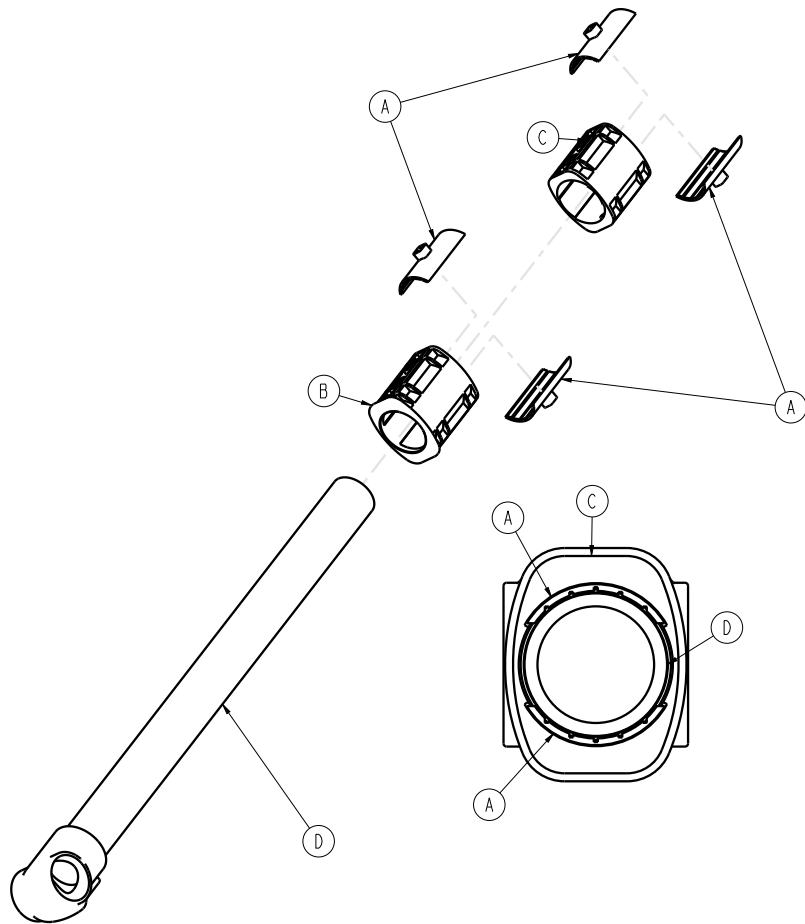

Item	Part no.	Part name	Qty
A	6500-101-327	Half shell bearing	4
B	6500-001-328	Bearing carrier, lower	1
C	6500-001-329	Bearing carrier, middle	1
D	6500-301-051	Lift tube weldment, base pivot	1

Inner lift tube, litter pivot, patient right assembly - 6500-001-034

Rev F (Reference only)

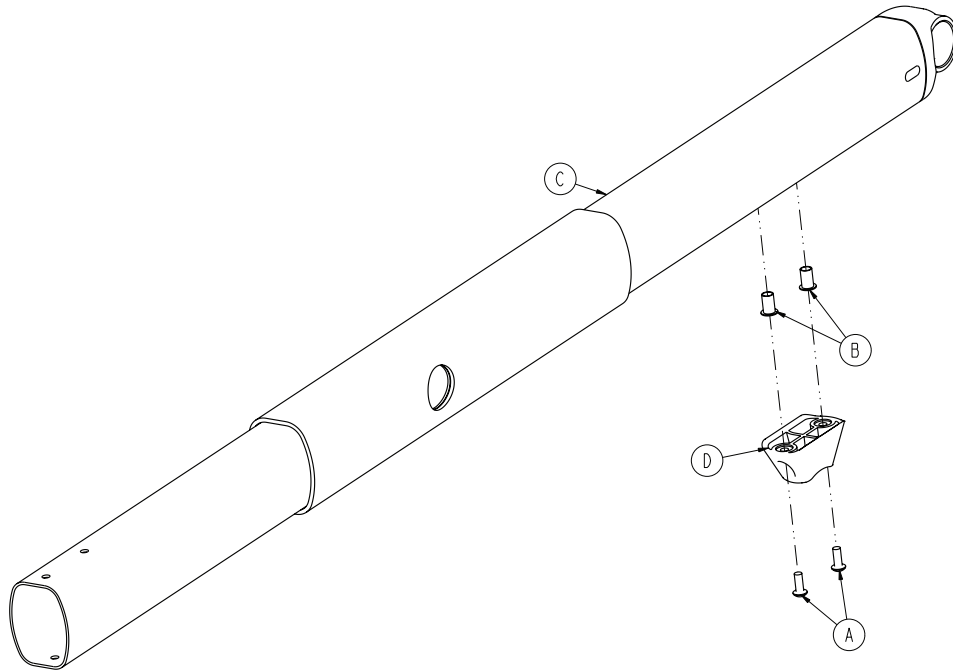

Item	Part no.	Part name	Qty
A	0004-634-000	Button head cap screw	2
B	0055-100-075	Nut	2
C	6500-001-355	Inner lift tube weldment	1
D	6500-001-125	Dead stop	1

Inner lift tube, litter pivot, patient left assembly - 6500-001-035

Rev F (Reference only)

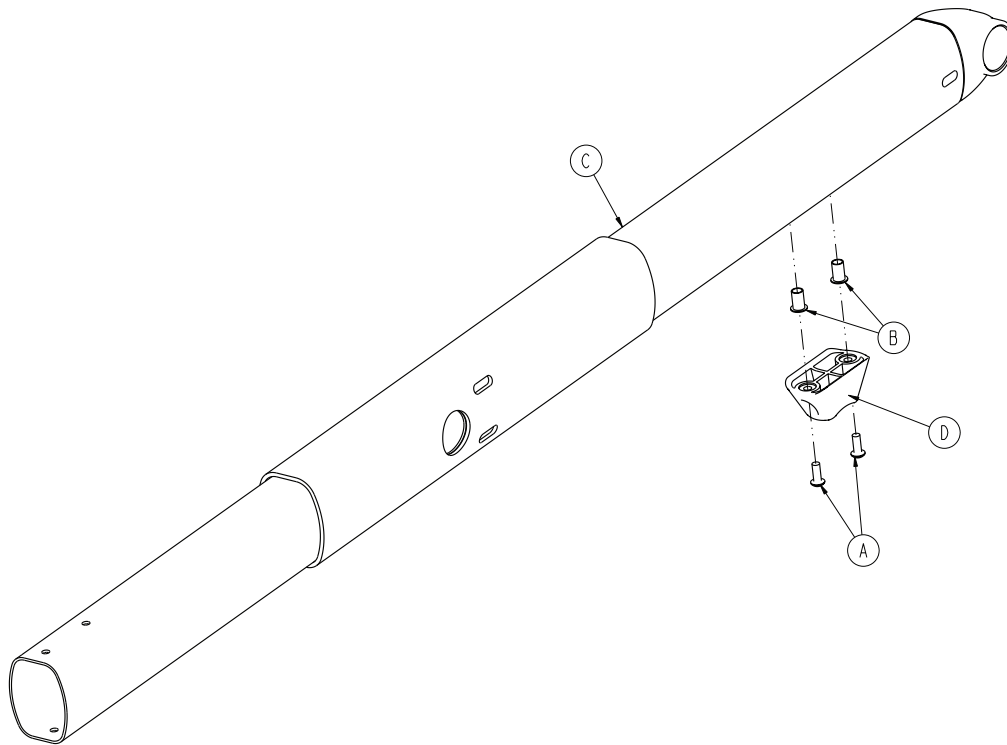

Item	Part no.	Part name	Qty
A	0004-634-000	Button head cap screw	2
B	0055-100-075	Nut	2
C	6500-301-053	Inner lift tube weldment	1
D	6500-001-125	Dead stop	1

Standard siderail

6506-031-000 Rev B (Reference only)

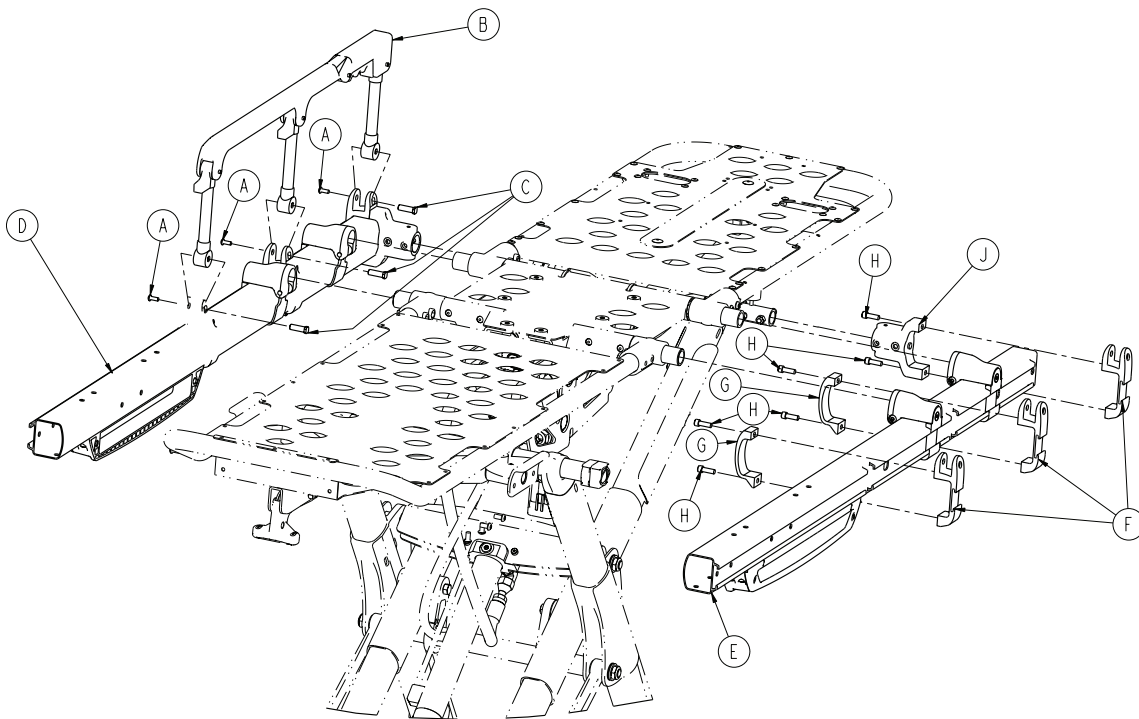

Item	Part no.	Part name	Qty
A	0004-585-000	Button head cap screw	6
B	6082-026-010	Siderail assembly - 6082-026-010 on page 155	2
C	6500-001-118	Siderail nut	6
D	6500-002-032	Outer rail sub assembly, right on page 156	1
E	6500-002-033	Outer rail sub assembly, left on page 157	1
F	6500-001-116	Siderail bracket	6
G	6500-001-117	Siderail clamp	4
H	0004-591-000	Socket head cap screw	12
J	6500-001-102	Base/litter interface bracket	2

Siderail assembly - 6082-026-010

Rev B (Reference only)

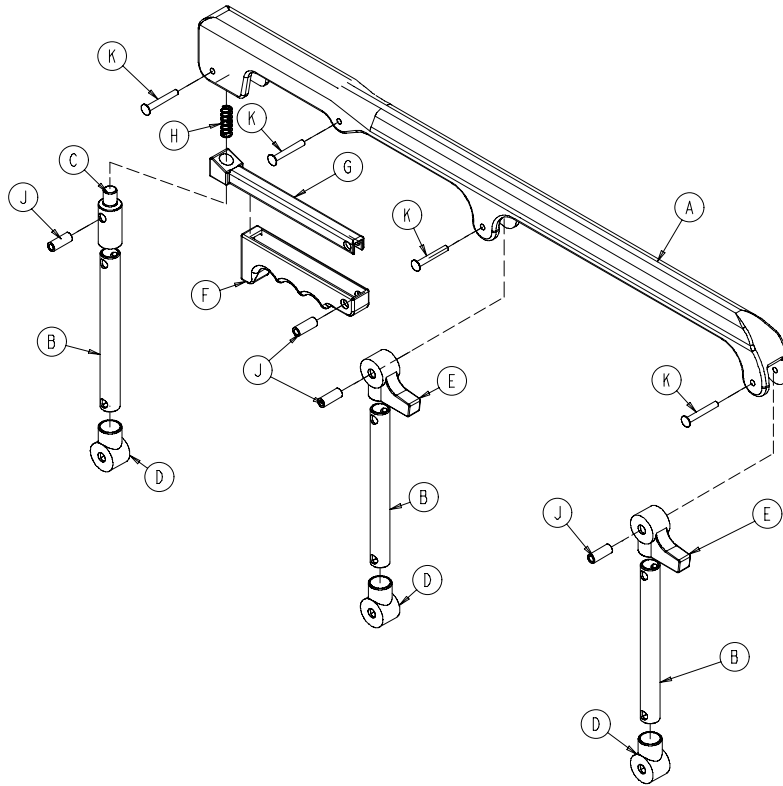

Item	Part no.	Part name	Qty
A	6060-025-024	Top rail	1
B	6060-025-043	Spindle	3
C	6060-025-047	Spindle lock	1
D	6060-025-041	Spindle pivot	3
E	6060-025-040	Spindle pivot stop	2
F	6060-025-029	Lock release grip	1
G	6061-125-030	Lock bar casting	1
H	0038-344-000	Lock release compression spring	1
J	6060-025-035	Pivot bushing	4
K	0025-131-000	Rivet	4

Outer rail sub assembly, right

6500-002-032 Rev C (Reference only)

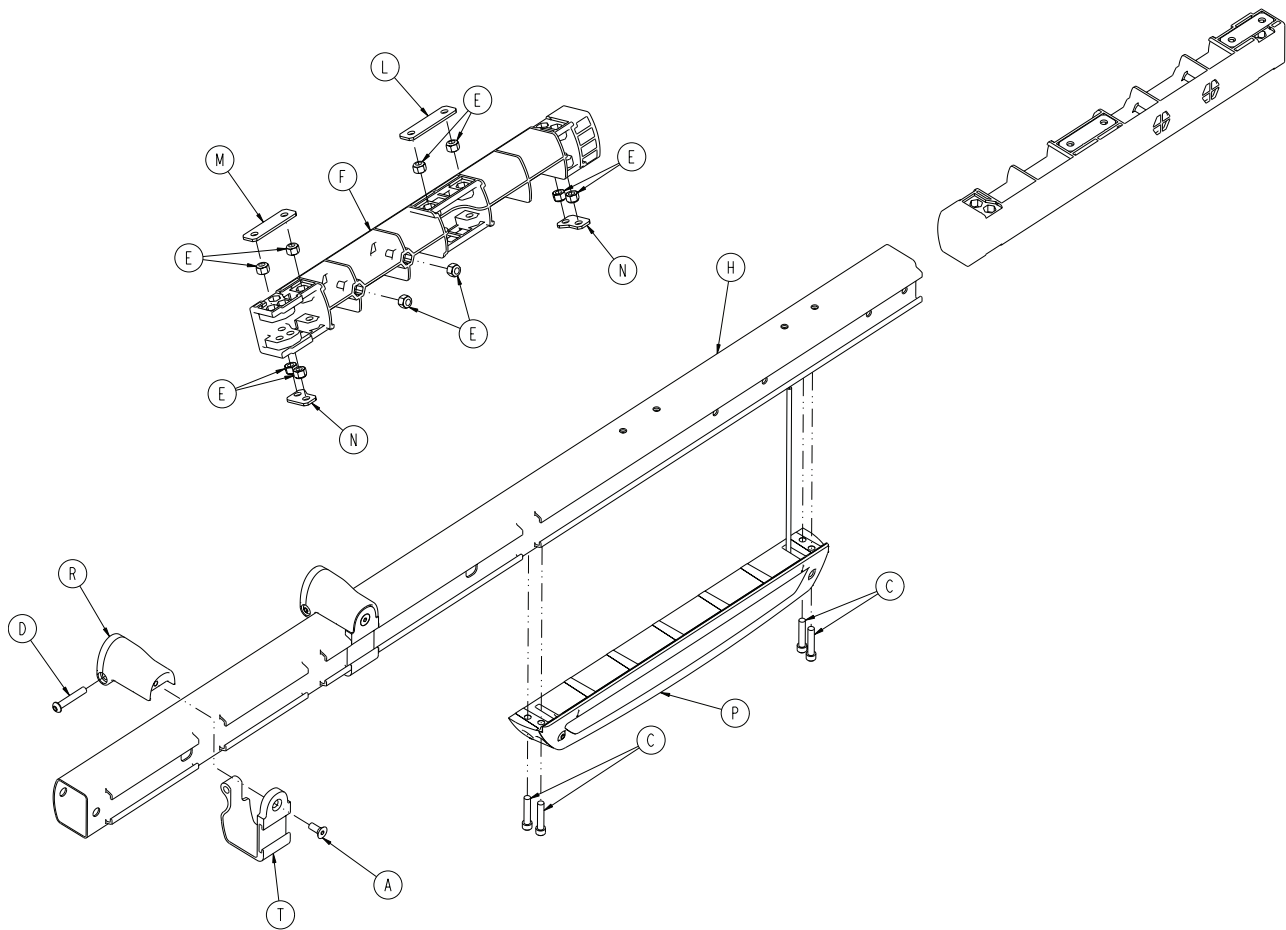

Item	Part no.	Part name	Qty
A	0001-004-011	Flat head cap screw	2
C	0004-613-000	Socket head cap screw	4
D	0004-848-000	Button head cap screw	2
E	0016-028-000	Fiberlock hex nut	10
F	6500-001-098	Litter dead stop, internal	1
H	6500-001-114	Outer rail extrusion	1
L	6500-001-243	IV pole backer plate	1
M	6500-001-244	IV clip backer plate	1
N	6500-001-245	Sensor housing backer plate	2
P	6500-002-028	Hall sensor assembly on page 158	1
R	6500-002-130	Litter support bracket	2
T	6500-002-131	Litter support bracket, inner	2

Outer rail sub assembly, left

6500-002-033 Rev C (Reference only)

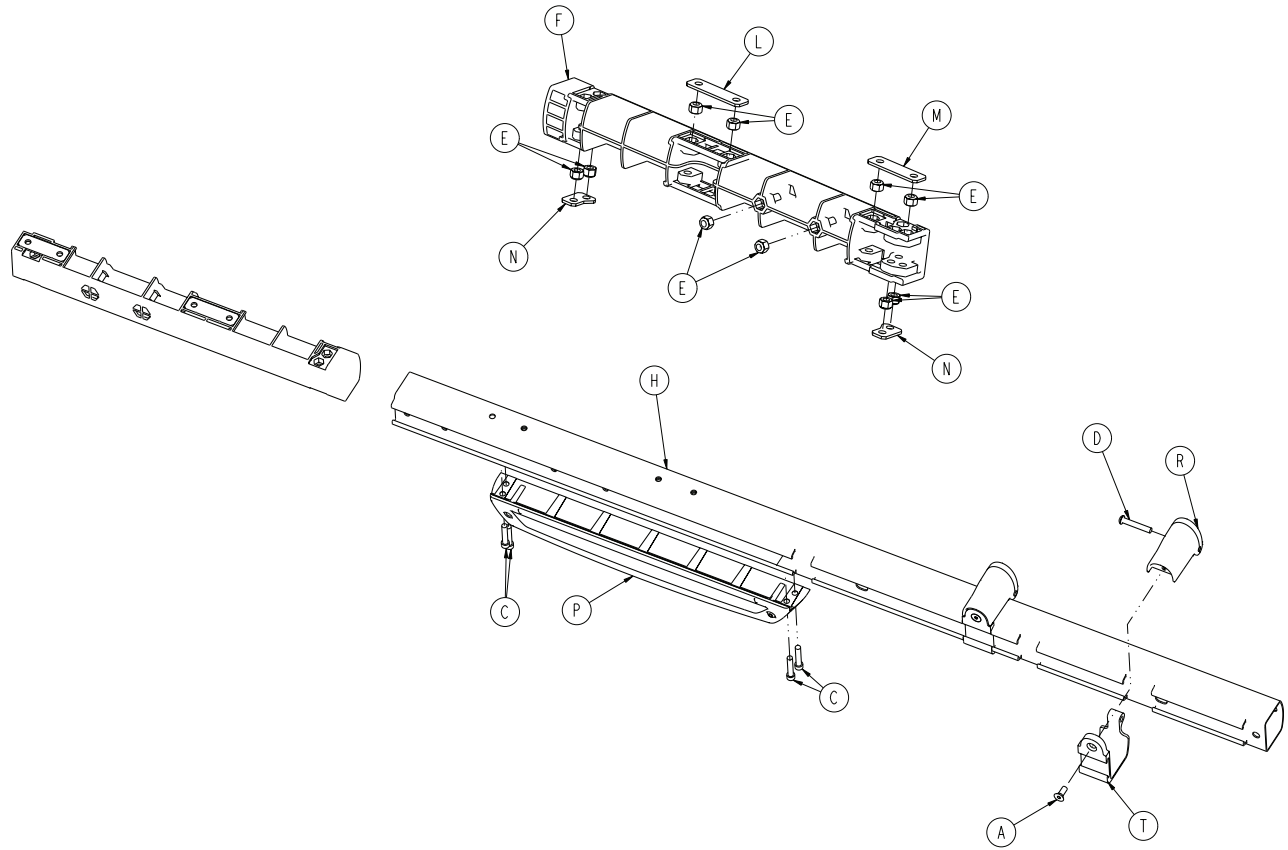

Item	Part no.	Part name	Qty
A	0001-004-011	Flat head cap screw	2
C	0004-613-000	Socket head cap screw	4
D	0004-848-000	Button head cap screw	2
E	0016-028-000	Fiberlock hex nut	10
F	6500-001-098	Litter dead stop, internal	1
H	6500-001-115	Outer rail, right	1
L	6500-001-243	IV pole backer plate	1
M	6500-001-244	IV clip backer plate	1
N	6500-001-245	Sensor housing backer plate	2
P	6500-002-029	Sensor housing assembly on page 159	1
R	6500-002-130	Litter support bracket	2
T	6500-002-131	Litter support bracket, inner	2

Hall sensor assembly

6500-002-028 Rev A (Reference only)

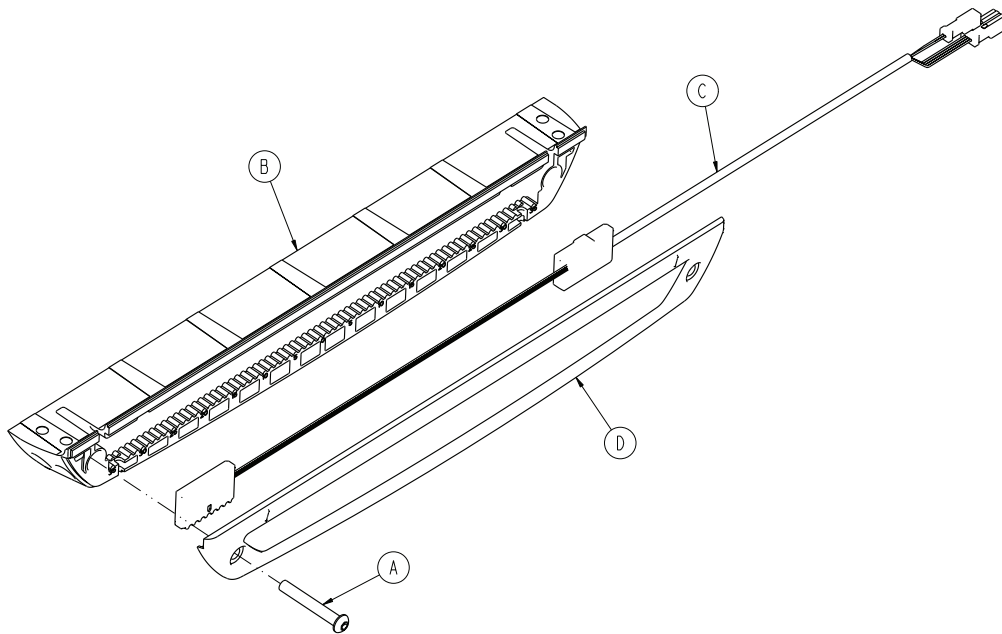

Item	Part no.	Part name	Qty
A	0004-596-000	Button head cap screw	1
B	6500-001-124	Sensor housing	1
C	6500-001-160	Hall effects sensor	1
D	6500-001-199	Housing cover	1

Sensor housing assembly

6500-002-029 Rev A (Reference only)

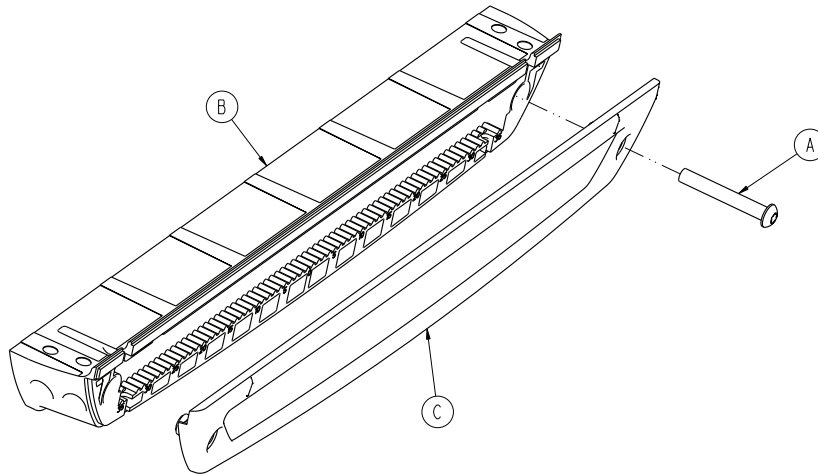

Item	Part no.	Part name	Qty
A	0004-596-000	Button head cap screw	1
B	6500-001-124	Sensor housing	1
C	6500-001-199	Housing cover	1

Siderail (XPS option), optional

6506-040-000 Rev A (Reference only)

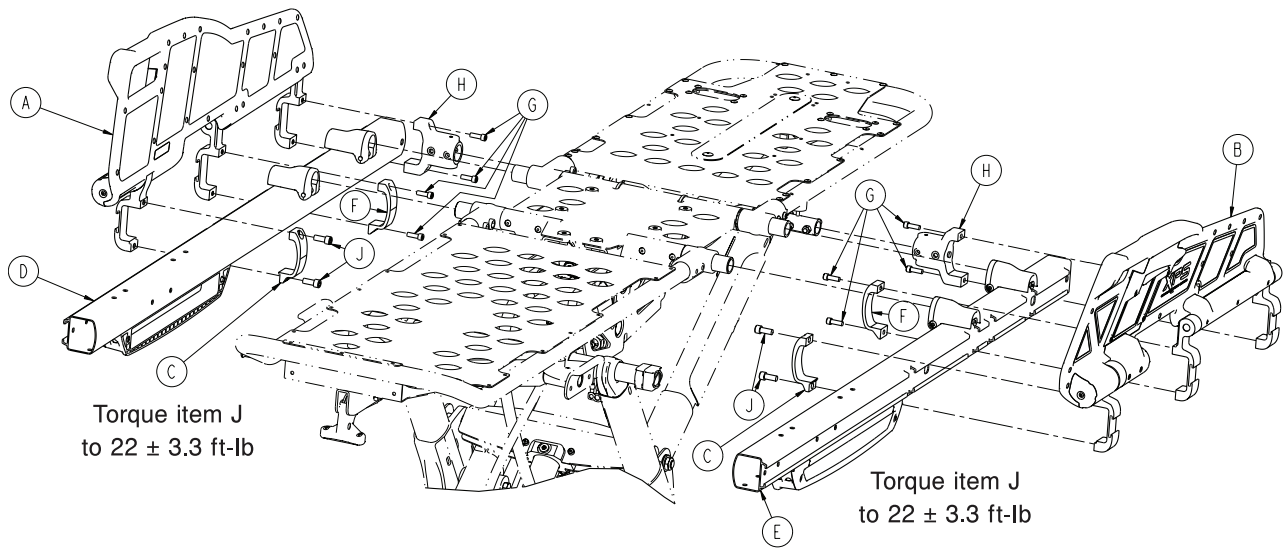

Item	Part no.	Part name	Qty
A	6500-003-034	XPS main assembly, right - 6500-003-034 on page 161	1
B	6500-003-044	XPS main assembly, left - 6500-003-044 on page 162	1
C	6500-003-099	XPS siderail clamp	2
D	6500-002-032	Outer rail sub assembly, right on page 156	1
E	6500-002-033	Outer rail sub assembly, left on page 157	1
F	6500-001-117	Siderail clamp	2
G	0004-591-000	Socket head cap screw	8
H	6500-001-102	Base/litter interface bracket	2
J	0004-900-000	Socket head cap screw	4

XPS main assembly, right - 6500-003-034

Rev C (Reference only)

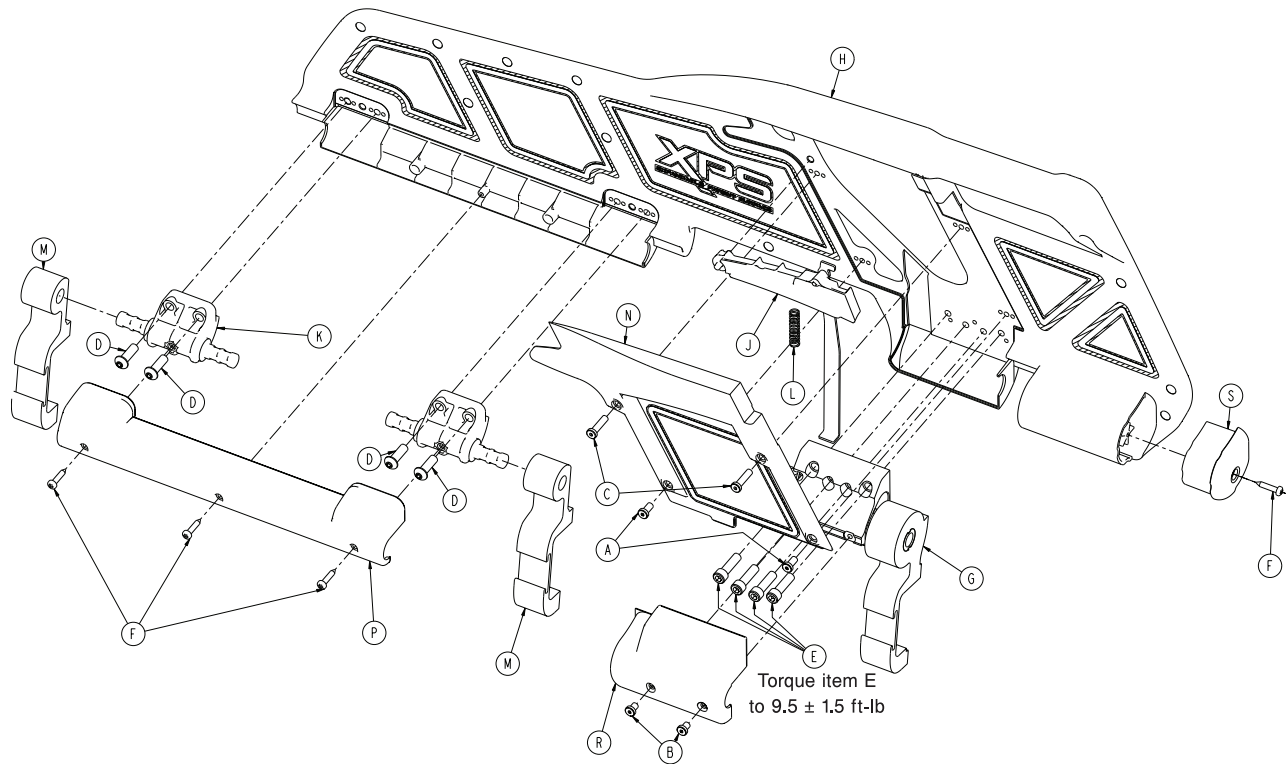

Item	Part no.	Part name	Qty
A	0004-400-000	Socket head cap screw	2
B	0004-402-000	Socket head cap screw	2
C	0004-403-000	Socket head cap screw	2
D	0004-468-000	Button head cap screw	4
E	0004-661-000	Socket head cap screw	4
F	0023-297-000	Delta screw	4
G	6500-003-035	XPS ratchet assembly, right	1
H	6500-003-037	XPS overmold assembly, right	1
J	6500-003-043	XPS handle assembly, right	1
K	6500-003-084	Support pivot	2
L	6500-003-085	XPS spring handle	1
M	6500-003-086	XPS siderail pivot	2
N	6500-003-094	XPS release cover, right	1
P	6500-003-097	XPS pivot cover	1
R	6500-003-119	XPS ratchet cover, right/left	1
S	6500-003-121	End cap cover, right	1

XPS main assembly, left - 6500-003-044

Rev C (Reference only)

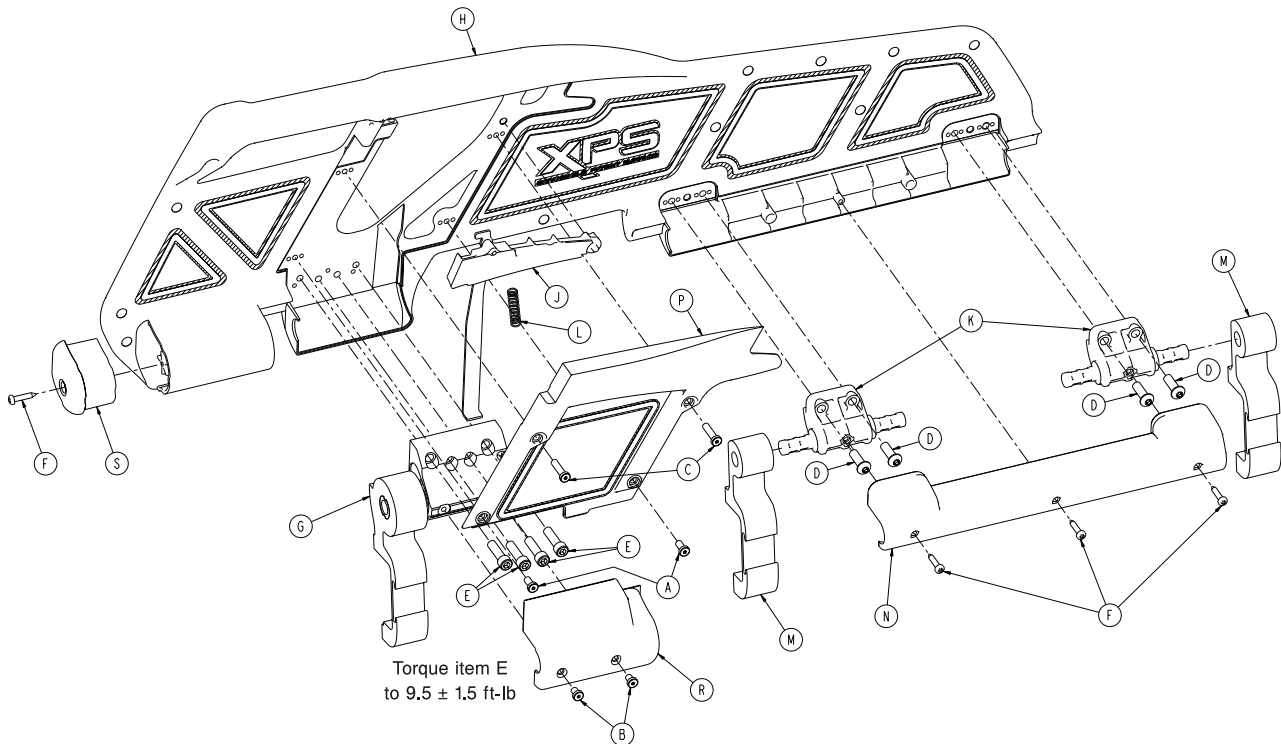

Item	Part no.	Part name	Qty
A	0004-400-000	Socket head cap screw	2
B	0004-402-000	Socket head cap screw	2
C	0004-403-000	Socket head cap screw	2
D	0004-468-000	Button head cap screw	4
E	0004-661-000	Socket head cap screw	4
F	0023-297-000	Delta screw	4
G	6500-003-036	XPS ratchet assembly, right	1
H	6500-003-038	XPS overmold assembly, right	1
J	6500-003-045	XPS handle assembly, right	1
K	6500-003-084	Support pivot	2
L	6500-003-085	XPS spring handle	1
M	6500-003-086	XPS siderail pivot	2
N	6500-003-097	XPS pivot cover	1
P	6500-003-102	XPS release cover, left	1
R	6500-003-120	XPS ratchet cover, right/left	1
S	6500-003-122	End cap cover, right	1

Power assembly

6500-002-031 Rev C (Reference only)

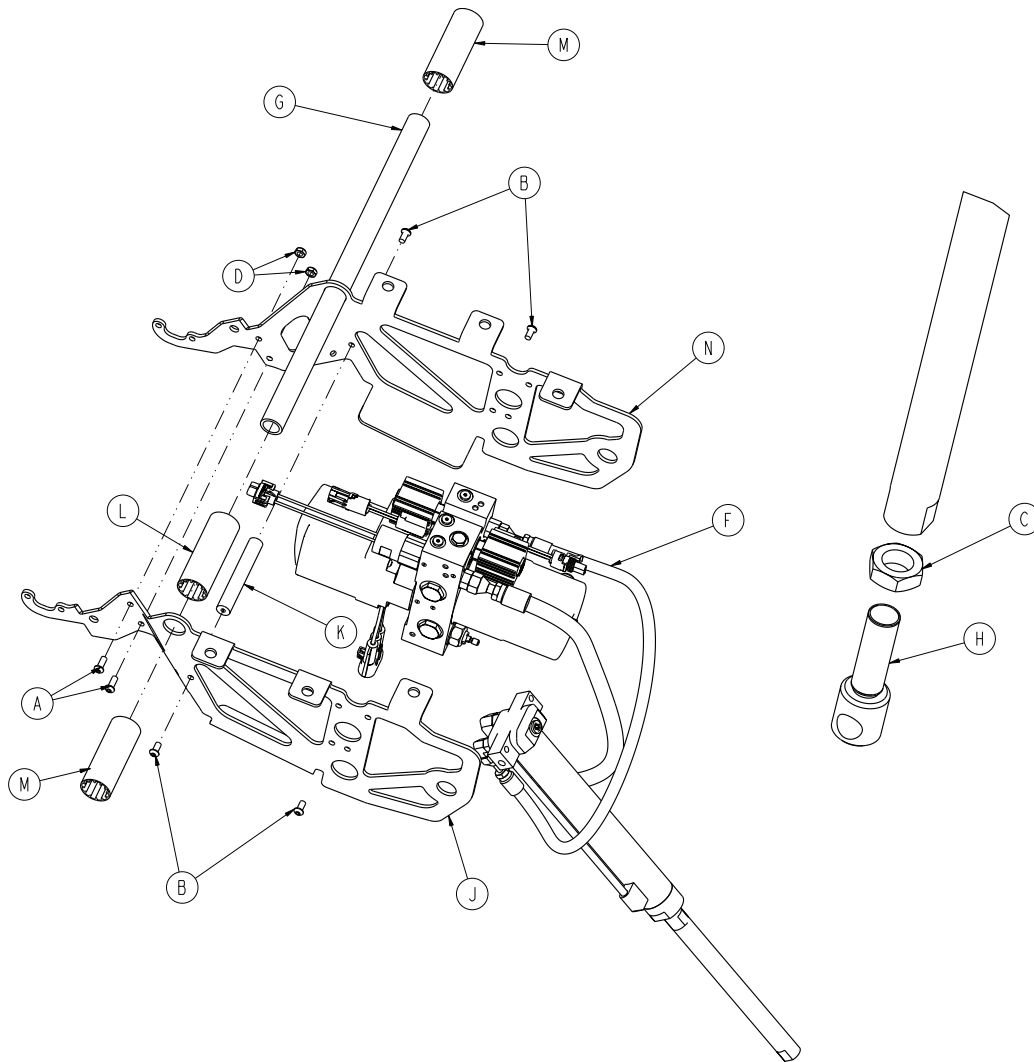

Power assembly

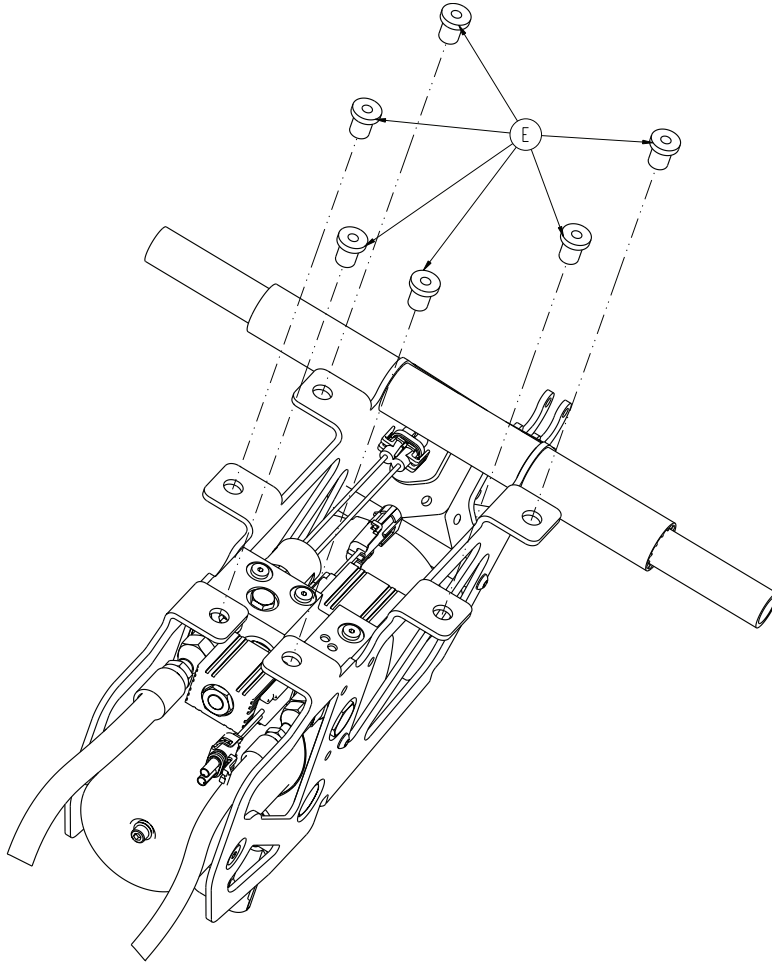

Item	Part no.	Part name	Qty
A	0004-577-000	Button head cap screw	2
B	0004-589-000	Button head cap screw	4
C	0015-052-000	Hex jam nut	1
D	0016-102-000	Nylock hex nut	2
E	0055-100-074	Well nut	6
F	6500-101-030	Hydraulic sub assembly - 6500-101-030 on page 165	1
G	6500-001-105	Litter support cross tube	1
H	6500-001-169	Cylinder rod end	1
J	6500-002-194	Motor mount, right	1
K	6500-001-212	Motor mount cross bar	1
L	6500-001-249	Plastic extrusion spacer	1
M	6500-001-250	Plastic extrusion spacer	2
N	6500-002-294	Motor mount, left	1

Hydraulic sub assembly - 6500-101-030

Rev B (Reference only)

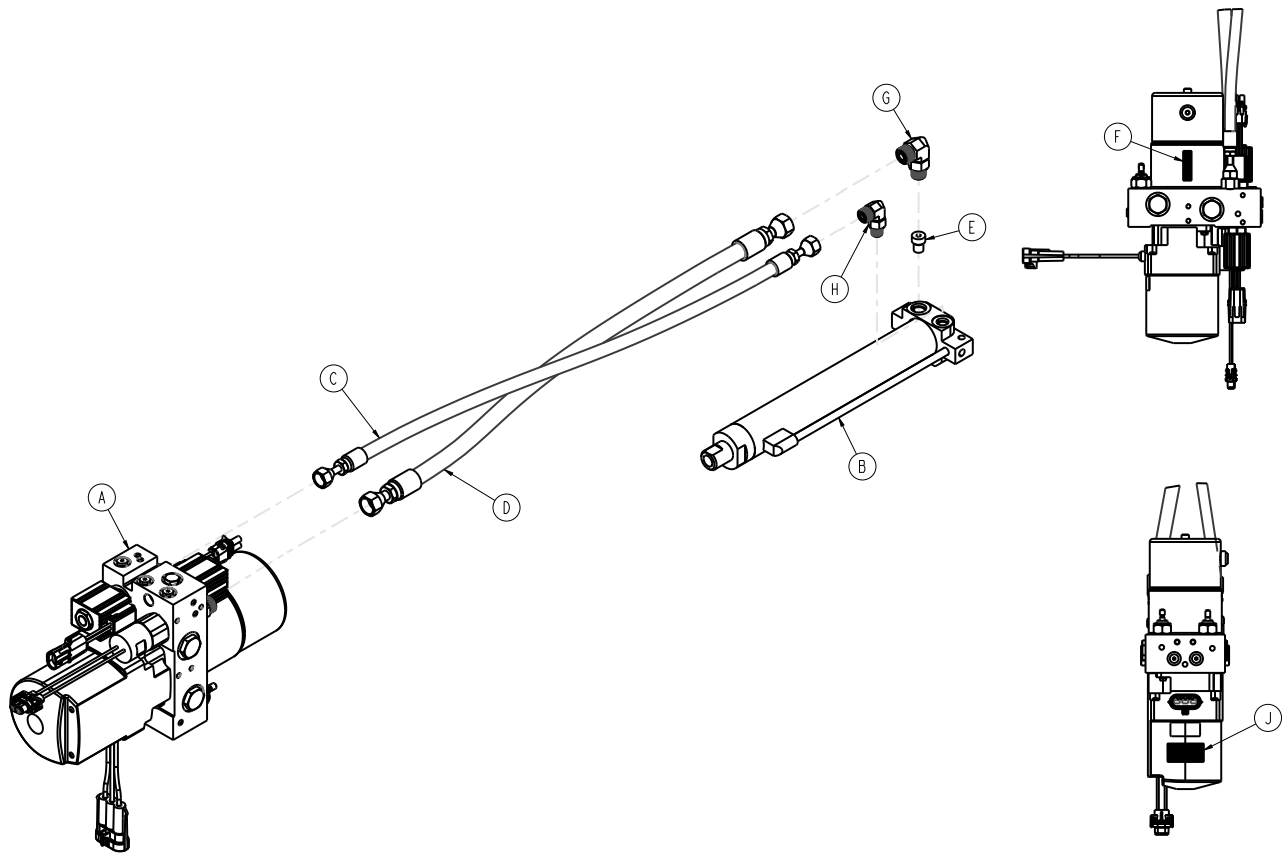

Item	Part no.	Part name	Qty
A	6500-001-210	Cap side hose	1
B	6500-001-211	Rod side hose	1
C	6500-001-213	Cylinder	1
D	6500-001-214	Manifold assembly	1
E	6500-001-270	Pressure compensated flow control	1
F	6500-001-282	Manifold cap side hose fitting	1
G	6500-001-283	Manifold rod side hose fitting	1
H	6500-001-284	A value solenoid	1
J	6500-001-285	B value solenoid	1
K	6500-001-286	A valve	1
L	6500-001-287	B valve	1
M	6500-001-288	Locking manual valve	1
N	6500-001-289	Non-locking manual valve	1
P	6500-001-290	Pressure switch	1
R	6500-001-291	Reservoir	1
T	6500-001-293	Hydraulic fluid	1
U	6500-001-295	Motor	1
V	6500-001-296	Cylinder cap side hose fitting	1
W	6500-001-297	Cylinder rod side hose fitting	1
Y	6500-001-299	Hydraulic fill plug	1

Foot end assembly

6500-102-015 Rev B (Reference only)

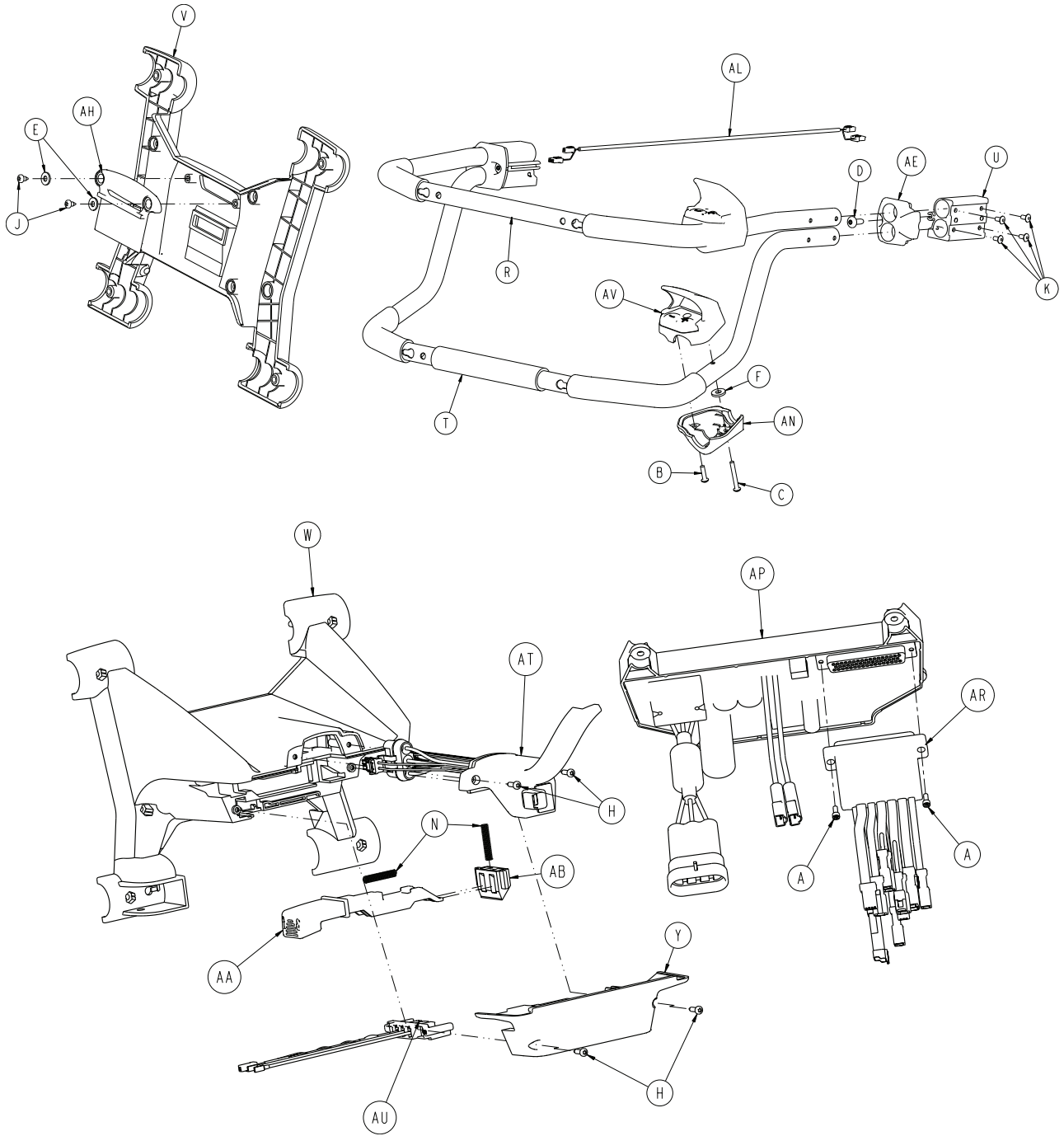

Foot end assembly

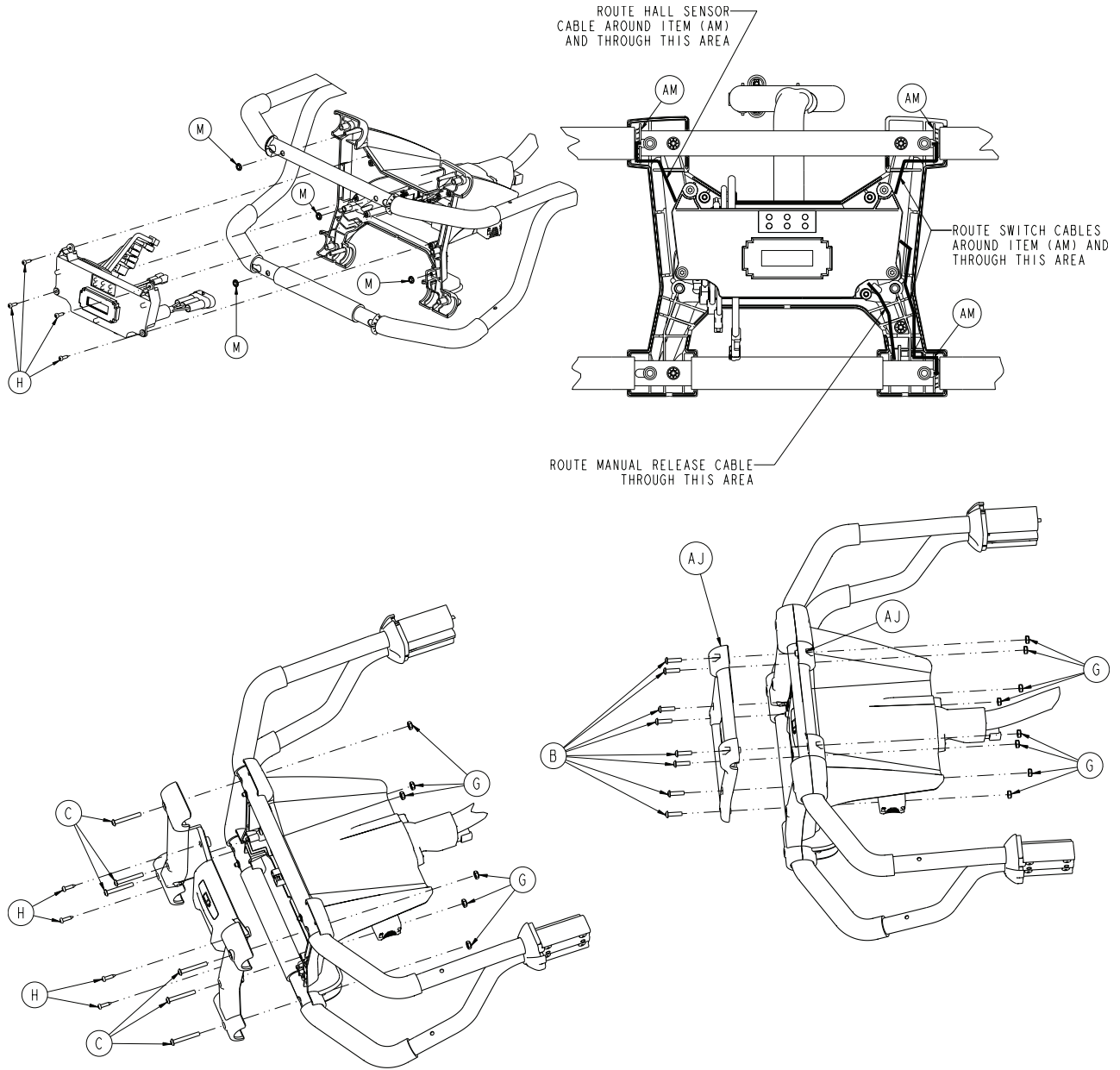

Foot end assembly

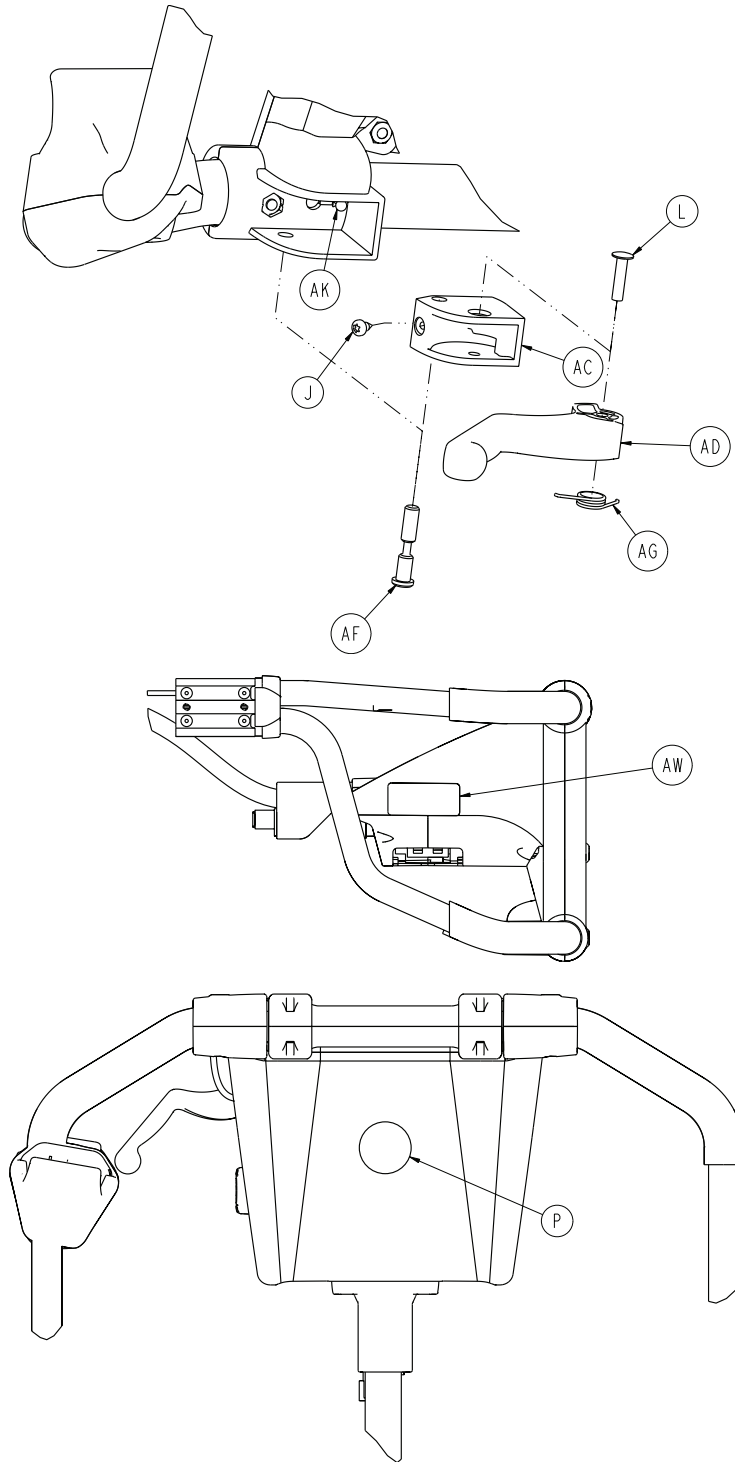

Item	Part no.	Part name	Qty
A	0004-874-000	Socket head cap screw	2
B	0004-614-000	Button head cap screw	10
C	0004-615-000	Button head cap screw	8
D	0007-086-000	Truss head screw	2
E	0011-062-000	Washer	2

Foot end assembly

Item	Part no.	Part name	Qty
F	0011-543-000	Washer	2
G	0016-131-000	Nylock hex nut	14
H	0023-162-000	Screw	12
J	0023-163-000	Screw	3
K	0025-079-000	Dome head rivet	8
L	0025-187-000	Semi-tubular rivet	1
M	0028-116-000	Pushnut	4
N	0038-572-000	Compression spring	2
P	6506-001-900	Label	1
R	6500-001-131	Upper lifting bar	1
T	6500-001-132	Lower lift bar	1
U	6500-001-133	Machined extruded bracket	2
V	6500-001-134	Battery enclosure face plate	1
W	6500-001-135	Foot end enclosure top plate	1
Y	6500-001-136	Foot end enclosure bottom plate	1
AA	6500-001-138	Battery release button	1
AB	6500-001-139	Battery release lock	1
AC	6500-001-140	Manual release actuator pivot	1
AD	6500-001-141	Manual release actuator lever	1
AE	6500-001-144	Transition cap	2
AF	6500-001-146	Manual release pivot pin	1
AG	6500-001-147	Single spring	1
AH	6500-001-153	Light panel orb	1
AJ	6500-001-154	Pull handle, outside	2
AK	6500-001-156	Manual release cable assembly	1
AL	6500-001-161	Hall effects cable	1
AM	6500-001-275	Wire route clip	3
AN	6500-001-358	Lower housing button, foot end	2
AP	6500-002-014	Control board	1
AR	6500-002-103	Cot dongle	1
AT	6500-002-159	Cable assembly	1
AU	6500-002-216	Cot connector cable assembly	1
AV	6500-101-016	Button assembly - 6500-101-016 on page 170	2
AW	6500-001-356	Label, SMRT power	1

Button assembly - 6500-101-016

Rev D (Reference only)

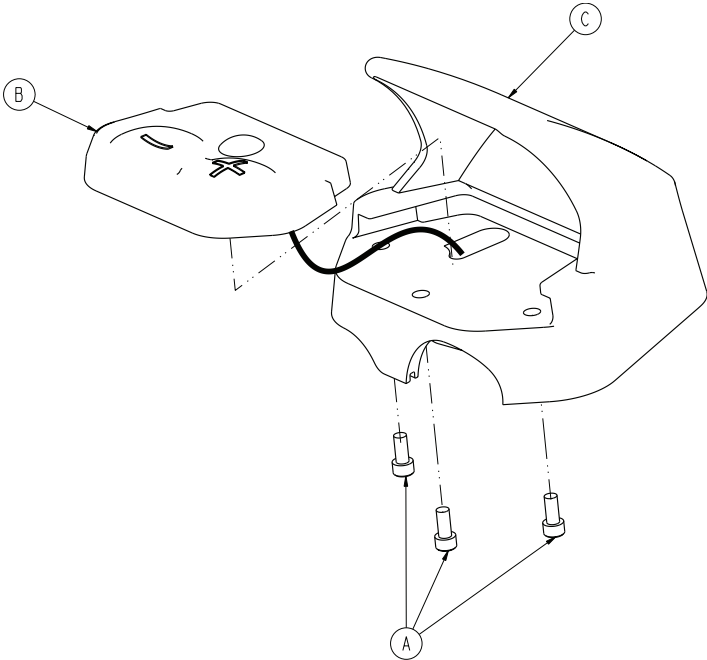

Item	Part no.	Part name	Qty
A	37J102-1	Socket head cap screw	3
B	6500-101-130	Switch	1
C	6500-001-359	Button upper housing, foot end	1

Trend - 6085-031-000

Rev A (Reference only)

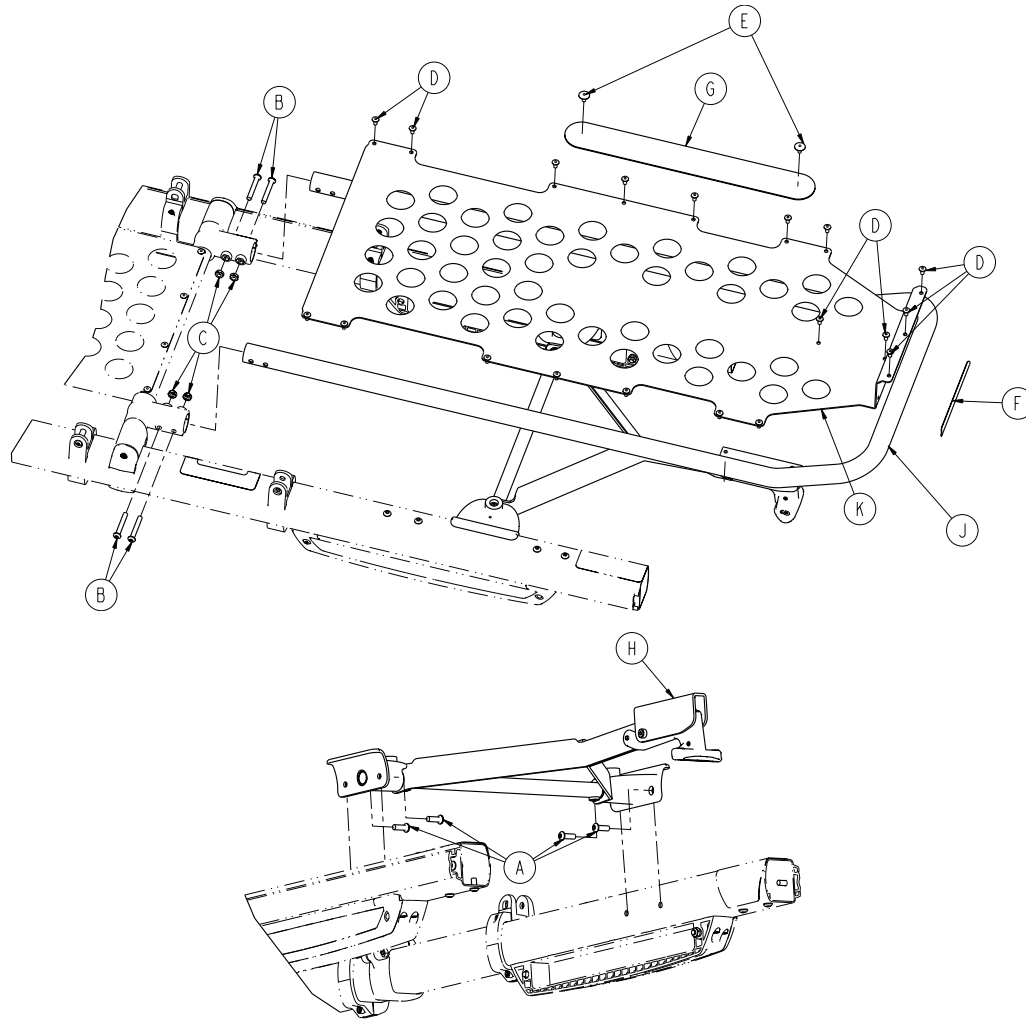

Item	Part no.	Part name	Qty
A	0004-592-000	Button head cap screw	4
B	0004-596-000	Button head cap screw	4
C	0016-102-000	Nylock hex nut	4
D	0025-079-000	Dome head rivet	19
E	0025-132-000	Dome head rivet	2
F	6060-090-004	Label, small	1
G	6082-001-085	2" adhesive loop pole	1
H	6500-001-019	Trend assembly on page 172	1
J	6500-001-197	Foot section tube	1
K	6500-001-198	Foot section skin	1

Trend assembly

6500-001-019 Rev D (Reference only)

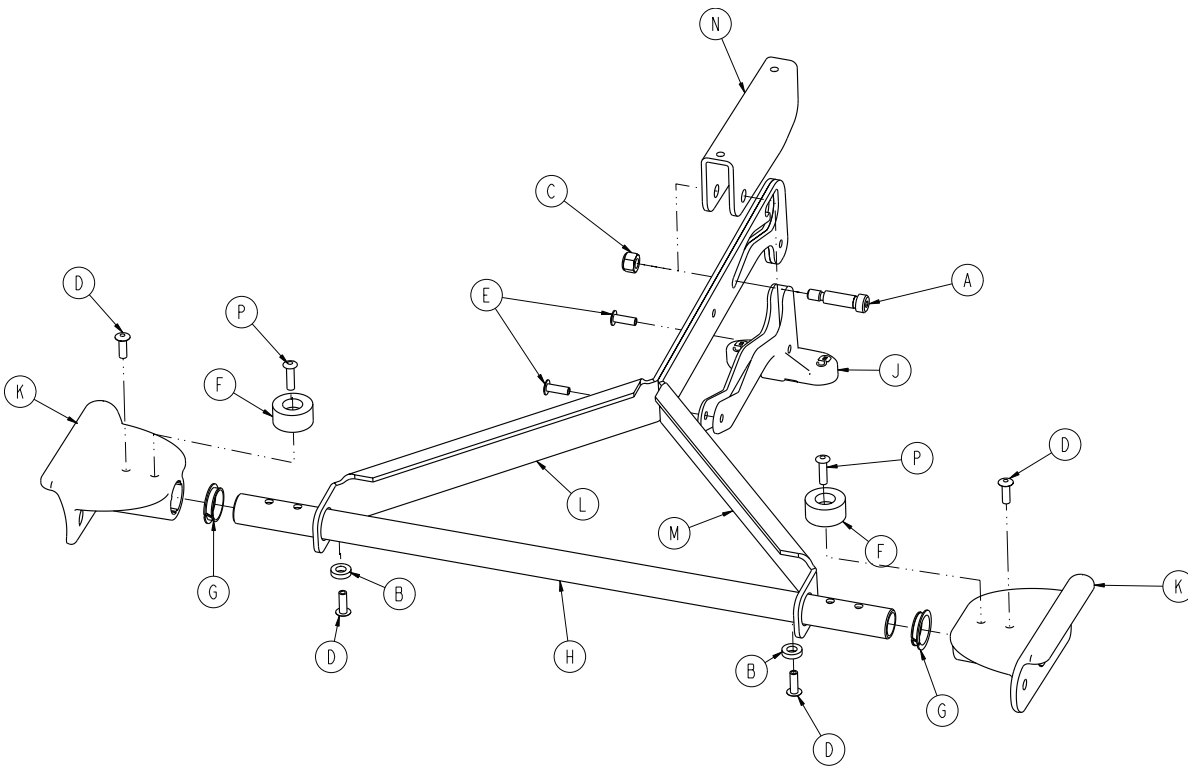

Item	Part no.	Part name	Qty
A	0008-074-000	Socket head shoulder screw	1
B	0014-067-000	Washer	2
C	0016-028-000	Nut	1
D	0025-133-000	Rivet	4
E	0025-186-000	Rivet	2
F	0056-016-000	Bumper	2
G	0081-255-000	Split bearing	2
H	6500-001-107	Litter cross tube	1
J	6500-001-108	Trend release	1
K	6500-001-109	Trend bracket	2
L	6500-001-203	Calf stand support, right	1
M	6500-001-204	Calf stand support, left	1
N	6500-001-205	Retainer, calf stand	1
P	0025-086-000	Rivet	2

Gatch, optional - 6500-082-000

Rev A (Reference only)

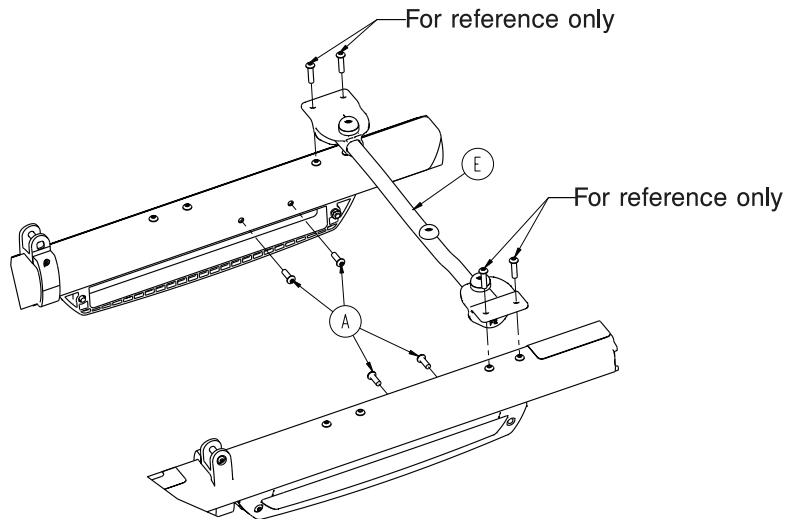
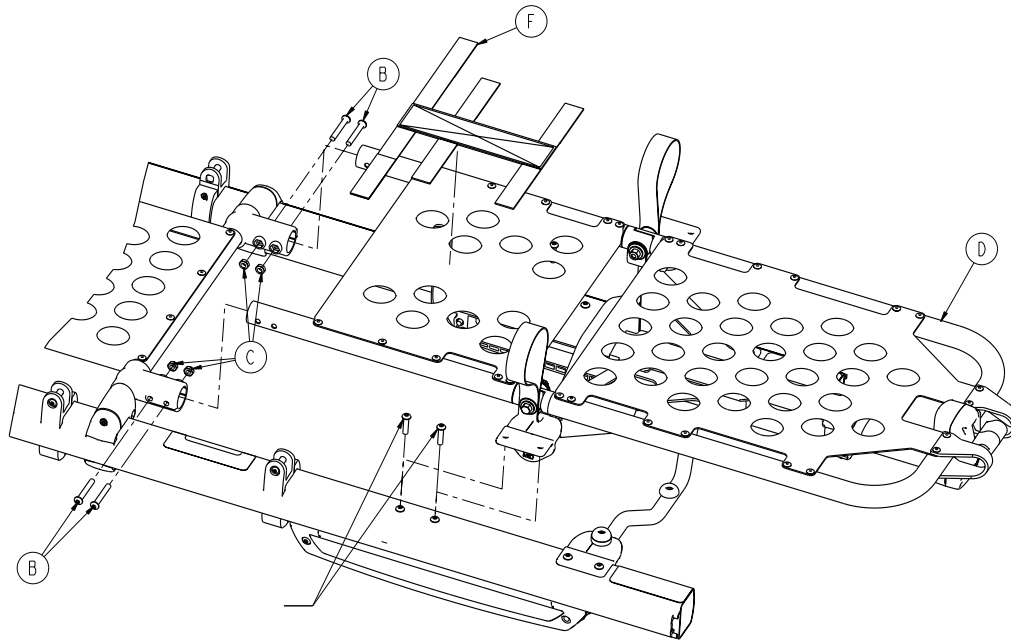

Item	Part no.	Part name	Qty
A	0004-592-000	Button head cap screw	4
B	0004-596-000	Button head cap screw	4
C	0016-102-000	Nylock hex nut	4
D	6500-001-048	Gatch assembly, optional on page 174	1
E	6085-001-031	Gatch support assembly, optional on page 177	1
F	6550-001-197	Velcro® strap	1

Gatch assembly, optional

6500-001-048 Rev B (Reference only)

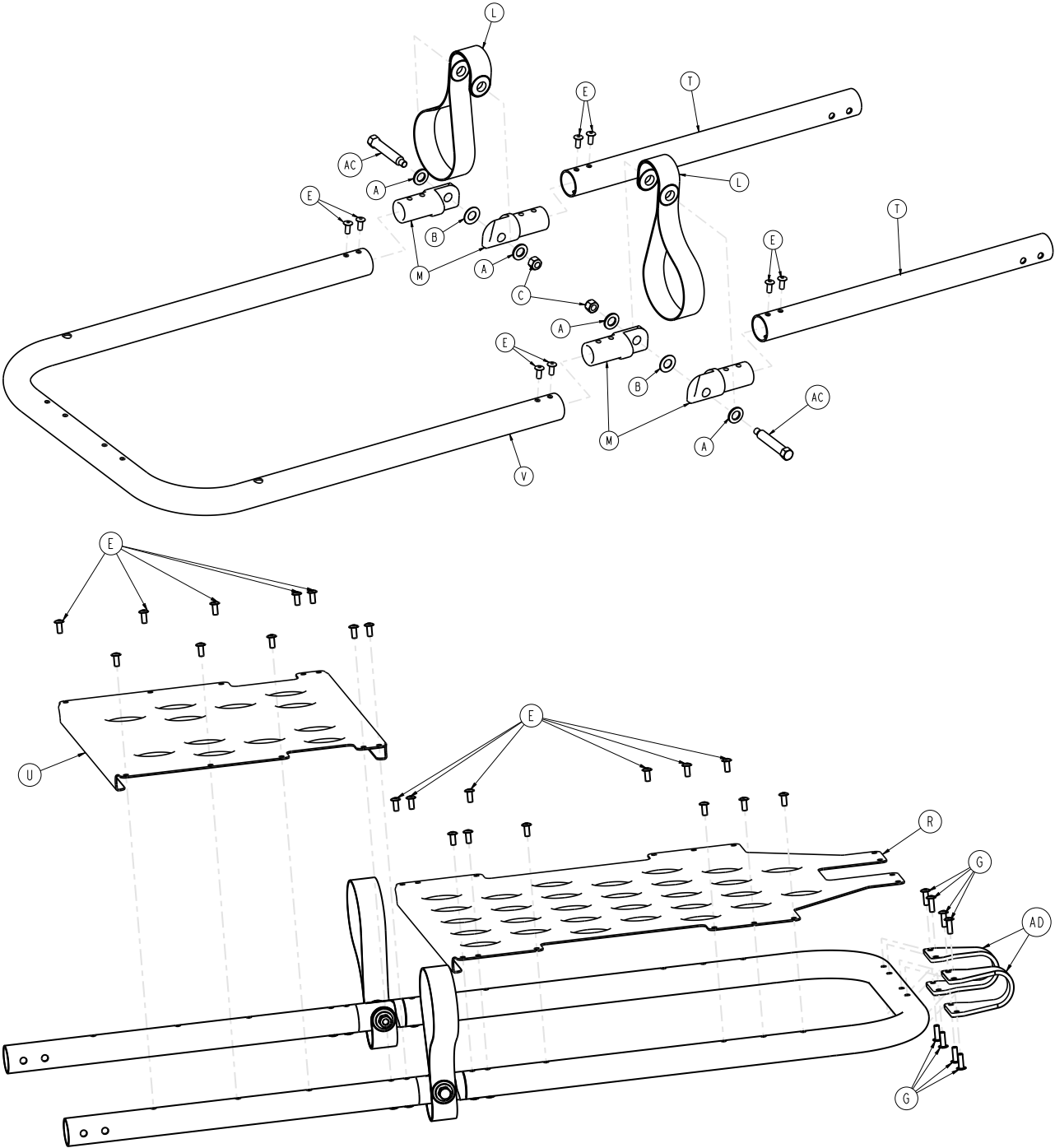

Gatch assembly, optional

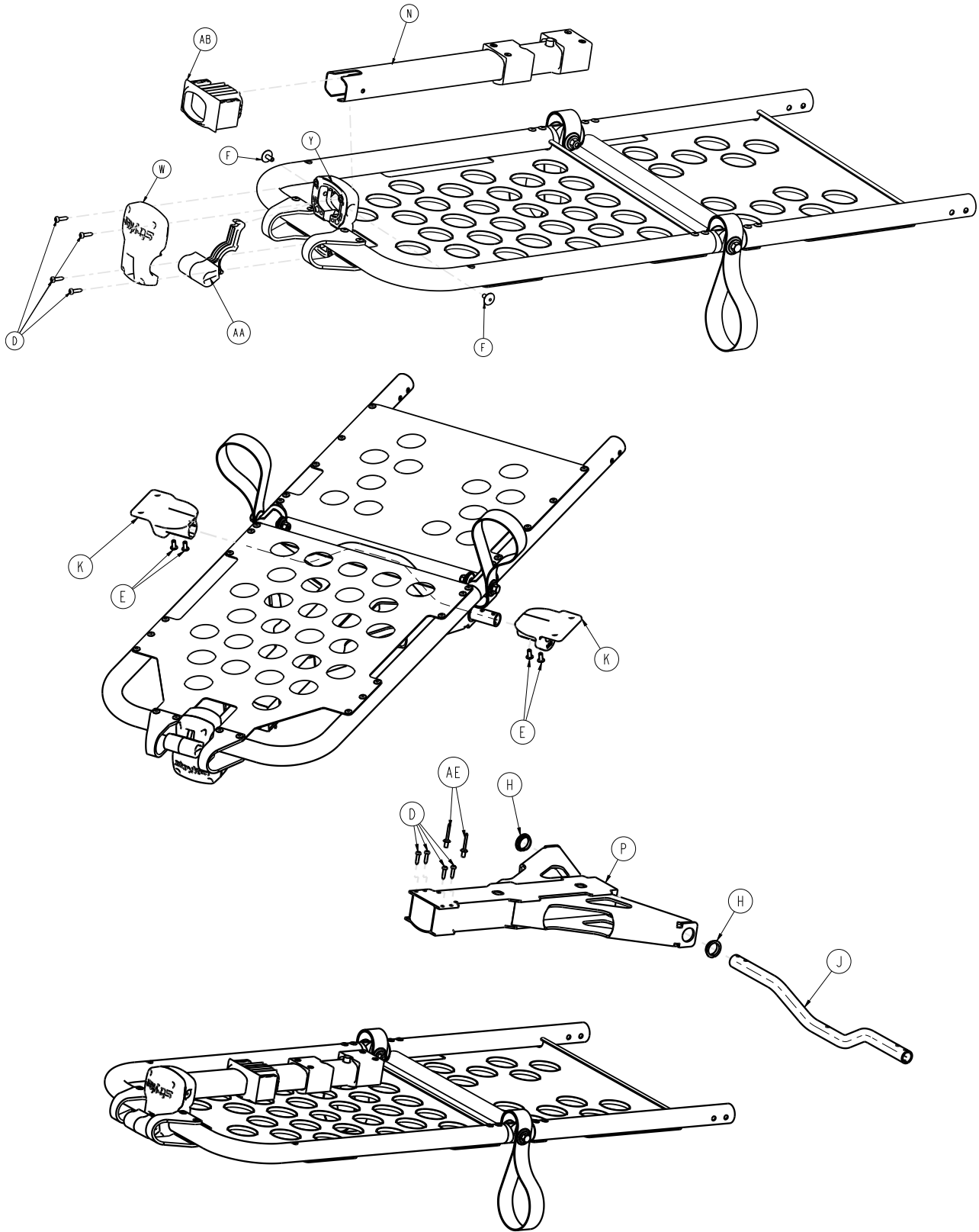

Gatch assembly, optional

Item	Part no.	Part name	Qty
A	0011-448-000	Washer	4
B	0014-020-000	Washer	2
C	0016-028-000	Fiberlock hex nut	2
D	0023-162-000	Delta screw	8
E	0025-079-000	Dome head rivet	34
F	0025-132-000	Dome head rivet	2
G	0025-133-000	Dome head rivet	8
H	0081-255-000	Split bearing	2
J	6500-001-346	Gatch cross tube	1
K	6085-001-125	Gatch support, mid	2
L	6100-031-096	Trend lift strap	2
M	6100-031-108	Gatch pivot	4
N	6550-001-017	Gatch telescoping assembly	1
P	6550-001-057	Gatch lock tube weldment	1
R	6550-001-110	Foot section skin	1
T	6550-001-111	Thigh section tube	2
U	6550-001-112	Thigh section skin	1
V	6550-001-116	Foot section u-tube	1
W	6550-001-124	Front gatch release	1
Y	6550-001-125	Back gatch release	1
AA	6550-001-126	Gatch release lever	1
AB	6550-001-131	Gatch bearing end cap	1
AC	6550-001-186	Gatch pivot pin	2
AD	6550-001-193	Gatch handle guard	2
AE	0025-271-000	Dome head rivet	2

Gatch support assembly, optional

6085-001-031 Rev C (Reference only)

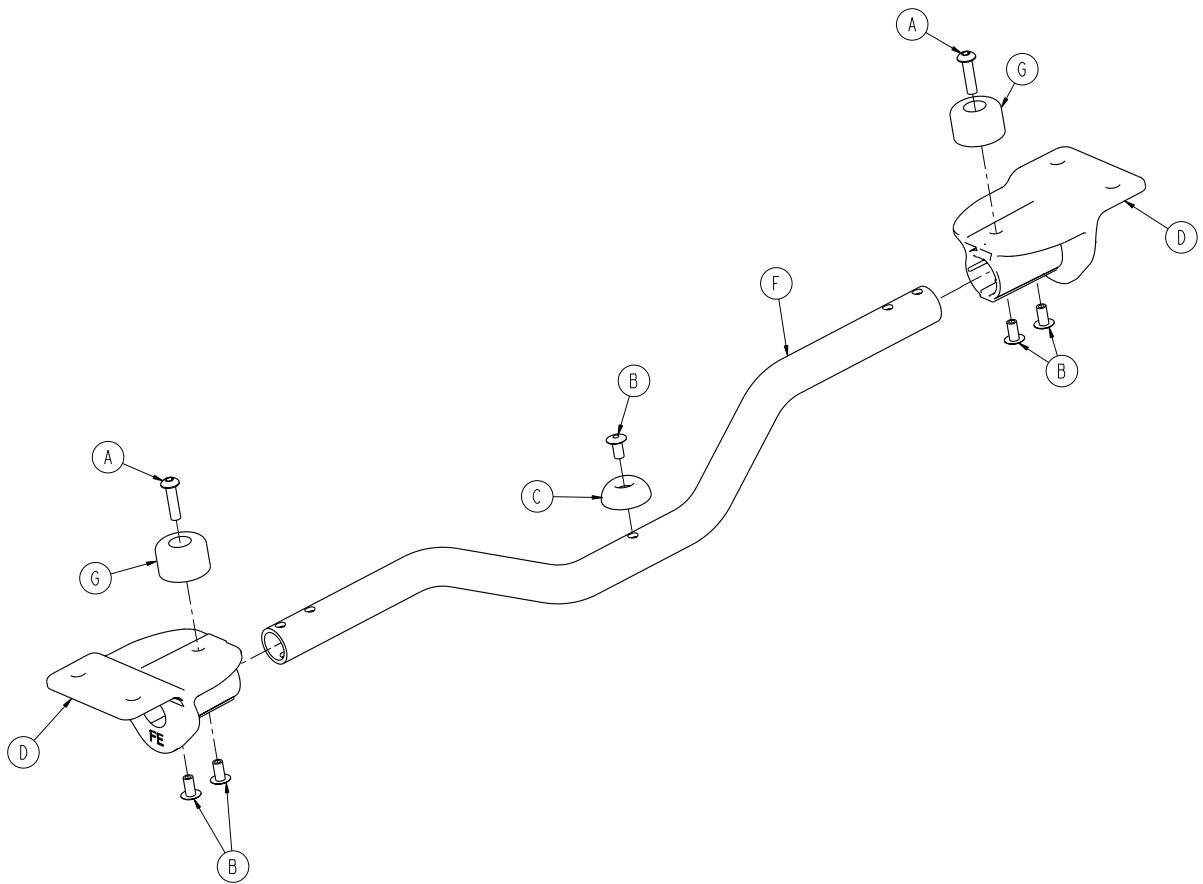

Item	Part no.	Part name	Qty
A	0004-614-000	Button head cap screw	2
B	0025-079-000	Dome head rivet	5
C	0946-001-155	Bumper	1
D	6085-001-135	Gatch support, foot end	2
F	6500-001-346	Gatch crosstube	1
G	0056-028-000	Bumper, black	2

Fowler assembly

6500-001-018 Rev D (Reference only)

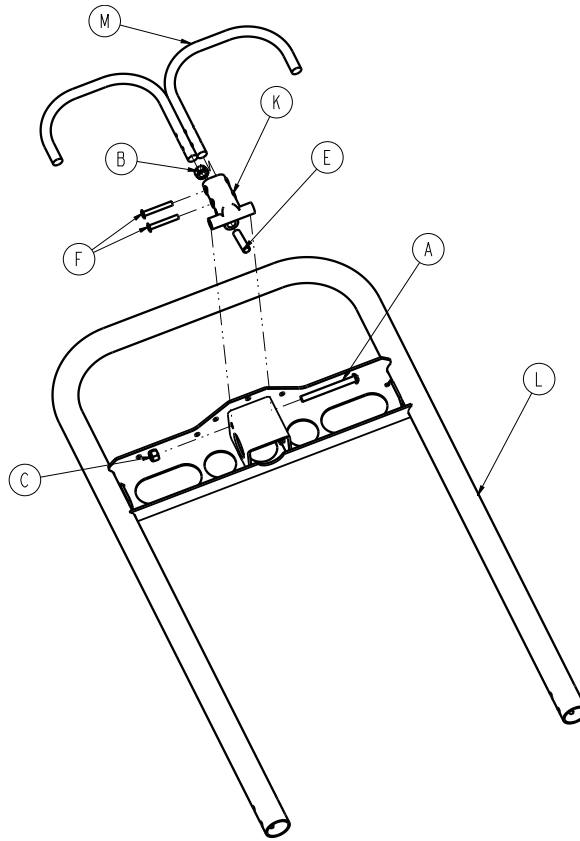

Item	Part no.	Part name	Qty
A	0004-597-000	Button head cap screw	1
B	0015-050-000	Hex nut	1
C	0016-028-000	Hex nut	1
E	0021-138-000	Set screw	1
F	0025-131-000	Rivet	2
K	6060-032-040	Fowler lift pivot	1
L	6082-032-050	Fowler weldment	1
M	6082-032-052	Release handle weldment	1

Standard fowler

6506-012-003 Rev A (Reference only)

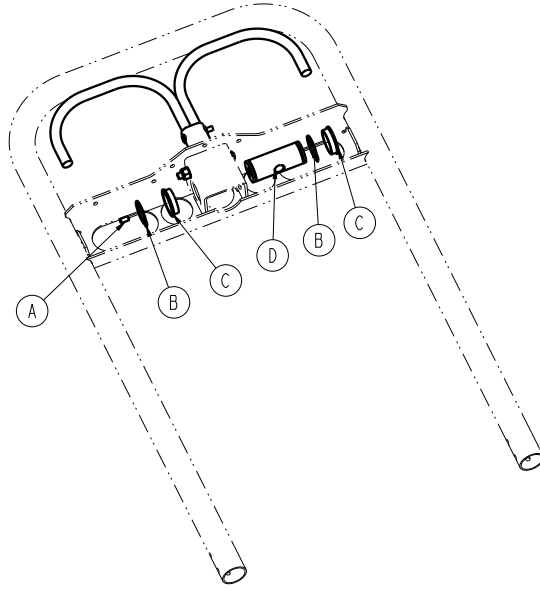

Item	Part no.	Part name	Qty
A	0021-180-000	Set screw	1
B	0028-076-000	External retaining ring	2
C	0946-035-025	Liner	2
D	6060-032-038	Gas spring yoke	1

1865 fowler option

6506-012-004 Rev A (Reference only)

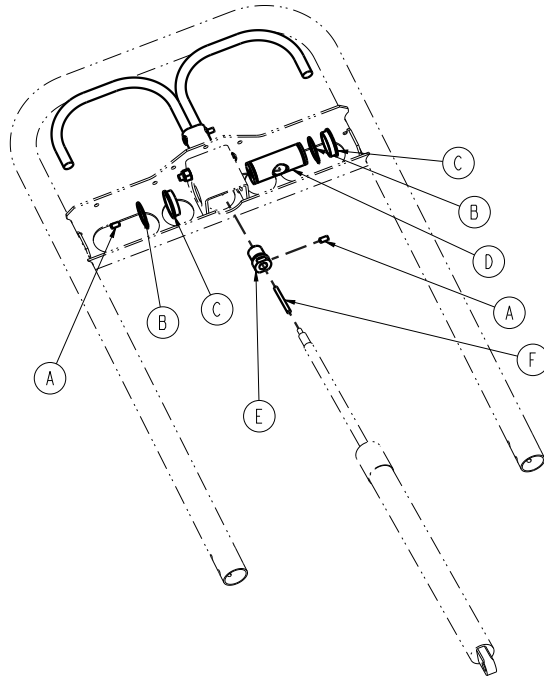

Item	Part no.	Part name	Qty
A	0021-180-000	Set screw	1
B	0028-076-000	External retaining ring	2
C	0946-035-025	Liner	2
D	6060-032-053	Fowler yoke	1
E	6506-012-001	Fowler extension sleeve	1
F	6506-012-002	Fowler plunger	1

Non-Power-LOAD compatible option

6506-029-000 Rev B (Reference only)

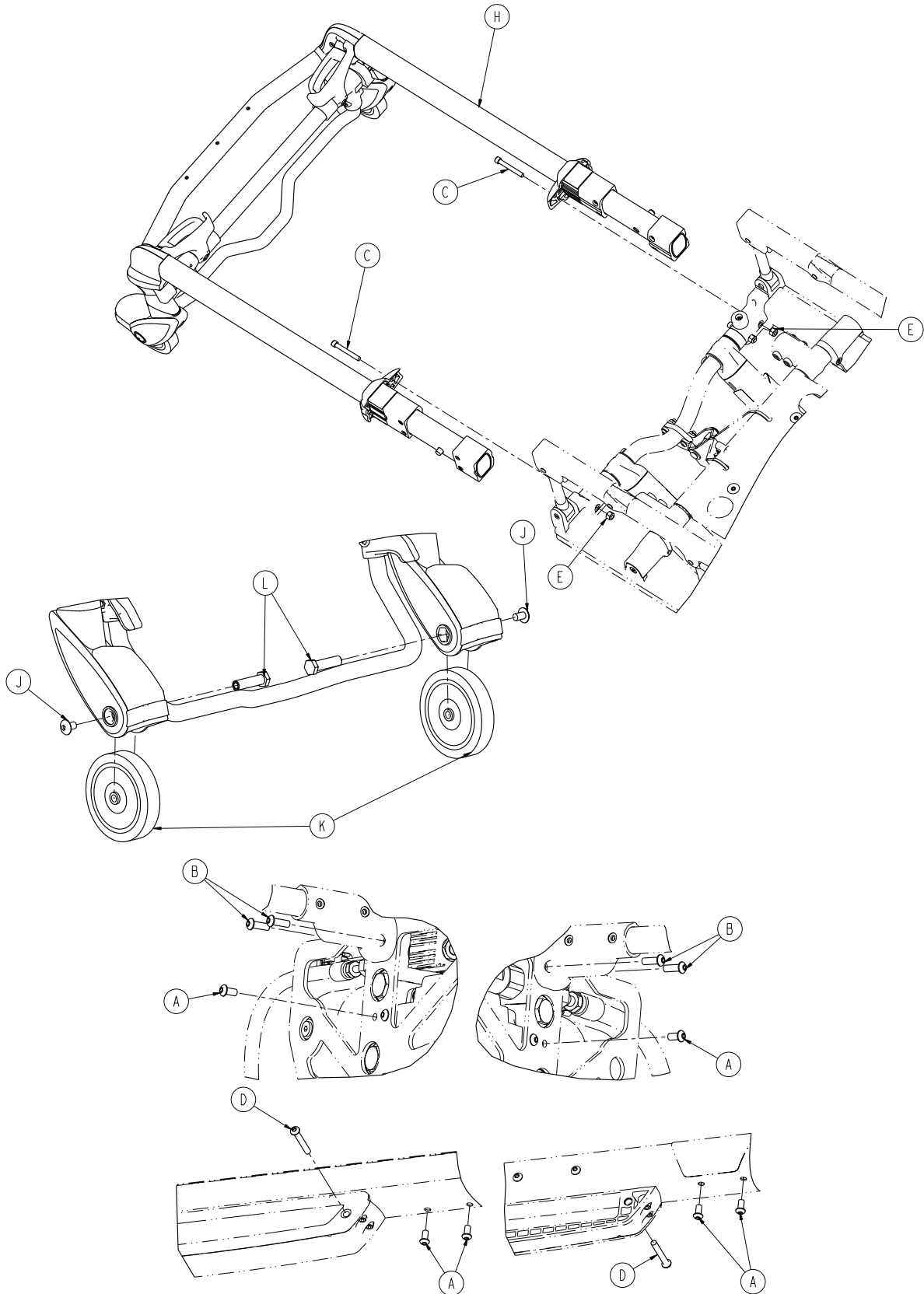

Non-Power-LOAD compatible option

Item	Part no.	Part name	Qty
A	0004-589-000	Button head cap screw	6
B	0004-593-000	Button head cap screw	4
C	0004-595-000	Socket head cap screw	2
D	0004-596-000	Button head cap screw	2
E	0016-028-000	Fiberlock hex nut	2
H	6500-002-020	Head section - 6500-002-020 on page 185	1
J	0007-556-000	Truss head machine screw	2
K	6500-001-086	Front wheel	2
L	6500-002-106	Load wheel spacer	2

Head section (Not Power-LOAD compatible) - 6506-001-020

Rev A (Reference only)

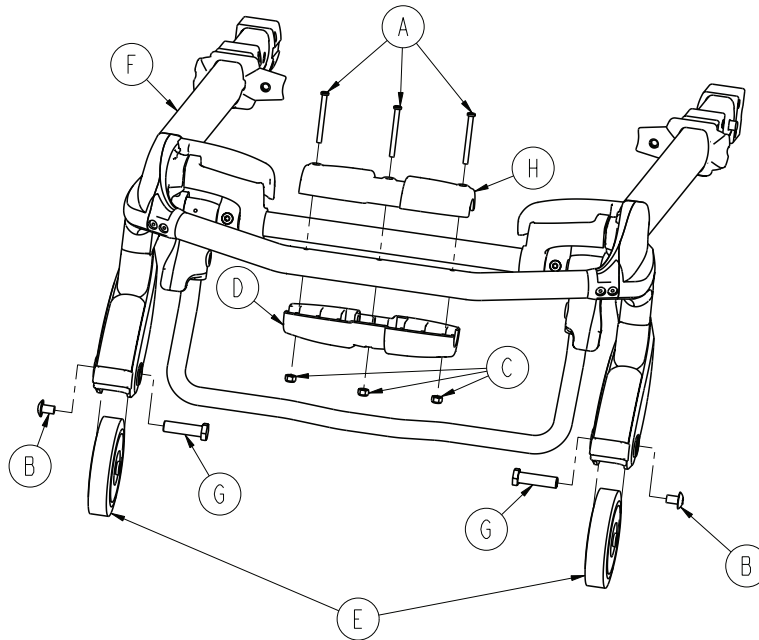

Item	Part no.	Part name	Qty
A	0004-656-000	Socket head cap screw	3
B	0007-556-000	Truss head machine screw	2
C	0016-002-000	Fiberlock hex nut	3
D	6085-001-174	Oxygen bottle holder, bottom	1
E	6500-001-086	Front wheel	2
F	6500-002-020	Head section - 6500-002-020 on page 185	1
G	6500-002-106	Load wheel fastener	2
H	6500-002-156	Top guide, head end	1

Head section (Power-LOAD compatible) - 6506-001-021

Rev A (Reference only)

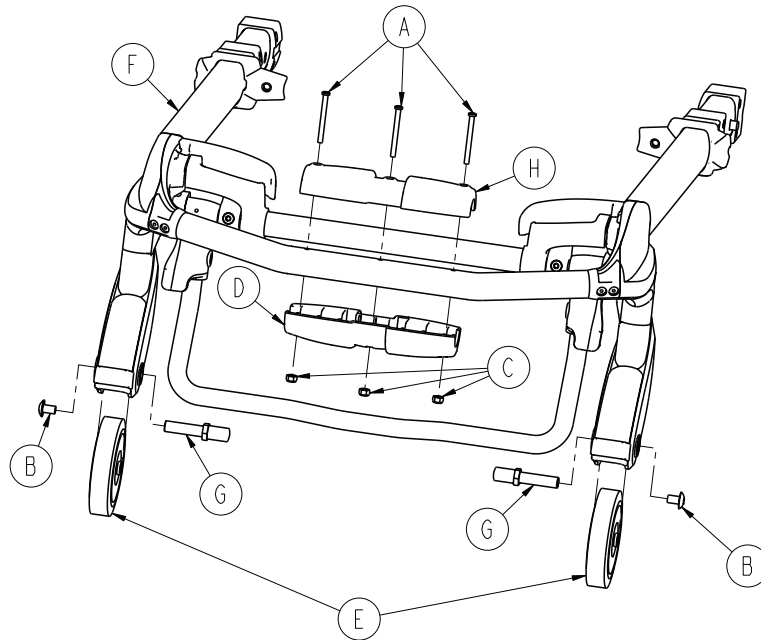

Item	Part no.	Part name	Qty
A	0004-656-000	Socket head cap screw	3
B	0007-556-000	Truss head machine screw	2
C	0016-002-000	Fiberlock hex nut	3
D	6085-001-174	Oxygen bottle holder, bottom	1
E	6500-001-086	Front wheel	2
F	6500-002-020	Head section - 6500-002-020 on page 185	1
G	6500-002-104	Load wheel pin	2
H	6500-002-156	Top guide, head end	1

Head section - 6500-002-020

Rev D (Reference only)

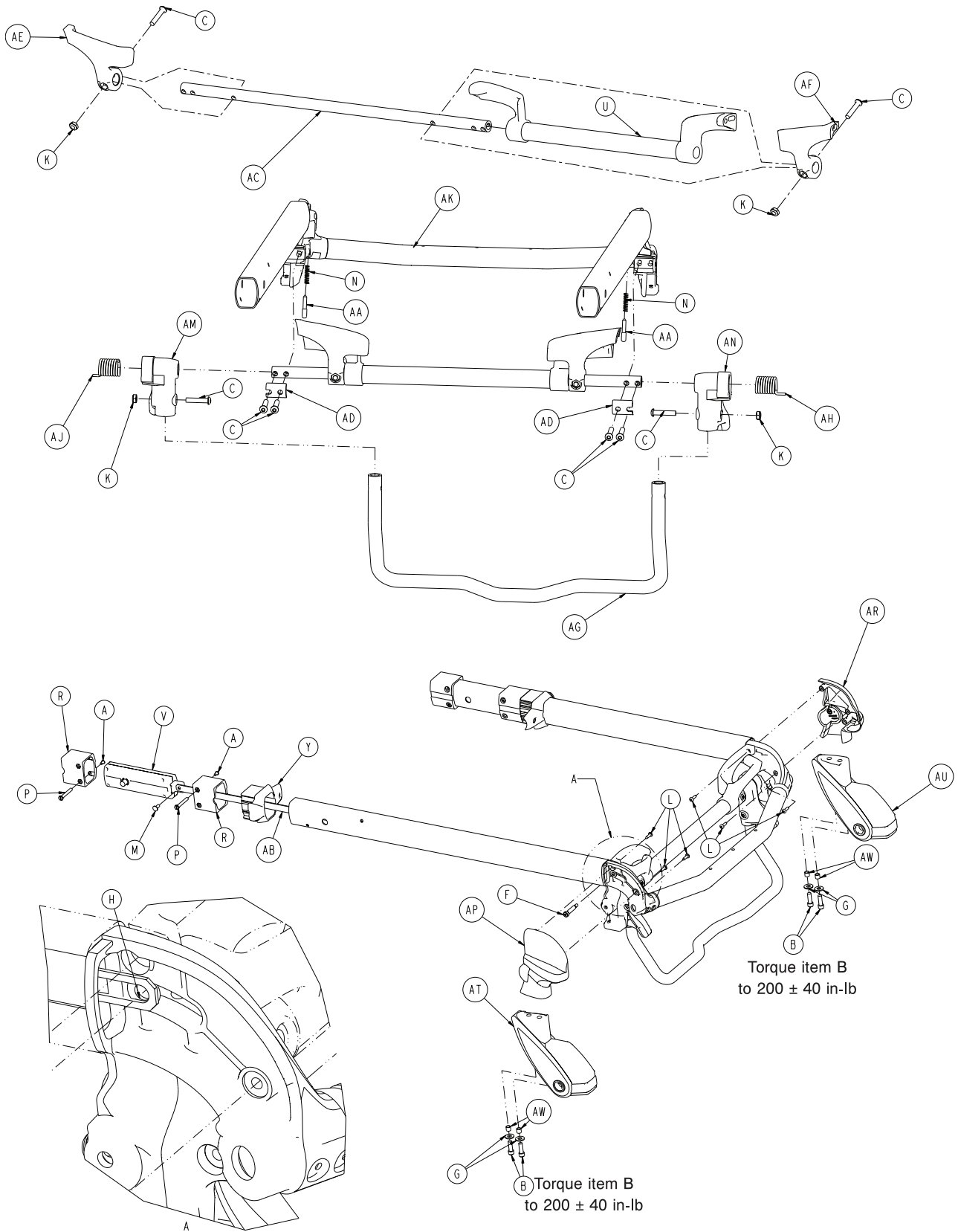

Head section - 6500-002-020

Item	Part no.	Part name	Qty
A	0004-168-000	Button head cap screw	4
B	0004-591-000	Socket head cap screw	4
C	0004-612-000	Button head cap screw	8
F	0008-030-000	Socket head shoulder screw	2
G	0011-624-000	Washer	4
H	0014-002-000	Washer	2
K	0016-102-000	Nylock hex nut	4
L	0023-162-000	Delta screw	6
M	0025-126-000	Semi-tubular rivet	2
N	0038-570-000	Compression spring	2
P	6085-001-169	Head section nut	4
R	6085-001-170	Internal bearing	4
U	6500-001-023	Head trigger assembly	1
V	6500-001-026	Head section lock assembly - 6500-001-026 on page 187	2
Y	6500-001-087	Cap bearing	2
AA	6500-001-093	Safety bar lock pin	2
AB	6500-001-096	Head section release link	2
AC	6500-001-220	Head section pivot cross tube	1
AD	6500-001-221	Cross tube clamp	2
AE	6500-001-280	Head section guard, right	1
AF	6500-001-281	Head section guard, left	1
AG	6500-001-322	Sliding head section safety bar	1
AH	6500-001-325	Safety bar torsion spring, left	1
AJ	6500-001-326	Safety bar torsion spring, right	1
AK	6500-002-025	Telescoping tube assembly	1
AM	6500-002-107	Safety bar pivot, right	1
AN	6500-002-108	Safety bar pivot, left	1
AP	6500-002-109	Load wheel horn cover, left	1
AR	6500-002-110	Load wheel horn cover, right	1
AT	6500-002-120	Load wheel horn, left	1
AU	6500-002-121	Load wheel horn, right	1
AW	6500-002-114	Compression limiter sleeve	4

Head section lock assembly - 6500-001-026

Rev C (Reference only)

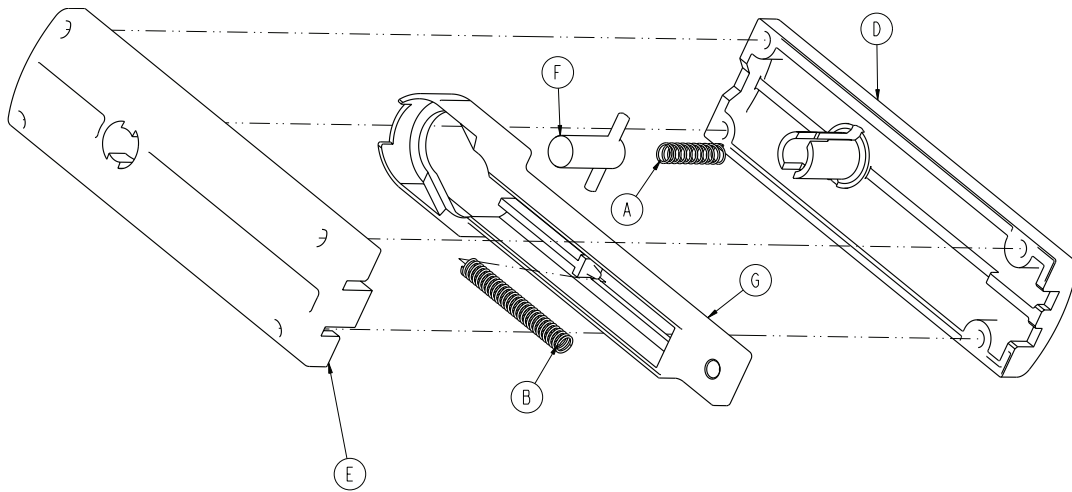

Item	Part no.	Part name	Qty
A	0038-570-000	Compression spring	1
B	0038-134-000	Compression spring	1
D	6500-001-091	Top latch housing	1
E	6500-001-092	Bottom latch housing	1
F	6500-001-025	Latch assembly	1
G	6500-001-095	Actuation slide	1

In-fastener shut-off assembly, optional - 6500-001-027

Rev C (Reference only)

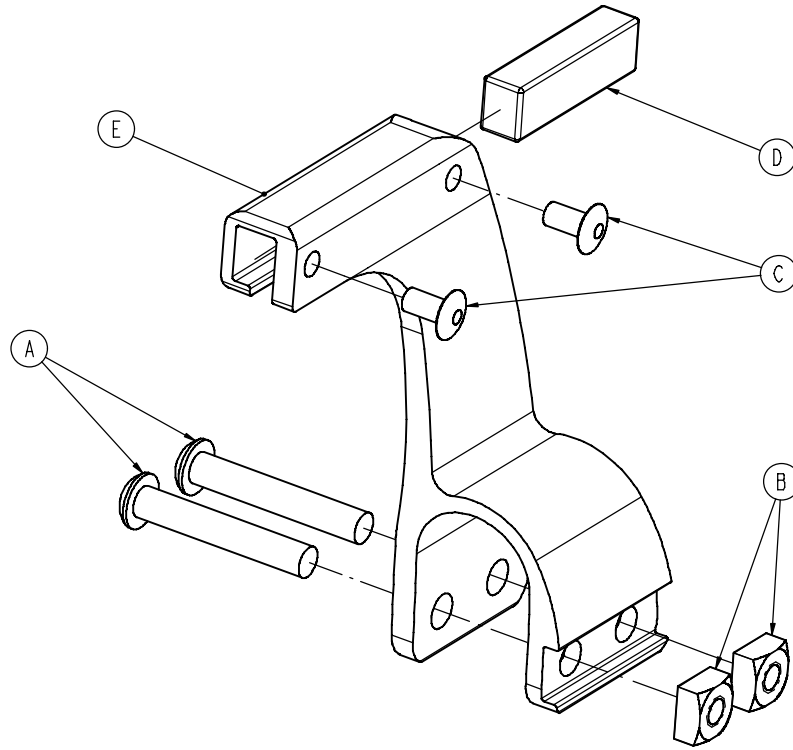

Item	Part no.	Part name	Qty
A	0004-376-000	Button head cap screw	2
B	0015-016-000	Square nut	2
C	0025-079-000	Rivet	2
D	6500-001-271	Magnet	1
E	6500-001-272	Holder	1

No head section oxygen bottle holder option - 6506-036-000

Rev A (Reference only)

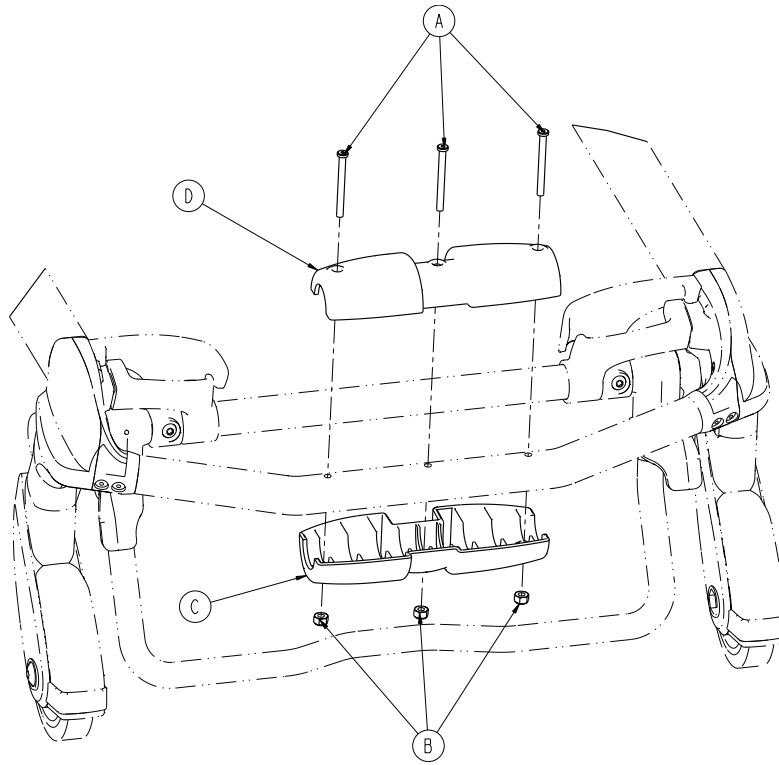

Item	Part no.	Part name	Qty
A	0004-656-000	Socket head cap screw	3
B	0016-002-000	Fiberlock hex nut	3
C	6085-001-174	Oxygen bottle holder, bottom	1
D	6500-002-156	Top guide, head end	1

Power-LOAD compatible option - 6506-127-000

Rev B (Reference only)

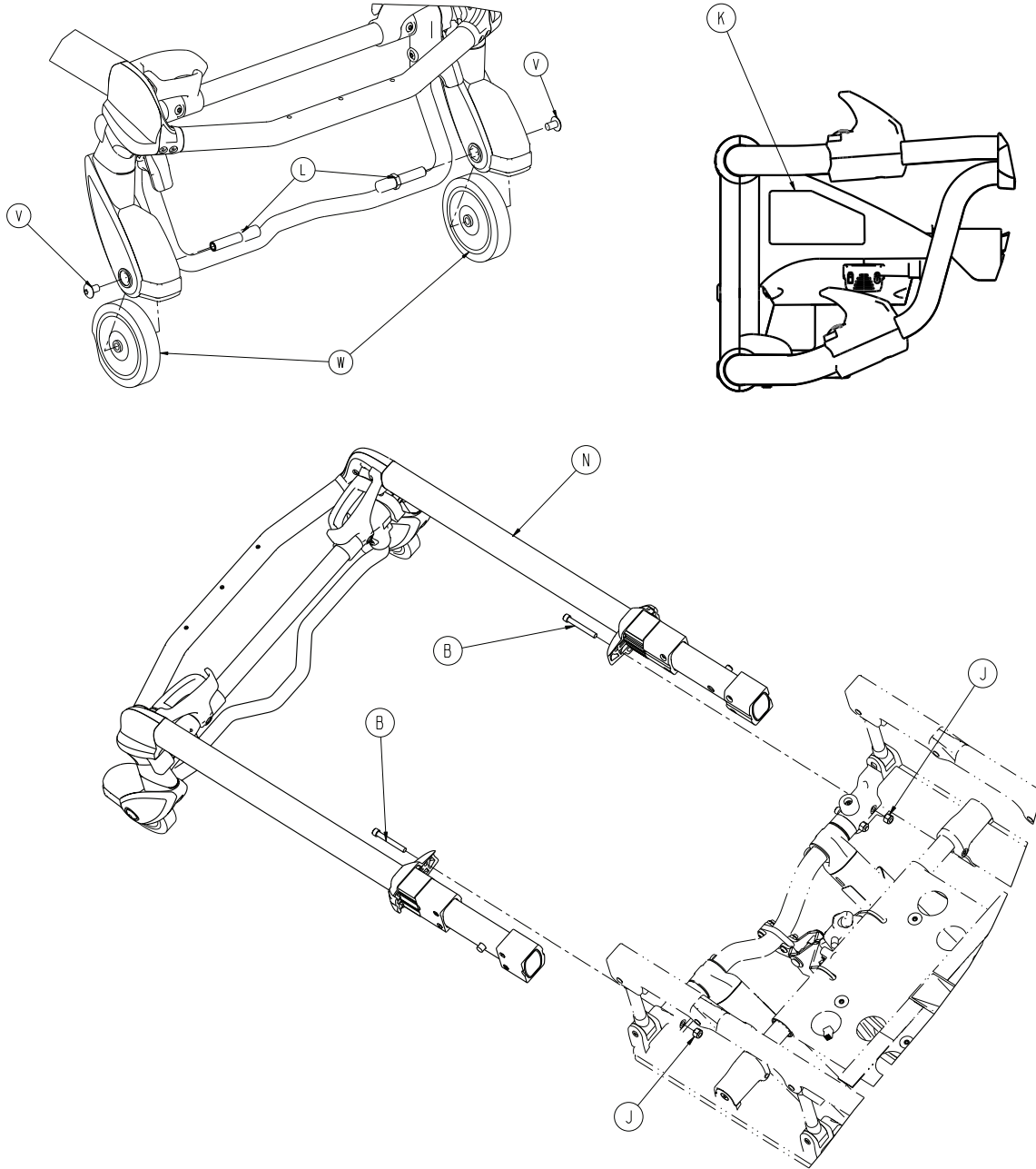

Power-LOAD compatible option - 6506-127-000

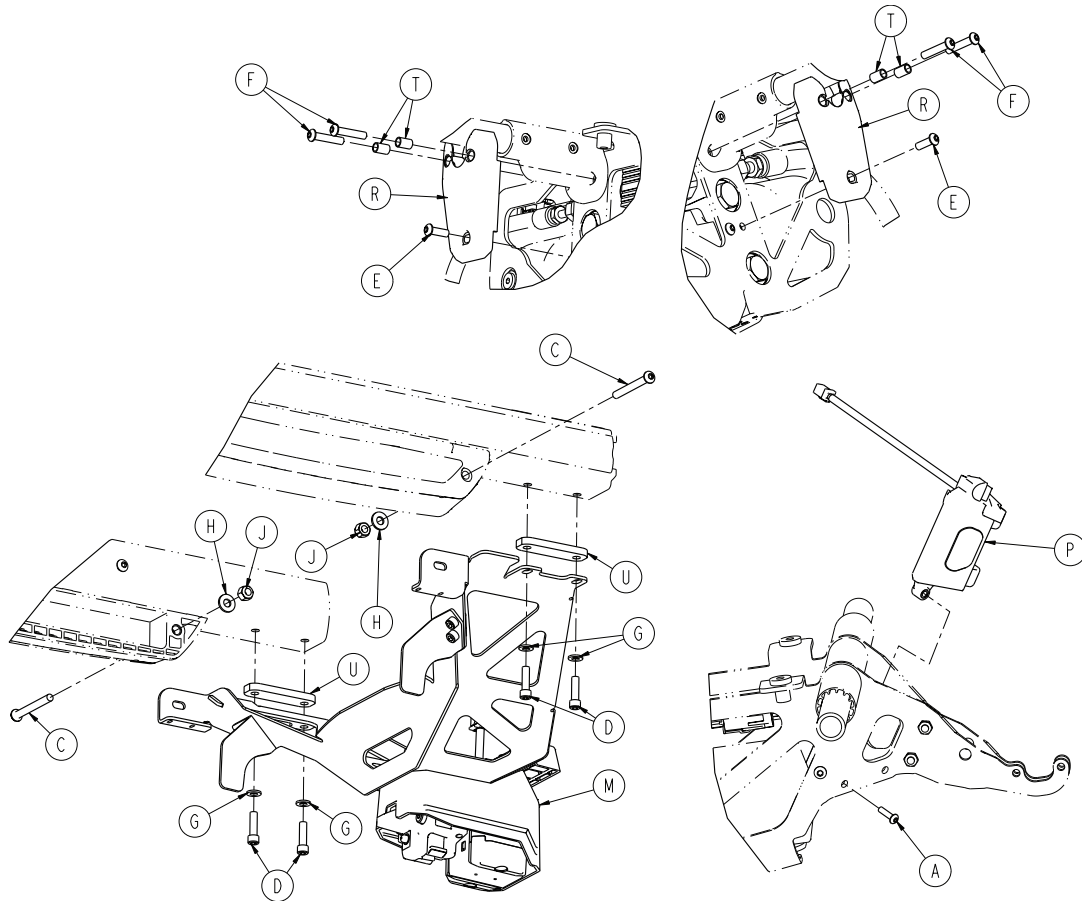

Item	Part no.	Part name	Qty
A	0004-614-000	Button head cap screw	1
B	0004-595-000	Socket head cap screw	2
C	0004-387-000	Button head cap screw	2
D	0004-661-000	Socket head cap screw	4
E	0004-593-000	Button head cap screw	2
F	0004-395-000	Button head cap screw	4
G	0011-065-000	Washer	4
H	0011-077-000	Washer	2
J	0016-028-000	Fiberlock hex nut	4
K	6506-201-101	Label, FCC	1
L	6500-002-104	Load wheel pin	2
M	6500-002-013	Foot end fastener assembly (Power-LOAD compatible option) on page 192	1
N	6500-002-020	Head section - 6500-002-020 on page 185	1
P	6500-002-100	Cot communication board	1
R	6500-002-123	Load arm guide	2
T	6500-002-124	Arm cot spacer sleeve	4
U	6500-002-126	Foot end fastener spacer plate	2
V	0007-556-000	Truss head machine screw	2
W	6500-001-086	Front wheel	2

Foot end fastener assembly (Power-LOAD compatible option)

6500-002-013 Rev F (Reference only)

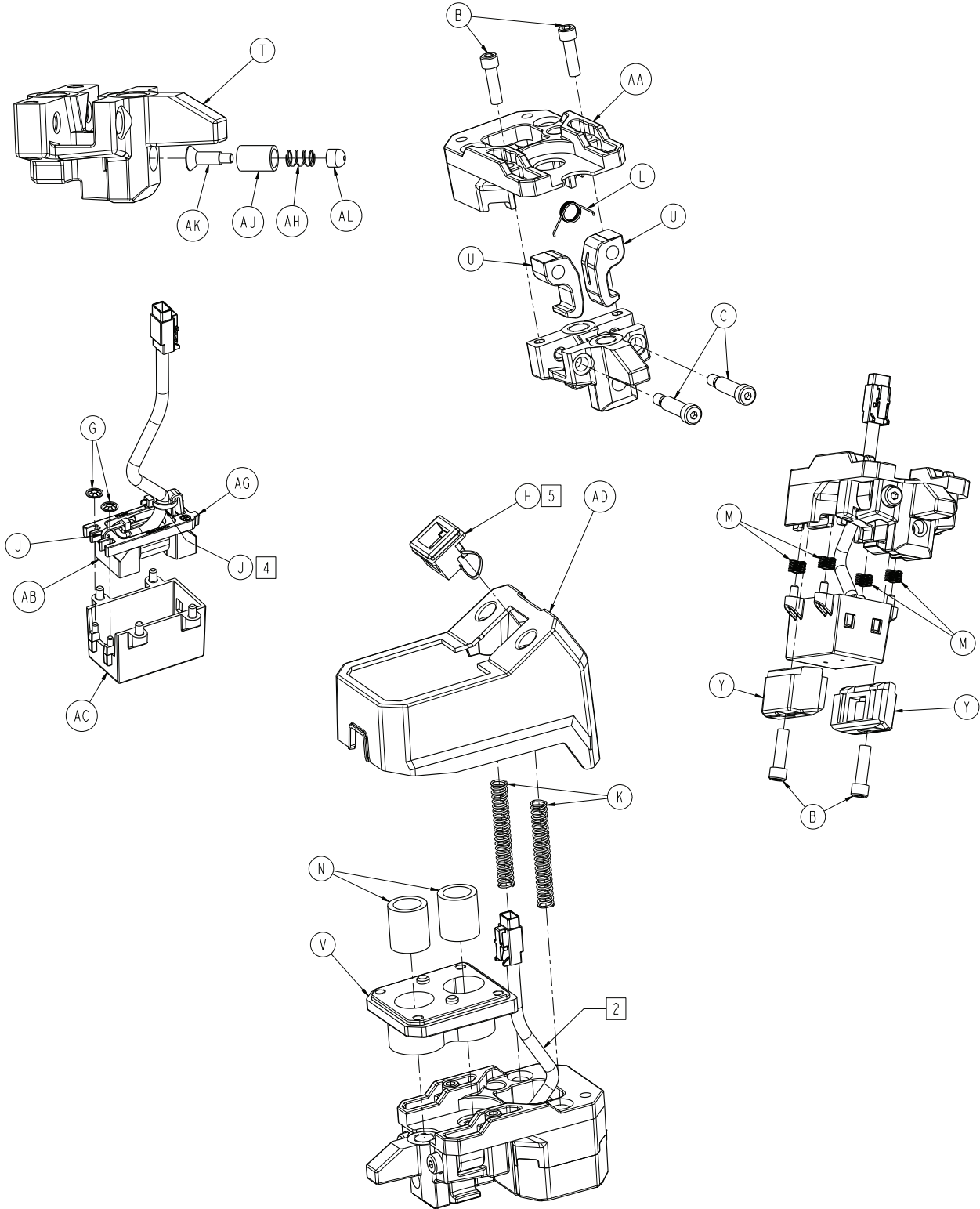

Foot end fastener assembly (Power-LOAD compatible option)

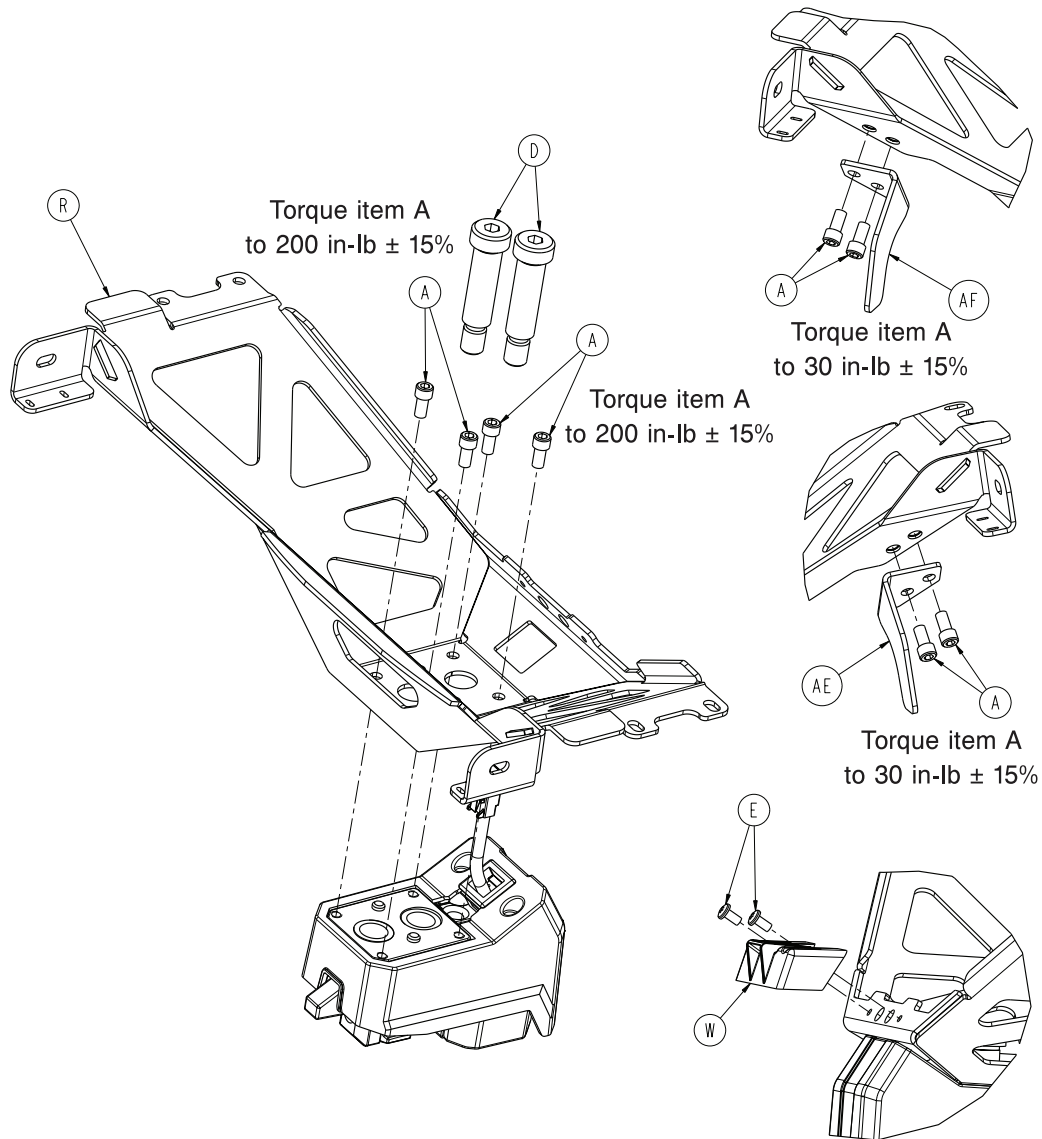

Item	Part no.	Part name	Qty
A	0004-660-000	Socket head cap screw	8
B	0004-661-000	Socket head cap screw	4
C	0008-088-000	Socket head set screw	2
D	0008-087-000	Socket head set screw	2
E	0023-296-000	Pan head machine screw	2
G	0028-217-000	Pushnut	2
H	0037-248-000	Strain relief	1
J	0038-111-000	Zip tie	2
K	0038-889-000	Compression spring	2
L	0038-891-000	Torsion spring	1
M	0038-900-000	Wave spring	4
N	0081-437-000	Sleeve bearing	2
R	6500-002-050	Bracket weldment	1
T	6500-002-111	Foot end fastener guide	1

Foot end fastener assembly (Power-LOAD compatible option)

Item	Part no.	Part name	Qty
U	6500-002-112	Cot foot end fastener hook	2
V	6500-002-113	Foot end fastener bearing plate	1
W	6500-002-119	Foot end faster cot spacer	1
Y	6500-002-122	Foot end faster cot wear pad	2
AA	6500-002-129	Floating plate	1
AB	6500-002-133	Cot secondary coil	1
AC	6500-002-135	Cot foot end fastener coil holder	1
AD	6500-002-136	Foot end fastener cot housing	1
AE	6500-002-146	Foot end fastener cot hook, right	1
AF	6500-002-147	Foot end fastener cot hook, left	1
AG	6500-002-144	Cot tie down coil strap	1
AH	6500-001-012	Compression spring	1
AJ	6500-002-148	Plunger housing	1
AK	6500-002-149	Plunger	1
AL	6500-002-152	Plunger cap	1

- 2 Leave enough slack in cable in indicated area to allow item AC to have full range of travel after assembly.
- 4 Install zip tie around large wire jacket, as shown for item J.
- 5 Leave strain relief loose on wire, as shown for item H.

G-rated restraint package - 6500-002-030

Rev F (Reference only)

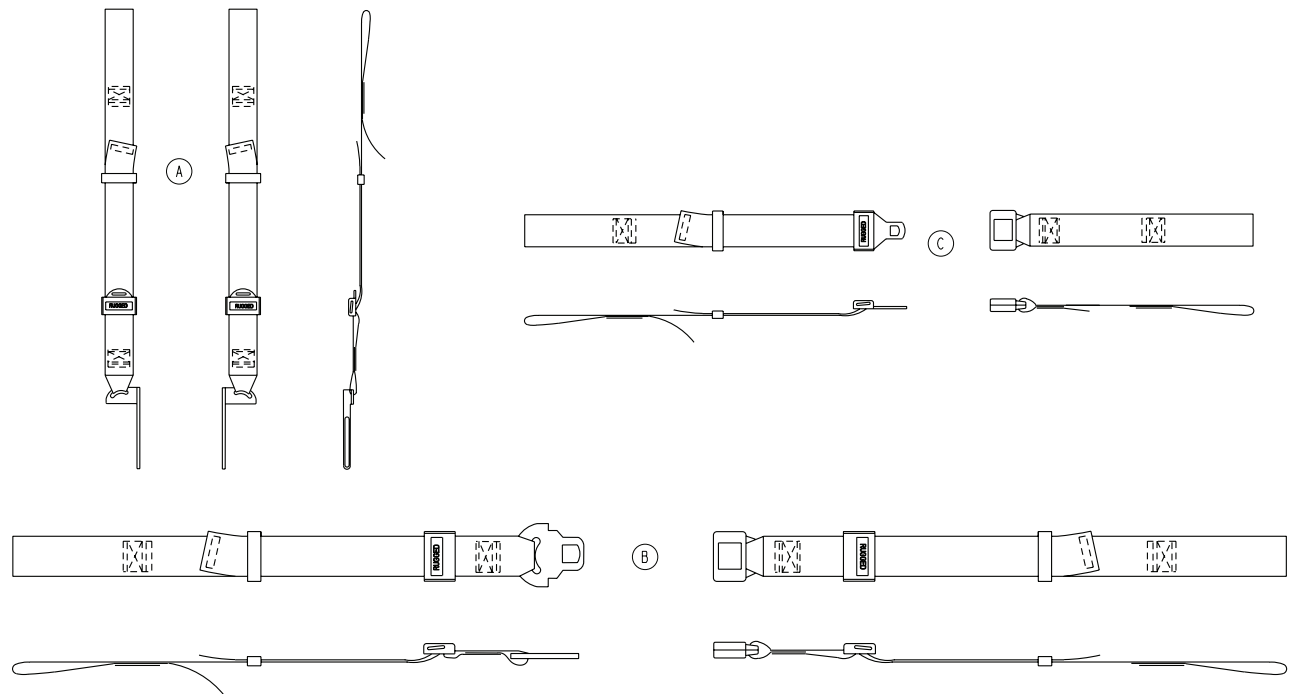

Item	Part no.	Part name	Qty
A	6500-001-391	Shoulder harness restraint	1
B	6500-001-393	Waist restraint	1
C	6500-001-395	Leg restraint	2

X-restraint package - 6500-001-430

Rev E (Reference only)

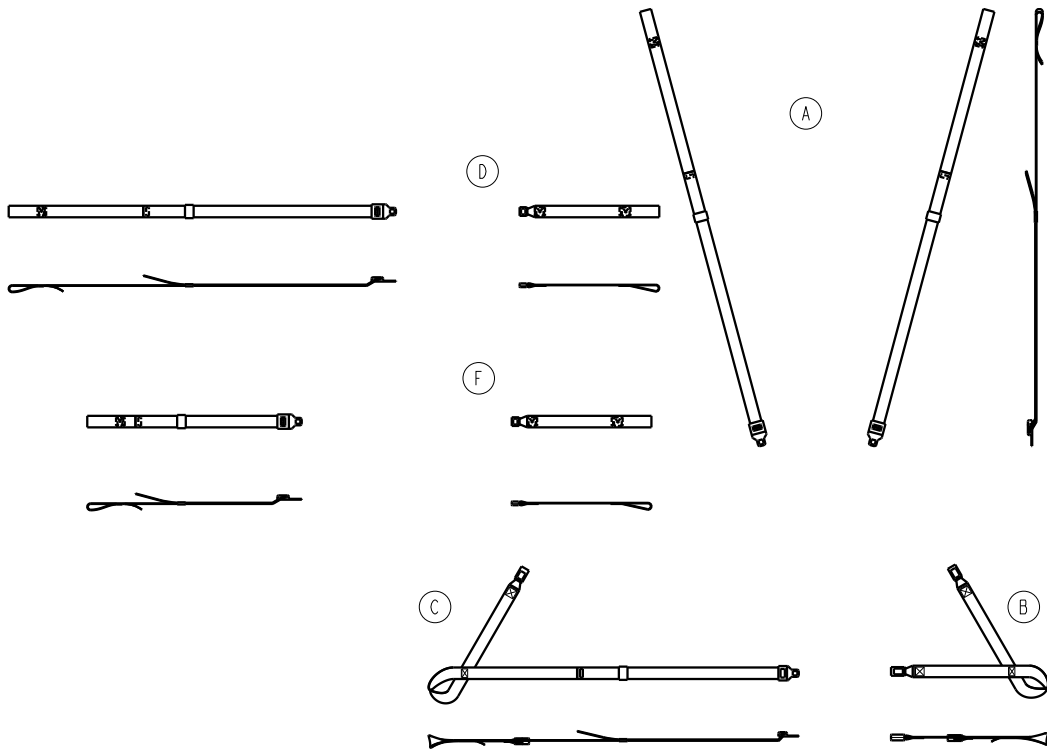

Item	Part no.	Part name	Qty
A	6500-001-401	Shoulder restraint	2
B	6500-001-402	X-double buckle strap	1
C	6500-001-403	X-buckle and tongue strap	1
D	6500-001-404	Thigh restraint	1
F	6500-001-405	Ankle restraint	1

X-restraint package, cobalt blue - 6500-001-431

Rev A (Reference only)

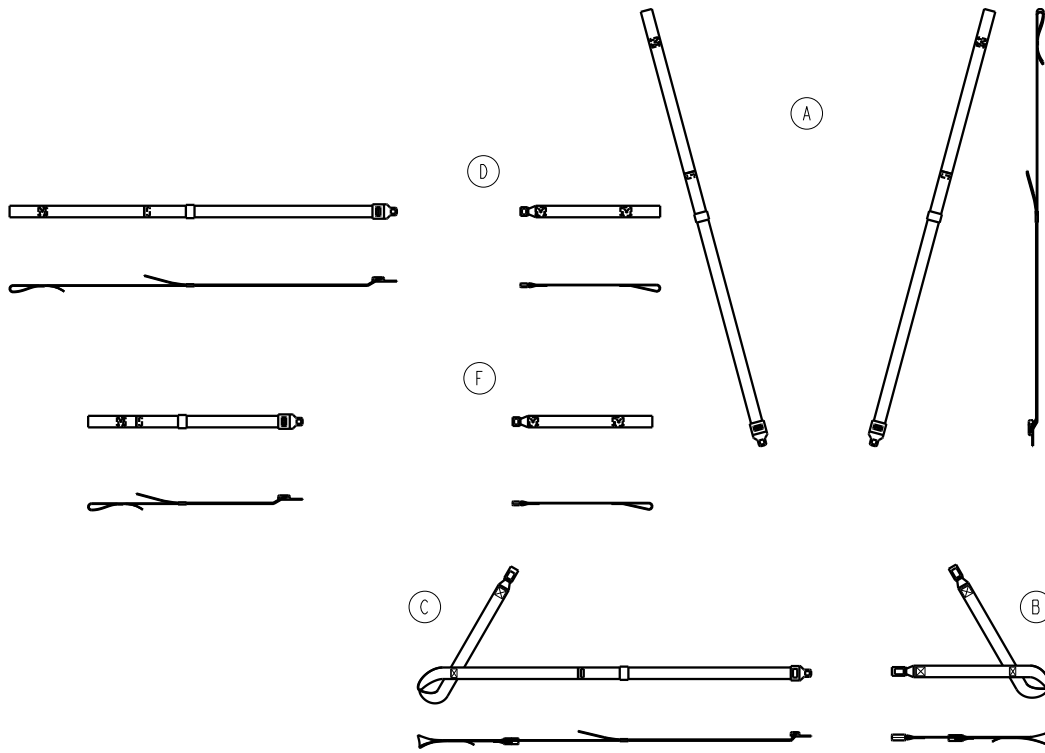

Item	Part no.	Part name	Qty
A	6500-001-411	Shoulder restraint, cobalt blue	2
B	6500-001-412	X-double buckle strap, cobalt blue	1
C	6500-001-413	X-buckle and tongue strap, cobalt blue	1
D	6500-001-414	Thigh restraint, cobalt blue	1
F	6500-001-415	Ankle restraint, cobalt blue	1

Restraint extender, 3' - 6082-160-050

Rev B (Reference only)

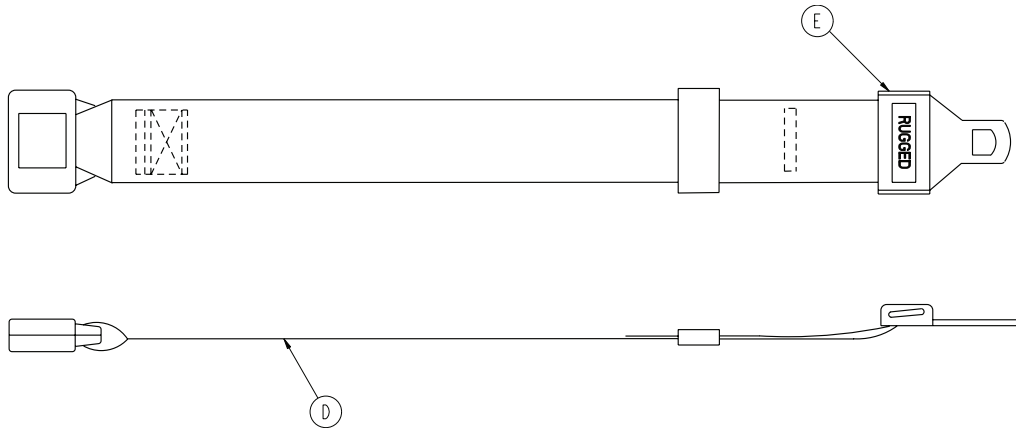

Item	Part no.	Part name	Qty
D	6082-090-001	Label, Stryker part number	1
E	6060-090-011	Label	1

Battery pack, SMRT - 6500-033-000

Rev A/6500-101-010 Rev E (Reference only)

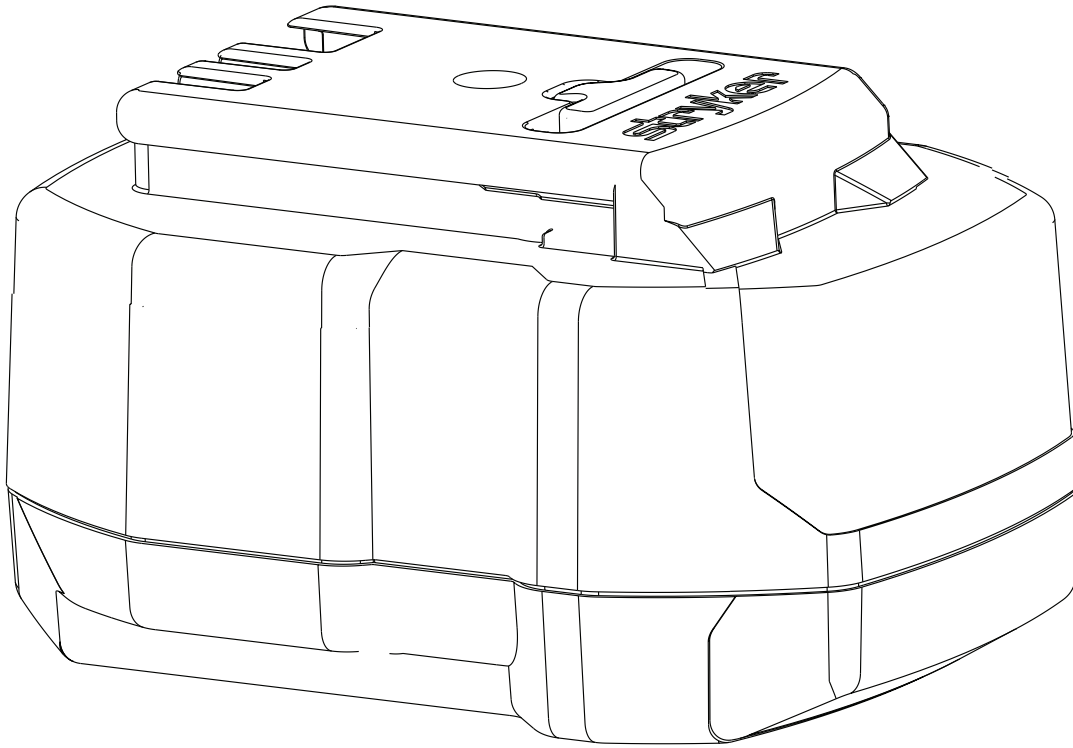

Defibrillator platform - 6506-170-000

Rev A / 6500-101-046 Rev A (Reference only)

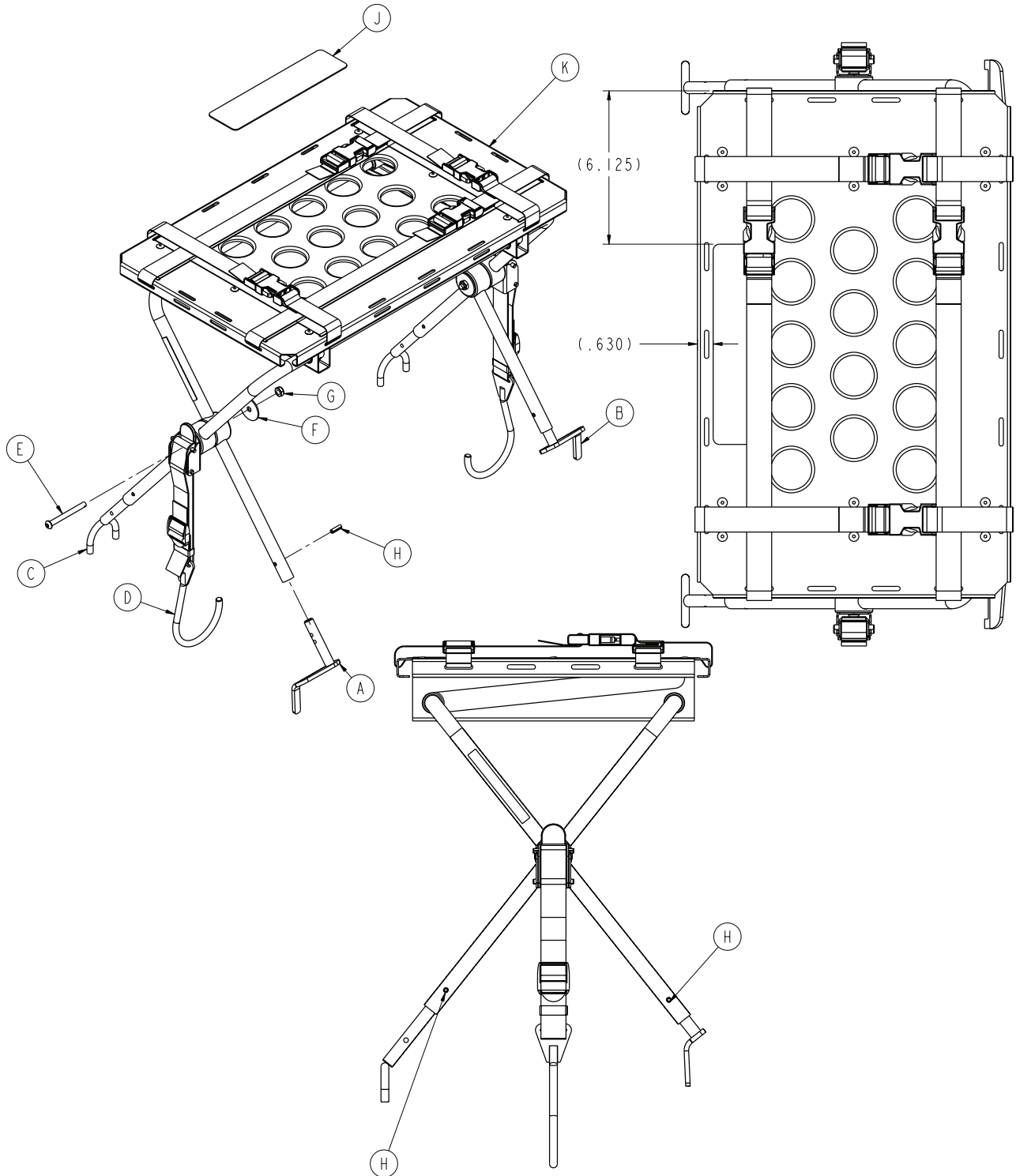

Item	Part no.	Part name	Qty
A	6100-170-050	Head end bracket weldment, left	1
B	6100-170-051	Head end bracket weldment, right	1
C	6082-170-050	Defib u-foot weldment	2

Defibrillator platform - 6506-170-000

Item	Part no.	Part name	Qty
D	6100-170-020	Defib latch strap assembly	2
E	0004-234-000	Button head cap screw	2
F	0011-355-000	Washer	2
G	0016-102-000	Nylock nut	2
H	0026-172-000	Slotted spring pin	4
J	6500-101-298	Label, defib platform	1
K	6082-170-020	Defibrillator platform common components on page 202	1

Defibrillator platform common components

6082-170-020 Rev B (Reference only)

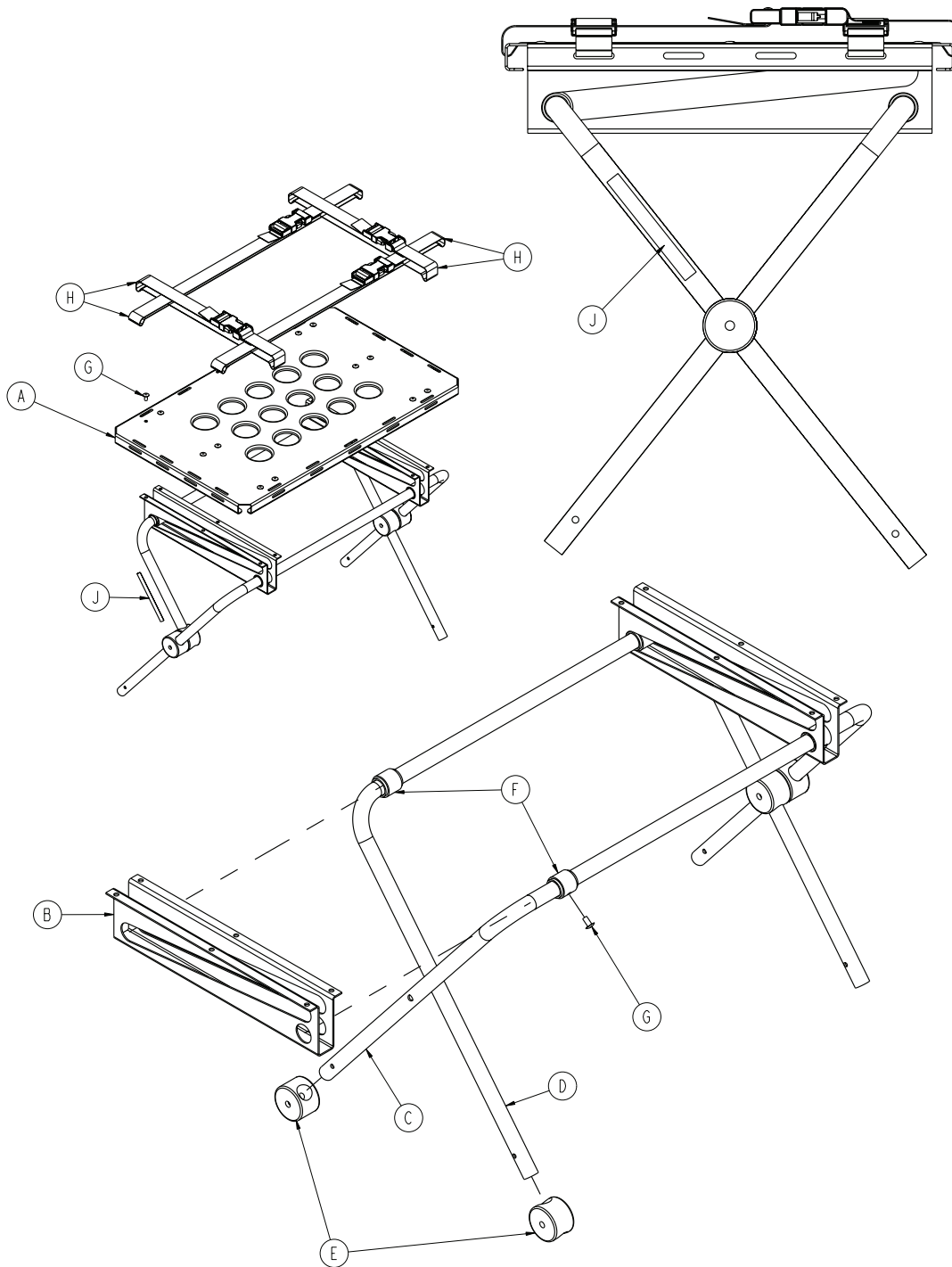

Item	Part no.	Part name	Qty
A	6080-170-011	Top panel	1
B	6080-170-012	Leg support	2
C	6080-170-013	Stationary defibrillator leg	1
D	6080-170-014	Sliding defibrillator leg	1
E	6080-170-015	Support pivot leg	4

Defibrillator platform common components

Item	Part no.	Part name	Qty
F	6080-170-016	Leg collar	4
G	0025-079-000	Dome head rivet	16
H	6060-170-022	Defibrillator platform strap, long	4
J	6080-090-023	Label	2

Equipment hook - 6500-147-000

Rev B (Reference only)

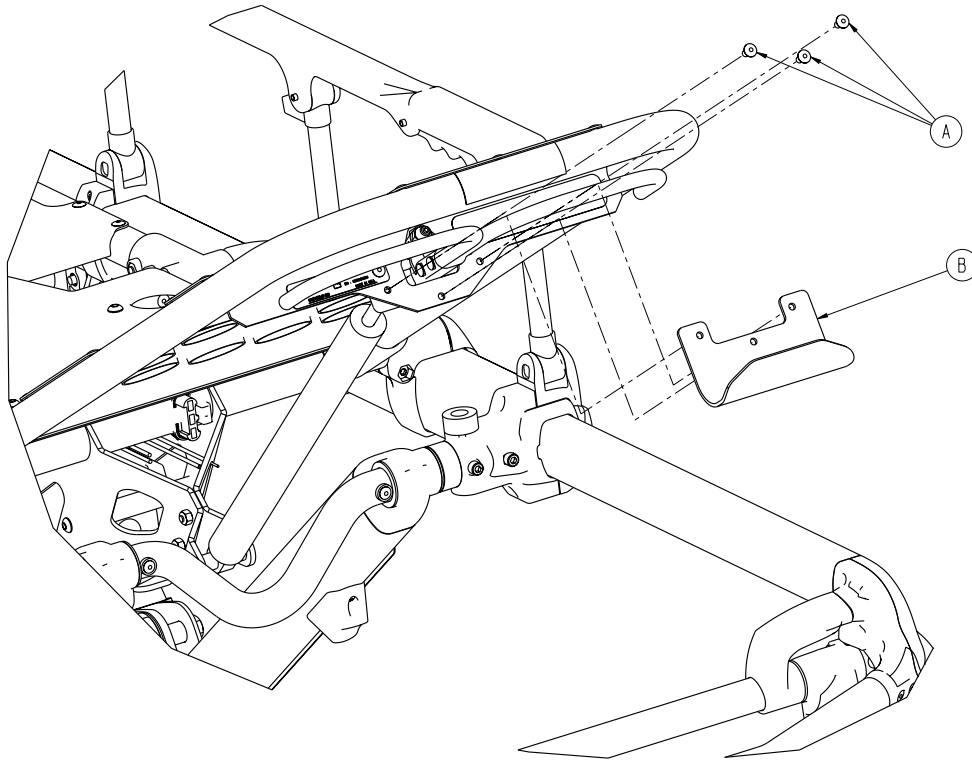

Item	Part no.	Part name	Qty
A	0025-079-000	Dome head rivet	3
B	6500-001-237	Equipment hook	1

Head extension - 6100-044-000

Rev B (Reference only)

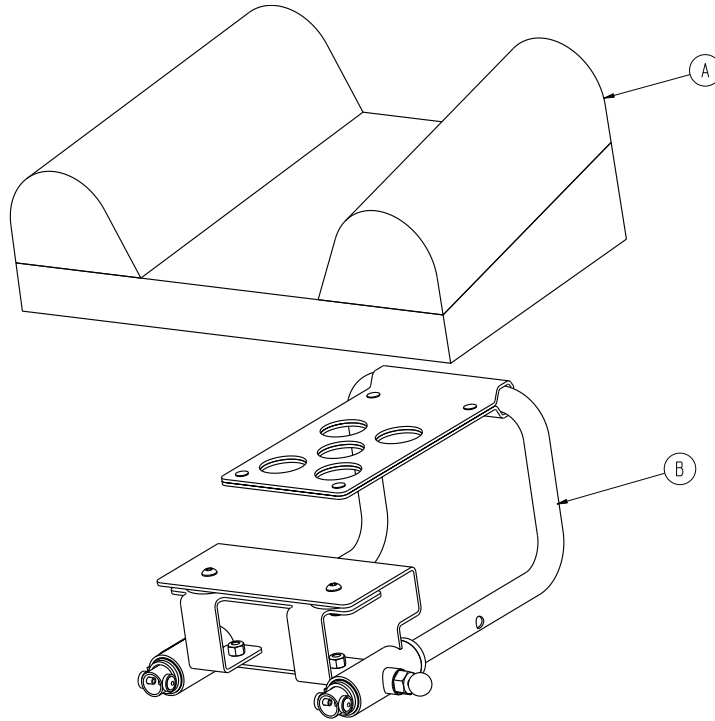

Item	Part no.	Part name	Qty
A	6100-041-030	Pillow	1
B	6100-044-012	Head extension assembly - 6100-044-012 on page 206	1

Head extension assembly - 6100-044-012

Rev F (Reference only)

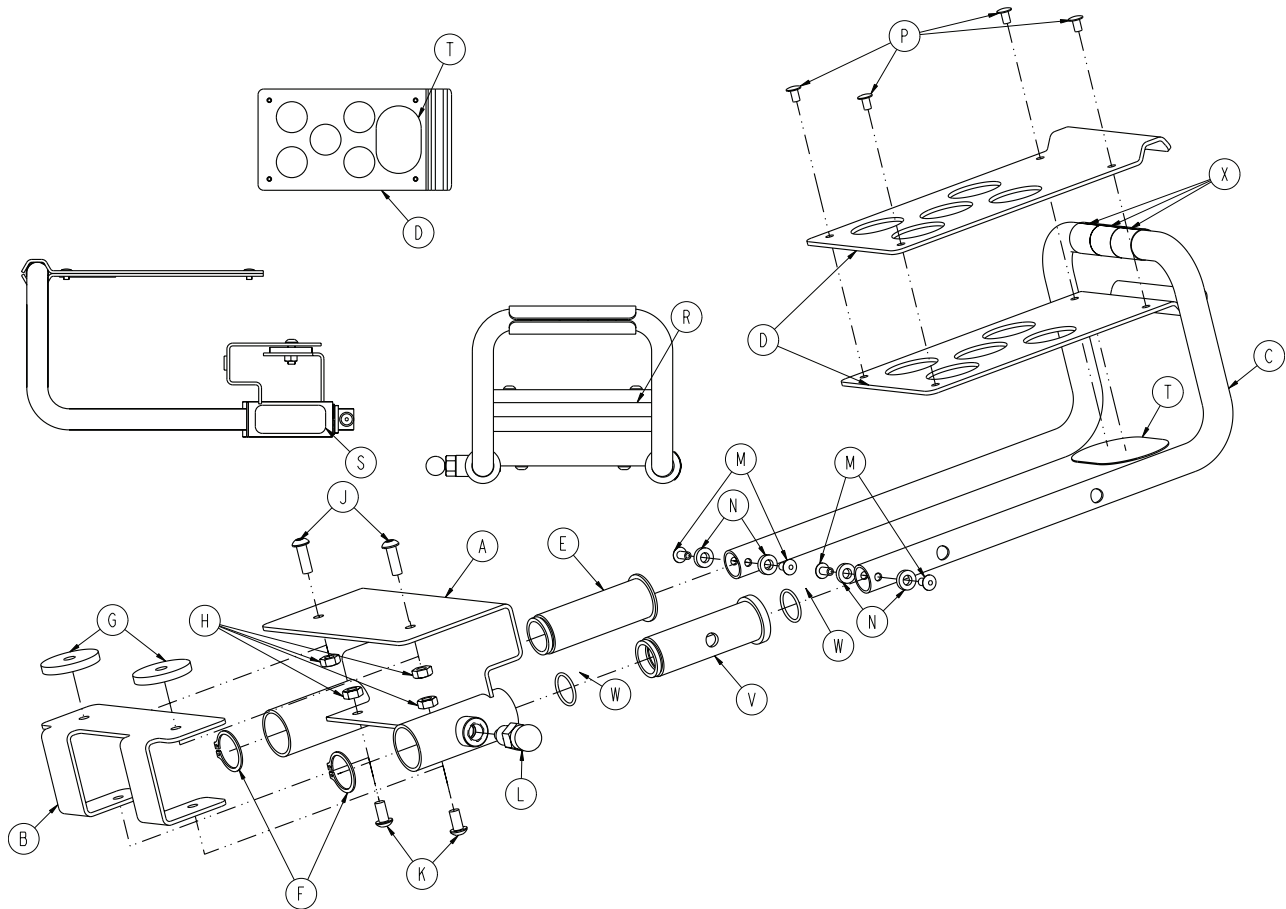

Item	Part no.	Part name	Qty
A	6100-044-010	Bracket weldment	1
B	6100-044-007	Support	1
C	6100-044-011	Extension tube	1
D	6100-044-008	Pillow support	2
E	6100-044-005	Insert	1
F	0028-076-000	Clip	2
G	6100-044-006	Spacer	2
H	0016-028-000	Nylock nut	4
J	0004-161-000	Button head cap screw	2
K	0004-232-000	Button head cap screw	2
L	6372-010-016	Pull pin assembly	1
M	0025-079-000	Dome head rivet	4
N	0014-067-000	Washer	4
P	0025-031-000	Semi-tubular rivet	4
R	6060-090-004	Label, small	1
S	6100-090-013	Label, spec	1
T	6100-044-013	Velcro® hook	1
V	6100-044-004	Insert	1

Head extension assembly - 6100-044-012

Item	Part no.	Part name	Qty
W	0045-999-603	O-ring	2
X	6100-044-014	Head extension tape	3

IV pole assembly, two-stage, right - 6500-310-000

Rev B (Reference only)

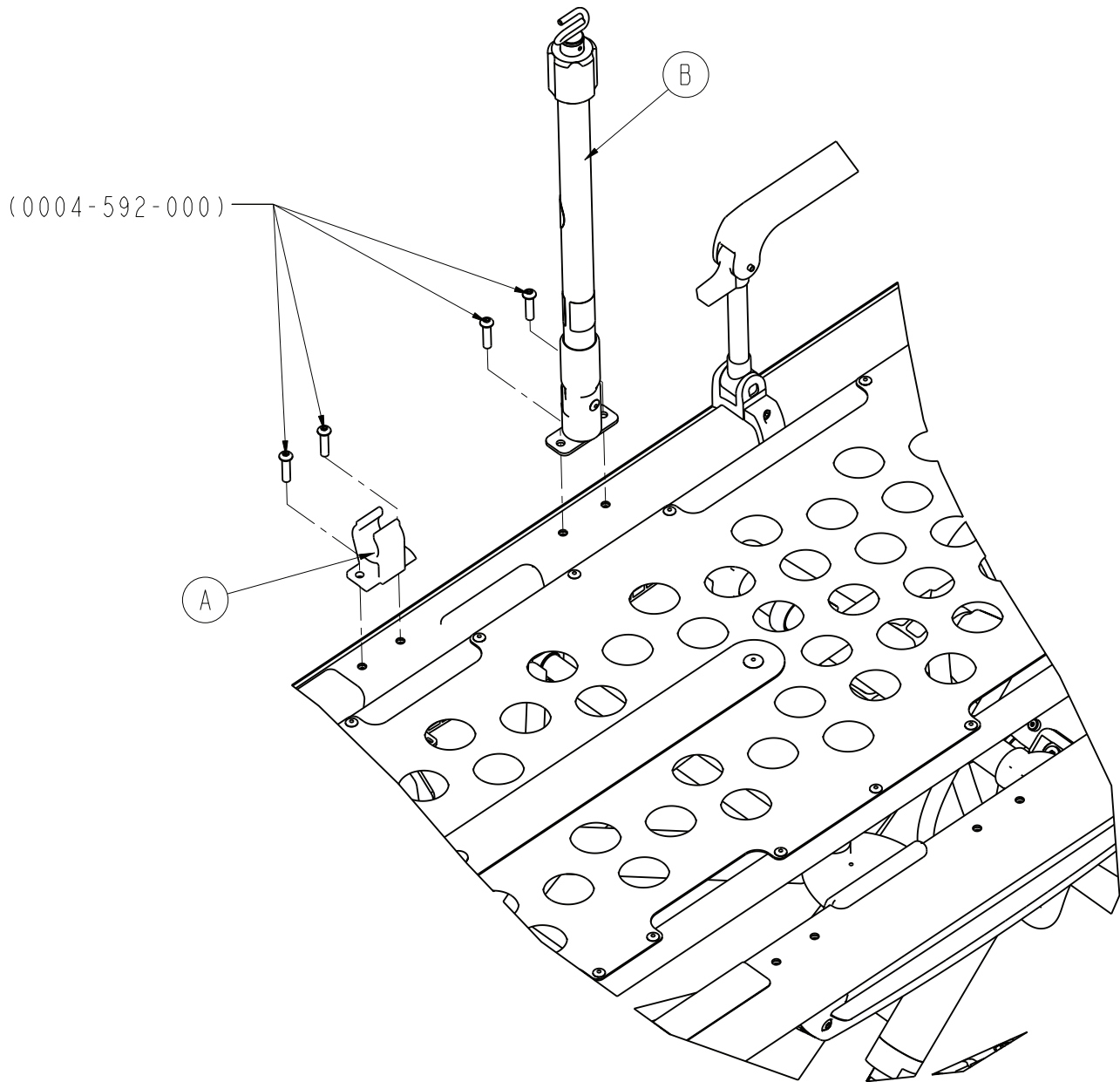

Item	Part no.	Part name	Qty
A	6100-115-060	Clip, IV pole	1
B	6500-101-041	IV pole assembly, two-stage, right - 6500-101-041 on page 210	1

IV pole assembly, three-stage, right - 6500-315-000

Rev B (Reference only)

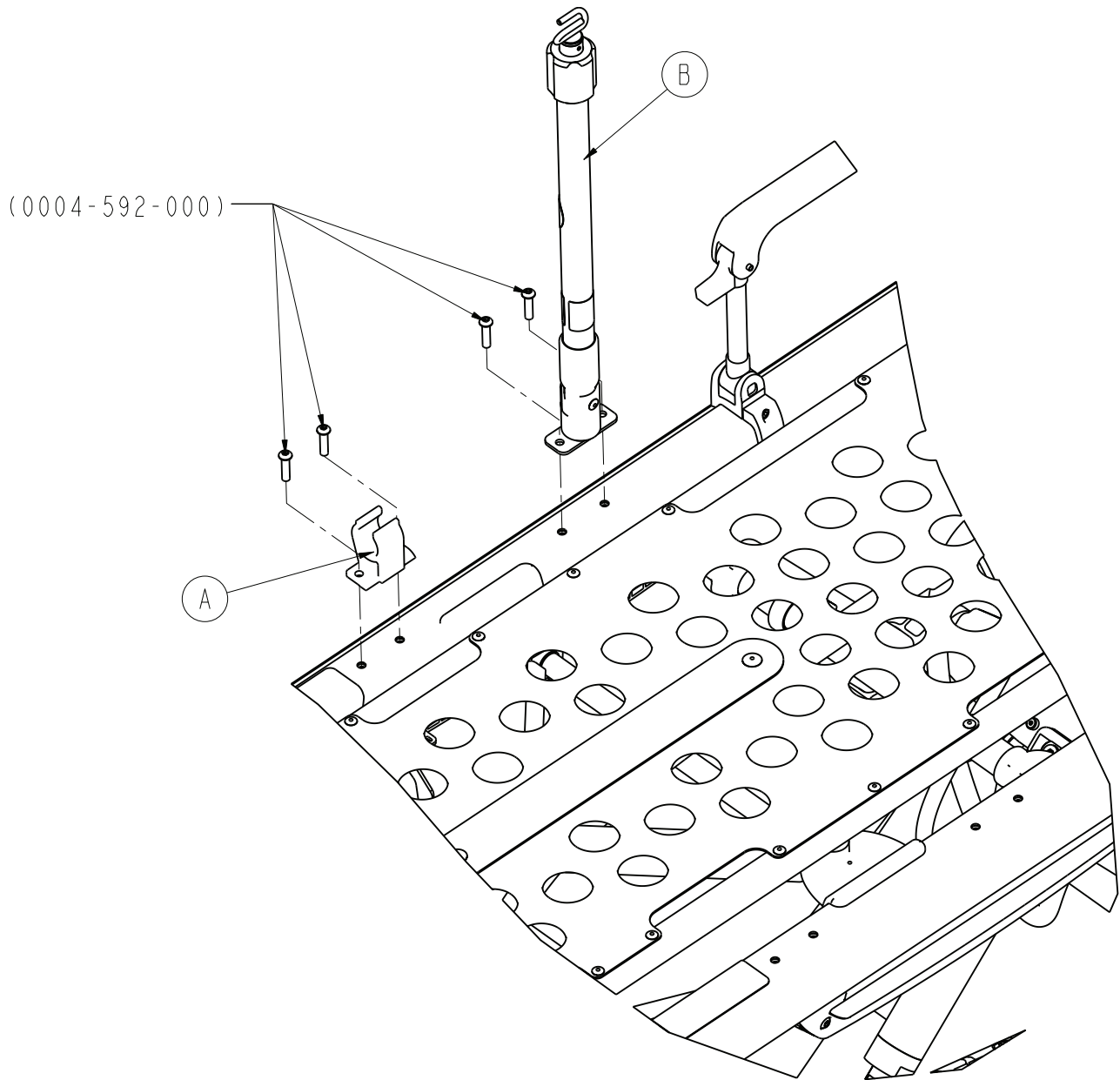

Item	Part no.	Part name	Qty
A	6100-115-060	Clip, IV pole	1
B	6500-101-043	IV pole assembly, three-stage, right - 6500-101-043 on page 211	1

IV pole assembly, two-stage, right - 6500-101-041

Rev A (Reference only)

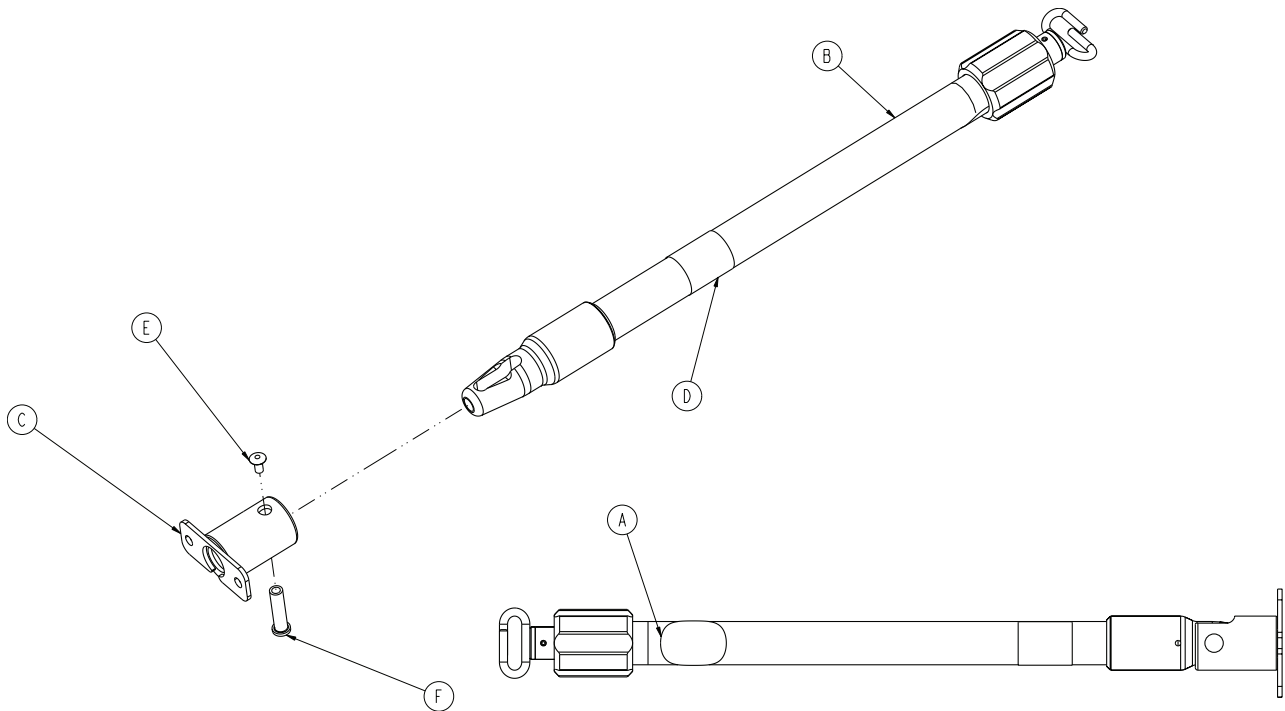

Item	Part no.	Part name	Qty
A	6506-001-901	Label, no pushing	1
B	6070-210-070	Pole assembly	1
C	6100-115-051	Socket weldment	1
D	6500-101-253	Label	1
E	0025-079-000	Dome head rivet	1
F	6070-110-037	IV pivot pin	1

IV pole assembly, three-stage, right - 6500-101-043

Rev A (Reference only)

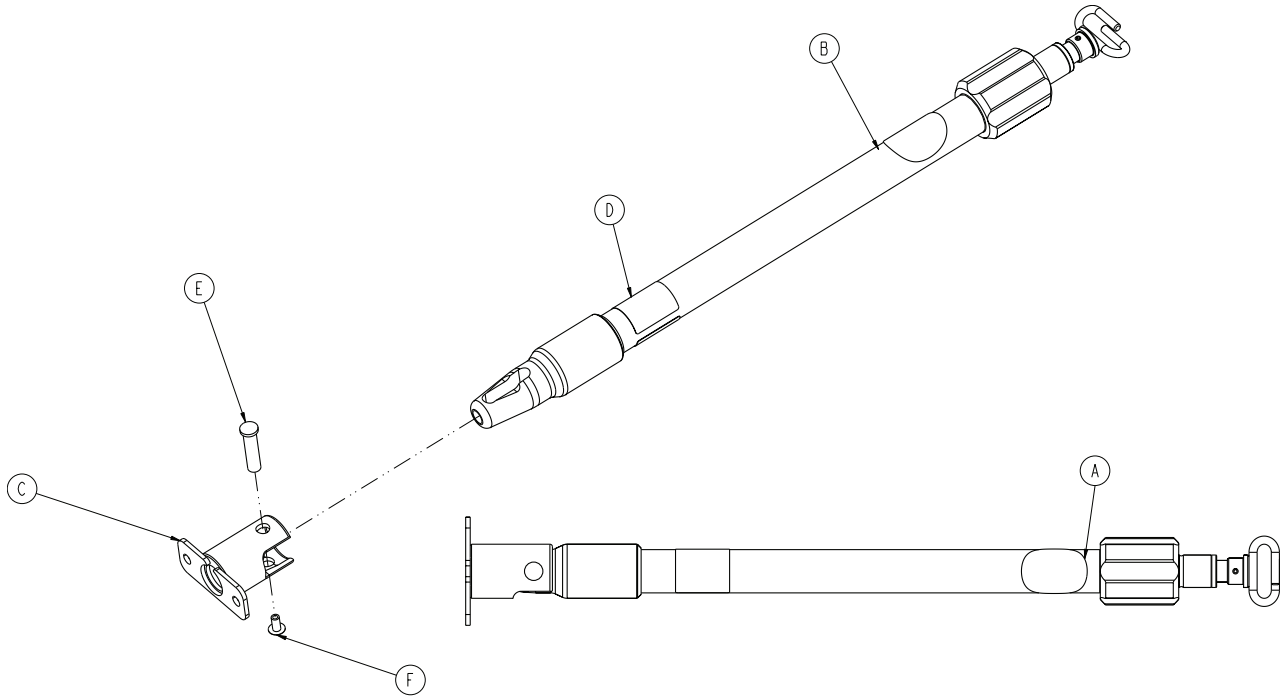

Item	Part no.	Part name	Qty
A	6506-001-901	Label, no pushing	1
B	6070-215-070	Pole assembly	1
C	6100-115-051	Socket weldment	1
D	6500-101-255	Label	1
E	6070-110-037	IV pivot pin	1
F	0025-079-000	Dome head rivet	1

IV pole assembly, two-stage, left - 6500-311-000

Rev B (Reference only)

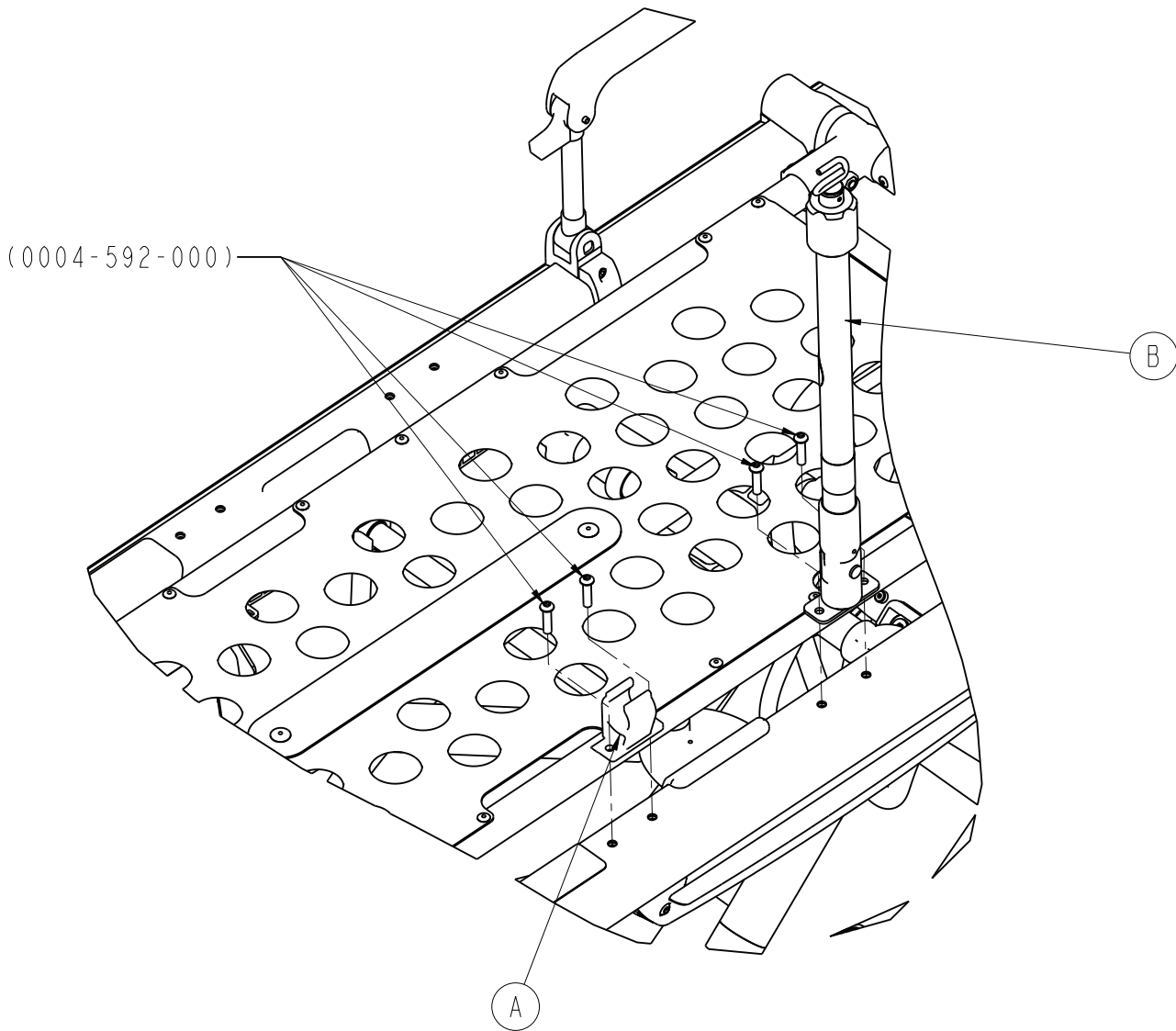

Item	Part no.	Part name	Qty
A	6100-115-060	Clip IV pole	1
B	6500-101-042	IV pole assembly, two-stage, left - 6500-101-042 on page 214	1

IV pole assembly, three-stage, left - 6500-316-000

Rev B (Reference only)

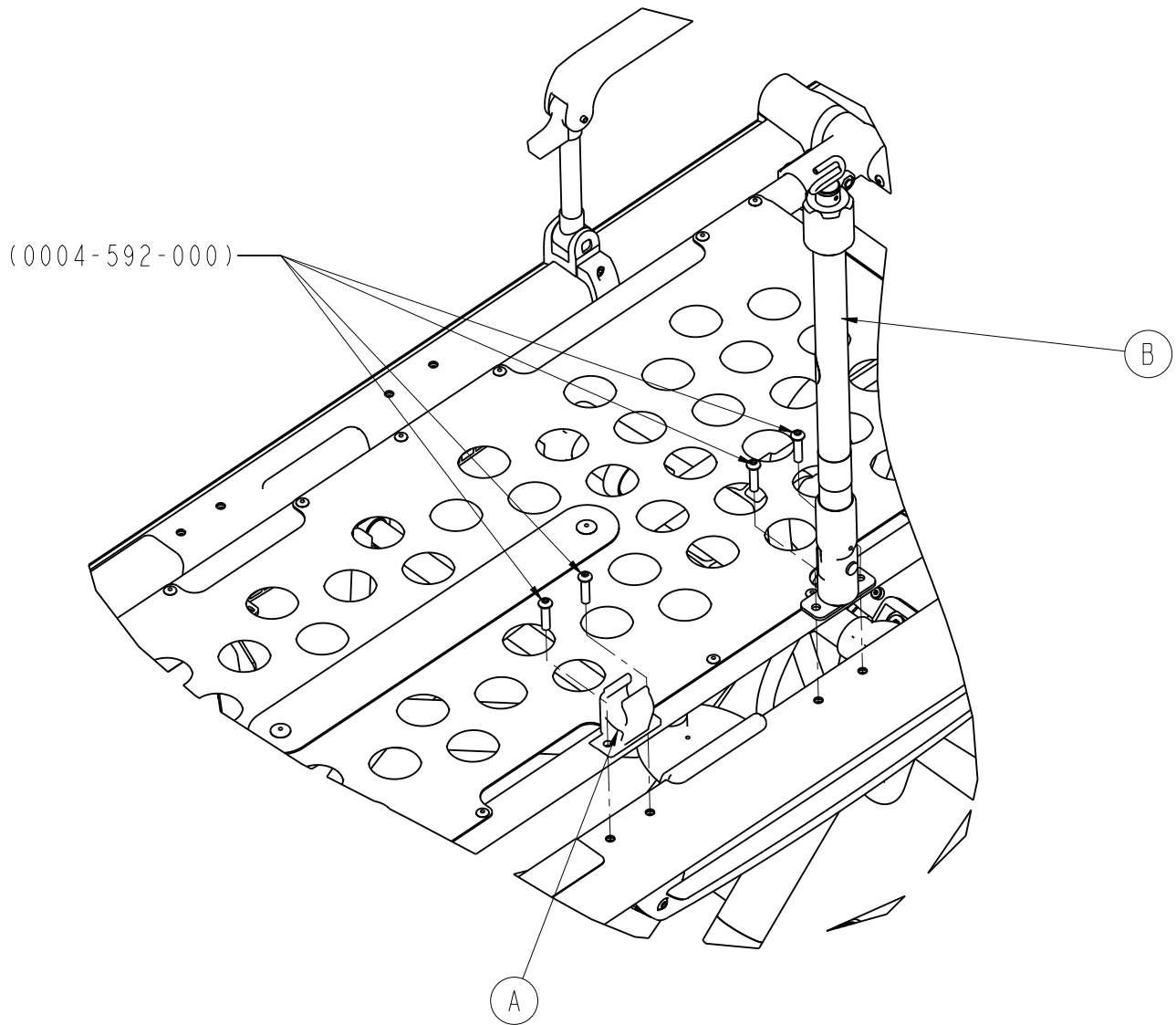

Item	Part no.	Part name	Qty
A	6100-115-060	Clip IV pole	1
B	6500-101-044	IV pole assembly, three-stage, left - 6500-101-044 on page 215	1

IV pole assembly, two-stage, left - 6500-101-042

Rev A (Reference only)

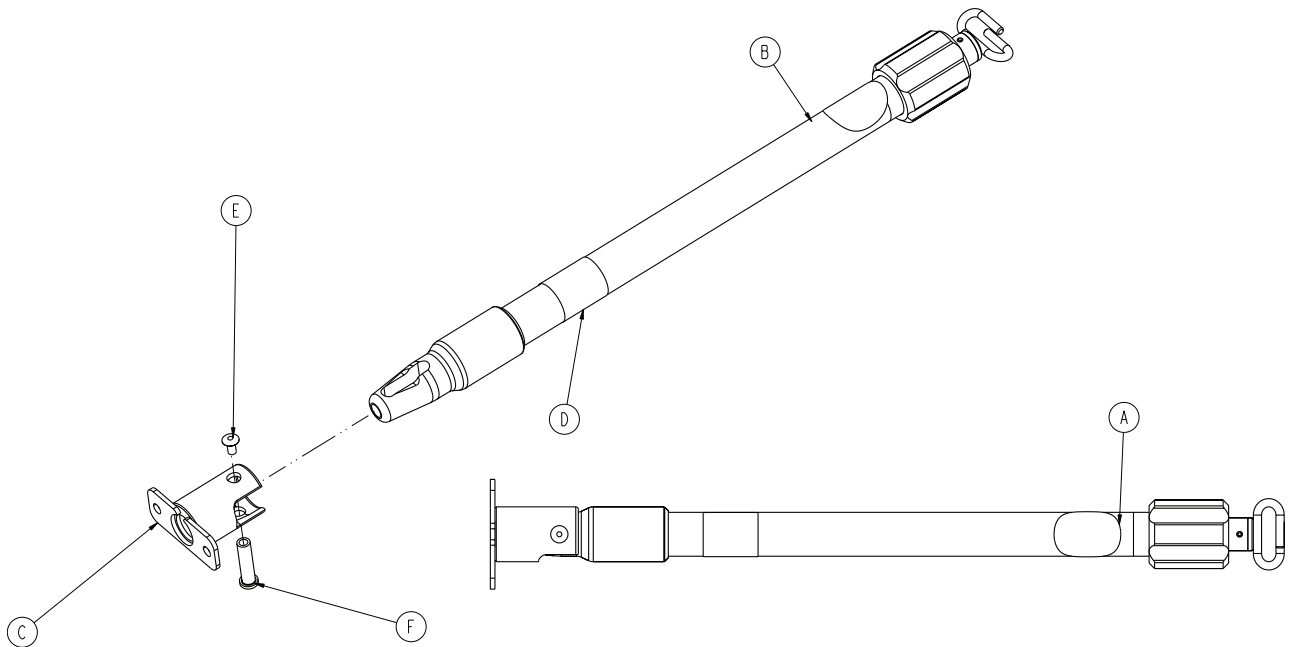

Item	Part no.	Part name	Qty
A	6506-001-901	Label, no pushing	1
B	6070-210-070	IV pole assembly, two-stage	1
C	6100-115-051	Socket weldment	1
D	6500-101-254	Label	1
E	0025-079-000	Dome head rivet	1
F	6070-110-037	IV pivot pin	1

IV pole assembly, three-stage, left - 6500-101-044

Rev A (Reference only)

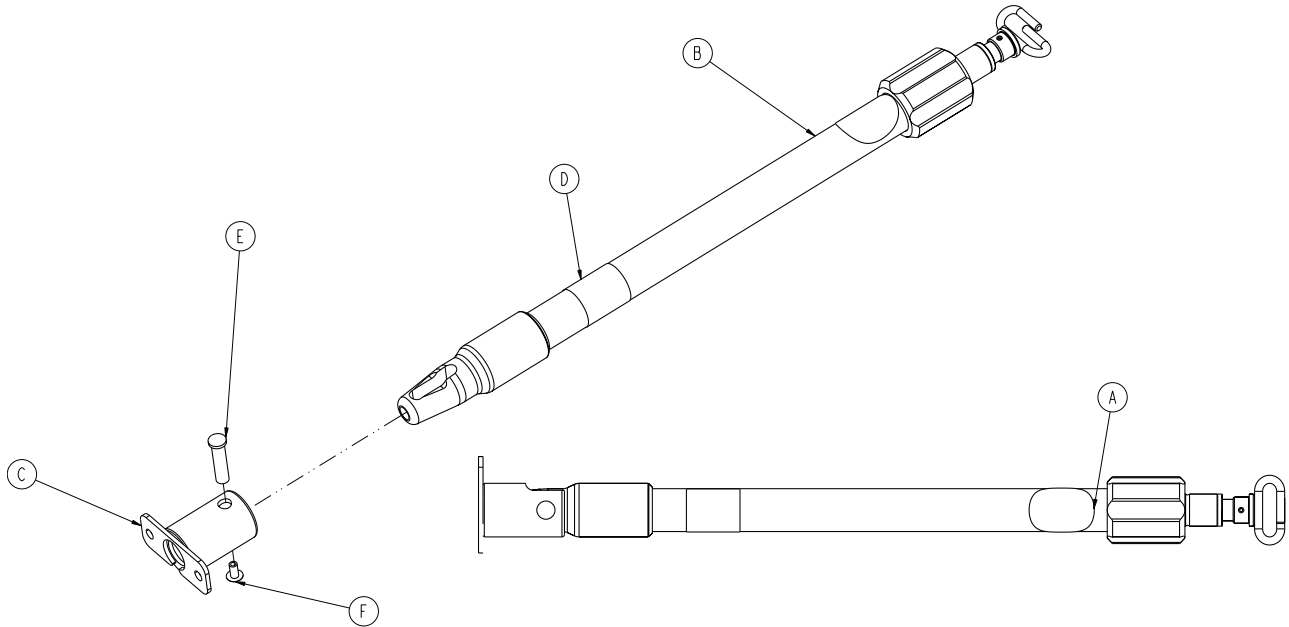

Item	Part no.	Part name	Qty
A	6506-001-901	Label, no pushing	1
B	6070-215-070	Pole assembly	1
C	6100-115-051	Socket weldment	1
D	6500-101-256	Label	1
E	6070-110-037	IV pivot pin	1
F	0025-079-000	Dome head rivet	1

IV pole assembly, two-stage, dual - 6500-312-000

Rev B (Reference only)

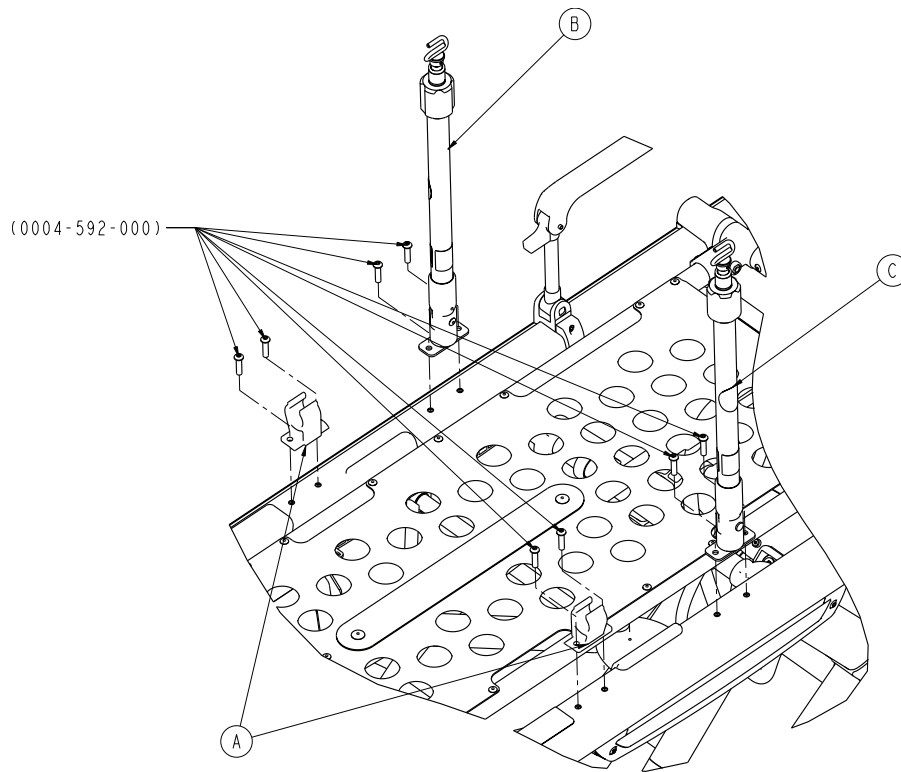

Item	Part no.	Part name	Qty
A	6100-115-060	Clip, IV pole	2
B	6500-101-041	IV pole assembly, two-stage, right - 6500-101-041 on page 210	1
C	6500-101-042	IV pole assembly, two-stage, left - 6500-101-042 on page 214	1

IV pole assembly, three-stage, dual - 6500-317-000

Rev B (Reference only)

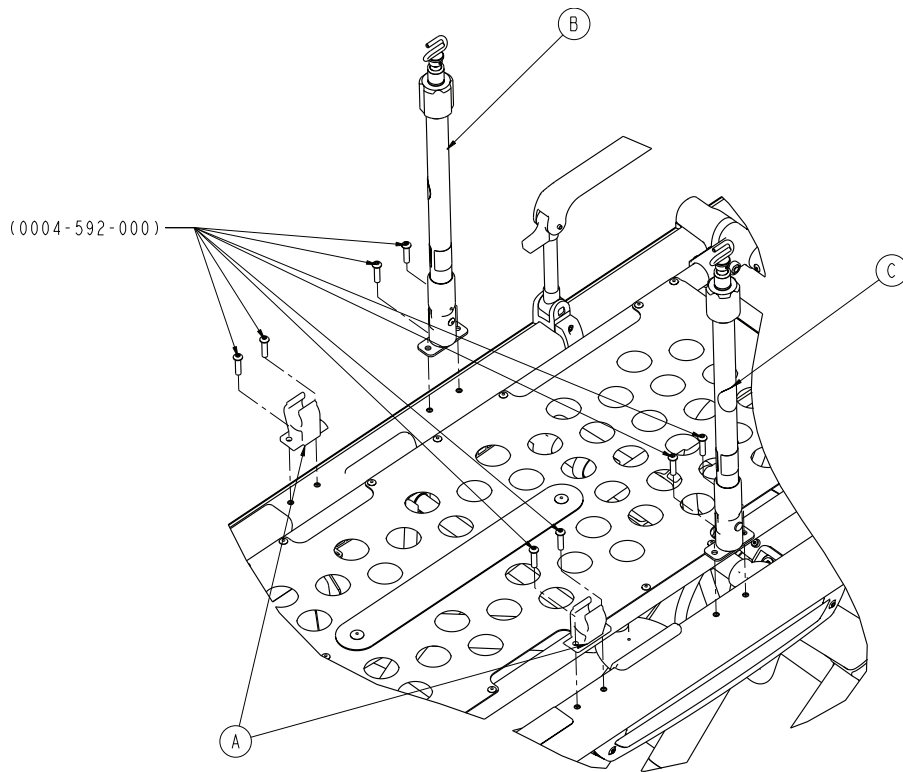

Item	Part no.	Part name	Qty
A	6100-115-060	Clip, IV pole	2
B	6500-101-043	IV pole assembly, three-stage, right - 6500-101-043 on page 211	1
C	6500-101-044	IV pole assembly, three-stage, left - 6500-101-044 on page 215	1

Oxygen bottle holder, foot end - 6500-240-000

Rev A (Reference only)

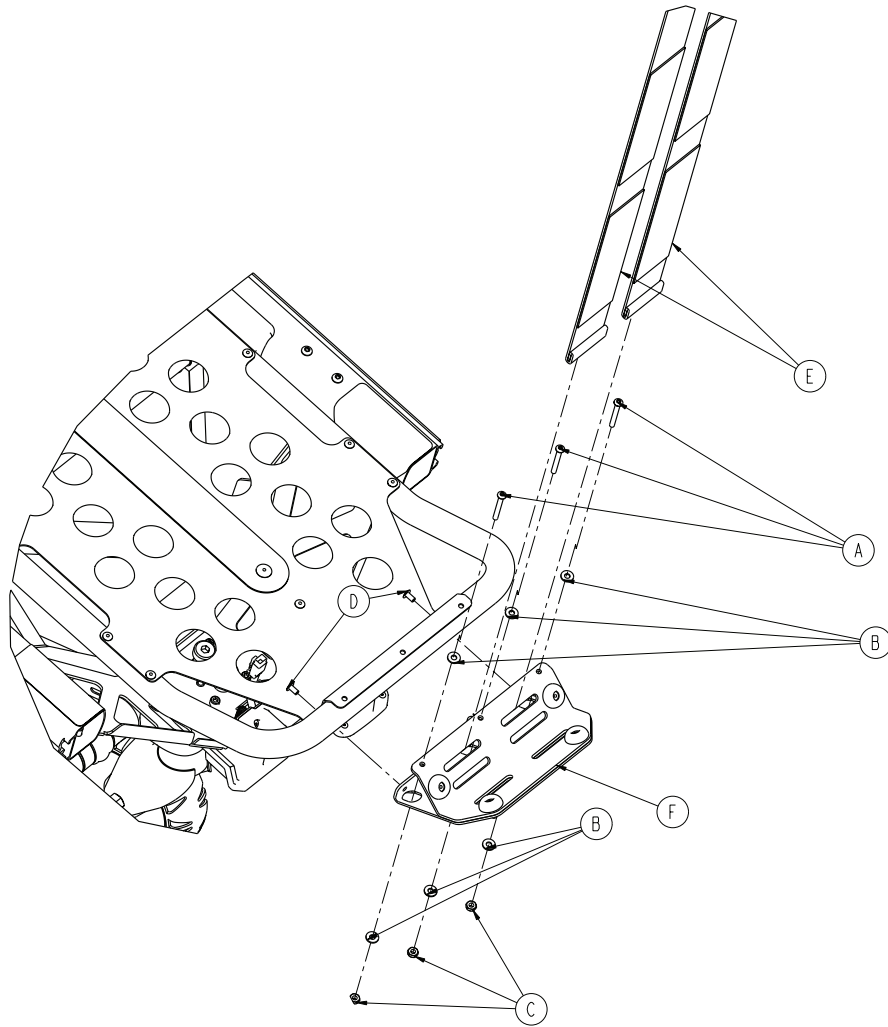

Item	Part no.	Part name	Qty
A	0004-862-000	Button head cap screw	3
B	0011-001-000	Flat washer	6
C	0016-131-000	Nylock hex nut	3
D	0025-079-000	Dome head rivet	2
E	6060-140-013	Oxygen bottle restraint strap	2
F	6500-101-040	Oxygen bottle holder assembly - 6500-101-040 on page 219	1

Oxygen bottle holder assembly - 6500-101-040

Rev A (Reference only)

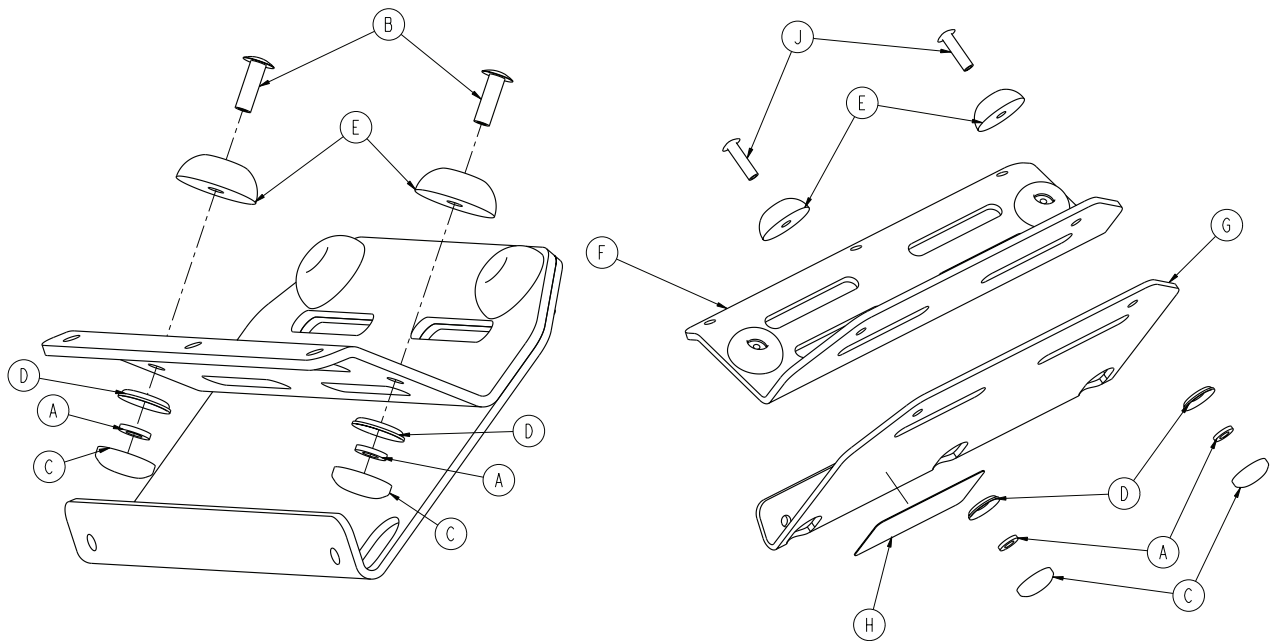

Item	Part no.	Part name	Qty
A	0011-436-000	Washer	4
B	0025-133-000	Dome head rivet	2
C	0037-055-000	Black protective cap	4
D	0037-056-000	Retaining washer	4
E	0946-001-155	Bumper	4
F	6500-001-239	Tray	1
G	6500-001-240	Bracket	1
H	6500-101-257	Label	1
J	0025-086-000	Blind rivet	2

Oxygen bottle holder, fowler - 6500-241-000

Rev B (Reference only)

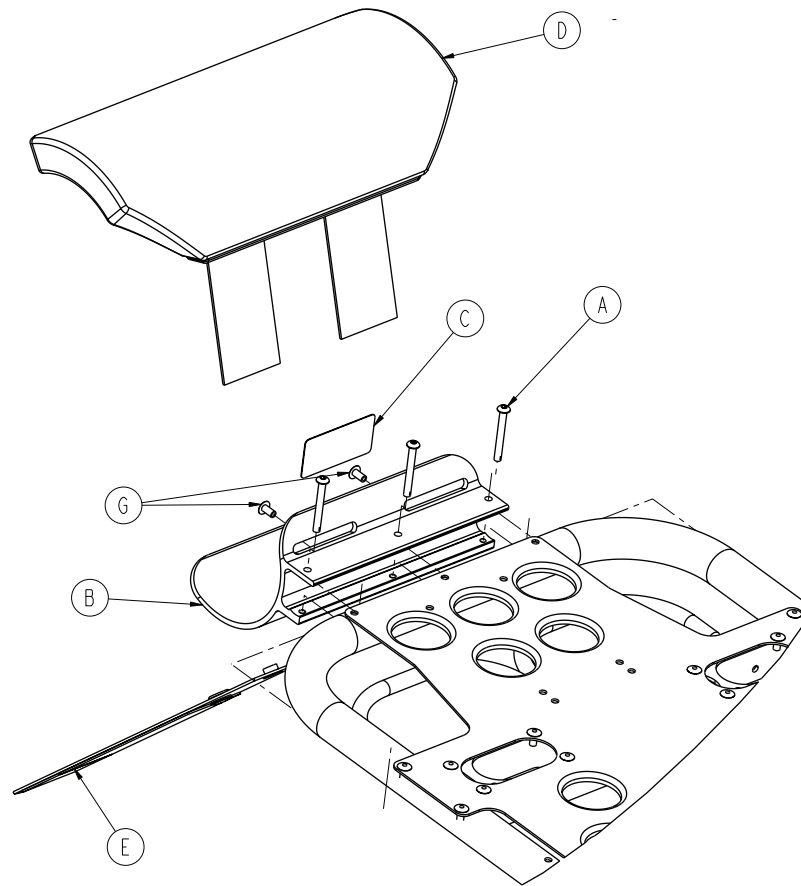

Item	Part no.	Part name	Qty
A	0004-636-000	Button head cap screw	3
B	6500-001-119	Backrest oxygen holder bracket	1
C	6500-101-231	Label, fowler oxygen bottle holder	1
D	6500-001-260	Fowler oxygen bottle holder cover	1
E	6500-001-261	Fowler oxygen bottle holder strap	1
G	0025-079-000	Dome head rivet	2

Removable oxygen bottle holder - 6080-140-000

Rev A / 6080-140-010 Rev A (Reference only)

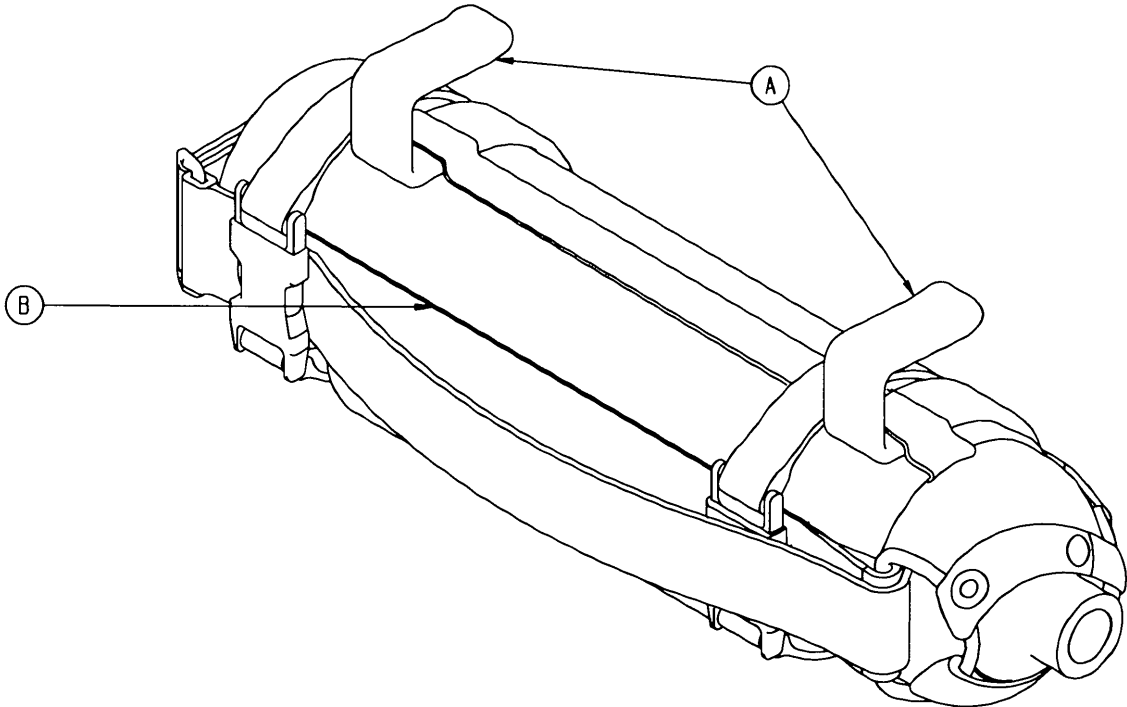

Item	Part no.	Part name	Qty
A	6080-140-011	Oxygen bottle holder hanger	2
B	6080-140-012	Oxygen bottle holder	1

Retractable head section oxygen bottle holder - 6085-046-000

Rev B (Reference only)

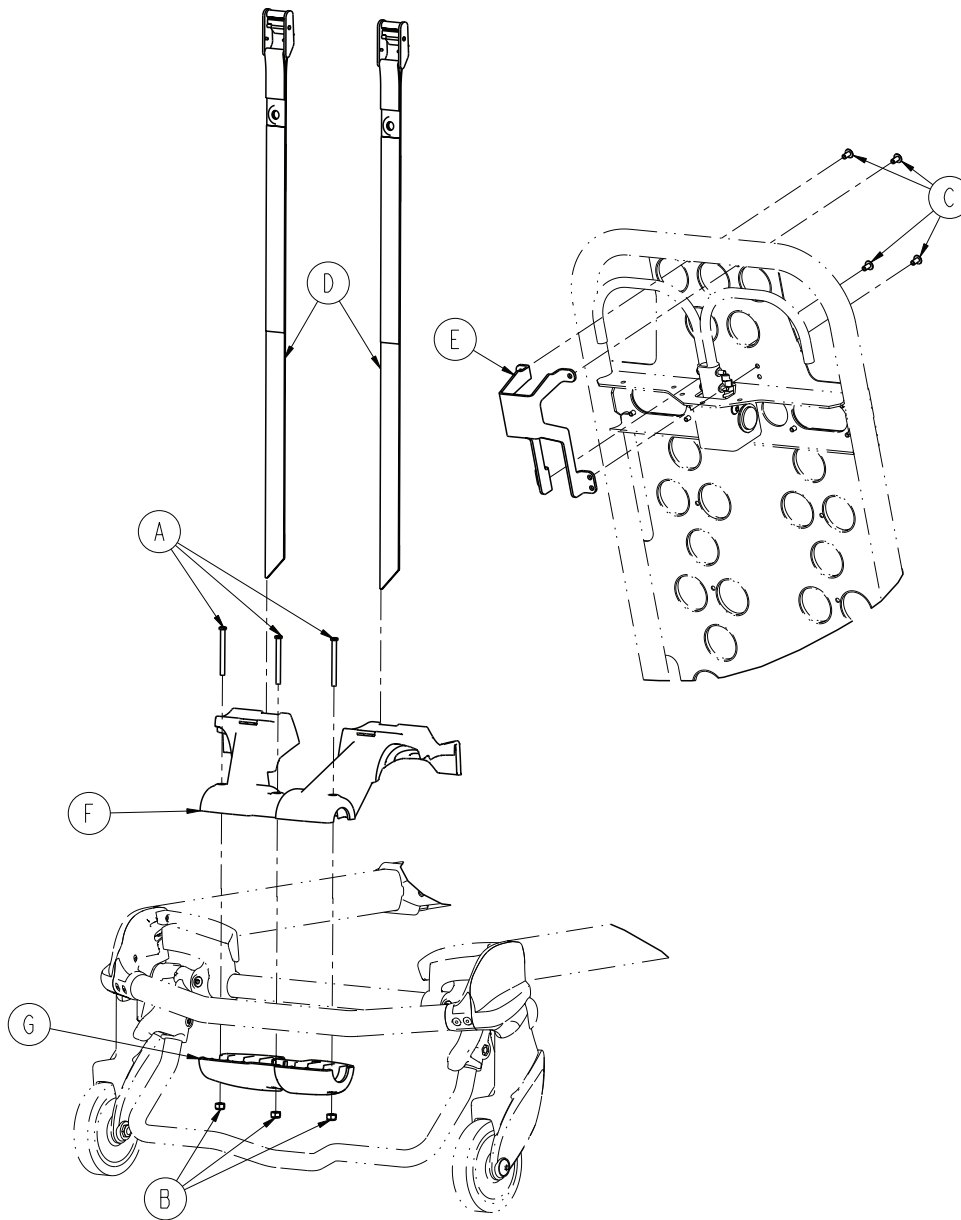

Item	Part no.	Part name	Qty
A	0004-656-000	Socket head cap screw	3
B	0016-002-000	Fiberlock hex nut	3
C	0025-079-000	Dome head rivet	4
D	6085-001-171	Oxygen strap, head end	2
E	6085-001-172	Oxygen fowler guard	1
F	6085-001-173	Oxygen bottle holder, top	1
G	6085-001-174	Oxygen bottle holder, bottom	1

Base storage net - 6500-160-000

Rev A/6500-001-126 Rev E (Reference only)

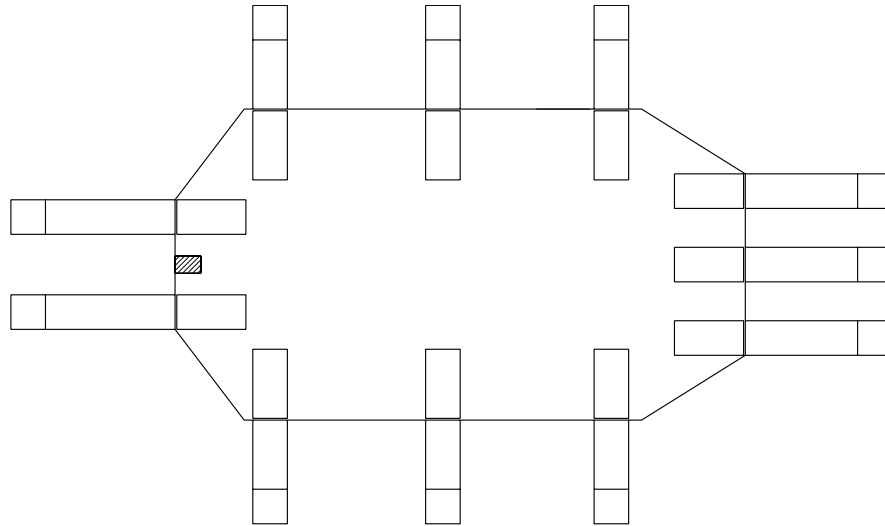

Backrest pouch - 6500-130-000

Rev A (Reference only)

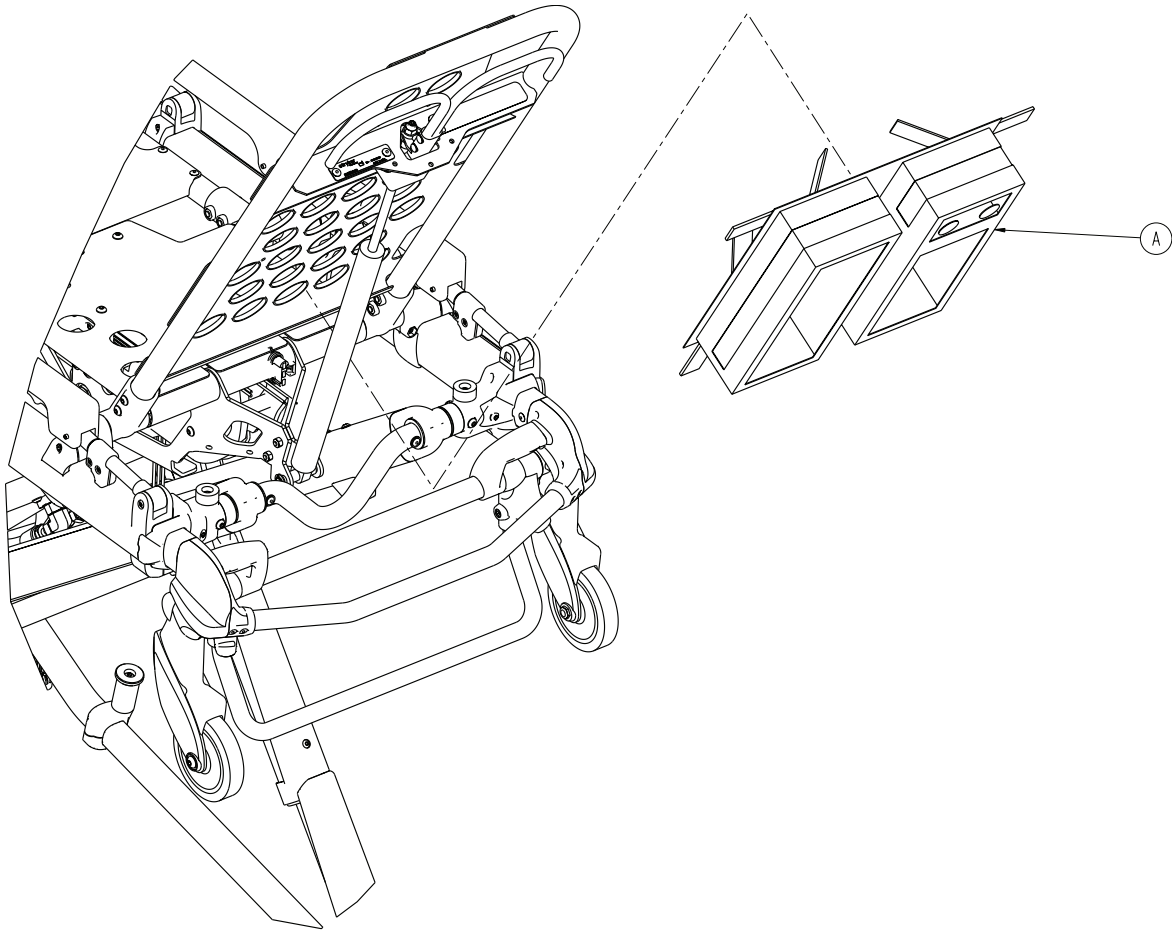

Item	Part no.	Part name	Qty
A	6500-001-241	Pocketed backrest storage pouch	1

Head end storage flat - 6500-128-000

Rev A (Reference only)

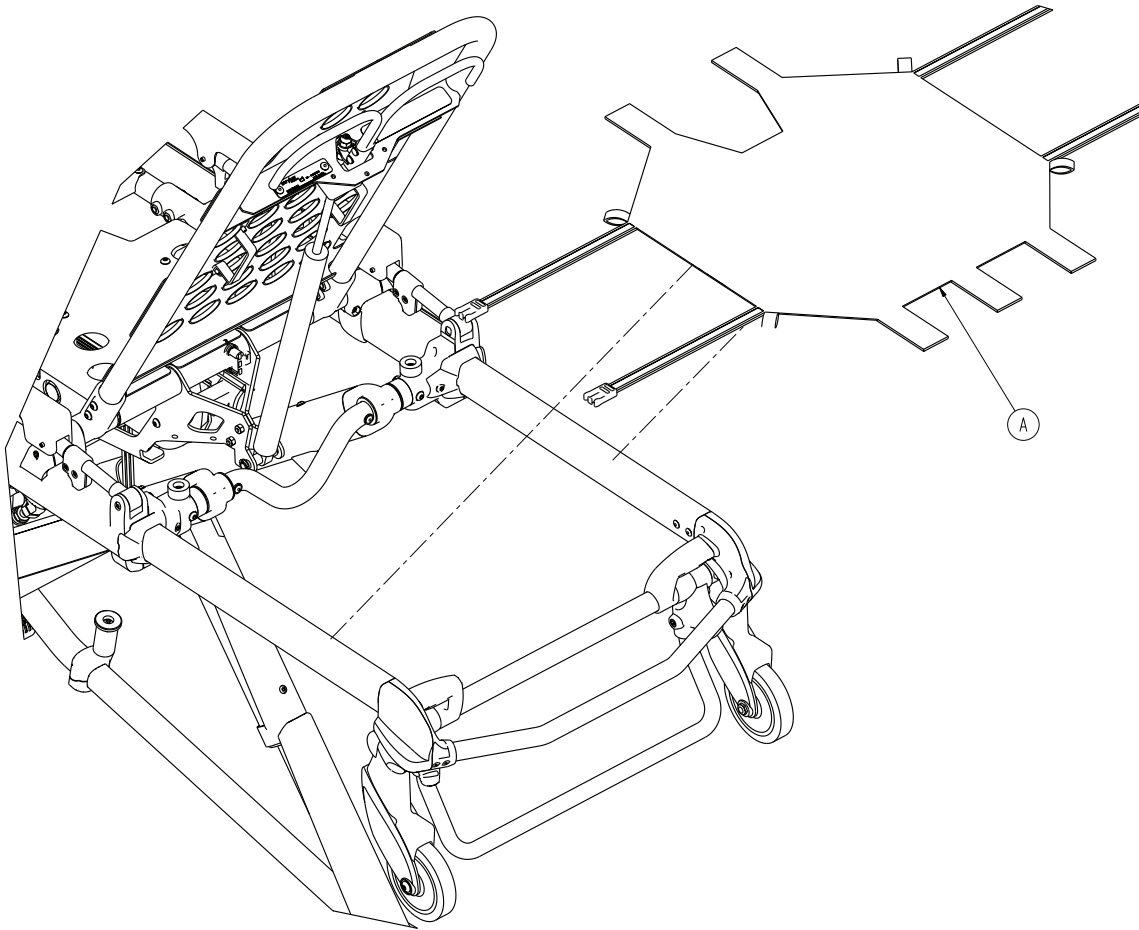

Item	Part no.	Part name	Qty
A	6500-001-232	Head end storage flat	1

Transfer flat - 6005-001-001

Rev E (Reference only)

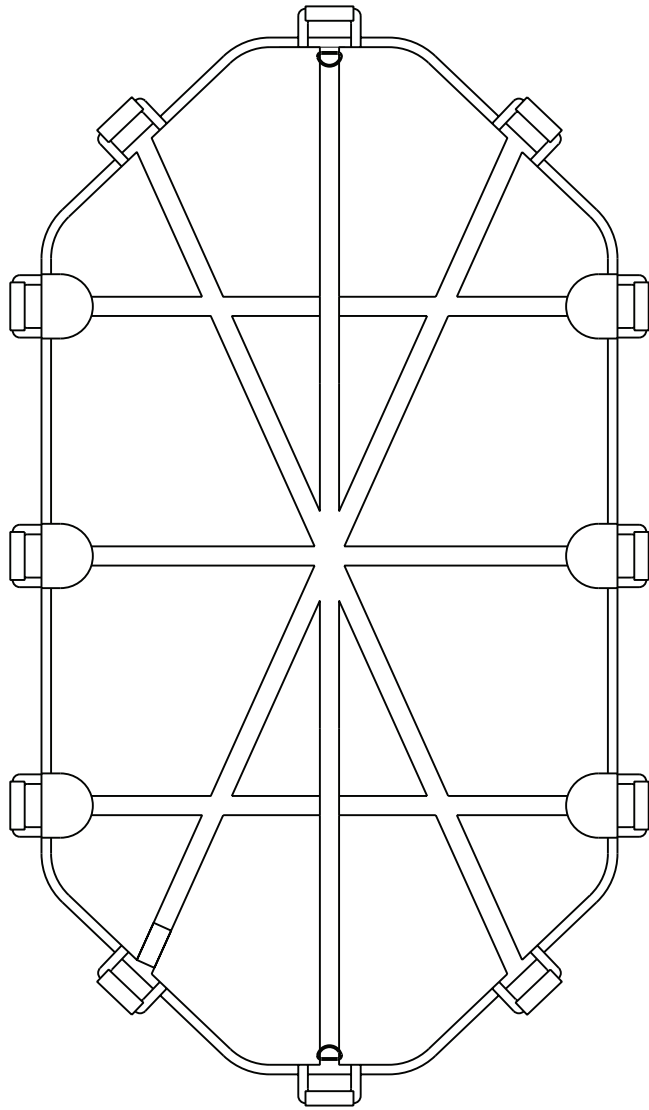

Mattress, standard - 6500-002-150

Rev F/6506-034-000 Rev A (Reference only)

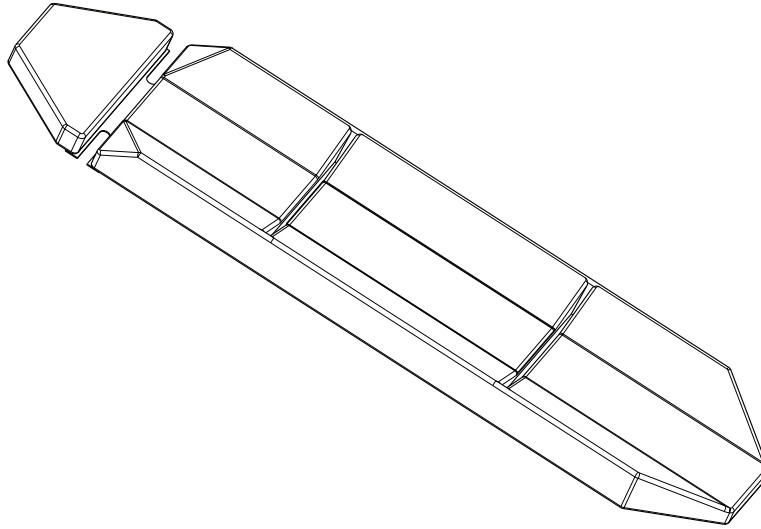

Mattress, standard, grey - 6506-002-150

Rev A / 6506-033-000 Rev A (Reference only)

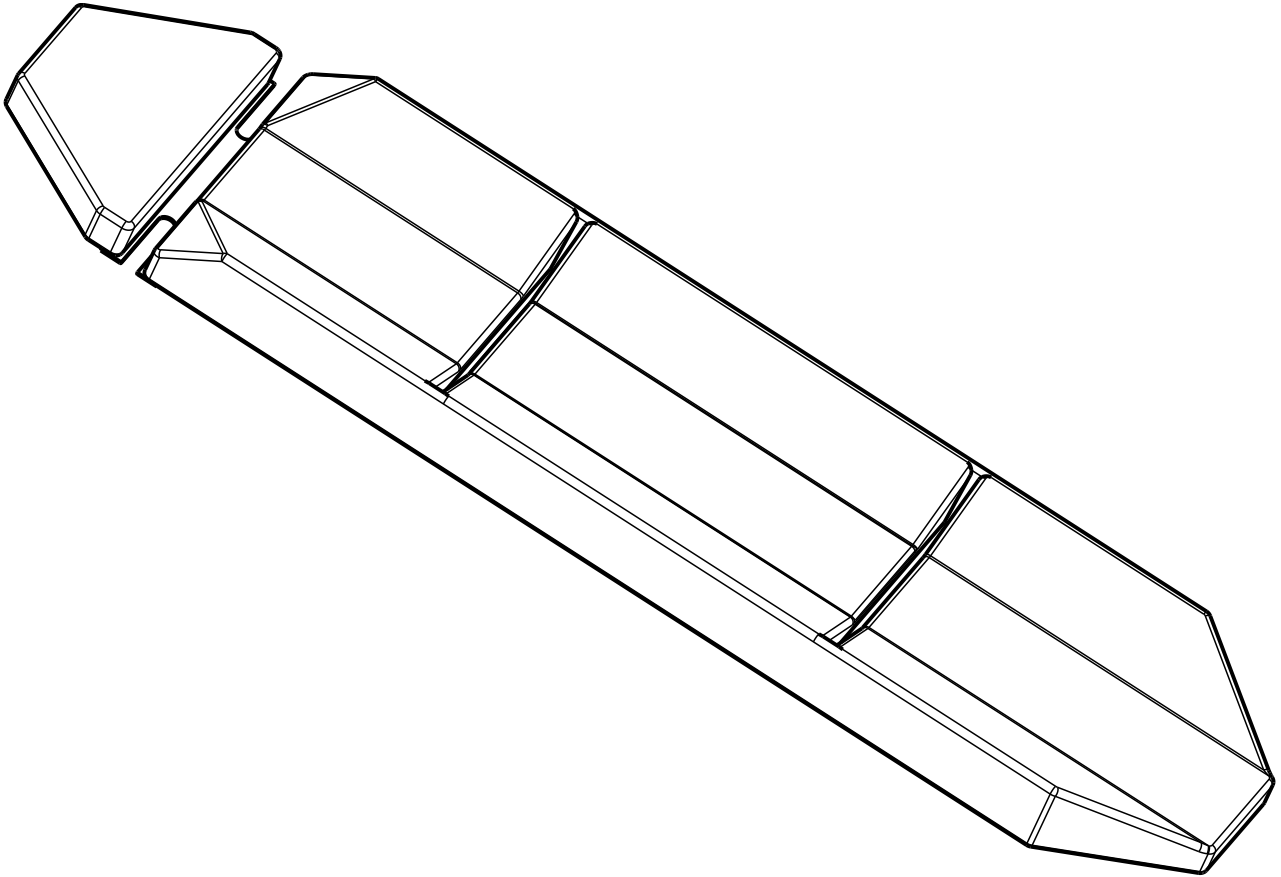

Mattress, gatch bolster (XPS option) - 6500-003-130

Rev G (Reference only)

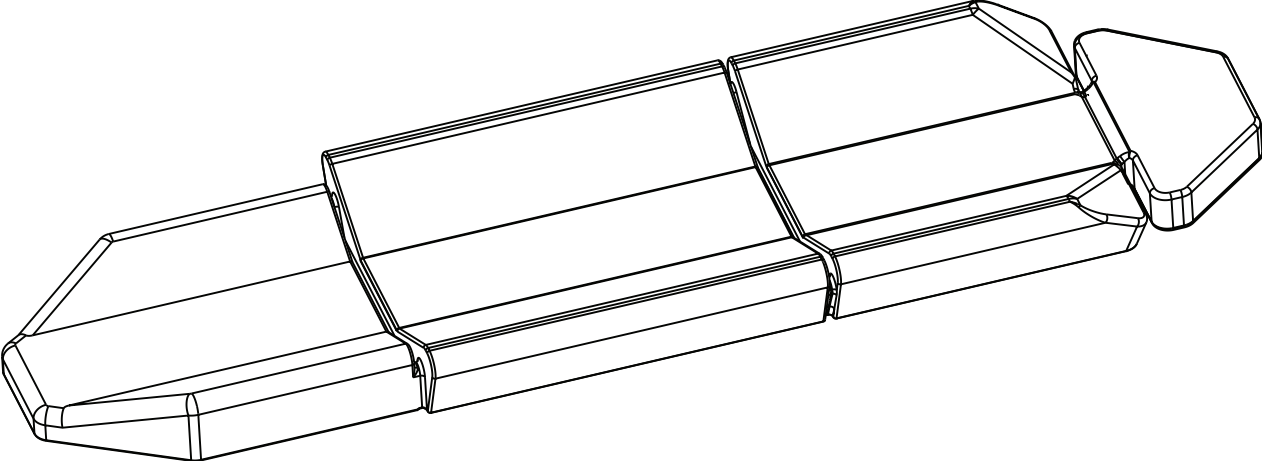

Safety hook, short - 6060-036-017/ Safety hook, long - 6060-036-018/ Safety hook, J - 6092-036-018

Safety hook, short - 6060-036-017 Rev A (Reference only)

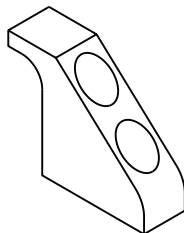

Safety hook, long - 6060-036-018 Rev D (Reference only)

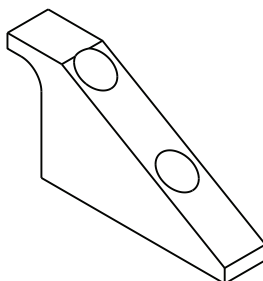

Safety hook, J - 6092-036-018 Rev A (Reference only)

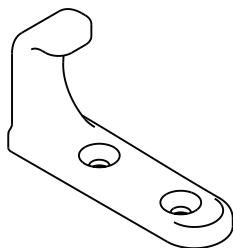

Recycling passport



6390-101-010 (Reference only)

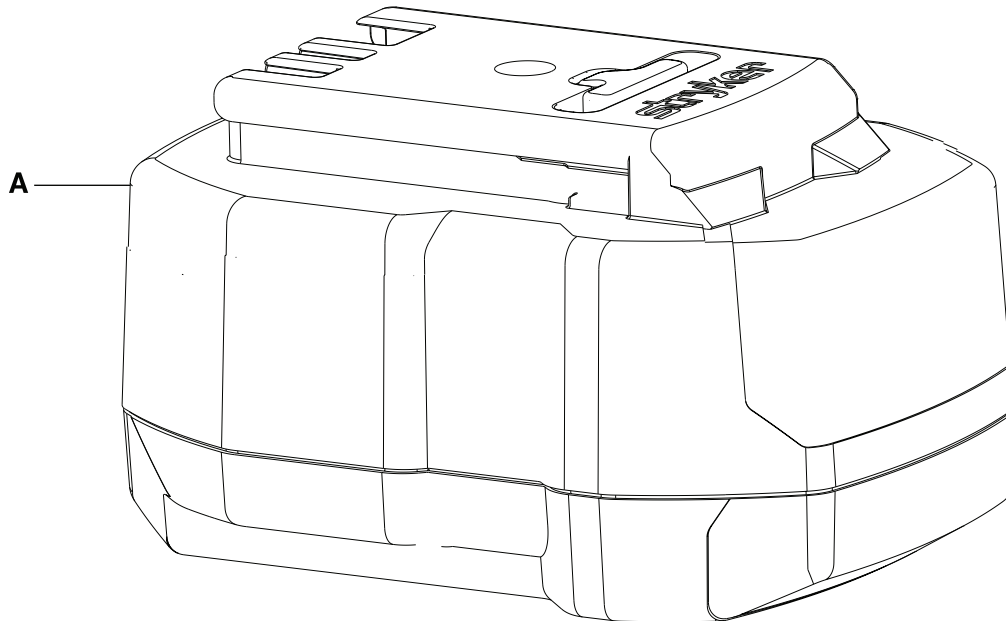

Item	Recycling/material code	Important information	Qty
A	SMRT™ Pak (6500-101-010)	NiCd	2



The Rechargeable Battery Recycling Corporation (RBRC) is a non-profit, public service organization that promotes the recycling of portable rechargeable batteries. Batteries must be delivered to a battery collection site. Visit the RBRC website (www.rbrc.org) to find a nearby collection site or call the phone number shown on the recycling symbol.

Recycling passport



6500-101-016 (Reference only)

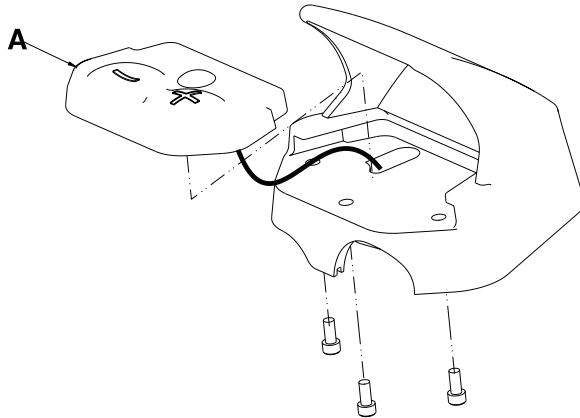

Item	Recycling/material code	Important information	Qty
A	Printed circuit board		2

Recycling passport



6500-002-028 (Reference only)

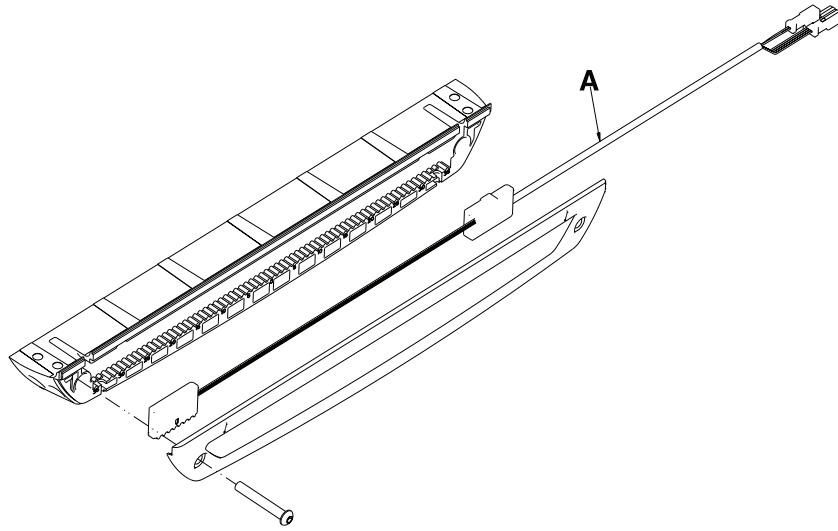

Item	Recycling/material code	Important information	Qty
A	Printed circuit board		1

Recycling passport



6500-102-015 (Reference only)

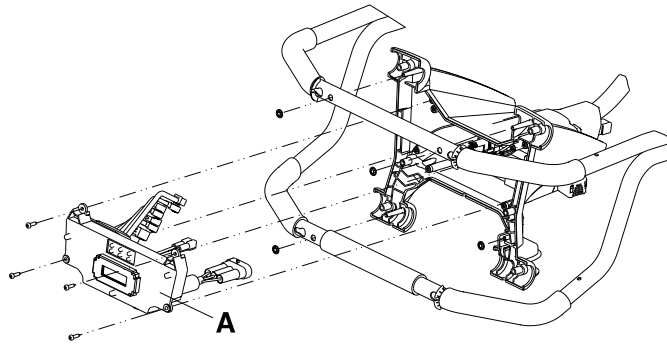

6500-002-014 (Reference only)

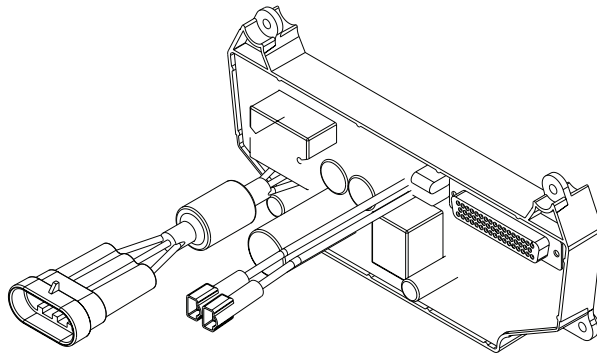

Item	Recycling/material code	Important information	Qty
A	Printed circuit board	Contains liquid crystal display	1

Recycling passport



6500-001-030 (Reference only)

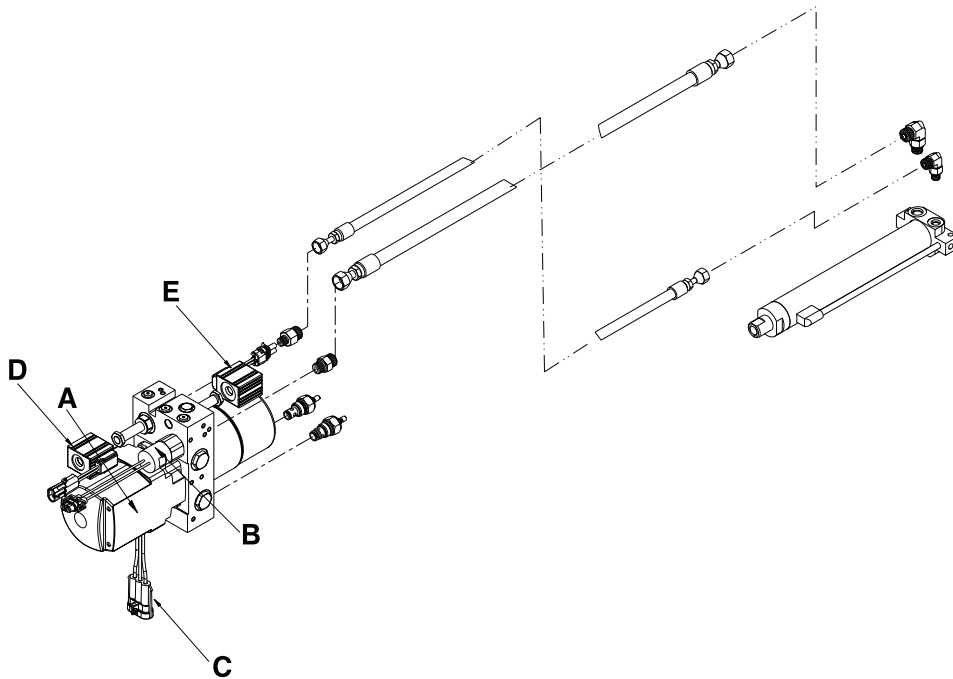

Item	Recycling/material code	Important information	Qty
A	Motor	Contains automatic transmission fluid*	1
B	External electrical cable		1
C	External electrical cable		1
D	External electrical cable		1
E	External electrical cable		1

* Mobil Mercon V Synthetic blend or equivalent

Recycling passport



6500-002-159 (Reference only)

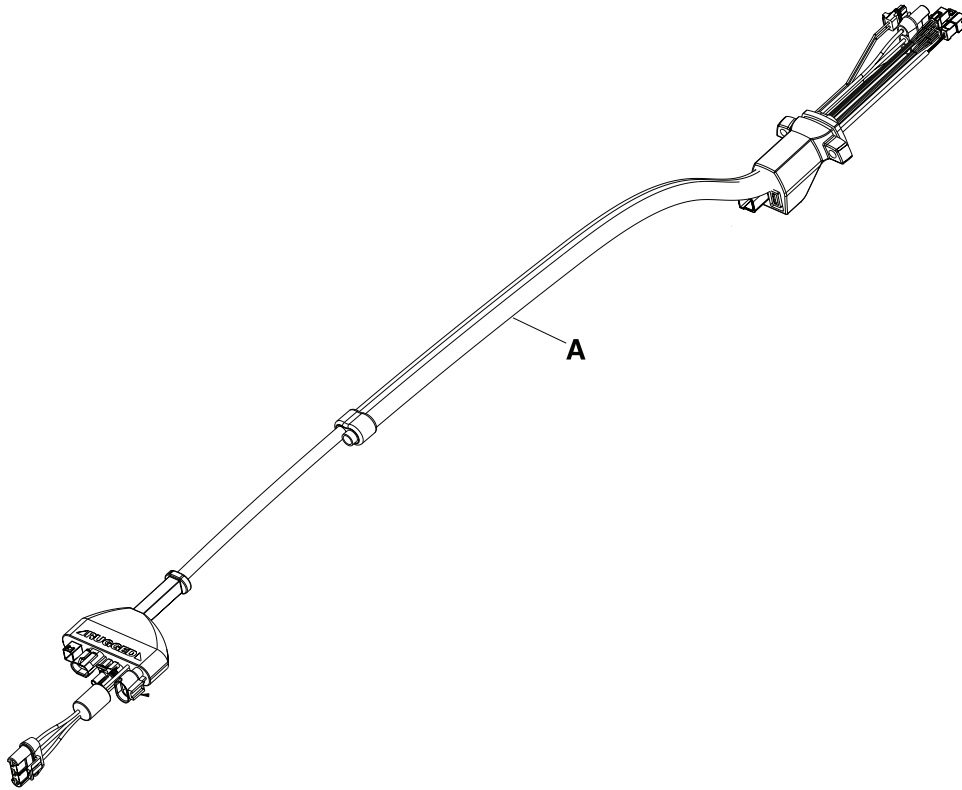

Item	Recycling/material code	Important information	Qty
A	External electrical cable		1



Stryker Medical
3800 E. Centre Ave.
Portage, Michigan 49002
USA

stryker[®]