

Power-PRO™ XT

REF 6506

stryker®

Parts Manual



Table of Contents

6506-001-010	4
6506-001-012	11
6086-500-010	17
6086-601-010	18
6086-602-010	19
6082-002-012	20
6086-200-010	21
6506-037-000	22
6506-038-000	23
6506-002-265	24
6060-002-010	25
6085-033-000	26
6085-102-000	27
6085-002-016	28
6500-301-021	29
6500-301-022	30
6500-001-034	31
6500-001-035	32
6506-031-000	33
6082-026-010	34
6500-002-032	35
6500-002-033	36
6500-002-028	37
6500-002-029	38
6506-040-000	39
6500-003-034	40
6500-003-044	41
6500-002-031	42
6500-101-030	44
6500-102-015	45
6500-101-016	49
6085-031-000	50
6500-001-019	51
6500-082-000	52
6500-001-048	53
6085-001-031	56
6500-001-018	57
6506-012-003	58
6506-012-004	59
6506-029-000	60
6506-001-020	62
6506-001-021	63
6500-002-020	64

Table of Contents

6500-001-026	66
6500-001-027	67
6506-036-000	68
6506-127-000	69
6500-002-013	71
6500-002-030	74
6500-001-430	75
6500-001-431	76
6082-160-050	77
6500-033-000	78
6506-170-000	79
6082-170-020	81
6500-147-000	83
6100-044-000	84
6100-044-012	85
6500-310-000	86
6500-315-000	87
6500-101-041	88
6500-101-043	89
6500-311-000	90
6500-316-000	91
6500-101-042	92
6500-101-044	93
6500-312-000	94
6500-317-000	95
6500-240-000	96
6500-101-040	97
6500-241-000	98
6080-140-000	99
6085-046-000	100
6500-160-000	101
6500-130-000	102
6500-128-000	103
6005-001-001	104
6500-002-150	105
6506-002-150	106
6500-003-130	107
6060-036-017/6060-036-018/6092-036-018	108
6060-036-018	109
6092-036-018	110
6390-101-010	111
6500-101-016	112
6500-002-028	113

Table of Contents

6500-102-015/650 0-002-014	114
6550-101-030	115
6500-002-159	116

Rev G (Reference only)

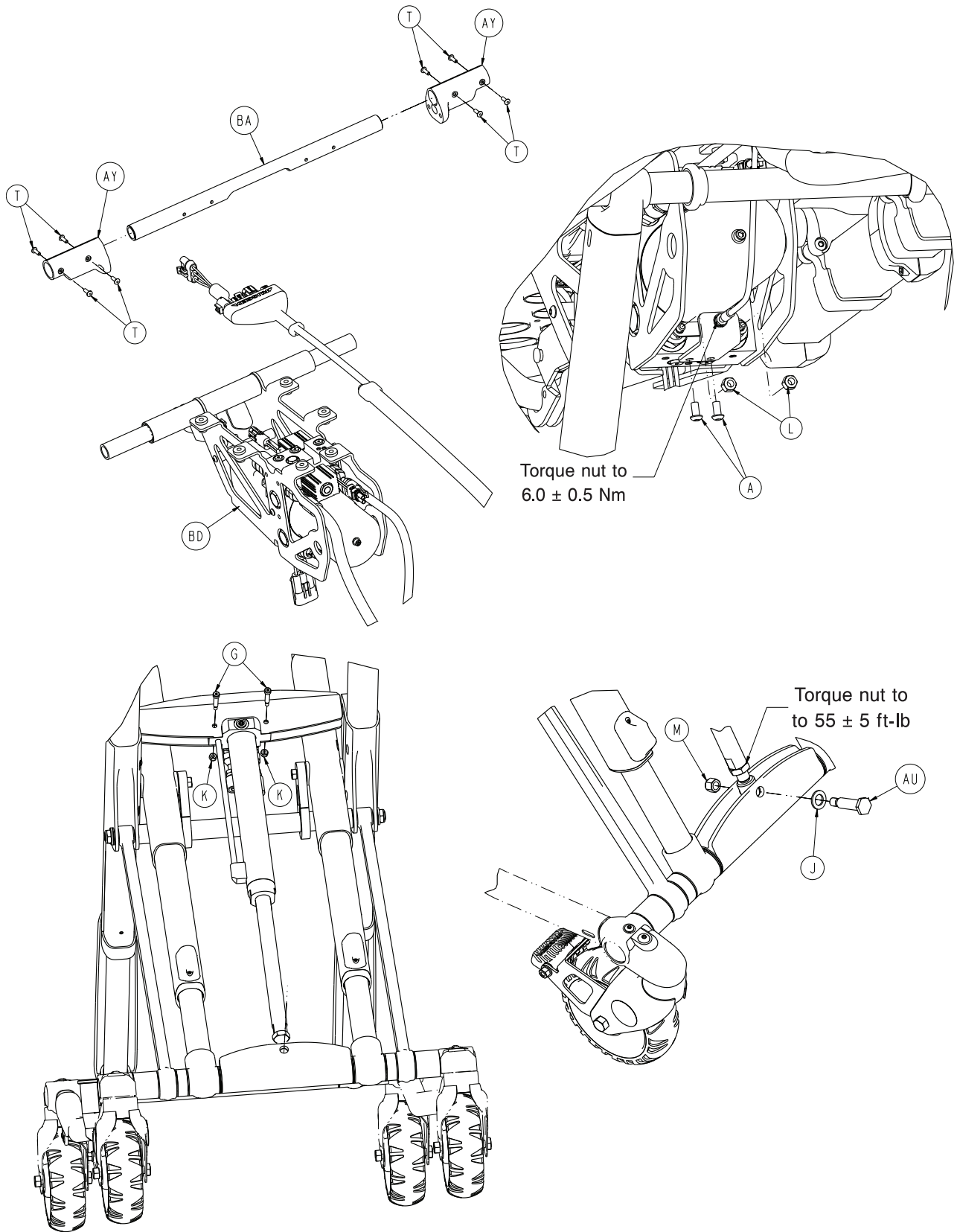

6506-001-010

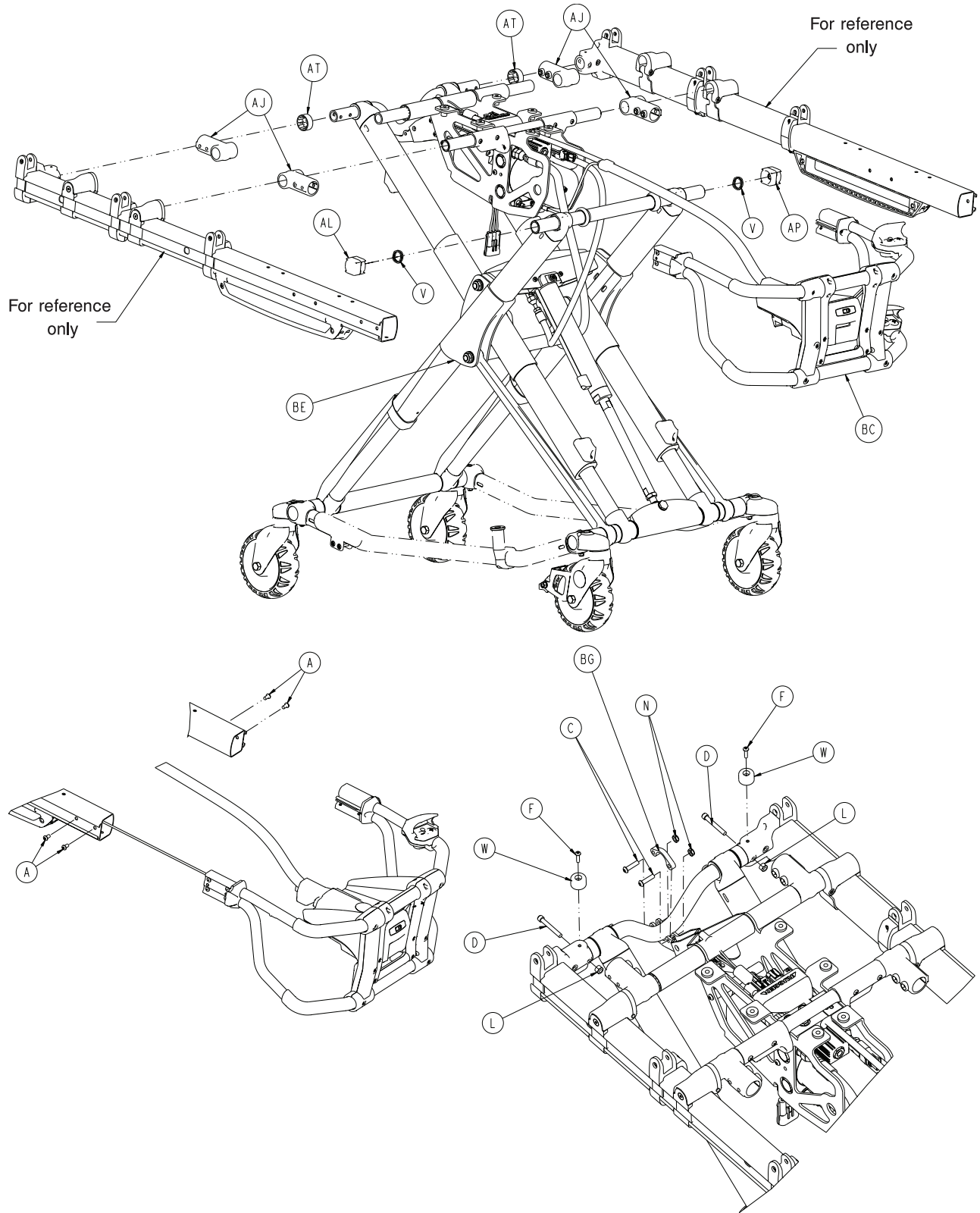

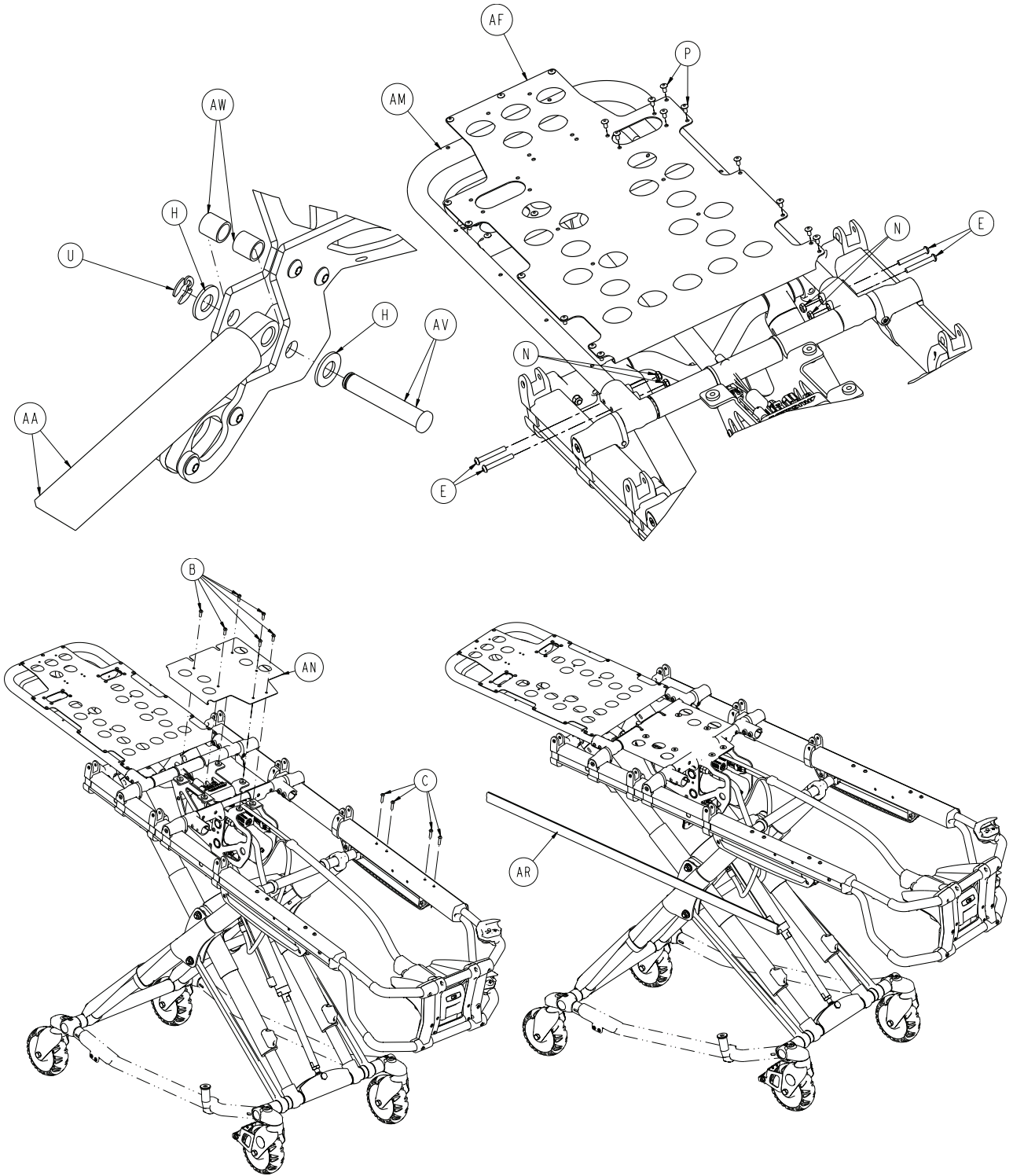

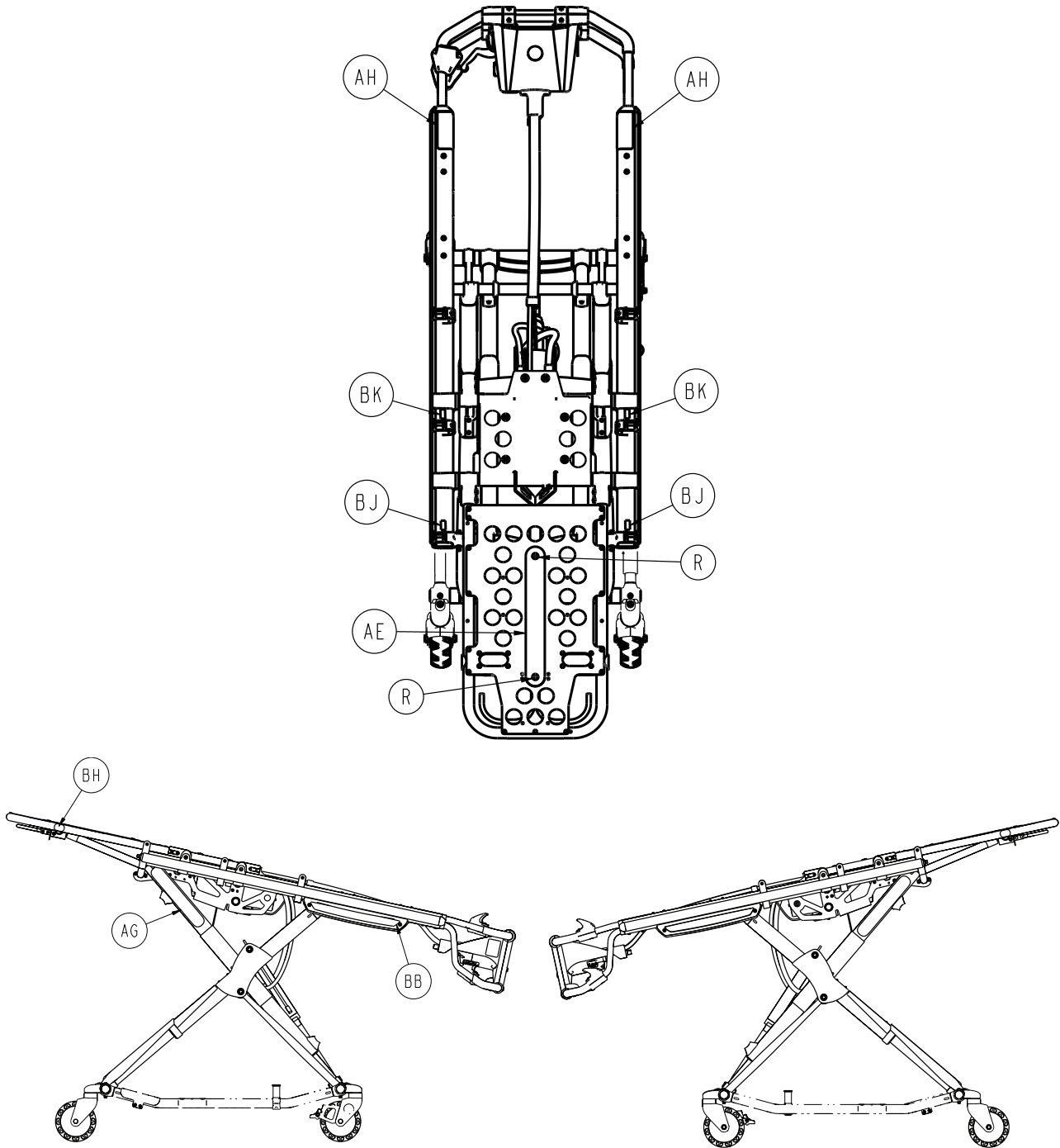

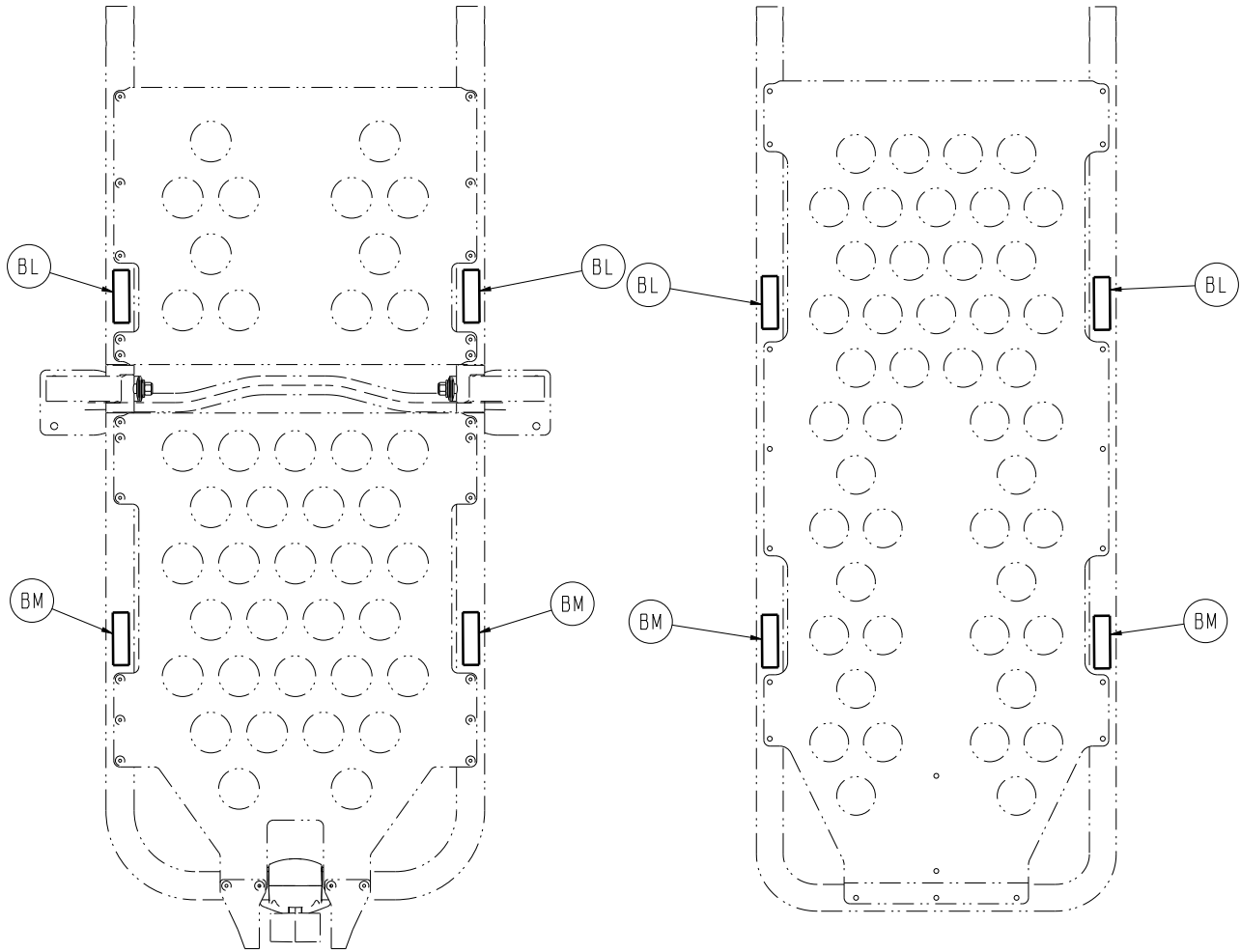
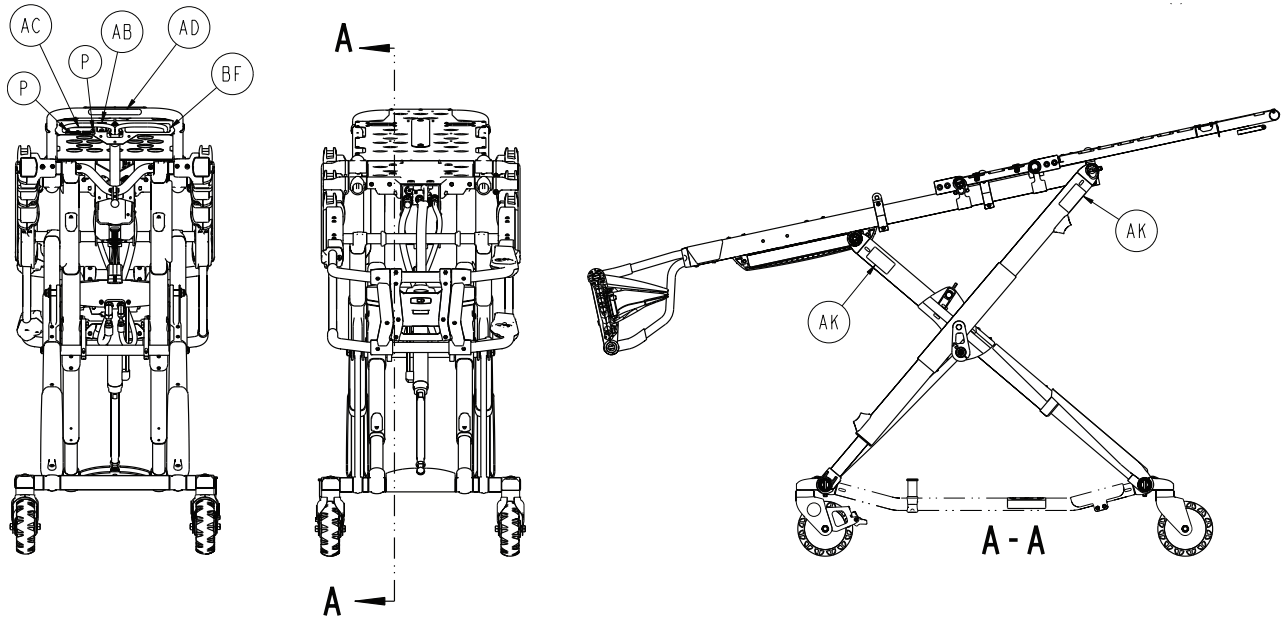

A	0004-589-000	6
B	0004-592-000	6

6506-001-010

C	0004-594-000	10
D	0004-595-000	2
E	0004-596-000	4
F	0004-614 -000	2
G	0008-030-000	2
H	0011-004 -000	2
J	0011-013 -000	1
K	0016-002-000	2
L	0016-028-000	4
M	0016-035-000	1
N	0016-102 -000	6
P	0025-079-000	25
R	0025-132 -000	2
T	0025-133 -000	8
U	0028-181 -000	1
V	0038-574-000	2
W	0056-028-000	2
Y	0059-211 -000	2
AA	6500-031 -077	1
AB	2030-009-901	1
AC	6060-090-002	1
AD	6060-090-004	1
AE	6082-001-085	1
AF	6082-032-045	1
AG	6082-090-043	2
AH	6085-101 -155	2
AJ	6100-003 -125	4
AK	6252-101 -139	4
AL	6500-001-017	1
AM	6500-001-018	1
AN	6500-001-111	1
AP	6500-001-123	1
AR	6500-001-127	2
AT	6500-001-128	2
AU	6500-001-168	1
AV	6085-101 -143	1
AW	6500-001-191	2
AY	6500-001-195	2
BA	6500-001-196	1
BB	6500-101 -233	2
BC	6500-102 -015	1
BD	6500-002-031	1
BE	6506-001-012	1
BF	6506-101 -100	1
BG	6500-002-195	1
BH	6506-001-901	2

6506-001-010

BJ	6506-001-916	2
BK	6506-001-917	2
BL	6506-001-918	2
BM	6506-001-919	2

Rev B (Reference only)

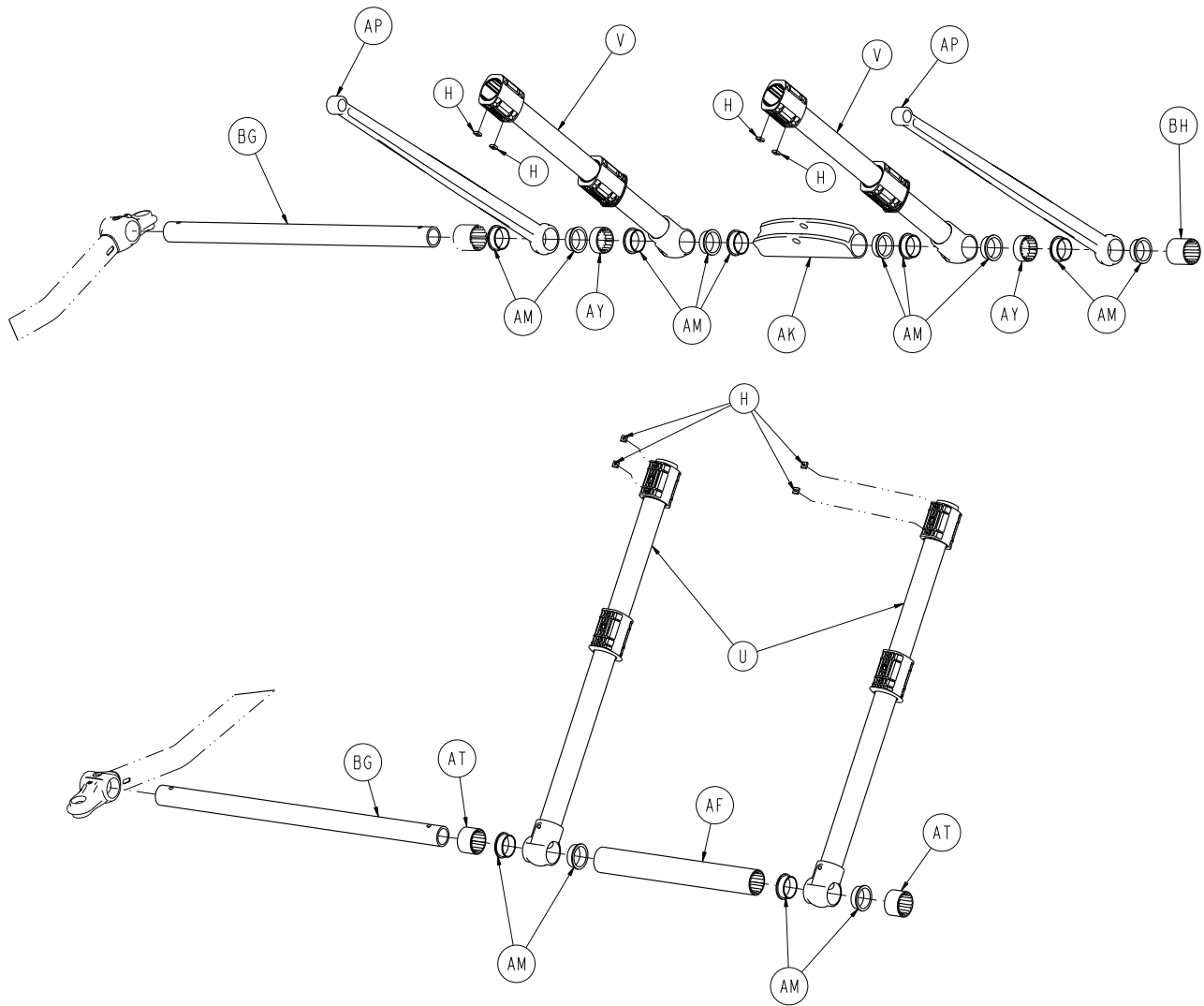

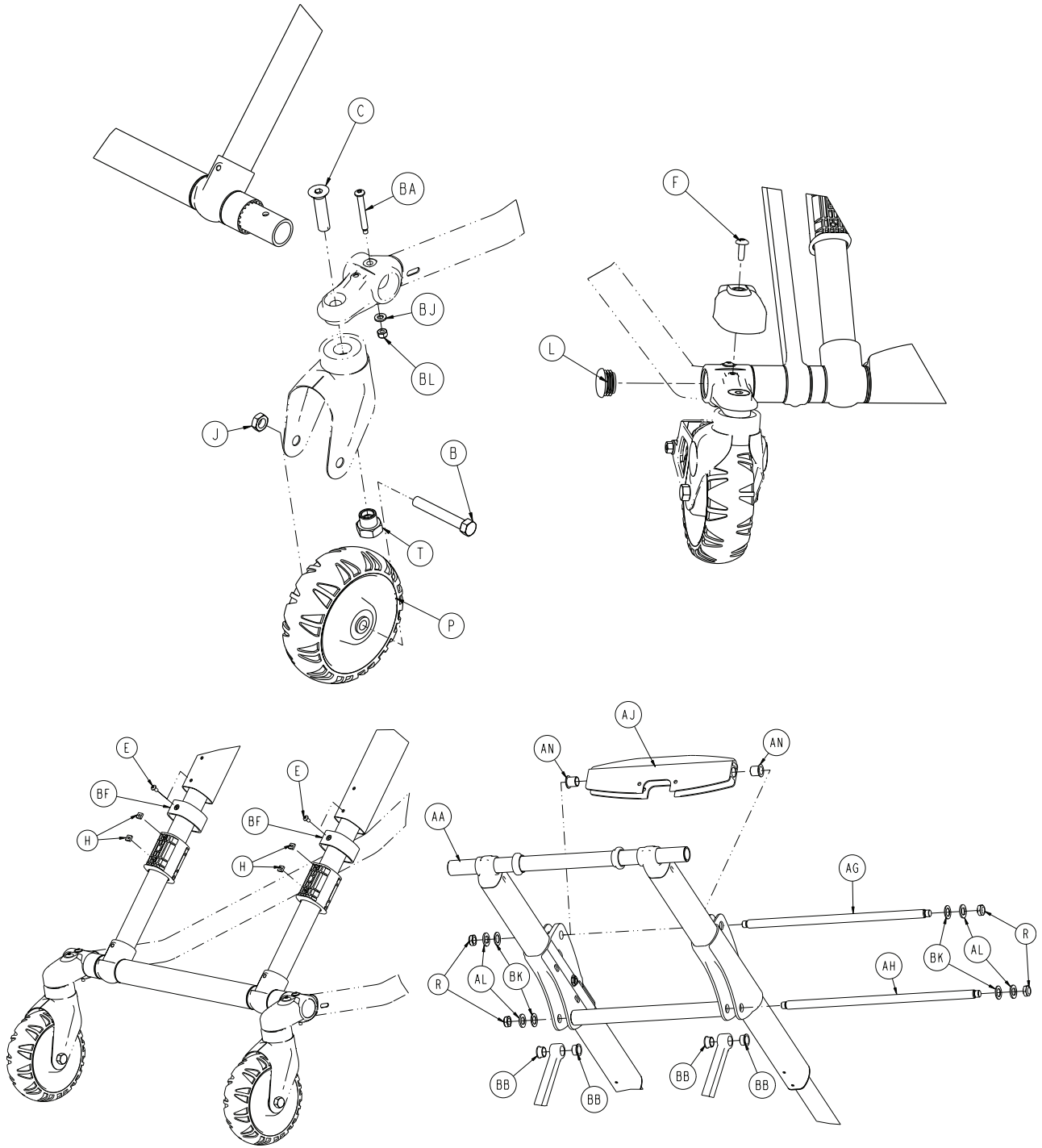

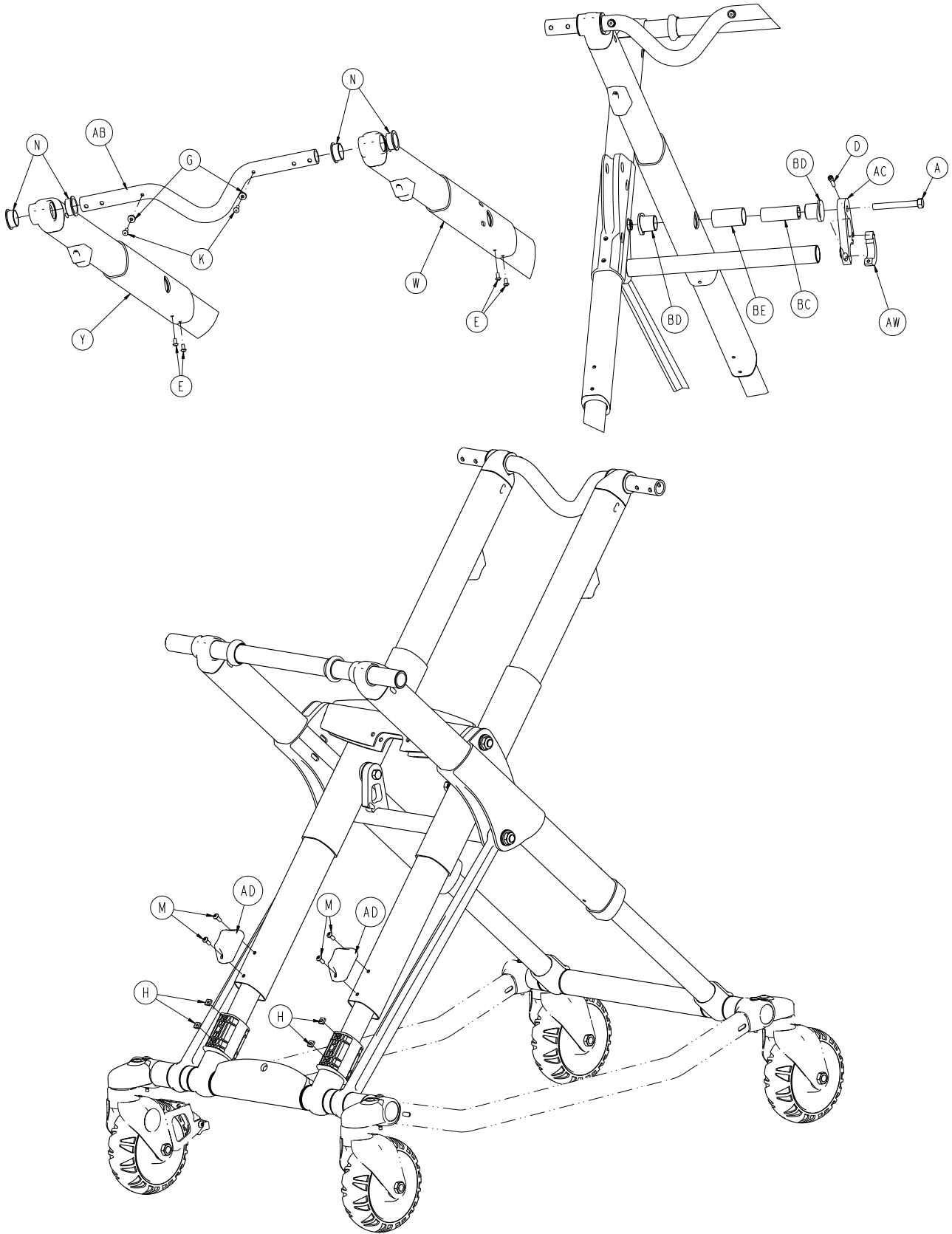

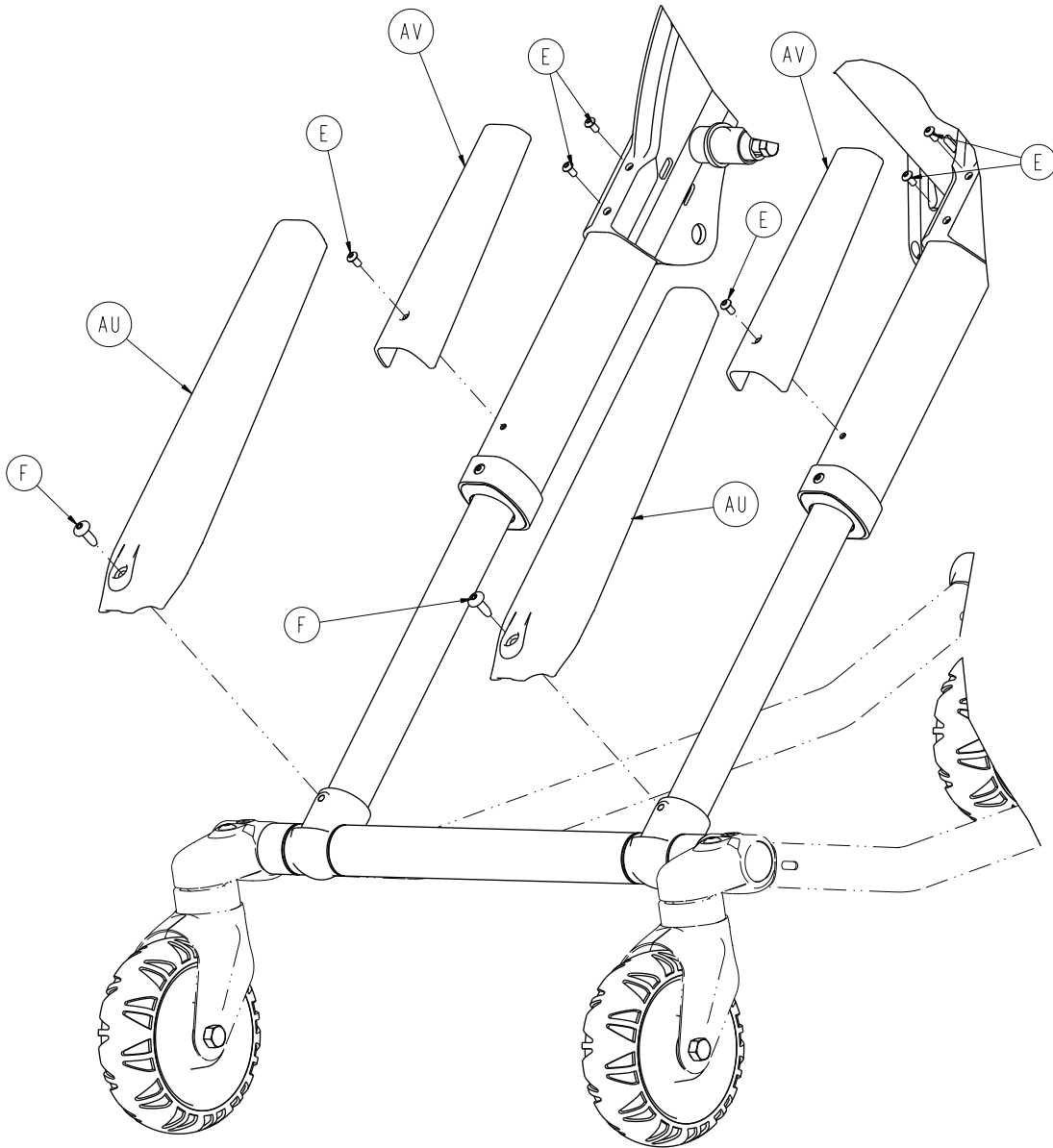

6506-001-012

A	0003-388-000	2
B	0003-205-000	4
C	0004-319-000	4
D	0004-659-000	2
E	0004-587-000	12
F	0007-086-000	6
G	0014-115-000	2
H	0015-051-000	16
J	0016-060-000	4
K	0025-133-000	2
L	0037-083-000	4
M	0004-634-000	4
N	0081-244-000	4
P	6060-002-010	4
R	0016-049-000	4
T	6090-001-009	4
U	6500-301-021	2
V	6500-301-022	2
W	6500-001-034	1
Y	6500-001-035	1
AA	6500-001-056	1
AB	6500-001-090	1
AC	6500-001-308	1
AD	6500-001-125	2
AE	6500-001-309	1
AF	6500-001-129	1
AG	6500-001-171	1
AH	6500-001-182	1
AJ	6500-001-164	1
AK	6500-001-165	1
AL	6500-001-225	4
AM	6500-001-166	14
AN	6500-001-157	2
AP	6500-001-172	2
AT	6500-001-178	2
AU	6500-001-179	2
AV	6500-001-180	2
AW	6500-001-310	2
AY	6500-001-183	2
BA	6085-001-097	4
BB	6500-001-162	4
BC	6500-001-341	2
BD	6500-001-226	4
BE	6500-001-227	2
BF	6500-001-228	2
BG	6500-001-229	2

6506-001-012

BH	6500-001-23 0	1
BJ	0014-002-000	4
BK	0014-040-000	4
BL	0016-002-000	4

Rev A (Reference only)

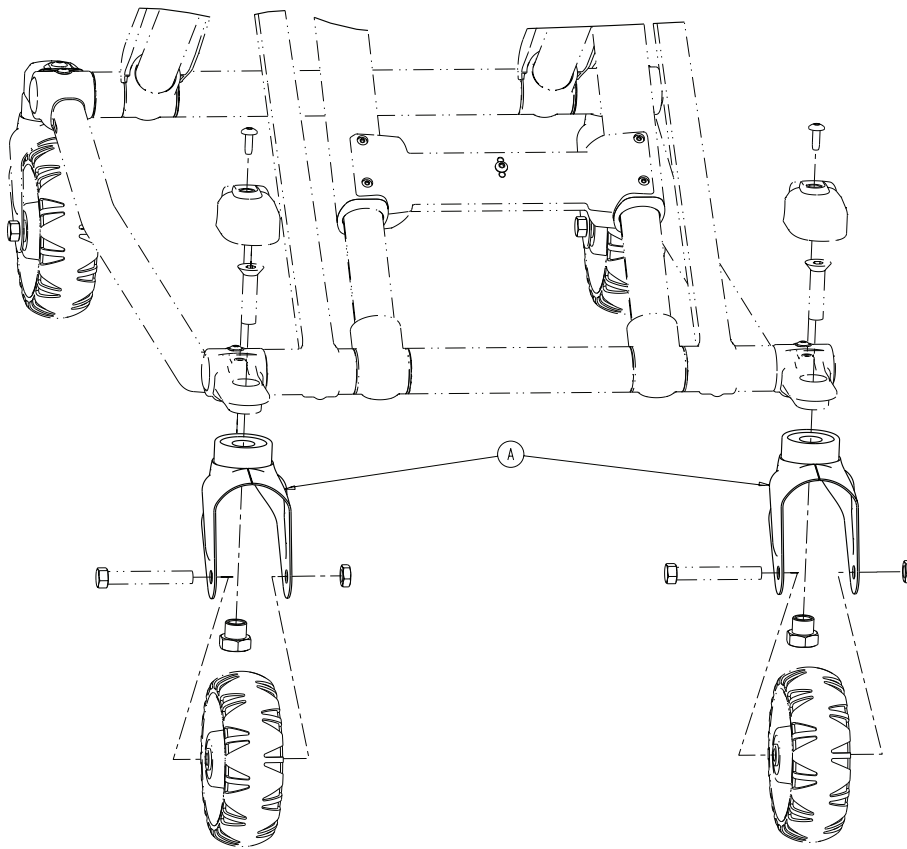

A

6082-002-012

2

6086-601-010

Rev A (Reference only)

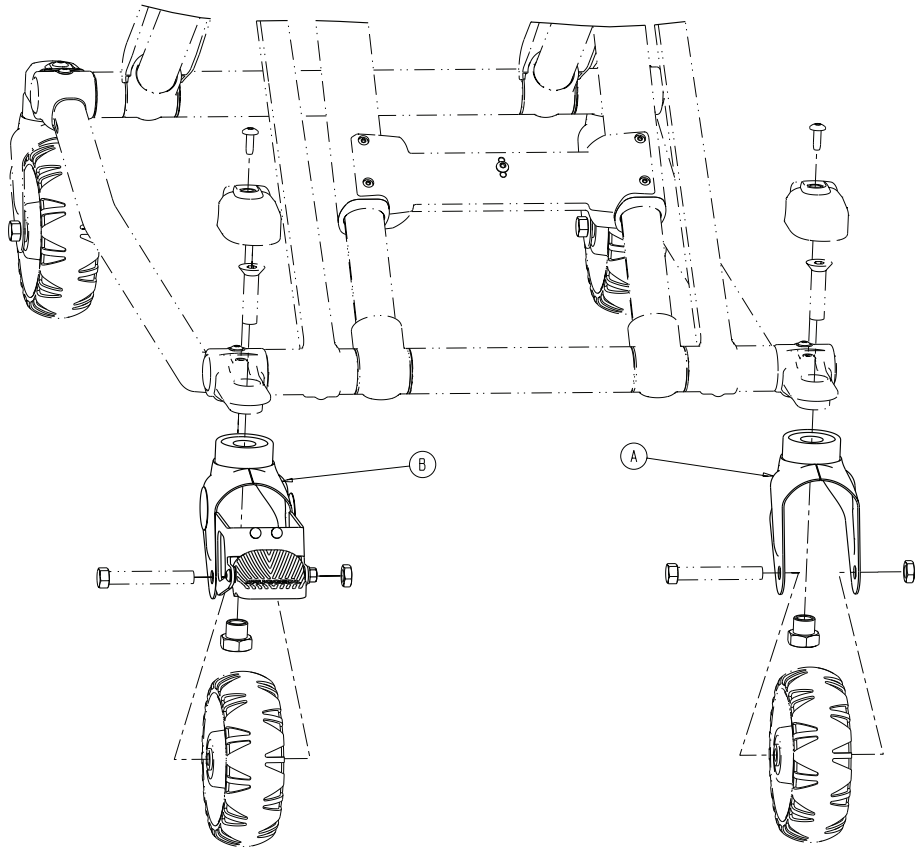

A	6082-002-012	1
B	6086-200-010	1

6086-602-010

Rev A (Reference only)

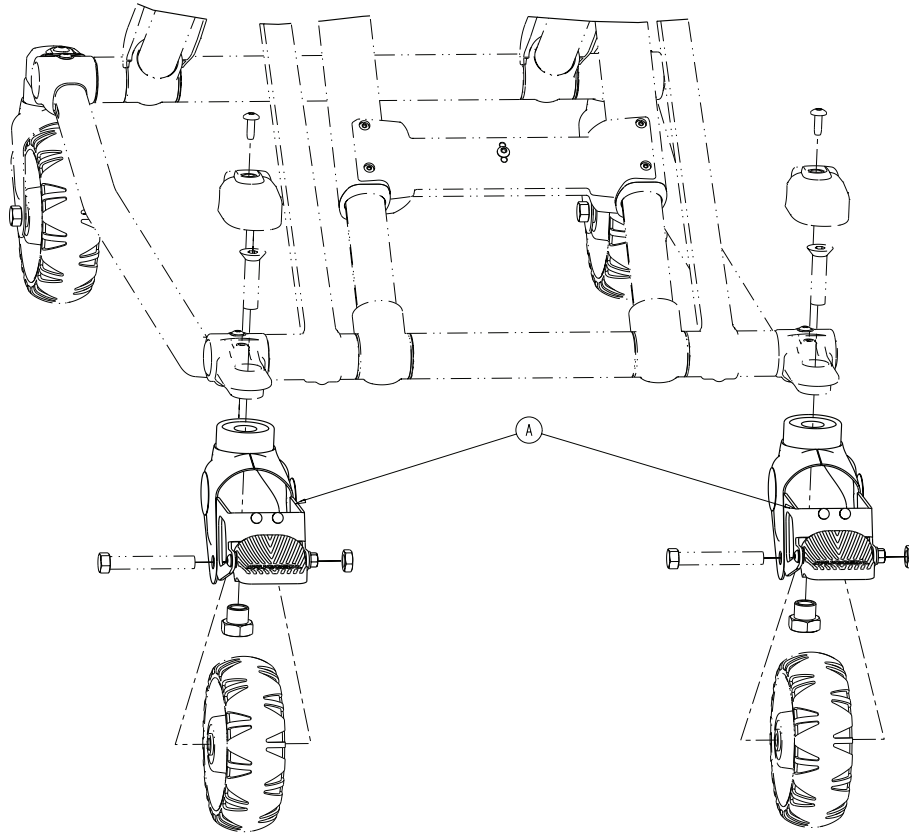

A

6086-200-010

2

6082-002-012

Rev C (Reference only)

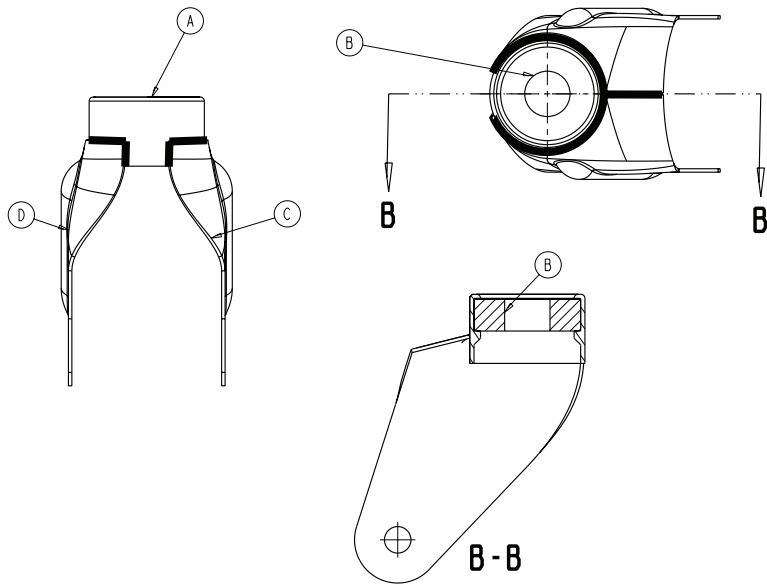

A	6082-002-039	1
B	0081-227-00 0	1
C	6082-002-042	1
D	6082-002-043	1

6086-200-010

Rev A (Reference only)

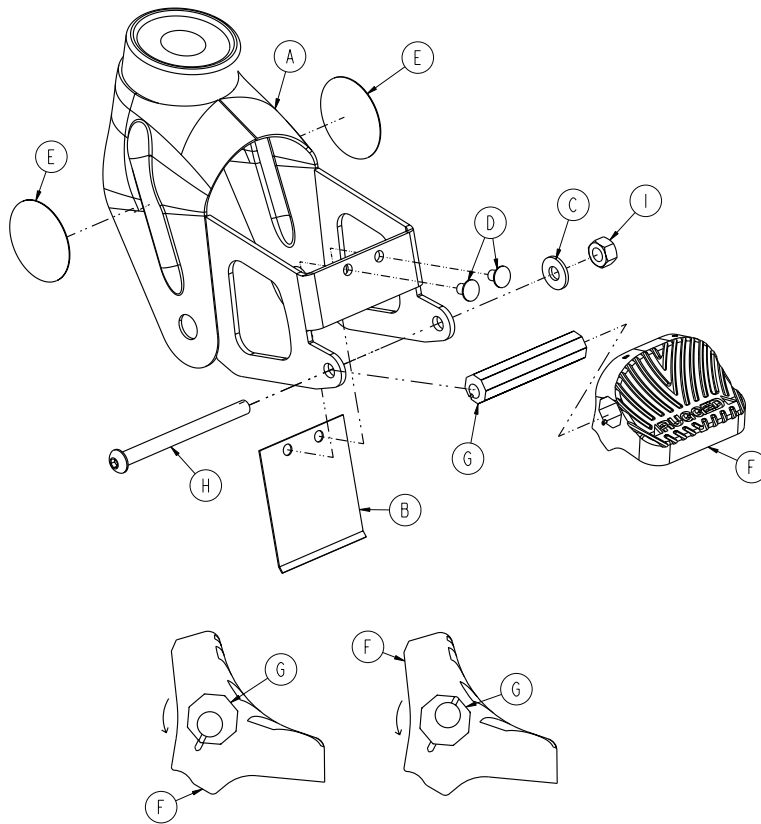

A	6082-100 -012	1
B	6080-100 -032	1
C	0011-456 -000	1
D	0025-153 -000	2
E	6506-001 -900	2
F	6080-300 -030	1
G	6080-200 -041	1
H	0004-098 -000	1
I	0016-118 -000	1

6506-037-000

Rev A (Reference only)

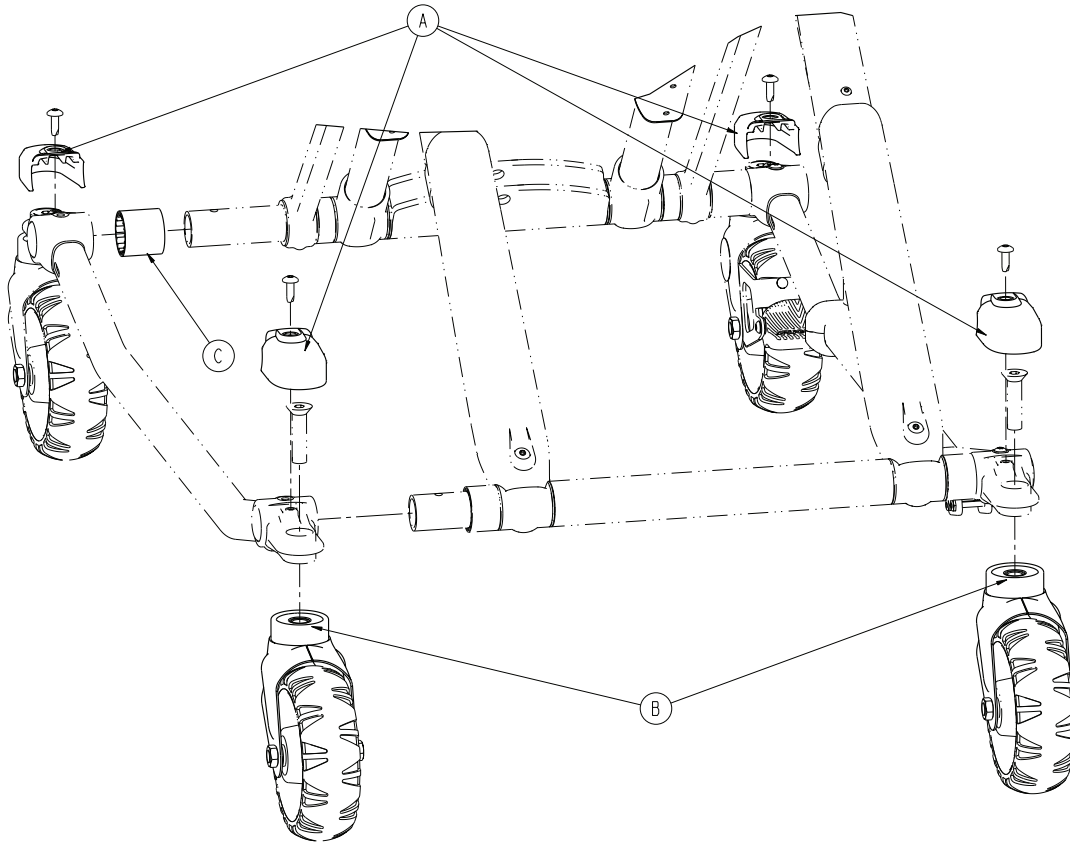

A	6500-001-17	7	4
B	6082-002-012		2
C	6500-001-230		1

6506-038-000

Rev A (Reference only)

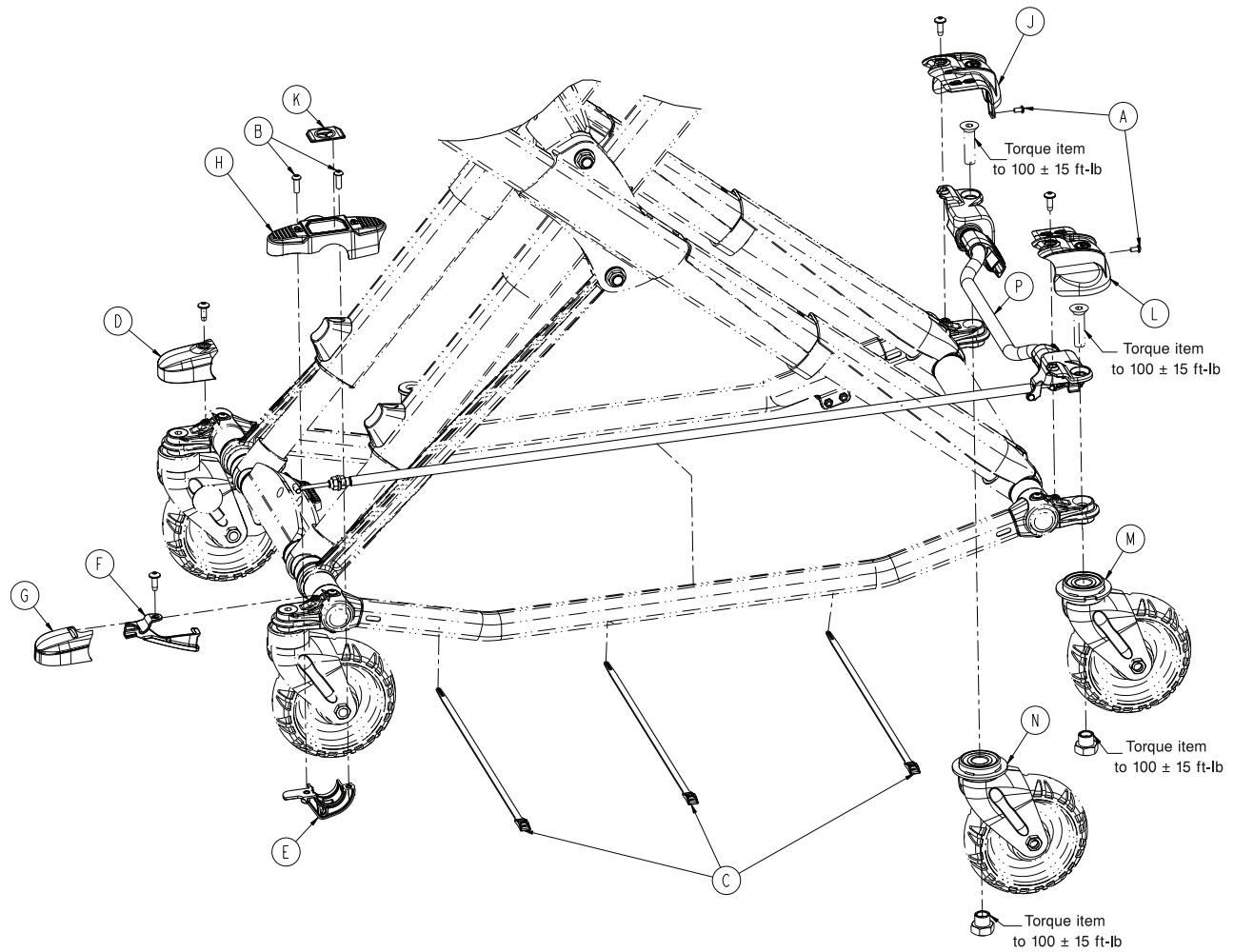

A	0004-587-000	2
B	0004-592-000	2
C	0059-211-000	3
D	6500-001-177	1
E	6500-002-243	1
F	6500-002-244	1
G	6500-002-245	1
H	6500-002-246	1
J	6500-002-247	1
K	6500-002-248	1
L	6500-002-249	1
M	6500-002-255	1
N	6500-002-260	1
P	6506-002-265	1

6506-002-265

Rev A (Reference only)

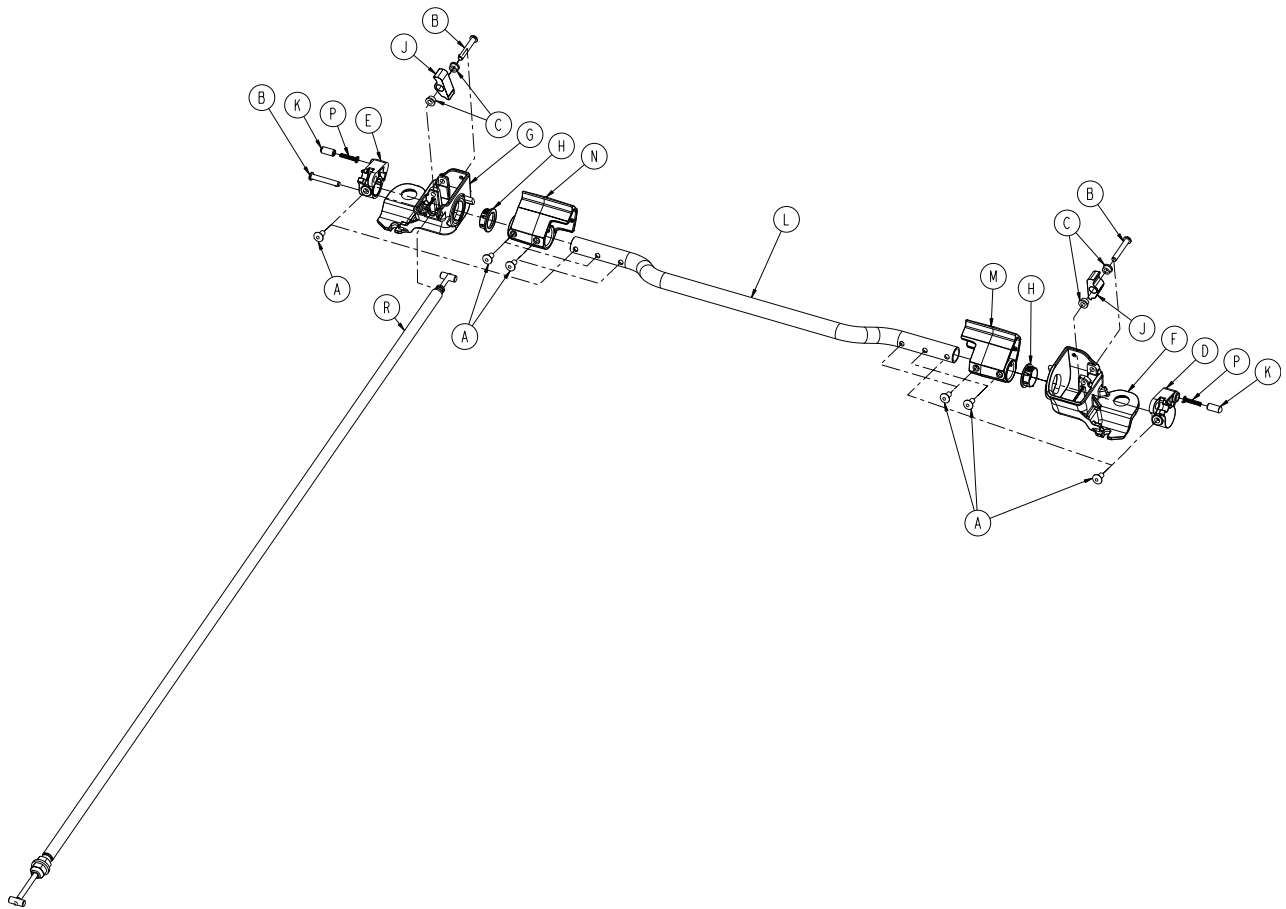

A	0025-079-000	6
B	0027-036-000	3
C	0081-347-00 0	4
D	6500-002-230	1
E	6500-002-231	1
F	6500-002-234	1
G	6500-002-235	1
H	6500-002-236	2
J	6500-002-237	2
K	6500-002-238	2
L	6500-002-240	1
M	6500-002-241	1
N	6500-002-251	1
P	6500-002-252	2
R	6500-002-250	1

6060-002-010

Rev C (Reference only)

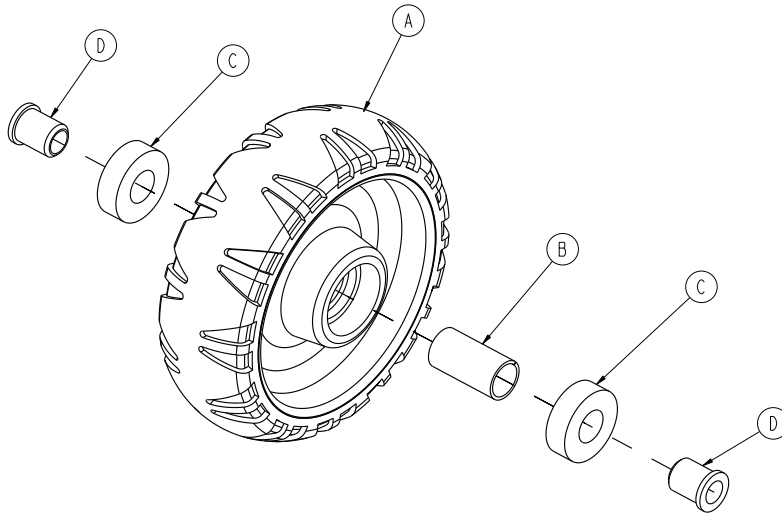

A	6060-002-045	1
B	6060-002-046	1
C	0081-226 -000	2
D	0715-001 -255	2

Rev E (Reference only)

Torque item C
to 100-140 in-lb

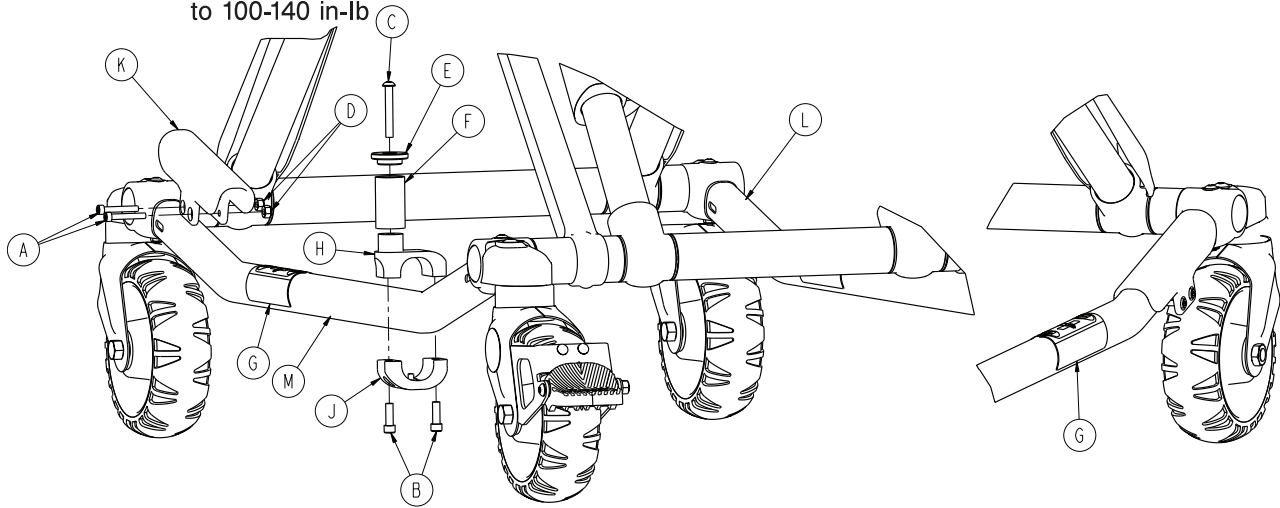

A	0004-160-000	2
B	0004-591-000	2
C	0004-503-000	1
D	0016-003-000	2
E	6060-004-043	1
F	6060-004-044	1
G	6080-090-10 8	2
H	6500-101-18 9	1
J	6500-101-19 0	1
K	6500-001-30 2	1
L	6085-001-056	1
M	6085-001-057	1

6085-102-000

Rev A (Reference only)

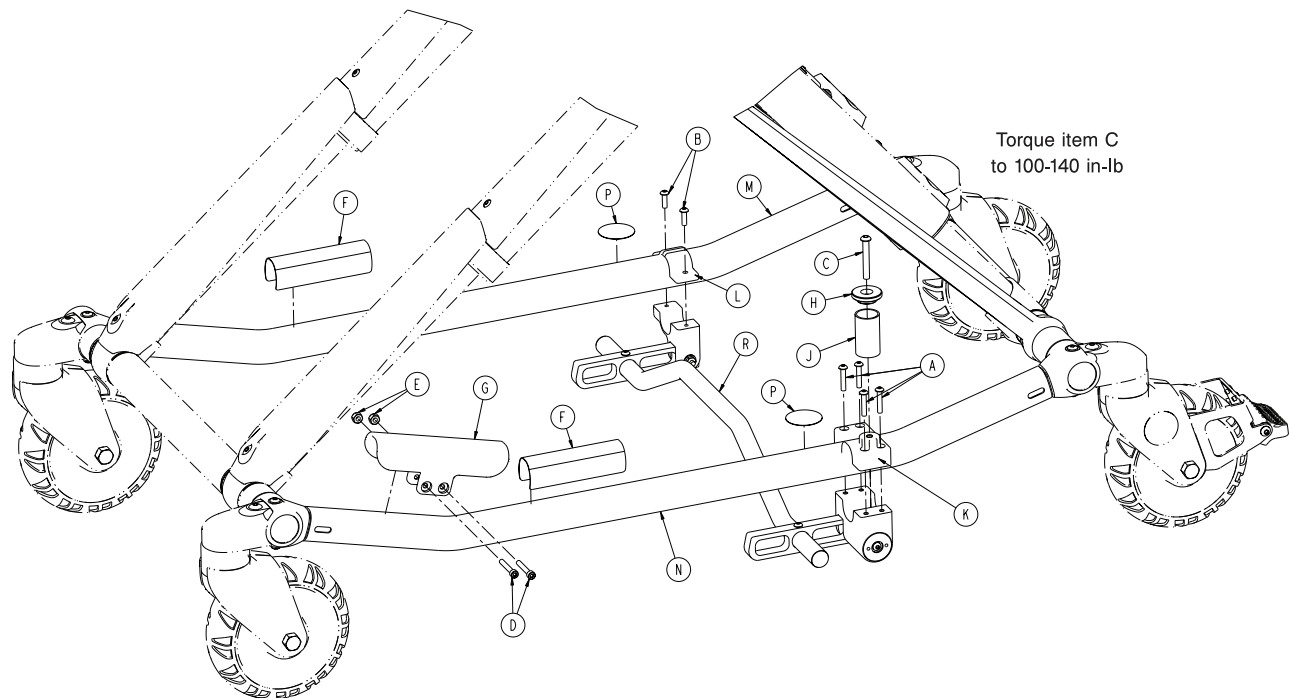

A	0004-460-000	4
B	0004-515-000	2
C	0004-503-000	1
D	0004-160-000	2
E	0016-003-000	2
F	6080-090-108	2
G	6500-001-302	1
H	6060-004-043	1
J	6060-004-044	1
K	6085-002-001	1
L	6085-002-002	1
M	6085-001-056	1

6085-002-016

Rev A (Reference only)

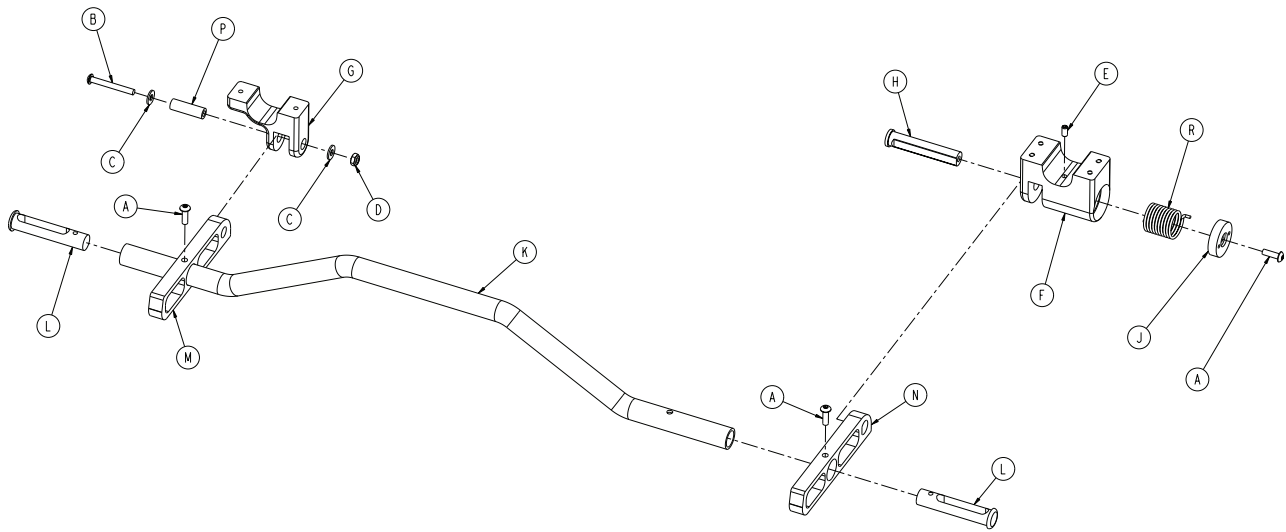

A	0004-515-000	3
B	0004-636-000	1
C	0011-302-000	2
D	0016-131-00 0	1
E	0021-180-00 0	1
F	6085-002-003	1
G	6085-002-004	1
H	6085-002-006	1
J	6085-002-007	1
K	6085-002-008	1
L	6085-002-009	2
M	6085-002-011	1
N	6085-002-012	1
P	6085-002-013	1
R	6085-002-014	1

6500-301-021

Rev B (Reference only)

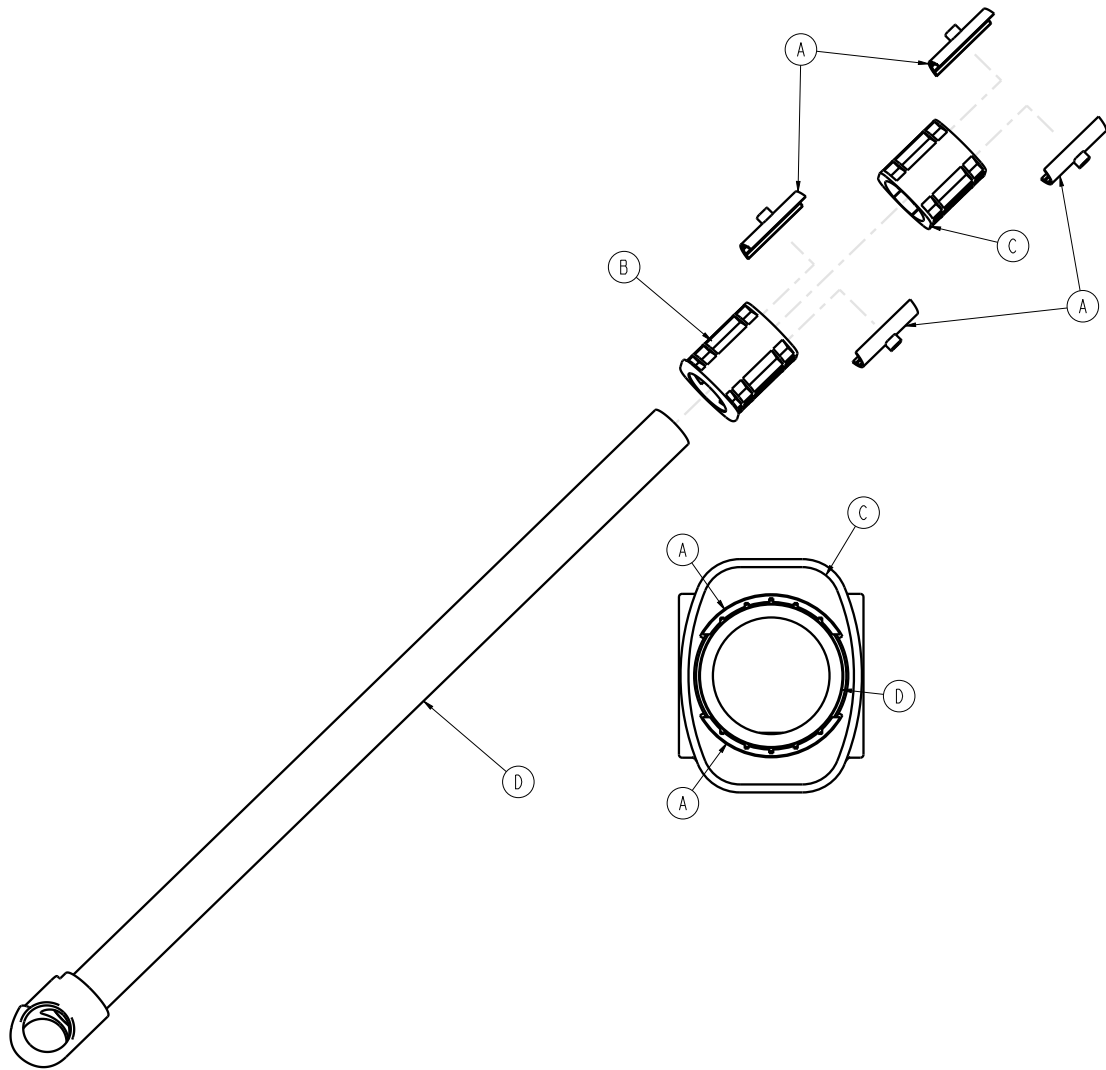

A	6500-001-327	4
B	6500-001-328	1
C	6500-001-329	1
D	6500-301-050	1

6500-301-022

Rev C (Reference only)

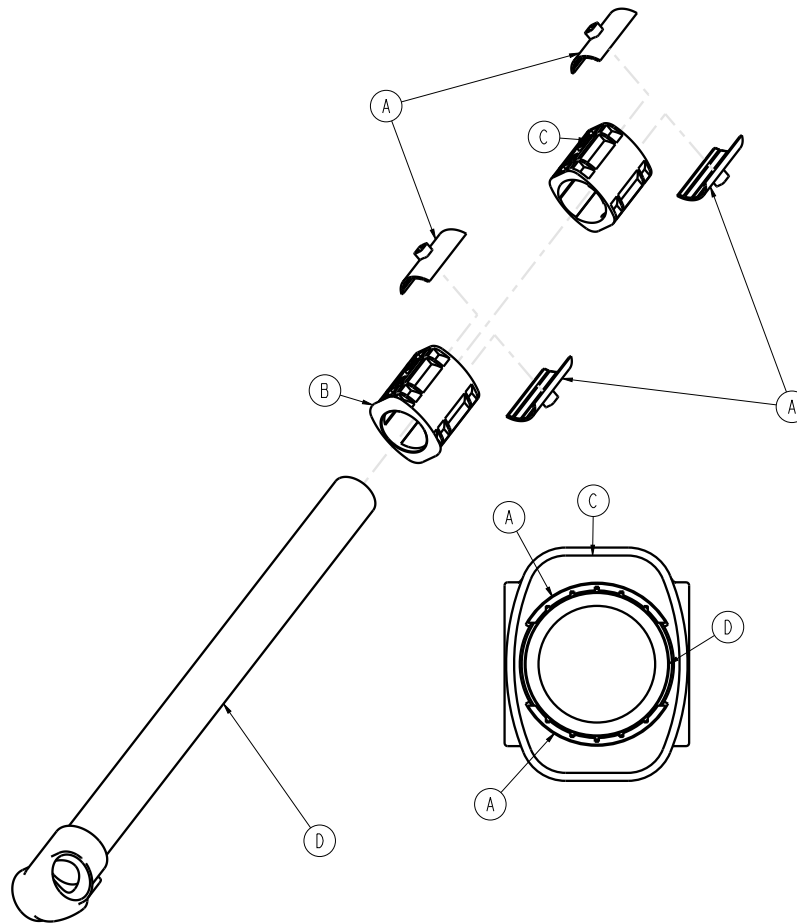

A	6500-101-32 7	4
B	6500-001-32 8	1
C	6500-001-32 9	1
D	6500-301-05 1	1

6500-001-034

Rev F (Reference only)

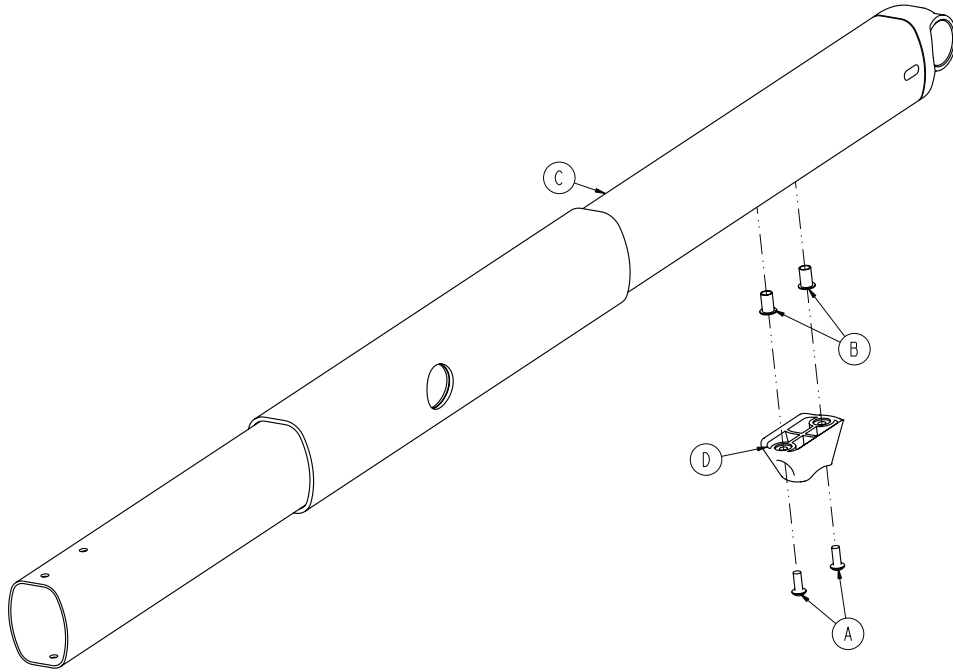

A	0004-634-000	2
B	0055-100 -075	2
C	6500-001-355	1
D	6500-001-125	1

6500-001-035

Rev F (Reference only)

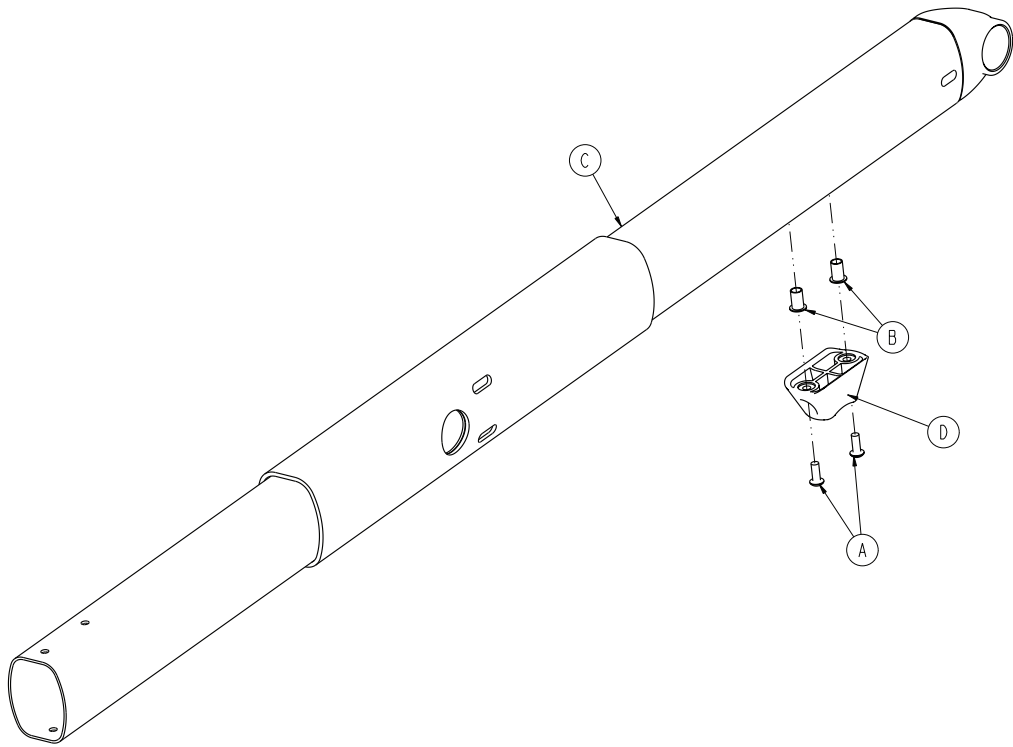

A	0004-634-000	2
B	0055-100-07 5	2
C	6500-301-05 3	1
D	6500-001-12 5	1

6506-031-000

Rev B (Reference only)

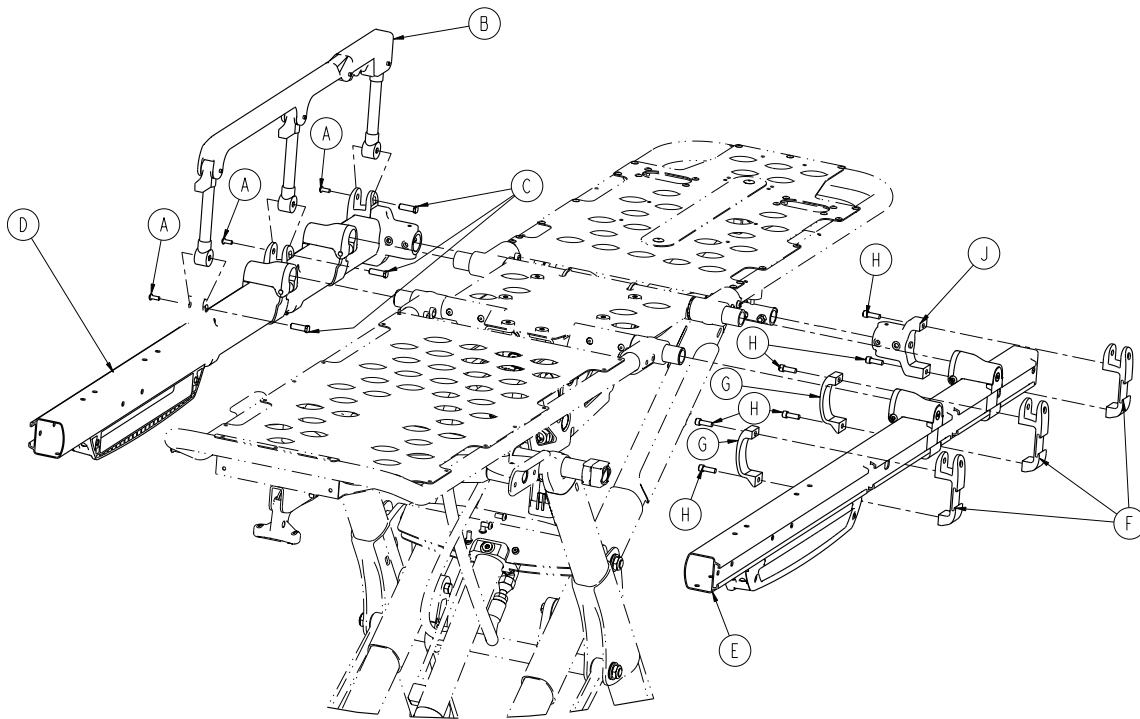

A	0004-585-000	6
B	6082-026-010	2
C	6500-001-118	6
D	6500-002-032	1
E	6500-002-033	1
F	6500-001-116	6
G	6500-001-117	4
H	0004-591-000	12
J	6500-001-102	2

6082-026-010

Rev B (Reference only)

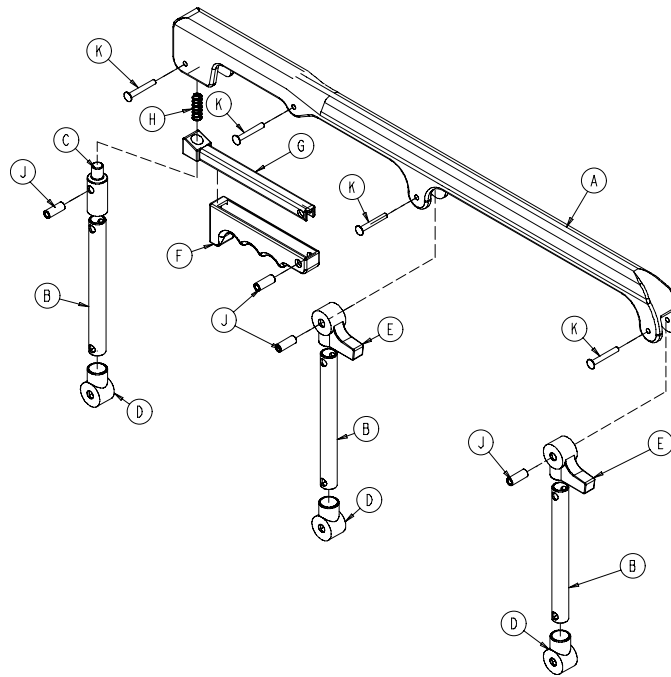

A	6060-025-024	1
B	6060-025-043	3
C	6060-025-047	1
D	6060-025-041	3
E	6060-025-040	2
F	6060-025-029	1
G	6061-125-03 0	1
H	0038-344-000	1
J	6060-025-035	4
K	0025-131-00 0	4

6500-002-032

Rev C (Reference only)

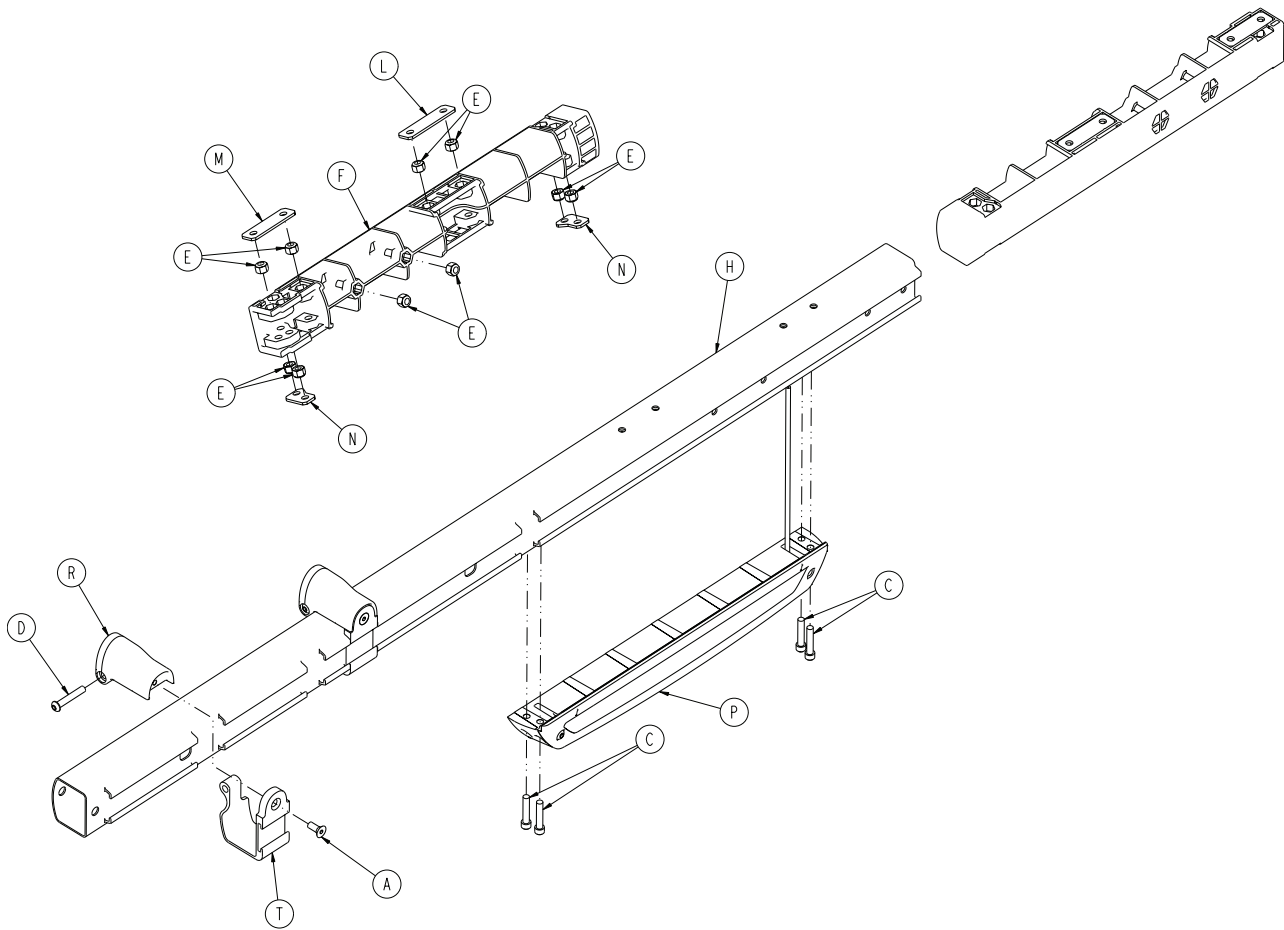

A	0001-004-011	2
C	0004-613-000	4
D	0004-848-000	2
E	0016-028-000	10
F	6500-001-098	1
H	6500-001-114	1
L	6500-001-243	1
M	6500-001-244	1
N	6500-001-245	2
P	6500-002-028	1
R	6500-002-130	2
T	6500-002-131	2

6500-002-033

Rev C (Reference only)

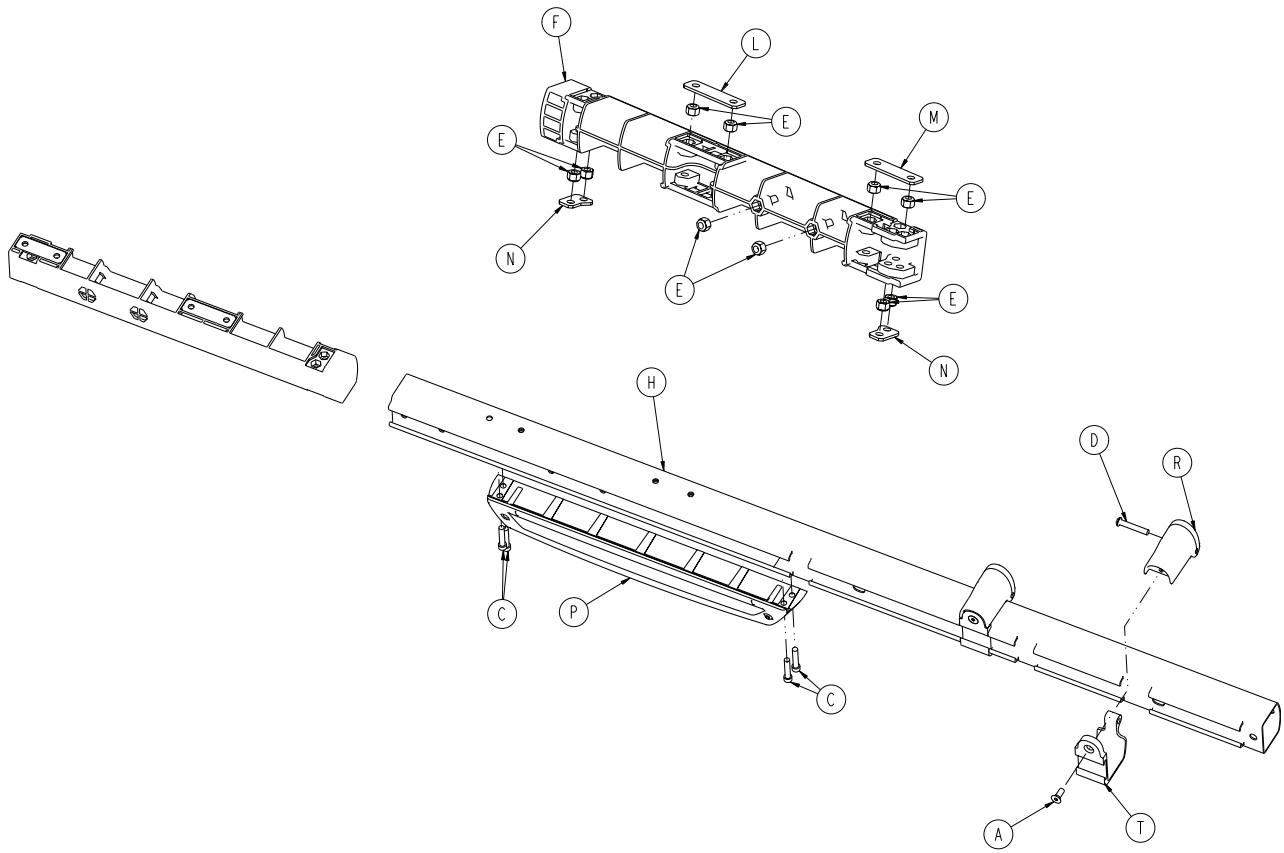

A	0001-004-011	2
C	0004-613-000	4
D	0004-848-000	2
E	0016-028-000	10
F	6500-001-098	1
H	6500-001-115	1
L	6500-001-243	1
M	6500-001-244	1
N	6500-001-245	2
P	6500-002-029	1
R	6500-002-130	2
T	6500-002-131	2

6500-002-028

Rev A (Reference only)

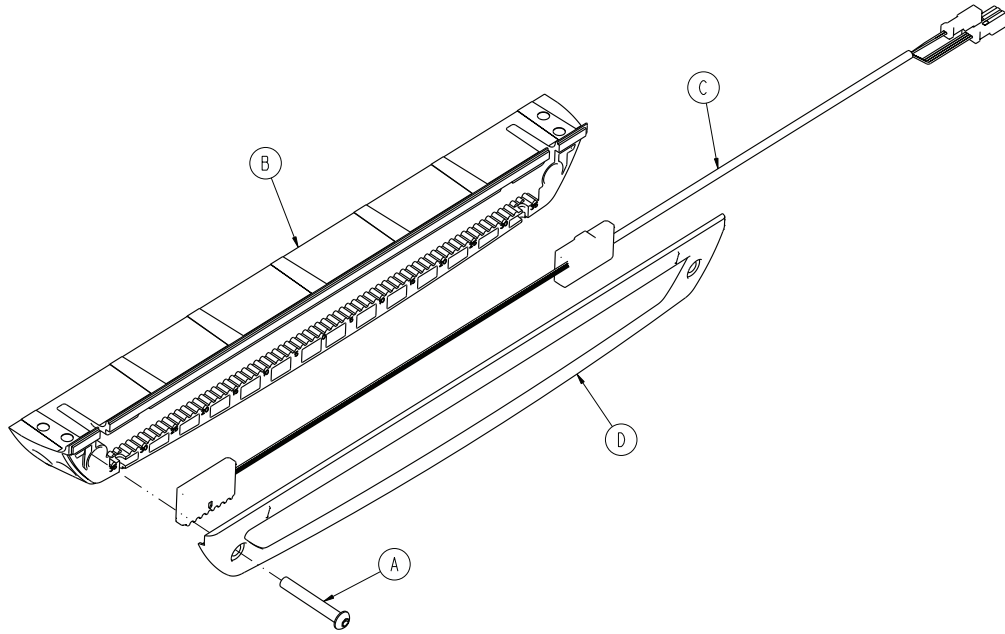

A	0004-596-000	1
B	6500-001-124	1
C	6500-001-160	1
D	6500-001-199	1

6500-002-029

Rev A (Reference only)

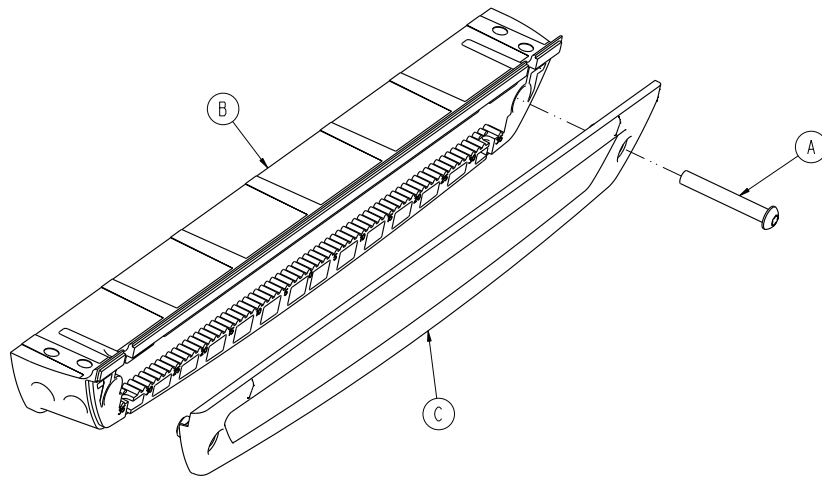

A	0004-596-000	1
B	6500-001-12 4	1
C	6500-001-19 9	1

6506-040-000

Rev A (Reference only)

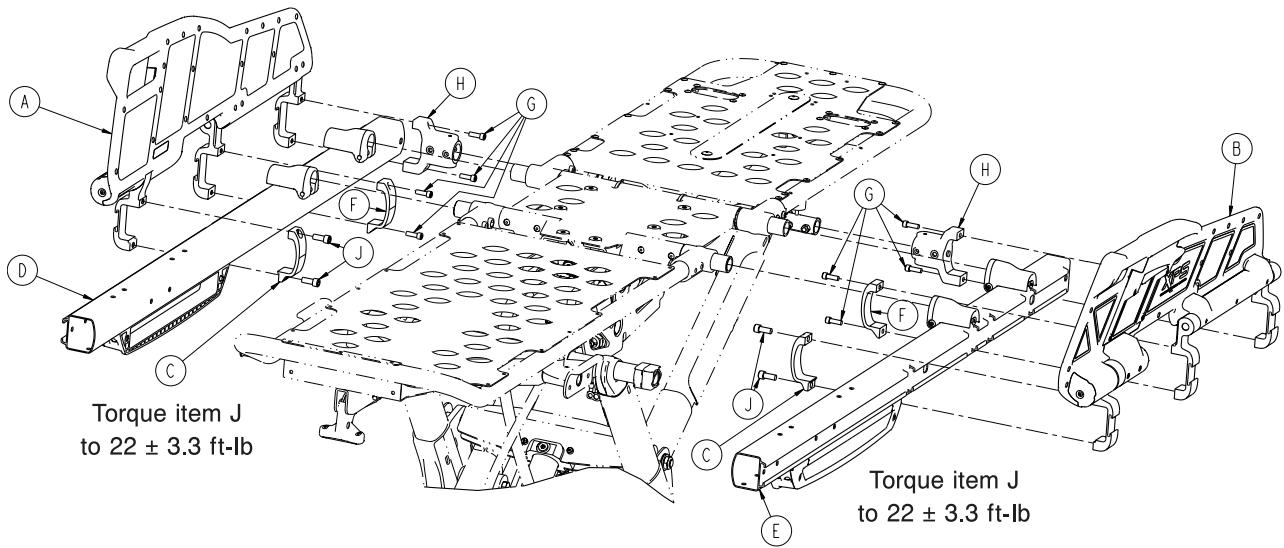

A	6500-003-034	1
B	6500-003-044	1
C	6500-003-099	2
D	6500-002-032	1
E	6500-002-033	1
F	6500-001-117	2
G	0004-591-000	8
H	6500-001-102	2
J	0004-900-000	4

6500-003-034

Rev C (Reference only)

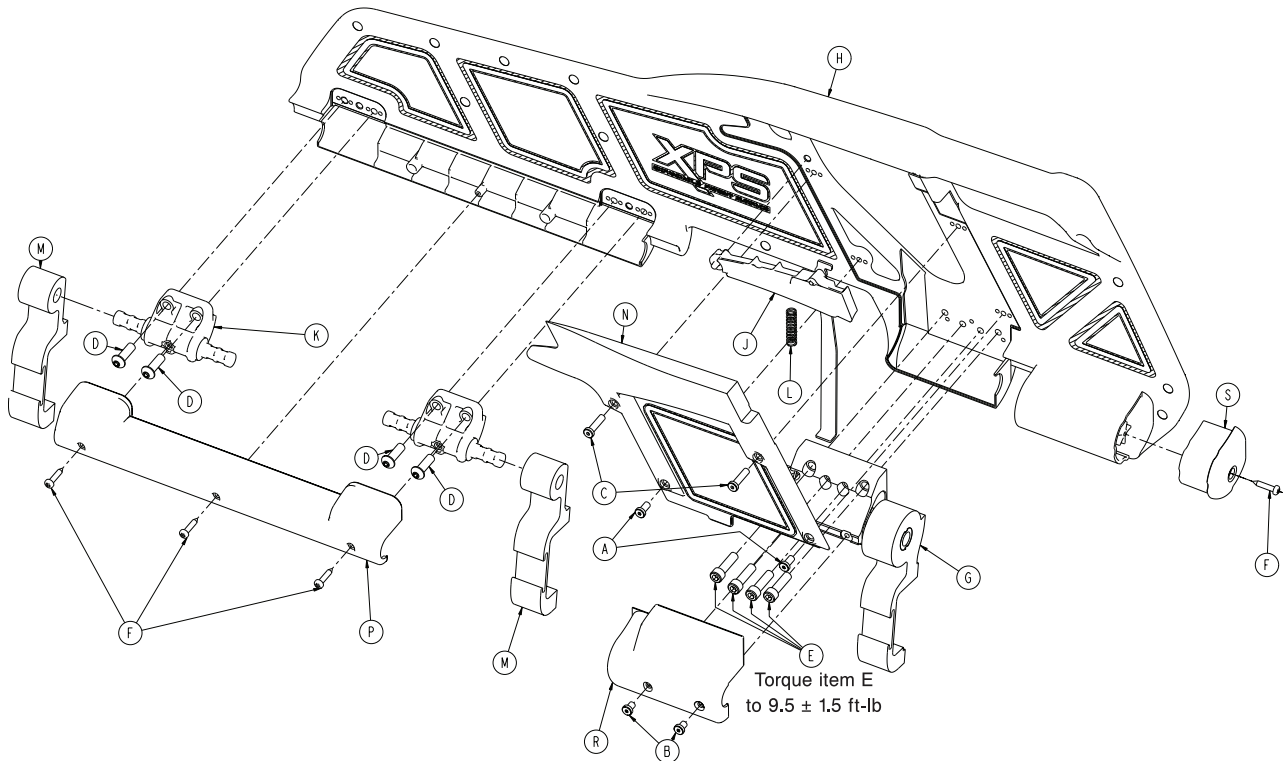

A	0004-400-000	2
B	0004-402-000	2
C	0004-403-000	2
D	0004-468-000	4
E	0004-661-000	4
F	0023-297-000	4
G	6500-003-035	1
H	6500-003-037	1
J	6500-003-043	1
K	6500-003-084	2
L	6500-003-085	1
M	6500-003-086	2
N	6500-003-094	1
P	6500-003-097	1
R	6500-003-119	1
S	6500-003-121	1

6500-003-044

Rev C (Reference only)

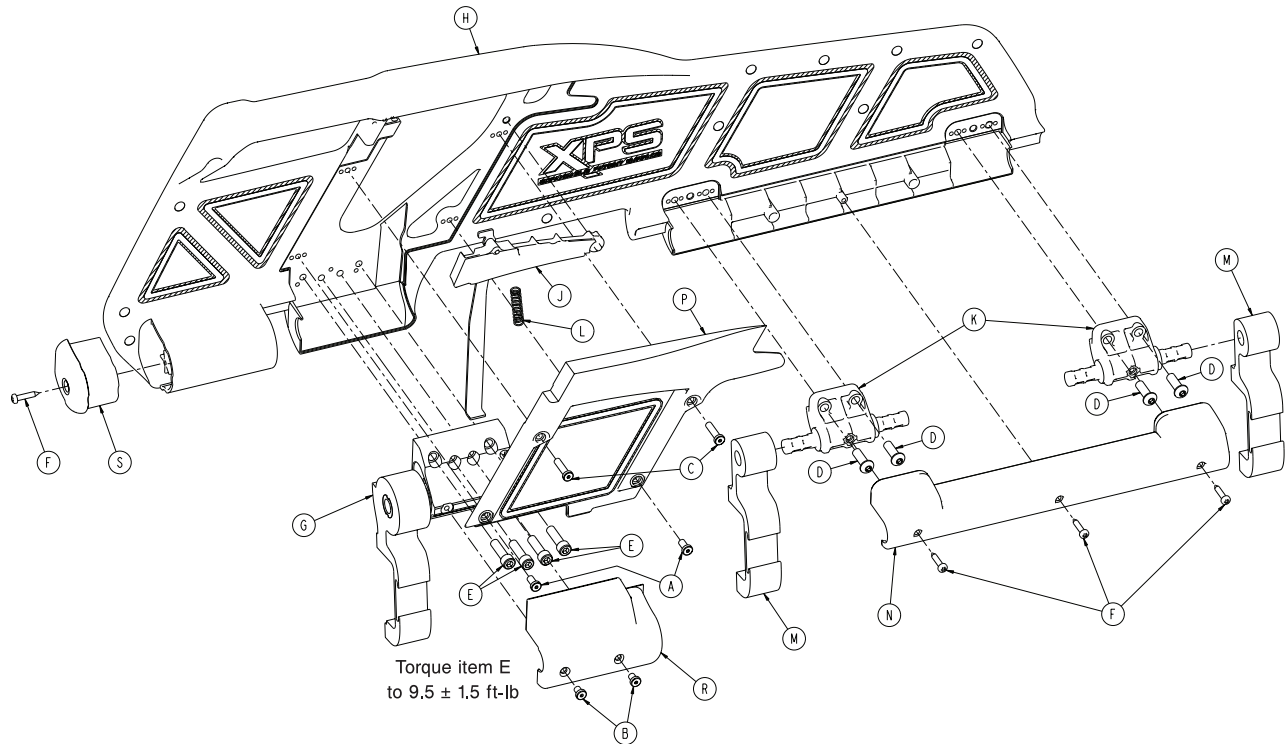

A	0004-400-000	2
B	0004-402-000	2
C	0004-403-000	2
D	0004-468-000	4
E	0004-661-000	4
F	0023-297-000	4
G	6500-003-036	1
H	6500-003-038	1
J	6500-003-045	1
K	6500-003-084	2
L	6500-003-085	1
M	6500-003-086	2
N	6500-003-097	1
P	6500-003-102	1
R	6500-003-120	1
S	6500-003-122	1

6500-002-031

Rev C (Reference only)

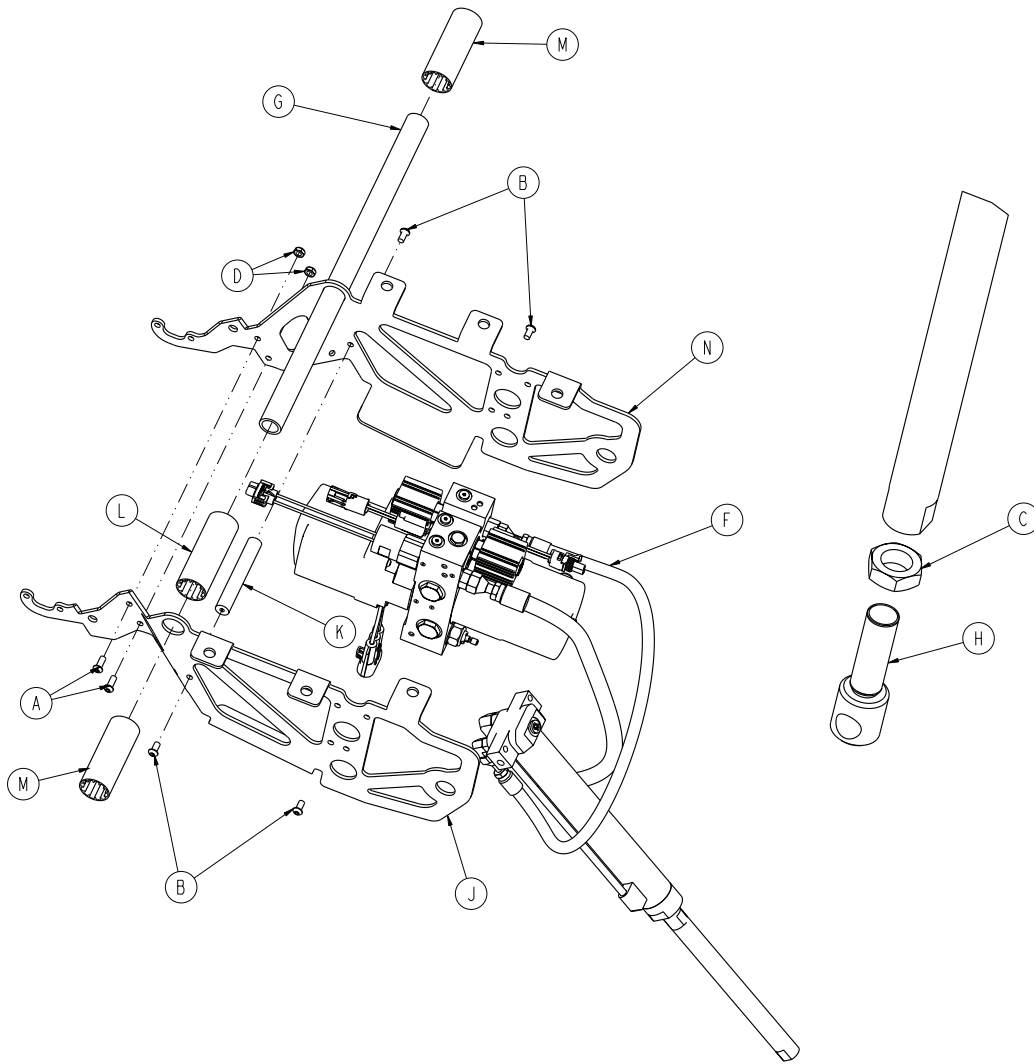

6500-002-031

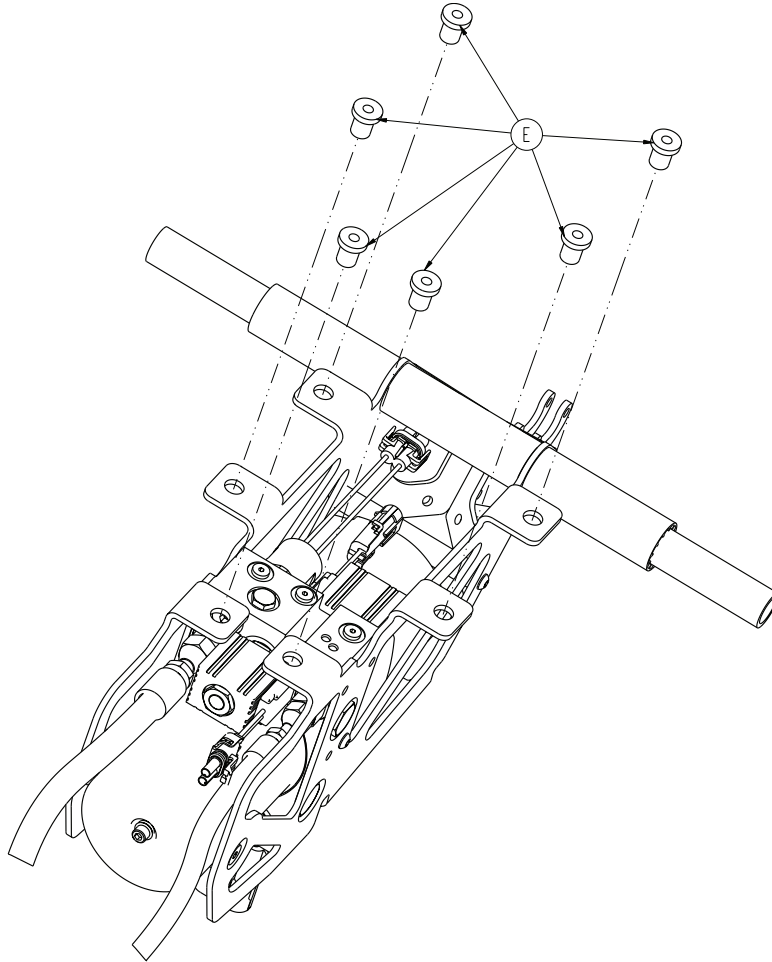

A	0004-577-000	2
B	0004-589-000	4
C	0015-052-000	1
D	0016-102-000	2
E	0055-100-074	6
F	6500-101-030	1
G	6500-001-105	1
H	6500-001-169	1
J	6500-002-194	1
K	6500-001-212	1
L	6500-001-249	1
M	6500-001-250	2
N	6500-002-294	1

6500-101-030

Rev B (Reference only)

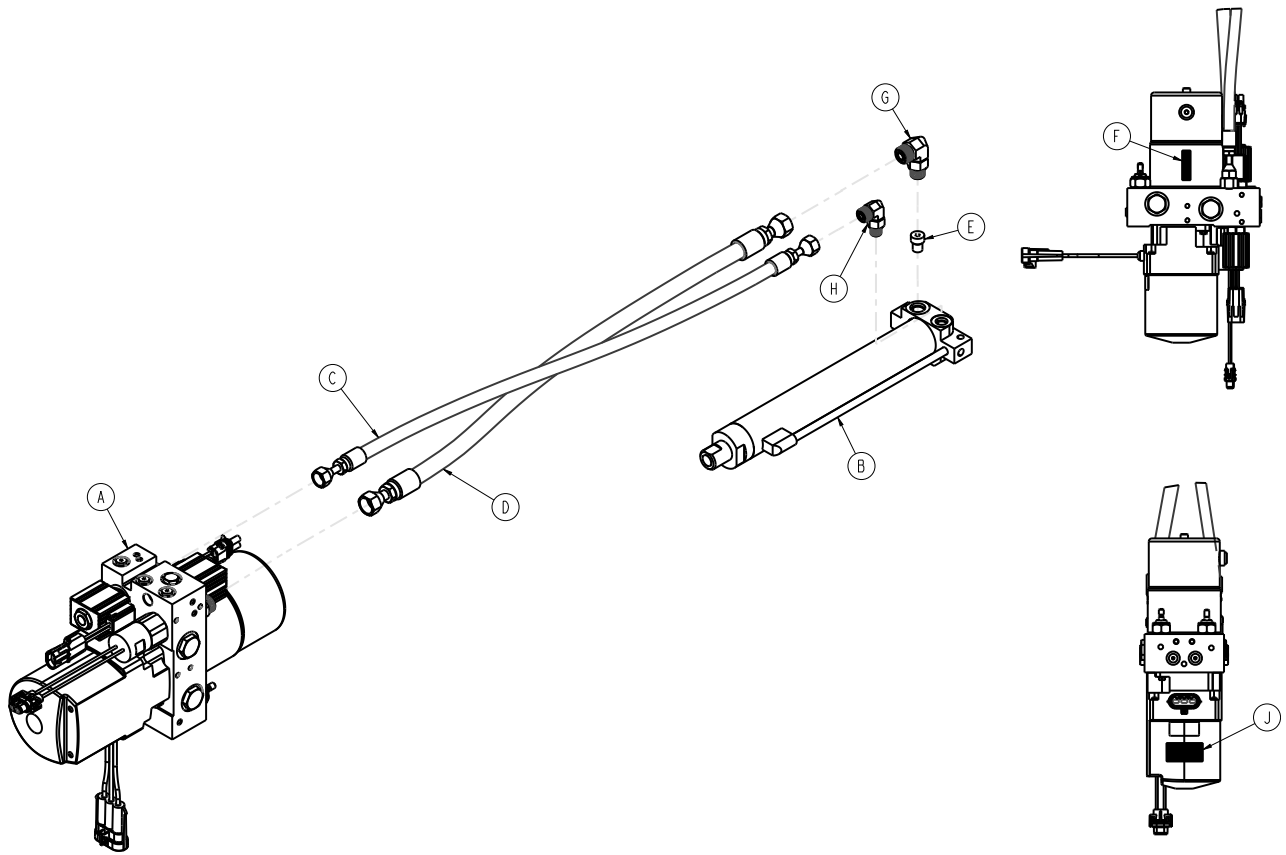

A	6500-101-21	4	1
B	6500-002-034		1
C	6500-001-21	1	1
D	6500-001-21	0	1
E			1
F			1
G	6500-001-29	6	1
H	6500-001-29	7	1
J			1

Rev B (Reference only)

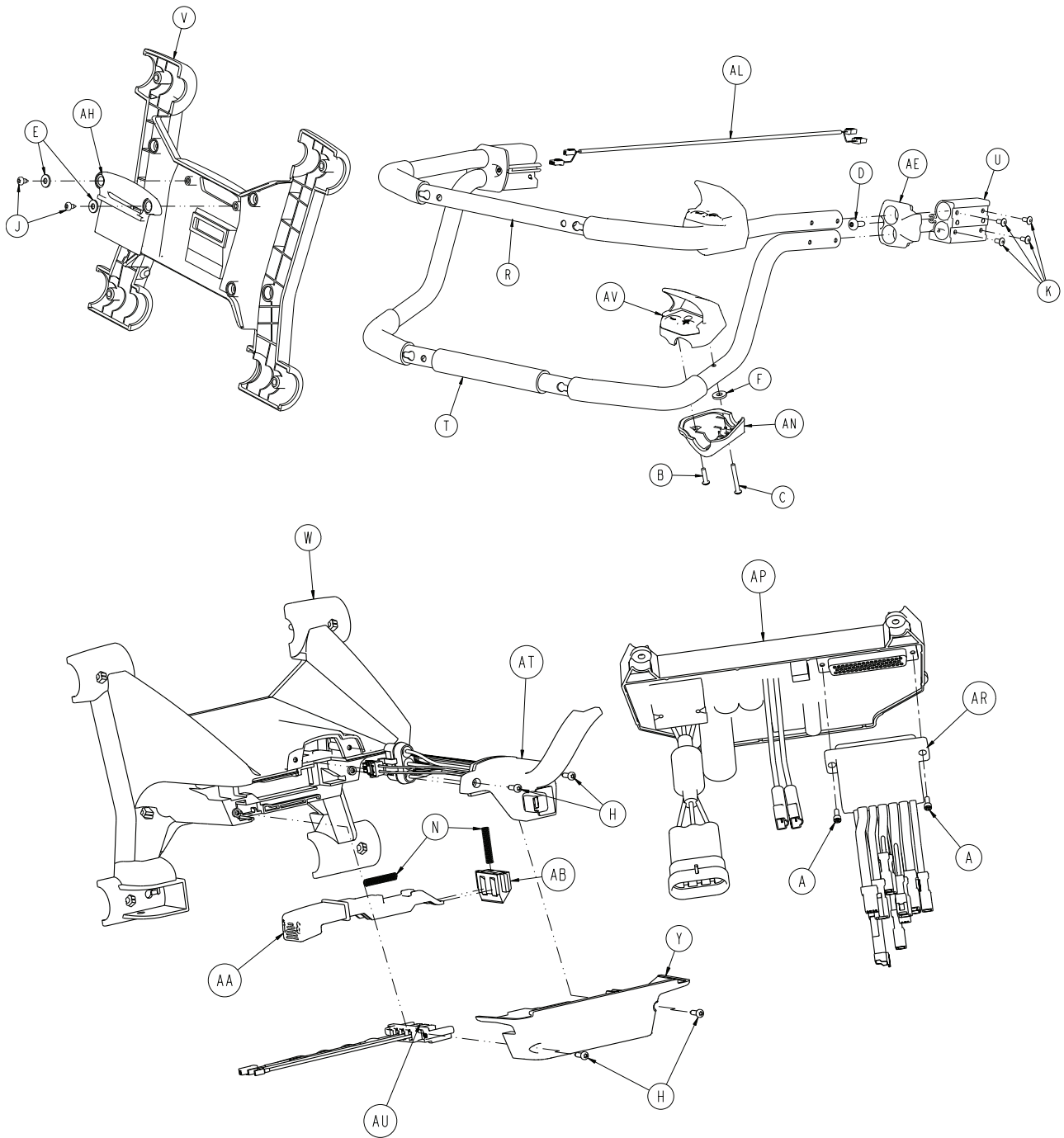

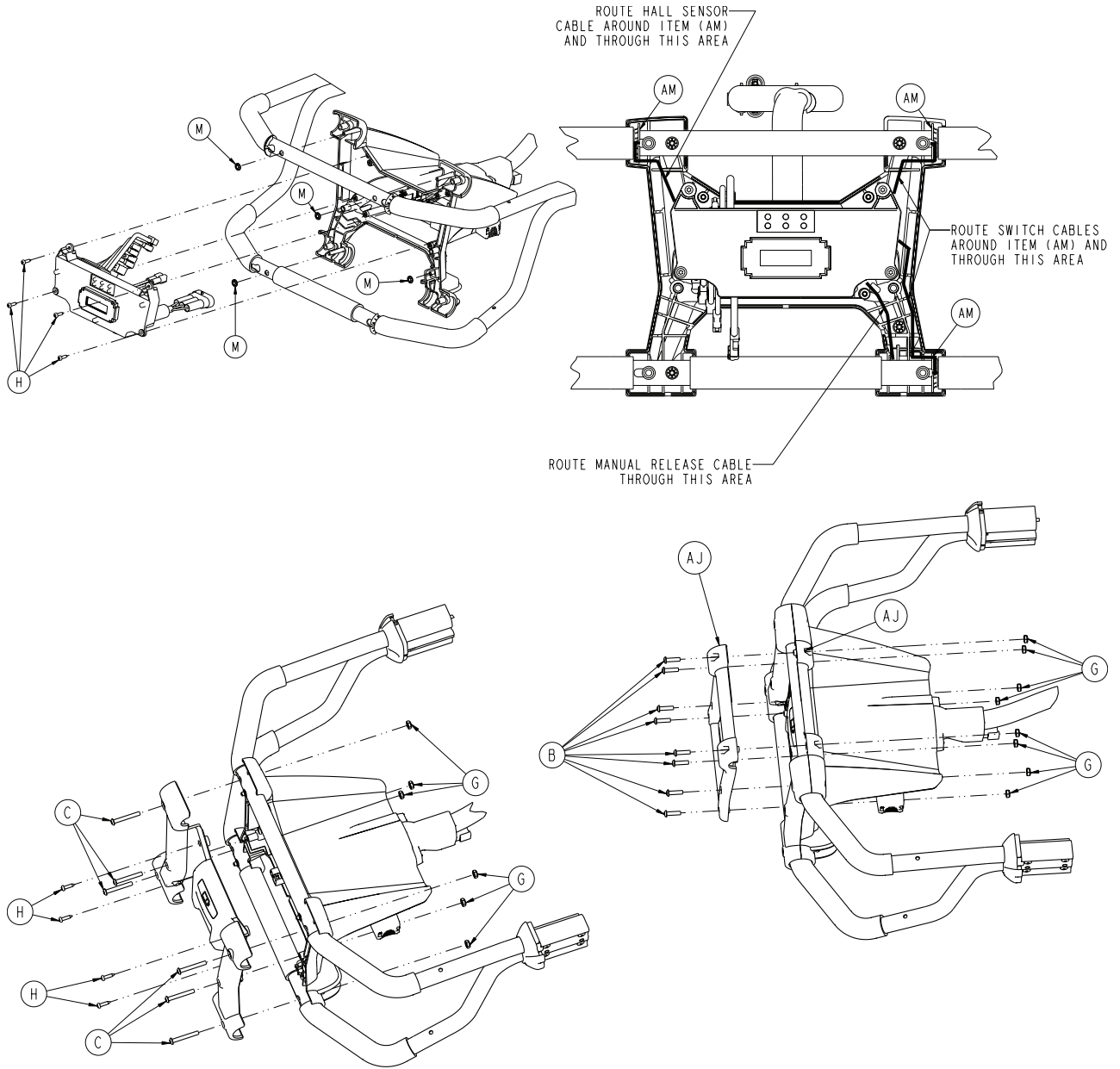

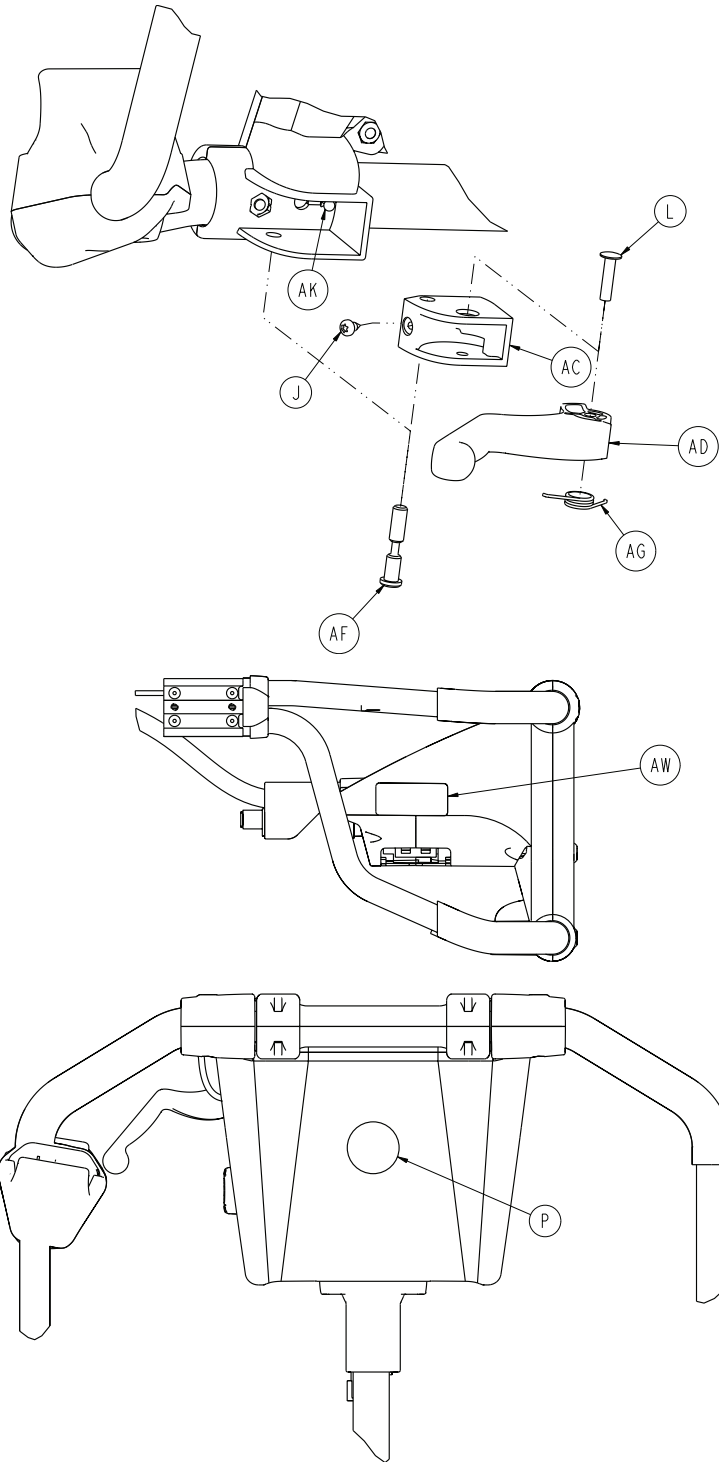

A	0004-874-000	2
B	0004-614-000	10
C	0004-615-000	8
D	0007-086-000	2
E	0011-062-000	2
F	0011-543-000	2

6500-102-015

G	0016-131-00 0	14
H	0023-162-00 0	12
J	0023-163-00 0	3
K	0025-079-000	8
L	0025-187-00 0	1
M	0028-116-00 0	4
N	0038-572-000	2
P	6506-001-900	1
R	6500-001-13 1	1
T	6500-001-13 2	1
U	6500-001-13 3	2
V	6500-001-13 4	1
W	6500-001-13 5	1
Y	6500-001-13 6	1
AA	6500-001-13 8	1
AB	6500-001-13 9	1
AC	6500-001-14 0	1
AD	6500-001-14 1	1
AE	6500-001-14 4	2
AF	6500-001-14 6	1
AG	6500-001-14 7	1
AH	6500-001-15 3	1
AJ	6500-001-15 4	2
AK	6500-001-15 6	1
AL	6500-001-16 1	1
AM	6500-001-27 5	3
AN	6500-001-35 8	2
AP	6500-002-014	1
AR	6500-002-10 3	1
AT	6500-002-15 9	1
AU	6500-002-21 6	1
AV	6500-101-01 6	2
AW	6500-001-35 6	1

6500-101-016

Rev D (Reference only)

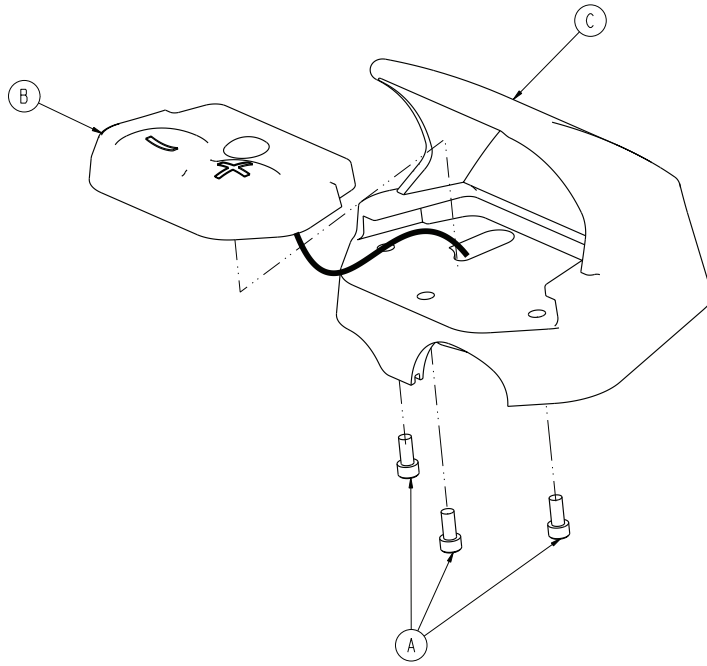

A	37J102-1	3
B	6500-101 -130	1
C	6500-001-359	1

6085-031-000

Rev A (Reference only)

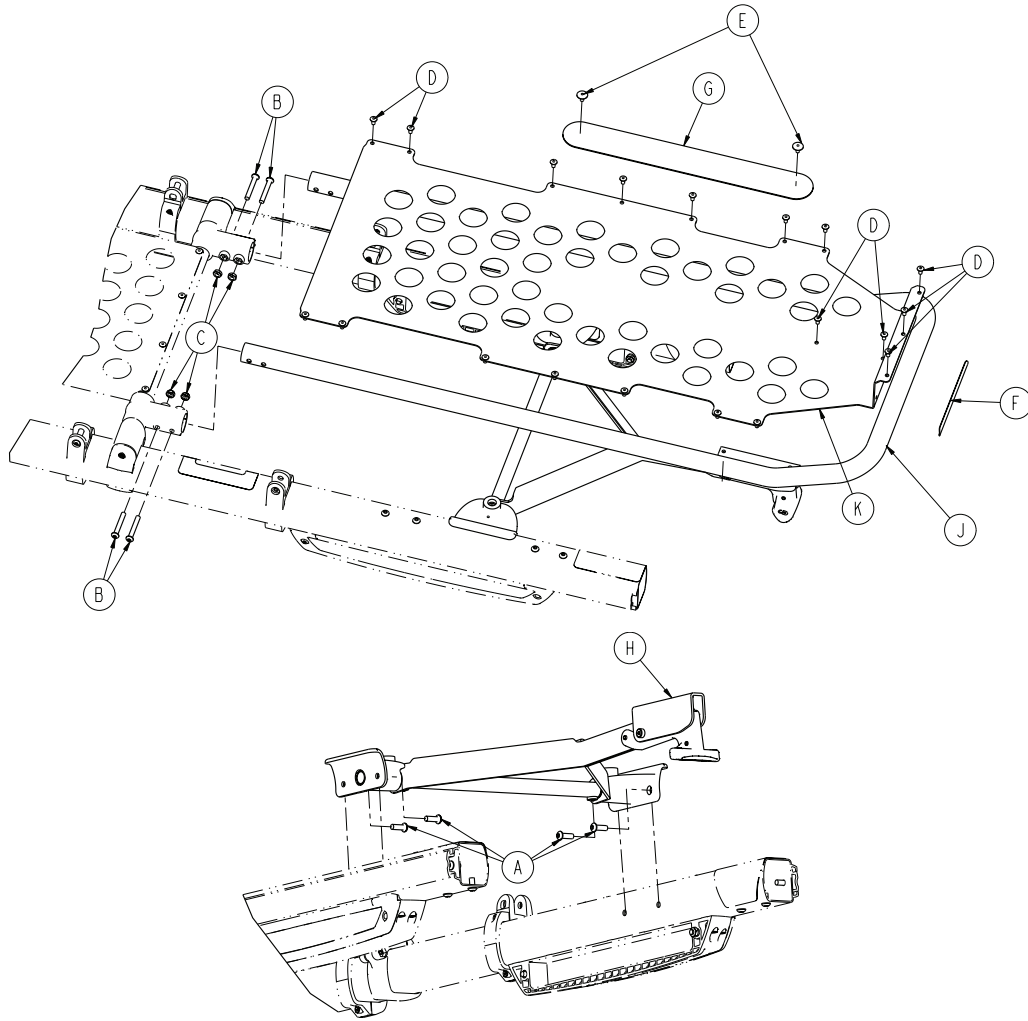

A	0004-592-000	4
B	0004-596-000	4
C	0016-102-00 0	4
D	0025-079-000	19
E	0025-132-00 0	2
F	6060-090-004	1
G	6082-001-085	1
H	6500-001-019	1
J	6500-001-19 7	1
K	6500-001-19 8	1

6500-001-019

Rev D (Reference only)

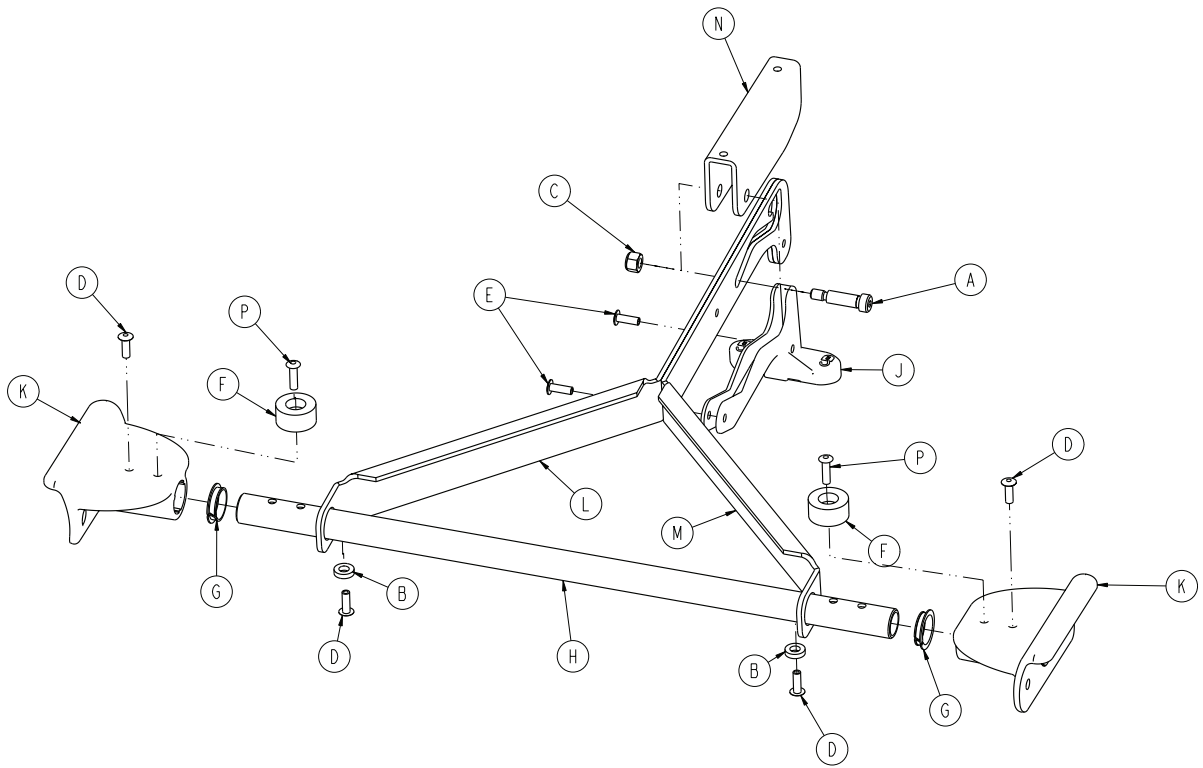

Item	Part no.	Qty
A	0008-074-000	1
B	0014-067-000	2
C	0016-028-000	1
D	0025-133-000	4
E	0025-186-000	2
F	0056-016-000	2
G	0081-255-000	2
H	6500-001-107	1
J	6500-001-108	1
K	6500-001-109	2
L	6500-001-203	1
M	6500-001-204	1
N	6500-001-205	1
P	0025-086-000	2

6500-082-000

Rev A (Reference only)

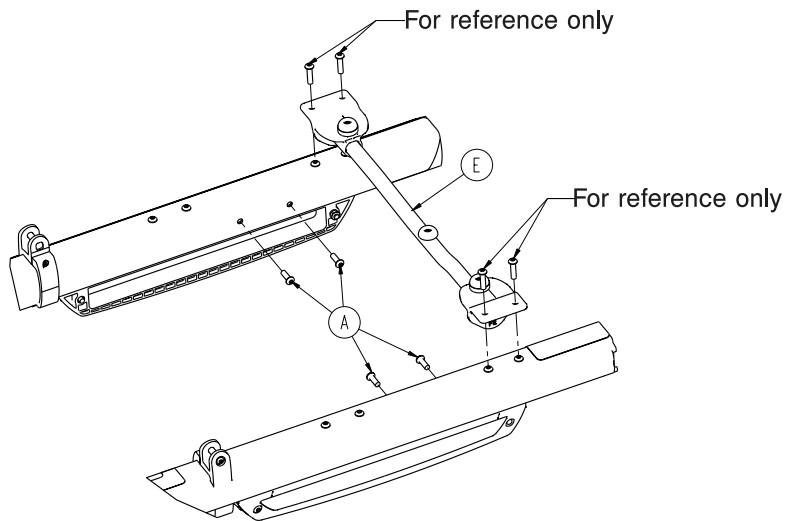
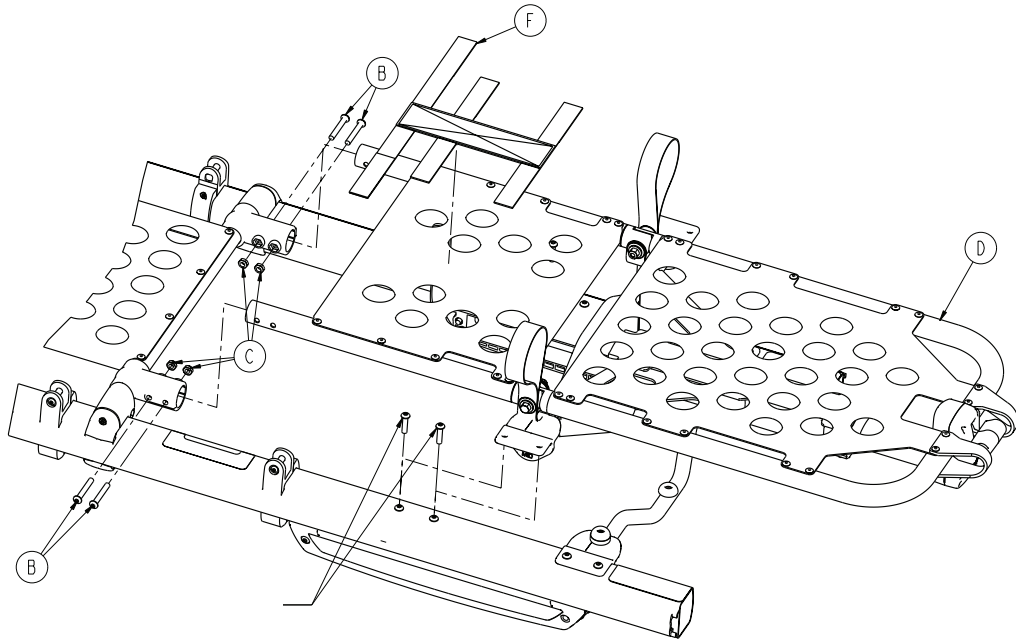

A	0004-592-000	4
B	0004-596-000	4
C	0016-102-00 0	4
D	6500-001-048	1
E	6085-001-031	1
F	6550-001-19 7	1

6500-001-048

Rev B (Reference only)

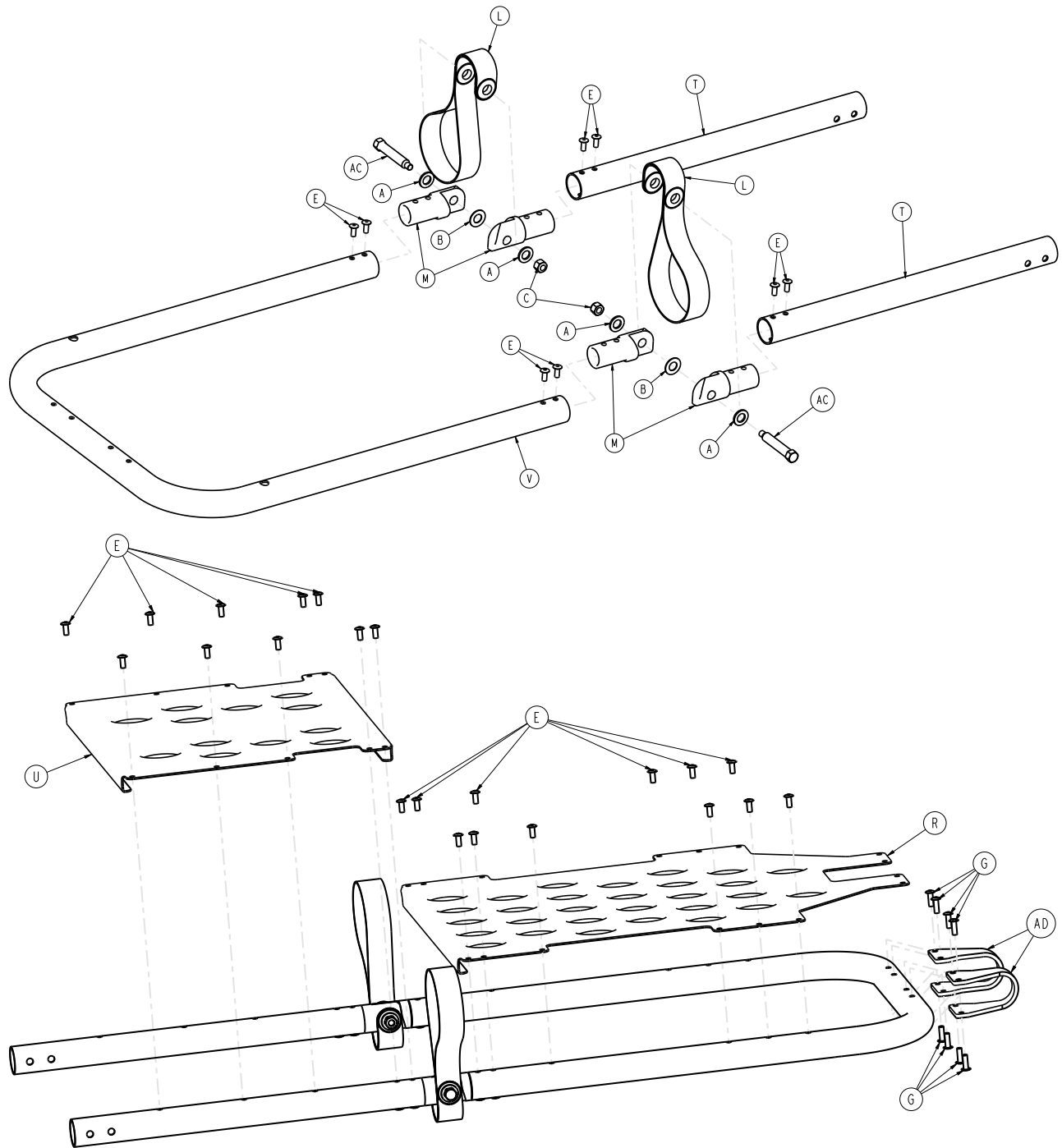

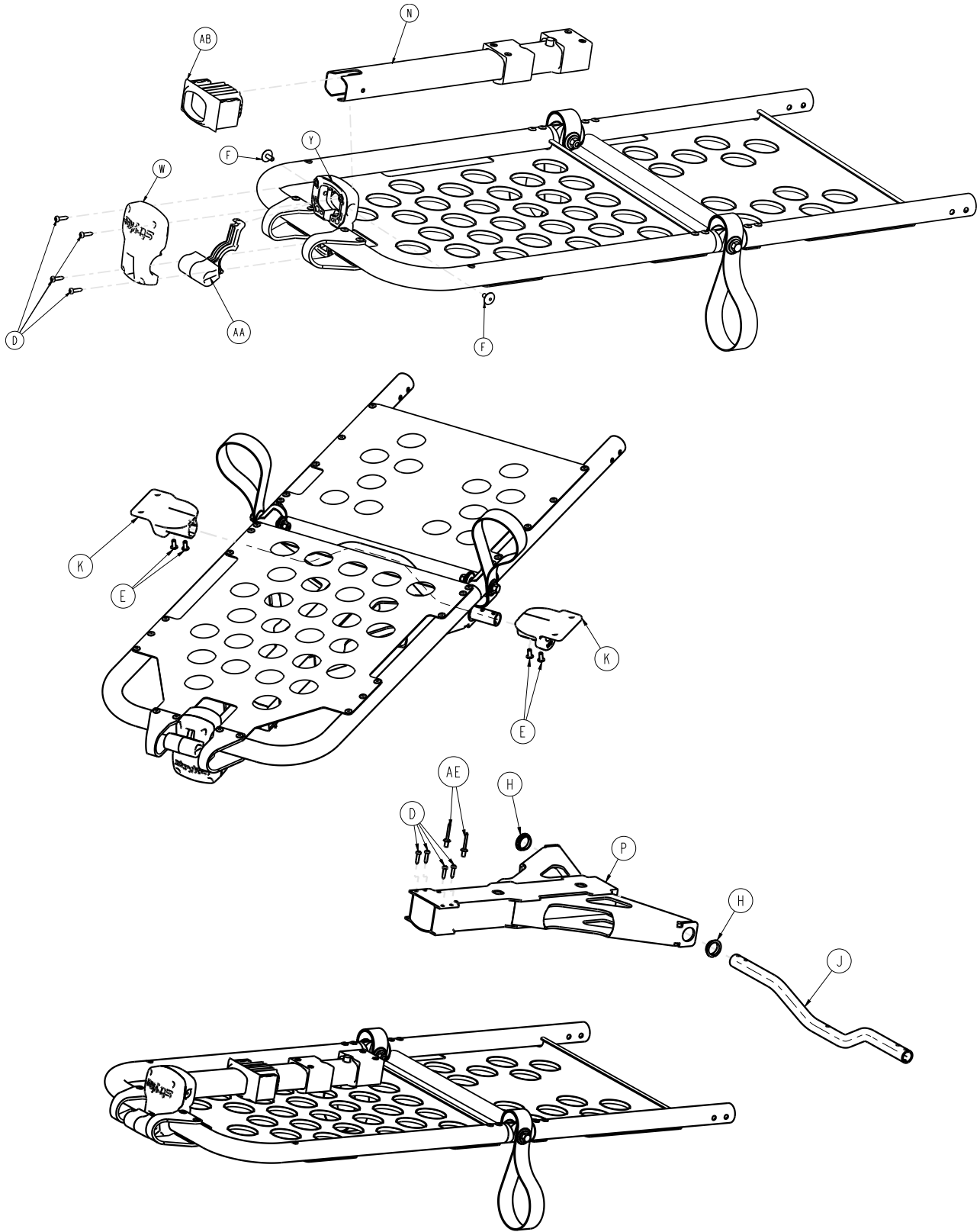

A	0011-448-000	4
B	0014-020-000	2

6500-001-048

C	0016-028-000	2
D	0023-162 -000	8
E	0025-079-000	34
F	0025-132 -000	2
G	0025-133 -000	8
H	0081-255 -000	2
J	6500-001-346	1
K	6085-001-125	2
L	6100-031 -096	2
M	6100-031 -108	4
N	6550-001-017	1
P	6550-001-057	1
R	6550-001-110	1
T	6550-001-111	2
U	6550-001-112	1
V	6550-001-116	1
W	6550-001-124	1
Y	6550-001-125	1
AA	6550-001-126	1
AB	6550-001-131	1
AC	6550-001-186	2
AD	6550-001-193	2
AE	0025-271 -000	2

6085-001-031

Rev C (Reference only)

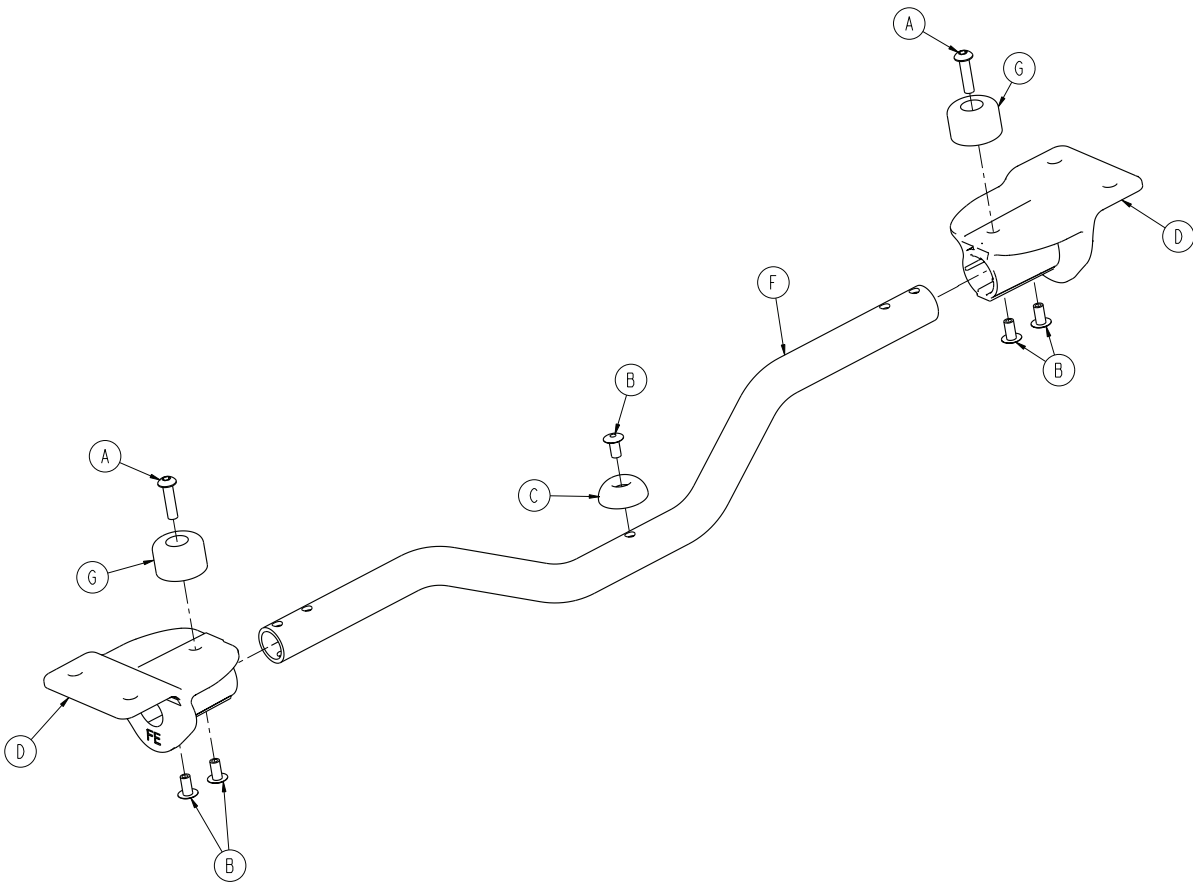

A	0004-614-000	2
B	0025-079-000	5
C	0946-001-15 5	1
D	6085-001-13 5	2
F	6500-001-34 6	1
G	0056-028-000	2

6500-001-018

Rev D (Reference only)

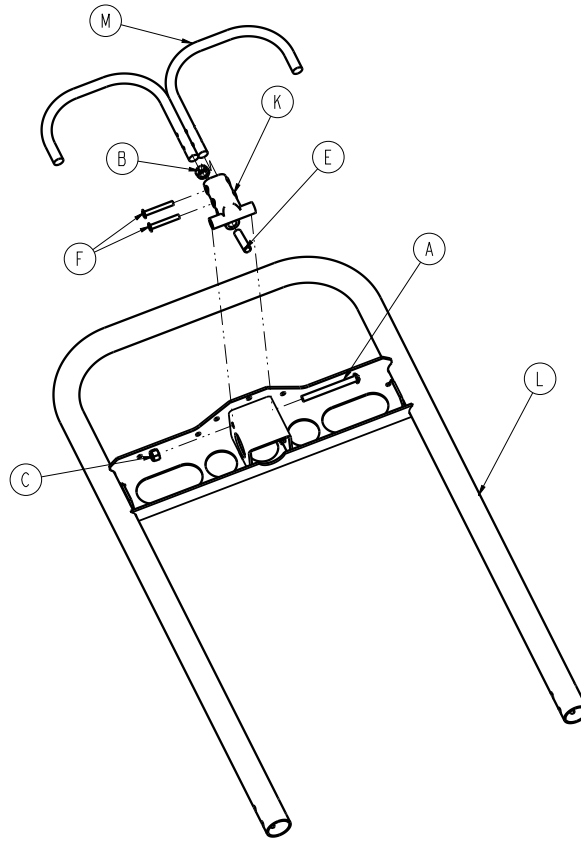

A	0004-597-000	1
B	0015-050-000	1
C	0016-028-000	1
E	0021-138-000	1
F	0025-131-000	2
K	6060-032-040	1
L	6082-032-050	1
M	6082-032-052	1

6506-012-003

Rev A (Reference only)

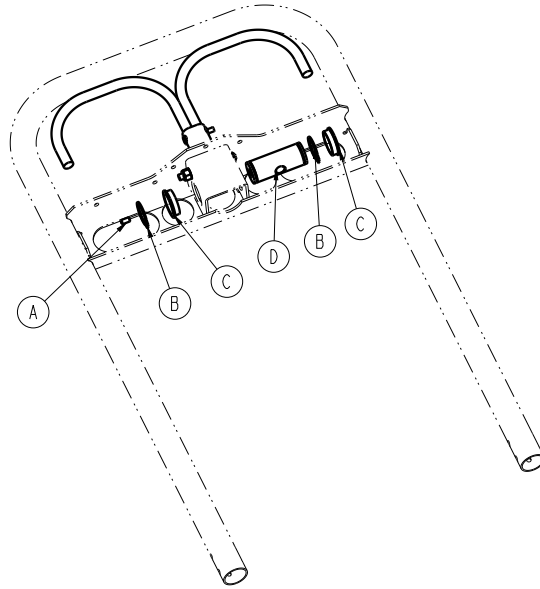

A	0021-180-00 0	1
B	0028-076-000	2
C	0946-035-025	2
D	6060-032-038	1

6506-012-004

Rev A (Reference only)

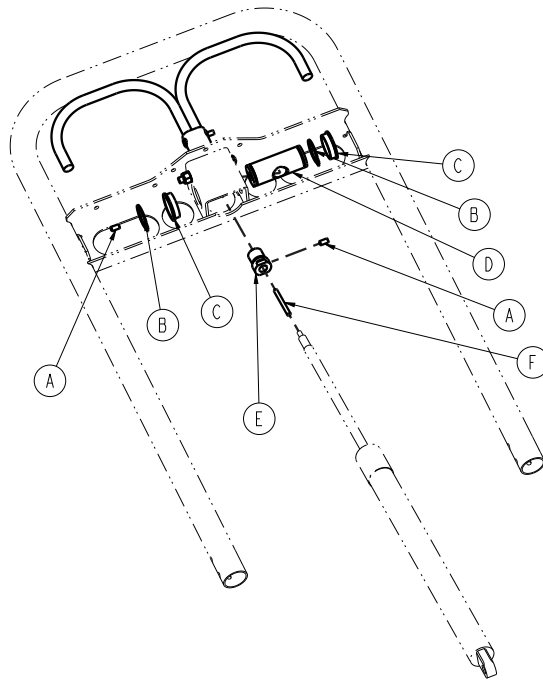

A	0021-180 -000	1
B	0028-076-000	2
C	0946-035-025	2
D	6060-032-053	1
E	6506-012-001	1
F	6506-012-002	1

Rev B (Reference only)

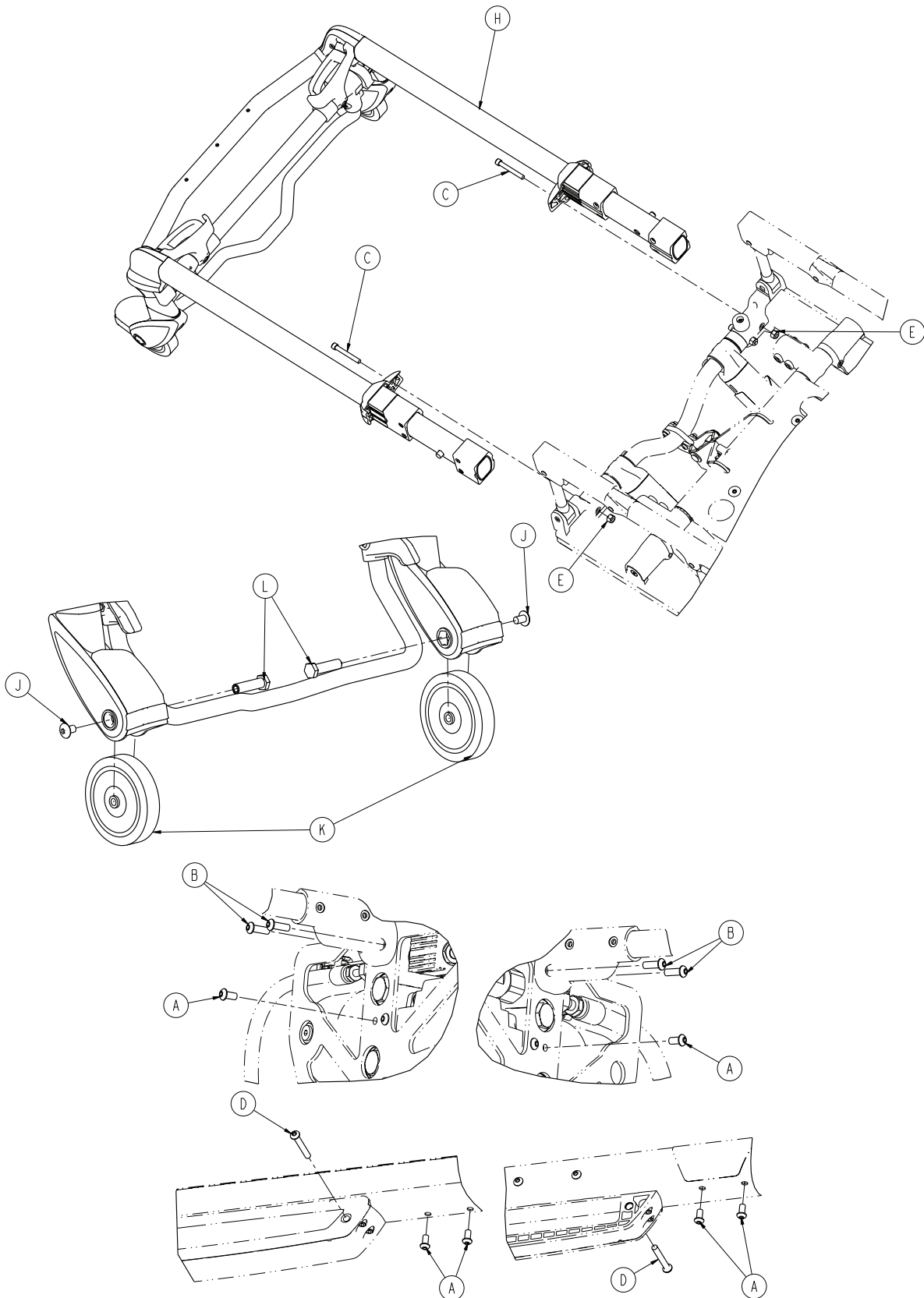

6506-029-000

A	0004-589-000	6
B	0004-593-000	4
C	0004-595-000	2
D	0004-596-000	2
E	0016-028-000	2
H	6500-002-020	1
J	0007-556-000	2
K	6500-001-086	2
L	6500-002-106	2

6506-001-020

Rev A (Reference only)

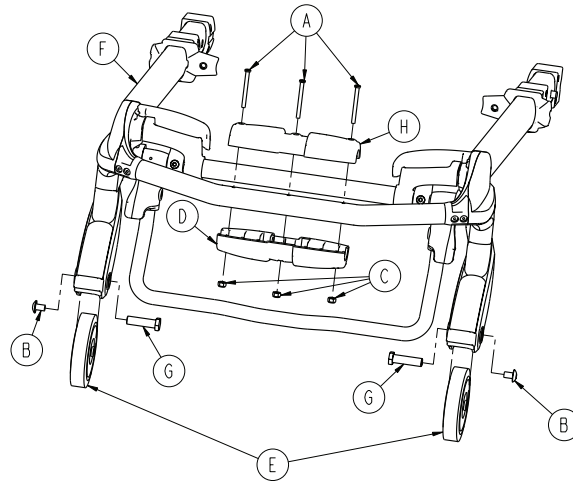

A	0004-656-000	3
B	0007-556-000	2
C	0016-002-000	3
D	6085-001-17 4	1
E	6500-001-086	2
F	6500-002-020	1
G	6500-002-10 6	2
H	6500-002-15 6	1

6506-001-021

Rev A (Reference only)

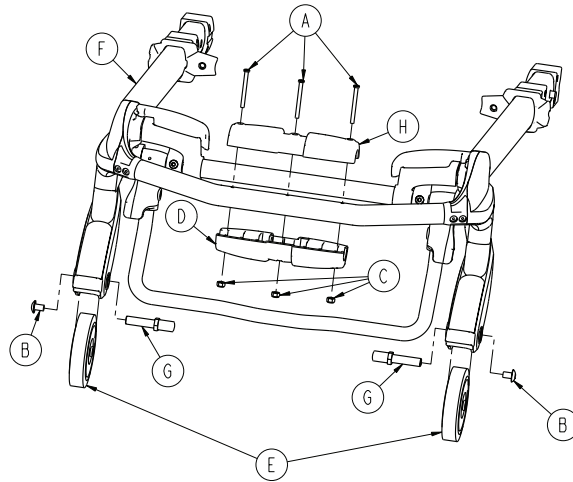

A	0004-656-000	3
B	0007-556-000	2
C	0016-002-000	3
D	6085-001-174	1
E	6500-001-086	2
F	6500-002-020	1
G	6500-002-104	2
H	6500-002-156	1

Rev D (Reference only)

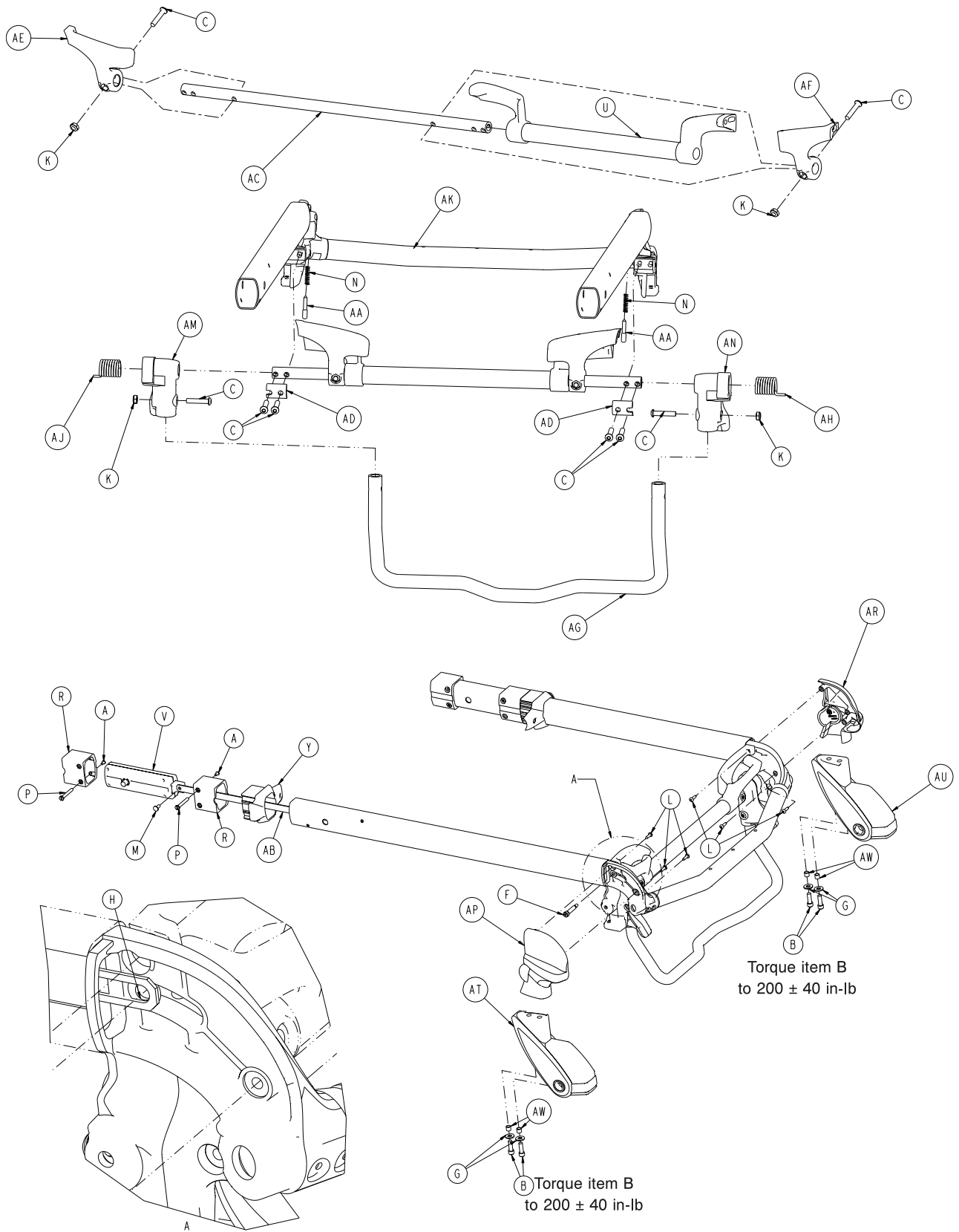

6500-002-020

A	0004-168 -000	4
B	0004-591-000	4
C	0004-612 -000	8
F	0008-030-000	2
G	0011-624-000	4
H	0014-002-000	2
K	0016-102 -000	4
L	0023-162 -000	6
M	0025-126 -000	2
N	0038-570-000	2
P	6085-001-169	4
R	6085-001-170	4
U	6500-001-023	1
V	6500-001-026	2
Y	6500-001-087	2
AA	6500-001-093	2
AB	6500-001-096	2
AC	6500-001-220	1
AD	6500-001-221	2
AE	6500-001-280	1
AF	6500-001-281	1
AG	6500-001-322	1
AH	6500-001-325	1
AJ	6500-001-326	1
AK	6500-002-025	1
AM	6500-002-107	1
AN	6500-002-108	1
AP	6500-002-109	1
AR	6500-002-110	1
AT	6500-002-120	1
AU	6500-002-121	1
AW	6500-002-114	4

6500-001-026

Rev C (Reference only)

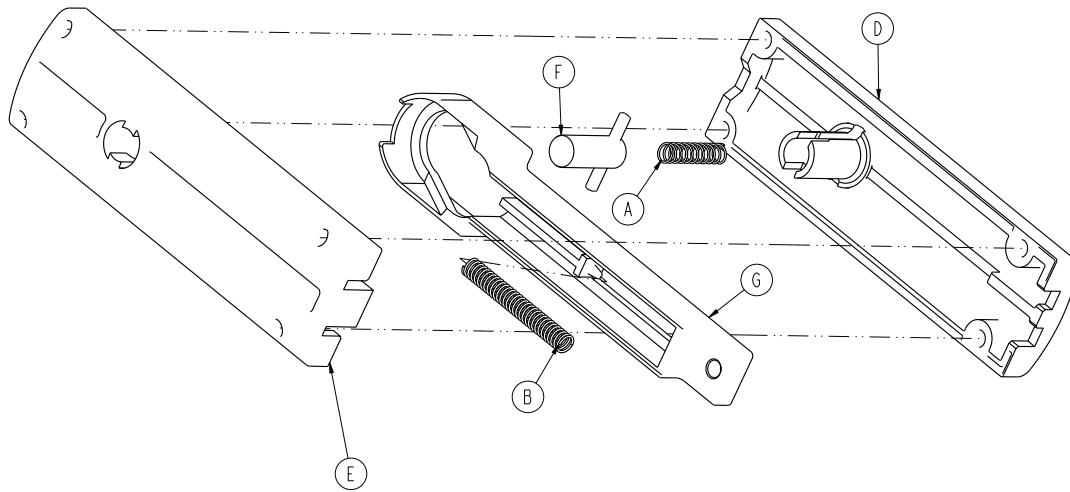

A	0038-570-000	1
B	0038-134-00 0	1
D	6500-001-091	1
E	6500-001-092	1
F	6500-001-025	1
G	6500-001-095	1

6500-001-027

Rev C (Reference only)

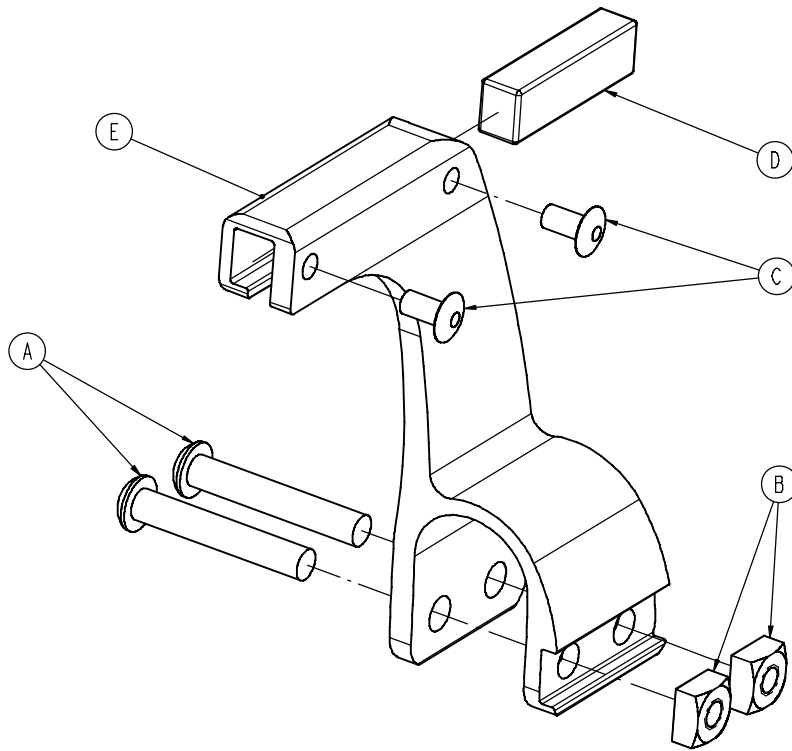

A	0004-376-000	2
B	0015-016-000	2
C	0025-079-000	2
D	6500-001-271	1
E	6500-001-272	1

6506-036-000

Rev A (Reference only)

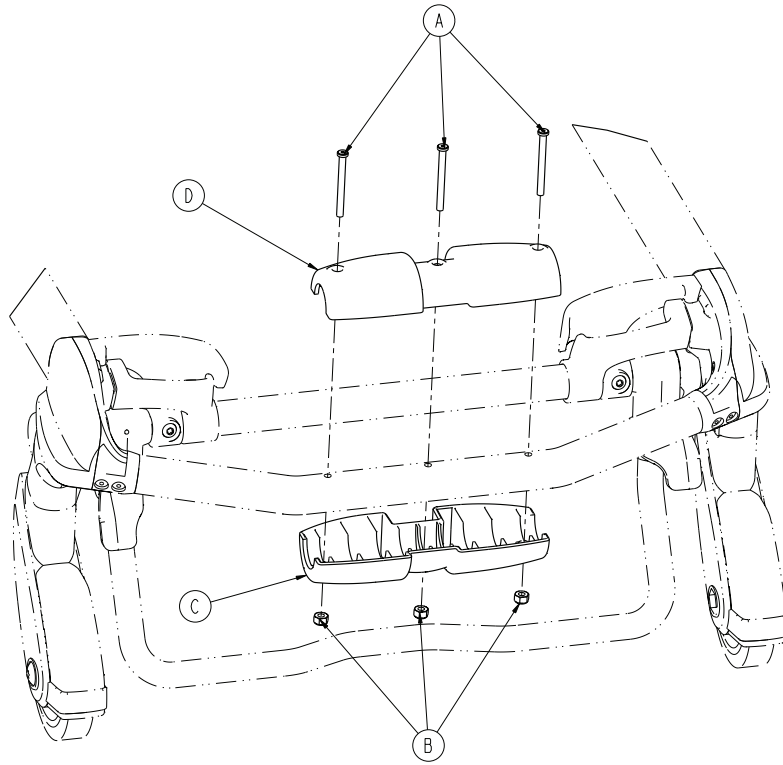

A	0004-656-000	3
B	0016-002-000	3
C	6085-001-17 4	1
D	6500-002-15 6	1

Rev B (Reference only)

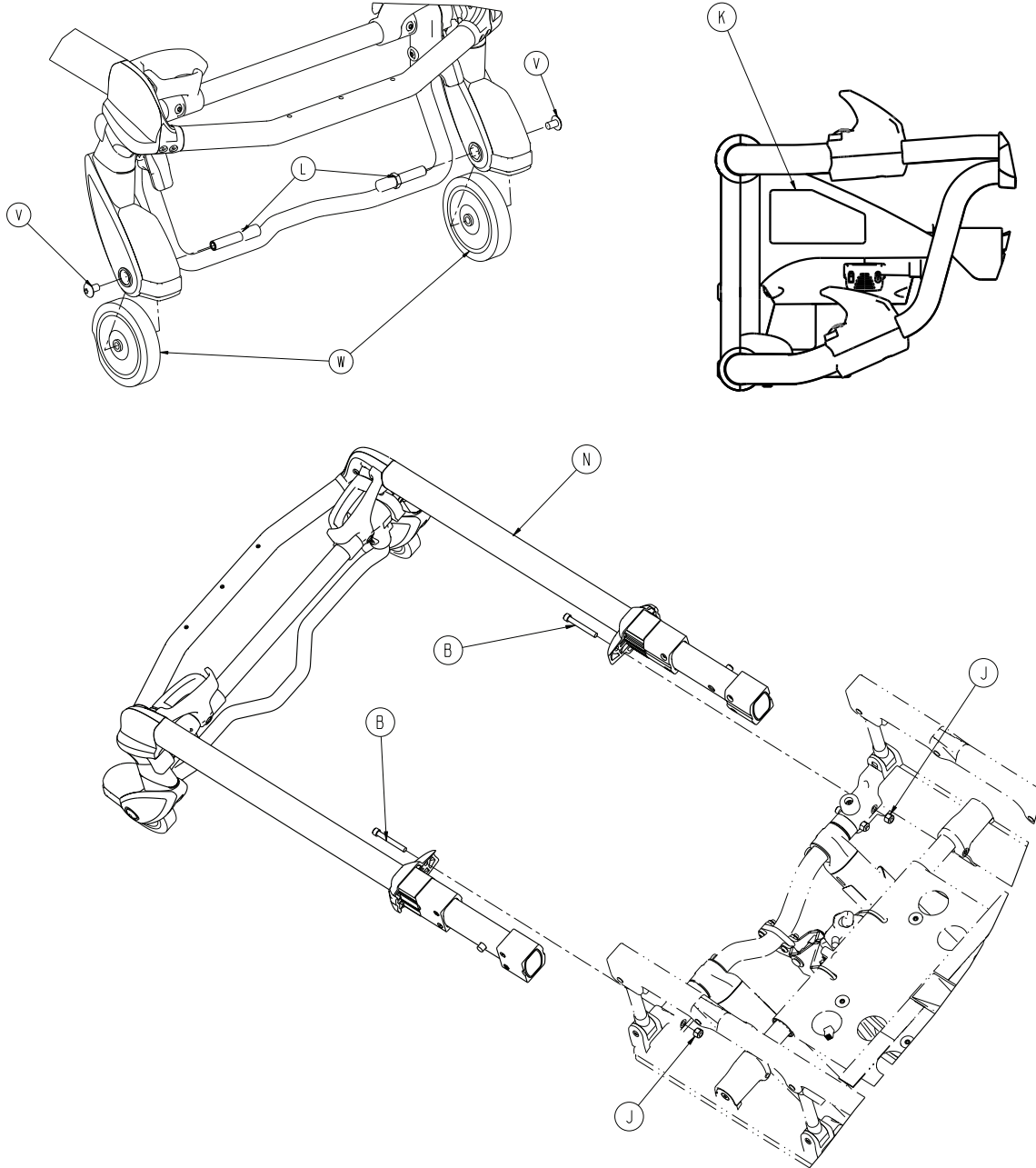

6506-127-000

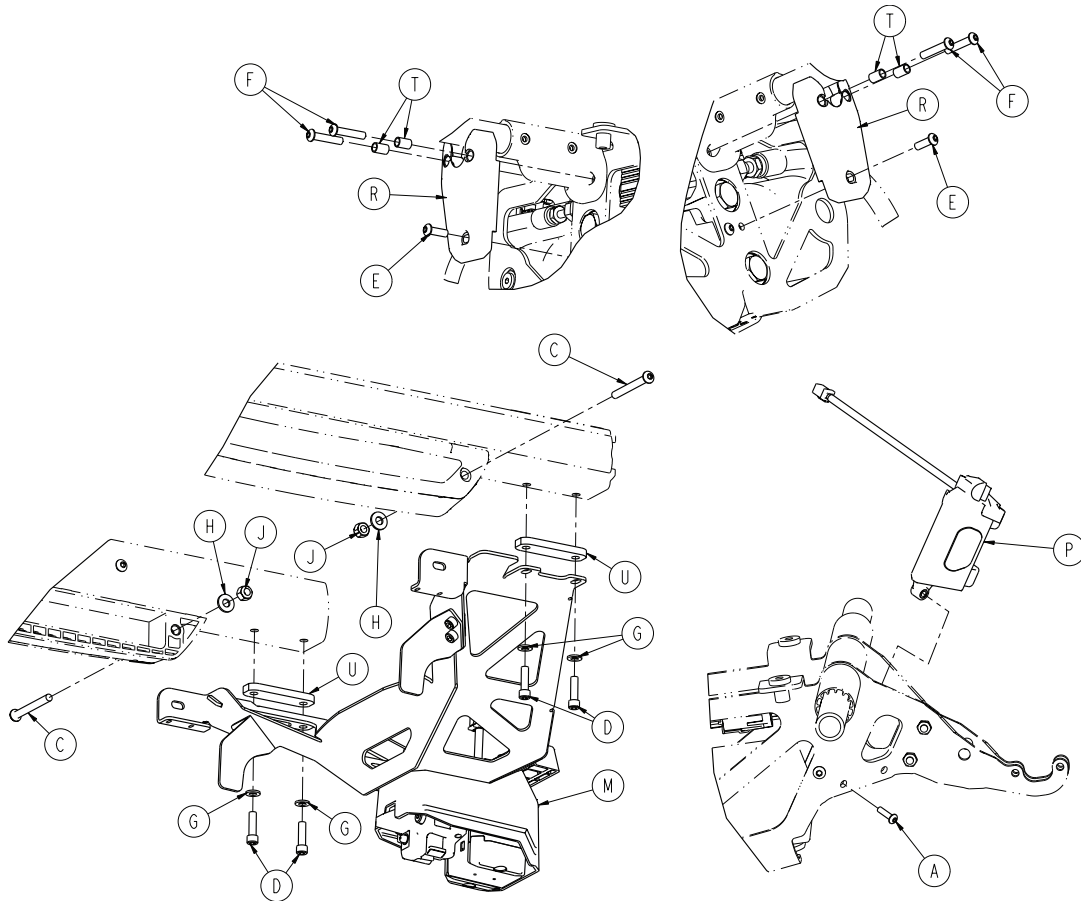

A	0004-614-000	1
B	0004-595-000	2
C	0004-387-000	2
D	0004-661-000	4
E	0004-593-000	2
F	0004-395-000	4
G	0011-065-000	4
H	0011-077-000	2
J	0016-028-000	4
K	6506-201-10 1	1
L	6500-002-10 4	2
M	6500-002-013	1
N	6500-002-020	1
P	6500-002-10 0	1
R	6500-002-12 3	2
T	6500-002-12 4	4
U	6500-002-12 6	2
V	0007-556-000	2
W	6500-001-086	2

6500-002-013

Rev F (Reference only)

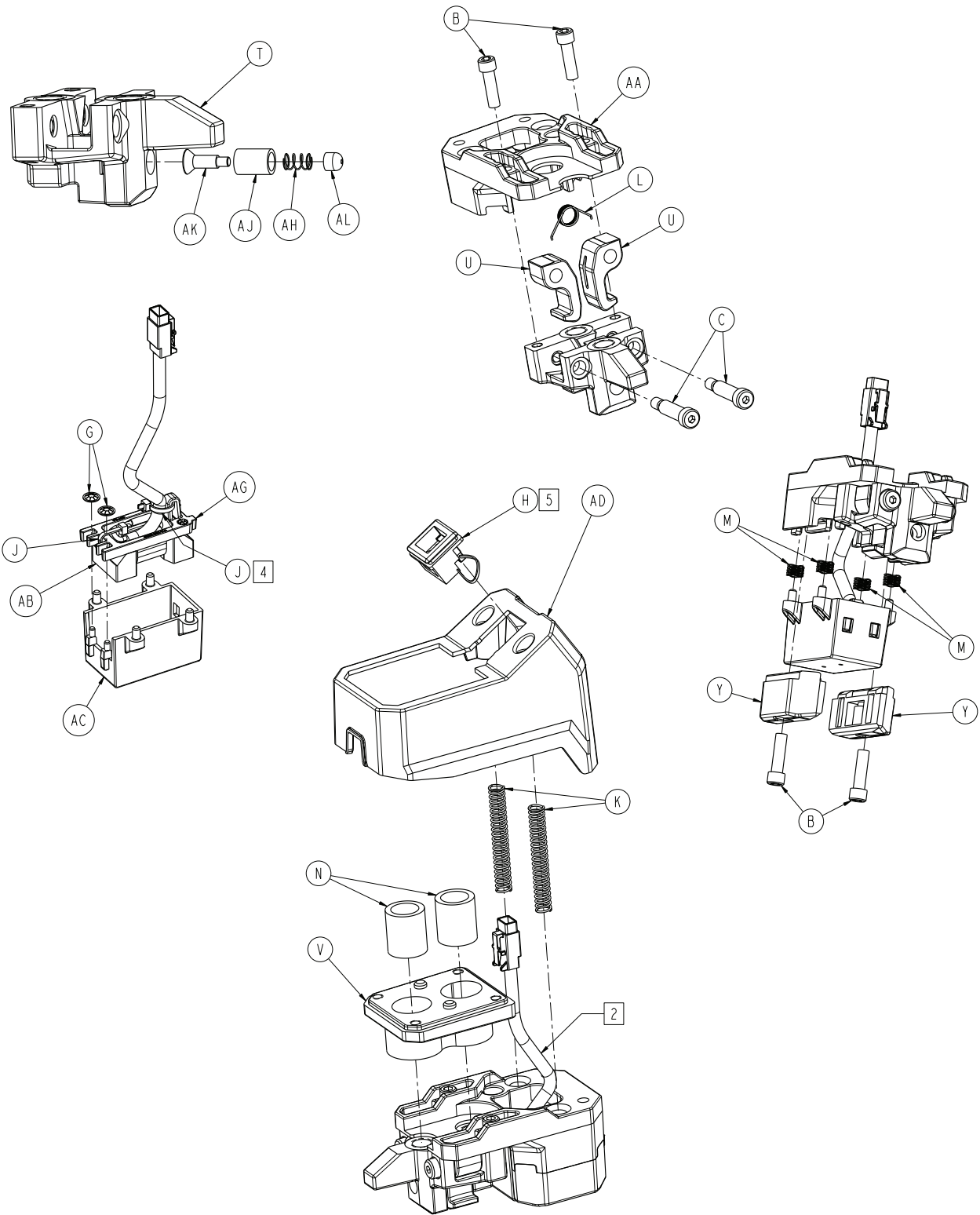

6500-002-013

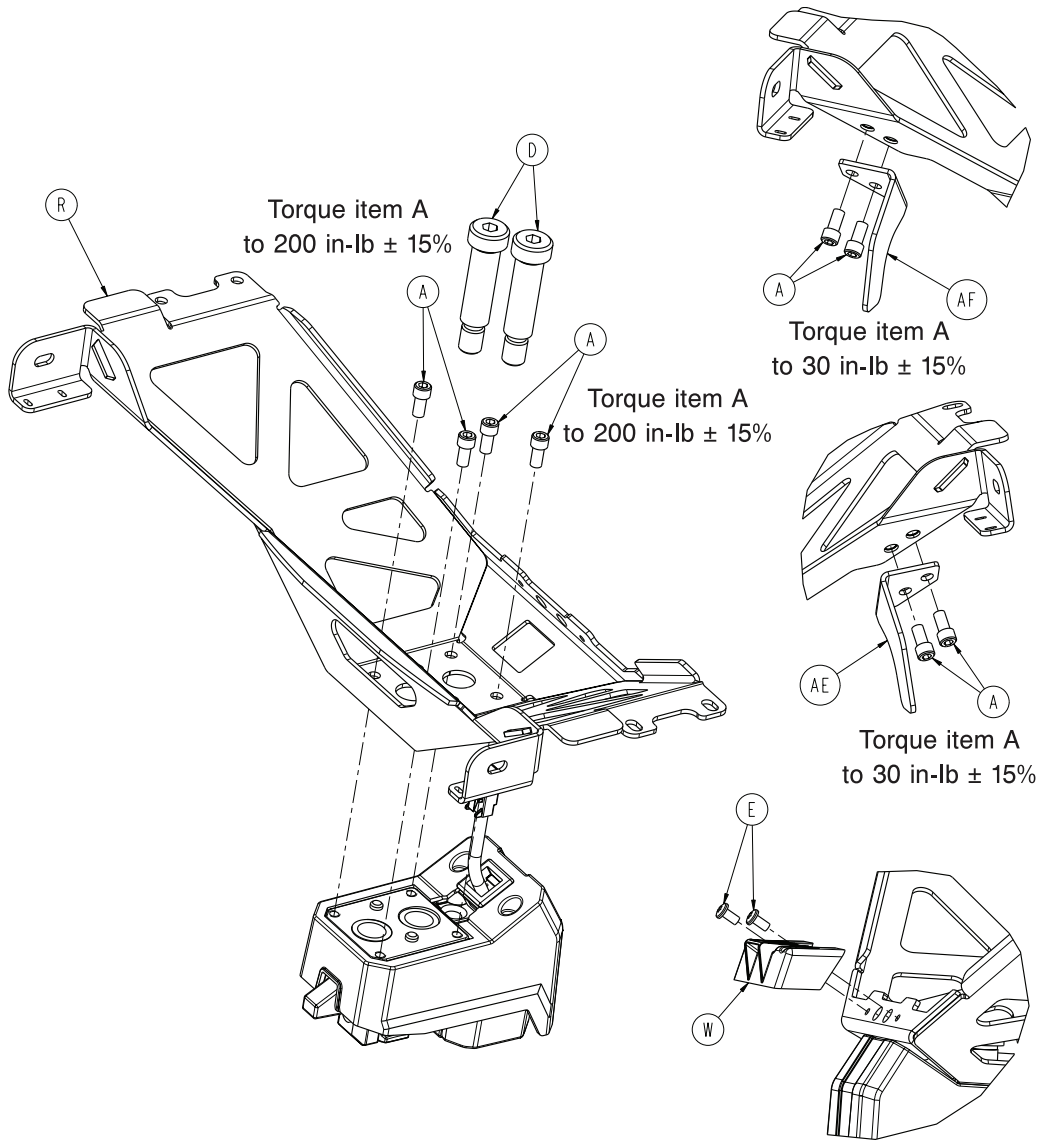

A	0004-660-000	8
B	0004-661-000	4
C	0008-088-000	2
D	0008-087-000	2
E	0023-296-000	2
G	0028-217-00 0	2
H	0037-248-000	1
J	0038-111-00 0	2
K	0038-889-000	2
L	0038-891-000	1
M	0038-900-000	4
N	0081-437-00 0	2
R	6500-002-050	1
T	6500-002-11 1	1
U	6500-002-11 2	2

6500-002-013

V	6500-002-113	1
W	6500-002-119	1
Y	6500-002-122	2
AA	6500-002-129	1
AB	6500-002-133	1
AC	6500-002-135	1
AD	6500-002-136	1
AE	6500-002-146	1
AF	6500-002-147	1
AG	6500-002-144	1
AH	6500-001-012	1
AJ	6500-002-148	1
AK	6500-002-149	1
AL	6500-002-152	1

Rev F (Reference only)

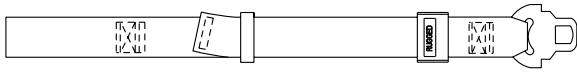
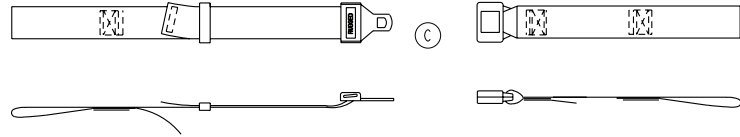
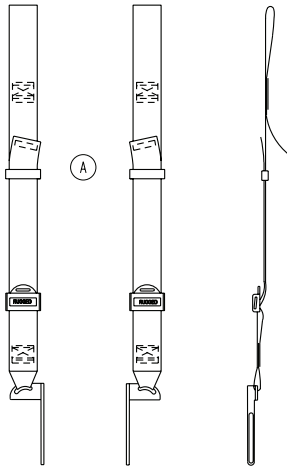

A	6500-001-39 1	1
B	6500-001-39 3	1
C	6500-001-39 5	2

6500-001-430

Rev E (Reference only)

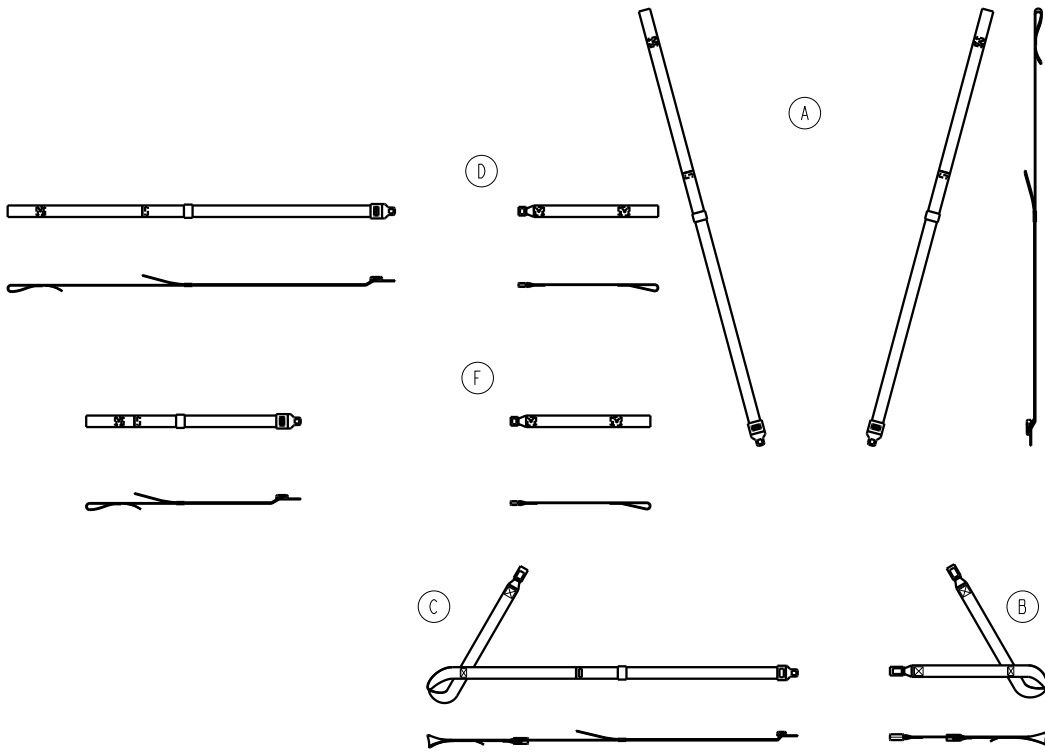

A	6500-001-401	2
B	6500-001-402	1
C	6500-001-403	1
D	6500-001-404	1
F	6500-001-405	1

6500-001-431

Rev A (Reference only)

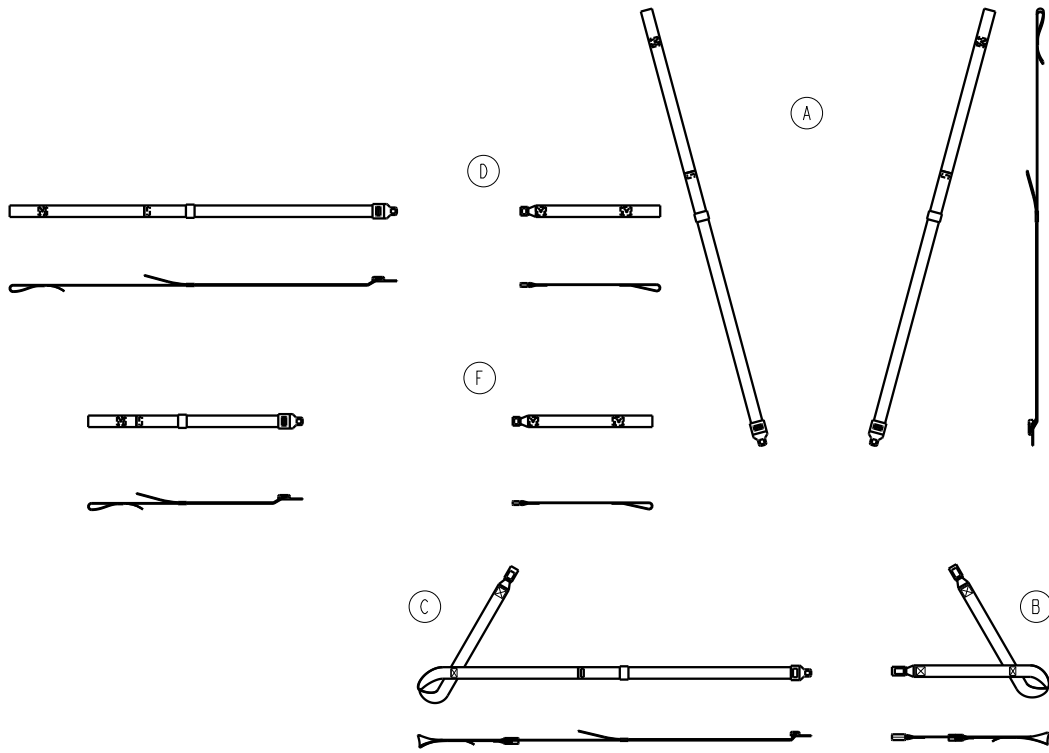

A	6500-001-41 1	2
B	6500-001-41 2	1
C	6500-001-41 3	1
D	6500-001-41 4	1
F	6500-001-41 5	1

6082-160-050

Rev B (Reference only)

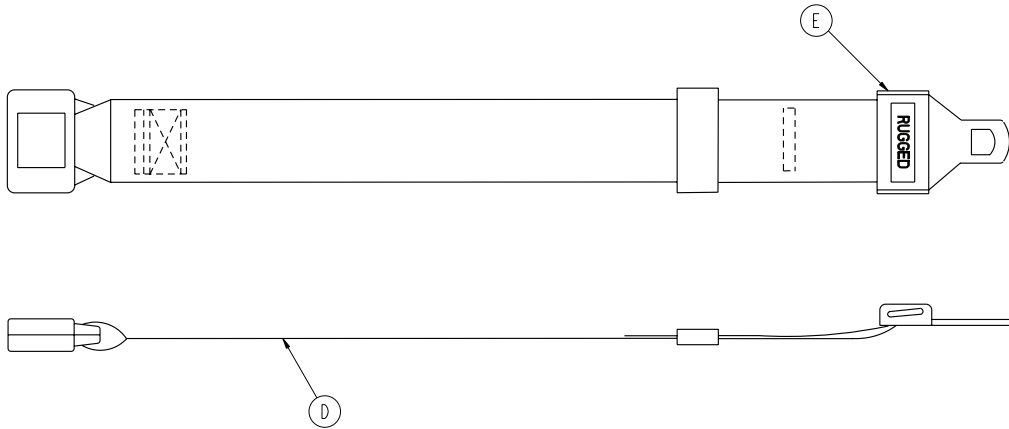

D	6082-090-001	1
E	6060-090-011	1

Rev A / 6500-101-010 Rev E (Reference only)

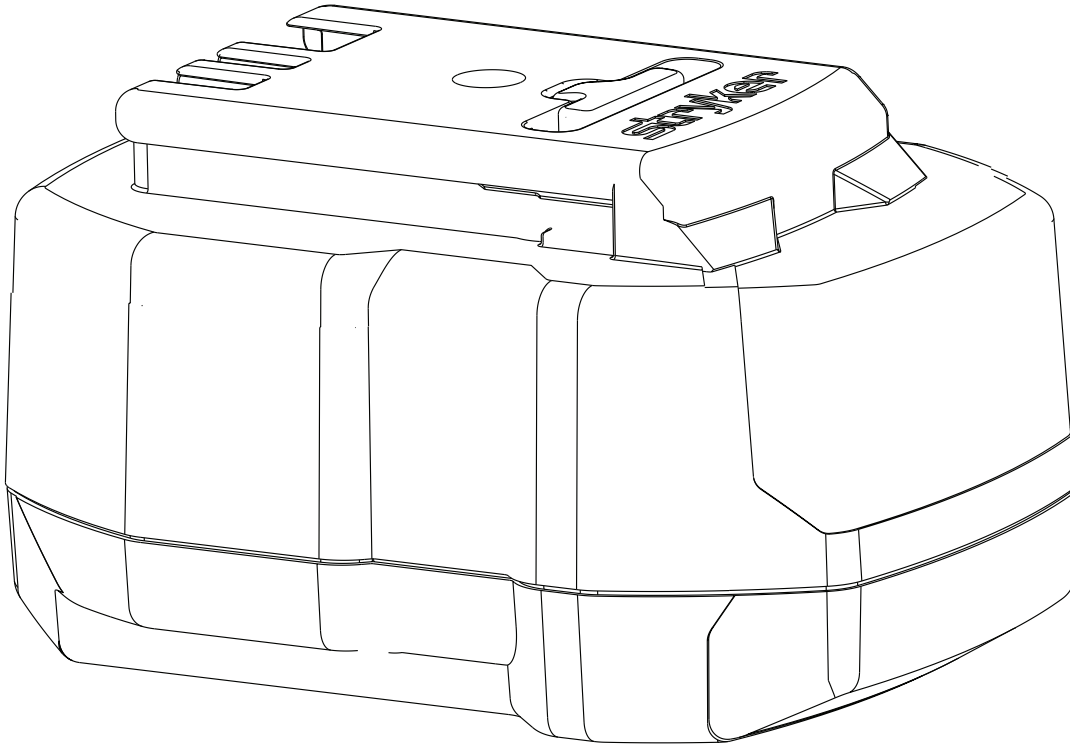

6506-170-000

Rev A / 6500-101-046 Rev A (Reference only)

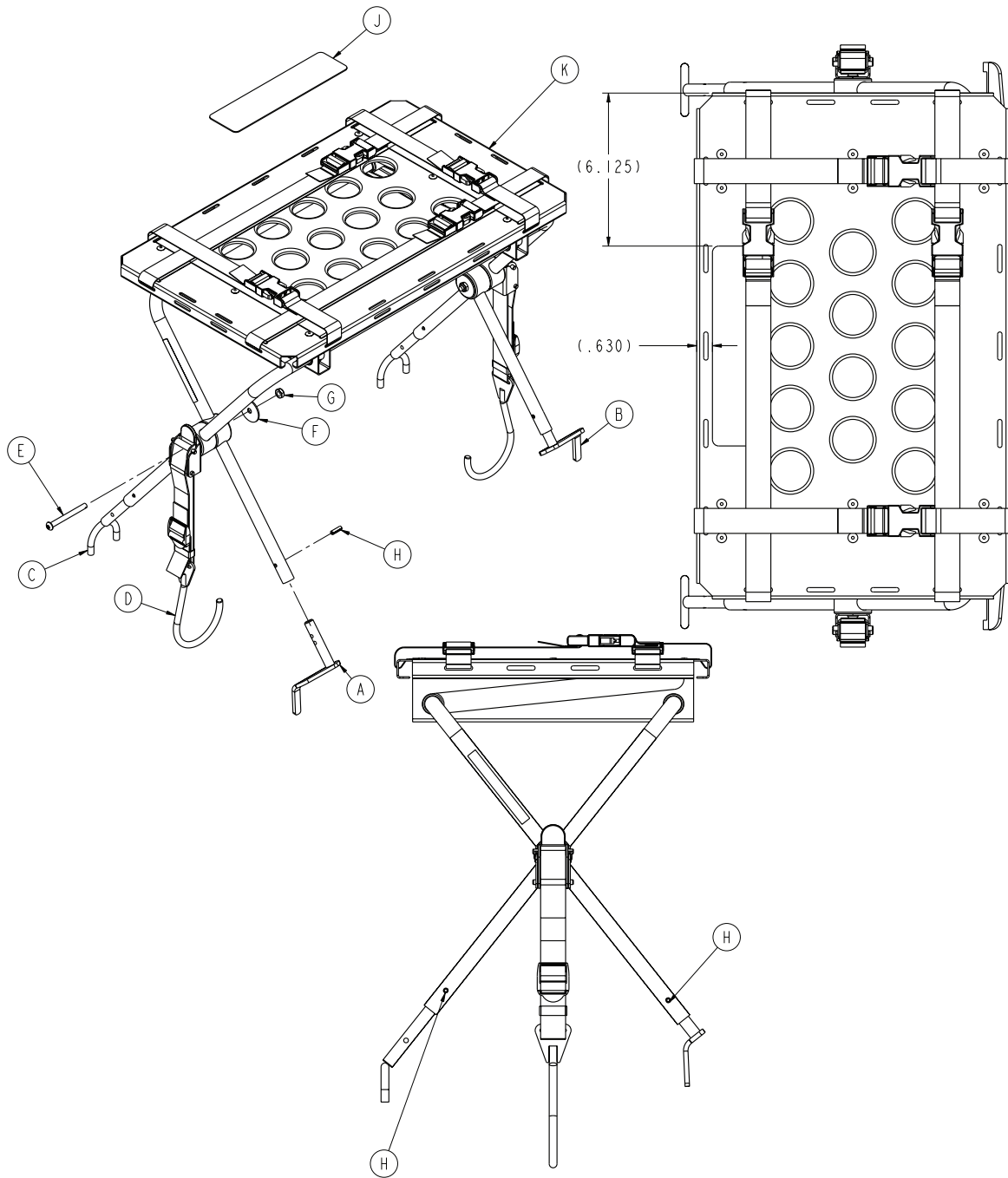

A	6100-170 -050	1
B	6100-170 -051	1
C	6082-170 -050	2
D	6100-170 -020	2
E	0004-234-000	2
F	0011-355-000	2
G	0016-102 -000	2
H	0026-172 -000	4

6506-170-000

J	6500-101-29 8	1
K	6082-170-02 0	1

6082-170-020

Rev B (Reference only)

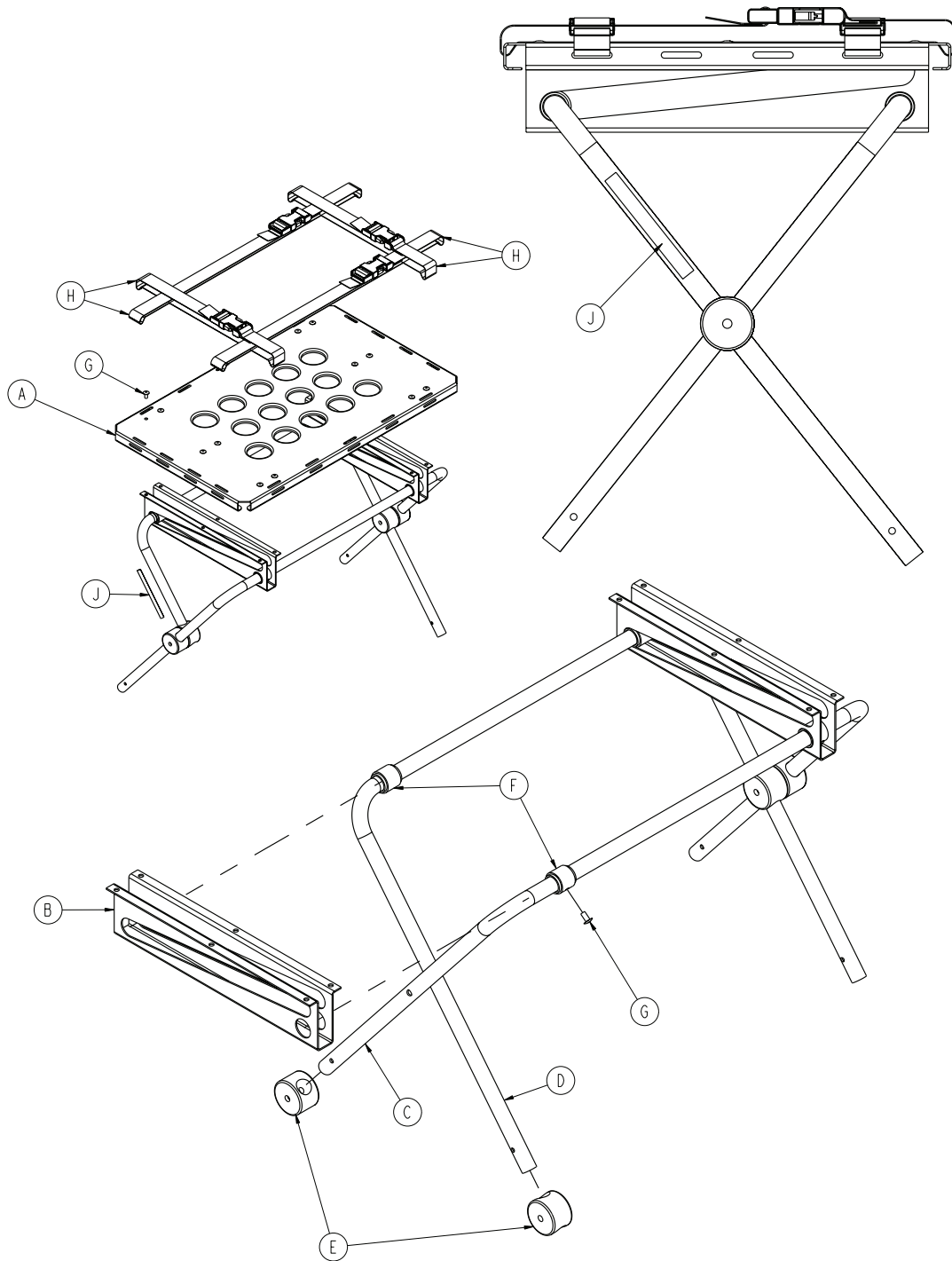

A	6080-170 -011	1
B	6080-170 -012	2
C	6080-170 -013	1
D	6080-170 -014	1
E	6080-170 -015	4
F	6080-170 -016	4

6082-170-020

G	0025-079-000	16
H	6060-170-02 2	4
J	6080-090-023	2

6500-147-000

Rev B (Reference only)

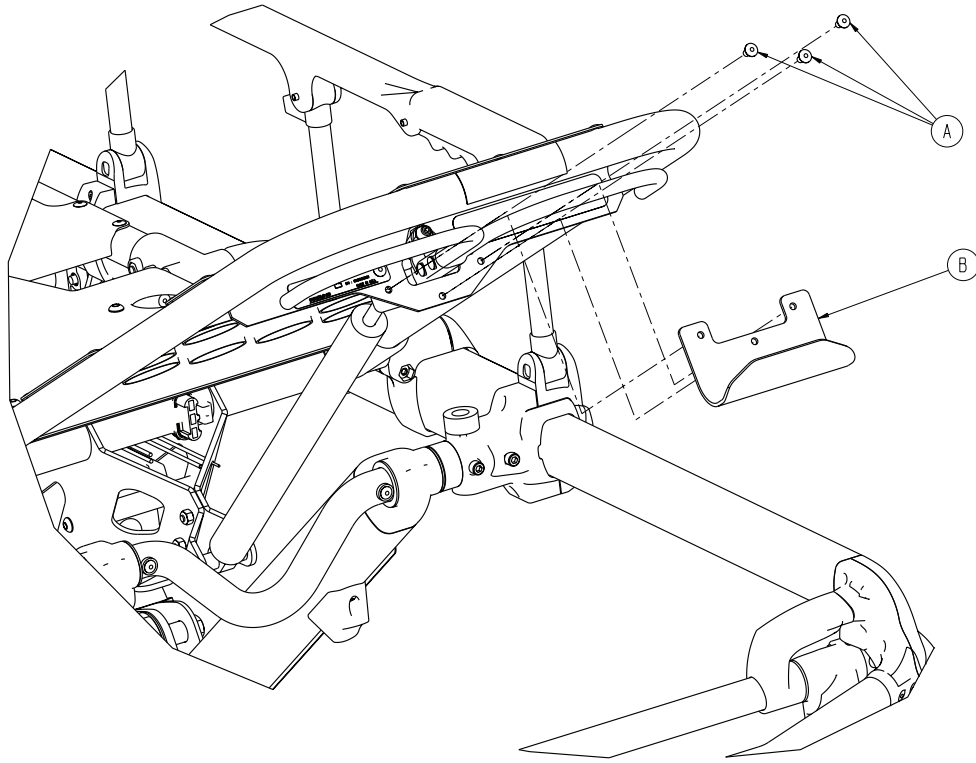

A	0025-079-000	3
B	6500-001-237	1

6100-044-000

Rev B (Reference only)

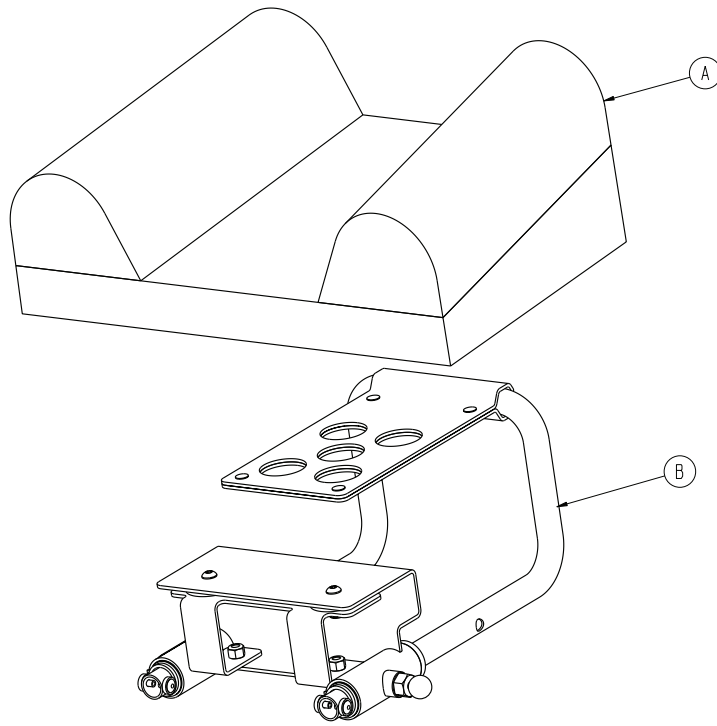

A	6100-041-03 0	1
B	6100-044-01 2	1

6100-044-012

Rev F (Reference only)

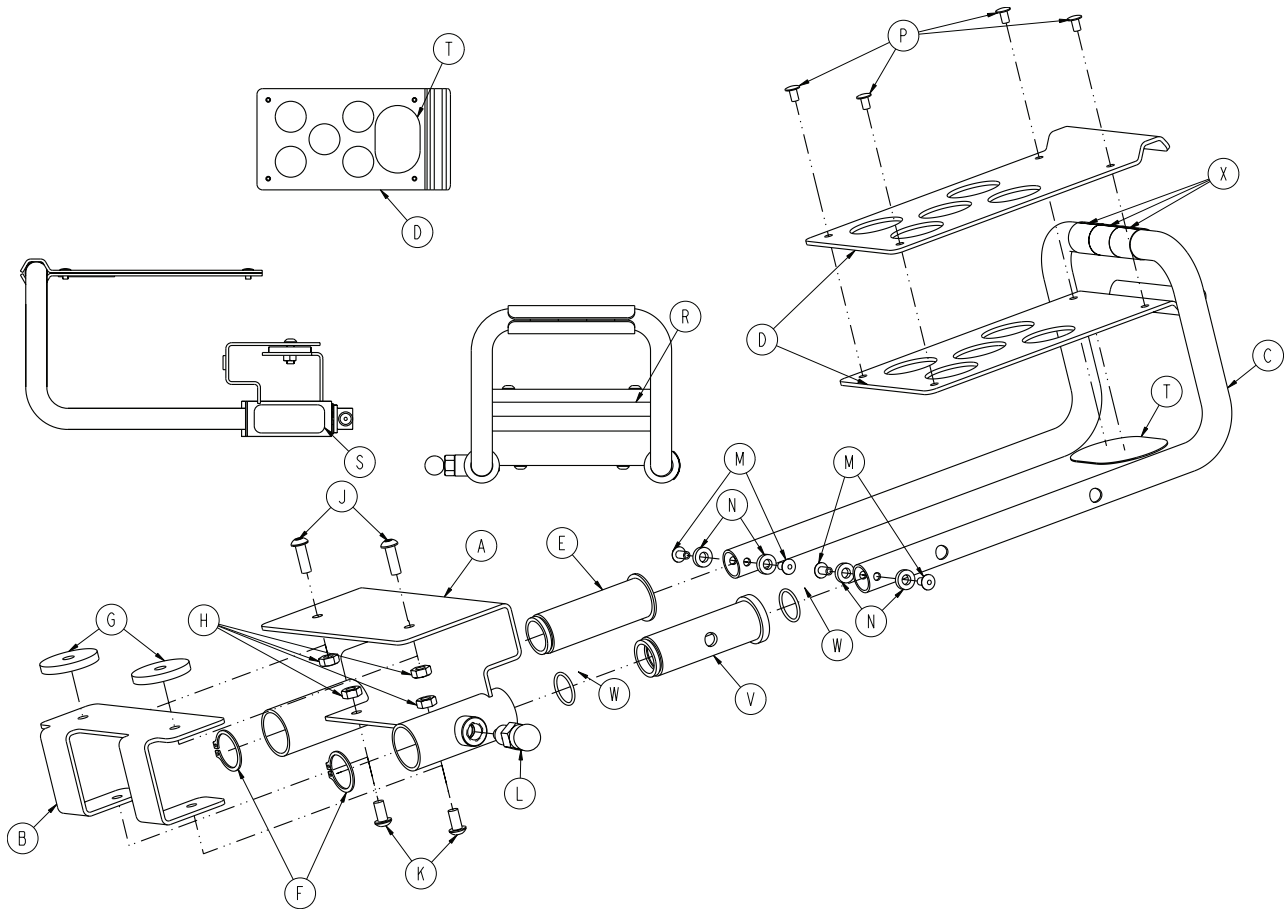

A	6100-044 -010	1
B	6100-044 -007	1
C	6100-044 -011	1
D	6100-044 -008	2
E	6100-044 -005	1
F	0028-076-000	2
G	6100-044 -006	2
H	0016-028-000	4
J	0004-161 -000	2
K	0004-232-000	2
L	6372-010 -016	1
M	0025-079-000	4
N	0014-067-000	4
P	0025-031-000	4
R	6060-090-004	1
S	6100-090 -013	1
T	6100-044 -013	1
V	6100-044 -004	1
W	0045-999-603	2
X	6100-044 -014	3

6500-310-000

Rev B (Reference only)

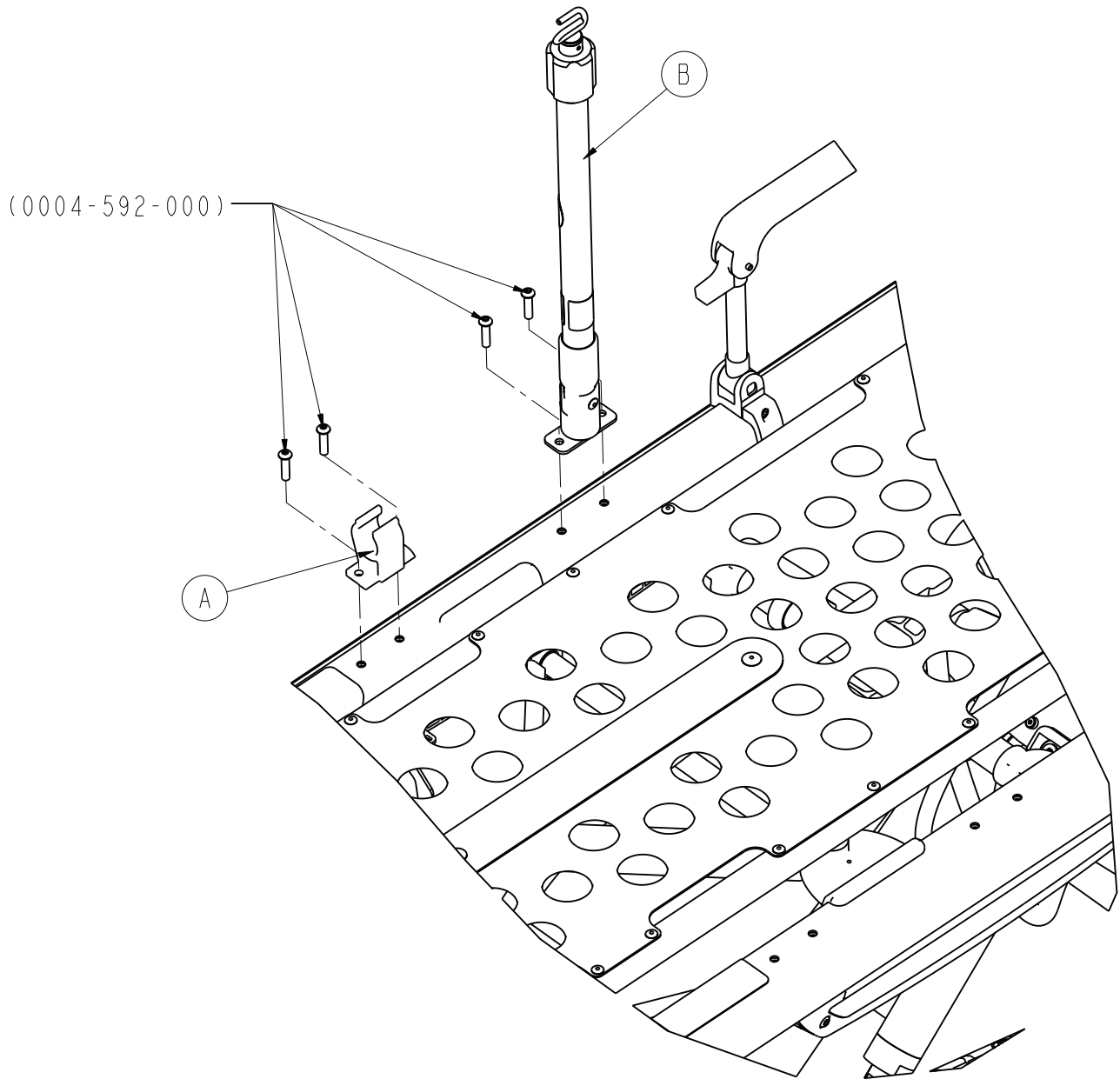

A	6100-115-06 0	1
B	6500-101-04 1	1

6500-315-000

Rev B (Reference only)

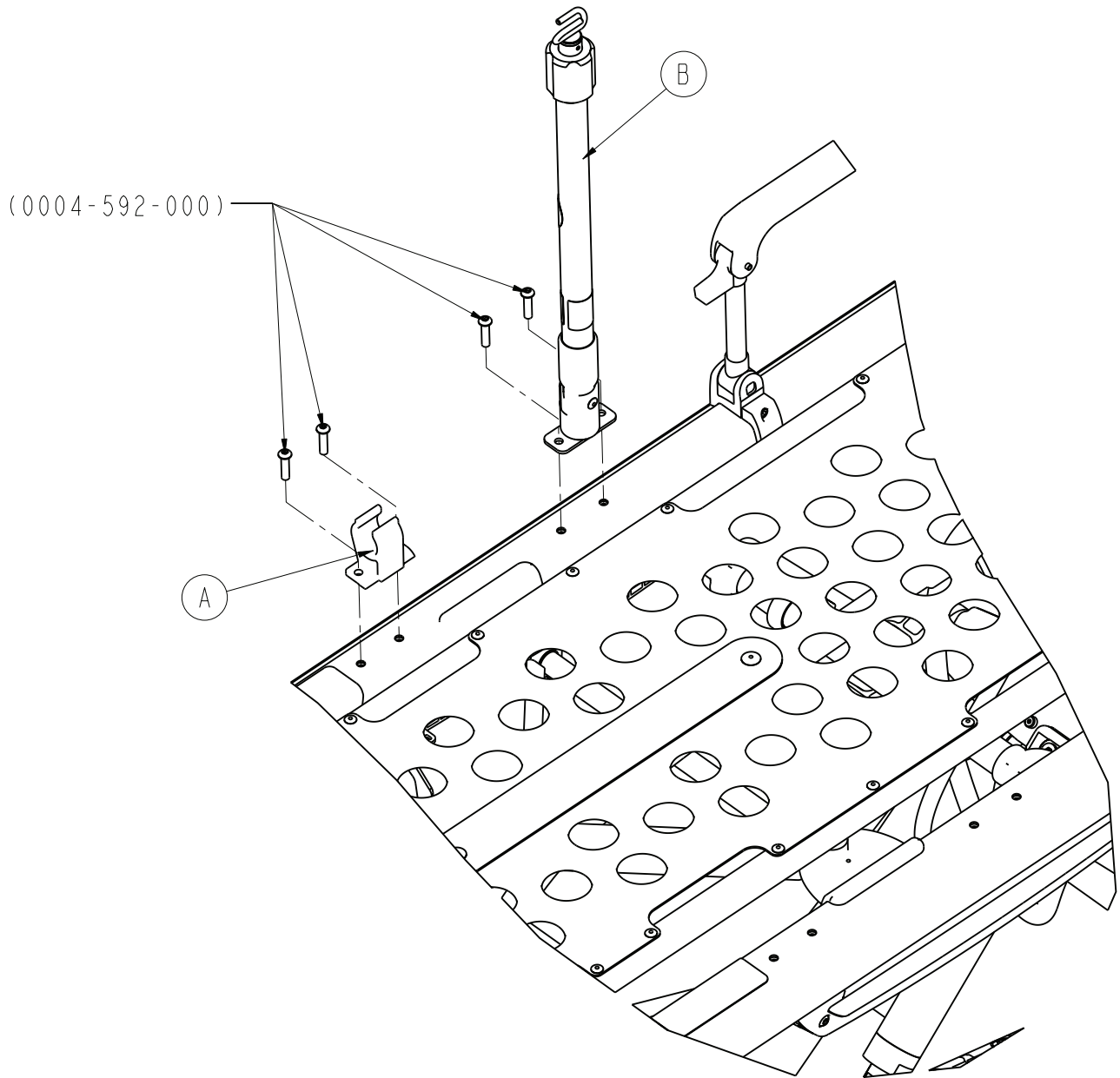

A	6100-115 -060	1
B	6500-101 -043	1

6500-101-041

Rev A (Reference only)

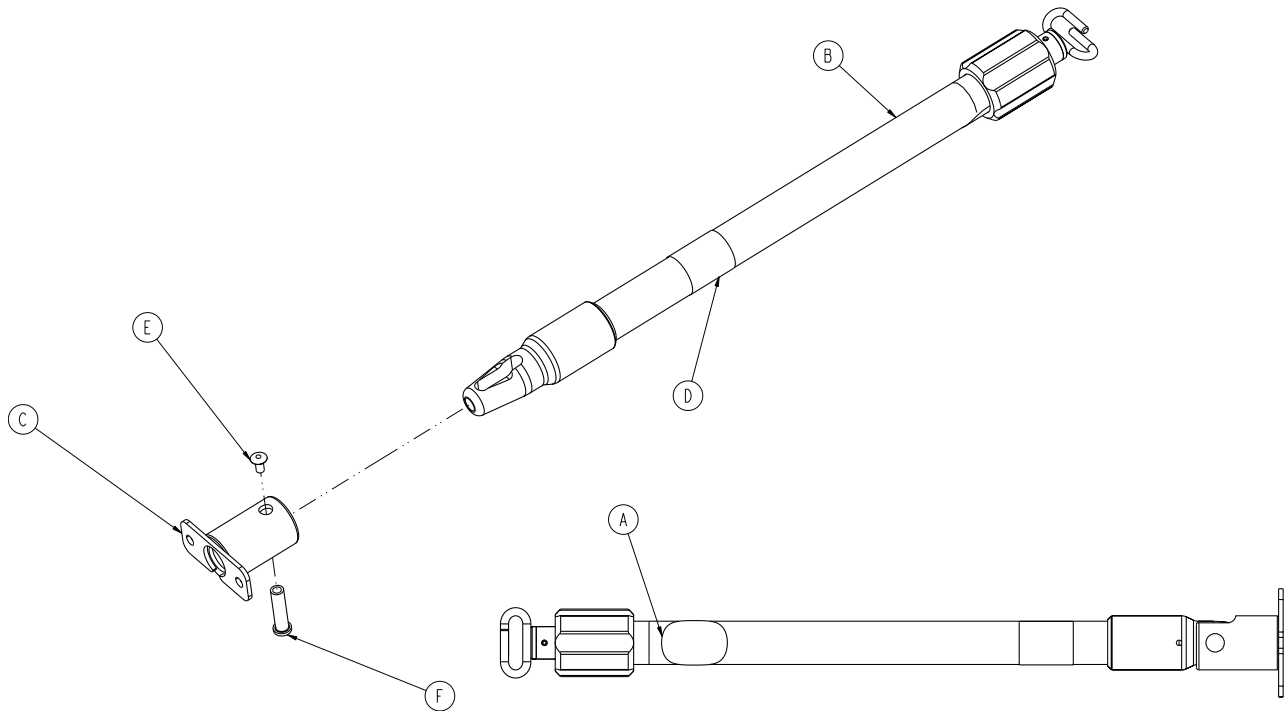

A	6506-001-901	1
B	6070-210-070	1
C	6100-115-05 1	1
D	6500-101-25 3	1
E	0025-079-000	1
F	6070-110-03 7	1

6500-101-043

Rev A (Reference only)

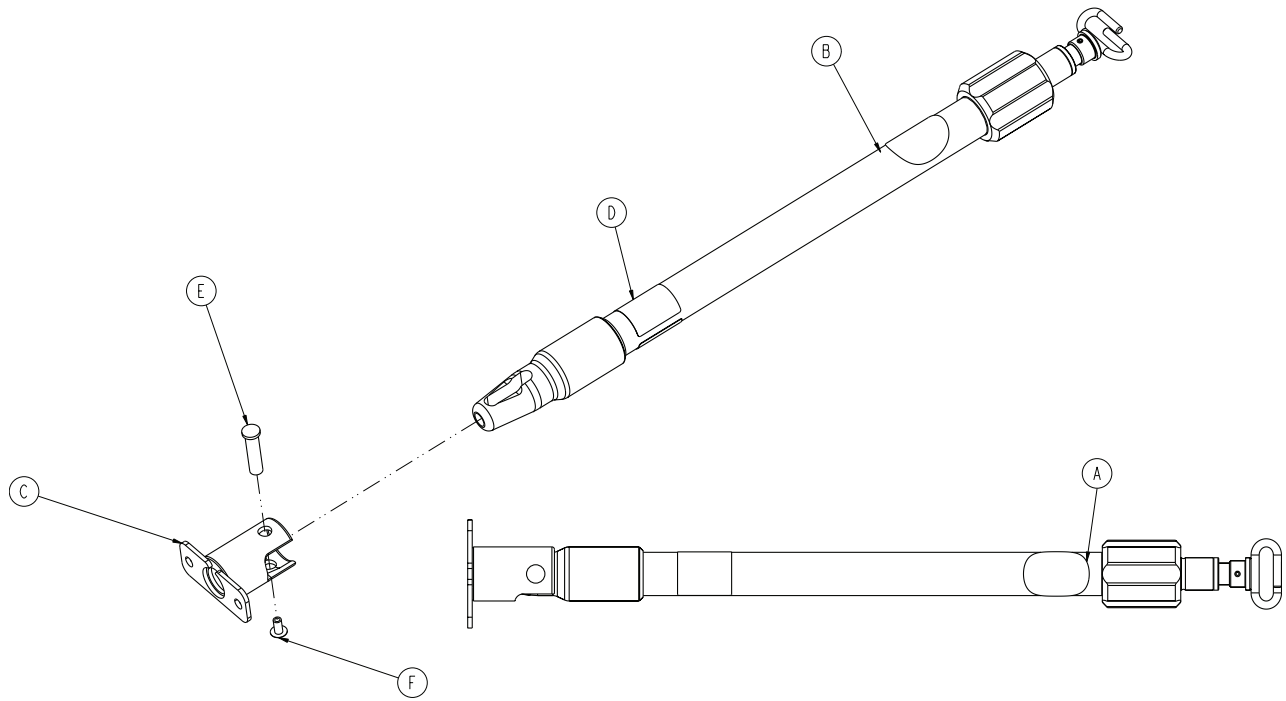

A	6506-001-901	1
B	6070-215 -070	1
C	6100-115 -051	1
D	6500-101 -255	1
E	6070-110 -037	1
F	0025-079-000	1

6500-311-000

Rev B (Reference only)

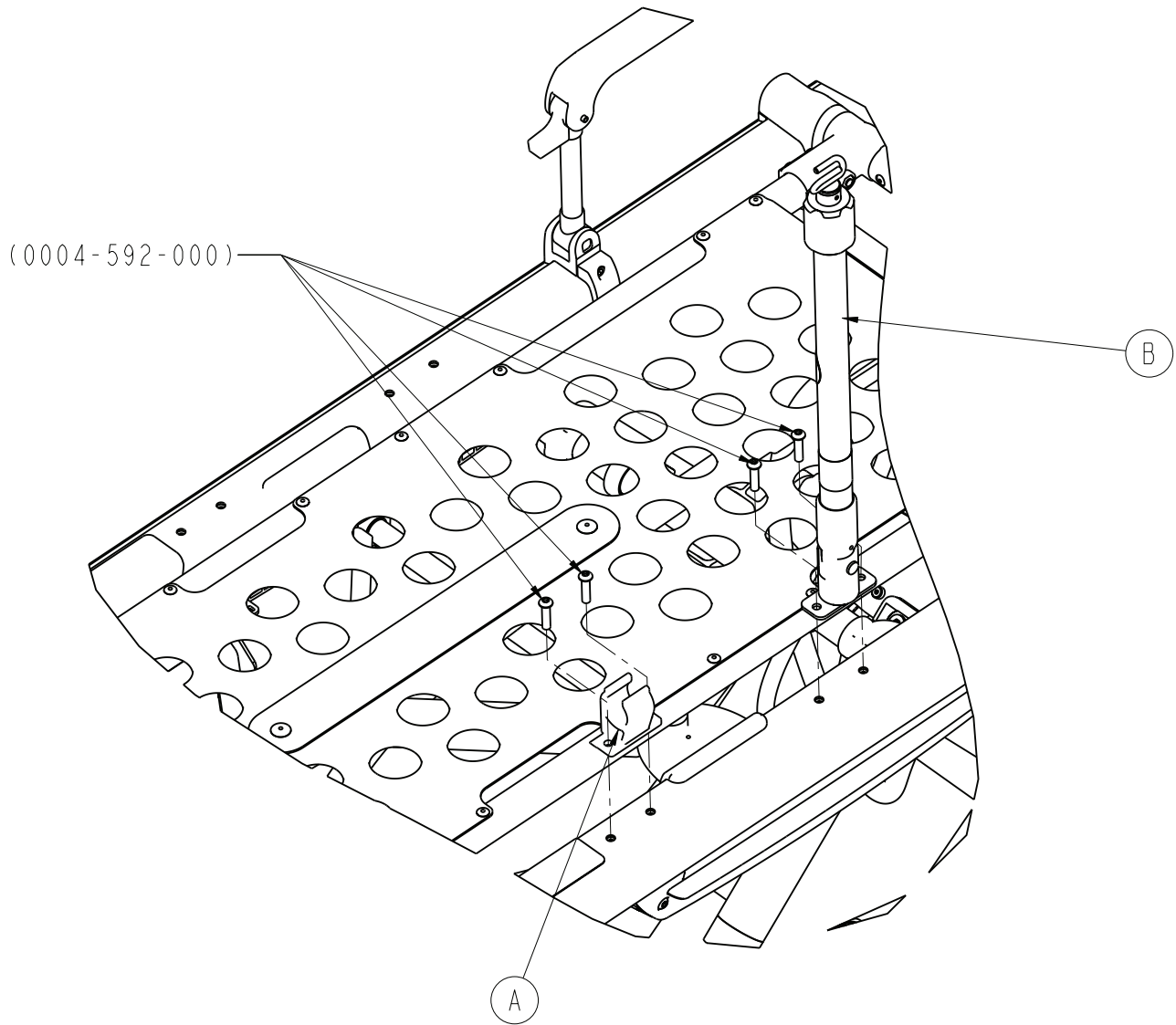

A	6100-115-06 0	1
B	6500-101-04 2	1

6500-316-000

Rev B (Reference only)

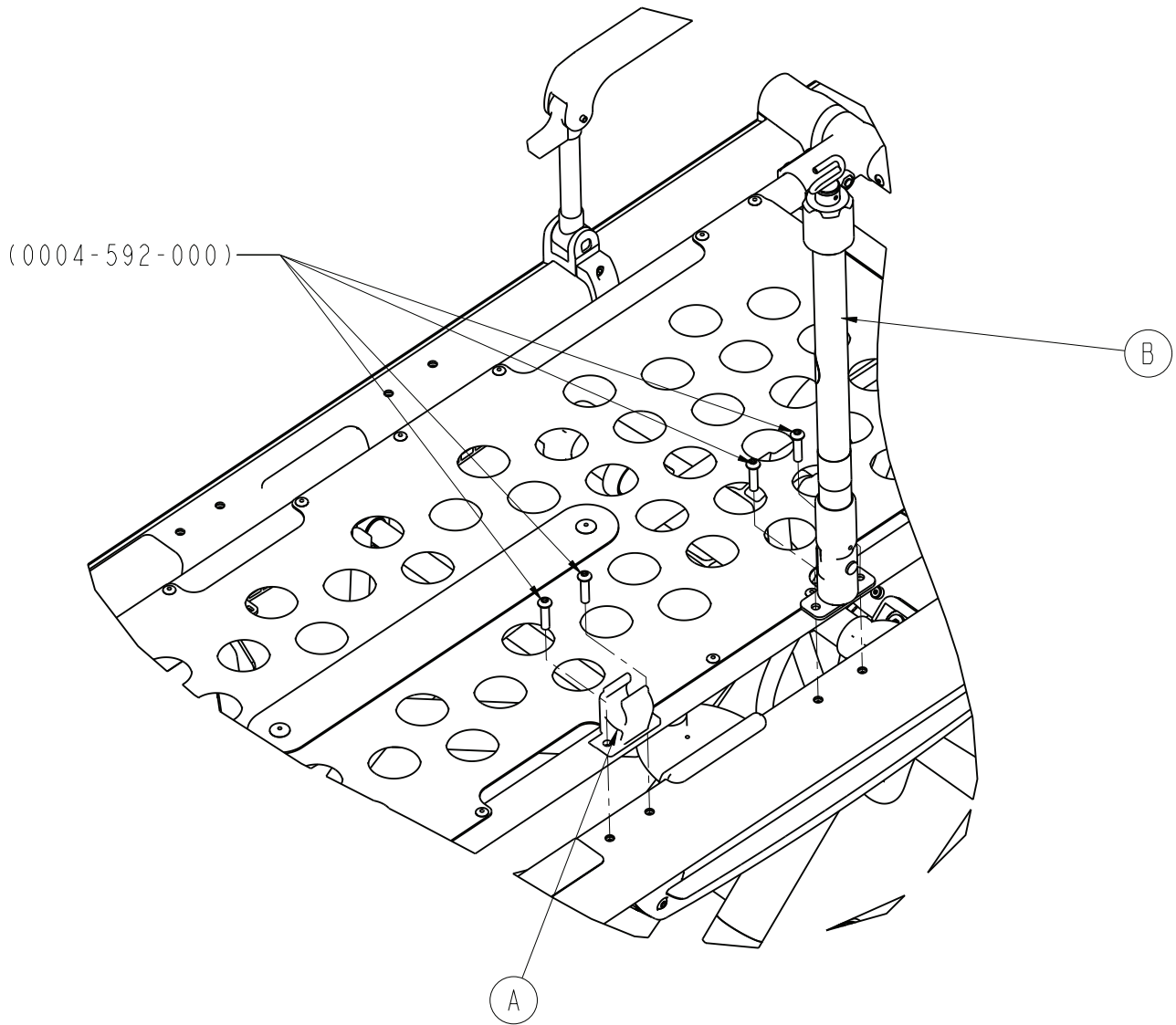

A	6100-115 -060	1
B	6500-101 -044	1

6500-101-042

Rev A (Reference only)

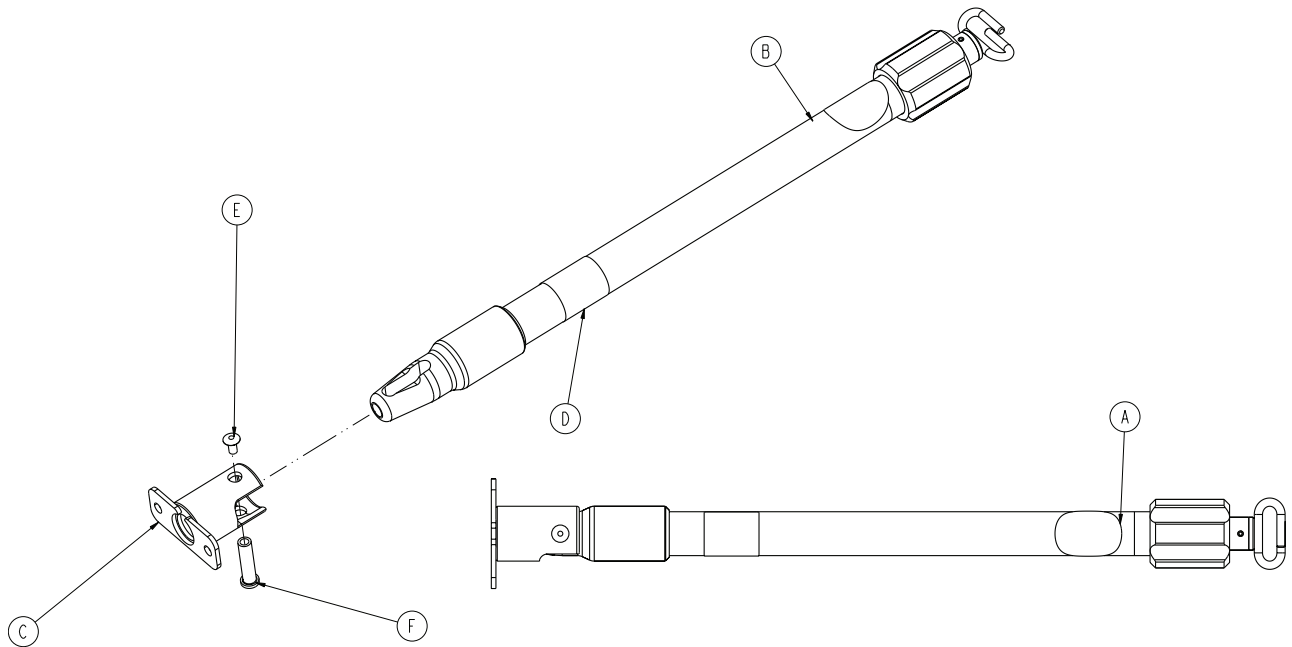

A	6506-001-90 1	1
B	6070-210-07 0	1
C	6100-115-05 1	1
D	6500-101-25 4	1
E	0025-079-000	1
F	6070-110-03 7	1

6500-101-044

Rev A (Reference only)

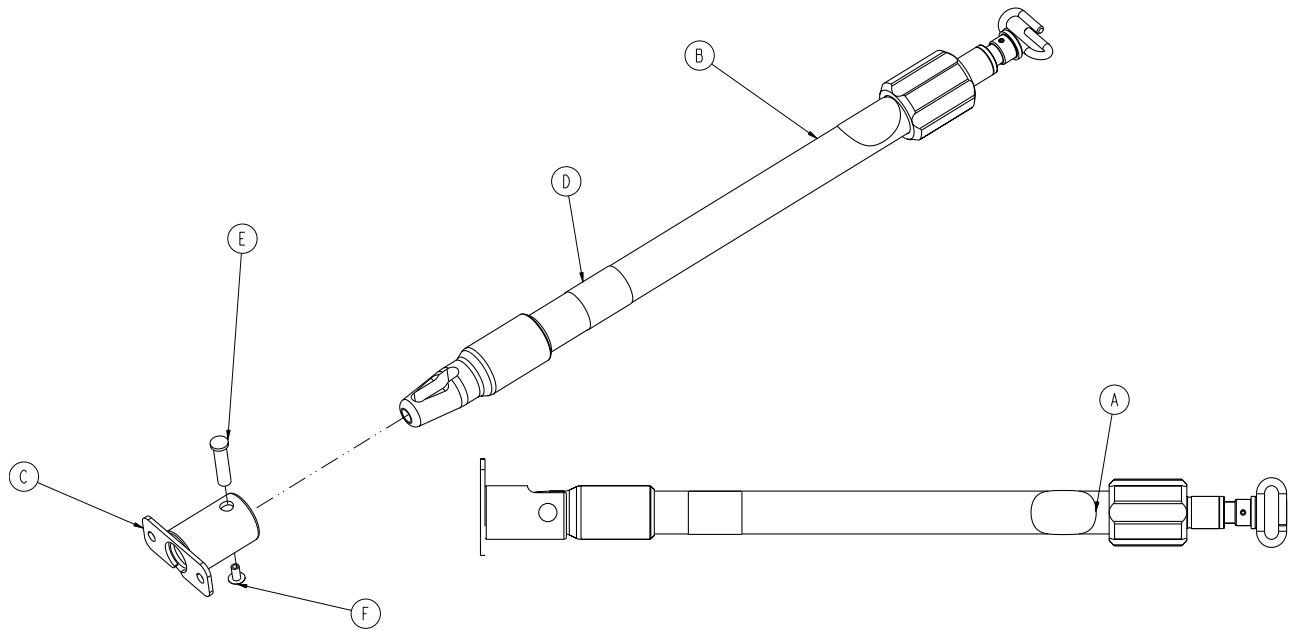

A	6506-001-901	1
B	6070-215 -070	1
C	6100-115 -051	1
D	6500-101 -256	1
E	6070-110 -037	1
F	0025-079-000	1

6500-312-000

Rev B (Reference only)

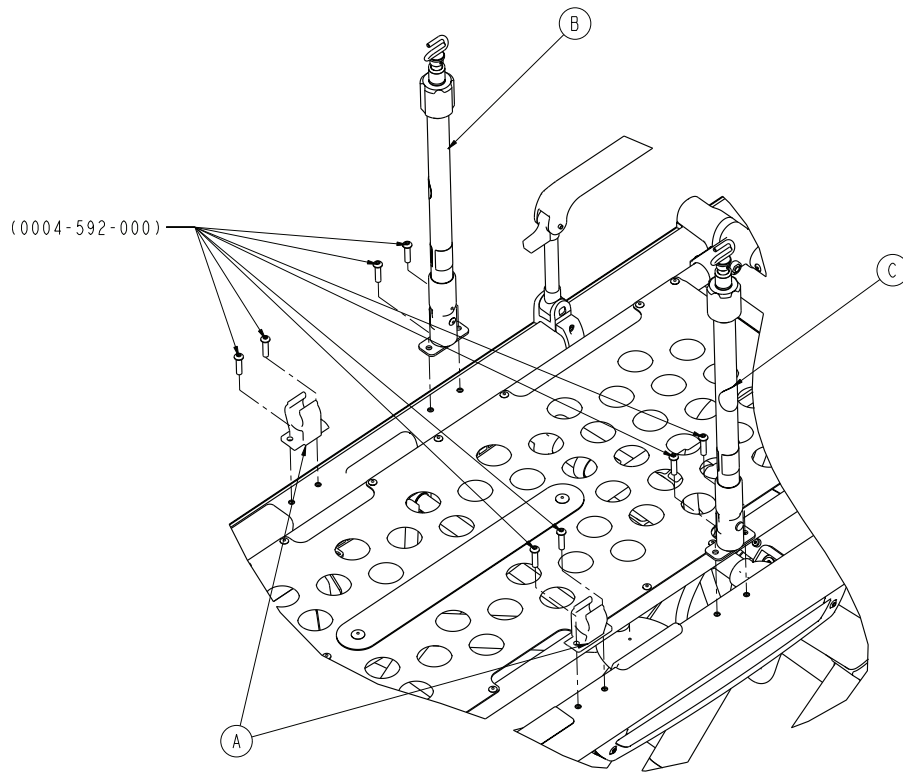

A	6100-115-06 0	2
B	6500-101-04 1	1
C	6500-101-04 2	1

6500-317-000

Rev B (Reference only)

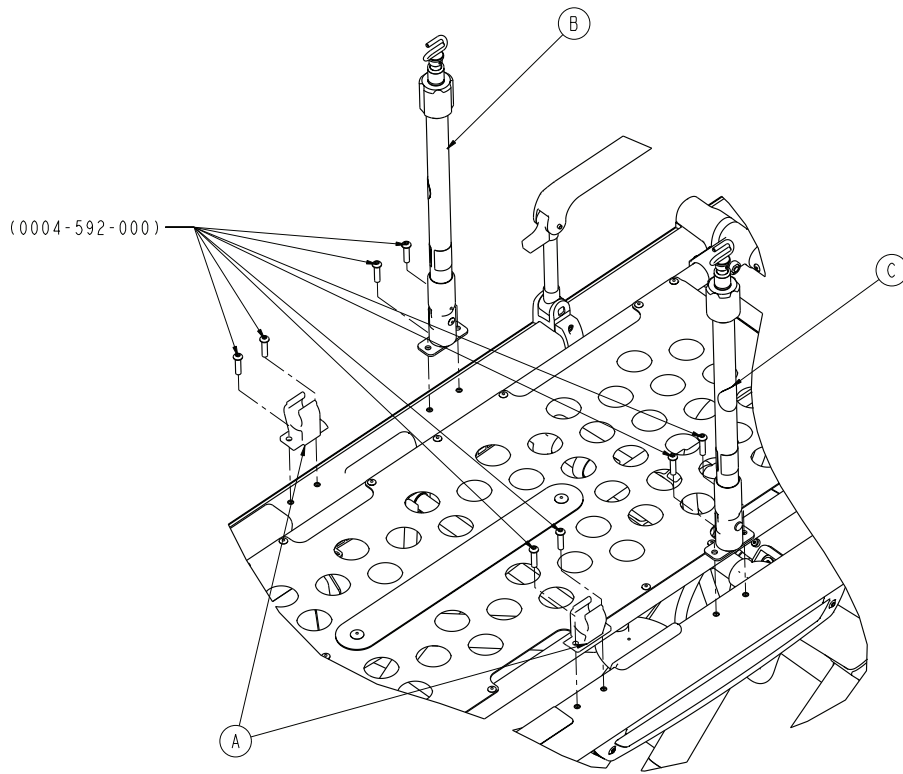

A	6100-115 -060	2
B	6500-101 -043	1
C	6500-101 -044	1

6500-240-000

Rev A (Reference only)

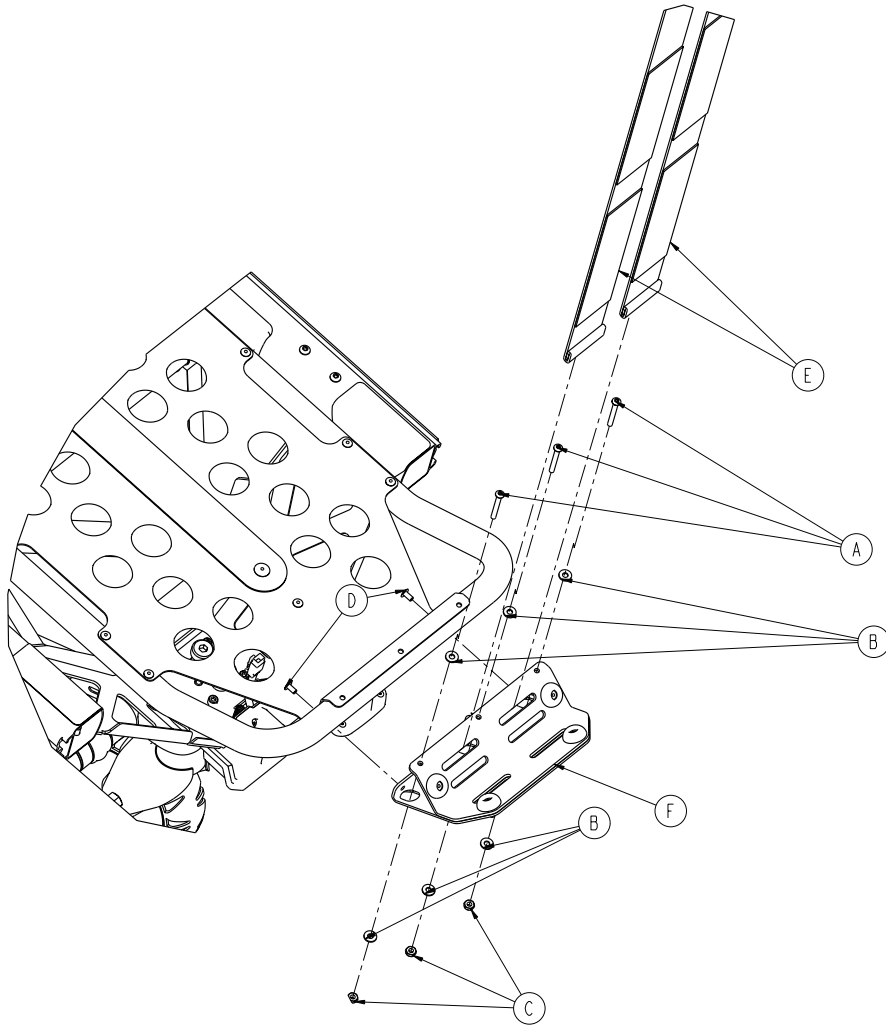

A	0004-862-000	3
B	0011-001-00 0	6
C	0016-131-00 0	3
D	0025-079-000	2
E	6060-140-01 3	2
F	6500-101-04 0	1

6500-101-040

Rev A (Reference only)

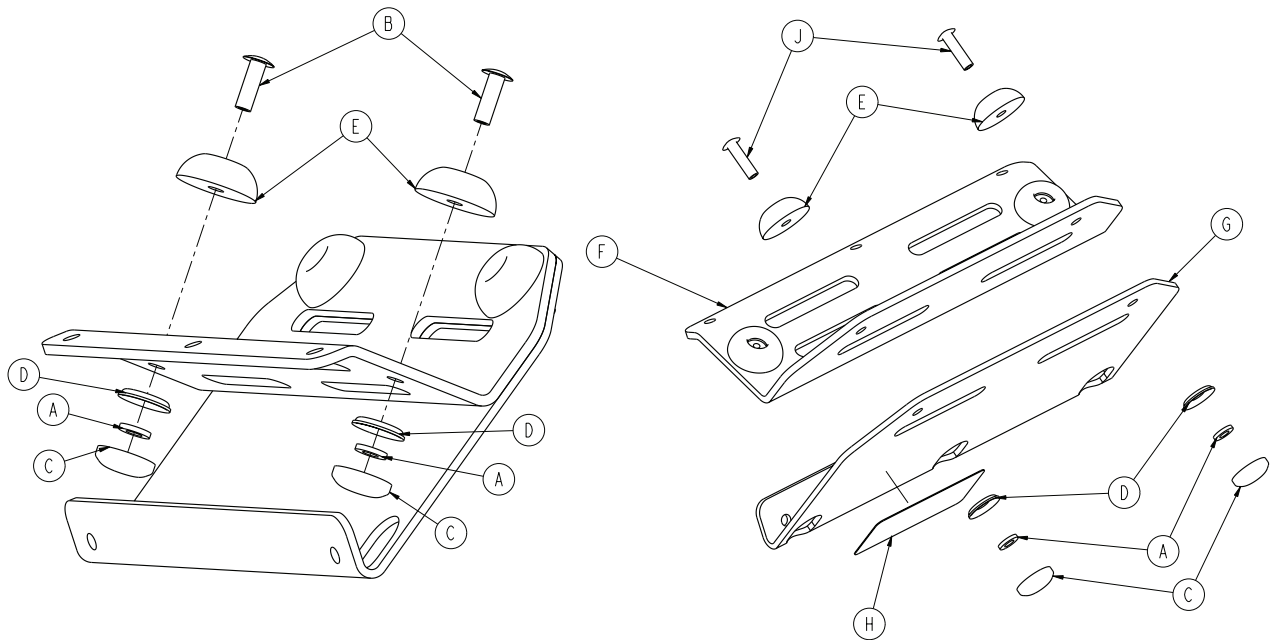

A	0011-436-000	4
B	0025-133-000	2
C	0037-055-000	4
D	0037-056-000	4
E	0946-001-155	4
F	6500-001-239	1
G	6500-001-240	1
H	6500-101-257	1
J	0025-086-000	2

6500-241-000

Rev B (Reference only)

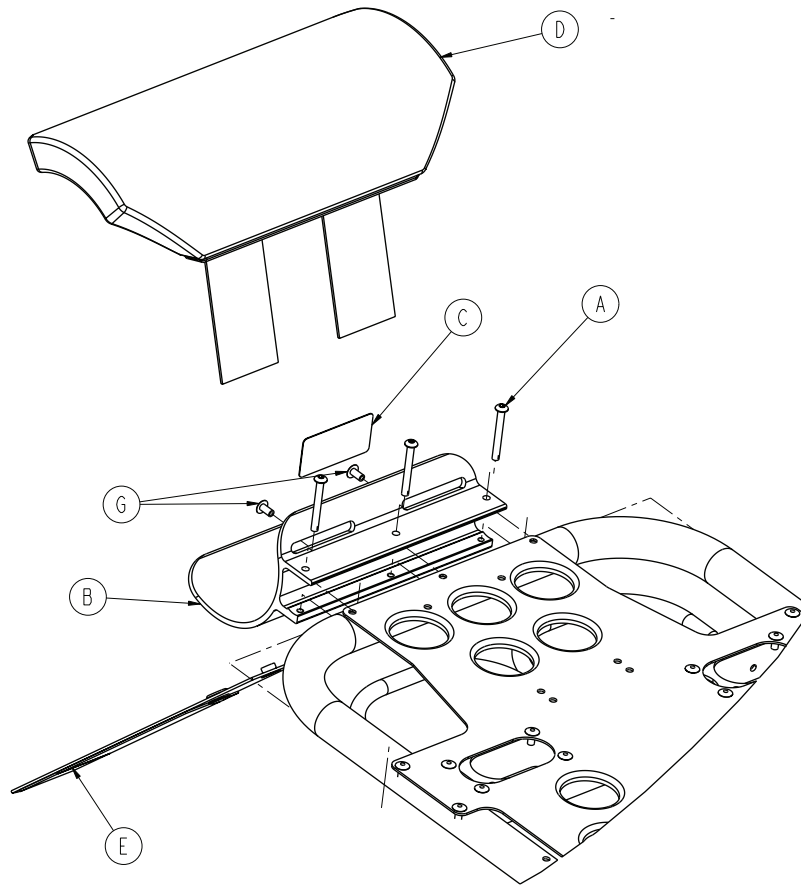

A	0004-636-000	3
B	6500-001-11 9	1
C	6500-101-23 1	1
D	6500-001-26 0	1
E	6500-001-26 1	1
G	0025-079-000	2

6080-140-000

Rev A/6080-140-010 Rev A (Reference only)

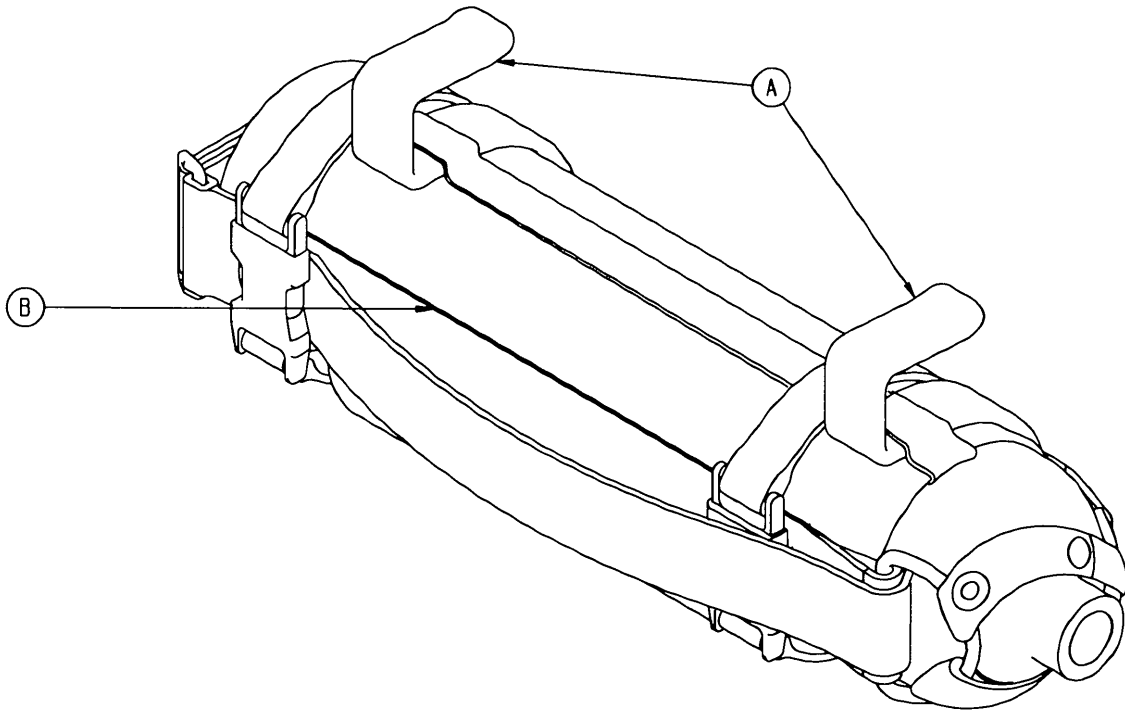

B

6080-140 -012

1

Rev B (Reference only)

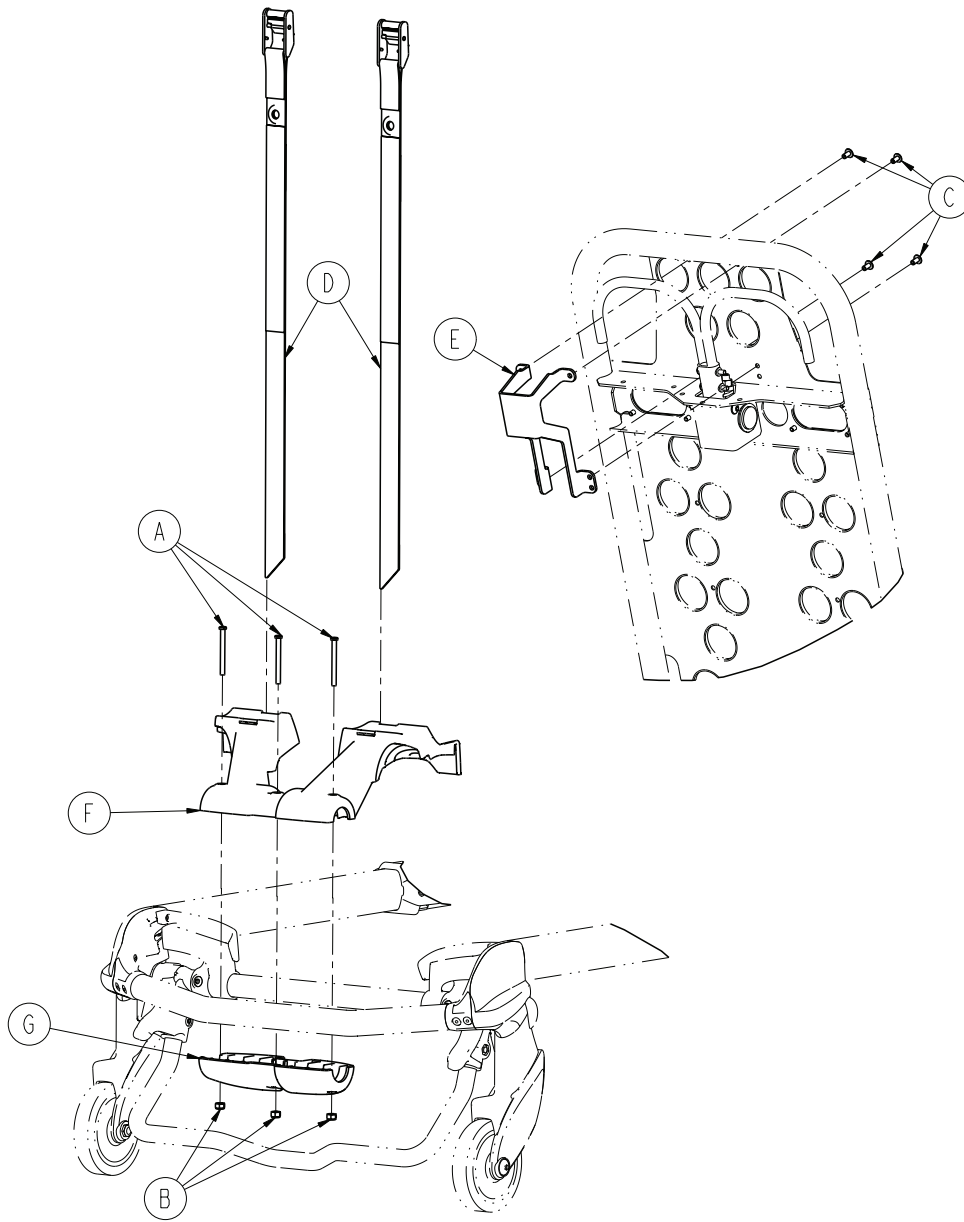

A	0004-656-000	3
B	0016-002-000	3
C	0025-079-000	4
D	6085-001-17 1	2
E	6085-001-17 2	1
F	6085-001-17 3	1
G	6085-001-17 4	1

Rev A/6500-001-126 Rev E (Reference only)

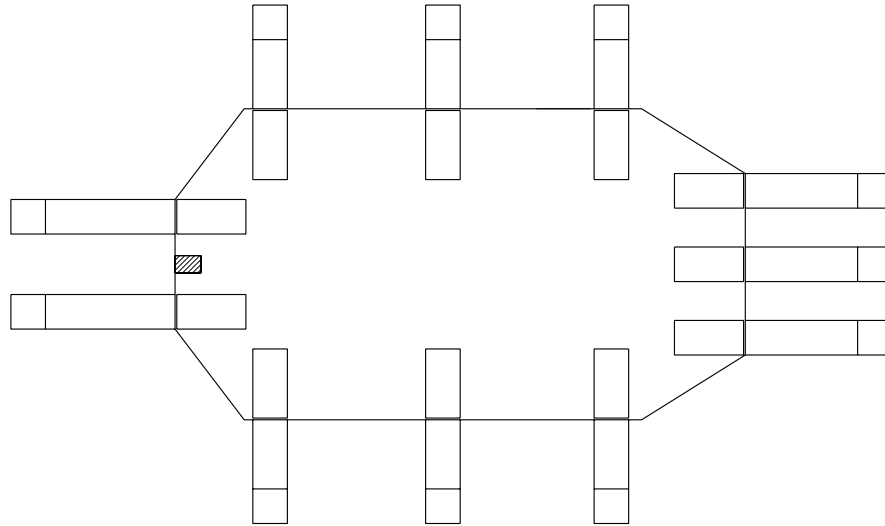

Rev A (Reference only)

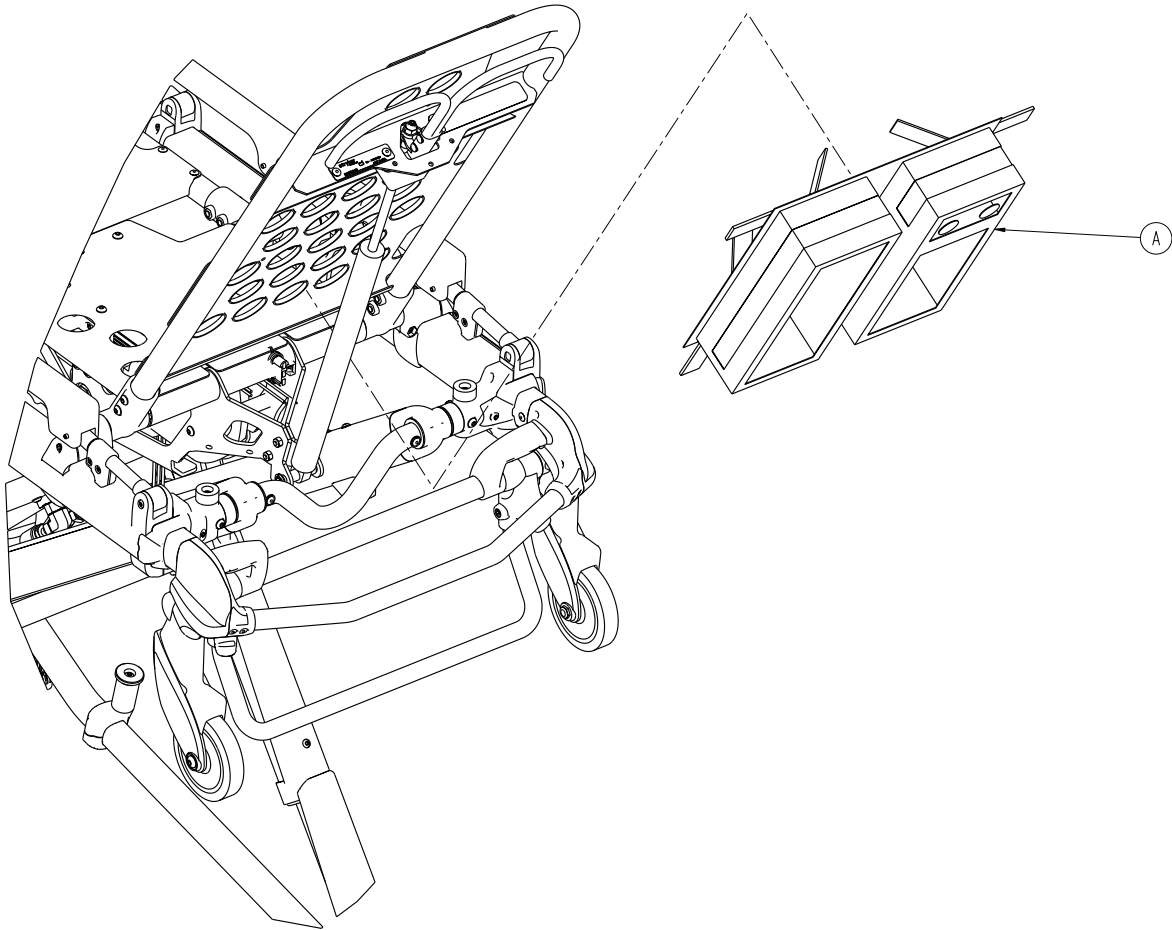

A

6500-001-24 1

1

Rev A (Reference only)

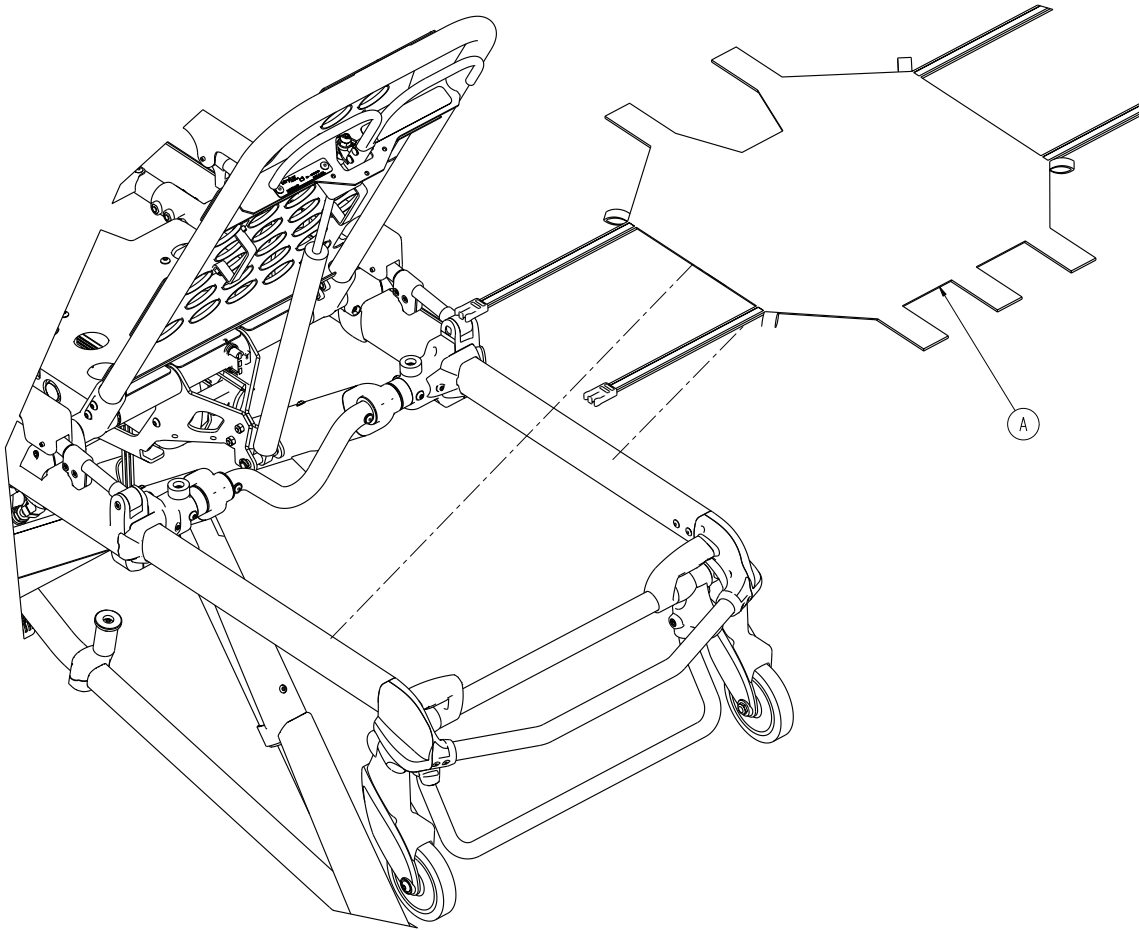

A

6500-001-232

1

Rev E (Reference only)

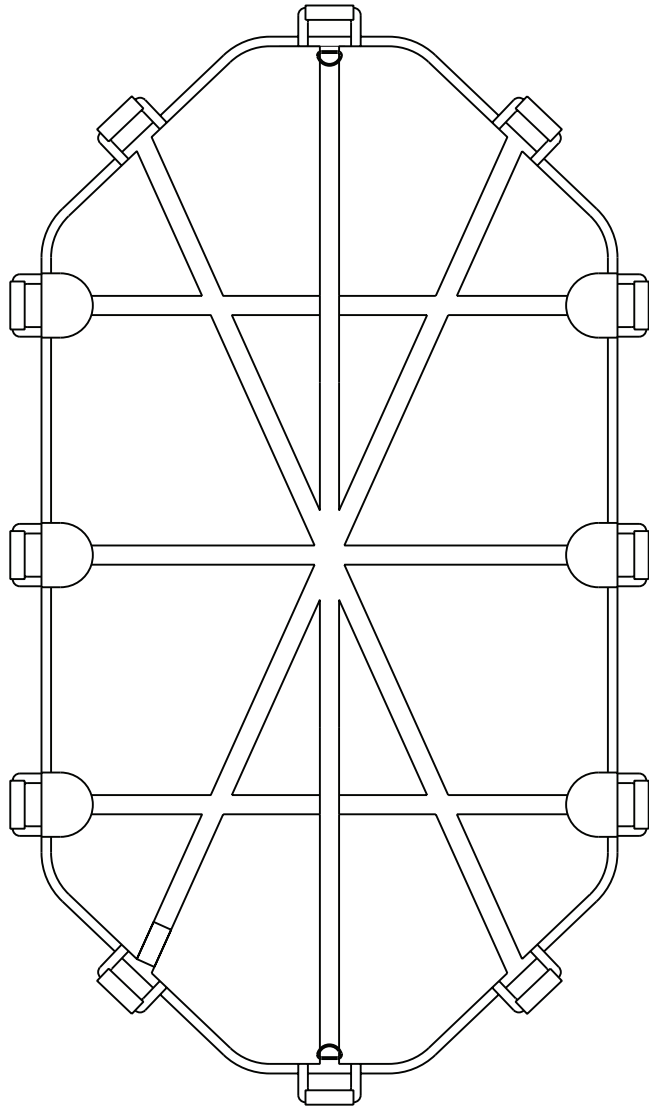

6500-002-150

Rev F/6506-034-000 Rev A (Reference only)

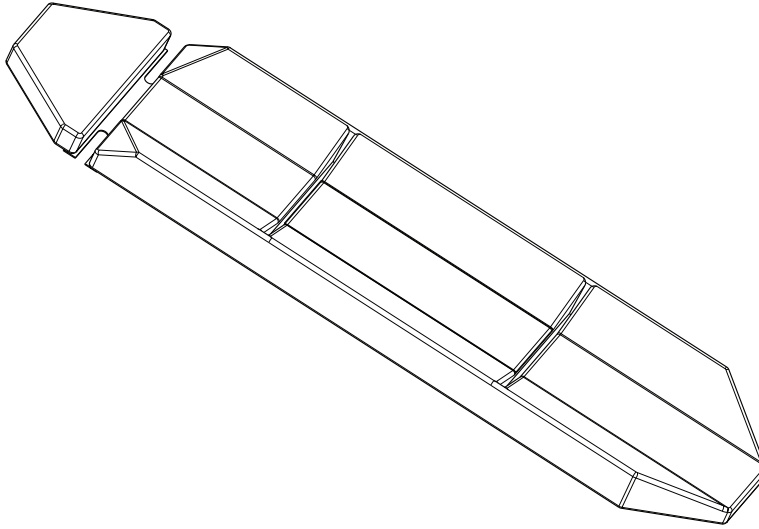

6506-002-150

Rev A / 6506-033-000 Rev A (Reference only)

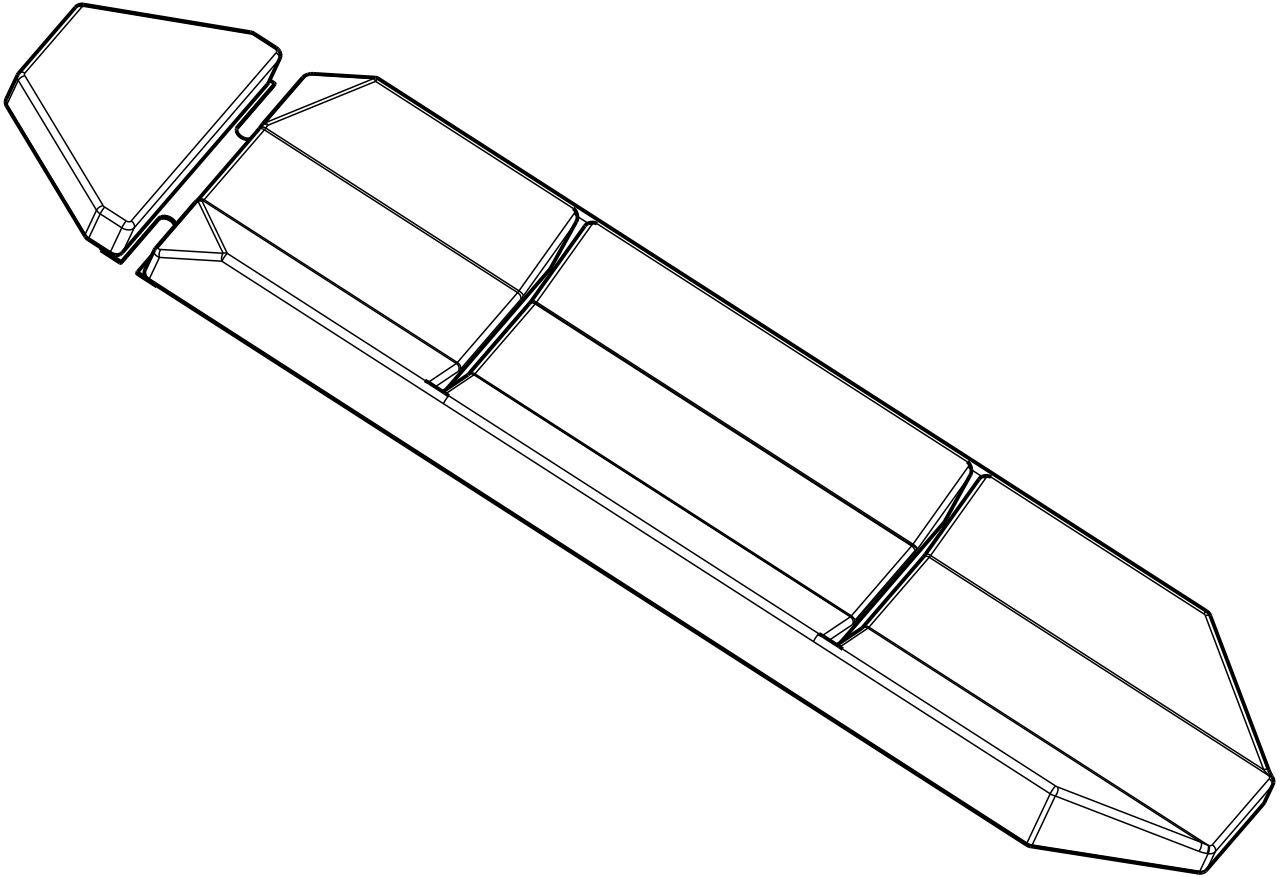

Rev G (Reference only)

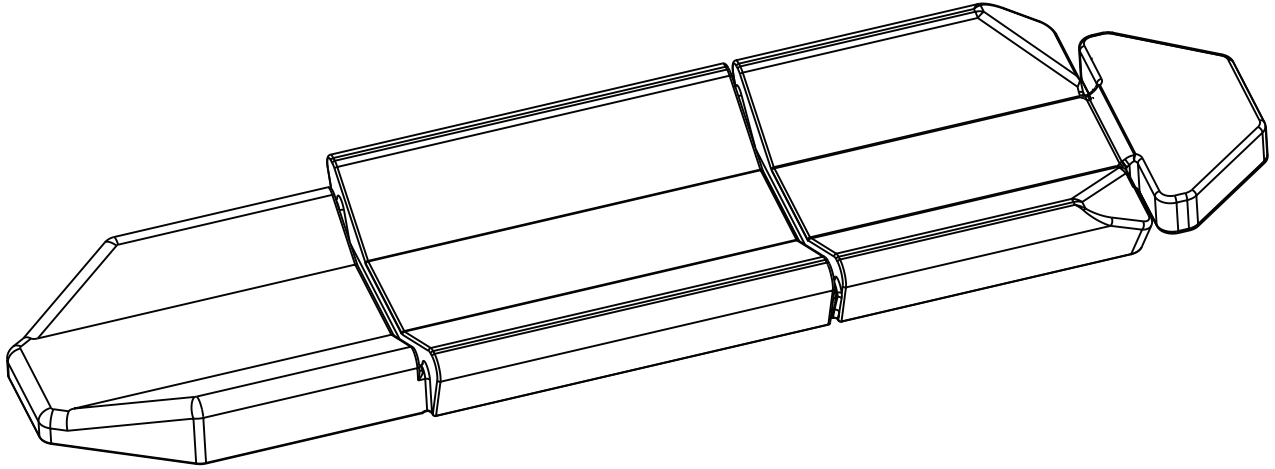

Rev A (Reference only)

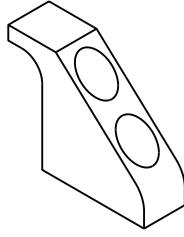

Rev D (Reference only)

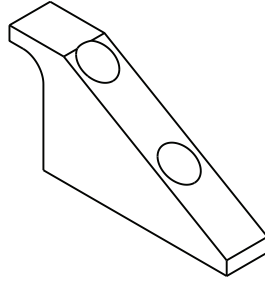

Rev A (Reference only)

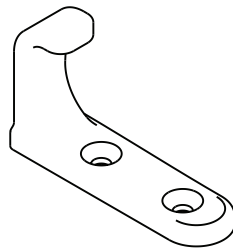

Rev D (Reference only)

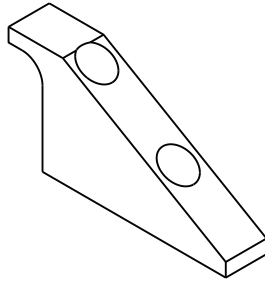

Rev A (Reference only)

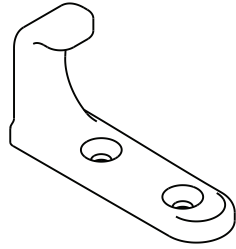

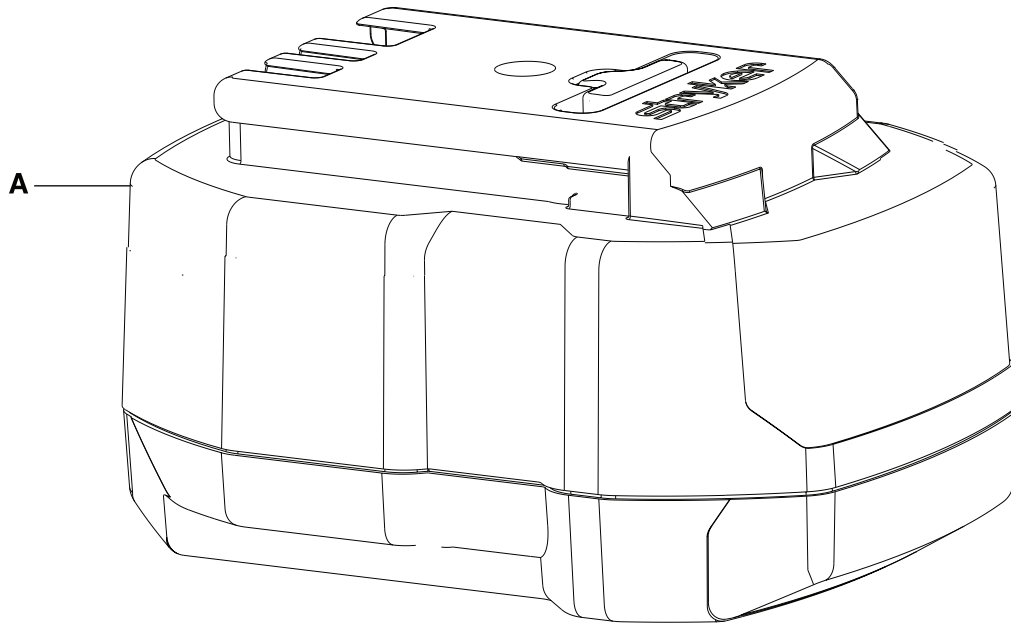

A	2
---	---



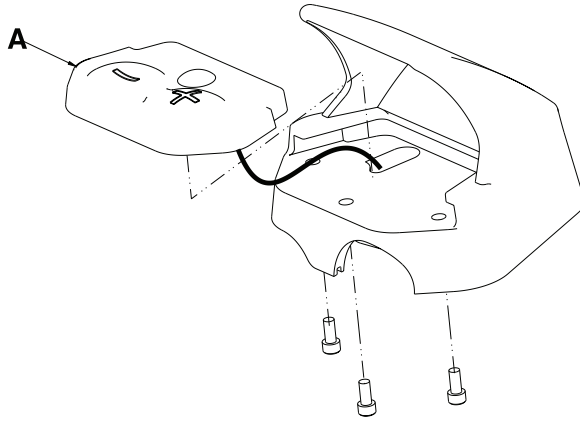

A	2
---	---

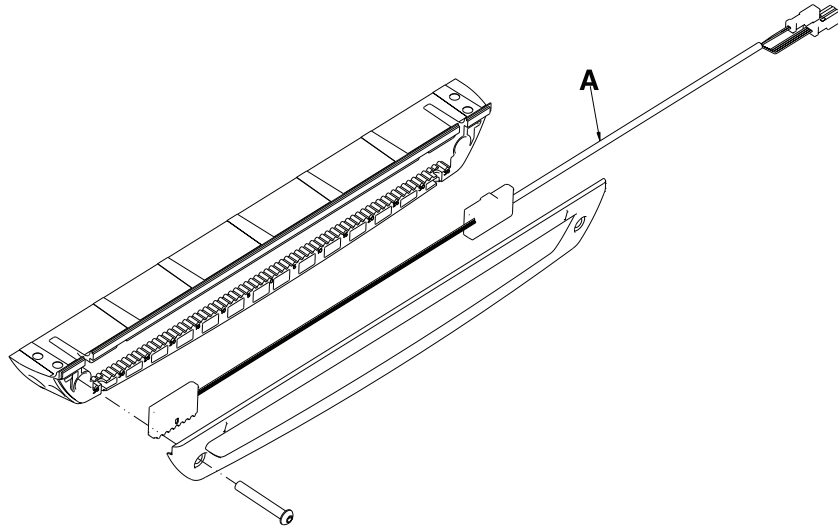

A	1
---	---

6500-102-015/6500-002-014



6500-102-015 (Reference only)

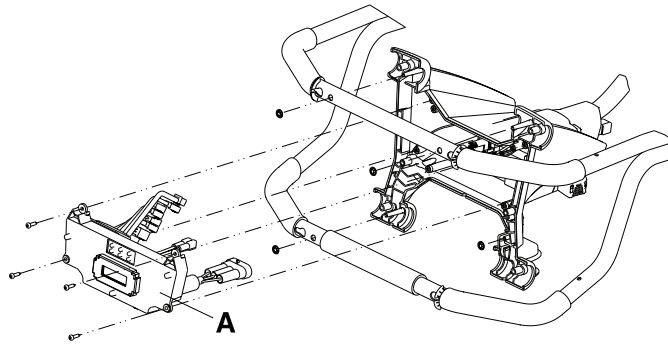

6500-002-014 (Reference only)

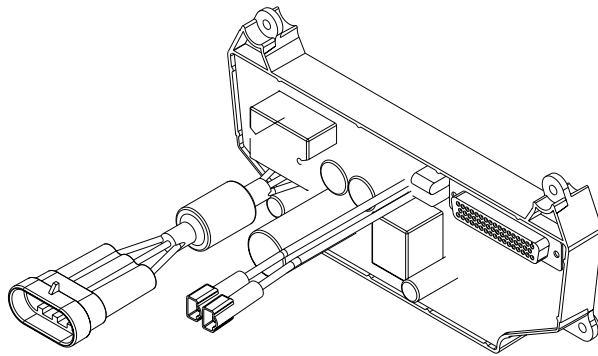

A	1
---	---

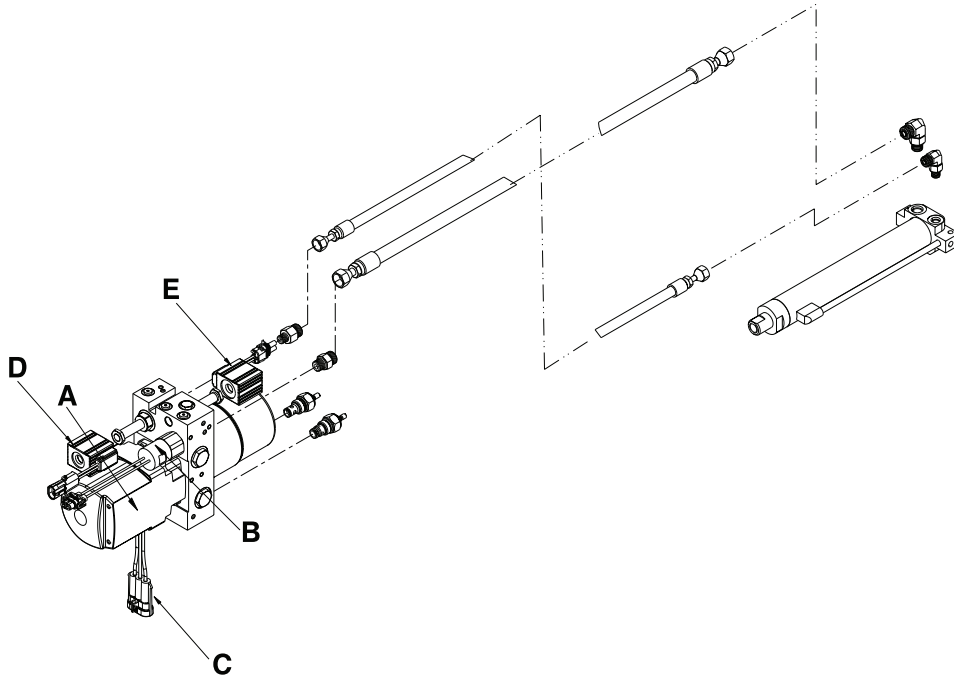

A	1
B	1
C	1
D	1
E	1

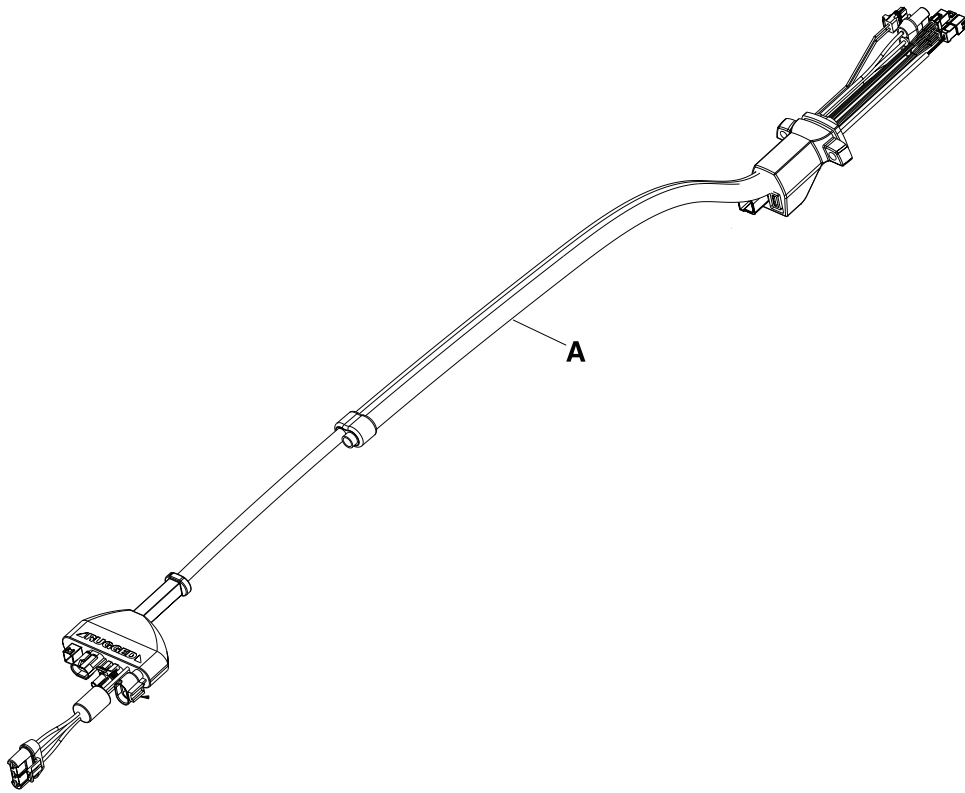

A	1
---	---

English Equivalence Part Number: 6506-109-001 REV E



Stryker Medical
3800 E. Centre Avenue
Portage, MI 49002
USA



Stryker EMEA RA/QA Director
ZAC - Avenue de Satolas Green
69881 MEYZIEU Cedex
France

stryker[®]