

MEDI-THERM® II

**HYPER/HYPOTHERMIA MACHINE
REF MTA6012CE**



Important

- Refer to the Medi-Therm II® Operator’s Manual for detailed operating instructions. Read and understand the Operator’s Manual and all precautions prior to using the Hyper/Hypothermia machine.
- Review the SAFETY PRECAUTIONS (see page 1) prior to servicing the Medi-Therm II machine.
- For technical assistance, contact your local dealer.

Receiving Inspection

Upon receipt, unpack the Medi-Therm II machine. Save all packing material. Perform a visual and mechanical inspection for concealed damage by removing the wraparound from the chassis (see figure 18, page 55). If any damage is found, notify the carrier at once and ask for a written inspection. Photograph any damage and prepare a written record. Failure to do this within 15 days may result in loss of claim.

Refer to section 2.0 of this *Medi-Therm II Service Manual* for additional details.

IMPORTANT

Before operating the Medi-Therm II machine, remove the compressor shipping braces. See p. 72, figure B, items 8 and 9.

Temporarily remove the power cord retainer (fig. 19, p. 56, item 6) and install the power cord. Reattach the power cord retainer.

Table of Contents

1.0	Safety Precautions	1
2.0	Repair Policy	2
3.0	Specifications	3
4.0	Blankets/Accessories	6
5.0	Operator Control Panel.....	8
6.0	Theory of Operation.....	10
7.0	Functional Check, Safety Inspection, and Preventive Maintenance	16
8.0	Service Modes and Troubleshooting	22
9.0	Repair Procedures.....	45
10.0	Service Information.....	50

Figures

1	Warm-up Rate	4
2	Cooldown Rate	4
3	Disposable Probe/Reusable Cable.....	6
4	Medi-Therm II System	7
5	Medi-Therm II Control Panel.....	9
6	Probe Check Well.....	17
7	Functional Check/Inspection Form	21
8	Initiating Service Mode 1	22
9	RFU Codes.....	23
10A-N	Troubleshooting Charts	26-44
11	Connecting Terminal Block Wires	47
12	Flow Switch	48
13	Temperature vs. Resistance Table.....	50
14	Circuit Boards/Connectors (Head).....	51
15A/B	Heating Flow; Cooling Flow.....	52
16	Refrigeration Flow Diagram.....	53
17A/B	Test Setup; Test Setup (alternate).....	54
18	Machine Disassembly.....	55
19	Parts Diagram (Base), Parts List.....	56
20	Parts Diagram (Head), Parts List.....	58
21	Thermostat Wiring Diagram.....	59
22	Control/Display Board, Parts List.....	60
23	Power Supply Board, Parts List.....	62
24	Alarm/Backup Board, Parts List.....	64
25	Wiring Diagram [foldout].....	66
26	Power Supply Board Schematic, 1 of 4 [foldout].....	67
27A	Control Display Board Schematic, 2 of 4 [foldout].....	68
27B	Control Display Board Schematic, 3 of 4 [foldout].....	69
28	Alarm/Backup Board Schematic, 4 of 4 [foldout].....	70
29	Block Diagram [foldout]	71
30	Shipping Instructions	73

1.0 Safety Precautions

Review the following safety precautions prior to testing the Medi-Therm II machine:

⚠ DANGER



Risk of electric shock. Refer servicing to qualified medical equipment service personnel.

⚠ WARNING

- Repairs should be performed only by qualified medical equipment service personnel and in accordance with this *Service Manual*. **Otherwise, damage to the Medi-Therm II machine and improper therapy may result.**
- Do not tip machine over without first draining the water out and unplugging the power cord. **Electrical shock or damage to the machine can result.**
- Use only Gaymar probes (see *Accessories*, page 6) or probes having characteristics equivalent to YSI 400 series probes in the Patient Probe jack. **Use of other probes could result in erroneous patient temperature values.**

⚠ CAUTION

Add distilled water only. **Failure to use distilled water may result in poor machine performance.**

- Do not use alcohol, since it is flammable. Alcohol may also accelerate blanket deterioration.
- Do not operate the machine without water, since damage to internal components may result.
- Do not overfill. Overfilling may result in overflow because the water in the blanket drains back into the machine when the machine is turned off.
- For grounding reliability, plug the Medi-Therm II machine only into a properly grounded outlet.
- To prevent damage to the power cord, always keep the power cord retainer in place.

2.0 Repair Policy

For customers who repair Gaymar Medi-Therm II machines at their location, this manual contains information to allow a qualified biomedical technician, familiar with practices for servicing medical devices, to make necessary repairs. Service training for the Hyper/Hypothermia machine is recommended and can be arranged through your local dealer.

2.1 Limited Warranty

The Medi-Therm II Hyper/Hypothermia machine is warranted free of defects in material and workmanship for a period of two (2) years, under the terms and conditions of the Gaymar warranty in place at the time of purchase. The compressor portion of the machine carries a five year prorated warranty. During the warranty period, contact your local dealer.

Warranty does not cover products abused, misused, or altered outside the factory. There are no obligations on the part of Gaymar for consequential damages arising out of or in connection with the use or performance of the product. Gaymar disclaims all implied warranties including, but not limited to, the implied warranties of merchantability and of fitness for a particular purpose.

2.2 Warranty Repairs

All in-warranty field repairs must be authorized by Gaymar's Export Department before proceeding.

2.3 Out-of-Warranty Repairs

The following repair options are available when local machine servicing is elected:

1. Defective Component

Replacement parts can be ordered from your local dealer. Specify the Gaymar part number; refer to the *Parts Lists* in section 10.0 of this manual.

2. Defective Printed Circuit (PC) Board

Defective PC boards can be exchanged for replacement boards at a fixed cost directly from your local dealer.

3. Defective Top Module

The defective top module can be returned (without base) for repair. Contact your local dealer for information.

4. Machine Repairs

If the Medi-Therm II machine becomes defective and the cause of the problem cannot be determined, the complete machine can be returned to your local dealer for servicing at the purchaser's expense. This normally represents the most expensive repair option. Contact your local dealer.

2.4 Return Authorization

Please contact your local dealer.

3.0 Specifications

3.1 Physical

Physical Specifications	
Model	MTA6012CE
Dimensions	94 cm high x 48 cm deep x 36 cm wide
Weight	73.9 kg (full); 66.2 kg (empty)
Normal Reservoir Operating Volume	9.5 liters distilled water
Operating Ambient Temperature Range	15.6°C TO 32.2°C
Power Loss Indicator Battery	8.4V NiMH
Refrigerant	* HFC-134a, 0.234 kg w/7mm (9/32 inch) O.D. 0.326 kg w/9.5 mm (3/8 inch) O.D.
Fuse (stepdown transformer)	5 mm x 20 mm T, 6.3 A, 250 V, L

* Section 9.1.1 for additional information

3.2 Thermal

Thermal Specifications	
High Temperature Limits Fixed Backup System 1--Overtemperature probe RT3	41.4°C to 43.6°C (Machine will go into a <i>REMOVE FROM USE NOW</i> shutdown condition and the alarm will be on.)
High Temperature Limits Fixed Backup System 2--Thermostat S2	44°C to 49°C (Machine will go into a <i>REMOVE FROM USE NOW</i> shutdown condition and the alarm will be on.)
Low Temperature Limits Fixed Backup System 2--Thermostat S1	-3.0°C to 2.5°C (Machine will go into a <i>REMOVE FROM USE NOW</i> shutdown condition and the audible alarm will be on.)
Add Water Alert Actuation	Less than 7.6 liters of water in the cold reservoir
Check Patient Alert Activation Temperature (whenever probe is used)	Below 29°C or above 40°C
Machine Ceases Therapy (whenever probe is used)	Below 29°C or above 45°C
Patient Temperature Control Range for <i>PATIENT CONTROL</i> mode	30°C to 39°C
Blanket Temperature Control Range for <i>BLANKET CONTROL</i> mode	4°C to 41°C
Flashing Temperature Display (with setpoint 30°C or greater)	<ul style="list-style-type: none"> Blanket Mode: Actuates when actual temperature is not within 0.5°C of setpoint 4 hours after powerup, 4 hours after a setpoint change, or 10 minutes after the first instance of the actual temperature becoming equal to the setpoint. Patient Mode: Actuates when actual temperature is not within 0.5°C of setpoint 4 hours after powerup or 4 hours after a setpoint change.

3.2 Thermal (continued)

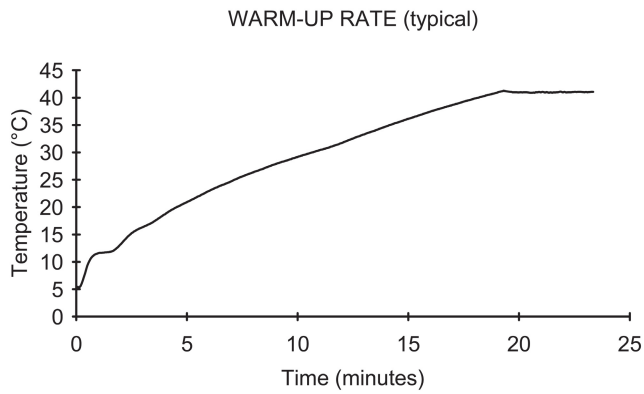

Figure 1—Typical warm-up rate
(with full size blanket)

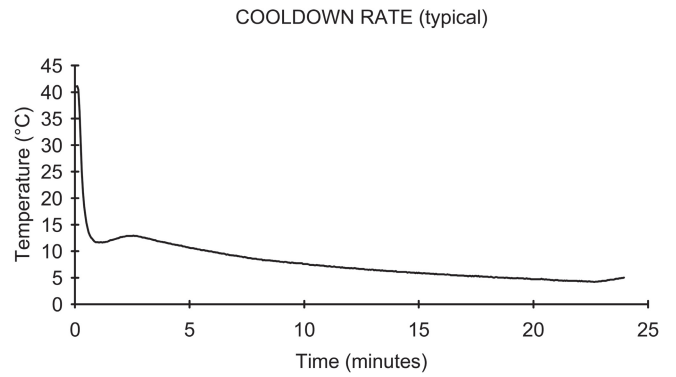

Figure 2—Typical cooldown rate
(with full size blanket)

3.3 Performance

Performance Specifications	
Patient Temperature Measurement Accuracy	± 0.4°C (using Gaymar disposable probe) ± 0.3°C (using Gaymar reusable probe)
Display Accuracy	± 0.2°C
Display Resolution <i>BLANKET WATER TEMPERATURE</i>	1°C
Display Resolution <i>PATIENT TEMPERATURE</i>	0.1°C
Controller Accuracy <i>BLANKET WATER TEMPERATURE</i>	± 0.8°C
Controller Accuracy <i>PATIENT TEMPERATURE</i>	± 0.5°C
Flow *	60.6 liters per hour
* Minimum flow rates through a full size Gaymar Hyper/Hypothermia Blanket	

3.4 Electrical

Electrical Specifications	
Current Leakage, Earth Neutral closed Neutral open	175 microamps maximum 125 microamps maximum
Current Leakage, Patient Probe Neutral closed Neutral open	100 microamps maximum 100 microamps maximum
Voltage	~220 V to ~240 V ± 10%
Frequency	50 Hz
Power Consumption Capacity	1575 VA
Current	6 A
Detachable Power Cord	Use only an International (harmonized) three-wire cordset using cordage approved to HD-21. Conductor size is 1.00 mm ² (H05VVF3G1.00).

3.5 Regulatory

Regulatory	Medical Device Directive (93/42/EEC) Class IIb (indicated by CE mark)
------------	---

3.6 Classification

Classification	<ul style="list-style-type: none"> IEC 601-1 Class 1, grounded, not suitable for use in the presence of flammable anaesthetic mixture with air or with oxygen or nitrous oxide. Not classified for protection against harmful ingress of liquid.  <ul style="list-style-type: none"> IEC 601-1-2, Class A, CISPR 11, emission requirements. IEC 601-2-35
----------------	--

4.0 Blankets/Accessories

Single Patient Use Blankets, Polymer with Nonwoven Fabric

- REF DHP810CE O.R. Table and General Use (64 cm x 163 cm)
- REF DHP812CE Pediatric General Use (56 cm x 84 cm)
- REF DHP813CE Adult General Use (76 cm x 163 cm)

Single Patient Use Blankets, All Polymer

- REF DHP901 Adult General Use (64 cm x 175 cm)
- REF DHP902 Pediatric General Use (64 cm x 91 cm)
- REF DHP903CE Adult General Use (Narrow) (51 cm x 150 cm)

Reusable Blankets, Heavy Duty Polymer

- REF HP7010 Adult General Use (64 cm x 175 cm)
- REF HP7020 Pediatric General Use (64 cm x 91 cm)

All blankets require use of the reusable DBK35CE Connector Hose.

Accessories *

- (see item 1, p. 57) Detachable Power Cords
- REF DBK35CE Connector Hose (3 meters)
- REF PAT101CE Reusable Adult Patient Probe (3 meters) Rectal/Esophageal (YSI 401AC)
- REF PAT102CE Reusable Pediatric Patient Probe (3 meters) Rectal/Esophageal (YSI 402AC)
- REF PAT108CE Reusable Patient Probe (3 meters) Skin Surface (YSI 409AC)

NOTE: Other style YSI 400 series probes are available through Yellow Springs Instruments.

REF DP400CE Disposable Adult and Pediatric Patient Probe (0.9 meter) Rectal/Esophageal [requires ADP10CE Adaptor Cable]

REF ADP10CE Reusable Probe Adaptor Cable (3 meters) for DP400CE Probe

* These Gaymar probes, adapters, and hoses should be used only with Gaymar Hyper/Hypothermia Machines.

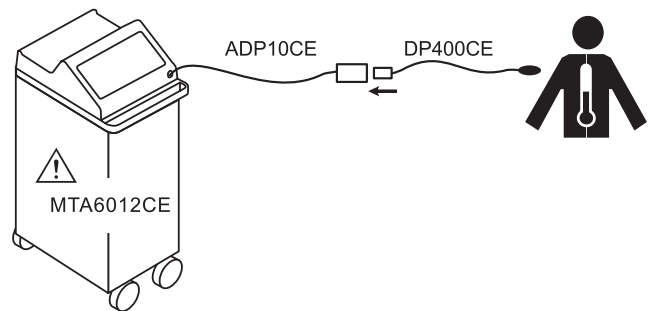

Figure 3—Disposable Probe/Reusable Adaptor Cable

Water Fill Opening
Lift cover. Fill unit with distilled water until green band on float is fully visible.

Patient Probe Jack
Accepts patient probe plug connecting patient probe to machine. Use only Gaymar probes or equivalent YSI 400 series probes.

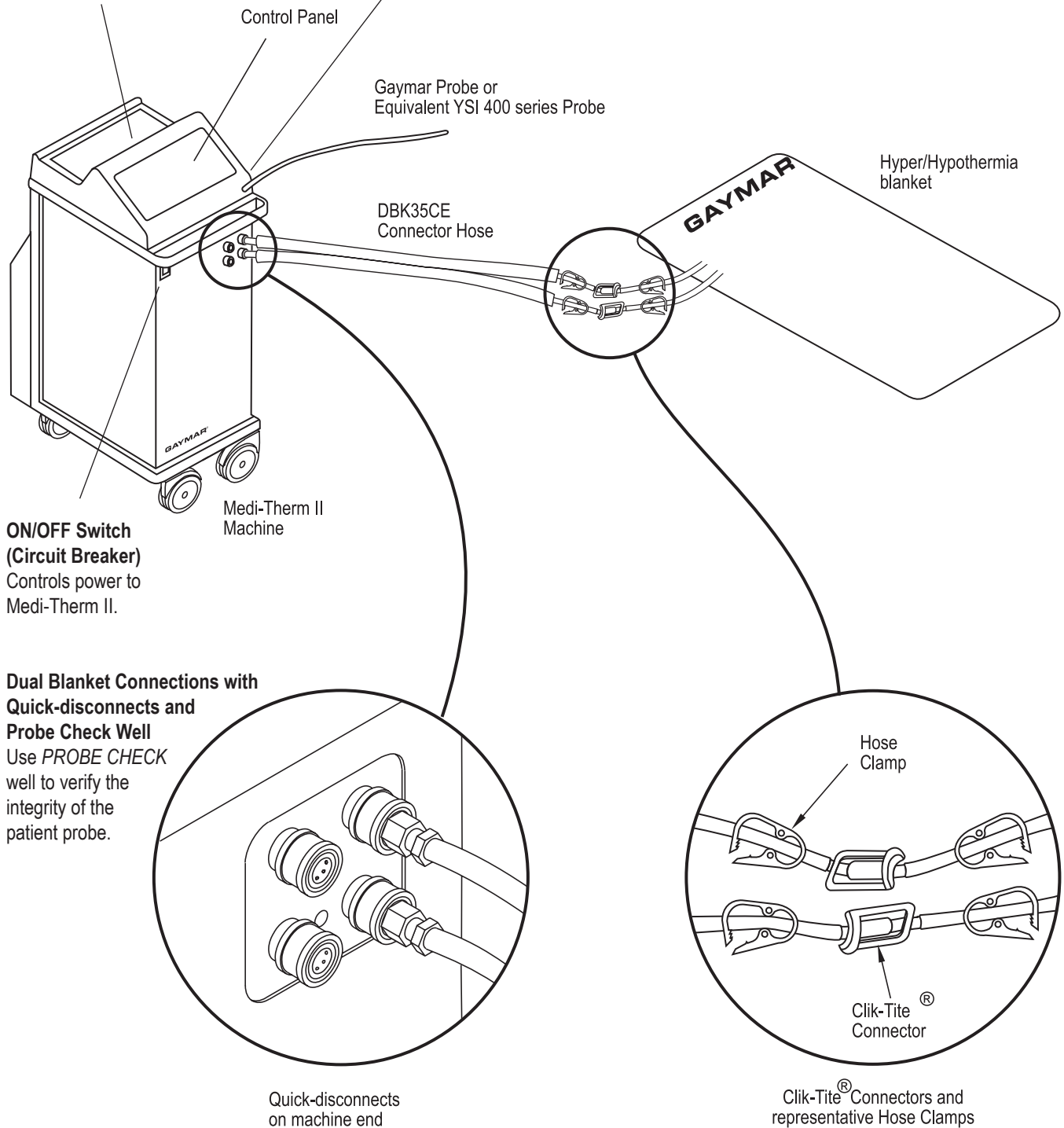







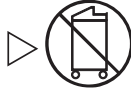

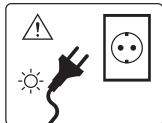

Figure 4—Medi-Therm II Hyper/Hypothermia System

5.0 Operator Control Panel

See figure 5, page 9.

MACHINE STATUS 	ALERTS
 <p>HEAT indicates the machine is heating.</p>	 <p>CHECK FLOW indicates the flow of water to the blanket has been restricted.</p>
 <p>IN-TEMP indicates that the blanket or patient temperature is at the desired temperature setting.</p>	 <p>CHECK PATIENT indicates the patient probe is sensing a temperature below 29°C or above 40°C.</p>
 <p>COOL indicates the machine is cooling.</p>	 <p>ADD WATER indicates the water reservoir is filled to less than the recommended level.</p>
 <p>TEST LIGHTS flashes all indicator lights and digital displays, while sounding an audible alarm.</p>	 <p>REMOVE FROM USE NOW indicates the Medi-Therm II machine has shut down. Remove the machine from use.</p>
 <p>ALARM SILENCE temporarily silences the <i>CHECK FLOW</i>, <i>CHECK PATIENT PROBE</i>, <i>FLASHING DISPLAY</i>, and <i>ADD WATER</i> alarms for 10 minutes.</p>	 <p>FLASHING DISPLAY indicates that the blanket or patient temperature is not being maintained within 0.5°C of the set point temperature. It is accompanied by an audible alarm.</p>
	 <p>POWER LOSS INDICATOR lights when power is removed and <i>ON/OFF</i> circuit breaker is <i>ON</i>. [located on front of machine]</p>

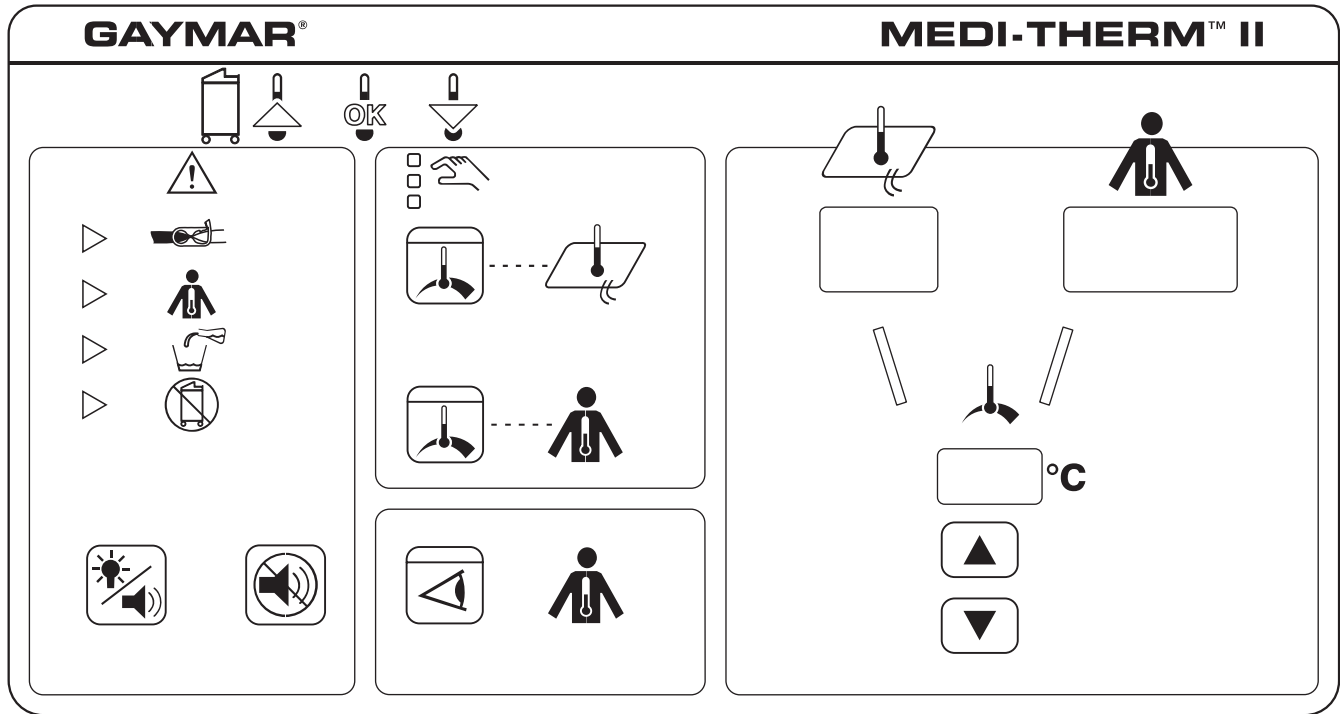

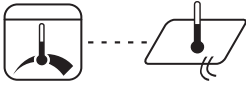

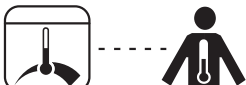





Figure 5—Medi-Therm II Control Panel

<p>SELECT MODE</p> 	<p>TEMPERATURE</p>
 <p>BLANKET CONTROL— Adjust <i>SET POINT</i> to control blanket temperature. (4°C to 41°C)</p>	 <p>BLANKET TEMPERATURE— This display lights when either <i>PATIENT CONTROL</i> or <i>BLANKET CONTROL</i> is selected.</p>
 <p>PATIENT CONTROL— Connect patient probe, then adjust <i>SET POINT</i> to control patient temperature. (30°C to 39°C)</p>	 <p>PATIENT TEMPERATURE— As measured by the patient probe. This display lights whenever a patient probe is plugged in.</p>
 <p>MONITOR ONLY— Connect patient probe, then use to monitor patient temperature. No therapy is provided.</p>	 <p>SET POINT CHANGE— Press the “▼” or “▲” button to select machine set point. When selecting a temperature outside the normothermic range (36°C to 38°C), an audible alarm will chime. Press and hold the “▼” or “▲” button until the chime stops to access the extended temperature range.</p>
	 <p>PATIENT PROBE JACK— Insert only a Gaymar probe or an equivalent YSI 400 series probe. [located on front of machine]</p>

6.0 Theory of Operation, System

The Gaymar Medi-Therm II machine provides a means of regulating patient temperature by supplying temperature-controlled water through a connector hose to a Gaymar Hyper/Hypothermia blanket. The blanket provides an interface for heating or cooling the patient. A patient probe senses patient temperature, which is displayed on the control panel. (See fig. 4, p. 7 and fig. 5, p. 9.)

The Medi-Therm II machine controls output water temperature by mixing hot and cold water using hot and cold solenoid valves under microcontroller control. A circulating pump, heater and refrigeration unit are also utilized.

Two backup systems limit output water temperature independent of the main microcontroller.

The feedback for control purposes depends upon the machine's operating mode. The machine may be operated in one of three operating modes:

- In *BLANKET CONTROL* mode, the operator sets the desired blanket temperature. A temperature sensor within the machine monitors the water temperature and the machine heats or cools the water as required to bring the blanket to the *SET POINT* temperature. The patient temperature may be monitored by use of a patient probe connected to the patient probe jack on the front of the unit.
- In *PATIENT CONTROL* mode, the Medi-Therm II machine automatically regulates the patient's temperature to the selected *SET POINT*. The machine constantly compares actual patient temperature with the *SET POINT* value, and automatically adjusts the blanket temperature so that the desired patient temperature is achieved.
- In *MONITOR ONLY* mode, the operator can monitor patient temperature through the patient probe, without providing therapy.

Hyperthermia/hypothermia blankets may be placed either under or over the patient, depending upon the type of procedure. Some applications may require a second blanket in order to achieve additional or more rapid heating or cooling. For these situations, a second blanket may be connected to the Medi-Therm II machine. The rate of patient heating or cooling may also be increased by positioning half- and full-sized blankets so that greater body surface is in contact with the blankets.

In the event of a power loss, a battery backup circuit will light the *POWER LOSS* light and sound the audible alarm. Upon restoring power, the mode of operation and the set points will have to be reselected.

6.1 Theory, Medi-Therm II Machine

Whenever the machine is on, 9½ liters of water are maintained cold in the cold water reservoir. A cold water reservoir probe provides temperature feedback to the main microcontroller which cycles the refrigeration unit on at 5.8°C and off at 3.3°C.

When the blanket water requires cooling, water is pumped from the cold water reservoir. When the blanket water requires heating, a cartridge heater is used to quickly heat the water.

WATER TEMPERATURE CONTROL

Hot and cold solenoid valves regulate the flow path by directing water returning from the blanket to either the hot or cold water reservoir. Regulating the flow path controls the temperature of water pumped to the blanket. The main microcontroller controls solenoid valve operation. Only one valve operates at a time:

- When the *HEAT* status light is lit, the hot solenoid valve is open. Water returning from the blanket circulates through the hot water reservoir and is heated before being pumped back to the blanket. The heater, pump, and hot solenoid valve are energized. See figure 15A, page 52.
- When the *COOL* status light is lit, the cold solenoid valve is open. Water returns from the blanket to the cold water reservoir and is replenished by chilled water from the cold water reservoir before being pumped back to the blanket. The pump and cold solenoid valve are energized. See figure 15B, page 52. The refrigeration unit maintains the cold water reservoir temperature and operates independently of the solenoid status.
- When the *IN-TEMP* status light is lit, either the **blanket** water temperature is within 0.5°C of the setpoint (in *BLANKET CONTROL* mode) or the **patient** temperature is within 0.5°C of the setpoint (in *PATIENT CONTROL* mode). Water temperature is controlled by alternating between heating and cooling (see figs. 15A and 15B, p. 52).

REFRIGERATION UNIT

The refrigeration circuit (see fig. 16, p. 53) consists of two heat exchangers operating at two pressures and two devices used to change these pressures. The first of these devices is the compressor which changes the gas pressure from low to high. The other device is the capillary tube which reduces the refrigerant pressure from high to low.

Beginning the cycle at the capillary tube, high pressure liquid refrigerant flows in the capillary tube and is discharged into the evaporator coil. The evaporator coil, which is a heat exchanger, receives the refrigerant as a mixture of liquid and vapor at a pressure low enough so that it boils and absorbs heat from the water surrounding it.

The heated refrigerant vapor then leaves the evaporator coils, enters the suction side of the compressor and is compressed, causing its pressure and temperature to increase. The vapor, much warmer than the ambient air, travels to the condenser.

The condenser is the other heat exchanger. The condenser fan draws the colder ambient air over the condenser coils and removes the heat being carried by the refrigerant and causes it to condense back into liquid refrigerant. This completes the cycle and the high pressure liquid refrigerant is returned to the capillary tube to be used over again. The temperature of the water surrounding the evaporator coil (in the cold water reservoir) is controlled by the main microcontroller. The microcontroller senses the temperature with a cold water reservoir probe and cycles the compressor relay on and off.

BACKUP SYSTEMS

Backup systems within the Medi-Therm II machine limit the temperature of water exiting the machine to specified ranges in the event of a failure of the control system including the main controller:

- **BACKUP SYSTEM I (PIC Microcontroller and probe)**

The first backup system is independent of the main microcontroller. It runs off its own power supply. It limits the temperature of water exiting the machine in the event of a failure of control circuitry (including the main microcontroller). Using an overtemperature probe in the same water path as the main microcontroller blanket water probe, water temperature is sensed. When limit temperatures are surpassed the PIC sends a signal to trigger an analog *REMOVE FROM USE NOW* circuit, which:

- shuts down the pump and heater
- lights the *ALERT* and the *REMOVE FROM USE NOW* indicators; and,
- sounds the audible alarm.

In addition, if the main microcontroller is operational, the compressor shuts down, the displays blank, and the *ALERT* indicator and audible alarm turn on and off. The power supply for this system is backed with a nickel hydride battery to provide a minimum 10 minute audible and visual *POWER LOSS* indication in the event of power failure.

- **BACKUP SYSTEM II (Thermostats)**

The second backup system is independent of both the main microcontroller and the first backup system. It limits the temperature of water exiting the machine in the event of a failure of control circuitry (including the main microcontroller). This is accomplished using two bimetallic thermostats. If either of these two thermostats is actuated, they open the heater circuit directly and

trigger an analog *REMOVE FROM USE NOW* circuit (separate from BACKUP SYSTEM I), which:

- shuts down the pump and heater
- lights the *ALERT* and the *REMOVE FROM USE NOW* indicators; and,
- sounds the audible alarm.

In addition, if the main microcontroller is operational, the compressor shuts down, the displays blank, and the *ALERT* indicator and audible alarm turn on and off.

6.2 Theory, System Component Interconnections

See figure 14, p. 51 for base-to-head and control/display board-to-power supply board connections; figure 25, p. 66 for the system wiring diagram; figures 26-28, pp. 67-70 for the electrical schematics; figures 22-24, pp. 60-65 for component layouts and part designations; and figure 29, p. 71 for the system block diagram.

CONTROL/DISPLAY BOARD, ALARM/BACKUP BOARD, AND POWER SUPPLY BOARD

The Medi-Therm II machine uses three printed circuit boards (see figure 14, p. 51):

- The control/display board contains the main microcontroller circuits, the display circuits, and all other low voltage control circuits.
- The alarm/backup board contains the BACKUP SYSTEM I microcontroller circuits, *POWER LOSS* indicator circuits and its own power supply.
- The power supply board contains the main microcontroller power supply, the low voltage to high voltage interface circuits, and the *REMOVE FROM USE NOW* latching circuits.

The control/display board connects to the patient probe jack J1 via P2 at J2 and to the digital control assembly panel via P4 at J4A. All other connections from the system's peripheral devices to the control/display board are made through the power supply board.

A 26-pin cable connects the control/display board via P1 at J1 to the power supply board via P3 at J4.

Five cables connect the components in the base of the machine to the PC boards in the head (see figure 14, p. 51):

- A **9-pin connector** P6 ties the blanket water probe RT2, cold water reservoir probe RT1, flow switch S5, and level switch S4 to the power supply board at J2 and ultimately to the control/display board.
- A **12-pin connector** P7 ties the high voltage devices (pump, heater, hot solenoid valve SV2, cold solenoid

valve SV1, and refrigeration compressor relay K1 to the interface circuits on the power supply board, as well as thermostats S1 and S2 to the high voltage latching circuitry on the power supply board, at J1 on the power supply board.

- A **6-pin connector** P5 connects transformer T1 housed in the base to the power supply circuitry at J3 on the power supply board.
- a **6-pin connector** P11 connects the over-temperature probe RT3 and auxiliary switch within the circuit breaker CB1 (for sensing *POWER LOSS*) to the alarm/backup board at J4.
- A **chassis ground harness** from the control/display board and alarm/backup board connects to the chassis.

6.3 Theory, Main Microcontroller Power Supply

See figure 25, p. 66 for the system wiring diagram; figures 26-28, pp. 67-70 for the electrical schematics; figures 22-24, pp. 60-65 for component layouts and part designations; and figure 29, p. 71 for the system block diagram.

Power enters the Medi-Therm II machine through circuit breaker CB1 to feed the refrigeration unit (through relay K1) and the stepdown transformer T2. The output of T2 is fused with a 6.3 amp fuse located below the TB1 terminal block; see figure 19, item 22. Stepped down voltage from T2 then enters the power supply board at J1 to feed the hot solenoid valve, cold solenoid valve, heater and pump triacs, the high voltage latching circuits and transformer T1.

Power to drive the low voltage circuits on the control/display board is derived from the machine's main microcontroller power supplies which reside entirely on the power supply board. The transformer T1 output is rectified and filtered to generate unregulated positive and negative voltages. Q5, D1, L1 and associated components are configured as a DC to DC switching regulator in a buck configuration yielding a nominal output of +5.3 volts DC. Q6 is a linear regulator with a nominal output of plus twelve (+12) volts DC, while Q7, also a linear regulator, delivers a nominal output of minus twelve (-12) volts DC.

6.4 Theory, Machine Functions

See figure 25, p. 66 for system wiring diagram; figures 26-28, pp. 67-70 for the electrical schematics; figures 22-24, pp. 67-70 for component layouts and part designations; and figure 29, p. 71 for the system block diagram.

The main microcontroller U37 is fully dependent on the code stored in the U31 EPROM. When the machine is on, the main microcontroller continually cycles through its main program loop to perform the following:

- Thermistor output measurement (see section 6.4.1)

- Digital control panel input (section 6.4.2)
- Display update (section 6.4.3)
- Peripheral input (section 6.4.4, p. 13)
- Blanket/Patient temperature control (section 6.4.5, p. 13)
- Cold water reservoir temperature control (section 6.4.6, p. 14)

Backup water temperature limiting is achieved independently of the microcontroller. See section 6.4.7, page 14.

6.4.1 Thermistor Output Measurement

Temperature measurement is achieved using 400 series thermistor beads located in the blanket water path (blanket water probe RT2), the cold water reservoir (cold water reservoir probe RT1), and in the patient via the patient probe jack J1.

The main microcontroller connects each of the three beads to the current source circuitry (U38 and associated components) using demultiplexor U49. At the same time, the resulting output voltage created by the current through the thermistor is presented to an amplifier circuit (U39 and associated components) via multiplexor U50. The amplified voltage is then applied to a voltage-to-frequency converter U24. A frequency up to 100kHz is presented to port pin P3.5 of the microcontroller. The microcontroller converts the incoming frequency to a temperature value.

At regular intervals two compensation resistors R13 and R12 are also processed in the same manner. These compensation resistors are precision resistors with values at each end of the probe temperature range of 0°C to 50°C. The values from the precision resistors are used to compensate for circuit drift.

6.4.2 Digital Control Panel Input

User input is entered via a digital control panel. The input from the buttons is decoded by U45. The "data available" line of U45 is tied to the main microcontroller port pin P3.3. When a button press is decoded and debounced by U45, the "data available" line goes high and the microcontroller responds by inputting the decoded value.

6.4.3 Display Update

For display of measured and set point temperatures, 7 segment LED displays are utilized:

- The set point display is driven by driver chip U48. The main microcontroller interfaces to it via the data bus at addresses 0FFF8H, 0FFF9H, 0FFFAH, 0FFFBH.
- The patient display is driven by driver chip U6. The main microcontroller interfaces to it via the data bus at addresses 0FFF4H, 0FFF5H, 0FFF6H, 0FFF7H.

- The blanket display is driven by driver chip U5. The main microcontroller interfaces to it via the data bus at addresses 0FFECH, 0FFEDH, 0FFEEH, 0FFEFH.

All alarm and status indicators are lit by LED bars driven by inverter/driver IC's:

- The alarm latch U53 is the interface between the main microcontroller and the *ALERT*, *ADD WATER*, *CHECK PATIENT*, *CHECK FLOW*, *REMOVE FROM USE NOW*, and *SELECT* drivers via the data bus at address 0FFBFH. A high signal written to the latch by the main microcontroller activates the individual inverter/drivers to light the corresponding indicator.
- The mode display latch U54 is the interface between main microcontroller and the *IN-TEMP*, *COOL*, *HEAT*, *PATIENT CONTROL*, *BLANKET CONTROL*, and *MONITOR ONLY* drivers via the data bus at address 0FFDFH. A high signal written to the latch by the main microcontroller activates the individual inverter/drivers.
- The control latch U51 is the interface between the main microcontroller and the two leader light drivers via the data bus at address 0FF7FH. When this latch is selected, a low signal on the data line from the microcontroller causes a high signal on the latch output. Therefore, these two LED bar displays are "active low" in the eyes of the microcontroller in contrast to all the other LED bar displays of the machine.

The audible alarm located on the alarm/backup board is driven by a high signal from the control latch U51 (from the main microcontroller via the data bus at address 0FF7FH) or a high RFU IN signal from Q10 on the power supply board or a high signal from the PIC microcontroller on the alarm/backup board. A low data line signal from the main microcontroller to U51 causes a high signal on the latch output. Therefore, the alarm is "active low" in the eyes of the main microcontroller. NOR gate U40, driver U26 and transistor Q1 work in conjunction to activate the alarm.

6.4.4 Peripheral Input

The input buffer U55 is the interface between the main microcontroller (via the data bus at a "read" address of 0FFFEH) and the input signals from the flow switch S5 and the level switch S4 (which travel from the base through the power supply board), the probe presence switch within the patient probe jack J1, and the service mode button S3 on the control/display board. The lines to the buffer from the peripheral devices are default high (via pull-up resistors).

The level switch S4 will pull its buffer input line low when it senses a sufficient water level.

The flow switch S5 will pull its buffer input line low when it senses sufficient flow.

The probe presence switch within J1 will pull its buffer input line low when it senses the presence of the patient probe.

Pressing the service mode switch S3 on the control/display board will pull its buffer input line low. Pressing this switch while powering up the machine will cause the machine to execute code which implements several service modes for troubleshooting use.

6.4.5 Blanket/Patient Temperature Control

If the machine is in *BLANKET CONTROL* mode, the blanket water temperature as sensed by the blanket water probe is used as the feedback signal for controlling the water temperature to the *BLANKET CONTROL* mode set point temperature.

If the machine is in *PATIENT CONTROL* mode, the patient temperature as sensed by the patient probe connected to the patient probe jack is used as the feedback signal for controlling the patient temperature to the *PATIENT CONTROL* mode set point temperature. The machine accomplishes this by adjusting the water temperature.

For water temperature control, the main microcontroller control system outputs a pulse train to each solenoid valve. The pulse train to the hot solenoid (and also heater) is the complement of the pulse train to the cold solenoid. The pulse train duty cycle depends on the magnitude and sense of the control signal calculated by the main microcontroller. That is, while the solenoids are each either on or off, the ratio of on time to off time is proportional to the calculated control signal amplitude. For large differences between set point and probe temperatures, the output to each solenoid valve will be either on or off. For differences approaching zero, the outputs to the solenoid valves (and heater) will switch on and off, with the on and off times automatically adjusted to maintain a probe temperature equal to the set point.

The circulating pump is energized whenever the unit is in *PATIENT CONTROL* or *BLANKET CONTROL* modes.

The control latch U51 on the control/display board is the interface between the main microcontroller (via the data bus at address 0FF7FH) and the peripheral drivers on the power supply board.

Interface circuitry on the power supply board consists of U1, U2, U7, U8, Q3, Q4, Q8, Q9, and associated components. U1, U2, U7, and U8 are optically coupled triac drivers used to control their respective triacs (Q3, Q4, Q8, and Q9); these combinations provide electrical isolation between the low voltage main microcontroller control circuits and the line voltage circuits.

The heater, pump, hot solenoid valve, and cold solenoid valve are individually controlled by the main microcontroller through latch U51 on the control/display board. A high signal on the data line from the main microcontroller causes a low signal on the appropriate output line of U51 which then sinks current from the power supply board to activate the peripheral devices.

Pin 11 of U51 on the control/display board and U8 and Q9 of the power supply board control the cold solenoid valve while pin 9 of U51 on the control/display board and U7 and Q8 of the power supply board control the hot solenoid valve. Pin 8 of U51 on the control/display board and U2 and Q4 of the power supply board control the circulating pump. Pin 7 of U51 on the control/display board and U1 and Q3 of the power supply board control power to the heater.

6.4.6 Cold Water Reservoir Temperature Control

The control latch U51 on the control/display board is the interface between the main microcontroller (via the data bus at address 0FF7FH) and the refrigeration compressor relay driver on the power supply board. A high signal on the appropriate data line causes a low signal at pin 6 of U51 on the control/display board, which then activates Q12 on the power supply board. Q12 on the power supply board is the interface between the control/display board and the coil of the power relay K1 located in the machine base. The main microcontroller switches power through the relay to the refrigeration compressor at cut-out and cut-in temperatures of 3.3°C and 5.8°C. These temperatures are sensed by the cold water reservoir probe RT1 located in the water reservoir. (See figure 16, p. 53.) Control of the cold water reservoir temperature takes place whenever the machine is on.

6.4.7 Backup Water Temperature Limiting

Water temperature limiting is provided by two systems; Backup System I and Backup System II.

Backup System I consists of a PIC microcontroller residing on the alarm/backup board, the over-temperature probe RT3 located in the base, and one of the *REMOVE FROM USE NOW* latching circuits on the power supply board.

Backup System II consists of two *REMOVE FROM USE NOW* latching circuits and two fixed non-adjustable temperature limit thermostats, S1 and S2 located in the base.

6.4.7.1 *REMOVE FROM USE NOW* Latching Circuits

The power supply board includes two *REMOVE FROM USE NOW* latching circuits made up of U3, U4, U5, U6, U9, U10, D2, D3, Q1, Q2, and their interconnecting components. Under normal circumstances, Q1 and Q2 are kept turned on by the action of R7, C10, and D4 and R5, C15, and D5 to complete the conduction path for the heater and pump.

6.4.7.2 Backup System I

The PIC microcontroller has its own power supply on the alarm/backup board which is independent of the main microcontroller's power supply circuits. Transformer T1 output is rectified and filtered to generate unregulated positive voltage. Q1 is a linear regulator with a nominal output of +5.0 volts. Interface circuitry for Backup System 1 consists of Q2 and R1 on the alarm/backup

board and optical coupler U4 on the power supply board which is powered by the independent power supply of the alarm/backup board.

The PIC microcontroller repetitively compares the resistance of the RT3 over-temperature probe (which is a 400 series thermistor in the blanket water flow path) with fixed precision resistor R11. When the blanket water temperature (as sensed by RT3) surpasses the temperature represented by the fixed resistor (see section 3.2, *Thermal Specifications*, page 3, for the RT3 high temperature limit) the PIC commands a *REMOVE FROM USE NOW* shutdown condition via optical coupler U4 on the power supply board. It also signals the audible alarm directly with a continuous tone (regardless of the main microcontroller operational status). These commanded signals by the PIC microcontroller will remain until the machine is powered down.

U4 prevents Q1 from turning on so full line voltage will appear between J1-2 and J1-3. In this case, U5 and U10 will be turned on by the action of R4, D3, and associated parts while U3 and U9 will be turned on by the action of R6, D2, and associated parts. U5 prevents Q2 from turning on and U3 prevents Q1 from turning on even if the PIC command signal is removed. The output of either U9 or U10, through buffer Q10, signals the main microcontroller that a *REMOVE FROM USE NOW* condition has resulted. Thus, should the PIC microcontroller sense an over temperature condition, the heater and pump are shut off and the main microcontroller is notified.

6.4.7.3 Backup System II

If the blanket water falls into the low temperature limit range, S1 will open. If the blanket water temperature rises into the high temperature range, S2 will open (see section 3.2, *Thermal Specifications*, page 3, for the high and low temperature limits).

When either of these thermostats opens, it directly interrupts the circuit and shuts off the pump and heater; at the same time, full line voltage will appear between J1-2 and J1-3. In this case, U5 and U10 will be turned on by the action of R4, D3, and associated parts while U3 and U9 will be turned on by the action of R6, D2, and associated parts. U5 prevents Q2 from turning on and U3 prevents Q1 from turning on even if the open thermostat(s) closes again. The output of either U9 or U10, through buffer Q10, signals the main microcontroller that a *REMOVE FROM USE NOW* condition has resulted. Thus, should either thermostat (S1 or S2) trip, the heater and pump are shut off and the main microcontroller is notified.

6.4.7.4 Both Backup System I and II

On the control/display board, a high signal from Q10 of the power supply boards feed drivers U52 to light the *REMOVE FROM USE NOW* LED, feeds driver U11 to light the *ALERT* LED, and feeds NOR gate U40 to drive the audible alarm located on the alarm/backup board. All this is done independent of the main

microcontroller. The same signal is sent to port P3.2 of the microcontroller through C1, R1, and driver U11.

6.4.7.5 If The Main Microcontroller Is Nonoperational

If the main microcontroller is nonoperational at the event of a signal from Q10 of the power supply board, the user is notified of the *REMOVE FROM USE NOW* condition by the fact that all the above mentioned indicators are on continuously. In addition, the separate redundant circuits on the power supply board, each triggered by either of the thermostats, or one triggered by the PIC microcontroller, insure that the pump and heater remain off even if the thermostat closes again or the PIC command signal is lost. The *REMOVE FROM USE NOW* condition remains latched and can be cleared only by an operator intervention in the form of turning the machine circuit breaker off. If upon machine turn on the fault condition still exists, the *REMOVE FROM USE NOW* condition will recur.

6.4.7.6 If the Main Microcontroller is Operational

If the main microcontroller is operational at the event of a high signal from Q10 of the power supply board (originating from BACKUP SYSTEM I or BACKUP SYSTEM II), the signal at P3.2 causes the main microcontroller to shut off the 7 segment displays, flash the *ALERT LED* and light the *REMOVE FROM USE NOW LED*, toggle the audible alarm, store the appropriate RFU (Remove From Use) code indicating the reason for the shutdown, turn off the heater and pump triacs Q3 and Q4, turn off the solenoid triacs Q8 and Q9, and turn off the compressor transistor Q12. (Separate machine service modes allow for viewing the RFU code and for debugging problems. See section 8.0.)

The process of turning off the heater and pump triacs Q3 and Q4 by the main microcontroller removes power from the *REMOVE FROM USE NOW* circuitry on the power board which then allows the indicators on the control/display board to toggle under main microcontroller control.

Note: The audible alarm will be a continuous tone for an over temperature condition sensed by BACKUP SYSTEM 1 regardless of the operational status of the main microcontroller since the PIC microcontroller puts out a continuous signal to the audible independently which does not get reset and which overrides any pulsing of the audible the main microcontroller may perform.

The shutdown condition by the main microcontroller program will remain until the machine is powered down. If, upon machine turn on, the fault condition still exists, power replaced to the *REMOVE FROM USE NOW* circuits on the power supply board when a mode is selected (or automatically every 60 seconds in standby mode) will cause the *REMOVE FROM USE NOW* condition to recur.

6.4.7.7 Other REMOVE FROM USE NOW Shutdown Conditions

If during normal operation the main microcontroller senses internal problems, it will cause a machine shutdown condition as in 6.4.7.6. As a precaution, it also sends an output signal from port pin P3.4 through U40 on the control/display board, to command, via Q11 and U6 on the power supply board a *REMOVE FROM USE NOW* shutdown condition of the latches. The appropriate RFU (Remove From Use) code for the shutdown will be stored. See section 8.0.

6.4.8 Power Loss

The PIC microcontroller also provides the *POWER LOSS* detection function. The Q1 linear regulator is provided voltage also from an 8.4V nominal nickel metal hydride battery when the auxiliary switch of the circuit breaker CB1 is closed (indicating the circuit breaker is in the on position) and the main microcontroller power supply circuits are not powered. The PIC microcontroller detects this *POWER LOSS* condition via the optical coupler U3 which is tied to the main microcontroller power supply circuits.

6.4.9 Battery Charging

When the main microcontroller power supply circuits are powered and the auxiliary switch of the circuit breaker CB1 is closed (indicating the circuit breaker is in the on position), the battery is trickle charged through R3 on the alarm/backup board.

6.4.10 Detection of Operational Backup System 1

The PIC microcontroller provides the 1 second power-up tone for the machine. This can be used by the user to ascertain whether the PIC microcontroller is operational. But, whenever the machine is on the PIC microcontroller also creates a 0.15 second on, 0.15 second off square wave pulse which is fed to the main microcontroller via optical coupler U4 on the alarm/backup board. The main microcontroller constantly monitors for this signal via the *CONN_SENSE* line. If the pulse is not there or if it is not correct, the main microcontroller shuts the machine down with a *REMOVE FROM USE NOW* condition because this indicates that the alarm/backup board has either been disconnected or the PIC is not operational.

7.0 Functional Check, Safety Inspection, and Preventive Maintenance

7.1 Receiving Inspection Procedures

CONCEALED DAMAGE

After unpacking the Medi-Therm II machine, inspect the machine for concealed damage. Save all packing material and carefully describe or photograph the damage. Notify the carrier at once and ask for an inspection (in writing). Failure to do this within 15 days may result in loss of claim.

Before placing the Medi-Therm II machine into service, remove the three compressor shipping braces (see p. 72, fig. B), attach the power cord (p. 57), fill the reservoir with distilled water (p. 3 and p. 7), make sure the power loss indication works (e), p. 18), and perform a *Functional Check and Safety Inspection* (pp. 17-21).

7.2 Cleaning and Storage Procedures

FLUID SYSTEM

Use distilled water to retard algae growth and mineral buildup. Change the distilled water monthly or more often depending upon use.

The water circulation system, including blankets, should be cleaned every month to retard algae growth.

To clean the fluid system, drain the machine and prepare an algaecidal solution according to manufacturer's instructions. Use AirKem A-33 or equivalent. Add the solution to the machine, attach blankets, set the machine in *BLANKET CONTROL* mode to a setpoint temperature of 27°C and circulate the solution for 12 hours. Drain the solution and refill the machine with distilled water. Algaecide solution may be readded to the water and left in the machine in the recommended concentration to further retard algae growth.

▲ CAUTION

- Do not exceed proper algaecidal solution concentration. **Excessive algaecide may cause foaming, which can damage the circulating pump.**
- Do not use bleach (sodium hypochlorite). **Bleach will damage the heating element in the machine, which could result in excessive leakage current.**

COMPRESSOR

Dirt that has accumulated on the condenser coils and cooling fins within the machine will reduce the efficiency of the compressor and should be removed with a vacuum cleaner or compressed air hose. This will require removal of the rear baffle assembly. This should be checked monthly or more frequently depending upon use. See figure 18, p. 55.

PUMP

Pump motor should be oiled once a year with 3-4 drops of general purpose motor oil in the locations identified on the pump label.

7.2.1 Machine Cleaning

▲ CAUTION

Users should not use cleaning or decontamination methods different from those recommended.

To clean the external surfaces of the machine and connector hose, use a nonabrasive cleaning solution (such as warm, soapy water) and a clean cloth. Wipe or air dry. Apply a disinfectant such as 10% chlorinated bleach solution (chlorinated bleach with 5.25% sodium hypochlorite) to the external surfaces and allow to dry.

Do not use bleach within the machine.

7.2.2 Blanket Care

▲ CAUTION

- Do not store filled blankets. Algae growth may occur inside.
- Do not use a blanket if severe algae buildup occurs.
- Do not expose blankets to temperatures over 65°C.

REUSABLE BLANKETS

To clean inside reusable blankets, attach the blankets to the machine and follow instructions for section 7.2, *Cleaning and Storage Procedures, Fluid System*.

To clean the outside of a reusable blanket:

1. Manually clean both sides of the blanket on a flat surface with warm water, a mild commercial detergent, and a sponge or cloth.
2. Thoroughly rinse with clean water for 30 seconds.
3. Air dry or wipe with a clean cloth.
4. Apply a disinfectant such as a 10% chlorinated bleach solution (chlorinated bleach with 5.25% sodium hypochlorite) to both sides of the blanket.
5. Allow to air dry. Solution contact time is what makes disinfection effective.

NOTE: Excess solution pooled in the buttons can be removed with a clean, dry cloth.

6. Loosely roll up the blanket and store for next use.

Reusable blankets can be cleaned and reused so long as they do not crack or leak.

7.2.3 Probe Care

REUSABLE PROBES

For cleaning, disinfecting, and sterilizing reusable Gaymar probes (or equivalent YSI 400 series reusable probes), refer to the instructions provided with the probe.

DISPOSABLE PROBES

Gaymar disposable probes should be discarded after use.

7.2.4 Probe Check Well Care

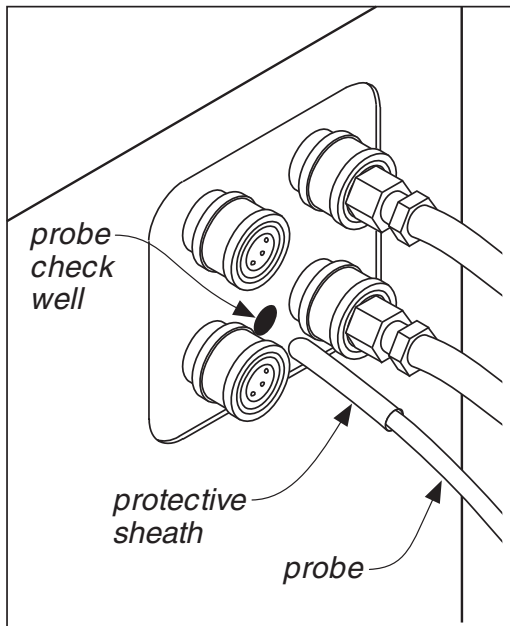

Figure 6—Probe Check Well

The *PROBE CHECK WELL* should be cleaned with a small tubular brush as outlined in section 7.2.1, *Machine Cleaning*.

7.2.5 Quick-Disconnects

The quick-disconnects joining the connector hose to the machine may become difficult to engage. This problem can be prevented by periodically applying a silicone base or light machine oil to the outside of the male connector prior to engagement.

7.3 Functional Check and Safety Inspection

To assure the optimum performance, dependability and safety, the following should be performed each year, or as specified in the facility's preventive maintenance program.

An Inspection Form is provided at the end of this section to facilitate and document the inspection process. Lower case letters preceding the subheadings within section 7.3 correspond to the lines on the *Inspection Form*.

⚠ WARNING

Always perform the *Functional Check and Safety Inspection* after making repairs and before returning the Medi-Therm II machine to patient use.

Improper repair may result in death or serious injury, equipment damage, or malfunction.

REQUIRED TEST EQUIPMENT

The following test equipment (or equivalent) is required to perform the preventive maintenance/functional check procedures:

- GAYMAR TPT9 Flowmeter/Temperature Tester †
- GAYMAR TFC1 Mercury Thermometer ($\pm 1^\circ\text{C}$ accuracy); -2°C to $+52^\circ\text{C}$ range †
- † As an alternative to the above TPT9 and TFC1 test equipment, you may use:
 - a liquid flow meter with a measurement range of 10 to 75 liters per hour and an accuracy of $\pm 5\%$ of full scale, and
 - an inline fluid temperature sensor with a measurement range of 0 to 50°C and an accuracy of $\pm 1^\circ\text{C}$.

- GAYMAR DBK35CE Blanket Connector Hose
- GAYMAR PRK2 Patient Temp Simulator Kit, or a Precision Decade Box (0-10K ohms, 0.2% accuracy, 1 ohm increments)
- GAYMAR DHP901CE or DHP813CE Hyper/Hypothermia Blanket
- Ground Resistance Checker
- Current Leakage Tester
- Static Control Wrist Strap

⚠ DANGER

Risk of electrical shock when parts are electrified.

Follow the following procedures carefully, paying particular attention to test setups. Any deviation from the setups, procedures, or test equipment may result in incorrect or misleading results.

Before making any repairs, be sure to recheck your test setup, procedure, and test equipment.

a) Condition of Chassis

The following inspections should be performed:

1. The chassis should be clean and relatively free of rust and corrosion.
2. Exterior screws should be tight
3. Legends, markings, and operator instructions should be legible.
4. Dirt that has accumulated in vents and cooling fins within the machine should be removed with a vacuum cleaner or compressed air hose. This will require removal of the rear baffle assembly.
5. Check that the casters are tight and functioning properly.
6. The quick-disconnect fittings on the machine may become stiff and difficult to engage. If so, apply a silicone-base lubricant to the inside of the machine fittings and the outside of the blanket connector.
7. Clean the Probe Check Well according to the procedure described in section 7.2.4, p. 17.
8. Inspect the fluid system for debris and any sign of algae growth. Clean according to *Cleaning and Storage Procedures, Fluid System* (section 7.2, p. 16).

b) Attachment Plug

Examine the attachment plug on the line cord to be sure that it is in good condition.

c) Power Cord and Cord Retainer

Make sure the detachable power cord is an approved cord set (see 3.4, p. 5). Examine the power cord along its entire length for physical damage, such as cuts or cracked insulation. A damaged power cord should be replaced rather than repaired. Check that the cord retainer is installed and secure. Do not operate without the cord retainer.

d) Circuit Breaker

A worn out circuit breaker can be responsible for intermittent shutoffs, with no other apparent indications of failure.

Examine the physical condition of the circuit breaker, paying particular attention to the push-on terminals at the rear of the breaker. Terminals should be snug. Replace breaker and/or terminals if there is discoloration or any indication of heating.

Cycle the switch on and off several times. The switch should have a positive engagement (“click”) for the *OFF* and *ON* positions.

e) POWER LOSS Indication

Test to insure that the *POWER LOSS* indication works. With the power cord unplugged, turn the circuit breaker to the *ON* position. The *POWER LOSS* indicator should flash and the audible alarm should sound continuously. If it doesn’t, the battery may have self-discharged due to nonuse. While the machine operates it trickle charges the battery, which powers this function. Operating the machine for four hours will recharge the battery sufficiently to allow 10 minutes of *POWER LOSS INDICATOR* operation. If the battery does not recharge, replace it. Dispose of battery. See the alarm/backup board parts list (p. 65).

⚠ WARNING

Replace with a rechargeable battery only (type V7/8H-Nickel Hydride, 8.4 V nominal, 150 mAh). Otherwise, battery damage may occur.

f) Condition of Lights and Alarm

Plug in the Medi-Therm II machine and turn it on. Press and hold the *TEST LIGHTS* button. The right and left halves of the display panel should light and blank alternately (along with the audible alarm). The three status legends (*HEAT*, *IN-TEMP*, and *COOL*), the *ALERT* legend and its four (triangular) indicators, and the three mode legends and *SELECT* heading should be lit. The three temperature displays should indicate “888”, “888.8”, and “888.8”. The two lines connecting *SET POINT* to both the *BLANKET TEMPERATURE* and *PATIENT TEMPERATURE* display should be lit. The audible alarm should sound. Replace any LED’s which do not light.

g) Flow

To measure the machine’s flow rate and check the flow switch actuation, perform the following:

1. Fill machine with distilled water until green band on float stem is fully visible.
2. Connect the test setup shown in figure 17A/B, p. 54.
3. Turn machine on. Set machine in *BLANKET CONTROL* mode.
4. Increase the temperature set point to light the *HEAT* status light. Note the flow rate.
5. Decrease the temperature set point to light the *COOL* status light. Note the flow rate.
6. The flow rate in both modes should exceed 60.6 liters per hour.

NOTE: If the unit has been completely drained, air can be trapped in the pump causing flow to be decreased. To clear the air, turn the unit off, wait approximately one minute, and start again from step 3.

7. Kink the hose to stop the flow. The *CHECK FLOW* indicator should light, the *ALERT* indicator should flash on and off, and the audible alarm should sound.

h) Level Switch Actuation

To test the actuation of the level switch, perform the following:

1. Fill machine with distilled water until green band on float stem is fully visible. The *ADD WATER* indicator should be off.
2. Connect a DBK35CE hose to a supply fitting on the machine and direct the other end to a drain or gallon (4 liter) container.
3. Turn machine on. Set machine in *BLANKET CONTROL* mode. Adjust the temperature set point to 4°C (*COOL* status light on).
4. Allow water to drain until bobber has bottomed out on the drain screen (about 3 liters). The *ADD WATER* indicator should be lit and the audible alarm should sound.
5. Refill machine with distilled water until the green band is fully visible. Verify that the *ADD WATER* indicator goes out.

i) Cold Water Reservoir Controller

To check the cold water reservoir controller, perform the following:

1. Fill machine with distilled water until green band on float stem is fully visible.
2. Connect the test setup shown in figure 17A/B, p. 54.
NOTE: To minimize the test time **for this test only**, remove the blanket from the flow path shown in figures 17A/17B.
3. Turn machine on and push the *BLANKET CONTROL* mode button.
4. Set the Temperature Setpoint to 4°C.
5. Verify that the machine can supply water anywhere within the 3°C to 6°C range as measured and that the compressor turns off one time. (This will take 15-30 minutes, depending upon room temperature and other conditions. The use of a blanket for this test can extend this time up to 60 minutes.)

j) Blanket Water Temperature Controller and Display Test

To check the temperature controller, perform the following:

1. Fill machine with distilled water until green band on float stem is fully visible.
2. Connect the test setup shown in figure 17, p. 54.

3. Turn machine on. Set in *BLANKET CONTROL* mode.
4. Set the Temperature Setpoint to the various settings specified on the *Inspection Form* (fig. 7, p. 21), wait until the *IN-TEMP* LED comes on and the water temperature stabilizes, then record the measured temperature and that shown on the display. Verify that the recorded values are within the limits outlined on *Inspection Form*, item j.

k) High Temperature Backup Trip Temperatures

The following checks k1) and k2) should be performed in the order shown:

k1) S2 High Temperature Thermostat Trip Temperature

1. Fill machine with distilled water until the green band on float stem is fully visible.
2. To test S2, RT3 will need to be disabled. This can be accomplished by disconnecting the alarm/backup board while the machine is operated in the service modes.

Note: In normal operating modes (non-service modes), a disconnected alarm/backup board will be detected and cause a *REMOVE FROM USE NOW* shutdown condition with a RFU code "P" stored.

3. Unplug the power cord.

4. Disconnect the 7-conductor cable harness connector P12 from the alarm/backup board. See figure 14, page 51.
5. Disconnect the 6 conductor cable harness connector P11 from the alarm/backup board. See figure 14.
6. Plug the machine in.
7. Place the machine in service mode 3. Refer to section 8.1, *Service Modes* (p. 22, 24) for instructions.
8. Run the machine for 5 minutes after the blanket water temperature has reached 41°C.
9. Enter service mode 4 (see section 8.1, pp. 22, 25) from service mode 3. Mode 4 will cause the machine to heat up until S2 trips.
10. Monitor the blanket water temperature. When the *ALERT* and *REMOVE FROM USE NOW* LED's light (no audible alarm), the measured temperature should be within the limits listed on the *Inspection Form*. This indicates that S2 has tripped. Record the temperature at which S2 tripped on the *Inspection Form*.
11. Turn the machine off and unplug the power cord. Disconnect supply hose from TPT9/flowmeter and allow water to gravity drain into a container for approximately one minute. This will circulate cold water from the reservoir past the thermostat causing it to reset. Reconnect supply hose and return drained water to machine reservoir.

12. Reconnect the 6-conductor cable harness connector P11 to the alarm/backup board. See figure 14.
13. Reconnect the 7-conductor cable harness connector P12 to the alarm/backup board. See figure 14.

k2) RT3 Over Temperature Probe Trip Temperature

1. **Unplug the power cord.**
2. Remove the six screws holding the top assembly (head) to the machine base. Carefully lift the head and position it on its side so that you can see DS1 on the alarm/backup board (fig. 14, p. 51).
3. Connect test setup as shown in figure 17A/B, p. 54.
4. Plug the machine in.
5. Place the machine in service mode 3. Refer to section 8.1, *Service Modes* (pp. 22, 24) for instructions.
6. To insure the correct measurement of the RT3 trip point, run the machine for 15 minutes after the blanket water temperature has reached 41°C. This allows the inside of the machine to achieve normal operating temperature.
7. Enter service mode 4 (see section 8.1, pp. 22, 25) from service mode 3. Mode 4 will cause the machine to heat up until RT3 trips. Monitor DS1 and the measured temperature. When DS1 lights, approximately 5 seconds later the *REMOVE FROM USE NOW* LED's should light and the audible alarm should sound. This indicates RT3 has tripped. Verify that the measured temperature is within the limits listed on the *Inspection Form* for RT3 and record the temperature on the form.
8. Turn the machine off and unplug the power cord. Disconnect the supply hose from TPT9/flowmeter and allow water to gravity drain into a container for approximately one minute. This will circulate cold water from the reservoir past the thermostat, causing it to reset. Reconnect supply hose and return drained water to machine reservoir.
9. Replace the head on the base. Replace the six screws.

l) Patient Temperature Display Test

To check the patient temperature display, perform the following:

1. Fill machine with distilled water until green band on float stem is fully visible.
2. Connect a resistance of 1355 ohms to the patient probe jack, to simulate a 37°C patient temperature.
3. Turn machine on and set it in the *BLANKET CONTROL* mode.
4. The *PATIENT* Temperature Display should indicate 37°C ± 0.2°C. Record appropriate value on *Inspection Form*.

m) Grounding Resistance

Use an ohmmeter to measure the resistance between the grounding pin on the line cord attachment plug and an exposed metal point on the chassis. The value should be less than 0.5 ohms.

n) Current Leakage

Current Leakage, EARTH

Measure and record the maximum earth current leakage (ground open). Measure all combinations of:

- line polarity
- neutral closed, open

Measure in all operating configurations (heating, cooling, compressor on, compressor off) in the neutral closed test. The leakage values should not exceed those listed on the *Inspection Form*.

Current Leakage, PATIENT PROBE

Measure and record *PATIENT PROBE* leakage current. It is first necessary to prepare a patient probe by wrapping it tightly along its entire length with metal foil. Measure current leakage at the foil for all combinations of:

- line polarity
- neutral closed, open

The leakage values should not exceed those listed on the *Inspection Form*.

o) Reset the RFU Code

The Medi-Therm II machine will retain the previously stored code. Before returning a machine to service, reset the RFU code to zero so that a previous code is not held in memory.

To reset the RFU code to zero:

1. Place the machine in service mode 1 (see section 8.1, pp. 22 and 24).
2. Press the *TEST LIGHTS* button on the control panel.

The RFU code is reset when the number on the blanket display shows "0".

.....

This completes the recommended functional test and preventive maintenance procedures for the Gaymar Medi-Therm II.

If a machine passes all the requirements of paragraphs "a" through "o", the machine should be considered operational and suitable for return to service.

Medi-Therm II Hyper/Hypothermia REF MTA6012CE Functional Check / Inspection Form *															
Location _____		Serial number _____													
Item	OK? (Y/N)	Action needed	Action Taken (Date / Initials)												
a. Condition of chassis															
b. Condition of attachment plug															
c. Power cord and cord retainer															
d. Circuit breaker															
e. Power Loss Indication															
f. Condition of lights and alarm															
g. Flow:															
1. [HEATING] Greater than . . .	60.6 liters per hour														
2. [COOLING] Greater than . . .	60.6 liters per hour														
3. Flow switch actuation															
h. Level switch actuation															
i. Cold water reservoir controller: 3°C to 6°C															
j. Blanket water temperature controller and display test:															
<table border="1" style="border-collapse: collapse; width: 100%;"> <thead> <tr> <th style="width: 30%;">Temperature Control Setpoint</th> <th style="width: 15%;">Display Reading</th> <th style="width: 15%;">Measured Temperature</th> </tr> </thead> <tbody> <tr> <td style="text-align: center;">10°C</td> <td></td> <td></td> </tr> <tr> <td style="text-align: center;">25°C</td> <td></td> <td></td> </tr> <tr> <td style="text-align: center;">41°C</td> <td></td> <td></td> </tr> </tbody> </table>	Temperature Control Setpoint	Display Reading	Measured Temperature	10°C			25°C			41°C					
Temperature Control Setpoint	Display Reading	Measured Temperature													
10°C															
25°C															
41°C															
Display readings within 1°C of temperature setpoint Measured temperature within 1°C of temperature setpoint															
k1. S2: High temperature backup thermostat: 44°C to 49°C															
k2. RT3: Over-temperature probe: 41.4°C to 43.6°C															
l. Patient temperature display test:															
<table border="1" style="border-collapse: collapse; width: 100%;"> <thead> <tr> <th style="width: 30%;">Probe Resistance (ohms)</th> <th style="width: 30%;">Patient Temperature Display</th> </tr> </thead> <tbody> <tr> <td style="text-align: center;">1355</td> <td style="text-align: center;">37°C ± 0.2°C</td> </tr> </tbody> </table>	Probe Resistance (ohms)	Patient Temperature Display	1355	37°C ± 0.2°C											
Probe Resistance (ohms)	Patient Temperature Display														
1355	37°C ± 0.2°C														
m. Ground resistance less than 0.5 ohms															
n. Current leakage:															
Earth	200 microamps max.														
Patient Probe	100 microamps max.														
o. Reset the RFU code															
* Complete the entire Functional Check / Inspection Form prior to troubleshooting unit.															

Figure 7—Functional Check/Safety Inspection Form

8.0 Service Modes and Troubleshooting

Some troubleshooting and functional checks may be aided by using the Medi-Therm II machine's service modes of operation.

8.1 Service Modes

All service modes are entered from service mode 1 by pressing the appropriate digital control panel button within 10 seconds of entry into service mode 1. If no button is pressed after service mode 1 is entered, the machine will reset itself to standby mode after 10 seconds. See table 3 for a description of each mode.

To initiate service mode 1:

1. Turn machine off.
2. Remove the 6 screws holding the head to the base.

⚠ CAUTION

Wear a static control device connected to the chassis ground to prevent electrostatic discharge. (See figure 8, page 22.)

Electrostatic discharge can damage the control/display board.

3. Lift the head, press and hold service button S3 on the low voltage control/display board (see fig. 8), then turn the machine on.

In service mode 1, the machine will display the last RFU* code (on the *BLANKET TEMPERATURE* display) and the software version (on the *PATIENT TEMPERATURE* display). An RFU code may help to debug a machine which has shut down due to a *REMOVE FROM USE NOW* condition (fig. 9, p. 23).

Pressing the *TEST LIGHTS* button while in service mode 1 will reset the RFU code to zero. Whenever returning a

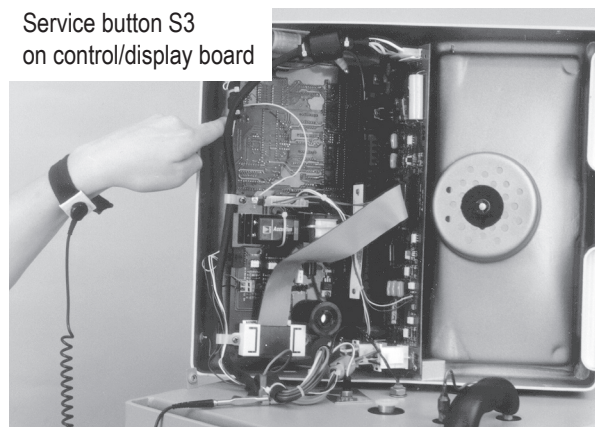

Figure 8—Initiating service mode 1

machine to service, reset the RFU code to zero to avoid basing future troubleshooting decisions on an old code.

* RFU = *REMOVE FROM USE NOW*

8.2 RT3 Indicator LED

For troubleshooting purposes, there is an indicator LED located on the alarm/backup board which will light when the RT3 overtemperature probe is sensing a temperature above that which is represented by the fixed precision resistor value R11. See figure 14, p. 53, for LED location. The PIC microcontroller on the alarm/backup board will command a *REMOVE FROM USE NOW* shutdown after this condition exists for 5 seconds.

8.3 Test Mode for the User

The MTA6012CE provides the operator with the ability to confirm operation of backup system 1 without having to open up the machine. The instructions from the *Operator's Manual* are repeated here for information. (This test does not test the trip point. Perform section "k", of 7.3 *Functional Check and Safety Inspection* to insure correct High Temperature Backup Trip Temperatures.)

NOTE: Because the test mode heats water above 41°C, to protect the patient, this mode will not function if the hoses are connected to the unit. The test mode operation relies on water flowing through the bypass within the machine. See figures 15A and 15B.

NOTE: Each time the TEST Mode is performed and backup system 1 trips, an "H" is stored as the last RFU code.

8.4 Overtemp Verification Test

Perform the following test to verify operation of the first overtemp safety backup without having to open up the machine.

1. Disconnect the hoses from the *SUPPLY* and *RETURN* fittings on the front of the machine.
2. Turn the machine on while simultaneously pressing the *TEST LIGHTS* button. This will put the unit into a *TEST MODE*. In this *TEST MODE*, the blanket temperature display will light, the set point will display "0", and the temperature will start to increase.

NOTE: If the unit flashes *CHECK FLOW*, the hoses have not been disconnected and the temperature will not increase. Disconnect the hoses.

RFU Code	Description	Troubleshooting Chart
0	Reset code -- indicates no RFU condition recorded.	None
1	Measured blanket or reservoir probe value is out of the range 0°C to 50°C.	Figure 10B
2, 3	Microprocessor system failure	Figure 10C
4	Compensation resistor 1 (R12) is out of spec -- too high or open-circuited.	Figure 10D
5	Compensation resistor 1 (R12) is out of spec -- too low or short-circuited.	Figure 10D
6	Compensation resistor 2 (R13) is out of spec -- too high or open-circuited.	Figure 10E
7	Compensation resistor 2 (R13) is out of spec -- too low or short-circuited.	Figure 10E
8	Blanket probe measurement is out of spec -- possibly open or short-circuited.	Figure 10F
9	Reservoir probe measurement is out of spec -- possibly open or short-circuited.	Figure 10G
—	Microprocessor system failure -- CHECKSUM.	Figure 10C
E	Microprocessor system failure -- RAMTEST.	Figure 10C
H	Microprocessor received <i>REMOVE FROM USE NOW</i> signal from the backup/system 1 or backup system 2 circuits.	Figure 10K
L	Microprocessor system failure	Figure 10C
P	Backup system 1 not functioning or alarm/backup board disconnected.	Figure 10H
† RFU = <i>REMOVE FROM USE NOW</i>		

Figure 9—RFU† Codes

3. If the first overtemp safety circuit is working properly, the unit should go into a *REMOVE FROM USE NOW* alert condition. The audible indicator will remain on continuously. The entire test should take approximately 3 minutes.

If the unit goes into a *REMOVE FROM USE NOW* alert condition, but the audible indicator does not remain on, the first overtemp backup is not functioning and the second overtemp backup has tripped. Do not use the machine. Request service.

If the unit does not go into a *REMOVE FROM USE NOW* alert condition, do not use the machine. Request service.
 4. Turn the machine off. This will end the *TEST MODE*.
 5. Reconnect hoses to the fittings on the front of the unit.
 6. Turn the unit on and select *BLANKET CONTROL* mode immediately. This will allow water to flow past the first overtemp probe and reset it.
- NOTE: If the machine goes into a *REMOVE FROM USE NOW* alert condition again when selecting *BLANKET CONTROL*, the second over-temp backup device (the thermostat) has also tripped. Turn the machine off. Connect a hose to the *SUPPLY* fitting. Direct the other end of the hose into a water container so that water from the cold reservoir will siphon past the thermostat and reset it. Allow water to flow for approximately two minutes.

Service Mode 1:	
To access:	Press and hold S3 (see figure 8, p. 22) on the control/display board, then turn machine on.
Uses:	<ul style="list-style-type: none"> • Verification of software version level. • Last RFU code indication and RFU code reset. • Verification of proper watchdog functioning (U34). • Entrance to other modes.
Description:	<ul style="list-style-type: none"> • Required for entrance to other modes. • <i>PATIENT TEMPERATURE</i> display shows software version level. • <i>BLANKET TEMPERATURE</i> display shows RFU code. • Pressing the <i>TEST LIGHTS</i> button will reset RFU code to zero. • <i>ALERT LED</i> flashes. • Leader lights flash. • Setpoint display flashes "1." • 10 second duration. Machine resets to standby mode after 10 seconds if no buttons are pressed.
To exit:	Pressing the <i>BLANKET CONTROL</i> , <i>PATIENT CONTROL</i> , or <i>MONITOR ONLY</i> buttons will cause entrance into other modes. If no further action is taken by the user, the machine will reset itself to standby mode after approximately 10 seconds.

Service Mode 2:	
To access:	Press <i>BLANKET CONTROL</i> while in service mode 1.
Uses:	To assist in testing trip point of backup system 2 S1 thermostat.
Description:	<ul style="list-style-type: none"> • <i>PATIENT TEMPERATURE</i> and <i>BLANKET TEMPERATURE</i> displays are blank. • <i>ALERT LED</i> flashes. • Leader lights flash. • Setpoint display flashes "2." • Pump and compressor are turned on, and cold solenoid valve is opened • No temperature measurement is performed by the machine.
To exit:	Pressing any button except the <i>BLANKET CONTROL</i> button will reset the machine to standby mode. (Pressing the <i>BLANKET CONTROL</i> button will do nothing.)

Service Mode 3:	
To access:	Press <i>PATIENT CONTROL</i> button while in service mode 1.
Uses:	To prewarm the machine for testing of the backup system 1 overtemperature probe RT3 and the backup system 2 S2 thermostat trip points.
Description:	<ul style="list-style-type: none"> • <i>PATIENT TEMPERATURE</i> display is blank. • <i>ALERT LED</i> flashes. • Leader lights flash. • Setpoint temperature display flashes "3." • The <i>BLANKET TEMPERATURE</i> display shows the blanket water temperature. • The output water temperature is controlled to 41°C.
To exit:	Pressing any button except the <i>PATIENT CONTROL</i> button or the <i>DOWN</i> button will reset the machine to standby mode. (Pressing the <i>PATIENT CONTROL</i> button again will do nothing.) Pressing the <i>DOWN</i> button will put the machine into mode 4 from mode 3.

Service Mode 4:	
To access:	Press <i>DOWN</i> button while in service mode 3.
Uses:	To test the trip points of the backup system 1 over-temperature probe RT3 and the backup system 2 S2 thermostat.
Description:	<ul style="list-style-type: none"> • <i>PATIENT TEMPERATURE</i> display is blank. • <i>ALERT</i> LED flashes. • Leader lights flash. • Setpoint temperature display flashes "4." • The <i>BLANKET TEMPERATURE</i> display shows the blanket water temperature. • The output water temperature is controlled to 48°C.
To exit:	Pressing any button except the <i>DOWN</i> button will reset the machine to standby mode. (Pressing the <i>DOWN</i> button again will do nothing.)

Service Mode 5:	
To access:	Press <i>MONITOR ONLY</i> button while in service mode 1.
Uses:	<ul style="list-style-type: none"> • To verify reservoir probe reading. • To assist troubleshooting cooling problems.
Description:	<ul style="list-style-type: none"> • <i>PATIENT TEMPERATURE</i> display shows the cold water reservoir temperature. • <i>ALERT</i> LED flashes. • Leader lights flash. • Setpoint temperature display flashes "5." • The <i>BLANKET TEMPERATURE</i> display is blank. • The pump is on and the cold solenoid valve is open. • The compressor is controlled using normal control algorithms.
To exit:	Pressing any button except the <i>MONITOR ONLY</i> button will reset the machine to standby mode. (Pressing the <i>MONITOR ONLY</i> button again will do nothing.)

RFU = REMOVE FROM USE NOW

8.5 Troubleshooting Charts

IMPORTANT

Whenever possible, perform the *Functional Check and Safety Inspection* (see section 7.3) prior to troubleshooting the machine.

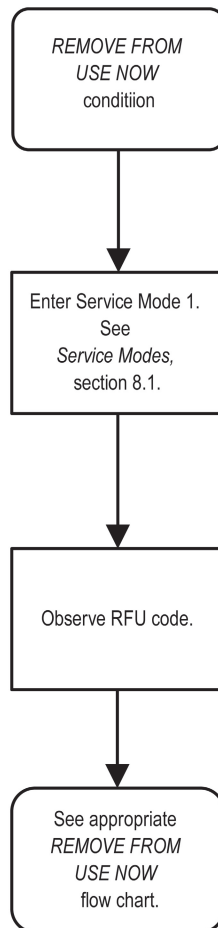

Figure 10A—Accessing RFU Codes

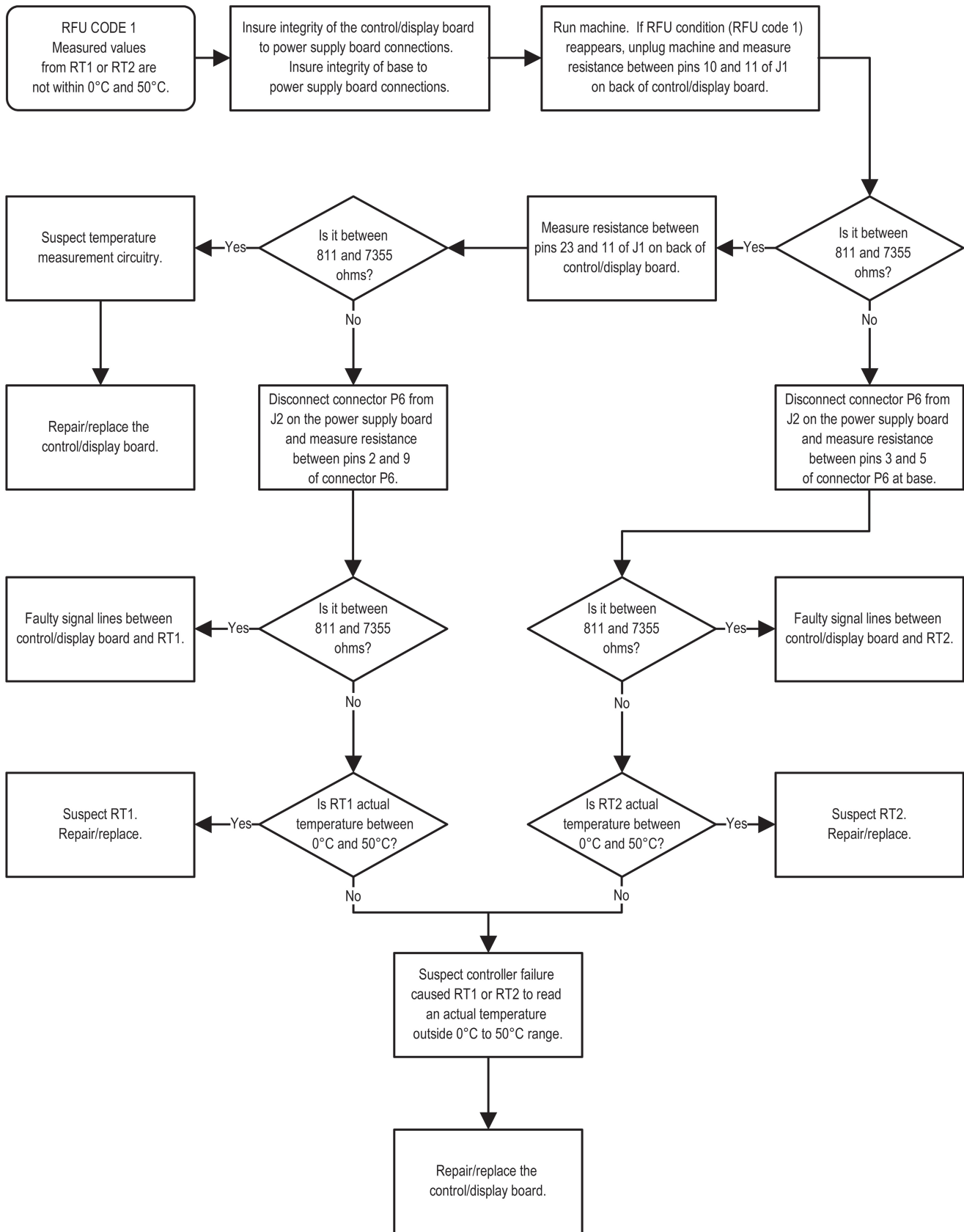

Figure 10B—RFU Code 1

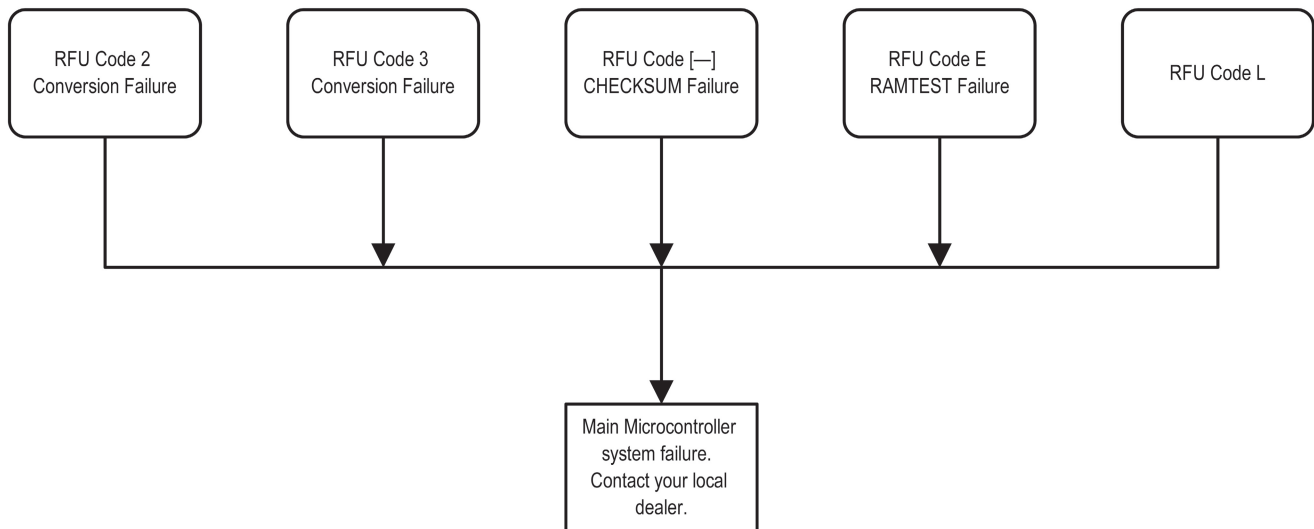

Figure 10C—RFU Codes 2, 3, —, E, and L

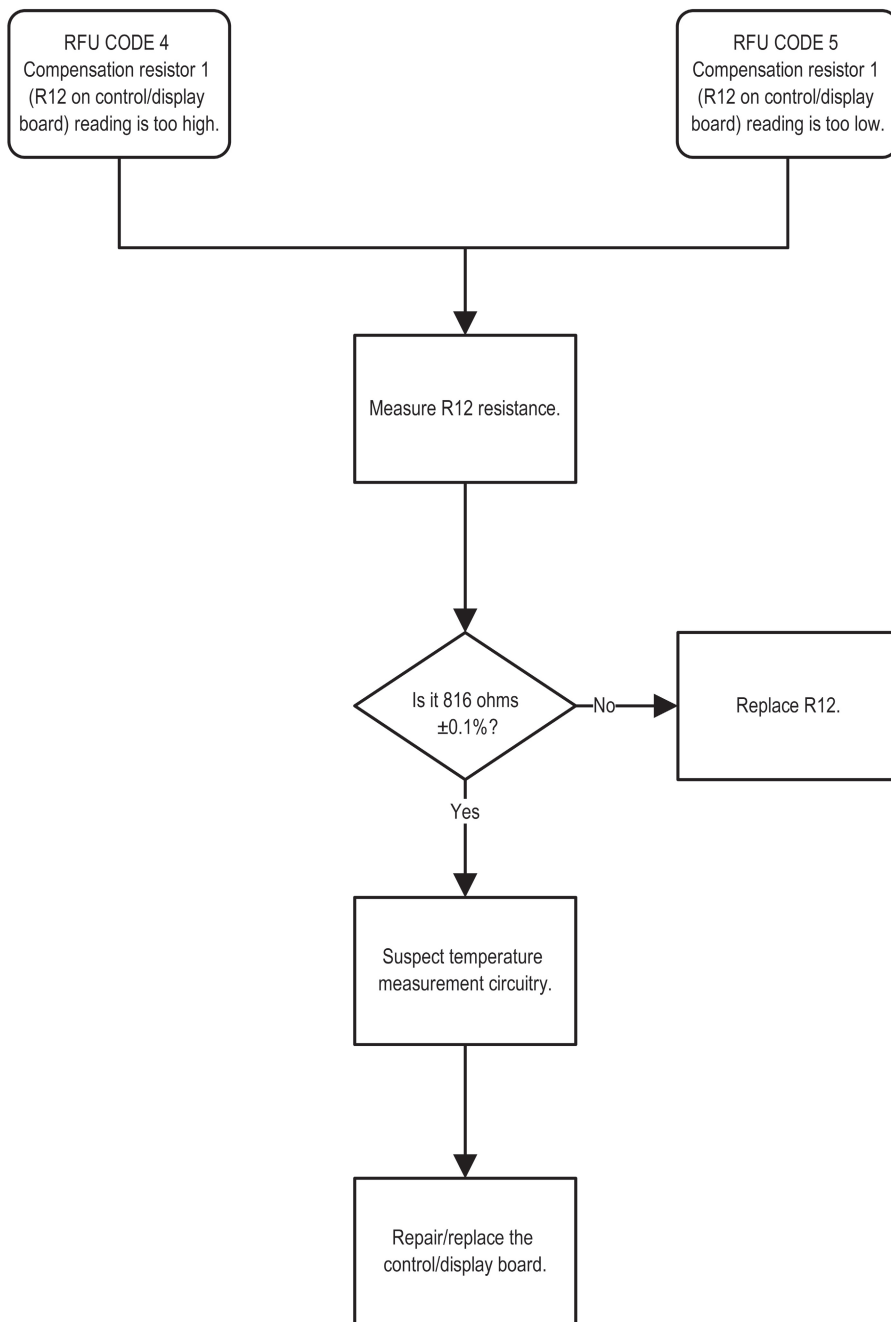

Figure 10D—RFU Codes 4, 5

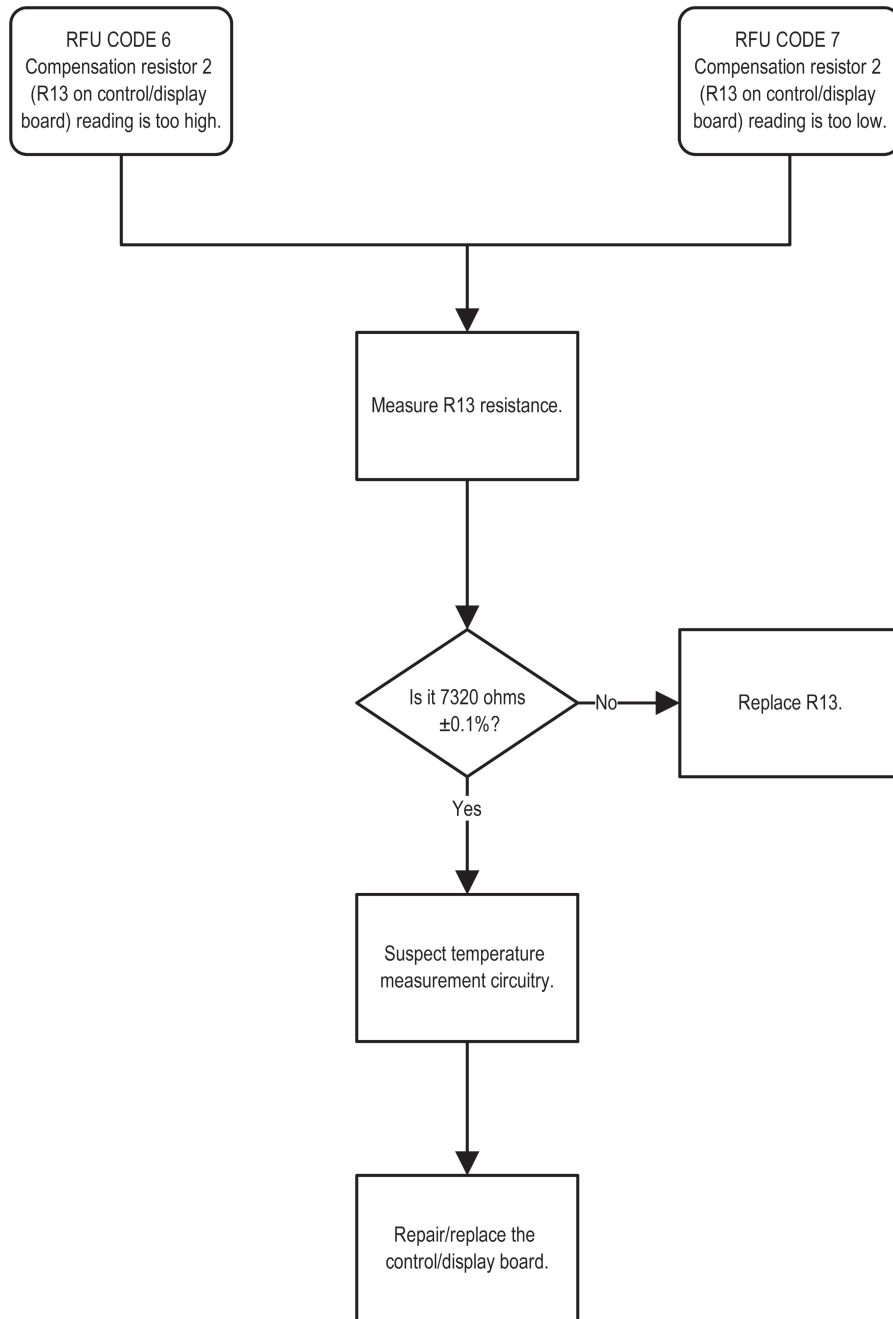

Figure 10E—RFU Codes 6, 7

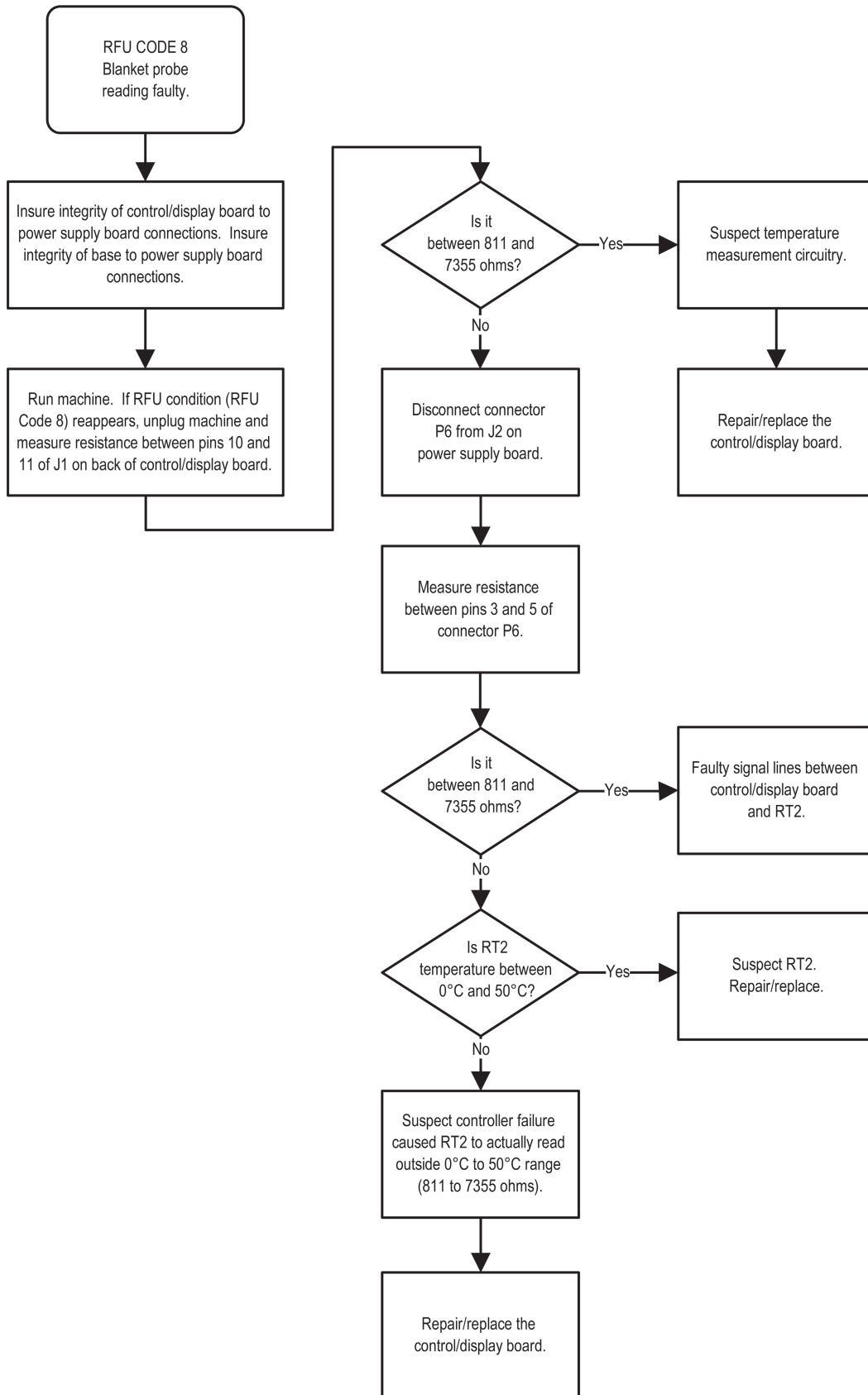

Figure 10F—RFU Code 8

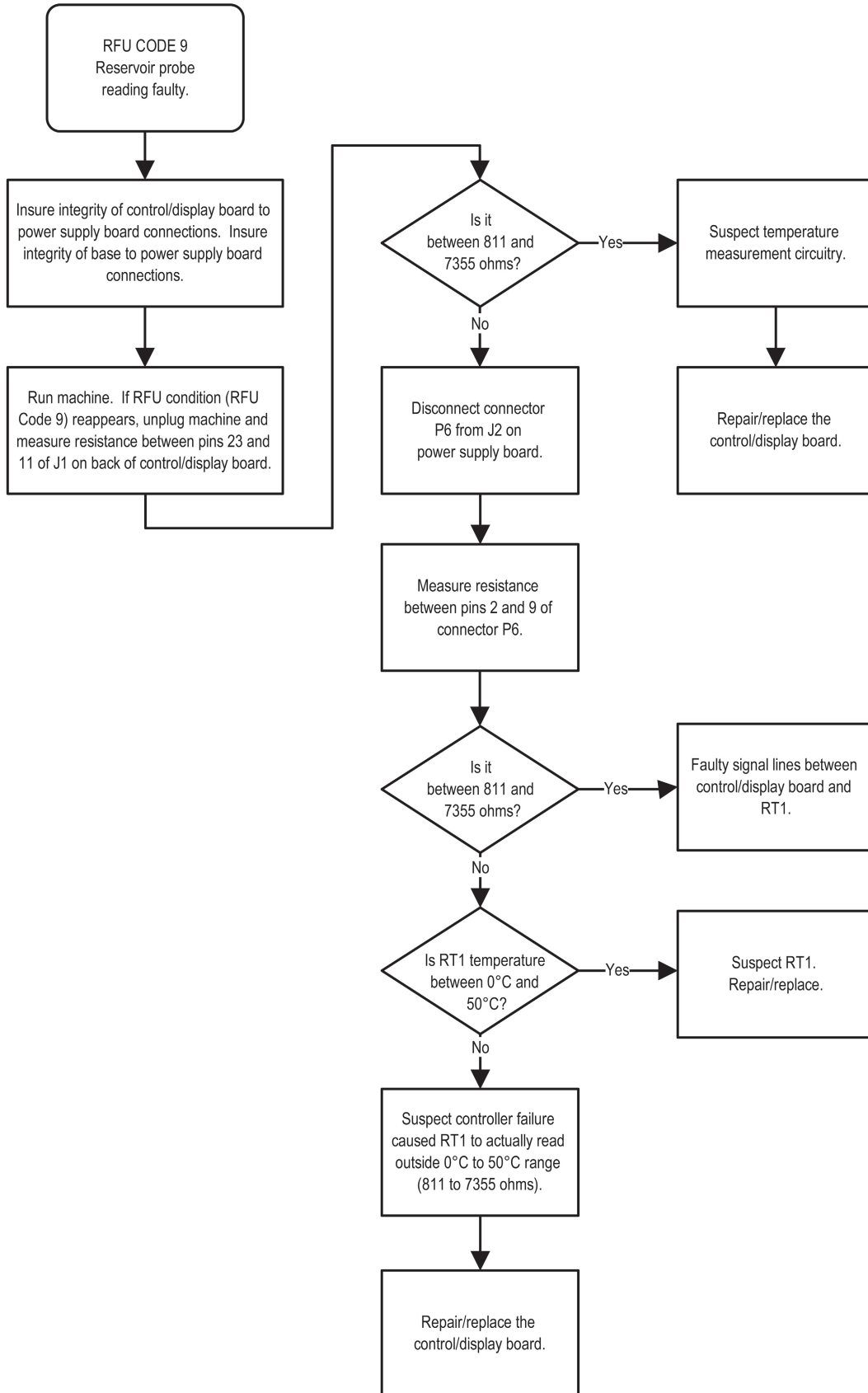

Figure 10G—RFU Code 9

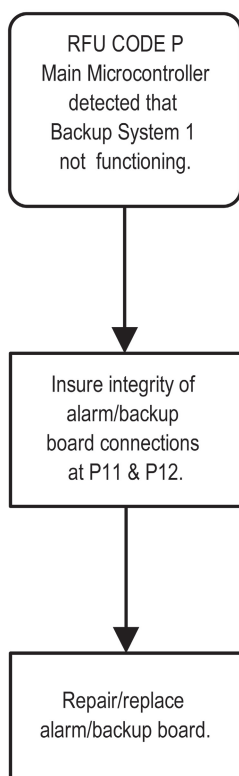

Figure 10H—RFU Code P

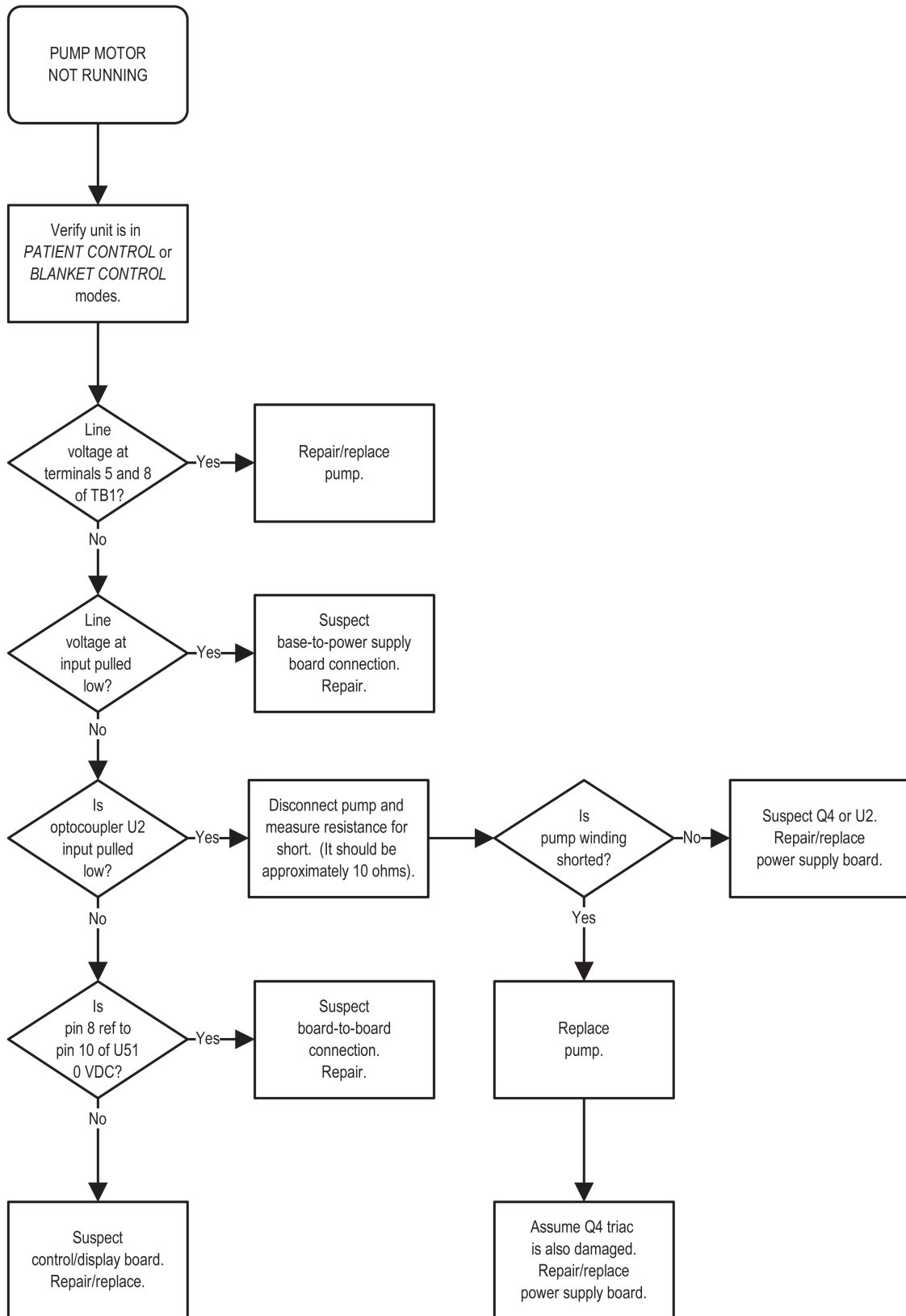

Figure 10I—Pump Motor Not Running

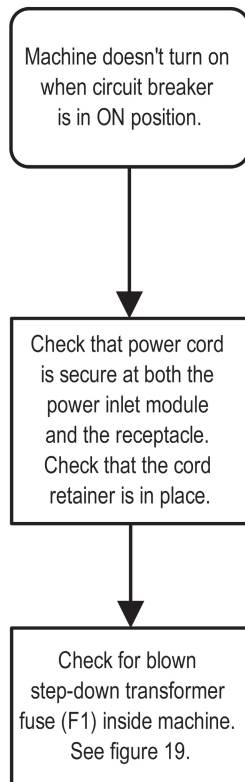

Figure 10J—Machine Doesn't Turn On

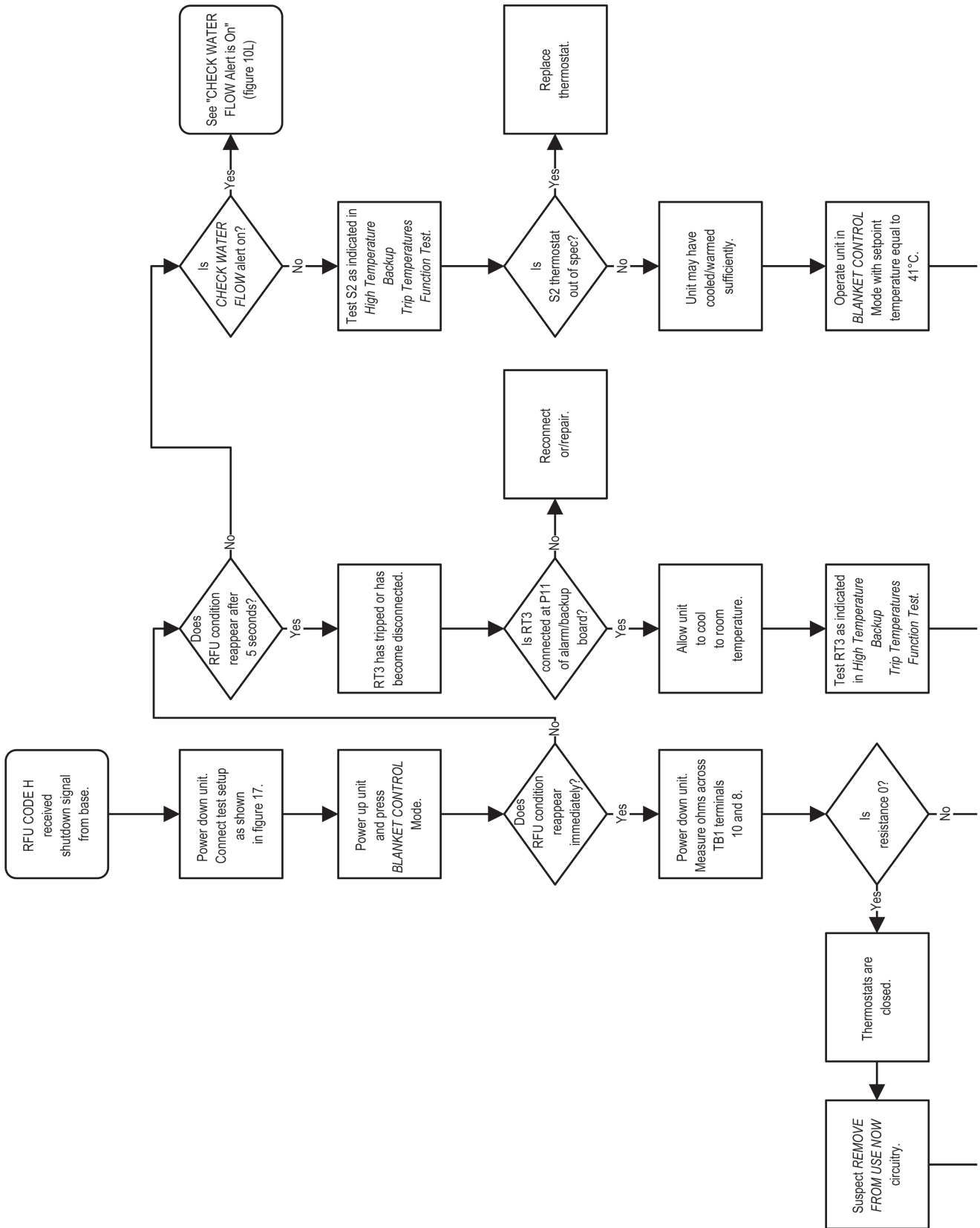
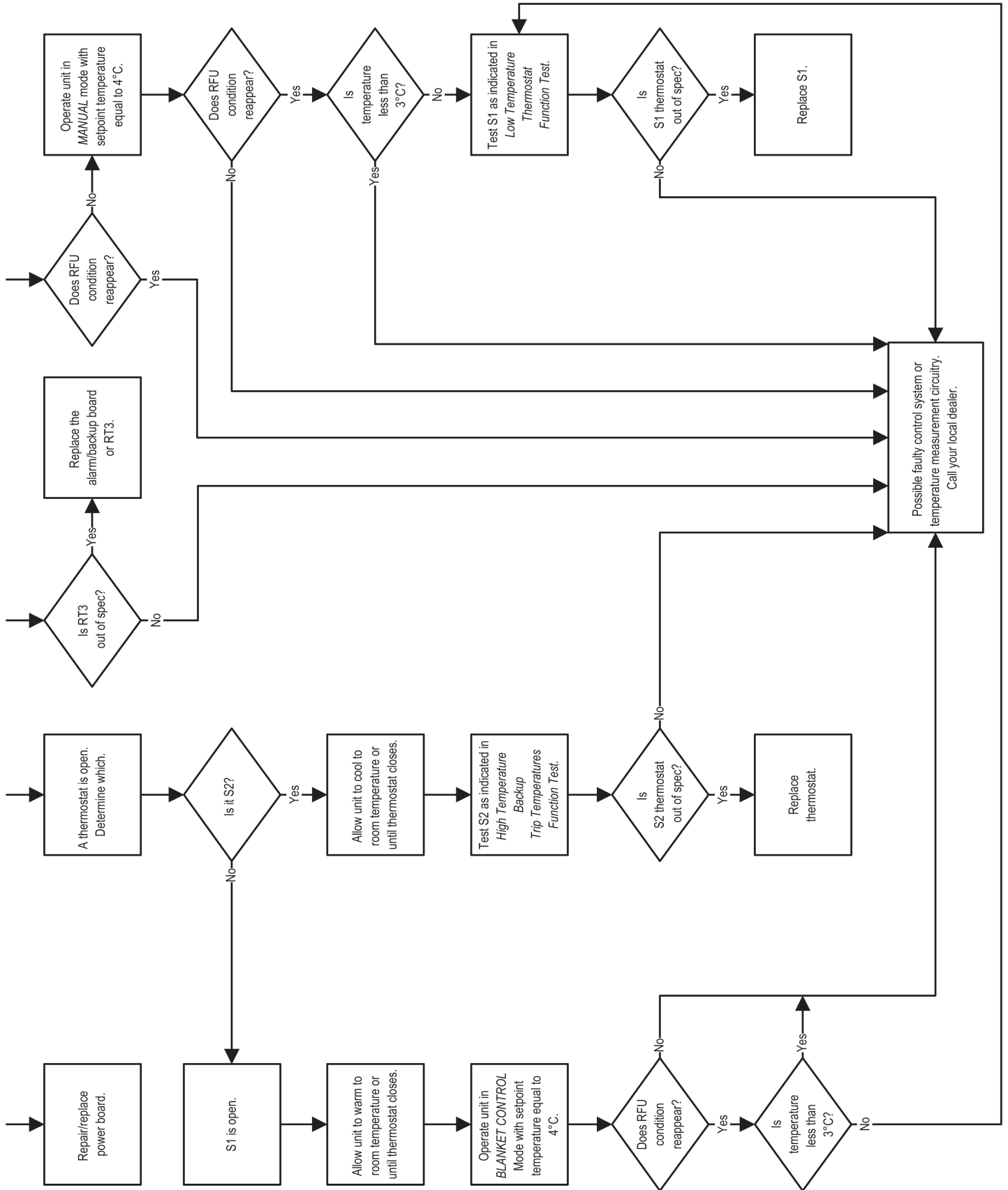

Figure 10K—RFU Code H



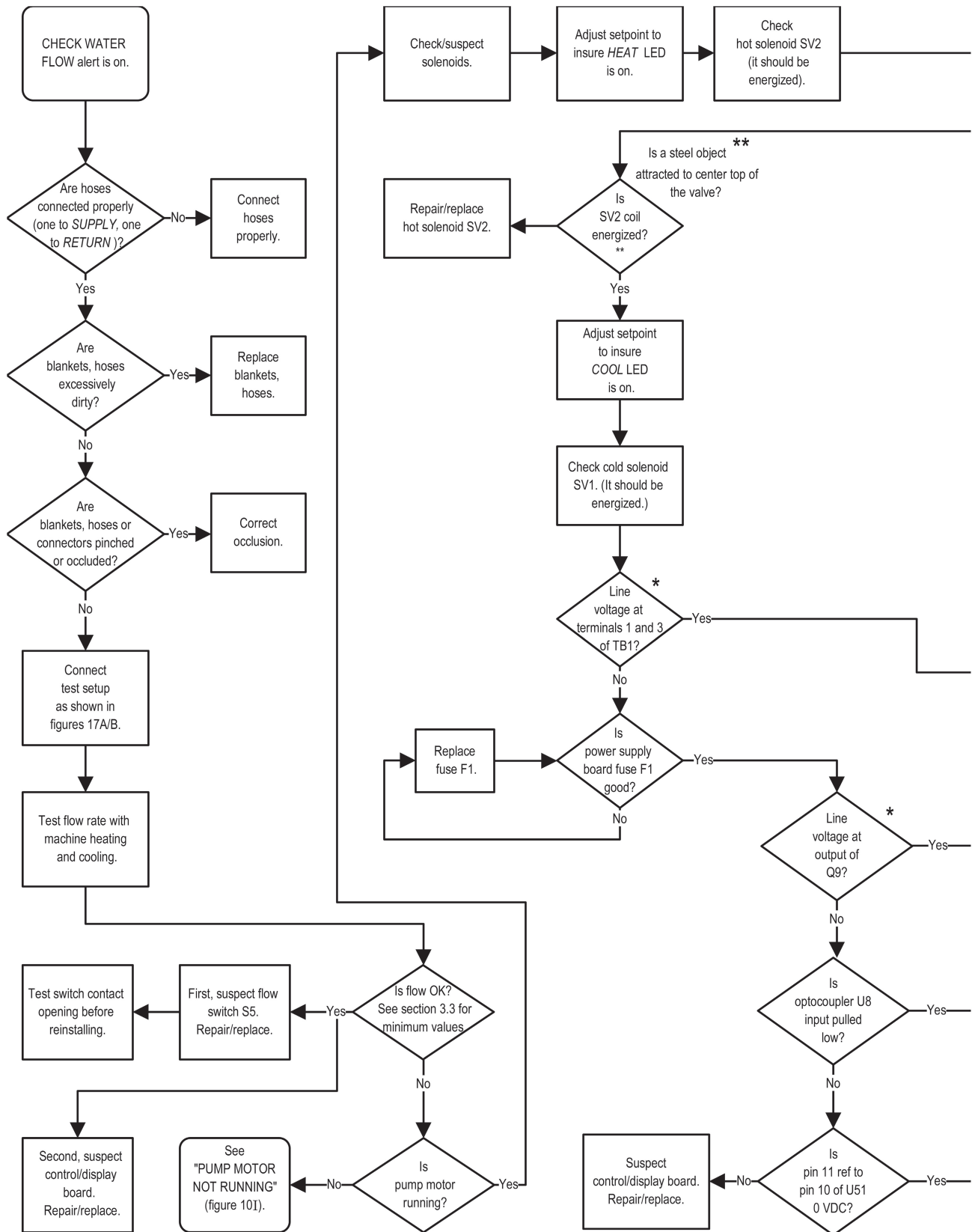
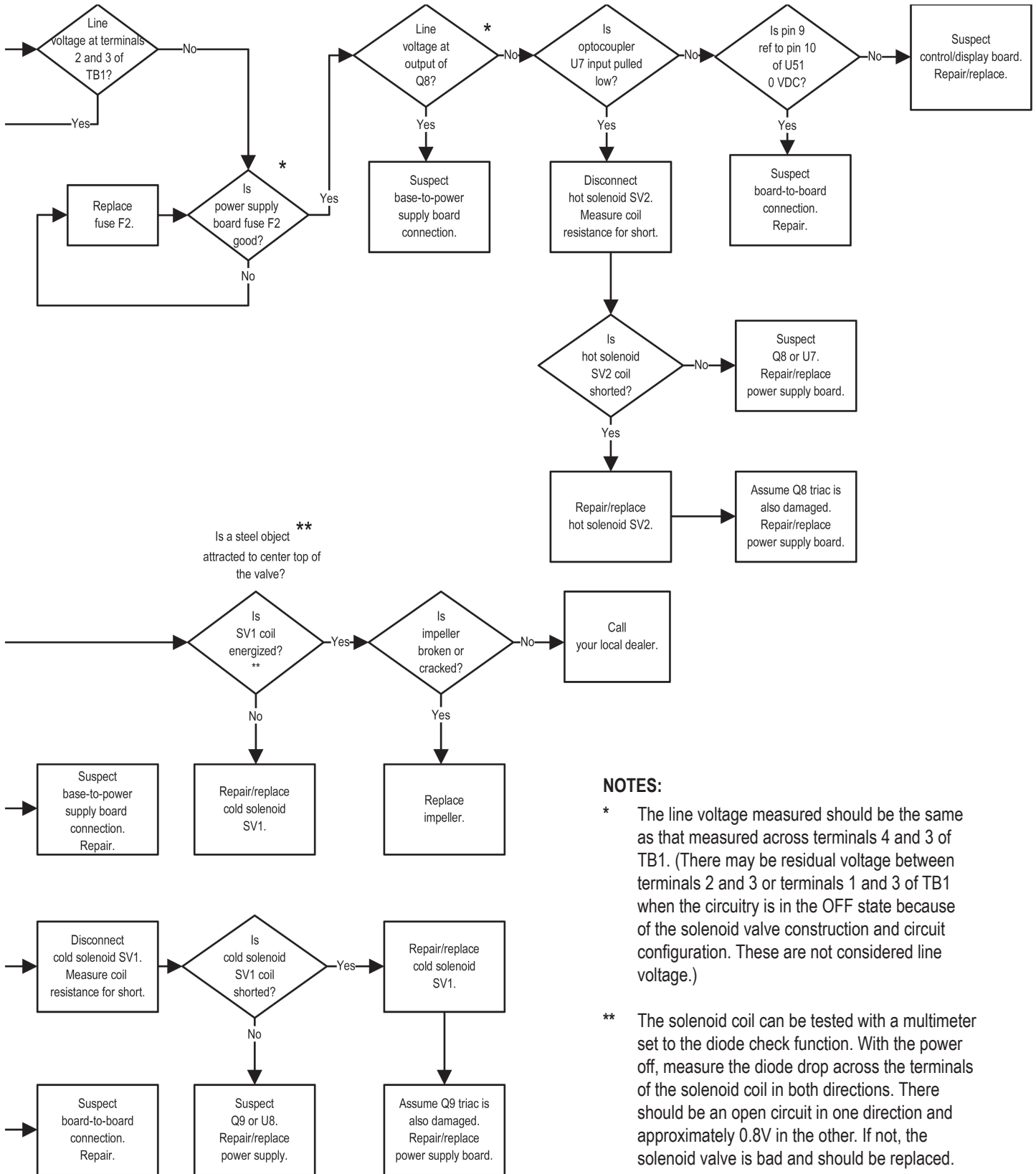

Figure 10L—Check Water Flow Alert Is On



NOTES:

* The line voltage measured should be the same as that measured across terminals 4 and 3 of TB1. (There may be residual voltage between terminals 2 and 3 or terminals 1 and 3 of TB1 when the circuitry is in the OFF state because of the solenoid valve construction and circuit configuration. These are not considered line voltage.)

** The solenoid coil can be tested with a multimeter set to the diode check function. With the power off, measure the diode drop across the terminals of the solenoid coil in both directions. There should be an open circuit in one direction and approximately 0.8V in the other. If not, the solenoid valve is bad and should be replaced.

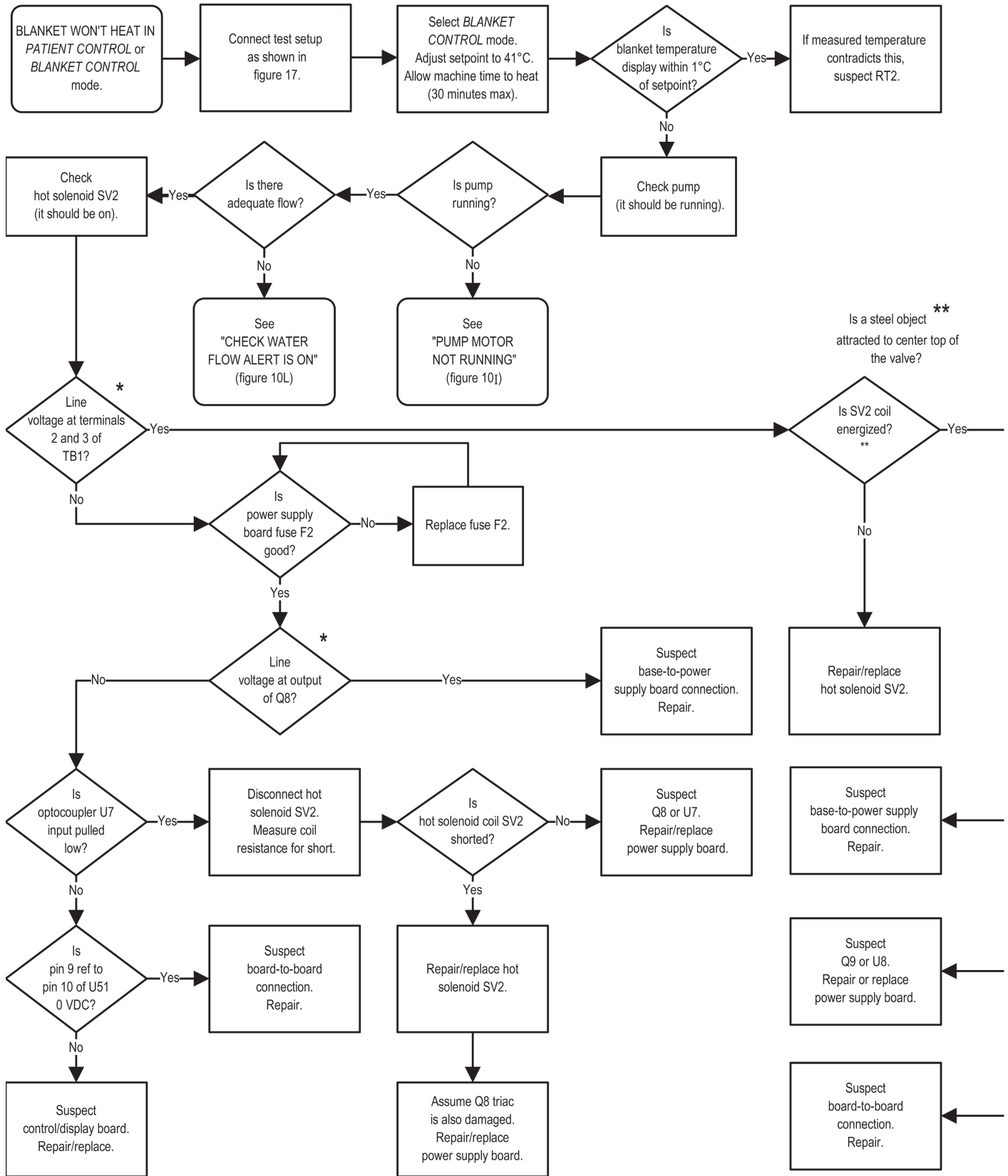
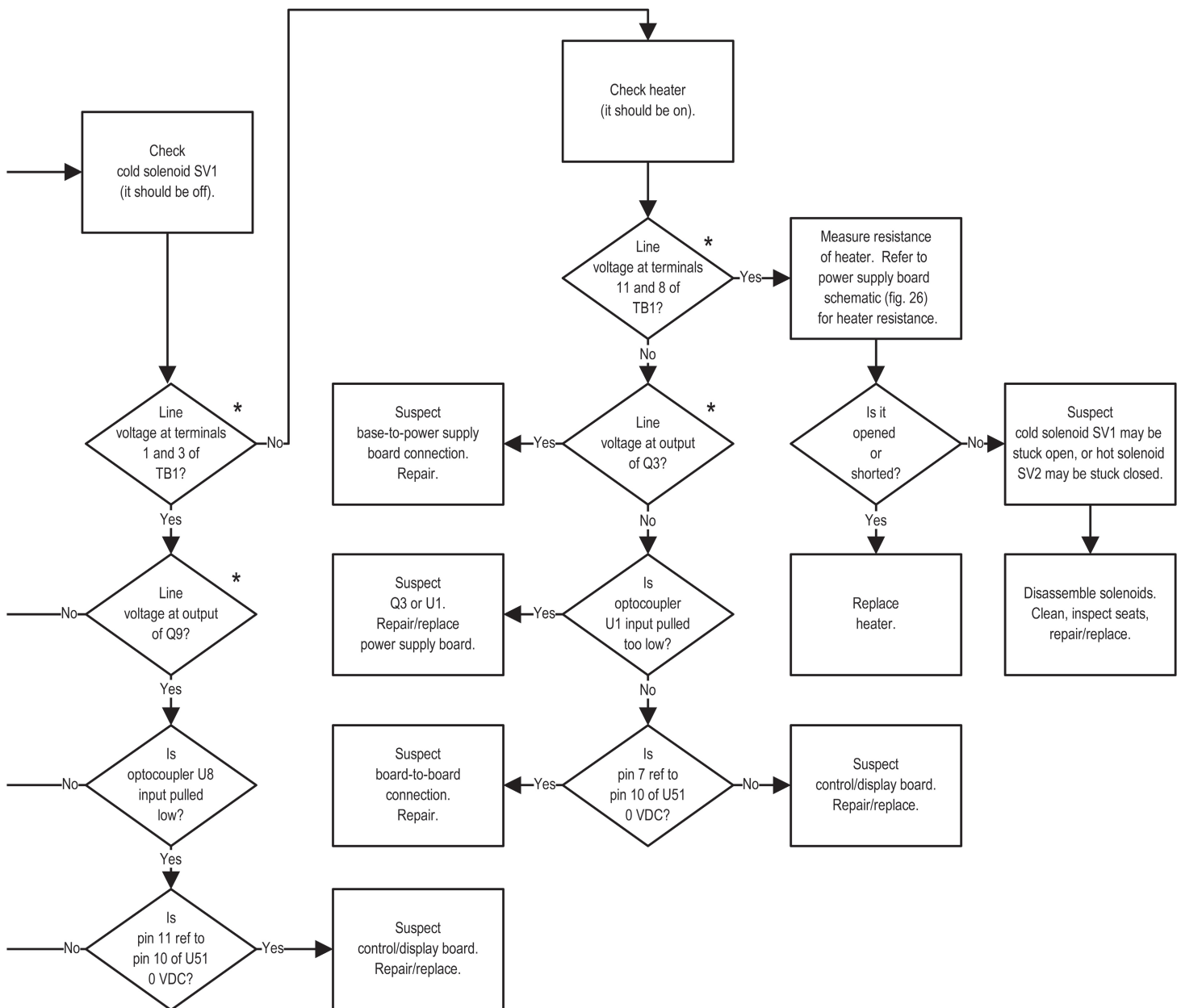

Figure 10M—Blanket Won't Heat in PATIENT CONTROL or BLANKET CONTROL Mode

NOTES:

* The line voltage measured should be the same as that measured across terminals 4 and 3 of TB1. (There may be residual voltage between terminals 2 and 3 or terminals 1 and 3 of TB1 when the circuitry is in the OFF state because of the solenoid valve construction and circuit configuration. These are not considered line voltage.)

** The solenoid coil can be tested with a multimeter set to the diode check function. With the power off, measure the diode drop across the terminals of the solenoid coil in both directions. There should be an open circuit in one direction and approximately 0.8V in the other. If not, the solenoid valve is bad and should be replaced.



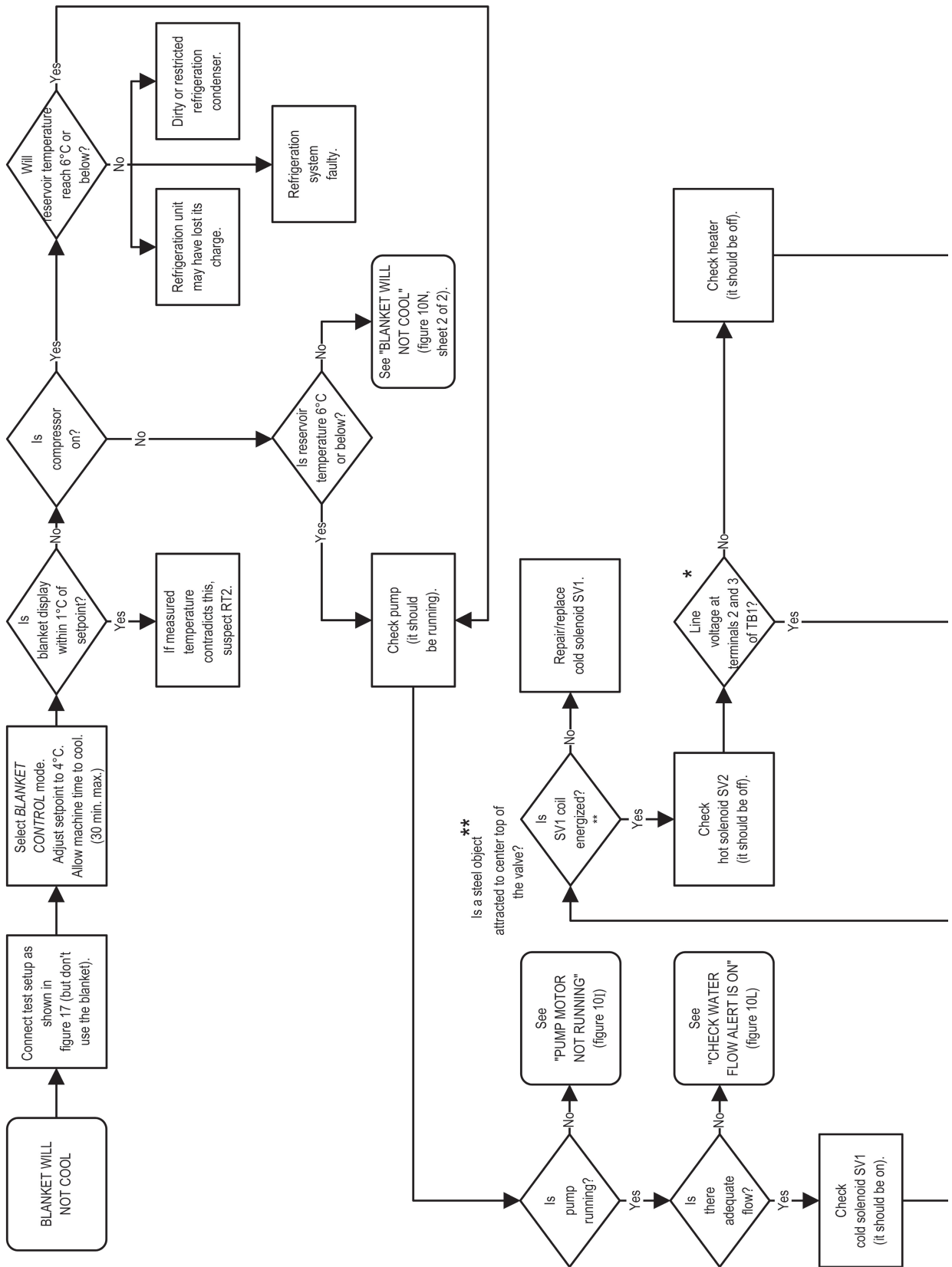
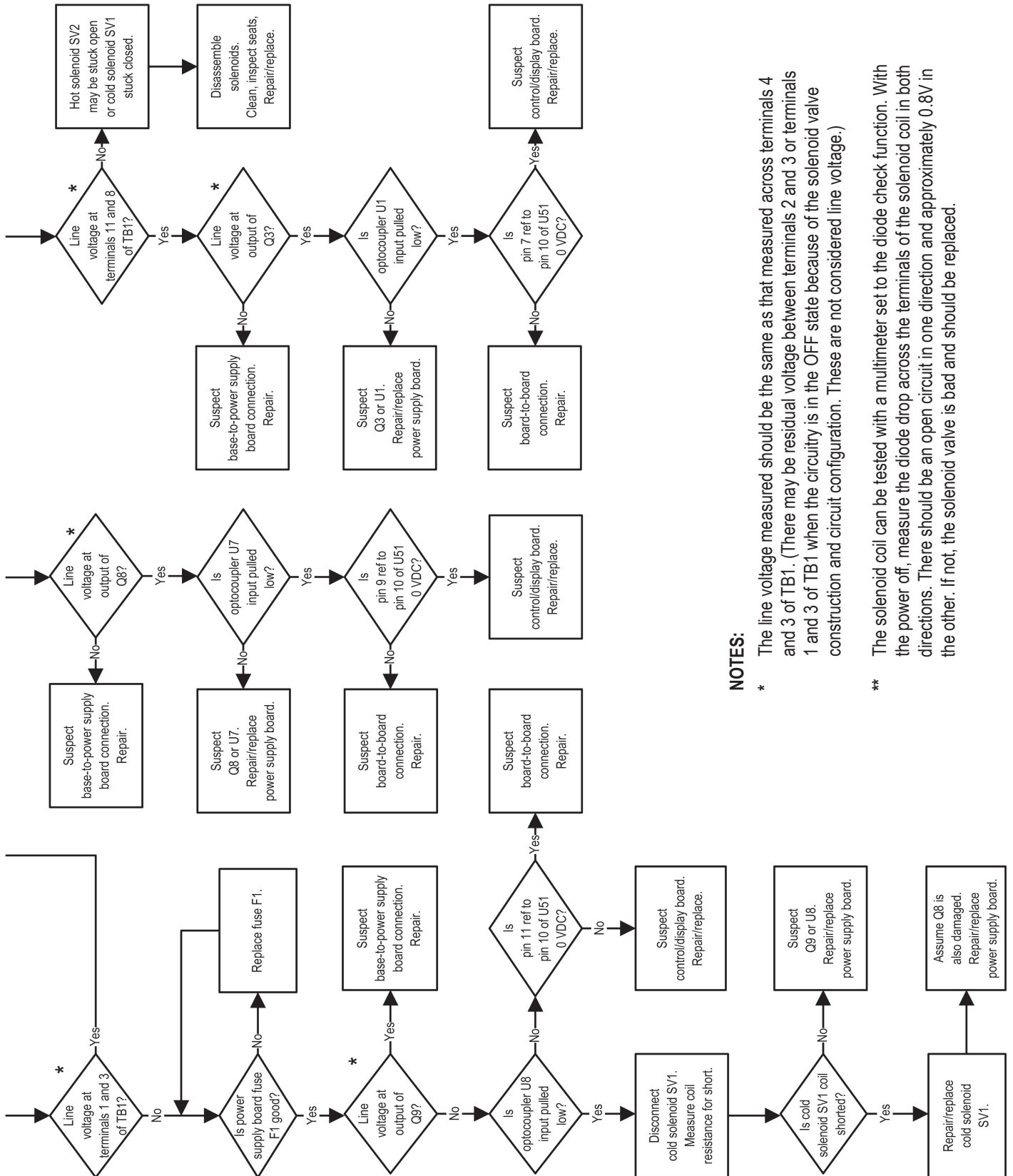

Figure 10N—Blanket Will Not Cool (sheet 1 of 2)



NOTES:

* The line voltage measured should be the same as that measured across terminals 4 and 3 of TB1. (There may be residual voltage between terminals 2 and 3 or terminals 1 and 3 of TB1 when the circuitry is in the OFF state because of the solenoid valve construction and circuit configuration. These are not considered line voltage.)

** The solenoid coil can be tested with a multimeter set to the diode check function. With the power off, measure the diode drop across the terminals of the solenoid coil in both directions. There should be an open circuit in one direction and approximately 0.8V in the other. If not, the solenoid valve is bad and should be replaced.

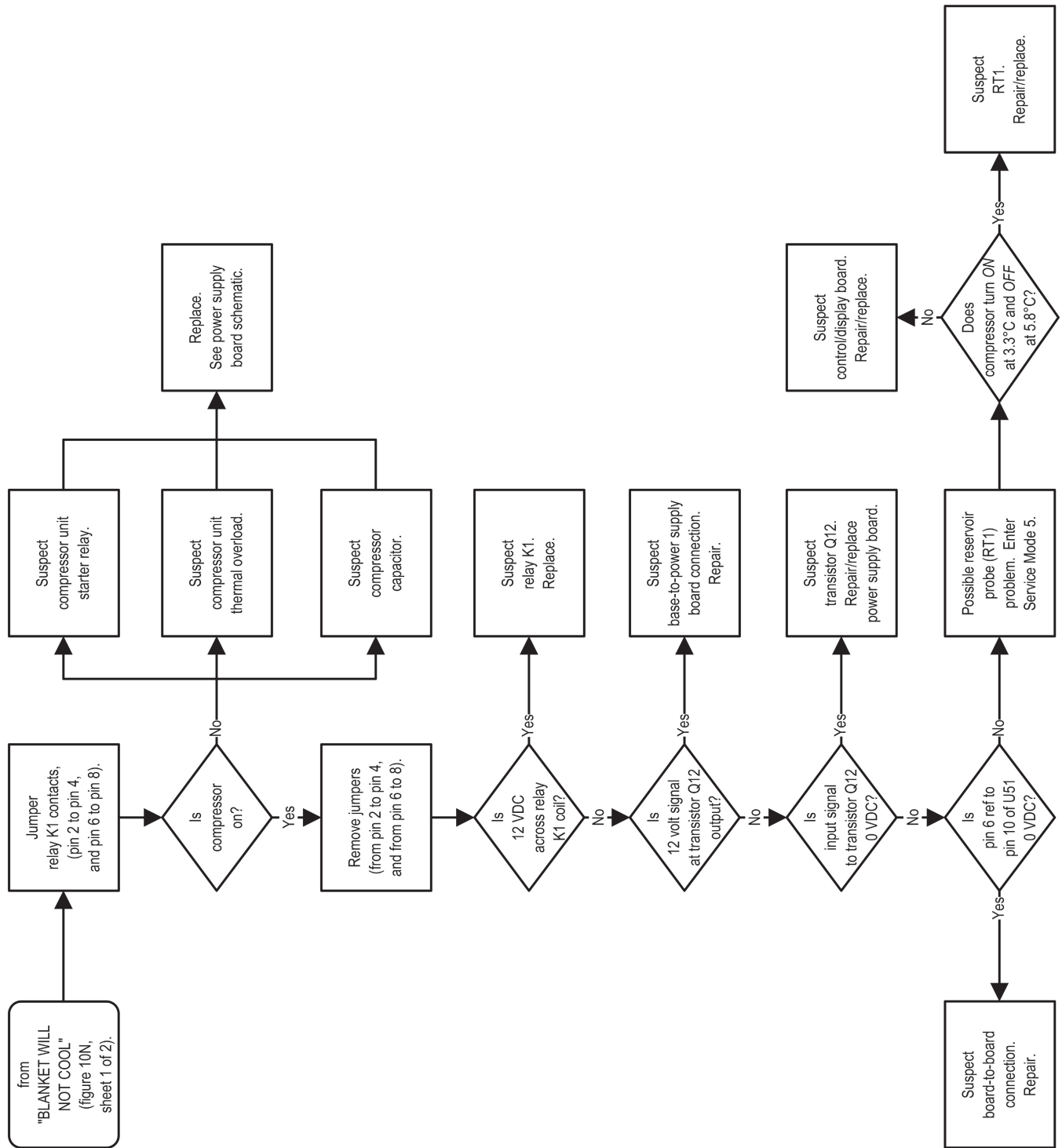

Figure 10N—Blanket Will Not Cool (sheet 2 of 2)

9.0 Repair Procedures

⚠ WARNING

Always perform the *Functional Check and Safety Inspection* (section 7.3) after making repairs and before returning the Medi-Therm II machine to patient use.

Improper repair may result in death or serious injury, equipment damage, or malfunction.

In addition to the following repair procedures, refer to the troubleshooting charts in section 8.5, pp. 26-44, *Service Modes and Troubleshooting*.

9.1 Refrigeration System

⚠ WARNING

- Equipment contains refrigerant under high pressure. Refer servicing to a certified refrigeration service technician.

Improper repair procedures can result in serious injury or damage the compressor unit.

- The refrigeration system contains rotating fan blades. Do not operate with fan shroud removed.

Injury could result.

NOTE: Servicing and/or repair of the refrigeration system should be performed in compliance with applicable regulations.

9.1.1 R-134a Systems

⚠ CAUTION

- Use only R-134a refrigerant and polyol ester oil when charging a Medi-Therm II R-134a system.
- Using other refrigerants or oils will damage the compressor.**
- The Medi-Therm II R-134a system uses a polyol ester oil for lubrication because conventional mineral oils do not provide sufficient lubricity and miscibility. R-134a refrigerant and polyol ester oil are highly susceptible to moisture absorption (more so than R-12 and mineral oil).

It is important that proper system evacuation, charging, and leak detection procedures be employed. Do not leave the refrigeration system open to ambient air when servicing. Moisture absorption will result in reduced compressor life.

Do not attempt servicing the R-134a refrigeration system unless you are certified in R-134a refrigeration maintenance, repair, and reclaiming procedures. Supply the following information to the refrigeration service technician:

- The smaller molecular size of R-134a refrigerant allows it to leak from smaller openings than R-12.
- Prior to charging the system, Gaymar recommends evacuating the system to below 500 microns. Then, perform a vacuum decay test to assure there is not a large differential between the system and the vacuum pump. After 5 minutes, the system should still be at 500 microns or below.
- **For optimum performance, charge the system with the appropriate weight of R-134a refrigerant.** Make sure that the entire charge is pulled from the gauge manifold and hoses into the system before disconnecting.
- If it is necessary to check a unit's charge, purge the refrigerant gauge manifold and hoses with R-134a refrigerant from an external source before opening the service valves to prevent affecting the unit's charge.

The R-134a refrigerant charge that is required by your system will depend on the O.D. of the condenser tubing, i.e.

- 7mm (9/32 inch) O.D. condenser tubing - 0.234kg (8.25oz.)
- 9.5mm (3/8 inch) O.D. condenser tubing - 0.326kg (11.5oz.)
- Systems with the 7mm O.D. condenser tubing have serial numbers starting with MTA6012CE G60001. Systems built before will have 9.5mm O.D. condenser tubing. In the above serial number the letter "G" indicates the month in which the device was made. Since "G" is the seventh letter in the English alphabet it stands for July, an "A" equals January, a "B" equals February, etc. The next digit to the left of "G" is "6" and it stands for the last digit of the year of manufacture, i.e. 2006. These numbers repeat every decade. The remaining digits to the left indicate the number of devices manufactured in that month.

Note: It is possible to have a system with a serial number before MTA6012CE G60001 that had the condensing unit replaced with one that has 7mm O.D. condenser tubing. Before charging a unit, always verify the condenser tubing O.D. then select the appropriate weight charge.

- In a properly charged unit with 7mm (9/32 inch) O.D. condenser tubing, the low side refrigerant gauge pressure should be approximately 83-131 kPa (12-19 PSI); the high side pressure should be approximately 758-848 kPa (110-123 PSI).
- In a properly charged unit with 9.5mm (3/8 inch) O.D. condenser tubing, the low side refrigerant gauge pressure should be approximately 124-172 kPa (18-25 PSI); the high side pressure should be approximately 779-931 kPa (113-135 PSI).

In either case the approximate gauge pressures will be observed under the following conditions.

1. the unit's wraparound is removed;
2. the ambient temperature is 22.2°C;
3. the unit is connected to a blanket, and the Medi-Therm II has been set to 4°C in *BLANKET CONTROL* mode;
4. the reservoir water temperature is 4.4°C; and,
5. the pressure check is performed with a gauge manifold connected to the system with flexible hoses.

Upon completion of the pressure check, turn the unit off and allow refrigerant in the manifold and hoses (especially the high side) to migrate back into the unit before closing the service valves and disconnecting the hoses. Warming the hose near the service valve with your hands for 2-3 minutes will ensure this.

- If recharging is required, most likely there is a leak in the system. Locate and repair any leaks before recharging the unit.
- Replace the two service valve caps and two gage port caps after servicing the refrigeration system.

After servicing the refrigeration unit, make sure to perform the *Functional Check and Safety Inspection* (see section 7.3).

9.2 Replacing the Power Supply Board

⚠ CAUTION

Wear a static control device connected to the chassis ground to prevent electrostatic discharge. See figure 8, page 22.

Electrostatic discharge can damage circuitry on PC boards.

The following procedures describe replacement of the power supply board. A digital voltmeter is required.

9.2.1 Power Supply Board Removal (see figure 14, p. 51):

1. **Unplug the power cord.**
2. Disconnect the 7-conductor cable harness connector P12 from the alarm/backup board.
3. Disconnect the 26-conductor cable harness connector P3 from the power supply board.
4. Disconnect the three cable harness connectors P5, P6, and P7.
5. Remove the seven (7) board mounting screws.
6. Lift board out of head.

9.2.2 Power Supply Board Installation (see fig. 14, p. 51):

1. **Unplug the power cord.**
2. Place the new power supply board in head.
3. Install seven (7) board mounting screws.
4. Connect the three cable harness connectors P5, P6, and P7 to J3, J2, and J1 on the power supply board.
5. Perform a voltage check of the power supply board. Do not use the board or connect it to the control/display board if the voltages are incorrect.

NOTE: To prevent an accidental short circuit, connect voltmeter leads while the machine is off.

With the 26-conductor cable harness assembly disconnected from the power supply board and the machine on, measure for the following voltages at the following board locations (see figure 27, p. 74):

	DVM Common to Pin	DVM + Lead to Pin	Voltage Reading
Q7	1	3	-12 ± 0.5V
Q6	2	3	+12 ± 0.5V
C16	-	+	+5.3 ± 0.3V

6. Turn machine off.
7. Connect the 26-conductor cable assembly.
8. Connect the 7-conductor cable harness connector P12 to the alarm/backup board.
9. Perform the *Functional Check and Safety Inspection* (section 7.3).

9.3 Replacing the Alarm/Backup Board

⚠ CAUTION

Wear a static control device connected to the chassis ground to prevent electrostatic discharge. See figure 8, page 22.

Electrostatic discharge can damage circuitry on PC boards.

9.3.1 Alarm/Backup Board Removal (see fig. 14, p. 51):

1. **Unplug the power cord.**
2. Disconnect the 26-conductor cable harness connector P1 from the control/display board and move it out of the way.
3. Disconnect the 7-conductor cable harness connector P12 from the alarm/backup board.
4. Disconnect the 6-conductor cable harness connector P11

from the alarm/backup board.

5. Disconnect the single conductor connector P9 from the alarm/backup board.
6. Note the polarity of the two LED wires before disconnecting the wires from the J3 terminal block on the alarm backup board. Disconnect the two wires. To release wires from terminal block, insert a small screwdriver in slot nearest wire and push screwdriver down (see fig. 11).
7. Remove the four board mounting screws.
8. Push aside the ground harness and transformer cable and lift board out of head.

9.3.2 Alarm/Backup Board Installation (see fig. 14, p. 51).

1. **Unplug the power cord.**
2. Place the new alarm/backup board in the head.
3. Install the four (4) board mounting screws. Install the corner screw through the ground harness. Install the two front screws through the transformer cable retaining clips.
4. Connect the single conductor connector P9 from the alarm/backup board.
5. Reconnect the two LED wires to the J3 terminal block on the alarm/backup board observing proper polarity.
6. Connect the 6-conductor cable harness connector P11 to the alarm/backup board.
7. Connect the 7-conductor cable harness connector P12 to the alarm/backup board.
8. Connect the 26-conductor cable harness connector P1 to the alarm/backup board.
9. Perform the *Functional Check and Safety Inspection* (section 7.3).

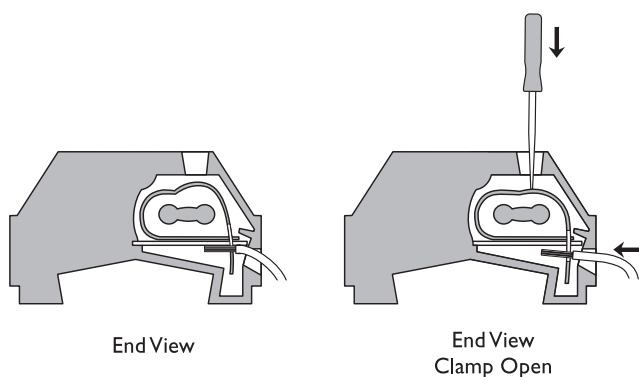

Figure 11—Connecting/disconnecting J3 terminal block wires

9.4 Replacing the Control/Display Board

⚠ CAUTION

Wear a static control device connected to the chassis ground to prevent electrostatic discharge. See figure 8, page 24.

Electrostatic discharge can damage circuitry on PC boards.

9.4.1 Control/Display Board Removal (see fig. 14, p. 51)

1. **Unplug the power cord.**
2. Remove the alarm/backup board (see section 9.3.1, steps 2-8).
3. Unfasten the patient probe assembly J1 from the head by removing the hex nut and pull the assembly from its mounting hole.
4. Remove the two (2) board mounting screws and four (4) standoffs.
5. Push aside the ground harness and transformer cable and lift board enough to gain access to the PC board.
6. Disconnect the digital control panel from the board at J4 and the patient probe assembly from the board at J2.

NOTE: These connectors have locking tabs that must be pressed in order to disengage them from the board.

⚠ CAUTION

Use care when disconnecting the digital control panel ribbon from the control board.

Folding the ribbon cable may cause failure of the control panel.

7. Lift board out of cover.

9.4.2 Control/Display Board Installation (see fig. 14, p. 51):

1. **Unplug the power cord.**
2. Place the new control/display board in head.
3. Install the two (2) board mounting screws and four (4) standoffs as follows:
 - a. Install two (2) board screws through the ground harness on the patient probe end of the board.

NOTE: Insure that the corner screw also connects the ground wire of the patient probe assembly to the board.

- b. Install the standoffs through the other four (4) holes.
- 4. Insert patient probe assembly into mounting hole and fasten with hex nut. Insure patient probe assembly is oriented so that the bevelled corner of the probe assembly is positioned as shown in figure 20, p. 58, item 59.
- 5. Connect the digital control panel plug P4 to the board at J4.
- 6. Connect the patient probe assembly plug P2 to the board at J2.
- 7. Perform a voltage check of the power supply board (see section 9.2.2, p. 46).
- 8. Install the alarm/backup board (see section 9.3.2, steps 2-8).
- 9. Perform the *Functional Check and Safety Inspection* (section 7.3).

9.5 Replacing the Top Cover

To install a new cover:

1. **Unplug the power cord.**
2. Remove old top cover from machine by removing six screws underneath top cover and disconnecting cables. See figure 18, p. 55.
3. Install new top cover.
4. Perform the *Functional Check and Safety Inspection* (section 7.3).

9.6 Replacing Thermostats

To replace the thermostat, see figures 19 (p. 56) and 21 (p. 61).

1. **Unplug the power cord.**
2. Remove wraparound from chassis.
3. Disconnect spade lugs from thermostat terminals.
4. Carefully peel back insulating material.
5. Remove the two screws holding the thermostat. Remove the thermostat.
6. Apply thermal grease * (P/N 50040-000) to the underside of the replacement thermostat to ensure proper operating temperature ranges.

* Recommended thermal greases:

- Silicone Heat Sink Compound (Dow Corning; Midland, Michigan)
- Thermal Joint Compound Type 120-5 (Wakefield Engineering; Wakefield, Massachusetts)

⚠ CAUTION

Always use thermal grease on thermostats.

Failure to use thermal grease could raise trip points above the acceptable range.

7. Reconnect spade lugs to terminals. Refer to figure 21, p. 59 to ensure thermostat is connected correctly.

⚠ CAUTION

Do not bend or alter terminals.

Terminals may break. Also, bending may alter the trip point range.

8. Mount thermostat, using existing screws.
9. Reapply insulating material.
10. Perform the *Functional Check and Safety Inspection* (section 7.3).

9.7 Cleaning the Flow Switch

To clean the flow switch (see fig. 12 below and fig. 19, p. 56):

1. Remove nuts (item A) and remove assembly.
2. Loosen hose clamps (items B and C) and remove hoses.
3. Remove barbed adapters (item D). Remove plunger.
4. Clean all parts with alcohol and remove any foreign matter.
5. To reassemble, reverse steps 1 through 3 above.

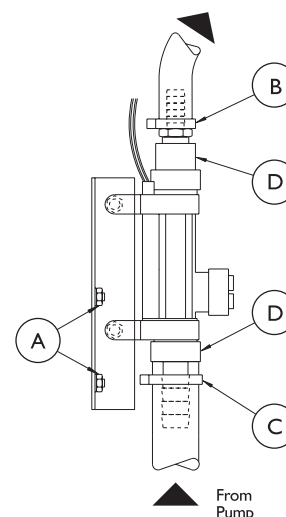

Figure 12—Flow Switch

9.8 Replacement Parts

For base replacement parts information, see figure 19 (pp. 56-57).
For head replacement parts information, see figure 20 (p. 58).

Repairs should only be performed by qualified personnel familiar with repair practices for servicing medical devices.

9.9 Shipping/Repackaging Instructions

▲ CAUTION

Failure to install compressor shipping braces before shipment can result in extensive damage to the refrigeration section. (See page 72, figure B.)

See figure 30 (pp. 72-73) for complete shipping/repackaging instructions.

10.0 Service Information

**PATIENT PROBE, BLANKET WATER PROBE (RT2),
RESERVOIR PROBE (RT1), AND
OVER-TEMPERATURE PROBE (RT3)
TEMPERATURE RESISTANCE**

TEMPERATURE (°C)	RESISTANCE (OHMS)	TEMPERATURE (°C)	RESISTANCE (OHMS)
0	7355	26	2156
1	6989	27	2064
2	6644	28	1977
3	6319	29	1894
4	6011	30	1815
5	5719	31	1739
6	5444	32	1667
7	5183	33	1599
8	4937	34	1533
9	4703	35	1471
10	4482	36	1412
11	4273	37	1355
12	4074	38	1301
13	3886	39	1249
14	3708	40	1200
15	3539	41	1152
16	3378	42	1107
17	3226	43	1064
18	3081	44	1023
19	2944	45	983.8
20	2814	46	946.2
21	2690	47	910.2
22	2572	48	875.8
23	2460	49	842.8
24	2354	50	811.3
25	2252		

Figure 13—Temperature vs. Resistance

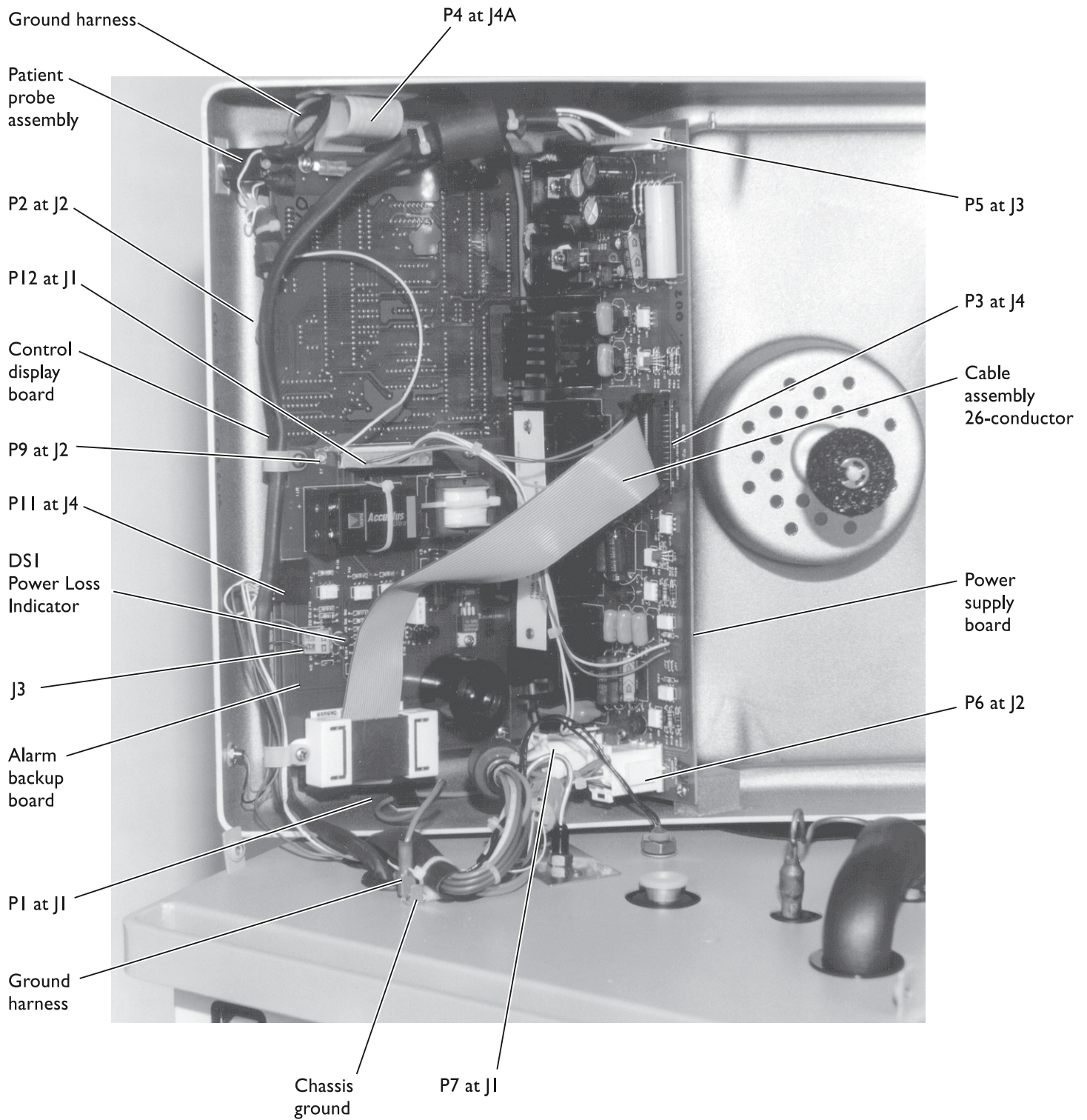
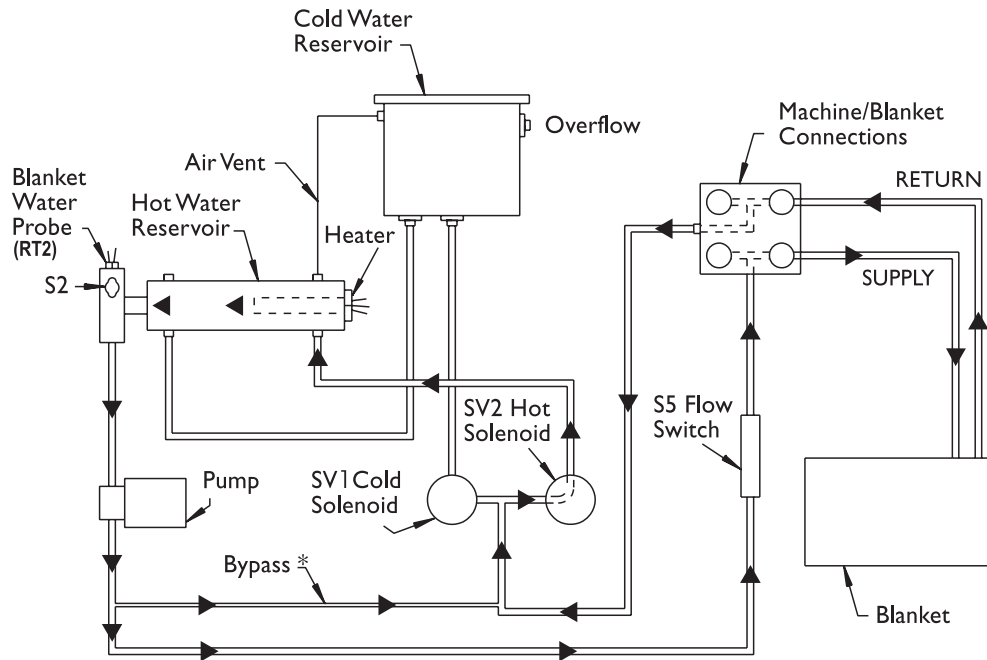

Figure 14—Circuit Boards and Connectors (head)

When the Medi-Therm II machine is **heating**, water flows in the path shown below.



*Water bypass prevents overheating when a blanket is not connected to the Medi-Therm II.

Figure 15A—Heating flow diagram

When the Medi-Therm II machine is **cooling**, water flows in the path shown below.

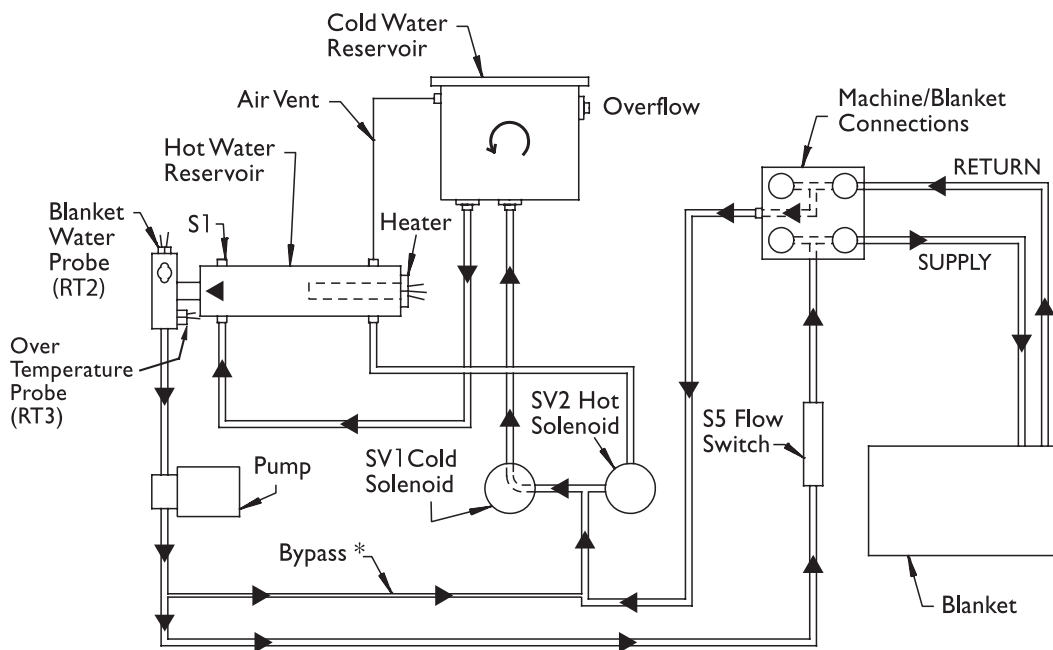

*Water bypass prevents overheating when a blanket is not connected to the RK-3000.

Figure 15B—Cooling flow diagram

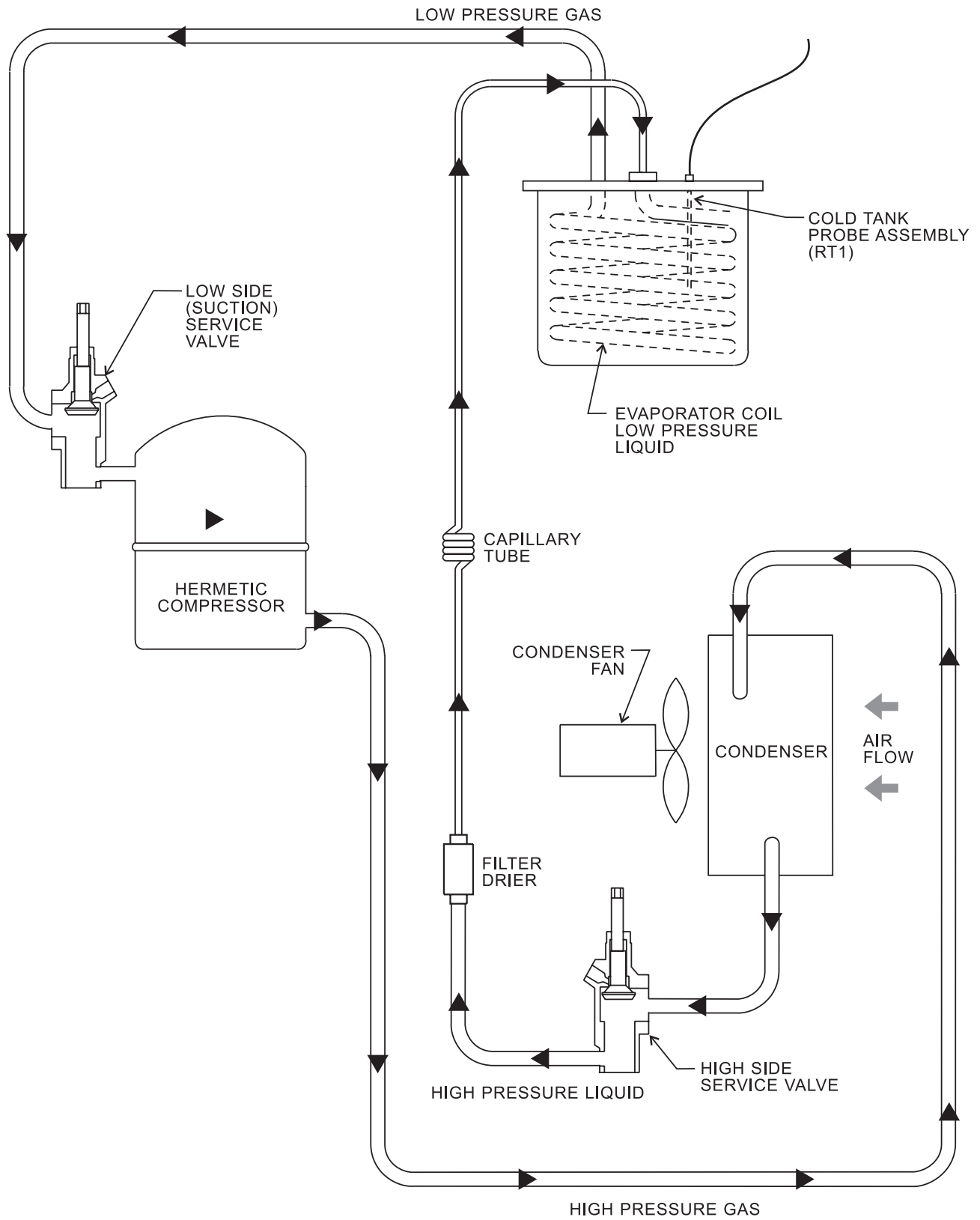

Figure 16—Refrigeration flow diagram

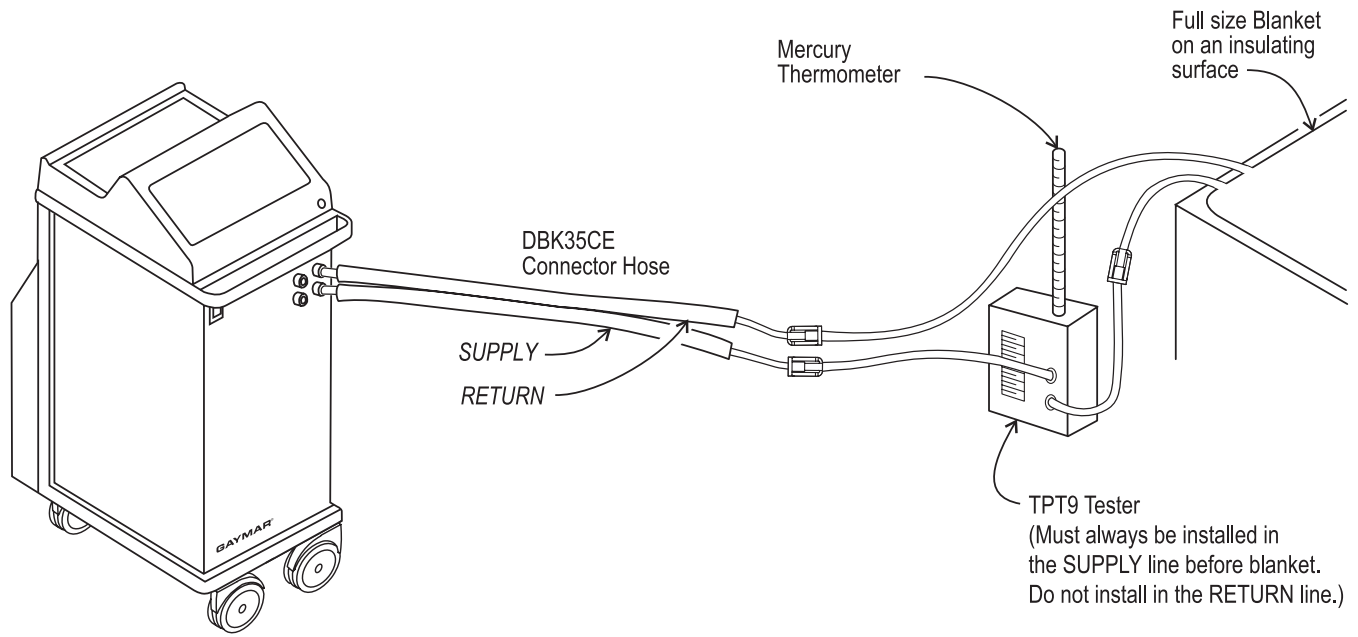

Figure 17A—Test setup [using TPT9 Tester and Mercury Thermometer]

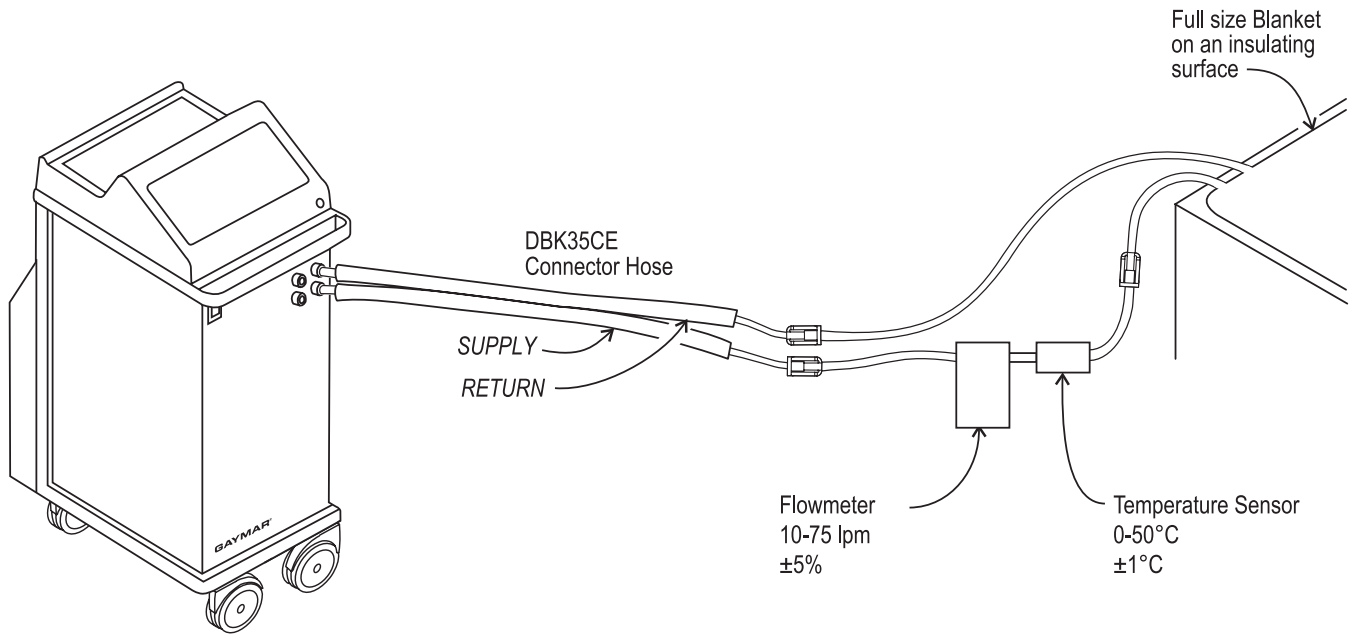

Figure 17B—Test setup [using alternate test equipment]

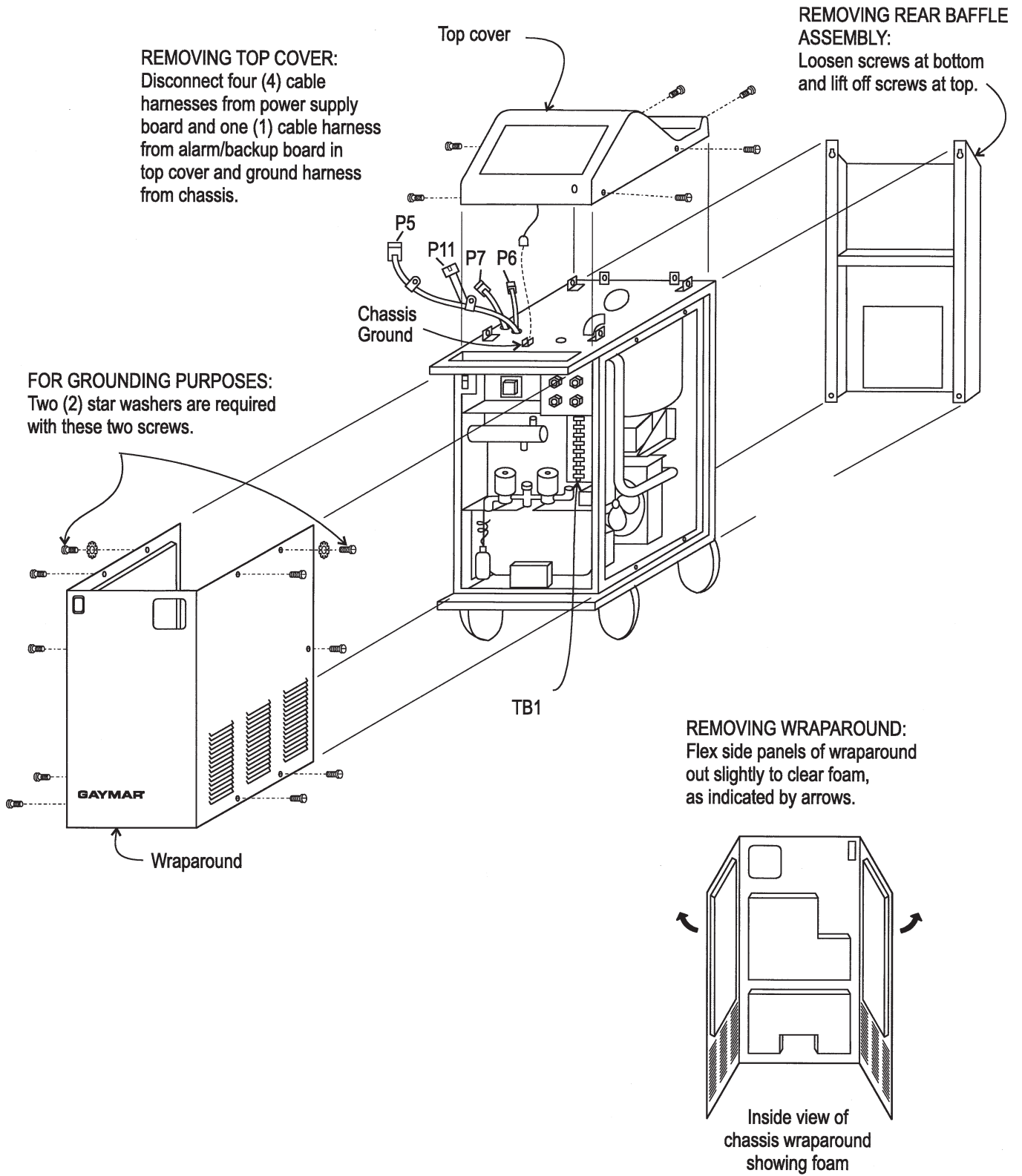

Figure 18—Machine disassembly

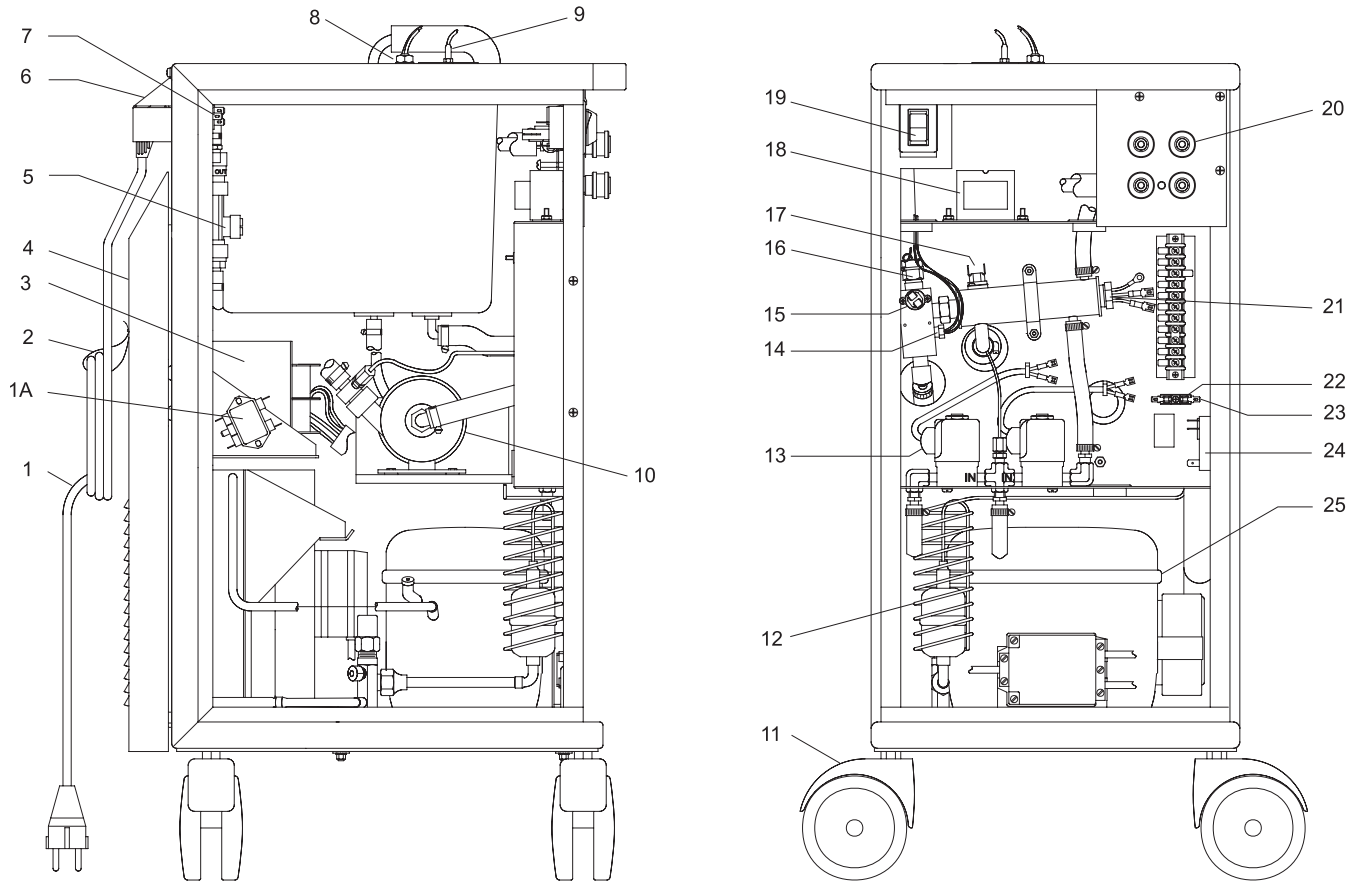

Figure 19—Parts Diagram (Base)

ITEM	DESCRIPTION	PART NUMBER
1	Power Cord	See below
1A	EMI Filter Replacement Kit	78197-000
2	Power Cord Strap	03791-000
3	Isolation Transformer (T2)	78186-000
4	Rear Baffle Assembly	07464-001
5	Flow Switch (S5) Kit	78184-000
6	Power Cord Retainer	10616-000
7	Power Inlet	91368-000
8	Water Level Sensor (S4) Kit	77757-000
9	Cold Tank Probe (RT1) Kit	77759-000
10	Pump (B1)	07368-001
11	Caster	91506-000
12	Filter Drier Assembly (includes suction service line and capillary tube)	10396-000
13	Solenoid Valve Kit (SV1 and SV2)	78180-000
14	Overtemp Probe (RT3) Kit	78187-000
15	Thermostat (S2) Kit	78191-000
16	Temperature Probe Assembly (RT2) Kit	77737-000

ITEM	DESCRIPTION	PART NUMBER
17	Thermostat (S1)	78193-000
18	Transformer (T1) Kit	78182-000
19	Circuit Breaker (CB1) Kit	78178-000
	Circuit Breaker Cover Kit	78179-000
20	Quick Disconnect (Female)	01080-000
21	Heater Assembly (HR1)	07370-000
22	Fuse (F1) 5 mm x 20 mm, T, L, 6.3A, 250V	90695-031
23	Fuse Holder	90877-001
24	Compressor Relay (K1)	91234-001
25	Kit, Condensing Unit	78174-000
	Capacitor Start	90701-141
	Start Relay	78175-000
	Fan Motor	78176-000
	Fan Blade	78177-000
26	Wraparound (Not Shown)	10288-000
27	RC Network (Not Shown); connected between pin 8 and pin 4 of Compressor Relay (Item 24).	10615-000

Parts List

ITEM 1, POWER CORD:

ITEM	DESCRIPTION
PC001	Power Cord (Continental Europe)
PC002	Power Cord (United Kingdom)
PC003	Power Cord (Australia)
PC004	Power Cord (Switzerland)
PC005	Power Cord (Italy)
PC006	Power Cord (Denmark)
PC007	Power Cord (Israel)

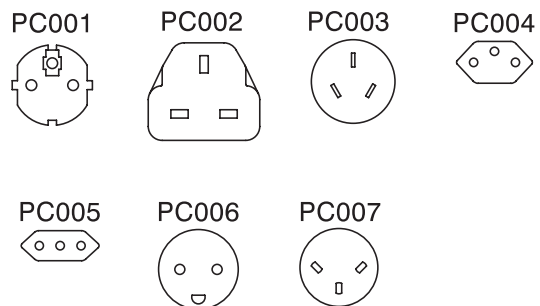

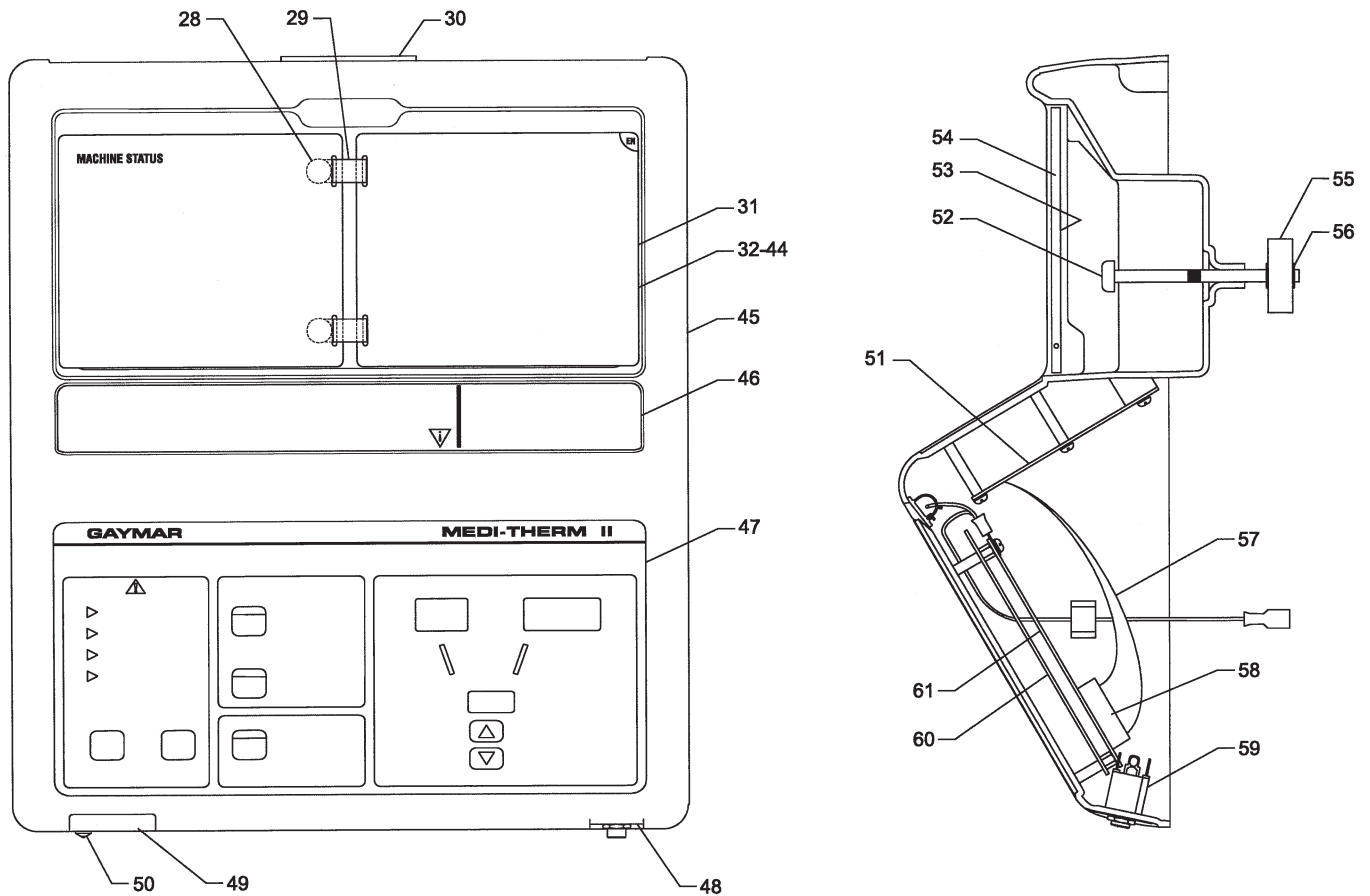

ITEM	DESCRIPTION	PART NUMBER
28	Ratchet Fastener	91428-002
29	Cable Clip	90228-005
30	Rating Label	10414-000
31	Operating Instruction Card Assembly	10605-000
32-44	Individual Instruction Cards	Various
45	Cover Assembly Kit	78195-000
46	Warning Label	10409-000
47	Panel Digital Control	10546-000
48	Patient Probe Label	10350-000
49	Power Out Label	10598-000
50	LED Chrome Bezel (DS1)	90761-038

ITEM	DESCRIPTION	PART NUMBER
51	PC Board, Power	10528-001
52	Stem (includes items 55, 56)	77760-000
53	Fill Label	10349-000
54	Door Kit	78189-000
55	Float (includes items 52, 56)	77760-000
56	Retaining Ring (includes items 52, 55)	77760-000
57	Cable Assembly, 26-conductor	07481-000
58	Battery	91509-000
59	Patient Probe Jack Assembly	07311-000
60	PC Board, Control/Display	10556-000
61	PC Board, Alarm/Backup	10512-000

Figure 20—Parts Diagram (Head), Parts List

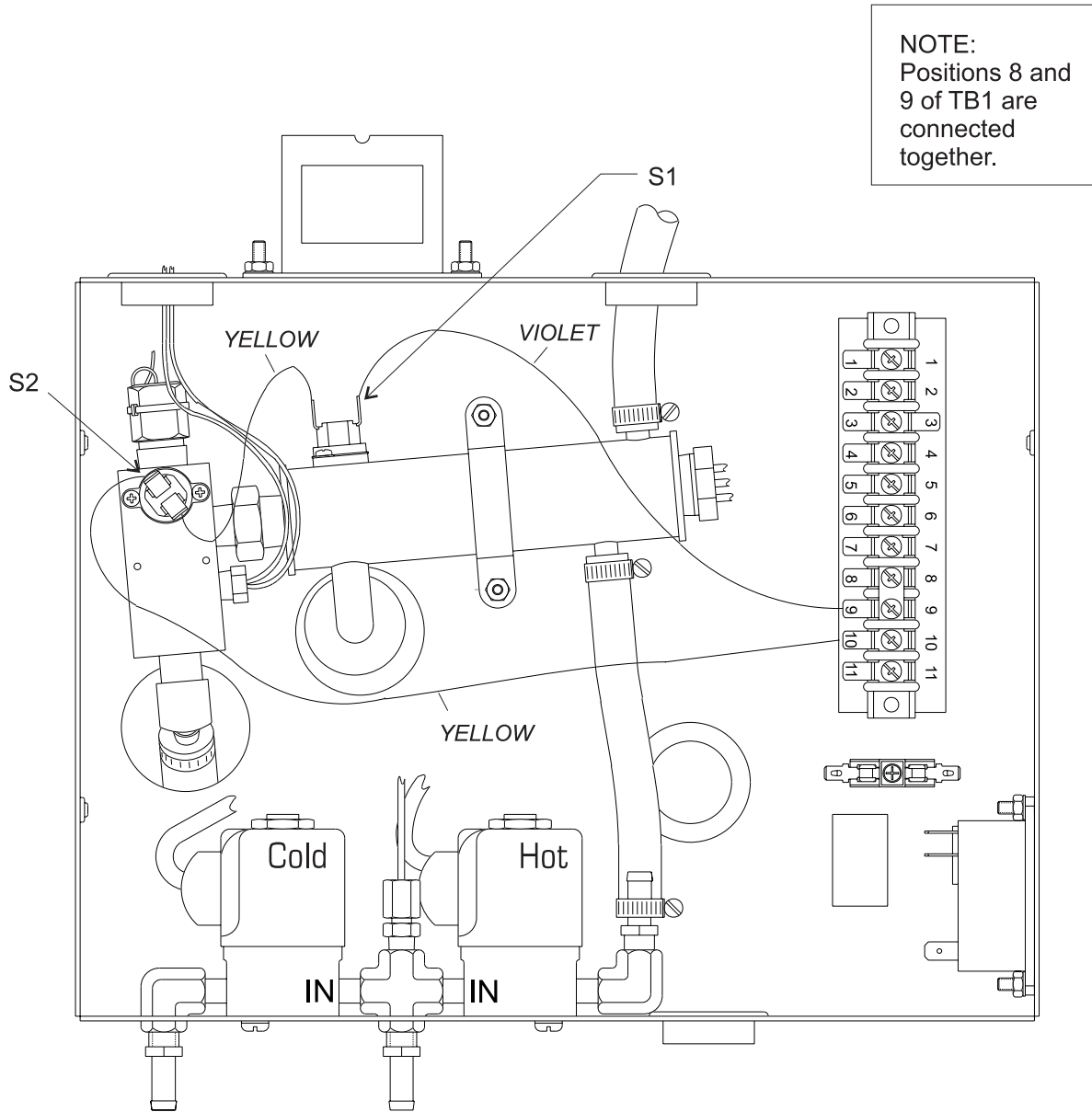

Figure 21—Thermostat Wiring Diagram

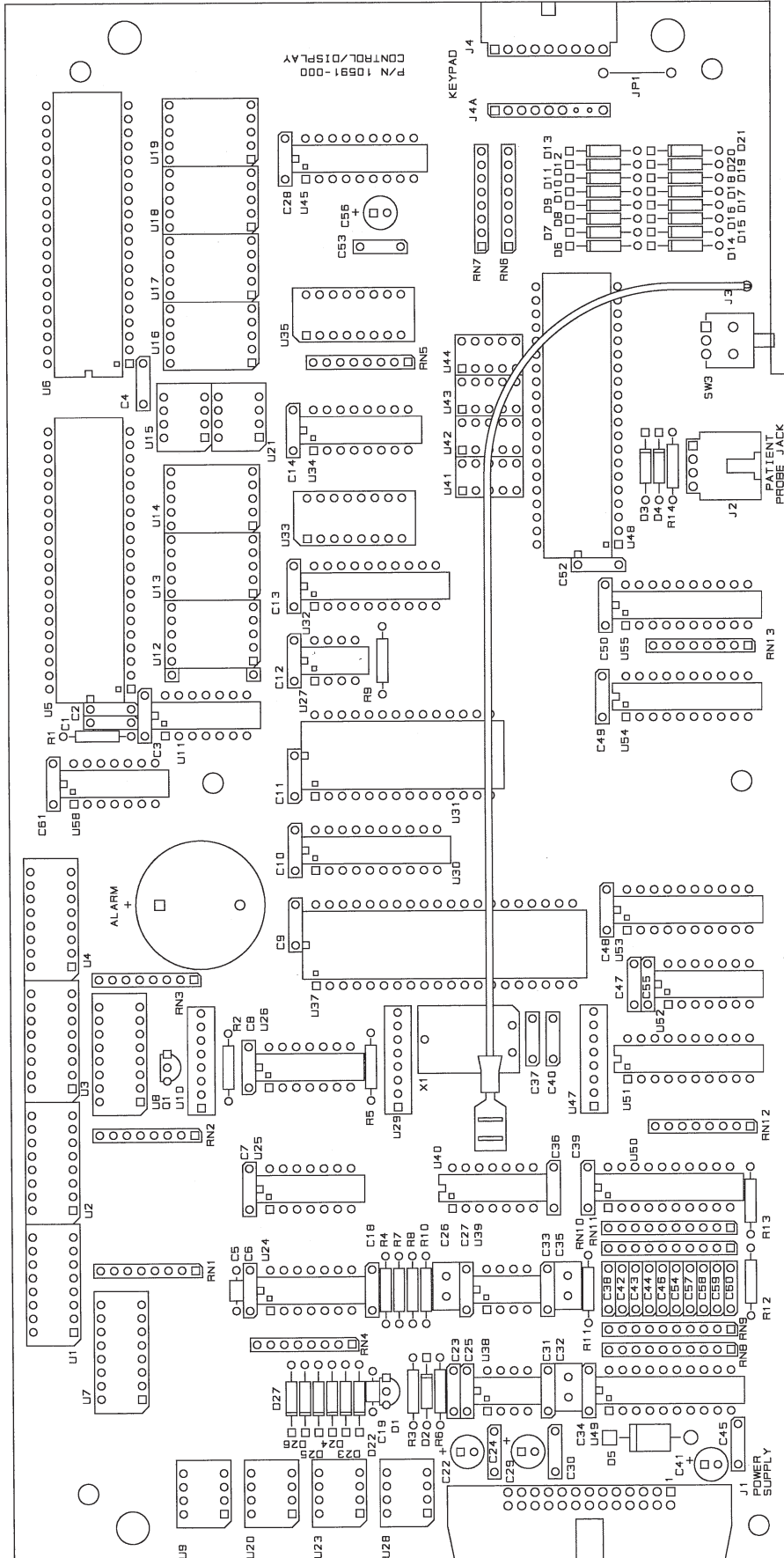

Figure 22—Control/Display Board

Designator	Description	P/N
C1-C4, C6-C14, C18, C23-C25, C27, C28, C30, C31, C33, C34, C36, C38, C39, C42-C50, C52-C55, C57-C61	Capacitor, 0.1µF, 50V	90701-169
C5	Capacitor, 330pf, 50V	90701-167
C19	Capacitor, 1000pF, 50V	90701-166
C22, C29, C41, C56	Capacitor, 10µF, 100V	90701-071
C26, C32, C35	Capacitor, 100pF, 300V	90701-111
C37, C40	Capacitor, 22pF, 50V	90701-168
D1	Diode, LM385Z-1.2	90717-058
D2	Diode, 1N914	90717-002
D3, D4, D6-D27	Diode, 1N5282	90717-006
D5	Transorb	91269-001
Q1	Transistor, 2N3904	90868-015
R1, R5	Resistor, 10K, 1/4W, 5%	90092-073
R2, R14	Resistor, 47K, 1/4W, 5%	90092-089
R3	Resistor, 249K, 1/8W, 1%	90092- 346
R4	Resistor, 750 ohm, 1/4W, 5%	90092-046
R6	Resistor, 12.4K, 1/8W, 1%	90092-343
R7	Resistor, 22.6K, 1/8W, 1%	90092-344
R8	Resistor, 10.0K, 1/8W, 1%	90092-368
R9	Resistor, 2K, 1/4W, 5%	90092-056
R10	Resistor, 66.5K, 1/8W, 1%	90092-345
R11	Resistor, 2.00K, 1/8W, 1%	90092-364
R12	Resistor, 816 ohm, 1/8W, 0.1%	90092-421
R13	Resistor, 7.32K, 1/8W, 0.1%	90092-422
RN1-RN3, RN5	Resistor Network, 27 ohm bussed	91248-001
RN4	Resistor Network, 47K isolated	91248-018
RN6, RN7	Resistor Network, 10K isolated	91248-017
RN8-RN11	Resistor Network, 4.7K isolated	91248-016

Designator	Description	P/N
RN12, RN13	Resistor Network, 10K bussed	91248-002
SW3	Pushbutton switch	91247-027
U1-U3, U33, U35	LED It bar, green 2885	90761-026
U5, U6, U48	IC, ICM7212	90886-072
U7, U8	LED It bar, yellow 2785	90761-003
U9, U20, U23, U28	LED It bar, yellow 2755	90761-005
U10, U29, U47	LED It bar, green 2550	90761-028
U11, U25, U26, U52	IC, DS75492	90886-038
U13, U14, U17-U19	LED digit, red 5551	90761-000
U24	IC, VFC32	90886-037
U27	IC, CAT93C57P	90886-021
U30	IC, 74HC373	90886-086
U31	Eprom, programmed	Contact your dealer
U32	IC, 74HC244	90886-085
U34	IC, MAX691	90886-052
U37	IC, 80C32	90886-071
U38, U39	IC, LM308AN	90886-016
U40	IC, 74HC02	90886-036
U42-U44	LED digit, red 7511	90761-006
U45	IC, 74C922	90886-058
U49, U50	IC, 74HC4351	90886-087
U51	IC, DP8310	90886-090
U53, U54	IC, 74HC377	90886-088
U55	IC, 74HC541	90886-089
U58	IC, 74HC32	90886-039
X1	Crystal, 12MHz	91226-001

Parts List

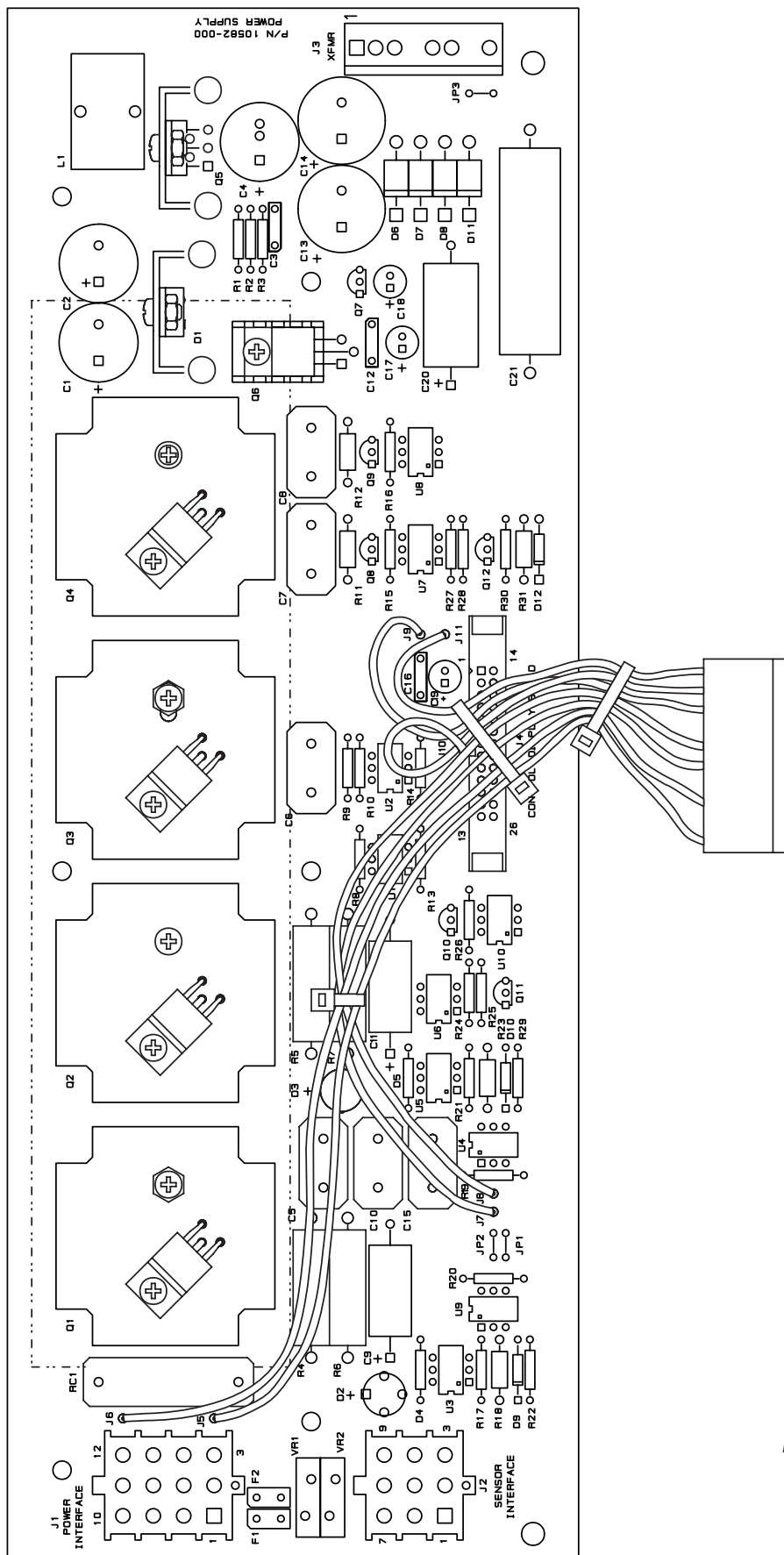

Figure 23—Power Supply Board

Designator	Description	P/N
C1, C2	Capacitor, 1000 μ F, 35V	90701-080
C3, C12, C16	Capacitor, 0.1 μ F, 50V	90701-169
C4	Capacitor, 390 μ F, 40V	90701-079
C5, C7, C8, C10, C15	Capacitor, 0.01 μ F, 400V	90701-096
C6	Capacitor, 0.001 μ F, 600V	90701-097
C9, C11, C20	Capacitor, 330 μ F, 35V	90701-064
C13, C14	Capacitor, 1000 μ F, 35V	90701-081
C17, C18, C19	Capacitor, 10 μ F, 100V	90701-071
C21	Capacitor, 0.47 μ F, 400VDC	90701-180
D1	Diode, Schottky MBR745	90717-098
D2, D3	Diode, bridge W04G	90717-042
D4, D5	Diode, trigger	90717-028
D6 thru D8, D11	Diode, power 501	90717-084
D9, D10	Diode, zener 1N749A	90717-014
D12	Diode, 1N4004	90717-001
F1, F2	Fuse, subminiature, 0.125A	90695-041
L1	Inductor, 55 μ H	91265-001
Q1 thru Q4	Triac, 2N6347A, 2N6348A, 2N6349A	90709-000
Q5	Voltage regulator, LT1074	90712-043
Q6	Voltage regulator, LM340T-12	90712-015
Q7	Voltage regulator, LM-320LZ-12	90712-001
Q8, Q9	Triac, Z0103MA	90709-014

Designator	Description	P/N
Q10, Q11	Transistor, 2N3904	90868-015
Q12	Transistor, 2N6727	90868-030
R1, R3	Resistor, 2.00K, 1/8W, 1%	90092-364
R2	Resistor, 2.80K, 1/8W, 1%	90092-348
R4 thru R7	Resistor, 8.2K, 5W, 5%	90092-440
R8, R10, R15, R16	Resistor, 390 ohm, 1/4W, 5%	90092-039
R9	Resistor, 100 ohm, 1/4W, 5%	90092-025
R11, R12	Resistor, 4.7K, 1/2W, 5%	90092-225
R13, R14, R19, R24, R27, R28	Resistor, 200 ohm, 1/4W, 5%	90092-032
R17, R21, R30	Resistor, 1K, 1/4W, 5%	90092-049
R18, R23	Resistor, 5.6K, 1/2W, 5%	90092-227
R20, R26	Resistor, 5.1M, 1/4W, 5%	90092-138
R22, R29	Resistor, 1.3K, 1/4W, 5%	90092-052
R25	Resistor, 3K, 1/4W, 5%	90092-060
R31	Resistor, 680R, 1/2W, 5%	90092-205
RC1	RC Network, 47 ohm, 0.5 μ F	91069-001
U1, U7, U8	IC, MOC3010	90886-001
U2	IC, MOC3021	90886-000
U3 thru U6	IC, MOC3063	90886-003
U9, U10	IC, H11A1	90886-002
VR1, VR2	Varistor	91266-000

Parts List

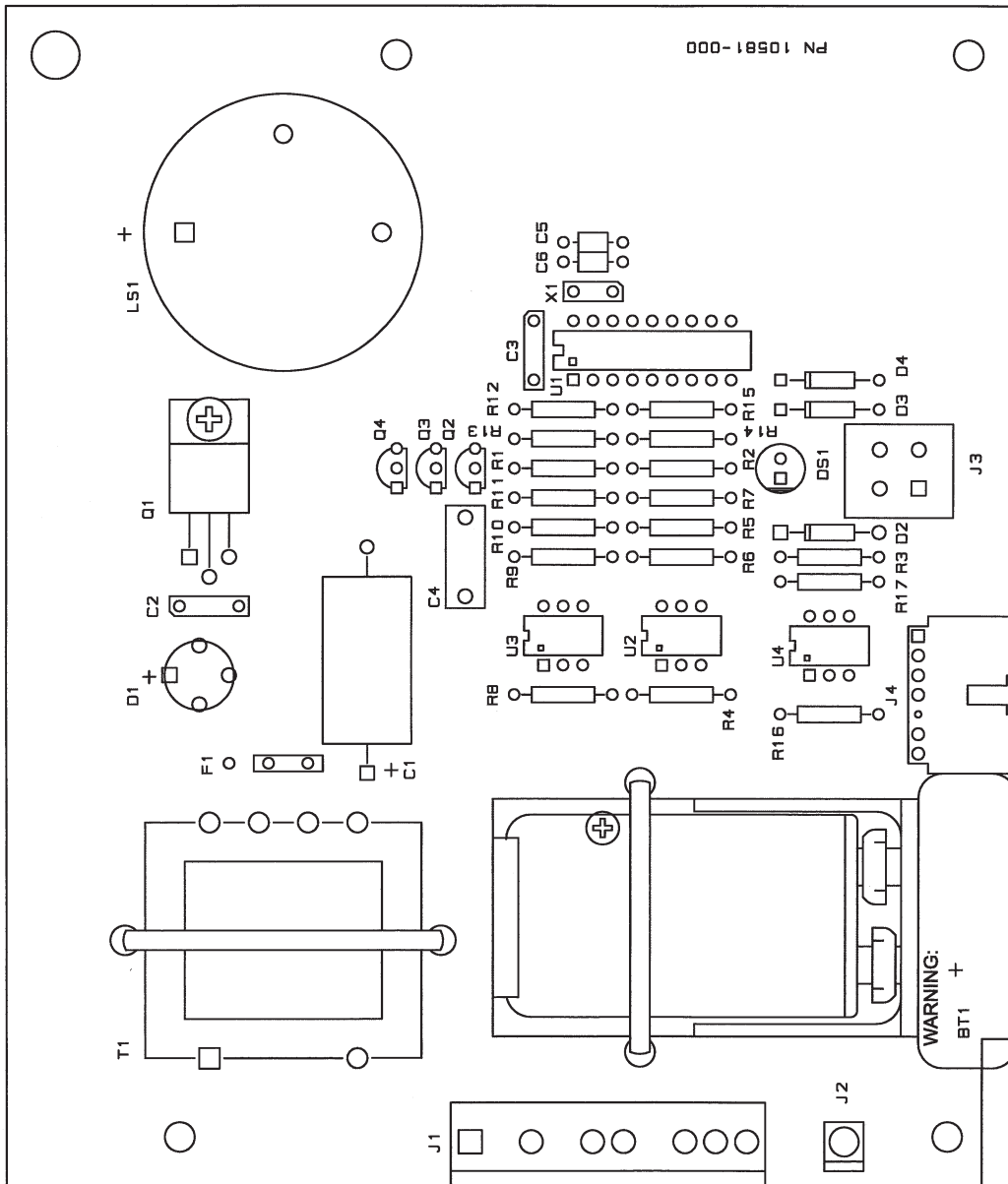
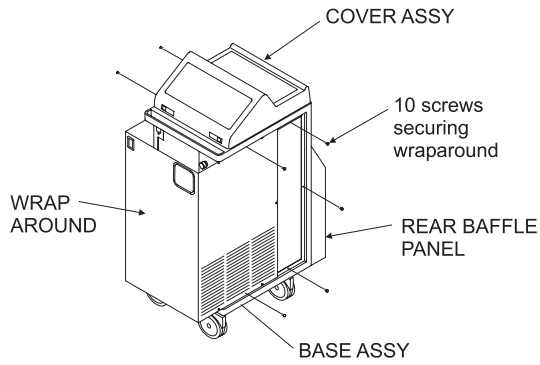

Figure 24—Alarm/Backup Board

Designator	Description	P/N
BT1	Rechargeable battery, 9V	See 7.3.e), page 18
C1	Capacitor, 470 μ F, 25V	90701-061
C2, C3	Capacitor, 0.1 μ F, 50V	90701-169
C4	Capacitor, 0.22 μ F, 100V	90701-017
C5, C6	Capacitor, 22pF, 50V	90701-168
D1	Diode, bridge W04G	90717-042
D2	Diode, 1N4004	90717-001
D3, D4	Diode, 1N5282	90717-006
DS1	LED, lamp red 4700	90761-015
F1	Subminiature fuse, 0.125A	90695-040
LS1	Audible alarm	90919-003
Q1	Voltage regulator, LM340T-5	90712-017
Q2, Q3, Q4	Transistor, 2N3904	90868-015

Designator	Description	P/N
R1, R7, R13	Resistor, 4.7K, 1/4W, 5%	90092-065
R2, R6, R10	Resistor, 10K, 1/4W, 5%	90092-073
R3	Resistor, 470 ohm, 1/4W, 5%	90092-041
R4, R8, R17	Resistor, 390 ohm, 1/4W, 5%	90092-039
R5, R9, R16	Resistor, 150K, 1/4W, 5%	90092-101
R11	Resistor, 1.050K, 1/8W, 0.1%	90092-424
R12	Resistor, 100 ohm, 1/4W, 5%	90092-025
R14, R15	Resistor, 2.7K, 1/4W, 5%	90092-059
T1	Transformer	91459-001
U1	Prom, programmed alarm	Contact your dealer
U2, U3, U4	IC, H11A1	90886-002
X1	Resonator, ceramic 4.00 MHz	91226-014

Parts List



MEDI-THERM UNIT
Figure A

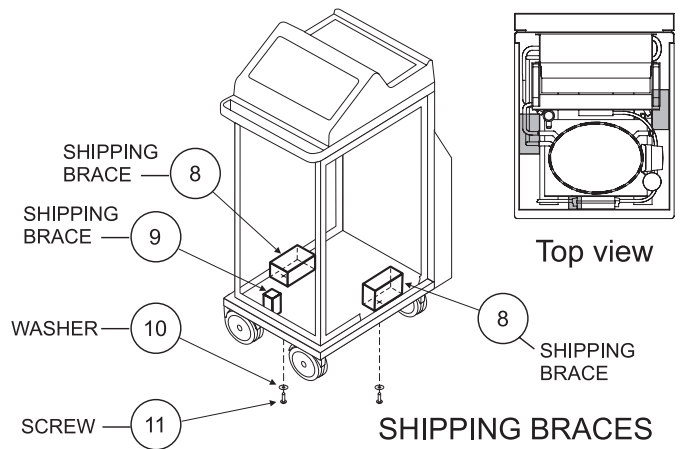

SHIPPING BRACES
Figure B

⚠ CAUTION

Failure to install the compressor shipping braces (see figure B) before shipment can result in extensive damage to the refrigeration section.

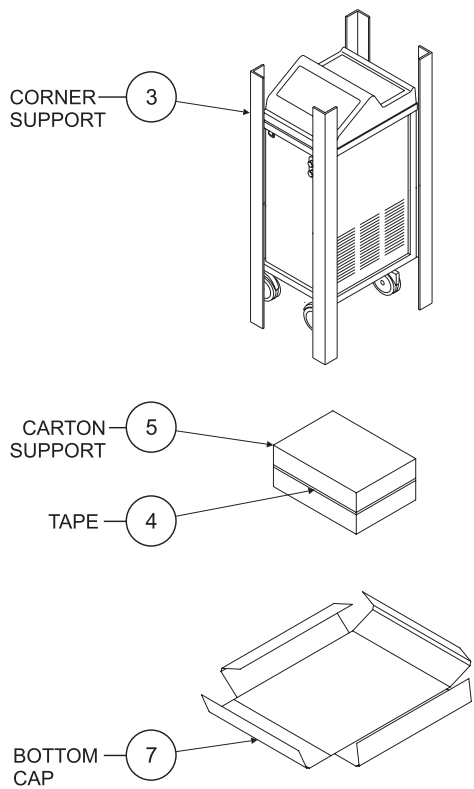
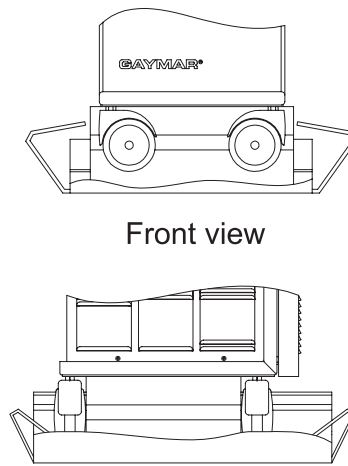

Figure C



Front view
Side view
Figure D

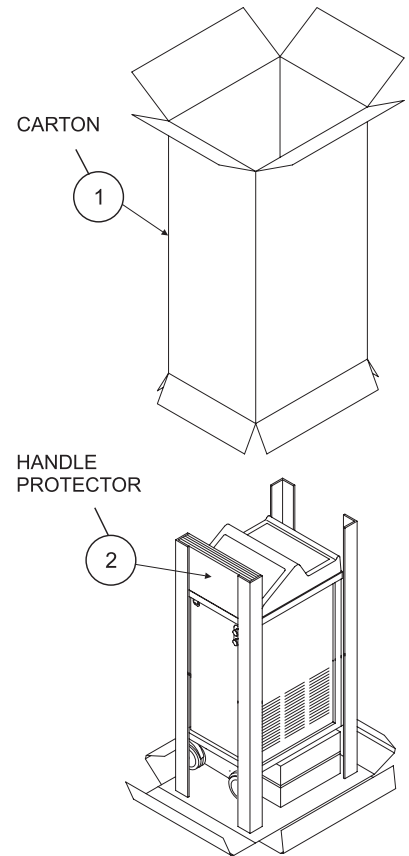
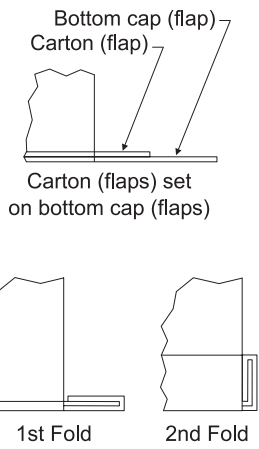
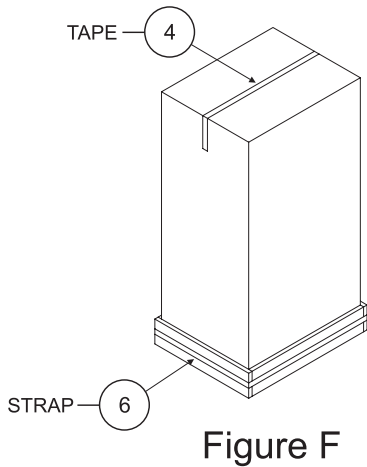

Figure E



BOTTOM CAP FOLDING DETAIL

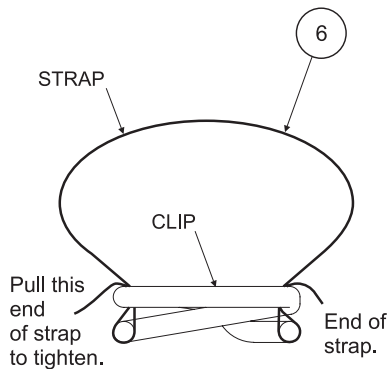

Figure G

INSTRUCTIONS

Before repacking the Medi-Therm II machine, perform Steps 1 & 2:

Step 1. Fill unit with distilled water to proper fill line. Close the DBK hose assembly clamps (refer to manual) and attach hose connectors to the supply quick disconnect fittings on the unit. Direct the DBK hose assembly Clik-Tite connectors to a drain or container having a minimum capacity of twelve (12) liters, open the DBK hose assembly clamps. Plug unit into proper voltage receptacle, turn unit on, select *BLANKET CONTROL MODE* and set temperature to 30°C. Drain approximately four (4) liters of water from unit. Turn unit off, close the DBK hose assembly clamps, fasten the Clik-Tite connectors together and reopen the clamps. Add 0.25 liter of isopropyl alcohol to unit. Turn unit on, select *BLANKET CONTROL MODE*, set temperature to 30°C and run unit for approximately three (3) minutes. Turn power off.

Step 2. Direct the DBK hose assembly Clik-Tite connectors to a drain or container. Unfasten the connectors. Turn unit on, select *BLANKET CONTROL MODE*, set temperature to 4°C, drain unit until no water comes out. Continue draining by tilting the unit forward and keep it in that position until the unit is completely empty. Turn unit off and unplug the power cord. Connect Clik-Tite connectors together and disconnect the DBK assembly from unit.

Step 3. Refer to figure A. Detach power cord. Remove lower wraparound by removing ten (10) screws.

Step 4. Refer to figure B. Insert three (3) shipping braces—for two of the braces, use a screw and washer through the housing

frame into the shipping brace; the third brace just fits in place.

Step 5. Refer to figure A. Replace lower wraparound and ten (10) screws.

Step 6. Refer to figure C. Place bottom cap (item 7) on floor.

NOTE: Steps 7 through 12 will require two (2) people.

Step 7. Refer to figure C. Tape up carton support (item 5) as shown using nylon tape (item 4) and place on top of bottom cap.

Step 8. Refer to figure D. Place the unit on top of carton support with the wheels oriented as shown.

Step 9. Refer to figure E. Position the four (4) corner supports (item 3) on the corners of the unit as shown in the exploded view.

NOTE: The hole in the left rear corner support must be positioned directly over the cord retainer in the unit base. No special positioning is required for the other three corner supports.

Step 10. Refer to figure E. Push handle protector (item 2) down behind the two (2) front corner supports so it rests on top of the handle. Slide master carton (item 1) over corner supports.

Step 11. Refer to figure F. Tape the top of the carton closed using nylon filament tape (item 4) supplied with kit.

Step 12. Refer to figure G for folding the bottom cap and securing the plastic strap and clip (item 6).

CONTENTS OF MEDI-THERM SHIPPING KIT (P/N 78196-000)					
ITEM	DESCRIPTION	QTY	ITEM	DESCRIPTION	QTY
1	Carton	1	7	Cardboard Bottom Cap	1
2	Handle Protector	1	8	Wood Shipping Brace	2
3	Cardboard Corner Support	4	9	Wood Shipping Brace	1
4	Nylon Filament Tape (3/4" wide)	1	10	Washer	2
5	Cardboard Carton Support	1	11	Screw	2
6	Plastic Strap with Attachment Clip	1	12	Shipping Kit Instructions	1

Figure 30—Shipping Instructions



GAYMAR INDUSTRIES, INC.

10 Centre Drive
Orchard Park, NY
14127-2295
USA

Phone:
(716) 662-8636

FAX:
(716) 662-0730

Authorized EU representative:
(Europe):

INVATECH GmbH & Co. KG
Königsreihe 22
D 22041 Hamburg, Germany