

## Nära Hospital Bassinet

### Maintenance Manual

**REF** 4402-000-001

**REF** 4402-000-002





# Table of Contents

Warning/Caution/Note Definition .....	2
Pinch points.....	2
Introduction for service .....	3
Expected device life .....	3
Contact information.....	3
Serial number location.....	3
Unit number.....	4
Preventive maintenance .....	5
Service .....	6
Upper cradle replacement.....	6
Lower cradle replacement.....	7
Push bar replacement .....	9
Caster replacement.....	11
Drawer slide replacement .....	12
Gas cylinder replacement .....	13
Base cover replacement.....	15
Top level assembly - 4402-100-001 .....	17
Bassinet assembly - 4402-010-001 .....	18
Base assembly - 4402-001-001.....	20
Top level assembly, International - 4402-100-002 .....	22
Bassinet assembly, International - 4402-010-009.....	23
Base assembly, International - 4402-001-007 .....	25
Cabinet-drawer assembly - 4402-050-001 .....	27
Drawer assembly - 4402-050-002 .....	28
Document holder assembly - 4402-050-007 .....	29
Cradle assembly - 4402-010-002 .....	30

# Warning/Caution/Note Definition

The words **WARNING**, **CAUTION**, and **NOTE** carry special meanings and should be carefully reviewed.

## WARNING

Alerts the reader about a situation which, if not avoided, could result in death or serious injury. It may also describe potential serious adverse reactions and safety hazards.

## CAUTION

Alerts the reader of a potentially hazardous situation which, if not avoided, may result in minor or moderate injury to the user or patient or damage to the product or other property. This includes special care necessary for the safe and effective use of the device and the care necessary to avoid damage to a device that may occur as a result of use or misuse.

**Note** - Provides special information to make maintenance easier or important instructions clearer.

## Pinch points

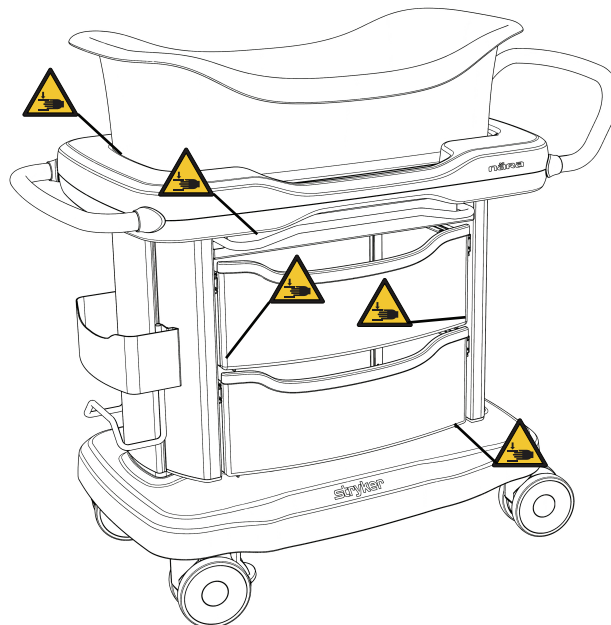



## Introduction for service

This manual assists you with the service of your Stryker product. Read this manual to service this product. This manual does not address the operation of this product. See the Operations Manual for operating and use instructions. To view your Operations Manual online, see <https://techweb.stryker.com/>.

## Expected device life

The **Nära** Hospital Bassinet has a five year expected service life under normal use conditions and with appropriate periodic maintenance.

## Contact information

Contact Stryker Customer Service or Technical Support at: 1-800-327-0770.

Stryker Medical  
3800 E. Centre Avenue  
Portage, MI 49002  
USA

To view your operations or maintenance manual online, see <https://techweb.stryker.com/>.

Have the serial number (A) of your Stryker product available when calling Stryker Customer Service or Technical Support. Include the serial number in all written communication.

## Serial number location

You can find the serial number inside the cabinet (A), opposite the chart holder (Figure 1).

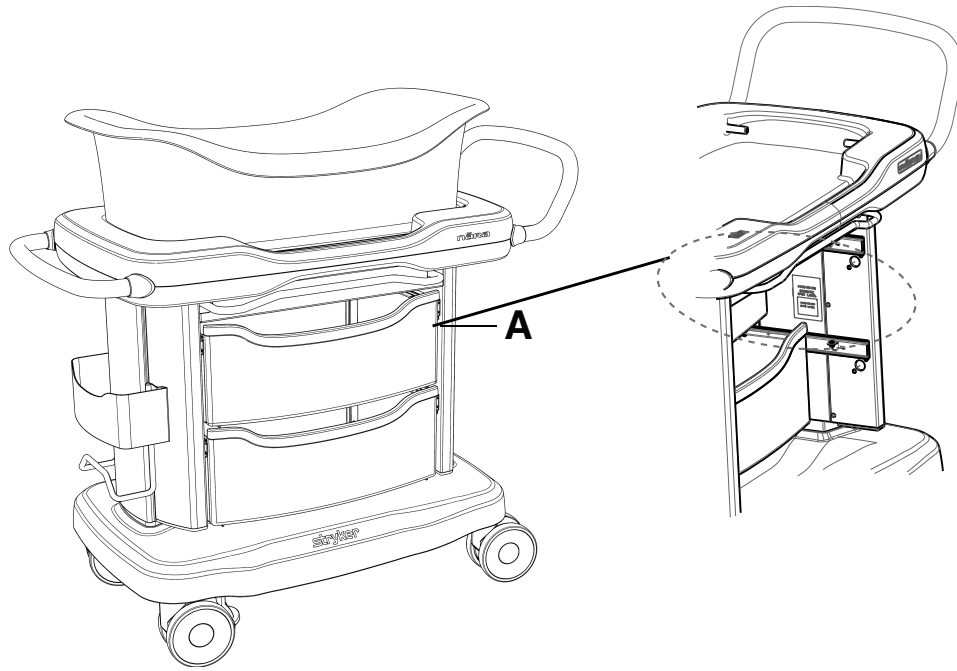
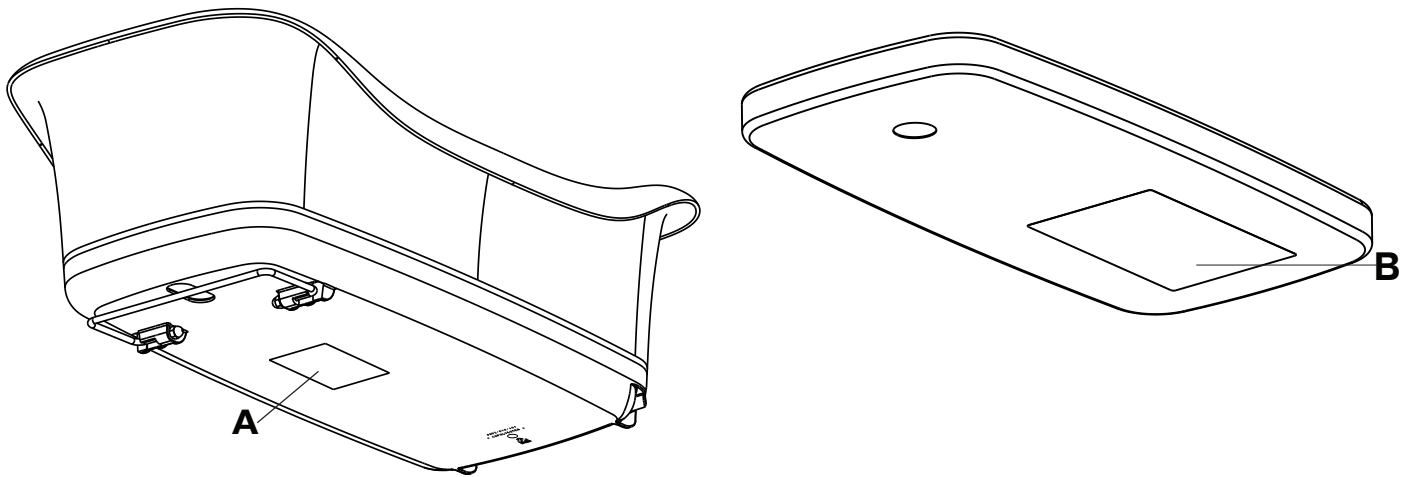

Figure 1 – Serial number location

## Unit number

Have the unit number of your basket (A) or mattress (B) available when calling Stryker Customer Service or Technical Support. Include the unit number in all written communication.



# Preventive maintenance

Remove product from service before you perform the preventive maintenance inspection. Check all items listed during annual preventive maintenance for all Stryker Medical products. You may need to perform preventive maintenance checks more often based on your level of product usage. Service only by qualified personnel.

Inspect the following items:

- \_\_\_\_\_ All fasteners are secure
- \_\_\_\_\_ Chart holder for damage
- \_\_\_\_\_ All four casters swivel
- \_\_\_\_\_ All four casters are free of wax and debris
- \_\_\_\_\_ All mechanisms operate
- \_\_\_\_\_ Two basket retention pins and tilt bar retainer are intact and secure
- \_\_\_\_\_ Retractable work surface is intact and secure
- \_\_\_\_\_ Basket tilt bar is intact
- \_\_\_\_\_ Drawers are intact and slide
- \_\_\_\_\_ Push handles
- \_\_\_\_\_ Height adjustment bars
- \_\_\_\_\_ Bassinet raises and lowers
- \_\_\_\_\_ Mattress for rips, tears, punctures, wear
- \_\_\_\_\_ Base cabinet for cracks or damage
- \_\_\_\_\_ Labels for legibility, proper adherence, and integrity

Product serial number:
Completed by:
Date:

# Service

## Upper cradle replacement

### Tools required:

- 3/16" hex wrench
- 3/8" nut driver
- T20 Torx driver
- Torque screwdriver (in-lb)
- Pick

### Procedure:

1. Apply the brakes.
2. Remove the basket and set aside.
3. Using a 3/16" hex wrench, remove the two yellow basket pivot pins (W and Y) from the upper cradle (Figure 2). Save the pivot pins.

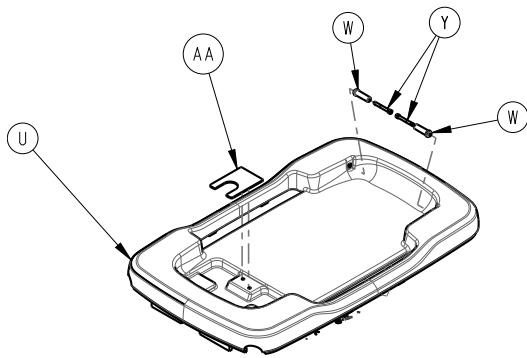

Figure 2 – Upper cradle

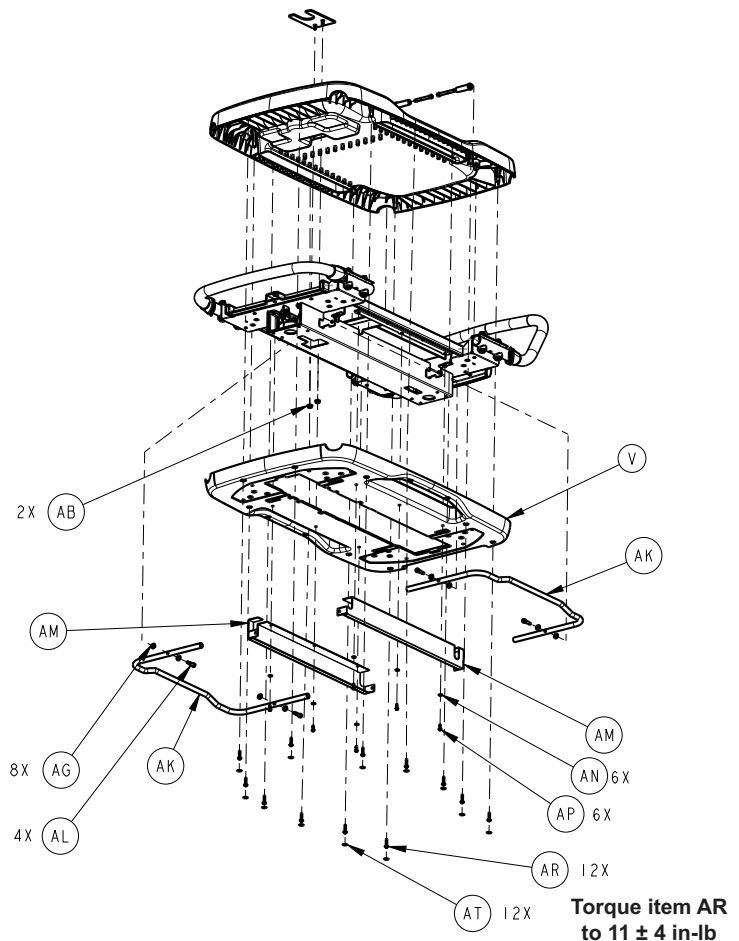

Figure 3 – Basket trend catch

4. Open the top and bottom drawers to access the cutout under the basket trend catch (AA).
5. Using a 3/8" nut driver, remove the two nuts (AB) that secure the basket trend catch to the upper cradle (Figure 3). Save the nuts.

6. Using a pick, remove the 12 cradle fastener cover labels (AT) from the bottom outside edge of the lower cradle.

**Note** - Replace the 12 cradle fastener cover labels when you install the upper cradle.

7. Using a T20 Torx driver, remove the 12 screws (AR) that secure the upper cradle to the lower cradle. Save the screws.

**Note** - Using a torque screwdriver, torque the screws to  $11 \pm 4$  in-lb when you reinstall.

8. Grasp both sides of the upper cradle (U) and pull up to separate the upper and the lower covers (Figure 2).

9. Remove and discard the upper cradle.

10. Reverse steps to install the supplied upper cradle.

**Note** - Affix the two supplied Nära logo labels (C) when you install the upper cradle (Figure 4).

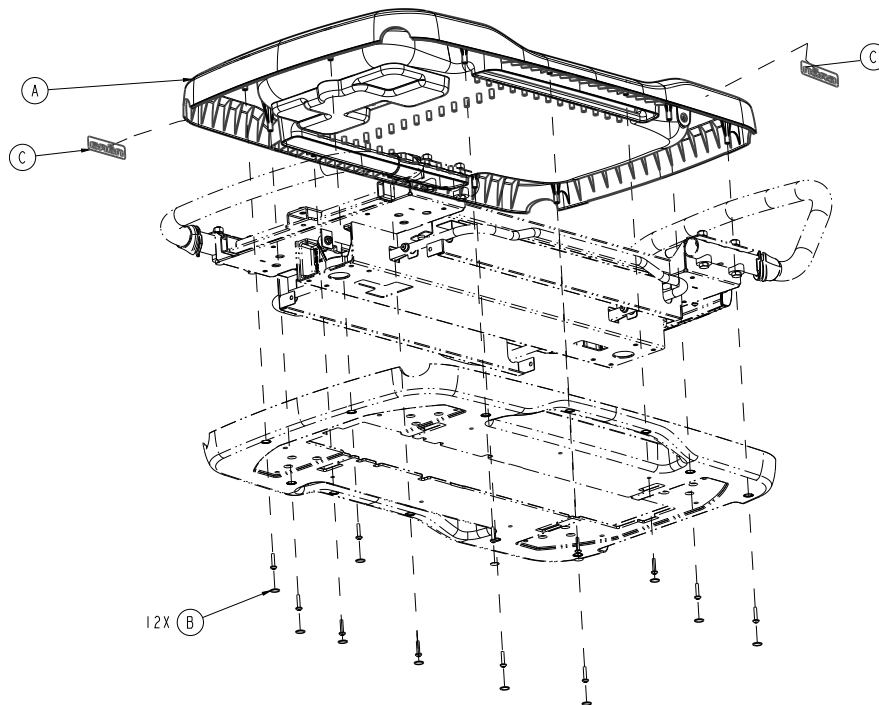

**Figure 4 – Upper cradle - logo labels**

11. Verify proper operation before you return the product to service.

## Lower cradle replacement

### Tools required:

- T15 Torx driver
- 1/8" hex wrench
- T25 Torx driver
- 5/32" hex wrench
- Rubber hammer

### Procedure:

1. Remove the upper cradle. See *Upper cradle replacement* (page 6).
2. Using a T15 Torx driver, remove the four screws (J) and washers (H) that secure the columns to the valance brackets (Figure 5). Save the screws and washers.

**Note** - Lower the product to the lowest height to minimize the column dropping.

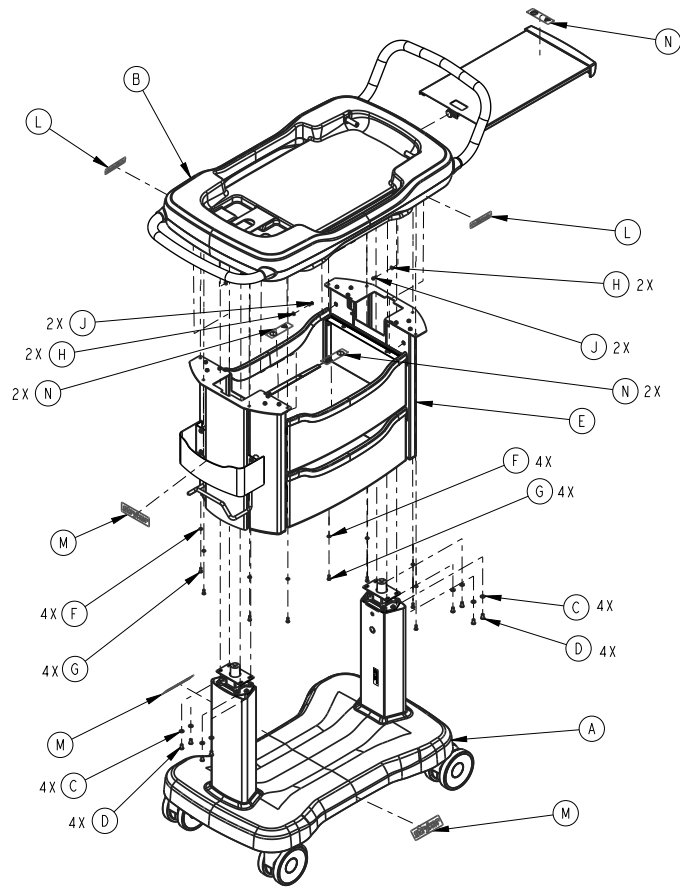
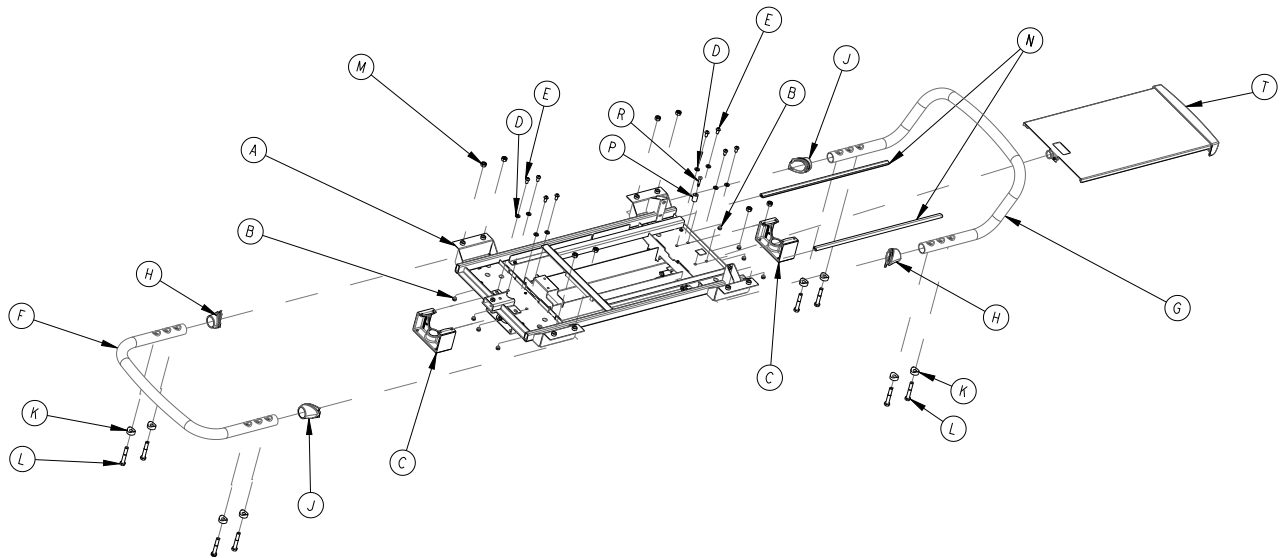

**Figure 5 – Column and drawer assembly**

- Using a 1/8" hex wrench, remove the eight screws (G) and washers (F) that secure the column and drawer assembly to the top cradle bracket. Save the screws and washers.

**Note** - The entire column and drawer assembly should rest on top of the base cover.

- Pull the workspace tray (T) out (Figure 6).



**Figure 6 – Cylinder bracket**

- Using a T25 Torx driver, remove the screw (R) and spacer (P) that stop the workspace tray. Save the screw and spacer.

6. Remove the workspace tray and set aside.
7. Using a 5/32" hex wrench, remove the four screws (E) and washers (D) from the cylinder brackets that secure the cylinder to the top cradle bracket. Save the screws and washers.
8. Using a rubber hammer, strike the top cradle bracket near the cylinder to remove the bracket from the cylinder top. Repeat on the opposite side.
9. Flip the top assembly upside down and place on a workbench or table.
10. Using a 1/8" hex wrench, remove the four screws (AL) that secure the release handles to the top cradle bracket (Figure 7). Save the handles and screws.

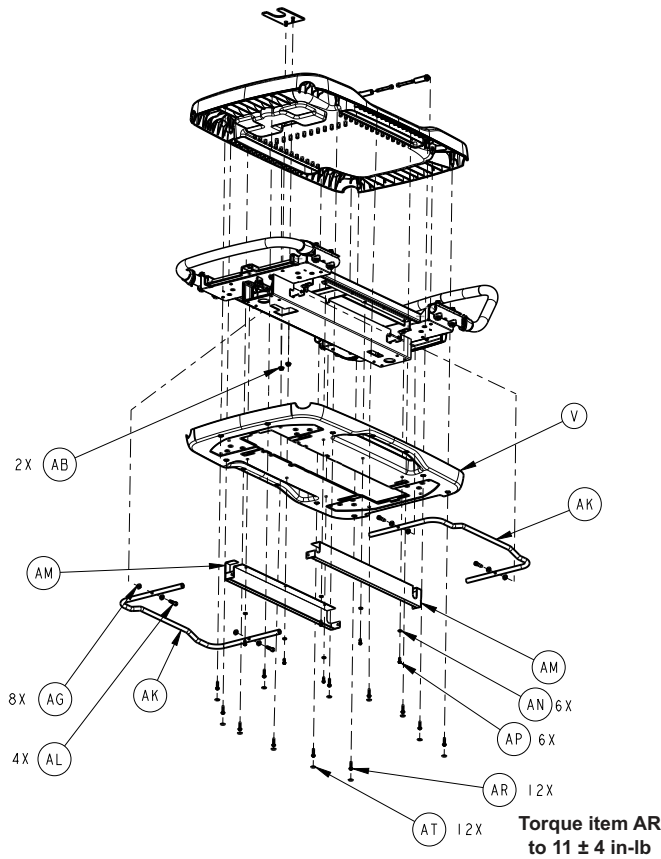

Figure 7 – Release handle

11. Using a T15 Torx driver, remove the six screws (AP) and washers (AN) that secure the valance brackets to the cover. Save the screws and washers.
12. Working from one side of the assembly, pull up on the lower cradle.
13. Remove and discard the lower cradle.
14. Reverse steps to install the supplied lower cradle.
15. Verify proper operation before you return the product to service.

## Push bar replacement

### Tools required:

- 1/8" hex wrench
- T15 Torx driver
- 1/2" speed ratchet
- **Loctite®** blue threadlocker

**Procedure:**

1. Remove the upper cradle cover. See *Upper cradle replacement* (page 6).
2. Using a 1/8" hex wrench, remove the eight screws (G) and washers (F) that secure the column and drawer assembly to the top cradle bracket (Figure 8). Save the screws and washers.

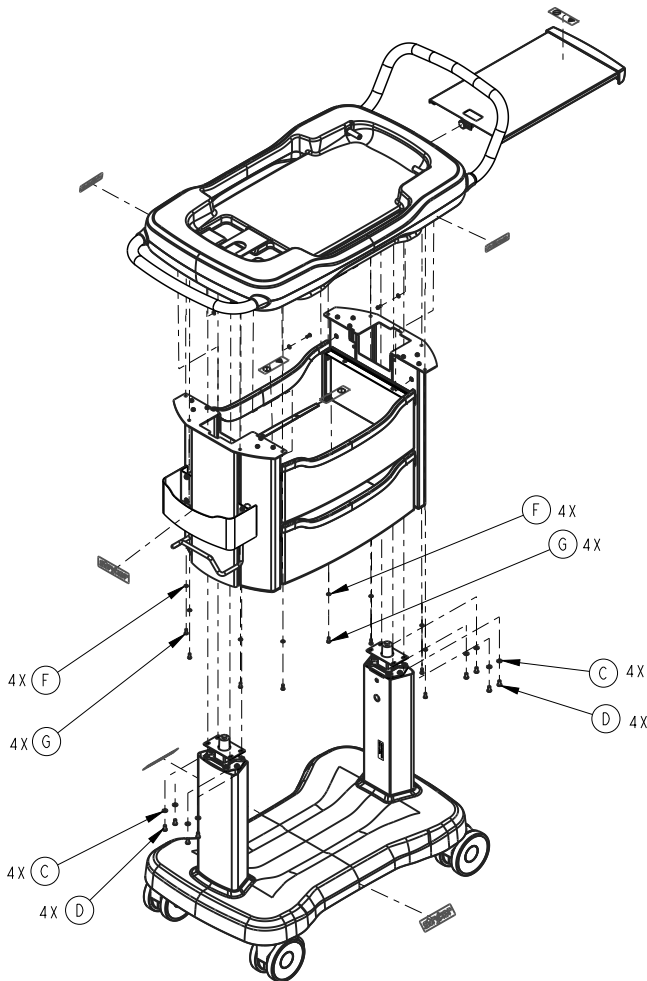

**Figure 8 – Column and drawer assembly**

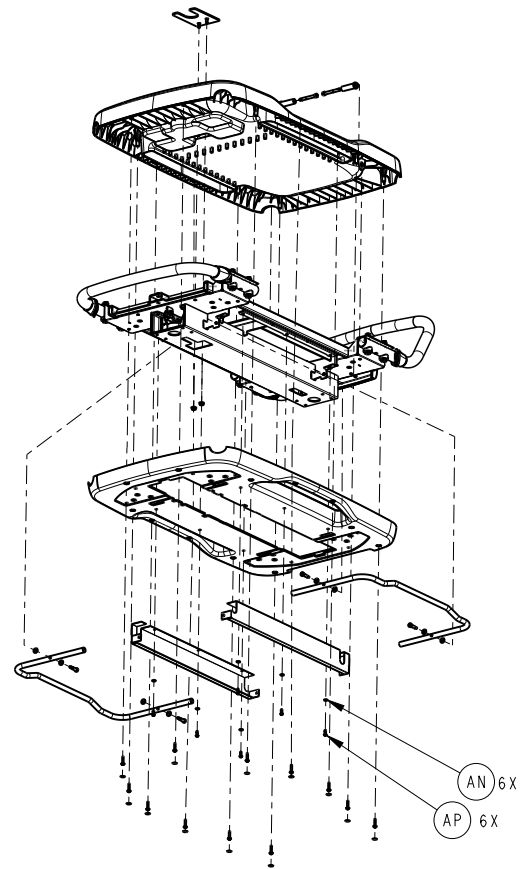

**Figure 9 – Valance brackets**

**Note** - Lower the product to the lowest height to minimize the column dropping.

3. Using a T15 Torx driver, remove the eight screws (D) and washers (C) that secure the columns to the valance brackets. Save the screws and washers.

**Note** - The entire column and drawer assembly should rest on top of the base cover.



4. Using a T15 Torx driver, remove the six screws (AP) and washers (AN) that secure the valance brackets to the cover (Figure 9). Save the screws and washers.
5. Using a 1/2" speed ratchet, remove the four screws (L) and washers (K) that secure the push bar to the cradle bracket (Figure 10). Save the screws and washers.

**Note**

- Pull down on the corner of the cradle bottom cover to access the four screws (L).
- Add **Loctite®** blue threadlocker to a minimum of three threads on the four screws (L).

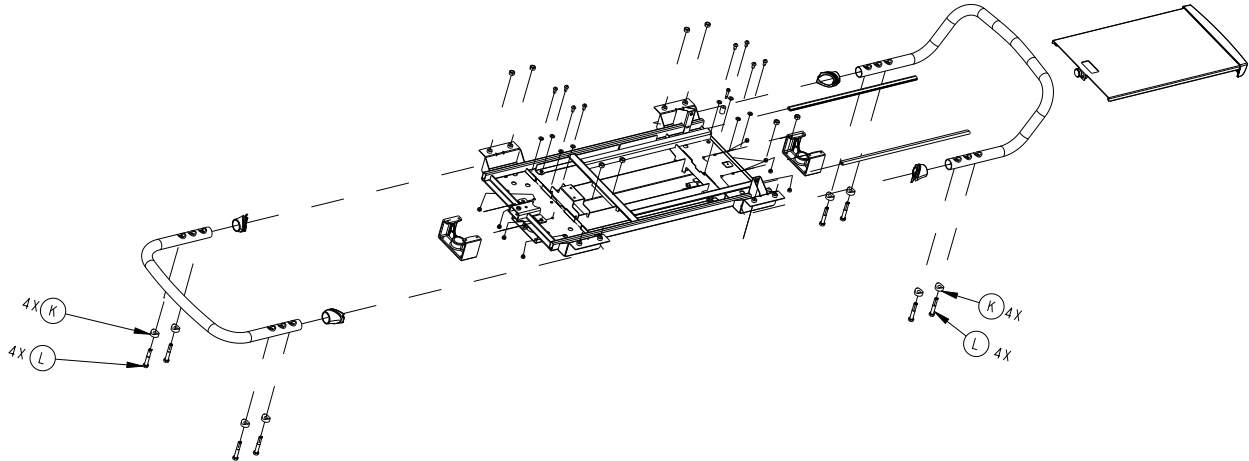

**Figure 10 – Push bar**

6. Remove and discard the push bar.
  - Note** - Remove and save the two rubber sleeves from the push bar.
7. Reverse steps to install the supplied push bar.
8. Verify proper operation before you return the product to service.

## Caster replacement

**Tools required:**

- 3/8" drive ratchet
- 5/16" hex driver
- Small jack
- Torque wrench ft-lb

**Procedure:**

1. Apply the brakes.
2. Using a small jack, raise the product on the side of the caster you are replacing.
3. Using a 3/8" drive ratchet and 5/16" hex driver, remove the screw (N) and caster assembly from the base weldment (Figure 11). Discard the caster assembly.

**Note** - Using a torque wrench, torque the screw to 35 - 45 ft-lb when you reinstall.

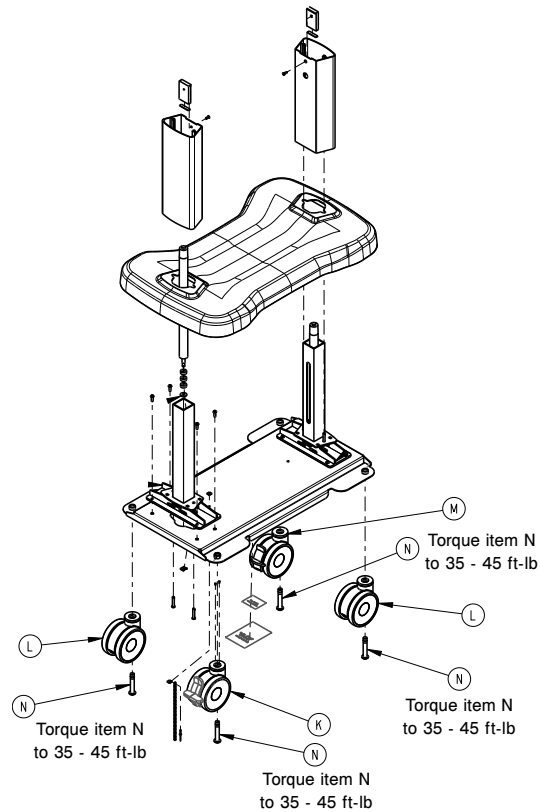

**Figure 11 – Base weldment**

4. Reverse steps to install the supplied caster.
5. Verify proper operation before you return the product to service.

## Drawer slide replacement

### Tools required:

- T15 Torx driver
- T10 Torx driver
- 5/16" wrench

### Procedure:

1. Apply the brakes.
2. Open the drawer.
3. Using a T10 Torx driver and 5/16" wrench, remove the two screws that secure the drawer slide to the drawer. Save the screws.
4. Using a T15 Torx driver, remove the screws (E) and washers (D) that secure the drawer slide to the column (Figure 12). Save the screws and washers.

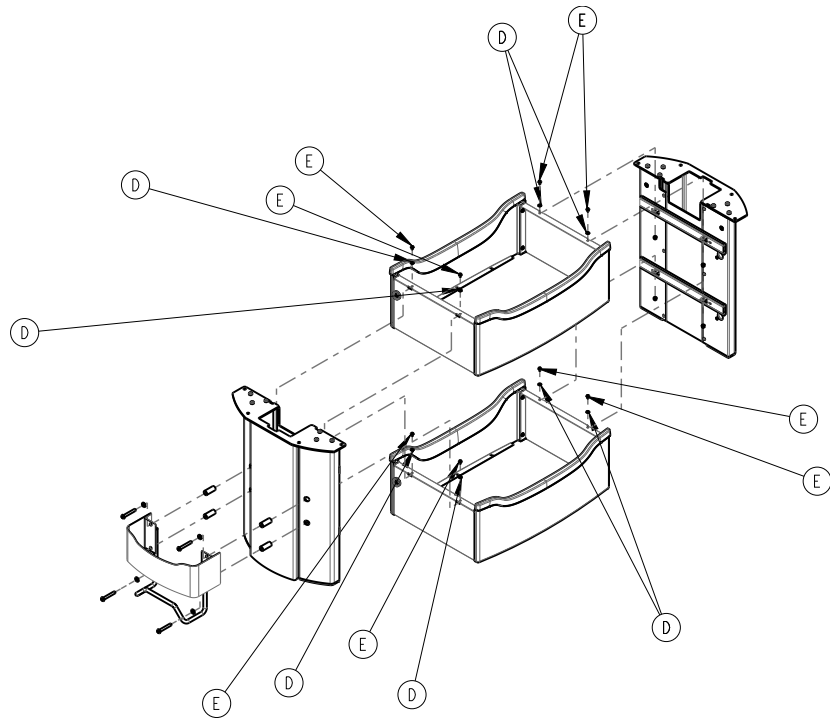

**Figure 12 – Drawer slide and columns**

5. Open the same drawer from the opposite side and repeat step 4.
6. From the open drawer, pull the drawer slide tab out of the drawer.
7. Open the same drawer from the opposite side and repeat step 6.
8. Remove and discard the entire drawer slide assembly.
9. Reverse steps to install the supplied drawer slide assembly.
10. Verify proper operation before you return the product to service.

## Gas cylinder replacement

### Tools required:

- 1/8" hex wrench
- 3/16" hex wrench
- 5/32" hex wrench
- T15 Torx driver
- Rubber hammer
- Needle nose pliers

### Procedure:

1. Using a 1/8" hex wrench, remove the eight screws (G) and washers (F) that secure the column and drawer assembly to the top cradle bracket (Figure 13). Save the screws and washers.

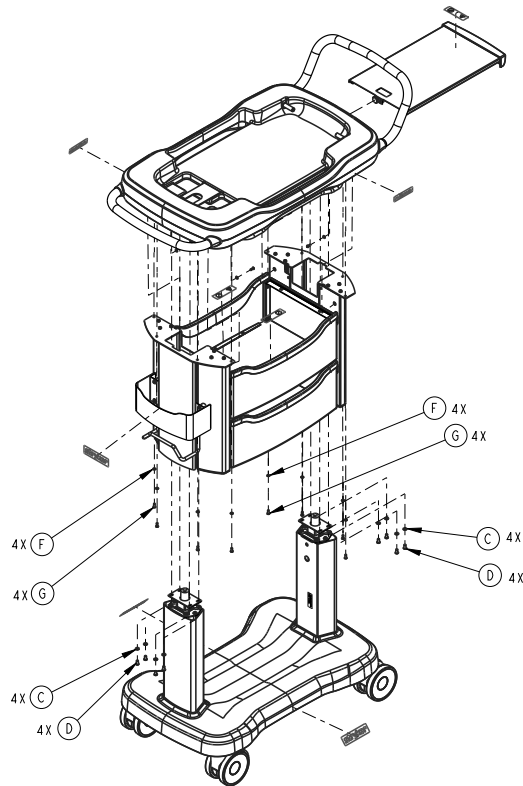
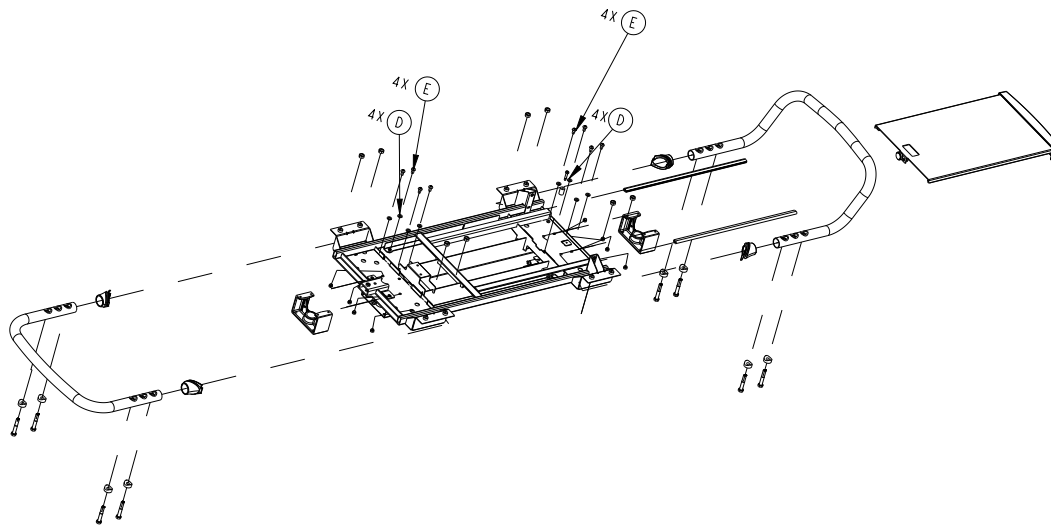

**Figure 13 – Column and drawer assembly**

**Note** - Lower the product to the lowest height to minimize the column dropping.

- Using a T15 Torx driver, remove the eight screws (E) and washers (D) that secure the columns to the valance brackets (Figure 14). Save the screws and washers.

**Note** - The entire column and drawer assembly should rest on top of the base cover.



**Figure 14 – Top cradle bracket**

- Using a 5/32" hex wrench, remove the eight screws (D) and washers (C) that secure the cylinder bracket to the top cradle bracket on the gas cylinder (Figure 13). Save the screws and washers.
- Using a rubber hammer, strike the top cradle bracket near the gas cylinder to remove the cradle bracket from the gas cylinder.
- Remove the cradle assembly and supports to access the gas cylinder. Save the cradle assembly.

6. Lift up on the cabinet-drawer assembly to remove. Save the cabinet-drawer assembly.
7. Using a 5/32" hex wrench, remove the two screws that secure the column support bracket. Save the screws.
8. Using a 3/16" hex wrench, remove the screw (AJ) and spacer (AH) from the lower guide tube (Figure 15). Save the screw and spacer.

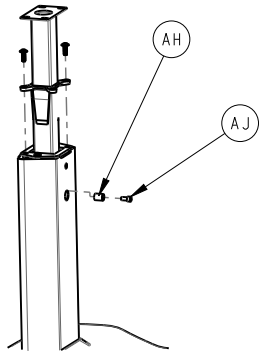

**Figure 15 – Column support bracket**

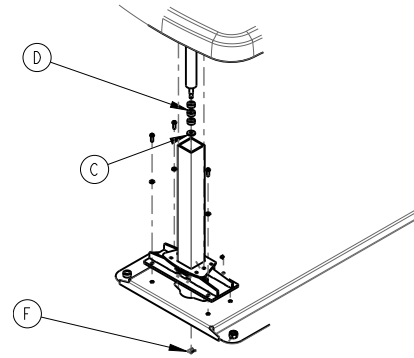

**Figure 16 – Gas cylinder shaft**

9. Using needle nose pliers, remove the gas cylinder clip. Save the clip.
10. Grab the shaft of the gas cylinder and pull up to remove the gas cylinder from the base support bracket. Remove and save the washers (D), bumpers (C), and clip (F) (Figure 16). Discard the gas cylinder.
11. Reverse steps to install the supplied gas cylinder.
12. Verify proper operation before you return the product to service.

## Base cover replacement

### Tools required:

- Small jack
- 5/32" hex t-handle

### Procedure:

1. Apply the brakes.
2. Using a small jack at one end of the product, raise the product a few inches off of the floor.

**Note** - Push the product up against a wall for added support, if needed.

3. Using a 5/32" hex t-handle, remove the four screws (W) and washers (G) that secure the column to the base weldment (Figure 17). Save the screws and washers.

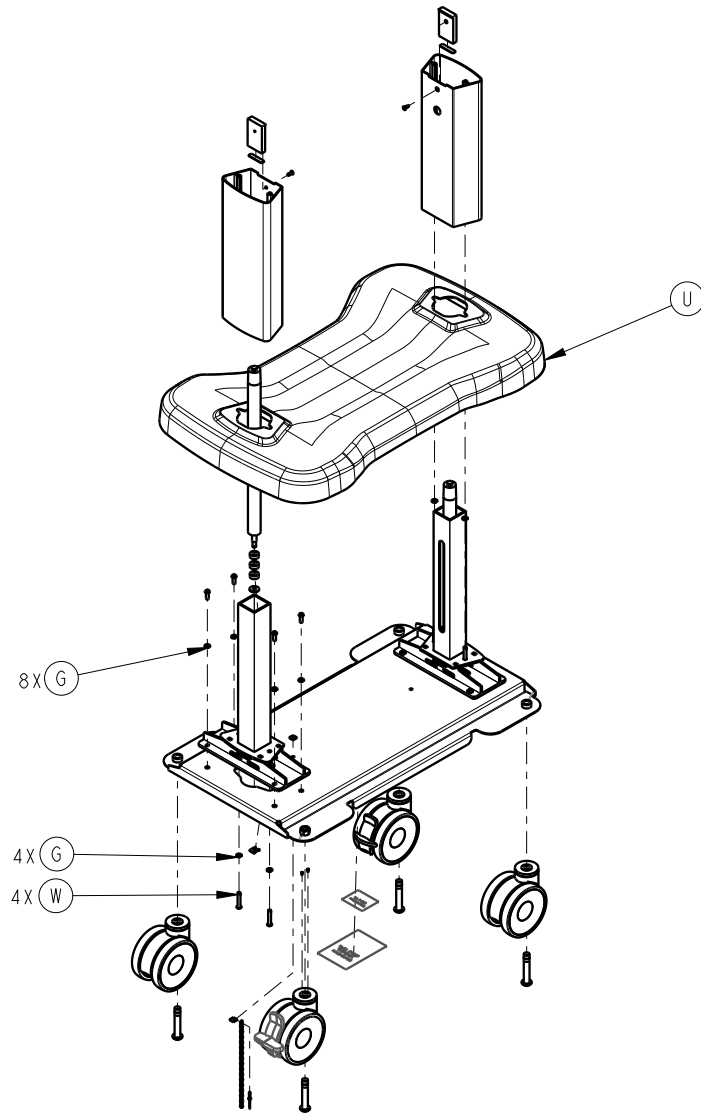

Figure 17 – Base weldment

4. Repeat steps 1-3 on the opposite side.
5. Remove the small jack.
6. With the help of a second person, grasp both pull handles and raise the entire column assembly off of the base assembly.

**Note** - Using one foot, step on top of the base cover to hold the base assembly in place while you pull up on the column assembly.

7. Set the column assembly aside.
8. Remove and discard the base cover (U).
9. Reverse steps to install the supplied base cover.
10. Verify proper operation before you return the product to service.

# Top level assembly - 4402-100-001

Rev C (Reference only)

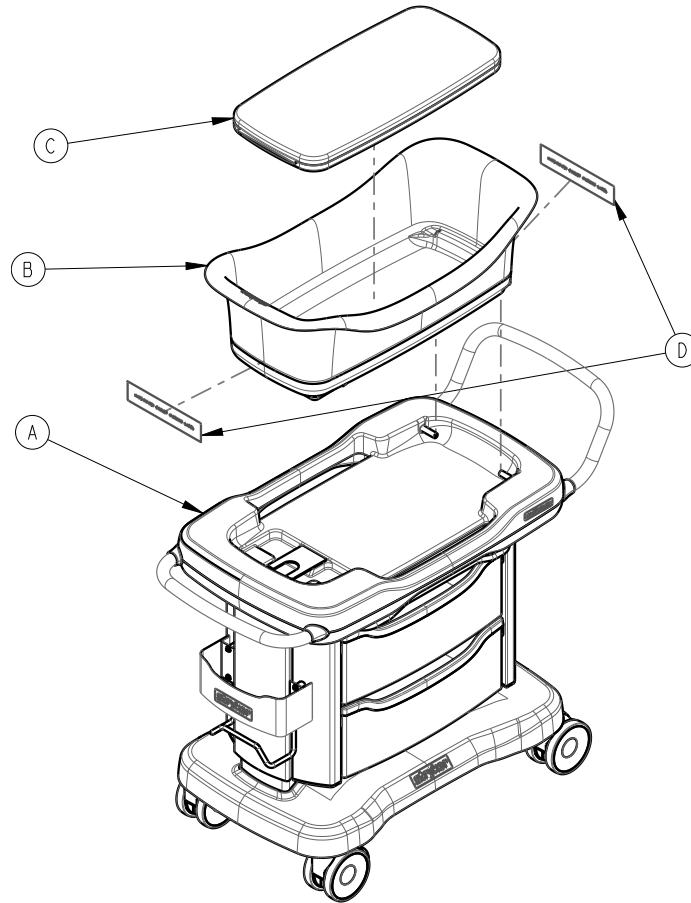

Item	Number	Name	Quantity
A	4402-010-001	<i>Bassinet assembly - 4402-010-001</i> (page 18)	1
B	4402-010-003	Basket assembly	1
C	4402-031-001	Mattress assembly	1
D	4402-010-921	Warning label, USA only	1

# Bassinet assembly - 4402-010-001

Rev AB (Reference only)

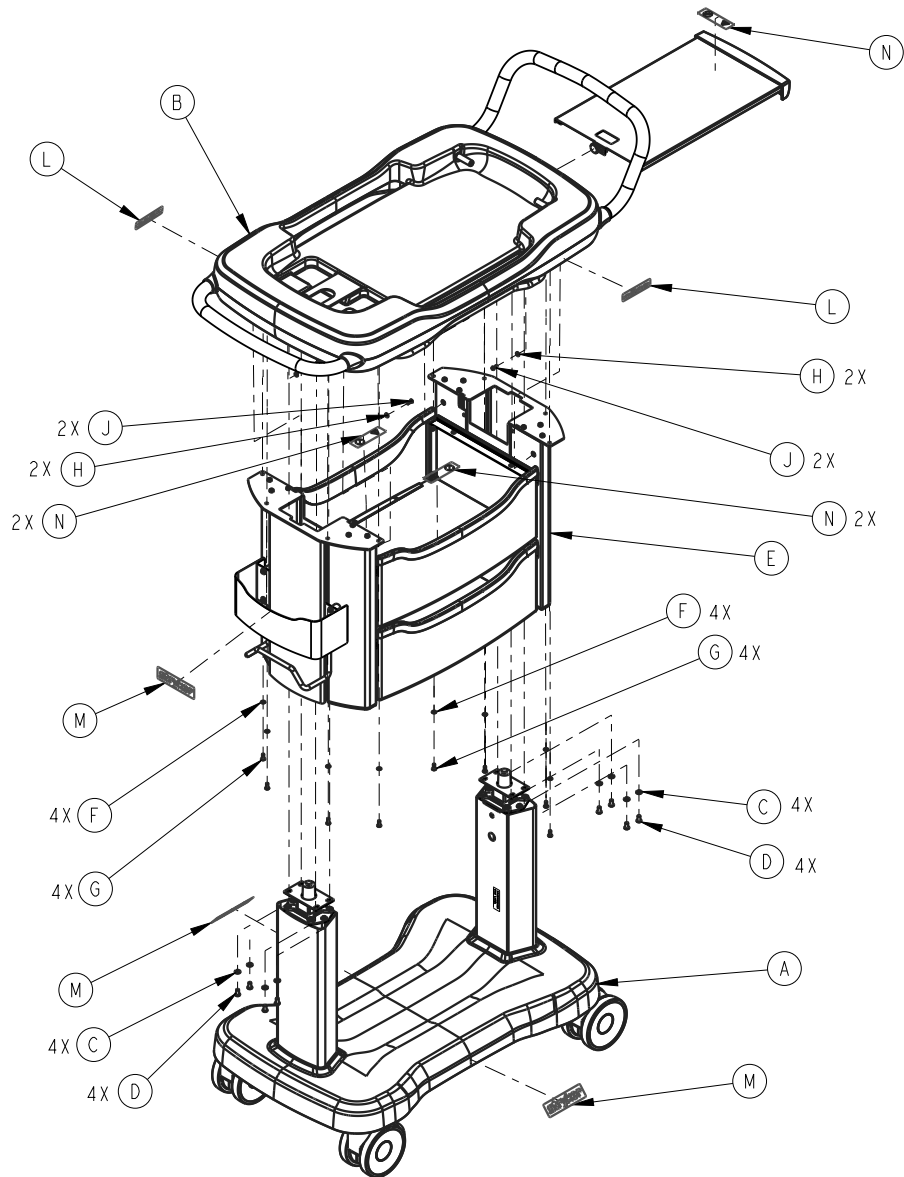



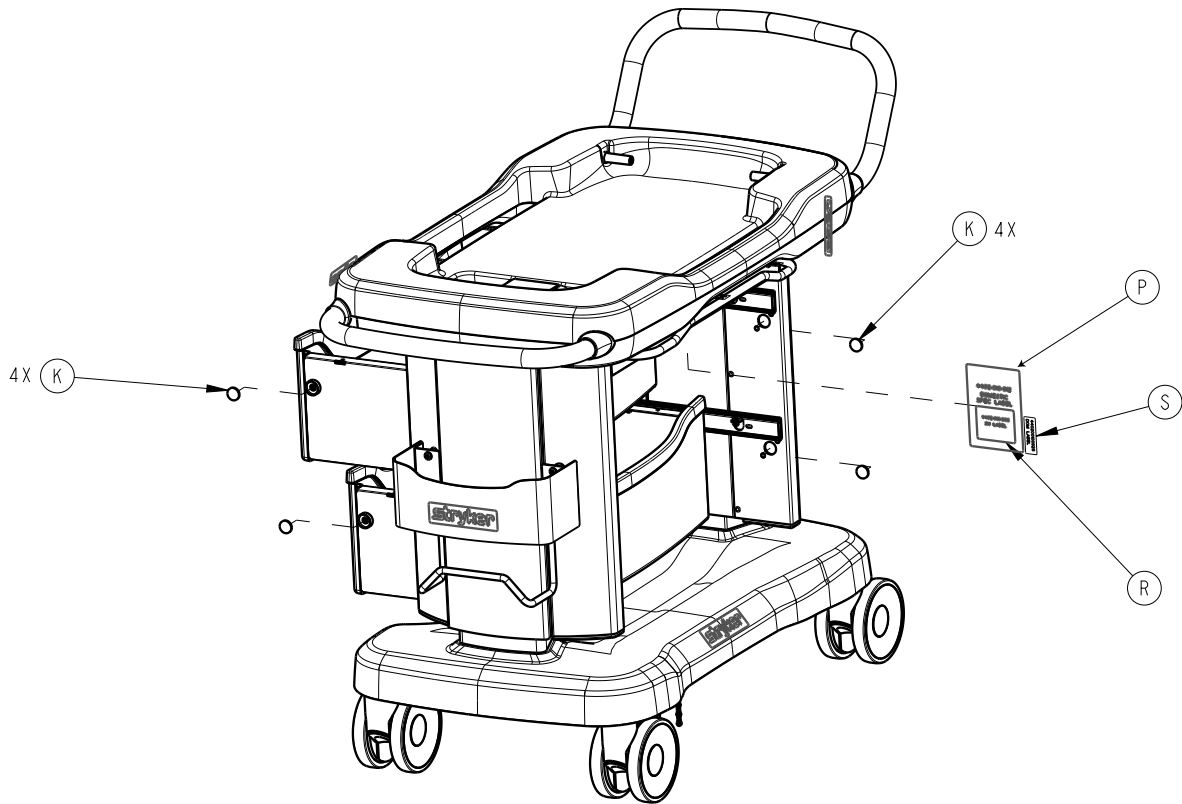

Item	Number	Name	Quantity
A	4402-001-001	Base assembly - 4402-001-001 (page 20)	1
B	4402-010-002	Cradle assembly - 4402-010-002 (page 30)	1
C	0012-131-000	Lock washer	8
D	0002-121-000	Button head cap screw	8
E	4402-050-001	Cabinet-drawer assembly - 4402-050-001 (page 27)	1
F	0013-055-000	Internal tooth lock washer	8
G	0004-913-000	Button head cap screw	8
H	0011-641-000	Washer	4
J	0002-123-000	Button head cap screw	4
K	4402-050-118	Magnet	8
L	4402-010-917	Nära logo label	2
M	4402-010-918	Stryker logo label	3
N	4402-010-914	Load/no baby label	5
P	4402-010-912	Domestic specification label	1
R	4402-010-906	Domestic serial number label	2
S	440200100928	Date of manufacture label	1

# Base assembly - 4402-001-001

Rev AC (Reference only)

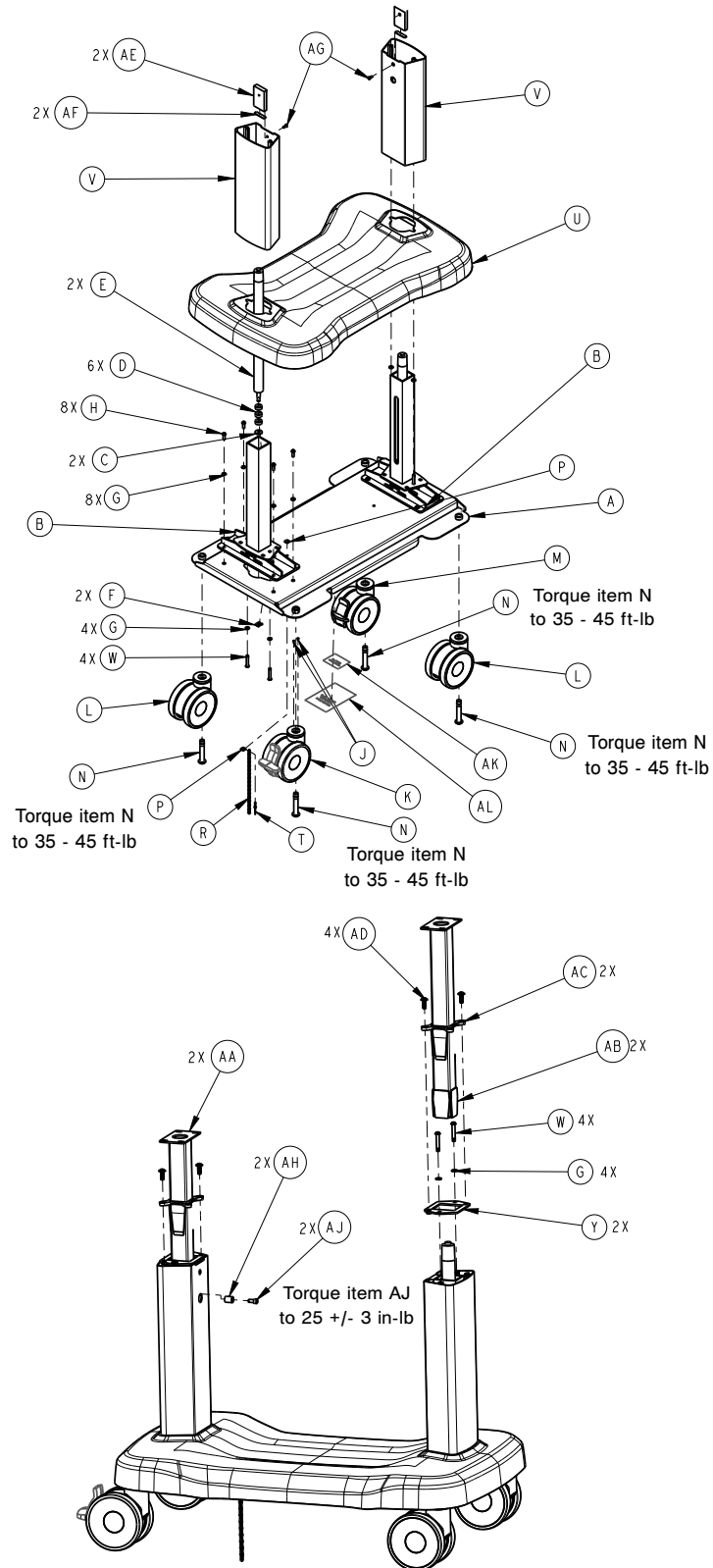

**Note** - Add Loctite® blue threadlocker to a minimum of 3 threads on item AJ.

Item	Number	Name	Quantity
A	4402-001-101	Base	1
B	4402-001-003	Lower guide tube assembly	2
C	4402-002-107	Washer	2
D	4402-002-108	Gas cylinder bumper	6
E	4402-002-111	Gas spring	2
F	4402-002-109	Cylinder gas clip	2
G	0012-131-000	Lock washer	16
H	0002-118-000	Button head cap screw	8
J	0026-679-000	Dowel pin	2
K	4402-001-106	5" swivel, brake, directional caster	1
L	4402-001-104	5" swivel caster	2
M	4402-001-107	5" swivel, brake caster	1
N	0002-119-000	Button head cap screw	4
P	0011-639-000	Washer	2
R	3001-200-052	Grounding chain	1
T	0025-653-000	Domed blind rivet	1
U	440200010208	Base cover assembly	1
V	4402-001-111	Inner extrusion	2
W	0002-125-000	Button head cap screw	8
Y	4402-001-126	Extrusion bushing mount plate	2
AA	4402-001-004	Upper guide tube assembly	2
AB	3150-002-405	Lower bushing	2
AC	3150-002-410	Upper bushing	2
AD	0002-117-000	Button head cap screw	2
AE	4402-001-132	Lift stop	4
AF	4402-001-134	Rubber bumper	2
AG	0001-214-000	Flat head machine screw	2
AH	4402-001-133	Spacer	2
AJ	0004-901-000	Socket head cap screw	2
AK	4402-010-906	Label, domestic serial number	1
AL	4402-010-912	Label, domestic specification	1

# Top level assembly, International - 4402-100-002

Rev AA (Reference only)

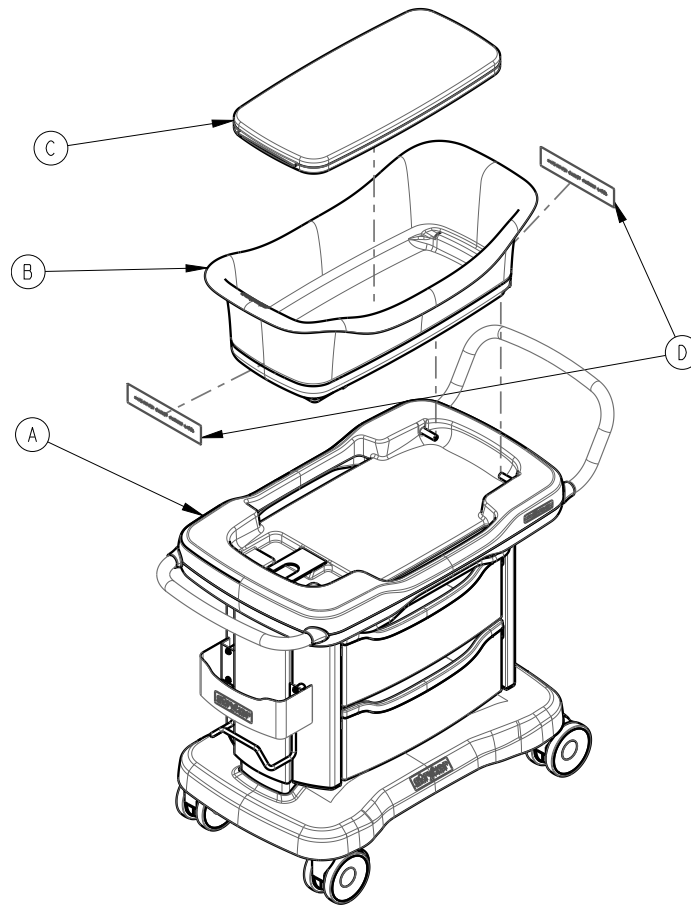

Item	Number	Name	Quantity
A	4402-010-009	Bassinet assembly, International - 4402-010-009 (page 23)	1
B	4402-010-003	Basket assembly	1
C	4402-031-004	Mattress assembly	1

# Bassinet assembly, International - 4402-010-009

Rev AB (Reference only)

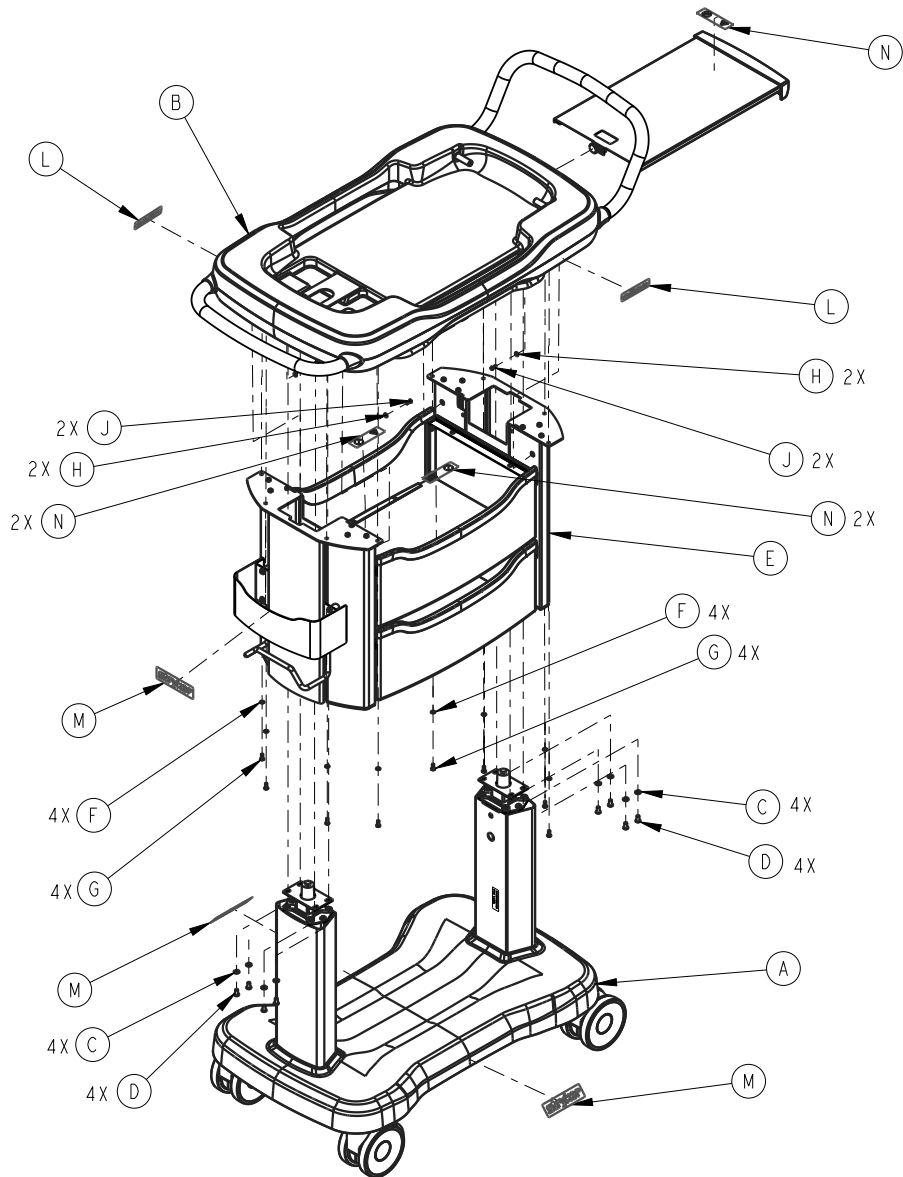

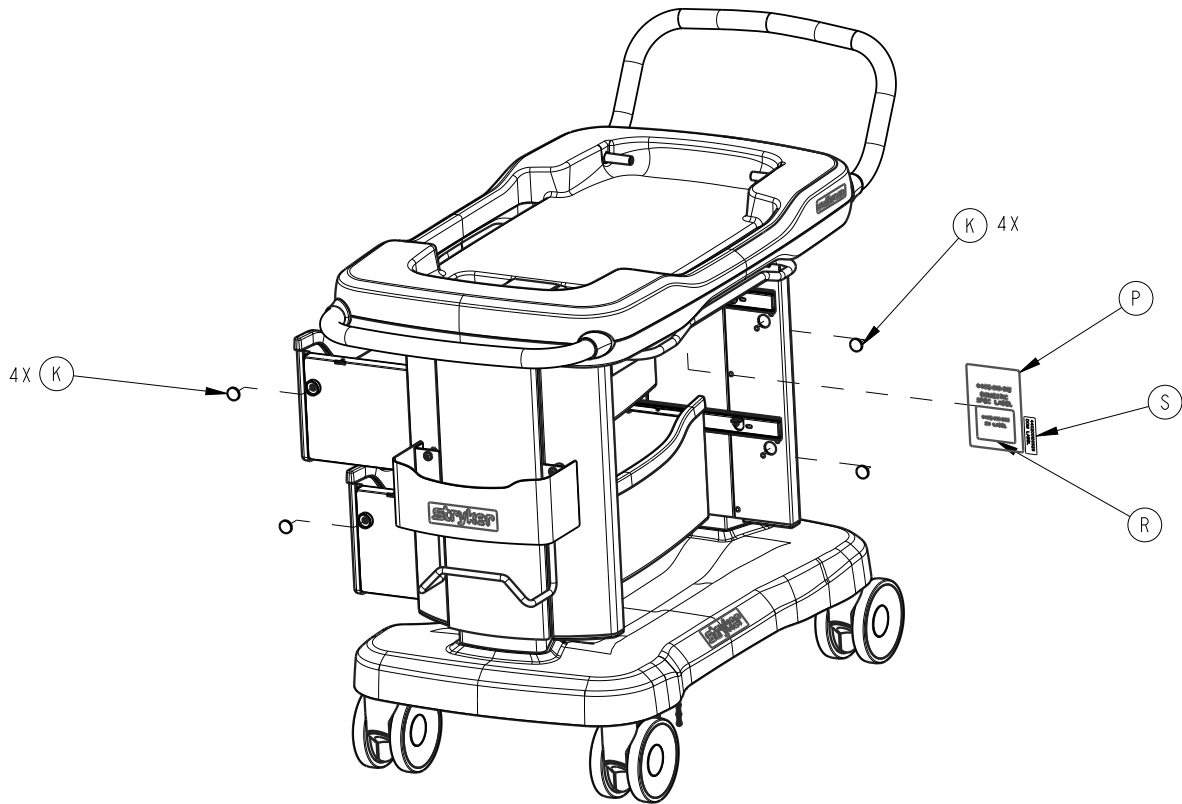

Item	Number	Name	Quantity
A	4402-001-007	Base assembly, International - 4402-001-007 (page 25)	1
B	4402-010-002	Cradle assembly - 4402-010-002 (page 30)	1
C	0012-131-000	Lock washer	8
D	0002-121-000	Button head cap screw	8
E	4402-050-001	Cabinet-drawer assembly - 4402-050-001 (page 27)	1
F	0013-055-000	Internal tooth lock washer	8
G	0004-913-000	Button head cap screw	8
H	0011-641-000	Washer	4
J	0002-123-000	Button head cap screw	4
K	4402-050-118	Magnet	8
L	4402-010-917	Nära logo label	2
M	4402-010-918	Stryker logo label	3
N	4402-010-914	Load/no baby label	5
P	4402-010-919	International specification label	1
R	4402-010-922	International serial number label	2
S	440200100928	Date of manufacture label	1



Item	Number	Name	Quantity
A	4402-001-101	Base	1
B	4402-001-003	Lower guide tube assembly	2
C	4402-002-107	Washer	2
D	4402-002-108	Gas cylinder bumper	6
E	4402-002-111	Gas spring	2
F	4402-002-109	Cylinder gas clip	2
G	0012-131-000	Lock washer	16
H	0002-118-000	Button head cap screw	8
J	0026-679-000	Dowel pin	2
K	4402-001-106	5" swivel, brake, directional caster	1
L	4402-001-104	5" swivel caster	2
M	4402-001-107	5" swivel, brake caster	1
N	0002-119-000	Button head cap screw	4
P	0011-639-000	Washer	2
R	3001-200-052	Grounding chain	1
T	0025-653-000	Domed blind rivet	1
U	440200010208	Base cover assembly	1
V	4402-001-111	Inner extrusion	2
W	0002-125-000	Button head cap screw	8
Y	4402-001-126	Extrusion bushing mount plate	2
AA	4402-001-004	Upper guide tube assembly	2
AB	3150-002-405	Lower bushing	2
AC	3150-002-410	Upper bushing	2
AD	0002-117-000	Button head cap screw	2
AE	4402-001-132	Lift stop	4
AF	4402-001-134	Rubber bumper	2
AG	0001-214-000	Flat head machine screw	2
AH	4402-001-133	Spacer	2
AJ	0004-901-000	Socket head cap screw	2
AK	4402-010-919	Label, international specification	1
AL	4402-010-922	Label, international serial number	1



# Cabinet-drawer assembly - 4402-050-001

Rev C (Reference only)

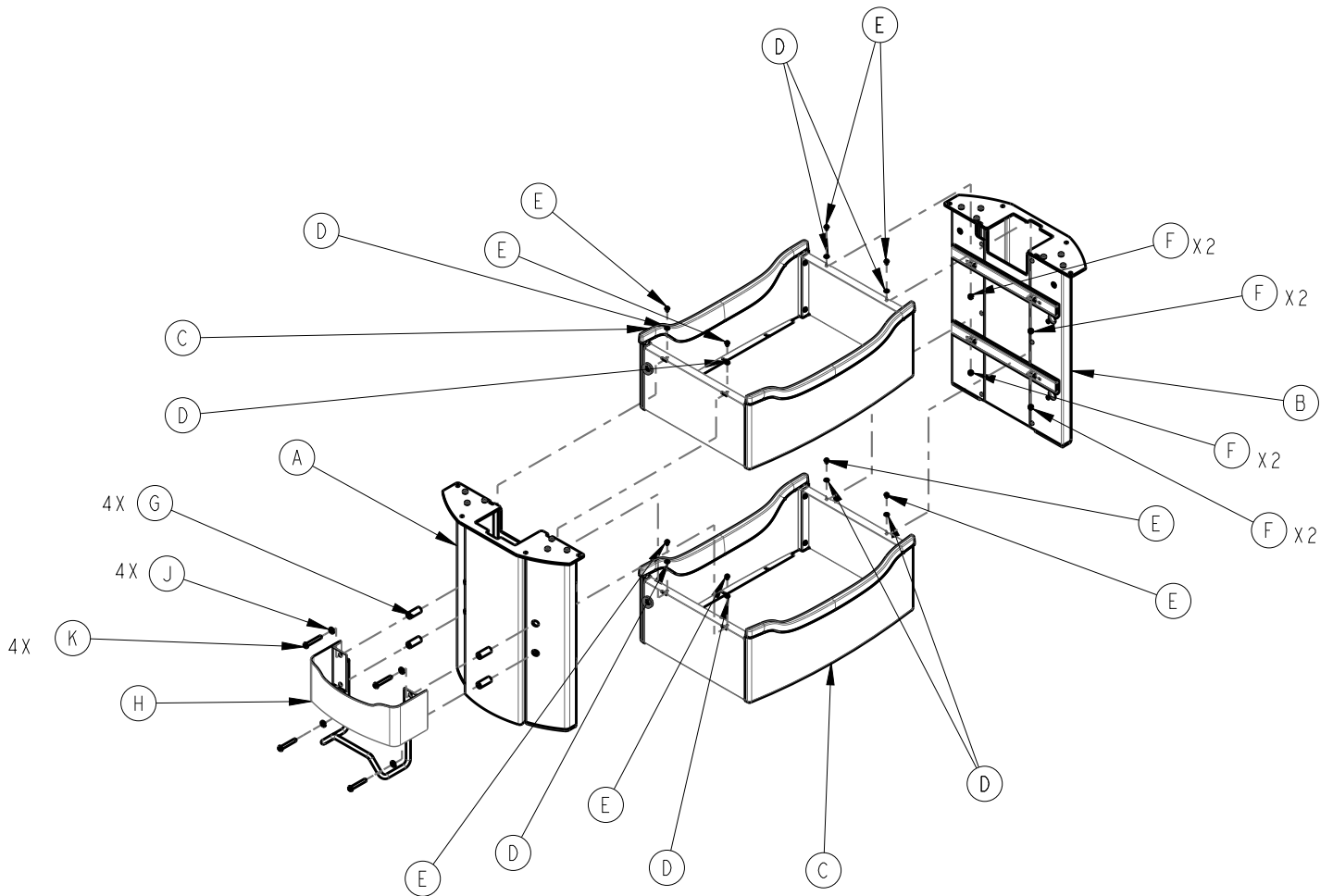

Item	Number	Name	Quantity
A	4402-050-003	Document holder column assembly	1
B	4402-050-004	Column assembly	1
C	4402-050-002	<i>Drawer assembly - 4402-050-002</i> (page 28)	2
D	0013-054-000	Internal tooth lock washer	8
E	0004-299-000	Button head cap screw	8
F	0017-032-000	Acorn nut	8
G	4402-050-127	Document holder spacer	4
H	4402-050-007	<i>Document holder assembly - 4402-050-007</i> (page 29)	1
J	0012-131-000	Lock washer	4
K	0002-120-000	Button head cap screw	4

# Drawer assembly - 4402-050-002

Rev A (Reference only)

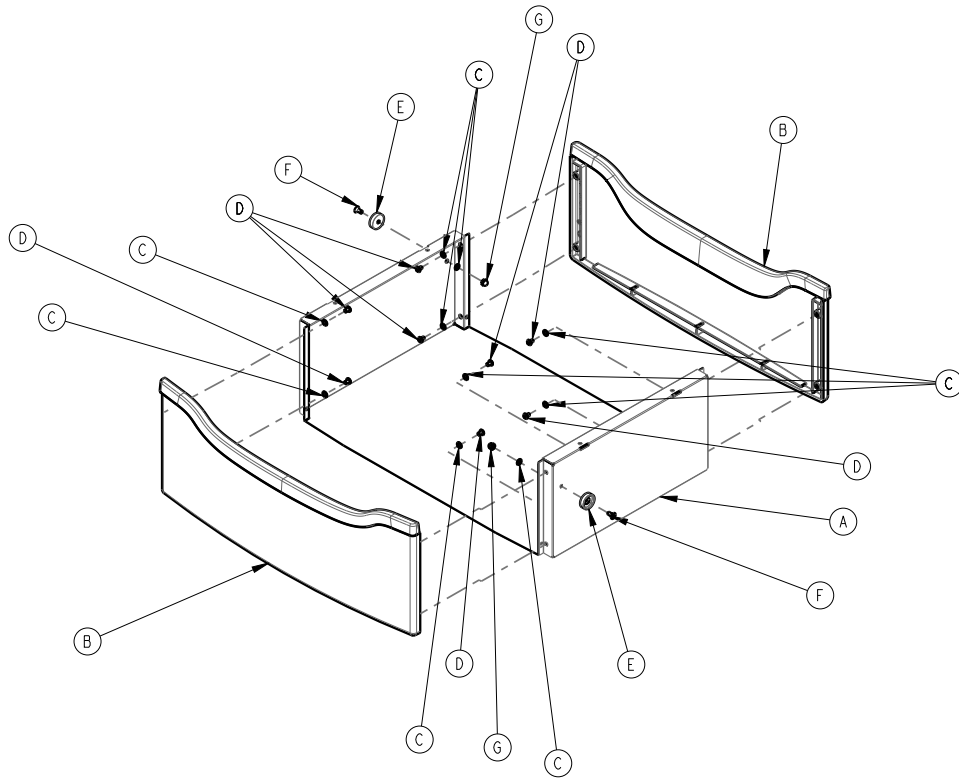

Item	Number	Name	Quantity
A	4402-050-101	Drawer body	1
B	4402-050-005	Drawer face assembly	2
C	0013-054-000	Internal tooth lock washer	10
D	0004-299-000	Button head cap screw	8
E	4402-050-117	Magnet cup	2
F	0001-213-000	Flat head machine screw	2
G	0017-032-000	Acorn nut	2

# Document holder assembly - 4402-050-007

Rev E (Reference only)

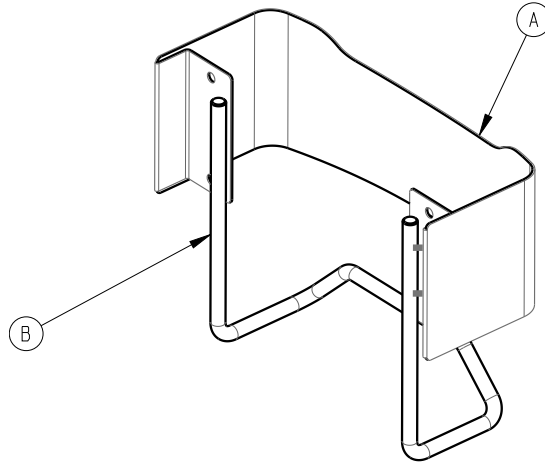

Item	Number	Name	Quantity
A	4402-050-124	Document holder body	1
B	4402-050-126	Document holder wire form	1

# Cradle assembly - 4402-010-002

Rev AA (Reference only)

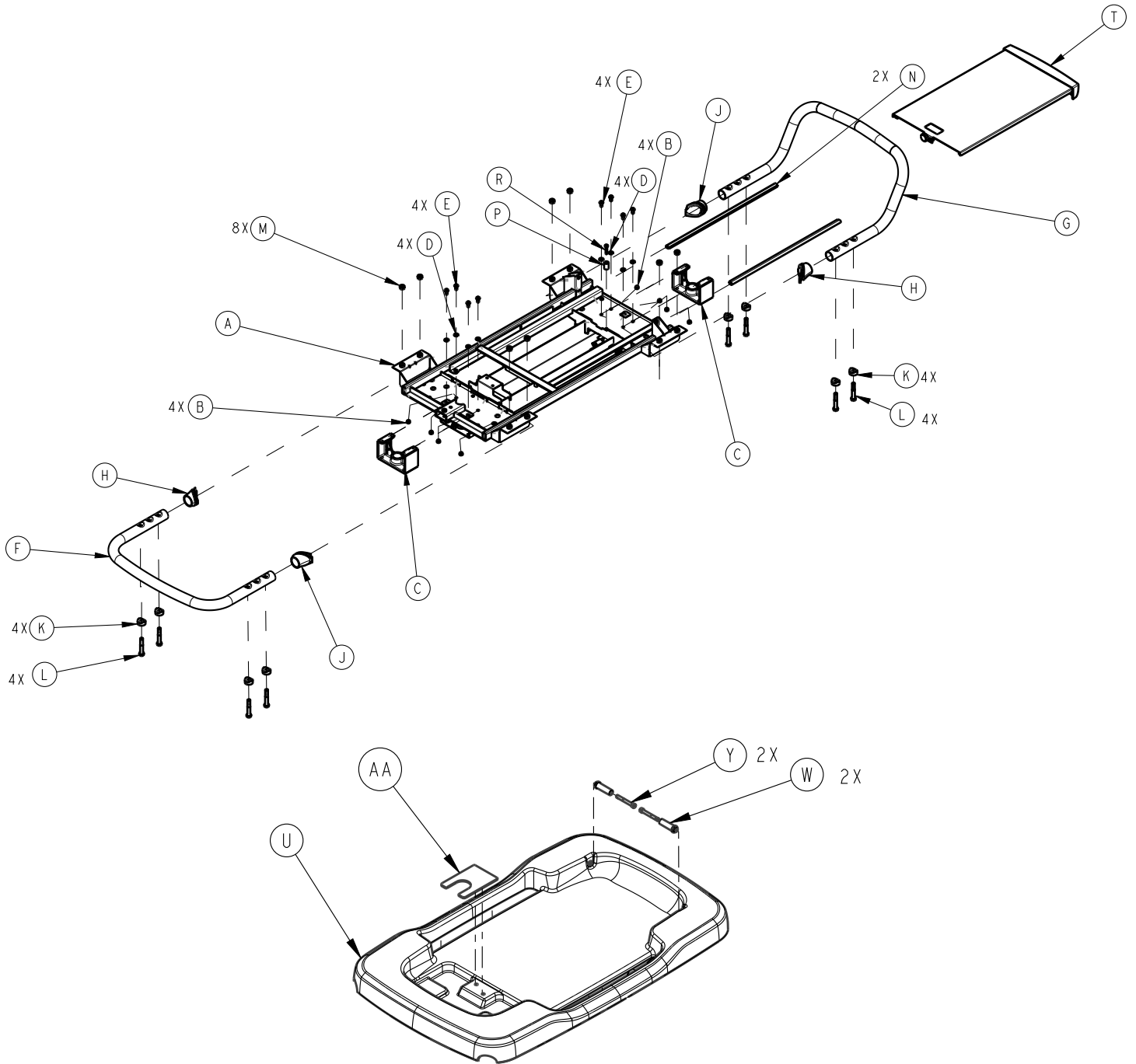

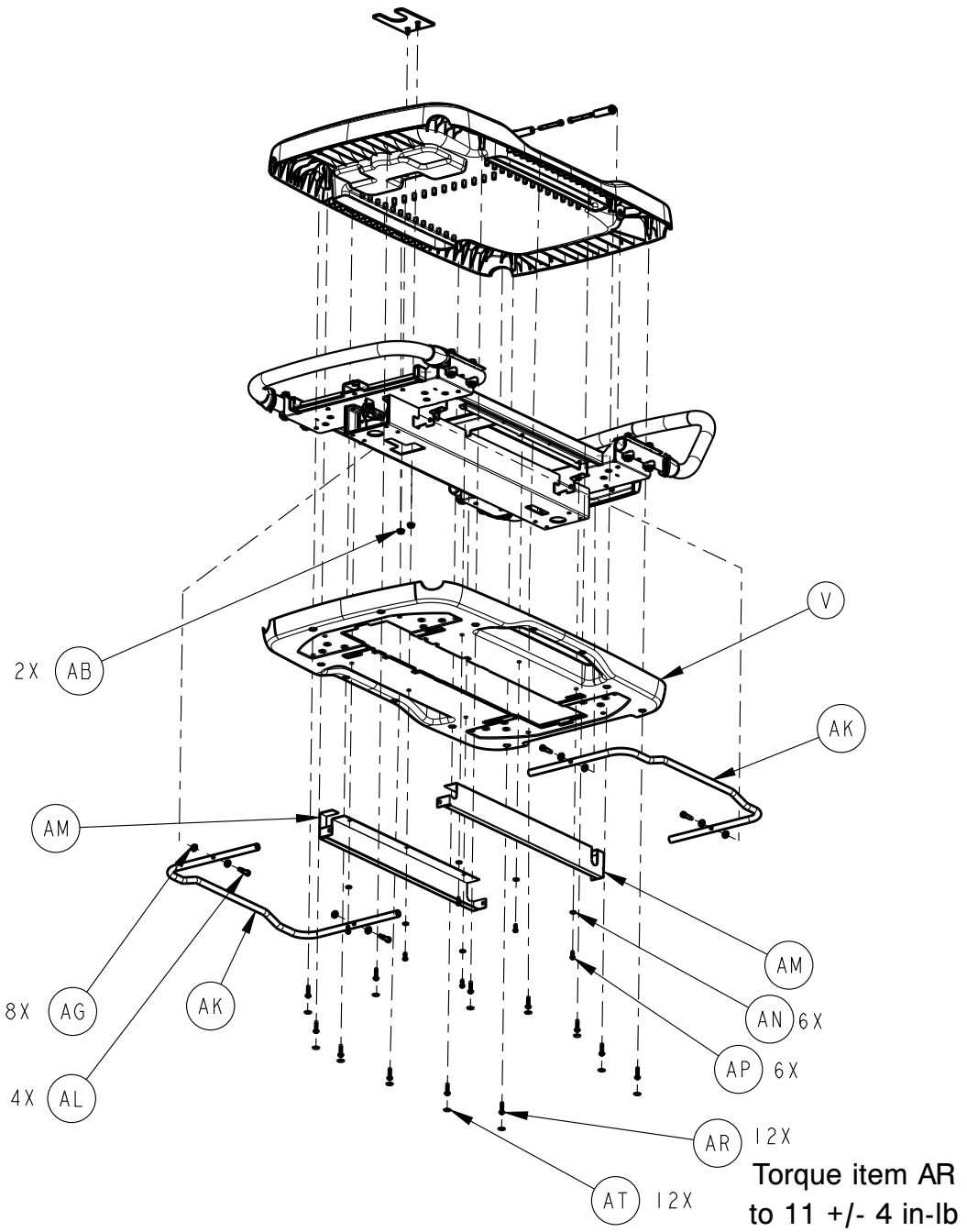

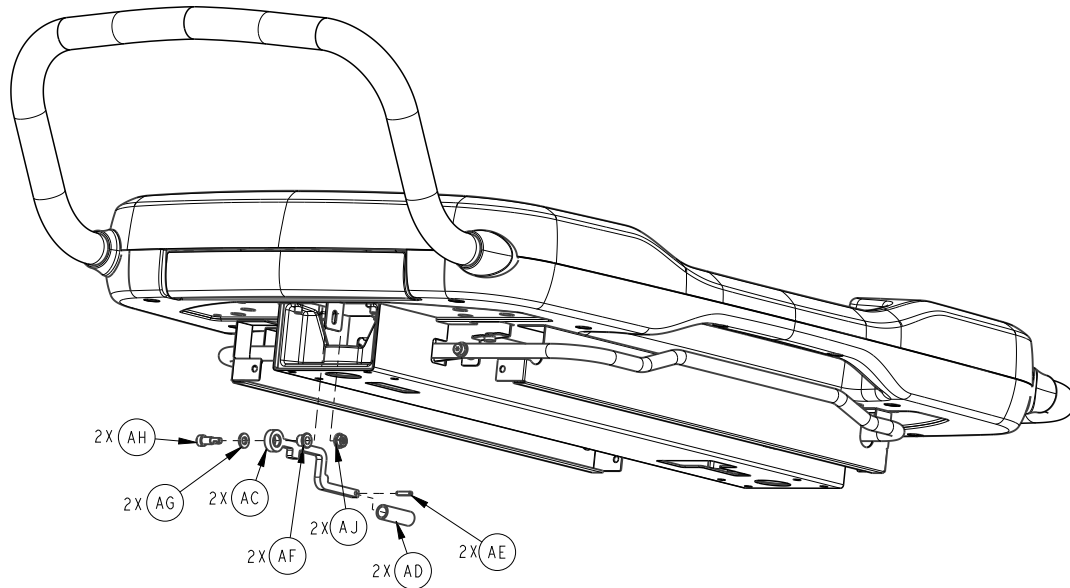

**Note** - Add Loctite® blue threadlocker to a minimum of three threads on item L.

Item	Number	Name	Quantity
A	4402-010-004	Cradle internal frame assembly	1
B	0056-042-000	Rubber bumper	8
C	4402-010-108	Machined gas cylinder top	2
D	0012-131-000	Lock washer	8
E	0002-121-000	Button head cap screw	8
F	4402-010-124	Bumper bar	1
G	4402-010-126	Push bar	1
H	4402-010-137	Grommet, bumper/push bar, left	2
J	4402-010-127	Grommet, bumper/push bar, right	2
K	700001542640	Saddle washer	8
L	0003-401-000	Hex head cap screw	8
M	0015-050-000	Nut	8
N	4402-010-122	Sliding tray extrusion	2
P	4402-010-131	Sliding tray stop spacer	1
R	0050-093-000	Pan head machine screw	1
T	4402-010-005	Sliding tray assembly	1
U	440200100203	Upper cradle assembly	1
V	440200100204	Lower cradle	1
W	4402-010-123	Tilt pin	2
Y	0004-904-000	Socket head cap screw	2
AA	4402-010-149	Support retainer	1

Item	Number	Name	Quantity
AB	0016-404-000	Serrated flange hex nut	2
AC	4402-010-141	Activation rod	2
AD	4402-010-143	Activation spacer	2
AE	0026-681-000	Roll pin	2
AF	4402-010-153	Flanged bronze bearing	2
AG	0011-640-000	Washer	10
AH	0008-093-000	Shoulder bolt	2
AJ	0016-403-000	Serrated flange hex nut	2
AK	4402-010-128	Lift bar	2
AL	0008-092-000	Shoulder bolt	4
AM	4402-010-129	Side valance	2
AN	0011-641-000	Washer	6
AP	0002-123-000	Button head cap screw	6
AR	700000687745	Round washer head tapping screw	12
AT	440200100929	Label, cradle fastener cover	12



Stryker Corporation or its divisions or other corporate affiliated entities own, use or have applied for the following trademarks or service marks: **Nara, Stryker**. All other trademarks are trademarks of their respective owners or holders.



Stryker Medical  
3800 E. Centre Avenue  
Portage, MI 49002  
USA