

**stryker**<sup>®</sup>  
**Medical**

---

---

***Secure II***<sup>®</sup> *Med/Surg Bed*

---

*Model 3002*

*Maintenance Manual*

*For Parts or Technical Assistance*  
*800-327-0770*

# Table of Contents

---

Introduction	
Specifications .....	5
Warning / Caution / Note Definition .....	5
Safety Tips And Guidelines .....	6, 7
Limited Warranty	
Obtaining Parts and Service .....	8
Extended Warranty Coverage .....	8
Return Authorization .....	9
Freight Damage Claims .....	9
Set-Up Procedures .....	10, 11
Bed Symbols .....	12
Bed Illustration .....	13
Bed Operation	
Brake Pedal Operation .....	14
Steer Pedal Operation .....	14
CPR Emergency Release Usage .....	15
Foley Bag Hooks .....	15
Foot Prop Usage .....	15
Fracture Frame Usage .....	15
Patient Restraint Strap Locations .....	15
Night Light Usage .....	16
Nurse Call Back-Up Battery .....	16
CPR Board Usage .....	16
I.V. Poles .....	17
Positioning Siderails .....	18
Control Panel Lights .....	18
Siderail Function Guide .....	19, 20
Foot Board Control Panel Guide .....	21-24
Weigh System Control Panel Guide .....	25, 26
Weigh System Usage .....	27, 28
Pendant Controller .....	29
Zoom Option Drive Wheel Operation .....	30, 31
Zoom Option Head End Control Panel Operation .....	32
Zoom Option Battery Charging and Operation .....	33
Cleaning and Preventative Maintenance .....	34, 35
Static Discharge Precautions .....	36
Troubleshooting .....	37, 38
Bed Circuit Boards .....	39-47
Bed Communications Tester .....	48
Headwall Output Configuration .....	49
CPU/Headwall Jumper Locations .....	49.1

# Table of Contents

---

Inverter Protection Features .....	50
Replacement Parts Quick Reference .....	51, 52
Base Maintenance Procedures	
Brake Pedal Replacement .....	53
Lift Motor and Capacitor Removal and Replacement .....	54
Lift Motor Isolation Plate Replacement .....	55
Lift Housing Removal and Replacement .....	56, 57
Lift Potentiometer Replacement and Adjustment .....	58, 59
Lift Potentiometer “Burn-In” Procedure .....	59
Lift Motor Coupler Replacement .....	60
Power and Sensor Coil Cord Replacement .....	61, 62
Zoom Option Battery Removal and Replacement .....	63
Zoom Option Power Board Removal and Replacement .....	64
Litter Maintenance Procedures	
Knee Motor Removal and Replacement .....	65
Head Motor Cam and Cam Guide Replacement .....	66
Head Motor Limit Setting .....	67
Head Motor Removal and Replacement .....	68
Head Motor Drive Isolator and CPR Decoupler Removal and Replacement .....	69
Head Motor Drive Screw and Ball Nut Replacement .....	70, 71
Head Motor Brake/Clutch Replacement .....	72
Scale System Diagnostics .....	72
Scale System Calibration .....	73
Load Cell Replacement .....	74, 75
Power Supply Replacement .....	75
CPU Board Replacement .....	76
Potentiometer “Burn-In” Procedure .....	76
Smart TV Interface “Burn-In” Procedure .....	77
Zoom Option Control Bar Potentiometer Replacement .....	78
Zoom Option Control Bar Potentiometer “Burn-In” Procedure .....	79
Zoom Option AC Crossover Board Replacement .....	80
Zoom Option Display/CPU Board Replacement .....	80
Siderail Cover Removal .....	81
Molded Siderail Replacement .....	82
Head End Siderail Cable Replacement .....	83, 84
Siderail Assembly Removal .....	85
Foot Board Hinge Removal .....	86
Foot Board Module Replacement .....	86
Foot Board Interface Plug Replacement .....	87

# Table of Contents

---

## Assembly Drawings and Parts Lists

Bed Assembly .....	88, 89
Base Assembly and Options .....	90-98
Lift Assembly .....	99-102
Motor Isolation Plate Assembly .....	103
Brake Shaft Assembly .....	104
Brake Crank Assembly .....	105
Brake Bar Assembly .....	106
Caster Assembly .....	107-112
Zoom Option Base Assembly .....	113-120
Zoom Option Drive Wheel Lift Lever Assembly .....	121
Zoom Option Bottom Covers .....	122
Zoom Option Drive Train Assembly .....	123
Zoom Option Battery Tray Assembly .....	124
Zoom Option Base Power Assembly .....	125
Litter Assembly and Options .....	126-132
Litter Covers .....	133, 134
Electrical Litter Assembly .....	135-140
Mechanical Litter Assembly .....	141-145
Lift Header Assembly .....	146, 147
230V Surge Suppressor Assembly .....	148
Gatch Motor Assembly .....	149
Fowler Drive Assembly .....	150-152
Fowler Limit Switch Assembly .....	154, 155
Night Light Assembly .....	156, 157
Optional 110V Outlet Assembly .....	158, 159
110 Outlet Box Assembly .....	160
Scale/Bed Exit Option Assembly .....	162, 163
Optional HWI Assembly with Communication .....	164, 165
Optional HWI Assembly with Communication & Ports .....	166-168
Battery Enclosure Assembly .....	169
Zoom Option Litter Assembly .....	170-176
Zoom Battery Enclosure Assembly .....	177
Head End Siderail Assembly .....	179-198
Siderail Panels .....	199, 200
Head End Siderail Latch Assembly .....	201, 202
Foot End Siderail Assembly .....	203-205
Foot End Siderail Support Assembly .....	206, 207
Foot End Siderail Latch Assembly .....	208
Siderail Release Lever Assembly .....	209, 210

# Table of Contents

---

## Assembly Drawings and Parts Lists (Continued)

Siderail Bypass Detent Clip Assembly .....	211
Pendants .....	212
Foot Board Assembly .....	213-221
Foot Board Standard Module .....	222
Foot Board Bed Exit Module .....	223, 224
Foot Board Scale Module .....	225
Head Board Assembly .....	226
CPR Board Assembly .....	227
Removable I.V. Assembly .....	228, 229
Permanent I.V. Assembly .....	230-232
Defibrillator Tray Assembly .....	233
Pleur-Evac Rack with Defibrillator Tray .....	234, 235
Pleur-Evac Rack Assembly .....	236
Siderail Pleur-Evac Rack Assembly .....	237
Pump Rack Assembly .....	238
90° Power Cord Assembly .....	239
Accessory Adapter Frame Assembly .....	240, 241
Litter Roller Assembly .....	242, 243
Bed Extender Assembly .....	244, 245
Bed Extender Mattress .....	246
Oxygen Bottle Holder Assembly .....	247
Traction Socket Extensions .....	248
Urine Bottle Hanger .....	249
Telephone Mounting Bracket .....	250
Padded Siderail Covers .....	251

# Introduction

---

## INTRODUCTION

This manual is designed to assist you with the maintenance of the Model 3002 Secure II Bed. Read it thoroughly before beginning any maintenance on the equipment.

## SPECIFICATIONS

Maximum Weight Capacity	500 pounds (227 kilograms)
Overall Bed Length/Width - Standard Bed	93" x 42.5" (siderails up) - 36" (siderails down) 236 cm. x 108 cm. (siderails up) - 92 cm. (siderails down)
Overall Bed Length/Width - Short Bed	85" x 42.5" (siderails up) - 36" (siderails down) 216 cm. x 108 cm. (siderails up) - 92 cm. (siderails down)
Overall Bed Length/Width - Zoom Bed	95" x 42.5" (siderails up) - 36" (siderails down) 241 cm. x 108 cm. (siderails up) - 92 cm. (siderails down)
Overall Bed Length/Width - Zoom Short Bed	87" x 42.5" (siderails up) - 36" (siderails down) 221 cm. x 108 cm. (siderails up) - 92 cm. (siderails down)
Patient Sleep Surface - Standard Bed	84" x 35" - 213 cm. x 89 cm.
Patient Sleep Surface - Short Beds	76" x 35" - 193 cm. x 89 cm.
Bed Height to Top of Seat Litter - 6" Casters (Add 2 inches if the bed has 8" casters.)	16" (Low) x 29.5" (High) - 41 cm. (Low) x 75 cm. (High) Beds with Zoom Option -19.5" x 30" - 50 cm. x 76 cm. Short Beds with Zoom Option -20.5" x 30" - 52 cm. x 76 cm.
Knee Gatch Angle	0° to 40°
Fowler Angle	0° to 60°
Trendelenburg/Reverse Trendelenburg	-12° to +12° ( $\pm 1^\circ$ ) -10° to +10° ( $\pm 1^\circ$ ) - Beds with Zoom Option
Weigh System Accuracy (optional equipment)	$\pm 1\%$ of total patient weight with the litter level $\pm 2\%$ of total patient weight with the litter at any angle
Electrical Requirements - all electrical requirements meet UL 2601 specifications.	115 VAC, 60 Hz, 7.0 Amp. 230 VAC, 50/60 Hz, 4.0 Amp.

Stryker reserves the right to change specifications without notice.

## WARNING / CAUTION / NOTE DEFINITION

The words WARNING, CAUTION and NOTE carry special meanings and should be carefully reviewed.



### WARNING

The personal safety of the patient or user may be involved. Disregarding this information could result in injury to the patient or user.



### CAUTION

These instructions point out special procedures or precautions that must be followed to avoid damaging the equipment.

### NOTE

This provides special information to make important instructions clearer.

# Introduction

---

## SAFETY TIPS AND GUIDELINES

Before operating the Secure II Bed, it is important to read and understand all information in this manual. Carefully read and strictly follow the safety guidelines listed on this page.

It is important that all users have been trained and educated on the inherent hazards associated with the usage of electric beds.

---

### **WARNING**

- Danger: Explosion hazard. Do not use in the presence of flammable anesthetics.
  - Always apply the caster brakes when a patient is getting on or off the bed. Always keep the caster brakes applied when a patient is on the bed (except during transport). Push on the bed to ensure the brakes are securely locked. Serious injury could result if the bed moves while a patient is getting in or out of bed.
  - Ensure the brakes are completely released prior to attempting to move the unit. Attempting to move the unit with the brakes actuated could result in injury to the user and/or patient.
  - Do not attempt to move the foot end of the bed laterally when the steer pedal is activated. When the steer pedal is activated, the steer caster at the foot end of the bed cannot swivel. Attempting to move the bed laterally when the steer pedal is activated may cause injury to the user.
  - The Secure II Bed is not intended for use with patients less than two years of age.
  - The Secure II Bed is intended for use by trained hospital personnel only. Failure to properly train personnel could result in injury.
  - Serious injury can result if caution is not used when operating the unit. Operate the unit only when all persons are clear of the electrical and mechanical systems.
  - To help reduce the number and severity of falls by patients, always leave the bed in the lowest position when the patient is unattended.
  - Leave the siderails fully up and locked when the patient is unattended. When raising the siderails, listen for the "click" that indicates the siderail has locked in the up position. Pull firmly on the siderail to ensure it is locked into position.  
Siderails are not intended to be a patient restraint device. It is the responsibility of the attending medical personnel to determine the degree of restraint necessary to ensure a patient will remain safely in bed.
  - When attaching equipment to the frame, ensure it will not impede normal frame operation. For example: hooks on hanging equipment must not actuate control buttons, or hide the nurse call button, etc.
  - The Chaperone™ Bed Exit System is intended only to aid in the detection of a patient exiting the unit. It is NOT intended to replace patient monitoring protocol. The bed exit system signals when a patient is about to exit. Adding or subtracting objects from the frame after zeroing the weigh system may cause a reduction in the sensitivity of the bed exit system.
  - Do not steam clean or hose off the bed. Do not immerse any part of the bed. The internal electric parts may be damaged by exposure to water. Hand wash all surfaces of the bed with warm water and mild detergent. Dry thoroughly. Quaternary Germicidal Disinfectants, used as directed, and/or Chlorine Bleach products, typically 5.25% Sodium Hypochlorite in dilutions ranging between 1 part bleach to 100 parts water, and 2 parts bleach to 100 parts water are **not** considered mild detergents. **THESE PRODUCTS ARE CORROSIVE IN NATURE AND MAY CAUSE DAMAGE TO YOUR BED IF USED IMPROPERLY.** If these types of products are used to clean Stryker patient care equipment, measures must be taken to insure the beds are wiped with clean water and thoroughly dried following cleaning. Failure to properly rinse and dry the beds will leave a corrosive residue on the surface of the bed, possibly causing premature corrosion of critical components. Failure to follow the above directions when using these types of cleaners may void this product's warranty.  
Clean Velcro **AFTER EACH USE**. Saturate Velcro with disinfectant and allow disinfectant to evaporate. (Appropriate disinfectant for nylon Velcro should be determined by the hospital.)
  - When large spills occur in the area of the circuit boards, 110 volt cables and motors, immediately unplug the bed power cord from the wall socket. Remove the patient from the bed and clean up the fluid. Have maintenance completely check the bed. Fluids can affect the operational capabilities of any electrical product. **DO NOT** put the bed back into service until it is completely dry and has been thoroughly tested for safe operation.
-

# Introduction

---

## SAFETY TIPS AND GUIDELINES (CONTINUED)

---

### **WARNING**

- Preventative maintenance should be performed at a minimum of biannually to ensure all bed features are functioning properly. Close attention should be given to safety features including, but not limited to: safety side latching mechanisms, frayed electrical cords and components, all electrical controls return to off or neutral position when released, caster braking systems, no controls or cabling entangled in bed mechanisms, leakage current 100 microamps maximum, scale and bed exit systems calibrated properly.
  - Always unplug the bed power cord from the wall socket and push the battery power on/off switch to the "OFF" position before servicing or cleaning the bed. When working under the bed with the bed in the high position, always place blocks under the litter frame and apply the brakes to prevent injury in case the Bed Down switch is accidentally pressed.
  - When using the manual override shaft to manually actuate bed functions, always unplug the bed power cord from the wall socket to avoid injury in the event of a sudden return of power to the bed.
  - Because individual beds may have different options, foot boards should not be moved from one bed to another. Mixing foot boards could result in unpredictable bed operation.
  - The CPR emergency release on the Short Bed frame may require assistance to lower the back when the Back is in the highest position. Attempting to lower the Back in this position without assistance may result in injury to the operator.
  - Do not modify the 3002 Patient Transport Frame. Modifying the unit can cause unpredictable operation resulting in injury to the patient or operator. Modifying the unit will also void its warranty.
- 

## SAFETY TIPS AND GUIDELINES (ZOOM OPTION)

In addition to the following warnings, all of the warnings listed above and on the previous page apply to units equipped with the Zoom™ option.

---

### **WARNING**

- **USE CAUTION** while maneuvering the unit with the drive wheel activated. Always ensure there are no obstacles near the unit while the drive wheel is activated. Injury to the patient, user or bystanders or damage to the frame or surrounding equipment could occur if the unit collides with an obstacle.
  - Put the drive wheel in the neutral position and release the brakes before pushing the unit manually. Do not attempt to push the unit manually with the drive wheel engaged. The unit will be difficult to push and injury could result.
  - To avoid damage while transporting the bed, verify the I.V. pole is at a low enough height to allow it to safely pass through door openings and under light fixtures.
  - If unanticipated motion occurs, unplug the power cord from the wall socket, push the battery power on/off switch to the "OFF" position (the LED will not be illuminated) and actuate the drive wheel pedal to the neutral position.
  - The power save mode is activated after one hour on battery power with no motion release switch activation. Functions including Bed Exit, scale and motion will cease to operate when the unit enters the power save mode. Injury to the patient could occur if proper patient monitoring protocol is not observed.
  - Always unplug the power cord and push the battery power on/off switch to the "OFF" position before service or cleaning. When working under the frame, always place blocks under the litter frame to prevent injury in case the Bed Down switch is accidentally activated.
  - The battery tray assembly weighs 50 pounds. Take care when removing the two hex head screws securing it to the base frame or personal injury could result.
  - Battery posts, terminals and related accessories contain lead and lead compounds, chemicals known to the State of California to cause cancer and birth defects or other reproductive harm. **Wash hands after handling.**
-



# Warranty

---

## Limited Warranty:

Stryker Medical Division, a division of Stryker Corporation, warrants to the original purchaser that its products should be free from defects in material and workmanship for a period of one (1) year after date of delivery. Stryker's obligation under this warranty is expressly limited to supplying replacement parts and labor for, or replacing, at its option, any product which is, in the sole discretion of Stryker, found to be defective. Stryker warrants to the original purchaser that the frame and welds on its beds will be free from structural defects for as long as the original purchaser owns the bed. If requested by Stryker, products or parts for which a warranty claim is made shall be returned prepaid to Stryker's factory. Any improper use or any alteration or repair by others in such manner as in Stryker's judgement affects the product materially and adversely shall void this warranty. Any repair of Stryker products using parts not provided or authorized by Stryker shall void this warranty. No employee or representative of Stryker is authorized to change this warranty in any way.

Stryker Medical beds are designed for a 15 year expected life under normal use conditions and appropriate periodic maintenance as described in the maintenance manual for each device.

This statement constitutes Stryker's entire warranty with respect to the aforesaid equipment. STRYKER MAKES NO OTHER WARRANTY OR REPRESENTATION, EITHER EXPRESSED OR IMPLIED, EXCEPT AS SET FORTH HEREIN. THERE IS NO WARRANTY OF MERCHANTABILITY AND THERE ARE NO WARRANTIES OF FITNESS FOR ANY PARTICULAR PURPOSE. IN NO EVENT SHALL STRYKER BE LIABLE HEREUNDER FOR INCIDENTAL OR CONSEQUENTIAL DAMAGES ARISING FROM OR IN ANY MANNER RELATED TO SALES OR USE OF ANY SUCH EQUIPMENT.

## To Obtain Parts and Service:

Stryker products are supported by a nationwide network of dedicated Stryker Field Service Representatives. These representatives are factory trained, available locally, and carry a substantial spare parts inventory to minimize repair time. Simply call your local representative, or call Stryker Customer Service at (800) 327-0770.

## Service Contract Coverage:

Stryker has developed a comprehensive program of service contract options designed to keep your equipment operating at peak performance at the same time it eliminates unexpected costs. We recommend that these programs be activated *before* the expiration of the new product warranty to eliminate the potential of additional equipment upgrade charges.

## **A SERVICE CONTRACT HELPS TO:**

- Ensure equipment reliability
- Stabilize maintenance budgets
- Diminish downtime
- Establish documentation for JCAHO
- Increase product life
- Enhance trade-in value
- Address risk management and safety

# Warranty

**Stryker offers the following service contract programs:**

<b>SPECIFICATIONS</b>	<b>GOLD</b>	<b>SILVER</b>	<b>PM* ONLY</b>
Annually scheduled preventative maintenance	X		X
All parts,** labor, and travel	X	X	
Unlimited emergency service calls	X	X	
Priority one contact; two hour phone response	X	X	X
Most repairs will be completed within 3 business days	X	X	
JCAHO documentation	X	X	X
On-site log book w/ preventative maintenance & emergency service records	X		
Factory-trained Stryker Service Technicians	X	X	X
Stryker authorized parts	X	X	X
End of year summary	X		
Stryker will perform all service during regular business hours (9-5)	X	X	X

\* Replacement parts and labor for products under PM contract will be discounted.

\*\* Does not include any disposable items, I.V. poles (except for Stryker HD permanent poles), mattresses, or damage resulting from abuse.

**Stryker Medical also offers *personalized* service contracts.**

**Pricing is determined by age, location, model and condition of product.**

**For more information on our service contracts,  
please call your local representative or call (800) 327-0770 (option #2).**

## **Return Authorization:**

Merchandise cannot be returned without approval from the Stryker Customer Service Department. An authorization number will be provided which must be printed on the returned merchandise. Stryker reserves the right to charge shipping and restocking fees on returned items.

**SPECIAL, MODIFIED, OR DISCONTINUED ITEMS NOT SUBJECT TO RETURN.**

## **Damaged Merchandise:**

ICC Regulations require that claims for damaged merchandise must be made with the carrier within fifteen (15) days of receipt of merchandise. **DO NOT ACCEPT DAMAGED SHIPMENTS UNLESS SUCH DAMAGE IS NOTED ON THE DELIVERY RECEIPT AT THE TIME OF RECEIPT.** Upon prompt notification, Stryker will file a freight claim with the appropriate carrier for damages incurred. Claim will be limited in amount to the actual replacement cost. In the event that this information is not received by Stryker within the fifteen (15) day period following the delivery of the merchandise, or the damage was not noted on the delivery receipt at the time of receipt, the customer will be responsible for payment of the original invoice in full.

Claims for any short shipment must be made within thirty (30) days of invoice.

## **International Warranty Clause:**

This warranty reflects U.S. domestic policy. Warranty outside the U.S. may vary by country. Please contact your local Stryker Medical representative for additional information.

# Set-Up Procedures

---

## SET-UP PROCEDURES

It is important that the Secure II Bed is working properly before it is put into service. The following list will help ensure that each part of the bed is tested.

- Plug the bed into a properly grounded, hospital grade wall receptacle and ensure the "Power" LED light at the foot end of the bed comes on.



### WARNING

The Secure II is equipped with a hospital grade plug for protection against shock hazard. It must be plugged directly into a properly grounded three-prong receptacle. Grounding reliability can be achieved only when a hospital grade receptacle is used.

- Plug the optional interface cable into the 37 pin connector under the litter frame at the head end of the bed, and into the "Patient Station", "Head Wall", "Docking Station", or equivalent (whichever applies). Test the interface cable to verify it is functioning properly.



### WARNING

Use only a Stryker supplied interface cable. Use of any other cable may cause the bed to function improperly which may result in patient or user injury.

- Ensure the siderails raise, lower and store smoothly and lock in the up position and in the intermediate position when lowered (page 18).
- Ensure that all four casters lock when the brake pedal is engaged (page 14).
- Raise the Back up to approximately 60°. Squeeze the CPR release handle and ensure the Back will drop with minimal effort.

### NOTE

Ensure that the "Brake Not Set" LEDs located on the outside of the head end siderails and on the foot board control panel come on when the brakes are disengaged.

- Run through each function on the foot board control panel to ensure that each function is working properly (page 21-26).
- Run through each function on both head end siderails to ensure that each is working properly (page 18-20).
- Activate the motion stop system to ensure it is functioning properly: press and hold down the BED DOWN key. As the bed lowers, lift up on the motion interrupt pan (reference drawing on page 13) and ensure the downward motion stops. Release the pan and allow the downward motion to continue.

### NOTE

The bed's upward motion or other functions are not disrupted by the motion stop system.

# Set-Up Procedures

---

## SET-UP PROCEDURES (ZOOM™ OPTION)

If your bed is equipped with the Zoom™ drive wheel option, run through the set-up procedures on page 10 and continue with the procedures listed below.

- Plug the power cord into a properly grounded, hospital grade wall receptacle. The 12 volt batteries that provide power to the drive wheel and back-up power to the unit functions will charge whenever the power cord is plugged into the wall socket. The batteries require approximately 10 hours of charging time before the bed is put into service.
- Unplug the power cord from the wall socket. Push the battery power switch located on the lower left corner of the head end to the “ON” position. Again, verify each function on the foot board and siderails is operating properly.
- With the battery power switch in the “ON” position and the brakes engaged, ensure the “Release Brakes” LED on the head end control panel is illuminated.
- With the battery power switch in the “ON” position and the drive wheel in the neutral position (not touching the floor), ensure the “Engage Drive Wheel” LED on the head end control panel is illuminated.
- Run through the operation of the drive wheel (see page 30 & 31) to ensure it is operating properly.

If any problems are found during bed set-up, contact Stryker Customer Service at 800-327-0770.

### Damaged Merchandise

ICC Regulations require that claims for damaged merchandise must be made with the carrier within fifteen (15) days of receipt of merchandise. **DO NOT ACCEPT DAMAGED SHIPMENTS UNLESS SUCH DAMAGE IS NOTED ON THE DELIVERY RECEIPT AT THE TIME OF RECEIPT.** Stryker Customer Service must be notified immediately. Stryker will aid the customer in filing a freight claim with the appropriate carrier for damages incurred. Claim will be limited in amount to the actual replacement cost. In the event that this information is not received by Stryker within the fifteen (15) day period following the delivery of the merchandise, or the damage was not noted on the delivery receipt at the time of receipt, the customer will be responsible for payment of the original invoice in full.

Claims for any short shipment must be made within thirty (30) days of invoice.

# Symbols

---



Warning, Refer to Service/Maintenance Manual



Alternating Current



Type B Equipment: equipment providing a particular degree of protection against electric shock, particularly regarding allowable leakage current and reliability of the protective earth connection.

Class 1 Equipment: equipment in which protection against electric shock does not rely on BASIC INSULATION only, but which includes an additional safety precaution in that means are provided for the connection of the EQUIPMENT to the protective earth conductor in the fixed wiring of the installation in such a way that ACCESSIBLE METAL PARTS cannot become live in the event of a failure of the BASIC INSULATION.

Mode of Operation: Continuous

IPX4: Protection from liquid splash



Dangerous Voltage Symbol



Protective Earth Terminal



Potential Equalization Symbol



Medical Equipment Classified by Underwriters Laboratories Inc. with Respect to Electric Shock, Fire, Mechanical and Other Specified Hazards Only in Accordance with UL 2601-1 and CAN/CSA C22.2 No. 601.1

# Bed Illustration

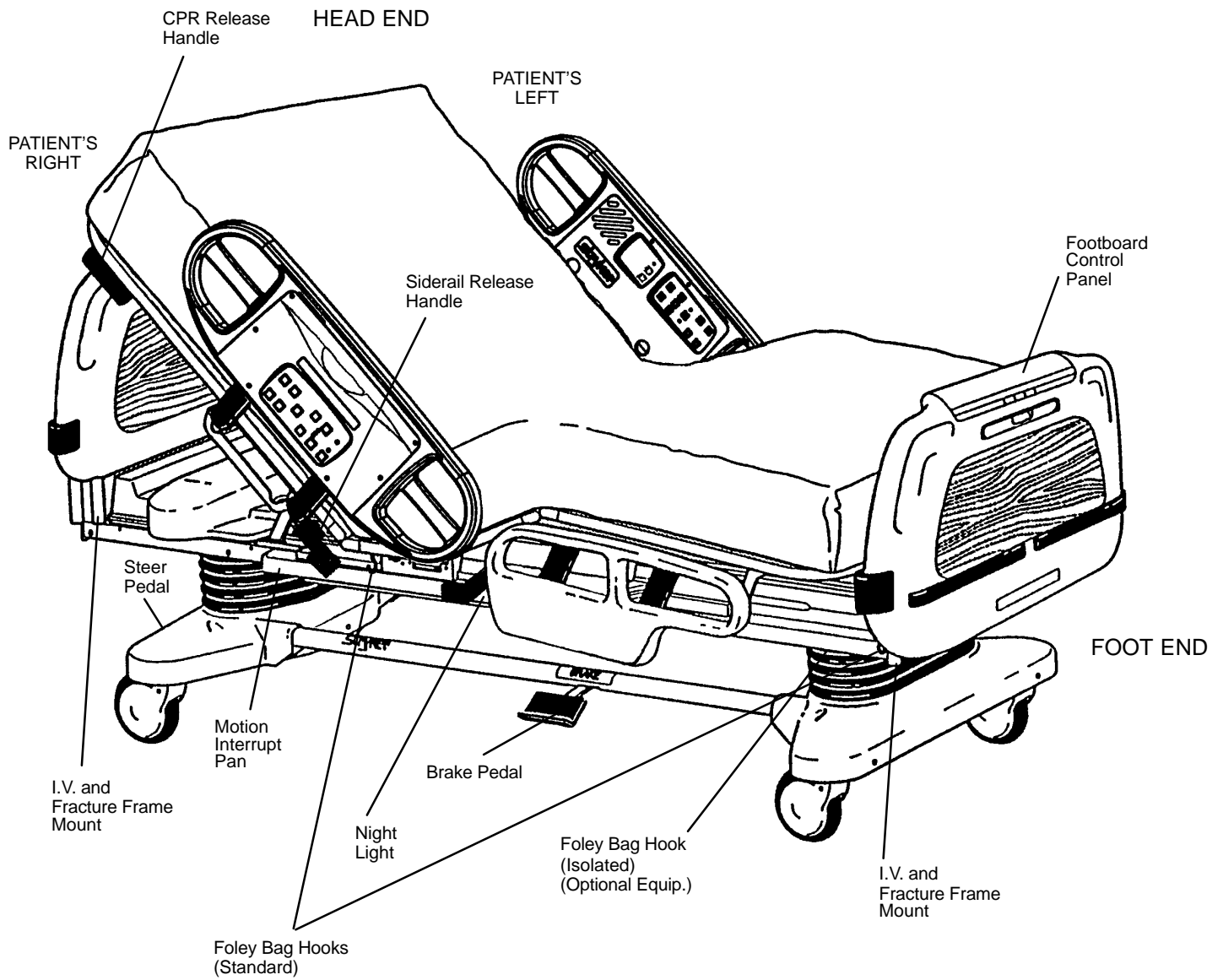

# Base Operation Guide

---

## BRAKE PEDAL OPERATION

---

### **WARNING**

Always apply the caster brakes when a patient is getting on or off the bed. Push on the bed to ensure the brakes are securely locked. Always engage the brakes unless the bed is being moved. Injury could result if the bed moves while a patient is getting on or off the bed.

---

To activate the brakes, push down once on one of the pedals located at the midpoint of the bed on both sides (identified by the label at right). The pedal will remain in the lowered position, indicating the brakes are engaged. To disengage the brakes, push down once and the pedal will return to the upper position.



**BRAKE**  
PRESS TO SET OR RELEASE

### **NOTE**

There are LED lights on the outside of the head end siderails and on the foot end control panel that will blink when the brakes are not engaged only if the bed is plugged into a wall socket (see pages 20 & 22). The brakes will still operate properly when the bed is not plugged in.

## STEER PEDAL OPERATION (BEDS WITHOUT THE ZOOM™ DRIVE WHEEL OPTION)

When the bed is moved, the steer caster helps guide the bed along a straight line and helps the bed pivot around corners.

To activate the steer caster, move the pedal located at the head end of the bed to your left as shown on the label.



### **NOTE**

For proper "tracking" of the steer caster, push the bed approximately 10 feet to allow the wheels to face the direction of travel before engaging the steer pedal. If this is not done, proper "tracking" will not occur and the bed will be difficult to steer.

---

### **WARNING**

Do not attempt to move the foot end of the bed laterally when the steer pedal is activated. When the steer pedal is activated, the steer caster at the foot end of the bed cannot swivel. Attempting to move the bed laterally when the steer pedal is activated may cause injury to the user.

---

# Litter Operation Guide

---

## CPR EMERGENCY RELEASE

When quick access to the patient is needed, and the Fowler is raised, squeeze one of the two red release handles (see illustration, page 13) and the Fowler can be quickly guided down to a flat position.

### NOTE

The handle can be released at any time to stop the Fowler from lowering.

## FOOT PROP USAGE

To prop the foot end of the Knee Gatch up, grasp the handle (A) at the end of the Knee Gatch and lift upward, allowing the foot prop (B) to engage at the desired height. To release the prop, lift up on the handle (A), swing the prop (B) toward the head end of the bed to disengage the hinge and lower the foot end.

---

### WARNING

To avoid injury while cleaning or servicing under the foot section, secure the foot section with string or bungee cords or hold it up out of the way.

---

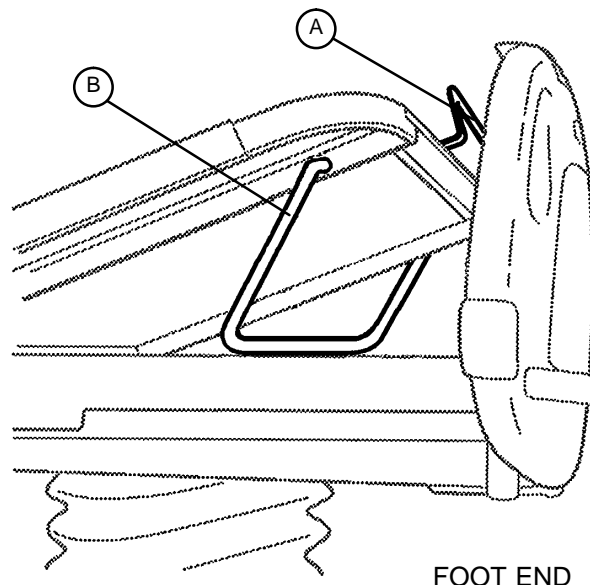

## FRACTURE FRAME USAGE

A standard fracture frame can be mounted on the bed using the I.V. sockets located on all four corners of the bed. I.V. poles can be used in conjunction with a fracture frame if I.V. pole adaptor sockets are purchased.

---

### WARNING

Use only retractable traction or fracture frames. Failure to use a retractable frame may result in injury to the patient and/or damage to the equipment.

---

## FOLEY BAG HOOKS USAGE

The standard Foley bag hooks are found at two locations on both sides of the frame: under the frame below the seat section and at the extreme foot end of the frame. The optional isolated Foley bag hooks are located at the foot end of the bed on top of the lift header. The patient weight reading on the scale system will not be affected when the optional isolated Foley bag hooks are used.

## PATIENT RESTRAINT STRAP LOCATIONS

The bed has 12 locations for installing patient restraint straps on the litter top, 6 on each side of the bed.

---

### WARNING

Improperly adjusted restraint straps can cause serious injury to a patient. The clinician must use her/his judgement to determine proper use of restraint straps and restraint strap locations.

---

Clean Velcro **AFTER EACH USE**. Saturate Velcro with disinfectant and allow disinfectant to evaporate. (Appropriate disinfectant for nylon Velcro should be determined by the hospital.)



# Litter Operation Guide

---

## NIGHT LIGHT USAGE

The bed is equipped with two night lights to illuminate the floor area around the bed.

There is a switch under the litter thigh section on the patient's left side that turns both lights on and off.

### NOTE

The night lights have sensors so the lights will turn off, even when the switch is on, if the light in the room is bright enough so a night light is not necessary.

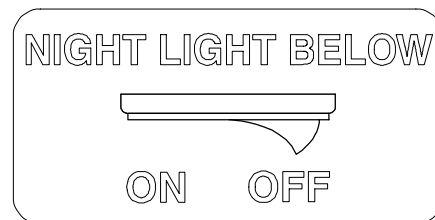

## NURSE CALL BACK-UP BATTERY (Optional Equipment)

To prevent a low battery condition when the bed is not plugged in, position the cord out switch at the head end of the bed to the off position. The switch is identified by the label shown below. If the switch is not positioned as shown below and the bed power cord and pendant cord are unplugged, the life of the back-up battery will be significantly reduced.

If the power light (located on the foot board) is flashing, the Nurse Call battery needs to be replaced. The battery is located on the patient's left side at the head end of the bed. No tools are required to replace the battery. Unplug the bed power cord from the wall socket and replace the battery.

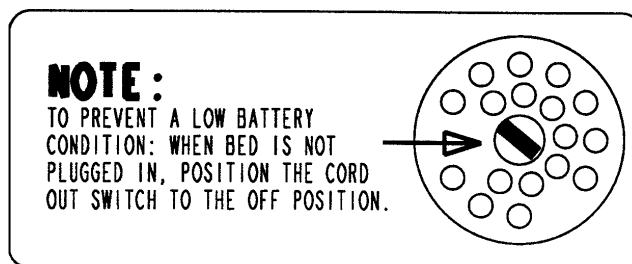

## USING THE 110 VOLT OUTLET (Optional Equipment)

The 110V outlet has its own power cord that must be plugged into a properly grounded three prong wall receptacle different from the wall receptacle the bed power cord is plugged into.

If the equipment plugged into the bed outlet is not receiving power, check the circuit breakers located on the litter frame under the head section (see page 158). Reset, if necessary.



### WARNING

Only use equipment with the following electrical specs: 110 VAC; 10A; 60Hz. Maximum total load drawn by equipment used in this receptacle outlet must not exceed 10A. The total system chassis risk current should not exceed 100uA. Grounding continuity should be checked periodically.

To avoid risk of electrical shock, unplug **all** power cords before opening the service compartment, junction box or receptacle.

Do not use the optional 110V outlet for life sustaining equipment.

---

## CPR BOARD USAGE (Optional Equipment)

If the bed is equipped with the optional CPR board, it is stored on the bed's head board. To remove it, pull it away from the head board and lift it out of storage position. If the CPR board option was not purchased, the head board can also be removed and used as an emergency CPR board.

# Litter Operation Guide

## OPERATING I.V. POLES

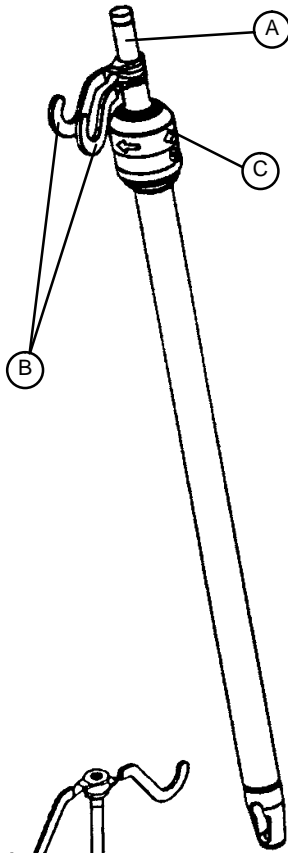

### To use the 2-Stage Permanently Attached I.V. pole:

#### NOTE

The 2-stage permanently attached I.V. pole is an option and may have been installed at either the head, foot or both ends. The choice was made at the time the unit was purchased.

1. Lift and pivot the pole from the storage position and push down until it rests in the receptacle.
2. To raise the height of the pole, pull up on the telescoping portion (A) until it locks into place at its fully raised position.
3. Rotate the I.V. hangers (B) to desired position and hang I.V. bags.
4. To lower the I.V. pole turn the latch (C) clockwise until section (A) lowers.



#### CAUTION

The weight of the I.V. bags should not exceed 40 pounds.



#### WARNING

To avoid pinching your fingers, place the I.V. pole in the upright position before using the drive handle .

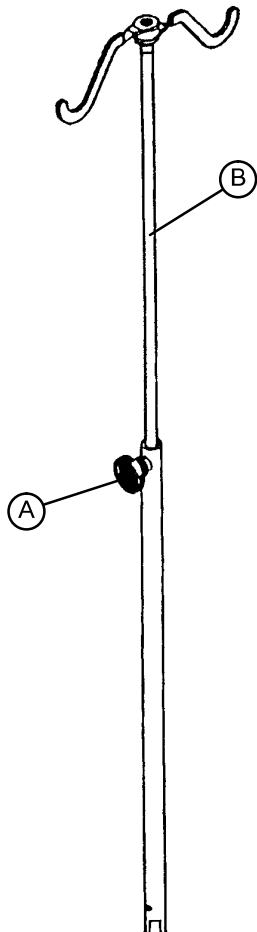

### To use the "Removable" I.V. pole:

1. Install the pole at any of the four receptacles on the bed top (located on all four corners of the frame.)
2. To raise the height of the pole, turn knob (A) counterclockwise and pull up on the telescoping portion (B) of the pole and raise it to the desired height.
3. Turn knob (A) clockwise to tighten the telescoping portion in place.



#### CAUTION

The weight of the I.V. bags should not exceed 40 pounds.

# Siderail Operation Guide

## POSITIONING SIDERAILS

### NOTE

The siderails can be locked at two heights (intermediate & full up). The foot end siderails on a Short Bed do not have an intermediate position.

The siderails can be tucked away under the bed when not in use. To remove the rail from the tucked position, grasp the top of the rail and pull outward.

To engage the head end siderail, grasp the rail and swing it upward to full height. When the siderail is being raised, it does not lock in the intermediate position. To lower the siderail, push in the blue release handle (A) and rotate the siderail until it locks in the intermediate position. To lower the siderail fully, push in the blue release handle (A) again and rotate the siderail until it is completely lowered.

To engage the foot end siderail, the same procedure is required as for the head end siderail, however, the siderail swings toward the foot end of the bed.

### **WARNING**

Be sure the siderail is locked securely into position. Siderails are not intended to keep patients from exiting the bed. They are designed to keep a patient from inadvertently rolling off the bed. Proper restraint methods should be utilized to ensure the patient remains in bed. The siderails are not intended to be used as a push device.

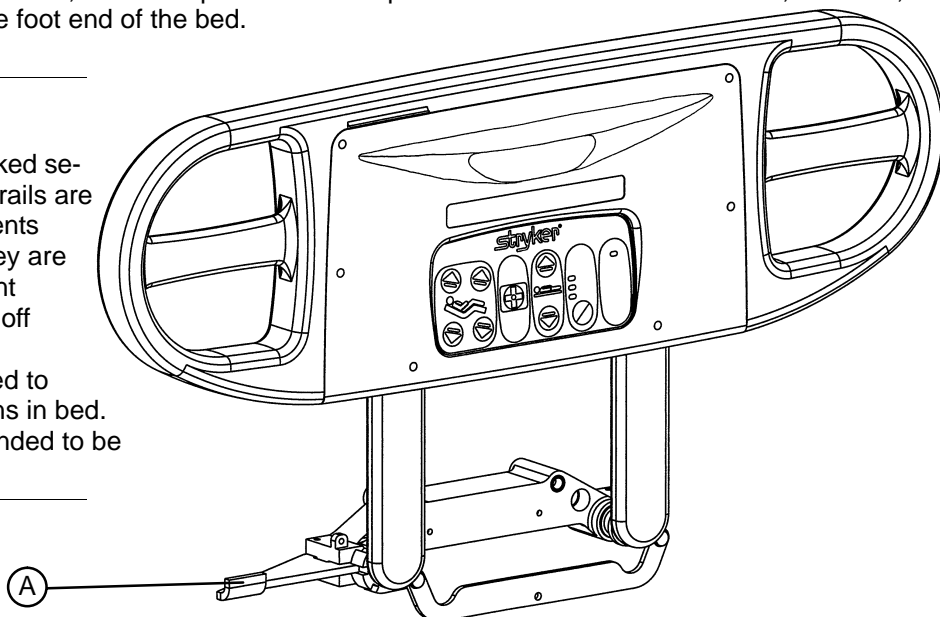

To disengage the rail, push in the blue release handle (A) and swing the rail down to the desired height. Store the siderails by tucking the rails under the bed. Rails must be in the full down position before they can be tucked.

## SIDERAIL CONTROL PANEL LIGHTS

The bed is equipped with lights to illuminate the head end siderail control panel and the red nurse call switches. Both can be activated at the foot board control panel. Three settings are available for the control panel lights: low, medium and high intensity. When all lights are off, push the siderail control light button at the foot board once to turn on both the control lights and the nurse call light at the siderail. Push again to change from low to medium setting, and a third time to change to the high setting. The nurse call light intensity is not affected. Pushing the button a fourth time will turn off the siderail control panel lights and pushing it a fifth time will turn off the red nurse call light as well (see control panel guide page 21).

### NOTE

The purpose of the red nurse call light on the siderails is to ensure the patient immediately knows which button to push to contact the nurse station. Turning the red light off may compromise this ability, especially in a darkened room.

# Siderail Operation Guide

## INSIDE SIDERAIL FUNCTION GUIDE

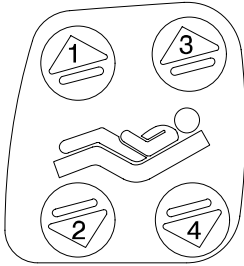

### (Patient's Right Rail)

1. Push to raise Knee Gatch.
2. Push to lower Knee Gatch.
3. Push to raise Fowler.
4. Push to lower Fowler.

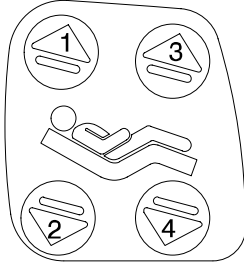

### (Patient's Left Rail)

1. Push to raise Fowler.
2. Push to lower Fowler.
3. Push to raise Knee Gatch.
4. Push to lower Knee Gatch.



1. Push to activate Nurse Call.

### NOTE

Yellow LED will light when button is pushed. Red LED will light with Nurse Station acknowledgment.

► This panel is optional equipment.

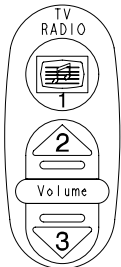

1. Push to turn TV or radio on and to select a channel.
2. Push to increase volume.
3. Push to decrease volume.

► This panel is optional equipment.

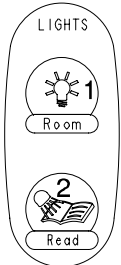

1. Push to turn the room light on.
2. Push to turn the bed overhead light on.

► This panel is optional equipment.

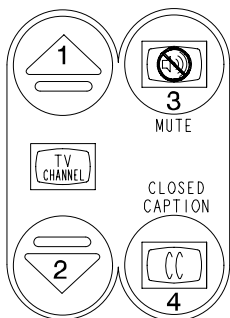

1. Push to change the TV channel up.
2. Push to change the TV channel down.
3. Push to mute TV volume. Push again to turn the sound back on.
4. Push to display closed captioning. Push again to turn off closed captioning.

► This panel is optional equipment.

# Siderail Operation Guide

## OUTSIDE SIDERAIL FUNCTION GUIDE

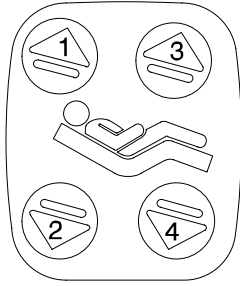

### (Patient's Right Rail)

1. Push to raise Fowler.
2. Push to lower Fowler.
3. Push to raise Knee Gatch.
4. Push to lower Knee Gatch.

► This panel is optional equipment.

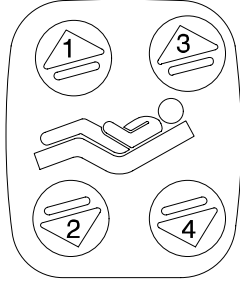

### (Patient's Left Rail)

1. Push to raise Knee Gatch.
2. Push to lower Knee Gatch.
3. Push to raise Fowler.
4. Push to lower Fowler.

► This panel is optional equipment.

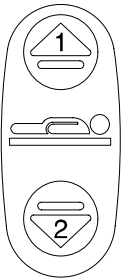

1. Push to raise bed height.

2. Push to lower bed height.

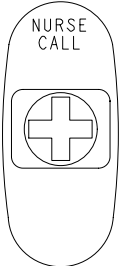

Push to activate Nurse Call.

► This panel is optional equipment.



LED will blink when the brakes are not set.

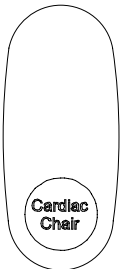

Push to activate the Cardiac Chair function. The Knee will raise, the Back will raise or lower to approximately 52° and the bed will tilt to approximately -12° (-10° if it's a Short Bed) reverse Trendelenburg (foot end down). Release the button to stop bed movement: hold the button until movement stops to complete the function.

► This panel is optional equipment.

# Foot Board Operation Guide

## FOOT BOARD CONTROL PANEL GUIDE

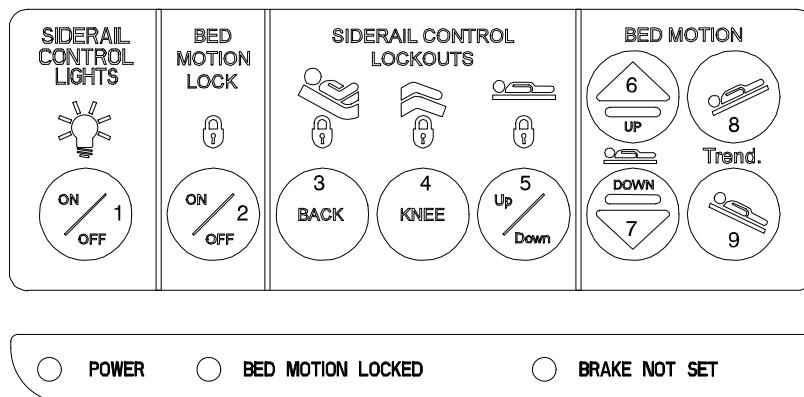

1. Push repeatedly for low, medium and high settings for the siderail control panel lights. Pushing a fourth and fifth time will turn off the siderail lights and the red nurse call light respectively (see page 18).

### NOTE

The intent of the red nurse call light on the siderails is to ensure the patient immediately knows which button to push to contact the nurse station. Turning the red light off may compromise this ability, especially in a darkened room.

2. Push to lock out all bed motions. The MOTION lock icon and the "BED MOTION LOCKED" LED will light. Push again to unlock.
3. Push to lock out Back Rest controls at both siderails. The HEAD lock icon will light. Push again to unlock.
4. Push to lock out Knee Gatch controls at both siderails. The KNEE lock icon will light. Push again to unlock.
5. Push to lock out bed height movement at both siderails. The UP/DOWN lock icon will light. Push again to unlock.
6. Push to raise bed height.
7. Push to lower bed height.
8. Push to lower head end/raise foot end of bed (Trendelenburg position).
9. Push to lower foot end/raise head end of bed (Reverse Trendelenburg position).



### WARNING

Because individual beds may have different options, foot boards should not be moved from one bed to another. Mixing foot boards could result in unpredictable bed operation.

## FUNCTION LOCKOUT SYSTEM USAGE

1. To lock out the bed movement functions on the siderails and prevent the patient from changing the positioning of the bed, push the "HEAD", "KNEE" and/or "UP/DOWN" switches in the "Siderail Control Lockouts" module on the foot board control panel.

### NOTE

The foot board controls for these motions are not affected by the lockout switches.

The "padlock" symbol on the control panel will be lighted when that function is locked out.

2. To lock out the entire bed motion for all switches on the bed (siderails and foot board), push the "ON/OFF" switch in the "Bed Motion Lock" module on the foot board control panel.

# Foot Board Operation Guide

---

## FOOT BOARD CONTROL PANEL GUIDE (CONTINUED)

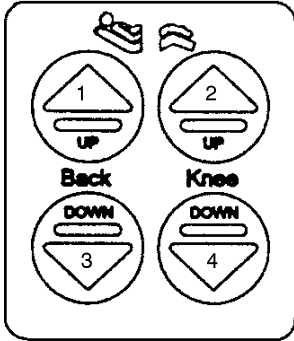

1. Push to raise Fowler.
  2. Push to raise Knee Gatch.
  3. Push to lower Fowler.
  4. Push to lower Knee Gatch.
- ▶ This panel is optional equipment.

## LED DISPLAY PANEL GUIDE

The LED Display Panel is located at the foot end of the bed, under the Control Panel.

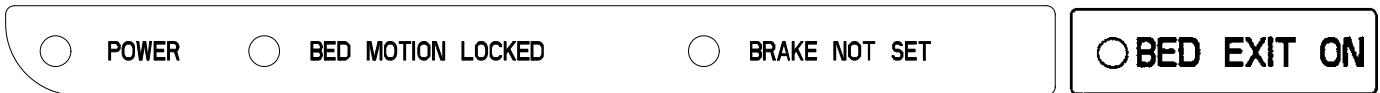

"POWER" - will light when the bed is plugged into the wall receptacle. Will blink if the 9V Nurse Call battery needs to be replaced.

"BED MOTION LOCKED" - will light when the Bed Motion Lock has been activated.

"BRAKE NOT SET" - will blink when the brakes have not been set.

"BED EXIT ON" - will light when the Bed Exit function has been activated (optional equipment).

# Foot Board Operation Guide

---

## CHAPERONE BED EXIT (OPTIONAL EQUIPMENT)

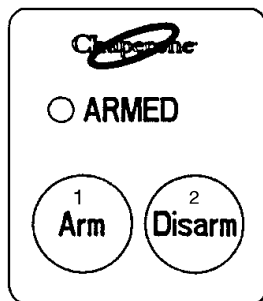

1. Push to activate Bed Exit function.
2. Push to deactivate Bed Exit function.



### NOTE

If the scale system is in use, it will switch to "off" when Bed Exit is armed. When the bed is equipped with scales, the scales must be properly zeroed for the Bed Exit System to function properly (see page 27 for scale system usage instructions). If bed is not equipped with a scale system, follow the procedure below.

1. Before putting a new patient on the bed: prepare bed for patient stay by adding linens and equipment to the bed.
2. Press and hold the "ARM" and the "DISARM" keys together for 5 seconds. The "ARMED" light will begin to flash.
3. Release the "ARM" and the "DISARM" keys and do not touch the bed until the "ARMED" light stops flashing.
4. Once the new patient is on the bed: push and release the "ARM" key ("ARMED" light will come on).
5. To deactivate Bed Exit, push "DISARM". The "ARMED" and "BED EXIT ON" LED's will turn off.

---

### **WARNING**

The Bed Exit System is intended only to aid in the detection of a patient exiting the bed. It is NOT intended to replace patient monitoring protocol. It signals when a patient is about to exit. Adding or subtracting objects from the bed after arming the bed exit system may cause a reduction in the sensitivity of the bed exit system.

---



# Foot Board Operation Guide

---

## CHAPERONE II BED EXIT WITH ZONE CONTROL (OPTIONAL EQUIPMENT)

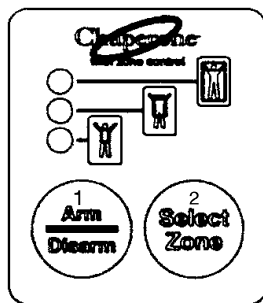

### NOTE

If the scale system is in use, it will switch to "off" when Bed Exit is armed. When the bed is equipped with scales, the scales must be properly zeroed for the Bed Exit System to function properly (see page 27 for scale system usage instructions). If bed is not equipped with a scale system, follow the procedure below.

1. Before putting a new patient on the bed: prepare bed for patient stay by adding linens and equipment to the bed.
2. Press and hold the "ARM/DISARM" and the "SELECT ZONE" keys together for 5 seconds. The top LED will begin to flash.
3. Release the "ARM/DISARM" and the "SELECT ZONE" keys and do not touch the bed until the top LED stops flashing.
4. Once the new patient is on the bed: push and release the "ARM/DISARM" key (top LED will come on).
5. The Bed Exit system with Zone Control will automatically select the first zone. To change the zone, push and hold the "SELECT ZONE" key until the LED indicating the desired zone comes on.
6. To deactivate Bed Exit, push the "ARM/DISARM" key. The selected zone LED and "BED EXIT ON" LED will turn off.

### CHAPERONE II ZONE SETTINGS

The first zone (top LED) is the traditional Bed Exit zone. The patient can move around the bed freely but cannot fully exit the bed or the alarm will sound.

The second zone (middle LED) is more restrictive. It allows the patient to sit up and roll over but any attempt to exit the bed will cause the alarm to sound.

The third zone (bottom LED) is the most movement restrictive zone. Small movements like raising an arm or lifting the shoulders off the bed will cause the alarm to sound. The third zone is used to alert staff to a change in the condition of an unconscious or paralyzed patient.



### WARNING

The Bed Exit System is intended only to aid in the detection of a patient exiting the bed. It is NOT intended to replace patient monitoring protocol. It signals when a patient is about to exit. Adding or subtracting objects from the bed after arming the bed exit system may cause a reduction in the sensitivity of the bed exit system. Failure to set the Chaperone zone properly could result in improper monitoring and patient injury. Verify the proper zone is selected before leaving the patient.

---

# Foot Board Operation Guide

## WEIGH SYSTEM CONTROL PANEL GUIDE

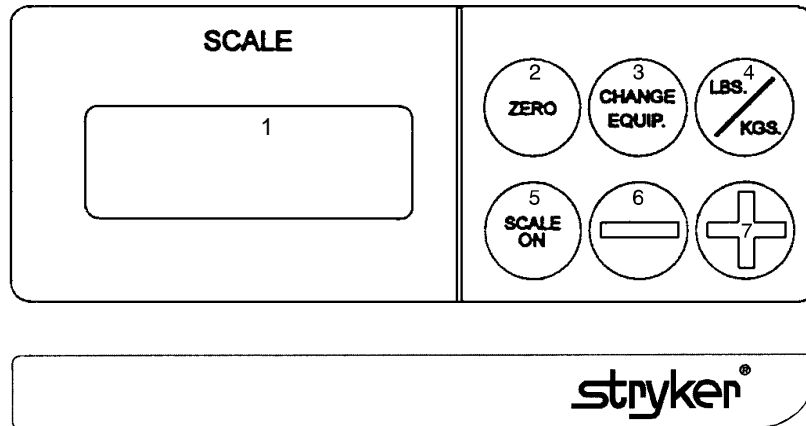

1. Display - displays patient weight and other information.
2. Push to zero bed.
3. Push when changing equipment on the bed.
4. Push to change weight from pounds to kilograms or back.
5. Push to turn weight system on.
6. Push to decrease numerical value of displayed weight.
7. Push to increase numerical value of displayed weight.



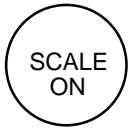
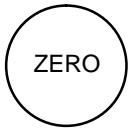

### NOTE

After approximately 30 seconds of idle time, the scale display will turn off and will show the Trendelenburg angle of the bed. Press "SCALE ON" to return to the weight display.

SYMBOL	ACTION	DISPLAY
	<b>To prepare bed for new patient:</b>	
	Press and hold "SCALE ON". Release the button <i>after</i> the display reads: "LET GO FOR SCALE"	"LET GO FOR SCALE" "WEIGHING..." "XXX.X LB"
	Press and hold "ZERO"  Release "ZERO"	"HOLD TO ZERO WT." "RELEASE TO ZERO" "DO NOT TOUCH BED" "0.0 LB"

# Foot Board Operation Guide

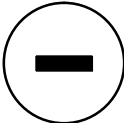
## WEIGH SYSTEM CONTROL PANEL GUIDE (CONTINUED)

SYMBOL	ACTION	DISPLAY
	<p><b>To add or remove equipment during patient stay without affecting registered patient weight:</b></p> <p>Press and release "SCALE ON"</p>	<p>"WEIGHING..." "XXX.X LB"</p>
	<p>Press "CHANGE EQUIP."</p> <p>Release "CHANGE EQUIP"</p> <p>Add or remove equipment.</p>	<p>"HOLD TO START" "RELEASE TO START" "DO NOT TOUCH BED" "ADD/REMOVE EQUIP."</p>
	<p>Press "CHANGE EQUIP"</p> <p>Release "CHANGE EQUIP"</p>	<p>"RELEASE TO FIN." "DO NOT TOUCH BED" "XXX.X LB"</p>
	<p><b>To convert the patient's weight:</b></p>	
	<p>To convert the patient's weight to kilograms, press and release "LBS./KG."</p> <p>Repeat the procedure to return to pounds.</p>	<p>"WEIGHT NOW KGS" "XXX.X KG"</p>
	<p><b>To change the numerical value of displayed weight:</b></p>	
	<p>Press <b>—</b> and hold to scroll to desired weight.</p>	<p>"HOLD TO DEC. WT." "XXX.X LB"</p>
	<p>Press <b>+</b> and hold to scroll to desired weight.</p>	<p>"HOLD TO INC. WT." "XXX.X LB"</p>

# Weigh System Usage

---

## OPERATING THE SCALE BEFORE PUTTING A NEW PATIENT ON THE BED

- Prepare the bed for a patient stay (linens, pillows, etc.).
- Press and hold "SCALE ON". Release the button *after* the display reads "LET GO FOR SCALE". (This will turn off the Trend. angle display and activate the scale). The display will read:  
"LET GO FOR SCALE"  
"WEIGHING"  
"XXX.X LB"
- Press and hold "ZERO". The display will read:  
"HOLD TO ZERO WT."  
"RELEASE TO ZERO"
- Release "ZERO". The display will now read:  
"DO NOT TOUCH BED"  
"0.0 LB"

The bed is now ready for the patient.

### NOTE

Do not zero the bed while a patient is on the bed. An inaccurate patient weight reading will result. If this should occur, remove the patient from the bed and zero the bed again.

## OPERATING THE SCALE IF A PATIENT IS ALREADY ON THE BED

- If it is necessary to add or remove special equipment (monitors, pumps, etc.) during the patient's stay, press and release "SCALE ON" to activate the weigh system. After the display reads "XXX.X LB", press and hold "CHANGE EQUIP.". The display will read:  
"HOLD TO START"  
"RELEASE TO START"
- Release "CHANGE EQUIP.". The display will read:  
"DO NOT TOUCH BED"  
"ADD/REMOVE EQUIP"
- Add or remove the equipment and press "CHANGE EQUIP.". The display will read:  
"RELEASE TO FIN."
- Release "CHANGE EQUIP.". The display will read:  
"DO NOT TOUCH BED"  
"XXX.X LB"

The weight displayed will be that of the patient only.

# Weigh System Usage

---

## CONVERTING THE PATIENT'S WEIGHT

- To convert the patient's weight from pounds to kilograms, press and release "SCALE ON" to activate the weigh system. After the display reads "XXX.X LB", press and release the "LBS/KGS" button. The display will read:

"WEIGHT NOW KGS"

"XXX.X KG"

- Repeat the procedure to return to pounds. The display will read:

"WEIGHT NOW LBS"

"XXX.X LB"

## CHANGING THE NUMERICAL VALUE OF THE DISPLAYED WEIGHT

- To decrease the numerical value of the displayed weight, press and hold "-". The display will read:

"HOLD TO DEC. WT."

"XXX.X LB"

- Hold "-" until desired value is achieved.

- To increase the numerical value of the displayed weight, press and hold "+". The display will read:

"HOLD TO INC. WT."

"XXX.X LB"

- Hold "+" until desired value is achieved.

## NOTE

The weigh system will shut off approximately one minute after a function has been used, if another function is not activated. The display light will shut off and the display will read "SCALE OFF".

The weigh system will retain all patient weight information in its memory even when the display is off or when the bed is unplugged from the wall socket.

# Optional Pendant Operation

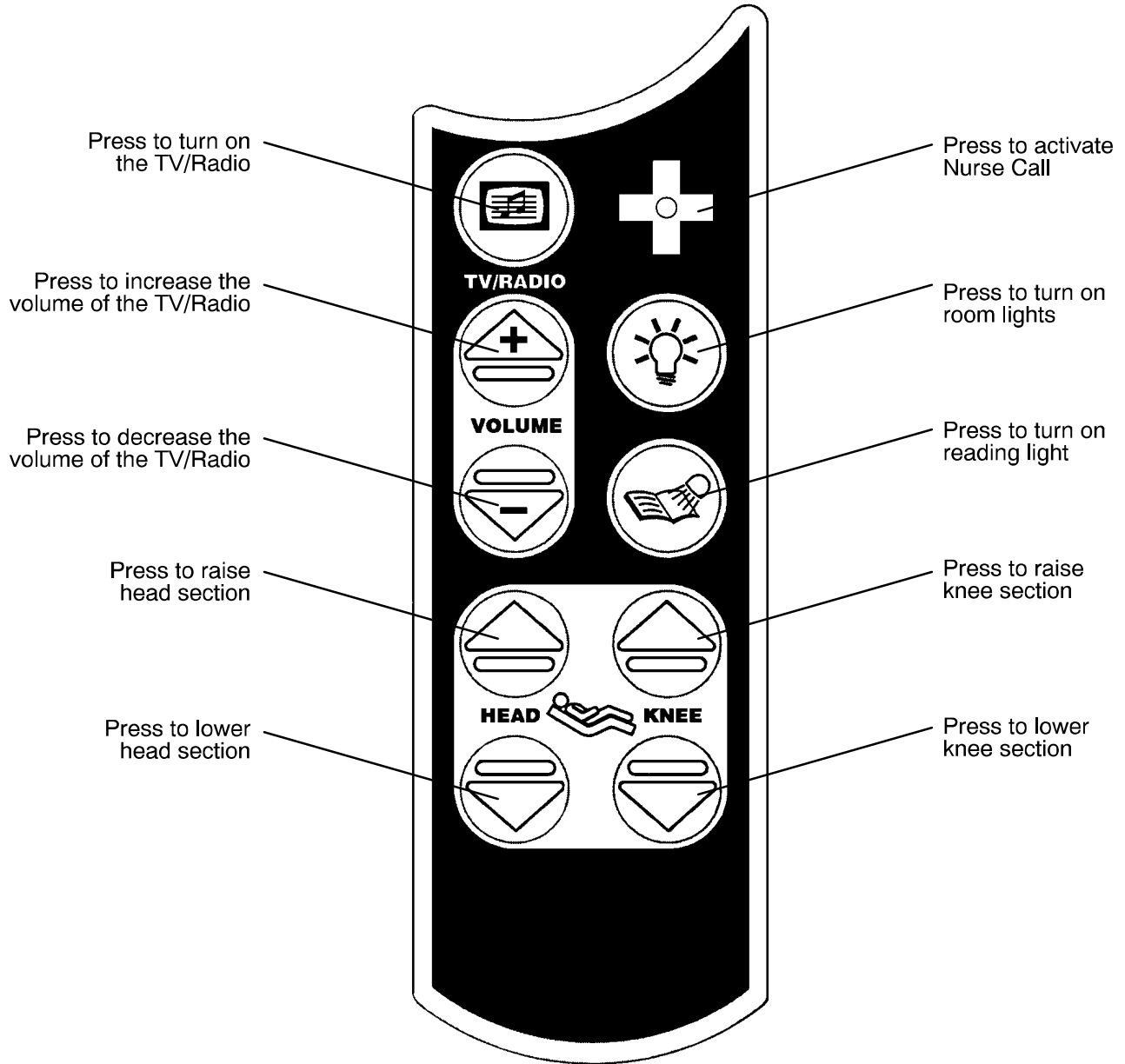

# Zoom Option Operation Guide

---

## DRIVE WHEEL OPERATION

1. Unplug the power cord from the wall socket and secure the cord sufficiently to prevent entanglement while the unit is in motion. The drive wheel will not operate if the power cord is plugged into the wall socket.
2. Activate the power to the drive wheel by placing the battery power switch located at the left side of the head end of the litter in the “ON” position. The LED will illuminate.
3. Engage the drive wheel by rotating the pedal located at the head end to the left as shown on the label. To place the drive wheel in the neutral position, rotate the pedal to the right.
4. Release the brakes. The drive system will not function while the brakes are engaged. The “Release Brakes” LED on the head end control panel will be illuminated if the brakes are engaged while the battery power switch is on.

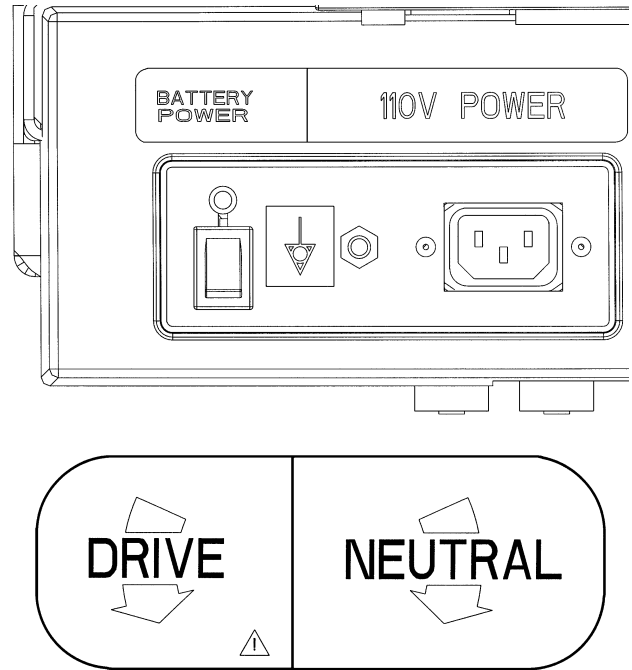

---

### **WARNING**

USE CAUTION while maneuvering the unit with the drive wheel activated. Always ensure there are no obstacles near the unit while the drive wheel is activated. Injury to the patient, user or bystanders or damage to the unit or surrounding equipment could occur if the unit collides with an obstacle.

---

# Zoom Option Operation Guide

---

## DRIVE WHEEL OPERATION (CONTINUED)

5. Grasp the drive handle at the two raised grip areas. Squeeze either of the motion release switches (A) located under the handle to enable the movement of the drive wheel. Either or both switches will enable movement but both switches must be released to stop movement.

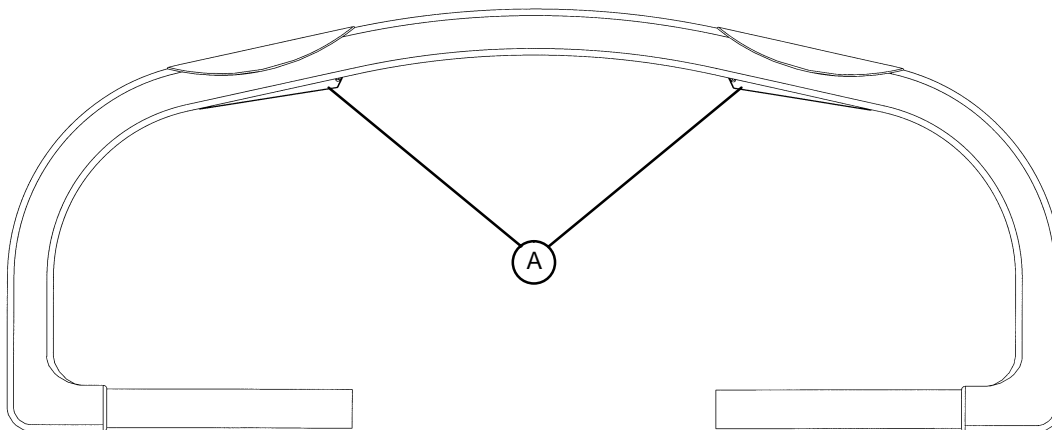

6. While continuing to squeeze the switch(es), push the handle away from you or pull the handle toward you to initiate motion in that direction. The forward speed will increase proportionally to the distance the drive handle is moved. I.E. the farther forward the drive handle is pushed, the faster the unit will move. **To stop motion, remove your hands from the switches and the handle.**

### NOTE

The drive wheel does not pivot. The unit cannot be moved directly sideways with the drive wheel engaged. With the drive wheel pedal in the neutral position and the unit's brakes released, the unit can be moved in any direction including sideways.

Driving a Zoom™-equipped unit over liquids or slick surfaces could decrease the traction of the drive wheel.

---

### **WARNING**

Put the drive wheel in the neutral position and release the brakes before pushing the unit manually. Do not attempt to push the unit manually with the drive wheel engaged. The unit will be difficult to push and injury could result.

---

### **WARNING**

When attaching equipment to the frame, ensure it will not impede normal operation. For example: hooks on hanging equipment must not actuate control buttons, equipment must not hide the nurse call button, etc.

---



# Zoom Option Operation Guide

## HEAD END CONTROL PANEL OPERATION

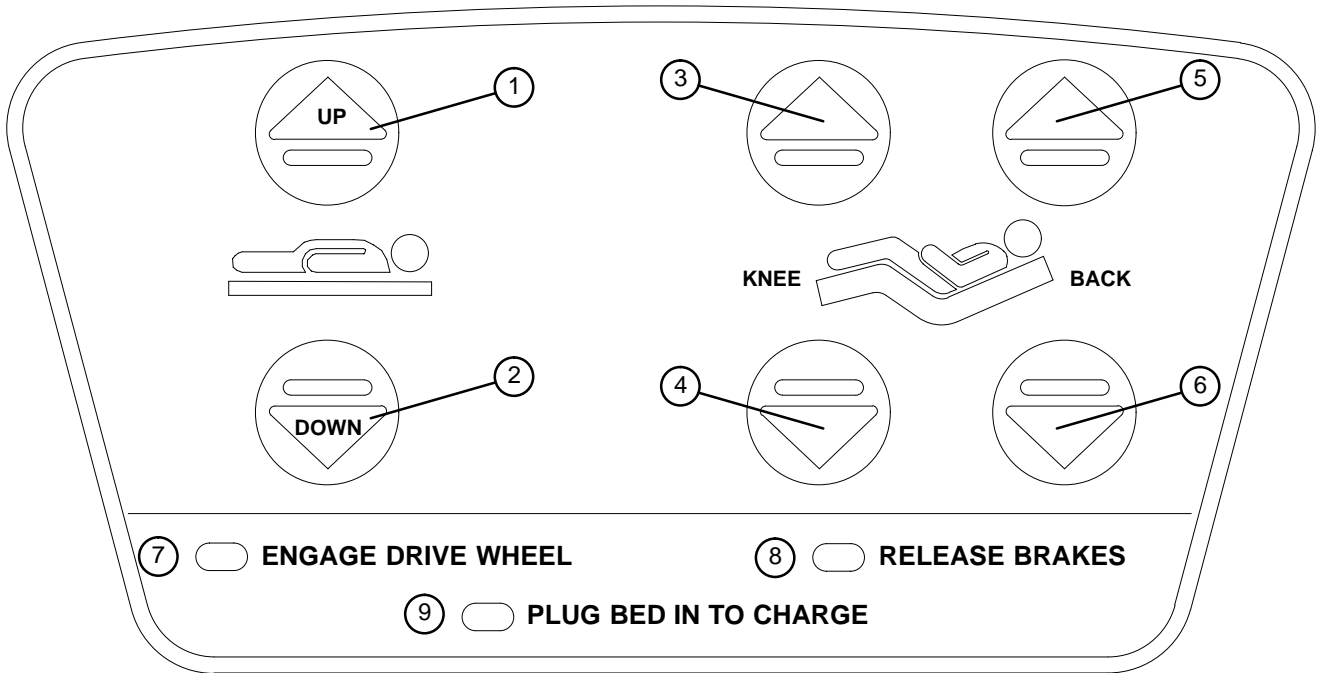

1. Press and hold to raise the litter.
2. Press and hold to lower the litter
3. Press to raise the Knee section.
4. Press to lower the Knee section.
5. Press to raise the Back section.
6. Press to lower the Back section.
7. The “Engage Drive Wheel” LED will be illuminated whenever the battery power switch is on and the drive wheel pedal is in the neutral position. The light will go off when the drive wheel is in the drive position.
8. The “Release Brakes” LED will be illuminated whenever the bed’s brakes are engaged while the battery power switch is on. The light will go off when the brakes are disengaged.
9. The “Plug Bed In To Charge” LED will be illuminated while the battery power switch is on if the battery level is low. Plug the bed power cord into the wall socket to charge the batteries.

# Zoom Option Operation Guide

---

## BATTERY CHARGING AND OPERATION

1. The unit has two 12 volt batteries to provide power to the drive wheel and back-up power to the unit functions if the power cord is unplugged from the wall socket. Neither the unit functions nor the drive wheel will operate properly if the batteries are not sufficiently charged. The batteries require approximately 10 hours of charging time when they are fully discharged.
2. The batteries are charging whenever the power cord is plugged into a properly grounded, hospital grade wall socket. When the unit is stationary, the power cord should be plugged into a wall socket whenever possible.

### NOTE

The battery will operate under slightly decreased power until it has run through 10-15 cycles of usage and recharging.

3. The “Plug Bed In To Charge” LED on the Head End Control Panel will be illuminated while the battery power switch is on if the battery level is low (see page 32). Plug the power cord into a wall socket to charge the batteries.
4. After one hour on battery power with no motion release switch activation, the unit will enter power save mode and none of the unit’s powered functions will operate. Squeeze either of the motion release switches located under the drive handle to enable the unit functions.

### NOTE

The three LED’s on the Head End Control Panel may still be illuminated when the unit is in power save mode. The Battery Power LED located at the left side of the head end of the unit will be illuminated when the unit is in power save mode.



### WARNING

Functions including Bed Exit, scale and bed motion will cease to operate when the unit enters the power save mode. Injury to the patient could occur if proper patient monitoring protocol is not observed.

---

# Preventative Maintenance

## CLEANING

Hand wash all surfaces of the bed with warm water and mild detergent. Dry thoroughly. Do not steam clean or hose off the Secure II Bed. Do not immerse any part of the bed. Some of the internal parts of the bed are electric and may be damaged by exposure to water.

### CAUTION

Quaternary Germicidal Disinfectants, used as directed, and/or Chlorine Bleach products, typically 5.25% Sodium Hypochlorite in dilutions ranging between 1 part bleach to 100 parts water, and 2 parts bleach to 100 parts water are **not** considered mild detergents. **THESE PRODUCTS ARE CORROSIVE IN NATURE AND MAY CAUSE DAMAGE TO YOUR BED IF USED IMPROPERLY.** If these types of products are used to clean Stryker patient care equipment, measures must be taken to insure the beds are wiped with clean water and thoroughly dried following cleaning. Failure to properly rinse and dry the beds will leave a corrosive residue on the surface of the bed, possibly causing premature corrosion of critical components. Failure to follow the above directions when using these types of cleaners may void this product's warranty.

Clean Velcro **AFTER EACH USE**. Saturate Velcro with disinfectant and allow disinfectant to evaporate. (Appropriate disinfectant for nylon Velcro should be determined by the hospital.)

In general, when used in those concentrations recommended by the manufacturer, either phenolic type or quaternary type disinfectants can be used with Staph-Chek fabrics. Iodophor type disinfectants are not recommended for use on Staph-Chek fabrics because staining may result. The following products have been tested by the Herculite Laboratory and have been found not to have a harmful effect on Staph-Chek fabrics **WHEN USED IN ACCORDANCE WITH MANUFACTURERS RECOMMENDED DILUTION.\***

TRADE NAME	DISINFECTANT TYPE	MANUFACTURER	*MANUFACTURER'S RECOMMENDED DILUTION
A33	Quaternary	Airwick (Professional Products Division)	2 ounces/gallon
A33 (dry)	Quaternary	Airwick (Professional Products Division)	1/2 ounce/gallon
Beaucoup	Phenolic	Huntington Laboratories	1 ounce/gallon
Blue Chip	Quaternary	S.C. Johnson	2 ounces/gallon
Elimstaph	Quaternary	Walter G. Legge	1 ounce/gallon
Franklin Phenomysan F2500	Phenolic	Purex Corporation	1 1/4 ounce/gallon
Franklin Sentinel	Quaternary	Purex Corporation	2 ounces/gallon
Galahad	Phenolic	Puritan Churchill Chemical Company	1 ounce/gallon
Hi-Tor	Quaternary	Huntington Laboratories	1/2 ounce/gallon
LPH	Phenolic	Vestal Laboratories	1/2 ounce/gallon
Matar	Phenolic	Huntington Laboratories	1/2 ounce/gallon
Omega	Quaternary	Airwick (Professional Products Division)	1/2 ounce/gallon
Quanto	Quaternary	Huntington Laboratories	1 ounce/gallon
Sanikleen	Quaternary	West Chemical Products	2 ounces/ gallon
Sanimaster II	Quaternary	Service Master	1 ounce/gallon
Vesphene	Phenolic	Vestal Laboratories	1 1/4 ounce/ gallon

## REMOVAL OF IODINE COMPOUNDS

To remove iodine stains from mattress cover surfaces, use a solution of 1-2 tablespoons Sodium Thiosulfate in a pint of warm water. Clean as soon as possible after staining occurs. If stains are not immediately removed, allow solution to soak or stand on the surface.

# Preventative Maintenance

---

## CHECKLIST

- \_\_\_\_\_ All fasteners secure (reference all assembly prints)
- \_\_\_\_\_ Engage brake pedal and push on the bed to verify all casters lock securely
- \_\_\_\_\_ "Brake Not Set" LED (on foot board) blinks when brakes are not engaged
- \_\_\_\_\_ Locking steer caster engages and disengages properly
- \_\_\_\_\_ Siderails move, latch and stow properly
- \_\_\_\_\_ CPR release working properly
- \_\_\_\_\_ Foot prop intact and working properly
- \_\_\_\_\_ I.V. pole working properly
- \_\_\_\_\_ Foley bag hooks intact
- \_\_\_\_\_ Optional CPR board not cracked or damaged and stores properly
- \_\_\_\_\_ No cracks or splits in head and foot boards
- \_\_\_\_\_ No rips or cracks in mattress cover
- \_\_\_\_\_ All functions on head end siderails working properly (including LED's)
- \_\_\_\_\_ All functions on footboard working properly (including LED's)
- \_\_\_\_\_ Optional Scale and Bed Exit systems calibrated properly
- \_\_\_\_\_ Motion Interrupt switches working properly
- \_\_\_\_\_ Night light working properly
- \_\_\_\_\_ Power cord not frayed
- \_\_\_\_\_ No cables worn or pinched
- \_\_\_\_\_ All electrical connections tight
- \_\_\_\_\_ All grounds secure to the frame
- \_\_\_\_\_ Ground impedance not more than 100 milliohms
- \_\_\_\_\_ Current leakage not more than 100 microamps
- \_\_\_\_\_ Apply grease to litter grease points
- \_\_\_\_\_ Engage drive wheel and ensure it is operating properly (Zoom™ option)
- \_\_\_\_\_ Motion release switches working properly (Zoom™ option)
- \_\_\_\_\_ Confirm Head End Control Panel functionality (Zoom™ option)
- \_\_\_\_\_ Confirm battery powered functionality (Zoom™ option)

Bed Serial No. \_\_\_\_\_  
\_\_\_\_\_  
\_\_\_\_\_  
\_\_\_\_\_  
\_\_\_\_\_

Completed By: \_\_\_\_\_ Date: \_\_\_\_\_

# Static Discharge Precautions

---

The electronic circuits in the Secure II are completely protected from static electricity damage only while the bed is assembled. It is extremely important that all service personnel always use adequate static protection when servicing the electronic systems of the Secure II. *Whenever you are touching wires, you should be using static protection.*

## Static Protection Equipment

The necessary equipment for proper static protection is:

- 1 static wrist strap; 3M part number 2214 or equivalent,
- 1 grounding plug; 3M part number 61038 or equivalent,
- 1 test lead with a banana plug on one end and an alligator clip on the other; Smith part number N132B699 or equivalent.

Stryker has available the following equipment for proper static protection:

- Complete static protection system - part number 3000-000-753
- 1 grounding plug - part number 3000-000-754
- 1 static wrist strap - part number 3000-000-755
- 1 test lead - part number 3000-000-756

---

## CAUTION

All electronic service parts will be shipped in static shielding bags. Do not open the bags until you have completed steps 2 and 3 of the following procedure. Do not place unprotected circuit boards on the floor. All circuit boards to be returned to Stryker Medical should be shipped in the static shielding bags the new boards were shipped in.

## Static Protection Procedure

1. Unplug the power cord from the wall receptacle.
2. Insert the grounding plug into a properly grounded hospital grade wall receptacle. Plug the banana plug of the test lead into the receptacle on the grounding plug. Connect the alligator clip on the other end of the test lead to a ground point on the bed.
3. Place the static control wrist strap on your wrist. Connect the alligator clip at the other end of the wrist strap cord to a ground point on the bed.

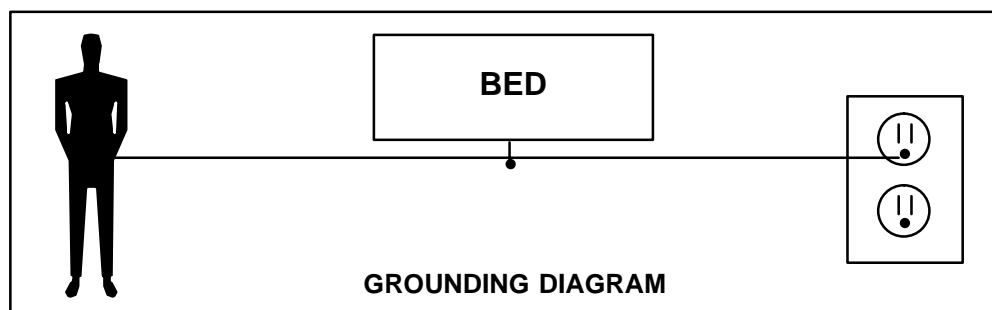

# Troubleshooting Guide

## TROUBLESHOOTING GUIDE

### DEFINITIONS:

DMM = Digital Multi-Meter

PCB = Printed Circuit Board

CPU = Central Processing Unit

### NOTE

See pages 39-47 for an outline of bed PCB's and voltage test points.

PROBLEM/FAILURE	RECOMMENDED ACTION
No power to bed	<p><b>A.</b> Unplug bed power cord and check continuity of fuses F1 and F2 with DMM.</p> <p><b>B.</b> Check for 120 VAC power at J1 on power supply. See page 41 for power supply voltage test points.</p> <p><b>C.</b> Check for DC voltages on J2 (Pins 1,2,3 &amp; 6) on power supply. See page 41 for power supply voltage test points.</p>
No bed down motion.	<p><b>A.</b> Enter diagnostics, (see page 72) and press bed down. If motion is present, re-burn lift potentiometers. Monitor Pin 3 (Red) and Pin 2 (Black) of HDR7 and HDR12 on the CPU PCB using DMM. Verify voltage changes on Pin 3 with changes in lift motion. See page 76 for voltage parameters for low and high limits.</p> <p><b>B.</b> If no down motion in diagnostic, check for 120 VAC power on HDR33 and HDR34, Pin 1 and Pin 3, of the CPU.</p> <p><b>C.</b> Check for 1.1-1.5 VDC signal on O6 and O8 Pin 1 and HDR2 Pin 5 of the CPU PCB.</p> <p><b>D.</b> Check if motion interrupt cable is connected on HDR3.</p>
No bed up motion.	<p><b>A.</b> Check 120 VAC power on HDR33 and HDR34, Pin 1 and Pin 6, of the CPU board.</p> <p><b>B.</b> Check for 1.1-1.5 VDC signal on O5 and O7 Pin 1 and HDR2 Pin 5 of the CPU PCB.</p>
No Gatch down motion.	<p><b>A.</b> Check for 120 VAC power on HDR29 Pin 1 and Pin 3 of the CPU board.</p> <p><b>B.</b> Check for 1.1-1.5 VDC signal on O3 Pin 1 and HDR2 Pin 5 of the CPU PCB.</p>
No Gatch up motion.	<p><b>A.</b> Check for 120 VAC on HDR29, Pin 1 and Pin 2 of the CPU board.</p> <p><b>B.</b> Check for 1.1-1.5 VDC on O1 Pin 1 and HDR2 Pin 5 of the CPU PCB.</p>
No Fowler down motion.	<p><b>A.</b> Check for 120 VAC power on HDR30 Pin 3 and Pin 1 of the CPU board.</p> <p><b>B.</b> Check for 1.1-1.5 VDC signal on O4 Pin 1 and HDR2 Pin 5 of the CPU PCB.</p>
No Fowler up motion.	<p><b>A.</b> Check for 120 VAC on HDR30, Pin 1 and Pin 3 of the power supply.</p> <p><b>B.</b> Check for 1.1-1.5 VDC on O2 Pin 1 and HDR2 Pin 5 of the CPU PCB.</p>

# Troubleshooting Guide

This section of the troubleshooting guide includes the Zoom™ self-propelled drive and the battery backup functions. When using this guide, assume the bed is functioning properly when powered by the AC line cord with the exception of the battery charging components.

PROBLEM/FAILURE	POSSIBLE CAUSE	RECOMMENDED ACTION
ON/OFF switch is in the on position but the power LED is off and the bed does not function.	No DC voltage from the batteries.	<b>A.</b> Check the fuse (F1) on the power supply (see page 41) - replace if necessary (p/n 59-730). <b>B.</b> Check battery + to battery - on the power board for greater than 22VDC. <b>C.</b> Verify the battery voltage is greater than 22 VDC. <b>D.</b> Check the battery fuse - replace if necessary (p/n 2040-1-802). <b>E.</b> Check the cable connections from the batteries to the display board. <b>F.</b> Check the ON/OFF switch and cabling.
ON/OFF switch is in the on position, the power LED is on but the bed does not function.	Display board is not functioning or is locking out all functions.	<b>A.</b> Check the safety switches on the drive bar. <b>B.</b> Verify the battery voltage is greater than 22 VDC. <b>C.</b> Verify the display board is functioning (see note below). <b>D.</b> Check all cable connections on the display and power boards.
ON/OFF switch is in the on position, the power LED is on, the Zoom™ drive works but the battery backup does not work.	The thermostat on the inverter/charger board has tripped, indicating a temperature above 110° C (230° F).	<b>A.</b> Wait approximately 3-5 minutes to allow the inverter/charger board to cool down.
The Zoom™ drive does not work - the bed does not drive - but all other functions are working.	Zoom drive circuitry is not responding.	<b>A.</b> Verify the display board is functioning (see note below). <b>B.</b> Perform the control bar potentiometer "burn-in" procedure (see page 79). <b>C.</b> Check the control bar potentiometer. When the bar is centered, there should be 2.25VDC - 2.75 VDC between pin 1 and pin 2 on header 1 on the display/CPU board (see page 44) <b>D.</b> Check all cable connections on the display and power boards. <b>E.</b> Verify the power board is functioning. <b>F.</b> Verify the drive wheel is functioning.
The Zoom drive does work - the bed will drive - but all other bed functions are not working.	No AC power from the Zoom base.	<b>A.</b> Check AC voltage coming out of the inverter. It should be 120VAC between pin 1 and pin 4 on header 5 on the AC crossover board (see page 43) <b>B.</b> Check all cable connections from the batteries to the converter. <b>C.</b> Check the AC crossover board.
The bed power cord is plugged in but the battery does not charge.	The battery charger is not functioning.	<b>A.</b> Check the circuit breakers on the litter. <b>B.</b> Check the battery charger. <b>C.</b> Check all cable connections on the charger.

## NOTE

The display board will display the state of battery charge when the bed is first powered using the ON/OFF switch:

Three LED's flash = 66% - 100% charged

Two LED's flash = 33% - 66% charged

One LED flashes = less than 33% charged

No LED's flash = No significant charge remaining.

# Bed Circuit Boards

## CPU BOARD

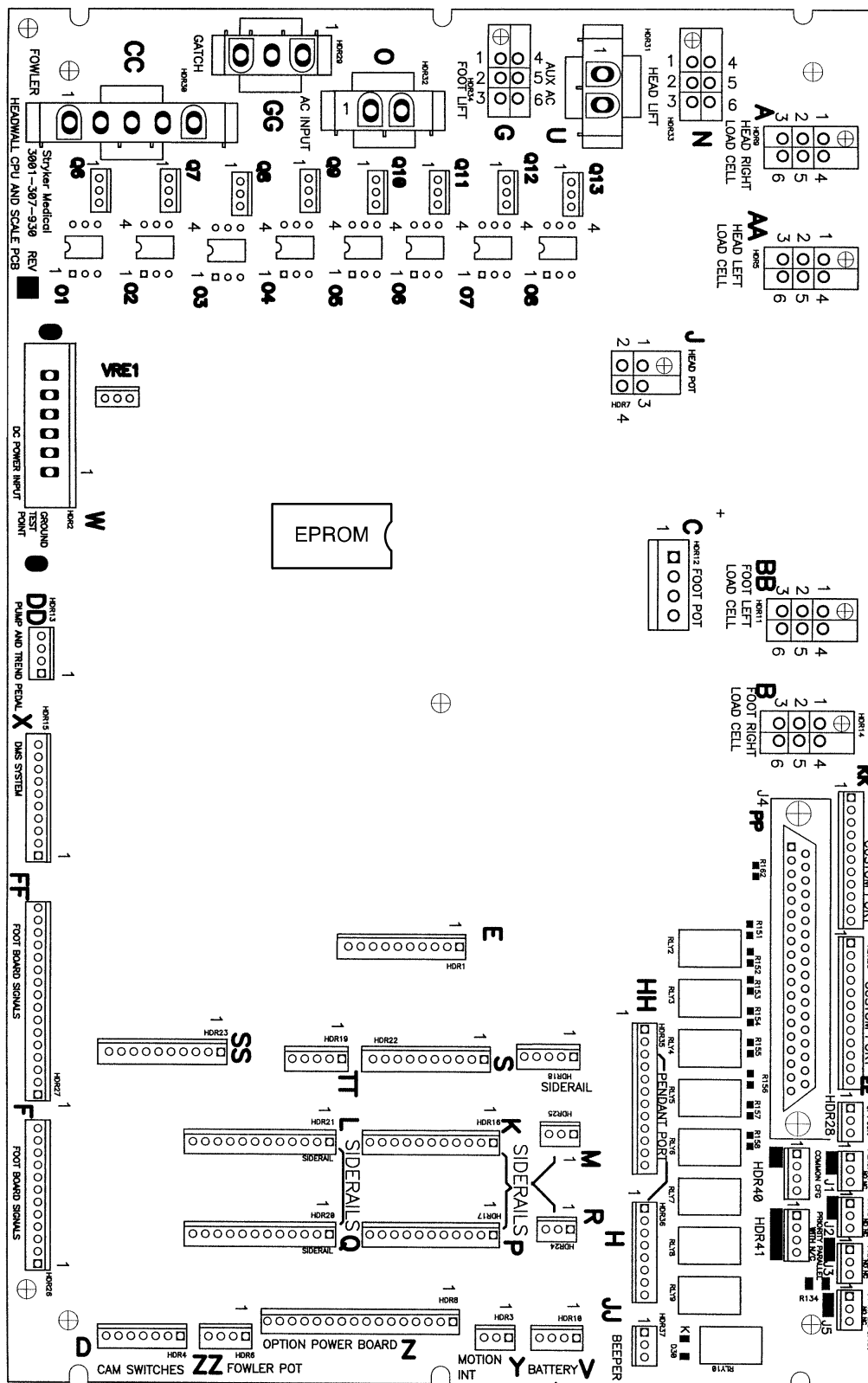

59-137  
Shunt for  
No Nurse Call



# Bed Circuit Boards

---

- CPU KIT (NO OPTIONS/NO ZOOM) - 3002-700-001**  
**CPU KIT (COMMUNICATIONS ONLY/NO ZOOM) - 3002-700-002**  
**CPU KIT (STANDARD BED EXIT AND/OR SCALE NO ZOOM) - 3002-700-003**  
**CPU KIT (ZONE BED EXIT AND/OR SCALE NO ZOOM) - 3002-700-004**  
**CPU KIT (NO OPTIONS W/ZOOM) - 3002-700-005**  
**CPU KIT (COMMUNICATIONS ONLY W/ZOOM) - 3002-700-006**  
**CPU KIT (STANDARD BED EXIT AND/OR SCALE WITH ZOOM) - 3002-700-007**  
**CPU KIT (ZONE BED EXIT AND/OR SCALE WITH ZOOM) - 3002-700-008**  
**CPU KIT (SHORT BED, BED EXIT AND/OR SCALE WITH ZOOM) - 3002-700-28**  
**CPU KIT (SHORT BED, ZONE BED EXIT AND/OR SCALE WITH ZOOM) - 3002-700-29**  
**CPU KIT (SHORT BED, NO OPTIONS WITH ZOOM) - 3002-700-30**

CONNECTOR LOCATION	CABLE LOCATION	VOLTAGE	POSITIVE LEAD	NEGATIVE LEAD	DESCRIPTION
HDR 2	W	+12 VDC	Pin 1	Pin 4 or 5	Relays & Siderails Light Voltage
HDR 2	W	+5 VDC	Pin 2 & 3	Pin 4 or 5	+5 VDC from Power Supply
HDR 2	W	-12 VDC	Pin 6	Pin 4 or 5	Relays & Siderails Light Voltage
HDR 7	J	0 - 5 VDC	Pin 3	Pin 2	Head Lift Pot Wiper
HDR 7	J	+5 VDC	Pin 4	Pin 2	+5 VDC for Head Lift Pot
HDR 12	C	+5 VDC	Pin 1	Pin 2	+5 VDC for Foot Lift Pot
HDR 12	C	0 - 5 VDC	Pin 3	Pin 2	Foot Lift Pot Wiper
HDR 29	GG	0 VAC w/o Switch 110 VAC w/Switch	Neutral Pin 1	Pin 2	Gatch Up
HDR 29	GG	0 VAC w/o Switch 110 VAC w/Switch	Neutral Pin 1	Pin 3	Gatch Down
HDR 30	CC	0 VAC w/o Switch 160 VAC w/Switch	Neutral Pin 3	Pin 1	Fowler Up
HDR 30	CC	0 VAC w/o Switch 120 VAC w/Switch	Neutral Pin 3	Pin 2	Fowler Down
HDR 32	O	110 VAC	Pin 1	Pin 2	Line Voltage to Bed
HDR 33	N	0 VAC w/o Switch 120 VAC w/Switch	Neutral Pin 1 or 4	Pin 3	Head Lift Down
HDR 33	N	0 VAC w/o Switch 120 VAC w/Switch	Neutral Pin 1 or 4	Pin 6	Head Lift Up
HDR 34	G	0 VAC w/o Switch 120 VAC w/Switch	Neutral Pin 1 or 4	Pin 3	Foot Lift Down
HDR 34	G	0 VAC w/o Switch 120 VAC w/Switch	Neutral Pin 1 or 4	Pin 6	Foot Lift Up

# Bed Circuit Boards

## POWER SUPPLY - P/N 59-157

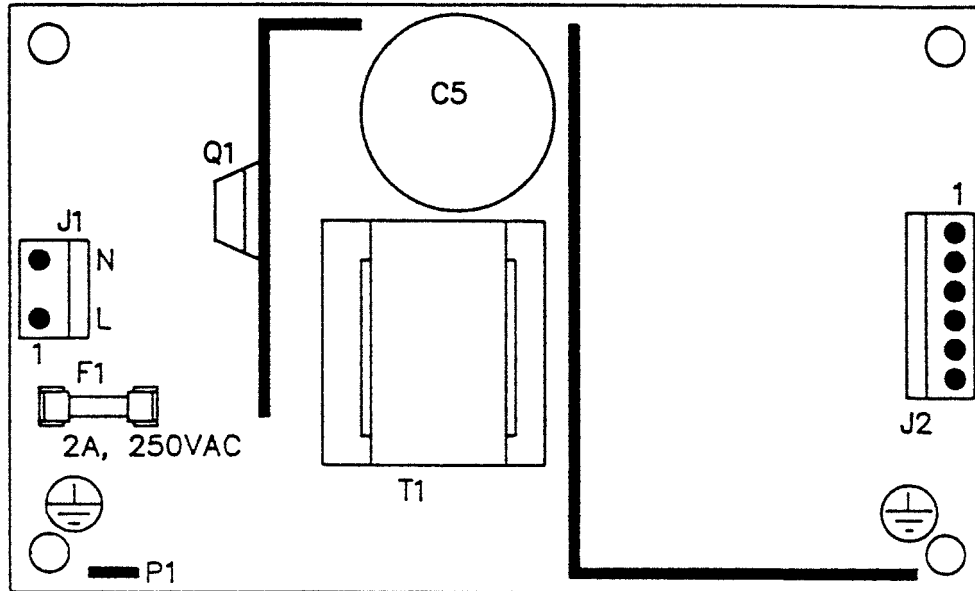

CONNECTOR LOCATION	VOLTAGE	POSITIVE LEAD	NEGATIVE LEAD
J1	110V	Pin 1	Pin 2
J2	12V	Pin 1	Pin 4 or 5
J2	5V	Pin 2	Pin 4 or 5
J2	5V	Pin 3	Pin 4 or 5
J2	GND	Pin 4	Pin 4 or 5
J2	GND	Pin 5	Pin 4 or 5
J2	-12V	Pin 6	Pin 4 or 5

# Bed Circuit Boards

## ZOOM OPTION INVERTER/CHARGER BOARD - PART NUMBER 3002-1-920

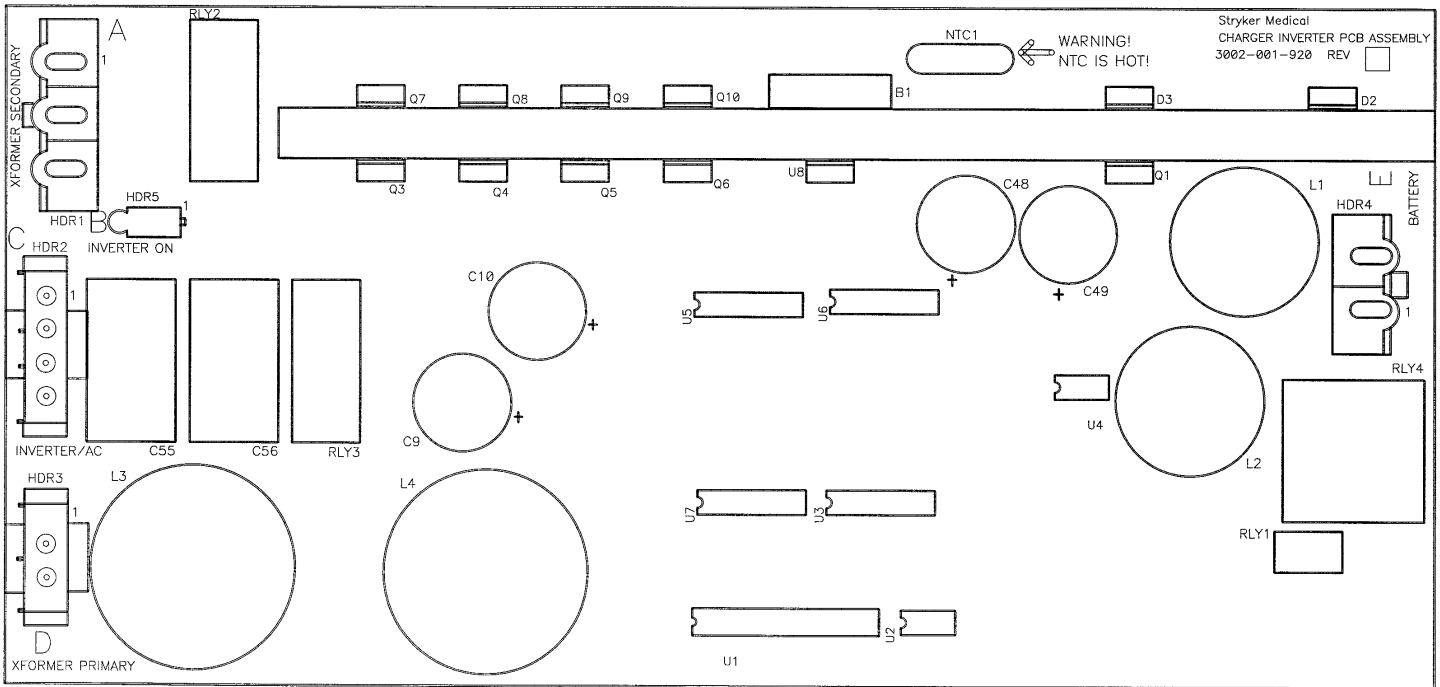

CONNECTOR LOCATION	NEGATIVE LEAD	POSITIVE LEAD	VOLTAGE	DESCRIPTION
HDR 4	Pin 1	Pin 2	24 VDC	From Battery
HDR 1	Plug-In Pin 2	Pin 3	22 VAC	Secondaries from Transfer
HDR 1	Plug-In Pin 2	Pin 1	34 VAC	Secondaries from Transfer
HDR 2	Inverter Module Pin 3	Pin 4	110-140 VAC	
HDR 2	Plug-In Pin 1	Pin 2	110 V	From Wall
HDR 3	Plug-In Pin 1	Pin 2	120 V	Wall Voltage

# Bed Circuit Boards

## ZOOM OPTION AC CROSSOVER BOARD - P/N 2040-31-900

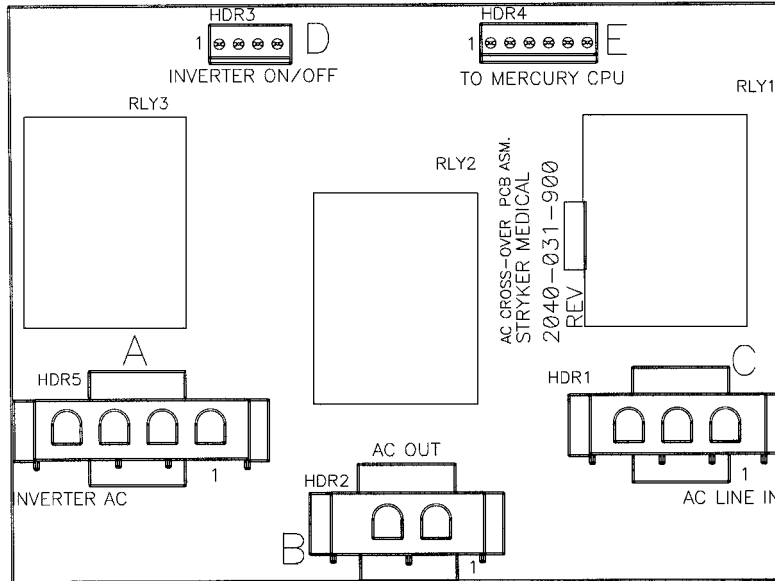

CONNECTOR LOCATION	VOLTAGE	POSITIVE LEAD	NEGATIVE LEAD	DESCRIPTION
HDR 5 (A)	120VAC	Pin 4	Pin 1	AC Input to Board from the Inverter with the Power Cord Unplugged
HDR 1 (C)	120VAC	Pin 3	Pin 1	AC Input to Board from the Wall Receptacle
HDR 2 (B)	120VAC	Pin 2	Pin 1	AC Output of Board to Main Power
HDR 4 (E)	+5VDC	Pin 4	Pin 1	+5VDC when AC is Unplugged from the Wall Receptacle
HDR 3 (D)	Continuity	Pin 3	Pin 1	Relay Contacts. Closed when Power Cord is Unplugged. Turns on the Inverter

# Bed Circuit Boards

## ZOOM OPTION DISPLAY/CPU - P/N 2040-31-910

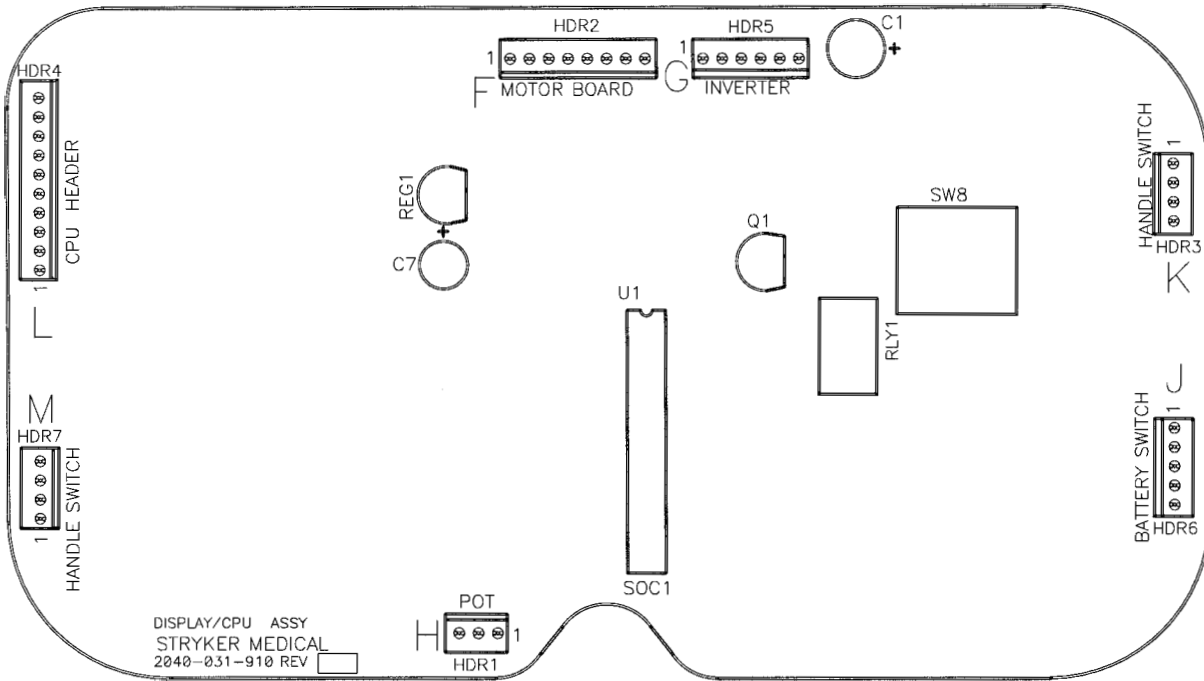

CONNECTOR LOCATION	VOLTAGE	POSITIVE LEAD	NEGATIVE LEAD	DESCRIPTION
HDR 4 (L)	Battery voltage around 24VDC	Pin 3	Pin 1	Battery Voltage into the Display/CPU Board
HDR 1 (H)	0-5VDC	Pin 2	Pin 1	Control Pot Wiper Voltage
HDR 6 (J)	Battery voltage around 24VDC	Pin 1	Pin 5	Battery Voltage Return from On/Off Switch

# Bed Circuit Boards

## OPTIONAL BED EXIT BOARD - PART NUMBER 3002-508-900

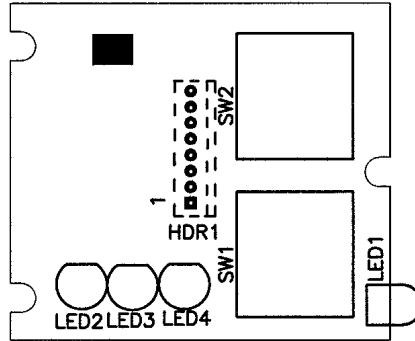

CONNECTOR LOCATION	NEGATIVE LEAD	POSITIVE LEAD	VOLTAGE	DESCRIPTION
HDR 1	Main Keypad HDR 2, Pin 3	Pin 8	5 VDC	LED Supply Voltage

# Bed Circuit Boards

## OPTIONAL NIGHT LIGHT BOARD - PART NUMBER 3002-310-900

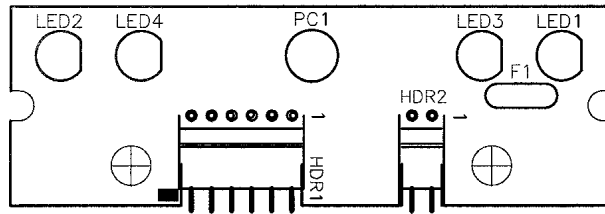

CONNECTOR LOCATION	NEGATIVE LEAD	POSITIVE LEAD	VOLTAGE	DESCRIPTION
HDR 2	Pin 1	Pin 2	5 VDC	Supply IN
HDR 1	Pin 1 HDR 2	Pin 2 Pin 4	5 VDC	Output Voltage for Optional LED's

# Bed Circuit Boards

## OPTIONAL SMART TV CIRCUIT BOARD - P/N 3001-330-960

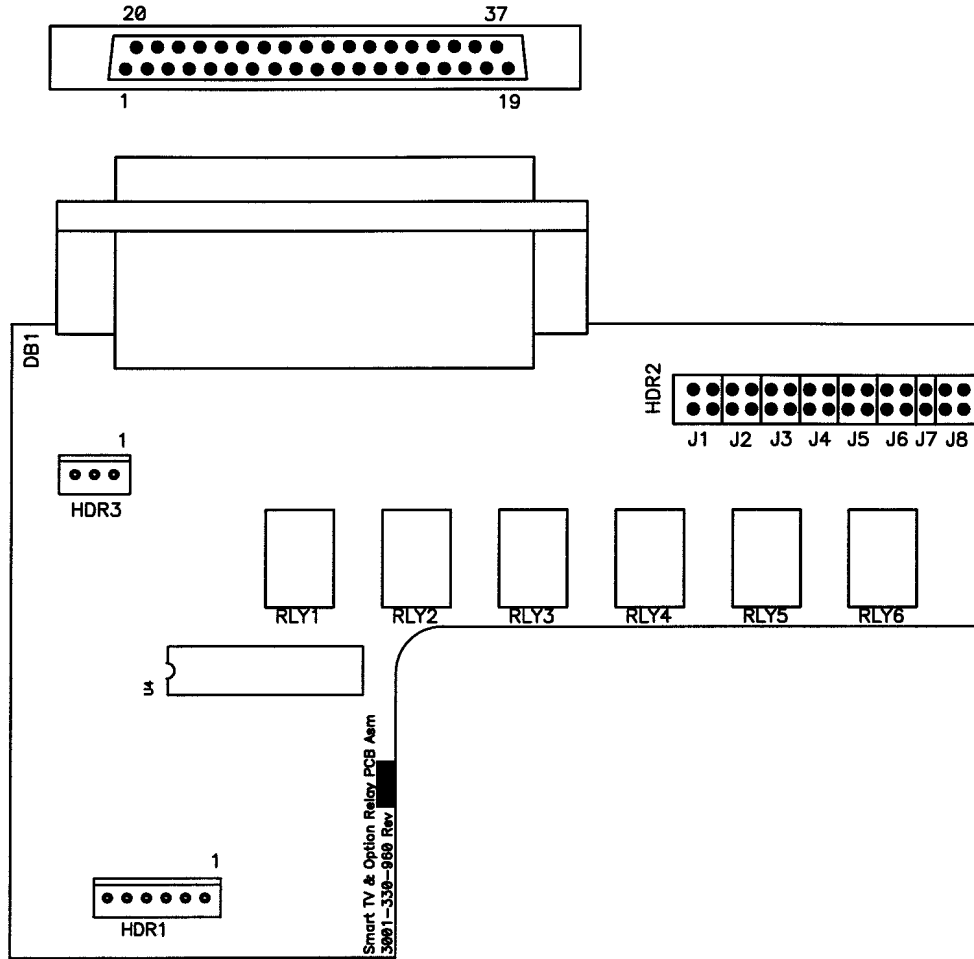

CONNECTOR LOCATION	VOLTAGE	POSITIVE LEAD	NEGATIVE LEAD	DESCRIPTION
HDR 1	5 VDC	Pin 2	Pin 1	Regulated 5 VDC Power to the board
HDR 1	Digital Control	Pin 3-5	Pin 1	Serial control lines
HDR 1	5 VDC	Pin 6	Pin 1	5 VDC for option relay
HDR 3	+5 or +12 VDC	2	Pin 1	Power/control line from the TV Note: This header provides TV control to a non-Stryker pendant
DB1	+5 or +12 VDC	Pin 34	Pin 33	Power/Control line from the TV Note: If this polarity is reversed, place the shunts of J8 in the alternate position



# 3001-303-165 Optional Bed Communucations Tester

---

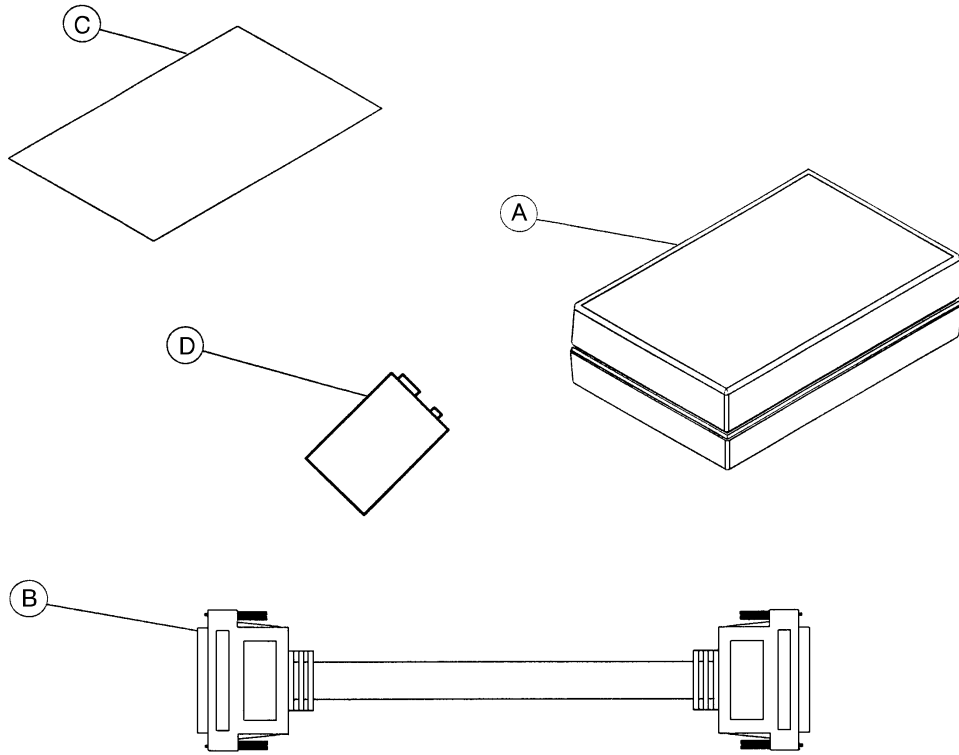

Item	Part No.	Part Name	Qty.
A	3001-303-160	BCT Unit	1
B	3001-303-825	37-Pin Cable	1
C	3001-303-162	Instructions	1
D	3000-303-871	9V Battery	1

# Head Wall Output Configuration

## 37-PIN CONNECTOR

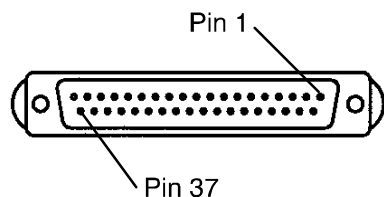

Pin 1	Option 2 Common
Pin 2	Read Light
Pin 3	Room Light
Pin 4	Speaker High
Pin 5	Pot Wiper
Pin 6	Radio Common
Pin 7	Nurse Call Interlock
Pin 8	Audio Transfer -
Pin 9	Audio Transfer +
Pin 10	Interlock +
Pin 11	Interlock -
Pin 12	Spare
Pin 13	Options 3 Common
Pin 14	Pot Low Common
Pin 15	Pot High Common (Std.)/Audio (STV)
Pin 16	Nurse Answer Light +
Pin 17	Option 1 NO/NC
Pin 18	Option 1 Common
Pin 19	Nurse Call Light +
Pin 20	Option 2 NO/NC
Pin 21	Option 3 NO/NC
Pin 22	Option 3A NO/NC
Pin 23	Option 2A Common
Pin 24	Option 2A NO/NC
Pin 25	Nurse Call +
Pin 26	Nurse Call NO/NC
Pin 27	Room/Read Light Common
Pin 28	Nurse Call Light -
Pin 29	Nurse Answer Light -
Pin 30	Priority NO/NC
Pin 31	Priority Common
Pin 32	Option 3A Common
Pin 33	TV - (Std.)/Data (STV)
Pin 34	TV + (Std.)/Common (STV)
Pin 35	Speaker Low Common
Pin 36	Audio Shield
Pin 37	Radio NO/NC

## STRYKER PENDANT PORT

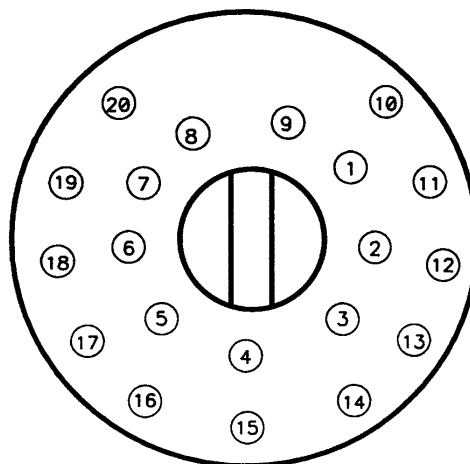

1	Scan Line
2	Audio (-)
3	Nurse Call (+)
4	+5 VDC
5	Scan Line
6	Scan Line
7	Nurse Call (-)
8	TV Channel Up
9	Backlight
10	Audio (+)
11	Gatch Up/Fowler In/Foot Up/DMS Firm
12	Gatch Down/Fowler Out/Foot Out/DMS Soft
13	Fowler Up/Trend In
14	Fowler Down/Trend Out
15	Audio Shield
16	Not Used - Socket Filled
17	Bed Up
18	Ground
19	Read Light/Bed Down
20	Room Light

# CPU/Headwall Jumper Locations

---

Jumper Locations	Default	Alternate
J5 - Pot. Wiper/Speaker	Pin 4 - Speaker High to Pin 5 Pot. Wiper	
J3 - Priority	Pin 30 - Priority No Nurse Call to Pin 31 Priority Common	
J2 - Nurse Call	Pin 25 - Nurse Call	
J1 - Pendant		
HDR 41 - Priority Parallel with Nurse Call	Pin 25 - Nurse Call+ to Pin 31 Priority Common & Pin 26 - Nurse Call No Nurse Call to Pin 30 Priority No Nurse Call	<b>Double Shunt</b> - Pin 33 - TV to Pin 35 - Speaker Low Common and Pin 14 - Pot Low Common
		<b>No Shunts</b> - Separates Pin 33, Pin 35 & Pin 14

# Notes

---

# Zoom Option Inverter Protection Features

---

The inverter has several features to prevent internal damage:

1. Low Battery Voltage - If the battery voltage at the inverter drops below the low voltage cut-off, the inverter will shut off.
2. Over-Temperature - If the inverter gets too hot, it will shut off. The overheating may be caused by high ambient temperature, blocked air flow or an overload condition. When the inverter reaches an acceptable temperature, it will restart.
3. Over-Power - The inverter will source up to its maximum power rating. If the load requires more, the output voltage will shut down. Turning the power switch off and on will reset the inverter. Plugging the bed power cord into the wall socket to charge the battery will reset the inverter.



## **WARNING**

The inverter generates 115VAC, the same as a wall receptacle. To prevent injury, do not put anything into the electrical outlets other than an appliance power cord. Keep the outlets covered when not in use. Do not submerge the unit or subject it to moisture.

---

# Replacement Parts List

---

## **ELECTRICAL COMPONENTS**

FOOT BOARD KEYBOARD (S/R LIGHTS, LOCKOUTS, ETC.)	3001-500-028
FOOT BOARD SCALE DISPLAY	3002-507-900
FOOT BOARD SCALE KEYBOARD	3002-507-910
FOOT BOARD BED EXIT KEYBOARD	3001-508-900
CPU KIT (NO OPTIONS/NO ZOOM)	3002-700-001
CPU KIT (COMMUNICATIONS ONLY/NO ZOOM)	3002-700-002
CPU KIT (BED EXIT AND/OR SCALE/NO ZOOM)	3002-700-003
CPU KIT (ZONE BED EXIT AND/OR SCALE NO ZOOM)	3002-700-004
CPU KIT (NO OPTIONS W/ZOOM)	3002-700-005
CPU KIT (COMMUNICATIONS ONLY W/ZOOM)	3002-700-006
CPU KIT (BED EXIT AND/OR SCALE W/ZOOM)	3002-700-007
CPU KIT (ZONE BED EXIT AND/OR SCALE W/ZOOM)	3002-700-008
CPU KIT (SHORT BED, BED EXIT AND/OR SCALE W/ZOOM)	3002-700-028
CPU KIT (SHORT BED, ZONE BED EXIT AND/OR SCALE W/ZOOM)	3002-700-029
CPU KIT (SHORT BED, NO OPTIONS W/ZOOM)	3002-700-030
POWER SUPPLY	59-157
SIDERAIL BOARD, INSIDE	3001-400-930
SIDERAIL BOARD, OUTSIDE	3001-400-910
SIDERAIL SPEAKER W/CABLE	3000-403-831
SMART TV CIRCUIT BOARD	3001-330-960
NIGHT LIGHT CIRCUIT BOARD	3002-310-900

## **OTHER COMPONENTS**

CAPACITOR, FOWLER	59-780
CAPACITOR, FOWLER, 230V	3221-300-453
CAPACITOR, GATCH	59-779
CAPACITOR, GATCH, 230V	59-153
CAPACITOR, LIFT	59-778
CAPACITOR, LIFT, 230V	3221-200-243
CASTER, 6"	3001-200-60
CASTER, STEER, 6"	3001-200-50
CASTER, 8", OPTIONAL	3001-200-90
CASTER, STEER, 8", OPTIONAL	3001-200-80
COIL CORD, LIFT POWER	3001-200-824
COIL CORD, LIFT SENSOR	3001-200-815
COIL CORD, LITTER POWER	3001-300-844
COIL CORD, LITTER SIGNAL	3001-300-846
FOWLER BRAKE KIT	3001-300-775
LOAD CELL	3001-307-57
MOTOR COUPLER KIT, LIFT	3000-200-725
MOTOR, FOWLER W/CLUTCH	3001-300-705
MOTOR, FOWLER W/CLUTCH, SHORT BED	3001-342-705
MOTOR, FOWLER W/CLUTCH, 230V	3221-300-705
MOTOR, GATCH	2025-232-70
MOTOR, GATCH, 230V	2026-232-70
MOTOR, LIFT (SAME FOR HEAD AND FOOT END)	3000-200-213
MOTOR, LIFT, 230V (SAME FOR HEAD AND FOOT END)	3221-200-213

# Replacement Parts List

---

## **OTHER COMPONENTS (CONTINUED)**

PADDED SIDERAIL COVER, HEAD, RIGHT	3000-336-1 1
PADDED SIDERAIL COVER, FOOT, LEFT	3000-336-14
PADDED SIDERAIL COVER, FOOT, RIGHT	3000-336-13
PADDED SIDERAIL COVER, HEAD, LEFT	3000-336-12
PADDED SIDERAIL COVERS, SET OF ALL FOUR	3000-336-701
PAINT, TOUCH-UP, OPAL, BOTTLE W/BRUSH	7000-1-321
PAINT, TOUCH-UP, OPAL, SPRAY CAN	7000-1-318
POTENTIOMETER, FOOT END	3001-200-230
POTENTIOMETER, HEAD END	3001-200-240
POWER CORD	39-254
SINGLE TUBE OF GREASE	3000-200-700
HEAD/FOOT BOARD "C" BUMPER ADHESIVE	72-2-71

## **KITS**

ADD SCALE & BED EXIT TO A STANDARD BED	3002-700-10
ADD SCALE & ZONE BED EXIT TO A STANDARD BED	3002-700-1 1
ADD SCALE TO A STANDARD BED	3002-700-12
ADD BED EXIT TO A STANDARD BED	3002-700-13
ADD ZONE BED EXIT TO A STANDARD BED	3002-700-14
ADD SCALE TO A BED EXIT BED	3002-700-15
ADD SCALE TO A ZONE BED EXIT BED	3002-700-16
ADD BED EXIT TO A SCALE BED	3002-700-17
ADD ZONE BED EXIT TO A SCALE BED	3002-700-18

## **ZOOM OPTION COMPONENTS**

BATTERY TRAY ASSEMBLY	3002-1-15
DRIVE POTENTIOMETER WITH CABLE	2040-31-804
DRIVE WHEEL MOTOR	3002-1-72
ON/OFF SWITCH	59-191
TRANSFORMER	3002-1-10
ZOOM INVERTER BOARD	3002-1-930
ZOOM DISPLAY/CPU BOARD	2040-31-910
ZOOM AC CROSSOVER BOARD	2040-31-900

## **KITS**

ADD SCALE & BED EXIT TO A STANDARD BED WITH ZOOM	3002-700-19
ADD SCALE & ZONE BED EXIT TO A STANDARD BED WITH ZOOM	3002-700-20
ADD SCALE TO A STANDARD BED WITH ZOOM	3002-700-21
ADD BED EXIT TO A STANDARD BED WITH ZOOM	3002-700-22
ADD ZONE BED EXIT TO A STANDARD BED WITH ZOOM	3002-700-23
ADD SCALE TO A BED EXIT ZOOM BED	3002-700-24
ADD SCALE TO A ZONE BED EXIT ZOOM BED	3002-700-25
ADD BED EXIT TO A SCALE ZOOM BED	3002-700-26
ADD ZONE BED EXIT TO A SCALE ZOOM BED	3002-700-27

# Maintenance Procedures - Base

---

## BRAKE PEDAL REPLACEMENT

### Required Tools:

5/16" Hex Allen Wrench  
Hammer

Torque Wrench  
Punch

Loctite 242  
#2 Phillips Screwdriver

### Procedure:

4. Unplug the bed power cord from the wall socket.
5. Using a #2 Phillips screwdriver, remove the three screws holding both the head end and the foot end upper lift covers. If desired, hold the covers out of the way by using bungee cords (or the equivalent) to secure them to the litter top.
6. Using a 5/16" hex Allen wrench, remove the two bolts holding the brake pedal to the brake rod.
7. Using a hammer and punch, remove the roll pins holding the brake shaft crank to the brake rod on both the head and the foot end.
8. Push the brake rod through the frame until the brake pedal is clear. Remove the brake pedal.
9. Reverse the above steps to attach the new brake pedal.

### NOTE

Use Loctite 242 when reinstalling the bolts and torque the bolts to 25 foot-pounds.



# Maintenance Procedures - Base

## LIFT MOTOR AND CAPACITOR REMOVAL AND REPLACEMENT

### Required Tools:

3/8" Socket Wrench  
Side Cutters

5/16" Socket Wrench  
Bungee Cord (or equivalent)

#2 Phillips Screwdriver

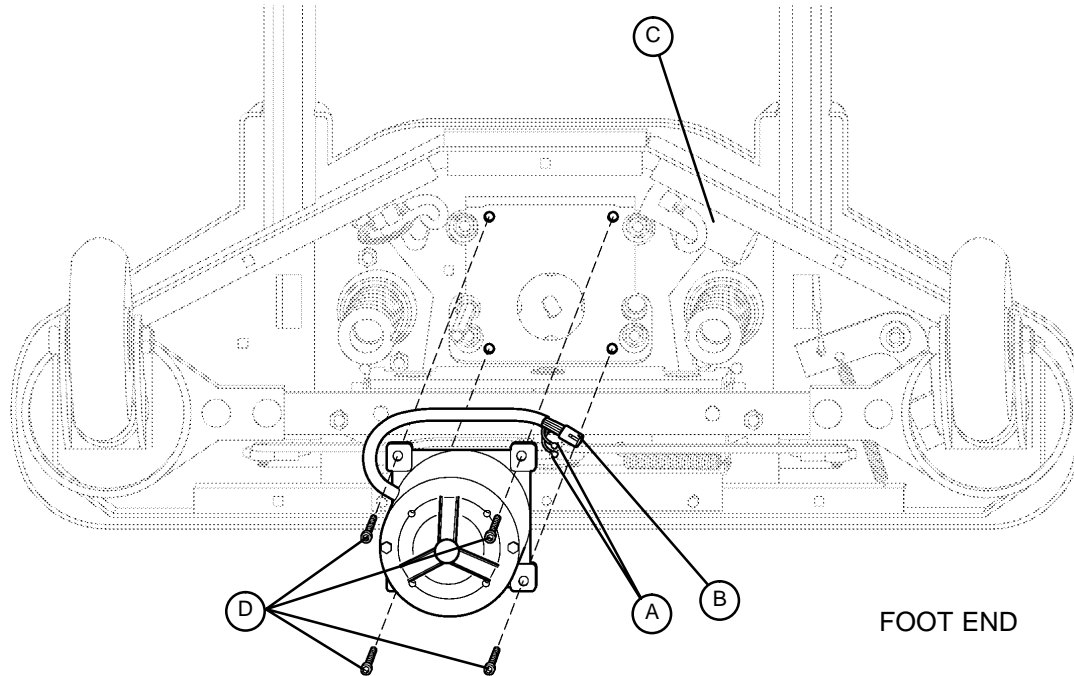

### Procedure:

1. Unplug the bed power cord from the wall socket. Using a 5/16" socket wrench, remove the five bolts holding the lower lift cover to the base and remove the cover.
2. Using a #2 Phillips screwdriver, remove the three screws holding the upper lift cover to the base.
3. Disconnect the two connectors (A) at the motor capacitor.
4. Disconnect the white connector (B) from the power cord.
5. Using side cutters, cut the cable ties holding the capacitor (C) to the base and remove the capacitor.
6. Using a 3/8" socket wrench, remove the four screws (D) holding the motor assembly in the lift housing and remove the motor assembly.
7. Reverse the above steps to install the new motor.

### NOTE

The drive shaft on the new motor probably will have to be turned to be aligned with the coupler. Use a 7/16" open end wrench to turn the drive shaft of the motor.

The procedure for lift motor and capacitor removal and replacement is the same for both ends of the bed.

# Maintenance Procedures - Base

## LIFT MOTOR ISOLATION PLATE REPLACEMENT

### Required Tools:

7/16" Open End Wrench

5/16" Nut Driver or 5/16" Socket Wrench

3/8" Socket Wrench (w/6" ext.)

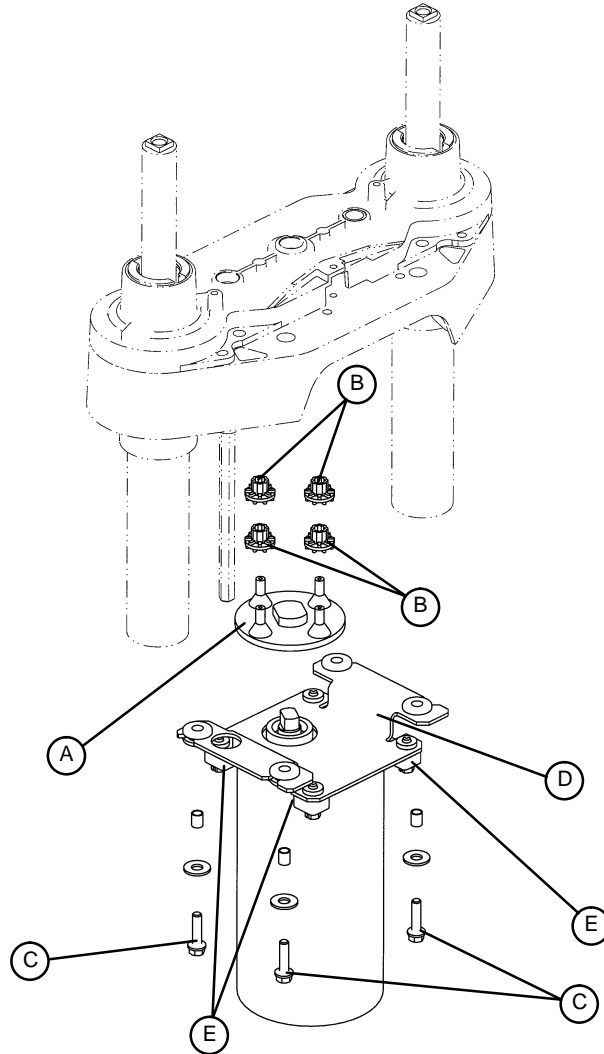

### Procedure:

1. Unplug the bed power cord from the wall socket.
2. Using a 5/16" socket wrench, remove the five bolts securing the lower lift cover and remove the cover.
3. Using a 3/8" socket with a 6" extension, remove the four bolts (C) holding the lift motor isolation plate to the lift housing and carefully lower the isolation plate to the floor.
4. Remove the motor coupler (A) and bushings (B).
5. Using a 3/8" socket, remove the bolts and washers (E) from the motor and remove the isolation plate (D).
6. Reverse the above steps to install the new isolation plate and reattach all components to the bed.

### NOTE

When reinstalling the lift motor, the drive shaft on the motor will have to be turned to be aligned with the coupler. Use a 7/16" open end wrench to turn the drive shaft of the motor.

# Maintenance Procedures - Base

---

## LIFT HOUSING REMOVAL AND REPLACEMENT

### Required Tools:

#2 Phillips Screwdriver	Bungee Cord (or equivalent)	5/16" Socket Wrench
Side Cutters	9/16" Socket Wrench	5/16" Nut Driver
7/32" Hex Allen Socket Wrench	Sawhorses (or equivalent)	T27 Torx
3/8" Socket Wrench (w/ approx. 6" extension)		

### Procedure:

1. Unplug the bed power cord from the wall socket.
2. Using a 5/16" socket wrench, remove the five bolts holding the lower lift cover to the base and remove the cover.
3. Using a #2 Phillips screwdriver, remove the three screws holding the upper lift cover to the base.
4. If you are working on the foot end of the bed, use a T27 Torx to remove the screw holding the litter access panel to the litter.
5. Remove the lift motor and capacitor (refer to procedure on page 54).
6. Remove lift potentiometer (refer to procedure on page 58).
7. Using a 5/16" socket wrench, remove the cable clamps holding the power and sensor coil cords on top of the lift housing assembly. Cut the cable ties and disconnect the coil cords from under the lift housing. The power and sensor coil cords are now free of the lift housing assembly. Drape them up out of the way.
8. Using a 7/32" hex Allen socket, remove the two screws (A) holding the lift screws to the header crossbar plate.

---

### CAUTION

The bed litter retracts on rollers. Secure it to prevent it from rolling while the procedure is being done.

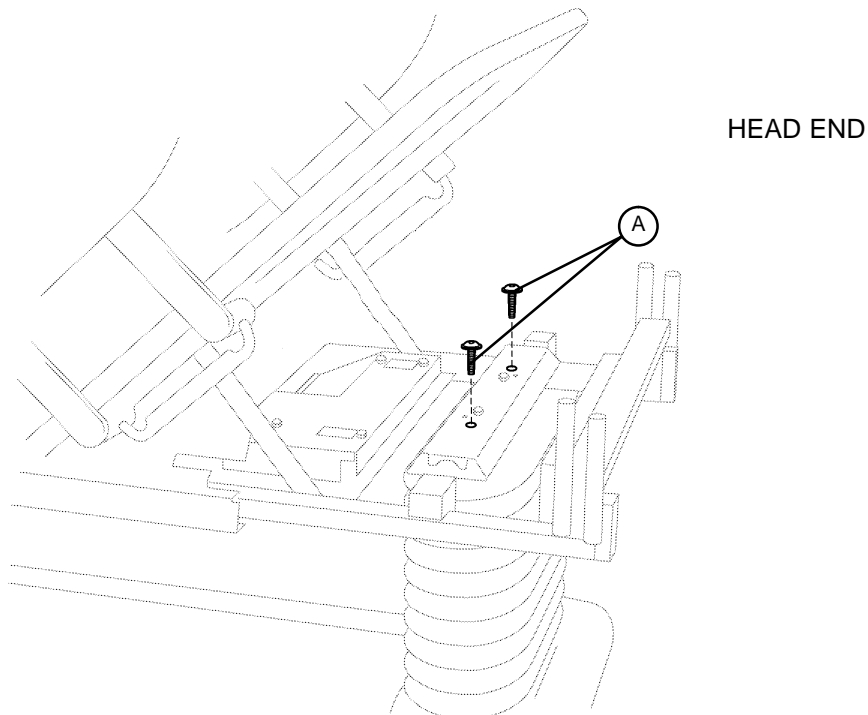

# Maintenance Procedures - Base

---

## LIFT HOUSING REMOVAL AND REPLACEMENT (CONTINUED)

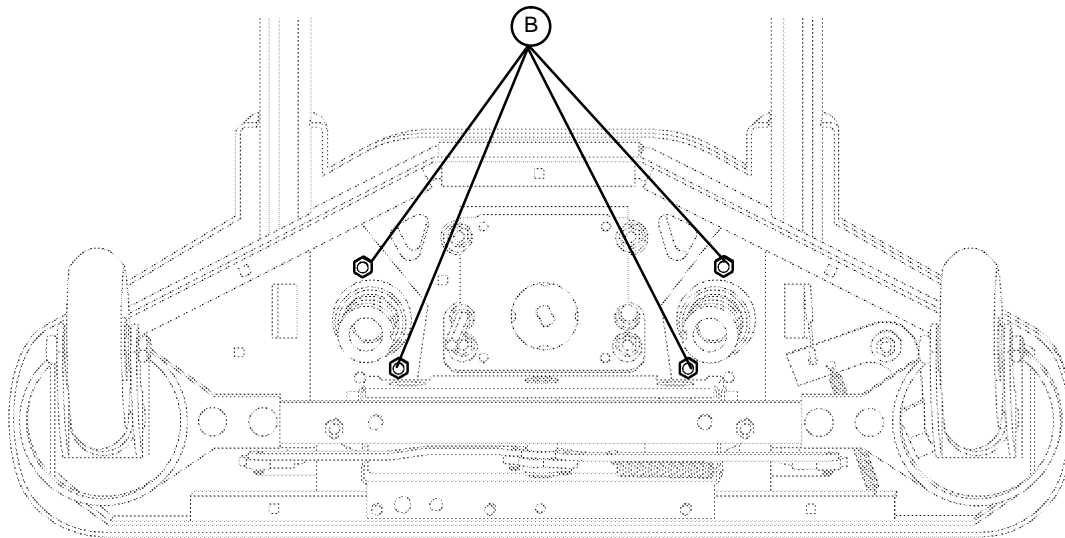

FOOT END - BOTTOM VIEW

9. Lift the litter top up and support it about 6" above the lift screws with sawhorses or the equivalent.
10. Under the base, using a 9/16" socket, remove the four nuts (B) holding the lift housing to the base.
11. Lift up and out on the lift housing assembly to remove it from the base.

---

### CAUTION

See pages 61 and 62 for proper reattachment procedure for power and sensor coil cords and page 58 for reattachment of the lift potentiometer .

12. Reverse the above steps to reinstall the lift housing assembly after service is completed.

### NOTE

The procedure for lift housing removal and replacement is the same for both ends of the bed.

# Maintenance Procedures - Base

---

## LIFT POTENTIOMETER REPLACEMENT AND ADJUSTMENT

### Required Tools:

#2 Phillips Screwdriver  
3/8" Open End Wrench

Bungee Cord (or equivalent)  
Side Cutters

5/16" Socket Wrench

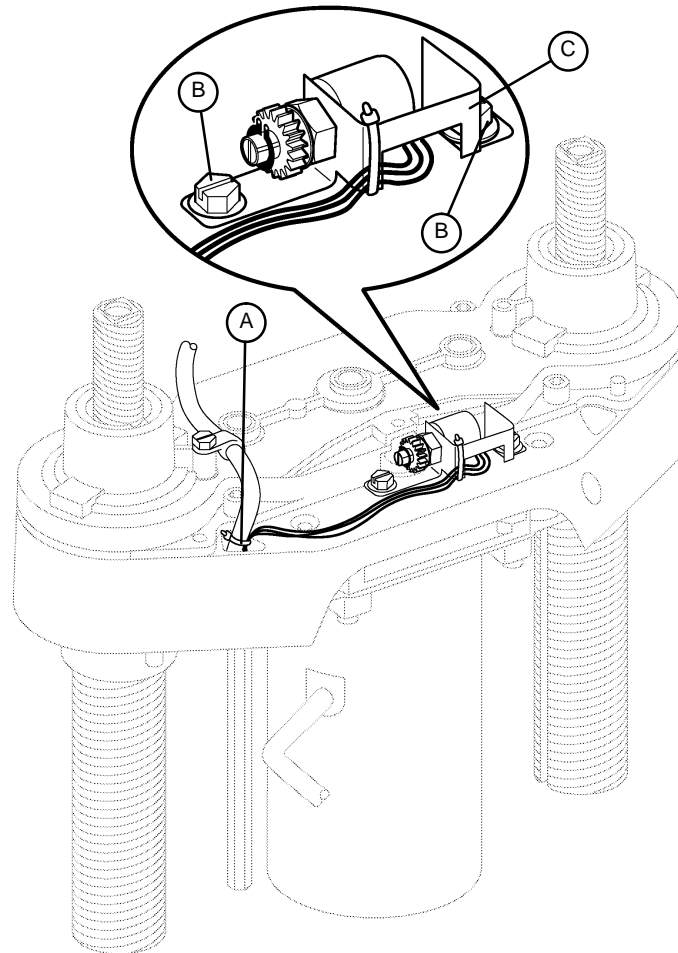

### Procedure:

1. Unplug the bed power cord from the wall socket.
2. Using a 5/16" socket wrench, remove the five bolts holding the lower lift cover to the base and remove the cover.
3. Using a #2 Phillips screwdriver, remove the three screws holding the upper lift cover to the base.
4. Using side cutters, cut the cable tie (A) holding the pot cable to the coil cord.
5. Unplug the pot cable from the sensor coil cord. If replacing a pot at the head end of the bed, unplug the cables attached to the brake sensor switch.
6. Pull the pot cable up through the base.
7. Using a 3/8" open end wrench, remove the two bolts (B) holding the pot housing (C) to the lift housing.

# Maintenance Procedures - Base

---

## LIFT POTENTIOMETER REPLACEMENT AND ADJUSTMENT (CONTINUED)

8. Lift up and out on the pot housing assembly to remove it from the lift housing.
9. Before installing the new pot on the bed, turn it clockwise until it stops. Turn it back counterclockwise two full (360°) revolutions. This allows a "window" position for proper upper and lower limits.
10. Reverse steps 4-8 to install the new pot and pot housing assembly.
11. After installing the new pot, the "burn-in" procedure below must be followed.

### NOTE

Be sure to maintain the pot position while installing.

## LIFT POTENTIOMETER "BURN-IN" PROCEDURE

1. Unplug the bed power cord from the wall socket.
2. On the foot board control panel, hold down the Siderail Control Lights, Head Lock Out, and Up/Down Lock Out buttons simultaneously.
3. While holding down the above three buttons, plug the power cord into the wall socket. The Lights button on the foot board control panel should flash, indicating the bed is in the diagnostics mode.
4. On a bed **without** the Zoom power drive option, run both ends of the bed *full down* to a "hard stop". On a bed **with** the Zoom option, run both ends of the bed *full up* to a "hard stop".
5. Hold down the Bed Motion Lock button until the light flashes.
6. Release the button and unplug the power cord from the wall socket.
7. Plug the power cord back in to the wall socket. Run the bed to full up, then full down to verify the bed limits.
8. The distance between the floor and the top of the litter seat section on a standard Secure bed (without a mattress) should be 16"- 16 3/8" with the litter fully down and 29 1/4" - 29 7/8" with the litter fully up. The distance between the floor and the top of the litter seat section on a Secure Zoom bed (without a mattress) should be 19.5" with the litter fully down and 30" - 30 1/4" with the litter fully up. The distance between the floor and the top of the litter seat section on a Secure short bed with Zoom (without a mattress) should be 20.5" with the litter fully down and 30" - 30 1/4" with the litter fully up.

### NOTE

These values are for beds equipped with 6 inch casters. Add two inches to both measurements for beds equipped with 8 inch casters.

# Maintenance Procedures - Base

---

## LIFT MOTOR COUPLER REPLACEMENT

### Required Tools:

5/16" Socket Wrench

3/8" Socket Wrench (w/6" Extension)

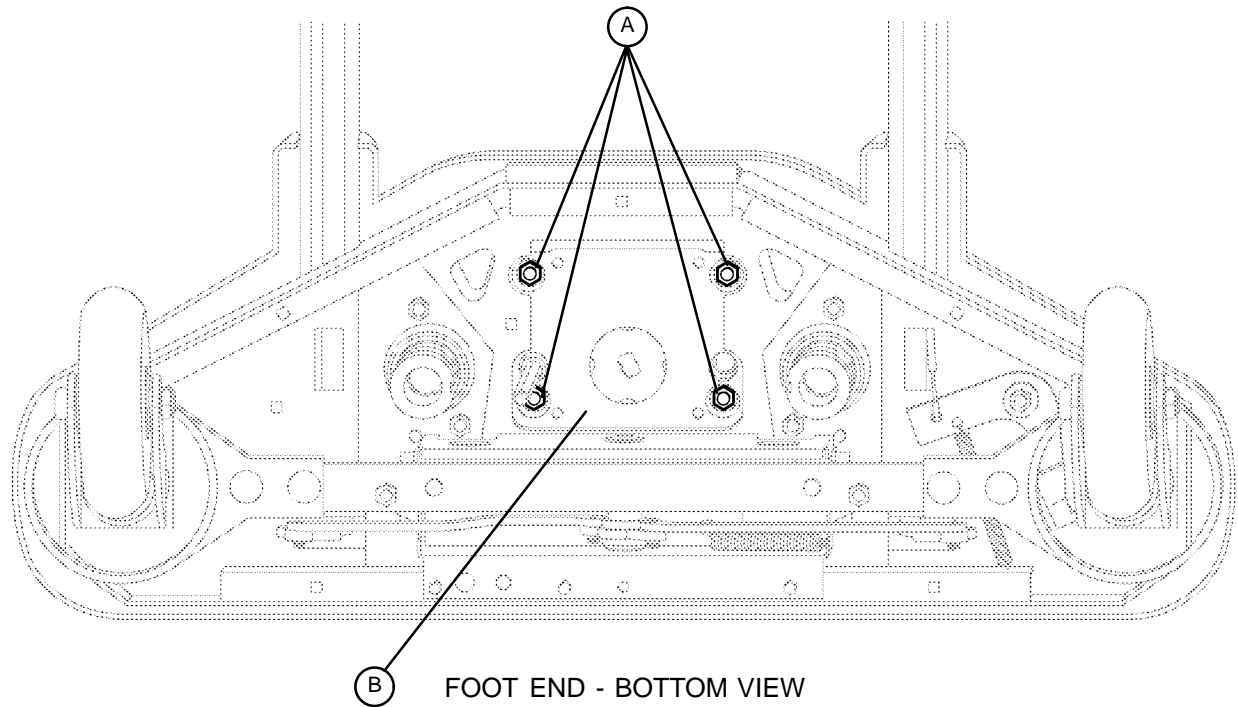

### Procedure:

1. Unplug the bed power cord from the wall socket.
2. Using a 5/16" socket wrench, remove the five bolts holding the lower lift cover to the base and remove the cover.
3. Using a 3/8" socket with an extension, remove the four bolts (A) holding the isolation plate (B) to the lift housing and lower the lift motor and isolation plate assembly to allow access to the coupler.
4. The motor coupler can now be removed from the lift housing.
5. Reverse the above steps to install the new motor coupler and bushings.

# Maintenance Procedures - Base

---

## POWER AND SENSOR COIL CORD REPLACEMENT

### Required Tools:

#2 Phillips Screwdriver	Side Cutters	5/16" Socket Wrench
Bungee Cord (or equivalent)	T27 Torx	5/16" Nut Driver

### Procedure:

1. Unplug the bed power cord from the wall socket.
2. Using a 5/16" socket wrench, remove the five bolts holding the lower lift cover to the base and remove the cover.
3. Using a #2 Phillips screwdriver, remove the three screws holding the upper lift cover to the base.
4. If you are working on the foot end of the bed, use a T27 Torx to remove the screw holding the litter access panel to the litter.
5. Using side cutters, cut the cable ties holding the power and sensor coil cords to the base. Remove the ground wire coming from the sensor cord that is attached to the base (note the star washer arrangement).
6. Disconnect the cables going to the motor and the lift potentiometer (at the head end, the sensor cord is also attached to the brake switch sensor).
7. Pull both cords up through the frame of the bed and the lift housing.
8. Using a 5/16" nut driver, remove the two screws (A) holding the cable clamps\* to the top of the lift housing.
9. Using a 5/16" nut driver, remove the two screws (B) securing the cable clamps\* to the underside of the header crossbar assembly.
10. Pull both coil cords up through the header crossbar assembly.
11. Disconnect the power and sensor coil cords from the connectors.
12. The cords should now be completely removed from the bed. Reverse the above steps to install the new power and sensor cords\*.

---

### CAUTION

\*When the power and sensor coil cords are being replaced, secure the cable clamps to the cords at the first coil on the top and on the bottom to assure there is not too much slack in the cords between the top of the lift housing assembly and the bottom of the header crossbar. Be sure the clamps are fastened at exactly the correct angle, as shown by the arrows in the illustration. Arrange the cords exactly as shown in the illustration (left in front of right). **If this is not done correctly, damage to the cords will result.**



# Maintenance Procedures - Base

## POWER AND SENSOR COIL CORD REPLACEMENT ILLUSTRATION

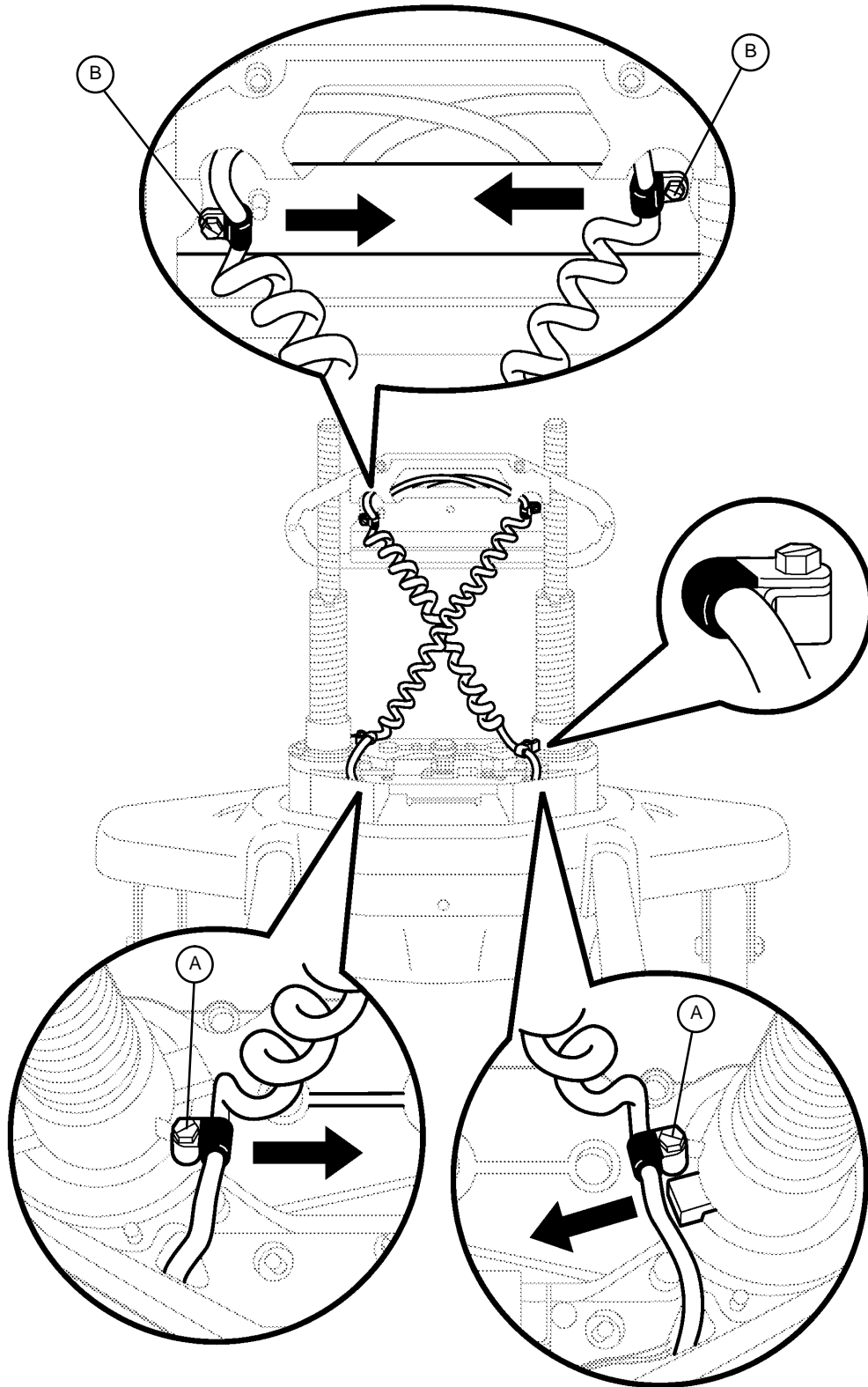

VIEW FROM CENTER OF BED

# Maintenance Procedures - Base

## ZOOM OPTION BATTERY REMOVAL AND REPLACEMENT

### Required Tools:

Torx T27  
1/2" Socket Wrench  
Phillips Screwdriver

7/16" Wrench  
Bungee Cords

### Procedure:

1. Raise the litter to full up. Unplug the power cord from the wall socket and push the battery power on/off switch to the "OFF" position.
2. Using a Phillips screwdriver, remove the four screws holding the base hood to the base frame.
3. Lift the base hood and support it from the litter frame using bungee cords or the equivalent.
4. Properly ground yourself (see page 36 for static discharge precautions).
5. Open the cable clamp at the head end, left side of the base frame and remove the cables from the clamp.
6. Using a Torx T27, remove the four screws (A) holding the electronics box cover and remove the cover.
7. Disconnect the two battery cables (B).



### WARNING

The battery tray assembly weighs 50 pounds. Use caution when removing the two hex head screws securing it to the base frame or personal injury could result. Battery posts, terminals and related accessories contain lead and lead compounds, chemicals known to the State of California to cause cancer and birth defects or other reproductive harm. **Wash hands after handling.**

8. Support the battery tray assembly from the bottom. Using a 7/16" hex socket or wrench, remove the two screws (C) supporting the battery tray.
9. The back of the battery tray assembly has a lip which catches on the electronics box. Lift up and out to remove the battery tray assembly.
10. Reverse steps 1 - 9 to install the new batteries. Complete the last four items of the set-up procedures on page 11.



A

B

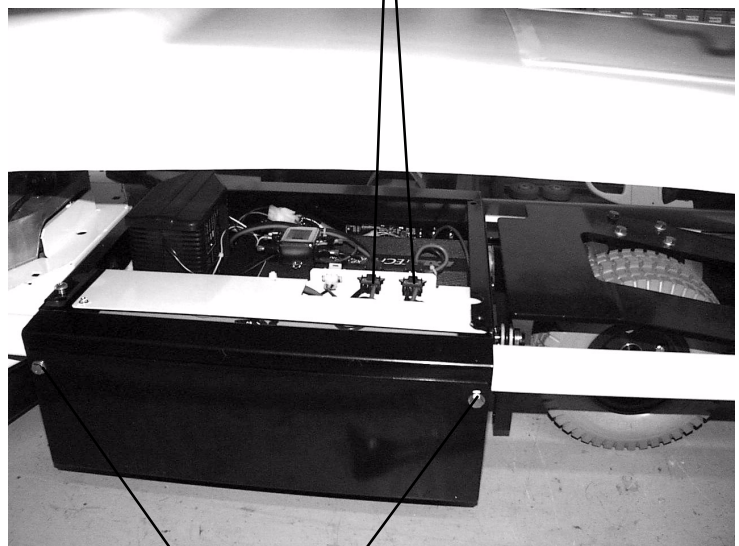

C

# Maintenance Procedures - Base

---

## ZOOM OPTION POWER BOARD REMOVAL AND REPLACEMENT

### Required Tools:

Phillips Screwdriver  
T27 Torx

1/8" Allen Wrench

Bungee Cords

### Procedure:

1. Raise the litter to the full up position.
2. Unplug the power cord from the wall socket and push the battery power on/off switch to the "OFF" position.
3. Using a Phillips screwdriver, remove the four screws holding the base hood to the base frame.
4. Open the cable clamp at the head end, left side of the base frame and remove the cables from the clamp.
5. Lift the base hood and support it from the litter frame using bungee cords or the equivalent.
6. Using a T27 Torx, remove the four screws holding the cover to the side of the electronics box.
7. Properly ground yourself (see page 36 for static discharge precautions).
8. Using a 1/8" Allen wrench, remove the four bolts and standoffs holding the power board to the electronics box.
9. Remove all cables from the power board and remove the board.

### NOTE

Notice the cable connections so you can connect them properly to the new power board.

10. Reverse steps 1 - 8 to install the new power board.

# Maintenance Procedures - Litter

## KNEE MOTOR REMOVAL AND REPLACEMENT

### Required Tools:

T27 Torx

Needle Nose Pliers

3/8" Socket Wrench

Wire Cutters

### Procedure:

1. Electrically run the litter fully up. Unplug the bed power cord from the wall receptacle.
2. Using a 3/8" socket wrench, remove the two bolts holding the motion interrupt pan to the litter frame and remove the pan.
3. Using needle nose pliers, remove the Rue pin (A) from the end of the drive tube.
4. Fold the Gatch section back toward the head end of the bed. Using a T27 Torx, remove the screw holding the mid-litter cover to the litter frame and remove the cover.
5. Remove the two wires from the auto contour micro switch (B) mounted next to the drive tube.
6. Using wire cutters, remove the cable ties. Disconnect the motor and capacitor wires.
7. Using needle nosed pliers, remove the Rue pin (C) from the motor bracket and lift the motor out.
8. Using a 3/8" socket wrench, remove the four bolts holding the motor bracket to the old motor. Remove the bracket and install it on the replacement motor using the same four bolts.
9. Install the replacement motor into the bed. **Do not** hook up the drive tube to the Gatch section yet.
10. Plug the bed power cord into a properly grounded wall receptacle. Using the button on the foot board or siderail, run the Gatch motor down until it stops.
11. Reinstall the mid-litter cover.
12. Fold the Gatch section back down. From underneath the bed, manually turn the drive tube in or out until it lines up with the hole in the Gatch section. Reinstall the pin, the wires for the auto contour switch, and the motion interrupt pan.
13. Test the bed for proper operation before returning it to service.

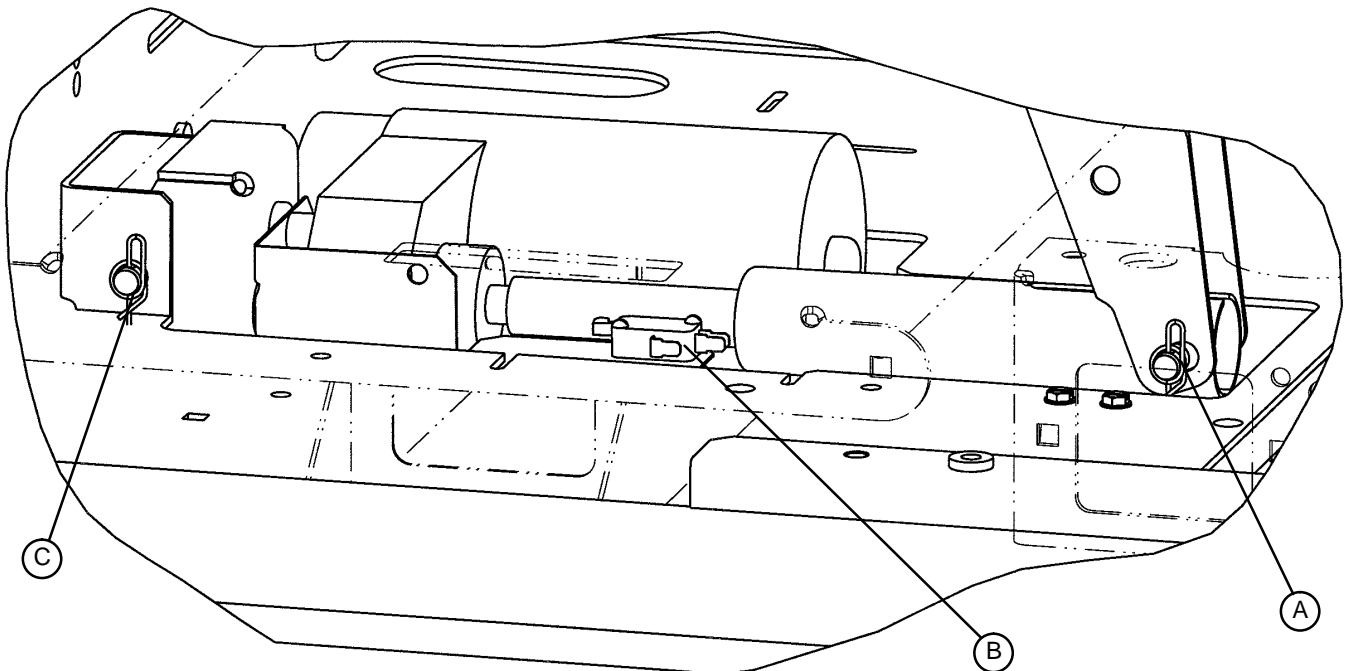

# Maintenance Procedures - Litter

## HEAD MOTOR CAM AND CAM GUIDE REPLACEMENT

### Required Tools:

5/16" Nut Driver

3/8" Socket Wrench

T27 Torx

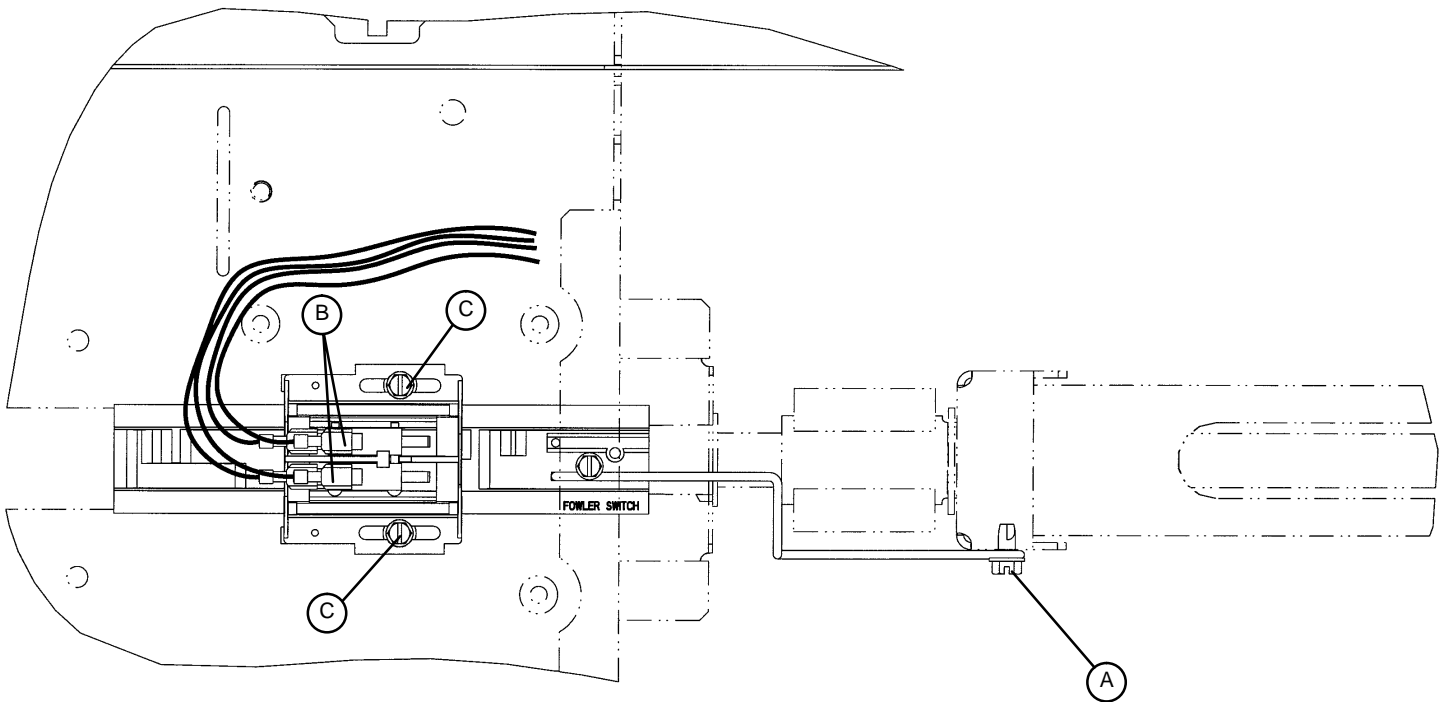

### Procedure:

1. Run the Knee Gatch fully up. Unplug the bed power cord from the wall socket.
2. Using a T27 Torx, remove the screw holding the foot end litter cover to the frame and remove the cover.
3. Using a 3/8" socket wrench, remove the two bolts holding the motion interrupt pan to the litter and remove the pan.
4. Using a 5/16" nut driver, remove the screw (A) holding the cam retention wire to the ball nut assembly.
5. Disconnect the cables (B) from the micro switches. Take note of the locations of the cables so they will be connected properly to the replacement cam.
6. Using a 5/16" nut driver, remove the two screws (C) holding the cam and cam guide to the support bracket and remove the cam and cam guide with the attached micro switches from the bed.
7. Reverse the above steps to install the replacement cam and cam guide/micro switch assembly.
8. Refer to page 67 for "Limit Setting - Head Motor".

# Maintenance Procedures - Litter

## LIMIT SETTING - HEAD MOTOR

### Required Tools:

5/16" Nut Driver

T27 Torx

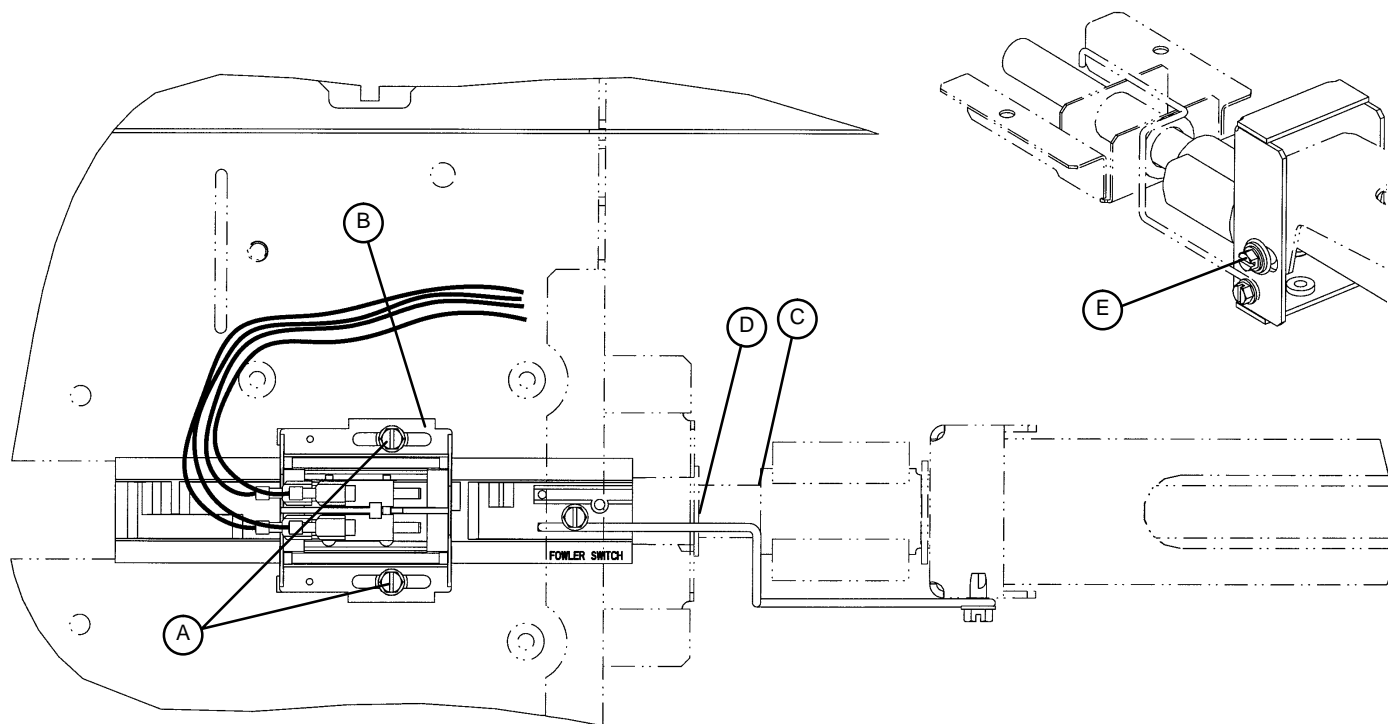

### Procedure:

1. Run the Knee Gatch fully up.
2. Using a T27 Torx, remove the screw holding the midsection litter access covers to the litter and remove the covers.
3. Run the head section down electrically until flat (0°) or use the CPR release handle to fully lower the head.
4. Lightly tap the Fowler down button until the bolt and bushing (E) are centered in the slot.
5. Unplug the power cord from the wall socket.
6. Using a 5/16" nut driver, loosen the two screws (A) on the cam (B).
7. Slide the cam toward the head of the bed just until the microswitch is activated (the switch will make a clicking noise).

### NOTE

Check that the cam "bump" is on the "head" side of the switch actuator.

8. Tighten the two screws (A).

### CAUTION

Be sure the head section stops when it is fully up and the ball nut bracket (C) is approximately 3/4" from panel (D). If not, damage to the unit could result.

9. Ensure the head section will lower to flat (0°) before returning the bed to service. Verify the head section lowers onto the rubber rests and the motor stops running. Re-install the litter access panels removed in step 1.

# Maintenance Procedures - Litter

---

## HEAD MOTOR REMOVAL AND REPLACEMENT

### Required Tools:

3/8" Socket Wrench

### Procedure:

---

#### WARNING

The head motor is not grounded and may be an electrical hazard. Use caution when working around motors.

---

1. Using the CPR release, lower the Fowler to flat (0°).
2. Unplug the bed power cord from the wall socket.
3. Using a 3/8" socket wrench, remove the two bolts at the foot end of the motion interrupt pan and remove the pan.
4. Using a 3/8" socket wrench, remove the two bolts holding the motor bracket to the bed frame. Remove the motor.

#### NOTE

Use caution when removing the motor to avoid having the coupler come off the ball screw shaft.

5. Unplug the head motor cables from the bed and capacitor.

#### NOTE

The replacement motor will come with the attached CPR clutch. The mounting bracket will be re-used with the replacement motor.

6. Reverse the above steps to install the new motor assembly and reattach all litter panels.

# Maintenance Procedures - Litter

## HEAD MOTOR DRIVE ISOLATOR AND CPR DECOUPLER REMOVAL AND REPLACEMENT

### Required Tools:

3/8" Socket Wrench

Needle Nose Pliers

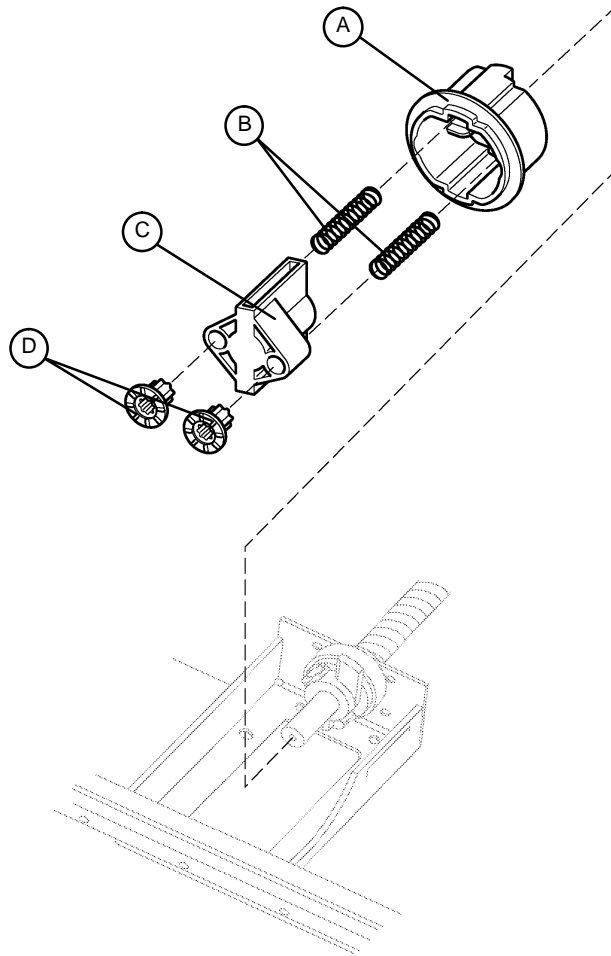

### Procedure:

1. Refer to page 68 for the "Head Motor Removal and Replacement" procedure to access the isolator, springs and decoupler.
2. Pull the drive isolator (C) with the bushings (D), springs (B) and CPR decoupler (A) off the drive screw and remove it from the litter.

### NOTE

These parts are spring-loaded. Use caution when removing them so they won't drop to the floor.

3. To reinstall, put the decoupler (A) on the shaft.
4. Using needle nose pliers, bend the end of the springs (B) out slightly to help hold the springs in the isolator. Put the springs in the isolator and install it on the shaft.
5. Reinstall the head motor (see page 68).
6. Run the Fowler up and down several times to test it before returning the bed to service.



# Maintenance Procedures - Litter

## DRIVE SCREW AND BALL NUT REPLACEMENT - HEAD MOTOR

### Required Tools:

Large Snap-Ring Pliers

3/8" Socket Wrench

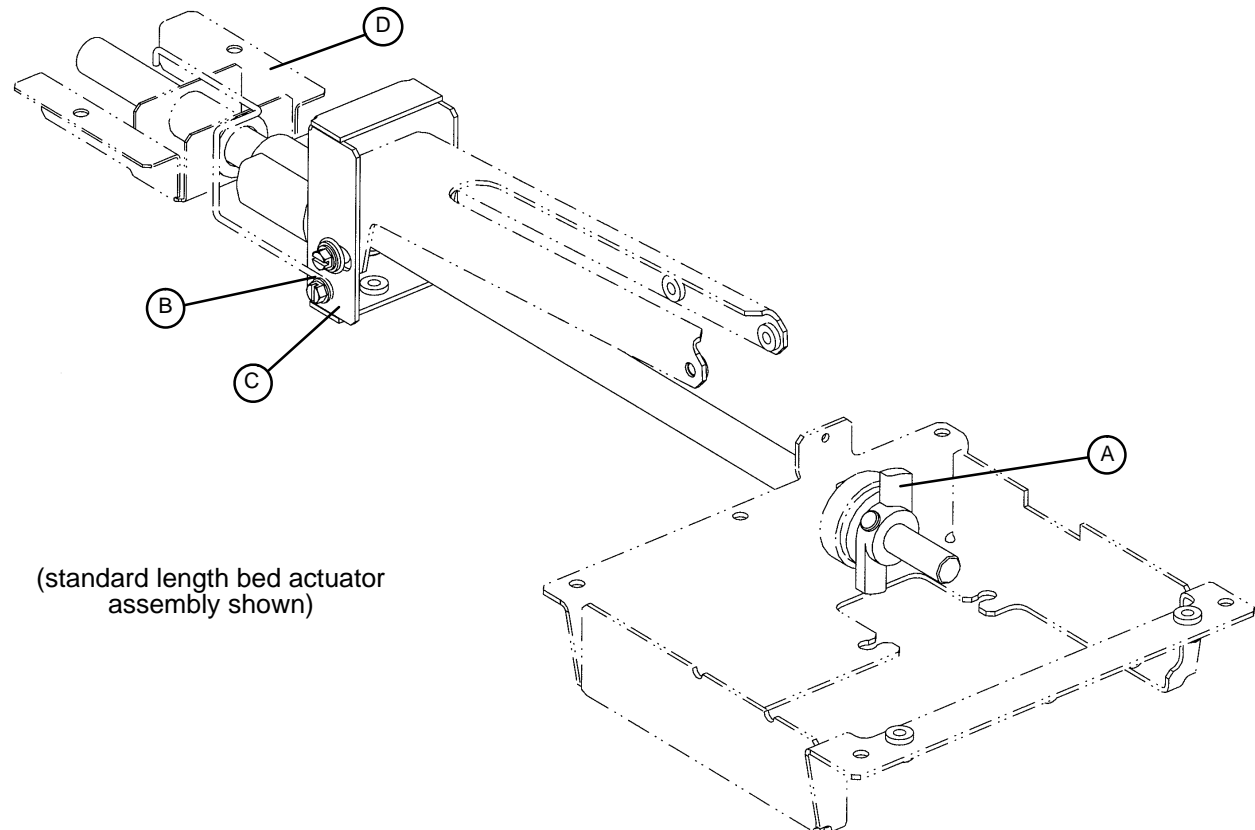

### Procedure:

1. Run the bed fully up. Unplug the bed power cord from the wall socket.
2. Using a 3/8" socket wrench, remove the two bolts holding the motion interrupt pan to the litter and remove the pan.
3. Remove the head motor (see page 68) for access to the screw and ball nut.
4. Remove the head motor drive isolator and CPR decoupler (see page 69).
5. Using needle-nose pliers, remove the cotter pin holding the clevis pin to the drive screw "wing" (A).
6. Remove the clevis pin and slide the wing and tapered roller bearing off the drive screw.
7. Using a 3/8" socket wrench underneath the litter, remove the screw holding the cam retention wire (B) to the ball nut assembly.
8. Using a 3/8" socket wrench, remove the two bolts holding the ball screw support bracket (D) to the bottom of the litter and remove the bracket.
9. Using large snap ring pliers, remove the snap ring holding the ball nut to the bracket (C).

# Maintenance Procedures - Litter

---

## DRIVE SCREW AND BALL NUT REPLACEMENT - HEAD MOTOR (CONTINUED)

10. To prevent the ball nut from coming off the drive screw, cable tie both ends of the ball nut to the drive screw.
11. Pull the drive screw toward the foot of the bed and remove the head end of the drive screw and ball nut assembly from the support.

### NOTE

**Do not** allow the ball nut assembly to come off the drive screw. The ball nut will be shipped attached to the drive screw and retained in position during shipment. Remove the restraining straps **after** installing the drive screw and nut.

12. Remove the thrust washers and bearing from the head end of the drive screw and set them aside.
13. Reverse the above steps to install the replacement drive screw and ball nut assembly.

### NOTE

Apply grease to all bearing areas.

---

### CAUTION

Verify the head motor stops properly at both upper and lower electric limits. If it does not, refer to page 67 for "Limit Setting - Head Motor".

## HEAD MOTOR BRAKE/CLUTCH REPLACEMENT

### Required Tools:

3/8" Socket Wrench

Snap Ring Pliers

9/16" Socket Wrench

9/16" Box End Wrench

Wire Cutters

### Procedure:

1. Remove the head motor (see page 68).
2. Using snap ring pliers, remove the snap ring from the motor shaft.

---

### CAUTION

The brake/clutch is spring-loaded. Use caution when removing the snap ring so the parts don't drop to the floor.

3. Remove the old brake/clutch from the motor and discard it.
4. Using a 9/16" socket wrench and a 9/16" box end wrench, remove the nut, bolt and washers from the new brake/clutch.
5. Install the new brake/clutch onto the motor. It may be necessary to turn the motor shaft to line up the key way with the brake/clutch.
6. Using the snap ring pliers, install the new snap ring.
7. Using the wire cutters, remove the two wire ties from the new brake/clutch.
8. Reinstall the head motor (see page 68).
9. Test the bed for proper operation before returning it to service.

# Maintenance Procedures - Litter

---

## SCALE SYSTEM DIAGNOSTICS

### Diagnostic Mode Functions:

1. **Calibrate Scale:** This may be required in the field if the scale CPU is replaced.
2. **Display Corner:** This function displays the individual corner weights for each load cell assembly and can be used to isolate a defective load cell.
3. **Init. to Defaults:** This may be required in the field when replacing the scale CPU board.
4. **Display Factors:** This is factory preset.
5. **Exit Diagnostics:** Changes made in the diagnostic mode (with the exception of Calibrate Scale) **must** be saved in permanent memory using this function. Switching off power without saving will reset all variables to their previous values.

### Diagnostic Mode:

#### NOTE

It requires **two people** to enable the diagnostic mode for the scale system.

1. To enter diagnostic mode, unplug the bed's power cord from the wall socket.
2. Press and **hold down** the LBS/KGS key.
3. While still holding the LBS/KGS key, plug the bed's power cord into the wall socket.
4. After two seconds, release the LBS/KGS key. The scale monitor should read CALIBRATE SCALE. The diagnostic mode is now active.

### Displaying Individual Load Cell Outputs:

A defective load cell can be detected by entering diagnostics and displaying individual load cell outputs.

1. Enter the diagnostic mode. The scale monitor will display CALIBRATE when the diagnostic mode is active.
2. Repeatedly press and release LBS/KGS until the scale monitor displays DISPLAY CORNER.
3. Press and release SCALE ON. The scale monitor should display PICK CORNER NOW.

The four keys listed in the group below function as POSITION keys corresponding with the four corners of the bed's litter. Whenever the scale monitor displays PICK CORNER NOW, press one of these keys to select the load cell assembly at the desired corner.

- A. ZERO = head end, patient's right side
  - B. DELTA = head end, patient's left side
  - C. PLUS = foot end, patient's right side
  - D. MINUS = foot end, patient's left side
4. Press and release the position key that corresponds with the load cell to be checked. The scale monitor should display X/X=NNN.N. "X/X" represents the initials of the selected corner, i.e. H/R will be displayed for the patient's head end, right side. "NNN.N" represents the resistance of the load cell.
  5. Repeat step four for each corner. Head end weight readings will normally be lower than foot end weights. Weight readings should be constant. A drifting 000.0 or 999.9 weight, or a reading that does not change when weight is applied to that corner of the bed indicates a problem with the selected load cell assembly or load cell cable.
  6. When all the load cell outputs have been checked, repeatedly press and release SCALE ON until scale monitor displays EXIT DIAGNOSTICS. Press SCALE ON to exit diagnostics.

# Maintenance Procedures - Litter

---

## SCALE SYSTEM CALIBRATION

### Verifying Scale Accuracy:

1. Zero the empty bed. Place a known weight on the center of the bed; the heavier the better and no less than 100 pounds. The displayed weight should be within 1% of the actual weight.
2. If the displayed weight is not accurate, remove the weight from the bed and place the scale CPU in calibration mode.

### Scale Calibration:

#### NOTE

It requires **two people** to enable the calibration mode for the scale system.

Calibrate the scale system with a known weight of approximately 200 pounds.

1. To enter the calibration mode, unplug the bed's power cord from the wall socket.
2. Press and **hold down** the LBS/KGS key.
3. While still holding the LBS/KGS key, plug the bed's power cord into the wall socket.
4. After two seconds, release the LBS/KGS key. The scale monitor should read CALIBRATE SCALE. The calibration mode is now active.
5. Press and hold SCALE ON. Zero the bed, following the displayed instructions. When the bed is zeroed, the scale monitor should display REF X100=<2>000.0.
6. The displayed number must now be changed to match the known weight times 100. For example, if REF number to equal 19240. Change the REF number using the LBS/KGS key to position the brackets (<>) around the digit needing to be changed and the "+" key to scroll through the bracketed digit.
7. After the number is corrected, press and release SCALE ON. The scale should display ADD LBS, HIT ON.
8. Place calibration weight on the center of the bed and press and hold SCALE ON. The scale monitor should display RELEASE TO CAL.
9. Release SCALE ON. The scale monitor should display DO NOT TOUCH BED. Don't touch the bed. When calibration is complete, the scale monitor should display CALIBRATE SCALE.
10. Calibration is now complete, press LBS/KG until EXIT DIAGNOSTICS appears. Press SCALE ON and the display will read WEIGHING. Re-zero the empty bed. Check the scale accuracy with the weight used previously.

# Maintenance Procedures - Litter

## LOAD CELL REPLACEMENT

### Required Tools:

1/4" Hex Allen Wrench

Wire Cutters

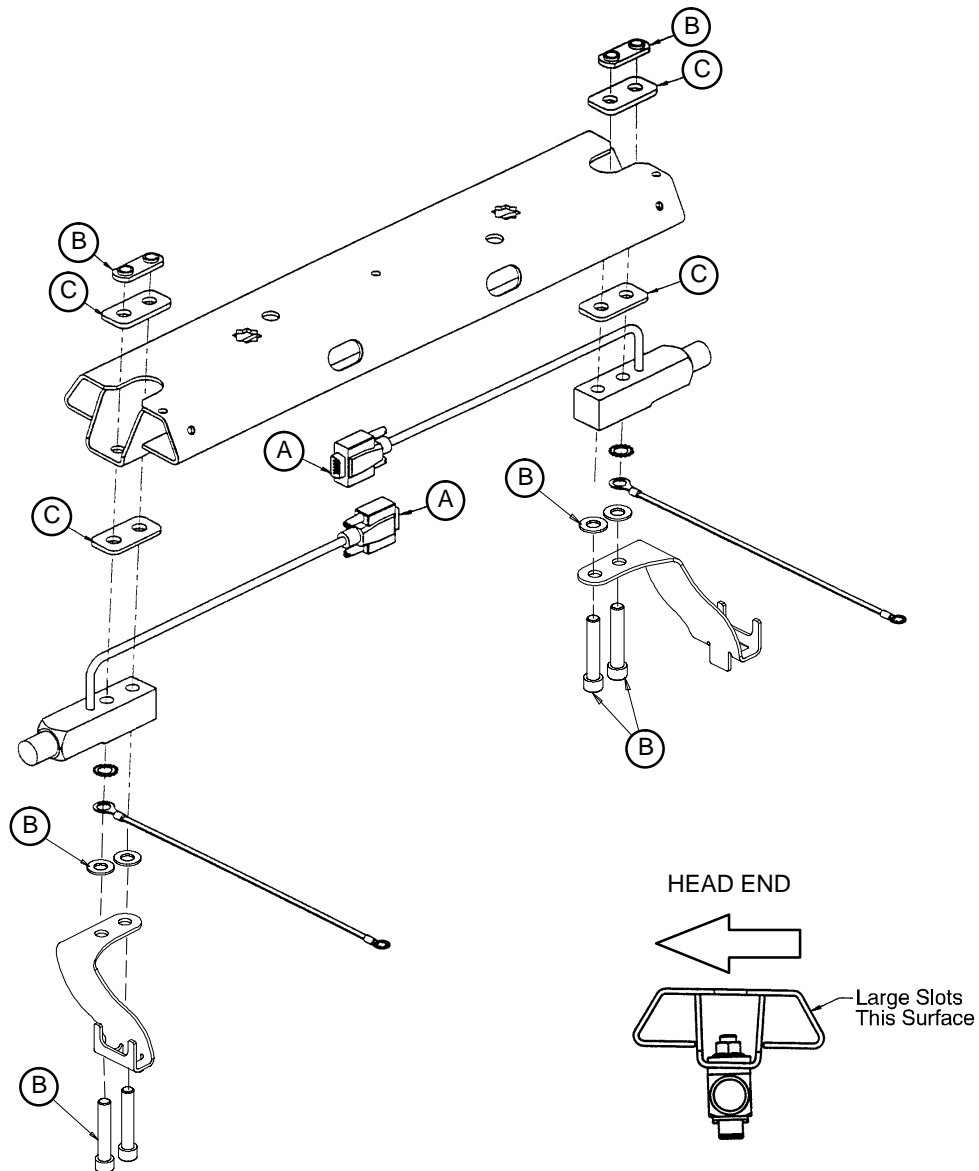

### Procedure:

1. Unplug the bed power cord from the wall socket.
2. Support the corner of the litter where the load cell is being removed.
3. Unplug the load cell connector (A) from the load cell cable. Using side cutters, cut the cable ties.
4. Using a 1/4" hex Allen wrench, remove the screws, washers, and nuts (B) holding the load cell to the bed.
5. To remove a load cell at the head end of the bed, slide the load cell toward the center of the bed to clear the bushing that supports the load cell. Remove the load cell by lifting it up and out. To remove a load cell at the foot end of the bed, slide the load cell with the roller bushing toward the center of the bed to clear the litter frame. Remove the load cell and the roller bushing by lifting them up and out.

# Maintenance Procedures - Litter

---

## LOAD CELL REPLACEMENT (CONTINUED)

### NOTE

If your bed is equipped with a scale system, there are two tapered shims (C) for each load cell. Refer to page 74 as reference for proper installation of the shims. Proper installation of these shims is very important for scale accuracy.

6. Reverse the above procedure to install the new load cell.

---

### CAUTION

Be sure the load cell's strain gauge is facing up when installing a new load cell or the weigh system will not work properly.

7. Recalibrate the weigh system (see page 72).

## POWER SUPPLY REPLACEMENT

### Required Tools:

#2 Phillips Screwdriver                      T27 Torx

### Procedure:

1. Adjust the Fowler to approximately 25-30°. Unplug the bed power cord from the wall socket.
2. Properly ground yourself (see page 36 for static discharge precautions).
3. Using a T27 Torx, remove the two screws holding the head end litter access cover and remove the cover.
4. Disconnect all cables at the power supply. Note the locations of the cables so they will be reconnected properly to the replacement power board.
5. To remove the board from the litter standoffs, use a #2 Phillips screwdriver to remove the four screws holding the board to the litter. Remove the board.
6. Install the new board and reconnect all cables.
7. Reinstall the litter access panel and plug the bed power cord into a properly grounded wall receptacle.
8. Test the bed for accurate operation before returning it to service.

# Maintenance Procedures - Litter

---

## CPU BOARD REPLACEMENT

### Required Tools:

T27 Torx

### Procedure:

1. Adjust the Fowler to approximately 25-30°. Unplug the bed power cord from the wall socket.
2. Properly ground yourself (see page 36 for static discharge precautions).
3. Using a T27 Torx, remove the two screws holding the head end litter access cover and remove the cover.
4. Disconnect all cables at the litter CPU board. Note the locations of the cables so they will be connected properly to the replacement litter CPU.
5. To remove the board from the litter standoffs, pull out on the retention clips and lift upward on the board.
6. Install the new board and reconnect all cables.
7. Reinstall the litter access panel and plug the bed power cord into a properly grounded wall receptacle.
8. When a new CPU board is installed, a "burn-in" procedure must be done (see below). If your bed is equipped with a scale system, scale calibration must also be done (see page 72).
9. Test bed operations before returning the bed to service.

## LIFT POTENTIOMETER "BURN-IN" PROCEDURE

1. Unplug the bed power cord from the wall socket.
2. On the foot board control panel, hold down the Siderail Control Lights, Head Lock Out, and Up/Down Lock Out buttons simultaneously.
3. While holding down the above three buttons, plug the power cord into the wall socket. The Lights button on the foot board control panel should flash, indicating the bed is in the diagnostics mode.
4. On a bed **without** the Zoom power drive option, run both ends of the bed *full down* to a "hard stop". On a bed **with** the Zoom option, run both ends of the bed *full up* to a "hard stop".
5. Hold down the Bed Motion Lock button until the light flashes.
6. Release the button and unplug the power cord from the wall socket.
7. Plug the power cord back in to the wall socket. Run the bed to full up, then full down to verify the bed limits.
8. The distance between the floor and the top of the litter seat section on a standard Secure bed (without a mattress) should be 16"- 16 3/8" with the litter fully down and 29 1/4" - 29 7/8" with the litter fully up. The distance between the floor and the top of the litter seat section on a Secure Zoom bed (without a mattress) should be 19.5" with the litter fully down and 30" - 30 1/4" with the litter fully up. The distance between the floor and the top of the litter seat section on a Secure short bed with Zoom (without a mattress) should be 20.5" with the litter fully down and 30" - 30 1/4" with the litter fully up.

### NOTE

These values are for beds equipped with 6 inch casters. Add two inches to both measurements for beds equipped with 8 inch casters.

# Maintenance Procedures - Litter

## OPTIONAL SMART TV INTERFACE “BURN-IN” PROCEDURE

This procedure is used for selecting the style of TV interface needed for your bed. If traditional TV is desired, no calibration is required. If optional Smart TV is available on the bed, select one of the TV manufacturers listed in the table below.

### SET-UP

- Ensure the communication cable is connected between the bed and the Db37 wall port or the pillow speaker port of the nurse call system. If available, a bed communication tester can be used instead of the hospital wiring.

### PROCEDURE

1. Place the bed in the lift potentiometer burn-in mode (see page 76).
2. Notice the Nurse Call LED (yellow) is flashing. Notice the Nurse Answer LED (green) is flashing on/off slowly.
3. Press and release the TV ON/OFF switch on the bed's siderail once. Notice the Nurse Call LED flashes once. This is the first selection of TV manufacturers for the Smart TV mode. Notice the Nurse Answer LED (green) is flashing on/off slowly. The Nurse Answer LED will only light when the Nurse Call LED (yellow) is flashing.
4. Press and release the TV ON/OFF switch on the bed's siderail to scroll to other TV manufacturers. Notice the number of times the Nurse Call LED flashes matches the number listed in the table below and represents the TV manufacturer selected.
5. When the desired TV manufacturer has been selected, unplug the bed power cord from the wall socket and plug it back in to complete the Smart TV burn-in procedure.

### NOTE

If the bed is connected to a television during the burn-in procedure, the television will turn on when the correct setting is selected.

TV MANUFACTURER SELECTION FOR SMART TV BURN-IN PROCEDURE		
Press and release TV ON/OFF switch:	Nurse Call LED (Yellow)	TV Manufacturer
One time	One flash	RCA 1
Two times	Two flashes	RCA 2
Three times	Three flashes	Zenith 1
Four times	Four flashes	Zenith 2
Five times	Five flashes	Phillips/Magnavox
Six times	Six flashes	Magnavox (models 9120, 9220, 9320)
Seven times	Seven flashes	Traditional TV
Eight times	Eight flashes	Traditional Plus



# Maintenance Procedures - Litter

## ZOOM OPTION CONTROL BAR POTENTIOMETER REPLACEMENT

### Required Tools:

T27 Torx	1/2" Box End Wrench	#2 Phillips Screwdriver
Wire Cutters	Small Flat Blade Screwdriver	5/16" Nut Driver

### Replacement Procedure:

1. Raise the litter and the head end to the full up position.
2. Remove the head board from the bed.
3. Unplug the power cord from the wall socket and push the battery power on/off switch to the "OFF" position.
4. Using a 5/16" nut driver, remove the screw holding the power cord clamp to the bumper weldment and remove the clamp from the bumper.
5. Using a T27 Torx, remove the four bolts (A) at the head end of the bed holding the control bar mounting bracket to the head end (see Figure 1).
6. Using a #2 Phillips screwdriver, remove the three screws (B) holding the control bar cover to the head end of the bed (see Figure 2).
7. Standing at the head end, pull the control bar toward you and fold down the control bar mounting bracket.
8. Using a 1/2" wrench, remove the nut holding the potentiometer to the mount. Using wire cutters, cut the wire ties. Unplug the pot cable from the CPU display board and remove the pot.
9. Install the new potentiometer. Using a small flat blade screwdriver, turn the pot shaft clockwise until it stops. Turn it back counterclockwise 1/2 turn.
10. After the new pot has been installed, the potentiometer "burn-in" procedure must be performed (see page 79).
11. After performing the "burn-in" procedure, reverse steps 1 - 7 to reassemble the bed.
12. Test all functions before returning the unit to service.

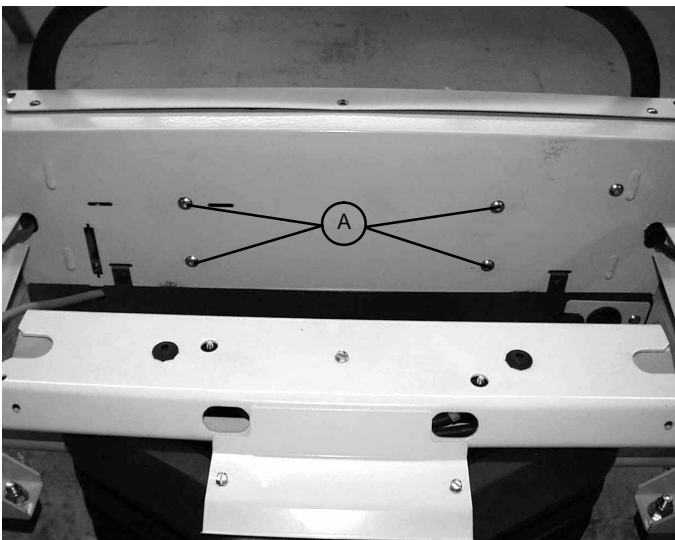

FIGURE 1

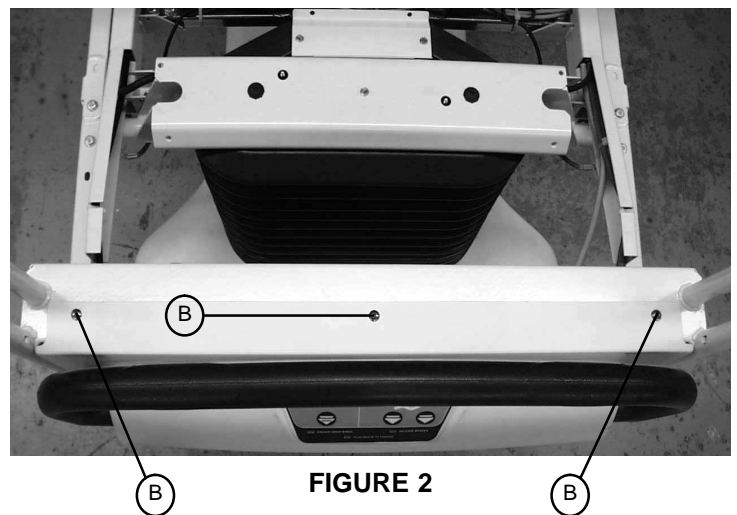

FIGURE 2

# Maintenance Procedures - Litter

---

## ZOOM OPTION CONTROL BAR POTENTIOMETER “BURN-IN” PROCEDURE

### Required Tools:

T27 Torx	1/2" Box End Wrench	#2 Phillips Screwdriver
Wire Cutters	Small Flat Blade Screwdriver	5/16" Nut Driver

1. If it has not already been done, follow steps 1 - 7 of the control bar potentiometer replacement procedure on page 78.
2. Hold down the switch on the back of the drive CPU board.
3. With the switch depressed, move the battery power on/off switch to the “ON” position.
4. Verify the “ENGAGE DRIVE WHEEL” LED at the head end of the bed is flashing.
5. Move the battery power on/off switch to the “OFF” position, close the drive control box, and move the switch back to the “ON” position.
6. The “ENGAGE DRIVE WHEEL” LED will flash once. The control bar potentiometer is calibrated.
7. Grasp the drive handle and squeeze the motion release switch without moving the drive handle forward or back. Verify the bed does not move.
8. Release the bed brakes and engage the drive wheel. Standing at the head end of the bed, grasp the drive handle and squeeze the motion release switch while moving the drive handle away from you. Verify the bed moves forward.
9. Grasp the drive handle and squeeze the motion release switch while moving the drive handle toward you. Verify the bed moves backward.
10. Reverse steps 1 - 7 of the control bar potentiometer replacement procedure on page 78 to reassemble the bed.

# Maintenance Procedures - Litter

---

## ZOOM OPTION AC CROSSOVER BOARD REPLACEMENT

### Required Tools:

T27 Torx	1/2" Box End Wrench	#2 Phillips Screwdriver
Wire Cutters	Small Flat Blade Screwdriver	Needle Nose Pliers
5/16" Nut Driver		

### Replacement Procedure:

1. Follow steps 1 - 7 of the control bar potentiometer replacement procedure on page 78.
2. Using a T-27 Torx, remove the 2 bolts holding the AC crossover board cover to the head end frame and remove the cover.
3. Disconnect all wires from the AC crossover board.
4. Using needle nose pliers, release the four mounting stand-offs from the board and remove the board.
5. Reverse steps 1 - 4 to install the new board.
6. Reverse steps 1 - 7 of the control bar potentiometer replacement procedure on page 78 to reassemble the bed.

## ZOOM OPTION DISPLAY/CPU BOARD REPLACEMENT

### Required Tools:

T27 Torx	1/2" Box End Wrench	#2 Phillips Screwdriver
Wire Cutters	Small Flat Blade Screwdriver	Needle Nose Pliers
5/16" Nut Driver		

### Replacement Procedure:

1. Follow steps 1 - 7 of the control bar potentiometer replacement procedure on page 78.
2. Disconnect all wires from the display/CPU board.
3. Using a #2 Phillips screwdriver, remove the six screws holding the display/CPU board to the control bar cover and remove the board.
4. Reverse steps 2 & 3 to install the new board. After the new board has been installed, the potentiometer "burn-in" procedure must be performed (see page 79).
5. Reverse steps 1 - 7 of the control bar potentiometer replacement procedure on page 78 to reassemble the bed.

# Maintenance Procedures - Siderail

---

## HEAD AND FOOT SIDERAIL COVER REMOVAL

### Required Tools:

#2 Phillips Screwdriver

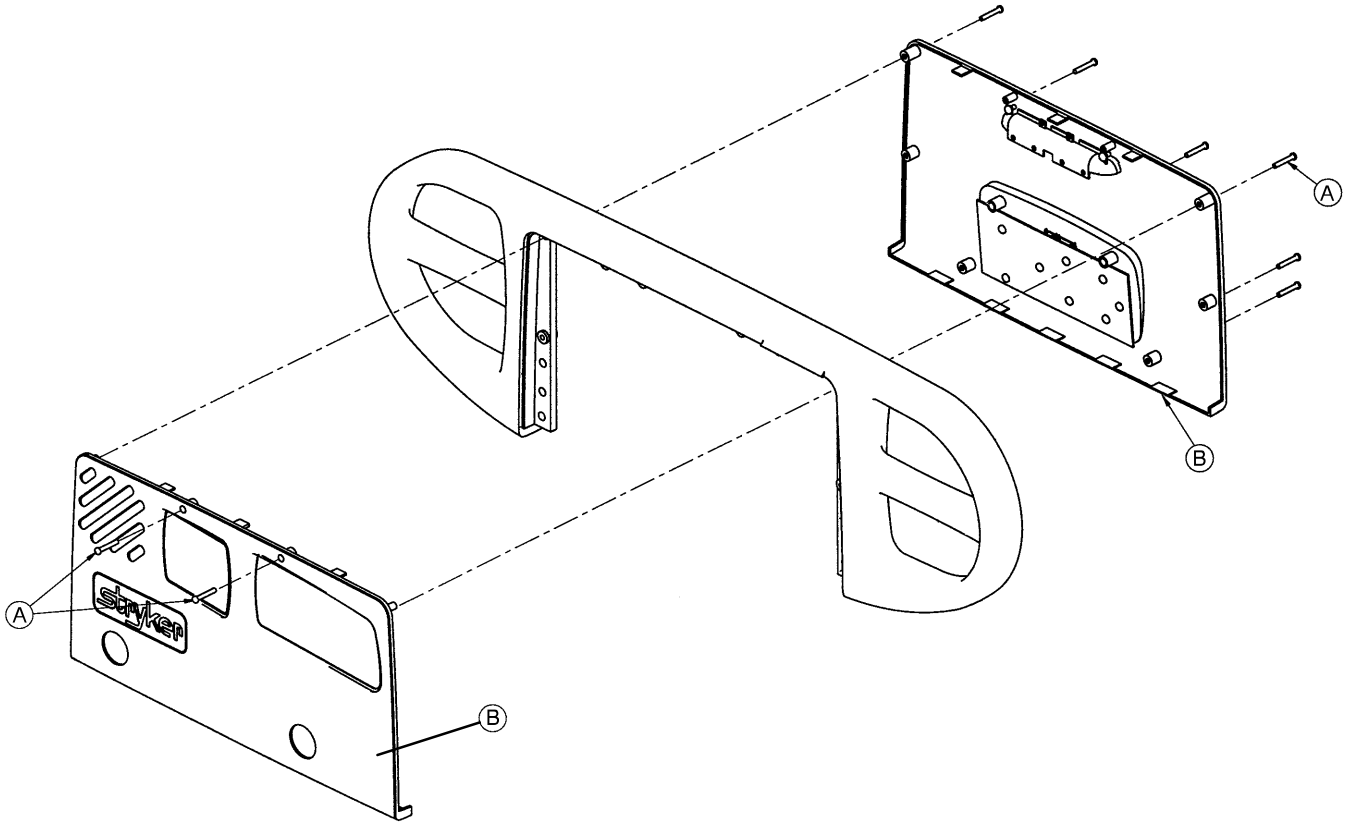

### Removal Procedure:

1. Unplug the power cord from the wall receptacle.
2. Using a #2 Phillips screwdriver, remove the 8 phillips screws (A) holding the covers (B) to the siderail.

---

### CAUTION

There are two cables connecting the outside cover to the head end siderail. Be careful not to pull on them when removing the cover.

3. Remove the cables from the siderail. Make note of the proper location for the cables.
4. Reverse the above steps to reattach the cover.

---

### CAUTION

Do not snag the cables when installing the siderail cover.

### NOTE

Follow the same procedure for siderail cover removal for the foot end rails.

# Maintenance Procedures - Siderail

## HEAD AND FOOT MOLDED SIDERAIL REPLACEMENT

### Required Tools:

#2 Phillips Screwdriver

3/8" Nut Driver

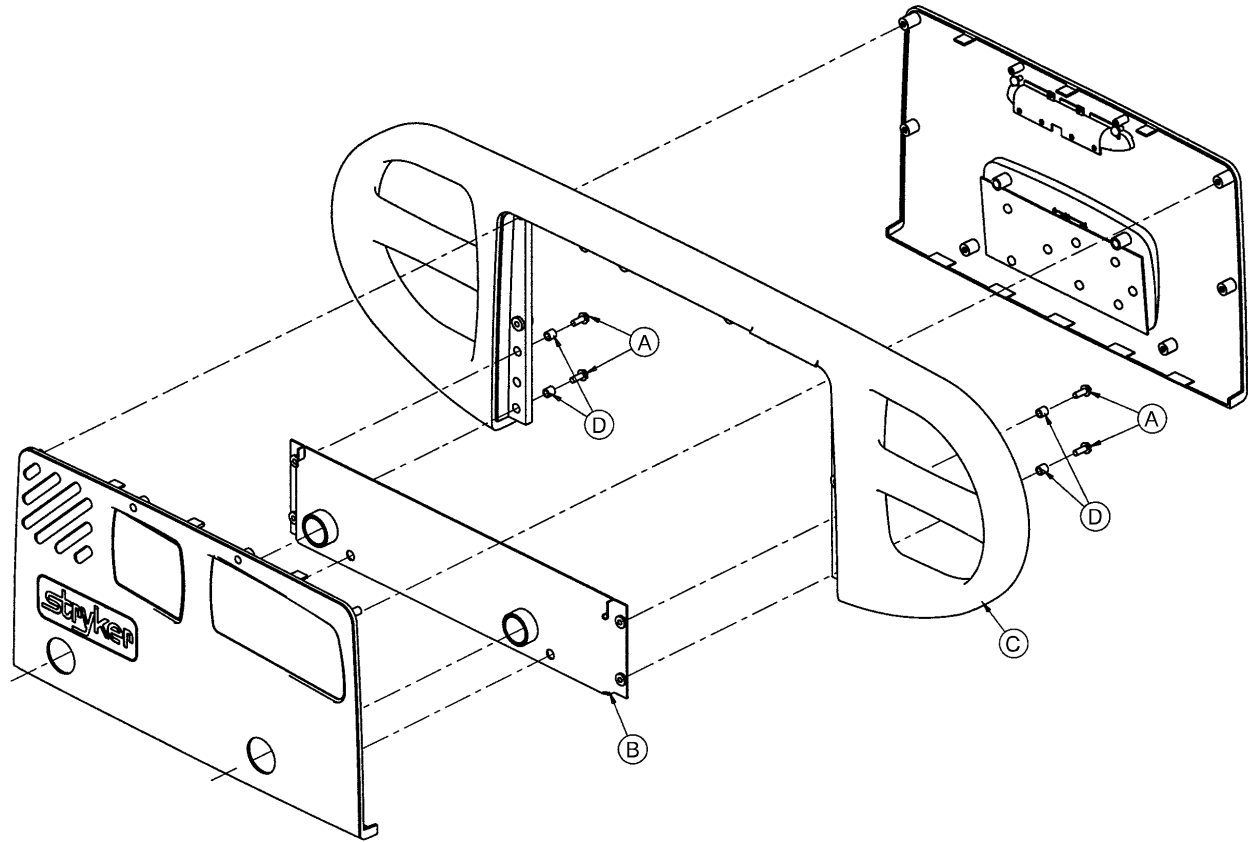

### Procedure:

1. Unplug the bed power cord from the wall socket.
2. Remove the siderail cover (see page 81).
3. Using a 3/8" nut driver, remove the four screws (A) holding the molded rail (C) to the siderail support assembly (B).

### NOTE

Note the location of the spacers (D) for re-assembly purposes.

4. Pull up on the molded rail (C) to remove it from the siderail assembly.
5. Reverse the above steps to install the new molded rail.

# Maintenance Procedures - Siderail

## HEAD END SIDERAIL CABLE REPLACEMENT

### Required Tools:

#2 Phillips Screwdriver

Side Cutters

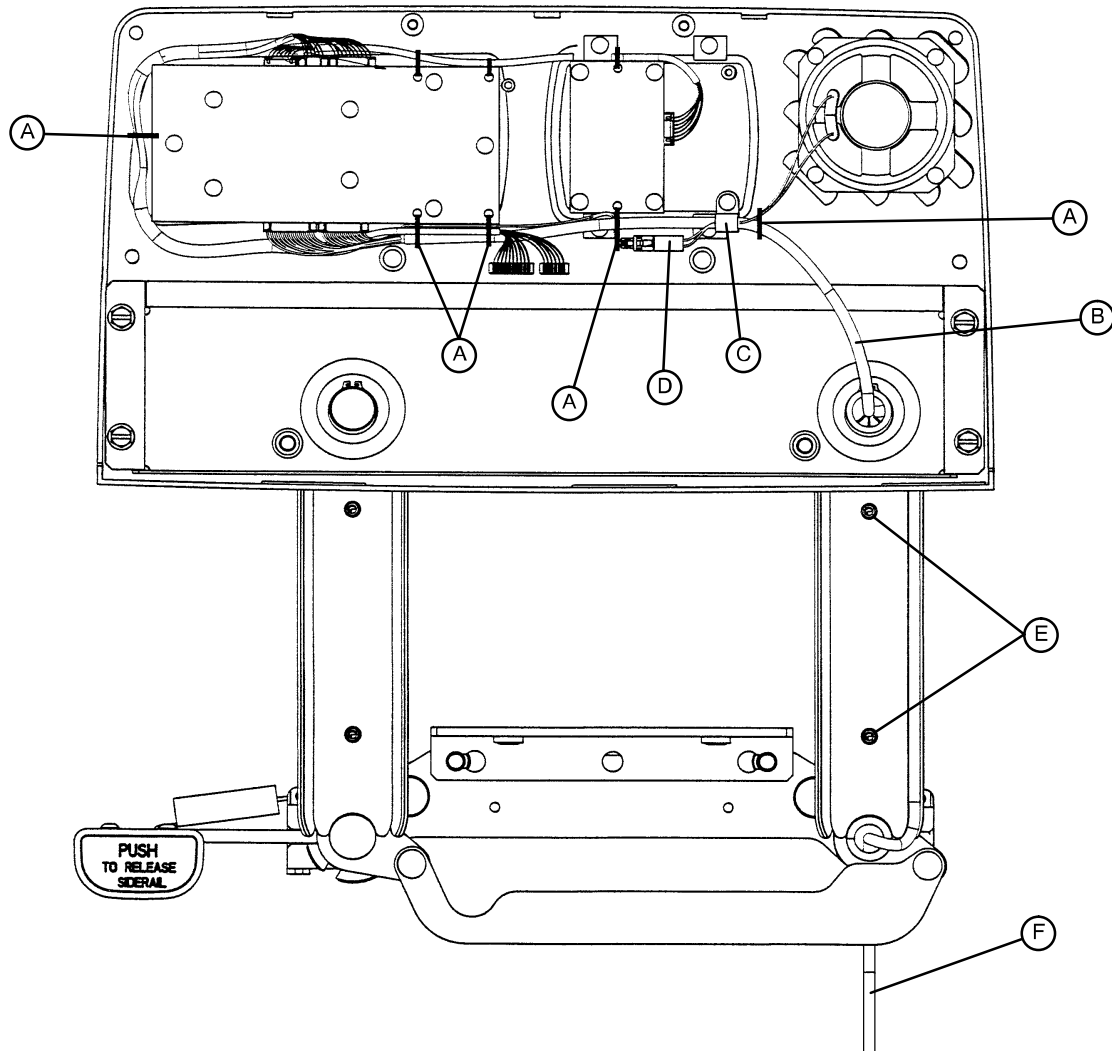

### Procedure:

1. Run the head section fully up.
2. Unplug the bed power cord from the wall socket.
3. Using a #2 Phillips screwdriver, remove the eight screws holding the siderail cover and remove the cover.
4. Put the siderail in the down position.
5. Using a #2 Phillips screwdriver, remove the two screws (E) holding the rear siderail pivot arm cover to the pivot arm. Remove the cover to expose the siderail cables.

# Maintenance Procedures - Siderail

---

## HEAD END SIDERAIL CABLE REPLACEMENT (CONTINUED)

6. Using side cutters, clip the cable ties (A) holding the cables together.
7. Using a #2 Phillips screwdriver, remove the cable clamp (C) from the siderail.
8. Disconnect cable (B) from the circuit board and cable (D) from the speaker.

### NOTE

The speaker and nurse call are optional equipment and may not be in the siderail as shown.

9. Pull the cables through the siderail (toward the center of the bed).
10. Unplug the cable assembly (F) underneath the head section.
11. Reverse the above steps to install the new cable.

---

### CAUTION

Be sure to position the cables on both sides of the pivot arm, as shown in the illustration on page 83, before reattaching the pivot arm cover. If not done properly, the cover will not fit tightly and damage could occur to the cables.

# Maintenance Procedures - Siderail

---

## SIDERAIL ASSEMBLY REMOVAL

### Required Tools:

T27 Torx

### Removal Procedure:

1. Run the head section up electrically when removing a head end siderail.
2. Unplug the bed power cord from the wall socket.
3. Lower the siderail being removed.

### NOTE

If removing a head end siderail, the cable must be unplugged.

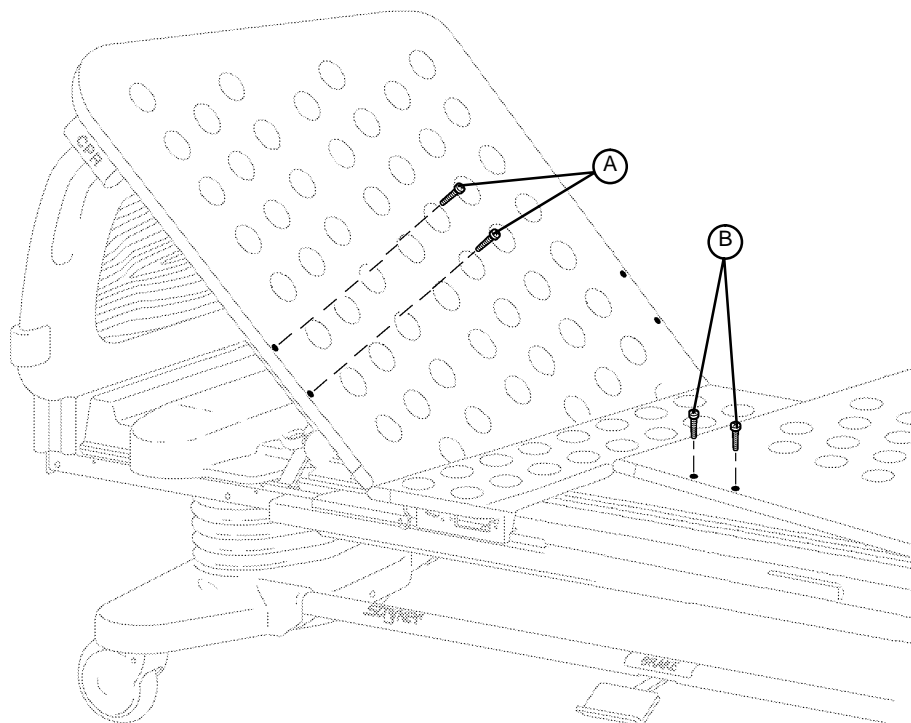

4. Using a T27 Torx, remove the screw from the ground strap and the two screws (A - head end) or (B - foot end) holding the complete siderail assembly on the head or foot section.
5. Push in on the siderail assembly to clear under the head or foot section and pull the siderail back to remove it from the bed.
6. Reverse the above steps to reinstall the siderail assembly.

### NOTE

Grease the glide rods on the replacement siderail assembly with Syntech grease.



# Maintenance Procedures - Foot Board

## FOOT BOARD HINGE REMOVAL

### Required Tools:

#2 Phillips Screwdriver

### Procedure:

1. Using a #2 Phillips screwdriver, remove the screws (A & B) holding the door and hinge assembly to the foot board.
2. If replacing the hinge only, use a Phillips screwdriver to remove the screws holding the hinge to the door.
3. Reverse the above steps to attach the replacement door and/or hinge.

### NOTE

Screw (B) is a machine screw and must be reinstalled in the proper hole.

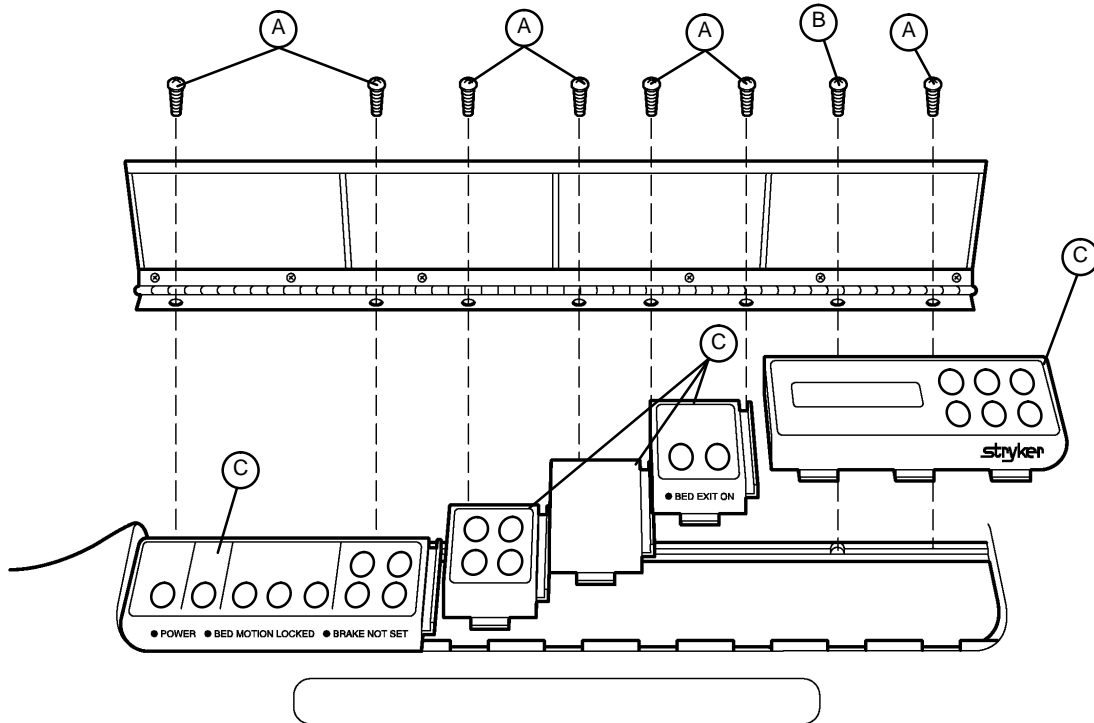

## FOOT BOARD MODULE REPLACEMENT

### Required Tools:

#2 Phillips Screwdriver

### Procedure:

1. Unplug the bed power cord from the wall socket. Remove the foot board hinge (see above).

### NOTE

No matter which module is being replaced, the farthest module to the right must be removed first.

2. Pull the module out of the foot board and disconnect the cable from the module (C).
3. Reverse the above steps to install the new module.

### CAUTION

The modules must be overlapped as shown in the illustration to prevent fluids from entering the board cavity and causing damage.

# Maintenance Procedures - Foot Board

---

## FOOT BOARD INTERFACE PLUG REPLACEMENT

### Required Tools:

#2 Phillips Screwdriver

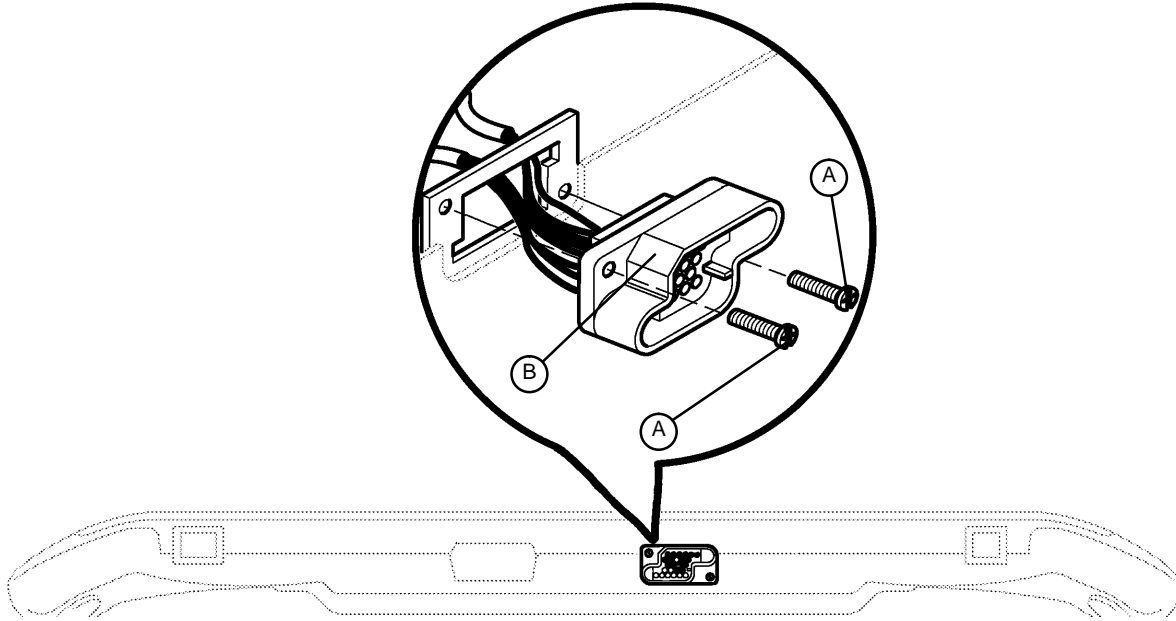

BOTTOM VIEW OF FOOT BOARD

### Procedure:

1. Unplug the bed power cord from the wall socket.
2. Remove the foot board from the bed to access the bottom of the board.
3. Properly ground yourself (see page 36 for static discharge precautions).
4. Using a #2 Phillips screwdriver, remove the eight screws holding the foot board door to the foot board and remove the door.
5. Using a #2 Phillips screwdriver, remove the two screws (A) holding the plug to the foot board.
6. Disconnect the cable from the foot board module cable. Note proper placement of the cable so it will be reconnected properly.
7. Reverse the above steps to install the new interface plug.

---

### CAUTION

Be sure to install the plug with the flat edge (B) at the top left, as shown in the illustration, or the foot board interface plug will not mate properly with the bed. Damage to the plug or the foot board could result.

# Secure II Bed Assembly

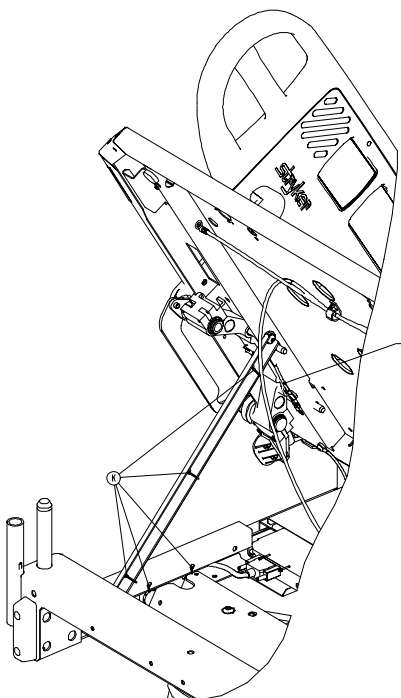
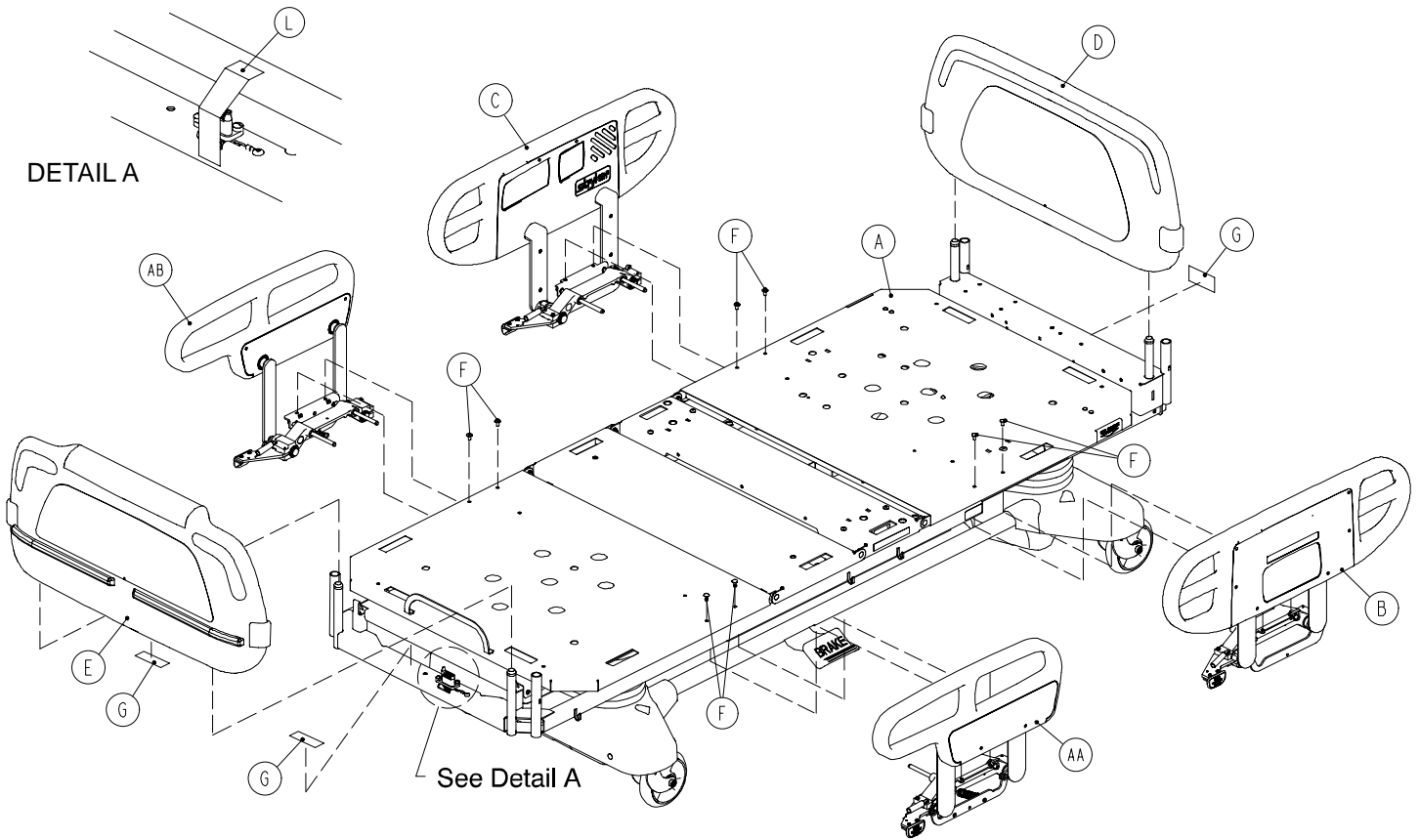

HEAD END SIDERAIL  
CABLE ROUTING

Locate the ground jumper on the outside of the Fowler link separate from the siderail cables on both sides of the bed.

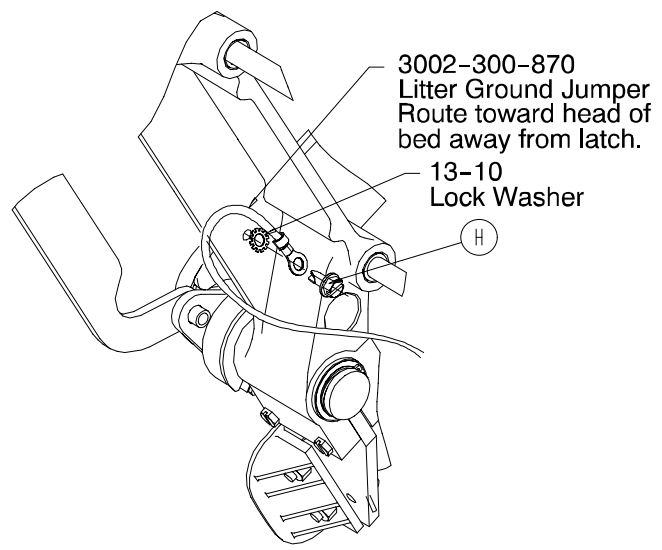

HEAD END SIDERAIL  
GROUND CONFIGURATION

# Secure II Bed Assembly

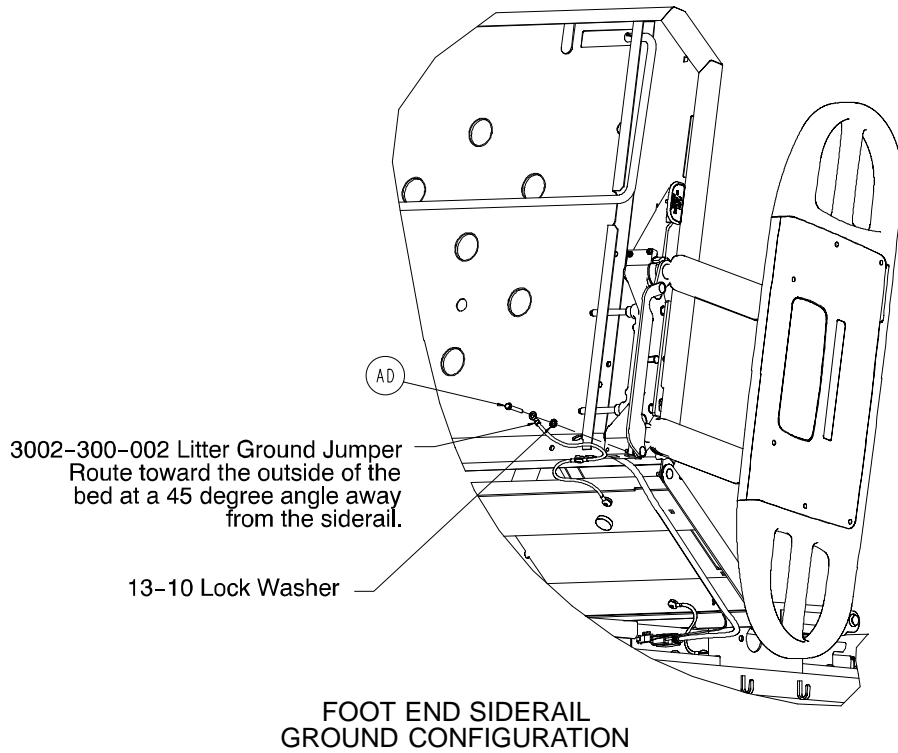

## Standard Bed Components

Item	Part No.	Part Name	Qty.	Item	Part No.	Part Name	Qty.
A	(page 126-132)	Litter Assembly	1	H	3-221	Hex Washer Hd. Screw	4
B	(page 179-198)	Lt. Hd. End Siderail Ass'y	1	K	3000-300-1 13	8" Cable Tie	6
C	(page 179-198)	Rt. Hd. End Siderail Ass'y	1	L	3000-300-641	Foot Board Ground Label	1
D	(page 226)	Head Board Assembly	1	AA	(page 203-205)	Lt. Ft. End Siderail Ass'y	1
E	(page 213-221)	Foot Board Assembly	1	AB	(page 203-205)	Rt. Ft. End Siderail Ass'y	1
F	7-65	Truss Hd. Screw	8		(page 156 & 157)	Night Light Assembly	1
G	3000-300-625	Date-of-Manu. Label	1				

## 8" Shorter Bed Components

Item	Part No.	Part Name	Qty.
A	(page 126-132)	Litter Assembly	1
B	(page 179-198)	Lt. Hd. End Siderail Ass'y	1
C	(page 179-198)	Rt. Hd. End Siderail Ass'y	1
AA	(page 203-205)	Lt. Ft. End Siderail Ass'y	1
AB	(page 203-205)	Rt. Ft. End Siderail Ass'y	1

## Standard Length Bed Components

Item	Part No.	Part Name	Qty.
A	(page 126-132)	Litter Assembly	1
B	(page 179-198)	Lt. Hd. End Siderail Ass'y	1
C	(page 179-198)	Rt. Hd. End Siderail Ass'y	1
AA	(page 203-205)	Lt. Ft. End Siderail Ass'y	1
AB	(page 203-205)	Rt. Ft. End Siderail Ass'y	1

## Zoom Option Bed Components

Item	Part No.	Part Name	Qty.
A	(page 126-132)	Litter Assembly	1
B	(page 179-198)	Lt. Hd. End Siderail Ass'y	1
C	(page 179-198)	Rt. Hd. End Siderail Ass'y	1
AA	(page 203-205)	Lt. Ft. End Siderail Ass'y	1
AB	(page 203-205)	Rt. Ft. End Siderail Ass'y	1
	3002-31-1 13	Umbilical Cable Iso. Brkt.	1

## Zoom Option 8" Shorter Bed Components

Item	Part No.	Part Name	Qty.
A	(page 126-132)	Litter Assembly	1
B	(page 179-198)	Lt. Hd. End Siderail Ass'y	1
C	(page 179-198)	Rt. Hd. End Siderail Ass'y	1
AA	(page 203-205)	Lt. Ft. End Siderail Ass'y	1
AB	(page 203-205)	Rt. Ft. End Siderail Ass'y	1
	3002-31-1 13	Umbilical Cable Iso. Brkt.	1

# Base Assembly and Options

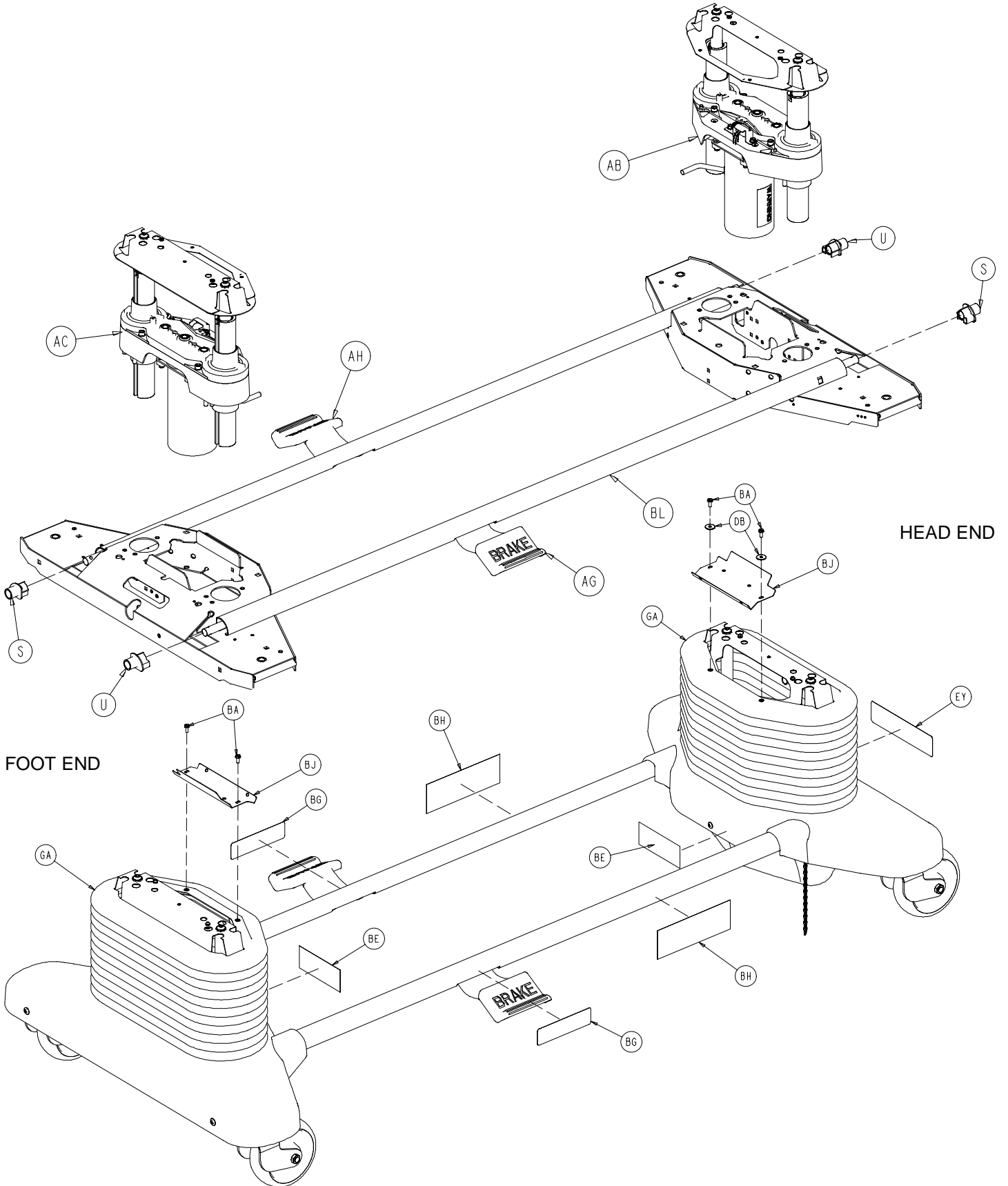

# Base Assembly and Options

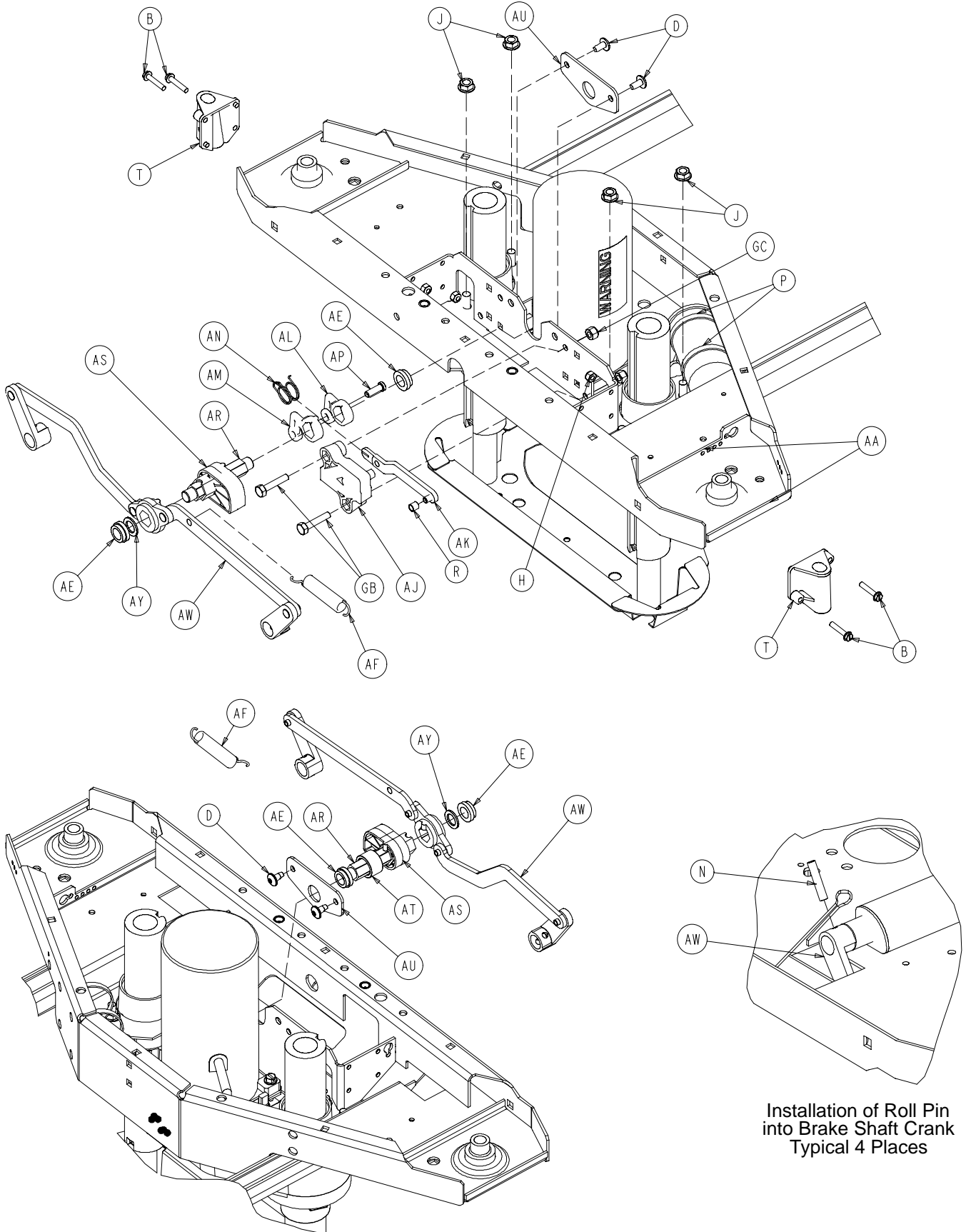

Installation of Roll Pin  
into Brake Shaft Crank  
Typical 4 Places

# Base Assembly and Options

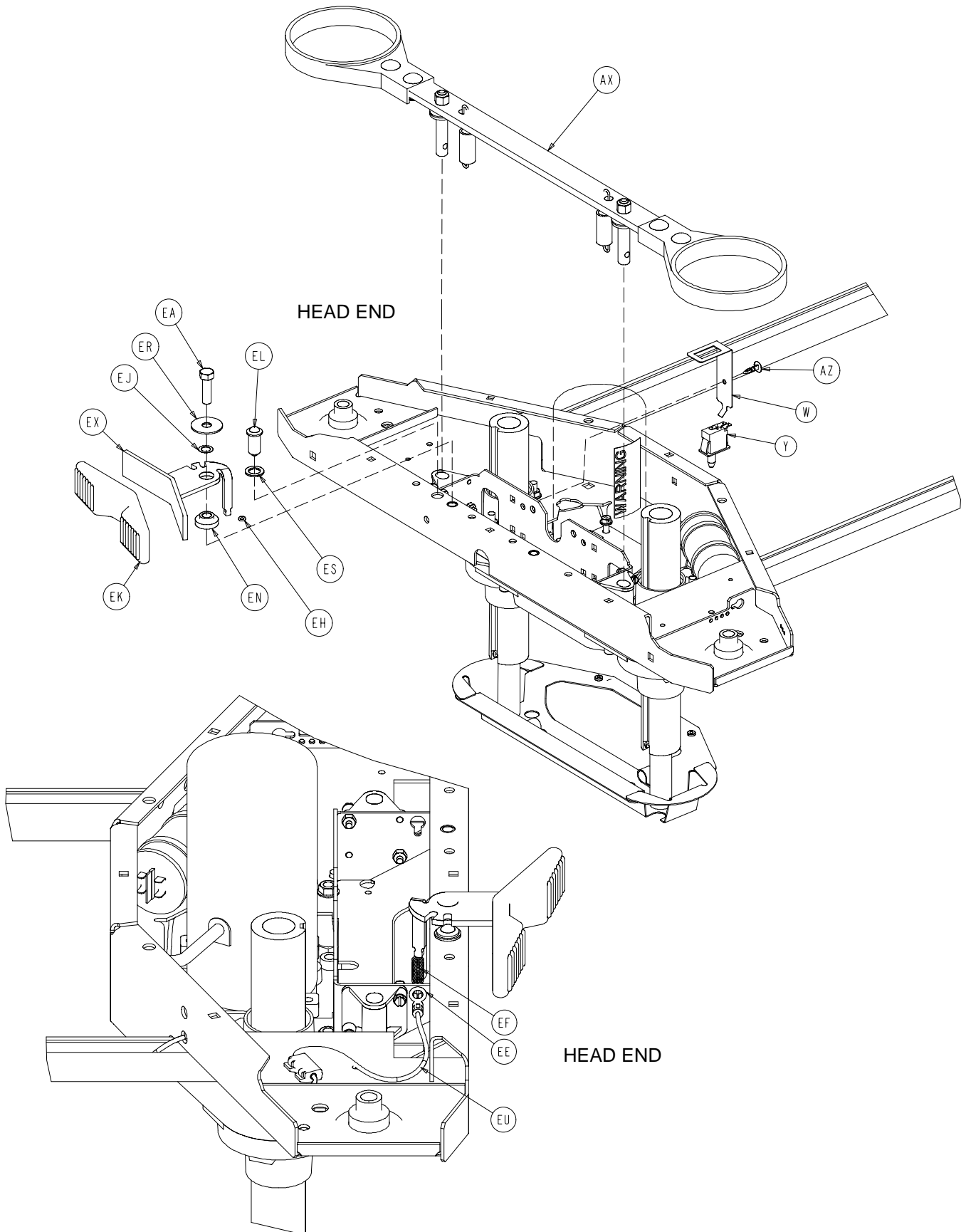

# Base Assembly and Options

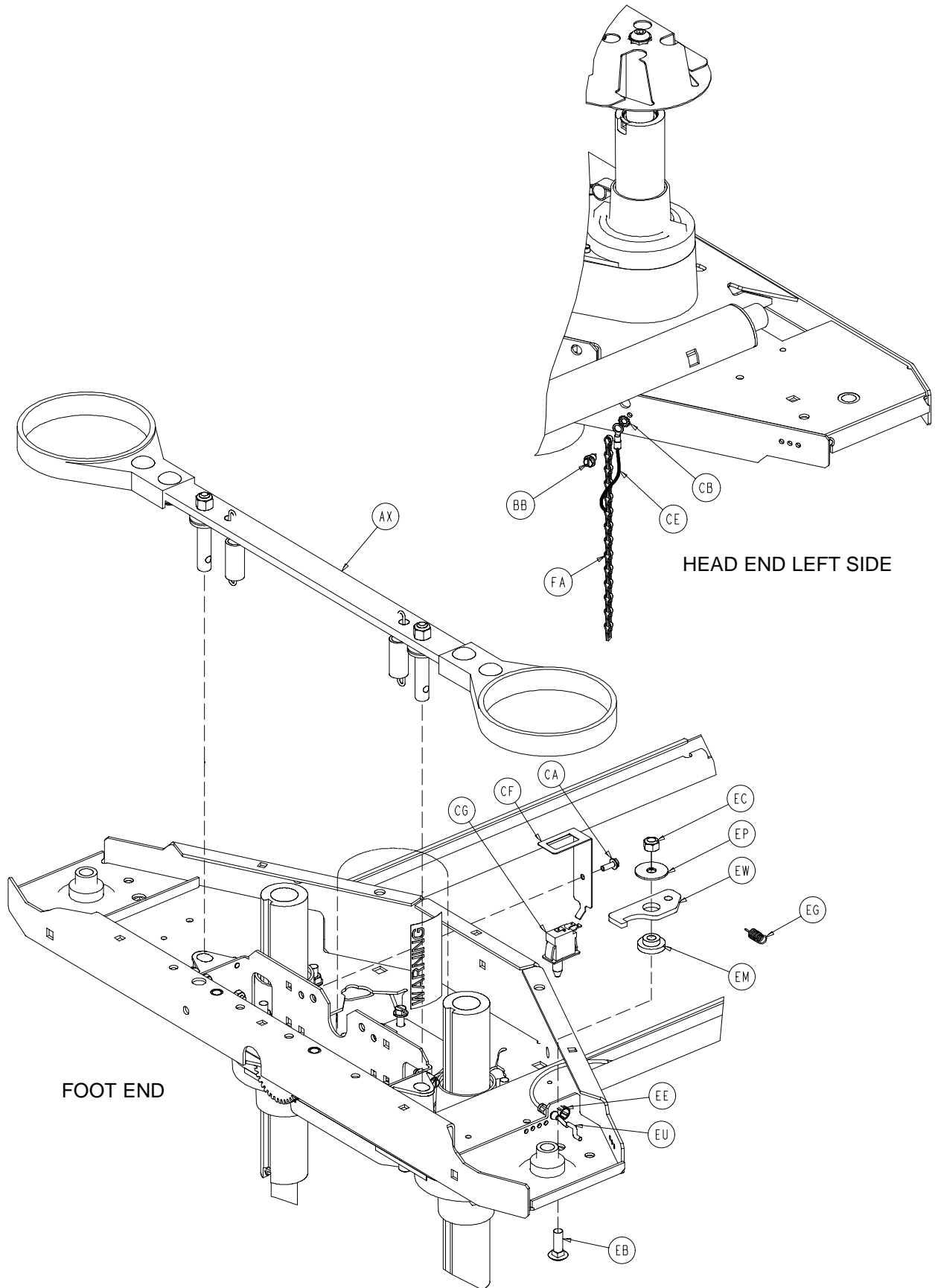



# Base Assembly and Options

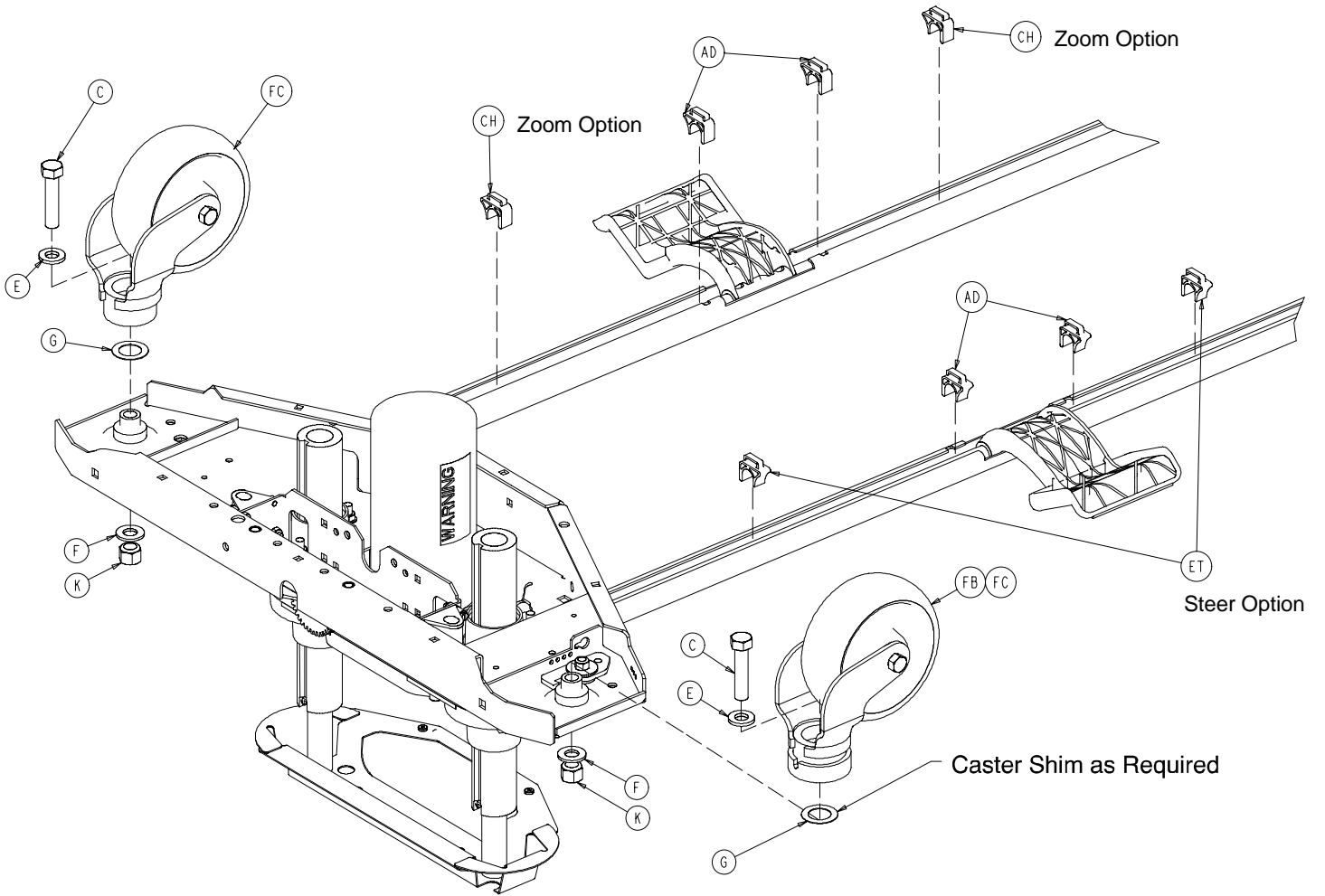

# Base Assembly and Options

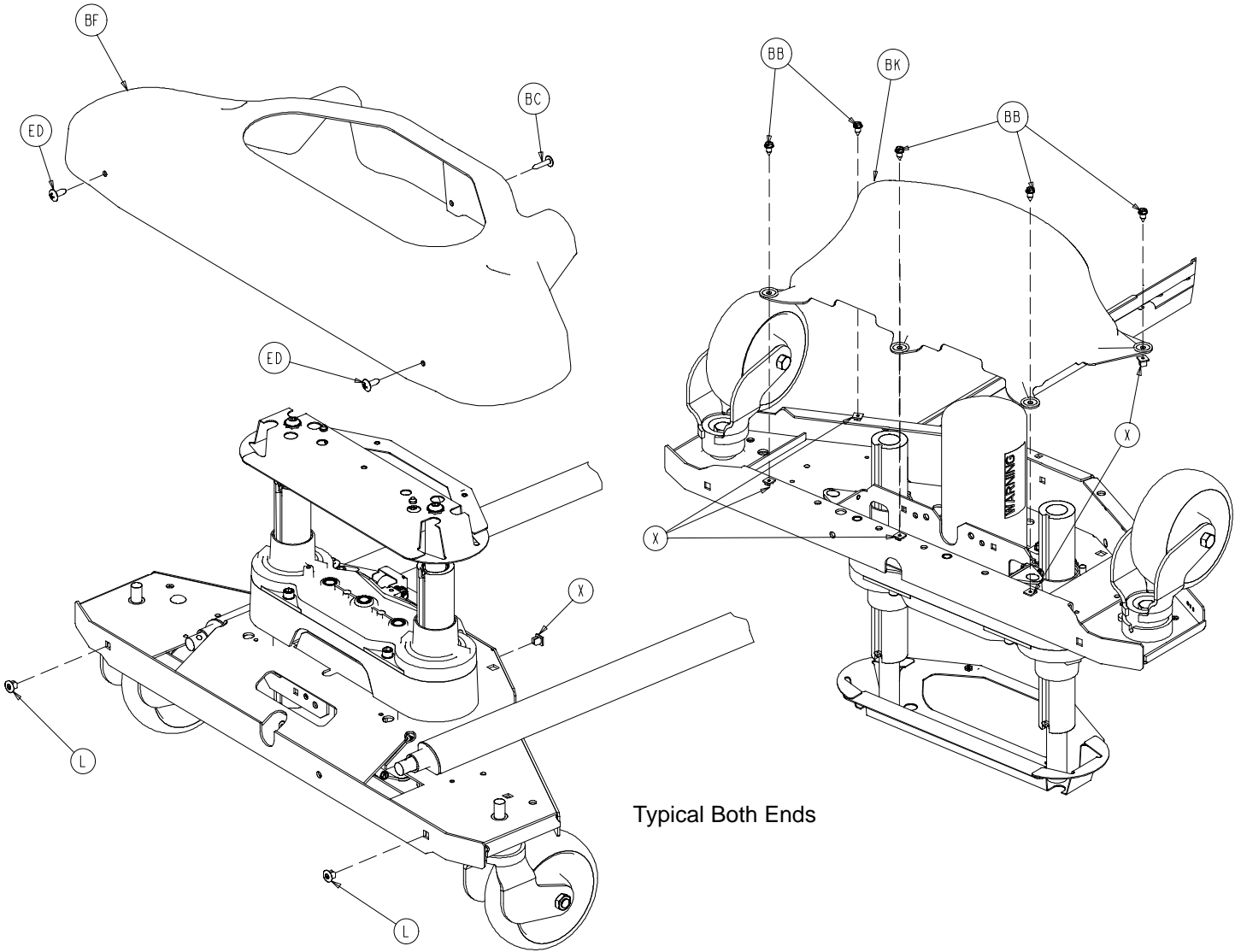

Typical Both Ends

Sensor Coil Cable p/n 3001-200-815 Ground

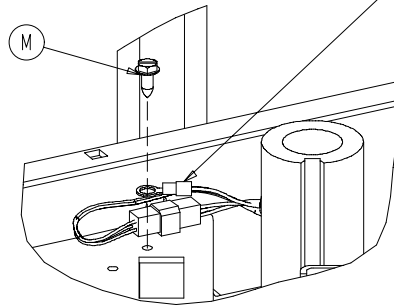

Typical Both Ends

# Base Assembly and Options

---

## Base Assembly Common Components - Part Number 3002-200-3 (Reference Only)

Item	Part No.	Part Name	Qty.
B	3-122	Hex Washer Hd. Screw	8
D	7-52	Truss Hd. Torx	4
E	11-310	Washer	4
G	11-343	Washer	4
H	16-2	Nylock Nut	8
J	16-98	Hex Flange Nut	8
K	16-104	Nylock Nut	4
L	18-36	Plastic Clip Nut	4
M	3-224	Hex Washer Hd. Screw	2
N	26-14	Roll Pin	4
P	38-151	Cable Tie	4
R	3002-200-316	Brake Track Roller	1
S	3000-200-305	Brake Shaft Bushing, Rt.	2
T	3000-200-328	Brake Guide Bushing	4
U	3000-200-331	Brake Shaft Bushing, Lt.	2
W	3000-200-343	Brake Switch Bracket	1
X	3000-300-2	Plastic Clip Nut	10
Y	3000-300-58	Plunger Switch	1
Z	3000-300-1 13	8" Cable Tie	6
AB	(page 99)	Head End Lift Assembly	1
AC	(page 99)	Foot End Lift Assembly	1
AD	3001-200-306	Brake Pedal Shaft Bearing	4
AE	3001-200-317	Brake Cam Shaft Bushing	4
AF	3001-200-334	Brake Return Ext. Spring	2
AG	(page 104)	Brake Shaft Assembly, Lt.	1
AH	(page 104)	Brake Shaft Assembly, Rt.	1
AJ	3002-201-301	Brake Ratchet Track	1
AK	3002-200-302	Brake Ratchet Link Ass'y	1
AL	3002-200-305	Brake Ratchet Crank, Lt.	1
AM	3002-200-306	Brake Ratchet Crank, Rt.	1
AN	3002-200-307	Brake Latch Spring	1
AP	3002-200-308	Brake Ratchet Crank Pin	1
AR	3002-200-31 1	Brake Shaft	2
AS	3002-201-312	Brake Cam	2
AT	3002-200-313	Brake Cam Spacer	1
AU	3002-200-314	Brake Mounting Bracket	2
AW	(page 105)	Brake Crank Assembly	2
AX	(page 106)	Brake Bar Assembly	2
AY	3000-200-349	Special Narrow Washer	2
AZ	3000-300-1 15	Stand-Of f	1
GA	2025-000-101	Bellows	2
GB	3-74	Hex Hd. Bolt	2
GC	16-28	Nylock Nut	2

# Base Assembly and Options

---

## Base Assembly, Standard Secure Bed - Part Number 3002-243-3 (Reference Only)

Item	Part No.	Part Name	Qty.
C	3-333	Hex Hd. Cap Screw	4
F	11-333	Flat Washer	4
X	3000-300-2	Clip Nut	2
AB	(page 99)	Head End Lift Assembly	1
AC	(page 99)	Foot End Lift Assembly	1
BA	3-224	Hex Washer Hd. Screw	4
BB	23-25	Hex Washer Hd. Screw	11
BC	23-80	Truss Hd. Screw	2
BE	988-2-708	Caution Label	2
BF	3002-300-9	Uni-Pan Cover	2
BG	3000-200-601	Brake Pedal Label	2
BH	3000-200-602	Stryker Logo Label	2
BJ	3001-200-8	Bellows Bracket	2
BK	(page 122)	Bottom Cover	2
BL	3002-200-102	Base Weldment	1

## Base Assembly, Zoom Secure Bed - Part Number 3002-244-3 (Reference Only)

Item	Part No.	Part Name	Qty.
C	3-204	Hex Hd. Cap Screw	4
AB	(page 99)	Head End Lift Assembly	1
AC	(page 99)	Foot End Lift Assembly	1
BL	3002-200-102	Base Weldment	1
CA	3000-300-1 15	Stand-Of f	1
CB	13-18	External Tooth Lock Washer	1
CE	2025-31-805	Ground Strap	1
CF	3000-200-343	Brake Switch Bracket	1
CG	3000-300-58	Switch Plunger	1
CH	3001-200-306	Brake Pedal Shaft Bearing	2

# Base Assembly and Options

---

## Base Assembly, Steer Option - Part Number 3001-999-137 (Reference Only)

Item	Part No.	Part Name	Qty.
EA	3-349	Hex Hd. Cap Screw	1
EB	5-20	Carriage Bolt	1
EC	16-36	Nylock Nut	1
ED	23-92	Truss Phillips Hd. Screw	4
EE	30-52	Snap Bushing	2
EF	38-414	Pedal Extension Spring	1
EG	38-416	Lever Extension Spring	1
EH	45-8	O-Ring	1
EJ	52-305	Brass Flat Washer	1
EK	3000-200-336	Steer Pedal	1
EL	3000-200-337	Push Fit Ball Plunger	1
EM	3000-200-339	Steer Lock Lever Bushing	1
EN	3000-200-341	Steer Pedal Bushing	1
EP	3000-200-347	Special Washer	1
ER	3000-200-348	Special Wide Washer	1
ES	3000-200-349	Special Narrow Washer	1
ET	3001-200-306	Brake Pedal Shaft Bearing	2
EU	3001-200-342	Steer Cable Assembly	1
EW	3001-200-370	Steer Lock Lever	1
EX	3001-200-371	Steer Pedal Arm	1
EY	5000-90-13	Steer Label	1

## Base Assembly, 6" Caster Option - Part Number 3001-999-138 (Reference Only)

Item	Part No.	Part Name	Qty.
FA	715-1-156	6" Ground Chain	1
FB	(page 108)	6" Steer Caster Assembly	1
FC	(page 107)	6" Caster Assembly	3

## Base Assembly, 8" Caster Option - Part Number 3001-999-139 (Reference Only)

Item	Part No.	Part Name	Qty.
FA	3001-200-53	8" Ground Chain	1
FB	(page 111)	8" Steer Caster Assembly	1
FC	(page 110)	8" Caster Assembly	3
FD	2025-1-47	Caster Cover, Right	4
FE	2025-1-48	Caster Cover, Left	4

## Zoom Base Assembly, 6" Caster Option - Part Number 3002-999-138 (Reference Only)

Item	Part No.	Part Name	Qty.
FA	715-1-156	6" Ground Chain	1
FC	(page 107)	6" Caster Assembly	4

## Zoom Base Assembly, 8" Caster Option - Part Number 3002-999-139 (Reference Only)

Item	Part No.	Part Name	Qty.
FA	3001-200-53	8" Ground Chain	1
FC	(page 110)	8" Caster Assembly	4
FD	2025-1-47	Caster Cover, Right	4
FE	2025-1-48	Caster Cover, Left	4

# Lift Assembly (Head & Foot End)

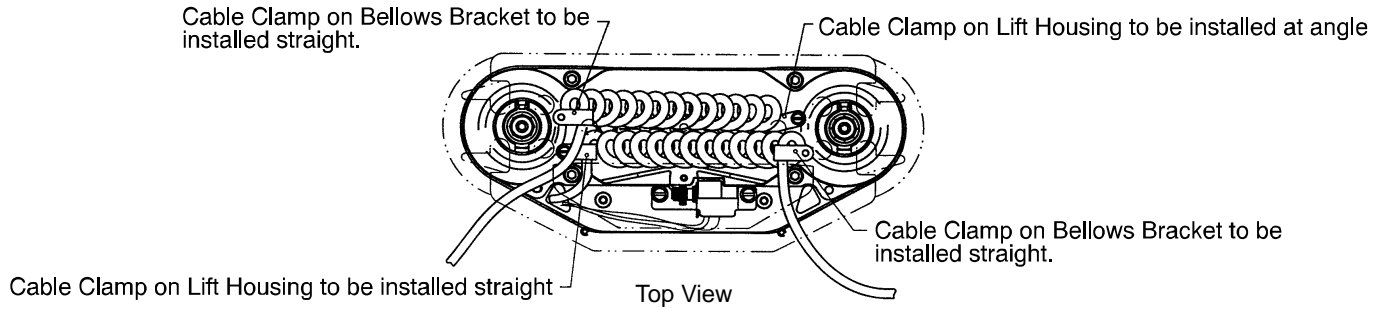

**3001-200-251 (Foot - Standard Height)**  
**2040-243-250 (Foot - Enhanced Height)**

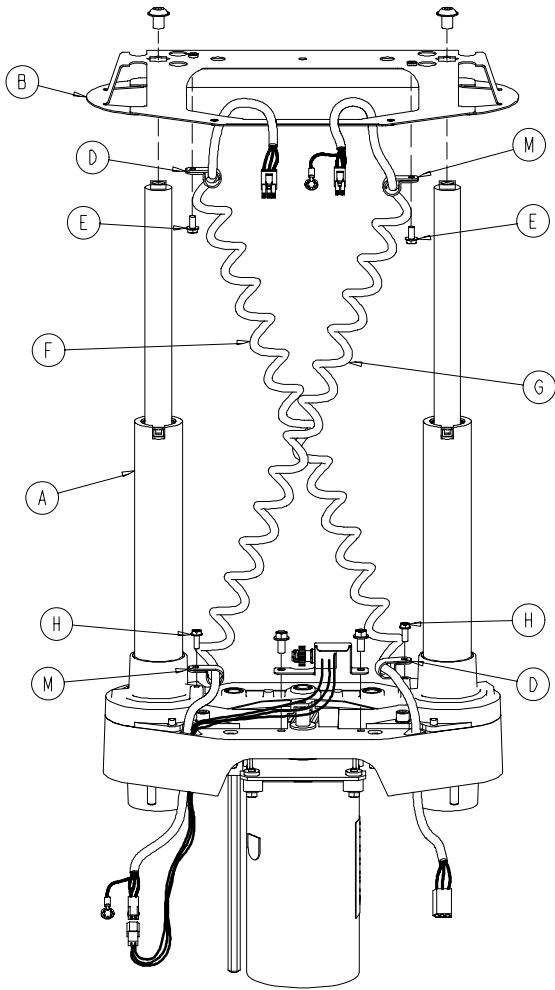

**3001-200-201 (Head - Standard Height)**  
**2040-243-200 (Head - Enhanced Height)**

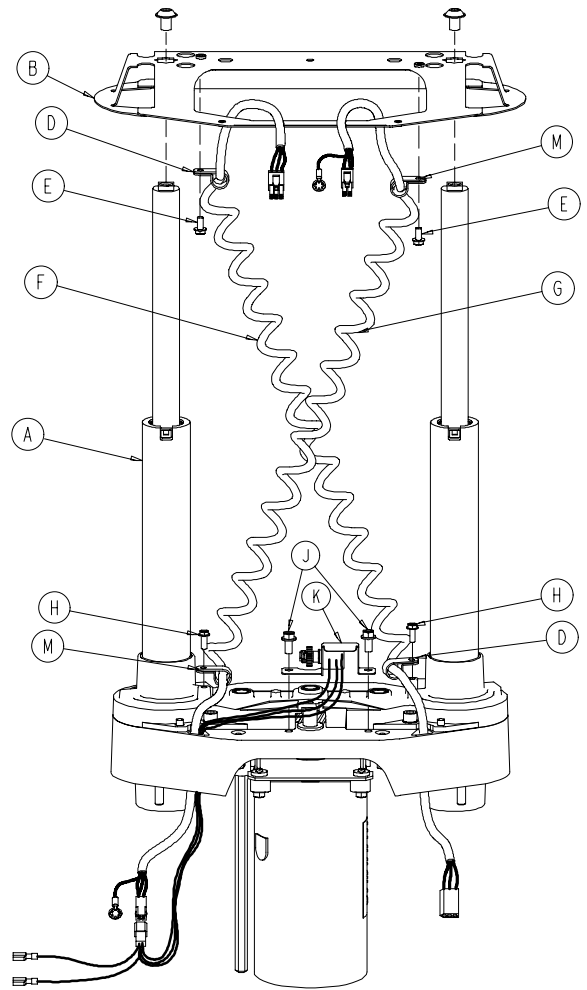

Item	Part No.	Part Name	Qty.	Item	Part No.	Part Name	Qty.
A	(page 100-102)	Common Lift Assembly	1	H	3-128	Hex Washer Hd. Screw	2
B	3000-200-52	Bellows Bracket	1	J	3-121	Hex Washer Hd. Screw	2
D	34-22	Cord Clamp	2	K	3001-200-240	Head End Pot. Ass'y	1
E	3-123	Hex Washer Hd. Screw	2		3001-200-230	Foot End Pot. Ass'y	1
F	3001-200-864	Power Coil Cord	1	M	34-381	Cord Clamp	2
G	3001-200-815	Sensor Coil Cord	1				

# Lift Assembly (Common)

Assembly part number 3000-200-275 (reference only)

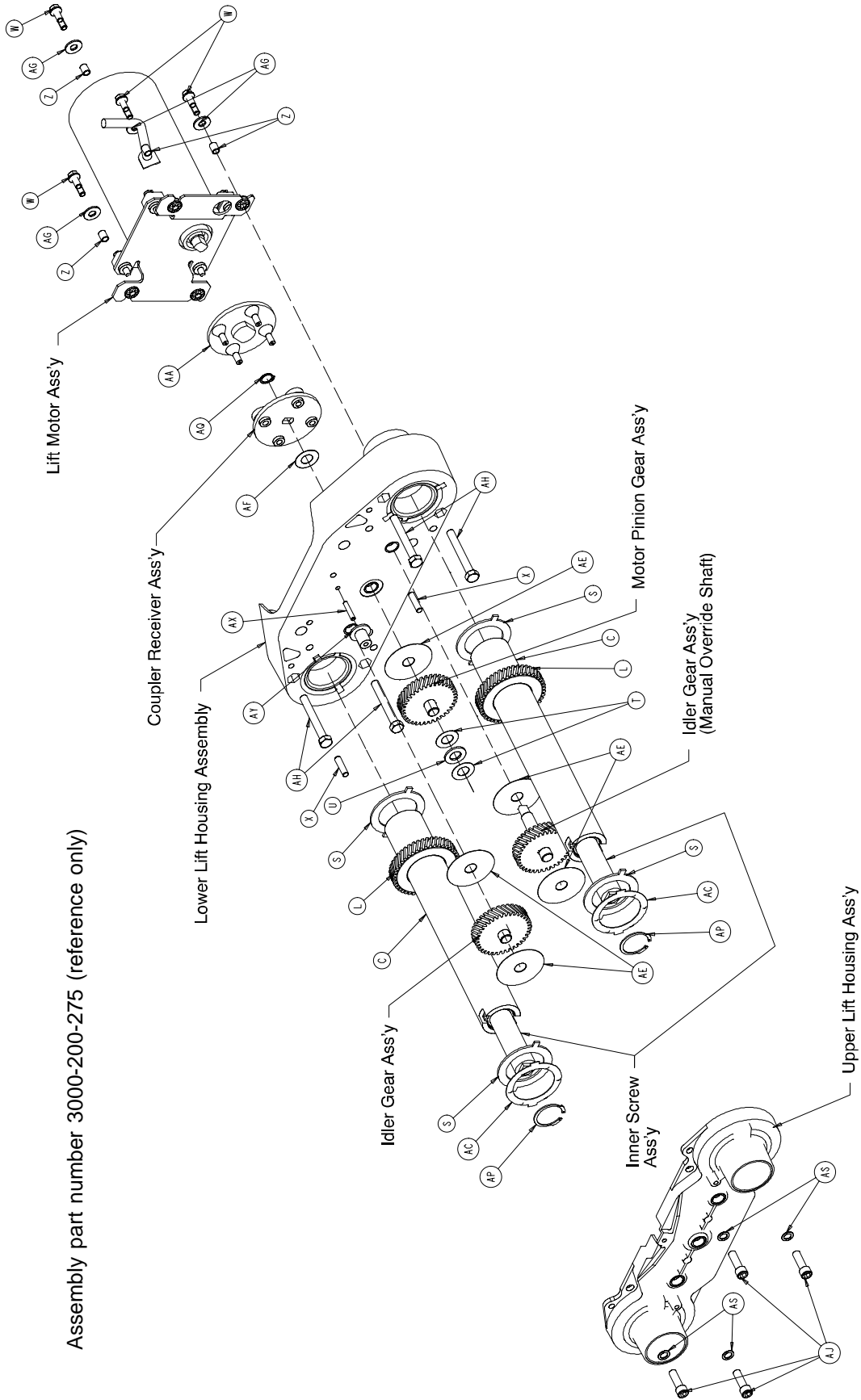

# Lift Assembly (Common)

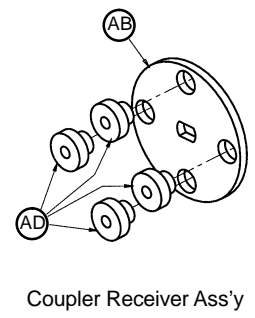
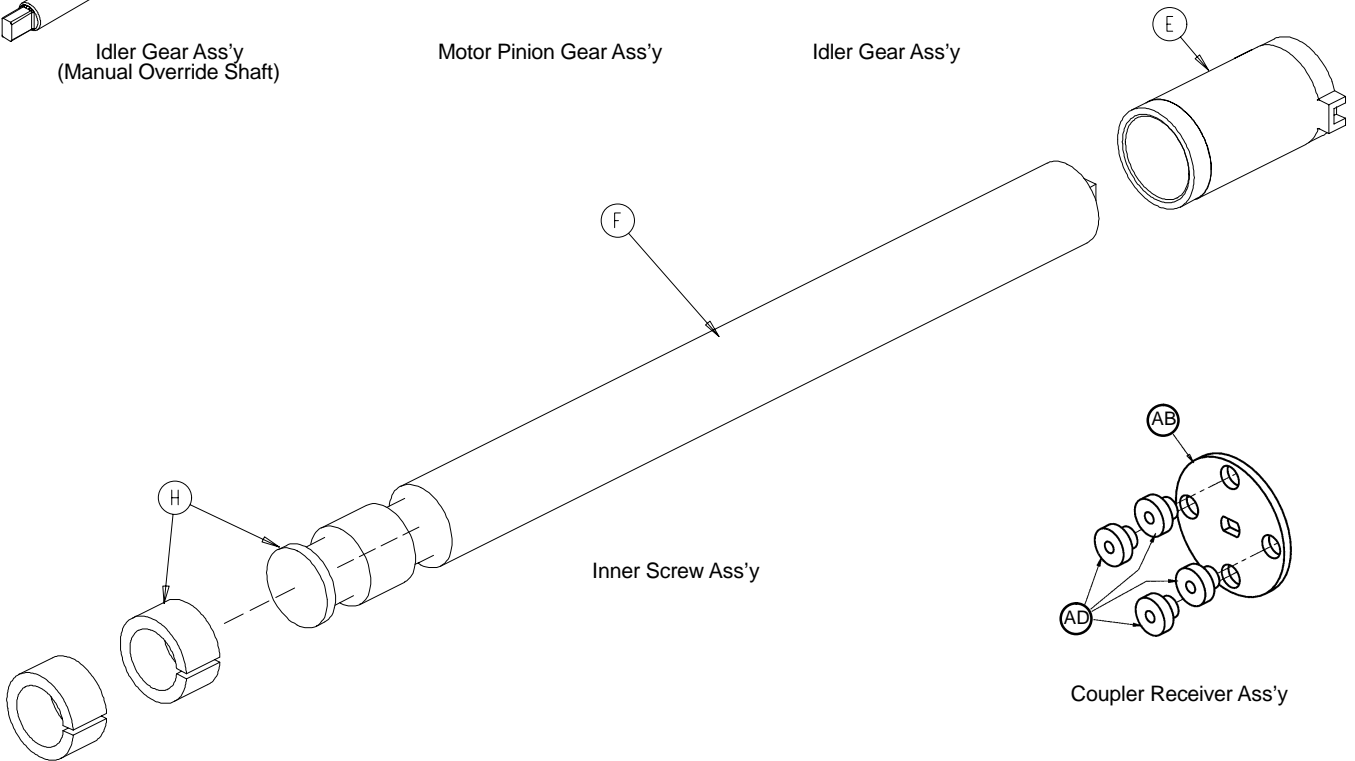
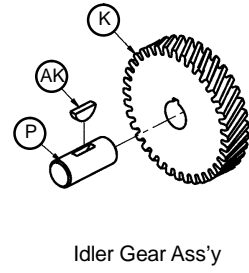
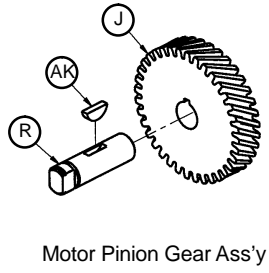
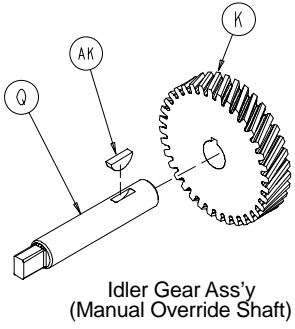
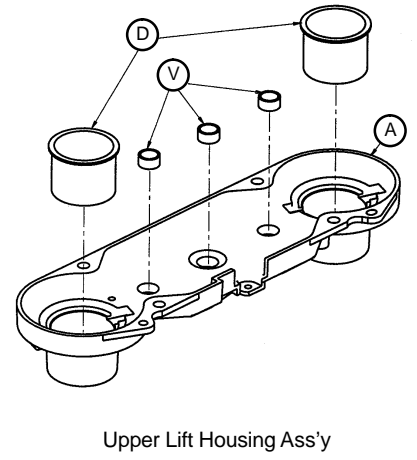
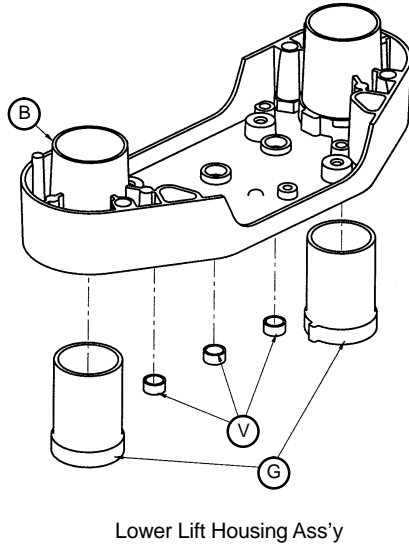
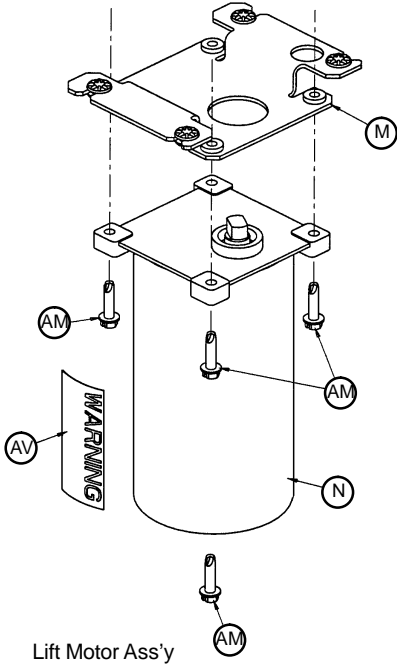



# Lift Assembly (Common)

---

Item	Part No.	Part Name	Qty.
A	3000-200-201	Upper Lift Housing	1
B	3000-200-202	Lower Lift Housing	1
C	3000-200-251	Outer Screw	2
D	3000-200-204	Upper Housing Sleeve	2
E	3000-200-205	Upper Stage Nut	2
F	3000-200-249	Inner Screw	2
G	3000-200-207	Lower Stage Nut	2
H	3000-200-208	Glide Bushing	4
J	3000-200-209	Motor Pinion Gear	1
K	3000-200-210	Idler Gear	2
L	3000-200-252	Output Gear	2
M	(page 103)	Motor Isolation Plate Ass'y	1
N	3000-200-213	Lift Motor	1
	3221-200-213	230V Lift Motor	1
P	3000-200-218	Idler Shaft, Lift	1
Q	3002-200-235	Idler Man. Over. Shaft	1
R	3000-200-220	Input Pinion Shaft	1
S	3000-200-223	Output Gear Thr. Washer	4
T	3000-200-224	Input Gear Thr. Washer	2
U	81-212	Thrust Needle Roller Brg.	1
V	3000-200-226	Pinion Shaft Bushing	6
W	3001-200-228	Mounting Standoff	4
X	26-231	Dowel Pin	2
Z	3001-300-19	Isolation Sleeve	4
AA	3000-200-233	Lift Motor Coupler	1
AB	3000-200-234	Coupler Receiver	1
AC	3000-200-241	Crush Washer	2
AD	3000-300-455	Isolation Bushing	4
AE	3000-200-245	Gear Washer	5
AF	3000-200-246	Nylon Washer	1
AG	11-408	Flat Washer	4
AH	3-82	Hex Hd. Cap Screw	4
AJ	4-213	Soc. Hd. Cap Screw	4
AK	58-44	Woodruff Key	3
AM	3-331	Hex Washer Hd. Screw	4
AP	28-121	Retaining Ring	2
AQ	28-97	Retaining Ring	1
AS	11-308	Serrated Belleville Washer	4
AV	3000-300-604	Warning Label	1
AX	3000-200-239	Pot. Drive Gear Shaft	1
AY	3000-200-216	Potentiometer Drive Gear	1

# 3000-200-723 Motor Isolation Plate Assembly

Assembly part number 3001-200-214 (reference only)

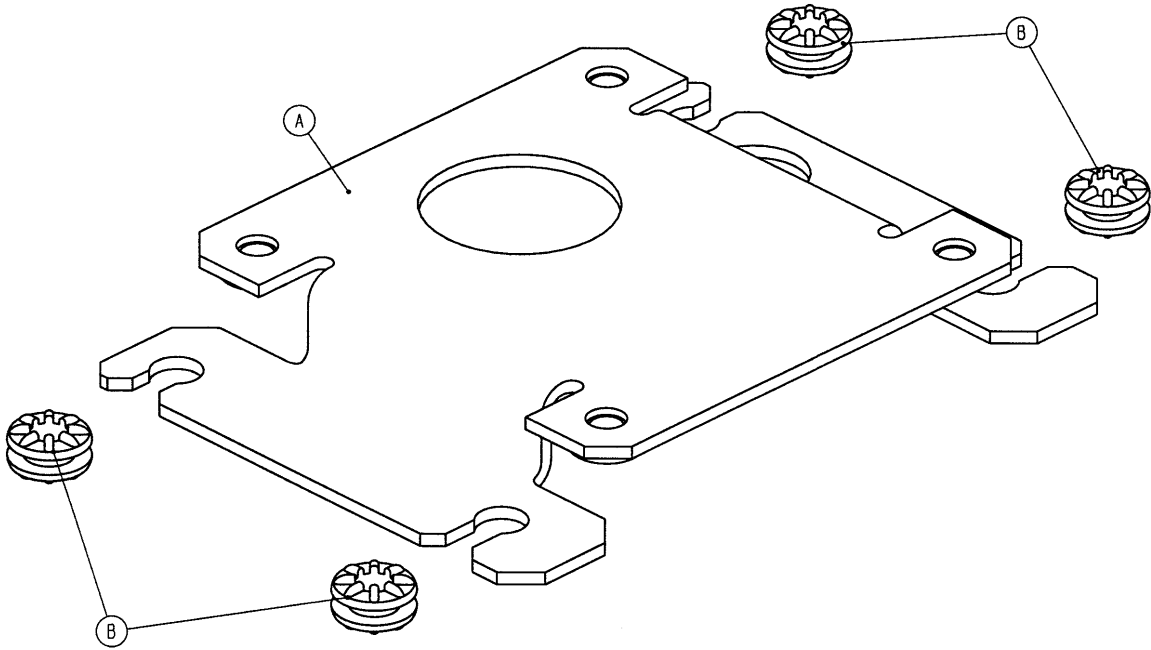

Item	Part No.	Part Name	Qty.
A	3001-200-213	Isolation Plate	1
B	3000-300-442	Grommet	4

# Brake Shaft Assembly, Left and Right

---

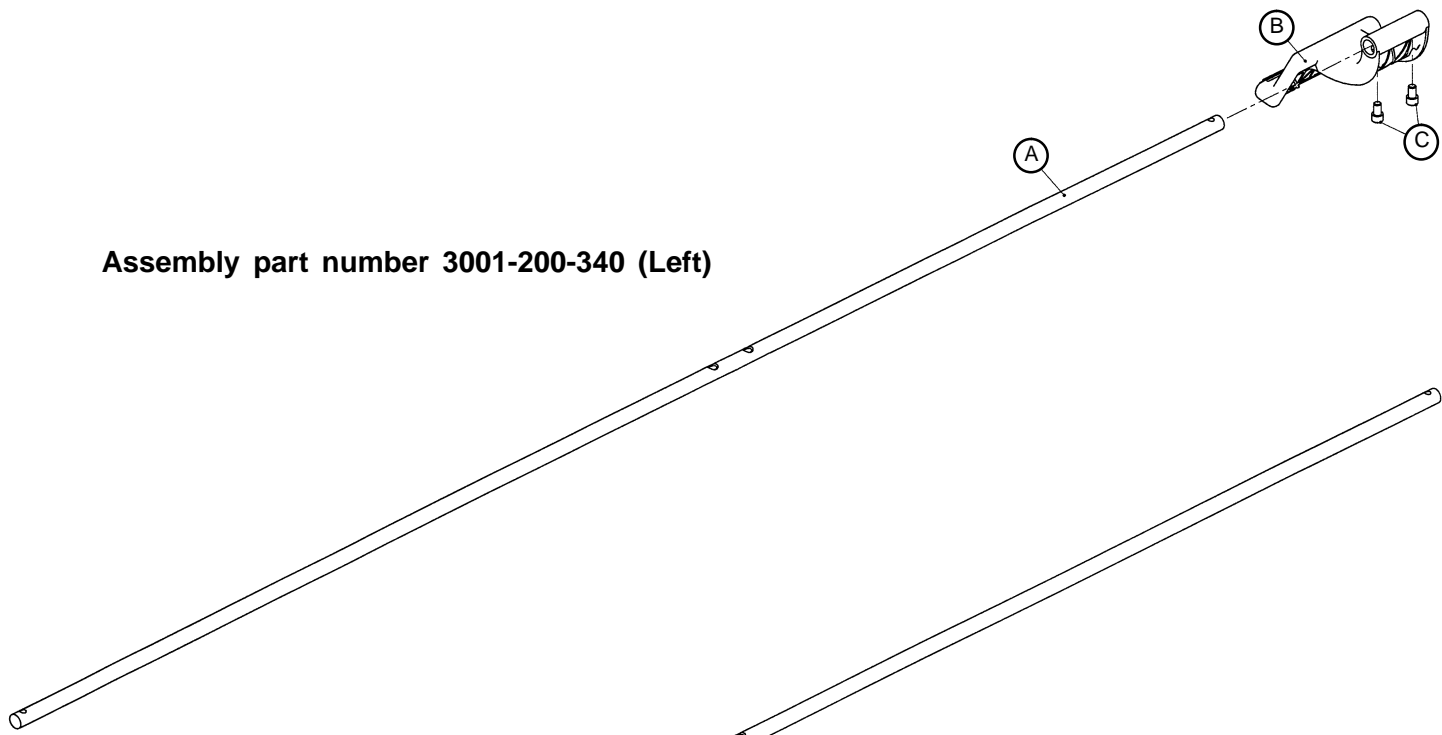

Assembly part number 3001-200-340 (Left)

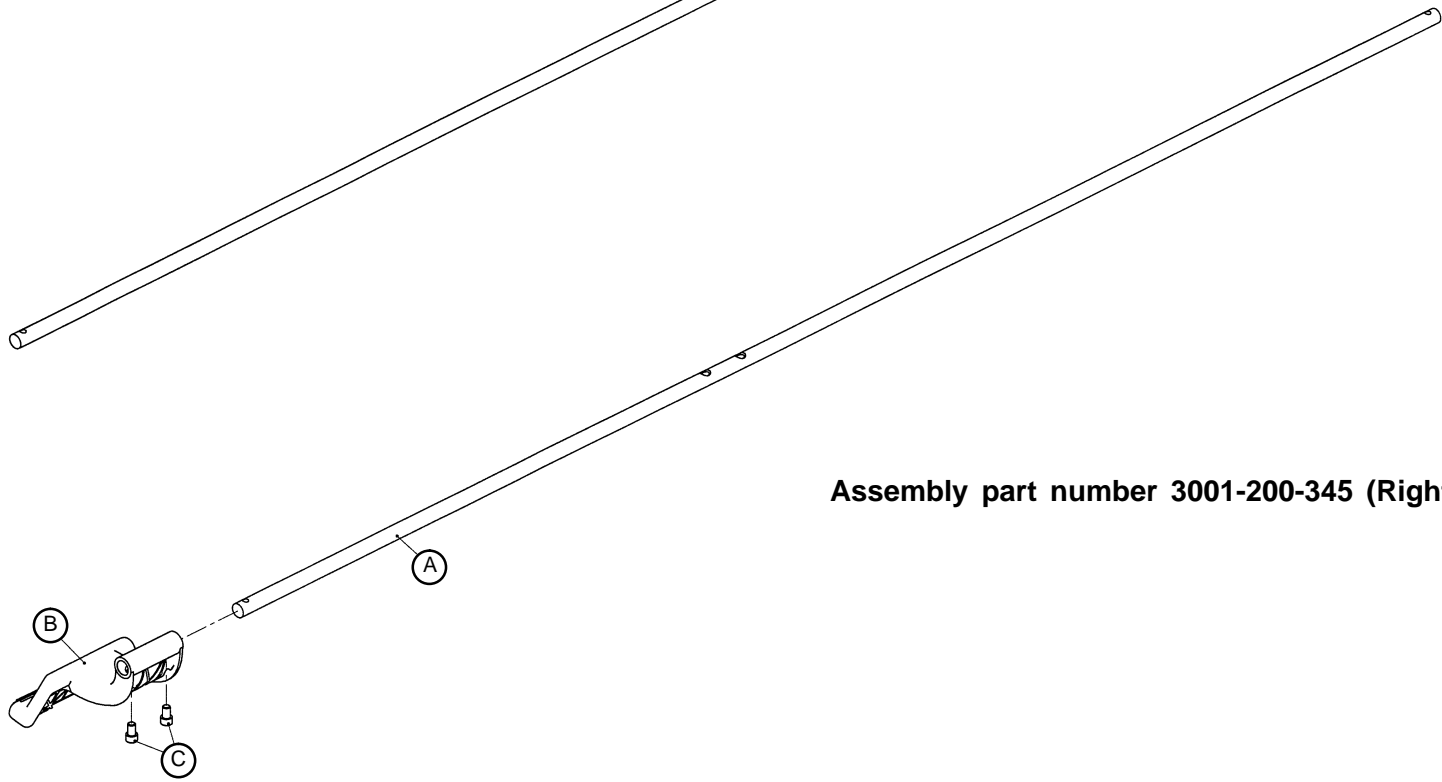

Assembly part number 3001-200-345 (Right)

Item	Part No.	Part Name	Qty.
A	3000-200-314	Brake Shaft	1
B	3001-200-325	Brake Pedal	1
C	4-270	Soc. Hd. Cap Screw	2

# 3002-200-330 Brake Crank Assembly

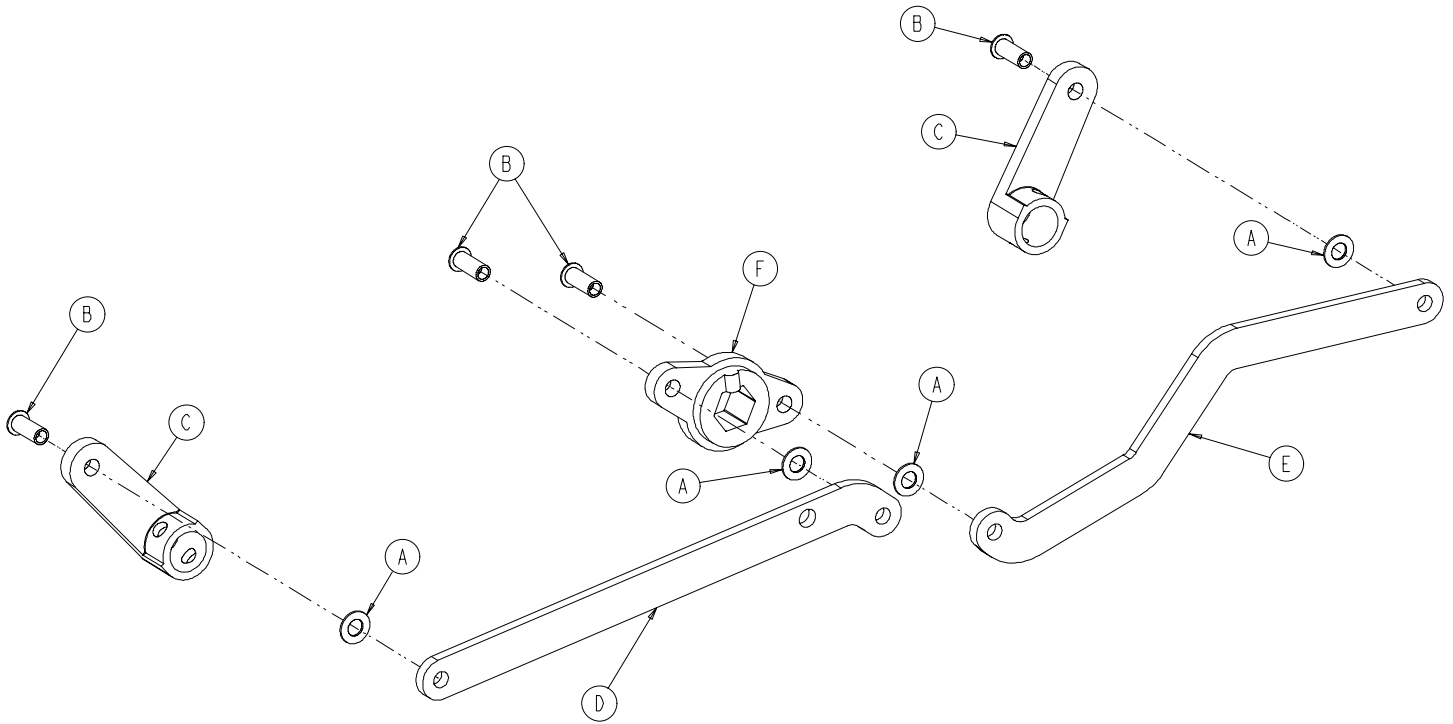

Item	Part No.	Part Name	Qty.
A	14-4	Washer	4
B	25-146	Semi-Tubular Rivet	4
C	3000-200-302	Brake Shaft Crank	2
D	3001-200-311	Brake Link	1
E	3001-200-312	Dog Leg Brake Link	1
F	3002-200-309	Brake Crank	1

# 3002-200-335 Brake Bar Assembly

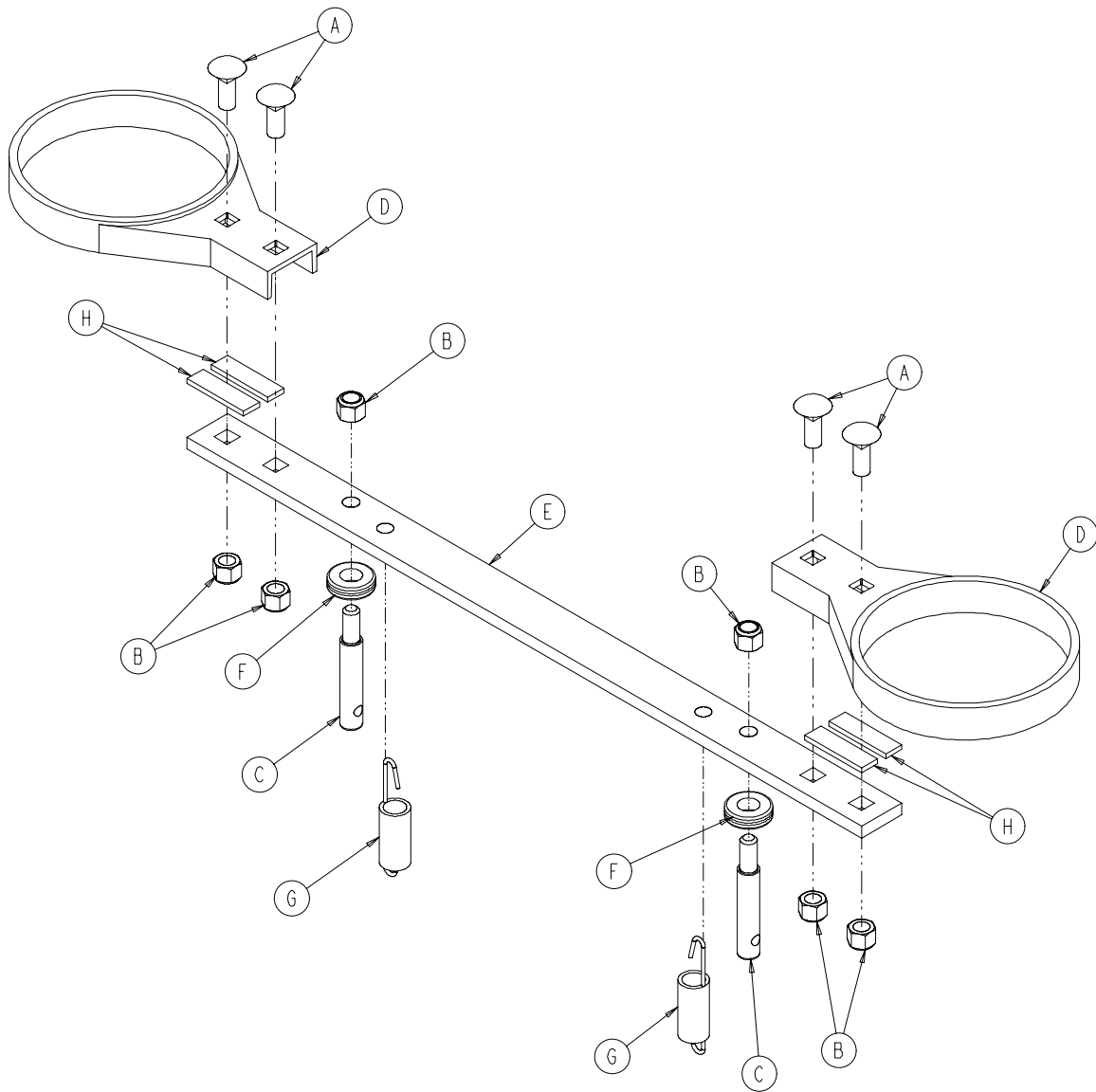

Item	Part No.	Part Name	Qty.
A	5-18	Carriage Bolt	4
B	16-35	Nylock Hex Nut	6
C	3000-200-318	Guide Pin	2
D	3000-200-321	Brake Ring	2
E	3000-200-323	Brake Bar	1
F	3000-200-324	Brake Bar Bumper	2
G	3002-200-310	Brake Bar Return Spring	2
H	7000-1-326	Sealing Tape	As Req'd

# 3001-200-60 6" Caster Assembly

---

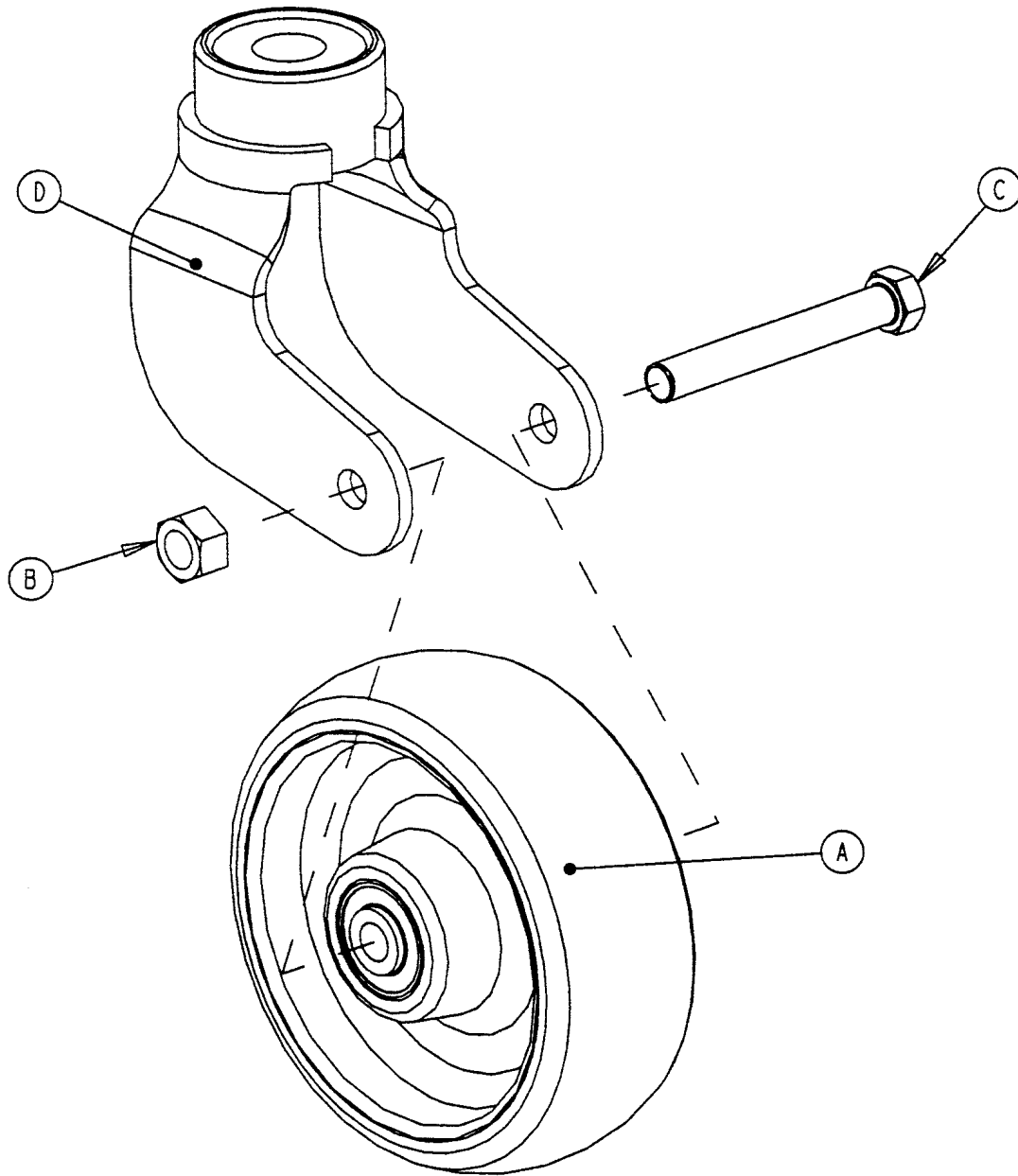

Item	Part No.	Part Name	Qty.
A	(page 109)	Wheel Assembly	1
B	16-60	Lock Nut	1
C	3-342	Hex Hd. Cap Screw	1
D	3001-200-61	Caster Horn w/Bearing	1

# 3001-200-50 6" Steer Caster Assembly

---

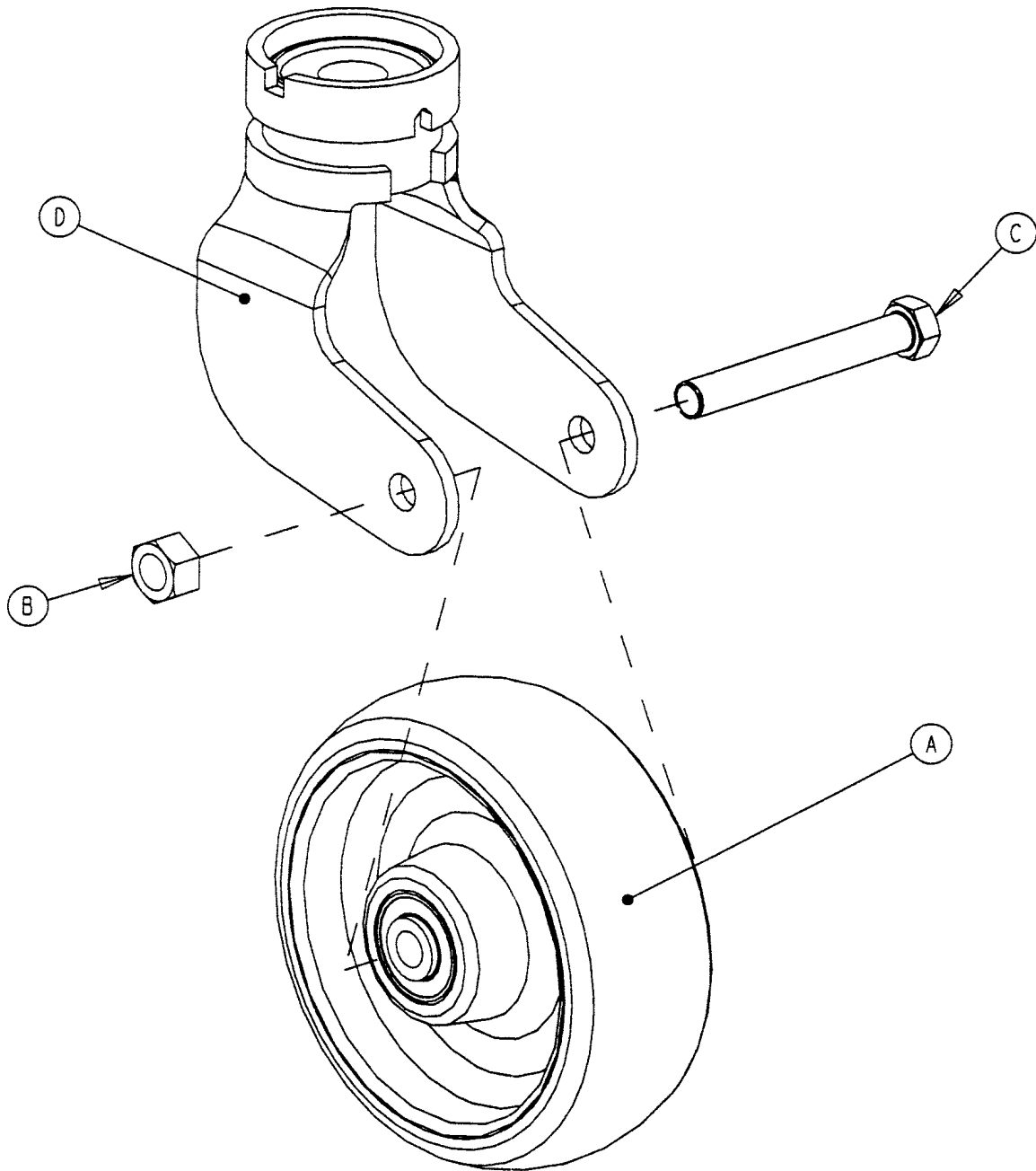

Item	Part No.	Part Name	Qty.
A	(page 109)	Wheel Assembly	1
B	16-60	Lock Nut	1
C	3-342	Hex Hd. Cap Screw	1
D	3001-200-51	Steer Caster Horn w/Bearing	1

# 5000-2-10 6" Molded Wheel Assembly

---

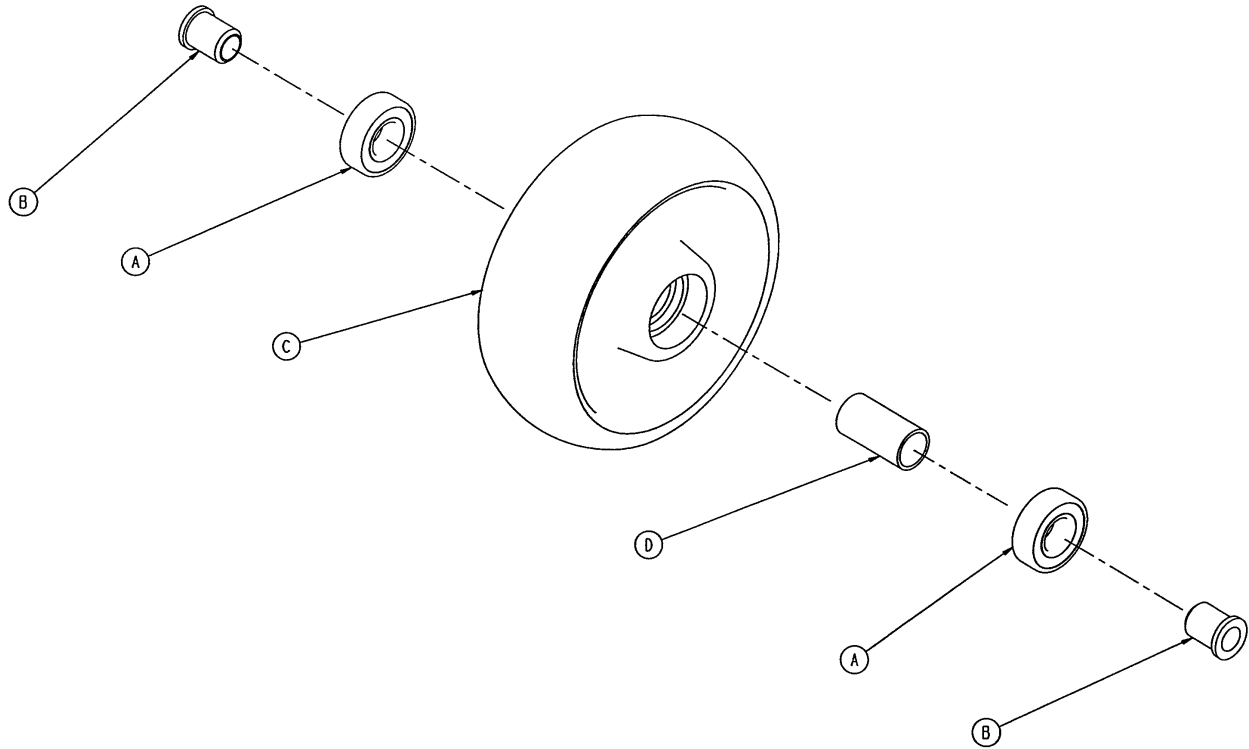

Item	Part No.	Part Name	Qty.
A	81-226	Bearing	2
B	715-1-255	Wheel Bushing	2
C	5000-2-20	Molded Wheel	1
D	6060-2-46	Bearing Spacer	1



# 3001-200-90 Optional 8" Caster Assembly

---

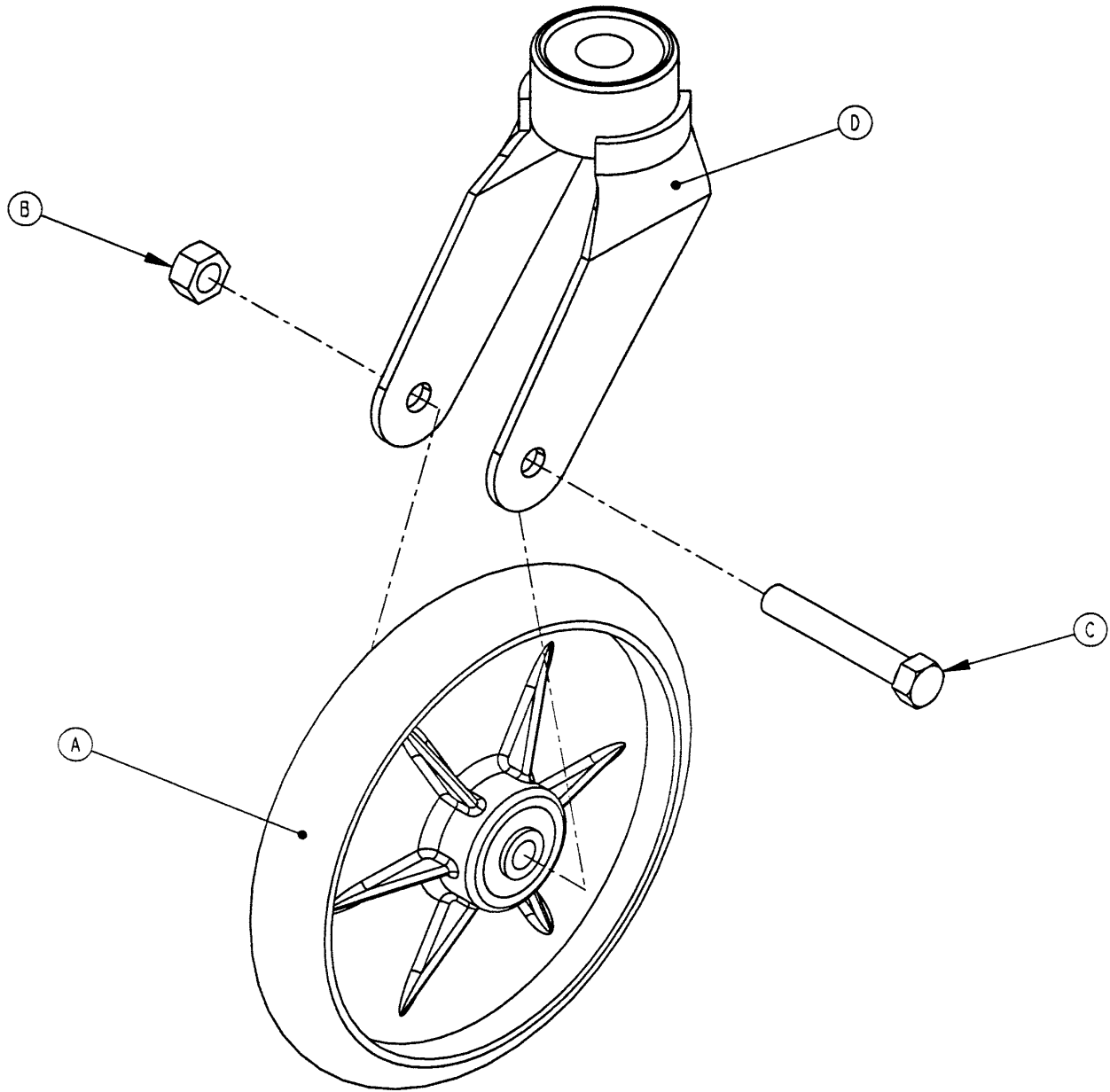

Item	Part No.	Part Name	Qty.
A	(page 112)	Wheel Assembly	1
B	16-60	Hex Nut	1
C	3-99	Hex Hd. Cap Screw	1
D	3001-200-76	Caster Horn	1

# 3001-200-80 Optional 8" Steer Caster Assembly

---

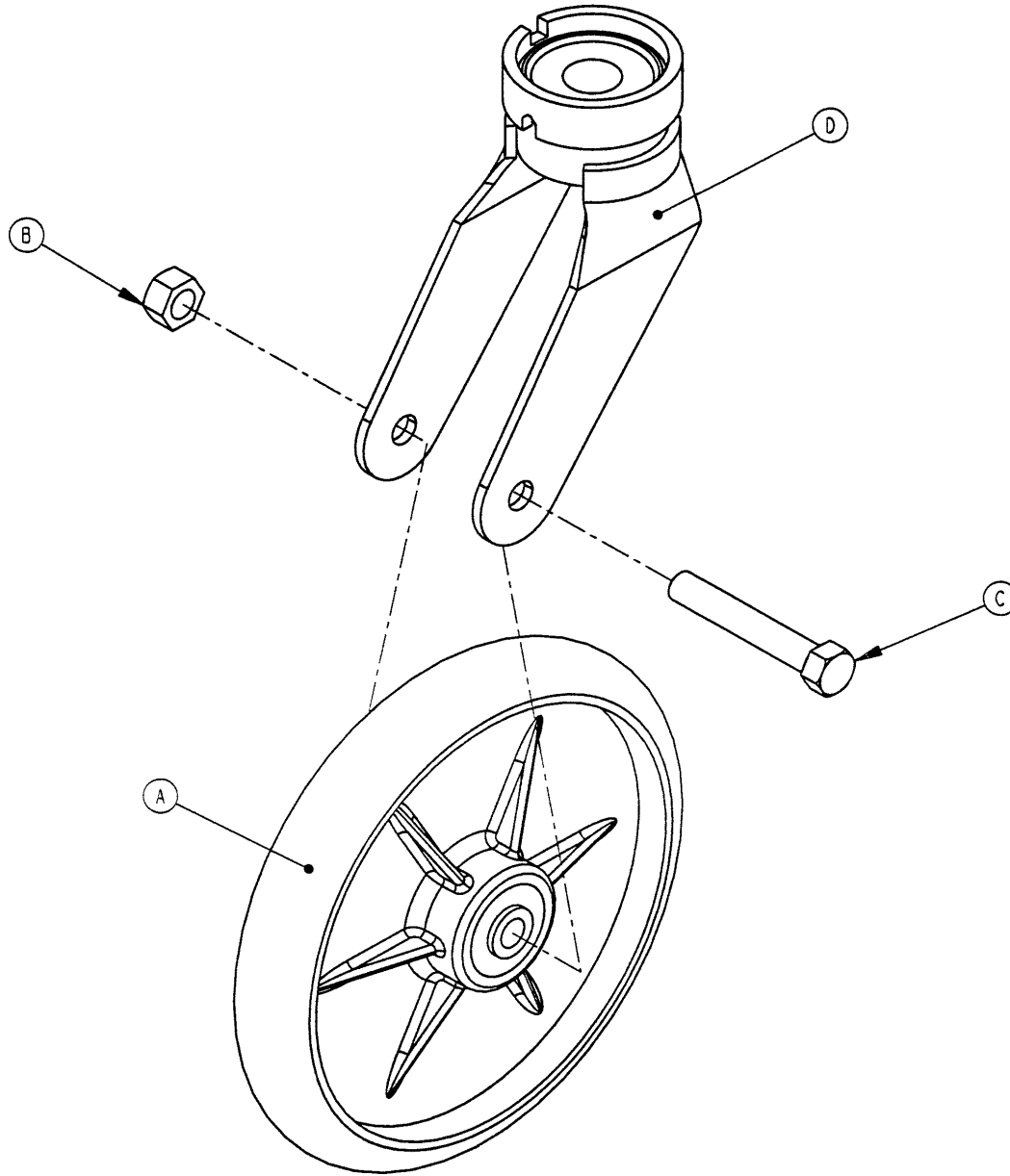

Item	Part No.	Part Name	Qty.
A	(page 112)	Wheel Assembly	1
B	16-60	Hex Nut	1
C	3-99	Hex Hd. Cap Screw	1
D	3001-200-81	Caster Horn	1

# 2025-1-49 Optional 8" Wheel Assembly

---

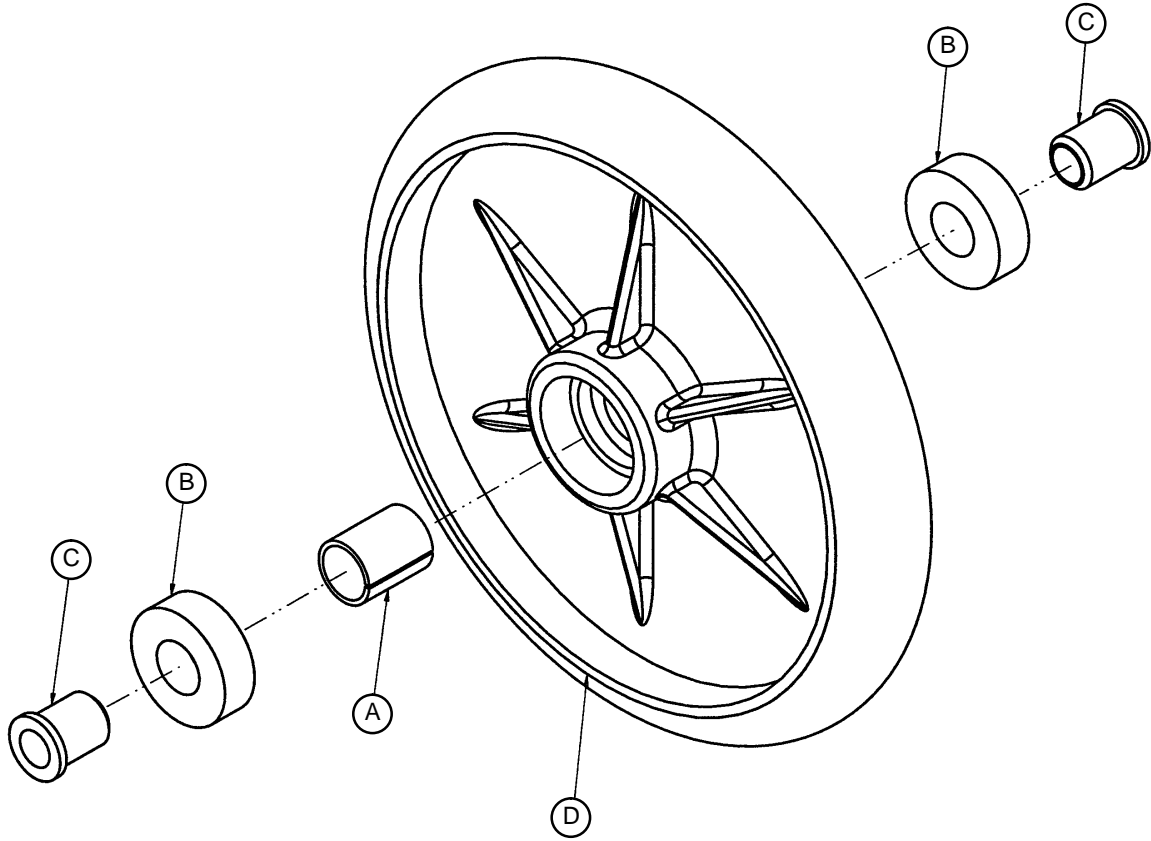

Item	Part No.	Part Name	Qty.
A	52-503	Bearing Spacer	1
B	81-226	Bearing	2
C	715-1-255	Wheel Bearing	2
D	2025-1-46	Wheel	1

# Zoom Option Base Assembly

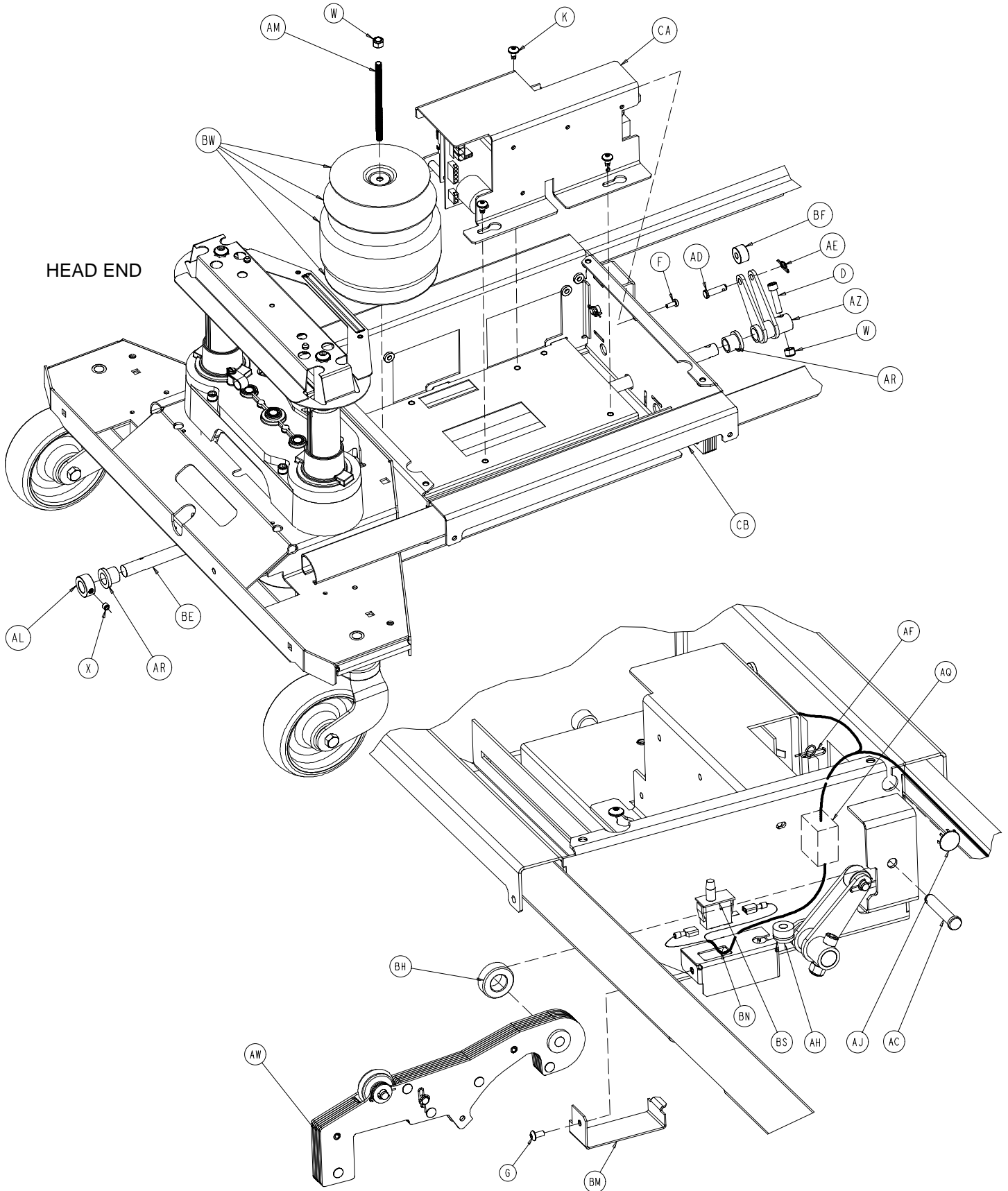

# Zoom Option Base Assembly

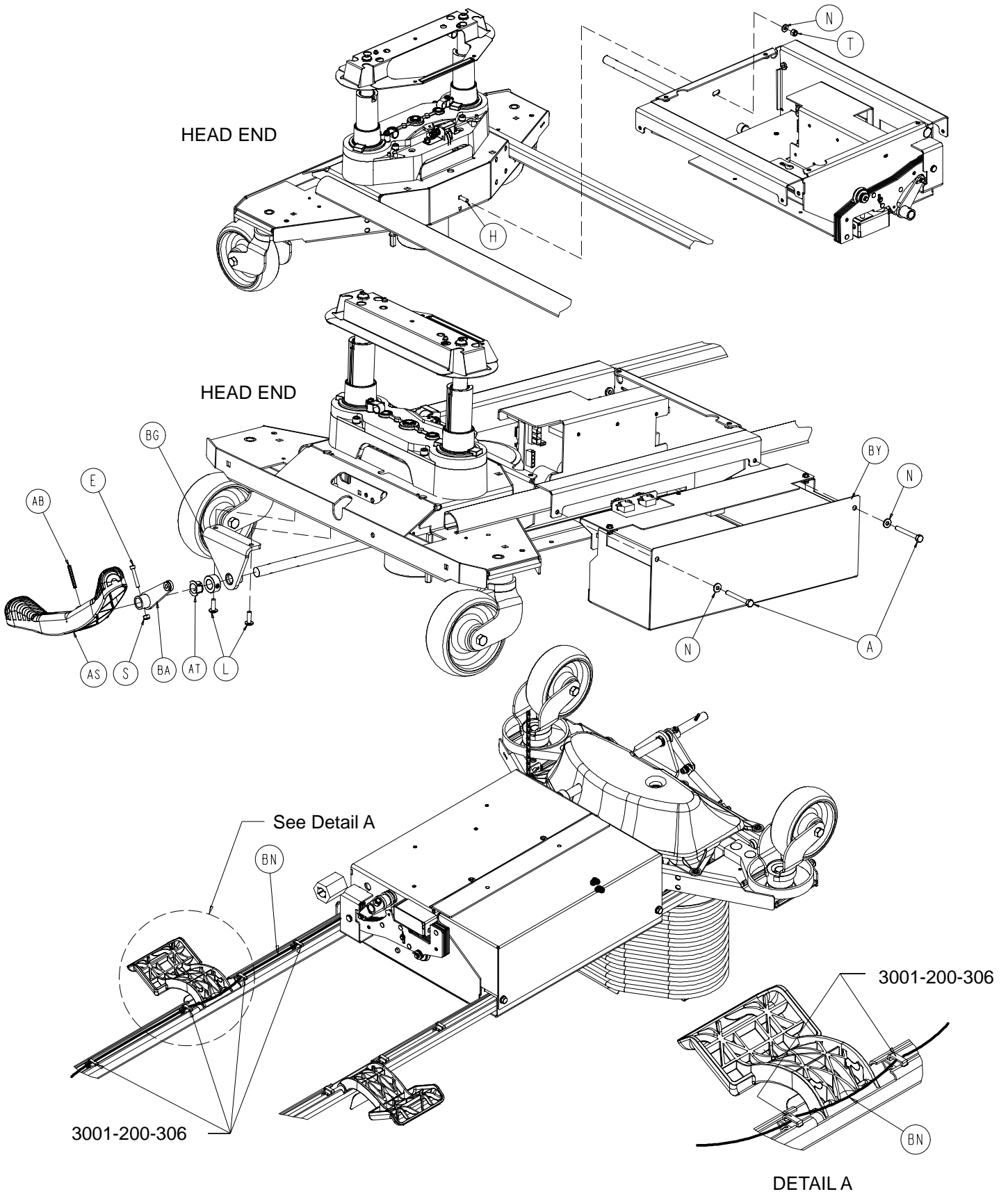

# Zoom Option Base Assembly

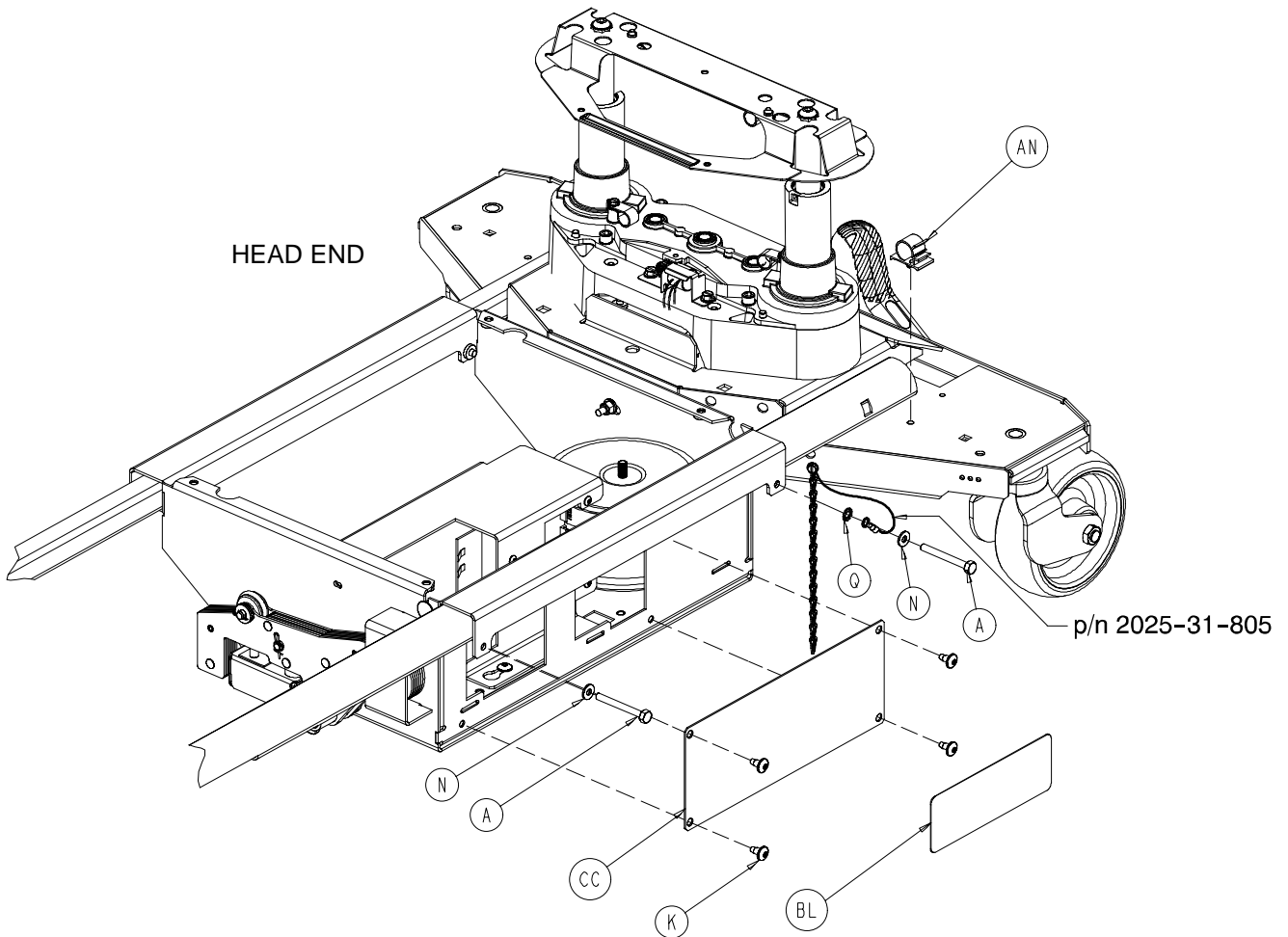
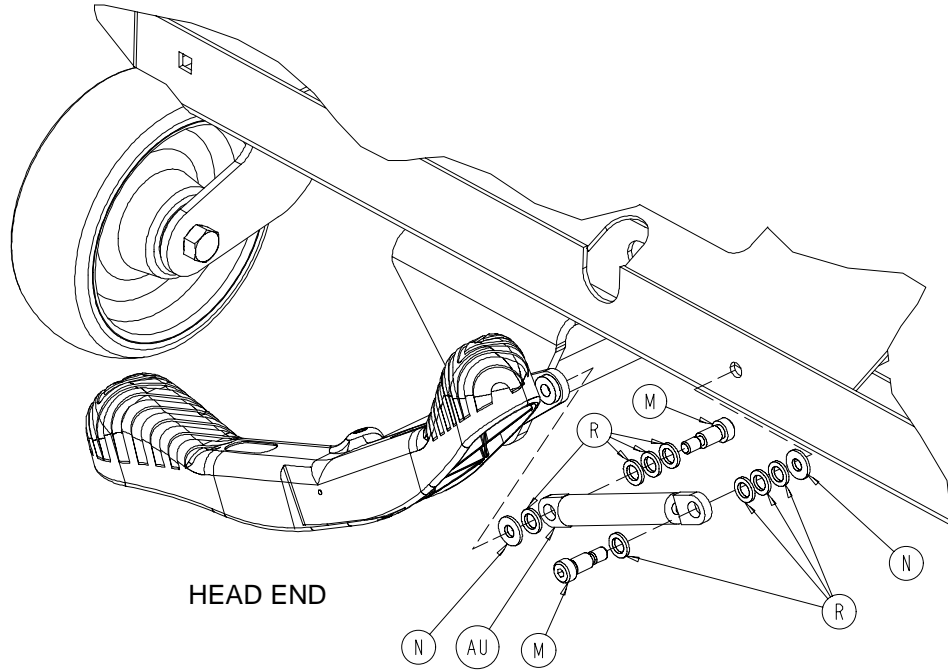

# Zoom Option Base Assembly

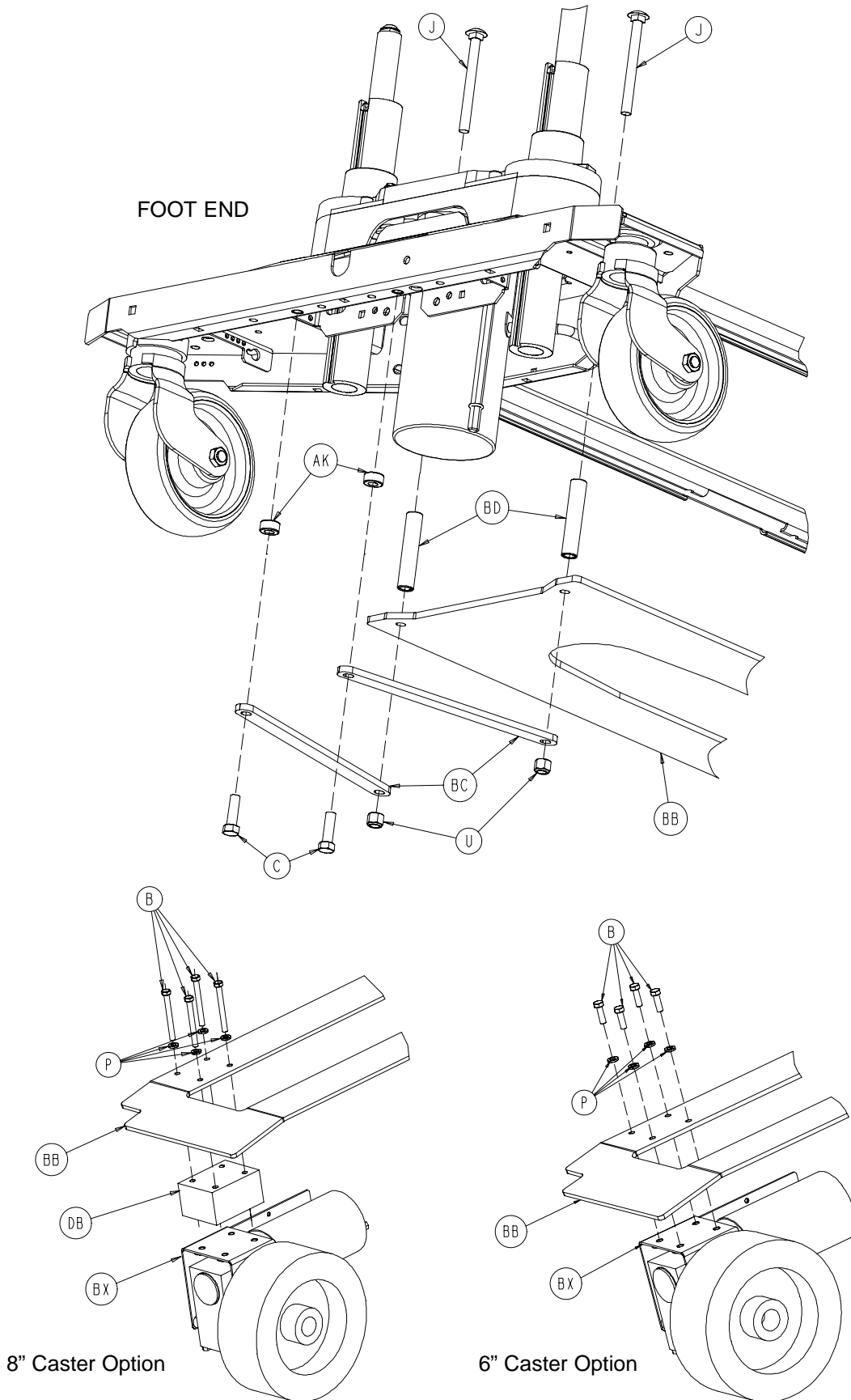

# Zoom Option Base Assembly

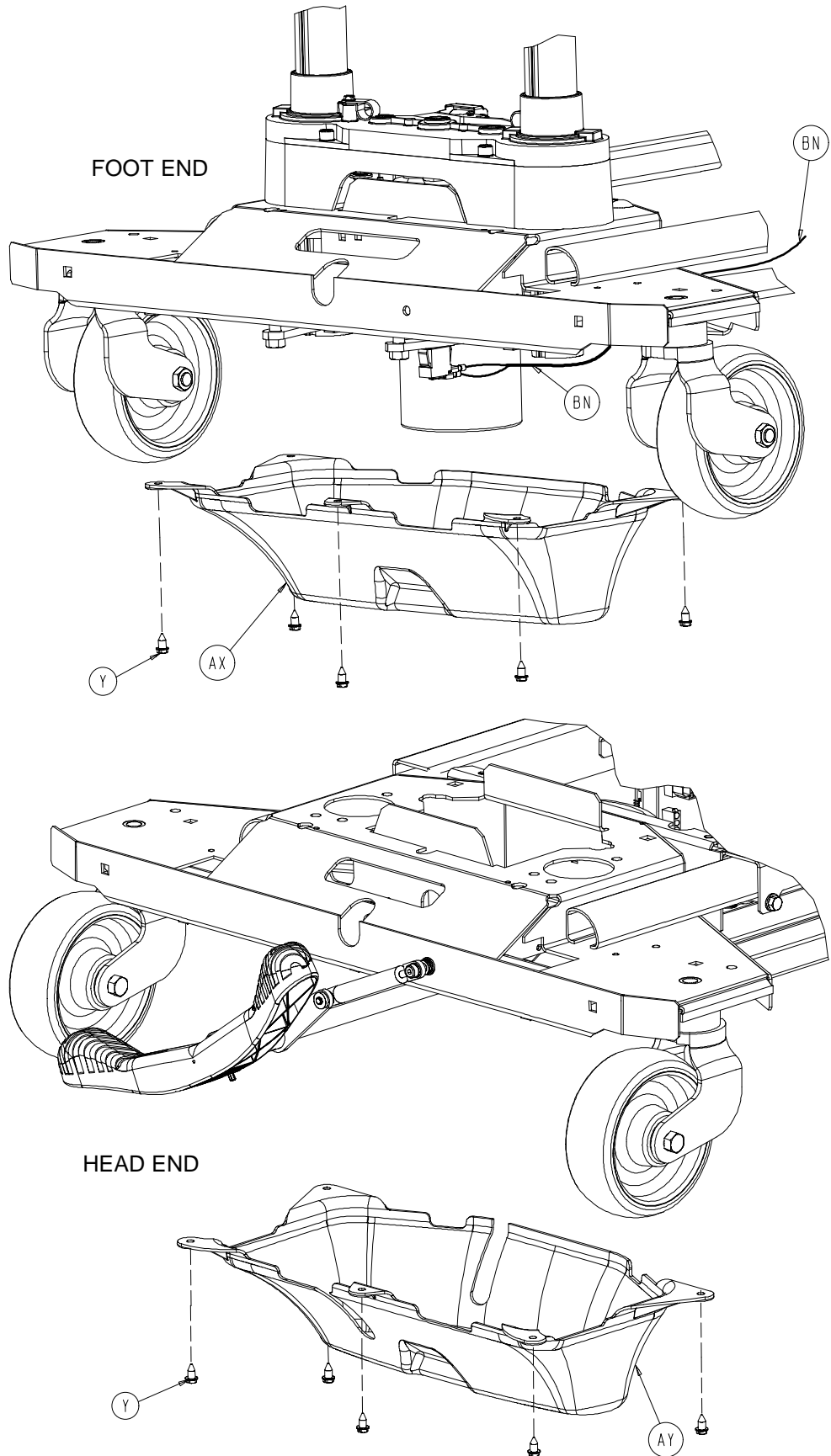



# Zoom Option Base Assembly

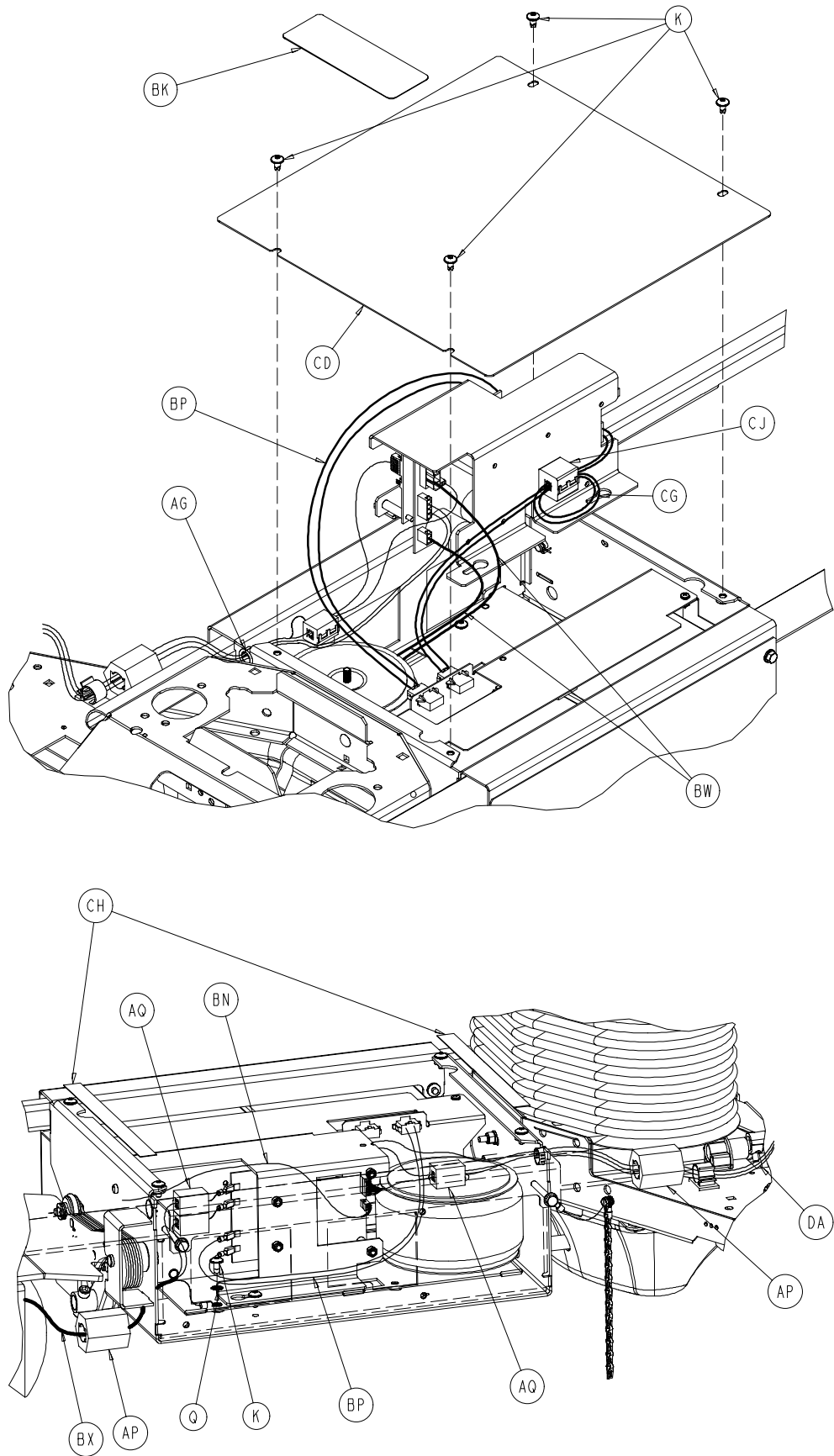

# Zoom Option Base Assembly

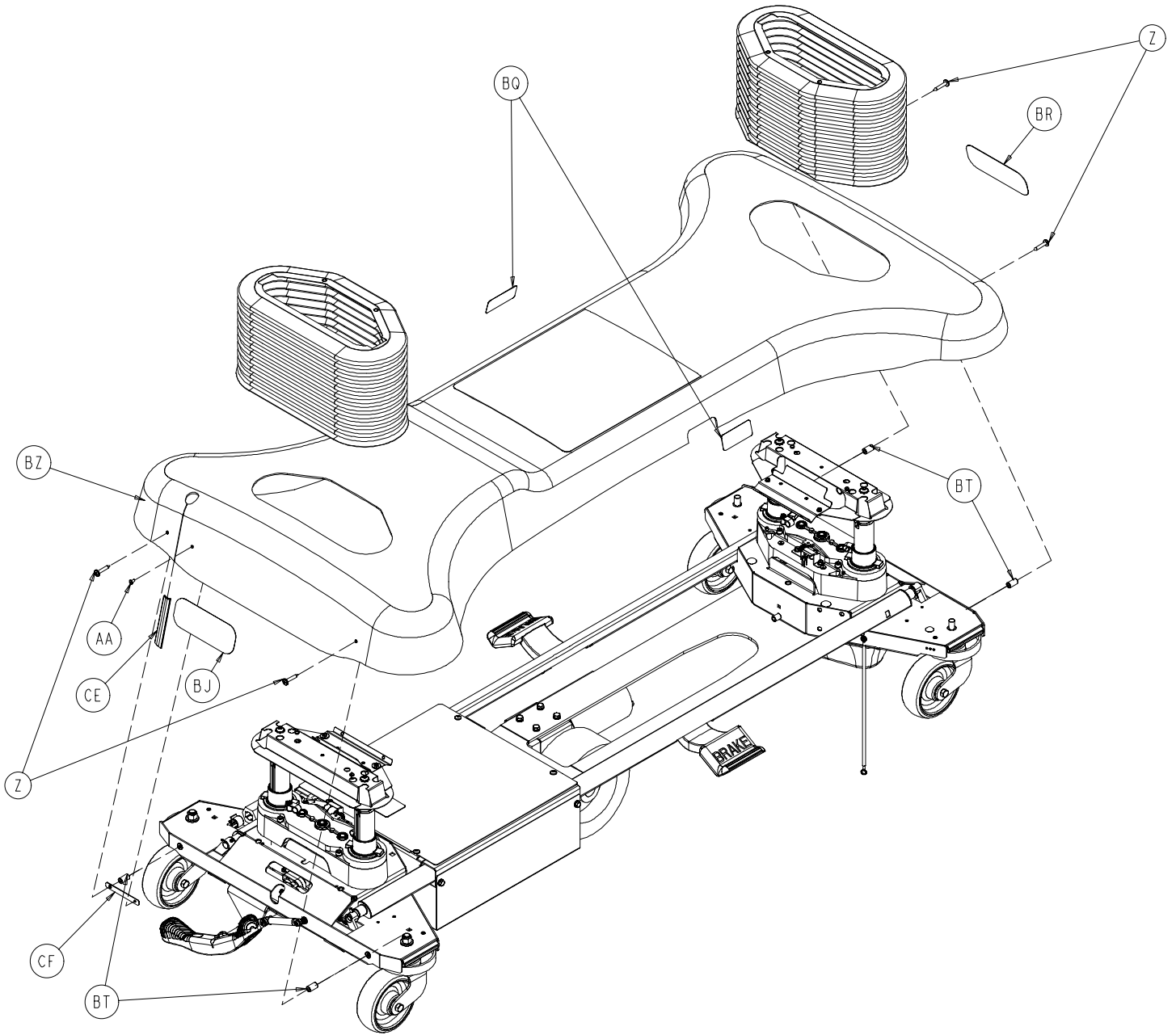

# Zoom Option Base Assembly

## Zoom Option Common Components - Part Number 3002-1-1 (Reference Only)

Item	Part No.	Part Name	Qty.	Item	Part No.	Part Name	Qty.
A	3-32	Hex Hd. Cap Screw	4	AT	1210-201-251	Insert Bushing	1
C	3-120	Hex Hd. Cap Screw	2	AU	1210-201-671	Damper	1
D	4-39	Soc. Hd. Cap Screw	1	AW	(page 121)	Drive Whl. Lift Lever Ass'y	1
E	4-160	Soc. Hd. Cap Screw	1	AX	(page 122)	Foot End Bottom Cover	1
F	4-263	H. Soc. But. Hd. Cap Screw	1	AY	(page 122)	Head End Bottom Cover	1
G	4-307	Soc. But. Hd. Cap Screw	1	AZ	2040-1-51	Pedal Crank Weldment	1
H	5-17	Carriage Bolt	1	BA	2040-1-53	Damper Crank Weldment	1
J	5-31	Carriage Bolt	2	BB	2040-1-60	Leaf Spring	1
K	7-52	Truss Hd. Torx	12	BC	2040-1-61	Tie Down Strap	2
L	7-63	Truss Hd. Torx	2	BD	2040-1-62	Reinforcement Tube	2
M	8-49	Soc. Hd. Shoulder Bolt	2	BE	2040-1-82	Pedal Rod	1
N	11-63	Washer	7	BF	2040-1-83	Pedal Crank Roller	1
P	12-20	Lock Washer	4	BG	2040-1-84	Pedal Rod Pivot Bracket	1
Q	13-10	Ext. Tooth Star Washer	4	BH	2040-1-98	Lift Lever Spacer	1
R	14-3	Plastic Washer	8	BJ	2040-1-100	Drive Whl. Position Label	1
S	16-3	Nylock Nut	1	BK	2040-1-101	Charger Box Cover	1
T	16-28	Nylock Nut	1	BL	2040-1-102	Power Bd. Cover Label	1
U	16-35	Nylock Nut	2	BM	2040-1-103	Charger Box Sw. Brkt. Cov.	1
W	16-36	Nylock Nut	2	BN	2040-1-801	Base Switch Cable	1
X	21-22	Set Screw	1	BP	2040-1-804	Pwr. Bd. DC Pwr. Cable	1
Y	23-25	Hex Washer Hd. Screw	10	BQ	3000-200-601	Brake Label	2
Z	23-281	Self-Tapping Screw	4	BR	3000-200-602	Stryker Logo Label	1
AA	25-79	Pop Rivet	1	BS	3000-300-58	Limit Switch	1
AB	26-261	Groove Pin	1	BT	3000-300-428	Gatch Link Sleeve	4
AC	26-277	Clevis Pin	1	BU	3000-300-1 13	Wire Ties	2
AD	26-297	Clevis Pin	1	BW	3001-1-10	Transformer	1
AE	27-21	Rue Ring Cotter	1	BX	(page 123)	Drive Train Assembly	1
AF	27-22	Rue Ring Cotter	1	BY	(page 124)	Battery Tray Assembly	1
AG	30-38	Split Bushing	1	BZ	3002-1-18	Hood Assembly	1
AH	30-40	E-A-R Grommet	1	CA	(page 125)	Base Power Assembly	1
AJ	37-221	Hole Plug	1	CB	3002-1-50	Charger Box Weldment	1
AK	42-6	Collar	2	CC	3002-1-68	Power PCB Cover	1
AL	42-20	Lock Collar	1	CD	3002-1-71	Charger/Inverter Cover	1
AM	58-90	Threaded Stud	1	CE	3002-1-78	Hood Slot Trim	1
AN	59-133	Push-Mount Wire Clip	1	CF	3002-1-79	Hood Slot Trim Bracket	1
AP	59-192	Split Ferrite	1	CG	3002-1-802	Inverter/Battery Cable	1
AQ	59-194	Split Ferrite	3	CH	7000-1-326	Foam Tape (10")	2
AR	81-245	Bronze Bushing	2	CJ	59-144	Split Ferrite	1
AS	1210-201-153	Butterfly "V" Pedal	1				

### Zoom Base, 6" Casters - 3002-244-10 (Ref.)

Item	Part No.	Part Name	Qty.
B	3-85	Hex Hd. Cap Screw	4
DA	3002-1-801	Umbilical Cable Ass'y	1

### Zoom Base, 8" Casters - 3002-248-10 (Ref.)

Item	Part No.	Part Name	Qty.
B	3-53	Hex Hd. Cap Screw	4
DA	3002-1-801	Umbilical Cable Ass'y	1
DB	2040-1-1	8" Caster Spacer	1

# Zoom Option Drive Wheel Lift Lever Assembly

Assembly part number 2040-1-12 (reference only)

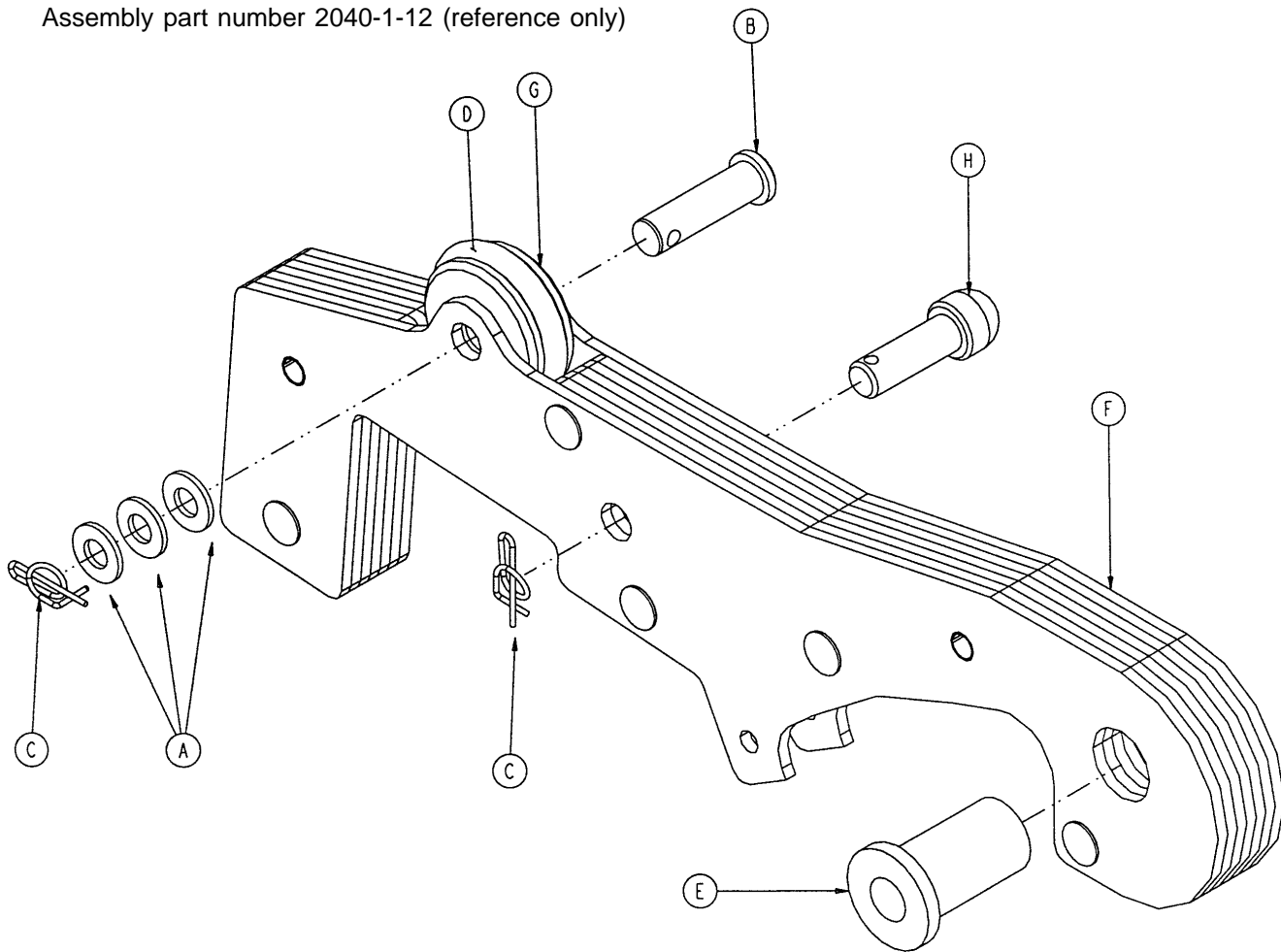

Item	Part No.	Part Name	Qty.
A	11-3	Washer	3
B	26-297	Clevis Pin	1
C	27-21	Rue Ring	2
D	45-232	O-Ring	1
E	81-70	Flange Bearing	1
F	2040-201-13	Drive Wheel Lift Plate Ass'y	1
G	2040-1-87	Lift Lever Roller	1
H	2040-1-99	Lift Lever Guide	1

## 3001-200-22 Foot End Bottom Cover

---

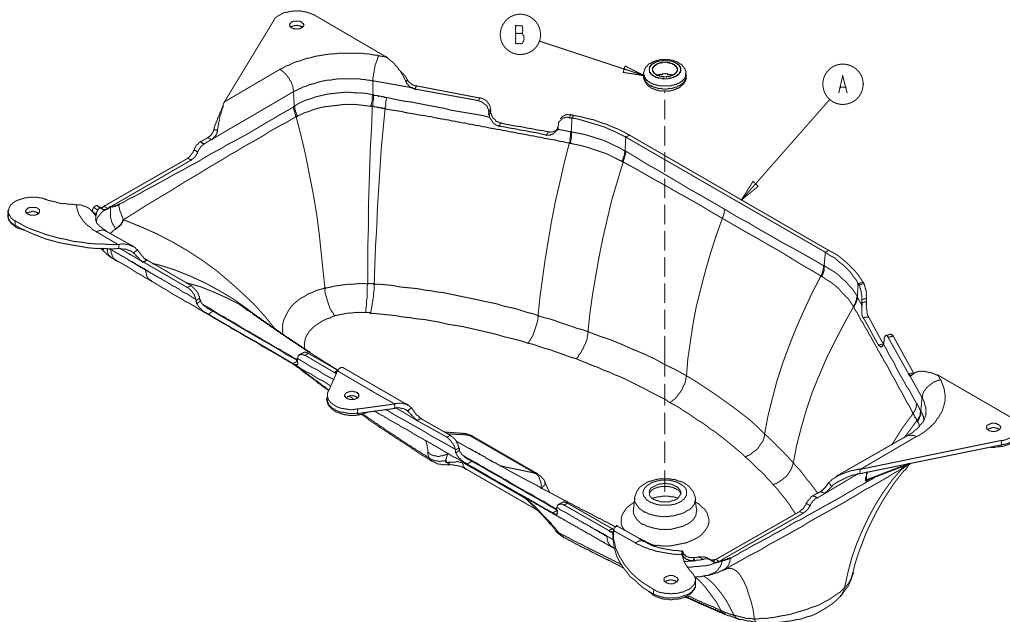

Item	Part No.	Part Name	Qty.
A	3002-1-100	Bottom Cover	1
B	3000-000-039	Grommet	1

## 2040-1-17 Zoom Option Head End Bottom Cover

---

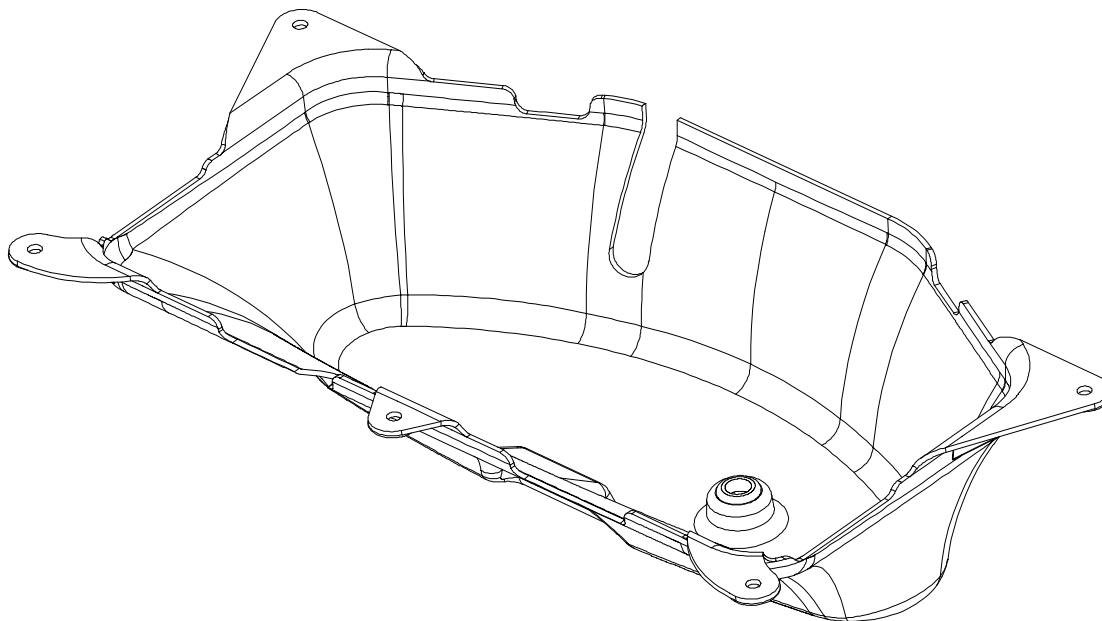

# 3002-1-14 Zoom Option Drive Train Assembly

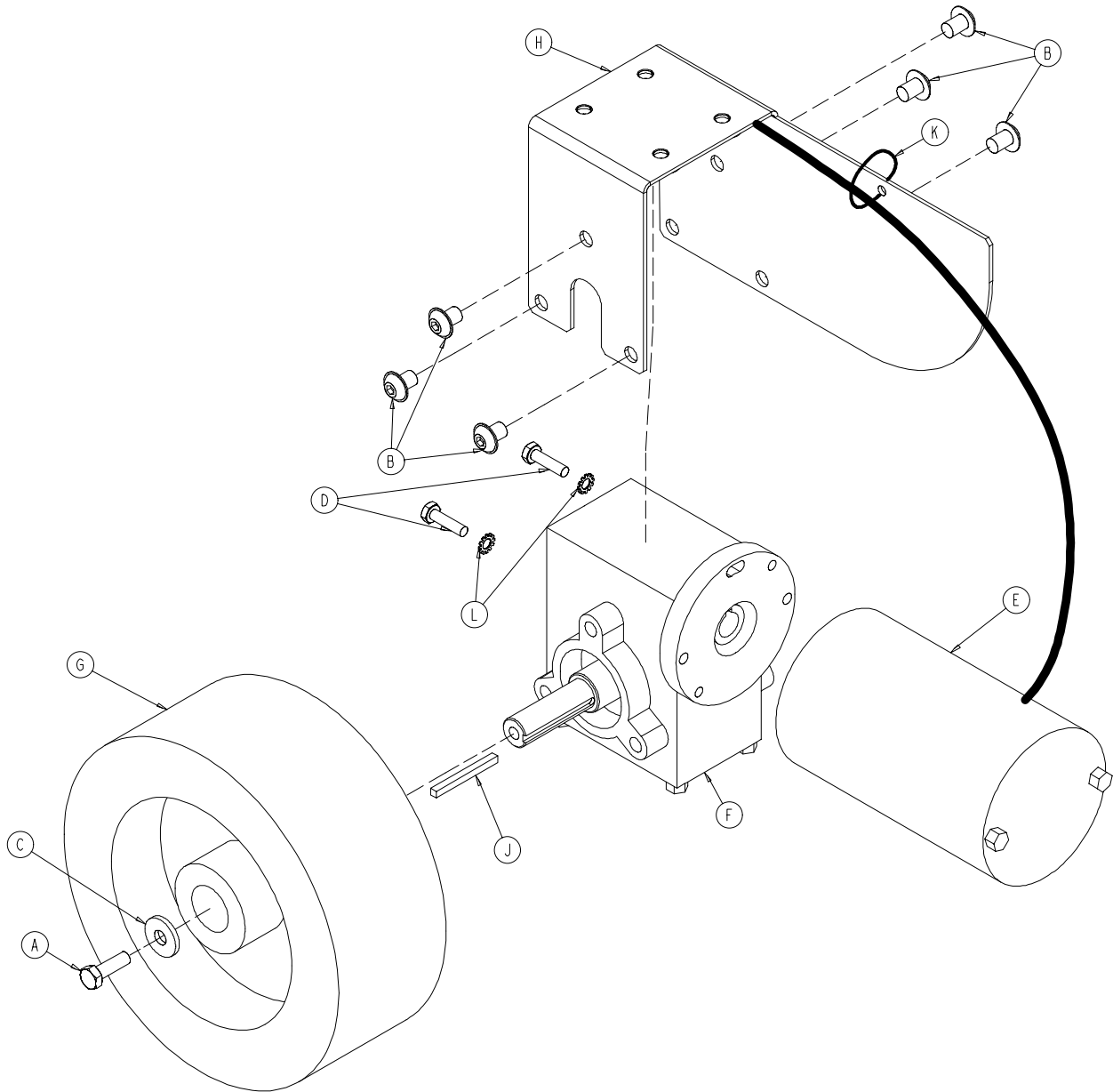

Item	Part No.	Part Name	Qty.
A	8839-793-700	Hex Hd. Cap Screw	1
B	4-338	Flanged But. Hd. Cap Screw	6
C	11-262	Washer	1
D	3-54	Hex Hd. Cap Screw	2
E	3002-1-72	Drive Train Motor	1
F	2040-1-73	Gear Box	1
G	2040-1-74	Drive Train Wheel	1
H	2040-1-75	Motor Mounting Bracket	1
J	2040-1-97	Square Key	1
K	3000-300-1 13	Wire Tie	1
L	13-10	Star Washer	2

# 3002-1-15 Zoom Option Battery Tray Assembly

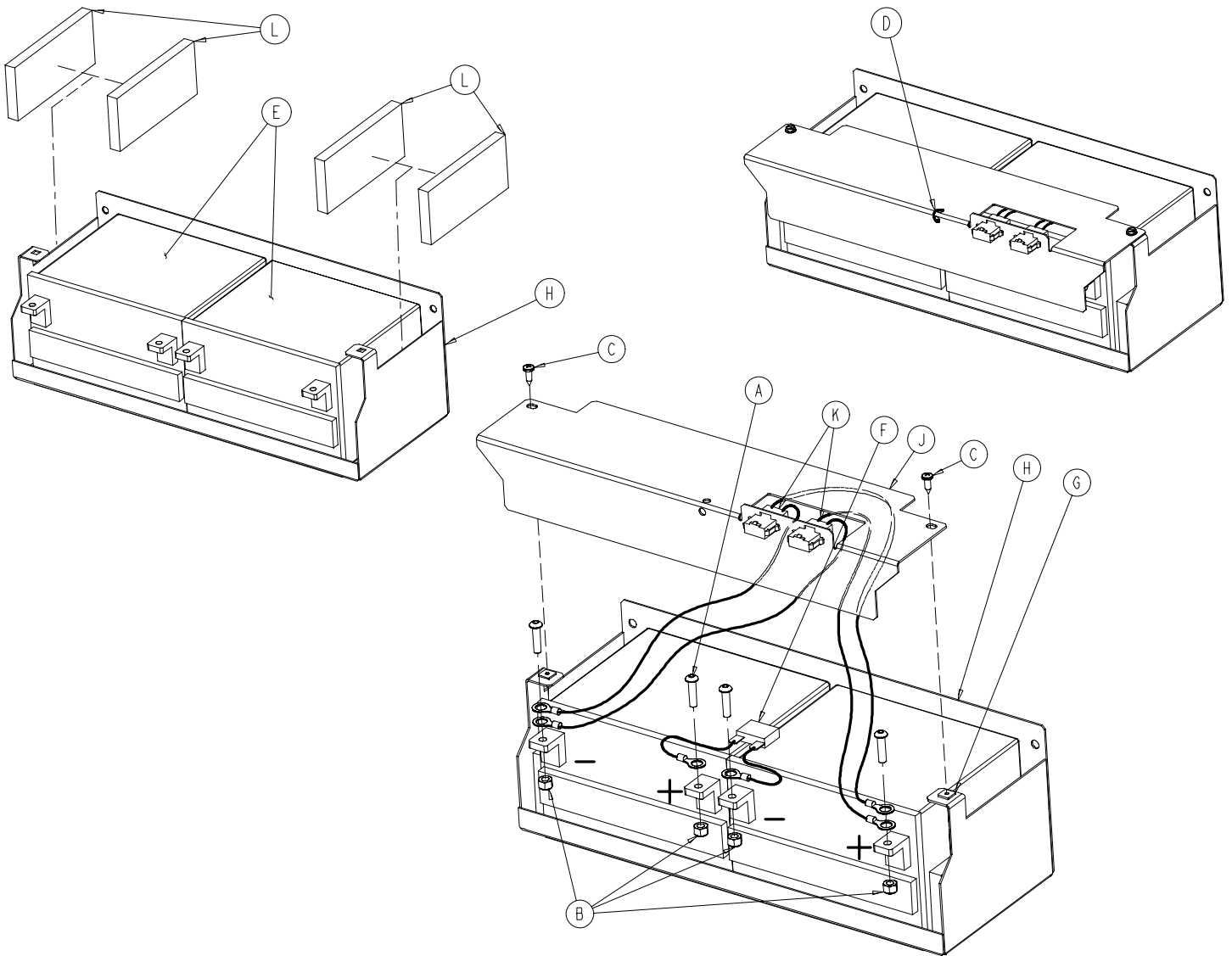

WIRING VIEW

Item	Part No.	Part Name	Qty.
A	4-46	But. Hd. Cap Screw	4
B	16-28	Nylock Nut	4
C	23-256	Pan Hd. Screw	2
D	38-151	Cable Tie	1
E	2040-1-70	Battery	2
F	2040-1-802	Battery Jumper Cable	1
G	3000-300-2	Push Nut	2
H	3002-1-69	Battery Tray	1
J	3002-1-91	Terminal Guard	1
K	3002-1-803	Battery Harness Cable	2
L	5000-101-43	Foam Block	4

# 3002-1-30 Zoom Option Base Power Assembly

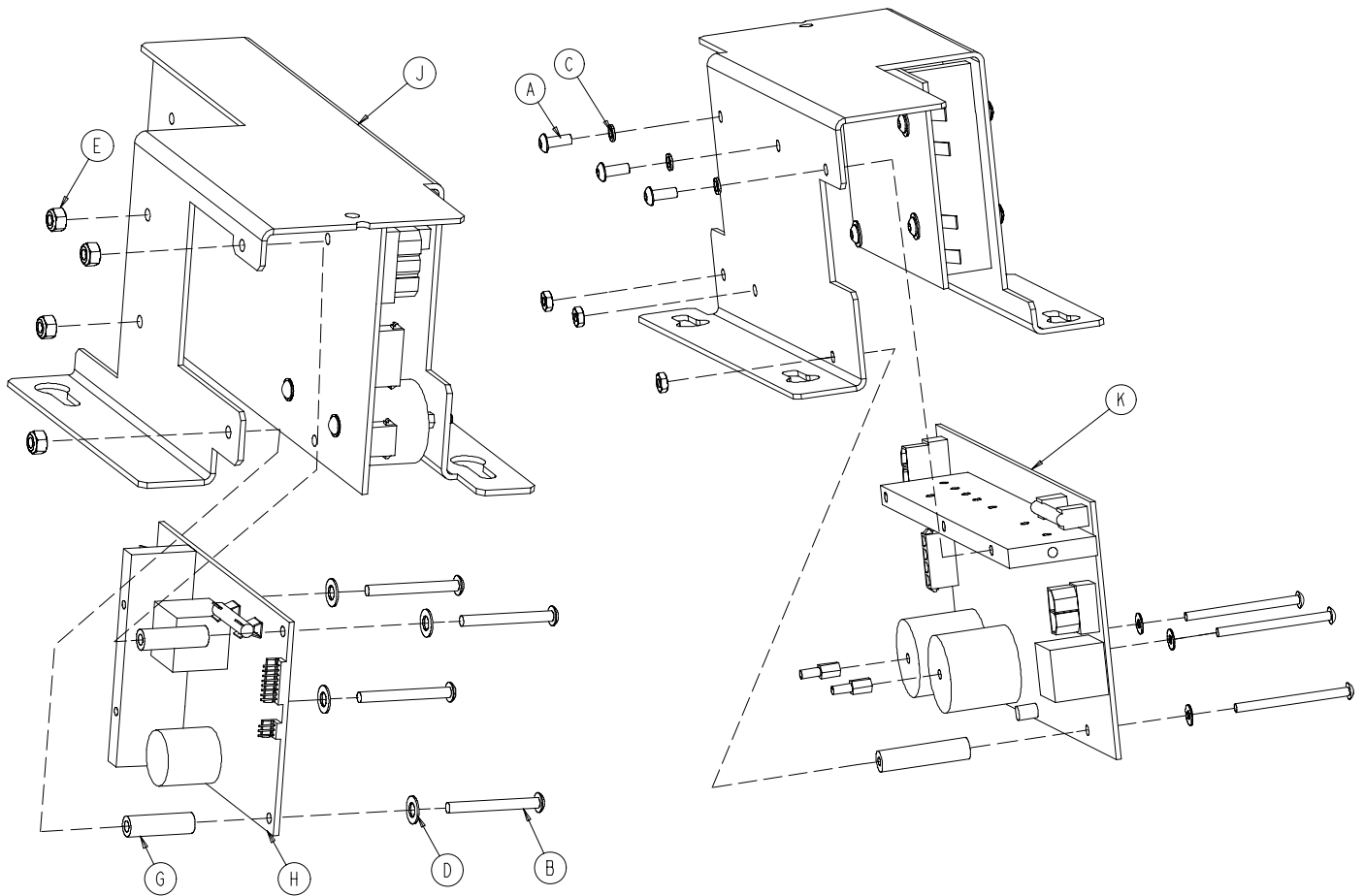

Item	Part No.	Part Name	Qty.
A	4-263	But. Hd. Cap Screw	3
B	4-315	But. Hd. Cap Screw	4
C	12-6	Helical Lock Washer	3
D	14-4	Nylon Washer	4
E	16-2	Fiberlock Nut	4
G	59-187	Spacer	2
H	2040-1-900	Power Board	1
J	3002-1-17	Charger/Inverter Heat Bracket	1
K	3002-1-930	Charger/Inverter Board Ass'y	1



# Litter Assembly

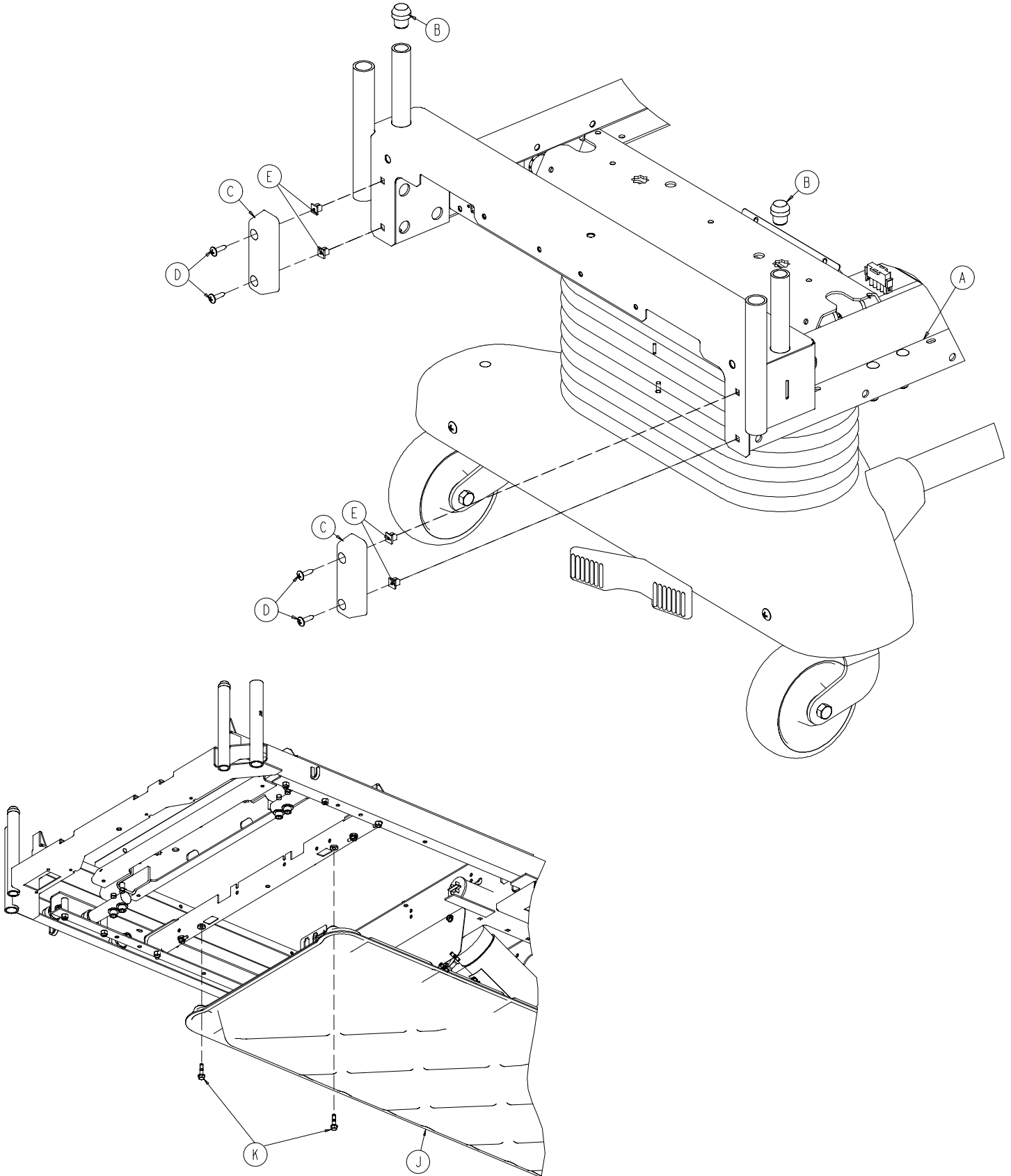

# Litter Assembly

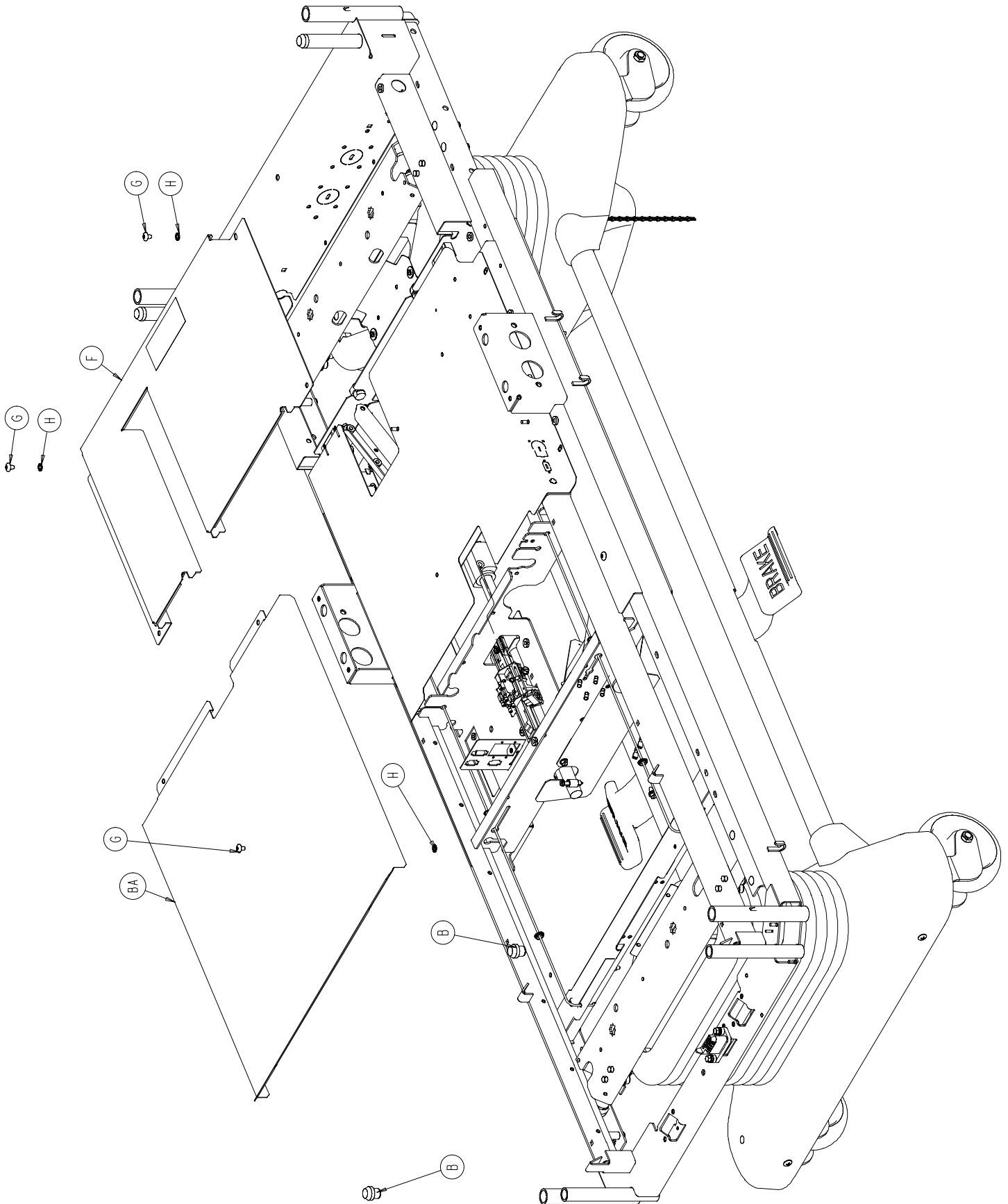

# Litter Assembly

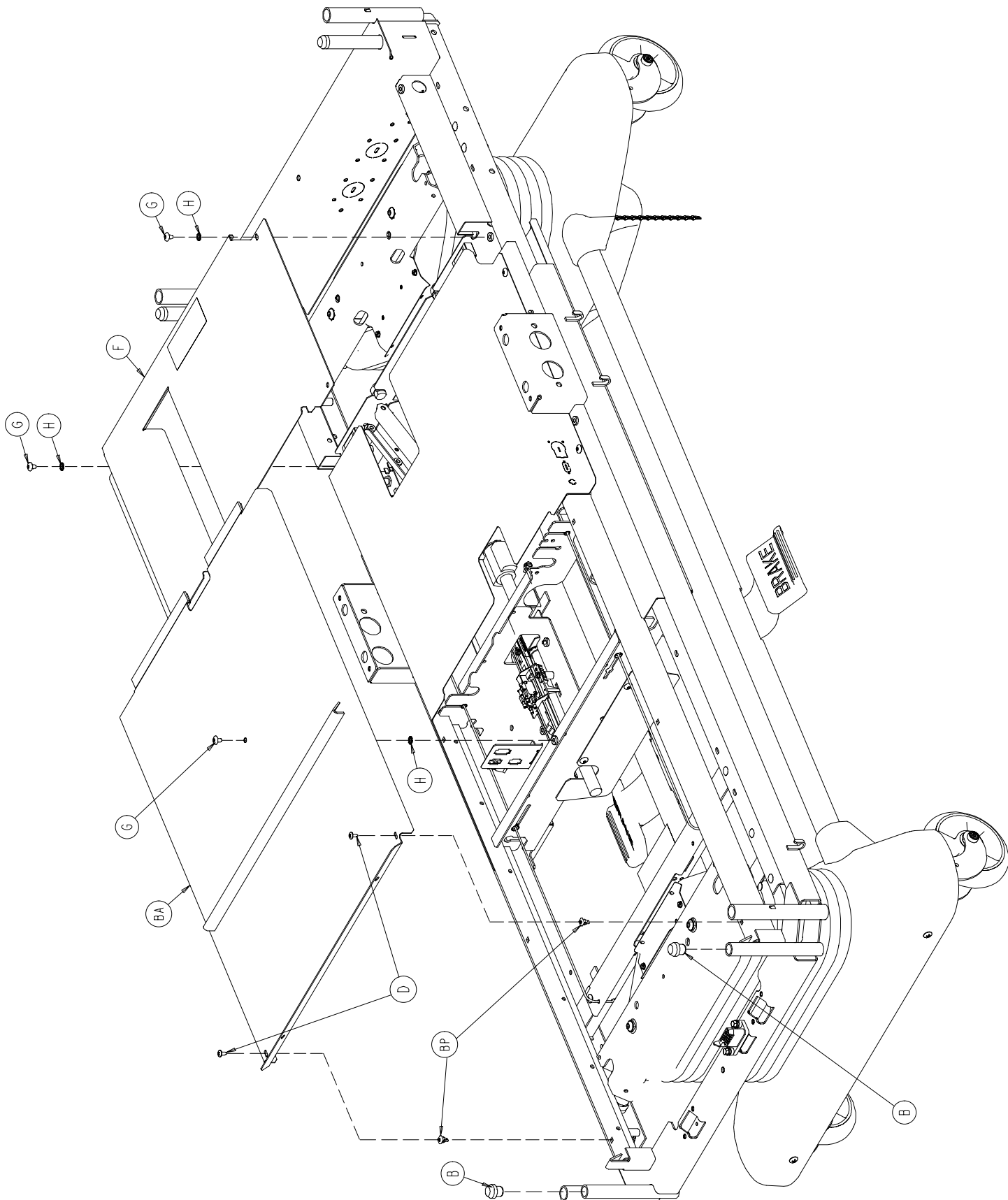

# Litter Assembly

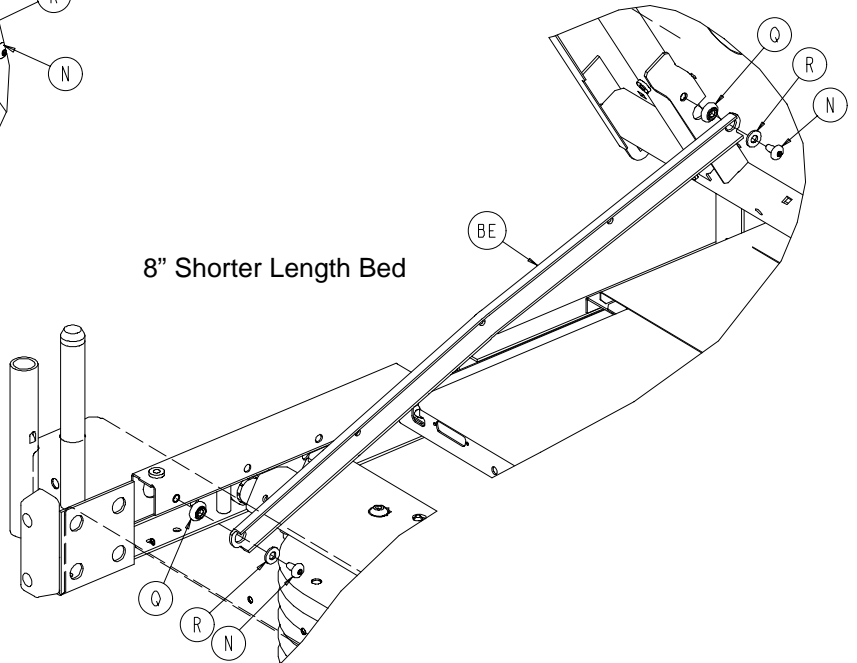
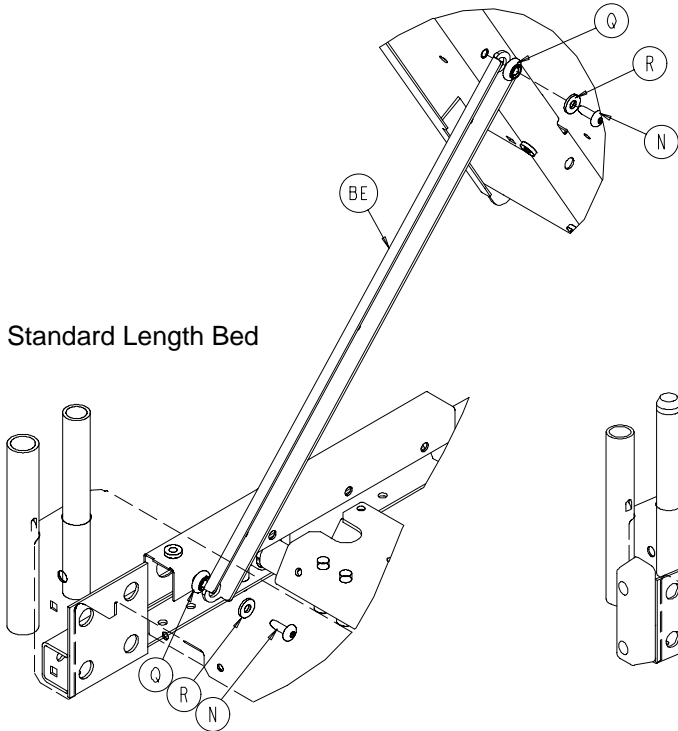
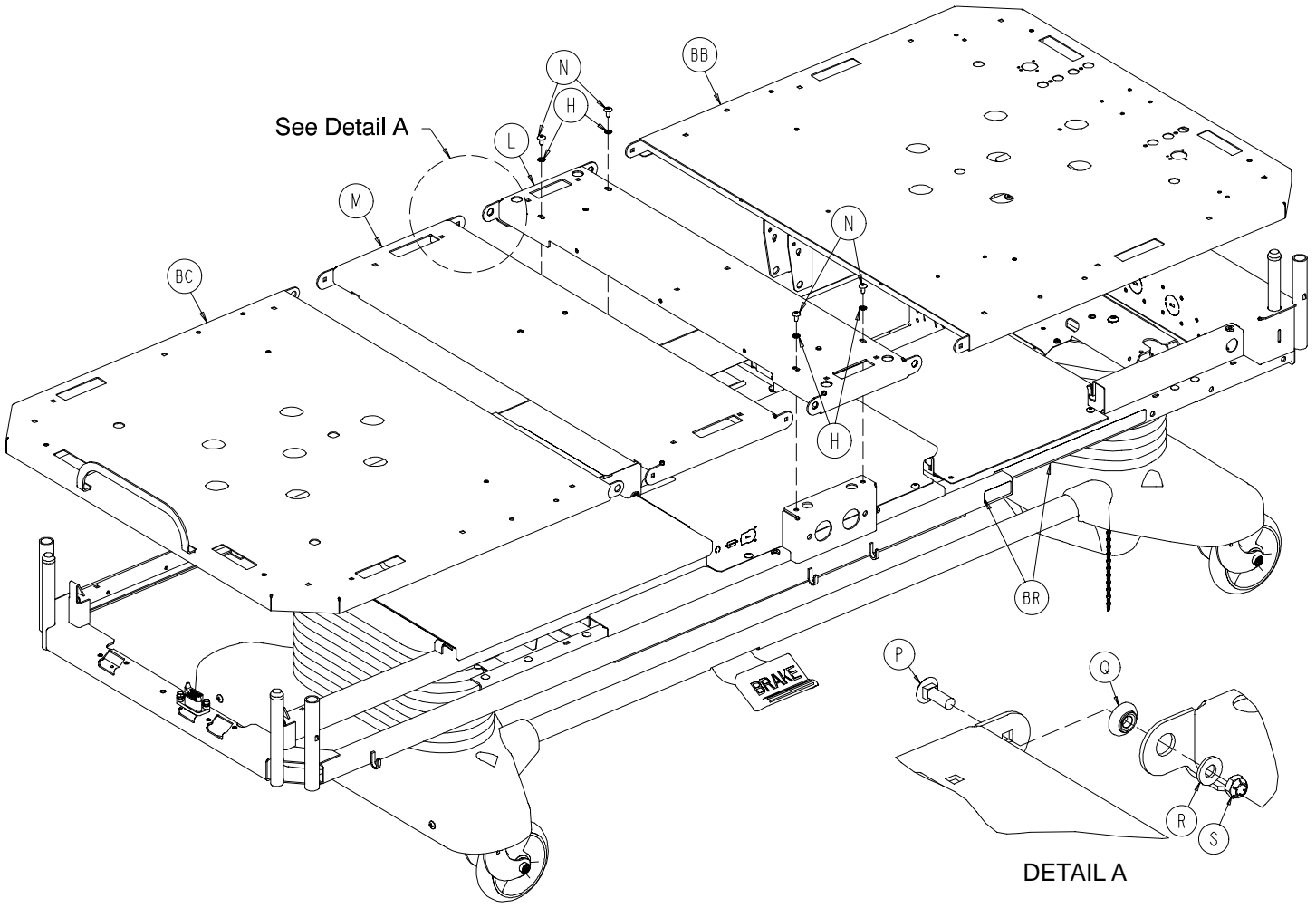

# Litter Assembly

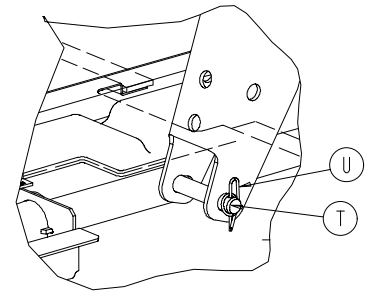
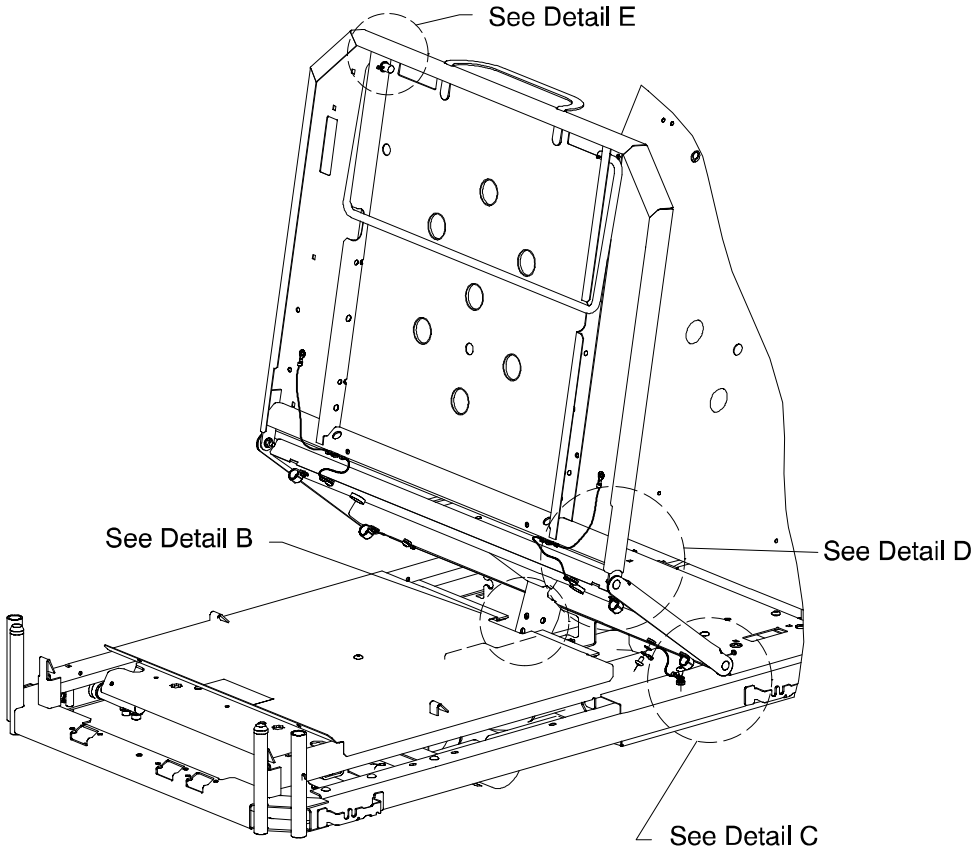

DETAIL B

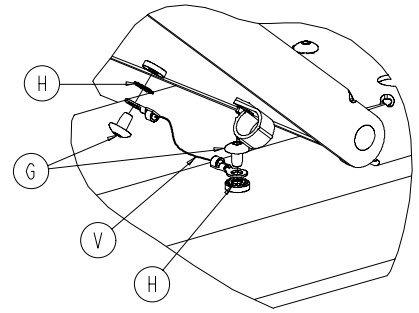

DETAIL C  
Litter Ground Jumper

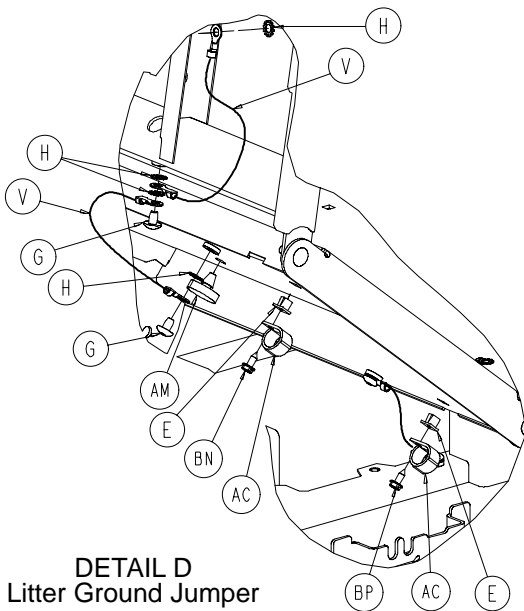

DETAIL D  
Litter Ground Jumper

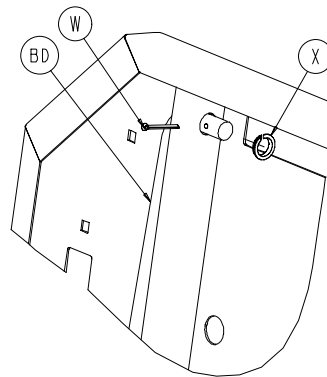

DETAIL E  
Standard Length Bed  
Foot Prop Installation

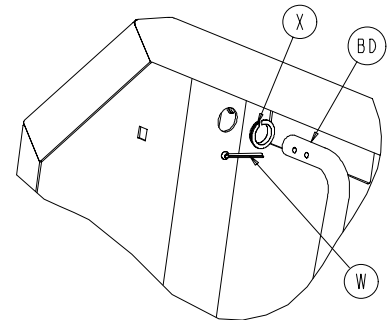

DETAIL E  
8" Shorter Length Bed  
Foot Prop Installation

# Litter Assembly

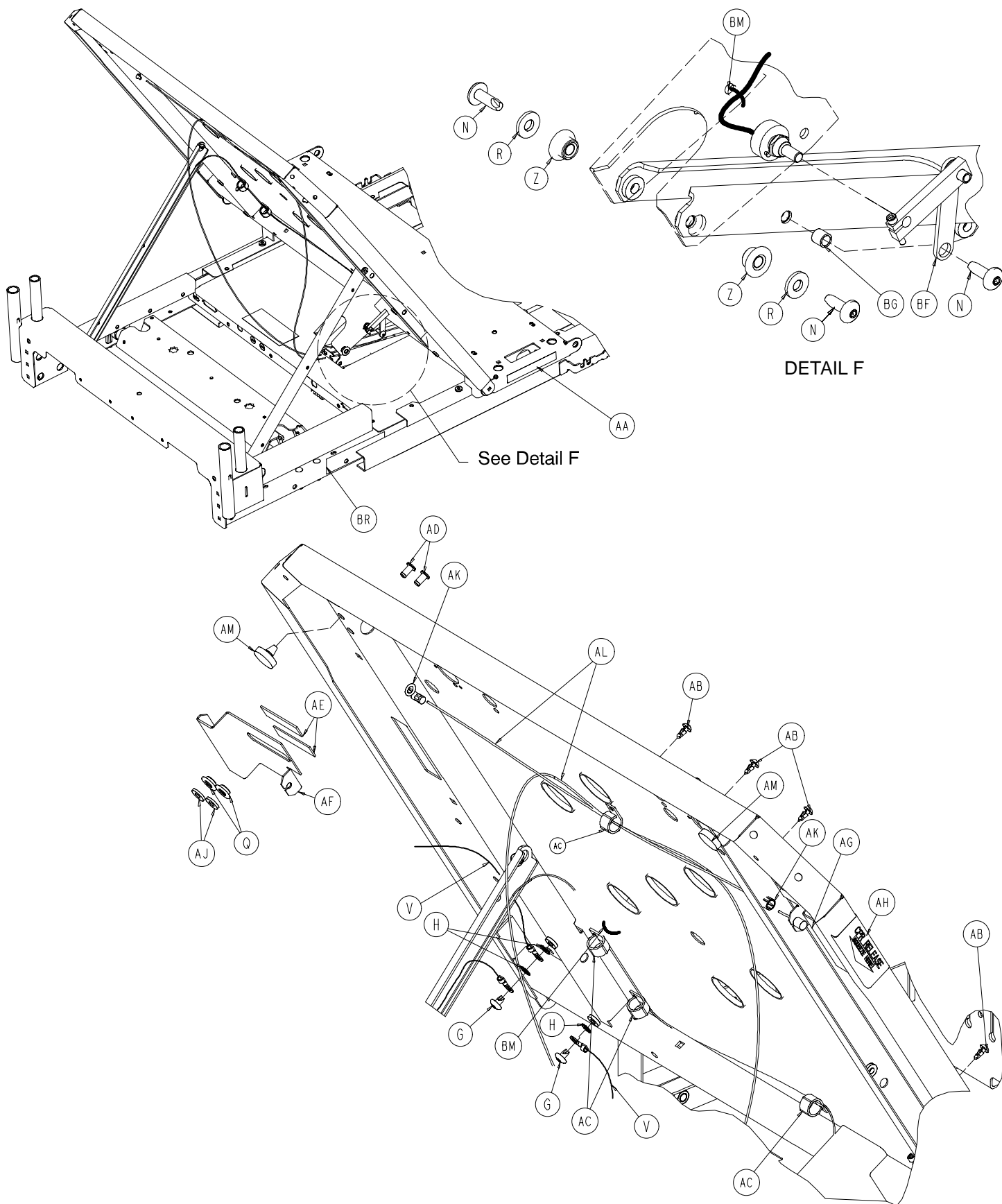

# Litter Assembly

## Litter Common Components - part number 3002-300-2 (reference only)

Item	Part No.	Part Name	Qty.	Item	Part No.	Part Name	Qty.
A	(page 135-140)	Electrical Litter Ass'y	1	W	27-7	Cotter Pin	2
B	3000-300-349	Cap	4	X	52-754	Bushing	2
F	(page 133)	CPU Cover Ass'y	1	AA	2020-88-820	Caution Label	2
G	7-53	Truss Hd. Screw	17	AB	3000-300-477	CPR Conduit Stud	1
H	13-10	Ext. Tooth Lock Washer	27	AC	59-743	Wire Harness Clip	1
K	3001-200-228	Mounting Standoff	2	AD	25-120	Pop Rivet	4
L	3001-300-135	Seat Litter	1	AE	3001-300-663	Velcro Strip	4
M	3001-300-170	Thigh Litter Ass'y	1	AF	3001-300-662	CPR Handle, Left	1
N	7-63	Truss Hd. Screw	10	AG	3001-300-661	CPR Handle, Right	1
P	5-17	Carriage Bolt	6	AH	3001-300-603	CPR Release Label	2
Q	3001-300-99	Fowler Bushing	14	AJ	11-376	Washer	4
R	11-77	Flat Washer	12	AK	30-52	Snap Bushing	2
S	16-28	Fiber Lock Nut	6	AL	3001-300-670	CPR Cable Ass'y	2
T	26-277	Clevis Pin	1	AM	3001-300-8	Bumper	2
U	27-22	Rue Ring	1	AN	4-338	Flange But. Hd. Cap Scr.	4
V	3002-300-870	Litter Ground Jumper	10				

### Std. Length Bed Litter - 3002-343-2 (ref.)

### 8" Shorter Litter Option - 3002-342-2 (ref.)

Item	Part No.	Part Name	Qty.	Item	Part No.	Part Name	Qty.
A	(page 135-140)	Electrical Litter Ass'y	1	A	(page 135-140)	Electrical Litter Ass'y	1
C	3000-300-350	Head End Bumper	2	C	3000-300-350	Head End Bumper	2
D	23-80	Truss Hd. Screw	4	D	23-80	Truss Hd. Screw	6
E	3000-300-2	Plastic Clip Nut	4	E	3000-300-2	Plastic Clip Nut	4
J	3002-300-83	Motion Interrupt Pan	1	J	3001-300-83	Motion Interrupt Pan	1
Z	3000-300-99	Fowler Bushing	2	Z	3001-300-99	Fowler Bushing	2
AM	3001-300-8	Bumper	2	AM	3001-300-8	Bumper	2
BA	(page 134)	Foot Cover Ass'y	1	BA	(page 134)	Foot Cover Ass'y	1
BB	3002-300-145	Fowler Litter Ass'y	1	BB	3002-342-130	Fowler Litter Ass'y	1
BC	3002-300-190	Foot Litter Ass'y	1	BC	3002-342-180	Foot Litter Assembly	1
BD	3001-300-162	Foot Prop Rod	1	BD	3001-342-162	Foot Prop Rod	1
BE	3001-300-5	Fowler Link	2	BE	3001-342-8	Fowler Link	2
BR	3002-300-602	Fowler Angle Label	1	BP	52-816	Screw Grommet	2
				BR	3002-300-602	Fowler Angle Label	1

### Zoom Litter Option - 3002-344-2 (ref.)

### 8" Shorter Zoom Litter Option - 3002-346-2 (ref.)

Item	Part No.	Part Name	Qty.	Item	Part No.	Part Name	Qty.
A	(page 135-140)	Electrical Litter Ass'y	1	A	(page 135-140)	Electrical Litter Ass'y	1
J	3002-300-83	Motion Interrupt Pan	1	D	23-80	Truss Hd. Screw	2
Z	3000-300-99	Fowler Bushing	2	J	3002-300-83	Motion Interrupt Pan	1
AM	3001-300-8	Bumper	2	Z	3001-300-99	Fowler Bushing	2
BA	(page 134)	Foot Cover Ass'y	1	AM	3001-300-8	Bumper	2
BB	3002-300-145	Fowler Litter Ass'y	1	BA	(page 134)	Foot Cover Ass'y	1
BC	3002-300-190	Foot Litter Ass'y	1	BB	3002-342-130	Fowler Litter Ass'y	1
BD	3001-300-162	Foot Prop Rod	1	BC	3002-342-180	Foot Litter Ass'y	1
BE	3001-300-5	Fowler Link	2	BD	3001-342-162	Foot Prop Rod	1
BR	3002-300-602	Fowler Angle Label	1	BE	3001-342-8	Fowler Link	2
				BP	52-816	Screw Grommet	2
				BR	3002-300-602	Fowler Angle Label	1

# 3001-300-97 Litter CPU Cover Assembly

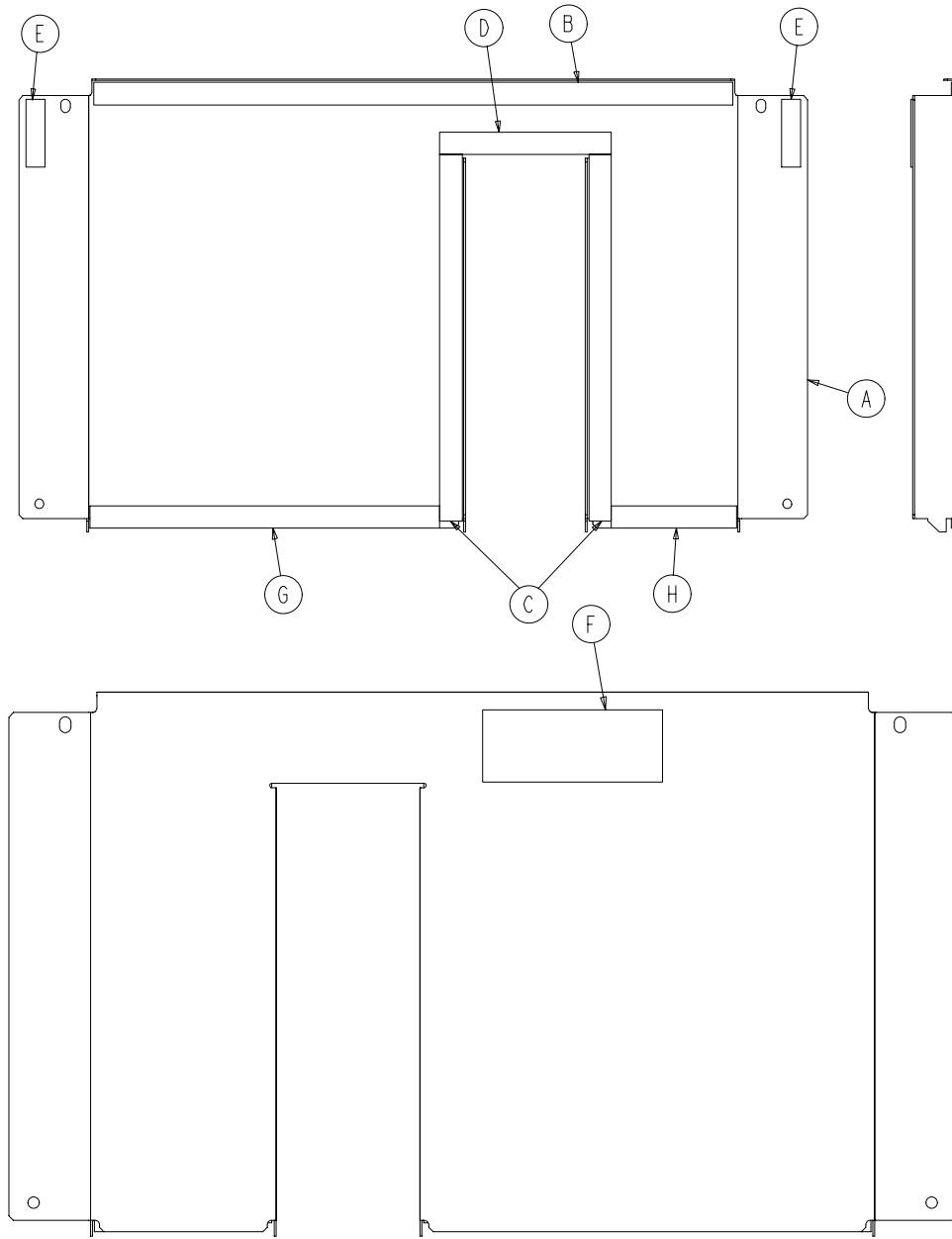

Item	Part No.	Part Name	Qty.
A	3001-300-98	CPU Cover	1
B	7900-1-291	Foam Tape (21.38")	1
C	7900-1-291	Foam Tape (12.25")	2
D	7900-1-291	Foam Tape (5.75")	1
E	3001-300-663	Velcro Strip	2
F	988-2-708	Service Caution Label	1
G	7900-1-291	Foam Tape (11.75")	1
H	7900-1-291	Foam Tape (4.25")	1



# 3001-300-42 Foot Cover Assembly, Standard Bed 3001-342-41 Foot Cover Assembly 8" Shorter Bed

---

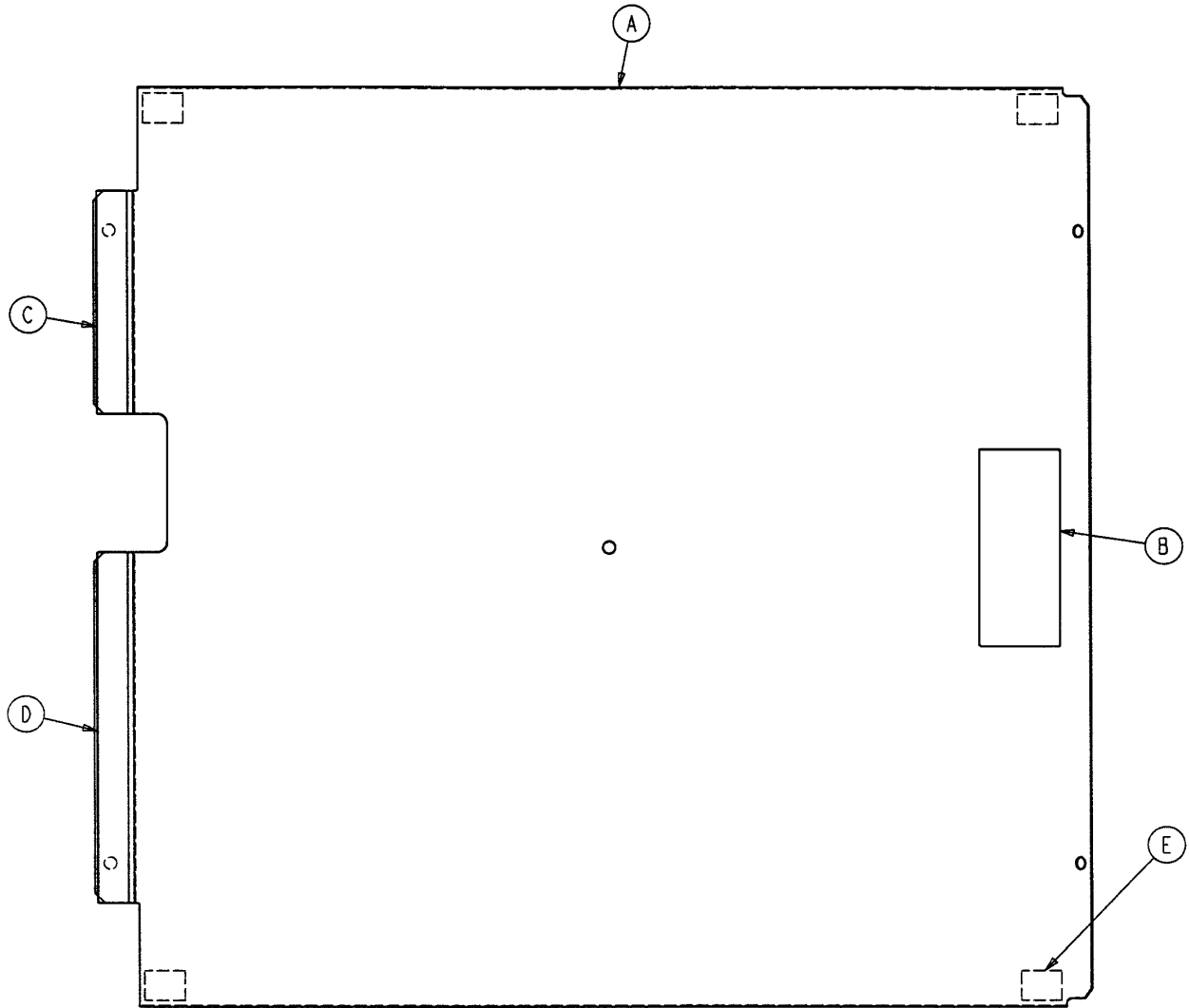

Item	Part No.	Part Name	Qty.
A	3001-300-43	Foot Cover (Standard)	1
	3001-342-42	Foot Cover (8" Shorter Bed)	1
B	988-2-708	Service Caution Label	1
C	7900-1-291	Foam Tape (5.63")	1
D	7900-1-291	Foam Tape (8.88")	1
E	7900-1-291	Foam Tape (1")	4

# Electrical Litter Assembly

- CPU Board
- 3002-700-1 No Options/No Zoom
  - 3002-700-2 Communications/No Zoom
  - 3002-700-3 Bed Exit and/or Scale/No Zoom
  - 3002-700-4 Zone Bed Exit and/or Scale/No Zoom
  - 3002-700-5 No Options/Zoom
  - 3002-700-6 Communications/Zoom
  - 3002-700-7 Bed Exit/Zoom
  - 3002-700-8 Zone Bed Exit/Zoom
  - 3002-700-28 Short Bed, Scale/Bed Exit/Zoom
  - 3002-700-29 Short Bed, Scale/Zone Bed Exit/Zoom
  - 3002-700-30 Short Bed, No Options/Zoom

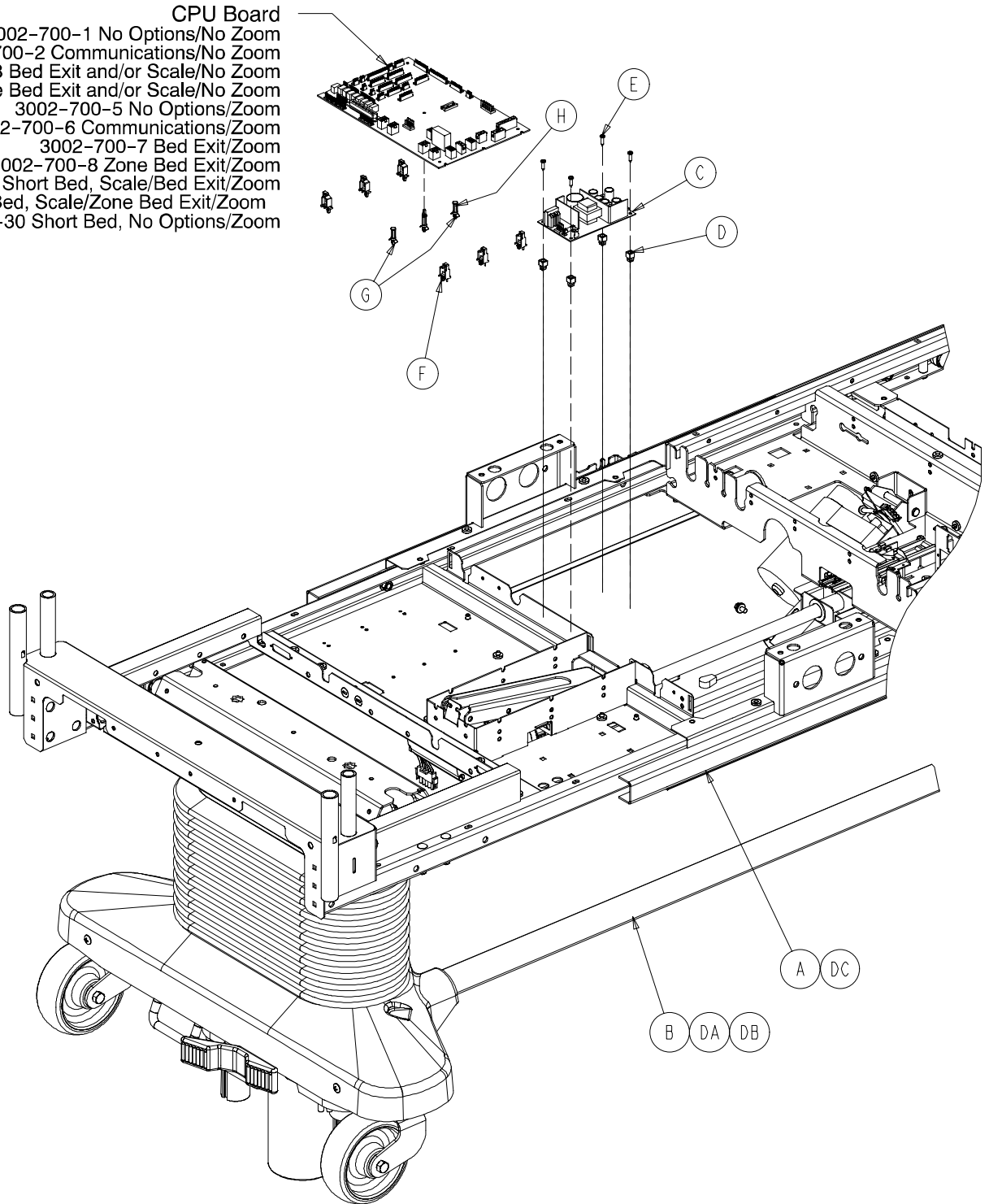

# Electrical Litter Assembly

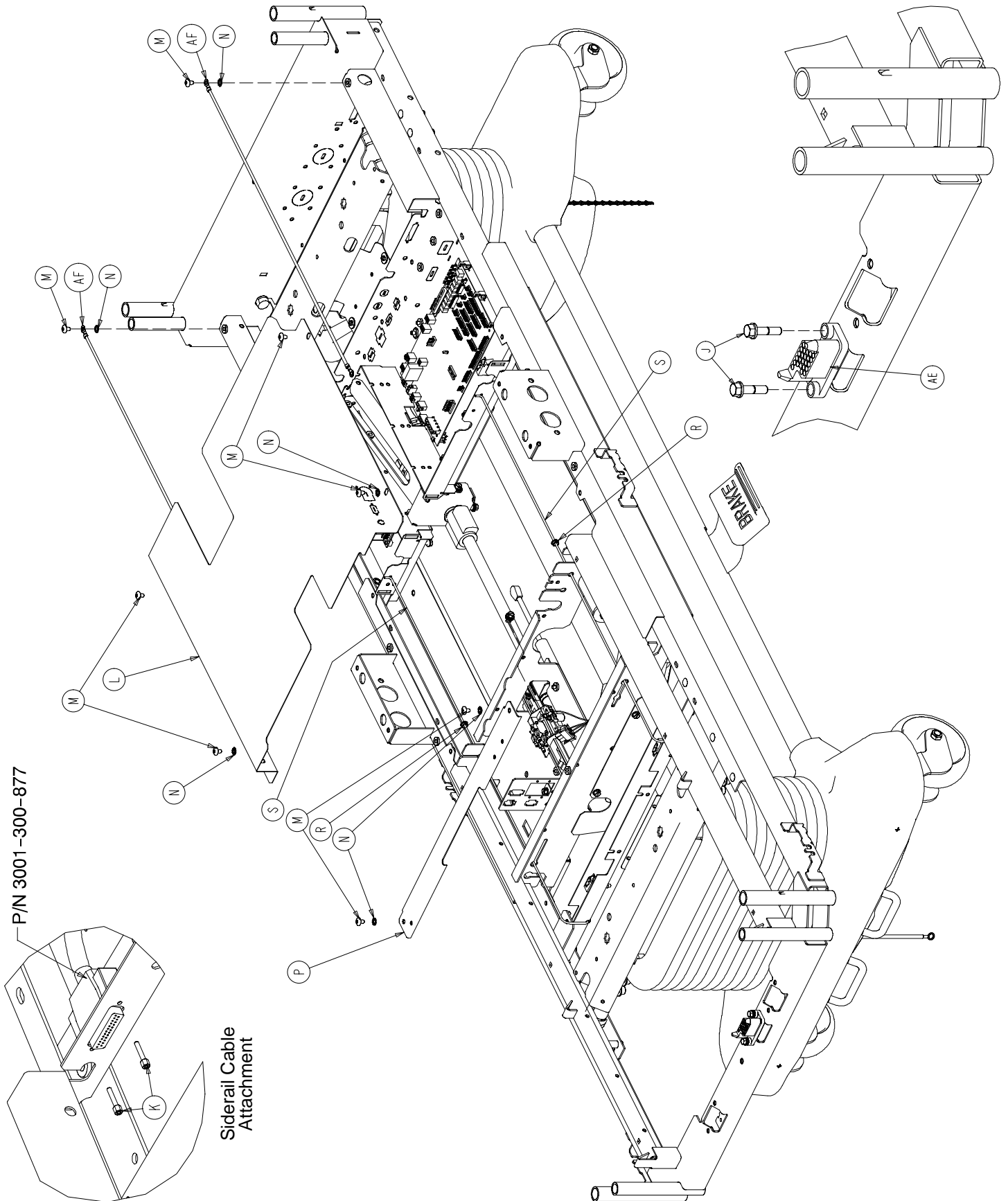

P/N 3001-300-877

Siderail Cable Attachment

# Electrical Litter Assembly

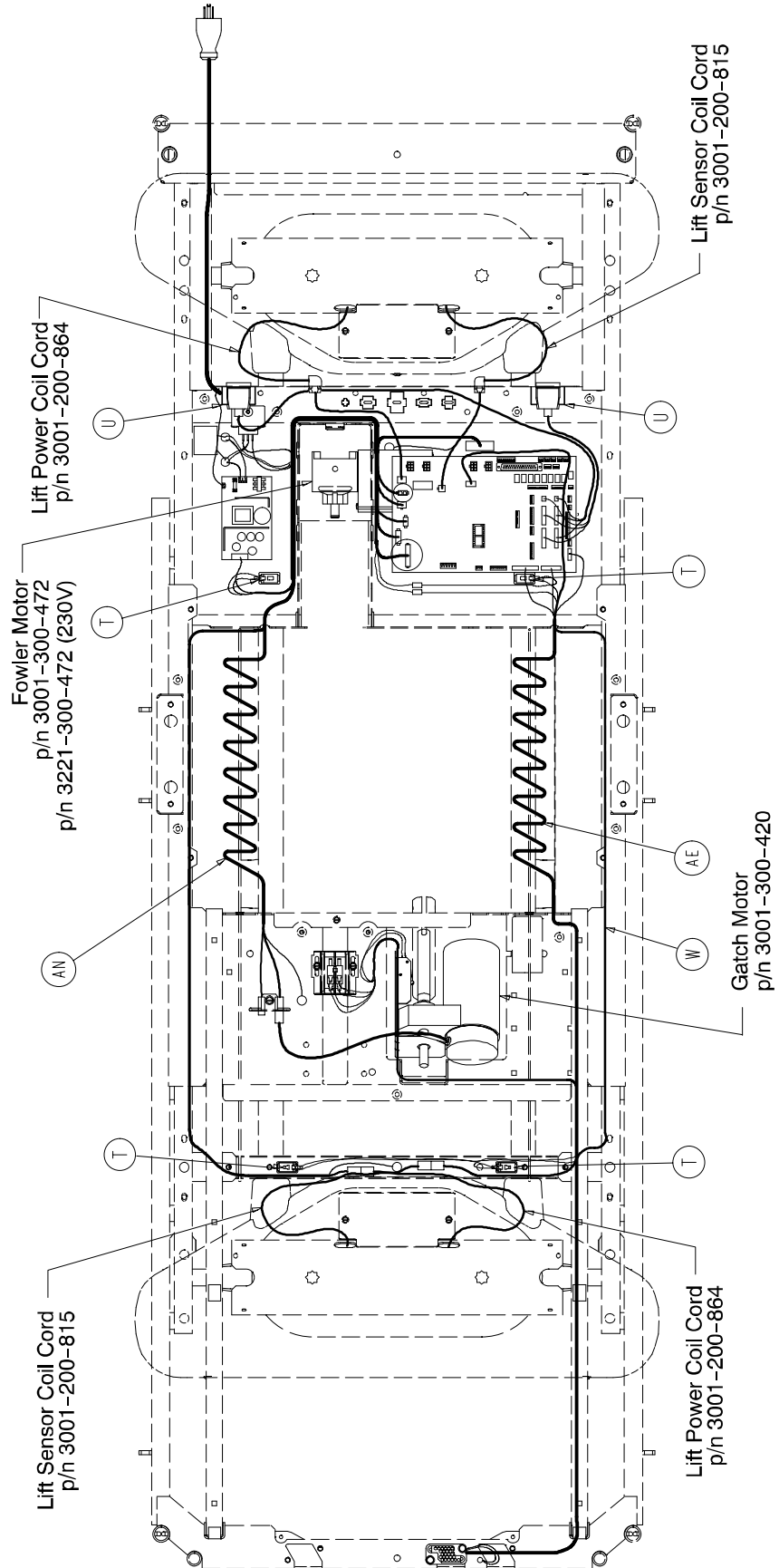

# Electrical Litter Assembly

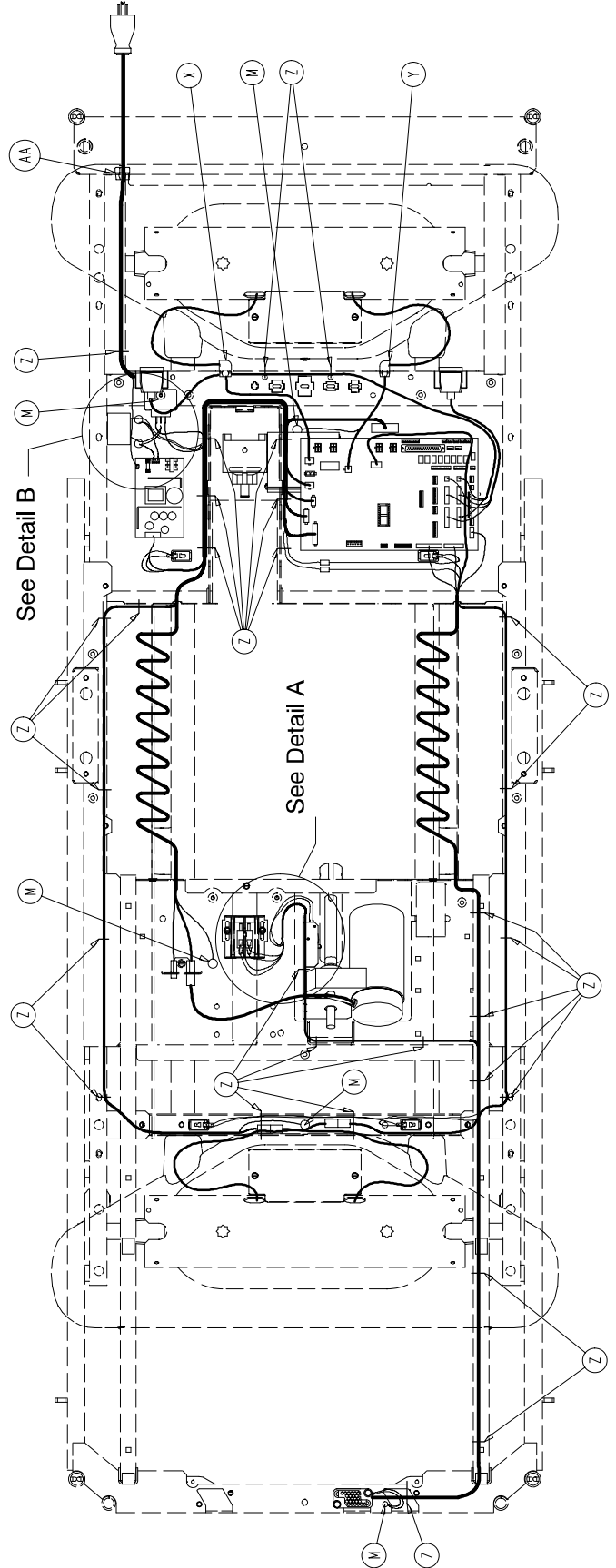
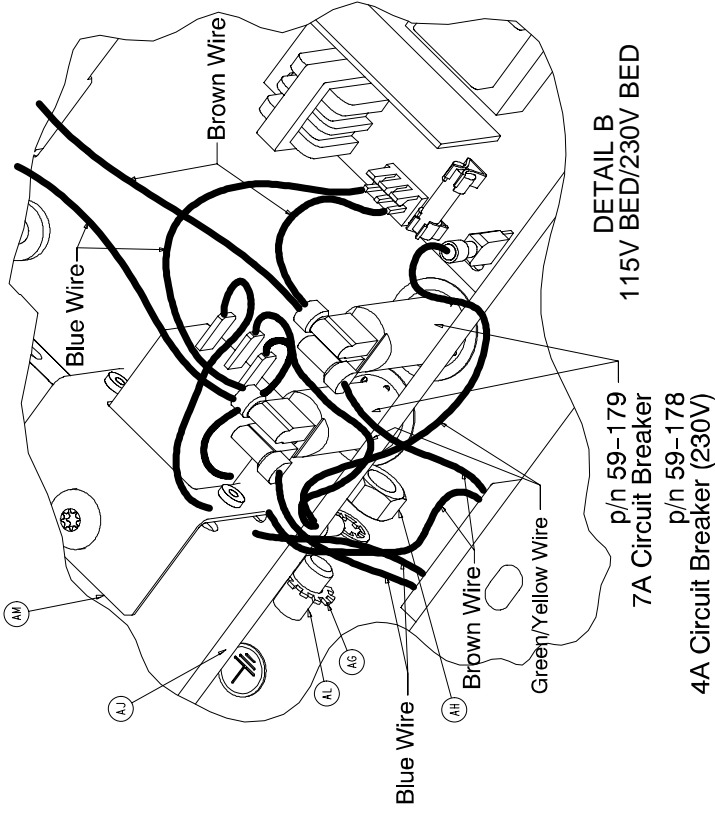
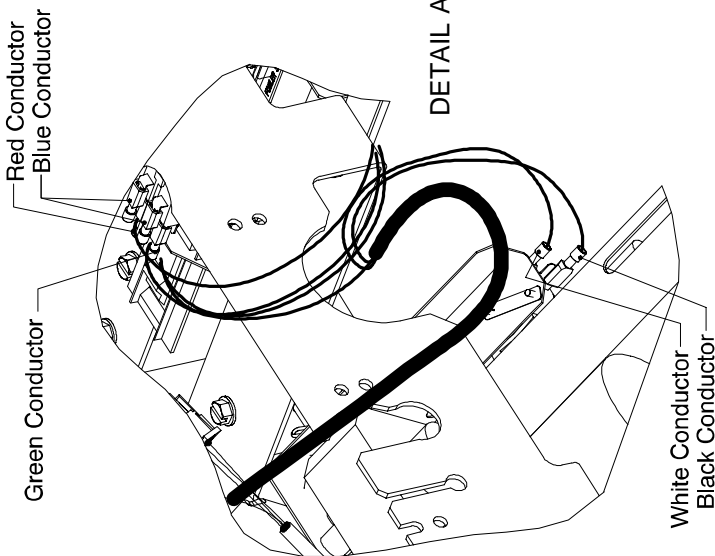

# Electrical Litter Assembly

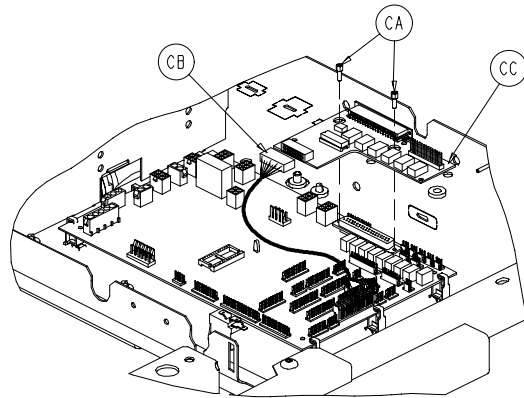

SMART TV OPTION

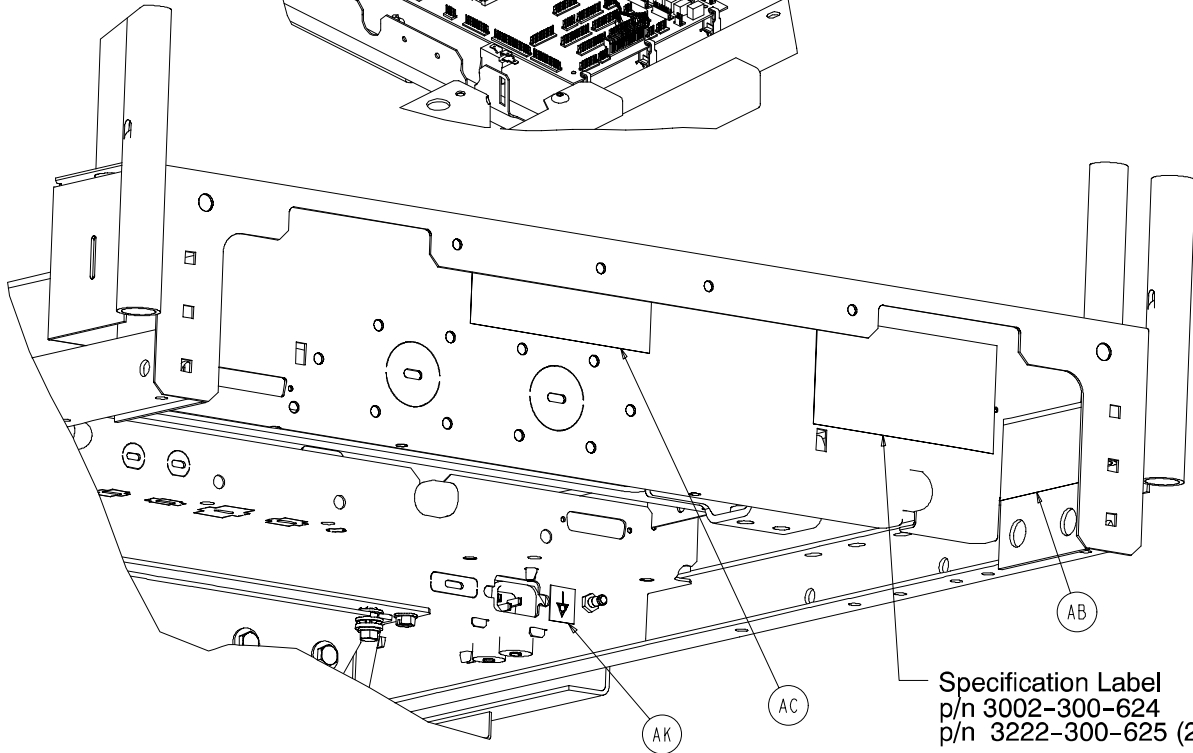

Specification Label  
p/n 3002-300-624  
p/n 3222-300-625 (230V)

## CABLE INSTALLATION UNITED KINGDOM POWER CORD

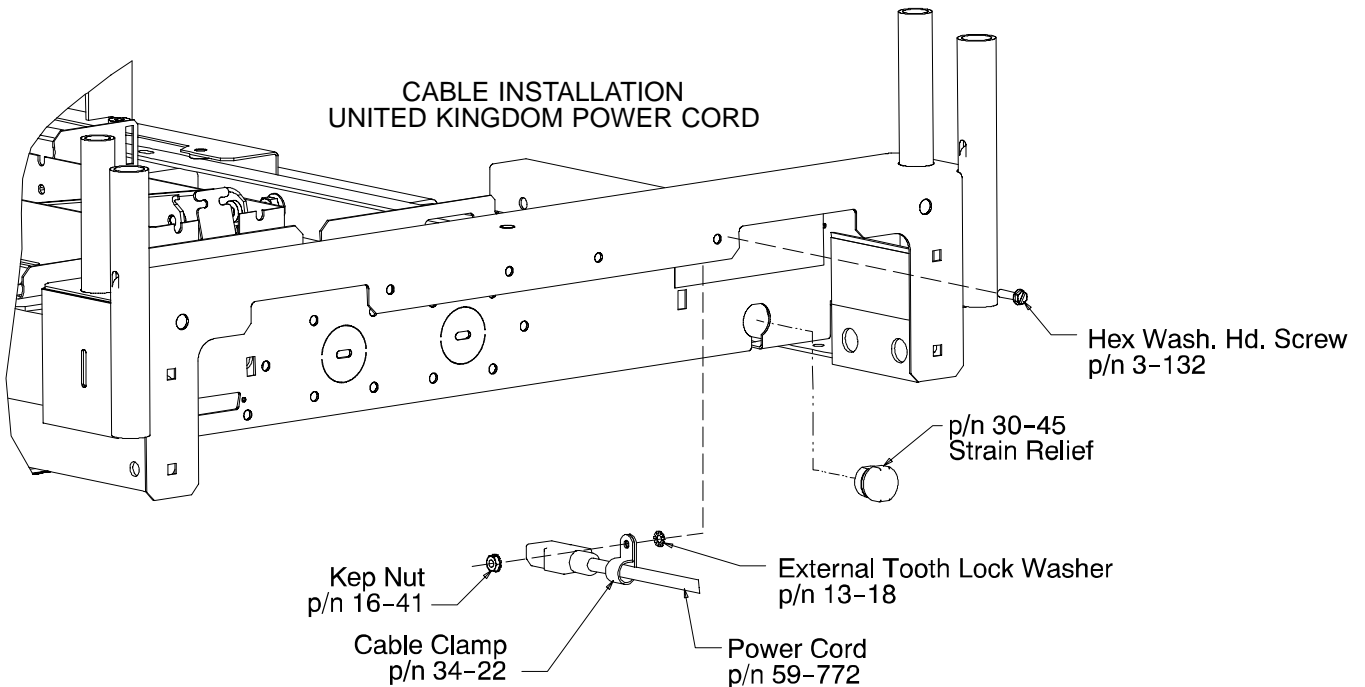

# Electrical Litter Assembly

## Electrical Litter Assembly - Common Components - p/n 3002-300-895 (reference only)

Item	Part No.	Part Name	Qty.	Item	Part No.	Part Name	Qty.
A	(page 141-145)	Litter Ass'y, Mechanical	1	U	3001-300-877	Siderail Extension Cable	1
B	(page 90-97)	Base Assembly	1	W	3001-300-865	Mot. Int. Lift Sen. Cable	1
C	59-157	Power Supply	1	X	30-48	Strain Relief	1
D	52-287	Grommet	4	Y	30-47	Strain Relief	1
E	23-138	Ph. Hd. Screw	4	Z	3000-300-1 13	Cable Tie	29
F	59-745	Board Mount	6	AA	30-45	Strain Relief	1
G	59-773	Push Spacer	2	AB	2011-1-104	Warning Label	1
H	59-774	Locking Circuit Bd. Supt.	1	AC	1550-90-1	Hosp. Grade Plug Label	1
J	3001-200-228	Mounting Standoff	2	AF	3002-300-874	Litter Ground Jumper	2
K	3001-300-7	Screw	4	AG	13-38	Lock Washer	1
L	3001-300-88	Mid Litter Cover Ass'y	1	AH	16-33	Keyp Nut	1
M	7-53	Truss Hd. Torx Screw	13	AJ	36-46	Ground Label	1
N	13-10	Ext. Tooth Lock Washer	6	AK	36-1 15	Ground Label	1
P	3001-300-23	Cross Support Cover	1	AL	2011-1-215	Grounding Lug	1
R	52-822	Nyliner Bearing	2	AM	3002-300-881	Power Inlet Cable	1
S	3001-300-1 1	Guide Rod	2	AN	3002-300-861	Power Harness	1
T	3000-300-58	Switch Plunger	4				

### Standard Bed - 3002-343-895 (ref. only)

Item	Part No.	Part Name	Qty.
A	(page 141-145)	Litter Ass'y, Mechanical	1
B	(page 90-97)	Base Assembly	1
AE	3002-300-866	Litter Signal Coil Cable	1

### 8" Shorter Bed - 3002-342-895 (ref. only)

Item	Part No.	Part Name	Qty.
A	(page 141-145)	Litter Ass'y, Mechanical	1
B	(page 90-97)	Base Assembly	1
AE	3002-300-866	Litter Signal Coil Cable	1

### Zoom Option - 3002-344-895 (ref. only)

Item	Part No.	Part Name	Qty.
A	(page 141-145)	Litter Ass'y, Mechanical	1
B	(page 113-120)	Secure Zoom Base Ass'y	1
AE	3002-300-866	Litter Signal Coil Cable	1
DA	(page 113-120)	Zoom Base Assembly	1
DC	(page 170-175)	Zoom Litter Assembly	1

### Zoom 8" Shorter Bed Option - 3002-346-895 (ref. only)

Item	Part No.	Part Name	Qty.
A	(page 141-145)	Litter Ass'y, Mechanical	1
B	(page 90-97)	Base Assembly	1
AE	3002-300-866	Litter Signal Coil Cable	1
DA	(page 113-120)	Zoom Base Assembly	1
DC	(page 170-175)	Zoom Litter Assembly	1

### Smart TV Option - p/n 3001-999-227 (ref. only)

Item	Part No.	Part Name	Qty.
CA	59-176	Jackscrew	2
CB	2035-232-806	Smart TV Control Cable	1
CC	3001-330-960	Smart TV CPU Ass'y	1

# Mechanical Litter Assembly

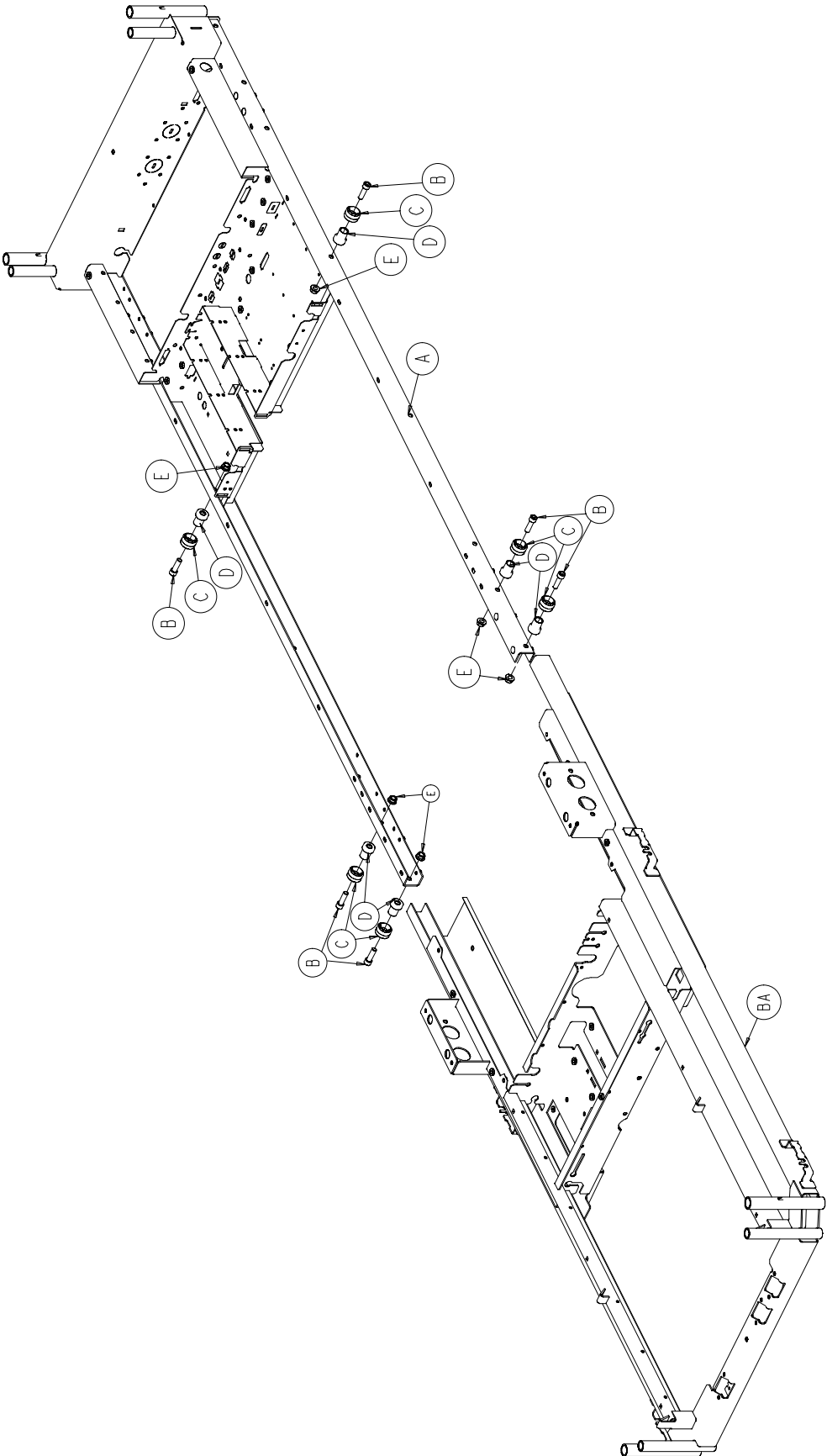



# Mechanical Litter Assembly

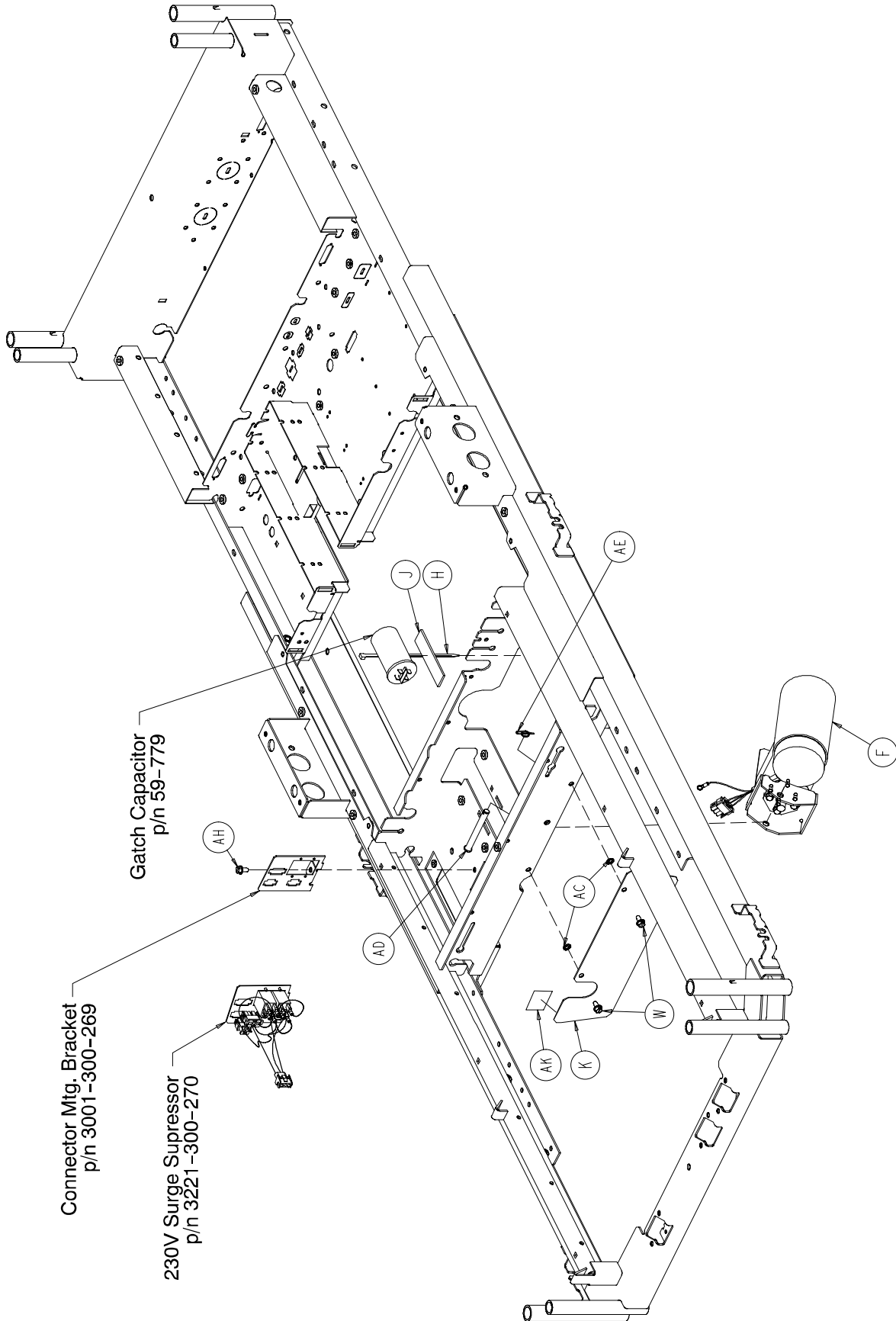

# Mechanical Litter Assembly

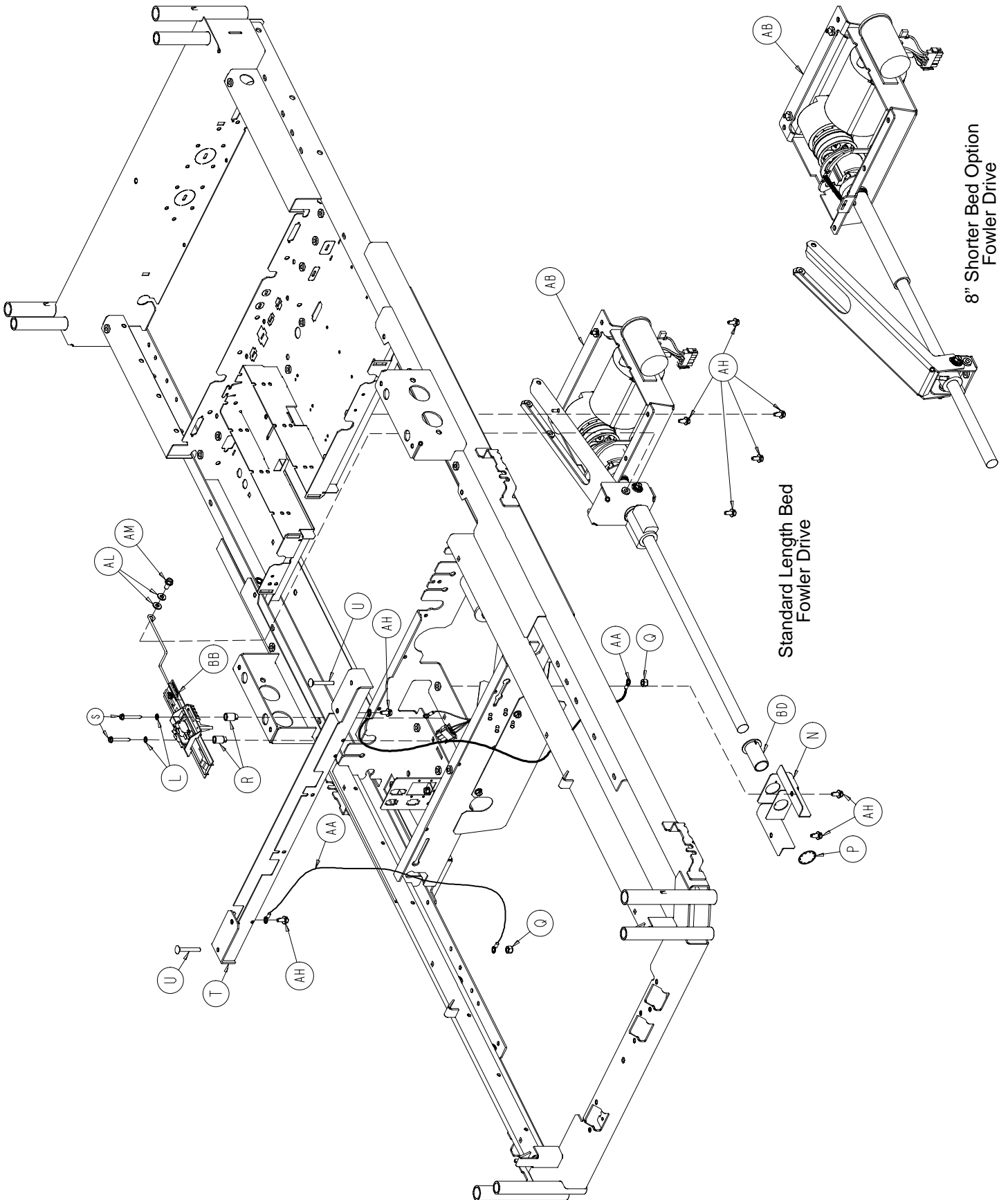

# Mechanical Litter Assembly

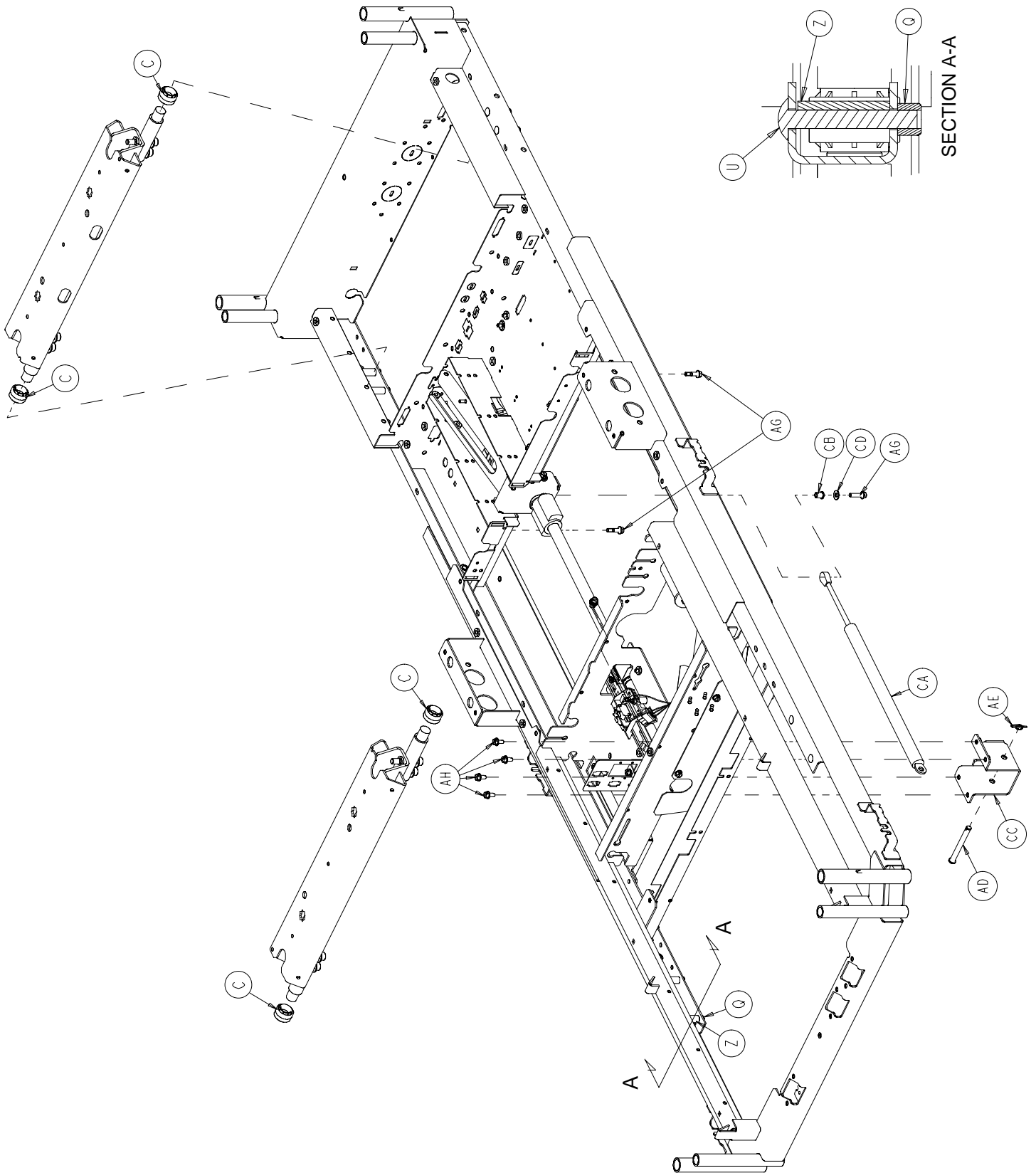

# Mechanical Litter Assembly

## Mechanical Litter Assembly Common Components - p/n 3002-300-197 (reference only)

Item	Part No.	Part Name	Qty.	Item	Part No.	Part Name	Qty.
A	3002-300-303	Stationary Frame Ass'y	1	T	3001-300-370	Cross Support Ass'y	1
B	4-21 1	Soc. Hd. Cap Screw	6	U	5-22	Carriage Bolt	10
C	3000-300-353	Roller	10	V	(page 146 & 147)	Lift Header Ass'y	2
D	3000-300-352	Roller Shaft	6	W	3-221	Truss Hd. Screw	2
E	16-93	Flange Lock Nut	6	Z	3001-300-4	Stationary Frame Spacer	8
F	(page 149)	Gatch Motor Ass'y	1	AA	3001-300-870	Litter Ground Jumper	2
H	38-151	11" Cable Tie	1	AB	(page 150 & 151)	Fowler Drive Ass'y	1
J	44-29	Double-Sided Tape	1	AC	13-10	Ext. Tooth Lock Washer	2
K	3001-300-417	Gatch Shield	1	AD	26-279	Clevis Pin	1
L	13-18	Ext. Tooth Lock Washer	2	AE	27-22	Rue Cotter Pin	1
N	3001-300-491	Screw Support Bracket	1	AG	3001-200-228	Mounting Standoff	2
P	28-122	Retaining Ring	1	AH	3-221	Hex Washer Hd. Screw	10
Q	16-6	Kep Nut	10	AK	7900-1-291	Vibration Tape	1"
R	52-800	Grommet	2	AL	11-63	Washer	2
S	23-251	Hex Washer Hd. Screw	2	AM	3-121	Hex Washer Hd. Screw	1

### Standard Bed - p/n 3002-343-197 (ref. only)

Item	Part No.	Part Name	Qty.
AB	(page 151)	Fowler Drive Ass'y	1
BA	3002-300-204	Moving Frame Assembly	1
BB	(page 154)	Fowler Limit Ass'y	1
BD	3000-300-9	Screw Support Bushing	1

### 8" Shorter Bed - p/n 3002-342-197 (ref. only)

Item	Part No.	Part Name	Qty.
AB	(page 151)	Fowler Drive Ass'y	1
AD	26-279	Clevis Pin	1
AE	27-22	Rue Cotter Pin	1
AG	3001-200-228	Mounting Standoff	1
AH	3-221	Hex Washer Hd. Screw	4
BA	3002-342-204	Moving Frame Assembly	1
BB	(page 155)	Fowler Limit Assembly	1
BD	3001-342-9	Screw Support Bushing	1
CA	52-819	Dampener Cylinder	1
CB	52-818	Flange Bearing	1
CC	3001-345-489	Cylinder Mtg. Bracket	1
CD	11-2	Flat Washer	1

# Lift Header Assembly

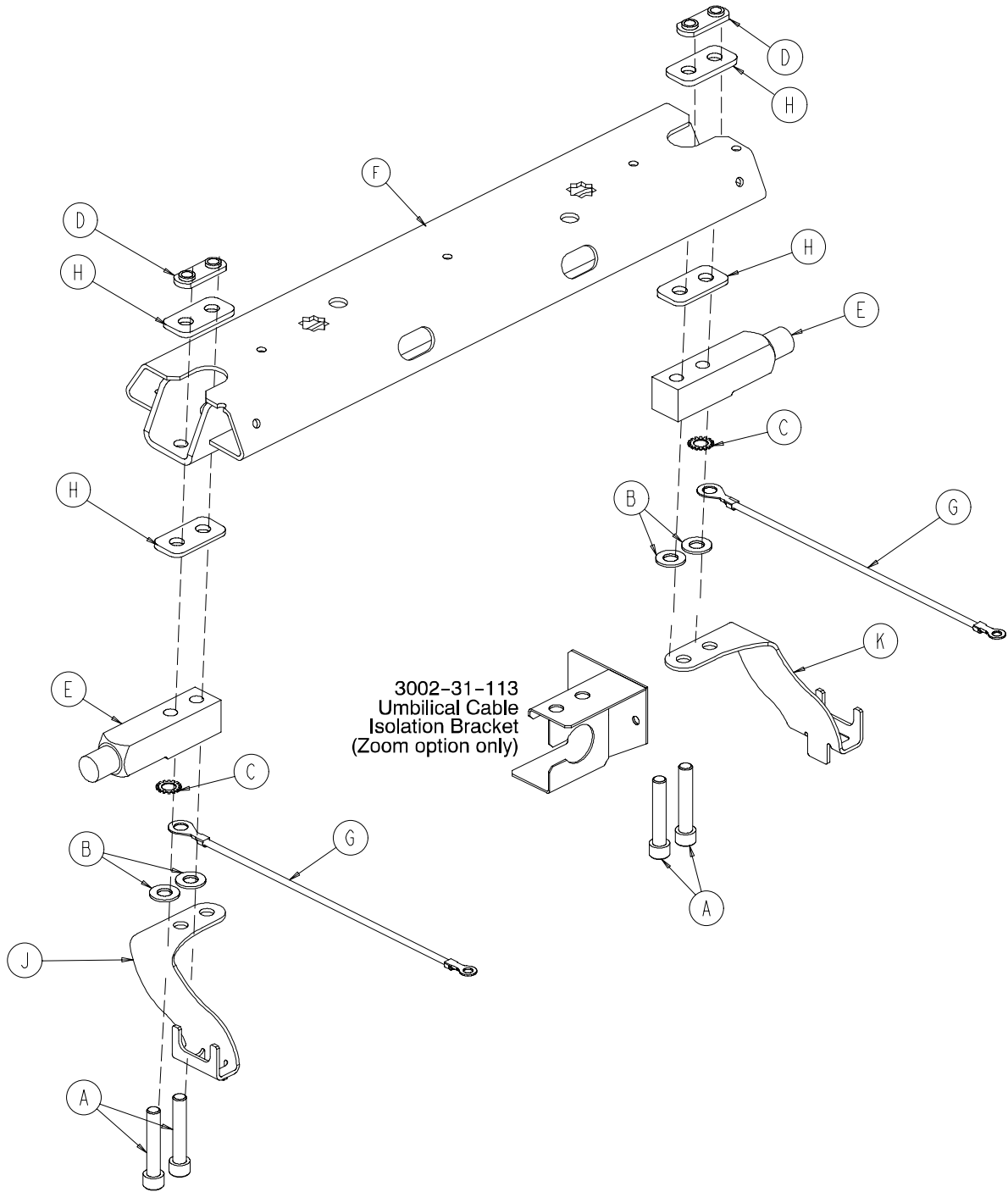

# Lift Header Assembly

---

## 3002-300-500 Lift Header - Standard Bed

Item	Part No.	Part Name	Qty.
A	4-288	Hex Soc. Hd. Cap Screw	4
B	11-4	Flat Washer	6
C	13-32	Ext. Tooth Lock Washer	2
D	3001-300-509	Lift Header Weld Nut	2
E	3001-300-51 1	"Imitation" Load Cell	2
F	3001-300-530	Lift Header Assembly	1
G	3002-300-871	Ground Jumper	2

## 3002-307-500 Lift Header - Scale Bed

Item	Part No.	Part Name	Qty.
A	4-288	Hex Soc. Hd. Cap Screw	4
B	11-4	Flat Washer	4
C	13-32	Ext. Tooth Lock Washer	2
D	3001-300-509	Lift Header Weld Nut	2
E	3001-307-57	Load Cell	2
F	3001-300-530	Lift Header Assembly	1
G	3002-300-871	Ground Jumper	2
H	3001-307-21	Load Cell Shim	4

## 3002-326-500 Lift Hdr. - Scale/Iso. Foley Hooks

Item	Part No.	Part Name	Qty.
A	4-288	Hex Soc. Hd. Cap Screw	4
B	11-4	Flat Washer	2
C	13-32	Ext. Tooth Lock Washer	2
D	3001-300-509	Lift Header Weld Nut	2
E	3001-307-57	Load Cell	2
F	3001-300-530	Lift Header Assembly	1
G	3002-300-871	Ground Jumper	2
J	3002-326-10	Iso. Foley Bag Ass'y, Lt.	1
K	3002-326-20	Iso. Foley Bag Ass'y, Rt.	1

## 3002-326-550 Lift Hdr. - Std. Bed/Iso. Foley Hooks

Item	Part No.	Part Name	Qty.
A	4-288	Hex Soc. Hd. Cap Screw	4
B	11-4	Flat Washer	6
C	13-32	Ext. Tooth Lock Washer	2
D	3001-300-509	Lift Header Weld Nut	2
E	3001-300-51 1	"Imitation" Load Cell	2
F	3001-300-530	Lift Header Assembly	1
G	3002-300-871	Ground Jumper	2
J	3002-326-10	Iso. Foley Bag Ass'y, Lt.	1
K	3002-326-20	Iso. Foley Bag Ass'y, Rt.	1

# 3221-300-270 230V Surge Suppressor Assembly

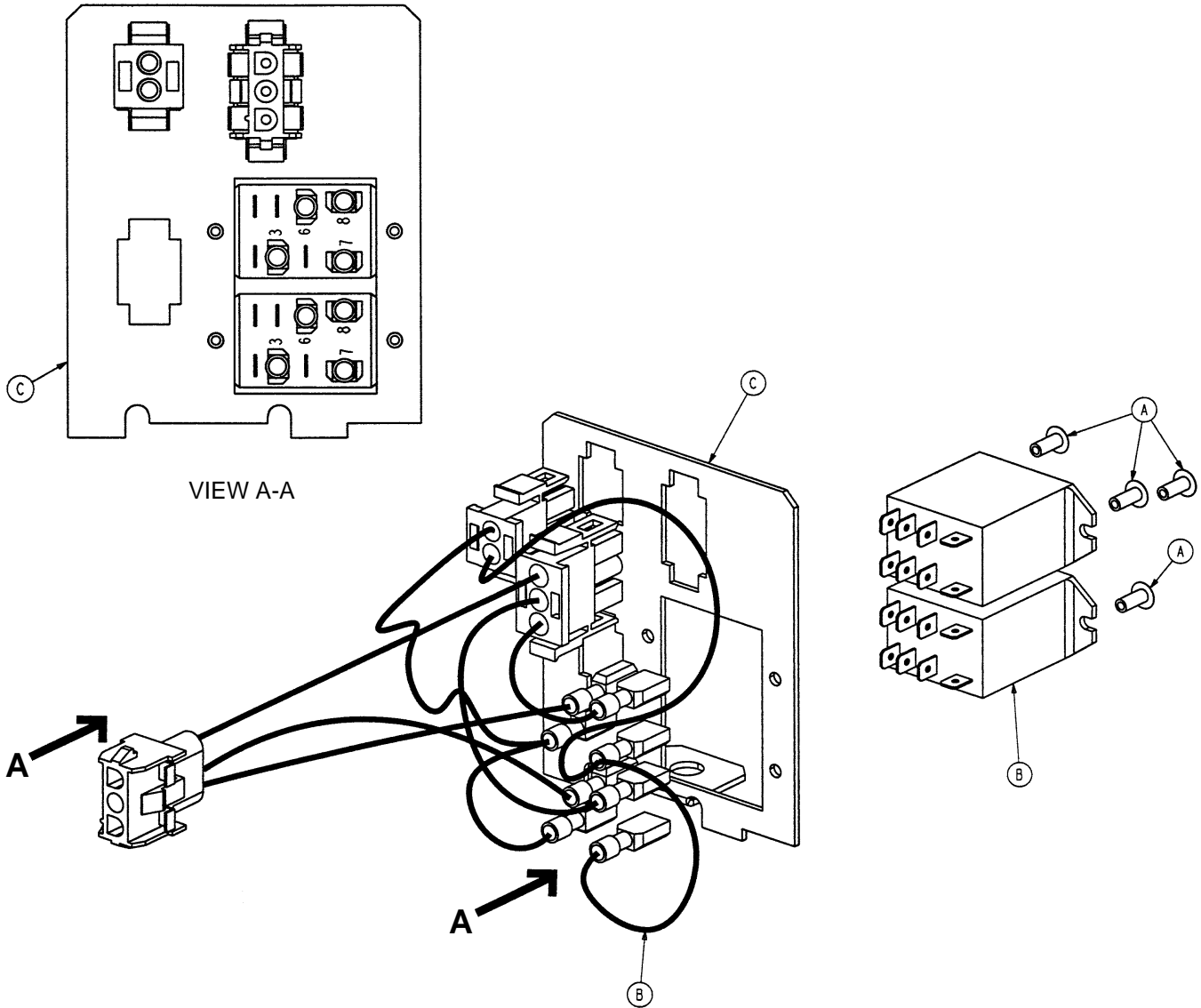

Item	Part No.	Part Name	Qty.
A	25-40	Pop Rivet	4
B	3221-300-268	Cable Assembly	1
C	3001-300-269	Connector Mtg. Bracket	1

# Gatch Motor Assembly

Assembly part number 3001-300-420  
(reference only)

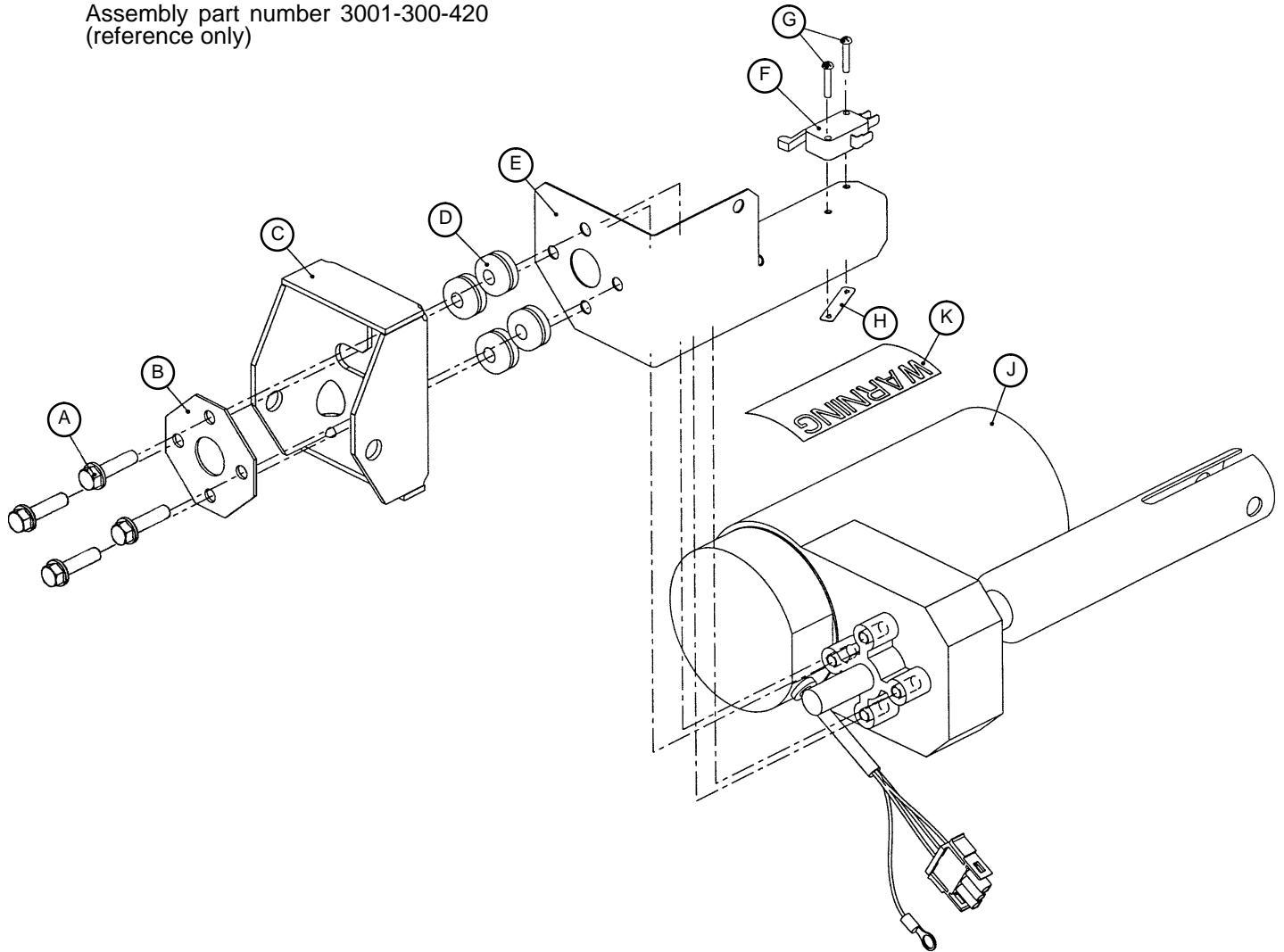

Item	Part No.	Part Name	Qty.
A	3001-200-228	Mounting Standoff	4
B	3001-300-499	Gatch Motor Mounting Plate	1
C	3001-300-225	Motor Mount Bracket	1
D	52-817	Grommet	4
E	3001-300-421	Gatch Limit Bracket	1
F	3000-300-41	Micro Switch	1
G	2-107	Phillips Round Hd. Screw	2
H	16-69	Twin-Type Fastener	1
J	2025-232-70	Gatch Motor	1
	2026-232-70	230V Gatch Motor	1
K	3000-300-604	Warning Label	1
L	3000-300-1 14	Wire Tie (not shown)	1



# Fowler Drive Assembly

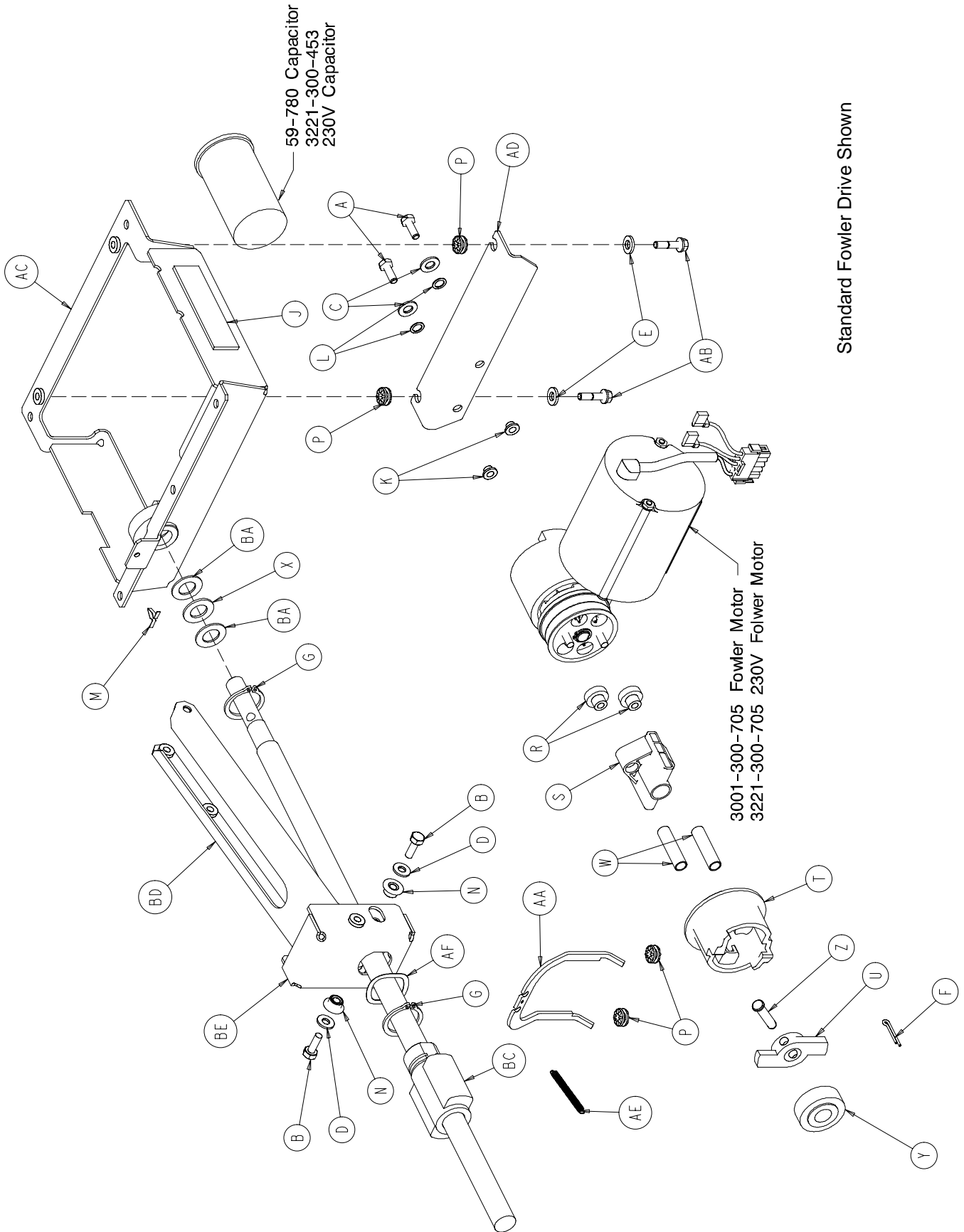

# Fowler Drive Assembly

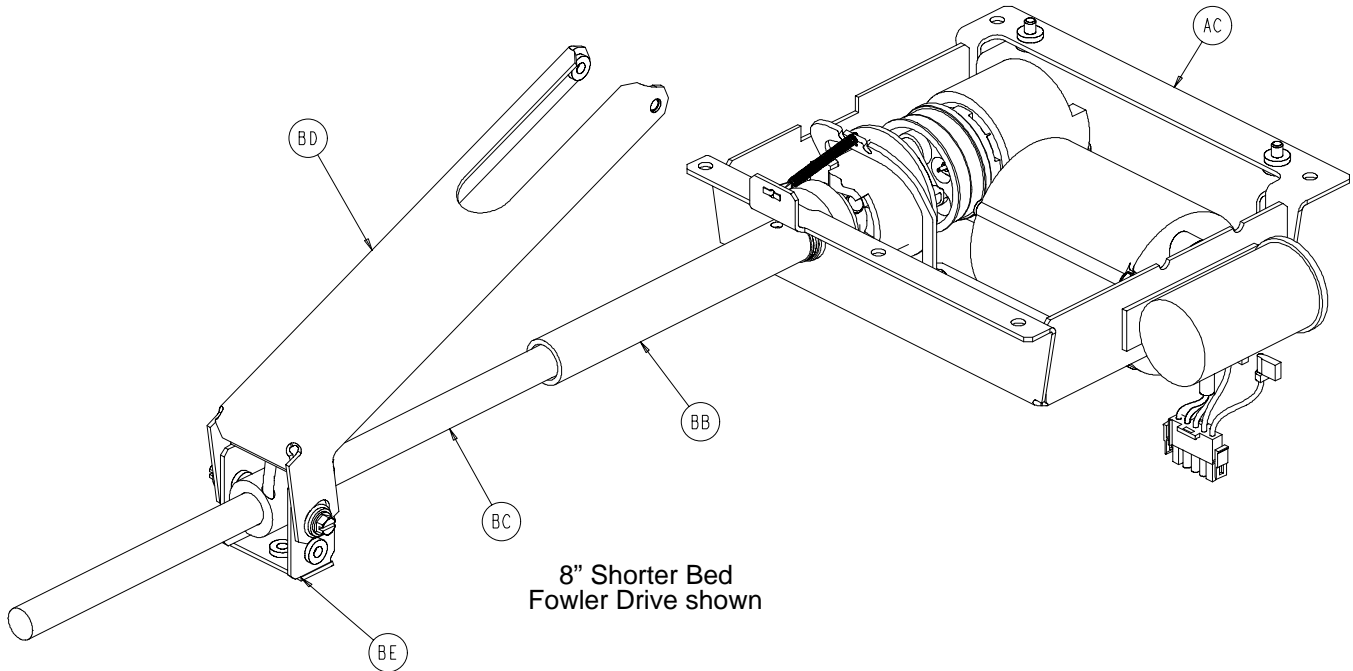

## 3002-300-550 Fowler Actuator Common Components

Item	Part No.	Part Name	Qty.	Item	Part No.	Part Name	Qty.
A	3-214	Hex Hd. Cap Screw	2	R	3000-300-455	CPR Isolation Bushing	2
B	3-50	Hex Washer Hd. Screw	2	S	3000-300-456	CPR Isolator	1
C	11-3	Flat Washer	2	T	3000-300-461	CPR Decoupler	1
D	11-303	Flat Washer	1	U	3000-300-462	CPR Wing	1
E	11-304	Shim Washer	2	W	3000-300-464	CPR Engagement Spring	2
F	27-17	Cotter Pin	1	X	3000-300-466	Thrust Bearing	1
G	28-120	External Retaining Ring	2	Y	3000-300-471	Roller Bearing	1
H	38-151	Cable Tie	2	Z	3000-300-473	Clevis Pin	1
J	44-29	Double-Stick Tape	1	AA	3000-300-658	CPR Release Arm	1
K	52-718	Nylon Insulator	2	AB	3001-200-228	Mounting Standoff	2
L	52-719	Nylon Flat Washer	2	AC	3001-300-485	Fowler Actuator Wldmt.	1
M	29-21	Dart Clip	1	AD	3001-300-487	Actuator Mounting Brkt.	1
N	3000-300-99	Litter Pivot Bushing	2	AE	3001-300-664	CPR Spring	1
P	3000-300-442	Fowler Drive Grommet	4	AF	38-478	Wave Spring	1

## 3002-343-550 Fowler Actuator - Standard Bed

Item	Part No.	Part Name	Qty.
BA	14-83	Thrust Washer	1
BC	3000-300-457	CPR Ball Screw	1
BD	3001-300-496	Fowler Link	1
BE	3002-300-493	Fowler Link Bracket	1

## 3002-342-550 Fowler Actuator - 8" Shorter Bed

Item	Part No.	Part Name	Qty.
BA	14-83	Thrust Washer	2
BB	3001-342-457	Fowler Nut Stop Tube	1
BC	3001-342-467	CPR Ball Screw	1
BD	3001-342-496	Fowler Link	1
BE	3001-342-499	Fowler Link Bracket	1

# 3001-300-775 Fowler Brake Kit Assembly

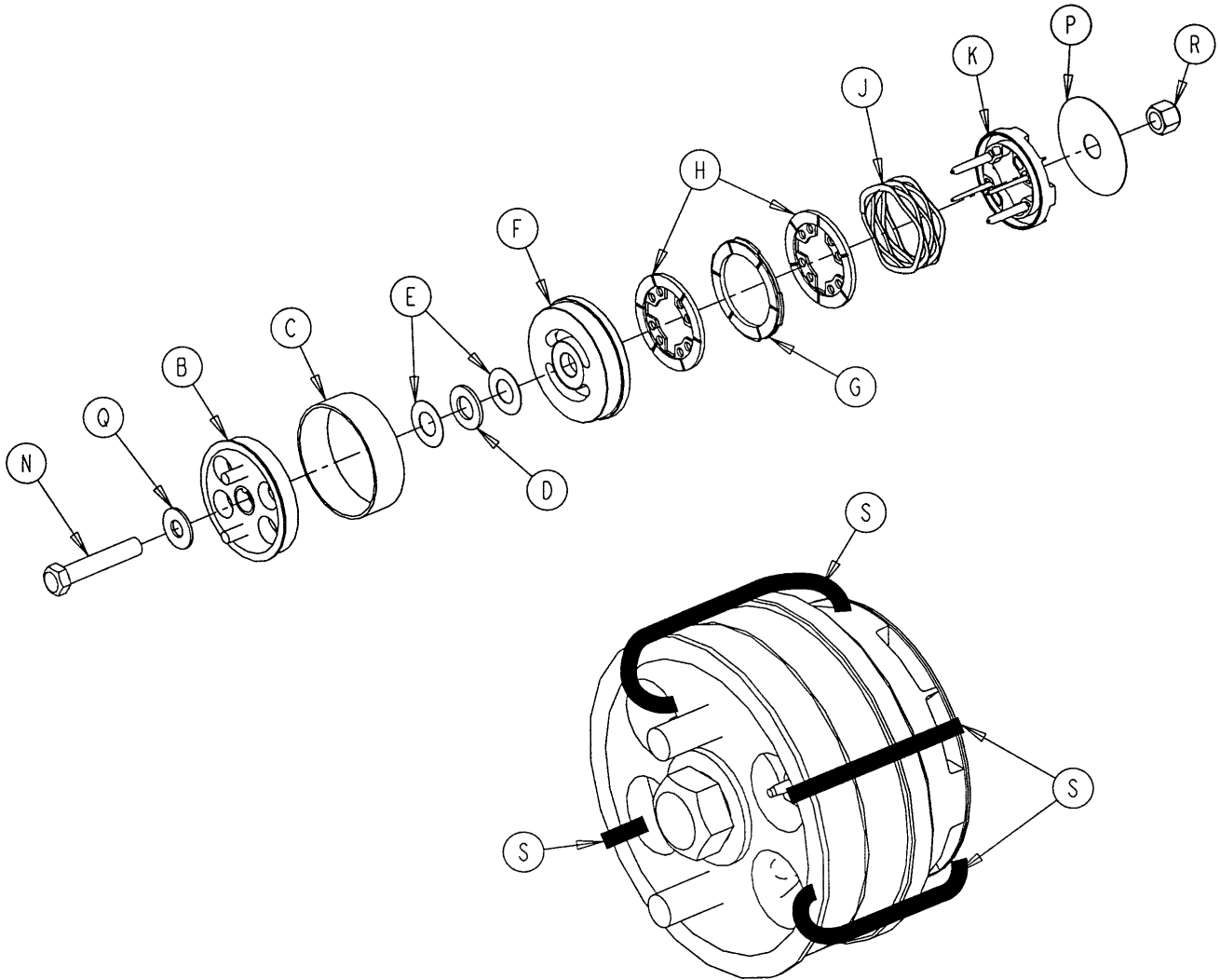

Item	Part No.	Part Name	Qty.
B	3001-300-455	CPR Coupler Assembly	1
C	3000-300-465	CPR Clutch Spring	1
D	81-212	Thrust Needle Roller Brg.	1
E	3000-200-224	Idler Gear Thrust Washer	2
F	3001-300-569	Brake Cup	1
G	3001-300-552	CPR Brake Disc	1
H	3001-300-551	CPR Spring Cup	2
J	3001-300-563	CPR Brake Spring	1
K	3001-300-570	CPR Spring Cup	1
N	3-64	Hex Hd. Cap Screw	1
P	3000-300-776	Flat Washer	1
Q	11-193	Heavy Flat Washer	1
R	16-35	Nylock Nut	1
S	3000-300-1 13	8" Wire Tie	4

# Notes

---

# 3002-343-35 Standard Bed Fowler Limit Switch Ass'y

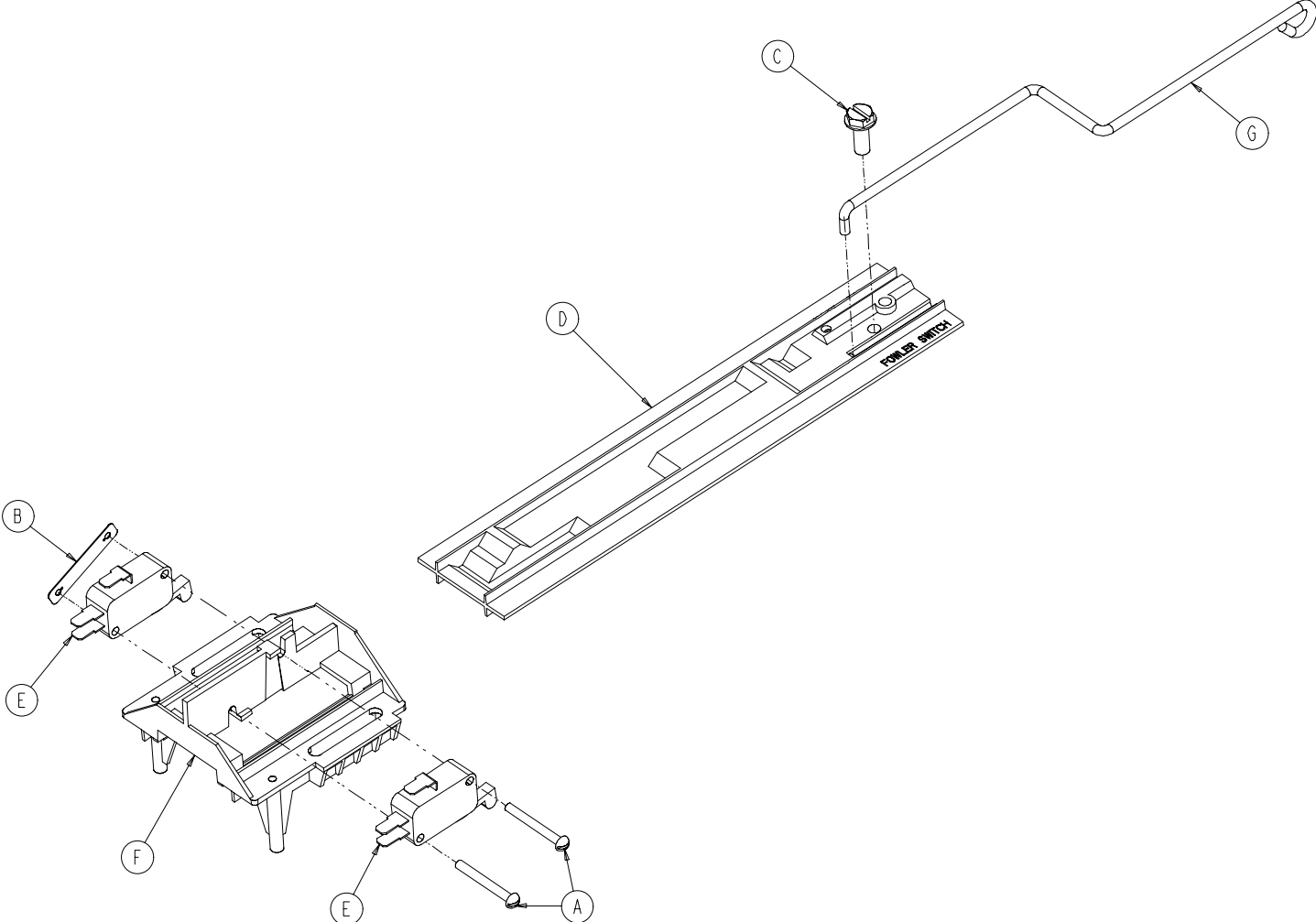

Item	Part No.	Part Name	Qty.
A	2-3	Round Hd. Screw	2
B	16-69	Twin Type Fastener	1
C	23-82	Hex Washer Hd. Screw	1
D	3000-300-36	Fowler Cam Card	1
E	3000-300-41	Micro Switch	2
F	3000-300-44	Cam Guide	1
G	3002-300-38	Link Wire	1

# 3002-342-25 8" Shorter Bed Fowler Limit Switch Ass'y

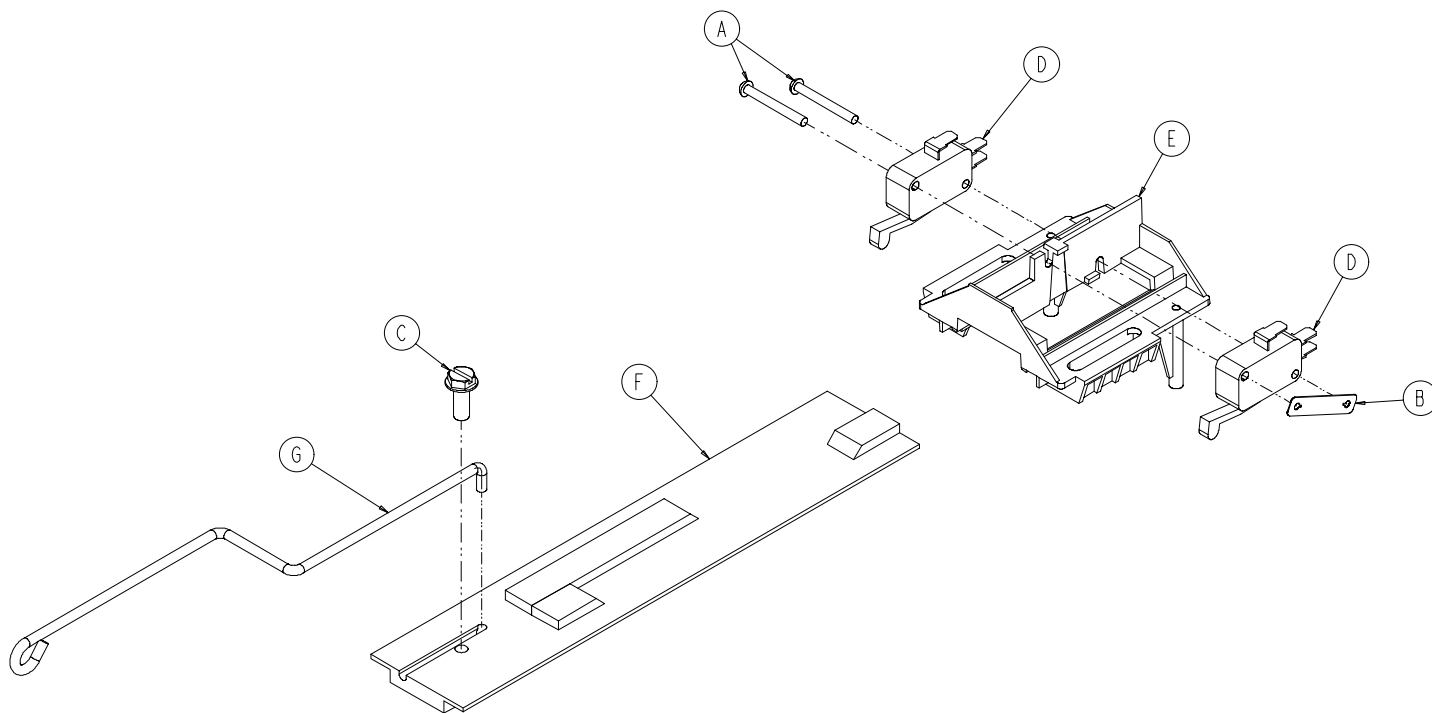

Item	Part No.	Part Name	Qty.
A	2-3	Round Hd. Screw	2
B	16-69	Twin Type Fastener	1
C	23-82	Hex Washer Hd. Screw	1
D	3000-300-41	Micro Switch	2
E	3000-300-44	Cam Guide	1
F	3001-342-32	Fowler Cam Card	1
G	3002-300-38	Link Wire	1

# 3002-310-20 Night Light Assembly

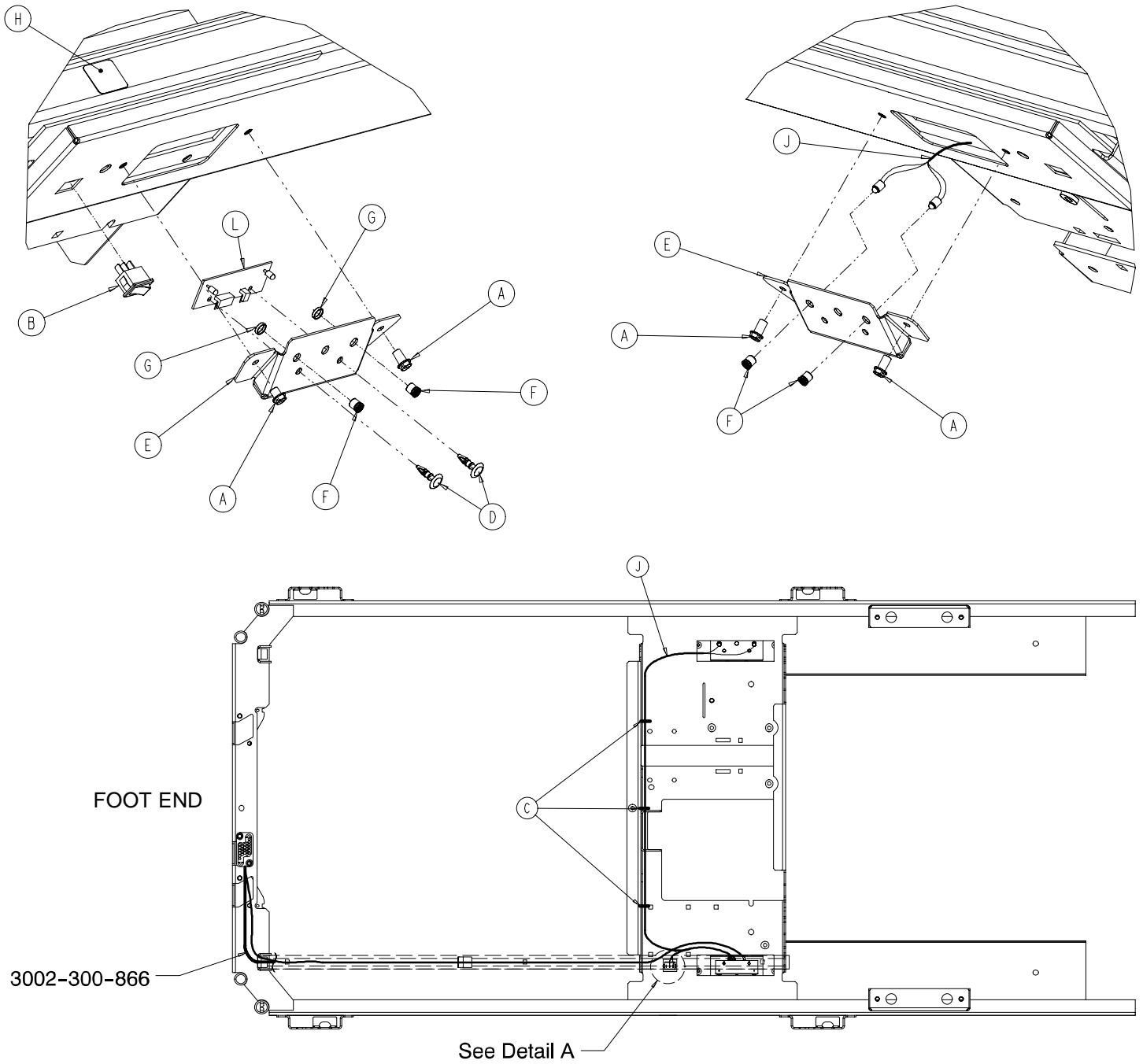

TOP VIEW - Some components are removed or shown in phantom for clarity.

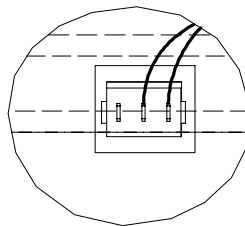

DETAIL A

# 3002-310-20 Night Light Assembly

---

<b>Item</b>	<b>Part No.</b>	<b>Part Name</b>	<b>Qty.</b>
A	3-224	Hex Washer Hd. Screw	4
B	59-191	Toggle Switch	1
C	3000-300-1 13	8" Cable Tie	4
D	3000-300-1 15	Stand-Of f	2
E	3002-310-9	Night Light Case	2
F	3002-310-10	LED Lens	4
G	3002-310-1 1	Lens Retainer	2
H	3002-310-601	Night Light Label	1
J	3002-310-801	Night Light Wiring Harness	1
L	3002-310-900	Night Light PCB	1



# 3002-320-50 Optional 110V Outlet Assembly

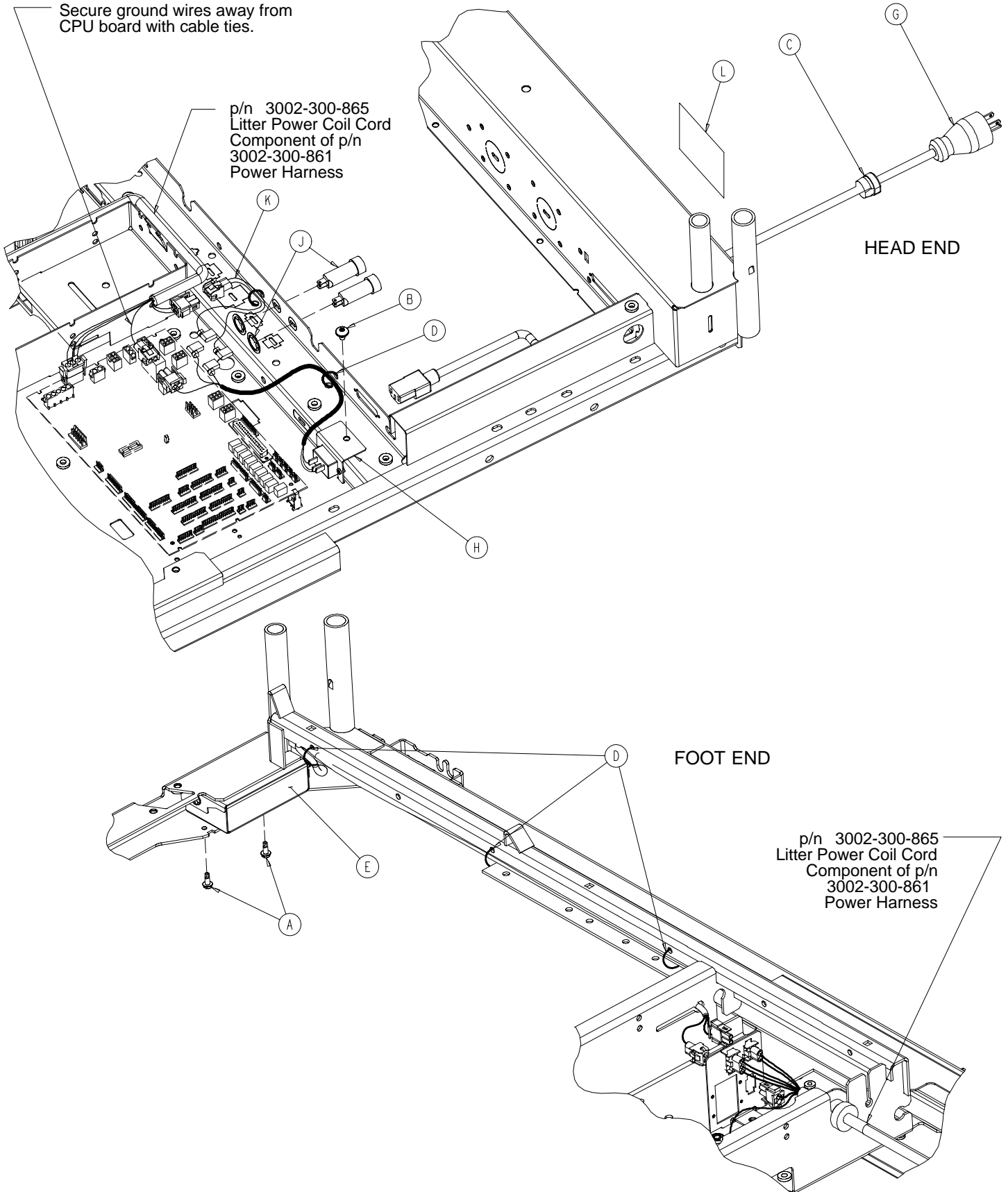

# 3002-320-50 Optional 110V Outlet Assembly

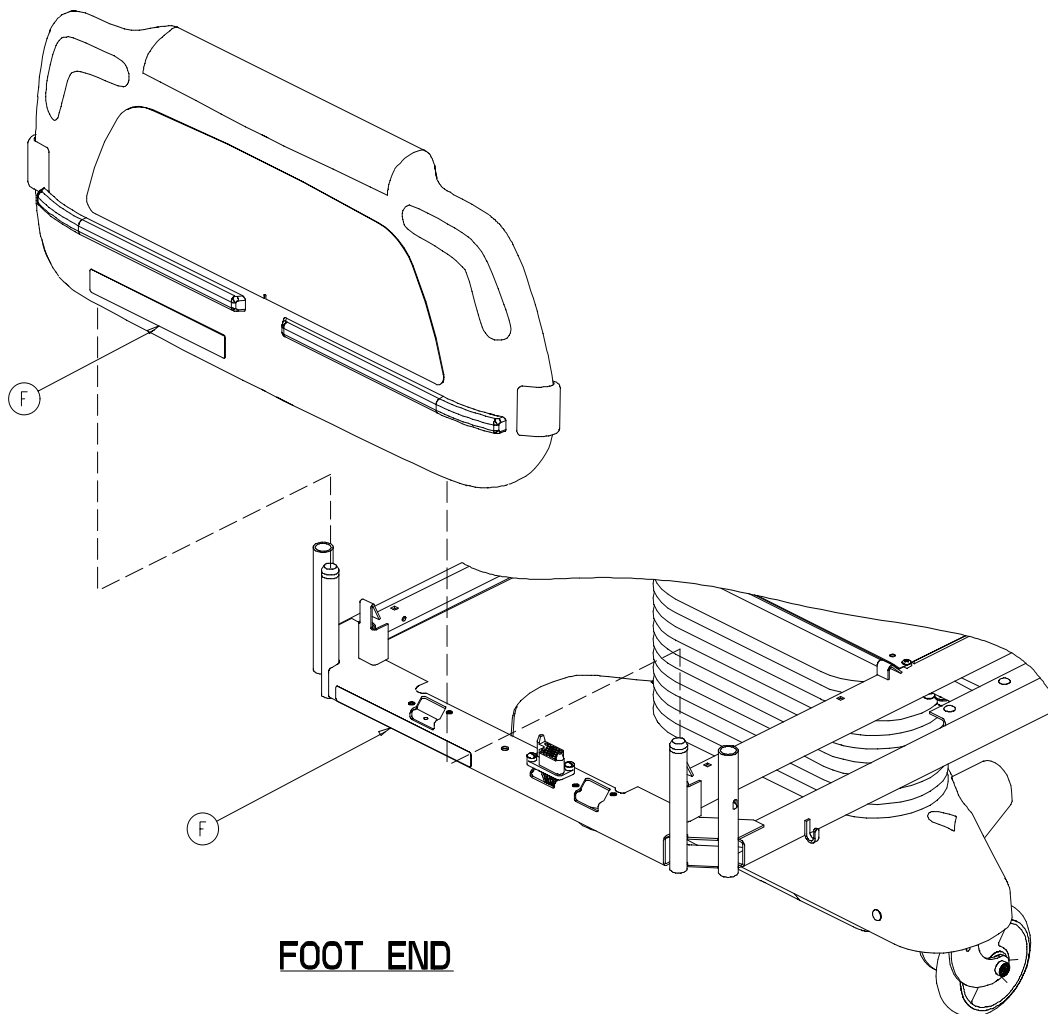

Item	Part No.	Part Name	Qty.
A	3-224	Hex Washer Hd. Screw	2
B	7-53	Truss Hd. Torx	1
C	30-45	Strain Relief	1
D	3000-300-1 13	Cable Tie	5
E	(page 160)	Outlet Box Assembly	1
F	3002-320-626	110V Outlet Label	2
G	3002-320-801	Power Cord	1
H	3002-320-878	110V Power Inlet Cable	1
J	59-196	10A Circuit Breaker	2
K	3002-320-803	110V Power Jumper	1
L	3002-320-625	Shock Hazard Caution Label	1

# 3002-320-60 110V Outlet Box Assembly

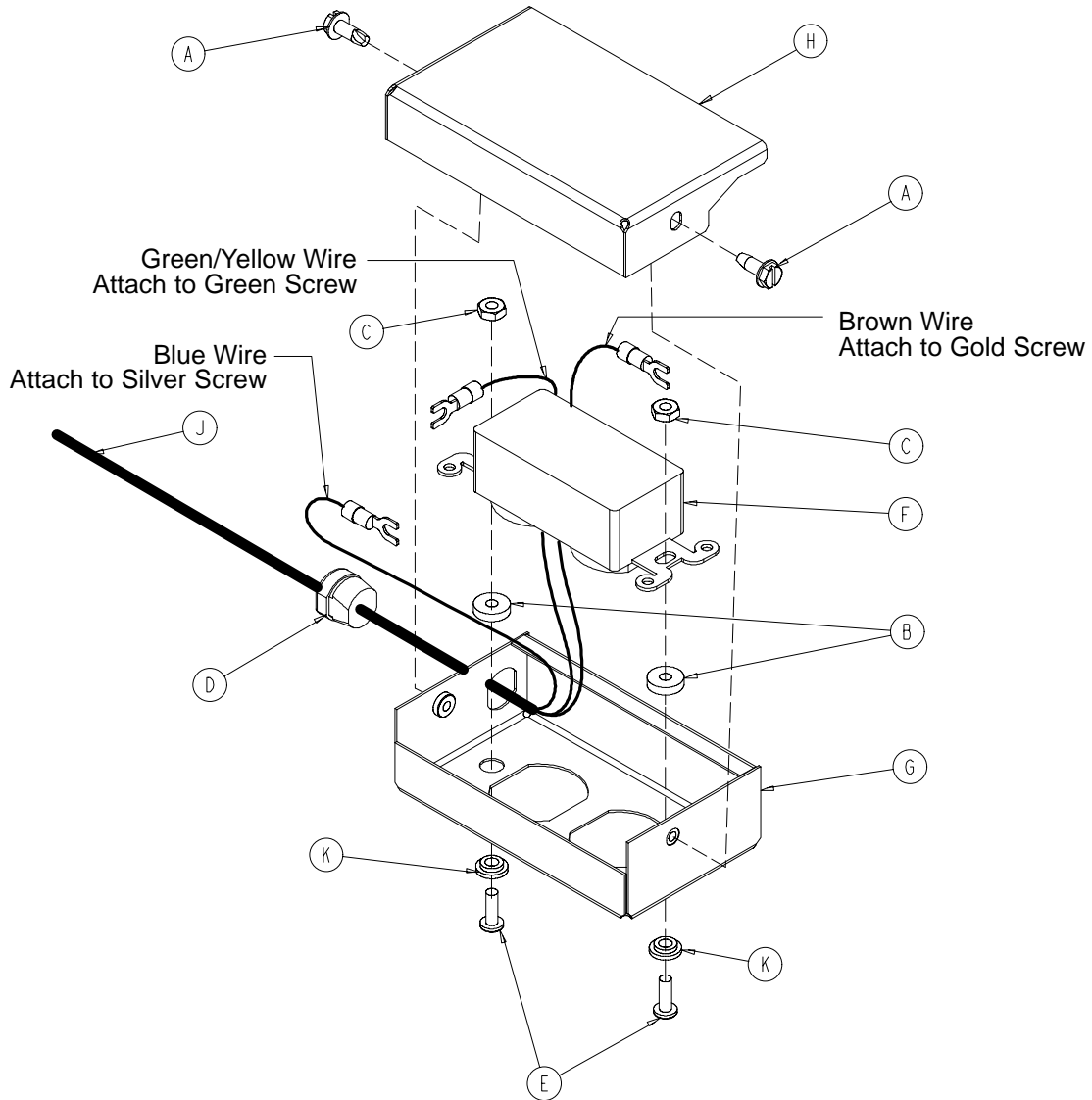

Item	Part No.	Part Name	Qty.
A	3-224	Hex Washer Hd. Screw	2
B	52-318	Round Spacer	2
C	16-14	Hex Nut	2
D	34-133	Strain Relief	1
E	4-265	But. Hd. Machine Screw	2
F	59-733	Hospital Grade Receptacle	1
G	3002-320-20	110V Outlet Box	1
H	3002-320-21	110V Outlet Box Cover	1
J	3002-320-802	110V Outlet Cable	1
K	52-317	Shoulder Washer	2

# Notes

---

# Optional Scale/Bed Exit Assembly

Assembly part number 3002-307-2 (reference only)

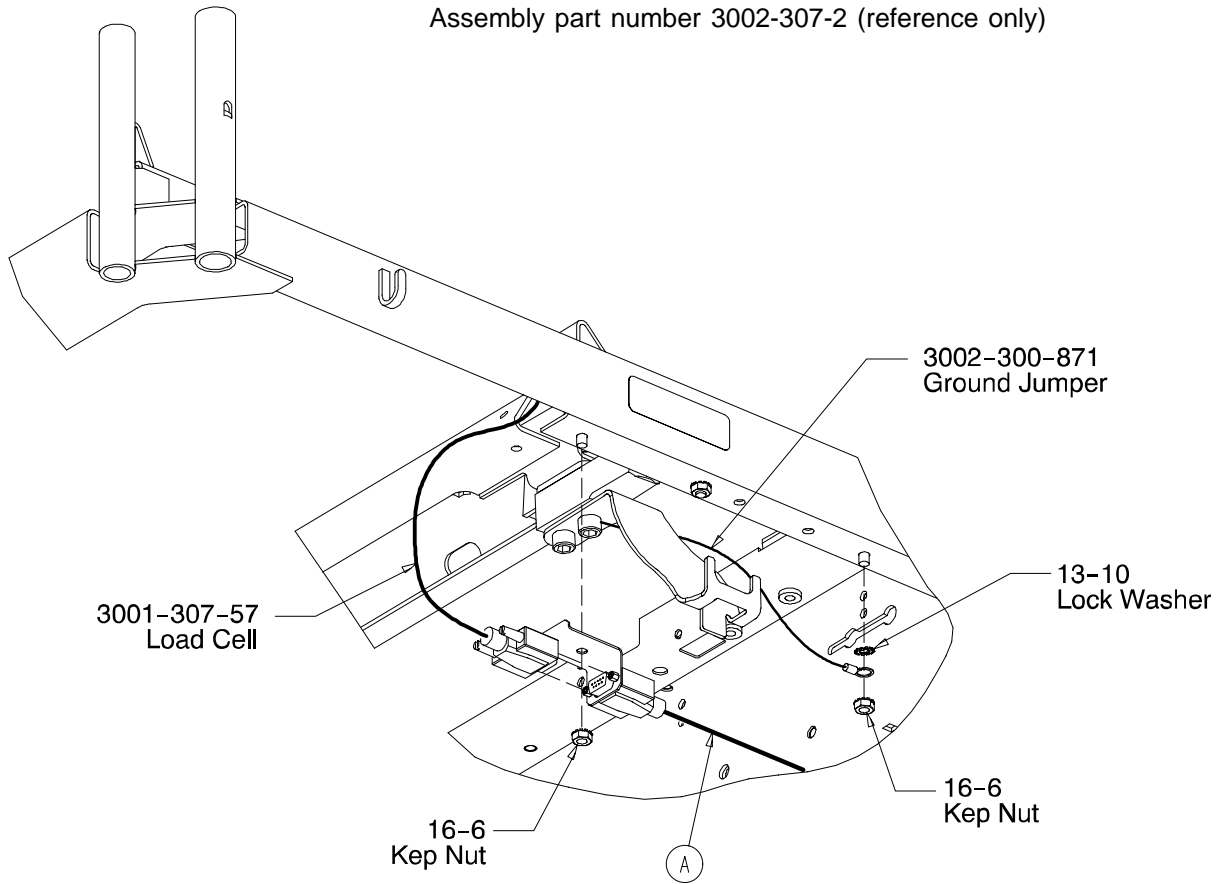

FOOT END LOAD CELL CABLE INSTALLATION  
(TYPICAL BOTH SIDES OF THE BED)

Item	Part No.	Part Name	Qty.
A	3001-307-835	Foot End Load Cell Cable	2
B	3001-307-834	Head End Load Cell Cable	2
C	7-53	Truss Hd. Torx	2
D	3000-300-1 13	Cable Tie	9

# Optional Scale/Bed Exit Assembly

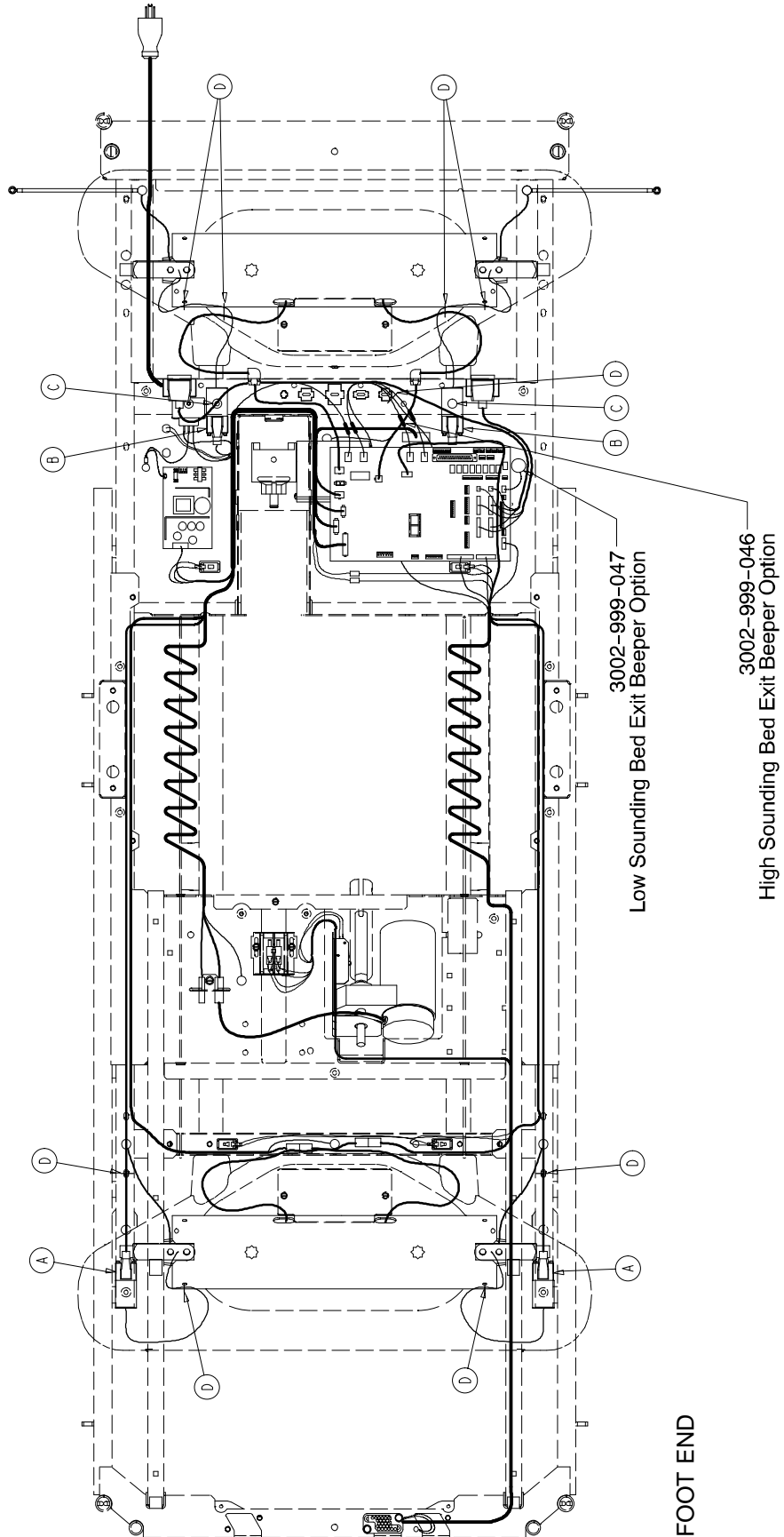

# Optional HWI Assembly with Communication

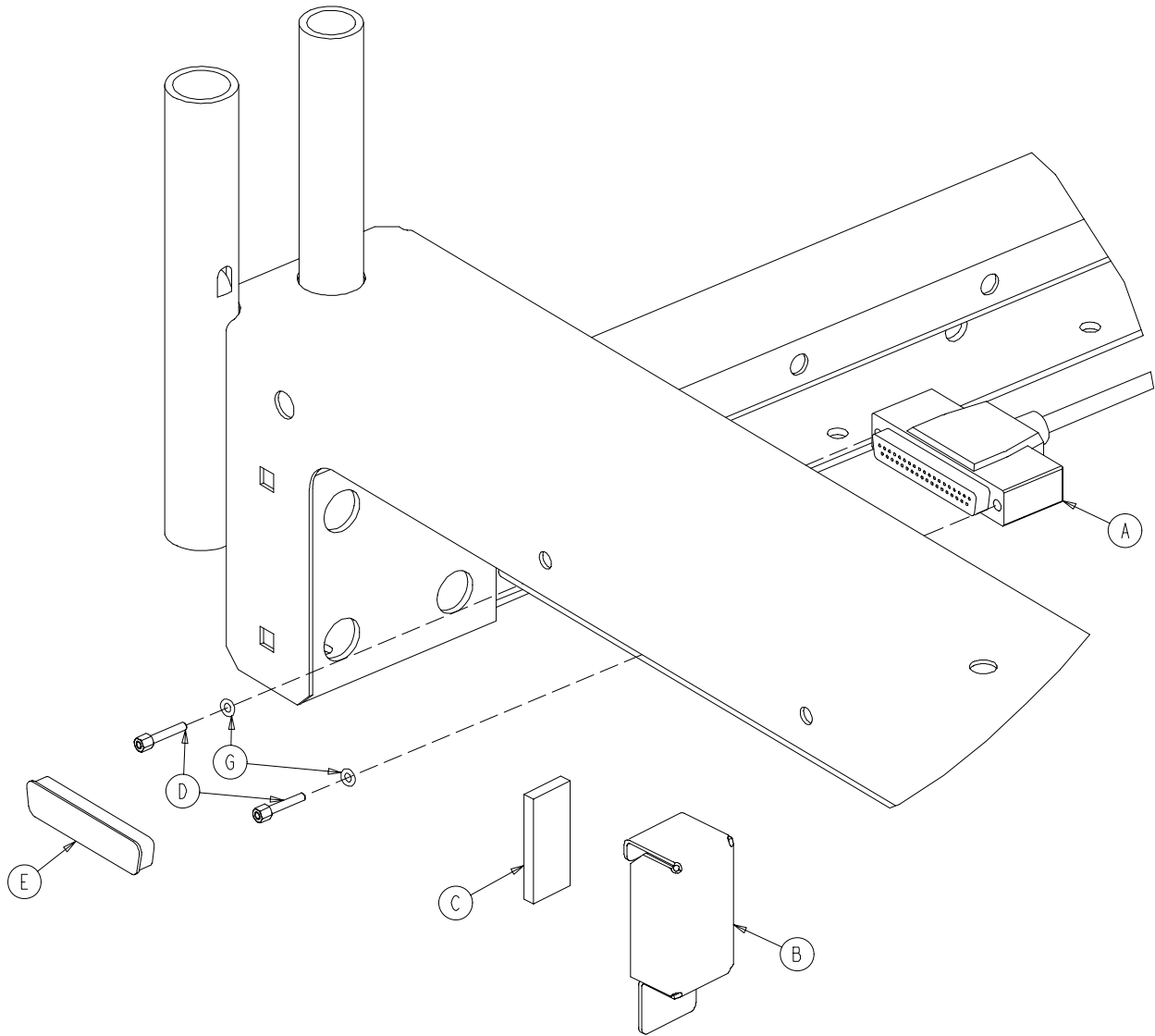

## 3001-303-52 Nurse Call & Communication

Item	Part No.	Part Name	Qty.
A	3001-303-821	Headwall Interface Cable	1
B	(page 169)	Battery Enclosure Ass'y	1
C	7900-1-291	Foam Tape	1
D	3001-300-7	Female Screwjack	2
E	59-710	Static Plug	1
F	3000-300-1 13	Cable Tie	4
G	12-46	Split Lock Washer	2

## 3001-303-122 Communication

Item	Part No.	Part Name	Qty.
A	3001-303-821	Headwall Interface Cable	1
D	3001-300-7	Female Screwjack	2
E	59-710	Static Plug	1
F	3000-300-1 13	Cable Tie	3
G	12-46	Split Lock Washer	2

# Optional HWI Assembly with Communication

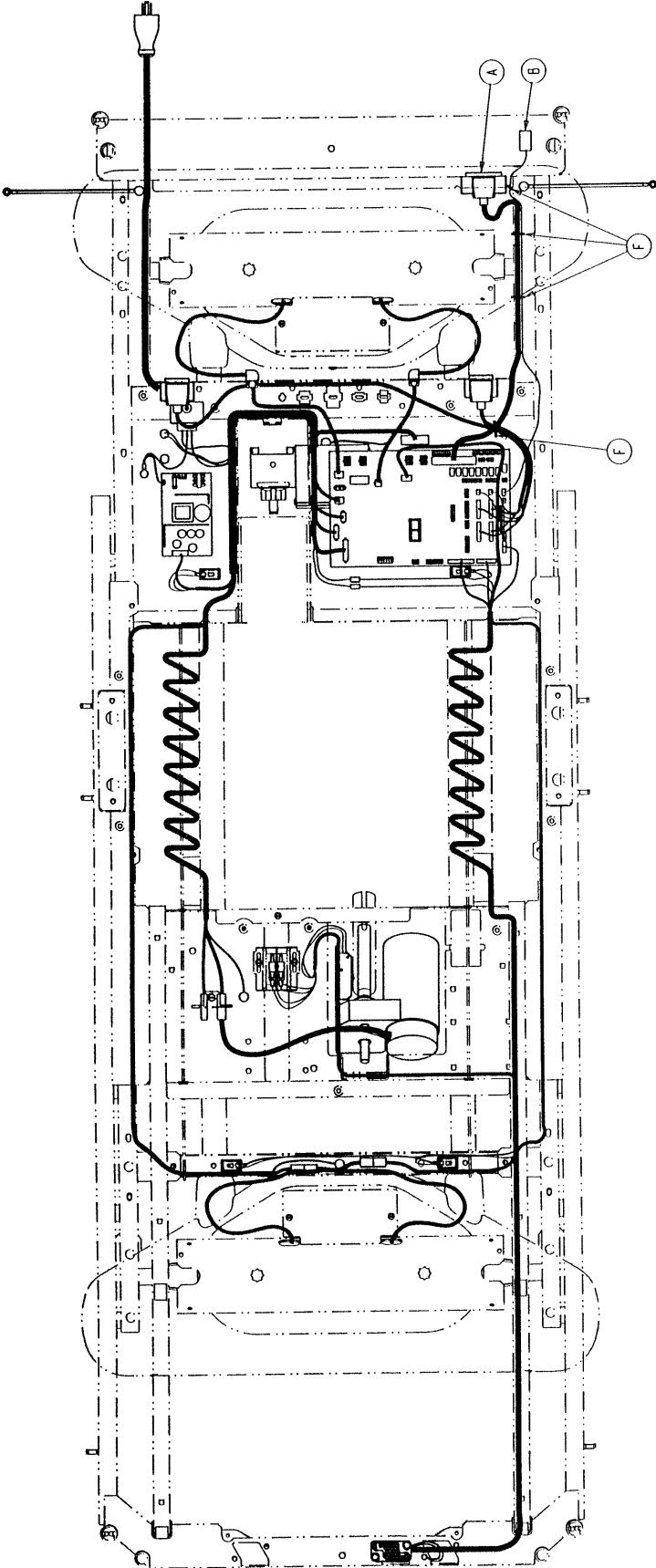



# Optional HWI Assembly w/Communication & Ports

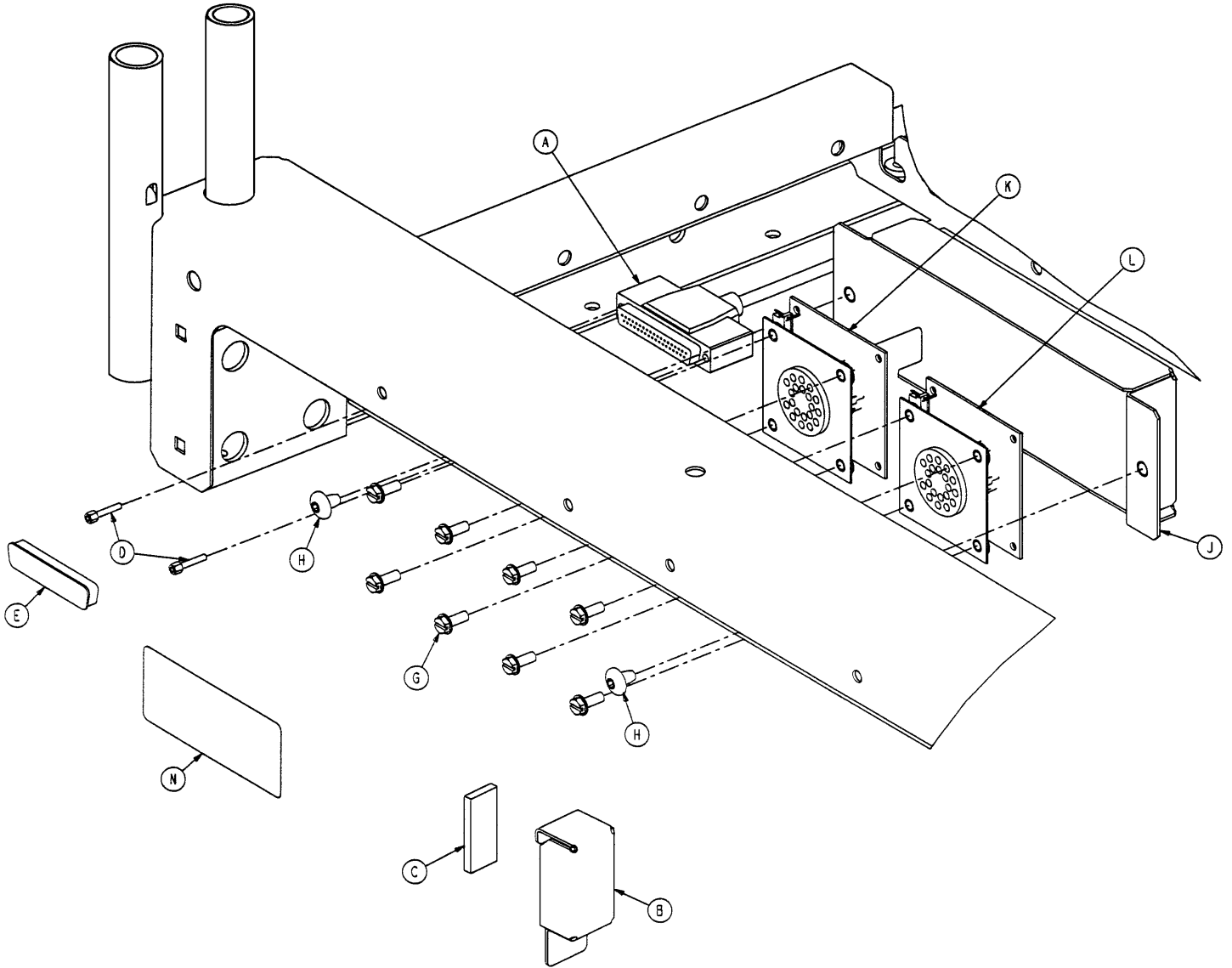

# Optional HWI Assembly w/Communication & Ports

---

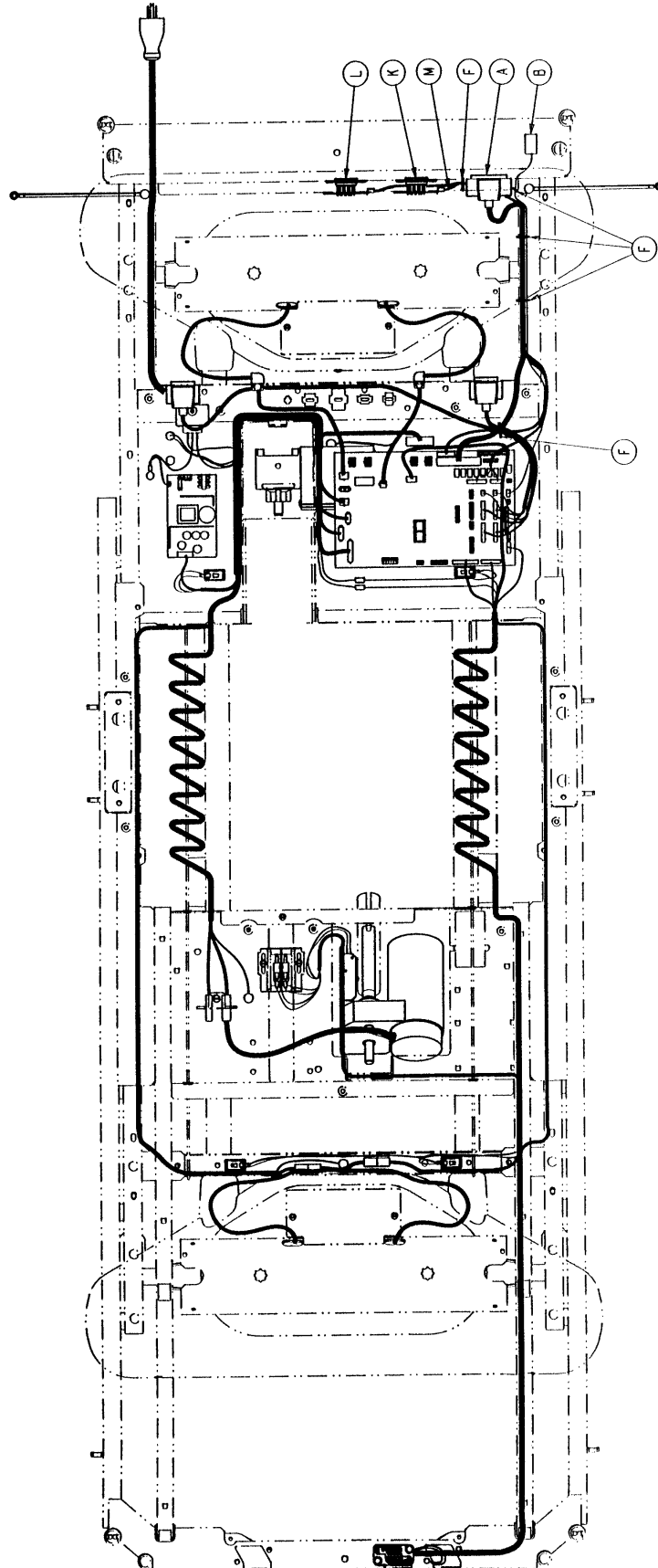

# Optional HWI Assembly w/Communication & Ports

## 3001-314-12 HWI w/1 Stryker Port

Item	Part No.	Part Name	Qty.
A	3001-303-821	Headwall Interface Cable	1
B	(page 169)	Battery Enclosure Ass'y	1
C	7900-1-291	Foam Tape	1
D	3001-300-7	Female Screwjack	2
E	59-710	Static Plug	1
F	3000-300-1 13	Cable Tie	5
G	3-224	Hex Washer Hd. Screw	4
H	7-53	Truss Hd. Screw	2
J	3001-314-006	Pendant Port Cover	1
K	3001-314-920	HWI Pendant Port PCB	1
M	3001-314-821	Pendant Port Cable	1
N	5000-90-28	Cord Out Label	1

## 3001-314-22 HWI w/2 Stryker Ports

Item	Part No.	Part Name	Qty.
A	3001-303-821	Headwall Interface Cable	1
B	(page 169)	Battery Enclosure Ass'y	1
C	7900-1-291	Foam Tape	1
D	3001-300-7	Female Screwjack	2
E	59-710	Static Plug	1
F	3000-300-1 13	Cable Tie	5
G	3-224	Hex Washer Hd. Screw	8
H	7-53	Truss Hd. Screw	2
J	3001-314-006	Pendant Port Cover	1
K	3001-314-920	HWI Pendant Port PCB	2
M	3001-314-821	Pendant Port Cable	1
N	5000-90-28	Cord Out Label	1

## 3001-314-1 12 HWI w/1 Custom Port

Item	Part No.	Part Name	Qty.
A	3001-303-821	Headwall Interface Cable	1
B	(page 169)	Battery Enclosure Ass'y	1
C	7900-1-291	Foam Tape	1
D	3001-300-7	Female Screwjack	2
E	59-710	Static Plug	1
F	3000-300-1 13	Cable Tie	5
G	3-224	Hex Washer Hd. Screw	4
H	7-53	Truss Hd. Screw	2
J	3001-314-006	Pendant Port Cover	1
K	3001-314-889	HWI Cust. Pend. Port PCB	1
M	3001-314-821	Pendant Port Cable	1
N	5000-90-28	Cord Out Label	1

## 3001-314-122 HWI w/1 Stryker & 1 Custom Port

Item	Part No.	Part Name	Qty.
A	3001-303-821	Headwall Interface Cable	1
B	(page 169)	Battery Enclosure Ass'y	1
C	7900-1-291	Foam Tape	1
D	3001-300-7	Female Screwjack	2
E	59-710	Static Plug	1
F	3000-300-1 13	Cable Tie	5
G	3-224	Hex Washer Hd. Screw	8
H	7-53	Truss Hd. Screw	2
J	3001-314-006	Pendant Port Cover	1
K	3001-314-920	HWI Pendant Port PCB	1
L	3001-314-889	HWI Cust. Pend. Port PCB	1
M	3001-314-821	Pendant Port Cable	1
N	5000-90-28	Cord Out Label	1

# 3001-303-45 Battery Enclosure Assembly

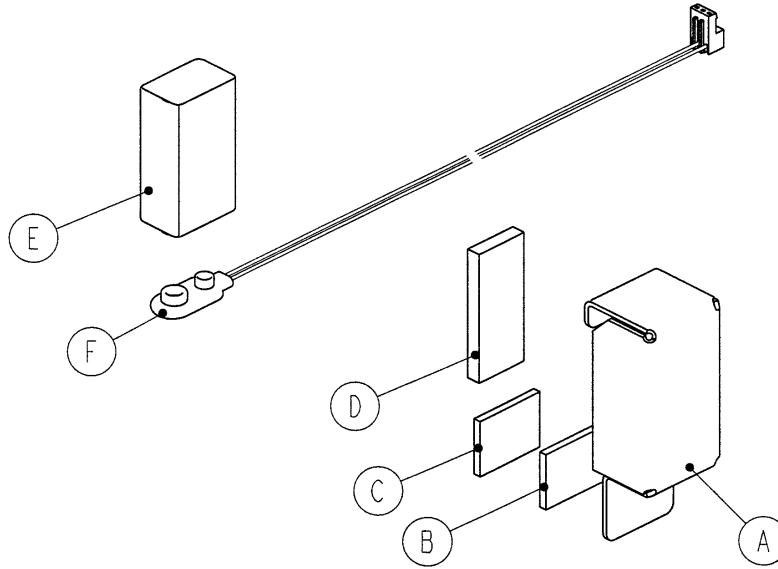

Item	Part No.	Part Name	Qty.
A	3001-303-12	Battery Enclosure	1
B	29-10	Fine Duo-Lock	1
C	29-8	Coarse Duo-Lock	1
D	7900-1-291	Foam Tape	1
E	3000-303-871	Battery	1
F	3001-303-81 1	Battery Cable	1

# Zoom Option Litter Assembly

Assembly part number 3002-31-10 (reference only)

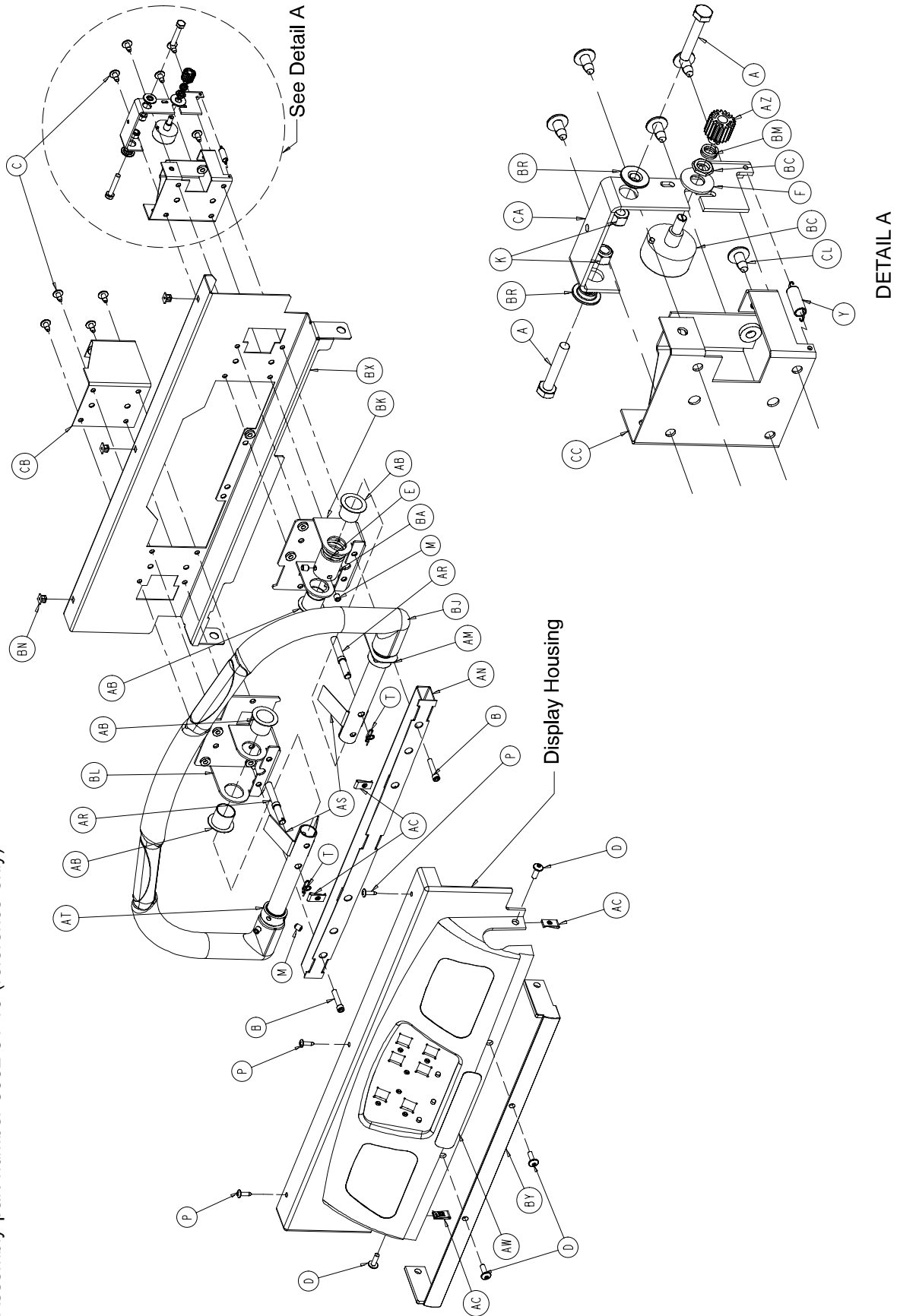

# Zoom Option Litter Assembly

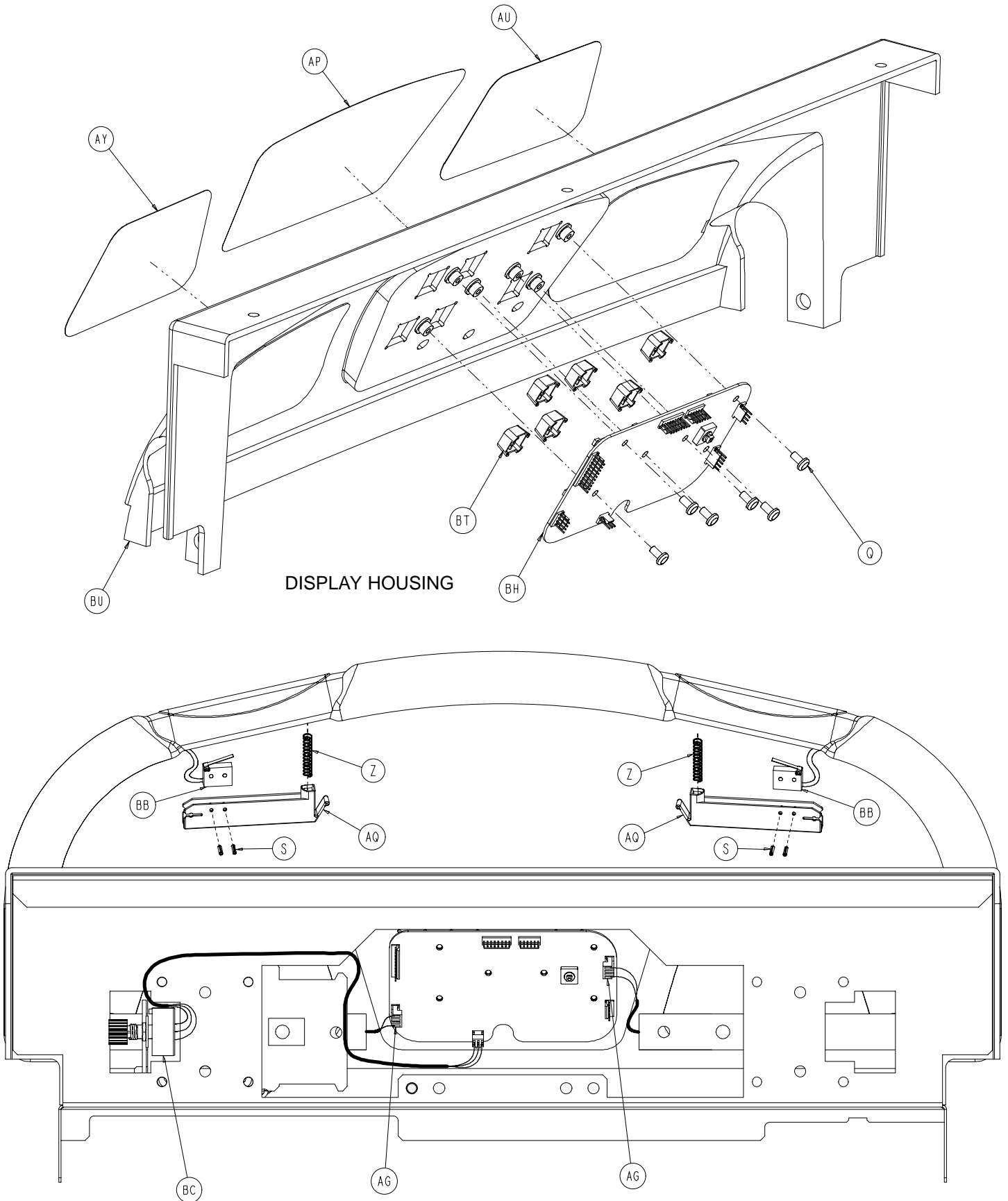

# Zoom Option Litter Assembly

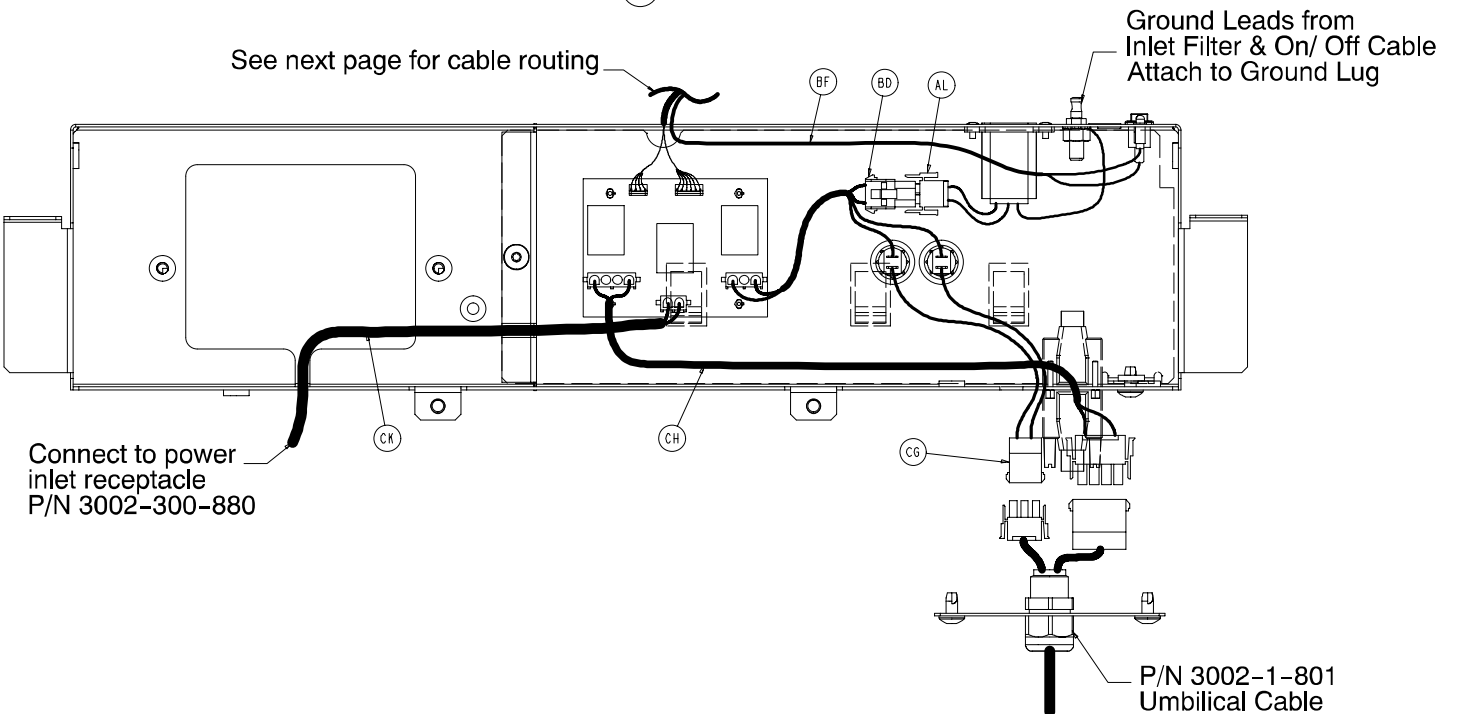
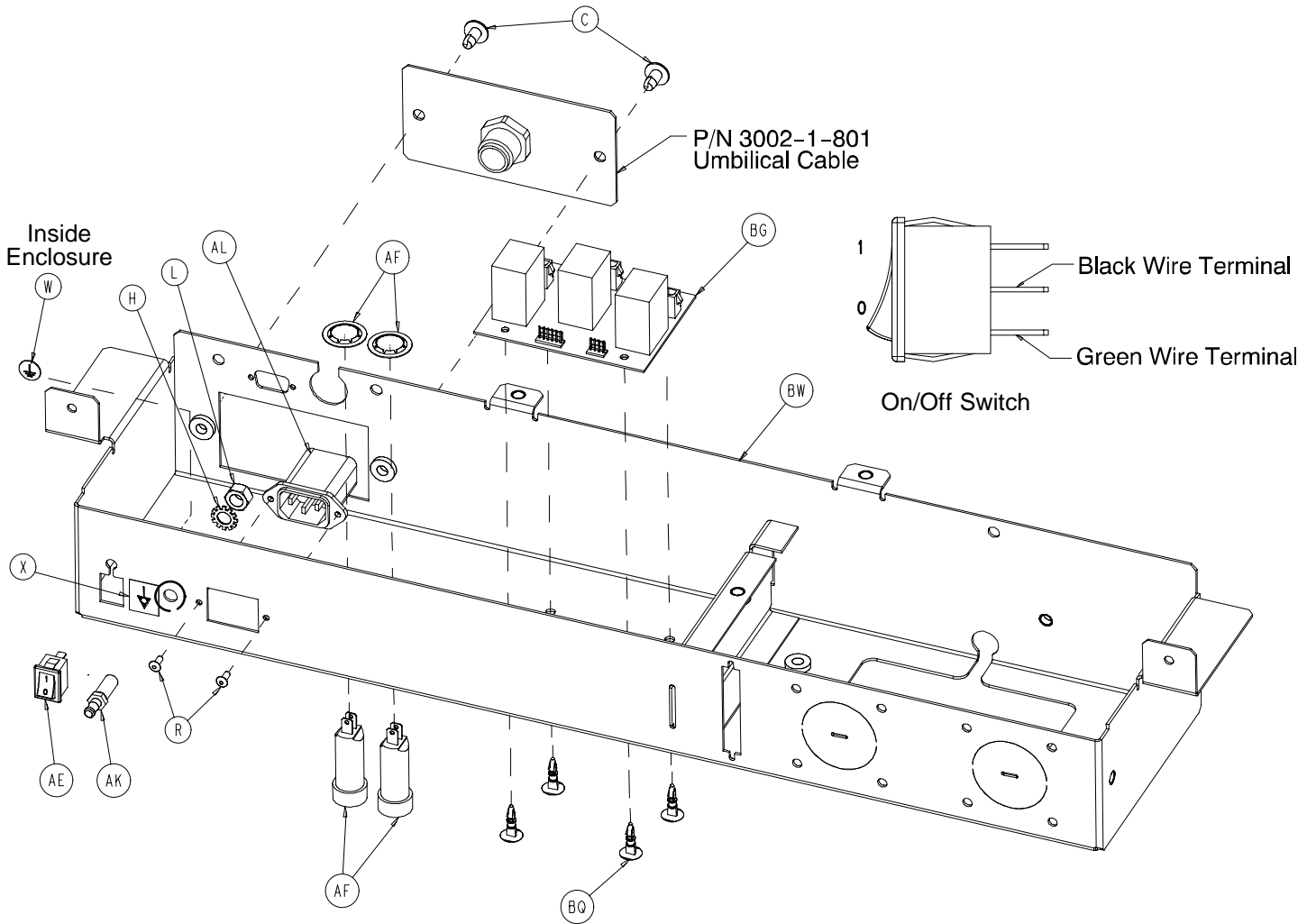

# Zoom Option Litter Assembly

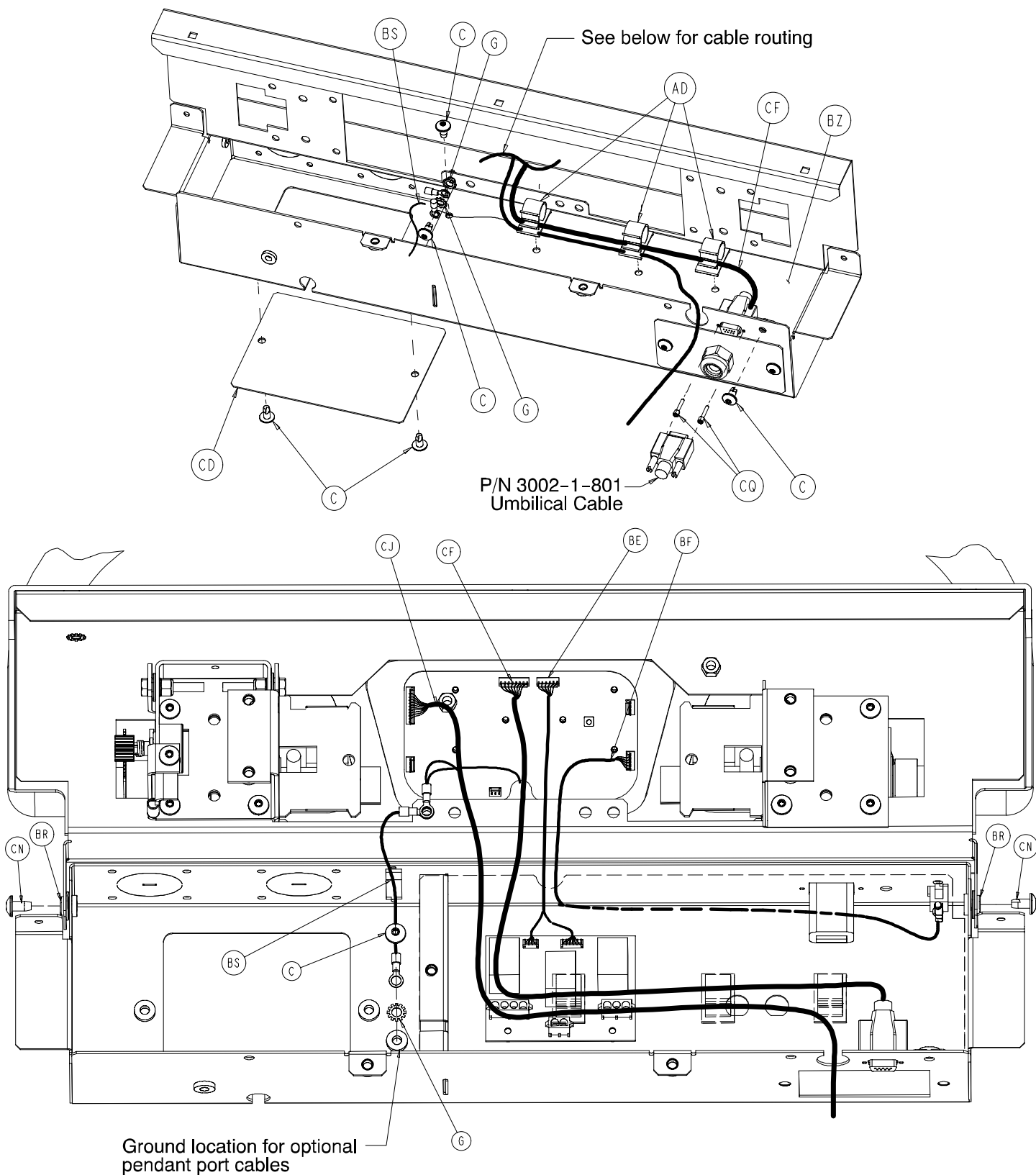



# Zoom Option Litter Assembly

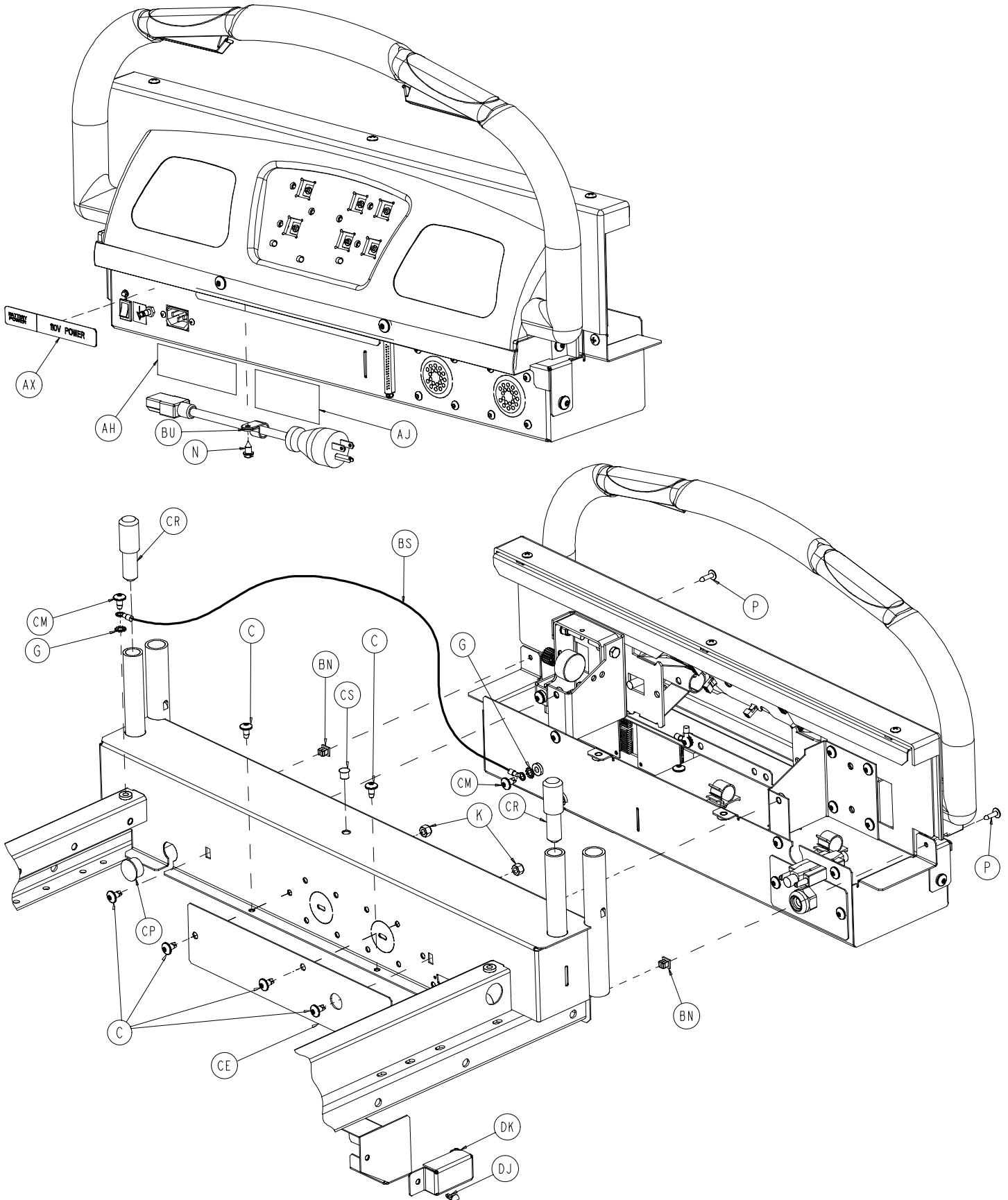

# Zoom Option Litter Assembly

Item	Part No.	Part Name	Qty.	Item	Part No.	Part Name	Qty.
A	3-50	Hex Hd. Cap Screw	2	AY	2040-31-105	Logo Label	1
B	4-142	Soc. Hd. Cap Screw	2	AZ	2040-31-106	Potentiometer Gear	1
C	7-52	Truss Hd. Torx	25	BA	2040-31-107	Locking Collar	1
D	7-56	Truss Hd. Torx	4	BB	2040-31-803	Mom. Cont. Swch. Cable	2
E	7-69	Nylon Washer	1	BC	2040-31-804	Potentiometer Cable	1
F	11-193	Flat Washer	1	BD	2040-31-808	Charger AC Jumper Cable	1
G	13-10	Ext. Tooth Lock Washer	5	BE	2040-31-809	CPU/Crossover Cable	1
H	13-38	External Lock Washer	1	BF	2040-31-810	On/Off Cable	1
K	16-28	Nylock Nut	4	BG	2040-31-900	AC/Switchover PCB Ass'y	1
L	16-33	Kep Nut	1	BH	2040-31-910	Display/CPU Assembly	1
M	21-140	Set Screw	4	BJ	2040-231-64	Control Bar	1
N	23-25	Hex Washer Hd. Screw	1	BK	2040-231-1 10	Pivot Bracket, Right	1
P	23-80	Truss Hd. Screw	5	BL	2040-231-1 11	Pivot Bracket, Left	1
Q	23-1 12	Hi-Low Tapping Screw	6	BM	3000-200-253	Pot. Worm Gear Retainer	1
R	25-40	Rivet	2	BN	3000-300-2	Plastic Clip Nut	5
S	26-303	Roll Pin	4	BP	3000-300-1 14	4" Wire Tie	5
T	27-22	Rue Pin	2	BQ	3000-300-1 15	Stand Off	4
U	34-22	Cord Clamp	1	BR	3001-300-99	Pivot Bearing	4
W	36-46	Ground Label	1	BS	3002-300-870	8" Ground Strap	2
X	36-1 15	Ground Label	1	BT	3001-400-953	Switch Cap	6
Y	38-482	Extension Spring	1	BU	3002-31-1 1	Top Display Housing	1
Z	38-448	Switch Handle Ret. Spring	2	BW	3002-31-53	Hd. End Bottom Enclosure	1
AB	52-762	Flange Bearing	4	BX	3002-31-63	Head End Top Enclosure	1
AC	55-27	"U"-Type Nut	4	BY	2040-231-69	Display Bumper	1
AD	59-133	Push-Mount Wire Clip	3	BZ	3002-31-92	Hd. End Electronics Cover	1
AE	59-191	On/Off Switch	1	CA	3002-31-108	Potentiometer Mount	1
AF	59-195	Circuit Breaker	2	CB	3002-31-109	Reinforcement Brkt., Left	1
AG	59-781	4-Position Connector	2	CC	3002-31-1 10	Reinforcement Brkt., Right	1
AH	1550-90-1	Hosp. Grade Plug Label	1	CD	3002-31-1 12	Pendant Port Cover	1
AJ	2011-1-104	Danger Label	1	CE	3002-31-1 15	Cover Plate	1
AK	2011-1-215	Grounding Lug	1	CF	3002-31-801	Zoom CPU Signal Jumper	1
AL	2035-31-803	Inlet Filter Cable	1	CG	3002-31-802	Zoom Breaker Jumper	1
AM	2040-31-51	Potentiometer Collar	1	CH	3002-31-803	Zoom Crossover PCB Jmpr.	1
AN	2040-31-54	Bumper Attachment Wldmt.	1	CJ	3002-31-804	Zoom/Bed CPU Jumper	1
AP	2040-31-62	Display Label	1	CK	3002-31-805	Bed AC Power Jumper	1
AQ	2040-31-68	Contact Switch Handle	2	CL	4-325	Soc. Hd. Cap Screw	1
AR	2040-31-73	Stop Pin	2	CM	7-53	Truss Hd. Torx	2
AS	2040-31-74	Control Bar Return Spring	2	CN	7-63	Truss Hd. Torx	2
AT	2040-31-82	Potentiometer Collar	1	CP	37-208	Hole Plug	1
AU	2040-31-101	Drive Instruction Label	1	CQ	3001-300-7	M/F Screw	2
AW	2040-31-102	Drive Warning Label	1	CR	3002-31-1 14	Head Board Extender	2
AX	2040-31-103	Power Label	1	CS	37-35	Hole Plug	1

# Zoom Option Litter Assembly

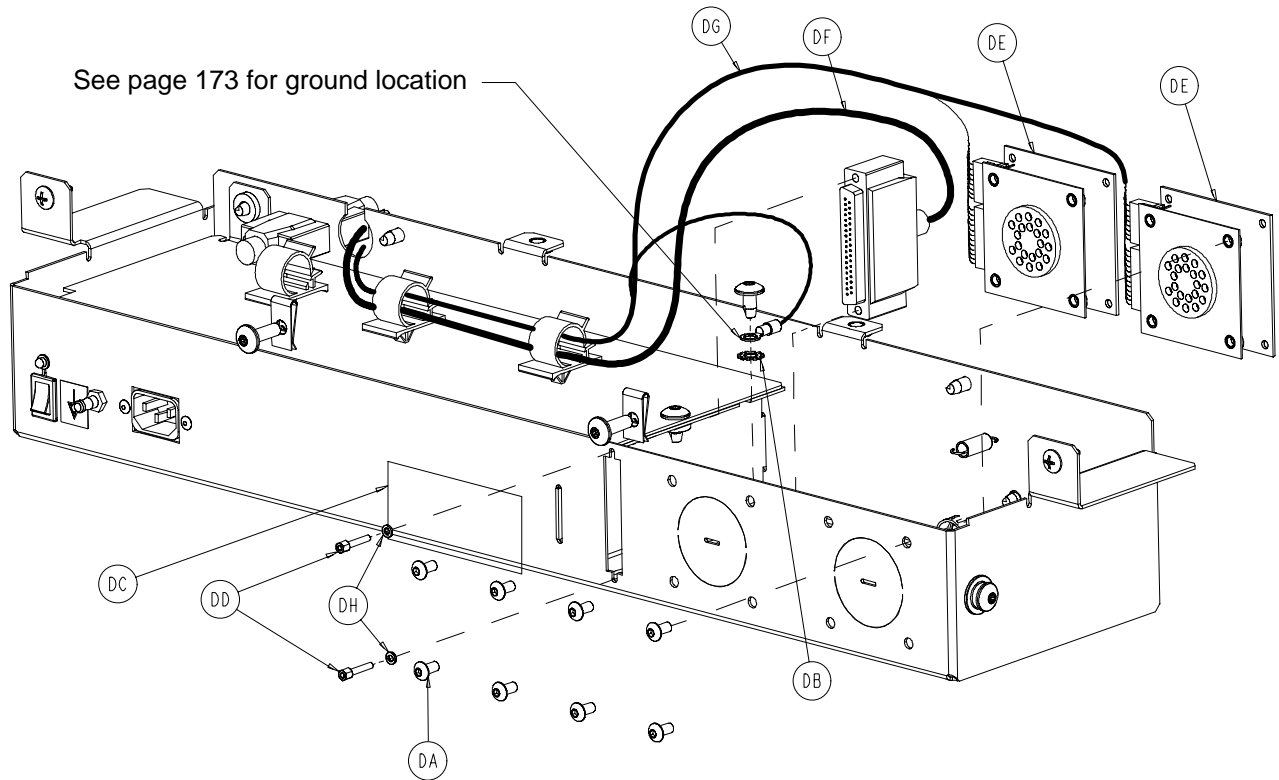

## 3002-31-200 Head Wall Communication Option

Item	Part No.	Part Name	Qty.
DD	3001-300-7	M/F Screw	2
DF	5010-80-8	Head Wall IF Cable	1

## 3002-31-201 Head Wall Comm. w/Nurse Call

Item	Part No.	Part Name	Qty.
DD	3001-300-7	M/F Screw	2
DF	5010-80-8	Head Wall Interface Cable	1
DH	12-46	Split Lock Washer	2
DJ	3000-300-477	CPR Conduit Stud	1
DK	(page 177)	Battery Enclosure Ass'y	1

## 3002-31-202 HW Comm. w/NC & 1 Stryker Port

Item	Part No.	Part Name	Qty.
DA	4-307	But. Hd. Cap Screw	4
DB	13-10	Ext. Tooth Lock Washer	1
DC	2040-31-104	Cord Out Label	1
DD	3001-300-7	M/F Screw	2
DE	3001-314-920	Head Wall Pend. Port PCB	1
DF	5010-80-8	Head Wall Interface Cable	1
DG	3002-31-807	Zoom Pendant Port Cable	1
DH	12-46	Split Lock Washer	2
DJ	3000-300-477	CPR Conduit Stud	1
DK	(page 177)	Battery Enclosure Ass'y	1

## 3002-31-203 HW Comm. w/NC & 2 Stryker Ports

Item	Part No.	Part Name	Qty.
DA	4-307	But. Hd. Cap Screw	8
DB	13-10	Ext. Tooth Lock Washer	1
DC	2040-31-104	Cord Out Label	1
DD	3001-300-7	M/F Screw	2
DE	3001-314-920	Head Wall Pend. Port PCB	2
DF	5010-80-8	Head Wall Interface Cable	1
DG	3002-31-808	Zoom Dual Pen. Port Cbl.	1
DH	12-46	Split Lock Washer	2
DJ	3000-300-477	CPR Conduit Stud	1
DK	(page 177)	Battery Enclosure Ass'y	1

# 3002-31-45 Zoom Option Battery Enclosure Assembly

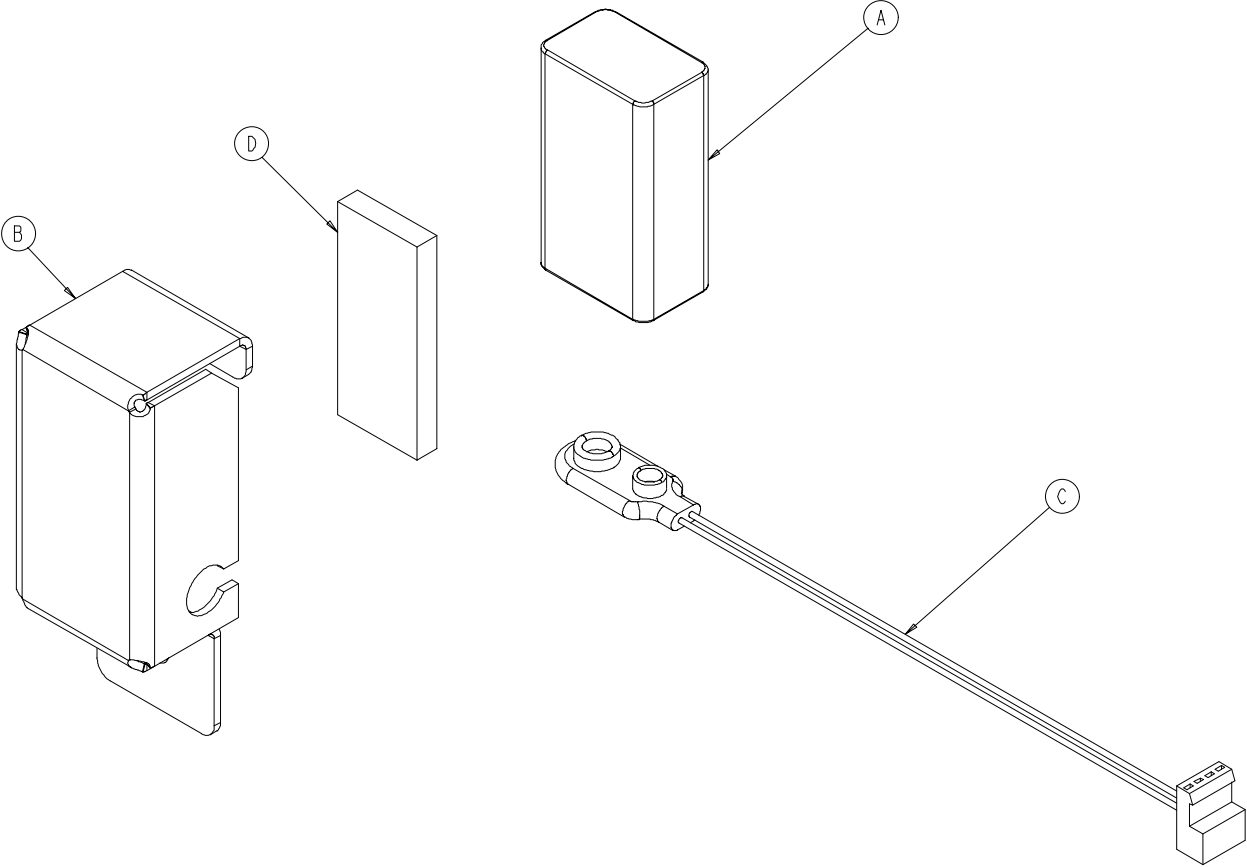

Item	Part No.	Part Name	Qty.
A	3000-303-871	9 Volt Battery	1
B	3001-303-12	Battery Enclosure	1
C	3001-303-81 1	Battery Cable	1
D	7900-1-291	Foam Tape	1

# Notes

---

# Head End Siderail Assembly

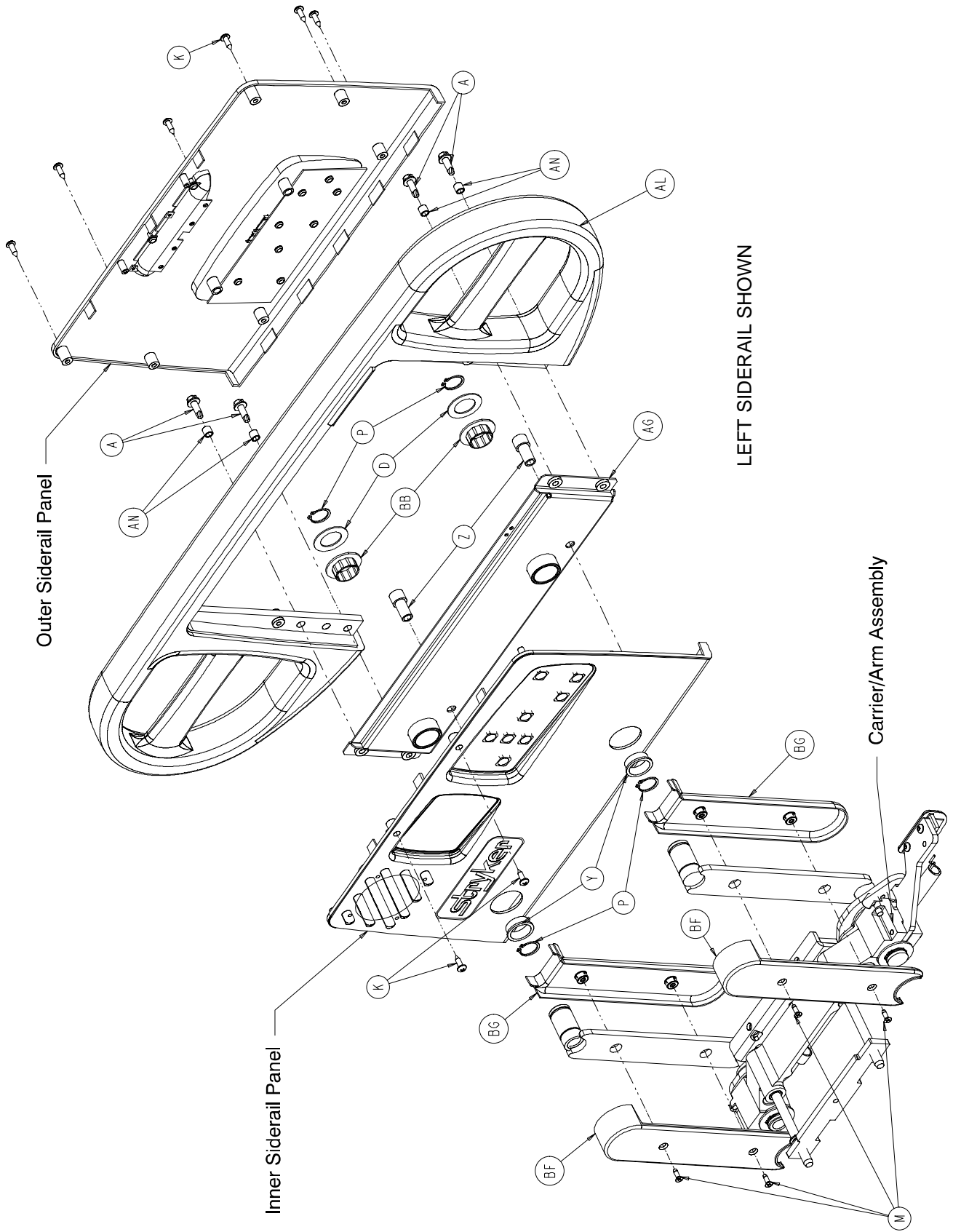

# Head End Siderail Assembly

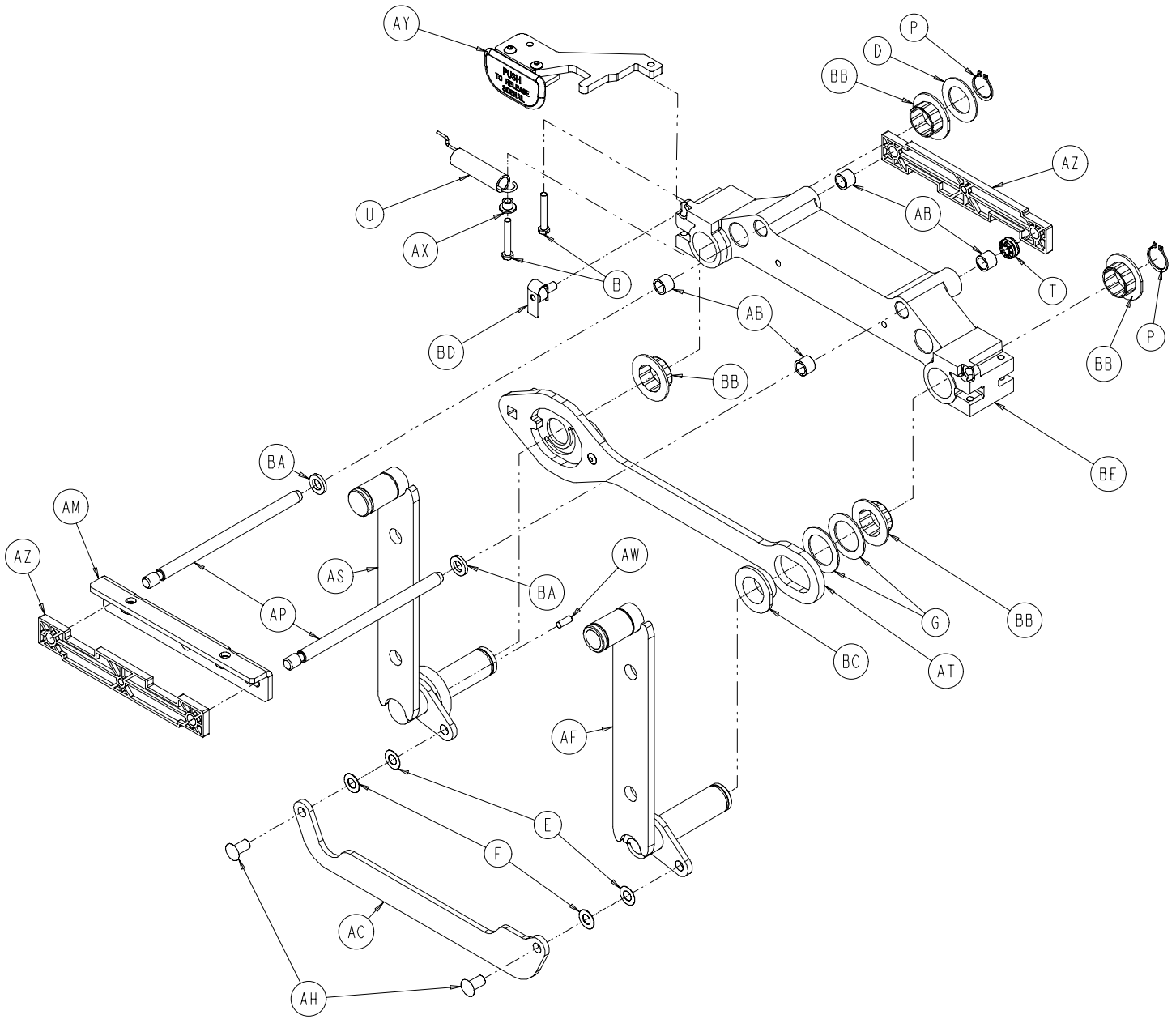

CARRIER/ARM ASSEMBLY  
LEFT SIDERAIL SHOWN

# Head End Siderail Assembly

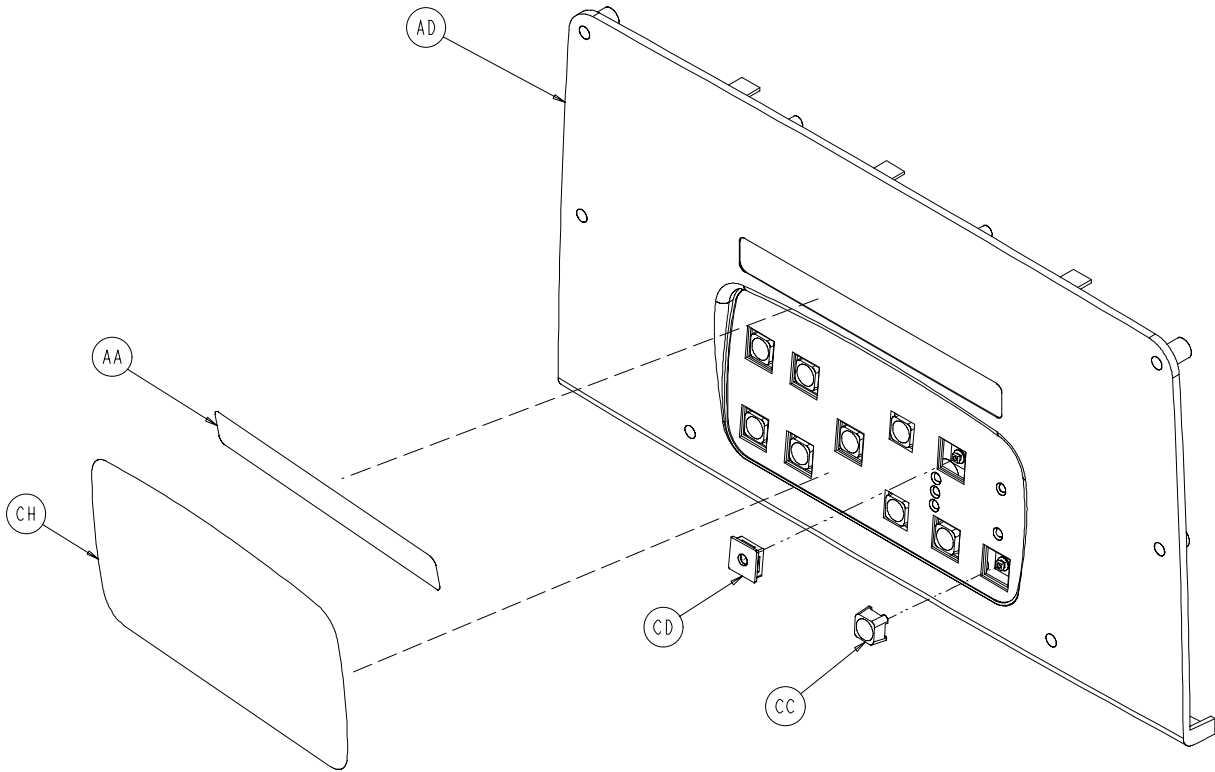

SIDERAIL OUTER PANEL ASSEMBLY

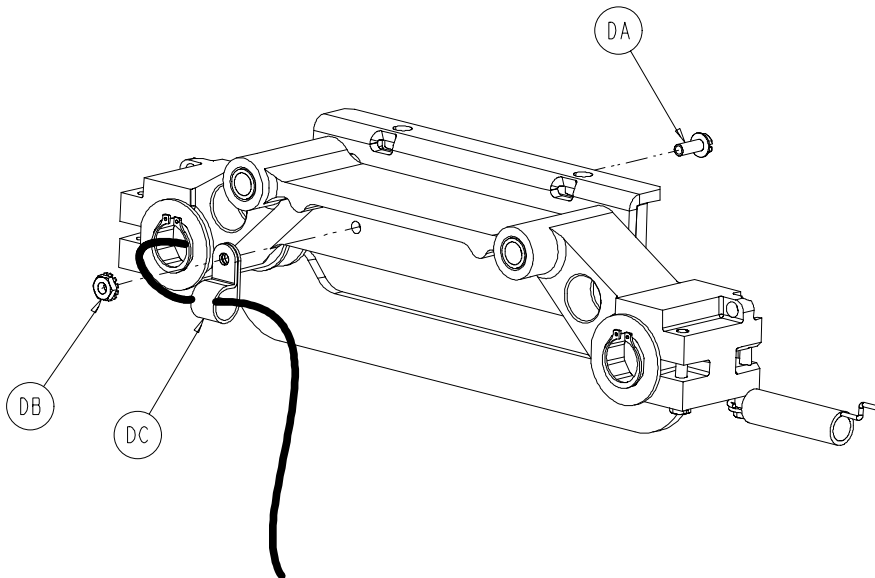

8" SHORTER BED ONLY - RIGHT AND LEFT SIDERAILS



# Head End Siderail Assembly

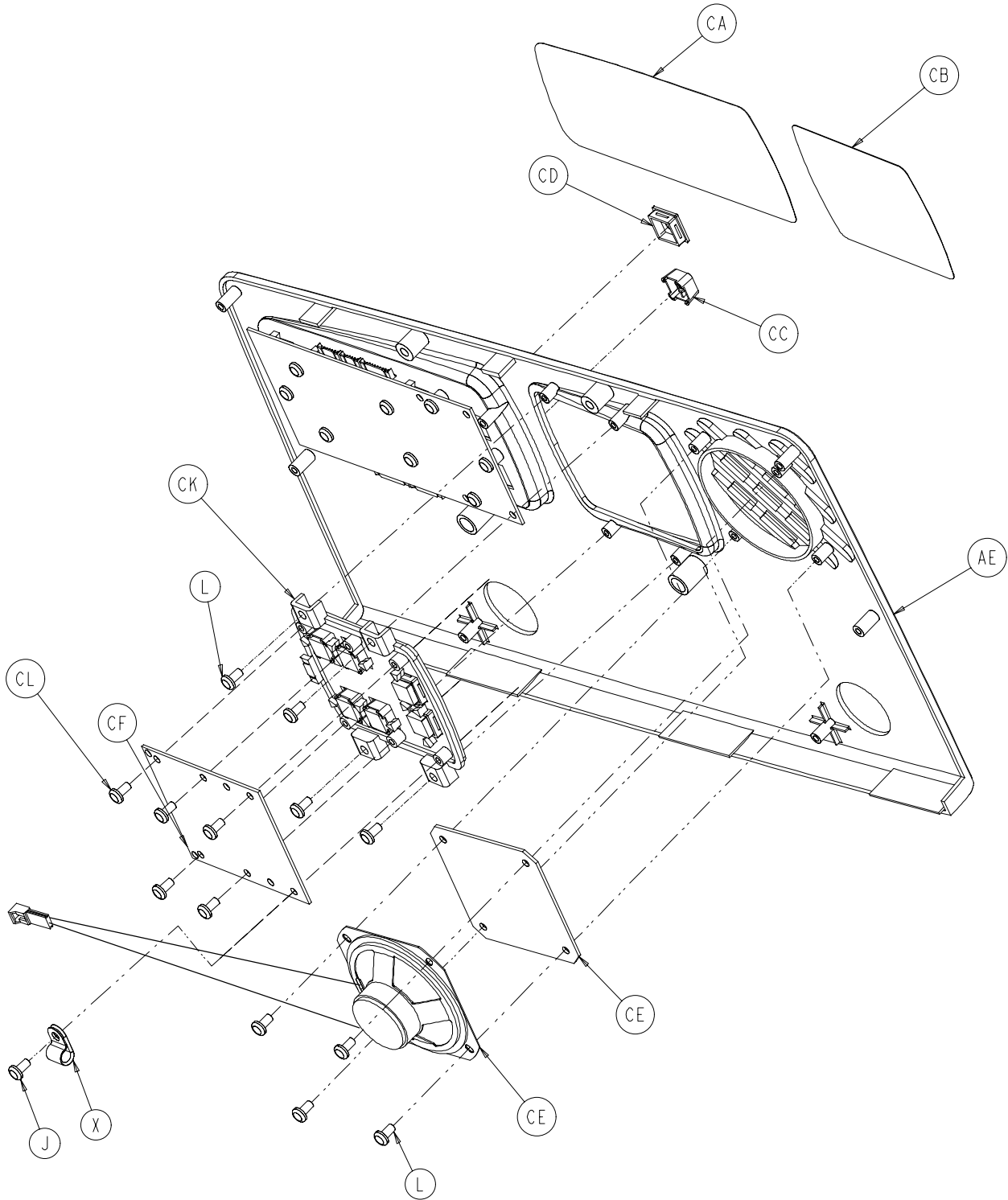

SIDERAIL INNER PANEL ASSEMBLY

# Head End Siderail Assembly

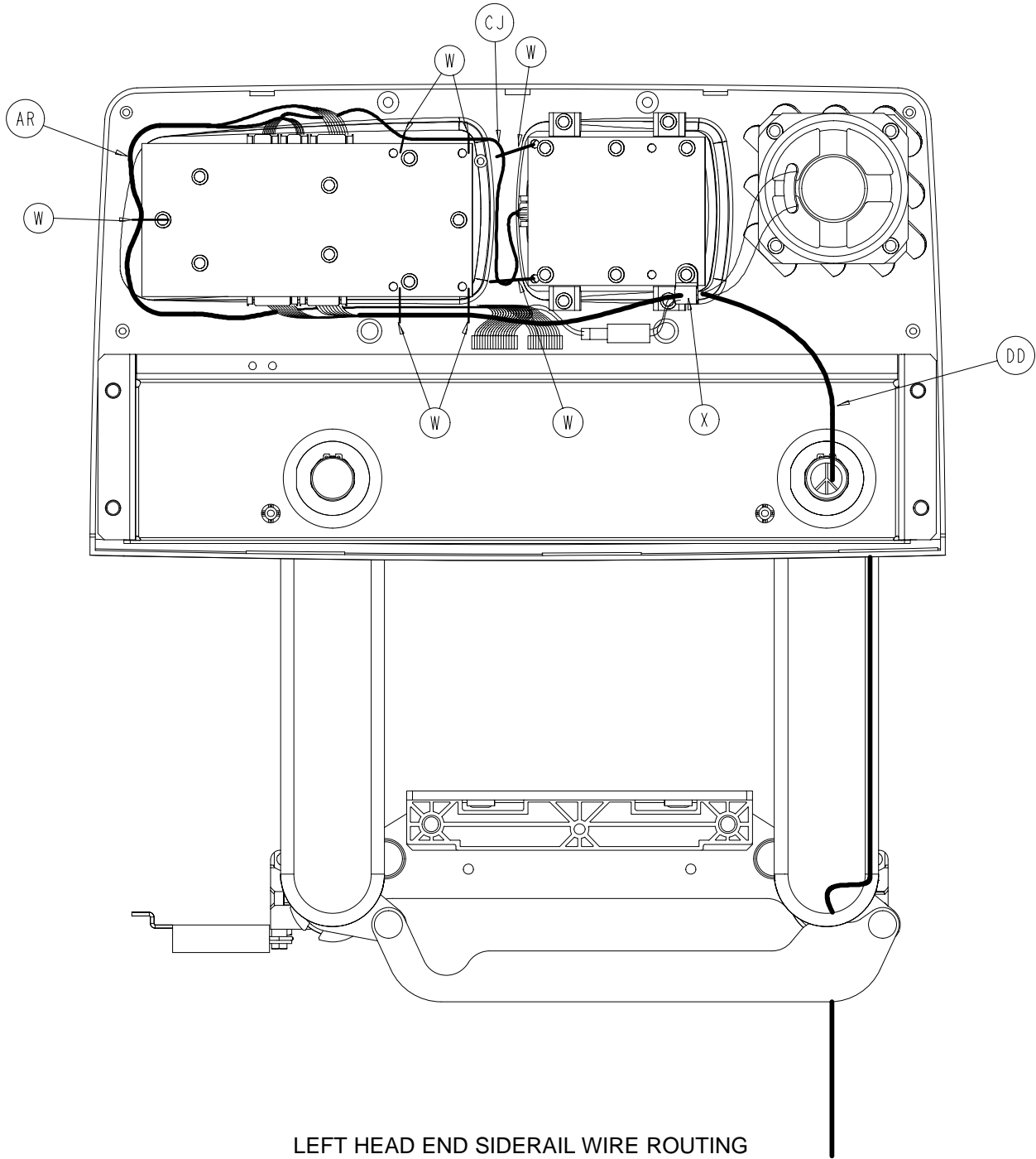

# Head End Siderail Assembly

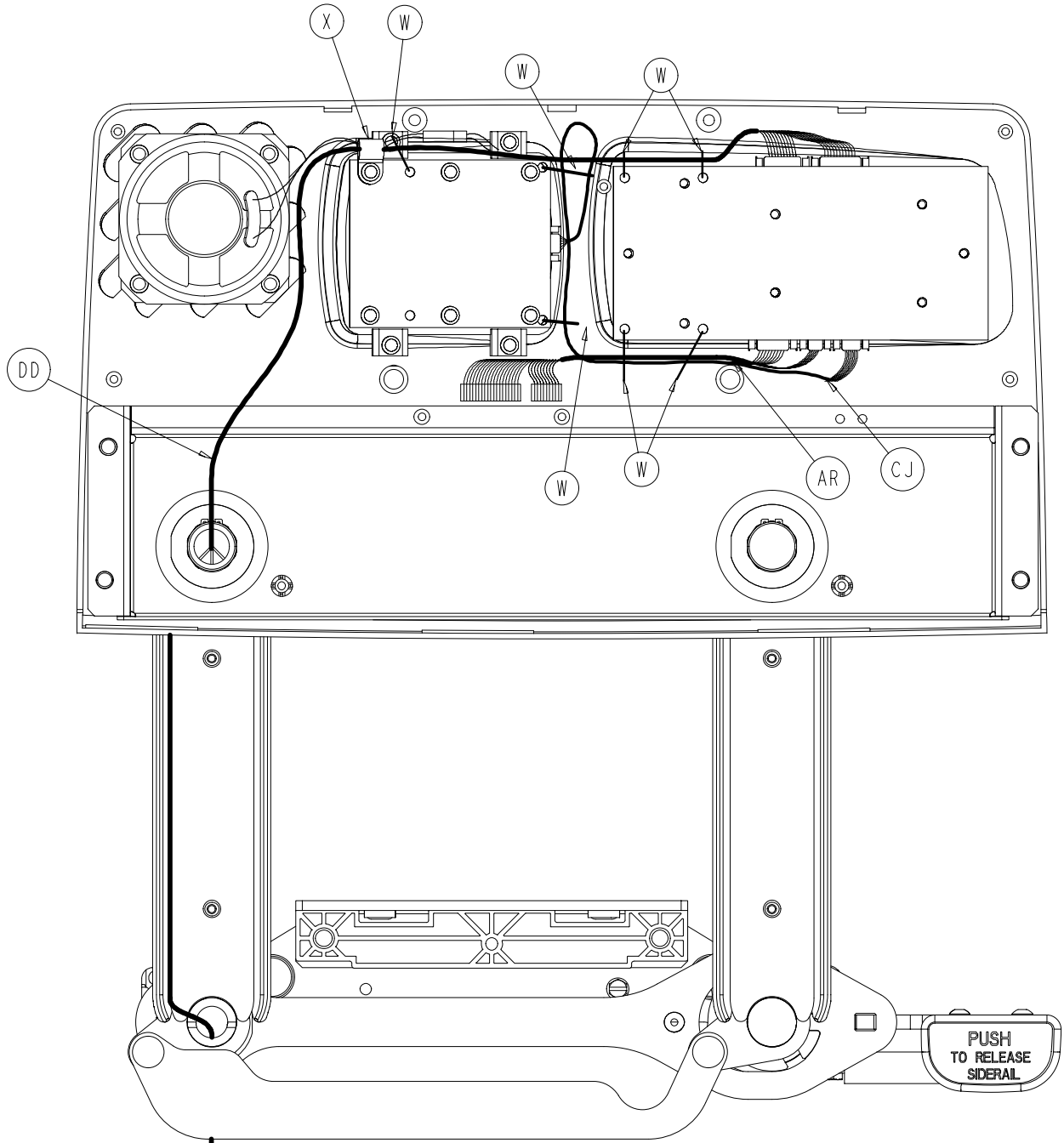

RIGHT HEAD END SIDERAIL WIRE ROUTING

# Head End Siderail Assembly

## 3002-401-105 Left Standard Components

## 3002-401-205 Right Standard Components

Item	Part No.	Part Name	Qty.	Item	Part No.	Part Name	Qty.
A	3-226	Hex Washer Hd. Screw	4	A	3-226	Hex Washer Hd. Screw	4
B	3-344	Hex Hd. Screw	2	B	3-344	Hex Hd. Screw	2
D	11-343	Shim Washer	3	D	11-343	Shim Washer	3
E	11-377	Washer	2	E	11-377	Washer	2
F	11-491	Steel Shim Washer	2	F	11-491	Steel Shim Washer	2
G	14-93	Washer	2	G	14-93	Washer	2
H	16-2	Hex Nut	2	H	16-2	Hex Nut	2
J	23-86	High-Low Tapping Screw	1	J	23-86	High-Low Tapping Screw	1
K	23-90	High-Low Tapping Screw	8	K	23-90	High Low Tapping Screw	8
L	23-88	High-Low Tapping Screw	8	L	23-88	High-Low Tapping Screw	8
M	1-72	Ph. Flat Hd. Mach. Screw	4	M	1-72	Ph. Flat Hd. Mach. Screw	4
P	28-128	Retaining Ring	6	P	28-128	Retaining Ring	6
T	3000-300-442	Grommet	1	T	3000-300-442	Grommet	1
U	3000-200-334	Release Lever Spring	1	U	3000-200-334	Release Lever Spring	1
W	3000-300-1 14	4" Cable Tie	7	W	3000-300-1 14	4" Cable Tie	7
X	3000-300-478	CPR Conduit Clamp	1	X	3000-300-478	CPR Conduit Clamp	1
Y	3000-400-513	Wear Bushing	2	Y	3000-400-513	Wear Bushing	2
Z	3000-400-523	Panel Spacer	2	Z	3000-400-523	Panel Spacer	2
AA	3000-400-556	Warning Label	1	AA	3000-400-556	Warning Label	1
AB	3000-400-557	Sleeve Bearing	4	AB	3000-400-557	Sleeve Bearing	4
AC	3001-400-1 1	Head End Timing Link	1	AC	3001-400-1 1	Head End Timing Link	1
AD	(page 199)	Outer Siderail Panel Ass'y	1	AD	(page 199)	Outer Siderail Panel Ass'y	1
AE	(page 200)	Inner Siderail Panel Ass'y	1	AE	(page 200)	Inner Siderail Panel Ass'y	1
AF	3001-401-128	Arm Wldmt., Left, Hd., Hd.	1	AF	3001-401-228	Arm Wldmt., Rt, Hd., Hd.	1
AG	3001-400-130	Support Wldmt., Hd., Lt.	1	AG	3001-400-230	Support Wldmt., Hd., Rt.	1
AH	3001-400-501	Siderail Linkage Rivet	2	AH	3001-400-501	Siderail Linkage Rivet	2
AL	3001-400-515	Head Rail	1	AL	3001-400-515	Head Rail	1
AM	3001-400-555	Mounting Bracket	1	AM	3001-400-555	Mounting Bracket	1
AN	3001-400-558	Siderail Spacer	4	AN	3001-400-558	Siderail Spacer	4
AP	3001-400-564	Glide Rod	2	AP	3001-400-564	Glide Rod	2
AR	3001-400-802	Main Outside Cable, Left	1	AR	3001-400-801	Main Outside Cable, Right	1
AS	3002-401-127	Arm Wldmt., Lt., Hd., Ft.	1	AS	3002-401-227	Arm Wldmt., Rt., Hd., Ft.	1
AT	(page 201)	Latch Ass'y, Hd., Left	1	AT	(page 202)	Latch Ass'y, Hd., Right	1
AW	3002-400-505	Bypass Pin	1	AW	3002-400-505	Bypass Pin	1
AX	3002-400-509	Bypass Spacer Bushing	1	AX	3002-400-509	Bypass Spacer Bushing	1
AY	(page 209)	Release Lever Ass'y, Lt.	1	AY	(page 210)	Release Lever Ass'y, Rt.	1
AZ	3002-400-51 1	Glide Rod Bumper Pad	2	AZ	3002-400-51 1	Glide Rod Bumper Pad	2
BA	3002-400-512	Bumper Washer	2	BA	3002-400-512	Bumper Washer	2
BB	3002-400-513	Pivot Bushing	6	BB	3002-400-513	Pivot Bushing	6
BC	3002-400-519	Latch Bushing	1	BC	3002-400-519	Latch Bushing	1
BD	(page 211)	Bypass Detent Clip Ass'y	1	BD	(page 211)	Bypass Detent Clip Ass'y	1
BE	3002-400-528	Siderail Carrier	1	BE	3002-400-528	Siderail Carrier	1
BF	5000-20-5	Inner Arm Cover	2	BF	5000-20-5	Inner Arm Cover	2
BG	3001-400-619	Outer Arm Cover	2	BG	3001-400-619	Outer Arm Cover	2

# Head End Siderail Assembly

---

## 3002-443-106 Left Rail - Standard Bed

Item	Part No.	Part Name	Qty.
DD	3001-400-862	Siderail Cable	1

## 3002-443-206 Right Rail - Standard Bed

Item	Part No.	Part Name	Qty.
DD	3001-400-862	Siderail Cable	1

## 3002-442-106 Left Rail - 8" Shorter Bed

Item	Part No.	Part Name	Qty.
DA	3-124	Hex Washer Hd. Screw	1
DB	16-41	Kep Nut	1
DC	34-22	Cable Clamp	1
DD	3001-442-862	Siderail Cable	1

## 3002-442-206 Right Rail - 8" Shorter Bed

Item	Part No.	Part Name	Qty.
DA	3-124	Hex Washer Hd. Screw	1
DB	16-41	Kep Nut	1
DC	34-22	Cable Clamp	1
DD	3001-442-862	Siderail Cable	1

# Head End Siderail Assembly

## Standard Siderail

Item	Part No.	Part Name	Qty.
CA	3002-400-620	Standard Label, Inner, Left	1
CA	3002-400-610	Standard Label, Inner, Right	1
CC	3001-400-953	Switch Cap	12
CD	3001-400-522	Filler Cap	28
CE	3001-400-517	Speaker Seal	2
CF	3001-400-535	Blank Module	2
CH	3002-400-630	Blue Standard Label, Outer, Left	1
	3002-401-630	Brown Standard Label, Outer, Left	1
CH	3002-400-640	Blue Standard Label, Outer, Right	1
	3002-401-640	Brown Standard Label, Outer, Right	1

Inner Right Siderail Label

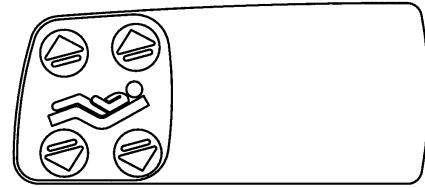

Outer Right Siderail Label

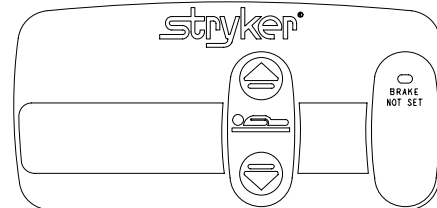

## Standard Siderail with Nurse Call

Item	Part No.	Part Name	Qty.
CA	3002-400-621	Nurse Call Label, Inner, Left	1
CA	3002-400-61 1	Nurse Call Label, Inner, Right	1
CC	3001-400-953	Switch Cap	16
CD	3001-400-522	Filler Cap	24
CE	3001-403-831	Speaker With Cable	2
CF	3001-400-535	Blank Module	2
CH	3002-400-631	Blue Nurse Call Label, Outer, Left	1
	3002-401-631	Brown Nurse Call Label, Outer, Left	1
CH	3002-400-641	Blue Nurse Call Label, Outer, Right	1
	3002-401-641	Brown Nurse Call Label, Outer, Rt.	1

Inner Right Siderail Label

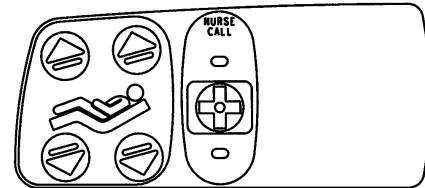

Outer Right Siderail Label

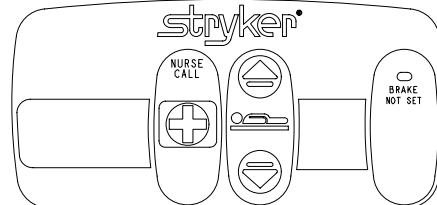

## Standard Siderail with TV/Radio

Item	Part No.	Part Name	Qty.
CA	3002-400-626	TV Label, Inner, Left	1
CA	3002-400-616	TV Label, Inner, Right	1
CC	3001-400-953	Switch Cap	18
CD	3001-400-522	Filler Cap	22
CE	3001-403-831	Speaker With Cable	2
CF	3001-400-535	Blank Module	2
CH	3002-400-630	Blue Standard Label, Outer, Left	1
	3002-401-630	Brown Standard Label, Outer, Left	1
CH	3002-400-640	Blue Standard Label, Outer, Right	1
	3002-401-640	Brown Standard Label, Outer, Right	1

Inner Right Siderail Label

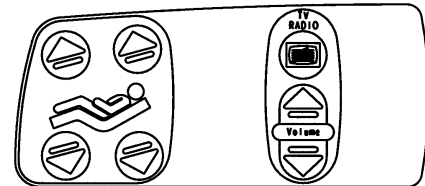

Outer Right Siderail Label

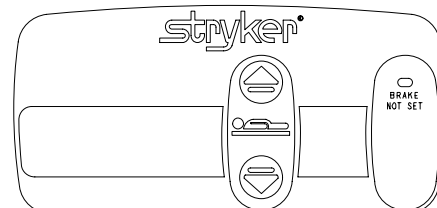

# Head End Siderail Assembly

## Standard Siderail with Lights

Item	Part No.	Part Name	Qty.
CA	3002-400-627	Lights Label, Inner, Left	1
CA	3002-400-617	Lights Label, Inner, Right	1
CC	3001-400-953	Switch Cap	16
CD	3001-400-522	Filler Cap	24
CE	3001-400-517	Speaker Seal	2
CF	3001-400-535	Blank Module	2
CH	3002-400-630	Blue Standard Label, Outer, Left	1
	3002-401-630	Brown Standard Label, Outer, Left	1
CH	3002-400-640	Blue Standard Label, Outer, Right	1
	3002-401-640	Brown Standard Label, Outer, Right	1

Inner Right Siderail Label

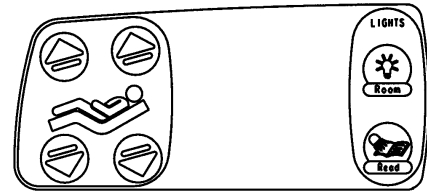

Outer Right Siderail Label

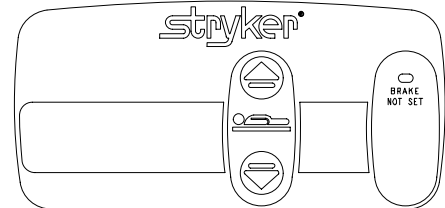

## Standard Siderail with Gatch/Fowler

Item	Part No.	Part Name	Qty.
CA	3002-400-620	Standard Label Inner, Left	1
CA	3002-400-610	Standard Label, Inner, Right	1
CC	3001-400-953	Switch Cap	20
CD	3001-400-522	Filler Cap	20
CE	3001-400-517	Speaker Seal	2
CF	3001-400-535	Blank Module	2
CH	3002-400-636	Blue G/F Label, Outer, Left	1
	3002-401-636	Brown G/F Label, Outer, Left	1
CH	3002-400-646	Blue G/F Label, Outer, Right	1
	3002-401-646	Brown G/F Label, Outer, Right	1

Inner Right Siderail Label

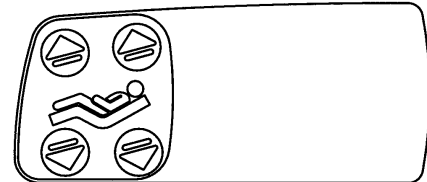

Outer Right Siderail Label

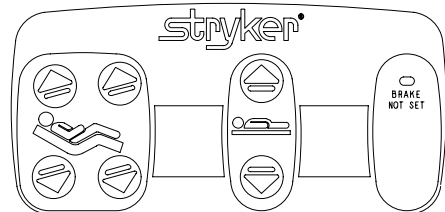

## Standard Siderail with Nurse Call & TV/Radio

Item	Part No.	Part Name	Qty.
CA	3002-400-622	NC, TV Label, Inner, Left	1
CA	3002-400-612	NC, TV Label, Inner, Right	1
CC	3001-400-953	Switch Cap	22
CD	3001-400-522	Filler Cap	18
CE	3001-403-831	Speaker With Cable	2
CF	3001-400-535	Blank Module	2
CH	3002-400-631	Blue Nurse Call Label, Outer, Left	1
	3002-401-631	Brown Nurse Call Label, Outer, Left	1
CH	3002-400-641	Blue Nurse Call Label, Outer, Right	1
	3002-401-641	Brown Nurse Call Label, Outer, Rt.	1

Inner Right Siderail Label

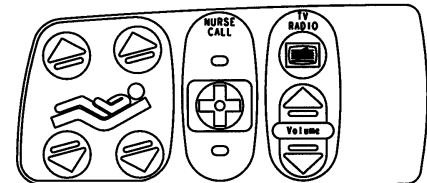

Outer Right Siderail Label

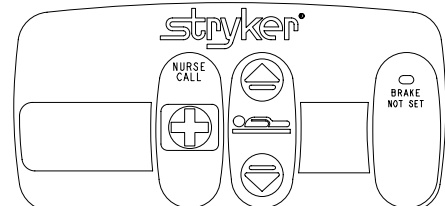

# Head End Siderail Assembly

## Standard Siderail with Nurse Call and Lights

Item	Part No.	Part Name	Qty.
CA	3002-400-625	NC, Lights Label, Inner, Left	1
CA	3002-400-615	NC, Lights Label, Inner, Right	1
CC	3001-400-953	Switch Cap	20
CD	3001-400-522	Filler Cap	20
CE	3001-403-831	Speaker With Cable	2
CF	3001-400-535	Blank Module	2
CH	3002-400-631	Blue NC Label, Outer, Left	1
	3002-401-631	Brown N/C Label, Outer, Left	1
CH	3002-400-641	Blue NC Label, Outer, Right	1
	3002-401-641	Brown NC Label, Outer, Right	1

Inner Right Siderail Label

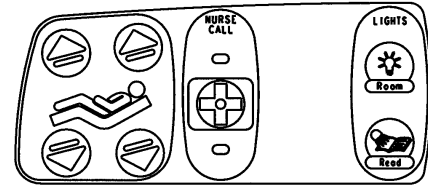

Outer Right Siderail Label

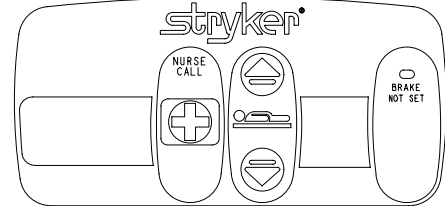

## Standard Siderail with Nurse Call and G/F

Item	Part No.	Part Name	Qty.
CA	3002-400-621	Nurse Call Label, Inner, Left	1
CA	3002-400-611	Nurse Call Label, Inner, Right	1
CC	3001-400-953	Switch Cap	24
CD	3001-400-522	Filler Cap	16
CE	3001-403-831	Speaker With Cable	2
CF	3001-400-535	Blank Module	2
CH	3002-400-632	Blue NC, G/F Label, Outer, Left	1
	3002-401-632	Brown NC, G/F Label, Outer, Left	1
CH	3002-400-642	Blue NC, G/F Label, Outer, Right	1
	3002-401-642	Brown NC, G/F Label, Outer, Right	1

Inner Right Siderail Label

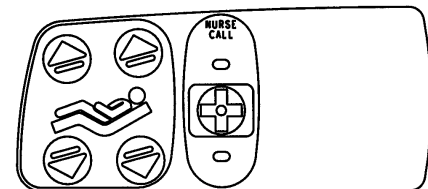

Outer Right Siderail Label

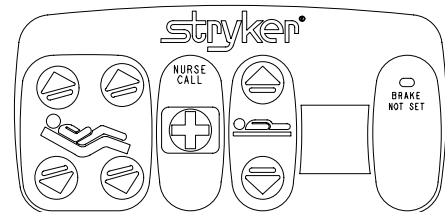

## Standard Siderail with Nurse Call, TV/Radio & Lights

Item	Part No.	Part Name	Qty.
CA	3002-400-623	NC, TV, Lights Label, Inner, Left	1
CA	3002-400-613	NC, TV, Lights Label, Inner, Right	1
CC	3001-400-953	Switch Cap	26
CD	3001-400-522	Filler Cap	14
CE	3001-403-831	Speaker with Cable	2
CF	3001-400-535	Blank Module	2
CH	3002-400-631	Blue Nurse Call Label, Outer, Left	1
	3002-401-631	Brown Nurse Call Label, Outer, Left	1
CH	3002-400-641	Blue Nurse Call Label, Outer, Right	1
	3002-401-641	Brown Nurse Call Label, Outer, Rt.	1

Inner Right Siderail Label

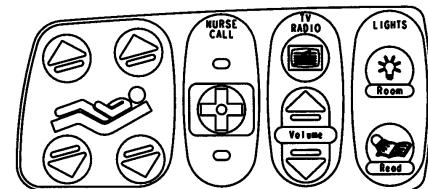

Outer Right Siderail Label

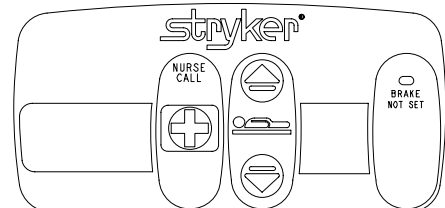



# Head End Siderail Assembly

## Standard Siderail with Nurse Call, Smart TV & Lights

Item	Part No.	Part Name	Qty.
AN	3000-300-1 14	Cable Tie	3
CA	3002-430-623	NC, STV, Lights Label, Inner, Left	1
CA	3002-430-613	NC, STV, Lights Label, Inner, Right	1
CB	3002-430-131	STV Label, Left	1
CB	3002-430-132	STV Label, Right	1
CC	3001-400-953	Switch Cap	34
CD	3001-400-522	Filler Cap	18
CE	3001-403-831	Speaker with Cable	2
CF	5000-400-930	STV PCB, Left	1
CF	5000-400-920	STV PCB, Right	1
CH	3002-400-631	Blue Nurse Call Label, Outer, Left	1
	3002-401-631	Brown Nurse Call Label, Outer, Left	1
CH	3002-400-641	Blue Nurse Call Label, Outer, Right	1
	3002-401-641	Brown Nurse Call Label, Outer, Rt.	1
CJ	3001-402-804	Main to Options PCB Cable	2
CK	3001-400-524	Module	1
CL	23-1 12	Pan Hd. High-Low Tapping Screw	5

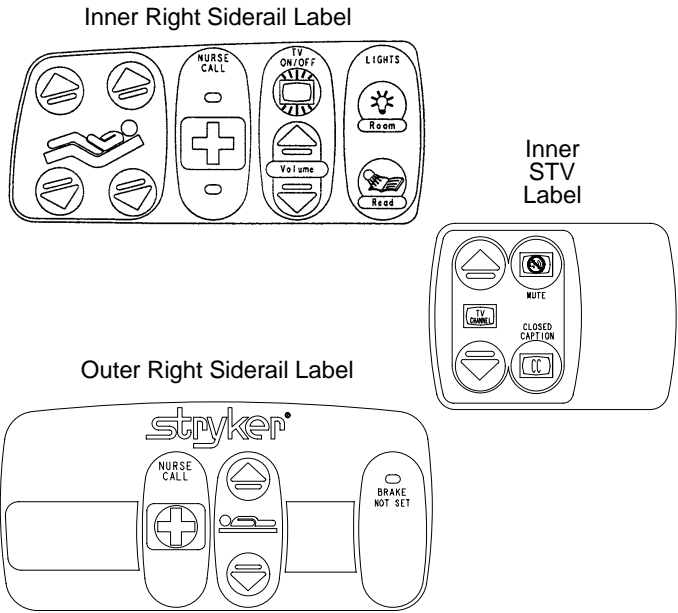

## Standard Siderail w/Nurse Call, TV/Radio, & G/F

Item	Part No.	Part Name	Qty.
CA	3002-400-622	NC, TV Label, Inner, Left	1
CA	3002-400-612	NC, TV Label, Inner, Right	1
CC	3001-400-953	Switch Cap	30
CD	3001-400-522	Filler Cap	10
CE	3001-403-831	Speaker with Cable	2
CF	3001-400-535	Blank Module	2
CH	3002-400-632	Blue NC, G/F Label, Outer, Left	1
	3002-401-632	Brown NC, G/F Label, Outer, Left	1
CH	3002-400-642	Blue NC, G/F Label, Outer, Right	1
	3002-401-642	Brown NC, G/F Label, Outer, Right	1

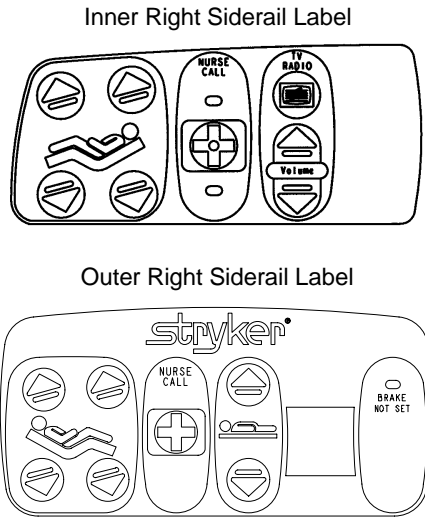

## Standard Siderail with Nurse Call, Lights, and G/F

Item	Part No.	Part Name	Qty.
CA	3002-400-625	NC, Lights Label Inner, Left	1
CA	3002-400-615	NC, Lights Label, Inner, Right	1
CC	3001-400-953	Switch Cap	28
CD	3001-400-522	Filler Cap	12
CE	3001-403-831	Speaker With Cable	2
CF	3001-400-535	Blank Module	2
CH	3002-400-632	Blue NC, G/F Label, Outer, Left	1
	3002-401-632	Brown NC, G/F Label, Outer, Left	1
CH	3002-400-642	Blue NC, G/F Label, Outer, Right	1
	3002-401-642	Brown NC, G/F Label, Outer, Right	1

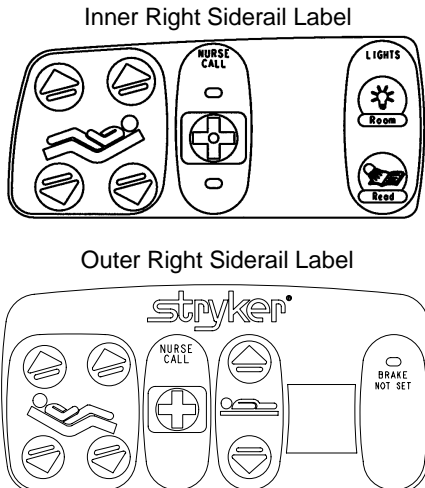

# Head End Siderail Assembly

## Standard Siderail w/Nurse Call, TV/Radio, Lights, & G/F

Item	Part No.	Part Name	Qty.
CA	3002-400-623	NC, TV, Lights Label, Inner, Left	1
CA	3002-400-613	NC, TV, Lights Label, Inner, Right	1
CC	3001-400-953	Switch Cap	34
CD	3001-400-522	Filler Cap	6
CE	3001-403-831	Speaker with Cable	2
CF	3001-400-535	Blank Module	2
CH	3002-400-632	Blue NC, G/F Label, Outer, Left	1
	3002-401-632	Brown NC, G/F Label, Outer, Left	1
CH	3002-400-642	Blue NC, G/F Label, Outer, Right	1
	3002-401-642	Brown NC, G/F Label, Outer, Right	1

Inner Right Siderail Label

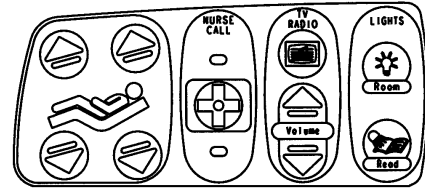

Outer Right Siderail Label

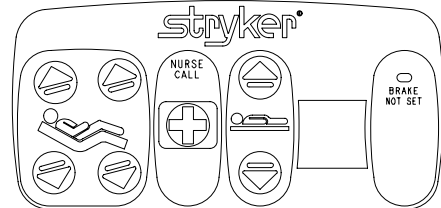

## Standard Siderail with TV/Radio and Lights

Item	Part No.	Part Name	Qty.
CA	3002-400-624	TV, Lights Label, Inner, Left	1
CA	3002-400-614	TV, Lights Label, Inner, Right	1
CC	3001-400-953	Switch Cap	26
CD	3001-400-522	Filler Cap	14
CE	3001-403-831	Speaker with Cable	2
CF	3001-400-535	Blank Module	2
CH	3002-400-630	Blue Standard Label, Outer, Left	1
	3002-401-630	Brown Standard Label, Outer, Left	1
CH	3002-400-640	Blue Standard Label, Outer, Right	1
	3002-401-640	Brown Standard Label, Outer, Right	1

Inner Right Siderail Label

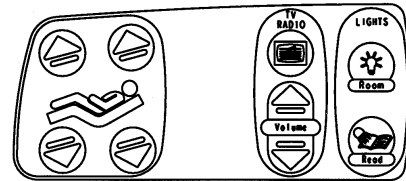

Outer Right Siderail Label

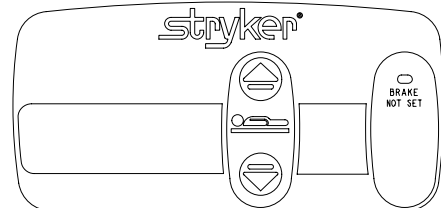

## Standard Siderail with TV/Radio and G/F

Item	Part No.	Part Name	Qty.
CA	3002-400-626	TV Label, Inner, Left	1
CA	3002-400-616	TV Label, Inner, Right	1
CC	3001-400-953	Switch Cap	26
CD	3001-400-522	Filler Cap	14
CE	3001-403-831	Speaker with Cable	2
CF	3001-400-535	Blank Module	2
CH	3002-400-636	Blue G/F Label, Outer, Left	1
	3002-401-636	Brown G/F Label, Outer, Left	1
CH	3002-400-646	Blue G/F Label, Outer, Right	1
	3002-401-646	Brown G/F Label, Outer, Right	1

Inner Right Siderail Label

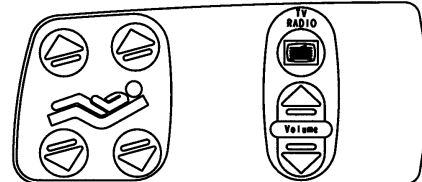

Outer Right Siderail Label

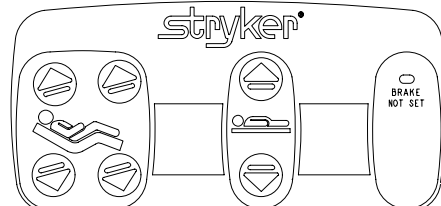

# Head End Siderail Assembly

## Standard Siderail with TV/Radio, Lights, and G/F

Item	Part No.	Part Name	Qty.
CA	3002-400-624	TV, Lights Label, Inner, Left	1
CA	3002-400-614	TV, Lights Label, Inner, Right	1
CC	3001-400-953	Switch Cap	30
CD	3001-400-522	Filler Cap	10
CE	3001-403-831	Speaker with Cable	2
CF	3001-400-535	Blank Module	2
CH	3002-400-636	Blue G/F Label, Outer, Left	1
	3002-401-636	Brown G/F Label, Outer, Left	1
CH	3002-400-646	Blue G/F Label, Outer, Right	1
	3002-401-646	Brown G/F Label, Outer, Right	1

Inner Right Siderail Label

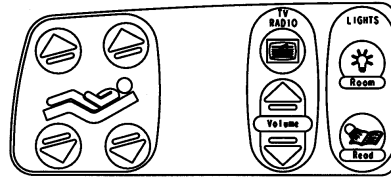

Outer Right Siderail Label

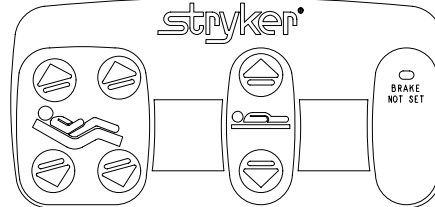

## Standard Siderail with Lights and Gatch/Fowler

Item	Part No.	Part Name	Qty.
CA	3002-400-627	Lights Label, Inner, Left	1
CA	3002-400-617	Lights Label, Inner, Right	1
CC	3001-400-953	Switch Cap	24
CD	3001-400-522	Filler Cap	16
CE	3001-400-517	Speaker Seal	2
CF	3001-400-535	Blank Module	2
CH	3002-400-636	Blue G/F Label, Outer, Left	1
	3002-401-636	Brown G/F Label, Outer, Left	1
CH	3002-400-646	Blue G/F Label, Outer, Right	1
	3002-401-646	Brown G/F Label, Outer, Right	1

Inner Right Siderail Label

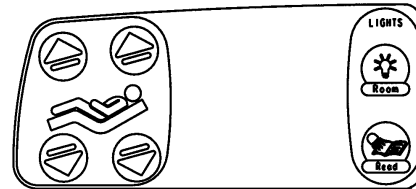

Outer Right Siderail Label

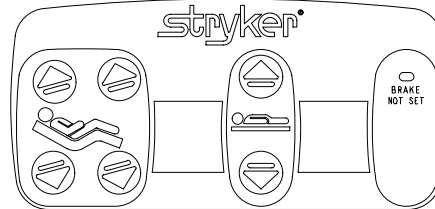

## Std. Siderail w/Nurse Call, STV, Lights, & G/F

Item	Part No.	Part Name	Qty.
AN	3000-300-1 14	Cable Tie	3
CA	3002-430-623	NC, TV Label, Inner, Left	1
CA	3002-430-613	NC, TV Label, Inner, Right	1
CB	3002-430-131	STV Label, Left	1
CB	3002-430-132	STV Label, Right	1
CC	3001-400-953	Switch Cap	42
CD	3001-400-522	Filler Cap	10
CE	3001-403-831	Speaker With Cable	2
CF	5000-400-930	STV PCB, Left	1
CF	5000-400-920	STV PCB, Right	1
CH	3002-400-632	Blue NC, G/F, Label, Outer, Left	1
	3002-401-632	Brown NC, G/F Label, Outer, Left	1
CH	3002-400-642	Blue NC, G/F, Label, Outer, Right	1
	3002-401-642	Brown NC, G/F Label, Outer, Right	1
CJ	3001-402-804	Main to Options PCB Cable	2
CK	3001-400-524	Module	1
CL	23-1 12	Pan Hd. High-Low Tapping Screw	5

Inner Right Siderail Label

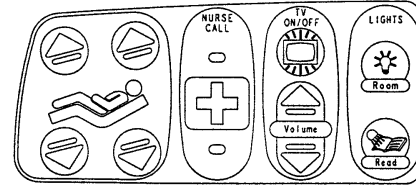

Inner STV Label

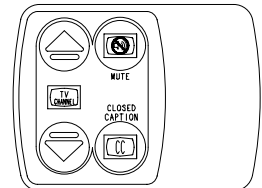

Outer Right Siderail Label

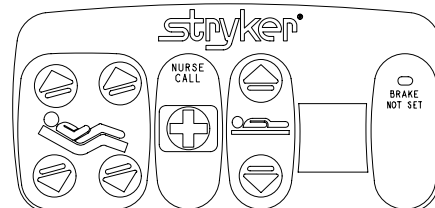

# Head End Siderail Assembly

## Standard Siderail with Cardiac Chair

Item	Part No.	Part Name	Qty.
CA	3002-400-620	Standard Label, Inner, Left	1
CA	3002-400-610	Standard Label, Inner, Right	1
CC	3001-400-953	Switch Cap	14
CD	3001-400-522	Filler Cap	26
CE	3001-400-517	Speaker Seal	2
CF	3001-400-535	Blank Module	2
CH	3002-400-637	Blue CC Label, Outer, Left	1
	3002-401-637	Brown CC Label, Outer, Left	1
CH	3002-400-647	Blue CC Label, Outer, Right	1
	3002-401-647	Brown CC Label, Outer, Right	1

Inner Right Siderail Label

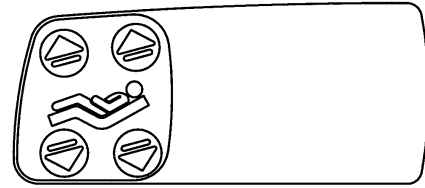

Outer Right Siderail Label

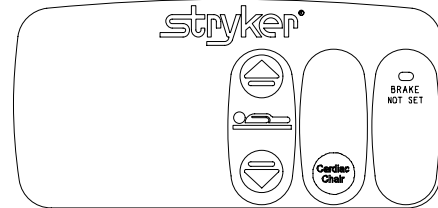

## Standard Siderail with Cardiac Chair and Nurse Call

Item	Part No.	Part Name	Qty.
CA	3002-400-621	Nurse Call Label, Inner, Left	1
CA	3002-400-61 1	Nurse Call Label, Inner, Right	1
CC	3001-400-953	Switch Cap	18
CD	3001-400-522	Filler Cap	22
CE	3001-403-831	Speaker With Cable	2
CF	3001-400-535	Blank Module	2
CH	3002-400-635	Blue CC & N/C Label, Outer, Left	1
	3002-401-635	Brown CC & N/C Label, Outer, Left	1
CH	3002-400-645	Blue CC & N/C Label, Outer, Right	1
	3002-401-645	Brown CC & N/C Label, Outer, Rt.	1

Inner Right Siderail Label

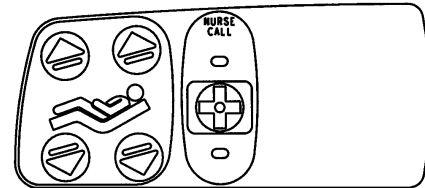

Outer Right Siderail Label

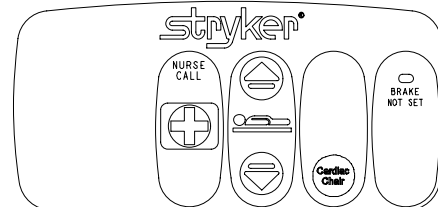

## Standard Siderail with Cardiac Chair and TV/Radio

Item	Part No.	Part Name	Qty.
CA	3002-400-626	TV Label, Inner, Left	1
CA	3002-400-616	TV Label, Inner, Right	1
CC	3001-400-953	Switch Cap	18
CD	3001-400-522	Filler Cap	22
CE	3001-403-831	Speaker With Cable	2
CF	3001-400-535	Blank Module	2
CH	3002-400-637	Blue CC, TV Label, Outer, Left	1
	3002-401-637	Brown CC Label, Outer, Left	1
CH	3002-400-647	Blue CC Label, Outer, Right	1
	3002-401-647	Brown CC Label, Outer, Right	1

Inner Right Siderail Label

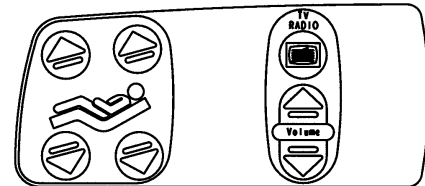

Outer Right Siderail Label

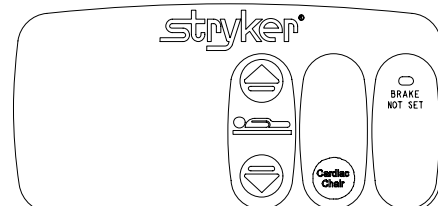

# Head End Siderail Assembly

## Standard Siderail with Cardiac Chair and Lights

Item	Part No.	Part Name	Qty.
CA	3002-400-627	Lights Label, Inner, Left	1
CA	3002-400-617	Lights Label, Inner, Right	1
CC	3001-400-953	Switch Cap	18
CD	3001-400-522	Filler Cap	22
CE	3001-400-517	Speaker Seal	2
CF	3001-400-535	Blank Module	2
CH	3002-400-637	Blue CC Label, Outer, Left	1
	3002-401-637	Brown CC Label, Outer, Left	1
CH	3002-400-647	Blue CC Label, Outer, Right	1
	3002-401-647	Brown CC Label, Outer, Right	1

Inner Right Siderail Label

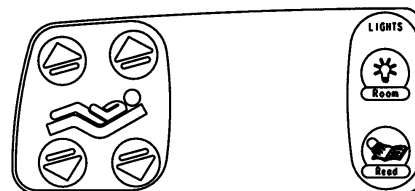

Outer Right Siderail Label

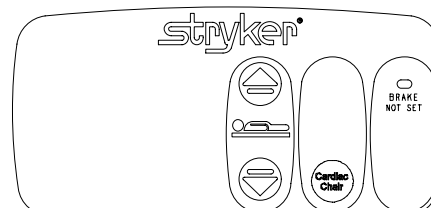

## Standard Siderail with Cardiac Chair and Gatch/Fowler

Item	Part No.	Part Name	Qty.
CA	3002-400-620	Standard Label Inner, Left	1
CA	3002-400-610	Standard Label, Inner, Right	1
CC	3001-400-953	Switch Cap	22
CD	3001-400-522	Filler Cap	18
CE	3001-400-517	Speaker Seal	2
CF	3001-400-535	Blank Module	2
CH	3002-400-634	Blue CC, G/F Label, Outer, Left	1
	3002-401-634	Brown CC, G/F Label, Outer, Left	1
CH	3002-400-644	Blue CC, G/F Label, Outer, Right	1
	3002-401-644	Brown CC, G/F/ Label, Outer, Right	1

Inner Right Siderail Label

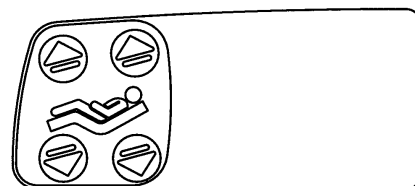

Outer Right Siderail Label

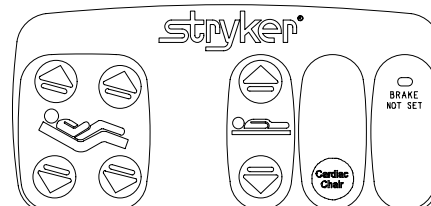

## Standard Siderail with Cardiac Chair, N/C and TV/Radio

Item	Part No.	Part Name	Qty.
CA	3002-400-622	NC, TV Label, Inner, Left	1
CA	3002-400-612	NC, TV Label, Inner, Right	1
CC	3001-400-953	Switch Cap	24
CD	3001-400-522	Filler Cap	16
CE	3001-403-831	Speaker With Cable	2
CF	3001-400-535	Blank Module	2
CH	3002-400-635	Blue CC & N/C Label, Outer, Left	1
	3002-401-635	Brown CC & N/C Label, Outer, Left	1
CH	3002-400-645	Blue CC & N/C Label, Outer, Right	1
	3002-401-645	Brown CC & N/C Label, Outer, Rt.	1

Inner Right Siderail Label

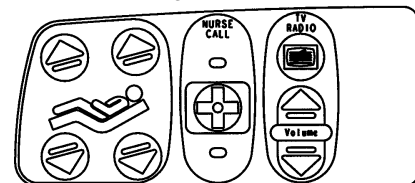

Outer Right Siderail Label

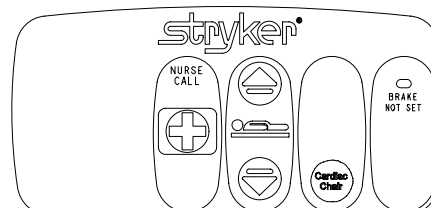

# Head End Siderail Assembly

## Standard Siderail with Cardiac Chair, Nurse Call & Lights

Item	Part No.	Part Name	Qty.
CA	3002-400-625	NC, Lights Label, Inner, Left	1
CA	3002-400-615	NC, Lights Label, Inner, Right	1
CC	3001-400-953	Switch Cap	22
CD	3001-400-522	Filler Cap	18
CE	3001-403-831	Speaker With Cable	2
CF	3001-400-535	Blank Module	2
CH	3002-400-635	Blue CC & N/C Label, Outer, Left	1
	3002-401-635	Brown CC & N/C Label, Outer, Left	1
CH	3002-400-645	Blue CC & N/C Label, Outer, Right	1
	3002-401-645	Brown CC & N/C Label, Outer, Right	1

Inner Right Siderail Label

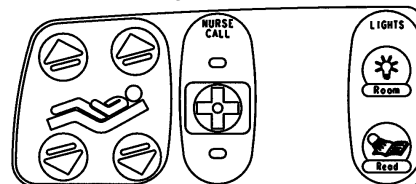

Outer Right Siderail Label

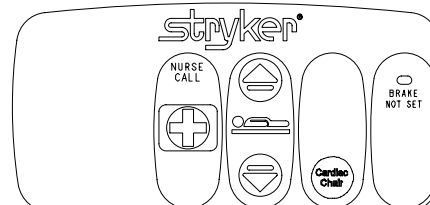

## Standard Siderail with Cardiac Chair, N/C & Gatch/Fowler

Item	Part No.	Part Name	Qty.
CA	3002-400-621	Nurse Call Label, Inner, Left	1
CA	3002-400-611	Nurse Call Label, Inner, Right	1
CC	3001-400-953	Switch Cap	26
CD	3001-400-522	Filler Cap	14
CE	3001-403-831	Speaker With Cable	2
CF	3001-400-535	Blank Module	2
CH	3002-400-633	Blue NC, G/F Label, Outer, Left	1
	3002-401-633	Brown NC, G/F Label, Outer, Left	1
CH	3002-400-643	Blue NC, G/F Label, Outer, Right	1
	3002-401-643	Brown NC, G/F Label, Outer, Right	1

Inner Right Siderail Label

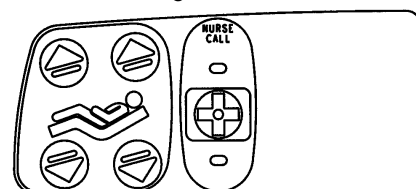

Outer Right Siderail Label

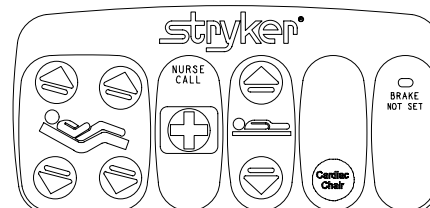

## Standard Siderail with Cardiac Chair, N/C, TV/Radio & Lights

Item	Part No.	Part Name	Qty.
CA	3002-400-623	NC, TV, Lights Label, Inner, Left	1
CA	3002-400-613	NC, TV, Lights Label, Inner, Right	1
CC	3001-400-953	Switch Cap	28
CD	3001-400-522	Filler Cap	12
CE	3001-403-831	Speaker with Cable	2
CF	3001-400-535	Blank Module	2
CH	3002-400-635	Blue CC & N/C Label, Outer, Left	1
	3002-401-635	Brown CC & N/C Label, Outer, Left	1
CH	3002-400-645	Blue CC & N/C Label, Outer, Right	1
	3002-401-645	Brown CC & N/C Label, Outer, Rt.	1

Inner Right Siderail Label

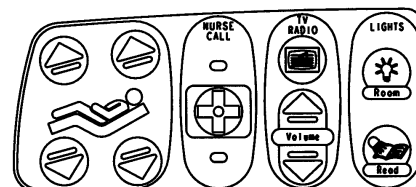

Outer Right Siderail Label

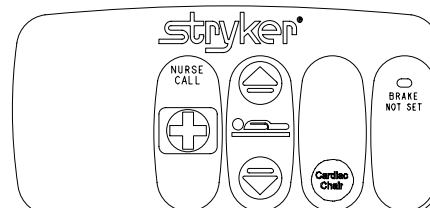

# Head End Siderail Assembly

## Standard Siderail with C. Chair, N/C, Smart TV & Lights

Item	Part No.	Part Name	Qty.
AN	3000-300-1	Cable Tie	3
CA	3002-430-623	NC, STV, Lights Label, Inner, Left	1
CA	3002-430-613	NC, STV, Lights Label, Inner, Right	1
CB	3002-430-131	STV Label, Left	1
CB	3002-430-132	STV Label, Right	1
CC	3001-400-953	Switch Cap	36
CD	3001-400-522	Filler Cap	16
CE	3001-403-831	Speaker with Cable	2
CF	5000-400-930	STV PCB, Left	1
CF	5000-400-920	STV PCB, Right	1
CH	3002-400-635	Blue CC & N/C Label, Outer, Left	1
CH	3002-401-635	Brown CC & N/C Label, Outer, Left	1
CH	3002-400-645	Blue CC & N/C Label, Outer, Right	1
CH	3002-401-645	Brown CC & N/C Label, Outer, Rt.	1
CJ	3001-402-804	Main to Options PCB Cable	2
CK	3001-400-524	Module	1
CL	23-112	Pan Hd. High-Low Tapping Screw	5

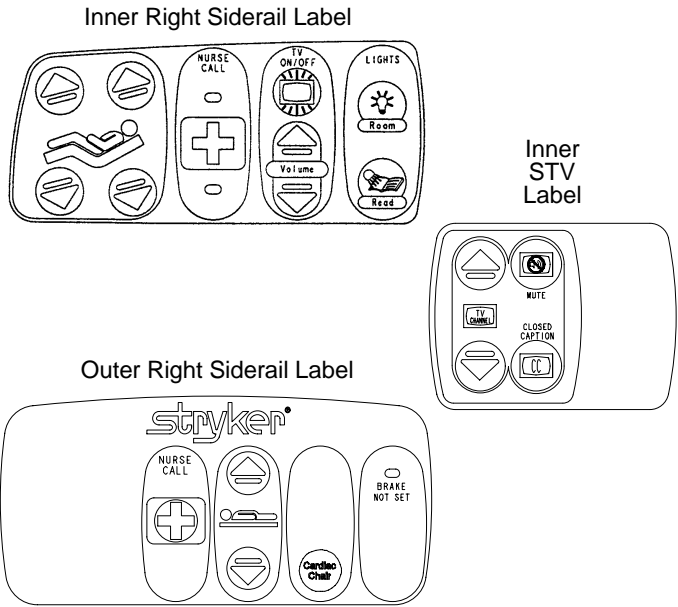

## Standard Siderail w/Cardiac Chair, N/C, TV/Radio & G/F

Item	Part No.	Part Name	Qty.
CA	3002-400-622	NC, TV Label, Inner, Left	1
CA	3002-400-612	NC, TV Label, Inner, Right	1
CC	3001-400-953	Switch Cap	32
CD	3001-400-522	Filler Cap	8
CE	3001-403-831	Speaker with Cable	2
CF	3001-400-535	Blank Module	2
CH	3002-400-633	Blue CC, N/C, G/F Label, Outer, Lt.	1
CH	3002-401-633	Brown CC, N/C, G/F Lbl., Outer, Lt.	1
CH	3002-400-643	Blue CC, N/C, G/F Label, Outer, Rt.	1
CH	3002-401-643	Brown CC, N/C, G/F Lbl., Outer, Rt.	1

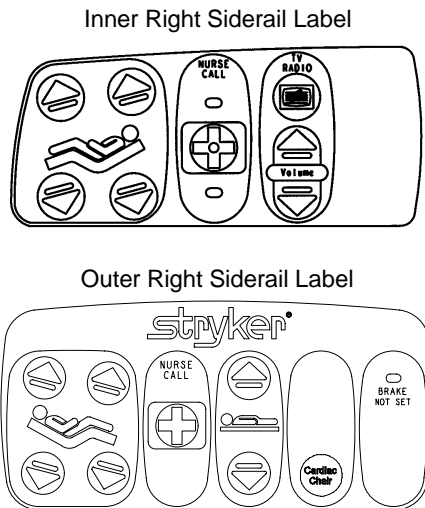

## Standard Siderail with Cardiac Chair, N/C, G/F & Lights

Item	Part No.	Part Name	Qty.
CA	3002-400-625	NC, Lights Label Inner, Left	1
CA	3002-400-615	NC, Lights Label, Inner, Right	1
CC	3001-400-953	Switch Cap	30
CD	3001-400-522	Filler Cap	10
CE	3001-403-831	Speaker With Cable	2
CF	3001-400-535	Blank Module	2
CH	3002-400-633	Blue CC, N/C, G/F Label, Outer, Lt.	1
CH	3002-401-633	Brown CC, N/C, G/F Lbl., Outer, Lt.	1
CH	3002-400-643	Blue CC, N/C, G/F Label, Outer, Rt.	1
CH	3002-401-643	Brown CC, N/C, G/F Lbl., Outer, Rt.	1

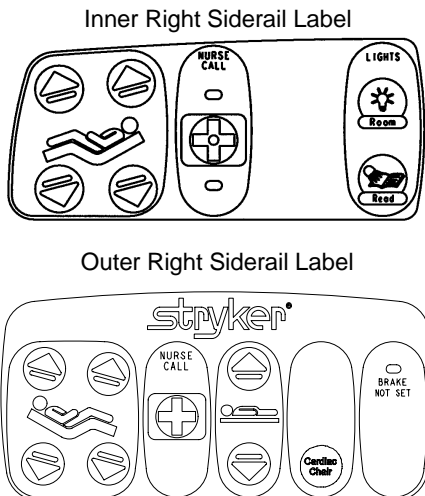

# Head End Siderail Assembly

## Standard Siderail w/C. Chair, N/C, TV/Radio, Lights & G/F

Item	Part No.	Part Name	Qty.
CA	3002-400-623	NC, TV, Lights Label, Inner, Left	1
CA	3002-400-613	NC, TV, Lights Label, Inner, Right	1
CC	3001-400-953	Switch Cap	36
CD	3001-400-522	Filler Cap	4
CE	3001-403-831	Speaker with Cable	2
CF	3001-400-535	Blank Module	2
CH	3002-400-633	Blue NC, G/F Label, Outer, Left	1
	3002-401-633	Brown NC, G/F Label, Outer, Left	1
CH	3002-400-643	Blue NC, G/F Label, Outer, Right	1
	3002-401-643	Brown NC, G/F Label, Outer, Right	1

Inner Right Siderail Label

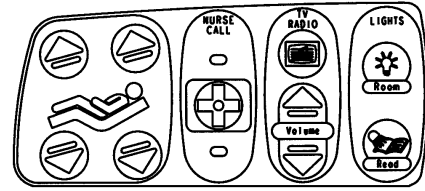

Outer Right Siderail Label

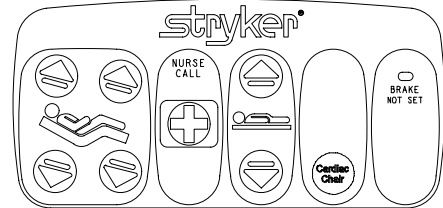

## Standard Siderail with Cardiac Chair, TV/Radio & Lights

Item	Part No.	Part Name	Qty.
CA	3002-400-624	TV, Lights Label, Inner, Left	1
CA	3002-400-614	TV, Lights Label, Inner, Right	1
CC	3001-400-953	Switch Cap	24
CD	3001-400-522	Filler Cap	16
CE	3001-403-831	Speaker with Cable	2
CF	3001-400-535	Blank Module	2
CH	3002-400-637	Blue C. Chair Label, Outer, Left	1
	3002-401-637	Brown C. Chair Label, Outer, Left	1
CH	3002-400-647	Blue C. Chair Label, Outer, Right	1
	3002-401-647	Brown C. Chair Label, Outer, Right	1

Inner Right Siderail Label

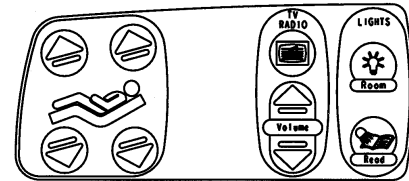

Outer Right Siderail Label

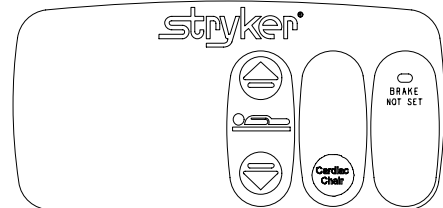

## Standard Siderail with Cardiac Chair, TV/Radio & G/F

Item	Part No.	Part Name	Qty.
CA	3002-400-626	TV Label, Inner, Left	1
CA	3002-400-616	TV Label, Inner, Right	1
CC	3001-400-953	Switch Cap	28
CD	3001-400-522	Filler Cap	12
CE	3001-403-831	Speaker with Cable	2
CF	3001-400-535	Blank Module	2
CH	3002-400-634	Blue CC, G/F Label, Outer, Left	1
	3002-401-634	Brown CC, G/F Label, Outer, Left	1
CH	3002-400-644	Blue CC, G/F Label, Outer, Right	1
	3002-401-644	Brown CC, G/F Label, Outer, Right	1

Inner Right Siderail Label

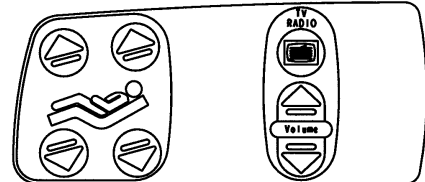

Outer Right Siderail Label

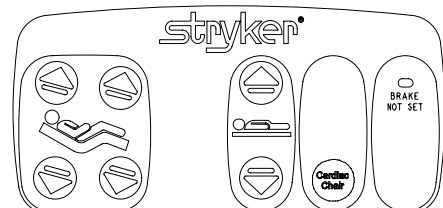



# Head End Siderail Assembly

## Standard Siderail with Cardiac Chair, Lights & G/F

Item	Part No.	Part Name	Qty.
CA	3002-400-627	Lights Label, Inner, Left	1
CA	3002-400-617	Lights Label, Inner, Right	1
CC	3001-400-953	Switch Cap	26
CD	3001-400-522	Filler Cap	14
CE	3001-400-517	Speaker Seal	2
CF	3001-400-535	Blank Module	2
CH	3002-400-634	Blue CC, G/F Label, Outer, Left	1
	3002-401-634	Brown CC, G/F Label, Outer, Left	1
CH	3002-400-644	Blue CC, G/F Label, Outer, Right	1
	3002-401-644	Brown CC, G/F Label, Outer, Right	1

Inner Right Siderail Label

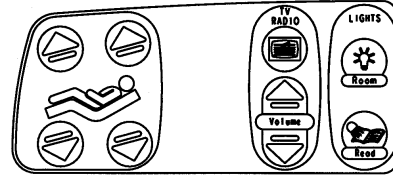

Outer Right Siderail Label



## Standard Siderail w/C. Chair, TV/Radio, Lights & G/F

Item	Part No.	Part Name	Qty.
CA	3002-400-624	TV, Lights Label, Inner, Left	1
CA	3002-400-614	TV, Lights Label, Inner, Right	1
CC	3001-400-953	Switch Cap	32
CD	3001-400-522	Filler Cap	8
CE	3001-403-831	Speaker with Cable	2
CF	3001-400-535	Blank Module	2
CH	3002-400-634	Blue CC, G/F Label, Outer, Left	1
	3002-401-634	Brown CC, G/F Label, Outer, Left	1
CH	3002-400-644	Blue CC, G/F Label, Outer, Right	1
	3002-401-644	Brown CC, G/F Label, Outer, Right	1

Inner Right Siderail Label

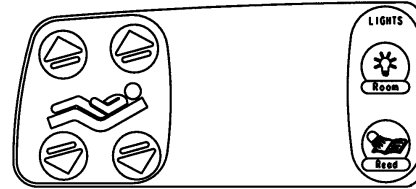

Outer Right Siderail Label

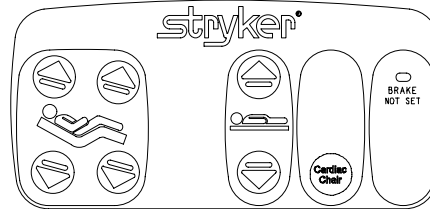

## Std. Siderail w/C. Chair, N/C, Smart TV, Lights & G/F

Item	Part No.	Part Name	Qty.
AN	3000-300-1	Cable Tie	14
CA	3002-430-623	NC, TV Label, Inner, Left	1
CA	3002-430-613	NC, TV Label, Inner, Right	1
CB	3002-430-131	STV Label, Left	1
CB	3002-430-132	STV Label, Right	1
CC	3001-400-953	Switch Cap	44
CD	3001-400-522	Filler Cap	8
CE	3001-403-831	Speaker With Cable	2
CF	5000-400-930	STV PCB, Left	1
CF	5000-400-920	STV PCB, Right	1
CH	3002-400-633	Blue CC, N/C, G/F, Label, Outer, Lt.	1
	3002-401-633	Brown CC, N/C, G/F Lbl., Outer, Lt.	1
CH	3002-400-643	Blue CC, N/C, G/F, Lbl., Outer, Rt.	1
	3002-401-643	Brown CC, N/C, G/F Lbl., Outer, Rt.	1
CJ	3001-402-804	Main to Options PCB Cable	2
CK	3001-400-524	Module	1
CL	23-1 12	Pan Hd. High-Low Tapping Screw	5

Inner Right Siderail Label

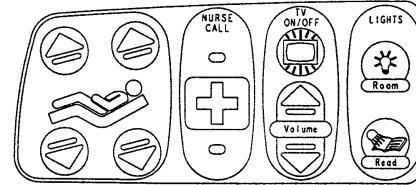

Inner STV Label

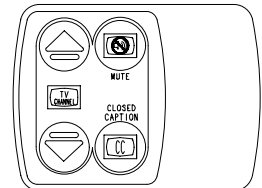

Outer Right Siderail Label

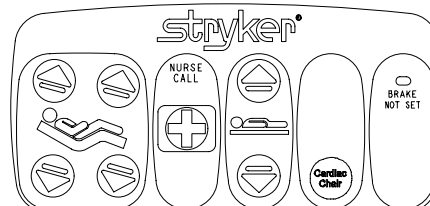

# Head End Siderail Outer Panel Assembly

Assembly part number 3001-400-35  
(reference only)

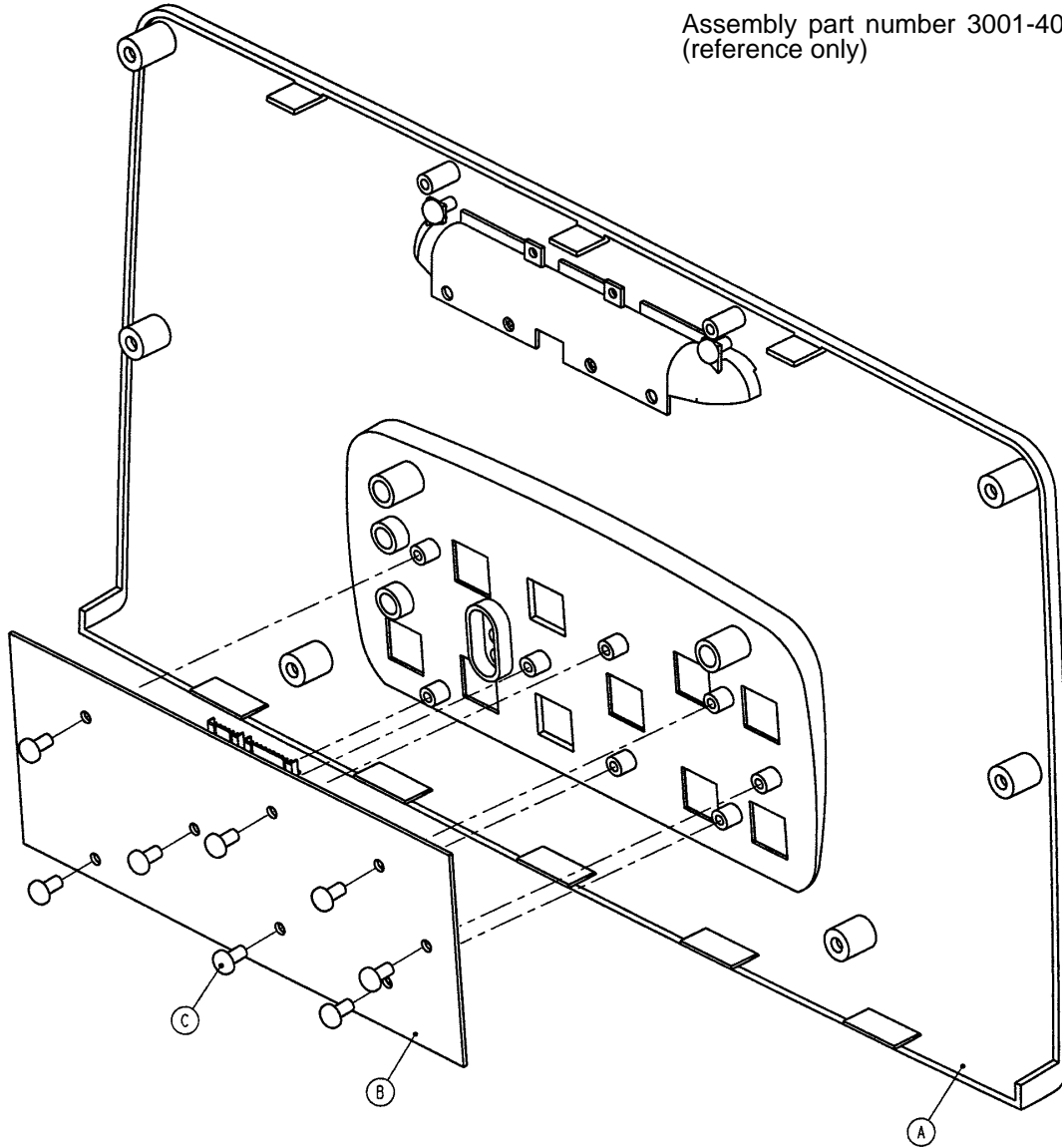

Item	Part No.	Part Name	Qty.
A	3001-400-50	Outer Panel Assembly	1
B	3001-400-910	Outer Siderail PCB Assembly	1
C	23-1 12	Hi-Low Tapping Screw	8

# Head End Siderail Inner Panel Assembly

Assembly part numbers  
 3001-400-40 (Left) &  
 3001-400-45 (Right)  
 (reference only)

(Left Side is Shown)

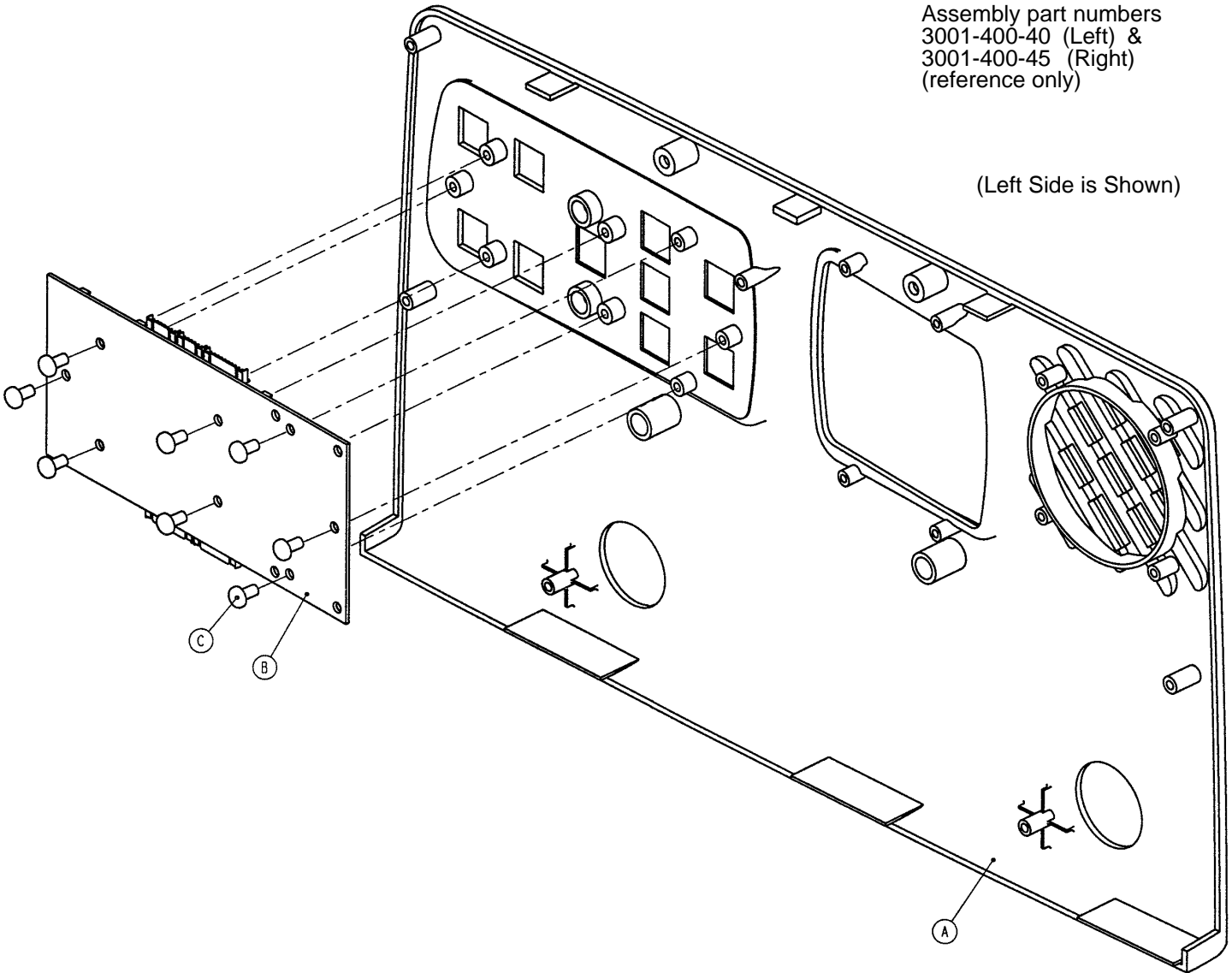

Item	Part No.	Part Name	Qty.
A	3001-400-101	Left Inner Panel	1
	3001-400-201	Right Inner Panel	1
B	3001-400-930	Inner Siderail PCB Assembly	1
C	23-1 12	Hi-Low Tapping Screw	8

# 3002-400-70 Siderail Latch Assembly, Head End, Left

---

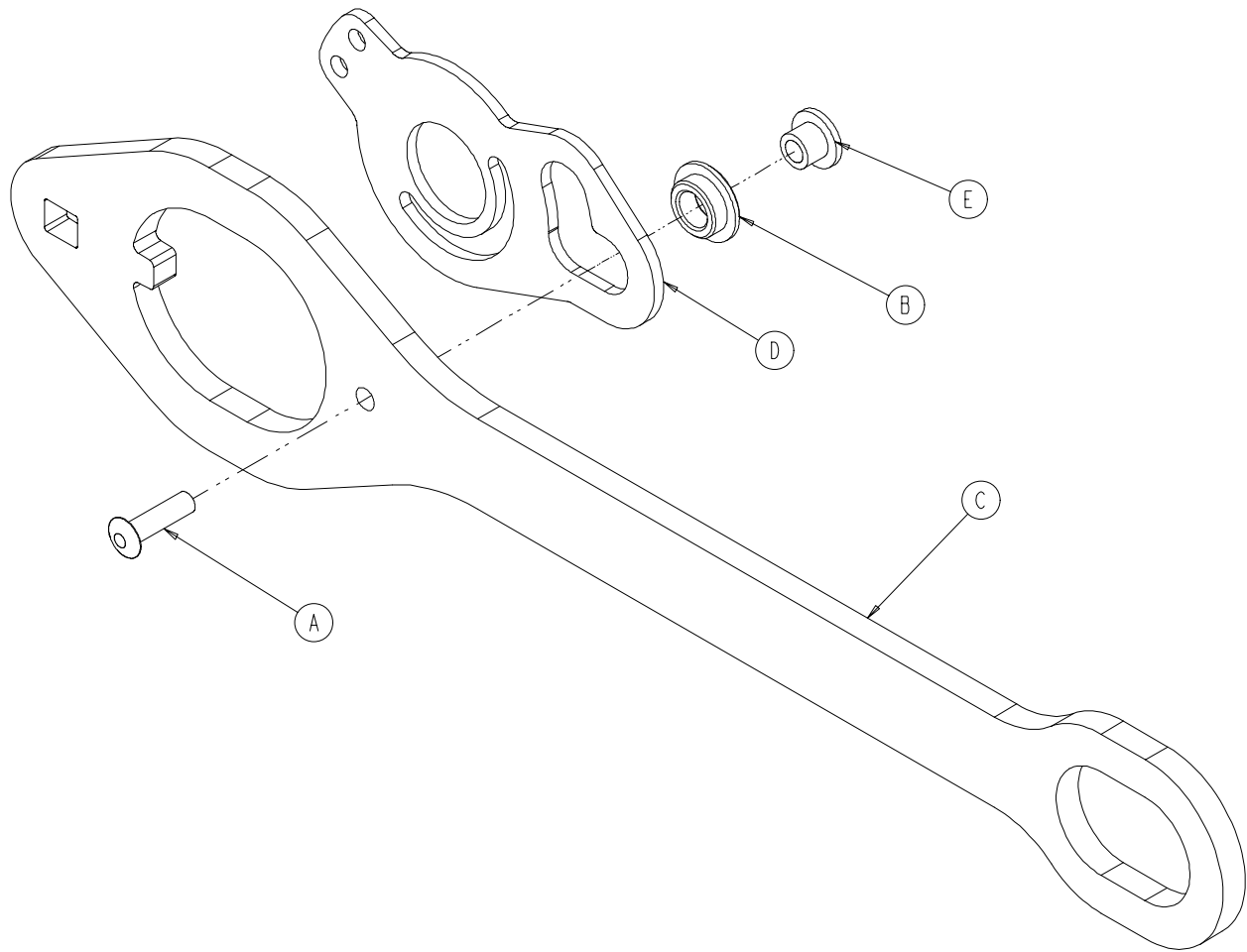

Item	Part No.	Part Name	Qty.
A	25-86	Blind Rivet	1
B	81-317	Bronze Bushing	1
C	3002-400-501	Latch	1
D	3002-400-503	Head End Bypass Plate	1
E	3002-400-509	Bypass Bushing Spacer	1

# 3002-400-75 Siderail Latch Assembly, Head End, Right

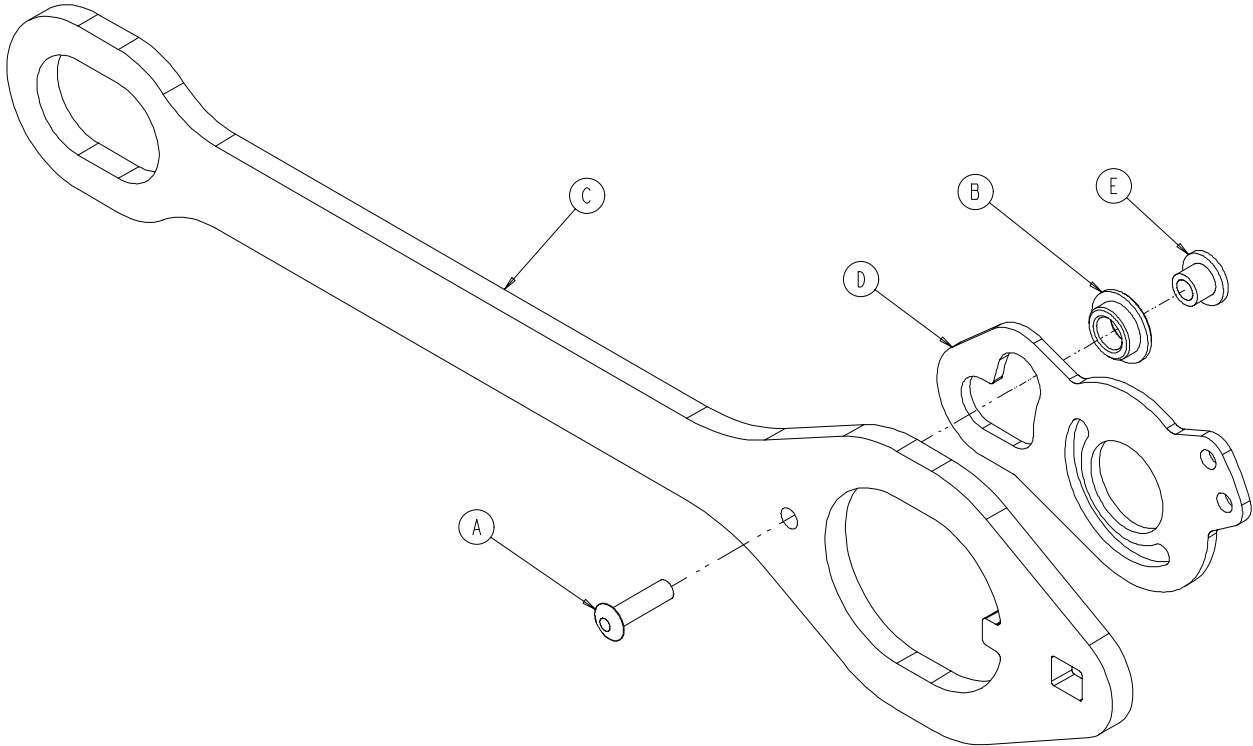

Item	Part No.	Part Name	Qty.
A	25-86	Blind Rivet	1
B	81-317	Bronze Bushing	1
C	3002-400-501	Latch	1
D	3002-400-503	Head End Bypass Plate	1
E	3002-400-509	Bypass Bushing Spacer	1

# 3002-401-300 Foot End Siderail Assembly, Left

---

# 3002-401-400 Foot End Siderail Assembly, Right

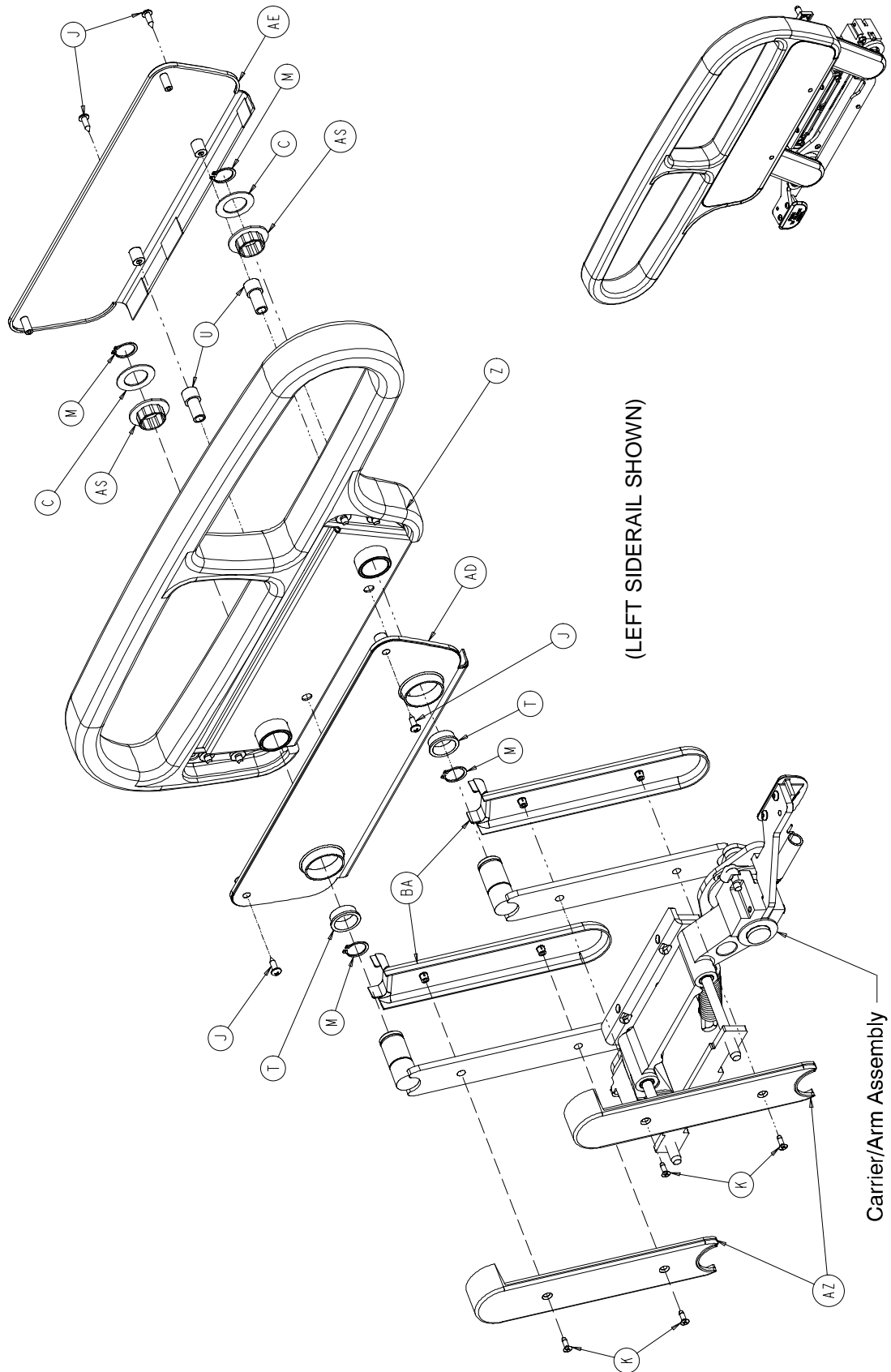

# 3002-401-300 Foot End Siderail Assembly, Left

---

# 3002-401-400 Foot End Siderail Assembly, Right

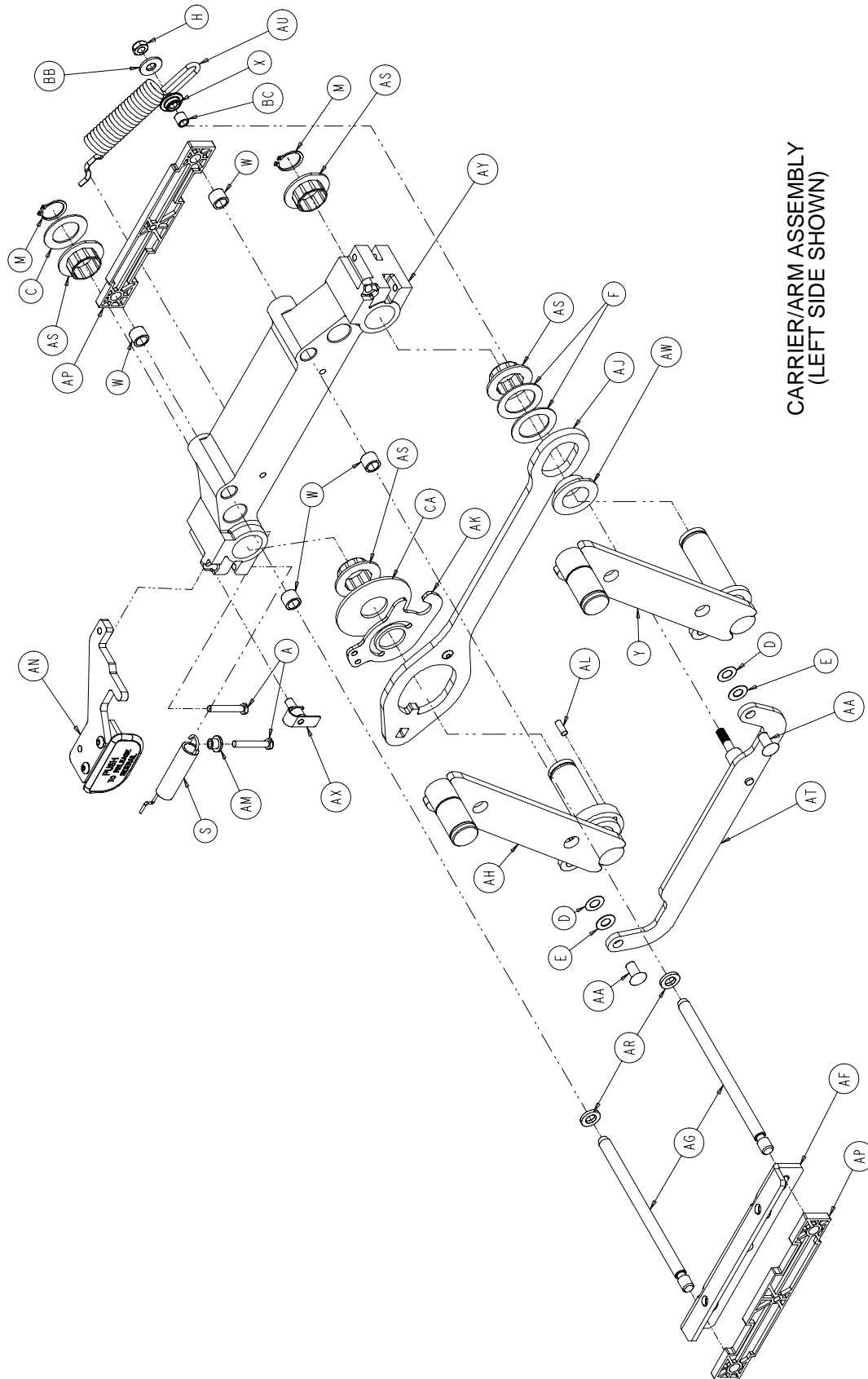

CARRIER/ARM ASSEMBLY  
(LEFT SIDE SHOWN)

# 3002-401-300 Foot End Siderail Assembly, Left

# 3002-401-400 Foot End Siderail Assembly, Right

## 3002-401-300 Left Common Components

## 3002-401-400 Right Common Components

Item	Part No.	Part Name	Qty.	Item	Part No.	Part Name	Qty.
A	3-344	Hex Hd. Cap Screw	2	A	3-344	Hex Hd. Cap Screw	2
C	11-343	Shim Washer	3	C	11-343	Shim Washer	3
D	11-377	Washer	2	D	11-377	Washer	2
E	11-491	Steel Shim Washer	2	E	11-491	Steel Shim Washer	2
F	14-93	Washer	2	F	14-93	Washer	2
H	16-102	Nylock Nut	1	H	16-102	Nylock Nut	1
J	23-90	Pan Hd. Tapping Screw	4	J	23-90	Pan Hd. Tapping Screw	4
K	1-72	Ph. Flat Hd. Mach. Screw	4	K	1-72	Ph. Flat Hd. Mach. Screw	4
M	28-128	Retaining Ring	6	M	28-128	Retaining Ring	6
S	3000-200-334	Extension Spring	1	S	3000-200-334	Extension Spring	1
T	3000-400-513	Flange Bearing	2	T	3000-400-513	Flange Bearing	2
U	3000-400-523	Panel Spacer	2	U	3000-400-523	Panel Spacer	2
W	3000-400-557	Sleeve Bearing	4	W	3000-400-557	Sleeve Bearing	4
X	3001-300-99	Modified Bushing	1	X	3001-300-99	Modified Bushing	1
Y	3001-401-327	Arm Wldmt., Left, Ft., Hd.	1	Y	3001-401-427	Arm Wldmt., Rt., Ft., Hd.	1
Z	(page 206)	Support Assembly, Left	1	Z	(page 207)	Support Assembly, Right	1
AA	3001-400-501	Rivet	2	AA	3001-400-501	Rivet	2
AD	3001-400-526	Inner Panel	1	AD	3001-400-526	Inner Panel	1
AE	3001-400-527	Outer Panel	1	AE	3001-400-527	Outer Panel	1
AF	3001-400-555	Mounting Bracket	1	AF	3001-400-555	Mounting Bracket	1
AG	3001-400-564	Glide Rod	2	AG	3001-400-564	Glide Rod	2
AM	3002-400-509	Bypass Bushing Spacer	1	AM	3002-400-509	Bypass Bushing Spacer	1
AN	(page 209)	Release Lever Ass'y, Lt.	1	AN	(page 210)	Release Lever Ass'y, Rt.	1
AP	3002-400-51 1	Glide Rod Bumper Pad	2	AP	3002-400-51 1	Glide Rod Bumper Pad	2
AR	3002-400-512	Bumper Washer	2	AR	3002-400-512	Bumper Washer	2
AS	3002-400-513	Pivot Bushing	6	AS	3002-400-513	Pivot Bushing	6
AT	3002-400-515	Timing Link, Foot, Left	1	AT	3002-400-514	Timing Link, Foot, Right	1
AU	3002-400-517	Tuck Spring	1	AU	3002-400-517	Tuck Spring	1
AW	3002-400-519	Latch Bushing	1	AW	3002-400-519	Latch Bushing	1
AY	3002-400-528	Siderail Carrier	1	AY	3002-400-528	Siderail Carrier	1
AZ	5000-20-5	Inner Arm Cover	2	AZ	5000-20-5	Inner Arm Cover	2
BA	3001-400-619	Outer Arm Cover	2	BA	3001-400-619	Outer Arm Cover	2
BB	11-408	Flat Washer	1	BB	11-408	Flat Washer	1
BC	3001-400-558	Siderail Spacer	1	BC	3001-400-558	Siderail Spacer	1

## 3002-443-301 Left Rail - Standard Bed

## 3002-443-401 Right Rail - Standard Bed

Item	Part No.	Part Name	Qty.	Item	Part No.	Part Name	Qty.
AH	3002-401-328	Foot Arm Wldmt., Lt., Foot	1	AH	3002-401-428	Foot Arm Wldmt., Rt., Foot	1
AJ	(page 208)	Latch Ass'y, Foot End	1	AJ	(page 208)	Latch Ass'y, Foot End	1
AK	3002-400-504	Foot Bypass Plate	1	AK	3002-400-504	Foot Bypass Plate	1
AL	3002-400-505	Bypass Pin	1	AL	3002-400-505	Bypass Pin	1
AX	(page 211)	Bypass Detent Clip Ass'y	1	AX	(page 211)	Bypass Detent Clip Ass'y	1

## 3002-442-301 Left Rail - 8" Shorter Bed

## 3002-442-401 Right Rail - 8" Shorter Bed

Item	Part No.	Part Name	Qty.	Item	Part No.	Part Name	Qty.
AH	3002-443-318	Foot Arm Wldmt., Lt., Foot	1	AH	3002-443-418	Foot Arm Wldmt., Rt., Foot	1
AJ	3002-400-501	Latch	1	AJ	3002-400-501	Latch	1
CA	11-185	Washer	1	CA	11-185	Washer	1



# Left Foot End Siderail Support Assembly

Assembly part number 3001-400-360 (reference only)

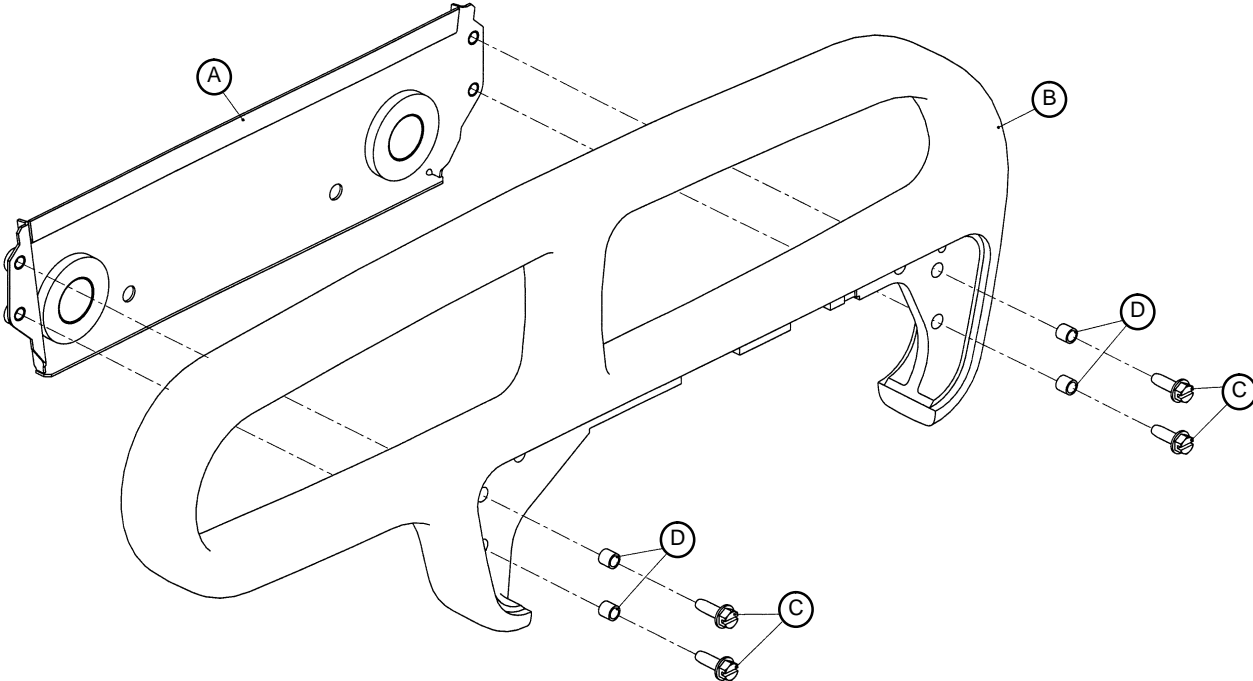

Item	Part No.	Part Name	Qty.
A	3001-400-31	Foot Support Weldment	1
B	3000-400-520	Foot Rail	1
C	3-224	Hex Washer Hd. Screw	6
D	3000-400-558	Siderail Spacer	6

# Right Foot End Siderail Support Assembly

Assembly part number 3001-400-460 (reference only)

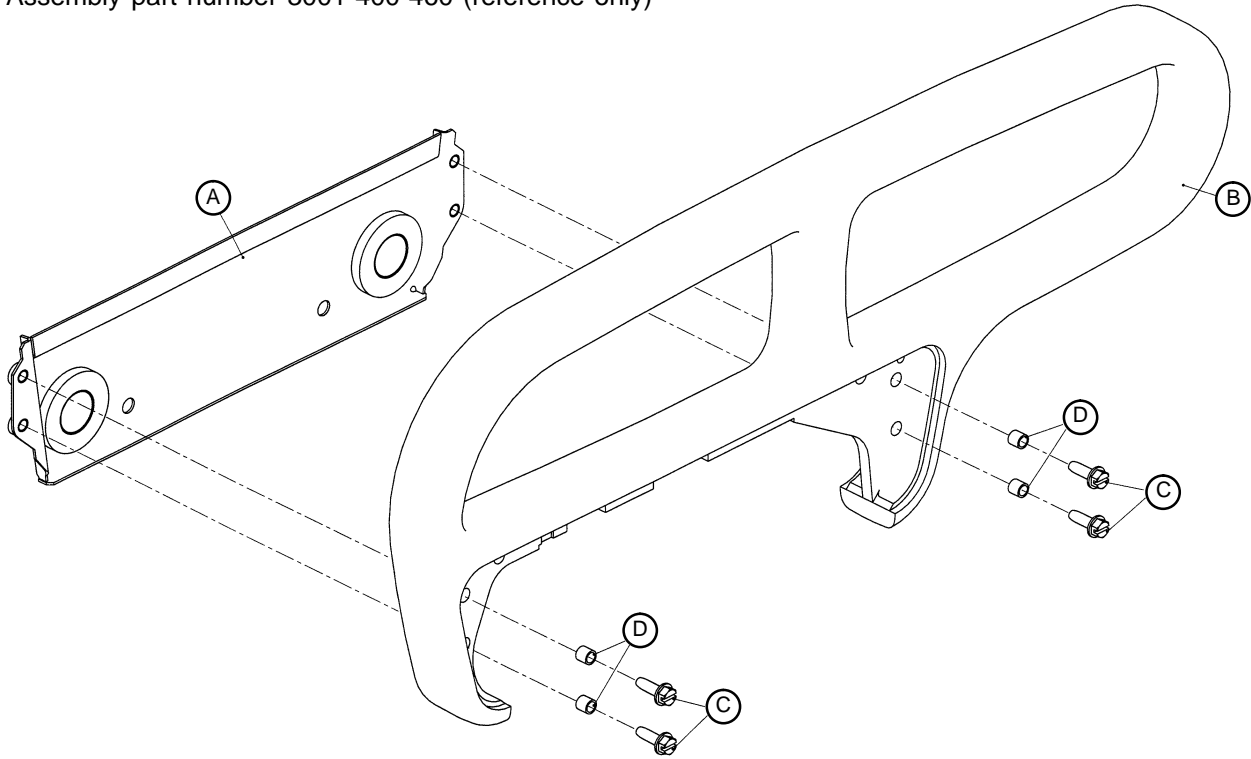

Item	Part No.	Part Name	Qty.
A	3001-400-580	Foot Support Weldment	1
B	3000-400-520	Foot Rail	1
C	3-226	Hex Washer Hd. Screw	4
D	3001-400-558	Siderail Spacer	4

# 3002-400-80 Siderail Latch Assembly, Foot End

---

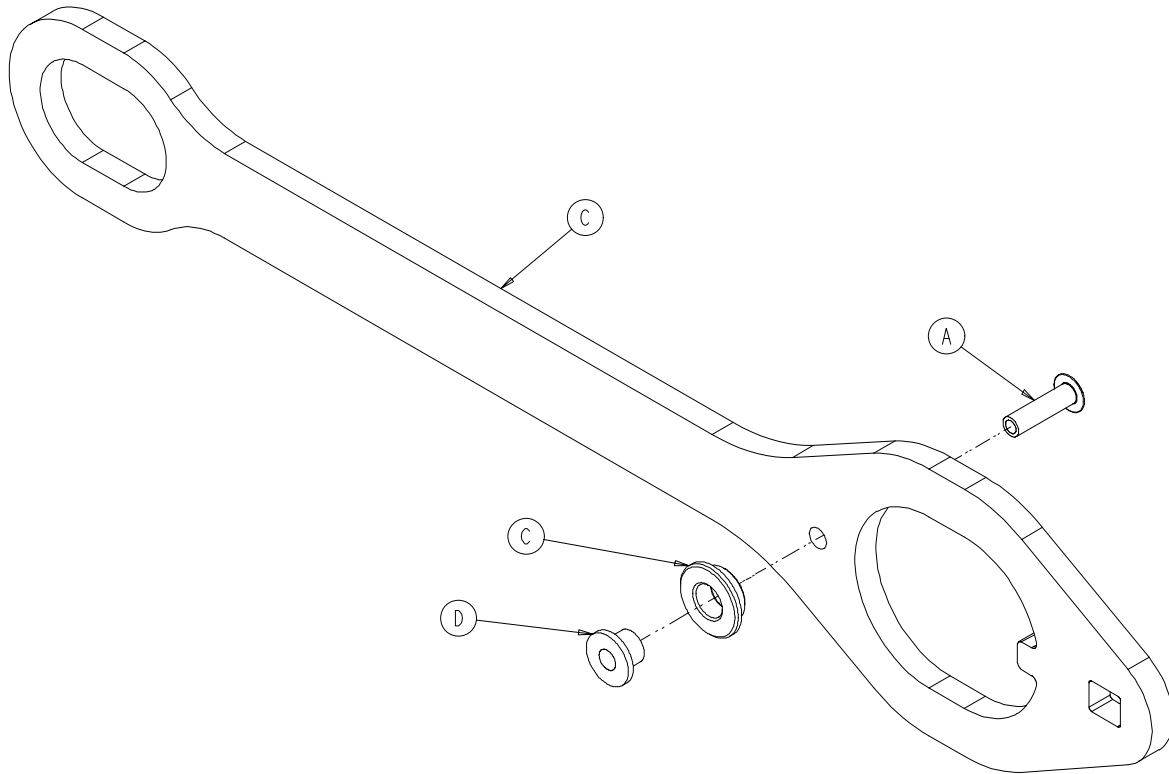

Item	Part No.	Part Name	Qty.
A	25-86	Blind Rivet	1
B	81-317	Bronze Bushing	1
C	3002-400-501	Latch	1
D	3002-400-509	Bypass Bushing Spacer	1

# 3002-400-55 Siderail Release Lever Assembly, Left

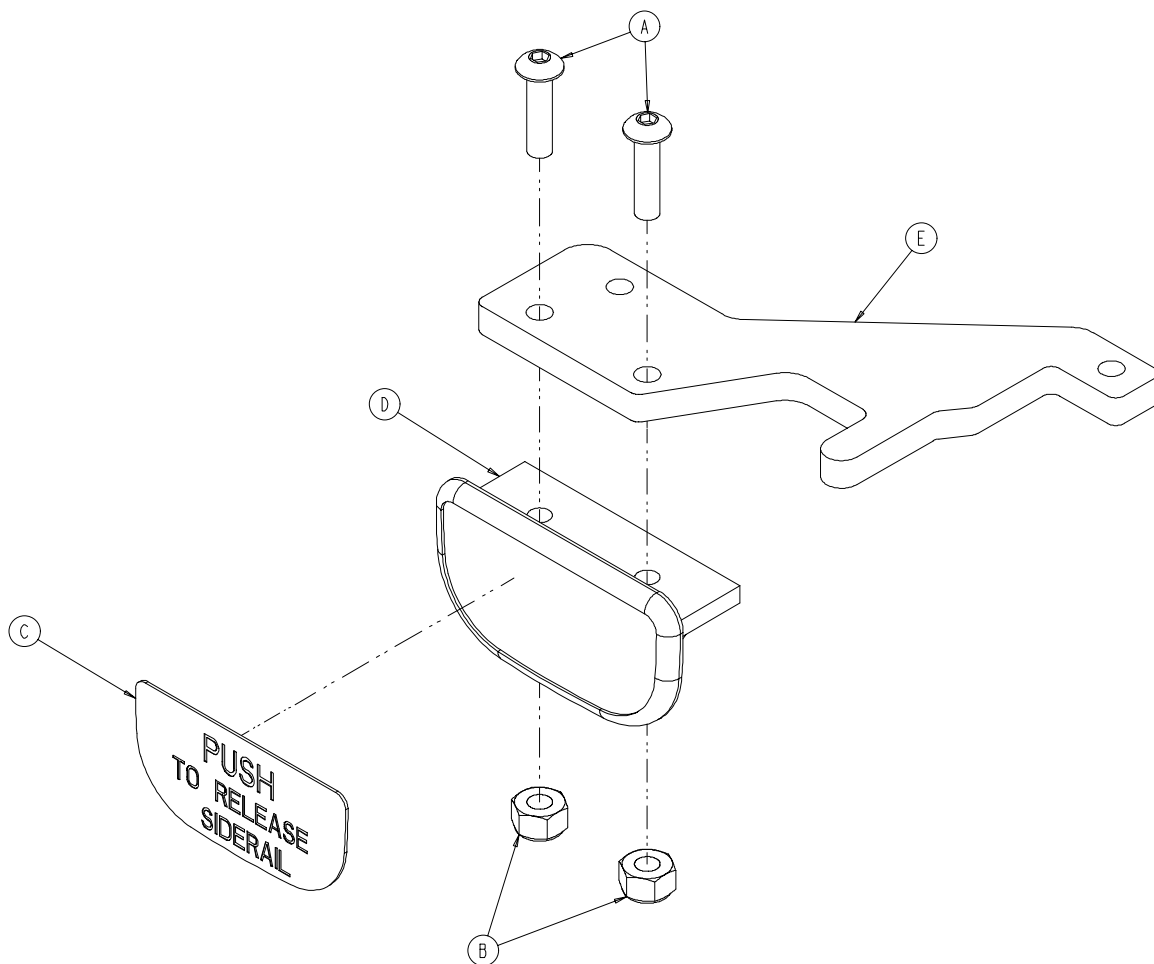

Item	Part No.	Part Name	Qty.
A	4-278	Socket But. Hd. Cap Screw	2
B	16-2	Hex Nut	2
C	3001-400-505	Release Label	1
D	3001-400-514	Release Lever Pad	1
E	3002-400-510	Release Lever	1

# 3002-400-65 Siderail Release Lever Assembly, Right

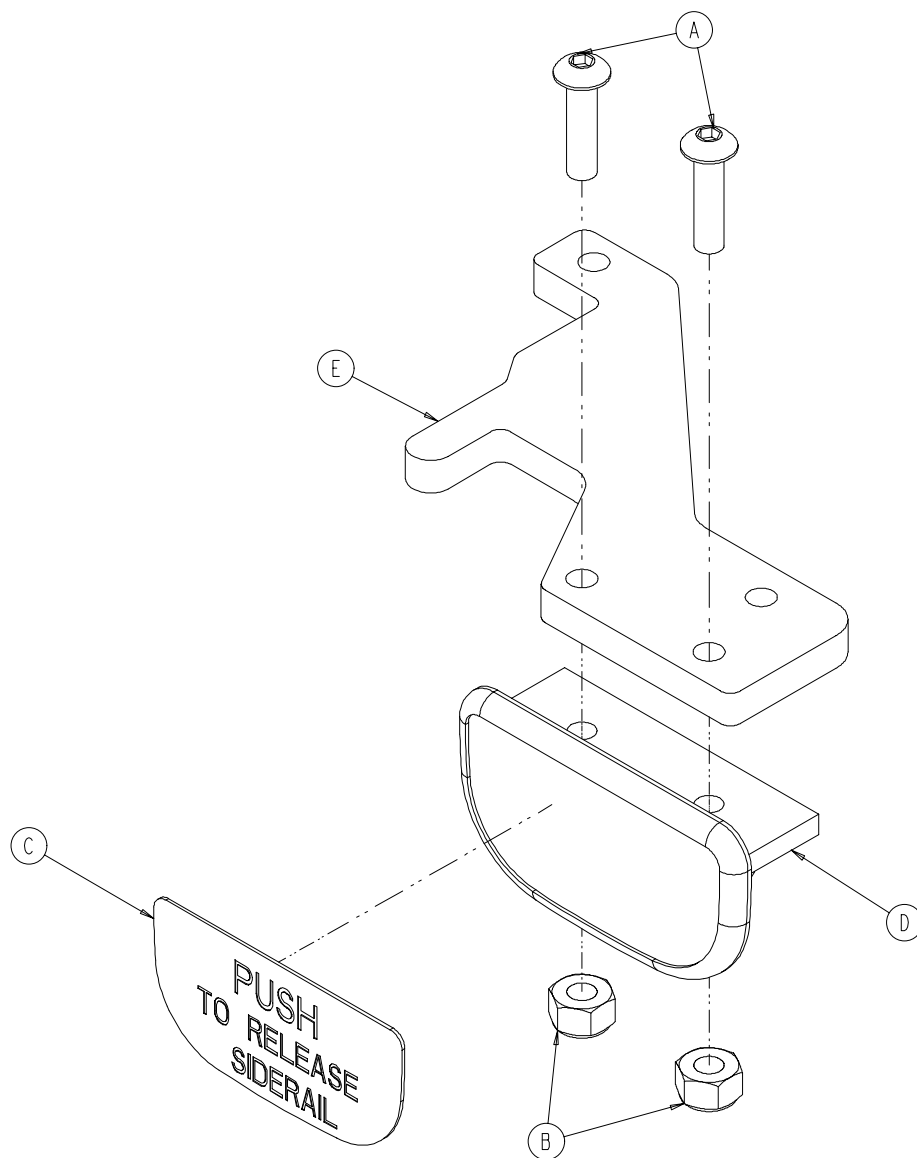

Item	Part No.	Part Name	Qty.
A	4-278	Socket But. Hd. Cap Screw	2
B	16-2	Hex Nut	2
C	3001-400-505	Release Label	1
D	3001-400-514	Release Lever Pad	1
E	3002-400-510	Release Lever	1

# 3002-400-90 Siderail Bypass Detent Clip Assembly

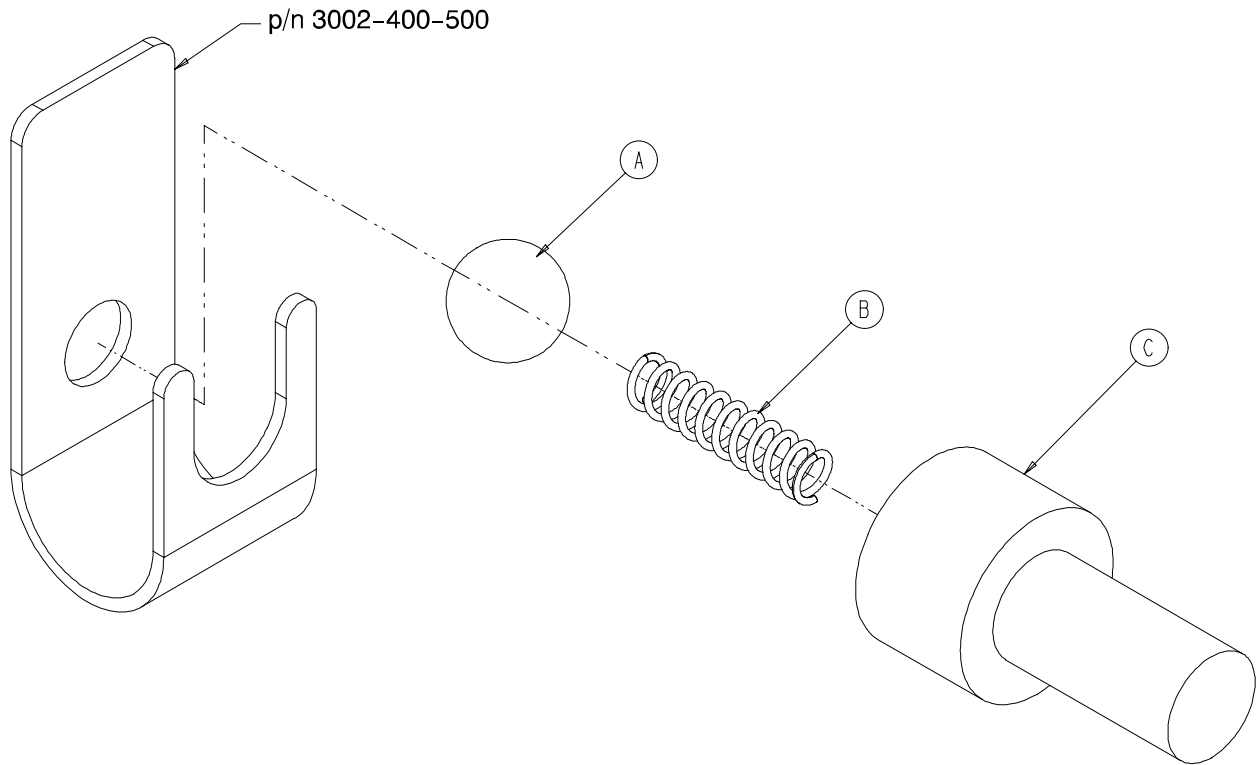

Item	Part No.	Part Name	Qty.
A	31-137	Steel Ball	1
B	38-464	Compression Spring	1
C	3002-400-524	Bypass Detent Housing	1

# Optional Pendant Assembly

---

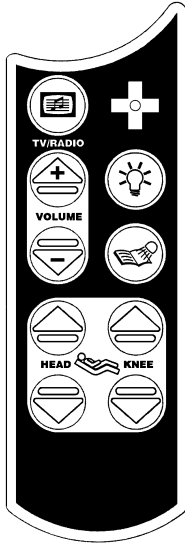

**3001-315-12 Combination Pendant  
Motion/Communication**

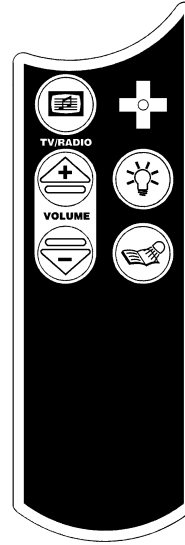

**3001-315-16 Combination Pendant  
Communication Only**

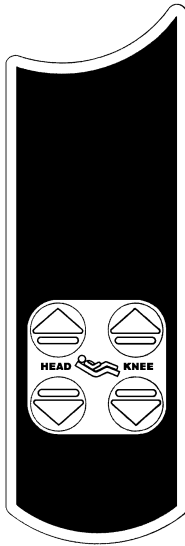

**3001-315-14 Combination Pendant  
Motion Only**

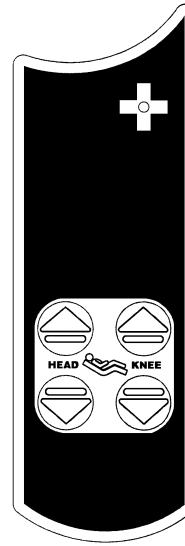

**3001-315-18 Combination Pendant  
Motion/NurseCall**

# Foot Board Assembly

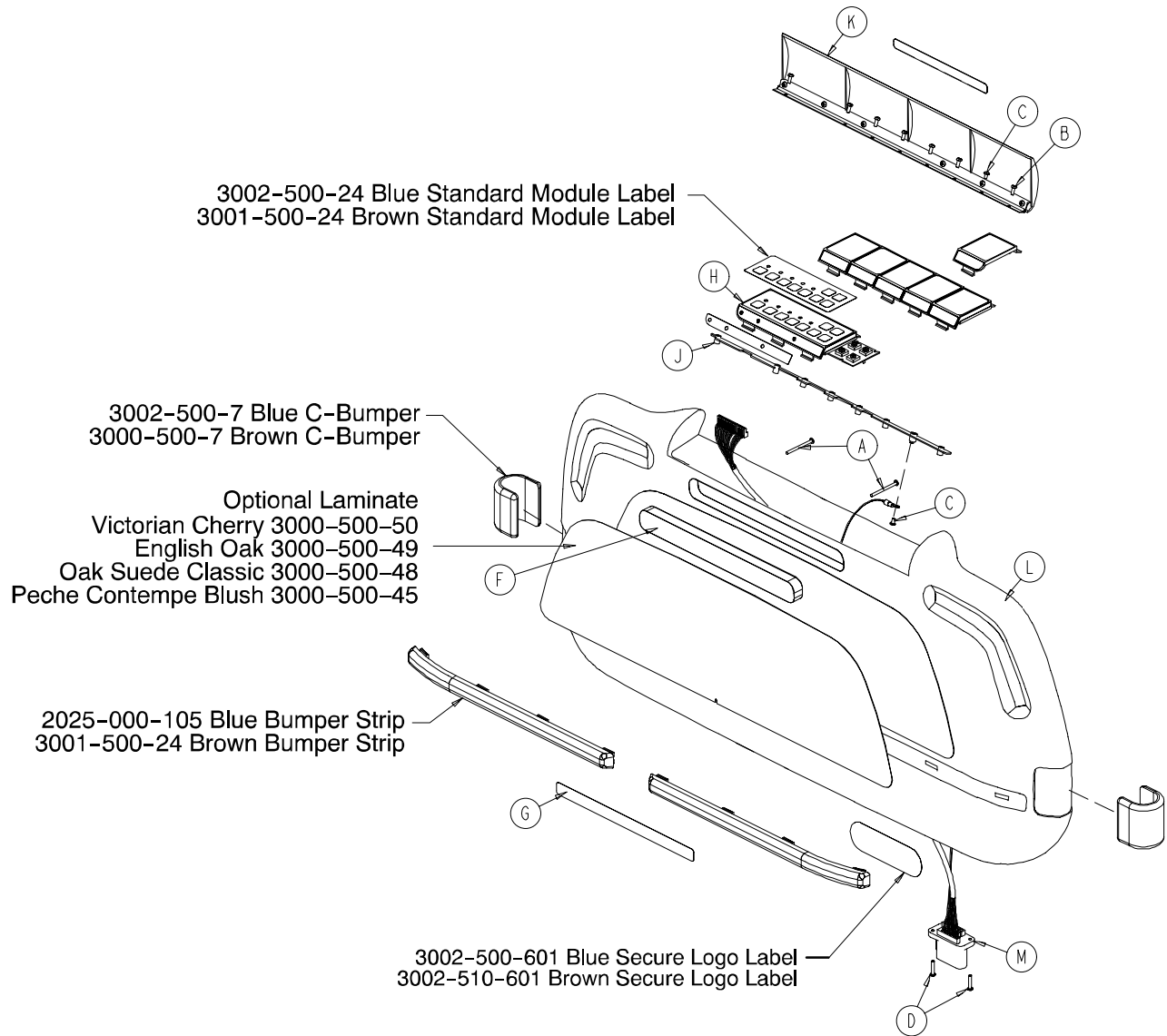

## 3002-500-1 1 Standard Components

Item	Part No.	Part Name	Qty.
A	23-99	Phillips Pan Hd. Screw	2
B	23-103	Pan Hd. Hi-Lo Tap. Screw	7
C	50-38	Pan Hd. Mach. Screw	2
D	50-39	Pan Hd. Mach. Screw	2
E	72-2-71	"C" Bumper Adhesive	1
F	3000-500-8	Chart Rack Cover	1
G	3000-500-29	Hazard Label	1
H	(page 222)	Std. Control Module Ass'y	1
J	3001-500-64	Hinge Plate	1
K	3001-500-1	Lid Assembly	1
L	3001-500-10	Clam Shell Assembly	1
M	3001-500-801	Foot Board Drawer Cable	1



# Foot Board Assembly

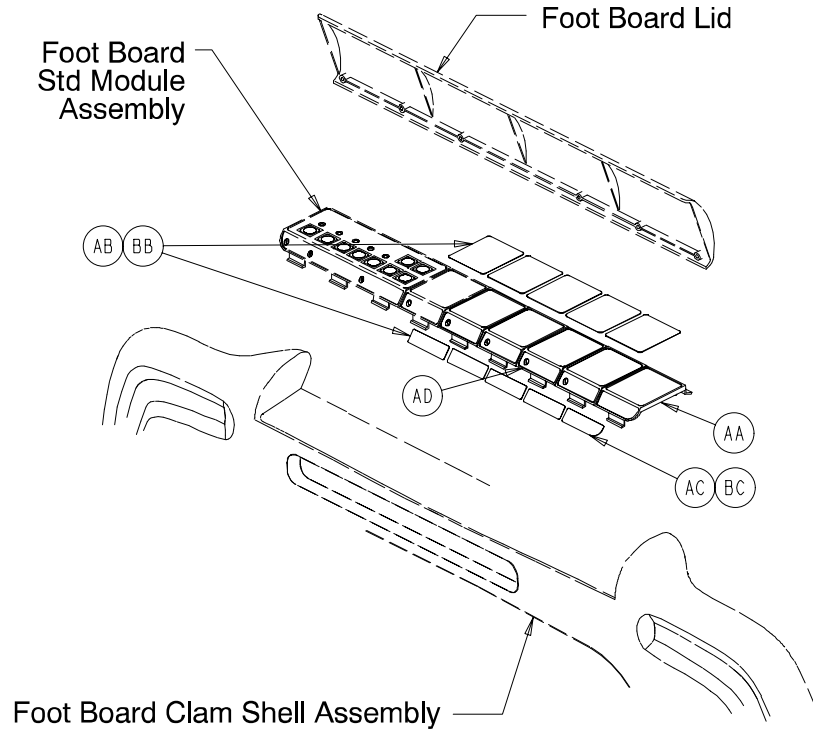

**No Scale/Bed Exit, Blue - p/n 3002-507-120**

**No Scale/Bed Exit, Brown - p/n 3002-517-120**

Item	Part No.	Part Name	Qty.	Item	Part No.	Part Name	Qty.
AA	3000-500-4	End Module	1	AA	3000-500-4	End Module	1
AB	3002-508-4	Blank Module Label	5	BB	3002-518-4	Blank Module Label	5
AC	3002-500-27	End Module Label	1	BC	3000-500-27	End Module Label	1
AD	3001-500-3	Blank Module	4	AD	3001-500-3	Blank Module	4

# Foot Board Assembly

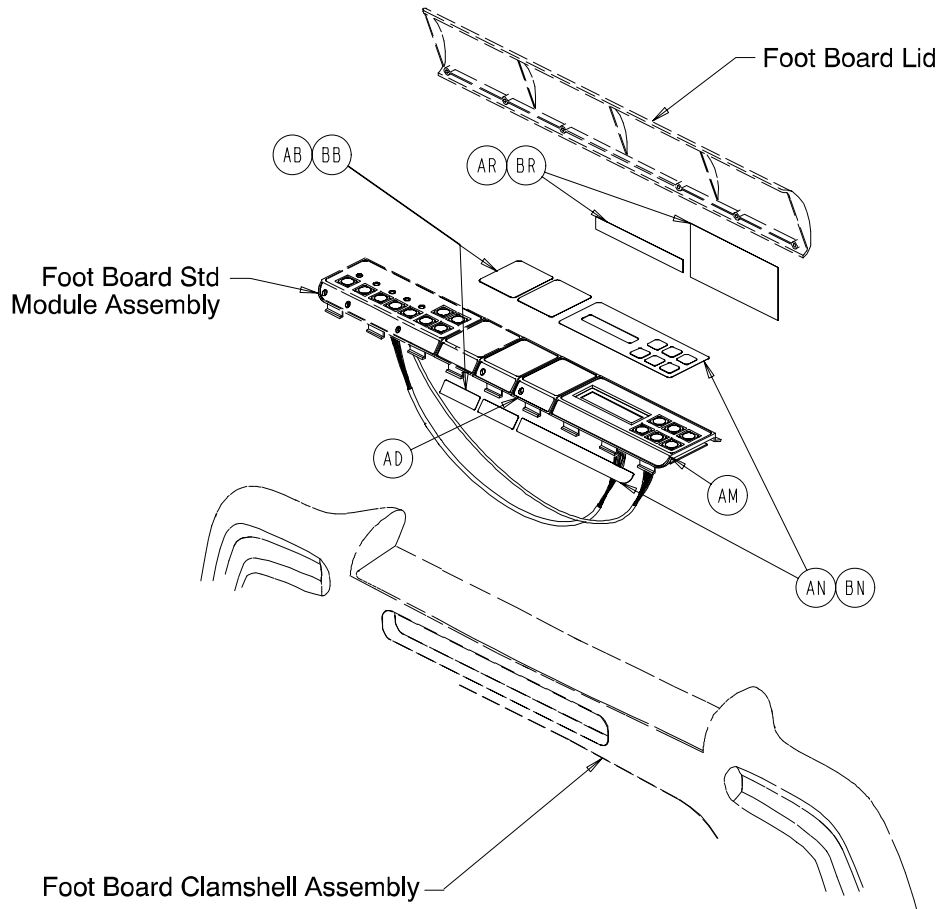

## Scale Only, Blue - p/n 3002-507-12

## Scale Only, Brown - p/n 3002-517-12

Item	Part No.	Part Name	Qty.	Item	Part No.	Part Name	Qty.
AB	3002-508-4	Blank Module Label	2	BB	3002-518-4	Blank Module Label	2
AD	3001-500-3	Blank Module	2	AD	3001-500-3	Blank Module	2
AM	(page 225)	Scale Module	1	AM	(page 225)	Scale Module	1
AN	3002-507-2	Scale Module Label	1	BN	3002-517-2	Scale Module Label	1
AR	3002-507-1 1	Scale Label	1	BR	3002-507-1 1	Scale Label	1

# Foot Board Assembly

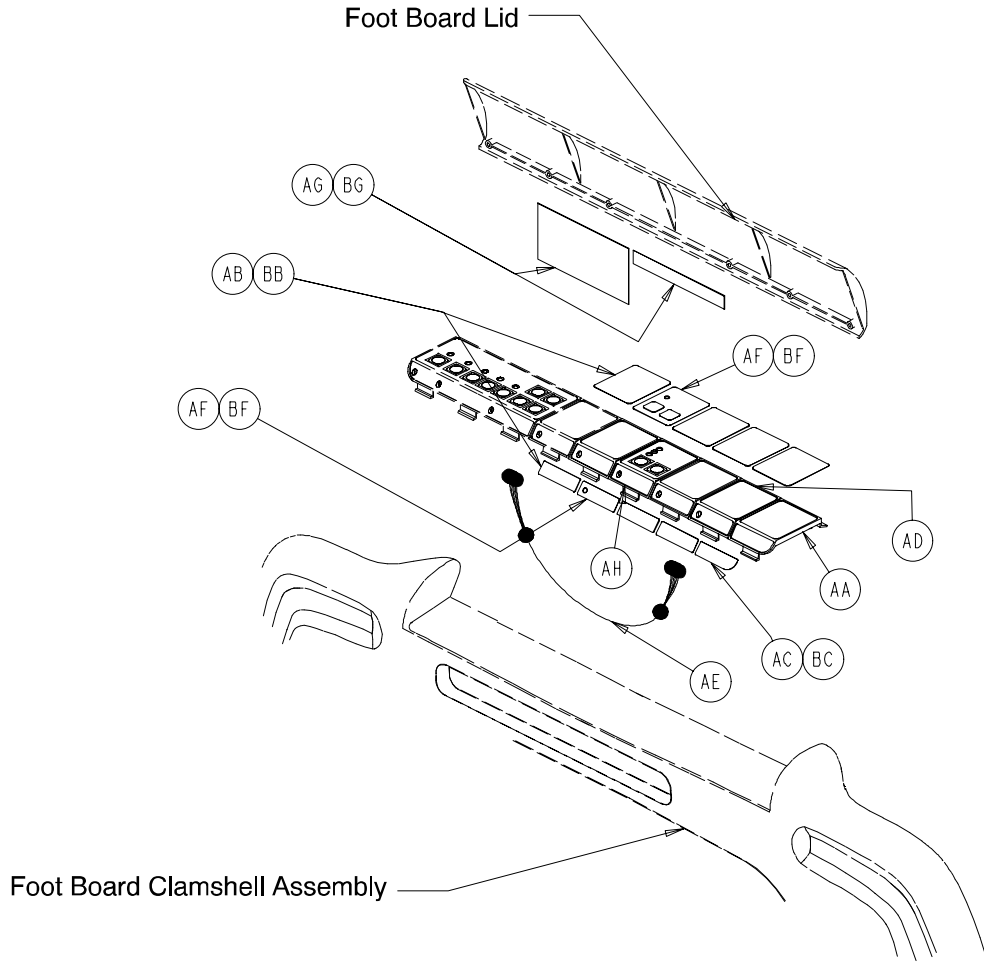

## Chaperone B/E Only, Blue - p/n 3002-508-11

Item	Part No.	Part Name	Qty.
AA	3000-500-4	End Module	1
AB	3002-508-4	Blank Module Label	4
AC	3002-500-27	End Module Label	1
AD	3001-500-3	Blank Module	3
AE	3001-508-800	Bed Exit Keypad Cable	1
AF	3002-508-2	Bed Exit Module Label	1
AG	3002-508-10	Bed Exit Label	1
AH	(page 223)	Bed Exit Module	1

## Chaperone B/E Only, Brown - p/n 3002-518-11

Item	Part No.	Part Name	Qty.
AA	3000-500-4	End Module	1
BB	3002-518-4	Blank Module Label	4
AC	3000-500-27	End Module Label	1
AD	3001-500-3	Blank Module	3
AE	3001-508-800	Bed Exit Keypad Cable	1
BF	3002-518-2	Bed Exit Module Label	1
BG	3002-508-10	Bed Exit Label	1
AH	(page 223)	Bed Exit Module	1

# Foot Board Assembly

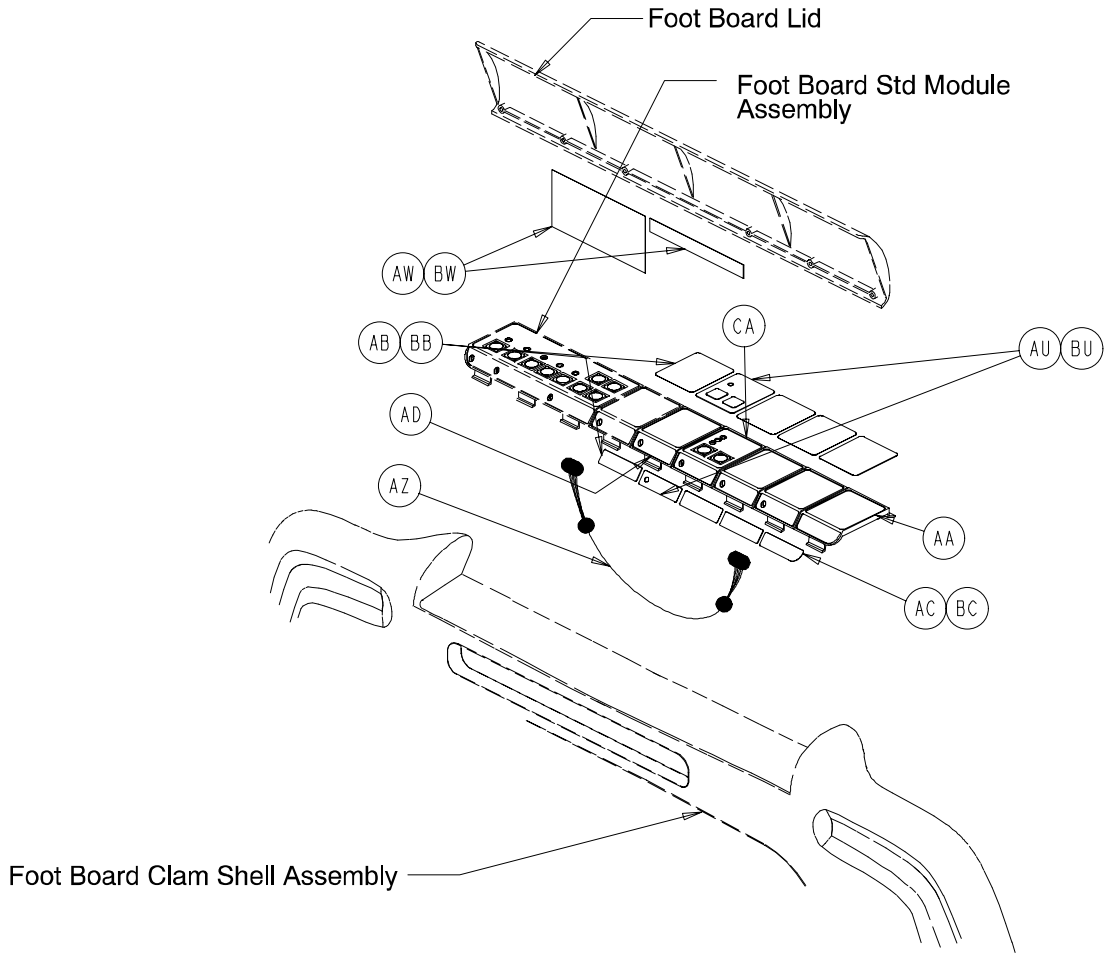

**Chaperone w/Zone Ctrl., Blue - p/n 3002-508-21**

**Chaperone w/Zone Ctrl., Brown - p/n 3002-518-21**

Item	Part No.	Part Name	Qty.	Item	Part No.	Part Name	Qty.
AA	3000-500-4	End Module	1	AA	3000-500-4	End Module	1
AB	3002-508-4	Blank Module Label	4	BB	3002-518-4	Blank Module Label	4
AC	3002-500-27	End Module Label	1	BC	3000-500-27	End Module Label	1
AD	3001-500-3	Blank Module	3	AD	3001-500-3	Blank Module	3
AU	3002-508-3	Chaperone II Module Label	1	BU	3002-518-3	Chaperone II Module Label	1
AW	3002-508-12	Chaperone II Label	1	BW	3002-508-12	Chaperone II Label	1
AZ	3002-508-800	Zone Ctrl. Keypad Cable	1	AZ	3002-508-800	Zone Ctrl. Keypad Cable	1
CA	(page 224)	Bed Exit Module	1	CA	(page 224)	Bed Exit Module	1

# Foot Board Assembly

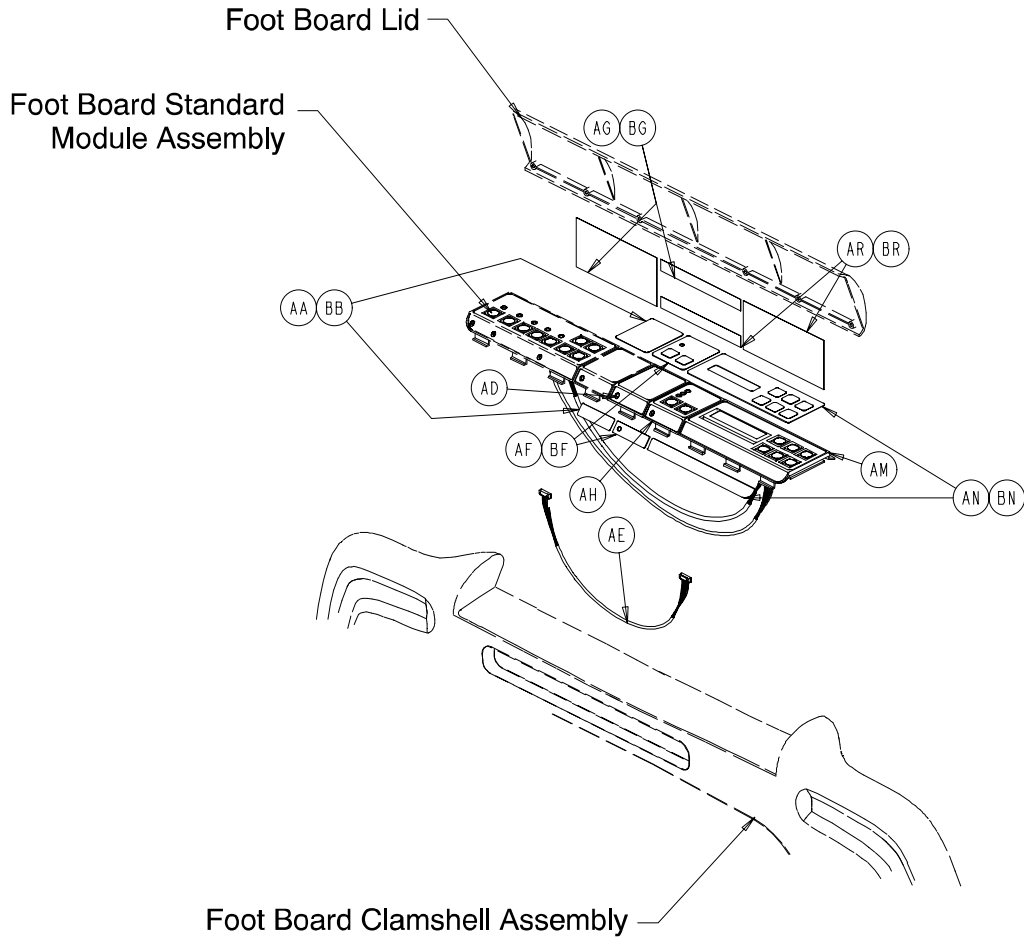

## Scale & Chaperone, Blue - p/n 3002-507-21

Item	Part No.	Part Name	Qty.
AB	3002-508-4	Blank Module Label	1
AD	3001-500-3	Blank Module	1
AE	3001-508-800	Bed Exit Keypad Cable	1
AF	3002-508-2	Bed Exit Module Label	1
AG	3002-508-10	Bed Exit Label	1
AH	(page 223)	Bed Exit Module	1
AM	(page 225)	Scale Module	1
AN	3002-507-2	Scale Module Label	1
AR	3002-507-1	Scale Label	1

## Scale & Chaperone, Brown - p/n 3002-517-21

Item	Part No.	Part Name	Qty.
BB	3002-518-4	Blank Module Label	1
AD	3001-500-3	Blank Module	1
AE	3001-508-800	Bed Exit Keypad Cable	1
BF	3002-518-2	Bed Exit Module Label	1
BG	3000-508-10	Bed Exit Label	1
AH	(page 223)	Bed Exit Module	1
AM	(page 225)	Scale Module	1
BN	3002-517-2	Scale Module Label	1
BR	3002-507-1	Scale Label	1

# Foot Board Assembly

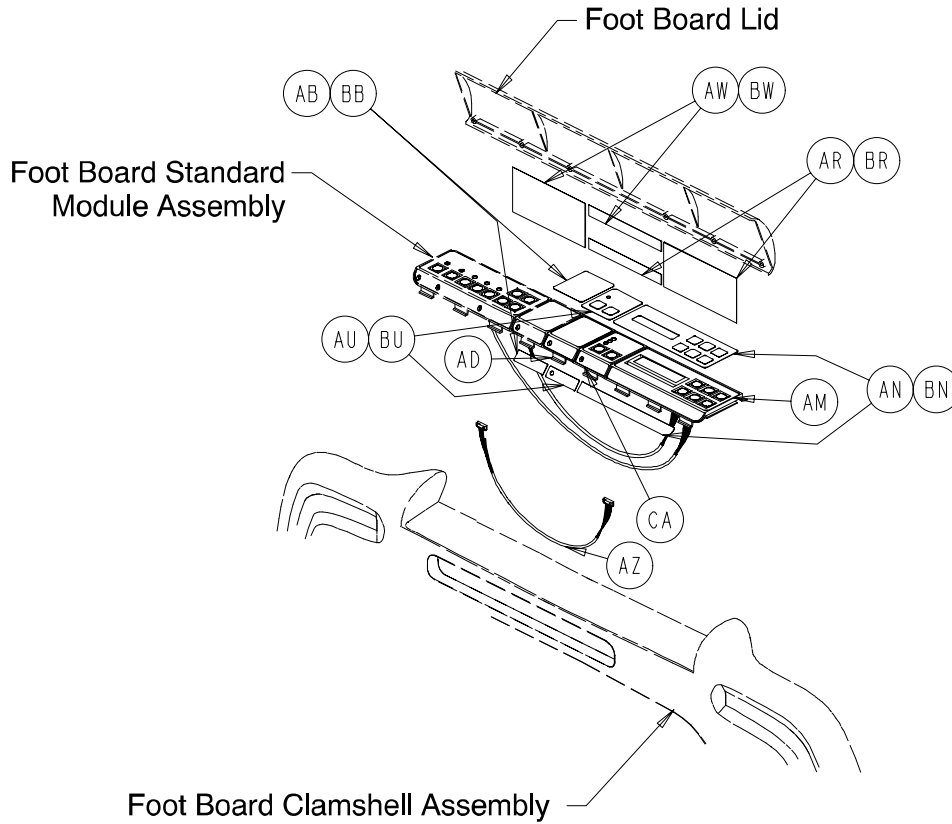

## Scale & Chaperone w/Zone, Blue - 3002-507-22

## Scale & Chaperone w/Zone, Brown - 3002-517-22

Item	Part No.	Part Name	Qty.	Item	Part No.	Part Name	Qty.
AB	3002-508-4	Blank Module Label	4	BB	3002-518-4	Blank Module Label	4
AD	3001-500-3	Blank Module	3	AD	3001-500-3	Blank Module	3
AM	(page 225)	Scale Module	1	AM	(page 225)	Scale Module	1
AN	3002-507-2	Scale Module Label	1	BN	3002-517-2	Scale Module Label	1
AR	3002-507-1 1	Scale Label	1	BR	3002-507-1 1	Scale Label	1
AU	3002-508-3	Chaperone II Module Label	1	BU	3002-518-3	Chaperone II Module Label	1
AW	3002-508-12	Chaperone II Label	1	BW	3002-508-12	Chaperone II Label	1
AZ	3002-508-800	Zone Ctrl. Keypad Cable	1	AZ	3002-508-800	Zone Ctrl. Keypad Cable	1
CA	(page 224)	Bed Exit Module	1	CA	(page 224)	Bed Exit Module	1

# Foot Board Assembly

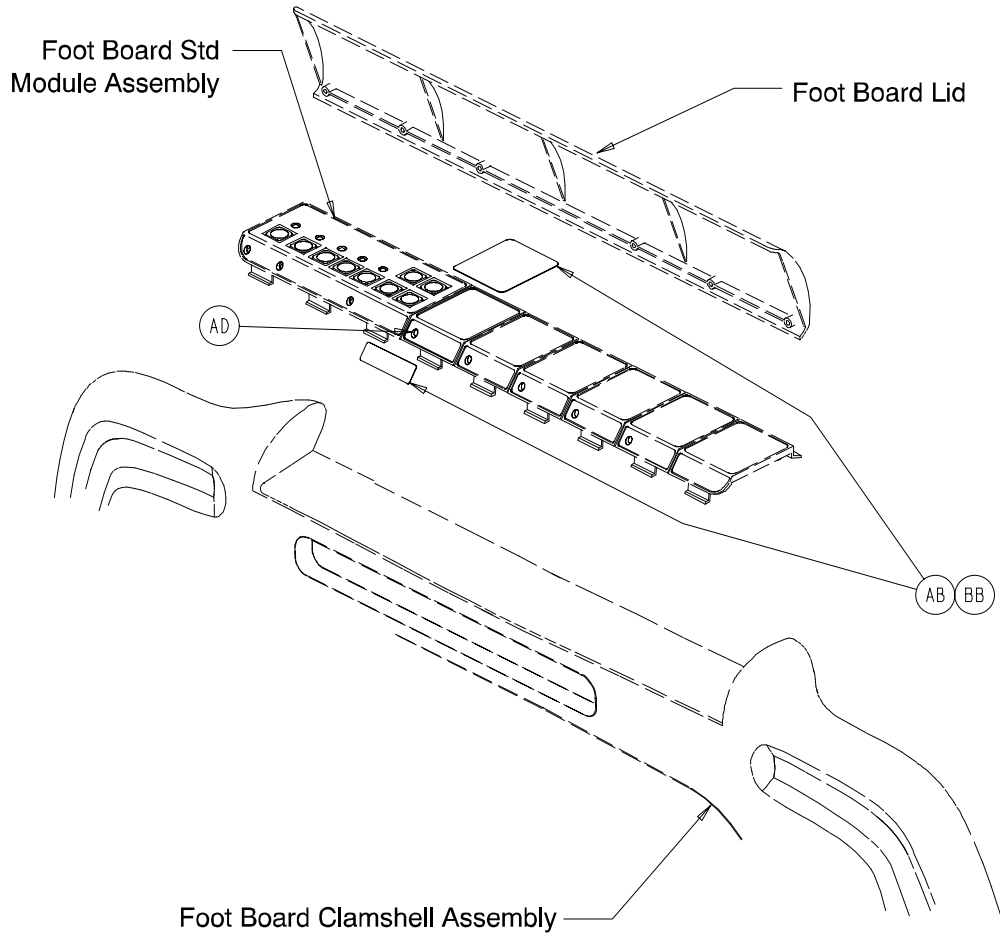

**No Gatch/Fowler, Blue - p/n 3002-501-110**

Item	Part No.	Part Name	Qty.
AB	3002-508-4	Blank Module Label	1
AD	3001-500-3	Blank Module	1

**No Gatch/Fowler, Brown - p/n 3002-511-1 10**

Item	Part No.	Part Name	Qty.
BB	3002-518-4	Blank Module Label	1
AD	3001-500-3	Blank Module	1

# Foot Board Assembly

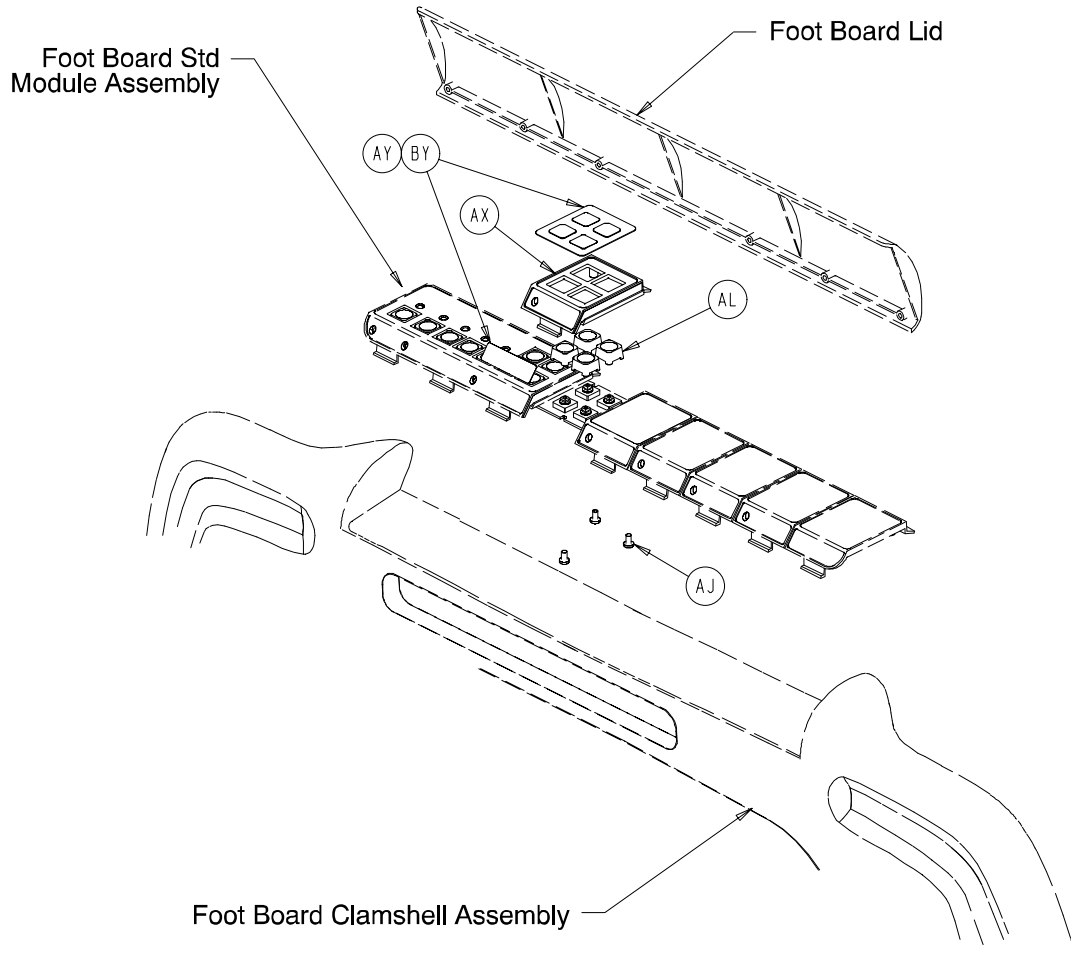

## Gatch/Fowler, Blue - p/n 3002-501-11

## Gatch/Fowler, Brown - p/n 3002-511-1 1

Item	Part No.	Part Name	Qty.	Item	Part No.	Part Name	Qty.
AJ	23-87	Pan Hd. Hi-Lo Tap. Screw	3	AJ	23-87	Pan Hd. Hi-Lo Tap. Scr.	3
AL	3001-400-953	Switch Cap	4	AL	3001-400-953	Switch Cap	4
AX	3000-501-1	Gatch/Fowler Module	1	AX	3000-501-1	Gatch/Fowler Module	1
AY	3002-501-2	Gatch/Fowler Module Label	1	BY	3001-501-2	Gatch/Fowler Module Label	1



# 3001-500-28 Foot Board Standard Module Assembly

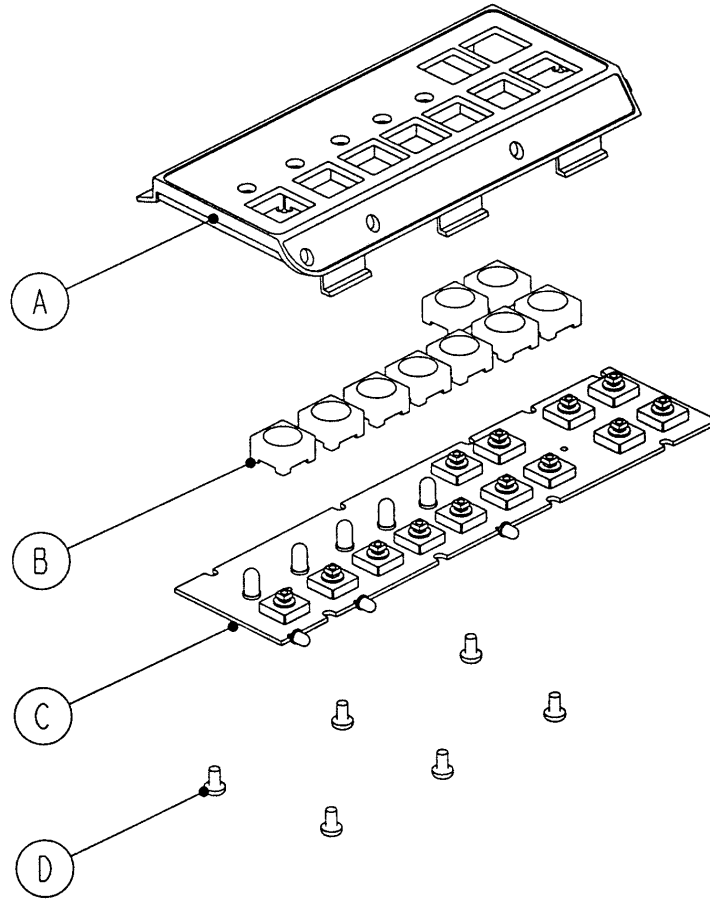

Item	Part No.	Part Name	Qty.
A	3000-500-2	Foot Board Standard Module	1
B	3001-400-953	Switch Cap	9
C	3001-500-930	Main Foot Board Keyboard	1
D	23-87	Pan Hd. Tapping Screw	6

# 3001-508-30 Optional Foot Board Module Assembly

## Chaperone Bed Exit

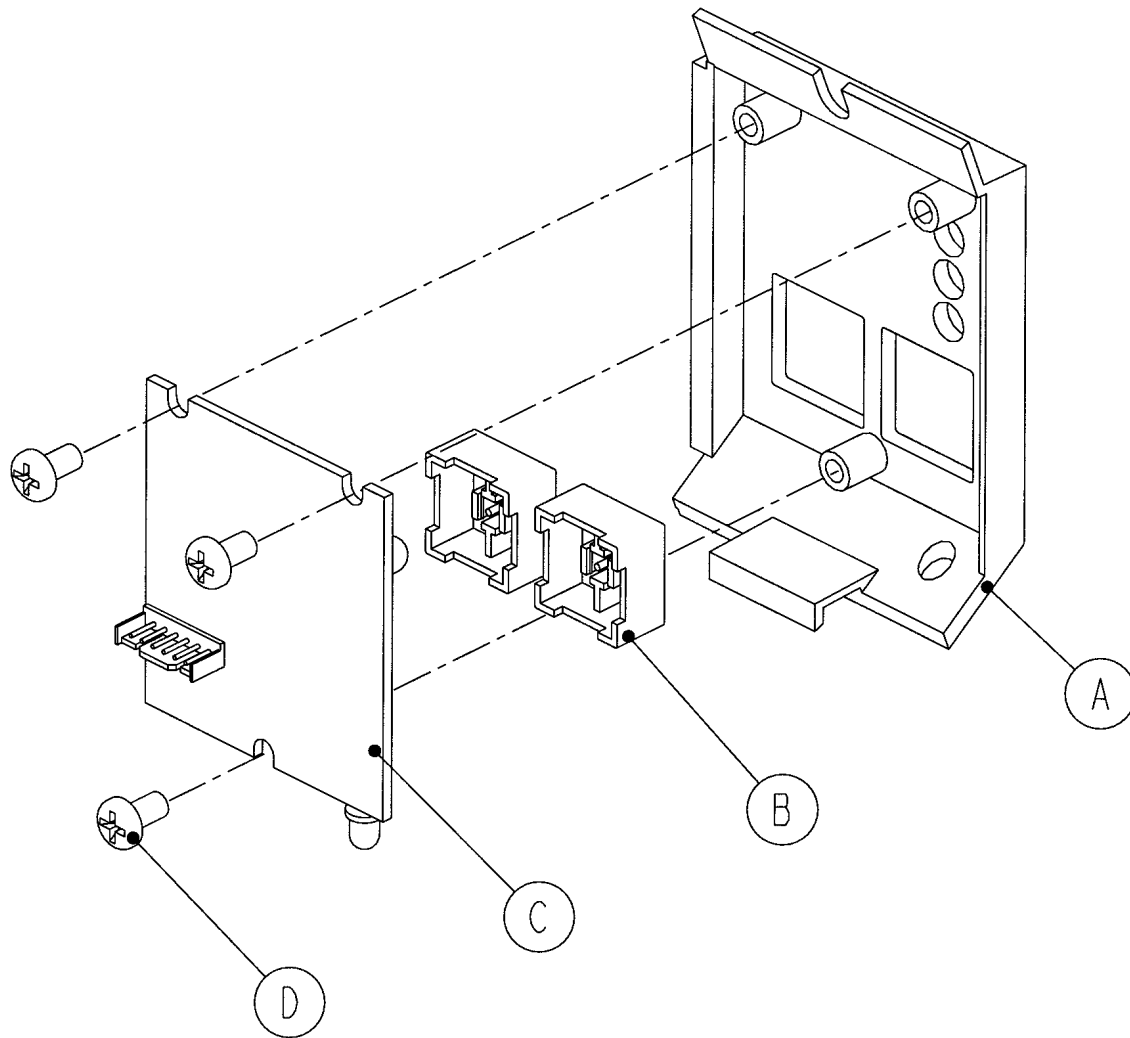

Item	Part No.	Part Name	Qty.
A	3000-508-1	Bed Exit Module Panel	1
B	3001-400-953	Switch Cap	2
C	3001-508-910	Bed Exit Keypad Ass'y	1
D	23-87	Tapping Screw	3

# 3002-508-30 Optional Foot Board Module Assembly

## Chaperone II Bed Exit with Zone Control

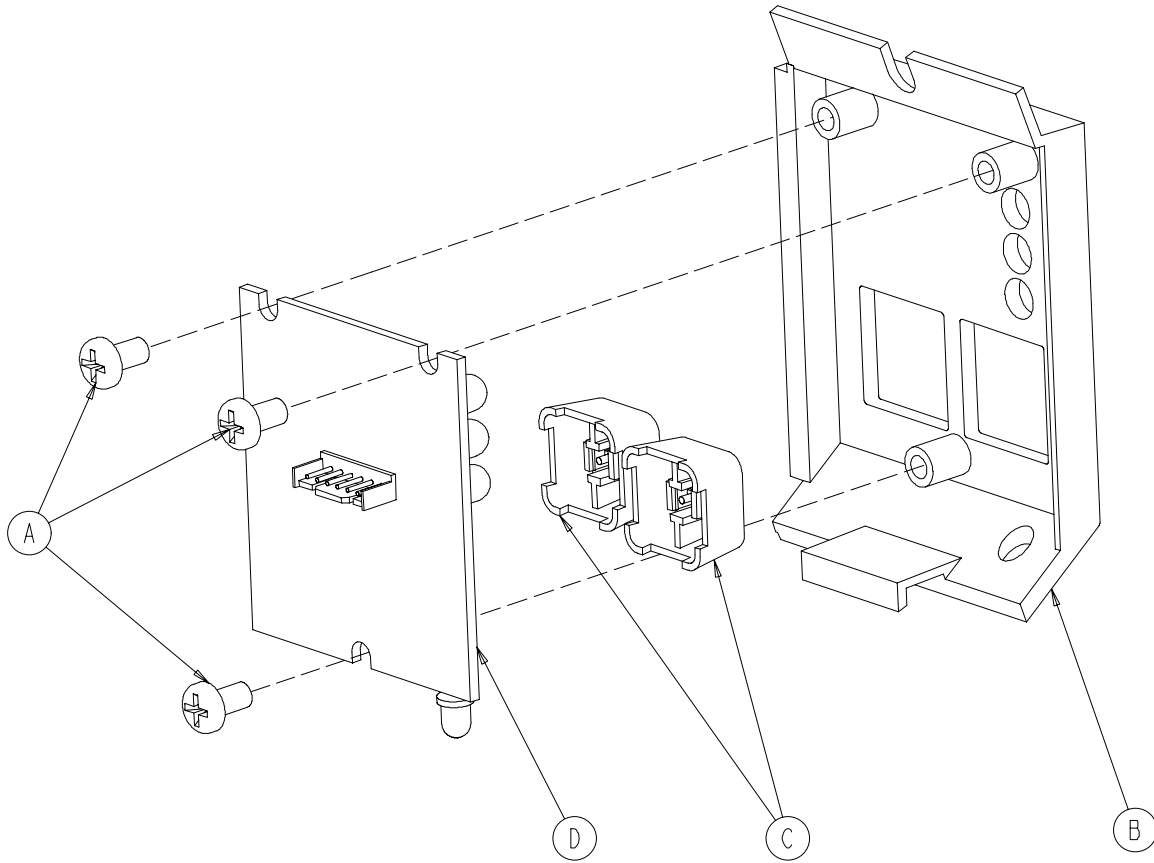

Item	Part No.	Part Name	Qty.
A	23-87	Hi-Low Tapping Screw	3
B	3000-508-1	End Exit Module Panel	1
C	3001-400-953	Switch Cap	2
D	3002-508-900	Bed Exit Board	1

# 3002-507-30 Foot Board Scale Module Assembly

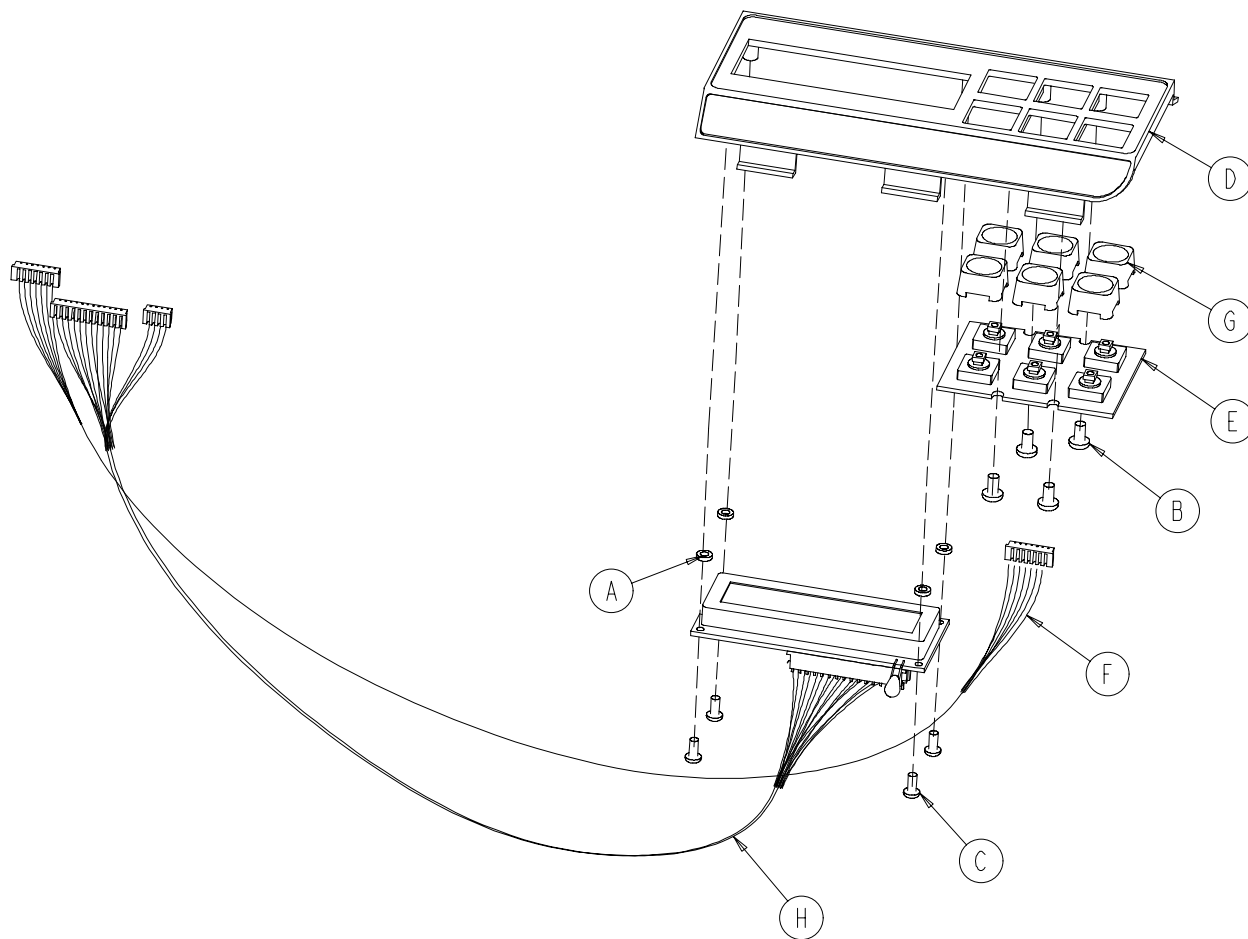

Item	Part No.	Part Name	Qty.
A	11-487	Nylon Washer	4
B	23-87	Pan Hd. Hi-Lo Tapping Screw	4
C	23-91	Pan Hd. Hi-Lo Tapping Screw	4
D	3001-507-1	Scale Module	1
E	3001-507-910	Scale Keypad	1
F	3001-507-800	Scale Keypad Cable	1
G	3001-400-953	Switch Cap	6
H	3002-507-900	Scale Display Cable	1

# 3000-600-000 Head Board Assembly

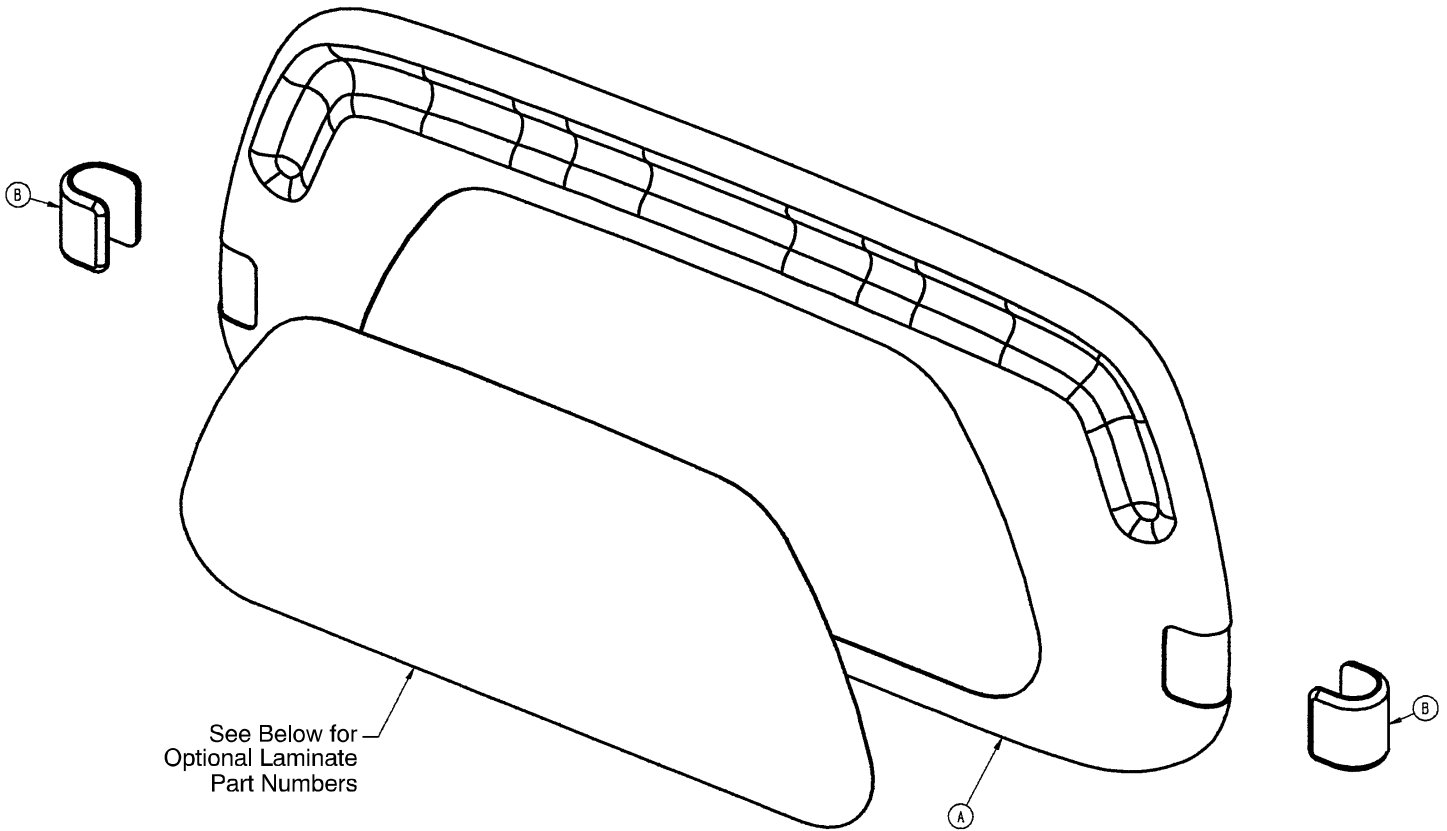

Item	Part No.	Part Name	Qty.
A	3000-600-10	Clamshell Assembly	1
B	3000-500-7	"C" Bumper	2
C	72-2-71	"C" Bumper Adhesive	1

Laminate Color	Part Number
Victorian Cherry	3000-600-50
English Oak	3000-600-49
Pech Contempe Blush	3000-600-45
Oak Suede Classic	3000-600-48

# 3000-526-10 Optional CPR Board Assembly

---

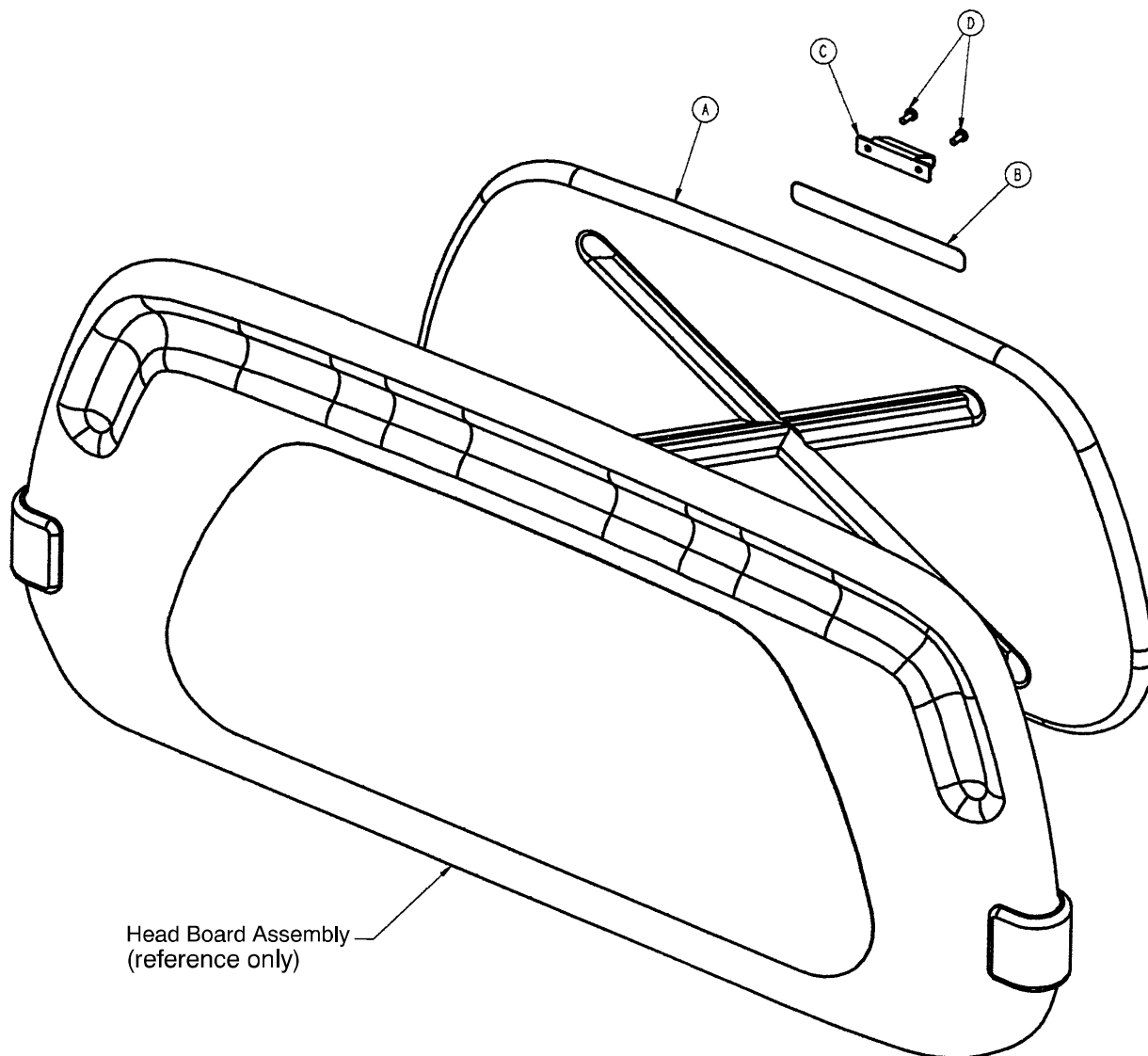

Item	Part No.	Part Name	Qty.
A	3000-526-1	CPR Board	1
B	3000-526-3	CPR Board Label	1
C	3000-526-2	CPR Head Board Clip	1
D	23-88	Pan Hd. Tapping Screw	2

# 3001-338-10 Removable I.V. Pole Mounting Assembly

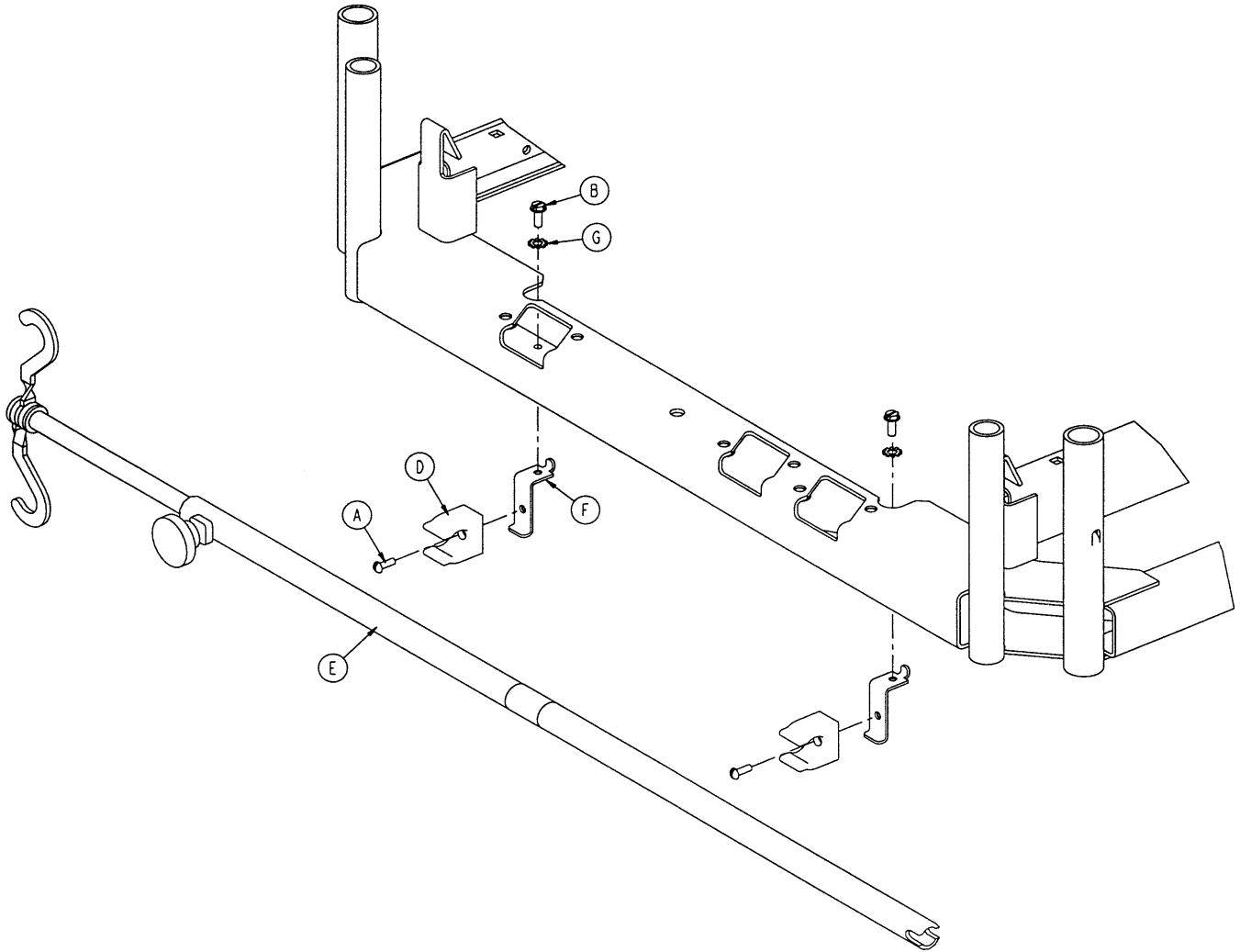

Item	Part No.	Part Name	Qty.
A	2-31	Round Hd. Screw	2
B	3-124	Hex Washer Hd. Screw	2
D	958-1-224	I.V. Clip	2
E	(page 229)	I.V. Pole Assembly	1
F	3001-300-87	Mounting Bracket	2
G	13-18	External Tooth Lock Washer	2

# 3000-300-80 Removable I.V. Pole Assembly

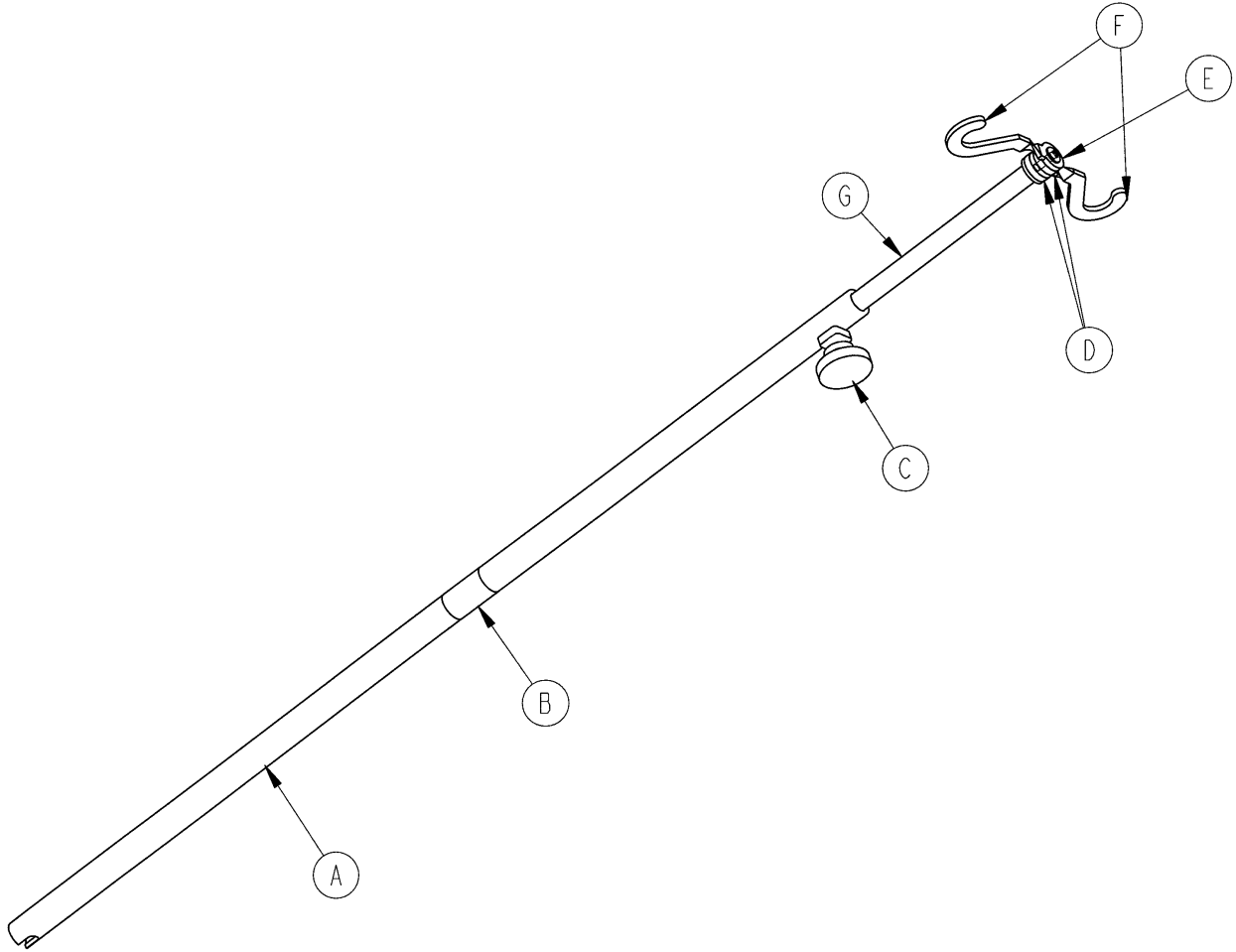

Item	Part No.	Part Name	Qty.
A	3000-300-81	Outer Tube	1
B	3000-300-89	Label	1
C	24-50	Fluted Knob	1
D	52-17	Spacer	2
E	7-40	Phillips Truss Hd. Screw	1
F	1010-59-16	I.V. Hook	2
G	3000-300-85	Inner Tube Assembly	1



# 2035-1 12 Optional 2-Stage I.V. Mounting Assembly

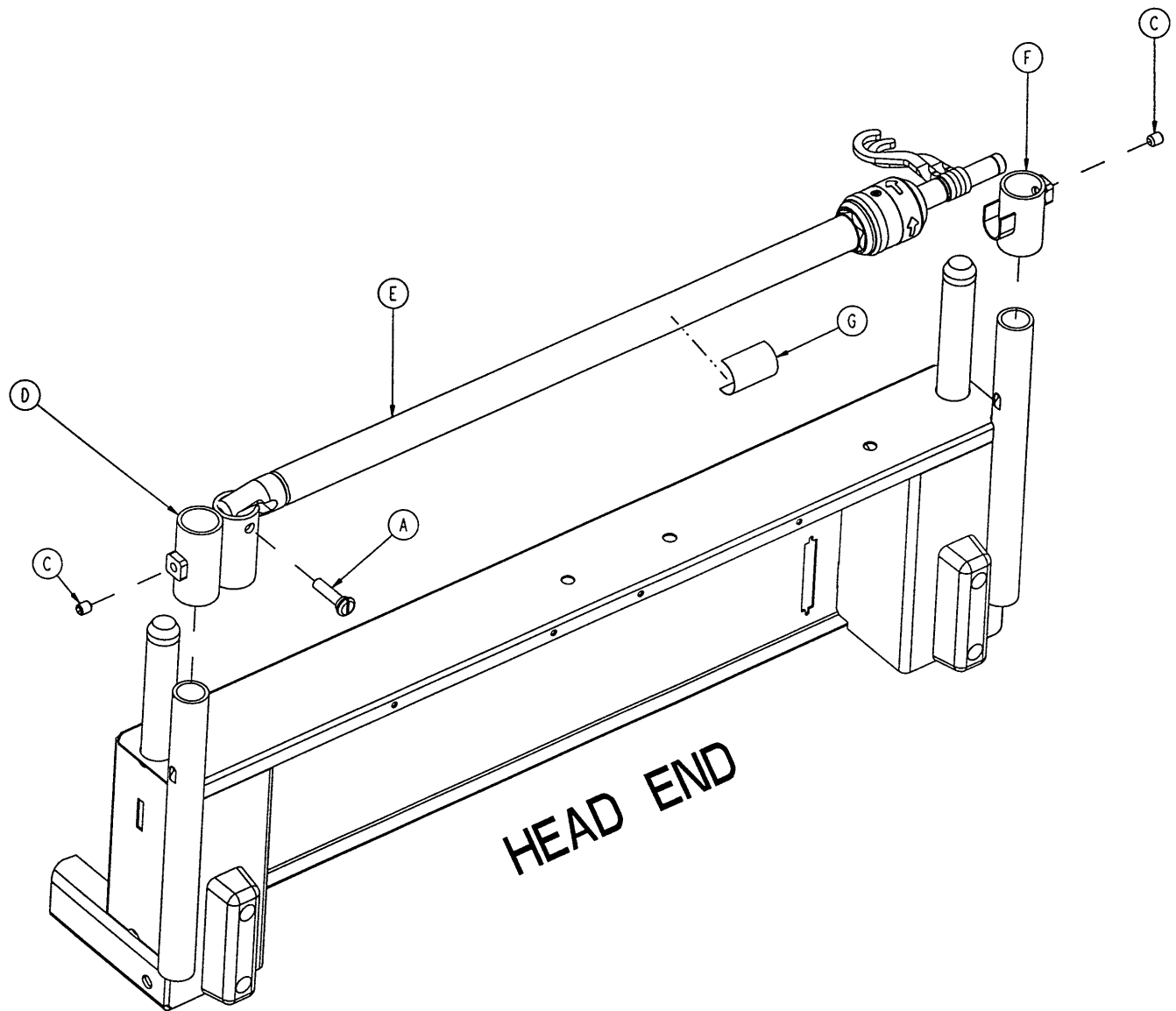

Item	Part No.	Part Name	Qty.
A	1015-24-35	Retaining Pin	1
C	21-140	Set Screw	2
D	2035-1 12-1	I.V. Receptacle, Head, Left	1
E	(page 231)	I.V. Pole Assembly	1
F	3000-311-16	I.V. Rest	1
G	2035-1 12-1 10	Specification Label	1

# 2035-1 12-10 2-Stage I.V. Pole Assembly

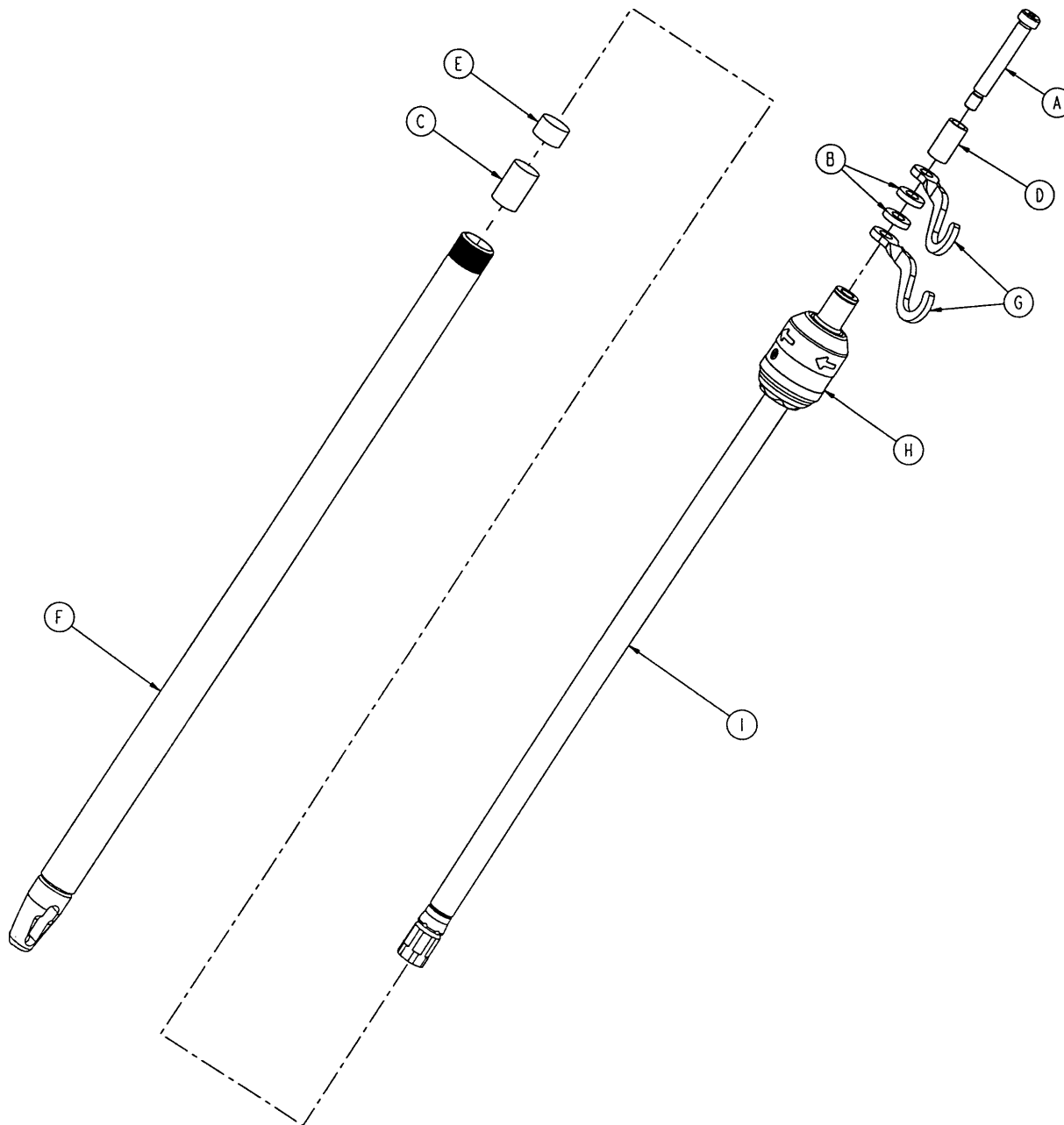

Item	Part No.	Part Name	Qty.
A	8-31	Soc. Hd. Shoulder Screw	1
B	52-17	Washer	2
C	52-310	Spacer	1
D	926-400-162	Spacer	1
E	1001-259-13	Dampener	1
F	1001-259-32	Base Tube Weldment	1
G	1010-259-16	I.V. Hook	2
H	(page 232)	I.V. Pole Latch	1
I	1211-1 10-29	2nd Stage Assembly	1

# 1211-210-26 Optional I.V. Pole Latch Assembly

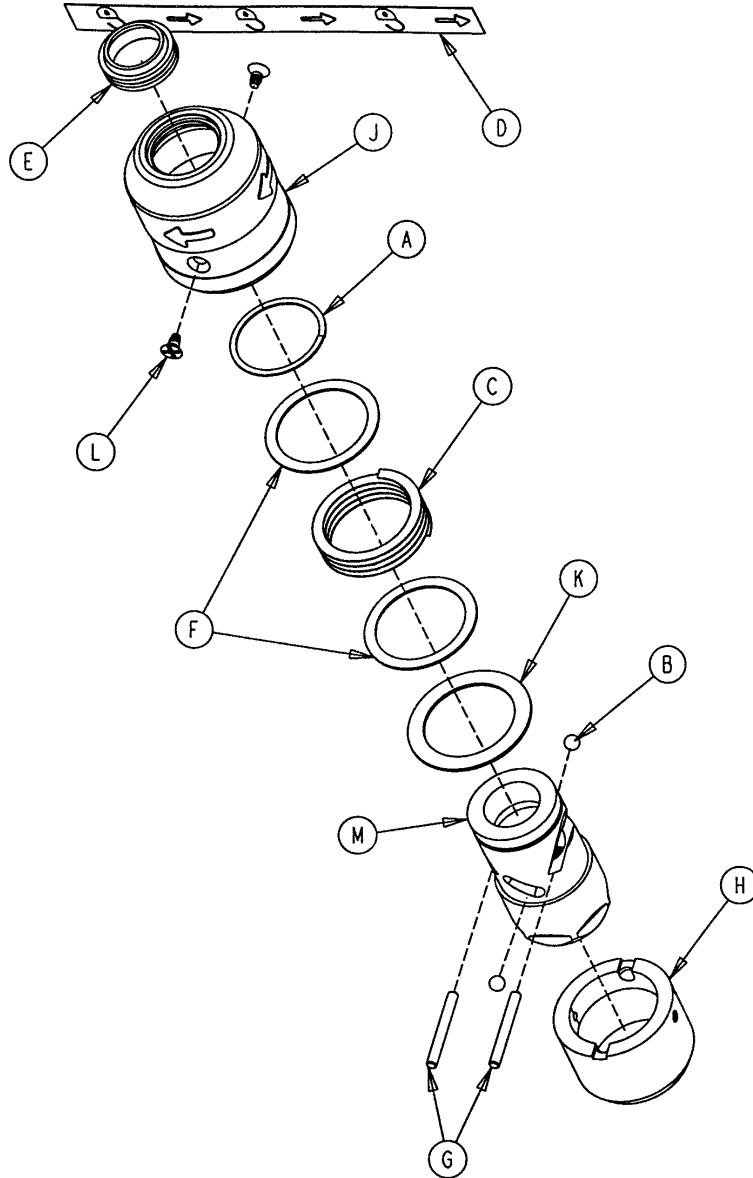

Item	Part No.	Part Name	Qty.
A	28-167	Retaining Ring	1
B	31-4	Steel Ball	2
C	38-392	Crest-to-Crest Spring	1
D	1211-91-34	Release Label	1
E	1211-1 10-18	I.V. Latch Seal	1
F	1211-1 10-20	Washer	2
G	1211-1 10-21	I.V. Latch Locking Pin	2
H	1211-1 10-22	I.V. Latch Guide	1
J	1211-1 10-24	I.V. Latch O.D. Housing	1
K	1211-1 10-35	Washer	1
L	1211-1 10-36	Self-Tapping Screw	2
M	1211-210-23	I.V. Latch I.D. Housing	1

# 2025-120 Optional Defibrillator Tray Assembly

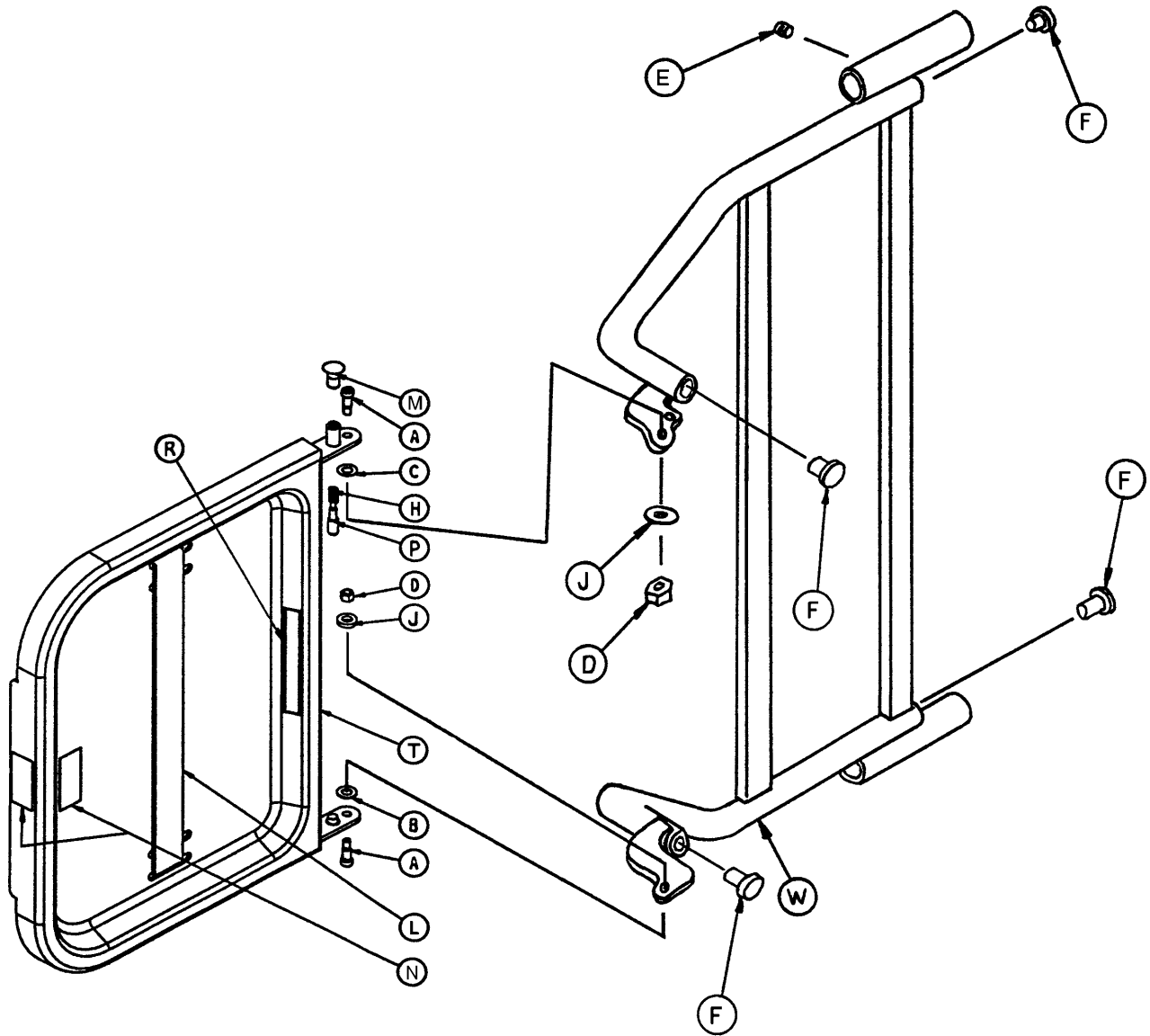

Item	Part No.	Part Name	Qty.	Item	Part No.	Part Name	Qty.
A	8-49	Soc. Hd. Shoulder Bolt	2	L	1010-50-21	Long Strap	1
B	14-20	Thrust Washer	1	M	1010-50-50	Knob	1
C	14-21	Thrust Washer	1	N	1010-50-57	Max. Weight Label	4
D	16-28	Fiberlock Nut	2	P	1010-50-242	Lock Pin	1
E	21-17	Set Screw	4	R	2025-120-5	Equipment Label	1
F	37-214	Hole Plug	4	S	2025-120-6	Specification Label	1
H	38-133	Spring	1	T	2025-120-18	Tray Assembly	1
J	52-17	Spacer	2	W	2025-120-25	Pivot Weldment Frame	1
K	1010-50-19	"Push/Pull" Label	1				

# 2040-120-4 Optional Pleur-Evac Rack w/Defib. Tray

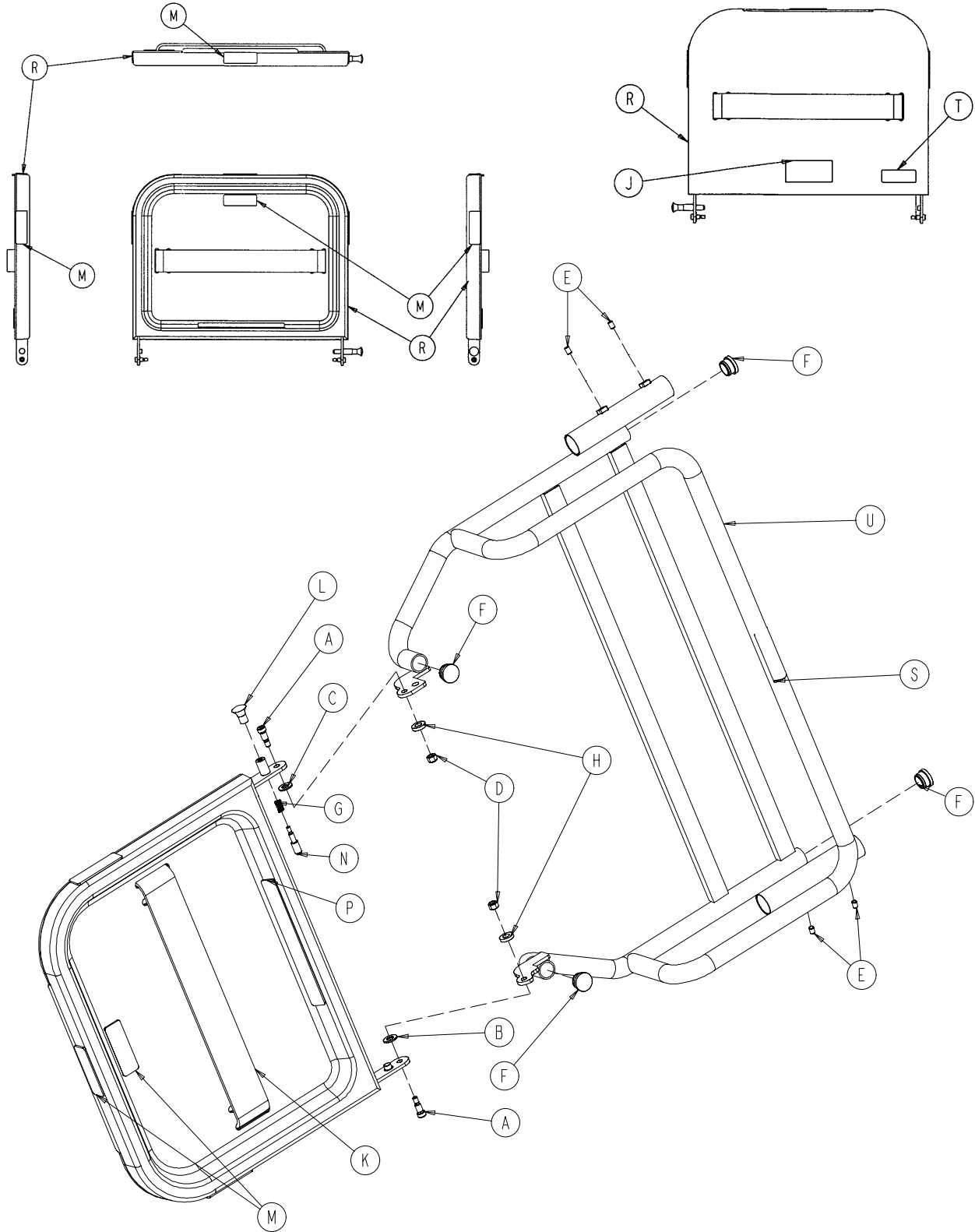

## 2040-120-4 Optional Pleur-Evac Rack w/Defib. Tray

---

<b>Item</b>	<b>Part No.</b>	<b>Part Name</b>	<b>Qty.</b>
A	8-49	Soc. Hd. Shoulder Bolt	2
B	14-20	Thrust Washer	1
C	14-21	Thrust Washer	1
D	16-28	Fiberlock Nut	2
E	21-17	Set Screw	4
F	37-214	Hole Plug	4
G	38-133	Spring	1
H	52-17	Spacer	2
J	1010-50-19	"Push/Pull" Label	1
K	1010-50-21	Long Strap	1
L	1010-50-50	Knob	1
M	1010-50-57	"Max. Weight" Label	4
N	1010-50-242	Lock Pin	1
P	2025-120-5	Equipment Label	1
R	2025-120-18	Tray Assembly	1
S	2040-90-1	Warning Label	1
T	2040-90-5	Specification Label	1
U	2040-120-3	Rack Weldment	1

# 2040-120-20 Optional Pleur-Evac Rack Assembly

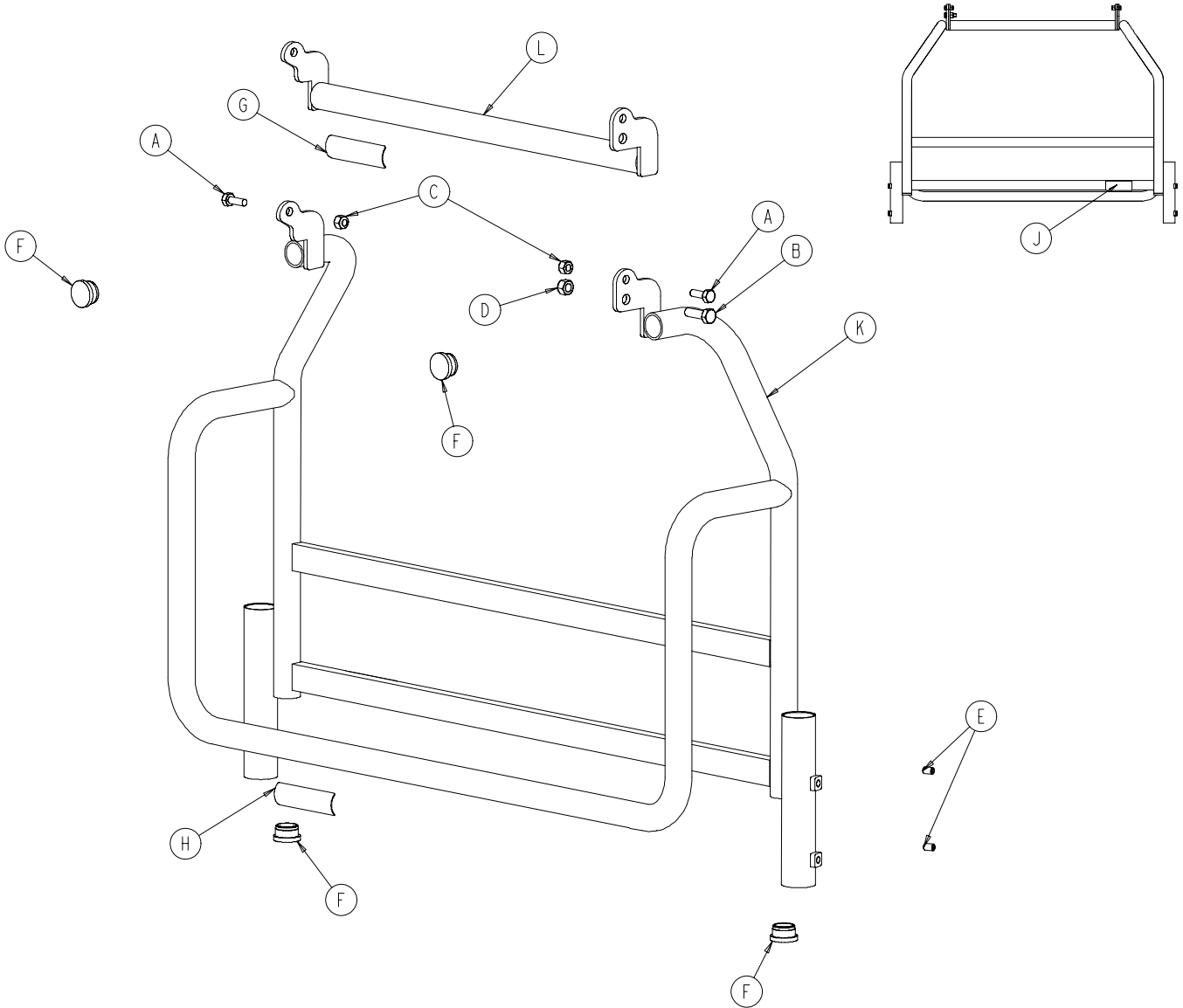

Item	Part No.	Part Name	Qty.
A	3-50	Hex Hd. Cap Screw	2
B	3-85	Hex Hd. Cap Screw	1
C	15-28	Nylock Nut	2
D	16-36	Nylock Nut	1
E	21-17	Set Screw	4
F	37-214	Hole Plug	4
G	1010-50-57	Maximum Weight Label	1
H	2040-90-1	Acc. Rail Warning Label	1
J	2040-90-4	Specification Label	1
K	2040-120-3	Rack Weldment	1
L	2040-120-10	Rack Top Weldment	1

# 2040-120-9 Optional Siderail Pleur-Evac Rack Ass'y

---

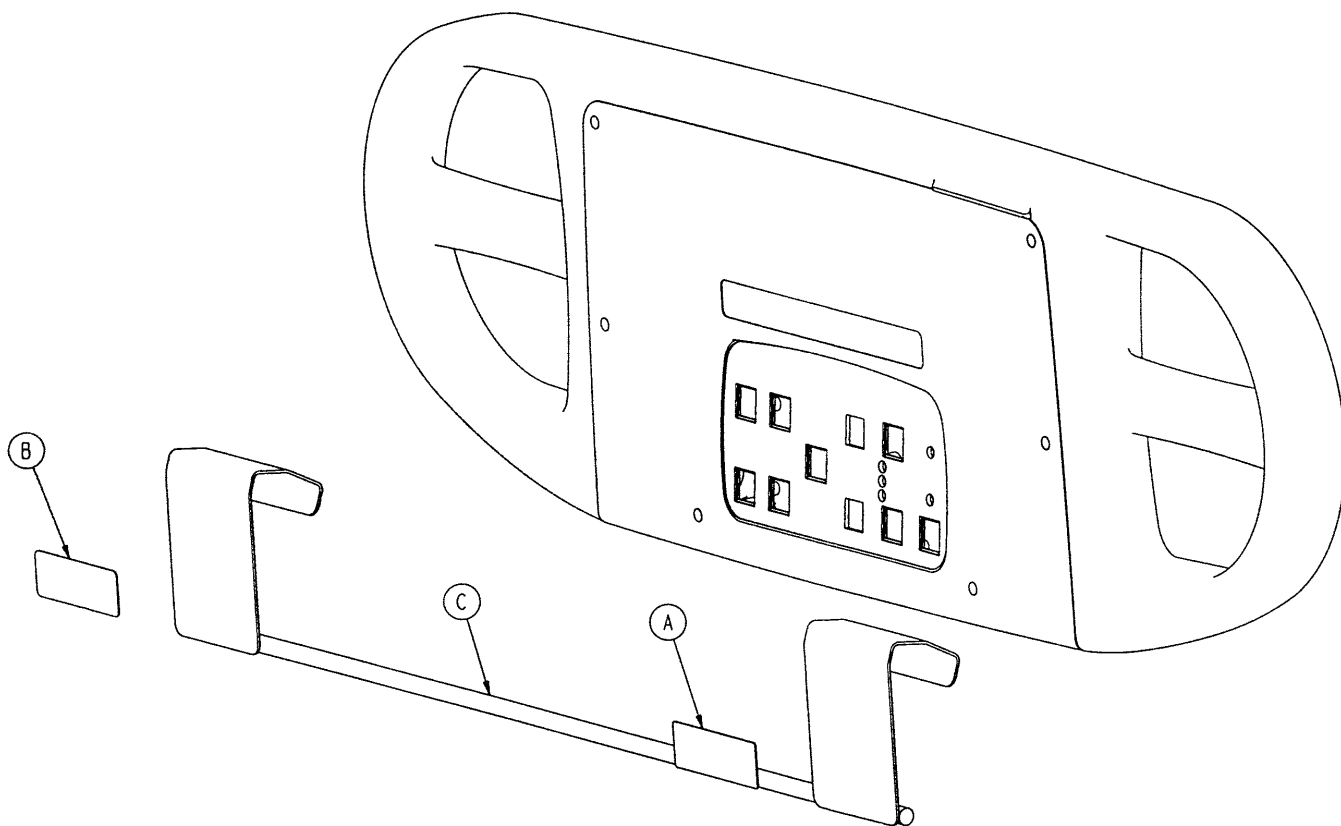

Item	Part No.	Part Name	Qty.
A	2040-90-1	Warning Label	1
B	2040-90-2	Maximum Weight Label	1
C	2040-120-8	Rack Weldment	1



# 2040-1 11 Optional Pump Rack Assembly

---

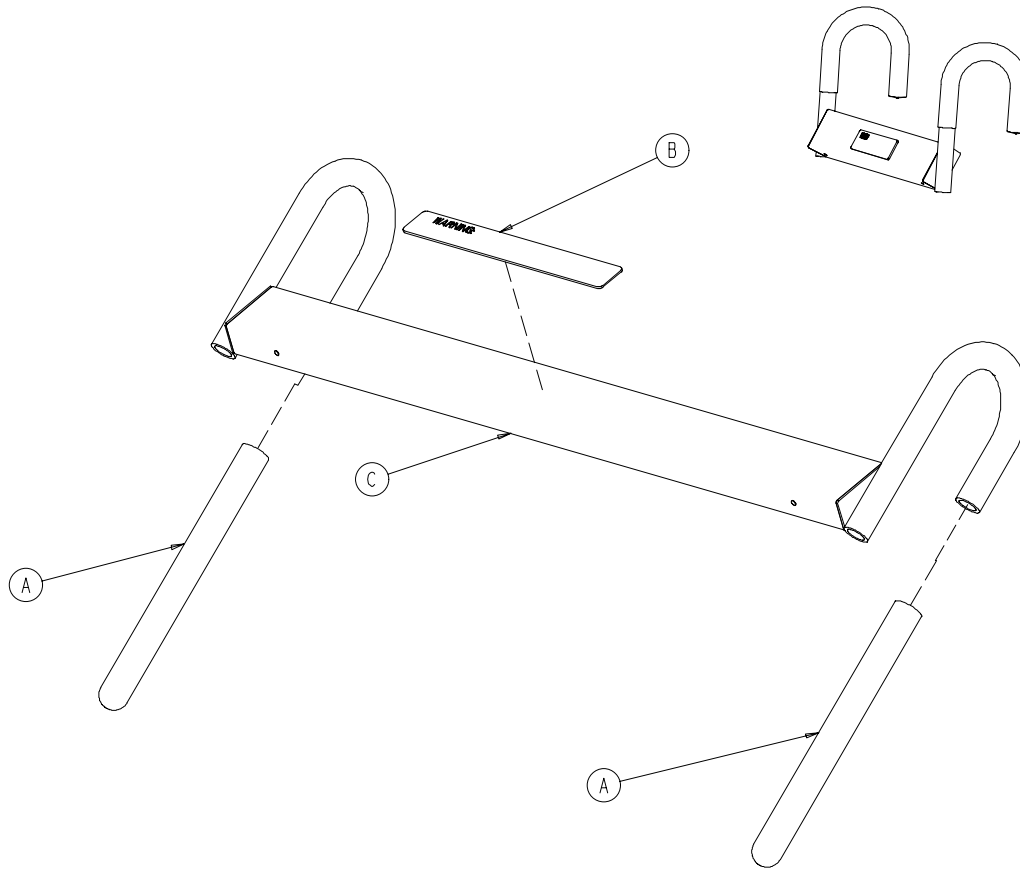

Item	Part No.	Part Name	Qty.
A	58-87	End Cap	2
B	2030-140-2	Pump Rack Label	1
C	2040-1 11-5	Pump Rack Tube	1

# Optional 90 Degree Power Cord

Assembly part number 3001-334-10 (reference only)

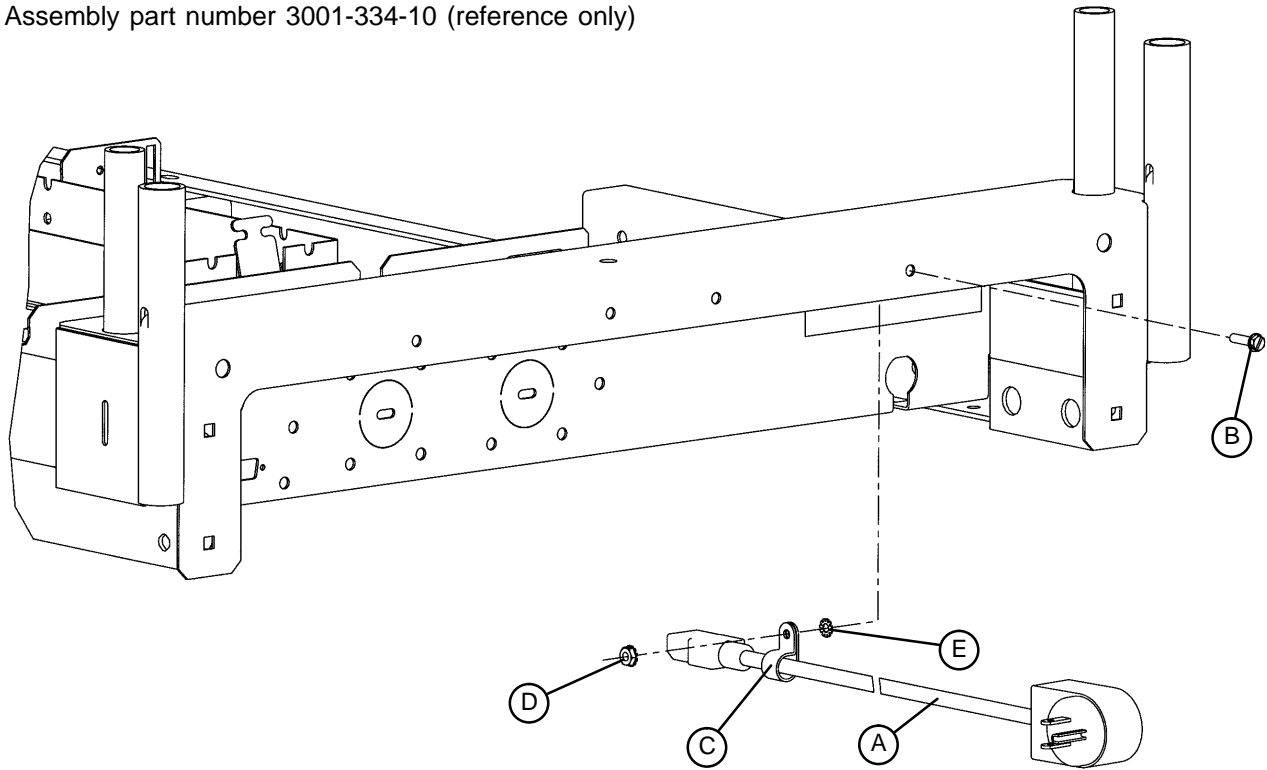

Item	Part No.	Part Name	Qty.
A	3001-334-860	90° Power Cord (12 O'Clock)	1
	3001-334-861	90° Power Cord (9 O'Clock)	1
	3001-334-862	90° Power Cord (6 O'Clock)	1
	3001-334-863	90° Power Cord (3 O'Clock)	1
B	3-132	Hex Washer Hd. Screw	1
C	34-22	Cable Clamp	1
D	16-41	Kep Nut	1
E	13-18	External Tooth Lock Washer	1

# 3001-333-000 Optional Accessory Adapter Frame

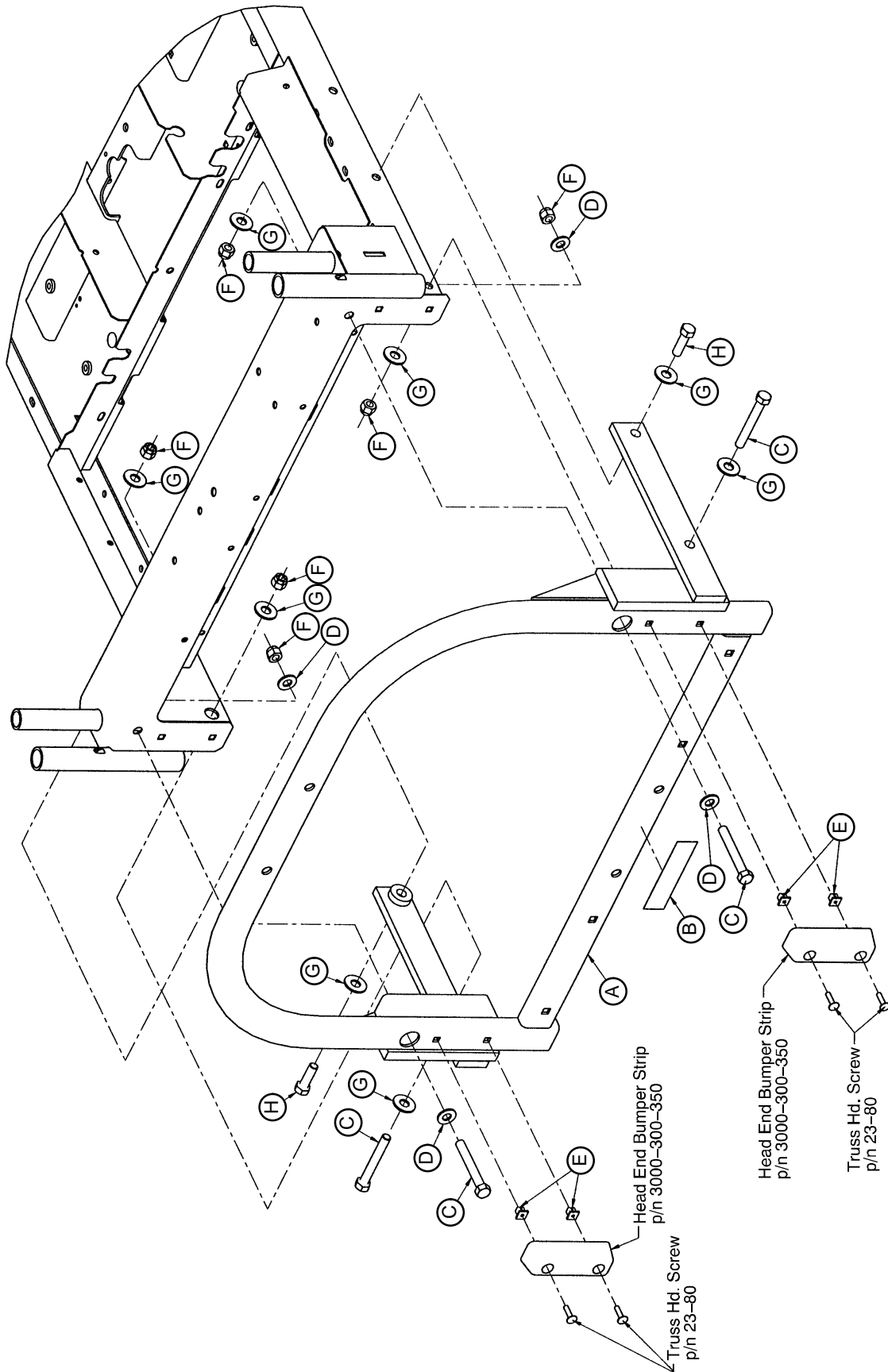

# 3001-333-000 Optional Accessory Adapter Frame

---

<b>Item</b>	<b>Part No.</b>	<b>Part Name</b>	<b>Qty.</b>
A	3001-333-10	Frame Assembly	1
B	3000-333-15	Accessory Adapter Label	1
C	3-208	Hex Hd. Cap Screw	4
D	11-301	Flat Washer	4
E	3000-300-2	Plastic Clip Nut	4
F	16-35	Nylock Nut	6
G	11-361	Flat Washer	8
H	3-120	Hex Hd. Cap Screw	2

# 3002-335 Optional Litter Roller Assembly

---

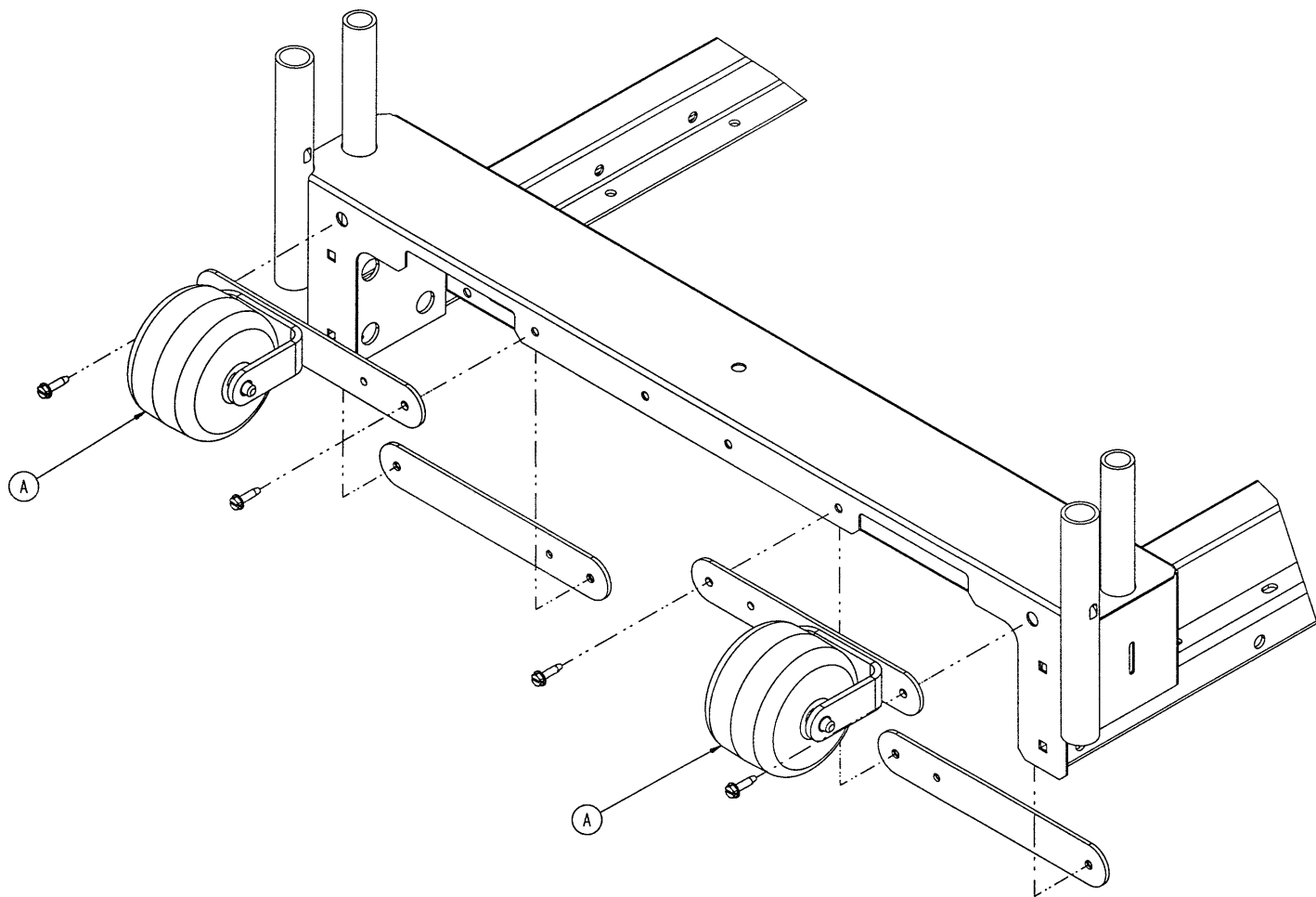

Item	Part No.	Part Name	Qty.
A	3002-335-5	Roller Assembly	2

# 3002-335-5 Roller Assembly

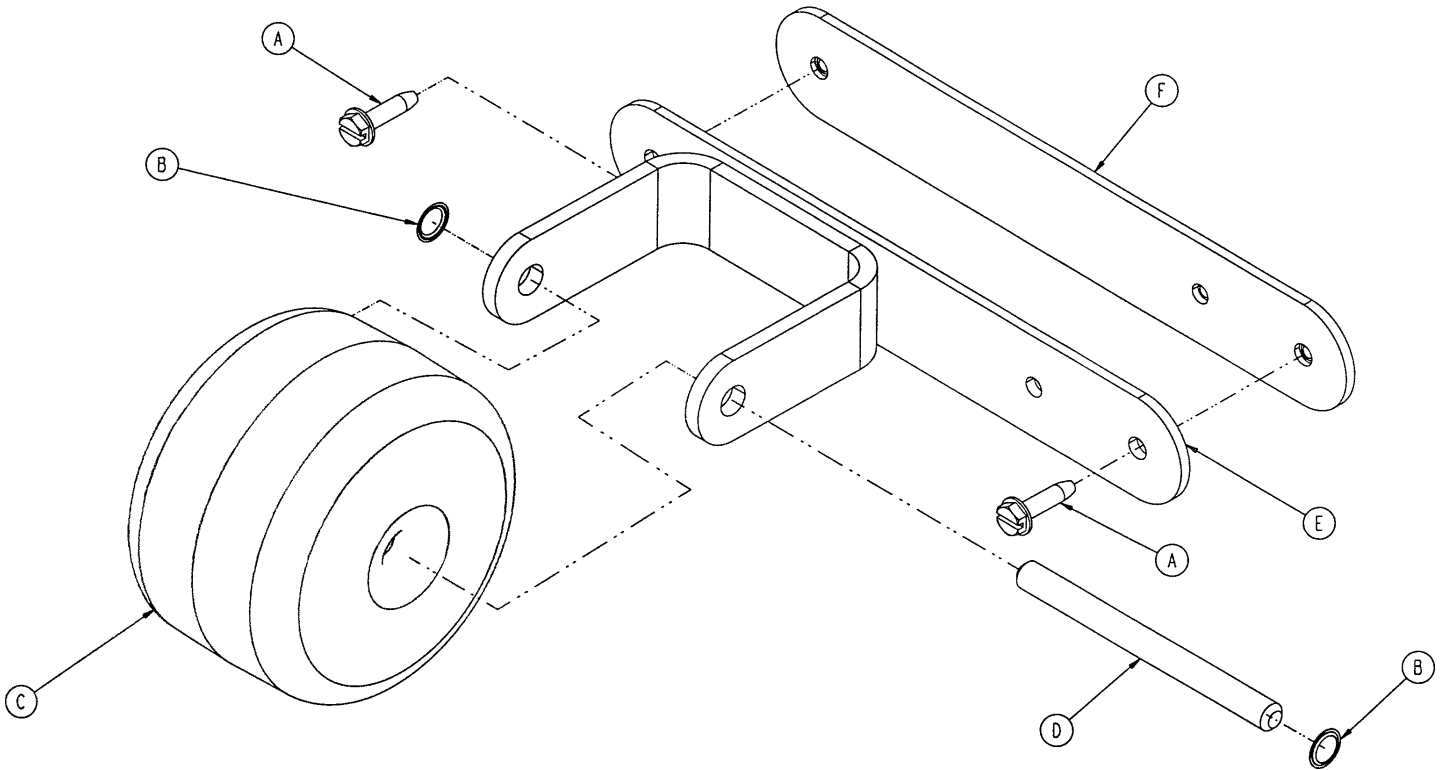

Item	Part No.	Part Name	Qty.
A	3-225	Hex Washer Hd. Screw	2
B	52-727	Grooveless Retainer Ring	2
C	3000-335-1 1	Roller Bumper	1
D	3000-335-12	Roller Shaft	1
E	3002-335-20	Roller Bracket	1
F	3002-335-25	Roller Mounting Plate	1

# 3001-318-20 Optional Bed Extender Assembly

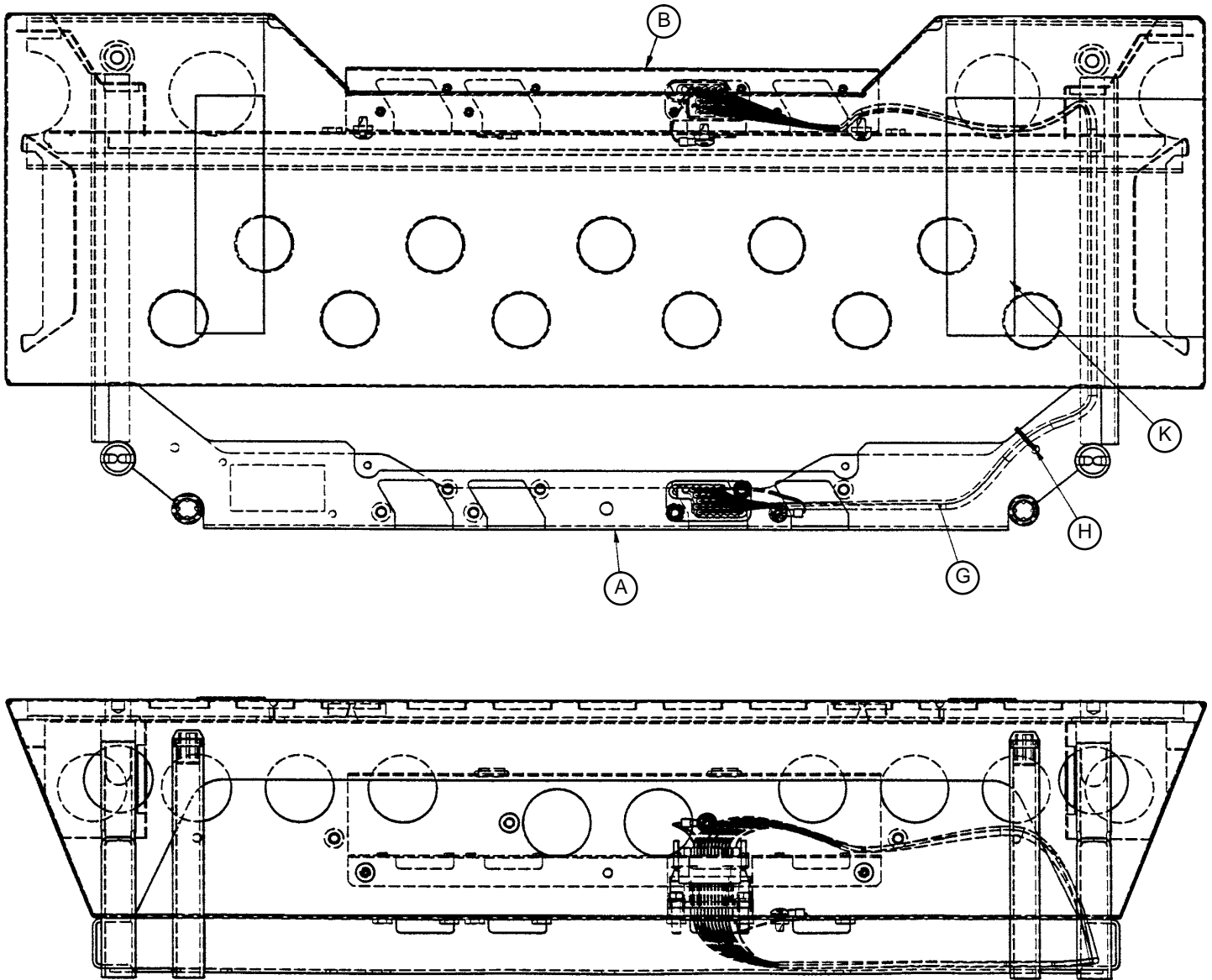

Item	Part No.	Part Name	Qty.
A	3001-318-50	Bed Extender Weldment	1
B	3001-318-31	Connector Mounting Bracket	1
C	7-52	Truss Hd. Screw	4
D	13-10	External Tooth Lock Washer	2
E	3001-200-228	Mounting Standoff	2
F	50-39	Pan Hd. Machine Screw	2
G	3000-318-801	Bed Extender Cable	1
H	3000-300-1 14	Cable Tie	2
J	3000-300-349	Cap	2
K	7900-1-102	Velcro Adhesive Pile	2

# 3001-318-20 Optional Bed Extender Assembly

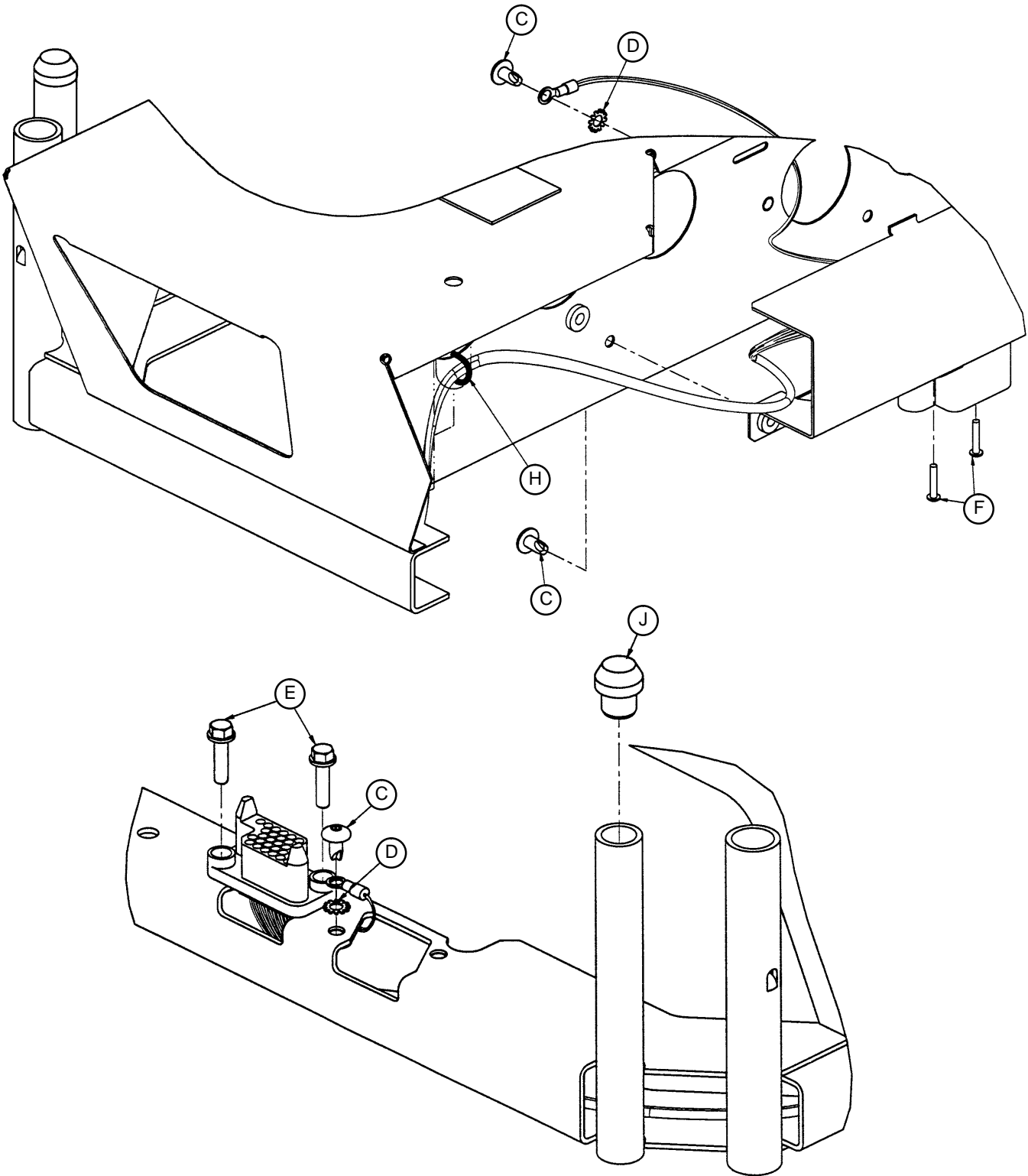



# 3000-318-50 Optional Bed Extender Mattress

---

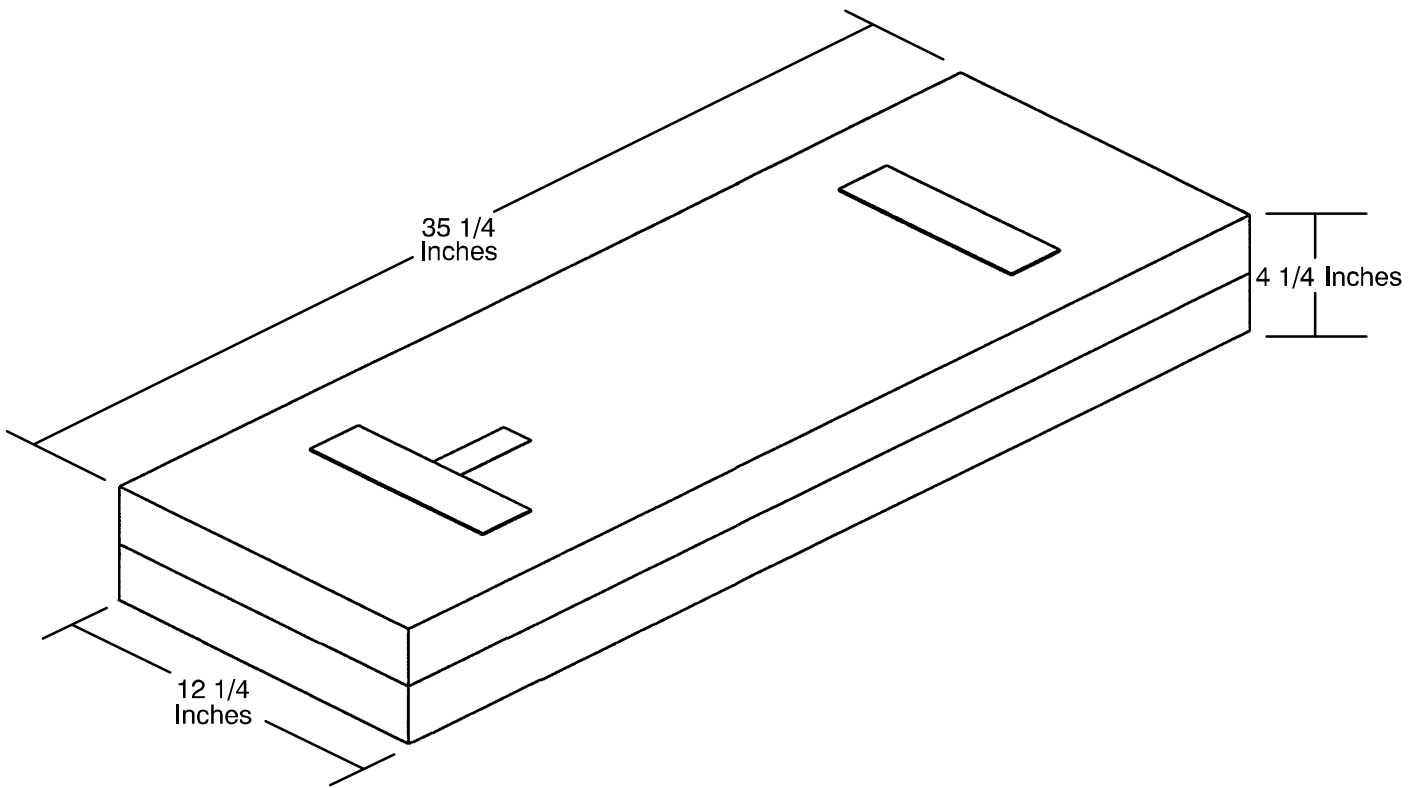

# 2025-150-10 Optional Upright O2 Bottle Holder Ass'y

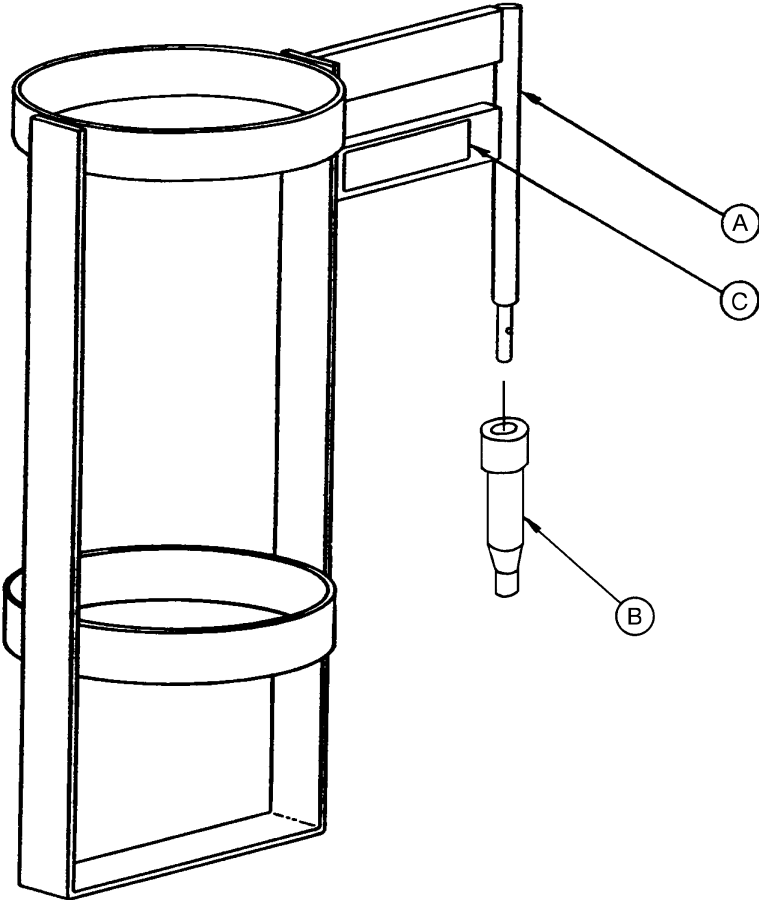

Item	Part No.	Part Name	Qty.
A	1010-30-1	Upright Bottle Holder	1
B	2025-150-1	Bottle Holder Adapter	1
C	2025-150-2	Specification Label	1

# Optional Traction Socket Extension

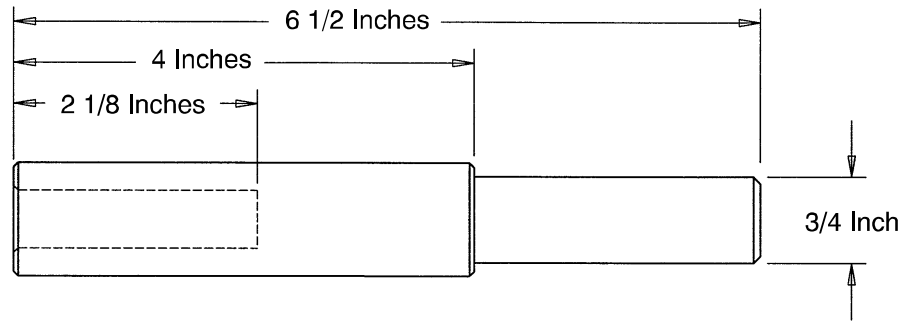
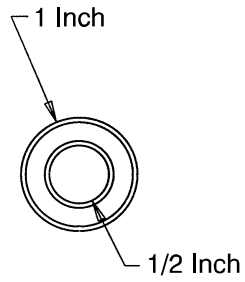

Part number 3000-337-450

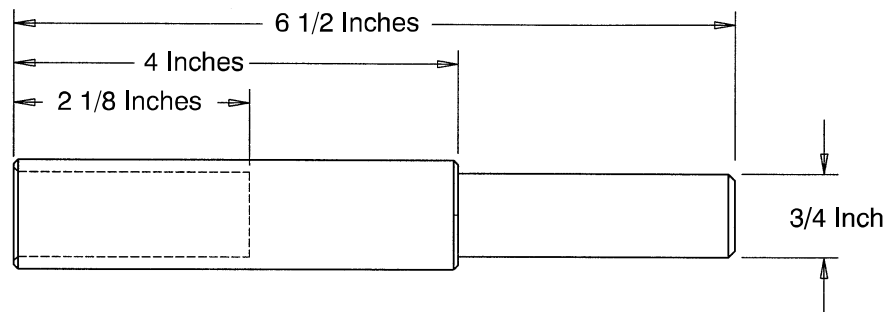
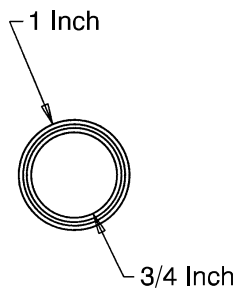

Part number 3000-337-475

# 3000-339-10 Optional Urine Bottle Hanger

---

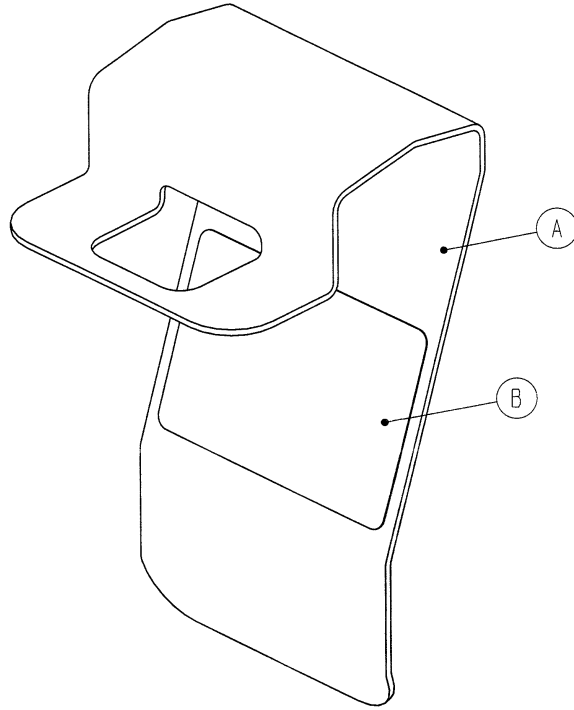

Item	Part No.	Part Name	Qty.
A	3000-339-1	Hanger	1
B	3000-339-12	Hanger Label	1

# 3001-305-702 Optional Telephone Mtg. Bracket Ass'y

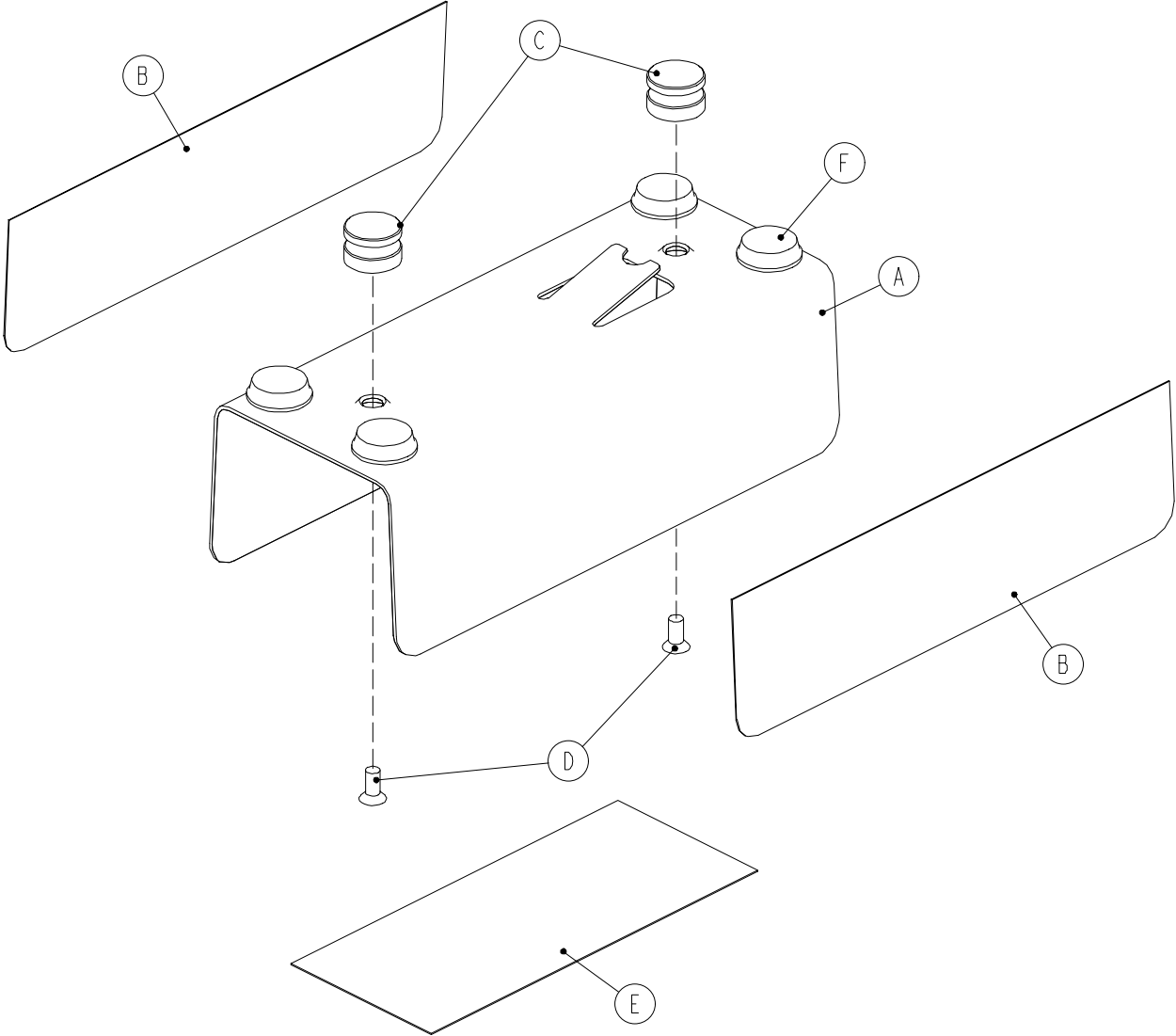

Item	Part No.	Part Name	Qty.
A	3001-305-1	Telephone Bracket	1
B	3000-305-1 1	Installation Label	2
C	3000-305-13	Mounting Post	2
D	1-122	Flat Soc. Hd. Cap Screw	2
E	3001-305-12	Identification Label	1
F	56-14	Bumper	4

# 3000-336-701 Optional Padded Siderail Cover Kit

---

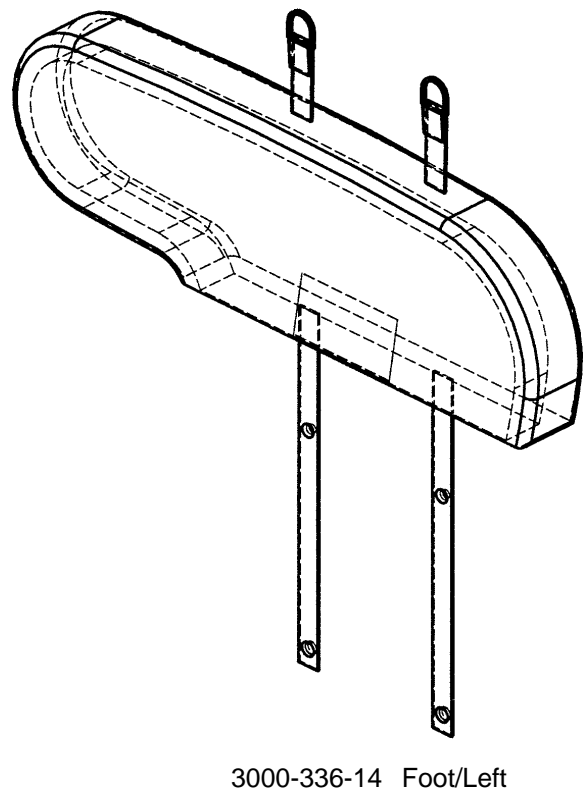
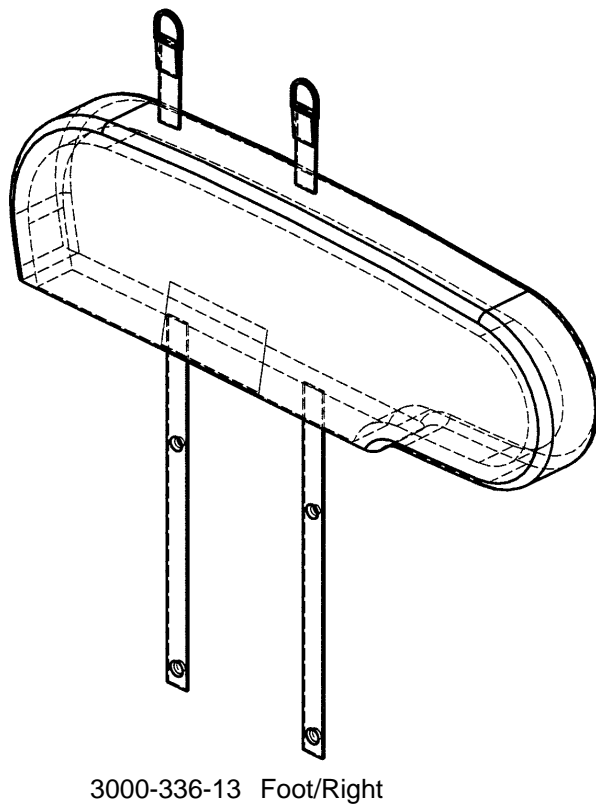
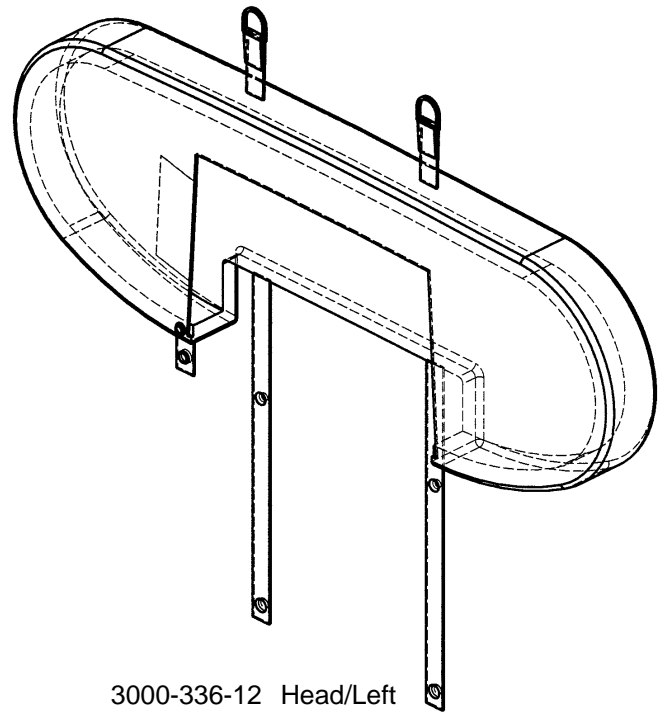
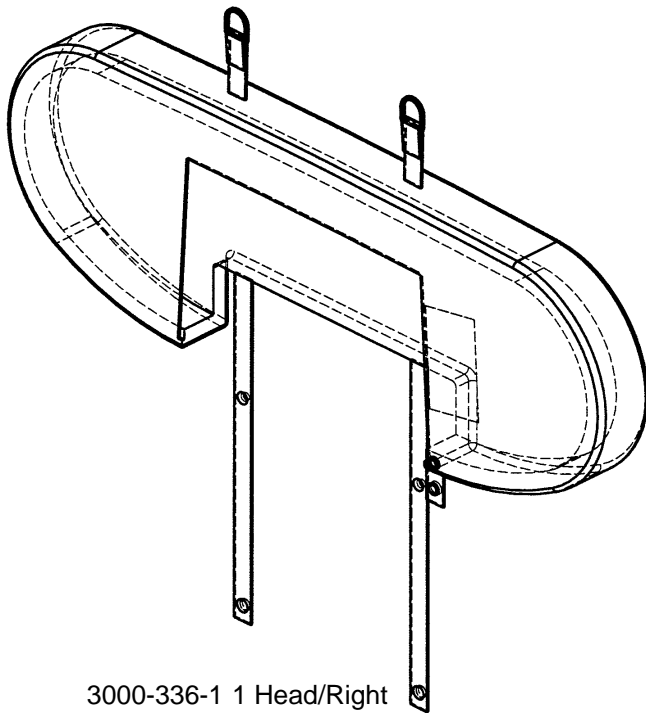



## European Representative

Stryker France  
BP 50040-95946 Roissy Ch. de Gaulle  
Cedex-France

Phone: 33148632290  
Fax: 33148632175

**stryker**<sup>®</sup>  
**Medical**

6300 Sprinkle Road, Kalamazoo, MI 49001-9799

(800) 327-0770  
[www.strykermedical.com](http://www.strykermedical.com)



---

DH 11/02 3002-006-001 REV E