

S3™ MedSurg Bed

REF Model 3002

stryker®

Maintenance Manual



For Parts or Technical Assistance:
USA: 1-800-327-0770

Table of Contents

| | |
|---|----|
| Symbols | 8 |
| Warning/Caution/Note Definition | 9 |
| Introduction | 10 |
| Intended Use – Stryker S3™ | 10 |
| Intended Use – <i>iBed</i> ® Wireless with <i>iBed</i> ® Awareness. | 10 |
| Specifications | 10 |
| Mattress Specifications | 11 |
| Environmental Conditions | 11 |
| Bed Illustration | 12 |
| Contact Information | 13 |
| Serial Number Location | 13 |
| Safety Tips and Guidelines | 14 |
| Zoom® Option. | 16 |
| <i>iBed</i> ® Awareness Option. | 17 |
| <i>iBed</i> ® Wireless Option. | 17 |
| 115V Option | 18 |
| Static Discharge Precautions | 19 |
| Setup Procedures. | 20 |
| Zoom® Option. | 21 |
| <i>iBed</i> ® Wireless Option. | 21 |
| Maintenance Menu Guide | 22 |
| Maintenance Menu Screen | 22 |
| Preventative Maintenance | 30 |
| Checklist | 30 |
| Grease Points | 31 |
| Product Labels | 32 |
| Cleaning. | 42 |
| Troubleshooting Guide | 43 |
| Optional <i>iBed</i> ® Wireless Troubleshooting | 49 |
| <i>iBed</i> ® Awareness System Error Codes | 50 |
| Error Handling | 50 |
| Logged Errors | 50 |
| Error Messages | 52 |
| Quick Reference Replacement Parts List | 54 |
| Service Information. | 56 |
| Brake Pedal Replacement | 56 |
| Lift Motor and Capacitor Removal and Replacement. | 57 |
| Lift Housing Removal and Replacement | 58 |
| Lift Potentiometer Replacement and Adjustment | 60 |
| Lift Potentiometer “Burn-in” Procedure | 61 |
| Lift Motor Isolation Plate Replacement | 62 |
| Lift Motor Coupler Replacement. | 63 |
| Power and Sensor Coil Cord Replacement | 64 |
| Power and Sensor Coil Cord Replacement Illustration. | 65 |
| Knee Motor Removal and Replacement | 66 |
| Fowler Motor CAM and CAM Guide Replacement | 67 |

Table of Contents

| | |
|---|---------------------|
| Service Information (Continued) | |
| Limit Setting - Fowler Motor | 68 |
| Fowler Motor Removal and Replacement | 69 |
| Fowler Motor Drive Isolator and CPR Decoupler Removal and Replacement | 70 |
| Fowler Motor Ball Screw Assembly Replacement | 71 |
| Head Motor Brake/Clutch Replacement | 72 |
| Load Cell Replacement | 73 |
| Load Cell Replacement - Grease Points | 74 |
| Power Supply Replacement | 75 |
| CPU Board Replacement | 75 |
| Replacement of the Wireless Module (Non-Zoom). | 76 |
| Replacement of the IR Module (Non-Zoom) | 77 |
| Replacement of the Wireless Module (Zoom) | 78 |
| Replacement of the IR Module (Zoom) | 80 |
| Soft Config. Procedures | 82 |
| Optional Smart TV Interface “Burn-In” Procedure | 94 |
| Fowler Potentiometer Replacement | 95 |
| Fowler Potentiometer “Burn-In” Procedure | 95 |
| Zoom® Option Battery Removal and Replacement | 96 |
| Zoom® Option DC Motor Board Removal and Replacement | 97 |
| Zoom® Option Drive Motor Removal and Replacement | 98 |
| Zoom® Option Control Bar Potentiometer Replacement | 99 |
| Zoom® Option Control Bar Potentiometer “Burn-In” Procedure | 100 |
| Zoom® Option AC Crossover Board Replacement. | 101 |
| Zoom® Option Display/CPU Board Replacement. | 102 |
| Head and Foot Siderail Cover Removal. | 103 |
| Head Siderail Hoop Replacement. | 104 |
| Footboard Module Removal | 105 |
| Footboard Interface Plug Replacement | 106 |
| Bed Circuit Boards | 107 |
| CPU Board - 3006-308-900 | 107 |
| CPU Board - 3006-308-900 (Continued). | 108 |
| Software Configuration. | 109 |
| Power Supply - 0059-157-000. | 110 |
| Battery Backup/Zoom® Option, Inverter/Charger Board - 3002-001-030 | 111 |
| Battery Backup/Zoom® Option, AC Crossover Board - 2040-031-900 | 112 |
| Battery Backup Option, Display/CPU - 2030-031-910 | 113 |
| Zoom® Option, Display/CPU - 2040-031-910 | 114 |
| iBed Enhanced Nurse Call Option, 37-Pin Plugover Board - 3006-303-900 | 116 |
| iBed Enhanced Nurse Call Option, Dip-Switch Settings (Default). | 116 |
| Head Wall Output Configuration | 118 |
| Battery Backup/Zoom® Option Inverter Protection Features. | 119 |
| Bed Assembly, Standard Bed | 120 |
| Bed Assembly, Battery Backup Option. | 126 |
| Bed Assembly, Zoom® Option | 132 |
| Bed Assembly, iBed® Awareness Option. | 138 |
| Bed Assembly, iBed® Wireless Option, Blue | 140 |

Table of Contents

| | |
|---|---------------------|
| Assembly Drawings (Continued) | |
| Bed Assembly, Battery Backup, <i>iBed</i> ® Wireless Option | 143 |
| Bed Assembly, Zoom®, <i>iBed</i> ® Wireless Option | 149 |
| Base Assembly, Common Components | 155 |
| Base Ass'y, Battery Backup or Zoom® Option, Common Comp. | 163 |
| Base Assembly, Standard Bed | 174 |
| Base Assembly, Battery Backup Option | 183 |
| Base Assembly, Zoom® Option | 187 |
| Lift Assembly (Head and Foot End) | 193 |
| Lift Assembly | 194 |
| Lift Motor Isolation Plate Assembly | 198 |
| Brake Shaft Assembly, Standard Bed | 199 |
| Brake Shaft Assembly, Battery Back-up or Zoom® Option | 199 |
| Brake Crank Assembly | 200 |
| Brake Bar Assembly | 201 |
| Swivel Lock Caster Assembly - 3006-200-060. | 202 |
| Steer Swivel Caster Assembly, White - 3006-200-065 | 203 |
| 6" Molded Wheel Assembly - 3006-200-142 | 204 |
| Bottom Cover | 205 |
| Zoom® Option Head End Bottom Cover | 205 |
| Battery Backup Option, Power Assembly | 206 |
| Battery Backup/Zoom® Option, Battery Tray Assembly | 207 |
| Zoom® Option, Drive Train Assembly | 208 |
| Zoom® Option, Drive Wheel Lift Lever Assembly | 209 |
| Zoom® Option, Base Power Assembly | 210 |
| Litter Assembly, Standard Components | 211 |
| Litter Assembly, Standard Bed | 216 |
| Litter Assembly, Battery Backup Option | 223 |
| Litter Assembly, Zoom® Option | 230 |
| Litter Assembly, Battery Backup, <i>iBed</i> ® Wireless | 237 |
| Litter Assembly, Zoom®, <i>iBed</i> ® Wireless | 244 |
| Foot Prop Assembly | 251 |
| Litter CPU Cover Assembly - 3006-301-097 | 252 |
| Foot Cover Assembly - 3003-300-042. | 253 |
| Electrical Litter Assembly, Standard Bed | 254 |
| Electrical Litter Assembly, Battery Backup | 261 |
| Electrical Litter Assembly, Zoom® Option | 269 |
| Electrical Litter Assembly, Battery Backup, <i>iBed</i> ® Wireless Option | 277 |
| Electrical Litter Assembly, Zoom®, <i>iBed</i> ® Wireless Option | 285 |
| Mechanical Litter Assembly | 293 |
| Moving Frame Assembly | 298 |
| CPR Damper Assembly Option | 299 |
| Lift Header Assembly - No Load Cells | 300 |
| Lift Header Assembly with Load Cells | 301 |
| Gatch Motor Assembly | 302 |
| Fowler Drive Assembly | 303 |
| Fowler Brake Kit Assembly -3001-300-775 | 305 |















Table of Contents

| | |
|---|---------------------|
| Assembly Drawings (Continued) | |
| Standard Bed Fowler Limit Switch Assembly - 3002-343-035 | 306 |
| Night Light Assembly - 3006-410-020 | 307 |
| Optional 110V Outlet Assembly - 3006-320-050 | 309 |
| 110V Outlet Box Assembly - 3006-320-060 | 311 |
| Optional Scale/Bed Exit Assembly | 312 |
| Optional Litter Assembly, Communication Capability | 314 |
| Optional Litter Assembly, Nurse Call and Communication | 316 |
| Optional Litter Assembly, Nurse Call and Communication | 317 |
| Optional Litter Assembly, HWI with 1 Stryker Port | 318 |
| Optional Litter Assembly, Nurse Call and 1/4" Port | 320 |
| Optional Zoom® Litter Assembly, Headwall Communication | 322 |
| Optional Battery Backup/Zoom® Litter Assembly, HWI w/Nurse Call | 324 |
| Optional Battery Backup/Zoom® Litter Assembly, | 326 |
| HWI w/Nurse Call & 1 Stryker Port | 326 |
| Optional Zoom® Litter Assembly, Nurse Call and 1/4" Port | 328 |
| Optional iBed Enhanced Nurse Call, 37-Pin Plugover Assembly | 330 |
| Battery Enclosure Assembly | 332 |
| Optional Battery Backup Option Head End Enclosure Ass'y | 333 |
| Optional Battery Backup, Head End Enclosure Assembly, iBed® Wireless Option | 338 |
| Optional Zoom® Head End Enclosure Assembly | 345 |
| Optional Zoom® Litter Assembly, iBed® Wireless Option | 351 |
| Optional Battery Backup/Zoom® Assembly, iBed® Wireless Option | 358 |
| Head End Siderail Assembly | 359 |
| Head End Siderail Assembly with Optional Cardiac Chair | 368 |
| Head End Siderail Assembly with Optional | 369 |
| Gatch/Fowler and Cardiac Chair | 369 |
| Head End Siderail Assembly with Optional | 370 |
| Nurse Call, Cardiac Chair and Gatch/Fowler | 370 |
| Head End Siderail Assembly with Optional | 371 |
| Nurse Call, Lights, Cardiac Chair and Gatch/Fowler | 371 |
| Head End Siderail Assembly with Optional | 372 |
| Nurse Call, Lights and Cardiac Chair | 372 |
| Head End Siderail Assembly with Optional | 373 |
| Nurse Call, TV/Radio, Lights and Cardiac Chair | 373 |
| Head End Siderail Assembly with Optional | 374 |
| Nurse Call, Lights, Cardiac Chair and Smart TV | 374 |
| Head End Siderail Assembly with Optional | 375 |
| Nurse Call, Lights, Cardiac Chair and Smart TV | 375 |
| Head End Siderail Assembly with Optional | 376 |
| NC, Lights, Gatch/Fowler, Cardiac Chair and Smart TV | 376 |
| Head End Siderail Assembly, Outer Panel | 378 |
| Head End Siderail Assembly, Inner Panel | 379 |
| Siderail Ass'y, iBed® Awareness Option, HE, Left - 3006-400-100 | 381 |
| Siderail Ass'y, iBed® Awareness Option, HE, Right - 3006-400-200 | 382 |
| Switch Assembly, iBed® Awareness Option, Head End, | 383 |
| 3006-400-120 (Left) / 3006-400-220 (Right) | 383 |

Table of Contents

| | |
|--|---------------------|
| Assembly Drawings (Continued) | |
| Foot End Siderail Assembly | 384 |
| Siderail Ass'y, iBed® Awareness Option, FE Left - 3006-400-305 | 392 |
| Siderail Ass'y, iBed® Awareness Option, FE, Right - 3006-400-405 | 393 |
| Switch Assembly, iBed® Awareness Option, Foot End, | 394 |
| 3006-400-315 (Left) / 3006-400-415 (Right) | 394 |
| Optional Pendant Assembly | 395 |
| Pendant - Motion/Nurse Call (3006-315-011). | 395 |
| Pendant - Motion/Nurse Call/Smart Tv (Digital) (3006-315-012) | 395 |
| Footboard Assembly, Standard | 397 |
| Footboard Module Assembly | 399 |
| Footboard Assembly, No Options. | 400 |
| Footboard Assembly, Bed Exit Option | 402 |
| Footboard Assembly, Bed Exit/Scale Option | 404 |
| Footboard Assembly, Bed Exit/Zone Control Option | 406 |
| Footboard Assembly, Bed Exit/Scale/Zone Control Option | 408 |
| Footboard Assembly, iBed® Awareness Option | 410 |
| Headboard Assembly - 3006-600-010 | 412 |
| Optional Accessories | 414 |
| CPR Board Assembly - 3006-626-010 | 415 |
| Removable I.V. Pole and Mounting Ass'y - 3001-338-010 | 416 |
| Removable I.V. Pole Assembly - 3000-300-080 | 417 |
| 2-Stage I.V. Pole Assembly - 2035-112-000 | 418 |
| Dual Head End I.V. Pole Assembly - 2035-113-000 | 419 |
| Dual Head End I.V. Pole Assembly - 2040-110-003 | 420 |
| 2-Stage I.V. Pole - 2035-112-010 & 2035-113-011 | 421 |
| I.V. Pole Latch Assembly - 0785-035-103 | 422 |
| Defibrillator Tray Assembly - 3006-120-004 | 423 |
| 90° Power Cord - 3001-334-010 | 424 |
| Upright Oxygen Bottle Holder Assembly - 3006-150-000 | 425 |
| Accessory Adapter Frame - 3006-333-000 | 426 |
| Litter Roller Assembly - 3006-335-000 | 427 |
| Roller Assembly - 3006-335-005 | 428 |
| Patient Helper Assembly - 3006-345-000 | 429 |
| Patient Helper Roller Assembly - 3006-345-005 | 430 |
| Bed Extender Assembly - 3006-346-020 | 431 |
| Bed Extender Mattress - 3000-318-050 | 433 |
| Traction Socket Extensions | 434 |
| Recycling Passport | 435 |
| EMC Information. | 443 |
| Warranty | 447 |
| Limited Warranty | 447 |
| To Obtain Parts and Service | 447 |
| Service Contract Coverage | 447 |
| Service Contract programs. | 448 |
| Return Authorization. | 448 |
| Damaged Merchandise | 448 |
| International Warranty Clause. | 448 |

Symbols

| | |
|---|---|
|  | Warning, consult accompanying documentation |
|  | Safe Working Load Symbol |
|  | Dangerous Voltage Symbol |
|  | Alternating Current |
|  | Direct Current |
|  | Protective Earth Terminal |
|  | Potential Equalization Symbol |
|  | <p>Type B Equipment: equipment providing a particular degree of protection against electric shock, particularly regarding allowable leakage current and reliability of the protective earth connection.</p> <p>Class 1 Equipment: equipment in which protection against electric shock does not rely on BASIC INSULATION only, but which includes an additional safety precaution in that means are provided for the connection of the EQUIPMENT to the protective earth conductor in the fixed wiring of the installation in such a way that ACCESSIBLE METAL PARTS cannot become live in the event of a failure of the BASIC INSULATION.</p> <p>Mode of Operation: Continuous</p> |
| IPX4 | Protection from liquid splash |
|  | Medical Equipment Classified by Underwriters Laboratories Inc. with Respect to Electric Shock, Fire, Mechanical and Other Specified Hazards Only in Accordance with UL 60601-1, First Edition (2003) and CAN/CSA C22.2 No. 601.1-M90 with updates 1 and 2 and IEC 60601-1 (1998) with Amendment 1 (1991) and Amendment 2 (1995). |
|  | In accordance with European Directive 2002/96/EC on Waste Electrical and Electronic Equipment, this symbol indicates that the product must not be disposed of as unsorted municipal waste, but should be collected separately. Refer to your local distributor for return and/or collection systems available in your country. |
|  | Non-ionizing radiation; i.e. RF transmitter (WiFi) |
|  | This icon means the iBed Locator is connected. |
|  | This icon means the iBed Locator is not connected. |
|  | This icon means the Network is connected. |
|  | This icon means the Network is not connected. |

Symbols and Definitions

WARNING/CAUTION/NOTE DEFINITION

The words **Warning**, **Caution** and **Note** carry special meanings and should be carefully reviewed.

WARNING

Alerts the reader about a situation, which if not avoided, could result in death or serious injury. It may also describe potential serious adverse reactions and safety hazards.

CAUTION

Alerts the reader of a potentially hazardous situation, which if not avoided, may result in minor or moderate injury to the operator or patient or damage to the equipment or other property. This includes special care necessary for the safe and effective use of the device and the care necessary to avoid damage to a device that may occur as a result of use or misuse.

Note

This provides special information to make maintenance easier or important instructions clearer.

Introduction

This manual is designed to assist you with the operations of the S3™ MedSurg Bed, Model 3002. Read it thoroughly before using the equipment.

INTENDED USE – STRYKER S3™

This device is an AC-powered adjustable hospital bed intended for medical purposes that consists of a bed with a built-in motor and remote controls that can be operated by the patient to adjust the height and surface contour of the bed. The device includes movable and latchable siderails.

INTENDED USE – /BED® WIRELESS WITH /BED® AWARENESS

The intended use for the /Bed® Wireless (with /Bed® Awareness) is to assist clinical staff to monitor bed parameters on specific Stryker beds. The desired bed parameters will be set by clinicians at the bedside. The /Bed® Wireless software is intended to be used only with specifically enabled Stryker beds that have been verified and validated with the /Bed® Wireless software, and is not intended to provide bed status information for non-Stryker beds. The /Bed® Wireless software is not intended to communicate any patient status information, nor to permanently store any type of data. The /Bed® Wireless with /Bed® Awareness System is not intended to provide automated treatment decisions or as a substitute for professional healthcare judgment. The /Bed® Wireless with /Bed® Awareness System is not a replacement or substitute for vital signs monitoring or alert equipment. All patient medical diagnosis and treatment are to be performed under direct supervision and oversight of an appropriate health care professional.

SPECIFICATIONS

| | | | | |
|--|--|-------------------|--|----------------------|
|  | Safe Working Load | | 500 lbs | 227 kg |
| | Note: Safe Working Load indicates the sum of the patient, mattress, and accessory weight. | | | |
| Bed Weight | | | 570 lbs | 259 kg |
| Scale System Capacity (optional equipment). Loads weighing up to | | | 500 lbs | 227 kg |
| Scale System Accuracy (optional equipment) | | | ± 2 pounds at $0^\circ - \pm 10^\circ$ Trendelenburg for patients weighing 100 pounds or less $\pm 2\%$ of the total patient weight at $0^\circ - \pm 10^\circ$ Trendelenburg for patients weighing greater than 100 pounds | |
| Overall Length/ Width | Standard Bed | Siderails Up | 93" x 41-1/2" | 236,2 cm x 105,41 cm |
| | | Siderails Down | 93" x 39-1/2" | 236,2 cm x 100,3 cm |
| | Battery Backup/ Zoom® Bed | Siderails Up | 95" x 41-1/2" | 241,3 cm x 105,4 cm |
| | | Siderails Down | 95" x 39-1/2" | 241,3 cm x 100,3 cm |
| Patient Sleep Surface - Standard Bed | | | 84" x 35" | 213,4 cm x 88,9 cm |
| Bed Height to Top of Seat Litter - 6" Casters | Standard | | 16" to 30" ± 0.5 | 40,6 cm to 76,2 cm |
| | Beds with Battery Backup/Zoom® Option | | 19.5" to 30" | 49,5 cm to 76,2 cm |
| Litter Platform to Top of Siderail | Full Up | Head End Siderail | 15" | 38,1 cm |
| | Full Up | Foot End Siderail | 15-1/2" | 39,37 cm |
| Space Between Siderails (Full Up) | | | 2-1/4" | 5,72 cm |
| Knee Gatch Angle | | | 0° to 45° | |
| Fowler Angle | | | 0° to 60° | |

Introduction

| | |
|--|--|
| Trendelenburg/Reverse Trendelenburg | +12° to -10° ± 1° +10° to -10° ± 1° - Beds with Battery Backup/Zoom® Option |
| Electrical Requirements - all electrical requirements meet UL 2601 specifications. | 115VAC, 60Hz, 8A |
| Wireless Radio (iBed® Wireless Option) | 802.11 b/g, 2.4 GHz <ul style="list-style-type: none"> • Minimum Operational Signal Strength: -65 dB • Supported Securities: <ul style="list-style-type: none"> WEP WPA-PSK (TKIP) WPA2-PSK (CCMP/AES) • Supports IPv4 and DHCPv4 |
| Outlet Option | 115VAC, 60Hz, 10A (not available with Zoom® Option) |
| Battery Voltage | (2) 12V 31Ah - Battery Backup/Zoom® (Gel Cell Battery) (1) 9V - Nurse Call Option (Alkaline Battery) |

MATTRESS SPECIFICATIONS

| | | |
|-----------|--------|-------------|
| Thickness | 6" | 15.2 cm |
| Width | >= 35" | >= 88.9 cm |
| Length | >= 84" | >= 213.4 cm |
| ILD | 80 lbs | 36.3 kg |

The above stated mattress specifications assist in ensuring the product conforms to HBSW and IEC specifications.

ENVIRONMENTAL CONDITIONS

| Environmental Conditions | Operation | Storage and Transportation |
|------------------------------------|--|--|
| Ambient Temperature | <p>50 °F (10 °C) to 104 °F (40 °C)</p> | <p>-22 °F (-30 °C) to 140 °F (60 °C)</p> |
| Relative Humidity (Non-Condensing) | <p>30% to 75%</p> | <p>10% to 95%</p> |
| Atmospheric Pressure | <p>700 hPa to 1060 hPa</p> | <p>500 hPa to 1060 hPa</p> |

Stryker reserves the right to change specifications without notice.

Specifications listed are approximate and may vary slightly from unit to unit or by power supply fluctuations.

[Return To Table of Contents](#)

Bed Illustration

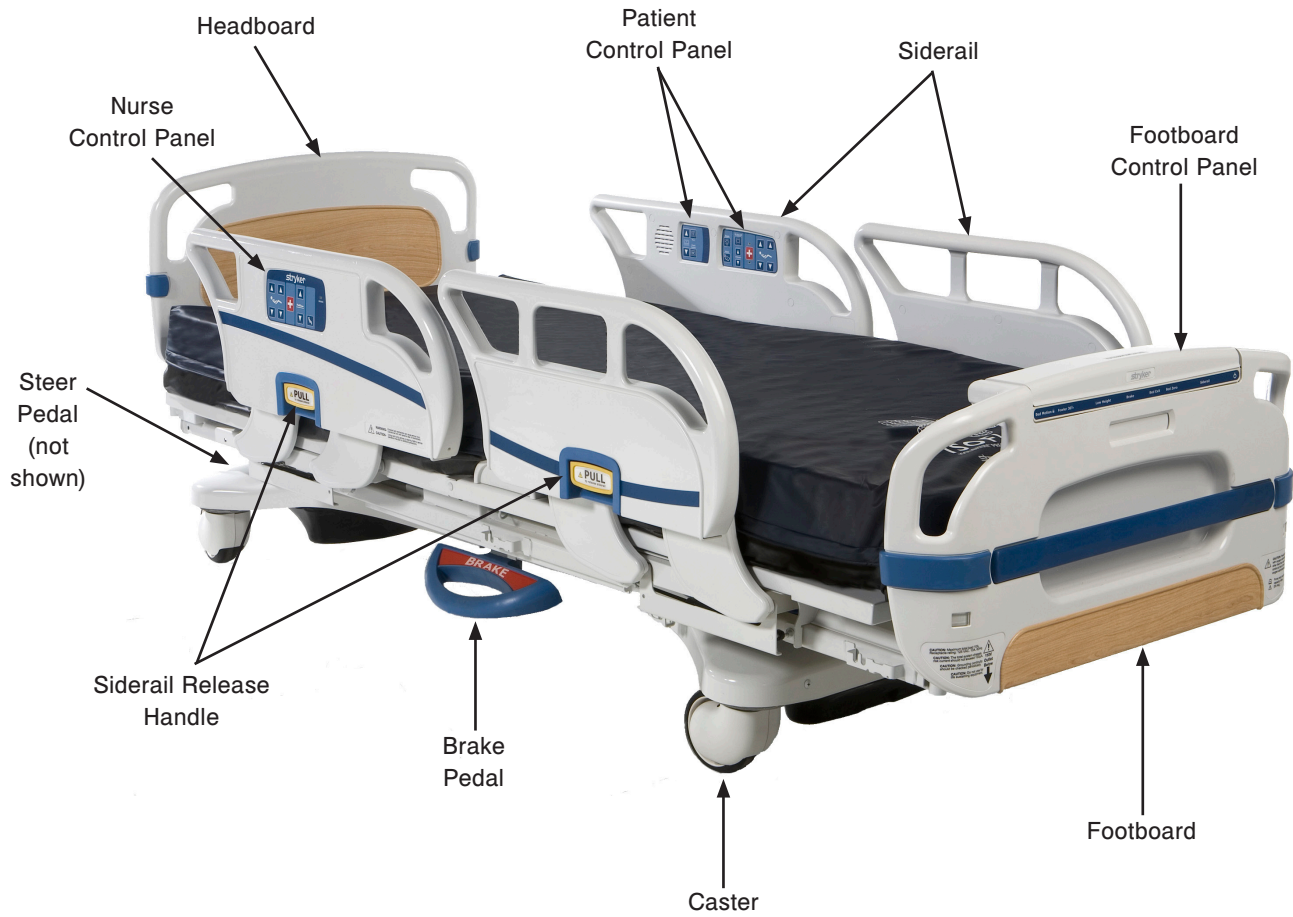

Introduction

CONTACT INFORMATION

Contact Stryker Customer Service or Technical Support at (800) 327-0770.

Stryker Medical
3800 E. Centre Avenue
Portage, Michigan 49002
USA

Please have the serial number (A) of your Stryker product available when calling Stryker Customer Service or Technical Support. Include the serial number in all written communication.

SERIAL NUMBER LOCATION

The serial number is located at the head end of the bed just below the headboard and above the power cord where it comes out from the frame.



A →

| | | | | |
|---|---|----------------|------------|------------|
| stryker [®] | | IPX4 | | |
| REF | 3002 S3 | | | 87VL |
| SN | Serial No. | | | MEDICAL |
| | Date of Mfg. | | | ELECTRICAL |
| | 115V~ 60 Hz, 8A | | | EQUIPMENT |
| | 500 lbs. [227 Kg.] | | | UL 2601-1 |
| | WARNING: Does not tolerate machine washing or jet wash! | | | |
| Portage, MI 49002 | | Made in U.S.A. | | |
| This product is protected by the following U.S. patents, and other patents pending: | | | | |
| US 5094418 | US 5187824 | US 5325551 | US 5343561 | |
| US 5172442 | US 5276432 | US 5326657 | | |

Safety Tips and Guidelines

Before operating the S3™ MedSurg Bed, Model 3002, it is important to read and understand all information in this manual. Carefully read and strictly follow the safety guidelines listed on this page. It is important that all users have been trained and educated on the inherent hazards associated with the usage of electric beds.

WARNING

- To prevent permanent damage to this unit, the unit must reach room temperature prior to conducting any setup and/or unit operations.
- Danger: Explosion hazard. Do not use in the presence of flammable anesthetics.
- Always apply the caster brakes when a patient is getting on or off the bed.
- Always keep the caster brakes applied when a patient is on the bed (except during transport). After the brake pedal is applied, push on the bed to ensure the brakes are locked. Serious injury could result if the bed moves while a patient is getting in or out of bed.
- Ensure the brakes are completely released prior to moving the unit. Attempting to move the unit with the brakes actuated could result in injury to the user and/or patient.
- Do not attempt to move the foot end of the bed laterally when the steer pedal is activated. When the steer pedal is activated, the steer caster at the foot end of the bed cannot swivel. Attempting to move the bed laterally when the steer pedal is activated may cause injury to the user.
- The 3002 S3™ MedSurg Bed is not intended for use with patients less than two years of age.
- Serious injury can result if caution is not used when operating the unit. Operate the unit only when all persons are clear of the electrical and mechanical systems.
- To help reduce the number and severity of falls by patients, always leave the bed in the lowest position when the patient is unattended.
- When attaching equipment to the frame, ensure it will not impede normal frame operation. For example: hooks on hanging equipment must not actuate control buttons, equipment must not hide the nurse call button, foley bags must not rest on brake pedal, etc. Use only a Stryker supplied interface cable. Use of any other cable may cause the bed to function improperly, which may result in patient or user injury.
- The 3002 S3™ MedSurg Bed is equipped with a hospital grade plug for protection against electric shock hazard. It must be plugged directly into a properly grounded three prong receptacle. Grounding reliability can be achieved only when a hospital grade receptacle is used.
- When raising the siderails, listen for the “click”. When raising the siderail, the first click will indicate you can return to the intermediate position, the second click indicates its full up position. Once in position, move siderail from side to side to ensure it is locked into position. Siderails are not intended to be a patient restraint device. It is the responsibility of attending medical personnel to determine the degree of restraint and the siderail positioning to ensure a patient will remain safely in bed.
- The Bed Exit System is intended only to aid in the detection of a patient exiting the unit. It is NOT intended to replace patient monitoring protocol. The bed exit system signals when a patient is about to exit. Adding or subtracting objects from the frame after zeroing the weigh system may cause a reduction in the sensitivity of the bed exit system.
- Before servicing or cleaning the bed, **always** unplug the bed power cord from the wall socket and push the battery power on/off switch to the “OFF” position (if applicable). When working under a bed in the high position, always place blocks under the litter frame and apply the brakes to prevent injury in case the Bed Down switch is accidentally pressed.
- To avoid pinching your fingers, place the I.V. pole in the upright position before using the drive handle.
- When using any mattress and/or mattress overlay that increases the overall height greater than 6,” extra caution and/or operator supervision is required to help reduce the likelihood of a patient fall occurring.

Safety Tips and Guidelines

WARNING (CONTINUED)

To avoid possible injury and to assure proper operation when using model number 2750, 2920, 2950 or 2981 mattress:

- Confirm proper scale system operation following mattress installation. For best results, secure the therapy mattress power cord to prevent damage to the cord or interference with the bed frame and the scale system.
- Do not zero bed scales or weigh patient with Percussion, Vibration, Rotation or Turn Assist active. Patient motion and position resulting from the dynamic therapy mattress may adversely affect scale system performance.
- Do not initialize (“arm”) bed exit with Percussion, Vibration, Rotation or Turn Assist active. The patient motion and position resulting from the dynamic therapy mattress may adversely affect bed exit system performance.
- When using an XPRT (2950), Position PRO (2920), Impression (2981) or Symmetric Aire (2750) mattress, extra caution and/or operator supervision is required to help reduce the likelihood of a patient fall occurring.

CAUTION

- When large spills occur in the area of the circuit boards, 115 volt cables and motors, immediately unplug the bed power cord from the wall socket. Remove the patient from the bed and clean up the fluid. Have maintenance completely check the bed. Fluids can affect the operational capabilities of any electrical product. DO NOT put the bed back into service until it is completely dry and has been thoroughly tested for safe operation.
- Preventative maintenance should be performed at a minimum of annually to ensure all bed features are functioning properly. Close attention should be given to safety features including, but not limited to, safety side latching mechanisms, frayed electrical cords and components, all electrical controls returning to the off or neutral position when released, caster braking systems, no controls or cabling entangled in bed mechanisms, leakage current 300 μ A (microamps) maximum, scale and bed exit systems calibrated properly, and the siderail gas spring not leaking oil.
- Because individual beds may have different options, footboards should not be moved from one bed to another. Mixing footboards could result in unpredictable bed operation.
- The lockout buttons on the footboard lock the Fowler, Gatch and Bed Up/Down functions and prevent motion of the bed. It is the responsibility of attending medical personnel to determine whether these functions should be locked and to use the buttons accordingly.
- The maximum safe working load for each I.V. pole is 40 pounds.
- I.V. Poles should not be used as a bed push/pull device.
- Scale function may be affected by siderail/caster interference. With the litter fully lowered or lowered in Reverse Trendelenburg, the siderails tucked under the litter in the storage position and the casters turned, there is the potential for interference between the siderail and the caster. Raise the siderails when lowering the litter to the full down position to prevent the interference from causing the scale system to weigh inaccurately
- The use of a mattress overlay may reduce the effectiveness of the siderail.
- The cleanliness and integrity of both ground chains must be maintained to minimize static build up and discharge.
- Do not add or remove weight when the bed exit system is armed.
- There is a possible fire hazard when using half bed length type oxygen administering equipment. Ensure that the siderails are outside of the tent.
- There is a possible fire hazard when used with oxygen administering equipment of other than the nasal or mask type. Lock the control at foot of bed when using oxygen administering equipment.
- The weight of the foley bags placed on isolated bag hooks should not exceed five pounds.
- The weight of pumps placed on footboard pump holder should not exceed 45 pounds.
- The safe working load of the defibrillator tray is 40 lbs.
- The safe working load of the oxygen holder is 45 lbs.
- Bed may be equipped with an integrated scale intended to weigh the patient in bed. If the scale output is being used to determine diagnosis and treatment, please consult with a medical professional and/or additional weight references.
- Scale accuracy specifications do not apply for patients under 20 lbs.

Safety Tips and Guidelines

ZOOM® OPTION

In addition to the previous warnings and cautions, all of the following warnings and cautions apply to units equipped with the Zoom® option.

WARNING

- The 3002 S3™ MedSurg Bed is intended for use by trained hospital personnel only. Failure to properly train personnel could result in injury.
- USE CAUTION while maneuvering the unit with the drive wheel activated. Always ensure there are no obstacles near the unit while the drive wheel is activated. Injury to the patient, user or bystanders, or damage to the frame or surrounding equipment could occur if the unit collides with an obstacle.
- Use caution when transporting the unit down hallways, through doors, in and out of elevators, etc. Damage to the siderails or other parts of the unit could occur if the unit comes in contact with walls or door frames.
- Put the drive wheel in the neutral position and release the brakes before pushing the unit manually. Do not attempt to push the unit manually with the drive wheel engaged. The unit will be difficult to push and injury could result.
- If unanticipated motion occurs, unplug the power cord from the wall socket, push the battery power on/off switch to the "OFF" position (the LED will not be illuminated) and actuate the drive wheel pedal to the neutral position.
- The power save mode is activated after one hour on battery power with no motion switch activation. Functions including Bed Exit, Scale, iBed® Awareness and Motion will cease to operate when the unit enters the power save mode. Injury to the patient could occur if proper patient monitoring protocol is not observed.
- Always unplug the power cord and push the battery power on/off switch to the "OFF" position before service or cleaning. When working under the frame, always place blocks under the litter frame to prevent injury in case the Bed Down switch is accidentally activated.
- Due to the weight the battery adds to the bed (approximately 50 pounds), additional force is required to move the bed. Caution should be used when transporting the bed. Additional assistance should be used when necessary. Failure to use caution while transporting the bed may result in injury to the user.
- Battery posts, terminals and related accessories contain lead and lead compounds, chemicals known to the State of California to cause cancer and birth defects or other reproductive harm. Wash hands after handling.
- Do not modify the 3002 S3™ MedSurg Bed. Modifying the unit can cause unpredictable operation resulting in injury to the patient or operator. Modifying the unit will also void its warranty.

CAUTION

- To avoid damage while transporting the bed, verify the I.V. pole is at a low enough height to allow it to safely pass through door openings and under light fixtures.
- The battery tray assembly weighs 50 pounds. Take care when removing the two hex head screws securing it to the base frame or personal injury could result.

Safety Tips and Guidelines

iBED® AWARENESS OPTION

In addition to the previous warnings and cautions, all of the following warnings and cautions apply to units equipped with the *iBed*® Awareness option.

WARNING

- The optional *iBed*® Awareness system only indicates the siderail position, it does NOT indicate if the siderail is locked. It is the caregiver's responsibility to ensure that the siderails are locked after every move and also before leaving a patient in the room.
- The optional *iBed*® Awareness system indicator lights are only an aid to the caregiver, and in no way replace the caregiver's responsibility of checking on patients. Caregivers should not rely on the lights to perform their duties.
- Before arming the optional *iBed*® Awareness system, the nurse must physically verify that the siderails are locked.

CAUTION

- If the optional *iBed*® Awareness system is being used, ensure the bed is in the desirable state (*iBed*® Awareness ON and with the light green) before leaving the room.
- If the optional *iBed*® Awareness system is being used and the *iBed*® Awareness is alerting, do not turn off *iBed*® Awareness as the display information to troubleshoot the bed will get lost.
- If the optional *iBed*® Awareness system is being used, use of accessories that cover the center and side alert lights at the footboard are not recommended.

iBED® WIRELESS OPTION

In addition to the previous warnings and cautions, all of the following warnings and cautions apply to units equipped with the *iBed*® Wireless option.

WARNING

- The optional *iBed*® Wireless function provides remote information of bedside information to aid the caregiver. In no way does this option replace the caregiver's responsibility of checking on patients. Caregivers should not rely **only** on the remote information to perform their duties.
- The *iBed* Locator must be correctly associated or mapped to the room / location in order to provide accurate location information. Failure to properly map the *iBed* Locator to the room / location will yield incorrect remote information. Additionally, if an *iBed* Locator is to be moved after it has been installed and mapped, it must be re-mapped to the new room / location in which it is moved to. *iBed* Locator re-mapping will also be required if the room / location information is changed after initial installation.
- Line of sight between *iBed* Locator and the head end of bed must be free of obstruction at all times. Any line of sight interference could impede communication and cause the room / location information not to be available.
- *iBed*® Wireless compatible footboard must be used for all *iBed*® Wireless beds. Some *iBed*® Wireless functionality will be lost if an older version of the footboard is used.
- *iBed*® Wireless functionality shall be verified after installation. Failure to do may result loss of remote information or wrong remote information. At a minimum, verify *iBed* locator communication with bed in all bed positions, and *iBed*® Wireless communication with the wireless access point.
- *iBed* Locators must be installed more than 71" apart from one another in the same room, such as in a semi-private room with more than one bed. Failure to do so could result in a bed communicating with the other adjacent *iBed* Locator, thus providing incorrect bed location information.

CAUTION

- Wireless bed only transmits bed information and not nurse call information. The wireless bed is not intended to replace the existing nurse call system.

Safety Tips and Guidelines

115V OPTION

In addition to the previous warnings and cautions, all of the following warnings and cautions apply to units equipped with the 115V option.

- Only use equipment with the following electrical specs: 115VAC; 10A; 60Hz. Maximum total load drawn by equipment used in this receptacle outlet must not exceed 10A. The total system chassis risk current should not exceed 300 microamps. Grounding continuity should be checked periodically.
- To avoid risk of electrical shock, unplug all power cords before opening the service compartment, junction box or receptacle.
- Do not use the optional 115V outlet for life sustaining equipment.

Static Discharge Precautions

The electronic circuits in the 3002 S3™ MedSurg Bed are completely protected from static electricity damage only while the bed is assembled. It is extremely important that all service personnel always use adequate static protection when servicing the electronic systems of the 3002 S3™ MedSurg Bed. Whenever you are touching wires, you should be using static protection.

Static Protection Equipment

The necessary equipment for proper static protection is:

- 1 static wrist strap; 3M part number 2214 or equivalent,
- 1 grounding plug; 3M part number 61038 or equivalent,
- 1 test lead with a banana plug on one end and an alligator clip on the other; Smith part number N132B699 or equivalent.

CAUTION

All electronic service parts will be shipped in static shielding bags. Do not open the bags until you have completed steps 2 and 3 of the following procedure. Do not place unprotected circuit boards on the floor. All circuit boards to be returned to Stryker Medical should be shipped in the static shielding bags the new boards were shipped in.

Static Protection Procedure

1. Unplug the power cord from the wall receptacle.
2. Insert the grounding plug into a properly grounded hospital grade wall receptacle. Plug the banana plug of the test lead into the receptacle on the grounding plug. Connect the alligator clip on the other end of the test lead to a ground point on the bed.
3. Place the static control wrist strap on your wrist. Connect the alligator clip at the other end of the wrist strap cord to a ground point on the bed.

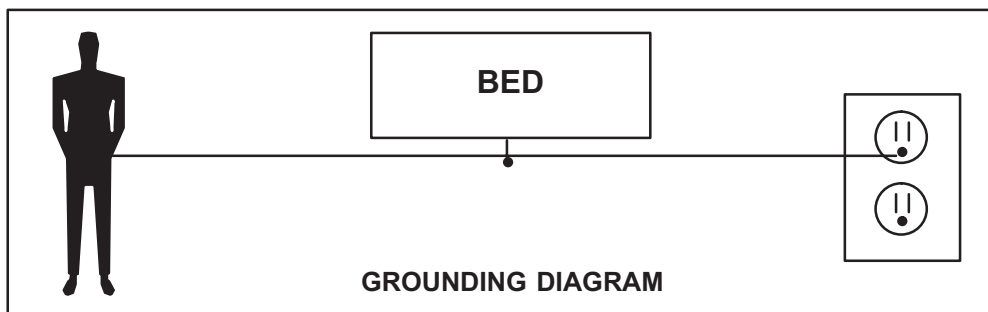

Setup Procedures

To prevent permanent damage to this unit, the unit must reach room temperature prior to conducting any setup and/or unit operations.

It is important that the 3002 S3™ MedSurg Bed is working properly before it is put into service. The following list will help ensure that each part of the bed is tested.

WARNING

- The 3002 S3™ MedSurg Bed is equipped with a hospital grade plug for protection against electric shock hazard. It must be plugged directly into a properly grounded three prong receptacle. Grounding reliability can be achieved only when a hospital grade receptacle is used.
- Use only a Stryker supplied interface cable. Use of any other cable may cause the bed to function improperly which may result in patient or user injury.
- Ensure there is no patient on the bed during the setup procedure.

1. Plug the bed into a properly grounded, hospital grade wall receptacle and ensure the  LED light at the foot end of the bed comes on.
2. Plug the optional interface cable into the 37 pin connector under the litter frame at the head end of the bed, into the “Patient Station”, “Head Wall”, “Docking Station”, or equivalent (whichever applies). Test the interface cable to verify it is functioning properly.
3. Ensure the siderails raise, lower, lock in the up position, lock in the intermediate position when lowered and store smoothly (see Operations Manual for further details).
4. Ensure that all four casters lock when the brake pedal is engaged ((see Operations Manual for further details).
5. Raise the fowler (head of bed) up to approximately 60°. Squeeze the CPR release handle and ensure the back will drop with minimal effort.

Note

Ensure that the “Brake” LED located on the outside of the head end siderails and on the footboard control panel blink when the brakes are not engaged.

6. Perform each function on the footboard control panel to ensure that each function is working properly (see Operations Manual for further details).
7. Perform each function on both head end siderails to ensure that each is working properly ((see Operations Manual for further details).
8. Activate the motion stop system to ensure it is functioning properly; press and hold down the BED DOWN button. As the bed lowers, push up on the motion interrupt pan under the bed and ensure the downward motion stops. Release the pan and allow the downward motion to continue.

Note

The bed’s upward motion or other functions are not disrupted by the motion stop system.

9. If the bed is equipped with the Nurse Call option, verify it is functioning properly prior to patient use.

Setup Procedures

ZOOM® OPTION

If your bed is equipped with the Zoom® drive wheel option, run through the setup procedures on the previous page and then continue with the procedures listed below.

- Plug the power cord into a properly grounded, hospital grade wall receptacle. The 12V batteries that provide power to the drive wheel and backup power to the unit functions will charge whenever the power cord is plugged into the wall socket. The batteries require approximately 10 hours of charging time before the bed is put into service.
- Unplug the power cord from the wall socket. Push the battery power switch located on the lower left corner of the head end to the On position. Again, verify each function on the footboard and siderails is operating properly.
- With the battery power switch in the On position and the brakes engaged, ensure the “Release Brakes” LED on the head end control panel is illuminated.
- With the battery power switch in the On position and the drive wheel in the neutral position (not touching the floor), ensure the “Engage Drive Wheel” LED on the head end control panel is illuminated.
- Run through the operation of the drive wheel ((see Operations Manual for further details).

If any problems are found during bed setup, contact Stryker Technical Support at 800-327-0770.

iBED® WIRELESS OPTION

In order for your bed to be capable of receiving a wireless connection the iBed Locator needs to be installed on the wall at the head end of the bed. The iBed Locator communicates with the IR Module installed in your bed. For detailed instructions on mounting the 5212 iBed Locator refer to the instruction sheet (part number 5212-009-101) packaged with your optional 5212 iBed Locator Installation kit.

If any problems are found during the iBed Locator Installation, contact Stryker Technical Support at (800) 327-0770.

WARNING

- The iBed Locator must be correctly associated or mapped to the room / location in order to provide accurate location information. Failure to properly map the iBed Locator to the room / location will yield incorrect remote information. Additionally, if an iBed Locator is to be moved after it has been installed and mapped, it must be re-mapped to the new room / location in which it is moved to. iBed Locator re-mapping will also be required if the room / location information is changed after initial installation.

The wireless connection settings need to be loaded before the device will communicate with the iBed Server application. Reference the **iBed Server Installation and Configuration Manual (5212-009-001)**.

Note

iBed® Wireless will not send iBed Locator information unless the brake is set (Battery Backup and Zoom® options only).

Maintenance Menu Guide

MAINTENANCE MENU SCREEN

The Maintenance Menu contains all of the non-regularly accessible features of the product. This menu provides an interface to the user and/or service personnel in order to provide the ability to control and access maintenance features.

Maintenance Menu Items

The following are menu items listed in the maintenance menu screen for a fully loaded bed:

1. Calib. Scale (Calibrate Scale)
2. TV Config. (TV Configuration)
3. Scale Info. (Scale Info/Stats)
4. Clear Scale Stats
5. Error Log (View Error Log)
6. Clear Errors (Clear Error Log)
7. Scale Units (Lock Scale Units)
8. About (About Product)
9. Exit Menu (Exit Maintenance)

The following are menu items listed in the maintenance menu screen for a standard bed:

1. TV Config. (TV Configuration)
2. Error Log (View Error Log)
3. Clear Errors (Clear Error Log)
4. About (About Product)
5. Exit Menu (Exit Maintenance)

The following are menu items listed in the maintenance menu screen for an iBed:

1. Calib. Scale (Calibrate Scale)
2. TV Config. (TV Configuration)
3. Scale Info. (Scale Info/Stats)
4. Clear Scale Stats (only if you have scale option)
5. Error Log (View Error Log)
6. Clear Errors (Clear Error Log)
7. Scale Units (Lock Scale Units)
8. About (About Product)
9. Exit Menu (Exit Maintenance)

- Each of the menu items provides the operator with a different function.
- Using the up and down menu buttons, you can scroll through the menu elements.
- To select a menu item, scroll to the desired menu item using the Up and Down menu button. When the desired feature is highlighted, press the Enter/Check button. Depending on the feature, the display will move into the sequence for the feature selected.

Load Cell Check (Where applicable: for beds with a minimum of Scale or either kind of Bed Exit)

- This feature automatically checks all four load cells to make sure they are working properly.
- The purpose of this feature is to provide a self diagnostic of the load cells.
- When maintenance is entered, a self-diagnostic feature should run and display results.
- While the procedure is running, the following message is displayed: "Load Cell Check".
- Any load cell errors will be displayed as a message "Load Cell Error" and then, depending on the error, an HL, HR, FL or FR will be displayed below the message. (Refer to the Error Handling Section, [page 50](#)).
- If no errors are present, then the maintenance menu will be displayed and menu items 1-9 above may be accessed where applicable.

Maintenance Menu Guide

Maintenance Menu (Continued)

Scale Calibration

- This feature allows the operator to calibrate the scale system.
- This calibration is used to provide the system with a weight offset that occurs when the product is put into trend and reverse trend.
- This calibration does not calibrate the load cells; the load cells are pre-calibrated.

To calibrate the scale system:

1. In the Maintenance Menu, select the Calibrate Scale item; then press and hold the Enter/Check button.
2. The display should present the following message:
“Do Not Touch Bed”. The message should be flashing.
3. Use the up and down arrow to select the proper weight (50lbs is the default).
4. Press the “Enter/Check” button when the display shows the proper weight.
5. The display should present the following message:
“Place Weight in Center”.
6. Place the weight in the center of the bed.
7. Press the “Enter/Check” button when completed.
8. The display should present the following message:
“Press Reverse Trend”.
9. Press the reverse trend button.
10. The display should present the following message when the bed is in the proper position:
“Release Button”.
11. Release the button and do not touch the bed. When the button is released, the following message is displayed:
“Do Not Touch Bed”. The message should be flashing.
12. The display should present the following message when the bed is ready to continue:
“Press Trend”.
13. Press the trend button.
14. The display should present the following message when the bed in the proper position:
“Release Button”.
15. Release the button and do not touch the bed. When the button is released the following message is displayed:
“Do Not Touch Bed”. The message should be flashing.
16. The display should present the following message when the bed is ready to continue:
“Save Calibration?”.
17. Press the “Enter/Check” button to save the calibration.
18. The display should present the following message when the bed is ready to continue:
“Save Successful”.

Note:

If an error occurs during the procedure the display will show an error message, “Calibration Error,” for four seconds.



WARNING

Ensure there is no patient on the bed while the calibration procedure is being performed.

Maintenance Menu Guide

Maintenance Menu (Continued)

TV Configuration

- This feature allows the operator to set up the TV configuration.
- This configuration provides the product with the information to communicate with the proper entertainment system.

To Configure the System:

1. In the Maintenance Menu, select the TV Config. item; then press and hold the Enter/Check button.
2. The TV Configuration Screen will be displayed. The current TV selection will be highlighted.
3. Use the up and down arrow buttons to highlight the desired item.
4. Press the “Enter/Check” button to select the new setting.
5. The following message will be shown on the display screen when the new setting is saved:
“Save Successful”.
6. The TV Configuration screen should reappear after two seconds and the new setting should be highlighted.
7. If you press the Exit/X button or if the screen remains dormant for more than 30 seconds, the display will return you to the maintenance menu without saving any changes.

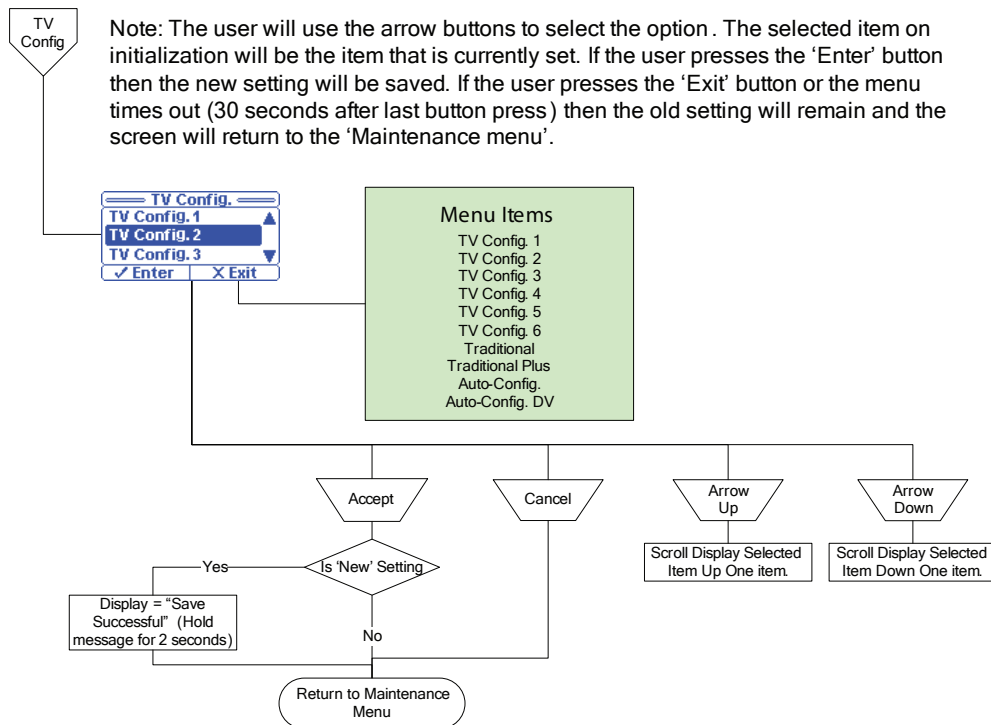

Maintenance Menu Guide

Maintenance Menu (Continued)

Scale Information

- This diagnostic feature shows data from the load cells. This includes the raw count data, the weight data (in lb), the maximums and the minimums.
- When the menu item is selected, the weight data from the four load cells will be displayed.
- When cancel/exit is pressed, the menu should return.
- Values should update every 0.25 seconds.

Note: The scale information and statistics are important when trying to diagnose the scale system.

To View the Scale Information:

1. In the Maintenance Menu select the Scale Info item; then press and hold the Enter/Check button.
2. The Scale Info screen will be displayed.
3. Use the arrows to navigate through the four screens: lb, counts, maximums, and minimums. Each screen will have the four load cells and the information in the format of that screen.
4. Press the Exit/X button to return to the Maintenance Menu screen.

Clear Scale Stats

- This diagnostic feature allows the statistics for the load cells to be cleared.

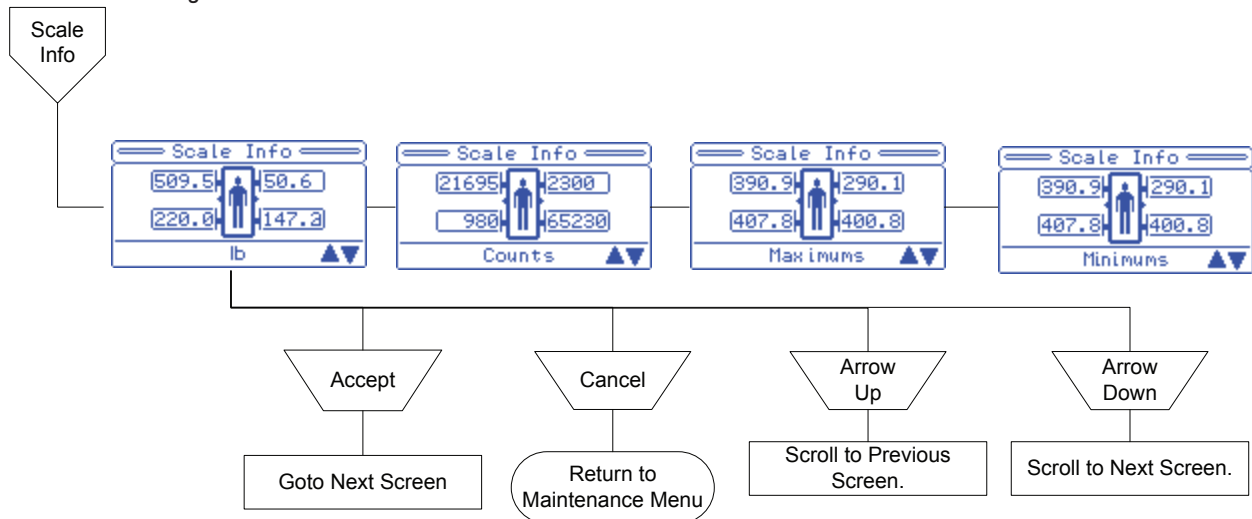

- This is done to remove old data. This may be done because the load cell is being replaced or the system has been re-calibrated.
- When the menu item is selected and held for one second, the statistics should be erased and a message should be displayed. When cancel/exit is pressed, the menu should return to the Maintenance Menu Screen.

Note: The scale statistics (Maximums and Minimums) can be cleared using this feature.

To Clear the Information:

1. In the Maintenance Menu, select the Clear Scale Stats item; then press and hold the Enter/Check button.
2. The following message will be shown on the display screen:
"Clear Scale Statistics?"

Maintenance Menu Guide

Maintenance Menu (Continued)

3. Press and hold the Enter/Check button to clear the stats.
4. The following message will be shown on the display screen when the stats are cleared:
“Statistics Cleared”.
5. The Maintenance Menu screen should reappear after two seconds and the new setting should be highlighted.

Note: Items that are cleared during this operation are:

- Maximums (for each load cell)
- Minimums (for each load cell)

Error Log

- This feature allows the operator to view the Error Log.
- This log provides information pertaining to the error system and any errors that are logged during product use.

To view the error log:

1. In the Maintenance Menu, select the Error Log item; then press the Enter/Check button.
2. The Error Log screen will be displayed. The most recent error will be at the top.
3. Use the up and down arrow buttons to view any errors that are not shown on the screen.
4. Pressing the Exit/X button will return you to the Maintenance Menu screen.
5. If the screen remains dormant for more than 30 seconds, you will be returned to the Maintenance Menu screen.

Clear Errors

This feature allows the user to clear the error log.

To clear the error log:

1. In the Maintenance Menu, select the Clear Errors item; then press and hold the Enter/Check button.
2. The following confirmation screen will be displayed:
“Clear Error Log?”
3. If ‘Exit’ is chosen, you will be returned to the Maintenance Menu screen.
4. If ‘Enter’ is chosen, then the error log is cleared and a message is displayed: **“Error Log Cleared”**; you will be returned to the Maintenance Menu screen.

Scale Units

- This feature allows the user to lock and/or unlock the unit of weight measurement as well as select the default scale units (lb or kg).
- When the Scale Units menu item is selected, the unit of measure will be locked and the current unit of measure will be displayed.
- When cancel/exit is pressed, the menu will return to the Maintenance Menu Screen.
- The default setting is Unlocked.

To lock/unlock the Scale Units:

1. In the Maintenance Menu, select the Scale Units item; then press and hold the Enter/Check button.
2. The Scale Units Screen will display Figure 41 with the current state as the highlighted item.

Maintenance Menu Guide

Maintenance Menu (Continued)

3. Use the Up and Down Arrow buttons to highlight the desired units and identify whether you want them locked or unlocked.
4. Press and hold the Enter/Check button to select and save the new state.
5. The following screen message will be displayed:
“Save Successful”.
6. The Scale Units screen will reappear after two seconds and the new setting will be highlighted.
7. Pressing the Exit/X button will return you to the Maintenance Menu screen without saving the new state.

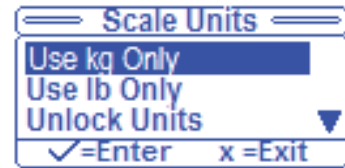

Figure 41

About Product

The display will indicate the current bed configuration including the bed type, bed options, serial number and the software versions for all software targets connected on the internal CAN network. For example, the menu will list out the bed configuration as follows:

```
Bed Information:  
S3  
-Zoom/Batt.  
-Scale  
-Bed Exit  
  Zone Control  
-Awareness  
-Wireless  
  
Serial Number:  
080115000  
  
CPU Board SW:  
3006-308-905_A  
v.1.1.001  
  
Foot Board SW:  
3006-501-905_A  
v.1.1.001
```

To view this information:

1. In the Maintenance Menu, select the About item then press and hold the “Enter”/Check button.
2. The About Screen will be displayed.
3. Use the Up and Down Arrow buttons to scroll through the information if it does not fit on one screen.
4. Press the “Exit”/X button to return to the Maintenance Menu screen.
5. The Type information should indicate, depending on the options: **“Zoom”, “Scale”, “Bed Exit” (if Multizone, “Zone Control” will be printed under the “Bed Exit” text) and “Awareness”**.

Maintenance Menu Guide

Maintenance Menu (Continued)

Connectivity Menu (*iBed*® Wireless Option Only)

This feature allows the operator to view the *iBed* Wireless product information. This information includes the Connectivity Status, Signal Strength, IP and MAC addresses, Locator ID and its Connectivity Status and Battery Status. To view this information:

1. Press and hold the Enter/Check button while in the Maintenance Menu and the “Connectivity Info” element is selected.
2. The display should present the Connectivity Information Screen.
3. Use the Up and Down arrows to scroll through the information if it does not fit on one screen.
4. Press the Exit/X button to return to the maintenance menu.

WiFi Module Status possible states:

- Trying to Connect
- Connected
- Not Connected

WiFi Signal Strength possible states:

- None
- Low
- Good
- Excellent

iBed Locator Status possible states:

- Connected
- Mobile
- Trying to Connect
- Connection Time Out

iBed Locator Battery possible states:

- Low Battery
- Good

WiFi Module Info
Status:
Connected
Signal Strength:
Excellent
IP Address:
XXX.XXX.XXX.XXX

MAC Address:
XXXXXXXXXXXX
Software:
5212-300-905_F
v.1.3.018

iBed Locator Info
Status:
Connected
ID:
XXXXXXXXXXXX
Battery:
Good

IR Software:
5212-300-935_C
V.1.1.002

Maintenance Menu Guide

Maintenance Menu (Continued)

- The Connectivity Info. menu will only be shown once the “Wireless” option on the bed in the Bed Config menu is enabled.
- The Wifi Module Info and *i*Bed Locator Info text fields shall always be printed in the Connectivity Menu.
- For the “WiFi Module Info” section, once the Wireless heartbeat is detected, then the “Status:”, “Signal Strength:”, “IP Address:”, “MAC Address:” and “Software:” fields will be displayed. Otherwise, if the Wireless heartbeat is not detected, the “WiFi Module Info” section shall list the text “Not Available”.
- For the “*i*Bed Locator Info” section, once the IR heartbeat is detected, then the “Status:” and “IR Software:” fields will be displayed. Otherwise, if the IR heartbeat is not detected, the “*i*Bed Locator Info” section shall list the text “Not Available”.
- The ID and Battery sections shall only be displayed if the *i*Bed Locator Status is “Connected”.

Exit Menu

- This feature allows the operator to exit the menu back to the previous screen.
- When this menu item is selected the screen will exit to the “Status” screen.

Preventative Maintenance

Beds require an effective maintenance program, we recommend checking these items annually. Use this sheet for your records. Keep on file.

CHECKLIST

- _____ All fasteners secure (reference all assembly drawings).
- _____ Engage brake pedal and push on the bed to ensure all casters lock securely.
- _____ Inspect the brake assembly (Brake Ratchet Spring and Brake Bar) for degradation or signs of wear at the foot end and head end of the bed. Ensure brake assembly components (locking caster and springs) are functioning properly.
- _____ “Brake” LED on the footboard and head end siderails blink when brakes are not engaged.
- _____ Locking steer caster engages and disengages properly.
- _____ Siderails move, latch and stow properly.
- _____ CPR release working properly.
- _____ Foot prop intact and working properly.
- _____ I.V. pole working properly.
- _____ Foley bag hooks intact.
- _____ Optional CPR board not cracked or damaged and stores properly.
- _____ No cracks or splits in head and footboards.
- _____ No rips or cracks in mattress cover.
- _____ All functions on head end siderails working properly (including LED’s).
- _____ All functions on footboard working properly (including LED’s).
- _____ Scale and Bed Exit system calibrated properly.
- _____ Motion Interrupt switches working properly.
- _____ Night light working properly.
- _____ Power cord and plug not frayed or damaged.
- _____ No cables worn or pinched.
- _____ All electrical connections tight.
- _____ All grounds secure to the frame.
- _____ Ground impedance not more than 100 mΩ (milliohms).
- _____ Current leakage not more than 300 μA (microamps).
- _____ Apply grease to the Litter grease points and fowler motor clutch ([page 31](#)).
- _____ Engage drive wheel and ensure it is operating properly (Zoom® option).
- _____ Motion release switches working properly (Zoom® option).
- _____ Confirm Head End Control Panel functionality (Zoom® / Battery Backup option).
- _____ Confirm battery powered functionality (Zoom® / Battery Backup option).
- _____ Ensure ground chains are clean, intact, and have at least two links touching the floor.
- _____ Check Fowler angle for accuracy 0° - 60°.
- _____ Siderail switches working properly (iBed® Awareness option).
- _____ Center Light Bar LED and side light LED working properly (iBed® Awareness option).
- _____ Inspect footboard control labeling for signs of degradation.
- _____ Inspect siderail gas spring for oil leaks and replace if necessary.
- _____ Check fowler motor flexible mounting for damage or wear.
- _____ Check all motion functionality.
- _____ Ensure power cord slack at the inlet filter (Zoom and Battery Backup Option).
- _____ Check Nurse Call functionality.
- _____ Check Nurse Call battery - optional equipment
- _____ Check labels, as specified in the Operations and Maintenance manuals to ensure legibility, proper adherence and integrity.
- _____ Confirm iBed® Wireless Module and IR Module are intact and footboard icons are displaying (iBed® Wireless Option)

| | | |
|--------------------|--|--|
| Bed Serial Number: | | |
| | | |
| | | |
| | | |

Completed by: _____ Date: _____

Preventative Maintenance

GREASE POINTS

1. H/E Glide Rod
2. Ball Screw
3. Brake Spring

Siderail Assembly (Reference p/n: 3006-400-105 (Head End) and 3006-400-300 (Foot End))

1. Apply Syn-Tech NS-18191-G grease (p/n 3000-200-700) to Glide Rod surface.

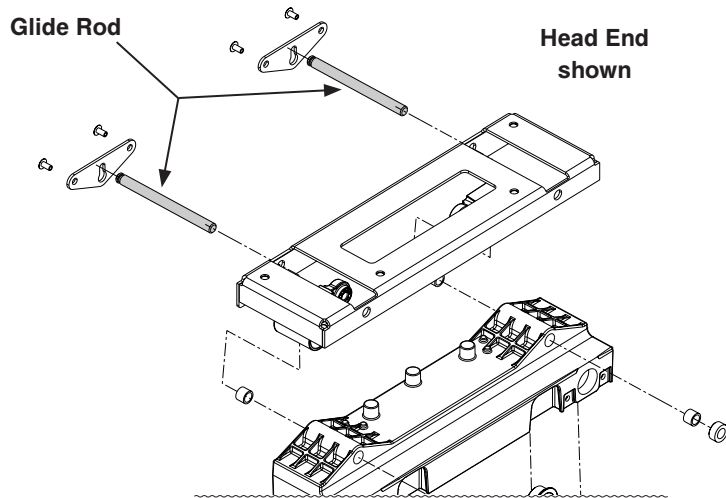

Fowler Drive Assembly (Reference p/n: 3006-300-550)

1. Apply Mobile #28 grease to the entire length of the ball screw.
2. If dry, apply a thin film layer of Syn-Tech grease (p/n 3000-200-700) to the outside of the brake spring.

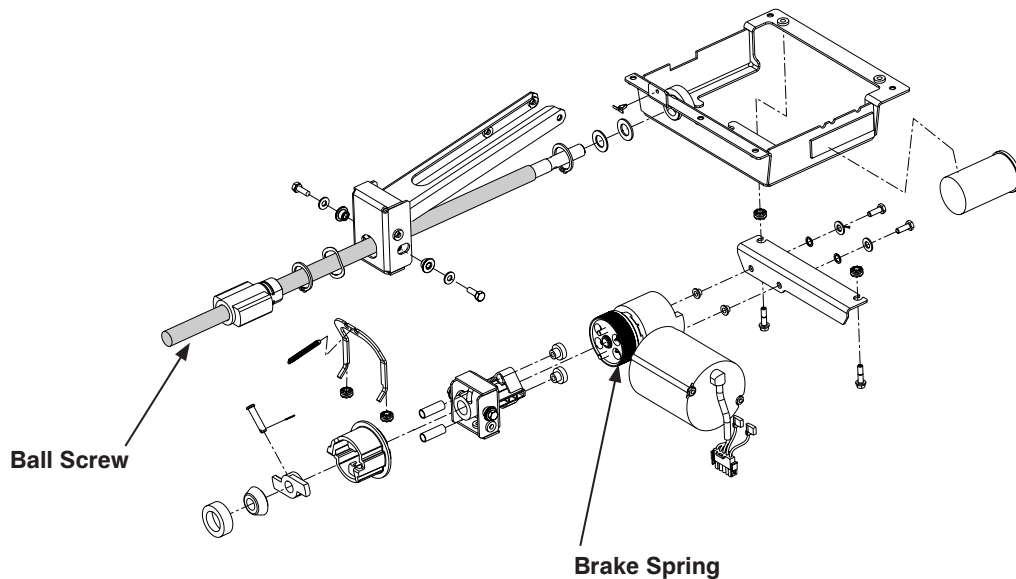



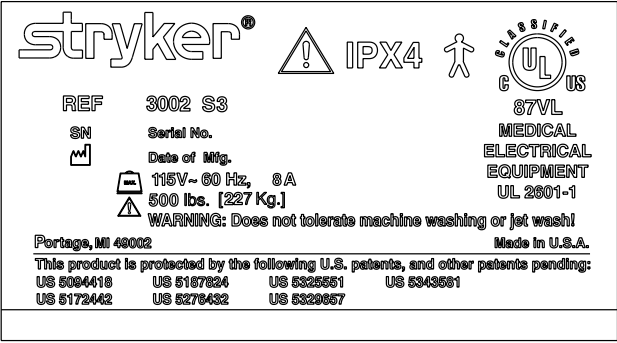
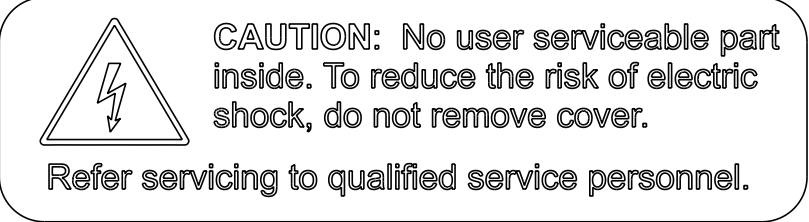
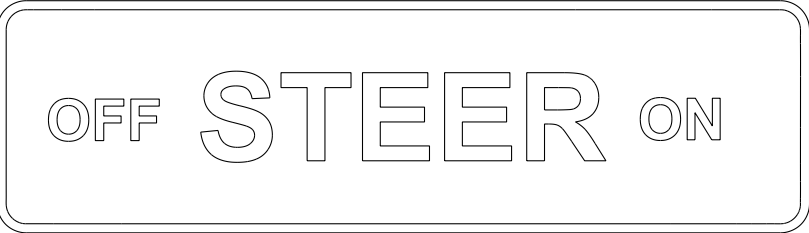
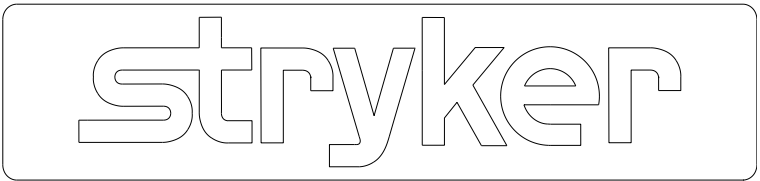
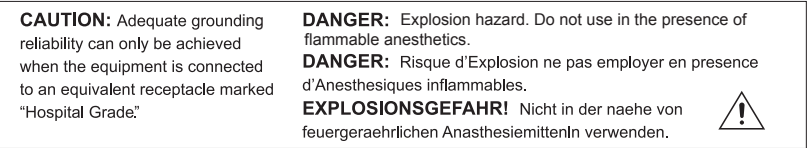

Product Labels

Note: All product labels are standard on the bed unless otherwise noted as being optional.

| Part Name/Number | Product Label |
|--|--|
| <p>Specification Label 3006-300-625</p> |  <p>The label contains the Stryker logo, an IPX4 rating, a person icon, and a UL Classified logo. It lists REF 3002 S3, SN, Serial No., Date of Mfg., 115V~60 Hz, 8A, and 500 lbs. [227 Kg.]. It includes a warning: 'WARNING: Does not tolerate machine washing or jet wash!' and 'Made in U.S.A.'. It also lists several U.S. patents: 5094418, 5172442, 5167824, 5276432, 5325551, 5322657, and 5343561.</p> |
| <p>Shock Hazard 3006-002-708</p> |  <p>The label features a lightning bolt warning symbol and the text: 'CAUTION: No user serviceable part inside. To reduce the risk of electric shock, do not remove cover. Refer servicing to qualified service personnel.'</p> |
| <p>Steer Lock 3006-090-013</p> |  <p>The label displays the text 'OFF STEER ON' in a large, outlined font.</p> |
| <p>Base Logo 3006-200-602</p> |  <p>The label displays the Stryker logo in a large, outlined font.</p> |
| <p>Caution/Danger Label 5212-100-807</p> |  <p>The label contains two columns of text. The left column reads: 'CAUTION: Adequate grounding reliability can only be achieved when the equipment is connected to an equivalent receptacle marked "Hospital Grade."'. The right column reads: 'DANGER: Explosion hazard. Do not use in the presence of flammable anesthetics. DANGER: Risque d'Explosion ne pas employer en presence d'Anesthésiques inflammables. EXPLOSIONSGEFAHR! Nicht in der naehen von feuergeraehrlichen AnesthesiemittelnIn verwenden.' and includes a warning symbol.</p> |

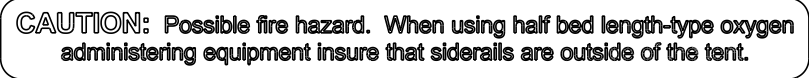

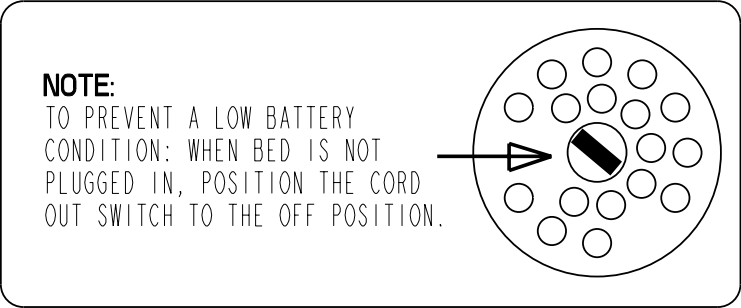
Product Labels

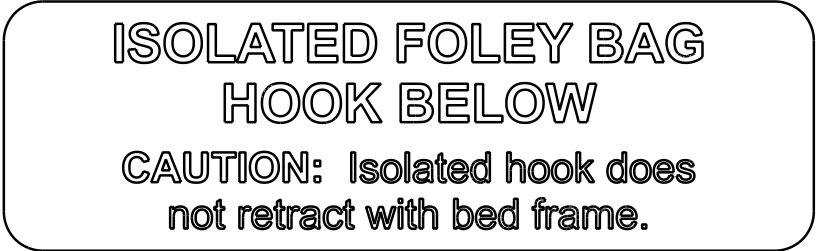
Note: All product labels are standard on the bed unless otherwise noted as being optional.

| Part Name/Number | Product Label |
|--|--|
| <p>Caution 3006-088-820</p> |  |
| <p>500 lb Max 3006-090-100</p> |  |
| <p>Cord Out Label 3006-090-028</p> |  |
| <p>Brake Pedal 3006-200-601</p> |  |
| <p>Foley Bag Hook 3006-300-601</p> |  |

Product Labels

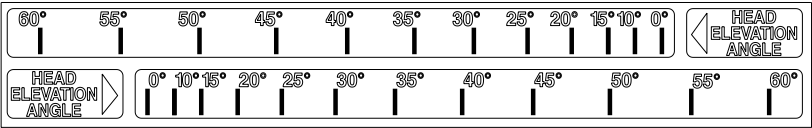
Note: All product labels are standard on the bed unless otherwise noted as being optional.

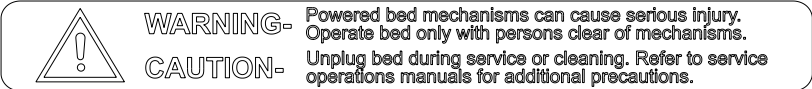
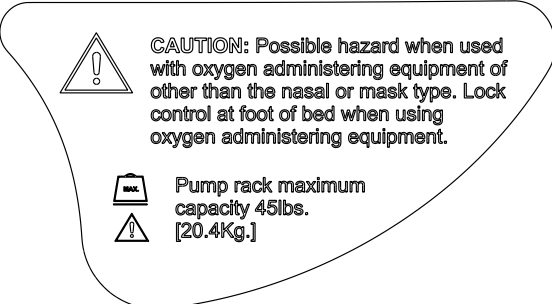
| Part Name/Number | Product Label |
|--|--|
| <p>Fowler Elevation Angle 3006-300-602</p> |  |
| <p>CPR Release 3006-300-603</p> |  |
| <p>Release Handle 3006-400-657</p> |  |
| <p>Warning 3006-400-656</p> |  |
| <p>Oxygen Warning 3006-508-010</p> |  |

Product Labels

Note: All product labels are standard on the bed unless otherwise noted as being optional.

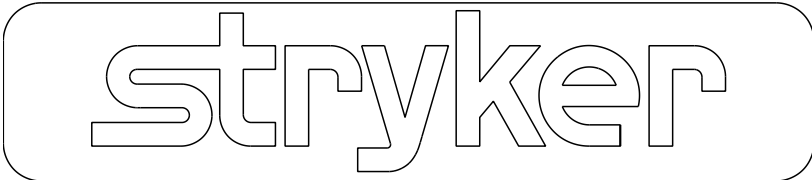
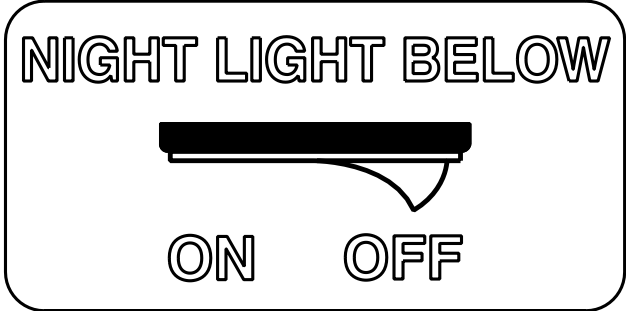
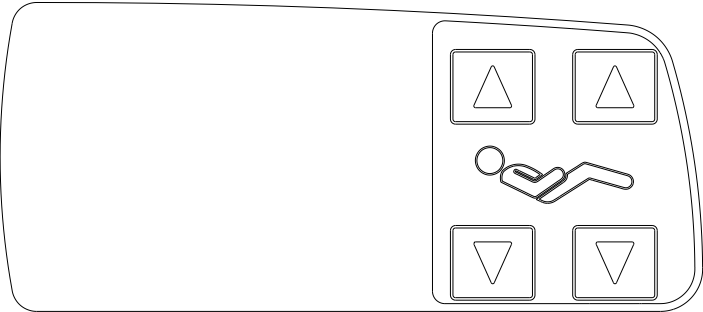
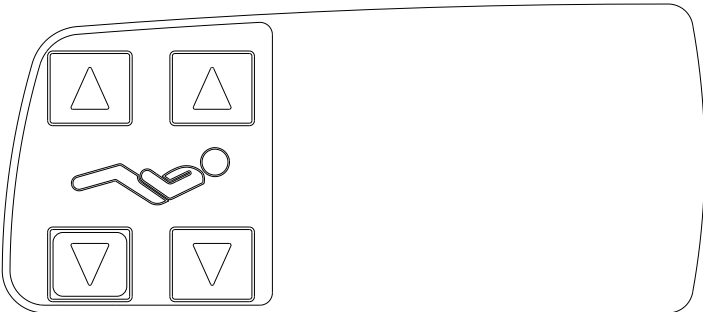
| Part Name/Number | Product Label |
|---|--|
| <p>For hospital staff use only 3006-508-013</p> |  |
| <p>Stryker Logo 3006-508-014</p> |  |
| <p>Night Light 3006-310-601</p> |  |
| <p>Head End Inner Siderail (Left) 3006-400-620</p> |  |
| <p>Head End Inner Siderail (Right) 3006-400-610</p> |  |

Product Labels

Note: All product labels are standard on the bed unless otherwise noted as being optional.

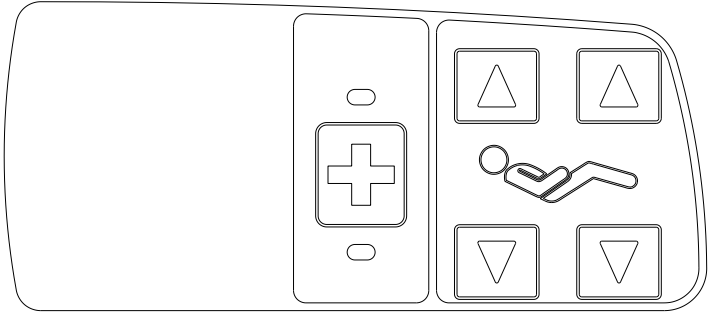
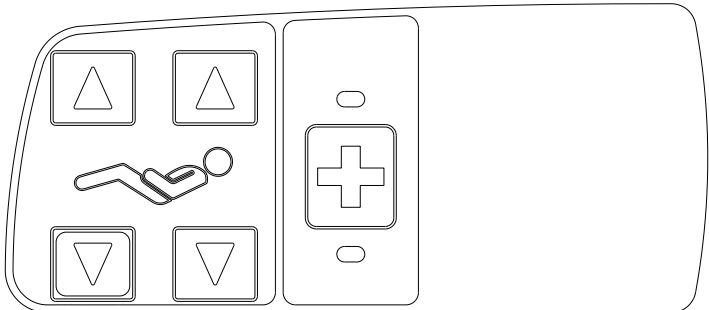
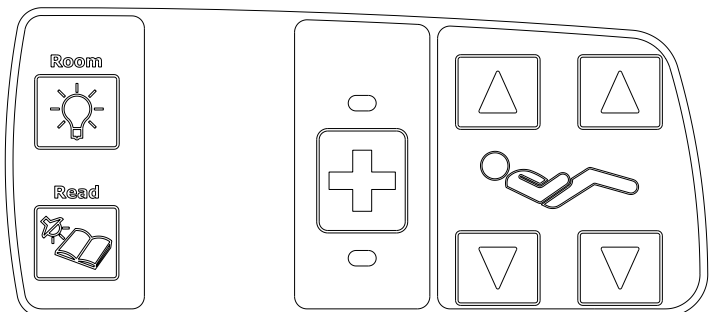
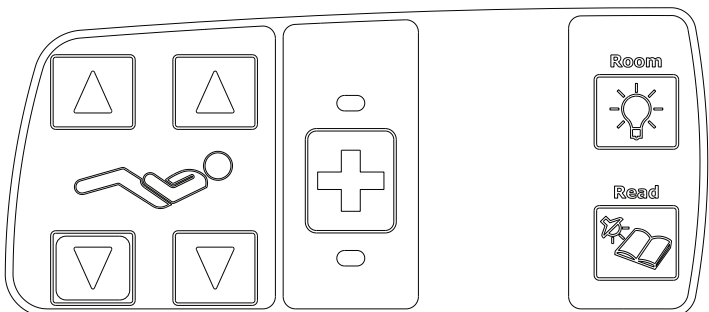
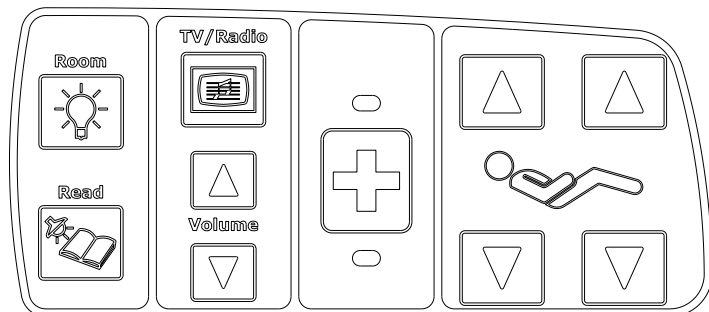
| Part Name/Number | Product Label |
|--|--|
| <p>Head End Inner Siderail with NC (Left) 3006-400-621 (Optional)</p> |  |
| <p>Head End Inner Siderail with NC (Right) 3006-400-611 (Optional)</p> |  |
| <p>Head End Inner Siderail with Nurse Call and Lights (Left) 3006-400-625 (Optional)</p> |  |
| <p>Head End Inner Siderail with Nurse Call and Lights (Right) 3006-400-615 (Optional)</p> |  |
| <p>Head End Inner Siderail with Nurse Call, Lights and TV-Radio (Left) 3006-400-623 (Optional)</p> |  |

Product Labels

Note: All product labels are standard on the bed unless otherwise noted as being optional.

| Part Name/Number | Product Label |
|---|---------------|
| <p>Head End Inner Siderail with Nurse Call, Lights and TV-Radio (Right) 3006-400-613 (Optional)</p> | |
| <p>Head End Inner Siderail with Smart TV (Left) 3006-430-131 (Optional)</p> | |
| <p>Head End Inner Siderail with Smart TV (Right) 3006-430-132 (Optional)</p> | |
| <p>Head End Outer Siderail with Cardiac Chair (Left) 3006-400-637</p> | |
| <p>Head End Outer Siderail with Cardiac Chair (Right) 3006-400-647</p> | |

Product Labels

Note: All product labels are standard on the bed unless otherwise noted as being optional.

| Part Name/Number | Product Label |
|--|---------------|
| <p>Head End Outer Siderail with Cardiac Chair and Nurse Call (Left) 3006-400-635 (Optional)</p> | |
| <p>Head End Outer Siderail with Cardiac Chair and Nurse Call (Right) 3006-400-645 (Optional)</p> | |
| <p>Head End Outer Siderail with Cardiac Chair and Gatch/Fowler (Left) 3006-400-634 (Optional)</p> | |
| <p>Head End Outer Siderail with Cardiac Chair and Gatch/Fowler (Right) 3006-400-644 (Optional)</p> | |
| <p>Head End Outer Siderail with Cardiac Chair, N/C and Gatch/Fowler (Left) 3006-400-633 (Optional)</p> | |

Product Labels

Note: All product labels are standard on the bed unless otherwise noted as being optional.

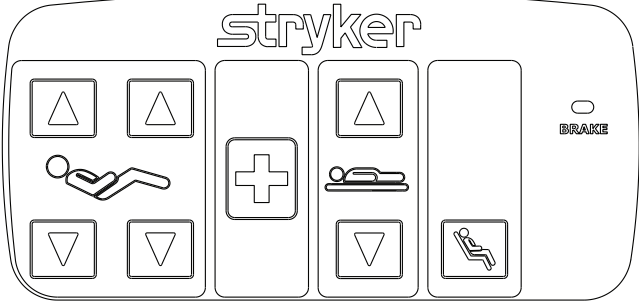
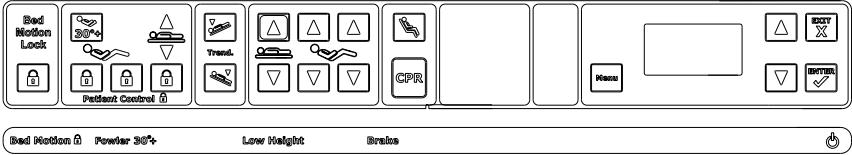
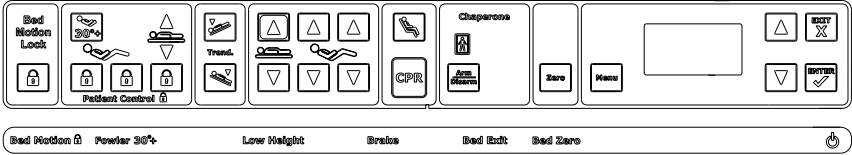
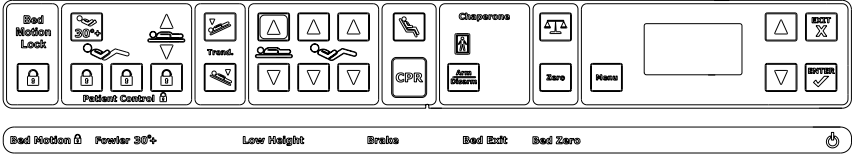
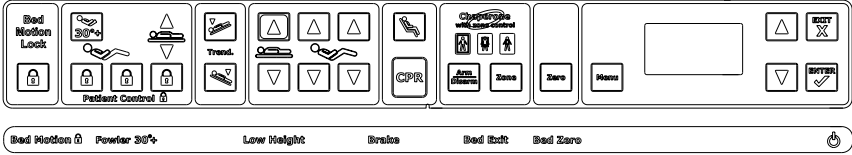
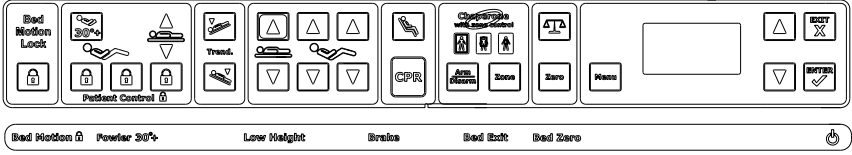
| Part Name/Number | Product Label |
|---|--|
| <p>Head End Outer Siderail with Cardiac Chair, N/C and Gatch/Fowler (Right) 3006-400-643 (Optional)</p> |  |
| <p>Footboard, without Scale and without Bed Exit 3006-508-004</p> |  |
| <p>Footboard, with Bed Exit 3006-508-005 (Optional)</p> |  |
| <p>Footboard, with Bed Exit and Scale 3006-508-007 (Optional)</p> |  |
| <p>Footboard, with Bed Exit and Zone Control 3006-508-006 (Optional)</p> |  |
| <p>Footboard, with Bed Exit, Scale and Zone Control 3006-508-009 (Optional)</p> |  |
| <p>Bed Exit 3006-508-109 (Optional)</p> | <div style="border: 1px solid black; padding: 10px;"> <h2 style="text-align: center;">Bed Exit</h2> <p><u>A. BEFORE putting a NEW PATIENT on the bed:</u></p> <ol style="list-style-type: none"> 1. Prepare the bed for patient stay by adding linen and equipment to the bed. 2. Press and HOLD the ZERO key. Follow the instructions on the display. 3. The 'BED ZERO' light will illuminate to indicate when the BED EXIT system is 'zeroed' and is ready for the patient to be helped to the bed. <p><u>B. To ARM BED EXIT System:</u></p> <ol style="list-style-type: none"> 1. Place patient on the bed. 2. Push the 'ARM / DISARM' key and release. The 'BED EXIT' light will illuminate. 3. Bed Exit system is now armed. <p>NOTE: Adding or subtracting objects from the bed after zeroing the bed will cause a change in the sensitivity of the BED EXIT system.</p> </div> |



Product Labels

Note: All product labels are standard on the bed unless otherwise noted as being optional.

| Part Name/Number | Product Label |
|---|--|
| <p>Bed Exit with Zone Control 3006-508-106 (Optional)</p> | <p style="text-align: center;">Bed Exit With Zone Control</p> <p><u>A. BEFORE putting a NEW PATIENT on the bed:</u></p> <ol style="list-style-type: none"> 1. Prepare the bed for patient stay by adding linen and equipment to the bed. 2. Press and HOLD the 'ZERO' key. Follow the instructions on the display. 3. The 'BED ZERO' light will illuminate to indicate when the BED EXIT system is 'zeroed' and is ready for the patient to be helped to the bed. <p><u>B. To ARM BED EXIT System:</u></p> <ol style="list-style-type: none"> 1. Place patient on the bed. 2. Push the 'ARM / DISARM' key and release. The 'BED EXIT' light will illuminate. 3. Bed Exit with ZONE CONTROL will automatically select the first zone. To change the zone, press the 'ZONE' key until the desired zone is illuminated. 4. Bed exit system is now armed. <p><u>NOTE:</u> Adding or subtracting objects from the bed after zeroing the bed will cause a change in the sensitivity of the BED EXIT system.</p> |
| <p>Scale System 3006-508-107 (Optional)</p> | <p style="text-align: center;">Scale System</p> <p><u>A. BEFORE putting a NEW PATIENT on the bed:</u></p> <ol style="list-style-type: none"> 1. Prepare the bed for patient stay by adding linen and equipment to the bed. 2. Press and HOLD the 'ZERO' key. Follow the instructions on the display. 3. The 'BED ZERO' light will illuminate to indicate when the SCALE system is 'zeroed' and is ready for the patient to be helped to the bed. <p><u>B. To USE the SCALE system display:</u></p> <ol style="list-style-type: none"> 1. To display the weight; press, hold and release the 'SCALE' key. The Scale display will read: 'WEIGHING... DO NOT TOUCH BED', then 'XXX.X LB' will be displayed. <p><u>C. To change linen or equipment:</u></p> <ol style="list-style-type: none"> 1. Press the 'MENU' key, select 'CHANGE EQUIPMENT' from the menu in the display, and follow the instructions. <p><u>NOTE:</u> Adding or subtracting objects from the bed after the SCALE system has been zeroed will cause a change in weight reading. Use the CHANGE EQUIPMENT function when objects are required to be added or removed from the bed.</p> |
| <p>Awareness Status 3006-508-108 (Optional)</p> | <p style="text-align: center;">Awareness Status</p> <p><u>A. Awareness monitors the following:</u></p> <ol style="list-style-type: none"> 1. Brake 2. Siderail position 3. Low height (optional) 4. Bed Exit (optional) 5. Fowler 30°+ (optional) <p><u>B. BEFORE arming the Awareness system:</u></p> <ol style="list-style-type: none"> 1. Make sure the brakes are set. 2. Configure the siderails as desired. 3. If low height is to be monitored, lower the bed completely. 4. If Bed Exit is to be monitored, arm the Bed Exit system. 5. If the Fowler 30°+ is to be monitored, turn the Fowler 30°+ on. <p><u>C. To USE the Awareness system:</u></p> <ol style="list-style-type: none"> 1. Enable the Awareness system by pressing the Awareness 'ON / OFF' key. The Awareness indicator light on the footboard will turn green if the system is successfully enabled. 2. When the Awareness state has changed, the Awareness indicator light will flash amber and the 'BRAKE', 'SIDERAIL', 'LOW HEIGHT', 'BED EXIT', and / or 'FOWLER 30°+' lights will flash. The Awareness display will also indicate what has changed. |

Product Labels

Note: All product labels are standard on the bed unless otherwise noted as being optional.

| Part Name/Number | Product Label |
|--------------------------------|---|
| WiFi Capable 3006-508-105 |  <p>Wi-Fi Capable</p> |
| WiFi CPU Cover 3006-300-105 |  <p>Wi-Fi Capable CPU P/N 3006-308-900 ONLY</p> |

Cleaning

Hand wash all surfaces of the bed with warm water and mild detergent. Dry thoroughly. Do not steam clean or hose off the bed. Do not immerse any part of the bed. Some of the internal parts of the bed are electric and may be damaged by exposure to water.

Suggested cleaners for bed surfaces:

Quaternary Cleaners (active ingredients - ammonium chloride)

Phenolic Cleaners (active ingredient - o-phenylphenol)

Chlorinated Bleach Solution (5.25% - less than 1 part bleach to 100 parts water)

Avoid over saturation and ensure the product does not stay wet longer than the chemical manufacturer's guidelines for proper disinfecting.



CAUTION

Some cleaning products are corrosive in nature and may cause damage to the product if used improperly. If the products described above are used to clean Stryker patient care equipment, measures must be taken to ensure the beds are wiped with a damp cloth soaked in clean water and thoroughly dried following cleaning. Failure to properly rinse and dry the beds will leave a corrosive residue on the surface of the bed, possibly causing premature corrosion of critical components. Failure to follow the above directions when using these types of cleaners may void this product's warranty.

For mattress cleaning instructions, please see the tag on the mattress, or contact the mattress manufacturer.

Clean Velcro® **after each use**. Saturate Velcro® with disinfectant and allow disinfectant to evaporate. (Appropriate disinfectant for nylon Velcro® should be determined by the hospital.)

Troubleshooting Guide

Note

See the “Bed Circuit Boards” section for an outline of bed PCB’s and voltage test points.

| Problem / Failure | Recommended Action |
|-------------------|--|
| No power to bed. | <ul style="list-style-type: none"> A. Verify the power cord connections at the wall and the bed. B. Check the circuit breakers under the Litter/Fowler section on the patient’s left side. If the circuit breaker is tripped, reset it by pushing in. C. Check for 120VAC at J1 on the power supply, Pin 1 and 2. D. Check for DC voltages on J2 (Pins 1, 2, 3 & 6) on power supply. See “Power Supply” in the Bed Circuit Boards section for power supply voltage test points. <ul style="list-style-type: none"> a. If voltage is present, check connector W on the CPU board and check for the same DC voltages. If OK, go to step E. b. If voltage is not present, unplug connector W on the CPU board and recheck for DC voltages at J2 on the power supply. <ul style="list-style-type: none"> 1. If voltages come back, re-connect cable W to the CPU board and go to step C. 2. If DC voltage does not come back, replace the power supply. a. Unplug all connectors except for F, FF, O, and W from the CPU board and recheck voltages on connector W. <ul style="list-style-type: none"> 1. If DC voltages come back, plug the cable connections back in until problem comes back, isolate the problem to a component or assembly. 2. If DC voltages do not come back, replace the CPU board. E. Check for 120VAC at connector O on the CPU board. <ul style="list-style-type: none"> a. If voltage is present, replace CPU board. F. If the CPU board has been replaced, reconfigure the bed by resetting the: Bed Type, Bed Options, Serial Number, Burn-in Limits (Fowler and Height) and calibrating the scale. G. Verify bed function and return to service. |

Troubleshooting Guide

| Problem / Failure | Recommended Action |
|---------------------|--|
| No bed down motion. | <p>A. Enter diagnostics (see Scale System Diagnostics and Calibration section) and press bed down.</p> <p>a. If motion is not present, verify the two wire connection is present on connector Z.</p> <p>1. Test bed down motion; if motion is present then go to step D.</p> <p>b. If motion is present, re-burn lift potentiometer limits (see Lift Potentiometer “Burn-In” Procedure).</p> <p>B. Check for 5VDC on TP 9 (HL) and TP 7 (FL); reference ground test point while pushing the bed down button.</p> <p>a. If 5VDC is present, go to step C.</p> <p>b. If 5VDC is not present, replace CPU board.</p> <p>C. Check for 120VAC power on connector N (HL) and G (FL), pin 1 white and pin 3 black, of the CPU board, while pressing bed motion up.</p> <p>a. If voltage is not present, replace CPU board.</p> <p>b. If voltage is present:</p> <p>1. Verify the motors are running, if so, replace lift couplers.</p> <p>2. If motors are not running, check voltage at motor connection.</p> <p>3. If voltage is present at motor, check capacitors or motors.</p> <p>D. Verify bed function and return to service.</p> |
| No bed up motion. | <p>A. Enter diagnostics (see Scale System Diagnostics and Calibration section) and press bed up.</p> <p>a. If motion is not present, got to step B.</p> <p>b. If motion is present, re-burn lift potentiometer limits (see Lift Potentiometer “Burn-In” Procedure).</p> <p>B. Check for 5VDC on TP 10 (HL) and TP 8 (FL) on the CPU board; reference ground test point while pushing the bed up button.</p> <p>d. If 5VDC is present, go to step C.</p> <p>e. If 5VDC is not present, replace CPU board.</p> <p>C. Check for 120VAC power on connector N (HL) and G (FL), pin 1 white and pin 6 red, of the CPU board while pressing bed motion up.</p> <p>a. If voltage is not present, replace CPU board.</p> <p>b. If voltage is present:</p> <p>1. Verify the motors are running, if so, replace lift couplers.</p> <p>2. If motors are not running, check voltage at motor connection.</p> <p>3. If voltage is present at motor, check capacitors or motors.</p> <p>D. Verify bed function and return to service.</p> |

Troubleshooting Guide

| Problem / Failure | Recommended Action |
|------------------------|--|
| No Gatch down motion. | <ul style="list-style-type: none"> A. Check for 5VDC on TP4 on the CPU board; reference ground test point while pushing the fowler down button. <ul style="list-style-type: none"> a. If 5VDC is present, go to step B. b. If 5VDC is not present, replace CPU board. B. Check for 120 VAC on connector GG, Pin 1 (white) and pin3 (red), of the CPU board while pressing Fowler down. <ul style="list-style-type: none"> a. If voltage is not present, replace the CPU board b. If 5VDC is present, check the capacitor and motor. C. Verify bed function and return to service. |
| No Gatch up motion. | <ul style="list-style-type: none"> A. Check for 5VDC on TP 3 on the CPU board; reference ground test point while pushing the fowler up button. <ul style="list-style-type: none"> a. If 5VDC is present, go to step B. b. If 5VDC is not present, replace CPU board. B. Check for 120VAC on connector GG, Pin 1 (white) and pin 2 (black), of the CPU board while pressing Fowler up. <ul style="list-style-type: none"> a. If voltage is not present, replace the CPU board b. If 5VDC is present, check the capacitor and motor. C. Verify bed function and return to service. |
| No Fowler up motion. | <ul style="list-style-type: none"> A. Check for 5VDC on TP 6 on the CPU board, reference ground test point while pushing the gatch up button. <ul style="list-style-type: none"> a. If 5VDC is present, go to step B. b. If 5VDC is not present, replace CPU board. B. Check for 120VAC on connector CC, pin 1 (black) and pin3 (white), of the CPU board while pressing gatch up. <ul style="list-style-type: none"> a. If voltage is not present, replace the CPU board b. If 5VDC is present, check the capacitor and motor. C. Verify bed function and return to service. |
| No Fowler down motion. | <ul style="list-style-type: none"> A. Check for 5VDC on TP 5 on the CPU board, reference ground test point while pushing the gatch down button. <ul style="list-style-type: none"> a. If 5VDC is present, go to step B. b. If 5VDC is not present, replace CPU board. B. Check for 120VAC power on connector CC, pin 2 (red) and pin 3 (white), of the CPU board while pressing gatch down. <ul style="list-style-type: none"> a. If voltage is not present, replace the CPU board. b. If 5VDC is present, check the capacitor and motor. C. Verify bed function and return to service. |

Optional Zoom® Troubleshooting Guide

This section of the troubleshooting guide includes the Zoom® self-propelled drive and the battery backup functions. When using this guide, assume the bed is functioning properly when powered by the AC line cord with the exception of the battery charging components.

| Problem/Failure | Possible Cause | Recommended Action |
|---|---|--|
| On/Off switch is in the On position but the power LED is Off and the bed does not function. | No DC voltage from the batteries. | A. Check the circuit breakers at the head end of the bed. B. Verify the battery voltage is greater than 24VDC. C. Check the battery fuse - replace if necessary (2040-001-802). D. Check the cable connections from the batteries to the display board. E. Check the On/Off switch and cabling. |
| On/Off switch is in the on position, the power LED is on but the bed does not function. | Display board is not functioning or is locking out all functions. | A. Check the safety switches on the drive bar. B. Verify the battery voltage is greater than 24VDC. C. Verify the display board is functioning (see note below). D. Check all cable connections on the display and power boards. |
| On/Off switch is in the on position, the power LED is on, the Zoom® drive works but the battery backup does not work. | The thermostat on the inverter/charger board has tripped, indicating a temperature above 110° C (230° F). | A. Wait approximately three to five minutes to allow the inverter/charger board to cool down. |
| The Zoom® drive does not work - the bed does not drive - but all other functions are working. | Zoom® drive circuitry is not responding. | A. Verify the display board is functioning (see note below). B. Perform the “Zoom® Option Control Bar Potentiometer ‘Burn-In’ Procedure”. C. Check the control bar potentiometer. When the bar is centered, there should be 2.25VDC - 2.75VDC between pin 1 and pin 2 on header 1 on the display/CPU board (see “Zoom® Option Display/CPU Board - 2040-031-900”). D. Check all cable connections on the display and power boards. E. Verify the power board is functioning. F. Verify the drive wheel is functioning. |
| The Zoom® drive does work - the bed will drive - but all other bed functions are not working. | No AC power from the Zoom® base. | A. Check AC voltage coming out of the inverter. It should be 120VAC between pin 1 and pin 4 on header 5 on the AC crossover board (see page 52) B. Check all cable connections from the batteries to the converter. C. Check the AC crossover board. |
| The bed power cord is plugged in but the battery does not charge | The battery charger is not functioning. | A. Check the circuit breakers on the litter. B. Check the battery charger. C. Check all cable connections on the charger. |

Note

The display board will display the state of battery charge when the bed is first powered using the On/Off switch:
 Three LED's flash = 66% - 100% charged One LED flashes = less than 33% charged
 Two LED's flash = 33% - 66% charged No LED's flash = No significant charge remaining.

Optional Zoom® Troubleshooting Guide

INVERTER, CHARGER, BATTERY & ZOOM®

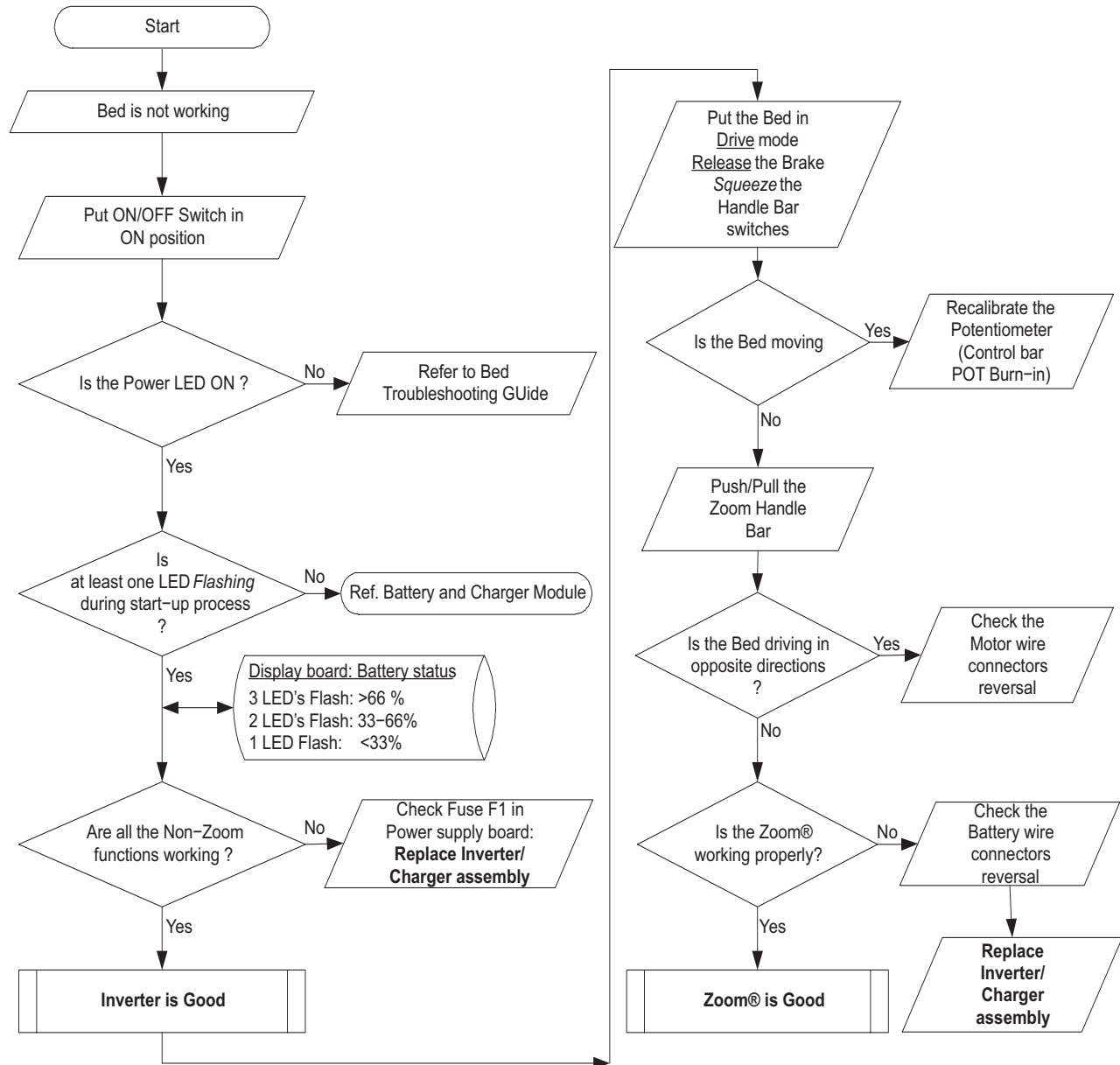

Optional Zoom® Troubleshooting Guide

INVERTER, CHARGER, BATTERY & ZOOM® (CONTINUED)

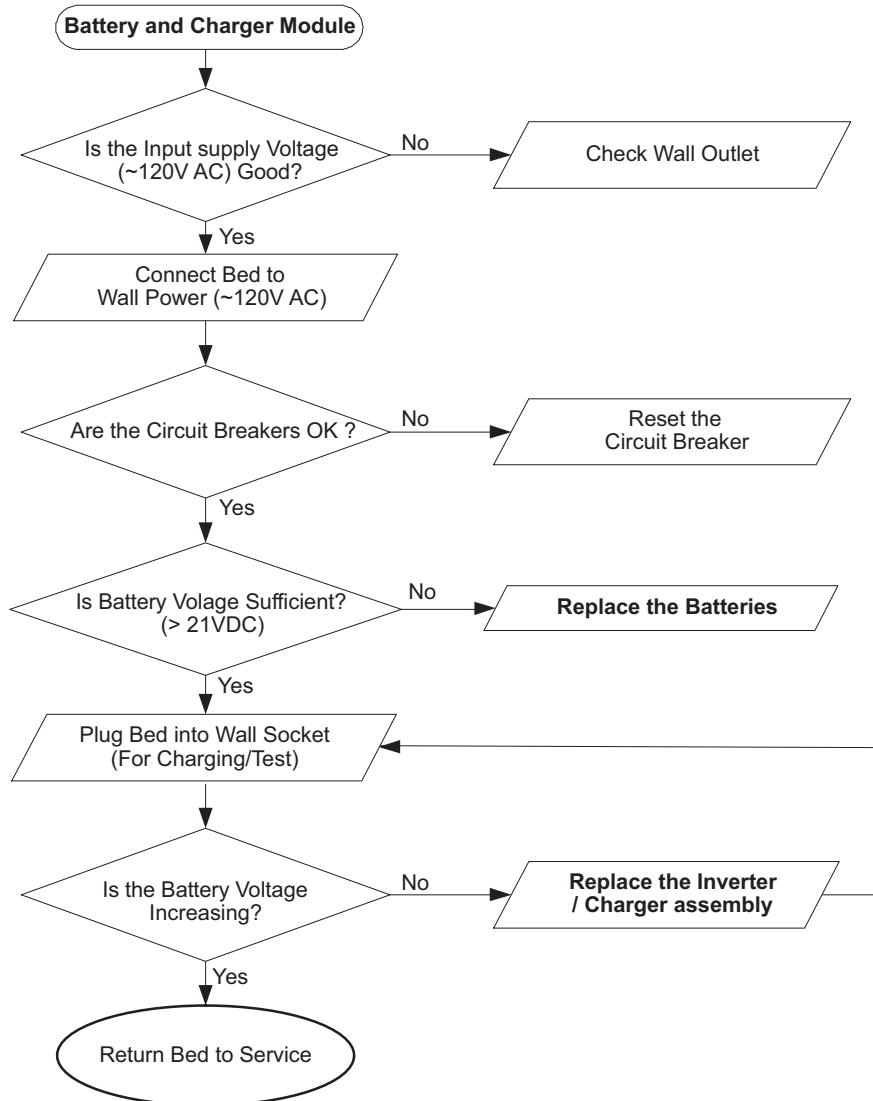

Optional *i*Bed® Wireless Troubleshooting

| Problem / Failure | Recommended Action |
|---|--|
| No Connection to the Wireless Network | <ol style="list-style-type: none"> 1. Unplug the bed from the wall outlet, then plug it back in and wait three minutes. <ol style="list-style-type: none"> a. If the footboard wireless icon shows connection to the wireless network, return the bed to service. b. If the footboard wireless icon does not show connection, go to step 2. 2. Look at the head end of the IR Module to verify if the status of the wireless LED. <ol style="list-style-type: none"> a. If the LED is solid troubleshoot the footboard by swapping it with a known working footboard. b. If the LED is flashing at a one second rate then move the bed to an area with better wireless coverage to see if it will connect to the wireless network. c. If the LED is flashing fast: <ol style="list-style-type: none"> i. Move the bed to an area with better wireless coverage to see if it will connect to the wireless network. ii. Work with IT to troubleshoot the wireless via the Stryker server application. Reference the <i>i</i>Bed® Wireless Server Manual 5212-009-001 |
| No Connection to the <i>i</i> Bed Locator | <ol style="list-style-type: none"> 1. Move the bed to another <i>i</i>Bed Locator to see if it connects. <ol style="list-style-type: none"> a. If it connects, replace the batteries in the original <i>i</i>Bed Locator. Reference the <i>i</i>Bed® Wireless <i>i</i>Bed Locator Manual 5212-009-101. b. If it does not connect, look at the head end of the IR Module to verify the status of the <i>i</i>Bed Locator connection LED. <ol style="list-style-type: none"> i. If it is flashing, move the bed to another locator to test if it connects. ii. If it is not lit, check the IR Module cable connection B in the bed. |

iBed® Awareness System Error Codes

ERROR HANDLING

- The error handling system provides a mechanism for capturing errors known to the product and providing feedback to the operator through logged errors or message errors.
- All Logged errors generate a generic blinking error message which will be displayed on the status screen in the lower area: “Error XXX Call Service”, where XXX is the error code.
- Errors will only be logged if the error log does not already contain the error.
- In the event multiple errors are displayed on the status screen, the error code is used to identify the priority. The lowest code has the highest priority.
- All logged errors and message errors are persistent until the power is cycled or the condition is fixed.
- The details for each logged error and error message are detailed in the table below.

LOGGED ERRORS

| Error Code | Name | Description | Type | Affected Systems |
|------------|--------------------|---|--------|----------------------------------|
| 000 | Not Used | High Priority Exceptions | | |
| 090 | Brake Switch Error | This error is checked while the product is “On.” If one of the two brake wires is disconnected or shorted to 5V then the exception message is shown immediately or upon a change in the brake state. This error shall persist on the display until both the power is cycled and the error condition has been fixed. | Logged | Brake |
| 100 | Not Used | Highest Priority Errors | | |
| 102 | StuckSafetyRelay | This error is checked while the product is “On”. If the safety relay signal is “On” and there is no button pressed on the product then set this error after 1 minute.” Note: This should not be checked when in Auto-Cycle Mode. | Logged | Motion |
| 103 | InputTimer | If any footboard motion or side rail/pendant input is sensed to be “On” continuously for a total of 5 minutes then provide an exception message. Note: This should not be checked when in Auto-Cycle Mode. | Logged | Motion |
| 200 | Not Used | Scale System | | |
| 201 | HL-Load Cell | Patient Head Left Load Cell. Under/Over range. | Logged | Scale, Bed Exit, iBed® Awareness |
| 202 | HR-Load Cell | Patient Head Right Load Cell. Under/Over range. | Logged | Scale, Bed Exit, iBed® Awareness |
| 203 | FL-Load Cell | Patient Foot Left Load Cell. Under/Over range. | Logged | Scale, Bed Exit, iBed® Awareness |
| 204 | FR-Load Cell | Patient Foot Right Load Cell. Under/Over range. | Logged | Scale, Bed Exit, iBed® Awareness |
| 206 | CS5533Fatal | Non-Recoverable Communication Error. CS5533 Fatal occurs when the CPU fails to communicate to the External ADC for the Load cells and cannot recover. | Logged | Scale, Bed Exit, iBed® Awareness |
| 207 | ZeroFail | Zero Fail error occurs when the system cannot provide a stable zero value for three consecutive attempts at zeroing the product. | Logged | Scale, Bed Exit, iBed® Awareness |
| 300 | Not Used | Side Rails | | |
| 301 | HLSRSwitch | Head Left Side Rail Switch General. | Logged | iBed® Awareness |

iBed® Awareness System Error Codes

LOGGED ERRORS (CONTINUED)

| Error Code | Name | Description | Type | Affected Systems |
|------------|--|---|--------|------------------|
| 302 | HRSRSwitch | Head Right Side Rail Switch General. | Logged | iBed® Awareness |
| 303 | FLSRSwitch | Foot Left Side Rail Switch General. | Logged | iBed® Awareness |
| 304 | FRSRSwitch | Foot Right Side Rail Switch General. | Logged | iBed® Awareness |
| 400 | Not Used | Memory System | | |
| 401 | EEPROM | EEPROM Memory Corruption Any detected non recoverable memory failure will produce an error and localize the error to a section of memory. | Logged | |
| 500 | Not Used | Motion System | | |
| 600 | Not Used | Wireless Connectivity System | | N/A |
| 601 | Incompatible Footboard* (*See Note: Incompatible Footboard) | This error occurs when a footboard placed on the bed is not 3006-501-900 rev A or later. This error shall flash in the lower section of the status screen and shall not prevent any product functionality from occurring. | Logged | |
| 602 | Network Connectivity Error | Wireless not on the network | Logged | |
| 603 | IP Conflict | Wireless not on the network | Logged | |
| 604 | IP Renew | Wireless not on the network | Logged | |
| 605 | WiFi Adapter | Wireless not on the network | Logged | |
| 606 | Schema Not Found | Schema file not found | Logged | |
| 607 | Schema Read | Schema file found, but there is a problem reading it | Logged | |
| 608 | Schema Property Mismatch | Property is part of the schema, but not available with Wireless | Logged | |
| 700 | Not Used | CAN Communication | | N/A |
| 701 | CAN Communication Failed | After 3 attempts to communicate to the IR and Wireless, SDO transaction is deemed a failure and this error is set | Logged | |

Note: Incompatible Footboard

If a non-Wireless footboard is installed on a Wireless bed:

- The bed will beep for six seconds on every power up.
- The footboard will display Error 601 (Footboard Incompatible).
- If trying to access the maintenance menu by holding down the **Enter** button on power up, it will not work.
 - a. After powering up and once the Stryker splash screen has appeared, push and hold the **Enter** button.
- When in the maintenance menu, double item selections will appear. They cannot be selected.

To resolve the above issues, install the original Wireless footboard.

iBed® Awareness System Error Codes

ERROR MESSAGES

| Error Code | Name | Description | Type | Affected Systems |
|------------|-------------------|---|------------|------------------|
| 800 | Not Used | Non-Logged Errors | | |
| 801 | NurseCallBattery | When the nurse call battery falls below the 5v threshold a message will appear in the lower status window "N/C Battery Low". | Non-Logged | N/A |
| 803 | FowlerCalibration | When the fowler calibration has not been completed then when in normal mode the message "Fowler Calib. Err" will be displayed in the lower status screen window. | Non-Logged | N/A |
| 804 | ScaleCalibration | Scale Calibration error occurs when the product in a normal operation mode and the scale system is present on the product but the scale system has not been calibrated. The message "Scale Calib. Err" will be displayed in the lower status screen window. | Non-Logged | N/A |

NOTE: The 900 error codes are not logged.

| Error Code | Name | Description | Type | Affected Systems |
|------------|---------------|--|---------|------------------|
| 900 | Not Used | Message Errors - When the timeout for the message error has expired the display should return to the status screen unless otherwise noted or unless a higher priority screen is being handled. | | |
| 901 | ScaleSystem | When turning on the Scale system, using the Scale Button, if a "Logged" error is present that affects the scale system (see affected systems column) the message "Function Disabled - Call Service" will blink. | System | N/A |
| 902 | BedExitSystem | When turning on the Bed Exit system if a "Logged" error is present that affects the scale or bed exit systems (see affected systems column) the message "Function Disabled - Call Service" will blink. Bed Exit will alarm if Bed Exit is armed and a 200 level exception occurs. The message will be displayed "Turn off Bed Exit - Call Service". When the system is disarmed, the display will go back to the status screen. Since the bed exit alarm has the highest priority, if the Bed Exit alarm is tripped due to the error condition this message will not be seen. | Message | N/A |

iBed® Awareness System Error Codes

ERROR MESSAGES (CONTINUED)

| Error Code | Name | Description | Type | Affected Systems |
|------------|----------------------|--|---------|------------------|
| 903 | LBSSystem | <p>When turning on the iBed® Awareness system if a “Logged” error is present that affects the iBed® Awareness system (see affected systems column) the message “Function Disabled - Call Service” will blink.</p> <p>iBed® Awareness will alarm if iBed® Awareness is “On” and a 200 or 300 level Logged error occurs. The message will be displayed “Turn off Awareness - Call Service”, When the system is turned off, the display will go back to the status screen.</p> | Message | N/A |
| 904 | UnknownBedType | Unknown bed type occurs when the configuration switch bank does not contain a value that is recognized by the software. This will cause the product to stop all function and product a message screen indicating the error number and the message “Unknown Bed Type - Call Service” | Message | N/A |
| 905 | CANConnectivity | If the footboard does not see the Main board Heart beat within 10 seconds then the message “Communication Failed - Call Service” | Message | N/A |
| 906 | ScaleFeatures | A message will be displayed when user tries to activate any scale function (Ex. Gain/Loss, Change Equipment...) that is disabled due to a logged scale exception (200 Series). Message “Function Disabled - Call Service” at 0.8 Hz (70% Duty Cycle) for 4 seconds. | Message | N/A |
| 907 | ZeroAttemptFailed | <p>The “Unable to Zero - Try Again” message will flash be displayed when the user tries to zero the bed and the scale system cannot stabilize the weight in time. Note: This applies to any use of the zeroing feature, even if that is within another scale function.</p> <p>If a zero attempt has failed then the scale system will be suspended until a successful zero is saved or the power is cycled. If the scale button is pressed the “Function Not Available - Zero Bed” message will flash.</p> | Message | N/A |
| 910 | LoadCellCheck | The load cells will be checked when the maintenance menu is entered and a message will be displayed if any load cell errors are detected. The message should be displayed “Load Cell Error – HL HR FL FR”. Note: Only the load cells that are in error will be displayed. This message will be persistent until any of the menu type buttons are pressed. | Message | N/A |
| 911 | MenuException | If the footboard menu system is provided with data that is out of range the display will present “Menu Error – Call Service”. The message will persist until a menu state is correct. | Message | N/A |
| 912 | CalibrationException | If the scale calibration routine fails then the message “Calibration Error” will be displayed for 4 seconds and then return to the maintenance menu. | Message | Motion |

[Return To Table of Contents](#)

Quick Reference Replacement Parts List

Note

The parts and accessories listed on this page are all currently available for purchase. Some of the parts identified on the assembly drawing parts in this manual may not be individually available for purchase. Please call Stryker Customer Service USA: 1-800-327-0770 for availability and pricing.

| Part Name | Part Number |
|---|--------------|
| Electrical Components | |
| Footboard Keyboard (S/R Lights, Lockouts, etc.) | 3006-501-011 |
| CPU Board | 3006-308-900 |
| Power Supply | 0059-157-000 |
| Siderail Board, Inside | 3006-400-930 |
| Siderail Board, Outside | 3006-400-910 |
| Siderail Speaker with Cable | 3006-403-831 |
| Siderail Switch Assembly, Head End, Left | 3006-400-120 |
| Siderail Switch Assembly, Head End, Right | 3006-400-220 |
| Siderail Switch Assembly, Foot End, Left | 3006-400-315 |
| Siderail Switch Assembly, Foot End, Right | 3006-400-415 |
| Other Components | |
| Beeper Kit, Bed Exit, High Sounding | 3002-700-030 |
| Capacitor, Fowler | 0059-785-000 |
| Capacitor, Gatch | 0059-783-000 |
| Capacitor, Lift | 0059-786-000 |
| Swivel Lock Caster Assembly | 3006-200-060 |
| Steer Swivel Caster Assembly | 3006-200-065 |
| Coil Cord, Lift Power | 3001-200-864 |
| Coil Cord, Lift Sensor | 3006-200-815 |
| Coil Cord, Litter Power | 3002-300-861 |
| Coil Cord, Litter Signal | 3006-300-808 |
| Fowler Brake Kit | 3001-300-775 |
| Load Cell | 3002-307-057 |
| Release Handle Assembly | 3006-400-570 |
| Main Siderail Cable | 3006-400-862 |
| Assembly, Lift, Head End | 3006-301-201 |
| Assembly, Lift, Foot End | 3006-301-251 |
| Smart TV Auto PCB Assembly | 3003-039-800 |

Quick Reference Replacement Parts List

| Part Name | Part Number |
|--|--------------|
| Other Components (Continued) | |
| Motor Coupler Kit, Lift | 3000-200-725 |
| Motor, Fowler with Clutch | 3006-300-705 |
| Motor, Gatch | 3003-016-602 |
| Motor, Lift (Same for Head and Foot End) | 3003-016-603 |
| Paint, Touch-Up, Bottle with Brush, 102 | 7000-001-147 |
| Paint, Touch-Up, Spray Can | 7000-001-148 |
| Pentimeter, Fowler | 3001-345-807 |
| Potentiometer, Foot End | 3001-200-230 |
| Potentiometer, Head End | 3006-200-240 |
| Power Cord Kit | 3002-700-049 |
| Single Tube of Grease | 3000-200-719 |
| Head/Footboard "C" Bumper Adhesive | 0072-002-071 |
| | |
| Zoom® Option Components | |
| Drive Potentiometer with Cable | 2040-031-804 |
| Drive Train Assembly | 3006-001-014 |
| On/Off Switch | 0059-191-000 |
| Transformer | 3002-001-010 |
| Zoom® Inverter/Charger Board | 3002-001-030 |
| Zoom® Display/CPU Board | 2040-031-910 |
| Zoom® AC Crossover Board | 2040-031-900 |
| Battery, Kit | 2040-700-013 |

Service Information

BRAKE PEDAL REPLACEMENT

TOOLS REQUIRED:

- 5/16" Hex Allen Wrench
- Torque Wrench
- Bungee Cords
- Loctite 242
- Hammer
- Punch
- #2 Phillips Screwdriver

PROCEDURE:

1. Raise the bed to the full upright position.
2. Remove the two uni-pan cover clips (A) holding the uni-pans together.
3. Unplug the bed power cord from the wall socket.
4. Using a #2 Phillips screwdriver, remove the three screws holding both the head end and the foot end upper lift covers. If desired, hold the covers out of the way by using bungee cords (or the equivalent) to secure them to the litter top.
5. Using a 5/16" hex Allen wrench, remove the two bolts holding the brake pedal to the brake rod on the side which needs to be changed.
6. Using a hammer and punch, remove the roll pins holding the brake shaft crank to the brake rod on both the head and the foot end.
7. Push the brake rod through the frame until the brake pedal is clear. Remove the brake pedal.
8. Reverse the above steps to attach the new brake pedal.

Note

Use Loctite 242 when reinstalling the bolts and torque the bolts to 25 foot-pounds.

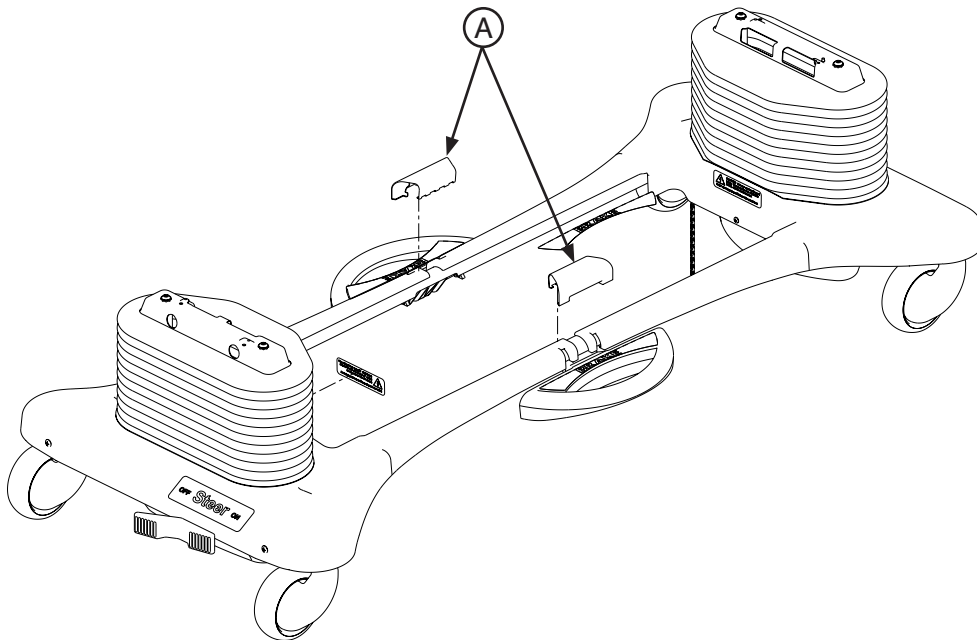

Service Information

LIFT MOTOR AND CAPACITOR REMOVAL AND REPLACEMENT

TOOLS REQUIRED:

- 3/8" Socket Wrench w/Extension
- 5/16" Socket Wrench
- Floor Jack
- Side Cutters
- 7/16" Open End Wrench
- 2x4 (or Equivalent)

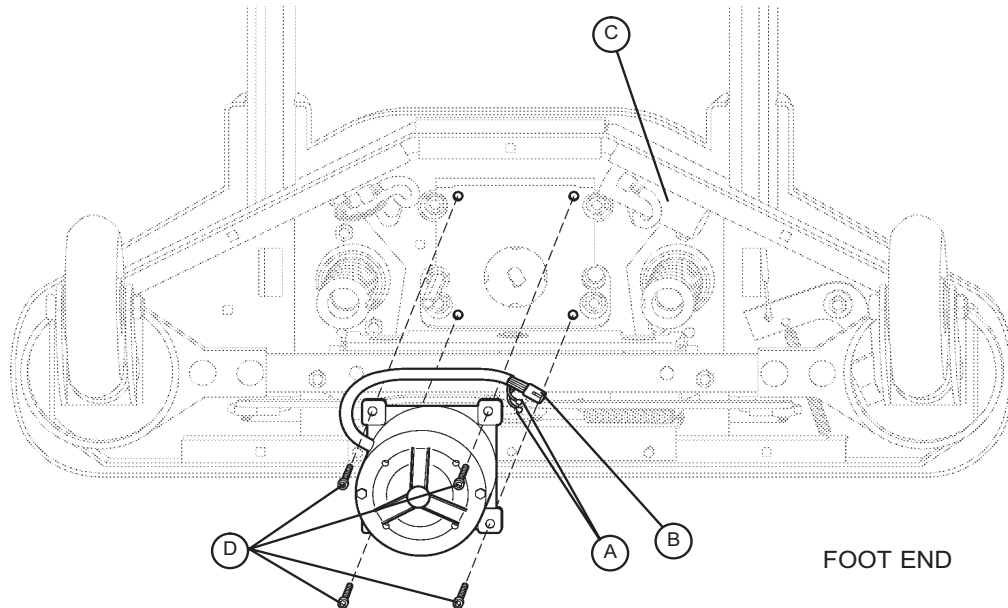

PROCEDURE:

Note

If you need more space to work under the base frame, place a 2 x 4 across the base frame rails and use a floor jack to raise the base frame off the floor.

1. Unplug the bed power cord from the wall socket. Using a 5/16" socket wrench, remove the five bolts holding the lower lift cover to the base and remove the cover.
2. Disconnect the two connectors (A) at the motor capacitor.
3. Disconnect the white connector (B) from the power cord.
4. Using side cutters, cut the cable ties holding the capacitor (C) to the base and remove the capacitor.
5. Using a 3/8" socket wrench, remove the four screws (D) holding the motor assembly in the lift housing and remove the motor assembly.
6. Reverse the above steps to install the new motor.

Note

The drive shaft on the new motor probably will have to be turned to be aligned with the coupler. Use a 7/16" open end wrench to turn the drive shaft of the motor.

The procedure for lift motor and capacitor removal and replacement is the same for both ends of the bed.

Service Information

LIFT HOUSING REMOVAL AND REPLACEMENT

TOOLS REQUIRED:

- #2 Phillips Screwdriver
- Bungee Cord (or equivalent)
- 5/16" Socket Wrench
- Side Cutters
- 9/16" Socket Wrench
- 5/16" Nut Driver
- 7/32" Hex Allen Socket Wrench
- Sawhorses (or equivalent)
- T27 Torx
- 3/8" Socket Wrench (with approximately 6" extension)

PROCEDURE:

1. Unplug the bed power cord from the wall socket.
2. Using a 5/16" socket wrench, remove the five bolts holding the lower lift cover to the base and remove the cover.
3. Remove the uni-pan cover clips.
4. Using a #2 Phillips screwdriver, remove the three screws holding the upper lift cover to the base.
5. If you are working on the foot end of the bed, use a T27 Torx to remove the screw holding the litter access panel to the litter.
6. Remove the lift motor and capacitor (refer to procedure "Lift Motor and Capacitor Removal and Replacement").
7. Remove lift potentiometer (refer to procedure "Lift Potentiometer Replacement and Adjustment").
8. Using a 5/16" socket wrench, remove the cable clamps holding the power and sensor coil cords on top of the lift housing assembly. Cut the cable ties and disconnect the coil cords from under the lift housing. The power and sensor coil cords are now free of the lift housing assembly. Drape them up out of the way.
9. Using a 7/32" hex Allen socket, remove the two screws (A) holding the lift screws to the header crossbar plate.

CAUTION

The bed litter retracts on rollers. Secure it to prevent it from rolling while the procedure is being done.

Service Information

LIFT HOUSING REMOVAL AND REPLACEMENT (CONTINUED)

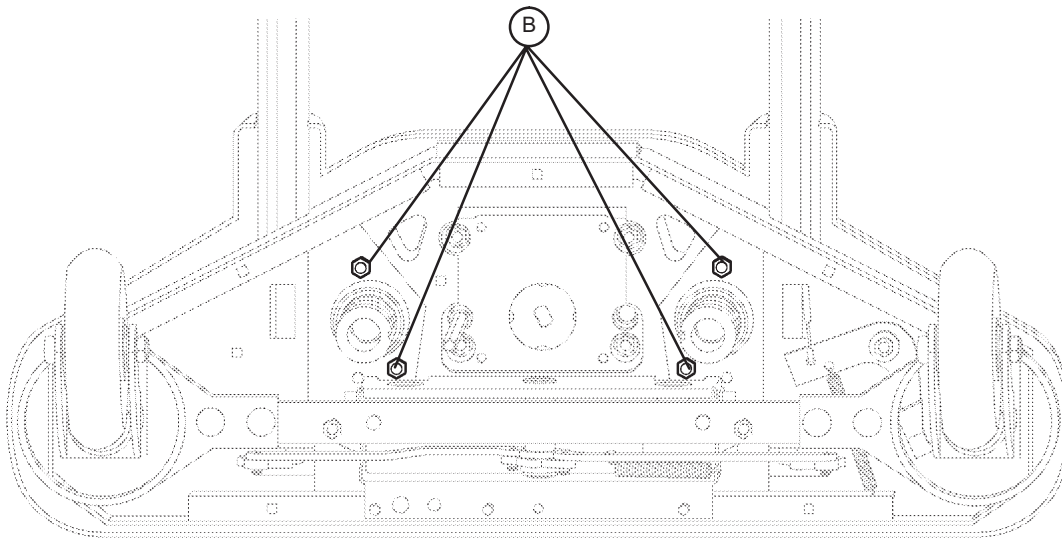

FOOT END – BOTTOM VIEW

9. Lift the litter top up and support it about 6" above the lift screws with sawhorses or the equivalent.
10. Under the base, using a 9/16" socket, remove the four nuts (B) holding the lift housing to the base.
11. Lift up and out on the lift housing assembly to remove it from the base.

 **CAUTION**

See "Power and Sensor Coil Cord Replacement" section for proper reattachment procedure for power and sensor coil cords and "Lift Potentiometer Replacement and Adjustment" for reattachment of the lift potentiometer.

12. Reverse the above steps to reinstall the lift housing assembly after service is completed.

Note

The procedure for lift housing removal and replacement is the same for both ends of the bed.

Service Information

LIFT POTENTIOMETER REPLACEMENT AND ADJUSTMENT

TOOLS REQUIRED:

- #2 Phillips Screwdriver
- Bungee Cord (or equivalent)
- 5/16" Socket Wrench
- 3/8" Open End Wrench
- Side Cutters

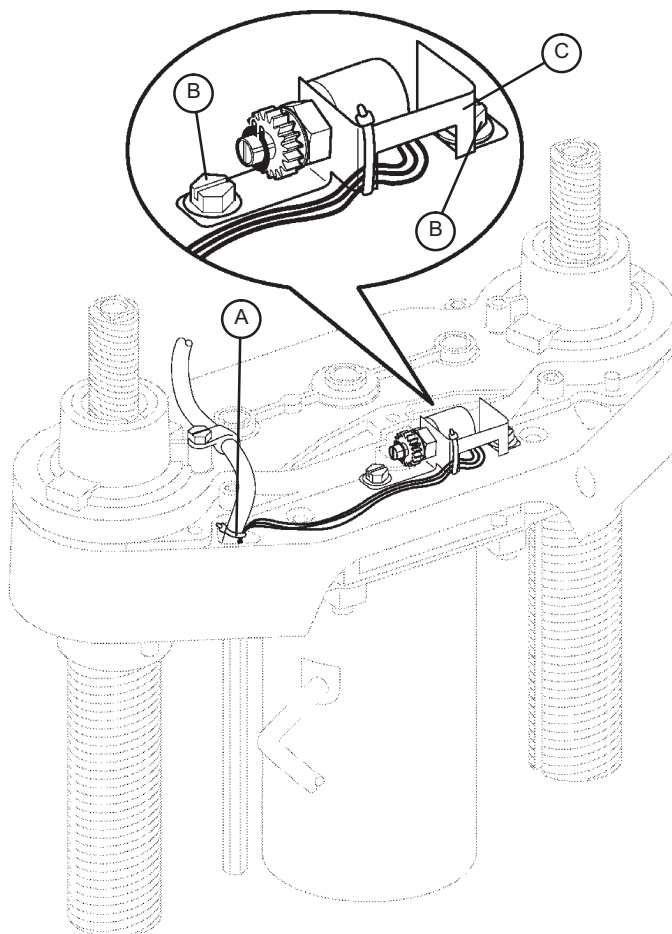

PROCEDURE:

1. Raise the bed to the full upright position.
2. Unplug the bed power cord from the wall socket.
3. Using a 5/16" socket wrench, remove the five bolts holding the lower lift cover to the base and remove the cover.
4. Using a #2 Phillips screwdriver, remove the three screws holding the upper lift cover to the base.
5. Remove the uni-pan cover clips.
6. Using side cutters, cut the cable tie (A) holding the potentiometer cable to the coil cord.
7. Unplug the potentiometer cable from the sensor coil cord. If replacing a potentiometer at the head end of the bed, unplug the cables attached to the brake sensor switch.
8. Pull the potentiometer cable up through the base.
9. Using a 3/8" open end wrench, remove the two bolts (B) holding the potentiometer housing (C) to the lift housing.
10. Lift up and out on the potentiometer housing assembly to remove it from the lift housing.
11. Before installing the new potentiometer on the bed, turn it clockwise until it stops. Turn it back counterclockwise two full (360) revolutions. This allows a "window" position for proper upper and lower limits.
10. Reverse steps 4-8 to install the new potentiometer and potentiometer housing assembly.
11. After installing the new potentiometer, the "burn-in" procedure below must be followed.

Note

Be sure to maintain the potentiometer position while installing.

Service Information

LIFT POTENTIOMETER “BURN-IN” PROCEDURE

1. Unplug the bed power cord from the wall socket.
2. On the footboard control panel, hold down the Bed Motion Lock, Gatch Lock, and Reverse Trend buttons simultaneously. While still holding down the buttons, plug the power cord into the wall socket. Release the footboard button. Scroll down to the “Burn-In” menu item and press enter. Then select the “Burn-In Height” item. Based on the type of bed, a message will be displayed. This message will indicate to the user whether to run the bed all the way down or all the way up.
3. On a bed without the Zoom® power drive option, run both ends of the bed full down to a “hard stop”. On a bed with the Zoom® option, run both ends of the bed full up to a “hard stop”.
4. Hold down the Bed Motion Lock button until the light flashes.
5. Release the button and unplug the power cord from the wall socket.
6. Plug the power cord back in to the wall socket. Run the bed to full up, then full down to verify the bed limits.
7. The distance between the floor and the top of the litter seat section on a standard Secure bed (without a mattress) should be 16” - 16 3/8” with the litter fully down and 29 1/4” - 29 7/8” with the litter fully up.
The distance between the floor and the top of the litter seat section on a Secure Zoom® bed (without a mattress) should be 19.5” with the litter fully down and 30” - 30 1/4” with the litter fully up. The distance between the floor and the top of the litter seat section on a Secure short bed with Zoom® (without a mattress) should be 20.5” with the litter fully down and 30” - 30 1/4” with the litter fully up.

Note

These values are for beds equipped with 6” casters.

WARNING

Ensure there is no patient on the bed while the burn-in procedure is being performed.

Service Information

LIFT MOTOR ISOLATION PLATE REPLACEMENT

TOOLS REQUIRED:

- 7/16" Open End Wrench
- 5/16" Nut Driver or 5/16" Socket Wrench
- 3/8" Socket Wrench (with 6" ext.)

PROCEDURE:

1. Unplug the bed power cord from the wall socket.
2. Using a 5/16" socket wrench, remove the five bolts securing the lower lift cover and remove the cover.
3. Using a 3/8" socket with a 6" extension, remove the four bolts (C) holding the lift motor isolation plate to the lift housing and carefully lower the isolation plate to the floor.
4. Remove the motor coupler (A) and bushings (B).
5. Using a 3/8" socket, remove the bolts and washers (E) from the motor and remove the isolation plate (D).
6. Reverse the above steps to install the new isolation plate and reattach all components to the bed.

Note

When reinstalling the lift motor, the drive shaft on the motor will have to be turned to be aligned with the coupler. Use a 7/16" open end wrench to turn the drive shaft of the motor.



WARNING

Ensure there is no patient on the bed while the procedure is being performed.

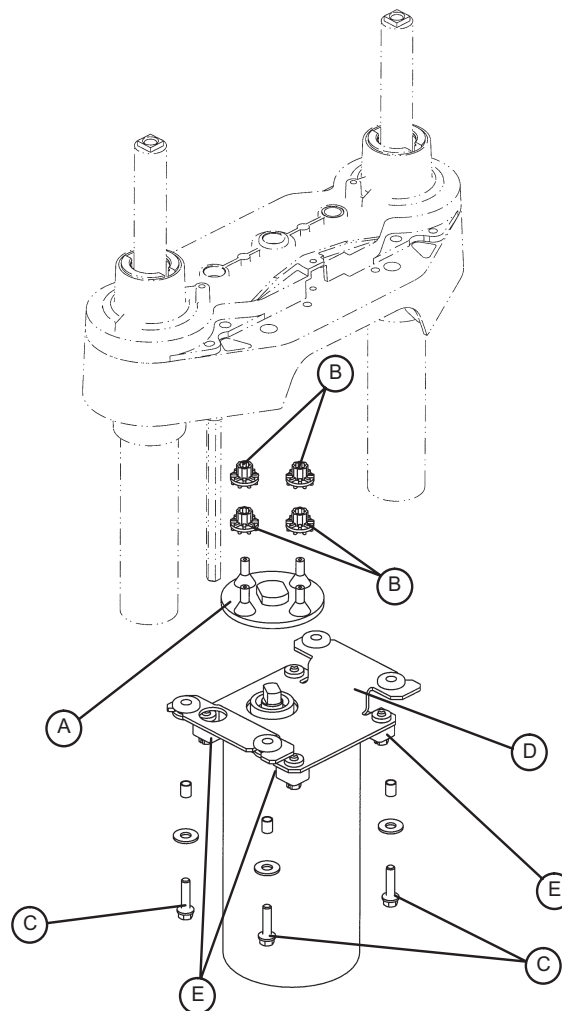

Service Information

LIFT MOTOR COUPLER REPLACEMENT

TOOLS REQUIRED:

- 5/16" Socket Wrench
- 3/8" Socket Wrench (with 6" Extension)
- Floor Jack
- 2x4 (or equivalent)

PROCEDURE:

Note

If you need more space to work under the base frame, place a 2 x 4 across the base frame rails and use a floor jack to raise the base frame off the floor.

1. Unplug the bed power cord from the wall socket.
2. Using a 5/16" socket wrench, remove the five bolts holding the lower lift cover to the base and remove the cover.
3. Using a 3/8" socket with an extension, remove the four bolts (A) holding the isolation plate (B) to the lift housing and lower the lift motor and isolation plate assembly to allow access to the coupler (C).
4. The motor coupler can now be removed from the lift housing.
5. Reverse the above steps to install the new motor coupler and bushings.

WARNING

Ensure there is no patient on the bed while the replacement procedure is being performed.

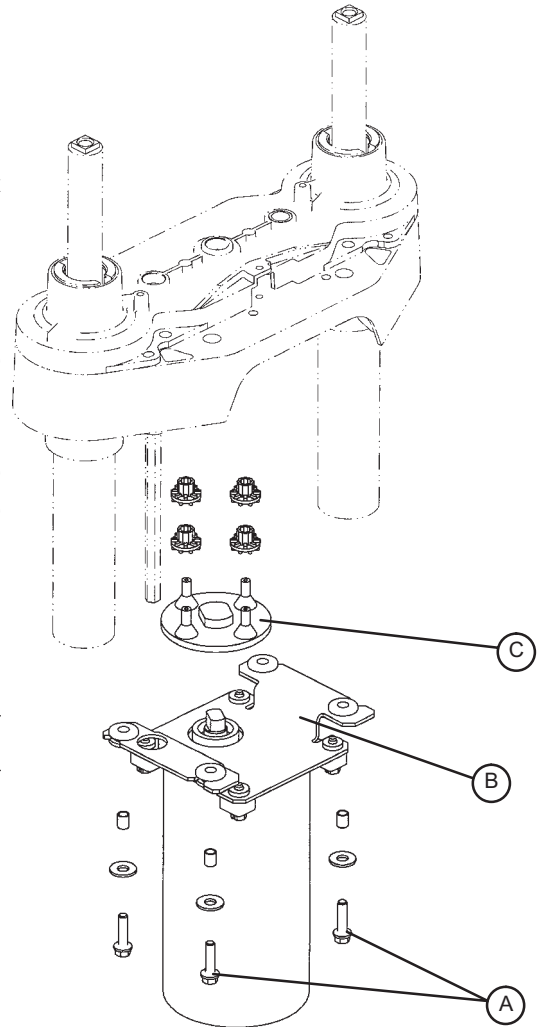

Service Information

POWER AND SENSOR COIL CORD REPLACEMENT

TOOLS REQUIRED:

- #2 Phillips Screwdriver
- Side Cutters
- 5/16" Socket Wrench
- Bungee Cord (or equivalent)
- 5/16" Nut Driver
- Floor Jack
- 2x4 (or equivalent)

PROCEDURE:

Note

If you need more space to work under the base frame, place a 2 x 4 across the base frame rails and use a floor jack to raise the base frame off the floor.

1. Unplug the bed power cord from the wall socket.
2. Using a 5/16" socket wrench, remove the five bolts holding the lower lift cover to the base and remove the cover.
3. Using a #2 Phillips screwdriver, remove the three screws holding the upper lift cover to the base. If you want, hold the covers out of the way by using bungee cords (or the equivalent) to secure them to the litter top.
4. Using side cutters, cut the cable ties holding the power and sensor coil cords to the base. Remove the ground wire coming from the sensor cord that is attached to the base (note the star washer arrangement).
5. Disconnect the cables going to the motor and the lift potentiometer (at the head end, the sensor cord is also attached to the brake switch sensor).
6. Pull both cords up through the frame of the bed and the lift housing.
7. Using a 5/16" socket wrench, remove the two screws (A) holding the cable clamps* to the top of the lift housing.
8. Using a 5/16" socket wrench, remove the two screws (B) securing the cable clamps* to the underside of the header crossbar assembly.
9. Pull both coil cords up through the header crossbar assembly.
10. Disconnect the power and sensor coil cords from the connectors.
11. The cords should now be completely removed from the bed. Reverse the above steps to install the new power and sensor cords.*

CAUTION

* When replacing the power and sensor coil cords, secure the cable clamps to the cords at the first coil both on the top and on the bottom to ensure there is not too much slack in the cords between the top of the lift housing assembly and the bottom of the header crossbar. Be sure the clamps are fastened at exactly the correct angle, as shown by the arrows in the illustration. Arrange the cords exactly as shown in the illustration (left in front of right). **If this is not done correctly, damage to the cords will result.**

WARNING

Ensure there is no patient on the bed while the replacement procedure is being performed.

Service Information

POWER AND SENSOR COIL CORD REPLACEMENT ILLUSTRATION

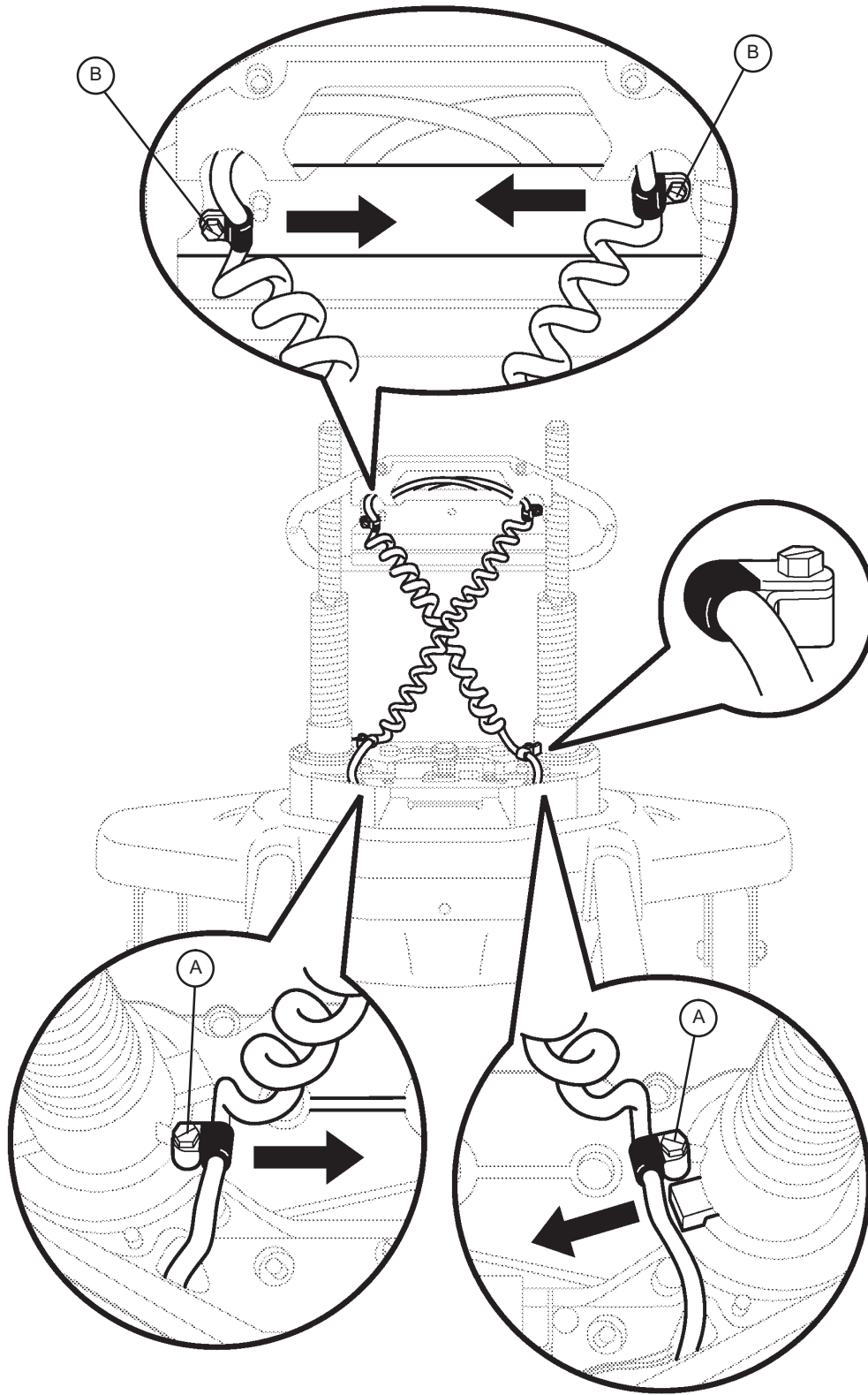

View from Center of Bed

Service Information

KNEE MOTOR REMOVAL AND REPLACEMENT

TOOLS REQUIRED:

- T27 Torx
- Needle Nose Pliers
- 3/8" Socket Wrench
- Wire Cutters

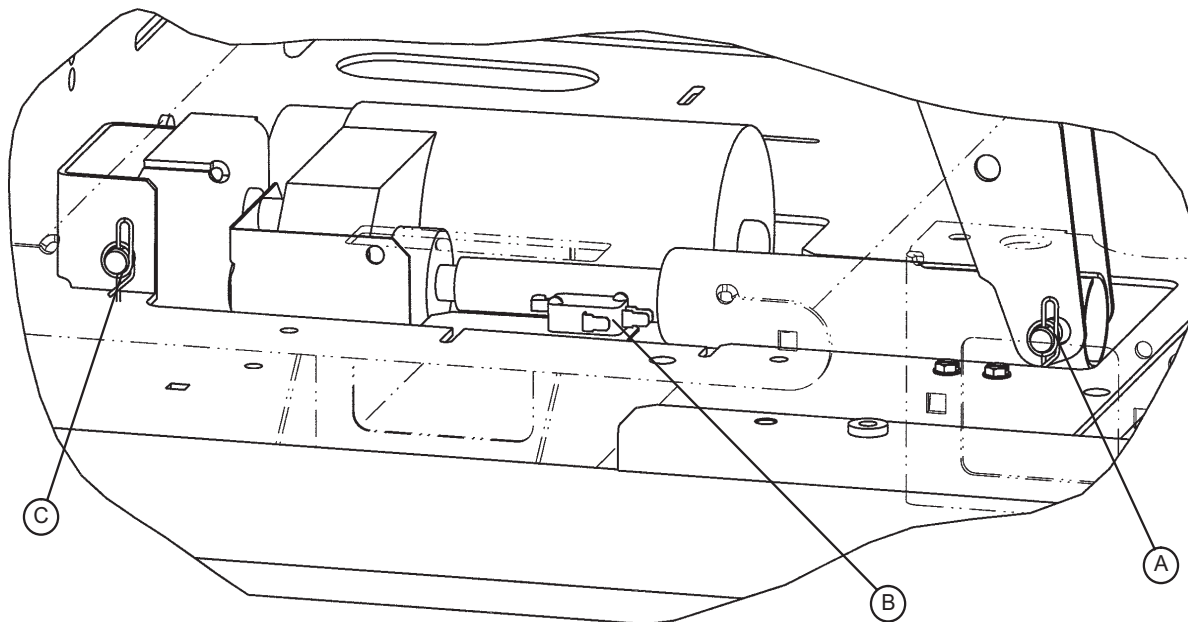

PROCEDURE:

1. Electrically run the litter fully up. Unplug the bed power cord from the wall receptacle.
2. Using a 3/8" socket wrench, remove the two bolts holding the motion interrupt pan to the litter frame and remove the pan.
3. Using needle nose pliers, remove the Rue pin (A) from the end of the drive tube.
4. Fold the Gatch section back toward the head end of the bed. Using a T27 Torx, remove the screw holding the mid-litter cover to the litter frame and remove the cover.
5. Remove the two wires from the auto contour micro switch (B) mounted next to the drive tube.
6. Using wire cutters, remove the cable ties. Disconnect the motor and capacitor wires.
7. Using needle nosed pliers, remove the Rue pin (C) from the motor bracket and lift the motor out.
8. Using a 3/8" socket wrench, remove the four bolts holding the motor bracket to the old motor. Remove the bracket and install it on the replacement motor using the same four bolts.
9. Install the replacement motor into the bed. Do not hook up the drive tube to the Gatch section yet.
10. Plug the bed power cord into a properly grounded wall receptacle. Using the button on the footboard or siderail, run the Gatch motor down until it stops.
11. Reinstall the mid-litter cover.
12. Fold the Gatch section back down. From underneath the bed, manually turn the drive tube in or out until it lines up with the hole in the Gatch section. Reinstall the pin, the wires for the auto contour switch, and the motion interrupt pan.
13. Test the bed for proper operation before returning it to service.

WARNING

Ensure there is no patient on the bed while the replacement procedure is being performed.

Service Information

FOWLER MOTOR CAM AND CAM GUIDE REPLACEMENT

TOOLS REQUIRED:

- 5/16" Nut Driver
- 3/8" Socket Wrench
- T27 Torx

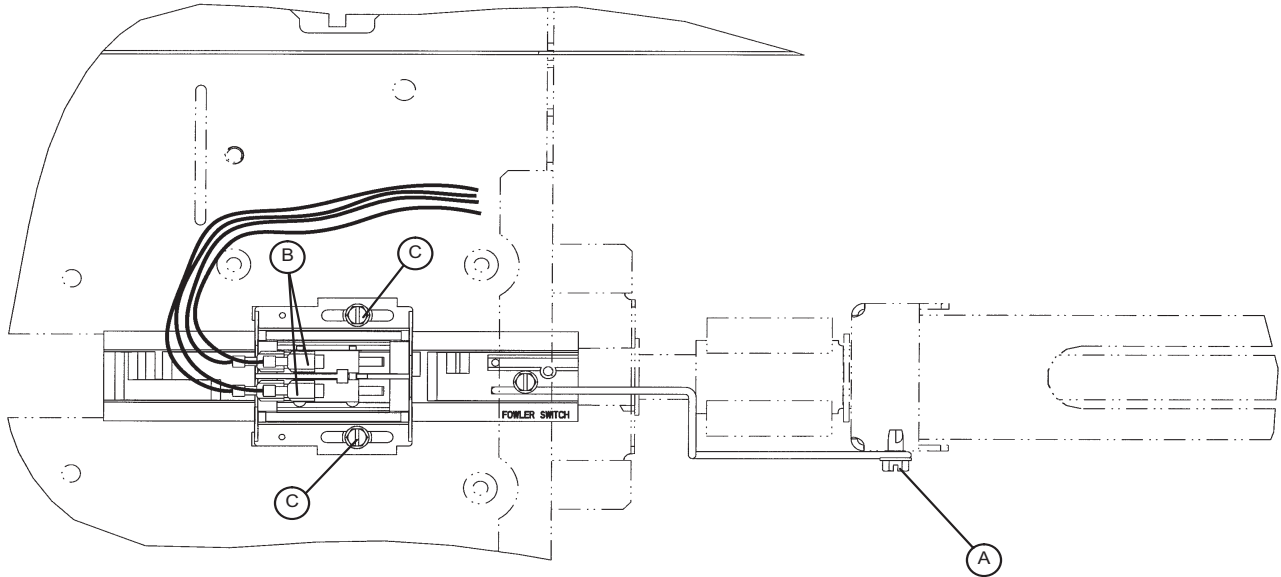

PROCEDURE:

1. Run the Knee Gatch fully up. Unplug the bed power cord from the wall socket.
2. Using a T27 Torx, remove the screw holding the foot end litter cover to the frame and remove the cover.
3. Using a 3/8" socket wrench, remove the two bolts holding the motion interrupt pan to the litter and remove the pan.
4. Using a 5/16" nut driver, remove the screw (A) holding the cam retention wire to the ball nut assembly.
5. Disconnect the cables (B) from the micro-switches. Take note of the locations of the cables so they will be connected properly to the replacement cam.
6. Using a 5/16" nut driver, remove the two screws (C) holding the cam and cam guide to the support bracket and remove the cam and cam guide with the attached micro-switches from the bed.
7. Reverse the above steps to install the replacement cam and cam guide/micro switch assembly.
8. Refer to "Limit Setting - Head Motor" section.

WARNING

Ensure there is no patient on the bed while the replacement procedure is being performed.

Service Information

LIMIT SETTING - FOWLER MOTOR

TOOLS REQUIRED:

- 5/16" Nut Driver
- T27 Torx

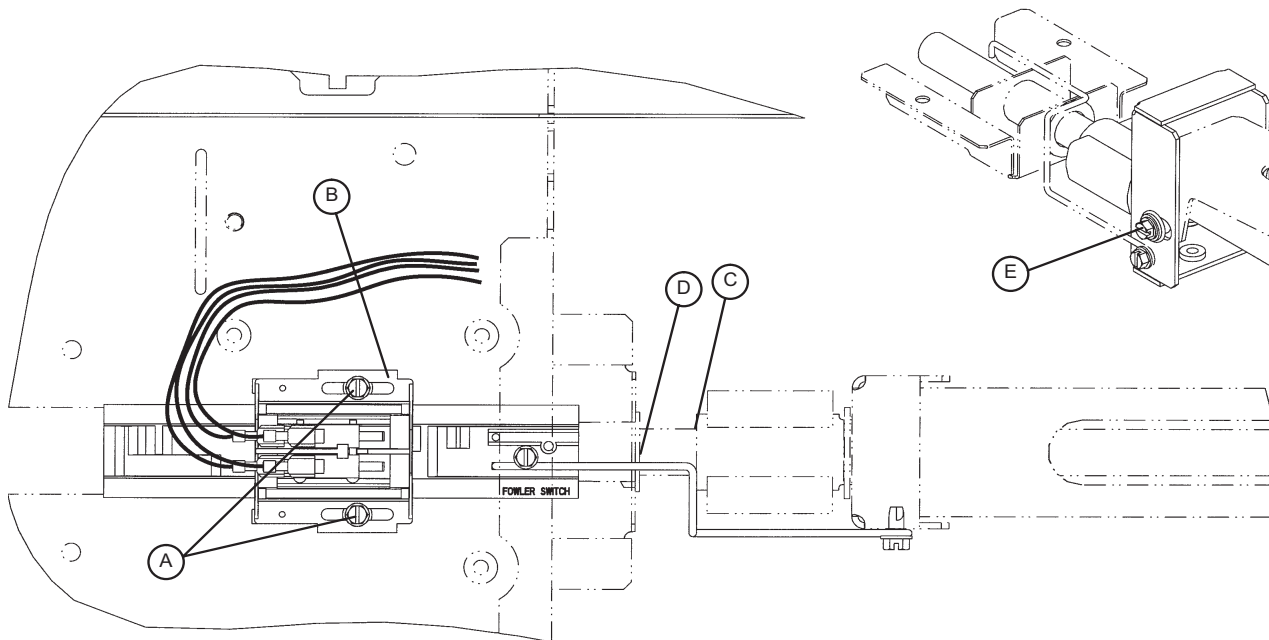

PROCEDURE:

1. Run the Knee Gatch fully up.
2. Using a T27 Torx, remove the screw holding the midsection litter access covers to the litter and remove the covers.
3. Run the head section down electrically until flat (0) or use the CPR release handle to fully lower the head.
4. Lightly tap the Fowler down button until the bolt and bushing (E) are centered in the slot.
5. Unplug the power cord from the wall socket.
6. Using a 5/16" nut driver, loosen the two screws (A) on the cam (B).
7. Slide the cam toward the head of the bed just until the micro-switch is activated (the switch will make a clicking noise).

Note

Check that the cam "bump" is on the "head" side of the switch actuator.

8. Tighten the two screws (A).

CAUTION

Be sure the head section stops when it is fully up and the ball nut bracket (C) is approximately 3/4" from panel (D). If not, damage to the unit could result.

9. Ensure the head section will lower to flat (0) before returning the bed to service. Verify the head section lowers onto the rubber rests and the motor stops running. Reinstall the litter access panels removed in step 1.

Service Information

FOWLER MOTOR REMOVAL AND REPLACEMENT

TOOLS REQUIRED:

- 3/8" Socket
- 7/16" Socket
- 3/8" Drive Ratchet

PROCEDURE:

WARNING

The head motor is not grounded and may be an electrical hazard. Use caution when working around motors.

CAUTION

Ensure the fowler is lowered all the way down.

1. Using the CPR release, lower the Fowler to a flat (0 degrees) position.
2. Unplug the bed power cord from the wall socket.
3. Using a 3/8" socket, remove the two bolts at the foot end of the motion interrupt pan and remove the pan.
4. Using a 7/16" socket, remove the four bolts holding the motor bracket to the bed frame as shown. Remove the motor.

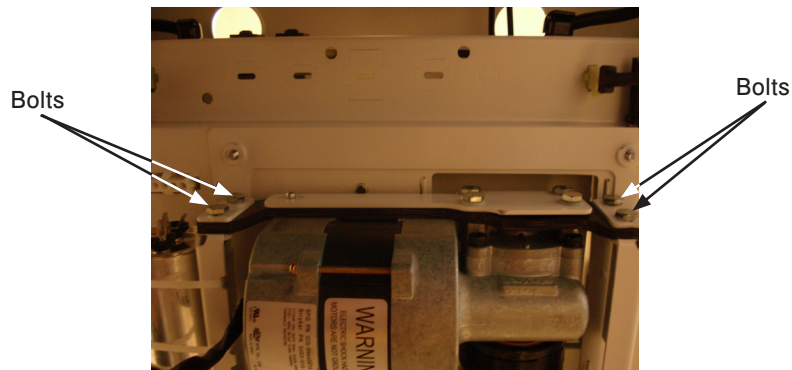

Note

Use caution when removing the motor to avoid having the coupler come off the ball screw shaft.

5. Unplug the head motor cables from the bed and capacitor.
6. Prior to installing the new motor assembly, apply a light coat of Syn-Tech grease (p/n 3000-200-700) to the brake spring.
7. Reverse the above steps to install the new motor assembly and reattach all litter panels.
8. Test the bed for proper operation before returning it to service.

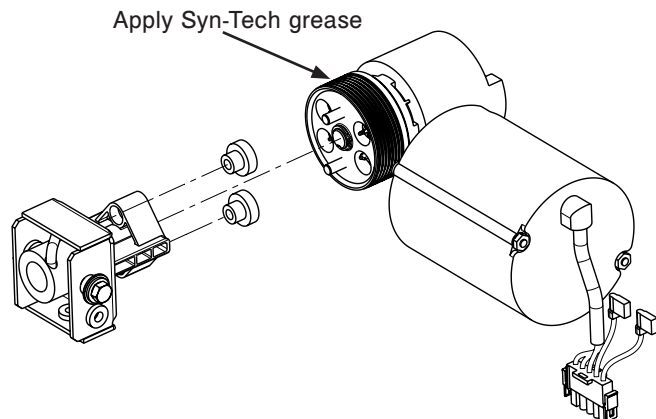

Service Information

FOWLER MOTOR DRIVE ISOLATOR AND CPR DECOUPLER REMOVAL AND REPLACEMENT

TOOLS REQUIRED:

- 3/8" Socket Wrench
- Needle Nose Pliers

PROCEDURE:

1. Refer to the "Fowler Motor Removal and Replacement" procedure to access the isolator, springs and decoupler.
2. Pull the drive isolator (C) with the grommets (D), springs (B) and CPR decoupler (A) off the drive screw and remove it from the litter.
3. To reinstall, put the decoupler (A) on the shaft.
4. Using needle nose pliers, bend the end of the springs (B) out slightly to help hold the springs in the isolator. Put the springs in the isolator and install it on the shaft.
5. Reinstall the fowler motor (see "Fowler Motor Removal and Replacement" section).
6. Run the Fowler up and down several times to test it before returning the bed to service.

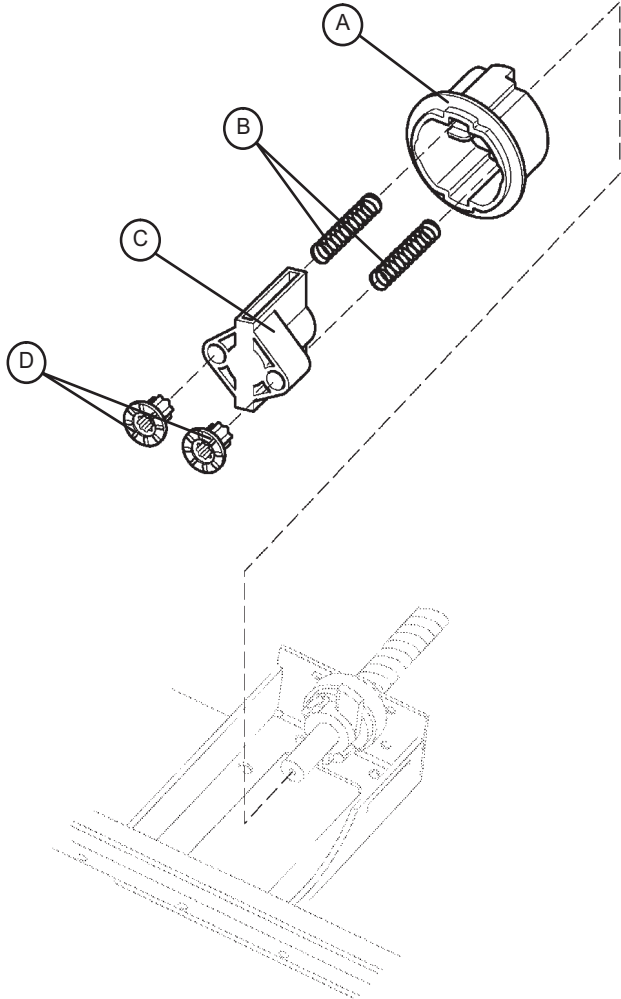

Service Information

FWLER MOTOR BALL SCREW ASSEMBLY REPLACEMENT

TOOLS REQUIRED:

- Large Snap-Ring Pliers
- 3/8" Socket
- 3/8" Ratchet
- Needle-Nose Pliers

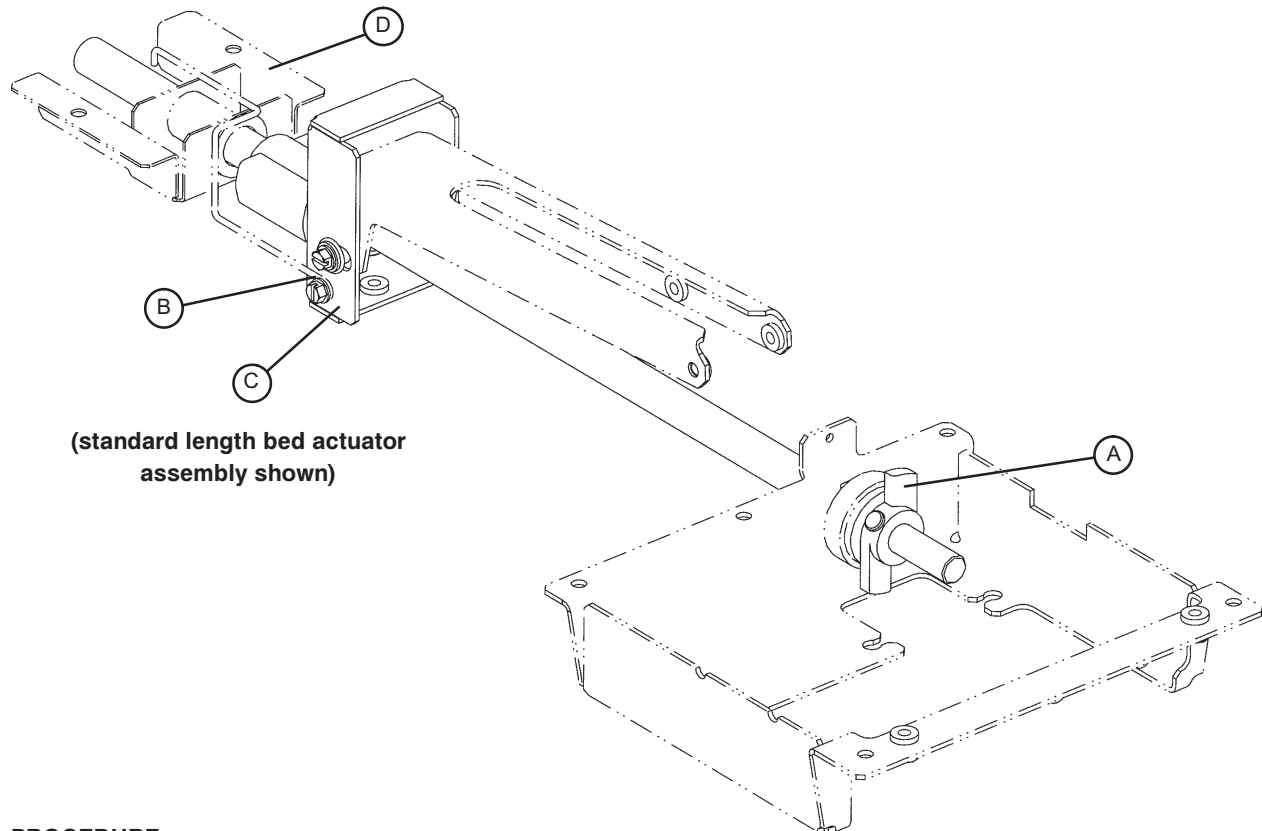

PROCEDURE:

1. Run the bed fully up. Unplug the bed power cord from the wall socket.
2. Using a 3/8" socket, remove the two bolts holding the motion interrupt pan to the litter and remove the pan.
3. Remove the fowler motor (see "Fowler Motor Removal and Replacement" section) for access to the ball screw assembly.
4. Remove the fowler motor drive isolator and CPR decoupler (see "Fowler Motor Drive Isolator and CPR Decoupler Removal and Replacement" section).
5. Using needle nose pliers, remove the cotter pin holding the clevis pin to the drive screw "wing" (A).
6. Remove the clevis pin and slide the wing and tapered roller bearing off the ball screw.
7. Using a 3/8" socket, underneath the litter, remove the screw holding the cam wire link (B) to the ball screw assembly.
8. Using a 3/8" socket, remove the two bolts holding the ball screw support bracket (D) to the bottom of the litter and remove the bracket.
9. Using large snap ring pliers, remove the snap ring holding the ball screw to the bracket (C).
10. To prevent the ball nut from coming off the drive screw, cable tie both ends of the ball screw.
11. Pull the ball screw toward the foot of the bed and remove the head end of the ball screw assembly from the support.

Service Information

Fowler Motor Ball Screw Assembly Replacement (Continued)

Note

Do not allow the ball nut assembly to come off the drive screw. The ball nut will be shipped attached to the drive screw and retained in position during shipment. Remove the wire ties after installing the drive screw assembly.

12. Remove the thrust washers and bearing from the head end of the drive screw and set them aside.
13. Reverse the above steps to install the replacement ball screw assembly.

Note

Apply grease to all bearing areas.



CAUTION

Verify the fowler motor stops properly at both upper and lower electric limits. If it does not, refer to “Limit Setting - Fowler Motor”.

HEAD MOTOR BRAKE/CLUTCH REPLACEMENT

TOOLS REQUIRED:

- 3/8” Socket Wrench
- Snap Ring Pliers
- 9/16” Socket Wrench
- 9/16” Box End Wrench
- Wire Cutters

PROCEDURE:

1. Remove the fowler motor (see “Fowler Motor Removal and Replacement” section).
2. Using snap ring pliers, remove the snap ring from the motor shaft.



CAUTION

The brake/clutch is spring-loaded. Use caution when removing the snap ring so the parts do not drop to the floor.

3. Remove the old brake/clutch from the motor and discard it.
4. Using a 9/16” socket wrench and a 9/16” box end wrench, remove the nut, bolt and washers from the new brake/clutch.
5. Install the new brake/clutch onto the motor. It may be necessary to turn the motor shaft to line up the key way with the brake/clutch.
6. Using the snap ring pliers, install the new snap ring.
7. Using the wire cutters, remove the four wire ties from the new brake/clutch.
8. Reinstall the fowler motor (see “Fowler Motor Removal and Replacement” section)
9. Test the bed for proper operation before returning it to service.

Service Information

LOAD CELL REPLACEMENT

TOOLS REQUIRED:

- 1/4" Hex Allen Wrench
- Wire Cutters

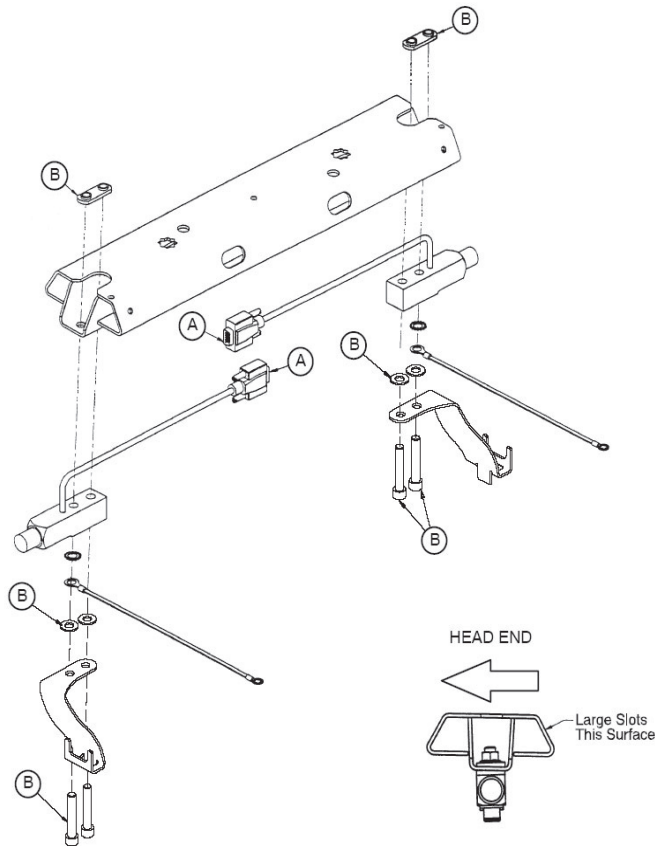

PROCEDURE:

1. Unplug the bed power cord from the wall socket.
2. Support the corner of the litter where the load cell is being removed.
3. Unplug the load cell connector (A) from the load cell cable. Using the side cutters, cut the cable ties.
4. Using a 1/4" hex Allen wrench, remove the screws, washers, and nuts (B) holding the load cell to the bed.
5. To remove a load cell at the head end of the bed, slide the load cell toward the center of the bed to clear the bushing that supports the load cell. Remove the load cell by lifting it up and out. To remove a load cell at the foot end of the bed, slide the load cell with the roller bushing toward the center of the bed to clear the litter frame. Remove the load cell and the roller bushing by lifting them up and out.
6. Reverse the above procedure to install the new load cell.

CAUTION

Be sure the load cell's strain gauge is facing up when installing a new load cell or the weigh system will not work properly.

7. Recalibrate the weigh system (see "Scale Calibration" in "Scale System Diagnostics and Calibration" section).

Service Information

LOAD CELL REPLACEMENT - GREASE POINTS

1. Apply Syn-Tech NS-18191-G grease to rollers on the Lift Header Assembly as shown in figure below.

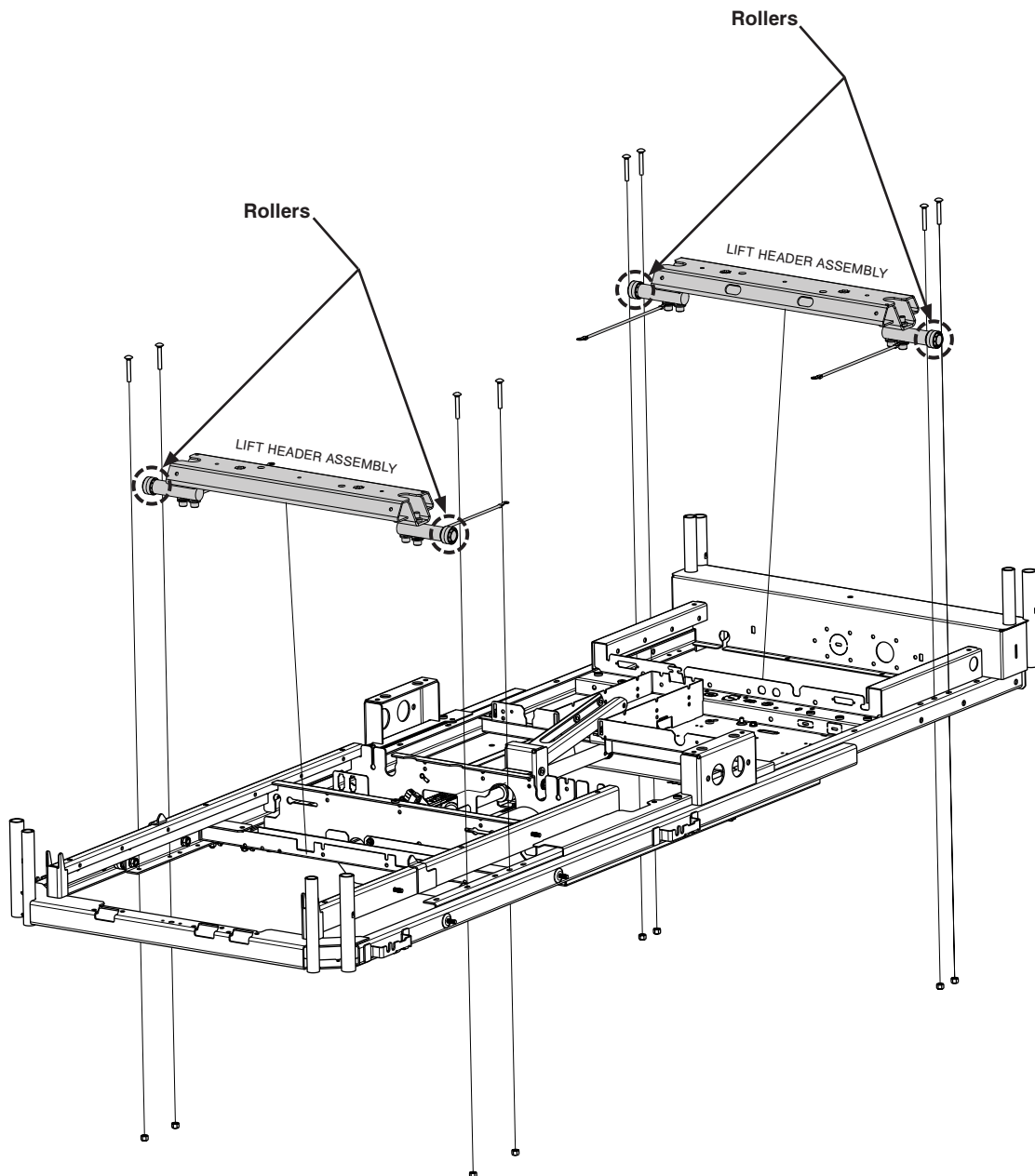

Litter Assembly (Reference p/n: 3006-300-197)

Service Information

POWER SUPPLY REPLACEMENT

TOOLS REQUIRED:

- #2 Phillips Screwdriver
- T27 Torx

PROCEDURE:

1. Adjust the Fowler to approximately 25-30. Unplug the bed power cord from the wall socket.
2. Properly ground yourself (see “Static Discharge Precautions” section, [page 19](#)).
3. Using a T27 Torx, remove the two screws holding the head end litter access cover and remove the cover.
4. Disconnect all cables at the power supply. Note the locations of the cables so they will be reconnected properly to the replacement power board.
5. To remove the board from the litter standoffs, use a #2 Phillips screwdriver to remove the four screws holding the board to the litter. Remove the board.
6. Install the new board and reconnect all cables.
7. Reinstall the litter access panel and plug the bed power cord into a properly grounded wall receptacle.
8. Test the bed for accurate operation before returning it to service.

CPU BOARD REPLACEMENT

TOOLS REQUIRED:

- T27 Torx Driver

PROCEDURE:

1. Adjust the Fowler to approximately 25-30. Unplug the bed power cord from the wall socket.
2. Properly ground yourself (see “Static Discharge Precautions” section, [page 19](#)).
3. Using a T27 Torx, remove the two screws holding the head end litter access cover and remove the cover.
4. Disconnect all cables at the litter CPU board. Note the locations of the cables so they will be connected properly to the replacement litter CPU.
5. To remove the board from the litter standoffs, pull out on the retention clips and lift upward on the board.
6. Install the new board and reconnect all cables.
7. Reinstall the litter access panel and plug the bed power cord into a properly grounded wall receptacle.
8. Before installing new CPU, mirror the dip switch settings (SB1, SB2, SB3 and SB4) of the old CPU to the new CPU (see “CPU Board - 3006-308-900” section, [page 107](#)).
9. When a new CPU board is installed, the following procedures must be executed:
 - a. Software Configuration procedures on [page 109](#).
 - b. Lift Potentiometer “Burn-In” procedures on [page 61](#).
 - c. If your Bed is equipped with a Scale System, execute the Scale Calibration procedures on [page 23](#).
10. Test bed operations before returning the bed to service.

Service Information

REPLACEMENT OF THE WIRELESS MODULE (NON-ZOOM)

TOOLS REQUIRED:

- 1/4" Ratchet
- 5/16" Socket
- T27 Torx Driver
- Small Slotted Screwdriver
- Diagonal Pliers

PROCEDURE:

1. Raise the bed to the high height.
2. Unplug the bed from the wall outlet.
3. Remove the headboard.
4. Using a T27 Torx driver, remove the two screws (B) securing the pendant port cover (A) to the litter frame shown in Figure 1.
5. Using diagonal pliers, cut the zip tie securing the cables to the litter frame shown in Figure 2.
6. Using a small slotted screwdriver, unclip the connector A going to the wireless module.
7. Using a 1/4" ratchet and a 5/16" socket, remove the two screws securing the wireless module to the litter frame shown in Figure 3.
8. Route the wireless module cable from its connection point out through the hole in the litter frame to remove the assembly shown in Figure 2.
9. Install the new wireless module assembly by routing the cable through the hole in the litter frame.
10. Using a 1/4" ratchet and 5/16" socket, re-install the screws to secure the wireless module to the frame.
11. Route the wireless module cable under the 37-pin connector and under the pendant port and then plug the cable into connector A.
12. Install a zip tie to secure the cables to the litter frame and using diagonal pliers cut off the excess cable tie.
13. Using a T27 Torx driver, re-install the two screws to secure the pendant port cover to the litter frame.

CAUTION

Make sure all cables are free and clear before tightening the screws.

14. IT will need to update the wireless device IP address or the DNS name to the new MAC address of the wireless module.
15. The bed will need to have the wireless network connection settings loaded prior to putting the bed back into service. Reference the *iBed Server Installation and Configuration Manual* 5212-009-001.
16. Test the bed functionality prior to returning the bed to service.

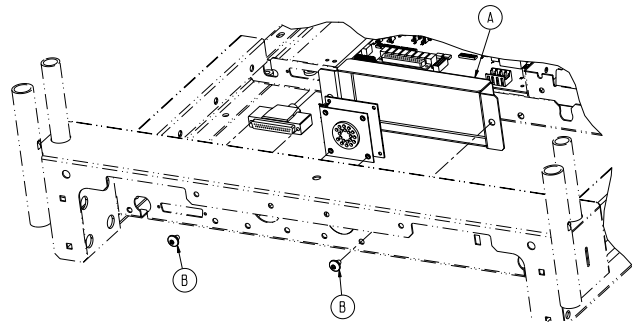

Figure 1

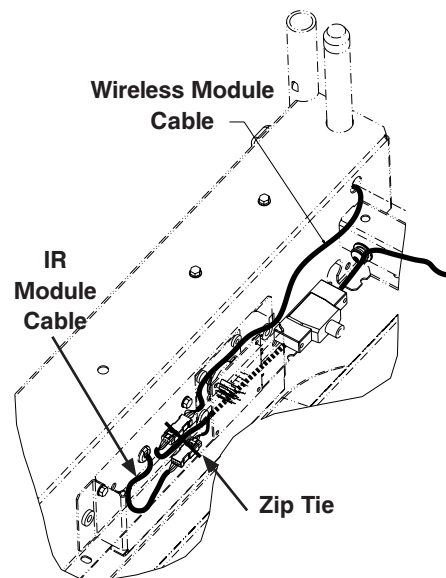

Figure 2

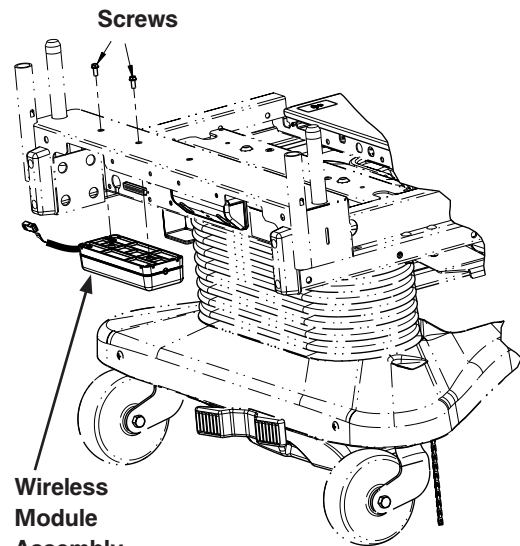

Figure 3

Service Information

REPLACEMENT OF THE IR MODULE (NON-ZOOM)

TOOLS REQUIRED:

- 1/4" Ratchet
- 5/16" Socket
- T27 Torx Driver
- Small Slotted Screwdriver
- Diagonal Pliers

PROCEDURE:

1. Raise the bed to the high height.
2. Unplug the bed from the wall outlet.
3. Remove the headboard.
4. Using a T27 Torx driver, remove the two screws securing the pendant port cover to the litter frame shown in Figure 1.
5. Using diagonal pliers, cut the zip tie securing the cables to the litter frame shown in Figure 2.
6. Using a small slotted screwdriver, unclip the connector B going to the IR module.
7. Using a 1/4" ratchet and 5/16" socket, remove the two screws securing the IR module to the litter frame shown in Figure 4.
8. Route the IR module cable out through the hole in the litter frame.
9. Install the new IR module assembly by routing the cable through the hole in the litter frame.
10. Using a 1/4" ratchet and a 5/16" socket, re-install the two screws which secure the IR module to the litter frame.
11. 11. Install a new zip tie to secure the cables to the litter frame and using diagonal pliers cut off the excess cable tie.
12. Using a T27 Torx driver, re-install the two screws to secure the pendant port cover to the litter frame.

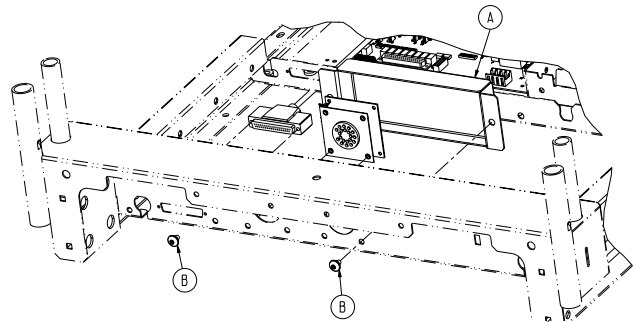

Figure 1

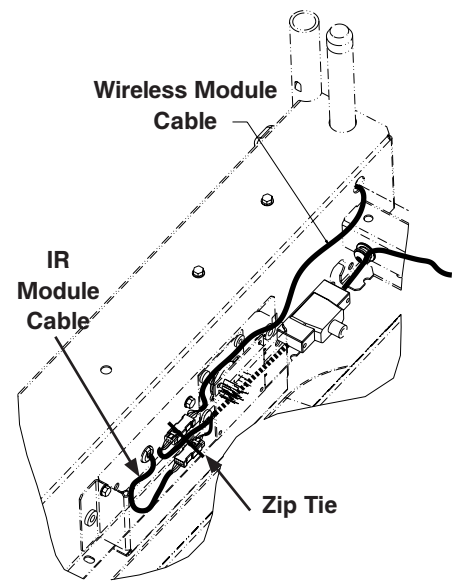

Figure 2

CAUTION

Make sure all cables are free and clear before tightening the screws.

13. Test the bed functionality prior to returning the bed to service.

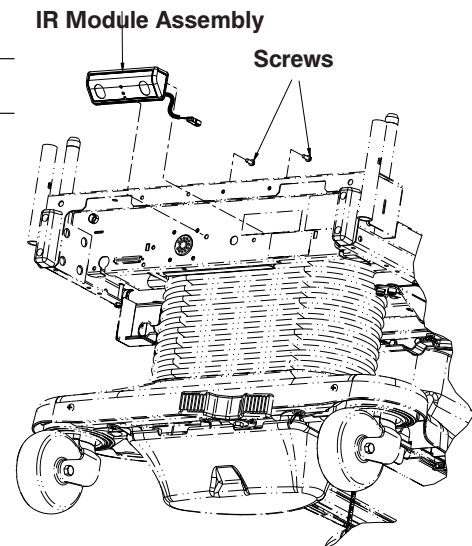

Figure 4

Service Information

REPLACEMENT OF THE WIRELESS MODULE (ZOOM)

TOOLS REQUIRED:

- 1/4" Ratchet
- 5/16" Socket
- T27 Torx Driver
- Small Slotted Screwdriver
- Diagonal Pliers

PROCEDURE:

1. Raise the bed to the high height.
2. Unplug the bed from the wall outlet.
3. Remove the head board.
4. Using a 5/16" nut driver, remove the screw that holds the power cord clamp to the bumper weldment and remove the power cord with the cable clamp.
5. Using a T27 Torx, remove the four bolts at the head end of the bed that hold the control bar mounting bracket to the head end (see Figure 1).
6. Standing at the head end, pull the head end housing / control bar toward you and fold it downward.
7. Using diagonal pliers, cut the zip tie securing the cables to the litter frame shown in Figure 2.
8. Using a small slotted screwdriver, unclip the connector A going to the wireless module.
9. Using a 1/4" ratchet and a 5/16" socket, remove the two screws securing the wireless module to the pendant port cover shown in Figure 3.
10. Route the wireless module cable from its connection point out through the hole in the pendant port cover to remove the assembly shown in Figure 2.
11. Install the new wireless module assembly by routing the cable through the hole in the pendant port cover.
12. Using a 1/4" ratchet and 5/16" socket, re-install the screws to secure the wireless module to the pendant port cover.

Note

Make sure the module cable exiting the wireless module is pointing inward towards the middle of the bed.

13. Route the wireless module and then plug the cable into connector A.



Figure 1

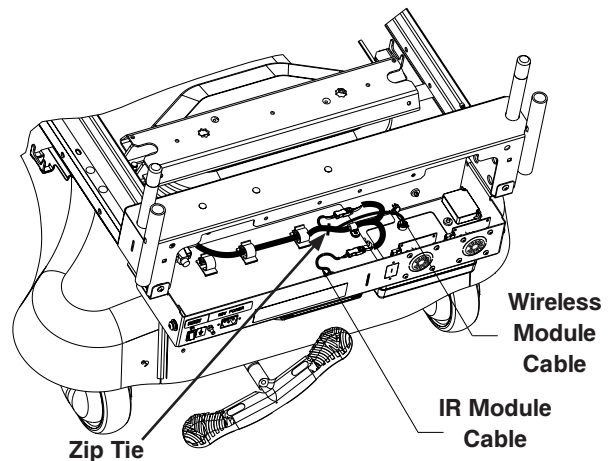

Figure 2

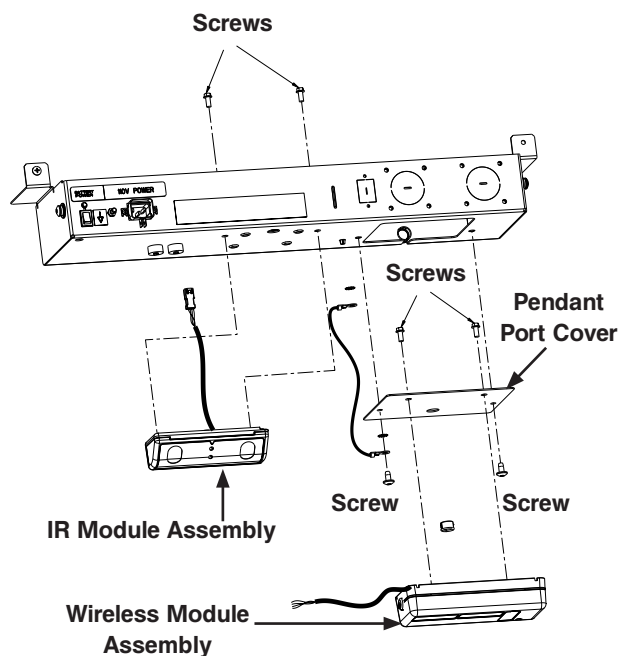

Figure 3

Service Information

REPLACEMENT OF THE WIRELESS MODULE (ZOOM) (CONTINUED)

14. Install a new zip tie to secure the cables to the litter frame and using diagonal pliers cut off the excess cable tie.
15. Fold the control bar mounting bracket to the head end enclosure and secure it with the four bolts removed earlier in step 14 using a T27 Torx driver.
16. Plug the power cord back into the bed, making sure it is completely seated.
17. Using a #2 Phillips screwdriver, tighten the power cord retainer at the inlet.
18. Using a 5/16" nut driver, re-secure the power cord strain relief cable clamp with the power cord from where it was removed earlier.
19. IT will need to update the wireless device IP address or the DNS name to the new MAC address of the wireless module.
20. The bed will need to have the wireless network connection settings loaded prior to putting the bed back into service. Reference the *iBed Server Installation and Configuration Manual 5212-009-001*.
21. Test the bed functionality prior to returning the bed to service.

Service Information

REPLACEMENT OF THE IR MODULE (ZOOM)

TOOLS REQUIRED:

- 1/4" Ratchet
- 5/16" Socket
- T27 Torx Driver
- Small Slotted Screwdriver
- Diagonal Pliers

PROCEDURE:

1. Raise the bed to the high height.
2. Unplug the bed from the wall outlet.
3. Remove the head board.
4. Using a 5/16" nut driver, remove the screw that holds the power cord clamp to the bumper weldment and remove the power cord with the cable clamp.
5. Using a T27 Torx, remove the four bolts at the head end of the bed that hold the control bar mounting bracket to the head end (see Figure 1).
6. Standing at the head end, pull the head end housing / control bar toward you and fold it downward.
7. Using a small slotted screwdriver, unclip the three wire holders and remove the cables from them, shown in Figure 4.
8. Using a T27 Torx driver remove the two screws securing the AC cross over board cover to the litter frame and remove the cover, shown in Figure 4.
9. Using a small slotted screwdriver, unclip the connector B going to the IR module.
10. Using a 1/4" ratchet and 5/16" socket, remove the two screws securing the IR module to the litter frame shown in Figure 3.
11. Route the IR module cable out through the hole in the litter frame.
12. Install the new IR module assembly by routing the cable through the hole in the litter frame.
13. Using a 1/4" ratchet and a 5/16" socket, re-install the two screws which secure the IR module to the litter frame.
14. Plug the IR module connector B back in.
15. Using a T27 Torx driver, re-install the two screws to secure the AC cross over board cover to the litter frame.



Figure 1

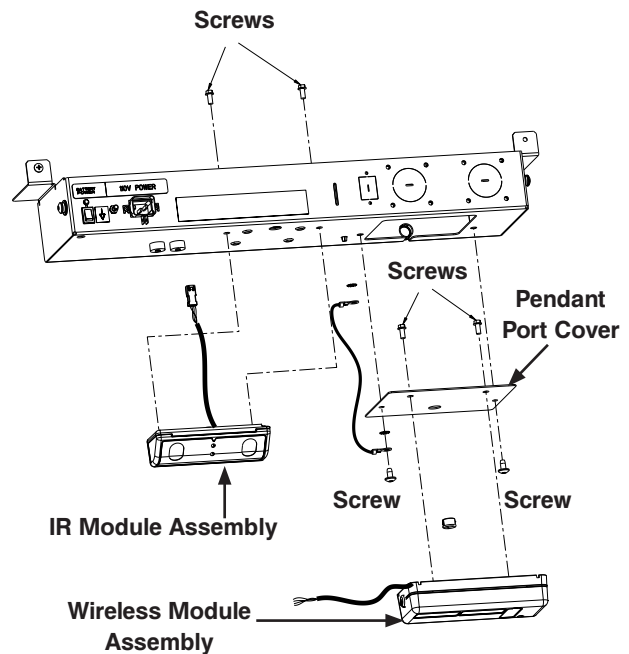

Figure 3

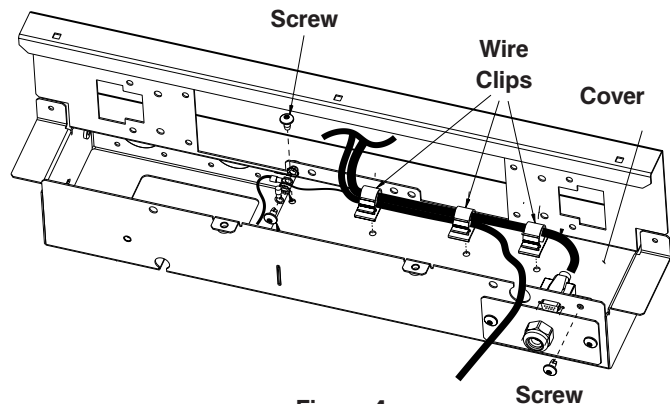

Figure 4

Service Information

REPLACEMENT OF THE IR MODULE (ZOOM) (CONTINUED)

 **CAUTION**

Make sure all cables are free and clear before tightening the screws.

16. Put the cables back into the wire holders and clip them together.
17. Fold the control bar mounting bracket to the head end enclosure and secure it with the four bolts removed earlier in step 14 using a T27 Torx driver.
18. Plug the power cord back into the bed, making sure it is completely seated.
19. Using a #2 Phillips screwdriver, tighten the power cord retainer at the inlet.
20. Using a 5/16" nut driver, re-secure the power cord strain relief cable clamp with the power cord from where it was removed earlier.
21. Test the bed functionality prior to returning the bed to service.

Service Information

SOFT CONFIG. PROCEDURES

1. On the first power up, the footboard screen will display Figure S-1. Only two items should be displayed.

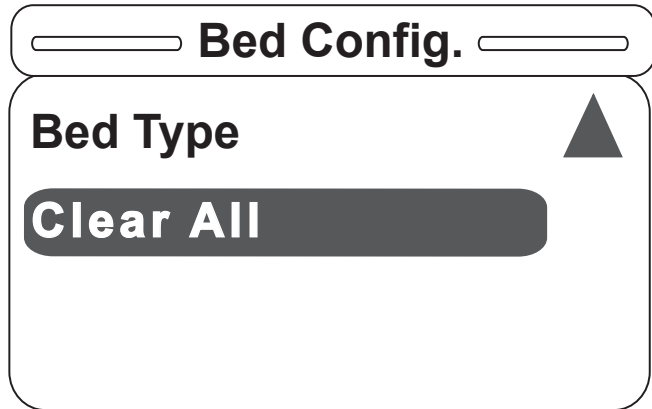

Figure S-1

2. Once the user selects the Bed Type item and hits "Enter" on the footboard panel, Figure S-2 will be displayed. To select an item hit "Enter" on the footboard panel. **Choose S3.**

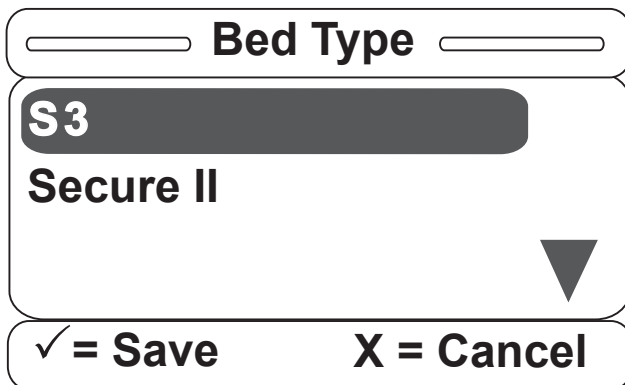

Figure S-2

3. Once a bed type has been selected from the list above, a confirmation screen such as that in Figure S-3 will be displayed, asking the user a question. (The confirmation screen text will vary based on the item selected. Figure S-3 indicates that the user chose the bed type S3.) Hit "Enter" on the footboard panel to confirm the bed type; hit "Exit" to cancel the operation.

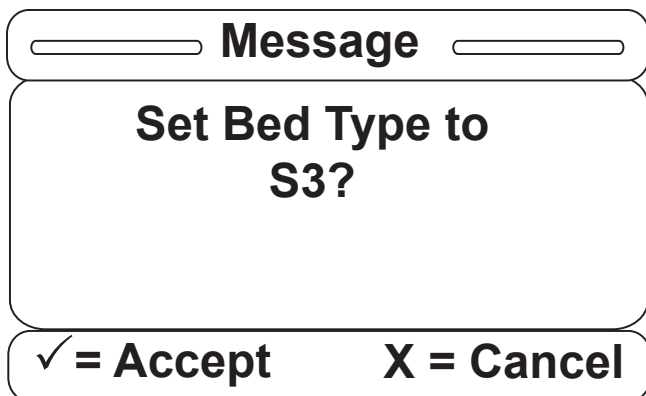

Figure S-3

Service Information

SOFT CONFIG. PROCEDURES (CONTINUED)

4. Once the bed type is selected, the Bed Options item becomes available. Note that you can also see the Bed type that you've previously selected. Hit "Enter" on the footboard panel to choose the options for the product.

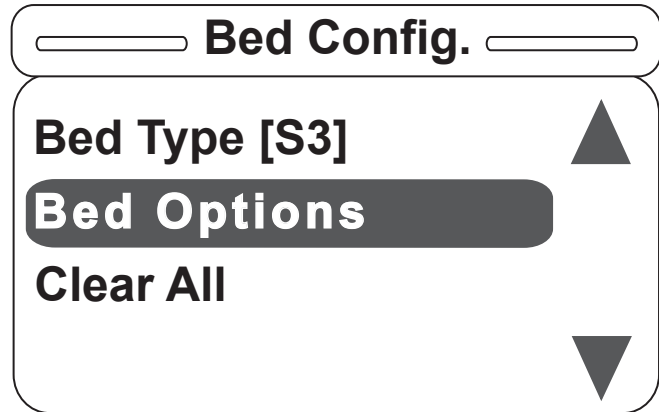

Figure S-4

5. Once the Bed Option item is selected, the menu in Figure S-5 will be displayed on the screen. **Each option must be set to OFF, ON or a variety of the option** (i.e., Zoom®/Batt. or Bed Exit). **Configure each option in the order presented on the screen** (i.e., set the Zoom®/Batt option before the Scale option, which should be set before the Bed Exit option, which should be set before the Awareness option).

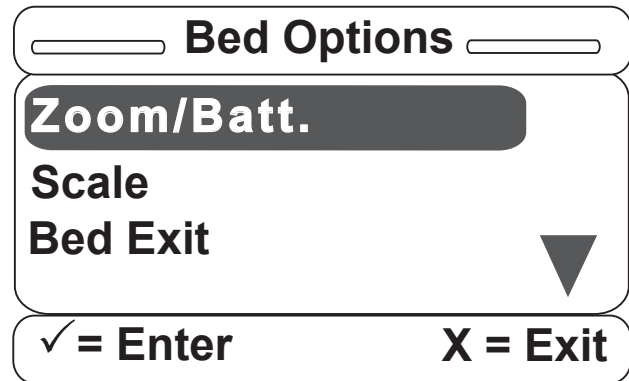

Figure S-5

6. Once the Zoom®/Batt. option is selected, Figure S-6 will be displayed. You can set this option to OFF, Zoom® or Battery Backup. Scroll up or down to select one of the three available items and hit "Enter" on the footboard panel.

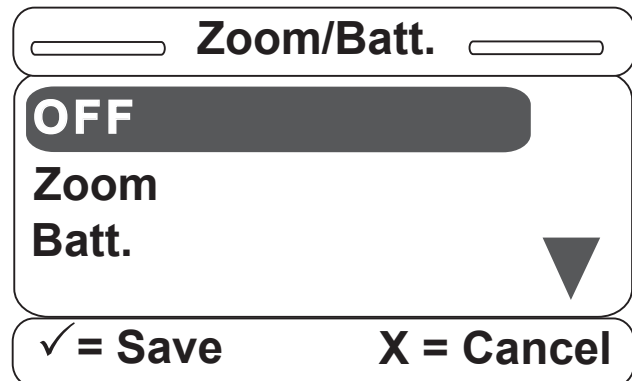

Figure S-6

Service Information

SOFT CONFIG. PROCEDURES (CONTINUED)

7. Once you have selected one of the items, a confirmation screen such as that in Figure S-7 will be displayed. The confirmation screen text will vary based on the item you have selected. The confirmation screen displayed in Figure S-7 indicates that the user chose Zoom®. Hit “Enter” on the footboard panel to confirm the Zoom®/Batt. option; hit “Exit” to cancel the operation.

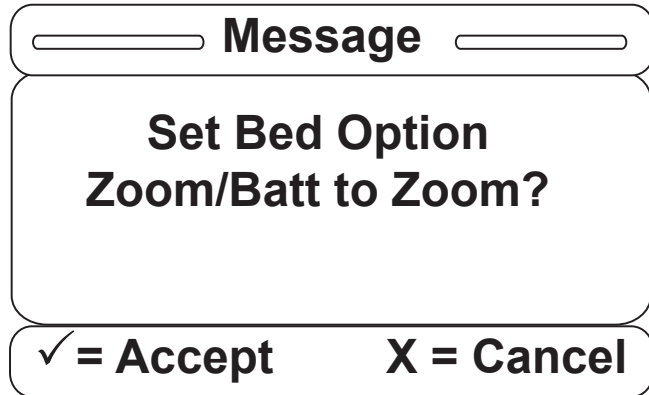

Figure S-7

8. Once the Zoom®/Batt. option is set, you will return to the Bed Options screen and the next item to be set will be highlighted. Note that you can also see what the previous option was set to.

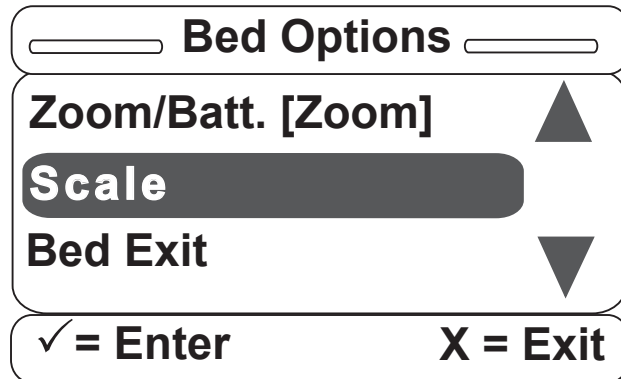

Figure S-8

9. Once the Scale item is selected, the screen in Figure S-9 will be displayed. You can set the Scale option to ON or OFF. Hit “Enter” on the footboard panel to make your selection or hit “Exit” to cancel.

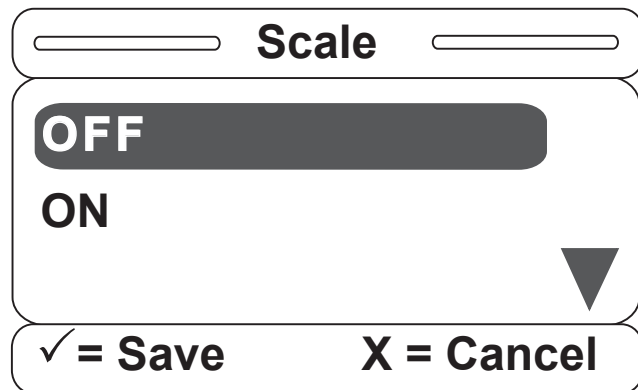

Figure S-9

Service Information

SOFT CONFIG. PROCEDURES (CONTINUED)

10. Once you have selected one of the items, a confirmation screen will be displayed. The confirmation screen text will vary based on the item you have selected. The confirmation screen in Figure S-10 indicates that the Scale option was chosen to be ON. Hit “Enter” on the footboard panel to confirm your Scale option; hit “Exit” to cancel the operation.

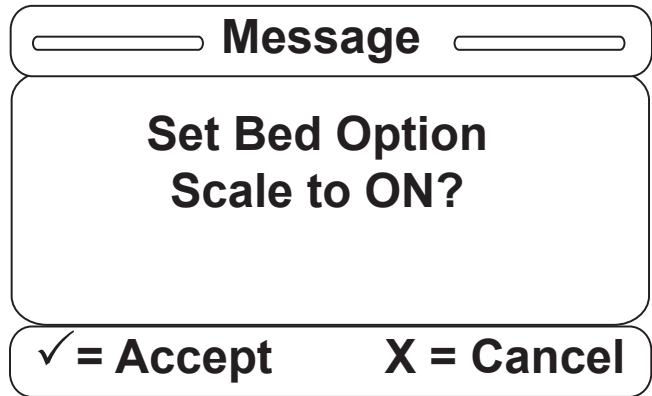

Figure S-10

11. Once the Scale option is set, you will be returned to the Bed Options screen to set the next option, which is Bed Exit.

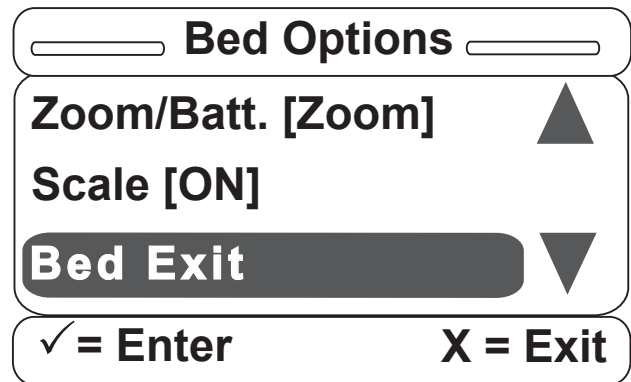

Figure S-11

12. Once the Bed Exit item is selected, the screen in Figure S-12 will be displayed. You can set the Bed Exit Option to OFF, Multi Zone or Single Zone. Hit “Enter” on the footboard panel to make your selection or “Exit” to cancel.

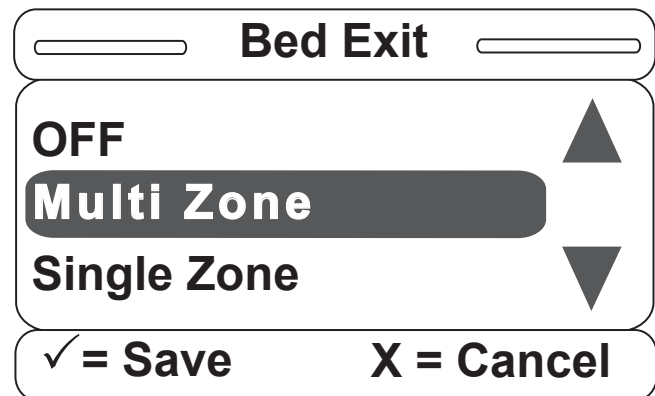

Figure S-12

Service Information

SOFT CONFIG. PROCEDURES (CONTINUED)

13. Once you have selected one of the items, a confirmation screen such as that in Figure S-13 will be displayed. The confirmation screen text will vary based on the item you have selected. The confirmation screen in Figure S-13 indicates that the user chose the Bed Exit option to be Multi Zone. Hit “Enter” on the footboard panel to confirm your Bed Exit option; hit “Exit” to cancel the operation.

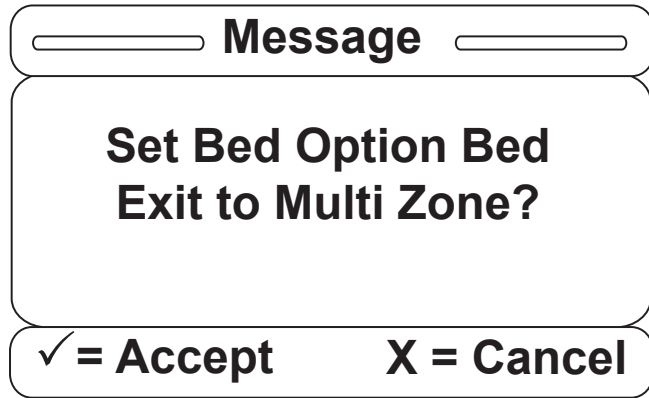

Figure S-13

14. Once the Bed Exit option is set, you will be returned to the Bed Options screen to set the next option, which is Awareness. **Note that you can see the state of each option that you have previously set.**

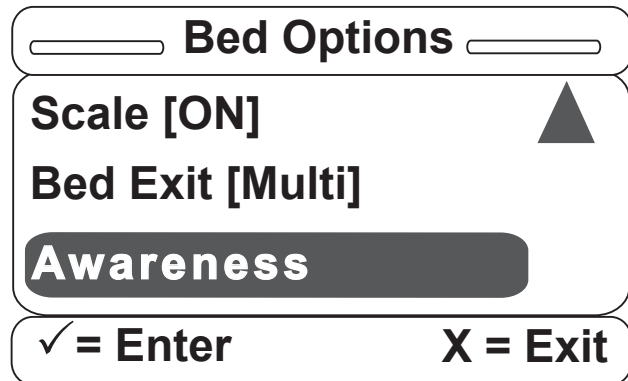

Figure S-14

15. Once the Awareness item is selected, the screen in Figure S-15 will be displayed. You can set the Awareness option to OFF or ON. Hit “Enter” on the footboard panel to make your selection or “Exit” to cancel. **Note that if Bed Exit was set to OFF, Awareness will then automatically be set to OFF as well. It cannot be set to ON unless either kind of Bed Exit was previously chosen.**

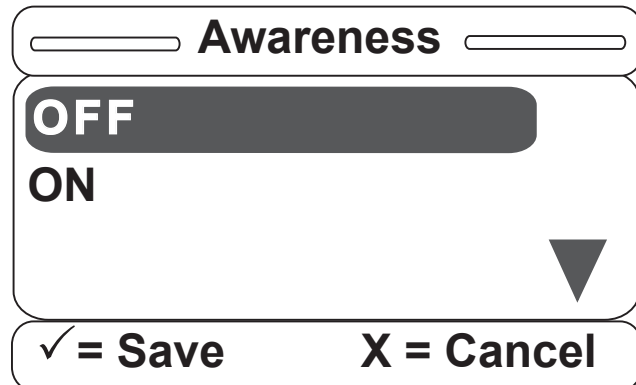

Figure S-15

Service Information

SOFT CONFIG. PROCEDURES (CONTINUED)

16. Once you have selected one of the items, a confirmation screen such as that in Figure S-16 will be displayed. The confirmation screen text will vary based on the item you have selected. The confirmation screen in Figure S-16 indicates that the user chose the Awareness option to be ON. Hit "Enter" on the footboard panel to confirm your Awareness option; hit "Exit" to cancel the operation.

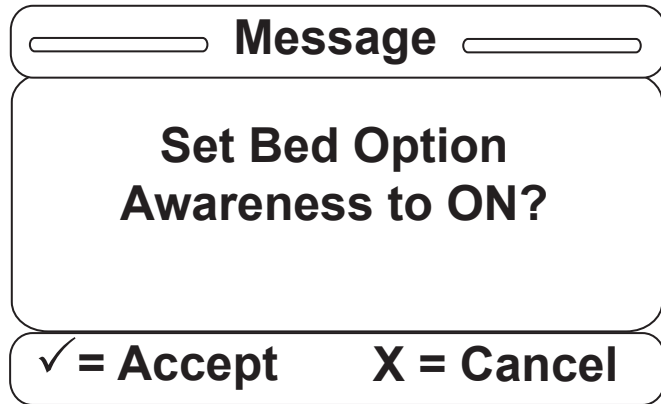

Figure S-16

17. Once the Awareness option is set, you will be returned to the Bed Options screen as shown in Figure S-17. Once there is text in square brackets next to each option in the Bed Options menu, all of your options have been set. You may re-enter any option and change the setting at any time.

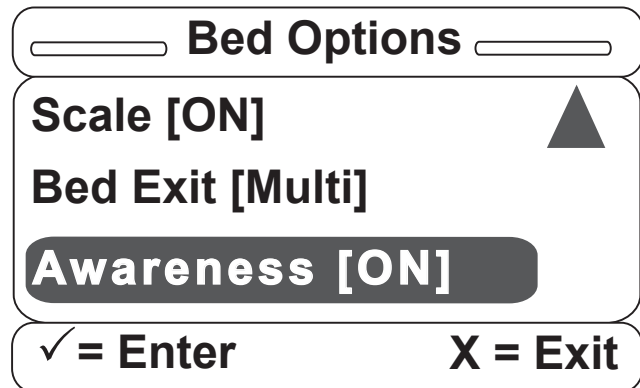

Figure S-17

18. Once the Awareness option is set, you will be returned to the Bed Options screen to set the next option, which is Wireless (Figure S-18). **Note that you can see the state of each option that you have previously set.**

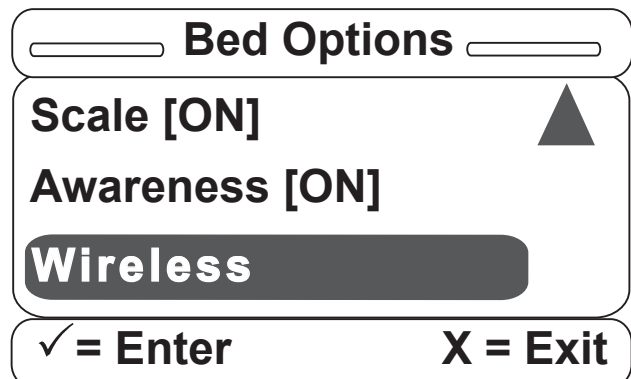

Figure S-18

Service Information

SOFT CONFIG. PROCEDURES (CONTINUED)

19. Once the Wireless item is selected, the screen in Figure S-19 will be displayed. You can set the Wireless option to ON. Hit “Enter” on the footboard panel to make your selection or “Exit” to cancel the operation.

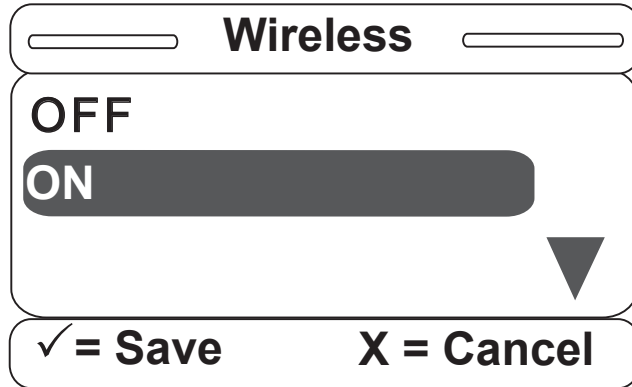

Figure S-19

20. Once you have selected one of the items, a confirmation screen such as that in Figure S-20 will be displayed. The confirmation screen text will vary based on the item you have selected. The confirmation screen in Figure S-20 indicates that the user chose the Awareness option to be ON. Hit “Enter” on the footboard panel to confirm your Wireless option; hit “Exit” to cancel the operation.

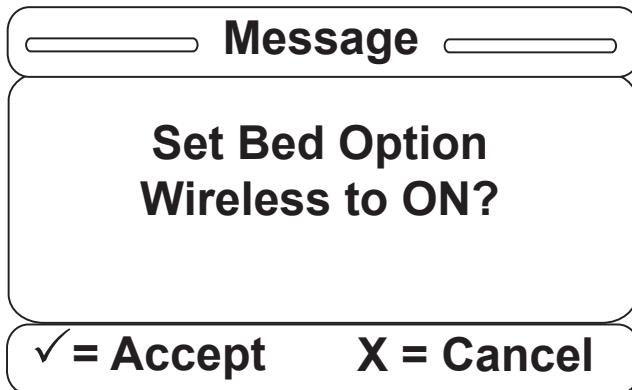

Figure S-20

21. Once the Wireless option is set, you will be returned to the Bed Options screen as shown in Figure S-21. Once there is text in square brackets next to each option in the Bed Options menu, all of your options have been set. You may re-enter any option and change the setting at any time.

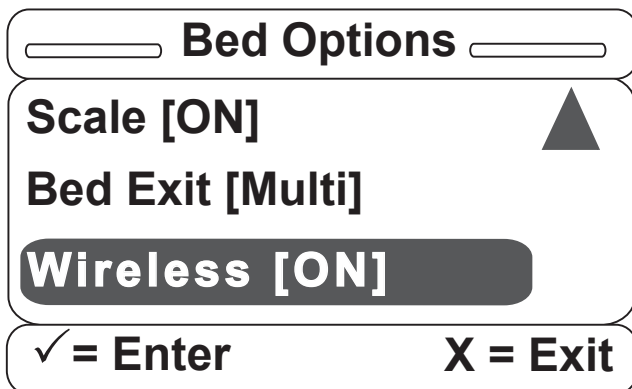

Figure S-21

Service Information

SOFT CONFIG. PROCEDURES (CONTINUED)

22. Hitting "Exit" on the footboard panel while in the Bed Options screen will return the user to the Bed Config. main menu as shown in Figure S-22. Note that the user can see the state of the items previously set.

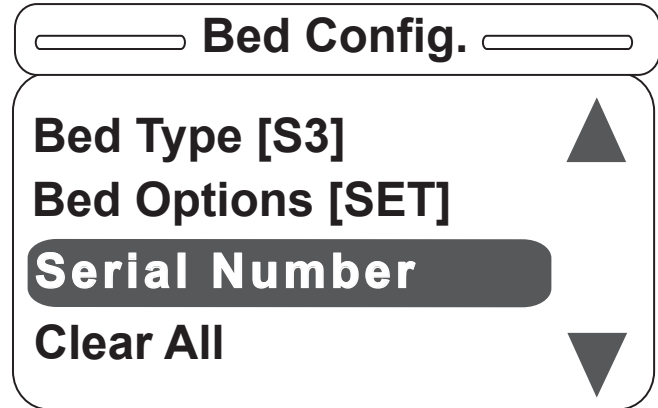

Figure S-22

23. There are two options available, as shown in Figure S-23. The Current SN item will display the saved serial number, while the Edit SN item will allow the user to edit the existing serial number.

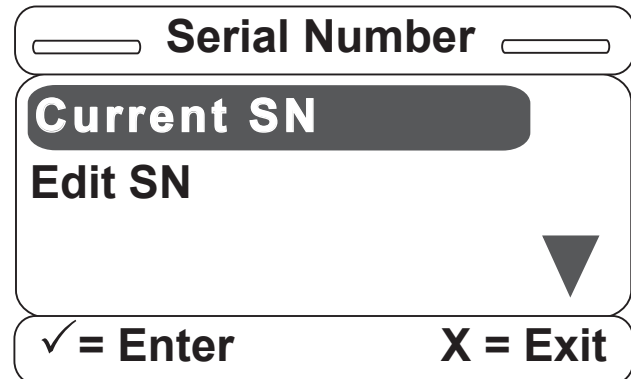

Figure S-23

24. If the Current SN item is selected and no serial number has been entered by the user, the screen in Figure S-24 will be displayed.

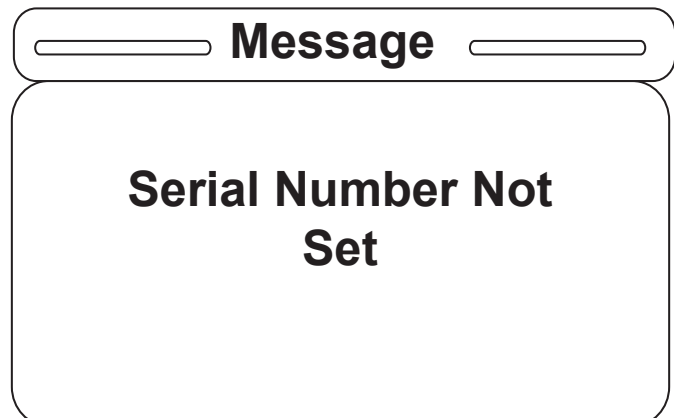

Figure S-24

Service Information

SOFT CONFIG. PROCEDURES (CONTINUED)

25. If the Edit SN item is selected, the screen in Figure S-25 will be displayed to the user.

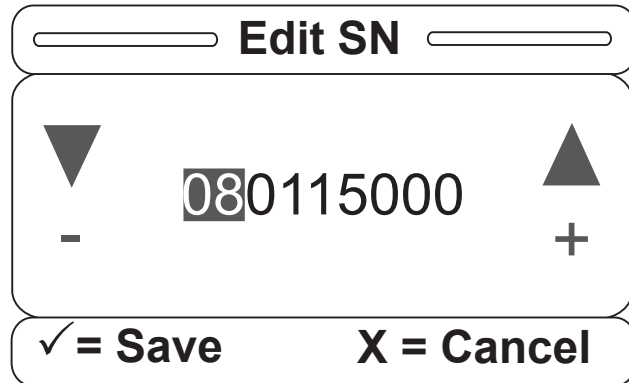

Figure S-25

26. Use the two blinking lock buttons to select the desired portion of the serial number. This selected portion will remain highlighted. Then use the footboard panel up/down buttons to edit the serial number.

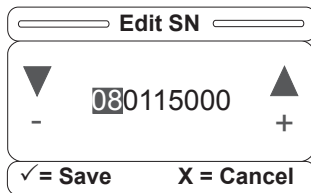

Figure S-26

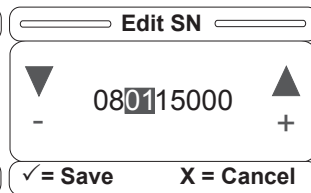

Figure S-27

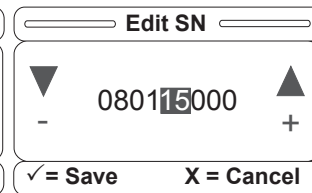

Figure S-28

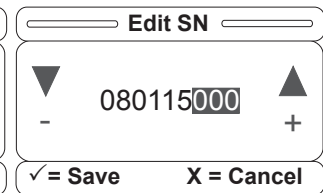

Figure S-29

27. Once the bed up/down lock button is pressed, the highlighted sections will change as indicated above in Figures S-26, 27, 28 and 29. Hold down "Enter" on the footboard panel for two seconds to save the serial number or press "Exit" to cancel the operation.

28. Once a serial number is saved and the user enters the Current SN item, the screen in Figure S-30 will be displayed. The entered serial number will be displayed until the user hits the "Exit" button on the footboard panel.

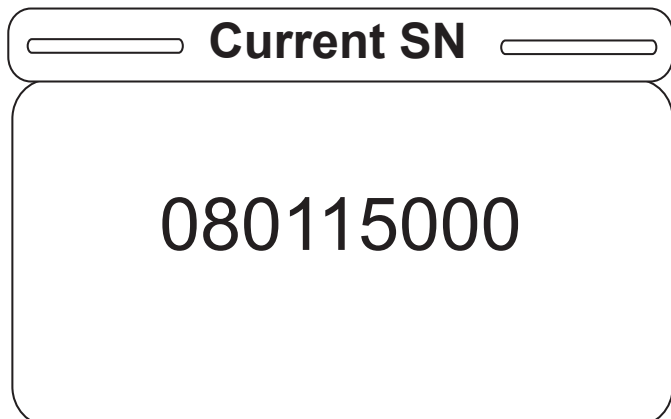

Figure S-30

Service Information

SOFT CONFIG. PROCEDURES (CONTINUED)

29. Hitting “Exit” on the footboard panel while in the Serial Number screen will return the user to the Bed Config main menu as shown in Figure S-31. Note that the user can see the state of the items previously set.

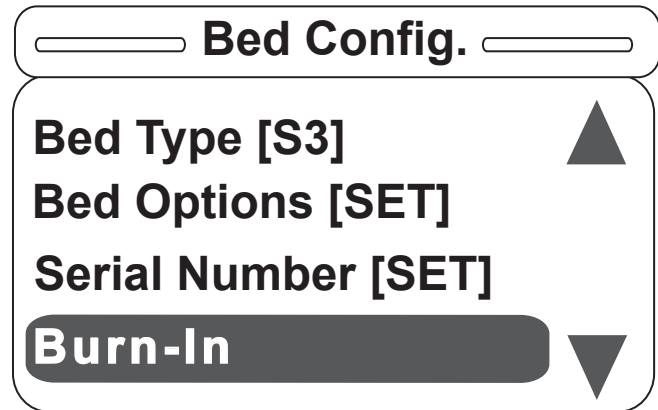

Figure S-31

30. Once the Burn-in item is selected, the screen in Figure S-32 will be displayed. The Burn-in Height item will walk the user through the burn-in height routine; and, similarly, the Burn-In Fowler item will walk the user through the burn-in fowler routine.

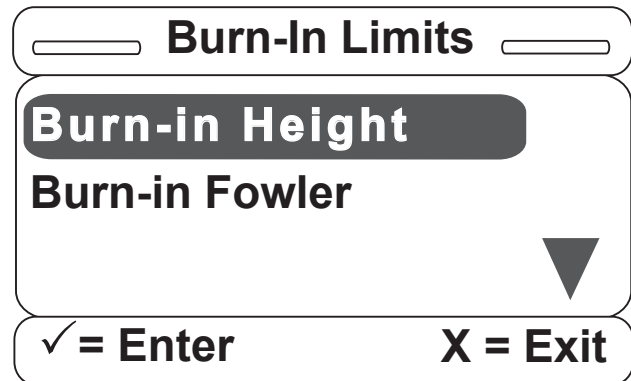

Figure S-32

31. The burn-in height routine will display different messages depending on if the user chooses to activate the Zoom®/Batt. option. **If the Zoom® or Battery Backup option is activated**, the message in Figure S-33 will be shown on the screen. If the Zoom®/Battery Backup option was deactivated, then the message would display: “Put Bed in Low Height.” Drive the bed to its high or low height (depending on the message displayed) and hold the Bed Motion Lock. The screen will display the message “Hold to Set Height Limits.” Once the lock button is held for two seconds, the message “Release Button” will flash.

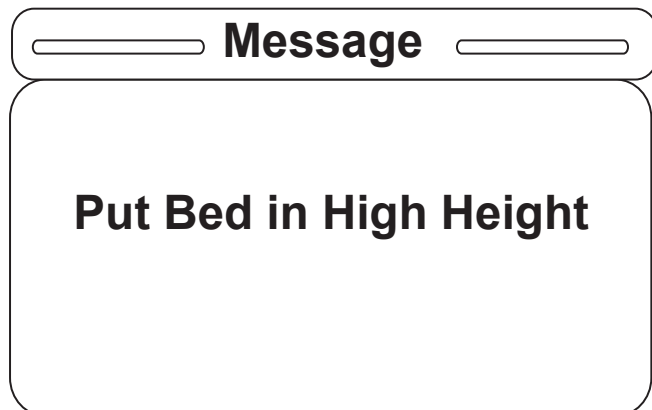

Figure S-33

Service Information

SOFT CONFIG. PROCEDURES (CONTINUED)

32. Once the lock button is released, the message “Height Limit Set” will be displayed and the user will be returned to the screen in Figure S-34 (The height limits are now burned in.) The “SET” text indicates that the limits are set. The process is similar for the Burn-in Fowler routine.

Once the Burn-in Fowler item is selected, the message “Set Fowler to Lower Limit” is displayed. Press and hold the “Enter” button to set the lower limit. The message “Set Fowler to 30°” will now be displayed. Once this is completed, the message “Set Fowler to Upper Limit” will be displayed.

Once all three limits are burned in, the message “Fowler Calibration Complete” will be displayed for two seconds and the user will be returned to the Bed Config. menu.

33. Once all Bed Config. items are set, the main screen will be displayed as in Figure S-35.

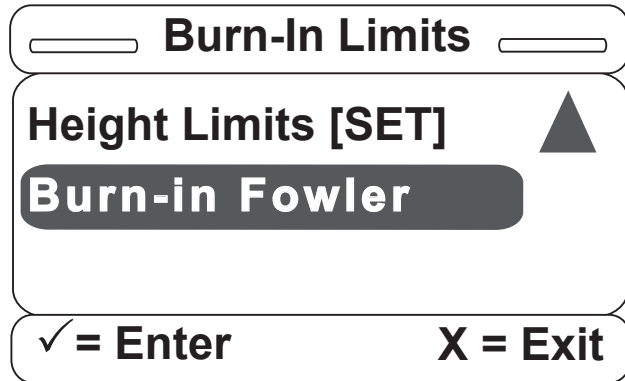

Figure S-34

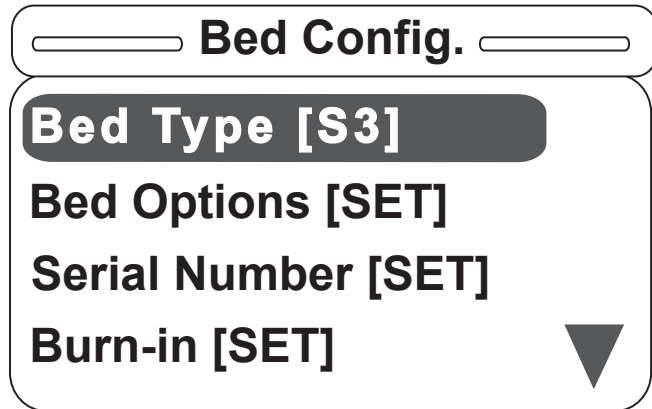

Figure S-35

34. Good to note:

- Any item may be adjusted at any time.
- If the Bed Type is changed, the serial number and burn-in limits are cleared and the process needs to be repeated by the user.
- If the Zoom® options are changed, the burn-in limits are cleared and the process needs to be repeated by the user.
- The user must cycle power to the bed to exit the Bed Config. mode.
- The user will not be able to exit the Bed Config. mode without setting all items (with the exception of the fowler limits). I.E., the user must choose the Bed Type, set all options to either ON, OFF or some variety of the option, enter the serial number and burn-in the height limits in order to exit the Bed Config. menu on a power cycle.

Service Information

SOFT CONFIG. PROCEDURES (CONTINUED)

35. Good to Note (Continued)

- To quickly clear all entered Bed Config. items, there is a Clear All item which will always be the last item in the Bed Config. menu.

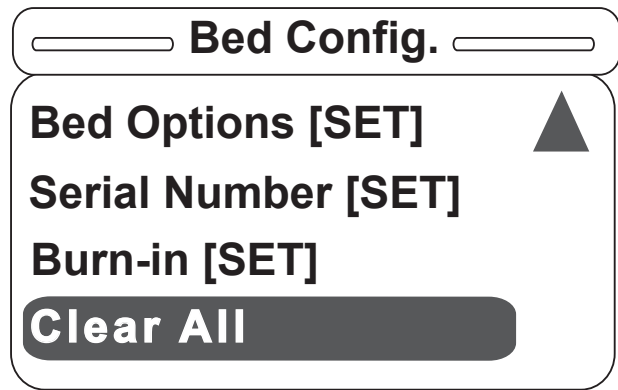

Figure S-36

- Once the "Clear All" item is selected, the confirmation screen in Figure S-37 will be displayed.

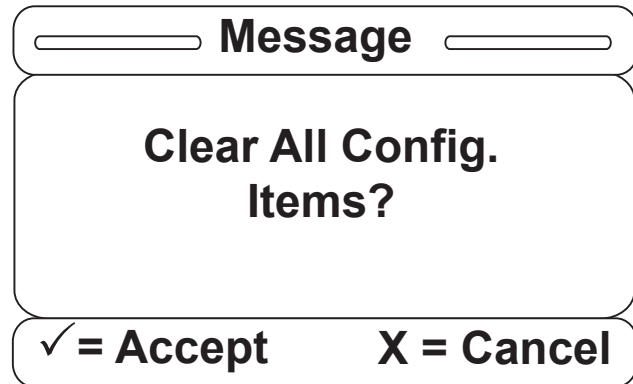

Figure S-37

- Once the user hits "Enter," the previously set Bed Config. items (Bed Type, Bed Options, Serial Number, Height Limits or Fowler Limits) will be erased and the message in Figure S-38 will be displayed.

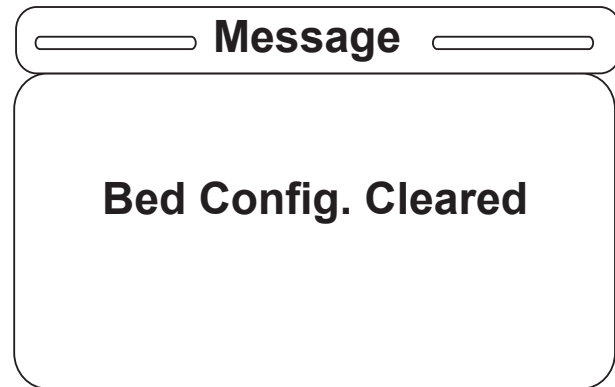

Figure S-38

- The Bed Config. menu will then only display the Bed Type menu item as shown in Figure S-39 and the user can now re-enter all the bed information starting with the Bed Type.

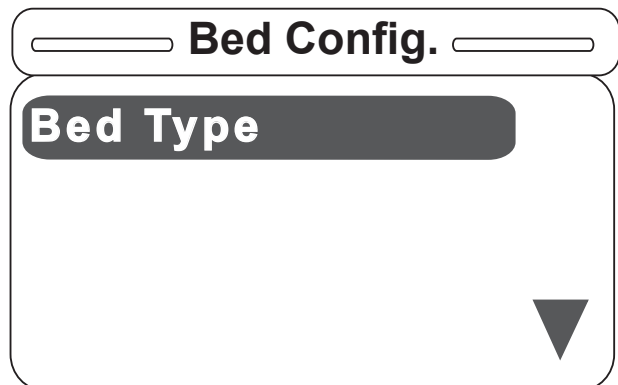

Figure S-39

Service Information

OPTIONAL SMART TV INTERFACE “BURN-IN” PROCEDURE

This procedure is used for selecting the style of TV interface needed for your bed. If traditional TV is desired, no calibration is required. If optional Smart TV is available on the bed, select one of the TV Mode/Brands listed in the table below.

PROCEDURE

1. Press and hold the “Enter” button. While holding, cycle bed power. Continue to hold until the display flashes “Load Cell Check.” Release.
2. The display should present the Maintenance Menu. Ensure the “TV Config” element is highlighted and press “Enter.”
3. The display should present the “TV Config” Screen. The current TV selection will be highlighted. (Default selection is Traditional.)
4. Use the up and down arrow buttons to highlight the desired “TV Config.” See Table below for Model/Selection list.
5. Press the “Enter” button to select the new setting.
6. The display should present the following message when the new setting is saved: “Save Successful”.
7. The “TV Config” screen should reappear after two seconds and the new setting should be highlighted.

TV Configuration Menu Settings

| TV Mode / Brand | Display TV Menu Select |
|-------------------|------------------------|
| RCA 1 | TV Config. 1 |
| RCA 2 | TV Config. 2 |
| Zenith 1 | TV Config. 3 |
| Zenith 2 | TV Config. 4 |
| Philips | TV Config. 5 |
| Magnavox | TV Config. 6 |
| Traditional | Traditional |
| Traditional Plus | Traditional Plus |
| Auto-Configure | Auto-Config. |
| Auto-Configure DV | Auto-Config. DV |

Service Information

FOWLER POTENTIOMETER REPLACEMENT

TOOLS REQUIRED:

- T27 Torx.
- Wire Cutters.
- 1/2" Open End Wrench.
- 7/64" Allen Wrench.

PROCEDURE

1. Unplug the bed power cord from the wall socket.
2. Manually raise the fowler to 60 degrees.
3. Using a 7/64" Allen wrench, loosen the screw holding the linkage to the potentiometer shaft and remove the linkage from the shaft.
4. Using a 1/2" open end wrench, remove the nut holding the potentiometer to the frame and disconnect from the 3 pin quick disconnect.
5. Install the fowler potentiometer to the Fowler platform arm using a 1/2" combination wrench, making sure to align the potentiometer alignment tab up with the notch in the fowler frame.
6. Using a multi-meter and small flat blade screwdriver, set the fowler potentiometer to 500 +/-50 ohms, using the black and white wires from the fowler potentiometer.
7. Using a 7/64" Allen wrench, tighten the set screw on the fowler potentiometer linkage attaching to the potentiometer. Make sure to double check the ohms reading after tightening the set screw; readjustment maybe necessary.
8. Refer to the Fowler Potentiometer "burn-in" procedure to set the Fowler angle.

FOWLER POTENTIOMETER "BURN-IN" PROCEDURE

Note: It requires **two people** to enable the diagnostics mode for the bed.

PROCEDURE

1. Unplug the bed power cord from the wall.
2. On the footboard control panel, hold down the bed motion lock button, the knee lock out button and the Reverse Trend button. While still holding the buttons, plug the power cord into the wall socket. Release the footboard buttons. Using the up/down arrow buttons, scroll to the "Burn-In" item and hit "Enter." Select "Burn-In Fowler" and hit "Enter." A message will appear: "Set Fowler to 0°".
3. Using the footboard controls, run the Fowler to 0 degrees. Press the "Enter" button; a message will appear on the display: "Set Fowler to 30 degrees."
4. Using the footboard controls, run the fowler to 30 degrees. Press the "Enter" button; a message will appear on the display: "Set Fowler to Upper Limit" (60 degrees).
5. Using the footboard controls, run the fowler to Upper Limit (60 degrees). Press the "Enter" button; a message will appear on the display: "Fowler Calibration Complete" for two seconds, and then the user will be returned to the "Burn-In" menu. The menu item should now read "Fowler Limits [SET]".
6. Unplug the bed and plug back in to return to normal operating mode.



Ensure there is no patient on the bed while the burn-in procedure is being performed.

Service Information

ZOOM® OPTION BATTERY REMOVAL AND REPLACEMENT

TOOLS REQUIRED:

- Torx T27
- 7/16" Wrench
- 1/2" Socket Wrench
- Bungee Cords
- Phillips Screwdriver
- 5/32" Allen

PROCEDURE:

1. Raise the litter to full up. Unplug the power cord from the wall socket and push the battery power On/Off switch to the "Off" position.
2. Using a Phillips screwdriver, remove the four screws holding the base hood to the base frame.
3. Lift the base hood and support it from the litter frame using bungee cords or the equivalent.
4. Properly ground yourself (see "Static Discharge Precautions" section).
5. Open the cable clamp at the head end, left side of the base frame and remove the cables from the clamp.
6. Using a Torx T27, remove the four screws (A) holding the electronics box cover and remove the cover.
7. Disconnect the two battery cables (B).

WARNING

The battery tray assembly weighs 50 pounds. Use caution when removing the two hex head screws securing it to the base frame or personal injury could result. Battery posts, terminals and related accessories contain lead and lead compounds, chemicals known to the state of California to cause cancer and birth defects or other reproductive harm. Wash hands after handling.

8. Support the battery tray assembly from the bottom. Using a 7/16" hex socket or wrench, remove the two screws (C) supporting the battery tray.
9. The back of the battery tray assembly has a lip which catches on the electronics box. Lift up and out to remove the battery tray assembly.
10. Using a Phillips screwdriver, remove the two screws holding the battery terminal to the battery tray assembly.
11. Using a 5/32" Allen wrench and a 7/16" wrench, remove the four screws and nuts holding the battery harness to the battery terminals.
12. Reverse steps 1 - 11 to install the new batteries. Complete the last four items of the setup procedures in the "Setup Procedures (Zoom® Option)" section.

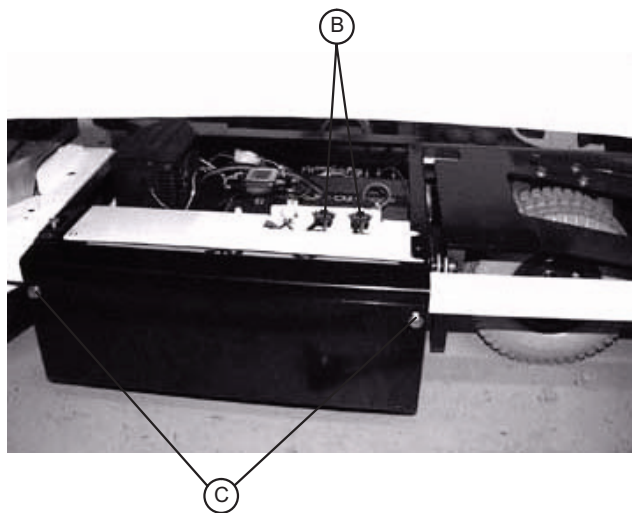
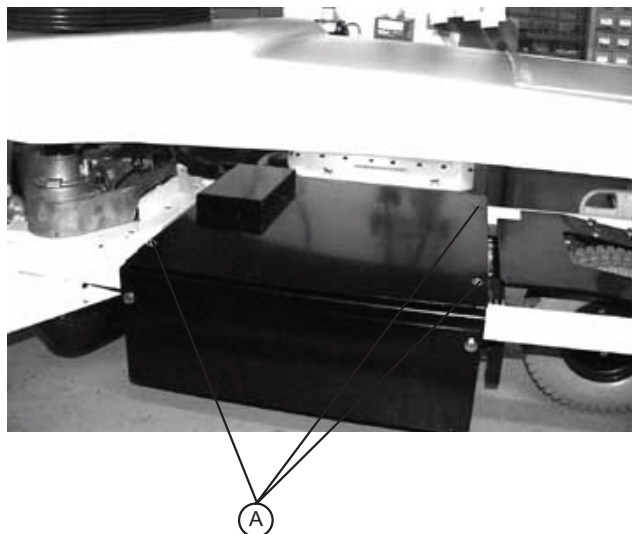

Service Information

ZOOM® OPTION DC MOTOR BOARD REMOVAL AND REPLACEMENT

TOOLS REQUIRED:

- Phillips Screwdriver
- 1/8" Allen Wrench
- Bungee Cords
- T27 Torx

PROCEDURE:

1. Raise the litter to the full up position.
2. Unplug the power cord from the wall socket and push the battery power On/Off switch to the "Off" position.
3. Using a Phillips screwdriver, remove the four screws holding the base hood to the base frame.
4. Open the cable clamp at the head end, left side of the base frame and remove the cables from the clamp.
5. Lift the base hood and support it from the litter frame using bungee cords or the equivalent.
6. Using a T27 Torx, remove the four screws holding the cover to the side of the electronics box.
7. Properly ground yourself (see "Static Discharge Precautions" section).
8. Using a 1/8" Allen wrench, remove the four bolts and standoffs holding the motor board to the electronics box.
9. Remove all cables from the motor board and remove the board.

Note

Note the locations of the cables so you can connect them properly to the new motor board.

10. Reverse steps 1 - 8 to install the new power board.

Service Information

ZOOM® OPTION DRIVE MOTOR REMOVAL AND REPLACEMENT

TOOLS REQUIRED:

- Phillips Screwdriver
- 1/2" Socket Wrench
- Bungee Cords
- Floor Jack
- T27 Torx

PROCEDURE:

1. Raise the litter to the full up position.
2. Unplug the power cord from the wall socket and push the battery power On/Off switch to the "Off" position.
3. Using a Phillips screwdriver, remove the four screws holding the base hood to the base frame.
4. Open the cable clamp at the head end, left side of the base frame and remove the cables from the clamp.
5. Lift the base hood and support it from the litter frame using bungee cords or the equivalent.
6. Using a T27 Torx, remove the four screws holding the power board cover to the side of the electronics box. Remove the two motor wires from the power board and remove the T27 Torx ground screw.
7. Apply the brakes and disengage the drive wheel. Place a floor jack under the leaf spring at the foot end of the bed and raise the wheels approximately 3" off the floor.
8. Using a 1/2" socket wrench, remove the four bolts holding the drive motor to the leaf spring.



CAUTION

Support the drive motor before removing the four bolts to prevent it from falling to the floor and becoming damaged.

9. Reverse steps 1 - 8 to install the new drive motor.
10. Run through the operation of the power drive wheel to ensure it is operating properly before returning the unit to service.

Service Information

ZOOM® OPTION CONTROL BAR POTENTIOMETER REPLACEMENT

Tools Required:

- T27 Torx
- 1/2" Box End Wrench
- #2 Phillips Screwdriver
- Wire Cutters
- Small Flat Blade Screwdriver
- 5/16" Nut Driver
- Multimeter

PROCEDURE:

1. Raise the litter and the head end to the full up position.
2. Remove the head board from the bed.
3. Unplug the power cord from the wall socket and push the battery power On/Off switch to the "Off" position.
4. Using a 5/16" nut driver, remove the screw holding the power cord clamp to the bumper weldment and remove the clamp from the bumper.
5. Using a T27 Torx, remove the four bolts (A) at the head end of the bed holding the control bar mounting bracket to the head end (see Figure 1).
6. Using a #2 Phillips screwdriver, remove the three screws (B) holding the control bar cover to the head end of the bed (see Figure 2).
7. Standing at the head end, pull the control bar toward you and fold down the control bar mounting bracket.
8. Using a 1/2" wrench, remove the nut holding the potentiometer to the mount. Using wire cutters, cut the wire ties. Unplug the potentiometer cable from the CPU display board and remove the potentiometer.
9. Install the new potentiometer. Using a small flat blade screwdriver, turn the potentiometer shaft clockwise until it stops. Turn it back counterclockwise a 1/2 turn until multimeter reads 2.35 ohms to 2.55 ohms using the black and red wires.
10. After the new potentiometer has been installed, the potentiometer "burn-in" procedure must be performed (see "Zoom® Option Control Bar Potentiometer 'Burn-In' Procedure").
11. After performing the "burn-in" procedure, reverse steps 1 - 7 to reassemble the bed.
12. Test all functions before returning the unit to service.

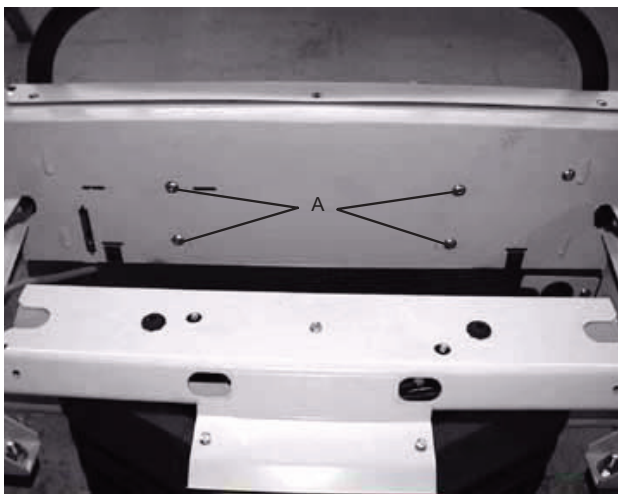

Figure 1

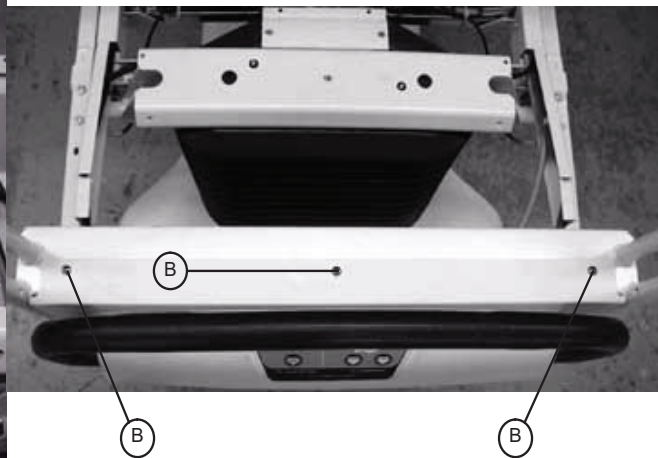

Figure 2

Service Information

ZOOM® OPTION CONTROL BAR POTENTIOMETER “BURN-IN” PROCEDURE

Tools Required:

- T27 Torx
- # 2 Phillips Screwdriver

PROCEDURE:

1. Raise the litter and the head end to the full up position.
2. Remove the head board from the bed.
3. Unplug the power cord from the wall socket and push the battery power On/Off switch to the “Off” position.
4. Using a 5/16” nut driver, remove the screw holding the power cord clamp to the bumper weldment and remove the clamp from the bumper.
5. Using a T27 Torx, remove the four bolts (A) at the head end of the bed holding the control bar mounting bracket to the head end (see Figure 1).
6. Using a #2 Phillips screwdriver, remove the three screws (B) holding the control bar cover to the head end of the bed (see Figure 2).
7. Standing at the head end, pull the control bar toward you and fold down the control bar mounting bracket.
8. Ensure the battery on/off switch is in the “Off” position (LED is Off).
9. Hold down the yellow button on the back of the display CPU board.
10. With the switch depressed, move the battery power on/off switch to the “ON” position (LED will light) and continue holding for three seconds.
11. Press and hold the yellow button on the back of the display CPU board.
12. Move the battery power on/off switch to the “on” position (LED will light) and continue holding switch for three seconds.
13. Verify the “Engage Drive Wheel” led at the head end display housing is flashing.
14. Move the battery power on/off switch back to the “Off” position (all LED’s will go out).
15. Close the drive box.
16. Ensure the control bar is in the center of travel by pushing and pulling the bar, then returning the bar to the neutral position.
17. With no objects touching the control bar, turn the battery power on/off switch to the “On” position.
18. The three LED’s on the front of the bed will flash initially to show the battery voltage of the bed by lighting zero, one, two or three LED’s.
19. After the battery charge has been displayed by the three LED’s, all three LED’s will flash twice.
20. After all three LED’s have flashed twice, push the drive handle to the full forward position. Hold the drive handle in the full forward position until all three LED’s flash twice again (three seconds).
21. The “ENGAGE DRIVE WHEEL” LED will flash once.
22. The control bar potentiometer is calibrated.
23. Return the control bar to the neutral position.
24. Grasp the control bar and squeeze either motion switch without moving the control bar forward or backward.
25. Verify the bed does not move.
26. Standing at the head end of the bed, grasp the control bar and squeeze either motion switch; then push the control bar forward.

Service Information

ZOOM® OPTION CONTROL BAR PENTIOMETER “BURN-IN” PROCEDURE (CONTINUED)

27. Verify the bed moves forward.
28. Standing at the head end of the bed, grasp the control bar and squeeze either motion switch, then pull the control bar backwards.
29. Verify the bed moves backward.
30. Move the battery power on/off switch “Off”, wait a few seconds, then back “On” again.
31. Repeat steps 18-23 to verify that the burn in procedure was performed correctly.

ZOOM® OPTION AC CROSSOVER BOARD REPLACEMENT

TOOLS REQUIRED:

- T27 Torx
- #2 Phillips Screwdriver
- Wire Cutters
- Needle Nose Pliers

PROCEDURE:

1. Raise the litter and the head end to the full up position.
2. Remove the head board from the bed.
3. Unplug the power cord from the wall socket and push the battery power On/Off switch to the “Off” position.
4. Using a 5/16” nut driver, remove the screw holding the power cord clamp to the bumper weldment and remove the clamp from the bumper.
5. Using a T27 Torx, remove the four bolts (A) at the head end of the bed holding the control bar mounting bracket to the head end (see Figure 1).
6. Using a #2 Phillips screwdriver, remove the three screws (B) holding the control bar cover to the head end of the bed (see Figure 2).
7. Standing at the head end, pull the control bar toward you and fold down the control bar mounting bracket.
8. Using a T-27 Torx, remove the two bolts holding the AC crossover board cover to the head end frame and remove the cover.
9. Disconnect all wires from the AC crossover board
10. Using needle nose pliers, release the four mounting standoffs from the board and remove the board.
11. Reverse steps.
12. Test Functionality.

Service Information

Zoom® OPTION DISPLAY/CPU BOARD REPLACEMENT

TOOLS REQUIRED:

- T27 Torx
- #2 Phillips Screwdriver

PROCEDURE:

1. Raise the litter and the head end to the full up position.
2. Remove the head board from the bed.
3. Unplug the power cord from the wall socket and push the battery power On/Off switch to the “Off” position.
4. Using a 5/16” nut driver, remove the screw holding the power cord clamp to the bumper weldment and remove the clamp from the bumper.
5. Using a T27 Torx, remove the four bolts (A) at the head end of the bed holding the control bar mounting bracket to the head end (see Figure 1).
6. Using a #2 Phillips screwdriver, remove the three screws (B) holding the control bar cover to the head end of the bed (see Figure 2).
7. Standing at the head end, pull the control bar toward you and fold down the control bar mounting bracket.
8. Disconnect all wires from the display/CPU board.
9. Using a #2 Phillips screwdriver, remove the six screws holding the display/CPU board to the control bar cover and remove the board.
10. Reverse steps 8 and 9 to install the new board. After the new board has been installed, the potentiometer “burn-in” procedure must be performed (see “Zoom® Option Control Bar Potentiometer ‘Burn-In’ Procedure” section, [page 61](#)).
11. Reverse procedure.
12. Test functionality.

Service Information

HEAD AND FOOT SIDERAIL COVER REMOVAL

TOOLS REQUIRED:

- #2 Phillips Screwdriver

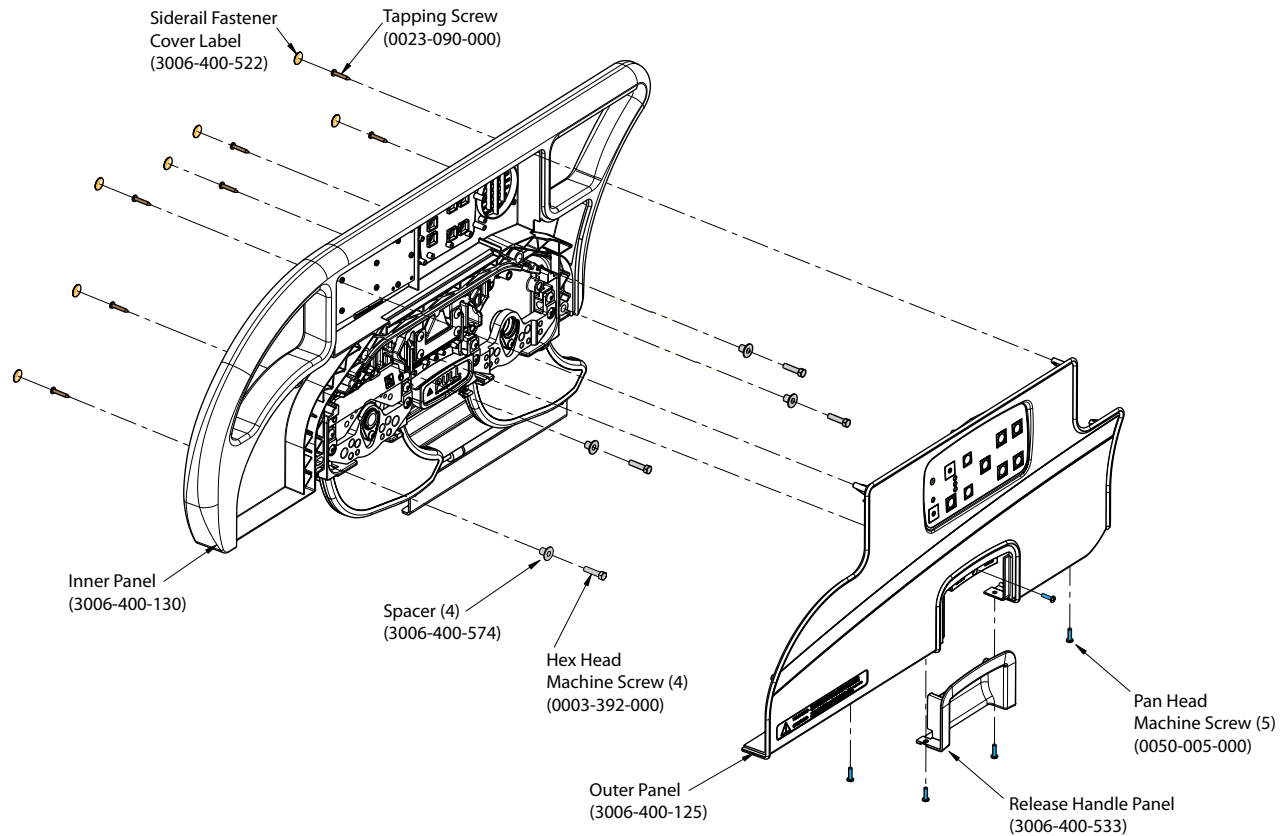

PROCEDURE:

1. Unplug the power cord from the wall receptacle.
2. Remove the seven screw cover labels from the inside of the rail.
3. Using a #2 Phillips screwdriver, remove the 8 phillips screws (A) holding the covers (B) to the siderail.
4. Remove the one screw holding the release handle panel and remove panel.

CAUTION

There are two cables connecting the outside cover to the head end siderail. Be careful not to pull on them when removing the cover.

5. Remove the cables from the siderail. Make note of the proper location for the cables.
6. Reverse the above steps to reattach the cover.

CAUTION

Do not snag the cables when installing the siderail cover.

Service Information

HEAD SIDERAIL HOOP REPLACEMENT

TOOLS REQUIRED:

#2 Phillips Screwdriver
3/8" Drive Ratchet
7/16" Socket

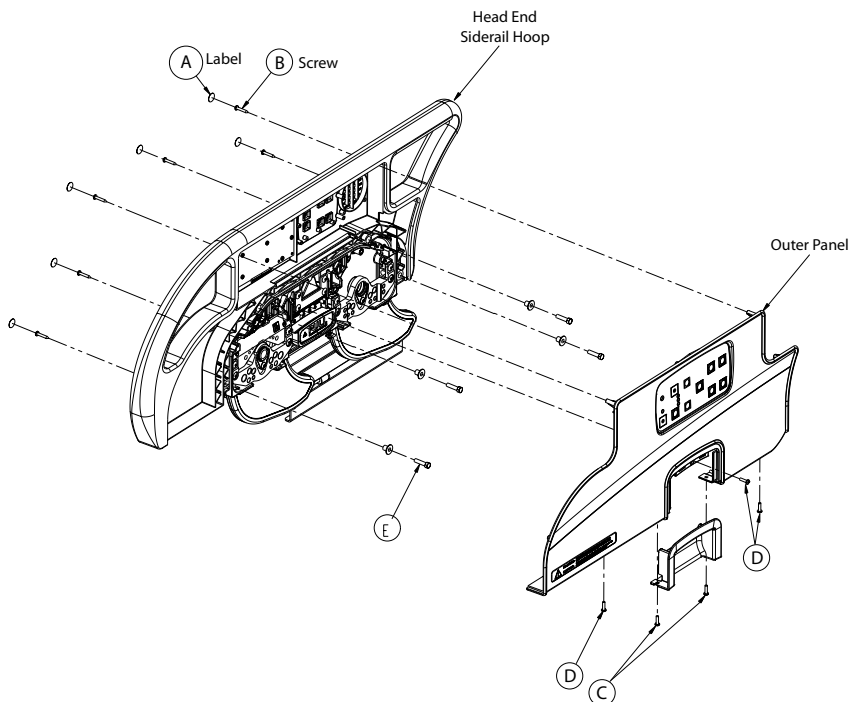

PROCEDURE:

1. Raise the siderail to the full upright position.
2. Using a regular screwdriver, remove the six labels (A) on the inside of the siderail.
3. Remove the six Pan Head screws (B) from the siderail panel.
4. Remove the two Pan Head screws (C) securing handle casing to panel and then pull down on the handle to remove.
5. Remove the three Pan Head screws (D) to remove the outer siderail panel.
6. Pull the outer siderail panel straight out.
7. Unplug the two cable harnesses from the siderail panel.
8. Unplug the cable connections from the inner siderail board and, using diagonal pliers, cut the cable ties securing the main cable.
9. Remove all four screws attached to the speaker and remove the speaker and cable clamp.
10. Using a 7/16" socket, remove the four screws (E) holding the head siderail hoop to the siderail support assembly.
11. Lift the head siderail hoop straight up and out.
12. Remove the inner siderail boards and reinstall on the new head siderail hoop.
13. Reverse steps 2-11 to install a new siderail hoop.

Service Information

FOOTBOARD MODULE REMOVAL

TOOLS REQUIRED:

- #2 Phillips Screwdriver
- 1/4" Nut Driver

Note

Labels will need to be replaced.

PROCEDURE:

1. Remove the footboard assembly.
2. Remove the 11 screw cover labels.
3. Using a Phillips screwdriver, remove the 13 screws holding the back cover to the footboard.
4. Using a 1/4" nut driver, remove the six screws holding the center lens assembly in.
5. Unplug the cable connection from the module.

Note

If you have *i*Awareness, there are two other connections.

6. Lift the module out and replace.
7. Reverse the above steps to attach the replacement door and/or hinge.

Note

Screw (B) is a machine screw and must be reinstalled in the proper hole.

Service Information

FOOTBOARD INTERFACE PLUG REPLACEMENT

TOOLS REQUIRED:

- #2 Phillips Screwdriver

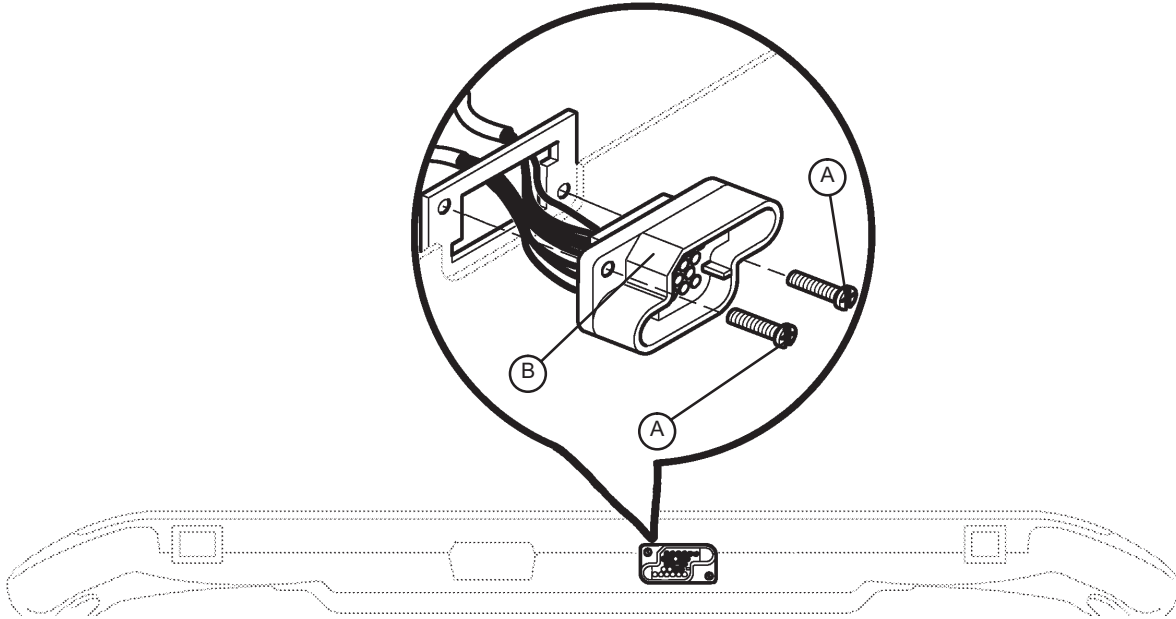

BOTTOM VIEW OF FOOT BOARD

PROCEDURE:

1. Remove the footboard assembly.
2. Remove the 11 screw cover labels.
3. Using a Phillips screwdriver, remove the 13 screws holding the back cover to the footboard.
4. Unplug the cable connection from the module.
5. Lift up on connector and replace.

CAUTION

Be sure to install the plug with the flat edge (B) at the top left, as shown in the illustration, or the footboard interface plug will not mate properly with the bed. Damage to the plug or the footboard could result.

Bed Circuit Boards

CPU BOARD - 3006-308-900

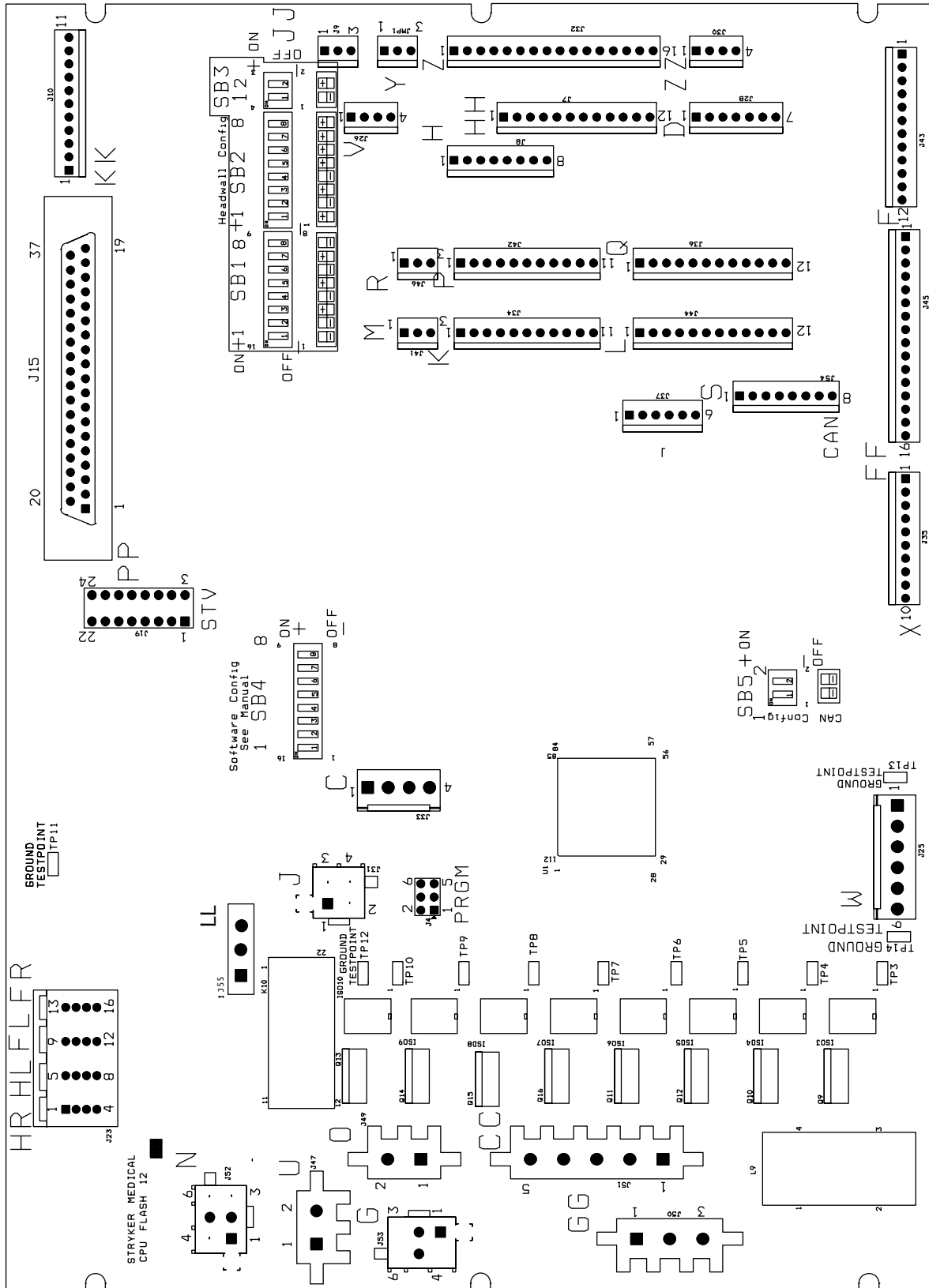

Bed Circuit Boards

CPU BOARD - 3006-308-900 (CONTINUED)

| Cable Location | Voltage | Positive Lead | Negative Lead | Description |
|----------------|------------------------------------|---------------|---------------|--------------------------------------|
| W | +12VDC | Pin 1 | Pin 4 or 5 | Relays & Siderails Light Voltage |
| W | +5VDC | Pin 2 & 3 | Pin 4 or 5 | +5VDC from Power Supply |
| W | -12VDC | Pin 6 | Pin 4 or 5 | Relays & Siderails Light Voltage |
| J | +5VDC | Pin 4 | Pin 2 | +5VDC for Head Lift Potentiometer |
| J | 0 - 5VDC | Pin 3 | Pin 2 | Head Lift Potentiometer Wiper |
| C | +5VDC | Pin 1 | Pin 2 | +5VDC for Foot Lift Potentiometer |
| C | 0 - 5VDC | Pin 3 | Pin 2 | Foot Lift Potentiometer Wiper |
| GG | 0VAC w/o Switch 120VAC w/Switch | Pin 2 Purple | Pin 1 Blue | Gatch Up |
| GG | 0VAC w/o Switch 120VAC w/Switch | Pin 3 Red | Pin 1 Blue | Gatch Down |
| CC | 0VAC w/o Switch 120VAC w/Switch | Pin 1 Black | Pin 3 Red | Fowler Up |
| CC | 0VAC w/o Switch 120VAC w/Switch | Pin 2 White | Pin 3 Red | Fowler Down |
| O | 110VAC | Pin 1 | Pin 2 | Line Voltage to Bed |
| N | 0VAC w/o Switch 120VAC w/Switch | Pin 3 Black | Pin 1 White | Head Lift Down |
| N | 0VAC w/o Switch 120VAC w/Switch | Pin 6 Red | Pin 1 White | Head Lift Up |
| G | 0VAC w/o Switch 120VAC w/Switch | Pin 3 Black | Pin 1 Red | Foot Lift Down |
| G | 0VAC w/o Switch 120VAC w/Switch | Pin 6 White | Pin 1 Red | Foot Lift Up |

Bed Circuit Boards

SOFTWARE CONFIGURATION

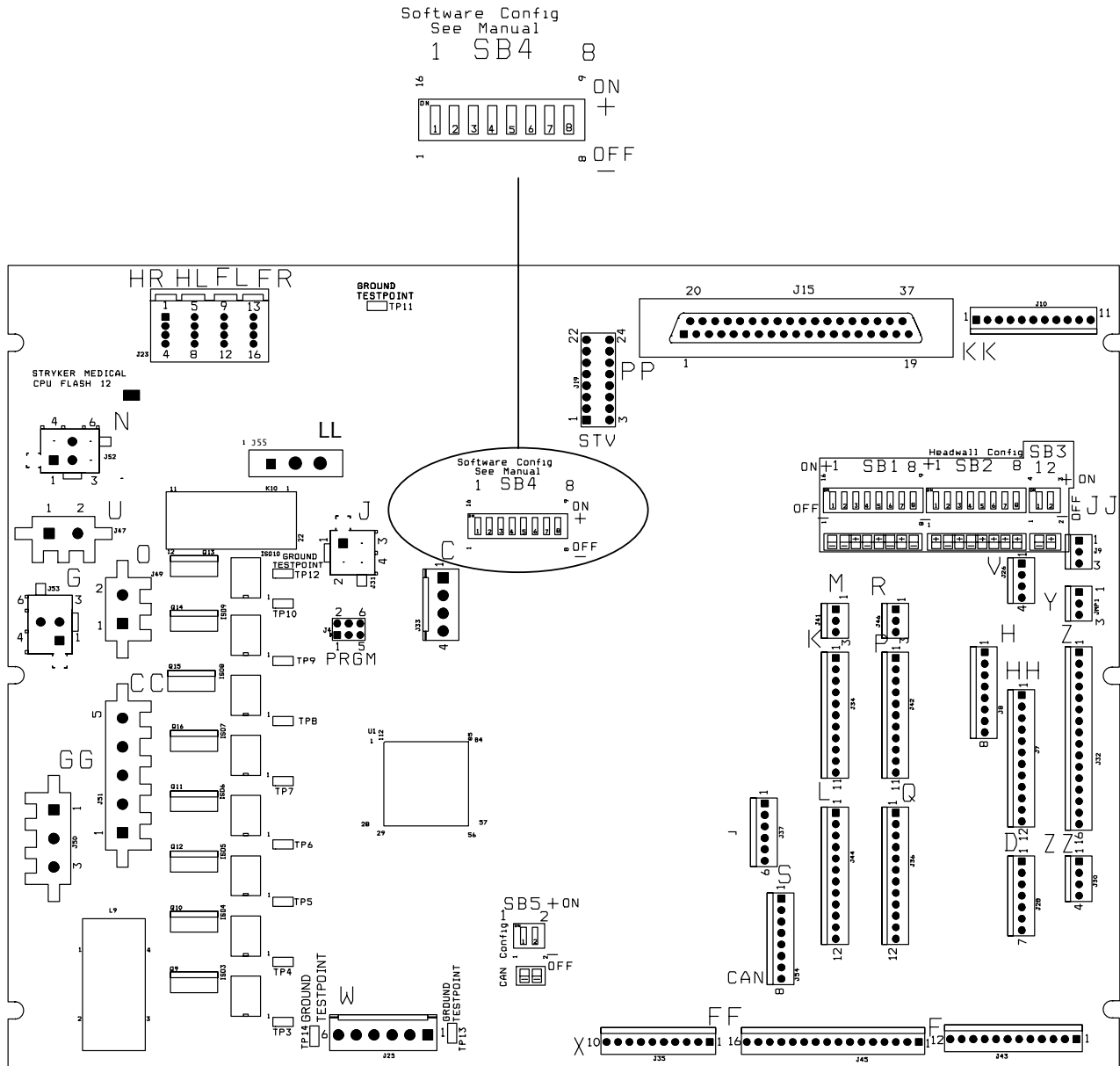

1. Locate switch bank 4, labeled SB4 on the CPU board (see above).
2. Move switch one to the “ON” position (see below).
3. To verify the switch settings, check what the footboard LCD displays.

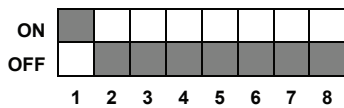

General Setting, S3™ Bed

Bed Circuit Boards

POWER SUPPLY - 0059-157-000

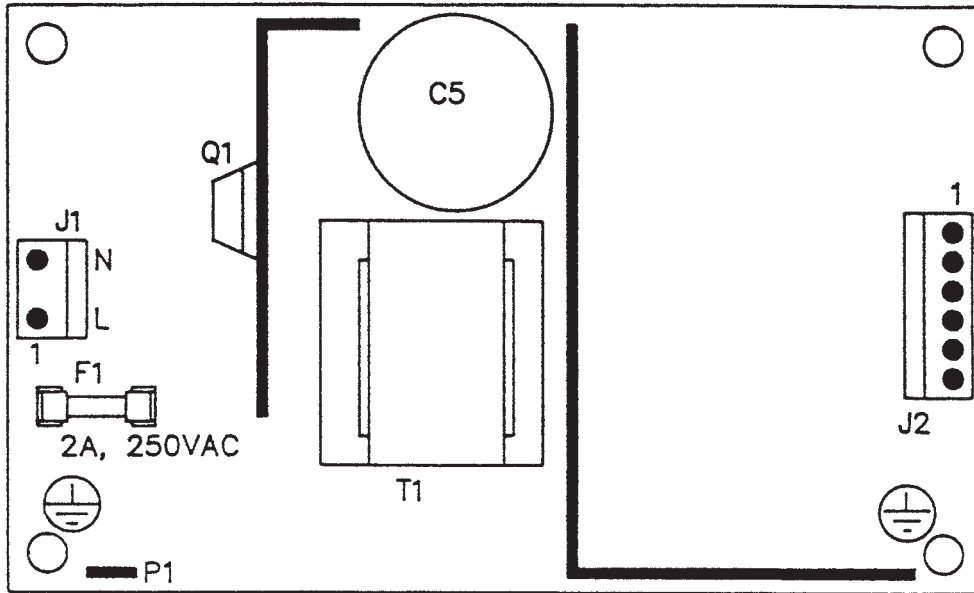

| Connector Location | Voltage | Positive Lead | Negative Lead |
|--------------------|---------|---------------|---------------|
| J1 | 115V | Pin 1 | Pin 2 |
| J2 | 12V | Pin 1 | Pin 4 or 5 |
| J2 | 5V | Pin 2 | Pin 4 or 5 |
| J2 | 5V | Pin 3 | Pin 4 or 5 |
| J2 | GND | Pin 4 | Pin 4 or 5 |
| J2 | GND | Pin 5 | Pin 4 or 5 |
| J2 | -12V | Pin 6 | Pin 4 or 5 |

Bed Circuit Boards

BATTERY BACKUP/ZOOM® OPTION, INVERTER/CHARGER BOARD - 3002-001-030

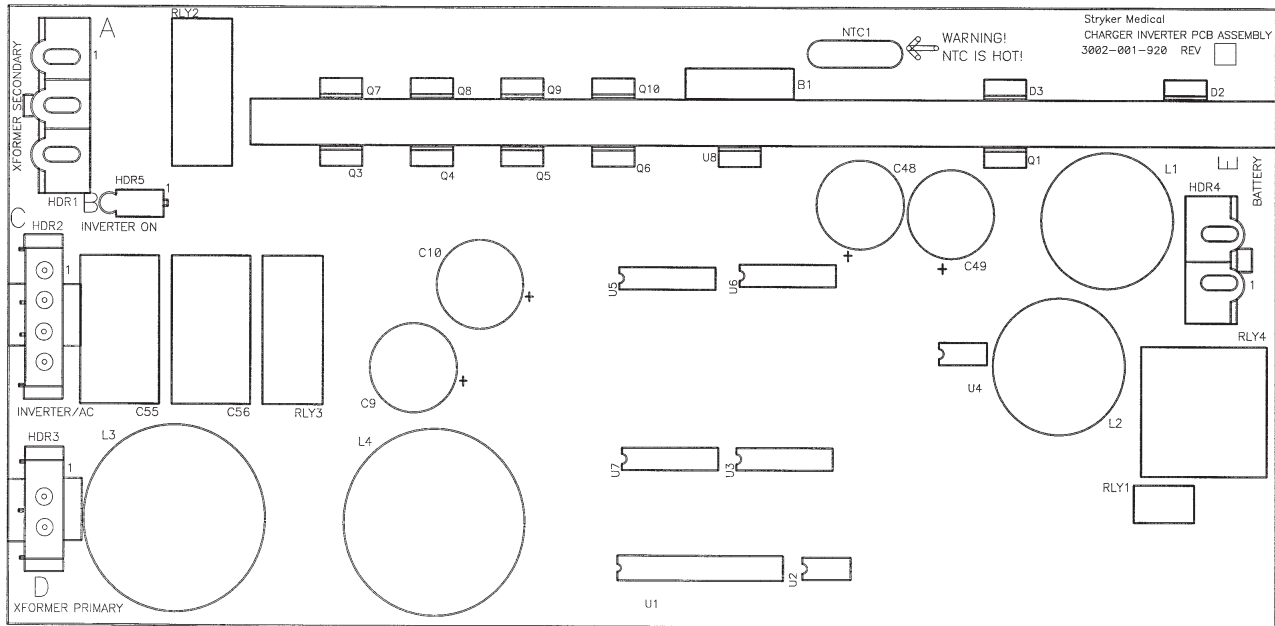

| Connector Location | Voltage | Positive Lead | Negative Lead | Description |
|--------------------|------------|---------------|-------------------------------|---|
| HDR 4 | 26VDC | Pin 2 Red | Pin 1 Black | From Battery - unplugged |
| HDR 1 | 22VAC | Pin 3 Red | Pin 2 | Secondaries from transformer - plugged in |
| HDR 1 | 34VAC | Pin 1 Green | Pin 2 Brown | Secondaries from transformer - plugged in |
| HDR 2 | 110-140VAC | Pin 4 Brown | Inverter Module Pin 3 Blue | Unplugged |
| HDR 2 | 110V | Pin 2 Brown | Pin 1 Blue | From Wall - plugged in |
| HDR 3 | 120V | Pin 2 | Plug-in Pin 1 | Wall Voltage - plugged in |

Bed Circuit Boards

BATTERY BACKUP/ZOOM® OPTION, AC CROSSOVER BOARD - 2040-031-900

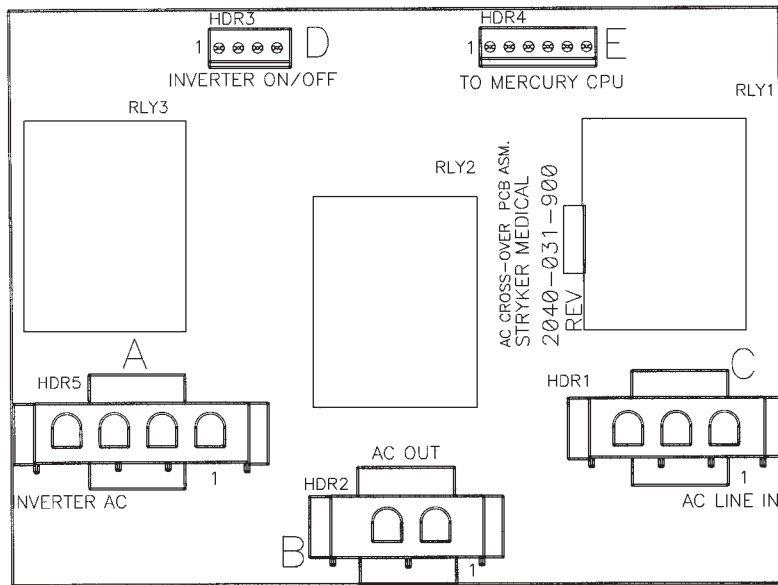

| Connector Location | Voltage | Positive Lead | Negative Lead | Description |
|--------------------|---------|---------------|---------------|---|
| HDR 5 (A) | 120VAC | Pin 4 | Pin 1 | AC Input to Board from the Inverter with the Power Cord Unplugged |
| HDR 1 (C) | 120VAC | Pin 3 | Pin 1 | AC Input to Board from the Wall Receptacle |
| HDR 2 (B) | 120VAC | Pin 2 | Pin 1 | AC Output of Board to Main Power |
| HDR 4 (E) | +5VDC | Pin 4 | Pin 1 | +5VDC when AC is Unplugged from the Wall Receptacle |

Bed Circuit Boards

BATTERY BACKUP OPTION, DISPLAY/CPU - 2030-031-910

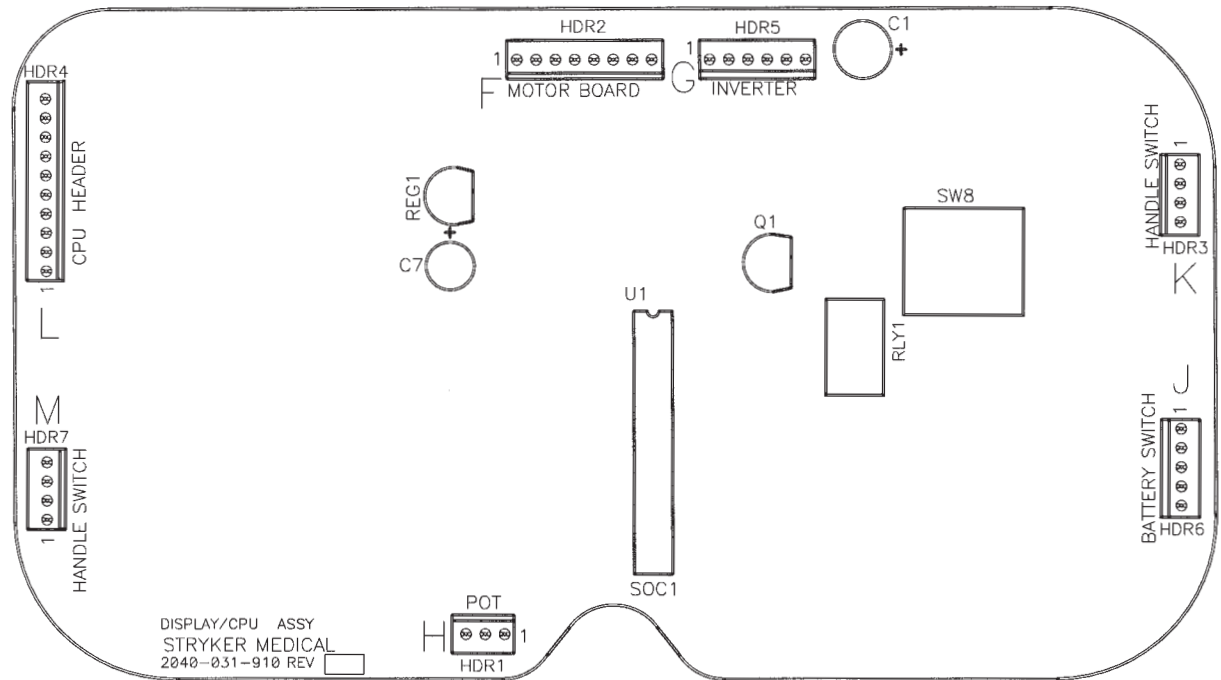

| Connector Location | Voltage | Positive Lead | Negative Lead | Description |
|--------------------|-------------------------------|---------------|---------------|--|
| HDR 1 (H) | 0-5 VDC | Pin 1 | Pin 2 | Control Pot Wiper Voltage (with Switch On) |
| HDR 6 (J) | Battery voltage around 26 VDC | Pin 1 | Pin 5 | Battery Voltage Return from On/Off Switch (with Switch On) |
| HDR 4 (L) | 5 VDC | Pin 9 | Pin 1 | Voltage from CPU |
| HDR 1 | 5 VDC | Pin 1 | Pin 3 | DC Voltage to Pot |
| HDR 7 | Continuity | Pin 1 | Pin 4 | Right Hand Switch |
| HDR 3 | Continuity | Pin 1 | Pin 4 | Left Hand Switch |
| HDR 2 | 26 VDC | Pin 3 | Pin 1 | Battery Voltage |

Bed Circuit Boards

ZOOM® OPTION, DISPLAY/CPU - 2040-031-910

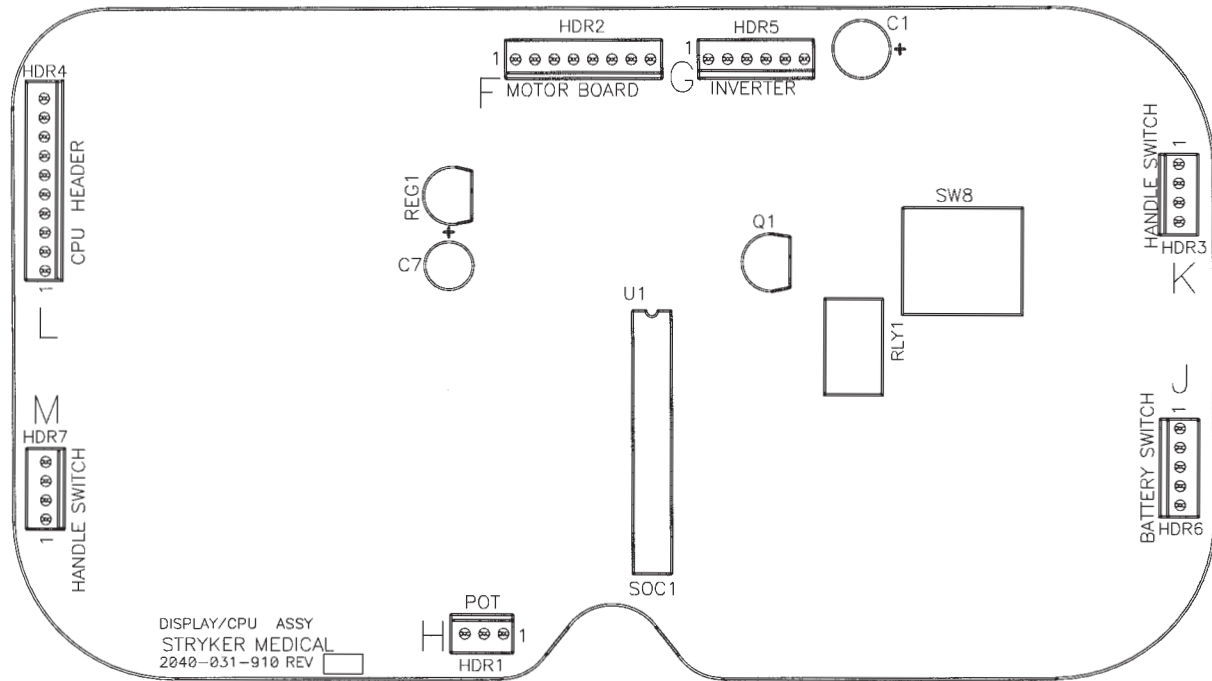

| Connector Location | Voltage | Positive Lead | Negative Lead | Description |
|--------------------|------------------------------|---------------|---------------|--|
| HDR 1 (H) | 0-5VDC | Pin 1 | Pin 2 | Control Potentiometer Wiper Voltage (with Switch On) |
| HDR 6 (j) | Battery voltage around 26VDC | Pin 1 | Pin 5 | Battery Voltage Return from On/Off Switch (with Switch On) |
| HDR 4 (L) | 5VDC | Pin 9 | Pin 1 | Voltage from CPU |
| HDR 1 | 5VDC | Pin 1 | Pin 3 | DC Voltage to Potentiometer |
| HDR 7 | Continuity | Pin 1 | Pin 4 | Right Hand Switch |
| HDR 3 | Continuity | Pin 1 | Pin 4 | Left Hand Switch |
| HDR 2 | 26VDC | Pin 3 | Pin 1 | Battery Voltage |

Bed Circuit Boards

ZOOM® OPTION, DC MOTOR POWER BOARD - 2040-001-900

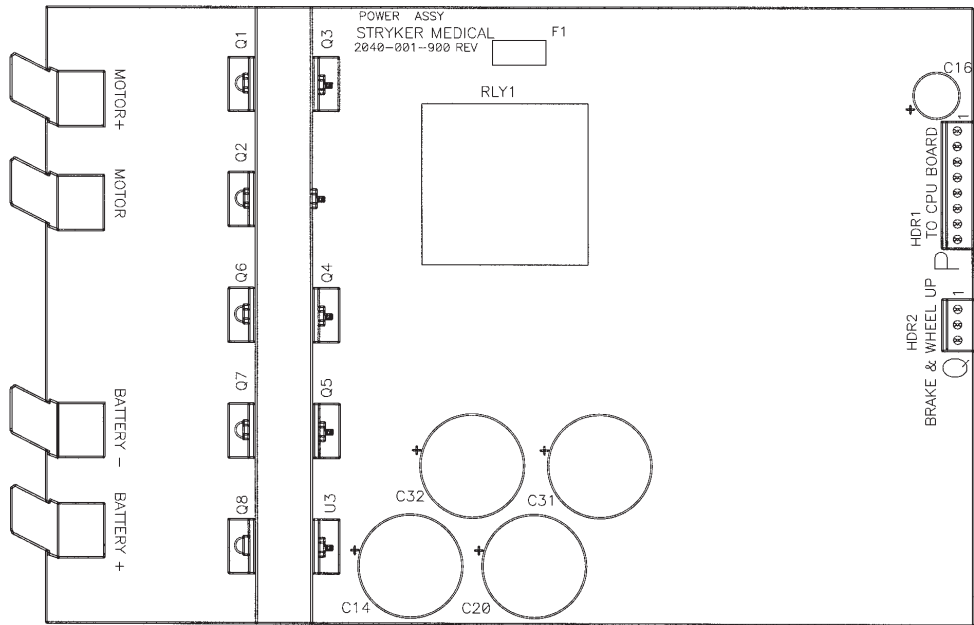

| Connector Location | Voltage | Positive Lead | Negative Lead | Description |
|--------------------|---------------------------------|---------------|---------------|---|
| HDR 1 (P) | Battery voltage around 26VDC | Pin 3 Red | Pin 1 Black | Battery Voltage out to the Display/ CPU Board |
| HDR 2 (Q) | 5VDC Disengaged 0VDC Engaged | Pin 1 Red | Pin 3 Black | Drive Wheel |
| HDR 2 (Q) | 5VDC Disengaged 0VDC Engaged | Pin 2 Red | Pin 3 Black | Brakes |

Bed Circuit Boards

iBED ENHANCED NURSE CALL OPTION, 37-PIN PLUGOVER BOARD - 3006-303-900

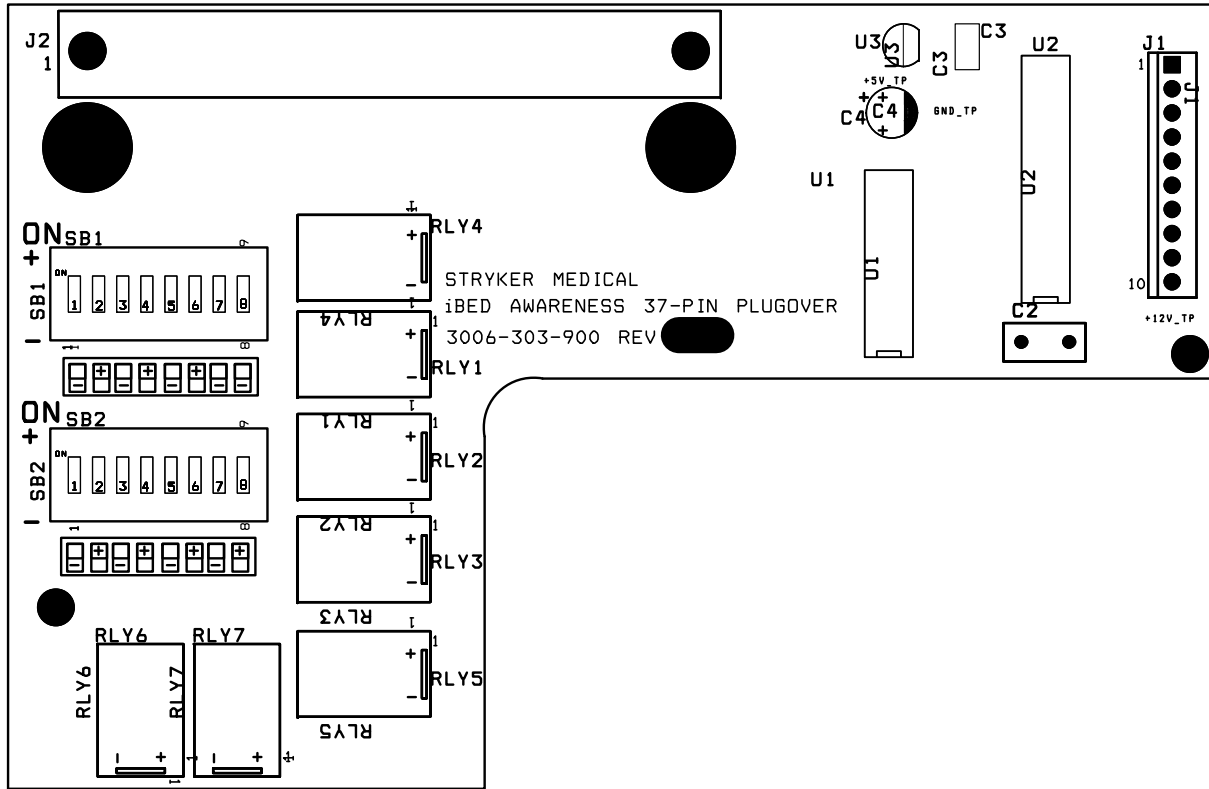

iBED ENHANCED NURSE CALL OPTION, DIP-SWITCH SETTINGS (DEFAULT)

For Reference Only: SK-31628 Rev C

| Headwall Function | Default Position | Alternate Position | Alternate Position |
|--|--|--|---|
| Side Rail Alert (SB2): SW3, SW4 (Select N.O. N.C. or OFF) | <p>N.O. <input type="checkbox"/></p> <p>(Check Here)</p> | <p>N.C. <input type="checkbox"/></p> <p>(Check Here)</p> | <p>OFF <input type="checkbox"/></p> <p>(Check Here)</p> |
| Fowler 30 Alert (SB2): SW5, SW6 (Select N.O. N.C. or OFF) | <p>N.O. <input type="checkbox"/></p> <p>(Check Here)</p> | <p>N.C. <input type="checkbox"/></p> <p>(Check Here)</p> | <p>OFF <input type="checkbox"/></p> <p>(Check Here)</p> |
| Low Height Alert (SB2): SW7, SW8 (Select N.O. N.C. or OFF) | <p>N.O. <input type="checkbox"/></p> <p>(Check Here)</p> | <p>N.O. <input type="checkbox"/></p> <p>(Check Here)</p> | <p>OFF <input type="checkbox"/></p> <p>(Check Here)</p> |

Bed Circuit Boards

/BED ENHANCED NURSE CALL OPTION, DIP-SWITCH SETTINGS (CONTINUED)

| Headwall Function | Default Position | Alternate Position | Alternate Position |
|---|--|--|---|
| I Bed ON (SB1): SW1, SW2 (Select N.O. N.C. or OFF) | <p style="text-align: center;">SB1</p> <p style="text-align: center;">N.O. <input type="checkbox"/> (Check Here)</p> | <p style="text-align: center;">SB1</p> <p style="text-align: center;">N.C. <input type="checkbox"/> (Check Here)</p> | <p style="text-align: center;">SB1</p> <p style="text-align: center;">OFF <input type="checkbox"/> (Check Here)</p> |
| Brakes ON (SB1): SW3, SW4 (Select N.O. N.C. or OFF) | <p style="text-align: center;">SB1</p> <p style="text-align: center;">N.O. <input type="checkbox"/> (Check Here)</p> | <p style="text-align: center;">SB1</p> <p style="text-align: center;">N.C. <input type="checkbox"/> (Check Here)</p> | <p style="text-align: center;">SB1</p> <p style="text-align: center;">OFF <input type="checkbox"/> (Check Here)</p> |
| Bed Exit ON (SB1): SW5, SW6 (Select N.O. N.C. or OFF) | <p style="text-align: center;">SB1</p> <p style="text-align: center;">N.O. <input type="checkbox"/> (Check Here)</p> | <p style="text-align: center;">SB1</p> <p style="text-align: center;">N.C. <input type="checkbox"/> (Check Here)</p> | <p style="text-align: center;">SB1</p> <p style="text-align: center;">OFF <input type="checkbox"/> (Check Here)</p> |
| Not Used (SB1): SW7, SW8 (Do Not Select) | <p style="text-align: center;">SB1</p> | | |
| I Bed Alert (SB2): SW1, SW2 (Select N.O. N.C. or OFF) | <p style="text-align: center;">SB1</p> <p style="text-align: center;">N.O. <input type="checkbox"/> (Check Here)</p> | <p style="text-align: center;">SB1</p> <p style="text-align: center;">N.C. <input type="checkbox"/> (Check Here)</p> | <p style="text-align: center;">SB1</p> <p style="text-align: center;">OFF <input type="checkbox"/> (Check Here)</p> |

Head Wall Output Configuration

37-Pin Connector

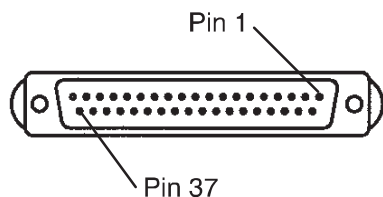

| | |
|--------|----------------------------------|
| Pin 1 | iBed® Awareness Status On |
| Pin 2 | Read Light |
| Pin 3 | Room Light |
| Pin 4 | Speaker High |
| Pin 5 | Potentiometer Wiper |
| Pin 6 | Bed Exit Status On |
| Pin 7 | Nurse Call Interlock |
| Pin 8 | Audio Transfer - |
| Pin 9 | Audio Transfer + |
| Pin 10 | Interlock + |
| Pin 11 | Interlock - |
| Pin 12 | iBed® Awareness Fowler 30° Alert |
| Pin 13 | No Connect |
| Pin 14 | Potentiometer Low Common |
| Pin 15 | Potentiometer High |
| Pin 16 | Nurse Answer Light + |
| Pin 17 | iBed® Awareness Alert |
| Pin 18 | iBed® Awareness Siderail Alert |
| Pin 19 | Nurse Call Light + |
| Pin 20 | No Connect |
| Pin 21 | No Connect |
| Pin 22 | No Connect |
| Pin 23 | Brake Status On |
| Pin 24 | No Connect |
| Pin 25 | Nurse Call + |
| Pin 26 | Nurse Call NO/NC |
| Pin 27 | Room/Read Light Common |
| Pin 28 | Nurse Call Light - |
| Pin 29 | Nurse Answer Light - |
| Pin 30 | Priority NO/NC |
| Pin 31 | Priority Common |
| Pin 32 | iBed® Awareness Low Height Alert |
| Pin 33 | TV - (Std.)/Data (STV) |
| Pin 34 | TV + (Std.)/Common (STV) |
| Pin 35 | Speaker Low Common |
| Pin 36 | Audio Shield |
| Pin 37 | iBed® Awareness Common |

Stryker Pendant Port

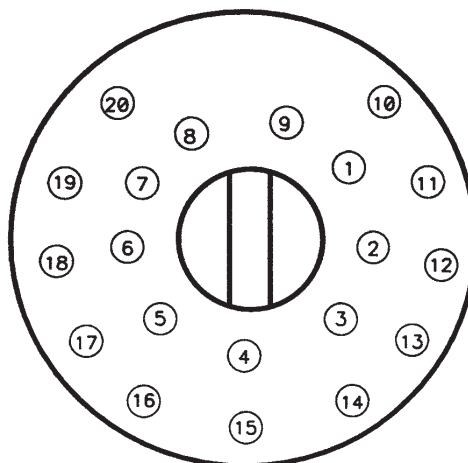

| | |
|----|---|
| 1 | Scan Line |
| 2 | Audio (-) |
| 3 | Nurse Call (+) |
| 4 | +5 VDC |
| 5 | Scan Line |
| 6 | Scan Line |
| 7 | Nurse Call (-) |
| 8 | TV Channel Up |
| 9 | Backlight |
| 10 | Audio (+) |
| 11 | Gatch Up/Fowler In/Foot Up/DMS Firm |
| 12 | Gatch Down/Fowler Out/Foot Out/DMS Soft |
| 13 | Fowler Up/Trend In |
| 14 | Fowler Down/Trend Out |
| 15 | Audio Shield |
| 16 | Not Used - Socket Filled |
| 17 | Bed Up |
| 18 | Ground |
| 19 | Read Light/Bed Down |
| 20 | Room Light |

Battery Backup/Zoom® Option Inverter Protection Features

The inverter has several features to prevent internal damage:

1. Low Battery Voltage - If the battery voltage at the inverter drops below the low voltage cutoff, the inverter will shut off.
2. Over-Temperature - If the inverter gets too hot, it will shut off. The overheating may be caused by high ambient temperature, blocked air flow or an overload condition. When the inverter reaches an acceptable temperature, it will restart.
3. Over-Power - The inverter will source up to its maximum power rating. If the load requires more, the output voltage will shut down. Turning the power switch off and on will reset the inverter. Plugging the bed power cord into the wall socket to charge the battery will reset the inverter.

 **WARNING**

The inverter generates 115VAC, the same as a wall receptacle. To prevent injury, do not put anything into the electrical outlets other than an appliance power cord. Keep the outlets covered when not in use. Do not submerge the unit or subject it to moisture.

Bed Assembly, Standard Bed

For Reference Only: 3006-043-102

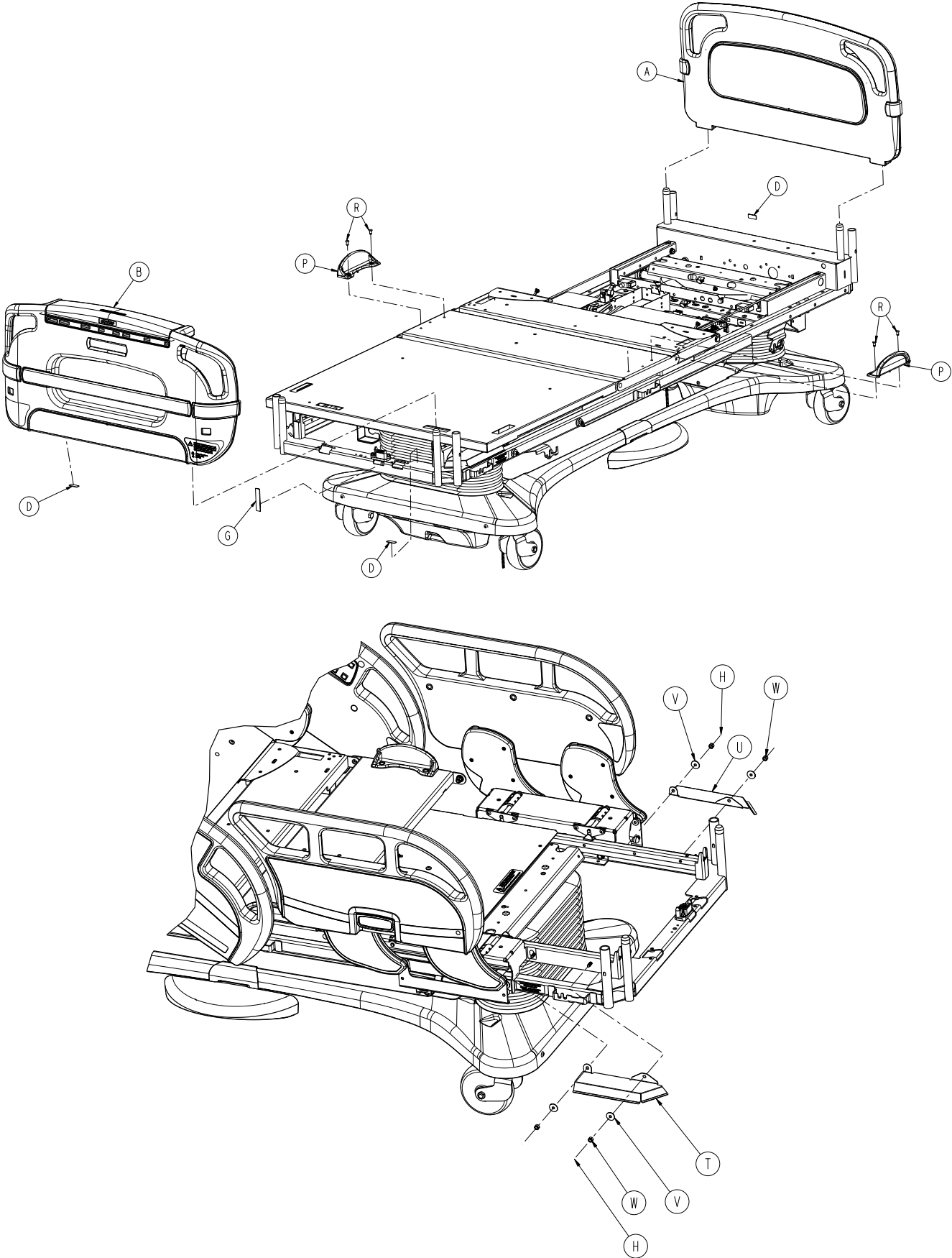

Bed Assembly, Standard Bed

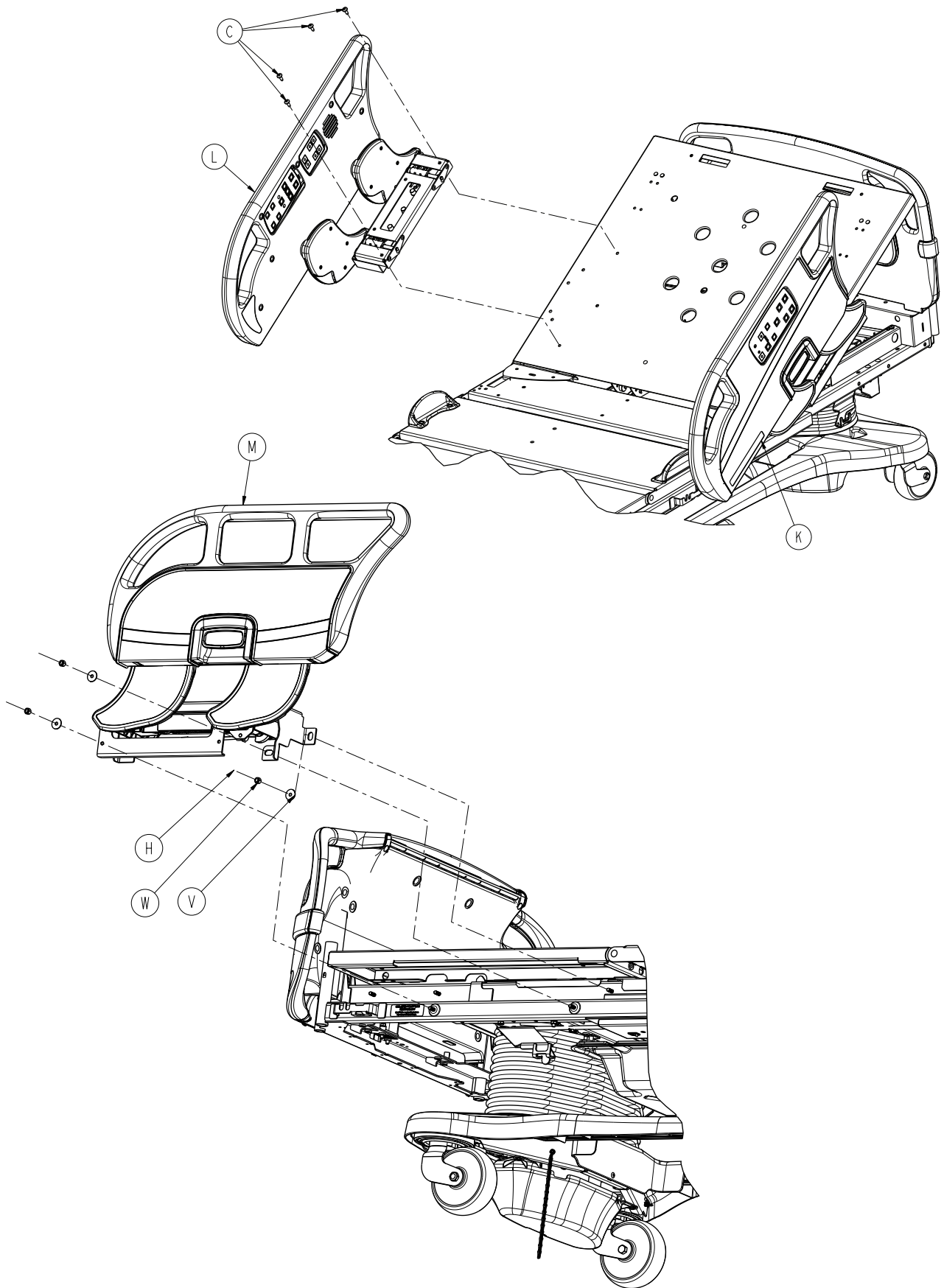

Bed Assembly, Standard Bed

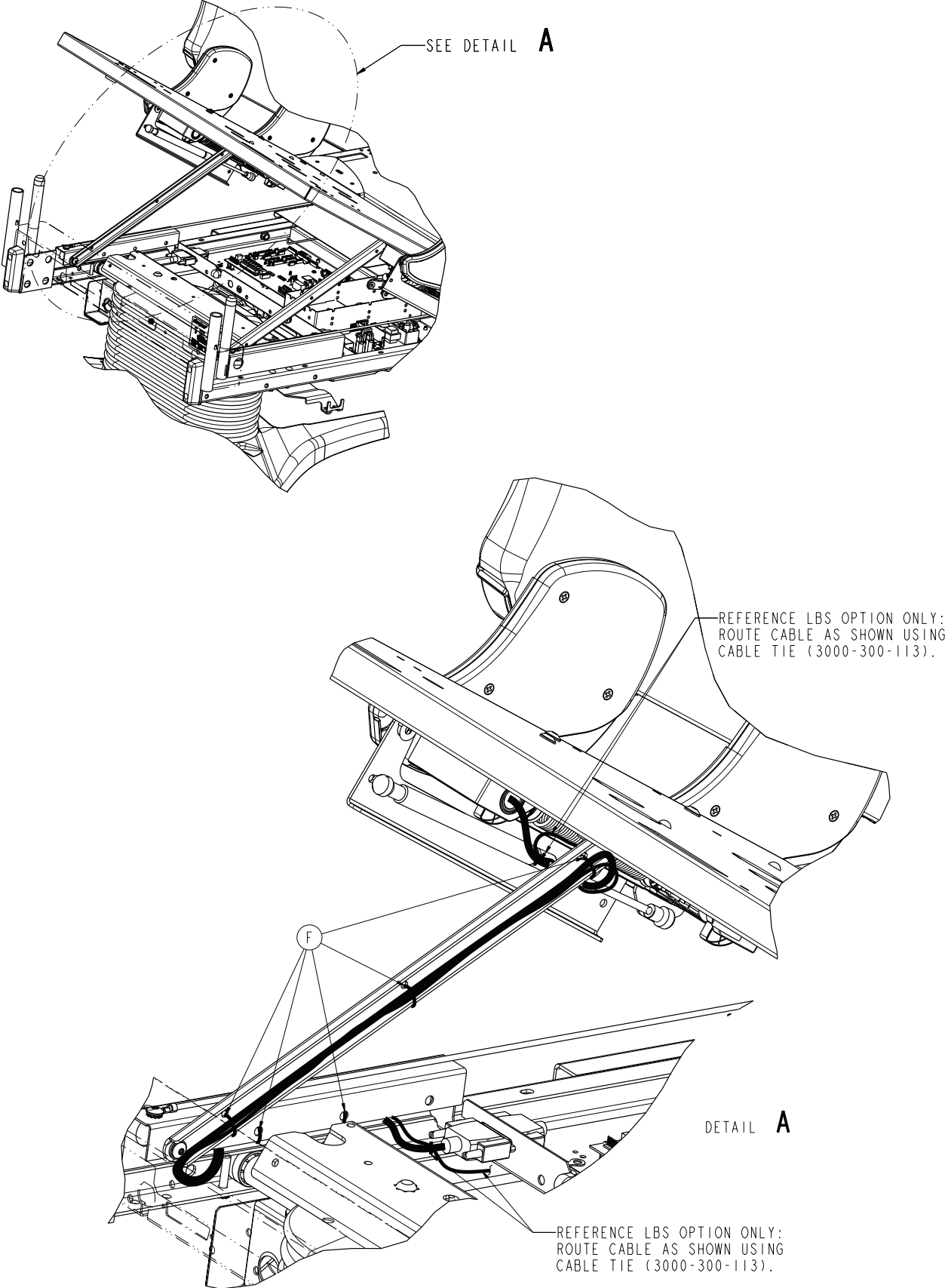

Bed Assembly, Standard Bed

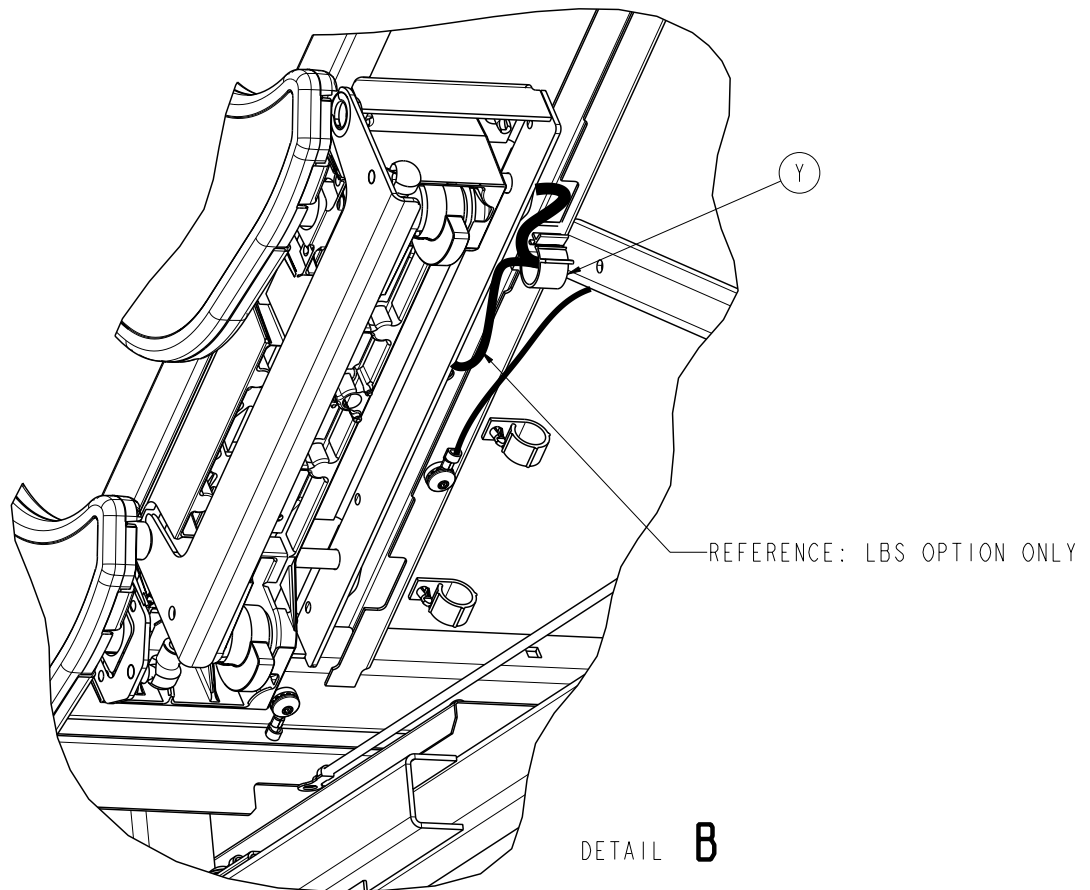
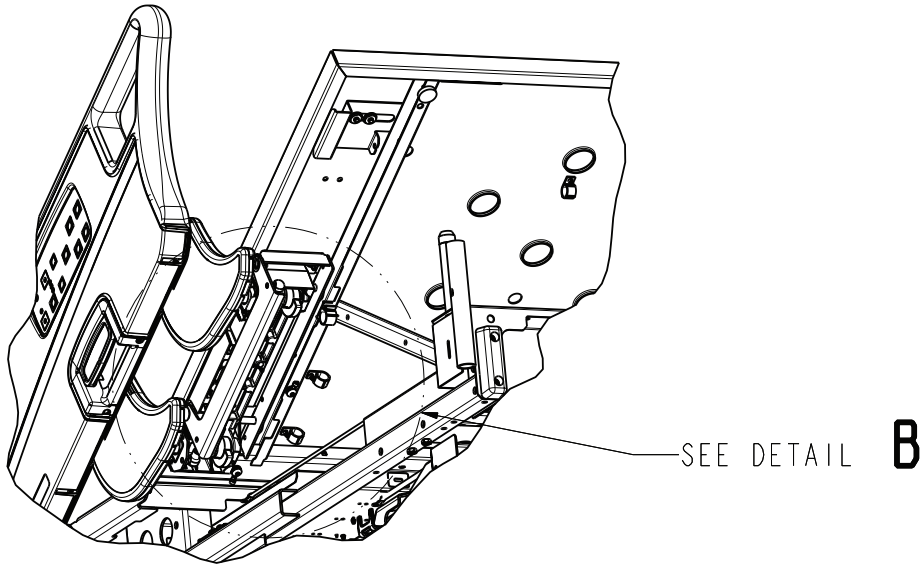

Bed Assembly, Standard Bed

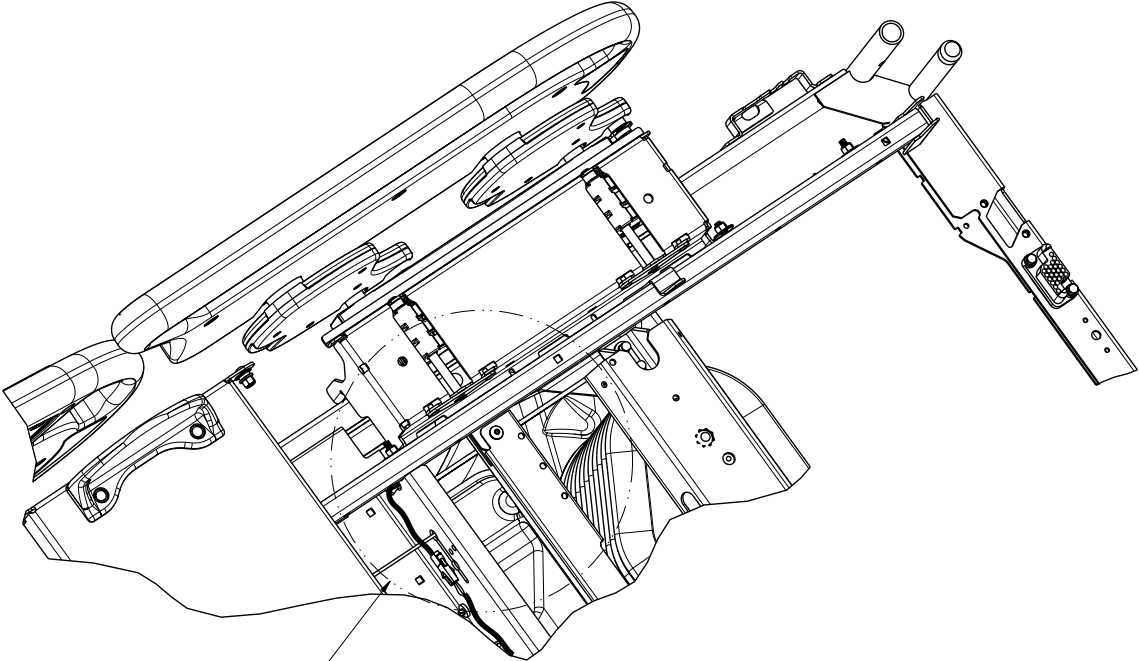

SEE DETAIL **C**

REFERENCE LBS OPTION ONLY:
ROUTE FOOT END CABLE AS SHOWN
USING CABLE TIE (3000-300-113)
TYPICAL BOTH SIDES.

(3000-300-113)

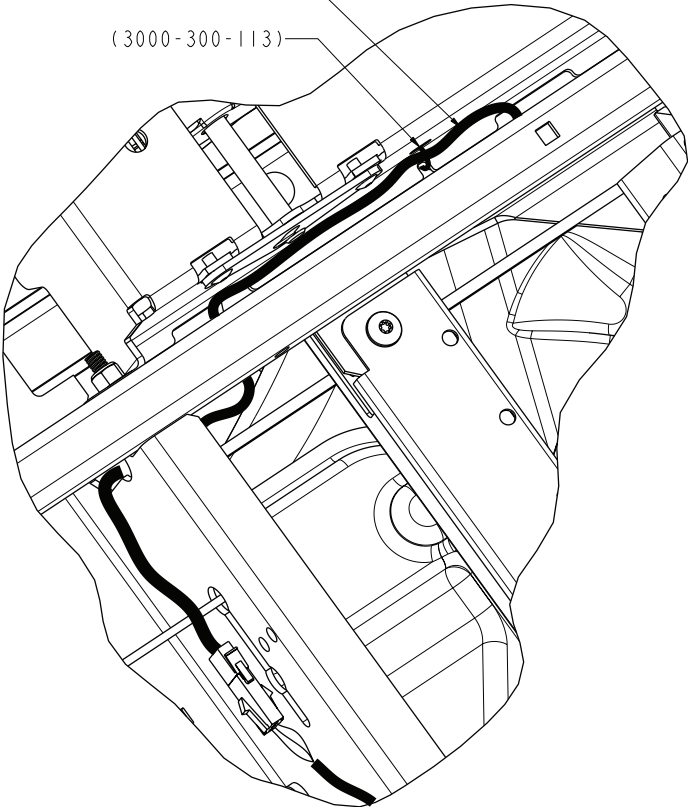

DETAIL **C**

Bed Assembly, Standard Bed

Bed Assembly, Standard Bed - 3006-043-102 (Reference Only)

| Item | Part No. | Part Name | Qty. |
|------|--------------|-------------------------------------|------|
| A | 3006-600-010 | Headboard Assembly | 1 |
| B | 3006-502-000 | Footboard Assembly, Standard Comp. | 1 |
| C | 0007-065-000 | Truss Head Screw | 8 |
| D | 3000-300-625 | Label, Dom | 1 |
| F | 3000-300-113 | 8" Cable Tie | 10 |
| G | 3000-300-641 | Label, Footboard Ground | 1 |
| H | 3006-400-493 | Stud Cap | 10 |
| J | 3006-343-002 | Litter Assembly | 1 |
| K | 3006-400-105 | HE Siderail Assy, Std. Comp., Left | 1 |
| L | 3006-400-205 | HE Siderail Assy, Std. Comp., Right | 1 |
| M | 3006-400-300 | FE Siderail Assy, Std. Comp., Left | 1 |
| N | 3006-400-400 | FE Siderail Assy, Std. Comp., Right | 1 |
| P | 3006-300-033 | Mattress Retainer | 2 |
| R | 0025-120-000 | Pop Rivet | 4 |
| T | 3006-300-275 | Shield, Right | 1 |
| U | 3006-300-276 | Shield, Left | 1 |
| V | 0011-180-000 | Flat Washer | 10 |
| W | 0016-028-000 | Fiberlock Hex Nut | 10 |
| Y | 0059-126-000 | Push-Mount Wire Clip | 2 |

Bed Assembly, Battery Backup Option

For Reference Only: 3006-350-000

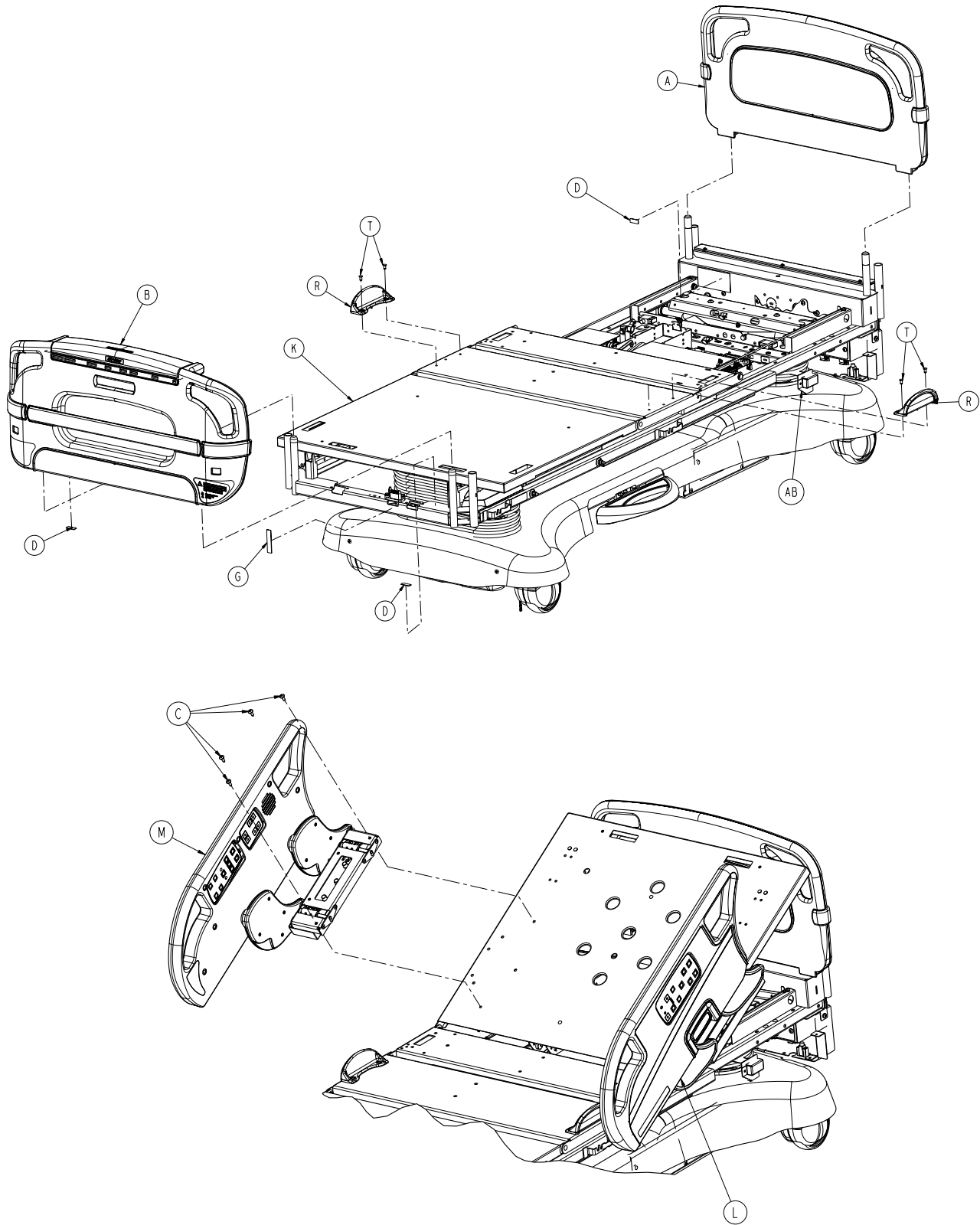

Bed Assembly, Battery Backup Option

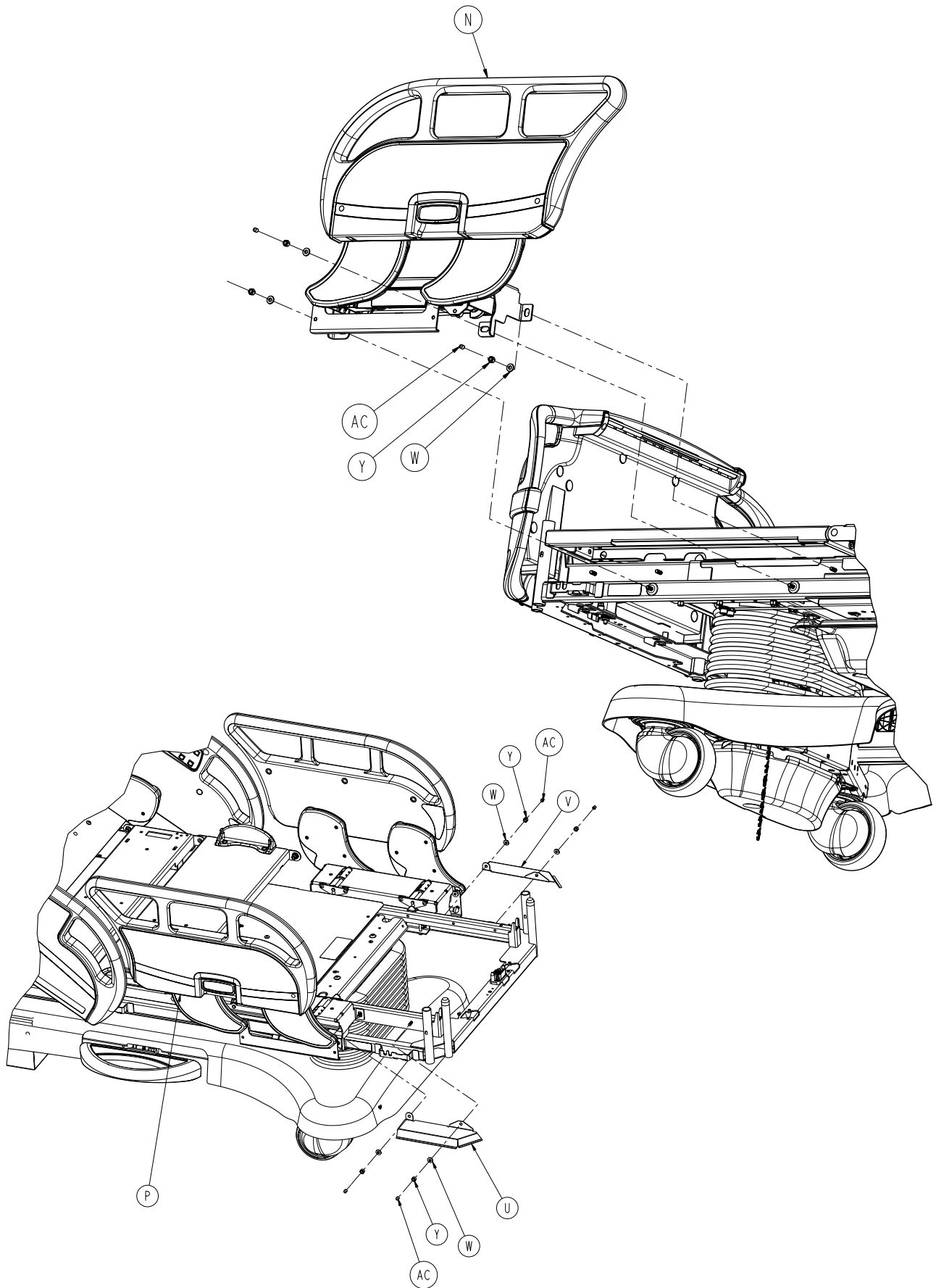

Bed Assembly, Battery Backup Option

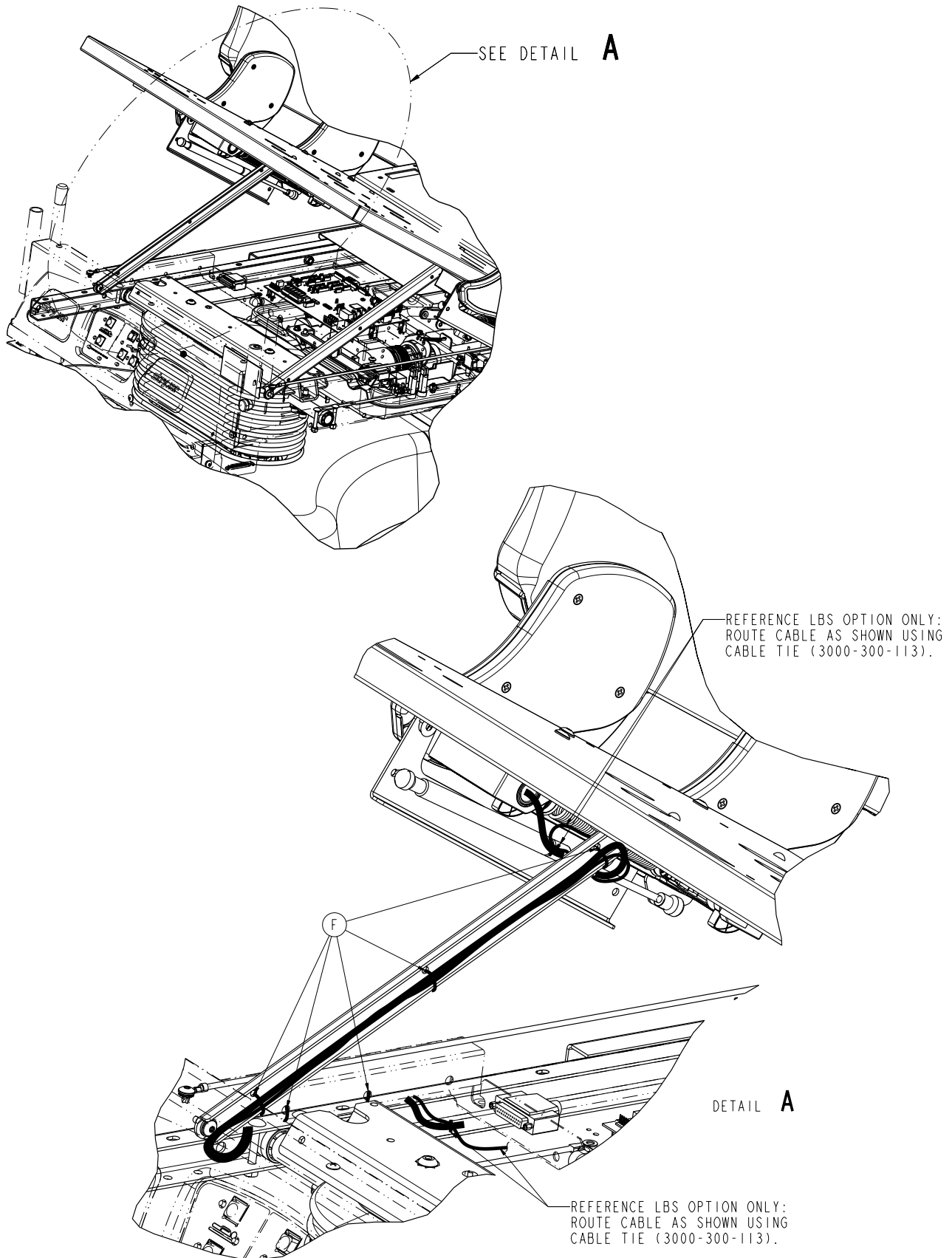

Bed Assembly, Battery Backup Option

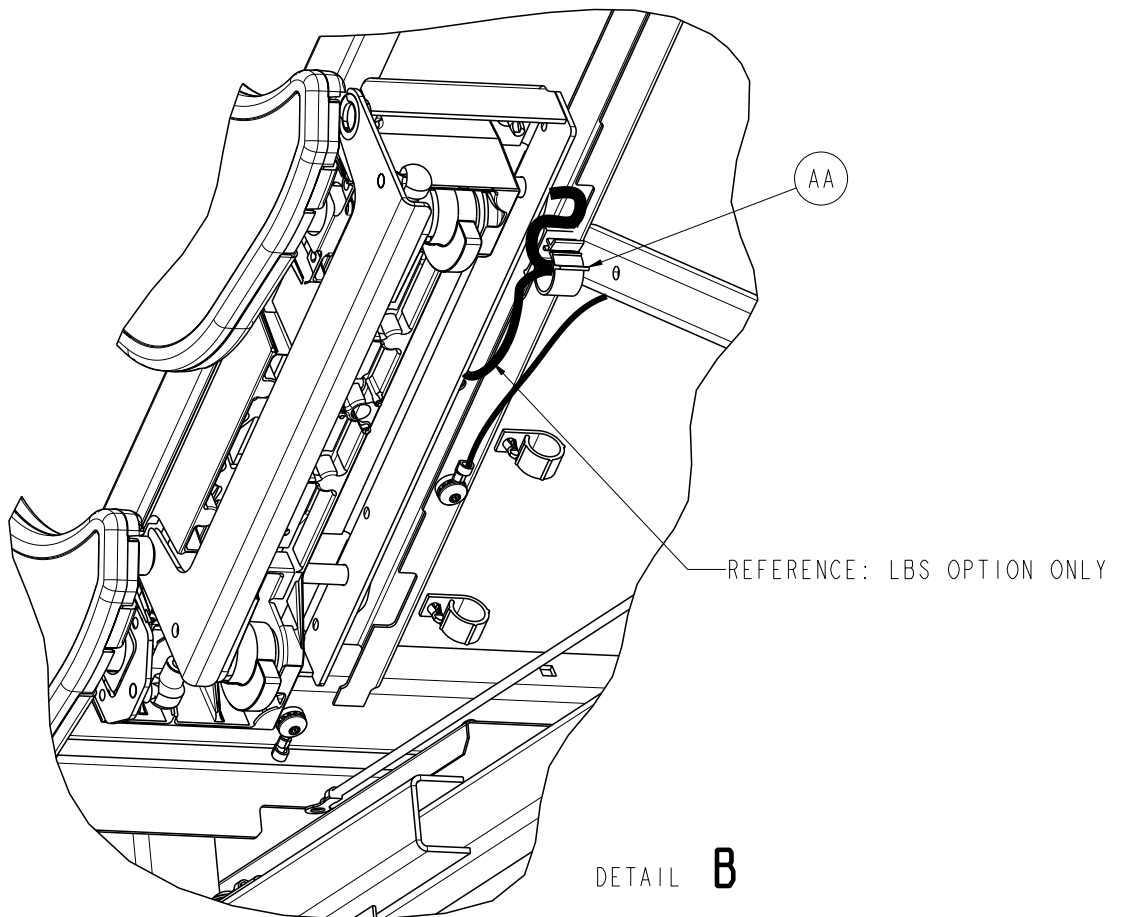
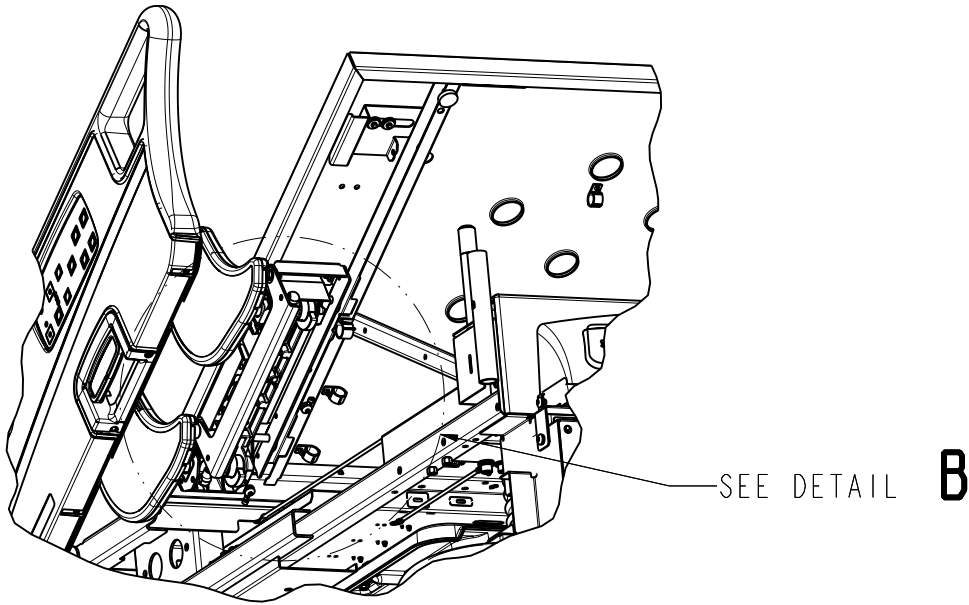

Bed Assembly, Battery Backup Option

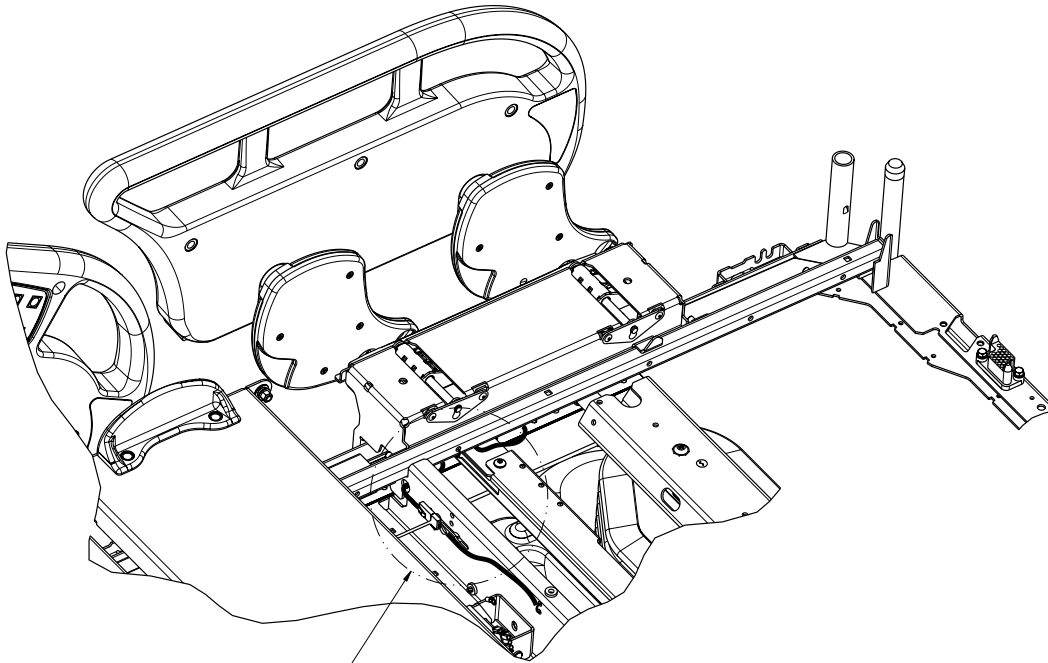

SEE DETAIL **C**

REFERENCE LBS OPTION ONLY:
ROUTE FOOT END CABLE AS SHOWN
USING CABLE TIE (3000-300-113)
TYPICAL BOTH SIDES.

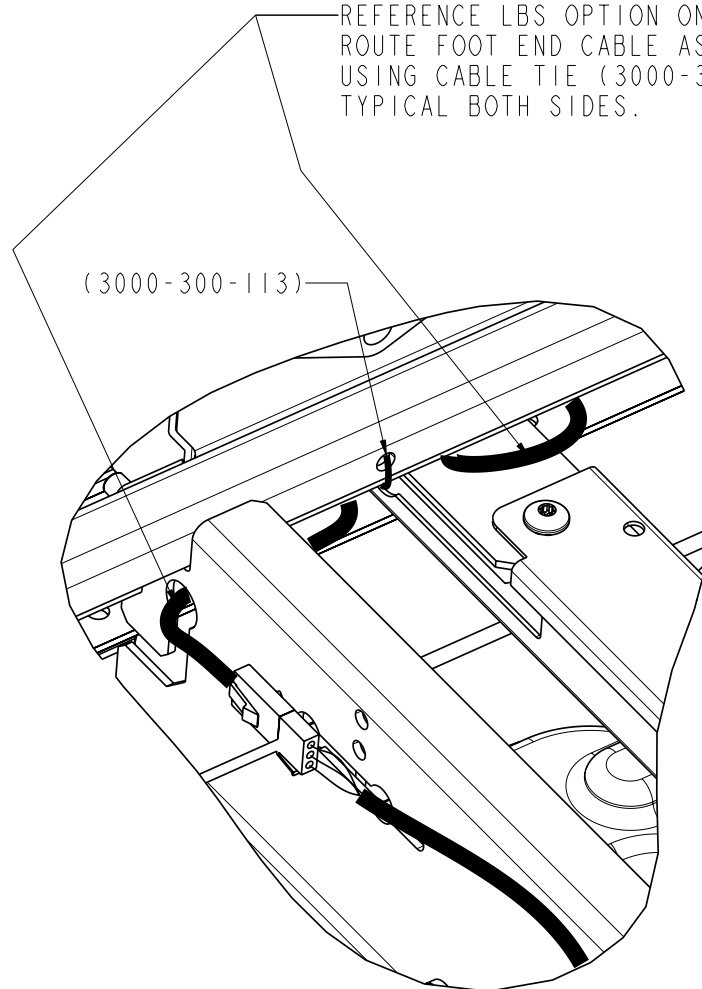

(3000-300-113)

DETAIL **C**

Bed Assembly, Battery Backup Option

Bed Assembly, Battery Backup Option - 3006-350-000 - (Reference Only)

| item | Part No. | Part Name | Qty. |
|------|--------------|-----------------------------|------|
| A | 3006-600-010 | Headboard Assembly | 1 |
| B | 3006-501-000 | Footboard Assembly | 1 |
| C | 0007-065-000 | Truss Head Screw | 8 |
| D | 3000-300-625 | Date of Manufacturing Label | 1 |
| F | 3000-300-113 | 8" Cable Tie | 10 |
| G | 3000-300-641 | Footboard Ground Label | 1 |
| K | 3006-350-200 | Litter Assembly | 1 |
| L | 3006-400-105 | HE Siderail Assembly, Left | 1 |
| M | 3006-400-205 | HE Siderail Assembly, Right | 1 |
| N | 3006-400-300 | FE Siderail Assembly, Left | 1 |
| P | 3006-400-400 | FE Siderail Assembly, Right | 1 |
| R | 3006-300-033 | Mattress Retainer | 2 |
| T | 0025-120-000 | Pop Rivet | 4 |
| U | 3006-300-275 | Shield, Right | 1 |
| V | 3006-300-276 | Shield, Left | 1 |
| W | 0011-002-000 | Light, Flat Washer | 10 |
| Y | 0016-028-000 | Fiberlock Hex Nut | 10 |
| AA | 0059-126-000 | Push-Mount Wire Clip | 2 |
| AB | 3002-031-113 | Umbilical Isolation Bracket | 1 |
| AC | 3006-400-493 | Stud Cap | 10 |

Bed Assembly, Zoom® Option

For Reference Only: 3006-044-102

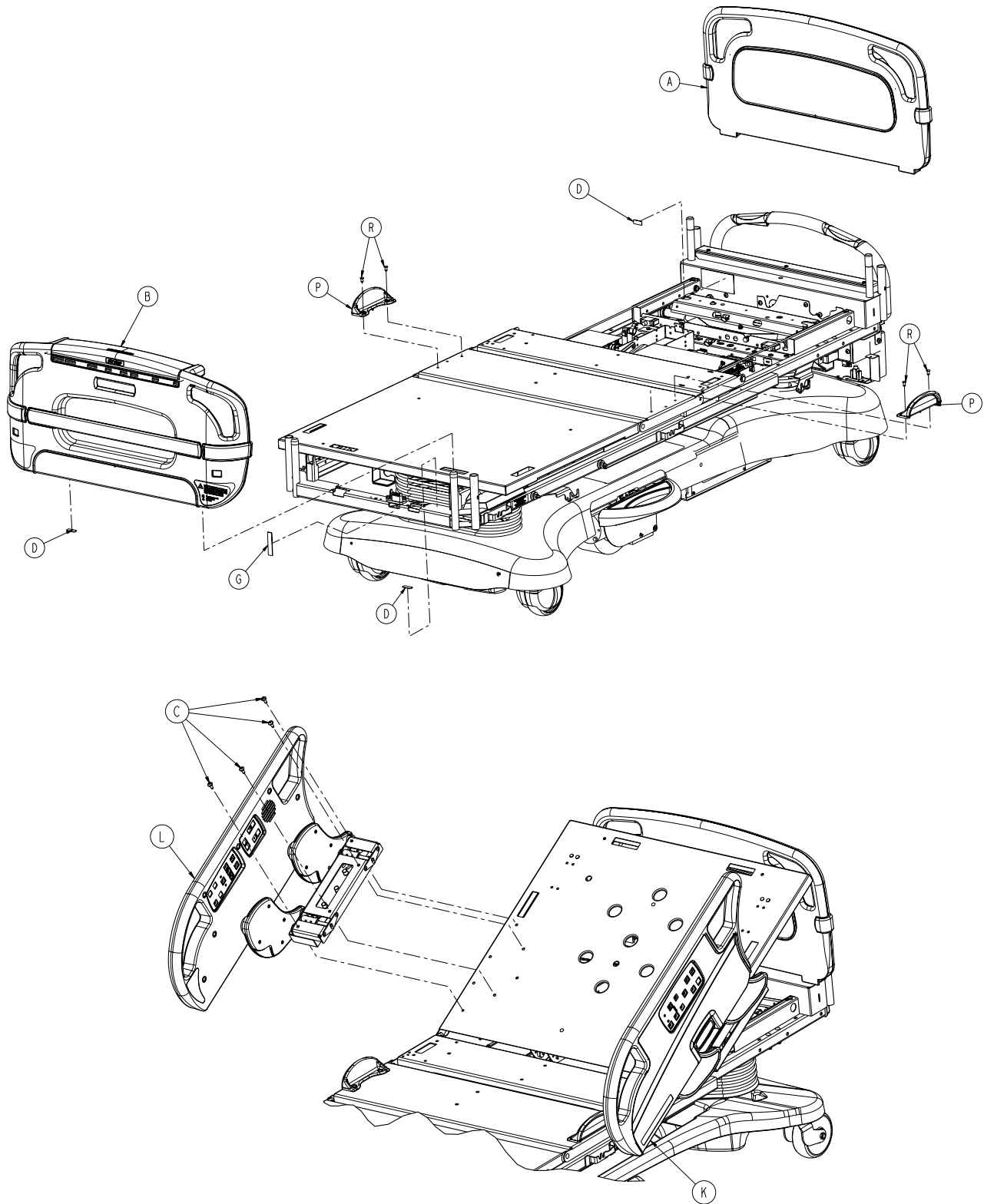

Bed Assembly, Zoom® Option

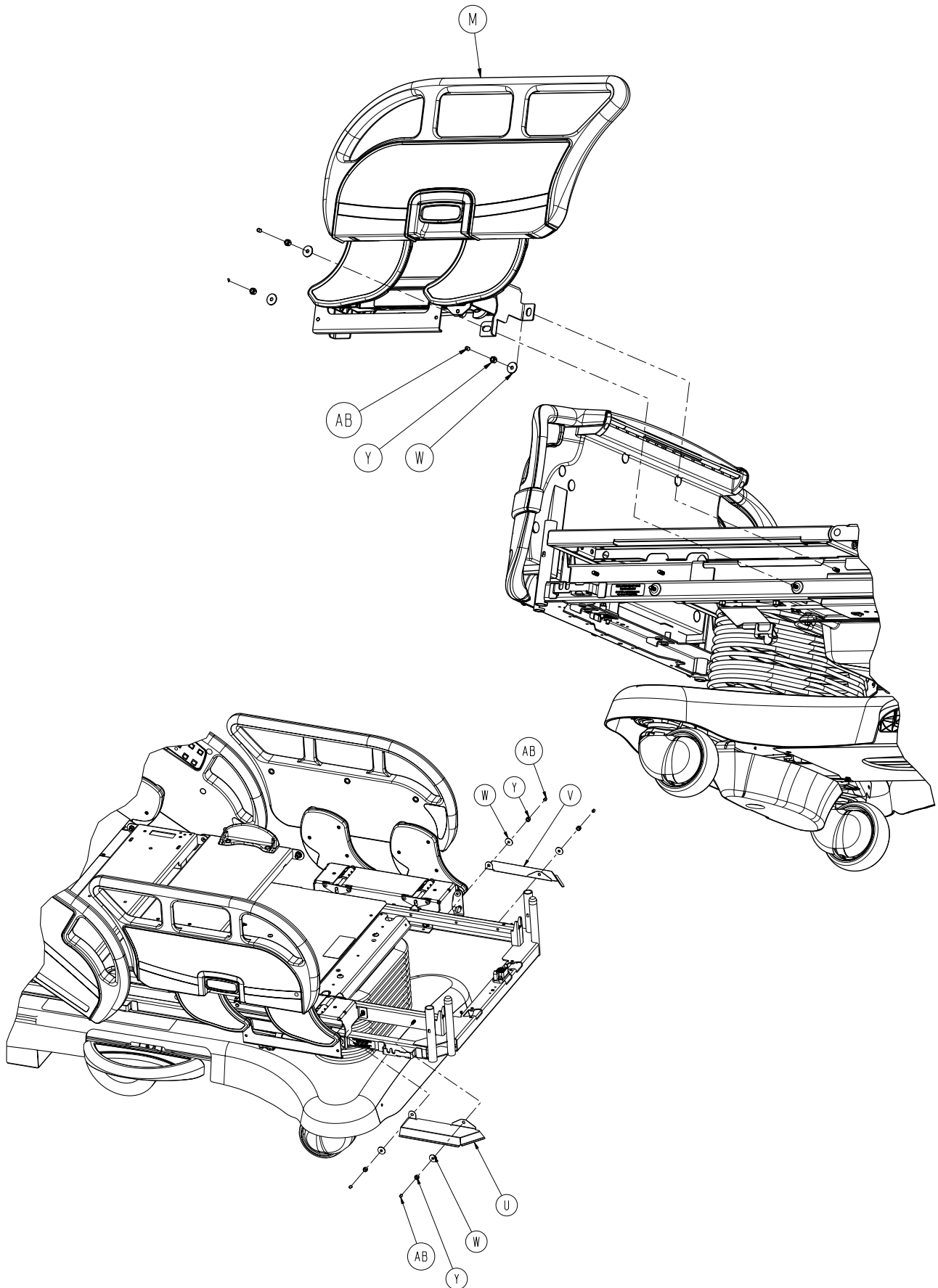

[Return To Table of Contents](#)

Bed Assembly, Zoom® Option

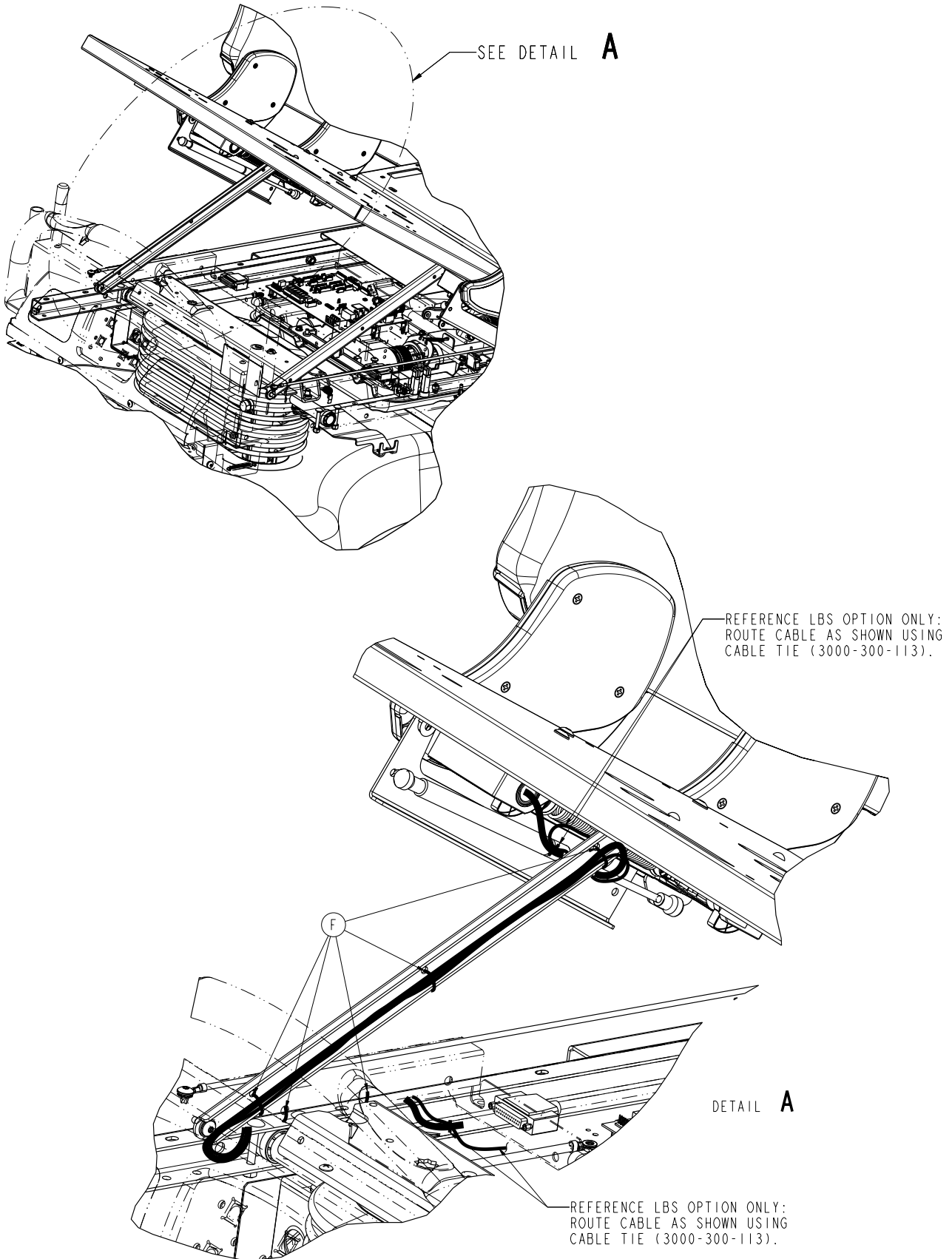

Bed Assembly, Zoom® Option

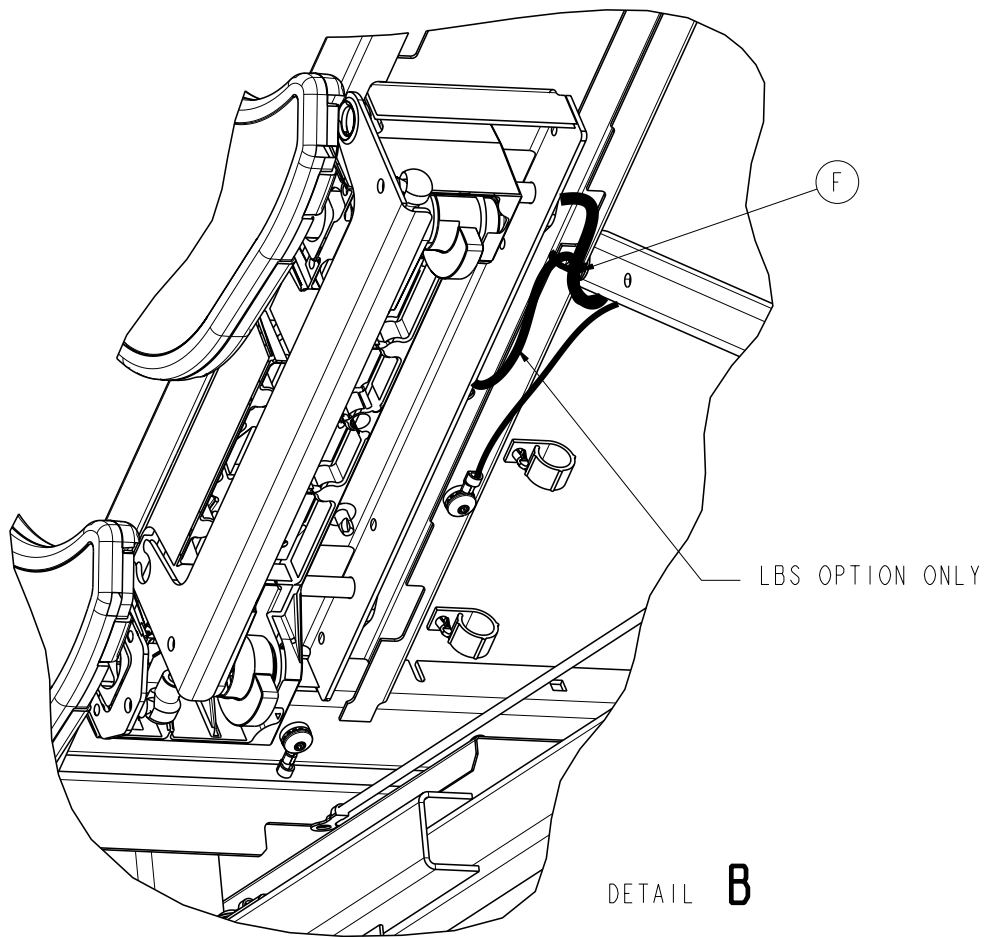
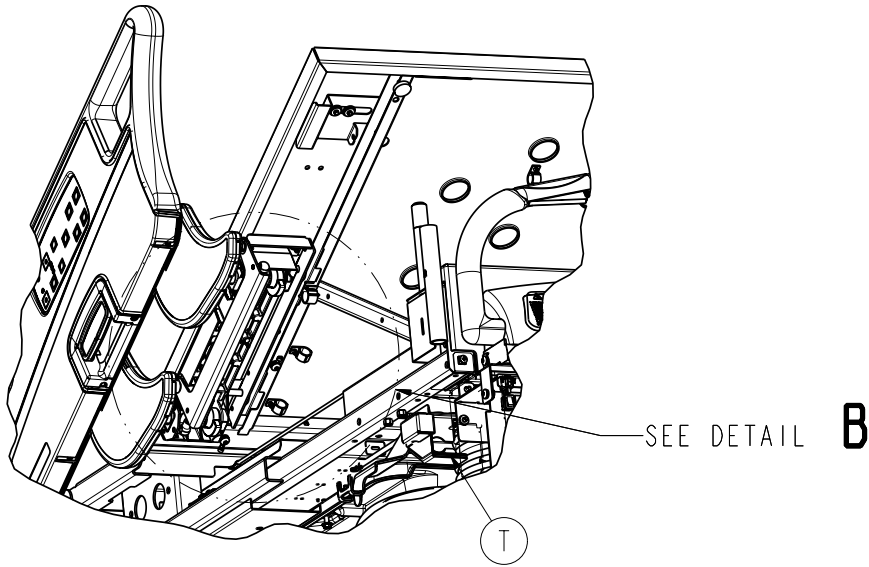

Bed Assembly, Zoom® Option

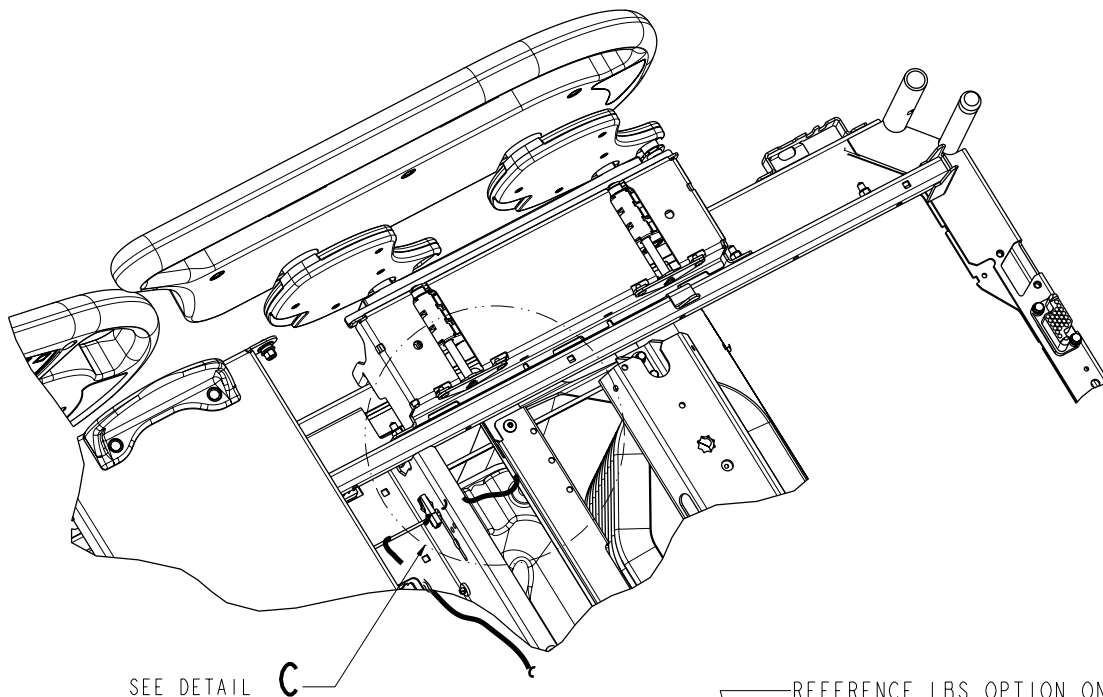

SEE DETAIL C

REFERENCE LBS OPTION ONLY:
ROUTE FOOT END CABLE AS SHOWN
USING CABLE TIE (3000-300-113)
TYPICAL BOTH SIDES.

(3000-300-113)

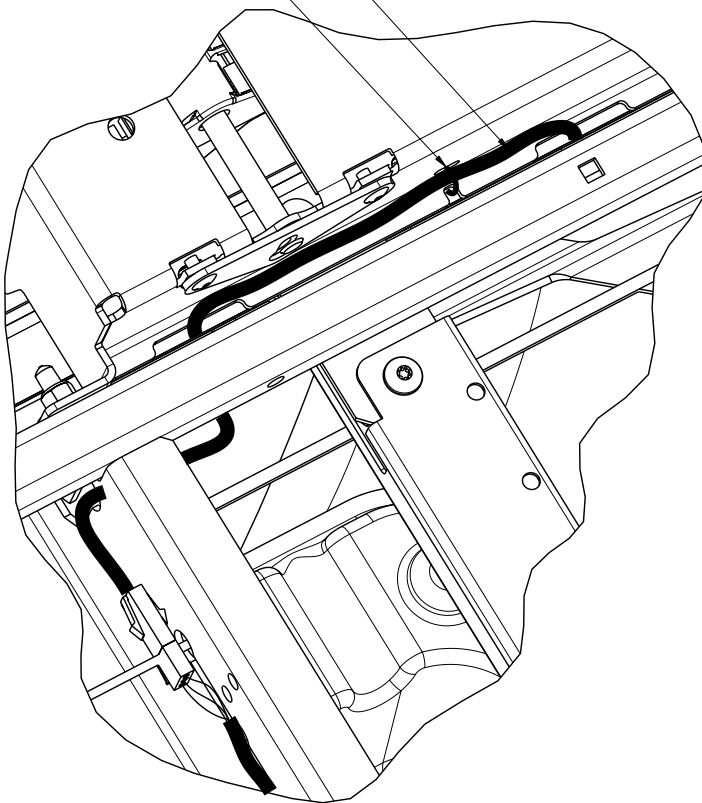

DETAIL C

Bed Assembly, Zoom® Option

Bed Assembly, Zoom® Option - 3006-044-102 - (Reference Only)

| item | Part No. | Part Name | Qty. |
|------|--------------|--------------------------------|------|
| A | 3006-600-010 | Headboard Assembly | 1 |
| B | 3006-501-000 | Footboard Assembly | 1 |
| C | 0007-065-000 | Truss Head Screw | 8 |
| D | 3000-300-625 | Dom Label | 1 |
| F | 3000-300-113 | 8" Cable Tie | 10 |
| G | 3000-300-641 | Footboard Ground Label | 1 |
| J | 3006-344-002 | Zoom® Bed Litter Assembly | 1 |
| K | 3006-400-105 | Head End Siderail Assembly, LH | 1 |
| L | 3006-400-205 | Head End Siderail Assembly, RH | 1 |
| M | 3006-400-300 | Foot End Siderail Assembly, LH | 1 |
| N | 3006-400-400 | Foot End Siderail Assembly, RH | 1 |
| P | 3006-300-033 | Mattress Retainer | 2 |
| R | 0025-120-000 | Pop Rivet | 4 |
| T | 3006-032-113 | Umbilical Isolation Bracket | 1 |
| U | 3006-300-275 | Shield, Right | 1 |
| V | 3006-300-276 | Shield, Left | 1 |
| W | 0011-180-000 | Light Flat Washer | 10 |
| Y | 0016-028-000 | Fiberlock Hex Nut | 10 |
| AA | 0059-126-000 | Push-Mount Wire Clip | 2 |
| AB | 3006-400-493 | Stud Cap | 10 |

Bed Assembly, iBed® Awareness Option

(Scale, Bed Exit, Zone Control)

For Reference Only: 3006-500-115

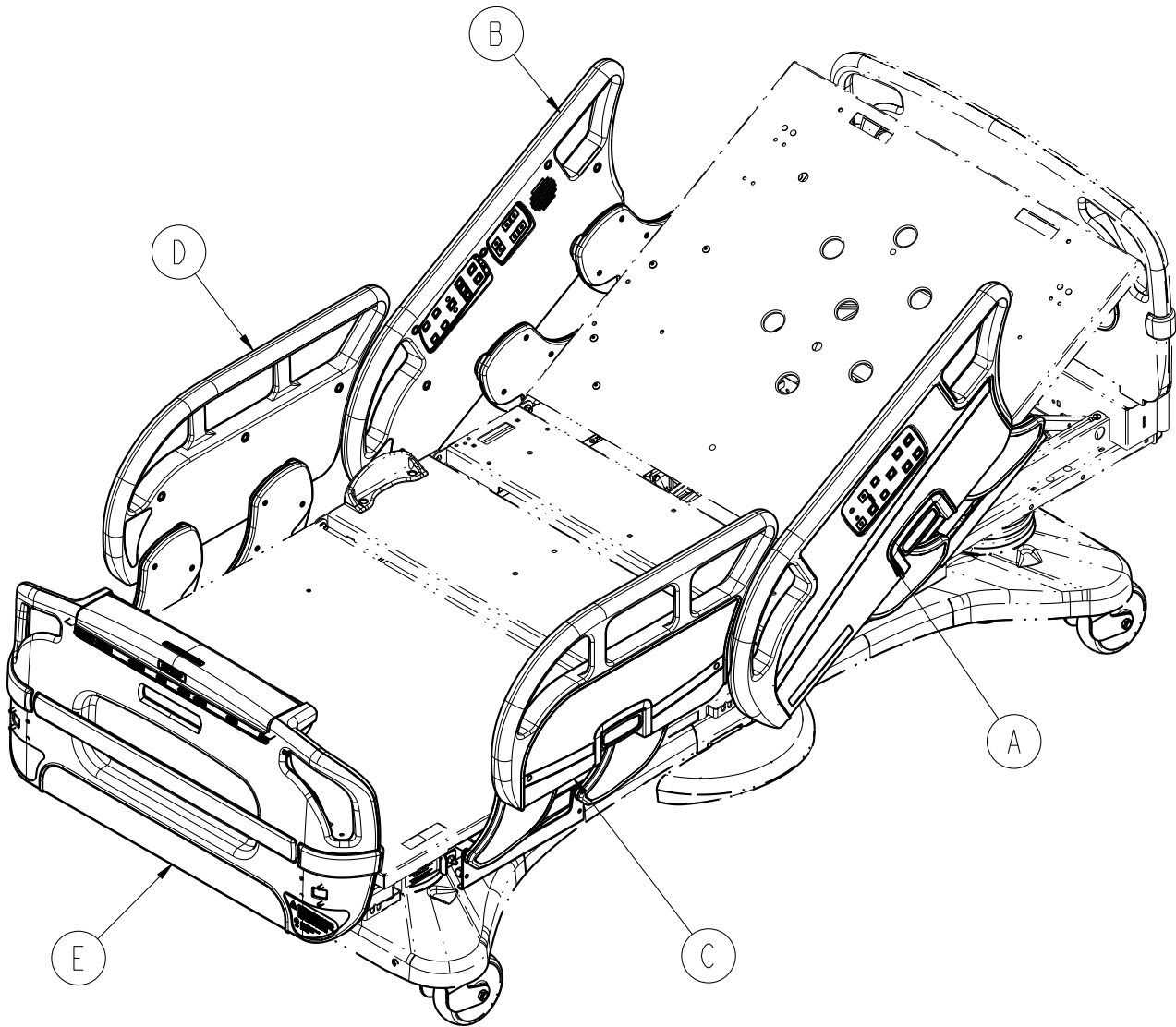

Bed Assembly, *iBed*® Awareness Option

(Scale, Bed Exit, Zone Control)

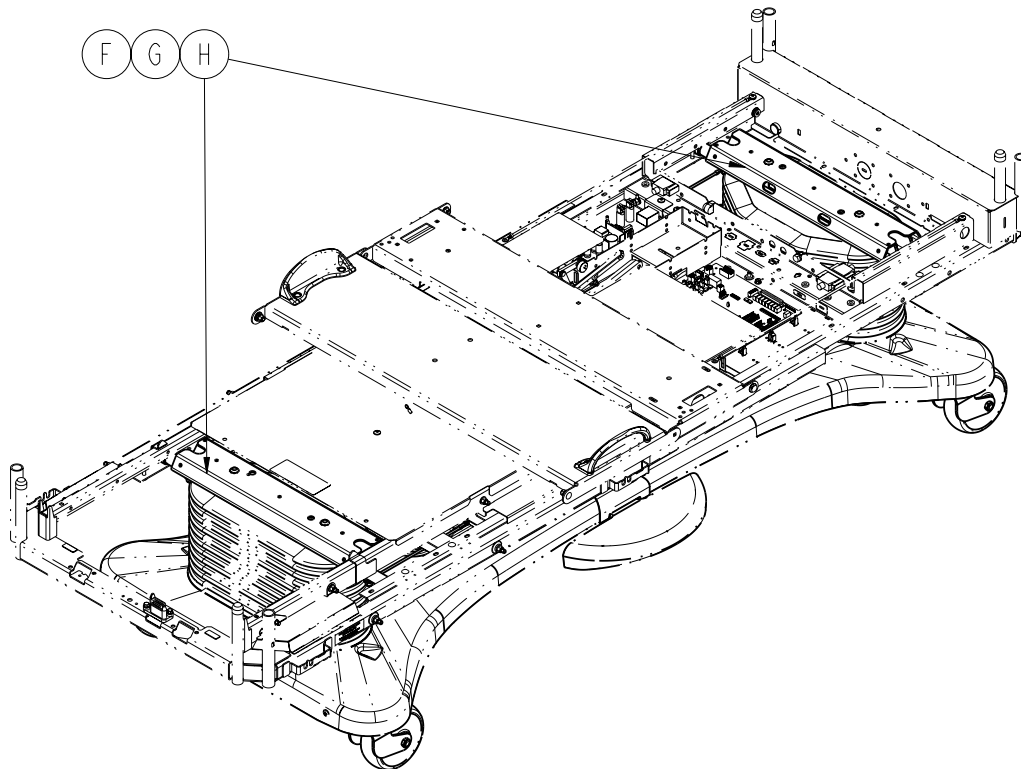

Bed Assembly, *iBed*® Awareness Option - 3006-500-115 - (Reference Only)

| item | Part No. | Part Name | Qty. |
|------|--------------|------------------------------------|------|
| A | 3006-400-100 | Head End Siderail Assembly, LH | 1 |
| B | 3006-400-200 | Head End Siderail Assembly, RH | 1 |
| C | 3006-400-305 | Foot End Siderail Assembly, LH | 1 |
| D | 3006-400-405 | Foot End Siderail Assembly, RH | 1 |
| E | 3006-500-100 | Footboard Assembly | 1 |
| F | 3002-317-003 | Scale/Bed Exit Option Assembly | 1 |
| G | 3006-326-501 | Load Cell Bed Lift Header Assembly | 1 |
| H | 3006-307-501 | Load Cell Bed Lift Header Assembly | 1 |

Bed Assembly, iBed® Wireless Option, Blue

For Reference Only: 5212-030-001

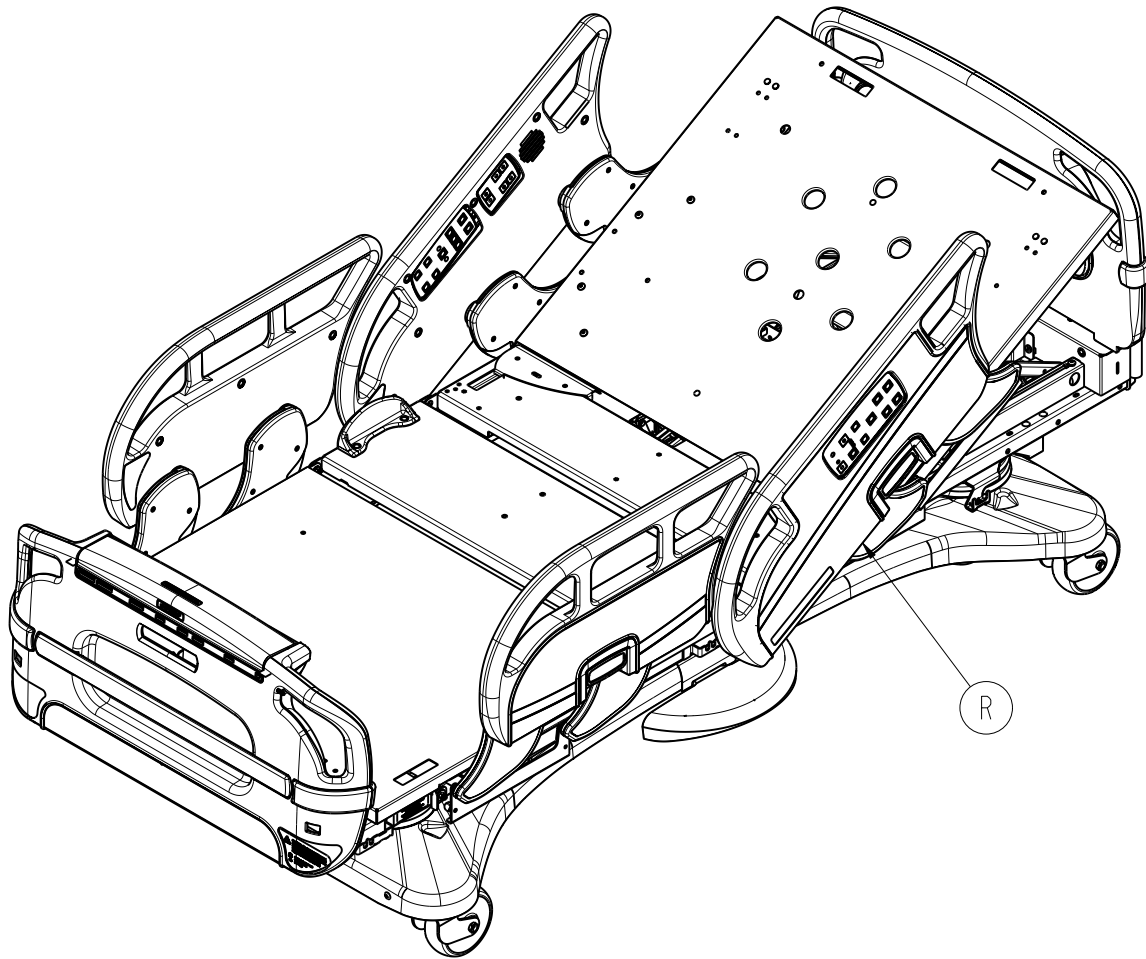

Bed Assembly, iBed® Wireless Option, Blue

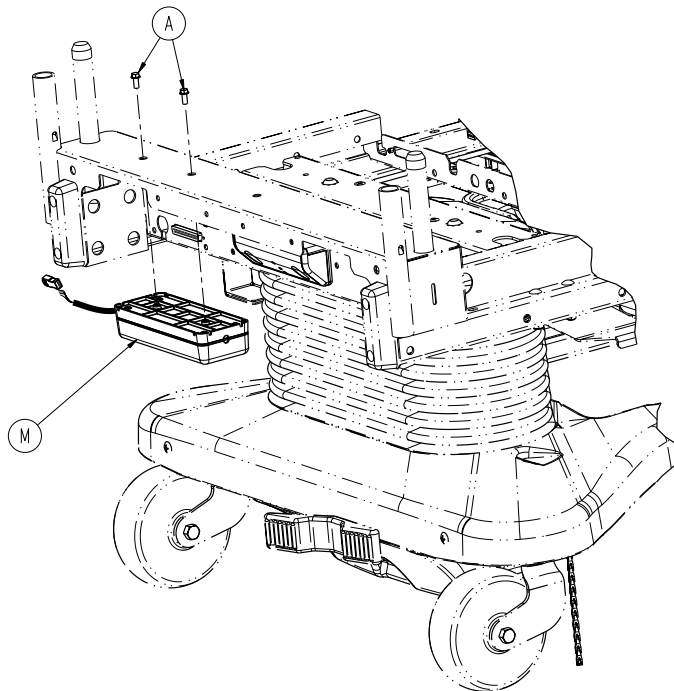
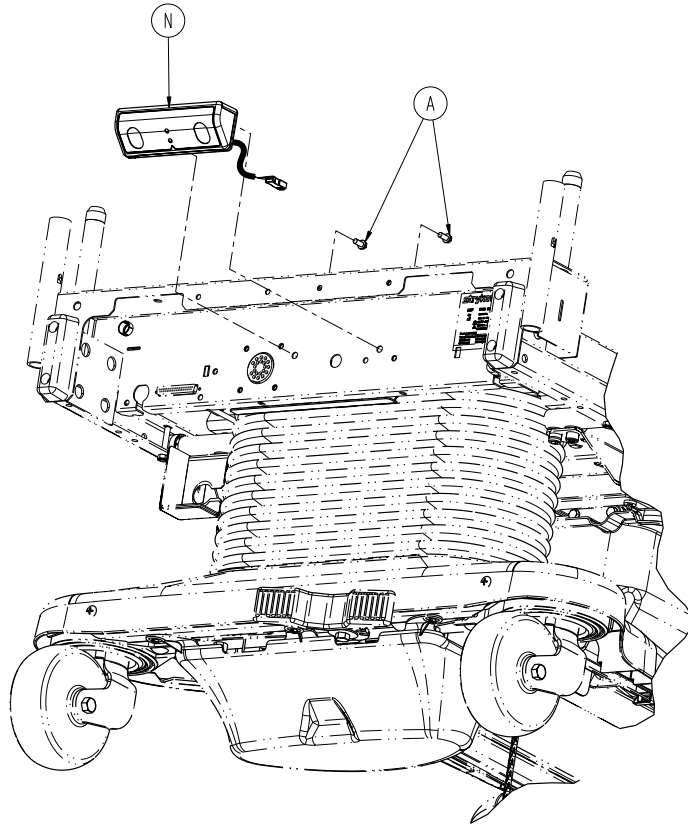

Bed Assembly, iBed® Wireless Option, Blue

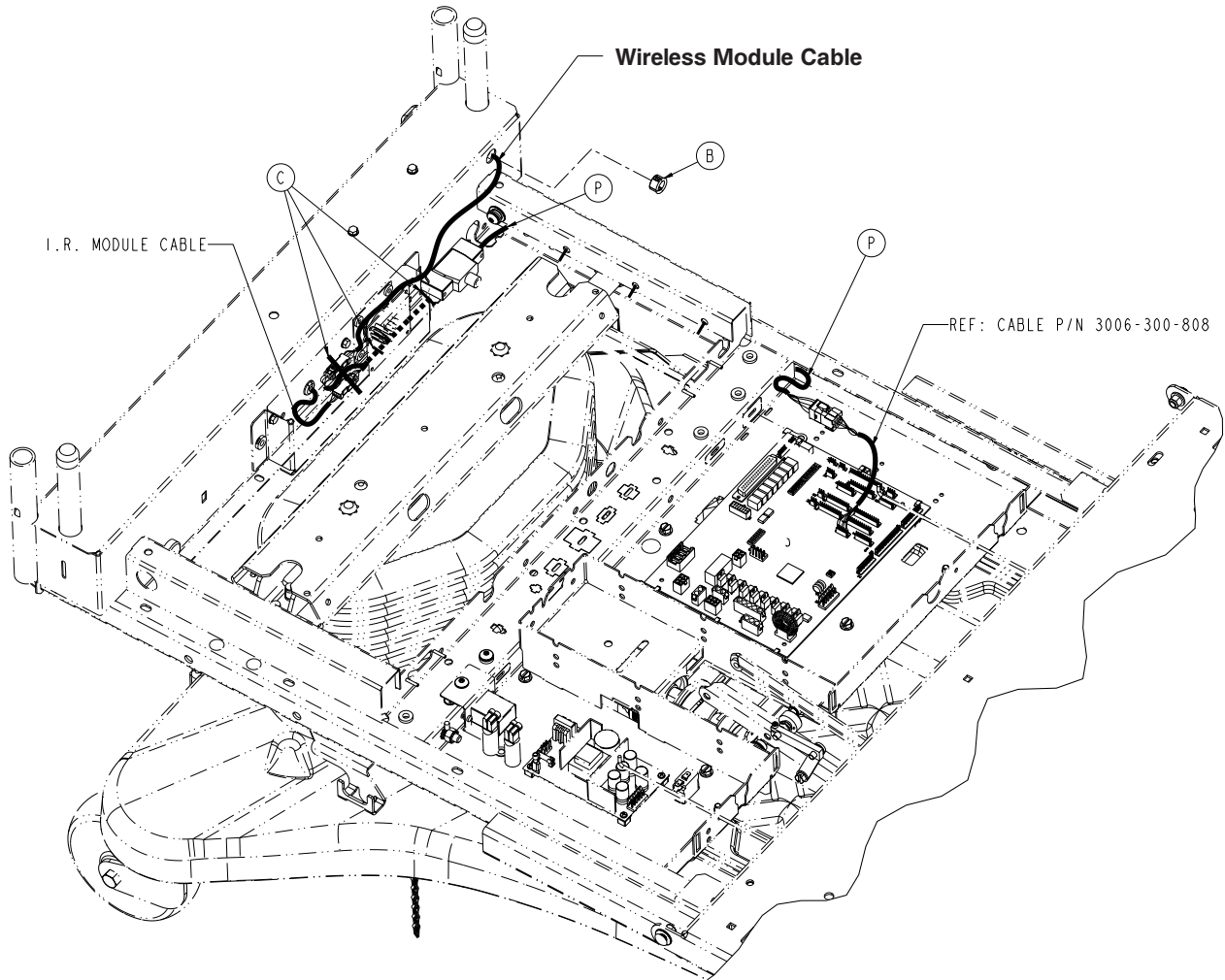

Bed Assembly, iBed® Wireless Option, Blue - 5212-030-001 - (Reference Only)

| item | Part No. | Part Name | Qty. |
|------|--------------|--------------------------------|------|
| A | 0023-126-000 | Hex Washer Head Hi-Lo Fastener | 4 |
| B | 0030-070-000 | Cable Management Bushing | 1 |
| C | 3000-300-113 | 8" Cable Tie | 3 |
| M | 5212-300-012 | Wireless Module Assembly | 1 |
| N | 5212-300-053 | I.R. Module Assembly | 1 |
| P | 5212-300-854 | Cable, Non-Zoom Wireless | 1 |
| R | 3006-043-102 | Standard Length Bed Assembly | 1 |

Bed Assembly, Battery Backup, *i*Bed® Wireless Option

For Reference Only: 5212-350-000

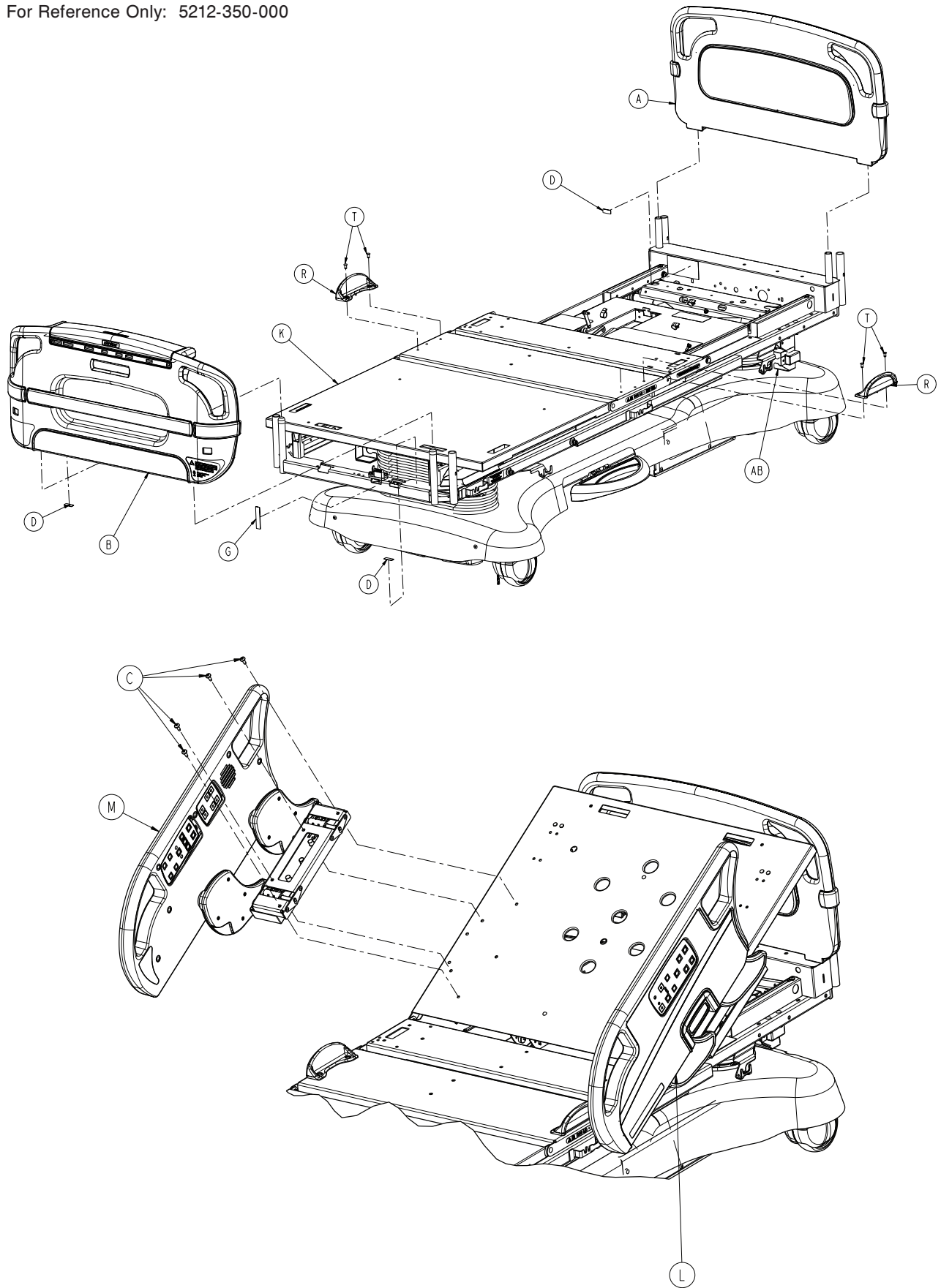

[Return To Table of Contents](#)

Bed Assembly, Battery Backup, iBed® Wireless Option

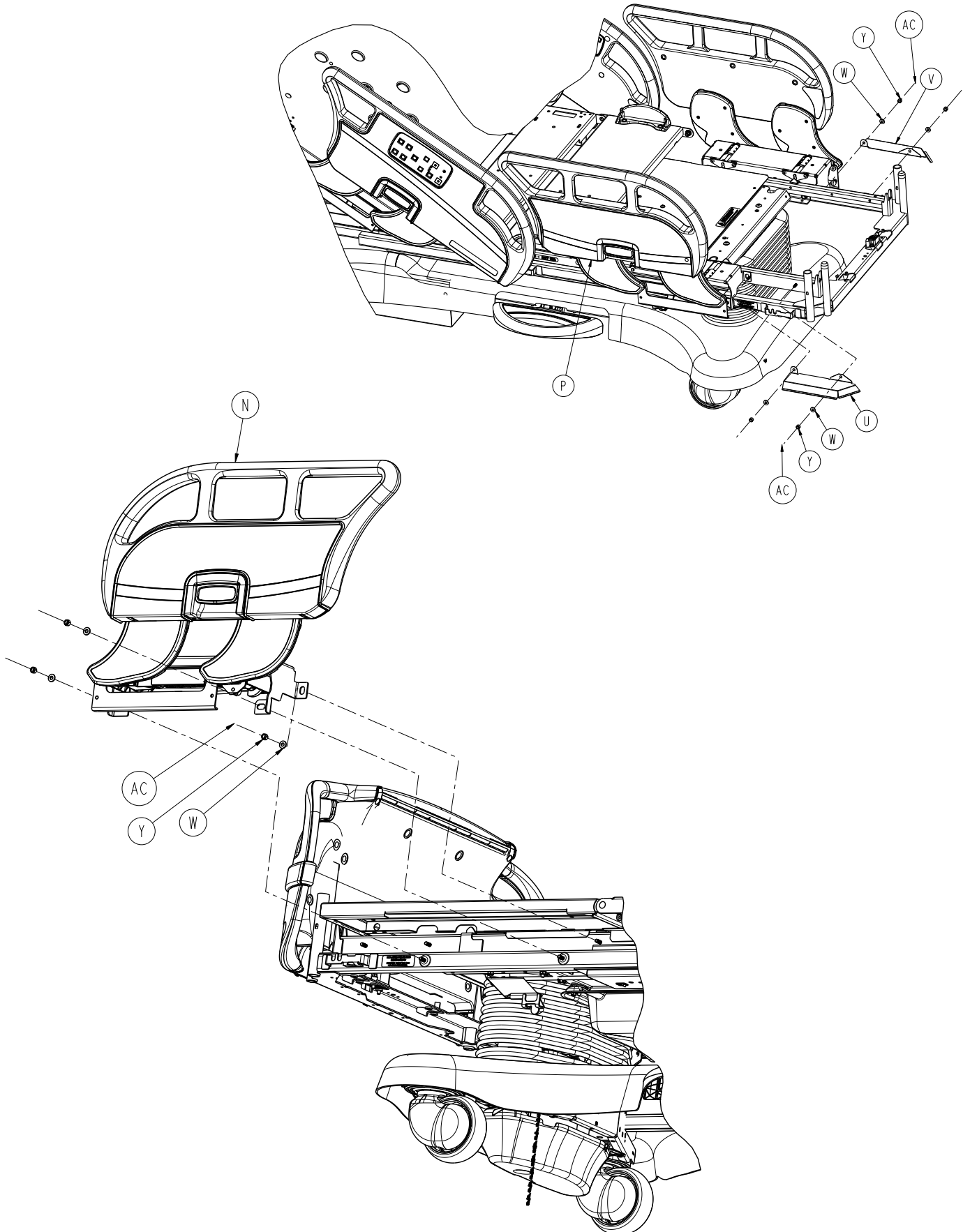

Bed Assembly, Battery Backup, iBed® Wireless Option

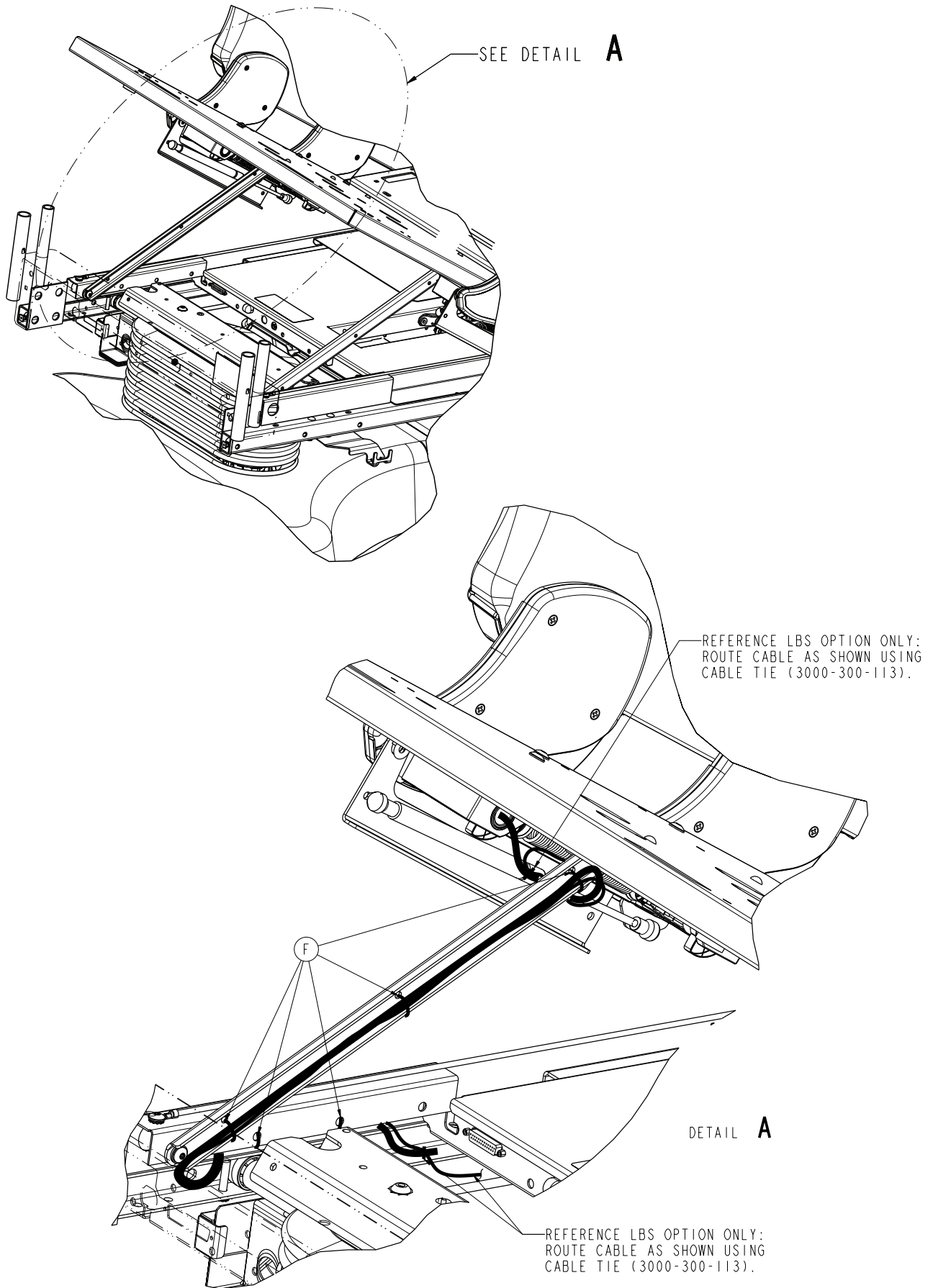

Bed Assembly, Battery Backup, iBed® Wireless Option

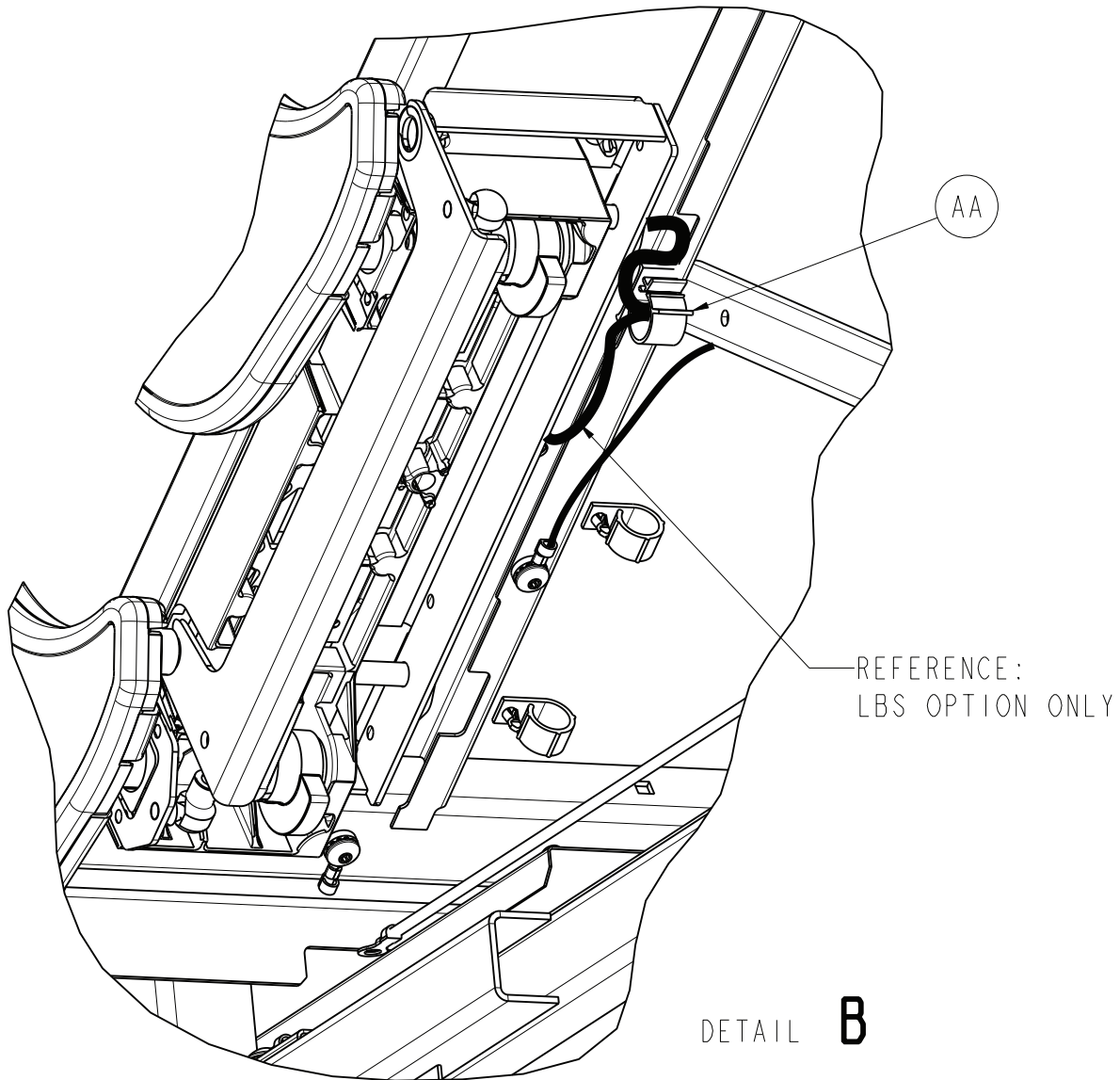
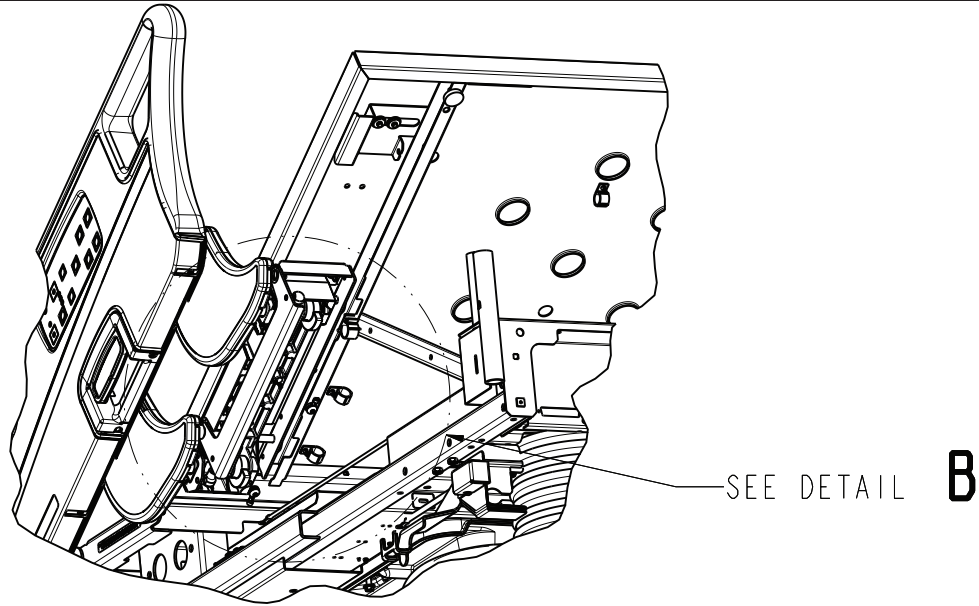

Bed Assembly, Battery Backup, iBed® Wireless Option

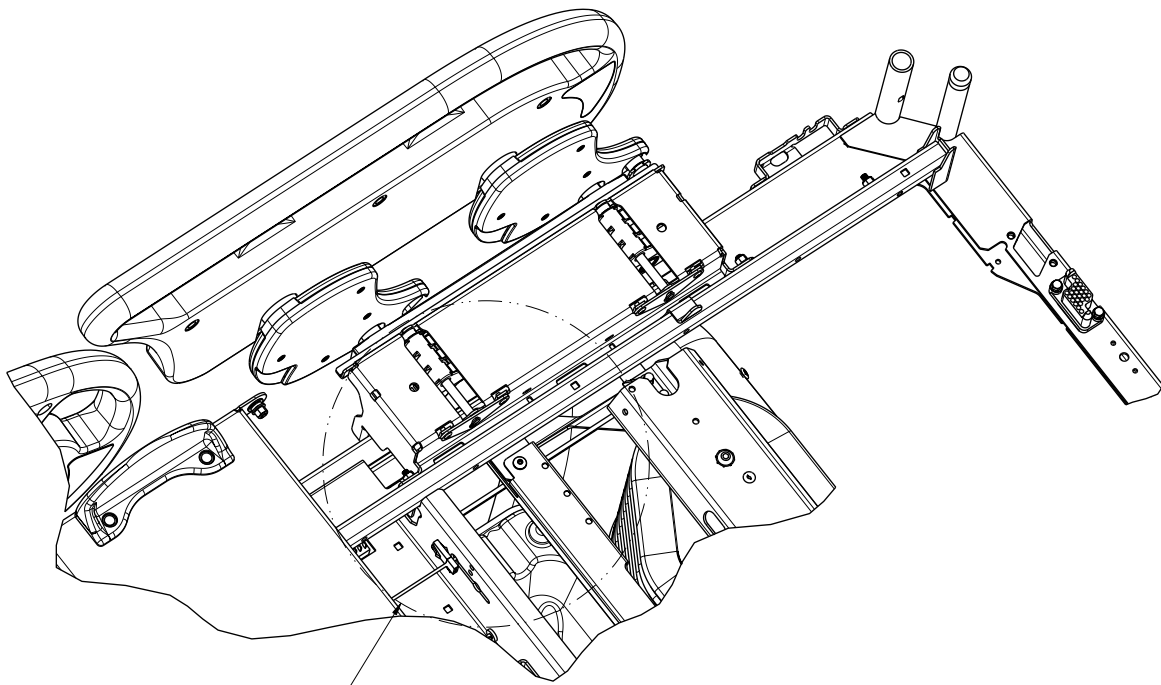

SEE DETAIL **C**

REFERENCE LBS OPTION ONLY:
ROUTE FOOT END CABLE AS SHOWN
USING CABLE TIE (3000-300-113)
TYPICAL BOTH SIDES.

(3000-300-113)

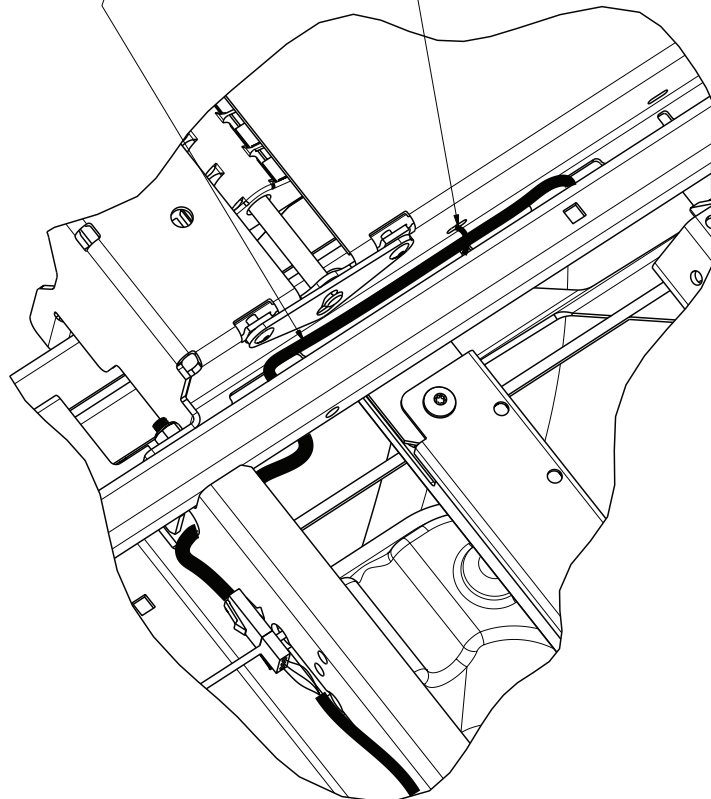

DETAIL **C**

[Return To Table of Contents](#)

Bed Assembly, Battery Backup, iBed® Wireless Option

Bed Assembly, Battery Backup, iBed® Wireless Option - 5212-350-000 - (Reference Only)

| item | Part No. | Part Name | Qty. |
|------|--------------|---------------------------------------|------|
| A | 3006-600-010 | Headboard Assembly | 1 |
| B | 3006-501-000 | Footboard Assembly | 1 |
| C | 0007-065-000 | Truss Head Screw | 8 |
| D | 3000-300-625 | Label, Date of Manufacturing | 1 |
| F | 3000-300-113 | 8" Cable Tie | 10 |
| G | 3000-300-641 | Label, Footboard Ground | 1 |
| K | 5212-350-200 | Litter Assembly, Battery Backup, iBed | 1 |
| L | 3006-400-105 | Head End Siderail Assembly, LH | 1 |
| M | 3006-400-205 | Head End Siderail Assembly, RH | 1 |
| N | 3006-400-300 | Foot End Siderail Assembly, LH | 1 |
| P | 3006-400-400 | Foot End Siderail Assembly, RH | 1 |
| R | 3006-300-033 | Mattress Retainer | 2 |
| T | 0025-120-000 | Pop Rivet | 4 |
| U | 3006-300-275 | Shield, Right | 1 |
| V | 3006-300-276 | Shield, Left | 1 |
| W | 0011-180-000 | Flat Washer | 10 |
| Y | 0016-028-000 | Fiberlock Hex Nut | 10 |
| AA | 0059-126-000 | Push-Mount Wire Clip | 2 |
| AB | 3006-031-113 | Umbilical Isolation Bracket | 1 |
| AC | 3006-400-493 | Stud Cap | 10 |

Bed Assembly, Zoom®, iBed® Wireless Option

For Reference Only: 5212-044-102

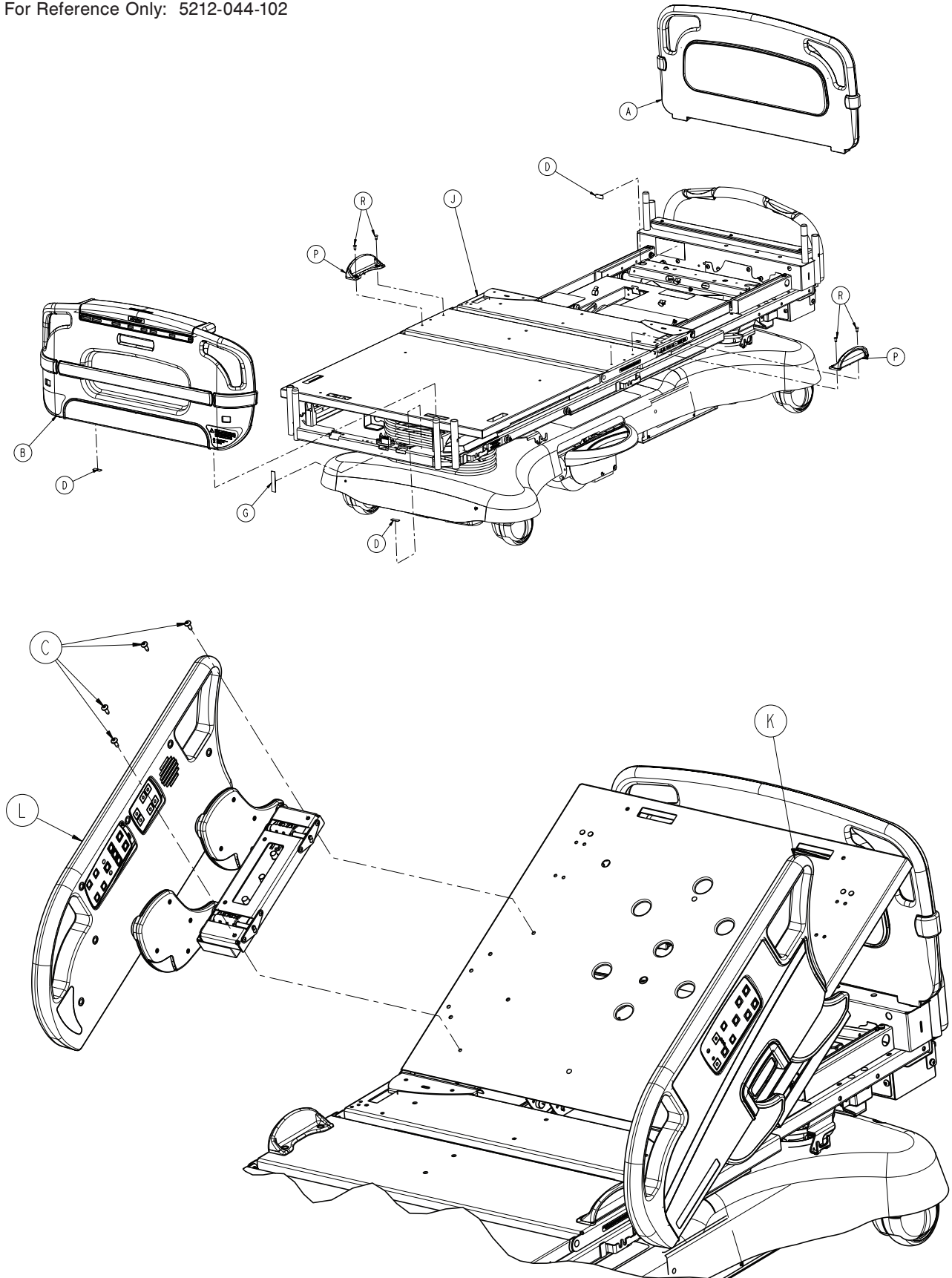

[Return To Table of Contents](#)

Bed Assembly, Zoom®, iBed® Wireless Option

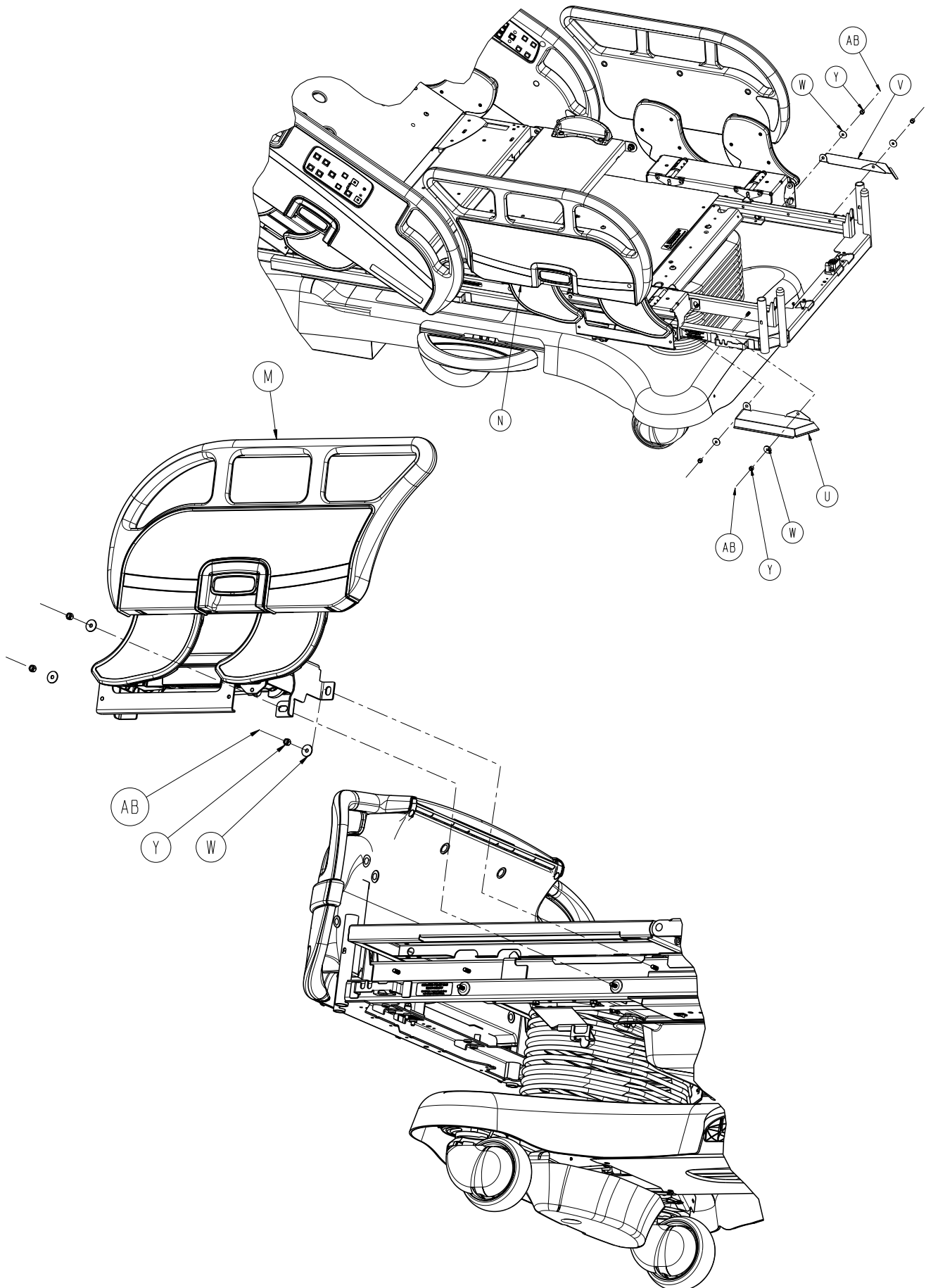

Bed Assembly, Zoom®, iBed® Wireless Option

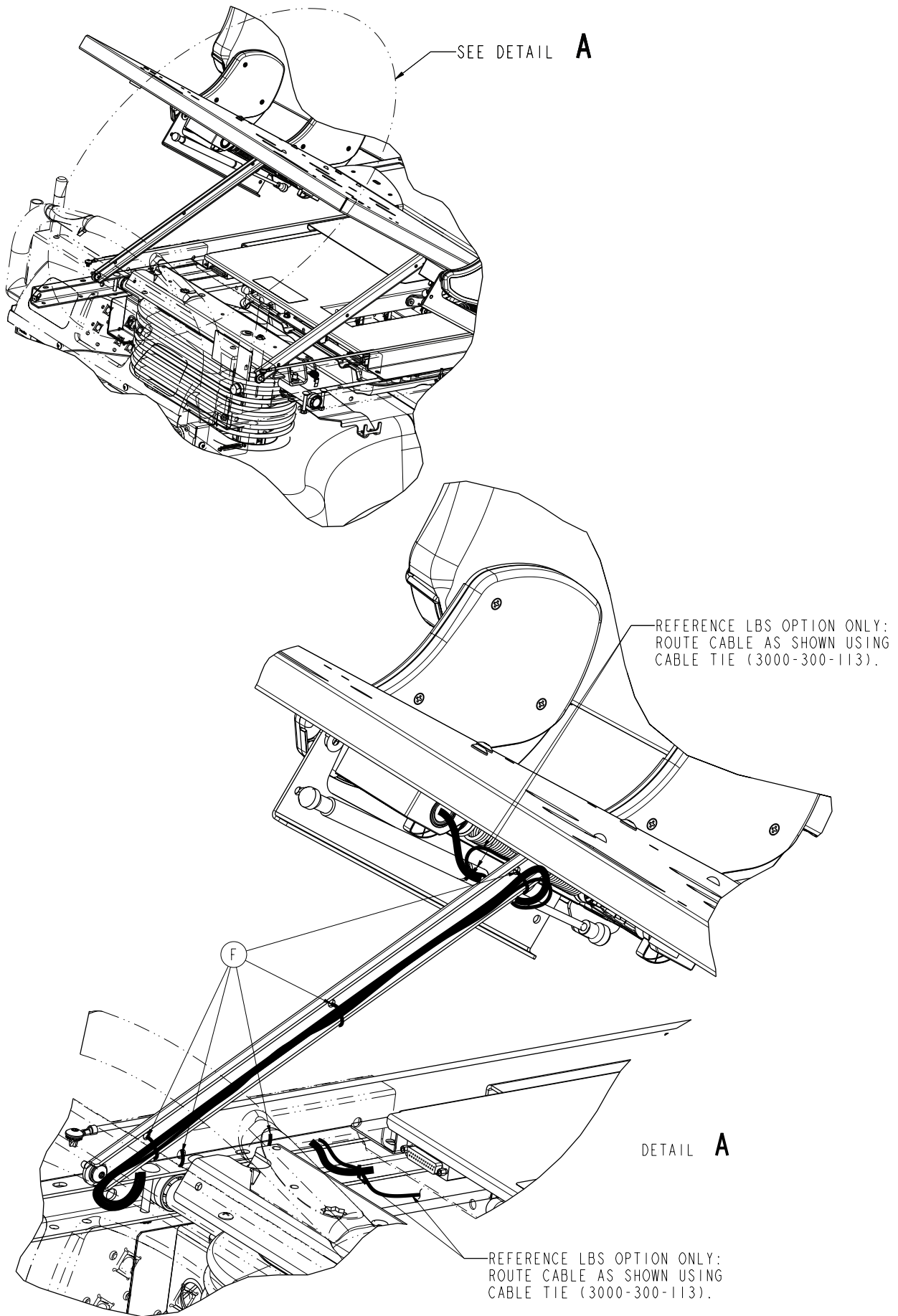

[Return To Table of Contents](#)

Bed Assembly, Zoom®, iBed® Wireless Option

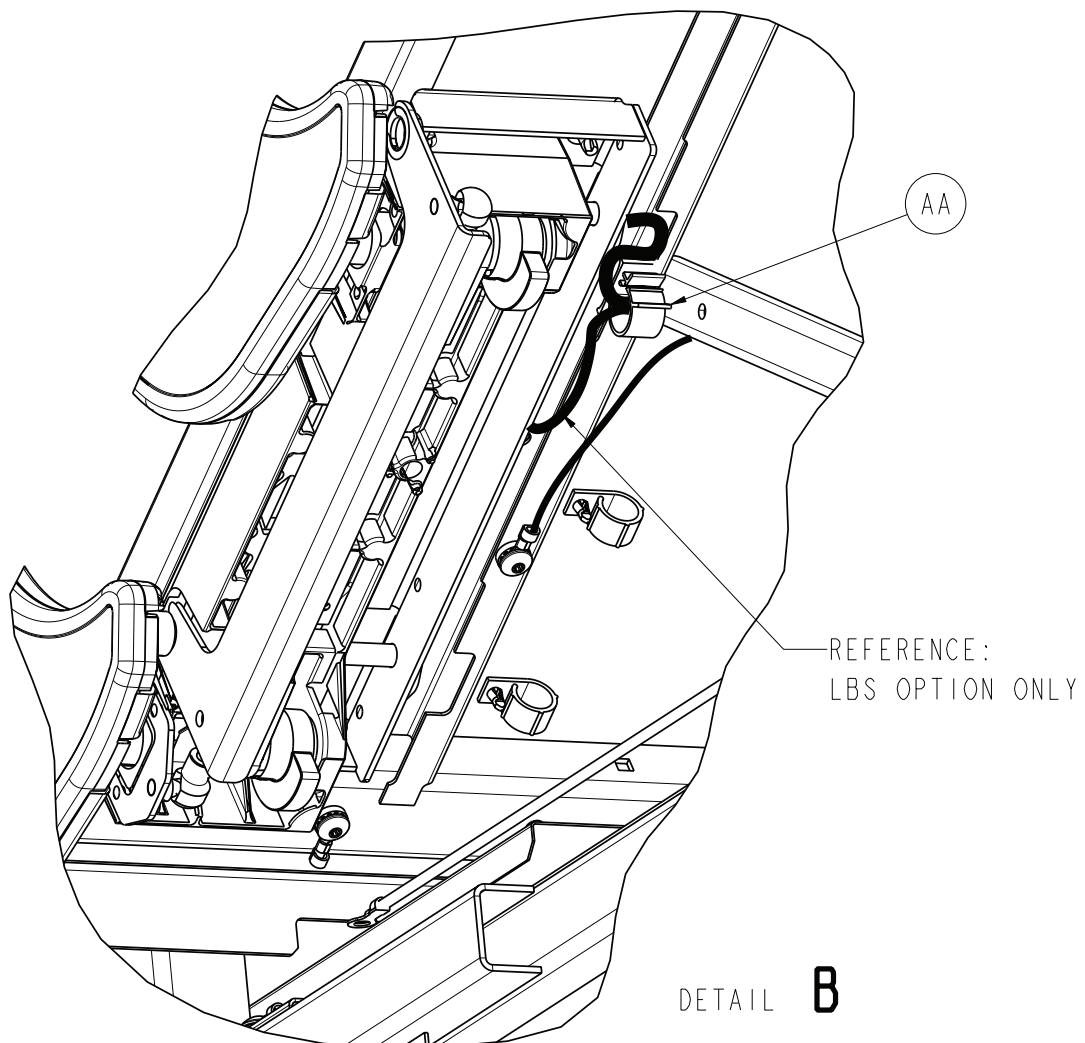
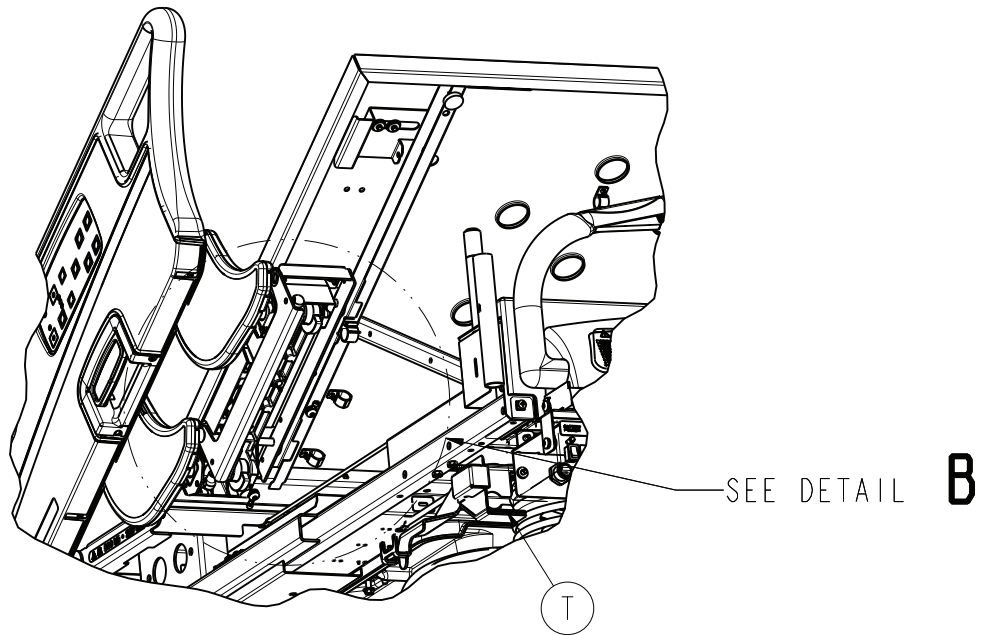

Bed Assembly, Zoom®, iBed® Wireless Option

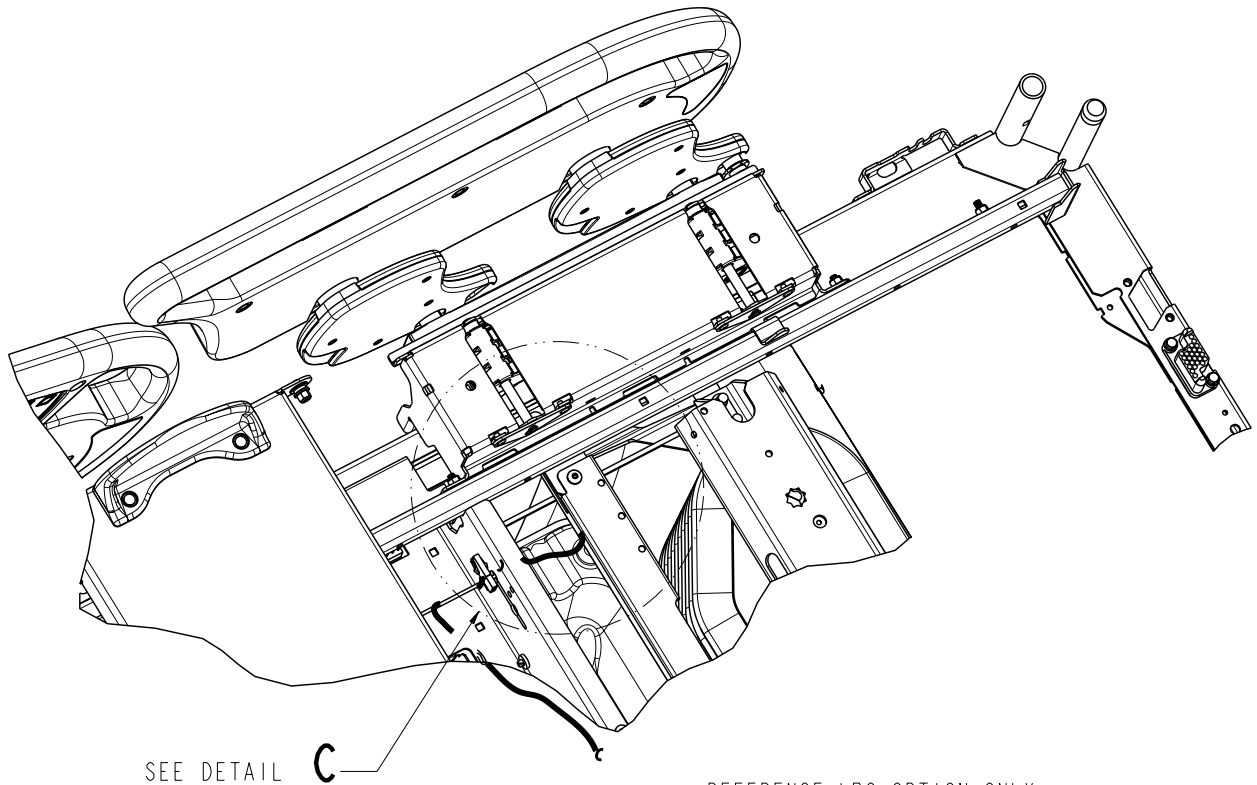

REFERENCE LBS OPTION ONLY:
ROUTE FOOT END CABLE AS SHOWN
USING CABLE TIE (3000-300-113)
TYPICAL BOTH SIDES.

(3000-300-113)

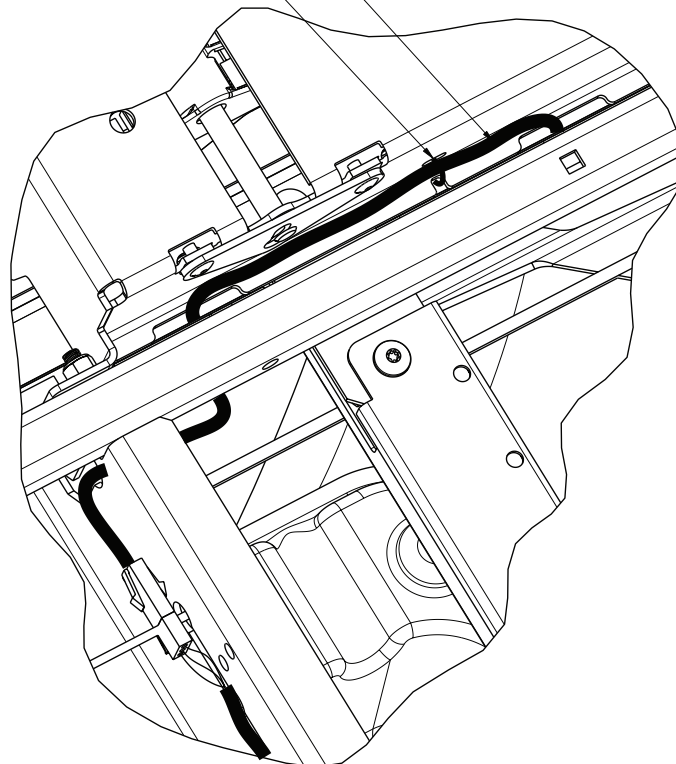

Bed Assembly, Zoom®, iBed® Wireless Option

Bed Assembly, Zoom®, iBed® Wireless Option - 5212-044-102 - (Reference Only)

| item | Part No. | Part Name | Qty. |
|------|--------------|------------------------------------|------|
| A | 3006-600-010 | Headboard Assembly | 1 |
| B | 3006-501-000 | Footboard Assembly | 1 |
| C | 0007-065-000 | Truss Head Screw | 8 |
| D | 3000-300-625 | Date of Manufacturing Label | 1 |
| F | 3000-300-113 | 8" Cable Tie | 10 |
| G | 3000-300-641 | Footboard Ground Label | 1 |
| J | 5212-344-002 | Litter Assy, Zoom®, iBed® Wireless | 1 |
| K | 3006-400-200 | Litter Assembly | 1 |
| L | 3006-400-105 | Head End Siderail Assembly, LH | 1 |
| M | 3006-400-205 | Head End Siderail Assembly, RH | 1 |
| N | 3006-400-300 | Foot End Siderail Assembly, LH | 1 |
| P | 3006-400-400 | Foot End Siderail Assembly, RH | 1 |
| R | 3006-300-033 | Mattress Retainer | 2 |
| T | 0025-120-000 | Pop Rivet | 4 |
| U | 3006-300-275 | Shield, Right | 1 |
| V | 3006-300-276 | Shield, Left | 1 |
| W | 0011-180-000 | Flat Washer | 10 |
| Y | 0016-028-000 | Fiberlock Hex Nut | 10 |
| AA | 0059-126-000 | Push-Mount Wire Clip | 2 |
| AB | 3006-031-113 | Umbilical Isolation Bracket | 1 |
| AC | 3006-400-493 | Stud Cap | 10 |

Base Assembly, Common Components

For Reference Only: 3006-200-002

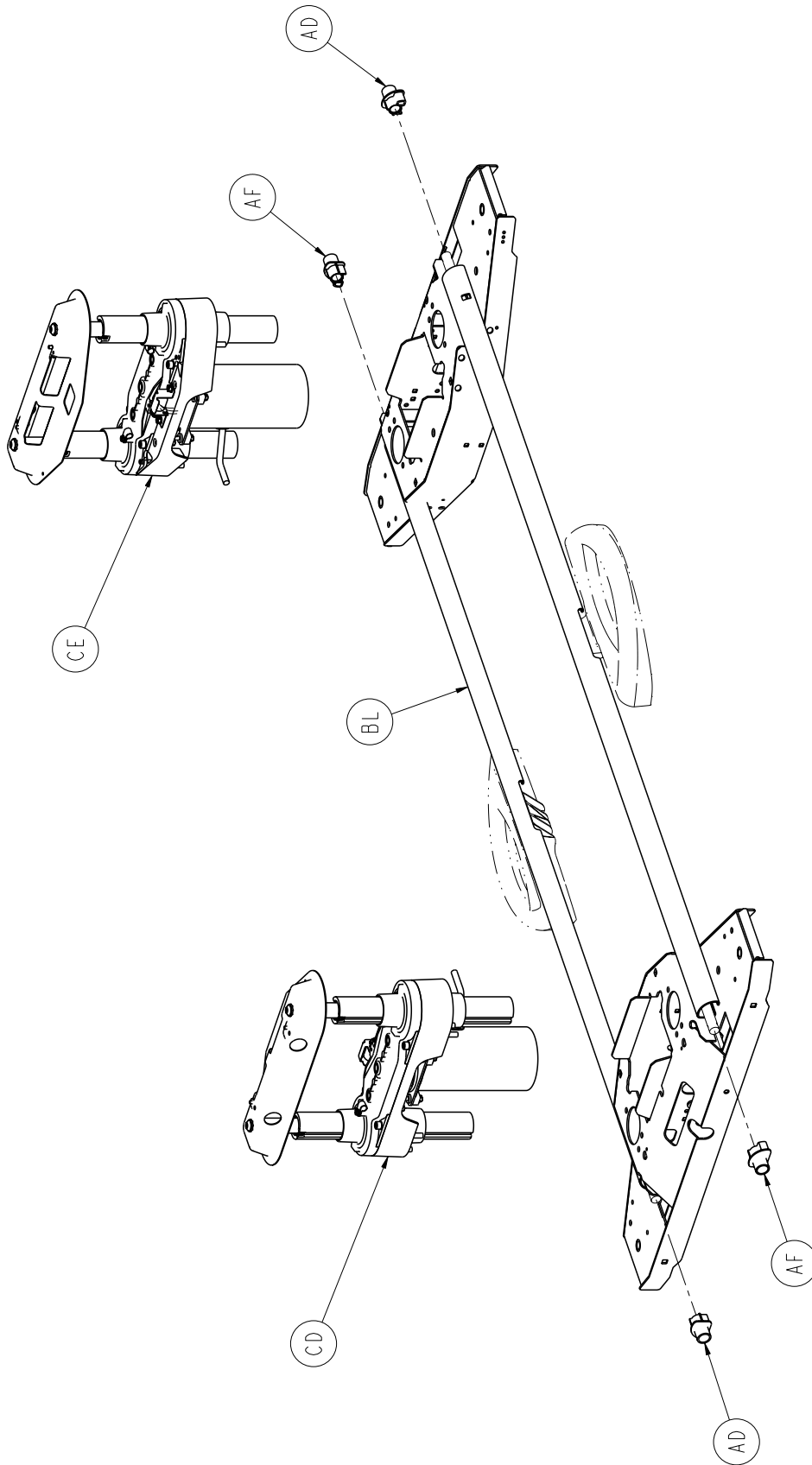

[Return To Table of Contents](#)

Base Assembly, Common Components

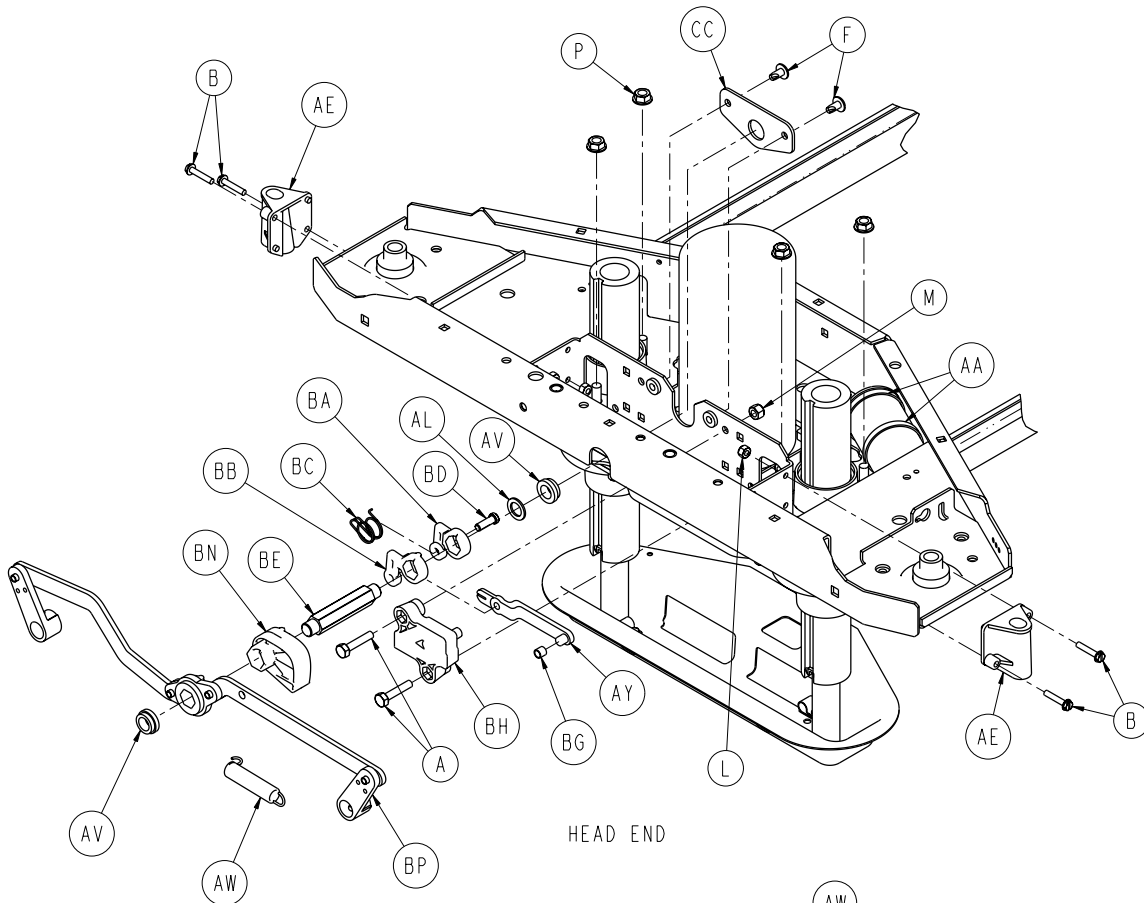

HEAD END

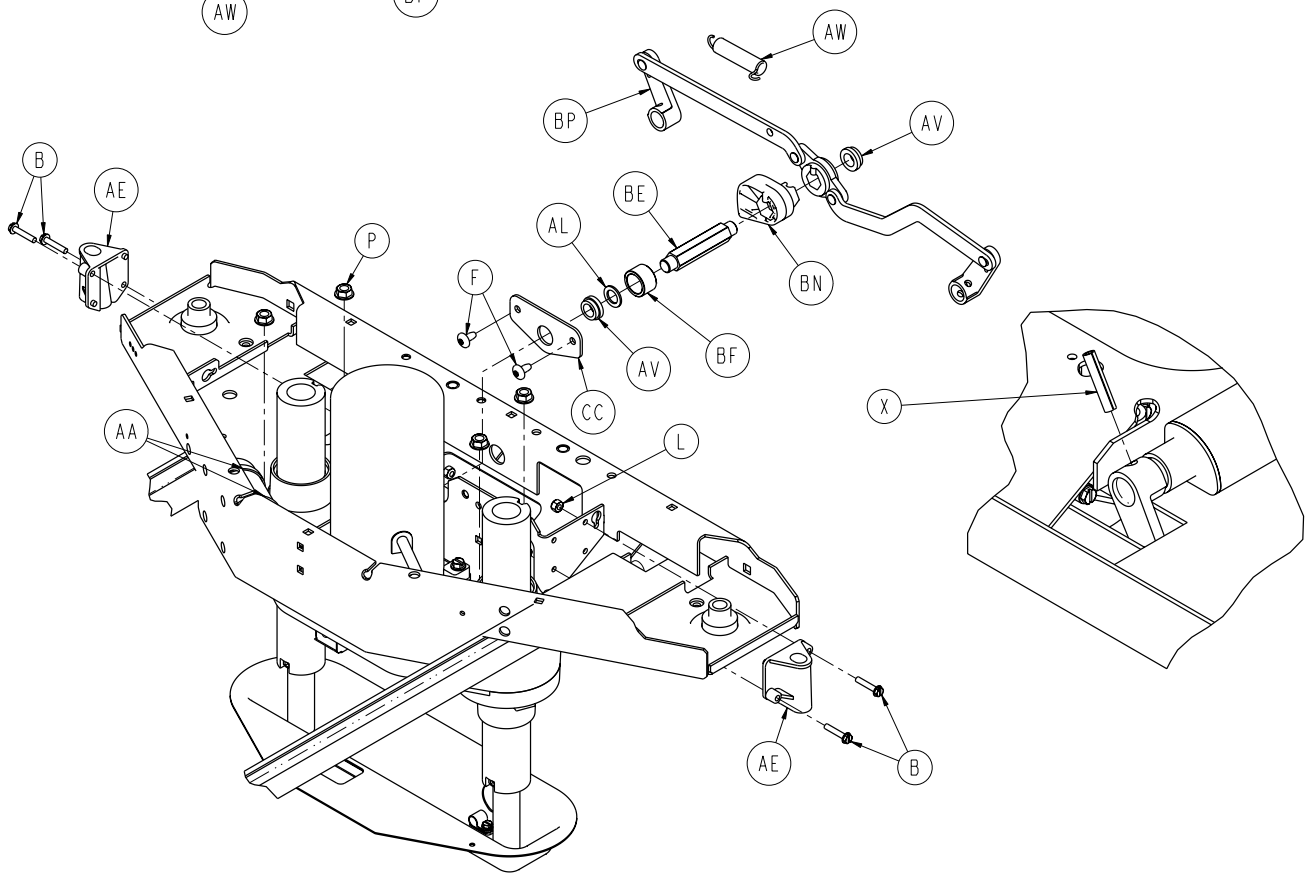

FOOT END

Base Assembly, Common Components

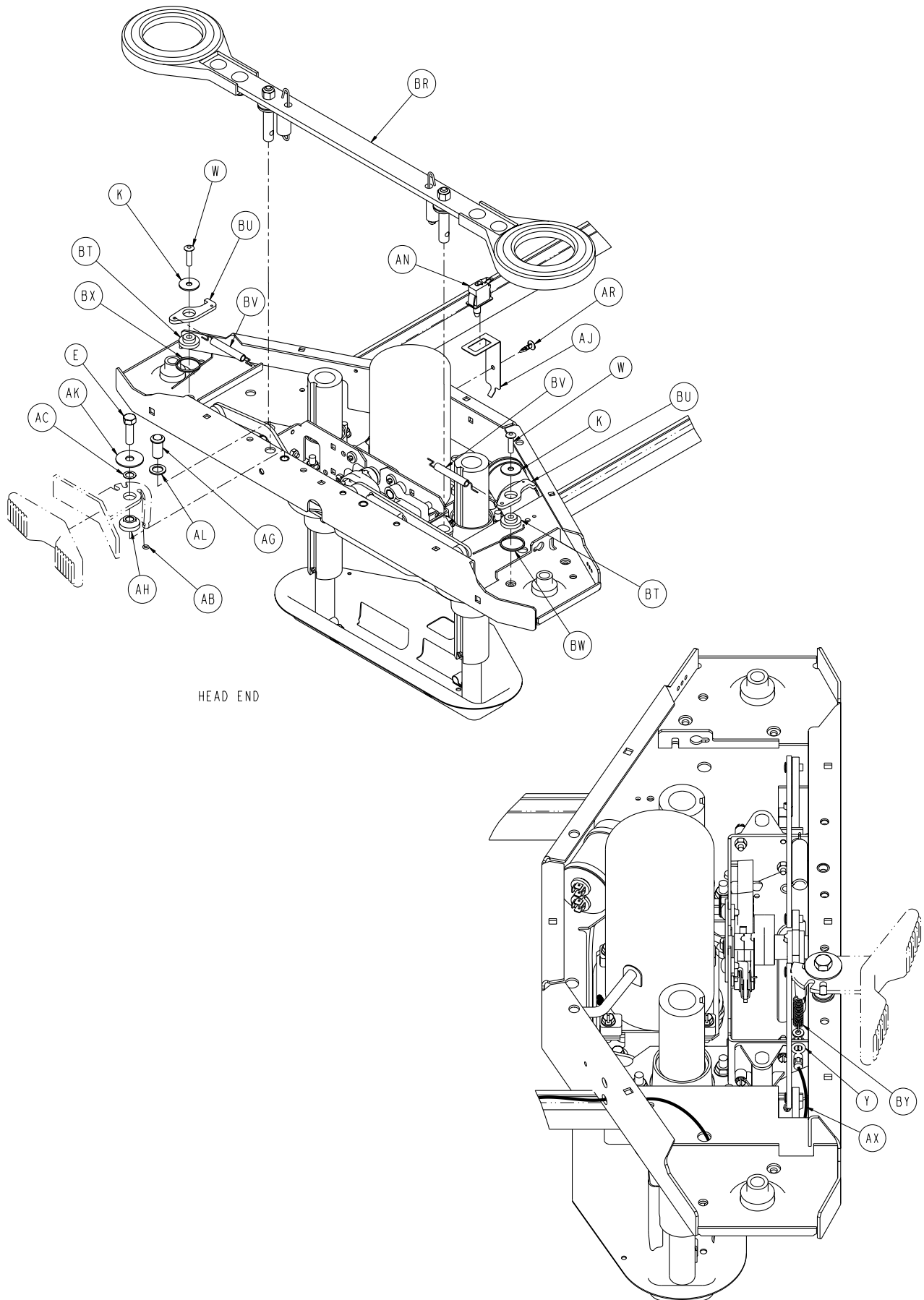

[Return To Table of Contents](#)

Base Assembly, Common Components

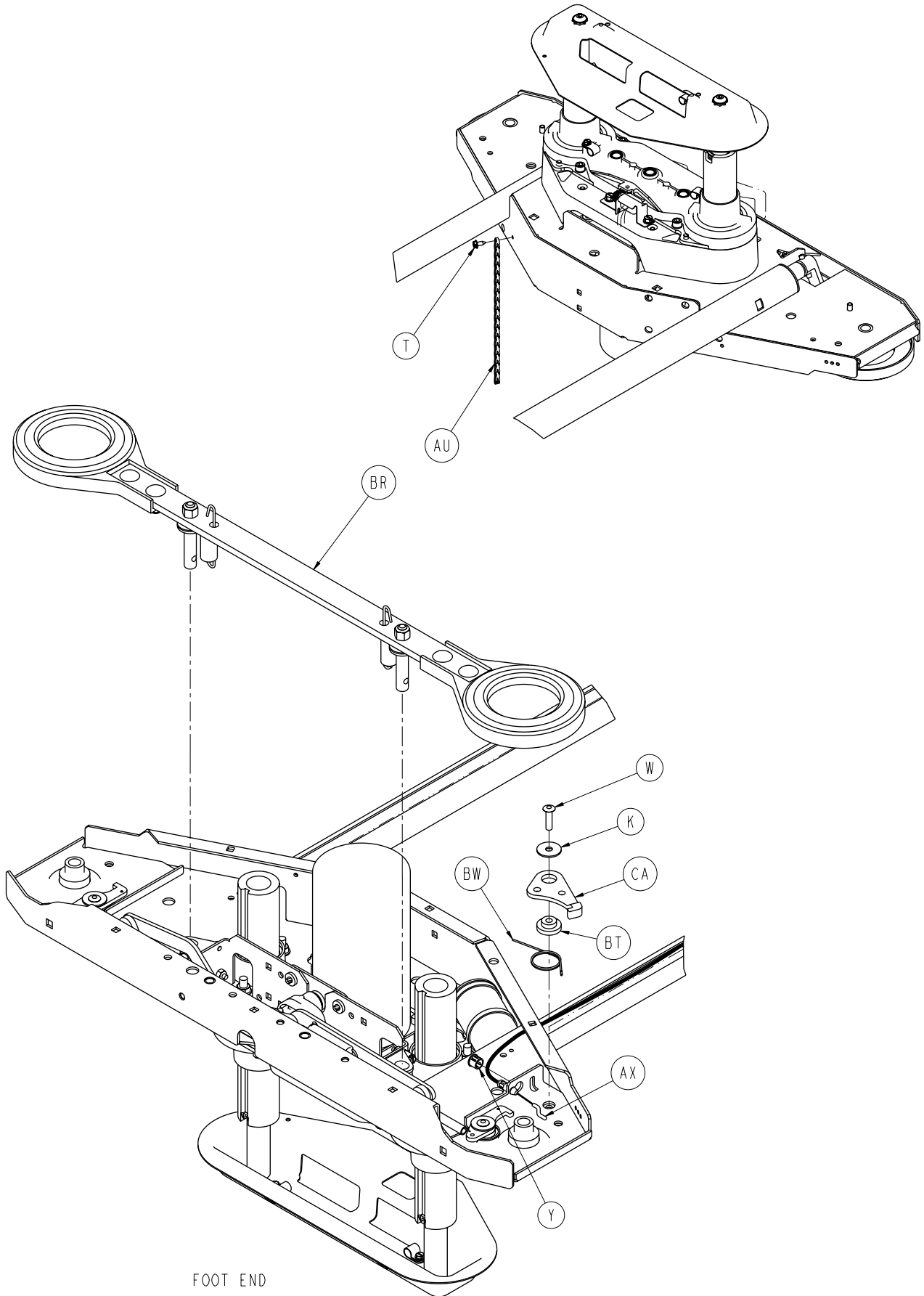

[Return To Table of Contents](#)

Base Assembly, Common Components

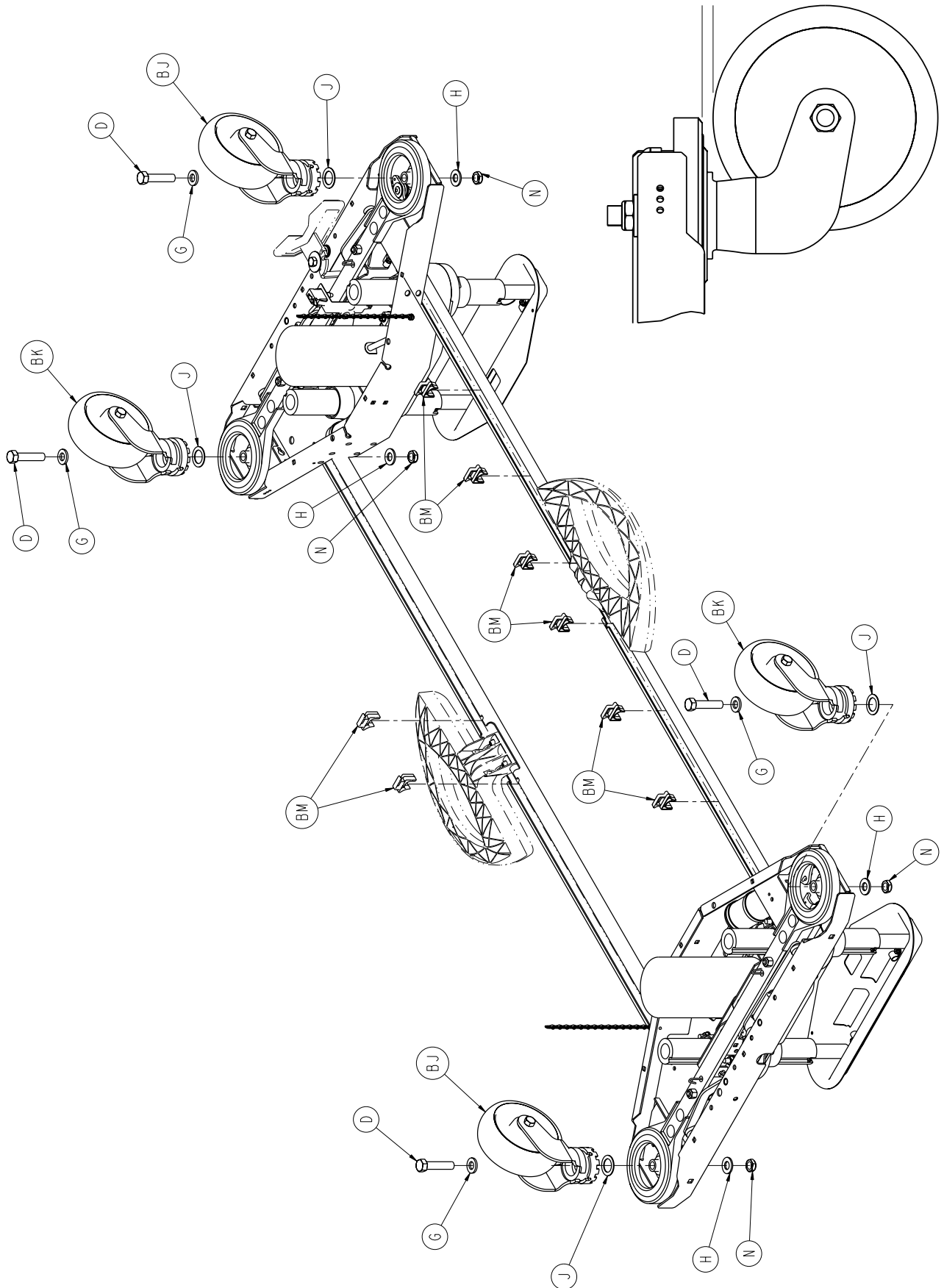

[Return To Table of Contents](#)

Base Assembly, Common Components

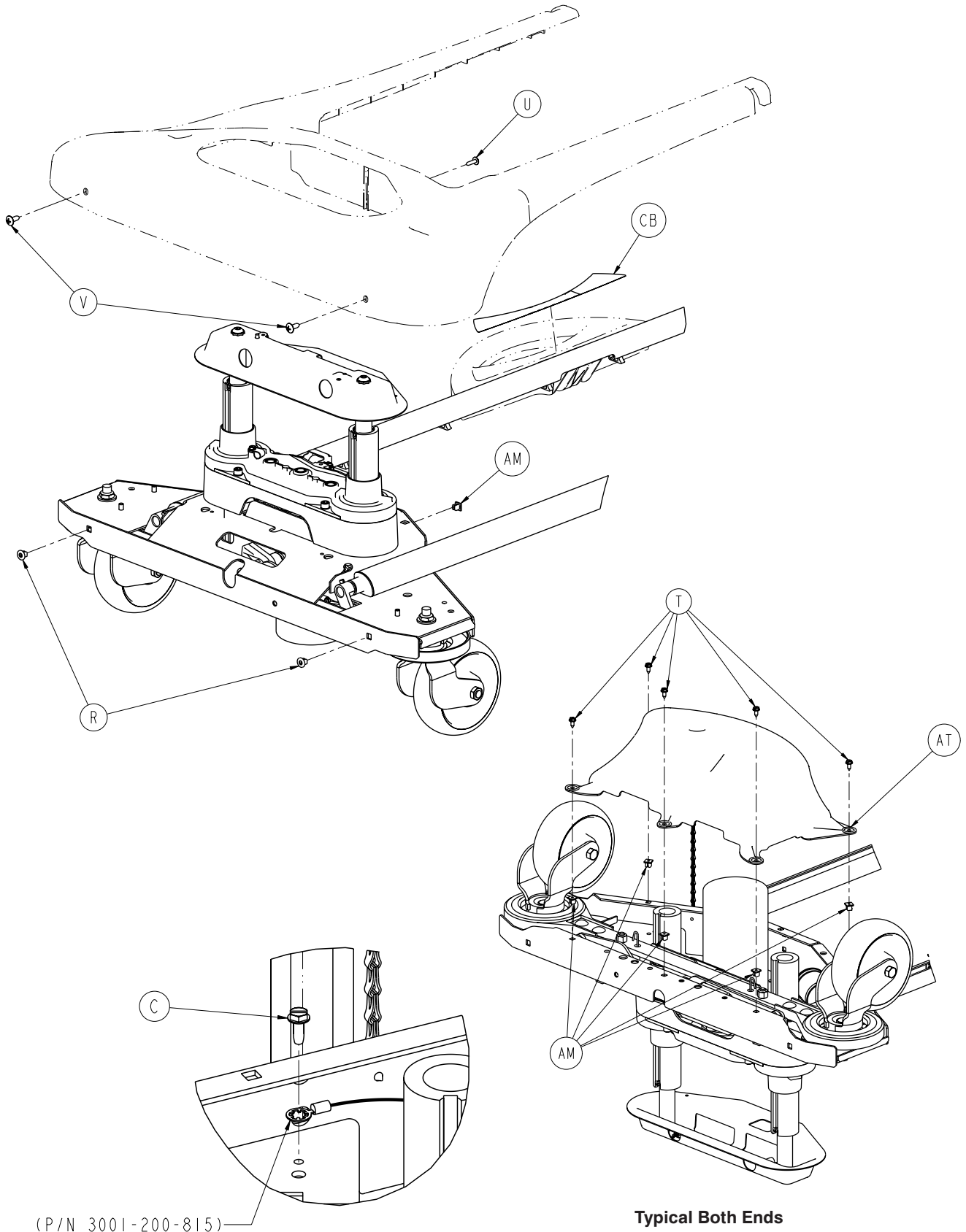

Base Assembly, Common Components

Base Assembly, Common Components - 3006-200-002 (Reference Only)

| Item | Part No. | Part Name | Qty. |
|------|--------------|-------------------------------|------|
| A | 0003-074-000 | Hex Head Cap Screw | 2 |
| B | 0003-122-000 | Hex Washer Head Screw | 8 |
| C | 0003-224-000 | Hex Washer Head Screw | 2 |
| D | 0003-333-000 | Hex Head Cap Screw | 4 |
| E | 0003-349-000 | Hex Head Cap Screw | 1 |
| F | 0007-052-000 | Truss Head Torx | 4 |
| G | 0011-310-000 | Washer | 4 |
| H | 0011-333-000 | Washer | 4 |
| J | 0011-343-000 | Washer | 4 |
| K | 0011-611-000 | Washer | 5 |
| L | 0016-002-000 | Fiberlock Hex Nut | 8 |
| M | 0016-028-000 | Fiberlock Hex Nut | 2 |
| N | 0016-049-000 | Nylock Hex Nut | 4 |
| P | 0016-098-000 | Hex Flange Nut | 8 |
| R | 0018-036-000 | Plastic Clip Nut | 4 |
| T | 0023-025-000 | Slotted Hex Washer Head Screw | 12 |
| U | 0023-080-000 | Truss Head Screw | 2 |
| V | 0023-092-000 | Truss Head Phillip Screw | 4 |
| W | 0025-191-000 | Rivet | 5 |
| X | 0026-014-000 | Roll Pin | 4 |
| Y | 0030-052-000 | Heyco Snap Bushing | 2 |
| AA | 0038-151-000 | Cable Tie | 4 |
| AB | 0045-008-000 | O-Ring | 1 |
| AC | 0052-305-000 | Washer | 1 |
| AD | 3000-200-305 | Brake Shaft Bushing, RH | 2 |
| AE | 3000-200-328 | Brake Shaft Bushing | 4 |
| AF | 3000-200-331 | Brake Shaft Bushing, LH | 2 |
| AG | 3000-200-337 | Pushfit Ball Plunger | 1 |
| AH | 3000-200-341 | Steer Pedal Bushing | 1 |
| AJ | 3000-200-343 | Brake Switch Bracket | 1 |
| AK | 3000-200-348 | Wide Special Washer | 1 |
| AL | 3000-200-349 | Narrow Special Washer | 3 |
| AM | 3000-300-002 | Plastic Clip Nut | 12 |
| AN | 3000-300-058 | Plunger Switch | 1 |
| AP | 3000-300-113 | 8" Cable Tie | 4 |
| AR | 3000-300-115 | Standoff | 1 |
| AT | 3001-200-022 | Bottom Cover Assembly | 2 |
| AU | 3001-200-052 | Grounding Chain | 2 |
| AV | 3001-200-317 | Cam Shaft Brake Bushing | 4 |
| AW | 3001-200-334 | Spring | 2 |
| AX | 3001-200-342 | Steer/Lock Cable | 1 |
| AY | 3002-200-302 | Brake Ratchet Link Assembly | 1 |
| BA | 3002-200-305 | Brake Ratchet Crank, Left | 1 |
| BB | 3002-200-306 | Brake Ratchet Crank, Right | 1 |
| BC | 3002-200-307 | Brake Latch Spring | 1 |
| BD | 3002-200-308 | Brake Ratchet Crank Pin | 1 |
| BE | 3002-200-311 | Brake Shaft | 2 |
| BF | 3002-200-313 | Brake Cam Spacer | 1 |
| BG | 3002-200-316 | Brake Track Roller | 1 |

Base Assembly, Common Components

Base Assembly, Common Components - 3006-200-002 (Reference Only) (Continued)

| Item | Part No. | Part Name | Qty. |
|------|--------------|-------------------------------------|------|
| BH | 3002-201-301 | Brake Ratchet Track | 1 |
| BJ | 3006-200-060 | Swivel Lock Caster Assembly | 2 |
| BK | 3006-200-065 | Steer/Swivel Caster Assembly, White | 2 |
| BL | 3006-200-102 | Base Weldment | 1 |
| BM | 3006-200-306 | Brake Shaft Pedal Bearing | 8 |
| BN | 3006-200-312 | Brake Cam | 2 |
| BP | 3006-200-330 | Brake Crank Assembly | 2 |
| BR | 3006-200-335 | Brake Bar Assembly | 2 |
| BT | 3006-200-339 | Steer/Swivel Lever Bushing | 5 |
| BU | 3006-200-374 | Swivel Lever | 4 |
| BV | 3006-200-376 | Swivel Lock Activation Spring | 4 |
| BW | 3006-200-378 | Swivel Lock Return Spring, RH | 3 |
| BX | 3006-200-379 | Swivel Lock Return Spring, LH | 2 |
| BY | 3006-200-380 | Steer Extension Spring | 1 |
| CA | 3006-200-381 | Steer/Swivel Lever | 1 |
| CB | 3006-200-601 | Brake Pedal Label | 2 |
| CC | 3002-200-314 | Brake Mounting Bracket | 2 |
| CD | 3006-301-201 | Lift Assembly, HE | 1 |
| CE | 3006-301-251 | Lift Assembly, FE | 1 |

Base Ass'y, Battery Backup or Zoom® Option, Common Comp.

For Reference Only: 3006-200-004

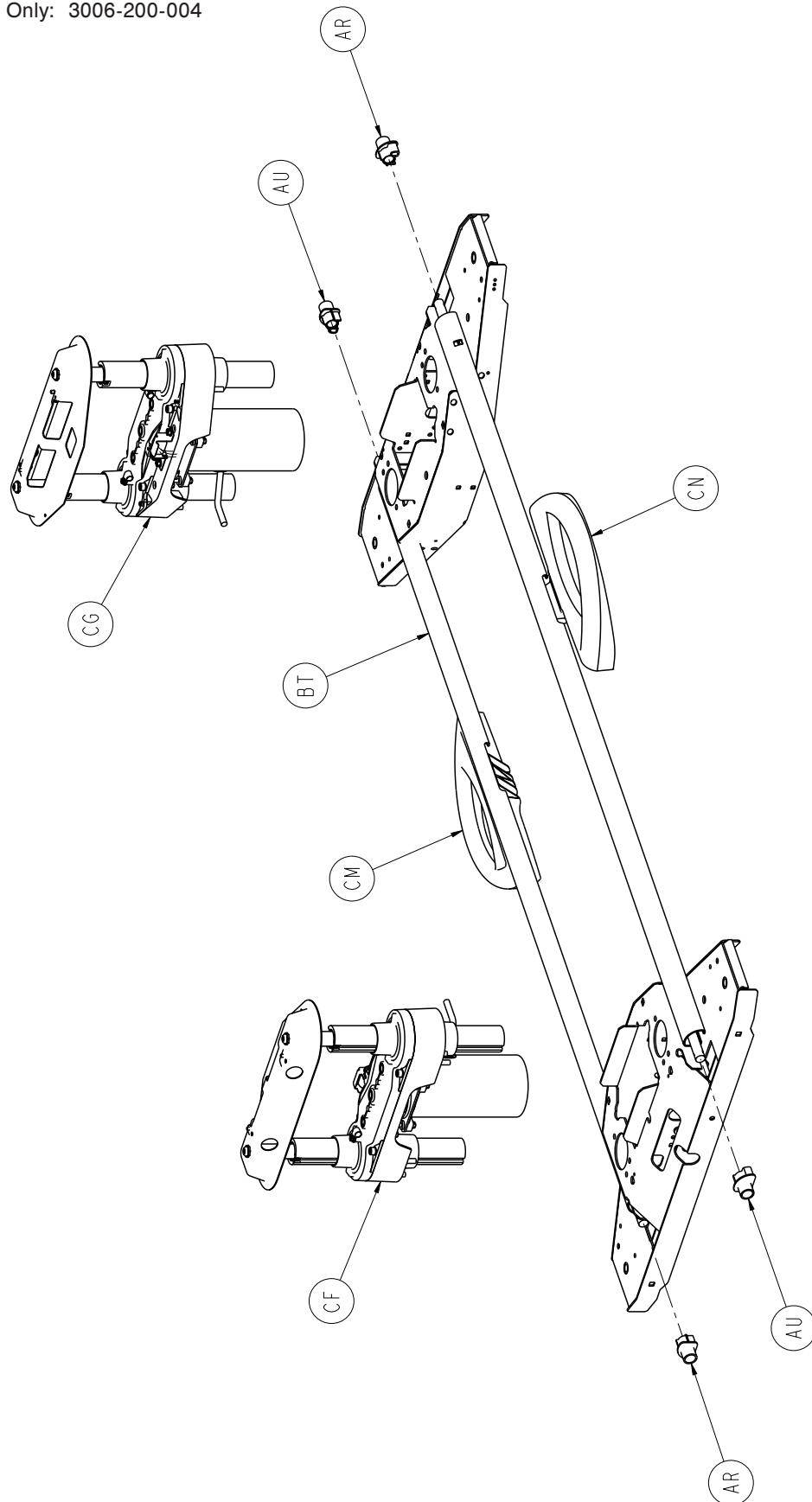

[Return To Table of Contents](#)

Base Ass'y, Battery Backup or Zoom® Option, Common Comp.

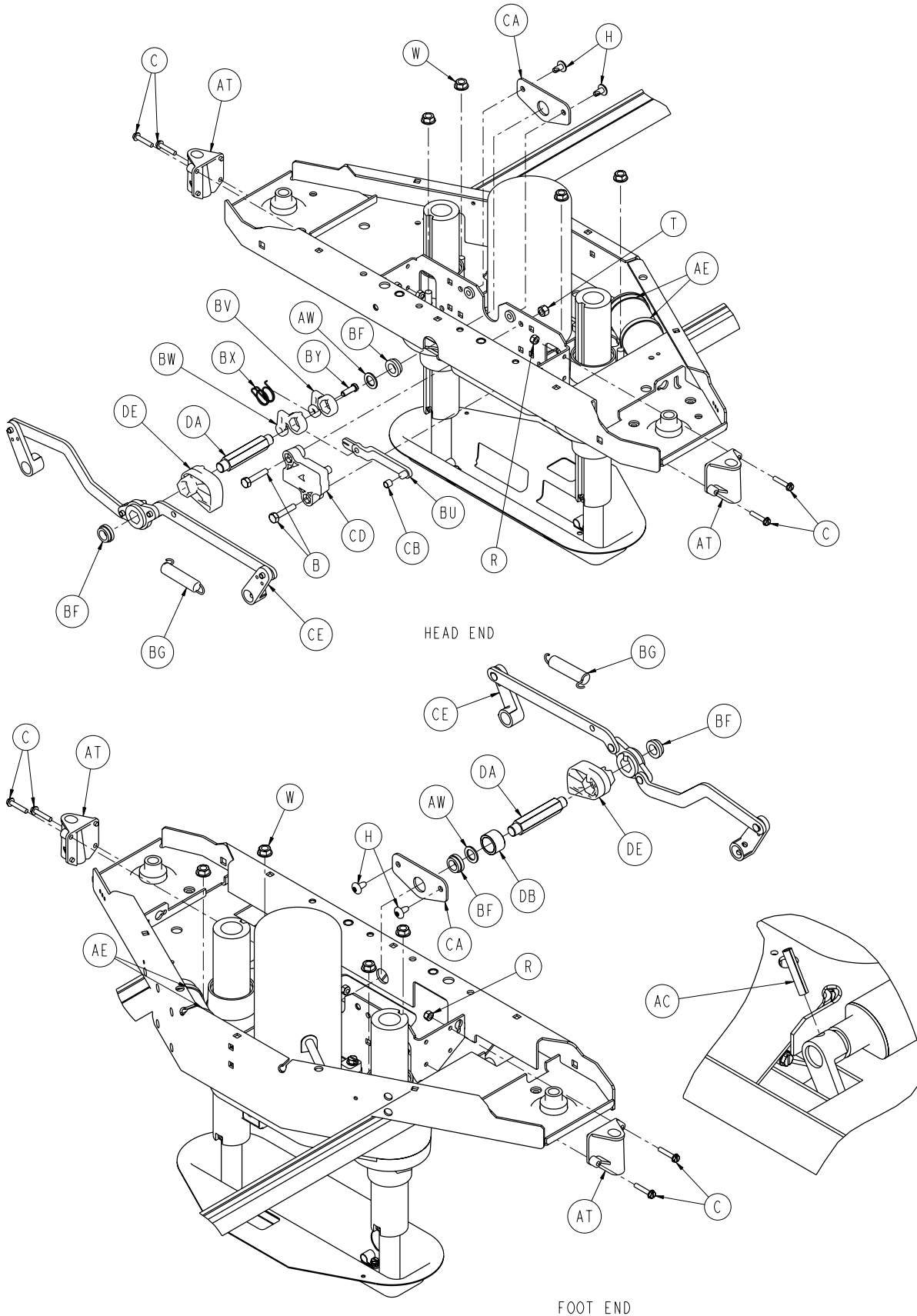

Base Ass'y, Battery Backup or Zoom® Option, Common Comp.

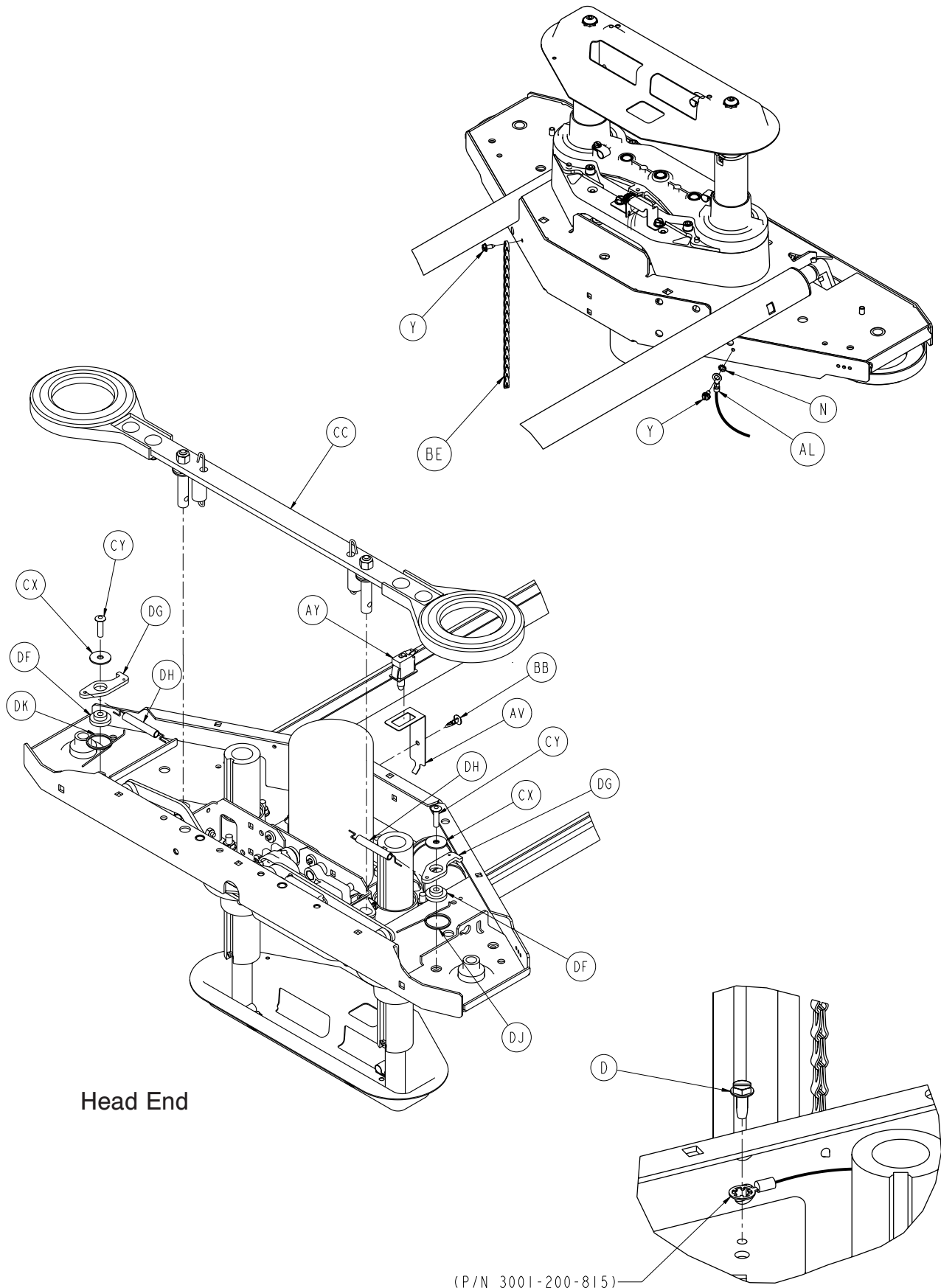

Base Ass'y, Battery Backup or Zoom® Option, Common Comp.

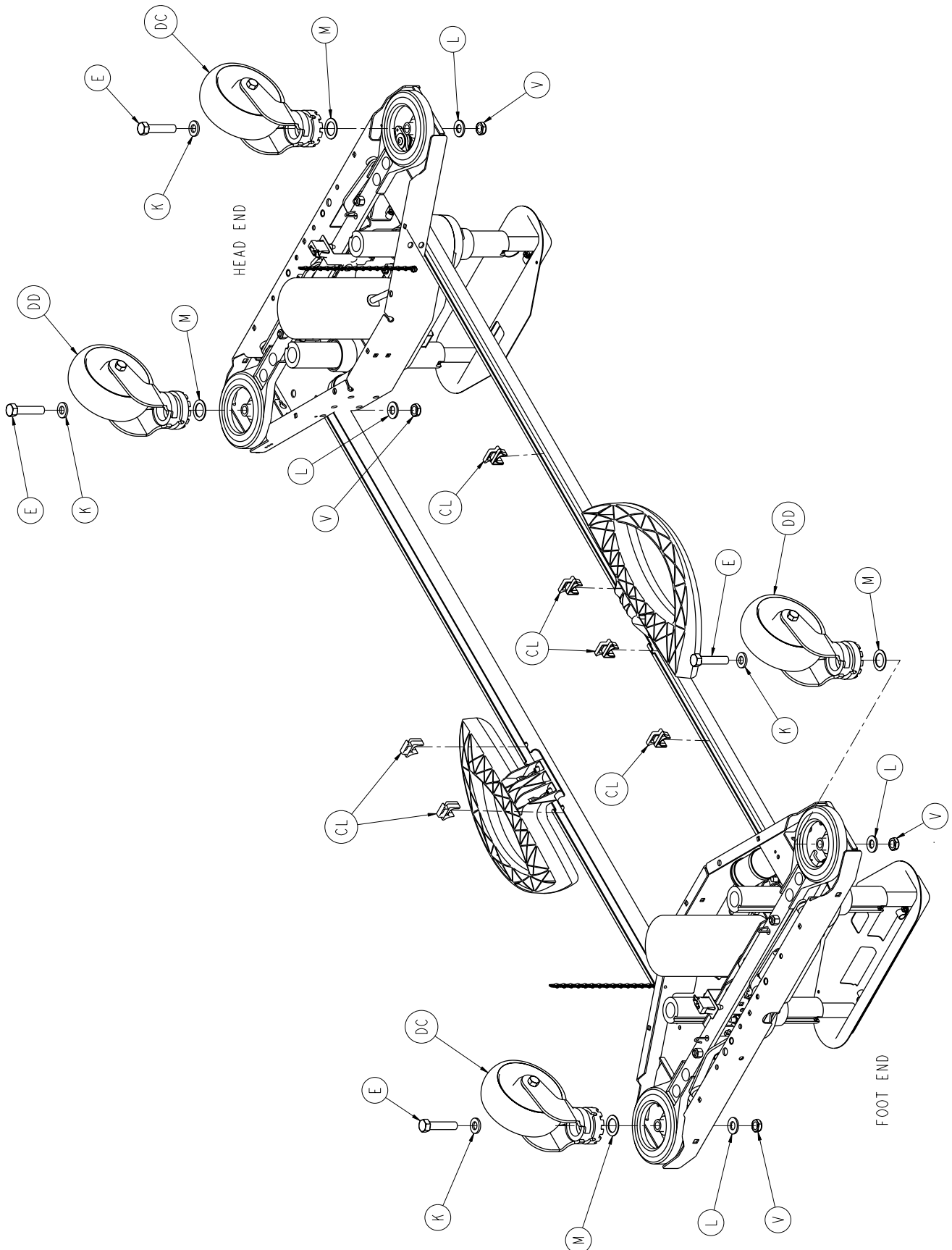

Base Ass'y, Battery Backup or Zoom® Option, Common Comp.

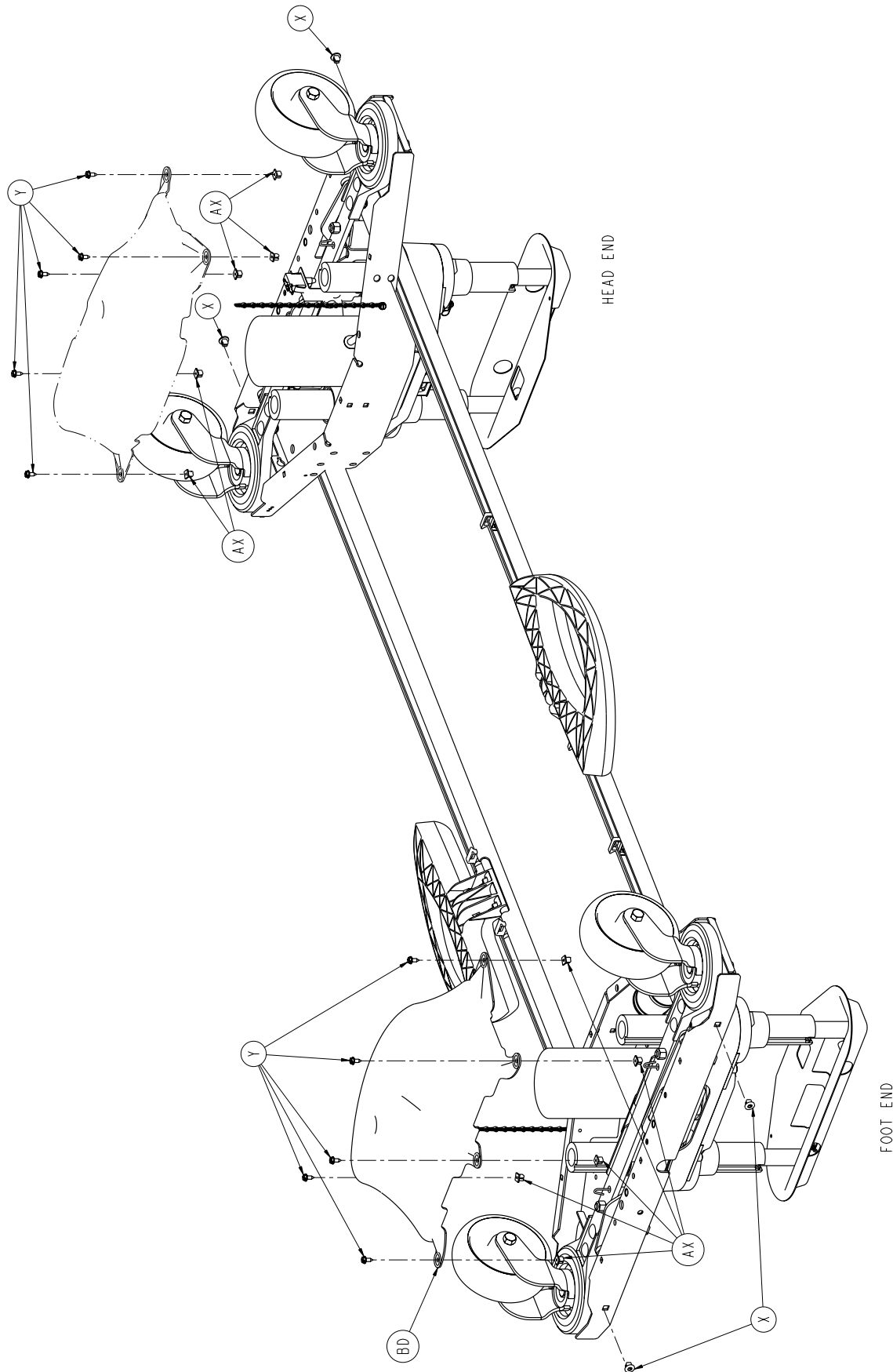

Base Ass'y, Battery Backup or Zoom® Option, Common Comp.

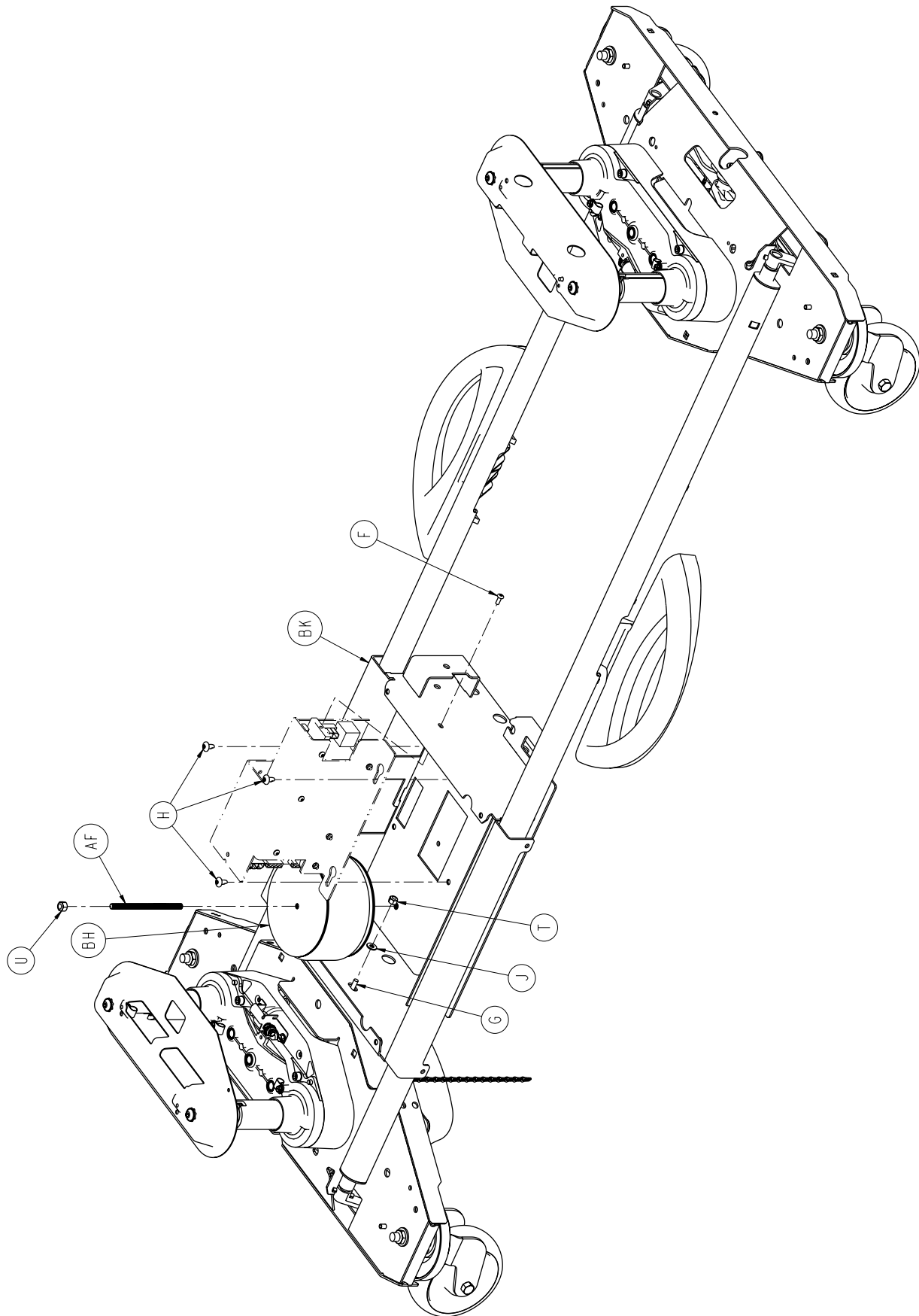

Base Ass'y, Battery Backup or Zoom® Option, Common Comp.

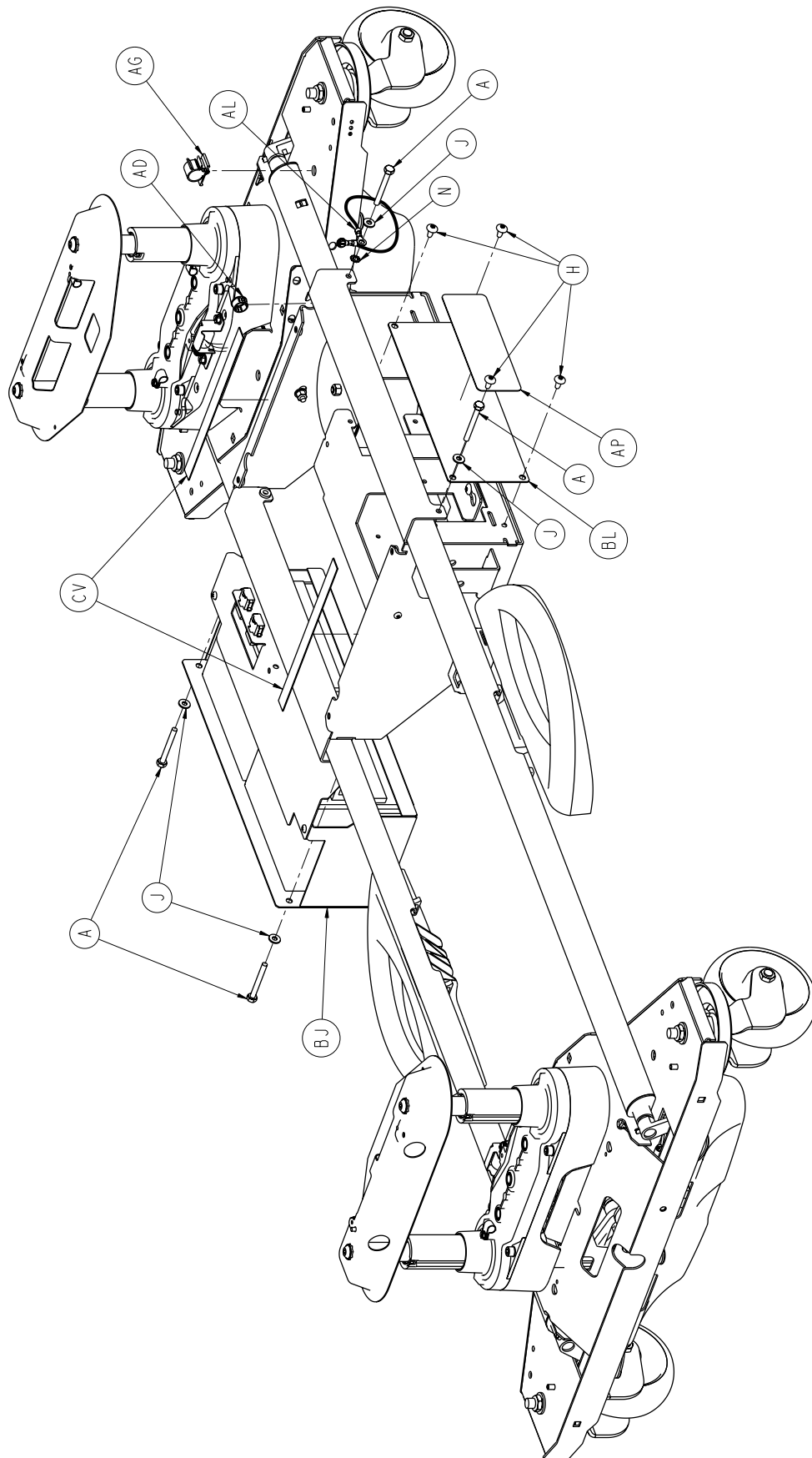

Base Ass'y, Battery Backup or Zoom® Option, Common Comp.

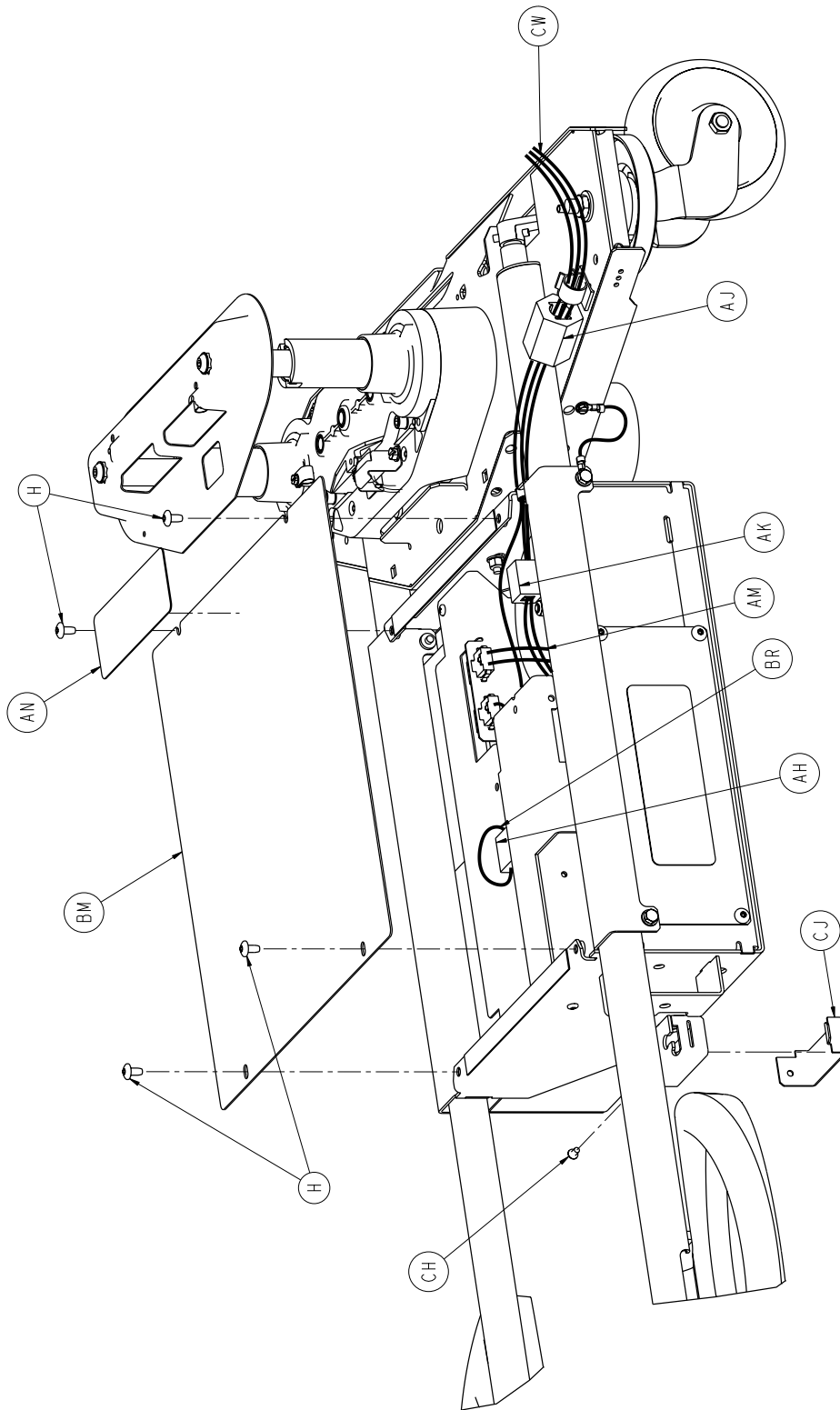

(REFER TO 3006-200-005 AND 3006-200-006 FOR CABLE ROUTING AND ASSEMBLY)

Base Ass'y, Battery Backup or Zoom® Option, Common Comp.

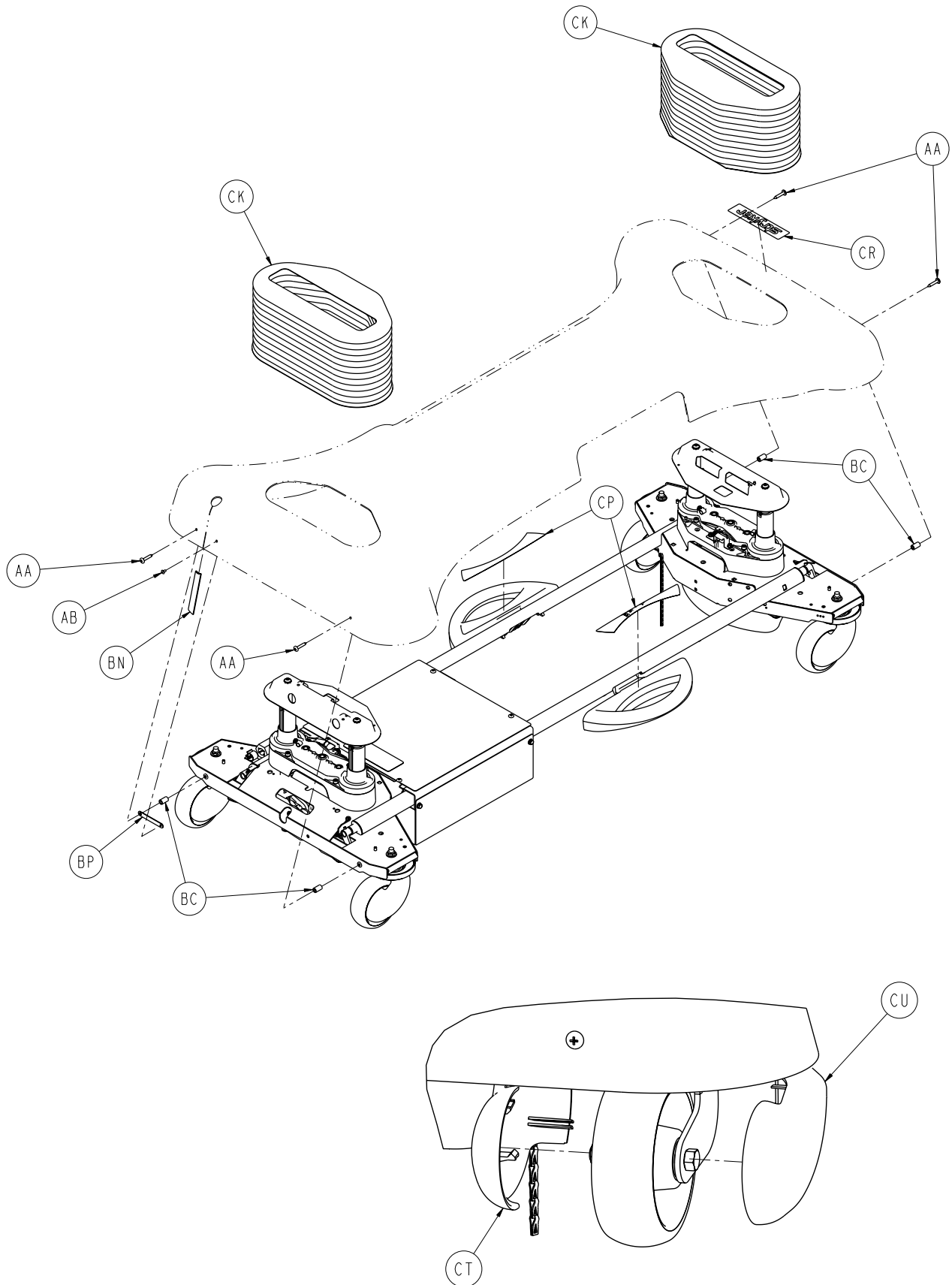

[Return To Table of Contents](#)

Base Ass'y, Battery Backup or Zoom® Option, Common Comp.

Base Assembly, Battery Backup or Zoom® Option, Common Components - 3006-200-004 (Reference Only)

| Item | Part No. | Part Name | Qty. |
|------|--------------|-------------------------------|------|
| A | 0003-032-000 | Hex Head Cap Screw | 4 |
| B | 0003-074-000 | Hex Head Cap Screw | 2 |
| C | 0003-122-000 | Hex Washer Head Screw | 8 |
| D | 0003-224-000 | Hex Washer Head Screw | 2 |
| E | 0003-333-000 | Hex Head Cap Screw | 4 |
| F | 0004-301-000 | Pan Head Machine Screw | 1 |
| G | 0005-017-000 | Carriage Bolt | 1 |
| H | 0007-052-000 | Truss Head Torx | 15 |
| J | 0011-063-000 | Washer | 5 |
| K | 0011-310-000 | Washer | 4 |
| L | 0011-333-000 | Washer | 4 |
| M | 0011-343-000 | Washer | 4 |
| N | 0013-010-000 | External Tooth Star Washer | 2 |
| R | 0016-002-000 | Fiberlock Hex Nut | 8 |
| T | 0016-028-000 | Fiberlock Hex Nut | 3 |
| U | 0016-036-000 | Nylock Hex Nut | 1 |
| V | 0016-049-000 | Nylock Hex Nut | 4 |
| W | 0016-098-000 | Hex Flange Nut | 8 |
| X | 0018-036-000 | Plastic Clip Nut | 4 |
| Y | 0023-025-000 | Hex Washer Head Tapping Screw | 13 |
| AA | 0023-281-000 | Truss Head Self Tapping Screw | 4 |
| AB | 0025-079-000 | Dome Head Pop Rivet | 1 |
| AC | 0026-014-000 | Roll Pin | 4 |
| AD | 0030-038-000 | Heyco Split Bushing | 1 |
| AE | 0038-151-000 | Cable Tie | 4 |
| AF | 0058-090-000 | Threaded Stud | 1 |
| AG | 0059-133-000 | Push-Mount Wire Clip | 1 |
| AH | 0059-144-000 | Split Ferrite | 1 |
| AJ | 0059-192-000 | Split Ferrite Core | 1 |
| AK | 0059-194-000 | Split Ferrite | 1 |
| AL | 3002-300-870 | Ground Strap | 1 |
| AM | 2040-001-804 | Power Board DC Power Cable | 1 |
| AN | 2040-001-101 | Power Board Cover Label | 1 |
| AP | 2040-001-102 | Charger Box Cover Label | 1 |
| AR | 3000-200-305 | Brake Shaft Bushing, RH | 2 |
| AT | 3000-200-328 | Brake Guide Bushing | 4 |
| AU | 3000-200-331 | Brake Shaft Bushing, LH | 2 |
| AV | 3000-200-343 | Brake Switch Bracket | 1 |
| AW | 3000-200-349 | Narrow, Special Washer | 2 |
| AX | 3000-300-002 | Plastic Clip Nut | 10 |
| AY | 3000-300-058 | Plunger Switch | 1 |
| BA | 3000-300-113 | 8" Cable Tie | 4 |
| BB | 3000-300-115 | Standoff | 1 |
| BC | 3000-300-428 | Gatch Link Sleeve | 4 |
| BD | 3001-200-022 | Bottom Cover Assembly | 1 |
| BE | 3001-200-052 | Grounding Chain | 2 |
| BF | 3001-200-317 | Cam Shaft Brake Bushing | 4 |
| BG | 3001-200-334 | Spring | 2 |
| BH | 3002-001-010 | Transformer | 1 |
| BJ | 3002-001-015 | Battery Tray Assembly | 1 |
| BK | 3002-001-050 | Charger Box Weldment | 1 |

Base Ass'y, Battery Backup or Zoom® Option, Common Comp.

Base Assembly, Battery Backup or Zoom® Option, Common Components - 3006-200-004 (Reference Only) (Continued)

| Item | Part No. | Part Name | Qty. |
|------|--------------|---|------|
| BL | 3002-001-068 | Charger/Inverter Side Cover | 1 |
| BM | 3002-001-071 | Charger Box Lid | 1 |
| BN | 3002-001-078 | Hood Slot Trim | 1 |
| BP | 3002-001-079 | Hood Slot Trim Bracket | 1 |
| BR | 3002-001-802 | Battery Cable Inverter | 1 |
| BT | 3006-200-104 | Base Weldment | 1 |
| BU | 3002-200-302 | Brake Ratchet Link Assembly | 1 |
| BV | 3002-200-305 | Brake Ratchet Crank, Left | 1 |
| BW | 3002-200-306 | Brake Ratchet Crank, Right | 1 |
| BX | 3002-200-307 | Brake Latch Spring | 1 |
| BY | 3002-200-308 | Brake Ratchet Crank Pin | 1 |
| CA | 3002-200-314 | Brake Mounting Bracket, White | 2 |
| CB | 3002-200-316 | Brake Track Roller | 1 |
| CC | 3006-200-335 | Brake Bar Assembly | 2 |
| CD | 3002-201-301 | Brake Ratchet Track | 1 |
| CE | 3006-200-330 | Brake Crank Assembly | 2 |
| CF | 3006-301-201 | Lift Assembly, Head End | 1 |
| CG | 3006-301-251 | Lift Assembly, Foot End | 1 |
| CH | 0004-307-000 | Socket Head Cap Screw | 1 |
| CJ | 2040-001-103 | Switch Bracket Cover | 1 |
| CK | 3006-200-012 | Bellows | 2 |
| CL | 3006-200-306 | Brake Shaft Pedal Bearing | 6 |
| CM | 3006-200-341 | Brake Shaft Assembly, LH | 1 |
| CN | 3006-200-342 | Brake Shaft Assembly, RH | 1 |
| CP | 3006-200-601 | Brake Pedal Label | 2 |
| CR | 3006-200-602 | Base Logo Label | 1 |
| CT | 3006-200-138 | Caster Cover, LH | 4 |
| CU | 3006-200-139 | Caster Cover, RH | 4 |
| CV | 7000-001-326 | Closed Cell Sealing Tape | 2 |
| CW | 3002-001-801 | Umbilical Cord Assembly | 1 |
| CX | 0011-611-000 | Washer | 4 |
| CY | 0025-191-000 | Rivet | 4 |
| DA | 3002-200-311 | Brake Shaft | 2 |
| DB | 3002-200-313 | Brake Cam Spacer | 1 |
| DC | 3006-200-060 | Swivel Lock Caster Assembly | 2 |
| DD | 3006-200-065 | Steer/Swivel Lock Caster Assembly, White | 2 |
| DE | 3006-200-312 | Brake Cam | 2 |
| DF | 3006-200-339 | Steer/Swivel Lever Bushing | 4 |
| DG | 3006-200-374 | Swivel Lever | 4 |
| DH | 3006-200-376 | Swivel Lock Activation Spring | 4 |
| DJ | 3006-200-378 | Swivel Lock Return Spring, RH | 2 |
| DK | 3006-200-379 | Swivel Lock Return Spring, LH | 2 |

Base Assembly, Standard Bed

For Reference Only: 3006-200-003

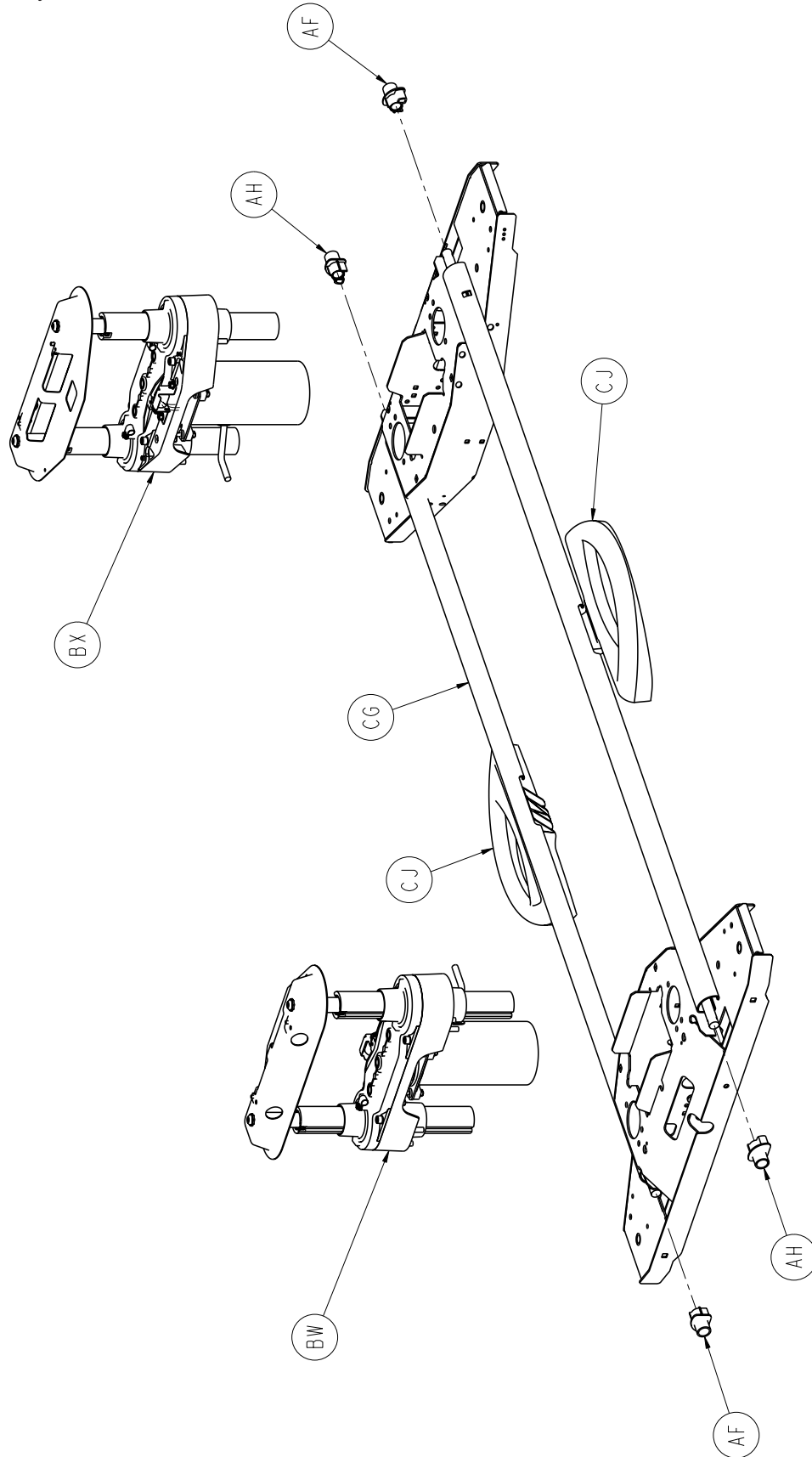

Base Assembly, Standard Bed

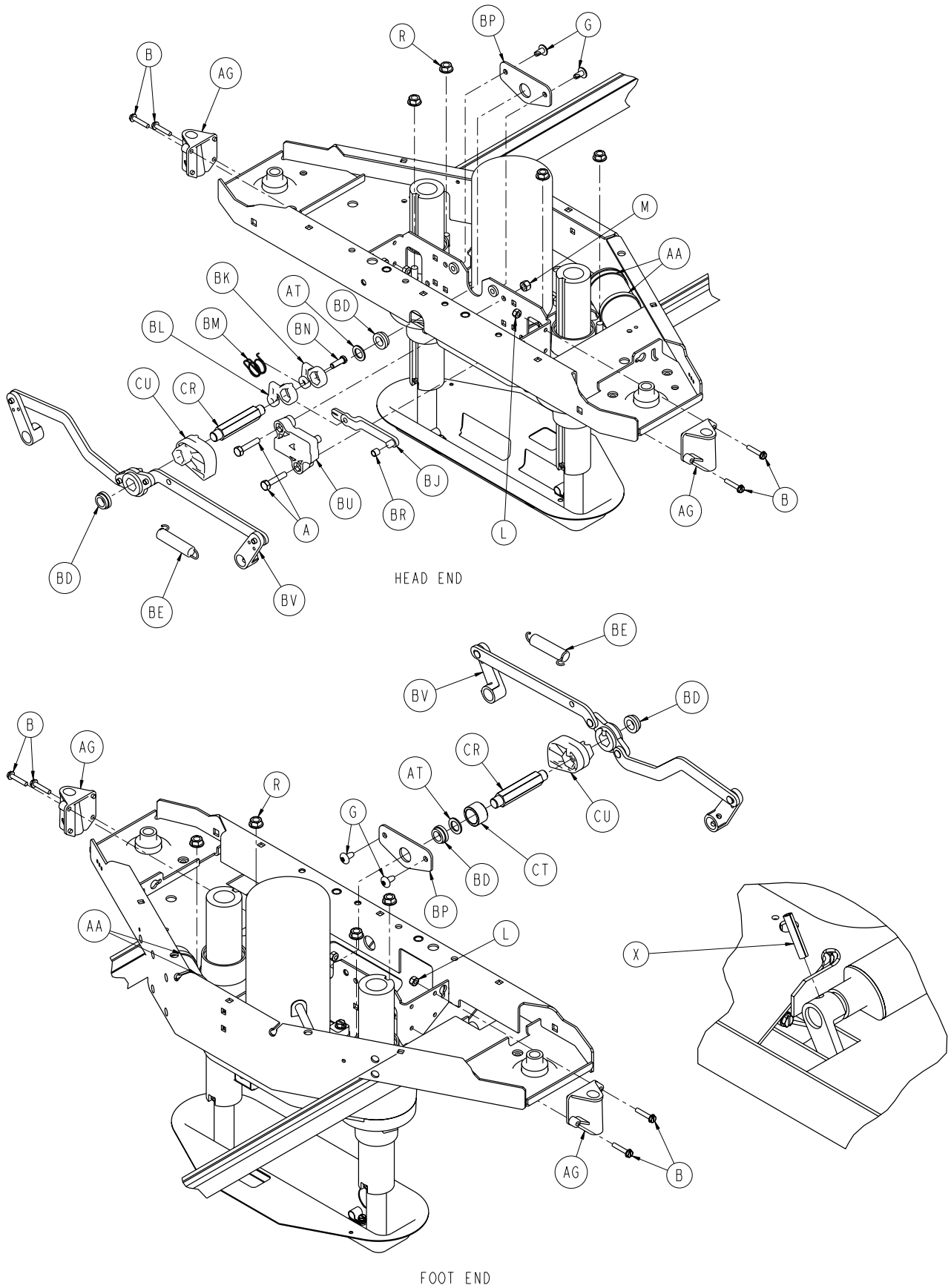

Base Assembly, Standard Bed

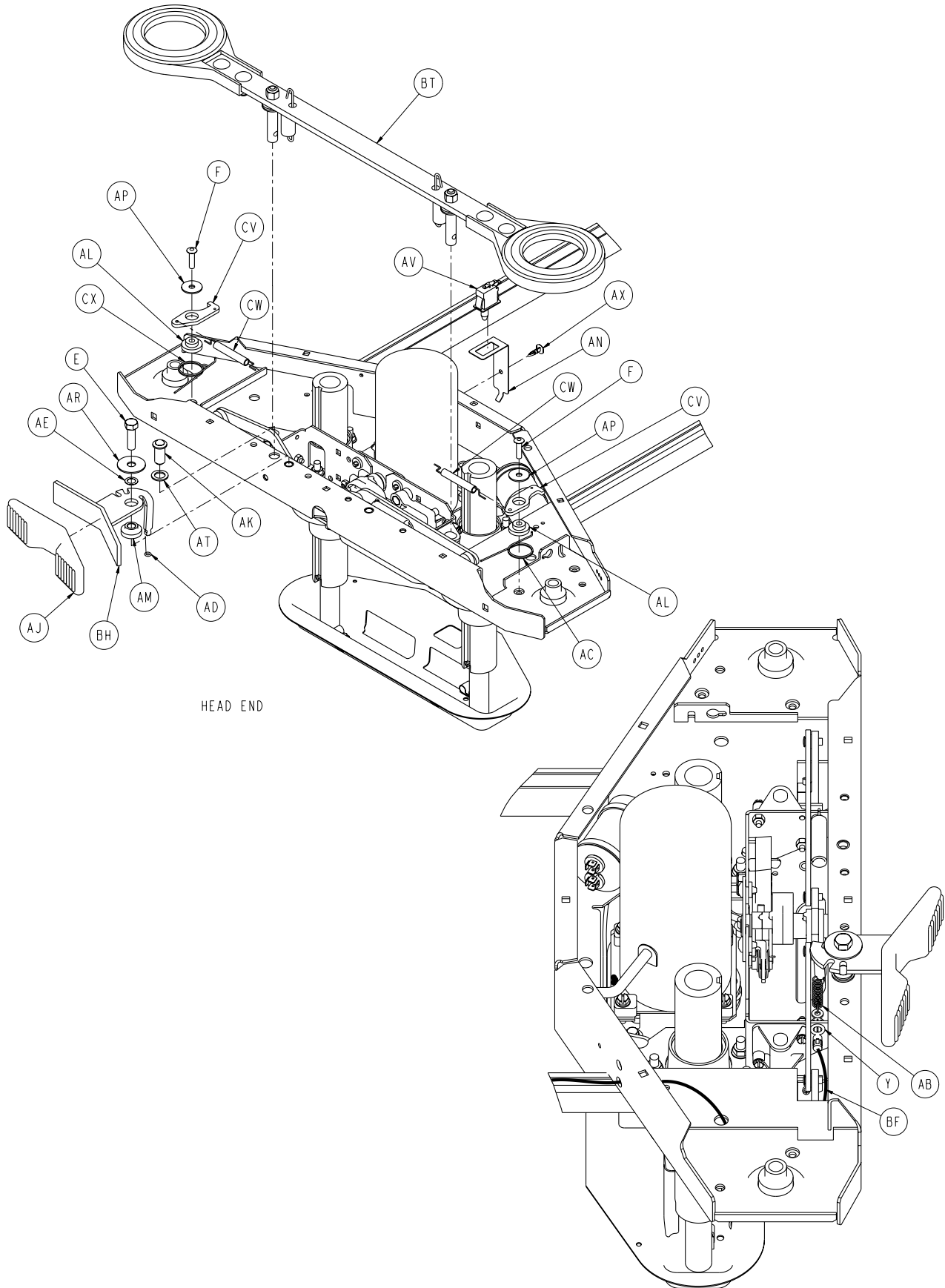

Base Assembly, Standard Bed

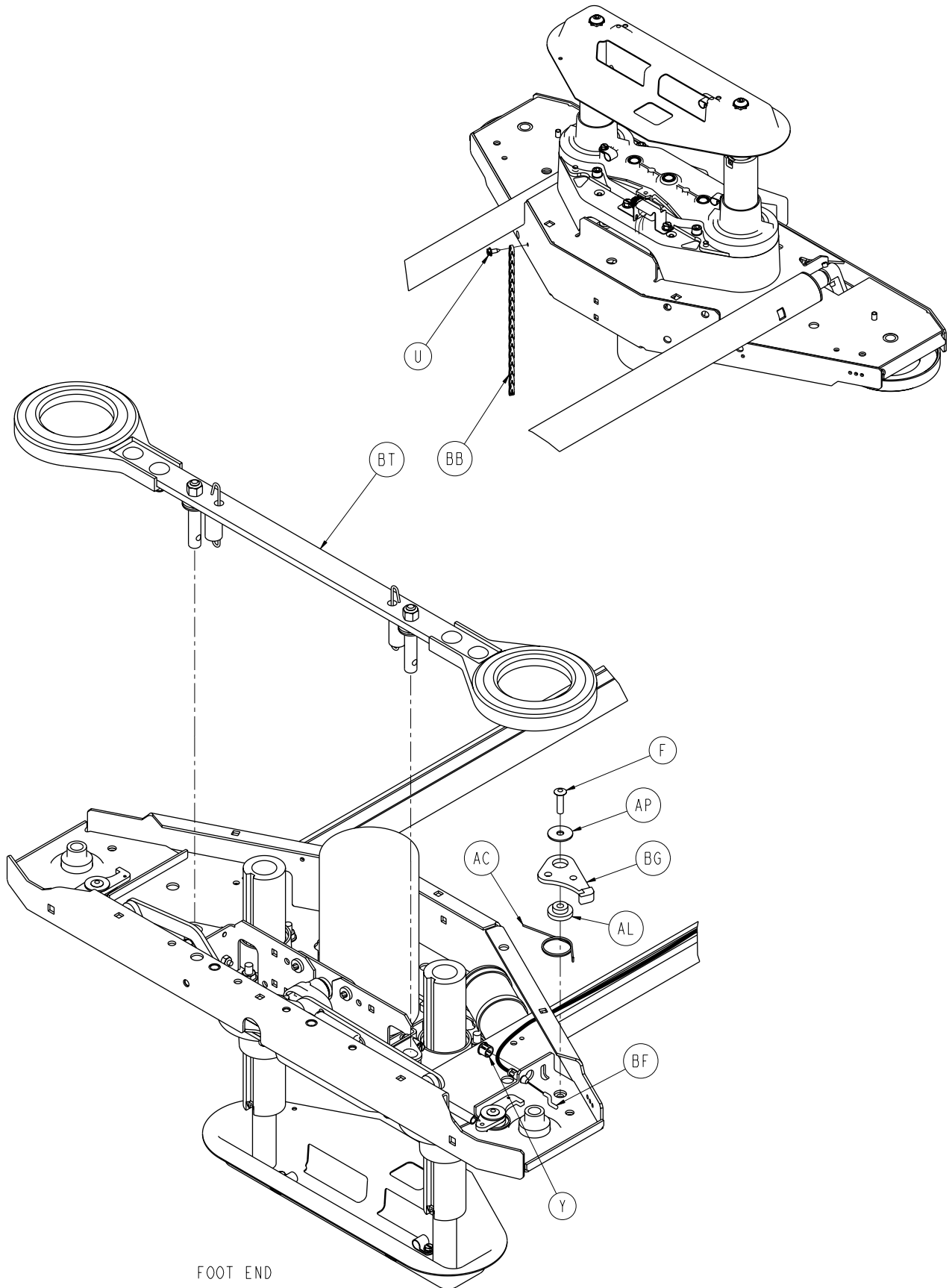

Base Assembly, Standard Bed

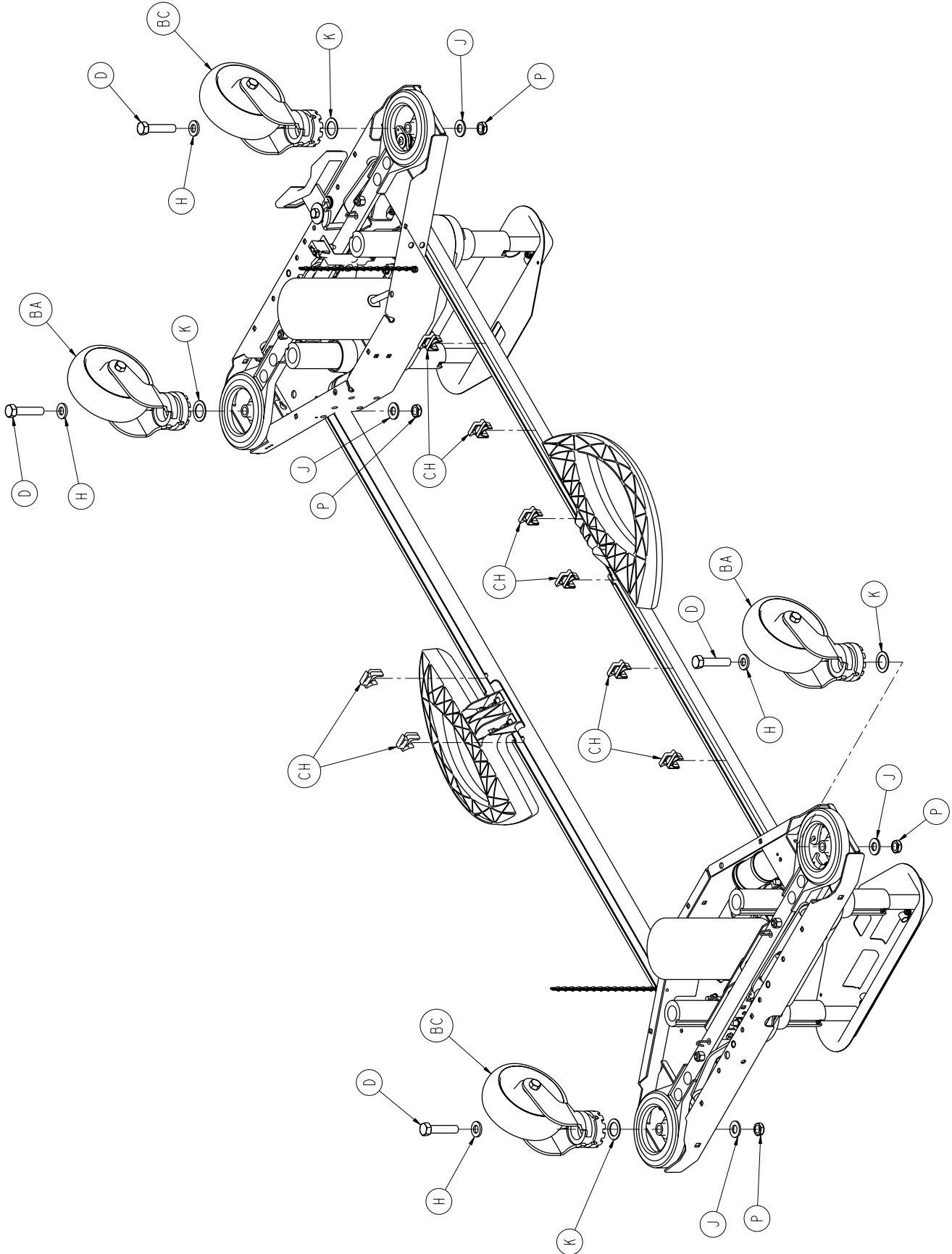

Base Assembly, Standard Bed

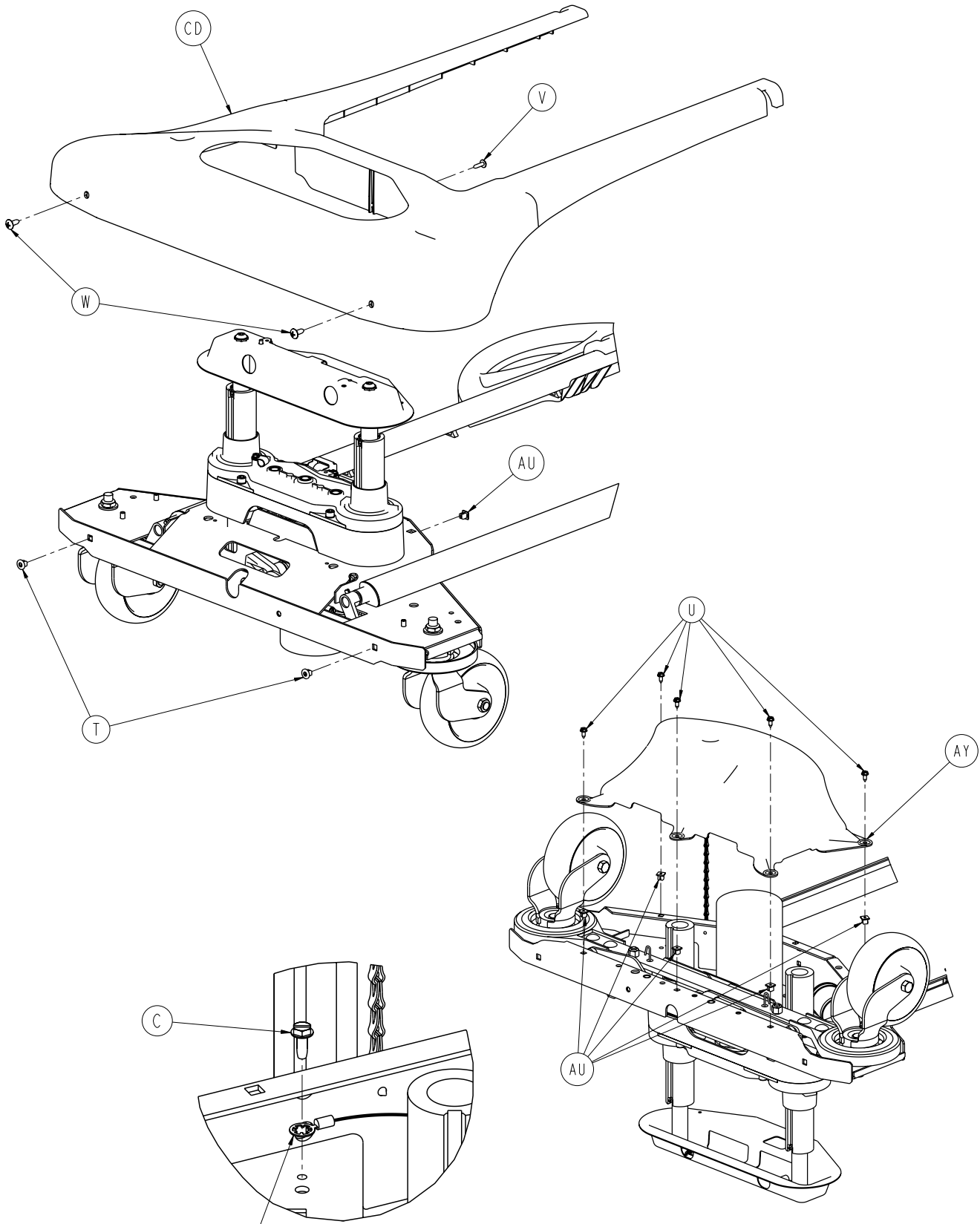

(P/N 3001-200-815)

Typical Both Ends

Base Assembly, Standard Bed

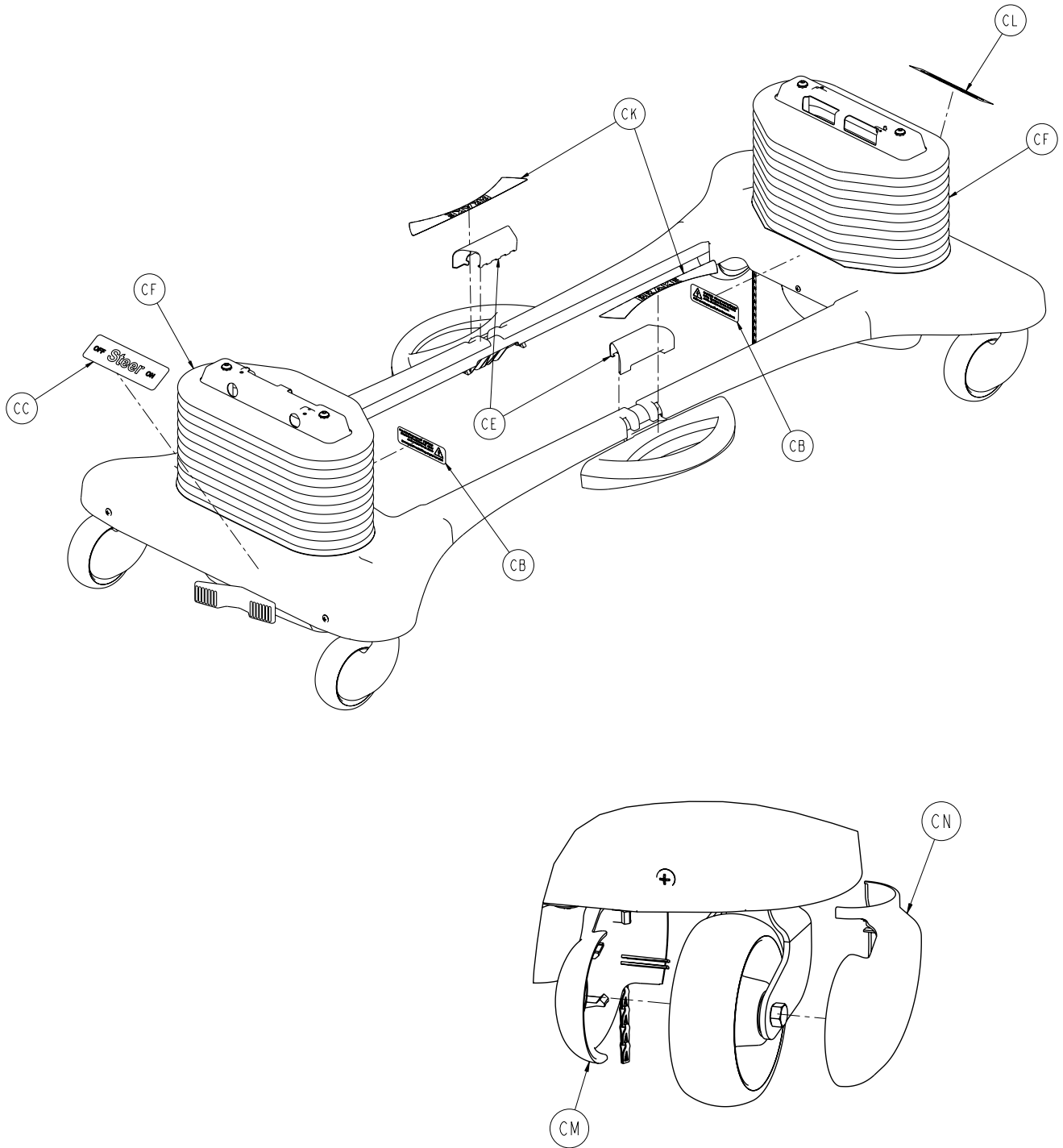

Base Assembly, Standard Bed

Base Assembly, Standard Bed - 3006-200-003 (Reference Only)

| Item | Part No. | Part Name | Qty. |
|------|--------------|----------------------------------|------|
| A | 0003-074-000 | Hex Head Cap Screw | 2 |
| B | 0003-122-000 | Hex Washer Head Screw | 8 |
| C | 0003-224-000 | Hex Washer Head Screw | 2 |
| D | 0003-333-000 | Hex Head Cap Screw | 4 |
| E | 0003-349-000 | Hex Head Cap Screw | 1 |
| F | 0025-191-000 | Rivet | 5 |
| G | 0007-052-000 | Truss Head Torx Screw | 4 |
| H | 0011-310-000 | Washer | 4 |
| J | 0011-333-000 | Washer | 4 |
| K | 0011-343-000 | Washer | 4 |
| L | 0016-002-000 | Fiberlock Hex Nut | 8 |
| M | 0016-028-000 | Fiberlock Hex Nut | 2 |
| P | 0016-049-000 | Nylock Hex Nut | 4 |
| R | 0016-098-000 | Hex Flange Nut | 8 |
| T | 0018-036-000 | Plastic Clip Nut | 4 |
| U | 0023-025-000 | Hex Washer Head Screw | 12 |
| V | 0023-080-000 | Truss Head S Torx Screw | 2 |
| W | 0023-092-000 | Truss Head Phillip | 4 |
| X | 0026-014-000 | Roll Pin | 4 |
| Y | 0030-052-000 | Heyco Snap Bushing | 2 |
| AA | 0038-151-000 | Cable Tie | 4 |
| AB | 3006-200-380 | Steer Extension Spring | 1 |
| AC | 3006-200-378 | Swivel Lock Return Spring, RH | 3 |
| AD | 0045-008-000 | O-Ring | 1 |
| AE | 0052-305-000 | Washer | 1 |
| AF | 3000-200-305 | Brake Shaft Bushing, RH | 2 |
| AG | 3000-200-328 | Brake Guide Bushing | 4 |
| AH | 3000-200-331 | Brake Shafting Bushing, LH | 2 |
| AJ | 3000-200-336 | Steer Pedal | 1 |
| AK | 3000-200-337 | Pushfit Ball Plunger | 1 |
| AL | 3006-200-339 | Steer/Swivel Level Bushing | 5 |
| AM | 3000-200-341 | Steer Pedal Bushing | 1 |
| AN | 3000-200-343 | Brake Switch Bracket | 1 |
| AP | 0011-611-000 | Washer | 5 |
| AR | 3000-200-348 | Wide Washer, Special | 1 |
| AT | 3000-200-349 | Narrow Washer, Special | 3 |
| AU | 3000-300-002 | Plastic Clip Nut | 12 |
| AV | 3000-300-058 | Plunger Switch | 1 |
| AW | 3000-300-113 | 8" Cable Tie | 4 |
| AX | 3000-300-115 | Standoff | 1 |
| AY | 3001-200-022 | Bottom Cover Assembly | 2 |
| BA | 3006-200-065 | Steer Swivel Caster Ass'y, White | 2 |
| BB | 3001-200-052 | Grounding Chain | 2 |
| BC | 3006-200-060 | Swivel Lock Caster Assembly | 2 |
| BD | 3001-200-317 | Brake Cam Shaft Bushing | 4 |
| BE | 3001-200-334 | Spring | 2 |
| BF | 3001-200-342 | Steer Lock Cable | 1 |
| BG | 3006-200-381 | Steer Swivel Lever | 1 |
| BH | 3006-201-371 | Steer Pedal Arm Assembly | 1 |
| BJ | 3002-200-302 | Brake Ratchet Link Assembly | 1 |
| BK | 3002-200-305 | Brake Ratchet Crank, Left | 1 |

Base Assembly, Standard Bed

Base Assembly, Standard Bed, - 3006-200-003 (Reference Only) (Continued)

| Item | Part No. | Part Name | Qty. |
|------|--------------|-------------------------------|------|
| BL | 3002-200-306 | Brake Ratchet Crank, Right | 1 |
| BM | 3002-200-307 | Brake Latch Spring | 1 |
| BN | 3002-200-308 | Brake Ratchet Crank Pin | 1 |
| BP | 3002-200-314 | Brake Mounting Bracket | 2 |
| BR | 3002-200-316 | Brake Track Roller | 1 |
| BT | 3006-200-335 | Brake Bar Assembly | 2 |
| BU | 3002-201-301 | Brake Ratchet Track | 1 |
| BV | 3006-200-330 | Brake Crank Assembly | 2 |
| BW | 3006-301-201 | Lift Assembly, Head End | 1 |
| BX | 3006-301-251 | Lift Assembly, Foot End | 1 |
| CB | 3006-002-708 | Shock Hazard Label | 2 |
| CC | 3006-090-013 | Steer Lock Label | 1 |
| CD | 3006-200-009 | Uni Pan Cover | 2 |
| CE | 3006-200-011 | Uni Pan Cover Clip | 2 |
| CF | 3006-200-012 | Bellows | 1 |
| CG | 3006-200-102 | Base Weldment | 1 |
| CH | 3006-200-306 | Brake Shaft Pedal Bearing | 8 |
| CJ | 3006-200-340 | Brake Shaft Assembly | 2 |
| CK | 3006-200-601 | Brake Pedal label | 2 |
| CL | 3006-200-602 | Base Logo Label | 1 |
| CM | 3006-200-138 | Caster Cover, LH | 4 |
| CN | 3006-200-139 | Caster Cover, RH | 4 |
| CR | 3002-200-311 | Brake Shaft | 2 |
| CT | 3002-200-313 | Brake Cam Spacer | 1 |
| CU | 3006-200-312 | Brake Cam | 2 |
| CV | 3006-200-374 | Swivel Lever | 4 |
| CW | 3006-200-376 | Swivel Lock Activation Spring | 4 |
| CX | 3006-200-379 | Sivel Lock Return Spring, LH | 2 |

Base Assembly, Battery Backup Option

For Reference Only: 3006-200-006

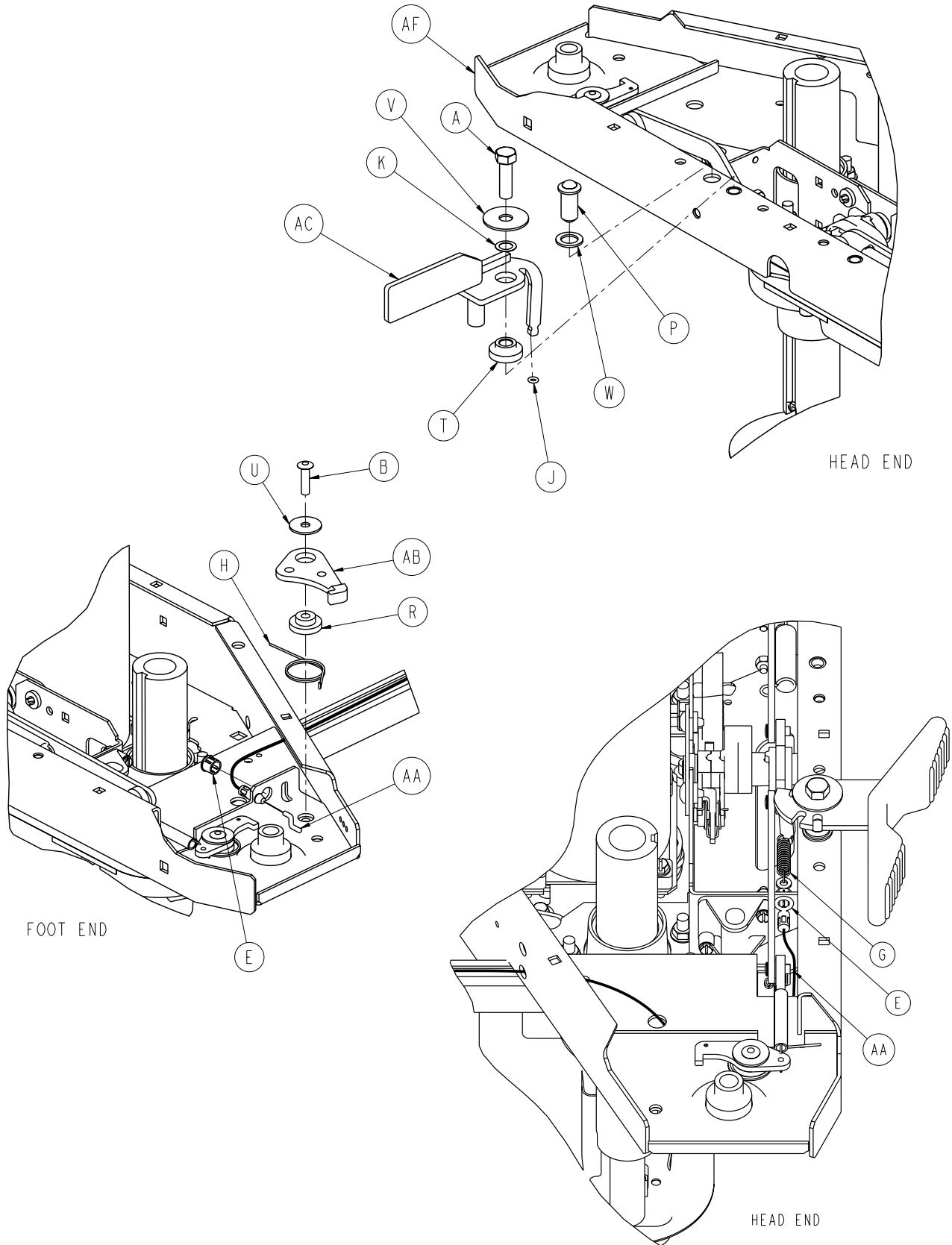

[Return To Table of Contents](#)

Base Assembly, Battery Backup Option

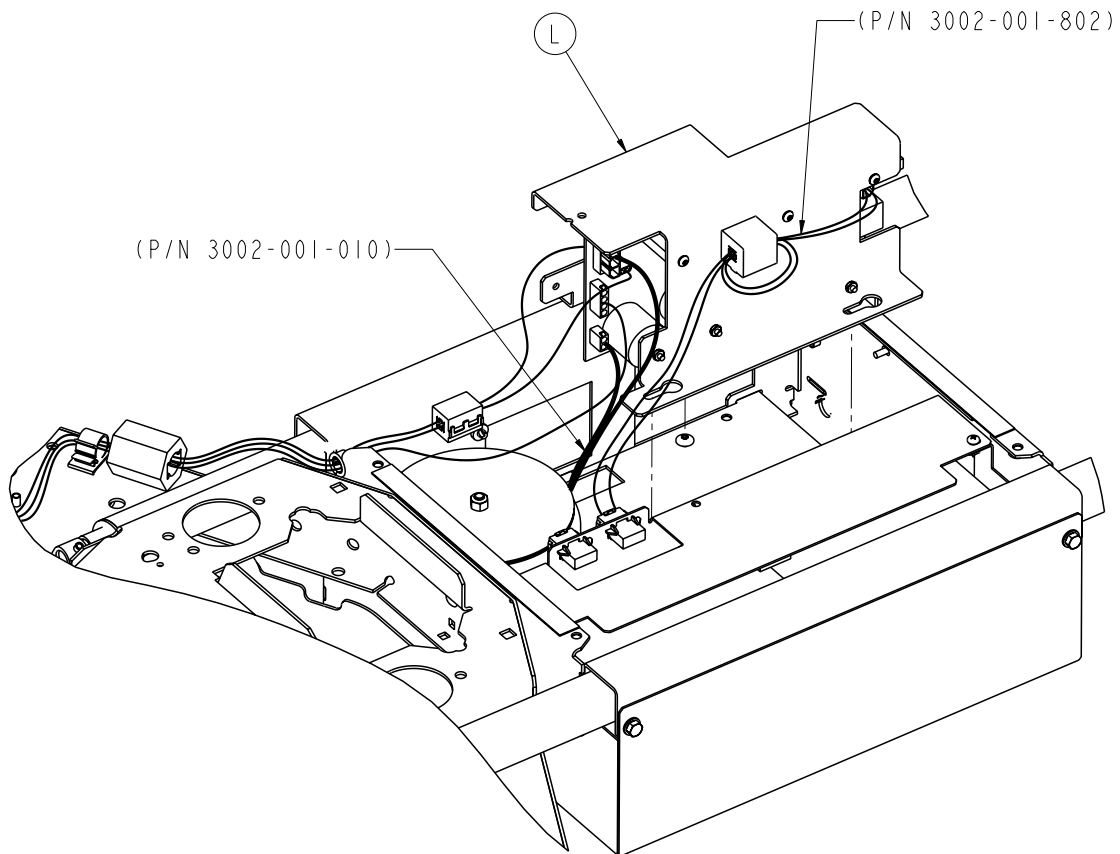
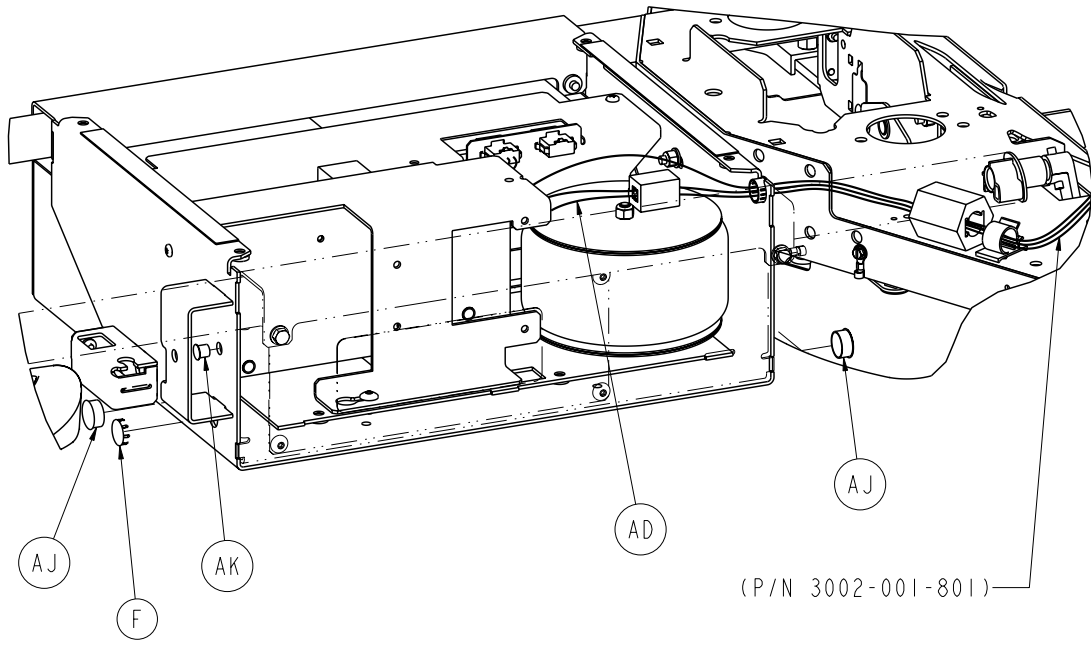

Base Assembly, Battery Backup Option

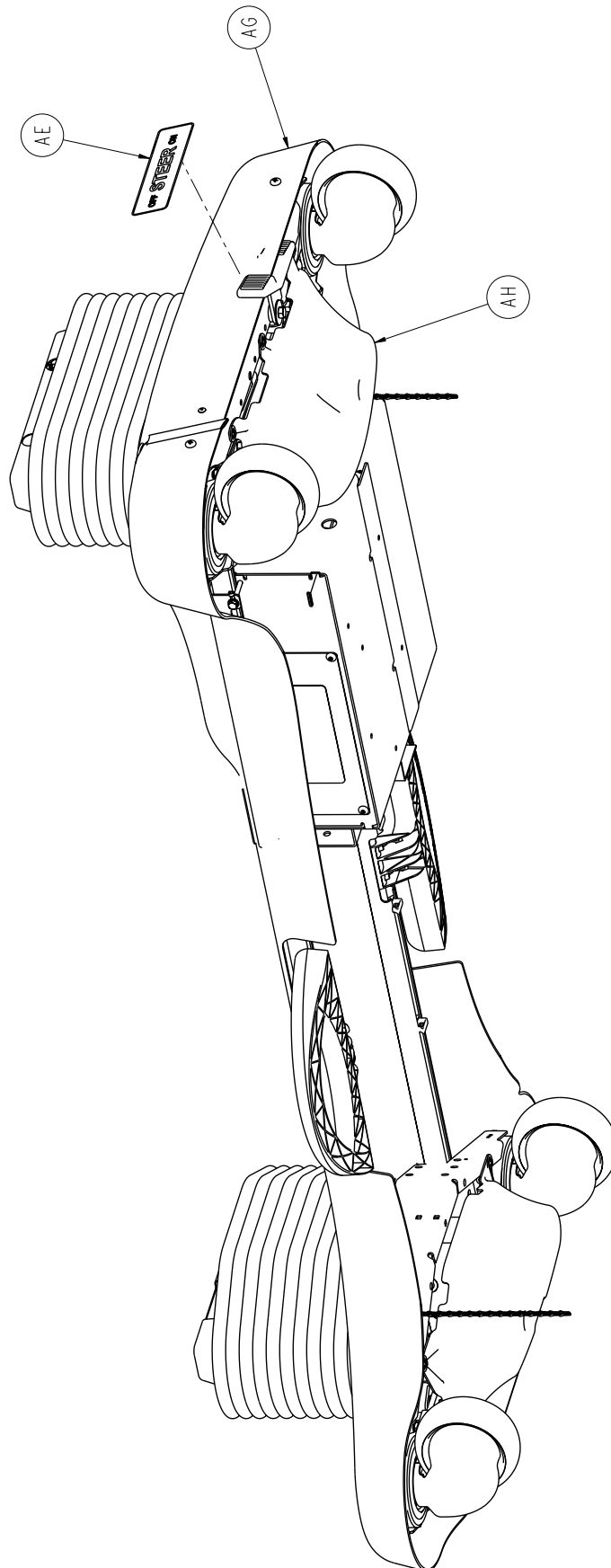

Base Assembly, Battery Backup Option

Base Assembly, Battery Backup Option - 3006-200-006 (Reference Only)

| Item | Part No. | Part Name | Qty. |
|------|---------------|-----------------------------------|------|
| A | 0003-349-000 | Hex Head Cap Screw | 1 |
| B | 0025-1991-000 | Rivet | 1 |
| E | 0030-052-000 | Heyco Snap Bushing | 2 |
| F | 0037-221-000 | Hole Plug | 1 |
| G | 3006-200-380 | Steer Extension Spring | 1 |
| H | 3006-200-378 | Swivel Lock Return Spring, RH | 1 |
| J | 0045-008-000 | O-Ring | 1 |
| K | 0052-305-000 | Washer | 1 |
| L | 2030-001-030 | Epic+Base Power Assembly | 1 |
| P | 3000-200-337 | Pushfit Ball Plunger | 1 |
| R | 3006-200-339 | Steer/Swivel Lever Bushing | 1 |
| T | 3000-200-341 | Steer Pedal Bushing | 1 |
| U | 0011-611-000 | Washer | 1 |
| V | 3000-200-348 | Wide, Special Washer | 1 |
| W | 3000-200-349 | Narrow, Special Washer | 1 |
| AA | 3001-200-342 | Steer Lock Cable | 1 |
| AB | 3006-200-381 | Steer/Swivel Lever | 1 |
| AC | 2030-200-001 | Steer Pedal Assembly | 1 |
| AD | 3002-031-113 | Umbilical Cable Isolation Bracket | 1 |
| AE | 3006-090-013 | Steer Lock Label | 1 |
| AF | 3006-200-004 | Zoom®/Battery Backup Base | |
| | | Standard Components | 1 |
| AG | 3006-201-005 | Hood Shroud | 1 |
| AH | 3001-200-022 | Bottom Cover Assembly | 1 |
| AJ | 0037-230-000 | Hole Plug | 2 |
| AK | 0059-738-000 | Dome Plug | 1 |

Base Assembly, Zoom® Option

For Reference Only: 3006-200-005

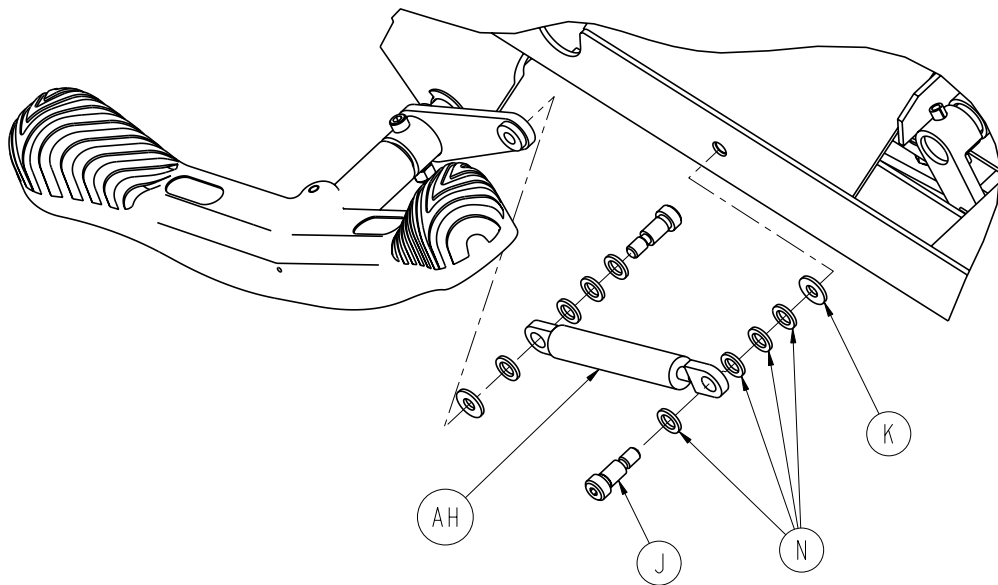
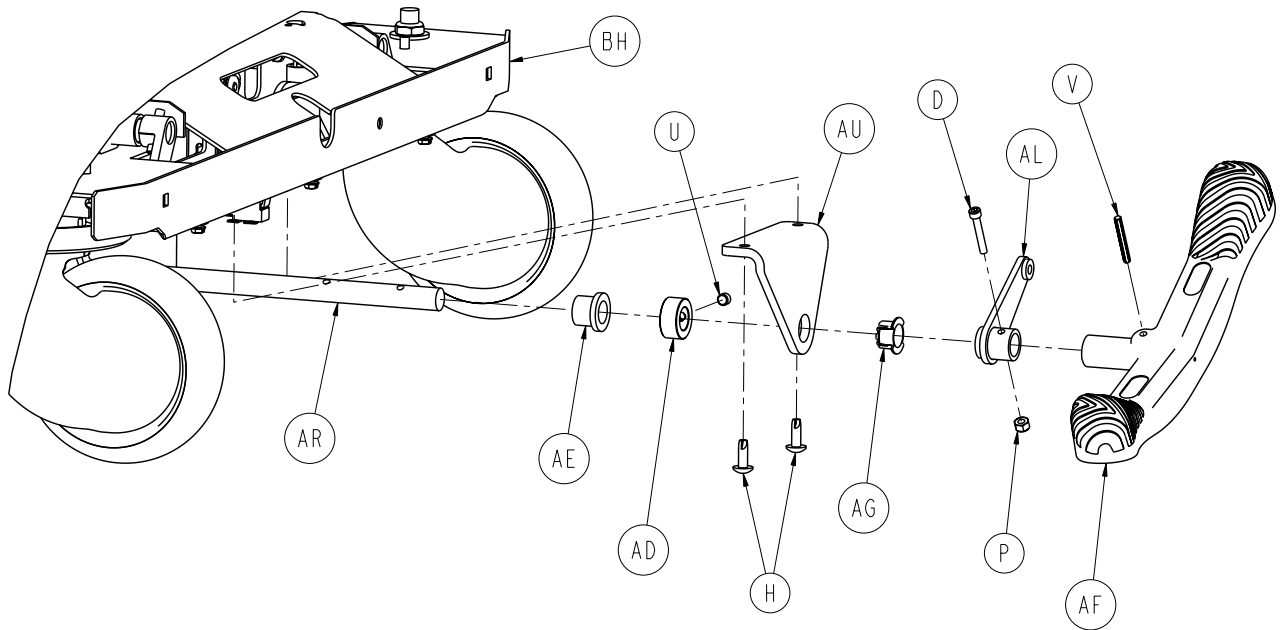

[Return To Table of Contents](#)

Base Assembly, Zoom® Option

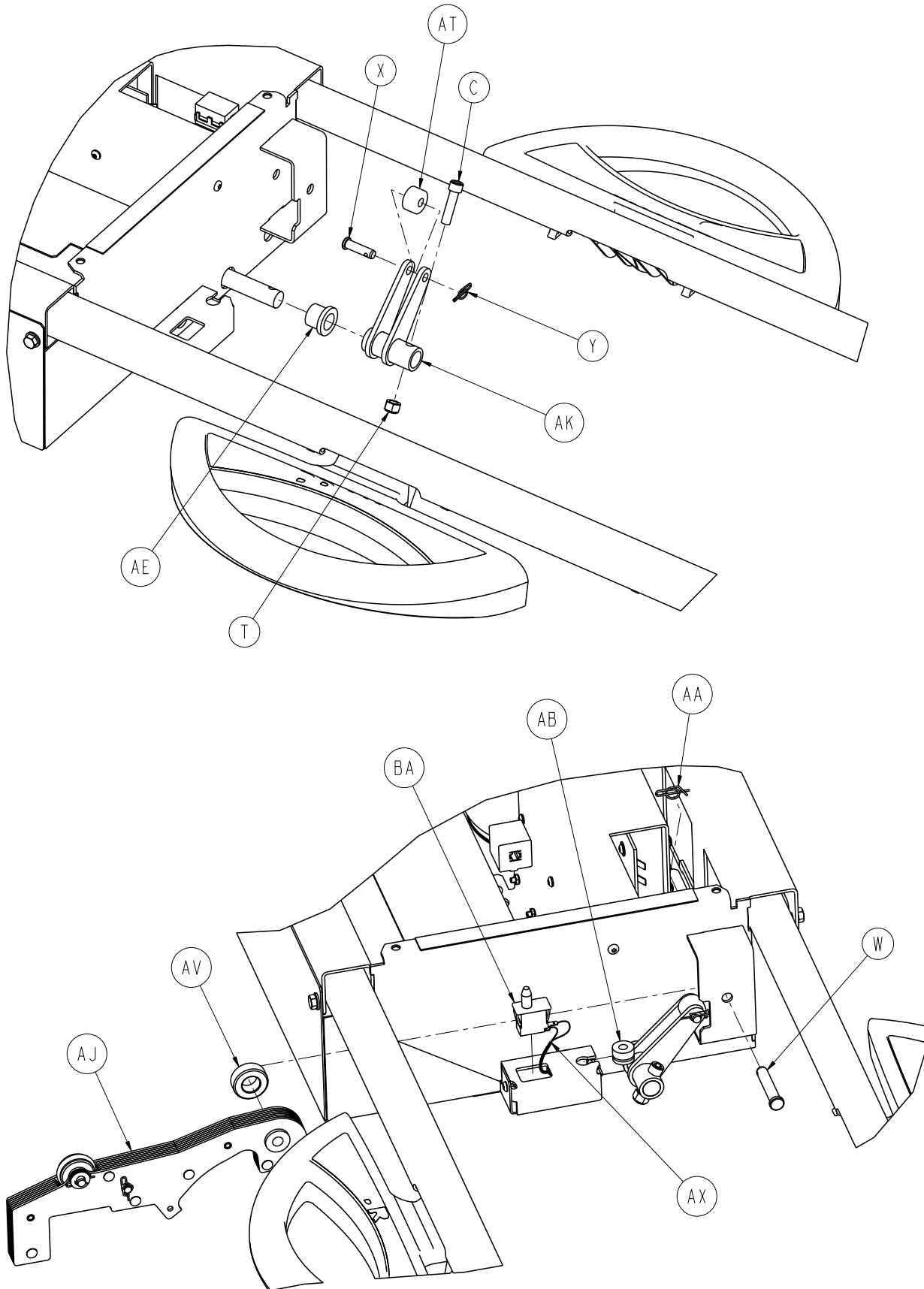

Base Assembly, Zoom® Option

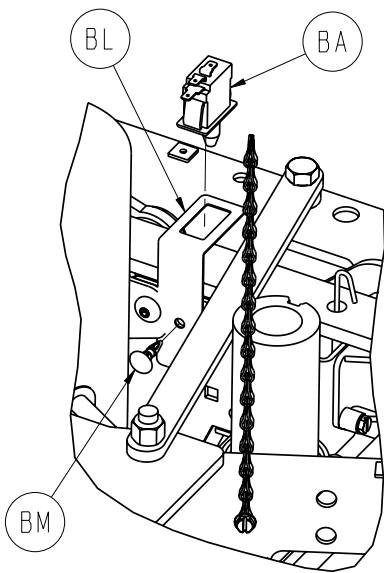
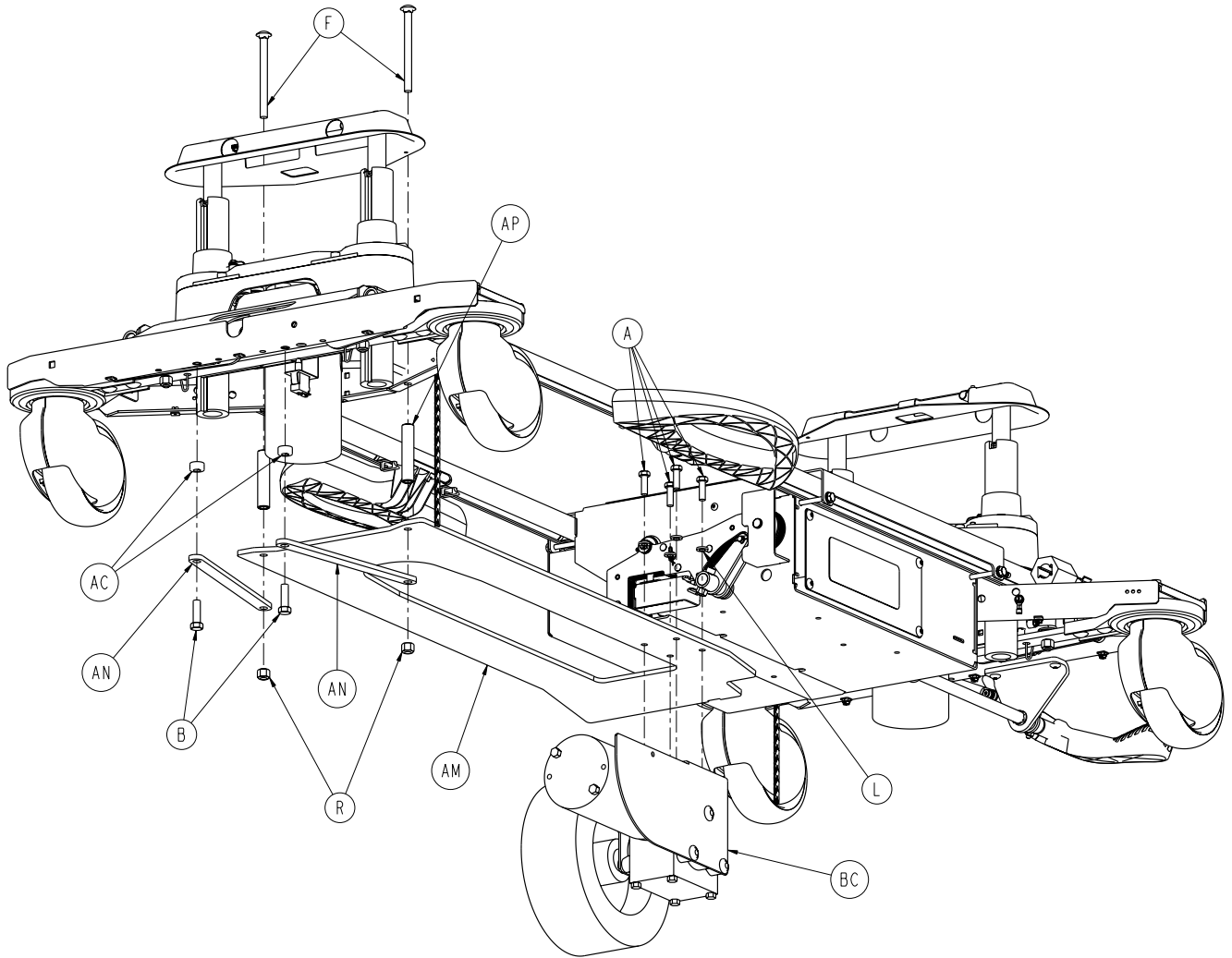

FOOT END

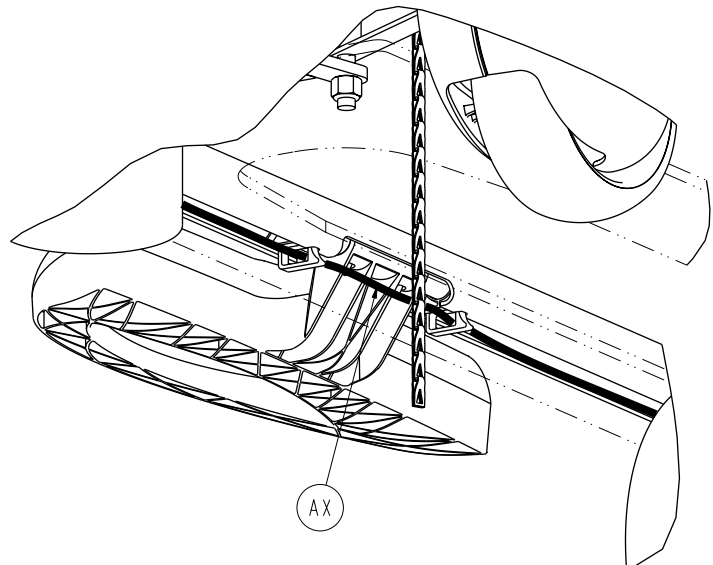

[Return To Table of Contents](#)

Base Assembly, Zoom® Option

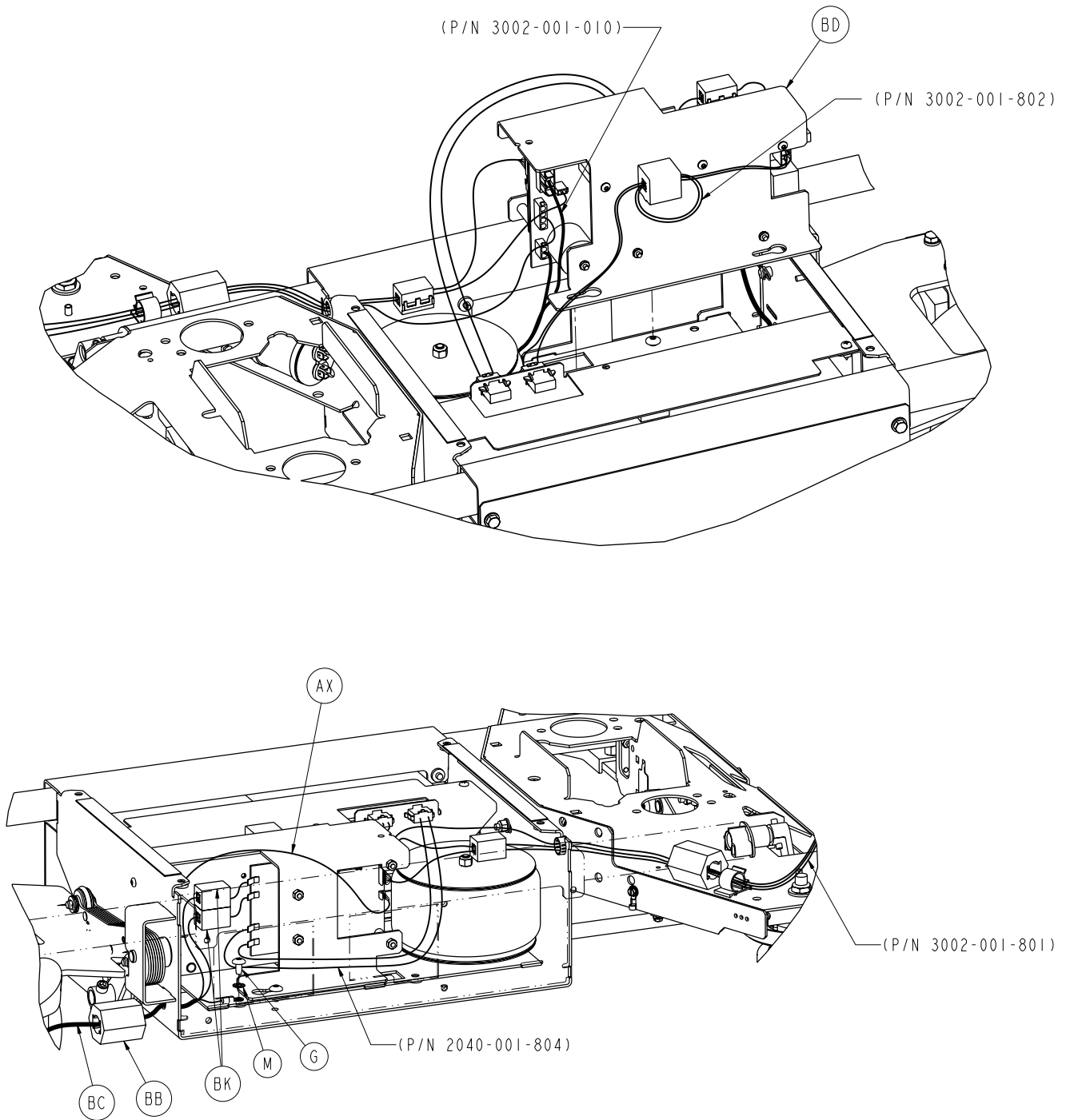

Base Assembly, Zoom® Option

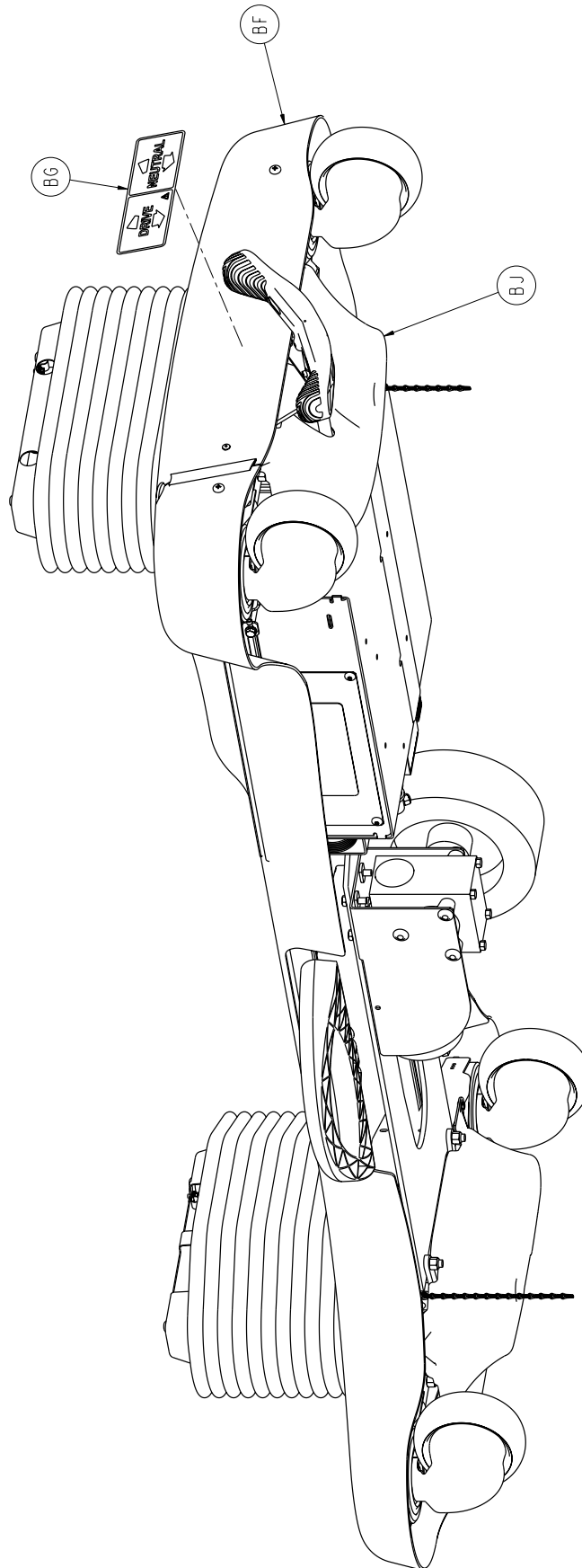

Base Assembly, Zoom® Option

Base Assembly, Zoom® Option - 3006-200-005 (Reference Only)

| Item | Part No. | Part Name | Qty. |
|------|--------------|--|------|
| A | 0003-085-000 | Hex Head Cap Screw | 4 |
| B | 0003-120-000 | Hex Head Cap Screw | 2 |
| C | 0004-039-000 | Socket Head Cap Screw, Black | 1 |
| D | 0004-160-000 | Socket Head Cap Screw | 1 |
| E | 0004-307-000 | Socket Button Head Cap Screw | 1 |
| F | 0005-031-000 | Carriage Bolt | 2 |
| G | 0007-052-000 | Truss Head Torx | 1 |
| H | 0007-063-000 | Truss Head Screw | 2 |
| J | 0008-049-000 | Shoulder Head Screw Bolt | 2 |
| K | 0011-063-000 | Washer | 2 |
| L | 0012-020-000 | Lock Washer | 4 |
| M | 0013-010-000 | External Tooth Star Washer | 1 |
| N | 0014-003-000 | Plastic Washer | 8 |
| P | 0016-003-000 | Nylok Nut | 1 |
| R | 0016-035-000 | Nylok Nut | 2 |
| T | 0016-036-000 | Nylok Hex Nut | 1 |
| U | 0021-022-000 | Set Screw | 1 |
| V | 0026-261-000 | Groove Pin | 1 |
| W | 0026-277-000 | Clevis Pin | 1 |
| X | 0026-297-000 | Clevis Pin | 1 |
| Y | 0027-019-000 | Rue Ring Cotter | 1 |
| AA | 0027-022-000 | Rue Ring Cotter | 1 |
| AB | 0030-040-000 | E.A.R. Grommet | 1 |
| AC | 0042-006-000 | Collar | 2 |
| AD | 0042-020-000 | Collar | 1 |
| AE | 0081-245-000 | Bronze Bushing | 2 |
| AF | 1210-201-153 | Butterfly 'V' Pedal | 1 |
| AG | 1210-201-251 | Celcon Insert | 1 |
| AH | 1210-201-671 | Damper | 1 |
| AJ | 2040-001-012 | Drive Wheel Lift Lever Assembly | 1 |
| AK | 2040-001-051 | Pedal Crank Weldment | 1 |
| AL | 2040-001-053 | Damper Crank Weldment | 1 |
| AM | 2040-001-060 | Leaf Spring | 1 |
| AN | 2040-001-061 | Tie Down Strap | 2 |
| AP | 2040-001-062 | Uni-Pan Reinforcement Tube | 2 |
| AR | 2040-001-082 | Pedal Rod | 1 |
| AT | 2040-001-083 | Pedal Crank Roller | 1 |
| AU | 2040-001-084 | Pedal Rod Pivot Bracket | 1 |
| AV | 2040-001-098 | Lift Lever Spacer | 1 |
| AW | 2040-001-103 | Switch Bracket Cover | 1 |
| AX | 2040-001-801 | Base Switch Cable | 1 |
| BA | 3000-300-058 | Plunger Switch | 2 |
| BB | 0059-192-000 | Split Ferrite Core | 1 |
| BC | 3002-001-014 | Drive Train Assembly | 1 |
| BD | 3002-001-030 | Zoom® Base Power Assembly | 1 |
| BF | 3006-001-018 | Hood Assembly | 1 |
| BG | 3006-001-100 | Drive Wheel Position Label | 1 |
| BH | 3006-200-004 | Base Standard Components - Zoom®/Battery Backup | 1 |
| BJ | 2040-001-017 | Bottom Cover Assembly, Head End | 1 |
| BL | 3000-200-343 | Brake Switch Bracket | 1 |
| BM | 3000-300-115 | Standoff | 1 |
| BN | 3000-300-113 | 8" Cable Tie | 4 |

Lift Assembly (Head and Foot End)

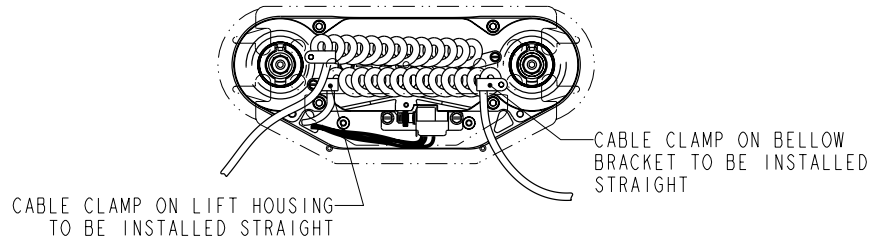

TOP VIEW

HEAD END: 3006-301-201

FOOT END: 3006-301-251

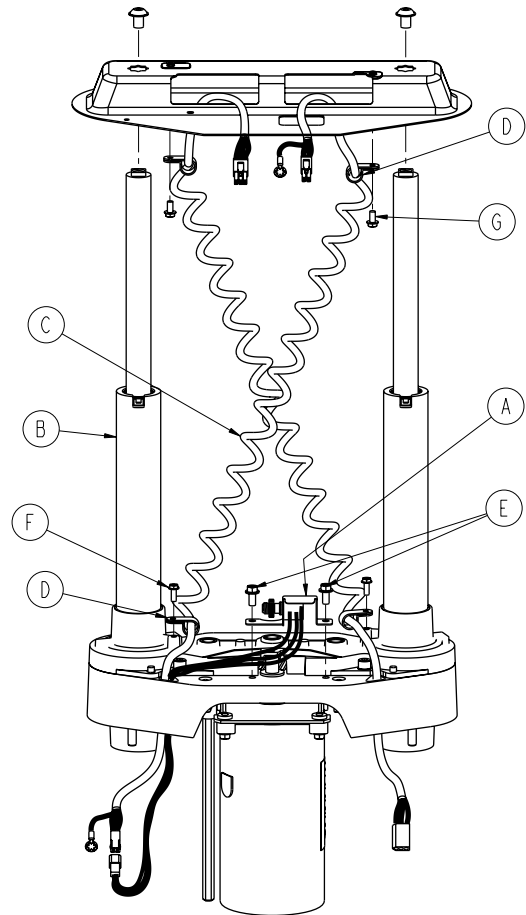
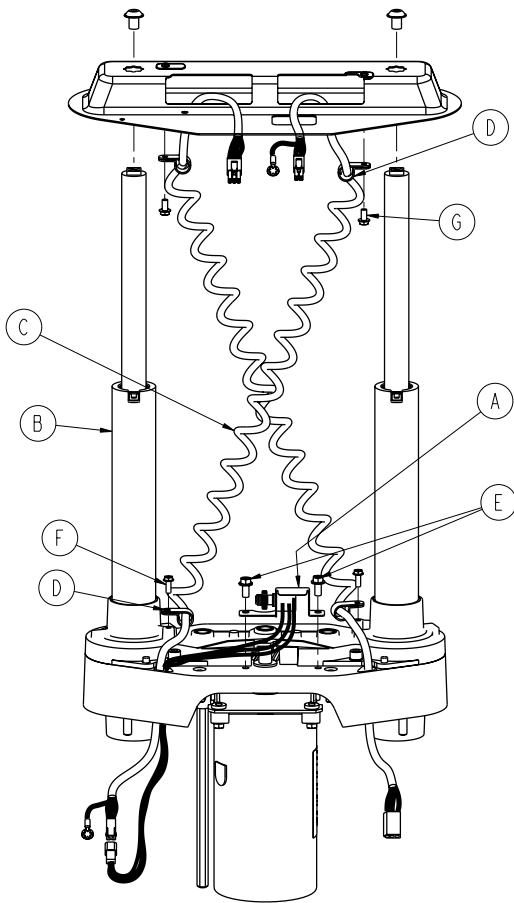

| Item | Part No. | Part Name | Qty. |
|------|--------------|---------------------------|------|
| A | 3006-200-240 | HE Potentiometer Assembly | 1 |
| | 3001-200-230 | FE Potentiometer Assembly | 1 |
| B | 3006-200-275 | Common Lift Assembly | 1 |
| C | 3006-200-815 | Sensor Coil Cord | 1 |
| D | 0034-022-000 | Cable Clamp, Head End | 2 |
| | 0034-021-000 | Cable Clamp, Foot End | 2 |
| E | 0003-121-000 | Hex Washer Head Screw | 2 |
| F | 0003-128-000 | Hex Washer Head Screw | 1 |
| J | 0023-164-000 | Hex Washer Head Screw | 1 |

Lift Assembly

For Reference Only: 3006-200-275

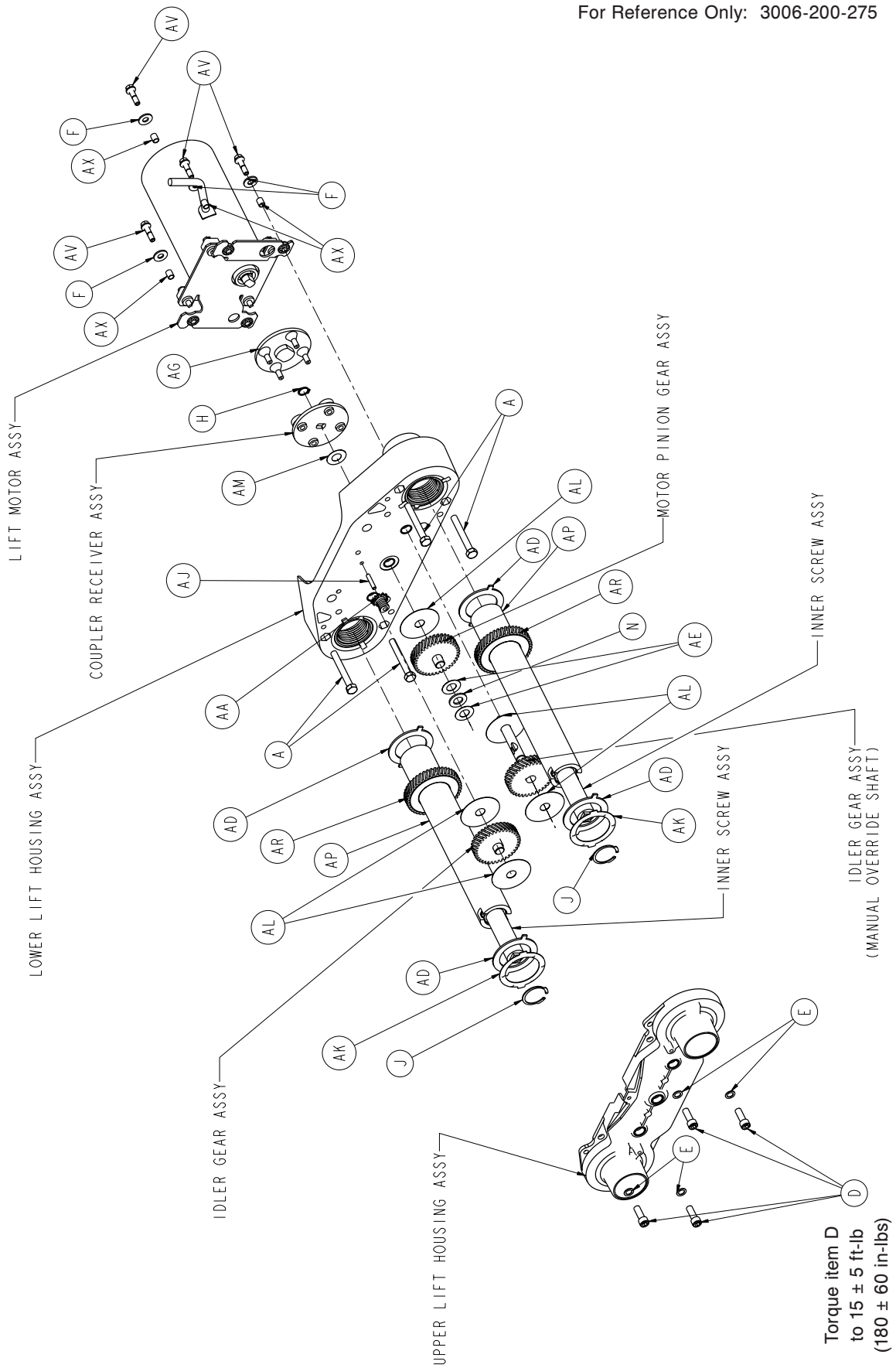

Lift Assembly

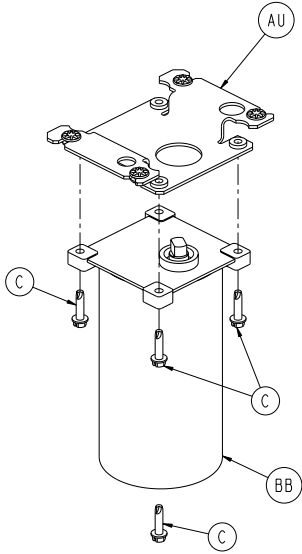

LIFT MOTOR ASSY

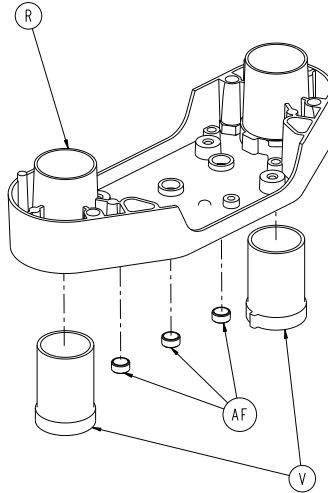

LOWER LIFT HOUSING ASSY

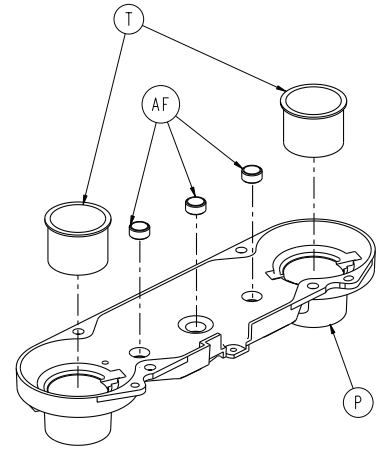

UPPER LIFT HOUSING ASSY

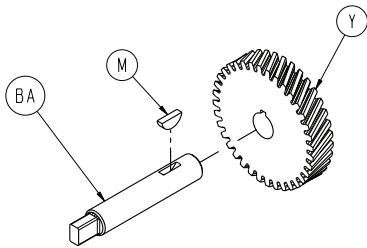

IDLER GEAR ASSY
(MANUAL OVERRIDE SHAFT)

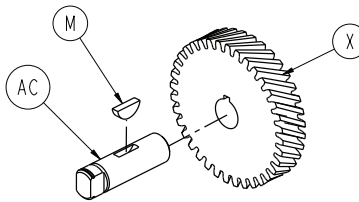

MOTOR PINION GEAR ASSY

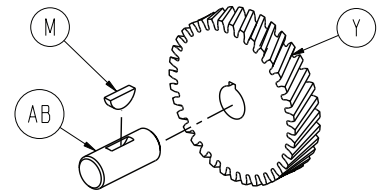

IDLER GEAR ASSY

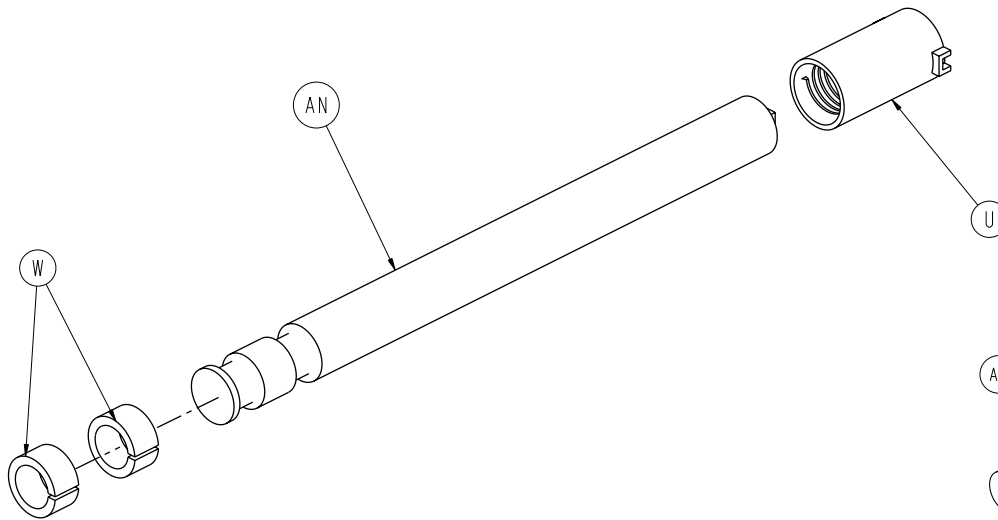

INNER SCREW ASSY

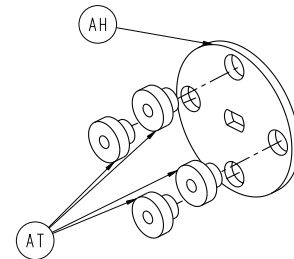

COUPLER RECEIVER ASSY

Lift Assembly

CABLE CLAMP ON BELLOWS BRACKET
TO BE INSTALLED STRAIGHT

CABLE CLAMP ON LIFT HOUSING
TO BE INSTALLED AT ANGLE

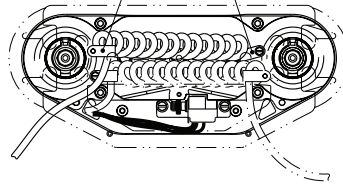

TOP VIEW

Torque item G
to 15-25 in-lbs

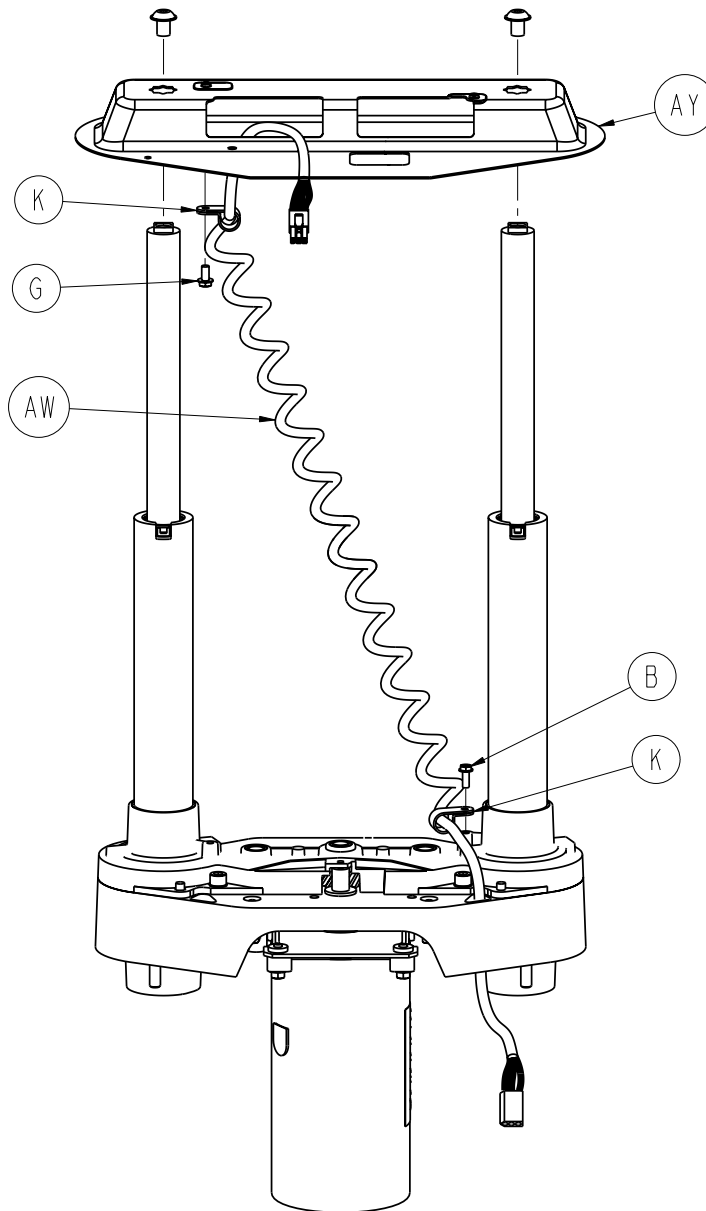

Lift Assembly

Lift Assembly - 3006-200-275 (Reference Only)

| Item | Part No. | Part Name | Qty. |
|------|--------------|------------------------------|------|
| A | 0003-082-000 | Hex Head Cap Screw | 4 |
| C | 0003-128-000 | Hex Washer Head Screw | 1 |
| D | 0003-331-000 | Hex Washer Head Screw | 4 |
| E | 0004-213-000 | Socket Head Cap Screw | 4 |
| F | 0011-308-000 | Serrated Washer | 4 |
| G | 0011-408-000 | Flat Washer | 4 |
| H | 0023-164-000 | Hex Washer Head Screw | 1 |
| J | 0028-097-000 | Retaining Ring | 1 |
| K | 0028-121-000 | Retaining Ring | 2 |
| L | 0034-022-000 | Cable Clamp | 2 |
| N | 0051-022-000 | Syn-Tech Grease | 4 |
| P | 0058-044-000 | #404 Woodruff Key | 3 |
| R | 0081-212-000 | Needle Roller Bearing | 1 |
| T | 3000-200-201 | Upper Lift Housing | 1 |
| U | 3000-200-202 | Lower Lift Housing | 1 |
| V | 3000-200-204 | Upper Housing Sleeve | 2 |
| W | 3000-200-205 | Upper Stage Nut | 2 |
| X | 3000-200-207 | Lower Stage Nut | 2 |
| Y | 3000-200-208 | Glide Bushing | 4 |
| AA | 3000-200-209 | Motor Pinion | 1 |
| AB | 3000-200-210 | Idler Gear | 2 |
| AC | 3000-200-216 | Potentiometer Drive Gear | 1 |
| AD | 3000-200-218 | Lift Idler Shaft | 1 |
| AE | 3000-000-220 | Input Pinion Shaft | 1 |
| AF | 3000-200-223 | Output Gear Thrust Washer | 4 |
| AG | 3000-200-224 | Input Gear Thrust Washer | 2 |
| AH | 3000-200-226 | Pinion Shaft Bushing | 6 |
| AJ | 3000-200-233 | Lift Motor Coupling | 1 |
| AK | 3000-200-234 | Coupler Receiver | 1 |
| AL | 3000-200-239 | Drive Gear Shaft, Pot | 1 |
| AM | 3000-200-241 | Wave Spring Washer | 2 |
| AN | 3000-200-245 | Gear Washer | 5 |
| AP | 3000-200-246 | Nylon Washer | 1 |
| AR | 3000-200-249 | Inner Screw | 2 |
| AT | 3000-200-251 | Tube Screw | 2 |
| AU | 3000-200-252 | Output Gear | 2 |
| AV | 3000-300-455 | Isolation Bushing | 4 |
| AW | 3001-200-214 | Isolation Plate Assembly | 1 |
| AX | 3001-200-228 | Mounting Standoff | 4 |
| BA | 3001-200-864 | Power Coil Cable | 1 |
| BB | 3001-300-019 | Isolation Sleeve | 4 |
| BC | 3002-200-052 | Bellows Bracket | 1 |
| BD | 3002-200-235 | Manual Override Shaft, Idler | 1 |
| BE | 3003-016-603 | Lift Motor | 1 |

Lift Motor Isolation Plate Assembly

For Reference Only: 3001-200-214

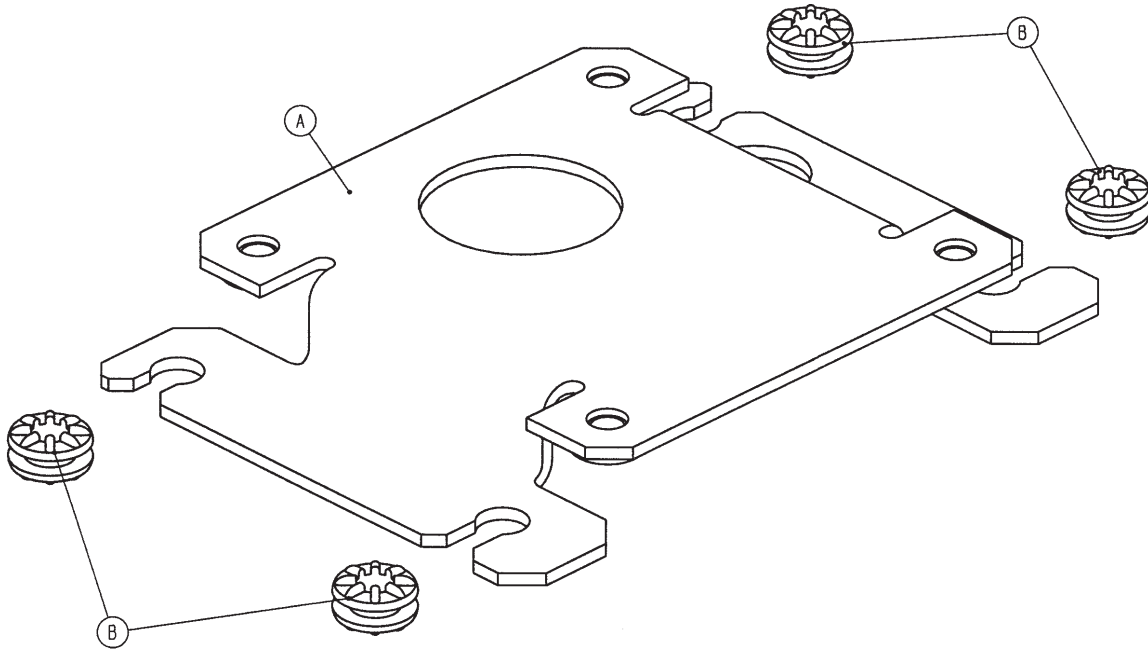

| Item | Part No. | Part Name | Qty. |
|------|--------------|-----------------|------|
| A | 3001-200-213 | Isolation Plate | 1 |
| B | 3000-300-442 | Grommet | 4 |

Brake Shaft Assembly, Standard Bed

For Reference Only: 3006-200-340

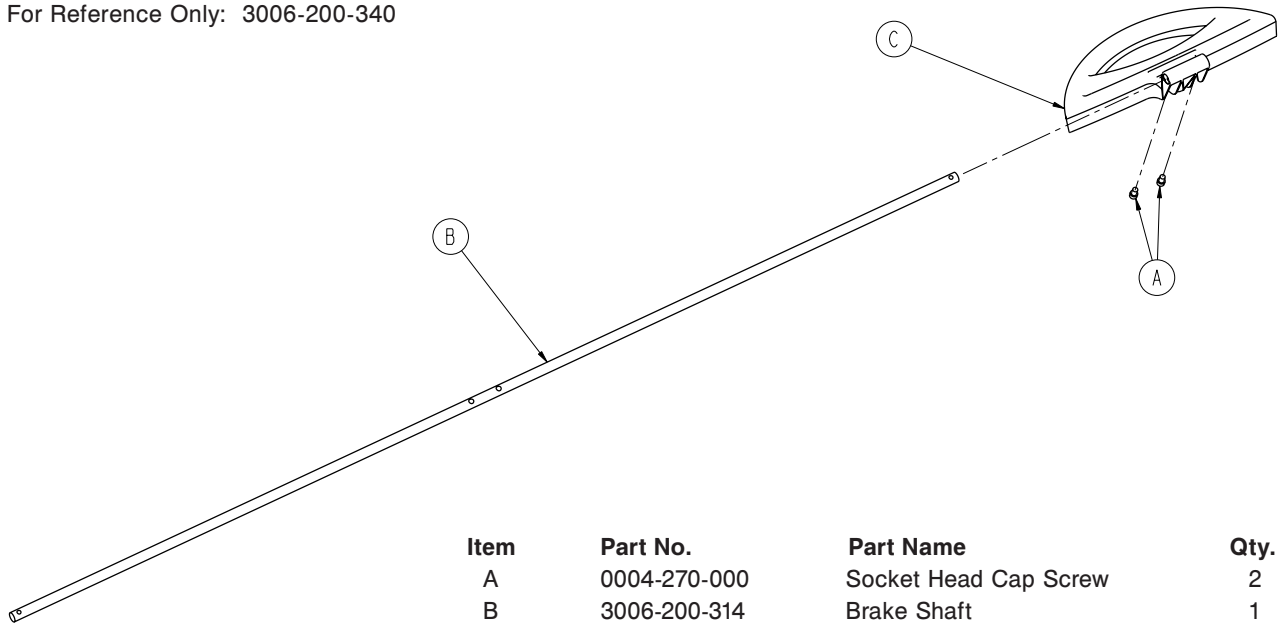

| Item | Part No. | Part Name | Qty. |
|------|--------------|-----------------------|------|
| A | 0004-270-000 | Socket Head Cap Screw | 2 |
| B | 3006-200-314 | Brake Shaft | 1 |
| C | 3006-200-325 | Brake Pedal | 1 |

Brake Shaft Assembly, Battery Back-up or Zoom® Option

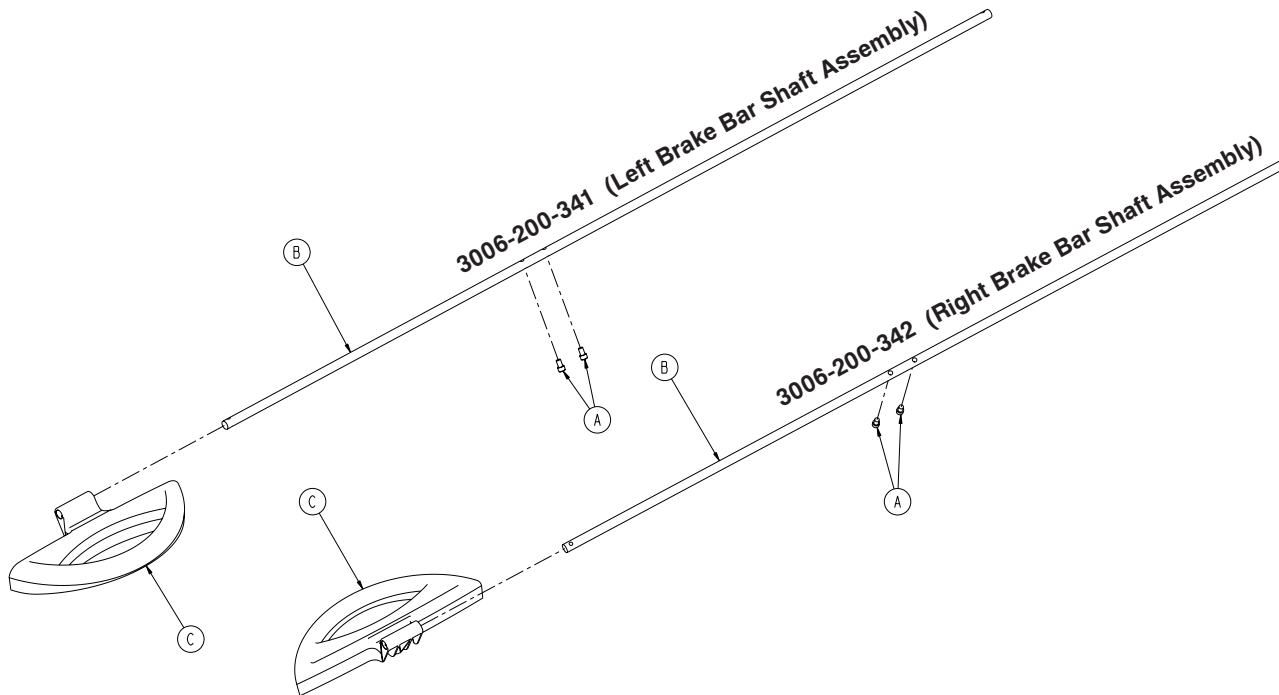

| Item | Part No. | Part Name | Qty. |
|------|--------------|-----------------------|------|
| A | 0004-270-000 | Socket Head Cap Screw | 2 |
| B | 3006-200-314 | Brake Shaft | 1 |
| C | 3006-200-325 | Brake Pedal | 1 |

[Return To Table of Contents](#)

Brake Crank Assembly

For Reference Only: 3006-200-330

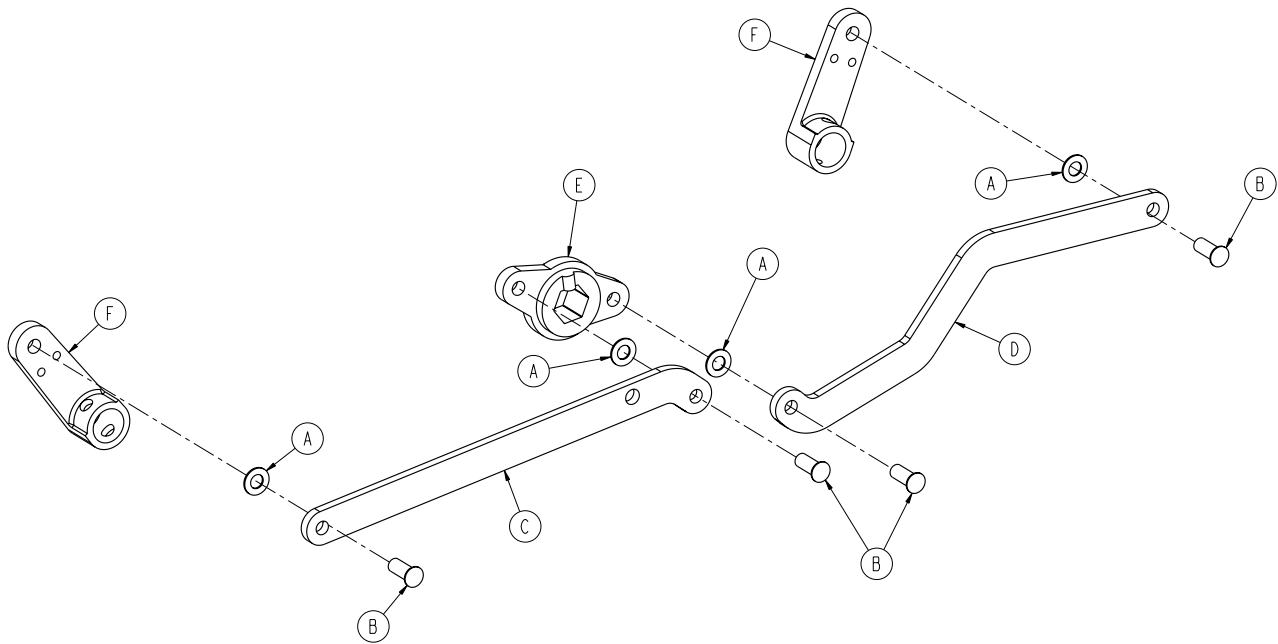

| Item | Part No. | Part Name | Qty. |
|------|--------------|--------------------|------|
| A | 0014-004-000 | Washer | 4 |
| B | 0025-146-000 | Rivet | 4 |
| C | 3001-200-311 | Brake Link | 1 |
| D | 3001-200-312 | Dog Leg Brake Link | 1 |
| E | 3002-200-309 | Brake Crank | 1 |
| F | 3006-200-302 | Brake Shaft Crank | 2 |

Brake Bar Assembly

For Reference Only: 3006-200-335

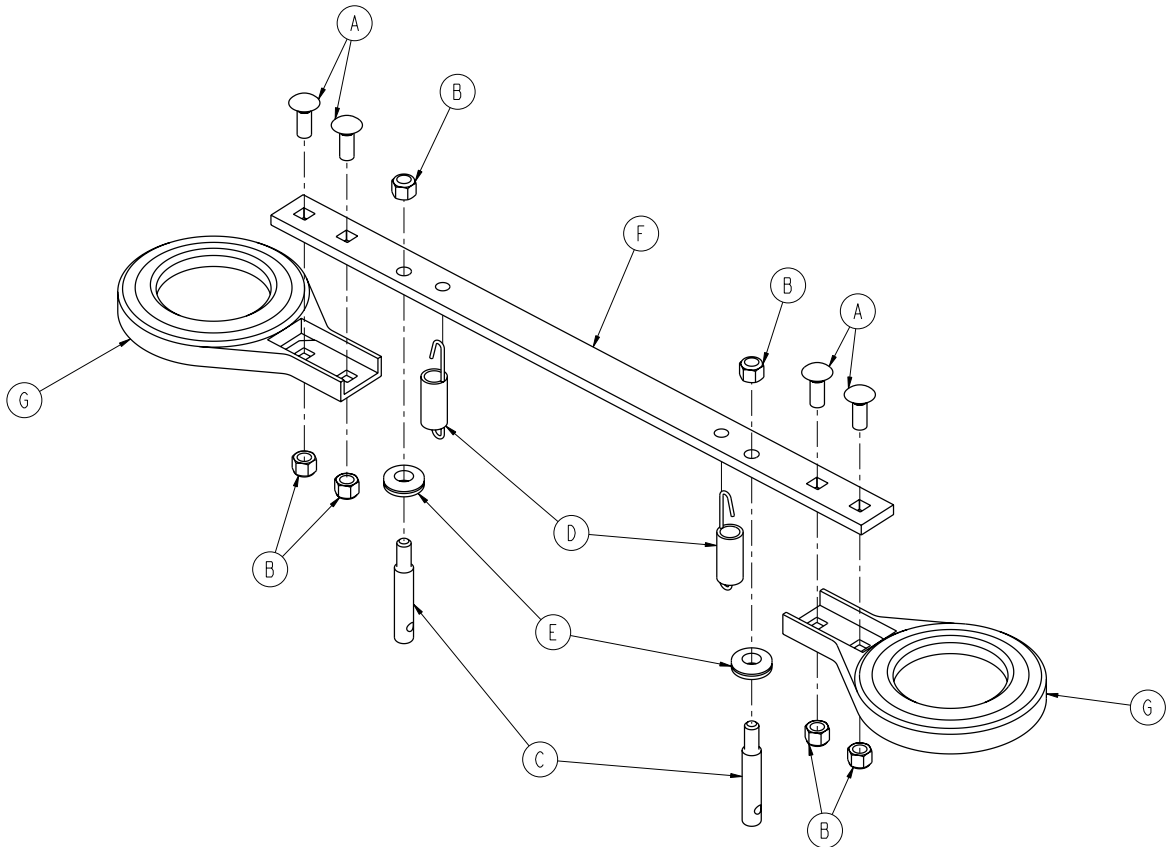

| Item | Part No. | Part Name | Qty. |
|------|--------------|-------------------------|------|
| A | 0005-018-000 | Carriage Bolt | 4 |
| B | 0016-035-000 | Nylock Hex Nut | 6 |
| C | 3000-200-318 | Guide Pin | 2 |
| D | 3000-200-310 | Brake Bar Return Spring | 2 |
| E | 3003-200-324 | Brake Bar Bumper | 2 |
| F | 3000-200-323 | Brake Bar | 1 |
| G | 3006-200-327 | Toothed Brake Ring | 2 |

Swivel Lock Caster Assembly - 3006-200-060

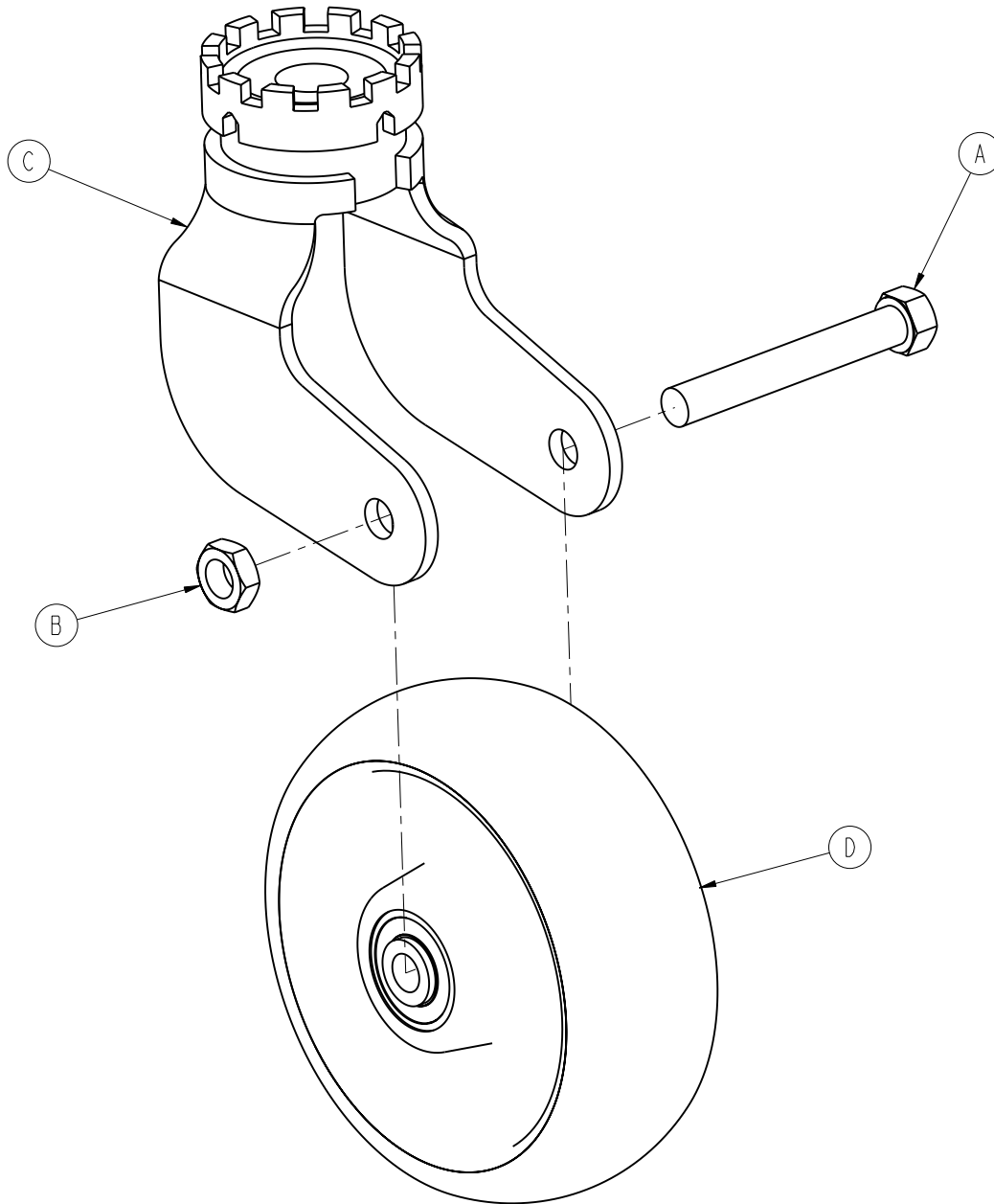

| Item | Part No. | Part Name | Qty. |
|------|--------------|-------------------------------------|------|
| A | 0003-342-000 | Hex Head Cap Screw | 1 |
| B | 0016-060-000 | Lock Nut | 1 |
| C | 3006-200-059 | Caster Horn with Bearing and Swivel | 1 |
| A | 3006-200-142 | Molded Wheel Assembly | 1 |

Steer Swivel Caster Assembly, White - 3006-200-065

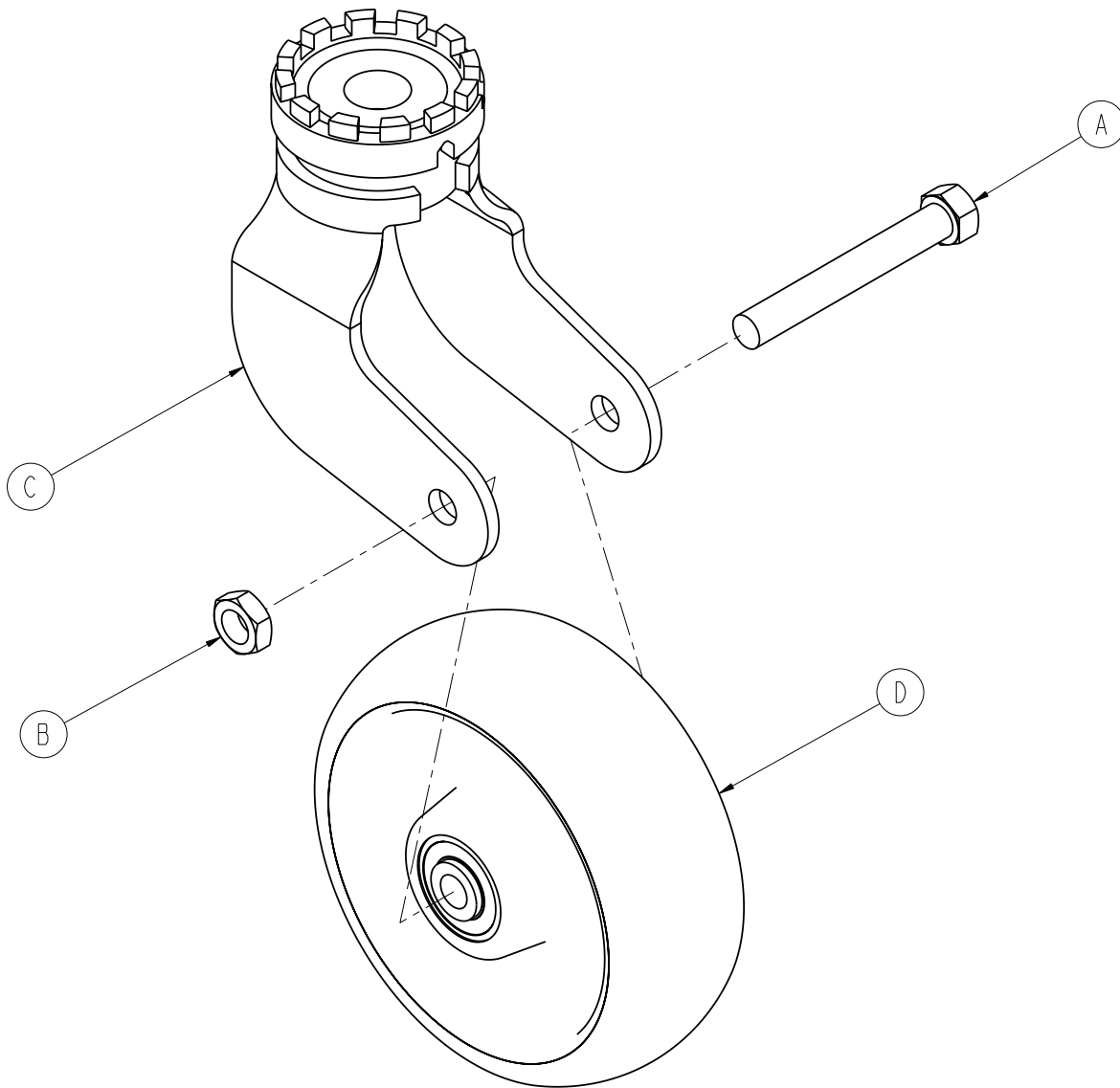

| Item | Part No. | Part Name | Qty. |
|------|--------------|--|------|
| A | 0003-342-000 | Hex Head Cap Screw | 1 |
| B | 0016-060-000 | Lock Nut | 1 |
| C | 3006-200-063 | Steer Caster Horn with Bearing and Steer Swivel, White | 1 |
| D | 3006-200-142 | Molded Wheel Assembly | 1 |

6" Molded Wheel Assembly - 3006-200-142

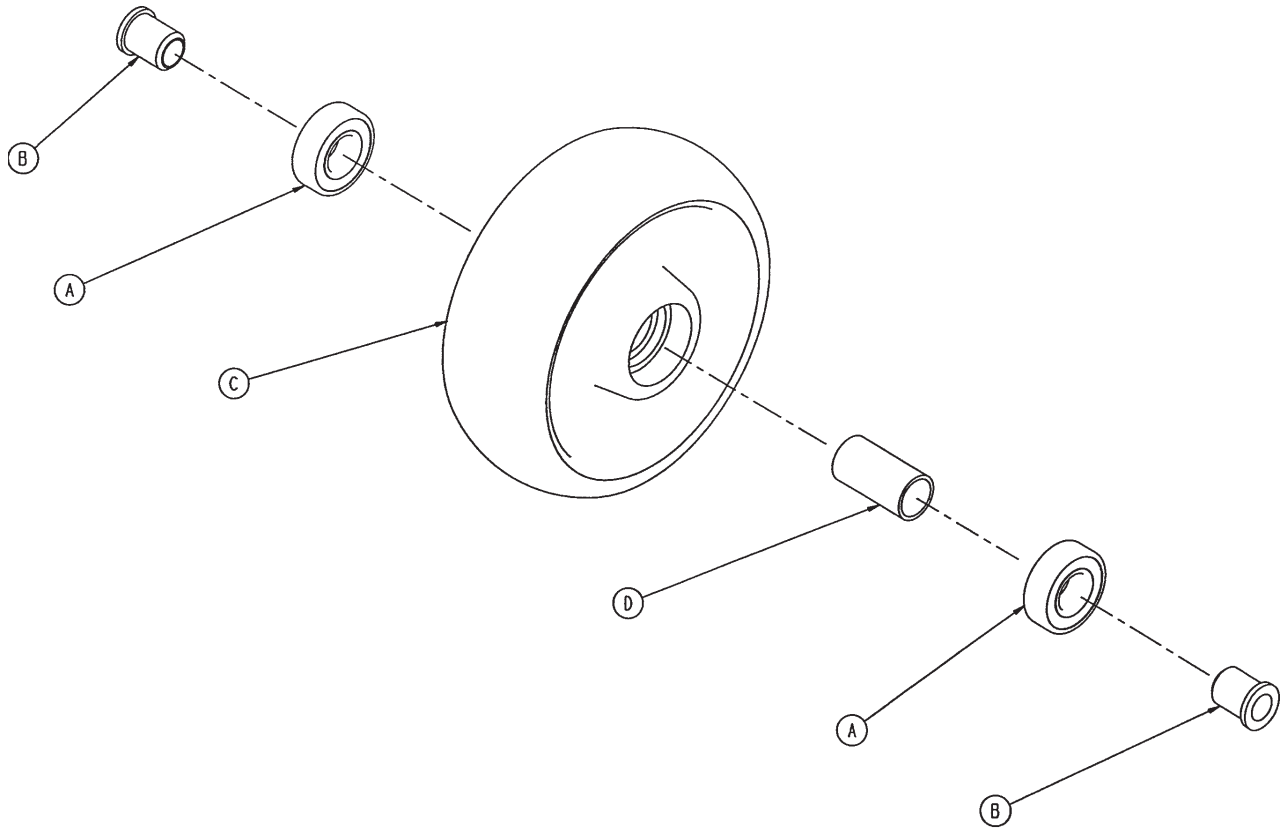

| Item | Part No. | Part Name | Qty. |
|------|--------------|----------------|------|
| A | 0081-226-000 | Bearing | 2 |
| B | 0715-001-255 | Wheel Bushing | 2 |
| C | 5000-002-020 | Molded Wheel | 1 |
| D | 6060-002-046 | Bearing Spacer | 1 |

Bottom Cover

3001-200-022

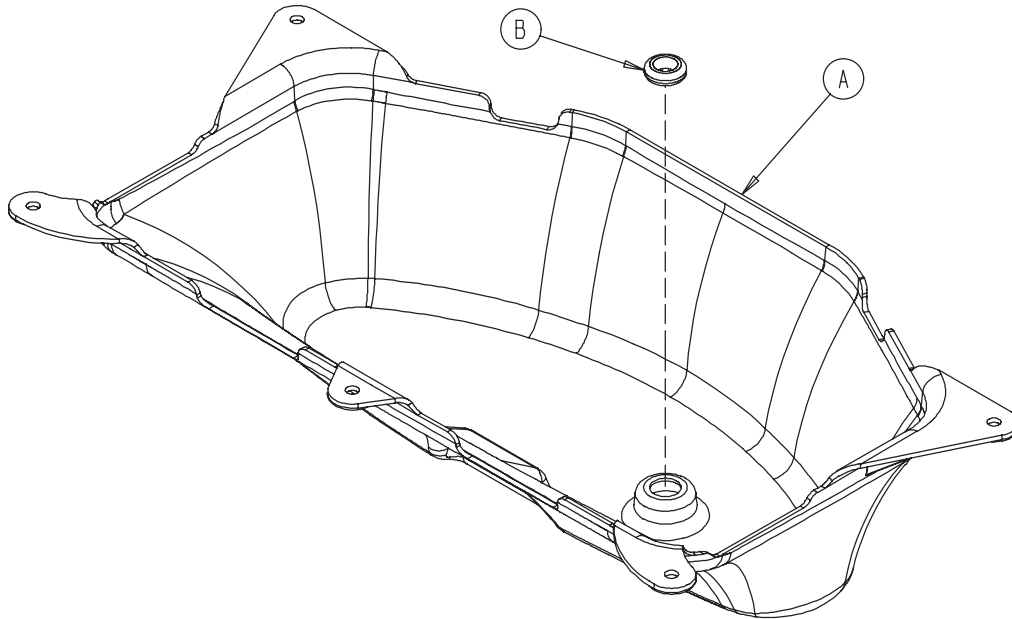

| Item | Part No. | Part Name | Qty. |
|------|--------------|--------------|------|
| A | 3002-001-100 | Bottom Cover | 1 |
| B | 3000-000-039 | Grommet | 1 |

Zoom® Option Head End Bottom Cover

2040-001-017

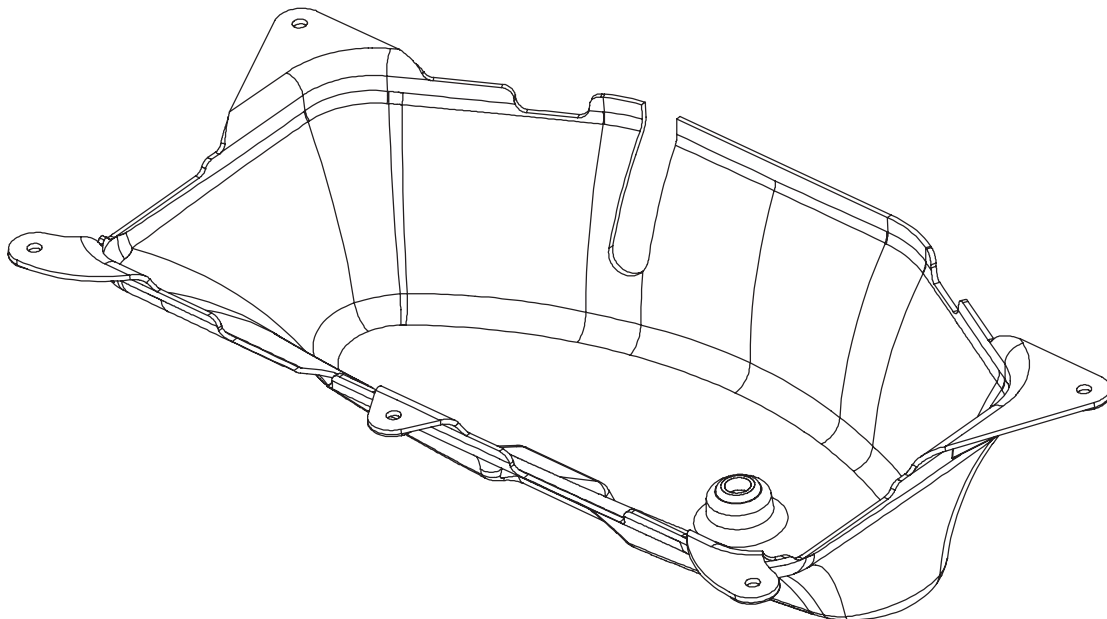

Battery Backup Option, Power Assembly

2030-001-030

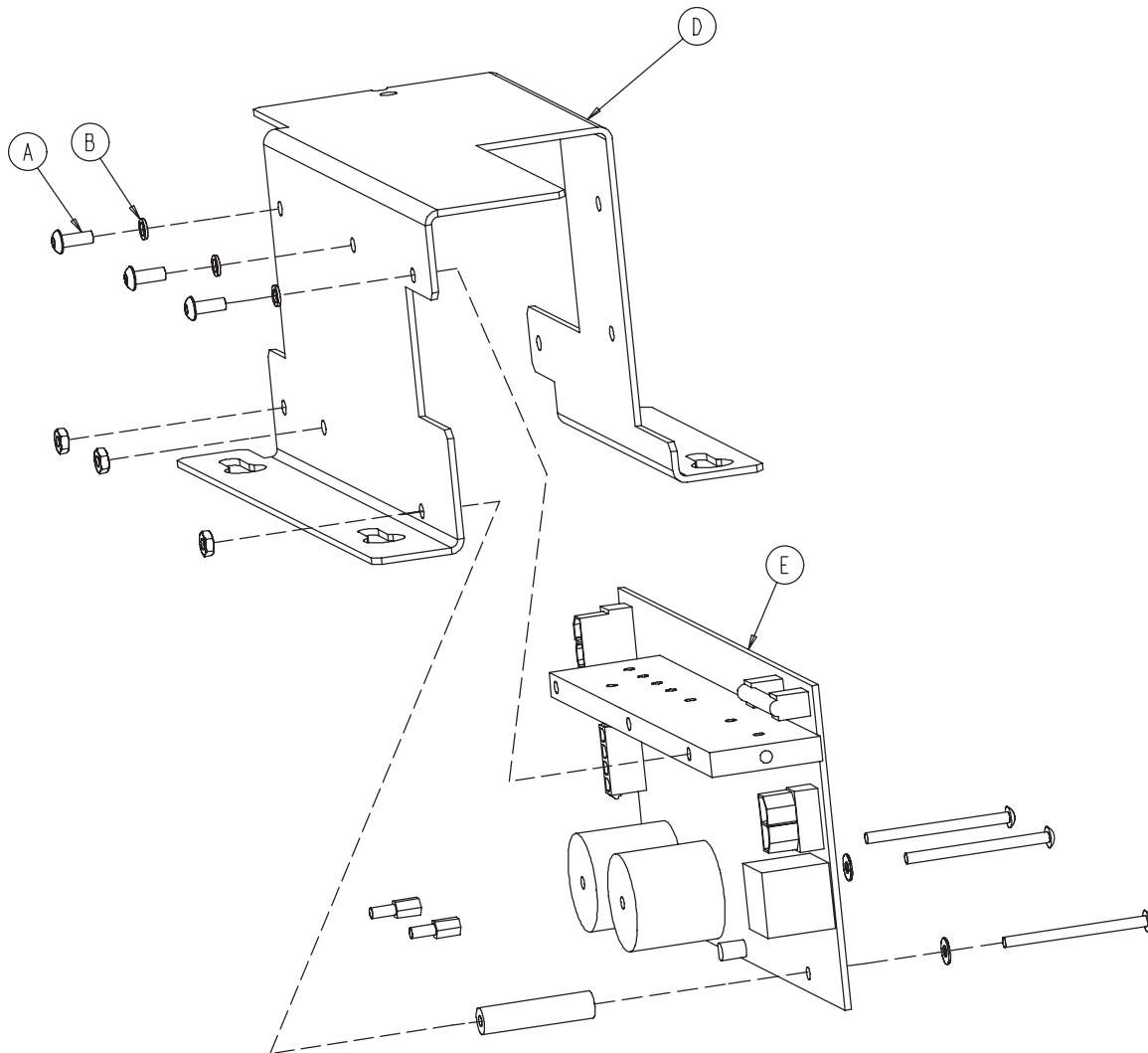

| Item | Part No. | Part Name | Qty. |
|------|--------------|-------------------------------|------|
| A | 0004-263-000 | Button Head Cap Screw | 3 |
| B | 0012-006-000 | Helical Lock Washer | 3 |
| D | 3002-001-017 | Charger/Inverter Heat Bracket | 1 |
| E | 3002-001-930 | Charger/Inverter Board | 1 |

Battery Backup/Zoom® Option, Battery Tray Assembly

Battery Kit Part Number 2040-700-013 (Includes Two Batteries)

For Reference Only: 3002-001-015

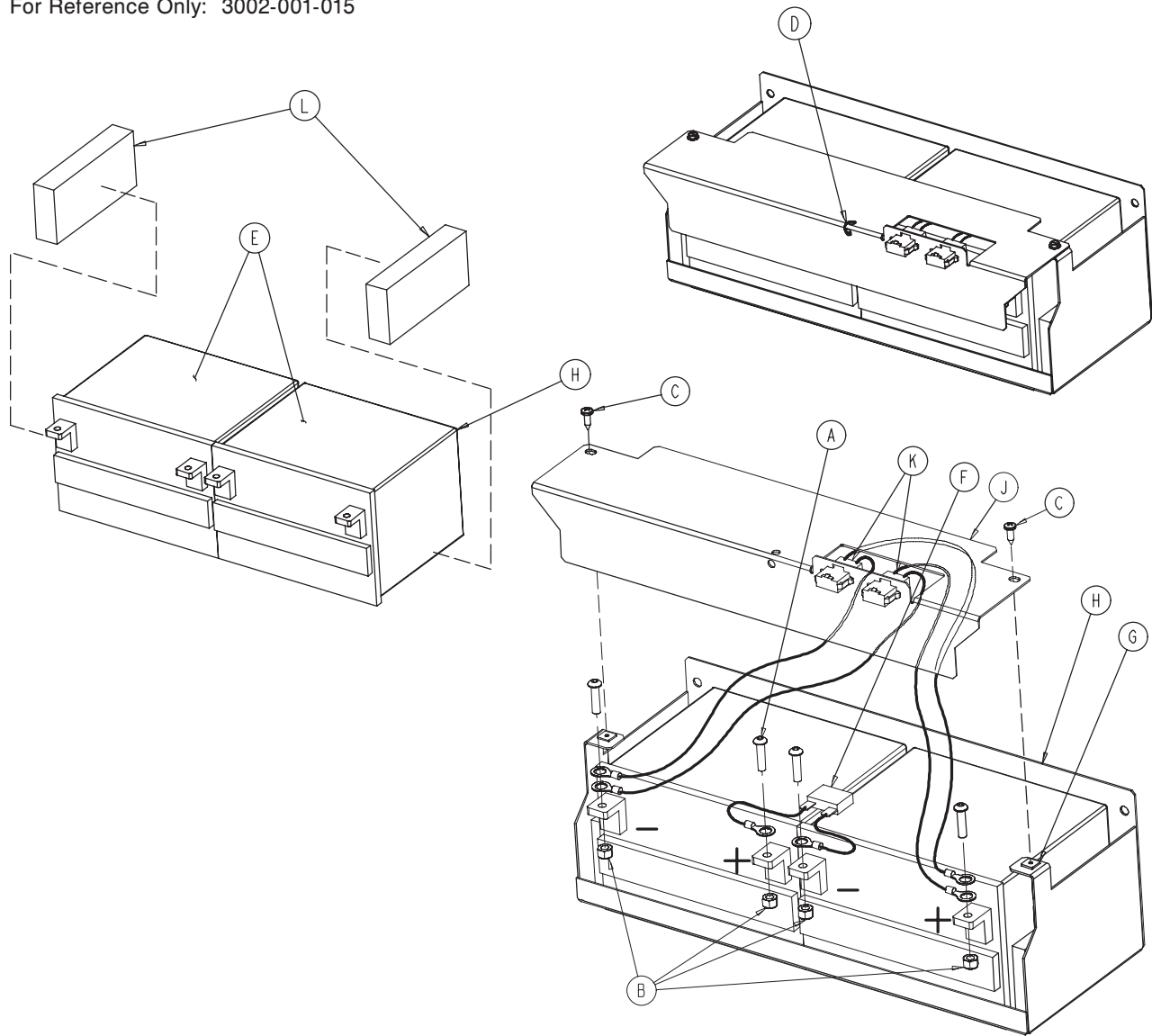

| Item | Part No. | Part Name | Qty. |
|------|--------------|-----------------------|------|
| A | 0004-046-000 | But. Head Cap Screw | 4 |
| B | 0016-028-000 | Nylock Nut | 4 |
| C | 0023-256-000 | Pan Head Screw | 2 |
| D | 0038-151-000 | Cable Tie | 1 |
| E | 2040-001-070 | Battery | 2 |
| F | 2040-001-802 | Battery Jumper Cable | 1 |
| G | 3000-300-002 | Push Nut | 2 |
| H | 3002-001-069 | Battery Tray | 1 |
| J | 3002-001-091 | Terminal Guard | 1 |
| K | 3002-001-803 | Battery Harness Cable | 2 |
| L | 3002-101-043 | Foam Spacer | 2 |

Zoom® Option, Drive Train Assembly

3002-001-014

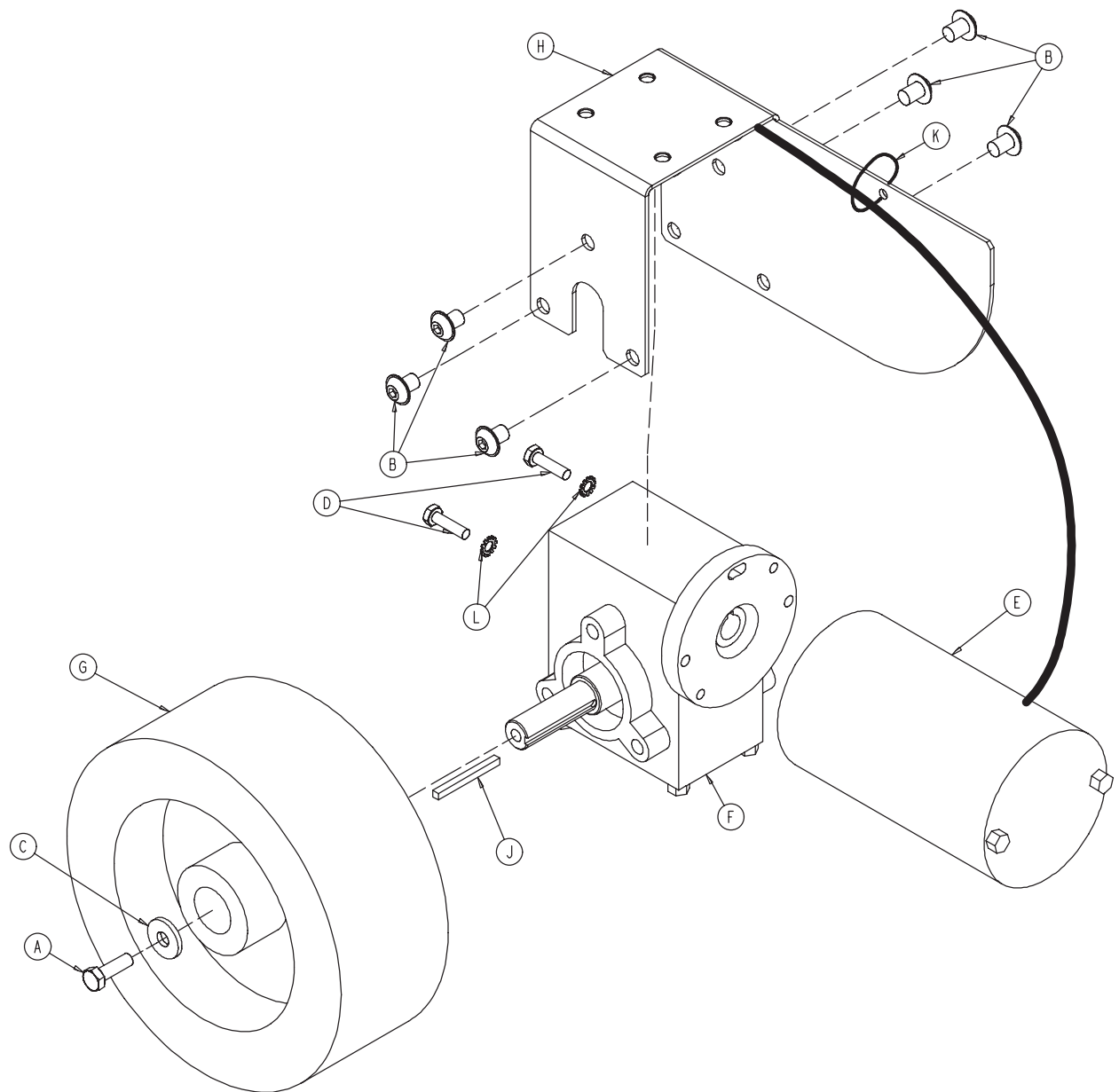

| Item | Part No. | Part Name | Qty. |
|------|--------------|-------------------------------|------|
| A | 8839-793-700 | Hex Head Cap Screw | 1 |
| B | 0004-338-000 | Flanged Button Head Cap Screw | 6 |
| C | 0011-262-000 | Washer | 1 |
| D | 0003-054-000 | Hex Head Cap Screw | 2 |
| E | 3002-001-072 | Drive Train Motor | 1 |
| F | 2040-001-073 | Gear Box | 1 |
| G | 2040-001-074 | Drive Train Wheel | 1 |
| H | 2040-001-075 | Motor Mounting Bracket | 1 |
| J | 2040-001-097 | Square Key | 1 |
| K | 3000-300-113 | Wire Tie | 1 |
| L | 0013-010-000 | Star Washer | 2 |

Zoom® Option, Drive Wheel Lift Lever Assembly

2040-001-012

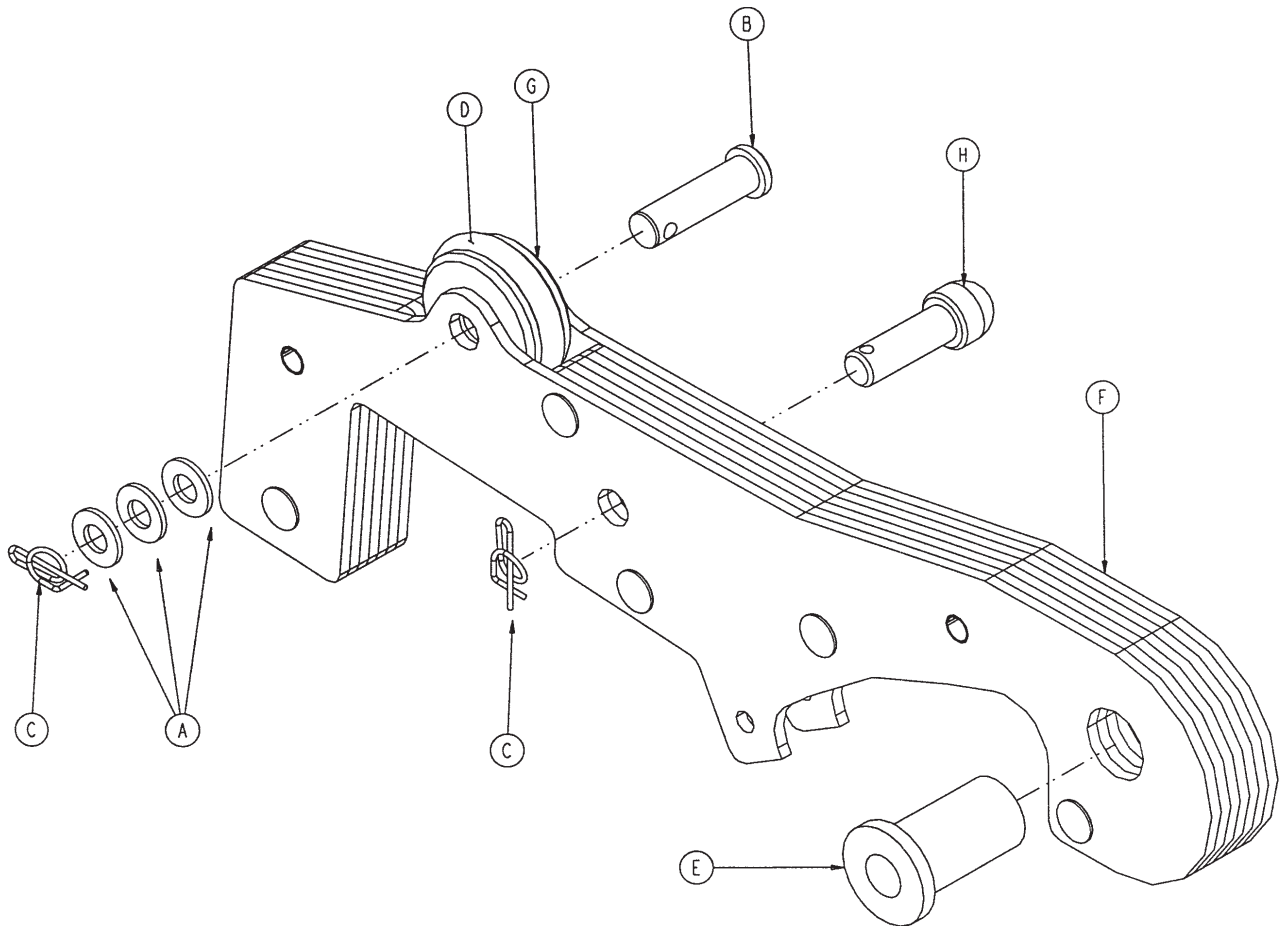

| Item | Part No. | Part Name | Qty. |
|------|--------------|------------------------------|------|
| A | 0011-003-000 | Washer | 3 |
| B | 0026-297-000 | Clevis Pin | 1 |
| C | 0027-021-000 | Rue Ring | 2 |
| D | 0045-232-000 | O-Ring | 1 |
| E | 0081-070-000 | Flange Bearing | 1 |
| F | 2040-201-013 | Drive Wheel Lift Plate Ass'y | 1 |
| G | 2040-001-087 | Lift Lever Roller | 1 |
| H | 2040-001-099 | Lift Lever Guide | 1 |

Zoom® Option, Base Power Assembly

3002-001-030

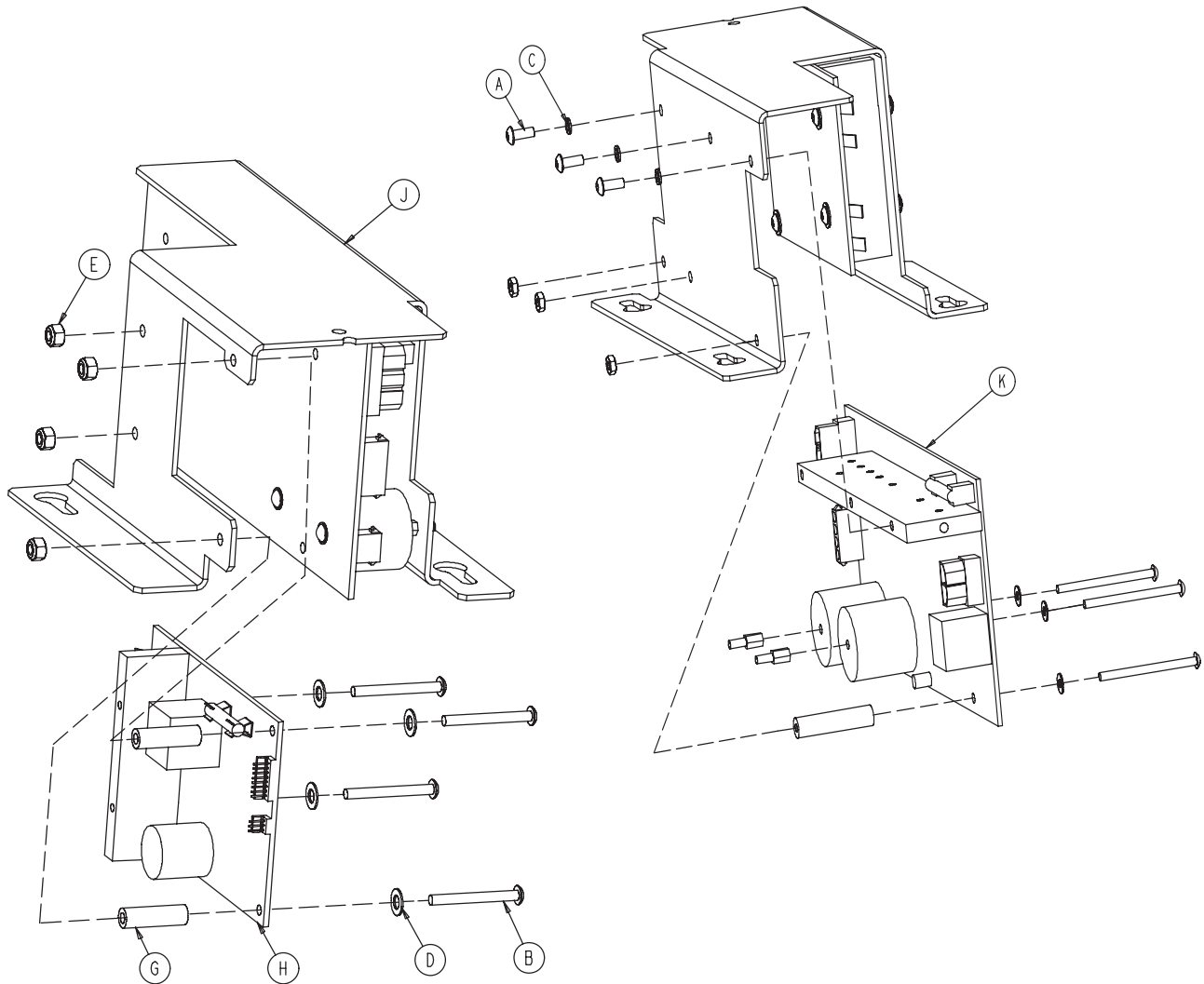

| Item | Part No. | Part Name | Qty. |
|------|--------------|---------------------------------|------|
| A | 0004-263-000 | But. Head Cap Screw | 3 |
| B | 0004-315-000 | But. Head Cap Screw | 4 |
| C | 0012-006-000 | Helical Lock Washer | 3 |
| D | 0014-004-000 | Nylon Washer | 4 |
| E | 0016-002-000 | Fiberlock Nut | 4 |
| G | 0059-187-000 | Spacer | 2 |
| H | 2040-001-900 | Power Board | 1 |
| J | 3002-001-017 | Charger/Inverter Heat Bracket | 1 |
| K | 3002-001-930 | Charger/Inverter Board Assembly | 1 |

Litter Assembly, Standard Components

For Reference Only: 3006-300-002

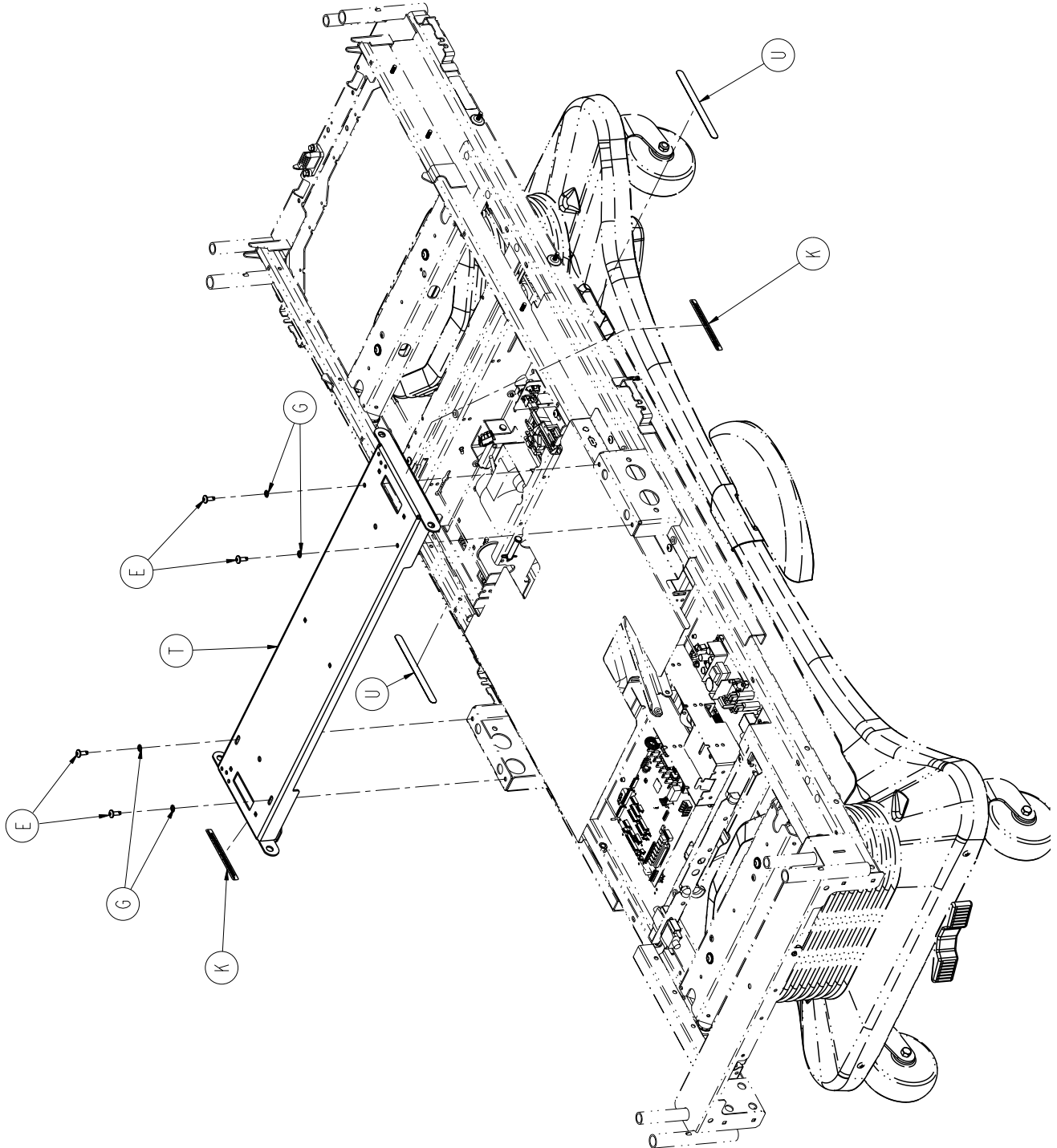

Litter Assembly, Standard Components

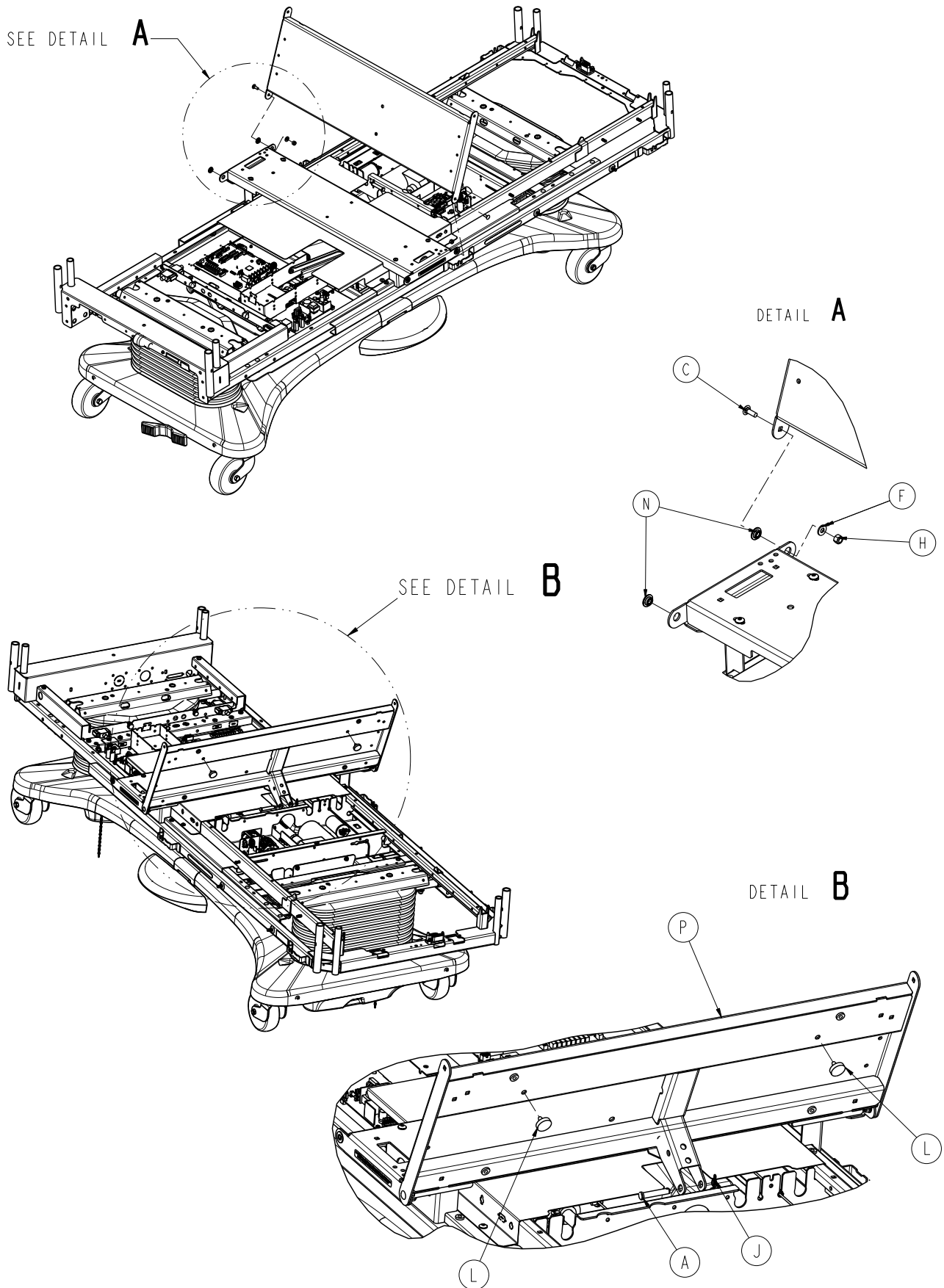

Litter Assembly, Standard Components

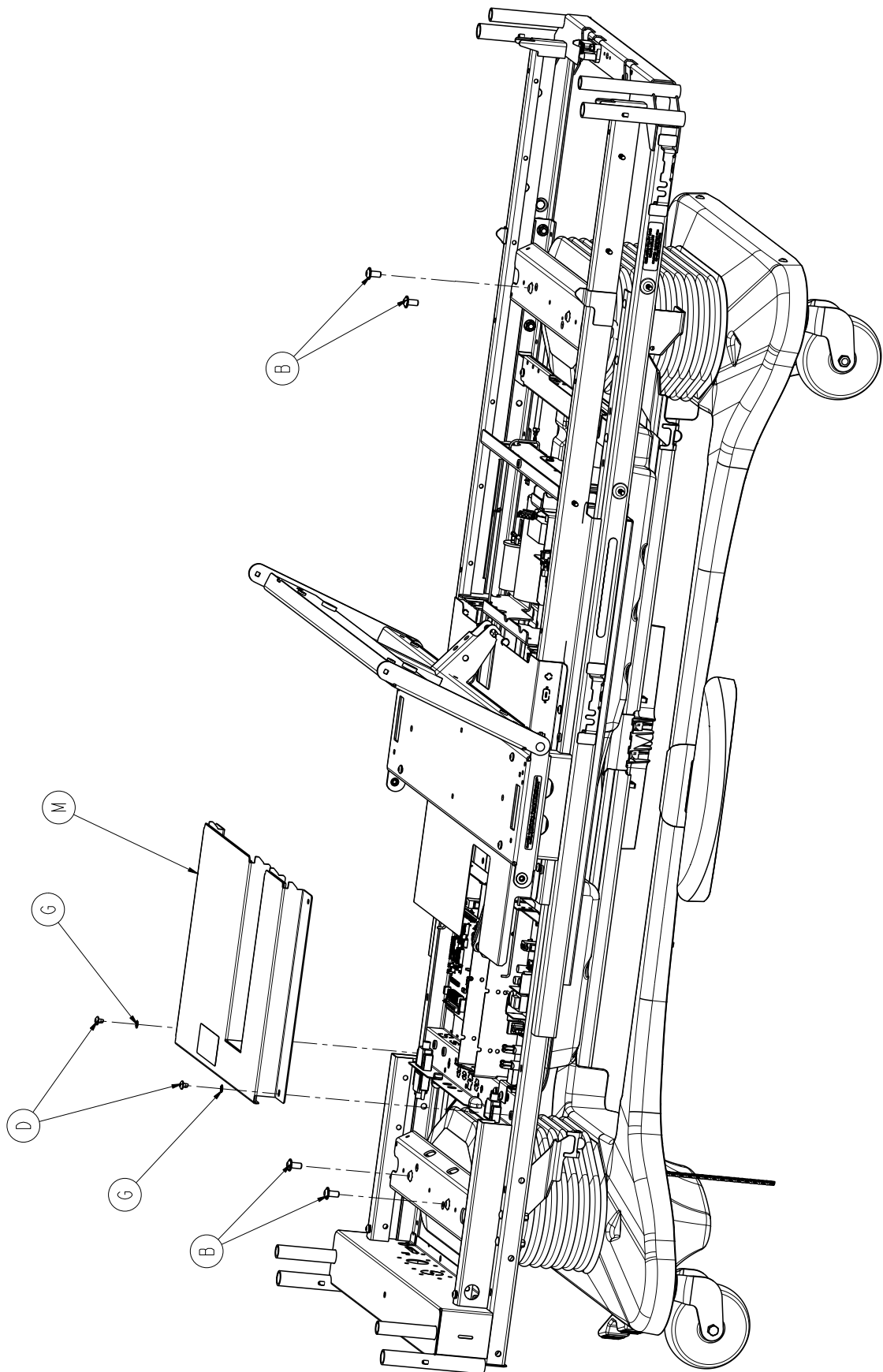

Litter Assembly, Standard Components

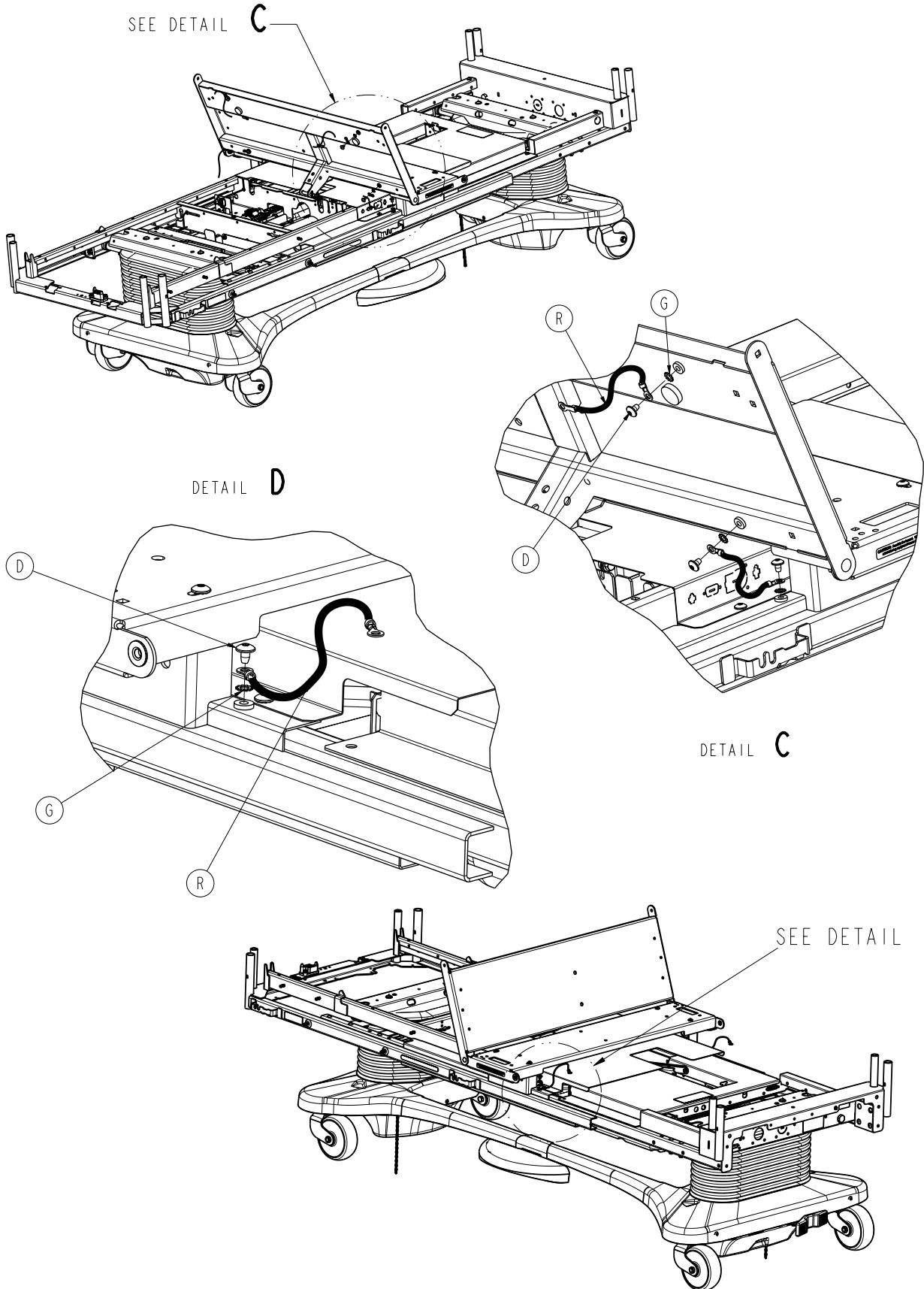

Litter Assembly, Standard Components

Litter Assembly, Standard Components - 3006-300-002 (Reference Only)

| Item | Part No. | Part Name | Qty. |
|------|--------------|----------------------------|------|
| A | 0026-277-000 | Clevis Pin | 1 |
| B | 0004-338-000 | Truss Head Screw | 4 |
| C | 0005-017-000 | Carriage Bolt | 2 |
| D | 0007-053-000 | Truss Head Screw | 10 |
| E | 0007-063-000 | Truss Head Screw | 4 |
| F | 0011-077-000 | Washer | 2 |
| G | 0013-010-000 | External Tooth Lock Washer | 14 |
| H | 0016-028-000 | Fiberlock Hex Nut | 2 |
| J | 0027-022-000 | Rue Ring Cotter | 1 |
| K | 3006-088-820 | Caution Label | 2 |
| L | 3001-300-008 | Bumper | 2 |
| M | 3006-301-097 | CPU Cover Assembly | 1 |
| N | 3001-300-099 | Fowler Modified Bushing | 4 |
| P | 3006-301-170 | Thigh Litter Assembly | 1 |
| R | 3002-300-870 | 8" Litter Ground Jumper | 2 |
| T | 3006-301-135 | Seat Weldment Skin | 1 |
| U | 3006-090-100 | 500 Lb. Maximum Label | 2 |

Litter Assembly, Standard Bed

For Reference Only: 3006-343-002

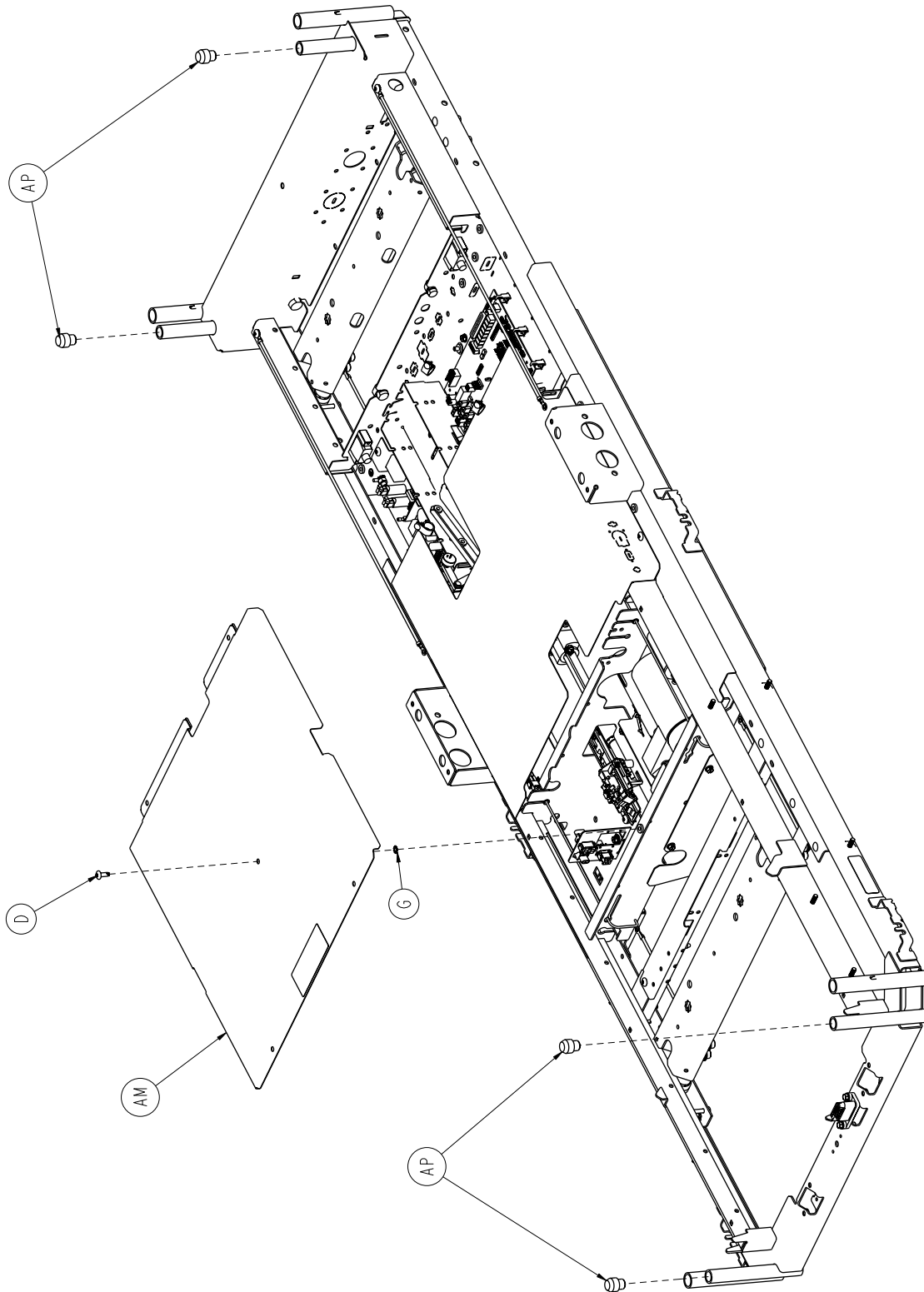

Litter Assembly, Standard Bed

DETAIL **A**

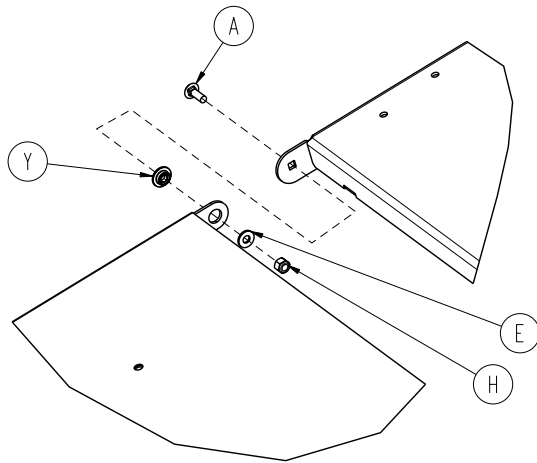

Reference 1:

Custom label option uses custom label 3006-300-950
(Part of Custom Label Kit 3006-900-000)

SEE DETAIL **A**

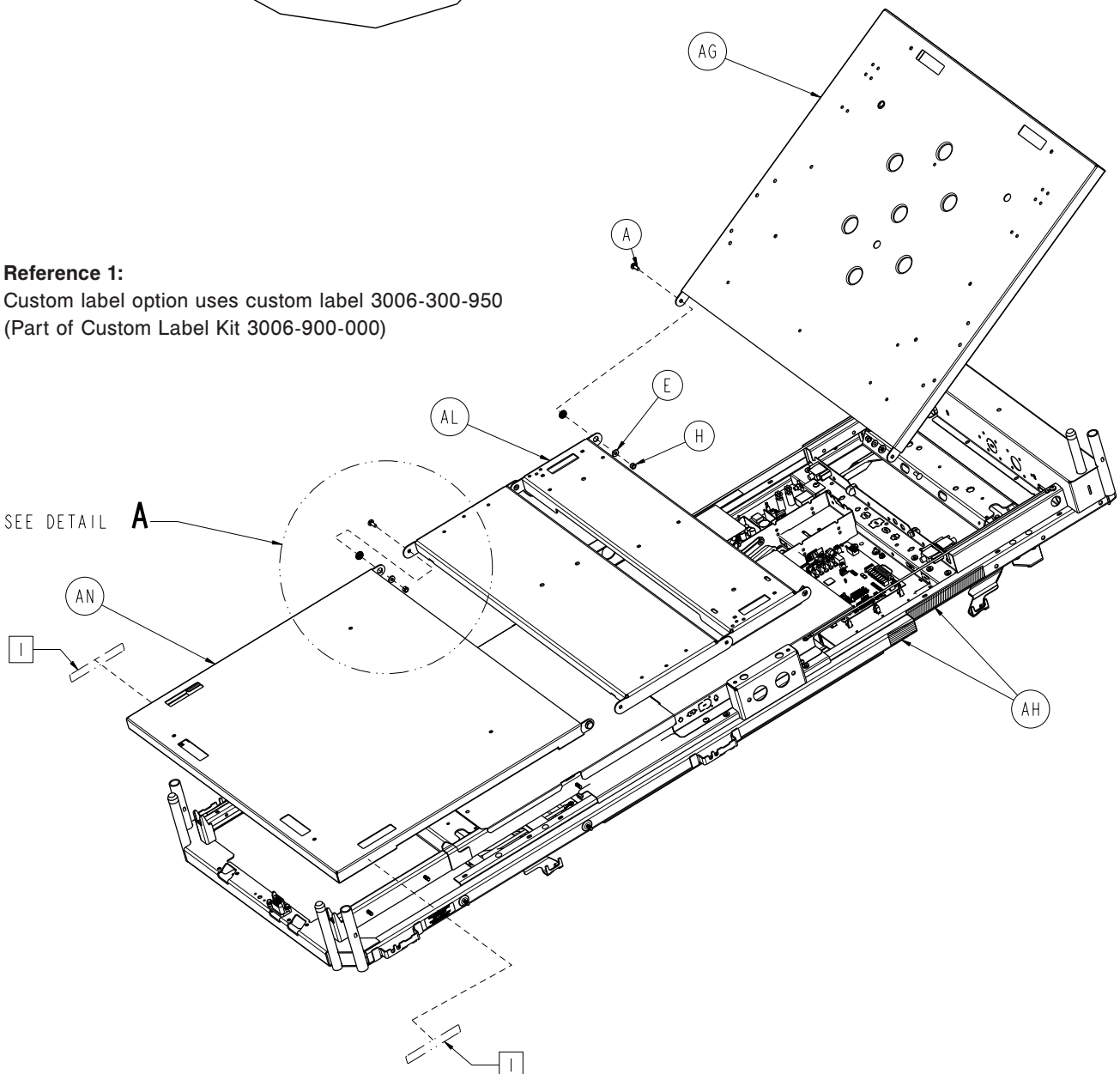

Litter Assembly, Standard Bed

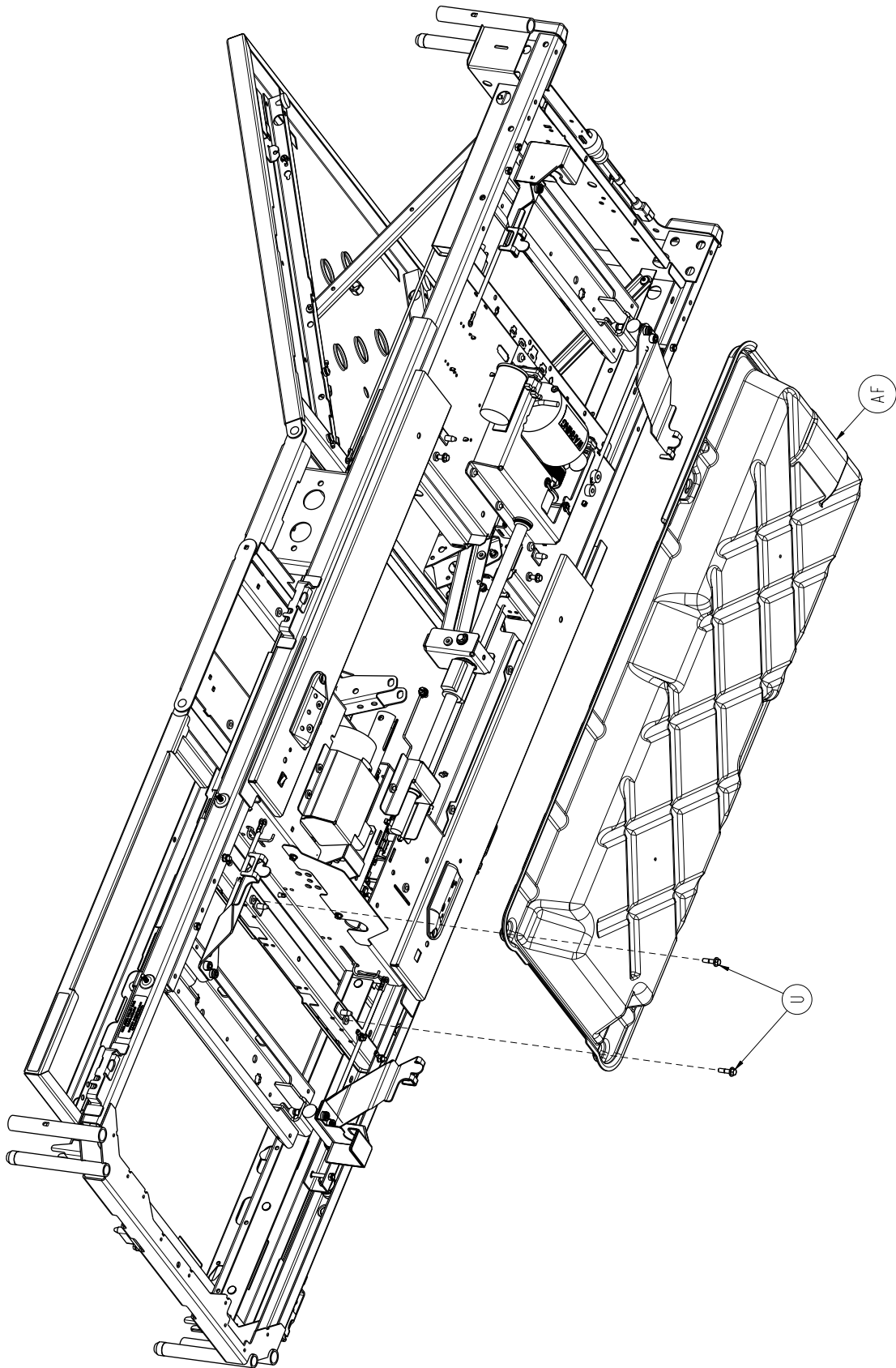

Litter Assembly, Standard Bed

SEE DETAIL

D

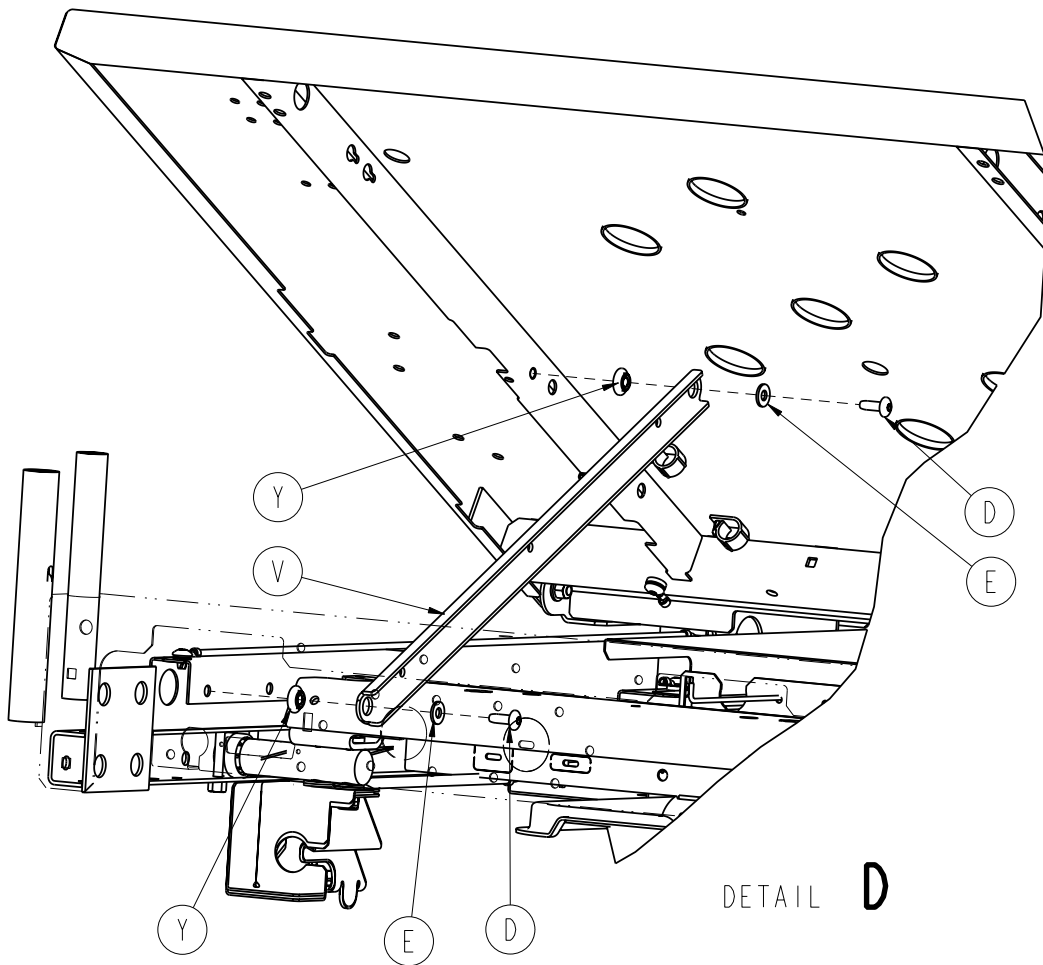
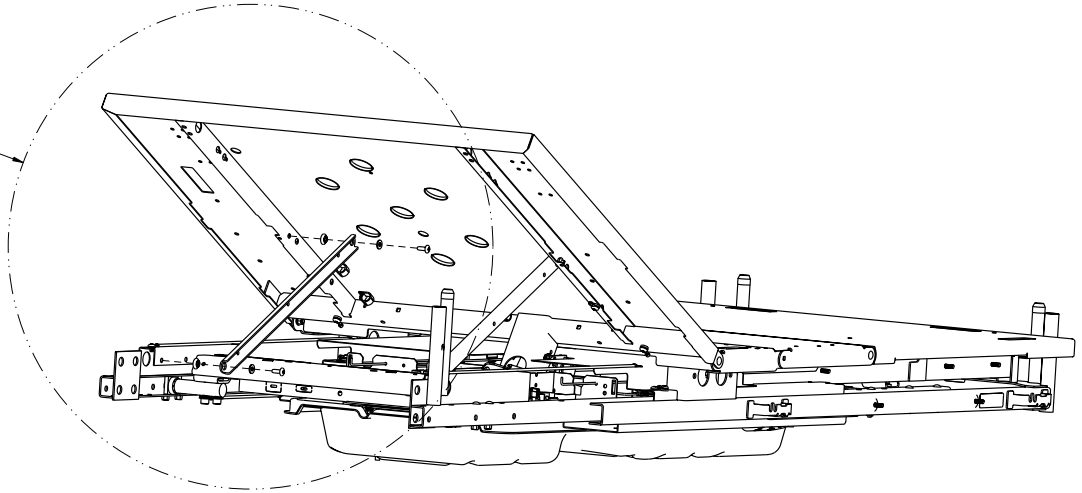

DETAIL **D**

Litter Assembly, Standard Bed

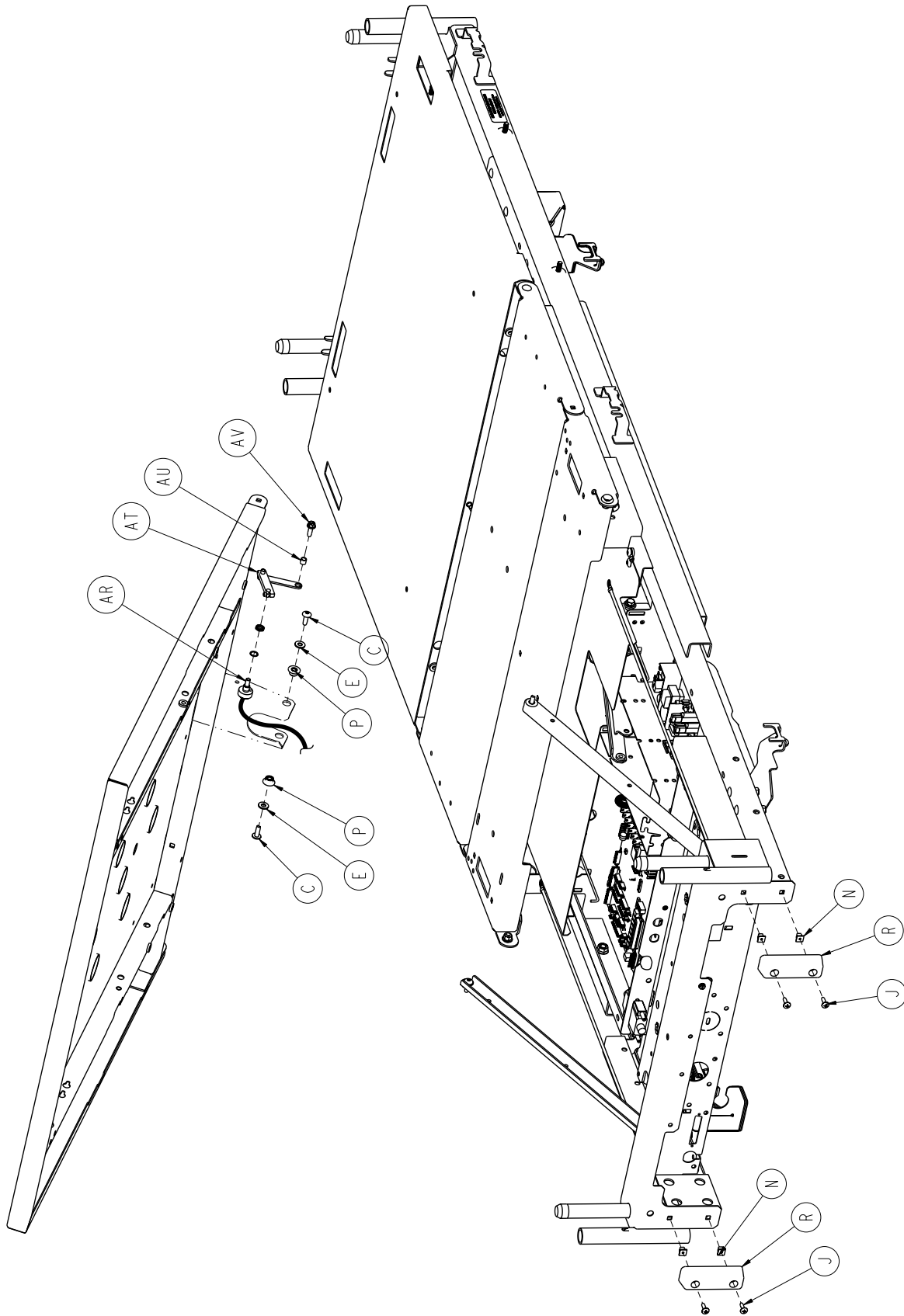

Litter Assembly, Standard Bed

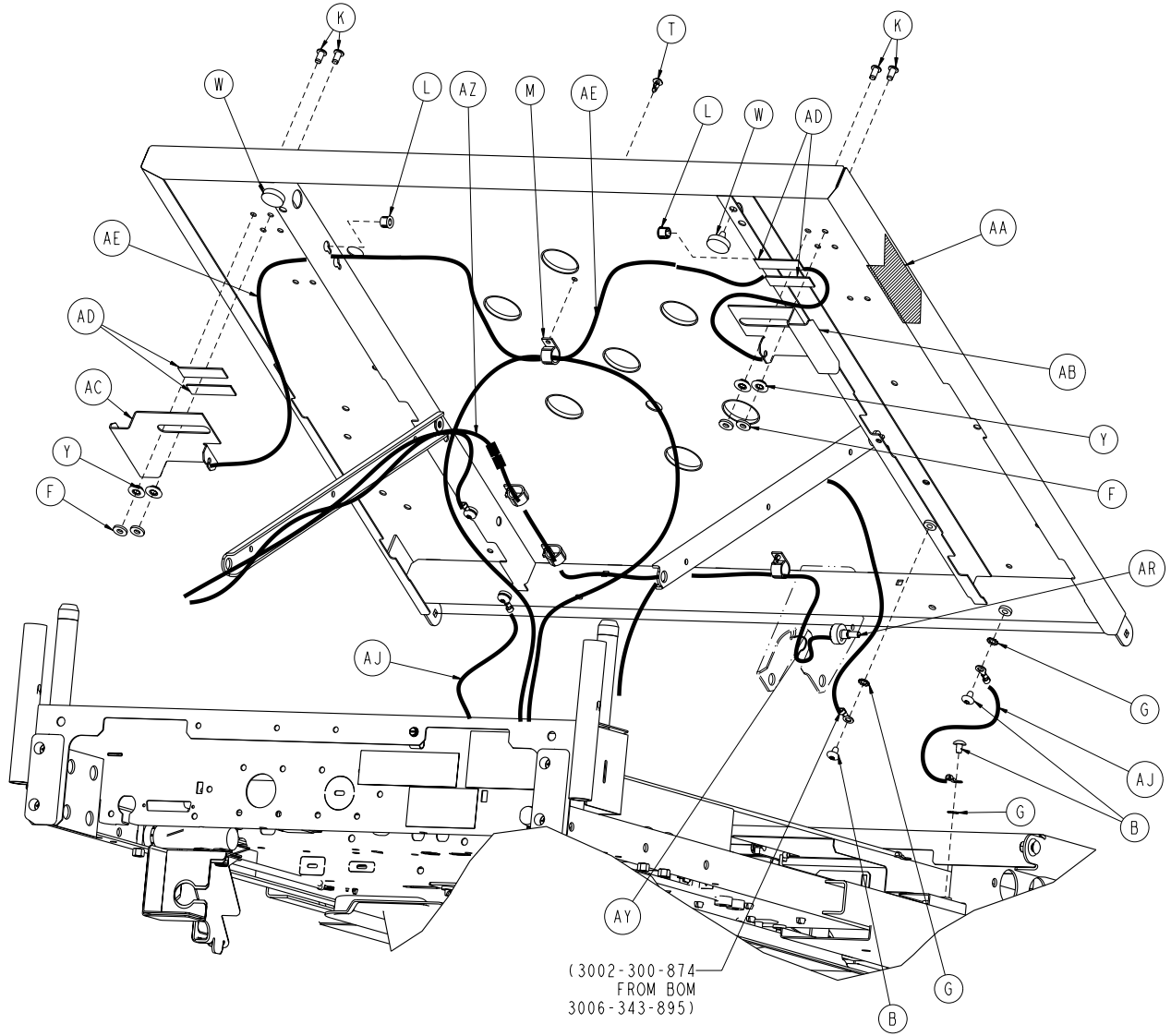

Litter Assembly, Standard Bed

Litter Assembly, Standard Bed 3006-343-002 (Reference Only)

| Item | Part No. | Part Name | Qty. |
|------|--------------|--|------|
| A | 0005-017-000 | Carriage Bolt | 4 |
| B | 0007-053-000 | Truss Head Screw | 6 |
| C | 0007-063-000 | Truss Head Screw | 2 |
| D | 0007-065-000 | Truss Head Screw | 5 |
| E | 0011-077-000 | Washer | 10 |
| F | 0011-376-000 | Washer | 4 |
| G | 0013-010-000 | External Tooth Lock Washer | 11 |
| H | 0016-028-000 | Fiberlock Hex Nut | 4 |
| J | 0023-080-000 | Truss Head Screw | 4 |
| K | 0025-120-000 | Pop Rivet | 4 |
| L | 0030-052-000 | Heyco Snap Bushing | 2 |
| M | 0059-743-000 | Wire Harness Clip | 4 |
| N | 3000-300-002 | Plastic Clip Nut | 4 |
| P | 3000-300-099 | Fowler Bushing | 2 |
| R | 3000-300-350 | Head End Bumper | 2 |
| T | 3000-300-477 | CPR Conduit Stud | 4 |
| U | 3001-200-229 | Mounting Standoff | 2 |
| V | 3006-300-005 | Fowler Link | 2 |
| W | 3001-300-008 | Bumper | 2 |
| Y | 3001-300-099 | Fowler Bushing | 10 |
| AA | 3001-300-603 | CPR Release Label | 2 |
| AB | 3001-300-661 | CPR Release Handle, Right | 1 |
| AC | 3001-300-662 | CPR Release Handle, Left | 1 |
| AD | 3001-300-663 | Velcro® Strip | 4 |
| AE | 3001-300-670 | CPR Cable Assembly | 2 |
| AF | 3006-300-084 | Motion Interrupt Pan | 1 |
| AG | 3006-300-145 | Fowler Litter Weldment | 1 |
| AH | 3006-300-602 | Fowler Elevation Angle, Label | 1 |
| AJ | 3002-300-870 | 8" Ground Litter Jumper | 2 |
| AK | 3006-343-895 | Electrical Assembly, Standard Length Bed | 1 |
| AL | 3006-300-002 | Litter Assembly, Standard Components | 1 |
| AM | 3006-300-042 | Foot Cover Assembly | 1 |
| AN | 3006-300-190 | Foot Litter Weldment | 1 |
| AP | 3006-300-349 | Cap | 4 |
| AR | 3001-345-807 | Fowler Pot Cable | 1 |
| AT | 3004-345-450 | Pot Linkage Assembly | 1 |
| AU | 3001-400-558 | Spacer | 1 |
| AV | 0003-226-000 | Hex Head Washer Screw | 1 |
| AY | 3000-300-113 | 8" Cable Tie | 1 |
| AZ | 3001-345-809 | Fowler Pot Extension Cable (KCI) | 1 |

Litter Assembly, Battery Backup Option

For Reference Only: 3006-350-200

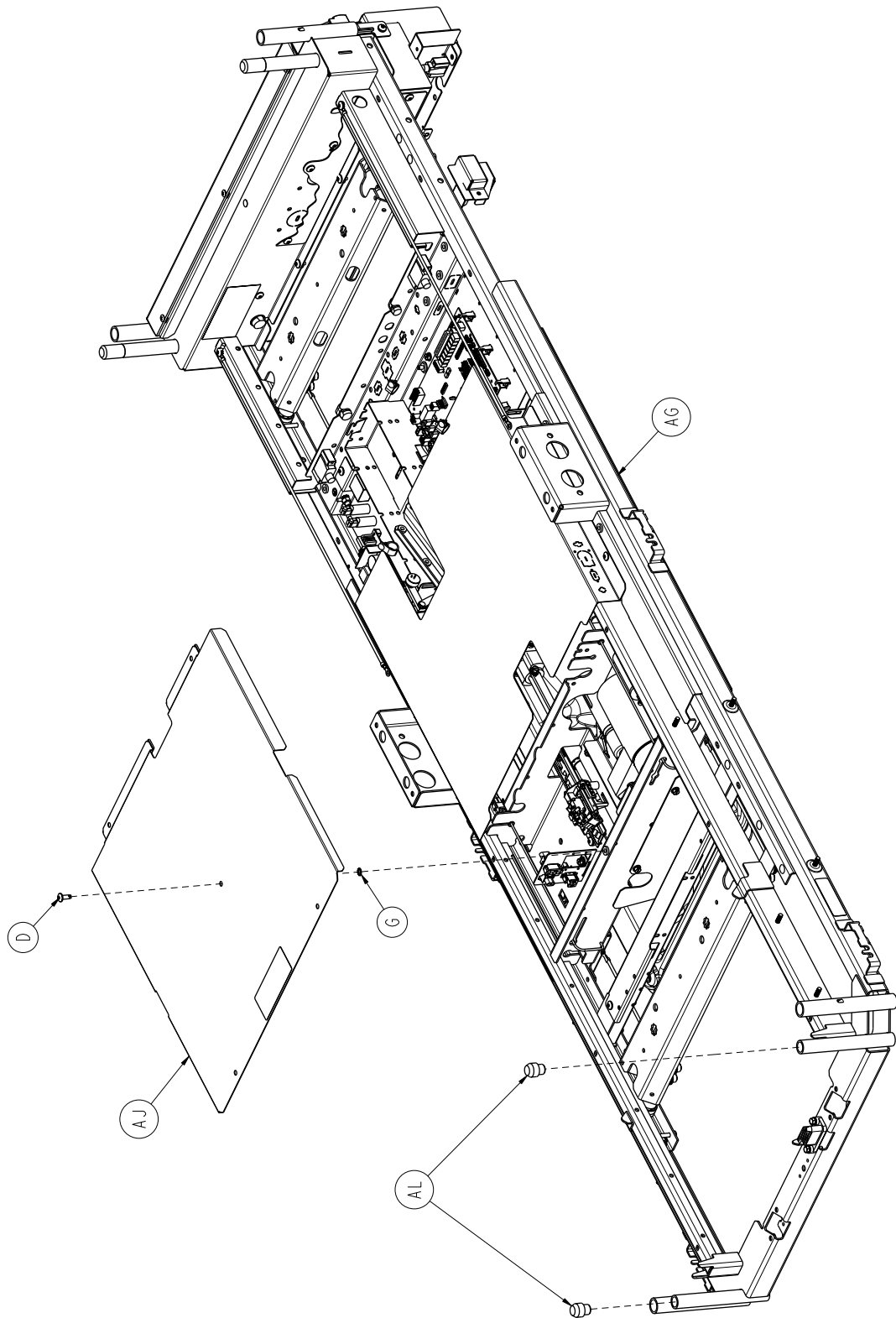

[Return To Table of Contents](#)

Litter Assembly, Battery Backup Option

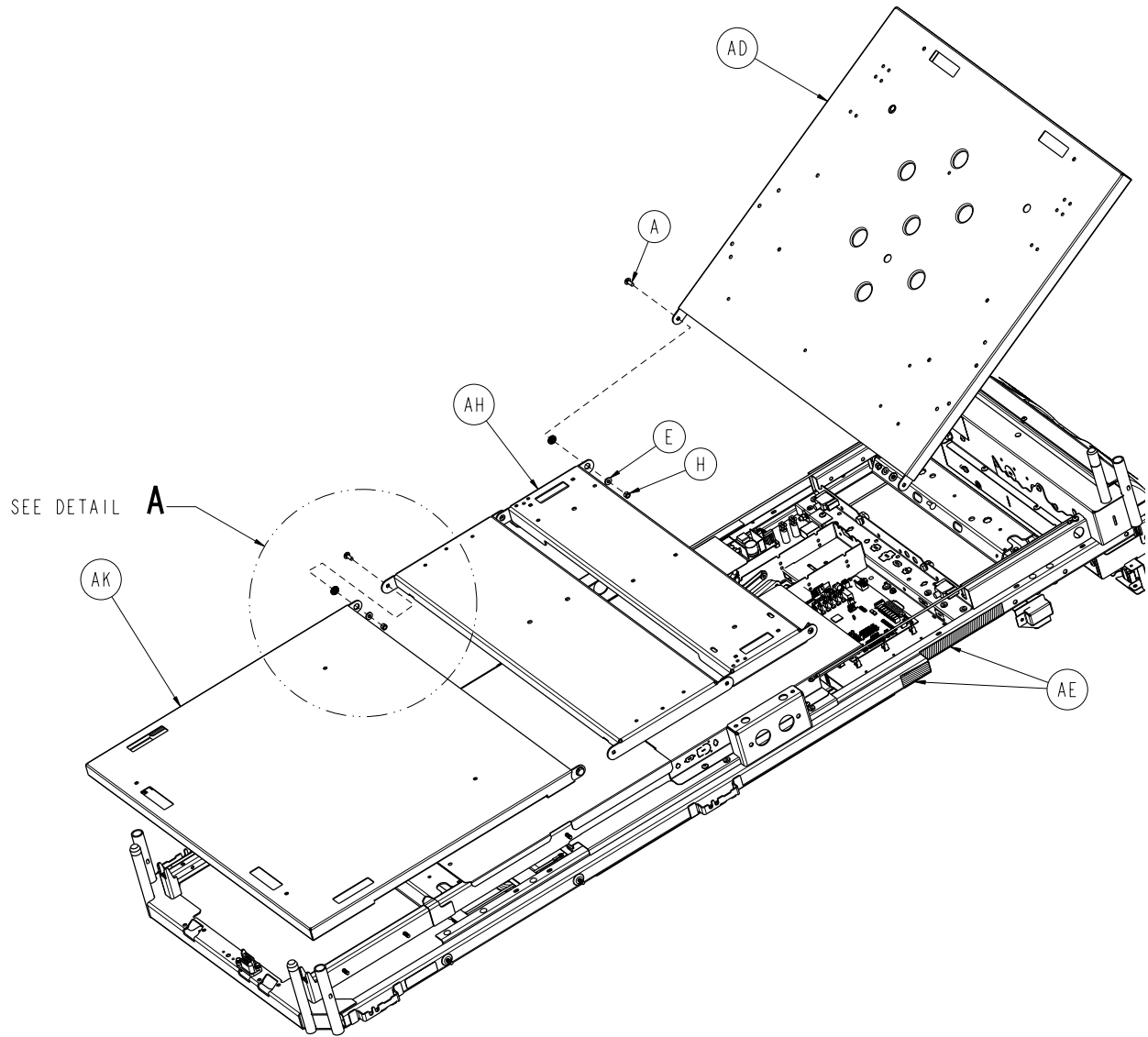

DETAIL **A**
(SCALE 0.200)

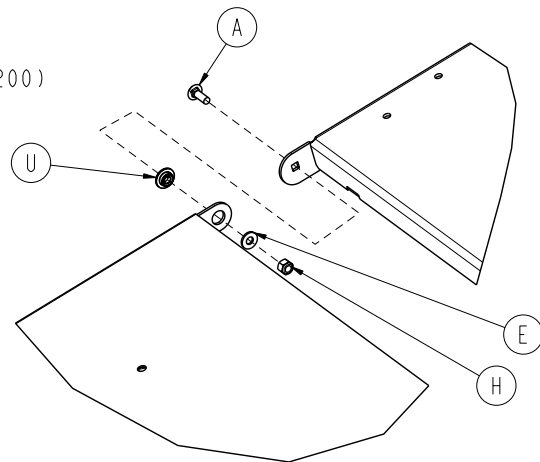

Litter Assembly, Battery Backup Option

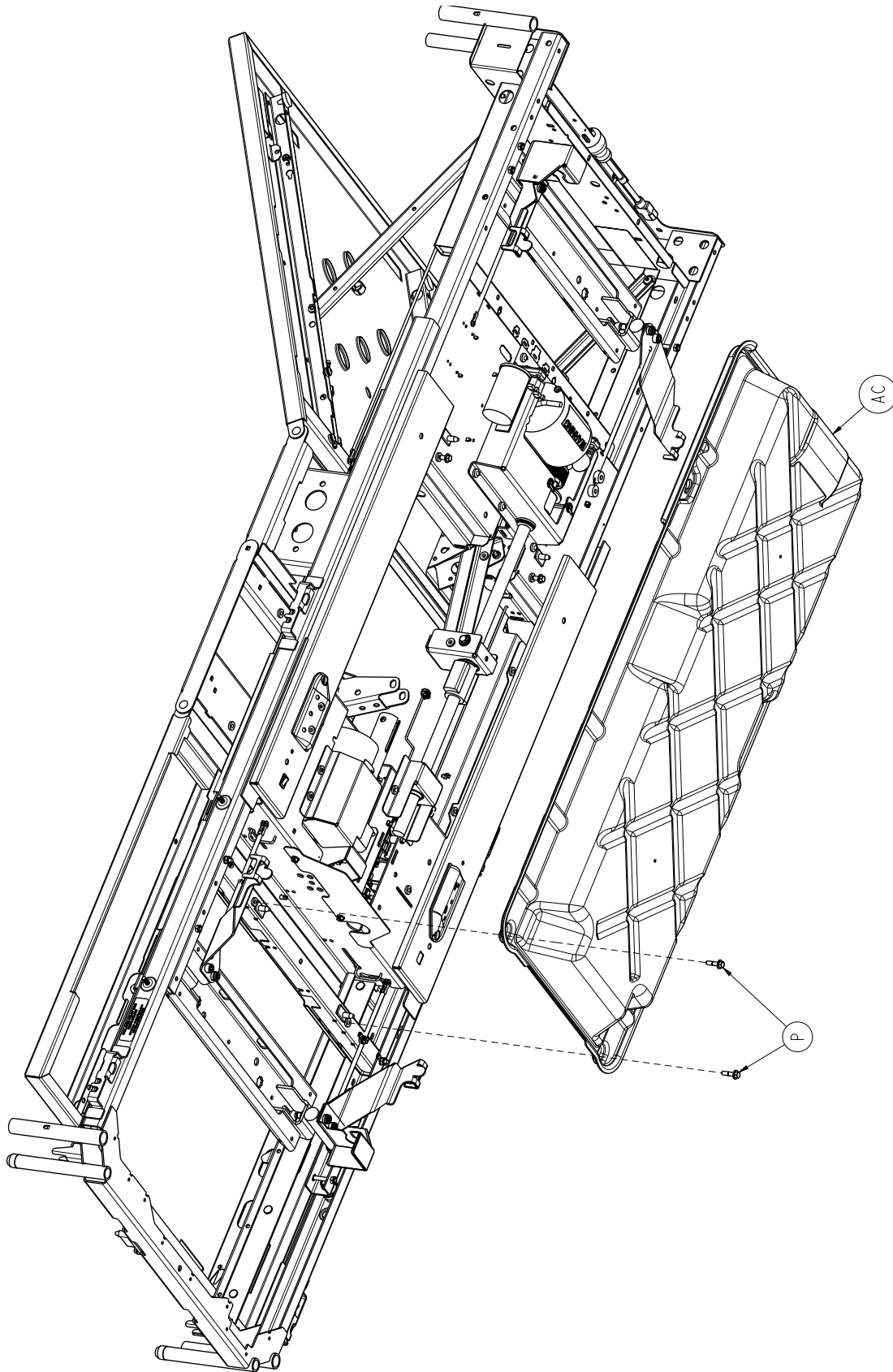

Litter Assembly, Battery Backup Option

SEE DETAIL

D

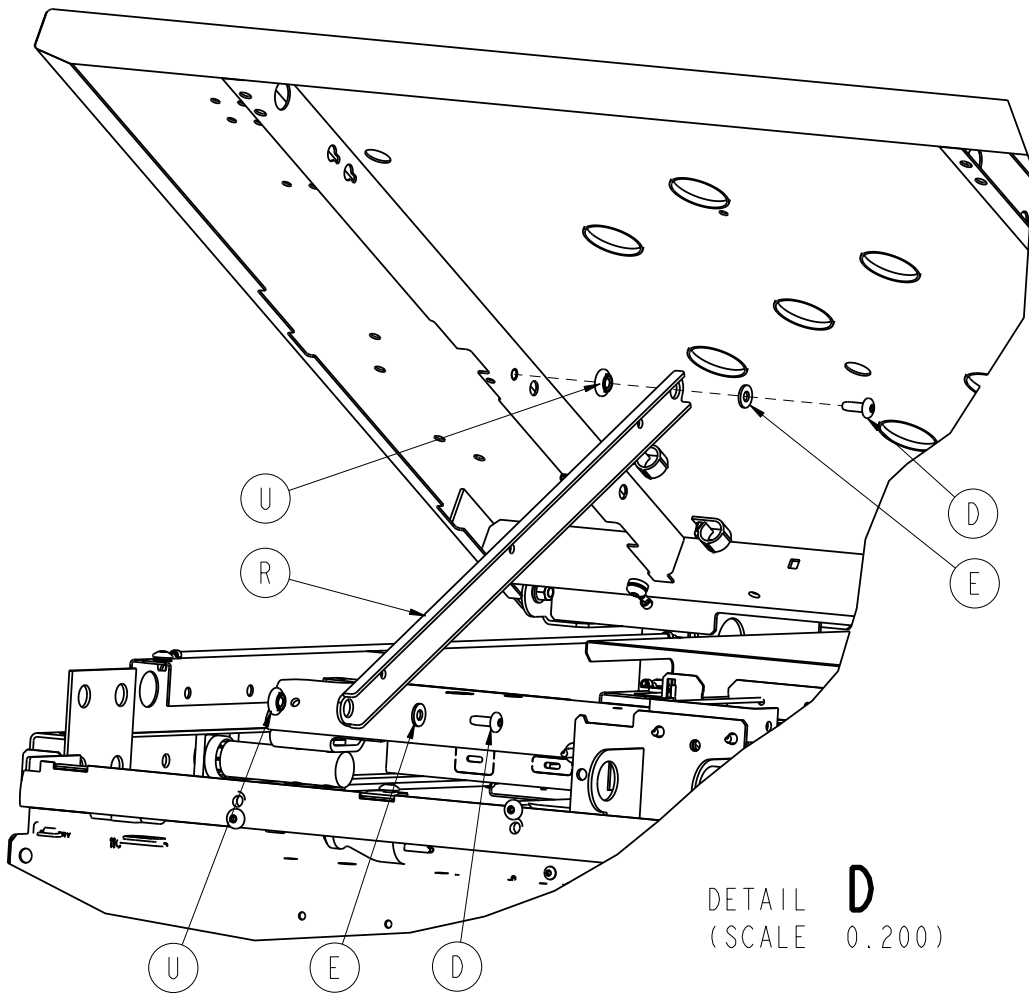
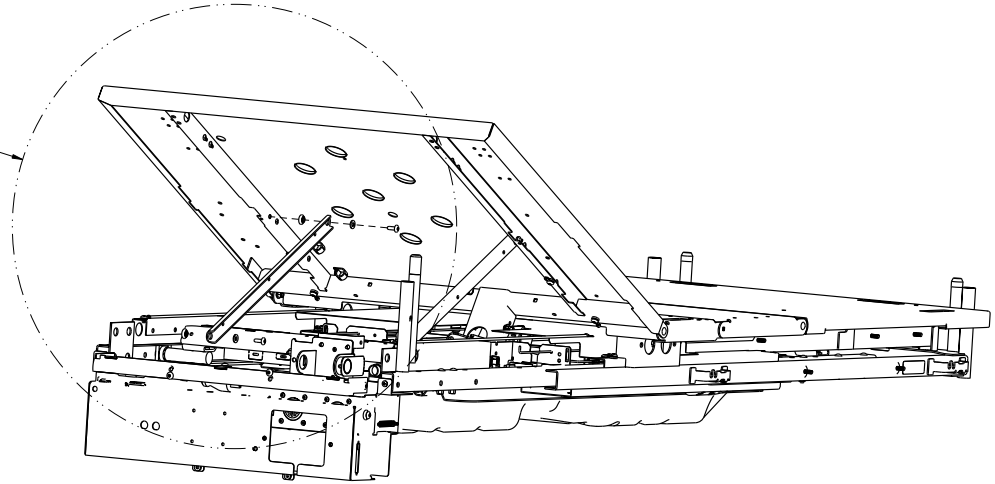

DETAIL **D**
(SCALE 0.200)

Litter Assembly, Battery Backup Option

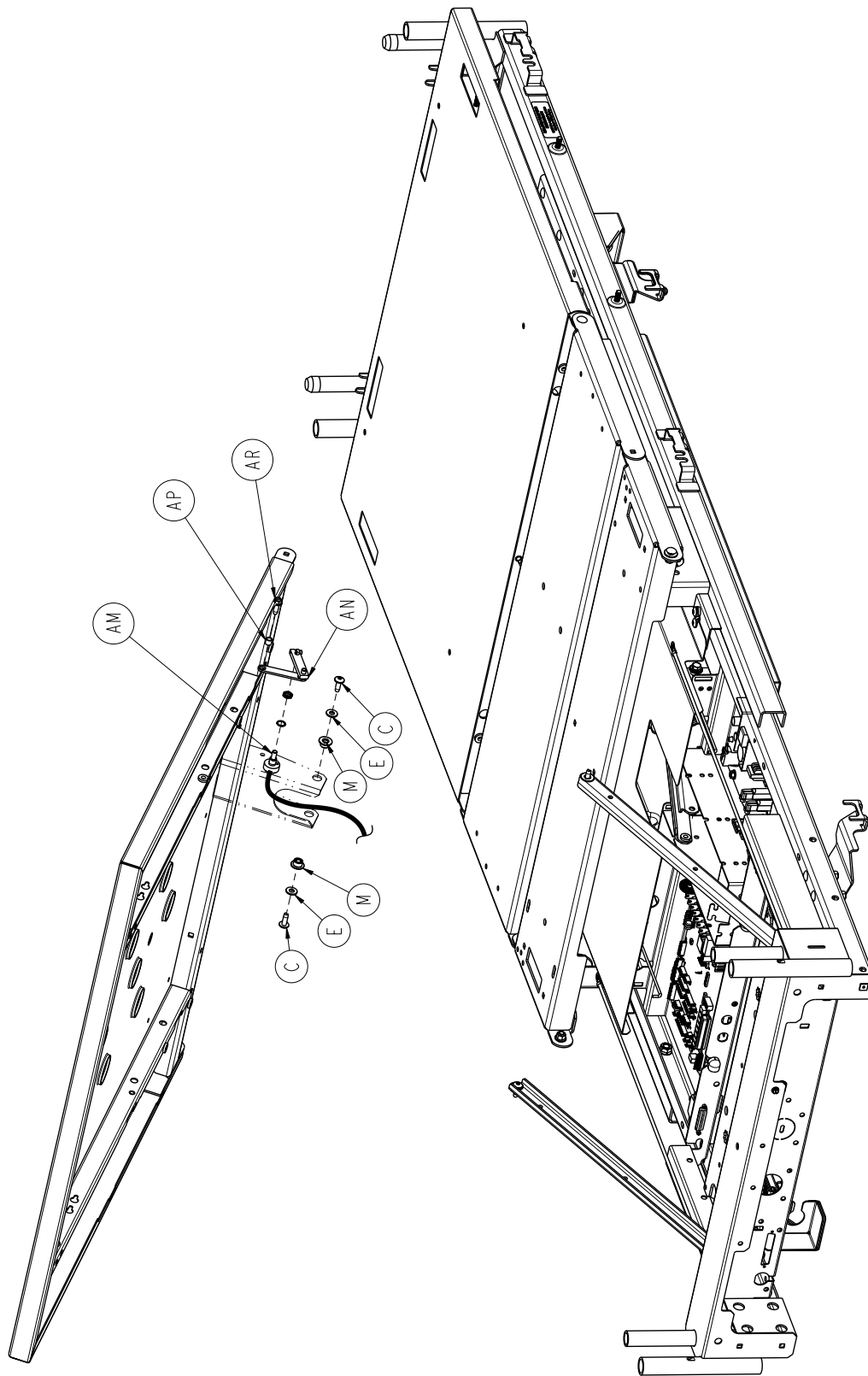

Litter Assembly, Battery Backup Option

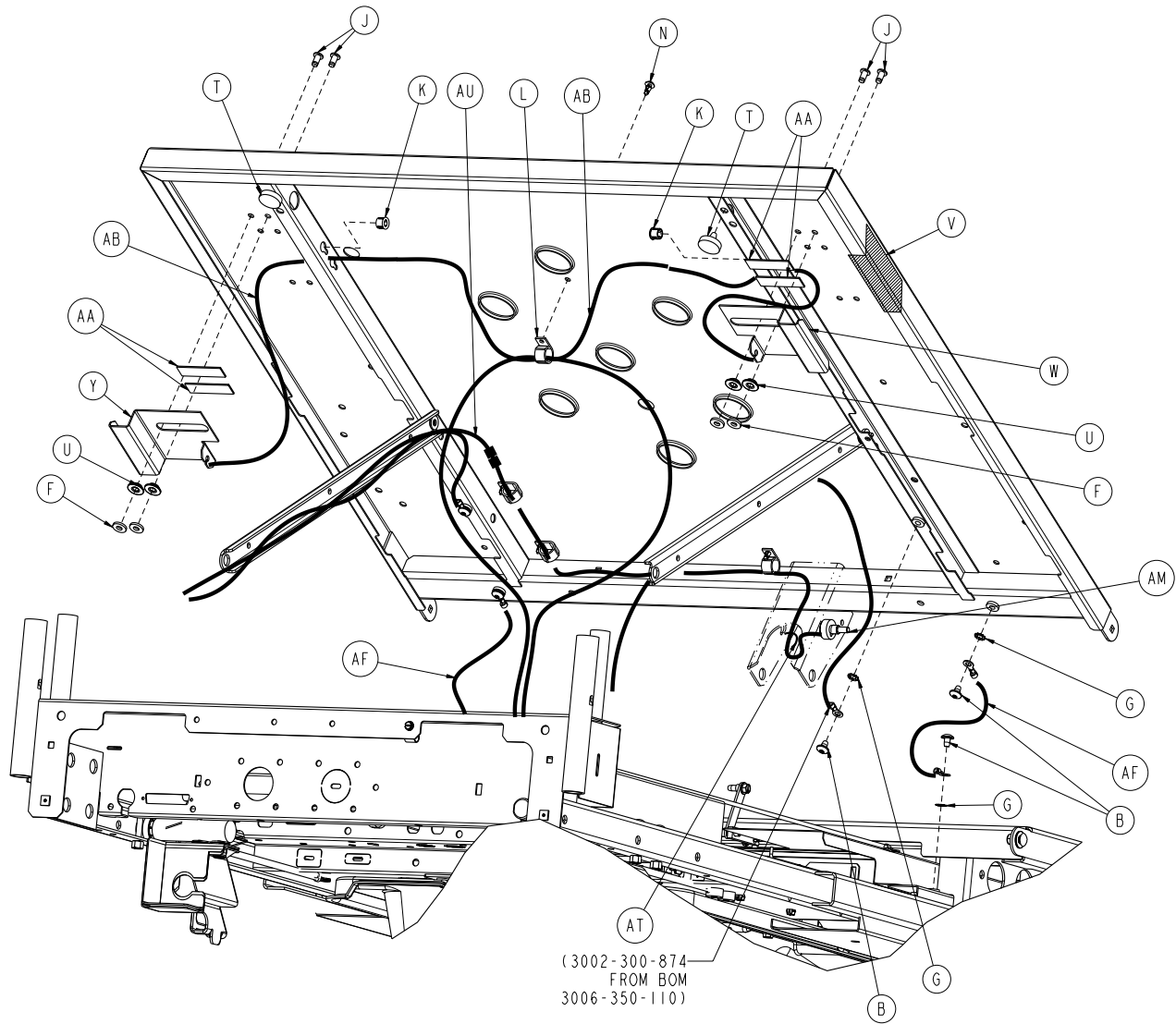

Litter Assembly, Battery Backup Option

Litter Assembly, Battery Backup Option 3006-350-200 (Reference Only)

| Item | Part No. | Part Name | Qty. |
|------|--------------|----------------------------------|------|
| A | 0005-017-000 | Carriage Bolt | 4 |
| B | 0007-053-000 | Truss Head Screw | 6 |
| C | 0007-063-000 | Truss Head Screw | 2 |
| D | 0007-065-000 | Truss Head Screw with Patch | 5 |
| E | 0011-077-000 | Washer | 10 |
| F | 0011-376-000 | Washer | 4 |
| G | 0013-010-000 | External Tooth Lock Washer | 11 |
| H | 0016-028-000 | Fiberlock Hex Nut | 4 |
| J | 0025-120-000 | Pop Rivet | 4 |
| K | 0030-052-000 | Heyco Snap Bushing | 2 |
| L | 0059-743-000 | Wire Harness Clip | 4 |
| M | 3000-300-099 | Fowler Modified Bushing | 2 |
| N | 3000-300-477 | CPR Conduit Stud | 1 |
| P | 3001-200-229 | Mounting Standoff | 2 |
| R | 3006-301-005 | Fowler Link | 2 |
| T | 3001-300-008 | Bumper | 2 |
| U | 3001-300-099 | Fowler Modified Bushing | 10 |
| V | 3006-300-603 | CPR Release Handle | 2 |
| W | 3001-300-661 | CPR Handle, RH | 1 |
| Y | 3001-300-662 | CPR Handle, LH | 1 |
| AA | 3001-300-663 | Velcro® Strip | 4 |
| AB | 3001-300-670 | CPR Cable Assembly | 2 |
| AC | 3006-300-084 | Motion Interrupt Pan | 1 |
| AD | 3006-300-145 | Fowler Litter Weldment | 1 |
| AE | 3006-300-602 | Fowler Elevation Angle Label | 1 |
| AF | 3002-300-870 | 8" Litter Ground Jumper | 2 |
| AG | 3006-350-110 | Electrical Litter Assembly | 1 |
| AH | 3006-300-002 | Litter Assembly, Std. Components | 1 |
| AJ | 3006-300-042 | Foot Cover Assembly | 1 |
| AK | 3006-300-190 | Foot Litter Weldment | 1 |
| AL | 3006-300-349 | Foot End Litter Cap | 2 |
| AM | 3001-345-807 | Fowler Pot Label | 1 |
| AN | 3004-345-450 | Pot Linkage Label | 1 |
| AP | 3001-400-558 | Spacer | 1 |
| AR | 0003-226-000 | Hex Washer Head Screw | 1 |
| AT | 3000-300-113 | 8" Cable Tie | 1 |
| AU | 3001-345-809 | Fowler Pot Extension Cable (KCI) | 1 |

Litter Assembly, Zoom® Option

For Reference Only: 3006-344-002

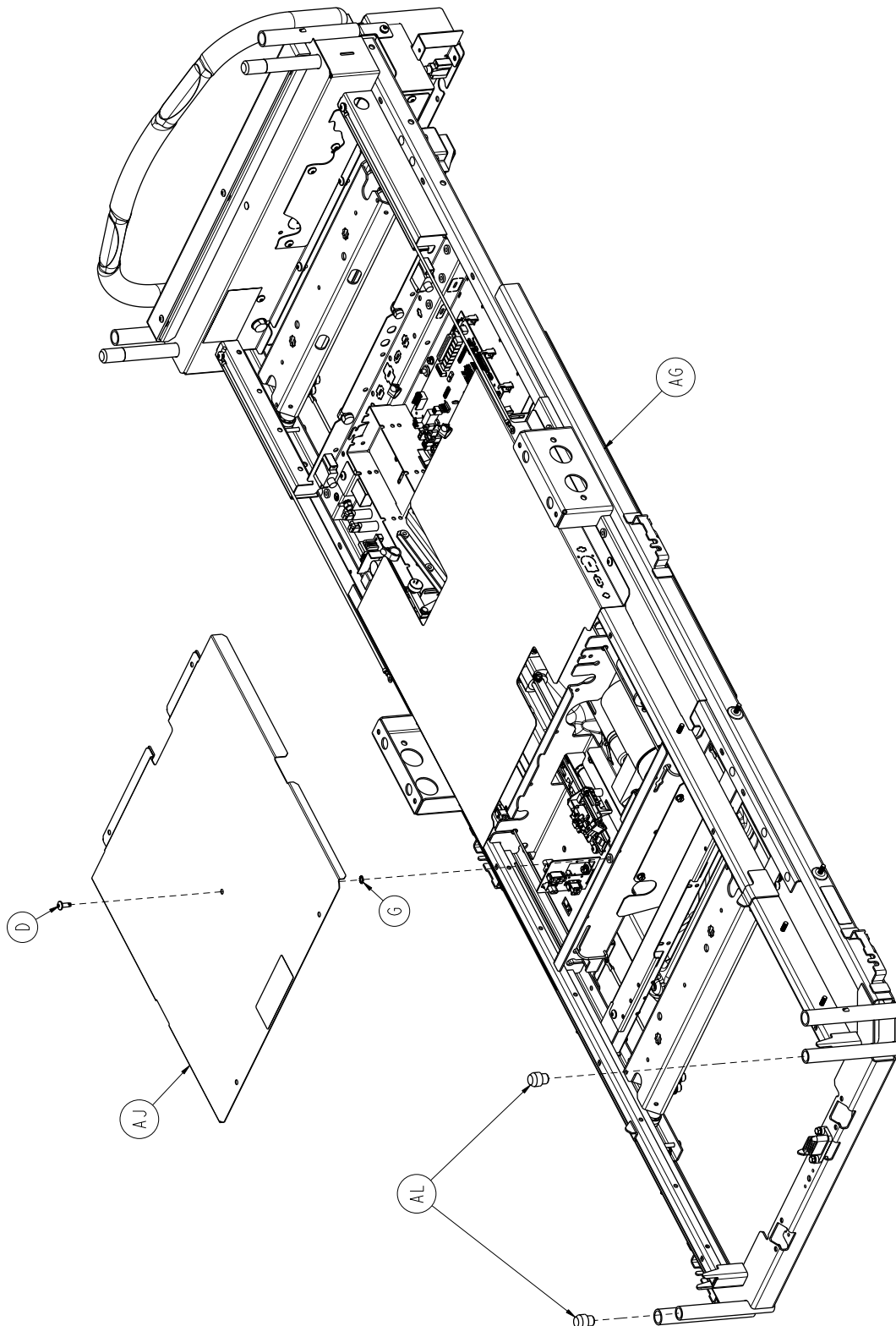

Litter Assembly, Zoom® Option

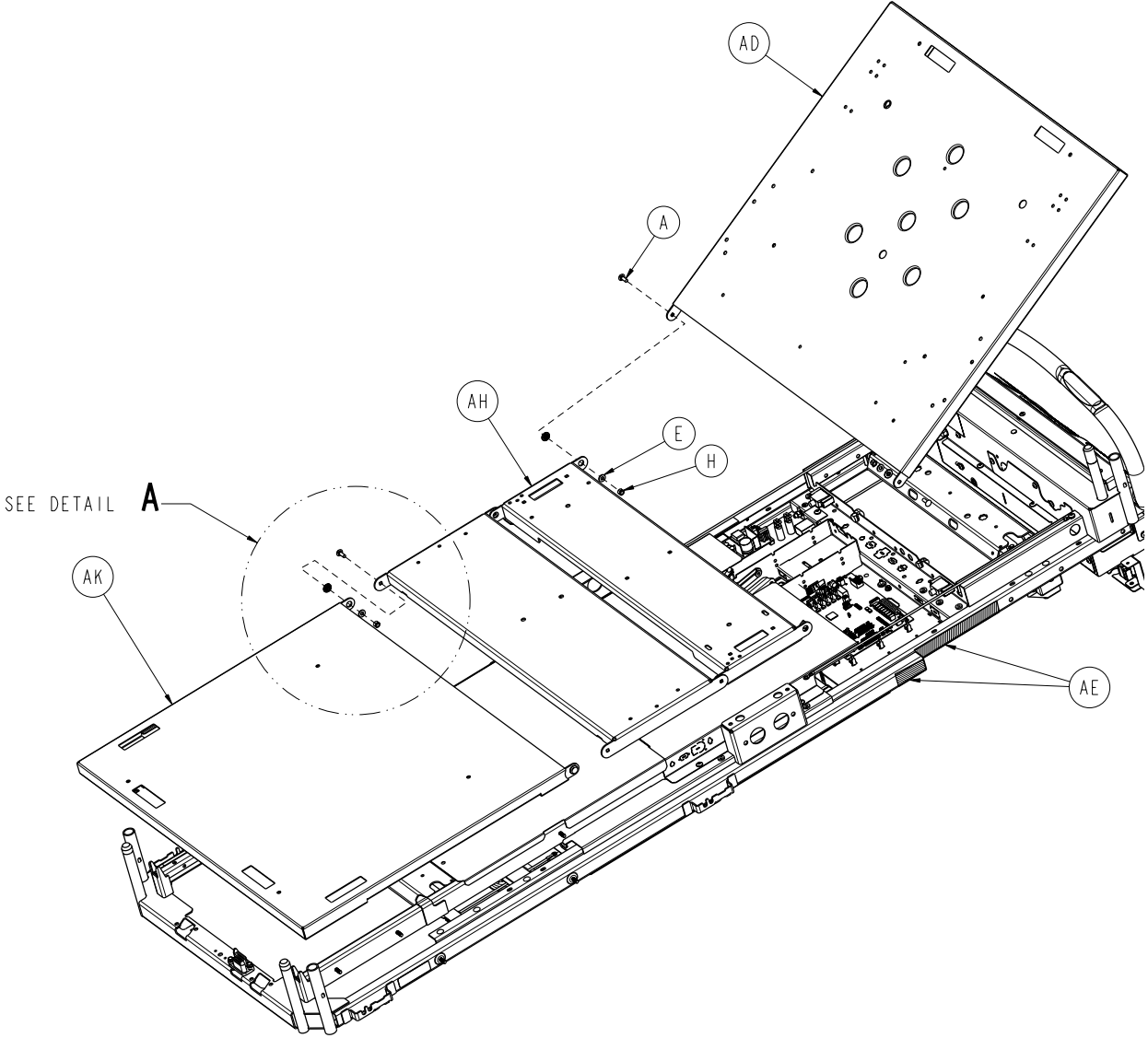

DETAIL **A**

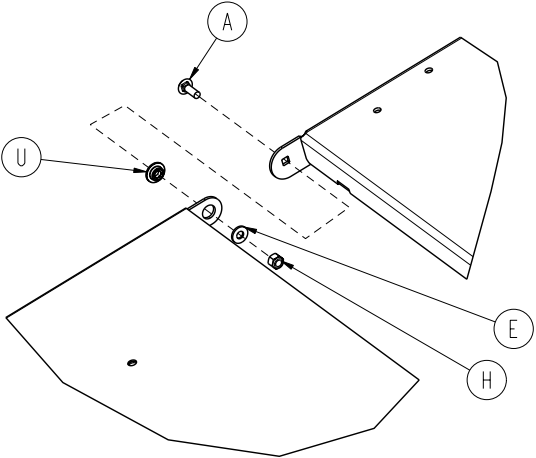

Litter Assembly, Zoom® Option

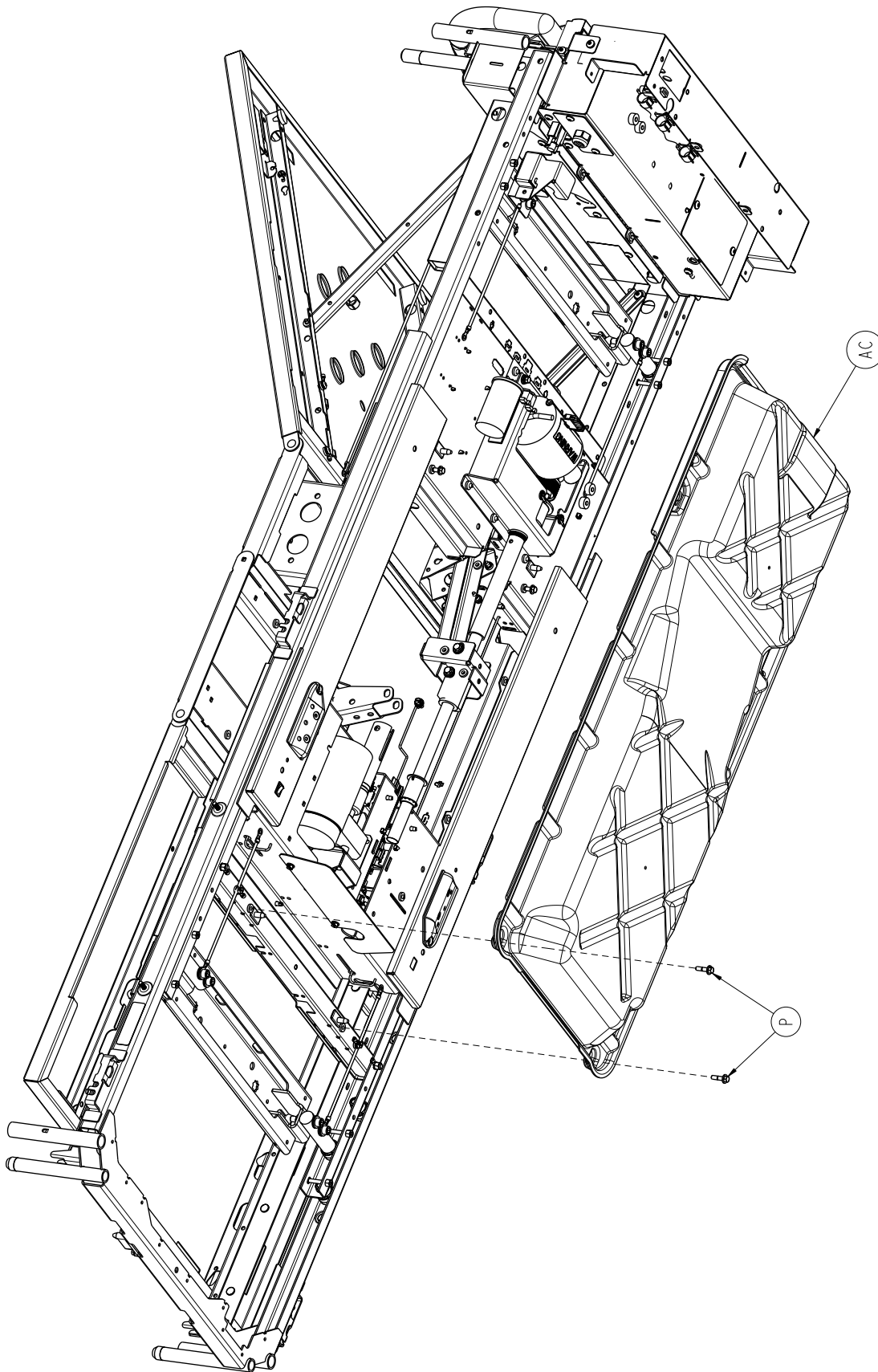

Litter Assembly, Zoom® Option

SEE DETAIL **D**

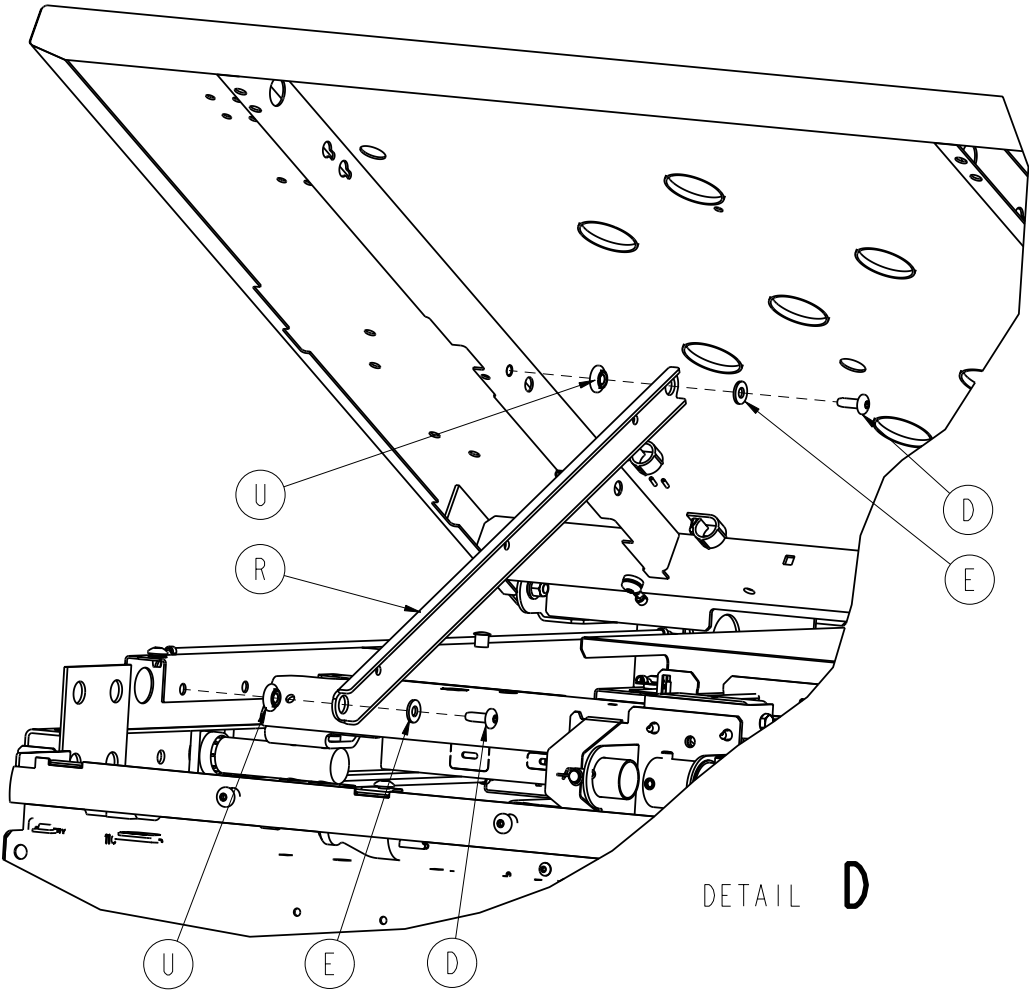
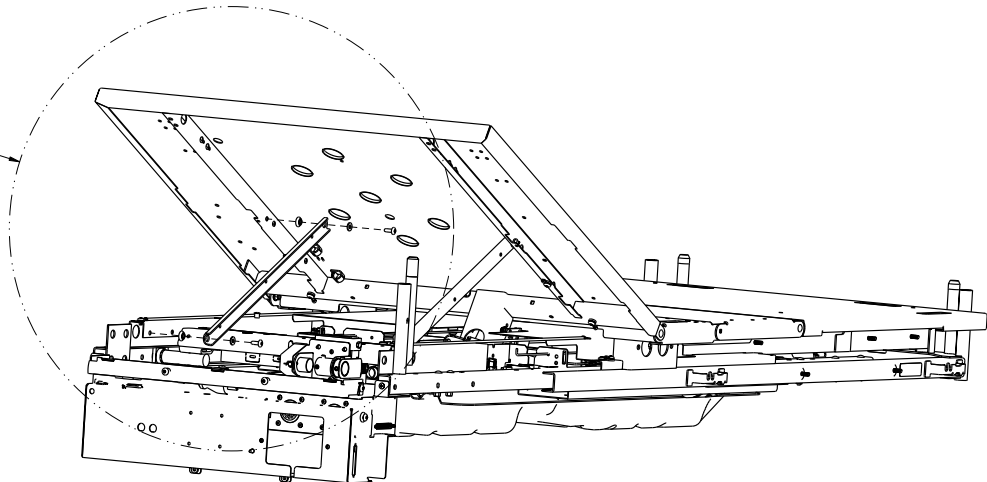

DETAIL **D**

Litter Assembly, Zoom® Option

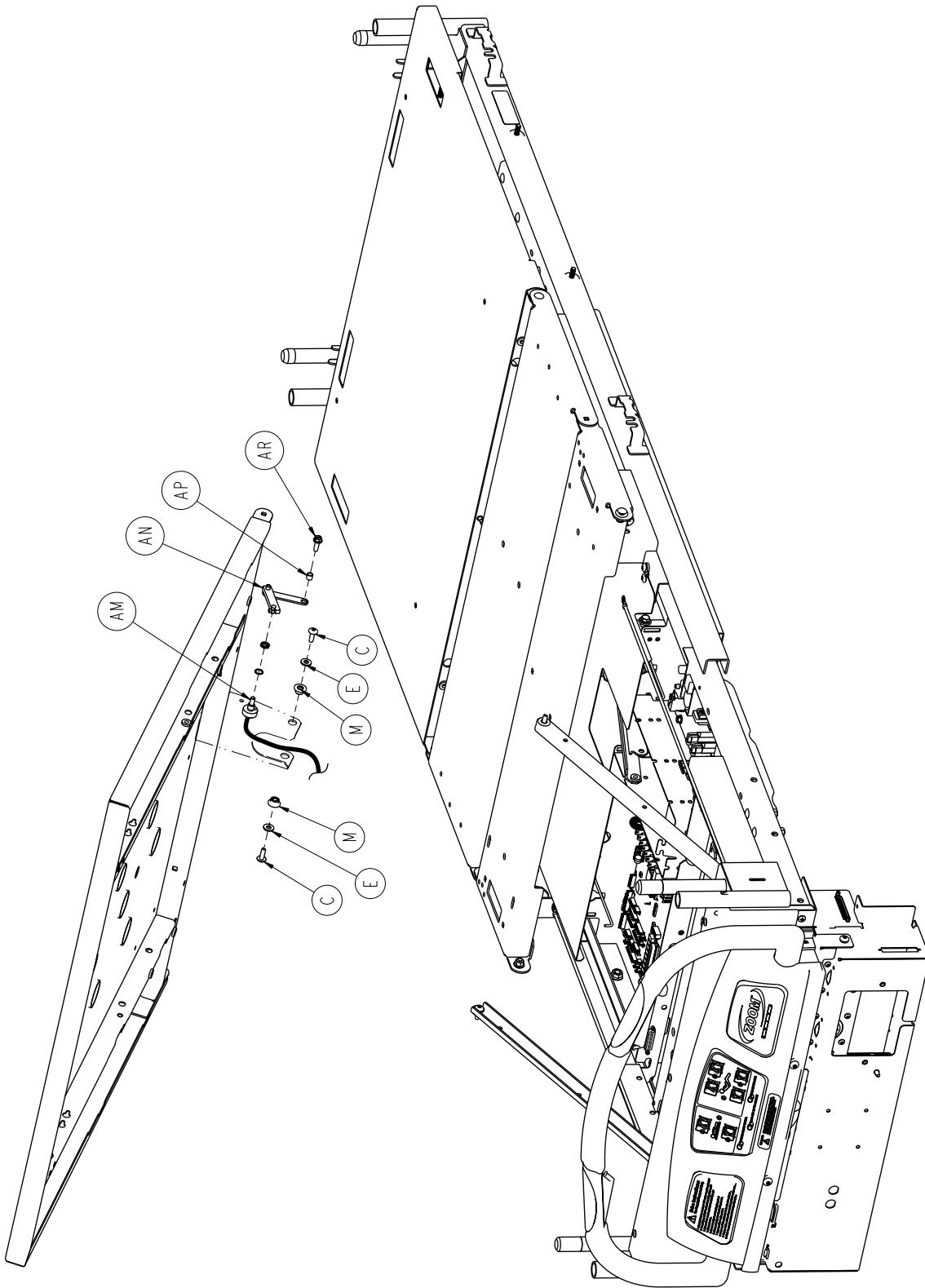

Litter Assembly, Zoom® Option

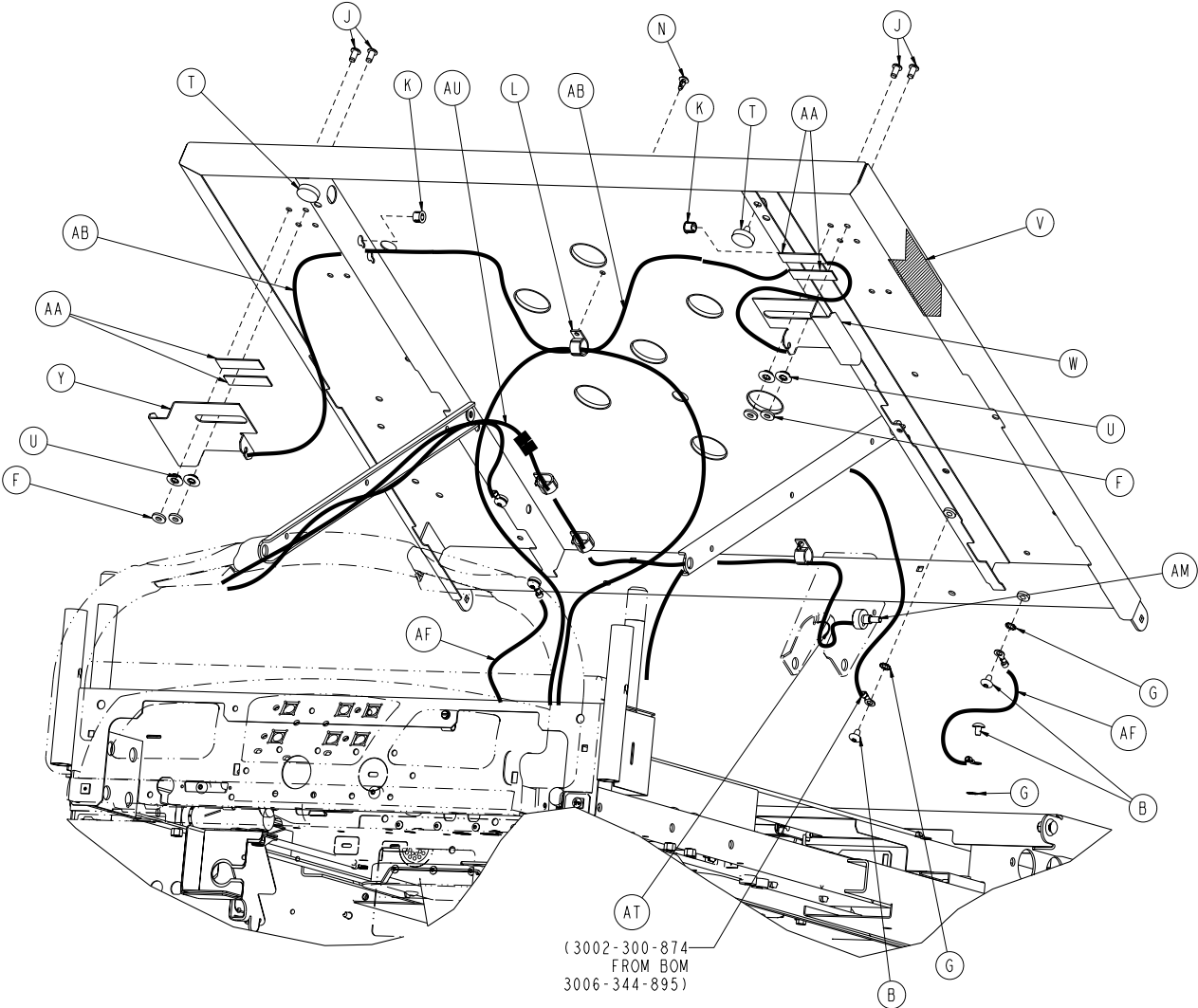

Litter Assembly, Zoom® Option

Litter Assembly, Zoom® Option 3006-344-002 (Reference Only)

| Item | Part No. | Part Name | Qty. |
|------|--------------|----------------------------------|------|
| A | 0005-017-000 | Carriage Bolt | 4 |
| B | 0007-053-000 | Truss Head Screw | 6 |
| C | 0007-063-000 | Truss Head Screw | 2 |
| D | 0007-065-000 | Truss Head Screw | 5 |
| E | 0011-077-000 | Washer | 10 |
| F | 0011-376-000 | Washer | 4 |
| G | 0013-010-000 | External Tooth Lock Washer | 11 |
| H | 0016-028-000 | Fiberlock Hex Nut | 4 |
| J | 0025-120-000 | Pop Rivet | 4 |
| K | 0030-052-000 | Heyco Snap Bushing | 2 |
| L | 0059-743-000 | Wire Harness Clip | 4 |
| M | 3000-300-099 | Fowler Modified Bushing | 2 |
| N | 3000-300-477 | CPR Conduit Stud | 1 |
| P | 3001-200-229 | Mounting Standoff | 2 |
| R | 3006-301-005 | Fowler Link | 2 |
| T | 3001-300-008 | Bumper | 2 |
| U | 3001-300-099 | Fowler Modified Bushing | 10 |
| V | 3006-300-603 | CPR Release Label | 2 |
| W | 3001-300-661 | CPR Handle RH | 1 |
| Y | 3001-300-662 | CPR Handle LH | 1 |
| AA | 3001-300-663 | Velcro® Strip | 4 |
| AB | 3001-300-670 | CPR Cable Assembly | 2 |
| AC | 3002-300-083 | Motion Interrupt Pan | 1 |
| AD | 3006-300-145 | Fowler Litter Weldment | 1 |
| AE | 3006-300-602 | Fowler Elevation Angle Label | 1 |
| AF | 3002-300-870 | 8" Litter Ground Jumper | 2 |
| AG | 3006-344-895 | Zoom® Bed Electrical Assembly | 1 |
| AH | 3006-300-002 | Litter Assembly, Std. Components | 1 |
| AJ | 3006-300-042 | Foot Cover Assembly | 1 |
| AK | 3006-300-190 | Foot Litter Weldment | 1 |
| AL | 3006-300-349 | Foot End Litter Cap | 2 |
| AM | 3001-345-807 | Fowler Pot | 1 |
| AN | 3004-345-450 | Pot Linkage | 1 |
| AP | 3001-400-558 | Spacer | 1 |
| AR | 0003-226-000 | Hex Washer Head Screw | 1 |
| AT | 3000-300-113 | 8" Cable Tie | 1 |
| AU | 3001-345-809 | Fowler Pot Extension Cable (KCI) | 1 |

Litter Assembly, Battery Backup, iBed® Wireless

For Reference Only: 5212-350-200

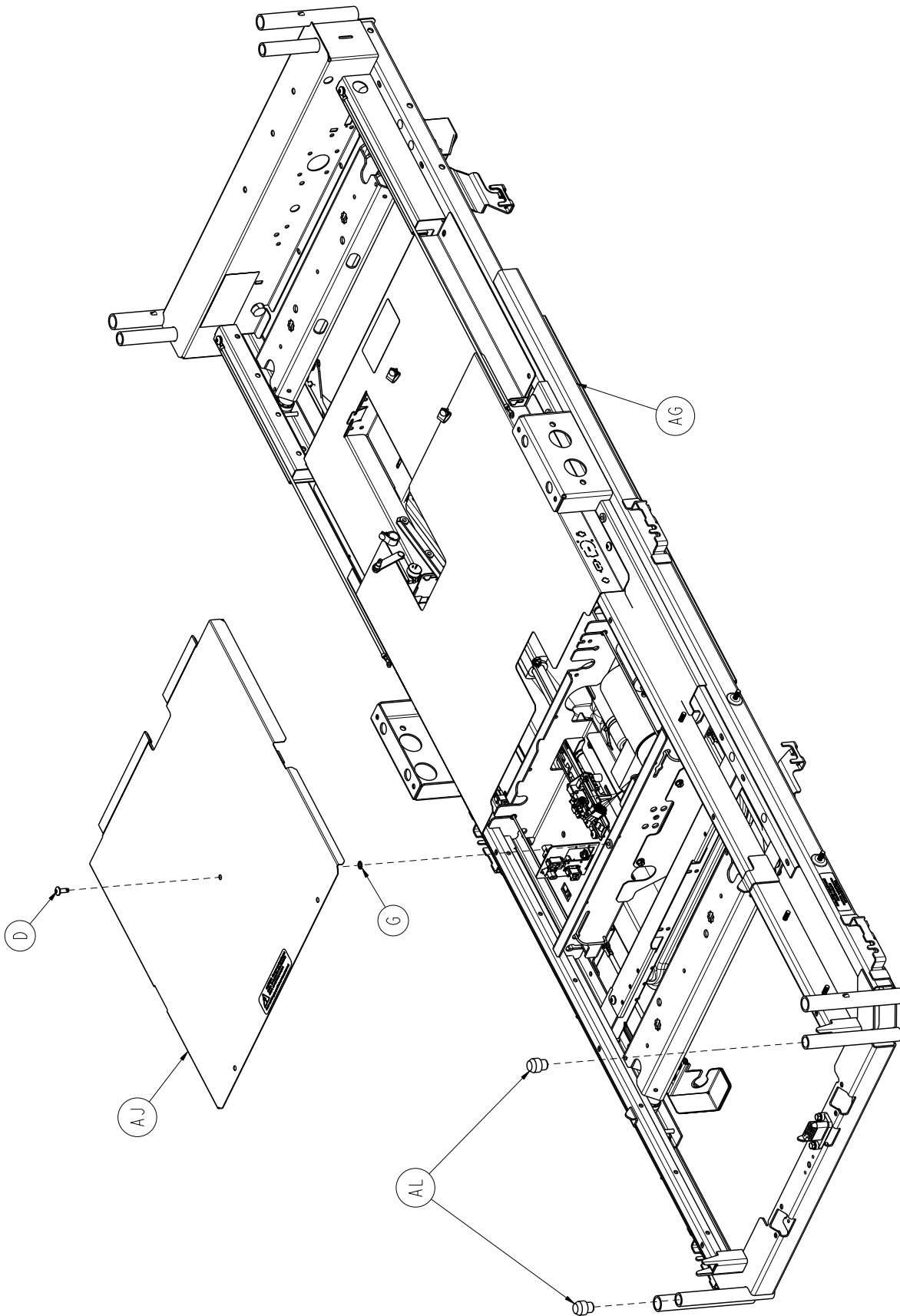

[Return To Table of Contents](#)

Litter Assembly, Battery Backup, iBed® Wireless

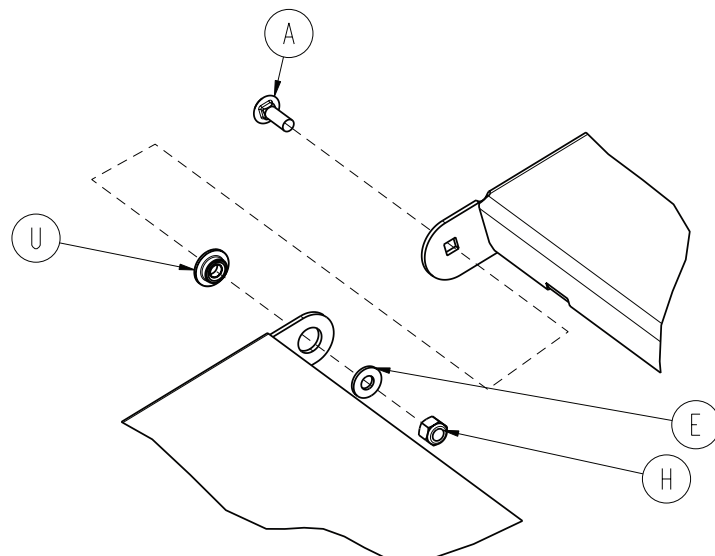
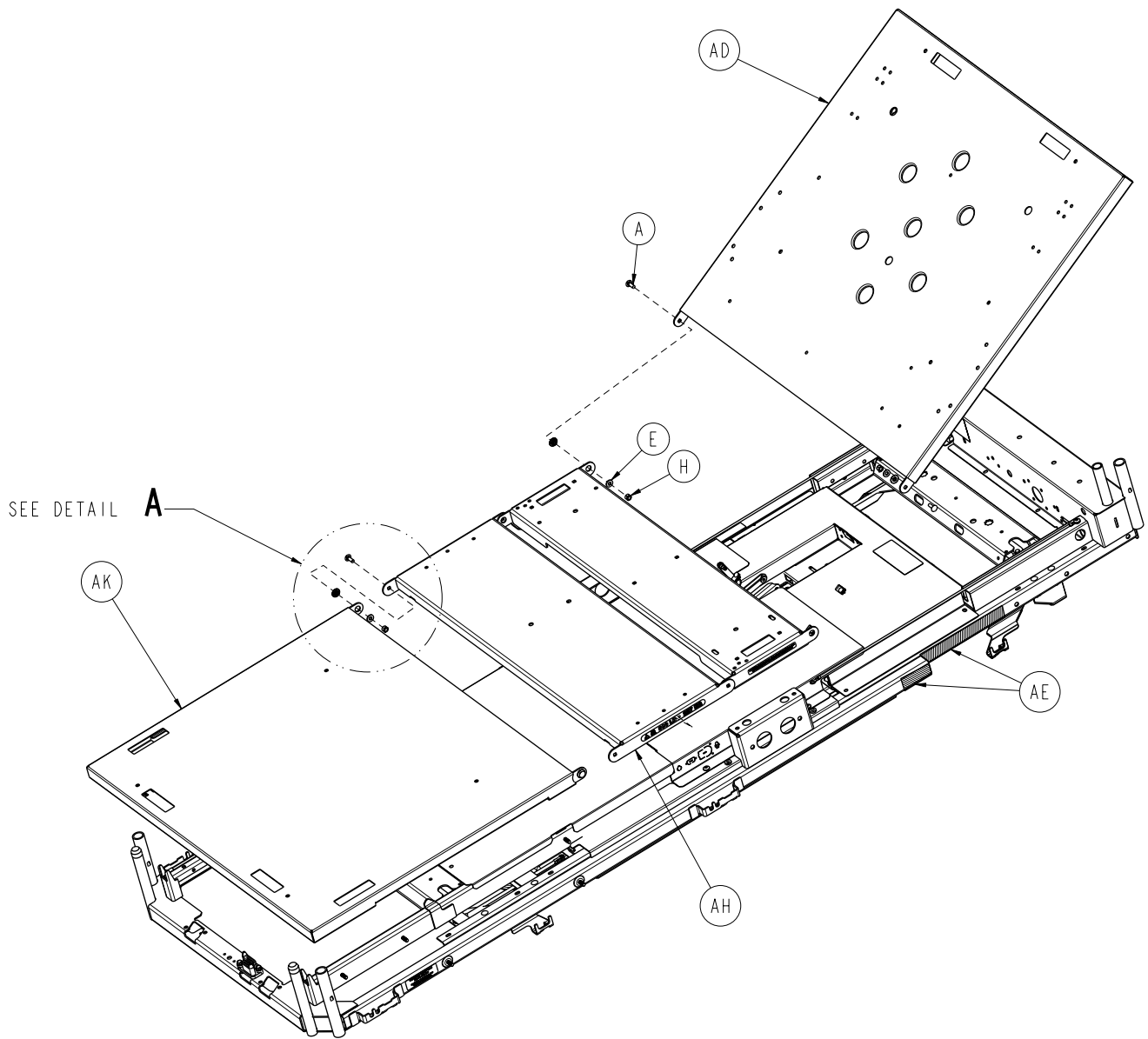

DETAIL **A**

Litter Assembly, Battery Backup, iBed® Wireless

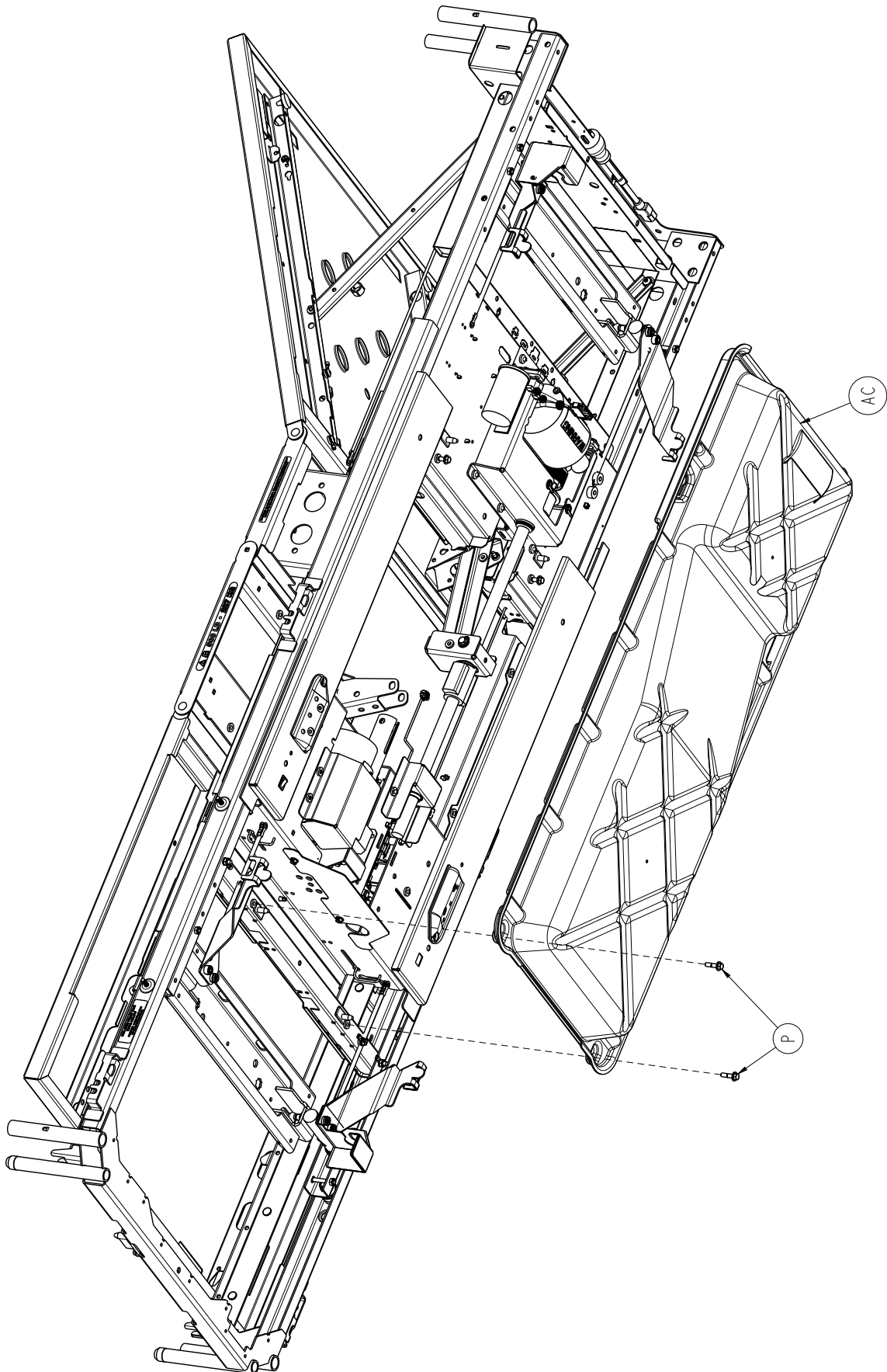

Litter Assembly, Battery Backup, iBed® Wireless

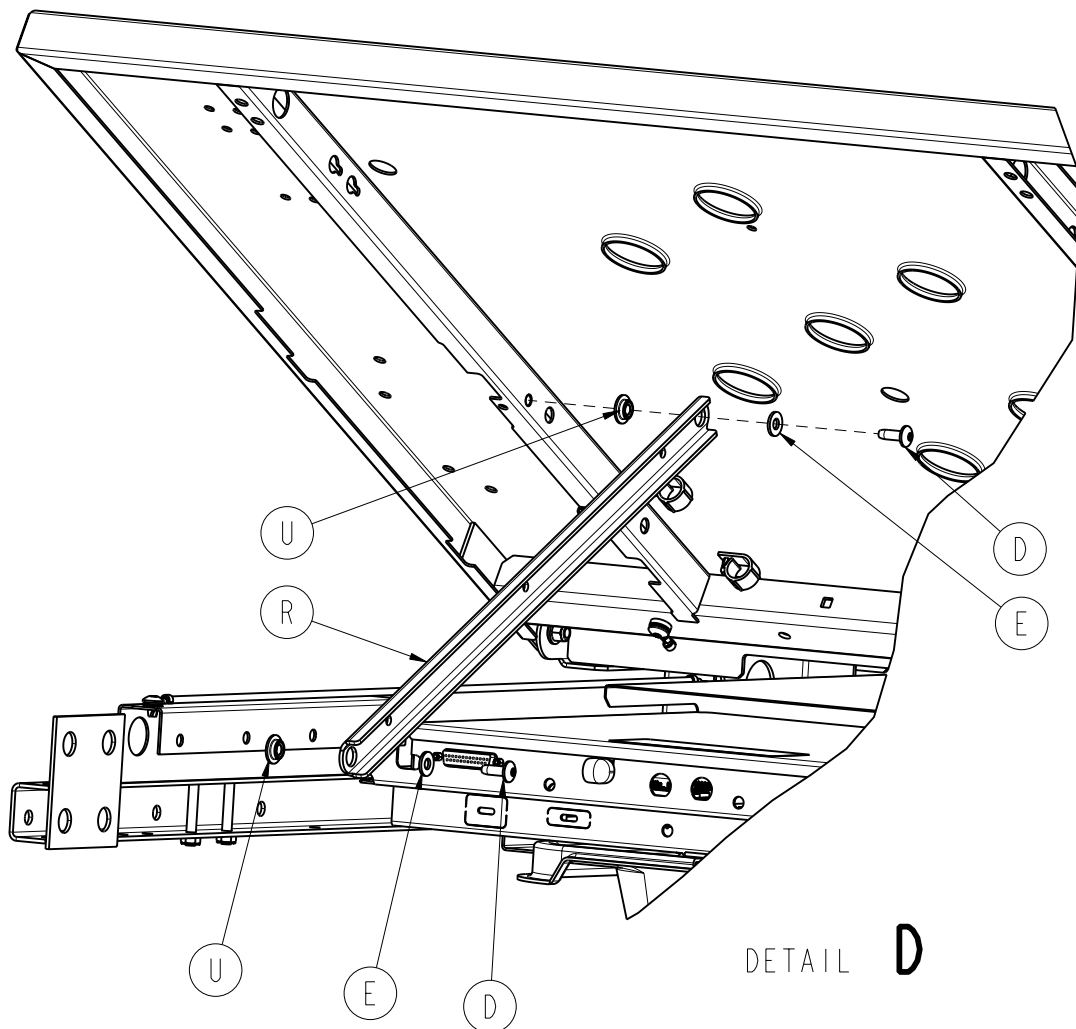
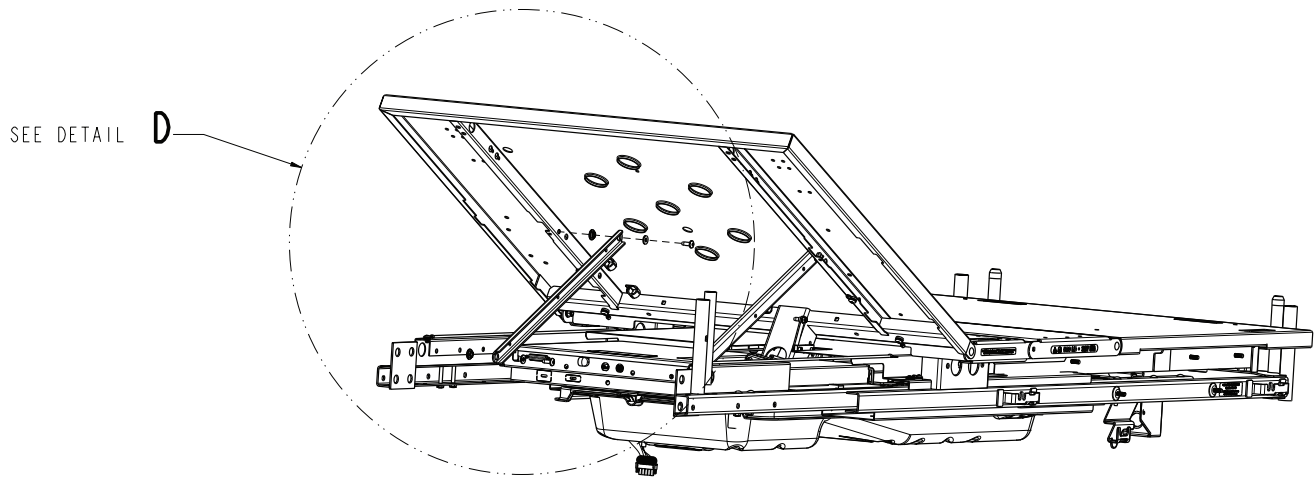

Litter Assembly, Battery Backup, iBed® Wireless

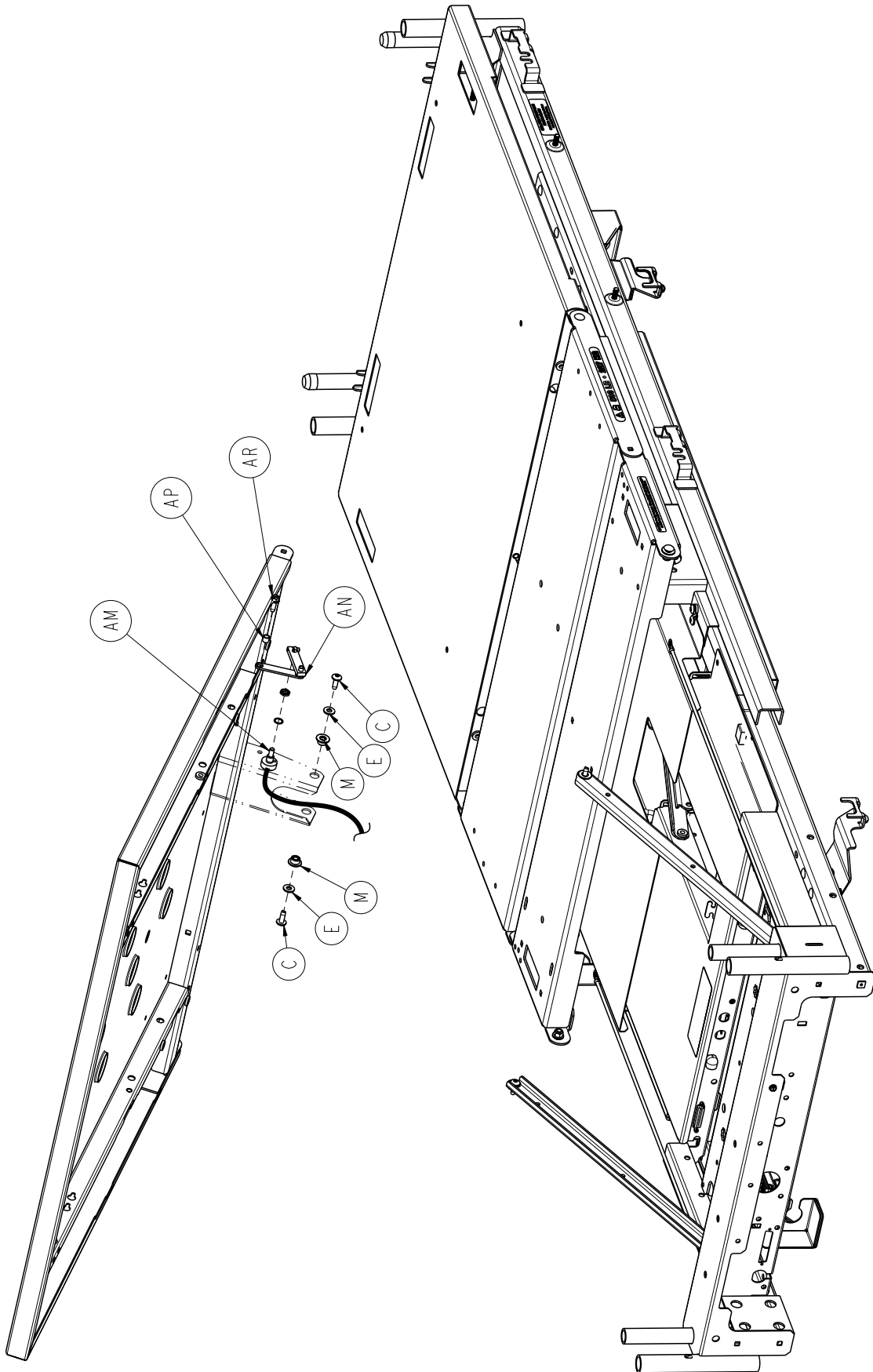

[Return To Table of Contents](#)

Litter Assembly, Battery Backup, iBed® Wireless

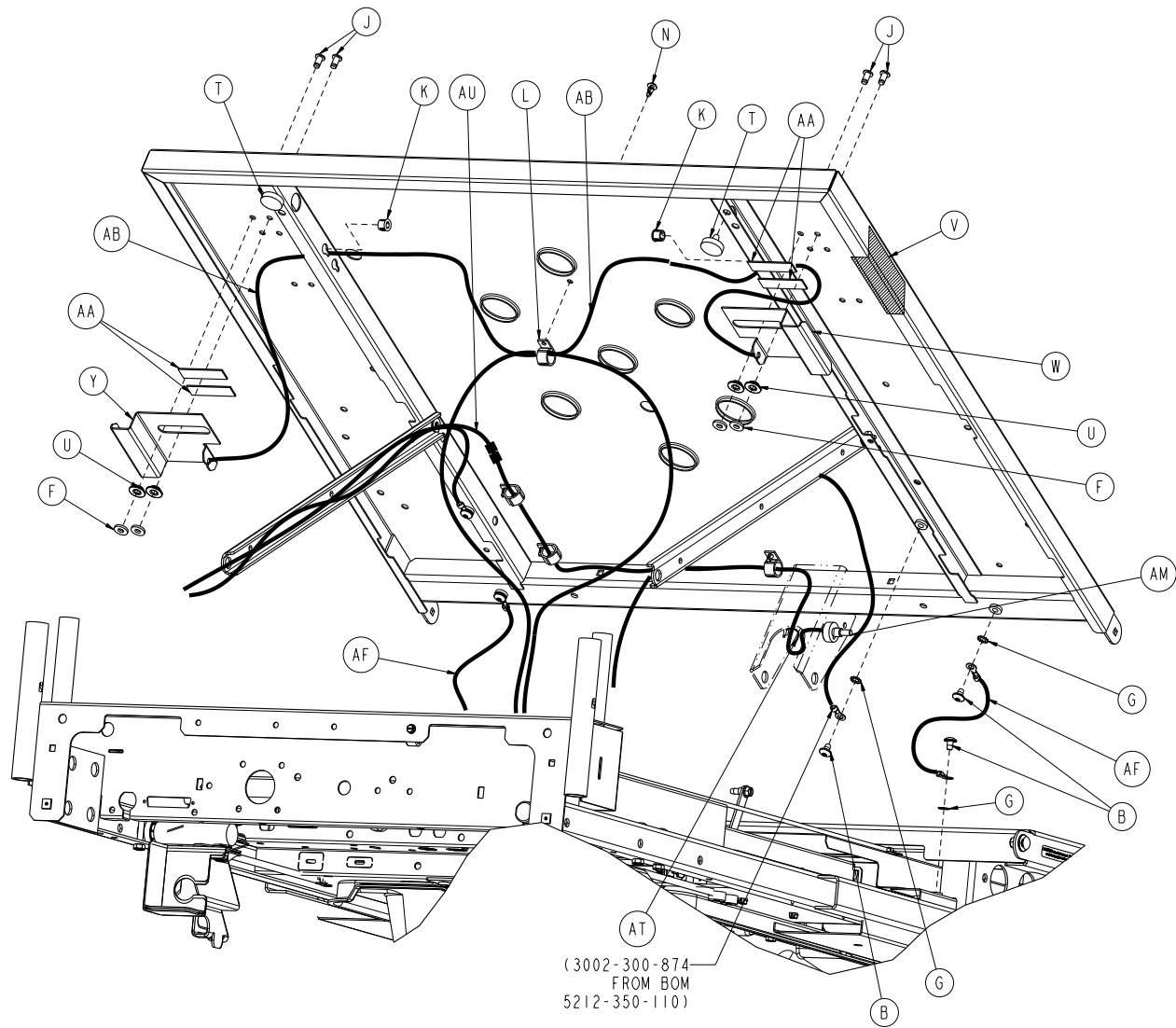

Litter Assembly, Battery Backup, iBed® Wireless

Litter Assembly, Battery Backup, iBed® Wireless - 5212-350-200 - (Reference Only)

| item | Part No. | Part Name | Qty. |
|------|--------------|---|------|
| A | 0005-017-000 | Carriage Bolt | 4 |
| B | 0007-053-000 | Truss Head Screw | 6 |
| C | 0007-063-000 | Truss Head Screw | 2 |
| D | 0007-065-000 | Truss Head Screw | 5 |
| E | 0011-077-000 | Washer | 10 |
| F | 0011-376-000 | Washer | 4 |
| G | 0013-010-000 | 1/4" External Tooth Lock Washer | 11 |
| H | 0016-028-000 | Fiberlock Hex Nut | 4 |
| J | 0025-120-000 | Pop Rivet | 4 |
| K | 0030-052-000 | Heyco Snap Bushing | 2 |
| L | 0059-743-000 | Wire Harness Clip | 4 |
| M | 3000-300-099 | Bushing-Fowler Modified | 2 |
| N | 3000-300-477 | CPR Conduit Stud | 1 |
| P | 3001-200-229 | Mounting Standoff | 2 |
| R | 3006-301-005 | Fowler Link | 2 |
| T | 3001-300-008 | Bumper | 2 |
| U | 3001-300-099 | Fowler Modified Bushing | 10 |
| V | 3006-300-603 | Label, CPR Release | 2 |
| W | 3001-300-661 | CPR Handle, Right | 1 |
| Y | 3001-300-662 | CPR Handle, Left | 1 |
| AA | 3001-300-663 | Velcro® Strip | 4 |
| AB | 3001-300-670 | CPR Cable Assembly | 2 |
| AC | 3002-300-083 | Motion Interrupt Pan | 1 |
| AD | 3006-300-145 | Weldment, Fowler Litter | 1 |
| AE | 3006-300-602 | Bl. Stn. Label, Fowler Elev. Angle | 1 |
| AF | 3002-300-870 | 8" Litter Ground Jumper | 2 |
| AG | 5212-350-110 | Assembly, Electrical Litter, Battery Backup, iBed Wireless | 1 |
| AH | 3006-300-002 | Litter Assembly, Std. Components | 1 |
| AJ | 3006-300-042 | Foot Cover Assembly | 1 |
| AK | 3006-300-190 | Foot Litter Weldment | 1 |
| AL | 3006-300-349 | Cap | 2 |
| AM | 3001-345-807 | Cable, Fowler Pot | 1 |
| AN | 3004-345-450 | Pot Linkage Assembly | 1 |
| AP | 3001-400-558 | Spacer | 1 |
| AR | 0003-226-000 | Hex Washer Head Screw | 1 |
| AT | 3000-300-113 | 8" Cable Tie | 1 |
| AU | 3001-345-809 | Cable, Fowler Pot Extension (KCI) | 1 |

Litter Assembly, Zoom[®], iBed[®] Wireless

For Reference Only: 5212-344-002

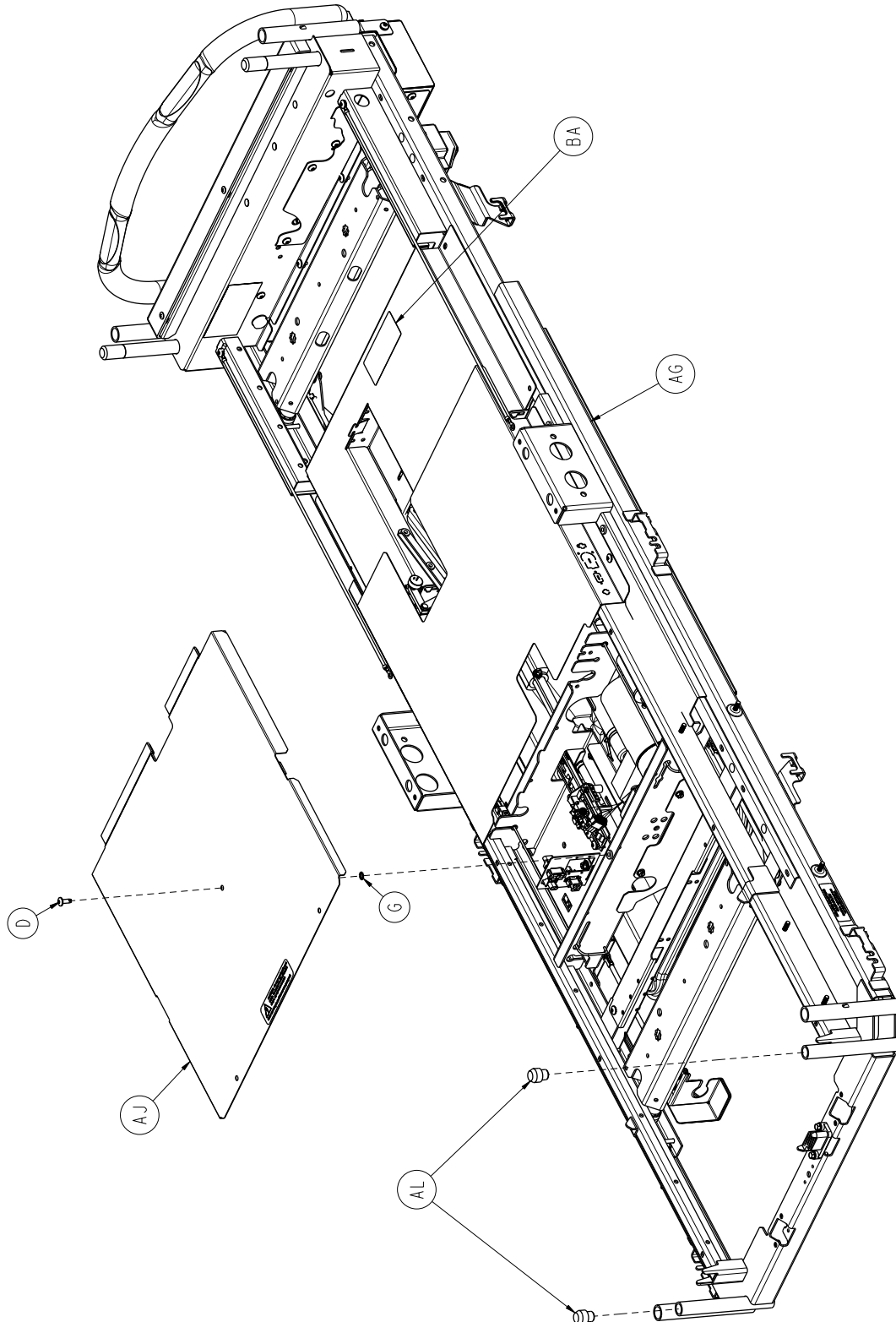

Litter Assembly, Zoom®, iBed® Wireless

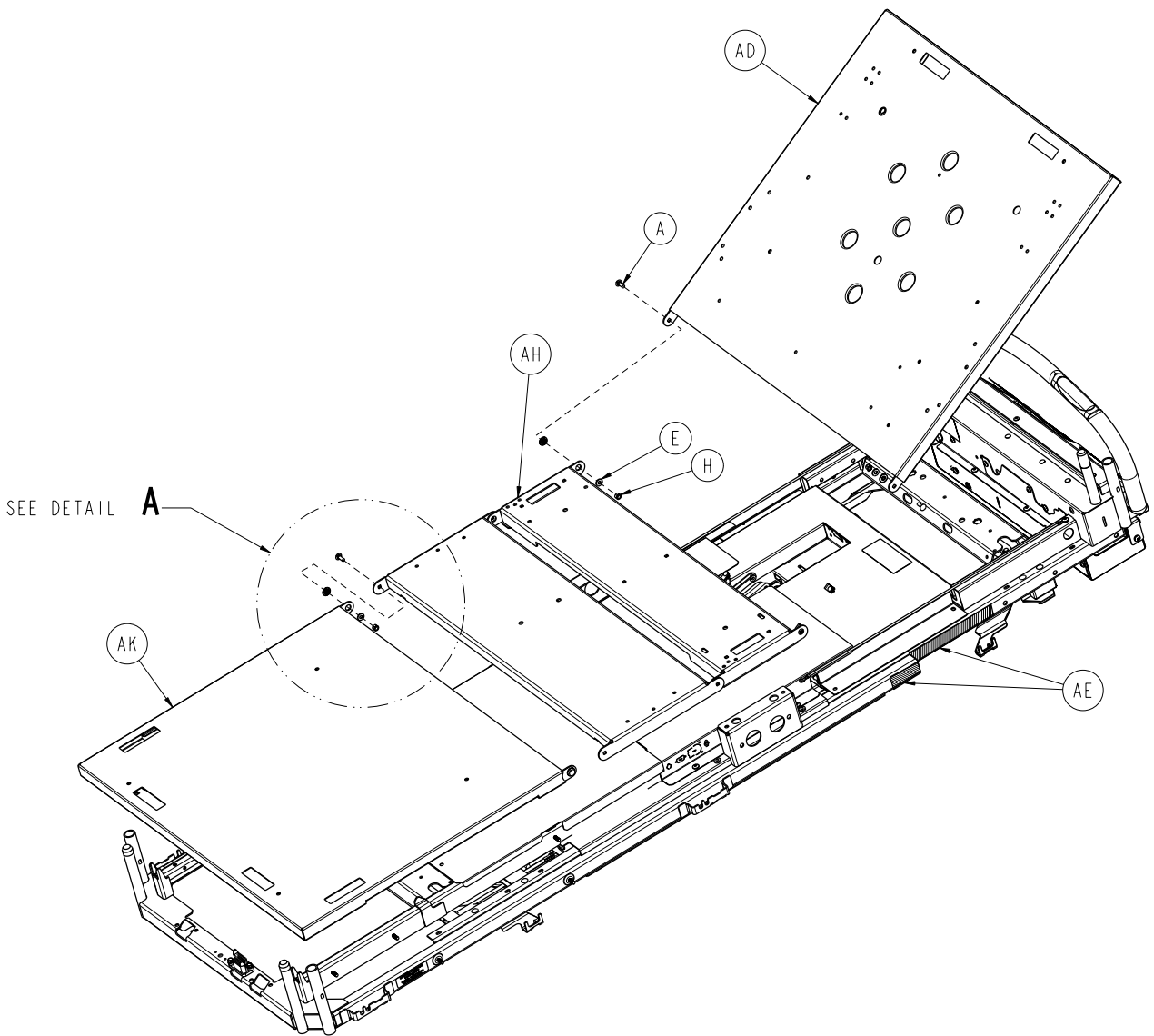

DETAIL A

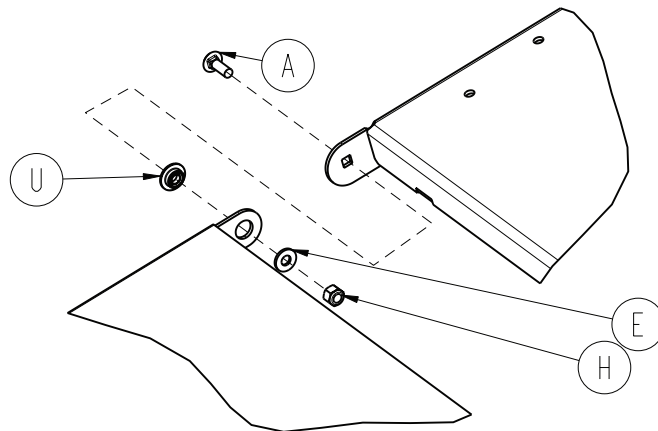

Litter Assembly, Zoom®, iBed® Wireless

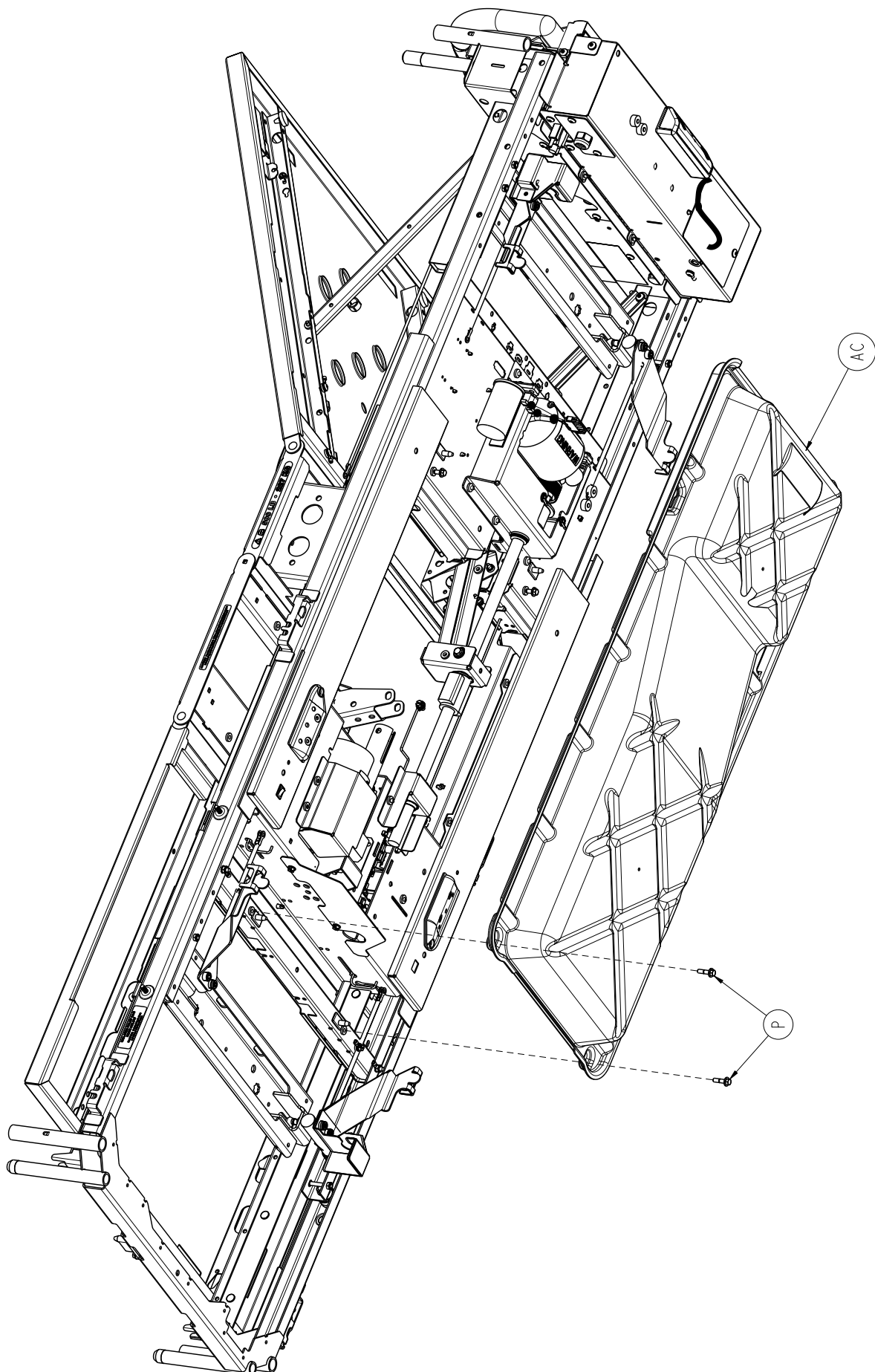

Litter Assembly, Zoom®, iBed® Wireless

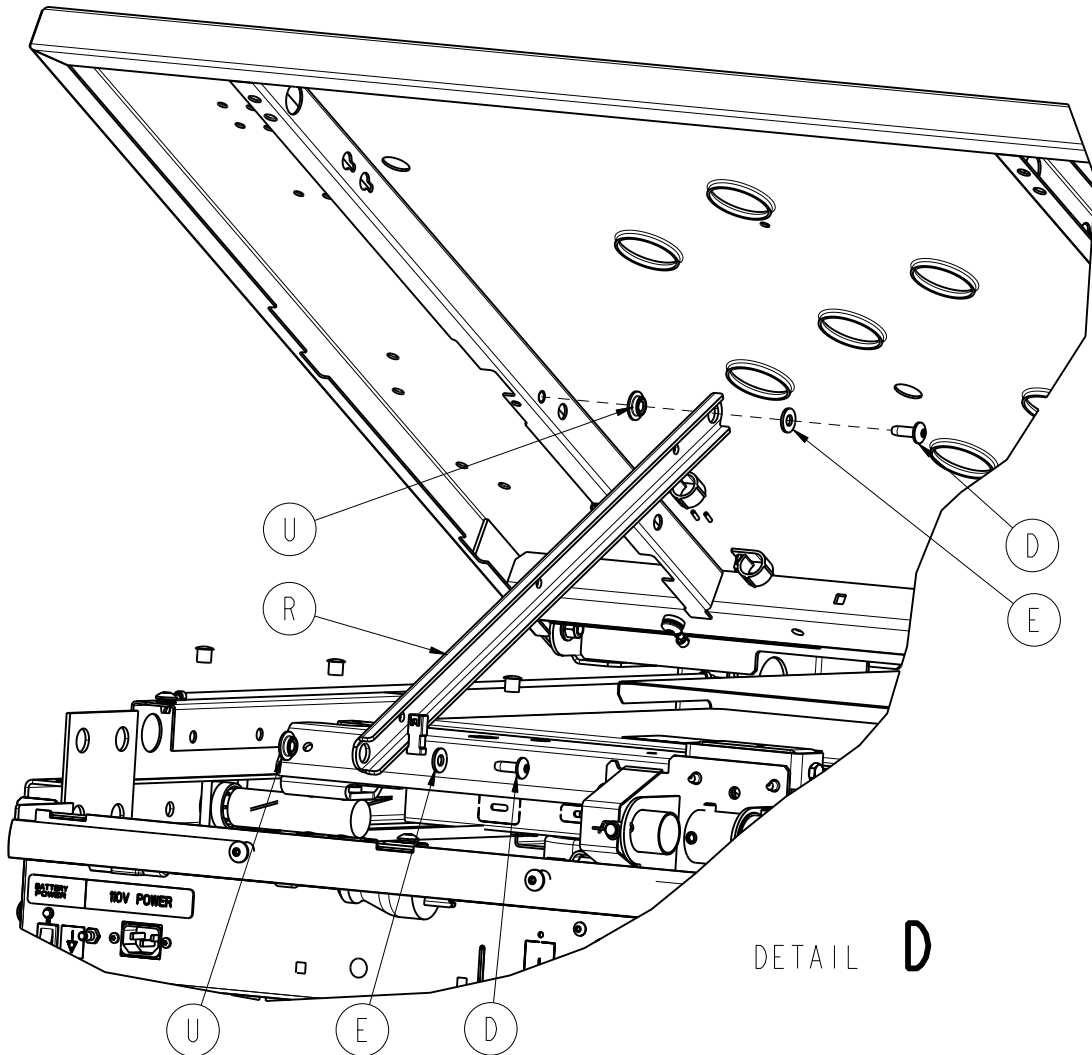
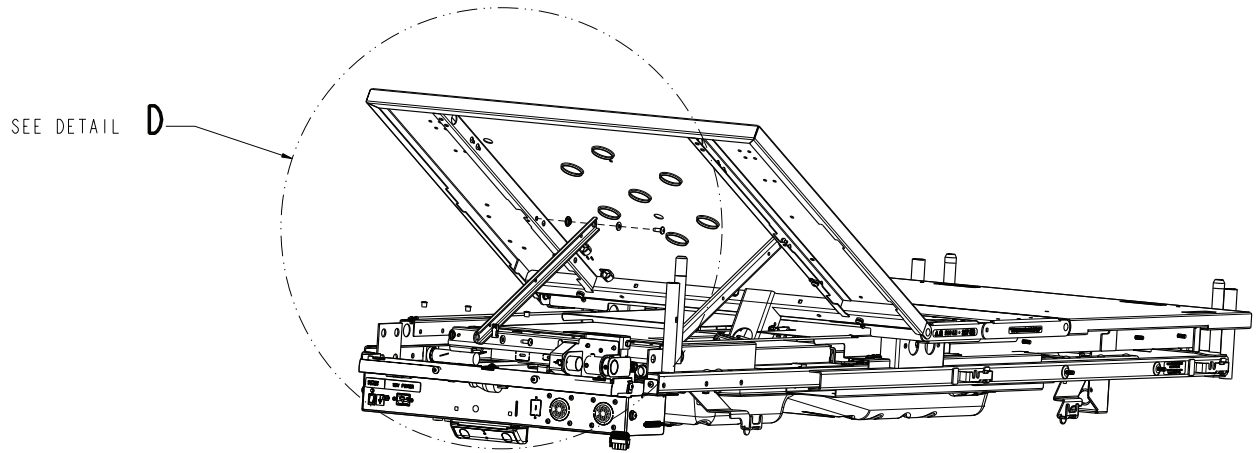

Litter Assembly, Zoom®, iBed® Wireless

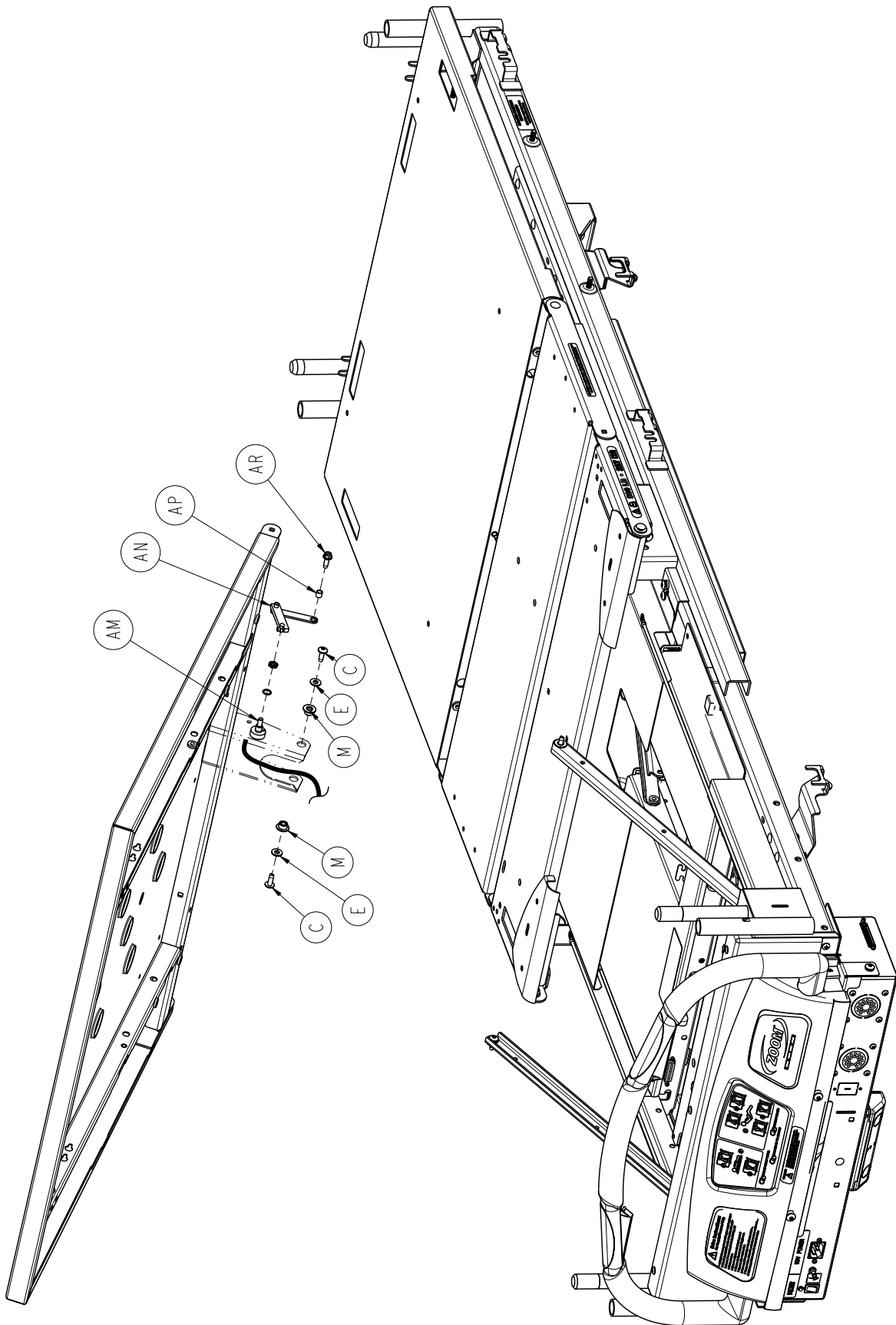

Litter Assembly, Zoom®, iBed® Wireless

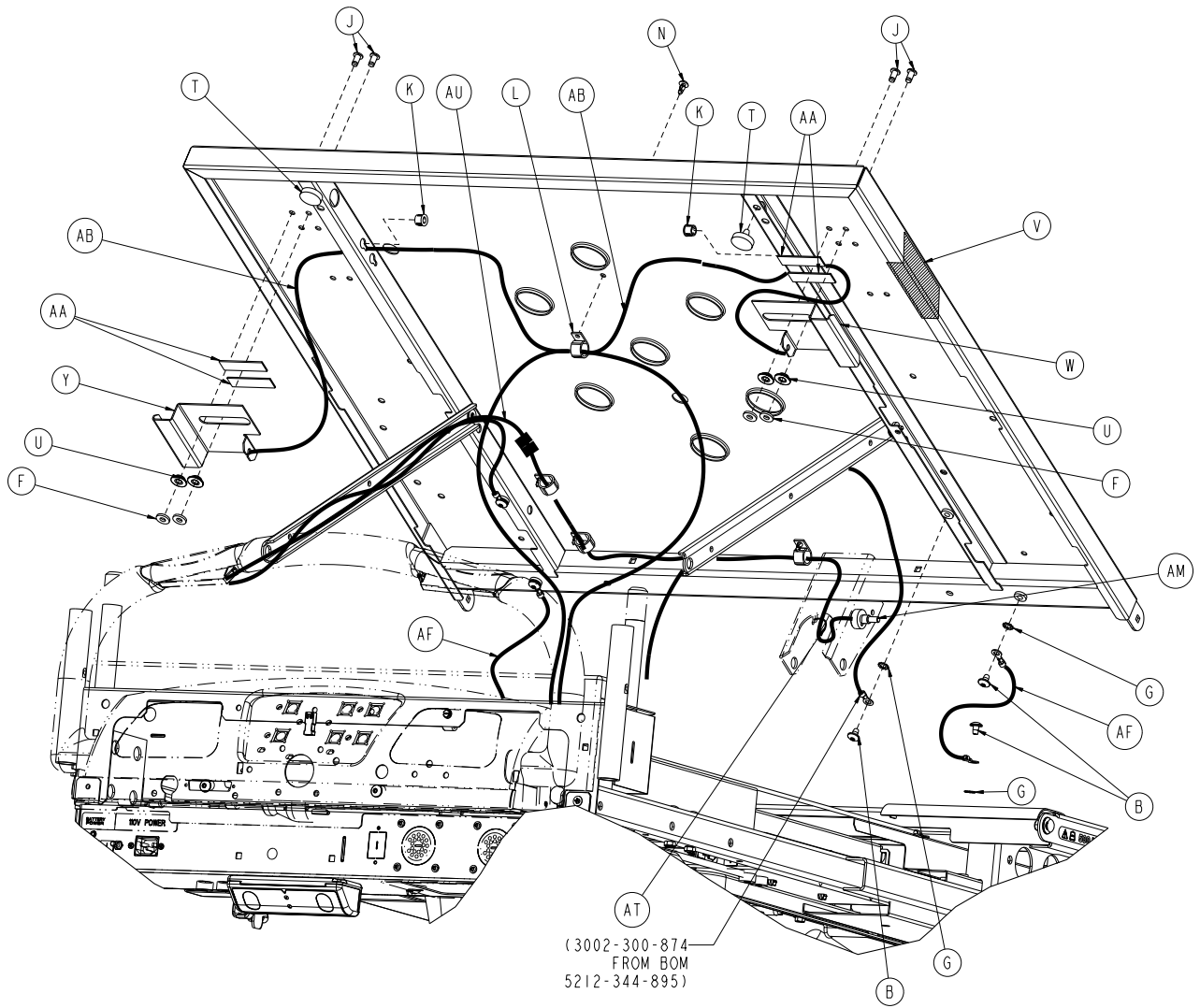

Litter Assembly, Zoom®, iBed® Wireless

Litter Assembly, Zoom®, iBed® Wireless - 5212-344-002 - (Reference Only)

| item | Part No. | Part Name | Qty. |
|------|--------------|--|------|
| A | 0005-017-000 | Carriage Bolt | 4 |
| B | 0007-053-000 | Truss Head Screw | 6 |
| C | 0007-063-000 | Truss Head Screw | 2 |
| D | 0007-065-000 | Truss Head Screw | 5 |
| E | 0011-077-000 | Washer | 10 |
| F | 0011-376-000 | Washer | 4 |
| G | 0013-010-000 | 1/4" External Tooth Lock Washer, | 11 |
| H | 0016-028-000 | Fiberlock Hex Nut | 4 |
| J | 0025-120-000 | Pop Rivet | 4 |
| K | 0030-052-000 | Heyco Snap Bushing 2043 | 2 |
| L | 0059-743-000 | Wire Harness Clip | 4 |
| M | 3000-300-099 | Bushing-Fowler Modified | 2 |
| N | 3000-300-477 | CPR Conduit Stud | 1 |
| P | 3001-200-229 | Mounting Standoff | 2 |
| R | 3006-301-005 | Fowler Link | 2 |
| T | 3001-300-008 | Bumper | 2 |
| U | 3001-300-099 | Fowler Modified Bushing | 10 |
| V | 3006-300-603 | Label, CPR Release | 2 |
| W | 3001-300-661 | CPR Handle, Right | 1 |
| Y | 3001-300-662 | CPR Handle, Left | 1 |
| AA | 3001-300-663 | Velcro® Strip | 4 |
| AB | 3001-300-670 | CPR Cable Assembly | 2 |
| AC | 3002-300-083 | Motion Interrupt Pan | 1 |
| AD | 3006-300-145 | Weldment, Fowler Litter | 1 |
| AE | 3006-300-602 | Label-Fowler Elevation Angle | 1 |
| AF | 3002-300-870 | 8" Litter Ground Jumper | 2 |
| AG | 5212-344-895 | Assembly, Electrical Litter, Zoom®, iBed Wireless | 1 |
| AH | 3006-300-002 | Litter Assy. Std. Components | 1 |
| AJ | 3006-300-042 | Foot Cover Assembly | 1 |
| AK | 3006-300-190 | Foot Litter Weldment | 1 |
| AL | 3006-300-349 | Cap | 2 |
| AM | 3001-345-807 | Fowler Pot Cable | 1 |
| AN | 3004-345-450 | Pot Linkage Assembly | 1 |
| AP | 3001-400-558 | Spacer | 1 |
| AR | 0003-226-000 | Hex Washer Head Screw | 1 |
| AT | 3000-300-113 | 8" Cable Tie | 1 |
| AU | 3001-345-809 | Cable, Fowler Pot Extension (KCI) | 1 |

Foot Prop Assembly

3003-034-010

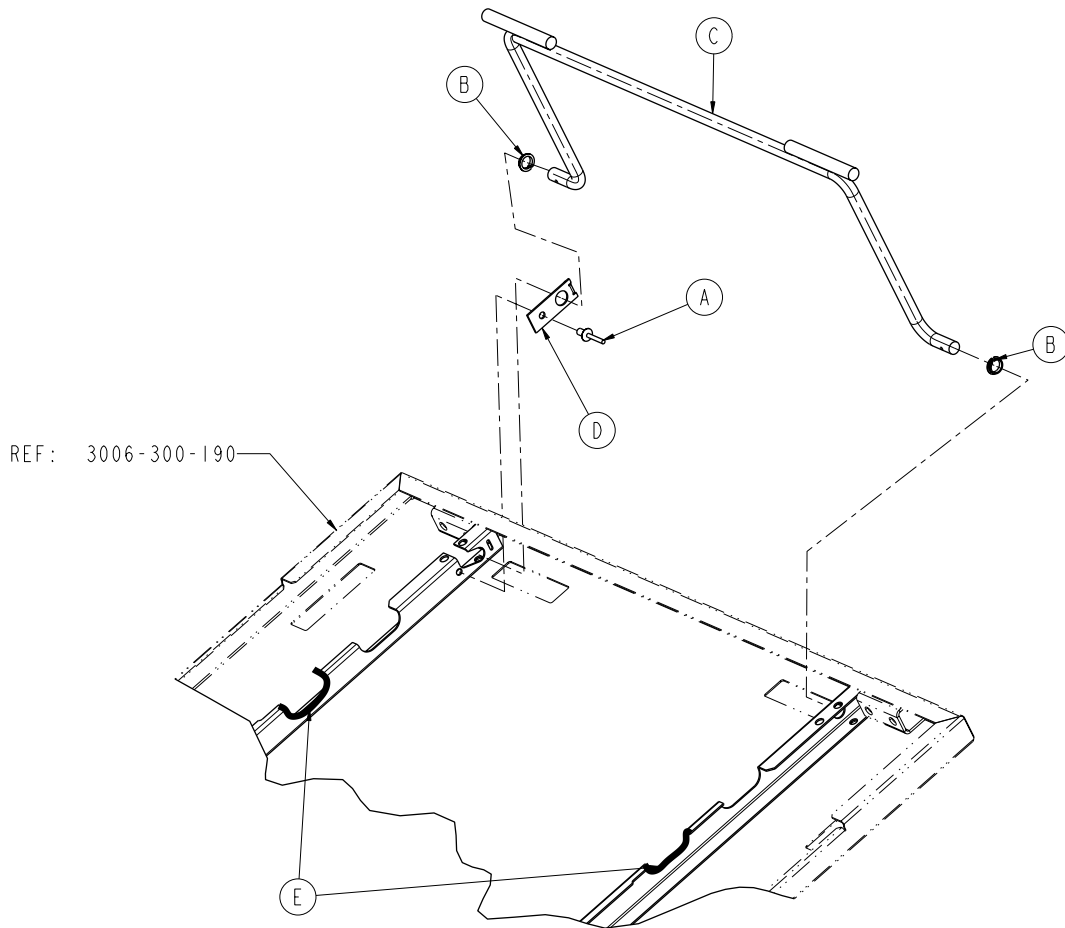

| Item | Part No. | Part Name | Qty. |
|------|--------------|-------------------------------|------|
| A | 0025-177-000 | Dome Head Rivet | 1 |
| B | 0052-754-000 | Nyliner Bearing | 2 |
| C | 3006-300-160 | Foot Prop Rod Weldment | 1 |
| D | 3006-300-186 | Prop Rod Retainer | 1 |
| E | 0058-056-000 | 1/8" Edge Cover with Adhesive | 3.0" |

Litter CPU Cover Assembly - 3006-301-097

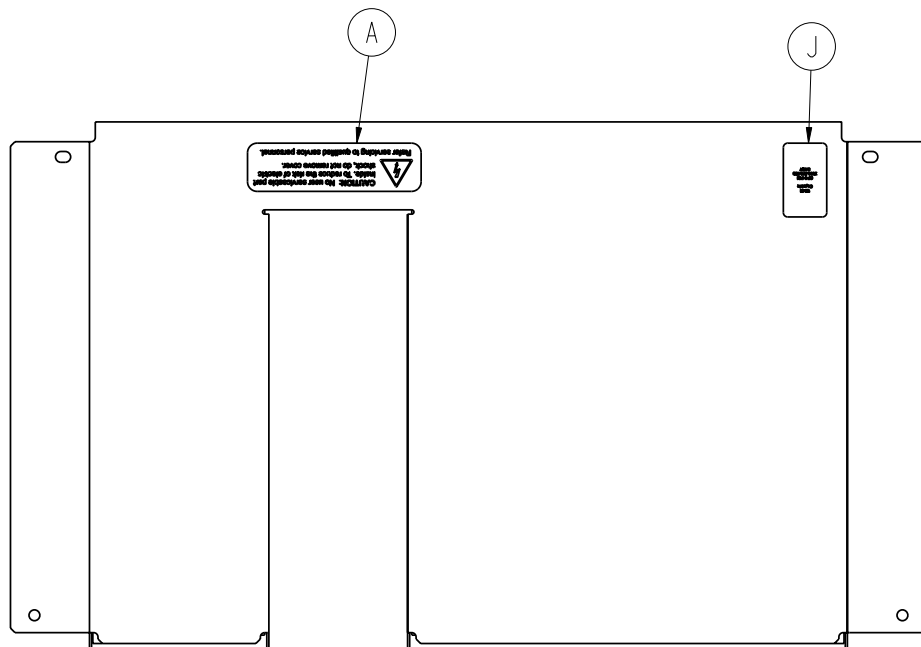
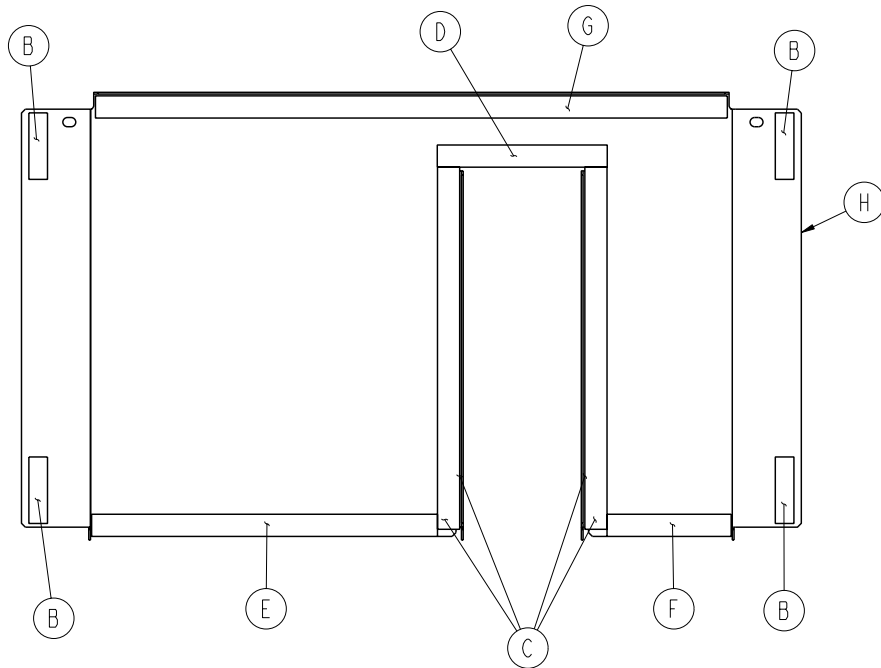

| Item | Part No. | Part Name | Qty. |
|------|--------------|---------------------|------|
| A | 3006-002-708 | Label, Shock Hazard | 1 |
| B | 3001-300-663 | Velcro® Strip | 4 |
| C | 7900-001-291 | Foam Tape (12.25") | 4 |
| D | 7900-001-291 | Foam Tape (5.75") | 1 |
| E | 7900-001-291 | Foam Tape (11.75") | 1 |
| F | 7900-001-291 | Foam Tape (4.25") | 1 |
| G | 7900-001-291 | Foam Tape (21.38") | 1 |
| H | 3006-300-098 | CPU Cover | 1 |
| J | 3006-508-105 | Label, WiFi Capable | 1 |

Foot Cover Assembly - 3003-300-042

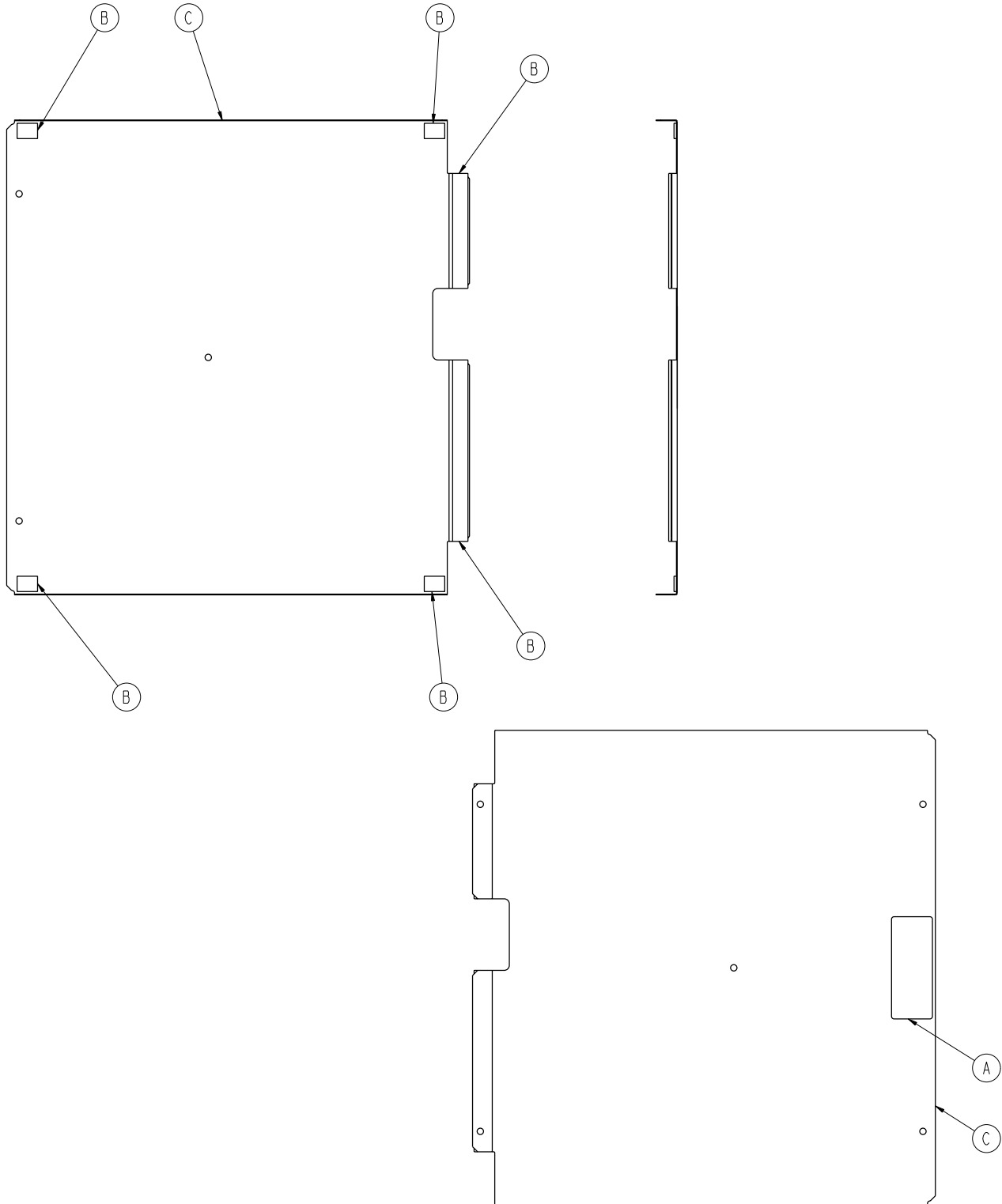

| Item | Part No. | Part Name | Qty. |
|------|--------------|---------------|------|
| A | 0988-002-708 | Caution Label | 1 |
| B | 7900-001-291 | Foam Tape | 1.5' |
| C | 3003-300-043 | Foot Cover | 1 |

Electrical Litter Assembly, Standard Bed

For Reference Only: 3006-343-895

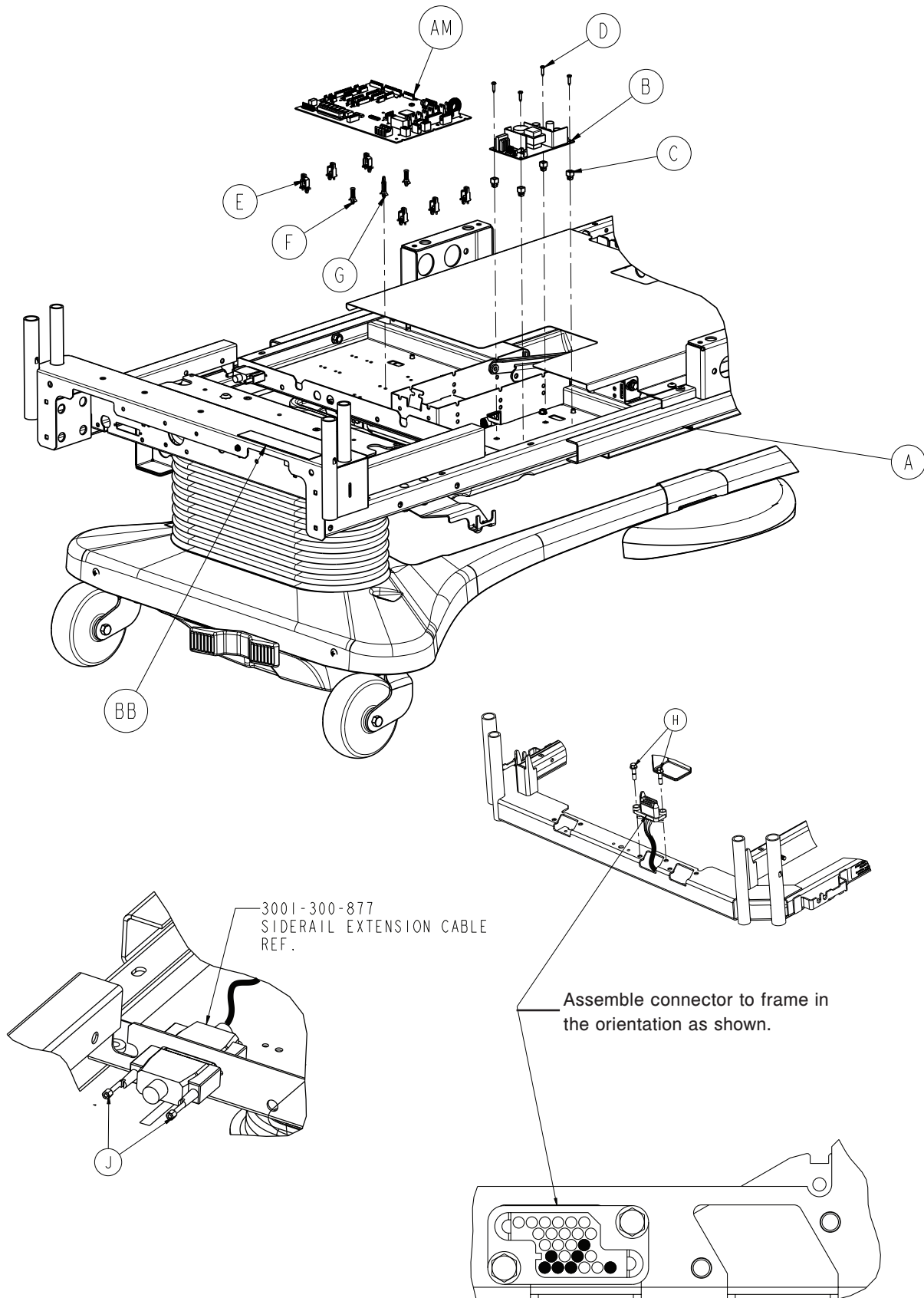

Electrical Litter Assembly, Standard Bed

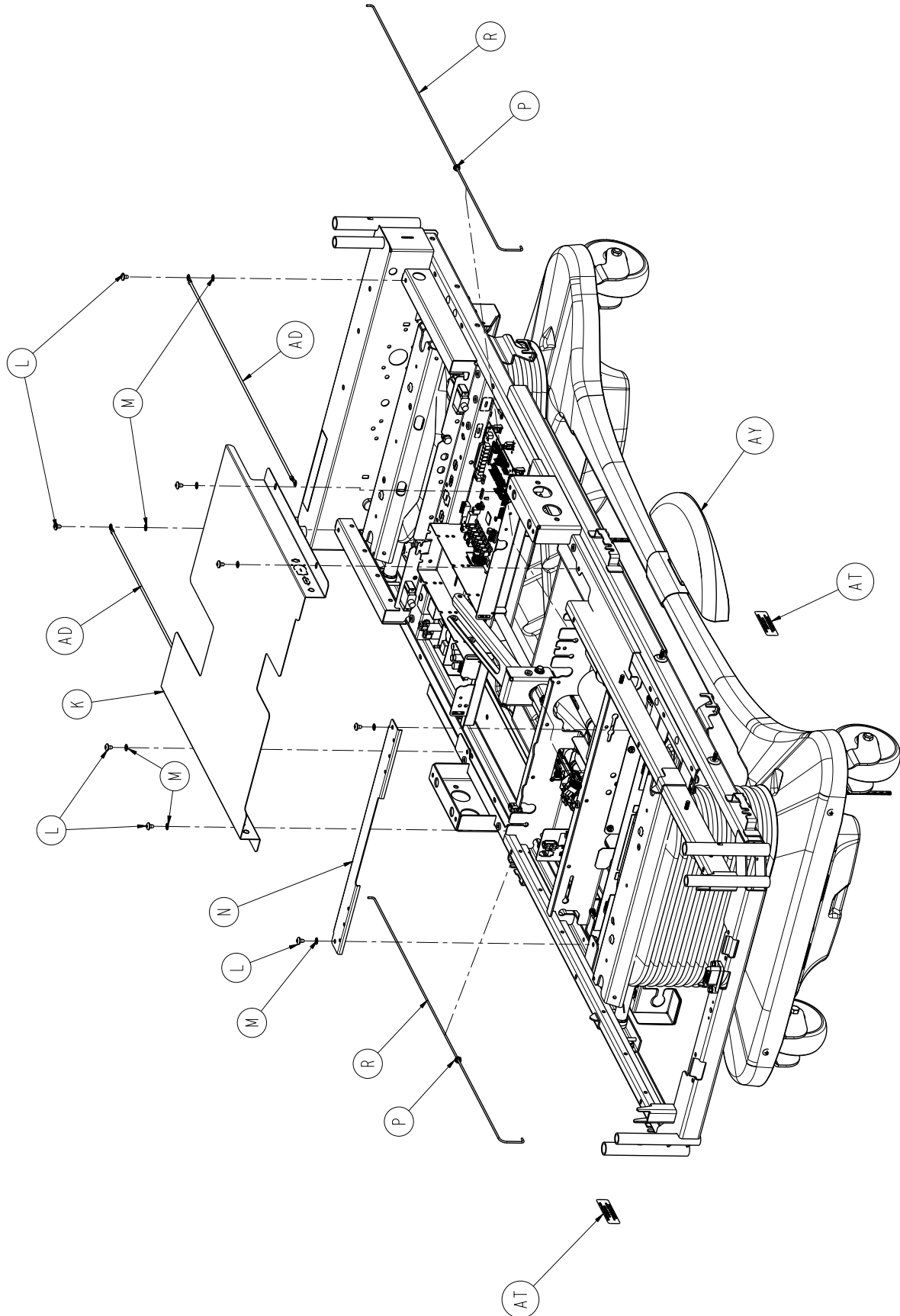

Electrical Litter Assembly, Standard Bed

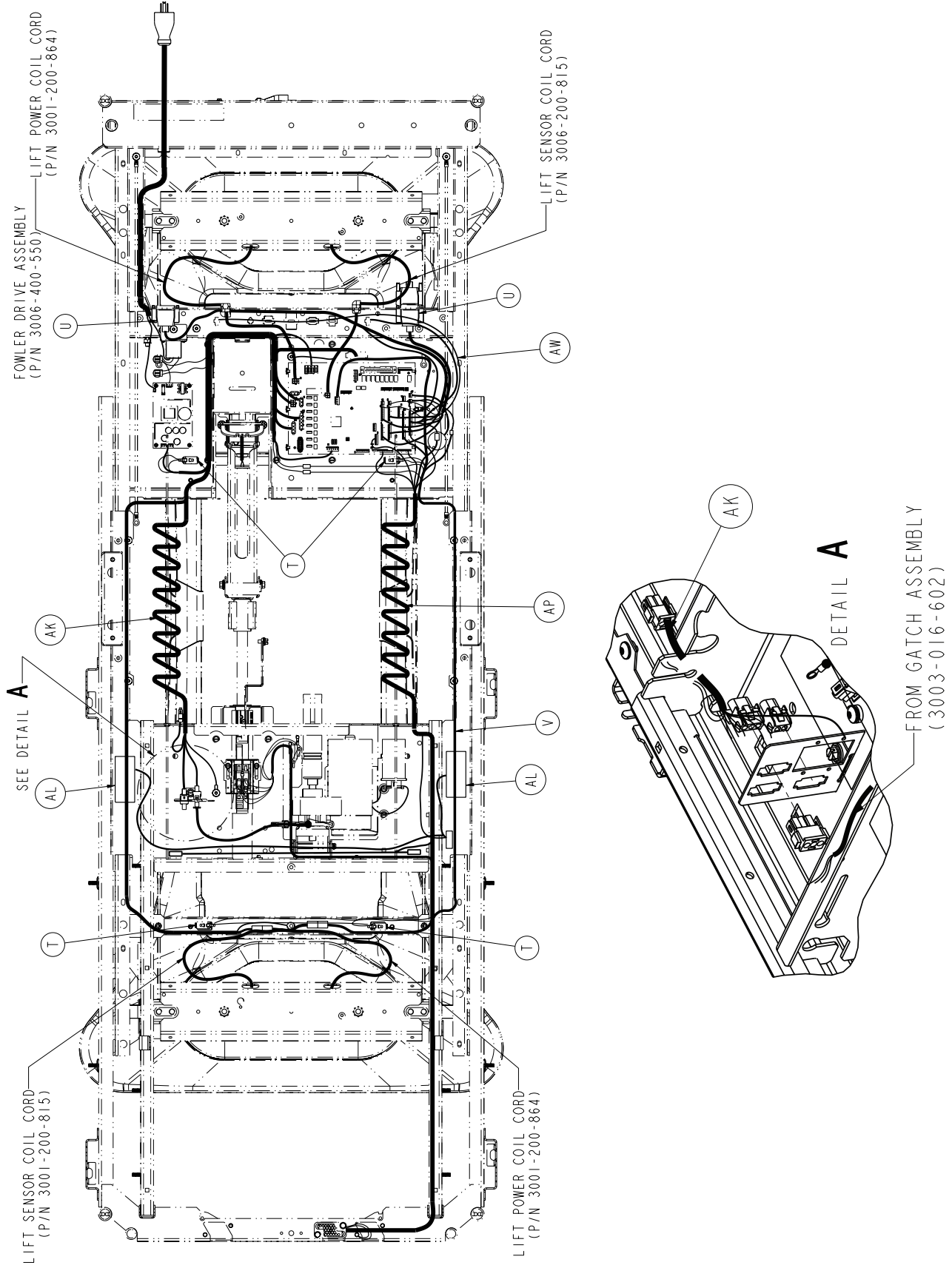

Electrical Litter Assembly, Standard Bed

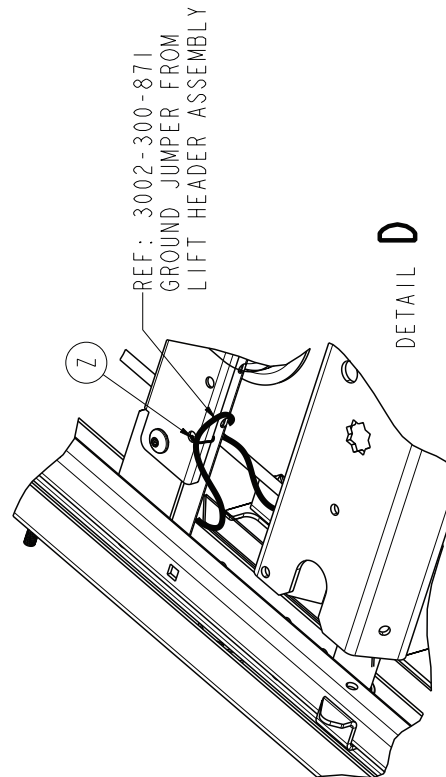
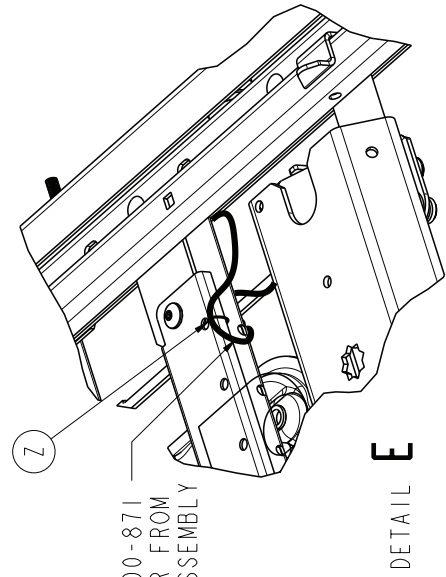
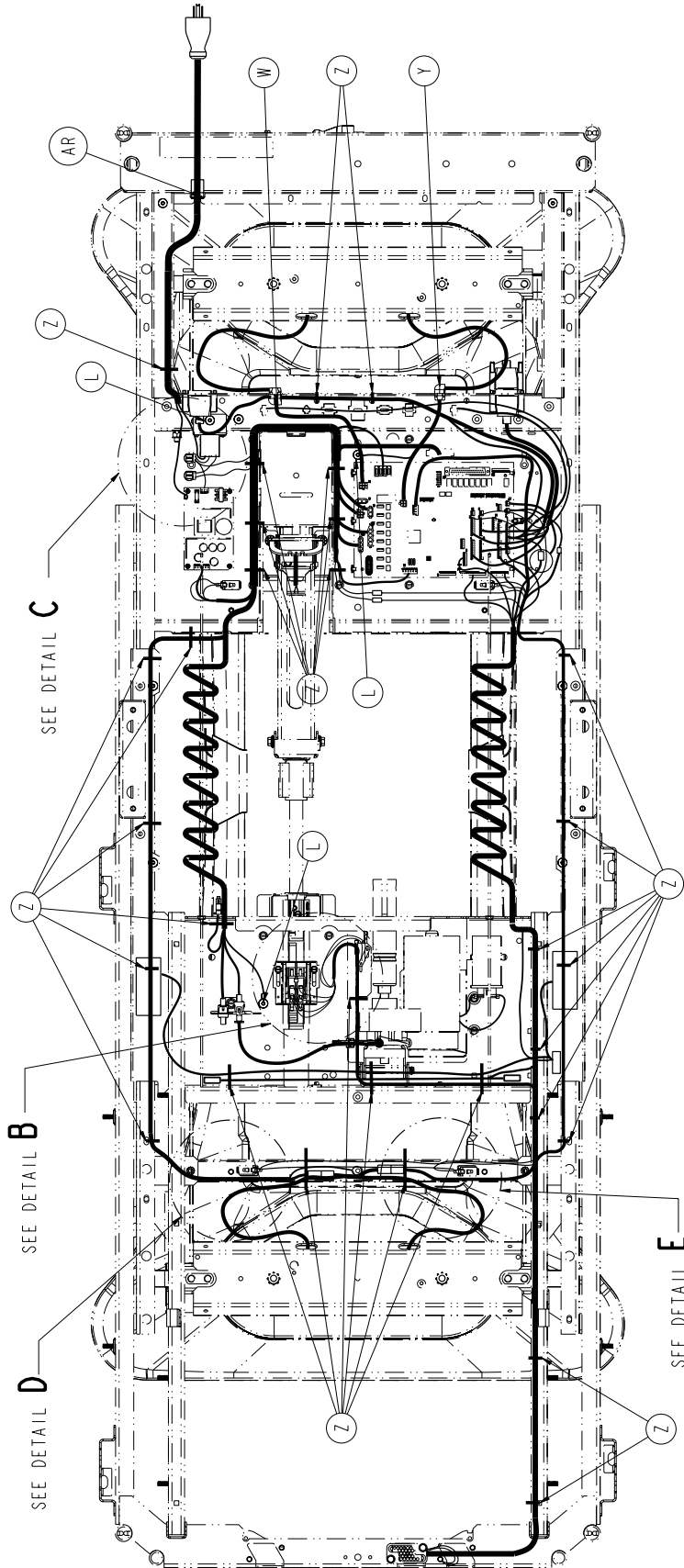

Electrical Litter Assembly, Standard Bed

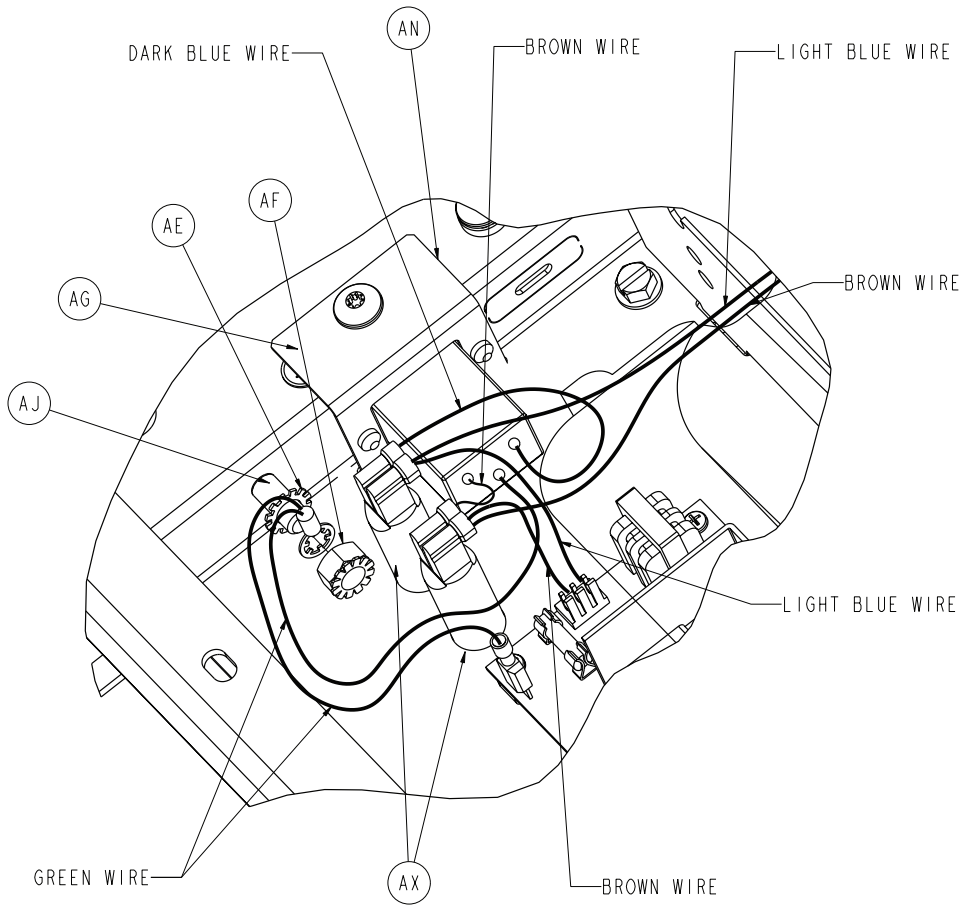

DETAIL C

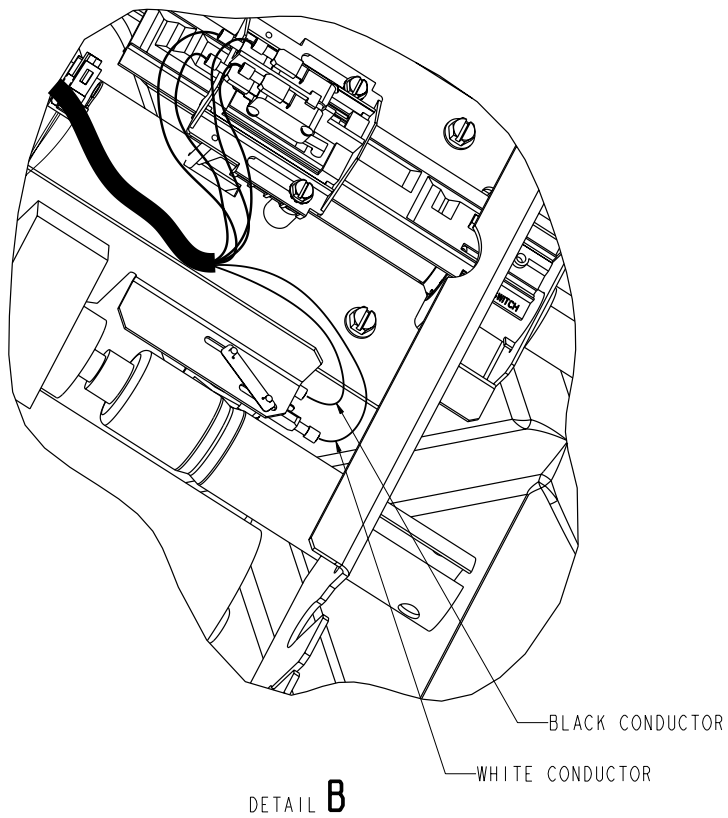

Electrical Litter Assembly, Standard Bed

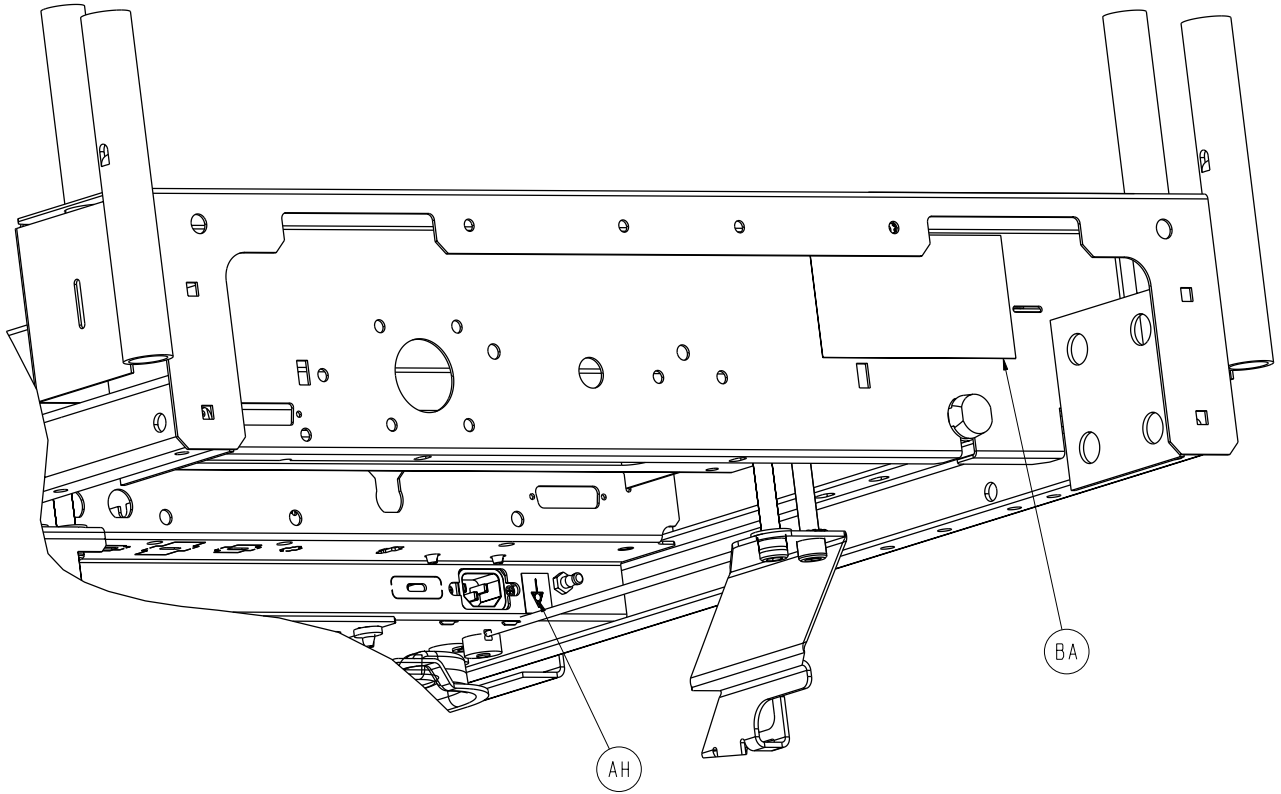

Electrical Litter Assembly, Standard Bed

Electrical Litter Assembly, Standard Bed 3006-343-895 (Reference Only)

| Item | Part No. | Part Name | Qty. |
|------|--------------|-------------------------------------|------|
| A | 3006-300-197 | Assembly, Mechanical Litter | 1 |
| B | 0059-157-000 | Power Supply | 1 |
| C | 0052-287-000 | Fastex Plasti-Grommet | 4 |
| D | 0023-138-000 | Pan Head Screw | 4 |
| E | 0059-745-000 | Universal Board Mount | 6 |
| F | 0059-773-000 | Push Spacer | 2 |
| G | 0059-774-000 | Locking Curcuit Board Support | 1 |
| H | 3001-200-228 | Mounting Standoff | 2 |
| J | 3001-300-007 | Screw Jack | 4 |
| K | 3006-301-088 | Mid Litter Cover Assembly | 1 |
| L | 0007-053-000 | Truss Head Screw | 13 |
| M | 0013-010-000 | External Tooth Lockwasher | 6 |
| N | 3006-301-023 | Cross Support Cover | 1 |
| P | 0052-822-000 | Snap-In Nyliner Bearing | 2 |
| R | 3001-300-011 | Guide Rod | 2 |
| T | 3000-300-058 | Plunger Switch | 4 |
| U | 3001-300-877 | Siderail Extension Cable | 1 |
| V | 3001-300-865 | Motion Interrupt Lift Sensor Cable | 1 |
| W | 0030-048-000 | Heyco Strain Relief | 1 |
| Y | 0030-047-000 | Heyco Strain Relief | 1 |
| Z | 3000-300-113 | 8" Cable Tie | 32 |
| AD | 3002-300-874 | Litter Ground Jumper | 2 |
| AE | 0013-038-000 | Lock Washer Ext. Spring | 1 |
| AF | 0016-033-000 | Kep Nut | 1 |
| AG | 0036-046-000 | Ground Label | 1 |
| AH | 0036-115-000 | Ground Label | 1 |
| AJ | 2011-001-215 | Grounding Lug Tuv | 1 |
| AK | 3002-300-861 | Power Harness | 1 |
| AL | 3006-410-020 | Night Light Option | 1 |
| AM | 3006-308-900 | CPU Board | 1 |
| AN | 3006-300-881 | Power Inlet Cable | 1 |
| AP | 3006-300-808 | Siderail Coil Cord | 1 |
| AR | 0030-027-000 | Straight Thru Strain Relief Bushing | 1 |
| AT | 3006-300-601 | Label, Foley Bag Hook | 2 |
| AW | 3003-300-803 | CPU To Siderail Sensor Cable | 1 |
| AX | 0059-400-000 | Circuit Breaker - 8 Amp | 2 |
| AY | 3006-200-003 | Base Assembly, Standard | 1 |
| BA | 3006-300-625 | Label, 115V Specification | 1 |
| BB | 5212-100-807 | Label, Caution | 1 |

Electrical Litter Assembly, Battery Backup

For Reference Only: 3006-350-110

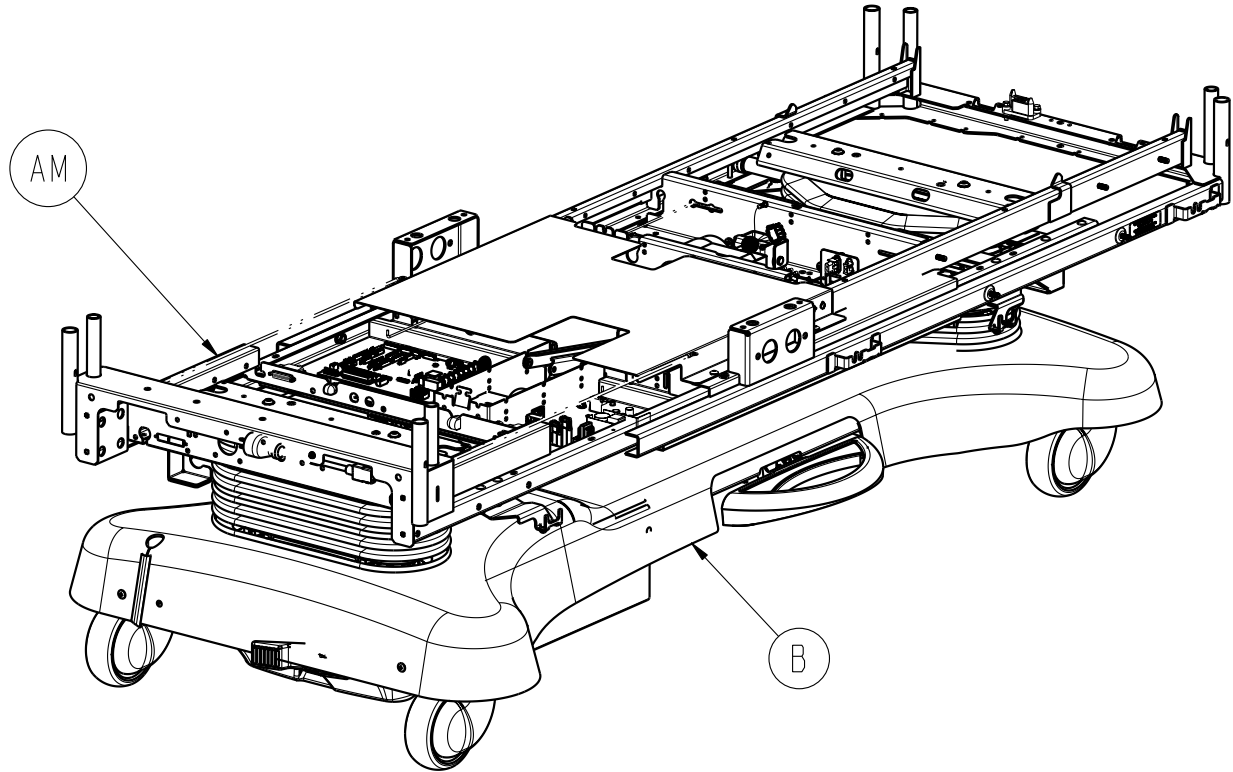

Electrical Litter Assembly, Battery Backup

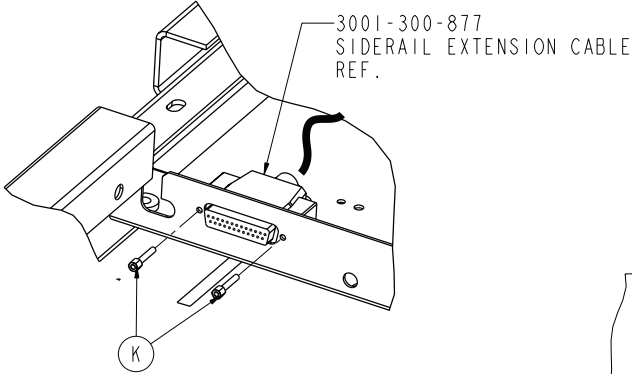
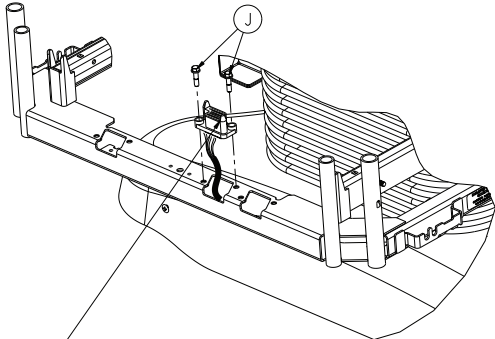
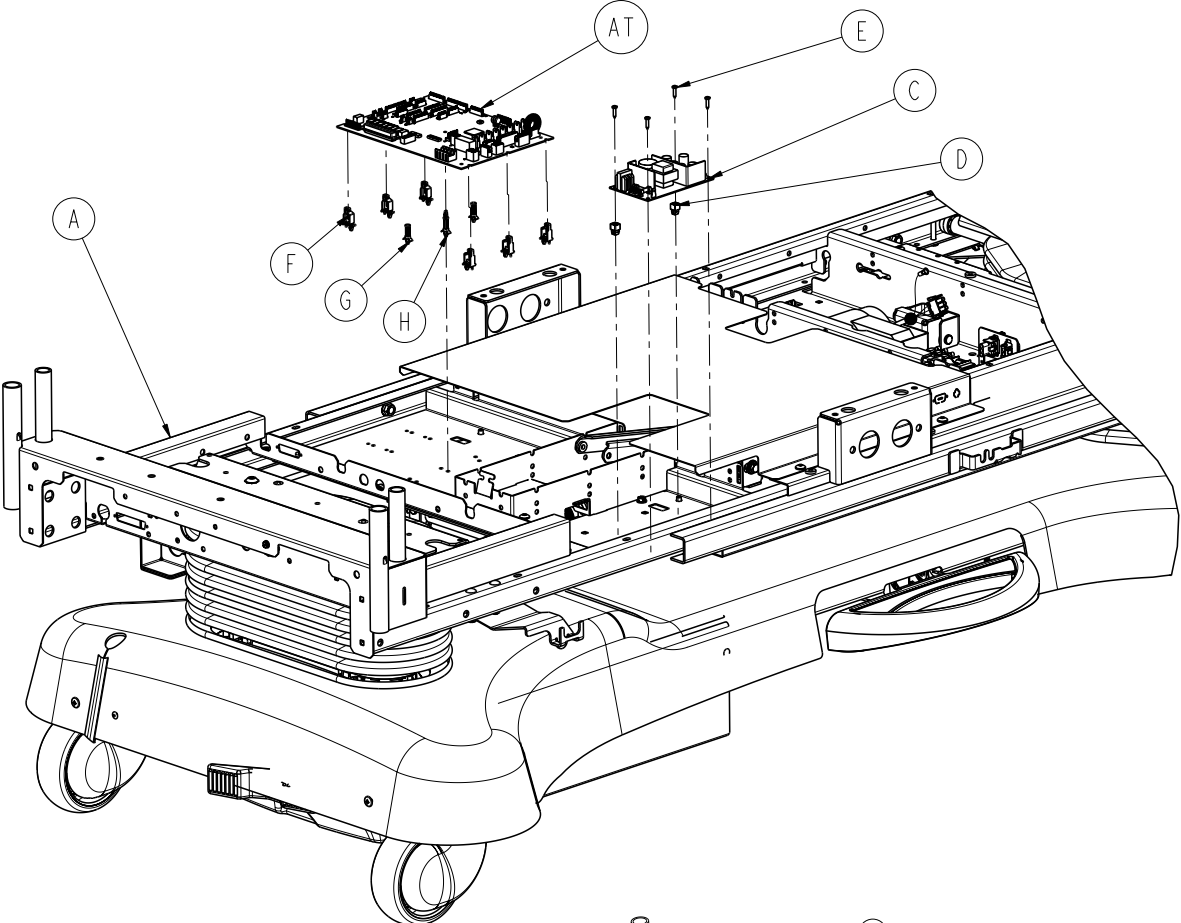

Assemble connector to frame in the orientation as shown.

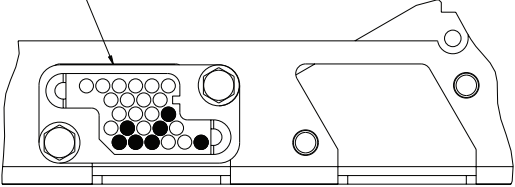

Electrical Litter Assembly, Battery Backup

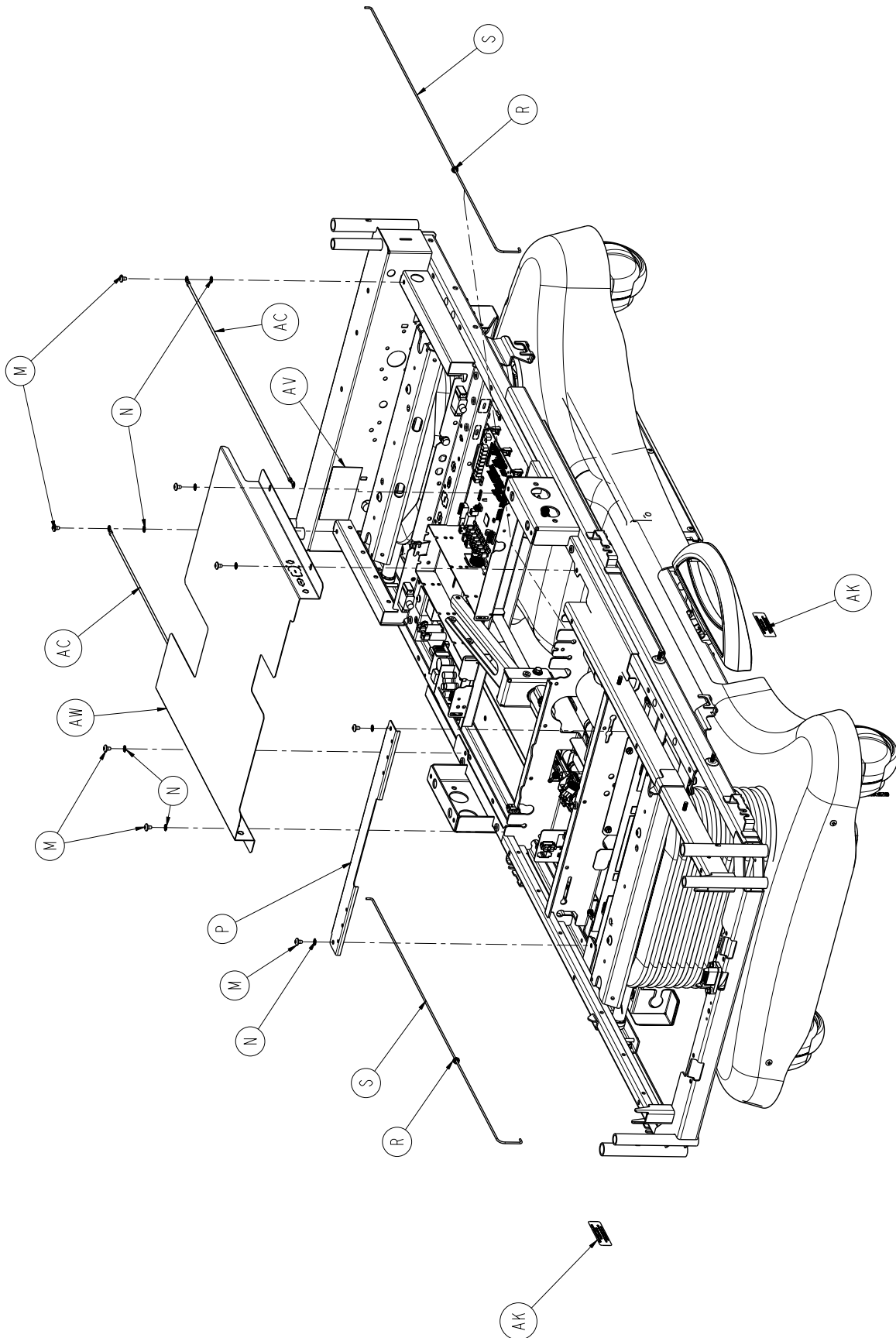

Electrical Litter Assembly, Battery Backup

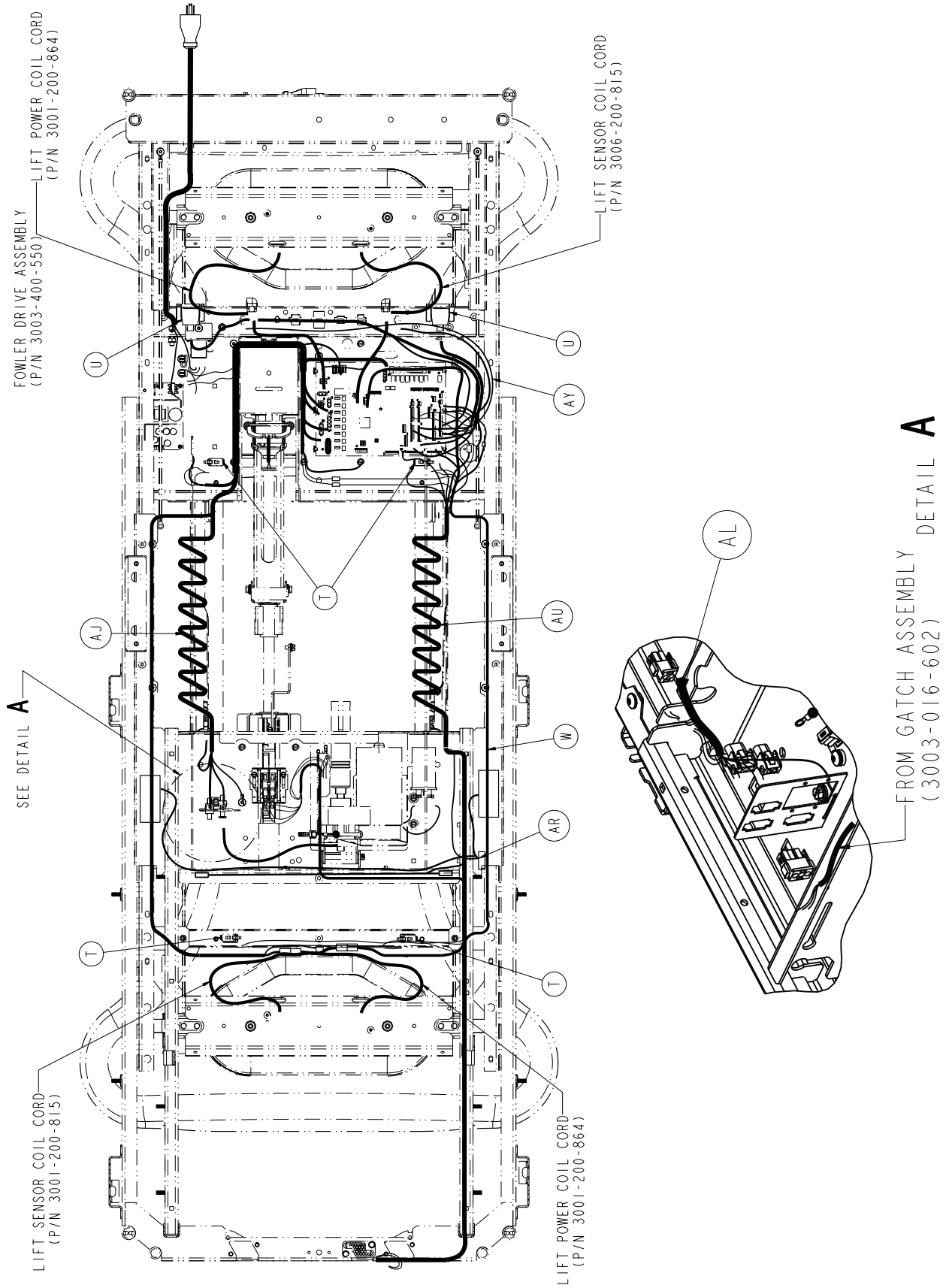

Electrical Litter Assembly, Battery Backup

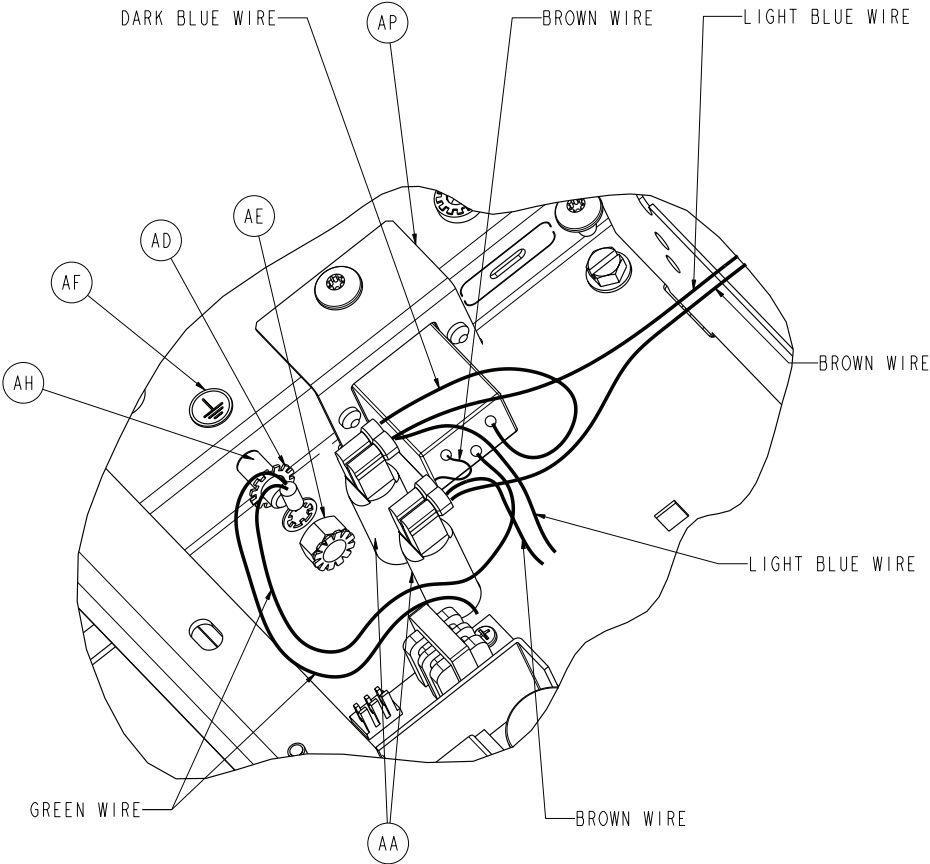

DETAIL C

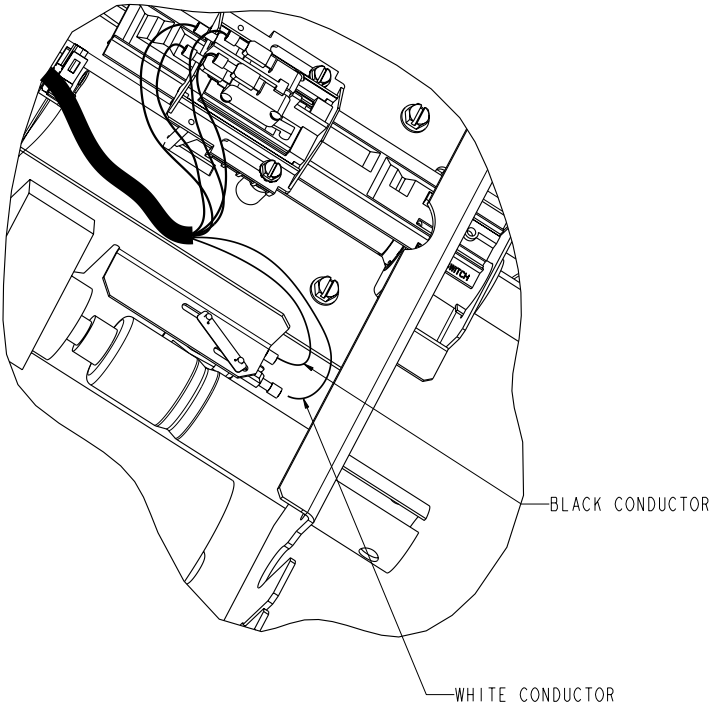

DETAIL B

Electrical Litter Assembly, Battery Backup

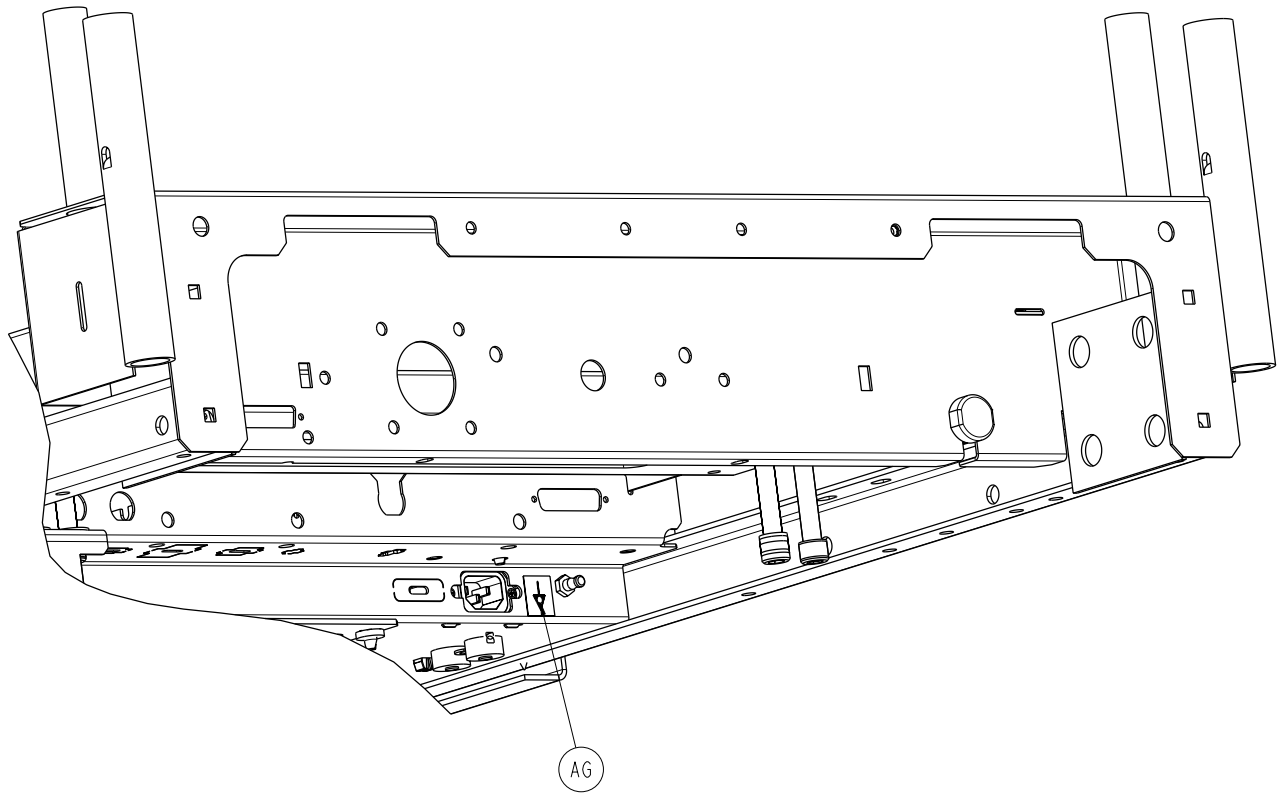

Electrical Litter Assembly, Battery Backup

Electrical Litter Assembly, Battery Backup 3006-350-110 (Reference Only)

| Item | Part No. | Part Name | Qty. |
|------|--------------|-------------------------------------|------|
| A | 3006-300-197 | Mechanical Litter Assembly | 1 |
| B | 3006-200-006 | Base Assembly, Battery Backup | 1 |
| C | 0059-157-000 | Power Supply | 1 |
| D | 0052-287-000 | Fastex Plasti-Grommet | 4 |
| E | 0023-138-000 | Pan Head Screw | 4 |
| F | 0059-745-000 | Universal Board Mount | 6 |
| G | 0059-773-000 | Push Spacer | 2 |
| H | 0059-774-000 | Locking Circuit Board Support | 1 |
| J | 3001-200-228 | Mounting Standoff | 2 |
| K | 3001-300-007 | Screw Jack | 4 |
| L | 0030-027-000 | Straight Thru Strain Relief Bushing | 1 |
| M | 0007-053-000 | Truss Head Screw | 13 |
| N | 0013-010-000 | External Tooth Lockwasher | 6 |
| P | 3006-301-023 | Cross Support Cover | 1 |
| R | 0052-822-000 | Snap-In Nyliner Bearing | 2 |
| S | 3001-300-011 | Guide Rod | 2 |
| T | 3000-300-058 | Plunger Switch | 4 |
| U | 3001-300-877 | Siderail Extension Cable | 1 |
| W | 3001-300-865 | Motion Interrupt Lift Sensor Cable | 1 |
| X | 0030-048-000 | Heyco Strain Relief | 1 |
| Y | 0030-047-000 | Heyco Strain Relief | 1 |
| Z | 3000-300-113 | 8" Cable Tie | 34 |
| AA | 0059-400-000 | Circuit Breaker - 8 Amp | 2 |
| AC | 3002-300-874 | Litter Ground Jumper | 2 |
| AD | 0013-038-000 | Lock Washer Ext. Spring | 1 |
| AE | 0016-033-000 | Kep Nut | 1 |
| AF | 0036-046-000 | Ground Label | 1 |
| AG | 0036-115-000 | Ground Label | 1 |
| AH | 2011-001-215 | Grounding Lug Tuv | 1 |
| AJ | 3002-300-861 | Power Harness | 1 |
| AK | 3006-300-601 | Label, Foley Bag Hook | 2 |
| AM | 3006-450-150 | Battery Backup Enclosure Assy, HE | 1 |
| AP | 3006-300-881 | Power Inlet Cable | 1 |
| AR | 3006-410-020 | Night Light Option | 1 |
| AT | 3006-308-900 | CPU Board | 1 |
| AU | 3006-300-808 | Siderail Coil Cord | 1 |
| AV | 3006-300-625 | Label, Specification | 1 |
| AW | 3006-301-088 | Mid Litter Cover Assembly | 1 |
| AY | 3003-300-803 | CPU To Siderail Sensor Cable | 1 |

Electrical Litter Assembly, Zoom® Option

For Reference Only: 3006-344-895

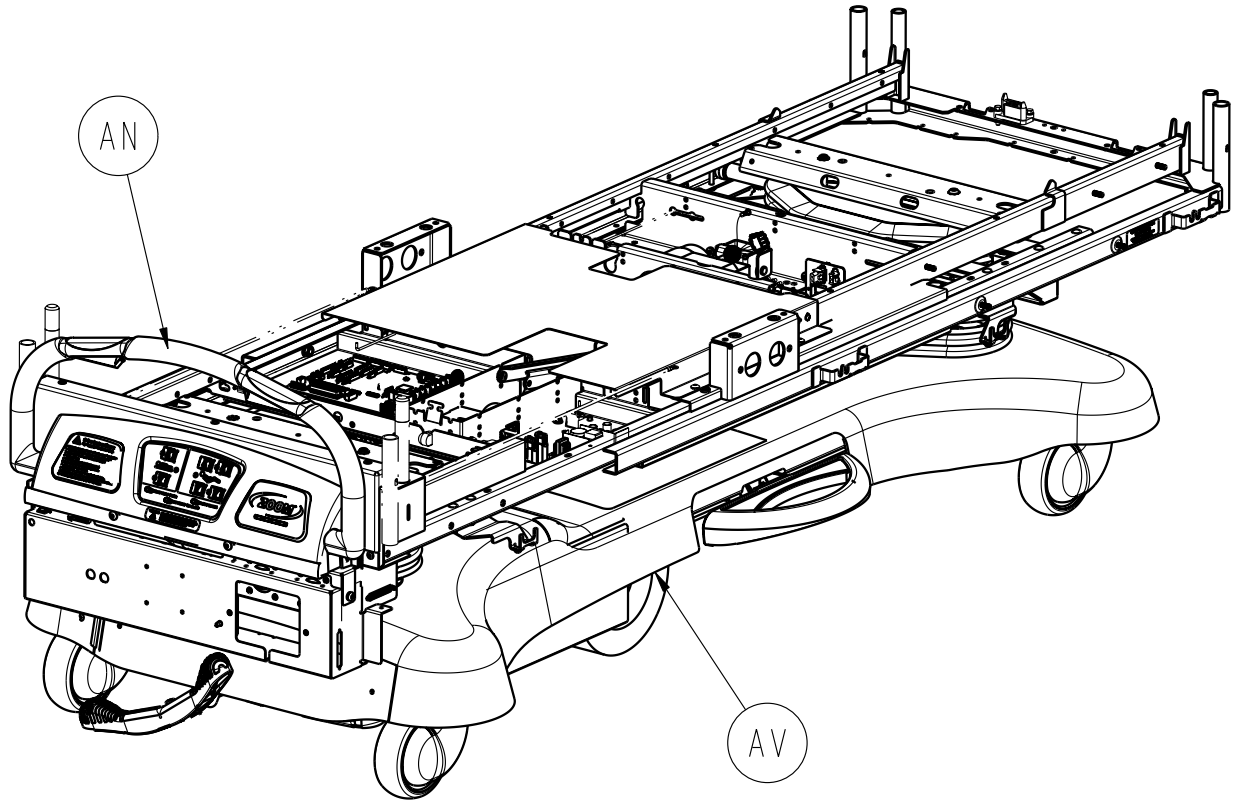

Electrical Litter Assembly, Zoom® Option

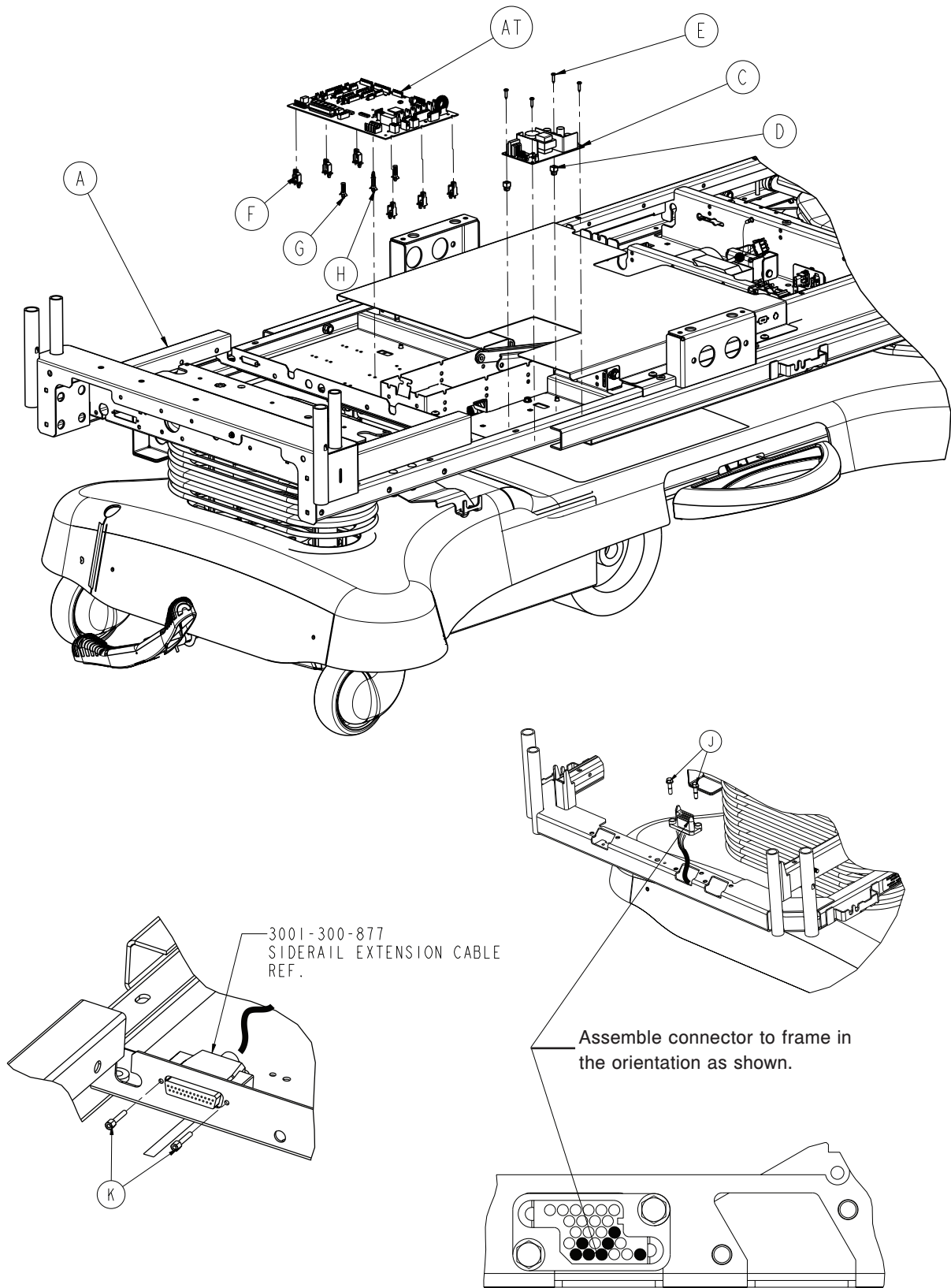

Electrical Litter Assembly, Zoom® Option

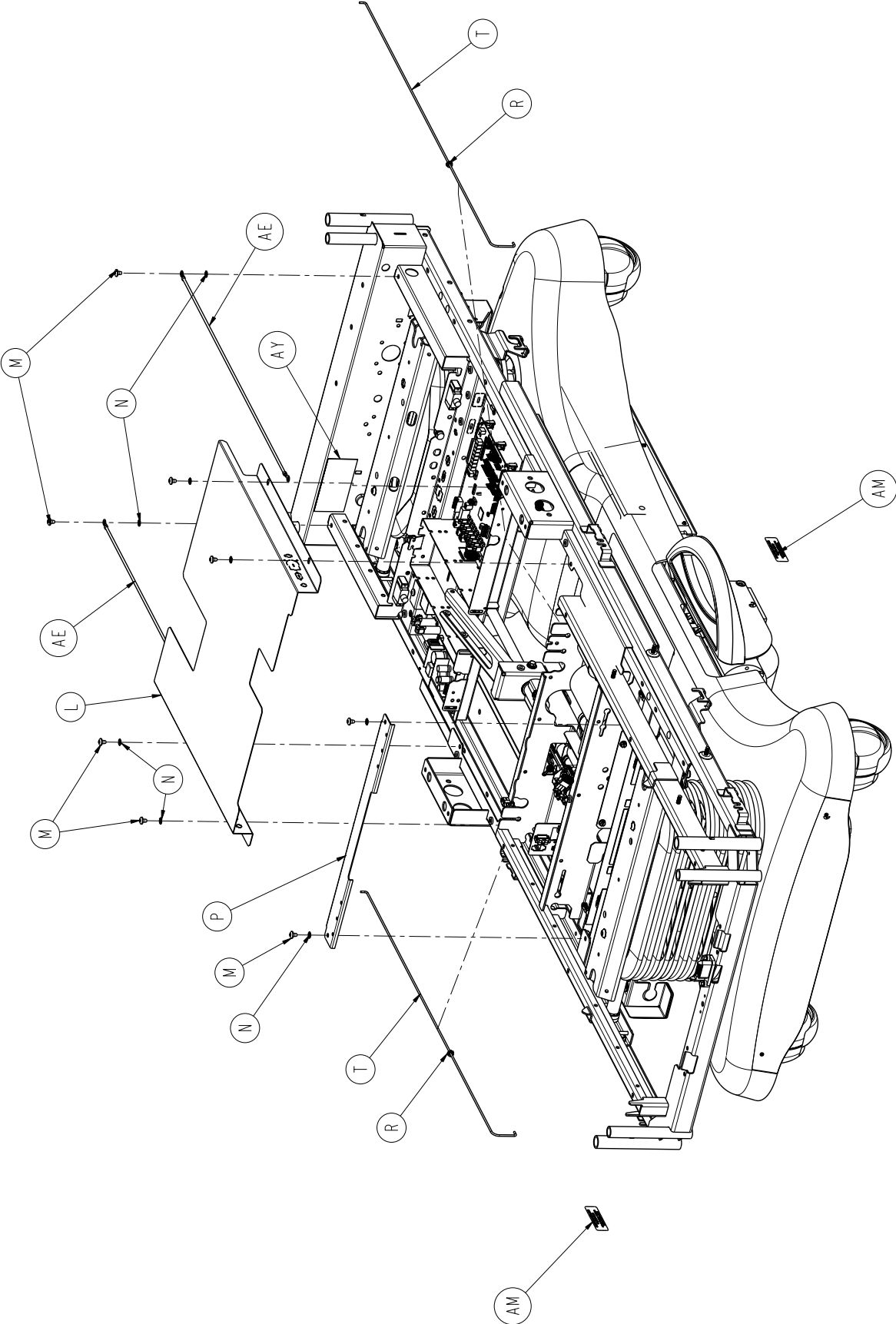

Electrical Litter Assembly, Zoom® Option

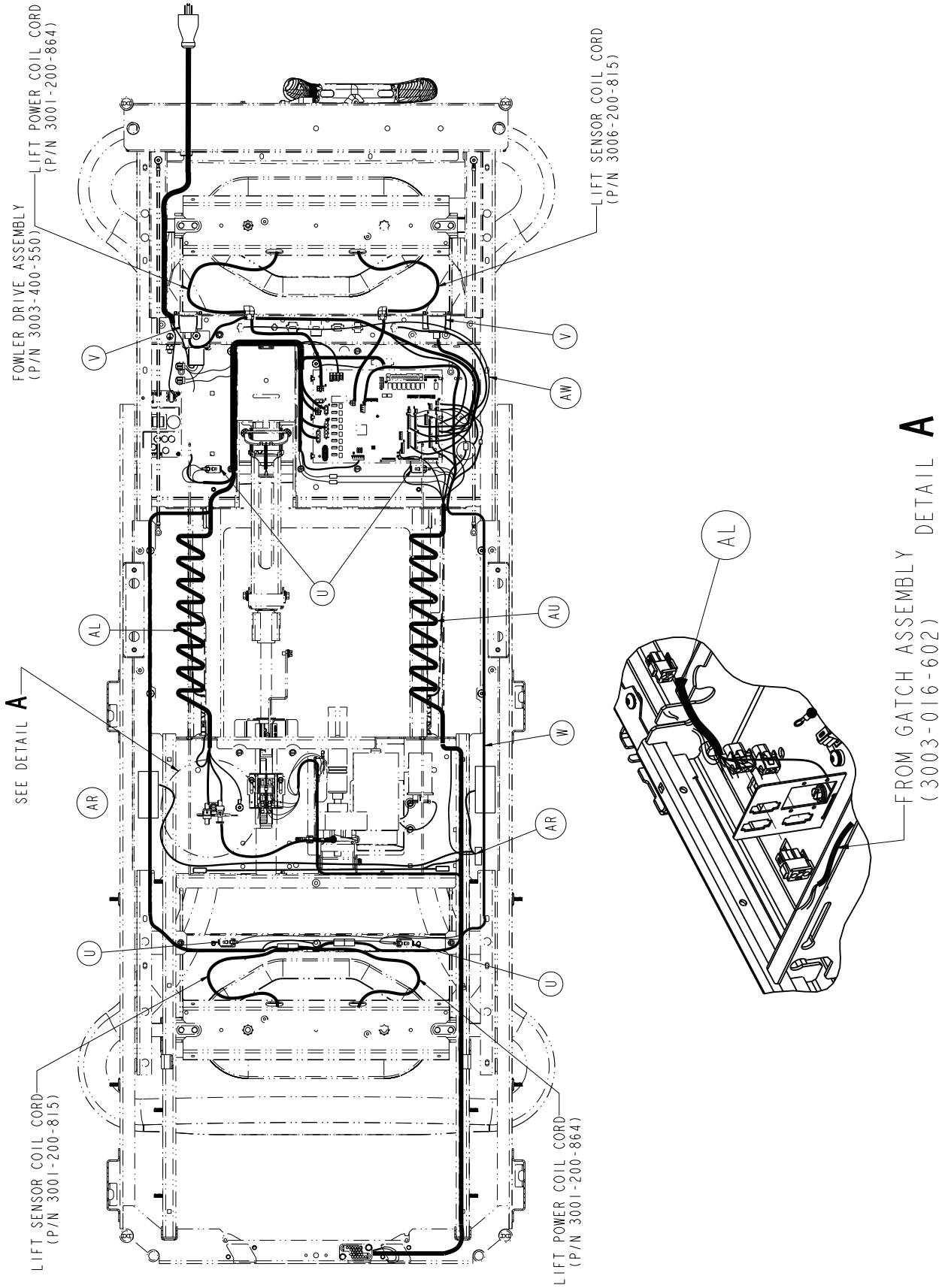

Electrical Litter Assembly, Zoom® Option

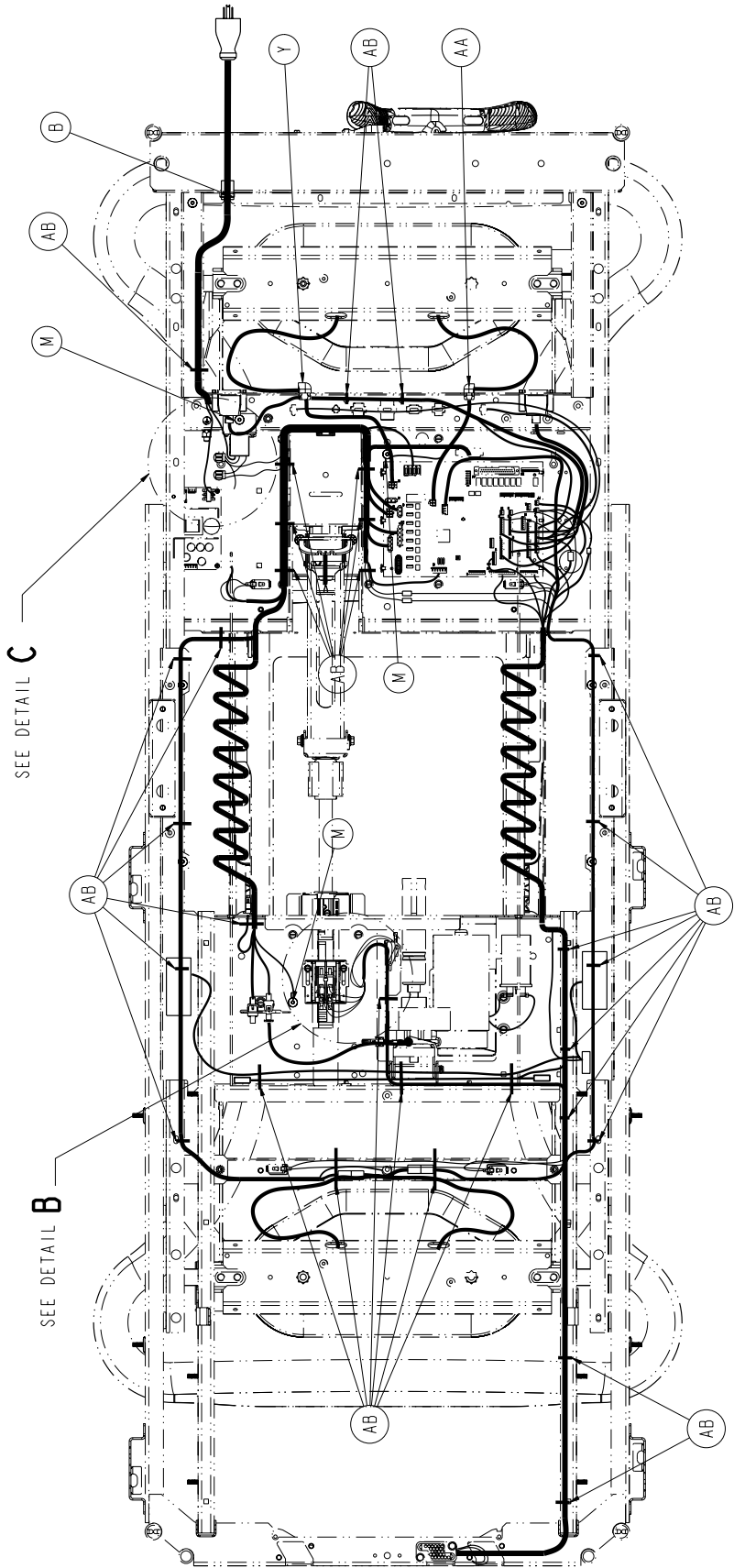

Electrical Litter Assembly, Zoom® Option

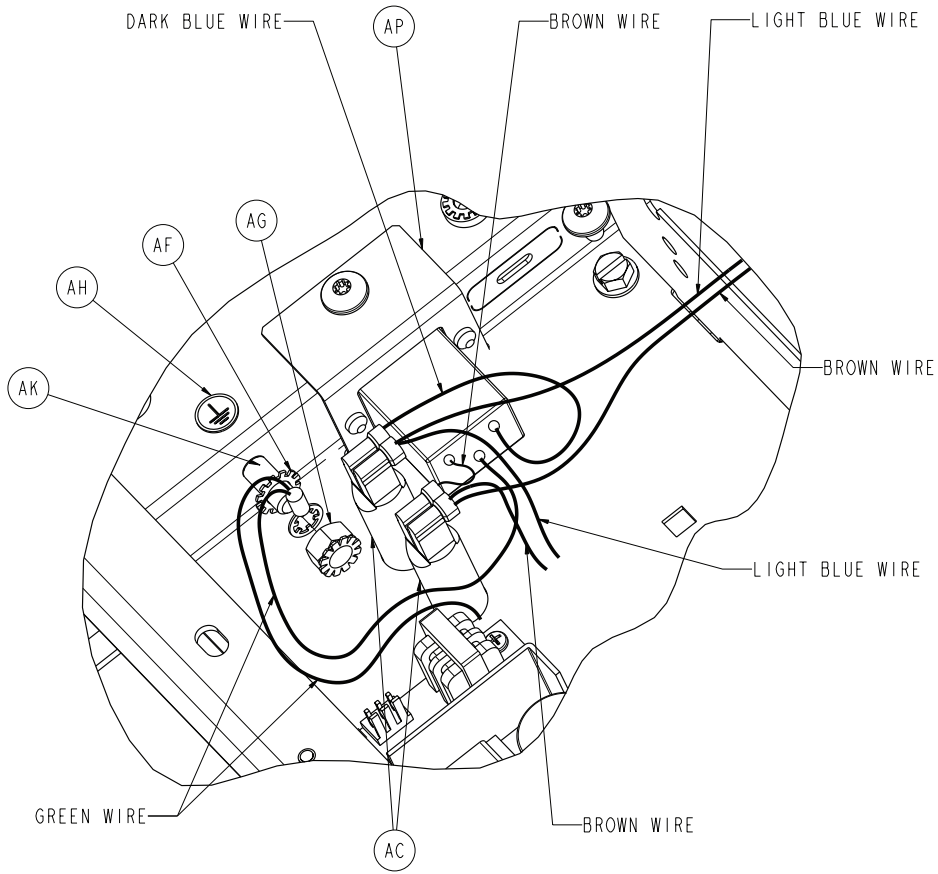

DETAIL C

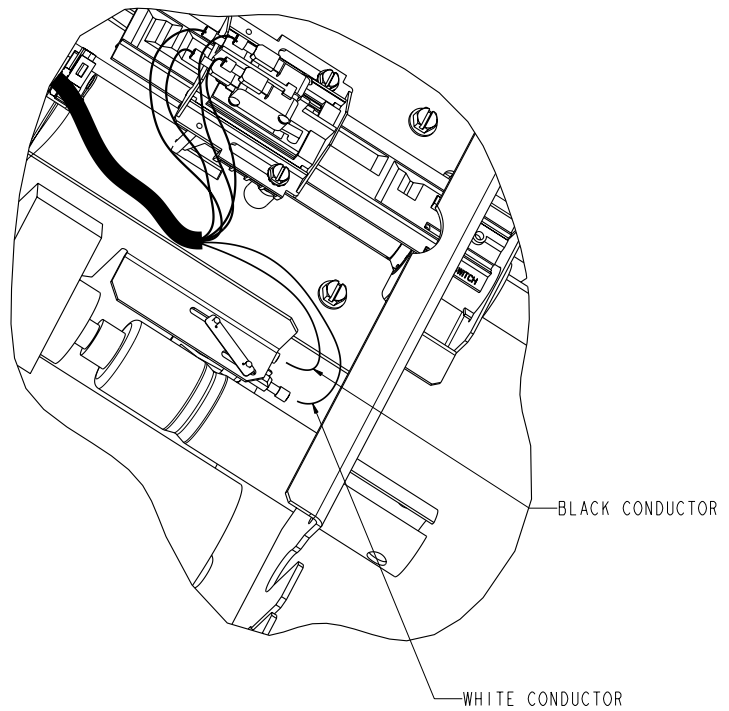

DETAIL B

Electrical Litter Assembly, Zoom® Option

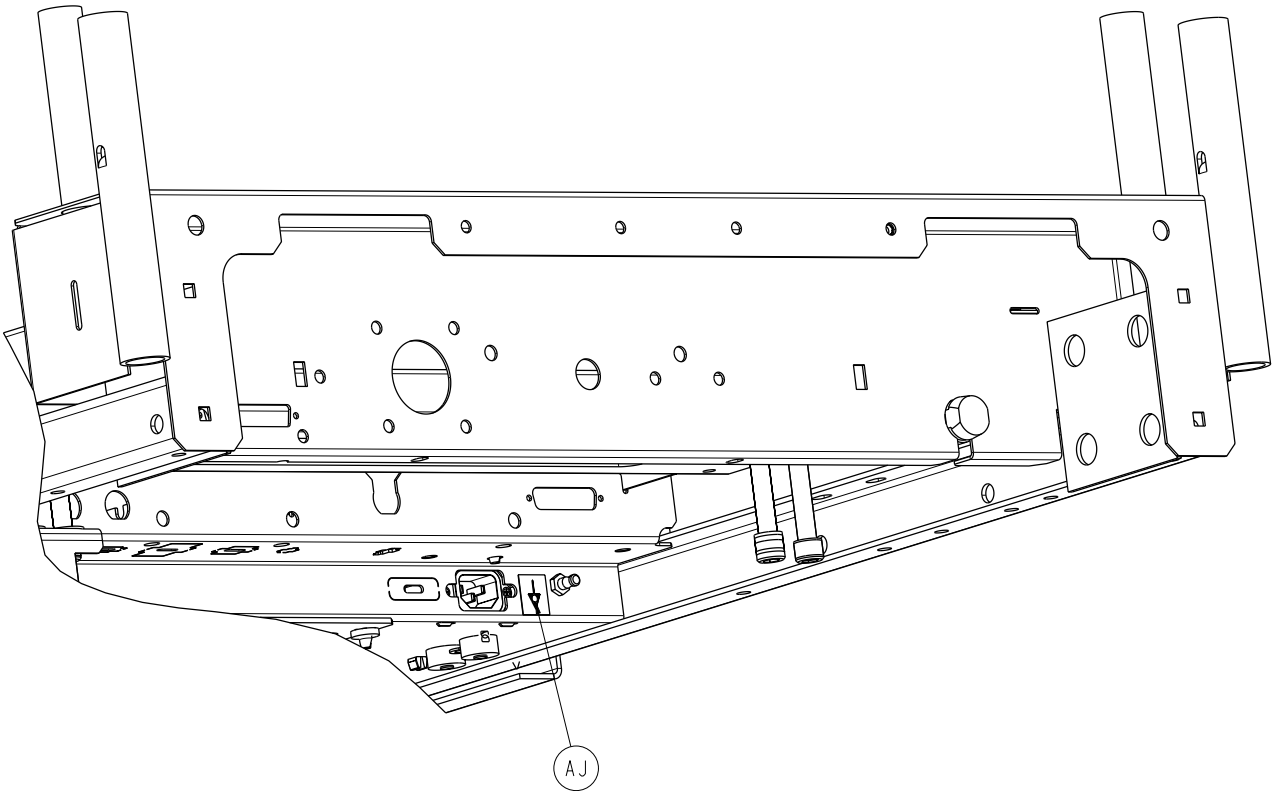

Electrical Litter Assembly, Zoom® Option

Electrical Litter Assembly, Battery Backup 3006-344-895 (Reference Only)

| Item | Part No. | Part Name | Qty. |
|------|--------------|-------------------------------------|------|
| A | 3006-300-197 | Mechanical Litter Assembly | 1 |
| B | 0030-027-000 | Straight Thru Strain Relief Bushing | 1 |
| C | 0059-157-000 | Power Supply | 1 |
| D | 0052-287-000 | Fastex Plasti-Grommet | 4 |
| E | 0023-138-000 | Pan Head Screw | 4 |
| F | 0059-745-000 | Universal Board Mount | 6 |
| G | 0059-773-000 | Push Spacer | 2 |
| H | 0059-774-000 | Locking Circuit Board Support | 1 |
| J | 3001-200-228 | Mounting Standoff | 2 |
| K | 3001-300-007 | Screw Jack | 4 |
| L | 3006-301-088 | Mid Litter Cover Assembly | 1 |
| M | 0007-053-000 | Truss Head Screw | 13 |
| N | 0013-010-000 | External Tooth Lockwasher | 6 |
| P | 3006-301-023 | Cross Support Cover | 1 |
| R | 0052-822-000 | Snap-In Nyliner Bearing | 2 |
| T | 3001-300-011 | Guide Rod | 2 |
| U | 3000-300-058 | Plunger Switch | 4 |
| V | 3001-300-877 | Siderail Extension Cable | 1 |
| W | 3001-300-865 | Motion Interrupt Lift Sensor Cable | 1 |
| Y | 0030-048-000 | Heyco Strain Relief | 1 |
| AA | 0030-047-000 | Heyco Strain Relief | 1 |
| AB | 3000-300-113 | 8" Cable Tie | 34 |
| AC | 0059-400-000 | Circuit Breaker - 8 Amp | 2 |
| AE | 3002-300-874 | Litter Ground Jumper | 2 |
| AF | 0013-038-000 | Lock Washer Ext. Spring | 1 |
| AG | 0016-033-000 | Kep Nut | 1 |
| AH | 0036-046-000 | Ground Label | 1 |
| AJ | 0036-115-000 | Ground Label | 1 |
| AK | 2011-001-215 | Grounding Lug Tuv | 1 |
| AL | 3002-300-861 | Power Harness | 1 |
| AM | 3006-300-601 | Label, Foley Bag Hook | 2 |
| AN | 3006-131-010 | Secure Zoom® Litter Assembly | 1 |
| AP | 3006-300-881 | Power Inlet Cable | 1 |
| AR | 3006-410-020 | Night Light Option | 1 |
| AT | 3006-308-900 | CPU Board | 1 |
| AU | 3006-300-808 | Siderail Coil Cord | 1 |
| AV | 3006-200-005 | Zoom® Bed Base Assembly | 1 |
| AW | 3003-300-803 | CPU To Siderail Sensor Cable | 1 |
| AY | 3006-300-625 | Label, 115V Specification | 1 |

Electrical Litter Assembly, Battery Backup, iBed® Wireless Option

For Reference Only: 5212-350-110

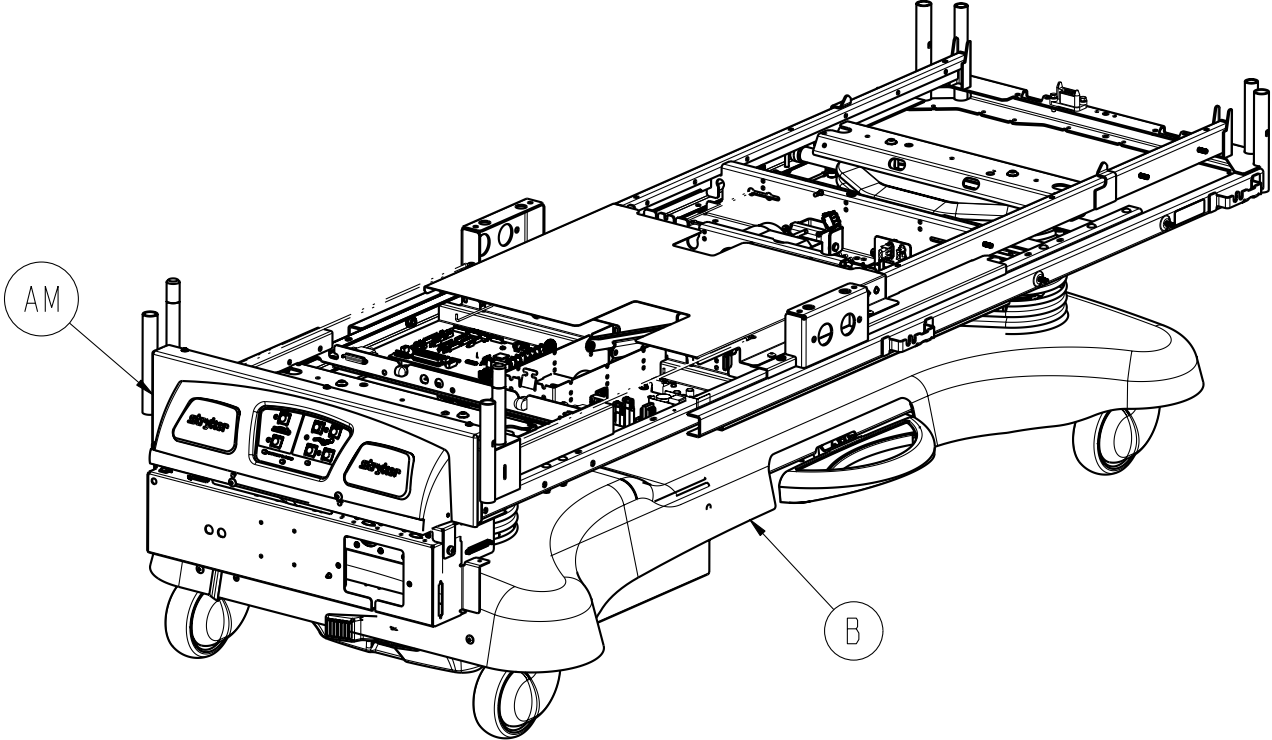

Electrical Litter Assembly, Battery Backup, iBed® Wireless Option

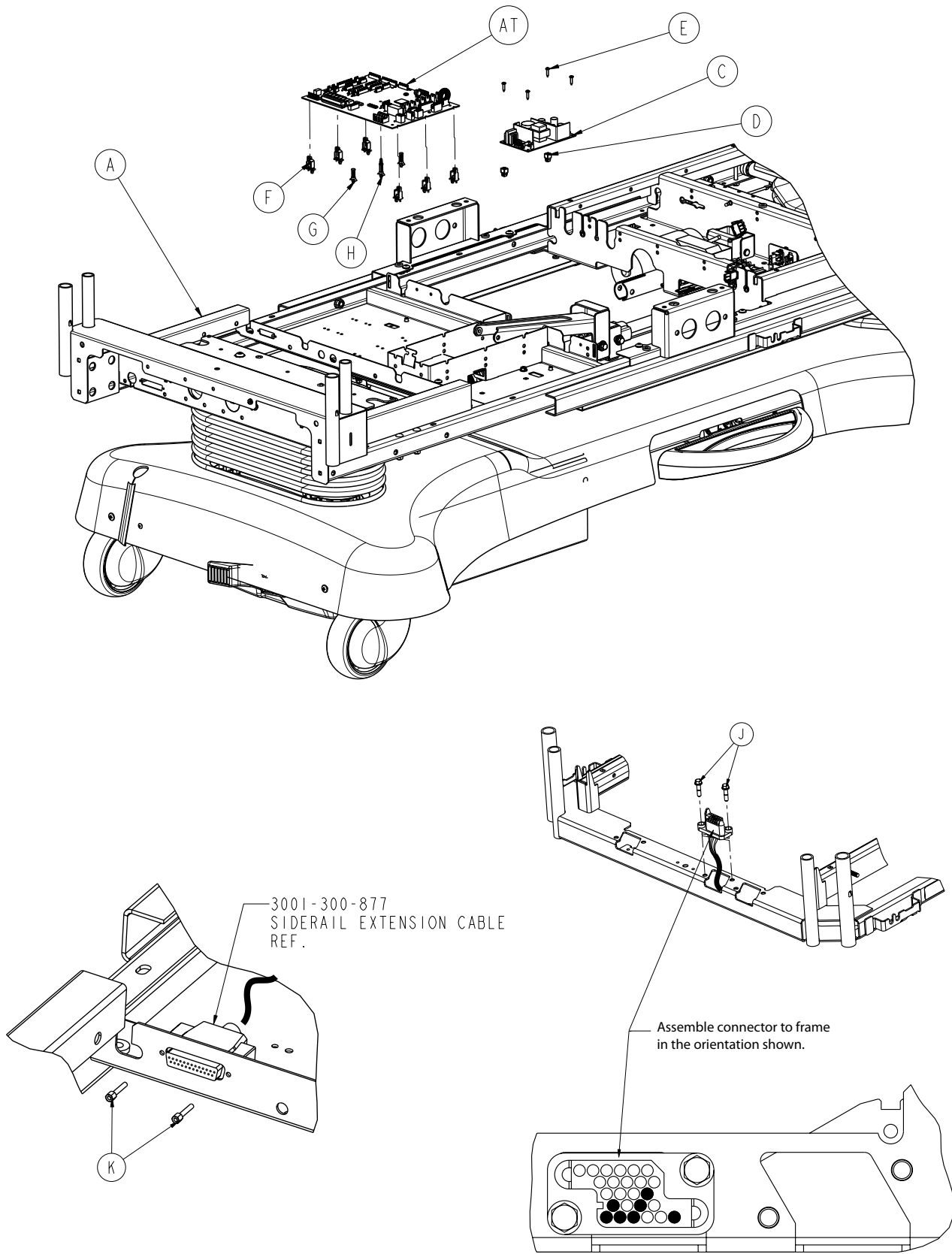

Electrical Litter Assembly, Battery Backup, iBed® Wireless Option

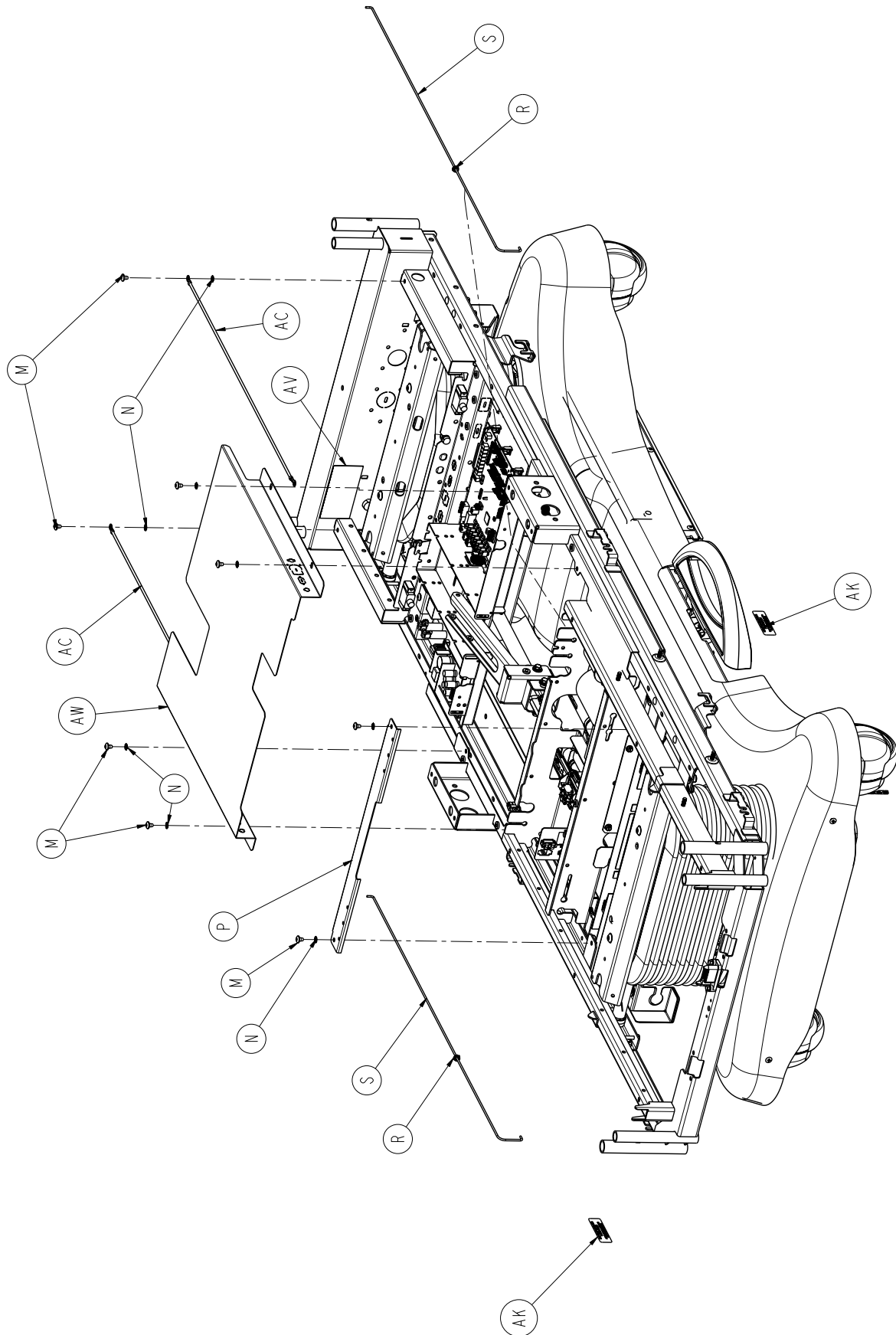

Electrical Litter Assembly, Battery Backup, iBed® Wireless Option

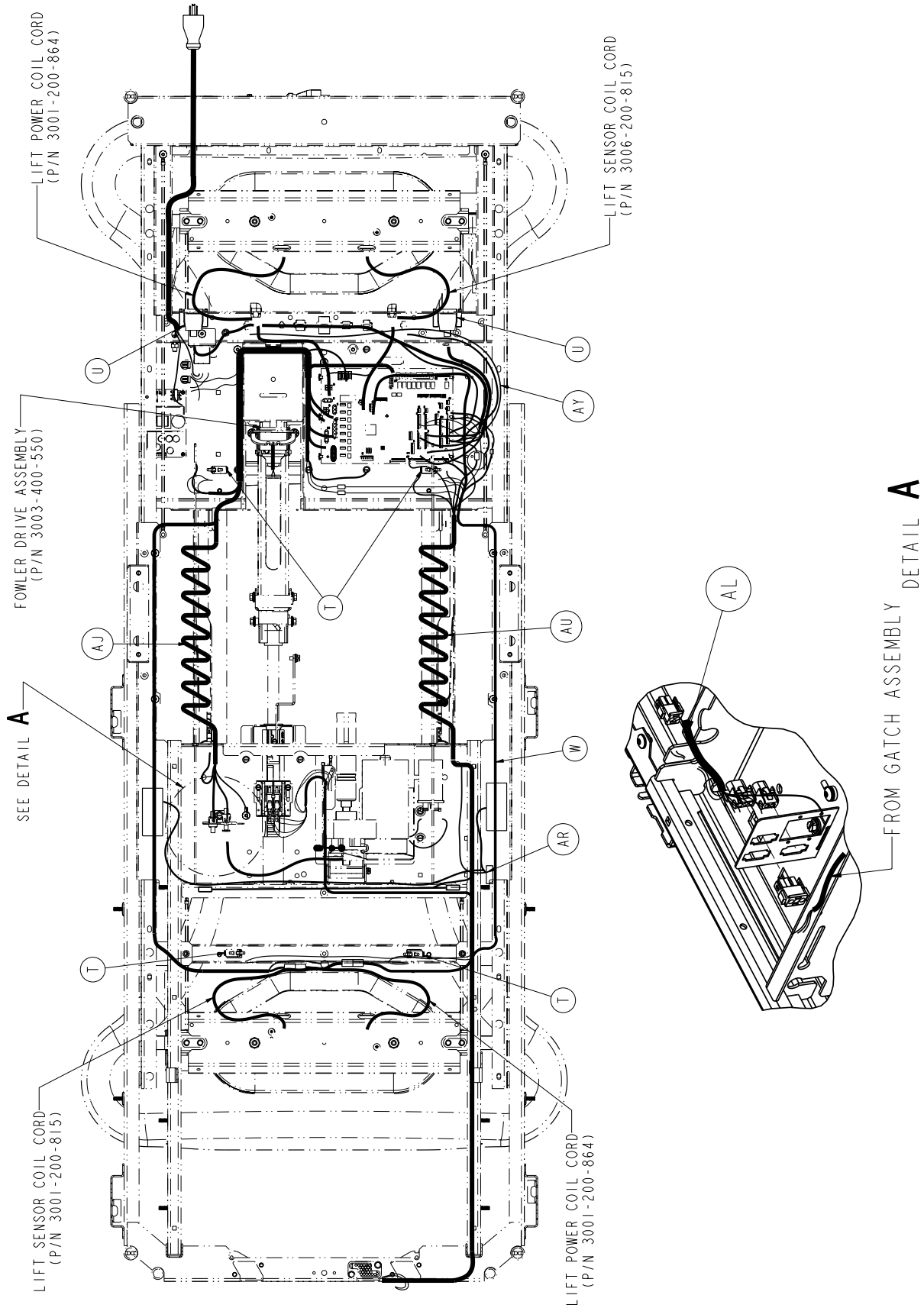

Electrical Litter Assembly, Battery Backup, iBed® Wireless Option

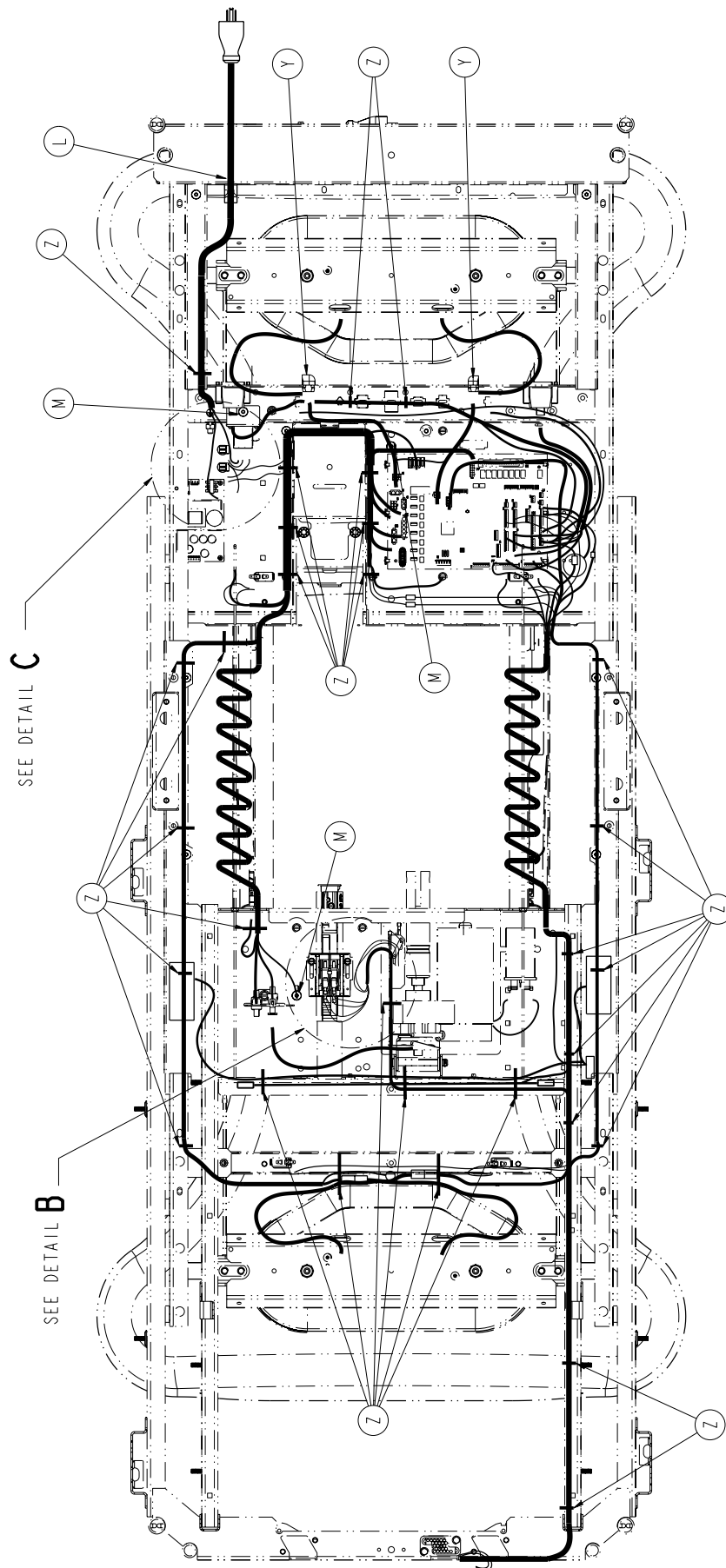

Electrical Litter Assembly, Battery Backup, iBed® Wireless Option

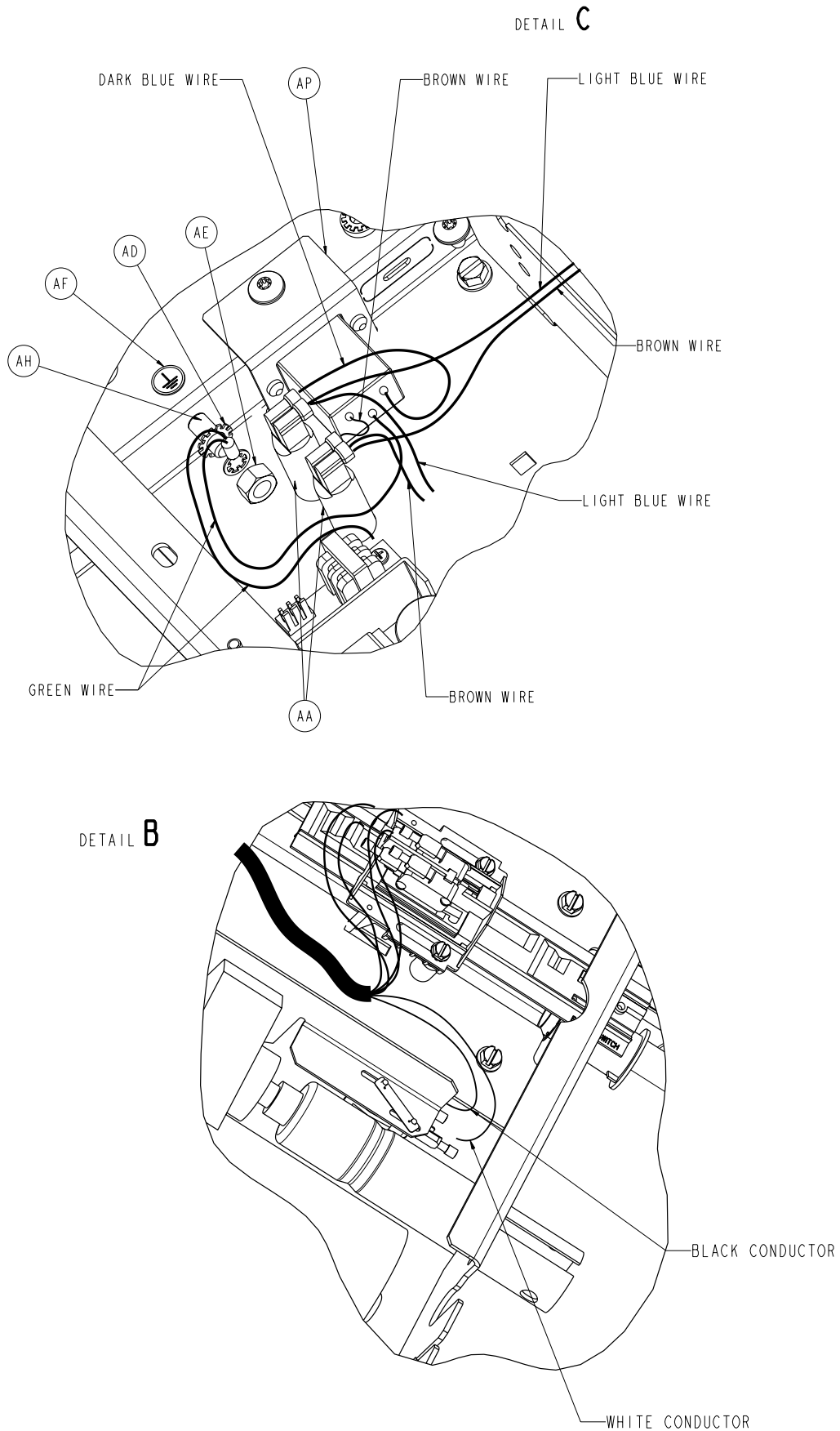

Electrical Litter Assembly, Battery Backup, iBed® Wireless Option

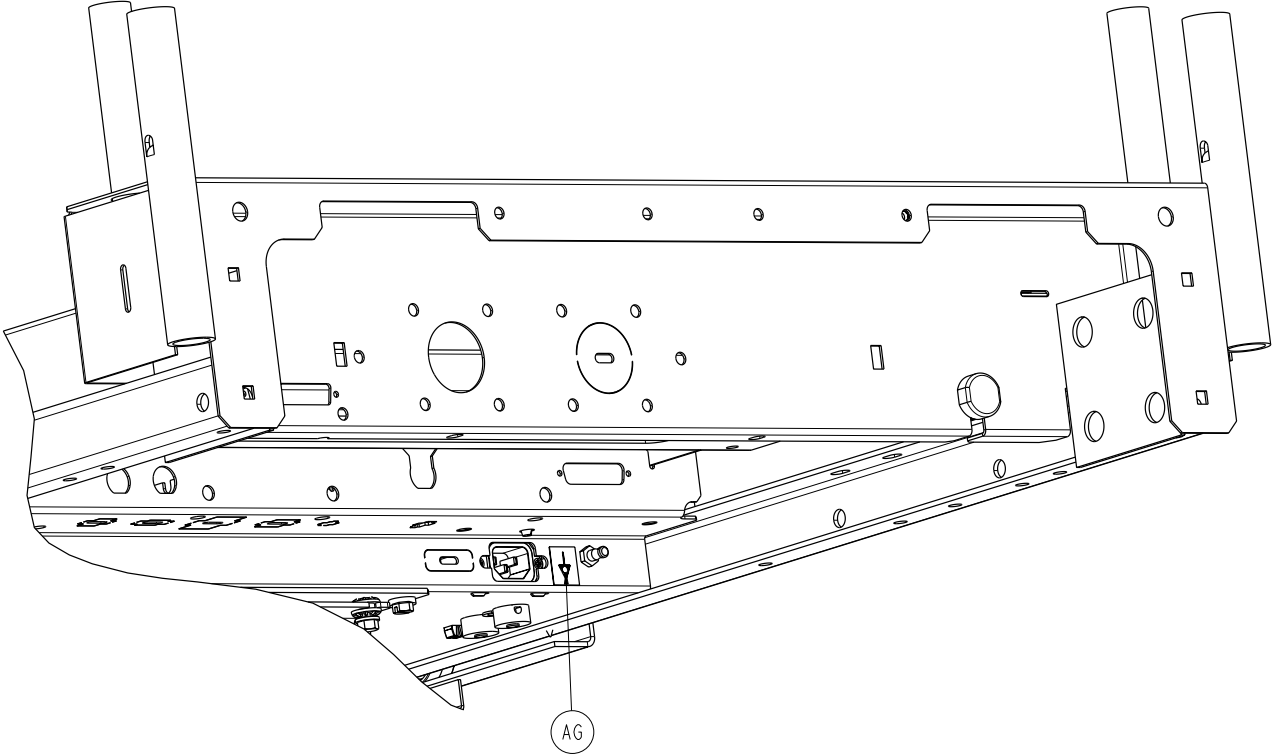

Electrical Litter Assembly, Battery Backup, iBed® Wireless Option

Electrical Litter Assembly, Battery Backup, iBed® Wireless Option - 5212-350-110 (Reference Only)

| Item | Part No. | Part Name | Qty. |
|------|--------------|---|------|
| A | 3006-300-197 | Mechanical Litter Assembly | 1 |
| B | 3006-200-006 | Battery Backup Base Assembly | 1 |
| C | 0059-157-000 | Power Supply | 1 |
| D | 0052-287-000 | Fastex Plastic Grommet | 4 |
| E | 0023-138-000 | Pan Head Screw | 4 |
| F | 0059-745-000 | Universal Board Mount | 6 |
| G | 0059-773-000 | Push Spacer | 2 |
| H | 0059-774-000 | Locking Circuit Board Support | 1 |
| J | 3001-200-228 | Mounting Standoff | 2 |
| K | 3001-300-007 | Jack Screw | 4 |
| L | 0030-027-000 | Straight Through Strain Relief Bushing | 1 |
| M | 0007-053-000 | Truss Head Screw | 13 |
| N | 0013-010-000 | External tooth Lockwasher | 6 |
| P | 3006-301-023 | Cross Support Cover | 1 |
| R | 0052-822-000 | Snap-in Nyliner Bearing | 2 |
| S | 3001-300-011 | Guide Rod | 2 |
| T | 3000-300-058 | Plunger Switch | 4 |
| U | 3001-300-877 | Siderail Extension Cable | 1 |
| W | 3001-300-865 | Motion Interrupt Lift Sensor Cable | 1 |
| X | 0030-048-000 | Heyco Strain Relief Siderail | 1 |
| Y | 0030-047-000 | Heyco Strain Relief Siderail | 1 |
| Z | 3000-300-113 | 8" Cable Tie | 34 |
| AA | 0059-400-000 | 8 Amp Circuit Breaker | 2 |
| AC | 3002-300-874 | Litter Ground Jumper | 2 |
| AD | 0013-038-000 | Lockwasher Extension Spring | 1 |
| AE | 0016-033-000 | Kep Nut | 1 |
| AF | 0036-046-000 | Ground Label | 1 |
| AG | 0036-115-000 | Ground Label | 1 |
| AH | 2011-001-215 | Grounding Lug Tuv | 1 |
| AJ | 3002-300-861 | Power Harness | 1 |
| AK | 3006-300-601 | Foley Bag Hook Label | 2 |
| AM | 3006-450-150 | HE Battery Backup Enclosure Assembly | 1 |
| AP | 3006-300-881 | Power Inlet Cable | 1 |
| AR | 3006-410-020 | Night Light Option | 1 |
| AT | 3006-308-900 | CPU Board | 1 |
| AU | 3006-300-808 | Siderail Coil Cord | 1 |
| AV | 3006-300-625 | Specification Label | 1 |
| AW | 3006-301-088 | Mid Litter Cover Assembly | 1 |
| AY | 3003-300-803 | CPU to Siderail Sensor Cable | 1 |

Electrical Litter Assembly, Zoom®, iBed® Wireless Option

For Reference Only: 5212-344-895

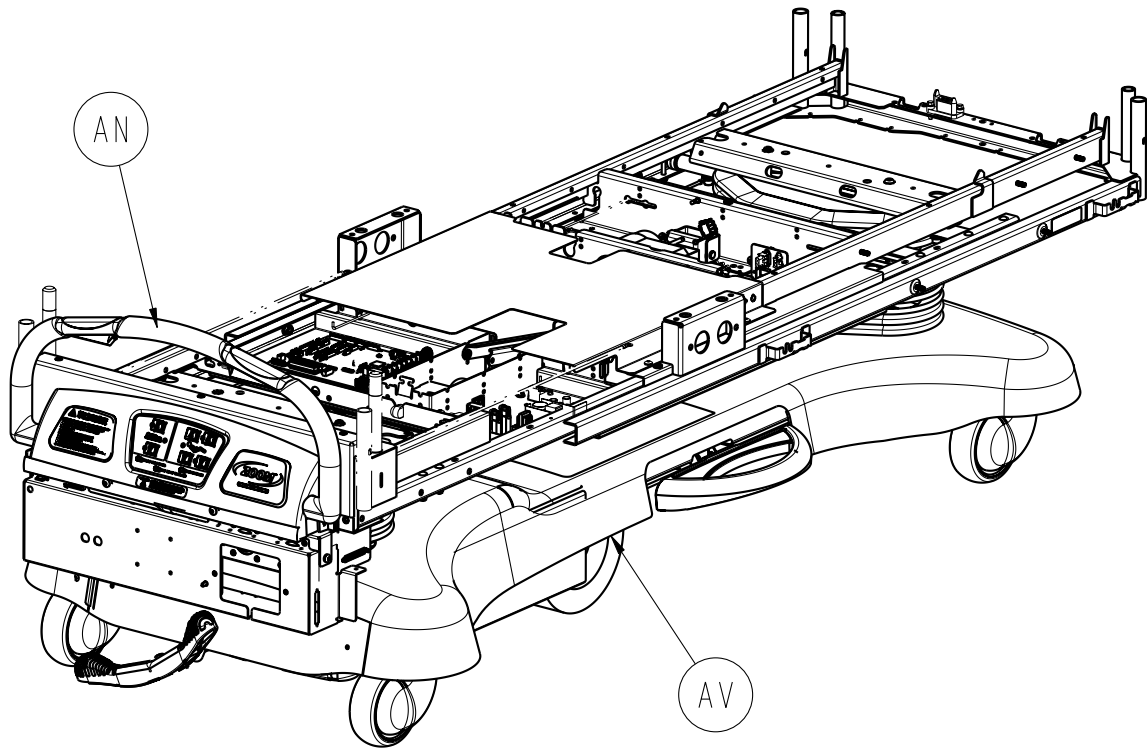

Electrical Litter Assembly, Zoom®, iBed® Wireless Option

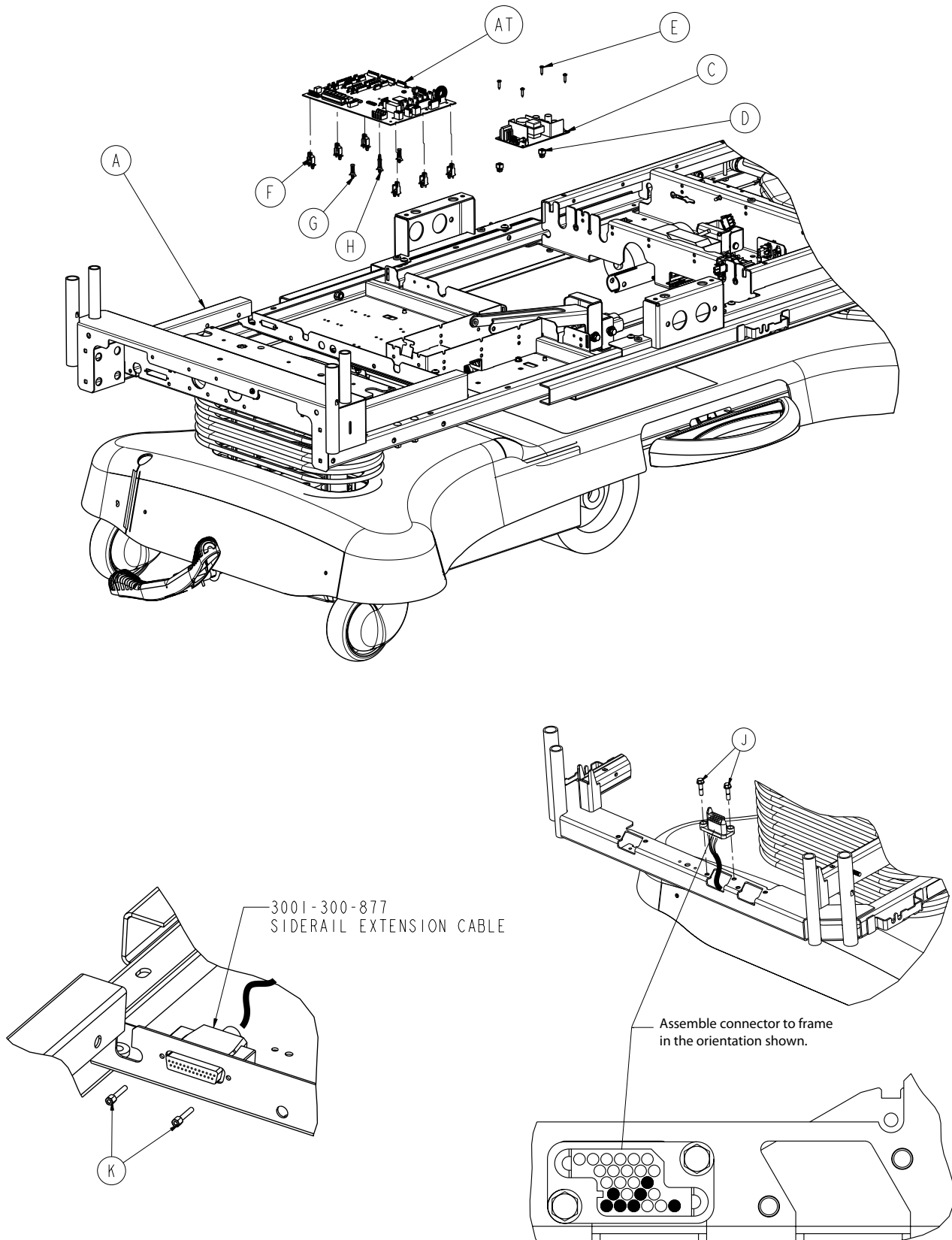

Electrical Litter Assembly, Zoom®, iBed® Wireless Option

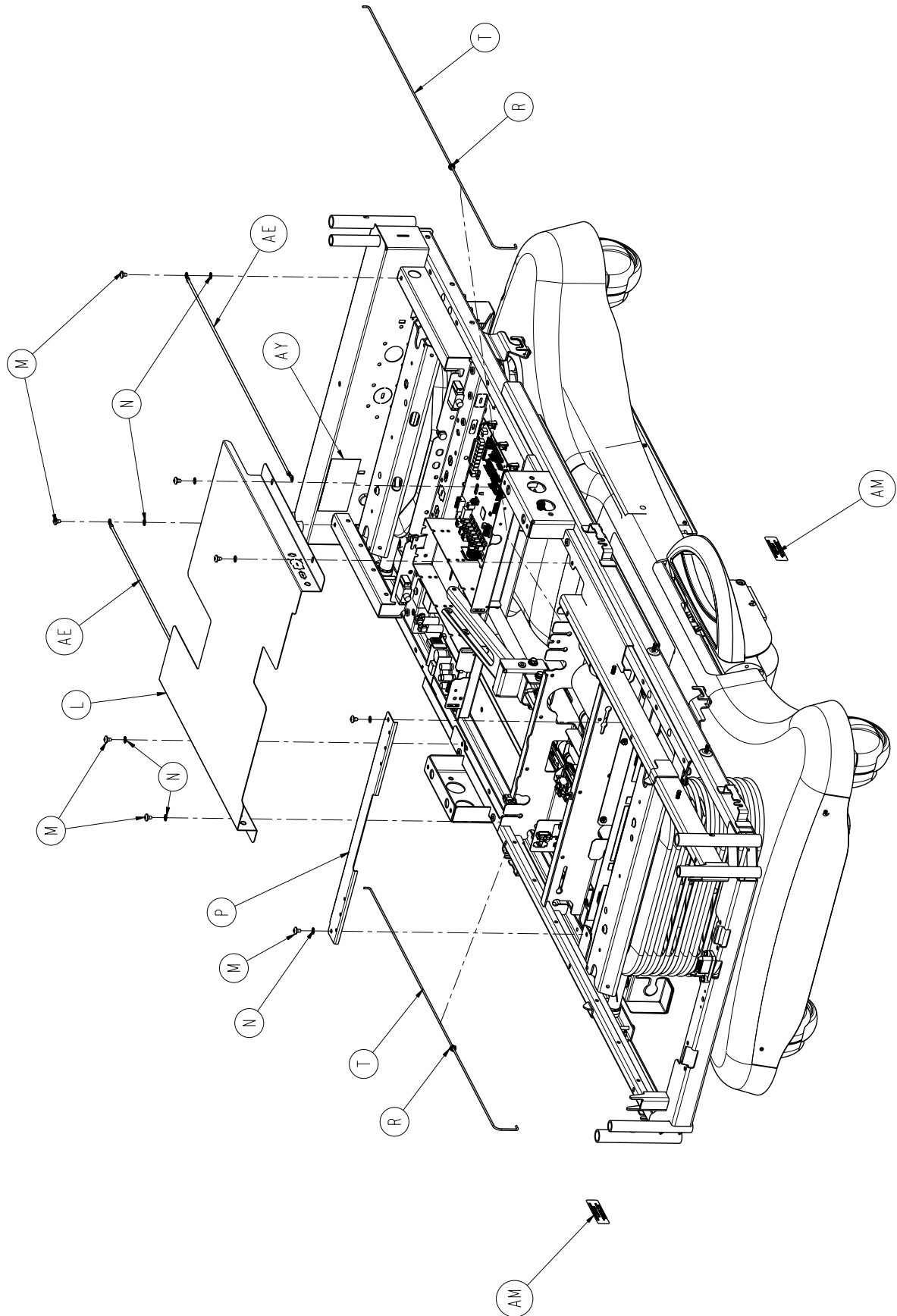

Electrical Litter Assembly, Zoom®, iBed® Wireless Option

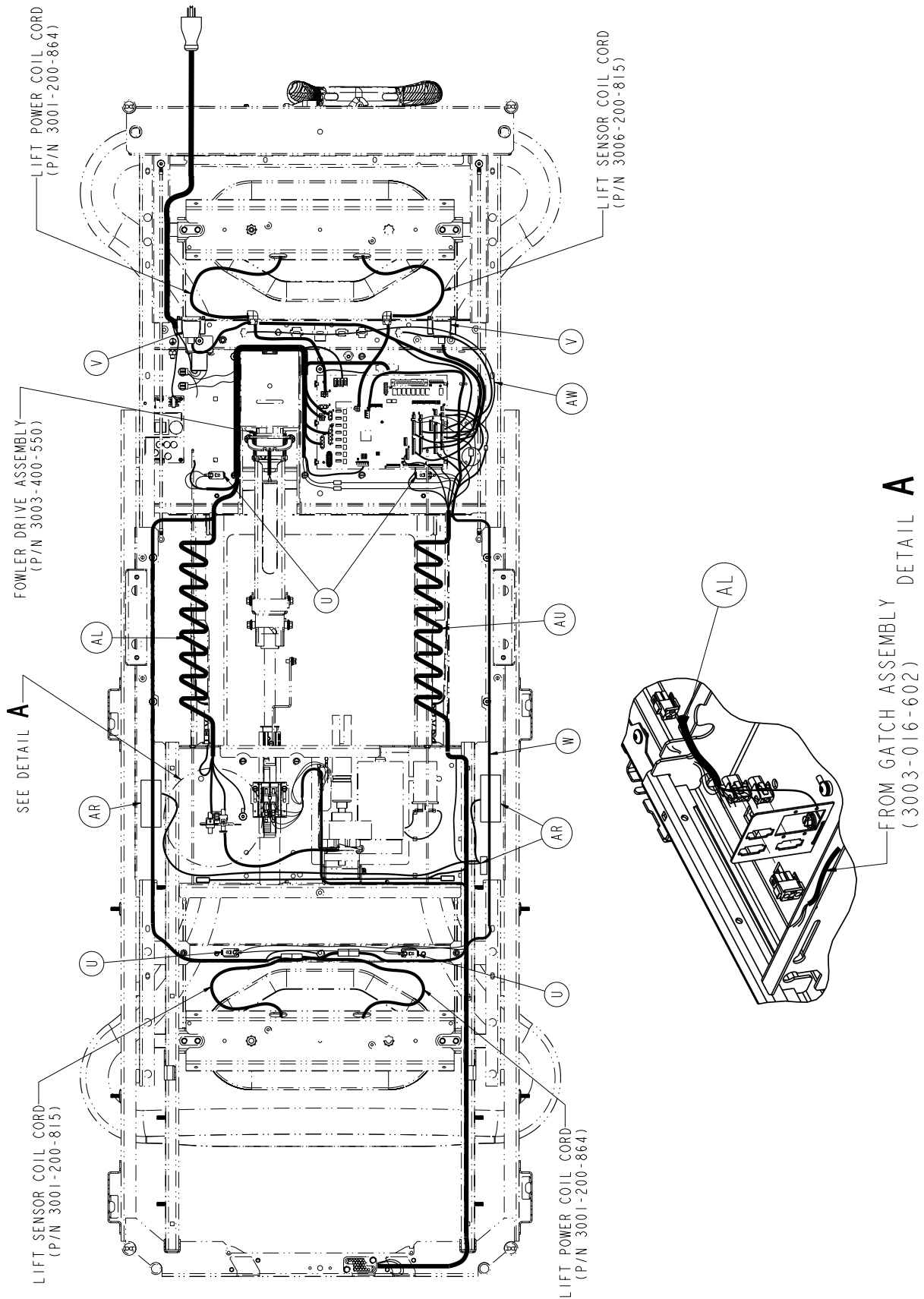

Electrical Litter Assembly, Zoom®, iBed® Wireless Option

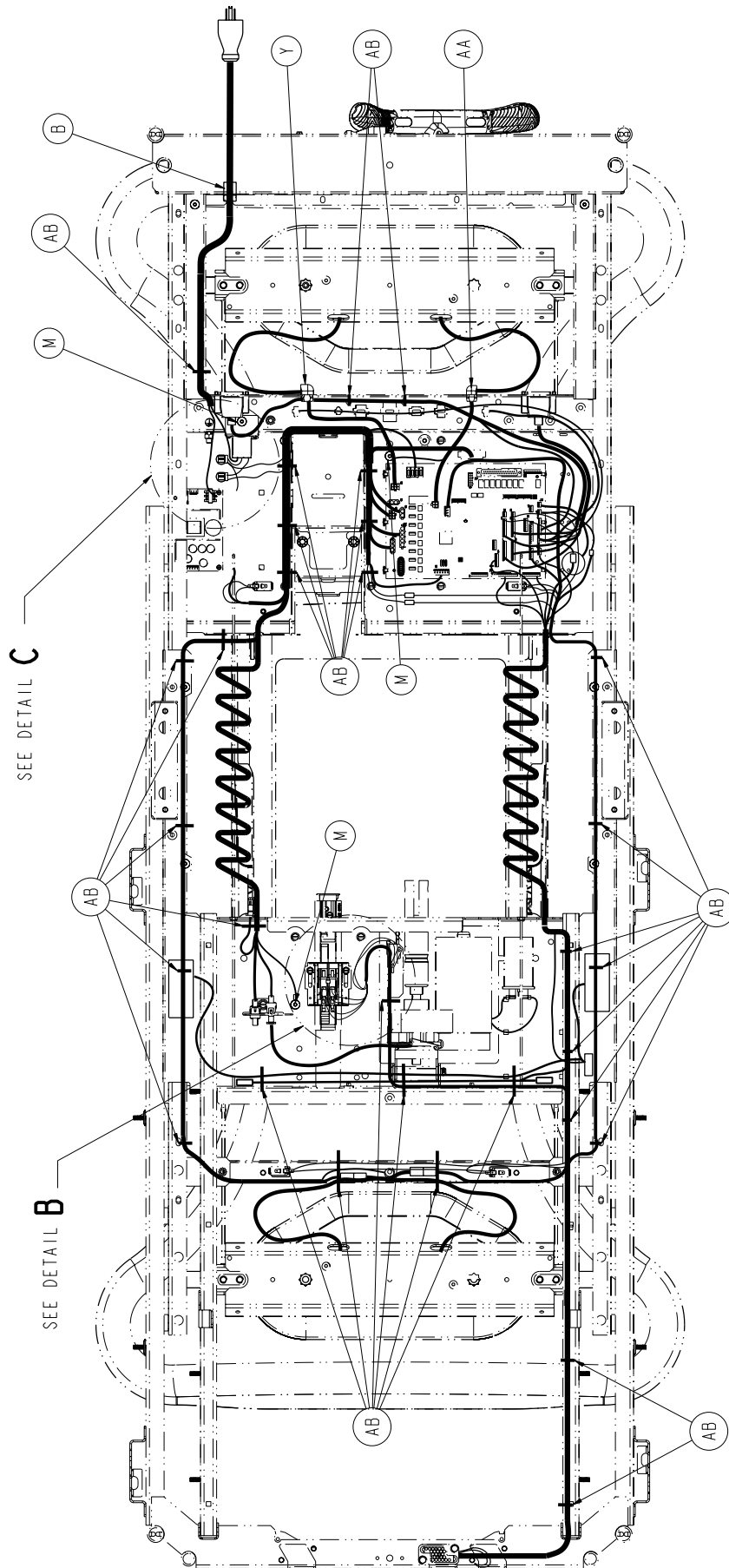

Electrical Litter Assembly, Zoom®, iBed® Wireless Option

DETAIL C

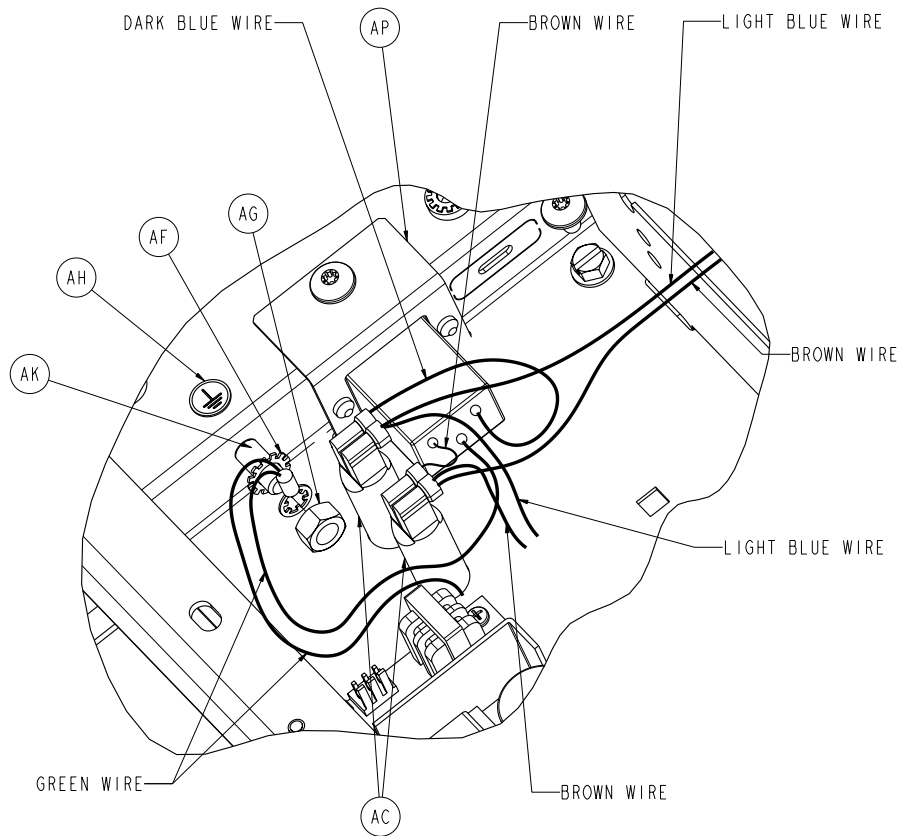

DETAIL B

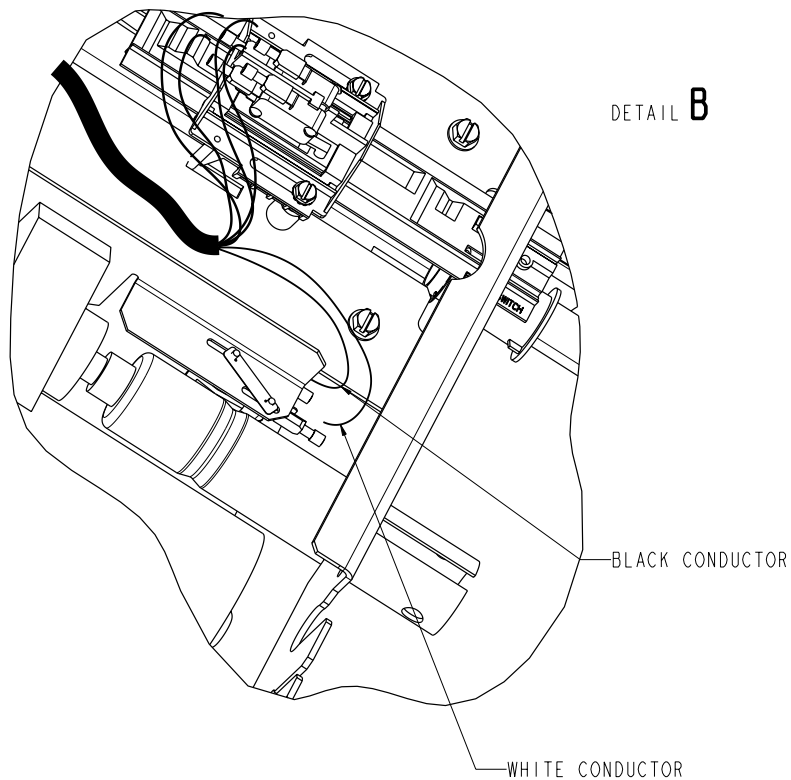

Electrical Litter Assembly, Zoom®, iBed® Wireless Option

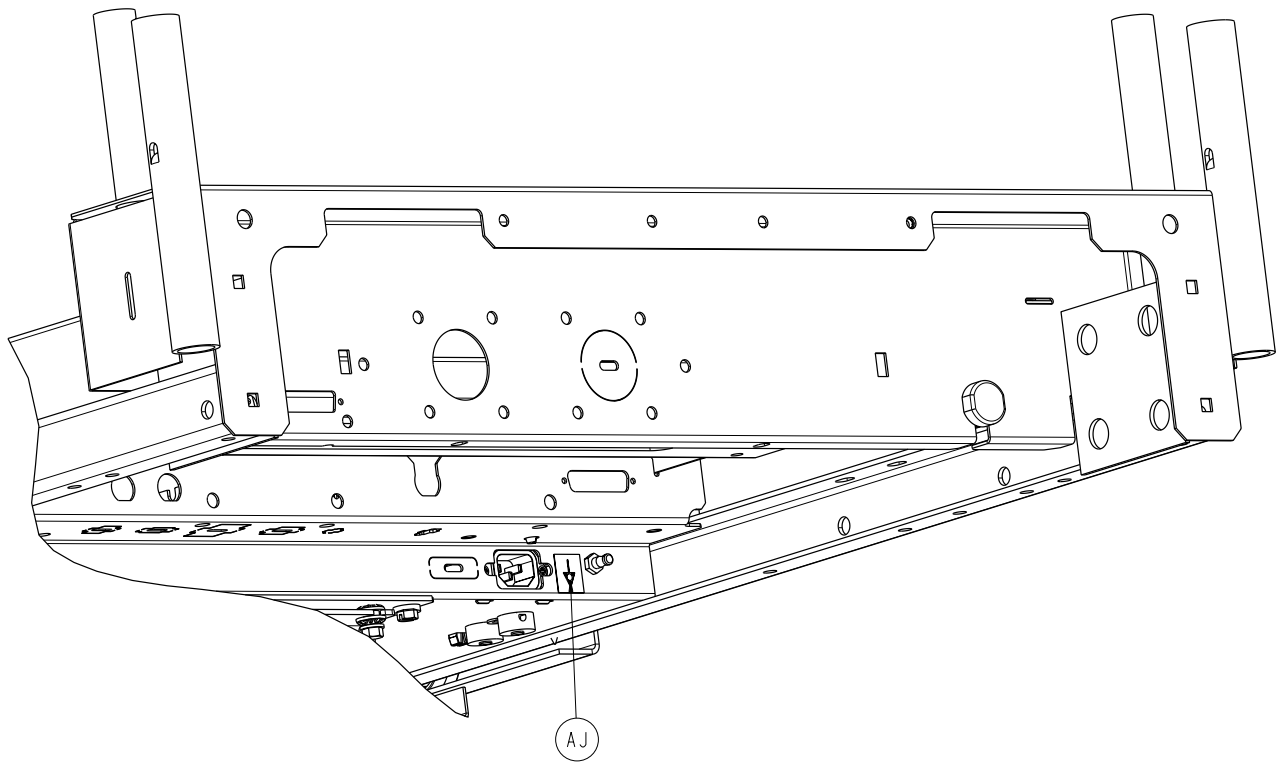

Electrical Litter Assembly, Zoom®, iBed® Wireless Option

Electrical Litter Assembly, Zoom®, iBed® Wireless Option 5212-344-895 (Reference Only)

| Item | Part No. | Part Name | Qty. |
|------|--------------|-------------------------------------|------|
| A | 3006-300-197 | Mechanical Litter Assembly | 1 |
| B | 0030-027-000 | Straight Thru Strain Relief Bushing | 1 |
| C | 0059-157-000 | Power Supply | 1 |
| D | 0052-287-000 | Fastex Plastic Grommet | 4 |
| E | 0023-138-000 | Pan Head Screw | 4 |
| F | 0059-745-000 | Universal Board Mount | 6 |
| G | 0059-773-000 | Push Spacer | 2 |
| H | 0059-774-000 | Locking Circuit Board Support | 1 |
| J | 3001-200-228 | Mounting Standoff | 2 |
| K | 3001-300-007 | Jack Screw | 4 |
| L | 3006-301-088 | Mid Litter Cover Assembly | 1 |
| M | 0007-053-000 | Truss Head Screw | 13 |
| N | 0013-010-000 | External Tooth Lockwasher | 6 |
| P | 3006-301-023 | Cross Support Cover | 1 |
| R | 0052-822-000 | Snap-in Nyliner Bearing | 2 |
| T | 3001-300-011 | Guide Rod | 2 |
| U | 3000-300-058 | Plunger Switch | 4 |
| V | 3001-300-877 | Siderail Extension Cable | 1 |
| W | 3001-300-865 | Motion Interrupt Lift Sensor Cable | 1 |
| Y | 0030-048-000 | Heyco Strain Relief SR | 1 |
| AA | 0030-047-000 | Heyco Strain Relief SR | 1 |
| AB | 3000-300-113 | 8" Cable Tie | 34 |
| AC | 0059-400-000 | 8 Amp Circuit Breaker | 2 |
| AE | 3002-300-874 | Ground Jumper Litter | 2 |
| AF | 0013-038-000 | Lock Washer Extension Spring | 1 |
| AG | 0016-033-000 | Kep Nut | 1 |
| AH | 0036-046-000 | Ground Label | 1 |
| AJ | 0036-115-000 | Ground Label | 1 |
| AK | 2011-011-215 | Grounding Lug Tuv | 1 |
| AL | 3002-300-861 | Power Harness | 1 |
| AM | 3006-300-601 | Foley Bag Hook Label | 2 |
| AN | 3006-131-010 | Secure Zoom® Litter Assembly | 1 |
| AP | 3006-300-881 | Power Inlet Cable | 1 |
| AR | 3006-410-020 | Night Light Option | 1 |
| AT | 3006-308-900 | CPU Board | 1 |
| AU | 3006-300-808 | Siderail Coil Cord | 1 |
| AV | 3006-200-005 | Zoom® Bed Base Assembly | 1 |
| AW | 3003-300-803 | CPU to Siderail Sensor Cable | 1 |
| AY | 3006-300-625 | 115 Volt Specification Label | 1 |

Mechanical Litter Assembly

For Reference Only: 3006-300-197

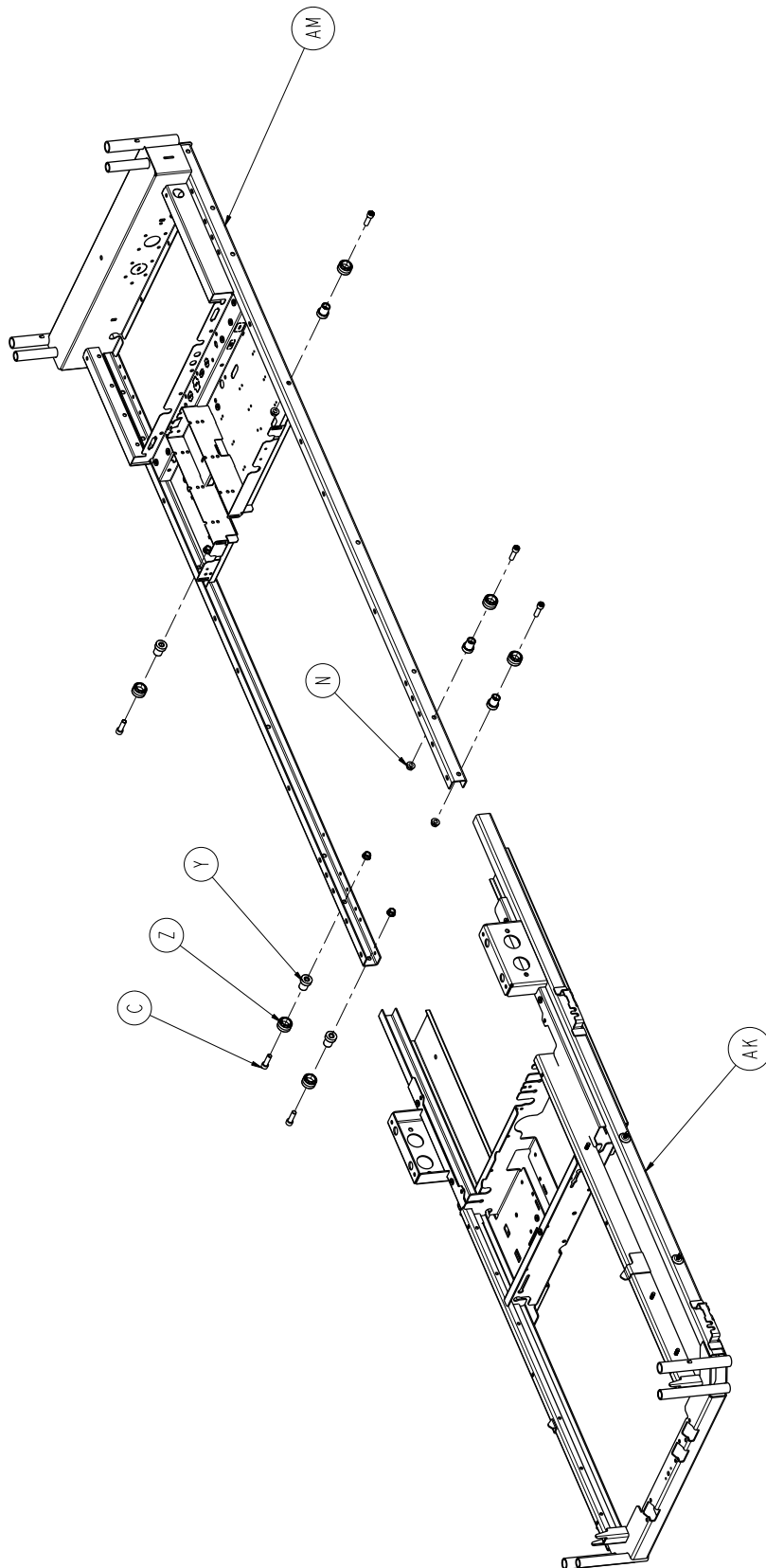

[Return To Table of Contents](#)

Mechanical Litter Assembly

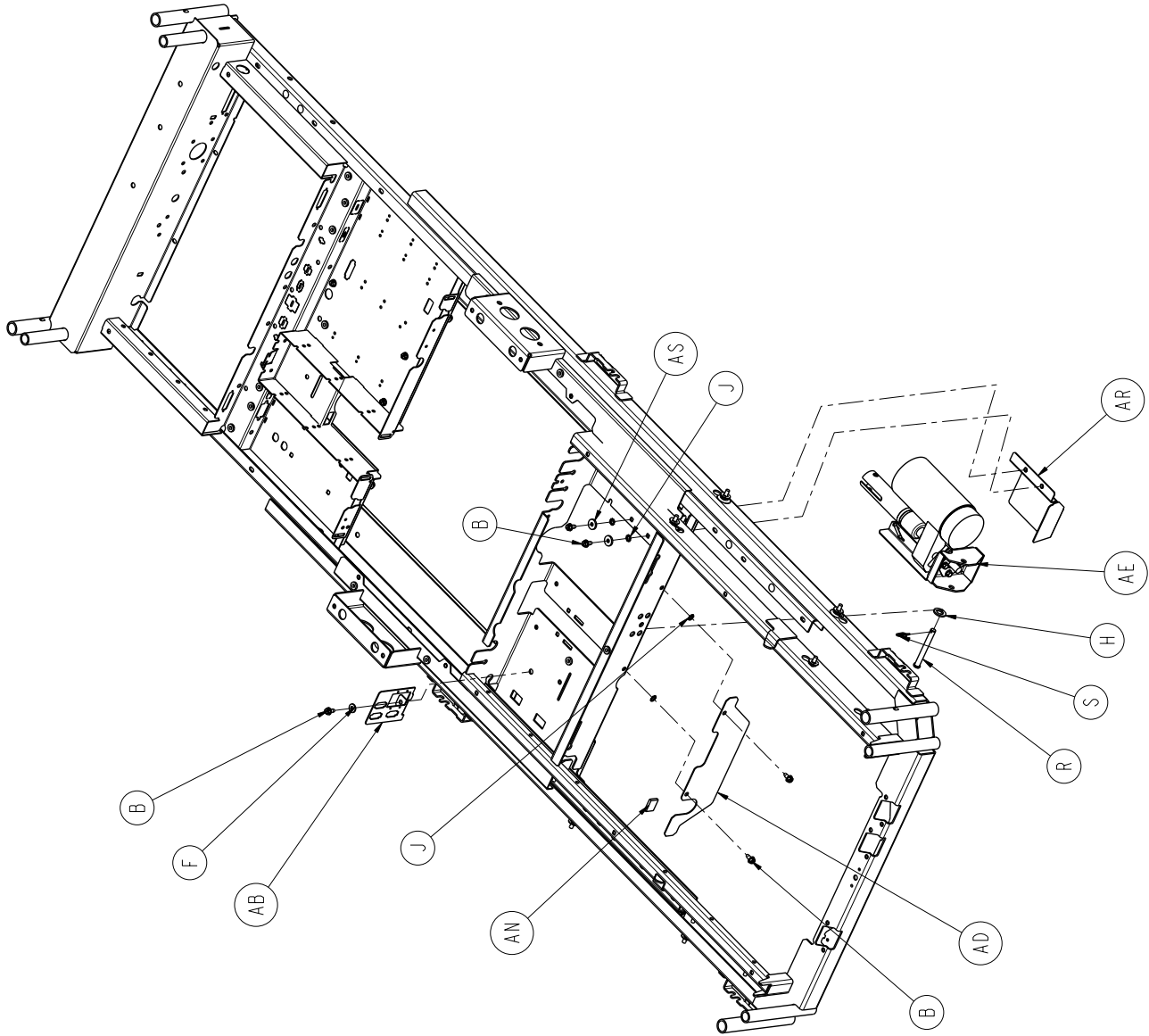

Mechanical Litter Assembly

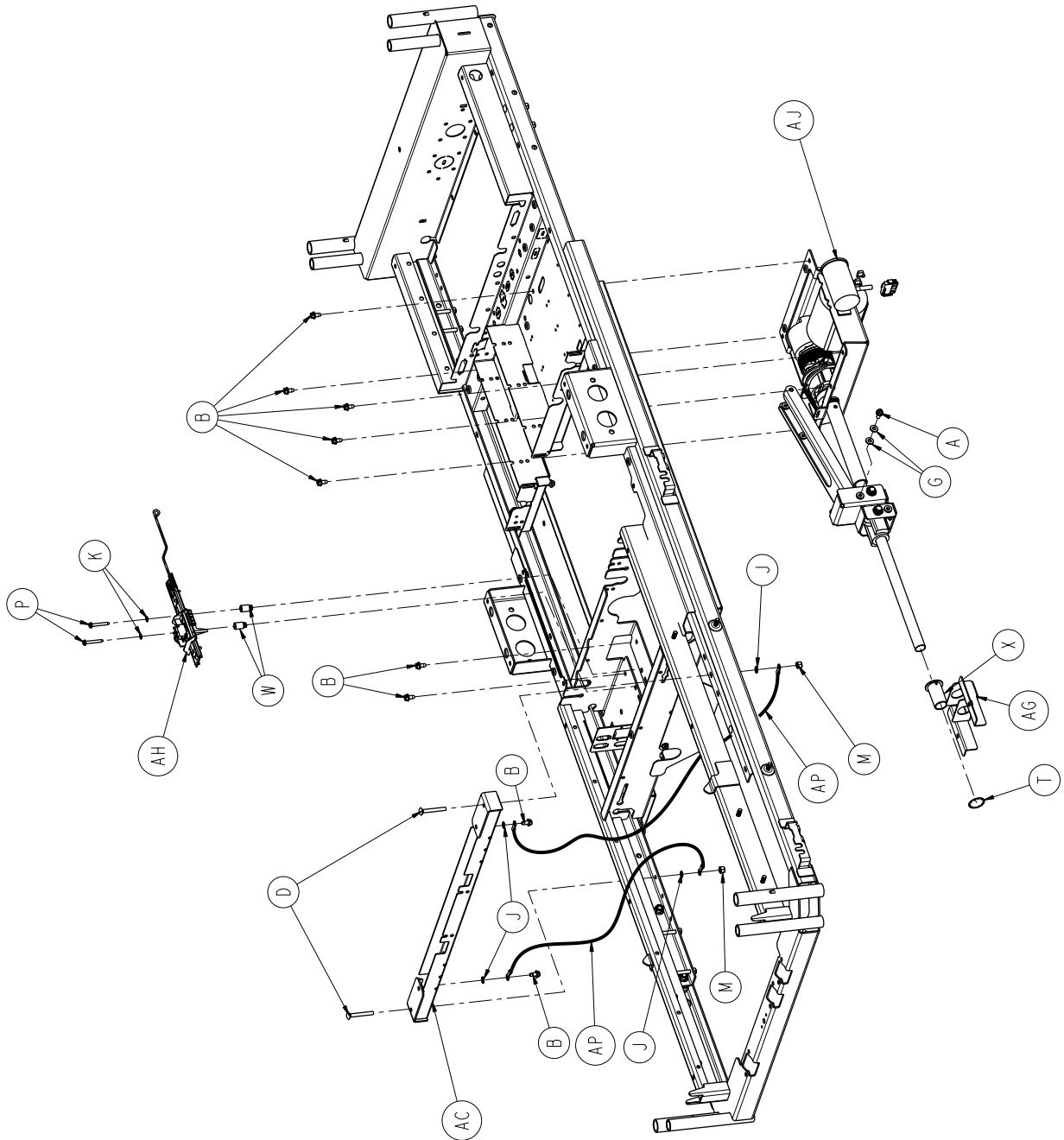

Mechanical Litter Assembly

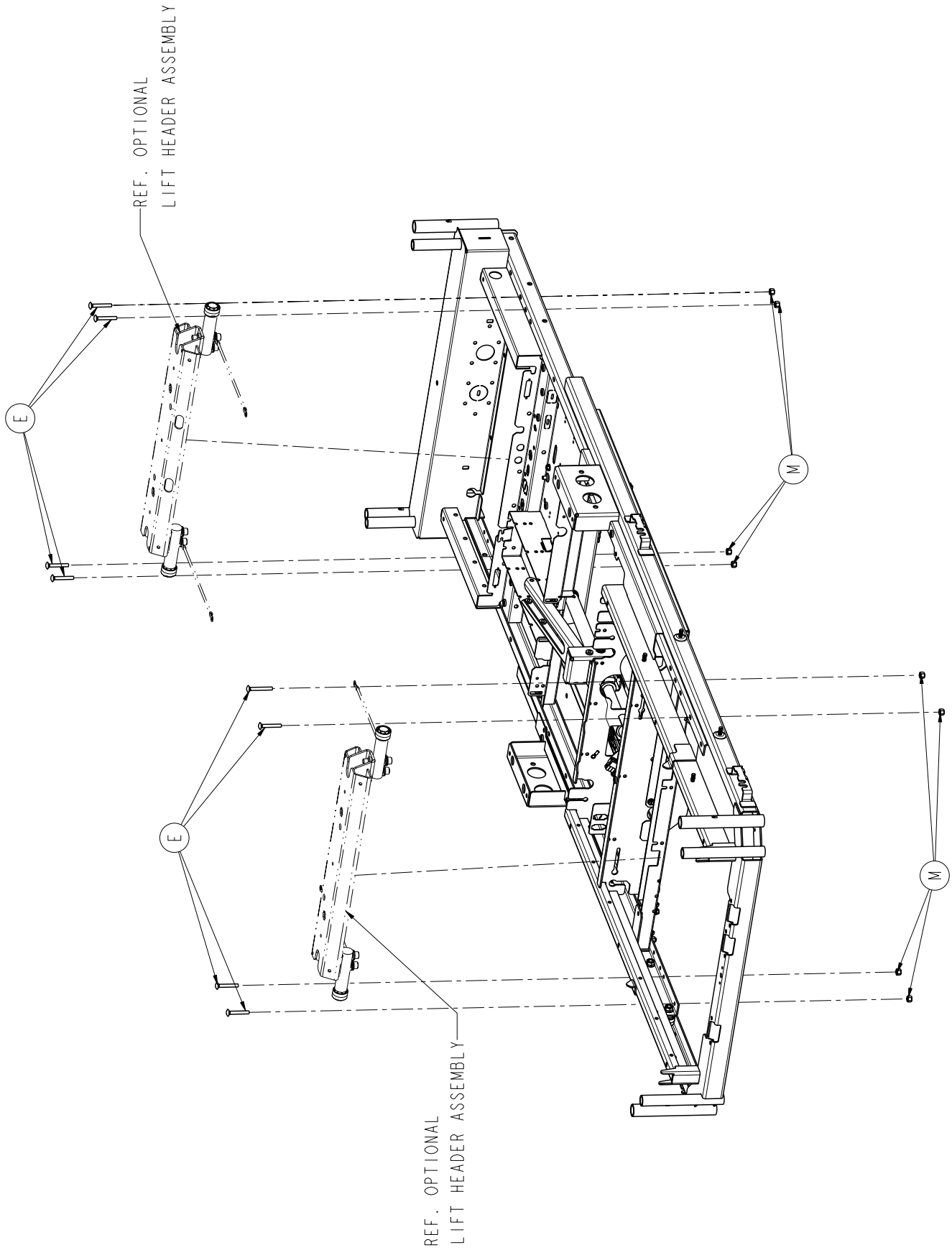

Mechanical Litter Assembly

Mechanical Litter Assembly - 3006-300-197 (Reference Only)

| Item | Part No. | Part Name | Qty. |
|------|--------------|------------------------------|------|
| A | 0003-121-000 | Hex Washer Head Screw | 1 |
| B | 0003-221-000 | Hex Washer Head Screw | 14 |
| C | 0004-211-000 | Socket Head Cap Screw | 6 |
| D | 0005-024-000 | Carriage Bolt | 2 |
| E | 0005-046-000 | Carriage Bolt | 8 |
| F | 0011-002-000 | Washer | 1 |
| G | 0011-063-000 | Washer | 2 |
| H | 0011-529-000 | Adhesive Rubber Washer | 1 |
| J | 0013-010-000 | External Tooth Lock Washer | 8 |
| K | 0013-018-000 | External Tooth Lock Washer | 2 |
| M | 0016-006-000 | Hex Kep Nut | 10 |
| N | 0016-093-000 | Flange Nut | 6 |
| P | 0023-251-000 | Tapping Head Screw | 2 |
| R | 0026-279-000 | Clevis Pin | 1 |
| S | 0027-022-000 | Rue Ring Cotter | 1 |
| T | 0028-122-000 | Retaining Ring | 1 |
| W | 0052-800-000 | Fastex Plastic Grommet | 2 |
| X | 3000-300-009 | Support Screw Bushing | 1 |
| Y | 3000-300-352 | Roller Shaft | 6 |
| Z | 3000-300-353 | Roller | 6 |
| AB | 3001-300-269 | Connector Mounting Bracket | 1 |
| AC | 3006-301-370 | Cross Support Assembly | 1 |
| AD | 3006-310-417 | Gatch Shield | 1 |
| AE | 3006-300-720 | Gatch Motor Assembly | 1 |
| AG | 3002-301-491 | Screw Support Bracket | 1 |
| AH | 3002-343-035 | Fowler Limit Switch Assembly | 1 |
| AJ | 3006-300-550 | Fowler Drive Assembly | 1 |
| AK | 3006-300-206 | Moving Frame Assembly | 1 |
| AM | 3006-300-303 | Stationary Frame Assembly | 1 |
| AN | 7900-001-291 | 1" Vibration Tape | 1 |
| AP | 3002-300-870 | 8" Litter Ground Jumper | 4 |
| AR | 3006-301-422 | Motor Shield | 1 |
| AS | 0011-159-000 | Steel Washer | 2 |

Moving Frame Assembly

For Reference Only: 3006-300-206

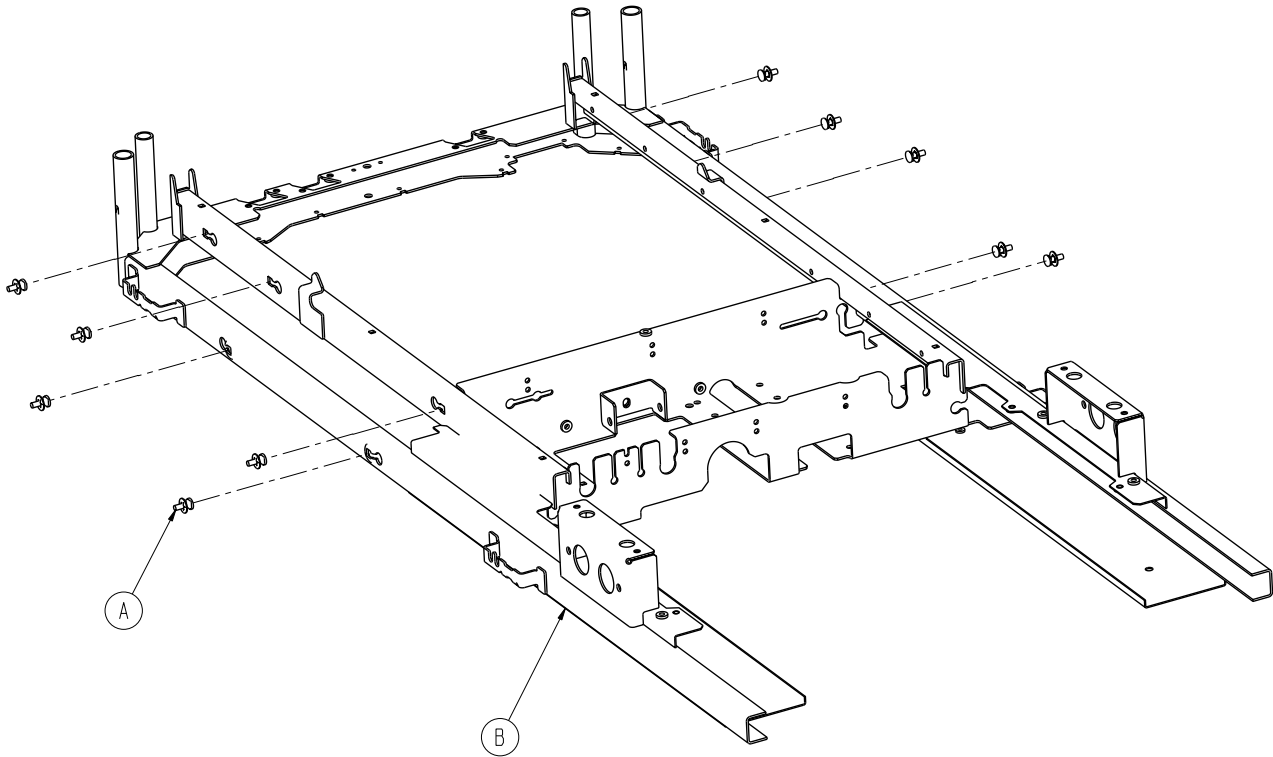

Moving Frame Assembly - 3006-300-206 (Reference Only)

| Item | Part No. | Part Name | Qty. |
|------|--------------|---------------------------------|------|
| A | 0005-049-000 | Flat Head Square Neck Bolt Assy | 10 |
| B | 3006-300-205 | Moving Frame Weldment | 1 |

CPR Damper Assembly Option

For Reference Only: 3006-999-070

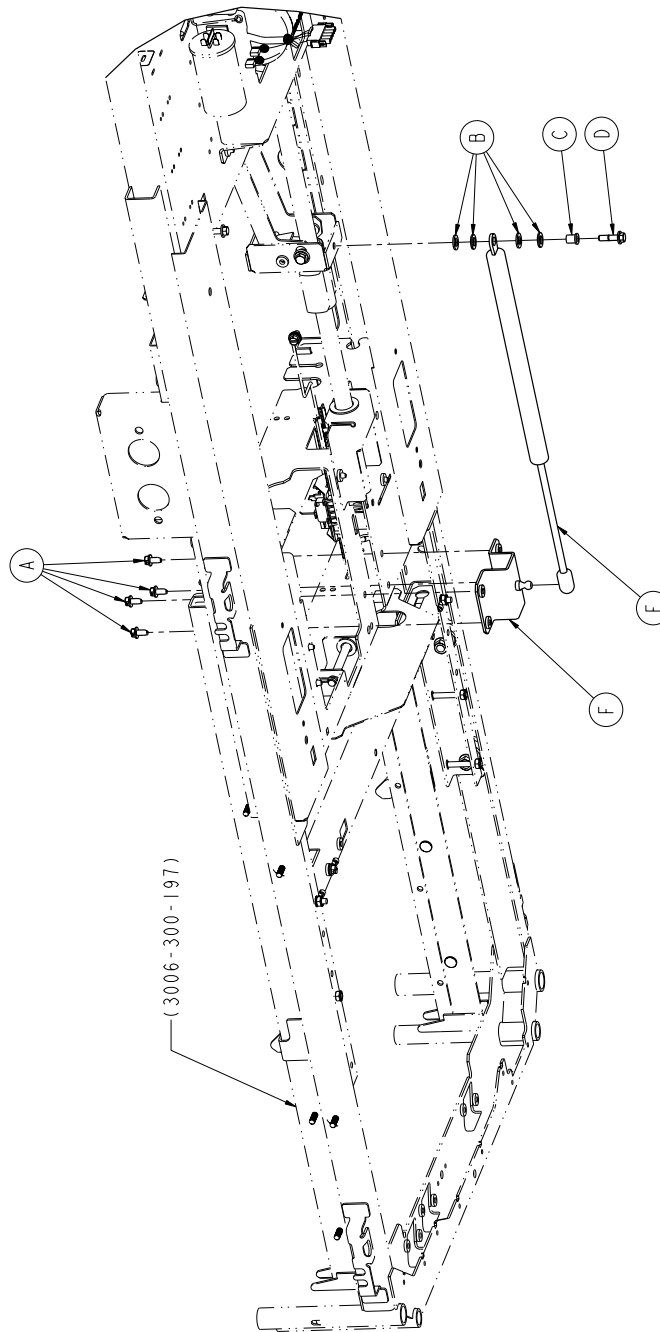

CPR Damper Assembly Option - 3006-999-070 (Reference Only)

| Item | Part No. | Part Name | Qty. |
|------|--------------|---------------------------------|------|
| A | 0003-221-000 | Hex Washer Head Screw | 4 |
| B | 0011-448-000 | Plain Washer | 4 |
| C | 0052-818-000 | Powdered Metal Flange Bearing | 1 |
| D | 3001-200-229 | Mounting Standoff | 1 |
| E | 3006-345-488 | CPR Damper | 1 |
| F | 3006-345-490 | Bracket - Damper Mount Assembly | 1 |

[Return To Table of Contents](#)

Lift Header Assembly - No Load Cells

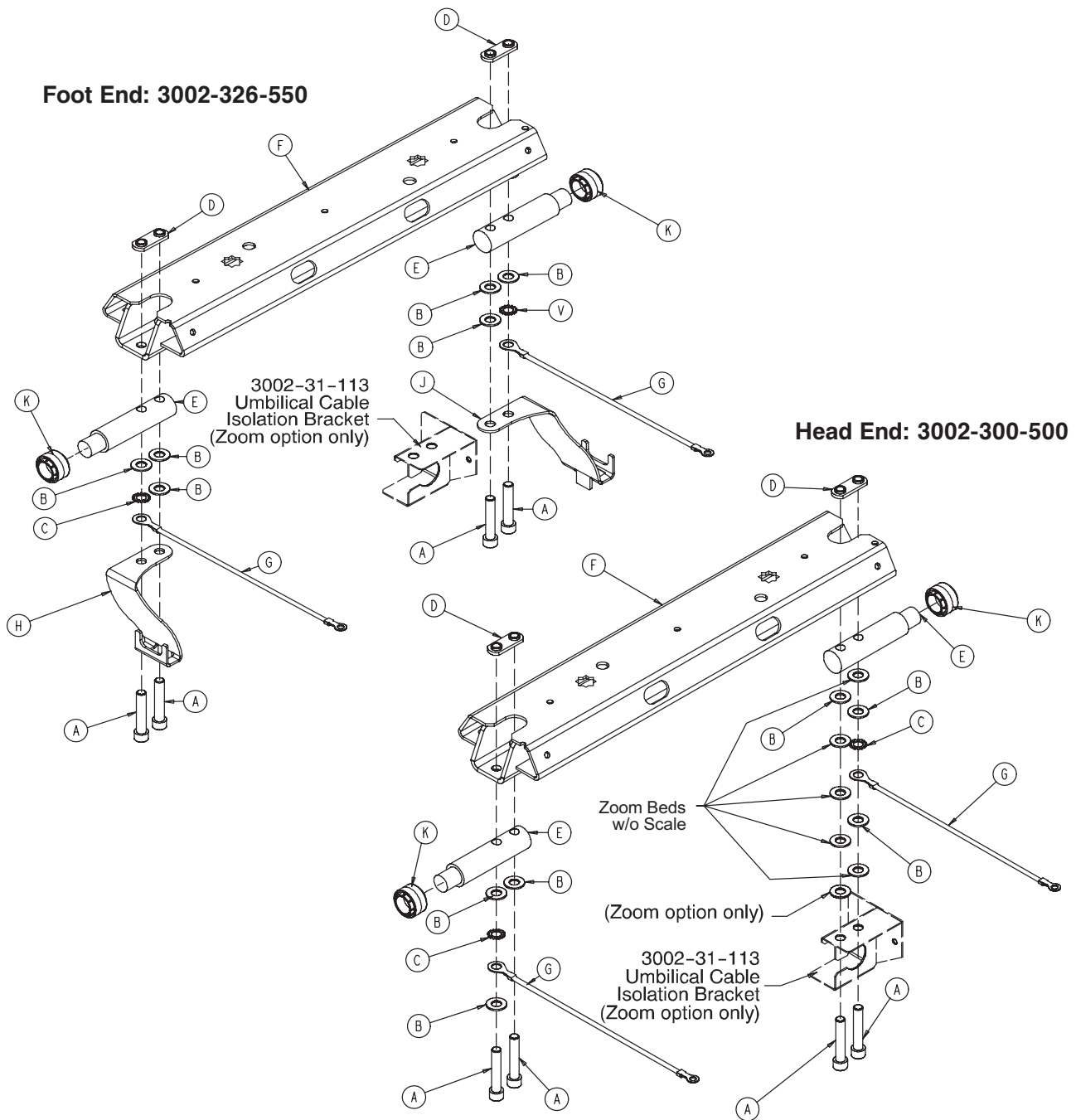

Lift Header - Std. Bed/Iso. Foley Bags - 3002-326-550

| Item | Part No. | Part Name | Qty. |
|------|--------------|---------------------------|------|
| A | 0004-288-000 | Hex Soc. Hd. Cap Screw | 4 |
| B | 0011-004-000 | Flat Washer | 2 |
| C | 0013-032-000 | Ext. Tooth Lock Washer | 2 |
| D | 3002-300-509 | Weldnut | 2 |
| E | 3002-300-511 | "Imitation" Load Cell | 2 |
| F | 3001-300-530 | Lift Header | 1 |
| G | 3002-300-871 | Ground Jumper | 2 |
| H | 3002-326-010 | Iso. Foley Bag Ass'y, Lt. | 1 |
| J | 3002-326-020 | Iso. Foley Bag Ass'y, Rt. | 1 |
| H | 3000-300-353 | Roller Cap | 2 |

Lift Header - Standard Bed - 3002-300-500

| Item | Part No. | Part Name | Qty. |
|------|--------------|------------------------|------|
| A | 0004-288-000 | Hex Soc. Hd. Cap Screw | 4 |
| B | 0011-004-000 | Flat Washer | 6 |
| C | 0013-032-000 | Ext. Tooth Lock Washer | 2 |
| D | 3002-300-509 | Weldnut | 2 |
| E | 3001-300-511 | "Imitation" Load Cell | 2 |
| F | 3001-300-530 | Lift Header | 1 |
| G | 3002-300-871 | Ground Jumper | 2 |
| H | 3000-300-353 | Roller Cap | 2 |

Lift Header Assembly with Load Cells

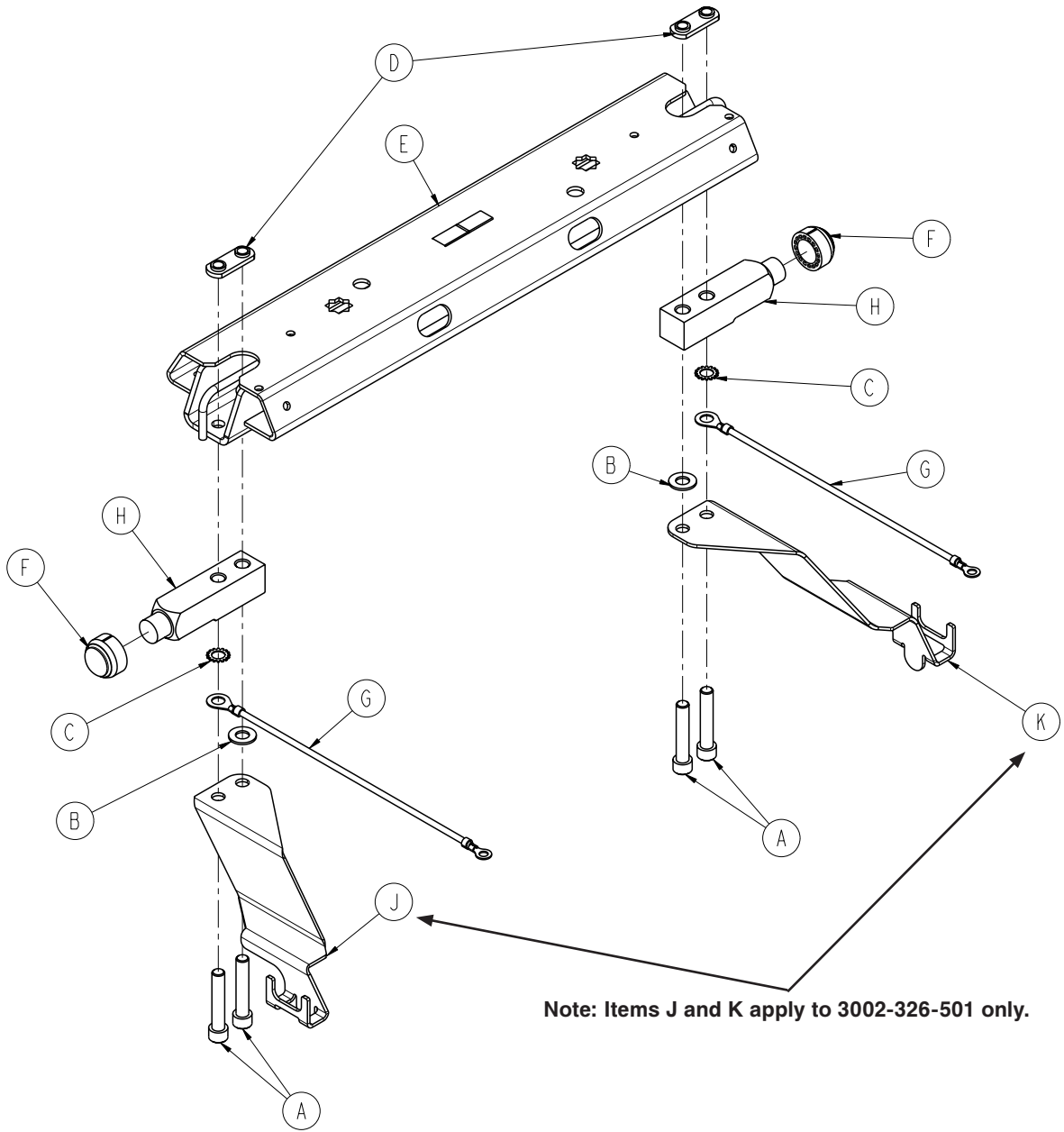

Note: Items J and K apply to 3002-326-501 only.

Lift Header, Head End - Load Cells - 3006-307-501

| Item | Part No. | Part Name | Qty. |
|------|--------------|------------------------|------|
| A | 0004-288-000 | Hex Soc. Hd. Cap Screw | 4 |
| B | 0011-004-000 | Flat Washer | 4 |
| C | 0013-032-000 | Ext. Tooth Lock Washer | 2 |
| D | 3001-300-509 | Weldnut | 2 |
| E | 3006-301-530 | Lift Header Assembly | 1 |
| F | 3002-300-353 | Roller Cap | 2 |
| G | 3002-300-871 | Ground Jumper | 2 |
| H | 3002-307-057 | Load Cell | 2 |

Lift Header - Load Cells/Iso. Foley Hooks, Foot End - 3002-326-501

| Item | Part No. | Part Name | Qty. |
|------|--------------|--------------------------|------|
| A | 0004-288-000 | Hex. Soc. Hd. Cap Screw | 4 |
| B | 0011-004-000 | Flat Washer | 2 |
| C | 0013-032-000 | Ext. Tooth Lock Washer | 2 |
| D | 3001-300-509 | Lift Header Weldnut | 2 |
| E | 3006-301-530 | Lift Header Assembly | 1 |
| F | 3002-300-353 | Roller Cap | 2 |
| G | 3002-300-871 | Ground Jumper | 2 |
| H | 3002-307-057 | Load Cell - 750 lbs | 2 |
| J | 3002-326-010 | Iso. Foley Bag Ass'y, LH | 1 |
| K | 3002-326-020 | Iso. Foley Bag Ass'y, RH | 1 |

[Return To Table of Contents](#)

Gatch Motor Assembly

3001-300-420

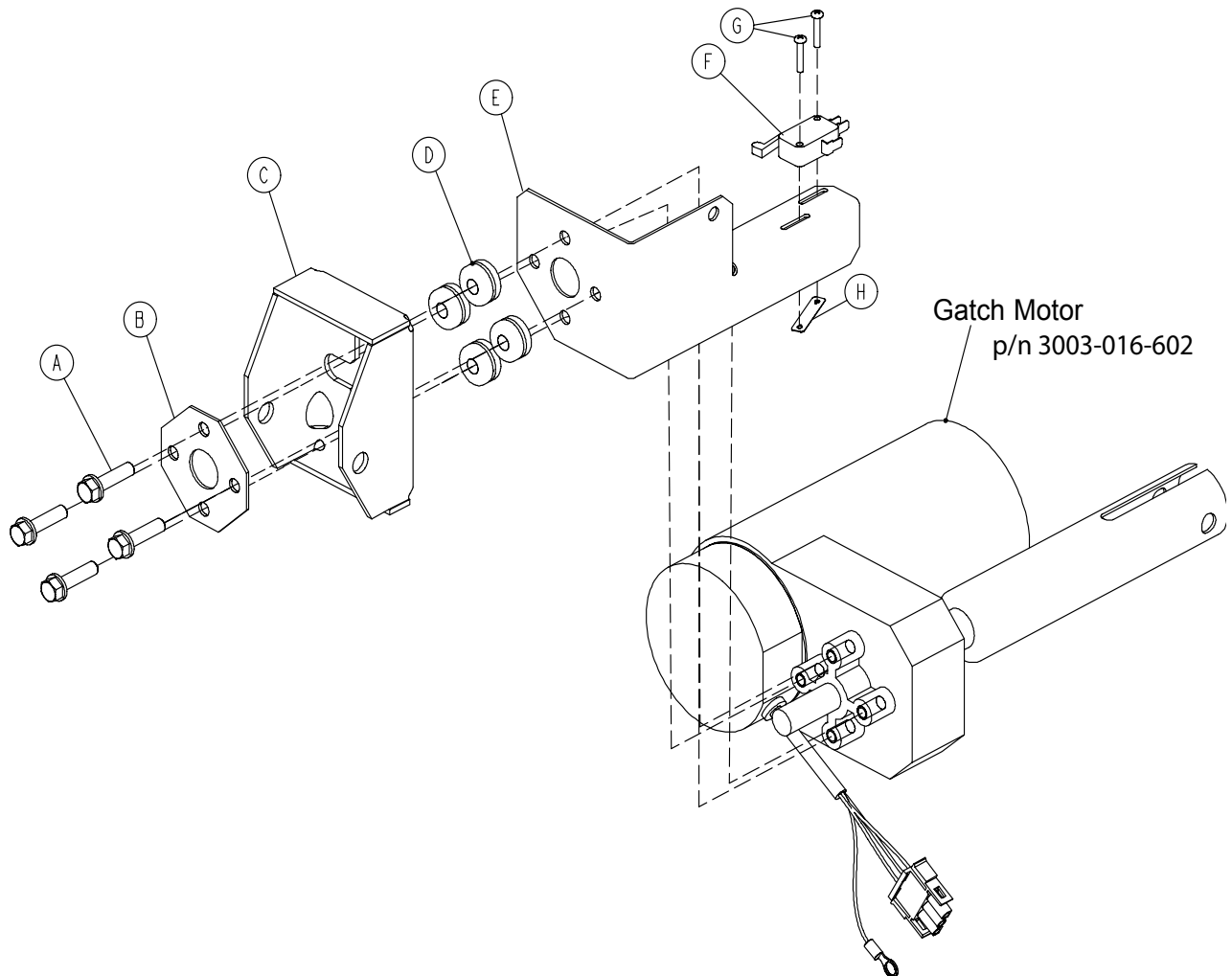

| Item | Part No. | Part Name | Qty. |
|------|--------------|----------------------------|------|
| A | 3001-200-228 | Mounting Standoff | 4 |
| B | 3001-300-499 | Gatch Motor Mounting Plate | 1 |
| C | 3001-300-225 | Motor Mount Bracket | 1 |
| D | 0052-817-000 | Grommet | 4 |
| E | 3002-300-421 | Gatch Limit Bracket | 1 |
| F | 3000-300-041 | Micro Switch | 1 |
| G | 0002-107-000 | Phillips Round Head Screw | 2 |
| H | 0016-069-000 | Twin-Type Fastener | 1 |
| L | 3000-300-114 | Wire Tie (not shown) | 1 |

Fowler Drive Assembly

For Reference Only: 3006-300-550

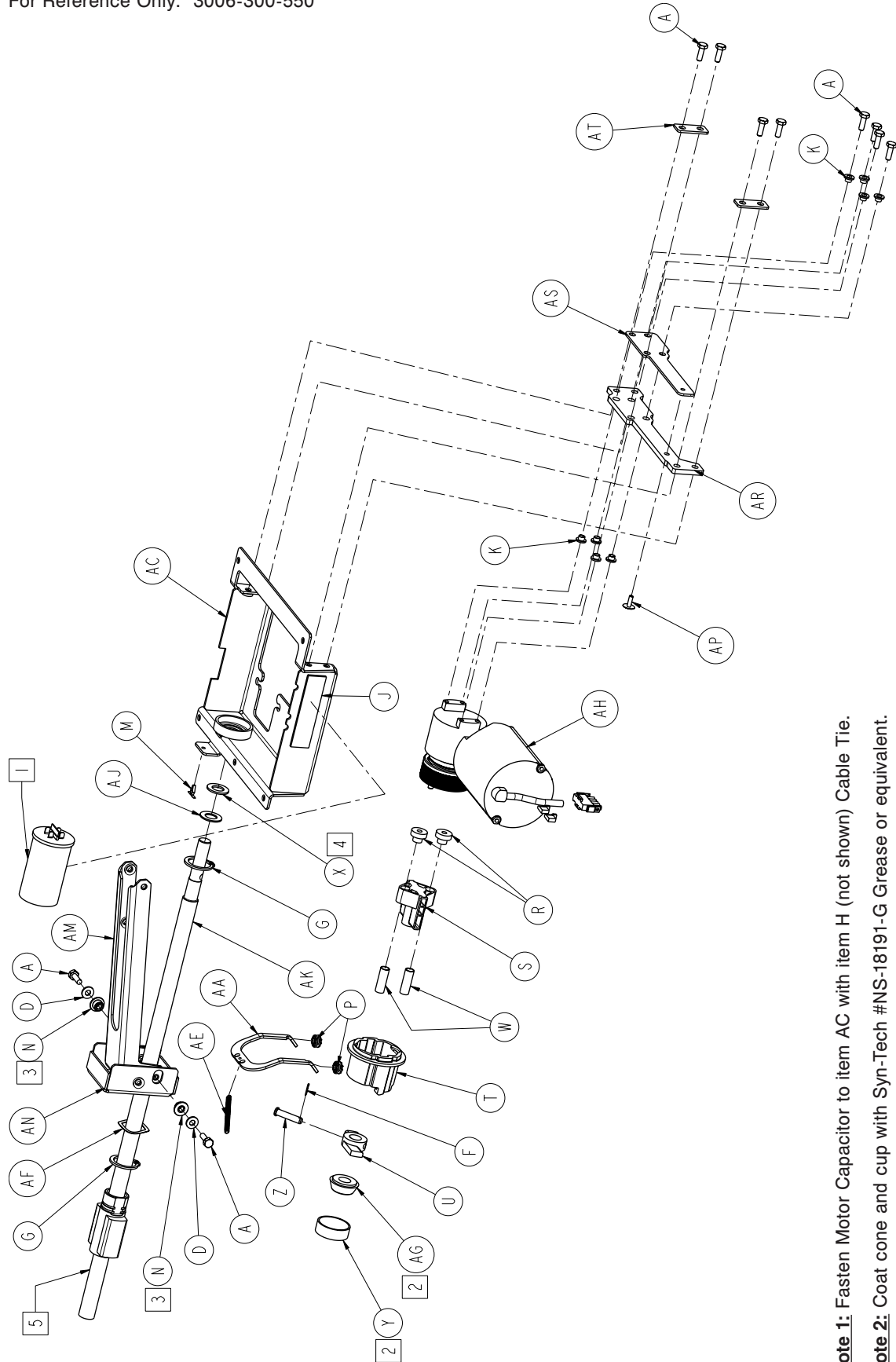

Note 1: Fasten Motor Capacitor to item AC with item H (not shown) Cable Tie.

Note 2: Coat cone and cup with Syn-Tech #NS-18191-G Grease or equivalent.

Note 3: After assembly, apply Syn-Tech #NS-18191-G Grease or equivalent to O.D. of items N (Litter Pivot Bushing).

Note 4: Apply Syn-Tech #NS-18191-G Grease or equivalent to both sides of item X.

Note 5: Apply Mobil #28 Grease to entire length of ball screw after assembly.

[Return To Table of Contents](#)

Fowler Drive Assembly

Fowler Actuator Assembly - 3006-300-550

| Item | Part No. | Part Name | Qty. |
|------|--------------|------------------------------|------|
| A | 0003-214-000 | Hex Head Cap Screw | 10 |
| F | 0027-017-000 | Cotter Pin | 1 |
| G | 0028-120-000 | External Retaining Ring | 2 |
| H | 0038-151-000 | Cable Tie | 2 |
| J | 0044-029-000 | Double-Sided Stick Tape (2") | 1 |
| K | 0052-718-000 | Molded Nylon Insulator | 8 |
| M | 0029-021-000 | Dart Type Clip | 1 |
| N | 3000-300-099 | Litter Pivot Bushing | 2 |
| P | 3000-300-442 | Fowler Drive Grommet | 4 |
| R | 3000-300-455 | CPR Isolation Bushing | 2 |
| S | 3000-300-456 | CPR Isolator | 1 |
| T | 3000-300-461 | CPR Decoupler | 1 |
| U | 3000-300-462 | CPR Wing | 1 |
| W | 3000-300-464 | CPR Engagement Spring | 2 |
| X | 3000-300-466 | Thrust Bearing | 1 |
| Y | 3000-300-471 | CPR Tapered Bearing Housing | 1 |
| Z | 3000-300-473 | Clevis Pin | 1 |
| AA | 3000-300-658 | CPR Release Arm | 1 |
| AC | 3006-303-485 | Fowler Actuator Weldment | 1 |
| AE | 3001-300-664 | CPR Spring | 1 |
| AF | 0038-478-000 | Wave Spring | 1 |
| AG | 3000-300-444 | CPR Tapered Bearing | 1 |
| AH | 3006-300-705 | Fowler Actuator Assembly | 1 |
| AJ | 0014-083-000 | Flat Washer | 1 |
| AK | 3000-300-457 | CPR Ball Screw | 1 |
| AM | 3006-301-496 | Fowler Link | 1 |
| AN | 3002-300-493 | Fowler Link Bracket | 1 |
| AP | 0025-092-000 | Rivet | 1 |
| AR | 3006-300-121 | Motor Mount Isolator | 1 |
| AS | 3006-300-122 | Isolator Plate | 1 |
| AT | 3006-300-123 | Mounting Plate Tabs | 2 |

Fowler Brake Kit Assembly -3001-300-775

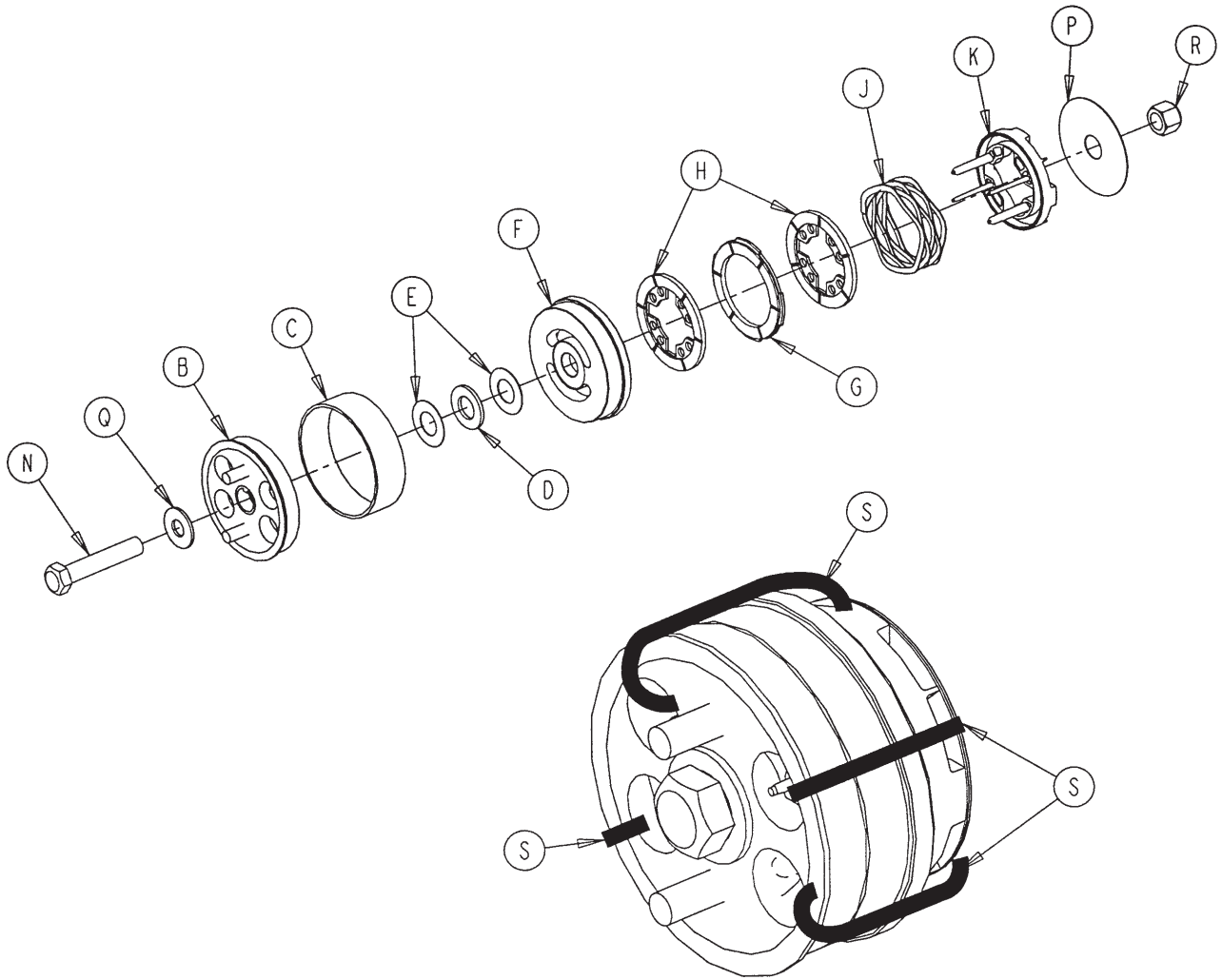

| Item | Part No. | Part Name | Qty. |
|------|--------------|---------------------------|------|
| B | 3001-300-455 | CPR Coupler Assembly | 1 |
| C | 3000-300-465 | CPR Clutch Spring | 1 |
| D | 0081-212-000 | Thrust Needle Roller Brg. | 1 |
| E | 3000-200-224 | Idler Gear Thrust Washer | 2 |
| F | 3001-300-569 | Brake Cup | 1 |
| G | 3001-300-552 | CPR Brake Disc | 1 |
| H | 3001-300-551 | CPR Spring Cup | 2 |
| J | 3001-300-563 | CPR Brake Spring | 1 |
| K | 3001-300-570 | CPR Spring Cup | 1 |
| N | 0003-064-000 | Hex Head Cap Screw | 1 |
| P | 3000-300-776 | Flat Washer | 1 |
| Q | 0011-193-000 | Heavy Flat Washer | 1 |
| R | 0016-035-000 | Nylock Nut | 1 |
| S | 3000-300-113 | 8" Wire Tie | 4 |

Standard Bed Fowler Limit Switch Assembly - 3002-343-035

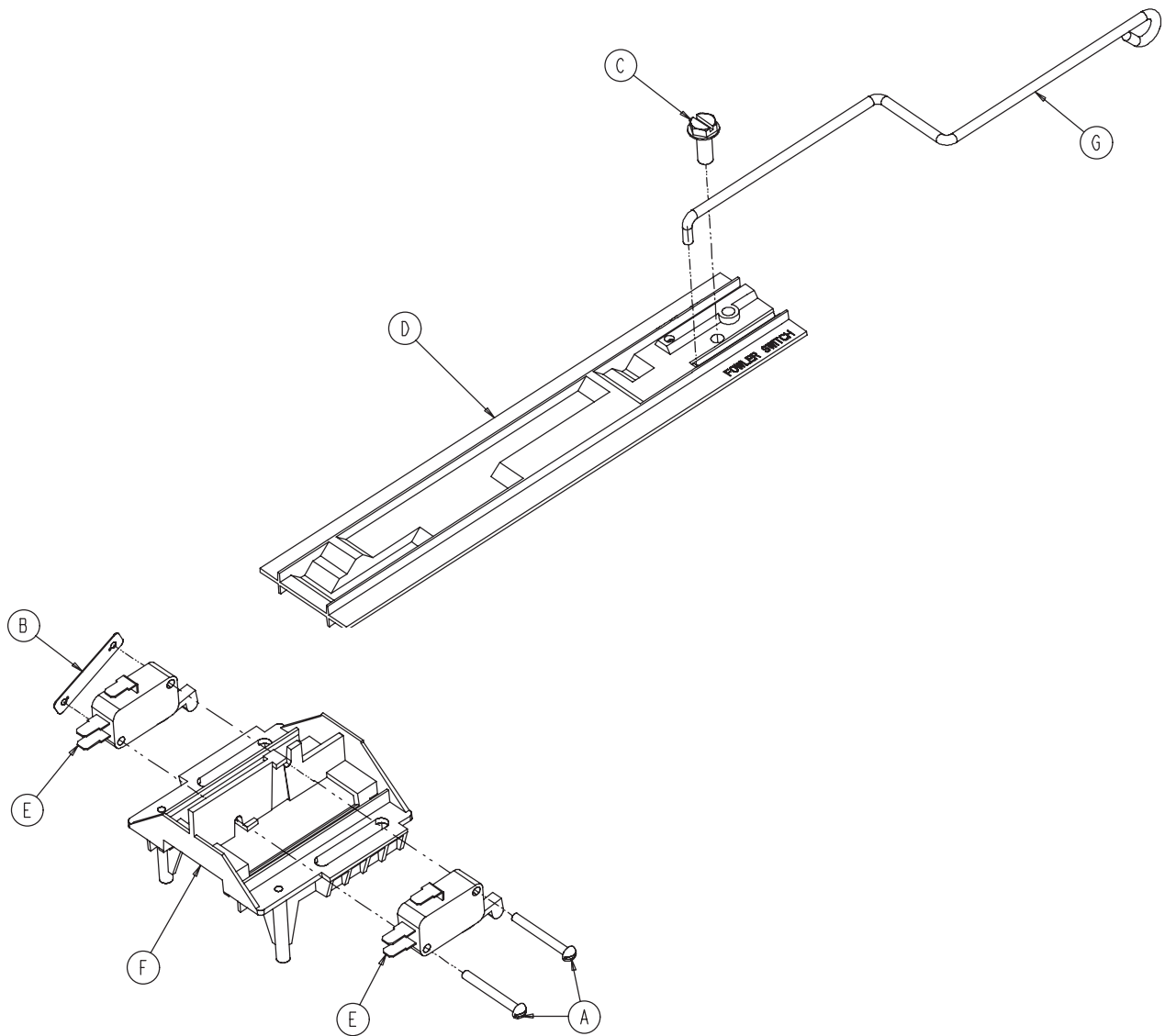

| Item | Part No. | Part Name | Qty. |
|------|--------------|-----------------------|------|
| A | 0002-003-000 | Round Head Screw | 2 |
| B | 0016-069-000 | Twin Type Fastener | 1 |
| C | 0016-129-000 | Hex Washer Head Screw | 1 |
| D | 3000-300-036 | Fowler Cam Card | 1 |
| E | 3000-300-041 | Micro Switch | 2 |
| F | 3000-300-044 | Cam Guide | 1 |
| G | 3002-300-038 | Link Wire | 1 |

Night Light Assembly - 3006-410-020

LH bottom side of moving frame (3006-300-206)

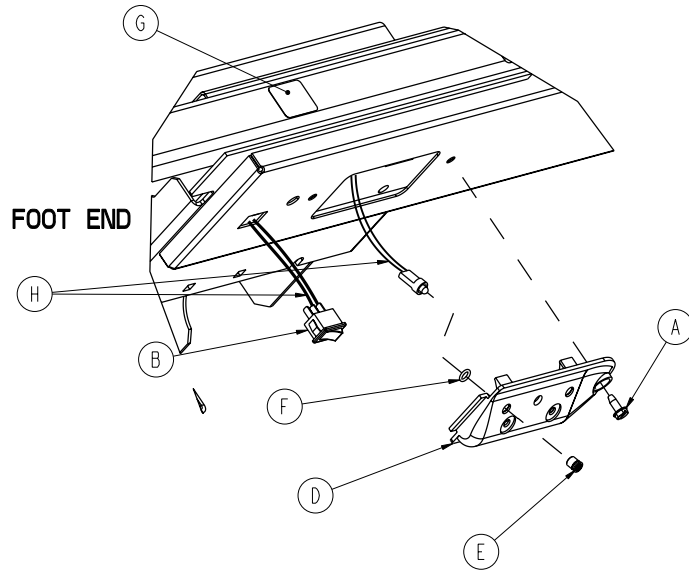

RH bottom side of moving frame (3006-300-206)
(No toggle switch required on RH side of bed.)

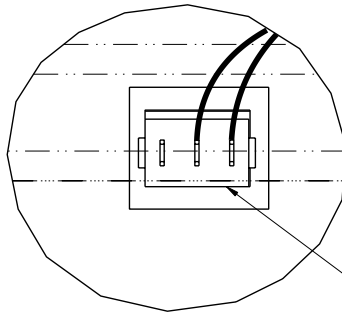
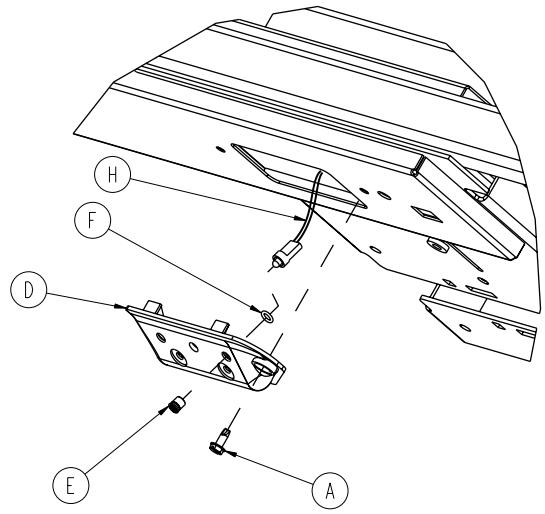

DETAIL A

Orient switch so that the "O" is towards the head end of the bed.

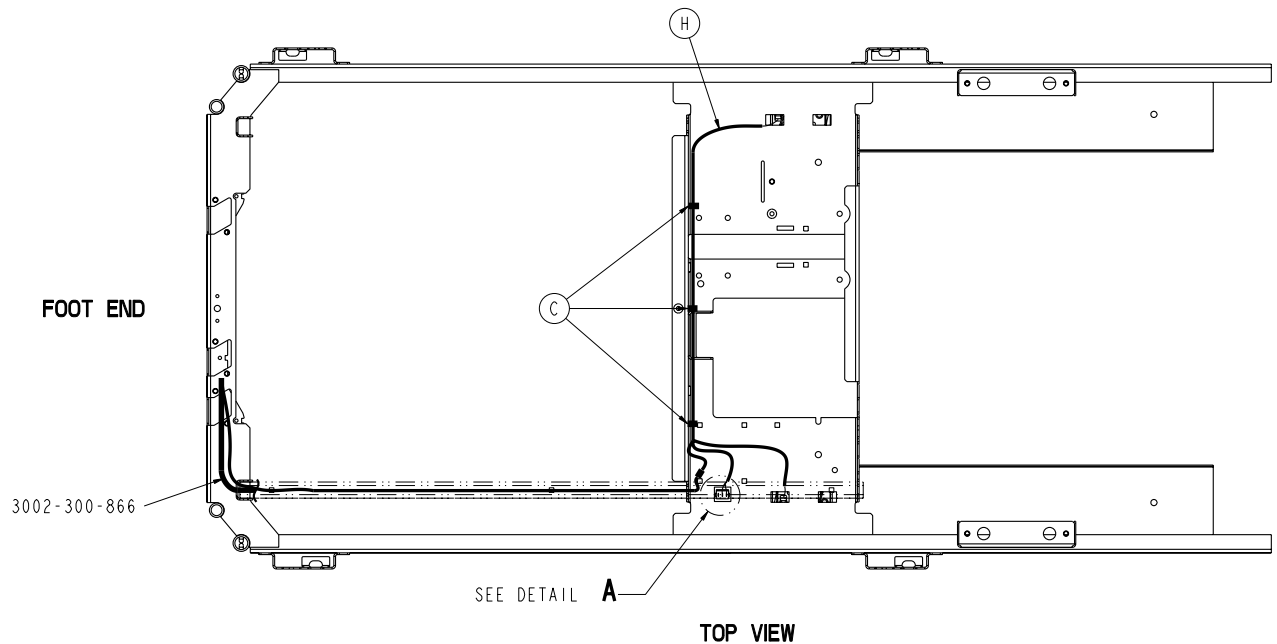

Night Light Assembly - 3006-410-020

Night Light Assembly - 3006-410-020

| Item | Part No. | Part Name | Qty. |
|-------------|-----------------|----------------------------|-------------|
| A | 0003-224-000 | Hex Washer Head Screw | 2 |
| B | 0059-191-000 | Toggle Switch | 1 |
| C | 3000-300-113 | 8" Cable Tie | 3 |
| D | 3002-310-018 | Night Light Cover | 2 |
| E | 3002-310-010 | LED Lens | 4 |
| F | 3002-310-025 | Retaining Spacer | 2 |
| G | 3006-310-601 | Night Light Label | 1 |
| H | 3002-036-801 | Night Light Wiring Harness | 1 |

Optional 110V Outlet Assembly - 3006-320-050

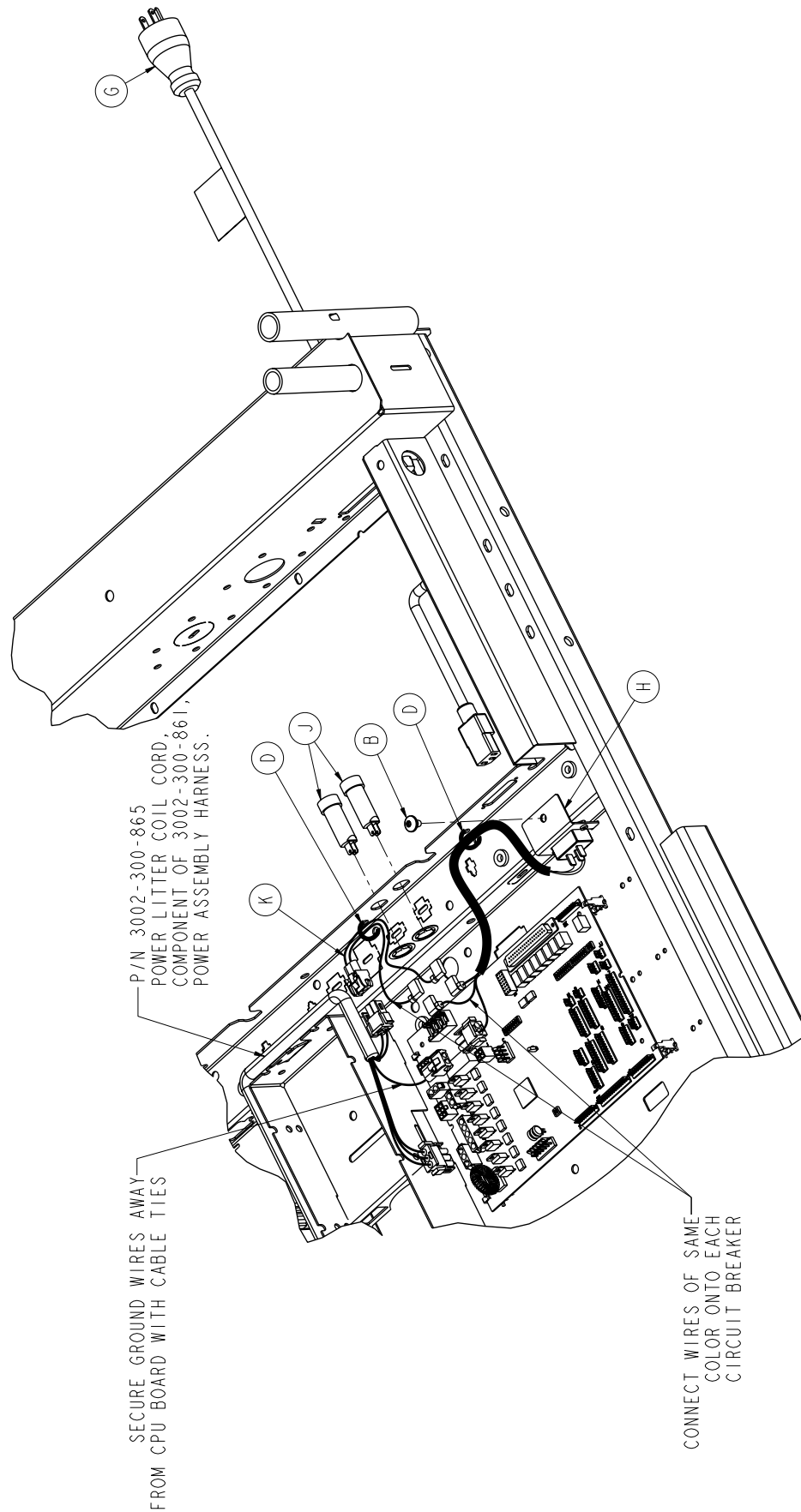

Optional 110V Outlet Assembly - 3006-320-050

Optional 110V Outlet Assembly - 3006-320-050

| Item | Part No. | Part Name | Qty. |
|------|--------------|-------------------------------------|------|
| A | 0003-224-000 | Hex Washer Head Screw | 2 |
| B | 0007-053-000 | Truss Head Torx | 1 |
| C | 0030-027-000 | Straight Thru Strain Relief Bushing | 1 |
| D | 3000-300-113 | 8" Cable Tie | 5 |
| E | 3006-320-060 | 115V Outlet Box Assembly | 1 |
| F | 3006-320-626 | 115V Outlet Label | 1 |
| G | 3002-320-801 | Power Cord | 1 |
| H | 3002-320-878 | 115V Outlet Power Inlet Cable | 1 |
| J | 0059-196-000 | Circuit Breaker with Clip Retainer | 2 |
| K | 3002-320-803 | 115V Power Jumper Cable | 1 |
| L | 3002-320-625 | Electrical Shock Hazard Label | 1 |
| M | 3006-508-015 | 115V Option Label | 1 |

110V Outlet Box Assembly - 3006-320-060

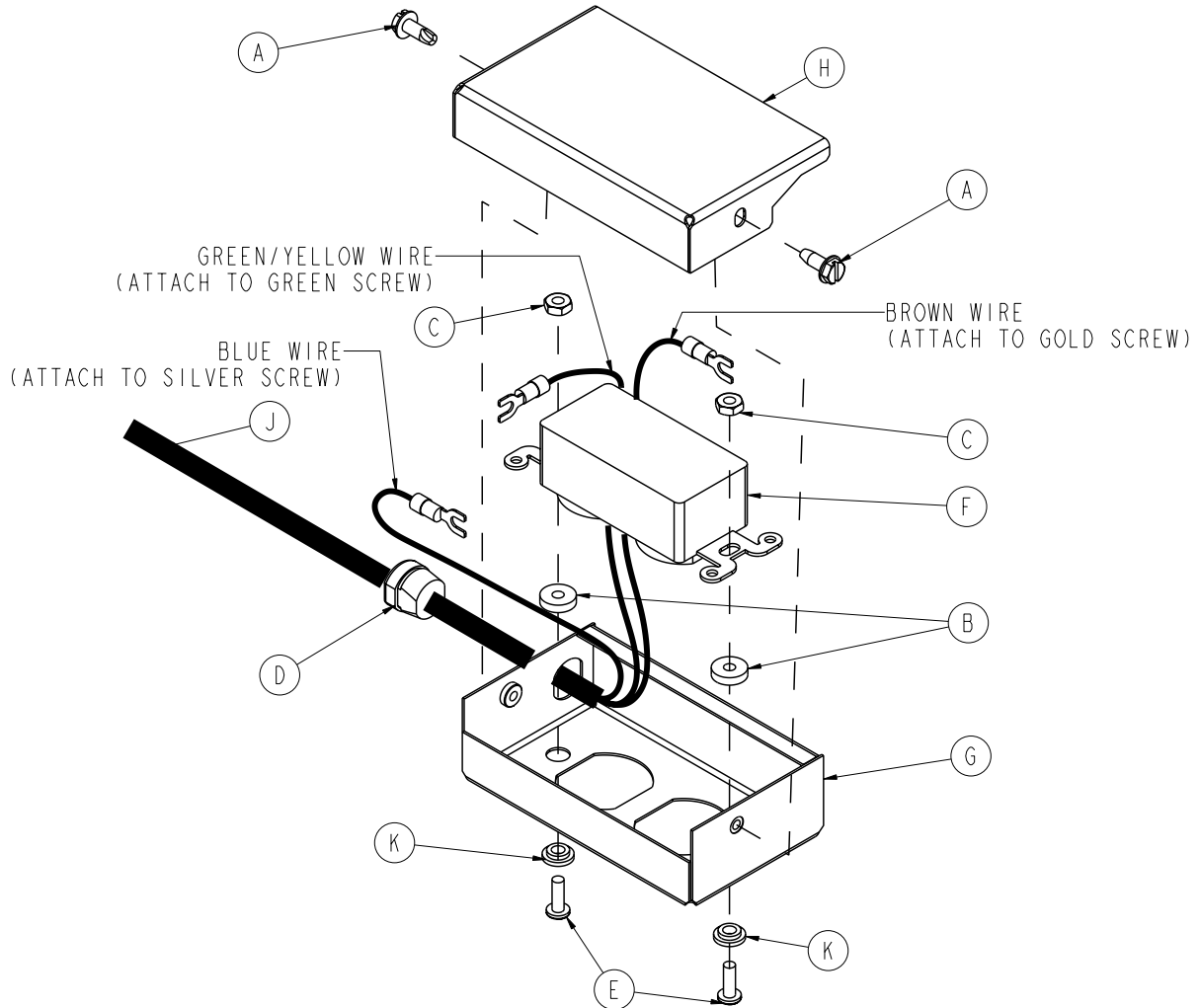

| Item | Part No. | Part Name | Qty. |
|------|--------------|------------------------------|------|
| A | 0003-224-000 | Hex Washer Head Screw | 2 |
| B | 0052-318-000 | Unthreaded Round Spacer | 2 |
| C | 0016-014-000 | Fiberlock Nut | 2 |
| D | 0034-133-000 | Strain Relief | 1 |
| E | 0004-265-000 | Button Head Cap Screw | 2 |
| F | 0059-733-000 | Hospital Grade Receptacle | 1 |
| G | 3006-321-000 | 115V Outlet Box | 1 |
| H | 3006-321-021 | 115V Outlet Box Cover | 1 |
| J | 3002-320-802 | 115V Outlet Cable | 1 |
| K | 0052-317-000 | Short Barrel Shoulder Washer | 2 |

Optional Scale/Bed Exit Assembly

For Reference Only: 3006-317-003

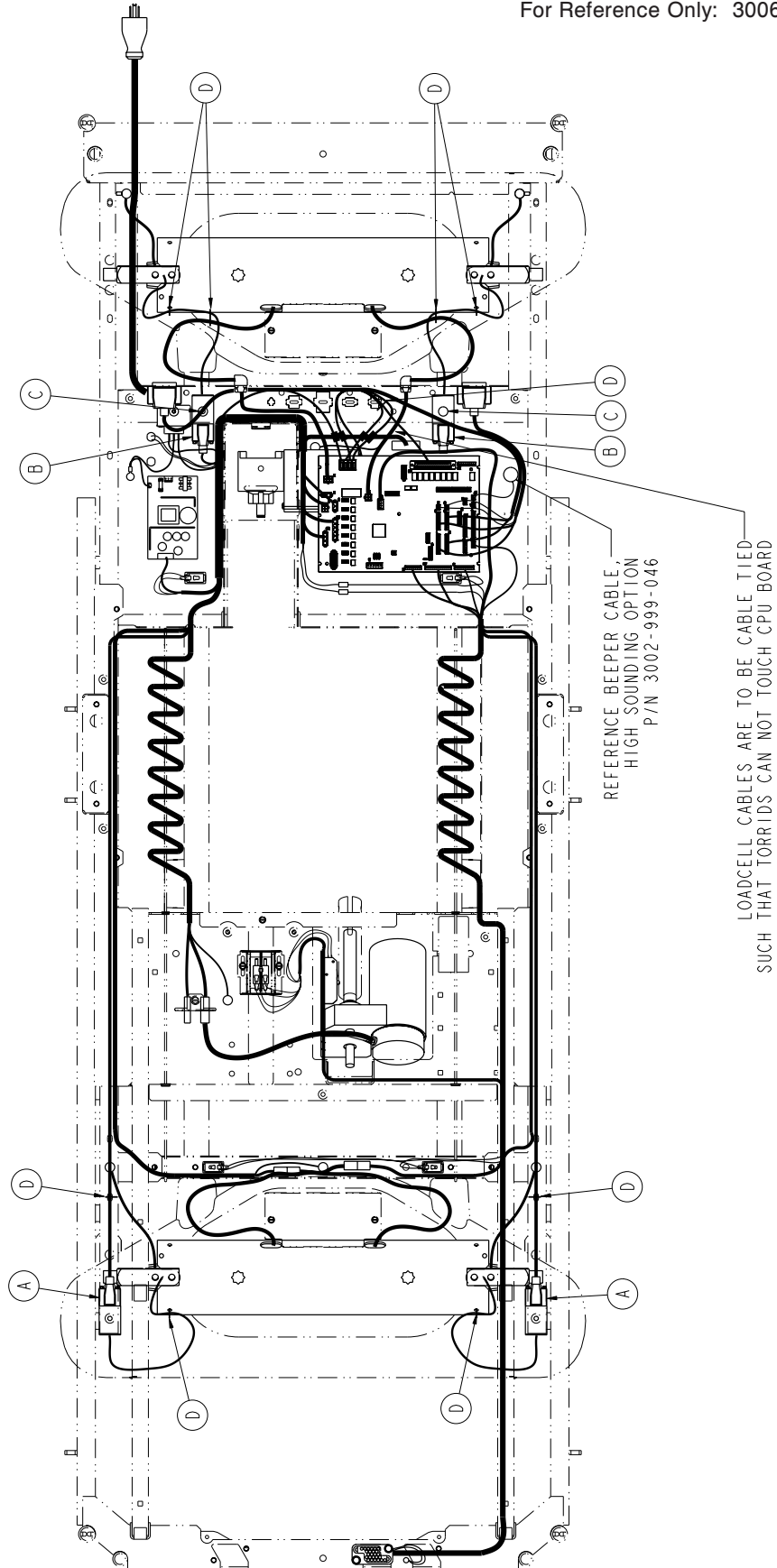

Optional Scale/Bed Exit Assembly

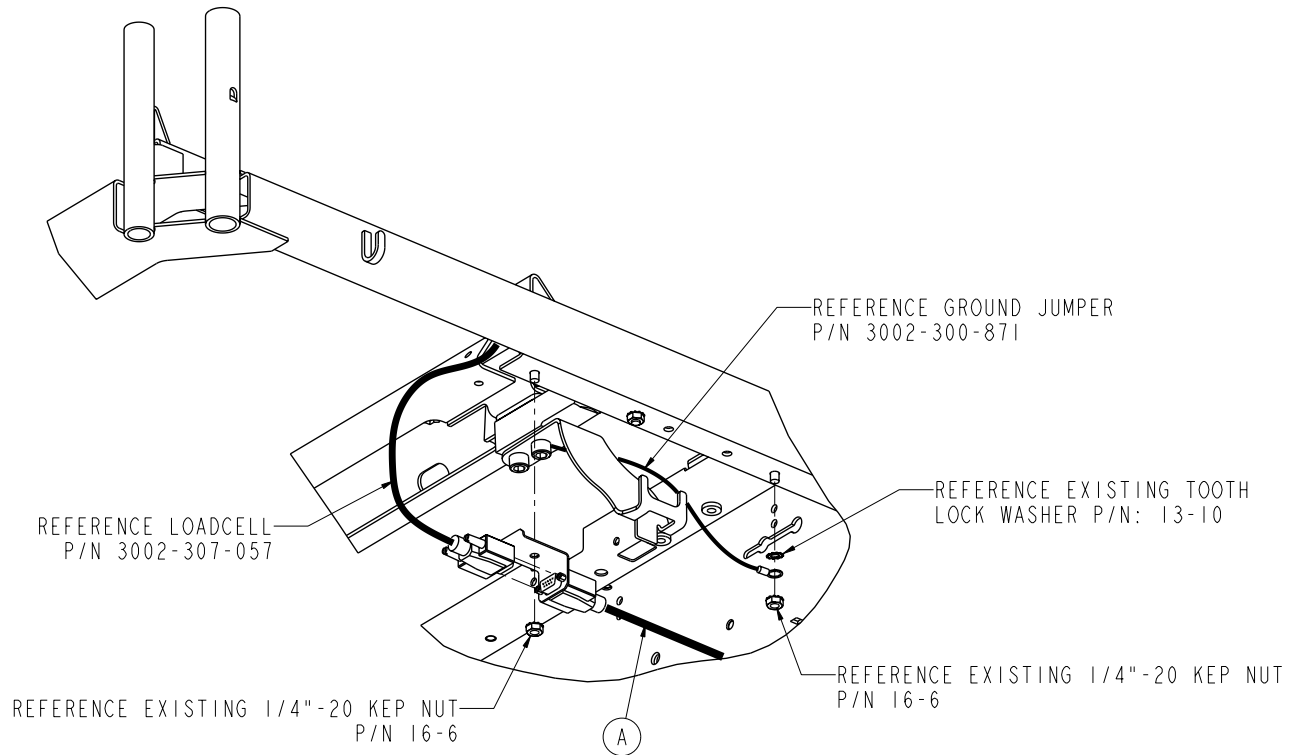

FOOTEND LOADCELL CABLE INSTALLATION
TYPICAL BOTH SIDES OF BED

Foot End Load Cell Cable Installation (Typical Both Sides of the Bed)

Optional Scale/Bed Exit Assembly - 3006-317-003 (Reference Only)

| Item | Part No. | Part Name | Qty. |
|------|--------------|--------------------|------|
| A | 3002-317-835 | FE Load Cell Cable | 2 |
| B | 3002-317-834 | HE Load Cell Cable | 2 |
| C | 0007-053-000 | Truss Head Torx | 2 |
| D | 3000-300-113 | 8" Cable Tie | 9 |

Optional Litter Assembly, Communication Capability

For Reference Only: 3006-303-122

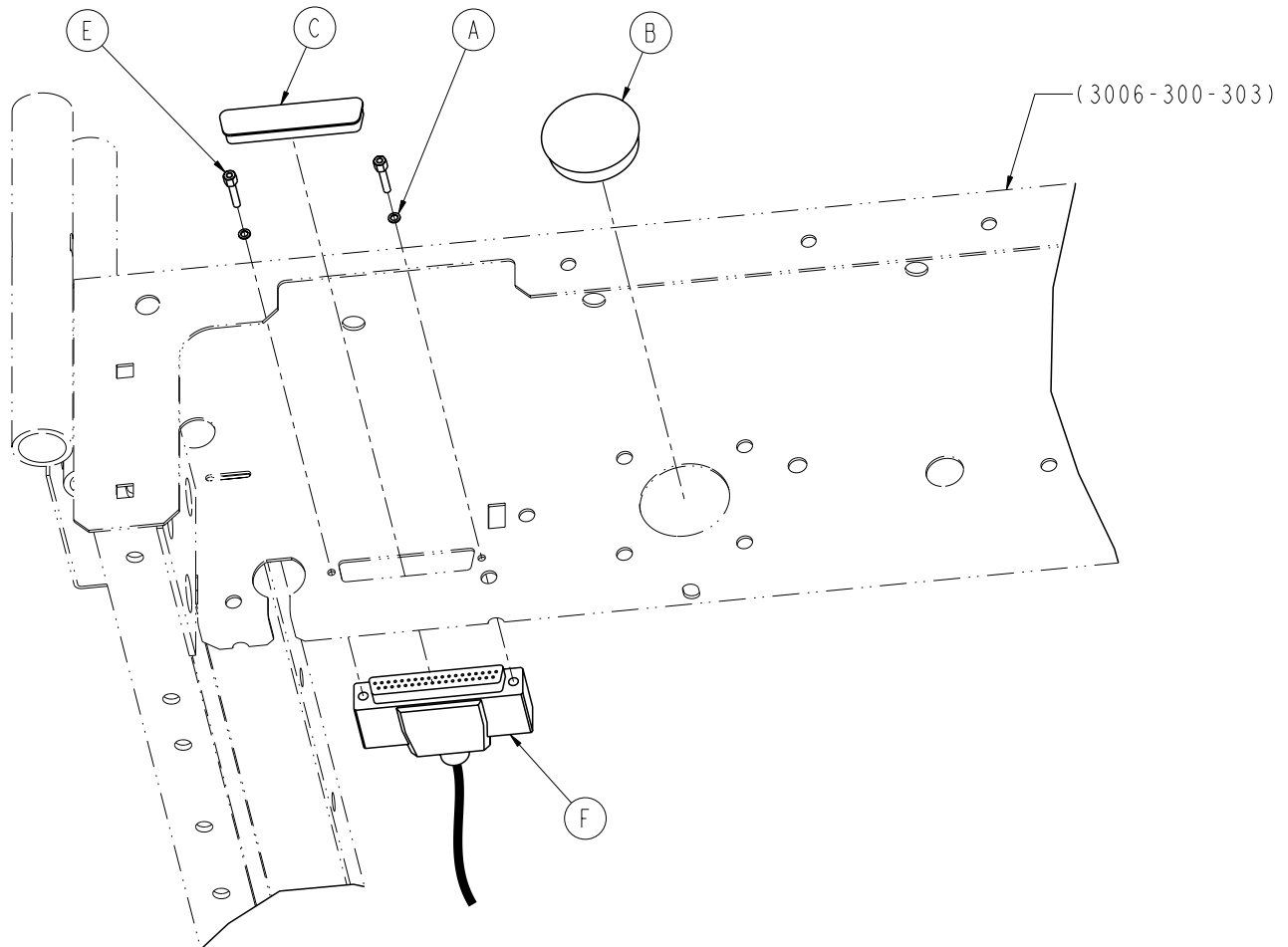

Optional Litter Assembly, Communication Capability

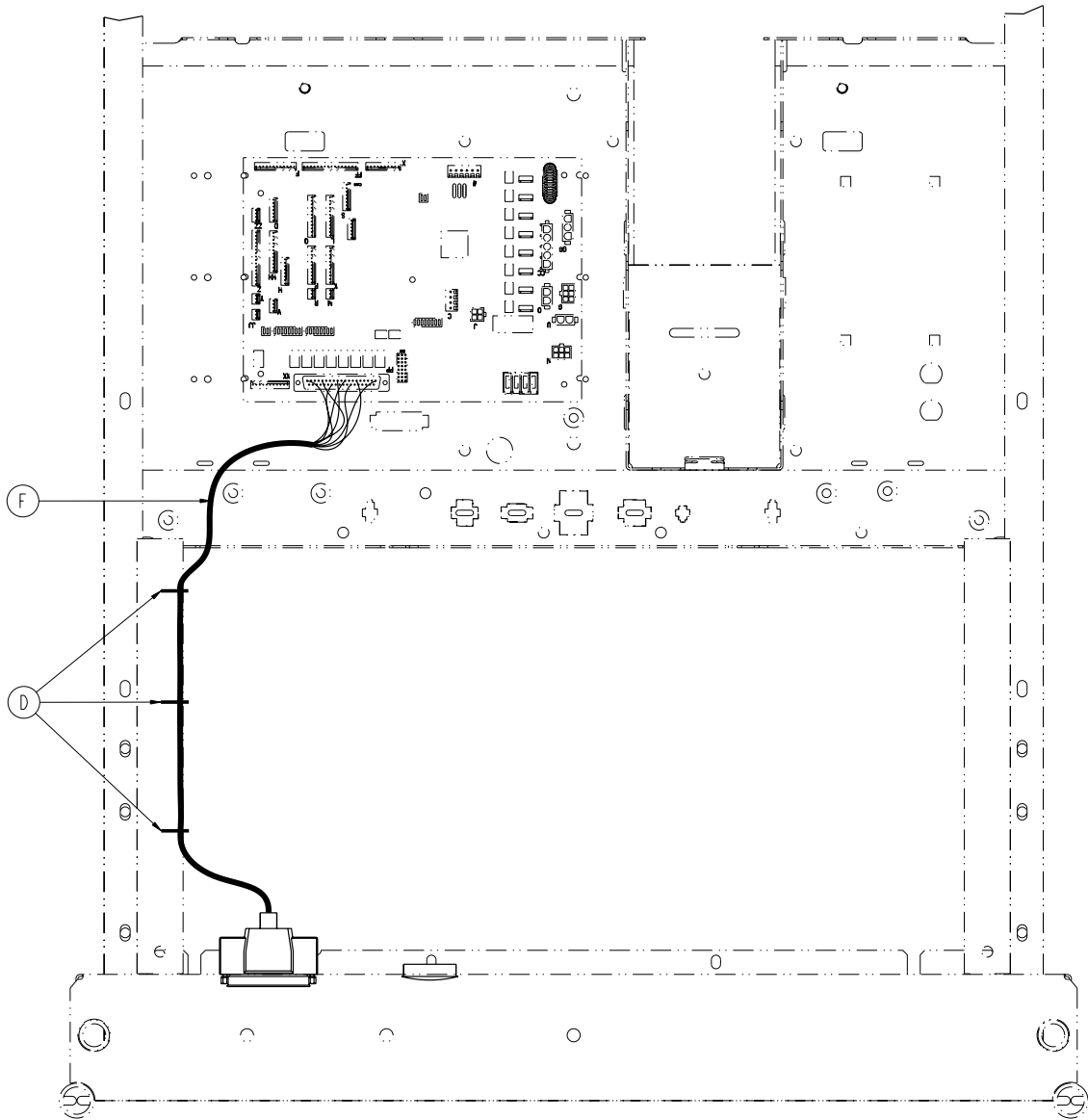

Optional Litter Assembly, Communication Capability - 3006-303-122 (Reference Only)

| Item | Part No. | Part Name | Qty. |
|------|--------------|--------------------------|------|
| A | 0012-046-000 | Split Lock Washer | 2 |
| B | 0037-220-000 | Hole Plug | 1 |
| C | 0059-710-000 | Caplug | 1 |
| D | 3000-300-113 | 8" Cable Tie | 3 |
| E | 3001-300-007 | Screwjack | 2 |
| F | 3001-303-821 | Headwall Interface Cable | 1 |

Optional Litter Assembly, Nurse Call and Communication

For Reference Only: 3006-303-052

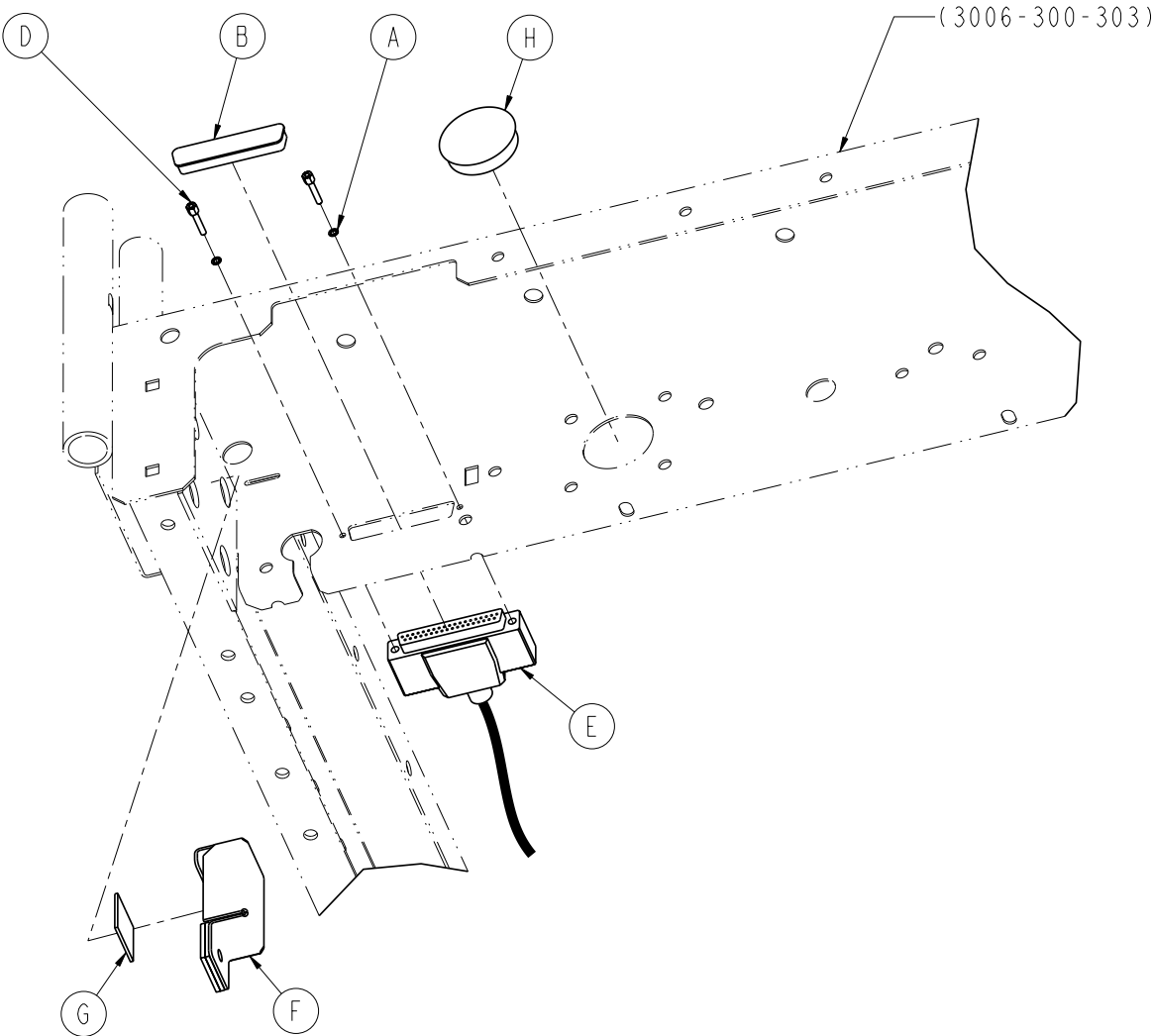

Optional Litter Assembly, Nurse Call and Communication

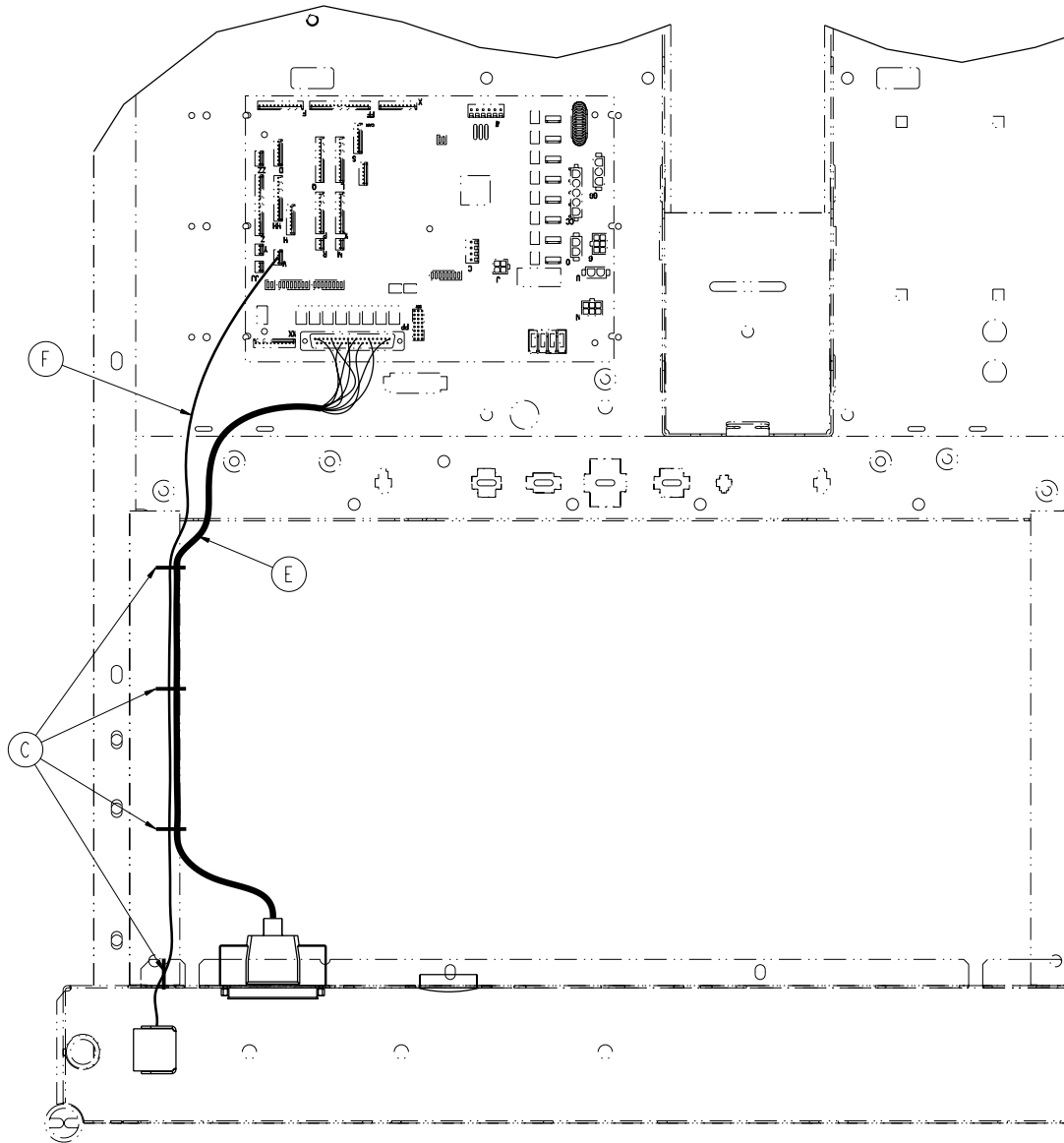

Optional Litter Assembly, Nurse Call and Communication - 3006-303-052 (Reference Only)

| Item | Part No. | Part Name | Qty. |
|------|--------------|----------------------------|------|
| A | 0012-046-000 | Lock Washer | 2 |
| B | 0059-710-000 | Static 6 Plug | 1 |
| C | 3000-300-113 | Cable Tie | 4 |
| D | 3001-300-007 | Screwjack | 2 |
| E | 3001-303-821 | Headwall Interface Cable | 1 |
| F | 3006-303-045 | Battery Enclosure Assembly | 1 |
| G | 0044-029-000 | 1" Tape | 1 |
| H | 0037-220-000 | Hole Plug | 1 |

Optional Litter Assembly, HWI with 1 Stryker Port

For Reference Only: 3006-314-012

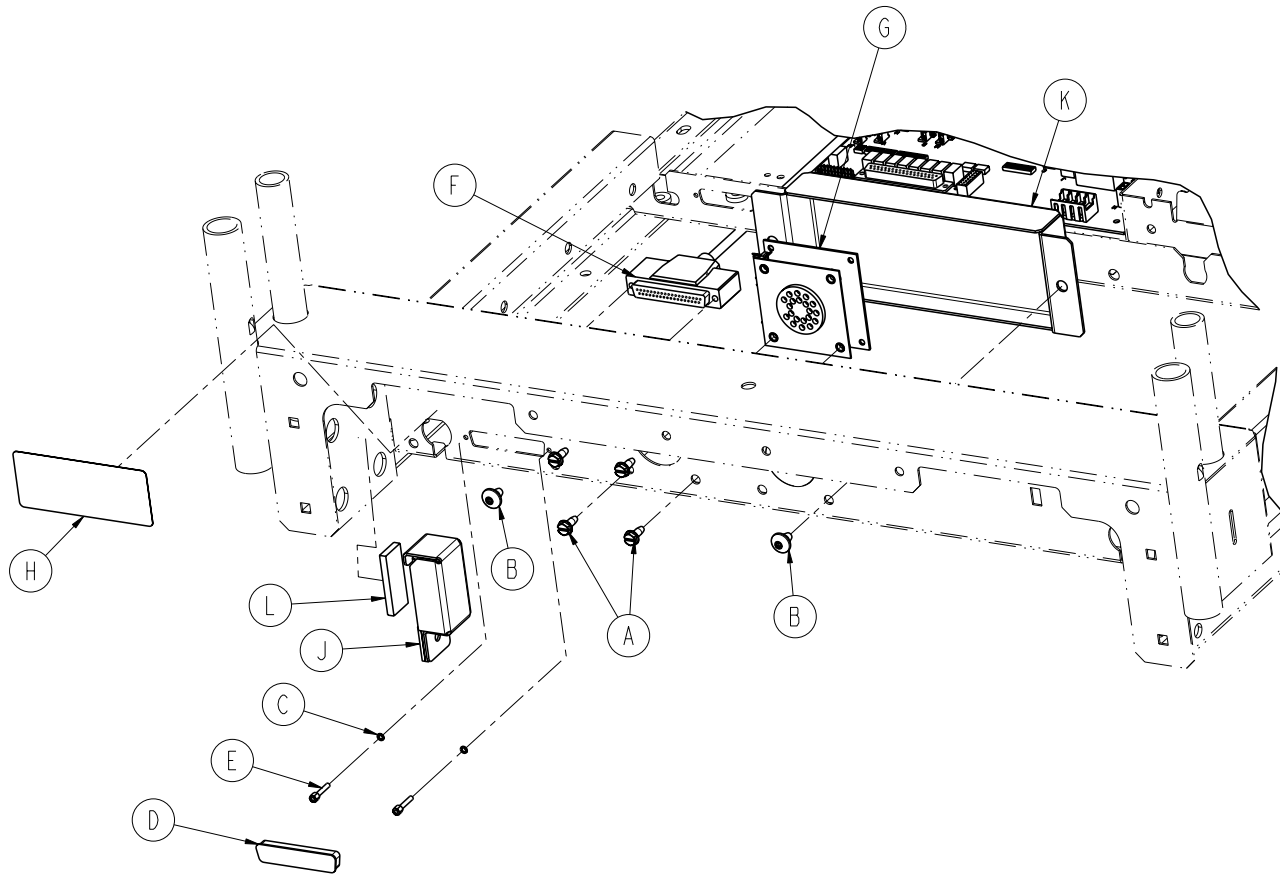

Optional Litter Assembly, HWI with 1 Stryker Port

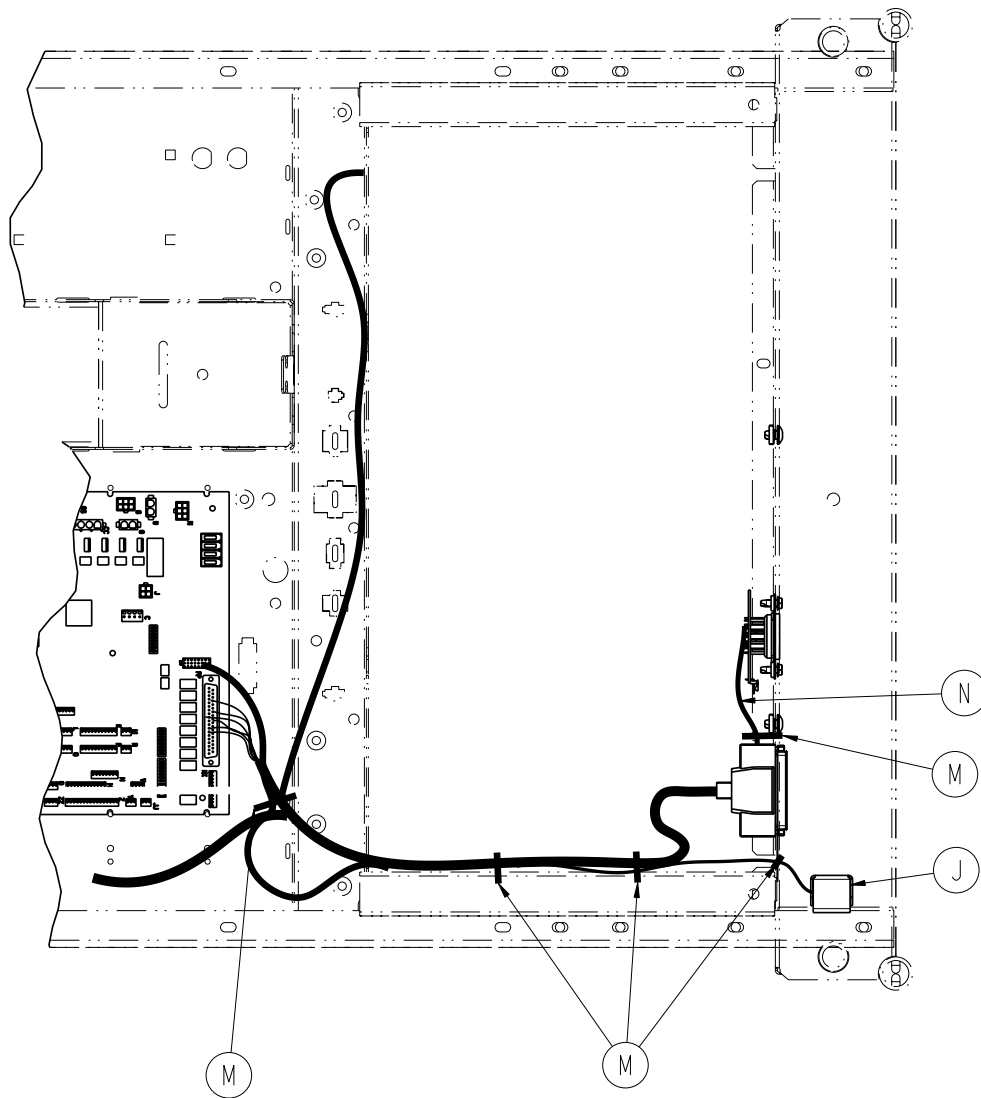

Optional Litter Assembly, HWI with 1 Stryker Port - 3006-314-012 (Reference Only)

| Item | Part No. | Part Name | Qty. |
|------|--------------|----------------------------|------|
| A | 0003-224-000 | Hex Washer Head Screw | 4 |
| B | 0007-053-000 | Truss Head Screw | 2 |
| C | 0012-046-000 | Lock Washer | 2 |
| D | 0059-710-000 | Static Plug | 1 |
| E | 3001-300-007 | Screwjack | 2 |
| F | 3001-303-821 | Headwall Interface Cable | 1 |
| G | 3001-314-920 | HWI Pendant Port PCB | 1 |
| H | 3006-090-028 | Cord Out Label | 1 |
| J | 3006-303-045 | Battery Enclosure Assembly | 1 |
| K | 3006-315-006 | Pendant Port Cover | 1 |
| L | 0044-029-000 | Foam Tape (1.0") | 1 |
| M | 3000-300-113 | 8" Cable Tie | 5 |
| N | 3002-314-821 | Pendant Port Cable | 1 |

Optional Litter Assembly, Nurse Call and 1/4" Port

For Reference Only: 3006-314-013

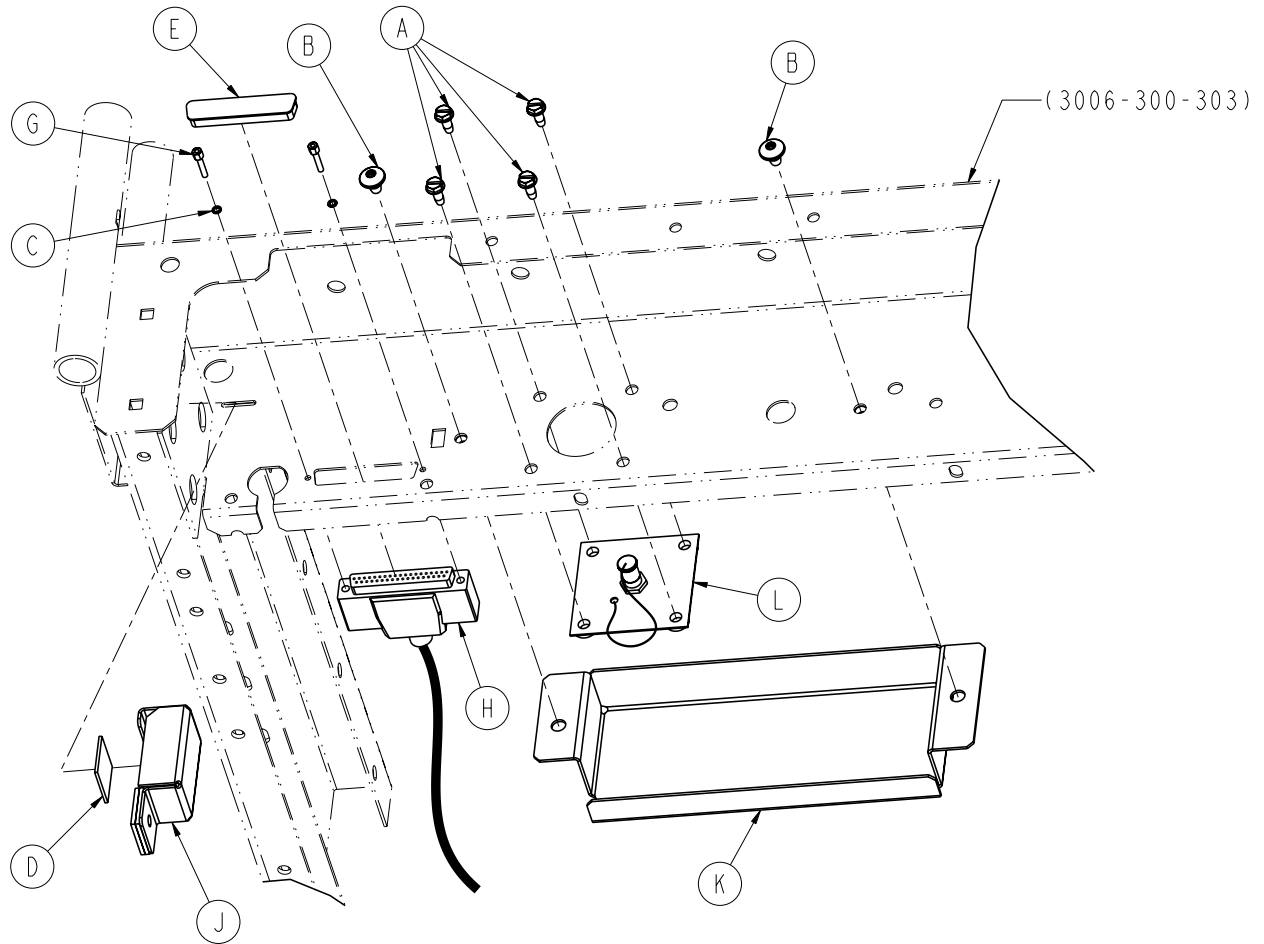

Optional Litter Assembly, Nurse Call and 1/4" Port

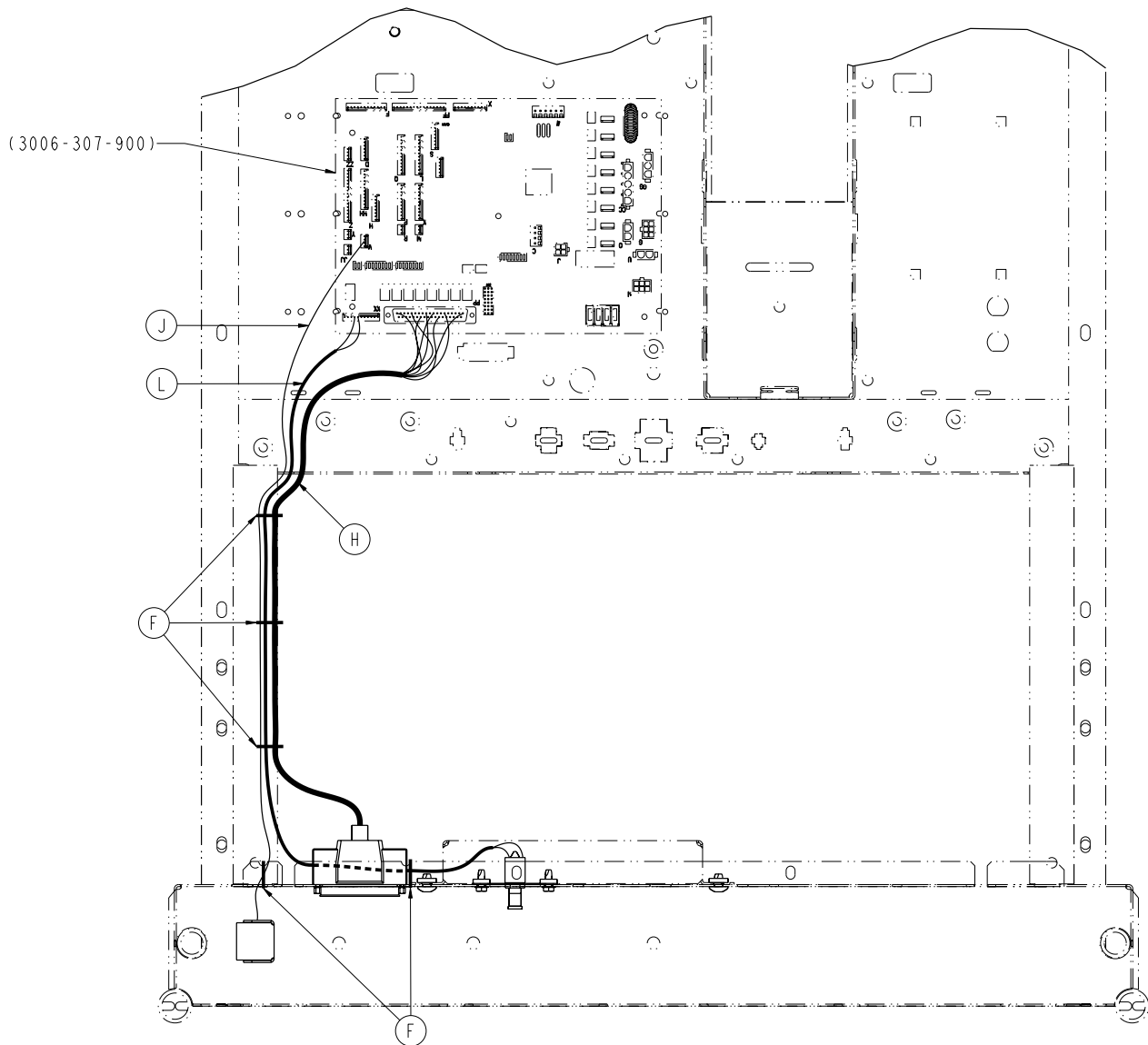

Optional Litter Assembly, Nurse Call and 1/4" Port - 3006-314-013 (Reference Only)

| Item | Part No. | Part Name | Qty. |
|------|--------------|------------------------------------|------|
| A | 0003-224-000 | Hex Screw, #10-24 x 1/2" | 4 |
| B | 0007-053-000 | Truss Head Screw, 1/4"-20 x 3/8" | 2 |
| C | 0012-046-000 | Split Lock Washer | 2 |
| D | 0044-029-000 | 1" Tape | 1 |
| E | 0059-710-000 | Caplug | 1 |
| F | 3000-300-113 | 8" Cable Tie | 5 |
| G | 3001-300-007 | Screwjack | 2 |
| H | 3001-303-821 | Head Interface Cable | 1 |
| J | 3006-303-045 | Battery Enclosure Assembly | 1 |
| K | 3006-315-006 | Pendant Port Cover, White | 1 |
| L | 3006-383-100 | 1/4" Headwall Interface Port Ass'y | 1 |

Optional Zoom® Litter Assembly, Headwall Communication

For Reference Only: 3006-031-200

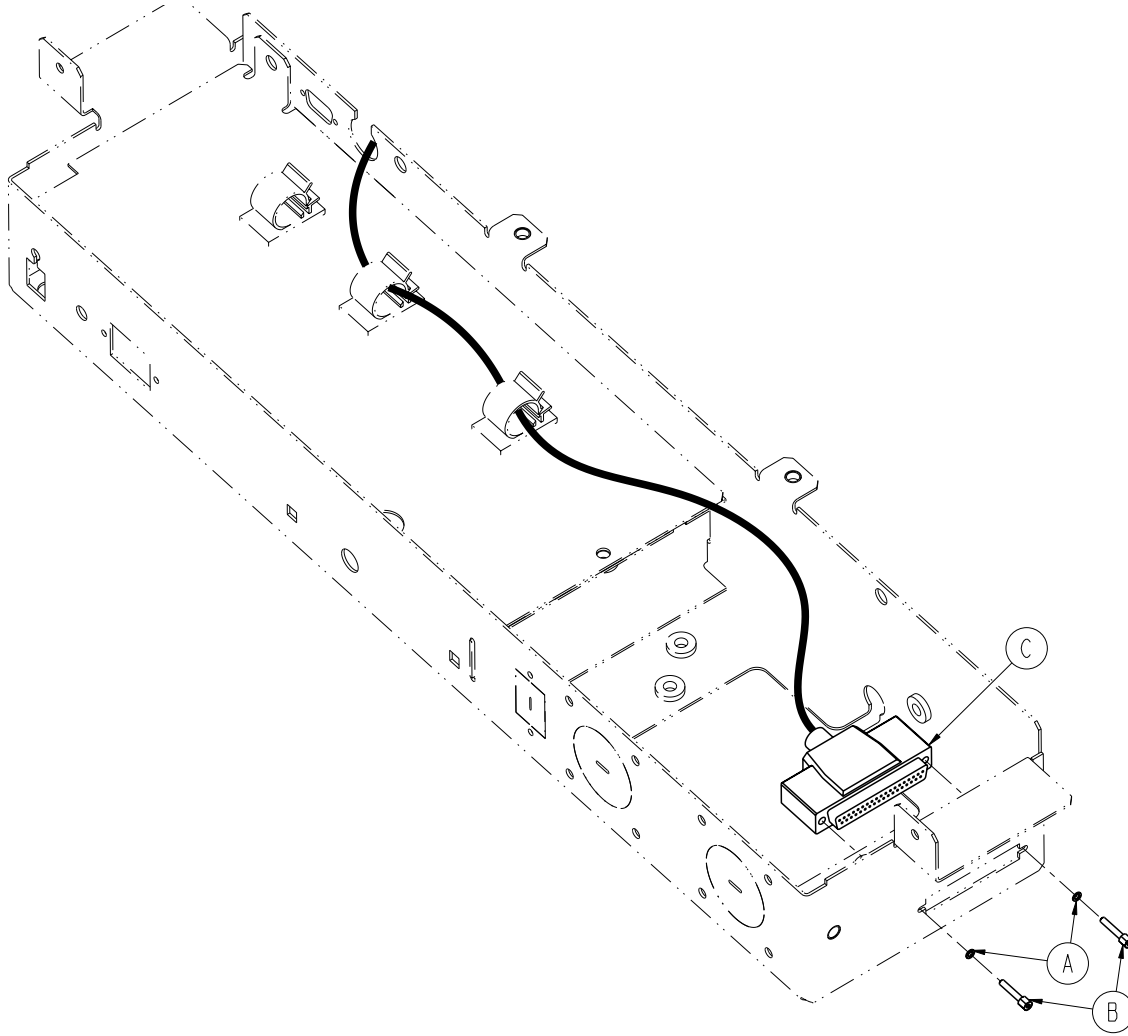

Optional Zoom® Litter Assembly, Headwall Communication

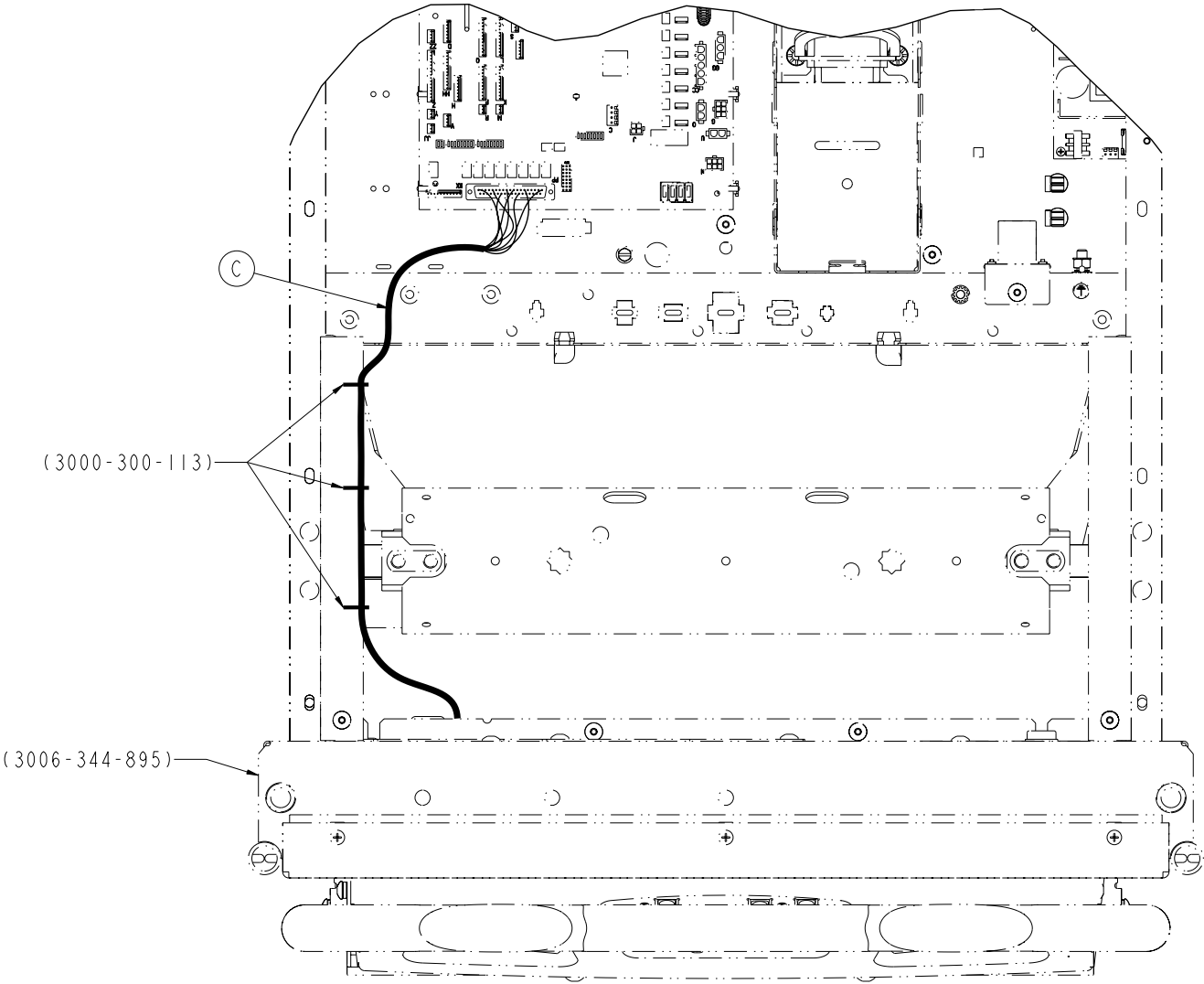

Optional Zoom® Litter Assembly, Headwall Communication - 3006-031-200 (Reference Only)

| Item | Part No. | Part Name | Qty. |
|------|--------------|----------------------------------|------|
| A | 0012-046-000 | Split Lock Washer | 2 |
| B | 3001-300-007 | Screwjack | 2 |
| C | 3002-080-008 | Headwall (Zoom®) Interface Cable | 1 |

Optional Battery Backup/Zoom® Litter Assembly, HWI w/Nurse Call

For Reference Only: 3006-031-201

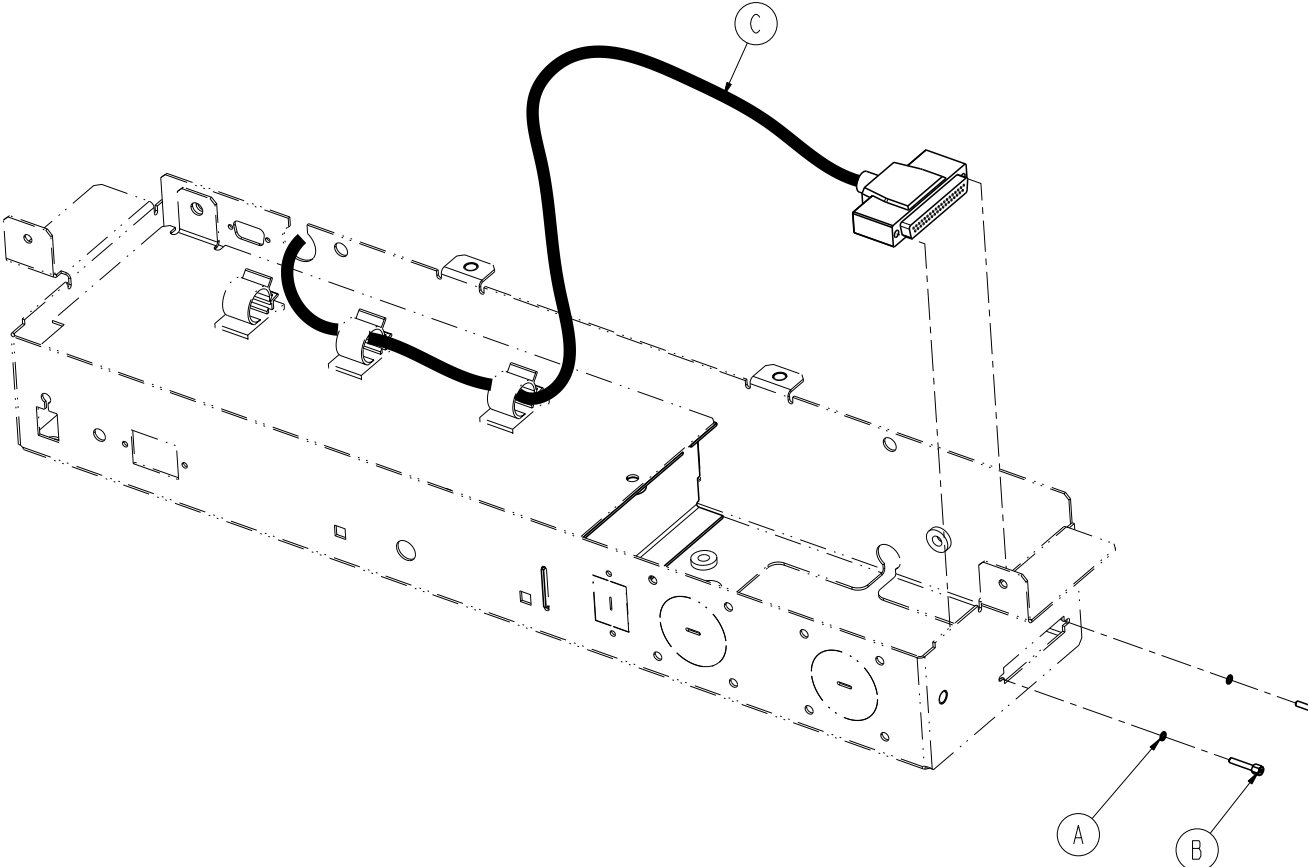

Optional Battery Backup/Zoom® Litter Assembly, HWI w/Nurse Call

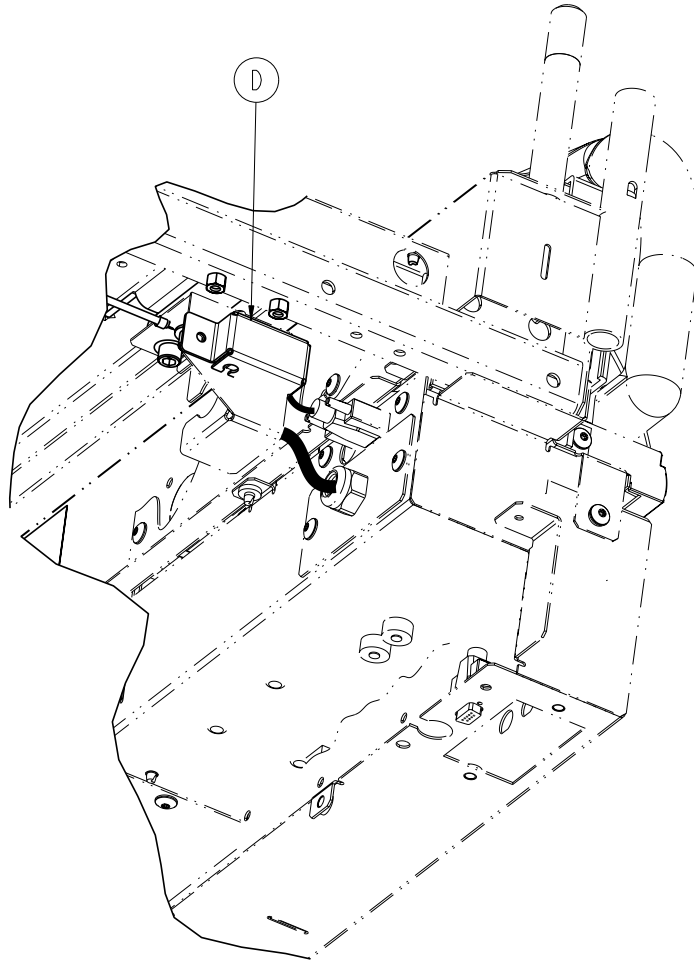

Optional Battery Backup/Zoom® Litter Assembly, HWI with Nurse Call - 3006-031-201 (Reference Only)

| Item | Part No. | Part Name | Qty. |
|------|--------------|----------------------------------|------|
| A | 0012-046-000 | Lock Washer | 2 |
| B | 3001-300-007 | Screwjack | 2 |
| C | 3002-080-008 | Headwall (Zoom®) Interface Cable | 1 |
| D | 3006-303-045 | Battery Enclosure Assembly | 1 |

Optional Battery Backup/Zoom® Litter Assembly, HWI w/Nurse Call & 1 Stryker Port

For Reference Only: 3006-031-202

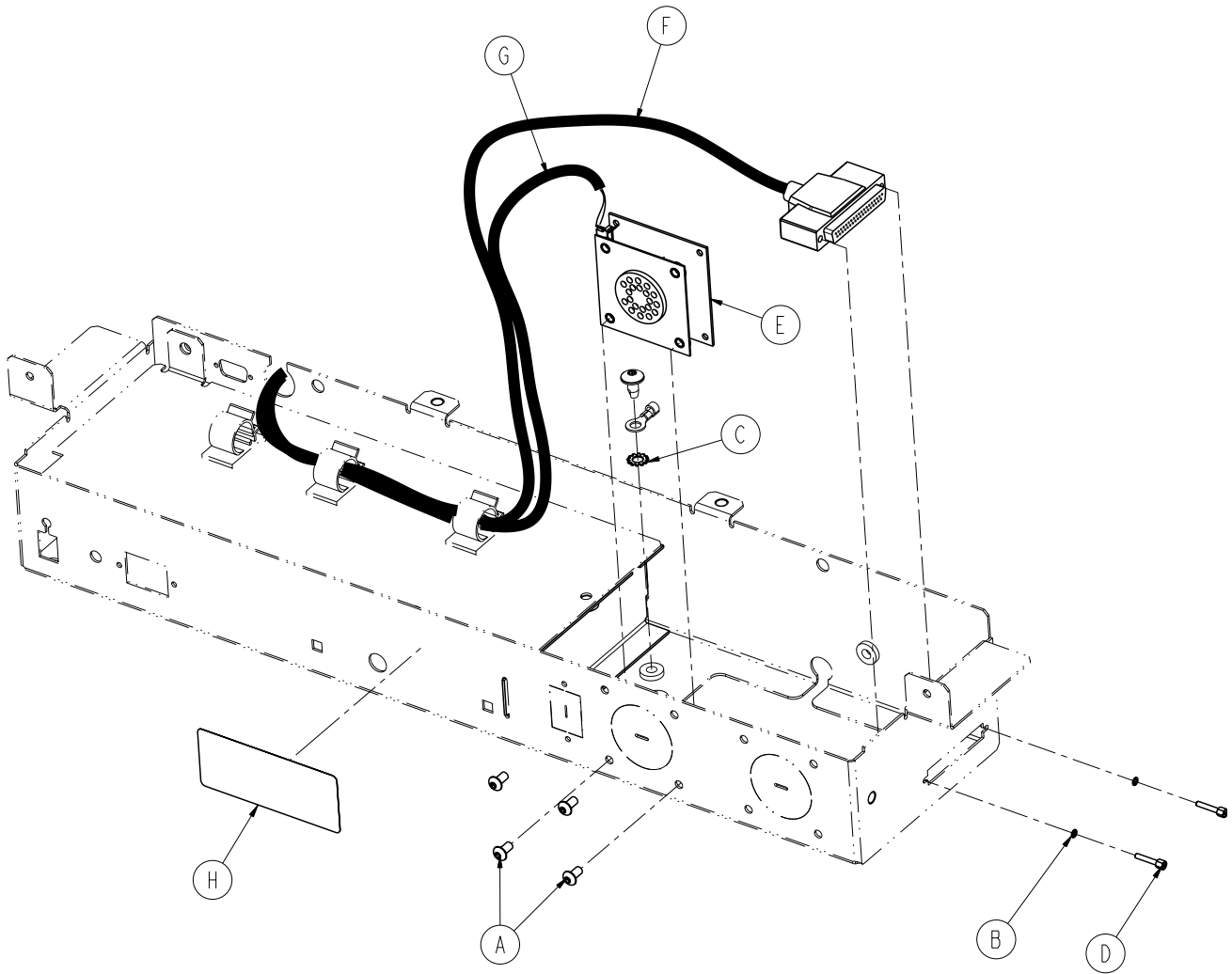

Optional Battery Backup/Zoom® Litter Assembly, HWI w/Nurse Call & 1 Stryker Port

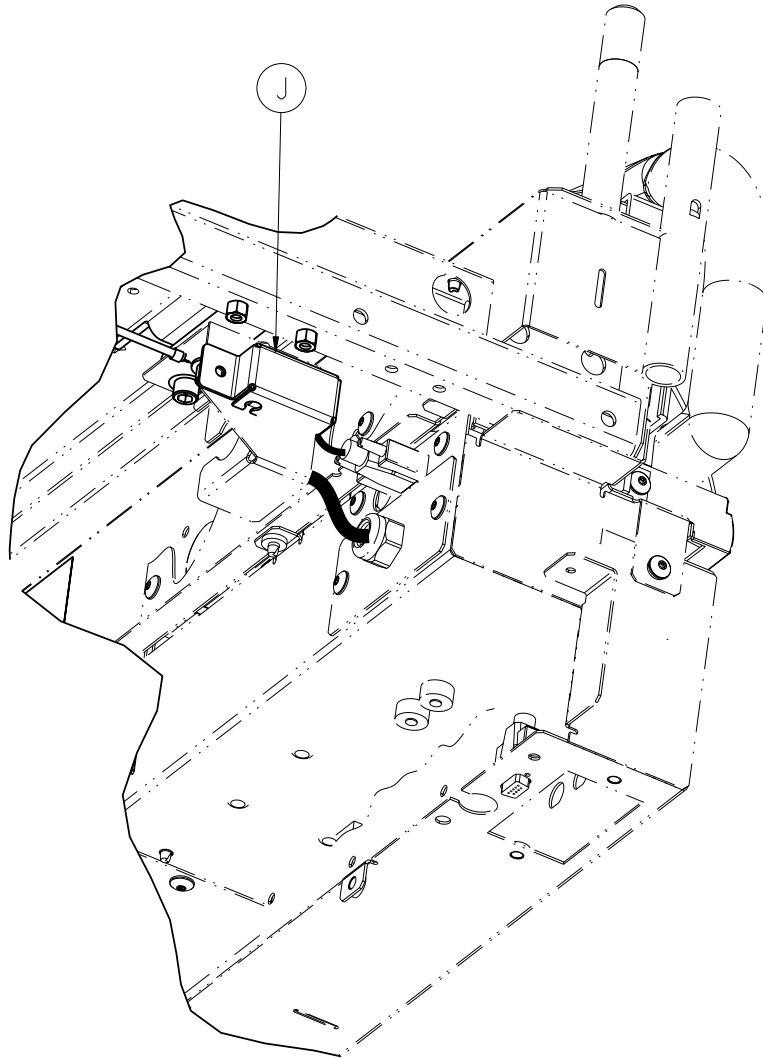

Optional Battery Backup/Zoom® Litter Assembly, HWI w/NC & 1 Stryker Port - 3006-031-202 (Reference Only)

| Item | Part No. | Part Name | Qty. |
|------|--------------|----------------------------|------|
| A | 0004-307-000 | Button Head Cap Screw | 4 |
| B | 0012-046-000 | Lock Washer | 2 |
| C | 0013-010-000 | External Lock Washer | 1 |
| D | 3001-300-007 | Screwjack | 2 |
| E | 3001-314-920 | HWI Pendant Port PCB | 1 |
| F | 3002-080-008 | Headwall Interface Cable | 1 |
| G | 3002-031-809 | Zoom® Pendant Port Cable | 1 |
| H | 3006-090-028 | Cord Out Label | 1 |
| J | 3006-303-045 | Battery Enclosure Assembly | 1 |

Optional Zoom® Litter Assembly, Nurse Call and 1/4" Port

For Reference Only: 3006-031-204

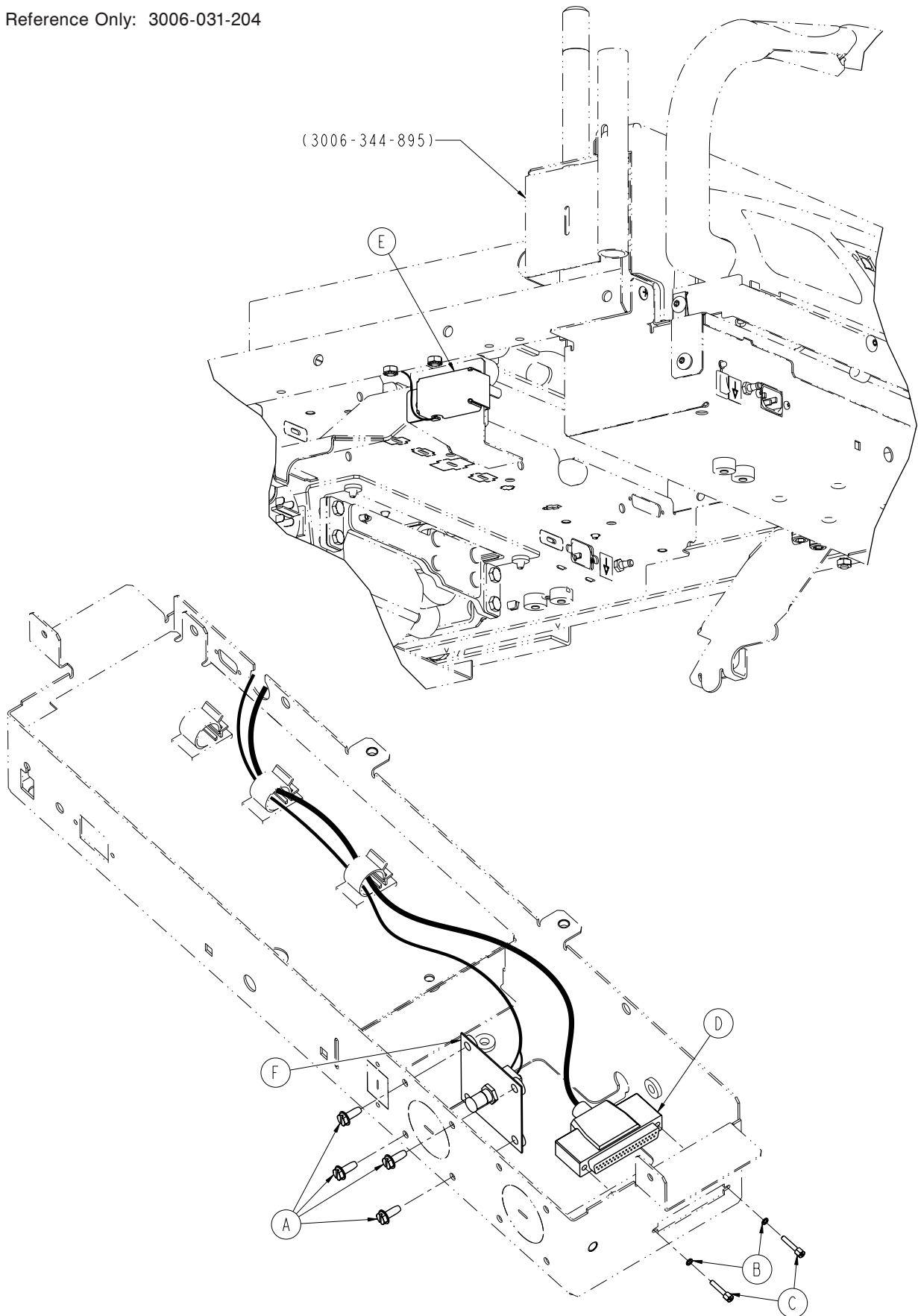

Optional Zoom® Litter Assembly, Nurse Call and 1/4" Port

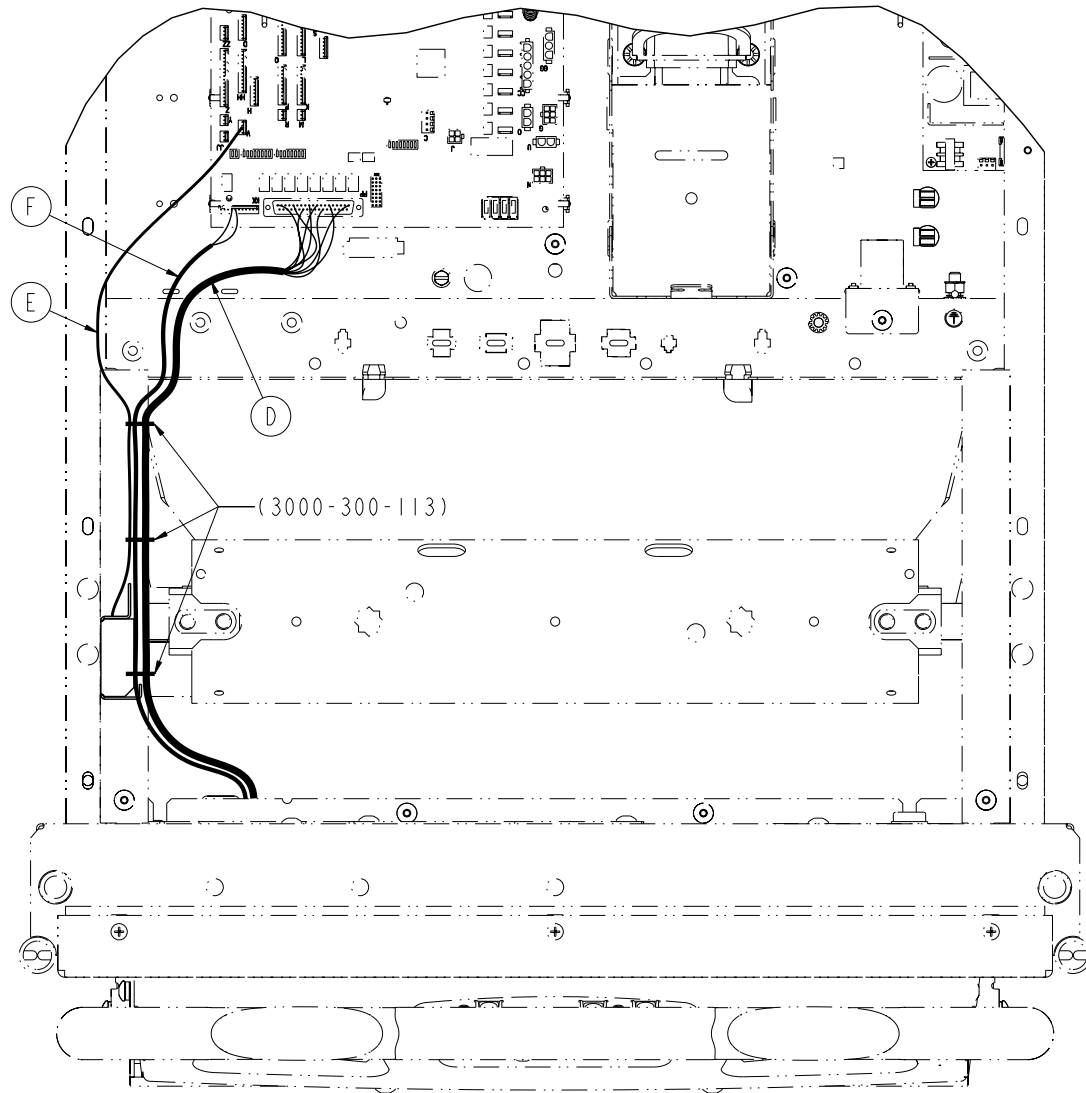

Optional Zoom® Litter Assembly, Nurse Call and 1/4" Port - 3006-031-204 (Reference Only)

| Item | Part No. | Part Name | Qty. |
|------|--------------|------------------------------------|------|
| A | 0003-224-000 | Hex Screw, #10-24 x 1/2" | 4 |
| B | 0012-046-000 | Split Lock Washer | 2 |
| C | 3001-300-007 | Screwjack | 2 |
| D | 3002-080-008 | Headwall (Zoom®) Interface Cable | 1 |
| E | 3006-303-045 | Battery Enclosure Assembly | 1 |
| F | 3006-383-100 | 1/4" Headwall Interface Port Ass'y | 1 |

Optional *i*Bed Enhanced Nurse Call, 37-Pin Plugover Assembly

(Applies to beds with iBed® Awareness option only)

For Reference Only: 3006-303-010 Rev E

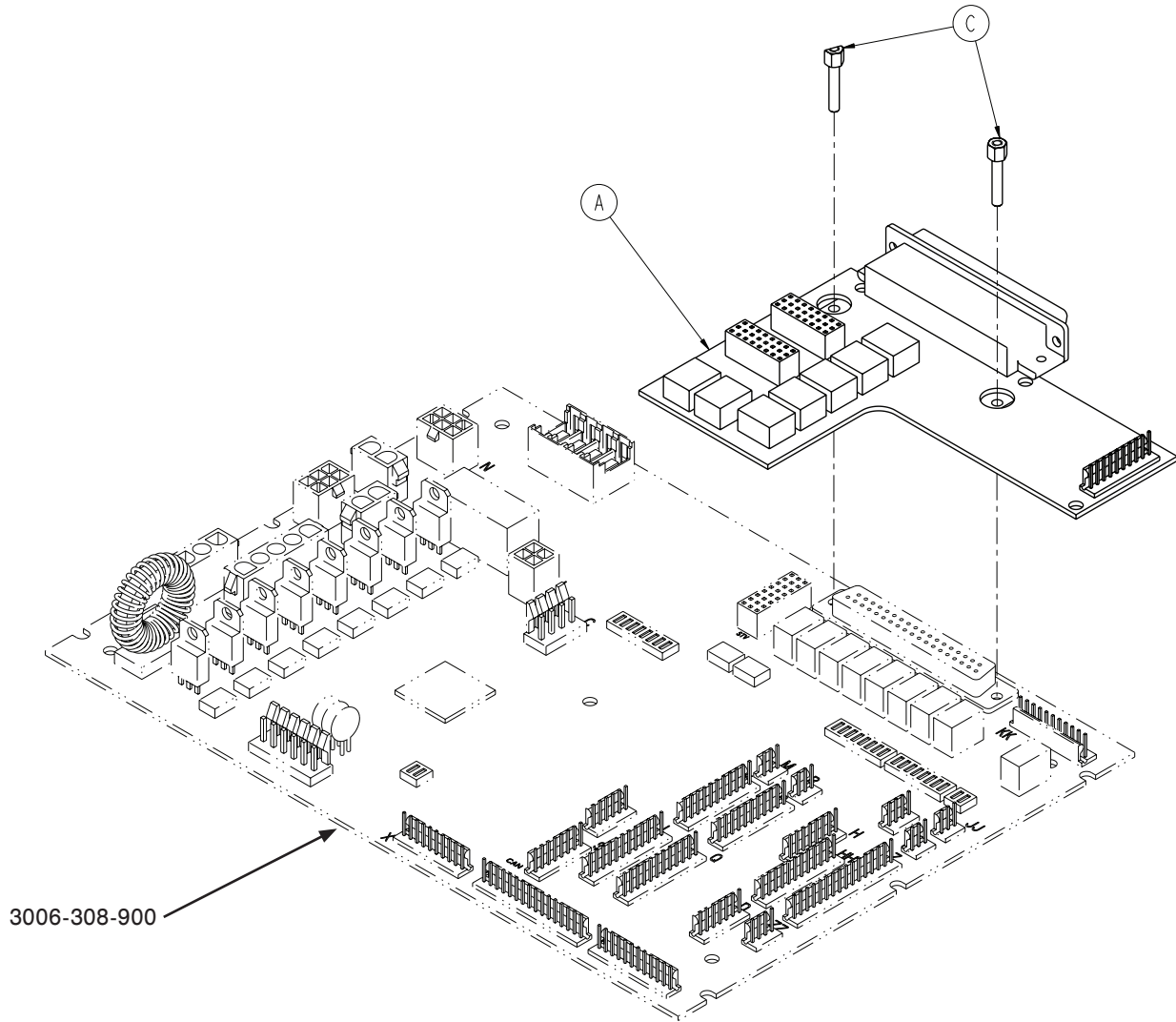

Optional *i*Bed Enhanced Nurse Call, 37-Pin Plugover Assembly

(Applies to beds with iBed® Awareness option only)

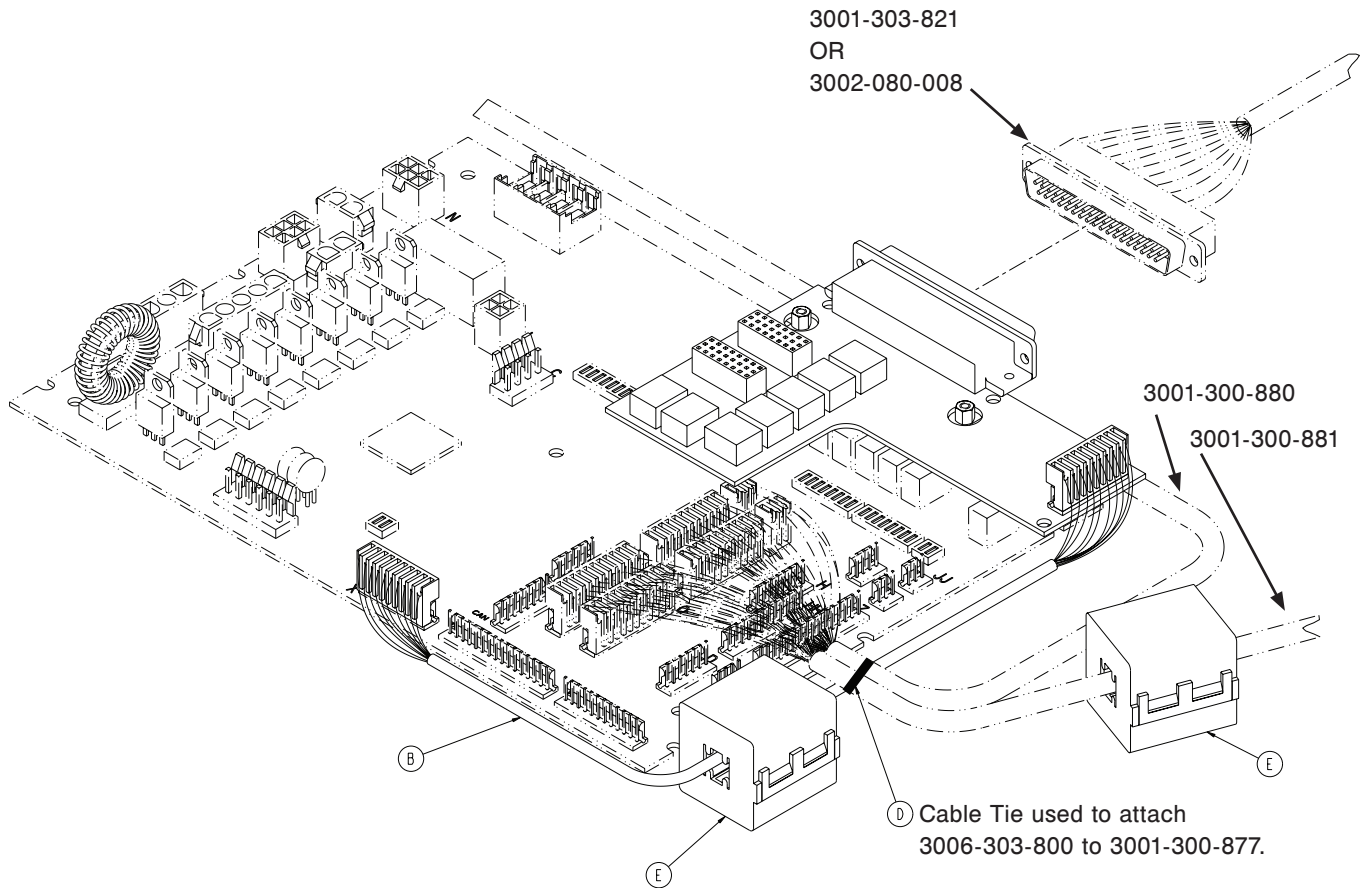

Optional *i*Bed Enhanced Nurse Call, 37-Pin Plugover Board - 3006-303-010 Rev E (Reference Only)

| Item | Part No. | Part Name | Qty. |
|------|--------------|--|------|
| A | 3006-303-900 | 37-Pin Plugover Board | 1 |
| B | 3006-303-800 | <i>i</i> Bed® Awareness Plugover Board | 1 |
| C | 3001-300-007 | Screwjack | 2 |
| D | 3000-300-113 | 8" Cable Tie | 1 |
| E | 0059-144-000 | Split Ferrite | 2 |

Battery Enclosure Assembly

For Reference Only: 3006-303-045

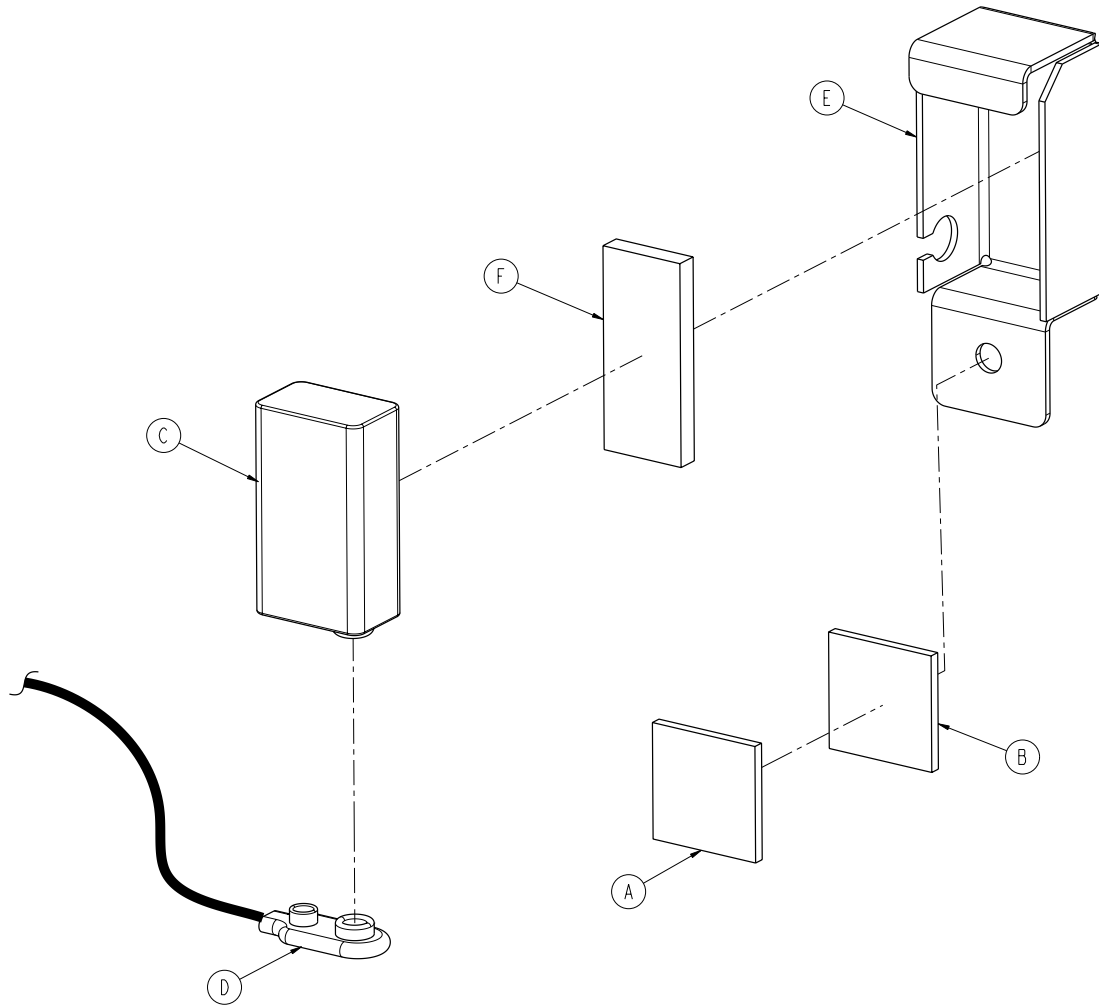

| Item | Part No. | Part Name | Qty. |
|------|--------------|-------------------------|------|
| A | 0029-008-000 | Dual-Lock | 1 |
| B | 0029-010-000 | Dual-Lock | 1 |
| C | 3000-303-871 | Battery - 9V | 1 |
| D | 3001-303-811 | Battery Cable | 1 |
| E | 3006-304-012 | Battery Enclosure | 1 |
| F | 7900-001-291 | Foam Tape (1.75 inches) | 1 |

Optional Battery Backup Option Head End Enclosure Ass'y

For Reference Only: 3006-450-150

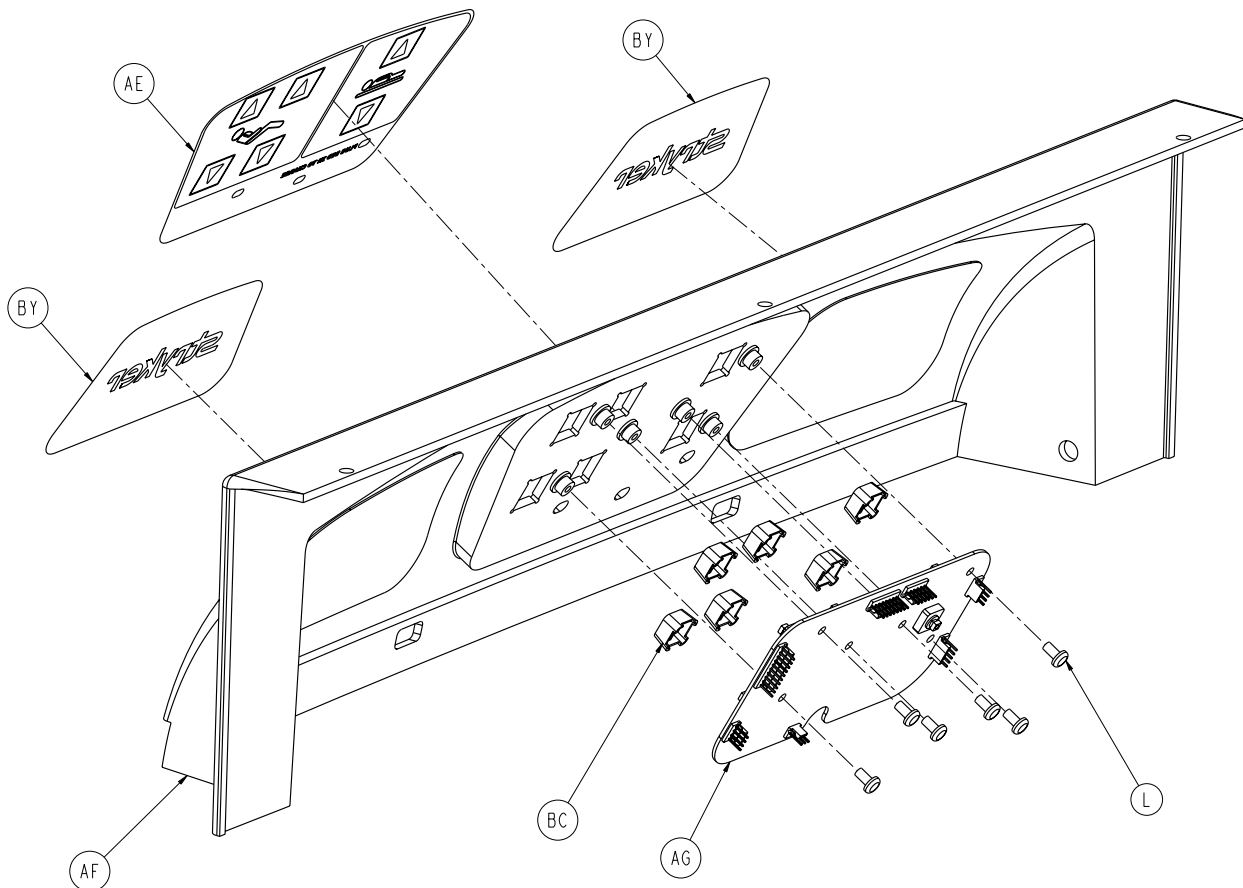
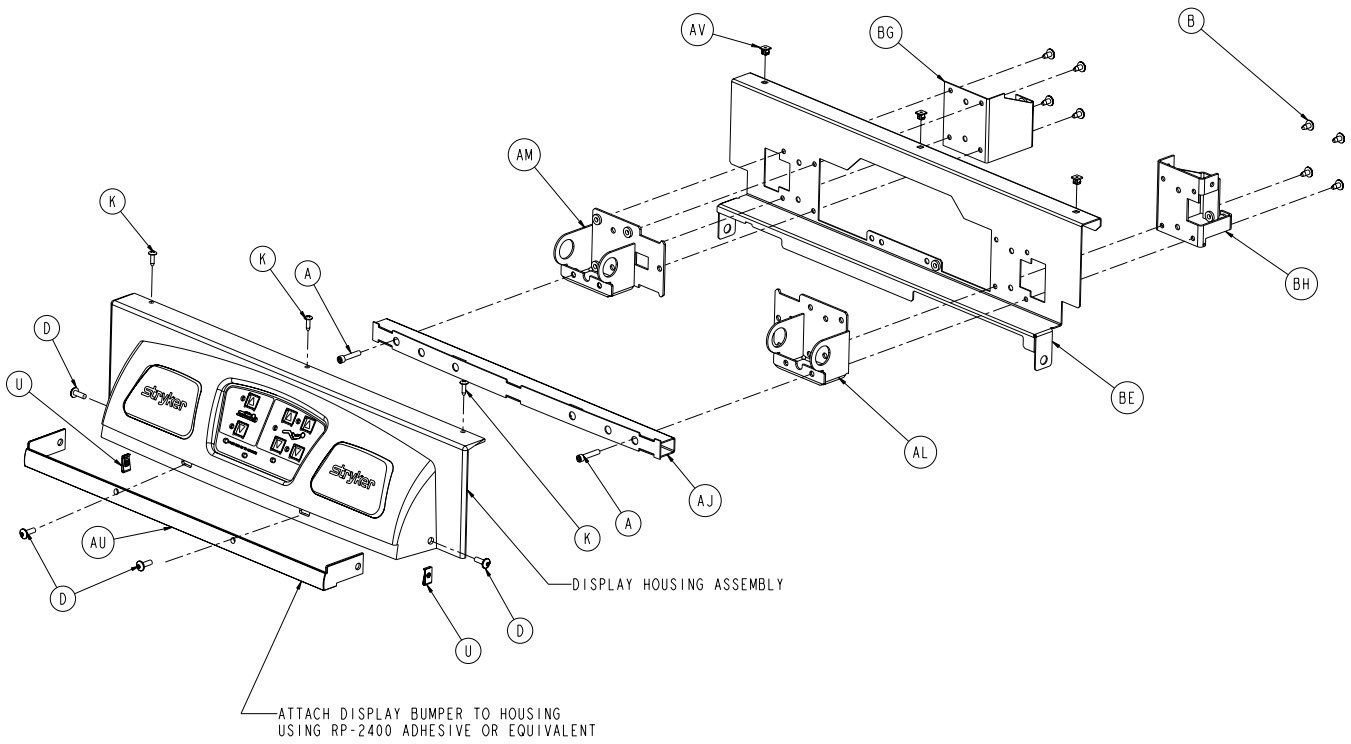

[Return To Table of Contents](#)

Optional Battery Backup Option Head End Enclosure Ass'y

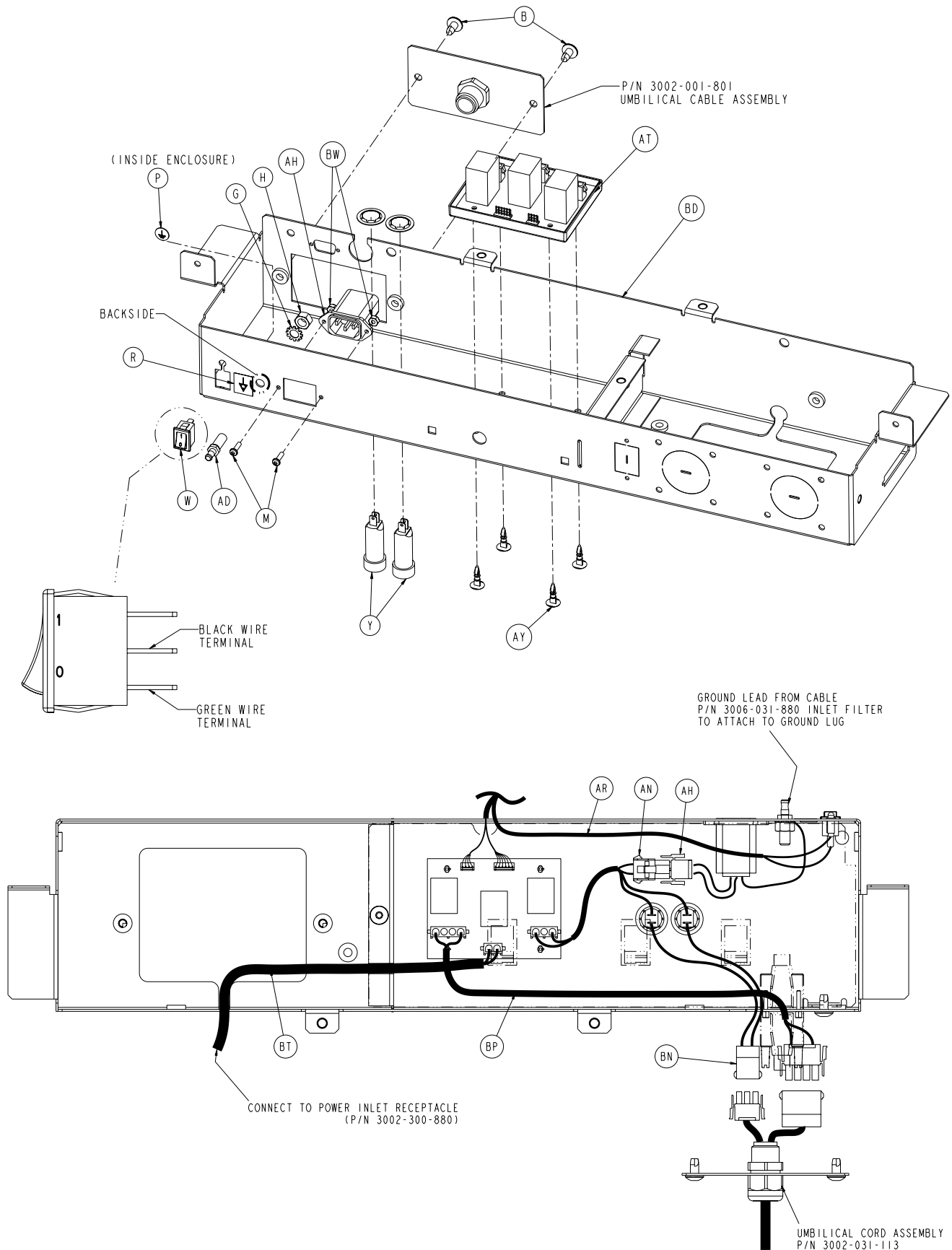

Optional Battery Backup Option Head End Enclosure Ass'y

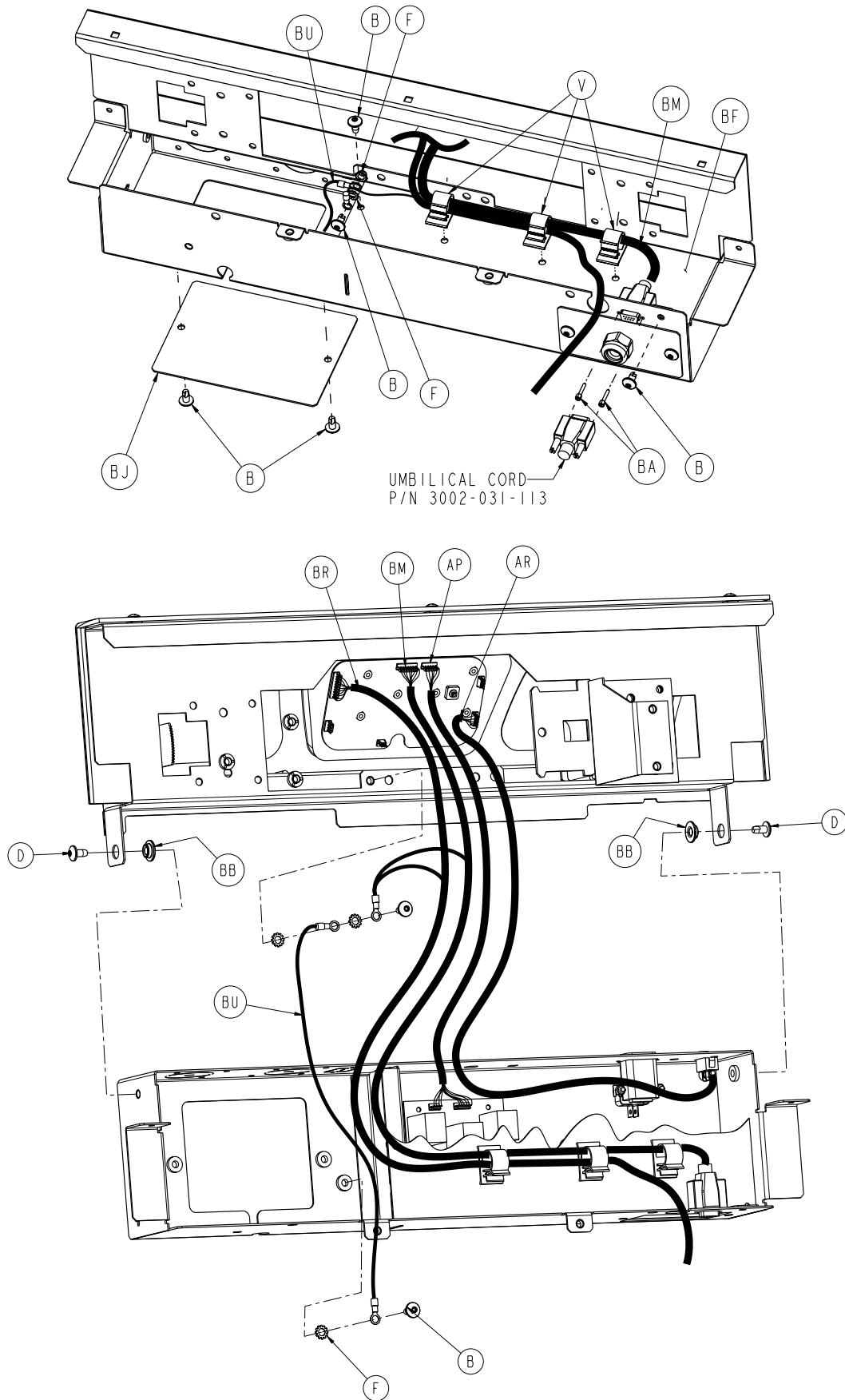

Optional Battery Backup Option Head End Enclosure Ass'y

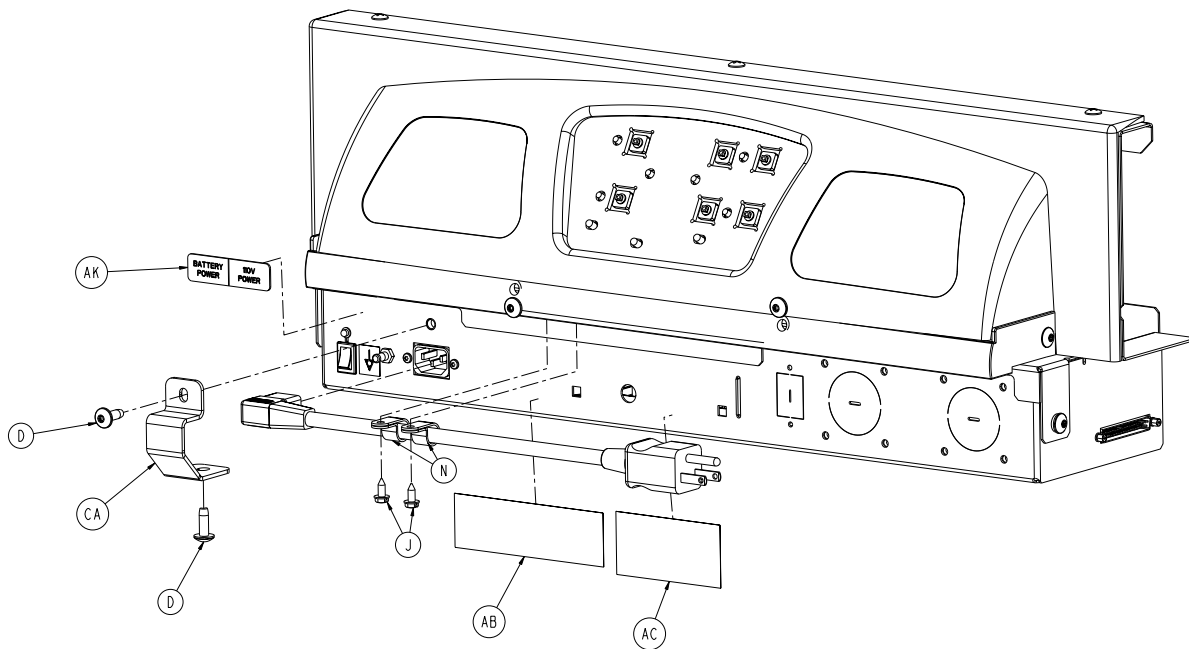
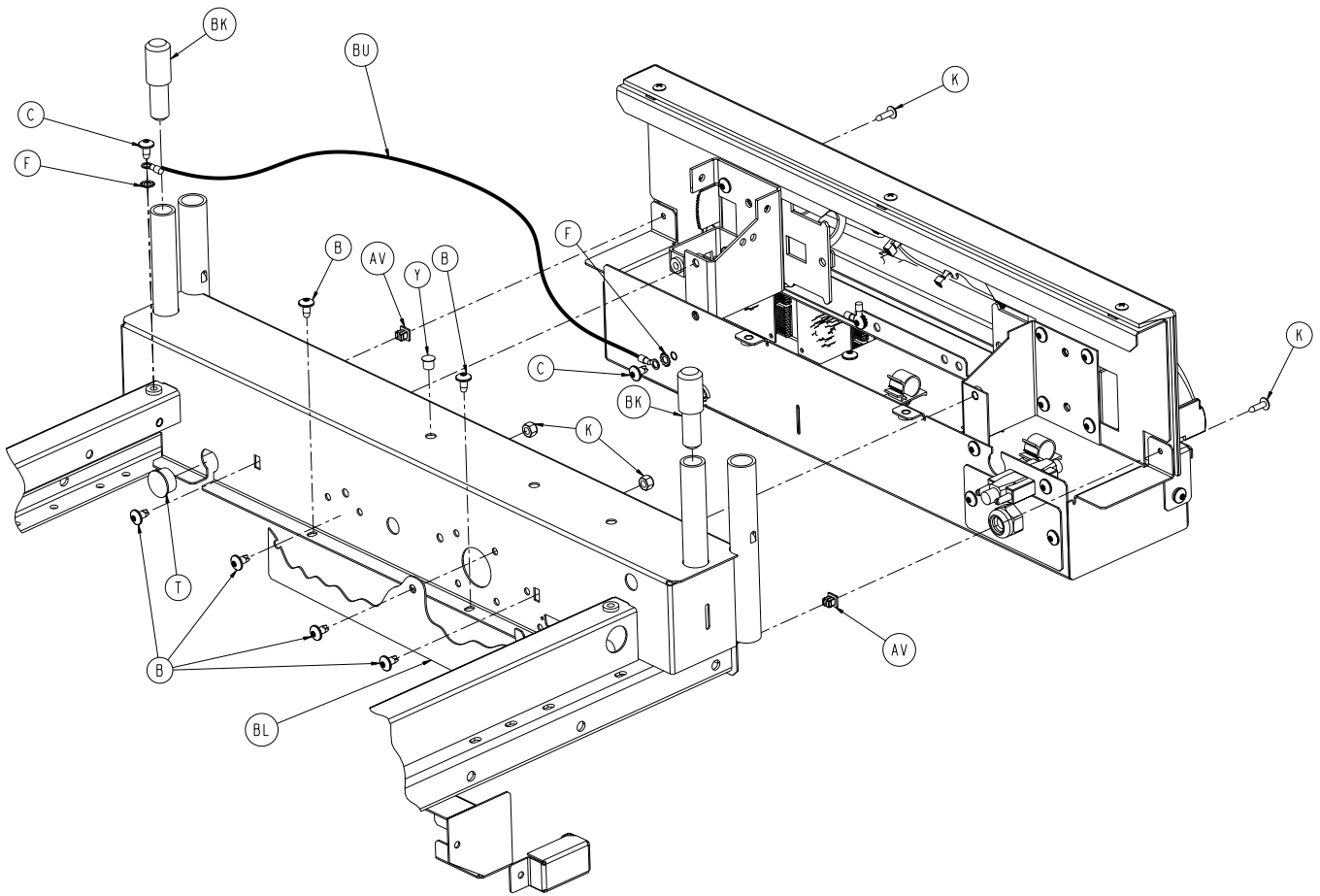

Optional Battery Backup Option Head End Enclosure Ass'y

Optional Battery Backup Option Head End Enclosure Assembly - 3006-450-150 (Reference Only)

| Item | Part No. | Part Name | Qty. | Item | Part No. | Part Name | Qty. |
|------|--------------|------------------------------------|------|------|--------------|--------------------------------|------|
| A | 0004-142-000 | Socket Head Cap Screw | 2 | BK | 3002-031-114 | Headboard Extender | 2 |
| B | 0007-052-000 | Truss Head Torx | 22 | BL | 3006-032-115 | Cover Plate | 1 |
| C | 0007-053-000 | Truss Head Torx | 2 | BM | 3002-031-801 | Zoom® CPU Signal Jumper | 1 |
| D | 0007-063-000 | Truss Head Torx | 8 | BN | 3002-031-802 | Zoom® Breaker Jumper | 1 |
| F | 0013-010-000 | External Tooth Lockwasher | 5 | BP | 3002-031-803 | Zoom® Cross-Over PCB Jumper | 1 |
| G | 0013-038-000 | External Spring Lockwasher | 1 | BR | 3002-004-805 | Zoom®-to-Bed CPU Jumper | 1 |
| H | 0016-033-000 | Kep Nut | 1 | BT | 3002-031-805 | Bed AC Power Jumper | 1 |
| J | 0023-025-000 | Hex Washer Head Screw | 2 | BU | 3002-300-870 | 8" Ground Strap | 2 |
| K | 0023-080-000 | Truss Head Screw | 5 | BW | 0016-023-000 | Nylock Hex Nut | 2 |
| L | 0023-112-000 | high/Low Tapping Screw | 6 | BY | 3006-350-151 | Label, Logo | 2 |
| M | 0050-032-000 | Pan Head Machine Screw | 2 | CA | 3006-031-040 | Power Inlet Shield | 1 |
| N | 0034-021-000 | Cord Clamp | 2 | | | | |
| P | 0036-046-000 | Ground Label | 1 | | | | |
| R | 0036-115-000 | Ground Label | 1 | | | | |
| T | 0037-240-000 | Black, Plastic Hole Plug | 1 | | | | |
| U | 0055-027-000 | "U"-type Nut | 2 | | | | |
| V | 0059-133-000 | Push-Mount Wire Clip | 3 | | | | |
| W | 0059-191-000 | On/Off Switch | 1 | | | | |
| Y | 0059-195-000 | Circuit Breaker | 2 | | | | |
| AA | 0059-738-000 | Heyco Black Dome Plug | 1 | | | | |
| AB | 1550-090-001 | Hospital Grade Plug Label | 1 | | | | |
| AC | 2011-001-104 | Danger Label | 1 | | | | |
| AD | 2011-001-215 | Grounding Lug Tuv | 1 | | | | |
| AE | 3006-031-010 | HE Battery Backup Display Label | 1 | | | | |
| AF | 3006-031-208 | Top Display Housing Ass'y | 1 | | | | |
| AG | 2030-031-910 | CPU Display Assembly | 1 | | | | |
| AH | 3006-031-880 | Inlet Filter Cable | 1 | | | | |
| AJ | 3006-031-054 | Bumper Attachment Wldmt. | 1 | | | | |
| AK | 3006-031-103 | Power Label | 1 | | | | |
| AL | 2040-031-110 | Pivot Bracket, RH | 1 | | | | |
| AM | 2040-031-111 | Pivot Bracket, LH | 1 | | | | |
| AN | 2040-031-808 | AC Charger Jumper Cable | 1 | | | | |
| AP | 2040-031-809 | CPU Cross-Over PCB Jumper Cable | 1 | | | | |
| AR | 2040-031-810 | On/Off Cable | 1 | | | | |
| AT | 2040-031-900 | AC Switchover PCB Ass'y | 1 | | | | |
| AU | 3006-231-069 | Display Bumper | 1 | | | | |
| AV | 3000-300-002 | Plastic Clip Nut | 5 | | | | |
| AW | 3000-300-114 | 4" Wire Tie | 5 | | | | |
| AY | 3000-300-115 | Standoff | 4 | | | | |
| BA | 3001-300-007 | Jack Screw | 2 | | | | |
| BB | 3001-300-099 | Pivot Bearing | 2 | | | | |
| BC | 3001-400-953 | Switch Cap | 6 | | | | |
| BD | 3006-033-053 | Bottom HE Enclosure Wldmt. | 1 | | | | |
| BE | 3006-032-063 | HE Top Enclosure | 1 | | | | |
| BF | 3006-031-092 | HE Electronics Cover | 1 | | | | |
| BG | 3006-032-109 | HE Reinforcement Brkt, LT | 1 | | | | |
| BH | 3006-032-110 | HE Reinforcement Brkt, RT | 1 | | | | |
| BJ | 3006-031-112 | Pendant Port Cover | 1 | | | | |

Optional Battery Backup, Head End Enclosure Assembly, iBed® Wireless Option

For Reference Only: 5212-450-150

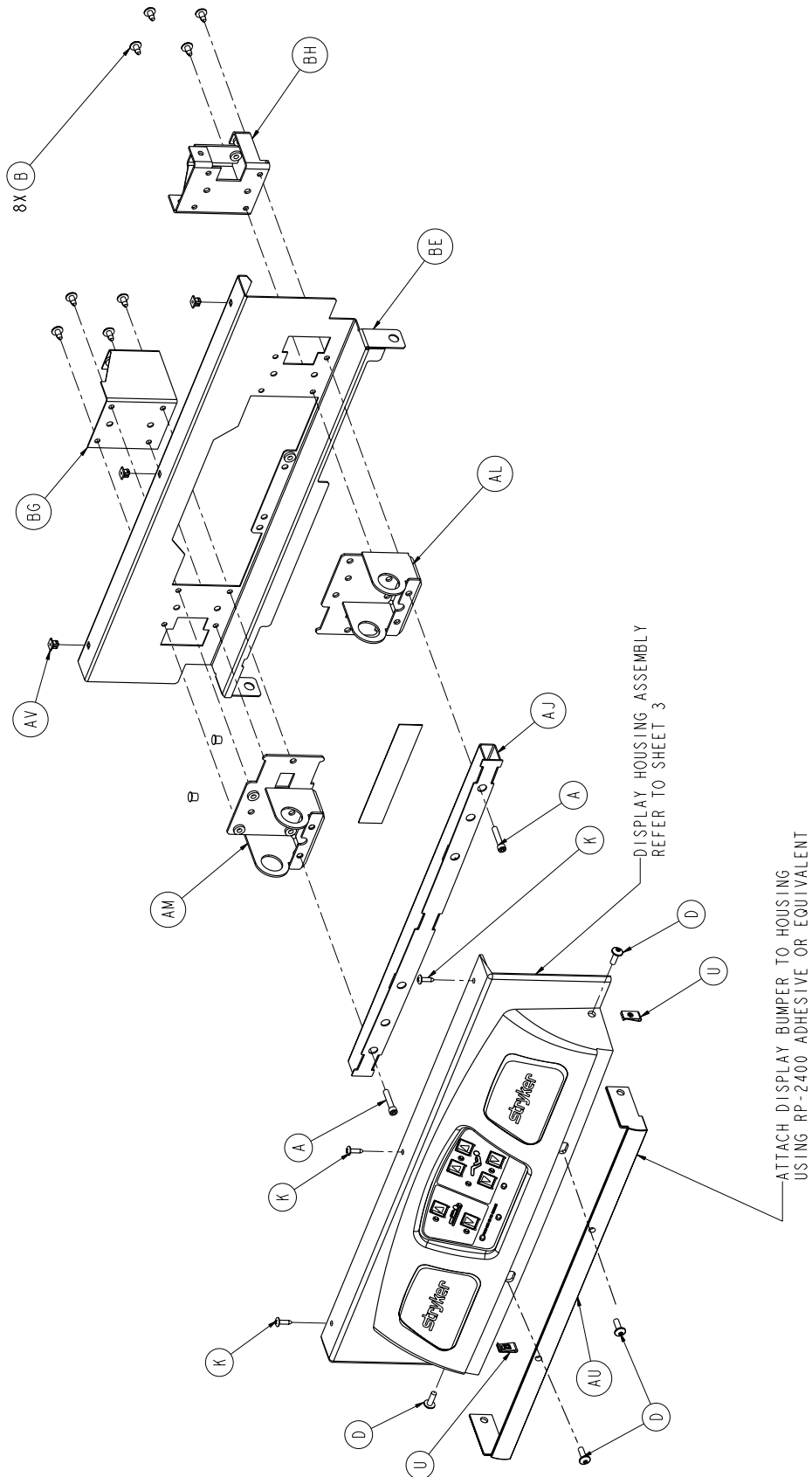

Optional Battery Backup, Head End Enclosure Assembly, iBed® Wireless Option

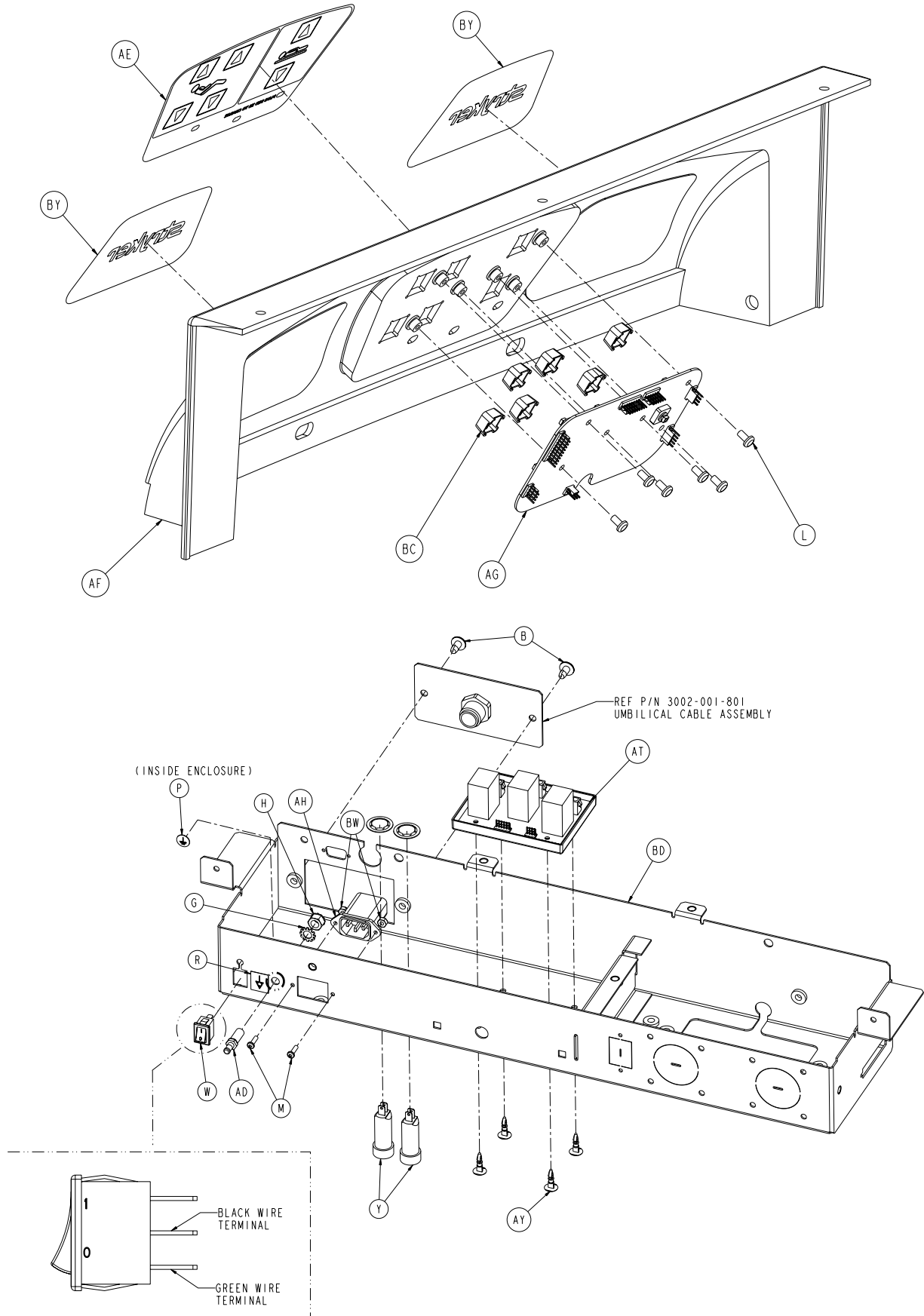

[Return To Table of Contents](#)

Optional Battery Backup, Head End Enclosure Assembly, iBed® Wireless Option

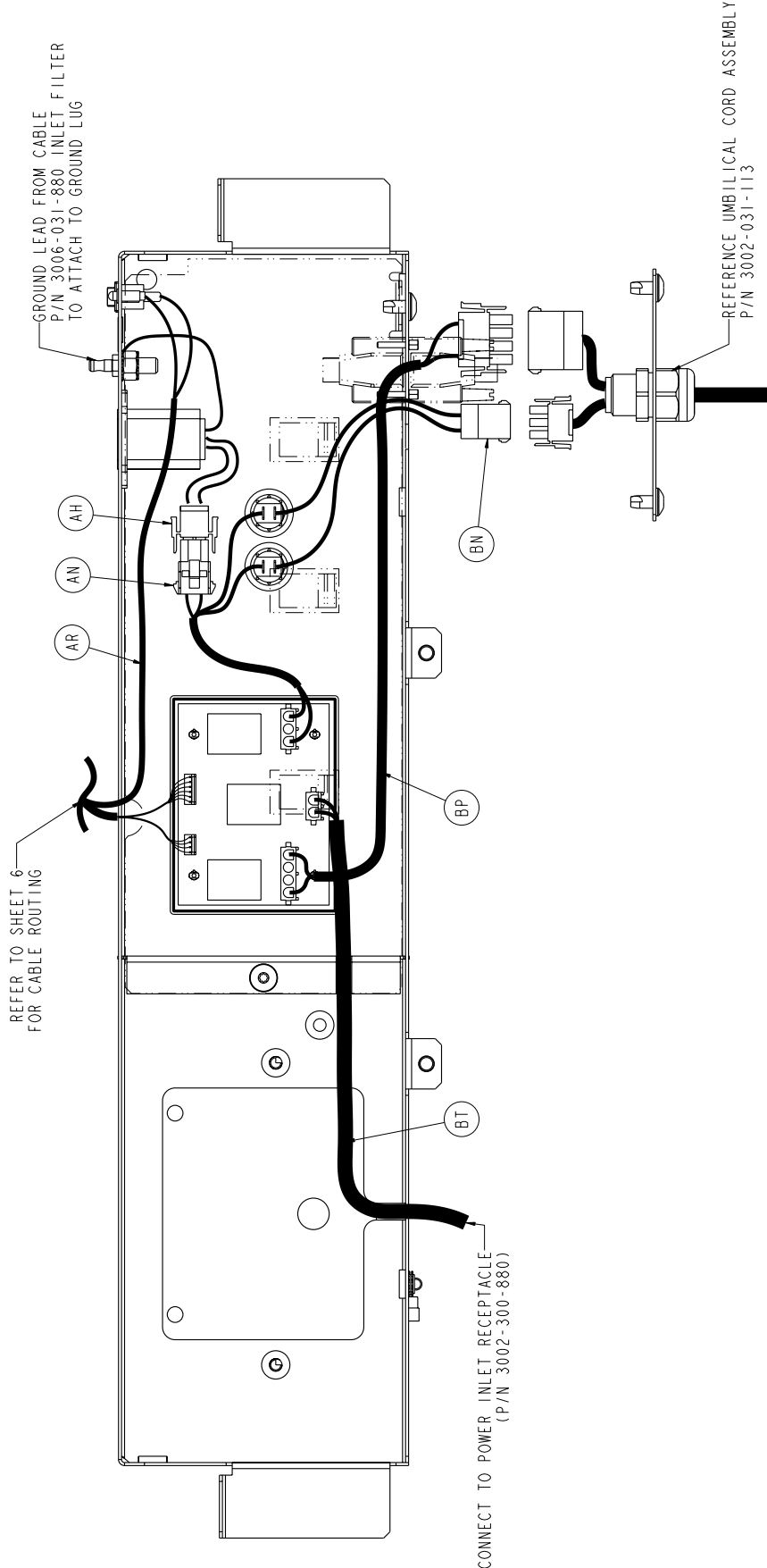

Optional Battery Backup, Head End Enclosure Assembly, iBed® Wireless Option

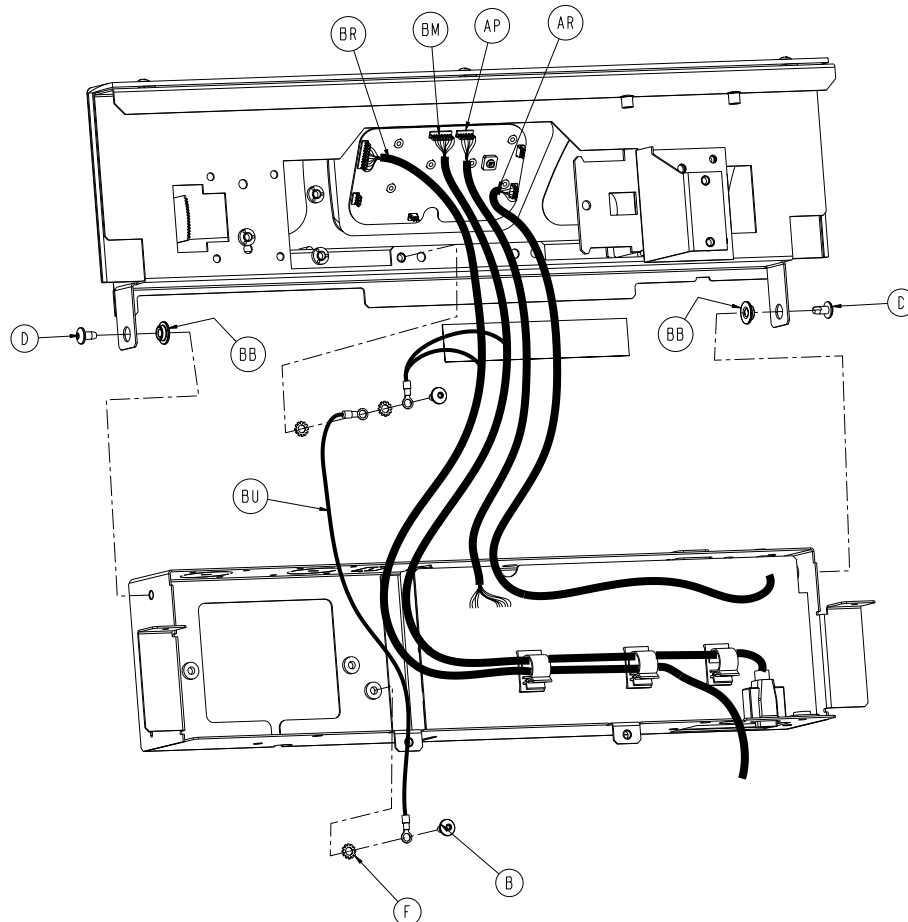
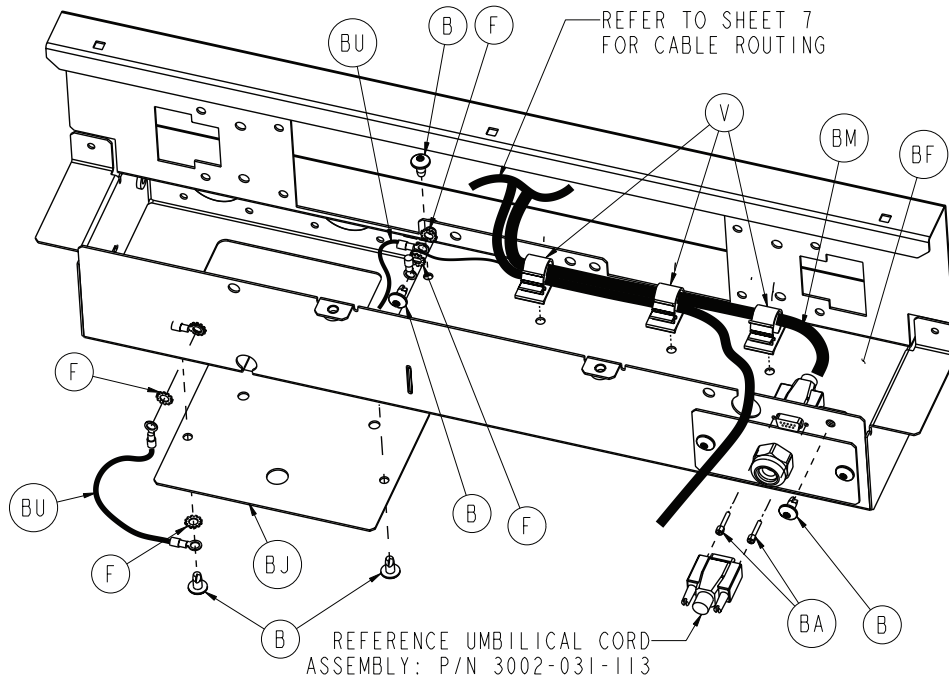

Optional Battery Backup, Head End Enclosure Assembly, iBed® Wireless Option

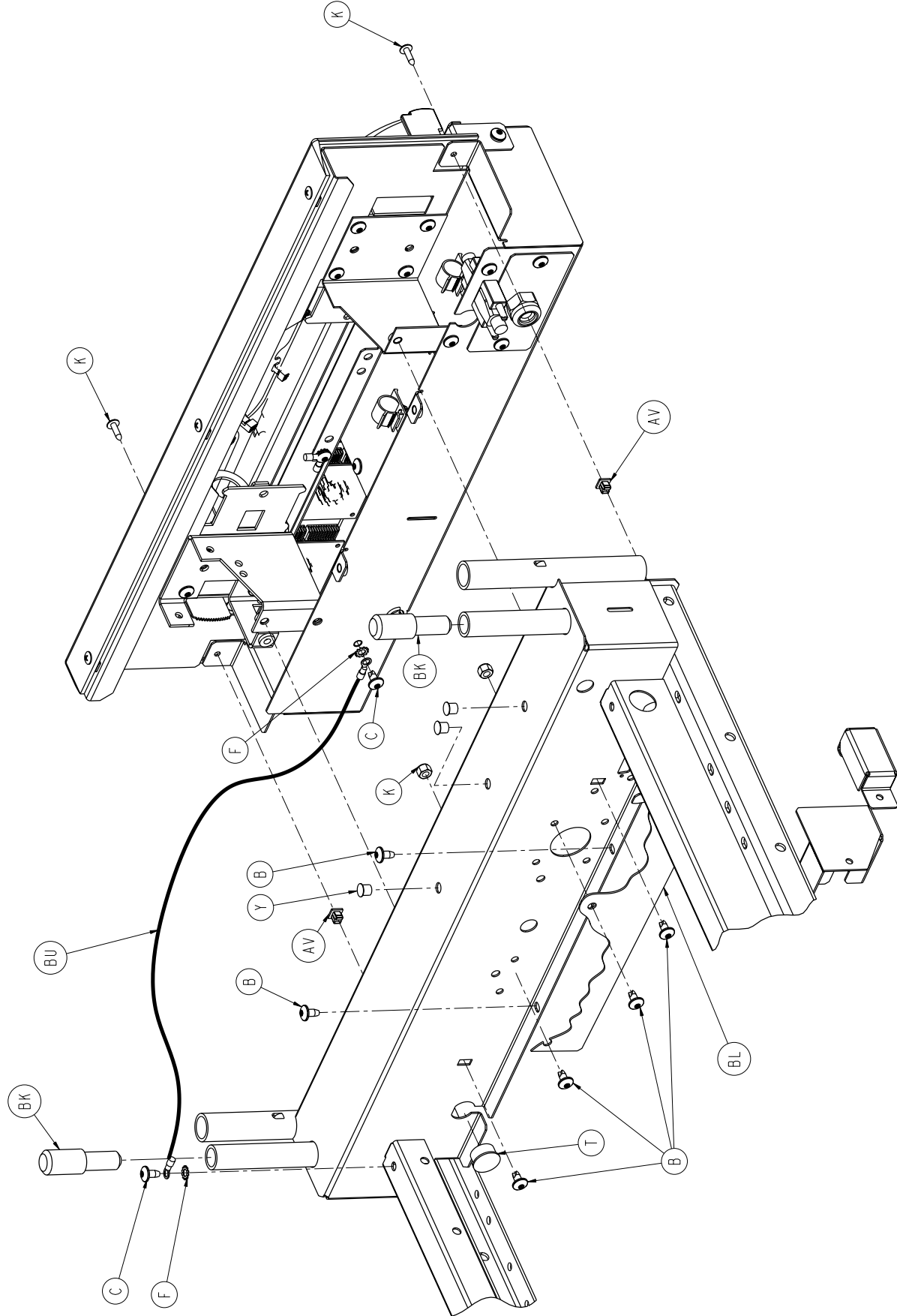

Optional Battery Backup, Head End Enclosure Assembly, iBed® Wireless Option

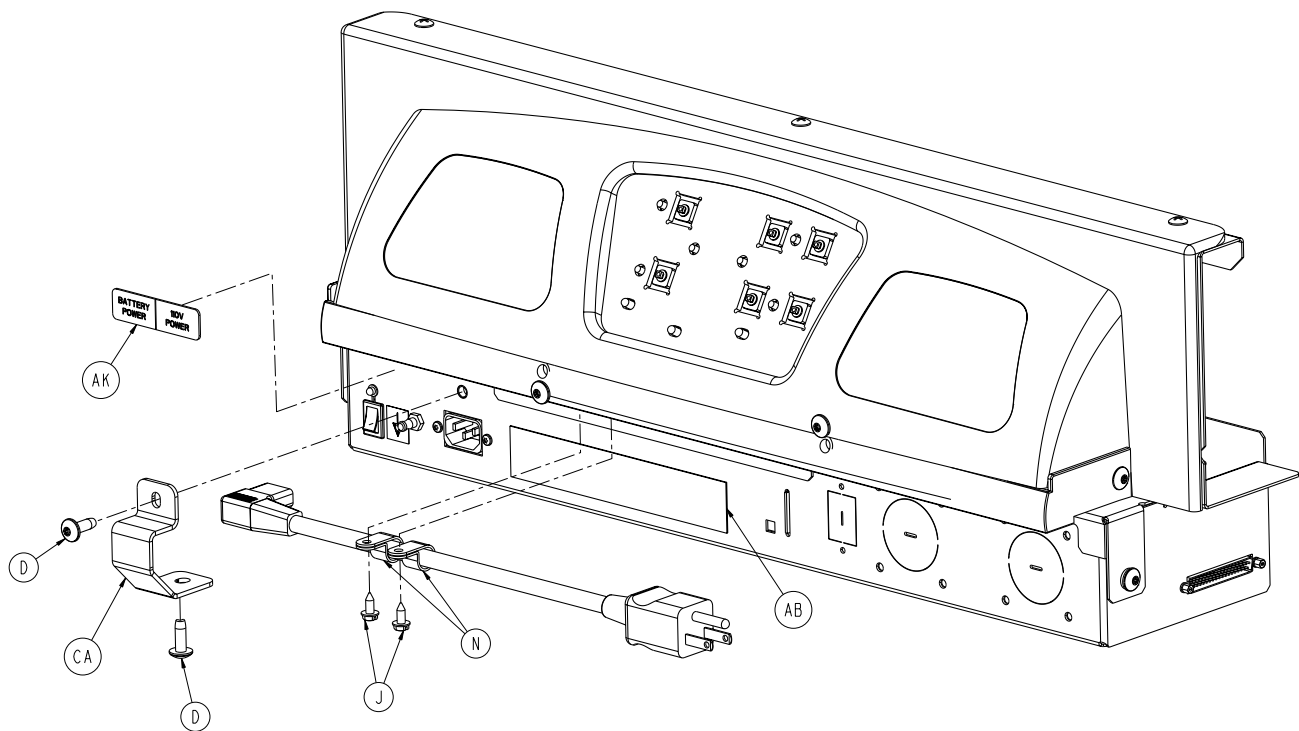

Optional Battery Backup, Head End Enclosure Assembly, *i*Bed® Wireless Option

Optional Battery Backup, Head End Enclosure Assembly, *i*Bed® Wireless Option - 5212-450-150 (Reference Only)

| Item | Part No. | Part Name | Qty. | Item | Part No. | Part Name | Qty. |
|------|--------------|--|------|------|--------------|--|------|
| A | 0004-142-000 | Socket Head Cap Screw | 2 | BG | 3006-032-109 | Reinforcement Bracket, Head End Left | 1 |
| B | 0007-052-000 | Truss Head Torx | 22 | BH | 3006-032-110 | Reinforcement Bracket, Head End Right | 1 |
| C | 0007-053-000 | Truss Hd Torx | 2 | BJ | 3006-031-113 | Pendant Port Cover | 1 |
| D | 0007-063-000 | Truss Head Torx | 8 | BK | 3002-031-114 | Headboard Extender | 2 |
| F | 0013-010-000 | 1/4" External Tooth Lockwasher | 7 | BL | 3006-032-115 | Plate Cover | 1 |
| G | 0013-038-000 | Lock Washer Ext. Spring | 1 | BM | 3002-031-801 | Zoom® CPU Signal Jumper | 1 |
| H | 0016-033-000 | Kep Nut | 1 | BN | 3002-031-802 | Zoom® Breaker Jumper | 1 |
| J | 0023-025-000 | Hex Washer Head Screw | 2 | BP | 3002-031-803 | Zoom® Cross-Over PCB Jumper | 1 |
| K | 0023-080-000 | Truss Head Screw | 5 | BR | 3002-007-805 | Zoom® To Bed CPU Jumper | 1 |
| L | 0023-112-000 | Hi-Low Tapping Screw | 6 | BT | 3002-031-805 | Bed AC Power Jumper | 1 |
| M | 0050-032-000 | Pan Head Machine Screw | 2 | BU | 3002-300-870 | 8" Ground Strap | 3 |
| N | 0034-021-000 | Cord Clamp | 2 | BW | 0016-023-000 | Nylock Hex Nut | 2 |
| P | 0036-046-000 | Label, Ground | 1 | BY | 3006-350-151 | Label, Logo | 2 |
| R | 0036-115-000 | Label, Ground | 1 | CA | 3006-031-040 | Power Inlet Shield | 1 |
| T | 0037-240-000 | Hole Plug | 1 | | | | |
| U | 0055-027-000 | "U" Type Nut | 2 | | | | |
| V | 0059-133-000 | Push-Mount Wire Clip | 3 | | | | |
| W | 0059-191-000 | On/Off Switch | 1 | | | | |
| Y | 0059-195-000 | Circuit Breaker | 2 | | | | |
| AA | 0059-738-000 | Heyco Hole Plug | 1 | | | | |
| AB | 5212-100-807 | Label, Caution | 1 | | | | |
| AD | 2011-001-215 | Grounding Lug Tuv | 1 | | | | |
| AE | 3006-031-010 | Label, Dispal,y, Battery Backup, Head End | 1 | | | | |
| AF | 3006-031-208 | Top Display Housing Assy | 1 | | | | |
| AG | 2030-031-910 | CPU Display Assembly | 1 | | | | |
| AH | 3006-031-880 | Inlet Filter Cable | 1 | | | | |
| AJ | 3006-031-054 | Bumper Attachment Weldment | 1 | | | | |
| AK | 3006-031-103 | Label, Power | 1 | | | | |
| AL | 2040-031-110 | Pivot Bracket, Right | 1 | | | | |
| AM | 2040-031-111 | Pivot Bracket, Left | 1 | | | | |
| AN | 2040-031-808 | Charger AC Jumper Cable | 1 | | | | |
| AP | 2040-031-809 | Cross-Over PCB Jumper CPU Cable | 1 | | | | |
| AR | 2040-031-810 | On/Off Cable | 1 | | | | |
| AT | 2040-031-900 | AC Switchover PCB Assy | 1 | | | | |
| AU | 3006-231-069 | Display Bumper | 1 | | | | |
| AV | 3000-300-002 | Plastic Clip Nut | 5 | | | | |
| AW | 3000-300-114 | 4" Wire Tie | 5 | | | | |
| AY | 3000-300-115 | Standoff | 4 | | | | |
| BA | 3001-300-007 | M/F Screw | 2 | | | | |
| BB | 3001-300-099 | Pivot Bearing | 2 | | | | |
| BC | 3001-400-953 | Switch Cap | 6 | | | | |
| BD | 3006-133-053 | Bottom Enclosure Weldment, Head End | 1 | | | | |
| BE | 3006-032-063 | Top Enclosure, Head End | 1 | | | | |
| BF | 3006-031-092 | Cover, Head End Enclosure, White | 1 | | | | |

[Return To Table of Contents](#)

Optional Zoom® Head End Enclosure Assembly

For Reference Only: 3006-131-010

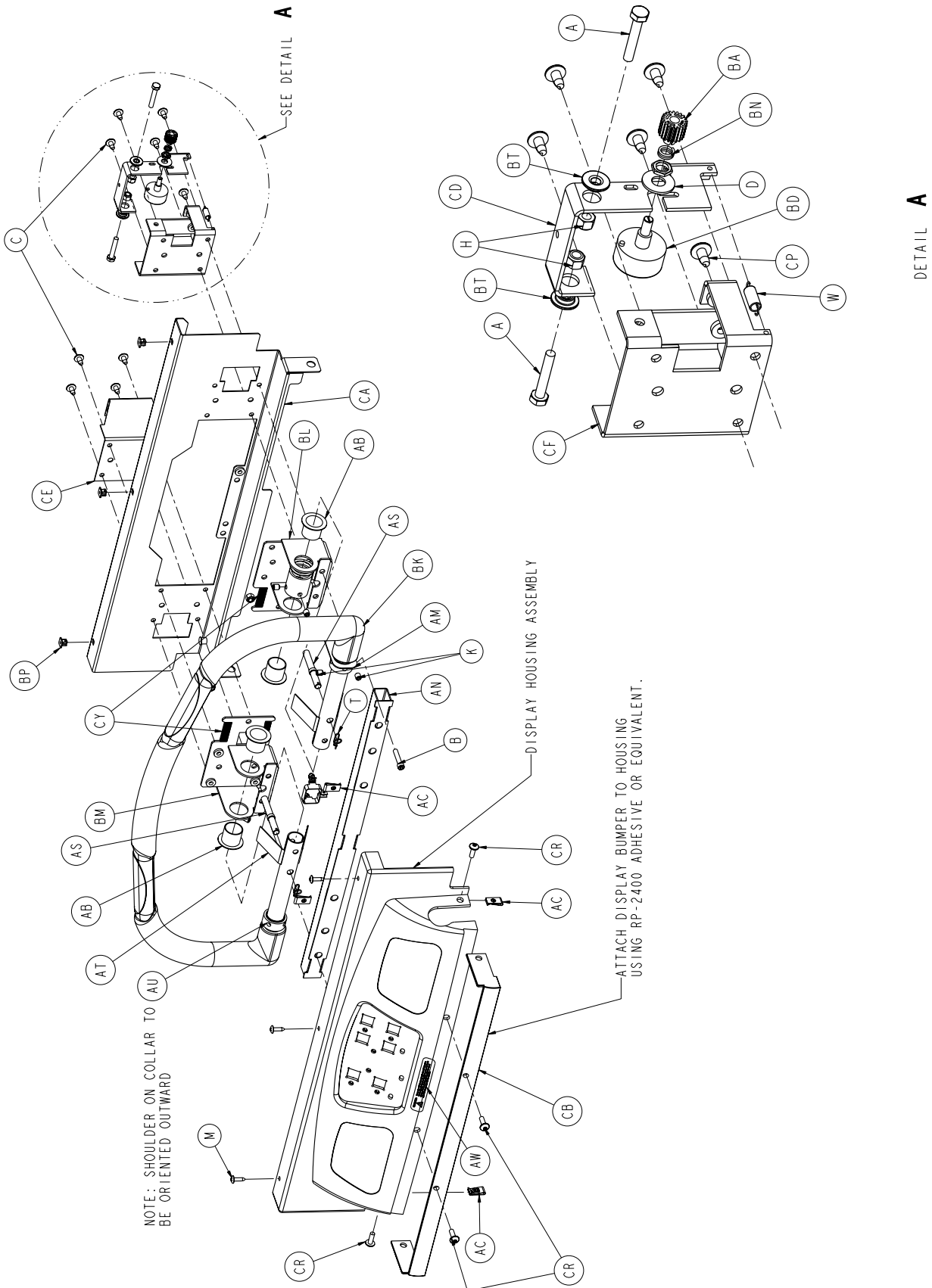

Optional Zoom® Head End Enclosure Assembly

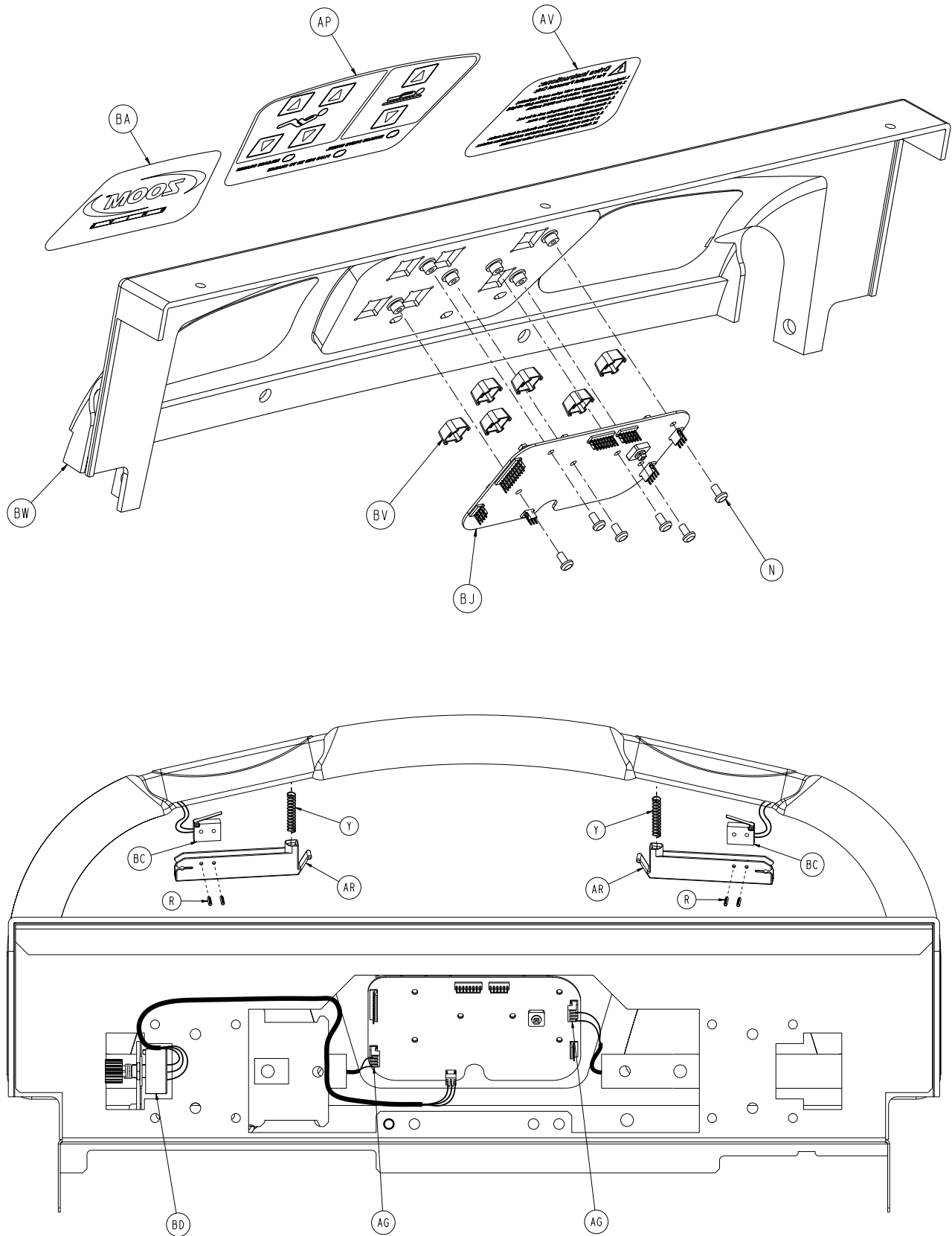

Optional Zoom® Head End Enclosure Assembly

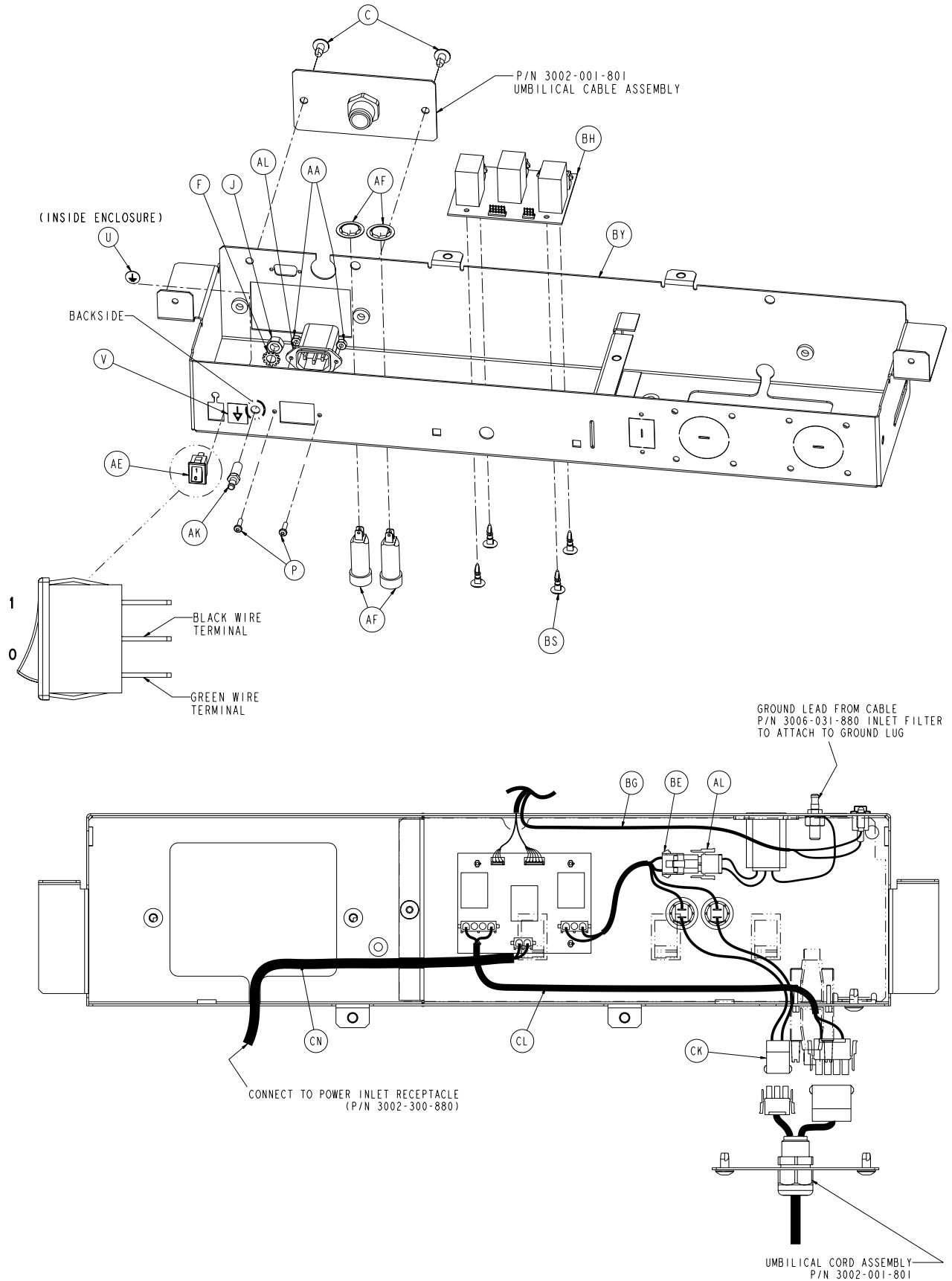

Optional Zoom® Head End Enclosure Assembly

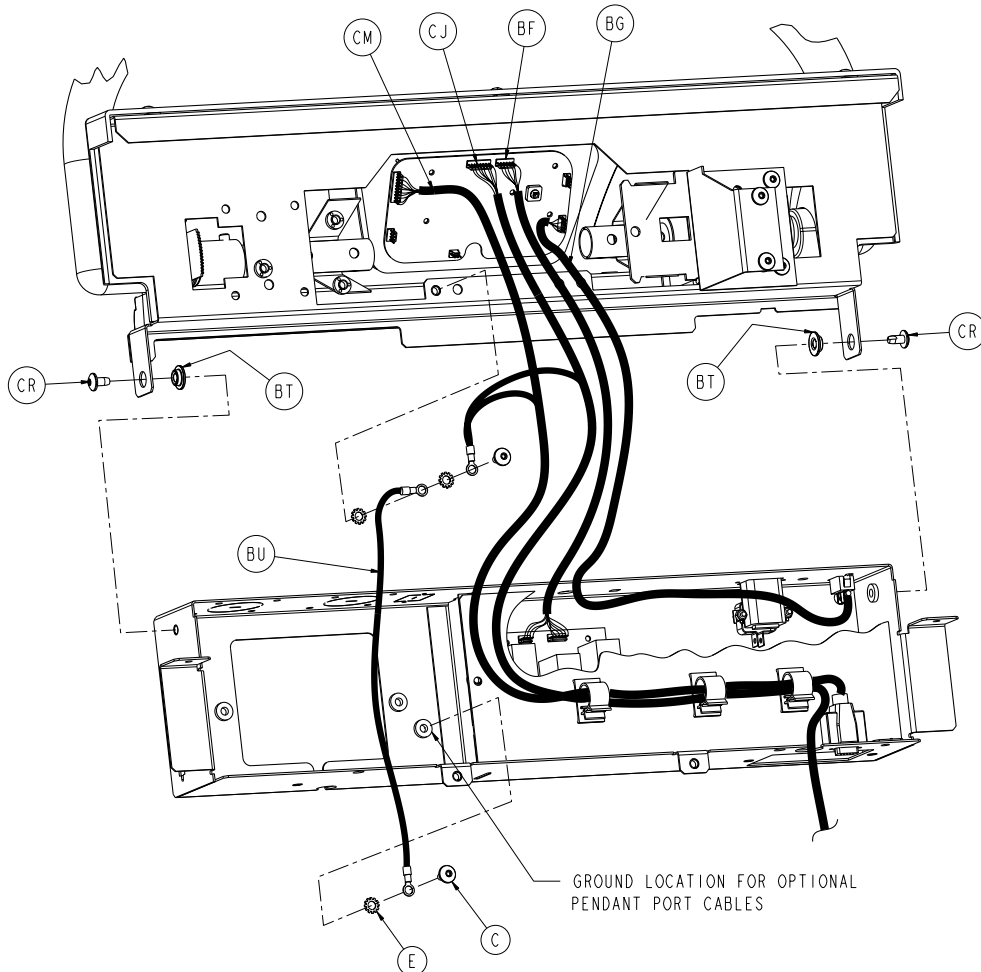
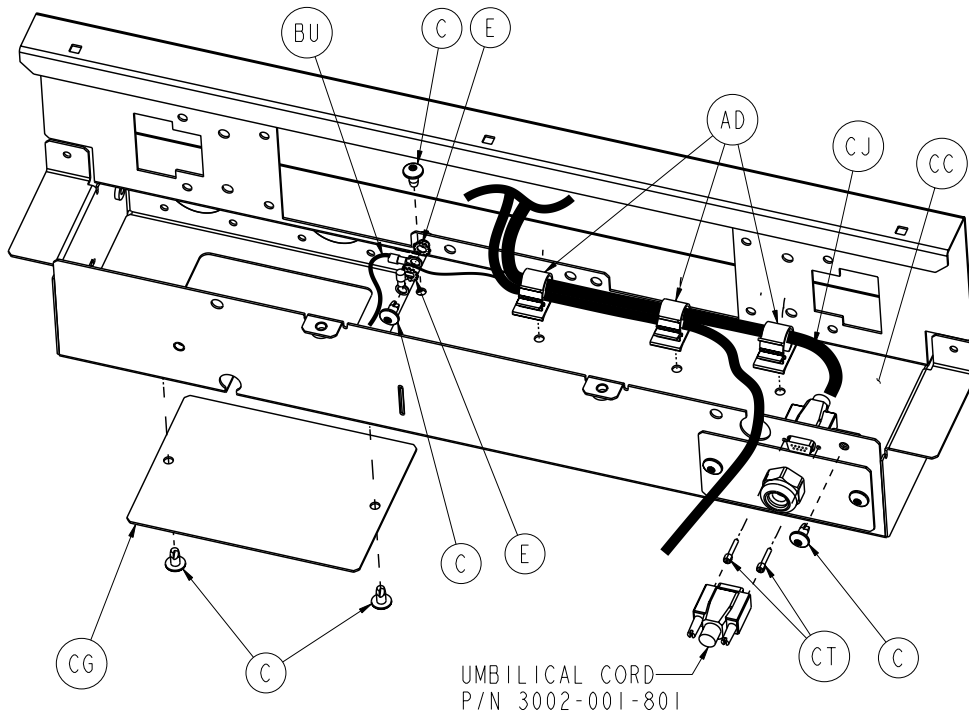

Optional Zoom® Head End Enclosure Assembly

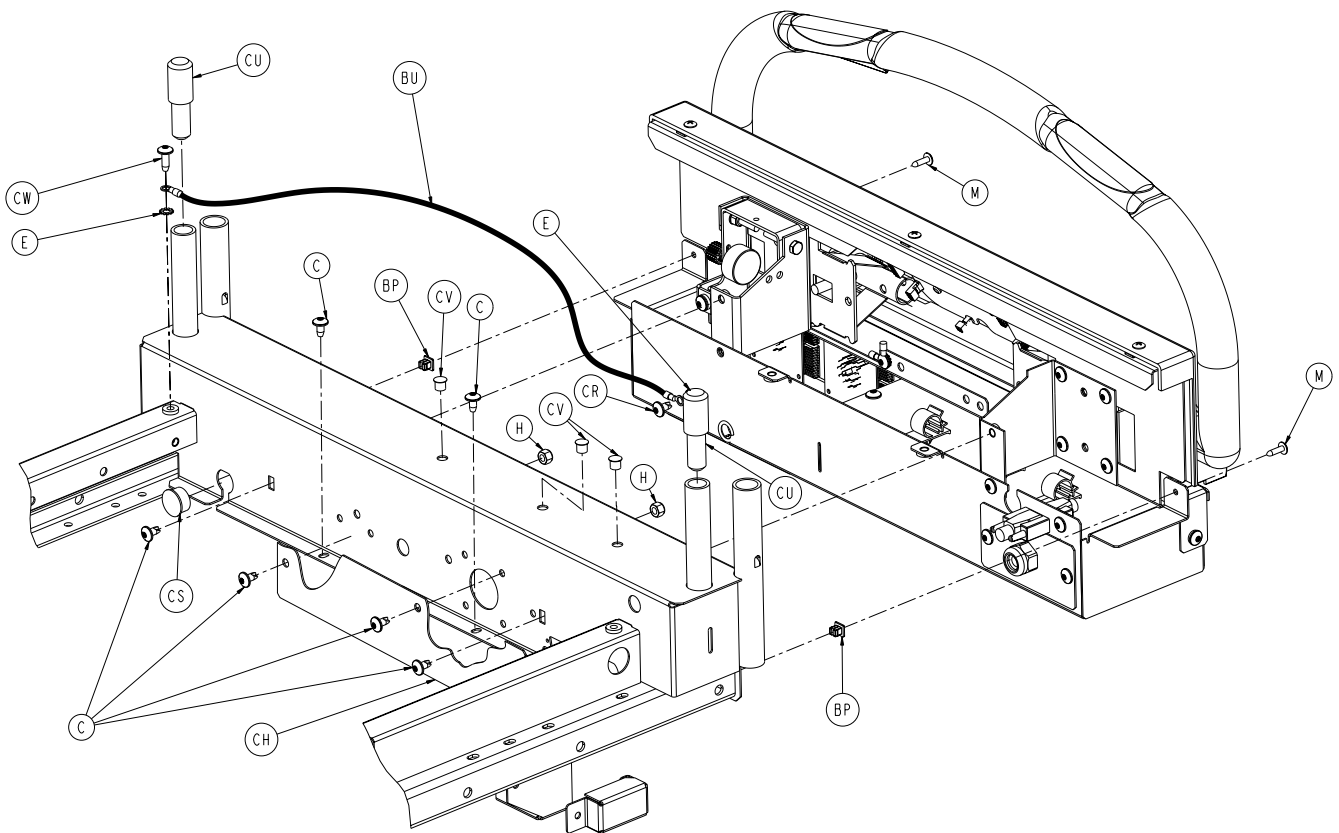
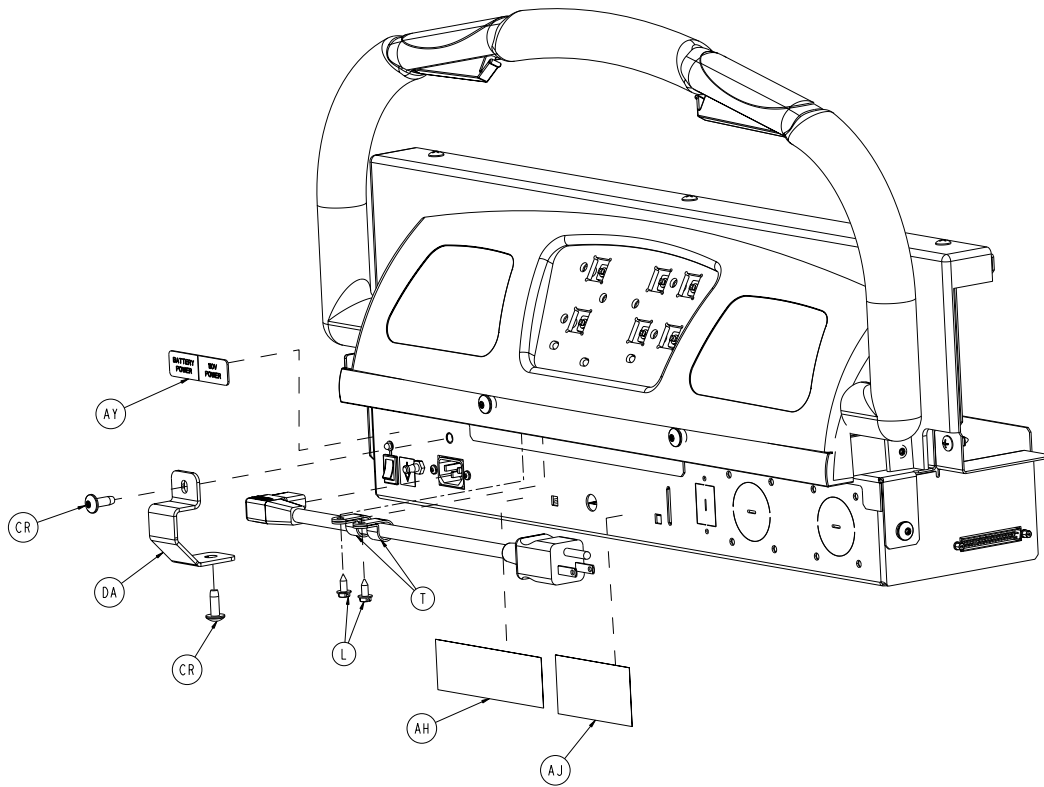

Optional Zoom® Head End Enclosure Assembly

Optional Zoom® Head End Enclosure Assembly - 3006-131-010 (Reference Only)

| Item | Part No. | Part Name | Qty. | Item | Part No. | Part Name | Qty. |
|------|--------------|------------------------------------|------|------|--------------|--------------------------------|------|
| A | 0003-050-000 | Hex Head Cap Screw | 2 | BK | 3006-231-064 | Control Bar | 1 |
| B | 0004-142-000 | Socket head Cap Screw | 2 | BL | 2040-031-110 | Pivot Bracket, RH | 1 |
| C | 0007-052-000 | Truss Head Torx | 25 | BM | 2040-031-111 | Pivot Bracket, LH | 1 |
| D | 0011-193-000 | Flat Washer | 1 | BN | 3000-200-253 | POT Worm Gear Retainer | 1 |
| E | 0013-010-000 | External Tooth Lockwasher | 5 | BP | 3000-300-002 | Plastic Clip Nut | 5 |
| F | 0013-038-000 | Lockwasher Extension Spring | 1 | BR | 3000-300-114 | 4" Wire Tie | 5 |
| H | 0016-028-000 | Nylock Nut | 4 | BS | 3000-300-115 | Standoff | 4 |
| J | 0016-033-000 | Kep Nut | 1 | BT | 3001-300-099 | Pivot Bearing | 4 |
| K | 0021-140-000 | Set Screw | 4 | BU | 3002-300-870 | 8" Ground Strap | 2 |
| L | 0023-025-000 | Hex Washer Head Screw | 2 | BV | 3001-400-953 | Switch Cap | 6 |
| M | 0023-080-000 | Truss Head Screw | 5 | BW | 3006-031-011 | Top Display Housing Ass'y | 1 |
| N | 0023-122-000 | High/Low Tapping Screw | 6 | BY | 3006-033-053 | Bottom HE Enclosure Wldmt. | 1 |
| P | 0050-032-000 | Pan Head Machine Screw | 2 | CA | 3006-032-063 | Head End Enclosure, Top | 1 |
| R | 0026-303-000 | Roll Pin | 4 | CB | 3006-231-069 | Display Bumper | 1 |
| S | 0027-022-000 | Rue Pin | 2 | CC | 3002-031-092 | Head End Electronics Cover | 1 |
| T | 0034-021-000 | Cord Clamp | 2 | CD | 3002-031-108 | Potentiometer Mount | 1 |
| U | 0036-046-000 | Ground Label | 1 | CE | 3006-032-109 | HE Reinforcement Brkt, LT | 1 |
| V | 0036-115-000 | Ground Label | 1 | CF | 3006-032-110 | HE Reinforcement Brkt, RT | 1 |
| W | 0038-482-000 | Extension Spring | 1 | CG | 3002-031-112 | Pendant Port Cover | 1 |
| Y | 0038-448-000 | Switch Handle Return Spring | 2 | CH | 3002-032-115 | Cover Plate | 1 |
| AA | 0016-023-000 | Nylock Hex Nut | 2 | CJ | 3002-031-801 | Zoom® CPU Signal Jumper | 1 |
| AB | 0052-762-000 | Flange Bearing | 4 | CK | 3002-031-802 | Zoom® Breaker Jumper | 1 |
| AC | 0055-027-000 | "U"-type Nut | 4 | CL | 3002-031-803 | Zoom® Cross-over PCB Jumper | 1 |
| AD | 0059-133-000 | Push-Mount Wire Clip | 3 | CM | 3002-007-805 | Zoom® to Bed CPU Jumper | 1 |
| AE | 0059-191-000 | On/Off Switch | 1 | CN | 3002-031-805 | Bed AC Power Jumper | 1 |
| AF | 0059-195-000 | Circuit Breaker | 2 | CP | 0004-325-000 | Shoulder Bolt Cap Screw | 1 |
| AG | 0059-781-000 | Position Connector Amp | 2 | CR | 0007-063-000 | Truss Head Screw | 9 |
| AH | 1550-090-001 | Hospital Grade Plug Label | 1 | CS | 0037-240-000 | Black, Plastic Hole Plug | 1 |
| AJ | 2011-001-104 | Danger Label | 1 | CT | 3001-300-007 | Jack Screw | 2 |
| AK | 2011-011-215 | Grounding Lug Tuv | 1 | CU | 3002-031-114 | Headboard Extender | 2 |
| AL | 3006-031-880 | Power Inlet Cable | 1 | CV | 0059-738-000 | Black Heyco Plug | 3 |
| AM | 2040-031-051 | Pot. Collar Weldment | 1 | CW | 0007-065-000 | Truss Head Screw | 1 |
| AN | 3006-031-054 | Bumper Attachment Wldmt. | 1 | CY | 0044-032-000 | Pressure Sensitive Tape | 4 |
| AP | 3006-031-062 | Display Label | 1 | DA | 3006-031-040 | Power Inlet Shield | 1 |
| AR | 2040-031-068 | Switch Label | 2 | | | | |
| AS | 2040-031-073 | Stop Pin | 2 | | | | |
| AT | 2040-031-074 | Control Bar Return Spring | 2 | | | | |
| AU | 2040-031-082 | Potentiometer Collar | 1 | | | | |
| AV | 3006-031-101 | Drive Instructions Label | 1 | | | | |
| AW | 3006-031-102 | Warning Label | 1 | | | | |
| AY | 3006-031-103 | Power Label | 1 | | | | |
| BA | 3006-031-105 | Logo Label | 1 | | | | |
| BB | 2040-031-106 | Potentiometer Gear | 1 | | | | |
| BC | 2040-031-803 | Switch Cable | 2 | | | | |
| BD | 2040-031-804 | Potentiometer Cable | 1 | | | | |
| BE | 2040-031-808 | AC Jumper Cable Charger | 1 | | | | |
| BF | 2040-031-809 | CPU/Cross-over PCB Jumper Cable | 1 | | | | |
| BG | 2040-031-810 | On/Off Cable | 1 | | | | |
| BH | 2040-031-900 | AC Switch Cover PCB Assembly | 1 | | | | |
| BJ | 2040-031-910 | Display/CPU Assembly | 1 | | | | |

Optional Zoom® Litter Assembly, iBed® Wireless Option

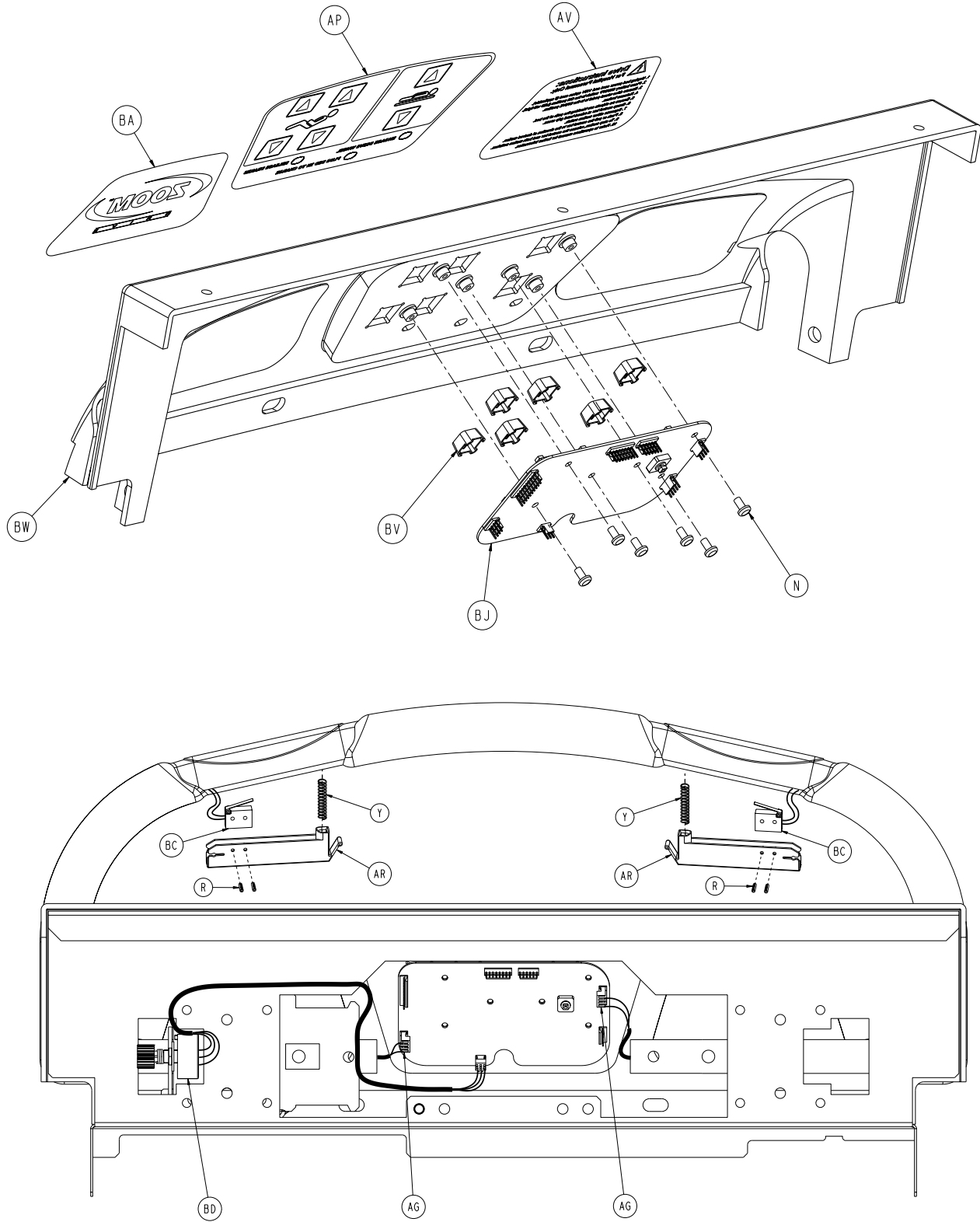

Optional Zoom® Litter Assembly, iBed® Wireless Option

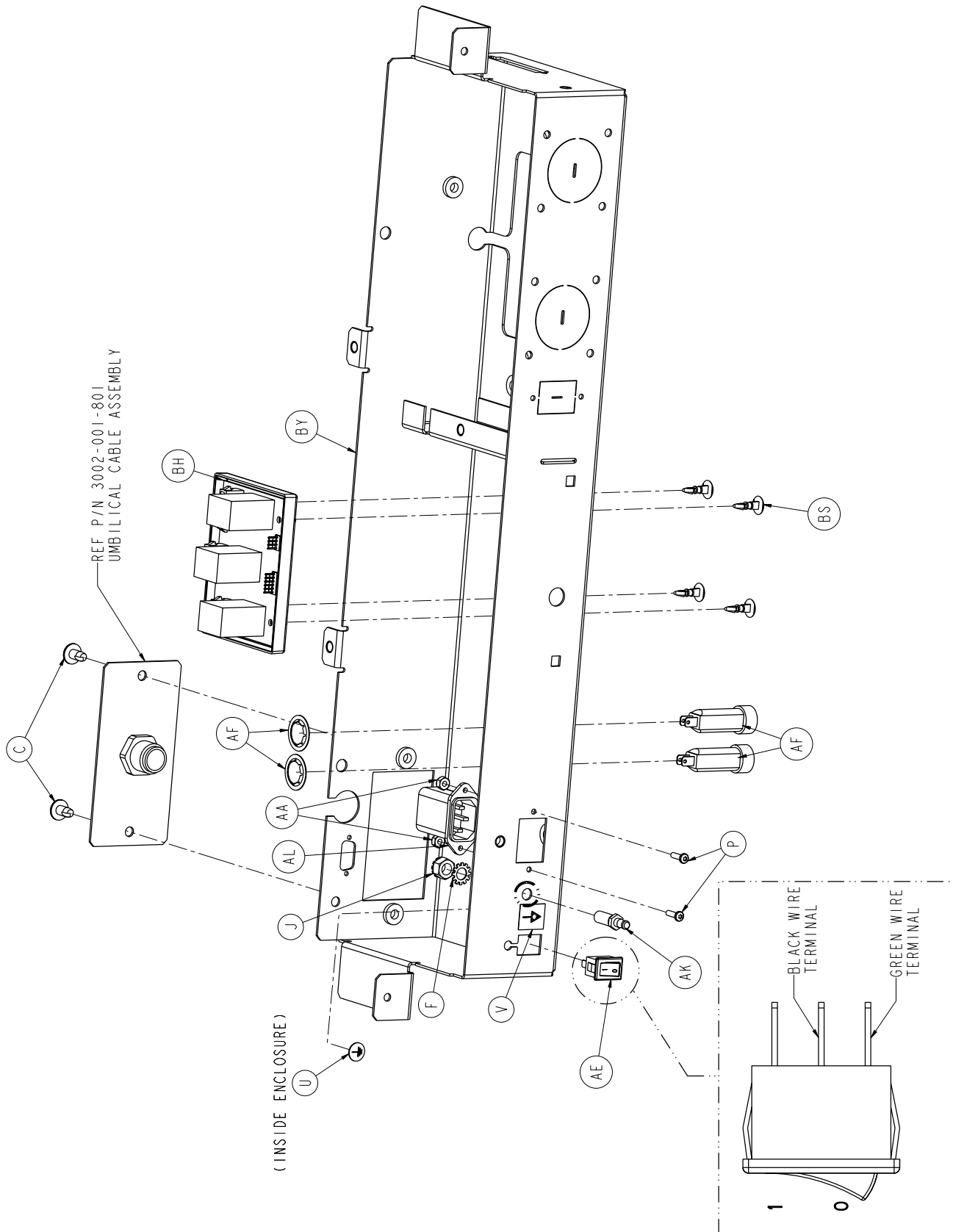

Optional Zoom® Litter Assembly, iBed® Wireless Option

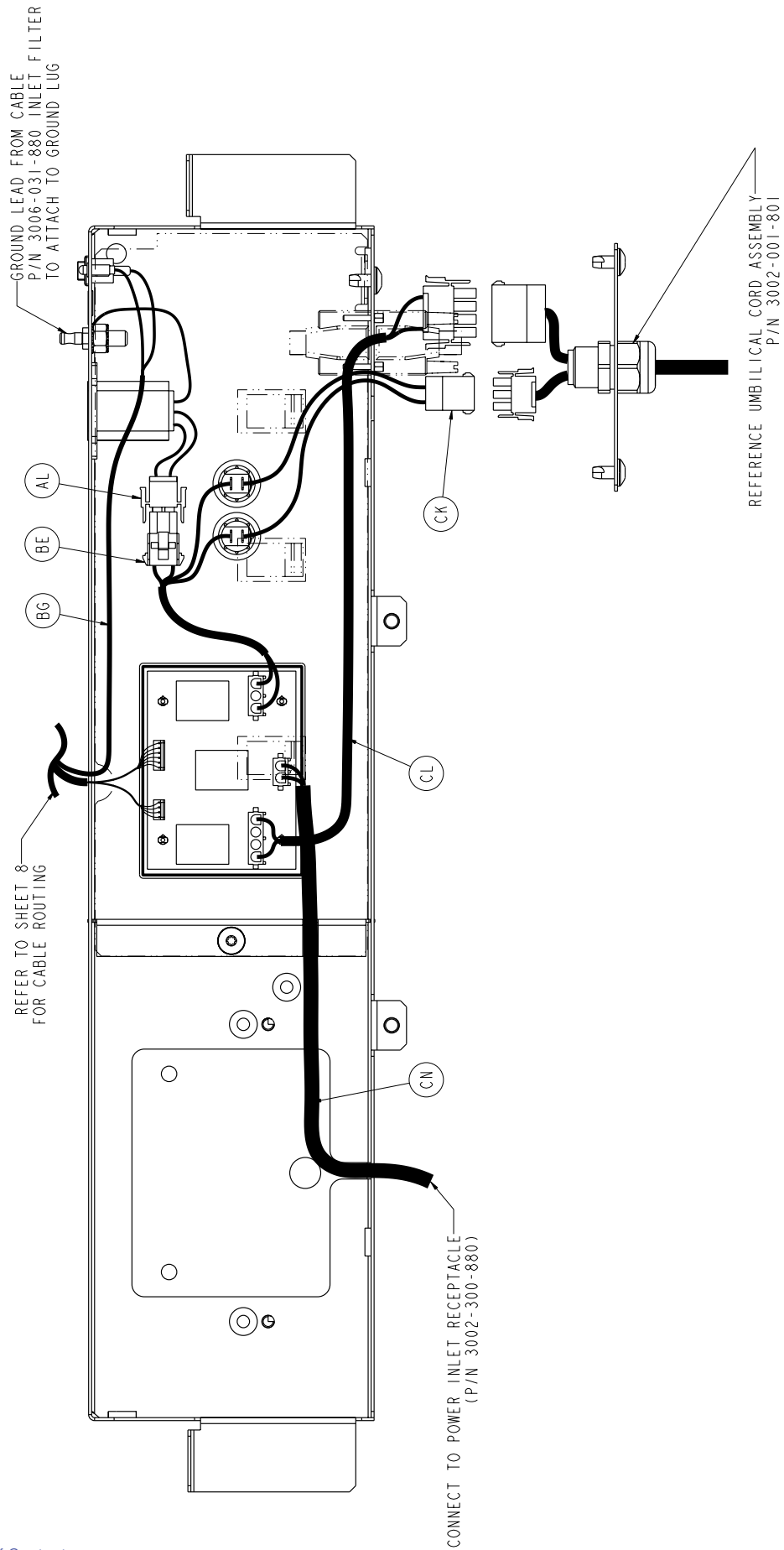

Optional Zoom® Litter Assembly, iBed® Wireless Option

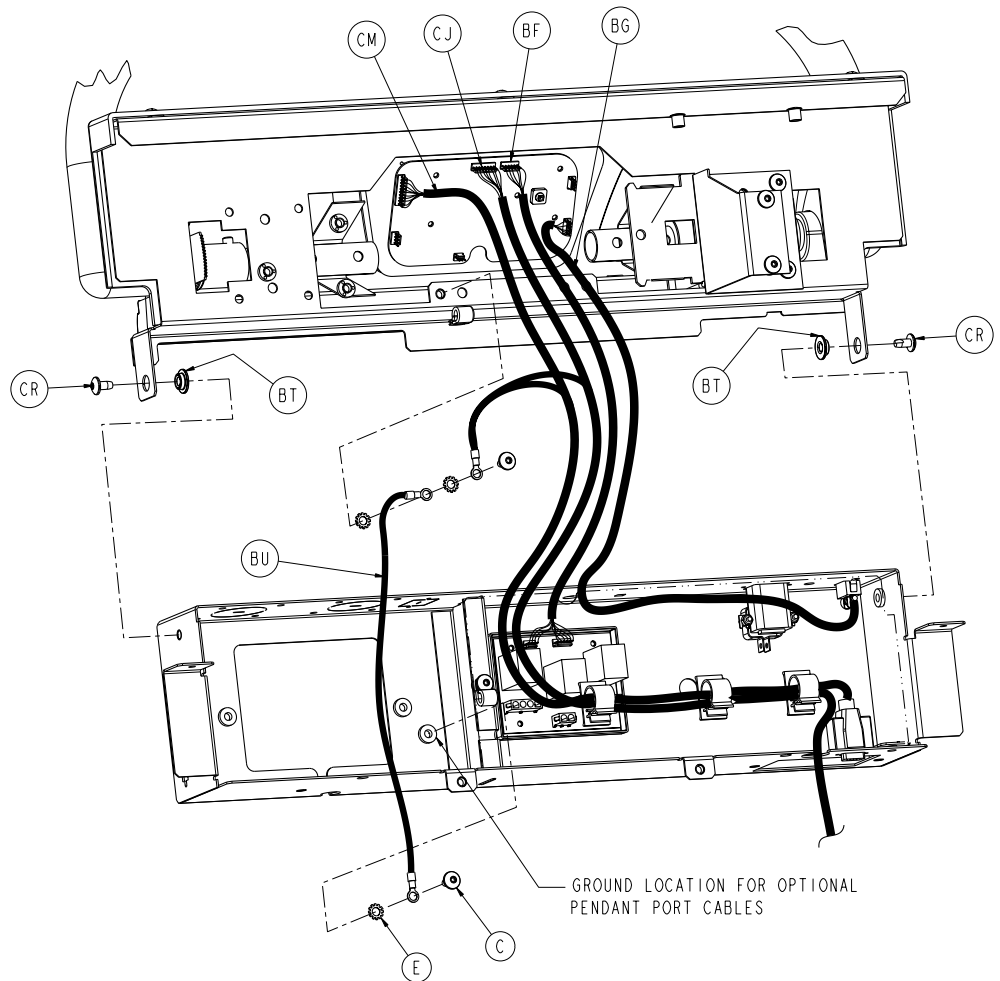
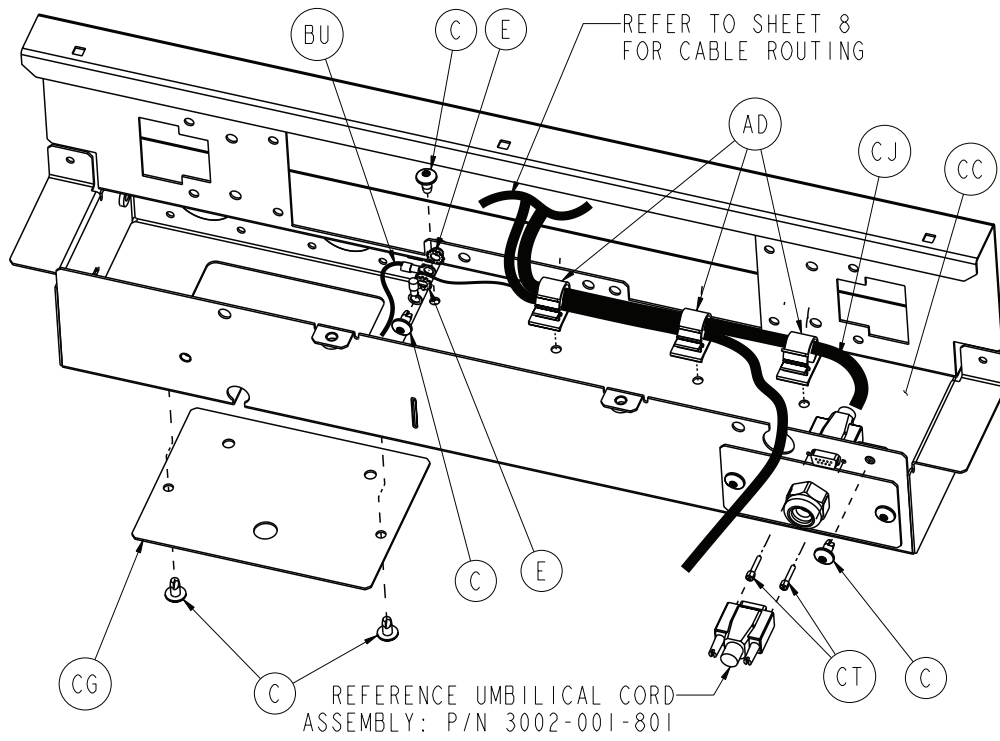

Optional Zoom® Litter Assembly, iBed® Wireless Option

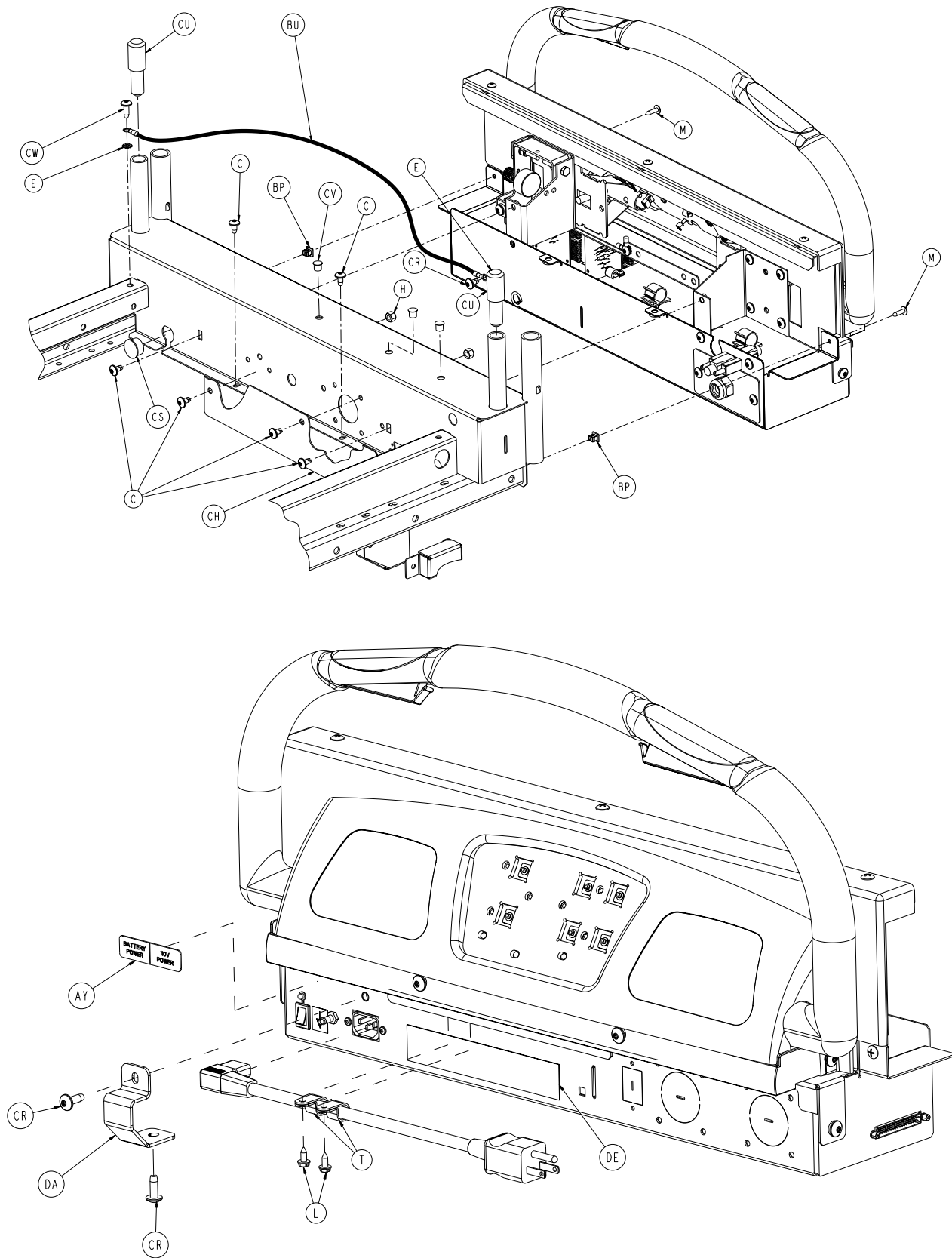

Optional Zoom® Litter Assembly, iBed® Wireless Option

Optional Zoom® Litter Assembly, iBed® Wireless Option - 5212-131-010 (Reference Only)

| Item | Part No. | Part Name | Qty. | Item | Part No. | Part Name | Qty. |
|------|--------------|------------------------------------|------|------|--------------|---|------|
| A | 0003-050-000 | Hex Head Cap Screw | 2 | BD | 2040-031-804 | Potentiometer Cable | 1 |
| B | 0004-142-000 | Socket Head Cap Screw | 2 | BE | 2040-031-808 | Charger AC Jumper Cable | 1 |
| C | 0007-052-000 | Truss Head Torx | 25 | BF | 2040-031-809 | CPU/Cross-Over | |
| D | 0011-193-000 | Flat Washer | 1 | | | PCB Jumper Cable | 1 |
| E | 0013-010-000 | 1/4" External Tooth Lockwasher | 6 | BG | 2040-031-810 | On/Off Cable | 1 |
| F | 0013-038-000 | Lockwasher Ext. Spring | 1 | BH | 2040-031-900 | AC Switchover PCB Assy | 1 |
| H | 0016-028-000 | Nylock Nut | 4 | BJ | 2040-031-910 | CPU Display Assembly | 1 |
| J | 0016-033-000 | Kep Nut | 1 | BK | 3006-231-064 | Control Bar | 1 |
| K | 0021-140-000 | Set Screw | 4 | BL | 2040-031-110 | Pivot Bracket, Right | 1 |
| L | 0023-025-000 | Hex Washer Head Screw | 2 | BM | 2040-031-111 | Pivot Bracket, Left | 1 |
| M | 0023-080-000 | Truss Head Screw | 5 | BN | 3000-200-253 | Pot Worm Gear Retainer | 1 |
| N | 0023-112-000 | Hi-Low Tapping Screw | 6 | BP | 3000-300-002 | Nut, Plastic Clip | 5 |
| P | 0050-032-000 | Pan Head Machine Screw | 2 | BR | 3000-300-114 | 4" Wire Tie | 5 |
| R | 0026-303-000 | Roll Pin | 4 | BS | 3000-300-115 | Standoff | 4 |
| S | 0027-022-000 | Rue Pin | 2 | BT | 3001-300-099 | Pivot Bearing | 4 |
| T | 0034-021-000 | Cord Clamp | 2 | BU | 3002-300-870 | 8" Ground Strap | 3 |
| U | 0036-046-000 | Ground Label | 1 | BV | 3001-400-953 | Switch Cap | 6 |
| V | 0036-115-000 | Ground Label | 1 | BW | 3006-031-011 | Top Display Housing Assy | 1 |
| W | 0038-482-000 | Extension Spring | 1 | BY | 3006-133-053 | Bottom Enclosure Weldment, Head End | 1 |
| Y | 0038-448-000 | Switch Handle Return Spring | 2 | CA | 3006-032-063 | Top Enclosure, Head End | 1 |
| AA | 0016-023-000 | Nylock Hex Nut | 2 | CB | 3006-231-069 | Display Bumper | 1 |
| AB | 0052-762-000 | Flange Bearing | 4 | CC | 3006-031-092 | Enclosure Cover, White, Head End | 1 |
| AC | 0055-027-000 | "U" Type Nut | 4 | CD | 3002-031-108 | Potentiometer Mount | 1 |
| AD | 0059-133-000 | Push-Mount Wire Clip | 3 | CE | 3006-032-109 | Reinforcement Bracket, Left, Head End | 1 |
| AE | 0059-191-000 | On/Off Switch | 1 | | | Reinforcement Bracket, Right, Head End | 1 |
| AF | 0059-195-000 | Circuit Breaker | 2 | CF | 3006-032-110 | Reinforcement Bracket, Right, Head End | 1 |
| AG | 0059-781-000 | 4 Position Connector | 2 | CG | 3006-031-113 | Pendant Port Cover | 1 |
| AK | 2011-001-215 | Grounding Lug Tuv | 1 | CH | 3006-032-115 | Cover Plate | 1 |
| AL | 3006-031-880 | Power Inlet Cable | 1 | CJ | 3002-031-801 | Zoom® CPU Signal Jumper | 1 |
| AM | 2040-031-051 | Potentiometer Collar Weldment | 1 | CK | 3002-031-802 | Zoom® Breaker Jumper | 1 |
| AN | 3006-031-054 | Bumper Attachment Weldment | 1 | CL | 3002-031-803 | Zoom® Cross-Over PCB Jumper | 1 |
| AP | 3006-031-062 | Label, Display | 1 | CM | 3002-007-805 | Zoom® To Bed CPU Jumper | 1 |
| AR | 2040-031-068 | Momentary Contact Switch Handle | 2 | CN | 3002-031-805 | Bed AC Power Jumper | 1 |
| AS | 2040-031-073 | Stop Pin | 2 | CP | 0004-325-000 | Socket Bottom Head Cap Screw | 1 |
| AT | 2040-031-074 | Control Bar Return Spring | 2 | CR | 0007-063-000 | Truss Head Screw | 9 |
| AU | 2040-031-082 | Potentiometer Collar | 1 | CS | 0037-240-000 | Hole Plug | 1 |
| AV | 3006-031-101 | Label, Drive Instructions | 1 | CT | 3001-300-007 | M/F Screw | 2 |
| AW | 3006-031-102 | Label, Warning | 1 | CU | 3002-031-114 | Headboard Extender | 2 |
| AY | 3006-031-103 | Label, Power | 1 | CV | 0059-738-000 | Heyco Hole Plug | 3 |
| BA | 3006-031-105 | Label, Logo | 1 | CW | 0007-065-000 | Truss Head Screw | 1 |
| BB | 2040-031-106 | Potentiometer Gear | 1 | CY | 0044-032-000 | Pressure Sensitive Tape (1.5") | 4 |
| BC | 2040-031-803 | Momentary Contact Switch Cable | 2 | DA | 3006-031-040 | Power Inlet Shield | 1 |
| | | | | DE | 5212-100-807 | Label, Caution | 1 |

Optional Battery Backup/Zoom® Assembly, iBed® Wireless Option

For Reference Only: 5212-999-005

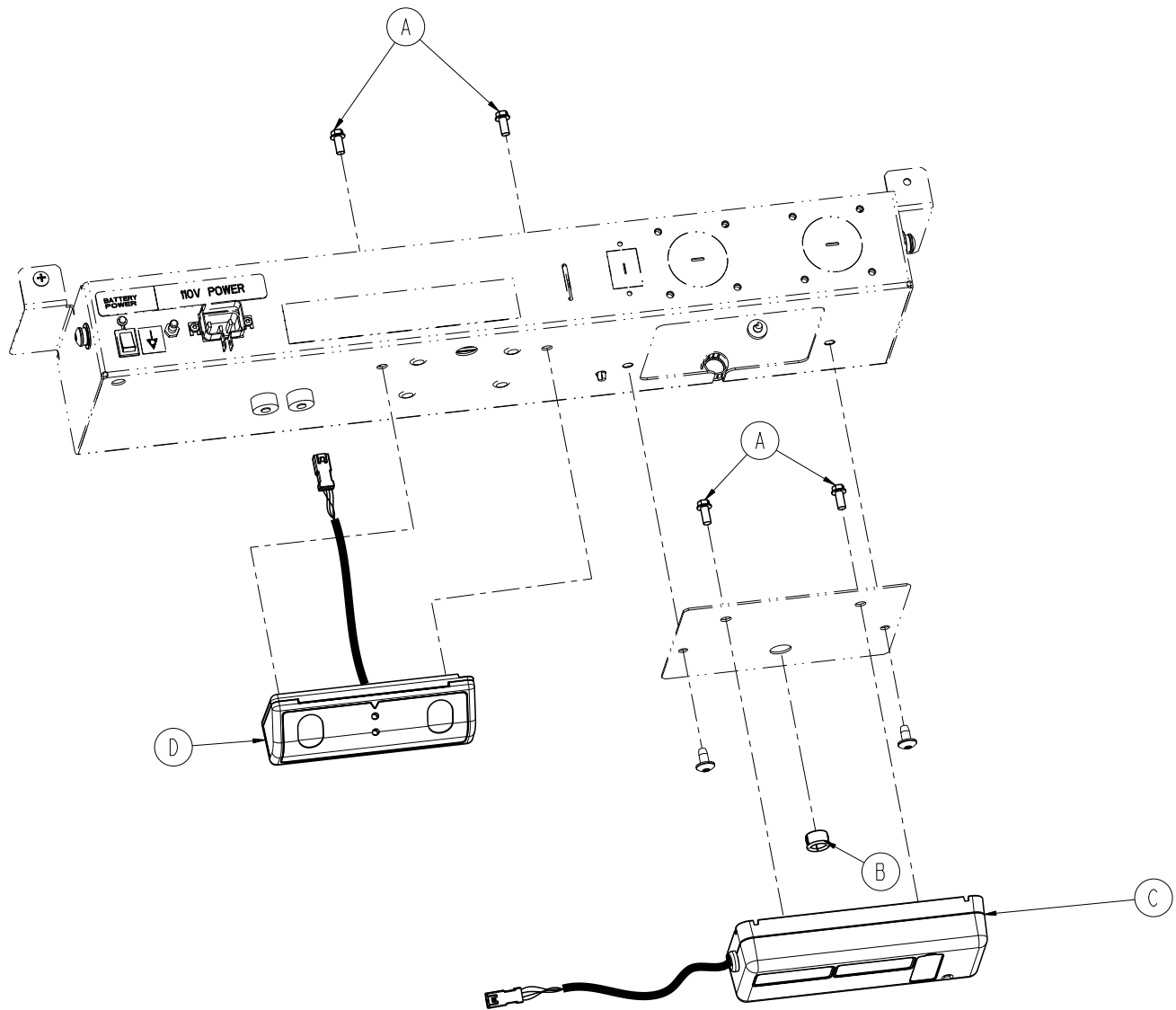

Optional Battery Backup/Zoom® Assembly, iBed® Wireless Option - 5212-999-005 (Reference Only)

| Item | Part No. | Part Name | Qty. |
|------|--------------|--------------------------------|------|
| A | 0023-126-000 | Hex Washer Head Hi-Lo Fastener | 4 |
| B | 0030-070-000 | Cable Management Bushing | 1 |
| C | 5212-300-012 | Wireless Module Assembly | 1 |
| D | 5212-300-053 | I.R. Module Assembly | 1 |

Head End Siderail Assembly

For Reference Only:
3006-400-105 (LH)
3006-400-205 (RH)

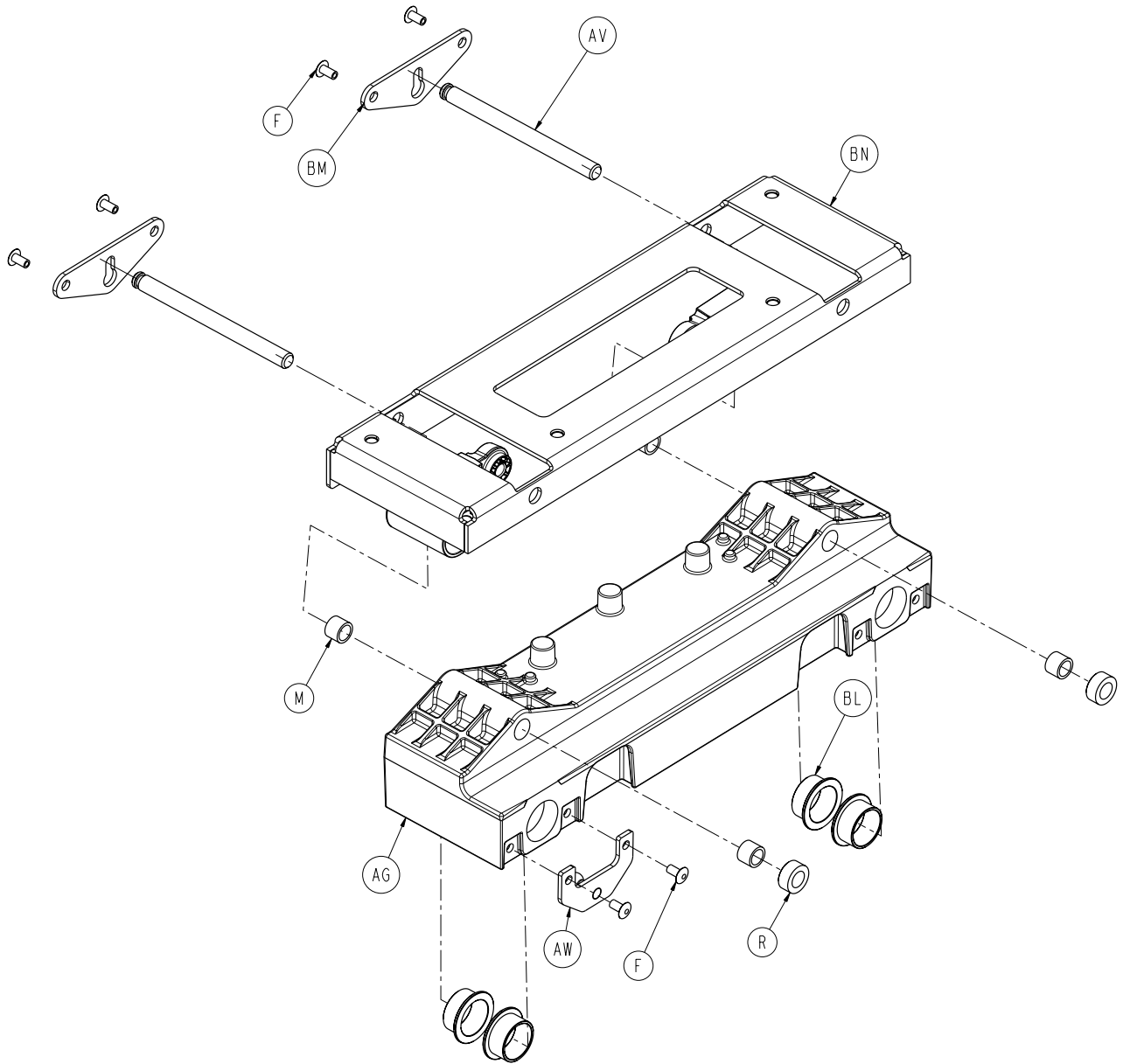

(LEFT SIDERAIL SHOWN)

Head End Siderail Assembly

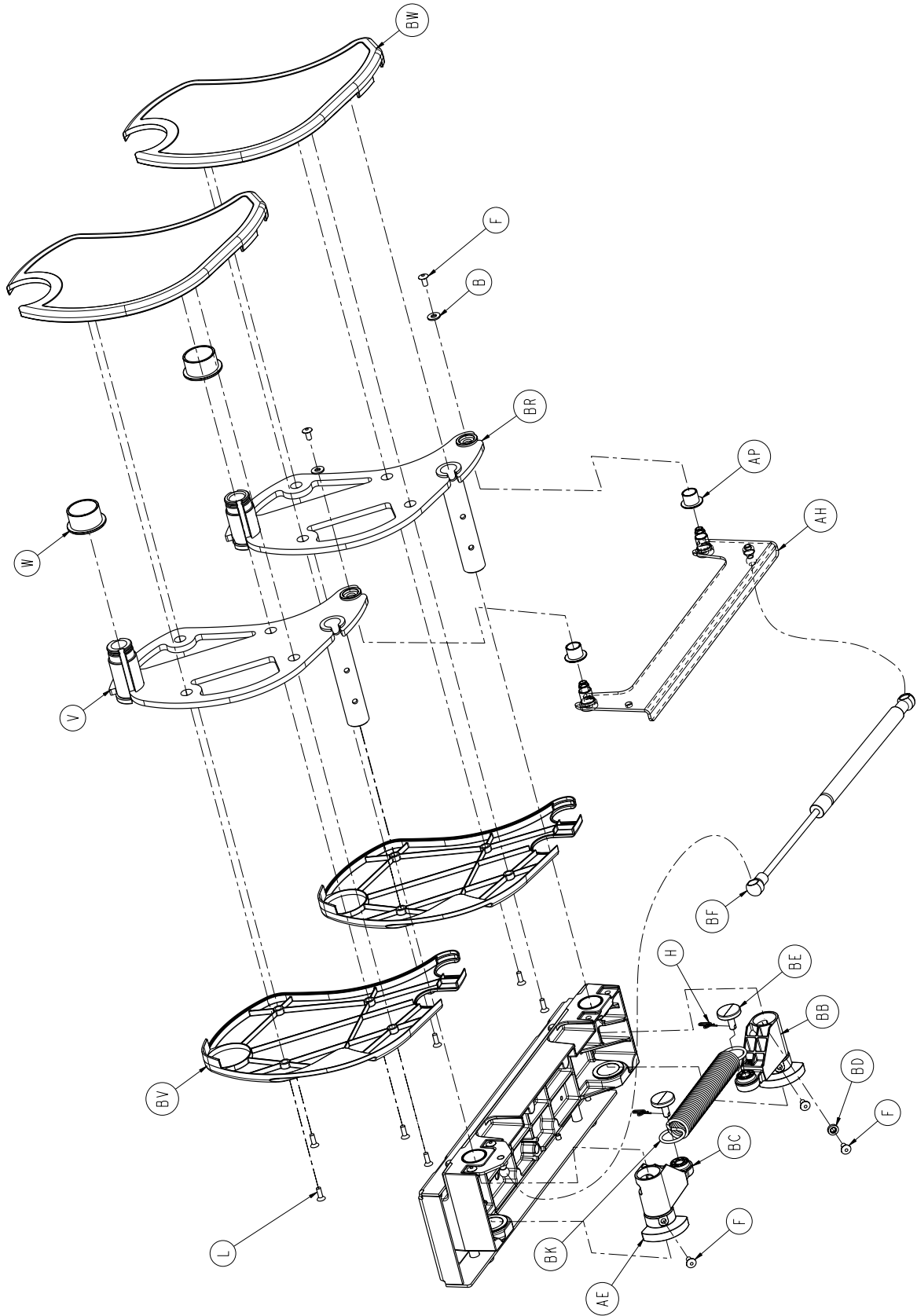

Head End Siderail Assembly

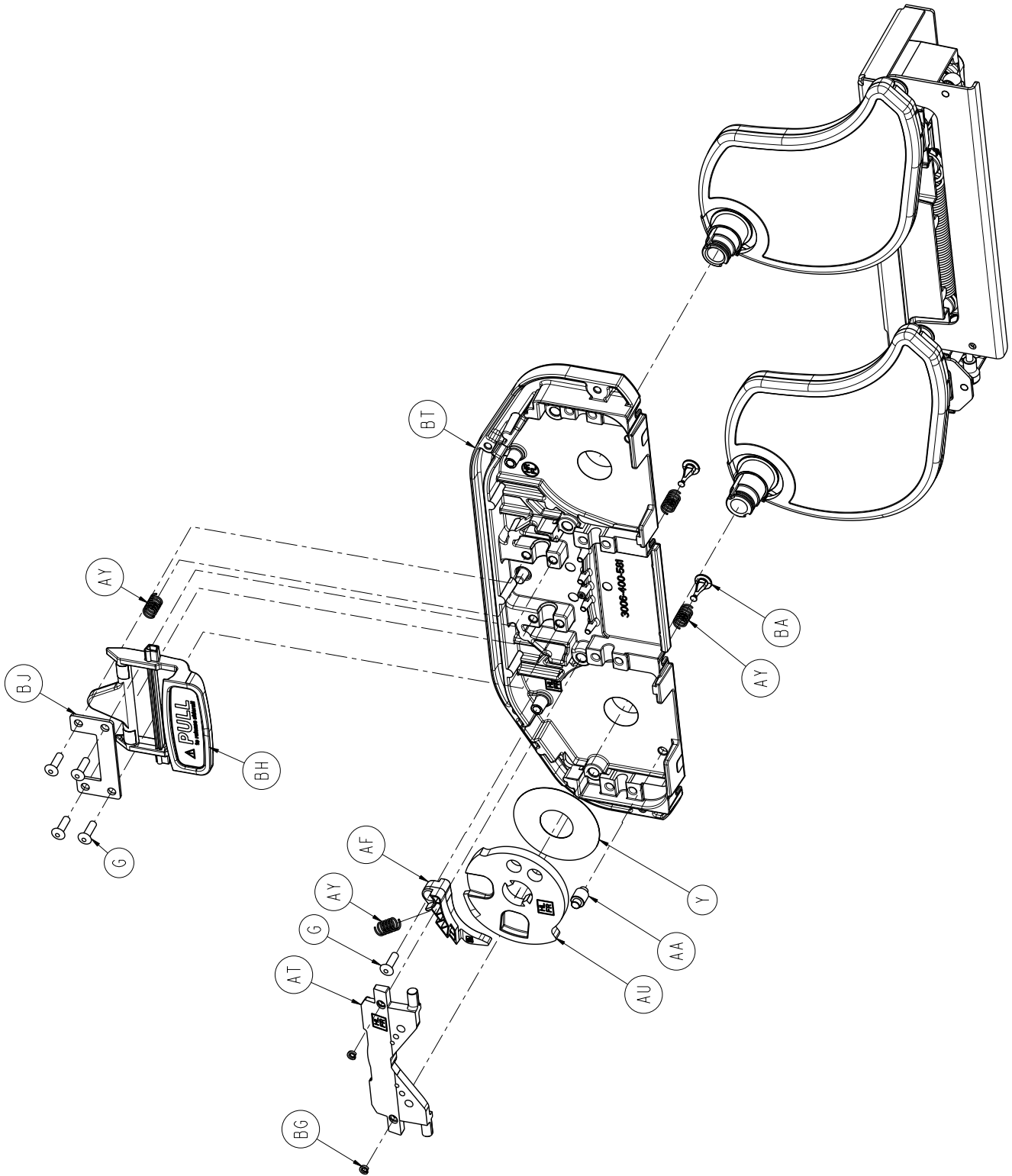

Head End Siderail Assembly

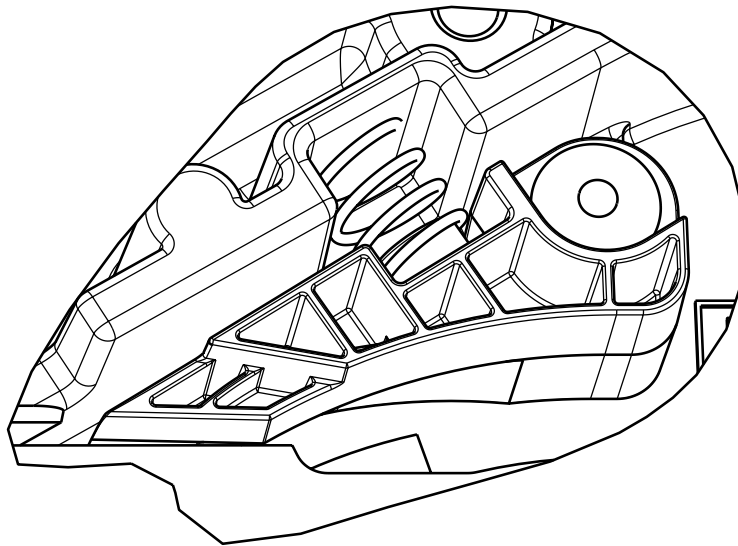
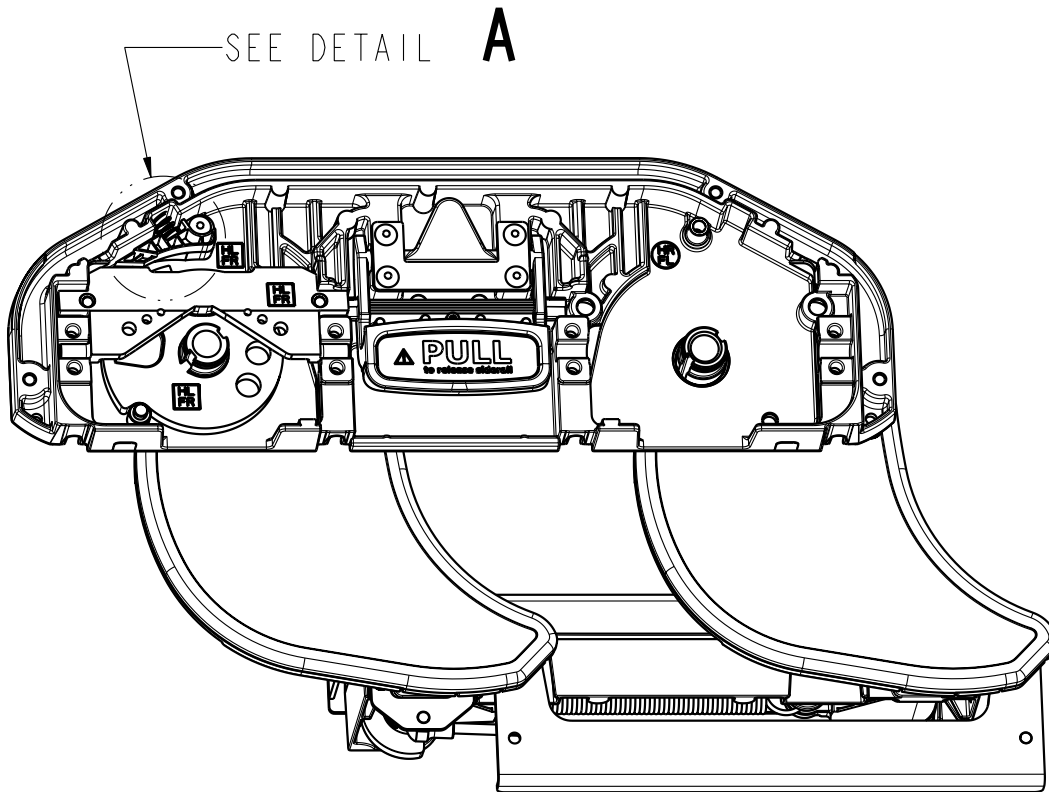

DETAIL **A**

Head End Siderail Assembly

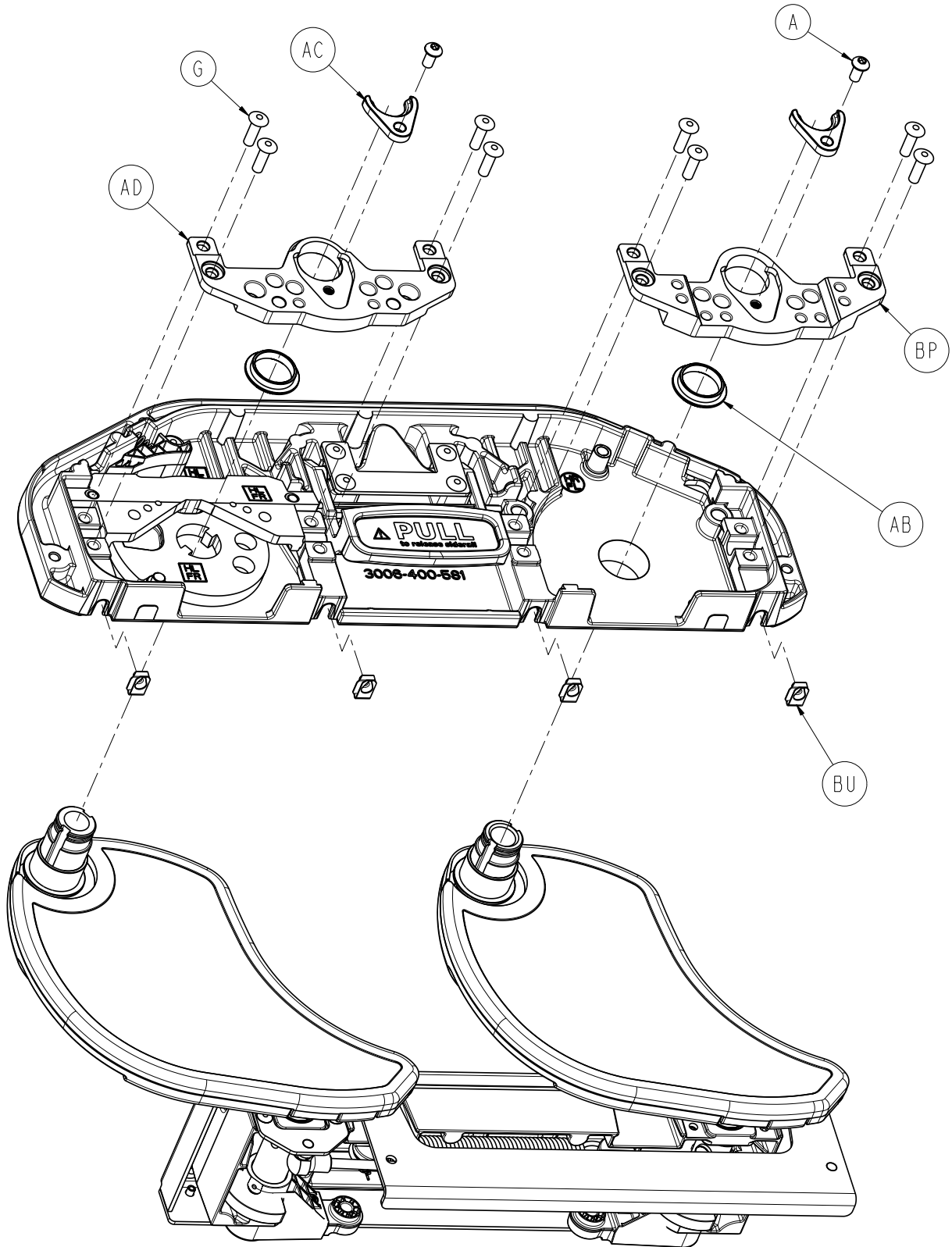

Head End Siderail Assembly

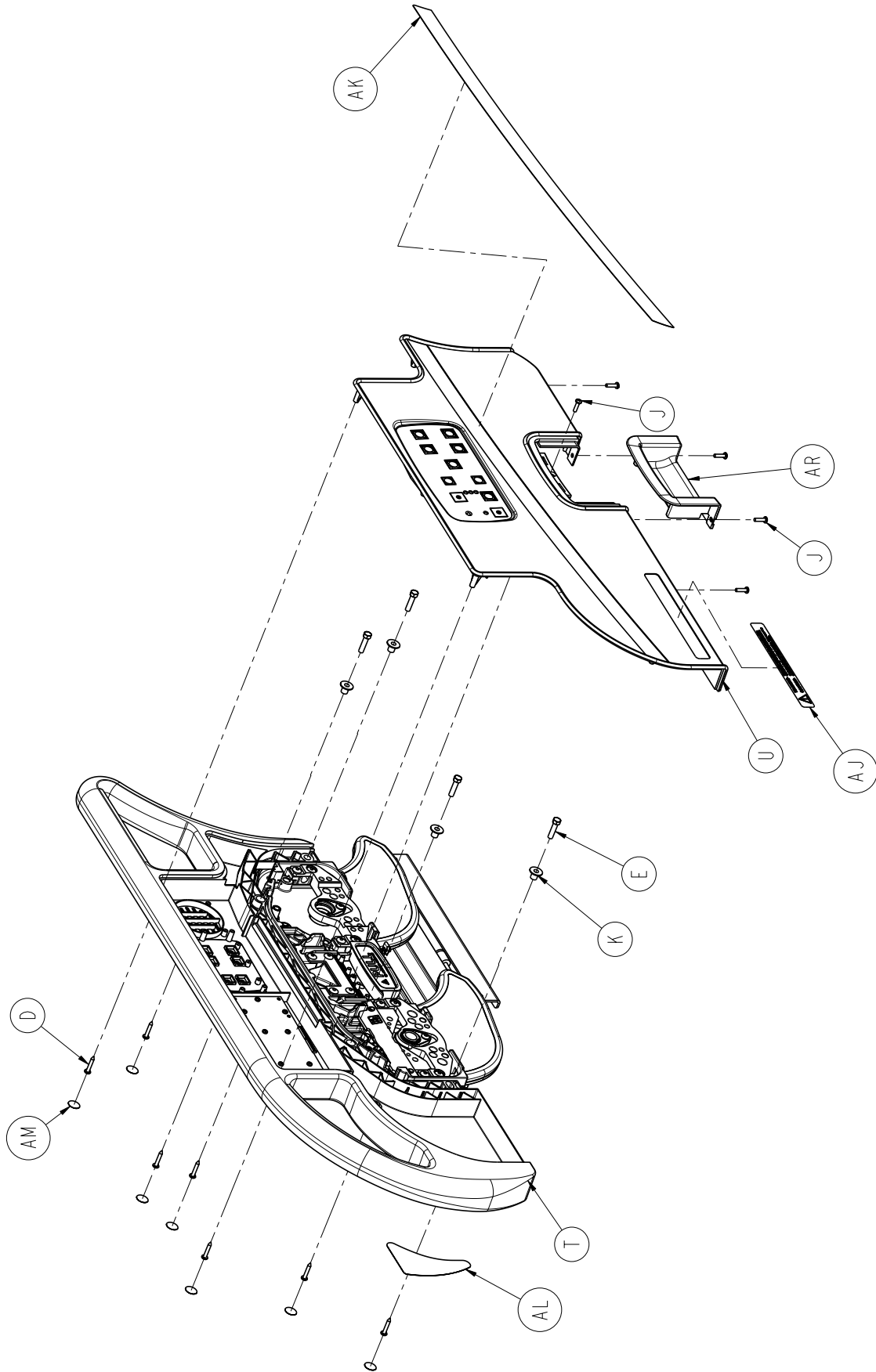

Head End Siderail Assembly

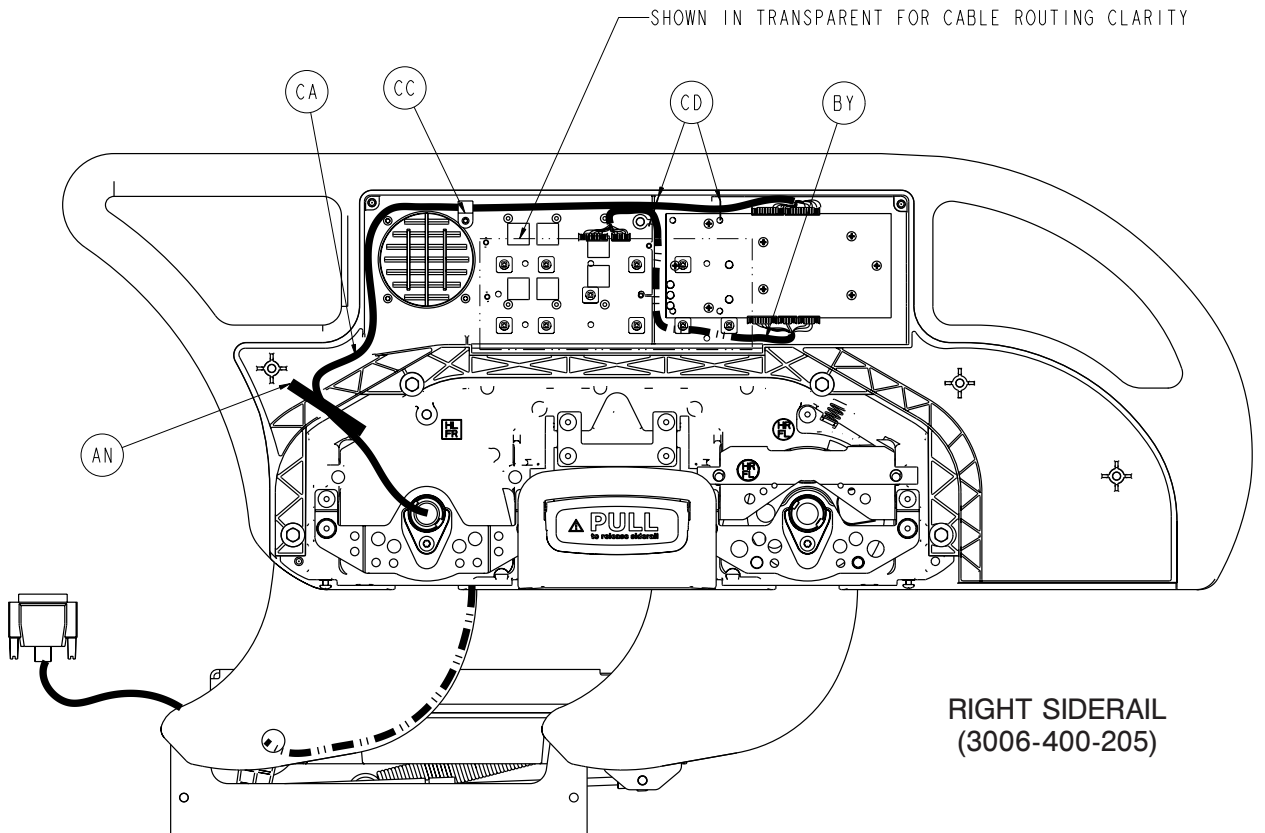
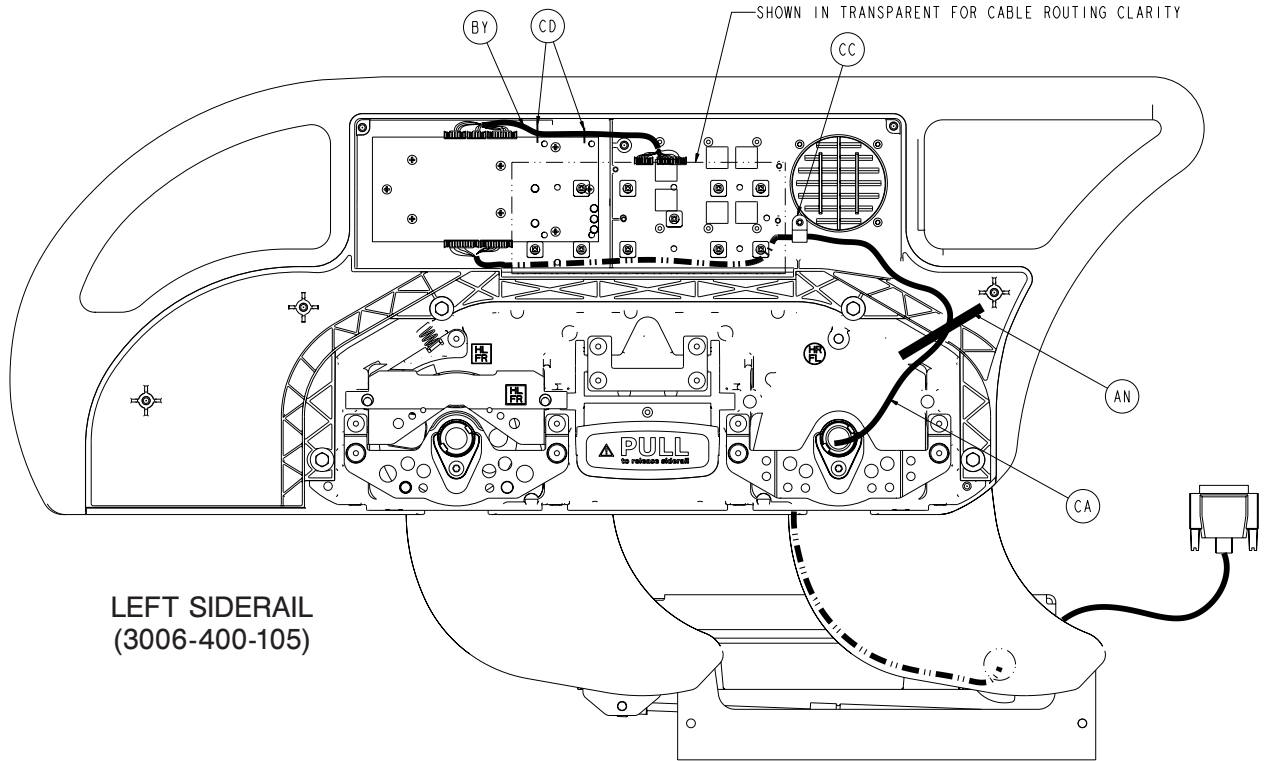

Head End Siderail Assembly

Head End Siderail Assembly - (Reference Only)

Left Common Components - 3006-400-105

| Item | Part No. | Part Name | Qty. | Item | Part No. | Part Name | Qty. |
|------|--------------|---|------|------|--------------|---------------------------------------|------|
| A | 0004-589-000 | Button Head Cap Screw | 2 | BJ | 3006-400-566 | Handle Retainer Plate | 1 |
| B | 0011-302-000 | Washer | 2 | BK | 3006-400-567 | Extension Spring | 1 |
| D | 0023-076-000 | High/Low Tapping Screw | 7 | BL | 3006-400-568 | Bearing | 4 |
| E | 0003-392-000 | Hex Head Machine Screw | 4 | BM | 3006-400-569 | Glide Rod Restraint | 2 |
| F | 0025-079-000 | Dome Head Rivet | 11 | BN | 3006-400-498 | Mounting Bracket | 1 |
| G | 0025-147-000 | Pop Rivet | 13 | BP | 3009-400-573 | Short Latch/Shaft Retainer | 1 |
| H | 0027-020-000 | Rue Ring Cotter | 2 | BR | 3006-400-576 | Short Arm Weldment | 1 |
| J | 0050-005-000 | Pan Head Machine Screw | 5 | BT | 3006-400-581 | Machined Support Plate | 2 |
| K | 3006-400-574 | Siderail Spacer | 4 | BU | 3006-400-584 | Speed Nut | 4 |
| L | 0001-072-000 | Flathead Machine Screw | 8 | BV | 3006-400-618 | Inner-A Arm Cover | 2 |
| M | 3000-400-557 | Sleeve Bearing | 4 | BW | 3006-400-619 | Outer-A Arm Cover | 3 |
| R | 3006-400-495 | Siderail Spacer | 2 | BY | 3006-400-804 | Main to Outside Siderail Cable, LH | 1 |
| T | 3006-400-130 | Inner Panel Siderail Ass'y, Head End, Left | 1 | CA | 3006-400-862 | Siderail Cable | 1 |
| U | 3006-400-125 | Outer Panel Siderail Ass'y, Head End, Left | 1 | CC | 3000-300-478 | CPR Conduit Clamp | 1 |
| V | 3006-400-515 | Arm Weldment | 1 | CD | 3000-300-114 | 4" Cable Tie | 5 |
| W | 3006-400-513 | Bearing | 2 | | | | |
| Y | 3006-400-541 | Pivot Washer | 1 | | | | |
| AA | 3006-400-516 | Hard Stop Pin | 1 | | | | |
| AB | 3006-400-517 | Bearing | 2 | | | | |
| AC | 3006-400-518 | Pivot Retainer Clip | 2 | | | | |
| AD | 3006-400-523 | Latch/Shaft Retainer | 1 | | | | |
| AE | 3006-400-524 | Pivot Retainer Sleeve | 2 | | | | |
| AF | 3006-400-505 | Bypass Arm | 1 | | | | |
| AG | 3006-400-528 | Siderail Carrier, Machined | 1 | | | | |
| AH | 3006-400-535 | Timing Link Weldment | 1 | | | | |
| AJ | 3006-400-656 | Warning Label | 1 | | | | |
| AK | 3006-400-106 | Siderail Head End Label, Left | 1 | | | | |
| AL | 3006-400-107 | Siderail Head End & Foot End Blank Label, Left | 1 | | | | |
| AM | 3006-400-522 | Siderail Fastener Cover Label | 7 | | | | |
| AN | 3006-400-208 | Cable Restraint Label | 1 | | | | |
| AP | 3006-400-532 | Igus Bearing | 2 | | | | |
| AR | 3006-400-533 | Accent Panel, Release Handle | 1 | | | | |
| AT | 3006-400-534 | Latch Plate | 1 | | | | |
| AU | 3006-400-537 | Latch Disk | 1 | | | | |
| AV | 3006-400-544 | Glide Rod | 2 | | | | |
| AW | 3006-400-540 | Gas Spring Mounting Bracket | 1 | | | | |
| AY | 3006-400-549 | Latch Return Spring | 4 | | | | |
| BA | 3006-400-551 | Spring Plunger | 2 | | | | |
| BB | 3006-400-552 | Spring Arm, A | 1 | | | | |
| BC | 3006-400-553 | Spring Arm, B | 1 | | | | |
| BD | 3006-400-554 | Spring Arm Stop | 1 | | | | |
| BE | 3006-400-557 | Spring Arm Cap | 2 | | | | |
| BF | 3006-400-560 | Gas Spring | 1 | | | | |
| BG | 3006-400-561 | Spring Plunger Clip | 2 | | | | |
| BH | 3006-400-570 | Release Handle Assembly | 1 | | | | |

Head End Siderail Assembly

Head End Siderail Assembly - (Reference Only)

Right Common Components - 3006-400-205

| Item | Part No. | Part Name | Qty. | Item | Part No. | Part Name | Qty. |
|------|--------------|--|------|------|--------------|------------------------------------|------|
| A | 0004-589-000 | Button Head Cap Screw | 2 | BH | 3006-400-570 | Release Handle Assembly | 1 |
| B | 0011-302-000 | Washer | 2 | BJ | 3006-400-566 | Handle Retainer Plate | 1 |
| D | 0023-076-000 | Pan Head Tapping Screw | 7 | BK | 3006-400-567 | Extension Spring | 1 |
| E | 0003-392-000 | Hex Head Machine Screw | 4 | BL | 3006-400-568 | Bearing | 4 |
| F | 0025-079-000 | Dome Head Rivet | 11 | BM | 3006-400-569 | Glide Rod Restraint | 2 |
| G | 0025-147-000 | Pop Rivet | 13 | BN | 3006-400-498 | Mounting Bracket | 1 |
| H | 0027-020-000 | Rue Ring Cotter | 2 | BP | 3006-400-573 | Short Latch/Shaft Retainer | 1 |
| J | 0050-005-000 | Pan Head Machine Screw | 5 | BR | 3006-400-575 | Arm Weldment | 1 |
| K | 3006-400-574 | Siderail Spacer | 4 | BT | 3006-400-581 | Machined Support Plate | 1 |
| L | 0001-072-000 | Flathead Machine Screw | 8 | BU | 3006-400-584 | Speed Nut | 4 |
| M | 3000-400-557 | Sleeve Bearing | 4 | BV | 3006-400-628 | Inner Arm Cover | 2 |
| R | 3006-400-495 | Siderail Spacer | 2 | BW | 3006-400-629 | Outer Arm Cover | 2 |
| T | 3006-400-230 | Inner Panel, Head End Siderail Assembly, Right | 1 | BY | 3006-400-803 | Main-to-Outside Siderail Cable, RH | 1 |
| U | 3006-400-225 | Outer Panel, Head End Siderail Assembly, Right | 1 | CA | 3006-400-862 | Siderail Cable | 1 |
| V | 3006-400-510 | Arm Weldment | 1 | CC | 3000-300-478 | CPR Conduit Clamp | 1 |
| W | 3006-400-513 | Bearing | 2 | CD | 3000-300-114 | 4" Cable Tie | 5 |
| Y | 3006-400-514 | Pivot Washer | 1 | | | | |
| AA | 3006-400-516 | Hard Stop Pin | 1 | | | | |
| AB | 3006-400-517 | Bearing | 2 | | | | |
| AC | 3006-400-518 | Pivot Retainer Clip | 2 | | | | |
| AD | 3006-400-523 | Latch/Shaft Retainer | 1 | | | | |
| AE | 3006-400-524 | Pivot Retainer Sleeve | 2 | | | | |
| AF | 3006-400-525 | Bypass Arm | 1 | | | | |
| AG | 3006-400-528 | Machined Siderail Carrier | 1 | | | | |
| AH | 3006-400-530 | Timing Link Weldment | 1 | | | | |
| AJ | 3006-400-656 | Warning Label | 1 | | | | |
| AK | 3006-400-206 | Head End Right Siderail Label | 1 | | | | |
| AL | 3006-400-207 | Head End and Foot End Right Blank Label | 1 | | | | |
| AM | 3006-400-522 | Siderail Fastener Cover Label | 7 | | | | |
| AN | 3006-700-208 | Cable Restraint Label | 1 | | | | |
| AP | 3006-400-532 | Bearing | 2 | | | | |
| AR | 3006-400-533 | Release Handle Accent Panel | 1 | | | | |
| AT | 3006-400-536 | Latch Plate | 1 | | | | |
| AU | 3006-400-541 | Latch Disk | 1 | | | | |
| AV | 3006-400-544 | Glide Rod | 2 | | | | |
| AW | 3006-400-540 | Gas Spring Mounting Bracket | 1 | | | | |
| AY | 3006-400-549 | Latch Return Spring | 4 | | | | |
| BA | 3006-400-551 | Spring Plunger | 2 | | | | |
| BB | 3006-400-552 | Spring Arm, A | 1 | | | | |
| BC | 3006-400-553 | Spring Arm, B | 1 | | | | |
| BD | 3006-400-554 | Spring Arm Stop | 1 | | | | |
| BE | 3006-400-557 | Spring Arm Cap | 2 | | | | |
| BF | 3006-400-560 | Gas Spring | 1 | | | | |
| BG | 3006-400-561 | Spring Plunger Clip | 2 | | | | |

Head End Siderail Assembly with Optional Cardiac Chair

For Reference Only: 3006-999-030

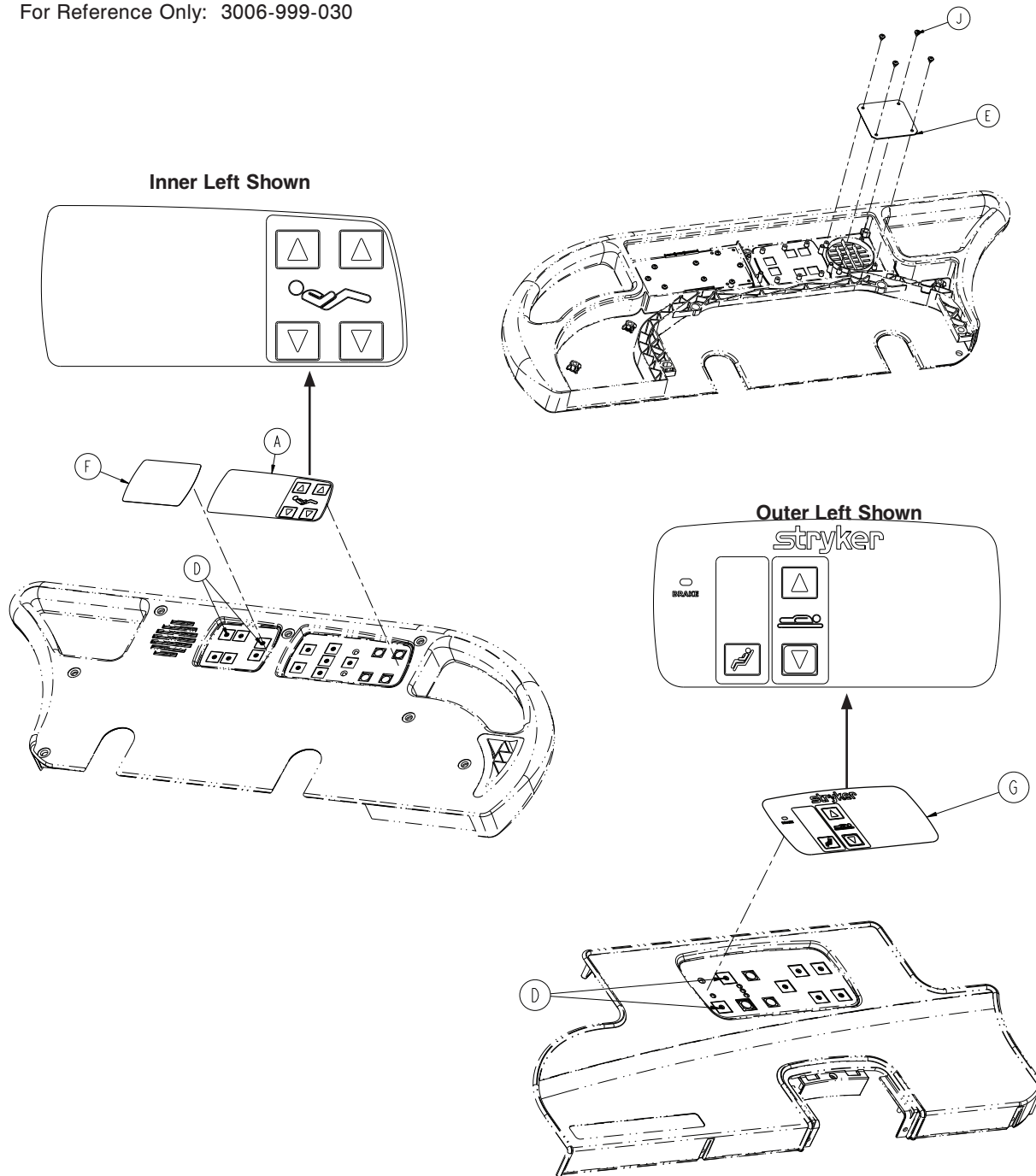

| Item | Part No. | Part Name | Qty. |
|------|--------------|------------------------------------|------|
| A | 3006-400-620 | Label Inner, Left | 1 |
| B | 3006-400-610 | Label Inner, Right, CC (not shown) | 1 |
| D | 3001-400-522 | Filler Cap | 30 |
| E | 3001-400-517 | Speaker Seal | 2 |
| F | 3006-430-133 | Label, Smart TV Blank | 2 |
| G | 3006-400-637 | Label Outer, Left, CC | 1 |
| H | 3006-400-647 | Label Outer, Right, CC (not shown) | 1 |
| J | 0023-112-000 | Pan Head Tapping Screw | 8 |

Head End Siderail Assembly with Optional Gatch/Fowler and Cardiac Chair

For Reference Only: 3006-999-031

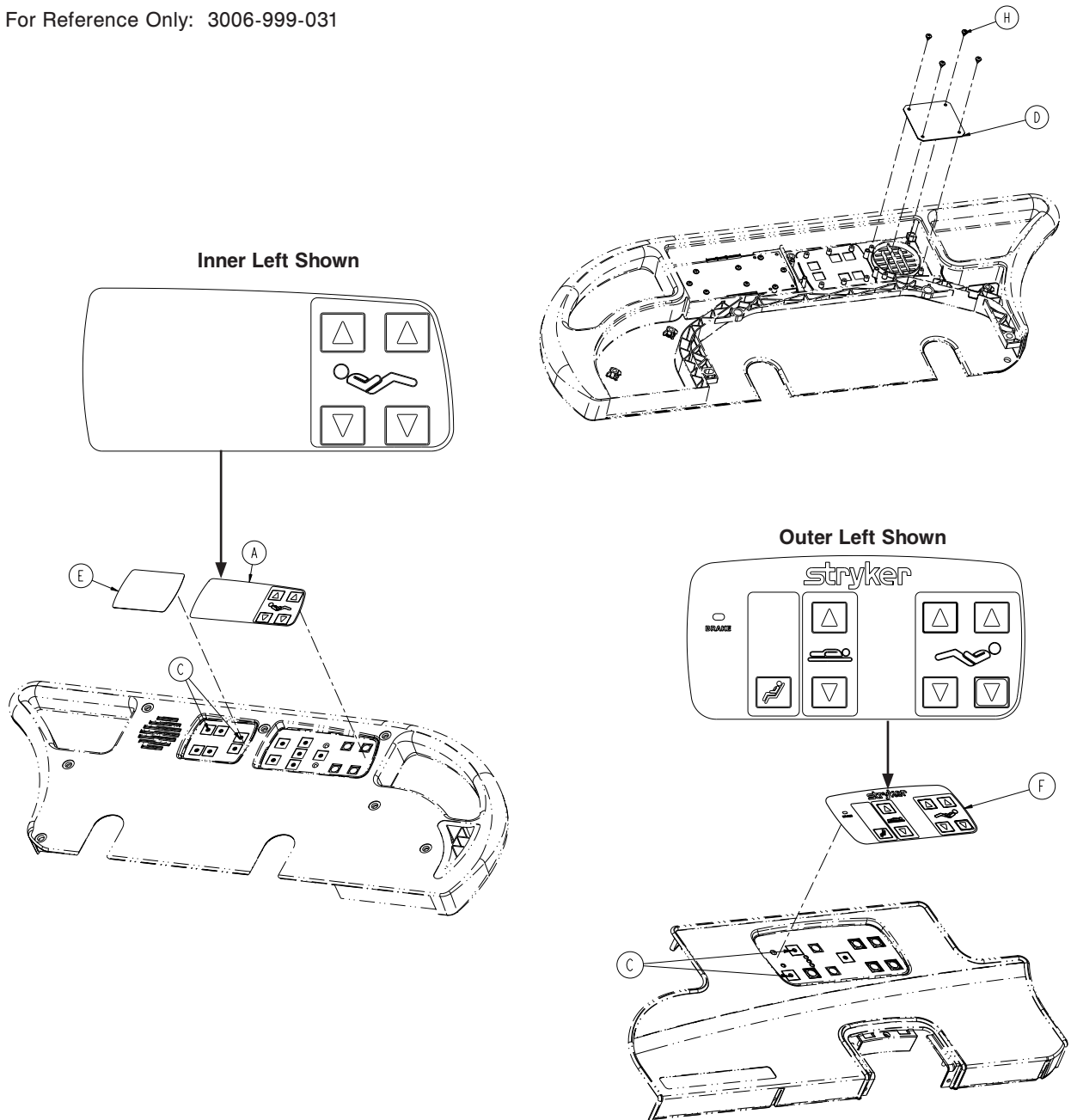

| Item | Part No. | Part Name | Qty. |
|------|--------------|--|------|
| A | 3006-400-620 | Label Inner, Left, Standard | 1 |
| B | 3006-400-610 | Label Inner, Right, Standard (not shown) | 1 |
| D | 3001-400-522 | Filler Cap | 26 |
| E | 3001-400-517 | Speaker Seal | 2 |
| F | 3006-430-133 | Label, Smart TV Blank | 2 |
| G | 3006-400-634 | Label Outer, Left, G/F, CC | 1 |
| H | 3006-400-644 | Label Outer, Right, G/F, CC (not shown) | 1 |
| J | 0023-112-000 | Pan Head Tapping Screw | 8 |

[Return To Table of Contents](#)

Head End Siderail Assembly with Optional Nurse Call, Cardiac Chair and Gatch/Fowler

For Reference Only: 3006-999-016

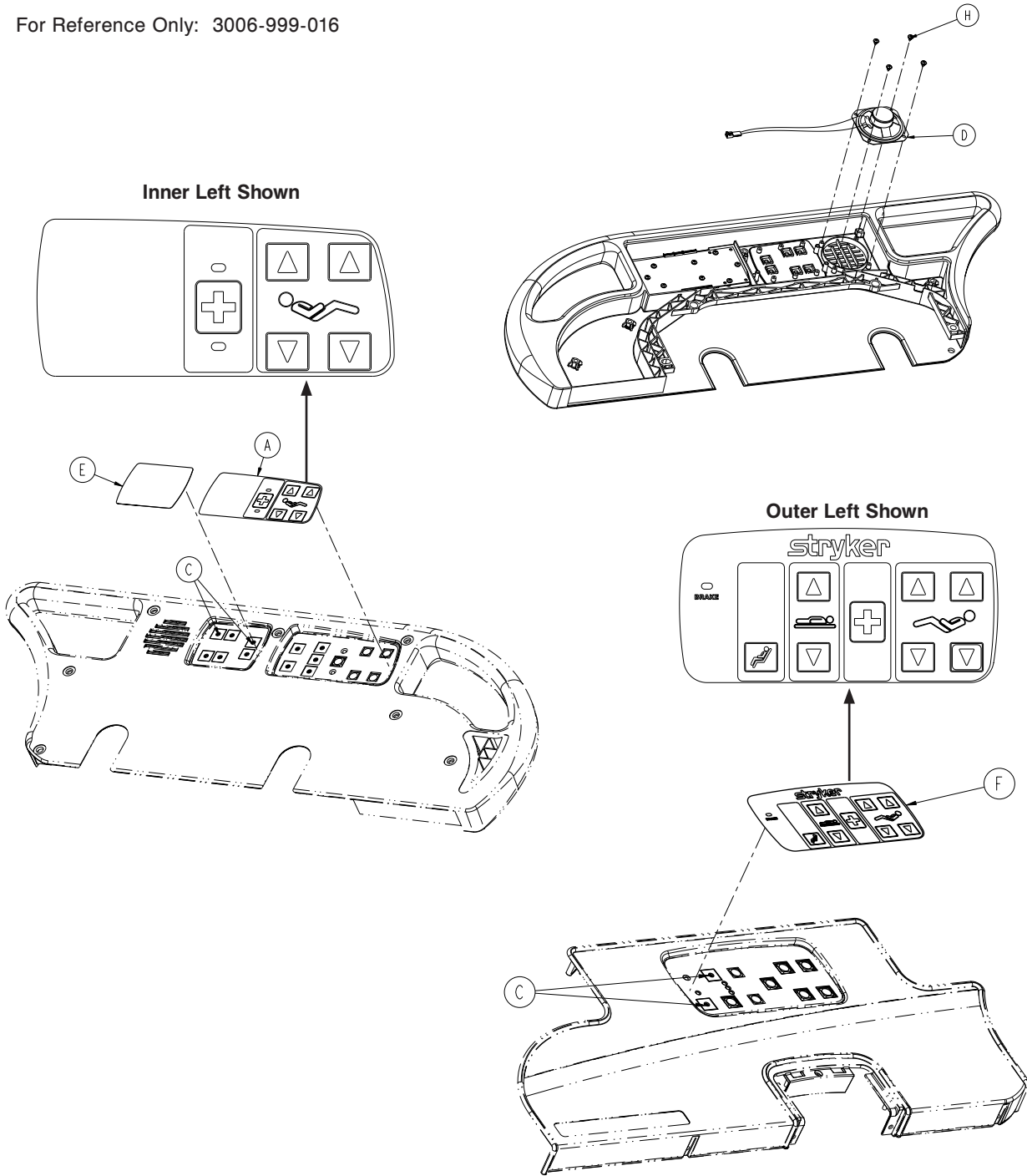

| Item | Part No. | Part Name | Qty. |
|------|--------------|--|------|
| A | 3006-400-621 | Label Inner, Left, N/C | 1 |
| B | 3006-400-611 | Label Inner, Right, N/C (not shown) | 1 |
| D | 3001-400-522 | Filler Cap | 18 |
| E | 3006-403-831 | Speaker with Cable | 2 |
| F | 3006-430-133 | Label, Smart TV Blank | 2 |
| G | 3006-400-633 | Label Outer, Left, N/C, G/F, CC | 1 |
| H | 3006-400-643 | Label Outer, Right, N/C, G/F, CC (not shown) | 1 |
| J | 0023-112-000 | Pan Head Tapping Screw | 8 |

Head End Siderail Assembly with Optional Nurse Call, Lights, Cardiac Chair and Gatch/Fowler

For Reference Only: 3006-999-013

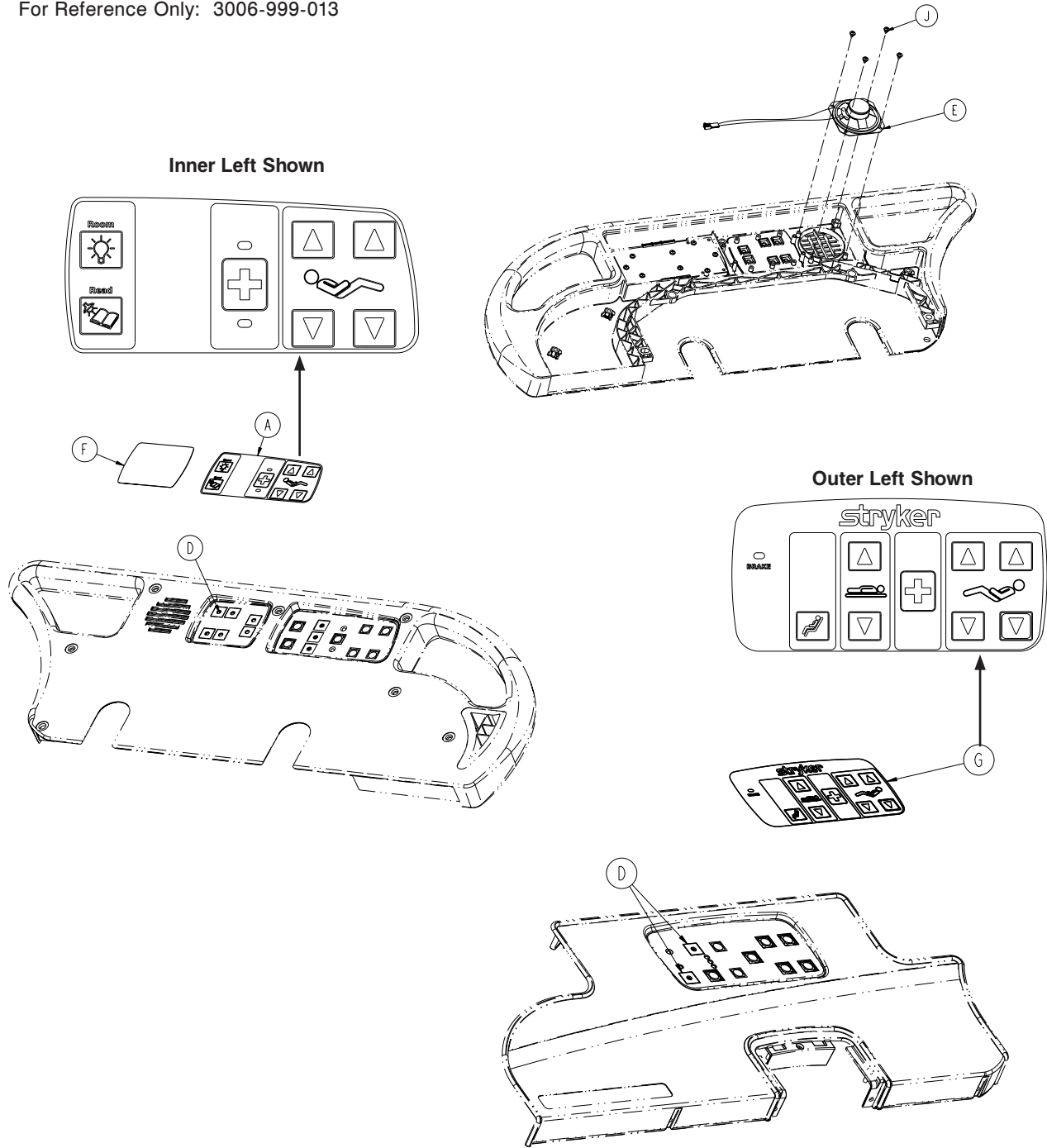

| Item | Part No. | Part Name | Qty. |
|------|--------------|--|------|
| A | 3006-400-625 | Label Inner, Left, N/C, Light, CC | 1 |
| B | 3006-400-615 | Label Inner, Right, N/C, Light, CC (not shown) | 1 |
| D | 3001-400-522 | Filler Cap | 14 |
| E | 3006-403-831 | Speaker with Cable | 2 |
| F | 3006-430-133 | Label, Smart TV Blank | 2 |
| G | 3006-400-633 | Label Outer, Left, N/C, G/F, CC | 1 |
| H | 3006-400-643 | Label Outer, Right, N/C, G/F, CC (not shown) | 1 |
| J | 0023-112-000 | Pan Head Tapping Screw | 8 |

[Return To Table of Contents](#)

Head End Siderail Assembly with Optional Nurse Call, Lights and Cardiac Chair

For Reference Only: 3006-999-005

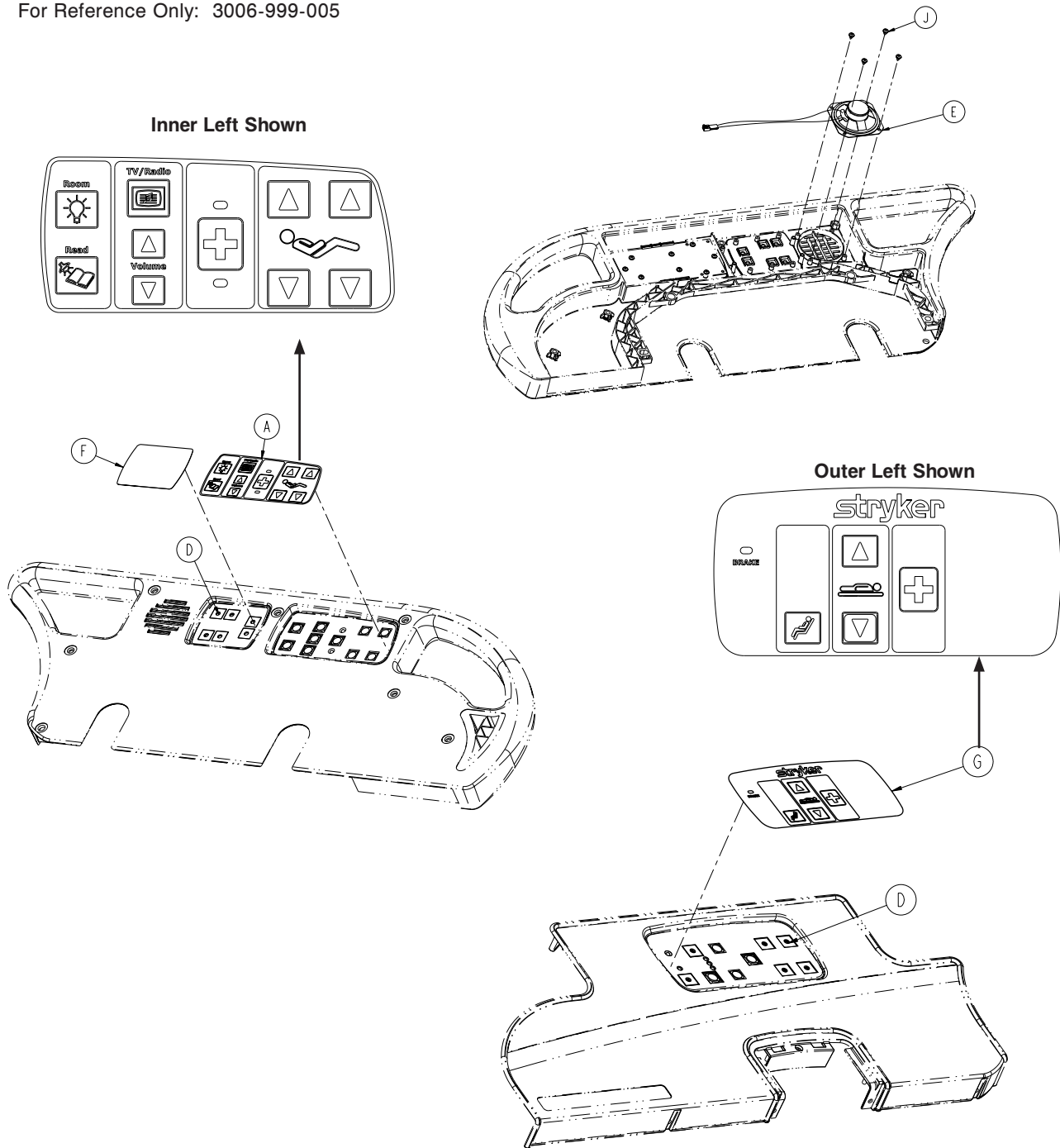

| Item | Part No. | Part Name | Qty. |
|------|--------------|--|------|
| A | 3006-400-623 | Label Inner, Left, N/C, TV, Light, CC | 1 |
| B | 3006-400-613 | Label Inner, Right, N/C, TV, Light, CC (not shown) | 1 |
| D | 3001-400-522 | Filler Cap | 16 |
| E | 3006-403-831 | Speaker with Cable | 2 |
| F | 3006-430-133 | Label, Smart TV Blank | 2 |
| G | 3006-400-635 | Label Outer, Left, N/C, CC | 1 |
| H | 3006-400-645 | Label Outer, Right, N/C, CC (not shown) | 1 |
| J | 0023-112-000 | Pan Head Tapping Screw | 8 |

Head End Siderail Assembly with Optional Nurse Call, TV/Radio, Lights and Cardiac Chair

For Reference Only: 3006-999-006

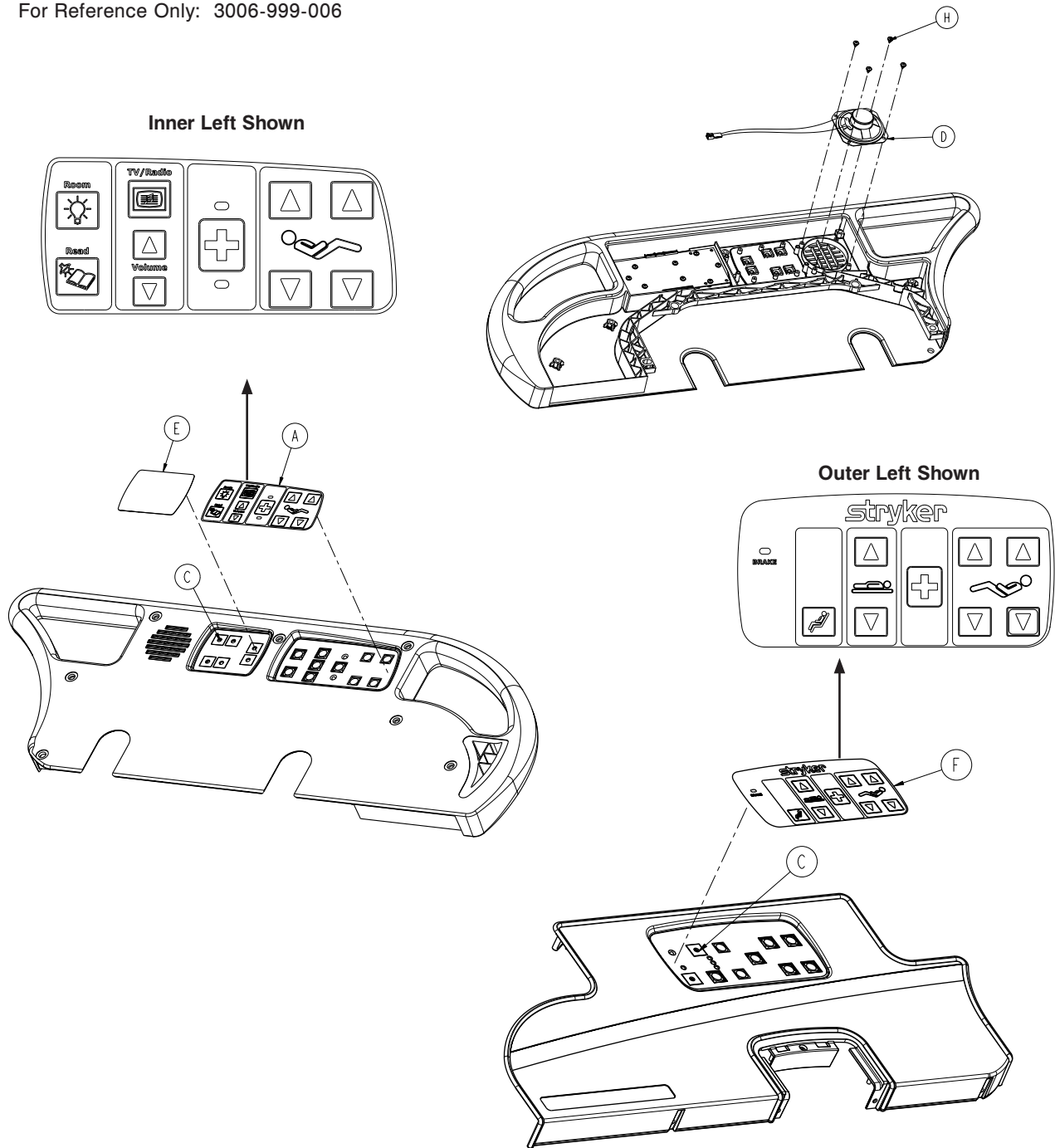

| Item | Part No. | Part Name | Qty. |
|------|--------------|--|------|
| A | 3006-400-623 | Label Inner, Left, N/C, TV, Light, CC | 1 |
| B | 3006-400-613 | Label Inner, Right, N/C, TV, Light, CC (not shown) | 1 |
| D | 3001-400-522 | Filler Cap | 8 |
| E | 3006-403-831 | Speaker with Cable | 2 |
| F | 3006-430-133 | Label, Smart TV Blank | 2 |
| G | 3006-400-633 | Label Outer, Left, N/C, G/F, CC | 1 |
| H | 3006-400-643 | Label Outer, Right, N/C, G/F, CC (not shown) | 1 |
| J | 0023-112-000 | Pan Head Tapping Screw | 8 |

[Return To Table of Contents](#)

Head End Siderail Assembly with Optional Nurse Call, Lights, Cardiac Chair and Smart TV

For Reference Only: 3006-999-403

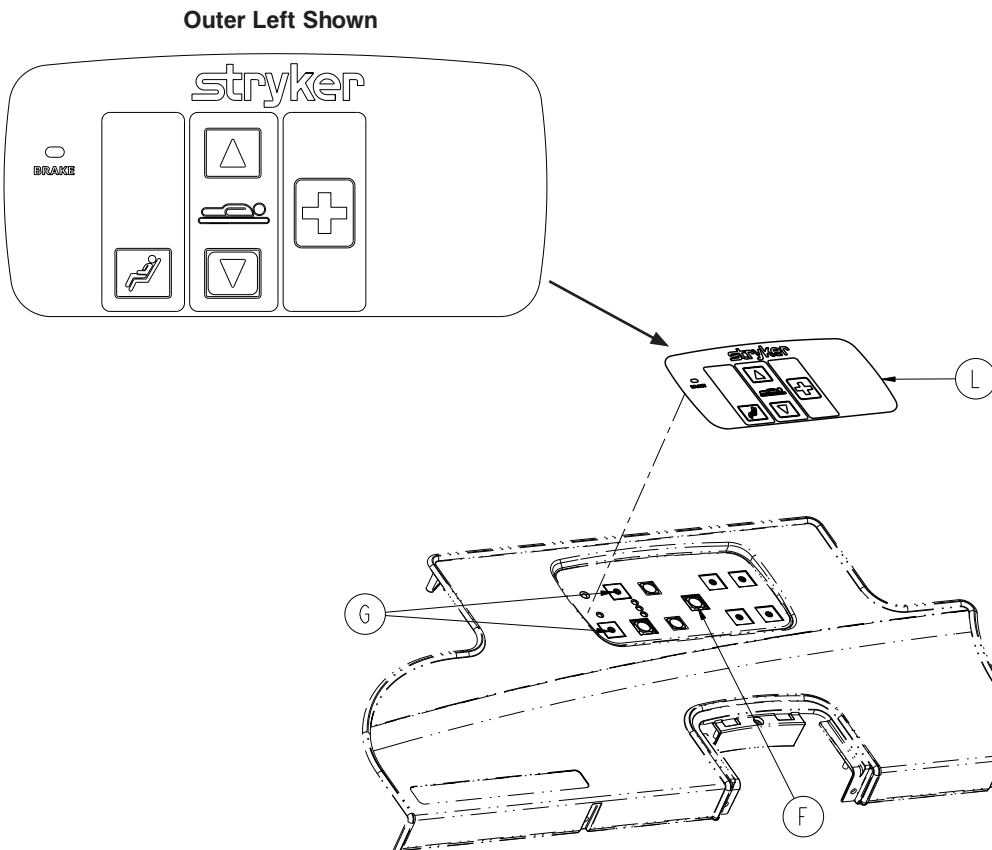
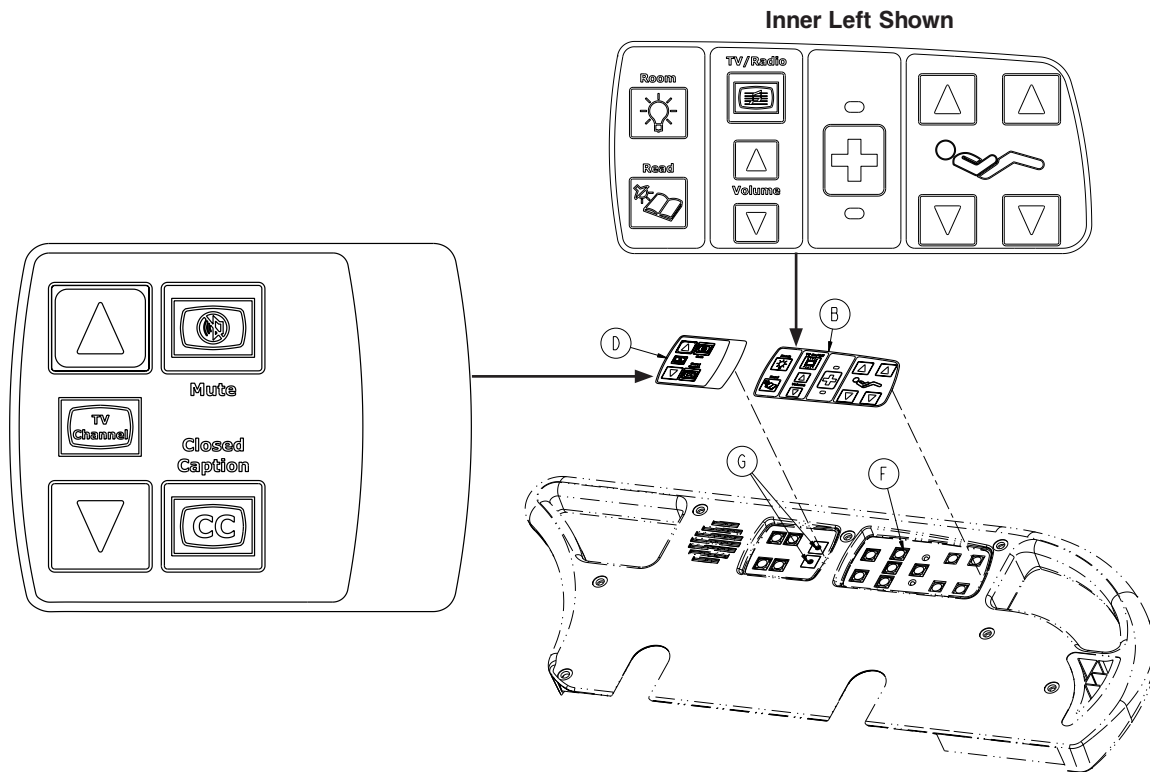

Head End Siderail Assembly with Optional Nurse Call, Lights, Cardiac Chair and Smart TV

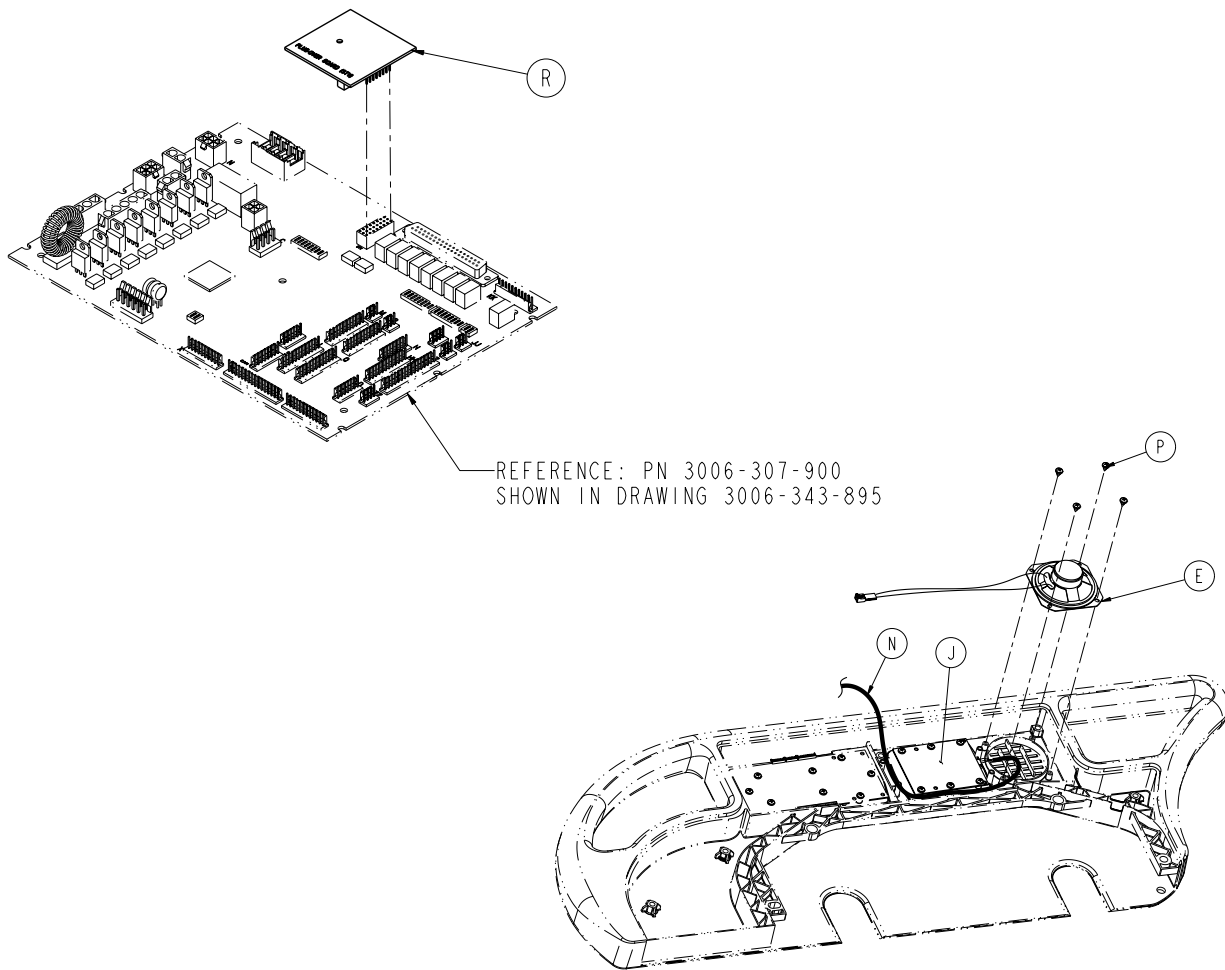

Head End Siderail Assembly with Optional NC, Lights, CC and Smart TV - 3006-999-403 (Reference Only)

| Item | Part No. | Part Name | Qty. |
|------|--------------|--|------|
| A | 3000-300-114 | 4" Cable Tie (not shown) | 6 |
| B | 3006-430-623 | Label Inner, Left, NC, Light, Smart TV | 1 |
| C | 3006-430-613 | Label Inner, Right, NC, Lights, Smart TV (not shown) | 1 |
| D | 3006-430-131 | Label, Left, CC, Smart TV | 1 |
| E | 3006-403-831 | Speaker with Cable | 2 |
| F | 3001-400-953 | Switch Cap | 8 |
| G | 3001-400-522 | Filler Cap | 8 |
| H | 3006-430-132 | Label, Right, CC, Smart TV (not shown) | 1 |
| J | 5000-400-930 | Siderail Lumbar Board, Left | 1 |
| K | 5000-400-920 | Siderail Lumbar Board, Right (not shown) | 1 |
| L | 3006-400-635 | Label Outer, Left, NC, CC | 1 |
| M | 3006-400-645 | Label Outer, Right, NC, CC (not shown) | 1 |
| N | 3006-402-803 | PCB Siderail Cable | 2 |
| P | 0023-112-000 | Pan Head Tapping Screw | 20 |
| R | 3003-039-800 | Smart TV Auto Detect PCB Assembly | 1 |

Head End Siderail Assembly with Optional NC, Lights, Gatch/Fowler, Cardiac Chair and Smart TV

For Reference Only: 3006-999-405

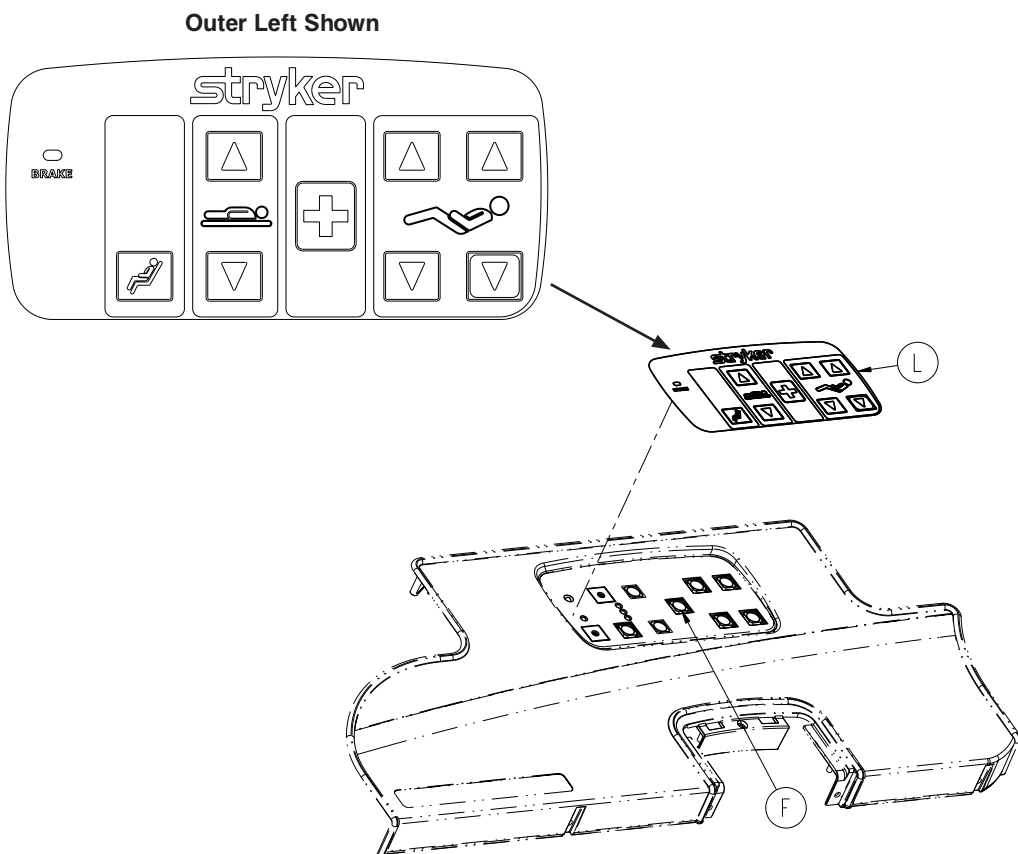
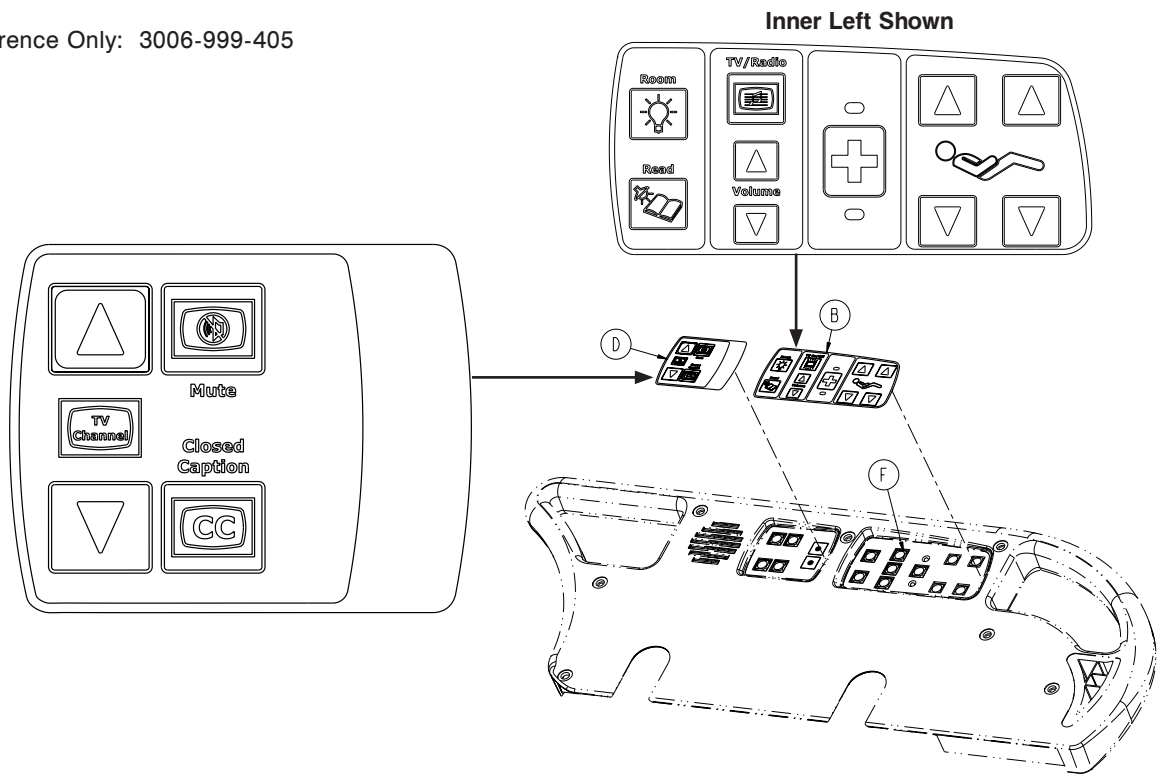

Head End Siderail Assembly with Optional NC, Lights, Gatch/Fowler, Cardiac Chair and Smart TV

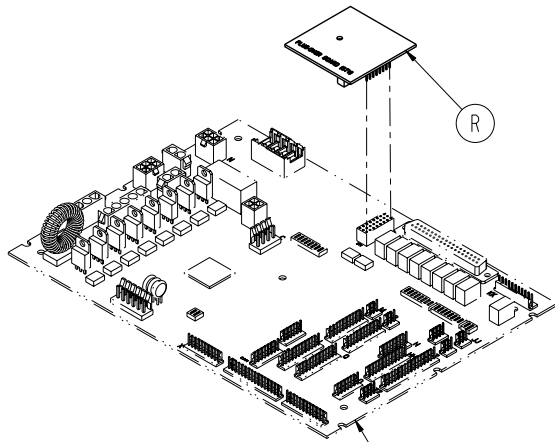

REFERENCE: PN 3006-307-900
SHOWN IN DRAWING 3006-343-895

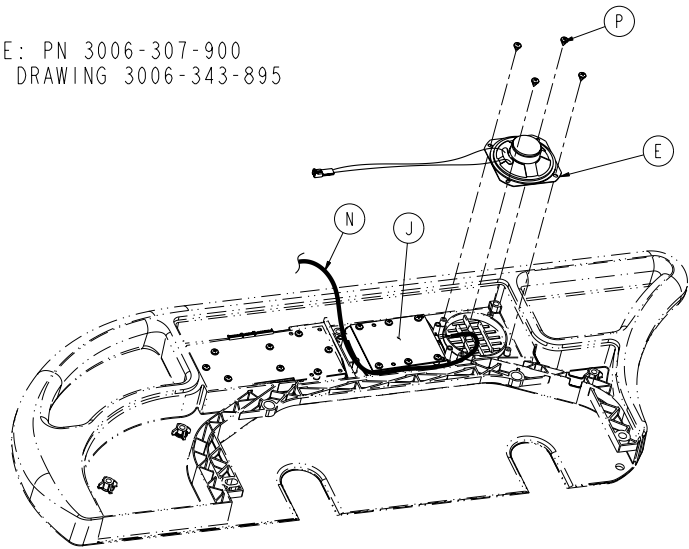

Head End Siderail Assembly with Optional NC, Lights, G/F, CC and Smart TV - 3006-999-405 (Reference Only)

| Item | Part No. | Part Name | Qty. |
|------|--------------|--|------|
| A | 3000-300-114 | 4" Cable Tie (not shown) | 6 |
| B | 3006-430-623 | Label Inner, Left, NC, Light, Smart TV | 1 |
| C | 3006-430-613 | Label Inner, Right, NC, Lights, Smart TV (not shown) | 1 |
| D | 3006-430-131 | Label, Left, CC, Smart TV | 1 |
| E | 3006-403-831 | Speaker with Cable | 2 |
| F | 3001-400-953 | Switch Cap | 8 |
| H | 3006-430-132 | Label, Right, CC, Smart TV (not shown) | 1 |
| J | 5000-400-930 | Siderail Lumbar Board, Left | 1 |
| K | 5000-400-920 | Siderail Lumbar Board, Right (not shown) | 1 |
| L | 3006-400-633 | Label Outer, Left, NC, G/F, DMS | 1 |
| M | 3006-400-643 | Label Outer, Right, NC, G/F, DMS (not shown) | 1 |
| N | 3006-402-803 | PCB Siderail Cable | 2 |
| P | 0023-112-000 | Pan Head Tapping Screw | 20 |
| R | 3003-039-800 | Smart TV Auto Detect PCB Assembly | 1 |

Head End Siderail Assembly, Outer Panel

For Reference Only
 3006-400-125 (LEFT)
 3006-400-225 (RIGHT)

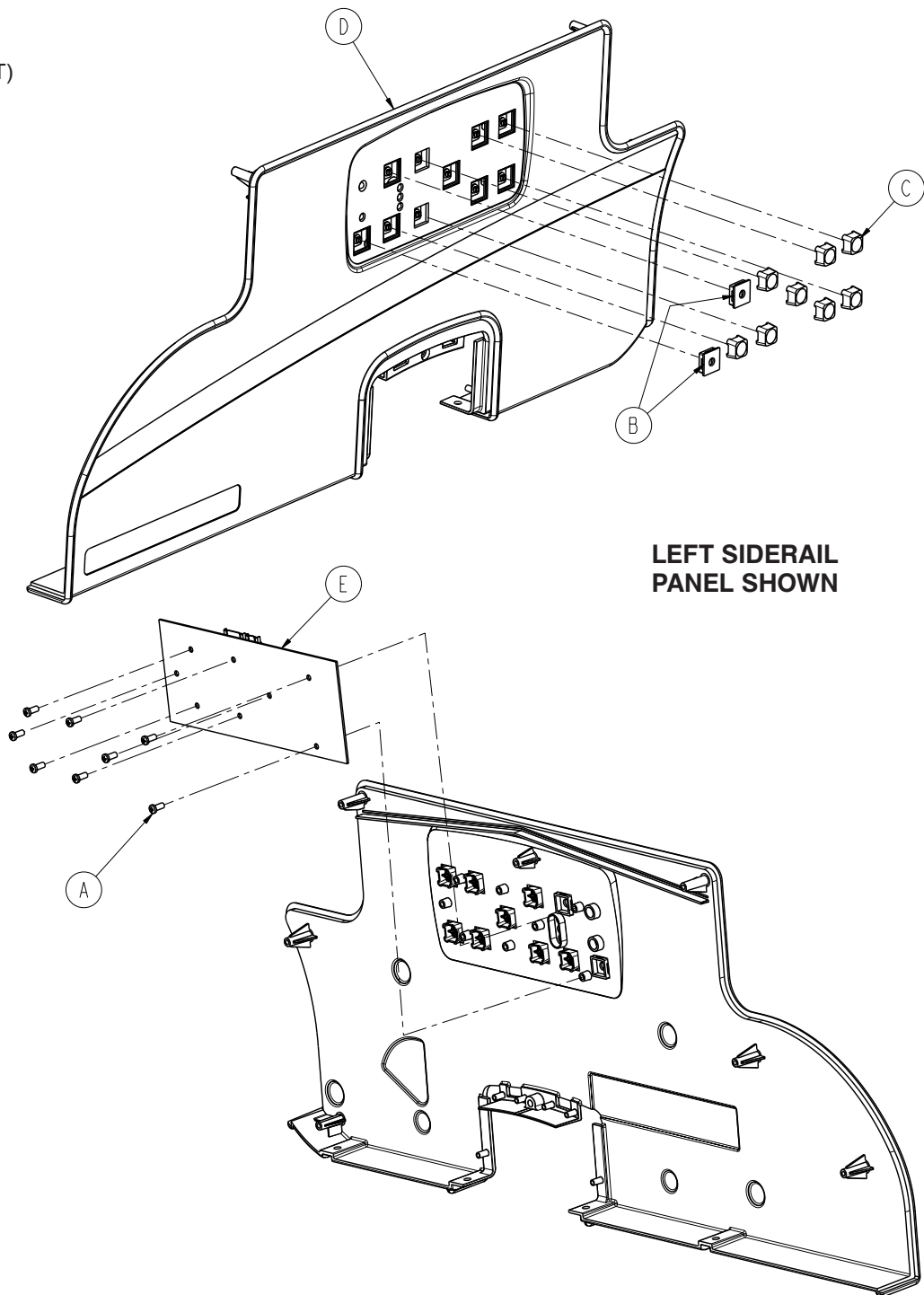

| Item | Part No. | Part Name | Qty. |
|------|--------------|---------------------------------|------|
| A | 0023-112-000 | Pan Head High/Low Tapping Screw | 8 |
| B | 3001-400-522 | Filler Cap | 2 |
| C | 3001-400-953 | Switch Cap | 8 |
| D | 3006-400-127 | Head End Siderail Cover, Left | 1 |
| | 3006-400-227 | Head End Siderail Cover, Right | 1 |
| E | 3006-400-910 | Outer Siderail | 1 |

Head End Siderail Assembly, Inner Panel

For Reference Only
 3006-400-130 (LEFT)
 3006-400-230 (RIGHT)

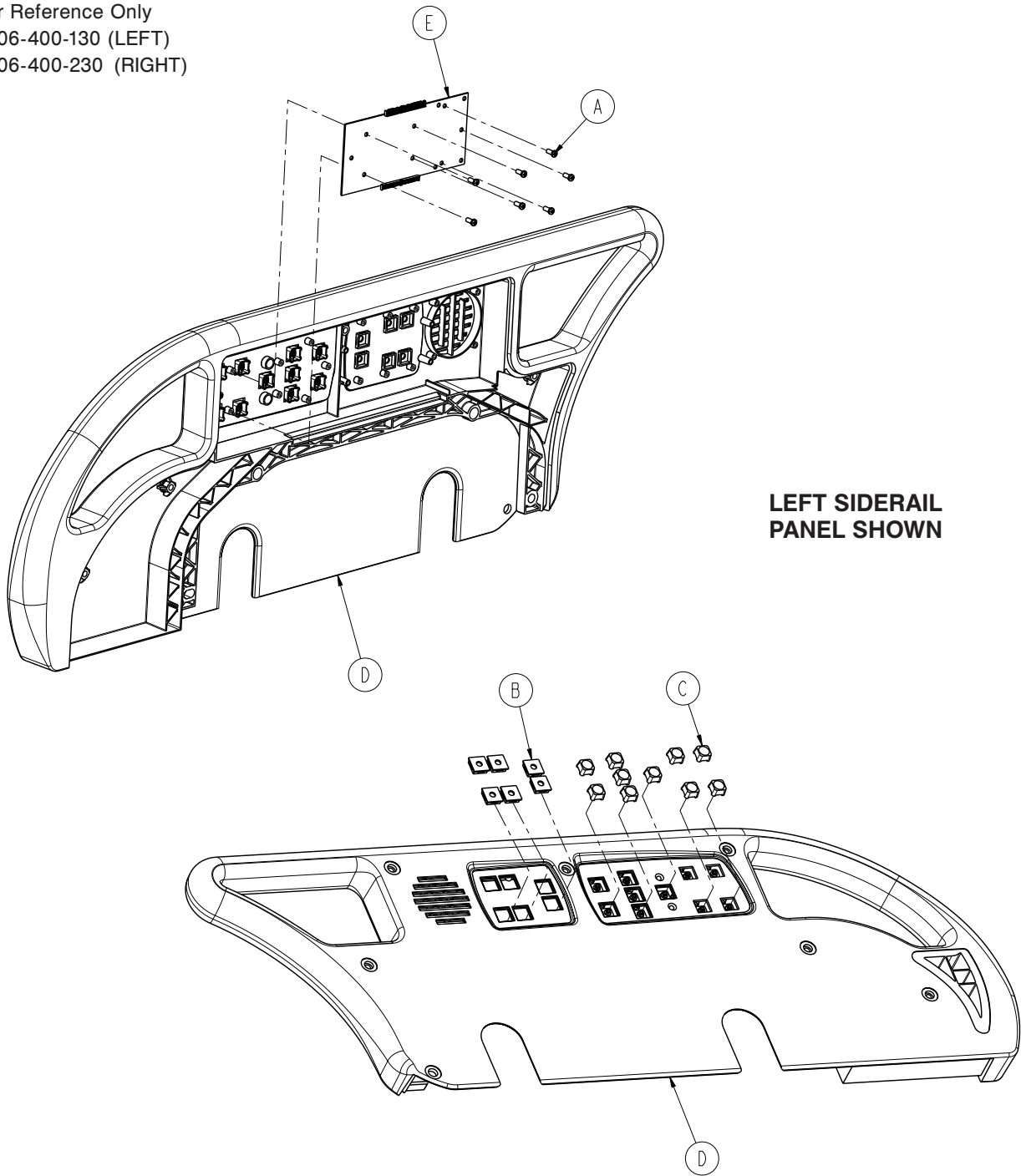

| Item | Part No. | Part Name | Qty. |
|------|--------------|---------------------------------|------|
| A | 0023-112-000 | Pan Head High/Low Tapping Screw | 8 |
| B | 3001-400-522 | Filler Cap | 6 |
| C | 3001-400-953 | Switch Cap | 10 |
| D | 3006-400-115 | Head End Toprail, Left | 1 |
| | 3006-400-215 | Head End Toprail, Right | 1 |
| E | 3006-400-930 | Main Siderail | 1 |

Release Handle Assembly

For Reference Only: 3006-400-570

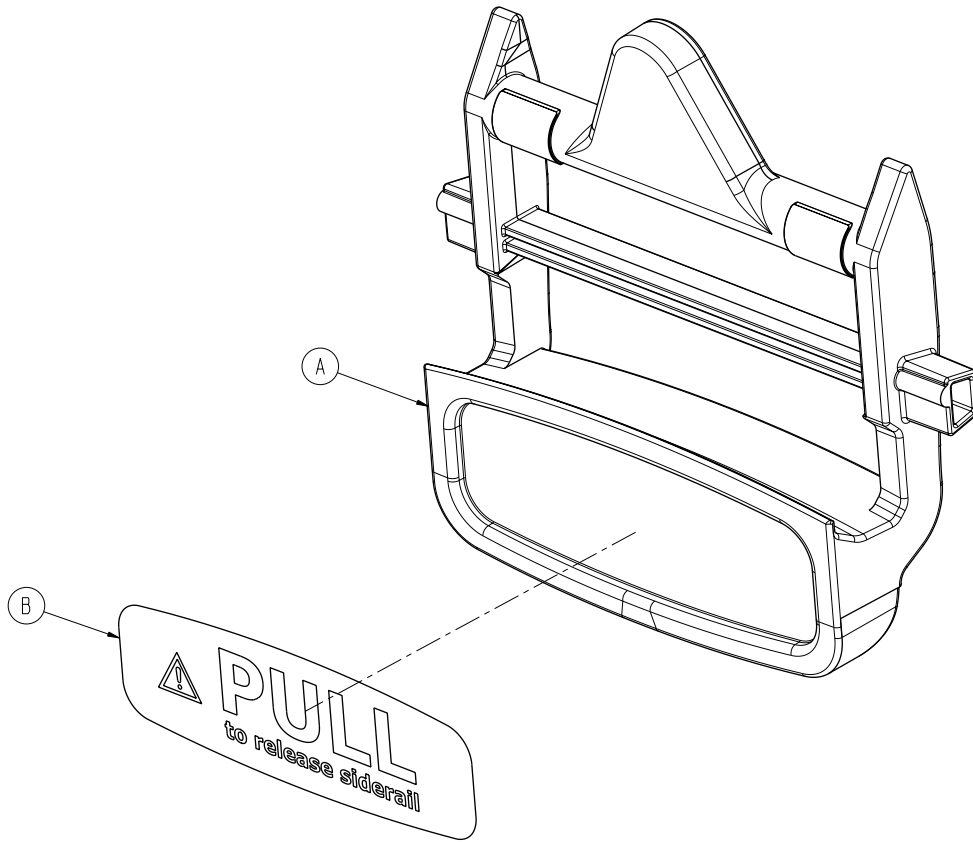

| Item | Part No. | Part Name | Qty. |
|------|--------------|------------------------|------|
| A | 3006-400-565 | Release Handle | 1 |
| B | 3006-400-657 | Siderail Release Label | 1 |

Siderail Ass'y, iBed® Awareness Option, HE, Left - 3006-400-100

REF: 3006-400-105
Siderail Standard Components

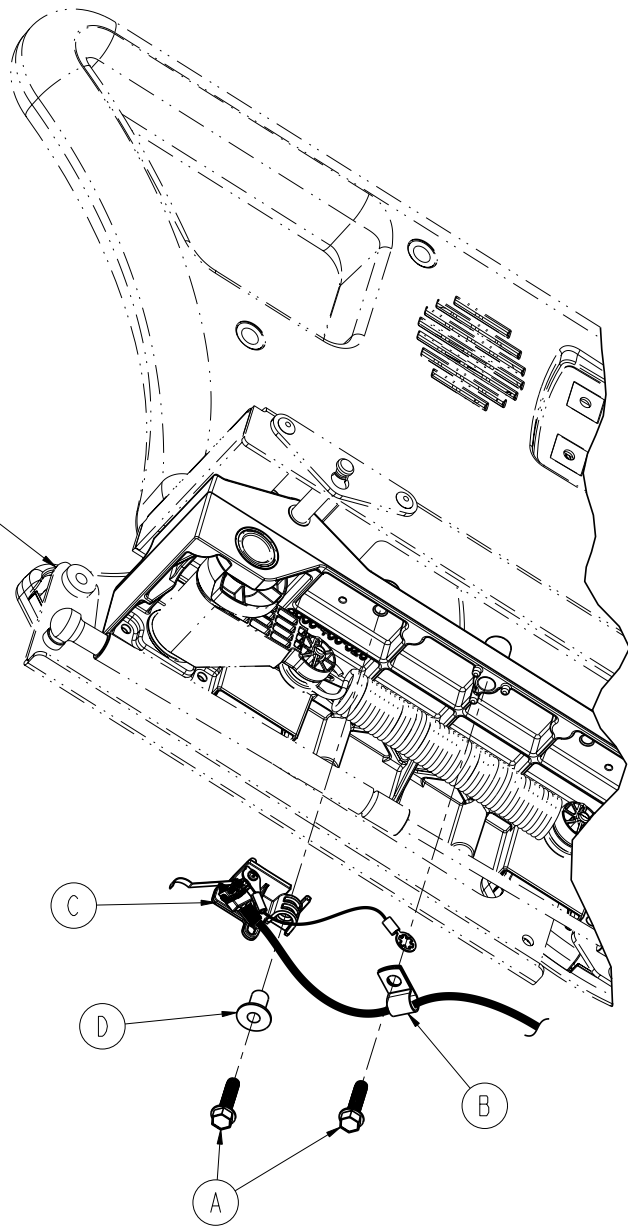

| Item | Part No. | Part Name | Qty. |
|------|--------------|-------------------------------------|------|
| A | 0023-123-000 | Hex Washer Head Screw | 2 |
| B | 0058-105-000 | P-Clamp | 1 |
| C | 3006-400-120 | Siderail Switch Assembly, Head Left | 1 |

Siderail Ass'y, iBed® Awareness Option, HE, Right - 3006-400-200

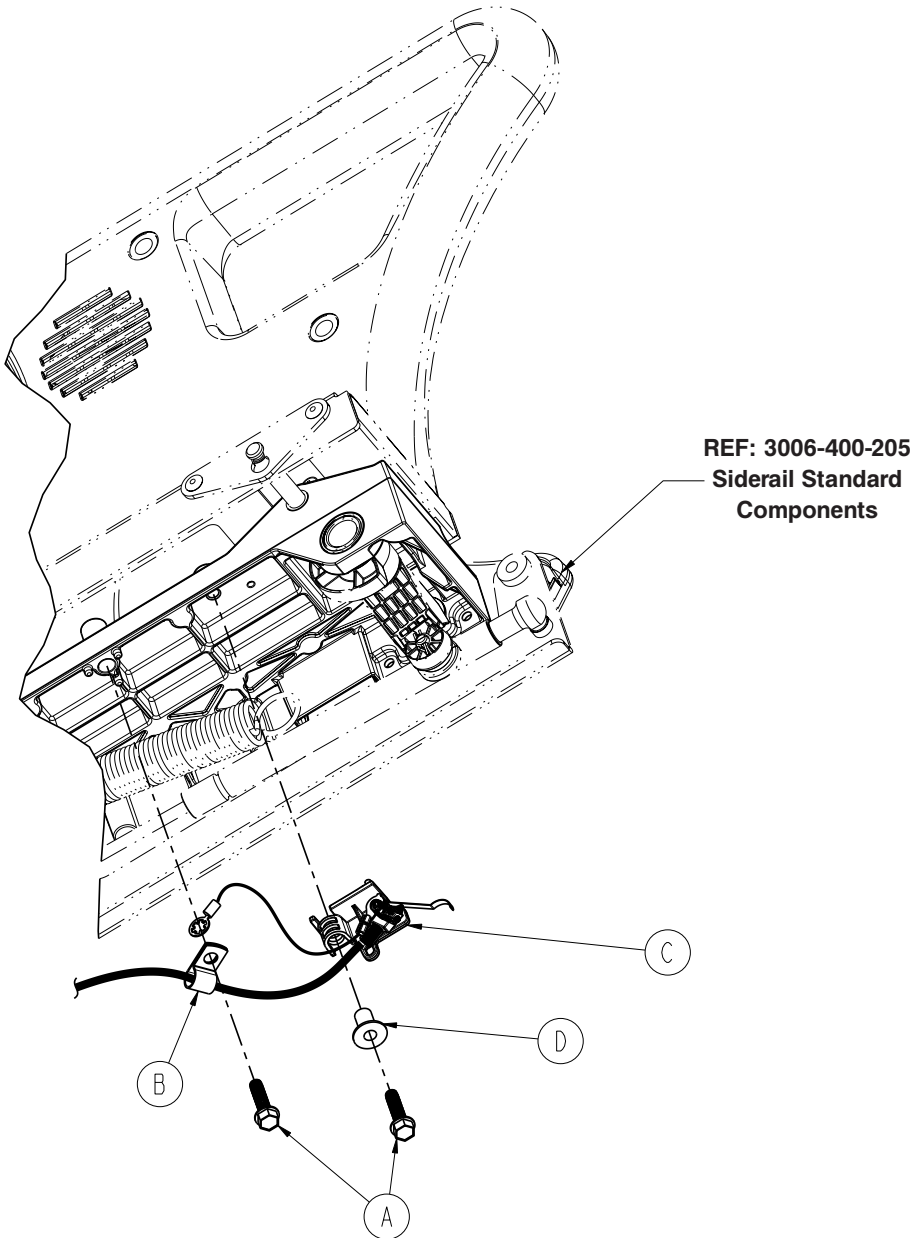

| Item | Part No. | Part Name | Qty. |
|------|--------------|--------------------------------------|------|
| A | 0023-123-000 | Hex Washer Head Screw | 2 |
| B | 0058-105-000 | P-Clamp | 1 |
| C | 3006-400-220 | Siderail Switch Assembly, Head Right | 1 |

Switch Assembly, *i*Bed® Awareness Option, Head End, 3006-400-120 (Left) / 3006-400-220 (Right)

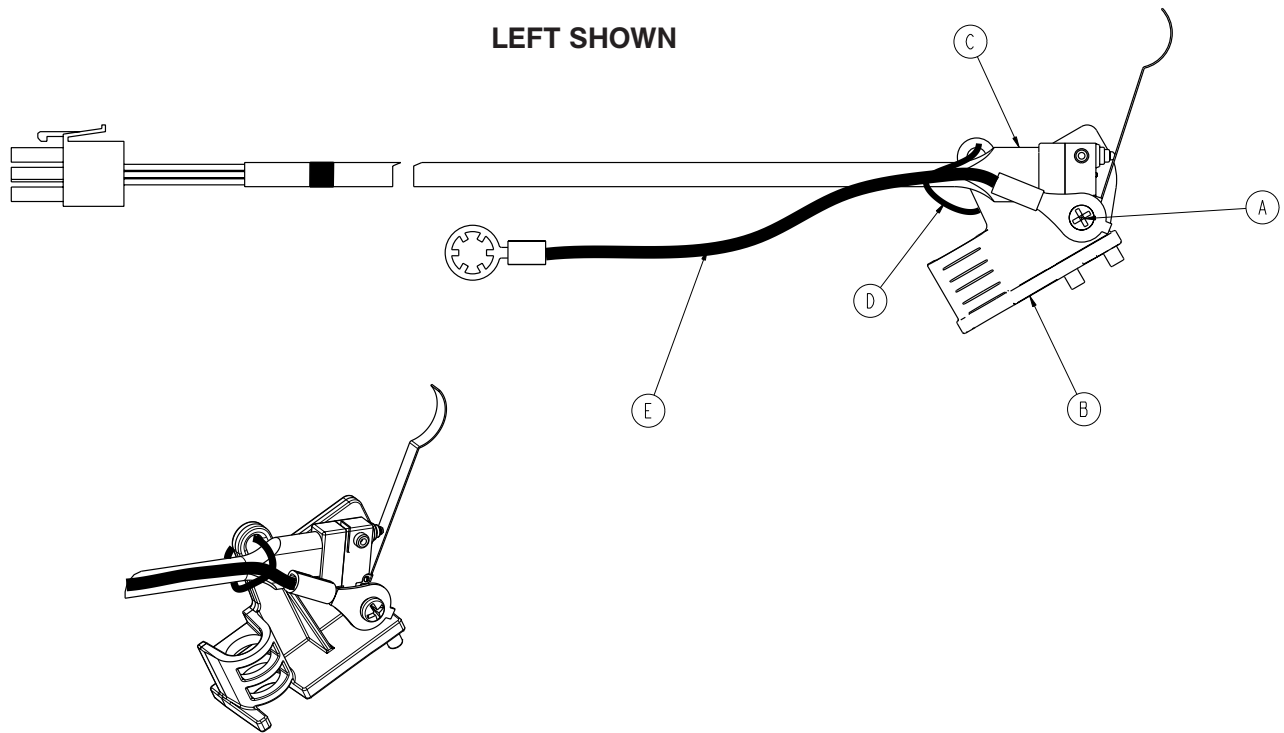

Head End Left - 3006-400-120 / Head End Right - 3006-400-220

| Item | Part No. | Part Name | Qty. |
|------|--------------|--------------------------------|------|
| A | 0023-294-000 | High-Low Tapping Screw | 1 |
| B | 3006-400-558 | Switch Holder, Left | 1 |
| | 3006-400-559 | Switch Holder, Right | 1 |
| D | 3006-400-802 | Head End Siderail Switch Cable | 1 |

Foot End Siderail Assembly

For Reference Only:
3006-400-300 (LH)
3006-400-400 (RH)

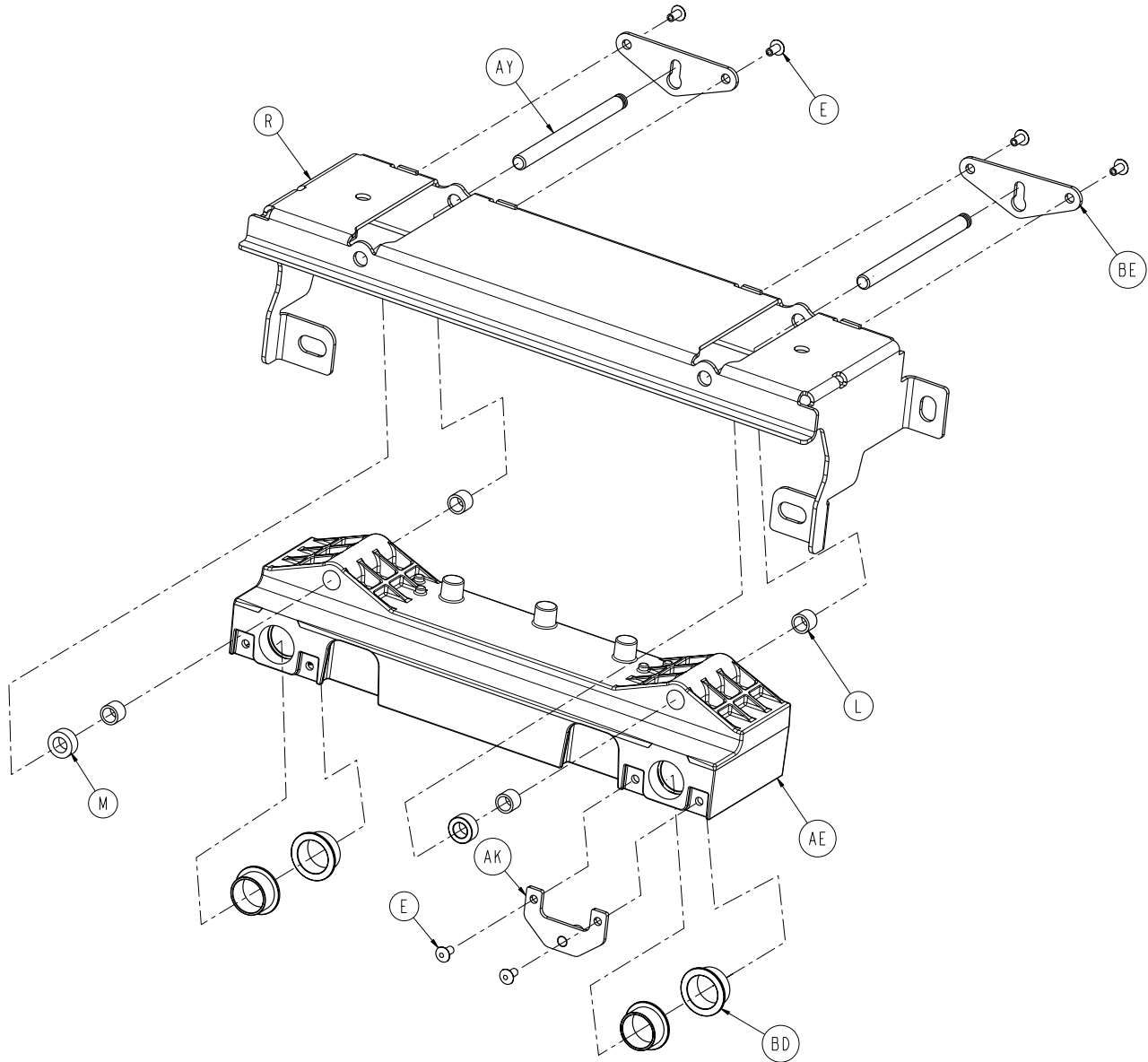

(LEFT SIDERAIL SHOWN)

Foot End Siderail Assembly

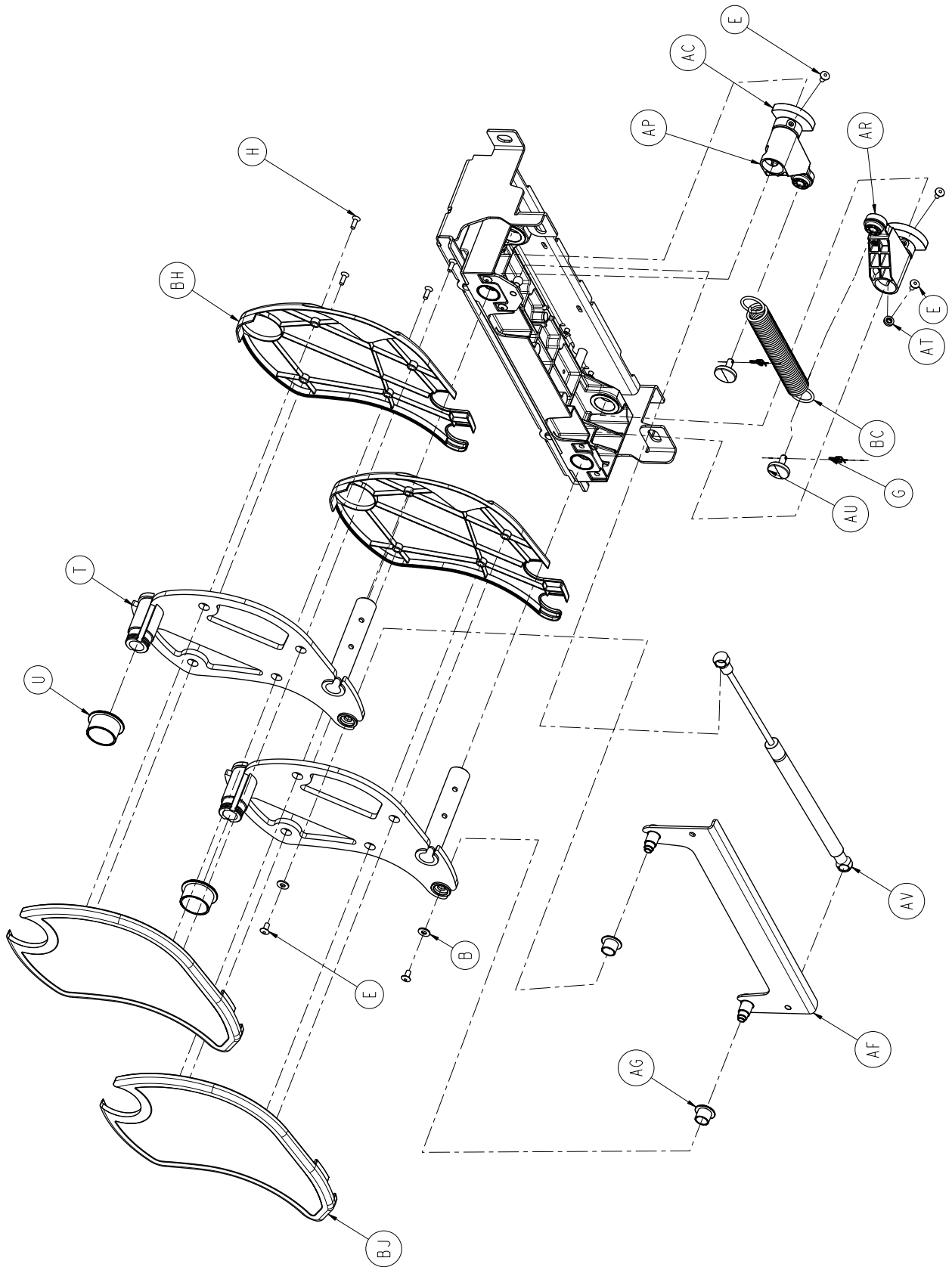

Foot End Siderail Assembly

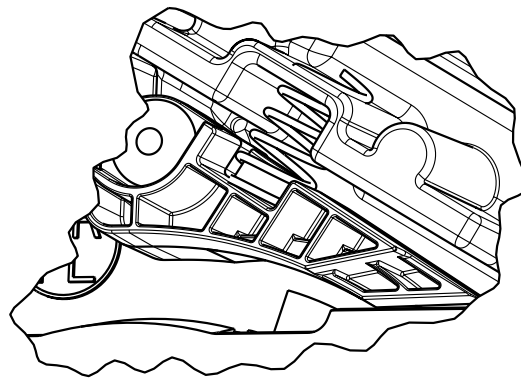
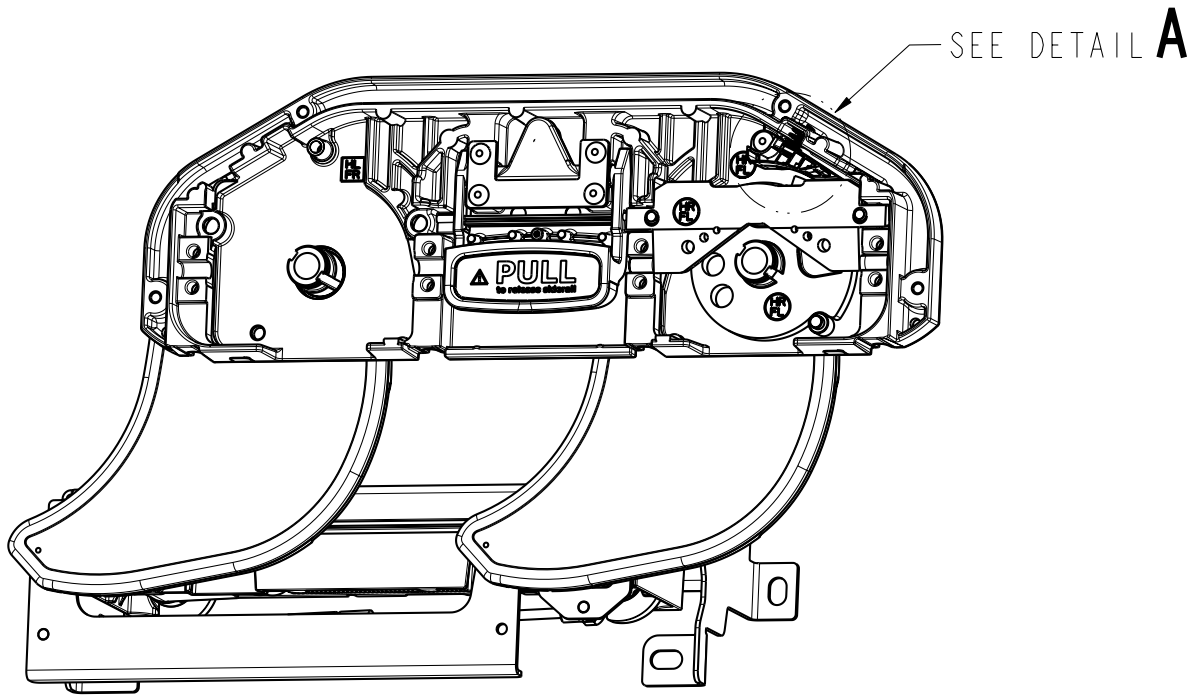

DETAIL **A**

Foot End Siderail Assembly

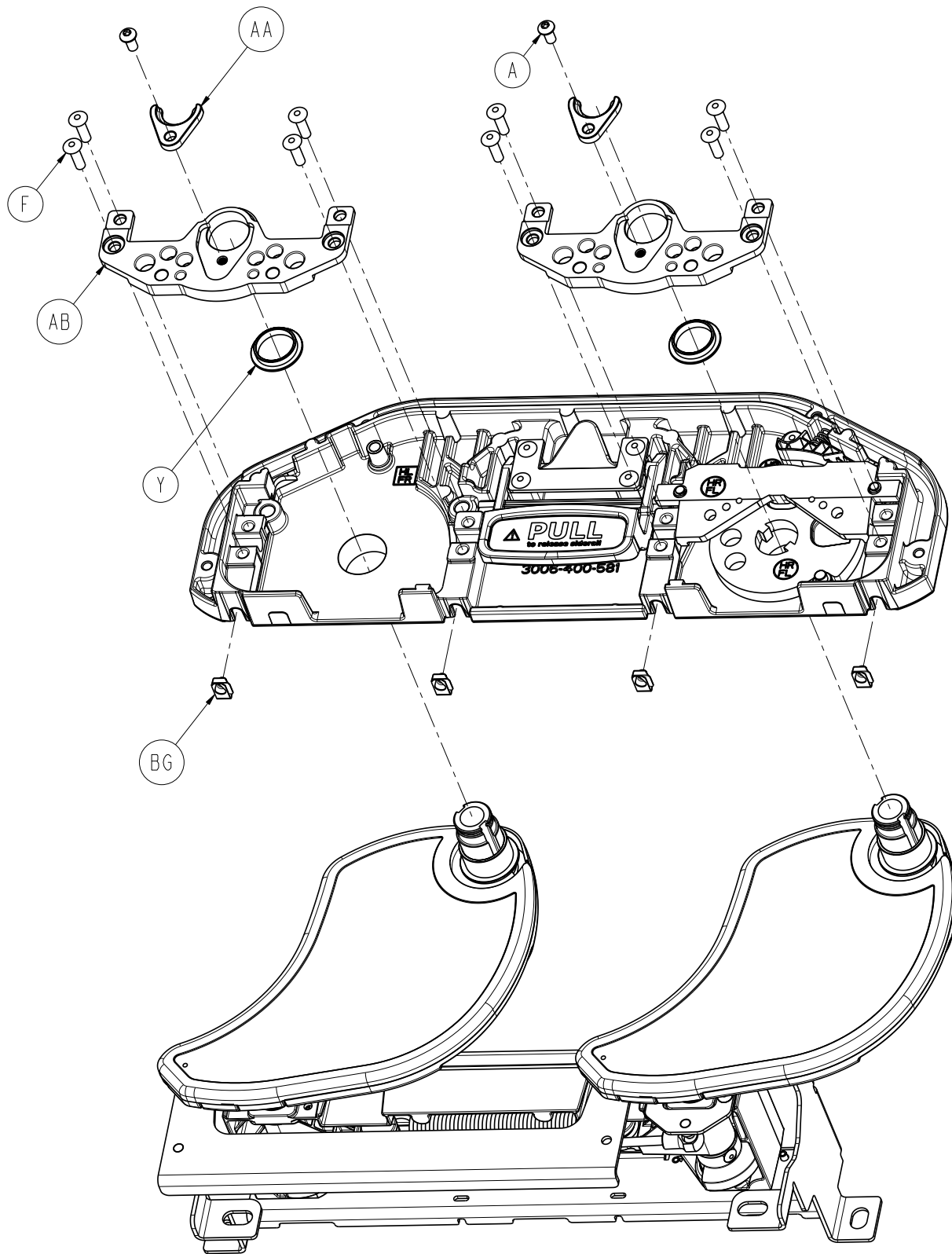

Foot End Siderail Assembly

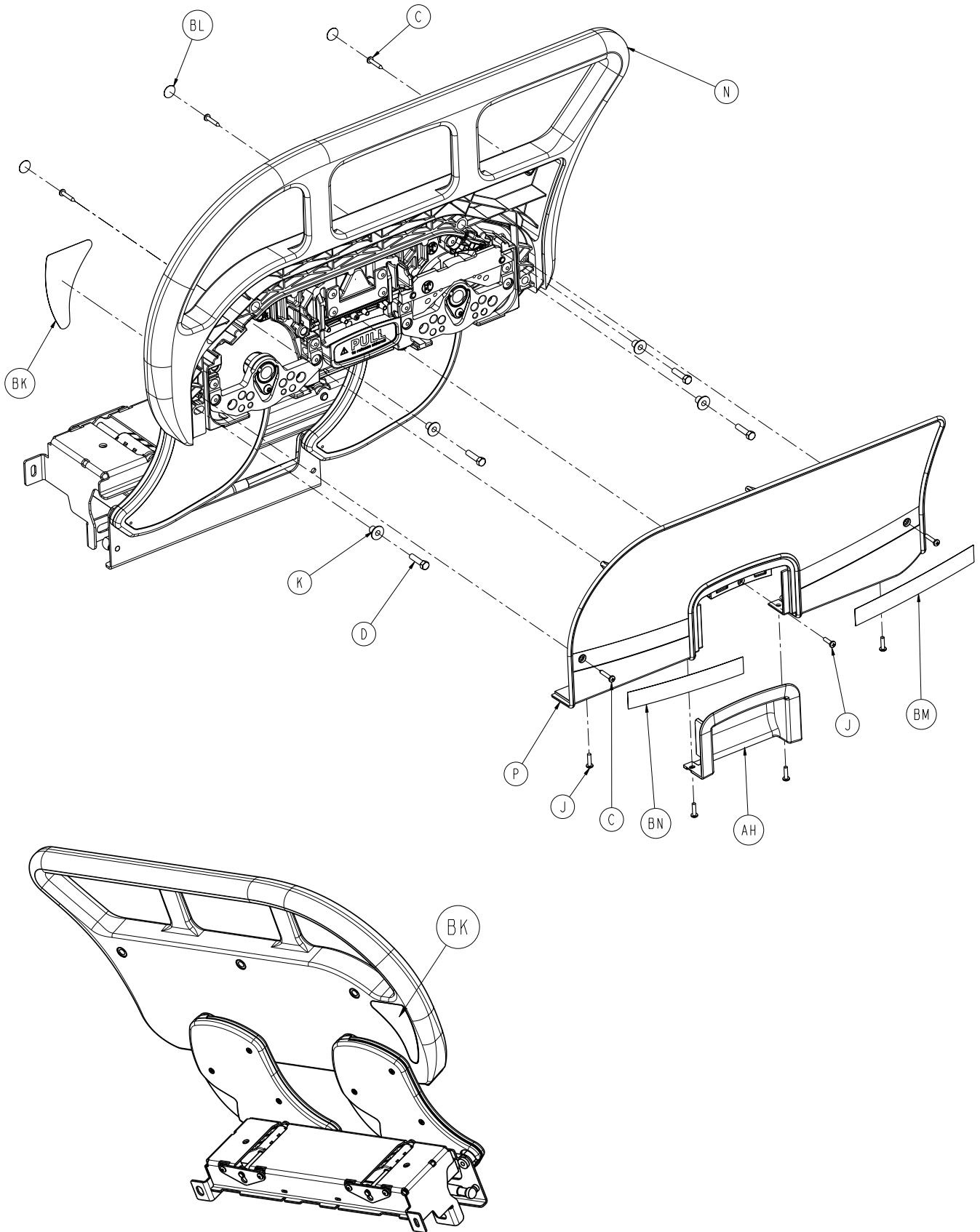

Foot End Siderail Assembly

Foot End Siderail Assembly - (Reference Only)

Left Standard Components - 3006-400-300

| Item | Part No. | Part Name | Qty. | Item | Part No. | Part Name | Qty. |
|------|--------------|-------------------------------|------|------|--------------|----------------------------|------|
| A | 0004-589-000 | Button Head Cap Screw | 2 | BJ | 3006-400-629 | Outer Arm Cover | 2 |
| B | 0011-302-000 | Washer | 2 | BK | 3006-400-107 | Head End & Foot End | |
| C | 0023-076-000 | Pan Head Tapping Screw | 5 | | | Blank Siderail Label, Left | 1 |
| D | 0003-392-000 | Hex Head Machine Screw | 4 | BL | 3006-400-522 | Siderail Fastener Cover | |
| E | 0025-079-000 | Dome Head Rivet | 11 | | | Label | 3 |
| F | 0025-147-000 | Pop Rivet | 13 | BM | 3006-400-301 | Foot Siderail Label | 1 |
| G | 0027-020-000 | Rue Ring Cotter | 2 | BN | 3006-400-302 | Foot LH Siderail Label | 1 |
| H | 0001-072-000 | Flat Head Machine Screw | 8 | | | | |
| J | 0050-005-000 | Pan Head Machine Screw | 5 | | | | |
| K | 3006-400-574 | Siderail Spacer | 4 | | | | |
| L | 3000-400-574 | Sleeve Bearing | 4 | | | | |
| M | 3006-400-495 | Siderail Spacer | 2 | | | | |
| N | 3006-400-320 | Foot End Toprail, Left | 1 | | | | |
| P | 3006-400-327 | Foot End Siderail Cover, Left | 1 | | | | |
| R | 3006-400-499 | Foot End Mounting Bracket | 1 | | | | |
| T | 3006-400-510 | Arm Weldment | 2 | | | | |
| U | 3006-400-513 | Bearing | 2 | | | | |
| V | 3006-400-514 | Pivot Washer | 1 | | | | |
| W | 3006-400-516 | Hard Stop Pin | 1 | | | | |
| Y | 3006-400-517 | Bearing | 2 | | | | |
| AA | 3006-400-518 | Pivot Retainer Clip | 2 | | | | |
| AB | 3006-400-523 | Latch/Shaft Retainer | 2 | | | | |
| AC | 3006-400-524 | Pivot Retainer Sleeve | 2 | | | | |
| AD | 3006-400-525 | Bypass Arm | 1 | | | | |
| AE | 3006-400-528 | Machined Siderail Carrier | 1 | | | | |
| AF | 3006-400-530 | Timing Link Weldment | 1 | | | | |
| AG | 3006-400-532 | Bearing | 2 | | | | |
| AH | 3006-400-533 | Release Handle | | | | | |
| | | Accent Panel | 1 | | | | |
| AJ | 3006-400-536 | Latch Plate | 1 | | | | |
| AK | 3006-400-540 | Gas Spring Mounting Bracket | 1 | | | | |
| AL | 3006-400-541 | Latch Disk | 1 | | | | |
| AM | 3006-400-549 | Latch Return Spring | 4 | | | | |
| AN | 3006-400-551 | Spring Plunger | 2 | | | | |
| AP | 3006-400-552 | Spring Arm, A | 1 | | | | |
| AR | 3006-400-553 | Spring Arm, B | 1 | | | | |
| AT | 3006-400-551 | Spring Arm Stop | 1 | | | | |
| AU | 3006-400-557 | Spring Arm Cap | 2 | | | | |
| AV | 3006-400-560 | Gas Spring | 1 | | | | |
| AW | 3006-400-561 | Spring Plunger Clip | 2 | | | | |
| AY | 3006-400-564 | Glide Rod | 2 | | | | |
| BA | 3006-400-570 | Release Handle Assembly | 1 | | | | |
| BB | 3006-400-566 | Handle Retainer Plate | 1 | | | | |
| BC | 3006-400-567 | Extension Spring | 1 | | | | |
| BD | 3006-400-568 | Bearing | 4 | | | | |
| BE | 3006-400-569 | Glide Rod Restraint | 2 | | | | |
| BF | 3006-400-581 | Machined Support Plate | 1 | | | | |
| BG | 3006-400-584 | Speed Nut | 4 | | | | |
| BH | 3006-400-628 | Inner Arm Cover | 2 | | | | |

Foot End Siderail Assembly

Foot End Siderail Assembly - (Reference Only)

Right Standard Components - 3006-400-400

| Item | Part No. | Part Name | Qty. | Item | Part No. | Part Name | Qty. |
|------|--------------|--------------------------------|------|------|--------------|--|------|
| A | 0004-589-000 | Button Head Cap Screw | 2 | BJ | 3006-400-619 | Outer Arm Cover | 2 |
| B | 0011-302-000 | Washer | 2 | BK | 3006-400-207 | Head End & Foot End Blank Siderail Label, Right | 1 |
| C | 0023-076-000 | Pan Head Tapping Screw | 5 | BL | 3006-400-522 | Siderail Fastener Cover Label | 3 |
| D | 0003-392-000 | Hex Head Machine Screw | 4 | BM | 3006-400-401 | Foot Siderail Label | 1 |
| E | 0025-079-000 | Dome Head Rivet | 11 | BN | 3006-400-402 | Foot RH Siderail Label | 1 |
| F | 0025-147-000 | Pop Rivet | 13 | | | | |
| G | 0027-020-000 | Rue Ring Cotter | 2 | | | | |
| H | 0001-072-000 | Flat Head Machine Screw | 8 | | | | |
| J | 0050-005-000 | Pan Head Machine Screw | 5 | | | | |
| K | 3006-400-574 | Siderail Spacer | 4 | | | | |
| L | 3000-400-557 | Sleeve Bearing | 4 | | | | |
| M | 3006-400-495 | Siderail Spacer | 2 | | | | |
| N | 3006-400-420 | Toprail | 1 | | | | |
| P | 3006-400-427 | Siderail Cover | 1 | | | | |
| R | 3006-400-499 | Mounting Bracket | 1 | | | | |
| T | 3006-400-515 | Arm Weldment | 2 | | | | |
| U | 3006-400-513 | Bearing | 2 | | | | |
| V | 3006-400-514 | Pivot Washer | 1 | | | | |
| W | 3006-400-516 | Hard Stop Pin | 1 | | | | |
| Y | 3006-400-517 | Bearing | 2 | | | | |
| AA | 3006-400-518 | Pivot Retainer Clip | 2 | | | | |
| AB | 3006-400-523 | Latch/Shaft Retainer | 2 | | | | |
| AC | 3006-400-524 | Pivot Retainer Sleeve | 2 | | | | |
| AD | 3006-400-505 | Bypass Arm | 1 | | | | |
| AE | 3006-400-528 | Machined Siderail Carrier | 1 | | | | |
| AF | 3006-400-535 | Timing Link Weldment | 1 | | | | |
| AG | 3006-400-532 | Bearing | 2 | | | | |
| AH | 3006-400-533 | Release Handle Accent Panel | 1 | | | | |
| AJ | 3006-400-534 | Latch Plate | 1 | | | | |
| AK | 3006-400-540 | Gas Spring Mounting Bracket | 1 | | | | |
| AL | 3006-400-537 | Latch Disk | 1 | | | | |
| AM | 3006-400-549 | Latch Return Spring | 4 | | | | |
| AN | 3006-400-551 | Spring Plunger | 2 | | | | |
| AP | 3006-400-552 | Spring Arm, A | 1 | | | | |
| AR | 3006-400-553 | Spring Arm, B | 1 | | | | |
| AT | 3006-400-554 | Spring Arm Stop | 1 | | | | |
| AU | 3006-400-557 | Spring Arm Cap | 2 | | | | |
| AV | 3006-400-560 | Gas Spring | 1 | | | | |
| AW | 3006-400-561 | Spring Plunger Clip | 2 | | | | |
| AY | 3006-400-564 | Glide Rod | 2 | | | | |
| BA | 3006-400-570 | Release Handle Assembly | 1 | | | | |
| BB | 3006-400-566 | Retainer Plate Handle | 1 | | | | |
| BC | 3006-400-567 | Extension Spring | 1 | | | | |
| BD | 3006-400-568 | Bearing | 4 | | | | |
| BE | 3006-400-569 | Glide Rod Restraint | 2 | | | | |
| BF | 3006-400-581 | Machined Support Plate | 1 | | | | |
| BG | 3006-400-584 | Speed Nut | 4 | | | | |
| BH | 3006-400-618 | Inner Arm Cover | 2 | | | | |

Siderail Ass'y, iBed® Awareness Option, FE Left - 3006-400-305

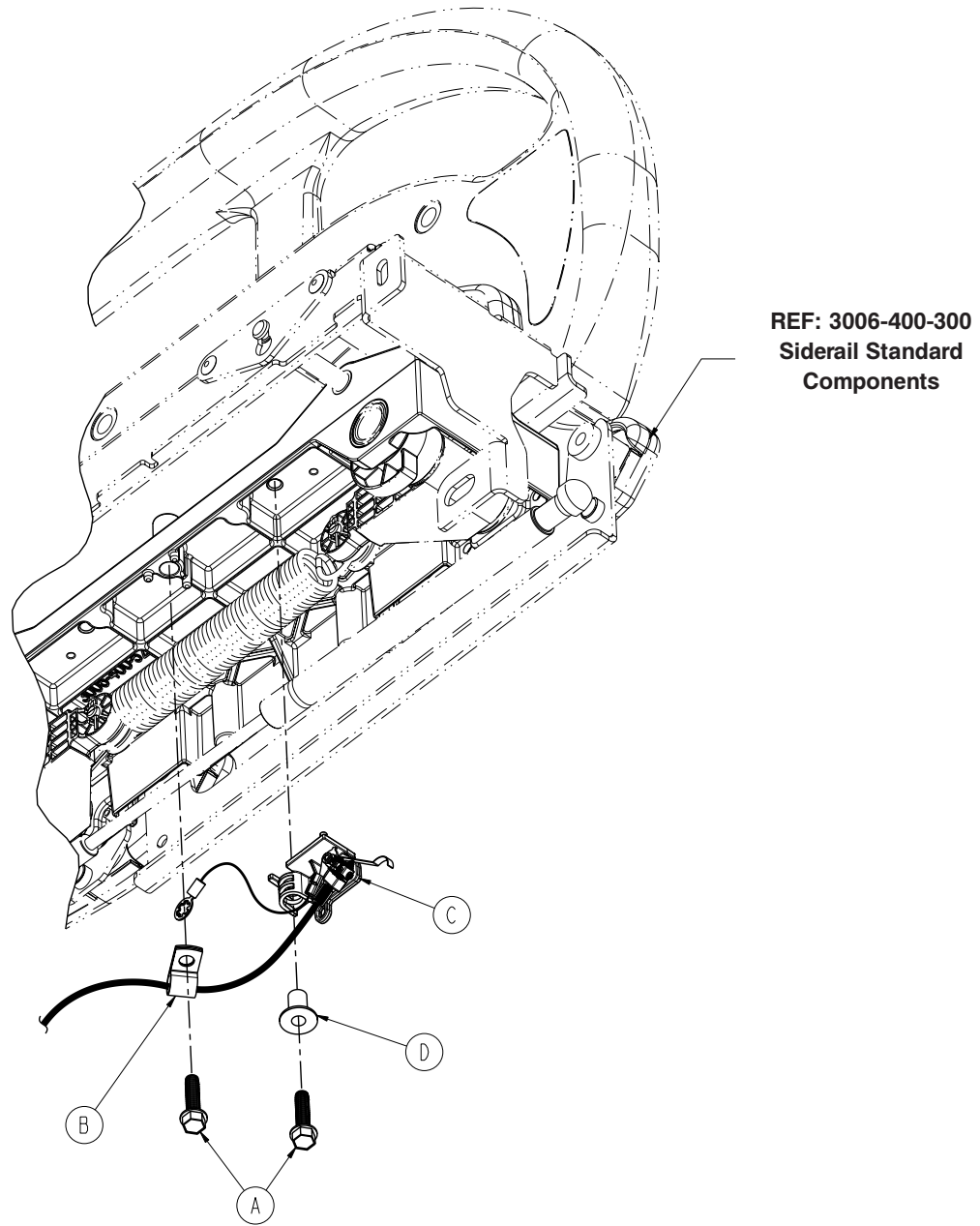

| Item | Part No. | Part Name | Qty. |
|------|--------------|------------------------------------|------|
| A | 0023-123-000 | Hex Washer Head Screw | 2 |
| B | 0058-105-000 | P-Clamp | 1 |
| C | 3006-400-315 | Siderail Switch Assembly, FE, Left | 1 |

Siderail Ass'y, iBed® Awareness Option, FE, Right - 3006-400-405

REF: 3006-400-400
Siderail Standard
Components

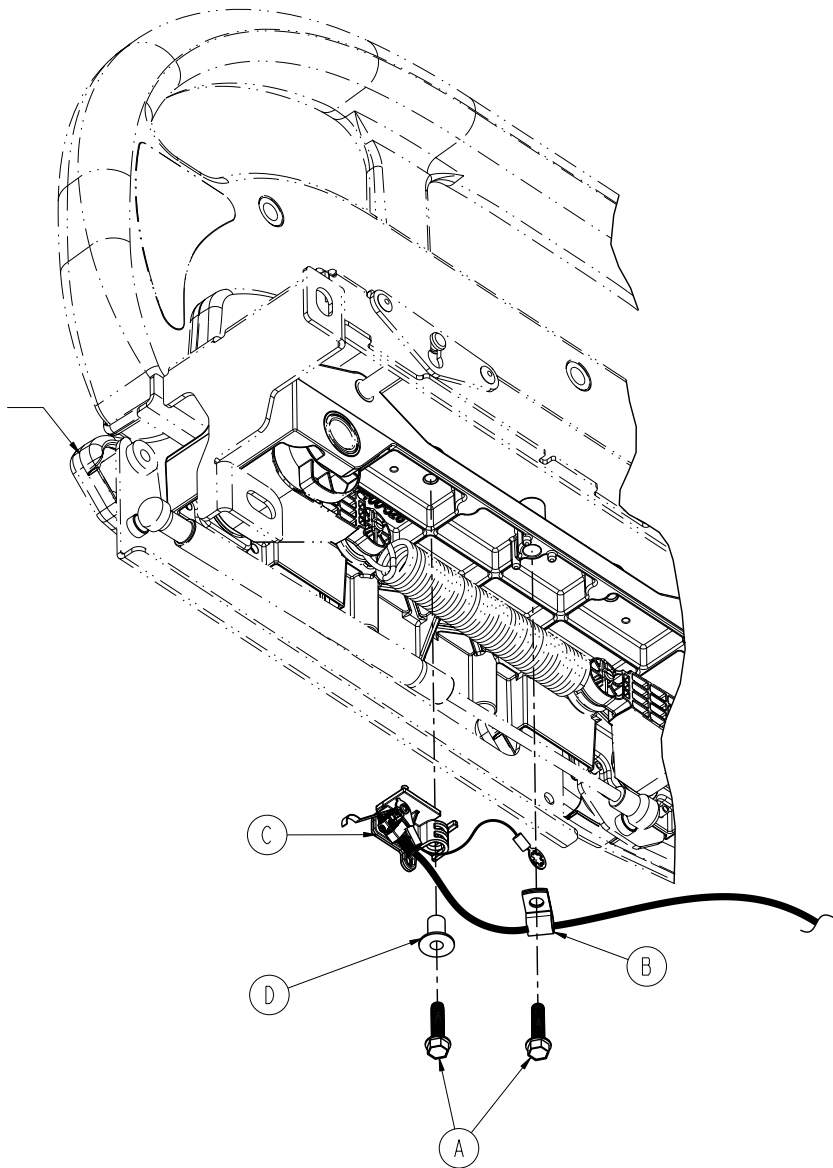

| Item | Part No. | Part Name | Qty. |
|------|--------------|-------------------------------------|------|
| A | 0023-123-000 | Hex Washer Head Screw | 2 |
| B | 0058-105-000 | P-Clamp | 1 |
| C | 3006-400-415 | Siderail Switch Assembly, FE, Right | 1 |

Switch Assembly, *i*Bed® Awareness Option, Foot End, 3006-400-315 (Left) / 3006-400-415 (Right)

LEFT SHOWN

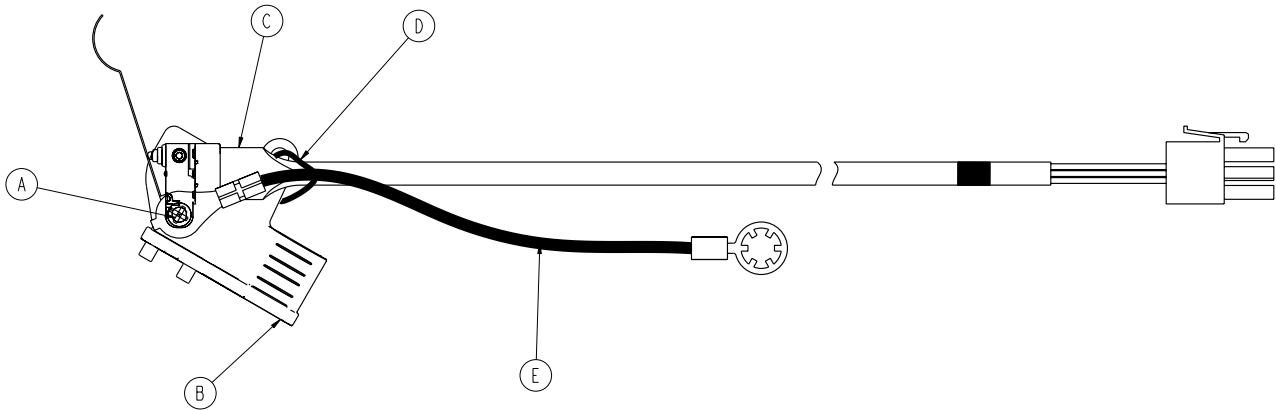

Foot End Left - 3006-400-315 / Foot End Right - 3006-400-415

| Item | Part No. | Part Name | Qty. |
|------|--------------|--------------------------------|------|
| A | 0023-294-000 | High-Low Tapping Screw | 1 |
| B | 3006-400-558 | Switch Holder, Left | 1 |
| | 3006-400-559 | Switch Holder, Right | 1 |
| D | 3006-400-801 | Head End Siderail Switch Cable | 1 |

Optional Pendant Assembly

PENDANT - MOTION/NURSE CALL (3006-315-011)

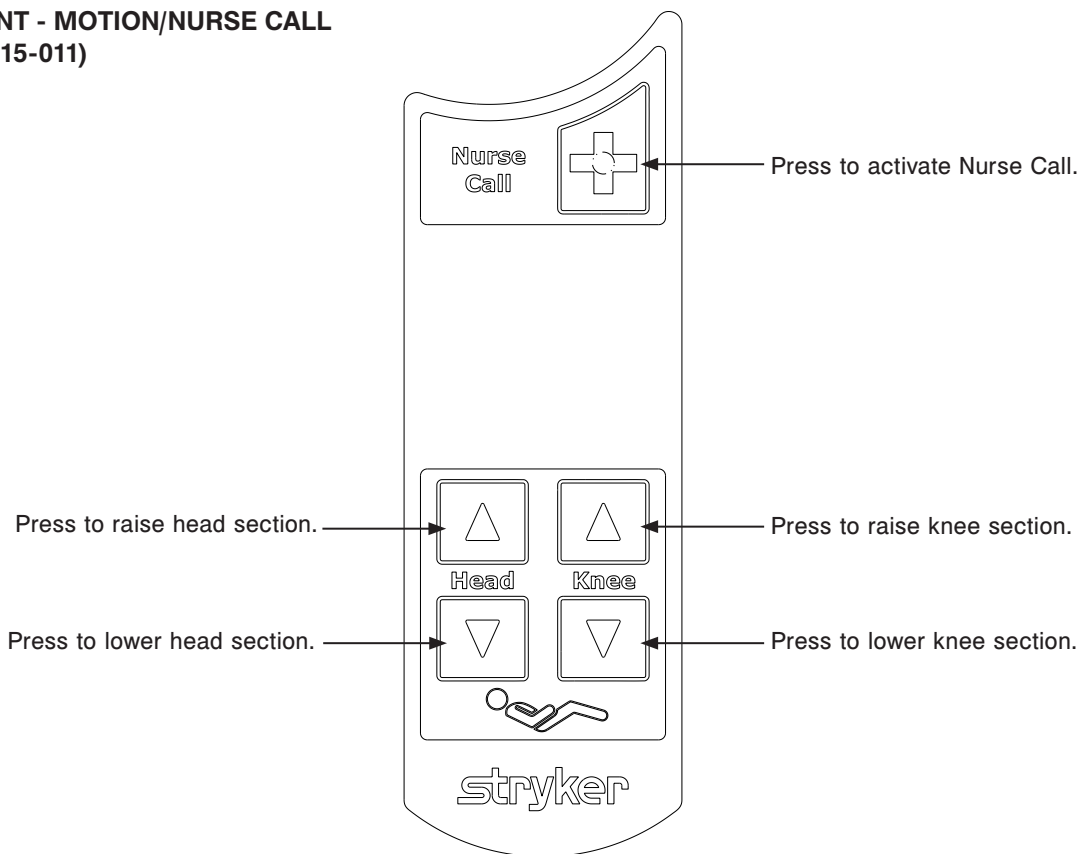

PENDANT - MOTION/NURSE CALL/SMART TV (DIGITAL) (3006-315-012)

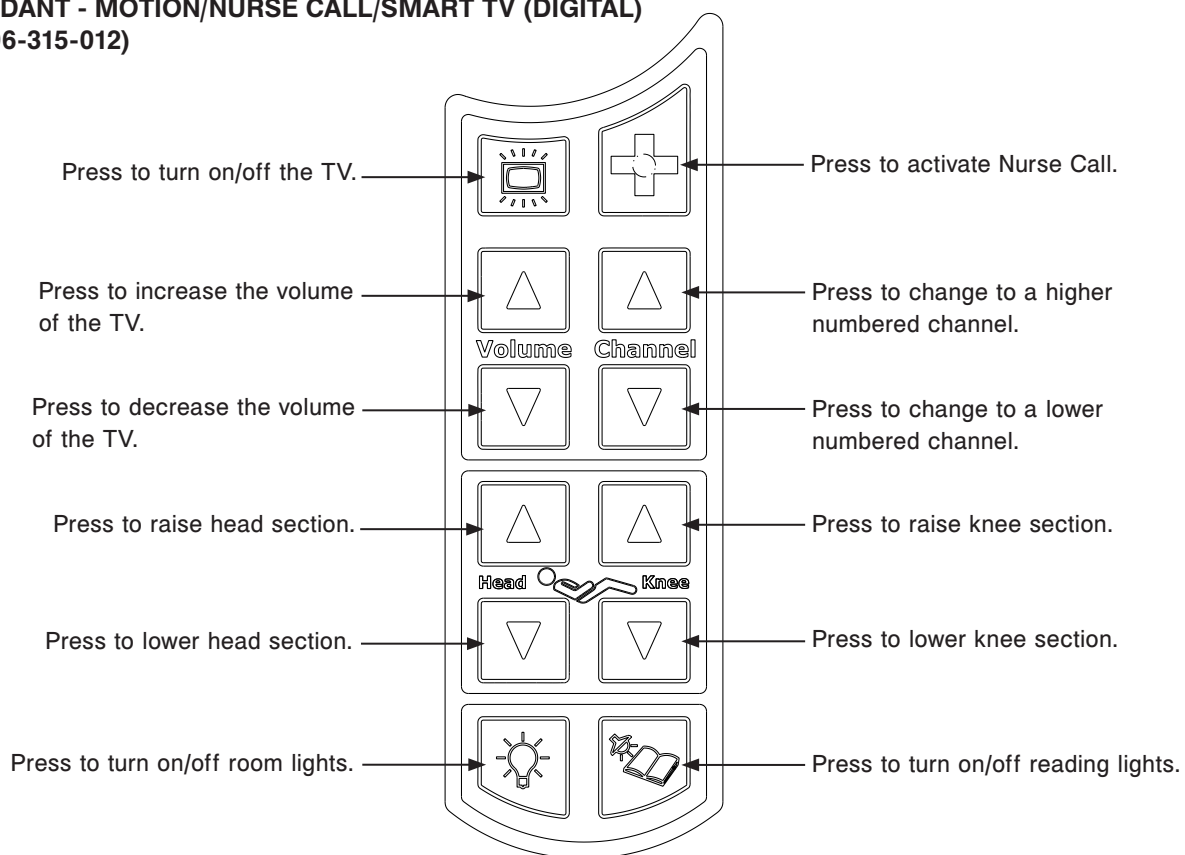

Notes

Footboard Assembly, Standard

For Reference Only: 3006-502-000

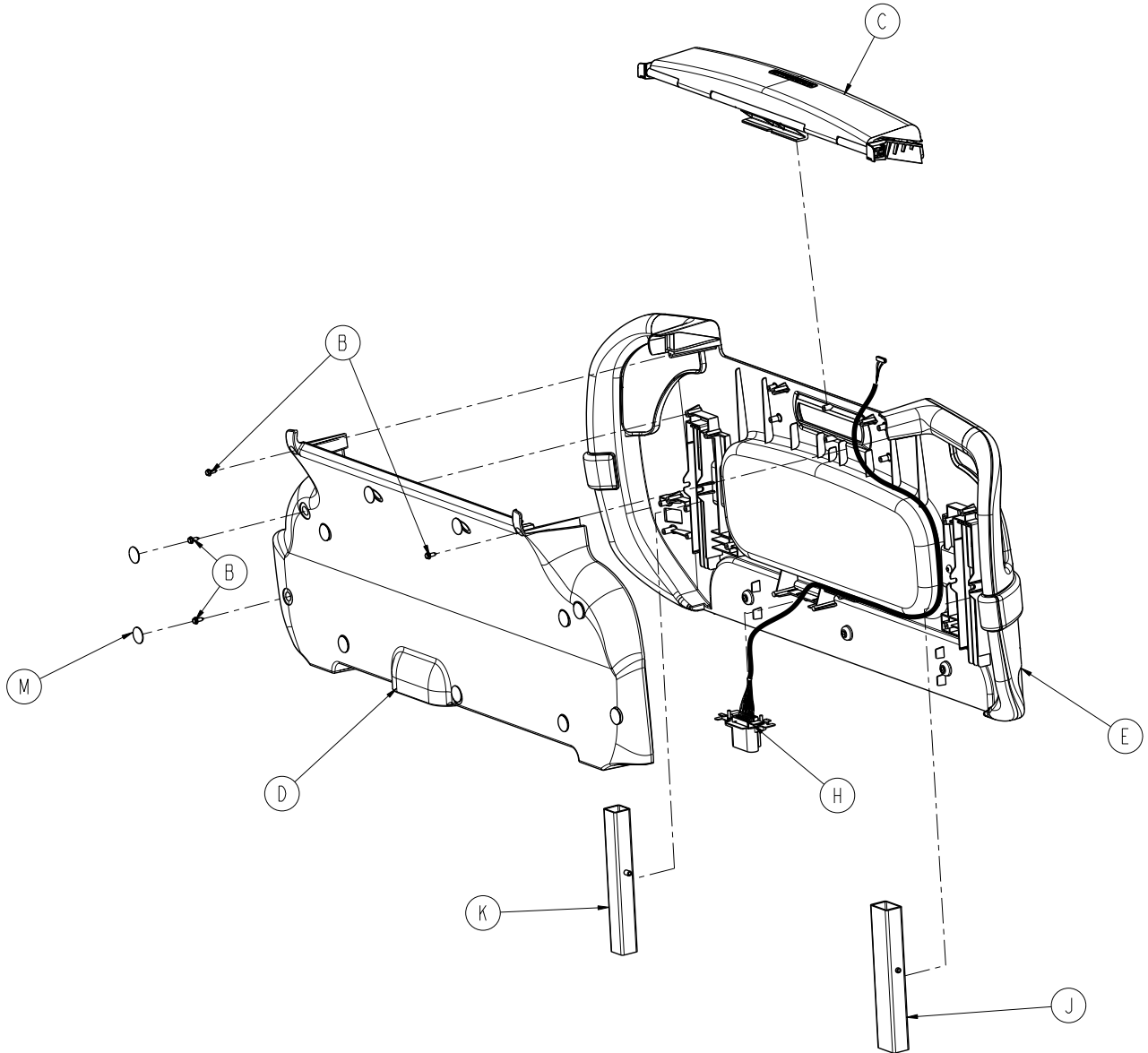

Footboard Assembly, Standard

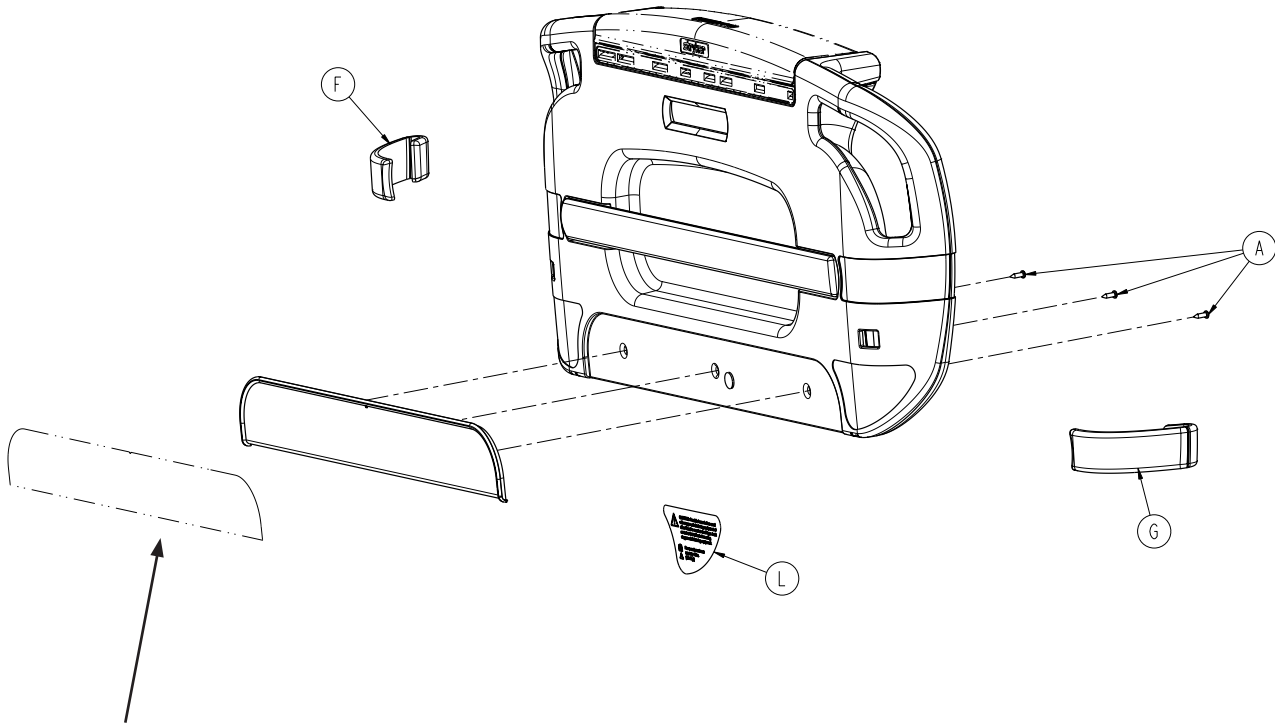

OPTIONAL ACCENT PANEL
(Not included with
Footboard Assembly)

| | |
|--------------------------|--------------|
| Hard Rock Maple | 3006-050-441 |
| Fine Oak | 3006-050-442 |
| Port Maple | 3006-050-443 |
| Wild Cherry | 3006-050-446 |
| Cayenne Maple | 3006-050-447 |
| Honey Maple | 3006-050-448 |
| Select Cherry | 3006-050-449 |
| Sand White (Standard) | 3006-050-450 |

| Item | Part No. | Part Name | Qty. |
|------|--------------|-----------------------------------|------|
| A | 0023-319-000 | Hex Washer Head Tapping Screw | 3 |
| B | 0023-318-000 | Pan Head Screw | 13 |
| C | 3006-501-011 | Module Footboard Assembly | 1 |
| D | 3006-500-112 | Footboard Cover | 1 |
| E | 3006-500-010 | Footboard Pump Rack Assembly | 1 |
| F | 3006-500-017 | Footboard Bumper, Right | 1 |
| G | 3006-500-018 | Footboard Bumper, Left | 1 |
| H | 3006-500-030 | Footboard Connector Assembly | 1 |
| J | 3006-500-050 | Guide Tube - Rectangular Assembly | 1 |
| K | 3006-500-055 | Guide Tube - Square Assembly | 1 |
| L | 3006-508-010 | Oxygen Warning Label | 1 |
| M | 3006-508-011 | Footboard Screw Cover Label | 11 |

* Kit, Footboard Assembly, Front Shell Only - 3006-700-100

Footboard Module Assembly

For Reference Only: 3006-501-011

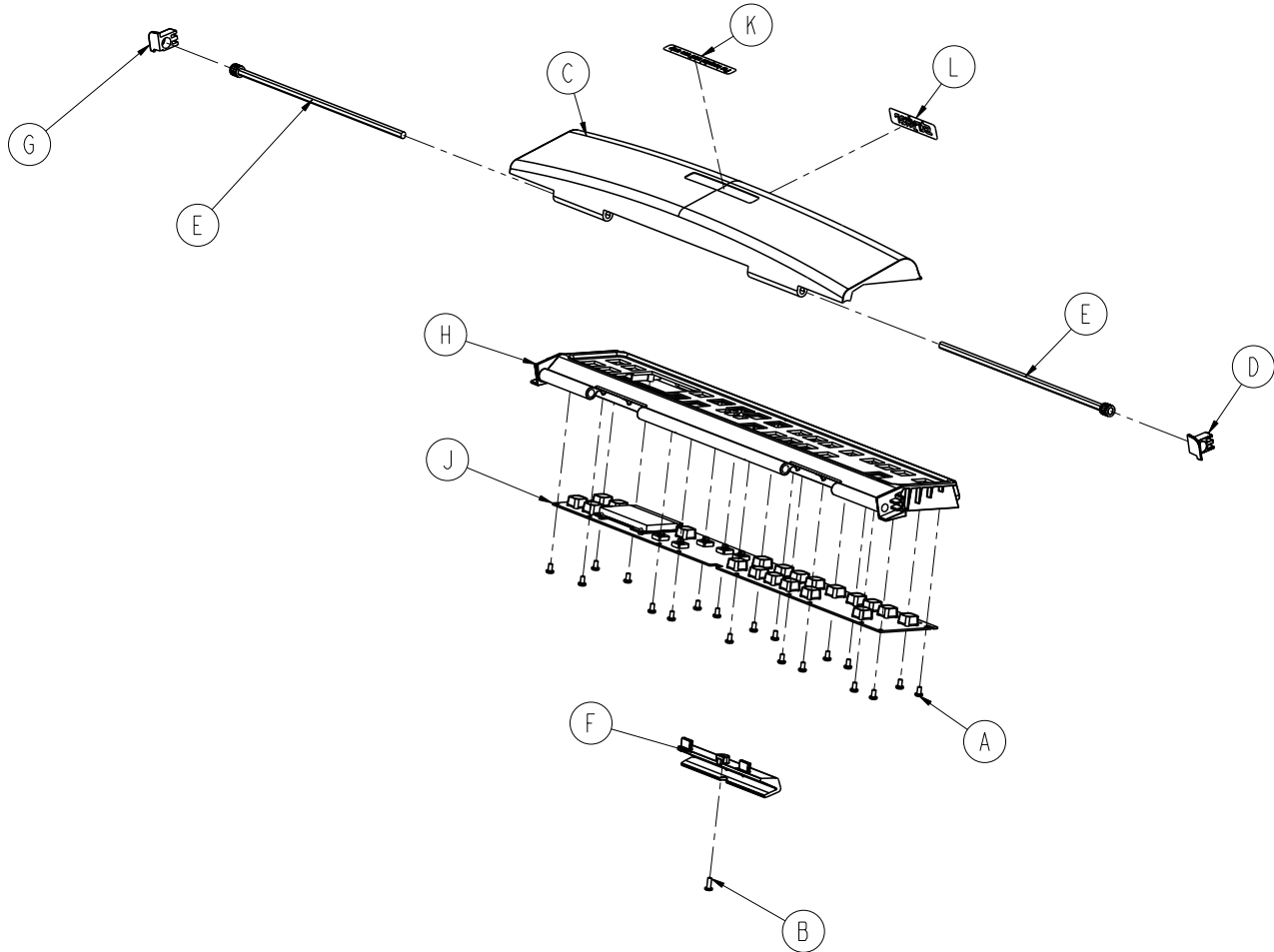

| Item | Part No. | Part Name | Qty. |
|------|--------------|---------------------------------|------|
| A | 0023-087-000 | Pan Head Tapping Screw | 19 |
| B | 0023-103-000 | Pan Head Tapping Screw | 1 |
| C | 3006-500-001 | Footboard Lid | 1 |
| D | 3006-500-028 | Bushing, Right | 1 |
| E | 3006-500-029 | PCB Shaft Damper Weldment | 2 |
| F | 3006-500-031 | PCB Mount Support | 1 |
| G | 3006-500-032 | Bushing, Left | 1 |
| H | 3006-500-202 | Footboard PCB Support | 1 |
| J | 3006-501-900 | Wireless Footboard PCB Assembly | 1 |
| K | 3006-508-013 | Lid, Hospital Staff Use Label | 1 |
| L | 3006-508-014 | Lid, Logo Label | 1 |

Footboard Assembly, No Options

For Reference Only: 3006-500-104

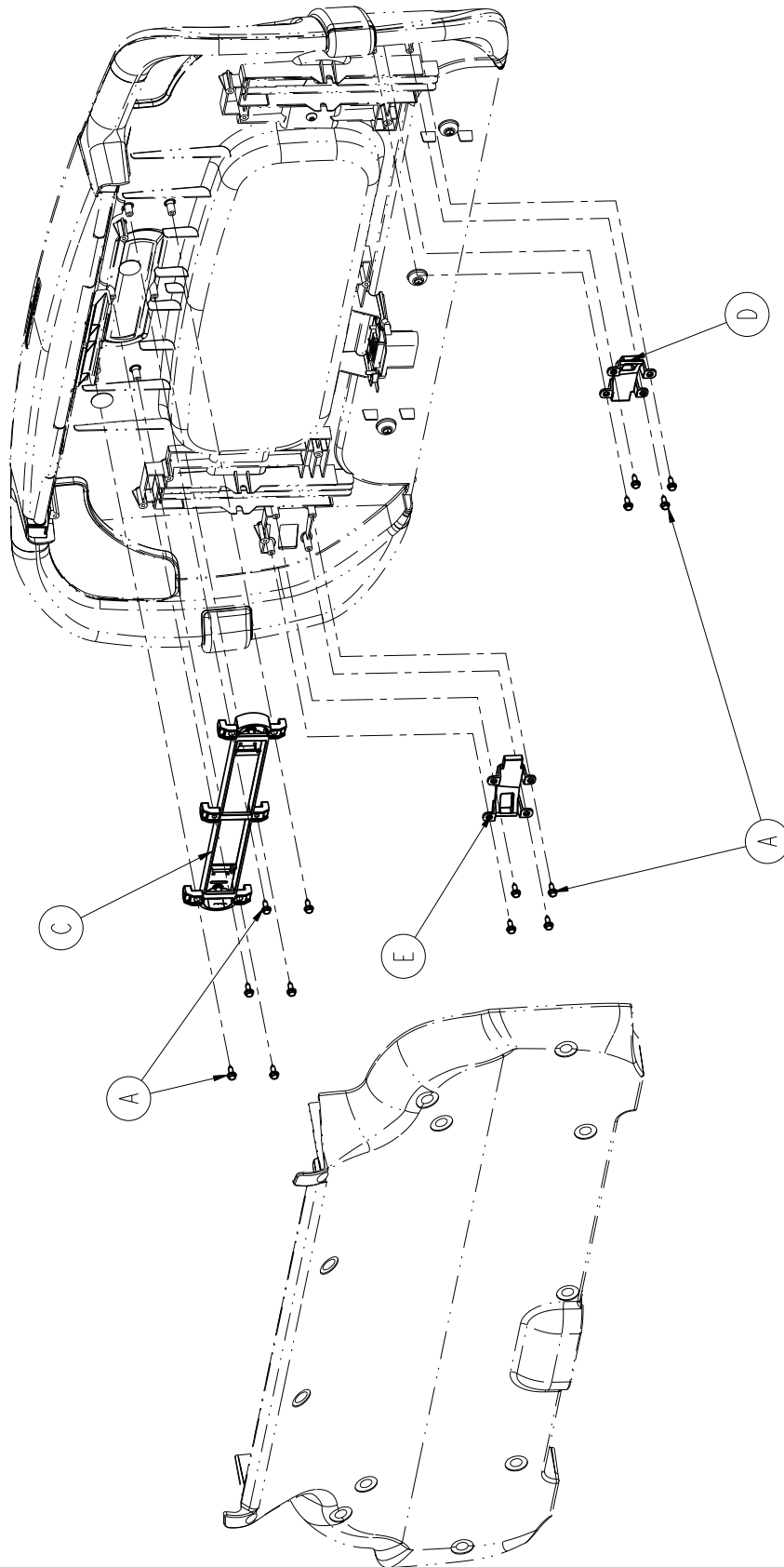

Footboard Assembly, No Options

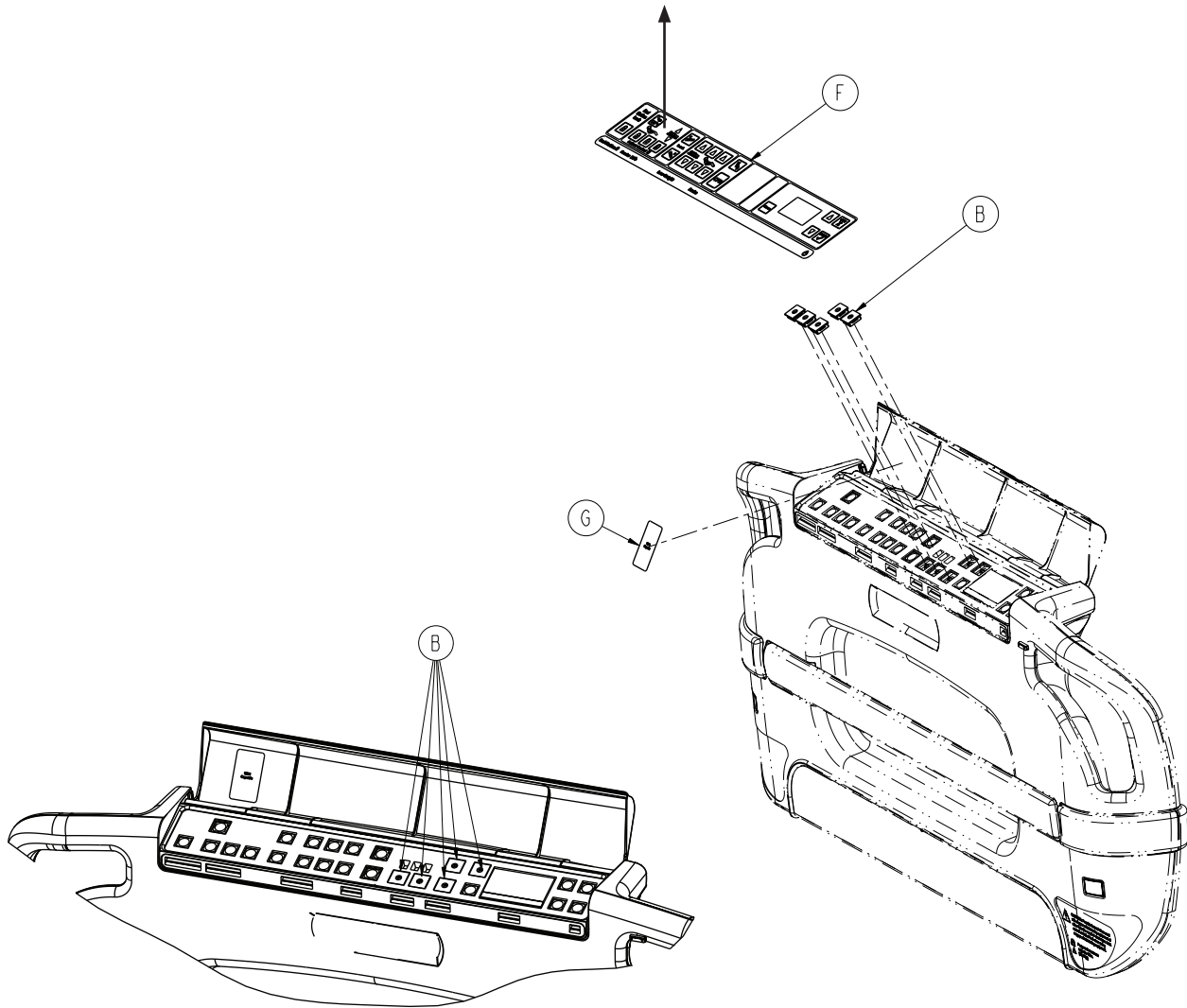
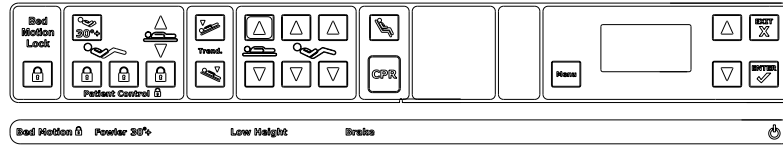

Footboard Assembly, No Options - 3006-500-104

| Item | Part No. | Part Name | Qty. |
|------|--------------|---|------|
| A | 0023-319-000 | Hex Washer Head Tapping Screw | 14 |
| B | 3001-400-522 | Filler Cap | 5 |
| C | 3006-500-007 | Center Lens Assembly | 1 |
| D | 3006-500-081 | Non-LBS Lens, Blank Inserts, RH | 1 |
| E | 3006-500-082 | Non-LBS Lens, Blank Inserts, LH | 1 |
| F | 3006-508-004 | Footboard Label, No Scale, No Bed Exit | 1 |
| G | 3006-508-105 | Label, WiFi Capable | 1 |

* Kit, Footboard Assembly, No Options - 3006-700-131

Footboard Assembly, Bed Exit Option

For Reference Only: 3006-500-105

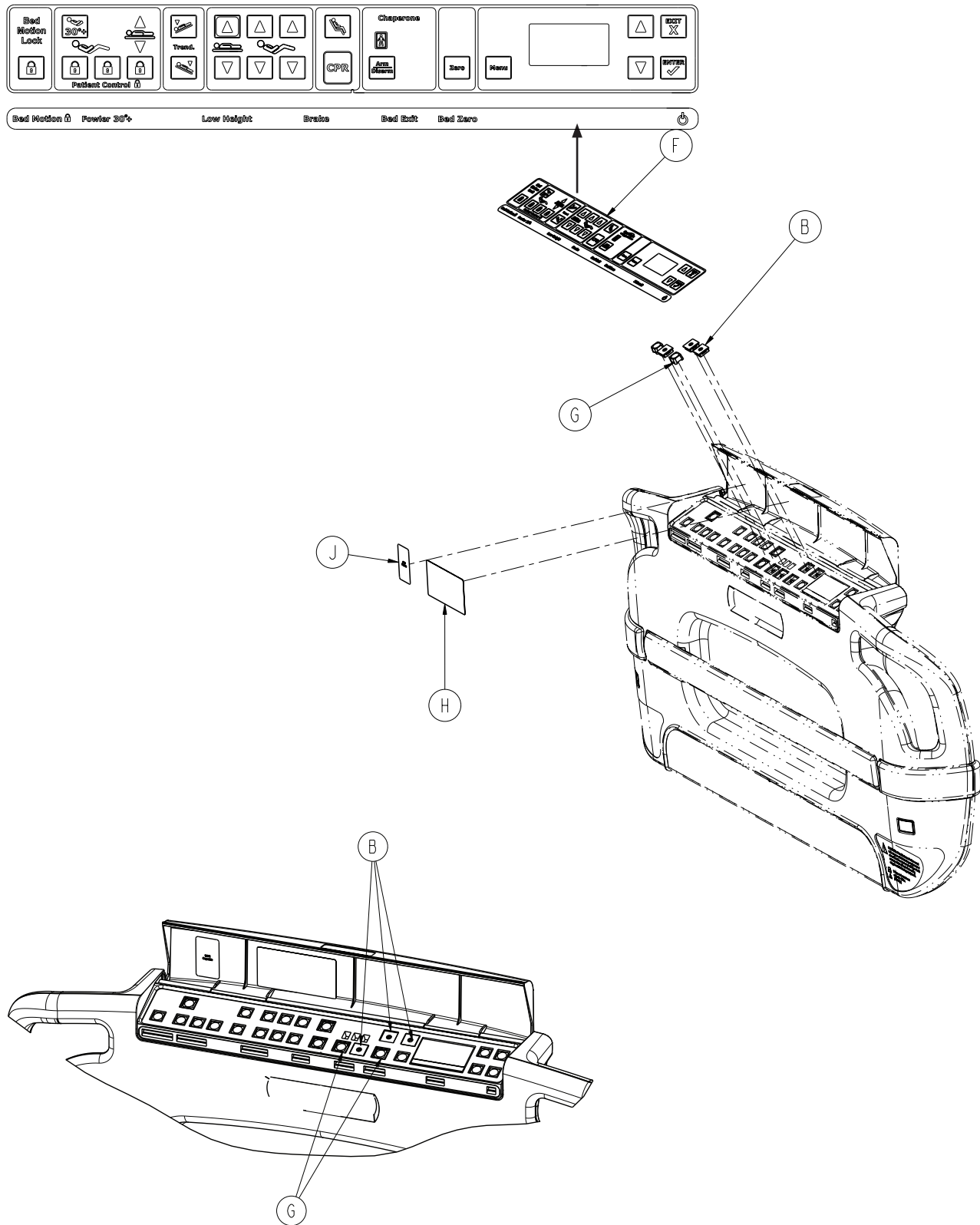

FILLER AND SWITCH CAP PLACEMENT

Footboard Assembly, Bed Exit Option

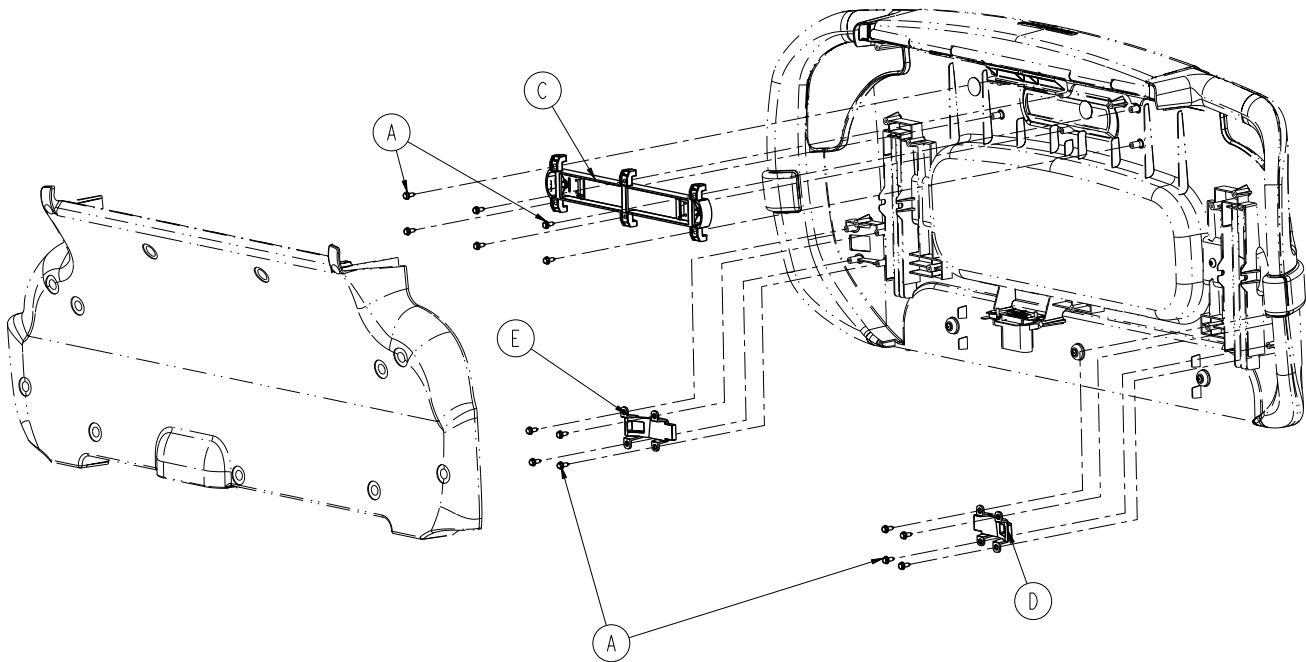

Footboard Assembly, Bed Exit Option - 3006-500-105

| Item | Part No. | Part Name | Qty. |
|------|--------------|-------------------------------------|------|
| A | 0023-319-000 | Hex Washer Head Tapping Screw | 14 |
| B | 3001-400-522 | Filler cap | 3 |
| C | 3006-500-007 | Center Lens Assembly | 1 |
| D | 3006-500-081 | Non-LBS Lens Blank Insert, RH | 1 |
| E | 3006-500-082 | Non-LBS Lens Blank Insert, LH | 1 |
| F | 3006-508-005 | Footboard Label, Bed Exit, No Scale | 1 |
| G | 3001-400-953 | Switch Cap | 2 |
| H | 3006-508-109 | Label, Bed Exit | 1 |
| J | 3006-508-105 | Label, WiFi Capable | 1 |

* Kit, Footboard Assembly, Single Zone Bed Exit - 3006-700-132

Footboard Assembly, Bed Exit/Scale Option

For Reference Only: 3006-500-107

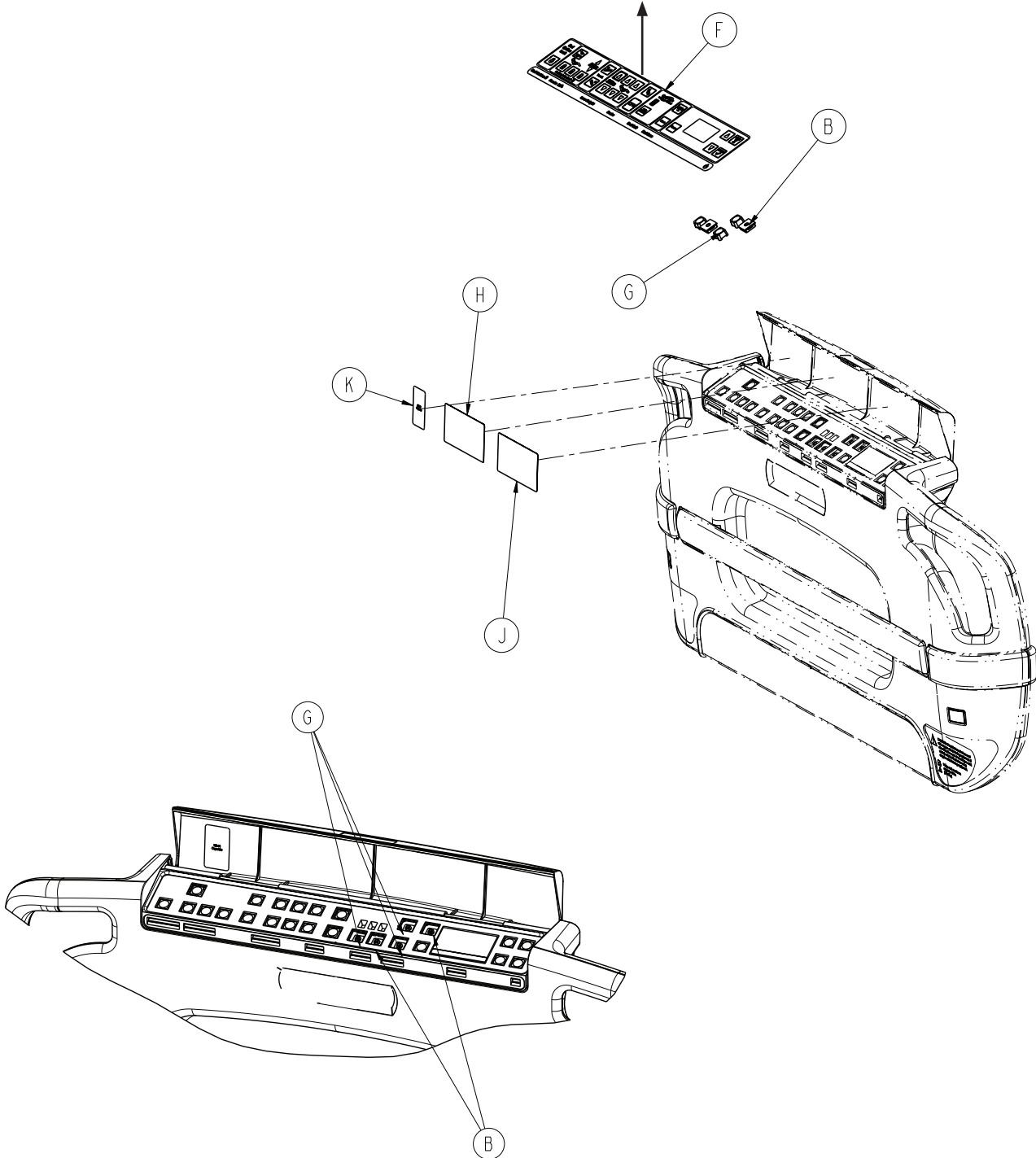
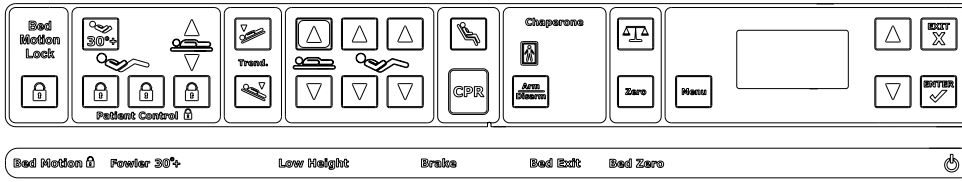

FILLER AND SWITCH CAP PLACEMENT

Footboard Assembly, Bed Exit/Scale Option

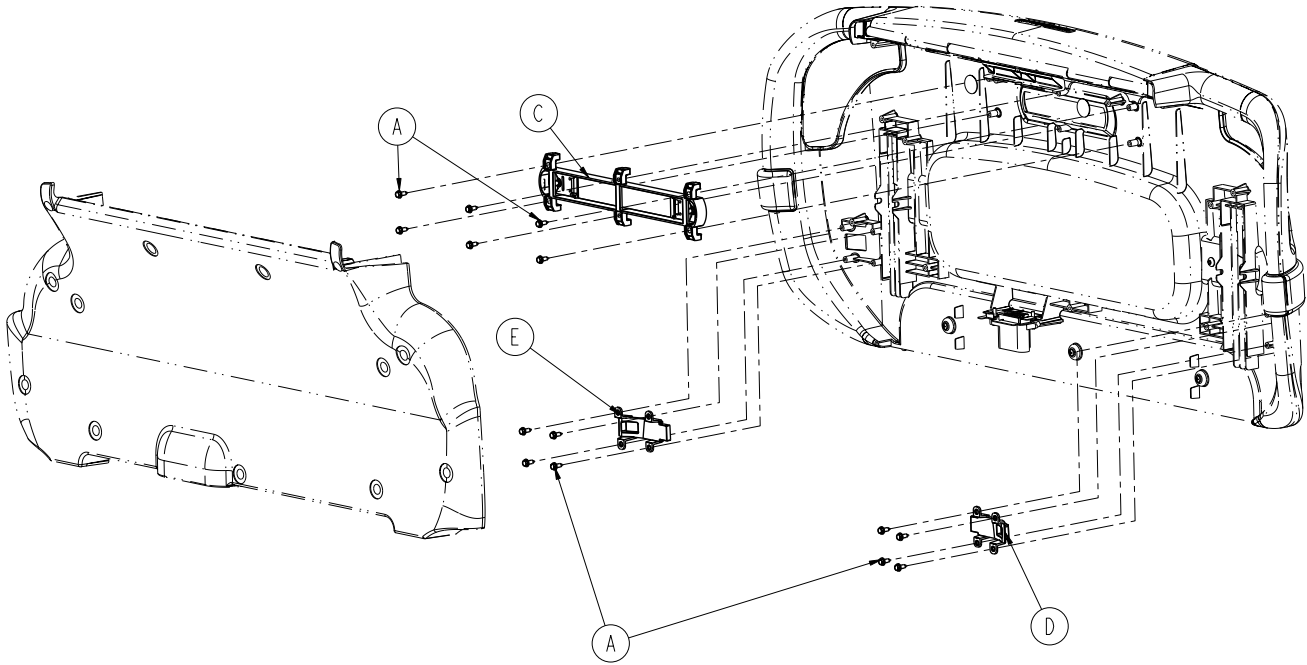

Footboard Assembly, Bed Exit/Scale Option - 3006-500-107

| Item | Part No. | Part Name | Qty. |
|------|--------------|----------------------------------|------|
| A | 0023-319-000 | Hex Washer Head Tapping Screw | 14 |
| B | 3001-400-522 | Filler cap | 2 |
| C | 3006-500-007 | Center Lens Assembly | 1 |
| D | 3006-500-081 | Non-LBS Lens Blank Insert, RH | 1 |
| E | 3006-500-082 | Non-LBS Lens Blank Insert, LH | 1 |
| F | 3006-508-007 | Footboard Label, Bed Exit, Scale | 1 |
| G | 3001-400-953 | Switch Cap | 3 |
| H | 3006-508-109 | Label, Bed Exit | 1 |
| J | 3006-508-107 | Label, Scale | 1 |
| K | 3006-508-105 | Label, WiFi Capable | 1 |

* Kit, Footboard Assembly, Single Zone Bed Exit/Scale - 3006-700-133

Footboard Assembly, Bed Exit/Zone Control Option

For Reference Only: 3006-500-106

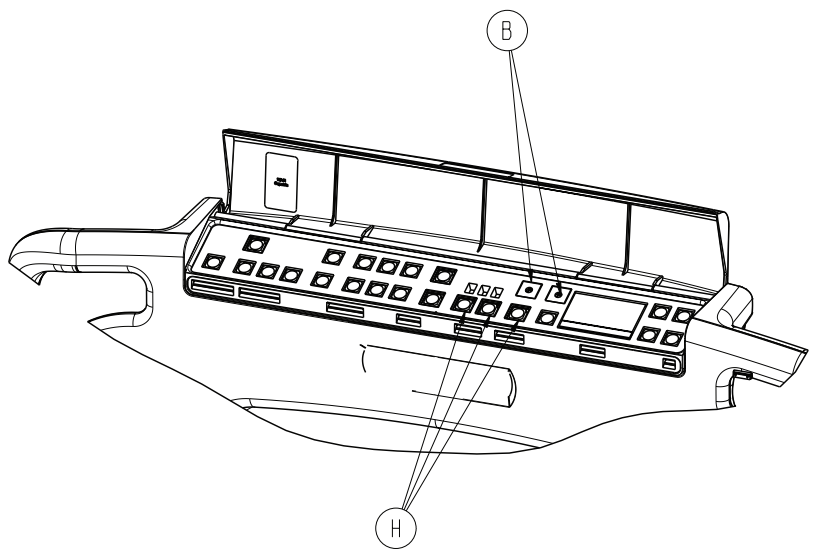
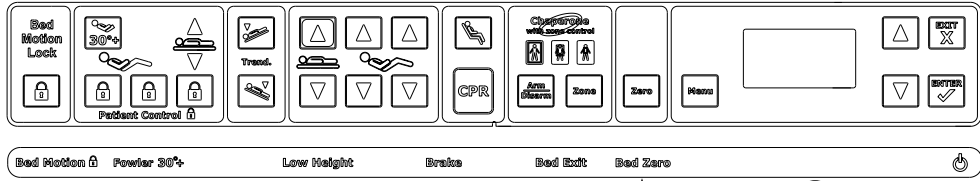

FILLER AND SWITCH CAP PLACEMENT

Footboard Assembly, Bed Exit/Zone Control Option

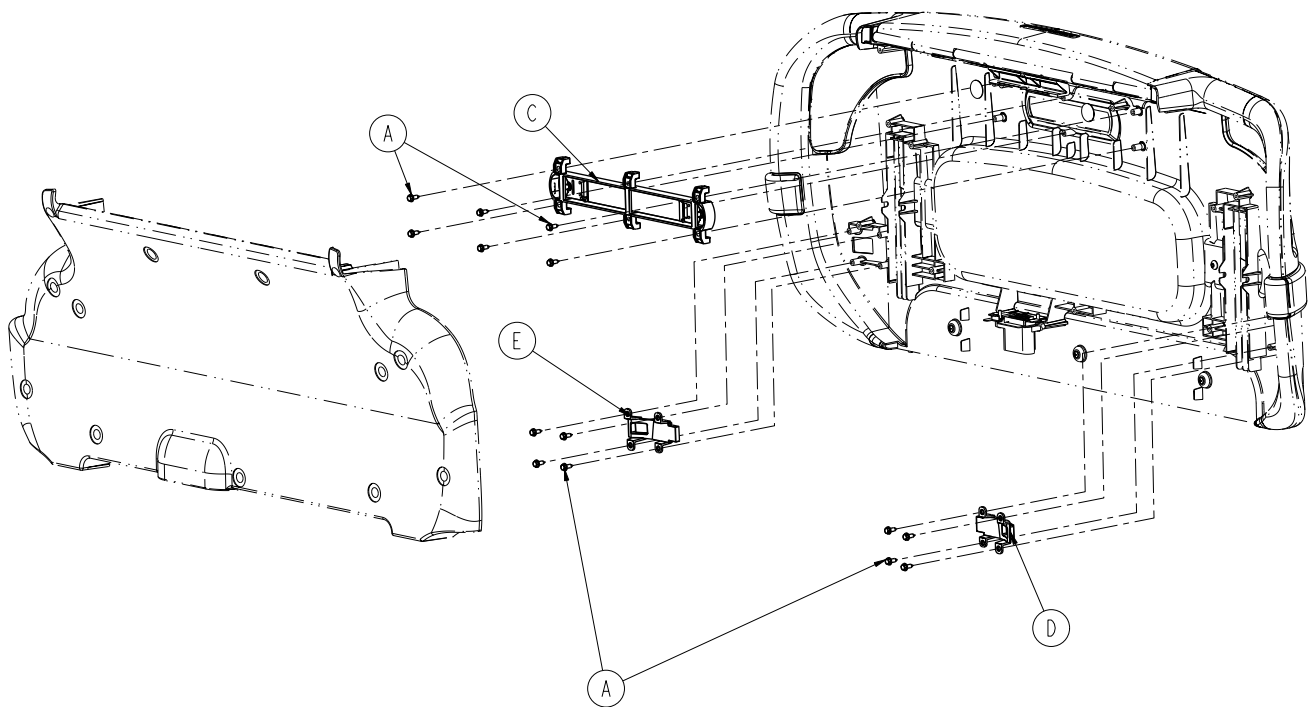

Footboard Assembly, Bed Exit/Zone Control Option - 3006-500-106

| Item | Part No. | Part Name | Qty. |
|------|--------------|--|------|
| A | 0023-319-000 | Hex Washer Head Tapping Screw | 14 |
| B | 3001-400-522 | Filler Cap | 2 |
| C | 3006-500-007 | Center Lens Assembly | 1 |
| D | 3006-500-081 | Non-LBS Lens Blank Insert, RH | 1 |
| E | 3006-500-082 | Non-LBS Lens Blank Insert, LH | 1 |
| F | 3006-508-006 | Footboard Label, Bed Exit with Zone Control | 1 |
| G | 3001-400-953 | Switch Cap | 3 |
| H | 3006-508-106 | Label, Bed Exit with Zone Control | 1 |
| J | 3006-508-105 | Label, WiFi Capable | 1 |

* Kit, Footboard Assembly, Multi-Zone Bed Exit - 3006-700-134

Footboard Assembly, Bed Exit/Scale/Zone Control Option

For Reference Only: 3006-500-109

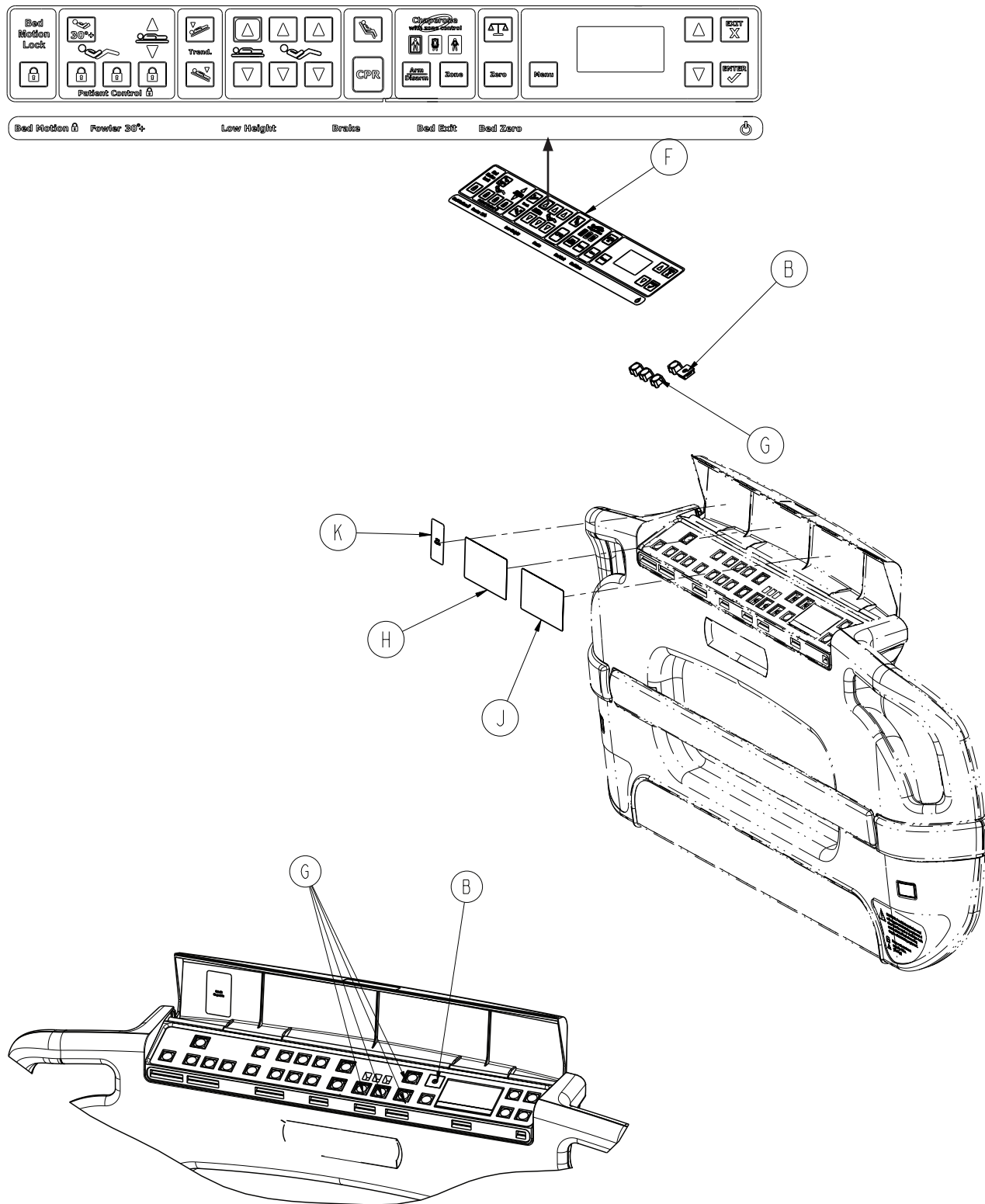

FILLER AND SWITCH CAP PLACEMENT

Footboard Assembly, Bed Exit/Scale/Zone Control Option

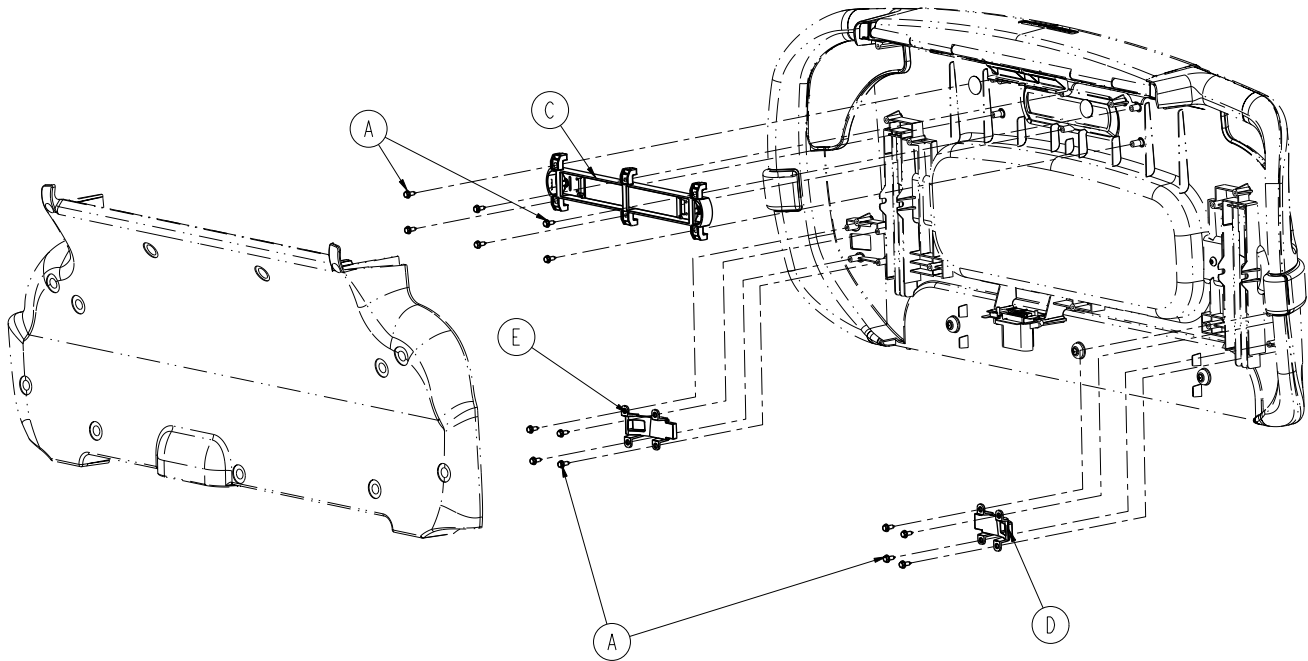

Footboard Assembly, Bed Exit/Scale/Zone Control Option - 3006-500-109

| Item | Part No. | Part Name | Qty. |
|------|--------------|--|------|
| A | 0023-319-000 | Hex Washer Head Tapping Screw | 14 |
| B | 3001-400-522 | Filler cap | 1 |
| C | 3006-500-007 | Center Lens Assembly | 1 |
| D | 3006-500-081 | Non-LBS Lens Blank Insert, RH | 1 |
| E | 3006-500-082 | Non-LBS Lens Blank Insert, LH | 1 |
| F | 3006-508-009 | Footboard Label, Bed Exit, Scale and Zone Control | 1 |
| G | 3001-400-953 | Switch Cap | 4 |
| H | 3006-508-106 | Label, Bed Exit with Zone Control | 1 |
| J | 3006-508-107 | Label, Scale | 1 |
| K | 3006-508-105 | Label, WiFi Capable | 1 |

* Kit, Footboard Assembly, Multi-Zone Bed Exit/Scale - 3006-700-135

Footboard Assembly, iBed® Awareness Option (with Bed Exit, Scale and Zone Control)

For Reference Only: 3006-500-100

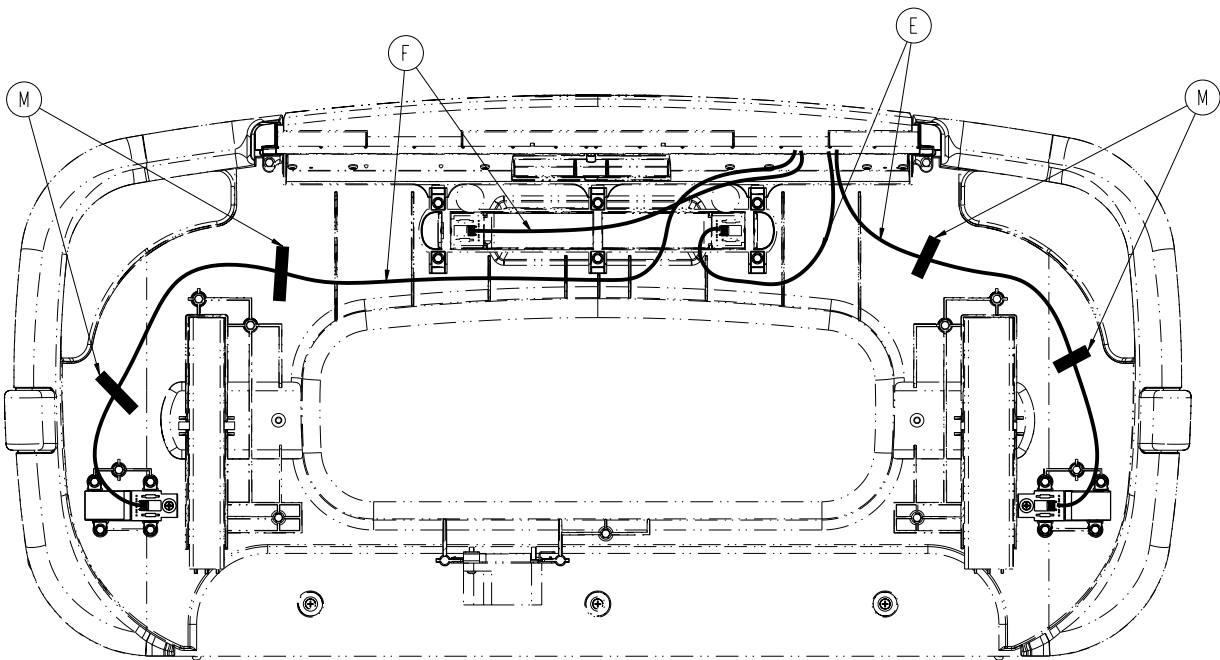
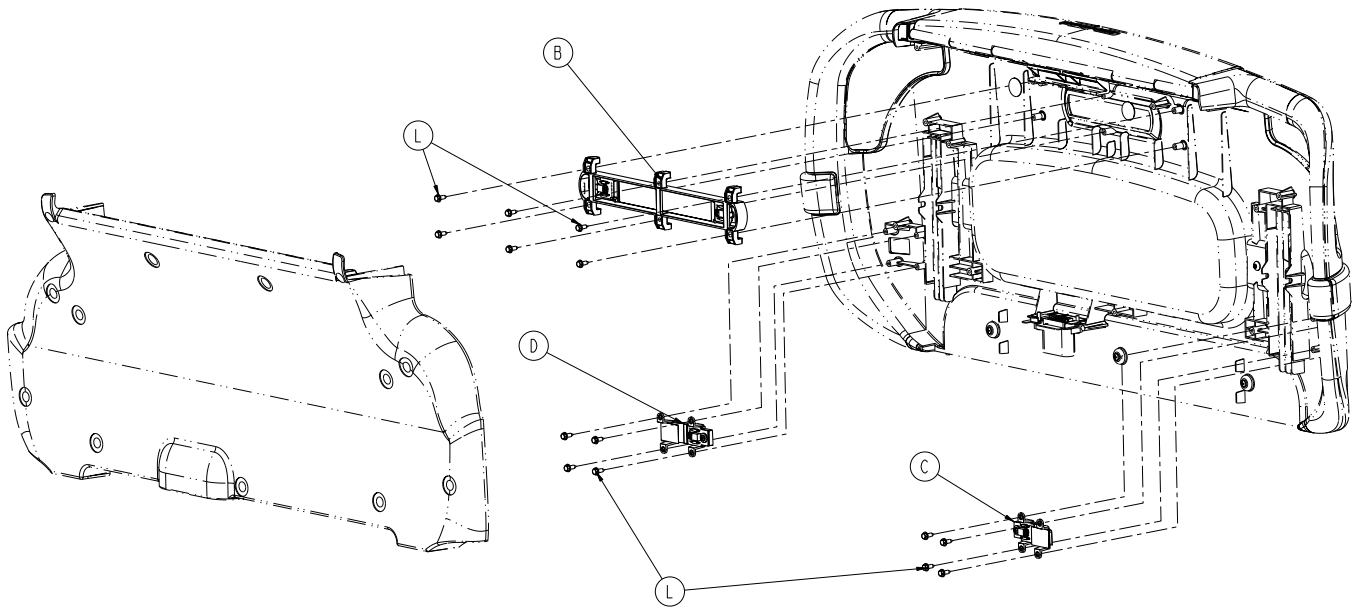

Footboard Assembly, *i*Bed® Awareness Option

(with Bed Exit, Scale and Zone Control)

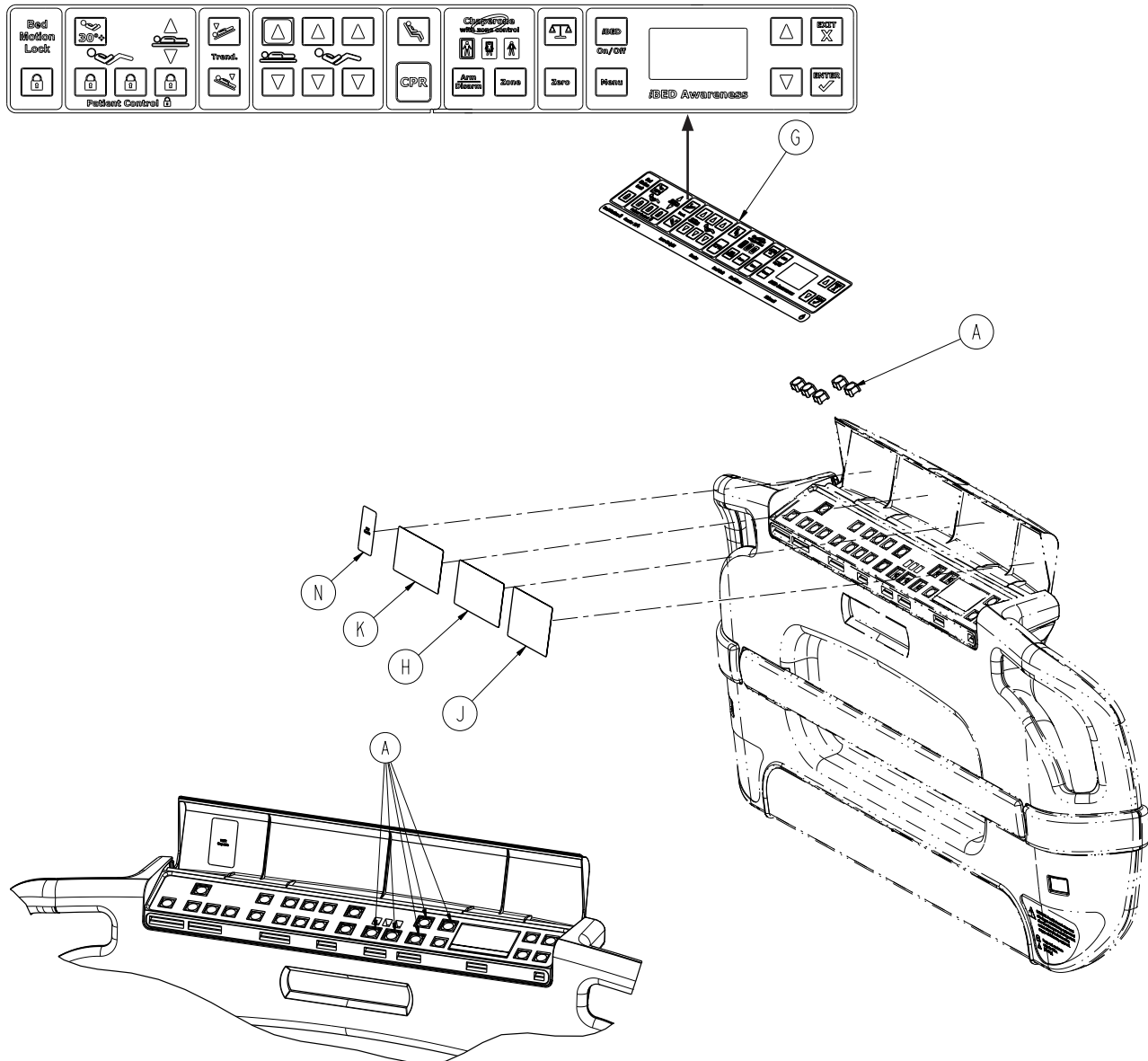

Footboard Assembly, *i*Bed® Awareness Option (with Bed Exit, Scale and Zone Control) - 3006-500-100

| Item | Part No. | Part Name | Qty. |
|------|--------------|-----------------------------------|------|
| A | 3001-400-953 | Switch Cap | 5 |
| B | 3006-500-008 | Indicator Light Assembly | 1 |
| C | 3006-500-080 | Footboard Right Lens Assembly | 1 |
| D | 3006-500-090 | Footboard Left Lens Assembly | 1 |
| E | 3006-500-804 | Footboard Cable, Right Lens | 1 |
| F | 3006-500-805 | Footboard Cable, Left Lens | 1 |
| G | 3006-508-002 | Label, Bed Exit with Zone Control | 1 |
| H | 3006-508-107 | Label, Scale | 1 |
| J | 3006-508-108 | Label, Awareness | 1 |
| K | 3006-508-106 | Label, Bed Exit with Zone Control | 1 |
| L | 0023-319-000 | Hex Washer Head Tapping Screw | 14 |
| M | 3006-400-208 | Label, Cable Restraint | 4 |
| N | 3006-508-105 | Label, WiFi Capable | 1 |

* Kit, Footboard Assembly, *i*Bed® Awareness - 3006-700-136

[Return To Table of Contents](#)

Headboard Assembly - 3006-600-010

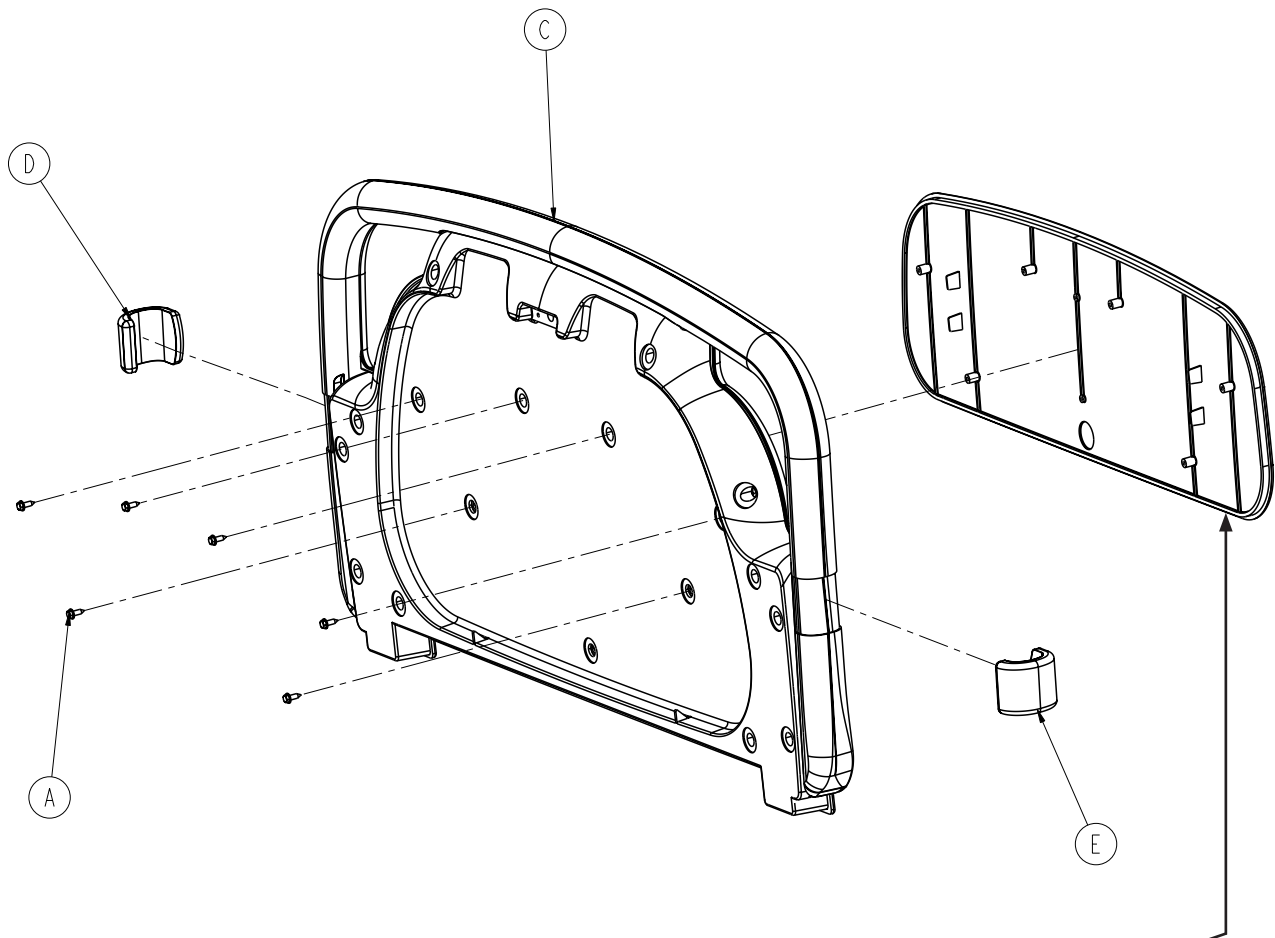

OPTIONAL LAMINATE
(Not included with
Headboard Assembly)

| | |
|--------------------------|--------------|
| Hard Rock Maple | 3006-060-441 |
| Fine Oak | 3006-060-442 |
| Port Maple | 3006-060-443 |
| Wild Cherry | 3006-060-446 |
| Cayenne Maple | 3006-060-447 |
| Honey Maple | 3006-060-448 |
| Select Cherry | 3006-060-449 |
| Sand White (Standard) | 3006-060-450 |

Headboard Assembly - 3006-600-010

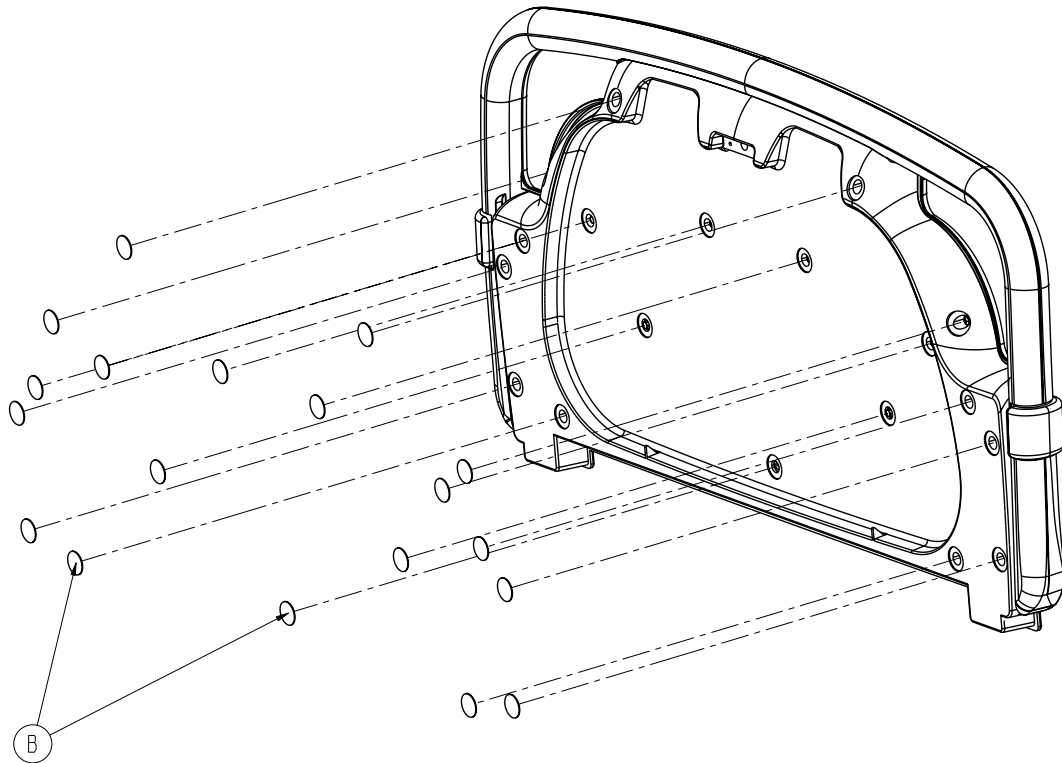

| Item | Part No. | Part Name | Qty. |
|------|--------------|---------------------------------|------|
| A | 0023-319-000 | Hex Washer Head Screw | 6 |
| B | 3006-508-011 | Footboard Screw Cover Label | 19 |
| C | 3006-600-000 | Headboard Ass'y, Standard Comp. | 1 |
| D | 3006-600-017 | Headboard Bumper, Right | 1 |
| E | 3006-600-018 | Headboard Bumper, Left | 1 |

Optional Accessories

| Accessory | Part Number | Page Reference |
|---|--|--------------------------|
| CPR Board Assembly | 3006-626-010 | page 415 |
| Removable I.V. Pole and Mounting Assembly | 3001-338-010 | page 416 |
| Removable I.V. Pole Assembly | 3000-300-080 | page 417 |
| Two Stage I.V. Pole Assembly | 2035-112-000 | page 418 |
| Dual Head End I.V. Pole Assembly | 2035-113-000 | page 419 |
| Dual Head End I.V. Pole Assembly - Zoom® | 2040-110-003 | page 420 |
| Two Stage I.V. Pole | 2035-112-010 2035-113-011 | page 421 |
| I.V. Pole Latch Assembly | 0785-035-103 | page 422 |
| Defibrillator Tray Assembly | 3006-120-004 | page 423 |
| 90° Power Cords | 3001-334-860 3001-334-861 3001-334-862 3001-334-863 | page 424 |
| Upright Oxygen Bottle Holder Assembly | 3006-150-000 | page 425 |
| Accessory Adapter Frame | 3006-333-000 | page 426 |
| Litter Roller Assembly | 3006-335-000 | page 427 |
| Roller Assembly | 3006-335-005 | page 428 |
| Patient Helper Assembly | 3006-345-000 | page 429 |
| Patient Helper Roller Assembly | 3006-345-005 | page 430 |
| Bed Extender Assembly | 3006-346-020 | page 431 |
| Bed Extender Mattress | 3000-318-050 | page 433 |
| Traction Socket Extensions | 3000-337-050 3000-337-450 3000-337-475 3000-337-850 3000-337-875 | page 434 |

CPR Board Assembly - 3006-626-010

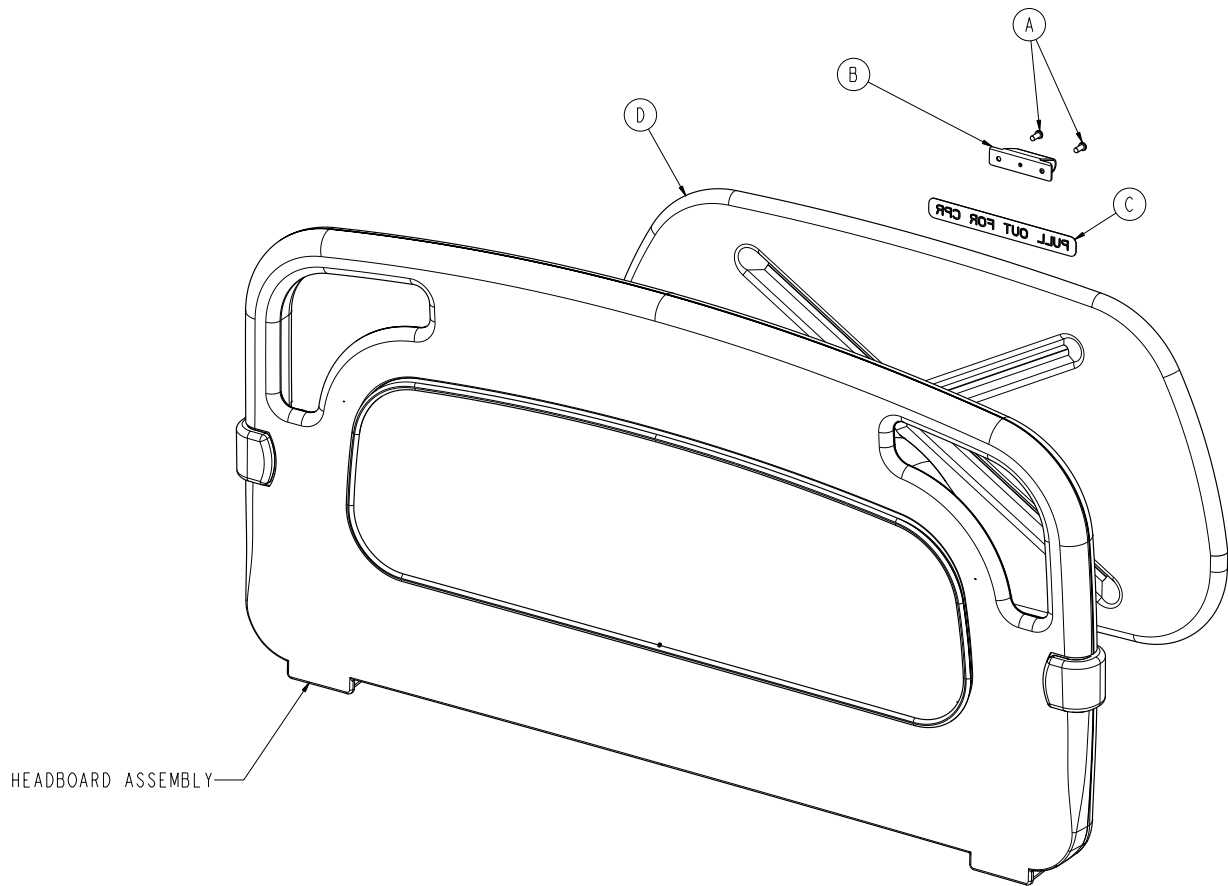

| Item | Part No. | Part Name | Qty. |
|------|--------------|------------------------|------|
| A | 0023-088-000 | Pan Head Tapping Screw | 2 |
| B | 3006-526-002 | CPR Headboard Clip | 1 |
| C | 3006-526-003 | CPR Board Label | 1 |
| D | 3006-626-001 | CPR Board | 1 |

Removable I.V. Pole and Mounting Ass'y - 3001-338-010

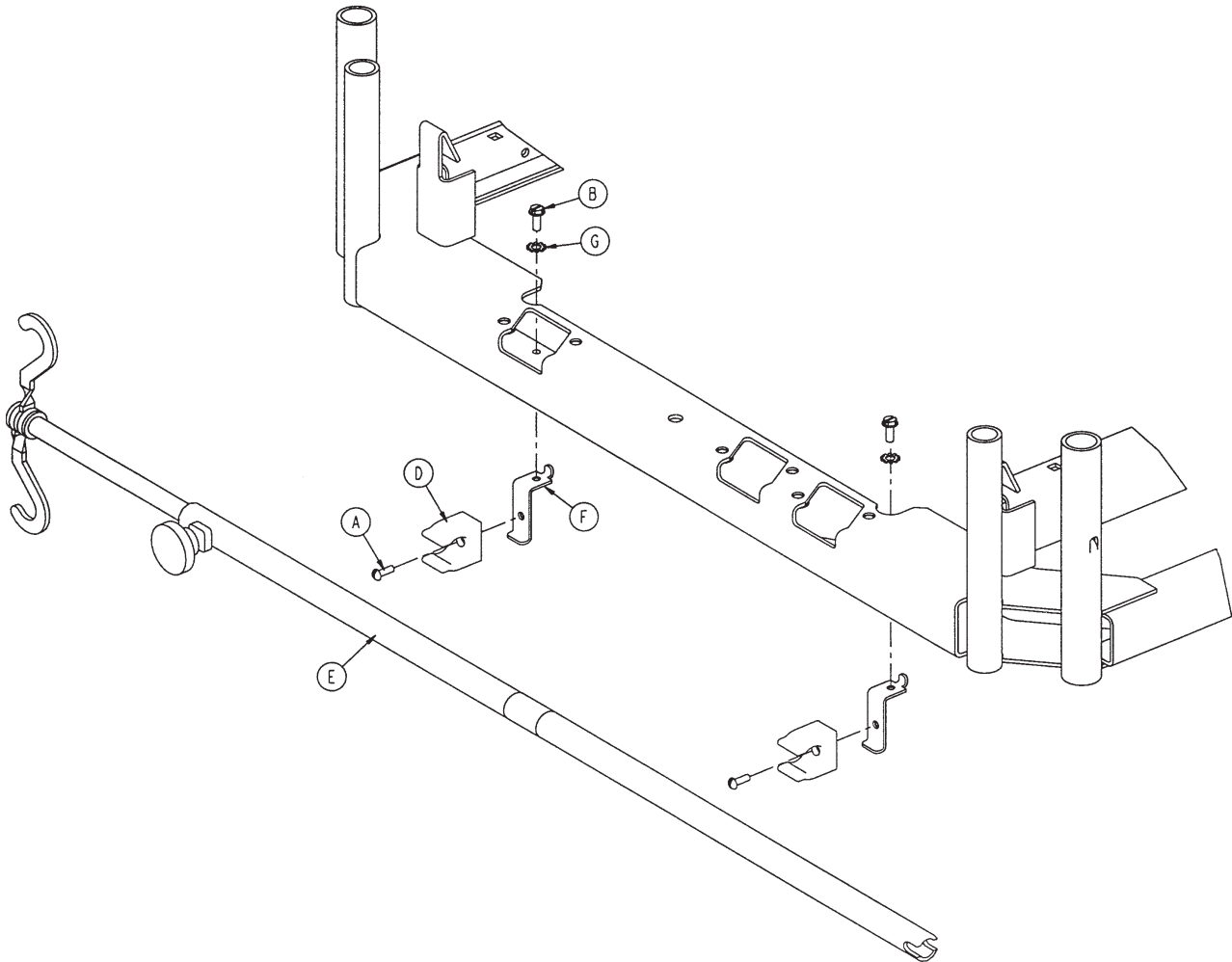

| Item | Part No. | Part Name | Qty. |
|------|--------------|----------------------------|------|
| A | 0002-031-000 | Round Head Screw | 2 |
| B | 0003-124-000 | Hex Washer Head Screw | 2 |
| D | 0958-001-224 | I.V. Clip | 2 |
| E | 3000-300-080 | I.V. Pole Assembly | 1 |
| F | 3001-300-087 | Mounting Bracket | 2 |
| G | 0013-018-000 | External Tooth Lock Washer | 2 |

Removable I.V. Pole Assembly - 3000-300-080

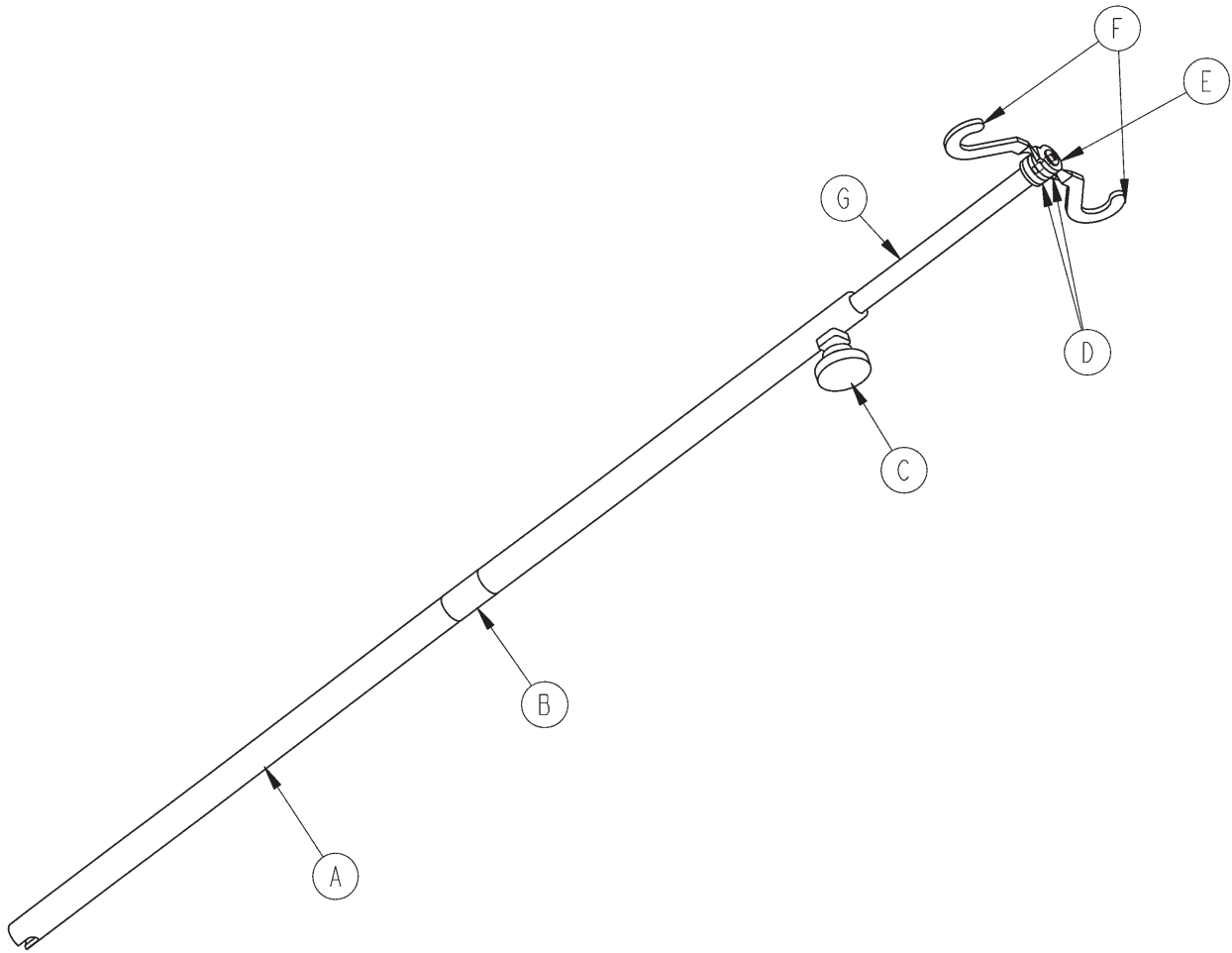

| Item | Part No. | Part Name | Qty. |
|------|--------------|---------------------------|------|
| A | 3000-300-081 | Outer Tube | 1 |
| B | 3000-300-089 | Label | 1 |
| C | 0024-050-000 | Fluted Knob | 1 |
| D | 0052-017-000 | Spacer | 2 |
| E | 0007-040-000 | Phillips Truss Head Screw | 1 |
| F | 1010-059-016 | I.V. Hook | 2 |
| G | 3000-300-085 | Inner Tube Assembly | 1 |

2-Stage I.V. Pole Assembly - 2035-112-000

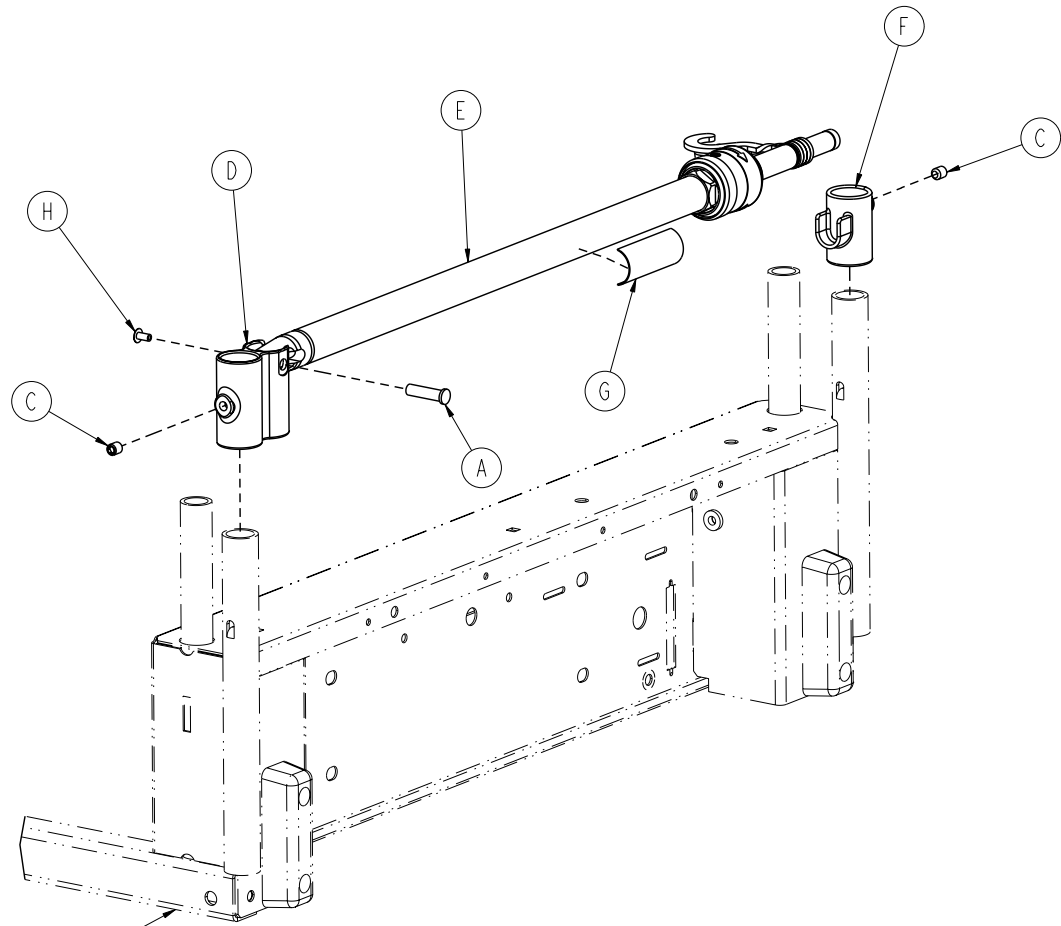

(2035-031-054)

| Item | Part No. | Part Name | Qty. |
|------|--------------|---------------------------|------|
| A | 0785-048-025 | Handle Pivot Pin | 1 |
| C | 0021-193-000 | Set Screw | 2 |
| D | 2035-112-011 | I.V. Receptacle, HE, Left | 1 |
| E | 2035-112-010 | I.V. Pole Ass'y, HE, Left | 1 |
| F | 3000-311-036 | I.V. Rest | 1 |
| G | 2035-112-110 | Specification Label | 1 |
| H | 0025-079-000 | Dome Head Rivet | 1 |

Dual Head End I.V. Pole Assembly - 2035-113-000

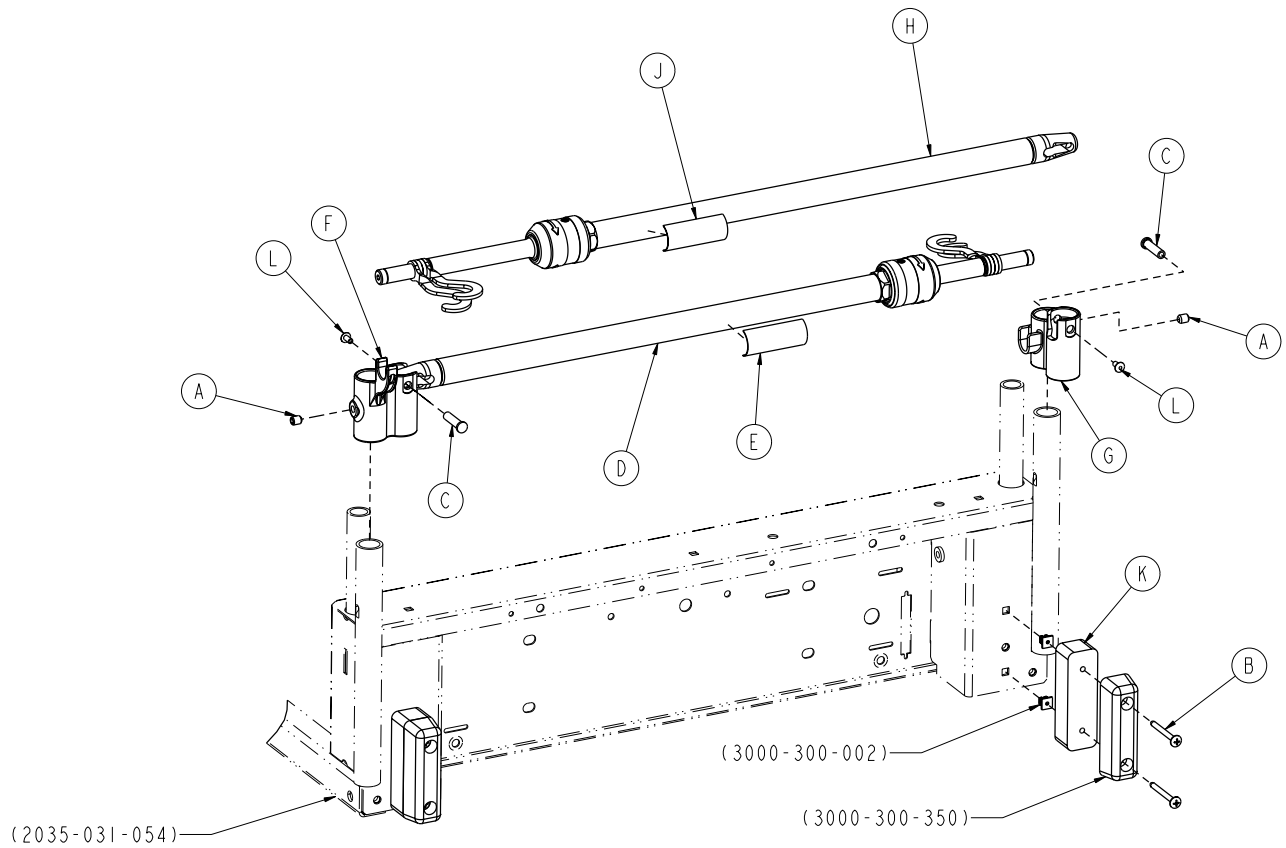

| Item | Part No. | Part Name | Qty. |
|------|--------------|---------------------------------|------|
| A | 0021-193-000 | Set Screw | 2 |
| B | 0023-277-000 | Truss Head Screw | 4 |
| C | 0785-048-025 | Handle Pivot Pin | 2 |
| D | 2035-112-010 | I.V. Pole Ass'y, HE, Left | 1 |
| E | 2035-112-110 | Specification Label | 1 |
| F | 2035-113-021 | I.V. Receptacle, Dual HE, Left | 1 |
| G | 2035-113-012 | I.V. Receptacle, Dual HE, Right | 1 |
| H | 2035-113-011 | I.V. Pole Assembly, HE, Right | 1 |
| J | 2035-113-111 | Specification Label | 1 |
| K | 2035-113-006 | Head End Bumper Spacer | 2 |
| L | 0025-079-000 | Dome Head Rivet | 2 |

Dual Head End I.V. Pole Assembly - 2040-110-003

FOR Zoom® OPTION ONLY

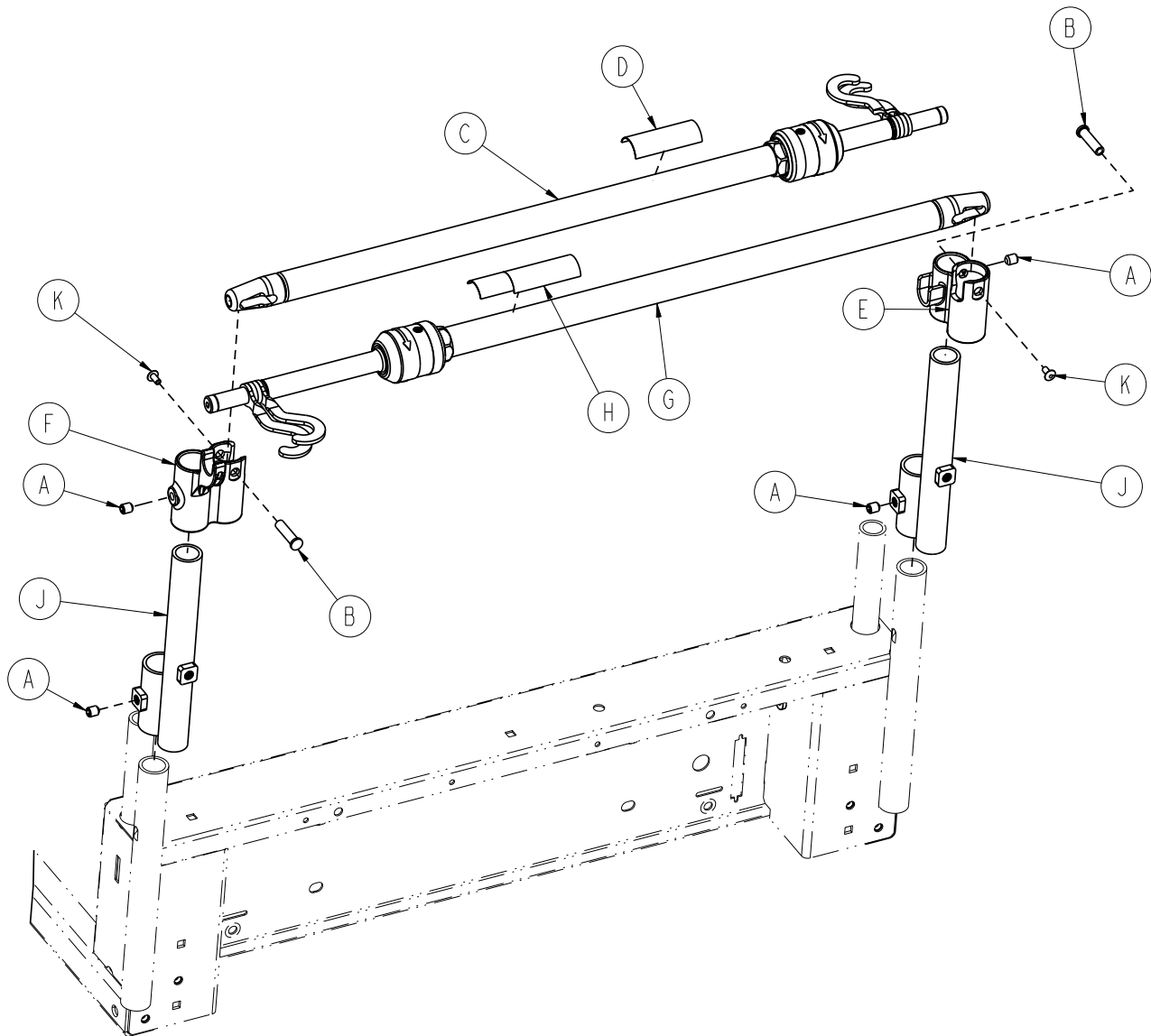

| Item | Part No. | Part Name | Qty. |
|------|--------------|---------------------------------|------|
| A | 0021-193-000 | Set Screw | 4 |
| B | 0785-048-025 | Handle Pivot Pin | 2 |
| C | 2035-112-010 | I.V. Pole Assembly, Left | 1 |
| D | 2035-112-110 | Specification Label | 1 |
| E | 2035-113-012 | I.V. Receptacle, Dual HE, Right | 1 |
| F | 2035-113-021 | I.V. Receptacle, Dual HE, Left | 1 |
| G | 2035-113-011 | I.V. Pole Assembly, Right | 1 |
| H | 2035-113-111 | Specification Label | 1 |
| J | 2040-110-002 | I.V. Pole Extension | 2 |
| K | 0025-079-000 | Dome Head Rivet | 2 |

2-Stage I.V. Pole - 2035-112-010 & 2035-113-011

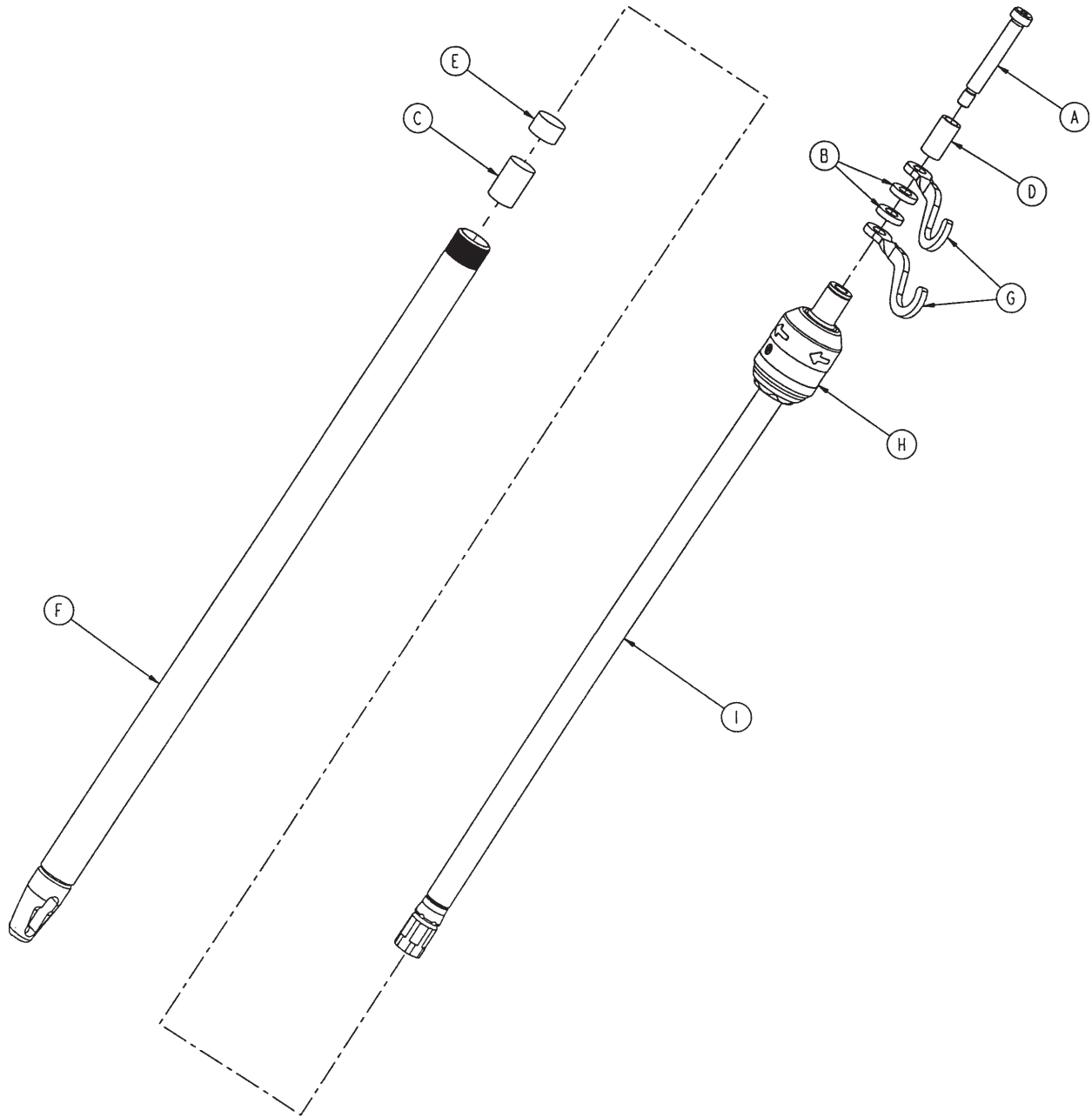

Left Side - 2035-112-010

| Item | Part No. | Part Name | Qty. |
|------|--------------|----------------------------|------|
| A | 0008-031-000 | Socket Head Shoulder Screw | 1 |
| B | 0052-017-000 | Washer | 2 |
| C | 0052-310-000 | Spacer | 1 |
| D | 0926-400-162 | Spacer | 1 |
| E | 1001-259-013 | Dampener | 1 |
| F | 1001-259-032 | Base Tube Weldment | 1 |
| G | 1010-259-016 | I.V. Hook | 2 |
| H | 0785-035-103 | I.V. Pole Latch | 1 |
| I | 1211-110-029 | 2nd Stage Assembly | 1 |

Right Side - 2035-113-011

| Item | Part No. | Part Name | Qty. |
|------|--------------|----------------------------|------|
| A | 0008-031-000 | Socket Head Shoulder Screw | 1 |
| B | 0052-017-000 | Washer | 2 |
| C | 0052-311-000 | Spacer | 1 |
| D | 0926-400-162 | Spacer | 1 |
| E | 1001-259-013 | Dampener | 1 |
| F | 1001-259-032 | Base Tube Weldment | 1 |
| G | 1010-259-016 | I.V. Hook | 2 |
| H | 0785-035-103 | I.V. Pole Latch | 1 |
| I | 1211-110-029 | 2nd Stage Assembly | 1 |

[Return To Table of Contents](#)

I.V. Pole Latch Assembly - 0785-035-103

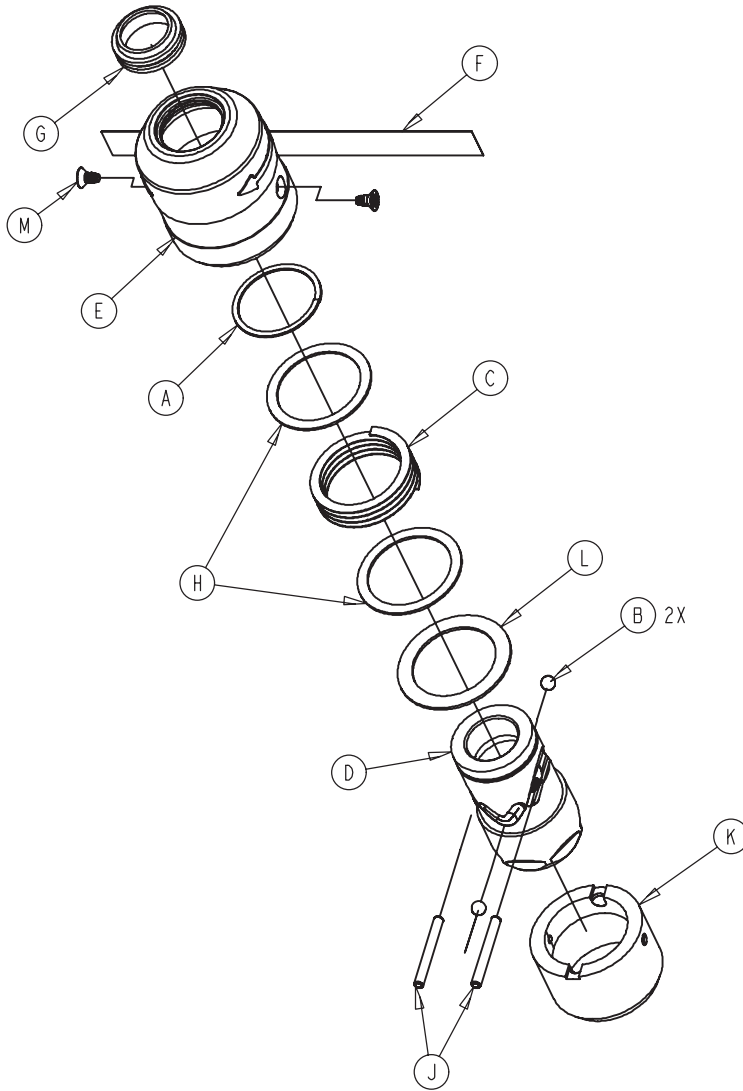

| Item | Part No. | Part Name | Qty. |
|------|--------------|------------------------|------|
| A | 0028-167-000 | Retaining Ring | 1 |
| B | 0031-004-000 | Steel Ball | 2 |
| C | 0038-392-000 | Wave Spring | 1 |
| D | 0785-035-023 | I.V. Latch ID Housing | 1 |
| E | 0785-035-024 | I.V. Latch OD Housing | 1 |
| F | 0785-035-029 | I.V. Release Label | 2 |
| G | 1211-011-018 | I.V. Latch Seal | 2 |
| H | 1211-110-020 | Washer | 2 |
| J | 1211-110-021 | I.V. Latch Locking Pin | 2 |
| K | 1211-110-022 | I.V. Latch Guide | 1 |
| L | 1211-110-035 | Washer | 1 |
| M | 1211-110-036 | Self-Tapping Screw | 2 |

Defibrillator Tray Assembly - 3006-120-004

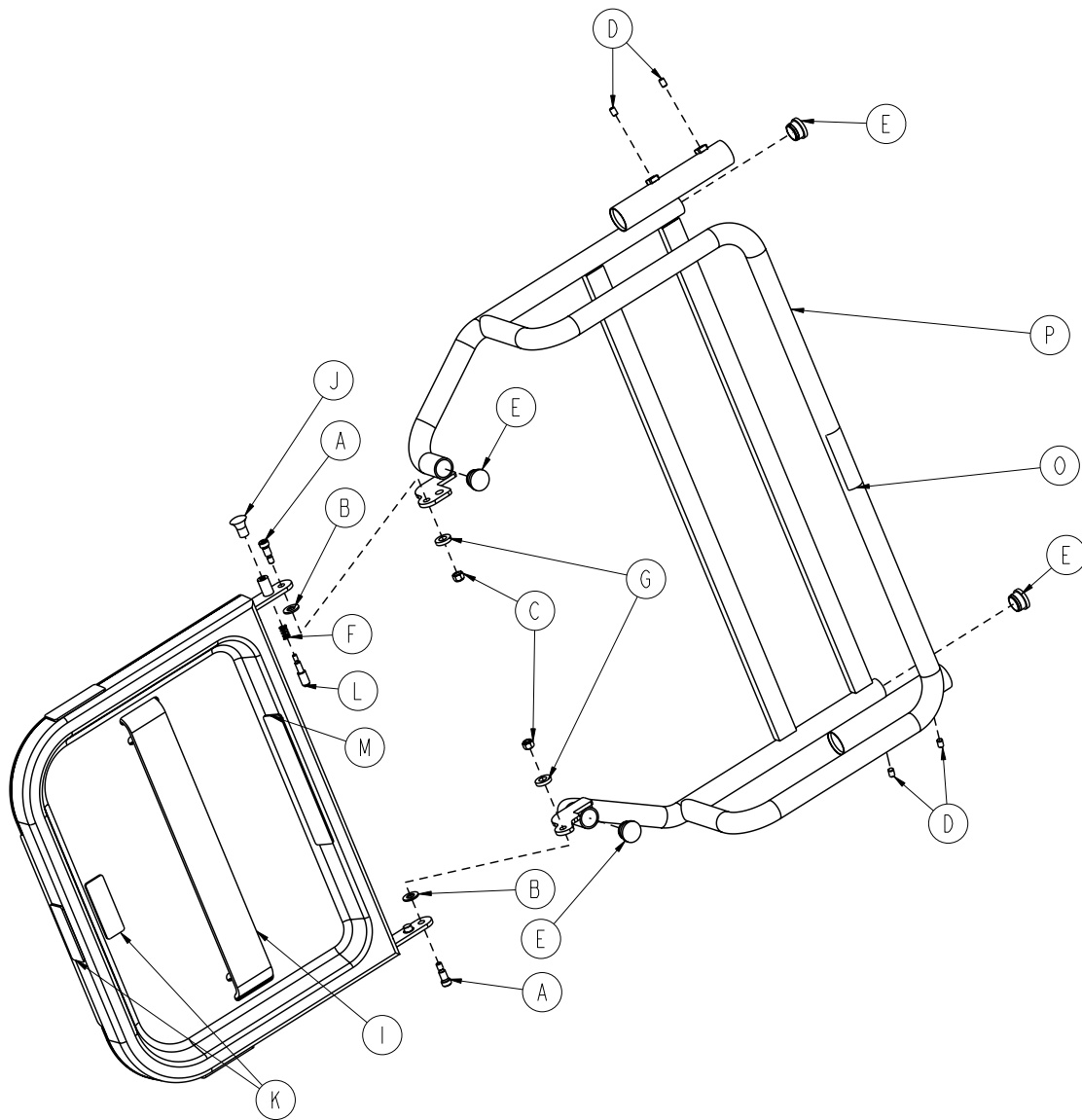

| Item | Part No. | Part Name | Qty. |
|------|--------------|-----------------------------|------|
| A | 0008-049-000 | Socket Head Shoulder Bolt | 2 |
| B | 0014-020-000 | Thrust Washer | 1 |
| C | 0016-028-000 | Fiberlock Nut | 2 |
| D | 0021-017-000 | Set Screw | 4 |
| E | 0037-214-000 | Hole Plug | 4 |
| F | 0038-133-000 | Spring | 1 |
| G | 0052-017-000 | Spacer | 2 |
| H | 1010-050-019 | "Push/Pull" Label | 1 |
| I | 1010-050-021 | Long Strap | 1 |
| J | 1010-050-050 | Knob | 1 |
| K | 1010-050-057 | Maximum Weight Label | 4 |
| L | 1010-050-242 | Lock Pin | 1 |
| M | 2025-120-005 | Equipment Label | 1 |
| N | 3006-120-018 | Tray Assembly | 1 |
| O | 2040-090-001 | Warning Label - Accessories | 1 |
| P | 3006-120-003 | Pivot Weldment Frame | 1 |

90° Power Cord - 3001-334-010

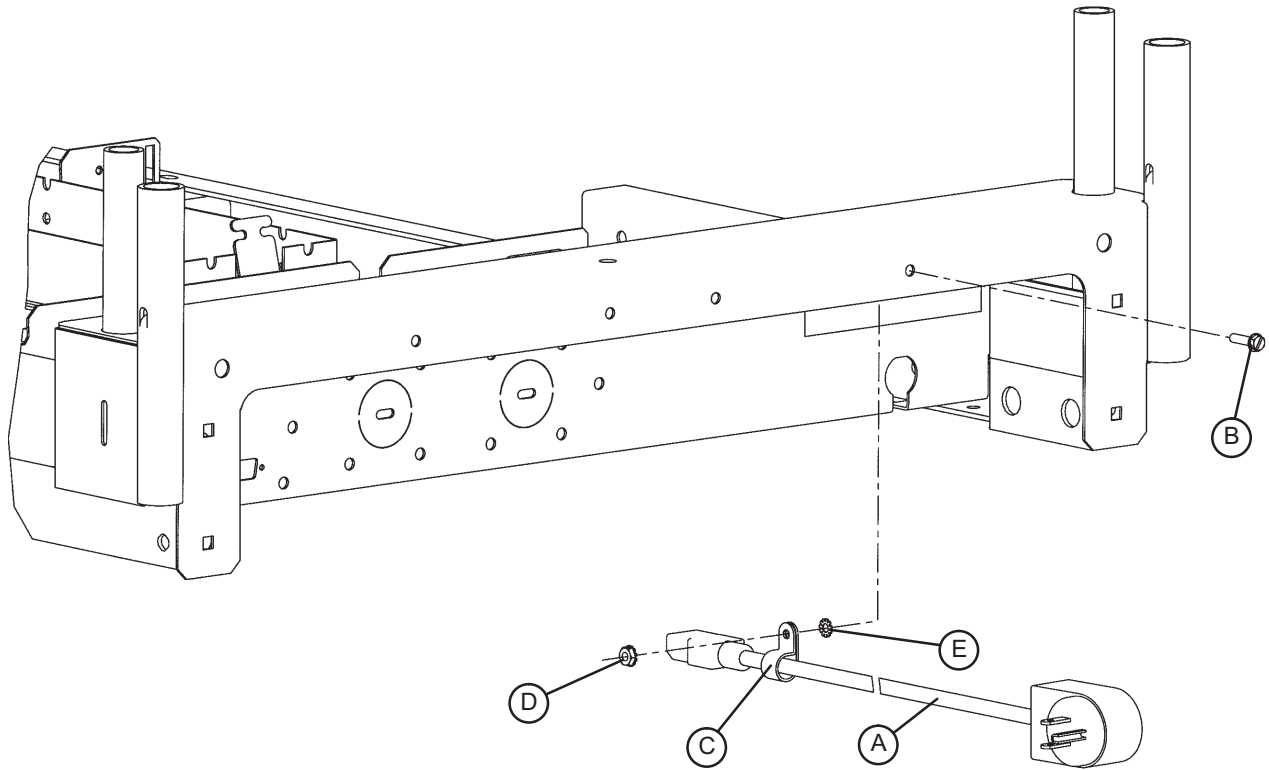

| Item | Part No. | Part Name | Qty. |
|------|--------------|-----------------------------|------|
| A | 3001-334-860 | 90° Power Cord (12 O'Clock) | 1 |
| | 3001-334-861 | 90° Power Cord (9 O'Clock) | 1 |
| | 3001-334-862 | 90° Power Cord (6 O'Clock) | 1 |
| | 3001-334-863 | 90° Power Cord (3 O'Clock) | 1 |
| B | 0003-132-000 | Hex Washer Head Screw | 1 |
| C | 0034-022-000 | Cable Clamp | 1 |
| D | 0016-041-000 | Kep Nut | 1 |
| E | 0013-018-000 | External Tooth Lock Washer | 1 |

Upright Oxygen Bottle Holder Assembly - 3006-150-000

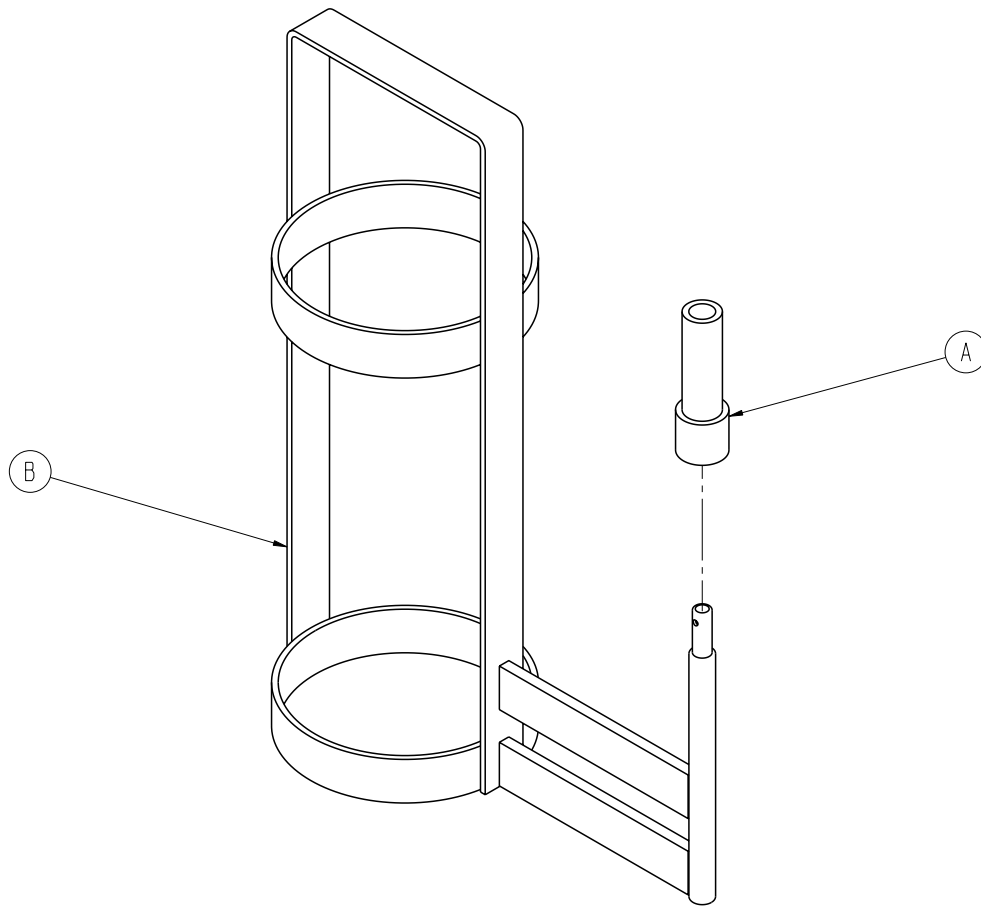

| Item | Part No. | Part Name | Qty. |
|------|--------------|-----------------------|------|
| A | 2025-150-001 | Bottle Holder Adapter | 1 |
| B | 3006-046-001 | Upright Bottle Holder | 1 |

Accessory Adapter Frame - 3006-333-000

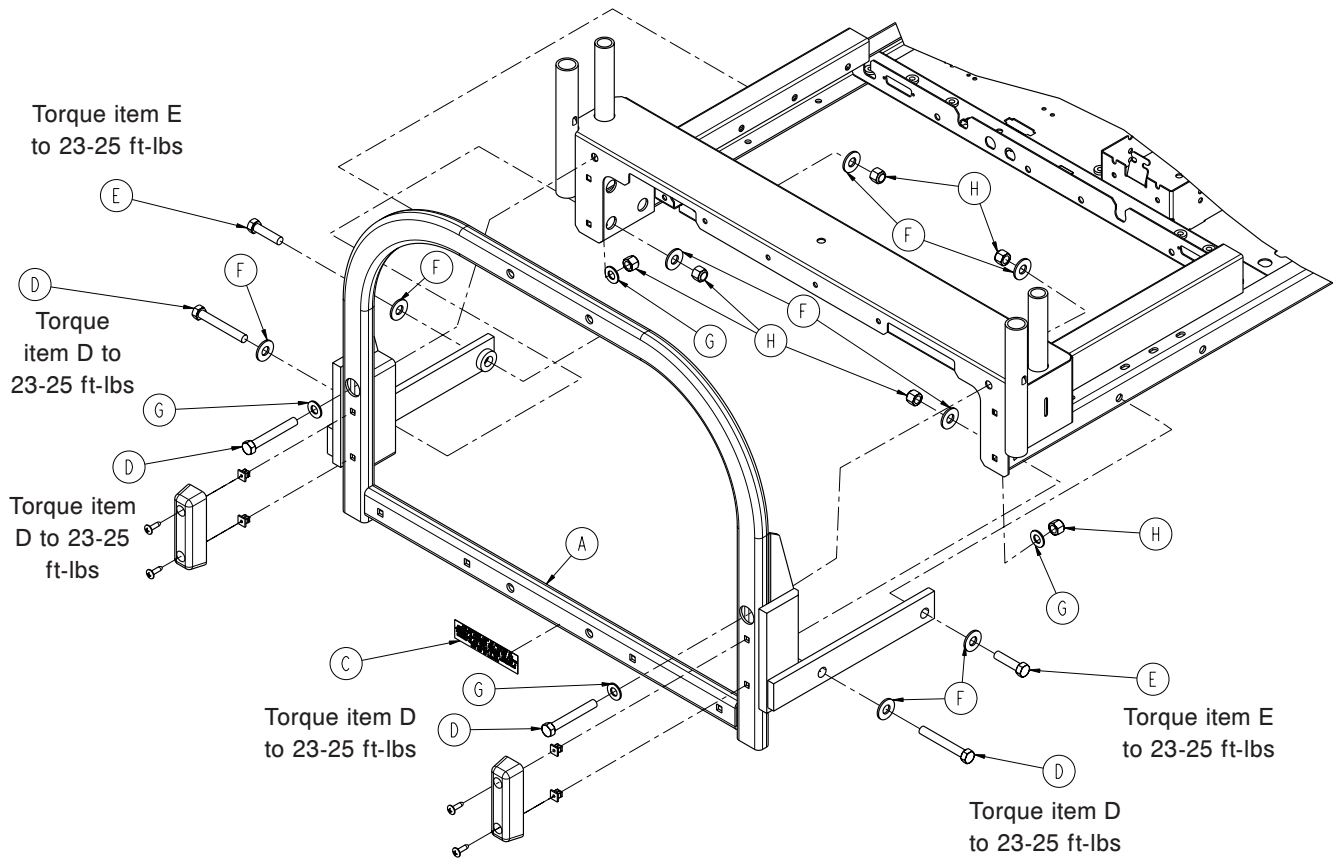

| Item | Part No. | Part Name | Qty. |
|------|--------------|-------------------------|------|
| A | 3006-334-010 | Adapter Frame Assembly | 1 |
| C | 3000-333-015 | Accessory Adapter Label | 1 |
| D | 0003-208-000 | Hex Head Cap Screw | 4 |
| E | 0003-025-000 | Hex Head Cap Screw | 2 |
| F | 0011-361-000 | 3/8" Flat Washer | 8 |
| G | 0011-004-000 | Flat Washer | 4 |
| H | 0016-035-000 | Nylock Nut | 6 |

Litter Roller Assembly - 3006-335-000

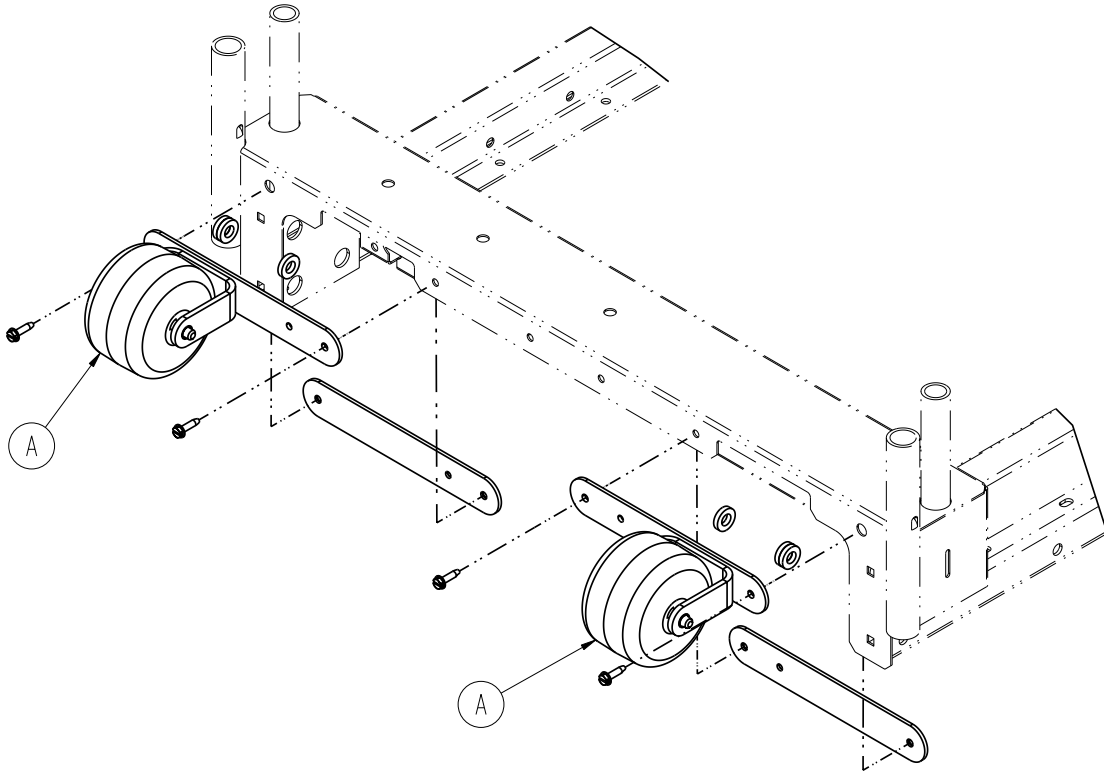

| Item | Part No. | Part Name | Qty. |
|------|--------------|-----------------|------|
| A | 3006-335-005 | Roller Assembly | 2 |

Roller Assembly - 3006-335-005

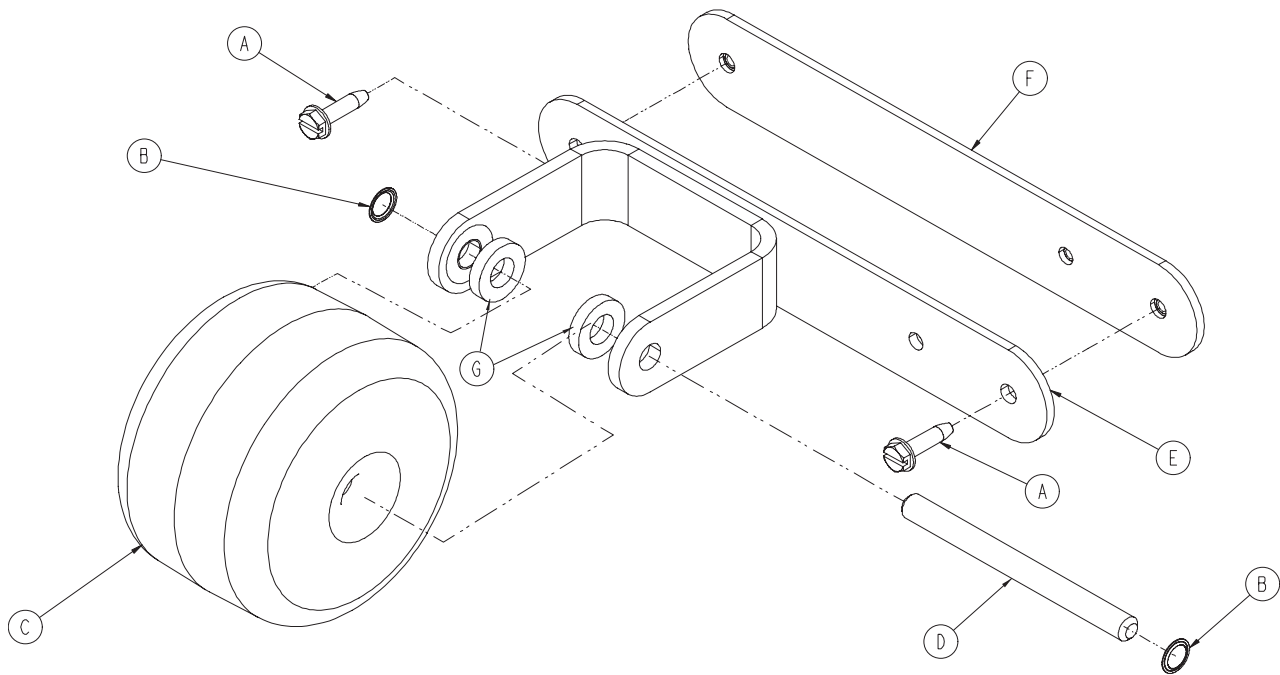

| Item | Part No. | Part Name | Qty. |
|------|--------------|--------------------------|------|
| A | 0003-225-000 | Hex Washer Head Screw | 2 |
| B | 0052-727-000 | Grooveless Retainer Ring | 2 |
| C | 3000-335-011 | Roller Bumper | 1 |
| D | 3000-335-012 | Roller Shaft | 1 |
| E | 3006-336-020 | Roller Bracket | 1 |
| F | 3006-336-025 | Roller Mounting Plate | 1 |
| G | 0052-017-000 | Plastic Washer | 2 |

Patient Helper Assembly - 3006-345-000

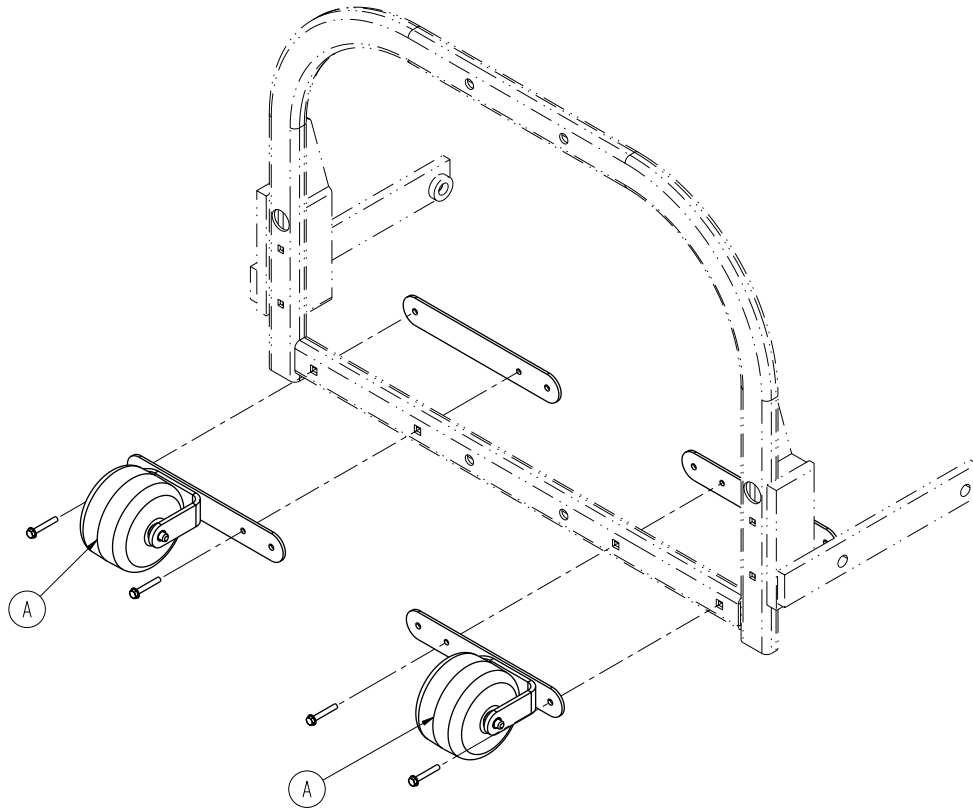

| Item | Part No. | Part Name | Qty. |
|------|--------------|-----------------------------------|------|
| A | 3006-345-005 | Patient Helper Roller Assembly | 2 |

Patient Helper Roller Assembly - 3006-345-005

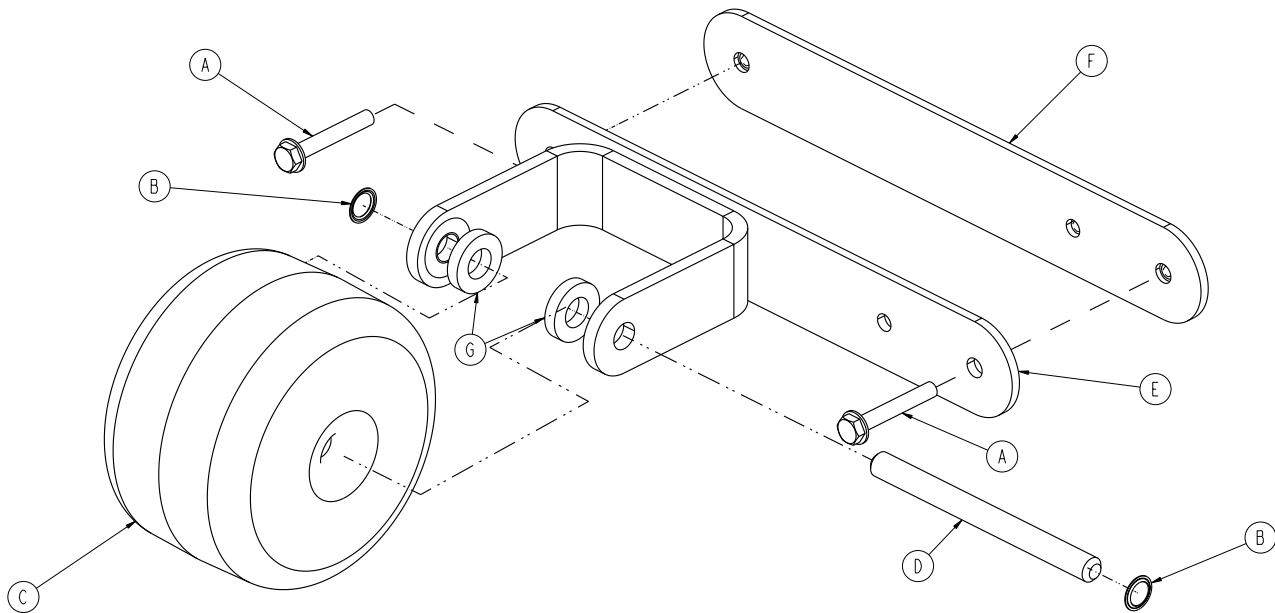

| Item | Part No. | Part Name | Qty. |
|------|--------------|--------------------------|------|
| A | 0003-369-000 | Hex Washer Head Screw | 2 |
| B | 0052-727-000 | Grooveless Retainer Ring | 2 |
| C | 3000-335-011 | Roller Bumper | 1 |
| D | 3000-335-012 | Roller Shaft | 1 |
| E | 3006-336-020 | Roller Bracket | 1 |
| F | 3006-336-025 | Roller Mounting Plate | 1 |
| G | 0052-017-000 | Plastic Washer | 2 |

Bed Extender Assembly - 3006-346-020

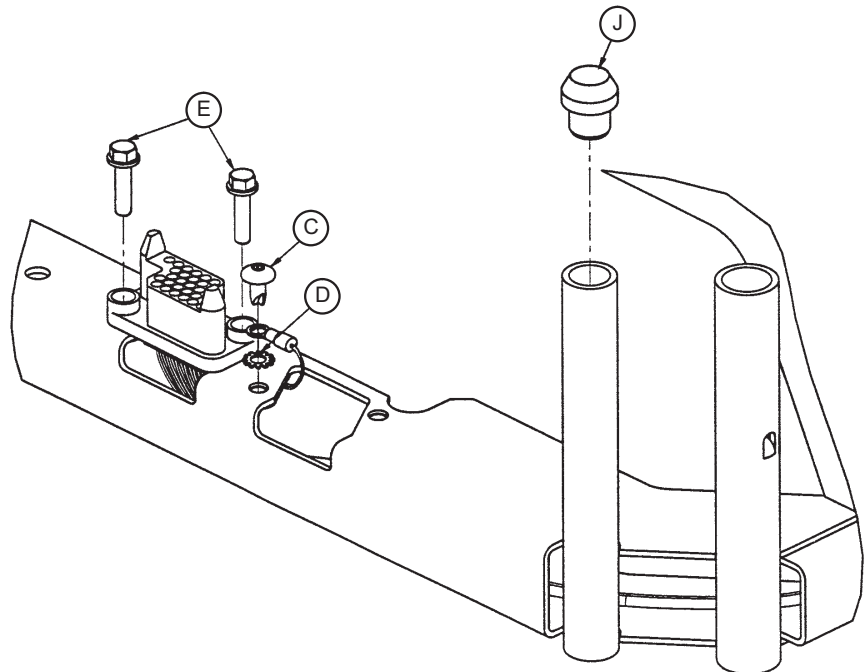
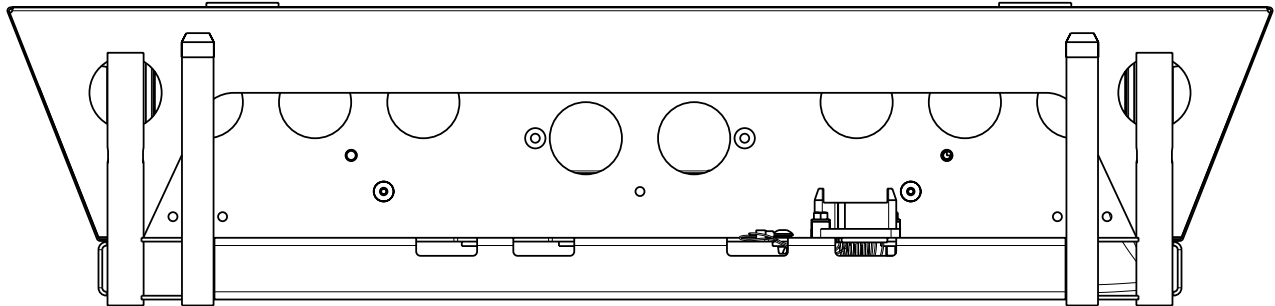
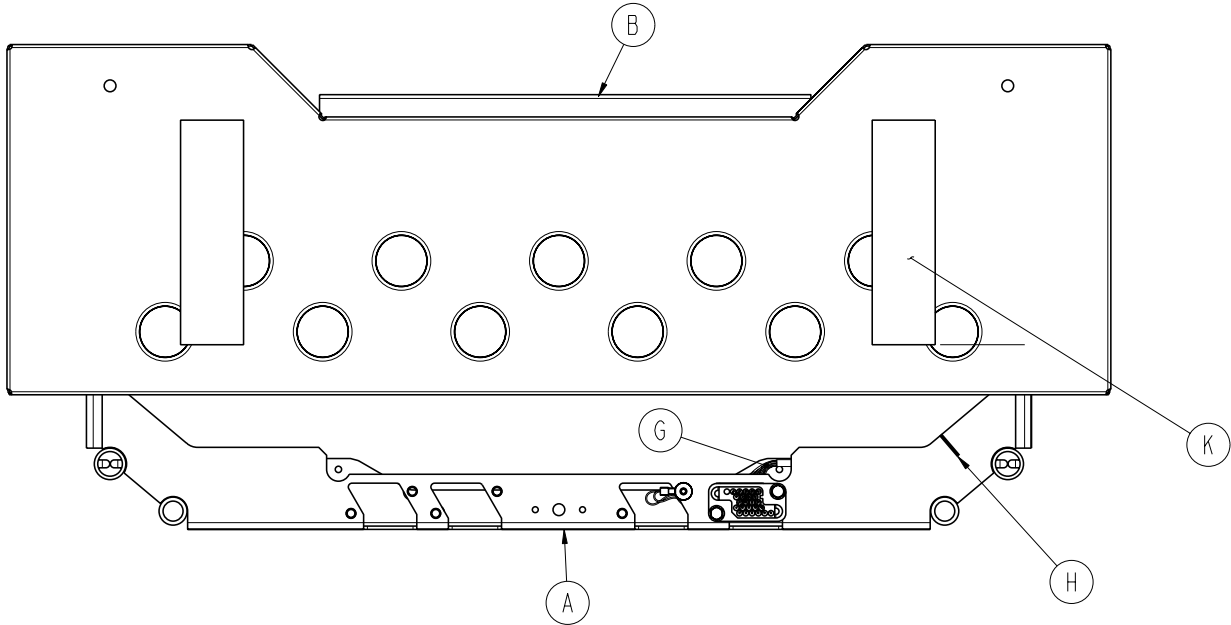

Bed Extender Assembly - 3006-346-020

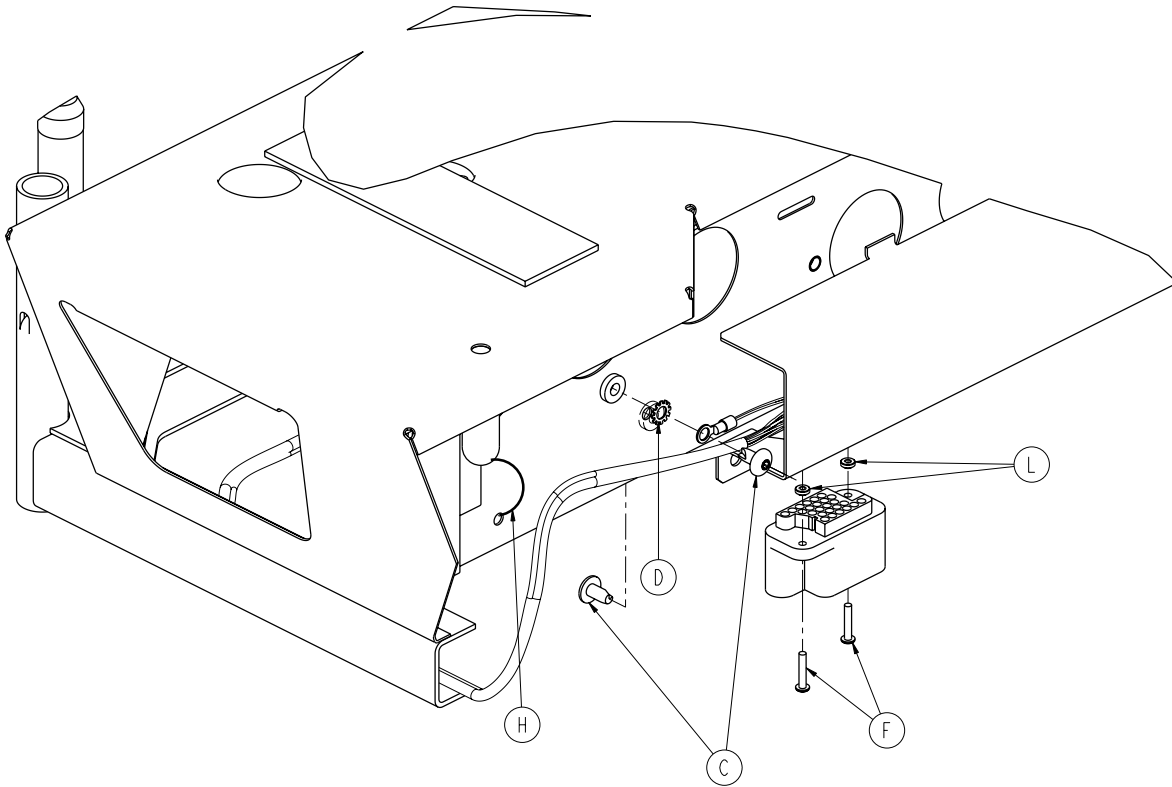

| Item | Part No. | Part Name | Qty. |
|------|--------------|----------------------------|------|
| A | 3001-318-050 | Bed Extender Weldment | 1 |
| B | 3001-318-031 | Connector Mounting Bracket | 1 |
| C | 0007-052-000 | Truss Head Screw | 4 |
| D | 0013-010-000 | External Tooth Lock Washer | 2 |
| E | 3001-200-228 | Mounting StandOff | 2 |
| F | 0050-039-000 | Pan Head Machine Screw | 2 |
| G | 3000-318-801 | Bed Extender Cable | 1 |
| H | 3000-300-114 | Cable Tie | 2 |
| J | 3000-300-349 | Cap | 2 |
| K | 7900-001-102 | Velcro® Adhesive Pile | 2 |
| L | 0011-146-000 | Washer | 4 |

Bed Extender Mattress - 3000-318-050

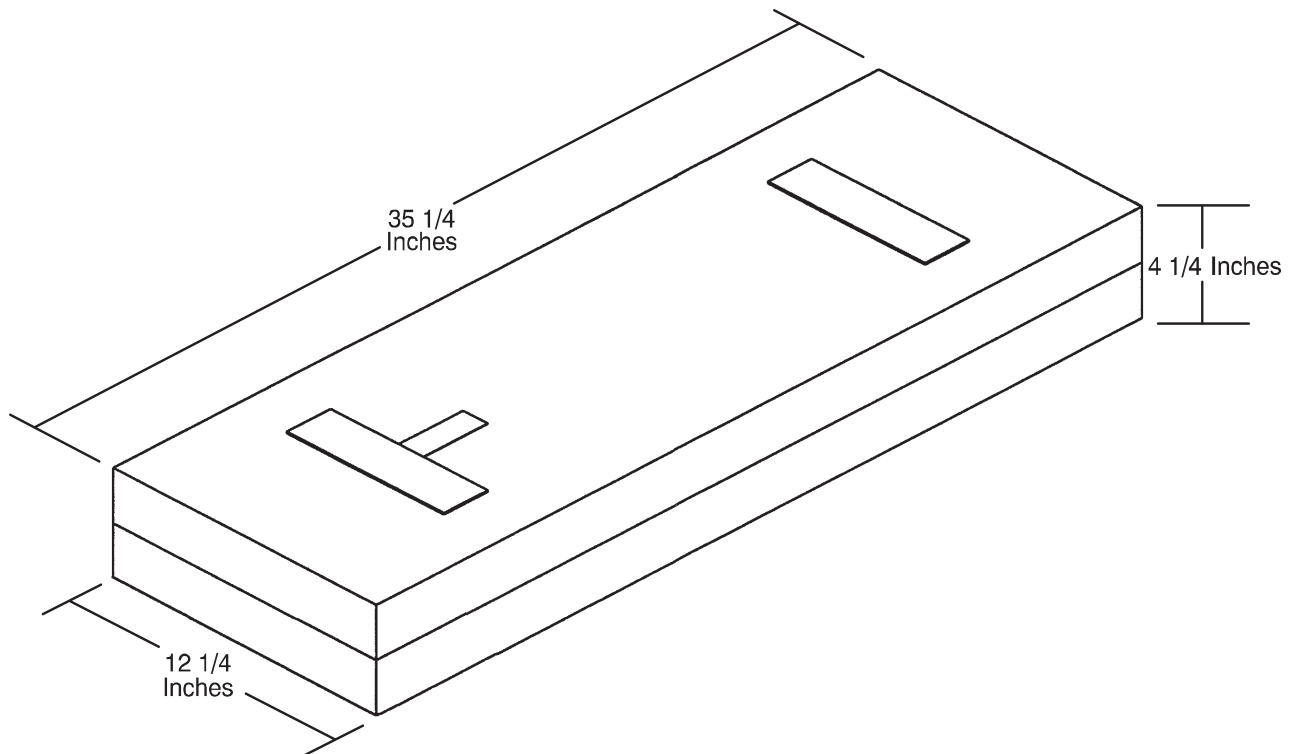

Traction Socket Extensions

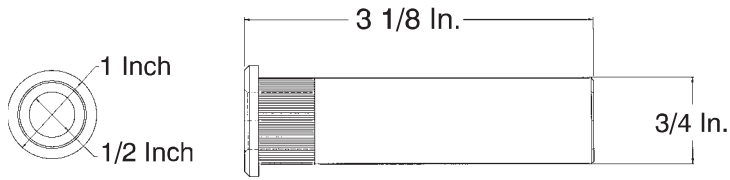

For Reference Only: 3000-337-050

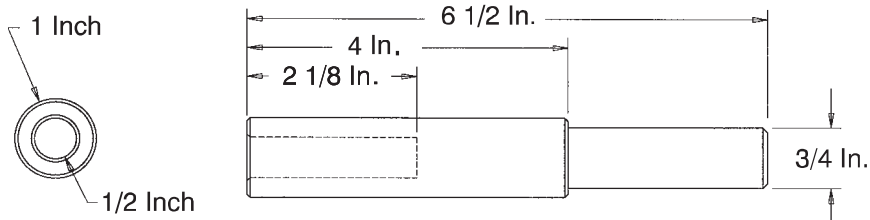

For Reference Only: 3000-337-450

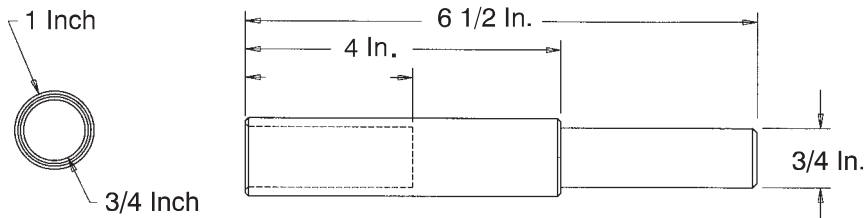

For Reference Only: 3000-337-475

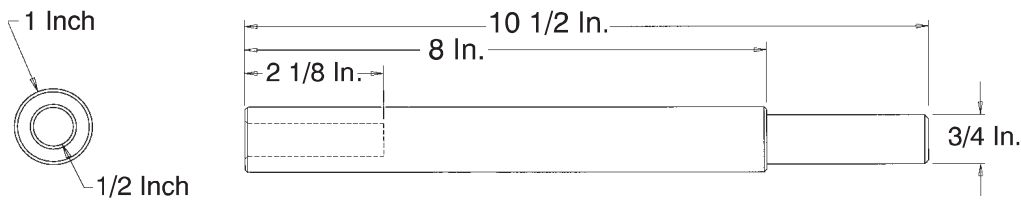

For Reference Only: 3000-337-850

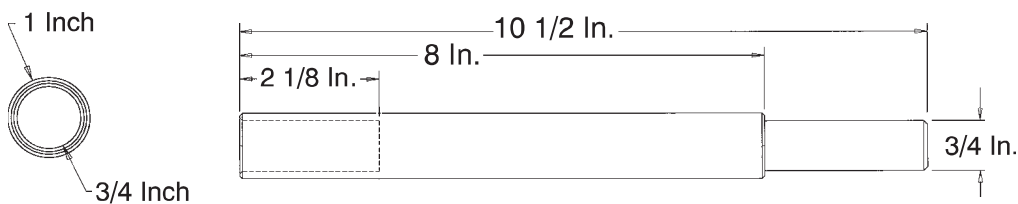

For Reference Only: 3000-337-875

Recycling Passport

Assembly Part number: 3006-375-895 (Reference Only)

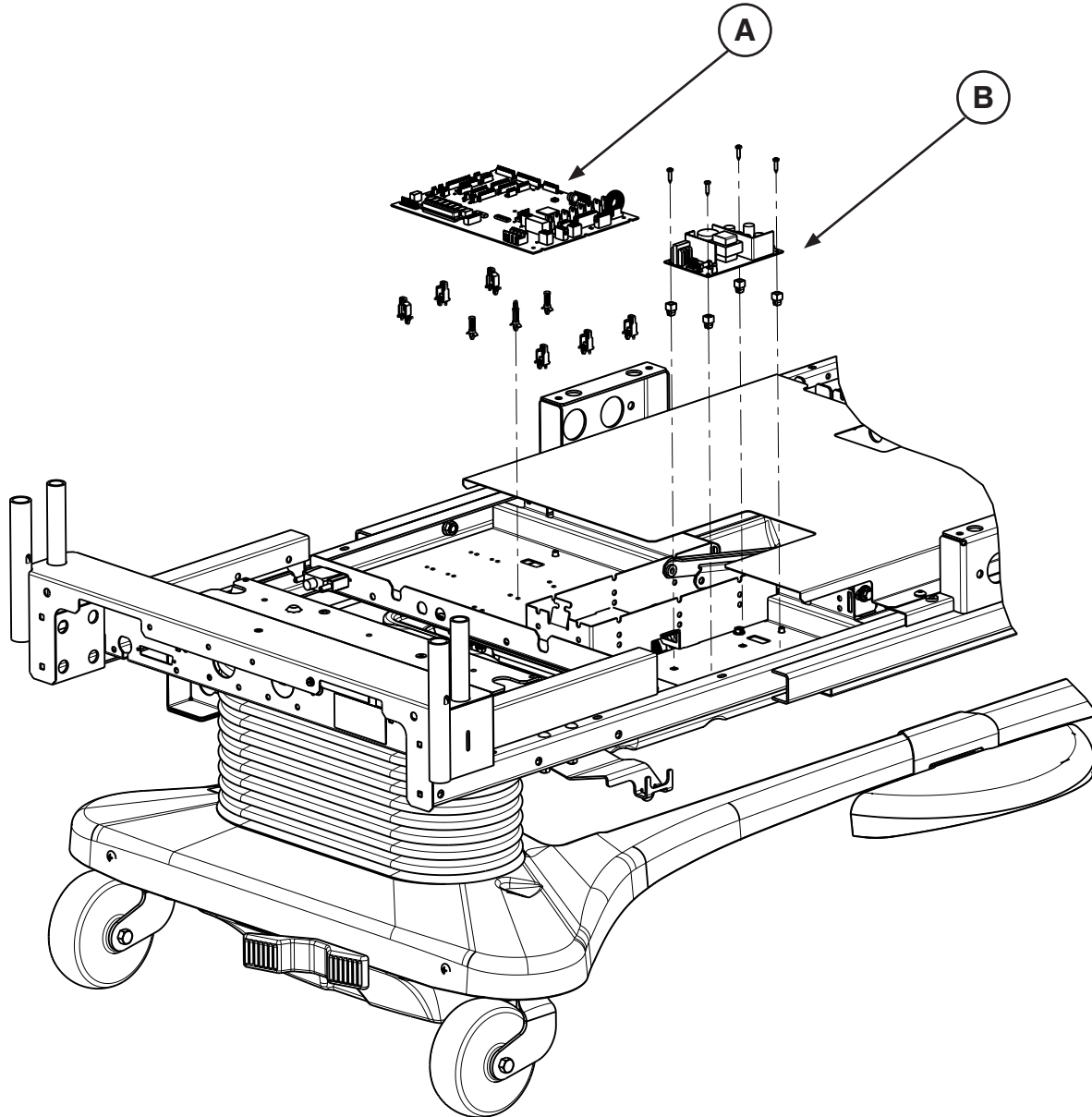

| Item | Recycling/Material Code | Important Information | Qty |
|------|-----------------------------|-----------------------|-----|
| A | (3006-308-900) CPU Board | | 1 |
| B | (0059-157-000) Power Supply | | 1 |

[Return To Table of Contents](#)

Recycling Passport

Assembly Part number: 3006-400-125 (Reference Only)

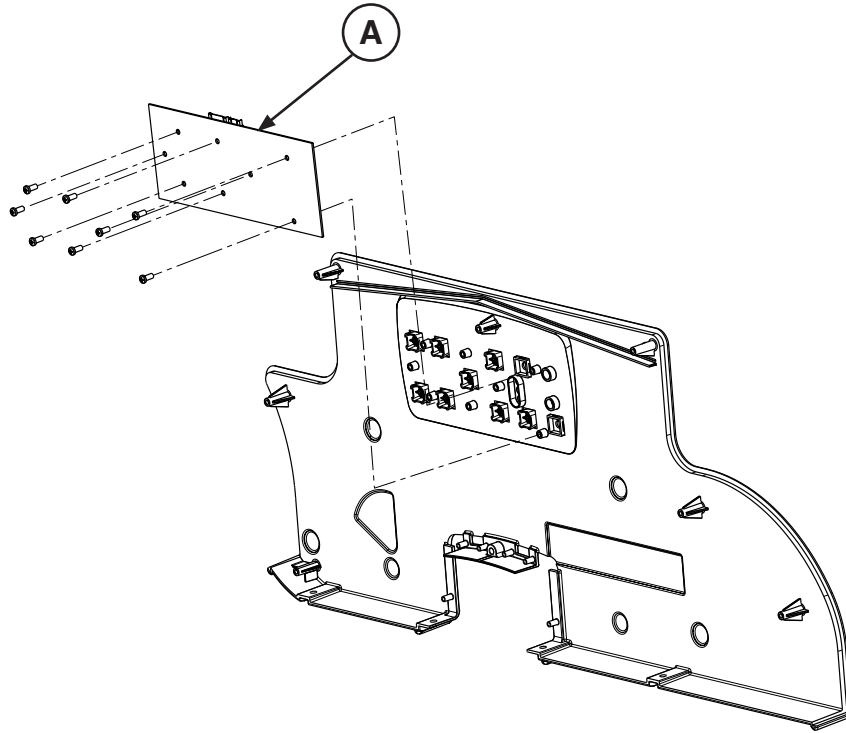

Assembly Part number: 3006-400-225 (Reference Only)

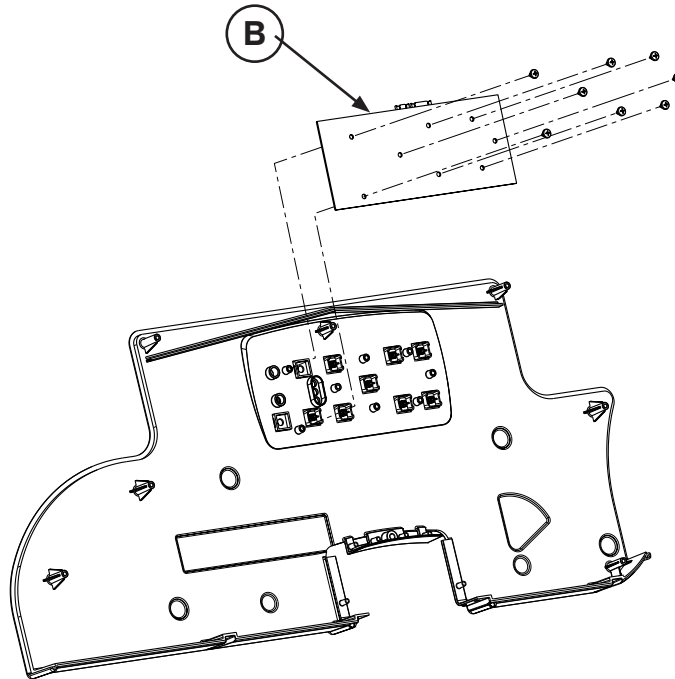

| Item | Recycling/Material Code | Important Information | Qty |
|------|--|-----------------------|-----|
| A | (3006-400-920) Siderail Outer PCB, Left | | 1 |
| B | (3006-400-910) Siderail Outer PCB, Right | | 1 |

Recycling Passport

Assembly Part number: 3006-400-130 (Reference Only)

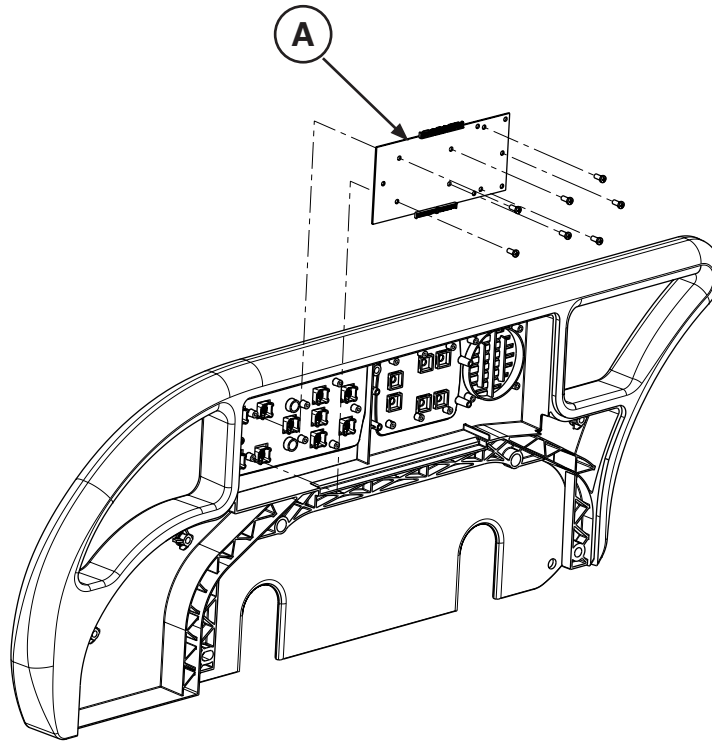

Assembly Part number: 3006-400-230 (Reference Only)

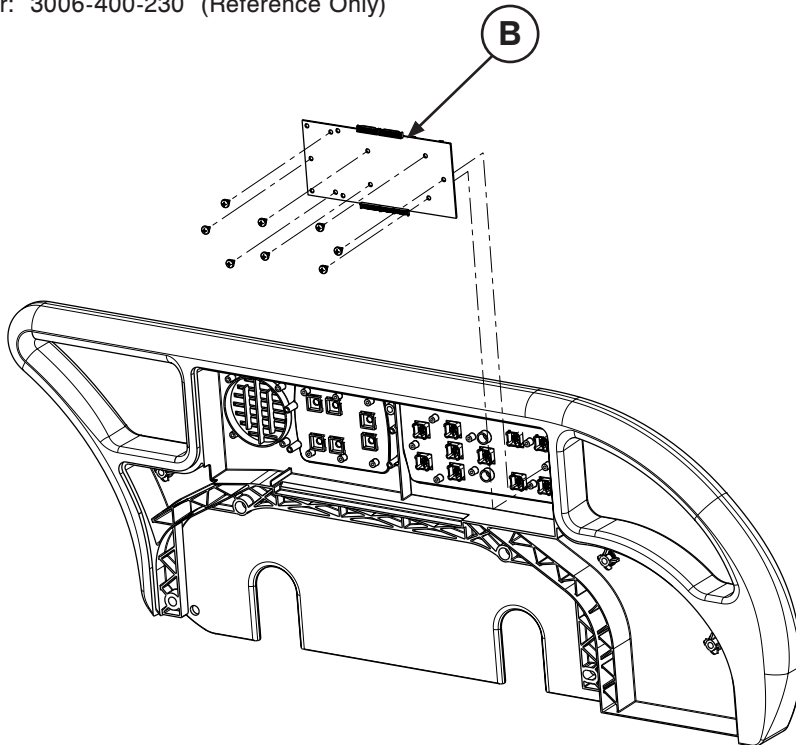

| Item | Recycling/Material Code | Important Information | Qty |
|------|--|-----------------------|-----|
| A | (3006-400-930) Siderail Outer PCB, Left | | 1 |
| B | (3006-400-930) Siderail Outer PCB, Right | | 1 |

[Return To Table of Contents](#)

Recycling Passport

Assembly Part number: 3006-303-045 (Reference Only)

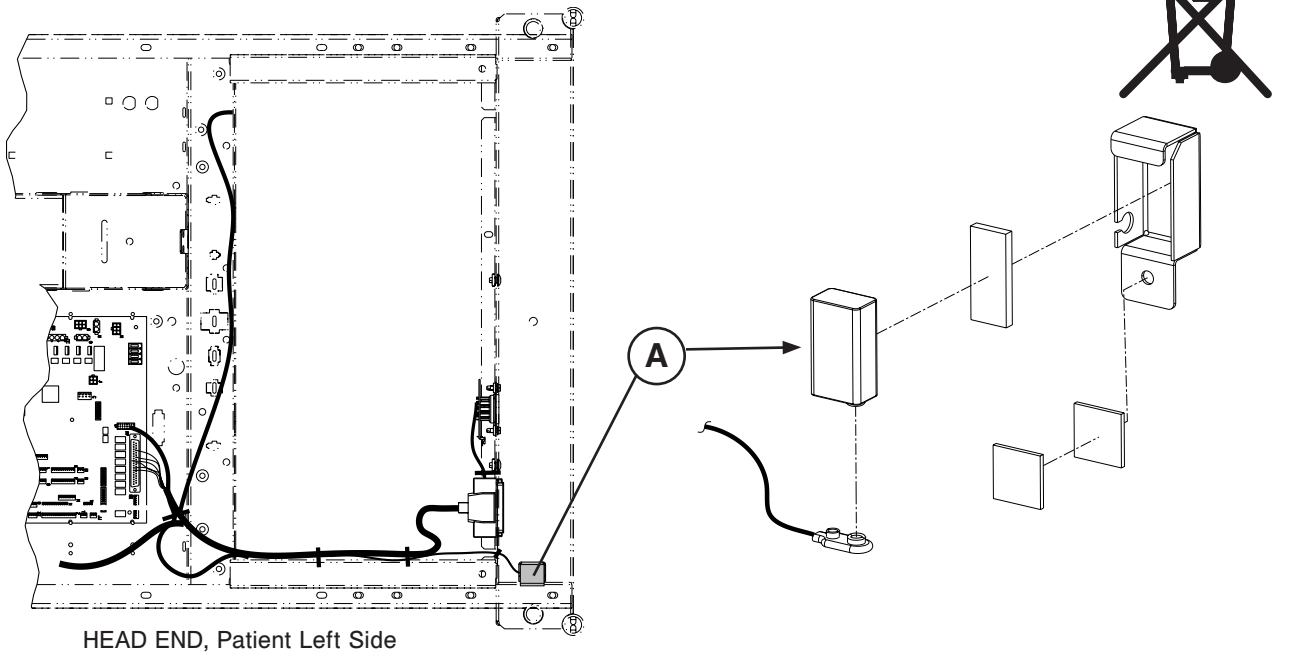

Assembly Part number: 3006-200-004 (Reference Only)

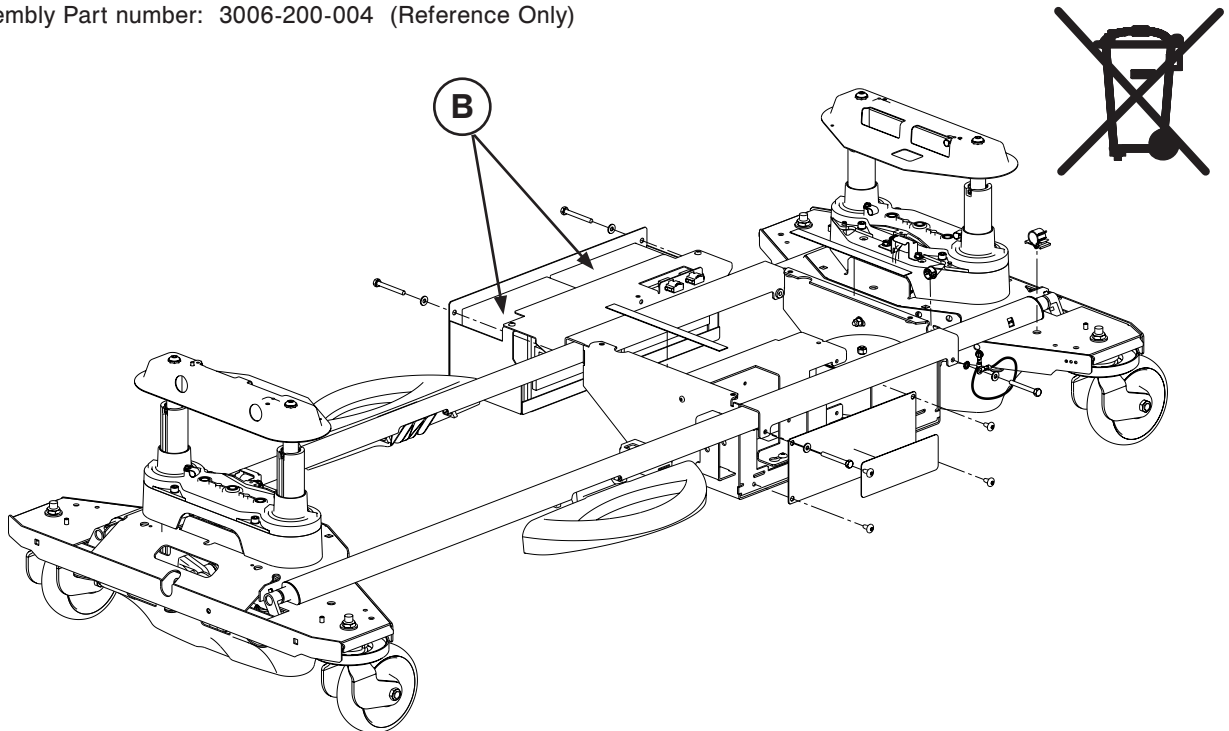

| Item | Recycling/Material Code | Important Information | Qty |
|------|----------------------------|-----------------------|-----|
| A | (3006-303-871) Battery 9V | | 1 |
| B | (2040-001-070) Battery 12V | | 2 |

Recycling Passport

Assembly Part number: 3001-314-012 (Reference Only)

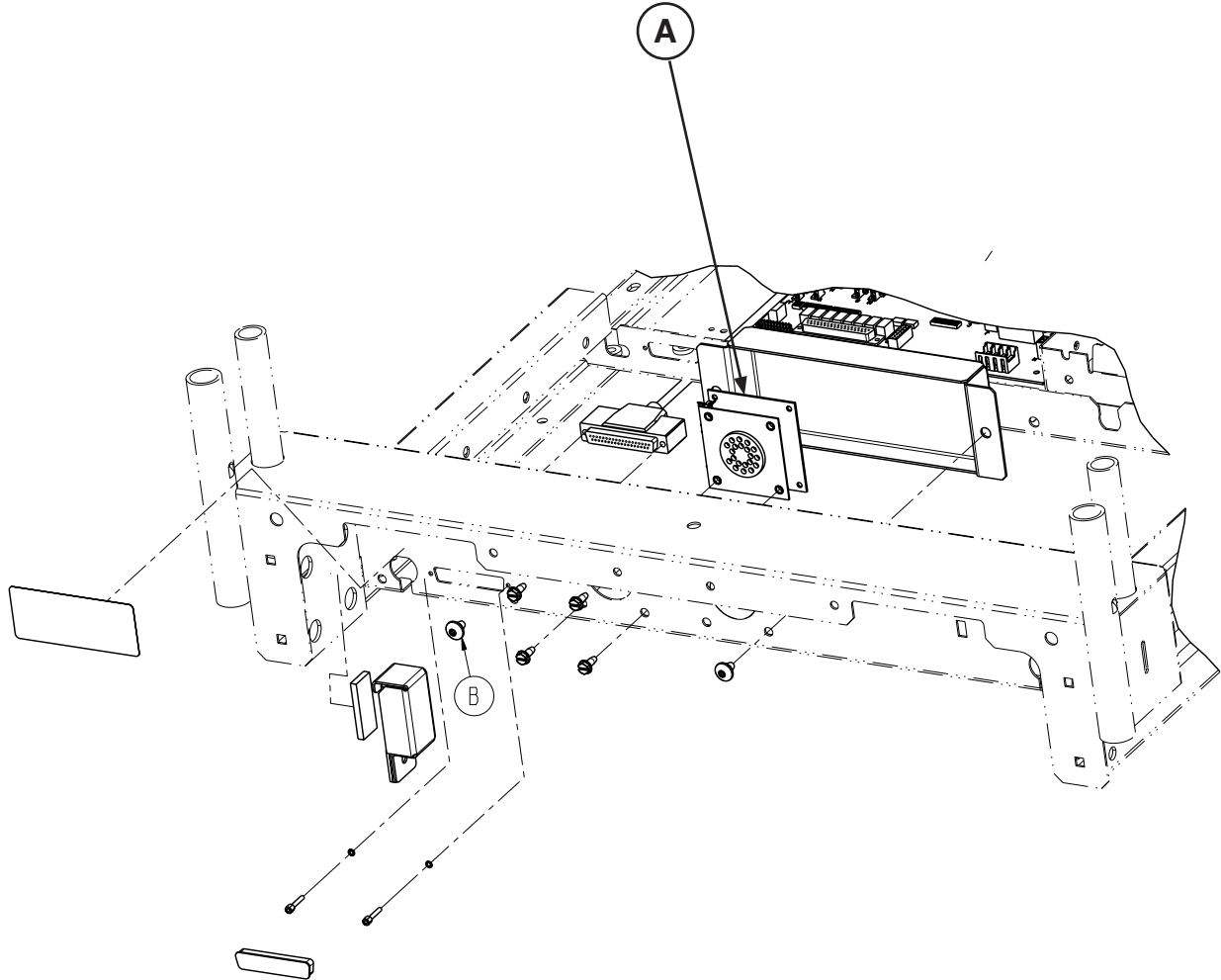

| Item | Recycling/Material Code | Important Information | Qty |
|------|---------------------------------|-----------------------|-----|
| A | (3001-314-920) Pendant Port PCB | | 1 |

Recycling Passport

Assembly Part number: 3006-501-011 (Reference Only)

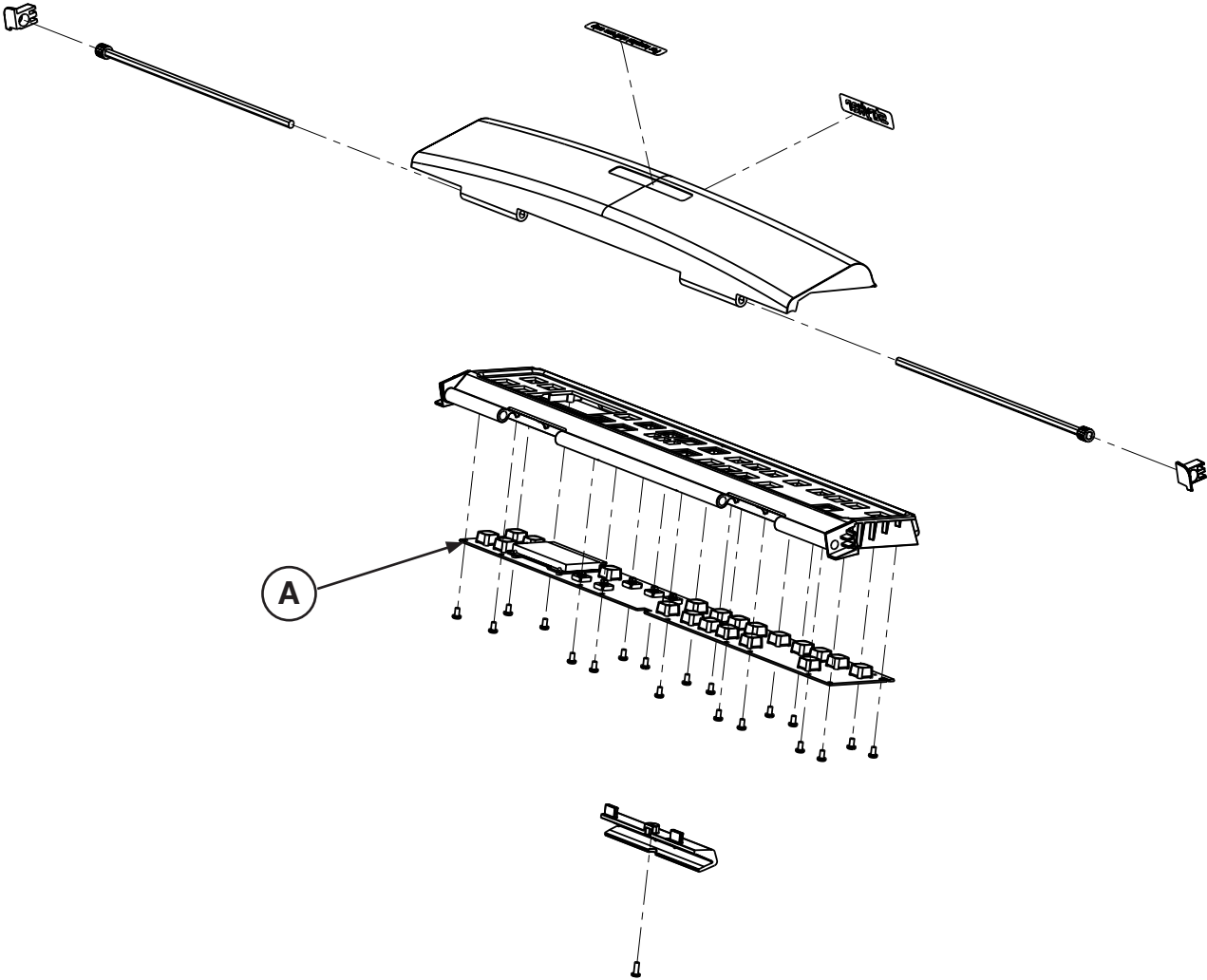

| Item | Recycling/Material Code | Important Information | Qty |
|------|------------------------------|-----------------------|-----|
| A | (3006-501-900) Footboard PCB | | 1 |

Recycling Passport

Assembly Part number: 5212-300-053 (Reference Only)

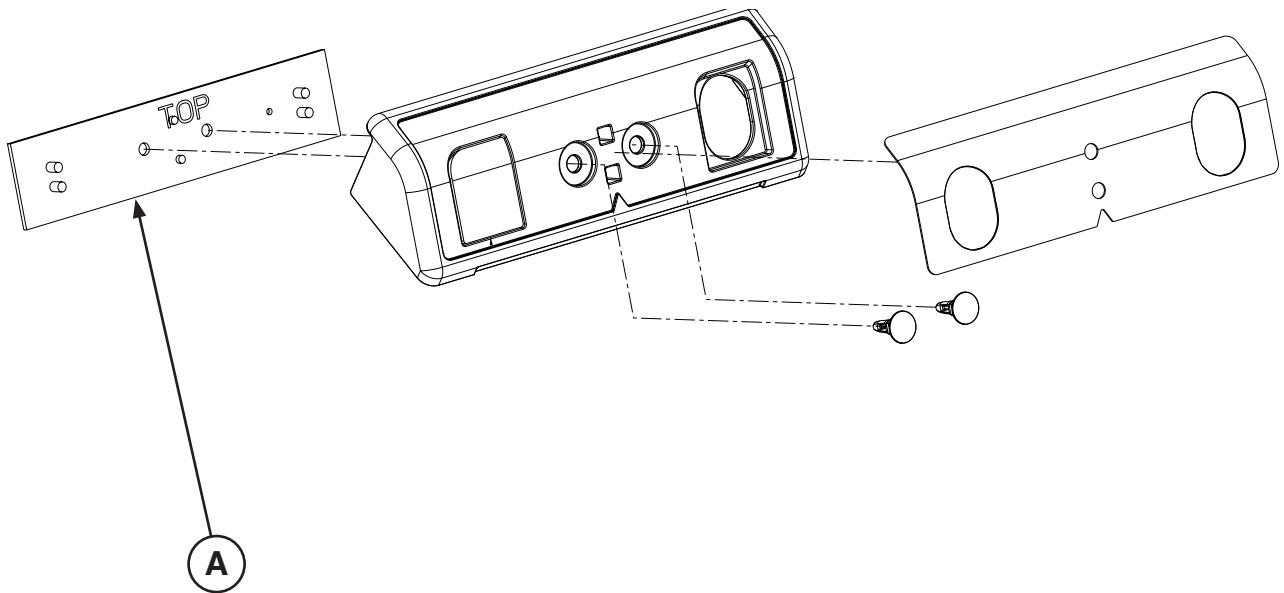

| Item | Recycling/Material Code | Important Information | Qty |
|------|--|-----------------------|-----|
| A | (5212-300-930) IR Module PCB Assembly | | 1 |

Recycling Passport

Assembly Part number: 5212-300-012 (Reference Only)

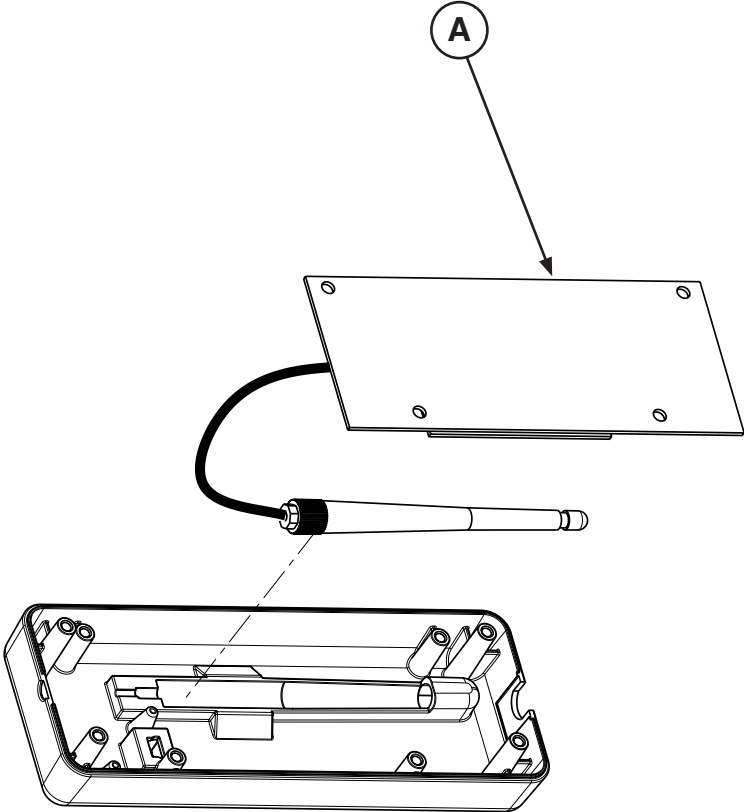

| Item | Recycling/Material Code | Important Information | Qty |
|------|--|-----------------------|-----|
| A | (5212-300-910) Wireless Module PCB Assembly | | 1 |

EMC Information

S3™ MEDSURG BED

| Guidance and Manufacturer's declaration - Electromagnetic Immunity | | | |
|---|---|---|---|
| The S3™ MedSurg Bed is suitable for use in the electromagnetic environment specified below. The customer or the user of the S3™ MedSurg Bed should assure that it is used in such an environment. | | | |
| Immunity Test | IEC 60601 Test Level | Compliance Level | Electromagnetic Environment Guidance |
| Electrostatic Discharge (ESD) IEC 61000-4-2 | +6 kV contact +8 kV air | +6 kV contact +8 kV air | Floors should be wood, concrete, or ceramic tile. If floors are covered with synthetic material, the relative humidity should be at least 30%. |
| Electrostatic fast Transient/burst IEC61000-4-4 | +2 kV for power supply lines +1 kV for input/output lines | +2 kV for power supply lines +1 kV for input/output lines | Main power quality should be that of a typical commercial or hospital environment. |
| Surge IEC 61000-4-5 | +8 kV differential mode +2 kV common mode | +8 kV differential mode +2 kV common mode | Main power quality is that of a typical commercial and/or hospital environment. |
| Voltage dips, voltage variations and short interruptions on power supply input lines IEC 61000-4-11 | <5%Ut (95% dipUt) for 0,5 cycle 40%Ut (60% dop in Ut) for 5 cycles 70%Ut (30% dip in Ut) for 25 cycles. <5% Ut (>95% dip in Ut) for 5 sec. | <5%Ut (95% dipUt) for 0,5 cycle 40%Ut (60% dop in Ut) for 5 cycles 70%Ut (30% dip in Ut) for 25 cycles. <5% Ut (>95% dip in Ut) for 5 sec. | Main power quality should be that of a typical commercial and/or hospital environment. If the user of the S3™ MedSurg Bed requires continued operation during power main interruptions, it is recommended that the device be powered from an uninterrupted power supply or a battery. |
| Power frequency (50/60 Hz) magnetic field IEC 61000-4-8 | 3 A/m | 3 A/m | Power frequency magnetic fields should be at levels characteristic of a typical location in a typical commercial and/or hospital environment. |
| Note: U_T is the a.c. mains voltage prior to applications of the test level. | | | |

EMC Information

S3™ MEDSURG BED (CONTINUED)

| Recommended separation distances between portable and mobile RF communications equipment and the S3™ MedSurg Bed. | | | |
|--|---|---------------------------------------|---|
| <p>The S3™ MedSurg Bed is intended for use in an electromagnetic environment in which radiated RF disturbances are controlled. The customer or the user of the S3™ MedSurg Bed can help prevent electromagnetic interferences by maintaining a minimum distance between portable and mobile RF communications equipment (transmitters) and the S3™ MedSurg Bed as recommended below, according to the maximum output power of the communications equipment.</p> | | | |
| Rated maximum output power of transmitter W | Separation distance according to frequency of transmitter | | |
| | m | | |
| | 150 kHz to 80 MHz $d=1,2 \sqrt{P}$ | 80 MHz to 800 MHz $d=1,2 \sqrt{P}$ | 8000 MHz to 2,5 GHz $d=2,3 \sqrt{P}$ |
| 0,01 | 1,12 | 0,12 | 0,23 |
| 0,1 | 0,38 | 0,38 | 0,73 |
| 1 | 1,2 | 1,2 | 2,3 |
| 10 | 3,8 | 3,8 | 7,3 |
| 100 | 12 | 12 | 23 |
| <p>For transmitters rated at a maximum output power not listed above, the recommended separation distance d in meters (m) can be estimated using the equation applicable to the frequency of the transmitter, where P is the maximum output power rating of the transmitter in watts (W) according to the transmitter manufacturer.</p> <p>Note 1 At 80 MHz and 800 MHz, the separation distance for the higher frequency range applies.</p> <p>Note 2 These guidelines may not apply in all situations. Electromagnetic propagation is affected by absorption and reflection from structures, objects and people.</p> | | | |

EMC Information

S3™ MEDSURG BED (CONTINUED)

| <p>The S3™ MedSurg Bed is suited for use in the electromagnetic environment specified below. The customer or the user of the S3™ MedSurg Bed should assure that it is used in such an environment.</p> | | | |
|---|--|--|--|
| Immunity Test | IEC 60601 Test Level | Compliance Level | Electromagnetic Environment - Guidance |
| <p style="text-align: center;">Conducted RF IEC 6100-4-6</p> <p style="text-align: center;">Radiated RF IEC 61000-4-3</p> | <p style="text-align: center;">3 Vrms 150 kHz to 80 MHz</p> <p style="text-align: center;">3 V/m 80 MHz to 2,5 GHz</p> | <p style="text-align: center;">3 Vrms</p> <p style="text-align: center;">3 V/m</p> | <p>Portable and mobile RF communications equipment should be used no closer to any part of the S3™ MedSurg Bed, including cables, than the recommended separation distance calculated from the equation appropriate for the frequency of the transmitter.</p> <p style="text-align: center;">Recommended Separation Distance</p> <div style="text-align: center;"> <p>d=1,2</p> \sqrt{P} <p>d=1,2</p> \sqrt{P} <p>80 MHz to 800 MHz</p> <p>d=2,3</p> $\sqrt{P} \quad \left(\left(\left(\bullet \right) \right) \right)$ </div> |
| <p>Note 1 At 80 MHz and 800 MHz, the higher frequency range applies.</p> <p>Note 2 These guidelines may not apply in all situations. Electromagnetic propagation is affected by absorption and reflection from structures, objects and people.</p> <p>^aField strengths from fixed transmitters, such as base stations for radio (cellular/cordless) telephones and land mobile radios, amateur radio, AM and FM radio broadcast, and TV broadcast cannot be predicted theoretically with accuracy. To assess the electromagnetic environment due to fixed RF transmitters, an electromagnetic site survey should be considered. If the measured field strength in the location in which the S3™ MedSurg Bed is used exceeds the applicable RF compliance level above, the S3™ MedSurg Bed should be observed to verify normal operation. If abnormal performance is observed, additional measures may be necessary, such as reorienting or relocating the S3™ MedSurg Bed.</p> <p>^bOver the frequency range 150 kHz to 80 MHz, field strengths are less than 3 V/m.</p> | | | |

EMC Information

S3™ MEDSURG BED (CONTINUED)

| Guidance and Manufacturer's declaration - Electromagnetic Emissions | | |
|--|-------------------|---|
| The S3™ MedSurg Bed is intended for use in an electromagnetic environment specified below. The customer or the user of the S3™ MedSurg Bed should assure that it is used in such an environment. | | |
| Emissions Test | Compliance | Electromagnetic Environment |
| RF Emissions CISPR 11 | Group 1 | The S3™ MedSurg Bed uses RF energy only for its internal function. Therefore, its RF emissions are very low and are not likely to cause any interference in nearby electronic equipment. |
| RF Emissions CISPR 11 | Class A | The S3™ MedSurg Bed is suitable for use in all establishments other than domestic and those directly connected to the public low voltage power supply network that supplies buildings used for domestic purposes. |
| Harmonic Emissions IEC 61000-3-2 | Class A | |
| Voltage Fluctuations Flicker Emissions IEC 6100-3-3 | Complies | |

Warranty

LIMITED WARRANTY

Stryker Medical Division, a division of Stryker Corporation, warrants to the original purchaser the S3™ MedSurg Bed, Model 3002 to be free from defects in material and workmanship for a period of one (1) year after date of delivery. Stryker's obligation under this warranty is expressly limited to supplying replacement parts and labor for, or replacing, at its option, any product which is, in the sole discretion of Stryker, found to be defective. If requested by Stryker, products or parts for which a warranty claim is made shall be returned prepaid to the factory. Any improper use or any alteration or repair by others in such manner as in Stryker's judgment affects the product materially and adversely shall void this warranty. Any repair of Stryker products using parts not provided or authorized by Stryker shall void this warranty. No employee or representative of Stryker is authorized to change this warranty in any way.

Stryker Medical beds are designed for a 15 year expected service life under normal use, conditions, and with appropriate periodic maintenance as described in the maintenance manual for each device. Stryker warrants to the original purchaser that the welds on its beds will be free from structural defects for the expected 15 year life of the bed as long as the original purchaser owns the product.

Stryker Medical optional components and/or accessories are warranted as follows:

- Motion/Nurse Call Pendant: Two (2) years service life under normal use and proper care
- Motion/Nurse Call/SmartTV Pendant: Two (2) years service life under normal use and proper care
- iBed® Wireless Components: Ten (10) years service life under normal use and proper care

This statement constitutes Stryker's entire warranty with respect to the aforesaid equipment. **Stryker Makes No Other Warranty Or Representation, Either Expressed Or Implied, Except As Set Forth Herein. There Is No Warranty Of Merchantability And There Are No Warranties Of Fitness For Any Particular Purpose. In No Event Shall Stryker Be Liable Here Under For Incidental Or Consequential Damages Arising From Or In Any Manner Related To Sales Or Use Of Any Such Equipment.**

TO OBTAIN PARTS AND SERVICE

Stryker products are supported by a nationwide network of dedicated Stryker Field Service Representatives. These representatives are factory trained, available locally, and carry a substantial spare parts inventory to minimize repair time. Simply call your local representative, or call Stryker Customer Service USA at 1-800-327-0770, Canada 1-888-233-6888.

SERVICE CONTRACT COVERAGE

Stryker has developed a comprehensive program of service contract options designed to keep your equipment operating at peak performance at the same time it eliminates unexpected costs. We recommend that these programs be activated before the expiration of the new product warranty to eliminate the potential of additional equipment upgrade charges.

A SERVICE CONTRACT HELPS TO:

- Ensure equipment reliability
- Stabilize maintenance budgets
- Diminish downtime
- Establish documentation for JCAHO
- Increase product life
- Enhance trade-in value
- Address risk management and safety

Warranty

SERVICE CONTRACT PROGRAMS

Stryker Offers the following service contract programs:

| Service Agreement Options * | Premium | Complete | Standard |
|---|---------|----------|----------|
| Annually scheduled preventative maintenance | X | | X |
| All parts | X | X | |
| All labor and travel | X | X | |
| Unlimited emergency service calls | X | X | |
| Priority one contact: two hour phone response | X | X | |
| Most repairs completed within 3 days | X | X | |
| JCAHO documentation | X | X | X |
| On-site record of PM & emergency service | X | | X |
| Factory-trained Stryker service technician | X | X | X |
| Stryker authorized parts used | X | X | X |
| Service during regular business hours (8-5) | X | X | X |

* Does not include maintenance due to abuse or for any disposable items. Stryker reserves the right to change options without notice.

Stryker Medical also Offers personalized service contracts.
Pricing is determined by age, location, model and condition of product.

**For more information on our service contracts,
please call your local representative.**

RETURN AUTHORIZATION

Merchandise cannot be returned without approval from the Stryker Customer Service Department. An authorization number will be provided which must be printed on the returned merchandise. Stryker reserves the right to charge shipping and restocking fees on returned items. **Special, Modified, Or Discontinued Items Not Subject To Return.**

DAMAGED MERCHANDISE

ICC Regulations require that claims for damaged merchandise must be made with the carrier within fifteen (15) days of receipt of merchandise. **Do Not Accept Damaged Shipments Unless Such Damage Is Noted On The Delivery Receipt At The Time Of Receipt.** Upon prompt notification, Stryker will file a freight claim with the appropriate carrier for damages incurred. Claim will be limited in amount to the actual replacement cost. In the event that this information is not received by Stryker within the fifteen (15) day period following the delivery of the merchandise, or the damage was not noted on the delivery receipt at the time of receipt, the customer will be responsible for payment of the original invoice in full. Claims for any short shipment must be made within thirty (30) days of invoice.

INTERNATIONAL WARRANTY CLAUSE

This warranty reflects U.S. domestic policy. Warranty outside the U.S. may vary by country. Please contact your local Stryker Medical representative for additional information.



UNITED STATES
Stryker Medical
3800 E. Centre Ave.,
Portage, Michigan USA
49002

| | |
|----|-----|
| EC | REP |
|----|-----|

European Representative
Stryker France
ZAC Satolas Green Pusignan
Av. De Satolas Green
69881 MEYZIEU Cedex
France



stryker[®]