

Secure® Connect

Service Manual

REF 521200380100

Connected Hospital®

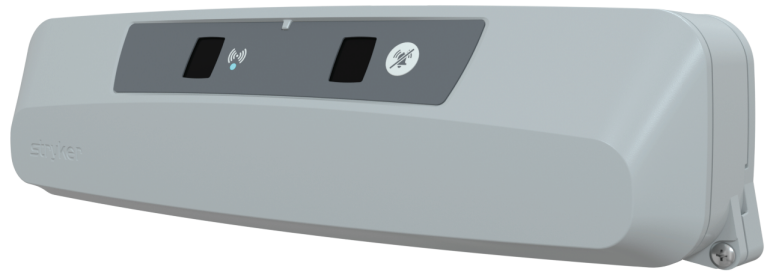

Table of Contents

Warning/Caution/Note Definition	2
Summary of safety precautions	2
Introduction for service	3
Expected service life	3
Contact information	3
Serial number location	3
Preventive maintenance	4
Troubleshooting	5
Service	6
Replacing the battery (37-pin connector, left side)	6
Replacing the battery (37-pin connector, right side)	9
Secure Connect locator assembly, left	11
Secure Connect locator assembly, right	16
EMC information	21
Recycling passport	25
521200380105/521200380110	25
700000886795	26
700000915390	27

Warning/Caution/Note Definition

The words **WARNING**, **CAUTION**, and **NOTE** carry special meanings and should be carefully reviewed.

WARNING

Alerts the reader about a situation which, if not avoided, could result in death or serious injury. It may also describe potential serious adverse reactions and safety hazards.

CAUTION

Alerts the reader of a potentially hazardous situation which, if not avoided, may result in minor or moderate injury to the user or patient or damage to the product or other property. This includes special care necessary for the safe and effective use of the device and the care necessary to avoid damage to a device that may occur as a result of use or misuse.

Note - Provides special information to make maintenance easier or important instructions clearer.

Summary of safety precautions

Always read and strictly follow the warnings and cautions listed on this page. Service only by qualified personnel.

WARNING

- Portable RF communications equipment, including peripherals such as antenna cables and external antennas, should be no closer than 12 inches (30 cm) to any part of the **Secure Connect** locator, including cables specified by the manufacturer.
 - Avoid stacking or placing equipment adjacent with other equipment to prevent improper operation of the product. If such use is necessary, carefully observe stacked or adjacent equipment to make sure that they operate properly.
 - The use of accessories, transducers, and cables, other than those specified or provided by the manufacturer, could result in increased electromagnetic emissions or decreased electromagnetic immunity and result in improper operation.
-

Introduction for service

This manual assists you with the service of your Stryker product. Read this manual to service this product. This manual does not address the operation of this product. See the Operations/Maintenance Manual for operating and use instructions. To view your Operations/Maintenance Manual online, see <https://techweb.stryker.com/>.

Expected service life

The **Secure Connect** has a 10 year expected service life under normal use conditions and with appropriate periodic maintenance.

The battery has a two year expected service life under normal use conditions.

Contact information

Contact Stryker Customer Service or Technical Support at: 1-800-327-0770.

Stryker Medical
3800 E. Centre Avenue
Portage, MI 49002
USA

Note - The user and/or the patient should report any serious product-related incident to both the manufacturer and the Competent authority of the European Member State where the user and/or patient is established.

To view your operations or maintenance manual online, see <https://techweb.stryker.com/>.

Have the serial number (A) of your Stryker product available when calling Stryker Customer Service or Technical Support. Include the serial number in all written communication.

Serial number location

The Stryker serial number and bed bay identification number (BBID) label (A) is located on the bottom of the product (Figure 1).

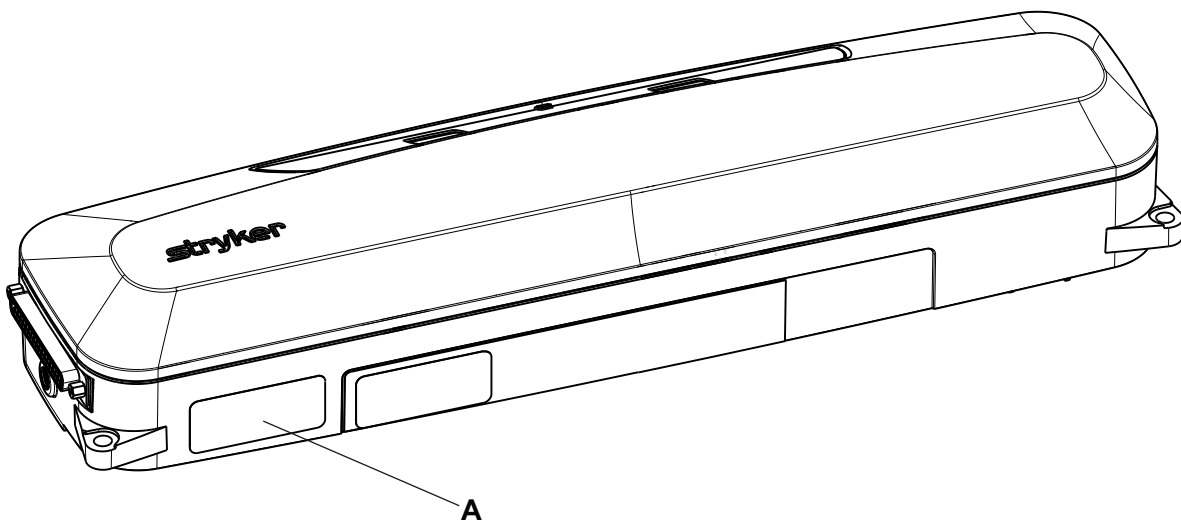

Figure 1 – Stryker serial number and BBID location

Preventive maintenance

Remove product from service before you perform the preventive maintenance inspection. Check all items listed during annual preventive maintenance for all Stryker Medical products. You may need to perform preventive maintenance checks more often based on your level of product usage. Service only by qualified personnel.

Inspect the following items:

- _____ All fasteners are secure
- _____ The **Secure Connect** casing is not cracked or damaged
- _____ Mounting plate not cracked or damaged
- _____ The **Secure Connect** front label is not damaged
- _____ Replace the battery (every two years)

Product serial number:
Completed by:
Date:

Troubleshooting

Problem	Solution
No nurse call communication cable connection (37 pin cable is not detected)	<ol style="list-style-type: none"> 1. Check the nurse call communication cable connection at the Secure Connect and at the wall connection. 2. Check the nurse call communication cable for damage.
No connection to the product	<ol style="list-style-type: none"> 1. Power cycle the product and the Secure Connect. 2. Check that the brakes are applied.
Low battery alert	<ol style="list-style-type: none"> 1. Check that the power supply is plugged into the Secure Connect and to the wall outlet. 2. Check the power supply for damage. 3. Check the DC output voltage from the power supply. 4. Replace the battery. See <i>Replacing the battery (37-pin connector, left side)</i> (page 6) or <i>Replacing the battery (37-pin connector, right side)</i> (page 9).
Nurse call actions or alarms are not working	<ol style="list-style-type: none"> 1. Power cycle the product and the Secure Connect. 2. Check that the brakes are applied. 3. Check that the headwall and Secure Connect dip-switches are set for the nurse call system and options. 4. Check that the headwall settings are configured for the nurse call system in the product maintenance configuration menu.

Service

Replacing the battery (37-pin connector, left side)

Tools required:

- #2 Phillips screwdriver
- #1 Phillips screwdriver
- Diagonal pliers
- Needle nose pliers
- Straight pick

Procedure:

1. Unplug the power supply from the **Secure Connect**.
2. Using a #1 Phillips screwdriver and needle nose pliers, disconnect the nurse call communication cable from the **Secure Connect**.
3. Using a #2 Phillips screwdriver, remove the two screws (G) that secure the **Secure Connect** (F) to the mounting plate (D) (Figure 2). Save the two screws.

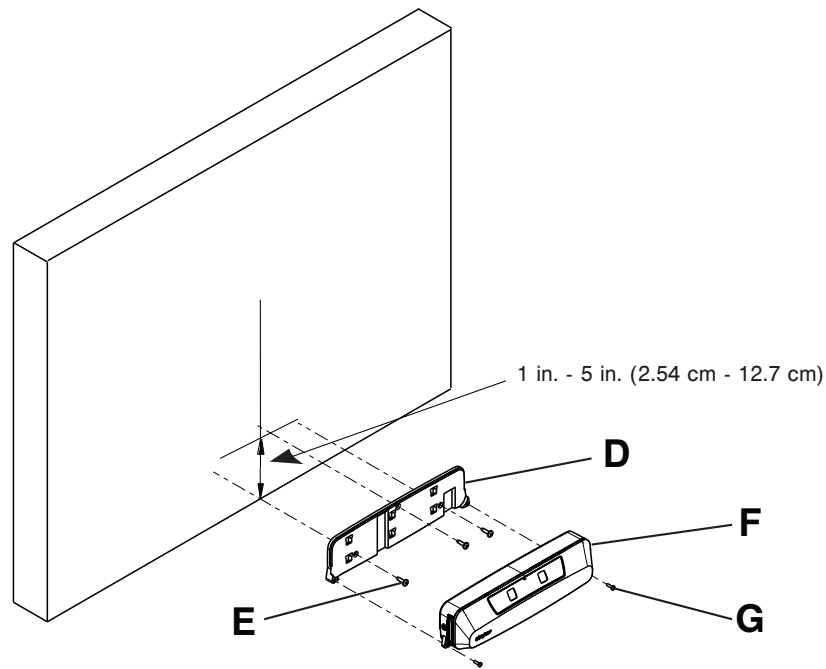

Figure 2 – Mounting specifications

4. Using a straight pick, remove and discard the label (521200380902) (C) that covers the **ON/OFF** switch (B) (Figure 3).
5. Turn the **ON/OFF** switch (B) to the **OFF** position (Figure 3).

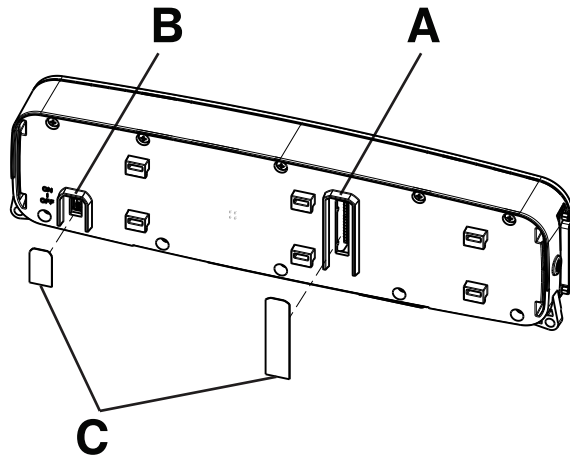

Figure 3 – Switch configuration

6. Using a #2 Phillips screwdriver, remove the ten screws (AC) that secure the front cover to the body (Figure 4). Save the screws and front cover.

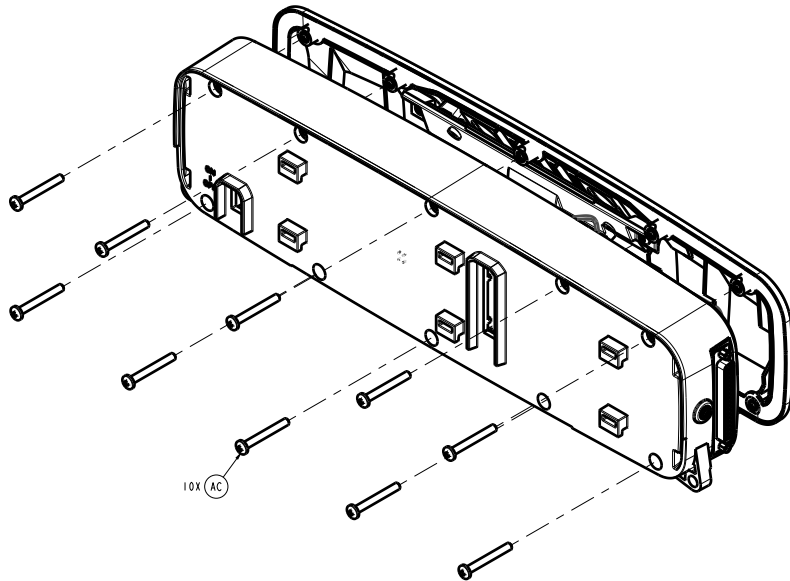

Figure 4 – Removing the cover

7. Using a #2 Phillips screwdriver, remove the two screws (AB) near the battery (V) that secure the cable routing tray (D) to the body (C) (Figure 5). Save the screws.

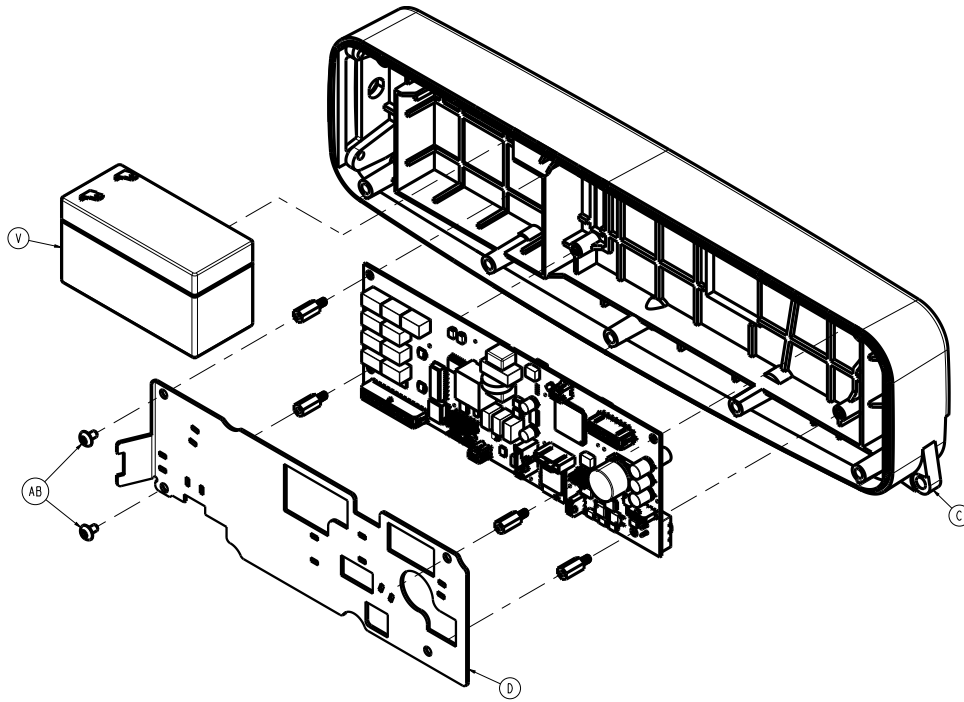

Figure 5 – Replacing the battery (left)

8. Using diagonal pliers, cut the cable tie (3000-300-114) (AK) that secures the 37-pin cable (M) to the cable routing tray (D) (Figure 6). Discard the cable tie.

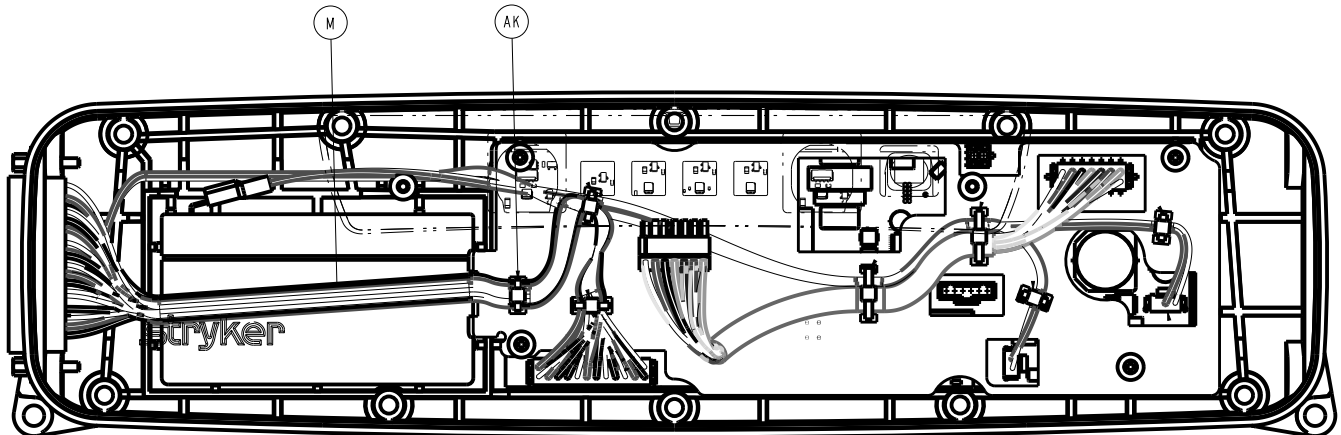

Figure 6 – Replacing the battery (left)

9. Move the 37-pin cable (M) and cable routing tray (D) up to remove the battery (700000341245) (V) from the body (C).
10. Unplug the two battery cables and discard the battery.

Note - When you reinstall, make sure that the red wire connects to positive (+) and the black wire connects to negative (-) on the battery.

11. Reverse steps to reinstall.
12. Verify proper operation before you return the product to service.

Replacing the battery (37-pin connector, right side)

Tools required:

- #2 Phillips screwdriver
- #1 Phillips screwdriver
- Needle nose pliers
- Straight pick

Procedure:

1. Unplug the power supply from the **Secure Connect**.
2. Using a #1 Phillips screwdriver and needle nose pliers, disconnect the nurse call communication cable from the **Secure Connect**.
3. Using a #2 Phillips screwdriver, remove the two screws (G) that secure the **Secure Connect** (F) to the mounting plate (D) (Figure 7). Save the two screws.

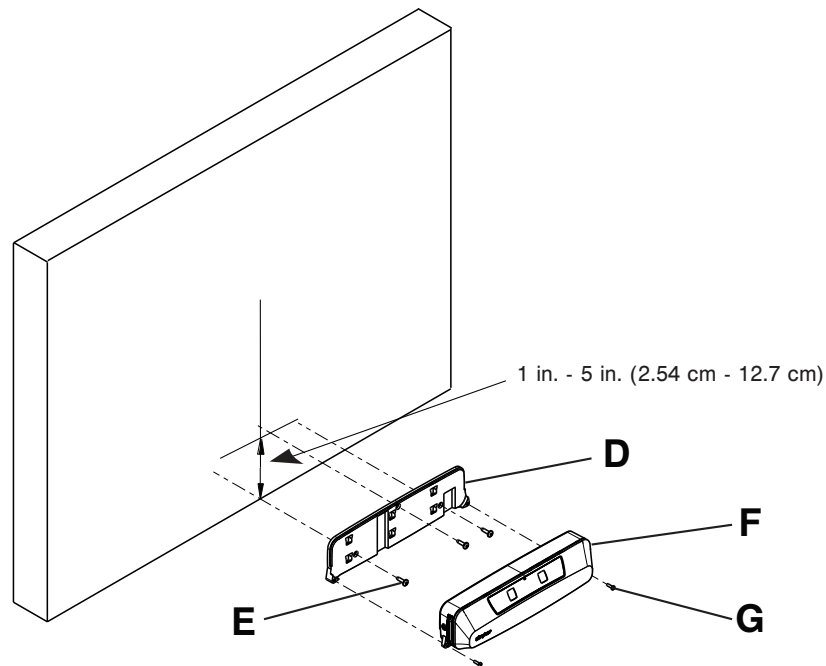

Figure 7 – Mounting specifications

4. Using a straight pick, remove and discard the label (521200380902) (C) that covers the **ON/OFF** switch (B) (Figure 8).

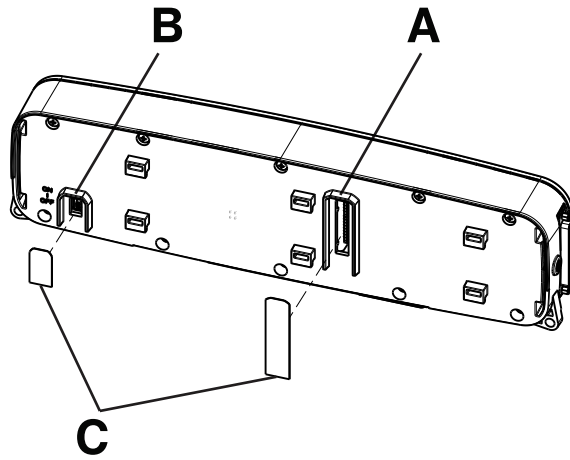
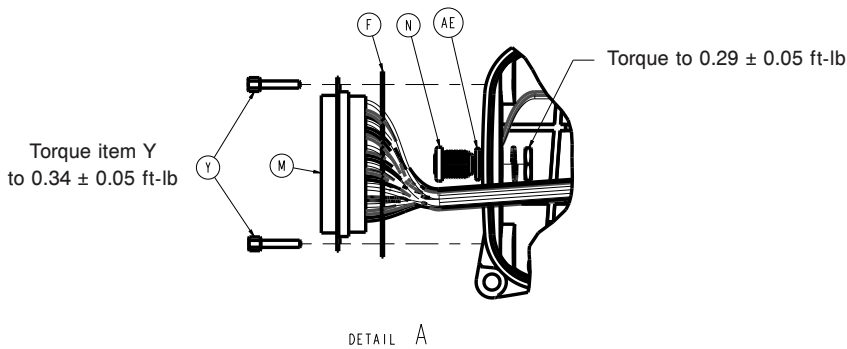
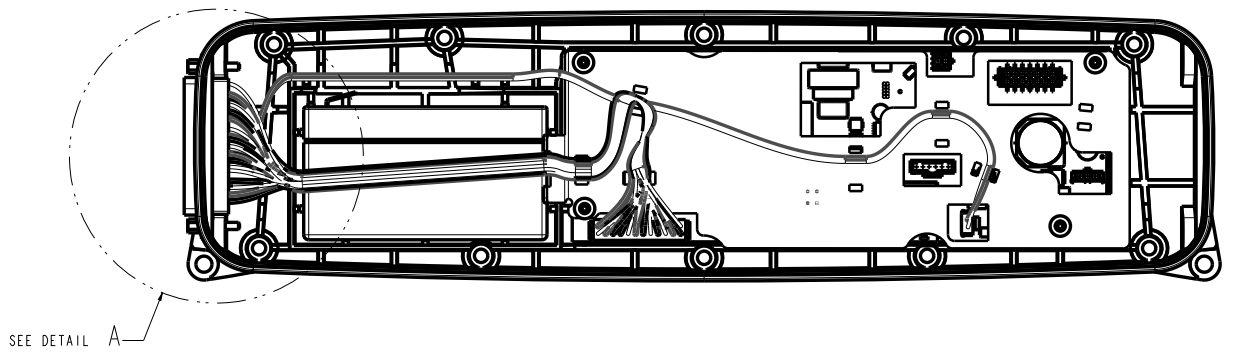
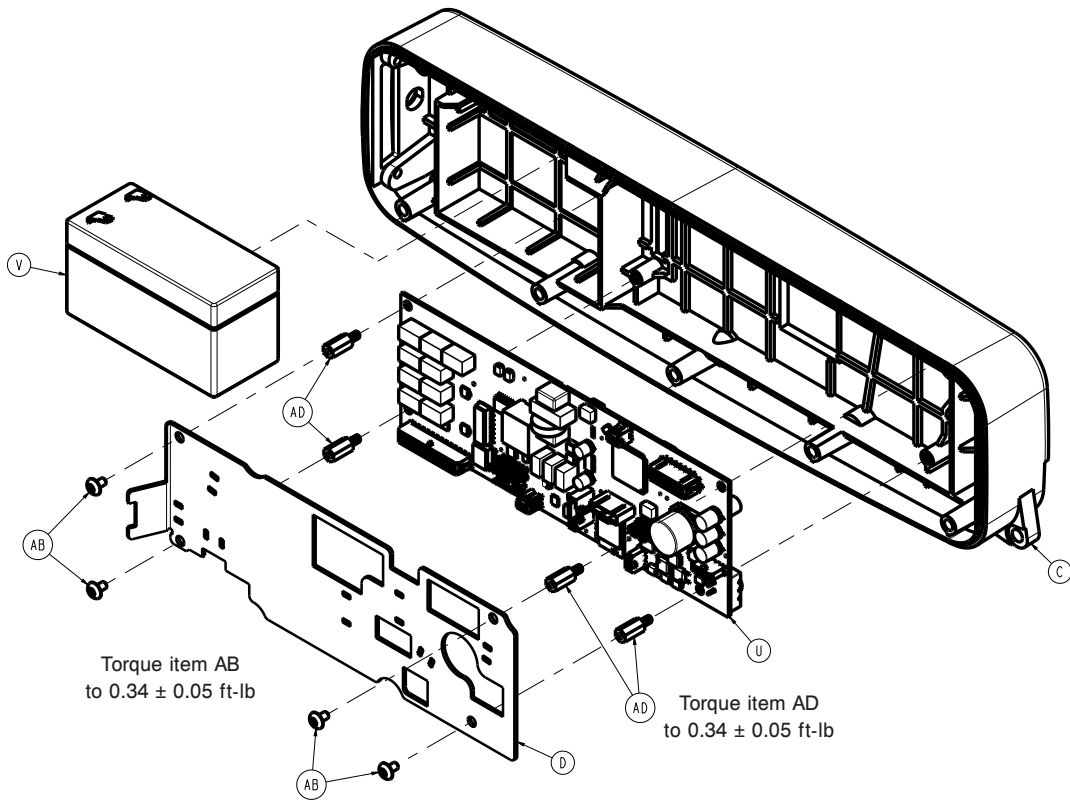

Figure 8 – Switch configuration

5. Turn the **ON/OFF** switch (B) to the **OFF** position (Figure 8).
6. Using a #2 Phillips screwdriver, remove the ten screws (AC) that secure the front cover to the body (Figure 4). Save the screws and front cover.
7. Unplug the two battery cables and discard the battery (700000341245) (V).
Note - When you reinstall, make sure that the red wire connects to positive (+) and the black wire connects to negative (-) on the battery.
8. Reverse steps to reinstall.
9. Verify proper operation before you return the product to service.

Secure Connect locator assembly, left

521200380105 Rev AD (Reference only)



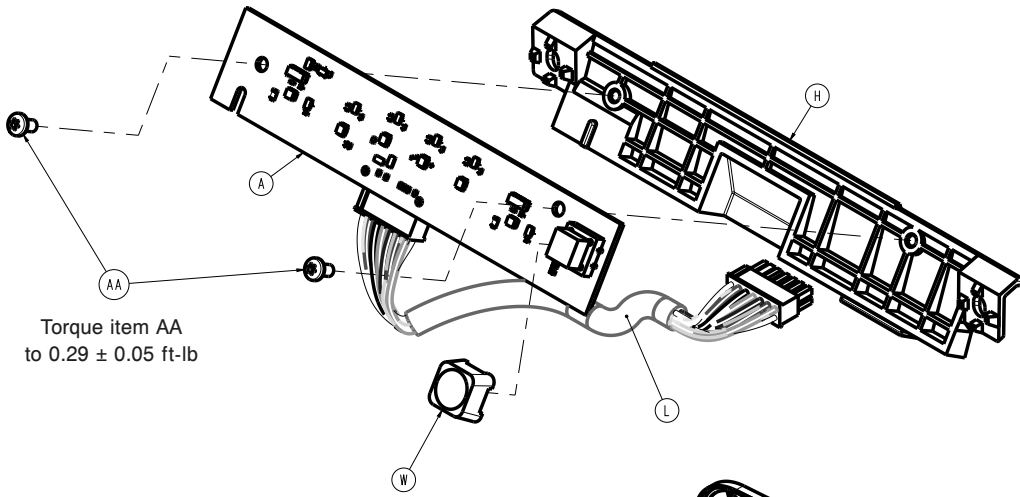

Torque item AA
to 0.29 ± 0.05 ft-lb

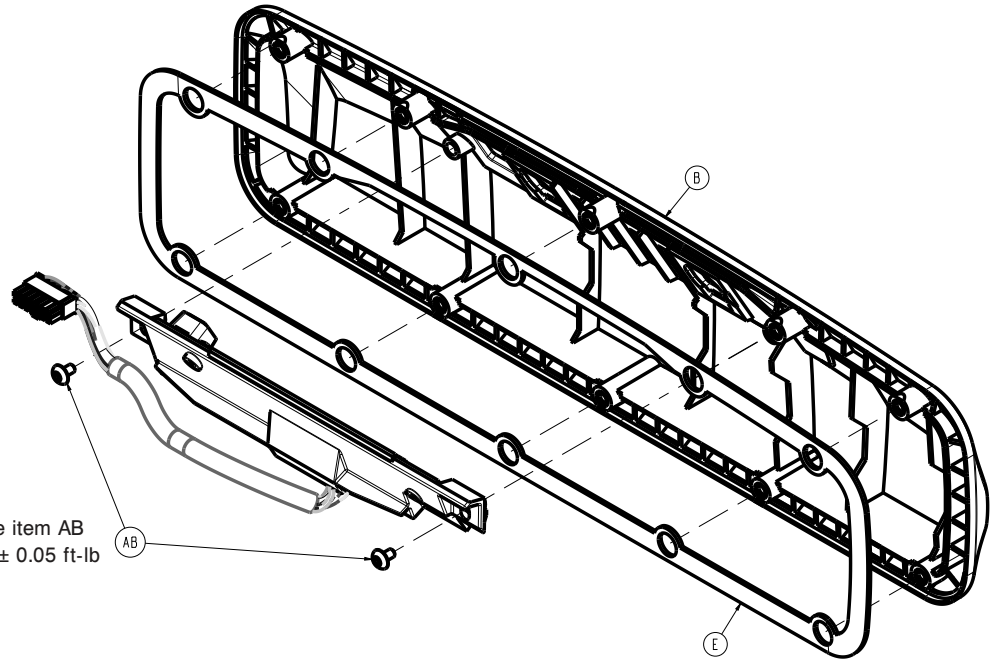

Torque item AB
to 0.34 ± 0.05 ft-lb

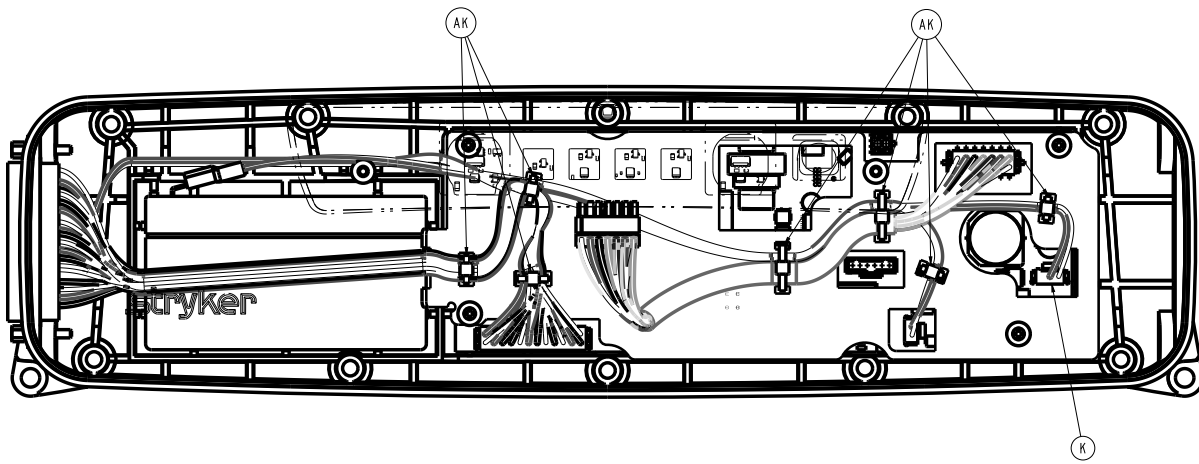

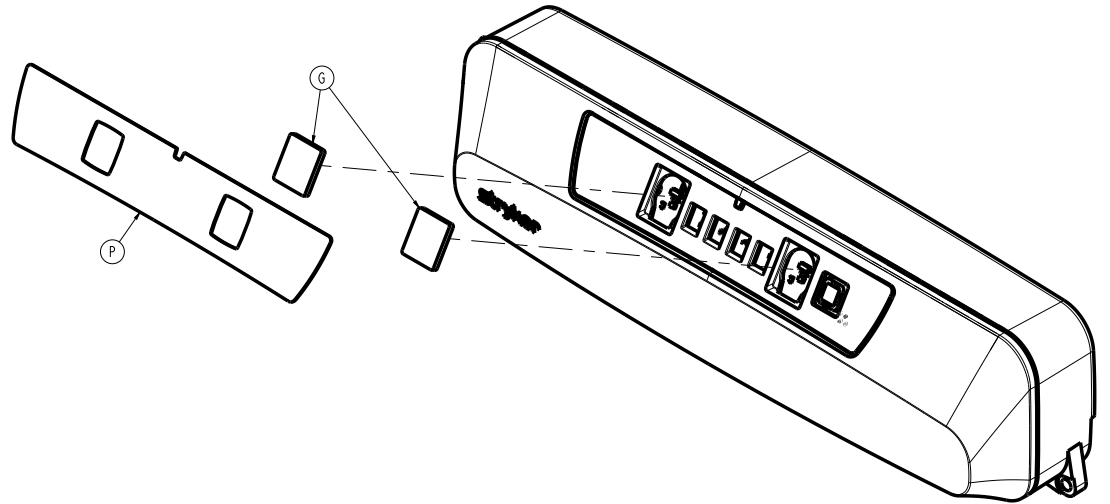
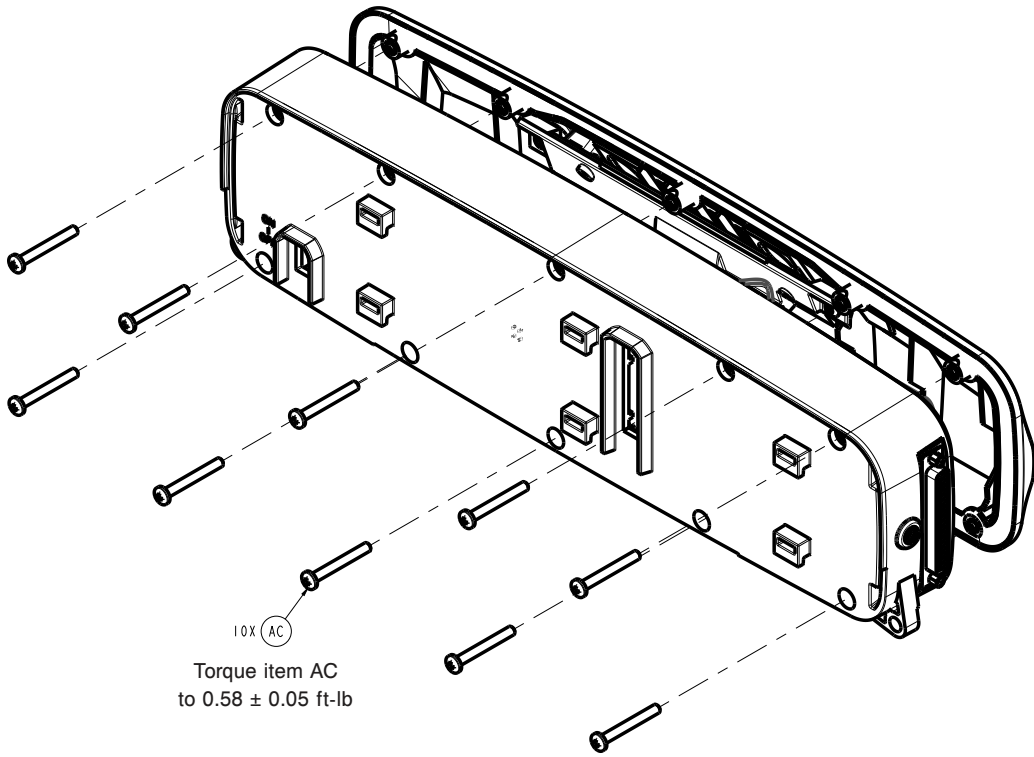

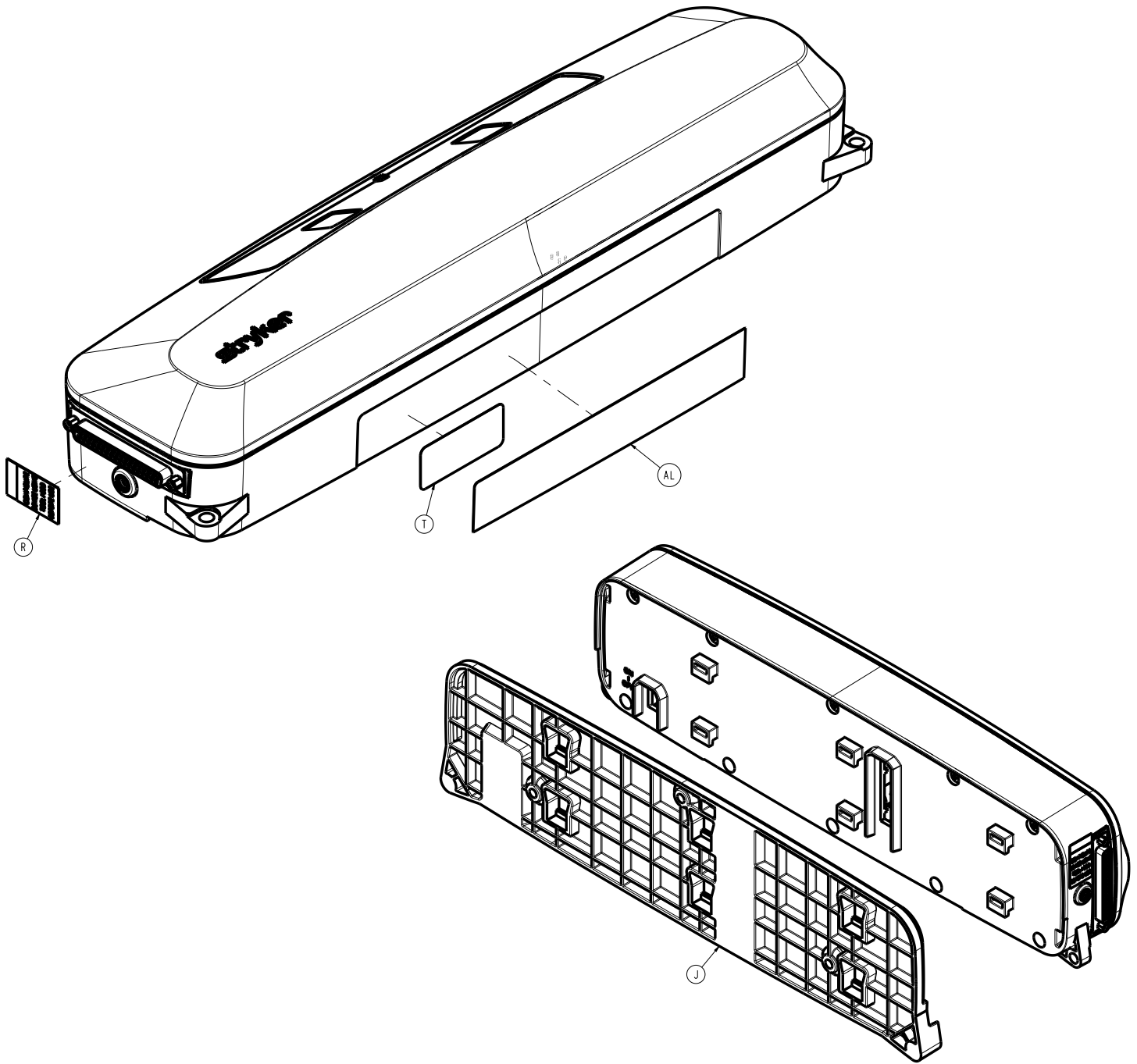

Item	Number	Name	Quantity
A	300900380940	Wallside infrared board	1
B	521200380111	Front cover	1
C	521200380112	Left body	1
D	521200380114	Left cable routing tray	1
E	521200380116	Front cover gasket	1
F	521200380117	37-pin connector gasket	1
G	521200380118	IR lens	2
H	521200380119	IR board mounting tray	1
J	521200380121	Mounting plate	1
K	521200380801	Battery cable assembly	1
L	521200380802	IR board cable assembly	1

Item	Number	Name	Quantity
M	521200380803	37-pin cable assembly	1
N	521200380806	Left power cable assembly	1
P	521200380901	Label, front	1
R	521200380904	Label, configuration warning	1
T	Reference only	Label, serial number/BBID	1
U	521200380950	Wallside room interface board	1
V	700000341245	Rechargeable battery 12V	1
W	3001-400-953	Switch cap	1
Y	Reference only	Jack screw	2
AA	Reference only	Pan head thread forming screw	2
AB	Reference only	Truss head machine screw	6
AC	Reference only	Pan head machine screw	10
AD	Reference only	Threaded hex standoff	4
AE	Reference only	O-ring	1
AK	Reference only	Cable tie	7
AL	521200380906	Label, Secure Connect locator information	1

Secure Connect locator assembly, right

521200380110 Rev AD (Reference only)

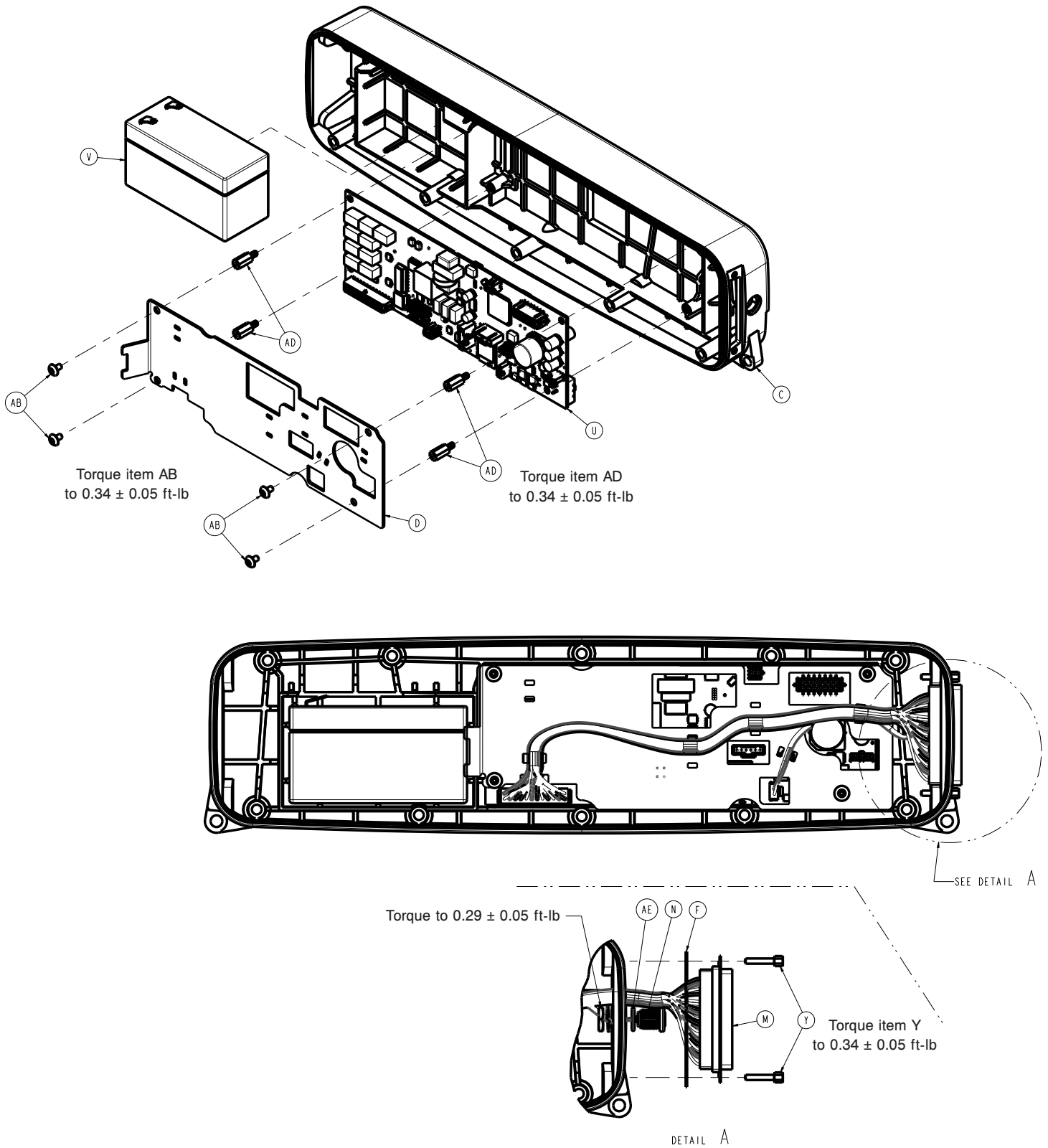

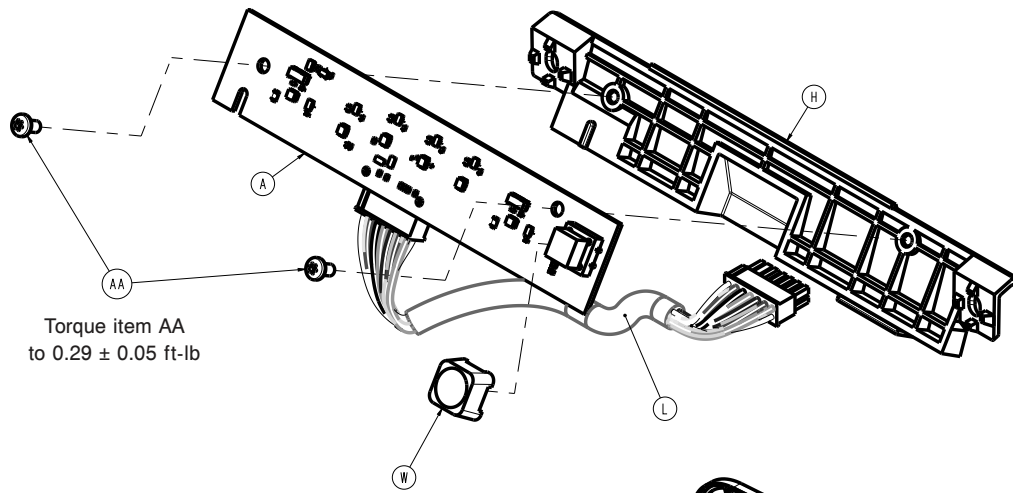

Torque item AA
to 0.29 ± 0.05 ft-lb

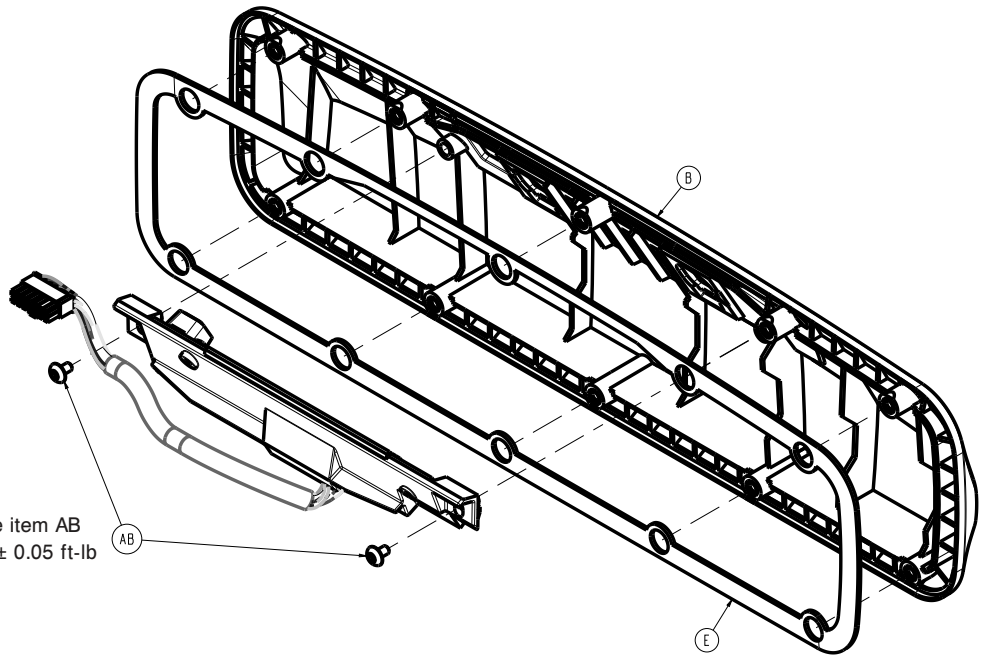

Torque item AB
to 0.34 ± 0.05 ft-lb

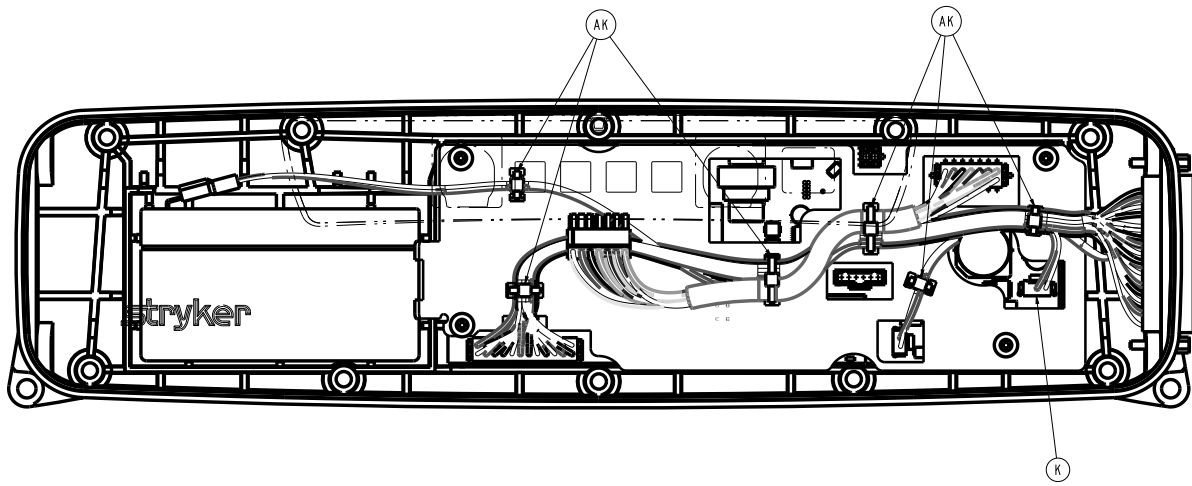

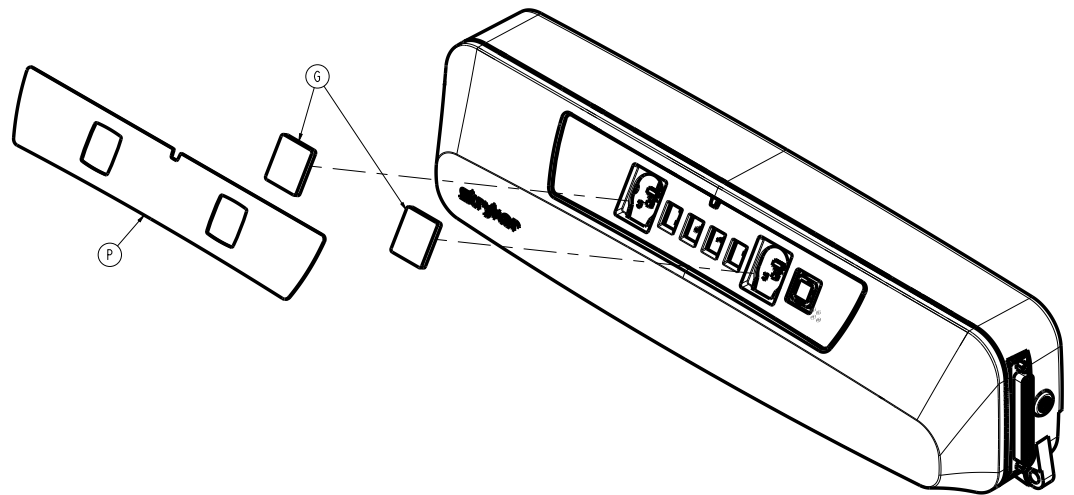
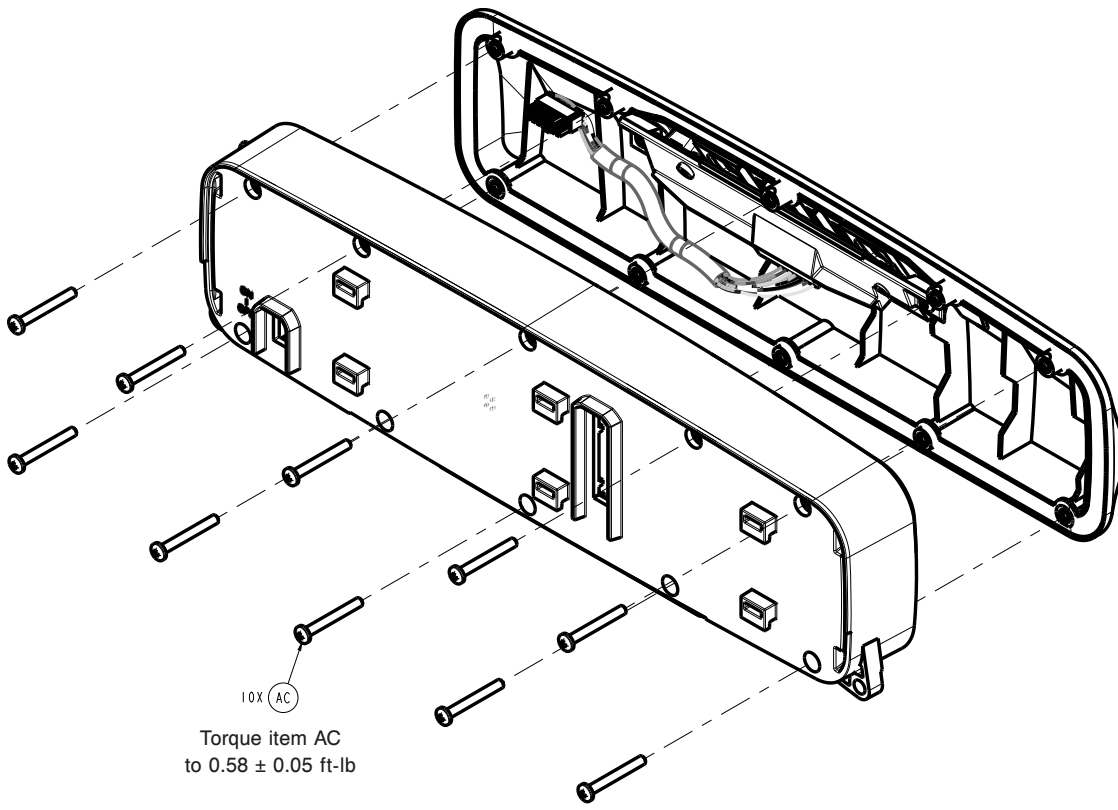

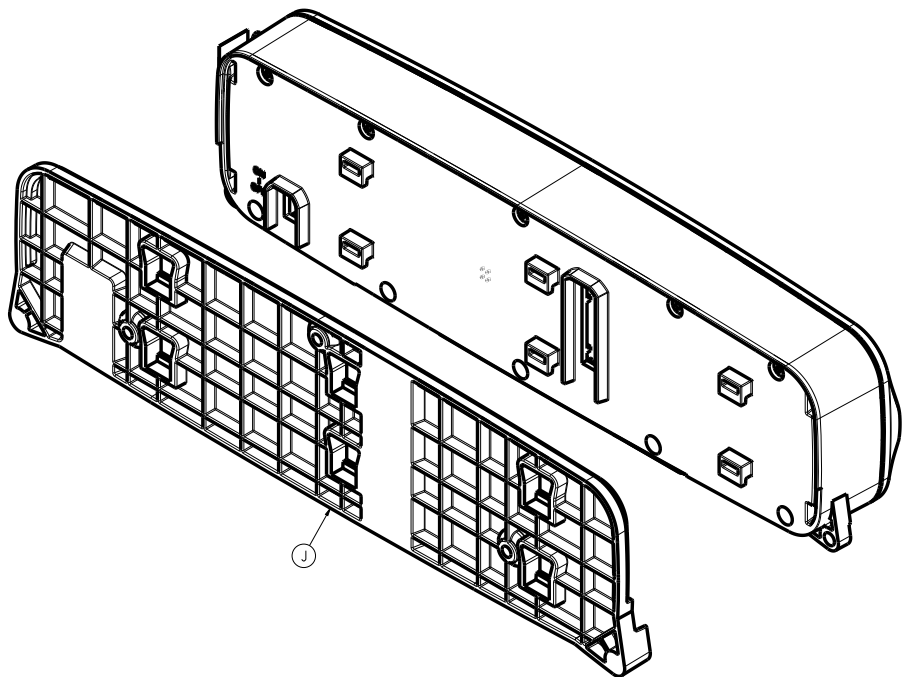
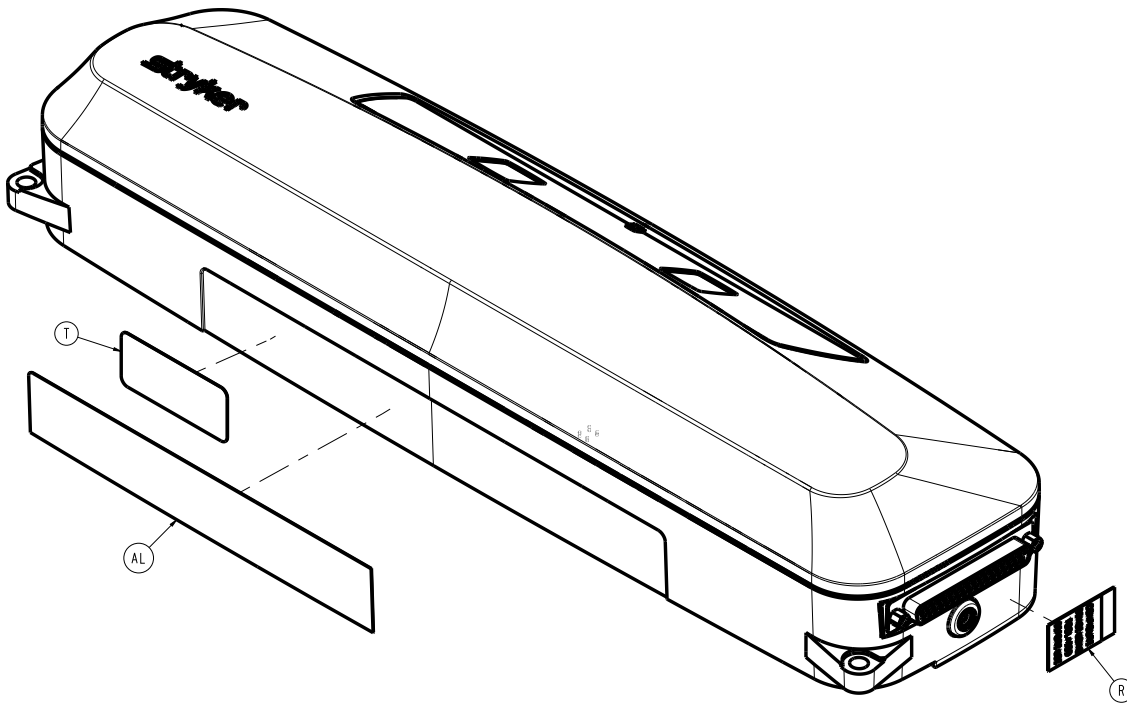

Item	Number	Name	Quantity
A	300900380940	Wallside infrared board	1
B	521200380111	Front cover	1
C	521200380113	Right body	1
D	521200380123	Right cable routing tray	1
E	521200380116	Front cover gasket	1
F	521200380117	37-pin connector gasket	1
G	521200380118	IR lens	2
H	521200380119	IR board mounting tray	1

Item	Number	Name	Quantity
J	521200380121	Mounting plate	1
K	521200380801	Battery cable assembly	1
L	521200380802	IR board cable assembly	1
M	521200380803	37-pin cable assembly	1
N	521200380804	Right power cable assembly	1
P	521200380901	Label, front	1
R	521200380904	Label, configuration warning	1
T	Reference only	Label, serial number/BBID	1
U	521200380950	Wallside room interface board	1
V	700000341245	Rechargeable battery 12V	1
W	3001-400-953	Switch cap	1
Y	Reference only	Jack screw	2
AA	Reference only	Pan head thread forming screw	2
AB	Reference only	Truss head machine screw	6
AC	Reference only	Pan head machine screw	10
AD	Reference only	Threaded hex standoff	4
AE	Reference only	O-ring	1
AK	Reference only	Cable tie	6
AL	521200380906	Label, Secure Connect locator information	1

EMC information

WARNING

- Portable RF communications equipment, including peripherals such as antenna cables and external antennas, should be no closer than 12 inches (30 cm) to any part of the **Secure Connect** locator, including cables specified by the manufacturer.
- Avoid stacking or placing equipment adjacent with other equipment to prevent improper operation of the product. If such use is necessary, carefully observe stacked or adjacent equipment to make sure that they operate properly.
- The use of accessories, transducers, and cables, other than those specified or provided by the manufacturer, could result in increased electromagnetic emissions or decreased electromagnetic immunity and result in improper operation.

The 521200380100 **Secure Connect** locator was evaluated using the following cables:

Cable	Length (m)
AC mains input cable	1.2
Nurse call (DB-37)	2.4

Guidance and manufacturer's declaration - electromagnetic emissions

The 521200380100 **Secure Connect** locator is intended for use in the electromagnetic environment specified below. The customer or the user of the 521200380100 **Secure Connect** locator should assure that it is used in such an environment.

Emissions test	Compliance	Electromagnetic environment
RF Emissions CISPR 11	Group 1	Note - The emissions characteristics of this equipment make it suitable for use in industrial areas and hospitals (CISPR 11 class A). If it is used in a residential environment (for which CISPR 11 class B is normally required) this equipment might not offer adequate protection to radio-frequency communication services. The user might need to take mitigation measures, such as relocating or re-orienting the equipment.
RF Emissions CISPR 11	Class A	
Harmonic Emissions IEC 61000-3-2	Class A	
Voltage Fluctuations Flicker Emissions IEC 61000-3-3	Complies	

Guidance and manufacturer's declaration - electromagnetic immunity

The 521200380100 **Secure Connect** locator is suitable for use in a professional healthcare facility environment and not in environments exceeding immunity test conditions that the product was evaluated to, such as near high frequency (HF) surgical equipment and inside of the radio frequency (RF) shielded room of magnetic resonance imaging (MRI) equipment. The customer or the user of the 521200380100 **Secure Connect** locator should assure that it is used in such an environment and that the electromagnetic environment guidance listed below is followed.

Immunity test	IEC 60601 test level	Compliance level	Electromagnetic environment-guidance
Electrostatic Discharge (ESD) IEC 61000-4-2	±8 kV contact ±15 kV air	±8 kV contact ±15 kV air	Floors should be wood, concrete, or ceramic tile. If floors are covered with synthetic material, the relative humidity should be at least 30%.
Electrostatic fast transient/burst IEC 61000-4-4	±2 kV for power supply lines ±1 kV for input/output lines	±2 kV for power supply lines ±1 kV for input/output lines	Main power quality should be that of a typical commercial or hospital environment.

Guidance and manufacturer's declaration - electromagnetic immunity

Surge IEC 61000-4-5	± 0.5 kV, ± 1 kV lines to lines ± 0.5 kV, ± 1 kV, ± 2 kV lines to earth	± 0.5 kV, ± 1 kV lines to lines ± 0.5 kV, ± 1 kV, ± 2 kV lines to earth	Main power quality should be that of a typical commercial or hospital environment.
Voltage dips, voltage variations and short interruptions on power supply input lines IEC 61000-4-11	0% U_T for 0.5 cycle at 0°, 45°, 90°, 135°, 180°, 225°, 270°, and 315° 0% U_T for 1 cycle 70% U_T (30% dip in U_T) for 25/30 cycles 0% U_T for 250/300 cycles	0% U_T for 0.5 cycle at 0°, 45°, 90°, 135°, 180°, 225°, 270°, and 315° 0% U_T for 1 cycle 70% U_T (30% dip in U_T) for 25/30 cycles 0% U_T for 250/300 cycles	Main power quality should be that of a typical commercial or hospital environment. If the user of the 521200380100 Secure Connect locator requires continued operation during power main interruptions, it is recommended that the device be powered from an uninterrupted power supply or a battery.
Power frequency (50/60 Hz) magnetic field IEC 61000-4-8	30 A/m	30 A/m	Power frequency magnetic fields should be at levels characteristic of a typical location in a typical commercial or hospital environment.

Note - U_T is the a.c. mains voltage before applications of the test level.

<p>Conducted RF IEC 61000- 4-6</p> <p>Radiated RF IEC 61000-4-3</p>	<p>3 Vrms 150 kHz to 80 MHz 3 V/m 80 MHz to 2.7 GHz</p>	<p>3 Vrms 3 V/m</p>	<p>Portable and mobile RF communications equipment should follow the guidance in the table titled “Recommended separation distances between portable and mobile RF communication equipment and the 521200380100 Secure Connect locator.” If the mobile service is not listed in the table, the recommended separation distance should be calculated from the equation appropriate for the frequency of the transmitter.</p> <p>Recommended separation distance $D=(2) (\sqrt{P})$ where P is the maximum output power rating of the transmitter in watts (W) according to the transmitter manufacturer and d is the recommended separation distance in meters (m).</p> <p>Field strengths from fixed RF transmitters, as determined by an electromagnetic site survey^a, should be less than the compliance level in each frequency range^b.</p> <p>Interference may occur in the vicinity of equipment marked with the following symbol: </p>
---	---	-------------------------	---

Note - These guidelines may not apply in all situations. Electromagnetic propagation is affected by absorption and reflection from structures, objects and people.

Note - The ISM (Industrial, Scientific, and Medical) bands between 0.15 MHz and 80 MHz are 6.765 MHz to 6.795 MHz; 13.553 MHz to 13.567 MHz; 26.957 MHz to 27.283 MHz; and 40.66 MHz to 40.70 MHz.

^aField strengths from fixed transmitters, such as base stations for radio (cellular/cordless) telephones and land mobile radios, amateur radio, AM and FM radio broadcast, and TV broadcast cannot be predicted theoretically with accuracy. To assess the electromagnetic environment due to fixed RF transmitters, an electromagnetic site survey should be considered. If the measured field strength in the location in which the 521200380100 **Secure Connect** locator is used exceeds the applicable RF compliance level above, the 521200380100 **Secure Connect** locator should be observed to verify normal operation. If abnormal performance is observed, additional measures may be necessary, such as reorienting or relocating the 521200380100 **Secure Connect** locator.

^bOver the frequency range 150 kHz to 80 MHz, field strengths are less than 3 Vrms.

Recommended separation distances between portable and mobile RF communication equipment and the 521200380100 Secure Connect locator

The 521200380100 **Secure Connect** locator is intended for use in an electromagnetic environment in which radiated RF disturbances are controlled. The customer or the user of the 521200380100 **Secure Connect** locator can help prevent electromagnetic interferences by maintaining a minimum distance between portable and mobile RF communications equipment (transmitters) and the 521200380100 **Secure Connect** locator, including cables, as recommended below, according to the maximum output power of the communications equipment.

Band (MHz)	Service	Maximum power (W)	Minimum separation distance (m)
380-390	TETRA 400	1.8	0.3
430-470	GMRS 460; FRS 460	2.0	0.3
704-787	LTE Band 13, 17	0.2	0.3
800-960	GSM 800/900; TETRA 800; iDEN 820; CDMA 850; LTE Band 5	2.0	0.3
1,700-1,990	GSM 1800; CDMA 1900; GSM 1900; DECT; LTE Band 1, 3, 4, 25; UMTS	2.0	0.3
2,400-2,570	Bluetooth; WLAN; 802.11 b/g/n; RFID 2450; LTE Band 7	2.0	0.3
5,100-5,800	WLAN 802.11 a/n	0.2	0.3

For transmitters rated at a maximum output power not listed above, the recommended separation distance d in meters (m) can be estimated using the equation applicable to the frequency of the transmitter, where P is the maximum output power rating of the transmitter in watts (W) according to the transmitter manufacturer.

Note - These guidelines may not apply in all situations. Electromagnetic propagation is affected by absorption and reflection from structures, objects and people.

Recycling passport

521200380105/521200380110

Rev AD/AD

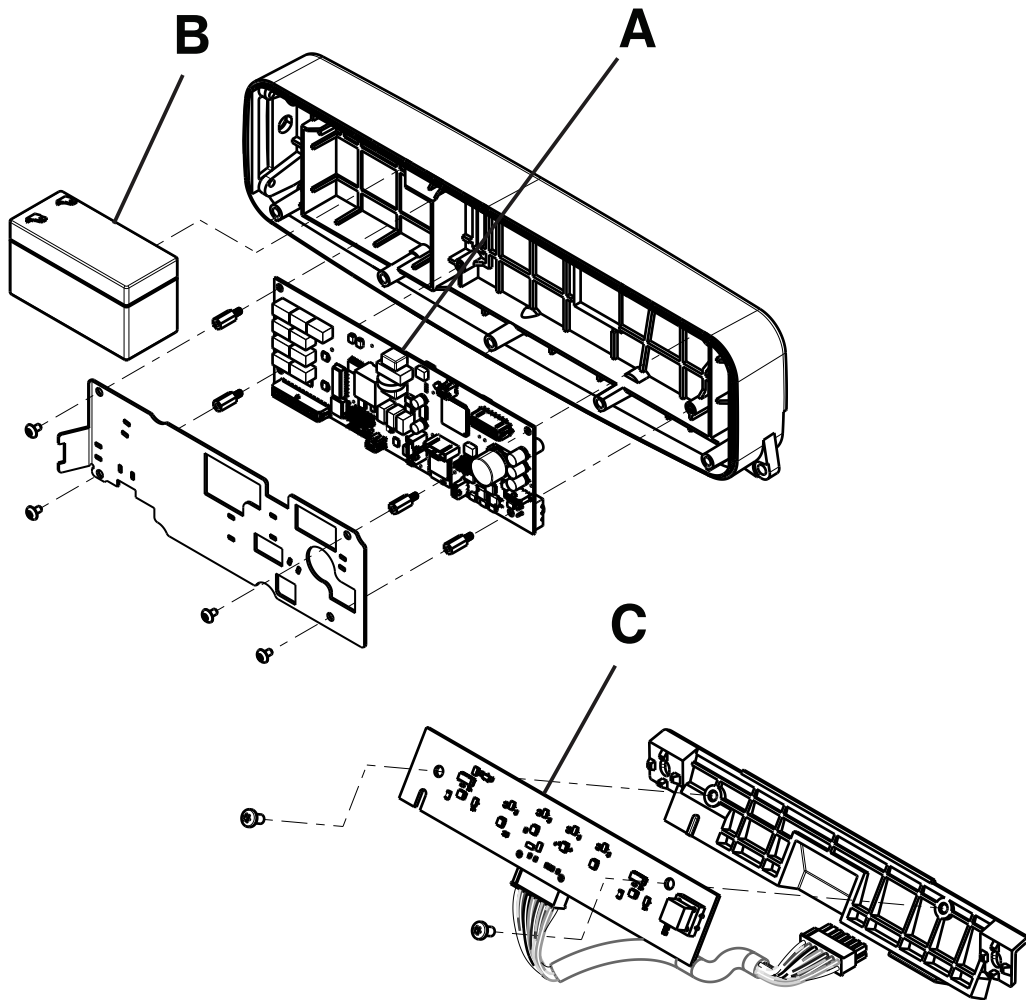

Item	Recyclable part number	Material code	Important information	Quantity
A	521200380950	Printed circuit board		1
B	700000341245	Battery		1
C	300900380940	Printed circuit board		1

700000886795

Rev AB

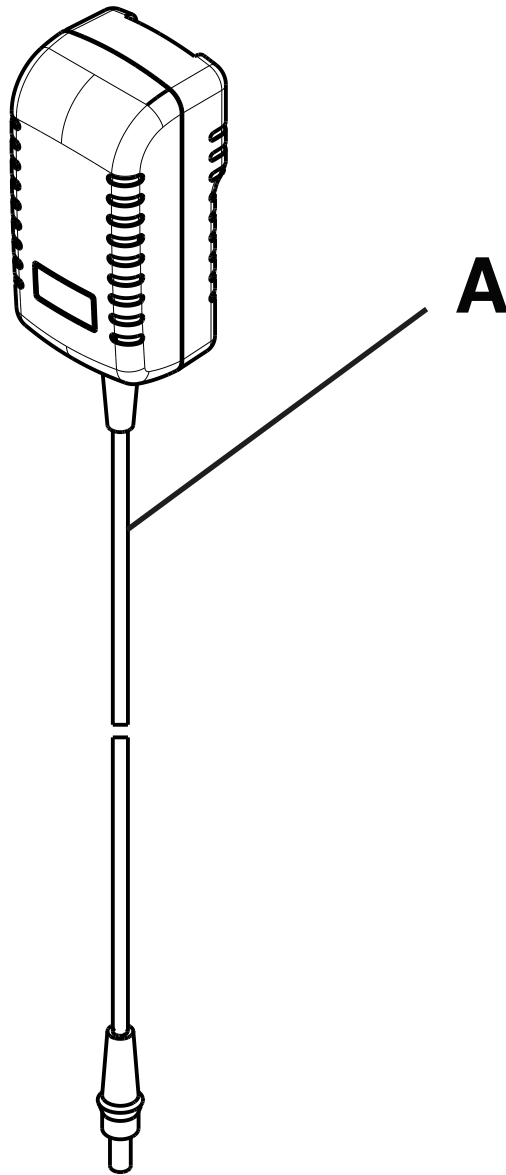

Item	Recyclable part number	Material code	Important information	Quantity
A	700000886795	Power adapter		1

700000915390

Rev AB

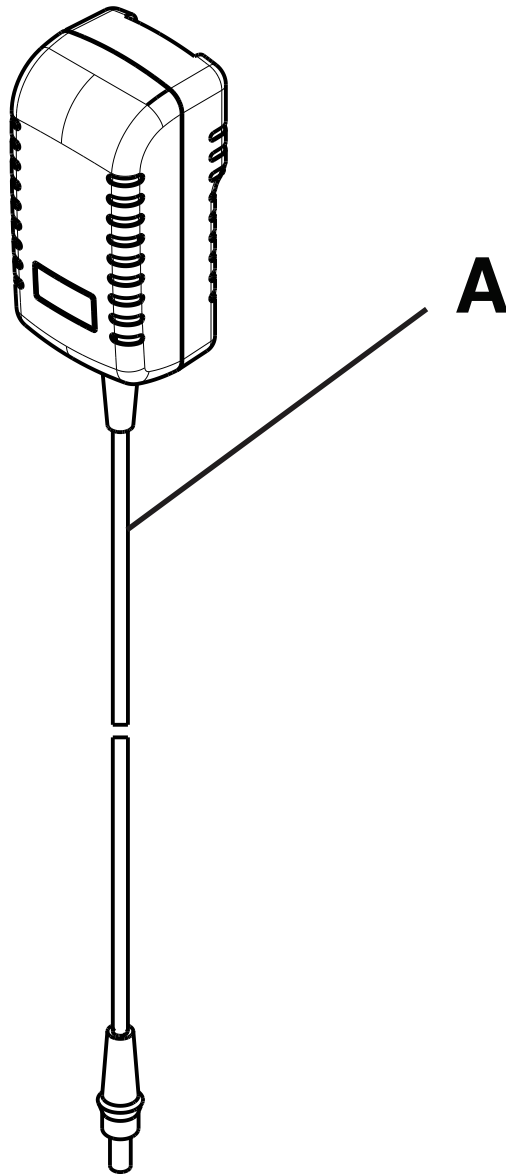

Item	Recyclable part number	Material code	Important information	Quantity
A	700000915390	Power adapter		1

stryker



Stryker Medical
3800 E. Centre Avenue
Portage, MI 49002
USA