

### ELECTRIC MED/SURG BED Model FL25E



#### TECHNICAL ASSISTANCE AND PARTS

Canada: 1 888 233-6888

United States: 1 800 327 0770

Outside Canada and the United States: Contact your local representative

Manufactured by Stryker

72-0714E REV A  
F15-43-B

January 2006  
Printed in Canada



# TABLE OF CONTENTS

1. INTRODUCTION.....	5
1.1 Bed Specifications .....	5
1.2 Technical Support.....	6
1.3 Warning / Caution / Note Definitions .....	6
1.4 Safety Tips and Guidelines .....	6
1.5 Warranty.....	8
Limited Warranty .....	8
To Obtain Service and/or Parts.....	8
Return Authorization.....	8
Damaged Merchandise.....	8
1.6 Symbols.....	9
1.7 Set-Up Procedure .....	10
1.8 Cleaning and Preventative Maintenance.....	11
Bed Cleaning and Mattress Care .....	11
Preventative Maintenance .....	12
1.9 Bed Position Pictograms.....	13
1.10 Bed Illustration .....	13
2. OPERATION GUIDE .....	14
2.1 Powering the Bed .....	14
2.2 Brake/Steer Pedal.....	14
2.3 Applying the Brakes.....	14
2.4 Moving the bed .....	15
2.5 Foley Bag Hook Usage.....	15
2.6 Patient Restraint Strap Locations.....	15
2.7 Night Light (Optional) Usage.....	15
2.8 CPR Emergency Release .....	16
Lowering the Fowler During a Power Failure .....	16
2.9 Nurse Call Usage (Optional) .....	16
2.10 Auxiliary Power Outlet Usage (Option Available w/120V~ Bed Model).....	16
2.11 Positioning Siderails .....	17
2.12 Head and Foot Board Operation .....	17
2.13 Head Siderail Function Guide .....	18
2.14 Foot Board Control Panel Guide .....	19
Weigh System Control Panel Guide (Optional) .....	20
Weigh System Usage .....	21
Operating (Zeroing) the Scale Before Putting a New Patient on the Bed.....	21
Registering the Reference Weight for Gain or Loss Readings.....	21
Adding or Removing Equipment when a Patient is on the Bed .....	22
Changing Manually the Numerical Value of Displayed Weight .....	22
Changing the Weight Measure Unit.....	22
Bed Exit System (Optional).....	23
Bed Exit System Usage .....	23
Zeroing the System .....	23
Arming the System.....	23
Adding or Removing Equipment with the System Active .....	23
Bed Exit with Zone Control System (Optional) .....	24

Bed Exit W/Zone Control System Usage .....	24
Zone Features .....	24
Zeroing the System.....	24
Arming the System .....	25
Adding or Removing Equipment with the System Active .....	25
3. ACCESSORIES.....	25

## 1. INTRODUCTION

This manual is designed to assist in the operation of Stryker's FL25E Med/Surg Beds. Read it thoroughly before operating the bed. Hospital staff should be able to refer to this manual at all time when using the bed.

This Operations Manual is an integral part of the bed and should be included if the bed is sold or transferred.

### 1.1 BED SPECIFICATIONS \*

Safe Working Load	500 lb (227 kg)
Weigh System (Optional) - Capacity - Accuracy  - Operating Angular Range	Patients weighing up to 500 lb (227 kg) ± 2 % for weight from 100 to 500 lb (45.3 to 227 kg) ± 2 lb for weight under 100 lb (45.3 kg) -12° to +12°
Overall Length/Width - Siderails Up - Siderails Down	93.75 x 42.9" (238 cm x 109 cm) 93.5 x 39.3" (237.5 cm x 99.8 cm)
Weight w/Boards	488 lb (221 kg)
Patient Sleep Surface	35 x 80" (89 x 203 cm) extendable to 82" (208 cm) and 84" (213 cm)
Recommended Mattress Size	35 x 80" (89 x 203 cm); 35 x 82" (89 x 208 cm); 35 x 84" (89 x 213 cm)
Mattress <b>Maximum</b> Thickness	6" (15.24 cm)
Min/Max Bed Height:	14 to 29" (36 to 73.7 cm)
Fowler Angle	0 to 62°
Knee Gatch Angle - W/Auto Contour - W/o Auto Contour	0 to 24° 0 to 32°
Trendelenburg/Reverse Trendelenburg	+14 to -14°
Environmental Conditions - Transport and Storage - Ambient Temperature - Relative Humidity - Atmospheric Pressure - Operating ** - Ambient Temperature - Relative Humidity - Atmospheric Pressure	-40 to 70°C (-40 to 158°F) 10 to 100% 500 to 1060 hPa  18.3 to 26.7°C (65 to 80°F) 20 to 80% without <b>condensation</b> 700 to 1060 hPa
*** Electrical Requirements - all electrical requirements meet CSA C22.2 No. 601.1, UL 60601-1 and IEC 60601-1, 60601-2-38 specifications.	100V~, 50-60Hz, 7.5A - Two 250V, 10A Fuses 120V~, 50-60Hz, 4.0A (9.8A w/120V Optional Auxiliary Outlet) - Two 250V, 10A Fuses 200V~, 50-60Hz, 3.2A -Two 250V, 6.3A Fuses 220V~, 50-60Hz, 2.9A -Two 250V, 6.3A Fuses 240V~, 50-60Hz, 2.7A -Two 250V, 6.3A Fuses

\* Stryker pays special attention to product improvement and reserves the right to change specifications without notice.

\*\* Operating environment recommended to ensure the scale precision.

\*\*\* The device has a 10% duty cycle.

## 1.2 TECHNICAL SUPPORT

For questions regarding this product, contact the following Technical Service department or your local representative:

### In Canada:

Stryker Canada  
1 888 233-6888  
45, Innovation Drive  
Hamilton, Ontario, L9H 7L8  
Canada

### In the United States:

Stryker Medical  
1 800 327-0770  
3800, East Centre Avenue  
Portage, MI 49002  
USA

## 1.3 WARNING / CAUTION / NOTE DEFINITIONS

The words WARNING, CAUTION and NOTE carry special meanings and should be carefully reviewed.



### WARNING

The personal safety of the patient or user may be involved. Disregarding this information could result in injury to the patient or user.



### CAUTION

These instructions point out special procedures or precautions that must be followed to avoid damaging the equipment.

### NOTE

Notes provide special information to make maintenance easier or important instructions clearer.

## 1.4 SAFETY TIPS AND GUIDELINES

Before operating the bed, it is important to read and understand all information in this manual. Carefully read and strictly follow the safety guidelines listed below.

It is important that all users have been trained and educated on the inherent hazards associated with the usage of electric beds.



### WARNING

- This bed is not intended for pediatric use.
- The mattress thickness should not exceed 6 inches (15.24 cm).
- This bed is equipped with a hospital grade plug for protection against shock hazard. It must be plugged directly into a properly grounded receptacle. Grounding reliability can be achieved only when a hospital grade receptacle is used.
- Shock Hazard - Improper handling of the power cord may result in damage to the power cord and potential shock hazards. If damage has occurred to the power cord, immediately remove the bed from service, and contact the appropriate maintenance personnel. Failure to do so could result in serious injury or death.
- Serious injury can result if caution is not used when operating the bed. Operate the bed only when all people and equipment are clear of the electrical and mechanical systems.
- Always apply the brakes when a patient is on the bed or entering/exiting the bed. Serious injury could result if the bed moves while a patient is getting on or off the bed. After the brake pedal is engaged, push on the bed to ensure the brakes are securely applied.
- Keep siderails in the fully raised position and the sleep surface horizontal in its lowest position when the patient is unattended, unless its medical condition dictates otherwise. When raising the siderails, be sure that you hear the "click" that signals the locked condition. Pull firmly on the siderail to ensure it is locked into position.

- When the sleep surface sections are articulated, ensure that all the patient's limbs are within the raised siderails to avoid patient injury.
- When a patient's condition requires greater safety measures for his/her security, use the lockout controls in the foot board control panel to inhibit the siderail functions or remove any optional pendant control and install protective pads on the siderails.
- Siderails, with or without their padded covers, are not intended to serve as restraint devices to keep patient from exiting the bed. Siderails are designed to keep a patient from inadvertently rolling off the bed. It is the responsibility of the attending medical personnel to determine the degree of restraint necessary to ensure a patient will remain safely in bed. Failure to utilize the siderails properly could result in serious patient injury.
- To reduce risk of injury, ensure the sleep surface is horizontal and in the lowest position with the siderails fully raised and locked when moving the bed with a patient in it.
- To avoid injury to the patient and/or user, do not attempt to move the bed laterally with the steer mode engaged. The steer wheel cannot swivel.
- The CPR emergency release is for emergency use only. When activating the CPR release handle, all people and equipment must be removed from the area below and around the head, thigh and foot sections of the bed or serious personal injury and/or equipment damage could occur.
- Possible fire hazard exists when this bed is used with oxygen administering equipment other than nasal, mask type or half bed-length tent type. Unplug the bed power cord from the wall when oxygen-administering equipment is used. When using a half bed-length tent type, ensure that the siderails are outside the oxygen tent and that the tent does not extend below the mattress support level.
- The Bed Exit system (optional) is intended only to aid in the detection of a patient exiting the bed. It is not intended to replace patient monitoring protocol. The Bed Exit system signals when a patient is about to exit the bed. The addition or removal of equipment with a Bed Exit system active must be done using the "Adding or Removing Equipment with the System Active" procedure, otherwise the sensitivity of the system may be affected and the readings of the patient's movements in the bed be erroneous.
- The Bed Exit system (optional) is not designed to be used with patients weighing less than 50 lb (23 kg).
- When large fluid spills occur in the area of the circuit boards, cables and motors, immediately unplug the bed power cord from the wall outlet, remove the patient from the bed and clean up the fluid. Have maintenance completely check the bed. Fluids can have an adverse effect on operational capabilities of any electrical product. **DO NOT** put the bed back into service until it is completely dried and has been thoroughly tested for safe operation.
- Do not steam clean, hose off or ultrasonically clean the bed. Do not immerse any part of the bed. The internal electrical parts may be damaged by exposure to water. Hand wash regularly all surfaces of the bed with warm water and a mild detergent. Wipe cleaned surfaces dry to avoid build up of cleaning substance. Inspect the mattress after each use. Discontinue use if any cracks or rips, which may allow fluid to enter the mattress, are found in the mattress cover. Failure to properly clean the mattress, or dispose of it if defective, may increase the risk of exposure to pathogenic substances and may bring about diseases to the patient and user.
- Preventive maintenance should be performed at least once a year to ensure all bed features are functioning properly. Ensure that any bed malfunction is promptly reported to your service personnel for immediate attention.
- Always unplug the bed power cord from the wall outlet when servicing or cleaning the bed. When working under the bed with the bed in the high position, always apply the brakes and place blocks under the Hi-Lo levers to prevent injury in case the bed down switch is accidentally pressed.

- To avoid damage to the siderail mechanisms, do not move the bed using the raised siderails. Move the bed using the push/pull handles integrated to the boards.
  - Before using the optional emergency crank during a power failure, always unplug the power cord. An unexpected return of the power could rotate the handle and cause injury to the user.
  - Because individual beds may have different options, foot boards should not be moved from one bed to another. Mixing foot boards could result in unpredictable bed operation.
  - When servicing use only identical replacement parts provided by Stryker.
- 

**NOTE**

Throughout this Operations Manual, the words “right” and “left” refer to the right and left sides of a patient lying face up on the bed.

## **1.5 WARRANTY**

### **LIMITED WARRANTY**

All Stryker products are guaranteed against material or manufacturing defects, improper operation of mechanisms, and premature wear of bed components under normal use conditions.

For questions regarding warranty, please contact the Technical Service department (see section 1.2) or your local representative.

### **TO OBTAIN SERVICE AND/OR PARTS**

For an on-site diagnosis of a malfunction by a Field Service Representatives or to order replacement parts, simply contact the Technical Service department (see section 1.2) or your local representative. For the part ordering procedure, refer to section 1.5 of the bed maintenance manual, “To Obtain Service and/or Parts”.

### **RETURN AUTHORIZATION**

Merchandise cannot be returned without approval from the Technical Service department. An authorization number will be provided, which must be clearly printed on the returned merchandise. Stryker reserves the right to charge shipping and restocking fees on returned items.

### **DAMAGED MERCHANDISE**

Claims for damaged merchandise must be made with the carrier within fifteen (15) days of receipt of merchandise. **DO NOT ACCEPT DAMAGED SHIPMENTS UNLESS SUCH DAMAGE IS NOTED ON THE DELIVERY RECEIPT AT THE TIME OF RECEIPT.** Upon prompt notification, Stryker will file a freight claim with the appropriate carrier for damages incurred. Claims will be limited in amount to the actual replacement cost. In the event that this information is not received by Stryker within the fifteen (15) day period following the delivery of the merchandise, or the damage was not noted on the delivery notice at the time of receipt, the customer will be responsible for payment of the original invoice in full.

Claims for any short shipment must be made within five days of invoice.



**1.6 SYMBOLS**

Warning, consult accompanying documents



Fuse rating for beds with the 100V~ or 120V~ electric system



Fuse rating for beds with the 200V~, 220V~ or 240V~ electric system



Protective Earth (ground)



Alternating Current



Type B Equipment

**IPX4** Protection from liquid splash

## 1.7 SET-UP PROCEDURE

### CHECKLIST

It is important to ensure that the bed is working properly before it is put into service. The following list will help ensure that each part of the bed is checked.

- Install the foot and head boards on the bed. Insert the foot board carefully so that the board and the casing connectors fit in smoothly.



#### WARNING

Because individual beds may have different options, foot boards should not be moved from one bed to another. Mixing foot boards could result in unpredictable bed operation.

- Ensure that the molded shells of the head and foot sections are properly positioned.
- Plug the power cord to the bed connector at the head end of the bed and into a properly grounded hospital grade wall outlet. Turn on the power switch located on the power connector.



#### WARNING

The bed is equipped with a hospital grade plug for protection against shock hazard. It must be plugged directly into a properly grounded receptacle. Grounding reliability can be achieved only when a hospital grade receptacle is used.

- On both sides of the bed, depress fully down the side of the pedal identified with a red sticker and ensure that the brakes are applied and the bed immobilized. Toggle the pedal to neutral and ensure the brakes are released.
- On both sides of the bed, depress fully down the side of the pedal identified with a green sticker and ensure that the 5th steer wheel is engaged. Toggle the pedal to neutral and ensure that the 5th wheel disengages.
- Ensure that the siderails raise, lock in the up position and lower smoothly. See page 17.
- Run through each control of the foot board panel. See page 19.
- Verify the optional Weigh system (see the "Scale System Calibration" procedure in the Maintenance Manual) and the optional Bed Exit system (see page 23) for proper operation.
- Run through each control on both inner and outer control panels of the head siderails (see page 18). If the bed is equipped with the optional Siderail Communications Package (see H, fig. 2.13B on page 18), plug the provided cable to the 37 pin connector located at the head end of the bed and into the proper wall outlet.
- Raise the bed to full up position and activate the Trendelenburg function. Ensure the head end lowers to the full down position. See **F1** page 19. Level the bed using the Hi-Lo controls.
- Raise the bed to full up position and activate the reverse Trendelenburg function. Ensure the foot end lowers to the full down position. See **F2** page 19. Level the bed using the Hi-Lo controls.
- Verify the CPR emergency release (optional) using both CPR release handles: raise the Fowler fully up and, using the CPR handle, lower the Fowler gradually to flat position by pulling, holding and releasing the handle several times. Ensure the Knee Gatch (if raised) also starts flattening when the Fowler is completely down. Following the complete lowering of the Fowler, wait approximately 30 seconds - the time for the Fowler control motor to reset - and verify that the motor has indeed reset by raising the Fowler fully up using the Fowler up control.
- Verify the following optional equipment for proper operation: 120V auxiliary outlet, night light, emergency crank operation, etc.

If any problems are found during bed set-up, contact our Technical Service department (see section 1.2).

---

**1.8 CLEANING AND PREVENTATIVE MAINTENANCE**

---

**BED CLEANING AND MATTRESS CARE**

---

**WARNING**

Always unplug the bed power cord from the wall outlet when cleaning or servicing the bed.

---

**CAUTION**

Do not use harsh cleaners, solvents or detergents. Do not steam clean, hose off or ultrasonically clean the bed. Do not immerse any part of the bed. The bed electrical parts may be damaged by exposure to water.

Germicidal disinfectant, used as directed, and/or Chlorine Bleach products are not considered mild detergents. These products are corrosive in nature and may cause damage to your bed if used improperly. If these types of products are used, ensure the beds are rinsed with clean water and thoroughly dried following cleaning. Failure to properly rinse and dry the beds will leave a corrosive residue on the surface of the bed, possibly causing premature corrosion of critical components. Failure to follow the above directions when using these types of cleaners may void this product warranty.

**Bed Cleaning**

Hand wash all surfaces of the bed with a soft cloth moistened with a solution of lukewarm water and a mild detergent.

Wipe the bed clean and dry thoroughly to avoid build up of cleaning solution.

**Mattress Care**

---

**WARNING**

Inspect the mattress after each use. Discontinue use if any cracks or rips, which may allow fluid to enter the mattress, are found in the mattress cover. Failure to properly clean the mattress, or dispose of it if defective, may increase the risk of exposure to pathogenic substances and may bring about diseases to the patient and user.

---

**• Inspection**

Implement local policies to address regular care, maintenance, and cleaning of mattresses and covers. The cover cleaning procedure can be found below and on the mattress label.

Inspect mattress cover surface (also zip fasteners and cover inner surface if mattresses have zip fasteners) regularly for signs of damage. If the mattress cover is heavily stained, soiled or torn, remove the mattress from service.

**• Cleaning**

Stains: Wash with lukewarm water using a mild detergent. Rinse with water and let dry. For tough stains, use bleach diluted with ten parts of water.

## PREVENTATIVE MAINTENANCE

### Annual Checklist

- All fasteners secure.
- The head and foot section molded shells are properly attached to the section structures.
- Inspect for excessive wear the oil-impregnated bronze shoulder spacers found at the bed hinge points. Replace as needed. **Do not** lubricate these spacers.
- Check the grease present on the actuator screws, lubricate if needed (see the screw lubrication procedure in the Maintenance Manual). The screws should be lubricated at least every two years.
- On both sides of the bed, depress fully down the side of the pedal identified with a red sticker and ensure that the brakes are applied and the bed immobilized. Toggle the pedal to neutral and ensure the brakes are released.
- On both sides of the bed, depress fully down the side of the pedal identified with a green sticker and ensure that the 5th steer wheel is engaged. Toggle the pedal to neutral (horizontal position) and ensure that the 5th wheel disengages.
- Siderails move, latch and stow properly (see page 17).
- All controls on the foot board panel working properly, including LEDs (see page 19).
- Calibrate the optional scale system (see the scale system calibration in the Maintenance Manual).
- All siderail controls working properly (see page 18).
  - Ensure that the optional nurse call alarm sounds in the nurse station.
  - Ensure that the optional Communications Package controls operate properly.
- Verify the CPR emergency release (optional) using both CPR release handles: raise the Fowler fully up and, using the CPR handle, lower the Fowler gradually to flat position by pulling, holding and releasing the handle several times. Ensure the Knee Gatch (if raised) also starts flattening when the Fowler is completely down. Following the complete lowering of the Fowler, wait approximately 30 seconds - the time for the Fowler control motor to reset - and verify that the motor has indeed reset itself by raising the Fowler fully up using the Fowler up control.
- Verify the Fowler, Knee Gatch and Hi-Lo movements to ensure that the motion interrupt switch integrated to the four electric actuators is operating properly.
- Auxiliary outlet (option available only with 120V electric system beds) working properly.
- Optional night light working properly.
- No cracks in the boards, siderails, wheel covers, 5th wheel hood (optional) and plastic molded shells of the head and foot sections. Velcro strips on molded shells and structures match properly.
- Head end bumpers tightly secured to frame and working properly.
- No rips or cracks in mattress cover.
- Power cord not frayed.
- No cables worn or pinched.
- All electrical connections tight.
- All grounds secure to the frame.
- All casters roll properly. Check caster for cuts, wear, etc.
- Measure current leakage and grounding continuity of the bed and the optional auxiliary outlet. Check with the Technical Service department (see section 1.2) for the acceptable values.

## 1.9 BED POSITION PICTOGRAMS

The following pictograms illustrate the bed basic positions. Note that the cardiac chair position is not illustrated.

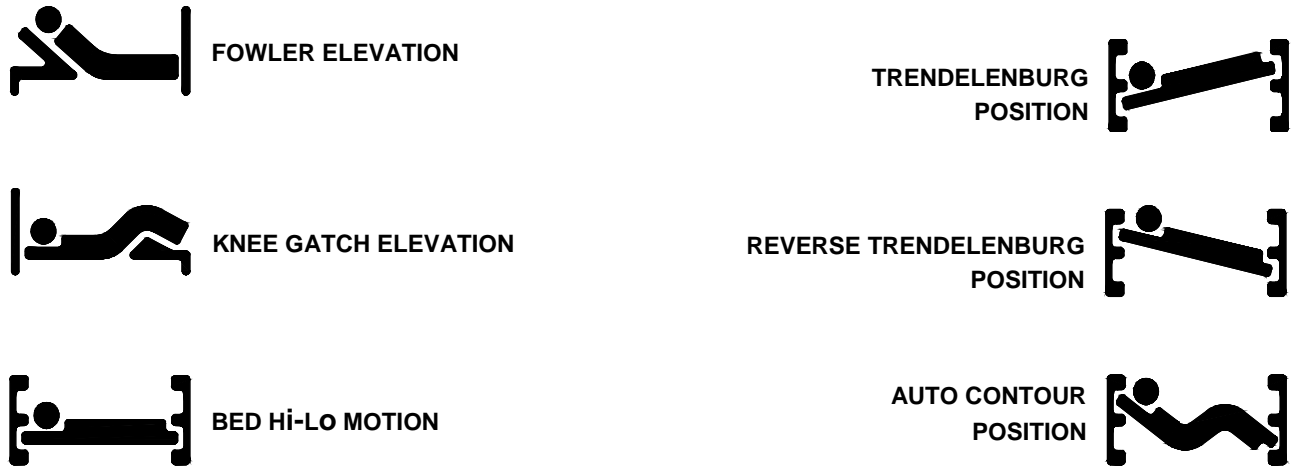

Figure 1.9

## 1.10 BED ILLUSTRATION

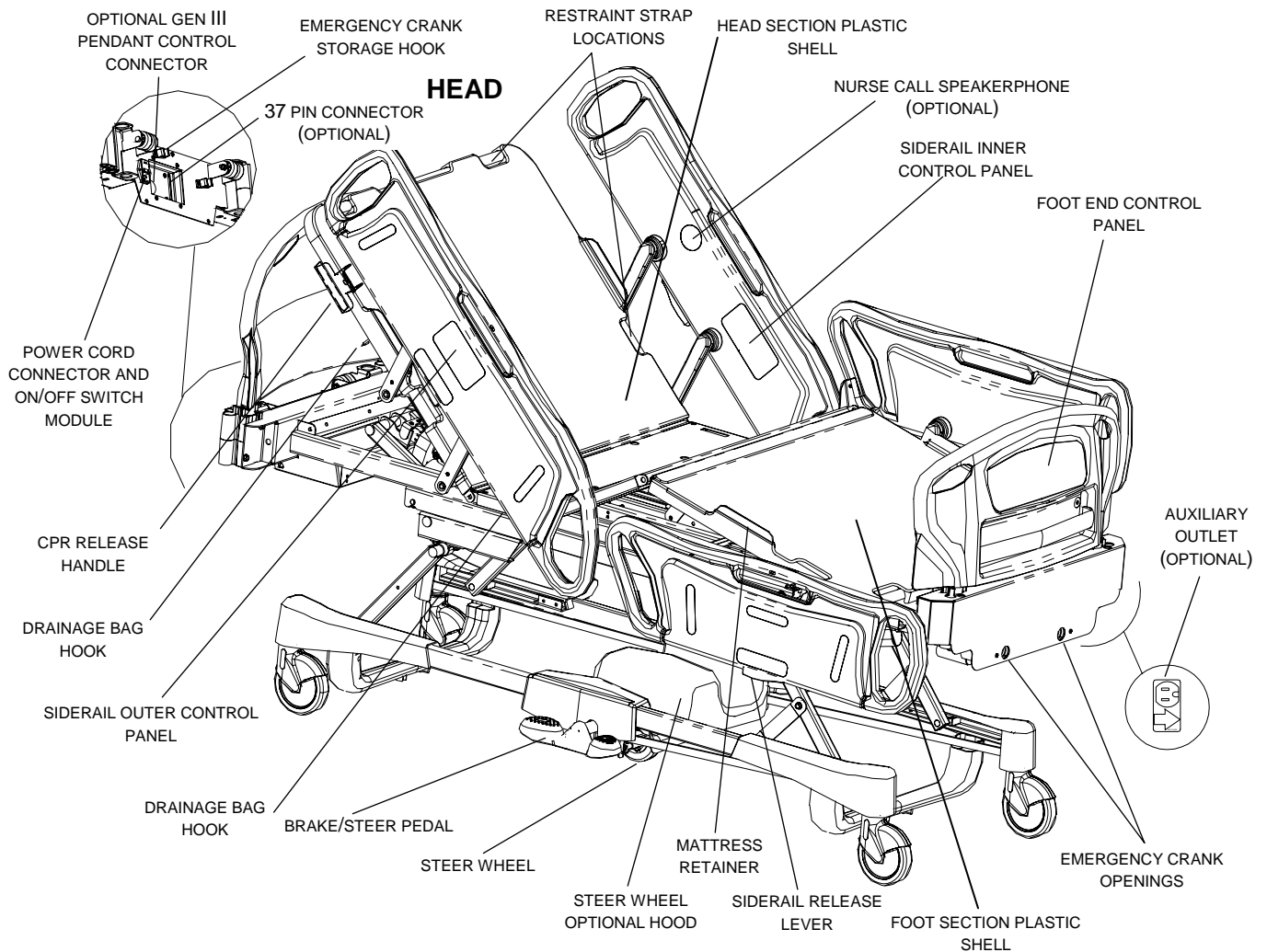

Figure 1.10

## 2. OPERATION GUIDE

### 2.1 POWERING THE BED

The bed is equipped with a main power switch located at the head end of the bed where the power cord connects to the bed. Turn it on to activate the bed functions. When the bed power switch is turned off or in the event of a power failure, the settings of the lockout controls and the optional Weigh and/or Bed Exit calibration data are preserved.



#### WARNING

Shock Hazard - Improper handling of the power cord may result in damage to the power cord and potential shock hazards. If damage has occurred to the power cord, immediately remove the bed from service, and contact the appropriate maintenance personnel. Failure to do so could result in death or serious injury.

### 2.2 BRAKE/STEER PEDAL

The bed is equipped with two lateral pedals. They control the brakes and the 5th steer wheel. The following illustrations, appearing on the label affixed on the optional 5th wheel hood or the frame, schematizes the operation of the pedals.

#### Left Side



#### Right Side



Figure 2.2

### 2.3 APPLYING THE BRAKES

The bed is equipped with a central locking system activated by either lateral brake/steer pedals (see figure 1.10 page 13).



#### WARNING

Always apply the brakes when a patient is on the bed (except during transport) or when entering/exiting the bed. Serious injury could result if the bed moves while a patient is getting on or off the bed. After the brake pedal is engaged, push on the bed to ensure the brakes are securely applied.

#### Brake Pedal Operation

To **engage** the wheel brakes, fully depress the side of the pedal identified with a red label and represented by the BRAKE red arrow (figure 2.2 above).

To **disengage** the wheel brakes, toggle the pedal to the neutral position.

## 2.4 MOVING THE BED

The bed is equipped with a fifth steer wheel activated by either lateral brake/steer pedals (see figure 1.10 page 13). The fifth steer wheel helps in guiding the bed along a straight line and helps the bed pivot around corners.



### WARNING

To reduce risk of injury, ensure the sleep surface is horizontal and in the lowest position with the siderails fully raised and locked when moving the bed with a patient in it.

To avoid injury to the patient and/or user, do not attempt to move the bed laterally with the steer mode engaged. The steer wheel cannot swivel.



### CAUTION

To avoid damage to the siderail mechanisms, do not move the bed using the raised siderails. Use the push/pull handles integrated to the boards to move the bed.

### Steer Pedal Operation

To **engage** the steer wheel, fully depress the side of the pedal identified with a green label and represented by the STEER green arrow (figure 2.2 on previous page).

To **remove** the steer wheel, toggle the pedal to the neutral position.

## 2.5 FOLEY BAG HOOK USAGE

The four Foley bag hooks (see figure 1.10, page 13) are located on both sides of the bed under the edges of the mattress support head and seat sections.

### NOTE

The Foley bag hooks move when the Fowler is raised or lowered. Fowler motion must be locked out when using these hooks to avoid inadvertent movement of the hooks.

## 2.6 PATIENT RESTRAINT STRAP LOCATIONS

The bed has 12 locations on the mattress support for installing patient restraint straps. Ten of them are located on the mattress support edges directly across from each other and the remaining two are located on the top edge of the head section (see figure 1.10, page 13).



### WARNING

Improperly adjusted restraint straps can cause serious injury to a patient. It is the responsibility of the attending medical personnel to determine proper use of the restraint straps.

## 2.7 NIGHT LIGHT (OPTIONAL) USAGE

The bed may be equipped with an optional photoelectric night light to illuminate the floor area around the bed. The night light turns on as the room lights dim.

## 2.8 CPR EMERGENCY RELEASE

---



### WARNING

The CPR emergency release is for emergency use only. When activating the CPR release handle, all people and equipment must be removed from the area below and around the head, thigh and foot sections of the bed or serious personal injury or equipment damage could occur.

---

When quick access to the patient is needed and the Fowler is raised, pull outward one of the two release handles located under the upper right and left sides of the head section (see figure 1.10, page 13). The Fowler will automatically flatten, so will the Knee Gatch if raised.

The CPR handle can be released at any time to stop the lowering movement of the Fowler. But doing so will subsequently require that the Fowler be completely lowered, using the CPR handle or the Fowler down control, to enable the Fowler motor to reset itself. **Failing to do so will prevent the Fowler from being fully raised.**

### NOTE

The use of the CPR release handle to partially lower the Fowler creates a situation where the course of the Fowler motor is temporarily out of sync with the actual position of the Fowler. The situation is automatically corrected, and only then, when the Fowler is completely lowered; then the Fowler motor begins an automatic resetting process to harmonize its course with the flat Fowler position. During the time the resetting process is on (approximately 30 seconds), the Fowler controls are not available.

- **Lowering the Fowler During a Power Failure**

The CPR emergency release can also be used during a power failure to partially or completely lower the Fowler. Simply pull one of the CPR handles until the desired angle is reached. When current resume, fully lower the Fowler to enable the Fowler motor to reset itself (see above note).

If the bed is not equipped with the CPR emergency release, unplug the bed power cord from the wall outlet and use the emergency handle (optional) to lower the Fowler. A pictogram affixed on the head end casing cover illustrate clearly in which direction the handle should be turned to obtain the desired angle.

## 2.9 NURSE CALL USAGE (OPTIONAL)

---

The nurse call function allows the patient to communicate through a speakerphone with the nurse station by simply pressing the nurse call red key  integrated to the inner control panels of the head siderails (see page 18).

The communication between the patient and the nurse station is established the moment a member of the nursing staff responds to the call signal.

### NOTE

The nurse call system will automatically send a call signal to the nurse station if the communication between the bed and the nurse station is interrupted following a power failure, the switching off of the bed or the disconnection of the nurse call communication cable.

## 2.10 AUXILIARY POWER OUTLET USAGE (OPTION AVAILABLE W/120V~ BED MODEL)

---

Located on the left side at the foot end of the bed (see figure 1.10, page 13), this feature provides nursing staff with a convenient power source for peripheral equipment. A 5A breaker is integrated to the power outlet.



### WARNING

Use only hospital grade electric equipment consuming 5A or less with the auxiliary power outlet (optional). The use of standard electric equipment may bring the current leakage to a level unacceptable for hospital equipment.

---



## 2.11 POSITIONING SIDERAILS

The bed siderails are designed to allow their lowering using only one hand. They have one lock position: in the upper position. They can be tucked away against the mattress support when not in use.



### WARNING

Keep siderails in the fully raised position and the sleep surface horizontal in its lowest position when the patient is unattended, unless its medical condition dictates otherwise. When raising the siderails, be sure that you hear the "click" that signals the locked condition. Pull firmly on the siderail to ensure it is locked into position.

Siderails, with or without their padded covers, are not intended to serve as restraint devices to keep patient from exiting the bed. Siderails are designed to keep a patient from inadvertently rolling off the bed. It is the responsibility of the attending medical personnel to determine the degree of restraint necessary to ensure a patient will remain safely in bed. Failure to utilize the siderails properly could result in serious patient injury.

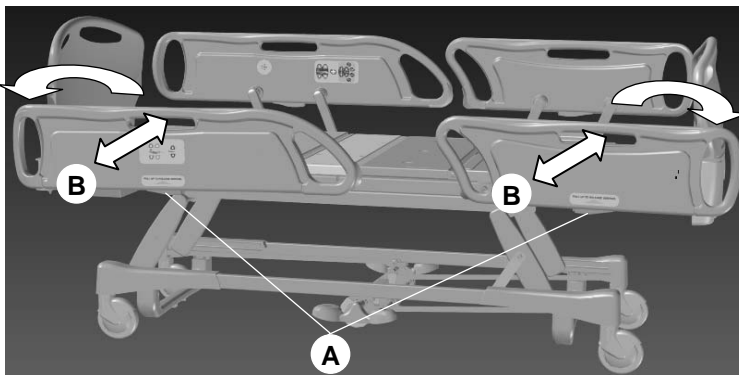

Figure 2.11

To **lower** the **head** siderail, lift the yellow lever (A) using one hand and rotate the siderail downward toward the head end of the bed until it is completely lowered. Tuck the siderail away by pushing it against the mattress support.

To **lower** the **foot** siderail, the same procedure is required as for the head end siderail; however, the siderail rotates toward the foot end of the bed.

To **engage** a tucked head siderail, **first pull it outward (B)**, then rotate it upward toward the head end of the bed until it locks in the full up position; you will then hear the "click" that signals the locked condition.

To **engage** a tucked foot siderail, the same procedure is required as for the head siderail; however, the siderail rotates to the foot end of the bed.

## 2.12 HEAD AND FOOT BOARD OPERATION

Both boards can be removed or replaced easily. The removal of the head board allows easy access to the patient head.

### Removing/Installing Boards

- Removing: Seize both ends of the board and lift up.
- Installing:
  - Head board: Insert the board posts inside the mounting sockets.
  - Foot board: Insert the board slowly in the mounting sockets while ensuring that the board connector properly fits on the connector of the foot end casing.

### NOTE

If the foot board must be removed and the bed electric functions remain accessible through the siderails, ensure that the siderail controls are operational by deactivating any lockout activated (see D1, D2 and D3, page 19) before removing the foot board.

**2.13 HEAD SIDERAIL FUNCTION GUIDE**

**Outer Control Panel (Patient's Right)**

**Outer Control Panel (Patient's Left)**

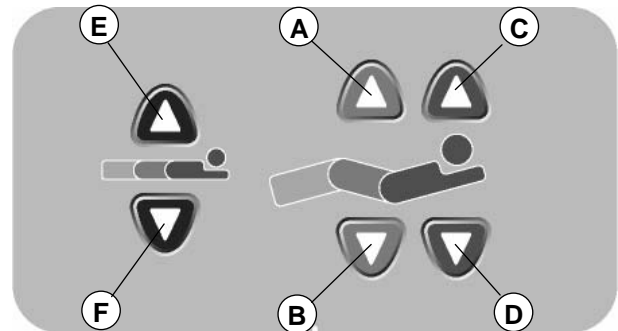
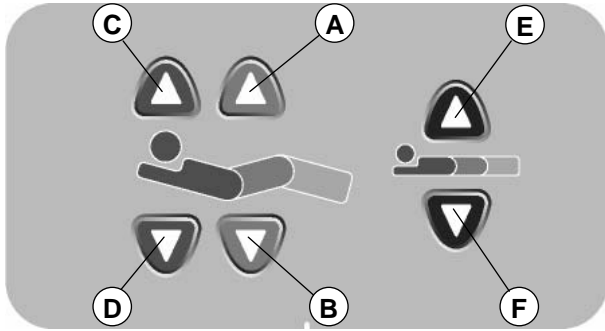

**Figure 2.13A**

- A:** Press to raise Knee Gatch
- B:** Press to lower Knee Gatch
- C:** Press to raise Fowler

- D:** Press to lower Fowler
- E:** Press to raise bed
- F:** Press to lower bed

**Inner Control Panel (Patient's Right)**

**Inner Control Panel (Patient's Left)**

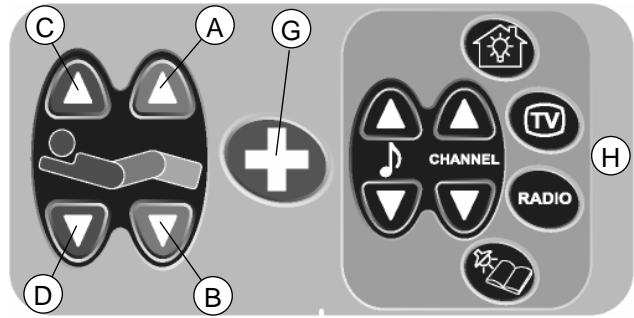
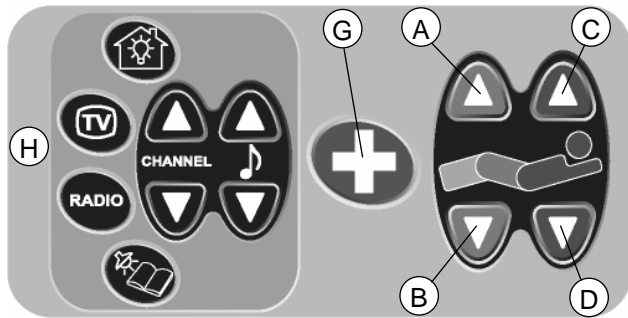
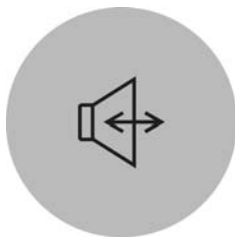

**Figure 2.13B**

- A:** Press to raise Knee Gatch
- B:** Press to lower Knee Gatch
- G:** Press to activate Nurse Call (optional)
- H:** Communications Package Controls (optional)

- C:** Press to raise Fowler
- D:** Press to lower Fowler

**Nurse Call (optional)**



Optional nurse call speakerphones, located on the inner control panel of both head siderails.

## 2.14 FOOT BOARD CONTROL PANEL GUIDE

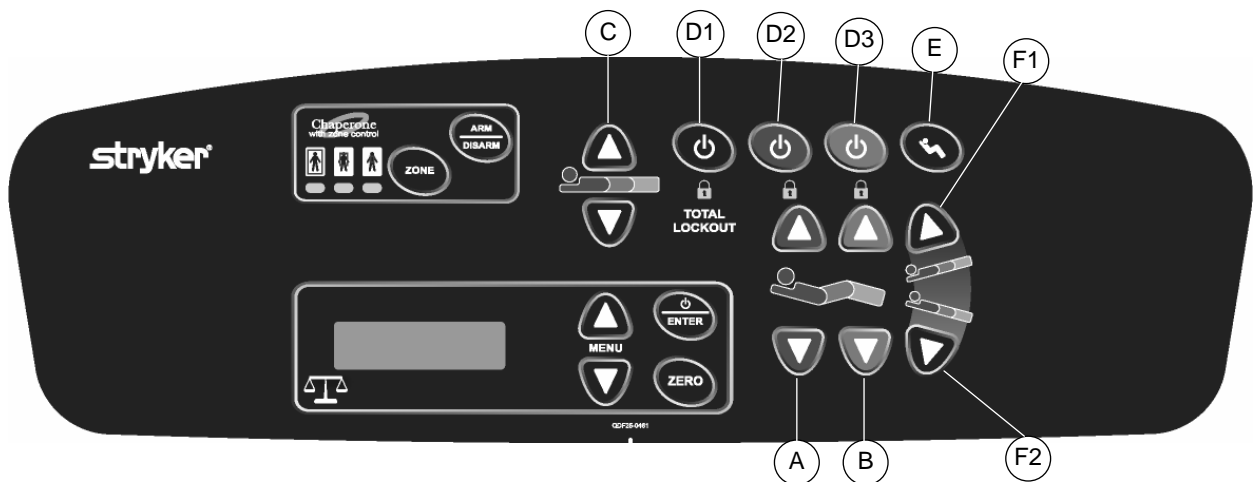

Figure 2.14A

**A:** Press to raise/lower the Fowler.

**B:** Press to raise/lower the Knee Gatch.

**NOTE**

The bed is equipped with the Auto Contour positioning. The function partially raises the Knee Gatch as the Fowler is raised. It prevents the patient from slipping toward the foot end of the bed. The function is operational by default; to deactivate it, press on the Knee Gatch lockout control (**D3**), the padlock icon will light up. Note that the Knee Gatch control available through the siderail control panels will no longer be available following the activation of the lockout.

**C:** Press to raise/lower the bed.

**D1:** Press to lockout all the controls related to the mattress support sections and the bed height. The padlock icon will light up. The total lockout control inactivates the foot end as well as the siderail controls.

**NOTE**

The total lockout control will not affect the operation of the nurse call (optional), nor that of the Weigh (optional) and Bed Exit (optional) systems.

**D2, D3:** Press to lockout the Fowler (**D2**) and Knee Gatch (**D3**) positioning controls available through the siderail inner and outer control panels. The padlock icon associated with the lockout activated will light up.

**NOTE**

The foot end controls are not affected by lockouts **D2** and **D3**.

The lockout settings will be saved should a power failure happen and will return unchanged with the power.

**E:** Press to obtain the Cardiac Chair position. Keep pressing the control until the complete cardiac chair position is obtained. The Fowler and Knee Gatch will simultaneously raise to full up, and then the bed will position itself into reverse Trendelenburg.

**F1:** Press to obtain the desired Trendelenburg (head down, foot up) position. To replace the sleep surface to horizontal position, simply use the bed Hi-Lo controls to either raise or lower the sleep surface to its limits.

**F2:** Press to obtain the desired reverse Trendelenburg (head up, foot down) position. To replace the sleep surface to horizontal position, simply use the bed Hi-Lo controls to either raise or lower the sleep surface to its limits.

**WEIGH SYSTEM CONTROL PANEL GUIDE (OPTIONAL)**

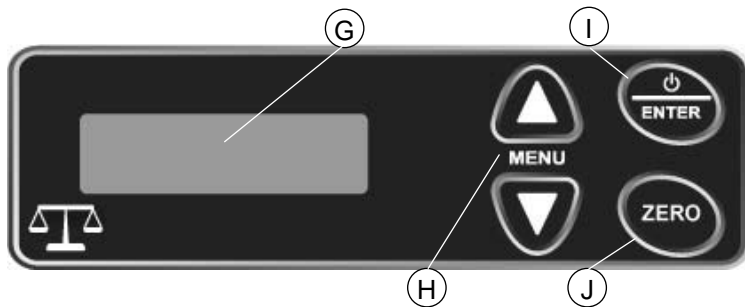

**Figure 2.14B**

**NOTE**

When the bed is switched on, the scale display will show a welcome message and the version (X.X) of the control software:

STRYKER  
SCALE VX.X.

**I: /ENTER Control:**

- Press once to activate the display. The Scale mode will be displayed.
- The display may be shut off by pressing the key
- Press ENTER when instructed to do so.

**J: ZERO Control**

- To zero the scale

**H: MENU Up/Down Controls:**

- Press either control repeatedly until desired mode is reached.

**G: Scale Display.**

**Scale Menu Modes**

Order of appearance of the modes when the MENU Down control is pressed repeatedly:

<b>Mode</b>	<b>First Line Appearing</b>
Scale	WEIGHT ANGLE
Gain or Loss	GAIN OR LOSS
Gain or Loss Reference Weight	GAIN/LOSS ZERO
Change Equipment	CHANGE EQUIP.
Change Patient Weight	CHG PTNT WEIGHT
Select Weight Unit (lb/kg)	UNITS

**NOTE**

The Weigh system does not operate when the bed is inclined more than 12° in the Trendelenburg or reverse Trendelenburg position. The LCD will display the current bed angle but not the patient's weight.

Should the message "No Scale Found" appear on the screen during the normal course of operation of the scale, press the ENTER key. Data will reappear on screen and the current operation will resume. If the message remains displayed, contact the Technical Service (see section 1.2).

## WEIGH SYSTEM USAGE

### Operating (Zeroing) the Scale Before Installing a New Patient in the Bed

- Prepare the bed for a patient stay (linens, pillows, etc.) and press , the display will read:  
WEIGHT ANGLE  
XXX.X LB +/- XX.X°
- Press and hold the ZERO key for 2 seconds. Display will read:  
HOLD TO ZERO WT. followed by:  
RELEASE TO ZERO (release ZERO), followed by:  
DO NOT TOUCH BED (make sure nobody touches the bed while this message is displayed)
- The system will return to the Scale mode and will display zero for the weight and the current angle value. The bed is now ready for the patient.

#### NOTE

The scale display turns off automatically after one minute of idle time, but the system itself remains active in the background. Pressing  will reactivate the display in the Scale mode. On beds equipped with the Weigh and Bed Exit systems, zeroing one system will also zero the other.

Do not zero the bed with a patient in the bed. An inaccurate patient weight reading will result. Should it occur, remove the patient from the bed and zero the scale (see above "Operating (Zeroing) the Scale ...").

### Registering the Reference Weight for Gain or Loss Readings

The scale system enables the reading of the patient's weight variation through the Gain or Loss menu.

- Press  to activate the scale. The display will read:  
WEIGHT ANGLE  
XXX.X LB +/- XX.X°
- Press the Menu Down control to access the Gain or Loss Reference Weight menu. Display will read:  
GAIN OR LOSS  
XXX.X LB G/L XX.X  
where xxx.x lb is the current weight reading and G xxx.x or L xxx.x is the positive (G) or negative (L) variation compared to the reference weight.
- Press the Menu Down control again. The display will then read:  
GAIN/LOSS ZERO  
PRESS ENTER
- Press ENTER. The system will register the current weight as the **reference weight** and will display the Gain or Loss menu.  
GAIN OR LOSS  
XXX.X LB G/L XX.X

To access the patient's weight variation anytime, go to the Gain or Loss menu through the Menu Up/Down controls once the scale is activated.

### Adding or Removing Equipment when a Patient is on the Bed

- Press  to activate the scale display. Access the Change Equipment mode using the MENU Down key, the display will read:  
CHANGE EQUIP  
PRESS ENTER
- Press ENTER. The display will read:  
RELEASE TO START (release ENTER), followed by:  
DO NOT TOUCH BED (ensure no one touches the bed while this message is displayed).
- The following message will then appear:  
ADD/REMOVE EQUIP  
PRESS ENTER  
signalling that equipment can now be added or removed from the bed.  
When done with the equipment, press ENTER.
- Display will then read RELEASE TO FIN. (release ENTER), followed by:  
DO NOT TOUCH BED (ensure that the patient stands still and that no one touches the bed while this message is displayed).  
The system will return to the Scale mode displaying the patient's weight (the weight should be the same as the one displayed before the procedure).

### Changing Manually the Numerical Value of Displayed Weight

In certain circumstances, it may be necessary to change manually the patient's weight displayed. To do so:

- Press  to activate the scale display. Access the Change Patient Weight mode using the MENU Down key. The display will read:  
CHG PTNT WEIGHT  
PRESS ENTER
- Press ENTER. The display will read:  
REL. TO CHNG WT. (release ENTER), followed by:  
DO NOT TOUCH BED (ensure no one touches the bed while this message is displayed).
- The display will then read ▲▼ XXX.X lb / press ENTER. Adjust the weight using the MENU Up/Down controls.  
Once done press the ENTER key. The system will return to the Scale mode and display the modified weight.

#### NOTE

The Change Patient Weight mode should not be used systematically for new patients. The scale should be zeroed each time a new patient occupies the bed (see page 21).

### Changing the Weight Measure Unit

- Press  to activate the scale display. Access the Select Weight Unit (lb/kg) mode using the MENU Up key. The display will read:  
UNITS  
PRESS ENTER
- Press ENTER. The display will read:  
▲▼ lb AND OR ▲▼ kg AND  
PRESS ENTER PRESS ENTER
- Select the weight unit using the MENU Up or Down control and press ENTER. The system will return to the Scale mode with the weight displayed in the unit chosen.

## BED EXIT SYSTEM (OPTIONAL)



### WARNING

The Bed Exit system (optional) is intended only to aid in the detection of a patient exiting the bed. It is not intended to replace patient monitoring protocol. The Bed Exit system signals when a patient is about to exit the bed. The addition or removal of equipment with a Bed Exit system active must be done using the "Adding or Removing Equipment with the Bed Exit System Active" procedure, otherwise the sensitivity of the system may be affected and the readings of the patient's movement in the bed be erroneous.

The Bed Exit system (optional) is not designed to be used with patients weighing less than 50 lb (23 kg).



Figure 2.14C

### NOTE

For the Bed Exit alarm signal to be heard in the nurse station, the bed must be equipped with the optional nurse call function. For beds without the optional nurse call, the alarm signal will be heard only in the patient's room.

## BED EXIT SYSTEM USAGE

### Zeroing the System

The Bed Exit system must absolutely be zeroed before use:

- If the bed is equipped with the Weigh system, zero the scale if not already done (see "Operating (Zeroing) the Scale... » page 21). This will ensure proper operation of the Bed Exit system.
- If the bed is not equipped with the Weigh system, apply the following procedure:
  - Before putting a new patient on the bed: prepare the bed for a patient stay by adding linens and equipment to the bed.
  - Press and hold the ARM/DISARM key (K) until the status LED (M) begins to flash, then release the key (do not touch the bed while the LED flashes). When the status LED turns off, the system is zeroed.

### Arming the System

Following the zeroing of the system, the Bed Exit system may now be activated:

- Install the patient in the bed. Ensure the patient lies in the bed in its usual position before activating the system.
- **Activate** the Bed Exit by pressing ARM/DISARM (K). The status LED (M) will light up.
- To **deactivate** the Bed Exit after an alarm or to simply turn it off, press ARM/DISARM (K). The status LED (M) will turn off.

### Adding or Removing Equipment with the System Active

A change of equipment on a bed equipped with an active Bed Exit system **absolutely** requires that the change be made using either procedure described below.

- If the bed is equipped with the Weigh system, apply the procedure "Adding or Removing Equipment when a Patient is on the Bed" described on page 22.
- If only the Bed Exit system is present on the bed, proceed as follow: remove the patient from the bed; change the equipment and zero the system (see the zeroing procedure above). The system may be activated once the patient has reintegrated the bed.

## BED EXIT WITH ZONE CONTROL SYSTEM (OPTIONAL)



### WARNING

The Bed Exit system (optional) is intended only to aid in the detection of a patient exiting the bed. It is not intended to replace patient monitoring protocol. The Bed Exit system signals when a patient is about to exit the bed. The addition or removal of equipment with a Bed Exit system active must be done using the "Adding or Removing Equipment with the Bed Exit System Active" procedure, otherwise the sensitivity of the system may be affected and the readings of the patient's movement in the bed be erroneous. Failure to set the zone properly could result in improper monitoring and patient injury. Verify that the proper zone is selected before leaving the patient.

The Bed Exit system (optional) is not designed to be used with patients weighing less than 50 lb (23 kg).

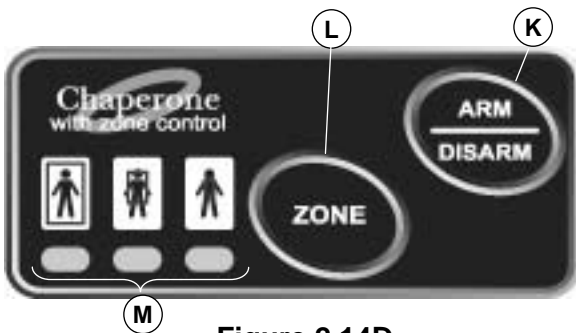

Figure 2.14D

**K:** Press to activate/deactivate the Bed Exit function

**L:** Press to select zone

**M:** Zone LEDs

### NOTE

For the Bed Exit alarm signal to be heard in the nurse station, the bed must be equipped with the optional nurse call function. For beds without the optional nurse call, the alarm signal will be heard only in the patient's room.

## BED EXIT W/ZONE CONTROL SYSTEM USAGE

### Zone Features

- The first zone (left LED) is the traditional Bed Exit zone. The patient can move in the bed freely but cannot fully exit the bed or the alarm will sound.
- The second zone (middle LED) is more restrictive. It allows the patient to sit up and roll over but any attempt to exit the bed will cause the alarm to sound.
- The third zone (right LED) is the most restrictive. Small movements like raising an arm or lifting the shoulder off the bed will cause the alarm to sound. The third zone is used to alert staff to a change in the condition of an unconscious or paralyzed patient.

### Zeroing the System

The Bed Exit system must absolutely be zeroed before use:

- If the bed is equipped with the Weigh system, zero the scale if not already done (see "Operating (Zeroing) the Scale..." page 21). This will ensure proper operation of the Bed Exit system.
- If the bed is not equipped with the Weigh system, apply the following procedure:
  - Before putting a new patient on the bed: prepare the bed for a patient stay by adding linens and equipment to the bed.
  - Press and hold the ARM/DISARM key (K) until the larger zone LED (left LED) begins to flash, then release the control (do not touch the bed while the LED flashes). When the zone LED turns off, the system is zeroed.



### Arming the System

Following the zeroing of the system, the Bed Exit system may now be activated:

- Install the patient in the bed. Ensure the patient lies in the bed in its usual position before activating the system.
- **Activate** the Bed Exit by pressing ARM/DISARM (K) and select the desired zone.
  - By default, the less restrictive zone will be selected and its LED (left LED) will come on. To change the zone, press ZONE (L) repeatedly until the desired zone LED comes on.
- To **deactivate** the Bed Exit after an alarm or to simply turn it off, press ARM/DISARM (K). The zone LED will turn off.

### Adding or Removing Equipment with the System Active

A change of equipment on a bed equipped with an active Bed Exit system **absolutely** requires that the change be made using either procedure described below.

- If the bed is equipped with the Weigh system, apply the procedure "Adding or Removing Equipment when a Patient is on the Bed" described on page 22.
- If only the Bed Exit system is present on the bed, proceed as follow: remove the patient from the bed; change the equipment and zero the system (see the zeroing procedure above). The system may be activated once the patient has reintegrated the bed.

## 3. ACCESSORIES

Listed below are the accessories certified compliant (IEC 60601-2-38) for use with the FL25E as well as their maximum load capacity, where applicable.

- Bed extension
- Monitor tray - Maximum load: 40 lb (18 kg)
- Two-stage fixed IV pole - Maximum load: 40 lb (18kg)
- Three-stage fixed IV pole - Maximum load: 40 lb (18 kg)
- Ø 1" removable anodized aluminum IV pole - Maximum load: 11 lb (5 kg)
- Ø 1/2" removable anodized aluminum IV pole - Maximum load: 11 lb (5 kg)
- Emergency crank
- Padded siderail covers (set of four)