

**stryker<sup>®</sup>**  
**Medical**

---

 *Stretcher*

---

*Model 660*

*Maintenance Manual*

*For Parts or Technical Assistance*  
*800-327-0770*

# Table of Contents

---

Introduction	
Specifications .....	3
Warning / Caution / Note Definition .....	3
Preventative Maintenance	
Checklist .....	4
Cleaning .....	5, 6
Service Information	
Caster Cover Installation and Removal .....	7
Caster Removal .....	7
Brake Rod Removal .....	8
Side Control Brake Rod Removal .....	8
Brake Ring Removal .....	9
Release Pedal Adjustment .....	9
Big Wheel Hubcap Removal .....	10
Big Wheel Removal .....	10
Big Wheel Carriage Removal .....	11
Side Control Big Wheel Linkage Assembly Removal .....	12
Big Wheel Cam Gas Spring Dampener Removal .....	12
Removal of Excess Air from the Hydraulic System .....	13
Jack Descent Rate Adjustment .....	13
Foot End Hydraulic Jack Removal .....	14, 15
Head End Hydraulic Jack Removal .....	16
Pneumatic Fowler Adjustment .....	17
Transfer Board Counterbalance Adjustment .....	17
Replacement Parts and Kits .....	18
Assembly Drawings and Parts Lists	
Big Wheel Base Assembly .....	19-21
Base Assembly with Standard Brakes (Big Wheel Base) .....	22, 23
Caster Assembly .....	24
Drive Link Assembly .....	25
Brake Rod Assembly .....	26
Base Assembly with Dual Side Hydraulics (Big Wheel Base) .....	27-29

# Table of Contents

---

Release Pedal Assembly .....	30
Pump Pedal Assembly .....	31
Cam Bracket Assembly .....	32, 33
Big Wheel Carriage Assembly .....	34
Side Control Big Wheel Base Assembly .....	35-37
Side Control Big Wheel Carriage Assembly .....	38, 39
Side Control Big Wheel Linkage Assembly .....	40
Constant Descent Hydraulic Jacks .....	41
Base Labeling Assembly .....	42, 43
Litter Assembly .....	44-46
Siderail Assembly .....	47-53
Pneumatic Fowler Assembly .....	54, 55
Stationary Foot Section Assembly .....	56
Knee Gatch Assembly .....	57, 58
Transfer System Assembly .....	59-62
Steer Handle Assembly .....	63-65
Removable I.V. Pole Assembly .....	66
Tethered I.V. Pole Assembly .....	67, 68
2-Stage I.V. Assembly .....	69-71
3-Stage I.V. Assembly .....	72-74
Defibrillator Tray Assembly .....	75
Foot Extension/Defibrillator Tray Assembly .....	76
Foot Board .....	77
O2 Bottle Holder .....	77
Fowler X-Ray Cassette Assembly .....	78, 79
Heel Stirrup Assembly .....	80-83
C-Spine Cassette Holder Assembly .....	84-86
O2 Bottle Retainer Assembly .....	87
Mattresses and Siderail Pads .....	88
Warranty	
Obtaining Parts and Service .....	89
Service Contract Coverage .....	89
Return Authorization .....	90
Freight Damage Claims .....	90

# Introduction

---

## INTRODUCTION

This manual is designed to assist you with the maintenance of the Model 660 Atlas Stretcher. Read it thoroughly before using the equipment or beginning any maintenance on it.

## SPECIFICATIONS

Maximum Weight Capacity	660 pounds
Overall Bed Length \ Width	83" \ 34.5"
Minimum \ Maximum Bed Height	21.5" \ 36"
Fowler Angle	0 to 90°
Knee Gatch Angle	0 to 35°
Trendelenburg \ Reverse Trendelenburg	+18 to -18°

Stryker reserves the right to change specifications without notice.

## WARNING / CAUTION / NOTE DEFINITION

The words WARNING, CAUTION and NOTE carry special meanings and should be carefully reviewed.

---

### WARNING

The personal safety of the patient or user may be involved. Disregarding this information could result in injury to the patient or user.

---

### CAUTION

These instructions point out special procedures or precautions that must be followed to avoid damaging the equipment.

---

### NOTE

This provides special information to make maintenance easier or important instructions clearer.

# Preventative Maintenance

---

## CHECKLIST

- \_\_\_\_\_ All fasteners secure
- \_\_\_\_\_ Siderails move and latch properly
- \_\_\_\_\_ Engage brake pedal and push on the stretcher to ensure all casters lock securely
- \_\_\_\_\_ All casters secure and swiveling properly
- \_\_\_\_\_ Big Wheel adjusted properly
- \_\_\_\_\_ Lubricate Big Wheel roller and linkage
- \_\_\_\_\_ Fowler operating and latching properly
- \_\_\_\_\_ Knee Gatch operating properly
- \_\_\_\_\_ Trendelenburg/Reverse Trendelenburg operating properly
- \_\_\_\_\_ Ground chain intact
- \_\_\_\_\_ No leaks at hydraulic connections
- \_\_\_\_\_ Hydraulic jacks holding properly
- \_\_\_\_\_ Hydraulic drop rate set properly
- \_\_\_\_\_ Hydraulic oil level sufficient
- \_\_\_\_\_ Lubricate where required
- \_\_\_\_\_ Body restraints intact and working properly
- \_\_\_\_\_ I.V. pole intact and operating properly
- \_\_\_\_\_ Oxygen bottle holder intact
- \_\_\_\_\_ No rips or cracks in mattress cover
- \_\_\_\_\_ Accessories and mounting hardware in good condition and working properly

Serial No. \_\_\_\_\_  
\_\_\_\_\_

_____	_____	_____
_____	_____	_____
_____	_____	_____

Completed By: \_\_\_\_\_ Date: \_\_\_\_\_

## NOTE

Preventative maintenance should be performed at a minimum of annually. A preventative maintenance program should be established for all Stryker Medical equipment. Preventative maintenance may need to be performed more frequently based on the usage level of the product.

# Preventative Maintenance

---

## CLEANING

Model 660 stretchers are designed to be power-washable. The unit may show some signs of oxidation or discoloration from continuous washing. However, no degradation of the stretcher's performance characteristics or functionality will occur due to power washing as long as the proper procedures are followed.

- Follow the cleaning solution manufacturer's dilution recommendations exactly.
- Remove the mattress prior to washing the unit; do not wash the mattress with the stretcher.
- Position the Fowler at 45°, place the unit in full reverse Trendelenburg (foot end down), raise the siderails, and place the I.V. poles and push handles in the up position.
- Stryker Medical recommends the standard hospital surgical cart washer for power washing Model 660 stretchers.
- Do not replace the mattress on the stretcher until the unit is completely dry.

DO NOT STEAM CLEAN THE UNIT. Use a maximum water temperature of 180°F/68°C. Maximum air dry temperature (cart washers) is 240°F/115°C. Water pressure - 1500 psi/130.5 bar. If a hand held wand is being used to wash the unit, the pressure nozzle must be kept a minimum of 24 inches/.61m from the unit.

Stretchers must have maintenance performed after a minimum of every fifth washing. Refer to the maintenance manual for specific lubrication instructions.

Failure to comply with these instructions may invalidate any/all warranties.

# Preventative Maintenance

## CLEANING (CONTINUED)

In general, when used in those concentrations recommended by the manufacturer, either phenolic type or quaternary type disinfectants can be used. Iodophor type disinfectants are not recommended for use because staining may result. The following products have been tested and have been found not to have a harmful effect WHEN USED IN ACCORDANCE WITH MANUFACTURERS RECOMMENDED DILUTION.\*

TRADE NAME	DISINFECTANT TYPE	MANUFACTURER	*MANUFACTURER'S RECOMMENDED DILUTION
A33	Quaternary	Airwick (Professional Products Division)	2 ounces/gallon
A33 (dry)	Quaternary	Airwick (Professional Products Division)	1/2 ounce/gallon
Beaucoup	Phenolic	Huntington Laboratories	1 ounce/gallon
Blue Chip	Quaternary	S.C. Johnson	2 ounces/gallon
Elimstaph	Quaternary	Walter G. Legge	1 ounce/gallon
Franklin Phenomysan F2500	Phenolic	Purex Corporation	1 1/4 ounce/gallon
Franklin Sentinel	Quaternary	Purex Corporation	2 ounces/gallon
Galahad	Phenolic	Puritan Churchill Chemical Company	1 ounce/gallon
Hi-Tor	Quaternary	Huntington Laboratories	1/2 ounce/gallon
LPH	Phenolic	Vestal Laboratories	1/2 ounce/gallon
Matar	Phenolic	Huntington Laboratories	1/2 ounce/gallon
Omega	Quaternary	Airwick (Professional Products Division)	1/2 ounce/gallon
Quanto	Quaternary	Huntington Laboratories	1 ounce/gallon
Sanikleen	Quaternary	West Chemical Products	2 ounces/ gallon
Sanimaster II	Quaternary	Service Master	1 ounce/gallon
Vesphene	Phenolic	Vestal Laboratories	1 1/4 ounce/ gallon

Quaternary Germicidal Disinfectants, used as directed, and/or Chlorine Bleach products, typically 5.25% Sodium Hypochlorite in **dilutions ranging between 1 part bleach to 100 parts water, and 2 parts bleach to 100 parts water are not considered mild detergents. These products are corrosive in nature and may cause damage to your stretcher if used improperly.** If these types of products are used to clean Stryker patient handling equipment, measures must be taken to insure the stretchers are rinsed with clean water and thoroughly dried following cleaning. Failure to properly rinse and dry the stretchers will leave a corrosive residue on the surface of the stretcher, possibly causing premature corrosion of critical components.

### NOTE

Failure to follow the above directions when using these types of cleaners may void this product's warranty.

## REMOVAL OF IODINE COMPOUNDS

This solution may be used to remove iodine stains from mattress cover and foam footrest pad surfaces.

1. Use a solution of 1-2 tablespoons Sodium Thiosulfate in a pint of warm water to clean the stained area. Clean as soon as possible after staining occurs. If stains are not immediately removed, allow solution to soak or stand on the surface.
2. Rinse surfaces which have been exposed to the solution in clear water before returning bed to service.

# Service Information

## CASTER COVER INSTALLATION AND REMOVAL

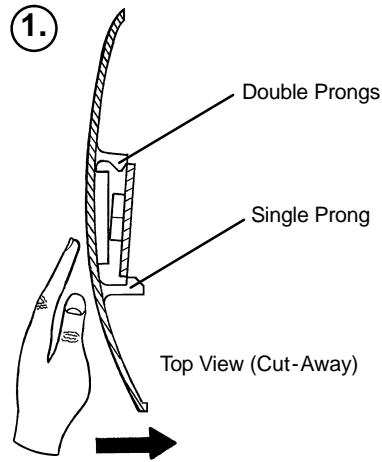

Looking through the larger of the two side cut-outs, align the cover with the axle nut or bolt head, as shown. Push down on the opposite side of the cover until the single prong engages the caster horn.

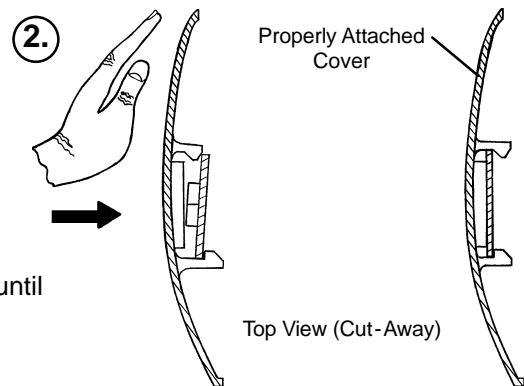

Push on the cover with your palm until the double prongs engage.

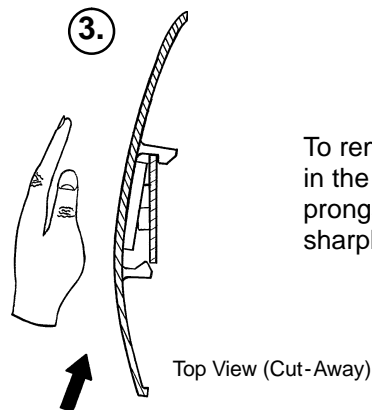

To remove the wheel cover, insert a large screwdriver into the cut-out in the side of the wheel cover and into the space between the double prongs. Pry up the cover to disengage the double prongs and push sharply upward to disengage the single prong.

## CASTER REMOVAL

### Required Tools:

9/16" Open End Wrench

1. Remove the caster cover.
2. While keeping pressure on the caster bolt with your index finger, use a 9/16" open end wrench to remove the nylock hex nut on top of the caster assembly.
3. Using the brake ring, lift up on the base assembly and pull the caster assembly down to remove it.
4. Reverse steps 1-3 to install the new caster.





# Service Information

---

## **BRAKE RING REMOVAL**

### **Required Tools:**

9/16" Socket w/Extension  
String or Bungee Cords

3/8" Drive Ratchet

Needle-Nose Pliers

1. Pump the litter up to full height.
2. Lift the base hood and support it from the litter using string or bungee cords.
3. Using needle-nose pliers, unhook the extension springs from the top of the base caster tubes.
4. Remove the plastic caster covers.
5. While putting pressure on the caster carriage bolt, use a 9/16" socket and a 3/8" drive ratchet to remove the caster nut on both sides of the stretcher.
6. Remove the casters.
7. Remove the brake rod (see procedure).
8. Remove the cotter pin from the clevis pin in the center of the brake ring weldment.
9. Remove the cotter pin from the bearing pivot support.
10. Remove the 3/4" nylock hex nut from the bearing pivot support.
11. Remove the drive link assembly.
12. Pull the brake ring down and out away from the stretcher base frame.
13. Reverse steps 1-12 to reinstall the brake ring.

## **RELEASE PEDAL ADJUSTMENT**

### **Required Tools:**

None

1. Manually disengage the release pedal swivel from the release pedal assembly.
2. To increase the release rod engagement with the release valve, turn the release pedal swivel clockwise on the threaded release rod.
3. To decrease the release rod engagement with the release valve, turn the release pedal swivel counter-clockwise on the threaded release rod.

### **NOTE**

If the pedal swivel assembly is threaded too far onto the release rod, the release valve will be partially activated and the jack will drift.

# Service Information

---

## BIG WHEEL HUBCAP REMOVAL

### Required Tools:

Large Standard Screwdriver

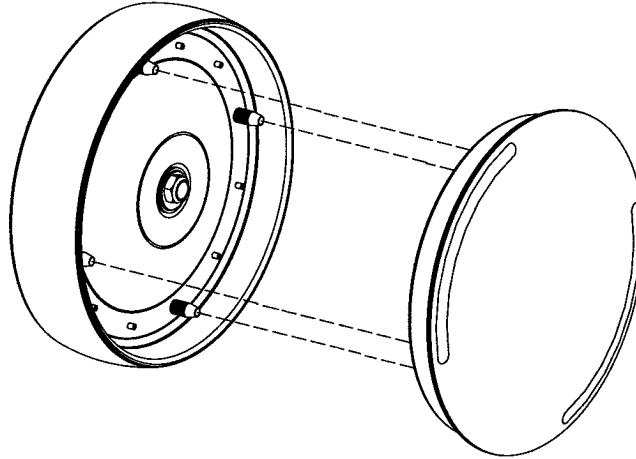

1. Using a large standard screwdriver, pry evenly around the entire edge of the Big Wheel hubcap until it pops off the mounting studs on the wheel.

---

### CAUTION

Do not attempt to pull off the hubcap after prying up only one side. Damage to the slots on the hubcap or the mounting studs on the wheel could result.

2. To reinstall the hubcap, place it on the wheel, aligning the slots in the hubcap with the mounting studs on the wheel. Press down evenly on the edges of the hubcap until it snaps into place.

## BIG WHEEL REMOVAL

### Required Tools:

Large Standard Screwdriver

Small Standard Screwdriver

String or Bungee Cords

1. Lift the base hood and separate the Velcro holding it to the base frame. Support the hood from the litter using bungee cords so it is out of the way.
2. Using a large, standard screwdriver, pop off the big wheel cover.
3. Using a small, standard screwdriver, remove the spiral retaining ring from the groove on the Big Wheel axle.
4. Remove the Big Wheel.
5. Reverse steps 1-4 to reinstall the Big Wheel.

# Service Information

---

## **BIG WHEEL CARRIAGE ASSEMBLY REMOVAL**

### **Required Tools:**

1/2" Socket

3/8" Drive Ratchet

Needle-Nose Pliers

1. Remove the litter top.
2. Lift the base hood off the base frame.
3. With the brake/steer pedal in the steer position, remove the clevis pin and rue ring cotter connecting the brake rod to the brake rod drive link at each end of the stretcher.
4. Remove the two hex washer head screws holding the adjustment cam bracket to the cam bracket housing on the patient left side of the base frame. One screw threads through the side of the bracket, the other from the top.
5. Remove the two clevis pins and rue ring cotters connecting the brake rods to the drive arm at the center of the base near the cam bracket assembly.
6. Pull the brake shafts straight out away from the base.

### **NOTE**

On a base with 4-sided brakes, remove the rue ring cotter and clevis pin connecting the side control big wheel linkage assembly to the yoke weldment on the end control brake pad at the foot end of the stretcher.

7. Remove the two hex washer head screws holding the carriage weldment to the base frame and remove the carriage assembly.
8. Reverse steps 1-7 to reinstall the carriage assembly.





# Service Information

---

## FOOT END HYDRAULIC JACK REMOVAL (BASE WITH DUAL CONTROLS)

### Required Tools:

1/2" Socket

3/8" Drive Ratchet

Pliers

1. Remove the litter top.
2. Lift the base hood off the base frame.
3. Remove the two hex washer head screws and washers connecting the pump pedal link to the foot end pump pedal assembly and pump connecting rod.
4. Remove the foot end release rod from the release valve on the jack assembly by dislodging the release pedal swivel from the pins on the release pedal weldment.
5. Dislodge the jack pump piston from the pump connecting rod.
6. Remove the two hex washer head screws holding the reservoir clamp.
7. Remove the jack assembly.
8. Reverse steps 1-7 to install the new jack.

### NOTE

The jack descent rate is preset at the factory and adjustment is not recommended.

# Service Information

---

## FOOT END HYDRAULIC JACK REMOVAL (BIG WHEEL BASE WITH 3-SIDED CONTROLS)

### Required Tools:

1/2" Socket

3/8" Drive Ratchet

Pliers

1. Remove the litter top.
2. Lift the base hood off the base frame.
3. Remove the hair pin cotter and washer connecting the side control Big Wheel linkage toggle pivot plates to the side control Big Wheel carriage weldment.
4. Remove the rue ring cotter and clevis pin connecting the side control Big Wheel rod end link to the yolk weldment on the end control brake rod.
5. Remove the Big Wheel carriage assembly (see page 11).
6. Remove the two hex washer head screws and washers connecting the pump pedal link to the foot end pump pedal assembly and pump connecting rod.
7. Remove the foot end pump pedal return spring.
8. Remove the cotter pin from the center of the foot end pump pedal assembly and slide out the pivot pin.
9. Slide the foot end pump pedal assembly up and over the foot end mounting bracket.
10. Remove the four hex washer head screws fastening the foot end mounting bracket to the base frame and set the bracket aside.
11. Remove the foot end release rod from the release valve on the jack assembly by dislodging the release pedal swivel from the pins on the release pedal weldment.
12. Dislodge the jack pump piston from the pump connecting rod.
13. Remove the two hex washer head screws holding the reservoir clamp.
14. Remove the jack assembly.
15. Reverse steps 1-11 to install the new jack.

### NOTE

The jack descent rate is preset at the factory and adjustment is not recommended.



# Service Information

---

## HEAD END HYDRAULIC JACK REMOVAL

### Required Tools:

1/2" Socket w/Extension

3/8" Drive Ratchet

1. Remove the litter from the stretcher.
2. Using a 1/2" socket with extension and a 3/8" drive ratchet, remove the two hex head screws holding the jack base to the stretcher base frame.
3. Remove the two hex head screws holding the jack reservoir clamp to the base frame and remove the clamps.
4. Lift straight up on the pump connecting rod and disconnect the pump piston from the connecting rod.
5. Disconnect the pump pedal swivel from the release pedal mounting plate.
6. Remove the head end release rod from the release valve assembly.
7. Using a 1/2" socket with extension and a 3/8" drive ratchet, remove the two hex head screws holding the jack base to the stretcher base frame.
8. Lift out the jack assembly.
9. To reinstall the jack, install the bolts on the jack and reservoir clamp but do not tighten them fully.
10. Reinstall the pump connecting rod and release rod.
11. Depress the pump pedal fully (to the floor). This will properly locate the jack onto the base frame.
12. Tighten the bolts on the jack and reservoir clamp.
13. Pump up the litter and apply weight to verify the jacks hold and do not drift.

### NOTE

The jack descent rate is preset at the factory and adjustment is not recommended.

# Service Information

---

## PNEUMATIC FOWLER ADJUSTMENT

### Required Tools:

3/32 Hex Allen Wrench	1/2 Socket w/Ratchet	1/8 Hex Allen Wrench
Channel Lock Pliers	5/32 Hex Allen Wrench	Towel or Cloth
7/16 Open End Wrench	Thread "Loctite"	

### Adjustment Procedure:

1. Refer to drawings 1711-31-10 & 1711-131-20 (Pneumatic Fowler Assembly, page 54 & 55) for parts reference.
2. For easier access, move Fowler to 75 degrees or higher.
3. Using a 3/32" hex Allen wrench, remove set screws (K on page 55), located in center of yokes (Y on page 55).
4. Using a 9/16" box end wrench and 5/16" hex Allen wrench, remove the cap screws (A on page 54), flat washers (C on page 54) and hex nuts (D on page 54) holding the gas cylinders (K on page 54) to the litter frame.
5. To adjust the Fowler, turn the gas cylinder 1 to 2 turns counterclockwise if the Fowler will not move and 1 to 2 turns clockwise if the Fowler will not hold its position.
6. Replace the cap screws (A) and check the Fowler adjustment. Lower the Fowler approximately 10° to 20°, release the handle and apply weight to the Fowler to assure it will hold its position. If the Fowler will not lower or will not hold its position when weight is applied, repeat step 5.
7. When the Fowler is properly adjusted, replace the washers (C) and hex nuts (D) to secure the pivot bolts.
8. Using thread locktite, reinstall set screws (K).

## TRANSFER BOARD COUNTERBALANCE ADJUSTMENT

### Required Tools:

7/16 Open End Wrench

1. Raise the transfer board to the full up position.
2. Unhook the extension spring at the eye bolt.
3. Using a 7/16 open end wrench, loosen the jam nut at the eye bolt.
4. Adjust the eye bolt to the desired position.
5. Tighten the jam nut.
6. Hook the extension spring to the eye bolt.
7. Allow the transfer board to lower on its own.
8. Repeat steps 1-7 until the desired counterbalance is achieved.

# Replacement Parts and Kits

---

<b><u>PART NAME</u></b>	<b><u>PART NUMBER</u></b>
Foot Board/Chartholder .....	0926-040-000
Foot Extension/Defibrillator Tray Assembly .....	1010-50-100
Head/Foot Board Assembly (2) .....	0946-029-100
Heel Stirrup Mounting Brackets .....	1001-055-019
Hydraulic Jack, Constant Descent .....	0753-002-001
I.V. Caddy .....	1050-001-100
I.V. Pole, Standard, Removable .....	0390-025-000
I.V. Pole, Tethered .....	1001-1 17-000
I.V. Pole, 2-Stage Permanently Attached, Head End .....	1711-1 10-000
I.V. Pole, 2-Stage Permanently Attached, Foot End .....	1711-1 12-000
I.V. Pole, 3-Stage Permanently Attached, Head End .....	1711-1 11-000
I.V. Pole, 3-Stage Permanently Attached, Foot End .....	1711-1 13-000
Mattress, 4" Thick x 31" Wide, Enhanced Comfort .....	0660-030-004
Mattress, 5" Thick x 31" Wide, Ultra Comfort .....	0660-040-005
Oxygen Bottle Holder, Upright .....	1020-030-000
Paint, Touch-Up, Gloss Black, Bottle w/Brush .....	7000-001-322
Paint, Touch-Up, Gloss Black, Spray Can .....	7000-001-319
Paint, Touch-Up, Gray, Bottle w/Brush .....	7000-001-320
Paint, Touch-Up, Gray, Spray Can .....	7000-001-317
Restraint Strap, Ankle .....	0946-043-100
Restraint Strap, Chest .....	1010-058-000
Restraint Strap, Wrist .....	0946-044-100
Restraint Strap, 2 Piece .....	0390-019-000
Serving/Instrument Tray .....	1052-129-000
Siderail Pads .....	1001-052-000
Steer Handles, Foot End .....	1211-151-000
Steer Handles, Head End .....	1711-151-000
Wheel Cover Replacement Kit (Big Wheel) .....	1210-301-656
Wheel Cover Replacement Kit (Standard Caster) .....	1010-056-200

# Big Wheel Base Assembly

Assembly part number 1040-015-005 (reference only)

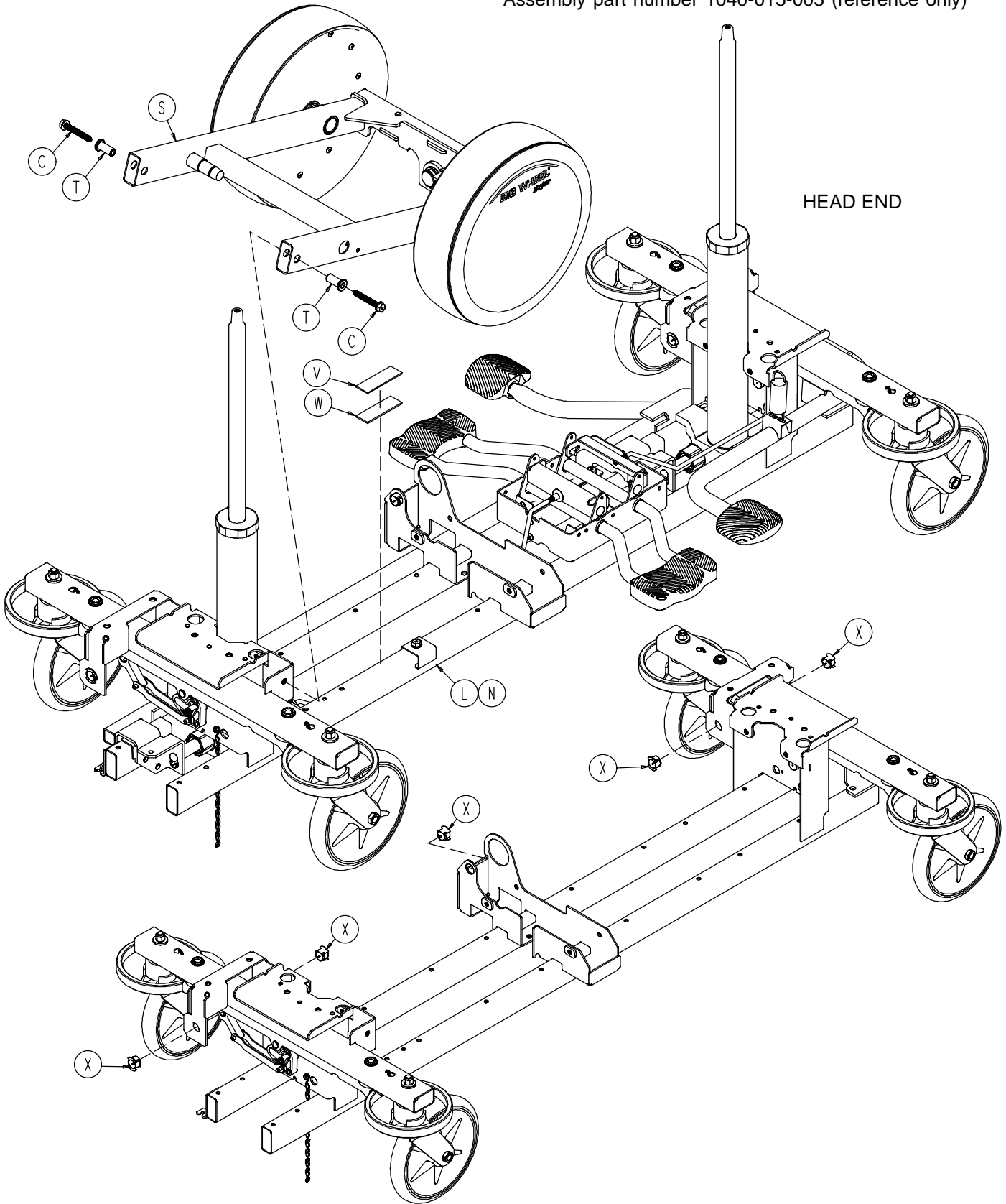

# Big Wheel Base Assembly

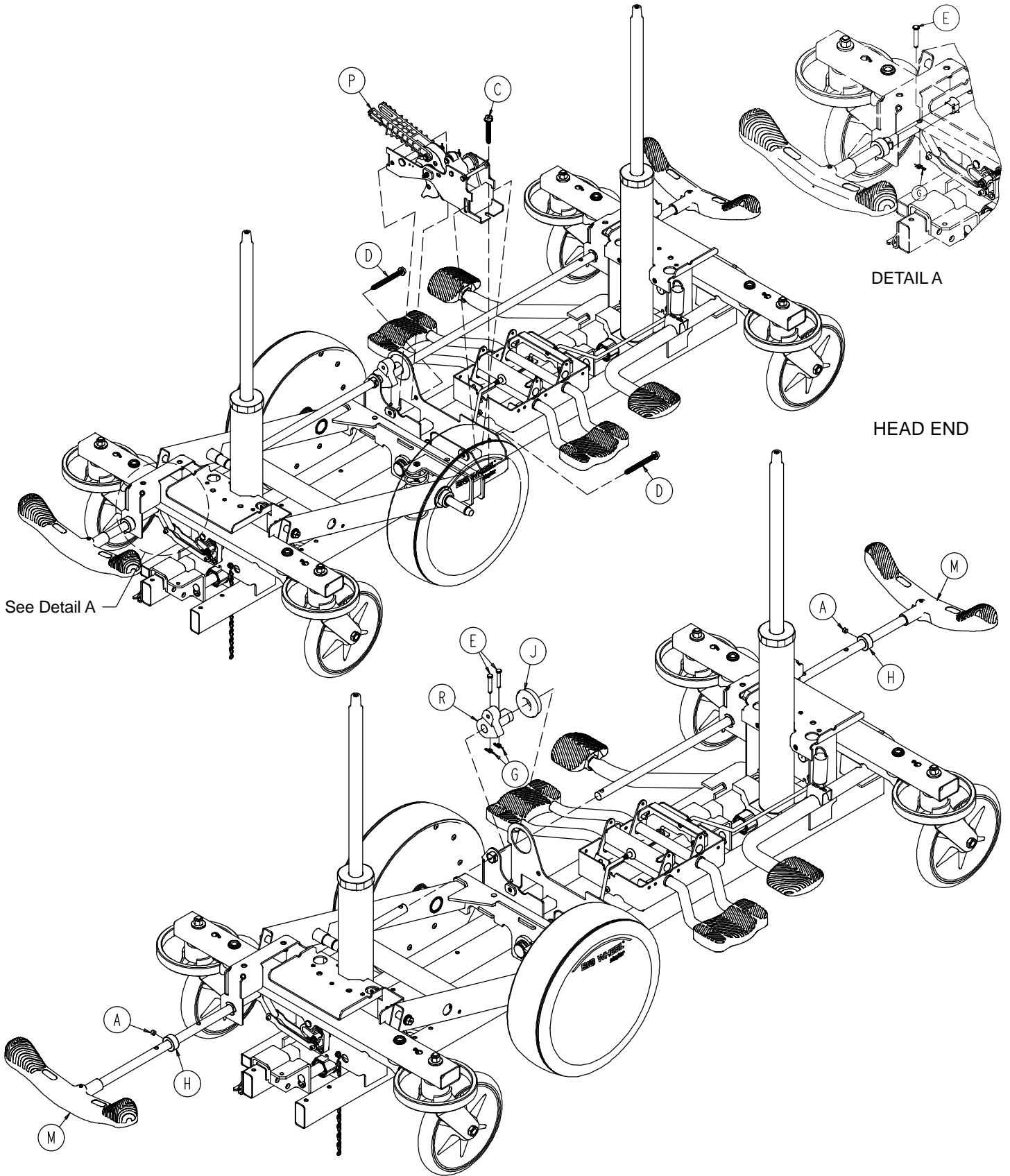

# Big Wheel Base Assembly

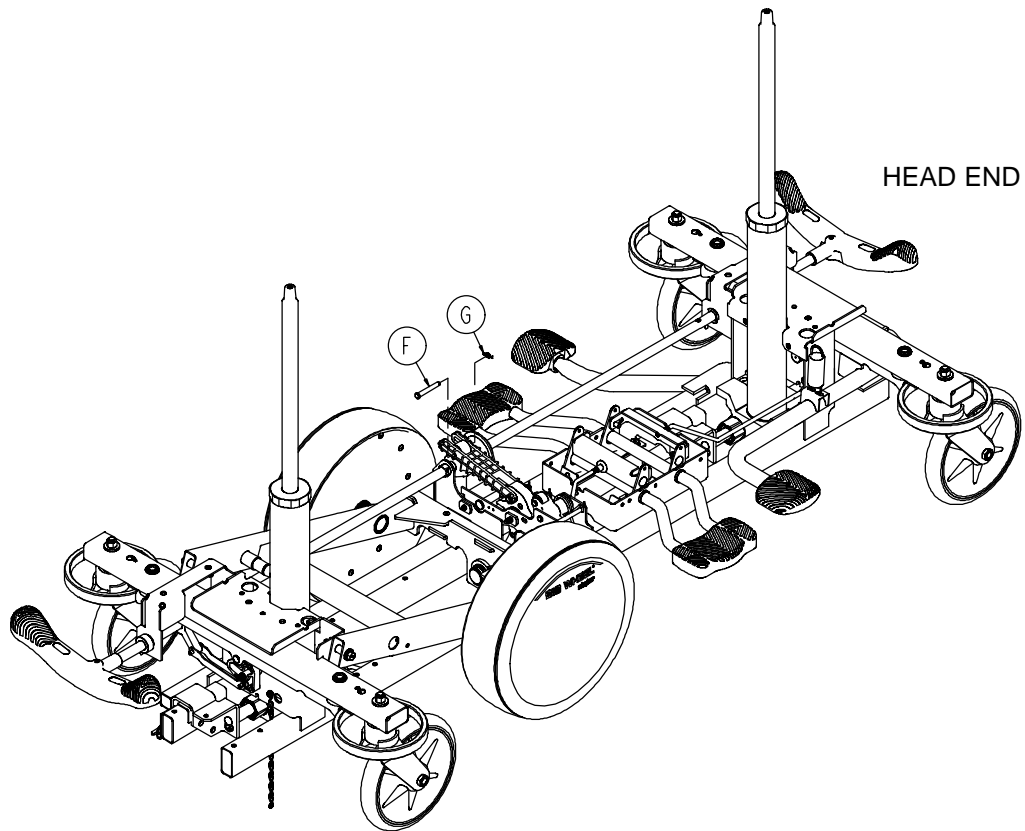

Item	Part No.	Part Name	Qty.
A	0021-166-000	Set Screw	2
C	0023-150-000	Hex Washer Hd. Screw	3
D	0023-151-000	Hex Washer Hd. Screw	2
E	0026-273-000	Clevis Pin	4
F	0025-330-000	Clevis Pin	1
G	0027-020-000	Rue Ring Cotter	5
H	0042-020-000	Collar	2
J	0081-330-000	Radial Bearing	1
L	(page 22)	Base Assembly w/ Standard Brakes	1
M	(page 26)	Brake Rod Assembly	2
N	(page 27)	Dual Sided Hydraulics	1
P	(page 32)	Cam Bracket Assembly	1
R	1040-006-131	Drive Arm	1
S	(page 34)	Big Wheel Carriage Assembly	1
T	1040-015-007	Carriage Pivot Bushing	2
V	0029-007-000	Dual Lock	1
W	0029-009-000	Dual Lock	1
X	1210-201-251	Insert	5

# Base Assembly w/Standard Brakes (Big Wheel Base)

Assembly part number 1040-003-105 (reference only)

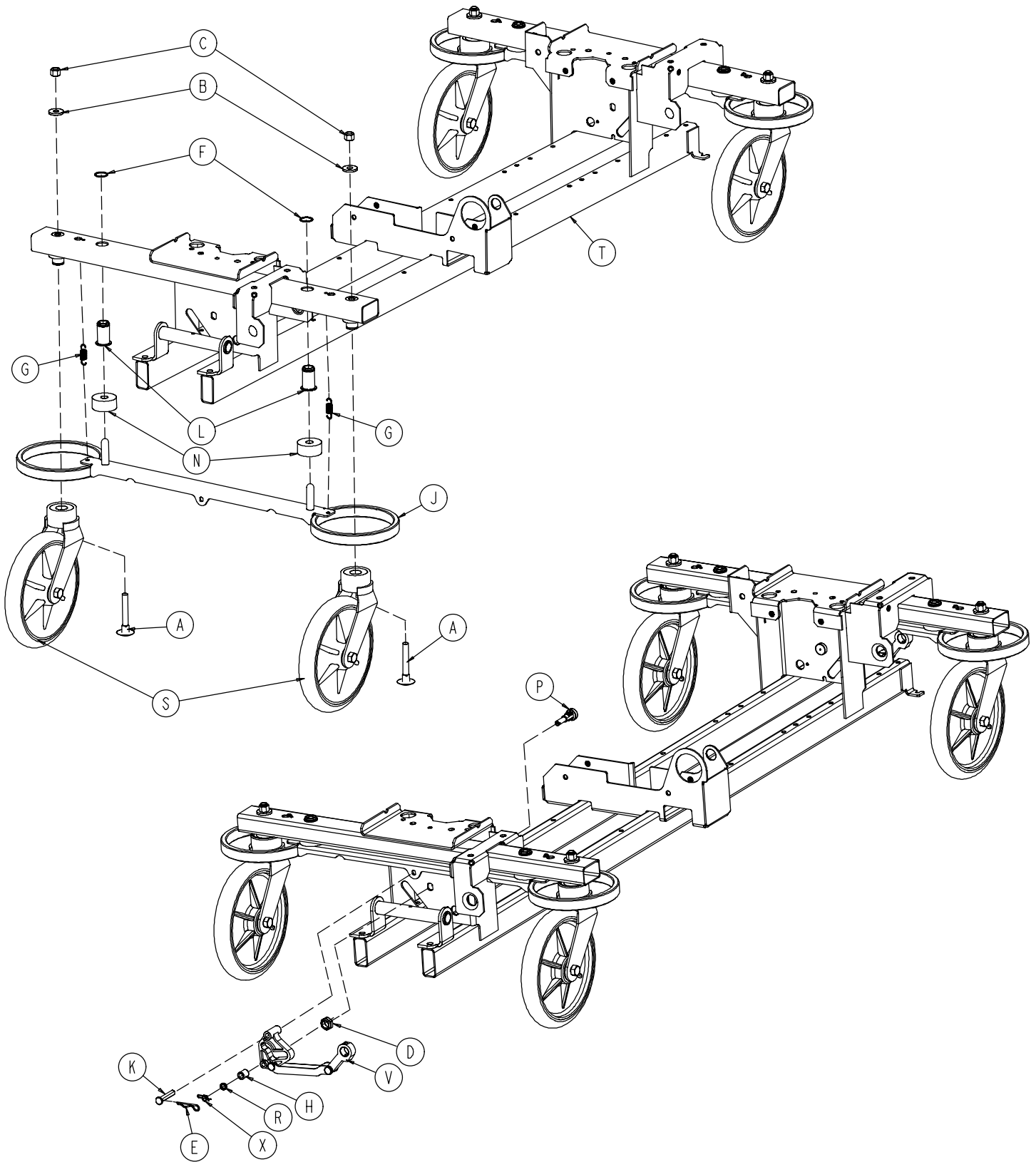

# Base Assembly w/Standard Brakes (Big Wheel Base)

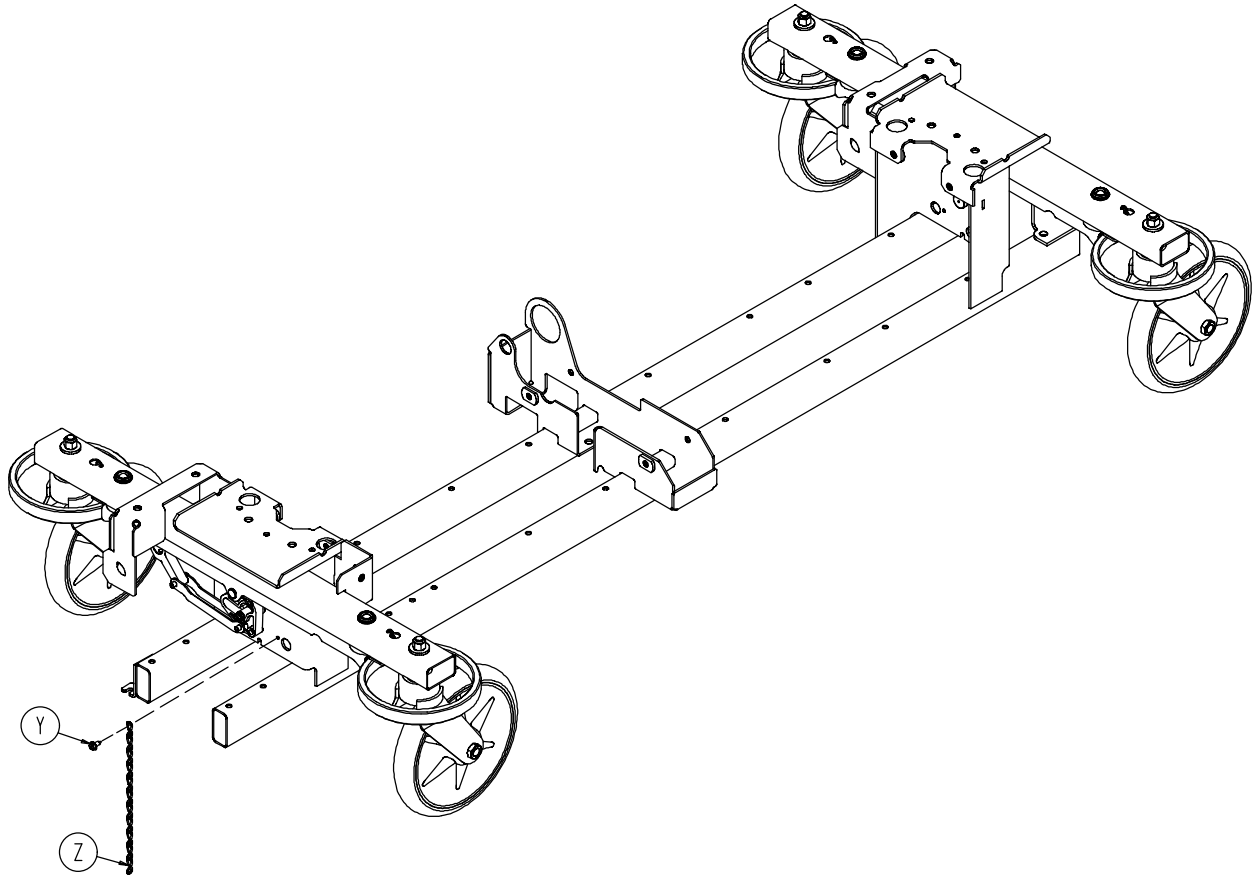

Item	Part No.	Part Name	Qty.
A	0005-039-000	Step Bolt	4
B	0011-262-000	Washer	4
C	0016-035-000	Nylock Hex Nut	4
D	0016-049-000	Nylock Hex Nut	2
E	0027-012-000	Hitch Pin	2
F	0028-037-000	External Retaining Ring	4
G	0038-439-000	Extension Spring	4
H	0081-272-000	Roller Bearing	2
J	0753-003-006	Brake Ring	2
K	0753-003-066	Clevis Pin	2
L	0753-003-079	Caster Tube Brake Pin Guide	4
N	0753-003-121	Brake Cushion	4
P	0753-003-130	Bearing Pivot Support	2
R	0753-003-131	Spacer	2
S	(page 24)	Caster Assembly	4
T	1040-001-001	Base Frame Weldment	1
V	(page 25)	Drive Link Assembly	2
X	0027-019-000	Rue Ring Cotter	2
Y	0023-025-000	Hex Washer Hd. Screw	1
Z	0753-010-012	Ground Chain	1



# 0753-010-020 8" Caster Assembly

---

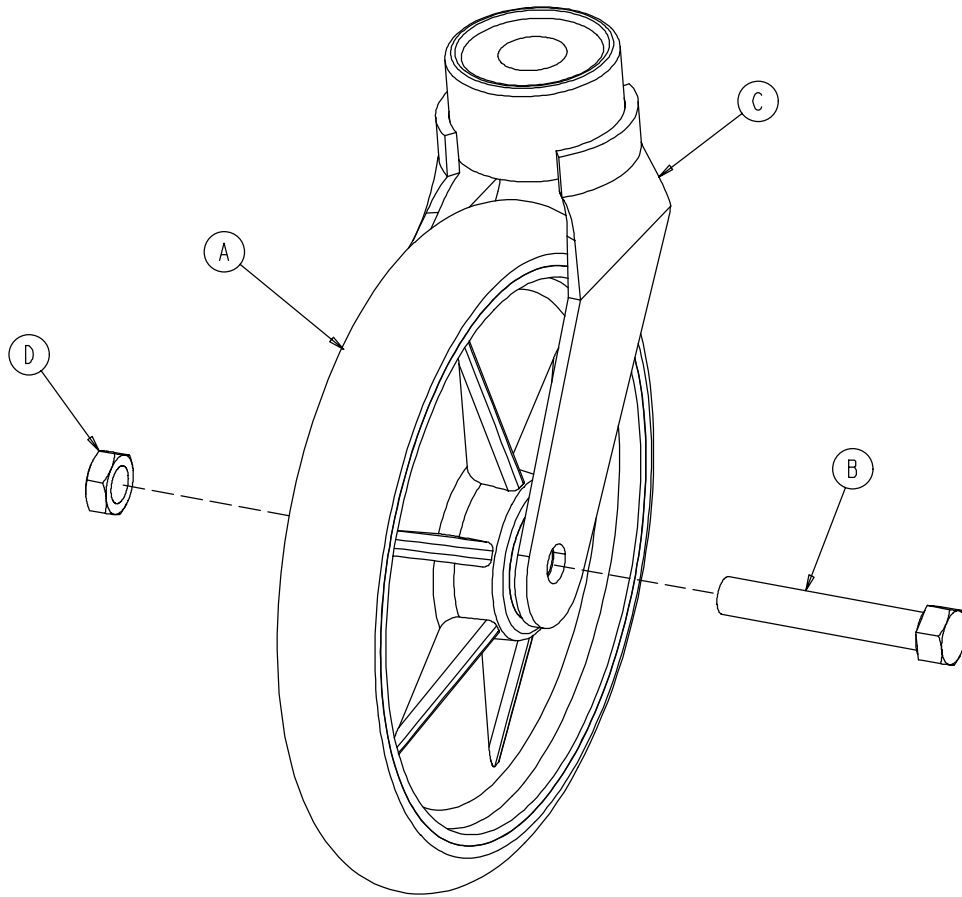

Item	Part No.	Part Name	Qty.
A	0715-002-025	Wheel	1
B	0003-099-000	Hex Hd. Cap Screw	1
C	0753-010-021	Caster Horn w/Bearing	1
D	0016-060-000	Centerlock Nut	1

# 1040-003-185 Drive Link Assembly

---

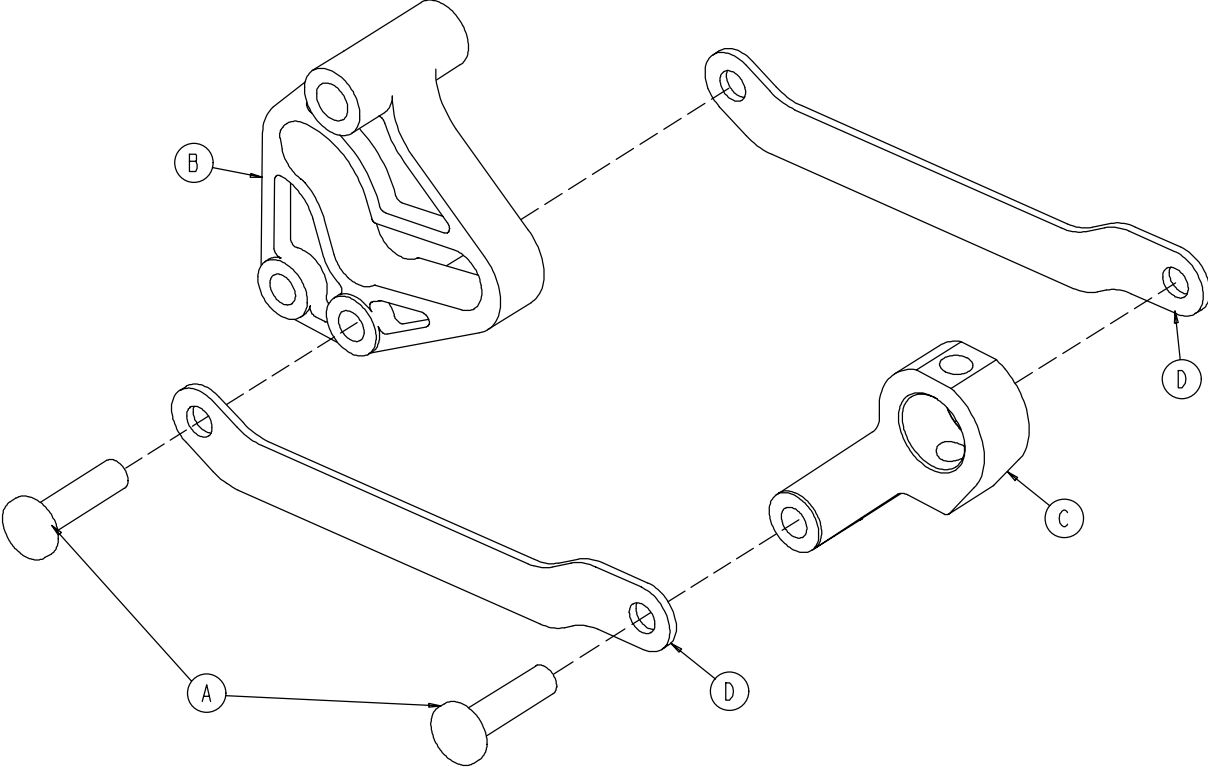

Item	Part No.	Part Name	Qty.
A	0753-003-098	Semi-Tubular Rivet	2
B	0753-003-102	Brake Cam	1
C	1040-003-174	Brake Rod Drive Link	1
D	1040-003-076	Cam Drive Link	2

# 1040-003-191 Brake Rod Assembly (Big Wheel Base)

---

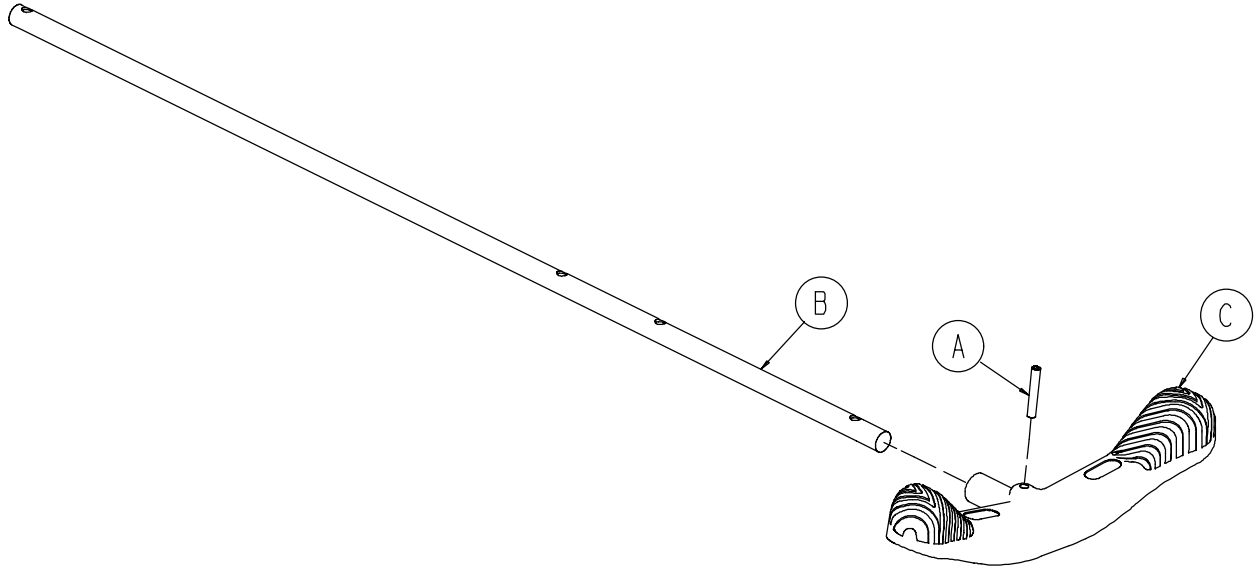

Item	Part No.	Part Name	Qty.
A	0026-067-000	Slotted Spring Pin	1
B	1040-003-113	Brake Rod	1
C	0753-003-099	Butterfly "V" Pedal	1

# Base with Dual Side Hydraulics (Big Wheel Base)

Assembly part number 1040-005-200 (reference only)

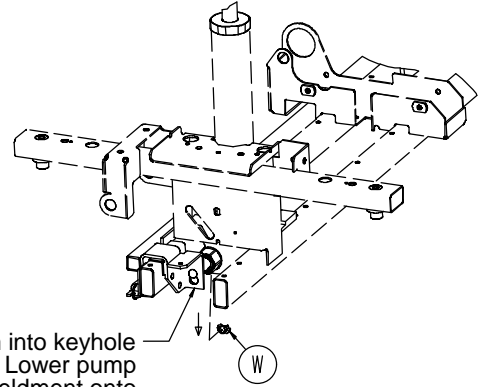

Insert pump ram into keyhole slot on both ends. Lower pump connecting rod weldment onto pump ram as shown. Insert item W to retain pump connecting rod.

0753-002-025 Constant Descent Jacks

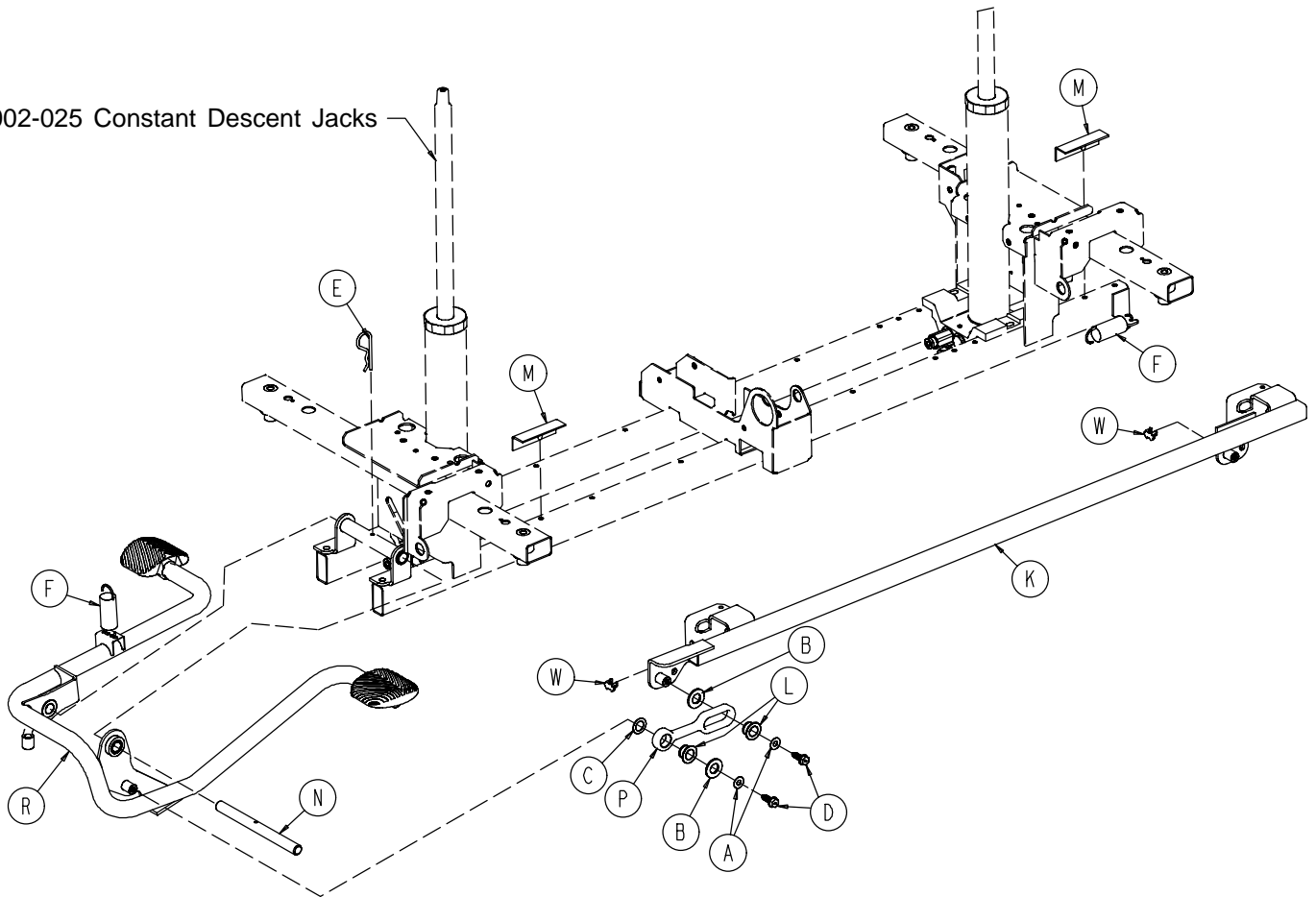

# Base with Dual Side Hydraulics (Big Wheel Base)

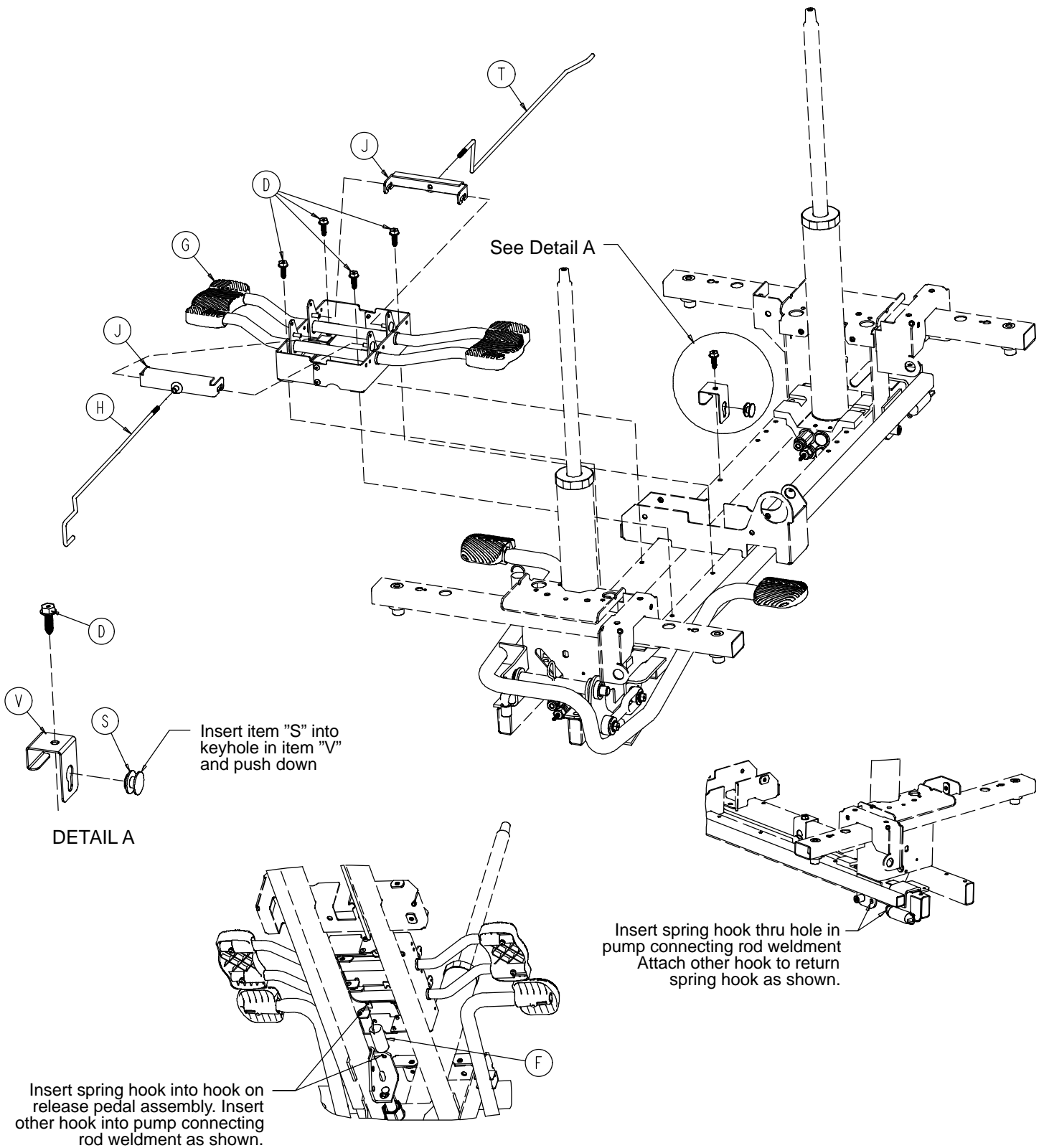

# Base with Dual Side Hydraulics (Big Wheel Base)

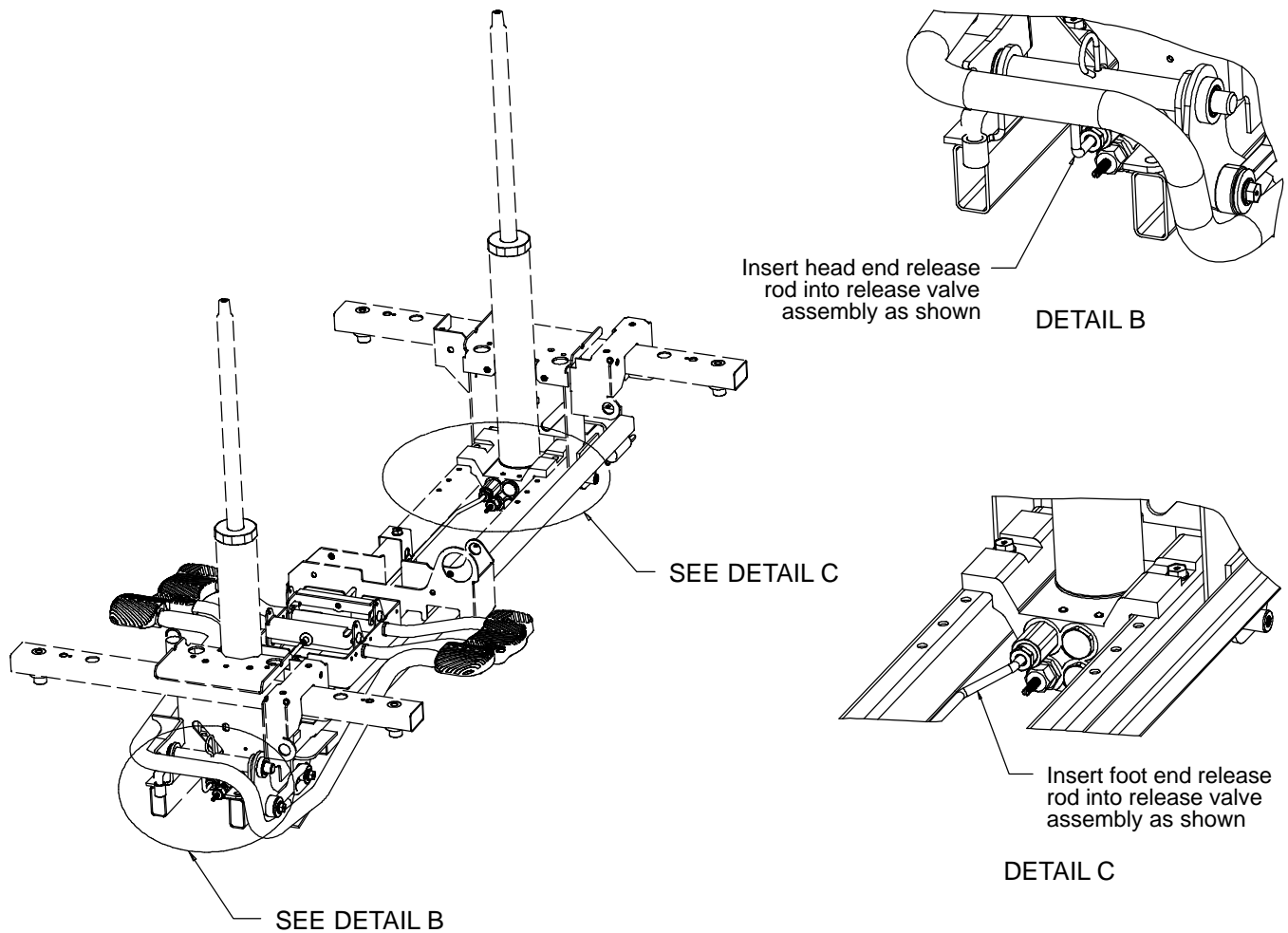

Item	Part No.	Part Name	Qty.
A	0011-023-000	Washer	2
B	0014-071-000	Washer	2
C	0014-080-000	Washer	1
D	0023-288-000	Hex Washer Hd. Screw	7
E	0027-031-000	Hair Pin Cotter	1
F	0038-497-000	Extension Spring	2
G	(page 30)	Release Pedal Assembly	1
H	0753-004-014	Head End Release Rod	1
J	0753-004-032	Release Pedal Swivel	2
K	0753-005-037	Pump Connecting Rod	1
L	0753-005-044	Pump Pedal Bushing	2
M	0753-005-088	Wear Strip	3
N	0753-005-074	Pivot Pin	1
P	0753-005-075	Pump Pedal Link	1
R	(page 31)	Head End Pump Pedal Ass'y	1
S	0753-010-015	Release Rod Guide	1
T	1040-004-015	Foot End Release Rod	1
V	1040-010-115	Release Rod Bracket	1
W	0753-005-089	Pump Ram Plug	2

# 0753-004-001 Release Pedal Assembly

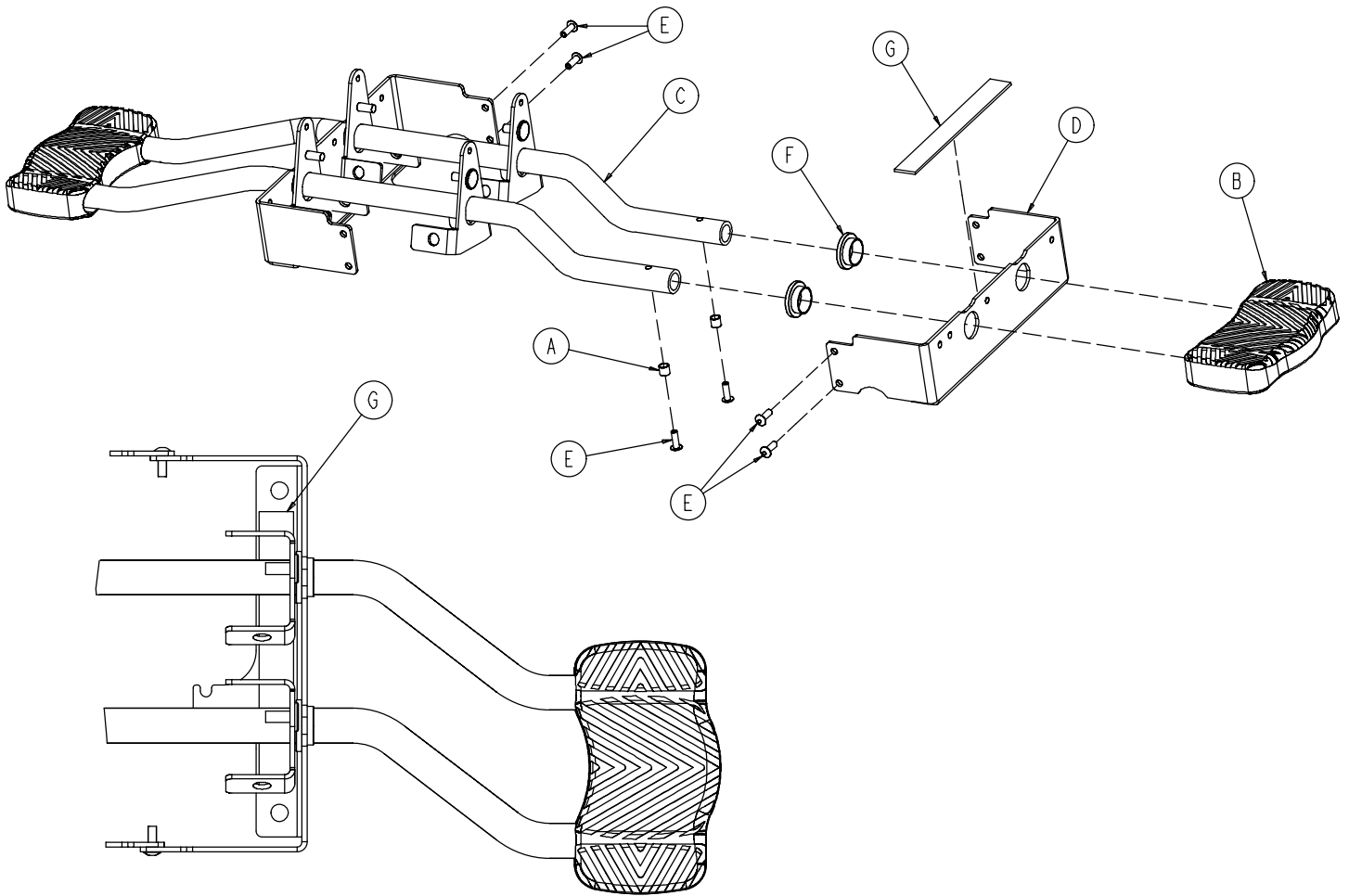

Item	Part No.	Part Name	Qty.
A	0715-001-333	Release Rod Stop Sleeve	4
B	1061-201-127	Short Uni Pedal	2
C	0753-004-004	Release Pedal Weldment	2
D	0753-004-121	Release Pedal Mtg. Plate	2
E	0025-171-000	Blind Rivet	8
F	0753-004-036	Bushing	4
G	0753-004-035	Rel. Pedal Bumper Strip	2

# 0753-005-085 Head End Pump Pedal Assembly

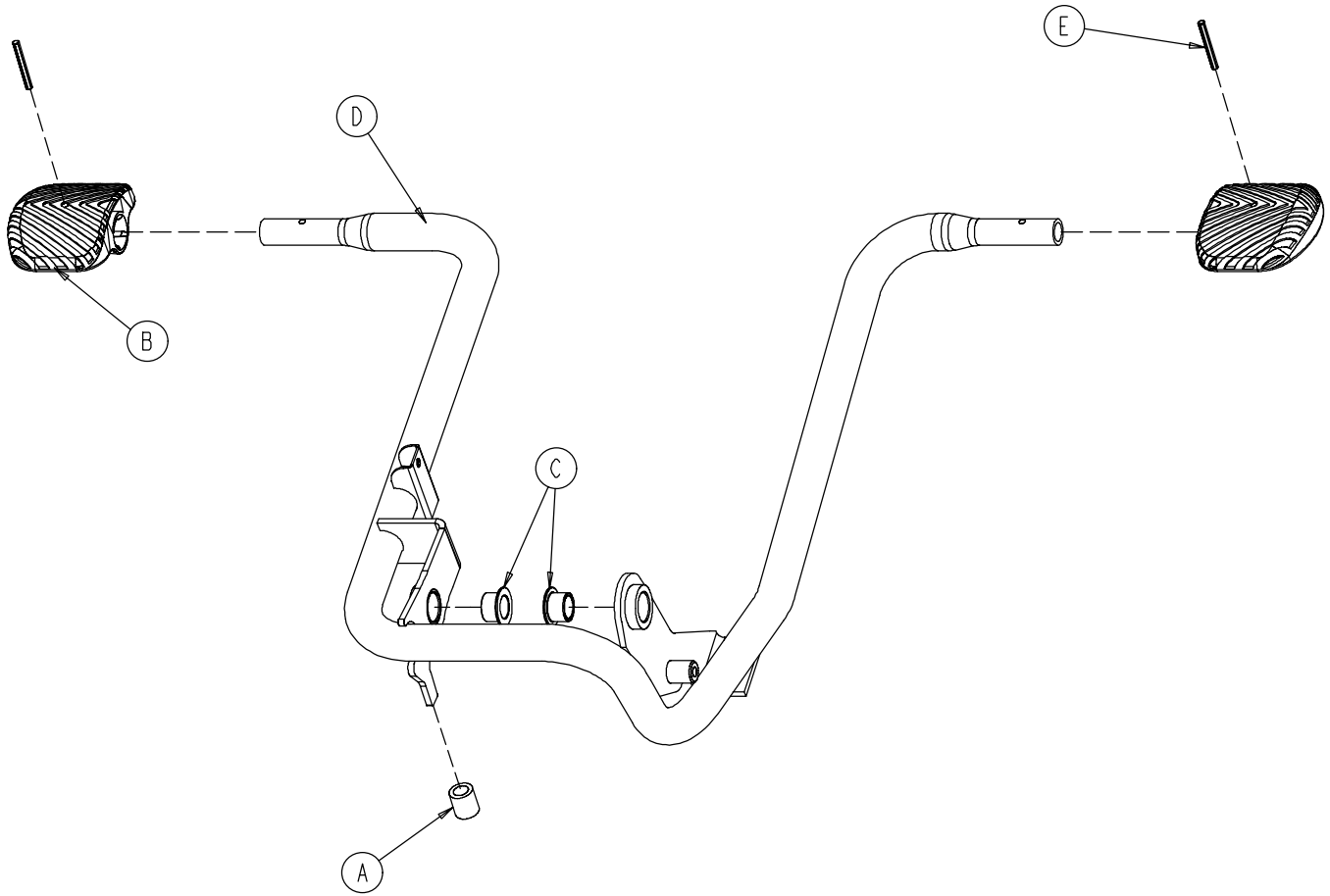

Item	Part No.	Part Name	Qty.
A	0715-001-140	Vinyl Tube	1
B	0715-201-126	Pump Pedal	2
C	0753-005-044	Pump Pedal Bushing	2
D	0753-005-080	Head End Pump Pedal Weldment	1
E	0026-143-000	Groove Pin	2



# Cam Bracket Assembly

Assembly part number 1040-006-101 (reference only)

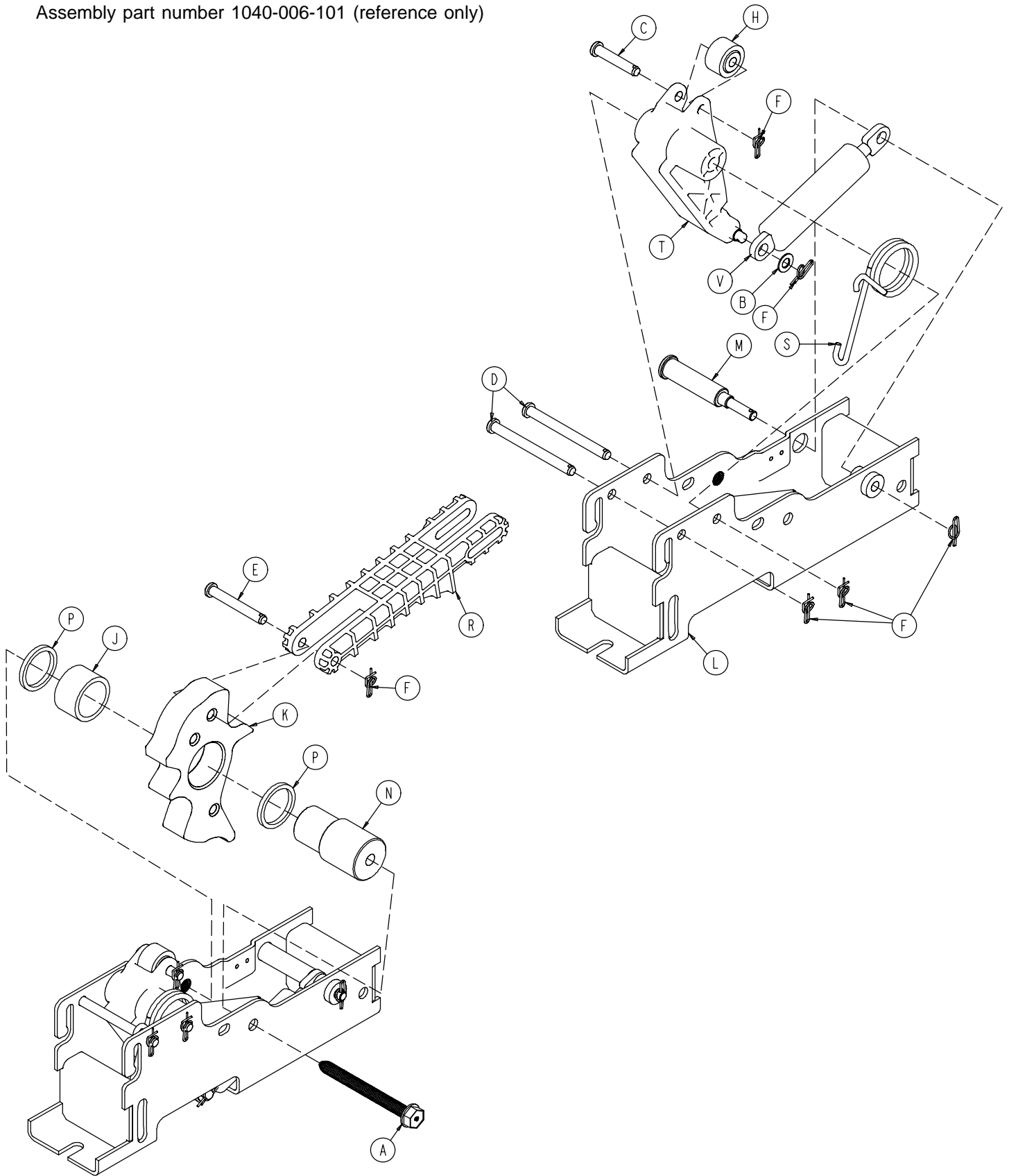

# Cam Bracket Assembly

---

<b>Item</b>	<b>Part No.</b>	<b>Part Name</b>	<b>Qty.</b>
A	0023-151-000	Hex Washer Hd. Screw	1
B	0014-004-000	Washer	1
C	0026-273-000	Clevis Pin	1
D	0026-341-000	Clevis Pin	2
E	0026-330-000	Clevis Pin	1
F	0027-020-000	Rue Ring Cotter	6
H	0081-305-000	Roller	1
J	0081-400-000	Needle Bearing	1
K	1040-006-113	Lift Cam	1
L	1040-006-121	Cam Bracket	1
M	1040-006-118	Dampener Mtg. Pin	1
N	1040-006-141	Cam Pivot	1
P	1040-015-008	Washer	2
R	1040-006-144	Drive Link	1
S	1210-001-146	Torsion Spring	1
T	1040-006-163	Dampener Arm	1
V	1040-006-109	Cam Damper	1

# Big Wheel Carriage Assembly

Assembly part number 1040-015-001 (reference only)

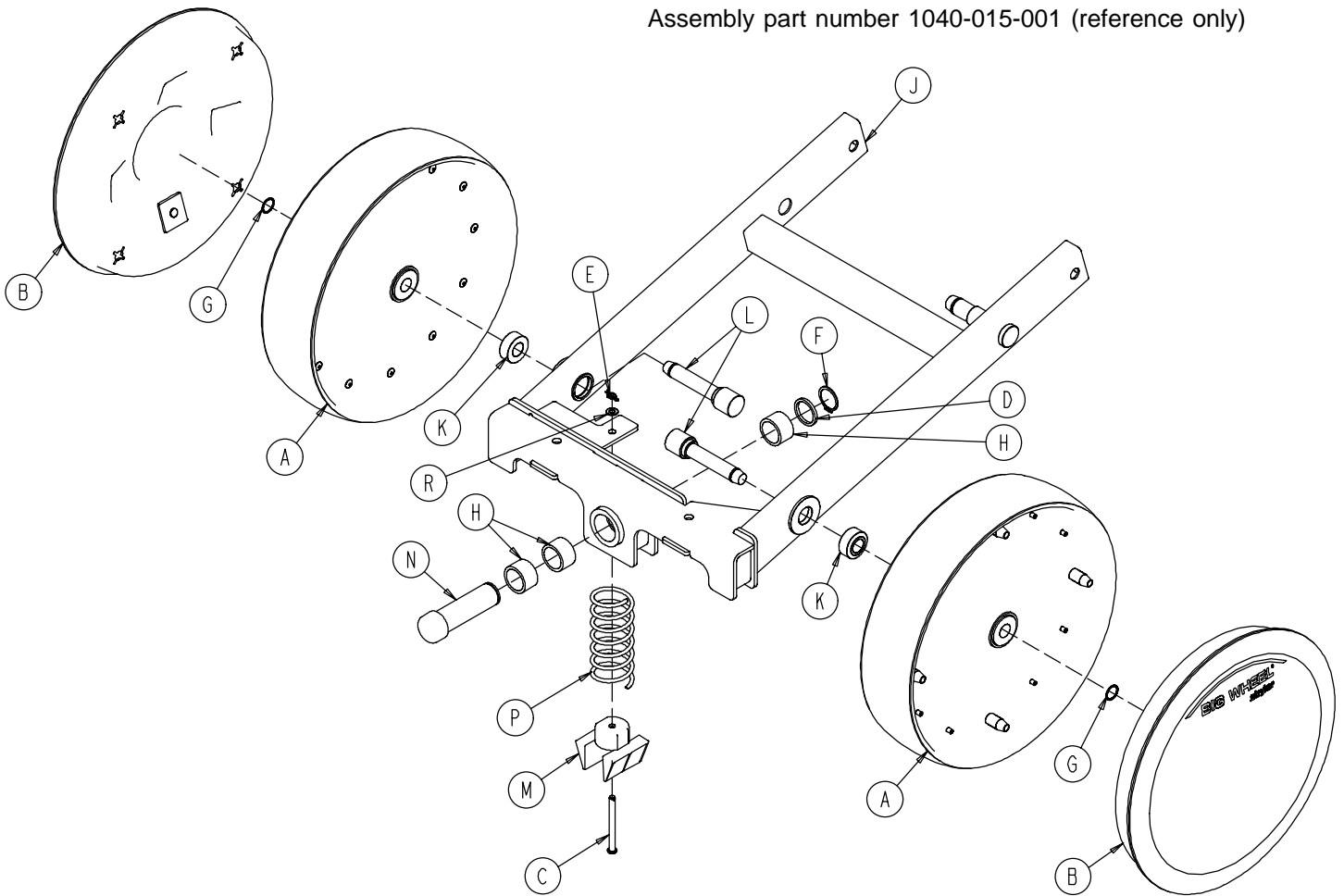

Item	Part No.	Part Name	Qty.
A	1210-301-619	Wheel Assembly	2
B	1040-015-030	Cover w/Counterweight	2
C	0026-341-000	Clevis Pin	1
D	1040-015-008	Washer	1
E	0027-020-000	Rue Ring Cotter	1
F	0028-173-000	External Retaining Ring	1
G	0028-330-000	Spiral Retaining Ring	2
H	0081-400-000	Needle Bearing	3
J	1040-015-010	Carriage Weldment	1
K	1040-015-051	Big Wheel Spacer	2
L	1040-015-052	Big Wheel Axle	2
M	1040-015-053	Carriage Spring Retainer	1
N	1040-015-028	Lift Cam Roller	1
P	1040-015-006	Carriage Return Spring	1
R	0014-004-000	Washer	1

# Side Control Big Wheel Base Assembly

Assembly part number 1040-025-005 (reference only)

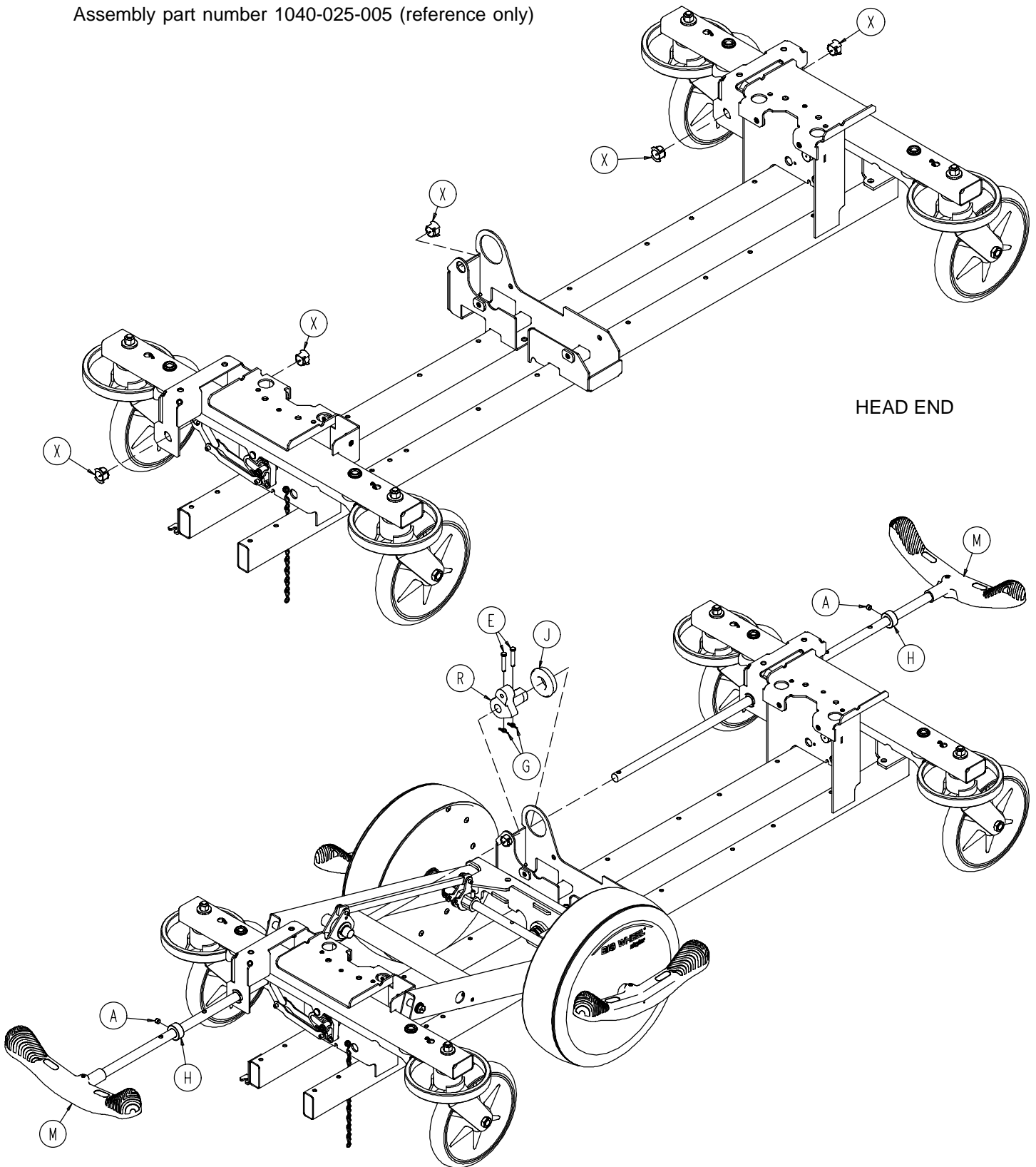

# Side Control Big Wheel Base Assembly

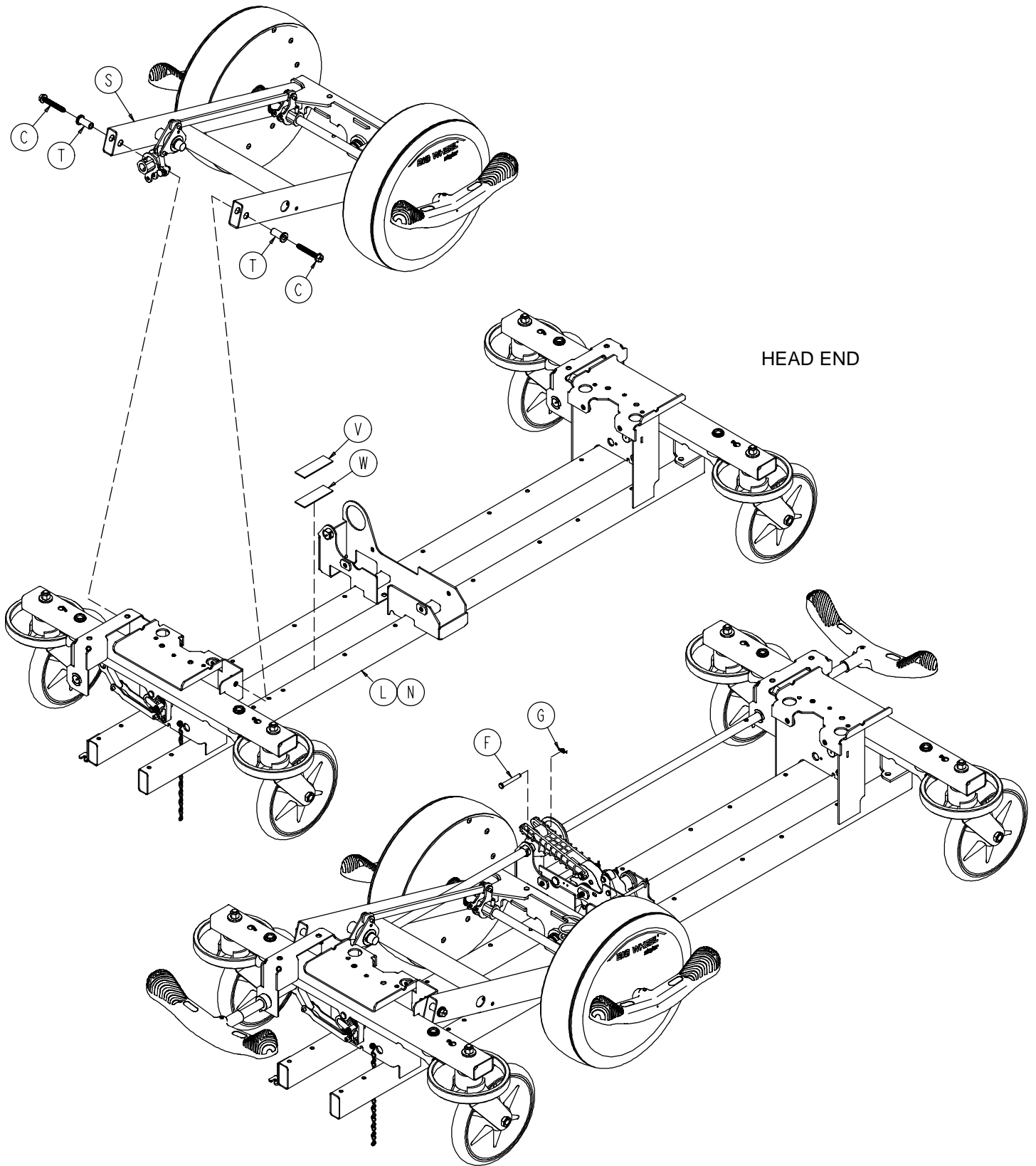

# Side Control Big Wheel Base Assembly

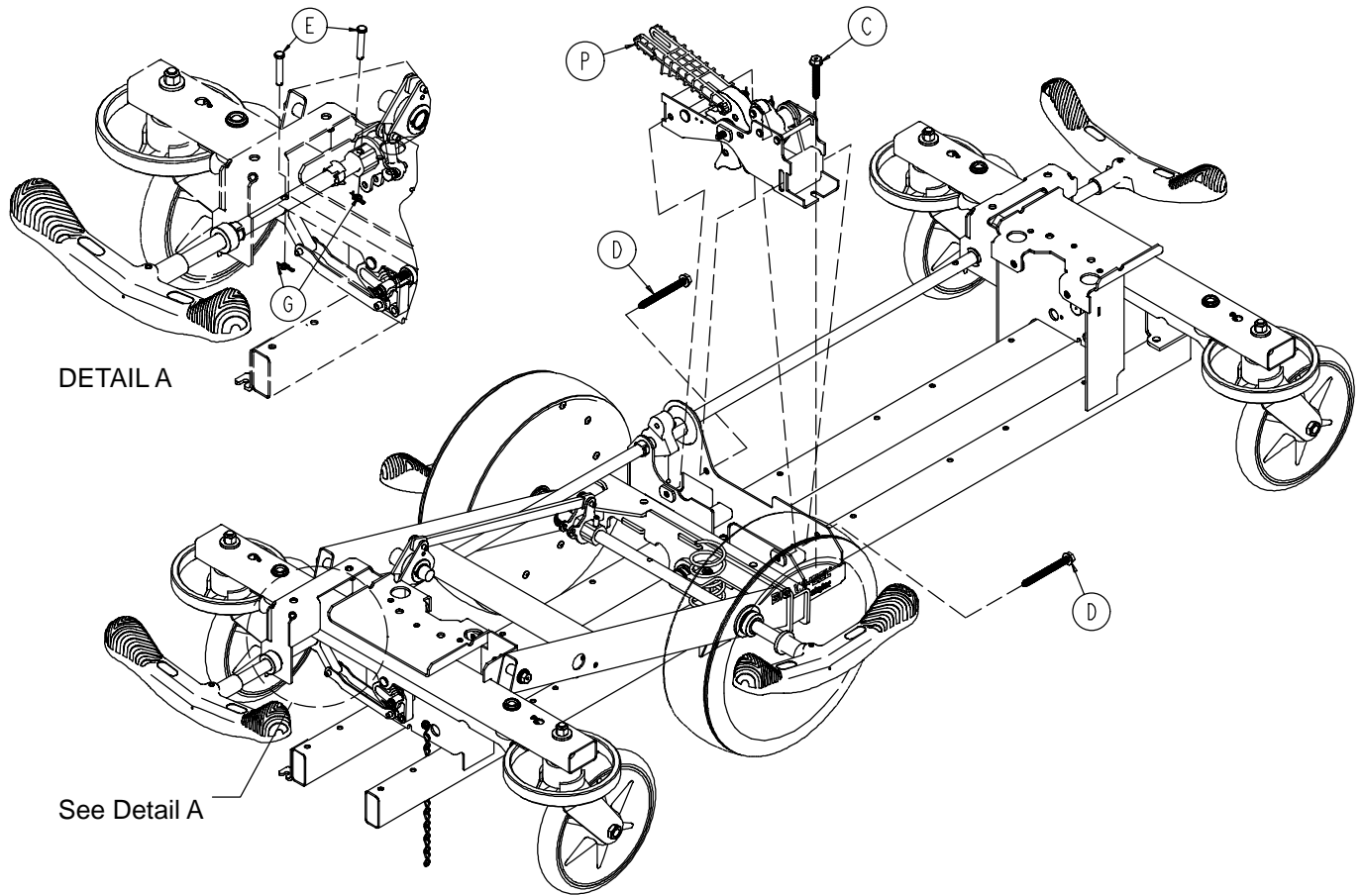

Item	Part No.	Part Name	Qty.
A	0021-166-000	Set Screw	2
C	0023-150-000	Hex Washer Hd. Screw	3
D	0023-151-000	Hex Washer Hd. Screw	2
E	0026-273-000	Clevis Pin	5
F	0026-330-000	Clevis Pin	1
G	0027-020-000	Rue Ring Cotter	6
H	0042-020-000	Collar	2
J	0081-330-000	Radial Bearing	1
L	(page 22)	Base Assembly w/ Standard Brakes	1
M	(page 26)	Brake Rod Assembly	2
N	(page 27)	Dual Sided Hydraulics	1
P	(page 32)	Cam Bracket Assembly	1
R	1040-006-131	Drive Arm	1
S	(page 38)	Side Control Big Wheel Carriage Ass'y	1
T	1040-015-007	Carriage Pivot Bushing	2
V	0029-007-000	Dual Lock	1
W	0029-009-000	Dual Lock	1
X	1210-201-251	Insert	5



# Side Control Big Wheel Carriage Assembly

---

Item	Part No.	Part Name	Qty.
A	0014-004-000	Washer	1
B	0011-148-000	Washer	2
E	0026-341-000	Clevis Pin	1
F	0026-342-000	Groove Pin	3
G	0027-020-000	Rue Ring Cotter	1
H	0028-166-000	External Retaining Ring	1
K	0028-173-000	External Retaining Ring	1
L	0081-011-000	Needle Bearing	3
M	0011-525-000	Washer	2
N	0081-175-000	Thrust Bearing	2
R	0081-400-000	Needle Bearing	3
S	0753-003-099	Butterfly "V" Pedal	2
T	1040-015-006	Carriage Return Spring	1
U	1040-015-008	Washer	1
W	1040-015-010	Carriage Weldment	1
X	1040-015-053	Carriage Spring Retainer	1
Y	1040-015-028	Lift Cam Roller	1
Z	0753-003-119	Side Control Brake Rod	1
AA	1040-025-014	Side Control Wheel Spacer	2
AB	1040-025-017	Side Control Pedal Spacer	2
AC	1040-025-030	Cover w/Counterweight	2
AD	1210-301-619	Wheel Assembly	2
AE	(page 40)	Side Control Linkage Ass'y	1
AF	1210-201-335	Red Brake Label	2
AG	1210-201-336	Green Steer Label	2



# 1040-025-010 Side Control Big Wheel Linkage Ass'y

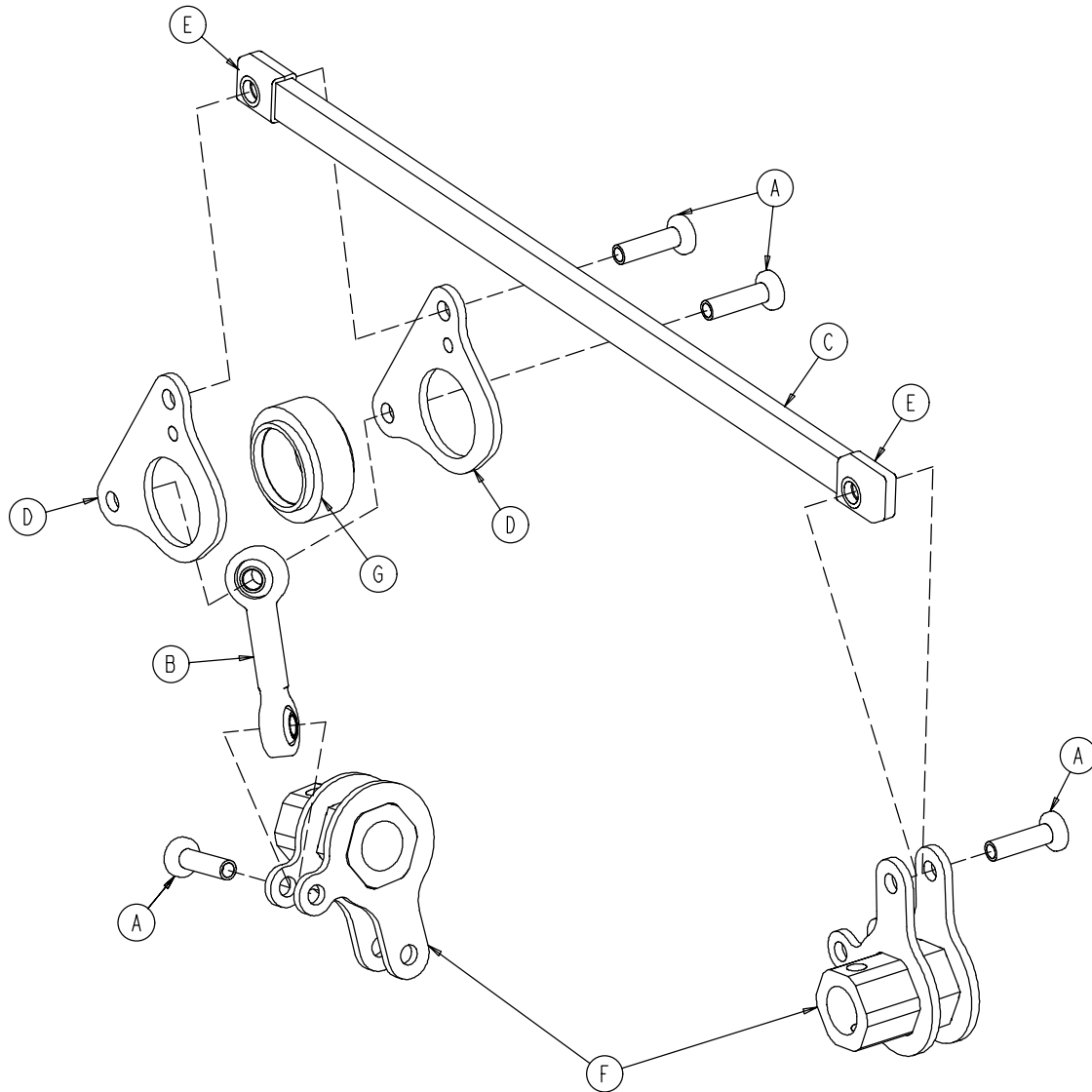

Item	Part No.	Part Name	Qty.
A	0753-003-098	Flat Hd. Semi-Tubular Rivet	4
B	0753-003-117	Rod End Link	1
C	1040-025-011	Main Link	1
D	1040-025-013	Toggle Pivot Plate	2
E	1040-025-016	Main Link Cover	2
F	1040-025-020	Yoke Weldment	2
G	1040-025-018	Toggle Pivot Spacer	1

# 0753-002-025 Constant Descent Jacks Option

---

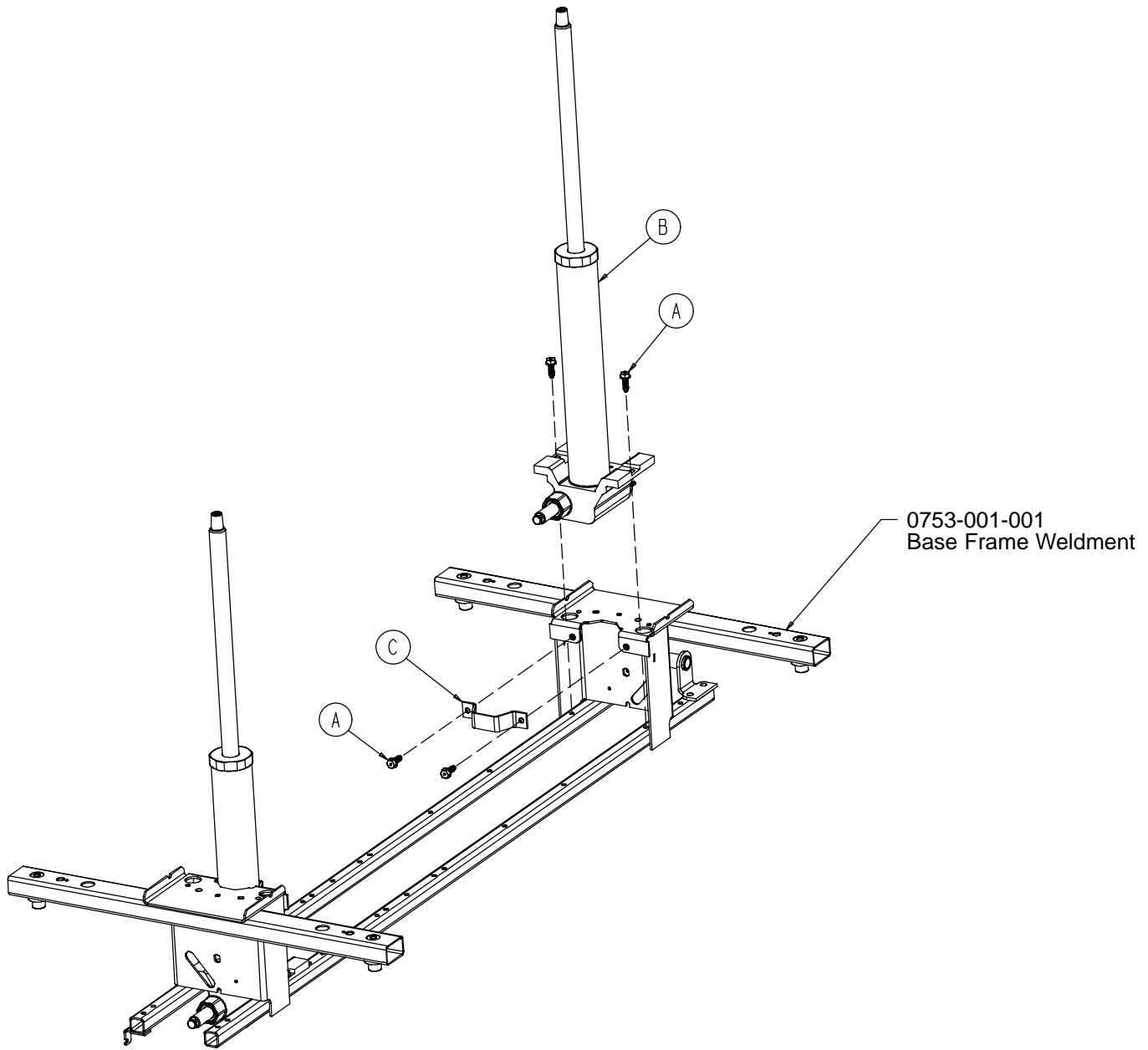

Item	Part No.	Part Name	Qty.
A	0023-288-000	Hex Washer Hd. Screw	8
B	0753-002-001	Constant Descent Jack Ass'y	2
C	0753-010-007	Reservoir Clamp	2

# Base Labeling Assembly - Big Wheel Base

Assembly part number 1040-015-300 (reference only)

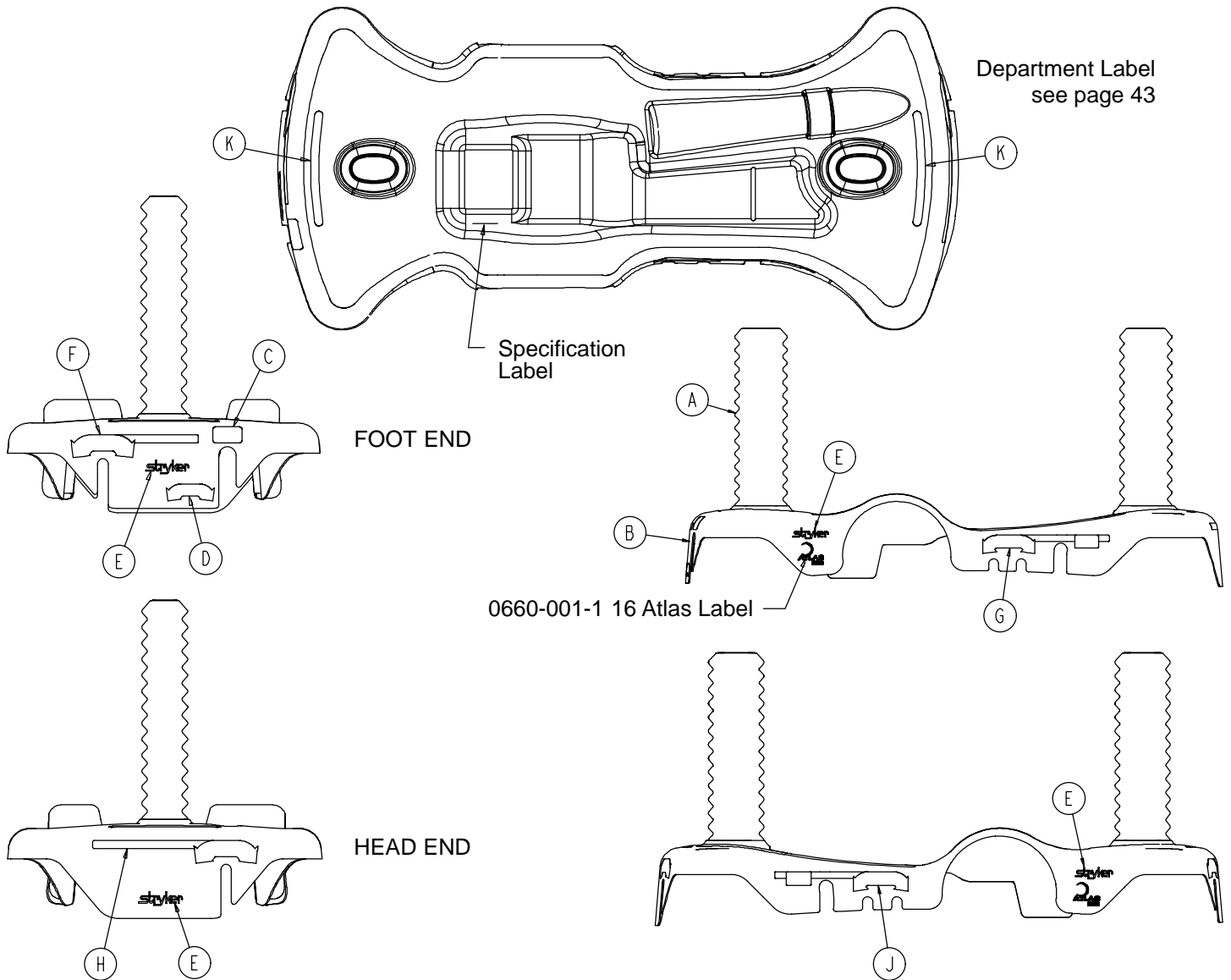

Item	Part No.	Part Name	Qty.
A	1040-010-134	Bellows	2
B	1040-015-004	Base Hood	1
C	0753-010-052	Foot End Pump Pedal Label	1
D	0753-010-053	Foot End Release Pedal Label	1
E	0946-201-060	Stryker Logo Label	4

# Base Labeling Assembly

---

<b>Color Set P/N</b>	<b>Item F Brake/Steer, Foot End</b>	<b>Item G Lift/Lower, Left</b>	<b>Item H Brake/Steer, Head End</b>	<b>Item J Lift/Lower, Right</b>	<b>Litter Bumper Strip</b>
RED 0753-010-100	0753-010-016	0753-010-055	0753-010-017	0753-010-054	1010-700-015
PURPLE 0753-010-101	0753-010-160	0753-010-155	0753-010-170	0753-010-154	1010-700-025
GREEN 0753-010-102	0753-010-260	0753-010-255	0753-010-270	0753-010-254	1010-700-035
GRAY 0753-010-103	0753-010-360	0753-010-355	0753-010-370	0753-010-354	1010-700-045
TEAL 0753-010-104	0753-010-460	0753-010-455	0753-010-470	0753-010-454	1010-700-055
PINK 0753-010-105	0753-010-560	0753-010-555	0753-010-570	0753-010-554	1010-700-065
BLUE 0753-010-106	0753-010-660	0753-010-655	0753-010-670	0753-010-654	1010-700-075

## BASE HOOD DEPARTMENT LABELS

<b>Department</b>	<b>Label Part Number</b>
Emergency	1010-900-215
PACU	1010-900-220
Transport	1010-900-225
Surgery	1010-900-230
Extended Stay	1010-900-235
Maternity	1010-900-240
Endoscopy	1010-900-245
Radiology	1010-900-250
Nuclear Medicine	1010-900-255
Ambulatory Surgery	1010-900-260
G.I. Lab	1010-900-265
Cath. Lab	1010-900-270
Same Day Surgery	1010-900-275
Cardio.	1010-900-280
Ultrasound	1010-900-285

### NOTE

All base hood department labels are quantity of two.

# Litter Assembly

Assembly part number 0660-230-010 (reference only)

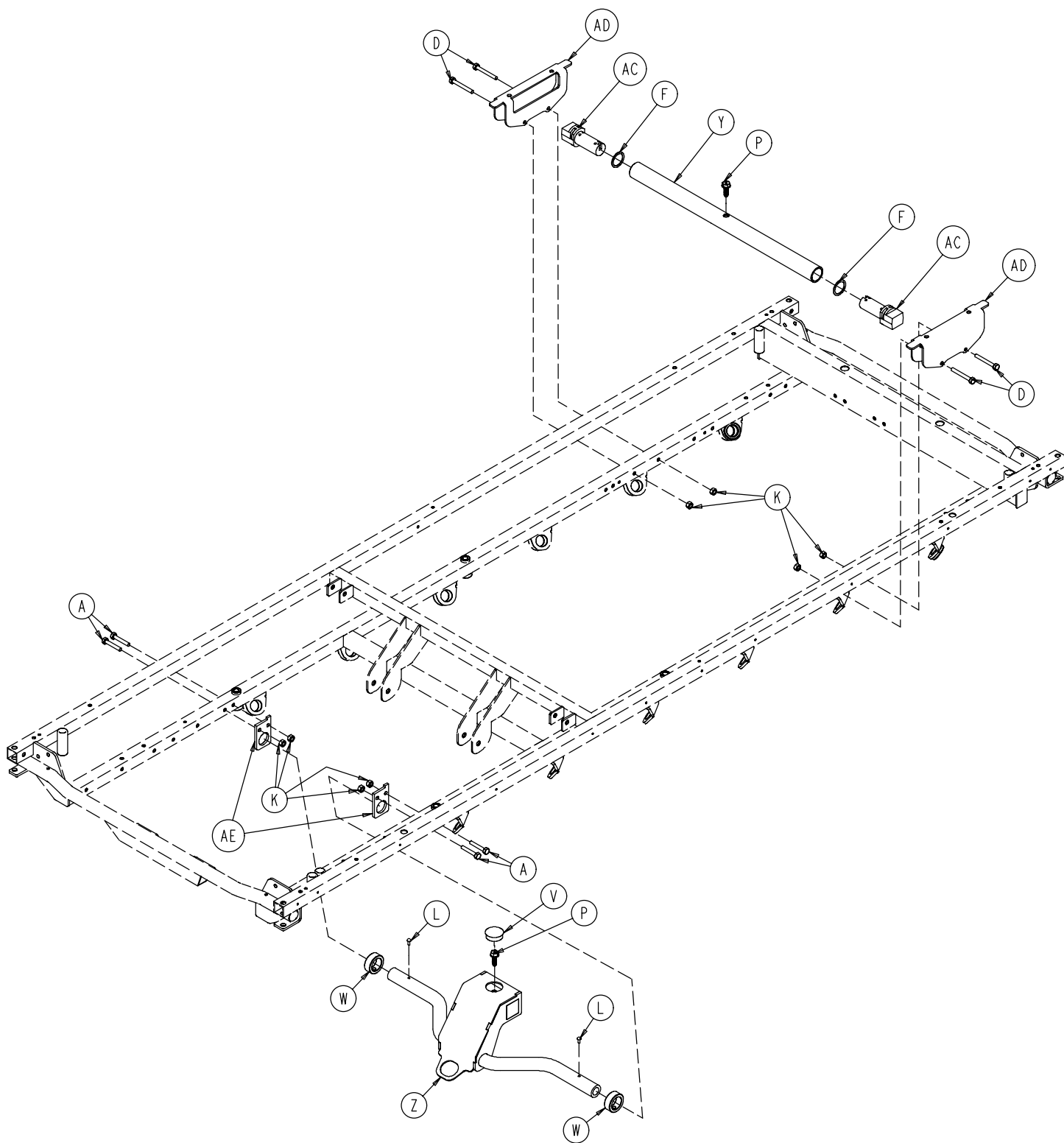

# Litter Assembly

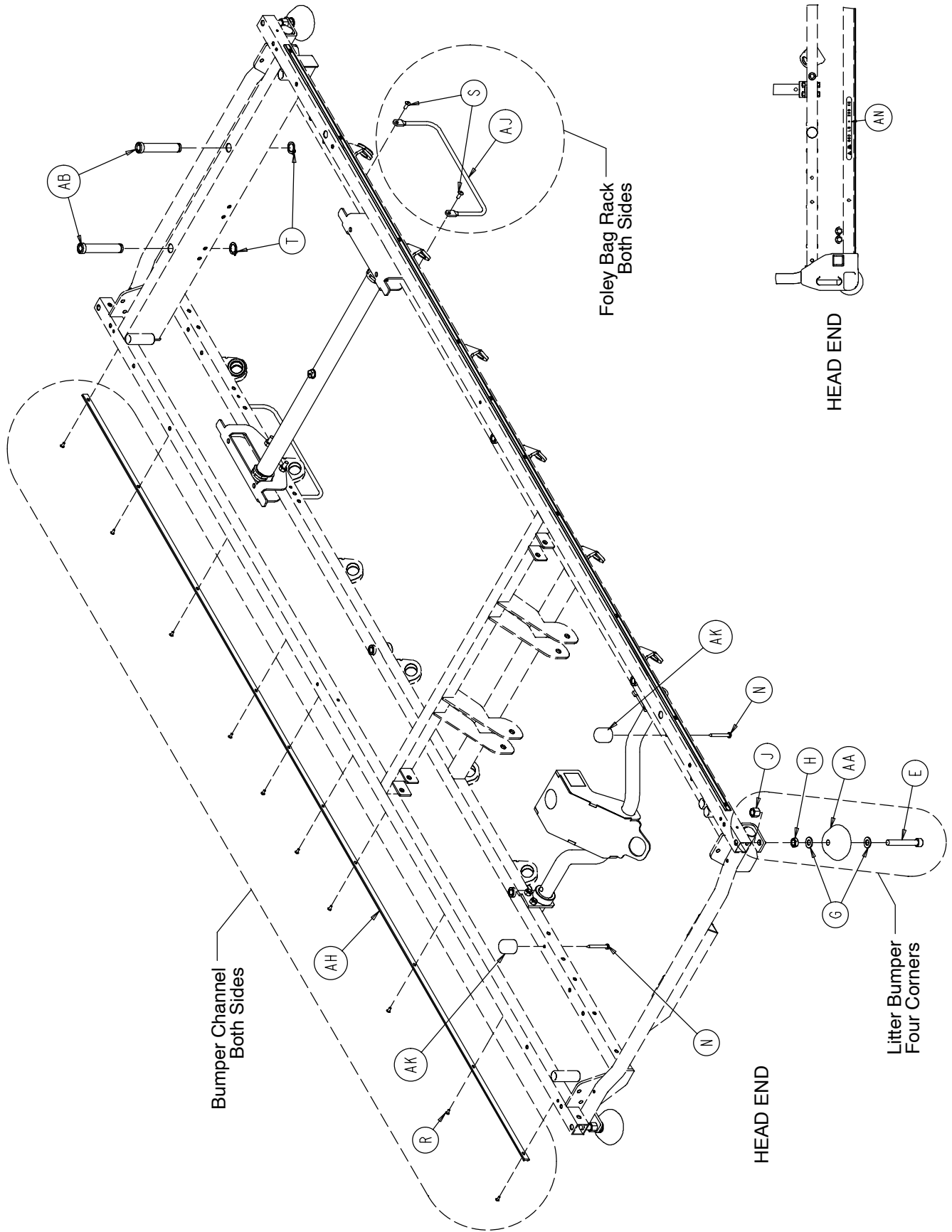

# Litter Assembly

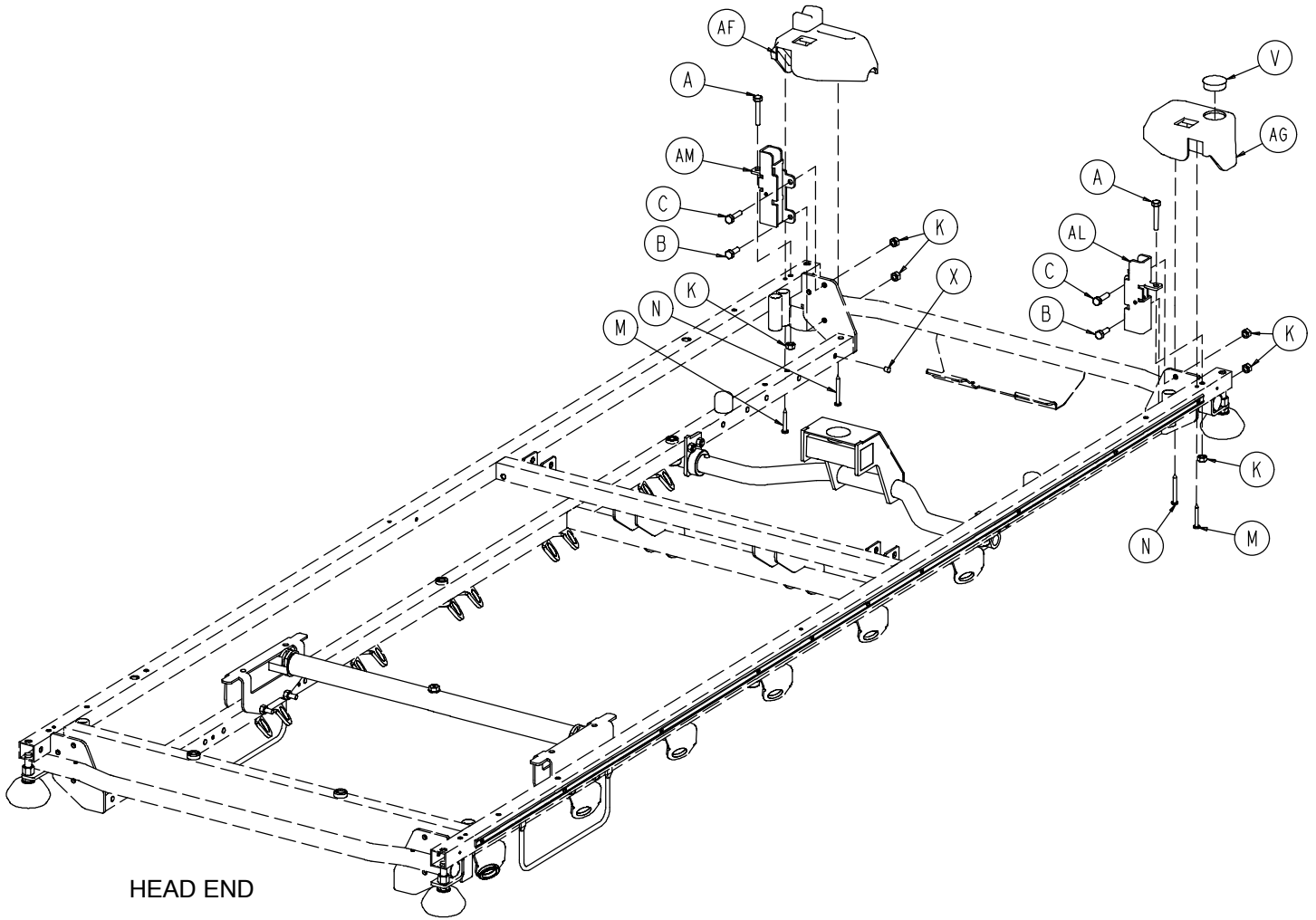

Item	Part No.	Part Name	Qty.	Item	Part No.	Part Name	Qty.
A	0003-355-000	Hex Hd. Cap Screw	6	W	0042-007-000	Collar Assembly	2
B	0003-356-000	Hex Hd. Cap Screw	2	X	0721-031-065	Hole Plug	50
C	0003-357-000	Hex Hd. Cap Screw	2	Y	0753-010-026	Support Tube	1
D	0003-358-000	Hex Hd. Cap Screw	4	Z	0753-010-027	Hd. End Jack Support	1
E	0004-330-000	Soc. Hd. Cap Screw	4	AA	0926-400-142	Bumper	4
F	0011-360-000	Washer	2	AB	1001-040-012	Foot Board Receptacle	2
G	0014-021-000	Washer	8	AC	1001-201-029	Nylon Insert	2
H	0015-027-000	Jam Nut	4	AD	1001-401-030	Trend Support	2
J	0016-117-000	Nylock Nut	4	AE	1211-030-018	Jack Support Bracket	2
K	0016-118-000	Nylock Nut	14	AF	1211-030-034	Cover, Hole/Slot	1
L	0022-010-000	Drive Screw	2	AG	1211-030-037	Cover, Hole/Hole	1
M	0023-282-000	Self-Tapping Screw	2	AH	1211-030-044	Bumper Channel	2
N	0023-283-000	Self-Tapping Screw	4	AJ	1211-030-046	Foley Bag Rack	2
P	0023-288-000	Hex Washer Hd. Screw	2	AK	1211-031-031	Pneumatic Fowler Rest	2
R	0025-038-000	Blind Rivet	20	AL	1211-351-004	Handle Receptacle, Right	1
S	0025-179-000	Blind Rivet	4	AM	1211-351-006	Handle Receptacle, Left	1
T	0028-072-000	External Snap Ring	2	AN	0660-001-018	660 Lb. Max Label	2
V	0037-059-000	Hole Plug	2				

# Siderail to Litter Assembly, Fold-to-Head

Assembly part number 1211-120-010 (reference only)

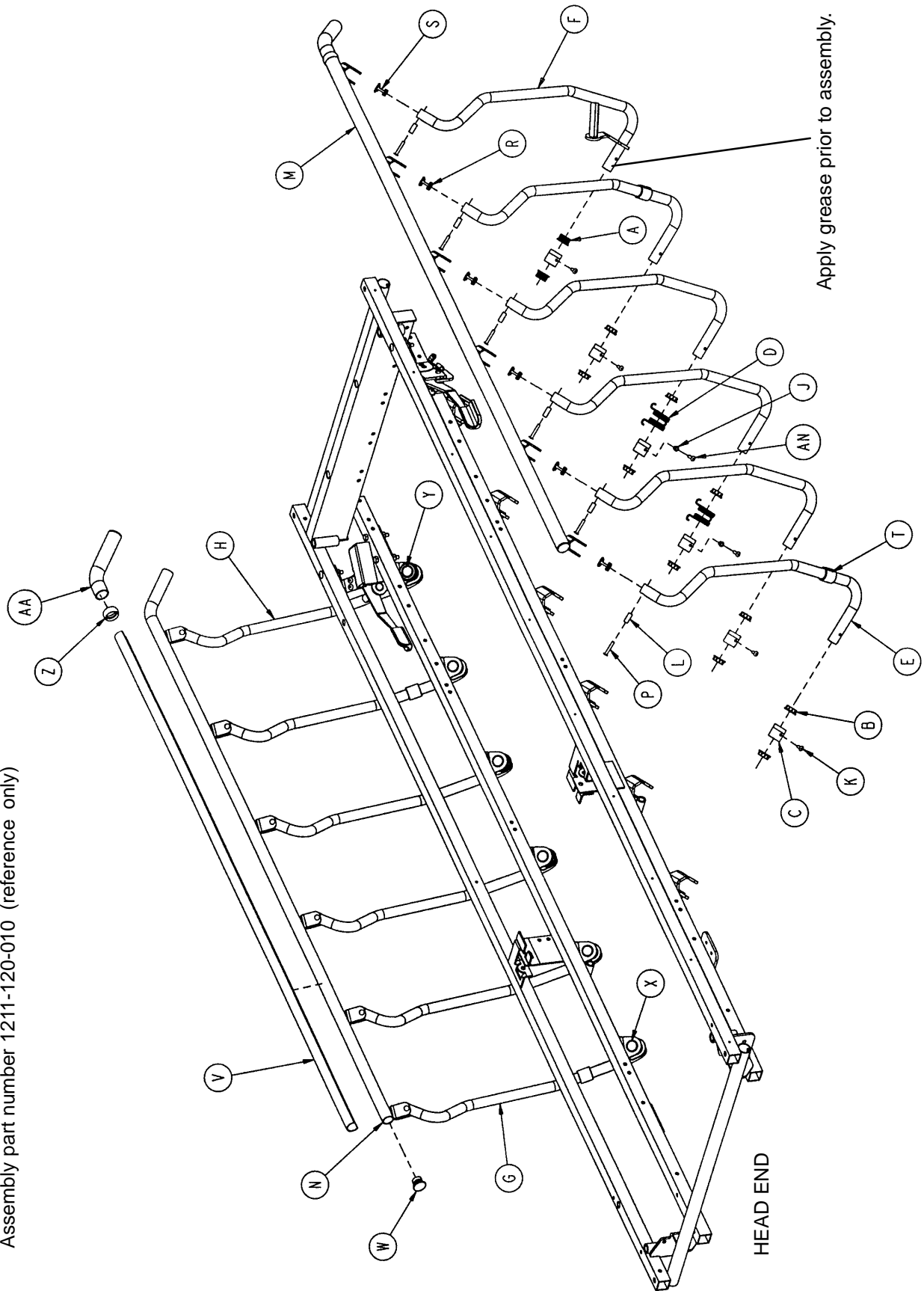



# Siderail to Litter Assembly, Fold-to-Head

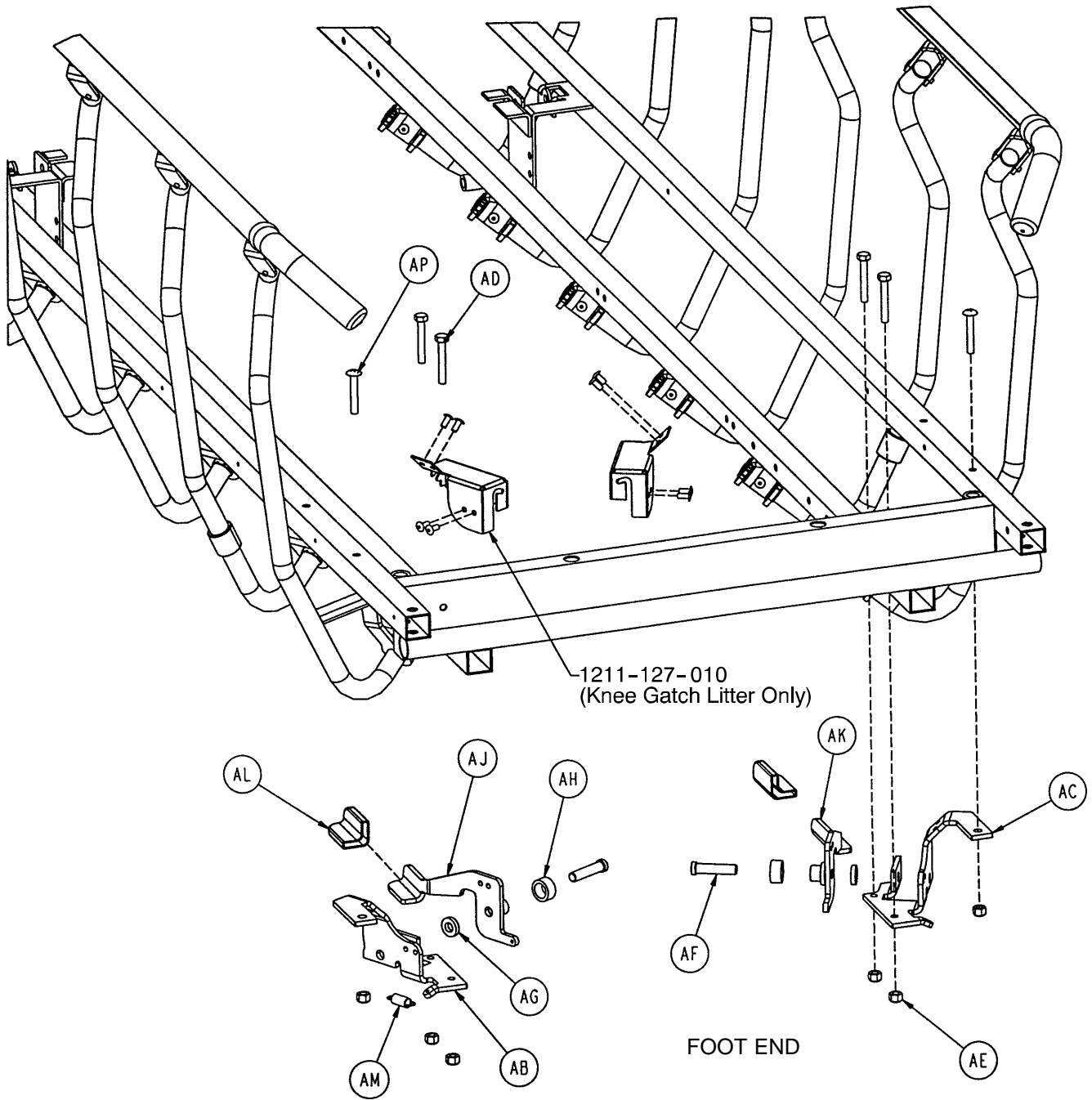

# Siderail to Litter Assembly, Fold-to-Head

---

Item	Part No.	Part Name	Qty.
A	1001-226-116	Pivot Bearing	4
B	1001-226-016	Pivot Bearing	20
C	1001-226-015	Pivot Sleeve	12
D	1001-226-017	Siderail Spring	2
E	1001-326-027	Right Spindle	5
F	1001-326-031	Lock Spindle Weldment, Rt.	1
G	1001-326-028	Left Spindle	5
H	1001-326-033	Lock Spindle Weldment, Lt.	1
J	1001-226-020	Siderail Spring Spacer	2
K	0025-172-000	Rivet	8
L	1010-226-082	Top Rail Bearing	12
M	1001-226-040	Top Rail Weldment, Right	1
N	1001-226-030	Top Rail Weldment, Left	1
P	0025-061-000	Semi-T ubular Rivet	12
R	1001-226-101	Plug Assembly	10
S	1001-226-102	Plug Assembly	2
T	1001-226-019	Rubber Stop	4
V	1001-226-063	Top Rail Cap	2
W	1001-226-100	End Cap Assembly	2
X	0037-215-000	Dome Plug	10
Y	0059-100-000	Dome Plug	2
Z	1001-226-163	Top Rail Retainer	2
AA	1001-226-162	Top Rail Handle	2
AB	1001-226-046	Latch Pivot, Right	1
AC	1001-226-047	Latch Pivot, Left	1
AD	0003-359-000	But. Hd. Cap Screw	4
AE	0016-1 18-000	Nylock Nut	6
AF	1001-226-142	Latch Pin	2
AG	0052-017-000	Washer	2
AH	1001-226-045	Latch Spacer	2
AJ	1001-226-152	Latch Plate Weldment, Rt.	1
AK	1001-226-153	Latch Plate Weldment, Lt.	1
AL	1001-226-158	Latch Cover	2
AM	0038-422-000	Extension Spring	2
AN	0025-181-000	Blind Rivet	2
AP	0007-070-000	Machine Screw	2

# Siderail to Litter Assembly, Fold-to-Foot

Assembly part number 1211-121-010 (reference only)

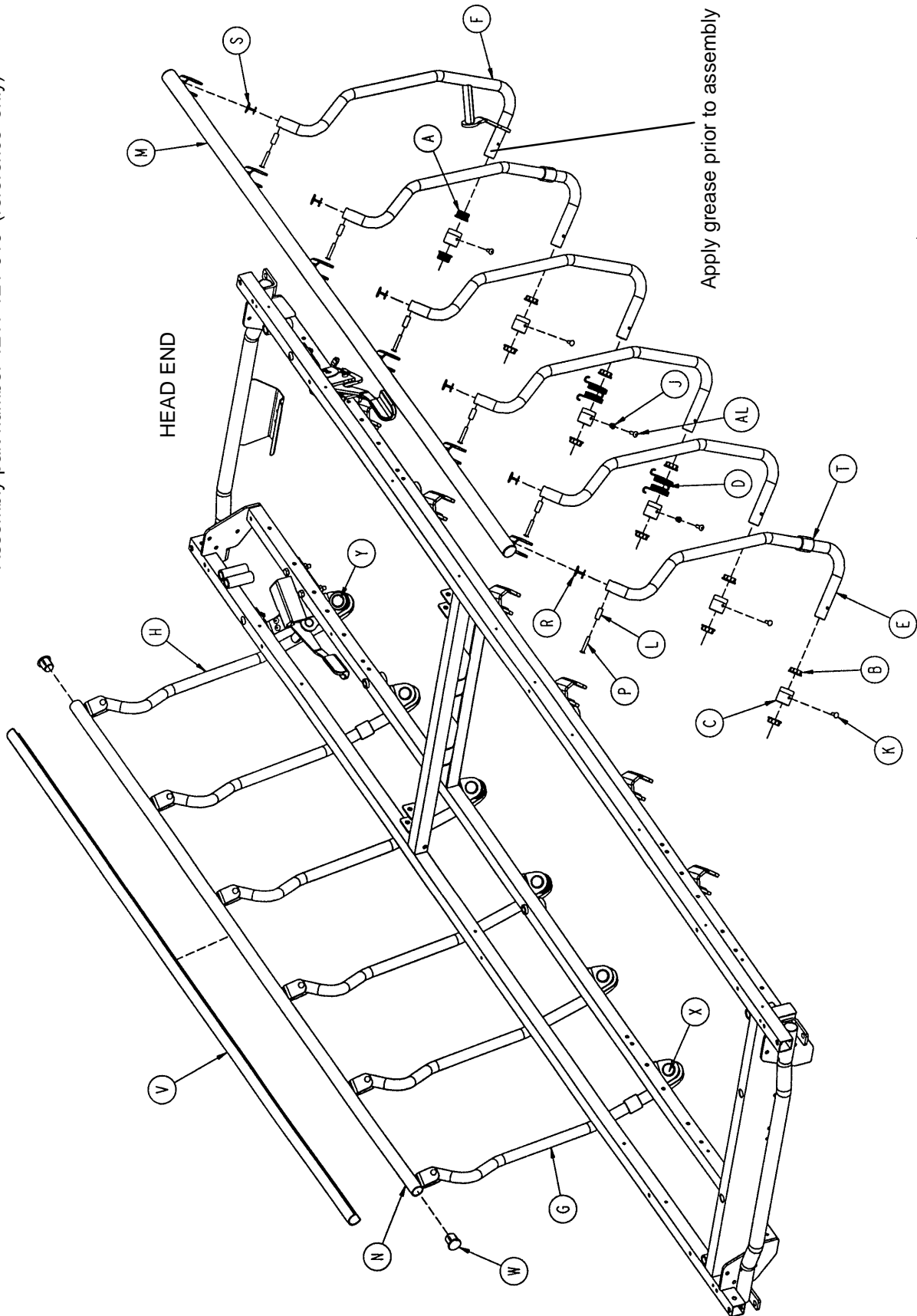

# Siderail to Litter Assembly, Fold-to-Foot

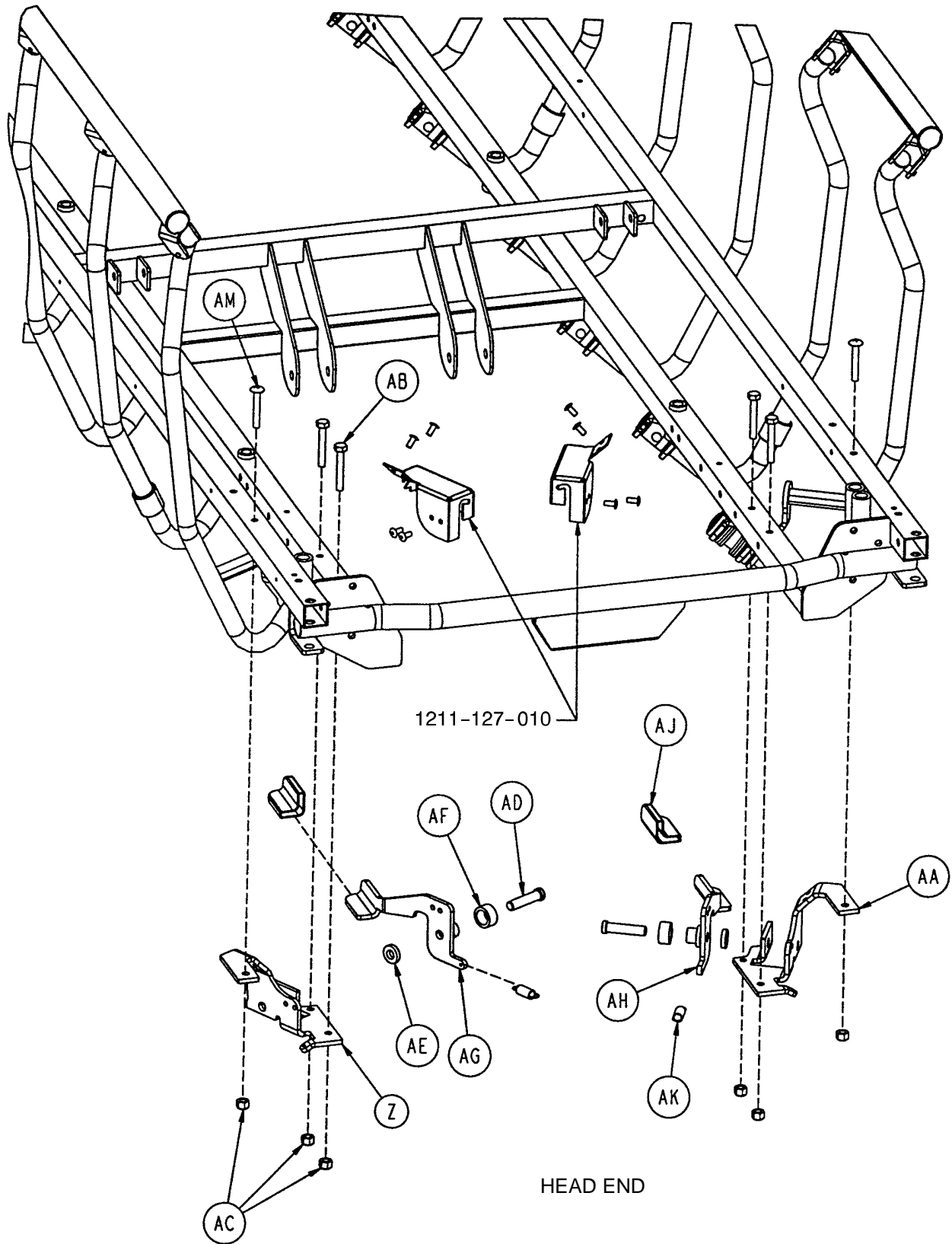

# Siderail to Litter Assembly, Fold-to-Foot

---

Item	Part No.	Part Name	Qty.
A	1001-226-116	Pivot Bearing	4
B	1001-226-016	Pivot Bearing	20
C	1001-226-015	Pivot Sleeve	12
D	1001-226-017	Siderail Spring	4
E	1001-326-027	Right Spindle	5
F	1001-326-031	Lock Spindle Weldment, Rt.	1
G	1001-326-028	Left Spindle	5
H	1001-326-033	Lock Spindle Weldment, Lt.	1
J	1001-226-020	Siderail Spring Spacer	4
K	0025-172-000	Semi-T ubular Rivet	8
L	1010-226-082	Top Rail Bearing	12
M	1001-226-140	Top Rail Weldment, Rt., FTF	1
N	1001-226-130	Top Rail Weldment, Lt., FTF	1
P	0025-061-000	Semi-T ubular Rivet	12
R	1001-226-101	Plug Assembly	10
S	1001-226-102	Plug Assembly	2
T	1001-226-019	Rubber Stop	4
V	1001-226-063	Top Rail Cap	2
W	1001-226-100	End Cap Assembly	4
X	0037-215-000	Dome Plug	10
Y	0059-100-000	Dome Plug	2
Z	1001-226-046	Right Latch Pivot	1
AA	1001-226-047	Left Latch Pivot	1
AB	0003-359-000	But. Hd. Cap Screw	4
AC	0016-118-000	Nylock Nut	6
AD	1001-226-142	Latch Pin	2
AE	0052-017-000	Washer	2
AF	1001-226-045	Latch Spacer	2
AG	1001-226-152	Latch Plate Weldment, Rt.	1
AH	1001-226-153	Latch Plate Weldment, Lt.	1
AJ	1001-226-158	Latch Cover	2
AK	0038-422-000	Extension Spring	2
AL	0025-181-000	Rivet	4
AM	0007-070-000	Machine Screw	2



# Pneumatic Fowler Assembly

Assembly part number 0660-031-010 (reference only)

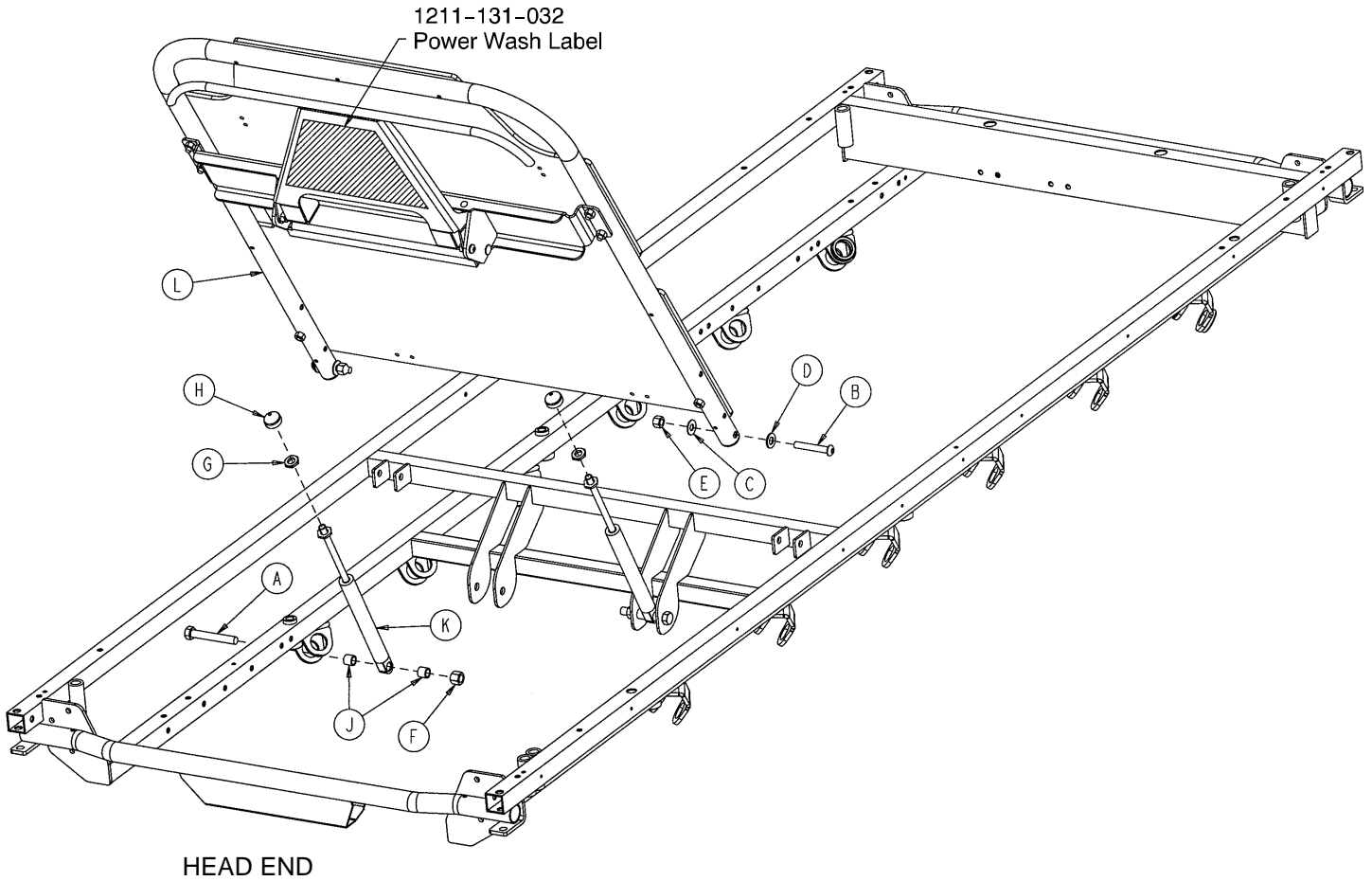

Item	Part No.	Part Name	Qty.
A	0003-360-000	Hex Hd. Cap Screw	2
B	0004-104-000	But. Hd. Cap Screw	2
C	0011-179-000	Washer	2
D	0014-021-000	Washer	2
E	0016-116-000	Hex Nut	2
F	0016-119-000	Hex Nut	2
G	0015-060-000	Metric Jam Nut	2
H	1211-131-026	Gas Spring Cap	2
J	0052-306-000	Washer	4
K	1010-031-077	Pneumatic Cylinder	2
L	(page 55)	Fowler Assembly	1

# Pneumatic Fowler Assembly

Assembly part number 1711-131-020 (reference only)

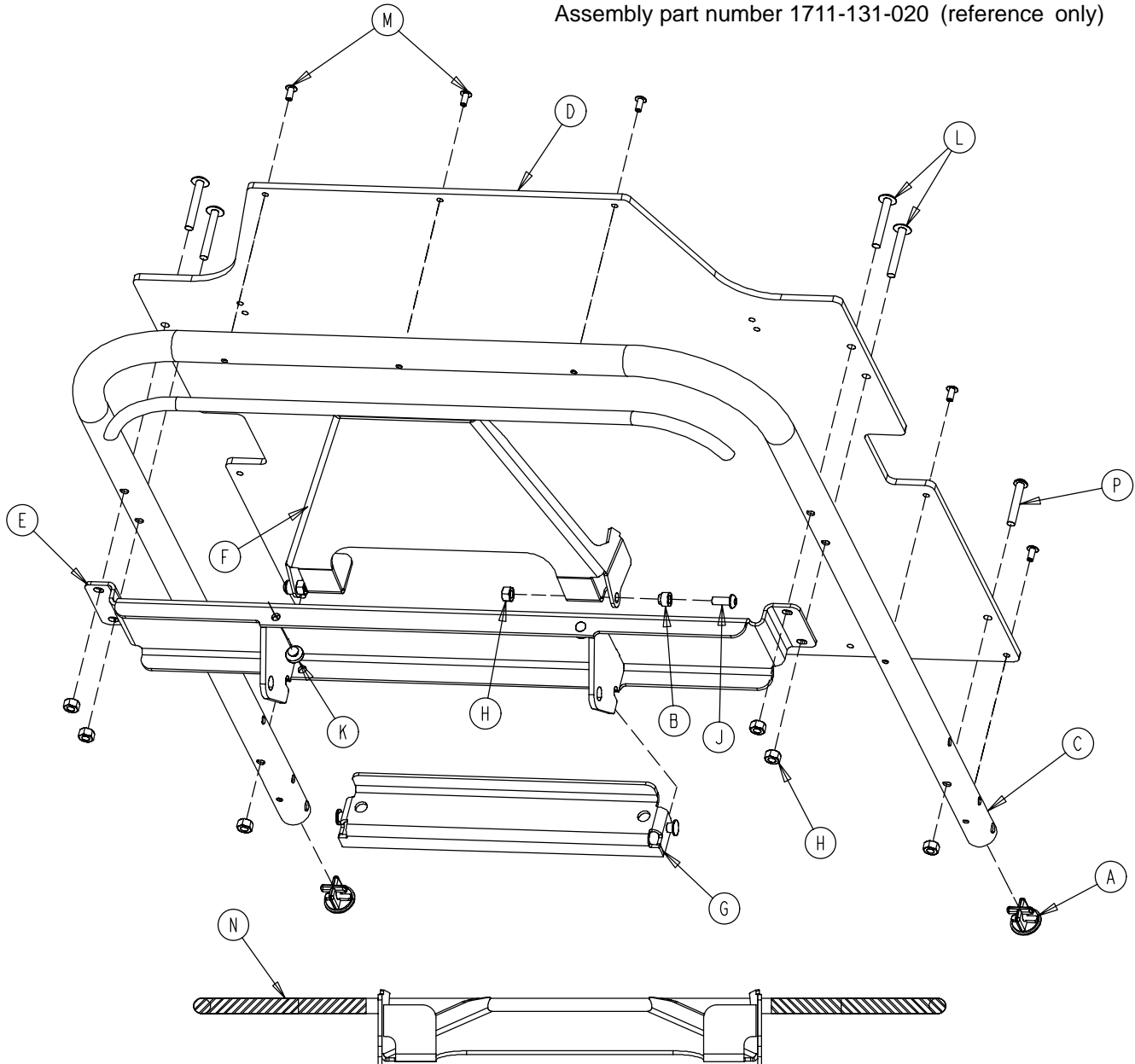

Item	Part No.	Part Name	Qty.	Item	Part No.	Part Name	Qty.
A	1001-001-036	Hole Plug	2	H	0016-1 18-000	Hex Nut	8
B	1211-231-025	Trip Bar Pivot	2	J	0004-455-000	But. Hd. Cap Screw	2
C	1501-031-013	Fowler Tube	1	K	0037-064-000	Grommet Bumper	2
D	1510-231-012	Fowler Skin (Fiberresin)	1	L	0007-070-000	Truss Hd. Mach. Screw	4
E	1711-131-014	Pneu. Pivot Bar Wldmt.	1	M	0025-172-000	Blind Rivet	7
F	1711-231-018	Trip Bar Weldment	1	N	1211-131-030	Handle Grip	2
G	1711-231-029	Gas Spring Mount Wldmt.	1	P	0004-135-000	But. Hd. Cap Screw	2



# Fiberresin Stationary Foot Section Assembly

Assembly part number (reference only):  
1731-019-001 - 29" Wide

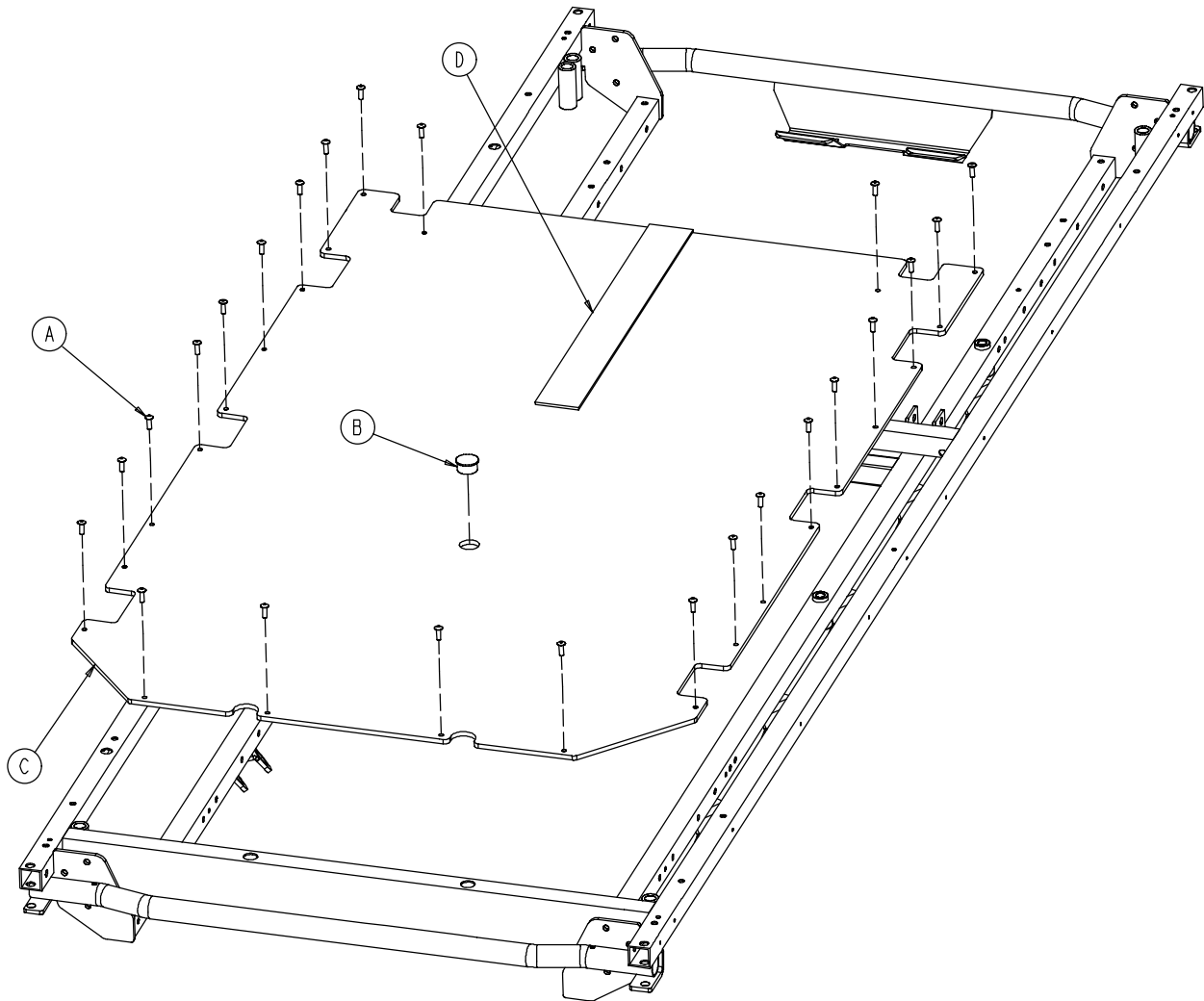

Item	Part No.	Part Name	Qty.
A	0025-171-000	Rivet	24
B	0037-208-000	Hole Plug	1
C	0753-010-032	29" Fiberresin Foot Section Skin	1
D	7900-001-102	Velcro Pile	24 1/2"

# 1711 Knee Gatch Assembly (Steel)

Assembly part number 1711-334-010 (reference only)

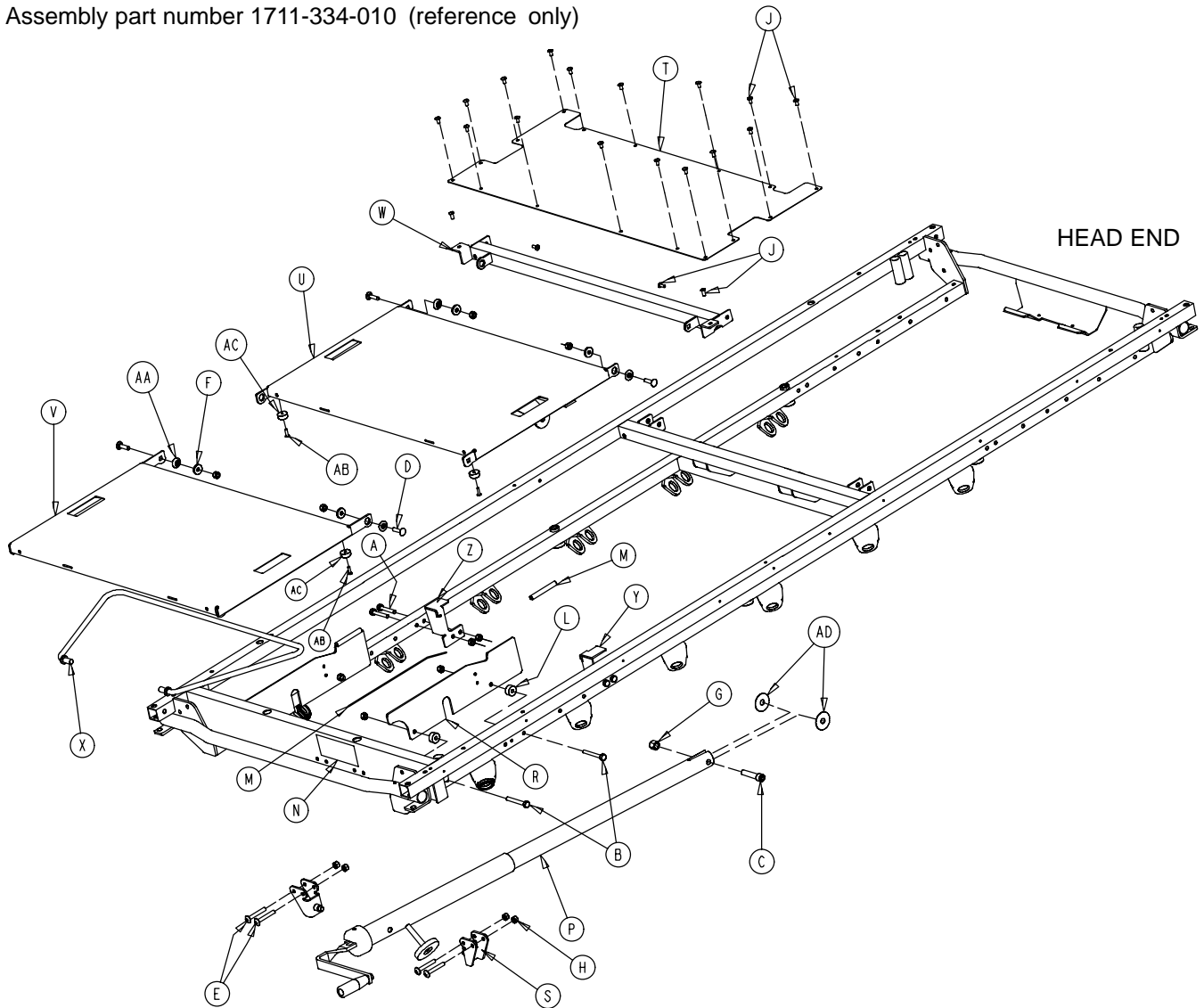

Item	Part No.	Part Name	Qty.	Item	Part No.	Part Name	Qty.
A	0003-355-000	Hex Hd. Cap Screw	4	R	1001-034-131	Slider Support	2
B	0003-358-000	Hex Hd. Cap Screw	4	S	1010-234-015	Mounting Bracket	2
C	0004-327-000	Soc. Hd. Cap Screw	1	T	1501-134-027	Midsection Skin	1
D	0005-034-000	Rd. Hd. Sq. Neck Bolt	4	U	1710-034-011	Thigh Section Wldmt.	1
E	0007-070-000	Truss Hd. Mach. Screw	4	V	1710-034-012	Calf Section Wldmt.	1
F	0011-159-000	Washer	4	W	1710-034-023	Midsection Supt. Wldmt.	1
G	0016-1 17-000	Flexlock Nut	1	X	1710-034-027	Calf Stand Bar	1
H	0016-1 18-000	Nylock Nut	16	Y	1211-234-025	Thigh Support, Right	1
J	0025-172-000	Blind Rivet	20	Z	1211-234-024	Thigh Support, Left	1
L	0052-291-000	Nylon Spacer	4	AA	3001-300-099	Modified Fowler Bushing	4
M	0058-056-000	Edge Cover	2'	AB	0026-157-000	Blind Rivet	4
N	0946-01-065	Knee Gatch Label	1	AC	0056-019-000	Bumper	4
P	(page 58)	Gatch Crankscrew Ass'y	1	AD	0011-351-000	Washer	2

# 1001-134-019 Knee Gatch Crankscrew Assembly

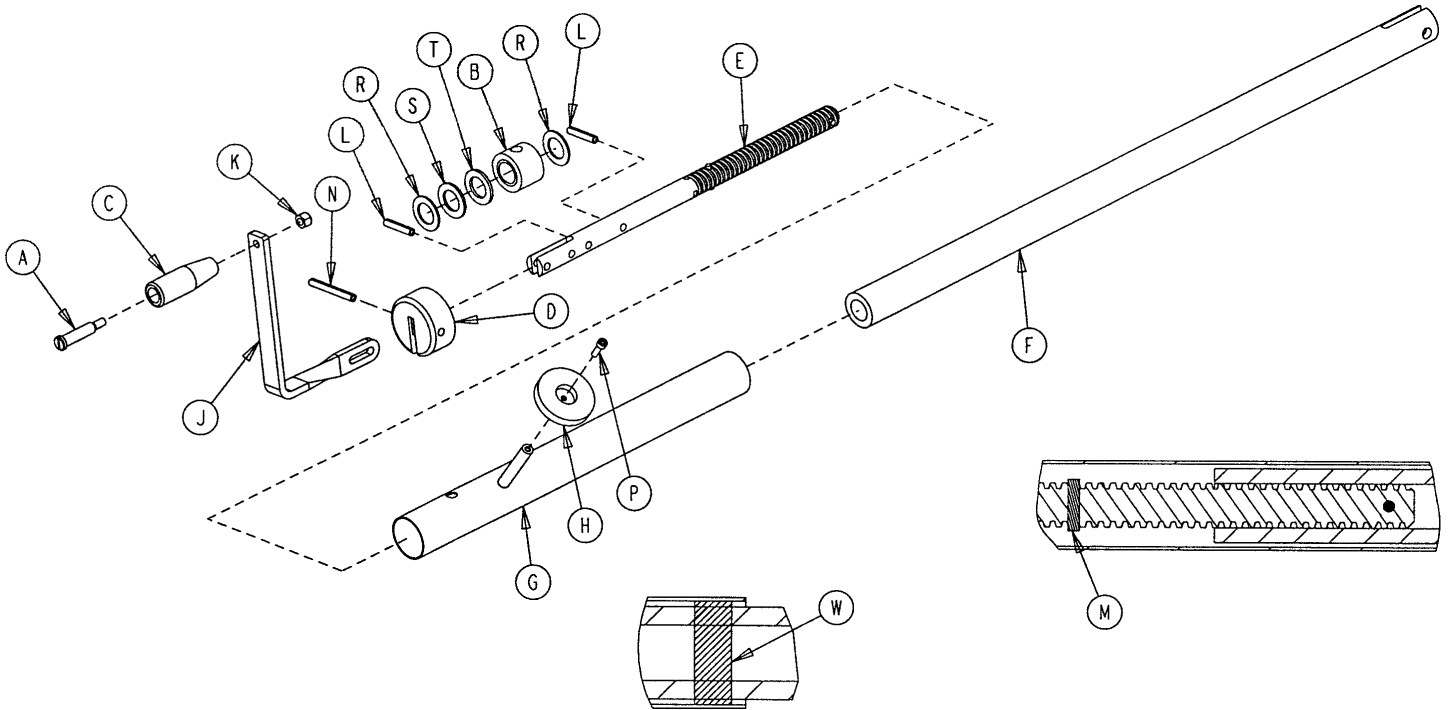

Item	Part No.	Part Name	Qty.
A	0378-124-029	Shoulder Bolt	1
B	0938-001-175	Bearing Assembly	1
C	0938-001-177	Knob	1
D	0946-033-018	Crank Disk	1
E	1001-134-047	Knee Gatch Screw	1
F	1510-034-055	Gatch Drive Tube Assembly	1
G	1510-034-084	Screw Cover Assembly	1
H	1550-001-014	Magnet	1
J	1550-001-016	Crank Assembly	1
K	0016-118-000	Nylock Nut	1
L	0026-014-000	Spring Pin	2
M	0026-043-000	Spring Pin	2
N	0026-145-000	Spring Pin	1
P	0004-107-000	Soc. Head Cap Screw	1
R	0081-174-000	Thrust Washer	2
S	0081-175-000	Thrust Bearing	1
T	0081-176-000	Thrust Washer	1
W	7900-001-102	Velcro Pile Tape	2

# Patient Transfer System to Litter Assembly

Assembly part number 1211-132-003 (reference only)

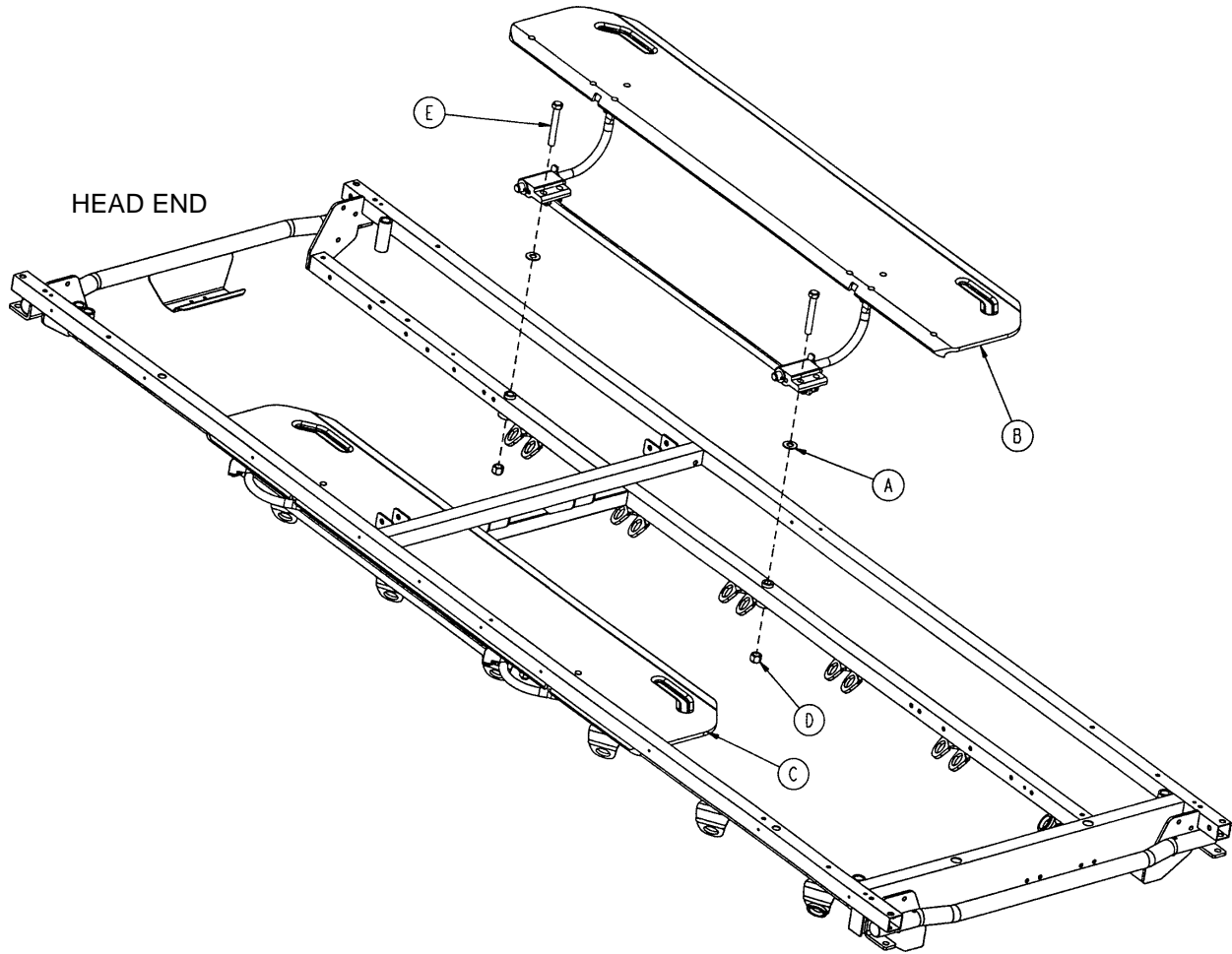

Item	Part No.	Part Name	Qty.
A	0011-418-000	Washer	4
B	(page 60)	Transfer System Ass'y, Lt.	1
C	(page 61)	Transfer System Ass'y, Rt.	1
D	0016-119-000	Nylock Nut	4
E	0003-360-000	Hex Hd. Cap Screw	4

# 1211-232-007 Patient Transfer System Assembly, Left

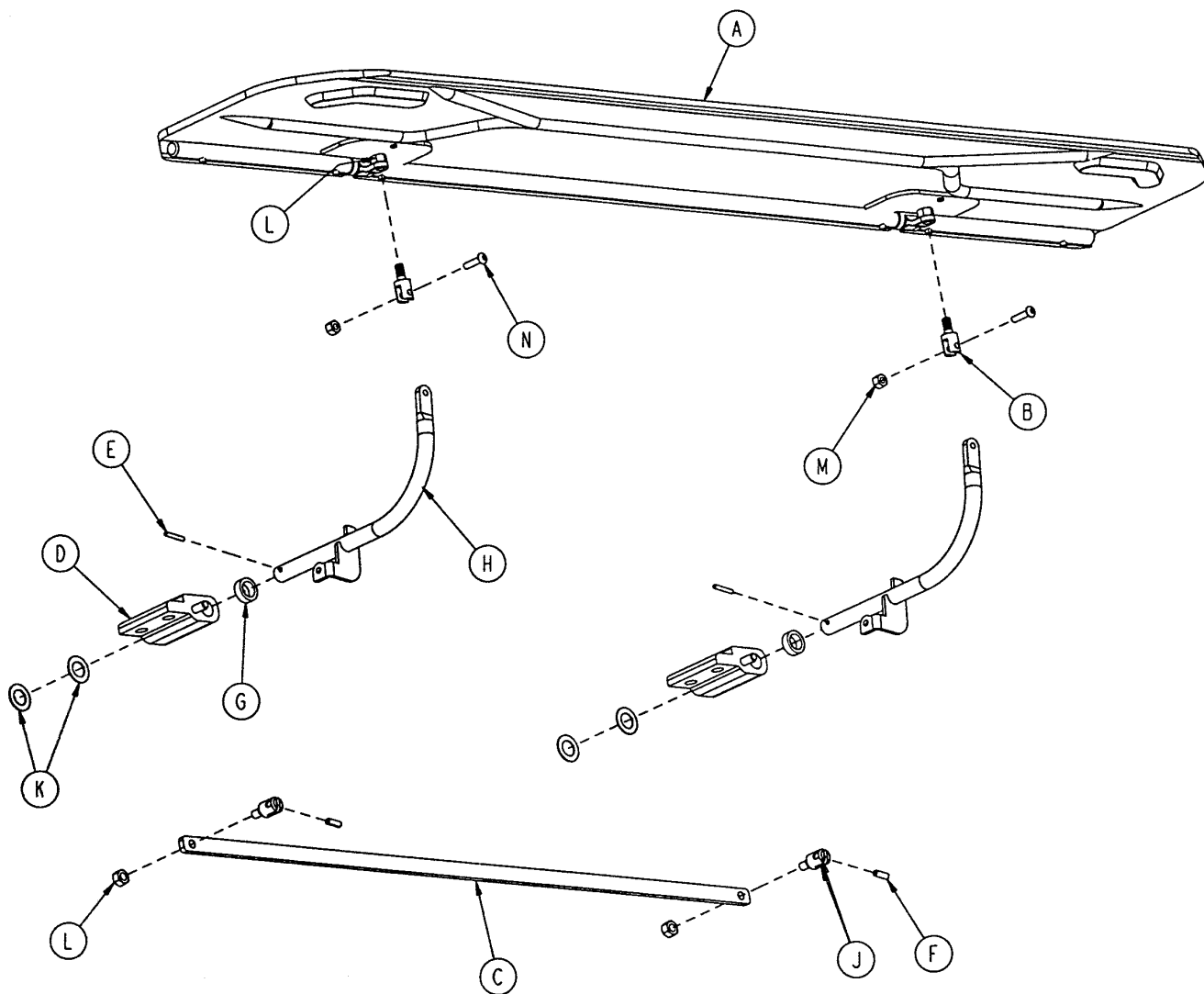

Item	Part No.	Part Name	Qty.
A	(page 62)	Transfer Board Assembly	1
B	1211-132-016	Transfer Board Swivel	2
C	1211-132-020	Transfer Board Link	1
D	1211-132-031	Transfer Bd. Pivot Ass'y, Lt.	2
E	0026-076-000	Spring Pin	2
F	0026-1 12-000	Spring Pin	2
G	0011-350-000	Washer	2
H	1211-232-011	Transfer Bd. Arm Wldmt.	2
J	1211-132-029	Link Swivel	2
K	0014-007-000	Washer	4
L	0016-1 18-000	Fiberlock Nut	4
M	0016-121-000	Fiberlock Nut	2
N	0004-456-000	Button Hd. Cap Screw	2

# 1211-232-008 Patient Transfer System Assembly, Right

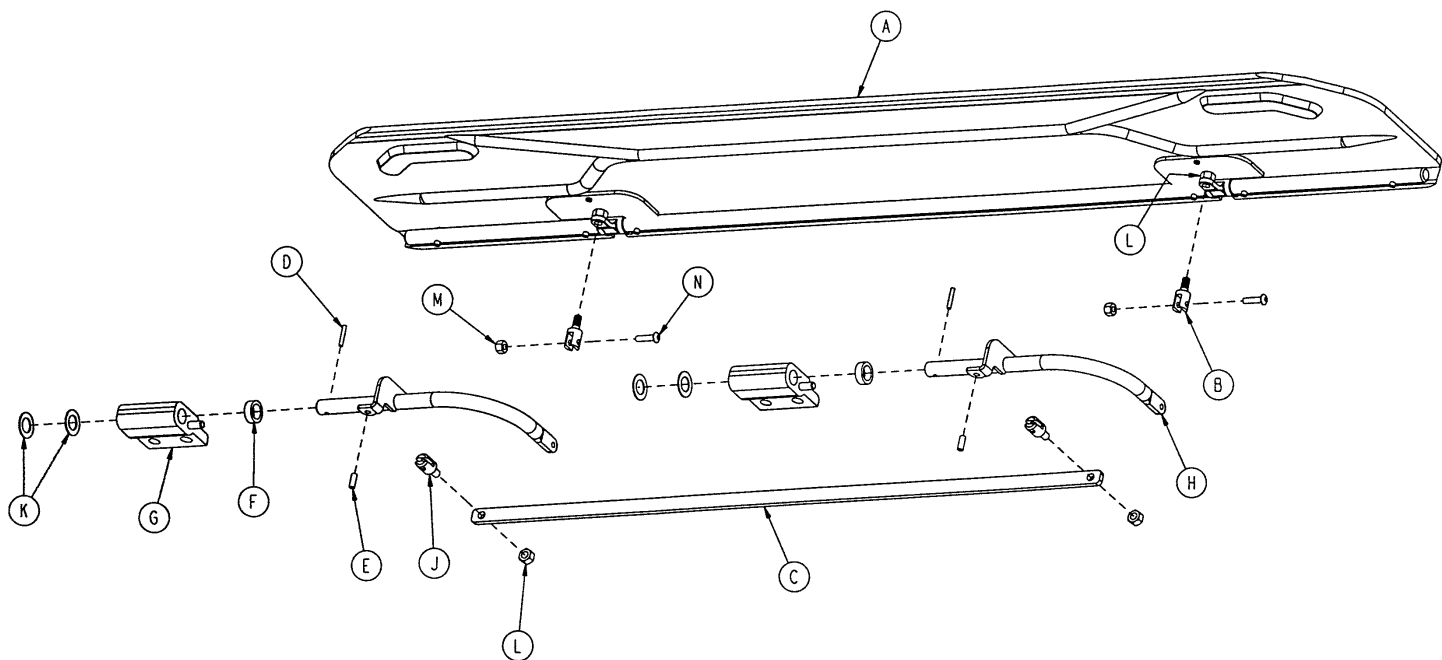

Item	Part No.	Part Name	Qty.
A	(page 62)	Transfer Board Assembly	1
B	1211-132-016	Transfer Board Swivel	2
C	1211-132-020	Transfer Board Link	1
D	0026-076-000	Roll Pin	2
E	0026-112-000	Roll Pin	2
F	0011-350-000	Washer	2
G	1211-132-030	Transfer Bd. Pivot Ass'y, Rt.	2
H	1211-232-012	Transfer Bd. Arm Wldmt.	2
J	1211-132-029	Link Swivel	2
K	0014-007-000	Washer	4
L	0016-118-000	Fiberlock Nut	4
M	0016-121-000	Fiberlock Nut	2
N	0004-456-000	Button Hd. Cap Screw	2

# 1211-132-009 Transfer Board Assembly

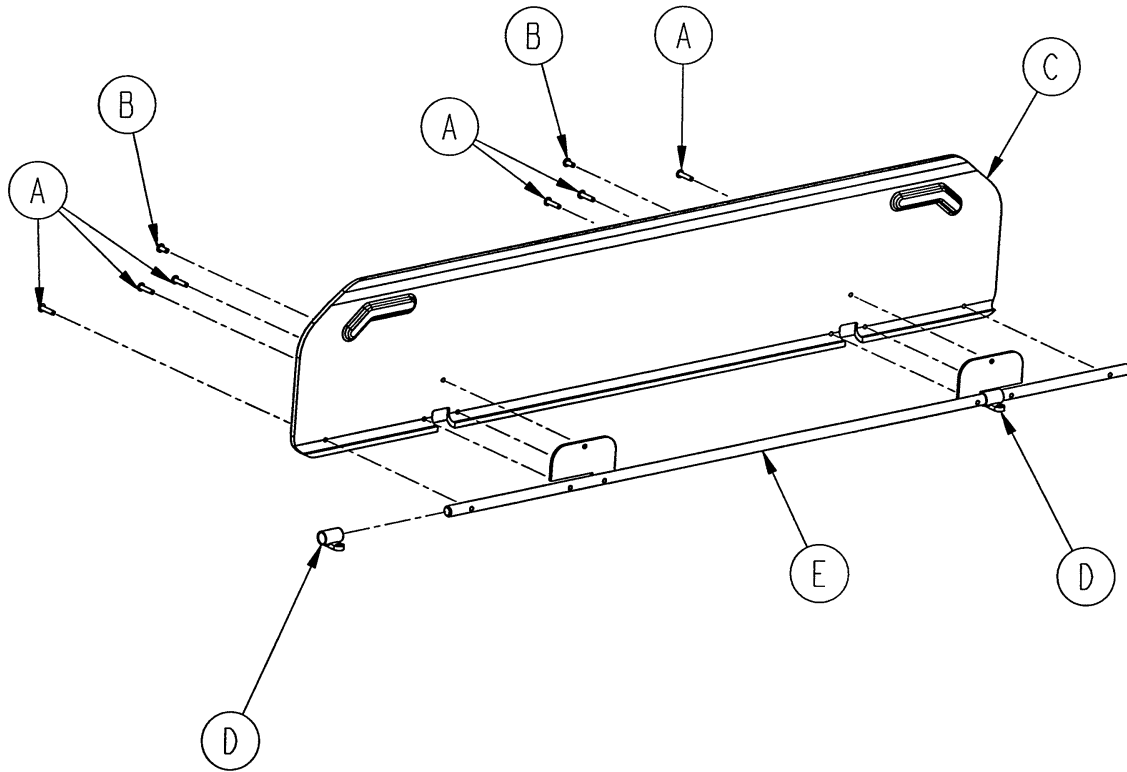

Item	Part No.	Part Name	Qty.
A	0025-125-000	Pop Rivet	6
B	0025-126-000	Pop Rivet	2
C	1211-132-004	Transfer Board	1
D	1211-132-017	Transfer Bd. Sleeve Wldmt.	2
E	1211-132-019	Stiffener Weldment	1

# 1211-151-000 Foot End Steering Handles Assembly

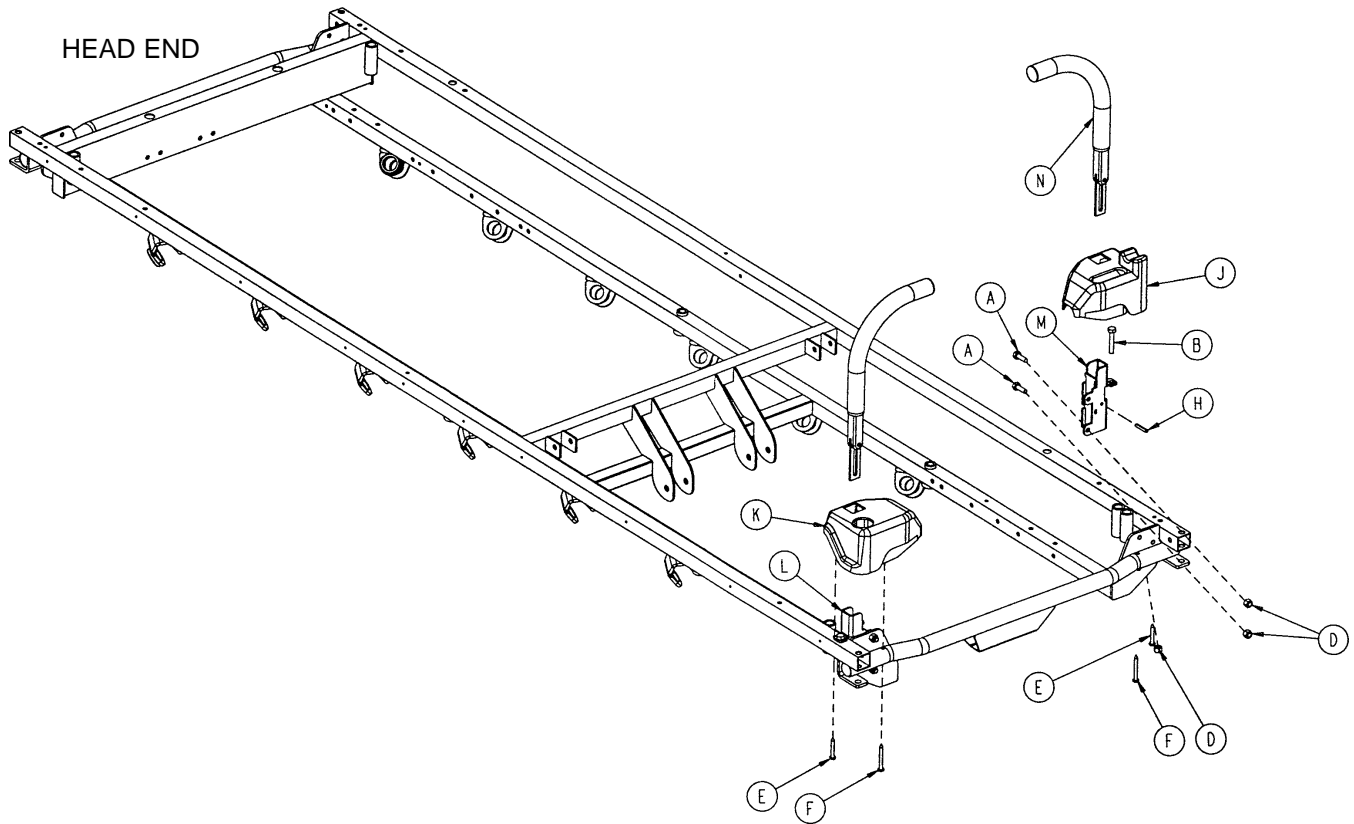

Item	Part No.	Part Name	Qty.
A	0003-356-000	Hex Hd. Cap Screw	4
B	0003-355-000	Hex Hd. Cap Screw	2
D	0016-1 18-000	Fiberlock Nut	6
E	0023-282-000	Self-Tapping Screw	2
F	0023-283-000	Self-Tapping Screw	2
H	0026-1 14-000	Roll Pin	2
J	1211-030-034	Cover, Hole/Slot	1
K	1211-030-037	Cover, Hole/Hole	1
L	1211-351-004	P.U.P. Receptacle Wldmt., Lt.	1
M	1211-351-006	P.U.P. Receptacle Wldmt., Rt.	1
N	(page 65)	Push Handle Ass'y	2



# 1711-151-000 Head End Steering Handles Assembly

---

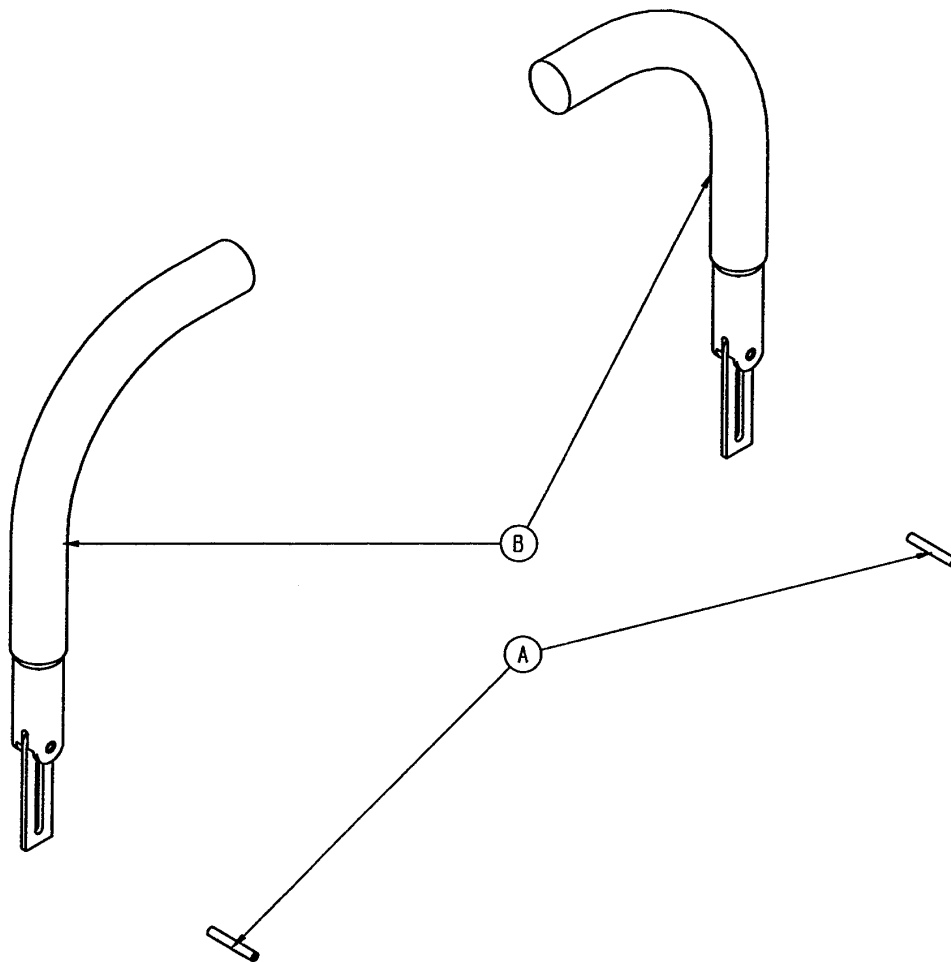

Item	Part No.	Part Name	Qty.
A	0026-1 14-000	Roll Pin	2
B	(page 65)	Push Handle Assembly	2

# 1211-351-010 Push Handle Assembly

---

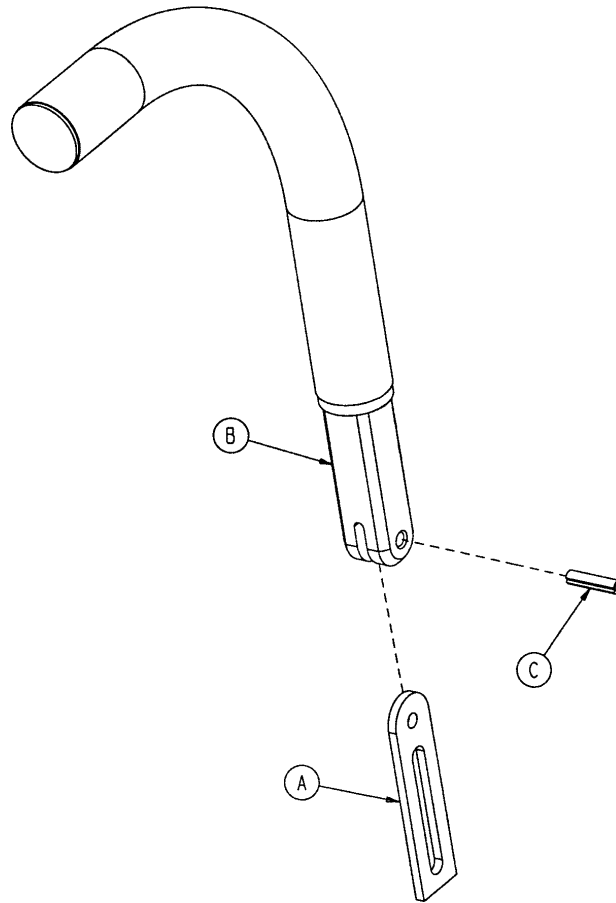

Item	Part No.	Part Name	Qty.
A	1010-354-024	Stop Link	1
B	1211-151-018	Sleeve Assembly	1
C	0026-1 18-000	Roll Pin	1

# 0390-025-000 Standard, Removable I.V. Pole Assembly

Item	Part No.	Part Name	Qty.
A	0024-023-000	Plastic Knob	1
B	0390-003-053	Double I.V. Ass'y	1
C	0393-003-043	Tube Assembly	1
D	0004-496-000	Soc. Hd. Cap Screw	1

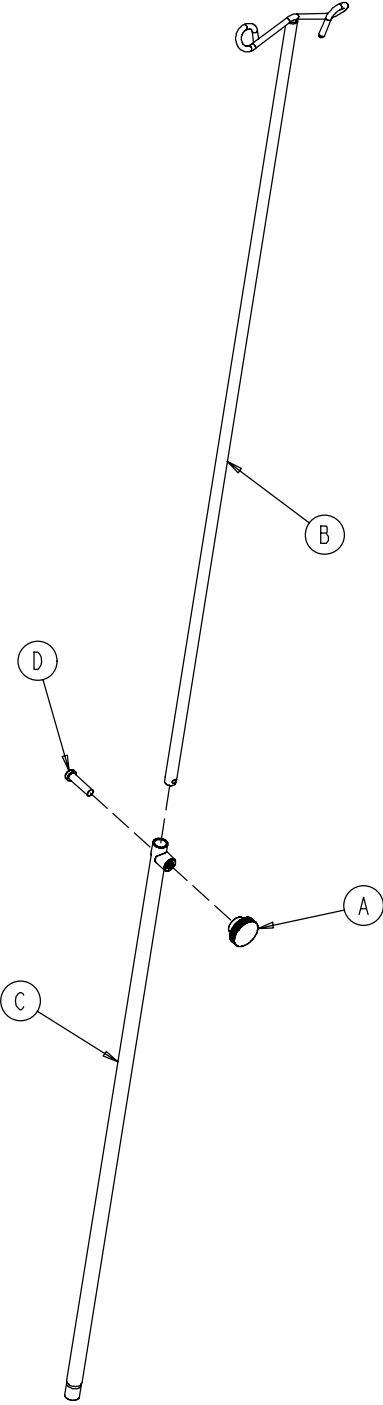

# 1711-117-000 Optional Tethered I.V. Assembly

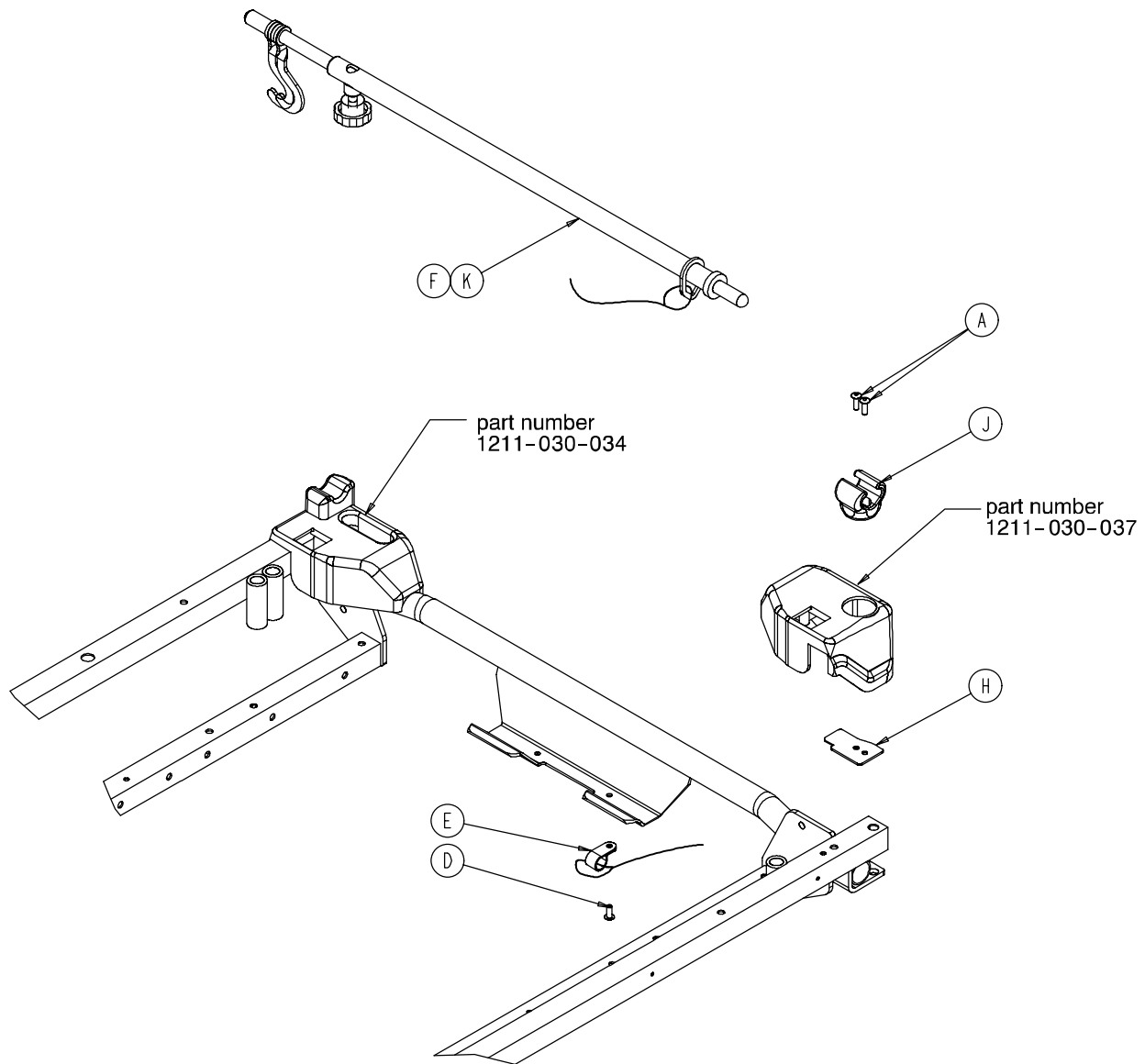

Item	Part No.	Part Name	Qty.
A	0025-133-000	Dome Head Rivet	2
D	0025-179-000	Closed End Rivet	1
E	0034-022-000	Cord Clamp	1
F	(page 68)	Tethered I.V. Pole Assembly	1
H	1211-1 17-021	Backing Plate	1
J	1211-1 17-022	I.V. Clip	1
K	1501-127-019	I.V. Plug	1

# 1211-117-010 Tethered I.V. Pole Assembly

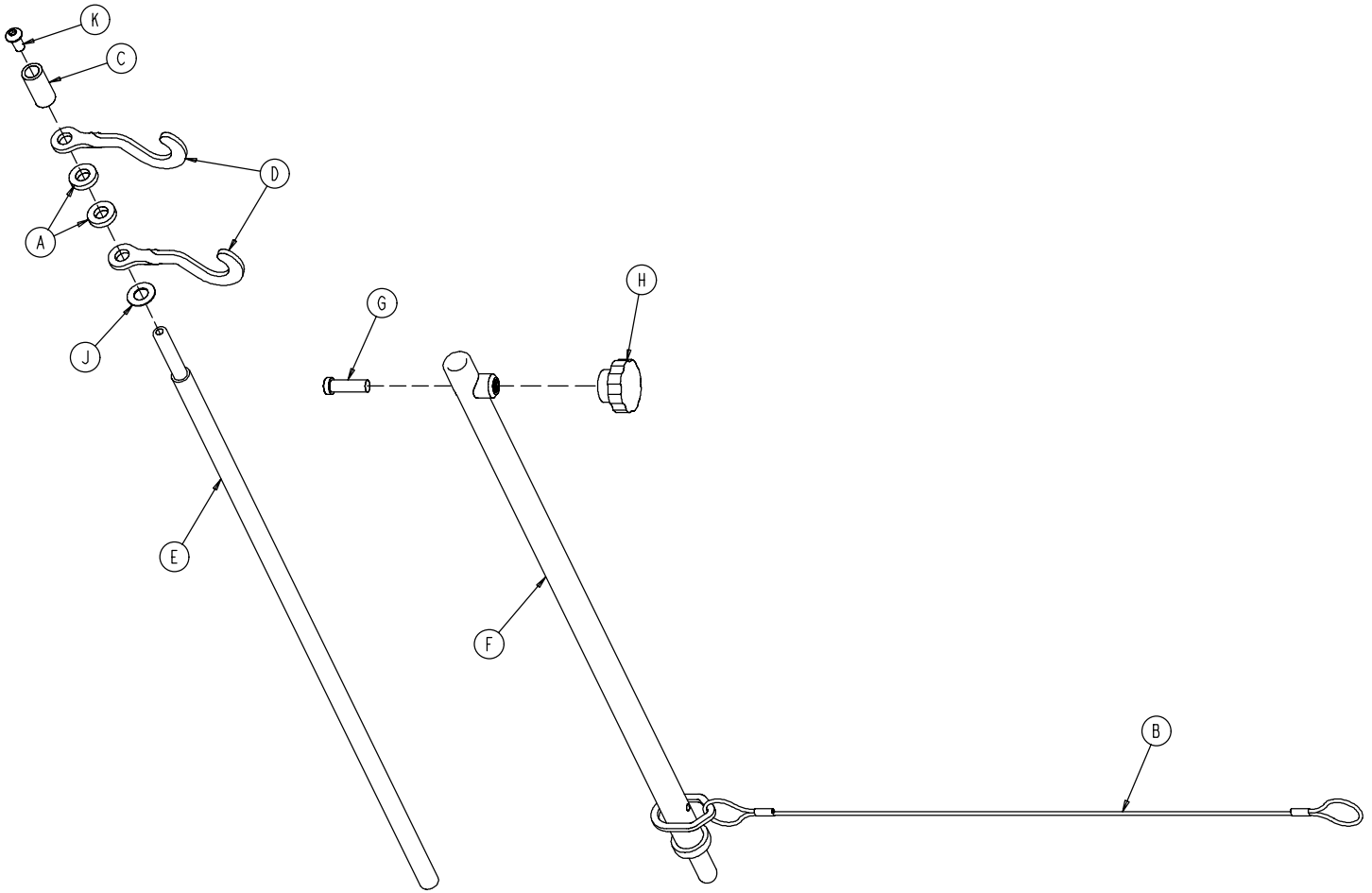

Item	Part No.	Part Name	Qty.
A	0052-017-000	Spacer	2
B	1211-1 17-020	Cable Assembly	1
C	0926-400-062	Stop Sleeve	1
D	1010-059-016	I.V. Hook	2
E	1211-1 17-011	Extension Rod	1
F	1211-1 17-012	Base Tube Weldment	1
G	0004-495-000	Low Hd. Soc. Hd. Cap Screw	1
H	1211-1 17-016	Knob	1
J	0014-020-000	Nylon Washer	1
K	0004-232-000	Button Hd. Cap Screw	1

# Optional 2-Stage I.V. Pole Mounting Assembly

Assembly part numbers  
 1711-1 10-000 (Head End) - 1731  
 1711-1 12-000 (Foot End) - 1731

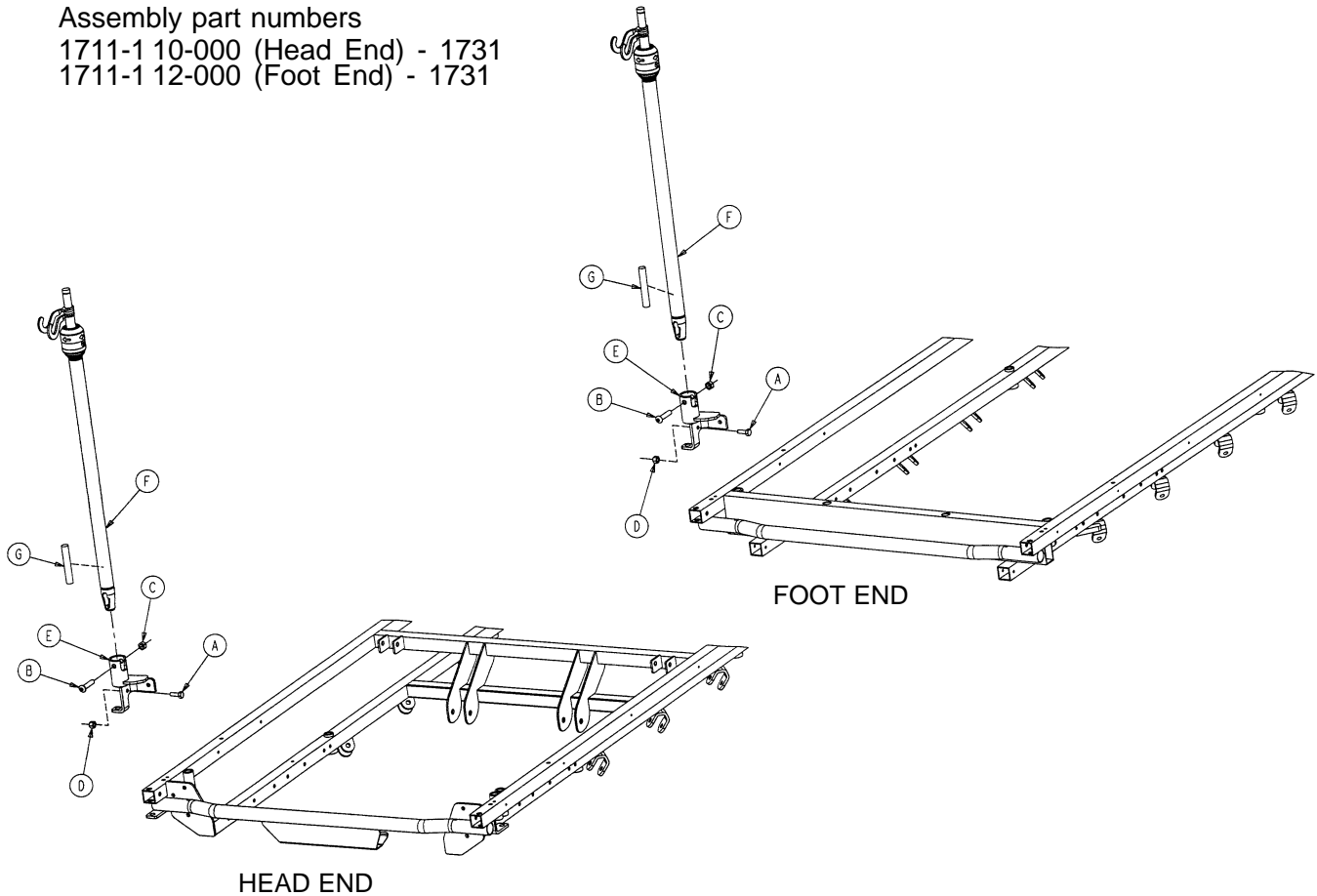

Item	Part No.	Part Name	Qty.
A	0003-356-000	Hex Hd. Cap Screw	1
B	0004-452-000	But. Hd. Cap Screw	1
C	0016-1 16-000	Fiberlock Nut	1
D	0016-1 18-000	Fiberlock Nut	1
E	1211-310-112	I.V. Pivot Weldment	1
F	(page 70)	I.V. Pole Assembly	1
G	1501-127-019	I.V. Plug	1

# 1211-210-010 Optional 2-Stage I.V. Pole Assembly

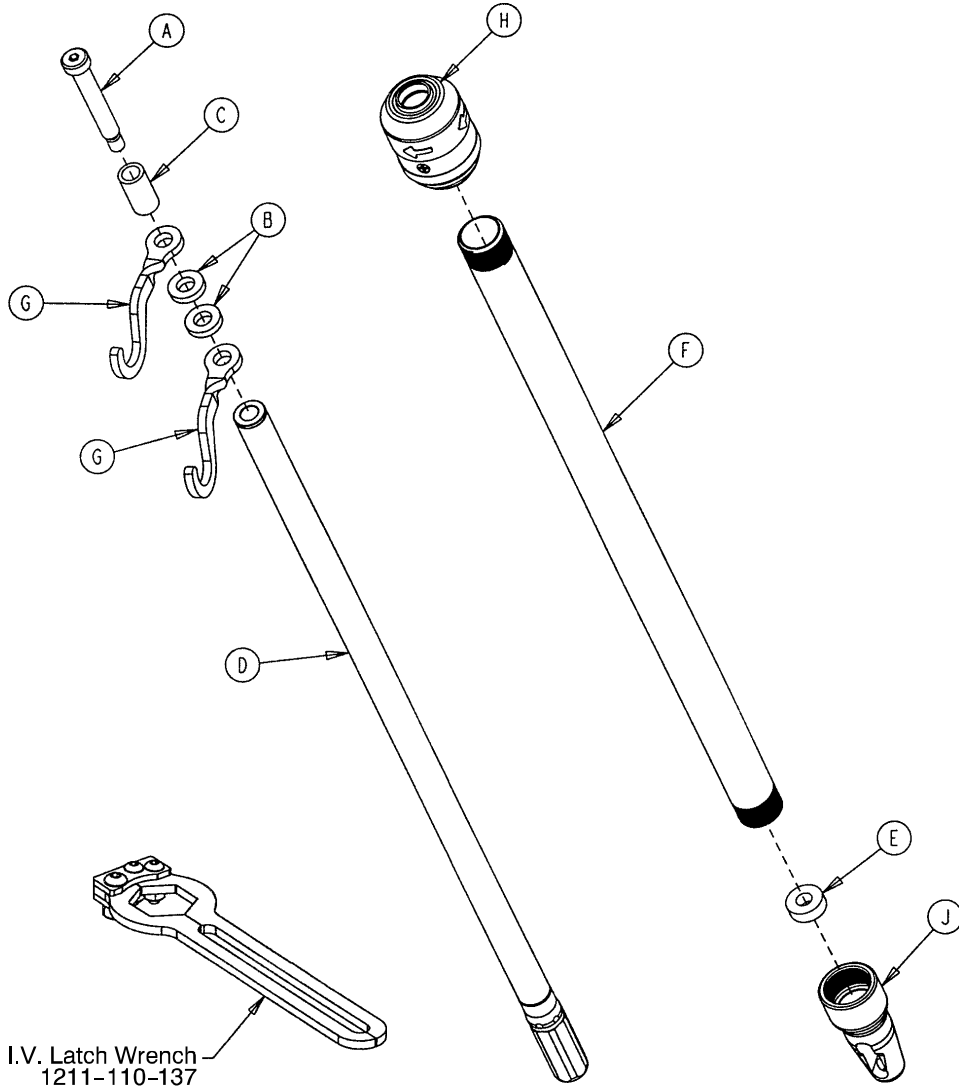

I.V. Latch Wrench  
1211-110-137

Item	Part No.	Part Name	Qty.
A	0008-031-000	Soc. Hd. Cap Screw	1
B	0052-017-000	Washer	2
C	0926-400-162	Spacer	1
D	1211-210-029	2nd Stage Assembly	1
E	1001-359-013	Dampener	1
F	1001-159-028	Base Tube	1
G	1010-259-016	I.V. Hook	2
H	(page 71)	I.V. Pole Latch	1
J	1001-359-112	Pivot	1

# 1211-210-026 I.V. Pole Latch Assembly

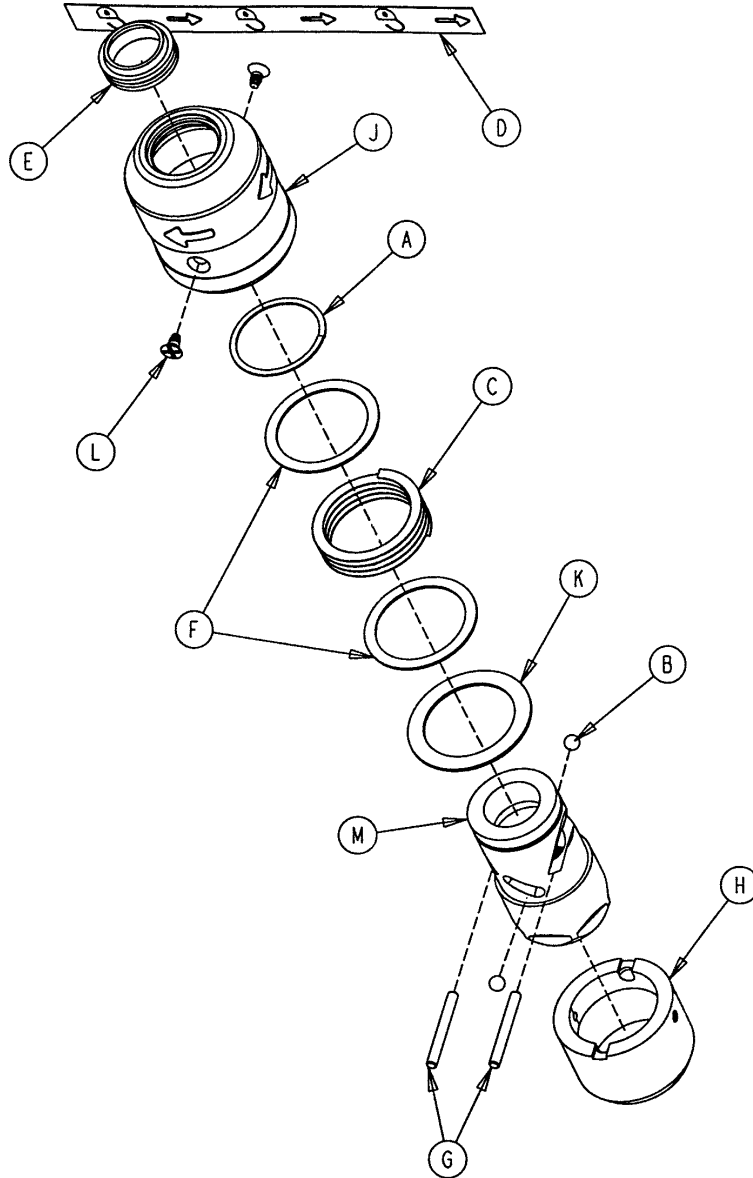

Item	Part No.	Part Name	Qty.
A	0028-167-000	Retaining Ring	1
B	0031-004-000	Steel Ball	2
C	0038-392-000	Crest-to-Crest Spring	1
D	1211-091-034	Release Label	1
E	1211-1 10-018	I.V. Latch Seal	1
F	1211-1 10-020	Washer	2
G	1211-1 10-021	I.V. Latch Locking Pin	2
H	1211-1 10-022	I.V. Latch Guide	1
J	1211-1 10-024	I.V. Latch O.D. Housing	1
K	1211-1 10-035	Washer	1
L	1211-1 10-036	Self-Tapping Screw	2
M	1211-210-023	I.V. Latch I.D. Housing	1



# Optional 3-Stage I.V. Pole Mounting Assembly

Assembly part numbers  
 1711-1 11-000 (Head End) - 1711  
 1711-1 13-000 (Foot End) - 1711

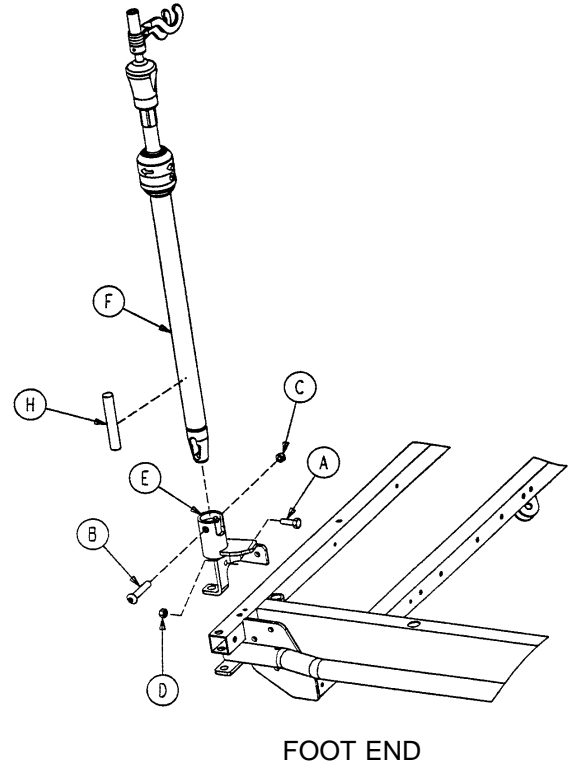
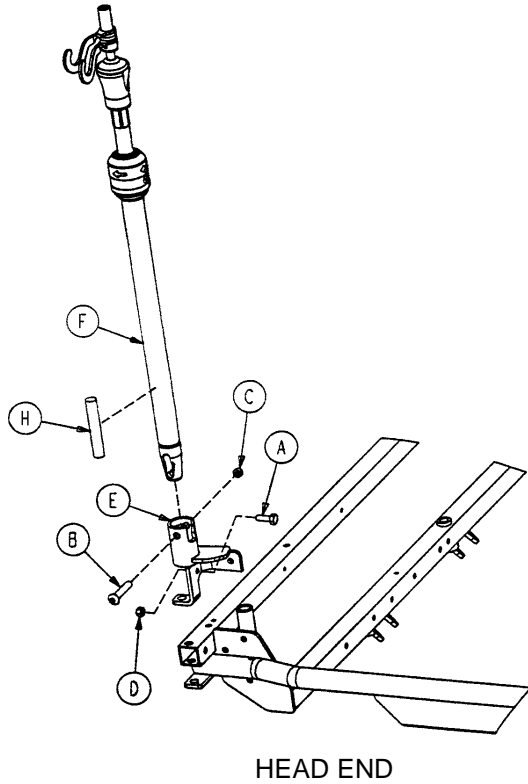

Item	Part No.	Part Name	Qty.
A	0003-356-000	Hex Hd. Cap Screw	1
B	0004-452-000	But. Hd. Cap Screw	1
C	0016-1 16-000	Flexlock Nut	1
D	0016-1 18-000	Fiberlock Nut	1
E	1211-310-112	I.V. Pivot	1
F	(page 73)	I.V. Pole Assembly	1
H	1501-127-019	Plug	1

# 1211-211-010 Optional 3-Stage I.V. Pole Assembly

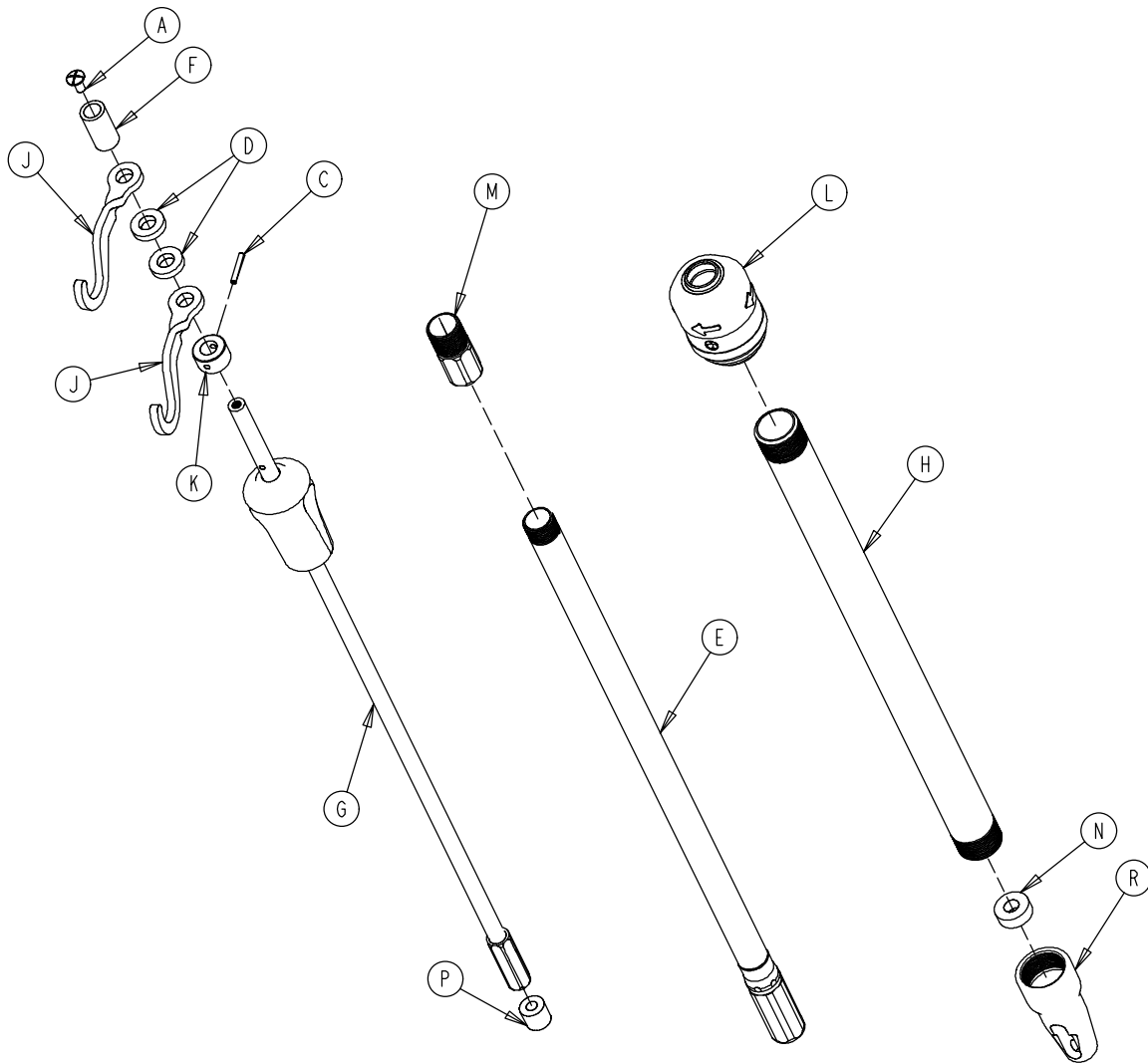

Item	Part No.	Part Name	Qty.
A	0007-004-000	Truss Hd. Machine Screw	1
C	0026-076-000	Roll Pin	1
D	0052-017-000	Spacer	2
E	1211-210-031	2nd Stage Assembly	1
F	0926-400-162	Spacer	1
G	(page 74)	3rd Stage Assembly	1
H	1001-161-023	Base Tube	1
J	1010-259-016	I.V. Hook	2
K	1010-061-014	Collar	1
L	(page 71)	I.V. Pole Latch	1
M	1211-110-016	Threaded Adaptor	1
N	1001-359-013	Dampener	1
P	1001-359-014	Dampener	1
R	1001-359-112	Pivot	1

# 3-Stage I.V. Pole 3rd Stage Assembly

Assembly part number 1211-1 10-032  
(reference only)

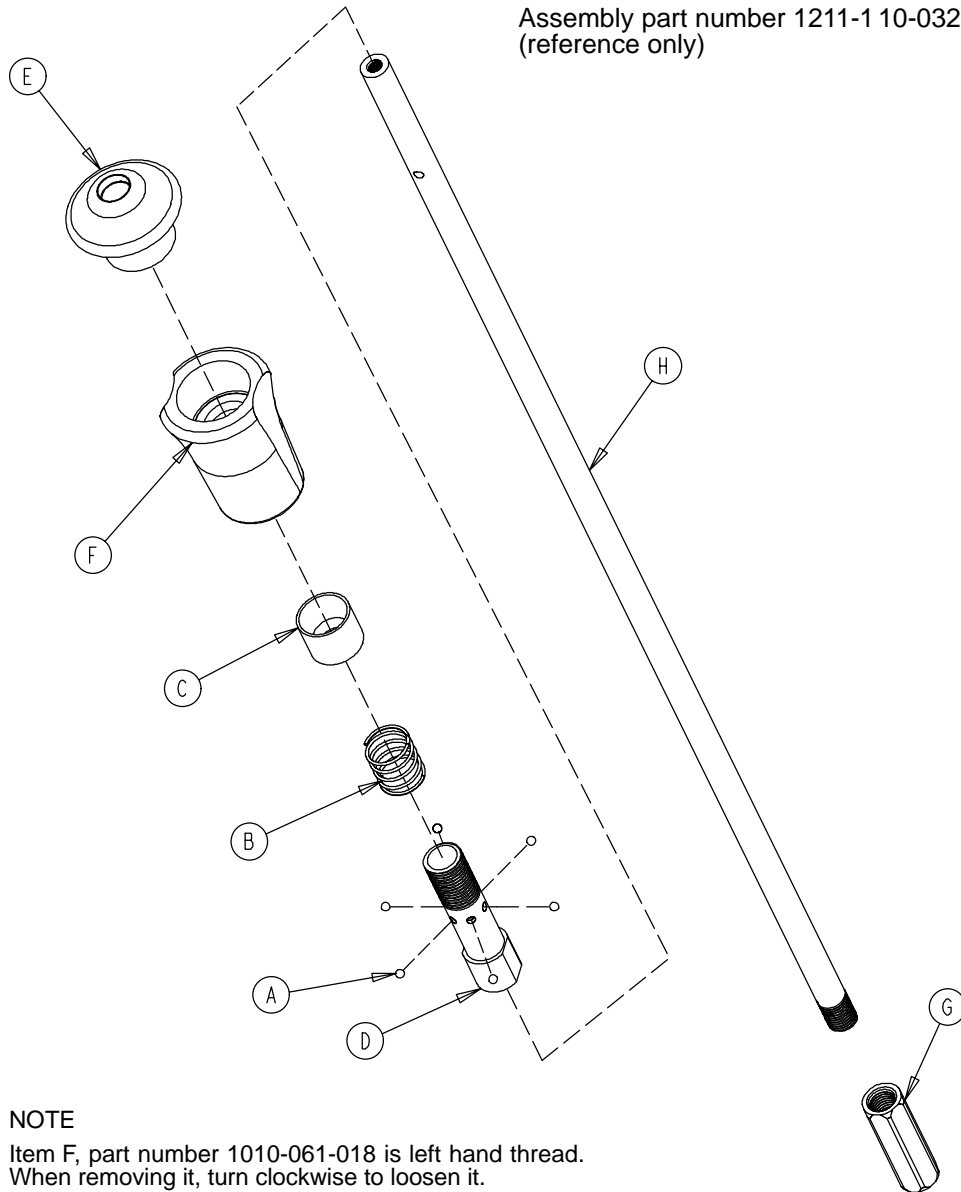

Item	Part No.	Part Name	Qty.
A	0031-021-000	Ball	6
B	0038-303-000	Compression Spring	1
C	1010-061-013	Ball Retainer	1
D	1010-061-016	Retaining Shaft	1
E	1010-061-017	Thumb Knob	1
F	1010-061-018	Hand Guard	1
G	1211-1 10-117	Nut	1
H	1211-1 10-033	3rd Extension Rod	1

# 0926-039-000 Optional Defibrillator Tray Assembly

Assembly part number 0926-039-010  
(reference only)

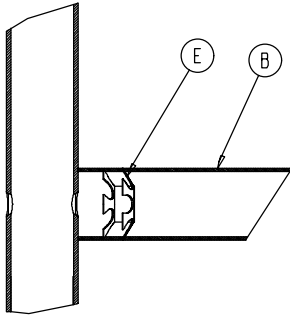

Umbrella Nut/Crosstube Detail

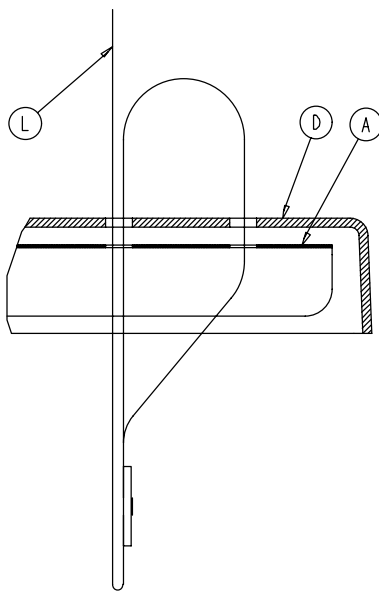

Strap Securing Detail

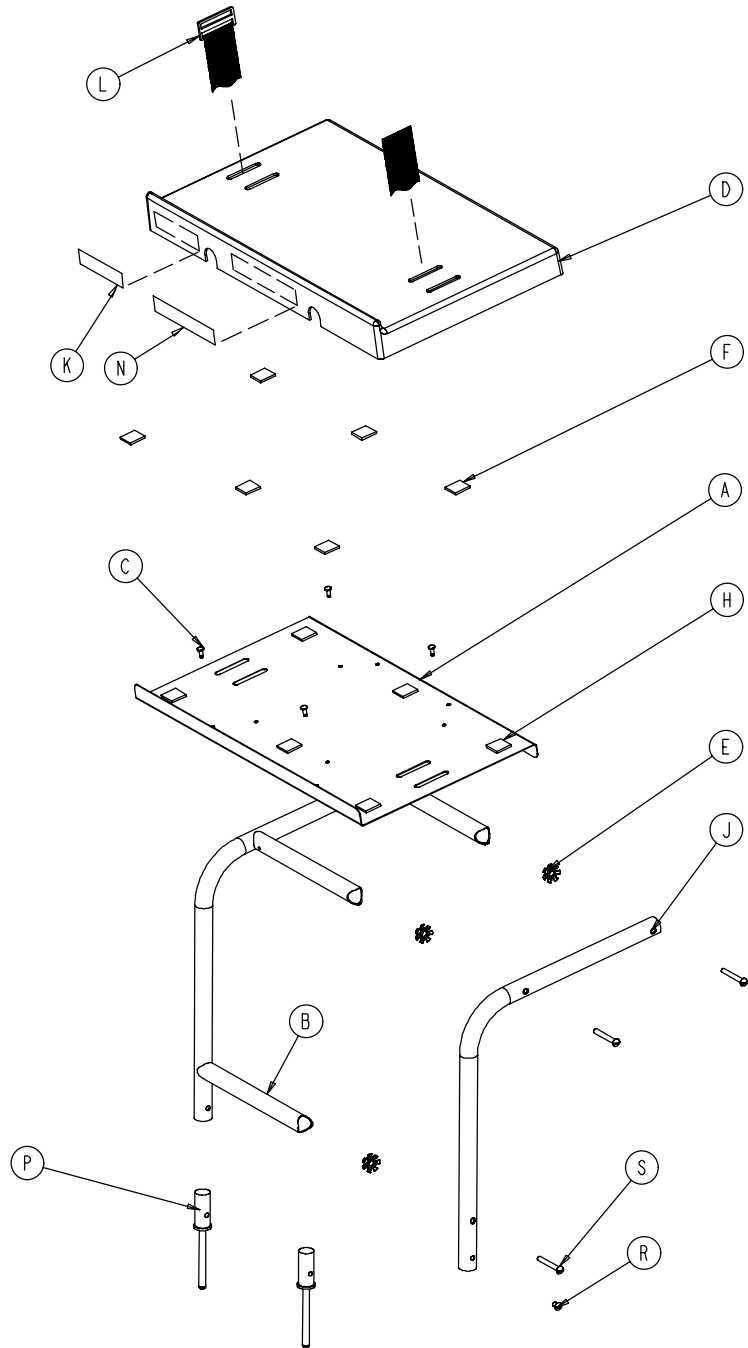

Item	Part No.	Part Name	Qty.	Item	Part No.	Part Name	Qty.
A	0946-039-004	Tray	1	J	0946-039-003	Support Tube	2
B	0926-039-016	Crosstube	3	K	0926-001-082	Label	1
C	0025-055-000	Rivet	4	L	1010-050-021	Long Strap	1
D	0926-039-009	Cover	1	N	0946-001-283	Label	1
E	0018-006-000	Umbrella Nut	6	P	0926-039-015	Holder	2
F	0029-008-000	Dual Lock	6	R	0002-044-000	Screw	2
H	0029-010-000	Dual Lock	6	S	0002-105-000	Rd. Hd. Mach. Screw	6

# 1010-050-100 Foot Extension/Defibrillator Tray Ass'y

Assembly part number 1010-050-210 (reference only)

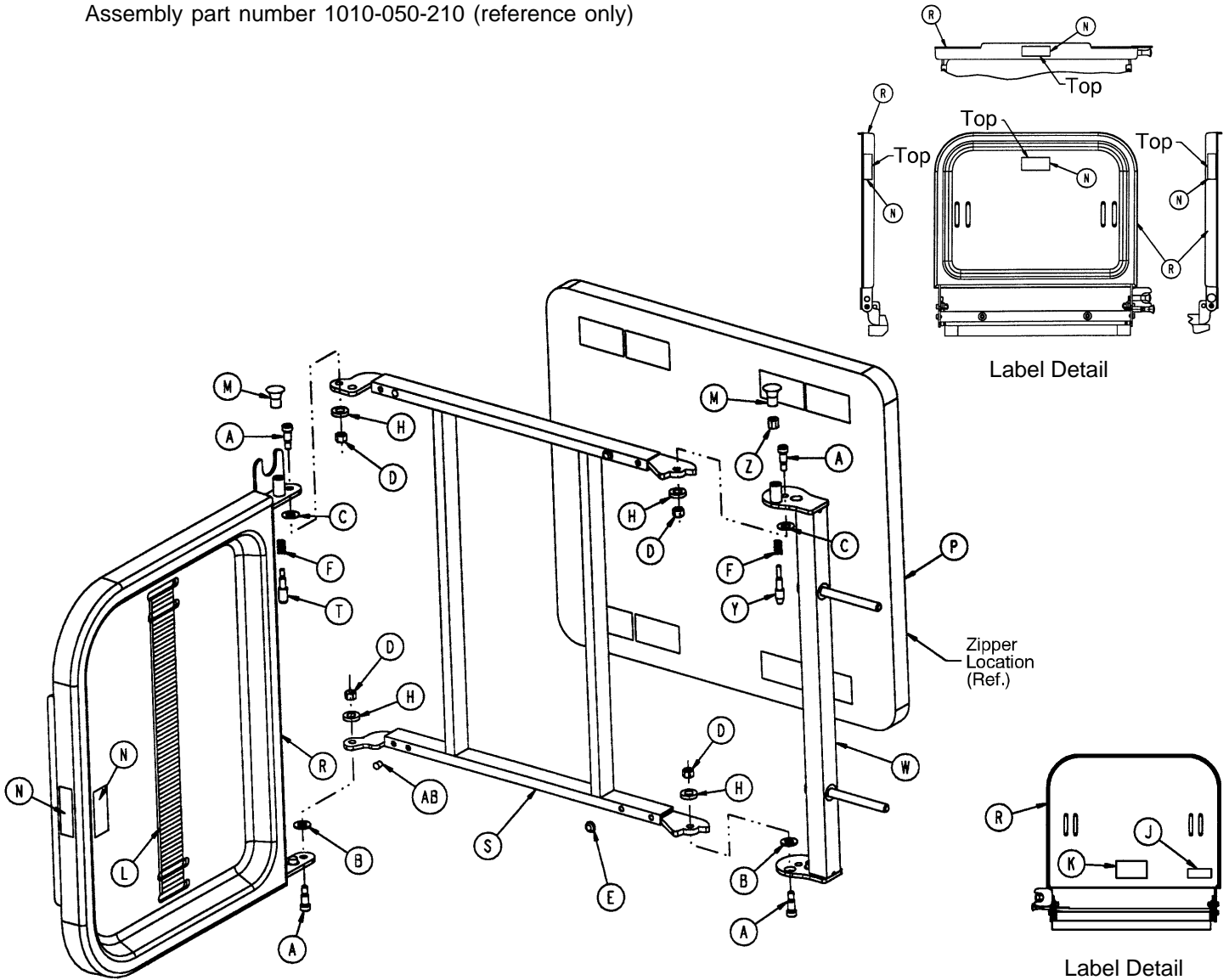

Item	Part No.	Part Name	Qty.	Item	Part No.	Part Name	Qty.
A	0008-049-000	Soc. Hd. Shoulder Bolt	4	M	1010-050-050	Knob	2
B	0014-020-000	Nylon Washer	2	N	1010-050-057	"Max. Weight" Label	4
C	0014-021-000	Nylon Washer	2	P	1010-050-205	Cushion Assembly	1
D	0016-028-000	Fiberlock Nut	4	R	1010-050-218	Foot & Tray Board	1
E	0037-052-000	Rubber Bumper	2	S	1010-050-225	Pivot Frame Weldment	1
F	0038-133-000	Spring	2	T	1010-050-242	Pin Lock	1
H	0052-017-000	Spacer	4	W	1010-050-246	Base Mounting Ass'y	1
J	1010-050-017	Specification Label	1	Y	1010-050-248	Lower Pin Lock	1
K	1010-050-019	"Push/Pull" Label	1	Z	1010-050-250	Pin Adjuster	1
L	1010-050-021	Long Strap	1	AB	0721-031-065	Hole Plug	2

# 0926-040-100 Foot Board/Chartholder Assembly

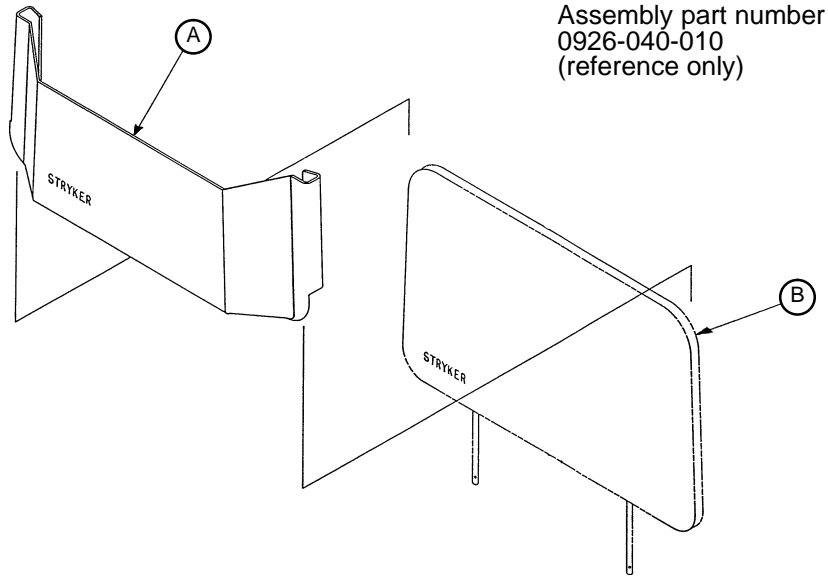

Item	Part No.	Part Name	Qty.
A	0946-028-011	Chart Holder	1
B	0946-029-006	Foot Board	1

# 1020-030-000 Upright Oxygen Bottle Holder Ass'y

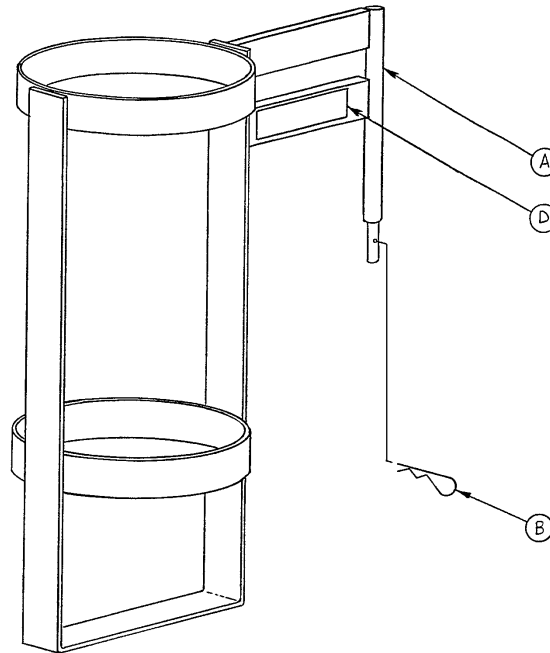

Item	Part No.	Part Name	Qty.
A	1020-030-011	Upright Bottle Holder	1
B	0027-012-000	Cotter Pin	1
D	1020-030-017	Specification Label	1

# Fowler X-Ray Cassette Mounting Assembly

Assembly part number 1711-243-010

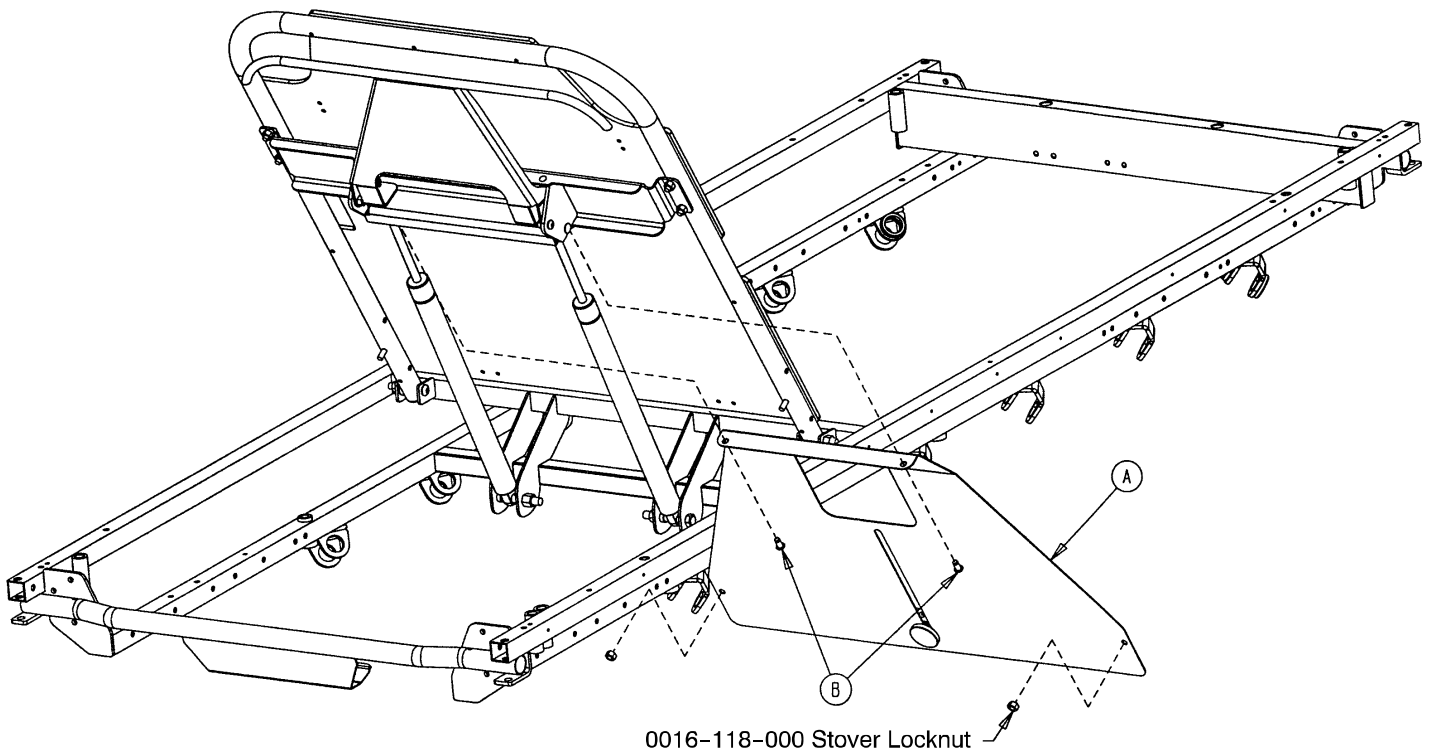

Item	Part No.	Part Name	Qty.
A	(page 79)	X-Ray Cassette Ass'y	1
B	0025-121-000	Rivet	2

# X-Ray Cassette Assembly

Assembly part numbers  
1711-243-020  
(reference only)

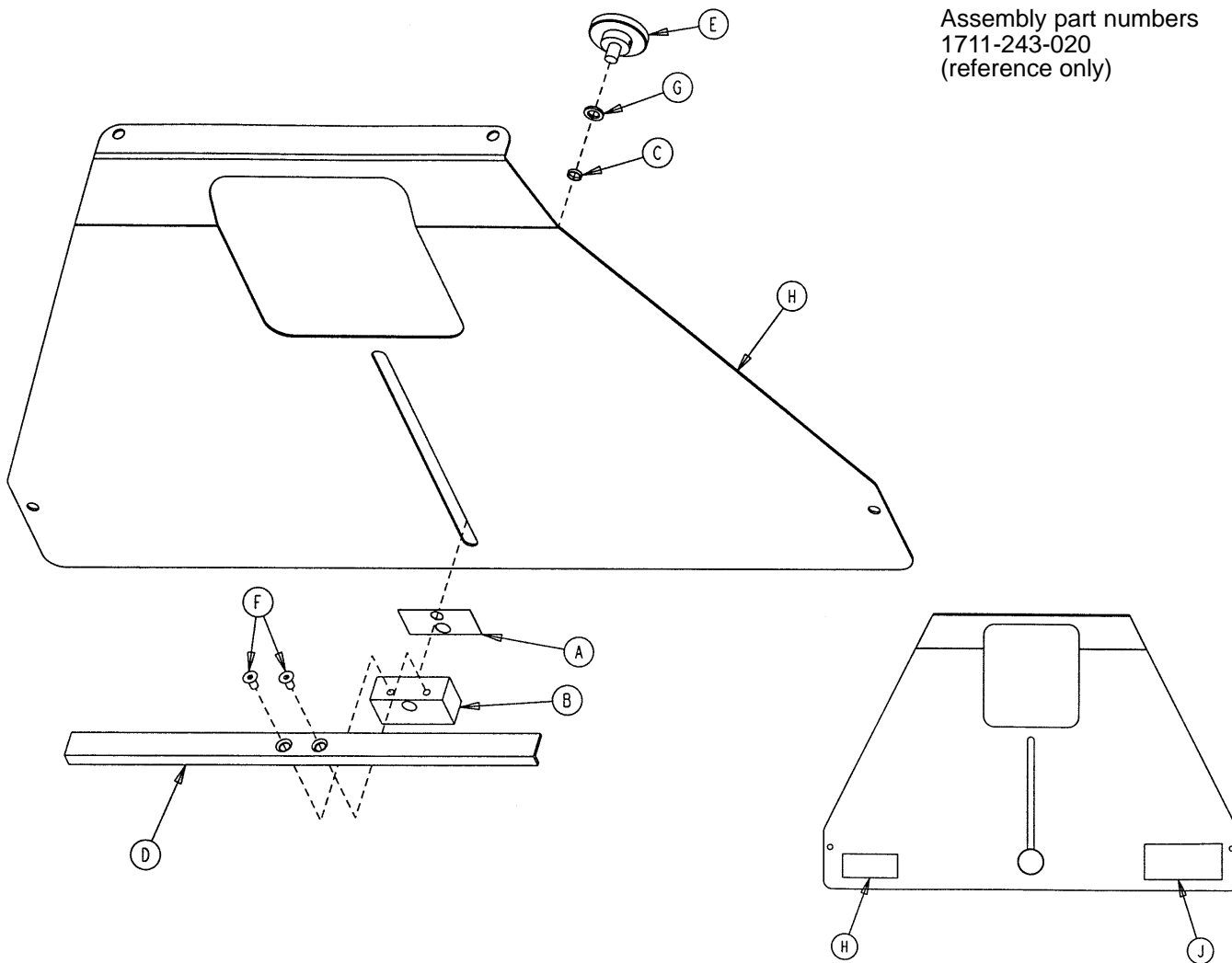

Item	Part No.	Part Name	Qty.
A	0926-023-069	Washer	1
B	0926-023-070	Block Assembly	1
C	0926-023-071	Bushing	1
D	1010-023-028	Tray Angle	1
E	1020-023-021	Knob Assembly	1
F	0001-030-000	Flat Hd. Mach. Screw	2
G	0014-003-000	Thrust Washer	1
H	1211-243-012	X-Ray Cassette Tray	1
	1711-243-012	X-Ray Cassette Tray	1
J	1010-023-018	Warning Label	1
K	1711-243-025	Specification Label	1



# 1001-055-000 Heel Stirrup and Support Assembly

Assembly part number 1001-055-010 (reference only)

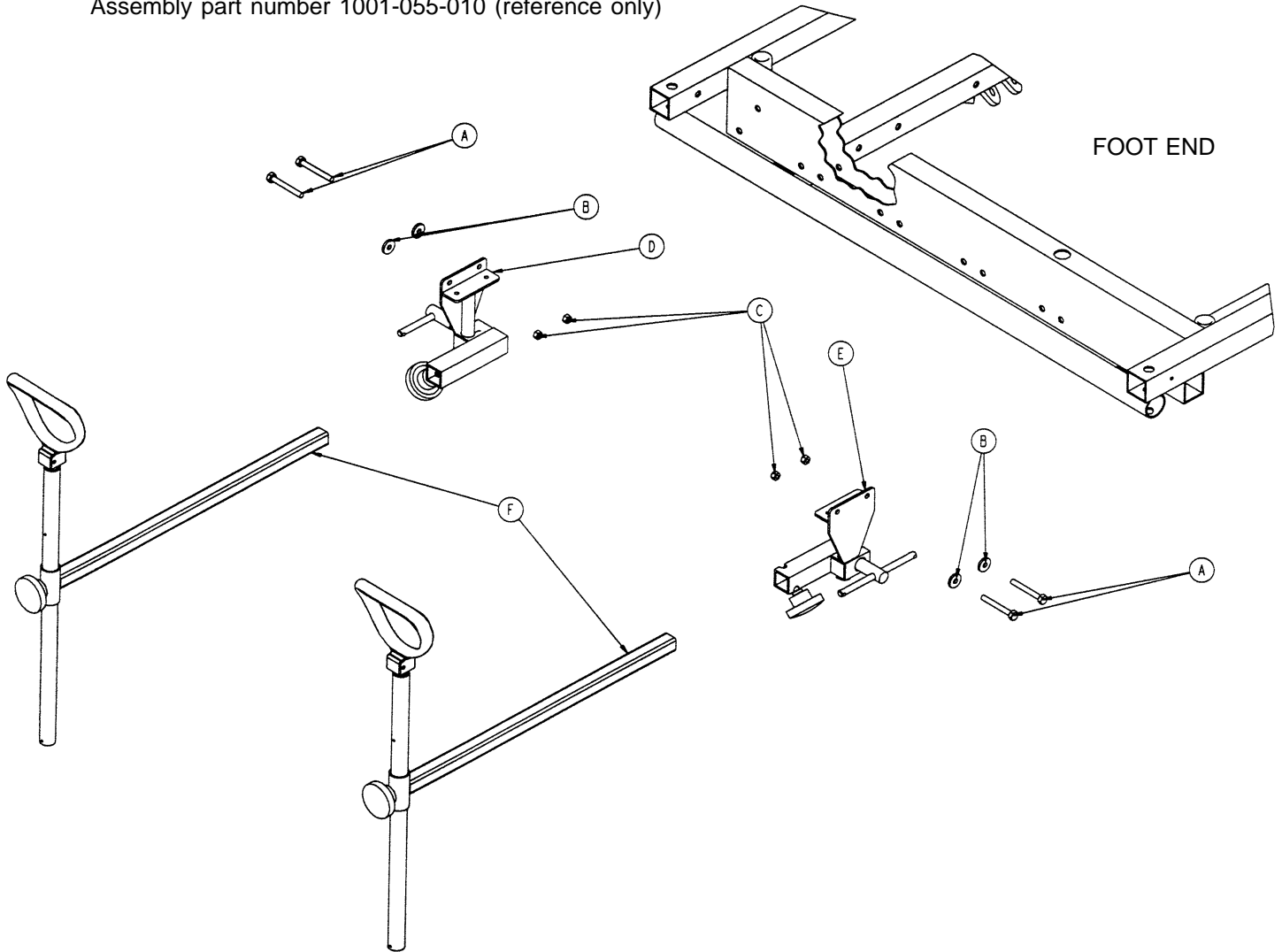

Item	Part No.	Part Name	Qty.
A	0003-359-000*	Hex Hd. Cap Screw	4
B	0011-159-000	Flat Washer	4
C	0016-1 18-000	Nylock Hex Nut	4
D	(page 81)	Stirrup Support Ass'y, Rt.	1
E	(page 82)	Stirrup Support Ass'y, Lt.	1
F	(page 83)	Stirrup Assembly	2

\* If the stretcher has the crank Fowler and/or crank Knee Gatch option, (2) 0003-355-000 and (2) 0003-358-000 replace (4) 0003-359-000.

# 1001-055-015 Right Stirrup Support Assembly

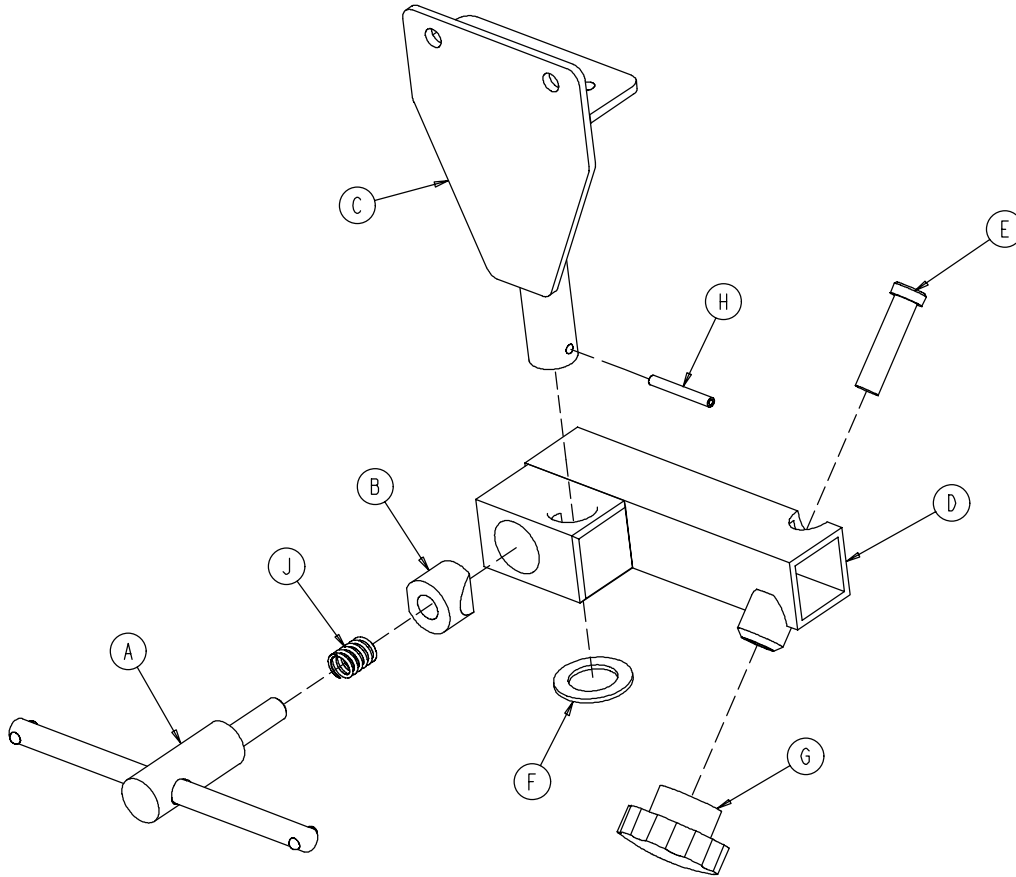

Item	Part No.	Part Name	Qty.
A	0650-002-032	Lock Screw Assembly	1
B	0966-051-019	Wedge Lock, Modified	1
C	1001-055-011	Mounting Bracket	1
D	1010-055-016	Right Support Tube Wldmt.	1
E	0004-494-000	Soc. Hd. Cap Screw	1
F	0011-410-000	Washer	1
G	1211-1 17-016	Knob	1
H	0026-007-000	Roll Pin	1
J	0038-171-000	Compression Spring	1

# 1001-055-016 Left Stirrup Support Assembly

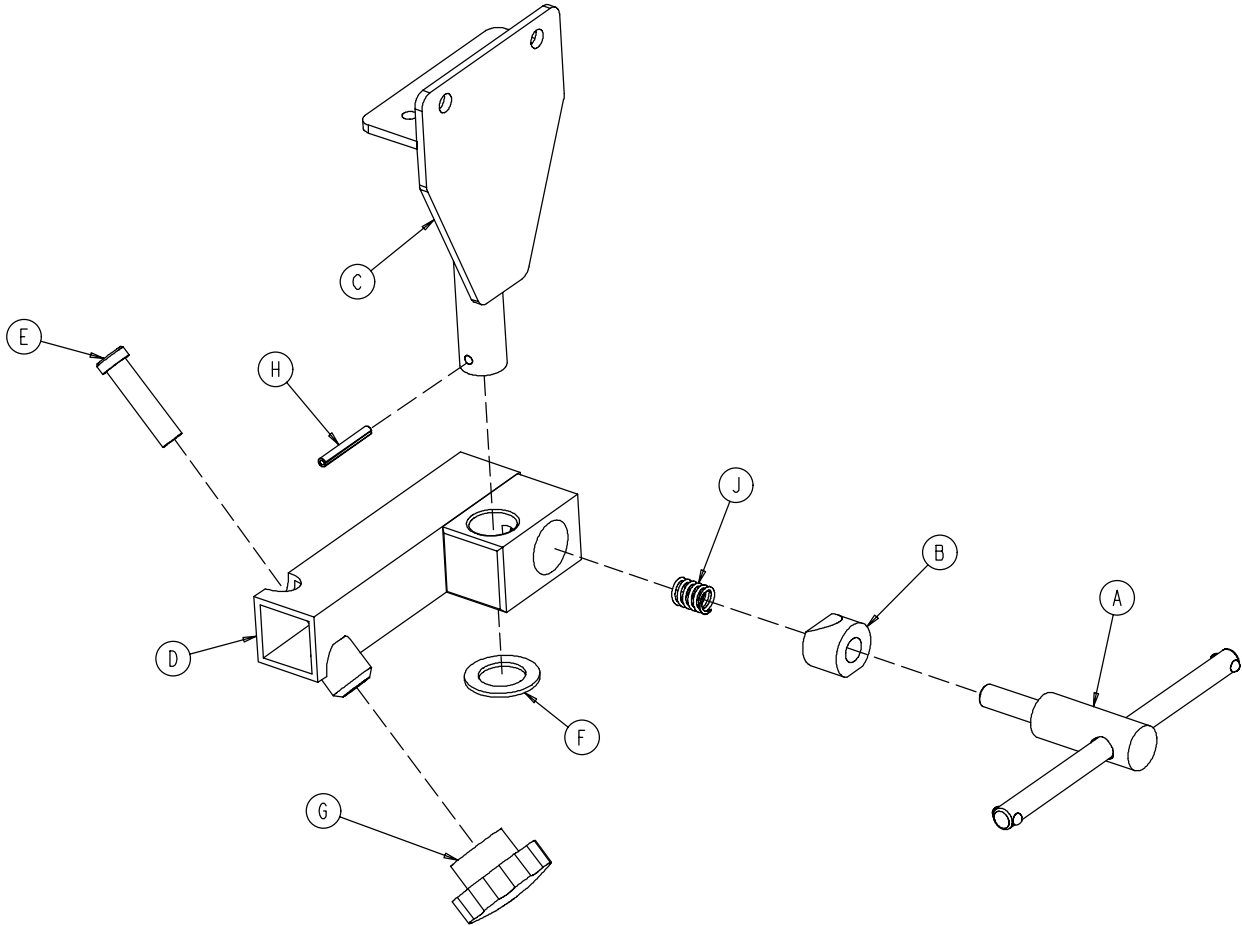

Item	Part No.	Part Name	Qty.
A	0650-002-032	Lock Screw Assembly	1
B	0966-051-019	Wedge Lock, Modified	1
C	1001-055-011	Mounting Bracket	1
D	1010-055-026	Left Support Tube Ass'y	1
E	0004-494-000	Soc. Hd. Cap Screw	1
F	0011-410-000	Washer	1
G	1211-1 17-016	Knob	1
H	0026-007-000	Roll Pin	1
J	0038-171-000	Compression Spring	1

# 1010-055-029 Heel Stirrup Assembly

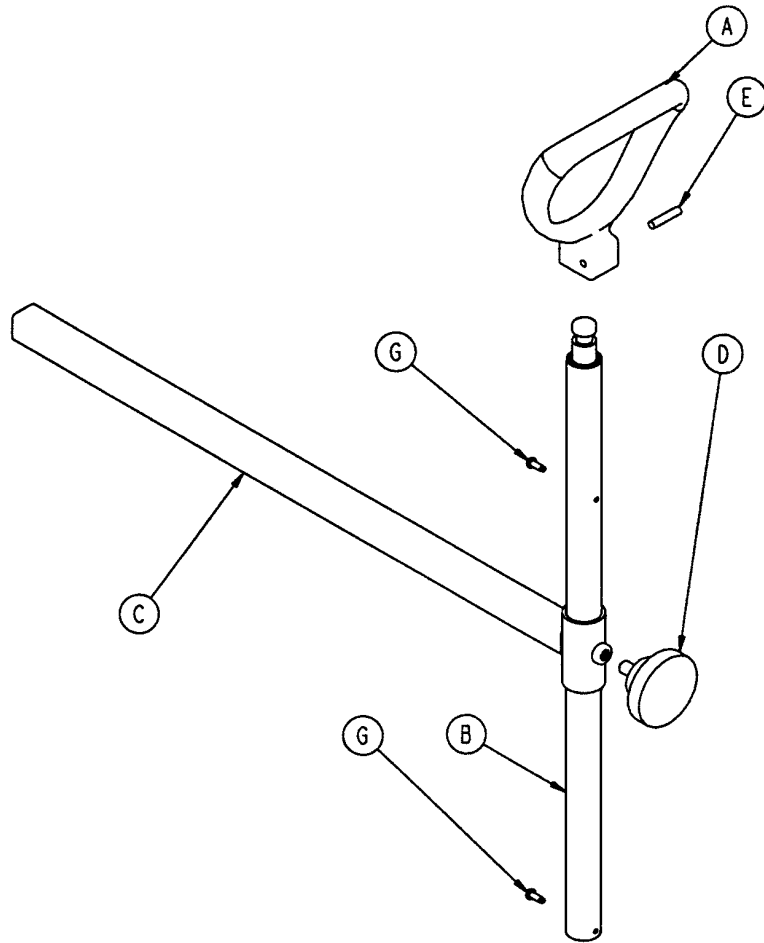

Item	Part No.	Part Name	Qty.
A	0390-020-013	Stirrup	1
B	0390-020-009	Stirrup Holder Assembly	1
C	1010-055-030	Extension Tube Assembly	1
D	0024-011-000	Knob	1
E	0026-043-000	Roll Pin	1
G	0022-008-000	Drive Screw	2

# 1001-070-000 C-Spine Cassette Holder Assembly

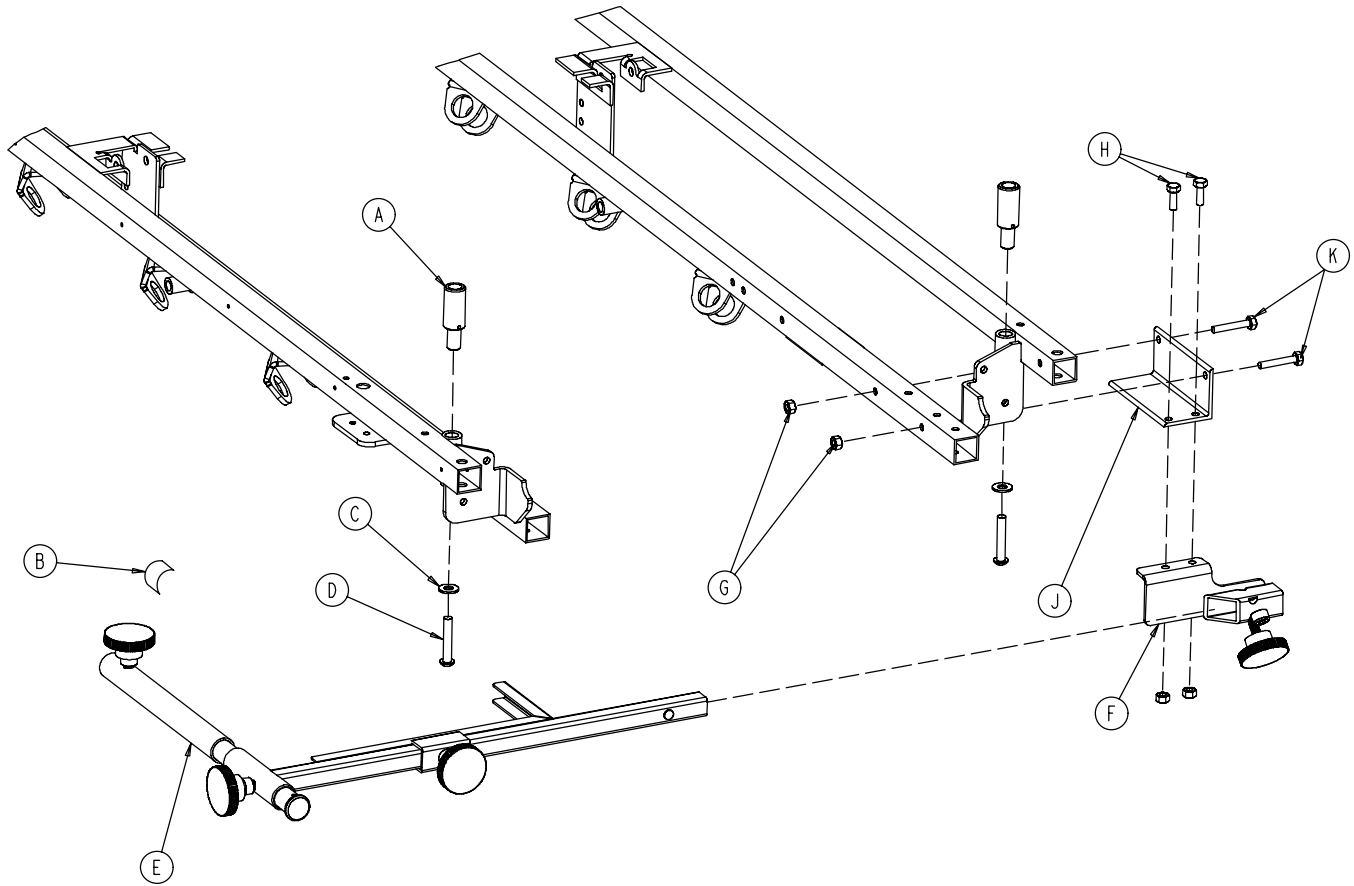

Item	Part No.	Part Name	Qty.
A	1010-070-025	I.V. Adaptor	2
B	1010-070-018	Specification Label	1
C	0011-447-000	Flat Washer	2
D	0004-054-000	But. Hd. Cap Screw	2
E	(page 85)	Support Pole Assembly	1
F	(page 86)	Storage Bracket Ass'y	1
G	0016-118-000	Nylock Nut	4
H	0003-356-000	Hex Hd. Cap Screw	2
J	1001-070-011	Attachment Bracket	1
K	0003-355-000	Hex Hd. Cap Screw	2

# 1010-070-010 C-Spine Support Pole Assembly

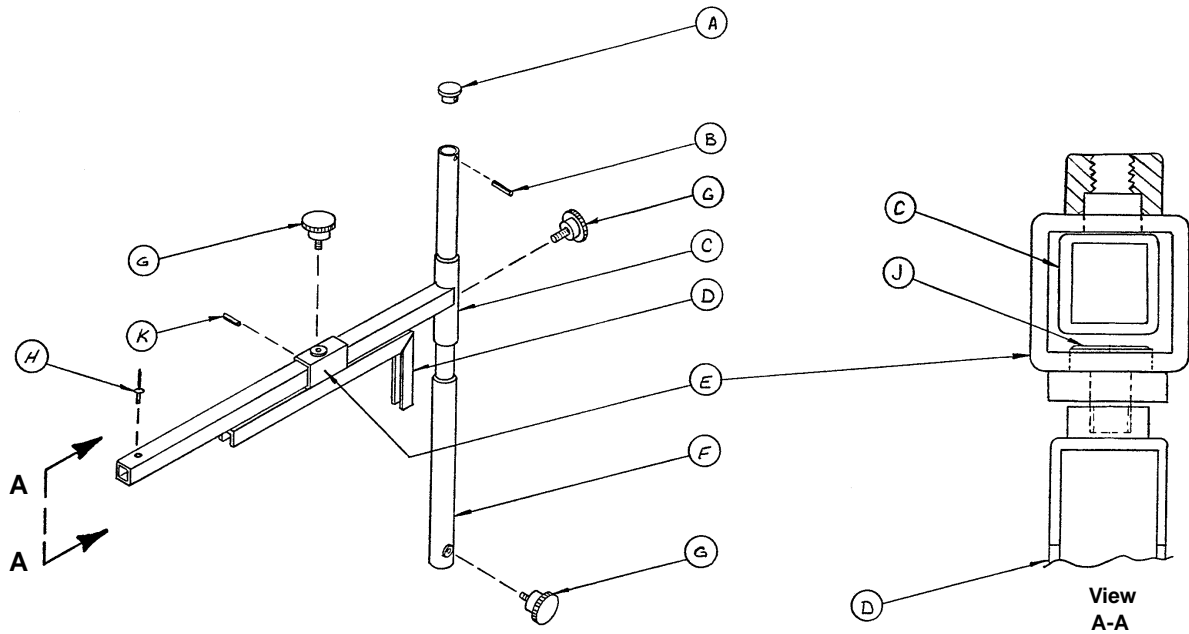

Item	Part No.	Part Name	Qty.
A	1010-070-033	Support Tube Cap	1
B	0026-006-000	Roll Pin	1
C	1010-070-034	Support Arm Weldment	1
D	1010-070-042	Cassette Holder Weldment	1
E	1010-070-050	Adjustment Tube Weldment	1
F	1010-070-030	Base Tube Weldment	1
G	1010-070-045	Knob	3
H	0025-055-000	Pop Rivet	1
J	1010-070-044	Pivot Pin	1
K	0026-005-000	Roll Pin	1

# 1010-070-019 C-Spine Storage Bracket Assembly

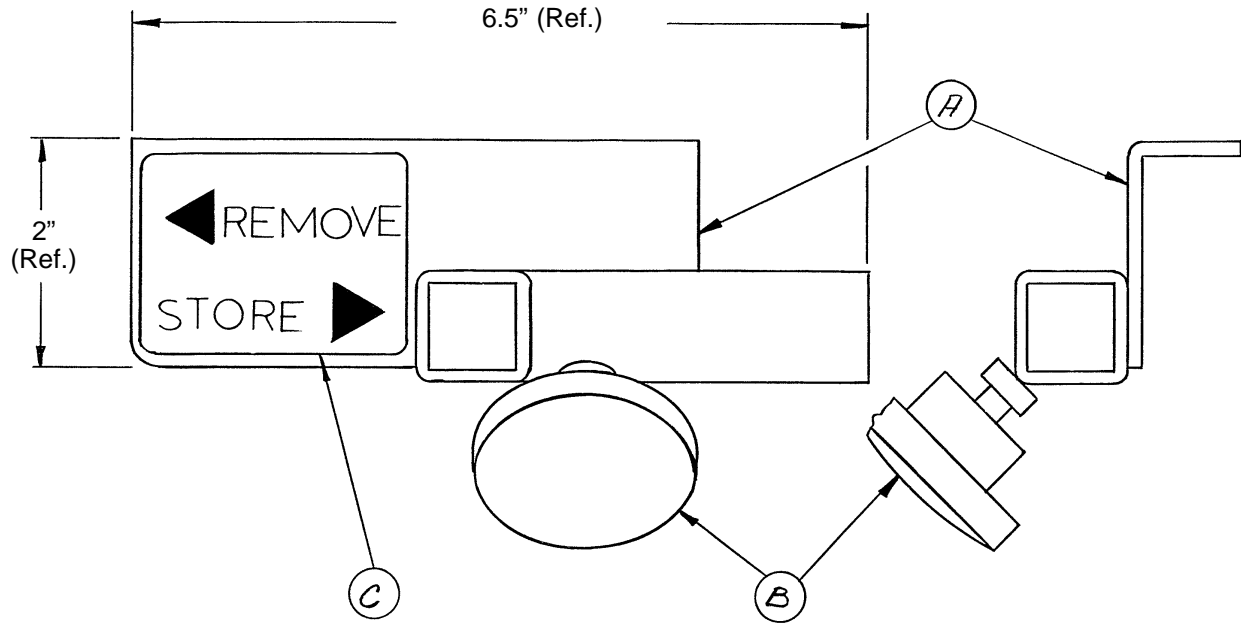

Item	Part No.	Part Name	Qty.
A	1010-070-020	Storage Bracket Weldment	1
B	1010-070-045	Knob	1
C	1010-070-023	Storage Label	1

# 1040-010-090 Optional O<sub>2</sub> Bottle Retainer Assembly

---

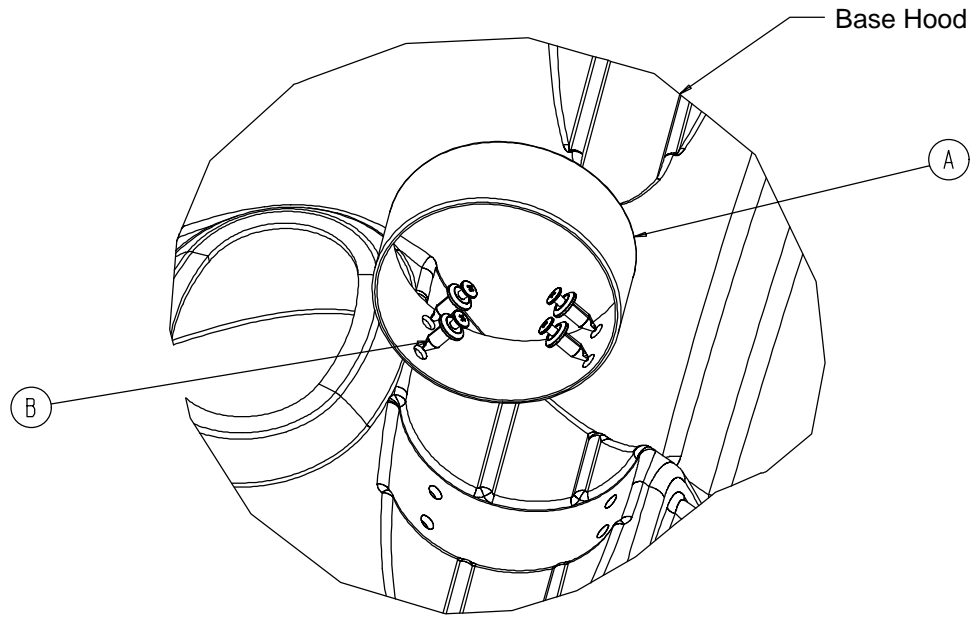

<b>Item</b>	<b>Part No.</b>	<b>Part Name</b>	<b>Qty.</b>
A	1040-010-091	Bottle Retainer	1
B	1040-010-092	Scrulok Fastener	4



# Mattresses and Siderail Pads

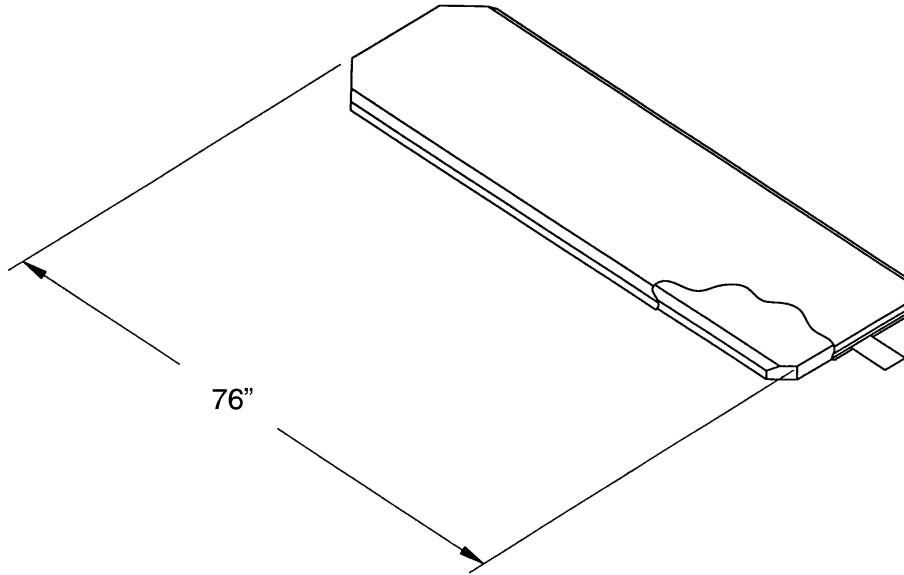

Mattress, 4" Thick x 31" Wide, Enhanced Comfort ..... part # 0660-030-004

Mattress, 5" Thick x 31" Wide, Ultra Comfort ..... part # 0660-040-005

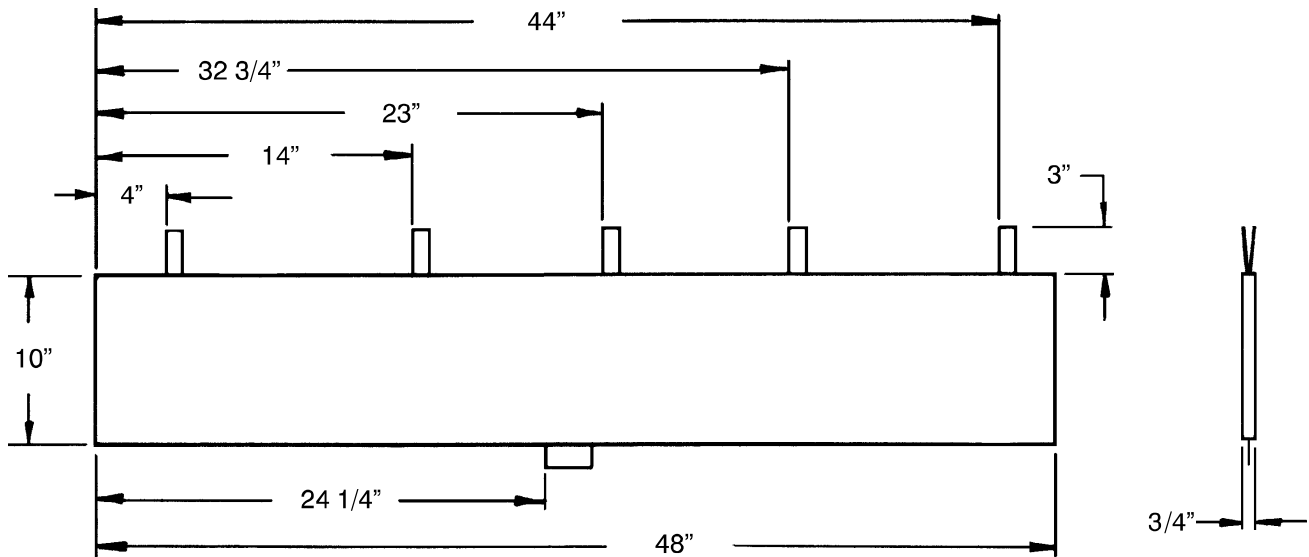

Siderail Pad Set ..... part # 1001-052-000

# Warranty

---

## Limited Warranty:

Stryker Medical Division, a division of Stryker Corporation, warrants to the original purchaser that its products should be free from defects in material and workmanship for a period of one (1) year after date of delivery. Stryker's obligation under this warranty is expressly limited to supplying replacement parts and labor for, or replacing, at its option, any product which is, in the sole discretion of Stryker, found to be defective. Stryker warrants to the original purchaser that the frame and welds on its beds will be free from structural defects for as long as the original purchaser owns the bed. If requested by Stryker, products or parts for which a warranty claim is made shall be returned prepaid to Stryker's factory. Any improper use or any alteration or repair by others in such manner as in Stryker's judgement affects the product materially and adversely shall void this warranty. Any repair of Stryker products using parts not provided or authorized by Stryker shall void this warranty. No employee or representative of Stryker is authorized to change this warranty in any way.

Stryker Medical stretchers are designed for a 10 year expected life under normal use conditions and appropriate periodic maintenance as described in the maintenance manual for each device.

This statement constitutes Stryker's entire warranty with respect to the aforesaid equipment. STRYKER MAKES NO OTHER WARRANTY OR REPRESENTATION, EITHER EXPRESSED OR IMPLIED, EXCEPT AS SET FORTH HEREIN. THERE IS NO WARRANTY OF MERCHANTABILITY AND THERE ARE NO WARRANTIES OF FITNESS FOR ANY PARTICULAR PURPOSE. IN NO EVENT SHALL STRYKER BE LIABLE HEREUNDER FOR INCIDENTAL OR CONSEQUENTIAL DAMAGES ARISING FROM OR IN ANY MANNER RELATED TO SALES OR USE OF ANY SUCH EQUIPMENT.

## To Obtain Parts and Service:

Stryker products are supported by a nationwide network of dedicated Stryker Field Service Representatives. These representatives are factory trained, available locally, and carry a substantial spare parts inventory to minimize repair time. Simply call your local representative, or call Stryker Customer Service at (800) 327-0770.

## Service Contract Coverage:

Stryker has developed a comprehensive program of service contract options designed to keep your equipment operating at peak performance at the same time it eliminates unexpected costs. We recommend that these programs be activated *before* the expiration of the new product warranty to eliminate the potential of additional equipment upgrade charges.

## **A SERVICE CONTRACT HELPS TO:**

- Ensure equipment reliability
- Stabilize maintenance budgets
- Diminish downtime
- Establish documentation for JCAHO
- Increase product life
- Enhance trade-in value
- Address risk management and safety

# Warranty

**Stryker offers the following service contract programs:**

<b>SPECIFICATIONS</b>	<b>GOLD</b>	<b>SILVER</b>	<b>PM* ONLY</b>
Annually scheduled preventative maintenance	X		X
All parts,** labor, and travel	X	X	
Unlimited emergency service calls	X	X	
Priority one contact; two hour phone response	X	X	X
Most repairs will be completed within 3 business days	X	X	
JCAHO documentation	X	X	X
On-site log book w/ preventative maintenance & emergency service records	X		
Factory-trained Stryker Service Technicians	X	X	X
Stryker authorized parts	X	X	X
End of year summary	X		
Stryker will perform all service during regular business hours (9-5)	X	X	X

\* Replacement parts and labor for products under PM contract will be discounted.

\*\* Does not include any disposable items, I.V. poles (except for Stryker HD permanent poles), mattresses, or damage resulting from abuse.

**Stryker Medical also offers *personalized* service contracts.**

**Pricing is determined by age, location, model and condition of product.**

***For more information on our service contracts, please call your local representative or call (800) 327-0770 (option #2).***

## **Return Authorization:**

Merchandise cannot be returned without approval from the Stryker Customer Service Department. An authorization number will be provided which must be printed on the returned merchandise. Stryker reserves the right to charge shipping and restocking fees on returned items.

**SPECIAL, MODIFIED, OR DISCONTINUED ITEMS NOT SUBJECT TO RETURN.**

## **Damaged Merchandise:**

ICC Regulations require that claims for damaged merchandise must be made with the carrier within fifteen (15) days of receipt of merchandise. **DO NOT ACCEPT DAMAGED SHIPMENTS UNLESS SUCH DAMAGE IS NOTED ON THE DELIVERY RECEIPT AT THE TIME OF RECEIPT.** Upon prompt notification, Stryker will file a freight claim with the appropriate carrier for damages incurred. Claim will be limited in amount to the actual replacement cost. In the event that this information is not received by Stryker within the fifteen (15) day period following the delivery of the merchandise, or the damage was not noted on the delivery receipt at the time of receipt, the customer will be responsible for payment of the original invoice in full.

Claims for any short shipment must be made within thirty (30) days of invoice.

## **International Warranty Clause:**

This warranty reflects U.S. domestic policy. Warranty outside the U.S. may vary by country. Please contact your local Stryker Medical representative for additional information.



## **European Representative**

Stryker EMEA RA/QA Director  
Stryker France  
ZAC Satolas Green Pusignan  
Av. De Satolas Green  
69881 MEYZIEU Cedex  
France

**stryker<sup>®</sup>**  
**Medical**

6300 S. Sprinkle Road, Kalamazoo, MI 49001-9799

(800) 327-0770  
[www.strykermedical.com](http://www.strykermedical.com)



DH 8/03 0660-009-004 REV A