

stryker[®]
Medical

ATLAS *Stretcher*
660

Model 660

Operations Manual

For Parts or Technical Assistance
800-327-0770

Table of Contents

Introduction	2, 3
Operating Base Controls	4, 5
Raising And Lowering Litter Height	6
Trendelenburg/Reverse Trendelenburg Positioning	6
Applying The Brake System	7
Operating the Big Wheel Option	8
Using Siderails	9
Operating The Fowler/Knee Gatch	10
Operating Optional 2-Stage Permanently Attached I.V. Pole	11
Operating Optional 3-Stage Permanently Attached I.V. Pole	12
Operating Optional Tethered I.V. Pole	13
Using The Optional X-Ray Cassette Holder	13
Operating Optional Heel Stirrups	14
Operating Optional Foot Extension/Defibrillator Tray	14
Preventative Maintenance Checklist	15
Cleaning	16, 17
Limited Warranty	
Obtaining Parts and Service	18
Supplemental Warranty Coverage	18
Return Authorization	19
Freight Damage Claims	19

Introduction

INTRODUCTION

This manual is designed to assist you with the operation of the Model 660 Atlas Stretcher. Read it thoroughly before using the equipment or beginning any maintenance on it.

SPECIFICATIONS

Maximum Weight Capacity	660 pounds
Overall Bed Length \ Width	84" \ 34.5"
Minimum \ Maximum Bed Height	21.5" \ 36"
Fowler Angle	0 to 90°
Knee Gatch Angle	0 to 35°
Trendelenburg \ Reverse Trendelenburg	+18 to -18°

Stryker reserves the right to change specifications without notice.

WARNING / CAUTION / NOTE DEFINITION

The words WARNING, CAUTION and NOTE carry special meanings and should be carefully reviewed.

WARNING

The personal safety of the patient or user may be involved. Disregarding this information could result in injury to the patient or user.

CAUTION

These instructions point out special procedures or precautions that must be followed to avoid damaging the equipment.

NOTE

This provides special information to make maintenance easier or important instructions clearer.

Introduction

Before operating this stretcher, it is important to read and understand all information in this manual. Carefully read and strictly follow the warnings listed on this page.

WARNING

To avoid damage, remove any equipment that may be in the way before raising or lowering the litter height.

Always apply the caster brakes when a patient is getting on or off the stretcher. Push on the stretcher to ensure the brakes are securely locked. Always engage the brakes unless the stretcher is being moved. Injury could result if the stretcher moves while a patient is getting on or off the stretcher. If brakes do not hold properly, refer to your stretcher maintenance manual for a brake adjustment procedure.

When lowering the siderail to the collapsed position, keep extremities of patients and staff away from the siderail spindles or injury could occur.

To avoid injury or damage to the equipment, do not allow the siderail to lower on its own.

Keep fingers/hands clear of area around Fowler release handle and Fowler frame when lowering the Fowler. Injury could result if care is not taken when lowering the Fowler.

If the pneumatic system appears to be difficult to operate, refer to the stretcher maintenance manual for "Pneumatic Fowler Adjustment"

To avoid damage, the weight of the I.V. bags should not exceed 40 pounds.

To avoid damage while transporting the stretcher, verify the I.V. pole is at a low enough height to allow it to safely pass through door openings and under light fixtures.

Stretcher Operation

OPERATING BASE CONTROLS - SIDE CONTROL

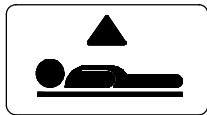
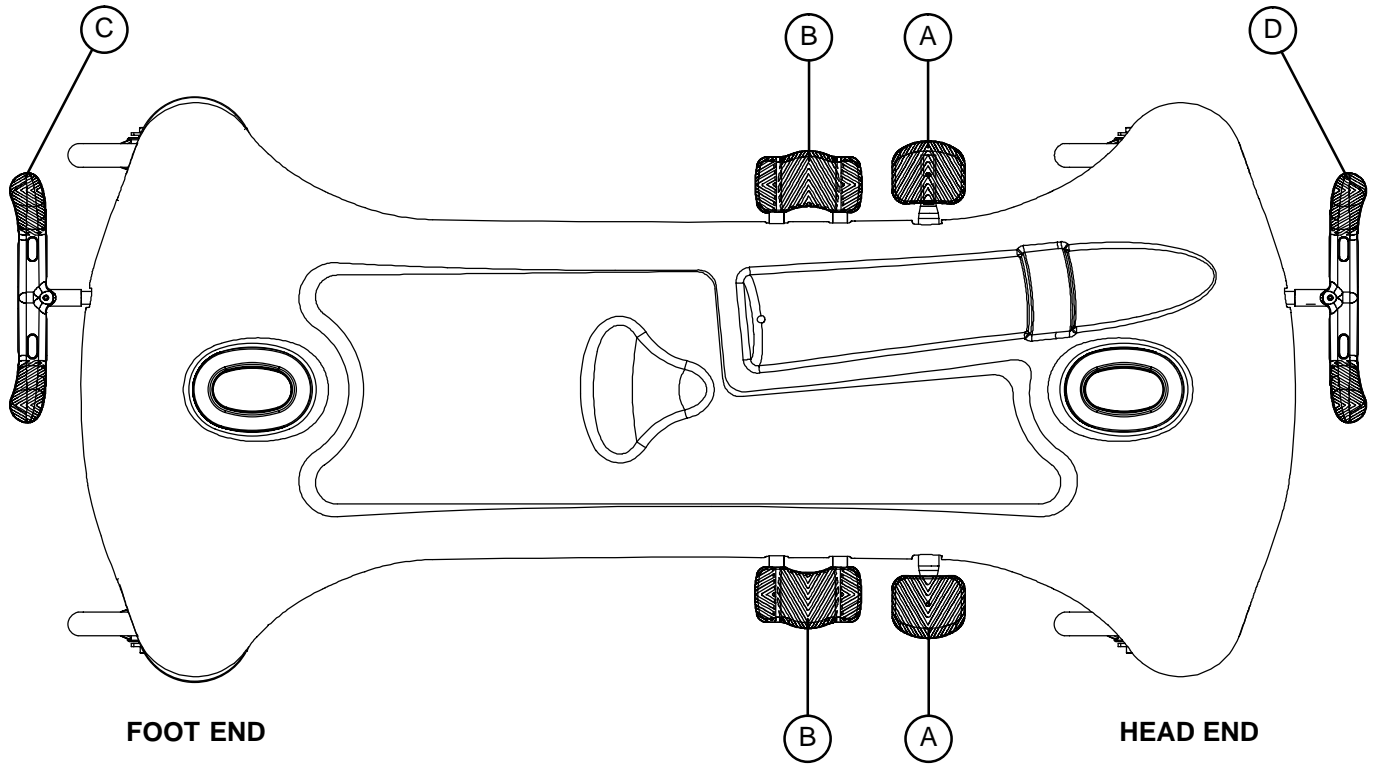

Pump pedal (A) to raise the litter.

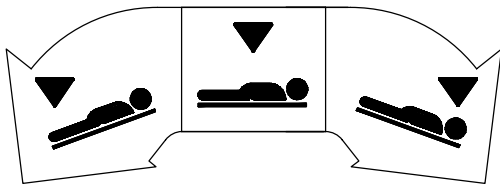

Depress in the center of pedal (B) to lower both ends of the stretcher together.

Depress the side of pedal (B) closest to the foot end of the stretcher to lower the foot end.

Depress the side of pedal (B) closest to the head end of the stretcher to lower the head end.

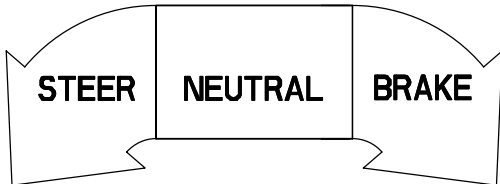

Pedal (C) - Brake and Steer functions (foot end)

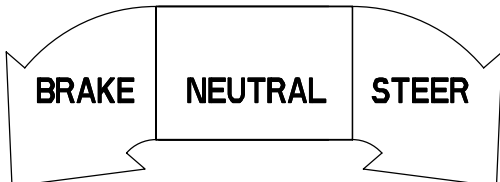

Pedal (D) - Brake and Steer functions (head end)

Stretcher Operation

OPERATING BASE CONTROLS - 3-SIDED CONTROLS

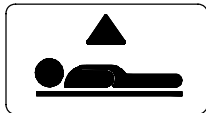
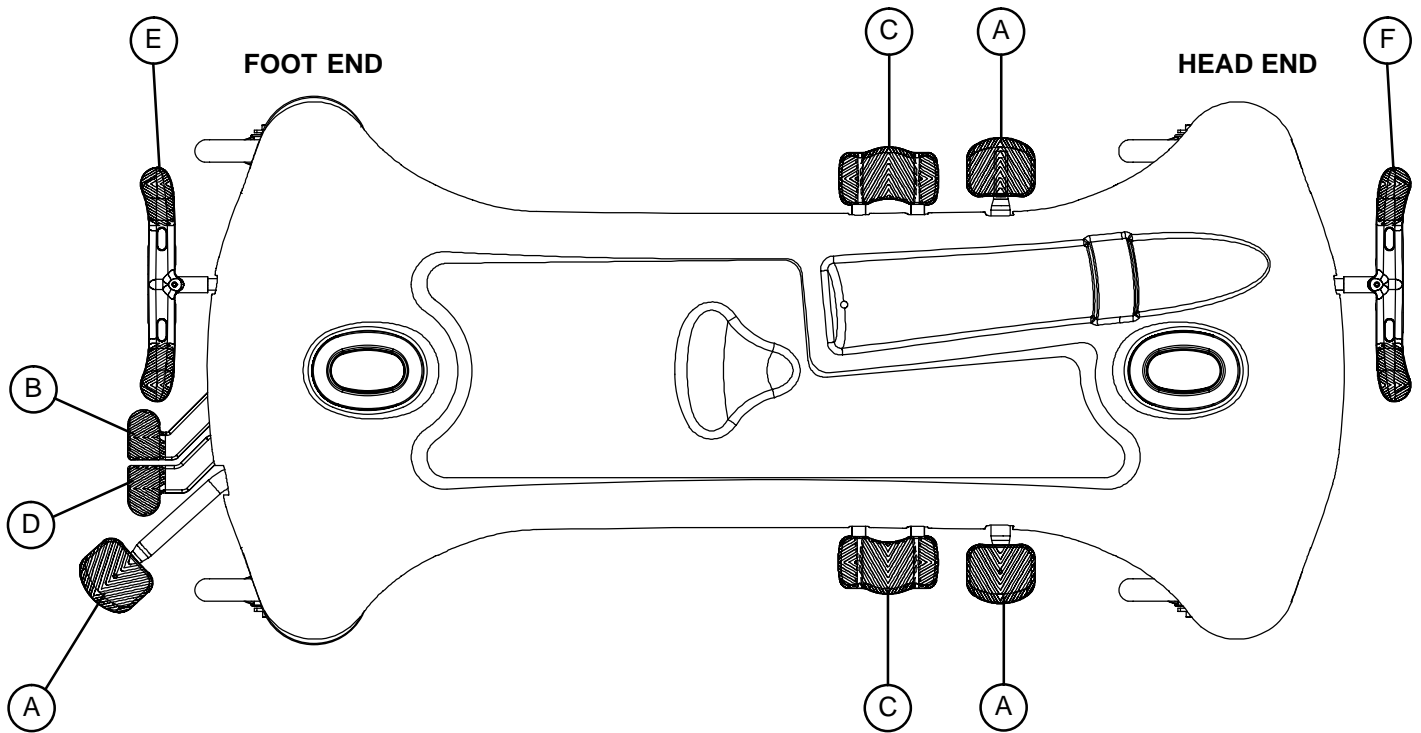

Pump pedal (A) at the foot end or sides of the stretcher to raise the litter

Depress pedal (B) or the side of pedal (C) closest to the head end of the stretcher to lower the head end of the stretcher.

Depress pedal (D) or the side of pedal (C) closest to the foot end of the stretcher to lower the foot end of the stretcher.

Depress in the center of pedal (C) or depress pedals (B) and (D) together to lower both ends of the stretcher together.

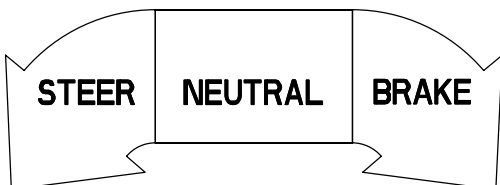
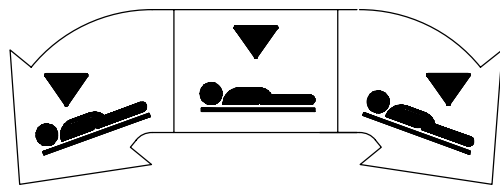

Pedal (E) - Brake and Steer functions (foot end).

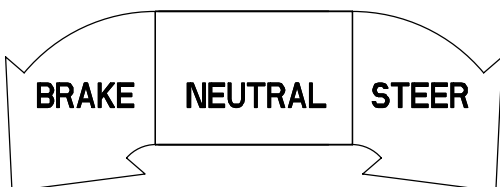

Pedal (F) - Brake and Steer functions (head end)

Stretcher Operation

RAISING AND LOWERING LITTER HEIGHT - SIDE CONTROL

CAUTION

To avoid damage, remove any equipment that may be in the way before raising or lowering the litter height.

To **raise** the litter height, pump pedal (A) repeatedly until the desired height is achieved (see illustration on page 4).

To **lower** both ends of the litter together, depress the center of pedal (B). To lower only the head end of the litter, depress the side of pedal (B) closest to the head end. To lower only the foot end of the litter, depress the side of pedal (B) closest to the foot end (see illustration on page 4). The base may be equipped with optional variable descent controls. With variable descent controls, the farther you press down on the pedal, the faster the litter will lower.

RAISING AND LOWERING LITTER HEIGHT - 3-SIDED CONTROLS

To **raise** the litter height, pump pedal (A) repeatedly until the desired height is achieved (see illustration on page 5).

To **lower** both ends of the litter simultaneously, depress pedal (B) and (D) together using the same foot or depress in the center of pedal (C). To lower only the head end of the litter, depress pedal (B) or the side of pedal (C) closest to the head end of the stretcher. To lower only the foot end of the stretcher, depress pedal (D) or the side of pedal (C) closest to the foot end of the stretcher.

The base may be equipped with optional variable descent controls. With variable descent controls, the farther you press down on the pedal, the faster the litter will lower.

TRENDELENBURG/REVERSE TRENDELENBURG - SIDE CONTROL

NOTE

Litter height must be raised first in order to achieve a trend. or reverse trend. position.

CAUTION

To avoid damage, remove any equipment that may be in the way before lowering the stretcher.

For **Trendelenburg** positioning (head down), depress the side of pedal (B) closest to the head end of the stretcher (see illustration, page 4).

For **Reverse Trendelenburg** positioning (foot down), depress the side of pedal (B) closest to the foot end.

NOTE

The higher the litter is before pedal (B) is activated, the greater the trend. or reverse trend. angle will be. (Maximum trend. angle is +18°. Maximum reverse trend. angle is -18°).

TRENDELENBURG/REVERSE TRENDELENBURG - 3-SIDED CONTROLS

CAUTION

To avoid damage, remove any equipment that may be in the way before lowering the stretcher.

For **Trendelenburg** positioning (head down), depress pedal (B) or the side of pedal (C) closest to the head end of the stretcher (see illustration, page 5).

For **Reverse Trendelenburg** positioning (foot down), depress pedal (D) or the side of pedal (C) closest to the foot end of the stretcher.

Stretcher Operation

APPLYING THE BRAKE SYSTEM

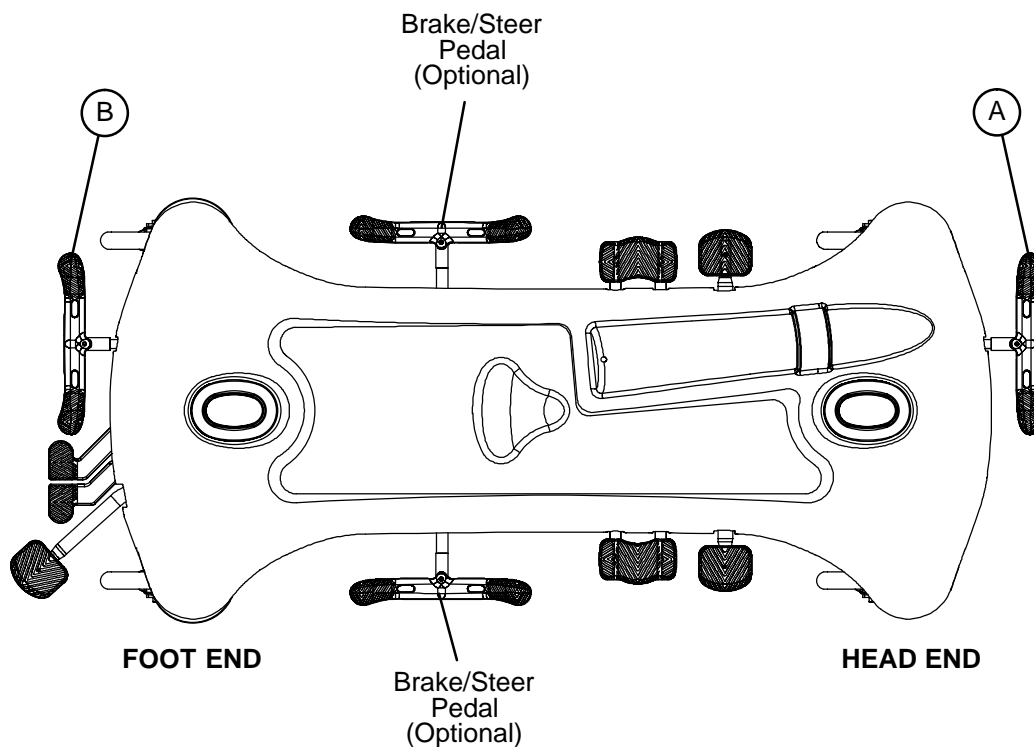

NOTE

For user convenience, a brake/steer control pedal is located on both ends of the stretcher.

WARNING

Always apply the caster brakes when a patient is getting on or off the stretcher. Push on the stretcher to ensure the brakes are securely locked. Always engage the brakes unless the stretcher is being moved. Injury could result if the stretcher moves while a patient is getting on or off the stretcher. If brakes do not hold properly, refer to your stretcher maintenance manual for a brake adjustment procedure.

To engage the brakes on the head end, push fully down on the left side of pedal (A).

To engage the brakes on the foot end, push fully down on the right side of pedal (B).

NOTE

Your stretcher may be equipped with optional side control brake and steer functions in addition to the standard head and foot end controls. The side control brakes operate the same as the head and foot end versions.

Stretcher Operation

OPERATING THE BIG WHEEL

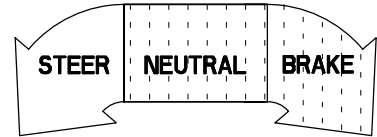
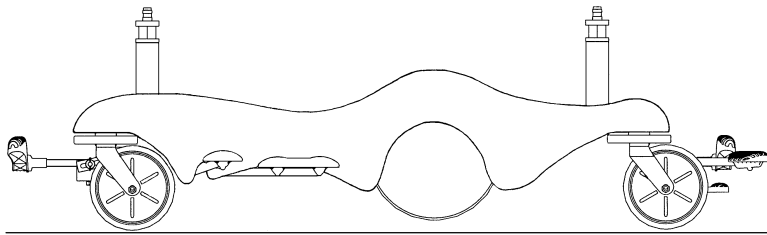

When the brake/steer pedal is in the **neutral or brake** position, the Big Wheel is elevated approximately 3/4" and the stretcher rests on the four casters.

NOTE

The two Big Wheels do not pivot. The stretcher cannot be moved directly sideways with the Big Wheel activated. With the pedal in the neutral position, the stretcher can be moved in any direction including sideways.

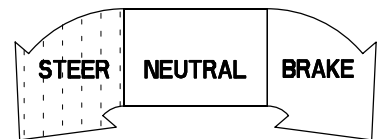
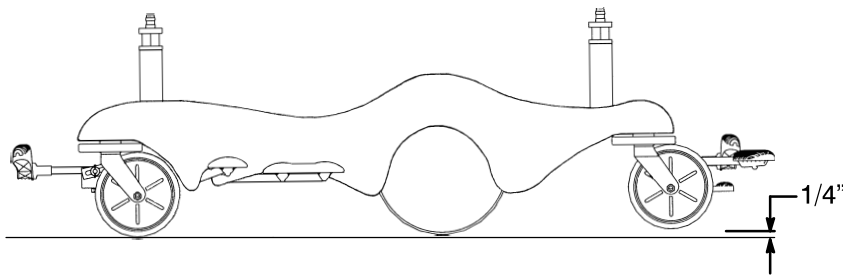

When the brake/steer pedal is in the **steer** position, the foot end casters are elevated approximately 1/4" and the stretcher rests on the two head end casters and the two Big Wheels. This provides increased mobility and ease of steering the stretcher.

Stretcher Operation

USING GLIDEAWAY™ SIDERAILS

NOTE

Raising and lowering the siderails is a two-handed operation. Use one hand to hold and position the siderail and the other hand to operate the siderail latch.

WARNING

When lowering the siderail to the collapsed position, keep the extremities of patients and staff away from the siderail spindles or injury could occur.

To raise siderails: Pull up on the siderail (A) and raise it to the full up position until the latch (B) engages.

To lower siderails: Pull up on the latch (B) and guide the siderail to the full down position.

NOTE

The latches (B) are colored red for easy identification.

WARNING

To avoid injury or damage to the equipment, do not allow the siderail to lower on its own.

NOTE

There is a dual siderail latch option available where there are latches on both ends of the stretcher.

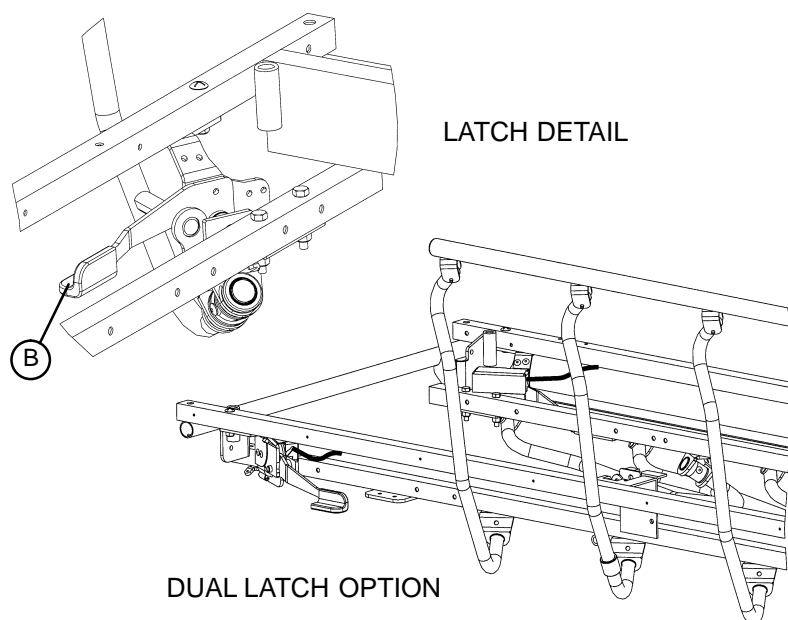
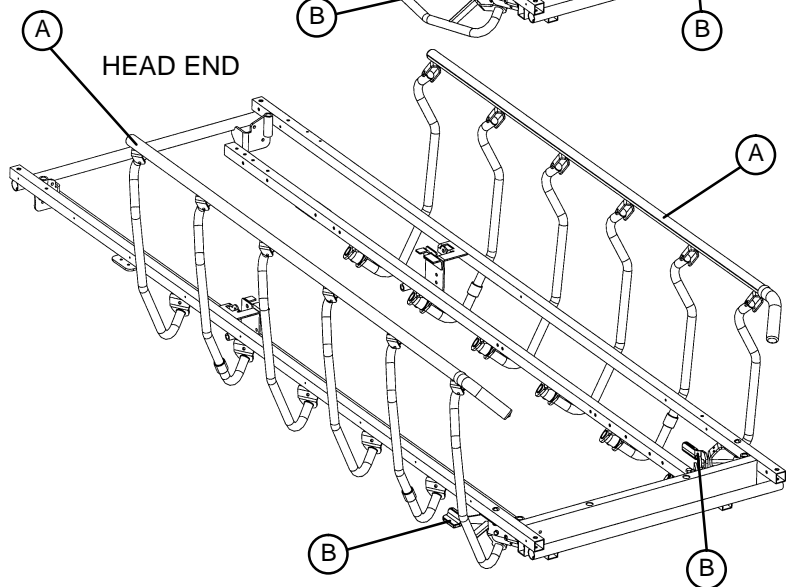
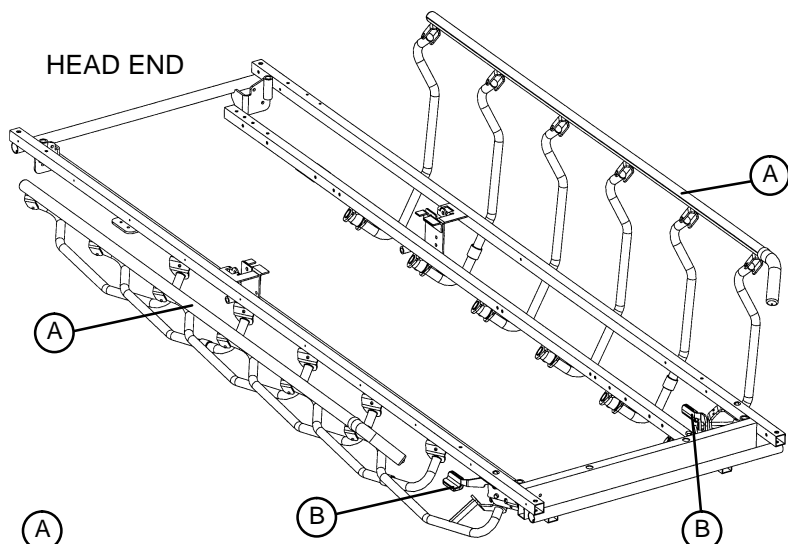

Stretcher Operation

OPERATING THE FOWLER/KNEE GATCH

Pneumatic Fowler (Center Mounted Cylinders):

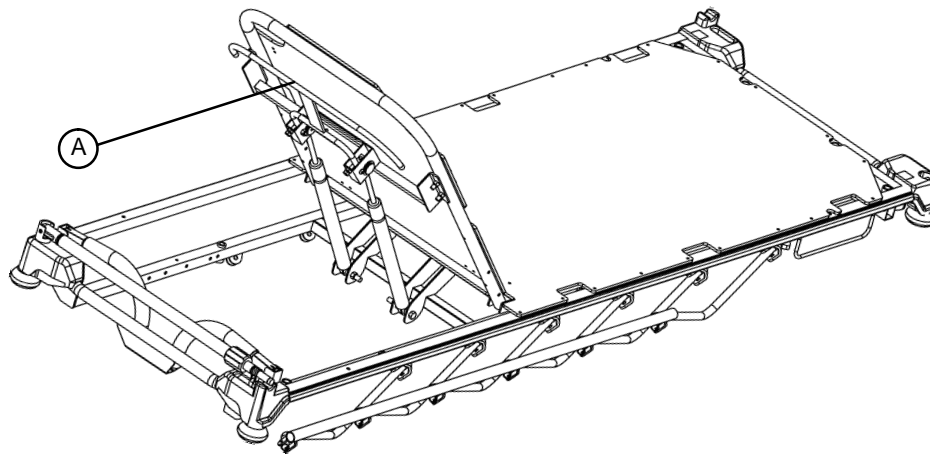

CAUTION

If the pneumatic system appears difficult to operate, refer to the stretcher maintenance manual for "Pneumatic Fowler Adjustment".

Squeeze handle (A) for pneumatic assist in lifting the Fowler to the desired height. Remove your hands from the handle when the desired height is reached.

To lower, squeeze handle (A) and push down on the Fowler until it has reached the desired height. Remove your hands from the handle when the desired height is reached.

WARNING

Keep hands/fingers clear of the area around the Fowler release handle and Fowler frame when lowering the Fowler. Injury could result if care is not taken when lowering the Fowler.

Crank Knee Gatch (Optional):

Turn the crank handle (A) clockwise to raise the Knee Gatch, counterclockwise to lower.

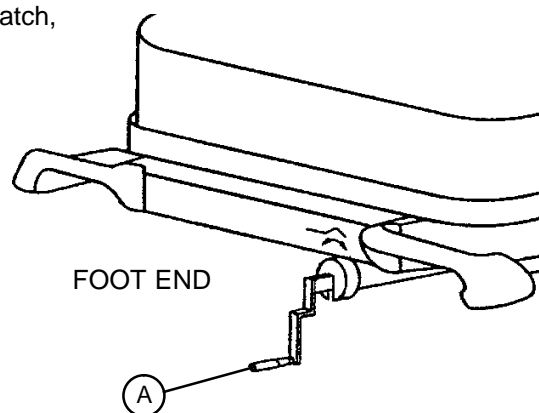

Stretcher Operation

OPERATING OPTIONAL 2-STAGE PERMANENTLY ATTACHED I.V. POLE

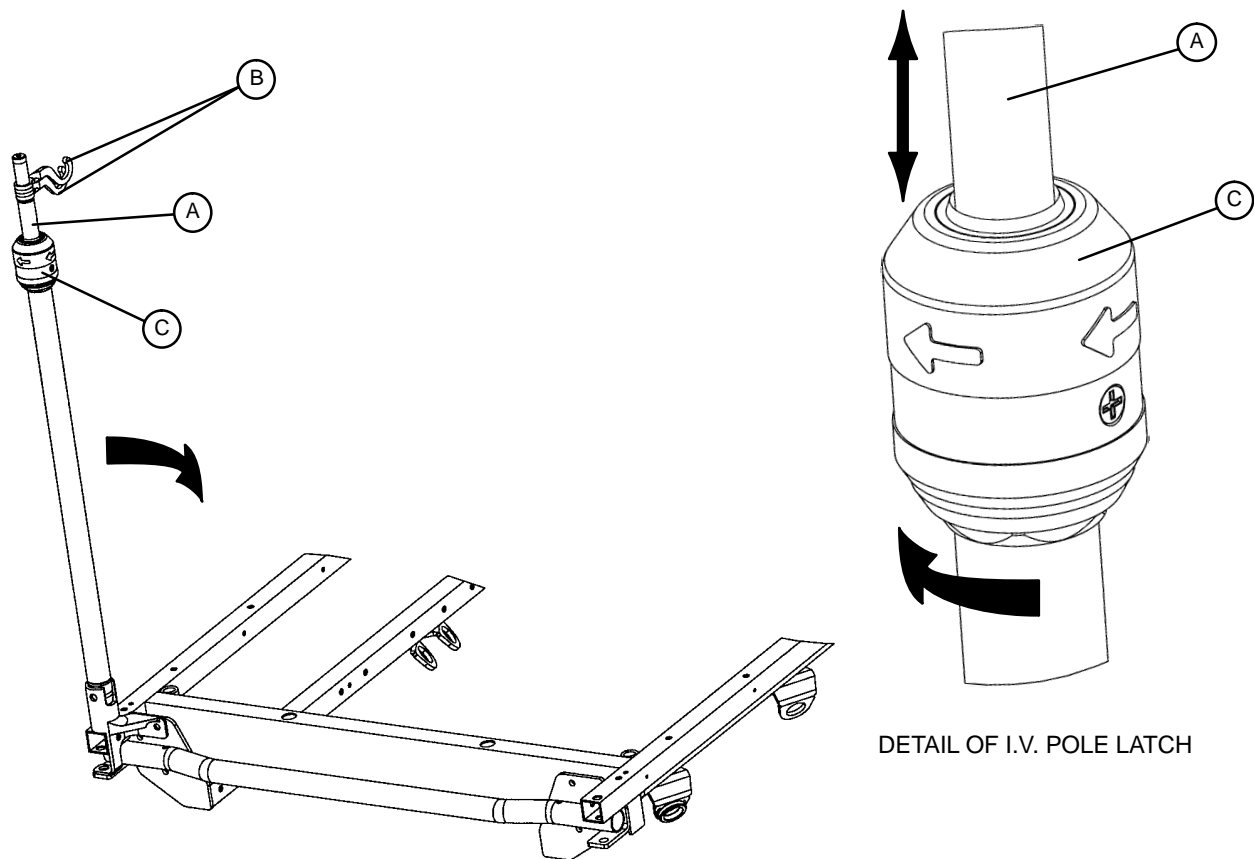

NOTE

The 2-stage permanently attached I.V. pole is an option and may have been installed at either the head, foot or both ends of the stretcher. The choice was made at the time the stretcher was purchased.

To use the 2-stage permanently attached I.V. pole:

1. Lift and pivot the pole from the storage position and push down until it is locked into the receptacle.
2. To raise the height of the pole, pull up on the telescoping portion (A) until it locks into place at its fully raised position.
3. Rotate the I.V. hangers (B) to desired position and hang the I.V. bags.
4. To lower the I.V. pole, turn the latch (C) clockwise until section (A) lowers.

CAUTION

To avoid damage, the weight of the I.V. bags should not exceed 40 pounds.

To avoid damage while transporting the stretcher, verify the I.V. pole is at a low enough height to allow it to safely pass through door openings and under light fixtures.

Stretcher Operation

OPERATING OPTIONAL 3-STAGE PERMANENTLY ATTACHED I.V. POLE

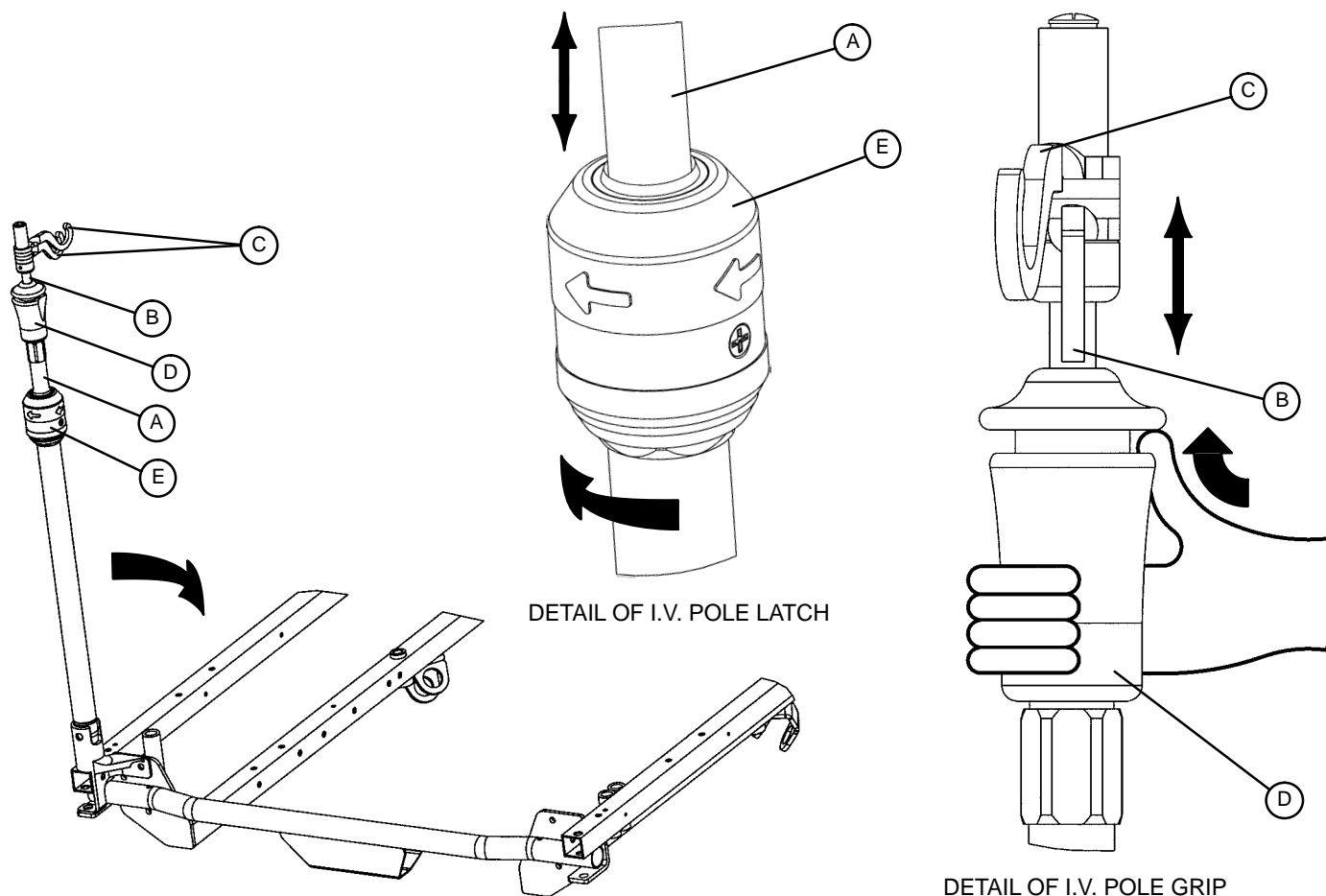

NOTE

The 3-stage permanently attached I.V. pole is an option and may have been installed at either the head, foot or both ends of the stretcher. The choice was made at the time the stretcher was purchased.

To use the 3-stage permanently attached I.V. pole:

1. Lift and pivot the pole from the storage position and push down until it is locked into the receptacle.
2. To raise the height of the pole, pull up on the telescoping portion (A) until it locks into place at its fully raised position.
3. For a higher I.V. pole, pull up on section (B). Release section (B) at any desired height and it will lock into place.
4. Rotate the I.V. hangers (C) to the desired position and hang the I.V. bags.
5. To lower the I.V. pole, push up on the red portion of grip (D) while holding onto section (B) until it lowers. Turn latch (E) clockwise until section (A) lowers.

CAUTION

To avoid damage, the weight of the I.V. bags should not exceed 40 pounds.

To avoid damage while transporting the stretcher, verify the I.V. pole is at a low enough height to allow it to safely pass through door openings and under light fixtures.

Stretcher Operation

OPERATING THE OPTIONAL TETHERED I.V. POLE

To use the tethered I.V. pole:

1. Remove the I.V. pole from the storage trough under the litter and insert it into the receptacle on the corner of the litter frame.
2. To raise the height of the pole, turn knob (A) counterclockwise and pull up on the telescoping portion (B) of the pole to raise it to the desired height.
3. Turn knob (A) clockwise to lock the telescoping portion in place.

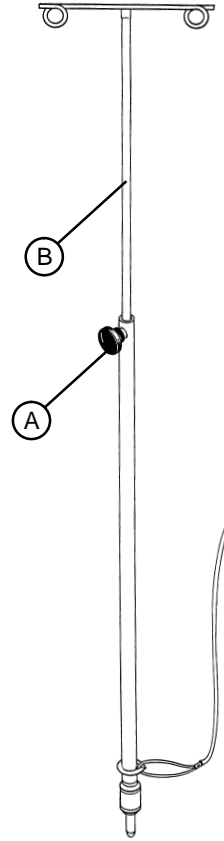

USING THE OPTIONAL X-RAY CASSETTE HOLDER

1. To access the Fowler x-ray cassette holder, raise the Fowler section.
2. Grasp handles (A) and squeeze, allowing the locating pins (B) to disengage from the mounting brackets (C).
3. Lower the tray and install the x-ray cassette.
4. Reverse steps 1 & 2 to engage the loaded tray to the Fowler mounting brackets (C).
5. To completely remove the tray from the Fowler, remove the bottom of the tray from the mounting brackets (D).

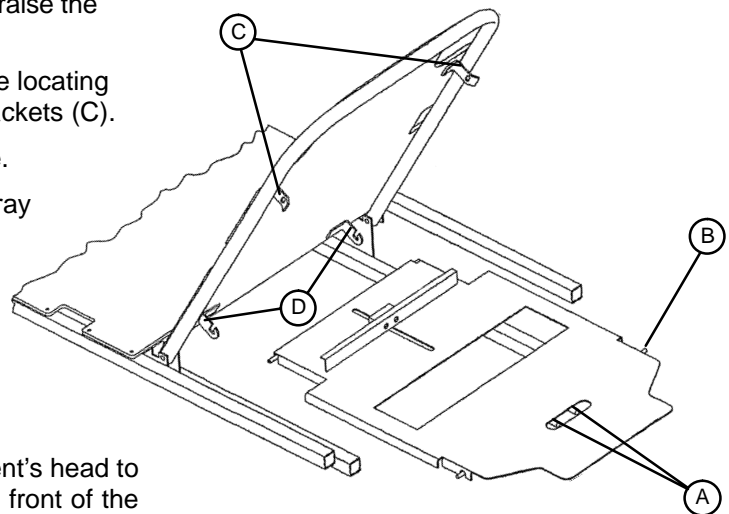

NOTE

The tray position can be adjusted, from the patient's head to the buttocks area, by loosening the knob on the front of the tray, sliding the tray to the desired position, and re-tightening the knob to hold the position.

Stretcher Operation

OPERATING OPTIONAL HEEL STIRRUPS

1. To use the optional heel stirrups, turn the handle (A) on the lock screw located under the litter frame and swing the stirrup assembly into position. Tighten the handle (A) to hold the assembly in place.
2. Loosen knob (B) and pull out the extension tube (C) to the desired length. Tighten knob (B).
3. Loosen knob (D) and raise or lower the stirrup (E) to the desired height. Tighten knob (D).

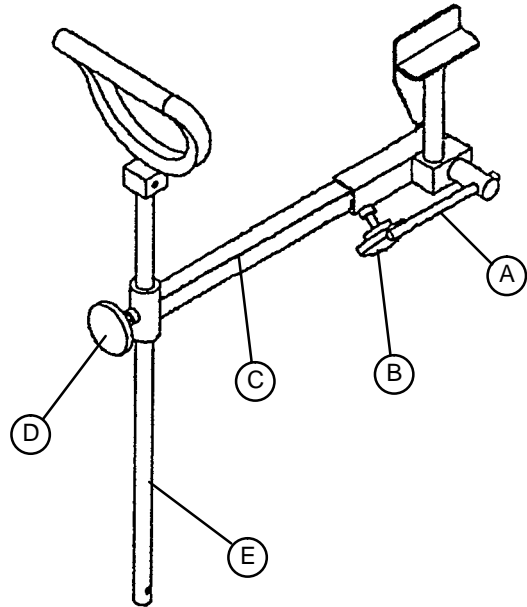

OPERATING OPTIONAL FOOT EXTENSION/DEFIBRILLATOR TRAY

1. To use as a defibrillator tray, pull out the top knob (A) and pivot the tray (B) over the foot extension (C) until the tray extends flat over the foot end of the stretcher.
2. To use as a foot extension, pull out knob (A) and pivot the defibrillator tray back until it locks against the foot extension (C). While holding onto the assembly, pull out the bottom knob (D) and lower the foot extension down until it is flat.

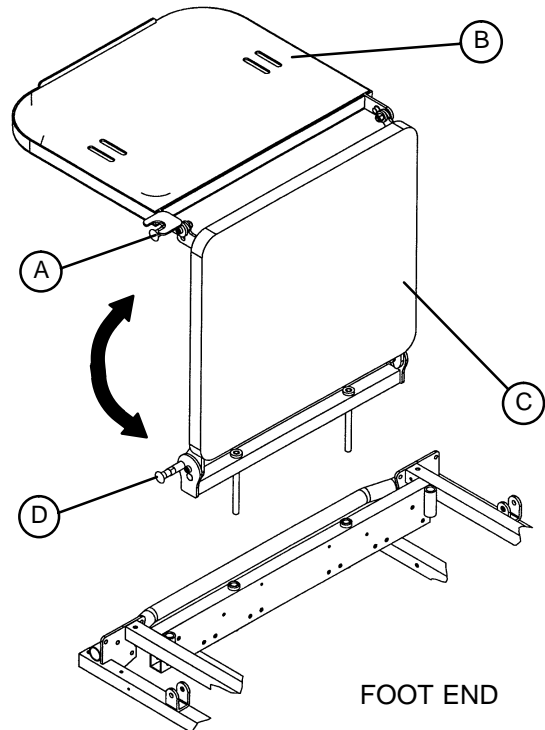

Preventative Maintenance

CHECKLIST

- _____ All fasteners secure
- _____ Siderails move and latch properly
- _____ Engage brake pedal and push on the stretcher to ensure all casters lock securely
- _____ All casters secure and swiveling properly
- _____ Fowler operating and latching properly
- _____ Knee Gatch operating properly
- _____ Trendelenburg/Reverse Trendelenburg operating properly
- _____ Ground chain intact
- _____ No leaks at hydraulic connections
- _____ Hydraulic jacks holding properly
- _____ Hydraulic drop rate set properly
- _____ Hydraulic oil level sufficient
- _____ Lubricate where required, including the brake adjuster assembly and brake cam
- _____ Body restraints intact and working properly
- _____ I.V. pole intact and operating properly
- _____ Oxygen bottle holder intact
- _____ No rips or cracks in mattress cover
- _____ Accessories and mounting hardware in good condition and working properly

Serial No. _____

_____	_____	_____
_____	_____	_____
_____	_____	_____

Completed By: _____ Date: _____

NOTE

Preventative maintenance should be performed at a minimum of annually. A preventative maintenance program should be established for all Stryker Medical equipment. Preventative maintenance may need to be performed more frequently based on the usage level of the product.

Preventative Maintenance

CLEANING

Model 660 stretchers are designed to be power-washable. The unit may show some signs of oxidation or discoloration from continuous washing. However, no degradation of the stretcher's performance characteristics or functionality will occur due to power washing as long as the proper procedures are followed.

- Follow the cleaning solution manufacturer's dilution recommendations exactly.
- Remove the mattress prior to washing the unit; do not wash the mattress with the stretcher.
- Position the Fowler at 45°, place the unit in full reverse Trendelenburg (foot end down), raise the siderails, and place the I.V. poles and push handles in the up position.
- Stryker Medical recommends the standard hospital surgical cart washer for power washing Model 660 stretchers.
- Do not replace the mattress on the stretcher until the unit is completely dry.

DO NOT STEAM CLEAN THE UNIT. Use a maximum water temperature of 180°F/68°C. Maximum air dry temperature (cart washers) is 240°F/115°C. Water pressure - 1500 psi/130.5 bar. If a hand held wand is being used to wash the unit, the pressure nozzle must be kept a minimum of 24 inches/.61m from the unit.

Stretchers must have maintenance performed after a minimum of every fifth washing. Refer to the maintenance manual for specific lubrication instructions.

Failure to comply with these instructions may invalidate any/all warranties.

Preventative Maintenance

CLEANING (CONTINUED)

In general, when used in those concentrations recommended by the manufacturer, either phenolic type or quaternary type disinfectants can be used. Iodophor type disinfectants are not recommended for use because staining may result. The following products have been tested and have been found not to have a harmful effect WHEN USED IN ACCORDANCE WITH MANUFACTURERS RECOMMENDED DILUTION.*

TRADE NAME	DISINFECTANT TYPE	MANUFACTURER	*MANUFACTURER'S RECOMMENDED DILUTION
A33	Quaternary	Airwick (Professional Products Division)	2 ounces/gallon
A33 (dry)	Quaternary	Airwick (Professional Products Division)	1/2 ounce/gallon
Beaucoup	Phenolic	Huntington Laboratories	1 ounce/gallon
Blue Chip	Quaternary	S.C. Johnson	2 ounces/gallon
Elimstaph	Quaternary	Walter G. Legge	1 ounce/gallon
Franklin Phenomysan F2500	Phenolic	Purex Corporation	1 1/4 ounce/gallon
Franklin Sentinel	Quaternary	Purex Corporation	2 ounces/gallon
Galahad	Phenolic	Puritan Churchill Chemical Company	1 ounce/gallon
Hi-Tor	Quaternary	Huntington Laboratories	1/2 ounce/gallon
LPH	Phenolic	Vestal Laboratories	1/2 ounce/gallon
Matar	Phenolic	Huntington Laboratories	1/2 ounce/gallon
Omega	Quaternary	Airwick (Professional Products Division)	1/2 ounce/gallon
Quanto	Quaternary	Huntington Laboratories	1 ounce/gallon
Sanikleen	Quaternary	West Chemical Products	2 ounces/ gallon
Sanimaster II	Quaternary	Service Master	1 ounce/gallon
Vesphene	Phenolic	Vestal Laboratories	1 1/4 ounce/ gallon

Quaternary Germicidal Disinfectants, used as directed, and/or Chlorine Bleach products, typically 5.25% Sodium Hypochlorite in **dilutions ranging between 1 part bleach to 100 parts water, and 2 parts bleach to 100 parts water are not considered mild detergents. These products are corrosive in nature and may cause damage to your stretcher if used improperly.** If these types of products are used to clean Stryker patient handling equipment, measures must be taken to insure the stretchers are rinsed with clean water and thoroughly dried following cleaning. Failure to properly rinse and dry the stretchers will leave a corrosive residue on the surface of the stretcher, possibly causing premature corrosion of critical components.

NOTE

Failure to follow the above directions when using these types of cleaners may void this product's warranty.

REMOVAL OF IODINE COMPOUNDS

This solution may be used to remove iodine stains from mattress cover and foam footrest pad surfaces.

1. Use a solution of 1-2 tablespoons Sodium Thiosulfate in a pint of warm water to clean the stained area. Clean as soon as possible after staining occurs. If stains are not immediately removed, allow solution to soak or stand on the surface.
2. Rinse surfaces which have been exposed to the solution in clear water before returning bed to service.

Warranty

Limited Warranty:

Stryker Medical Division, a division of Stryker Corporation, warrants to the original purchaser that its products should be free from defects in material and workmanship for a period of one (1) year after date of delivery. Stryker's obligation under this warranty is expressly limited to supplying replacement parts and labor for, or replacing, at its option, any product which is, in the sole discretion of Stryker, found to be defective. Stryker warrants to the original purchaser that the frame and welds on its beds will be free from structural defects for as long as the original purchaser owns the bed. If requested by Stryker, products or parts for which a warranty claim is made shall be returned prepaid to Stryker's factory. Any improper use or any alteration or repair by others in such manner as in Stryker's judgement affects the product materially and adversely shall void this warranty. Any repair of Stryker products using parts not provided or authorized by Stryker shall void this warranty. No employee or representative of Stryker is authorized to change this warranty in any way.

Stryker Medical stretchers are designed for a 10 year expected life under normal use conditions and appropriate periodic maintenance as described in the maintenance manual for each device.

This statement constitutes Stryker's entire warranty with respect to the aforesaid equipment. STRYKER MAKES NO OTHER WARRANTY OR REPRESENTATION, EITHER EXPRESSED OR IMPLIED, EXCEPT AS SET FORTH HEREIN. THERE IS NO WARRANTY OF MERCHANTABILITY AND THERE ARE NO WARRANTIES OF FITNESS FOR ANY PARTICULAR PURPOSE. IN NO EVENT SHALL STRYKER BE LIABLE HEREUNDER FOR INCIDENTAL OR CONSEQUENTIAL DAMAGES ARISING FROM OR IN ANY MANNER RELATED TO SALES OR USE OF ANY SUCH EQUIPMENT.

To Obtain Parts and Service:

Stryker products are supported by a nationwide network of dedicated Stryker Field Service Representatives. These representatives are factory trained, available locally, and carry a substantial spare parts inventory to minimize repair time. Simply call your local representative, or call Stryker Customer Service at (800) 327-0770.

Service Contract Coverage:

Stryker has developed a comprehensive program of service contract options designed to keep your equipment operating at peak performance at the same time it eliminates unexpected costs. We recommend that these programs be activated *before* the expiration of the new product warranty to eliminate the potential of additional equipment upgrade charges.

A SERVICE CONTRACT HELPS TO:

- Ensure equipment reliability
- Stabilize maintenance budgets
- Diminish downtime
- Establish documentation for JCAHO
- Increase product life
- Enhance trade-in value
- Address risk management and safety

Warranty

Stryker offers the following service contract programs:

SPECIFICATIONS	GOLD	SILVER	PM* ONLY
Annually scheduled preventative maintenance	X		X
All parts,** labor, and travel	X	X	
Unlimited emergency service calls	X	X	
Priority one contact; two hour phone response	X	X	X
Most repairs will be completed within 3 business days	X	X	
JCAHO documentation	X	X	X
On-site log book w/ preventative maintenance & emergency service records	X		
Factory-trained Stryker Service Technicians	X	X	X
Stryker authorized parts	X	X	X
End of year summary	X		
Stryker will perform all service during regular business hours (9-5)	X	X	X

* Replacement parts and labor for products under PM contract will be discounted.

** Does not include any disposable items, I.V. poles (except for Stryker HD permanent poles), mattresses, or damage resulting from abuse.

Stryker Medical also offers *personalized* service contracts.

Pricing is determined by age, location, model and condition of product.

For more information on our service contracts, please call your local representative or call (800) 327-0770 (option #2).

Return Authorization:

Merchandise cannot be returned without approval from the Stryker Customer Service Department. An authorization number will be provided which must be printed on the returned merchandise. Stryker reserves the right to charge shipping and restocking fees on returned items.

SPECIAL, MODIFIED, OR DISCONTINUED ITEMS NOT SUBJECT TO RETURN.

Damaged Merchandise:

ICC Regulations require that claims for damaged merchandise must be made with the carrier within fifteen (15) days of receipt of merchandise. **DO NOT ACCEPT DAMAGED SHIPMENTS UNLESS SUCH DAMAGE IS NOTED ON THE DELIVERY RECEIPT AT THE TIME OF RECEIPT.** Upon prompt notification, Stryker will file a freight claim with the appropriate carrier for damages incurred. Claim will be limited in amount to the actual replacement cost. In the event that this information is not received by Stryker within the fifteen (15) day period following the delivery of the merchandise, or the damage was not noted on the delivery receipt at the time of receipt, the customer will be responsible for payment of the original invoice in full.

Claims for any short shipment must be made within thirty (30) days of invoice.

International Warranty Clause:

This warranty reflects U.S. domestic policy. Warranty outside the U.S. may vary by country. Please contact your local Stryker Medical representative for additional information.



European Representative

Stryker France
BP 50040-95946 Roissy Ch. de Gaulle
Cedex-France

Phone: 33148632290
Fax: 33148632175

stryker[®]
Medical

6300 S. Sprinkle Road, Kalamazoo, MI 49001-9799

(800) 327-0770
www.strykermedical.com



DH 5/03 0660-009-003 REV A