

stryker®

Maintenance Manual

Medical

**Important
Information**

File in your
maintenance
records

**Transport Stretcher
Model 736**

**For parts or technical
assistance call
800 327 0770 (option 2)**



Table of Contents

Introduction

Specifications	4
Warning / Caution / Note Definition	4

Preventative Maintenance

Checklist	5
Cleaning	6

Service Information

Caster Cover Installation and Removal	7
Caster Removal	7
Brake Rod Removal	8
Side Control Brake Rod Removal	8
Release Pedal Adjustment	9
Foot End Release Pedal Replacement	9
Foot End Release Pedal Rod Removal	9
Brake Ring Removal	10
Fifth Wheel Assembly Removal	10
Litter Top Removal	11
Jack Descent Rate Adjustment	11
Removal of Excess Air from the Hydraulic System	11
Head End Hydraulic Jack Removal	12
Foot End Hydraulic Jack Removal	12
Pneumatic Fowler Adjustment	13
Folddown Siderail Latch Adjustment	13
Quick Reference Replacement Parts List	14

Table of Contents

Assembly Drawings and Parts Lists

Fifth Wheel Base Assembly	15
Fifth Wheel Assembly	16, 17
Base Assembly with Standard Brakes	18, 19
Brake Rod Assembly	20
Drive Link Assembly	21, 22
Caster Assembly	23
Base Assembly with Four-Sided Brakes	24, 25
Brake Rod Assembly	26
Side Control Brake Rod Assembly	27
Base Assembly with Dual Side Hydraulics	28–30
Release Pedal Assembly	31
Pump Pedal Assembly	32
Variable Descent Hydraulic Jack Option	33
Jack Base Assembly, Variable Descent Jacks	34
Base Labeling Assembly	36–38
Litter Assembly	39–43
Knee Gatch Crankscrew Assembly	44
Siderail Assembly	45
Pneumatic Fowler Assembly	46
Fowler to Litter Assembly	47
Pneumatic Fowler Outer Housing Assembly	48
Removable I.V. Pole Assembly	49
Corner Cover Assembly	50
Corner Cover, Push Handle Assembly	51
Corner Cover, 2-Stage I.V. Assembly	52

Table of Contents

Corner Cover, 2–Stage I.V., Push Handle Assembly	53
Corner Cover, 3–Stage I.V. Assembly	54
Corner Cover, 3–Stage I.V., Push Handle Assembly	55
Push Handle Assembly	56
Optional 2–Stage I.V. Pole Assembly	57
Optional 3–Stage I.V. Pole Assembly	58
3–Stage I.V. 3rd Stage Assembly	59
I.V. Pole Latch	60
Defibrillator Tray Assembly	61
Foot Extension/Defibrillator Tray Assembly	62
Foot Board/Chartholder Assembly	63
Upright O2 Bottle Holder Assembly	64
O2 Bottle Retainer Assembly	64
Mattresses and Siderail Pads	65
Warranty	
Obtaining Parts and Service	66
Service Contract Coverage	66
Return Authorization	67
Freight Damage Claims	67

Introduction

INTRODUCTION

This manual is designed to assist you with the maintenance of the Model 736 Transport Stretcher. Read it thoroughly before using the equipment or beginning any maintenance on it.

SPECIFICATIONS

Maximum Weight Capacity	500 pounds 
Overall Stretcher Length \ Width	83" / 30"
Minimum \ Maximum Bed Height	21.5" / 36"
Fowler Angle	0° to 90°
Trendelenburg \ Reverse Trendelenburg	+18° to -18°

Stryker reserves the right to change specifications without notice.

WARNING / CAUTION / NOTE DEFINITION

The words WARNING, CAUTION and NOTE carry special meanings and should be carefully reviewed.

WARNING

Alerts the reader about a situation, which if not avoided, could result in death or serious injury. It may also describe potential serious adverse reactions and safety hazards.

CAUTION

Alerts the reader of a potentially hazardous situation, which if not avoided, may result in minor or moderate injury to the user or patient or damage to the equipment or other property. This includes special care necessary for the safe and effective use of the device and the care necessary to avoid damage to a device that may occur as a result of use or misuse.

NOTE

This provides special information to make maintenance easier or important instructions clearer.



Safe Working Load

Preventative Maintenance

CHECKLIST

- _____ All fasteners secure
- _____ Siderails move and latch properly
- _____ Engage the brake pedal and push on the stretcher to ensure all casters lock securely
- _____ All casters secure and swiveling properly
- _____ Body restraints working properly
- _____ I.V. pole intact and operating properly
- _____ Oxygen bottle holder intact and operating properly
- _____ Fowler operates and latches properly
- _____ Trendelenburg/Reverse Trendelenburg operating properly
- _____ No rips or cracks in mattress cover
- _____ Transfer boards intact and operating properly
- _____ Ground chain intact
- _____ No leaks at hydraulic connections
- _____ Hydraulic jacks holding properly
- _____ Hydraulic drop rate set properly
- _____ Hydraulic oil level sufficient
- _____ Lubricate where required
- _____ Accessories and mounting hardware in good condition and working properly

Serial No. _____

Completed By: _____ Date: _____

NOTE

Preventative maintenance should be performed at a minimum of annually. A preventative maintenance program should be established for all Stryker Medical equipment. Preventative maintenance may need to be performed more frequently based on the usage level of the product.

Cleaning

Hand wash all surfaces of the stretcher with warm water and mild detergent. DRY THOROUGHLY. Do not steam clean, pressure wash, hose off or ultrasonically clean. Using these methods of cleaning is **not** recommended and may void this product's warranty.

Suggested cleaners for stretcher surfaces:

Quaternary Cleaners (active ingredient – ammonium chloride)

Phenolic Cleaners (active ingredient – o-phenylphenol)

Chlorinated Bleach Solution (5.25% – less than 1 part bleach to 100 parts water)

Avoid oversaturation and ensure the product does not stay wet longer than the chemical manufacturer's guidelines for proper disinfecting.

 **CAUTION**

SOME CLEANING PRODUCTS ARE CORROSIVE IN NATURE AND MAY CAUSE DAMAGE TO THE PRODUCT IF USED IMPROPERLY. If the products described above are used to clean Stryker patient care equipment, measures must be taken to insure the beds are wiped with clean water and thoroughly dried following cleaning. Failure to properly rinse and dry the beds will leave a corrosive residue on the surface of the bed, possibly causing premature corrosion of critical components. Failure to follow the above directions when using these types of cleaners may void this product's warranty.

For mattress cleaning instructions, please see the tag on the mattress, or contact the mattress manufacturer.

Clean Velcro® AFTER EACH USE. Saturate Velcro® with disinfectant and allow disinfectant to evaporate. (Appropriate disinfectant for nylon Velcro® should be determined by the hospital.)

Service Information

CASTER COVER INSTALLATION AND REMOVAL

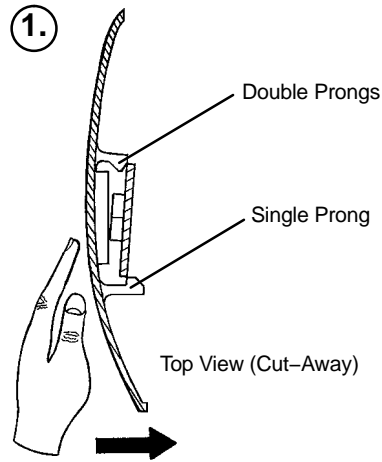

Looking through the larger of the two side cut-outs, align the cover with the axle nut or bolt head, as shown. Push down on the opposite side of the cover until the single prong engages the caster horn.

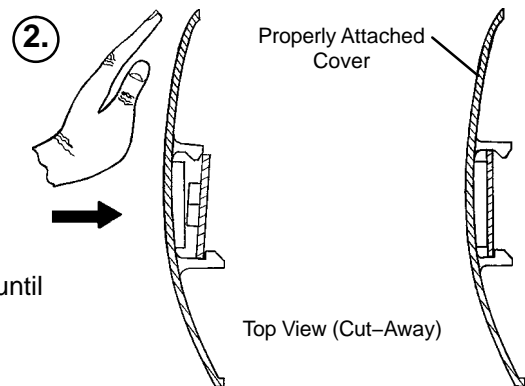

Push on the cover with your palm until the double prongs engage.

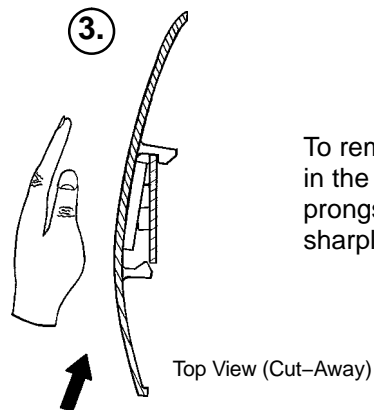

To remove the wheel cover, insert a large screwdriver into the cut-out in the side of the wheel cover and into the space between the double prongs. Pry up the cover to disengage the double prongs and push sharply upward to disengage the single prong.

CASTER REMOVAL

Required Tools:

9/16" Open End Wrench

1. Remove the caster cover.
2. While keeping pressure on the caster bolt with your index finger, use a 9/16" open end wrench to remove the nylock hex nut on top of the caster assembly.
3. Using the brake ring, lift up on the base assembly and pull the caster assembly down to remove it.
4. Reverse steps 1-3 to install the new caster.

Service Information

BRAKE ROD REMOVAL

Required Tools:

Hammer

7/32" Punch

String or Bungee Cords

1. Pump the litter up to full height.
2. Lift the base hood and support it from the litter using string or bungee cords.
3. Remove the hex head cap screws connecting the brake rod supports to the base frame.
4. Remove the bolt connecting the drive link assembly to the fifth wheel cam.
5. Remove the rue ring cotter and clevis pin connecting the rod end link to the side control link.
6. Remove the rue ring cotter connecting the drive link assembly to the bearing pivot support on the base frame (under the brake ring weldment).
7. Remove the three hex washer head screws holding the brake rod assembly to the base frame.
8. Remove the slotted spring pins connecting the butterfly "V" pedals, drive link assemblies and side control link to the brake rod.
9. Reverse steps 1–8 to reinstall the brake rod. When reinstalling the brake rod supports, torque the hex head cap screws to 12–15 ft.–lbs.

CAUTION

When reattaching the brake rod assembly to the base frame, set the torque specs **no higher** than 15 ft.–lbs. or damage could occur to the bolts.

SIDE CONTROL BRAKE ROD REMOVAL

Required Tools:

Hammer

7/32" Punch

Needle Nose Pliers

String or Bungee Cords

1. Pump the litter up to full height.
2. Lift the base hood and support it from the litter using string or bungee cords.
3. Remove the rue ring cotter and clevis pin connecting the rod end link to the side control link.
4. Remove the four bolts holding the brake rod assembly to the base frame and remove the entire assembly.
5. Using a hammer and 7/32" punch, drive the slotted spring pin out of the butterfly "V" pedal on the patient's left side and remove the pedal,
6. Using a hammer and 7/32" punch, drive the slotted spring pin out of the hard stop in the center of the support weldment.
7. Using a hammer and 7/32" punch, drive out the slotted spring pin connecting the side control link to the side control brake rod on the patient's right side.
8. Pull on the butterfly "V" pedal on the patient's right side to remove the side control brake rod from the base.
9. Reverse steps 1–8 to reinstall the brake rod. When reinstalling the assembly, torque the hex head cap screws to 12–15 ft.–lbs.

CAUTION

When reattaching the brake rod assembly to the base frame, set the torque specs **no higher** than 15 ft.–lbs. or damage could occur to the bolts.

Service Information

RELEASE PEDAL ADJUSTMENT

1. Manually disengage the release pedal swivel (item J on [page 29](#)) from the release pedal assembly.
2. To increase the release rod engagement with the release valve, turn the release pedal swivel clockwise on the threaded release rod.
3. To decrease the release rod engagement with the release valve, turn the release pedal swivel counter-clockwise on the threaded release rod.

NOTE

If the pedal swivel assembly is threaded too far onto the release rod, the release valve will be partially activated and the jack will drift.

FOOT END RELEASE PEDAL REPLACEMENT

Required Tools: Needle Nose Pliers

1. Apply the stretcher brakes.
2. Disconnect the release pedal return springs from the foot end release pedals.
3. Remove the rue ring cotters and the clevis pins connecting the foot end release pedals to the mounting bracket.
4. Rotate the pedals upward.
5. Remove the rue ring cotters connecting the head end and foot end release rods to the foot end release pedals and remove the pedals.
6. Reverse steps 2–5 to install the new pedals.

FOOT END RELEASE PEDAL ROD REMOVAL

Required Tools: Needle Nose Pliers

1. Remove the foot end release pedal (see procedure above).
2. Remove the snap in nyloners holding the foot end pedal release rods in the pedal mounting bracket.
3. Unsnap the foot end pedal release rods from the white plastic release rod brackets.
4. Dislodge the side control release pedal swivels from the studs on the side control release pedal weldments.
5. Remove the foot end pedal release rods.
6. Reverse steps 1–5 to reinstall the pedal rods.

Service Information

BRAKE RING REMOVAL

Required Tools:

9/16" Socket w/Extension 3/8" Drive Ratchet Needle–Nose Pliers String or Bungee Cord

1. Pump the litter up to full height.
2. Lift the base hood and support it from the litter using string or bungee cords.
3. Using needle–nose pliers, unhook the extension springs from the top of the base caster tubes.
4. Remove the plastic caster covers.
5. While putting pressure on the caster carriage bolt, use a 9/16" socket and a 3/8" drive ratchet to remove the caster nut on both sides of the stretcher.
6. Remove the casters.
7. Remove the brake rod (see procedure).
8. Remove the cotter pin from the clevis pin in the center of the brake ring weldment.
9. Remove the cotter pin from the bearing pivot support.
10. Remove the 3/4" nylock hex nut from the bearing pivot support.
11. Remove the drive link assembly.
12. Pull the brake ring down and out away from the stretcher base frame.
13. Reverse steps 1–12 to reinstall the brake ring.

FIFTH WHEEL ASSEMBLY REMOVAL

Required Tools:

1/2" Socket 3/8" Drive Ratchet

1. Using a 1/2" socket and 3/8" drive ratchet, remove the 1/2" bolt holding the fifth wheel cam drive link and fifth wheel drive link to the fifth wheel cam.
2. Remove the two 1/2" bolts holding the fifth wheel mounting bracket to the base frame weldment.
3. Remove the fifth wheel assembly.
4. Reverse steps 1 and 2 to reinstall the fifth wheel. When reinstalling the assembly, torque the hex head cap screws to 12–15 ft.–lbs.

CAUTION

When reattaching the fifth wheel assembly to the base frame, set the torque specs **no higher** than 15 ft.–lbs. or damage could occur to the bolts.

Service Information

LITTER TOP REMOVAL

Required Tools: 1/2" Socket w/Extension 3/8" Drive Ratchet Standard Screwdriver

1. Using the foot pedal, pump up the litter top to full height.
2. Remove the stretcher mattress
3. Remove the round, black hole plugs from the jack supports at each end of the litter to expose the jack support tube truss head screws.
4. Using a 1/2" socket, and a 3/8" drive ratchet, remove the truss head screws holding the jack support tubes to the jack shafts.
5. Thread a 7/16–20 fine thread bolt far enough into the top of the jack supports to separate the litter top from the jack shaft.
6. With the assistance of another person, lift the litter straight up to remove it from the jack shafts and set it aside.

JACK DESCENT RATE ADJUSTMENT

Required Tools:

Screwdriver Bungee Cords (or equivalent)

Adjustment Procedure:

1. Pump the litter up to full height.
2. Lift the base hood, separating the hood from the base frame. Support the hood from the litter using bungee cords so it is out of the way.
3. The descent rate needle valve is located on the base of the jack. Turning the needle valve clockwise, with a screwdriver, will decrease the rate of descent. Turning it counterclockwise will increase the rate of descent.

NOTE

The larger percentage of a patient's weight is located in the torso area. Adjust descent rate accordingly.

4. Remove the bungee cords supporting the base hood and secure the hood to the base frame.

NOTE

The jack descent rate is preset at the factory and adjustment is not recommended.

REMOVAL OF EXCESS AIR (VACUUM) FROM THE HYDRAULIC SYSTEM

1. Verify all hydraulic linkages are secure and operating properly.
2. Using the pump pedal, actuate the system several times to force the air through the system. The jack should now raise properly.

Service Information

HEAD END HYDRAULIC JACK REMOVAL

Required Tools: 1/2" Socket w/Extension 3/8" Drive Ratchet

1. Remove the litter top from the stretcher (see [page 11](#)).
2. Using a 1/2" socket with extension and a 3/8" drive ratchet, remove the two hex head screws holding the jack base to the stretcher base frame.
3. Remove the two hex head screws holding the jack reservoir clamp to the base frame and remove the clamps.
4. Lift straight up on the pump connecting rod and disconnect the pump piston from the connecting rod.
5. Disconnect the pump pedal swivel from the release pedal mounting plate.
6. Remove the head end release rod from the release valve assembly.
7. Using a 1/2" socket with extension and a 3/8" drive ratchet, remove the two hex head screws holding the jack base to the stretcher base frame.
8. Lift out the jack assembly.
9. To reinstall the jack, install the bolts on the jack and reservoir clamp but do not tighten them fully.
10. Reinstall the pump connecting rod and release rod.
11. Depress the pump pedal fully (to the floor). This will properly locate the jack onto the base frame.
12. Tighten the bolts on the jack and reservoir clamp.
13. Pump up the litter and apply weight to verify the jacks hold and do not drift.

NOTE

The jack descent rate is preset at the factory and adjustment is not recommended.

FOOT END HYDRAULIC JACK REMOVAL (BASE WITH DUAL CONTROLS)

Required Tools:

1/2" Socket 3/8" Drive Ratchet Pliers

1. Remove the litter top from the stretcher (see [page 11](#)).
2. Lift the base hood off the base frame.
3. Remove the two hex washer head screws and washers connecting the pump pedal link to the foot end pump pedal assembly and pump connecting rod.
4. Remove the foot end release rod from the release valve on the jack assembly by dislodging the release pedal swivel from the pins on the release pedal weldment.
5. Dislodge the jack pump piston from the pump connecting rod.
6. Remove the two hex washer head screws holding the reservoir clamp.
7. Remove the jack assembly.
8. Reverse steps 1–7 to install the new jack.

NOTE

The jack descent rate is preset at the factory and adjustment is not recommended.

Service Information

PNEUMATIC FOWLER ADJUSTMENT

Required Tools:

5/32" Hex Allen Wrench 1/2" Open End Wrench

1. Refer to the pneumatic Fowler assembly drawing on [page 46](#) for parts reference.
2. For easier access, raise the Fowler to 75° or higher.
3. Using a 1/2" open end wrench, loosen the hex nuts (item E) in the actuator arms on the end of the trip bar (item M).
4. To adjust the Fowler, use a 5/32" hex Allen wrench to turn the Allen screws (item J) 1 to 2 turns counter-clockwise if the Fowler will not move or 1 to 2 turns clockwise if the Fowler will not hold its position.
5. Retighten the hex nuts. Be sure the Fowler travels from flat up to 90° and down again and holds its position when weight is applied before returning the stretcher to service.

FOLDDOWN SIDERAIL LATCH ADJUSTMENT

Required Tools:

1/8" Hex Allen Wrench

WARNING

The siderail latches are preset at the factory, and do not normally need adjustment. If adjustment must be done, it is important to follow the procedure below. If adjustment is not done properly, injury to the patient or user could result.

1. Using a 1/8" hex Allen wrench, adjust the hex Allen screw located on the latch assembly opposite the latch. Turning the screw clockwise will **DECREASE** the amount of "play" in the latching mechanism. Turning counterclockwise will **INCREASE** the amount.

NOTE

The amount of "play" in the siderail, when in full up engaged position, should be approximately 1/8 to 3/16 inches.

CAUTION

Too much "play" when the siderail is in the full up engaged position will give the siderail the appearance of being unstable and could also cause premature wearing of the latch system.

Too little "play" will obstruct the latch and keep it from engaging completely in the full up position, which may result in damage to the latch and/or injury to the patient or user.

Quick Reference Replacement Parts List

<u>PART NAME</u>	<u>PART NUMBER</u>
Caster Assembly (1 complete)	0753-010-020
Defibrillator Tray/Foot Extension	0785-045-400
Foot Board/Chartholder Combination	0785-045-500
Hydraulic Jack Assembly, Variable Descent	0753-002-170
I.V. Pole, Standard Removable	0390-025-010
Mattress, 4" x 30", Enhanced Comfort	0785-034-323
Mattress, 4" x 30", Ultra Comfort	0785-034-303
Mattress, 5" x 30", Ultra Comfort	0785-034-333
Oxygen Bottle Holder, Upright	1020-030-000
Paint, Touch-Up, Gloss Black, Bottle w/Brush	7000-001-322
Paint, Touch-Up, Gloss Black, Spray Can	7000-001-319
Paint, Touch-Up, Gray, Bottle w/Brush	7000-001-320
Paint, Touch-Up, Gray, Spray Can	7000-001-317
Pneumatic Cylinder	1010-031-078
Restraint Strap, Ankle	0946-043-100
Restraint Straps, Body	0390-019-000
Restraint Strap, Wrist	0946-044-100
Siderail Pad Set	1010-052-000

NOTE

The parts and accessories listed on this page are all currently available for purchase. Some of the parts identified on the assembly drawings pages in this manual may not be individually available for purchase. Please call Stryker Customer Service at 1-800-327-0770 for availability and pricing.

0753-006-110 Retractable Fifth Wheel Base Assembly

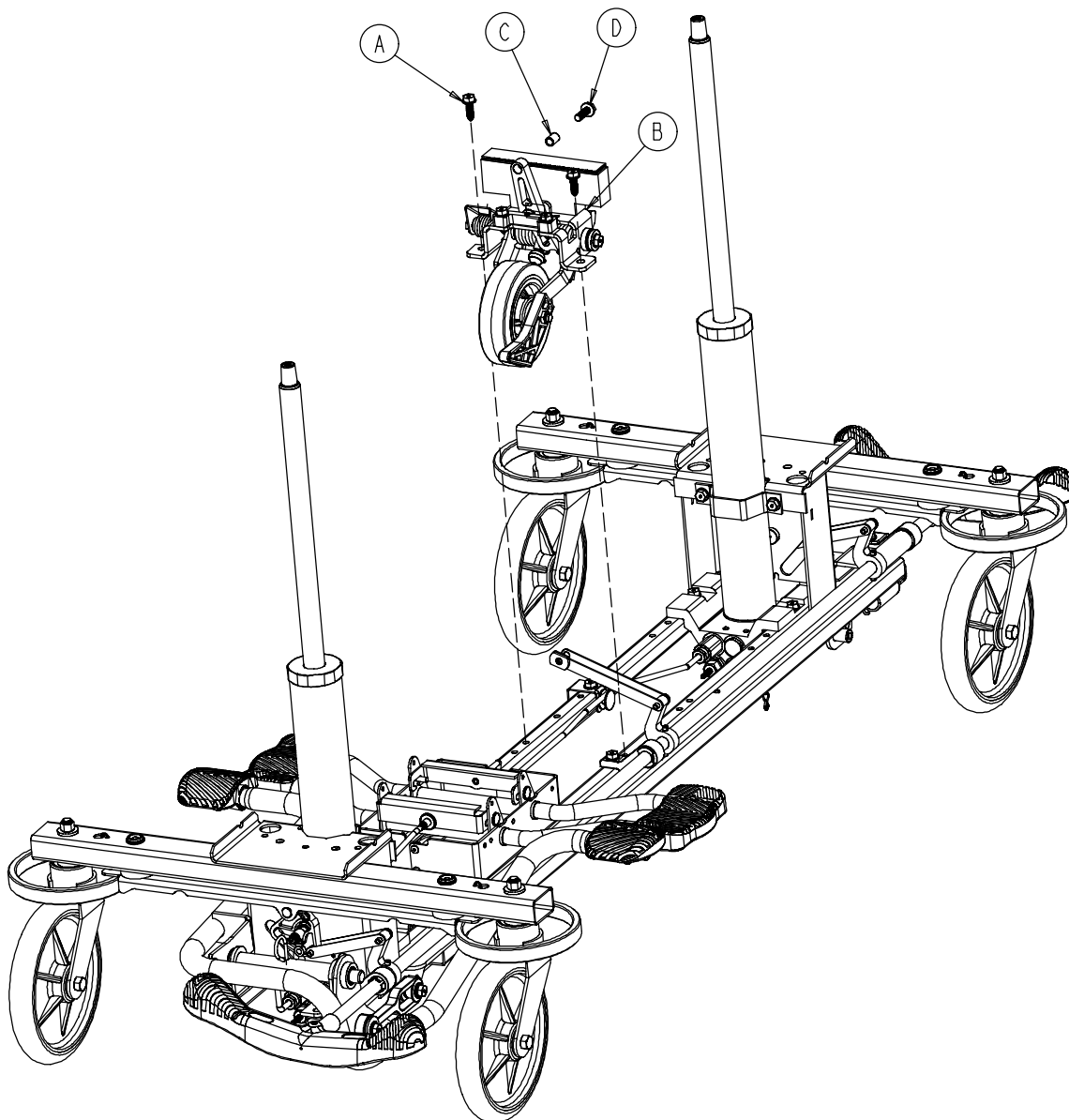

Item	Part No.	Part Name	Qty.
A	0023-288-000	Hex Washer Hd. Screw	2
B	(page 16)	Fifth Wheel Assembly	1
C	0753-006-148	Cam Bearing	1
D	0023-305-000	Hex Hd. Cap Screw	1

0753-006-130 Fifth Wheel Assembly

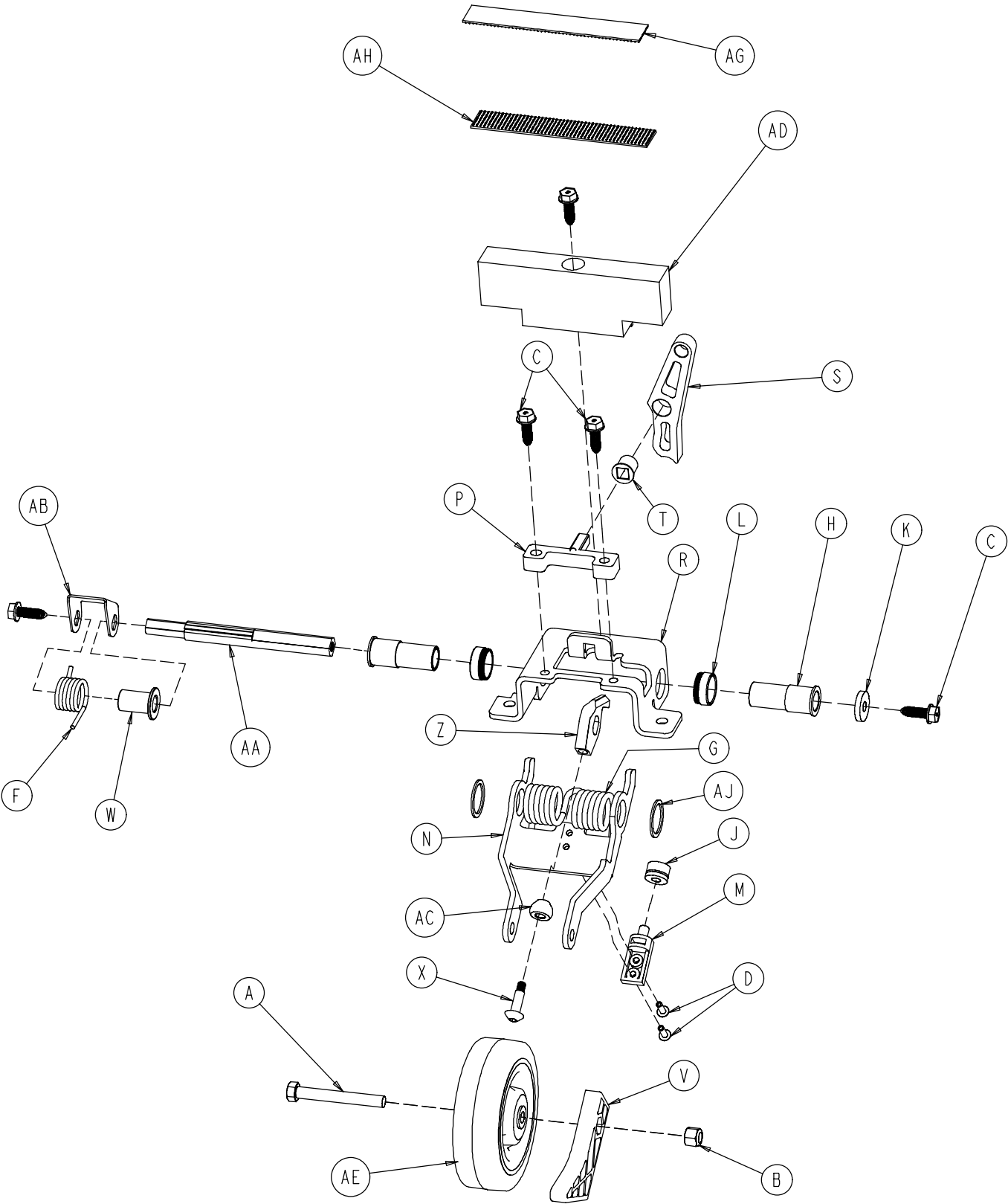

0753-006-130 Fifth Wheel Assembly

Item	Part No.	Part Name	Qty.
A	0003-083-000	Hex Hd. Cap Screw	1
B	0016-035-000	Nylock Hex Nut	1
C	0023-288-000	Hex Washer Hd. Screw	5
D	0025-050-000	Rivet	2
F	0753-006-074	Torsion Spring	1
G	0753-006-075	Torsion Spring	1
H	0753-006-097	Drive Shaft Bearing	2
J	0753-006-106	Dampener	1
K	0753-006-108	Thrust Washer	1
L	0753-006-115	Bearing	2
M	0753-006-120	Bumper Mounting Pin	1
N	0753-006-126	Wheel Bracket	1
P	0753-006-133	Cam Pivot Block	1
R	0753-006-134	Fifth Wheel Mounting Bracket	1
S	0753-006-142	Fifth Wheel Cam	1
T	0753-006-143	Cam Bearing	1
V	0753-006-149	5th Wheel Ramp	1
W	0753-006-152	Spring Spacer	1
X	0753-006-153	Roller Stem	1
Z	0753-006-198	Drive Pin	1
AA	0753-006-223	Drive Shaft	1
AB	0753-006-227	Return Spring Hook	1
AC	0753-006-277	Roller	1
AD	0753-010-045	Hood Standoff	1
AE	1210-001-147	Wheel	1
AG	0753-006-280	Dual Lock	1
AH	0753-006-281	Dual Lock	1
AJ	0011-360-000	Washer	2

Base Assembly w/Standard Brakes (Fifth Wheel Base)

Assembly part number
0753-003-105
(reference only)

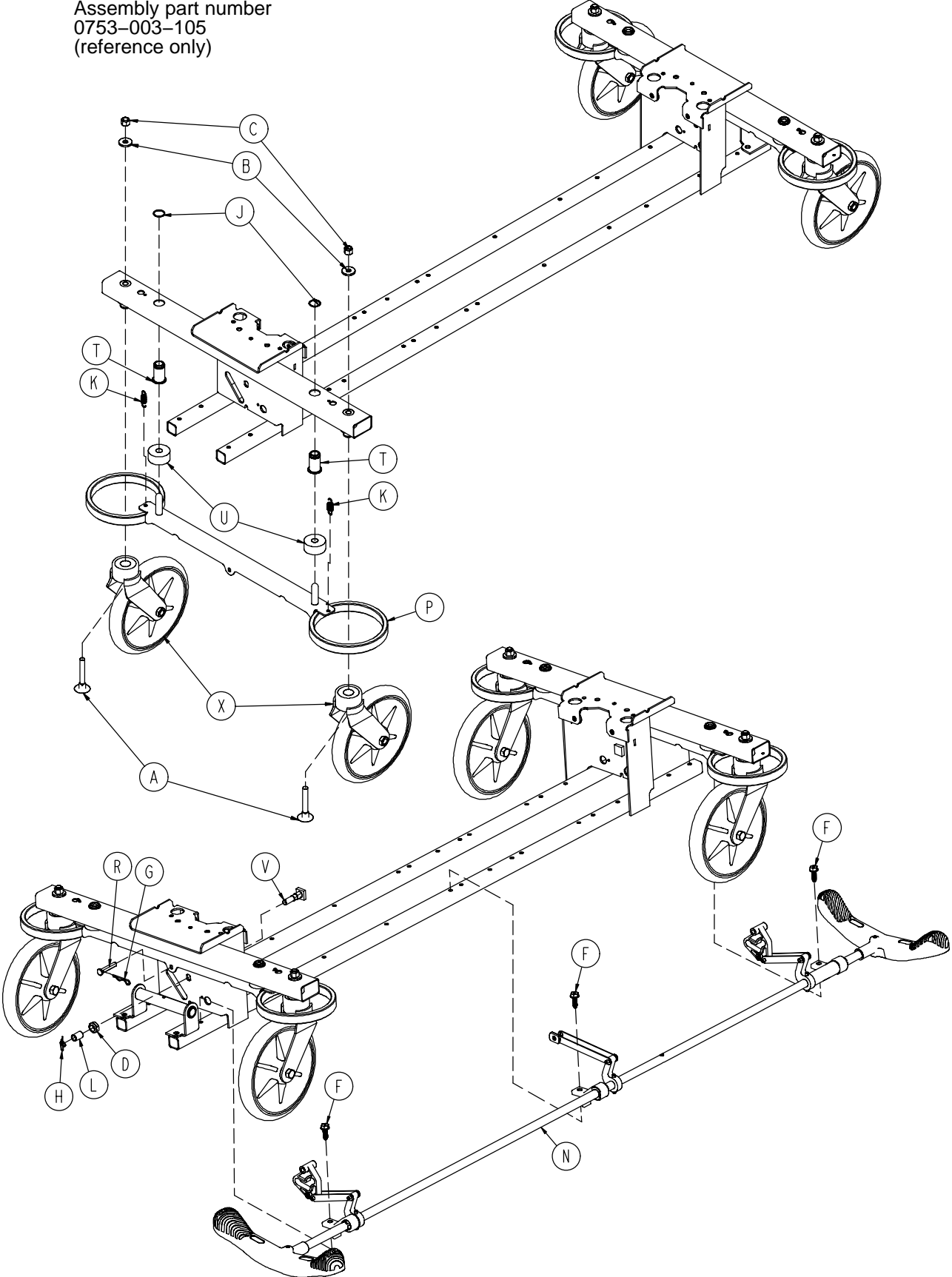

Base Assembly w/Standard Brakes (Fifth Wheel Base)

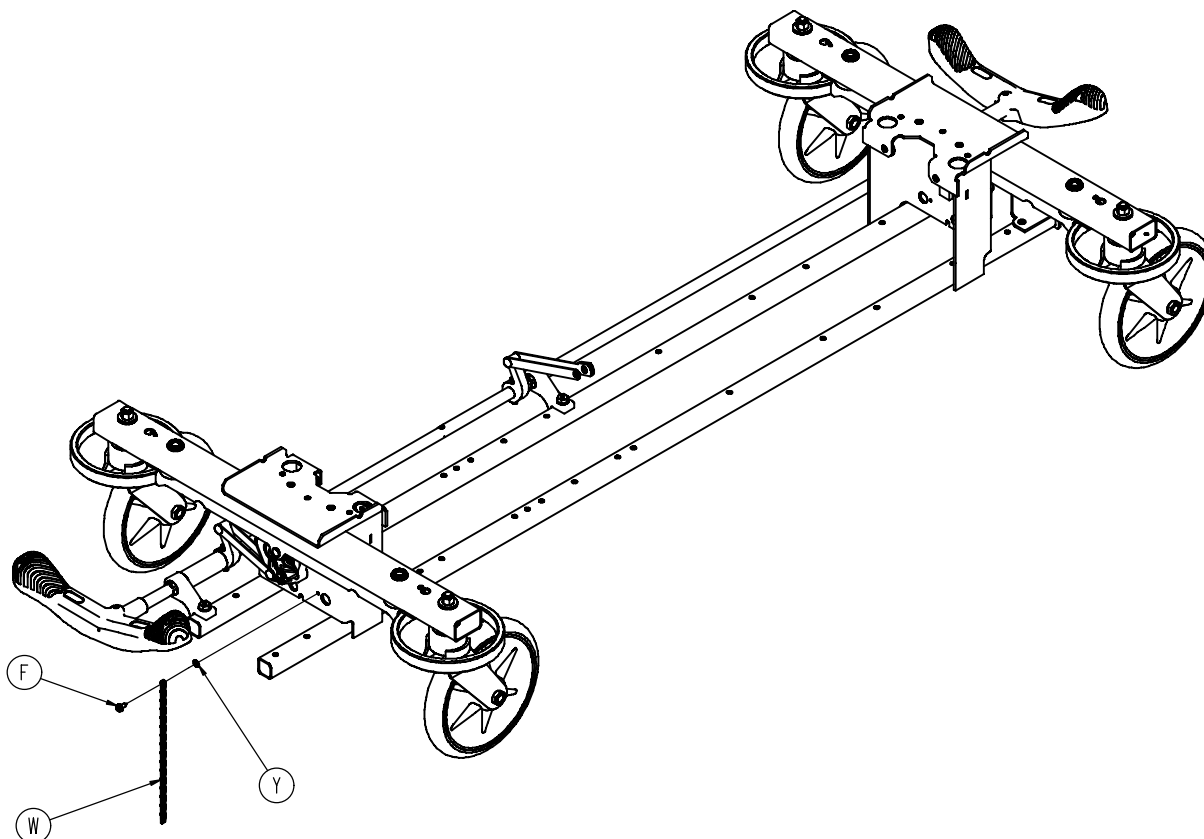

Item	Part No.	Part Name	Qty.
A	0005-044-000	Step Bolt	4
B	0011-262-000	Washer	4
C	0016-035-000	Nylock Hex Nut	4
D	0016-049-000	Nylock Hex Nut	2
E	0023-288-000	Hex Washer Hd. Screw	1
F	0003-364-000	Hex Washer Hd. Screw	1
G	0027-012-000	Hitch Pin	2
H	0027-022-000	Rue Ring Cotter	2
J	0028-037-000	External Retaining Ring	4
K	0038-439-000	Extension Spring	4
L	0081-037-000	Plane Bearing	2
M	0753-001-001	Base Frame	1
N	(page 20)	Brake Rod Assembly	1
P	0753-003-006	Brake Ring	2
R	0753-003-066	Clevis Pin	2
T	0753-003-079	Caster Tube Brake Pin Guide	4
U	0753-003-121	Brake Cushion	4
V	0753-003-230	Bearing Pivot Support	2
W	3001-200-052	Ground Chain	1
X	(page 23)	Caster Assembly	4
Y	0013-018-000	External Tooth Lock Washer	1

Brake Rod Assembly

Assembly part number 0753-003-001 (reference only)

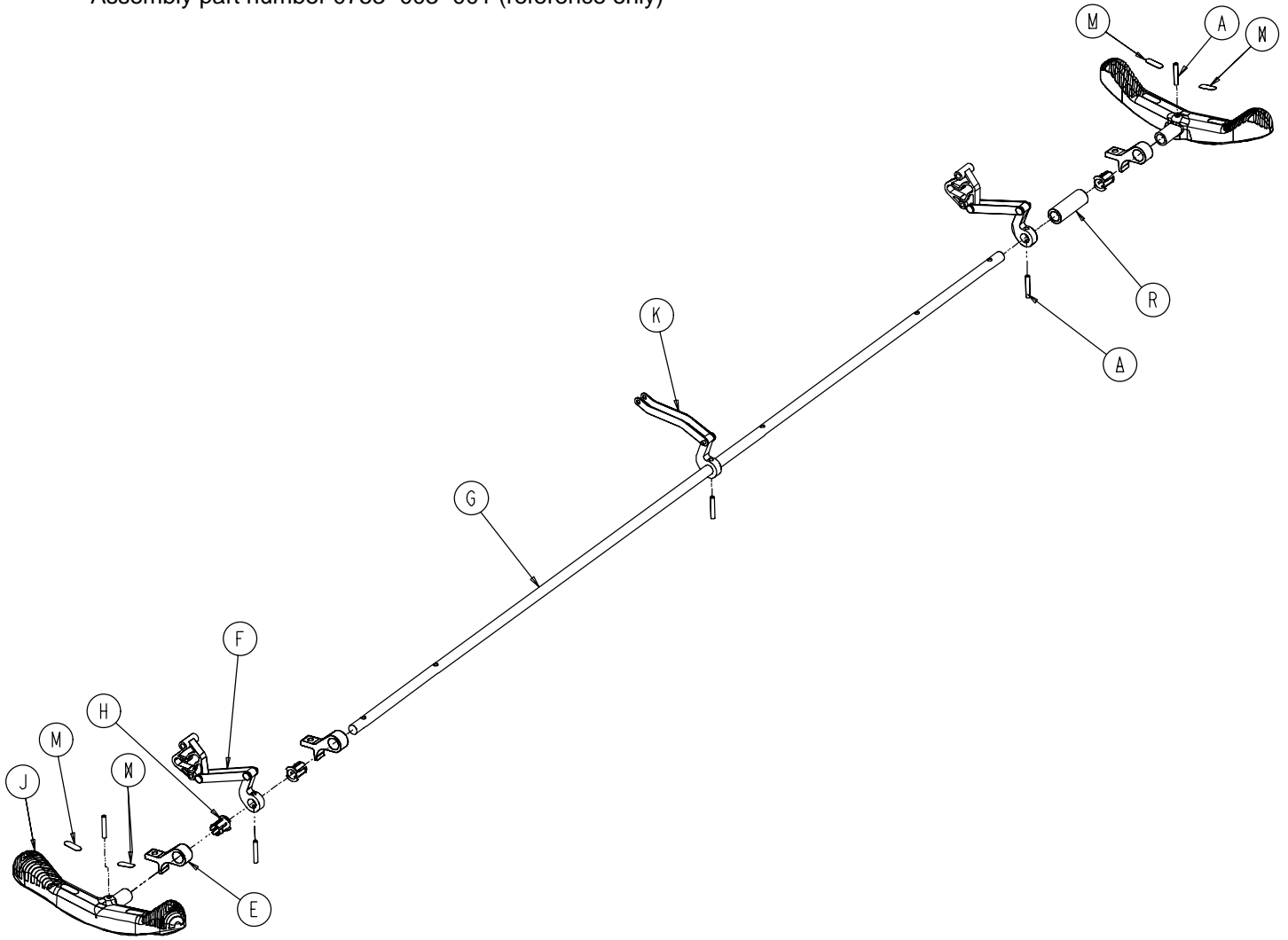

Item	Part No.	Part Name	Qty.
A	0026-067-000	Slotted Spring Pin	2
E	0753-003-004	Brake Rod Support	3
F	(page 21)	Drive Link Assembly	2
G	0753-003-014	Brake Rod	1
H	0753-003-015	Brake Rod Nyliner	3
J	0785-003-099	Butterfly "V" Pedal	2
K	(page 22)	Drive Link Assembly	1
M	1210-201-335	Red Brake Label	2
N	1210-201-336	Green Steer Label	2
R	0753-003-133	Retainment Spacer	1

0753-003-010 Drive Link Assembly

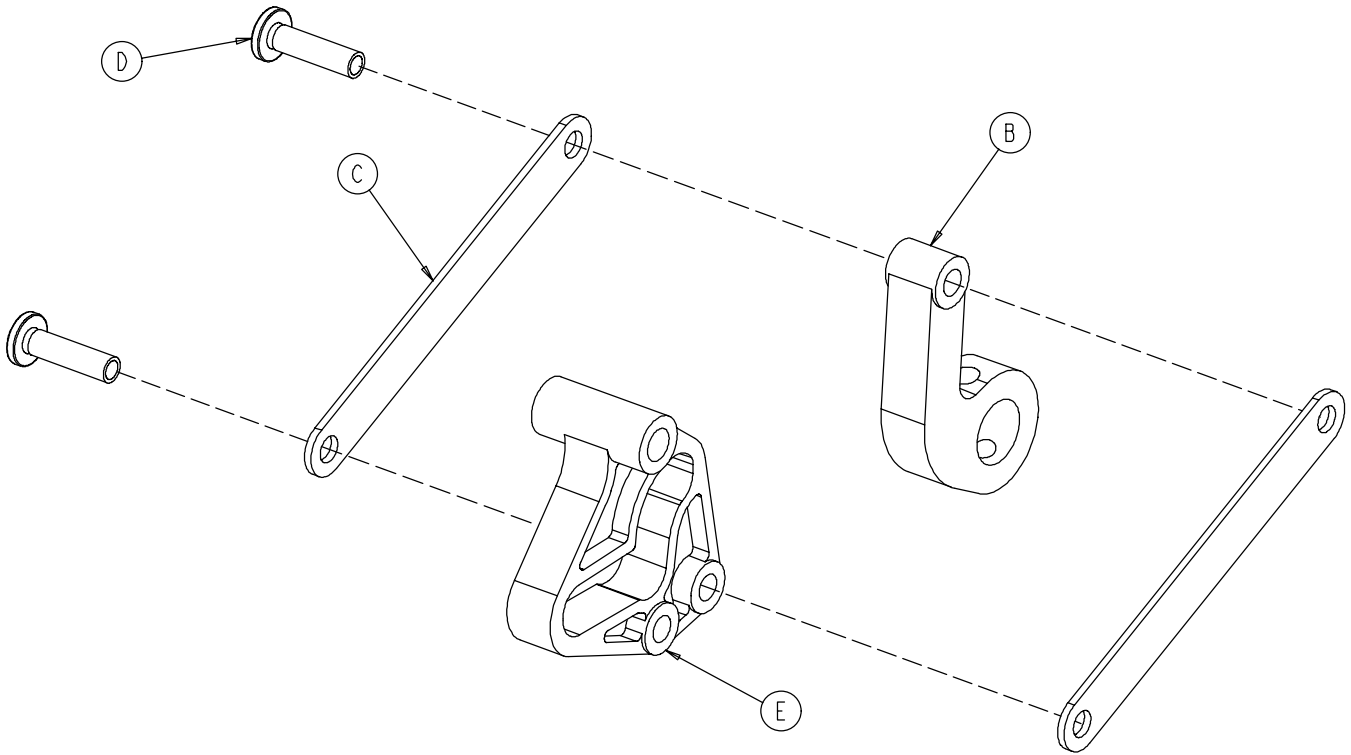

Item	Part No.	Part Name	Qty.
B	0753-003-011	Brake Rod Drive Link	1
C	0753-003-061	Brake Cam Drive Link	2
D	0753-003-098	Flat Hd. Semi-Tubular Rivet	2
E	0753-003-102	Brake Cam	1

0753-006-135 Drive Link Assembly

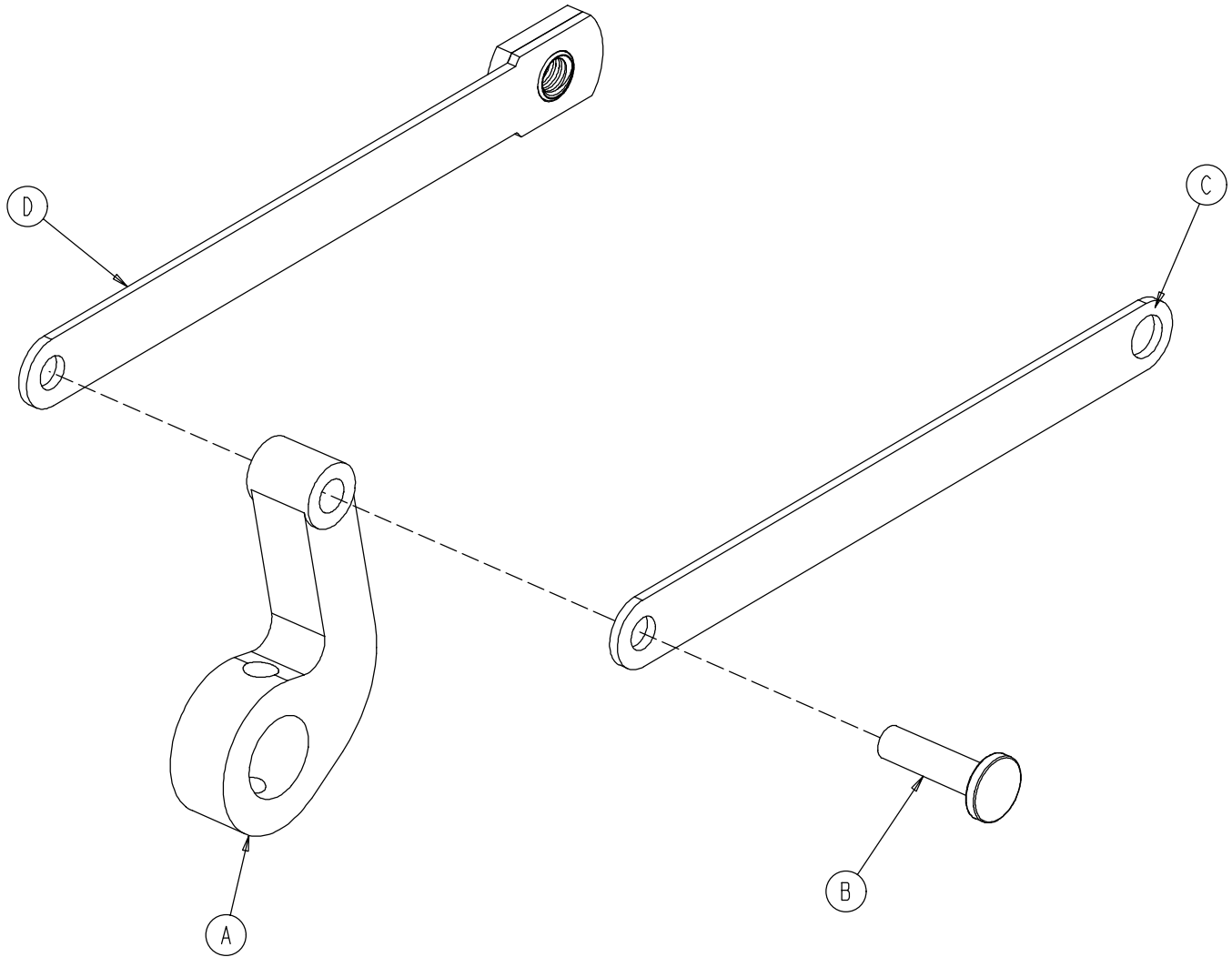

Item	Part No.	Part Name	Qty.
A	0753-003-011	Brake Rod Drive Link	1
B	0753-003-098	Semi-Tubular Rivet	1
C	0753-006-122	5th Wheel Cam Drive Link	1
D	0753-006-147	Fifth Wheel Drive Link	1

0753-010-220 8" Caster Assembly

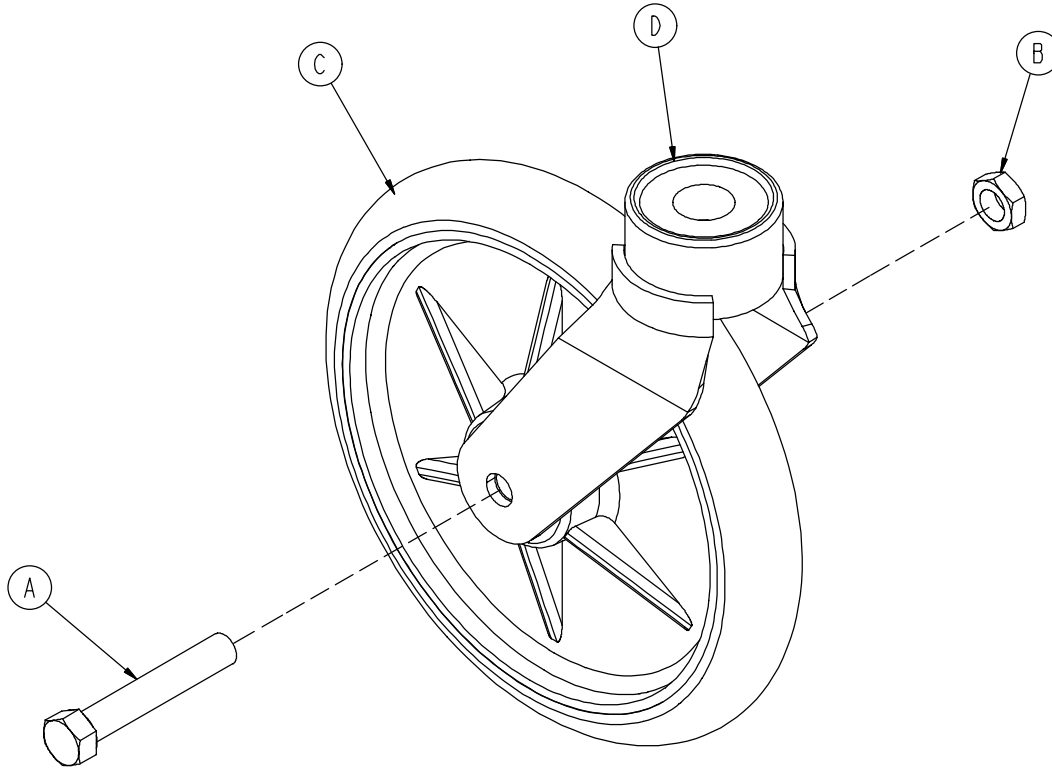

Item	Part No.	Part Name	Qty.
A	0003-099-000	Hex Hd. Cap Screw	1
B	0016-060-000	Centerlock Nut	1
C	0753-003-215	Wheel	1
D	0753-010-021	Caster Horn w/Bearing	1

Base Assembly with 4-Sided Brakes

Assembly part number 0753-003-120
(reference only)

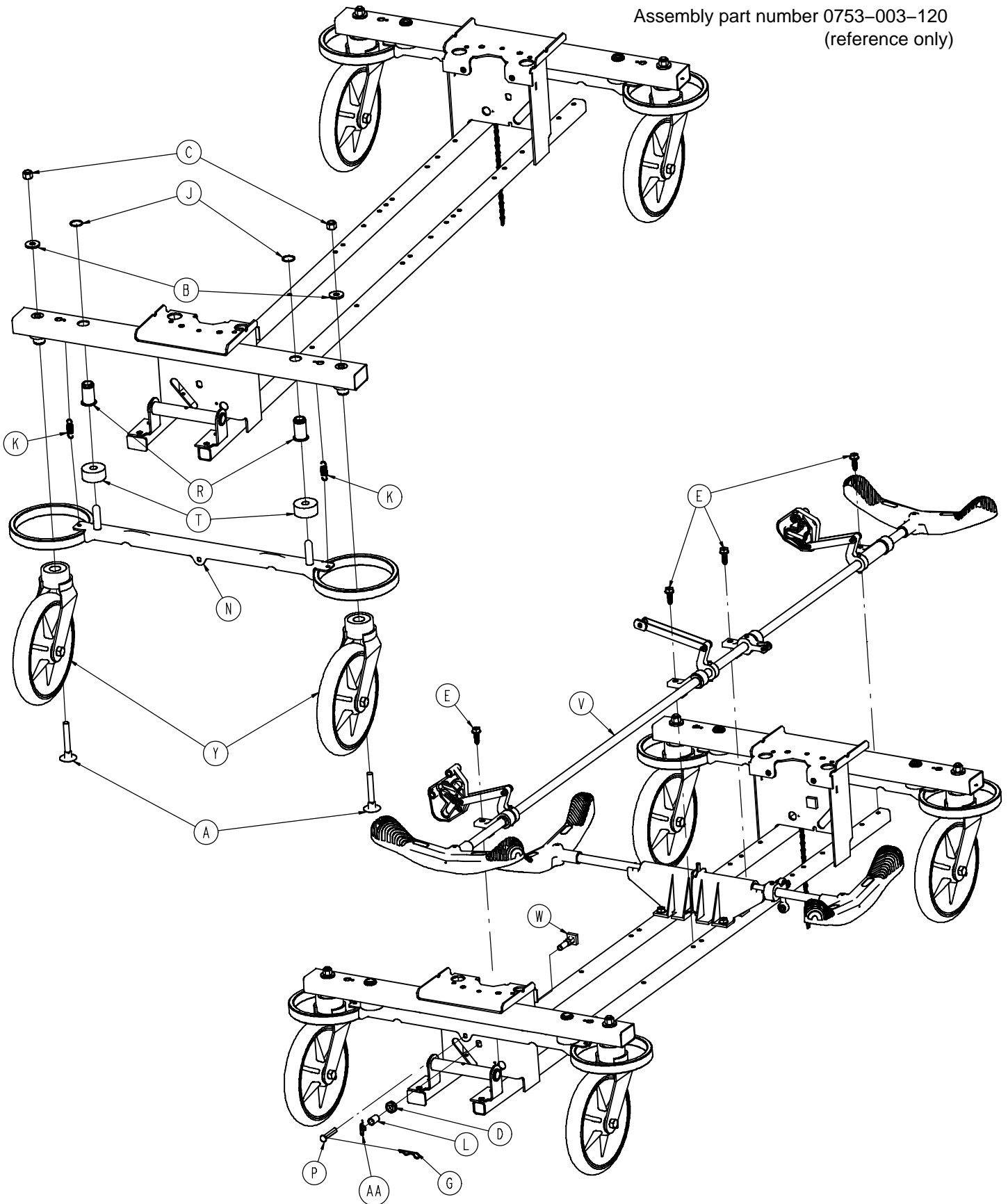

Base Assembly with 4-Sided Brakes

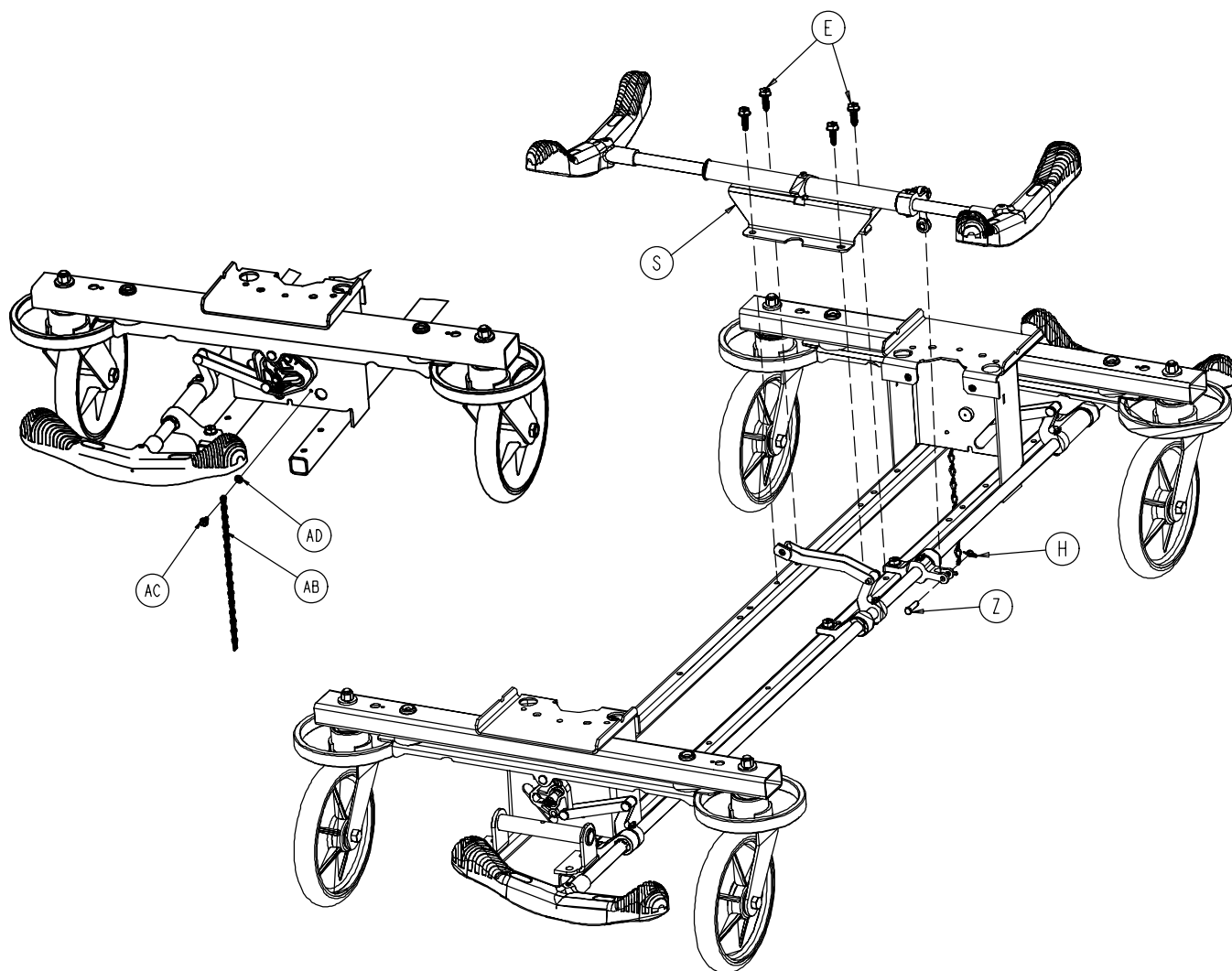

Item	Part No.	Part Name	Qty.	Item	Part No.	Part Name	Qty.
A	0005-044-000	Step Bolt	4	P	0753-003-066	Clevis Pin	2
B	0011-262-000	Washer	4	R	0753-003-079	Brake Pin Guide	4
C	0016-035-000	Nylock Hex Nut	4	S	(page 27)	Side Brake Rod Ass'y	1
D	0016-049-000	Nylock Hex Nut	2	T	0753-003-121	Brake Cushion	4
E	0023-288-000	Hex Washer Hd. Screw	8	V	(page 26)	Brake Rod Assembly	1
G	0027-012-000	Hitch Pin	2	W	0753-003-230	Bearing Pivot Support	2
H	0027-020-000	Rue Ring Cotter	1	Y	(page 23)	Caster Assembly	4
J	0028-037-000	External Retaining Ring	4	Z	0026-340-000	Clevis Pin	1
K	0038-439-000	Extension Spring	4	AA	0027-022-000	Rue Ring Cotter Pin	2
L	0081-037-000	Roller Bearing	2	AB	3001-200-052	Ground Chain	1
M	0753-001-001	Base Weldment	1	AC	0003-364-000	Hex Washer Hd. Screw	1
N	0753-003-006	Brake Ring Weldment	2	AD	0013-018-000	Ext. Tooth Lock Washer	1

Brake Rod Assembly, Base with 4-Sided Brakes

Assembly part number 0753-003-125 (reference only)

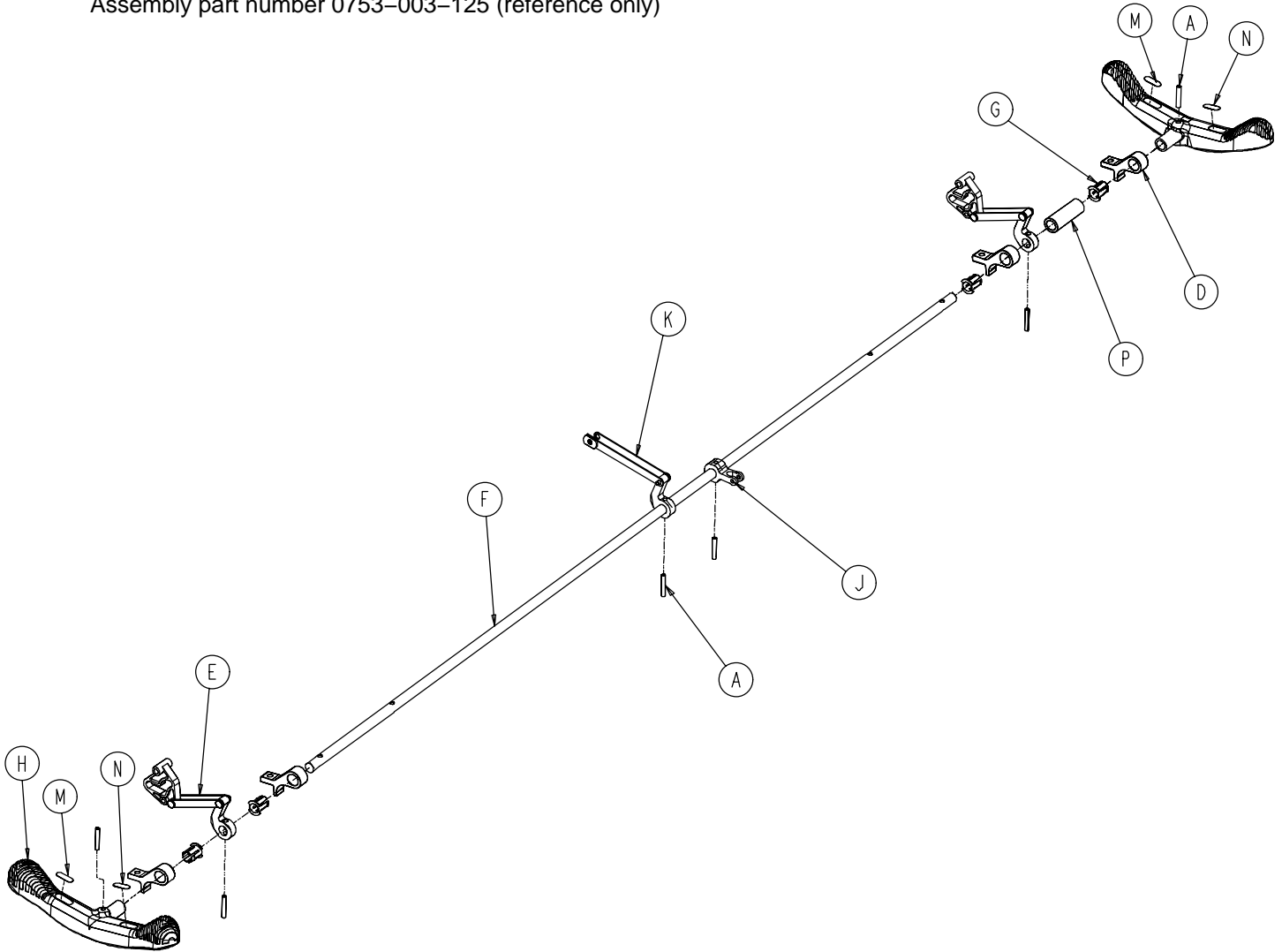

Item	Part No.	Part Name	Qty.
A	0026-067-000	Slotted Spring Pin	6
D	0753-003-004	Brake Rod Support	4
E	(page 21)	Drive Link Assembly	2
F	0753-003-014	Brake Rod	1
G	0753-003-015	Brake Rod Nyliner	4
H	0785-003-099	Butterfly "V" Pedal	2
J	0753-003-112	Side Control Link	1
K	(page 22)	Drive Link Assembly	1
M	1210-201-335	Red Brake Label	2
N	1210-201-336	Green Steer Label	2
P	0753-003-133	Retainment Spacer	1

Side Control Brake Rod Assembly

Assembly part number 0753-003-210 (reference only)

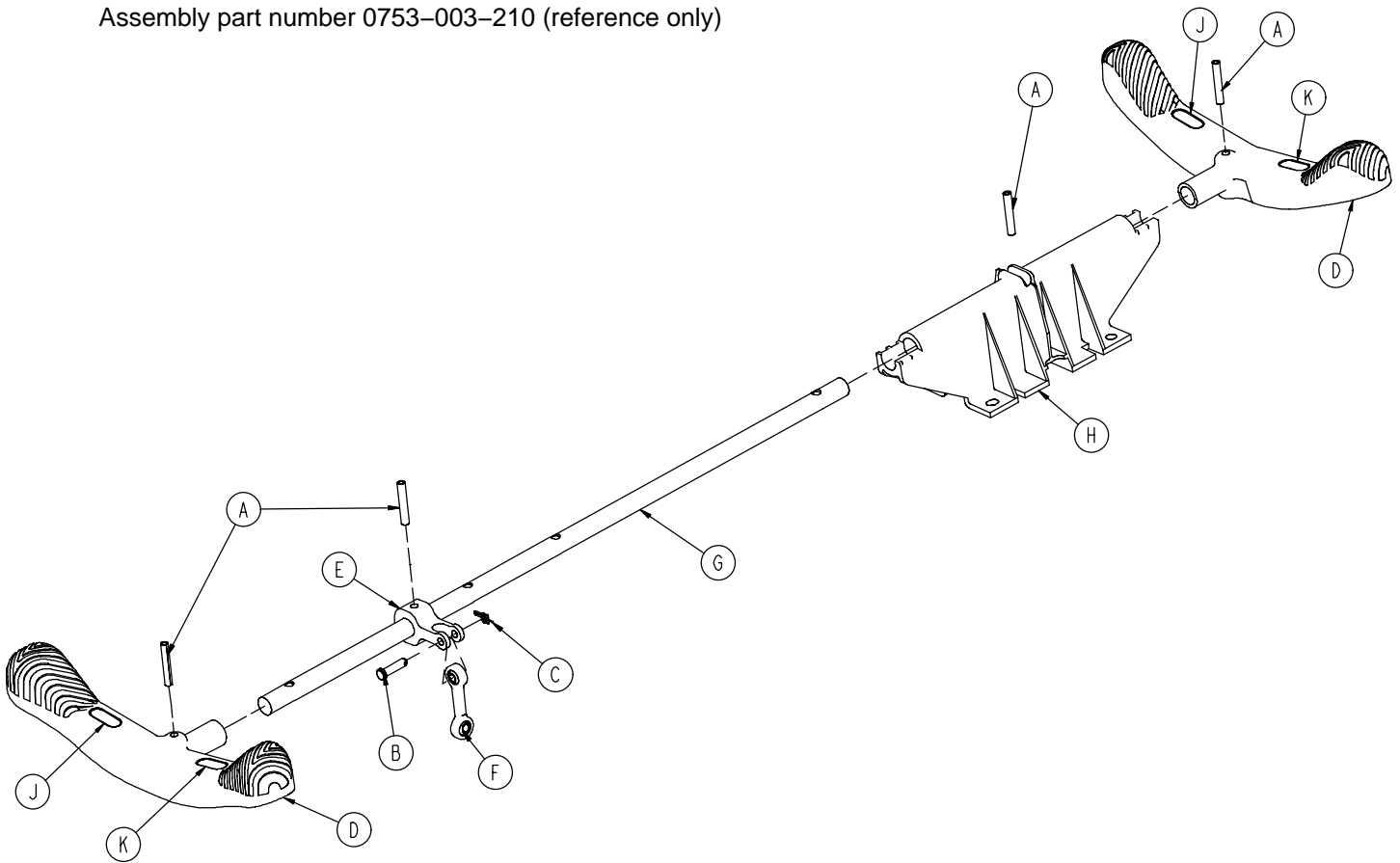

Item	Part No.	Part Name	Qty.
A	0026-067-000	Slotted Spring Pin	4
B	0026-340-000	Clevis Pin	1
C	0027-020-000	Rue Ring Cotter	1
D	0753-003-099	Butterfly "V" Pedal	2
E	0753-003-112	Side Control Link	1
F	0753-003-117	Rod End Link	1
G	0753-003-119	Side Control Brake Rod	1
H	0753-003-214	Shaft Support	1
J	1210-201-335	Red Brake Label	2
K	1210-201-336	Green Steer Label	2

Base with Dual Side Hydraulics (Fifth Wheel Base)

Assembly part number 0753-005-200 (reference only)

HEAD END

Insert pump ram into keyhole slot on both ends. Lower pump connecting rod weldment onto pump ram as shown

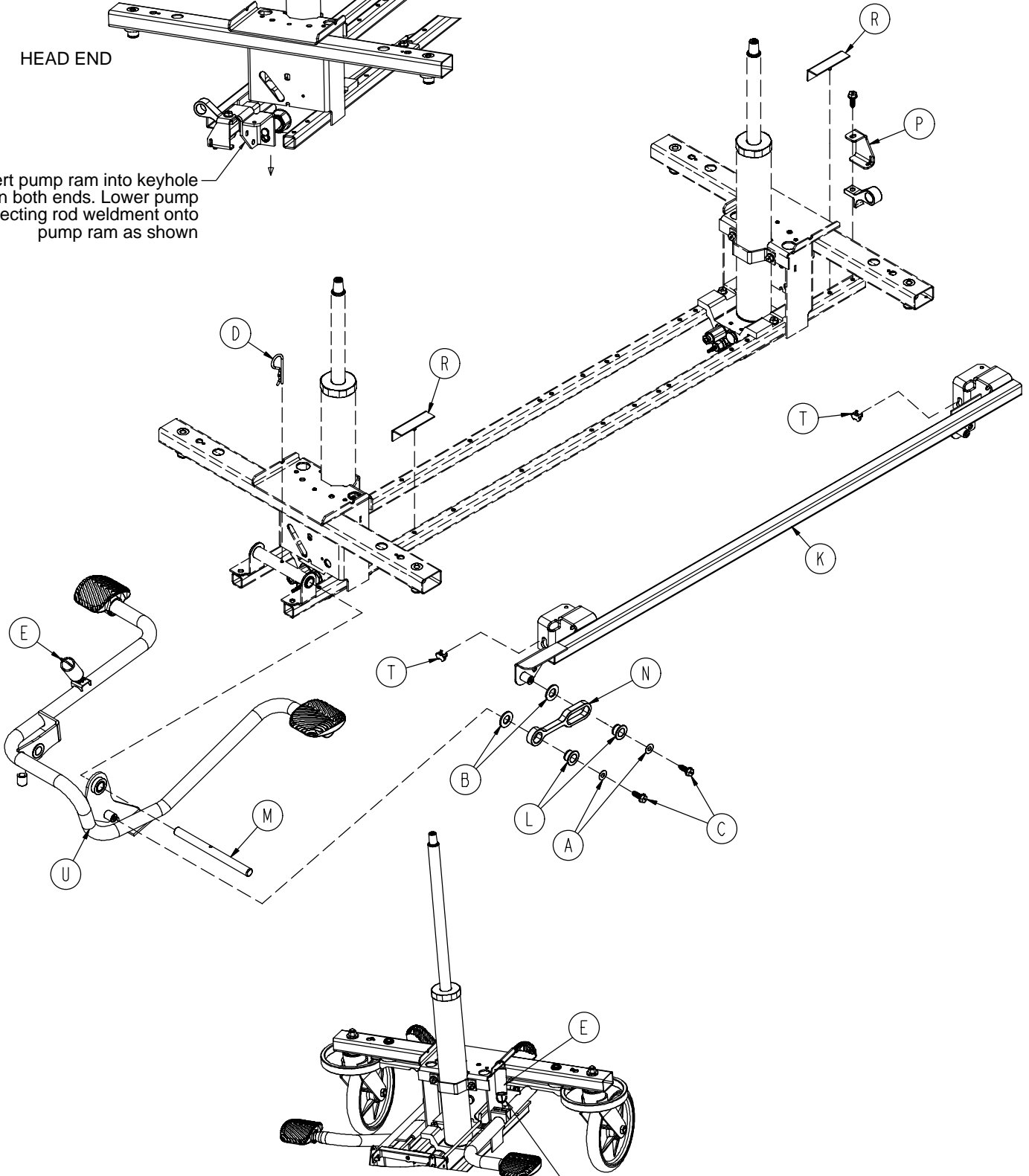

Insert spring hook thru slots in pump pedal
Attach other end onto jack tower as shown

Base with Dual Side Hydraulics (Fifth Wheel Base)

Insert spring hook thru hole in pump connecting rod. Attach other hook to return spring as shown

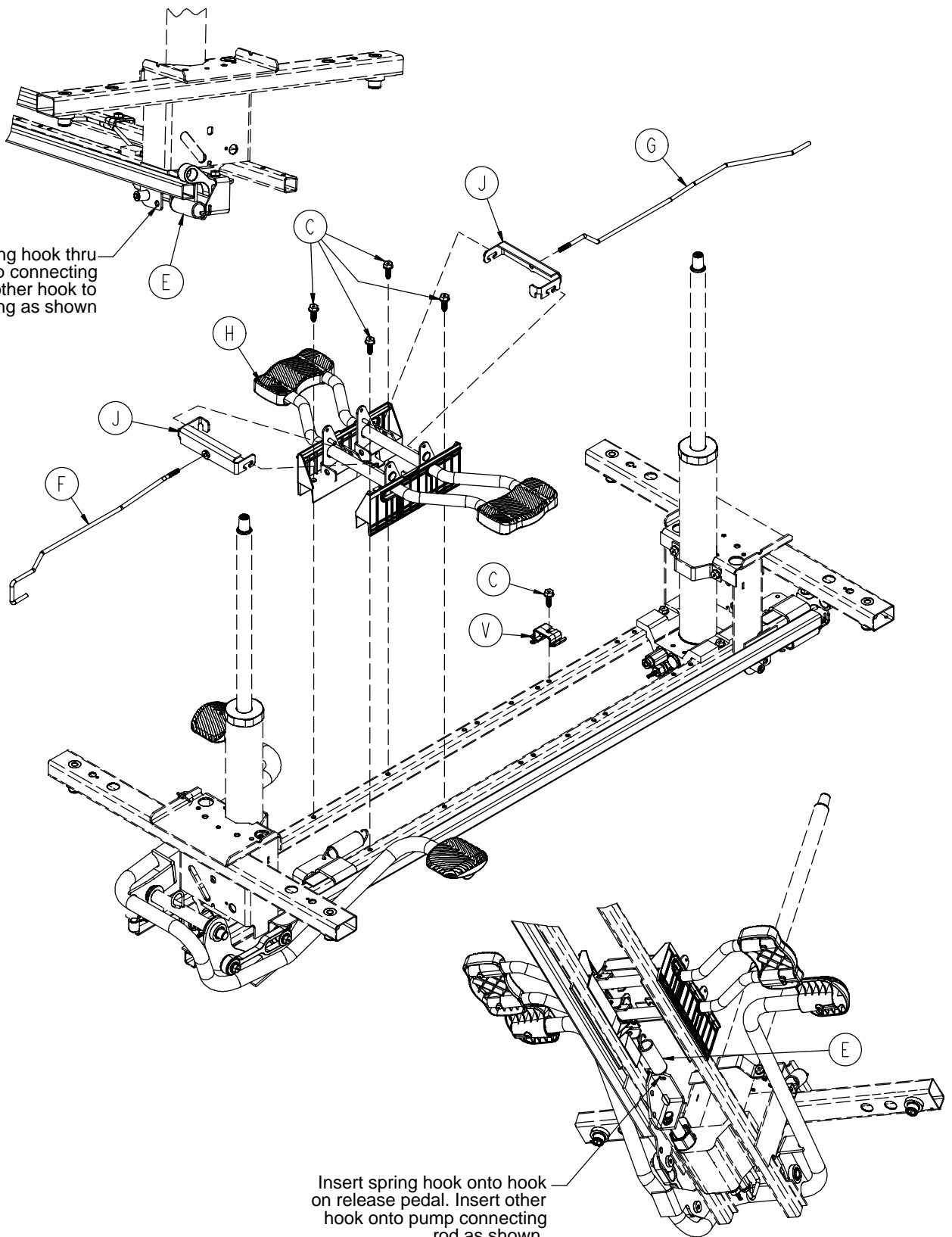

Insert spring hook onto hook on release pedal. Insert other hook onto pump connecting rod as shown.

Base with Dual Side Hydraulics (Fifth Wheel Base)

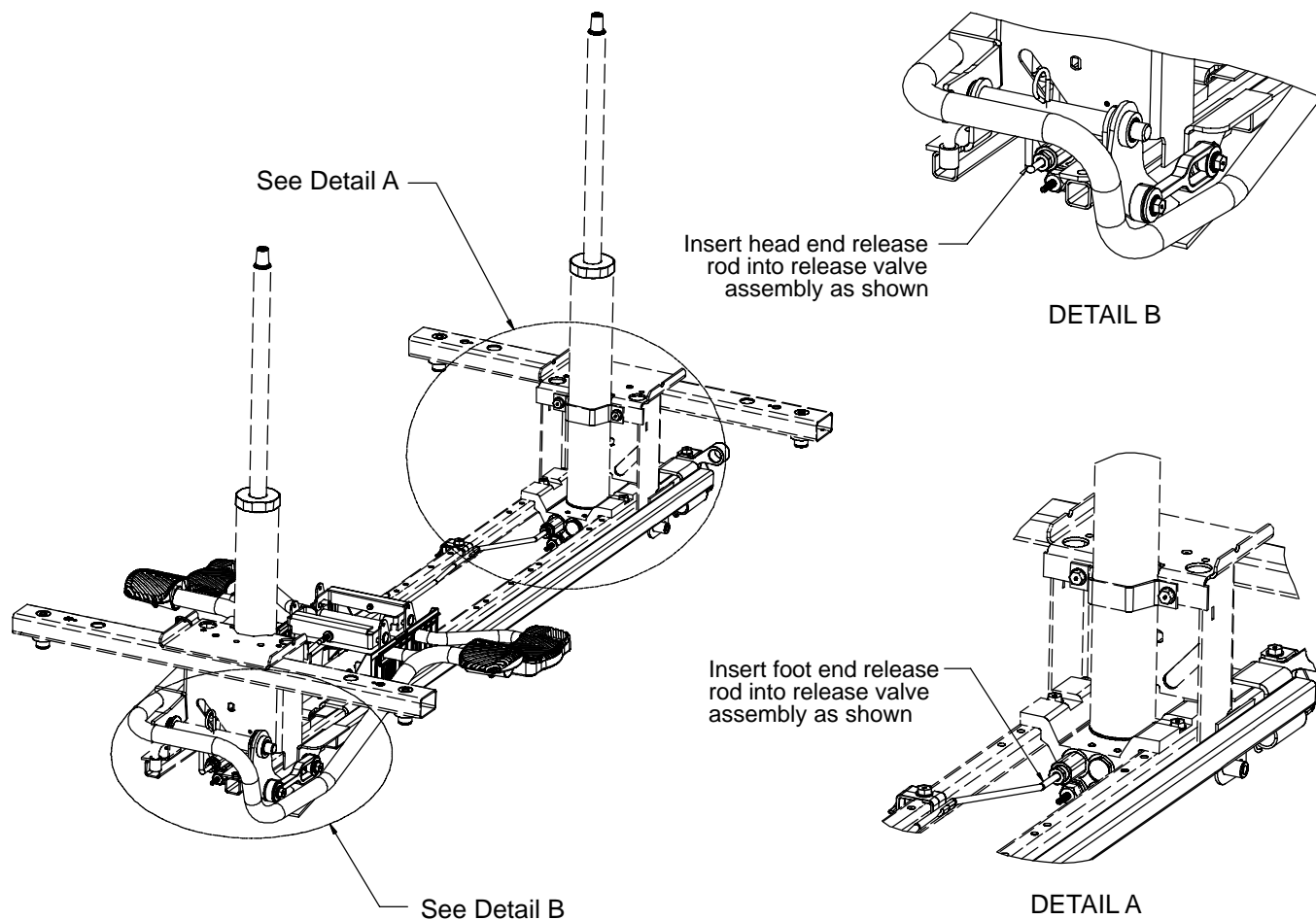

Item	Part No.	Part Name	Qty.
A	0011-023-000	Washer	2
B	0014-071-000	Washer	2
C	0023-288-000	Hex Washer Hd. Screw	7
D	0027-031-000	Hair Pin Cotter	1
E	0038-497-000	Extension Spring	3
F	0753-004-014	Head End Release Rod	1
G	0753-004-015	Foot End Release Rod	1
H	(page 31)	Release Pedal Assembly	1
J	0753-004-132	Release Pedal Swivel	2
K	0753-005-037	Pump Connecting Rod	1
L	0753-005-044	Pump Pedal Bushing	2
M	0753-005-074	Pivot Pin	1
N	0753-005-075	Pump Pedal Link	1
P	0753-005-087	Return Spring Hook	1
R	0753-005-088	Wear Strip	2
T	0753-005-089	Pump Ram Plug	2
U	(page 32)	Head End Pump Pedal Ass'y	1
V	0753-010-215	Release Rod Bracket	1

0753-004-101 Release Pedal Assembly

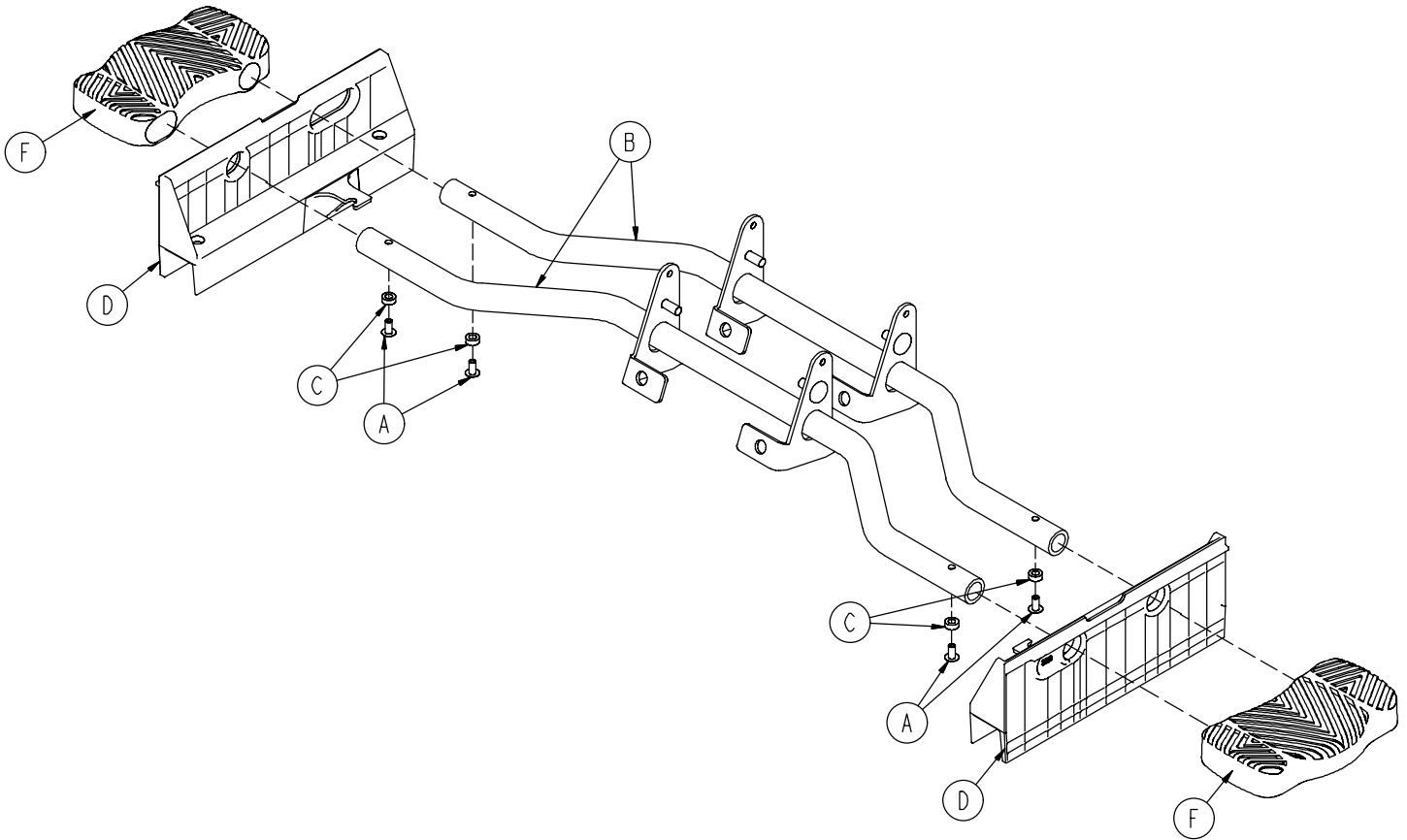

Item	Part No.	Part Name	Qty.
A	0025-079-000	Rivet	4
B	0753-004-004	Release Pedal Weldment	2
C	0753-004-029	Release Pedal Standoff	4
D	0753-004-320	Release Pedal Support	2
F	1061-201-127	Short Uni Pedal	2

0753-005-185 Head End Pump Pedal Assembly

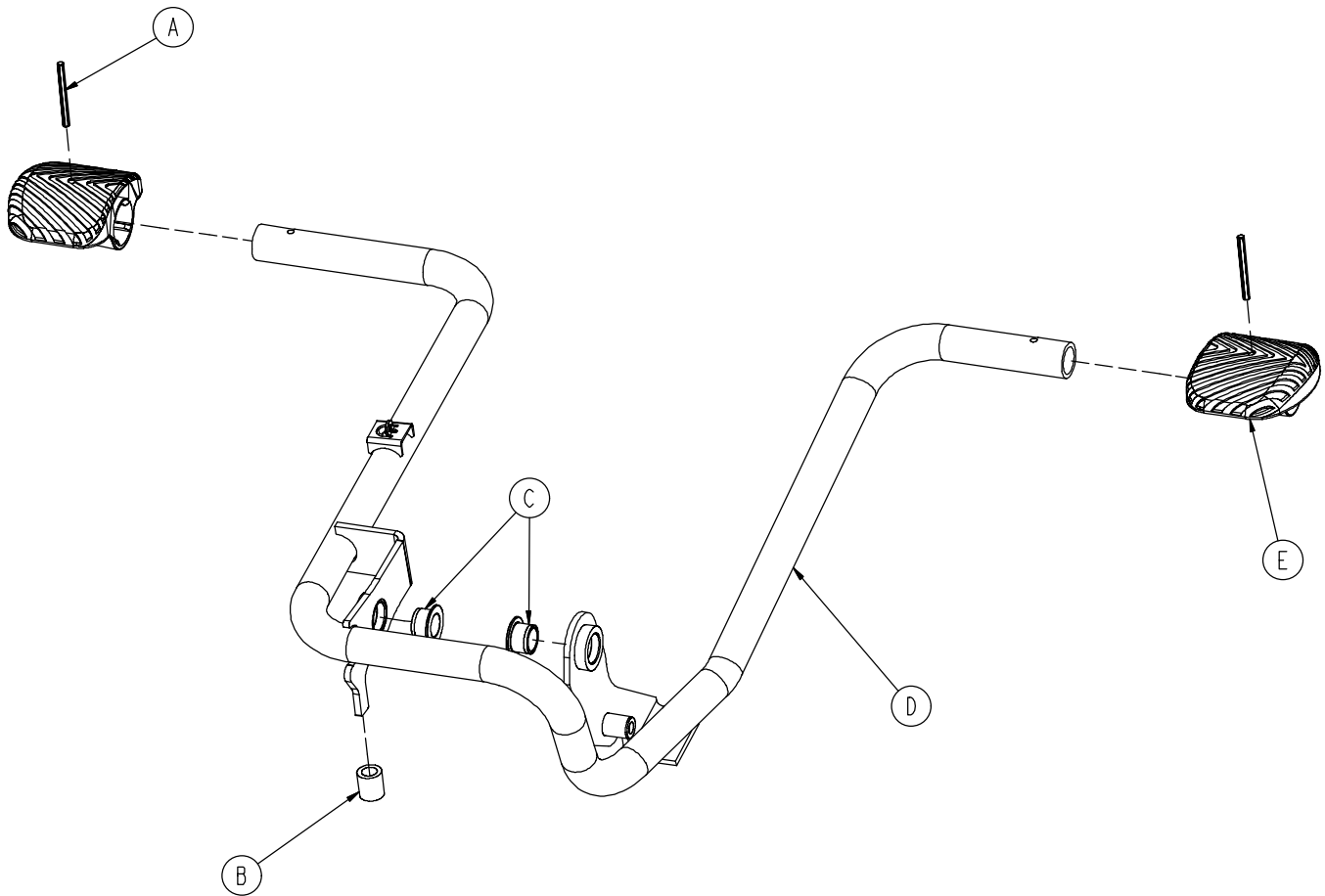

Item	Part No.	Part Name	Qty.
A	0026-343-000	Groove Pin	2
B	0715-001-140	Vinyl Tube	1
C	0753-005-044	Pump Pedal Bushing	2
D	0753-005-180	Head End Pump Pedal Weldment	1
E	0753-201-126	Pump Pedal	2

Variable Descent Jacks

Assembly part number 0753-002-180
(reference only)

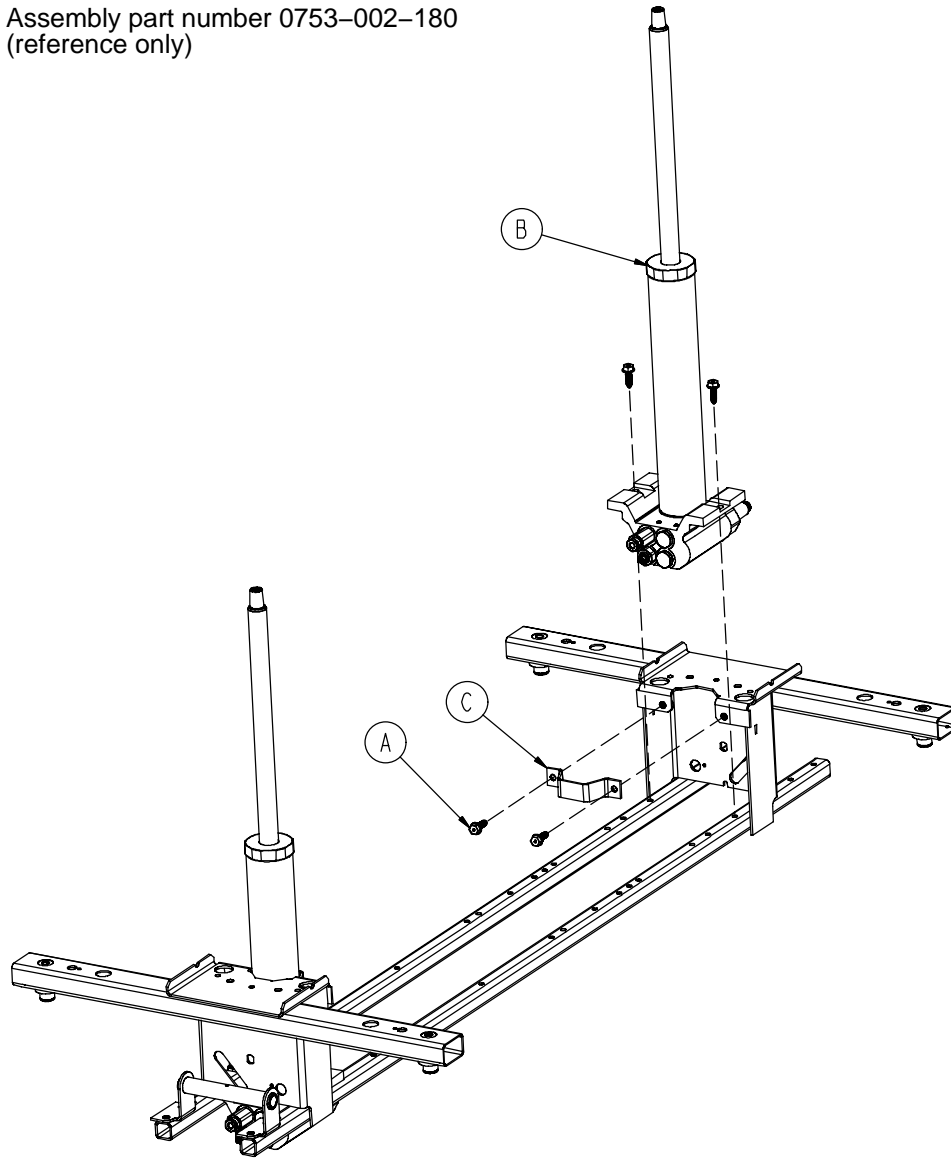

Item	Part No.	Part Name	Qty.
A	0023-288-000	Hex Washer Hd. Screw	8
B	0753-002-170	Variable Descent Jack Assembly	2
C	0753-010-007	Reservoir Clamp	2

Jack Base Assembly, Variable Descent Jack

Assembly part number 0753-002-075 (reference only)

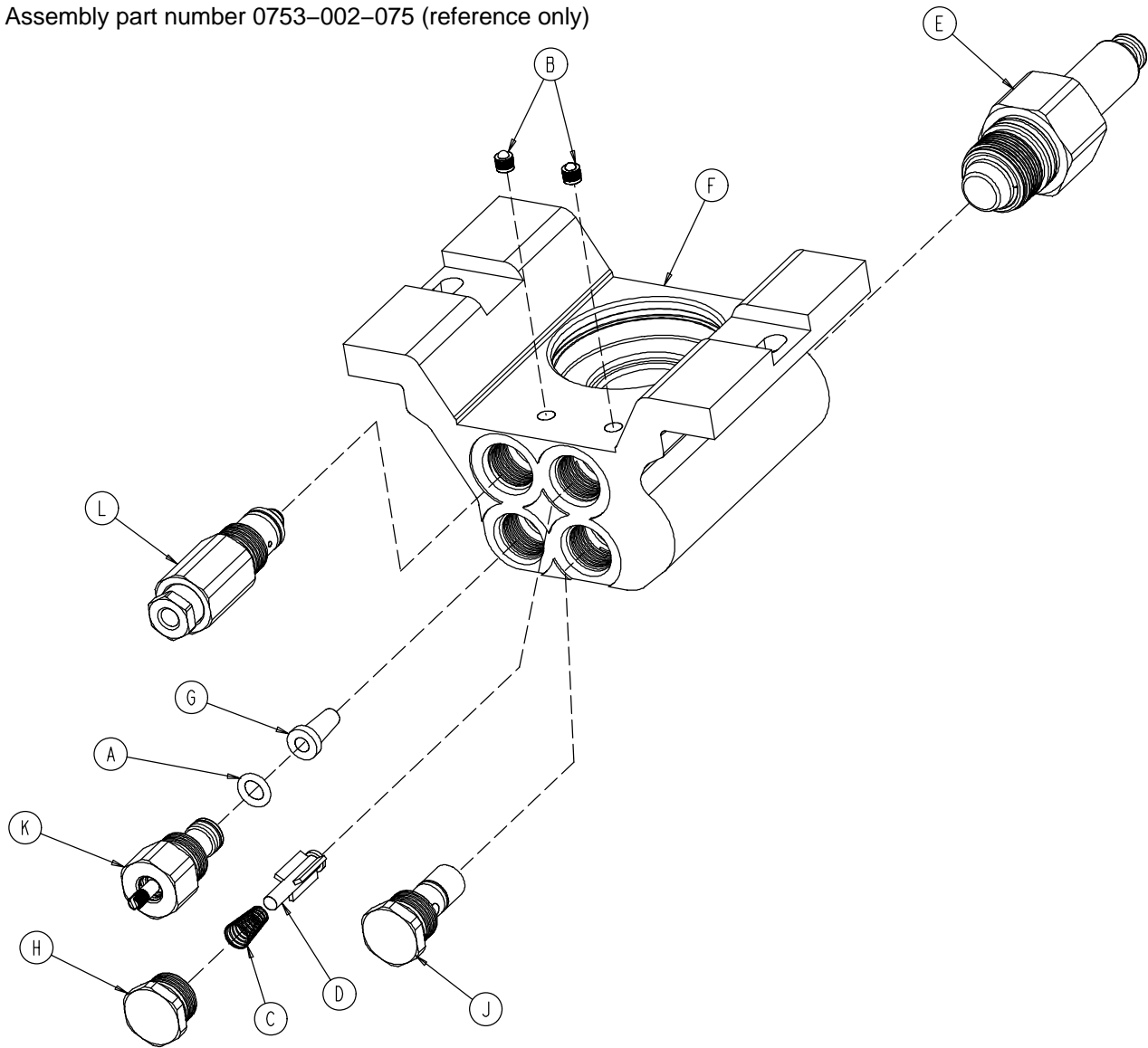

Item	Part No.	Part Name	Qty.
A	0046-004-000	O-Ring	1
B	0048-021-000	CV Plug	2
C	0390-002-134	Conical Compression Spring	1
D	0715-001-341	Poppet	1
E	0753-002-003	Pump Ram Assembly	1
F	0753-002-010	Jack Base	1
G	0753-002-019	Valve Filter	1
H	0753-002-051	Plug Assembly	1
J	0753-002-052	Check Valve Assembly	1
K	0753-002-063	Standard Descent Valve Assembly	1
L	0753-002-065	Release Valve Assembly	1

Notes

Base Labeling Assembly

Assembly part number 0753-010-062 (reference only)

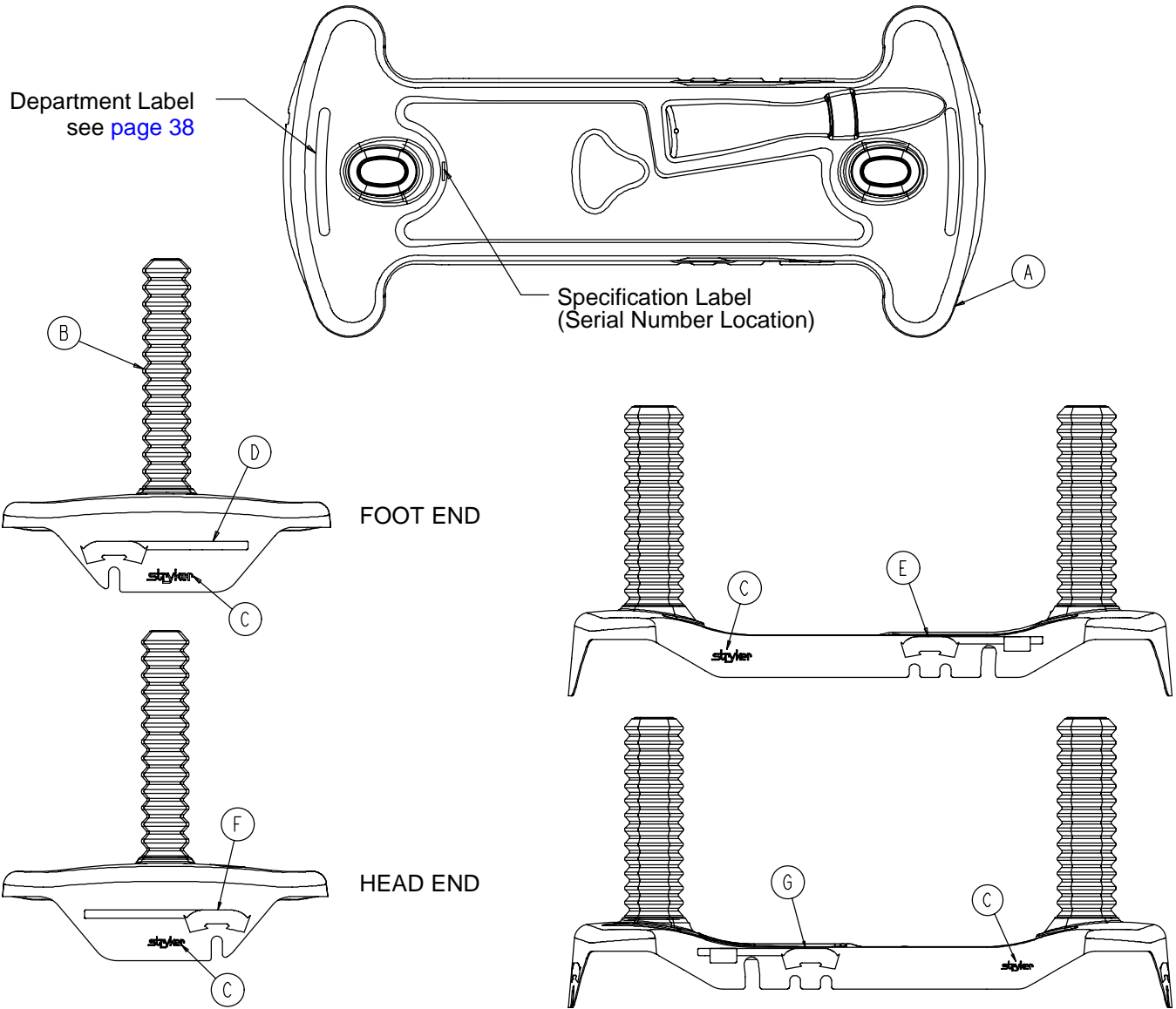

Item	Part No.	Part Name	Qty.
A	0753-010-040	Base Hood	1
B	1040-010-134	Bellows	2
C	0946-201-060	Stryker Logo Label	4

Base Labeling Assembly, 4-Sided Brakes

Assembly part number 0753-010-063 (reference only)

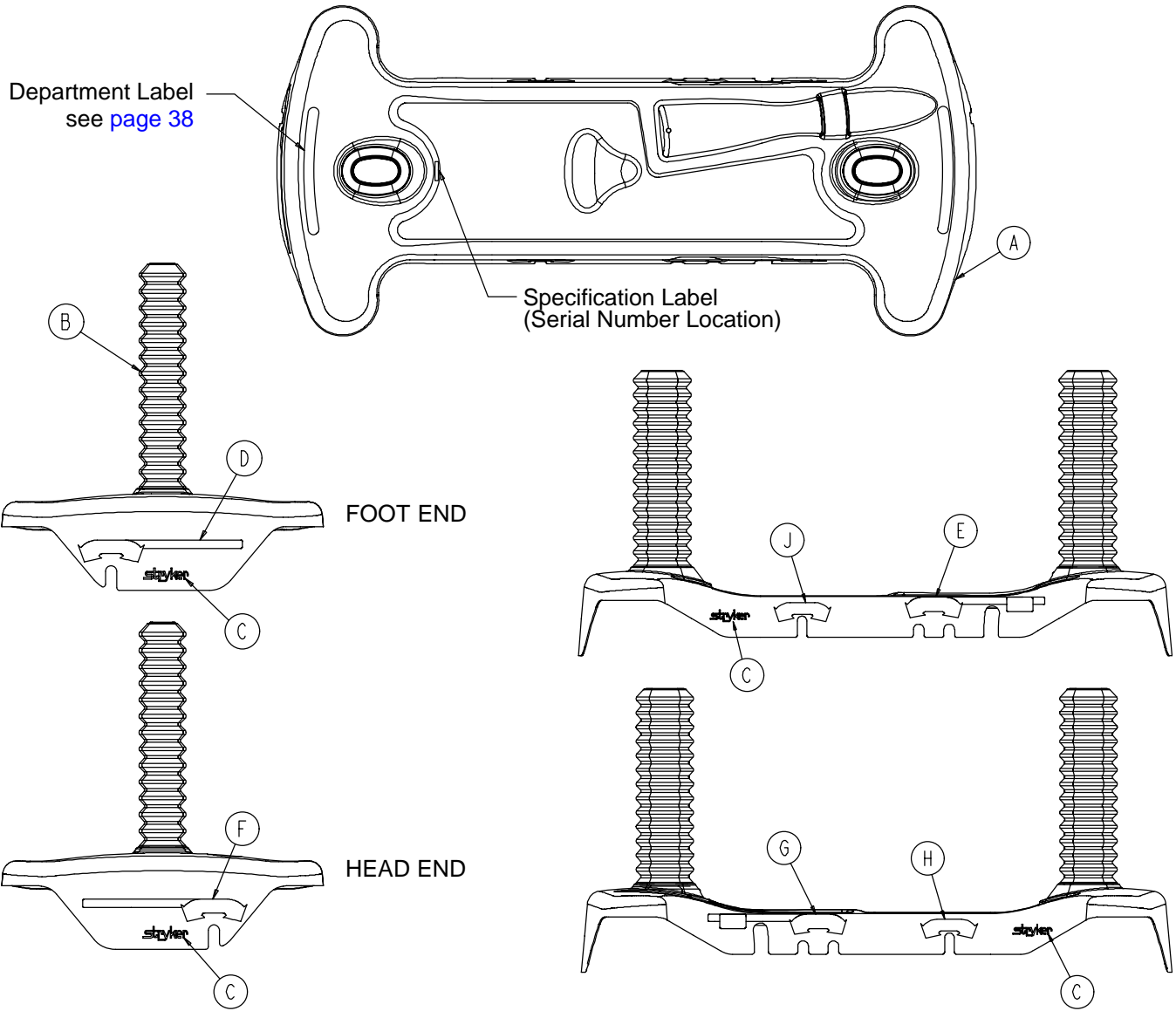

Item	Part No.	Part Name	Qty.
A	0753-010-040	Base Hood	1
B	1040-010-134	Bellows	2
C	0946-201-060	Stryker Logo Label	4
H	0753-010-018	Brake/Steer Label, Right	1
J	0753-010-019	Brake/Steer Label, Left	1

Base Labeling Assembly

Color Set P/N	Item D Brake/Steer, Foot End	Item E Lift/Lower, Left	Item F Brake/Steer, Head End	Item G Lift/Lower, Right	Litter Bumper Strip
RED 0753-010-120	0753-010-051	0753-010-055	0753-010-017	0753-010-054	1010-700-015
PURPLE 0753-010-121	0753-010-151	0753-010-155	0753-010-170	0753-010-154	1010-700-025
GREEN 0753-010-122	0753-010-251	0753-010-255	0753-010-270	0753-010-254	1010-700-035
GRAY 0753-010-123	0753-010-351	0753-010-355	0753-010-370	0753-010-354	1010-700-045
TEAL 0753-010-124	0753-010-451	0753-010-455	0753-010-470	0753-010-454	1010-700-055
PINK 0753-010-125	0753-010-551	0753-010-555	0753-010-570	0753-010-554	1010-700-065
BLUE 0753-010-126	0753-010-651	0753-010-655	0753-010-670	0753-010-654	1010-700-075

BASE HOOD DEPARTMENT LABELS

Department	Label Part Number
Emergency	1010-900-215
PACU	1010-900-220
Transport	1010-900-225
Surgery	1010-900-230
Extended Stay	1010-900-235
Maternity	1010-900-240
Endoscopy	1010-900-245
Radiology	1010-900-250
Nuclear Medicine	1010-900-255
Ambulatory Surgery	1010-900-260
G.I. Lab	1010-900-265
Cath. Lab	1010-900-270
Same Day Surgery	1010-900-275
Cardio.	1010-900-280
Ultrasound	1010-900-285

NOTE

All base hood department labels are quantity of two.

Litter Assembly

Assembly part number 0736-010-010
(reference only)

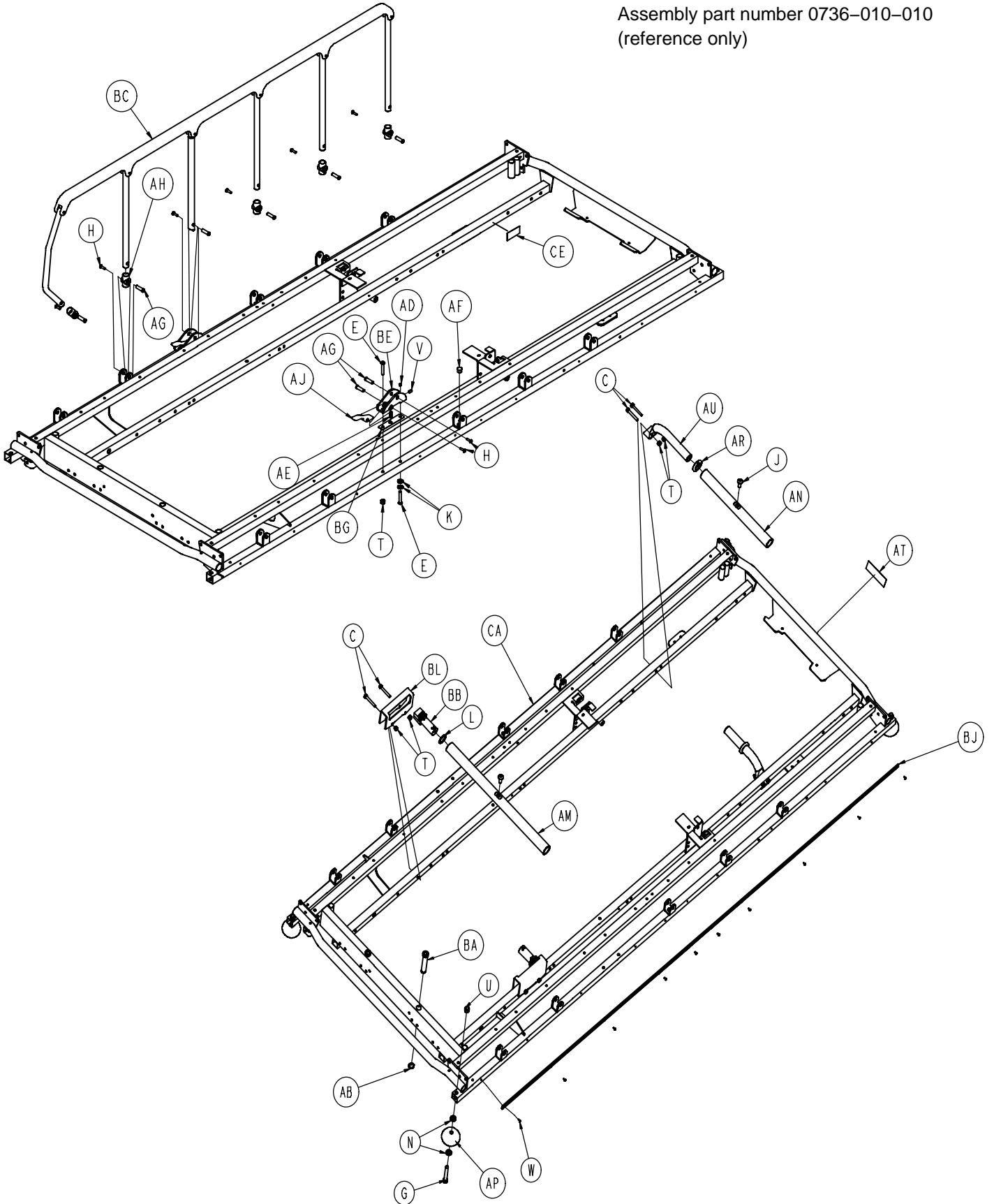

Litter Assembly

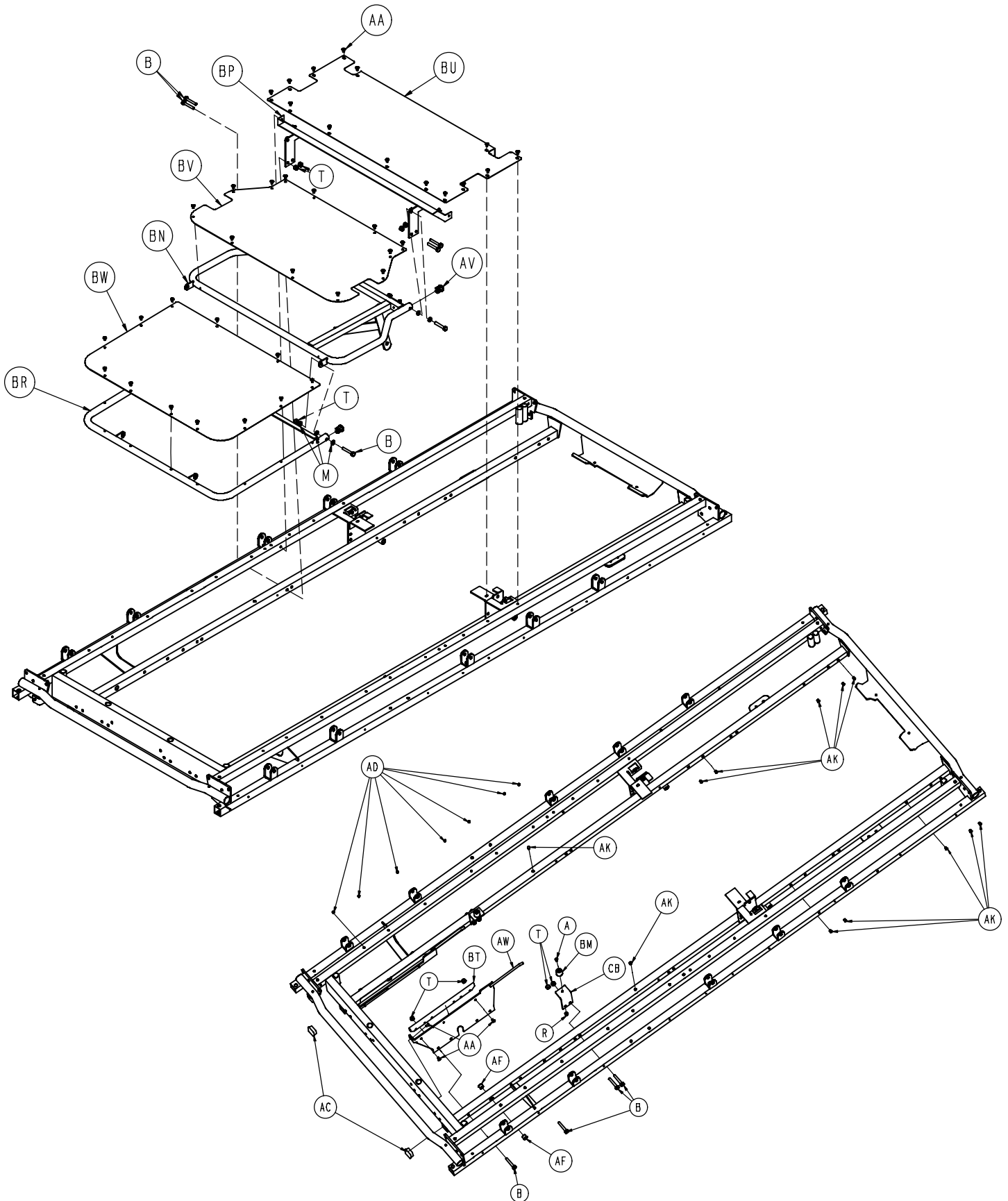

Litter Assembly

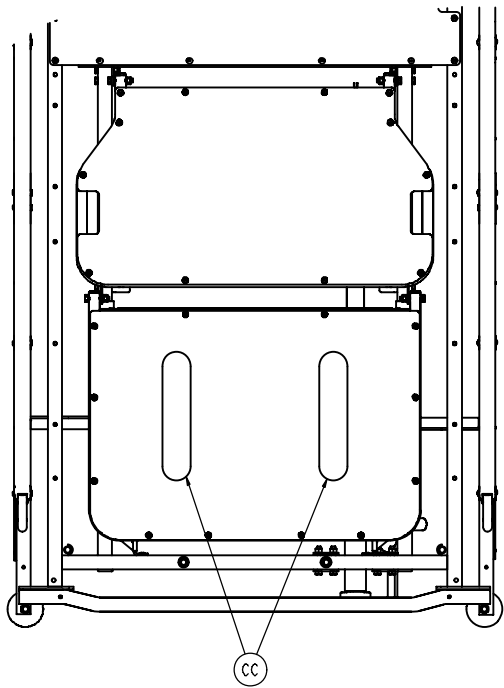
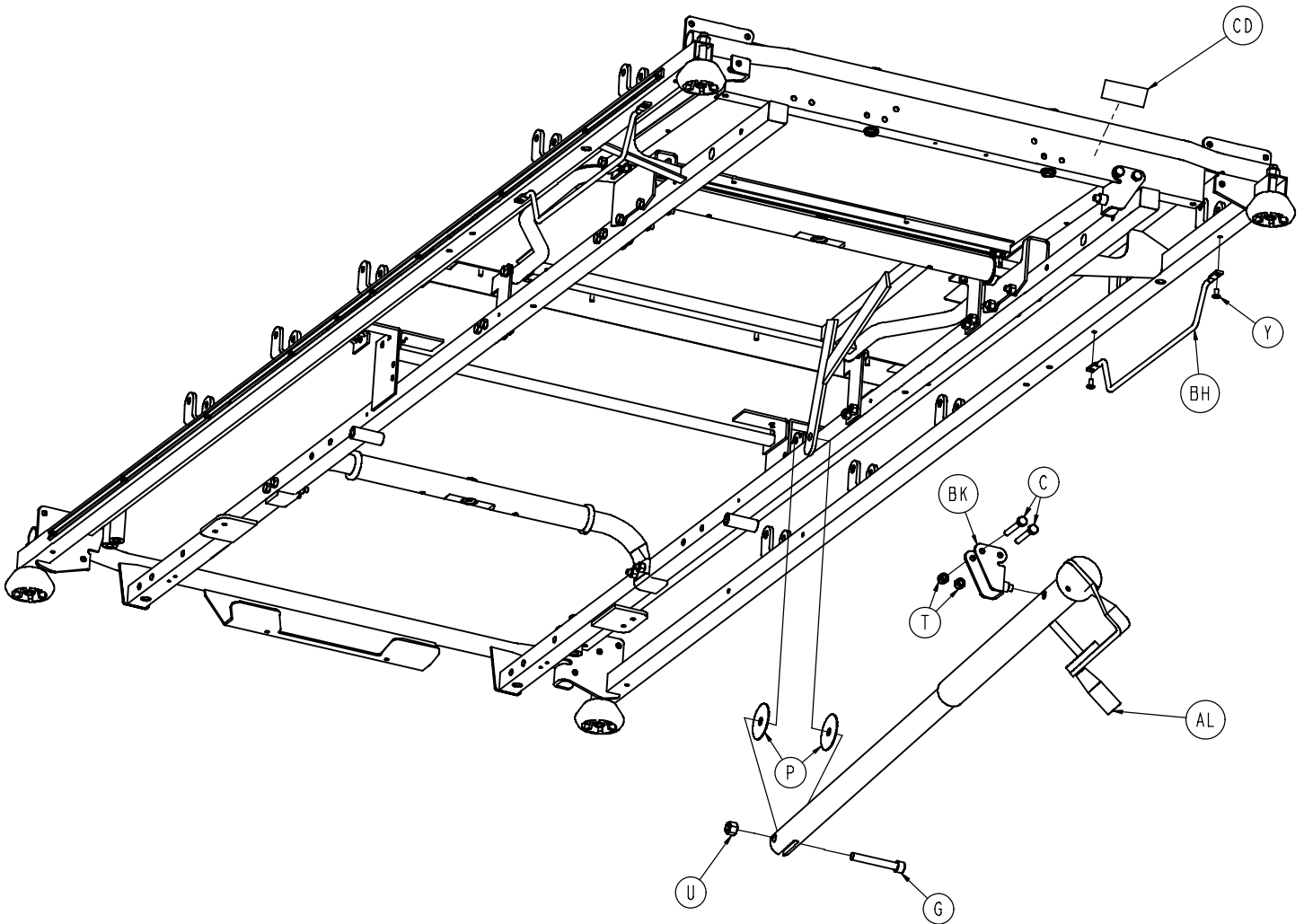

Litter Assembly

Item	Part No.	Part Name	Qty.
A	0002-031-000		2
B	0003-047-000	Hex Hd. Cap Screw	16
C	0003-078-000	Hex Hd. Cap Screw	12
E	0004-135-000	Button Hd. Cap Screw	4
G	0004-201-000		5
H	0004-515-000	Button Hd. Cap Screw	14
J	0007-074-000	Truss Hd. Machine Screw	20
K	0011-002-000	Washer	4
L	0011-360-000	Washer	2
M	0014-003-000	Washer	12
N	0014-021-000	Washer	8
P	0014-055-000	Washer	2
R	0016-014-000	Fiber Hex Nut	2
T	0016-028-000	Fiber Hex Nut	30
U	0016-035-000	Nylon Hex Nut	5
V	0021-104-000	Set Screw	2
W	0025-038-000	Dome Head Rivot	20
Y	0025-079-000	Dome Head Rivot	4
AA	0025-122-000	Dome Head Rivot	46
AB	0028-072-000	Retaining Ring	2
AC	0037-010-000	Hole Plug	2
AD	0037-074-000	Hole Plug	16
AE	0038-220-000	Compression	2
AF	0059-100-000	Hole Plug	6
AG	0721-026-066	Pivot Screw	14
AH	0721-026-069	Upright Sleeve	10
AJ	0721-026-074	Lock Handle	2
AK	0721-031-065	Hole Plug	22
AL	(page 48)	Knee Gatch Crankscrew Ass'y	1
AM	0753-010-026	Support Tube	1
AN	0753-010-030	Support Tube	1
AP	0926-400-142	Bumper	4
AR	0938-001-401	Collar	2
AT	0946-001-060	Label	1
AU	1001-001-037	Jack Support Tube	2
AV	1001-034-025	Hole Plug	4
AW	1001-034-029	Slider Support, Left	1
AY	1001-034-030	Slider Support, Right	1
BA	1001-040-012	Footboard Receptacle	2
BB	1001-201-029	Nylon Insert	2
BC	(page 49)	Siderail Assembly, Right	1
BD	(page 49)	Siderail Assembly, Left	1
BE	1010-026-080	Lock Housing, Left	1
BF	1010-026-081	Lock Housing, Right	1
BG	1010-026-103	Retainer Spring	2
BH	1010-032-092	Foley Back Rack	2
BJ	1010-201-027	Bumper Channel	2
BK	1010-234-015	Mounting Bracket	2
BL	1070-010-023	Trend Support	2
BM	1070-014-009	Bumper	2
BN	1501-034-011	Thigh Frame Assembly	1
BP	1501-034-023	Midsection Support Assembly	1
BR	1501-034-112	Calf Frame Weldment	1
BT	1510-034-090	Slider Pad	2

Litter Assembly

Item	Part No.	Part Name	Qty.
BU	1510-234-027	Mid-Section Skin	1
BV	1510-234-028	Thigh Section Skin	1
BW	1510-234-126	Calf Section Skin	1
CA	1550-030-005	Frame Weldment	1
CB	1550-034-021	Thigh Support	2
CC	0785-034-005	Velcro Pile	2
CD	1550-090-034	Engage Gatch Label	1
CE	1210-800-008	Patent Label	1

0736-046-010 Knee Gatch Crankscrew Assembly

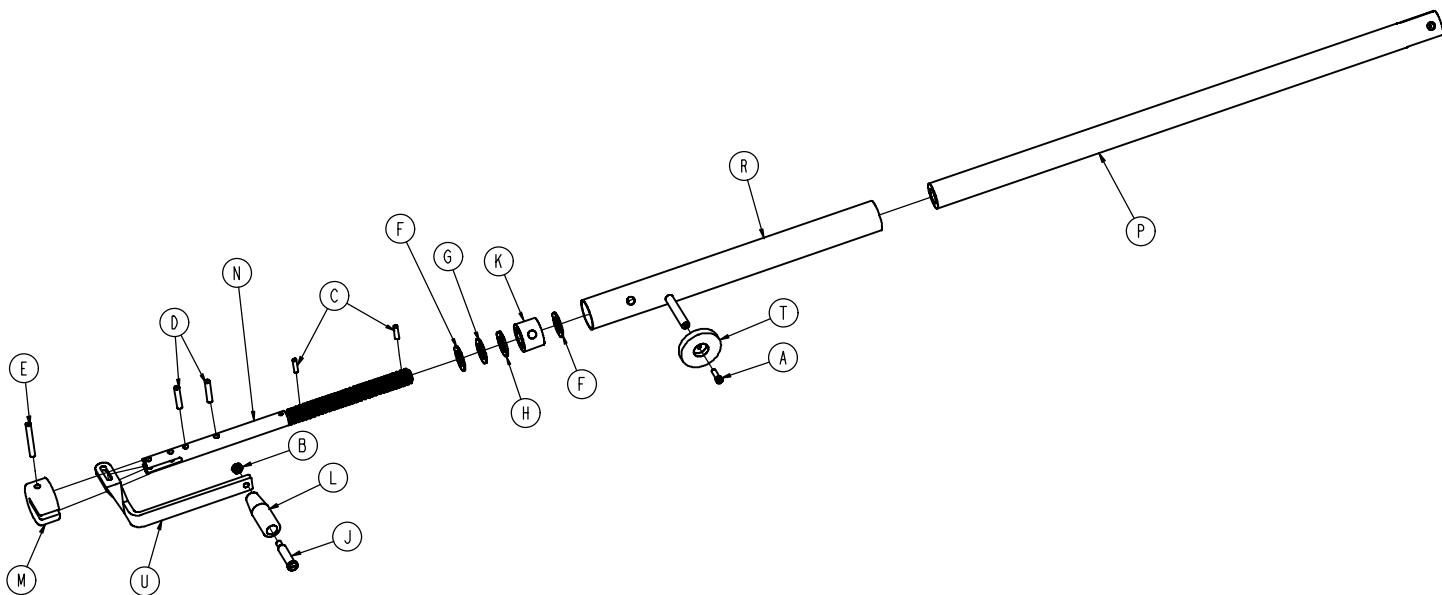

Item	Part No.	Part Name	Qty.
A	0004-007-000	Slot Head Cap Screw	1
B	0016-005-000	Nut	1
C	0026-010-000	Slotted Spring Pin	2
D	0026-014-000	Slotted Spring Pin	2
E	0026-045-000	Slotted Spring Pin	1
F	0081-174-000	Washer	2
G	0081-175-000	Washer	1
H	0081-176-000	Washer	1
J	0378-024-029	Slot Head Shoulder Bolt	1
K	0938-001-175	Bearing Assembly	1
L	0938-001-177	Knob	1
M	0946-033-018	Disc	1
N	1001-134-047	Knee Gatch Screw	1
P	1510-034-055	Gatch Tube Drive Assembly	1
R	1510-034-084	Screw Cover Assembly	1
T	1550-001-014	Magnet	1
U	1550-001-016	Crank Handle	1

1010-026-017 Siderail Assembly, Right

1010-026-019 Siderail Assembly, Left

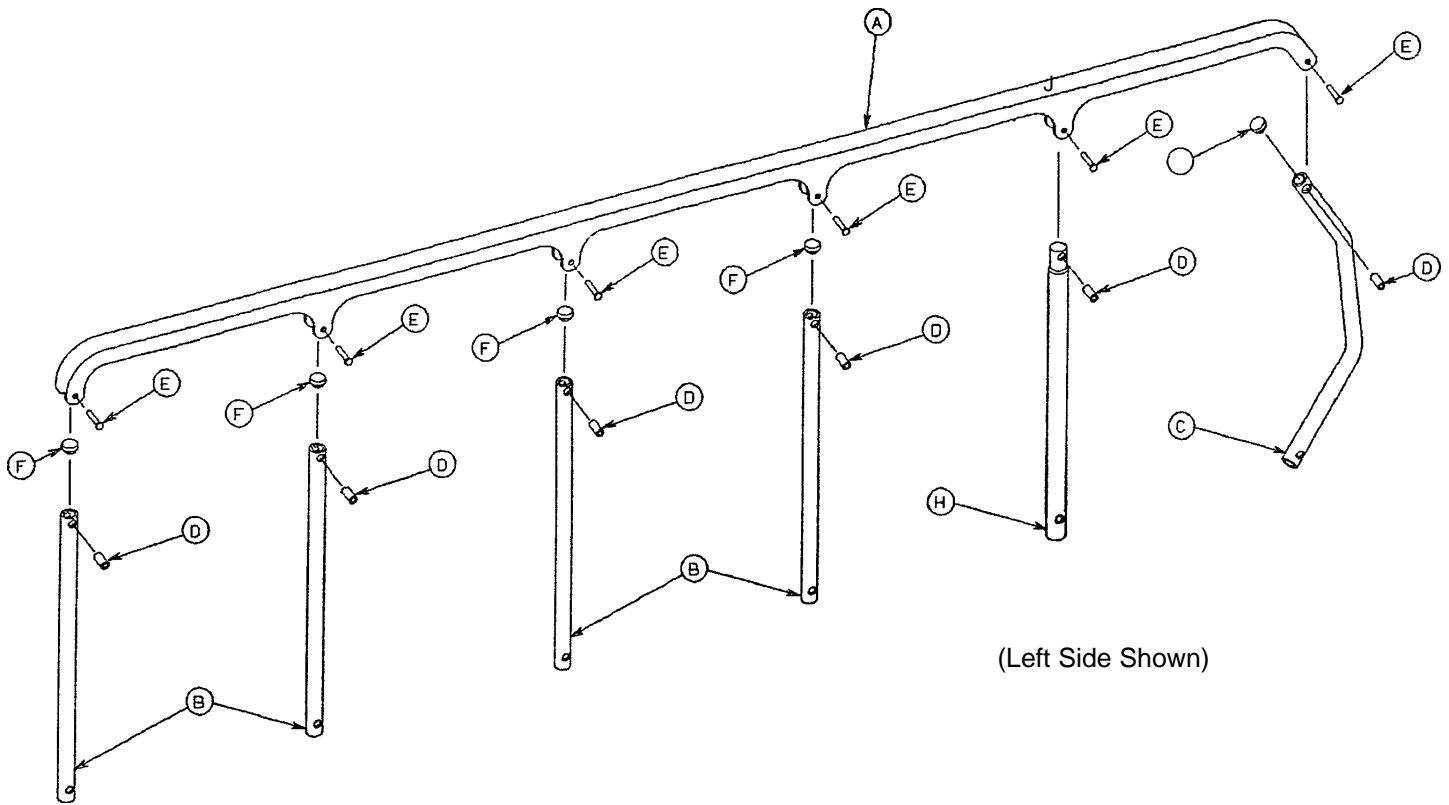

Item	Part No.	Part Name	Qty.
A	1010-026-015	Top Rail	1
B	1010-026-083	Upright	4
C	1010-026-084	Upright, Bent	1
D	1010-026-082	Spacer	6
E	0025-106-000	Semi-Tubular Rivet	6
F	1010-026-010	Round Hole Plug	4
H	1010-026-085	Upright, Latch	1
J	1010-026-012	Bent Spindle Stop	1

0736-031-120 Pneumatic Fowler Assembly

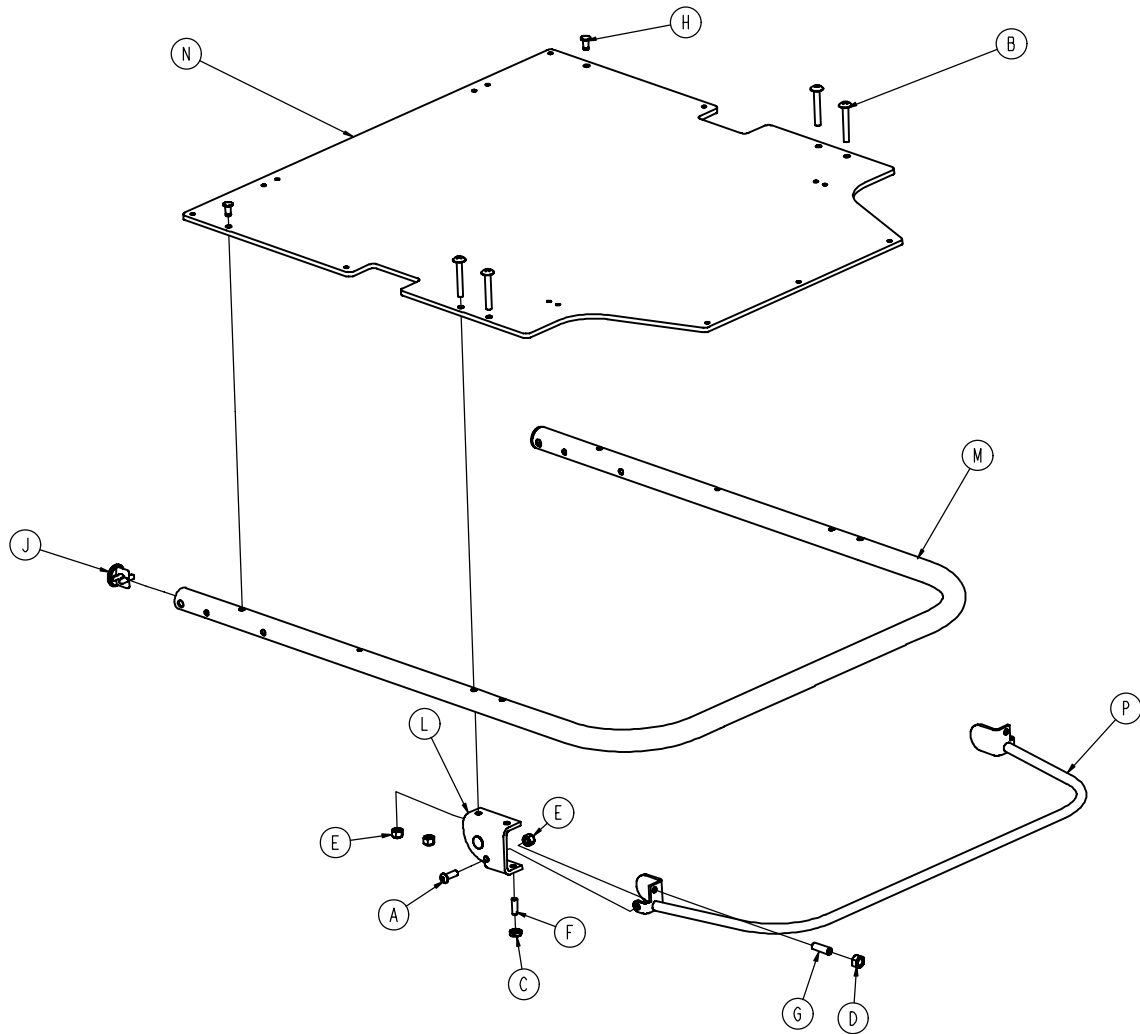

Item	Part No.	Part Name	Qty.
A	0004-161-000	Button Hd. Cap Screw	2
B	0007-020-000	Truss Hd. Machine Screw	4
C	0015-037-000	Hex Jam Nut	2
D	0015-050-000	Hex Nut	2
E	0016-028-000	Fiberlock Hex Nut	6
F	0021-125-000	Set Screw	2
G	0021-126-000	Set Screw	2
H	0025-120-000	Pop Rivot	2
J	1001-001-000	Hole Plug	2
K	(page 48)	Outer Housing Assembly, Right	1
L	(page 48)	Outer Housing Assembly, Left	1
M	1501-031-013	Fowler Tube	1
N	1510-231-012	Fowler Skin	1
P	1710-031-118	Trip Bar Assembly	1

0736-031-010 Fowler to Litter Assembly

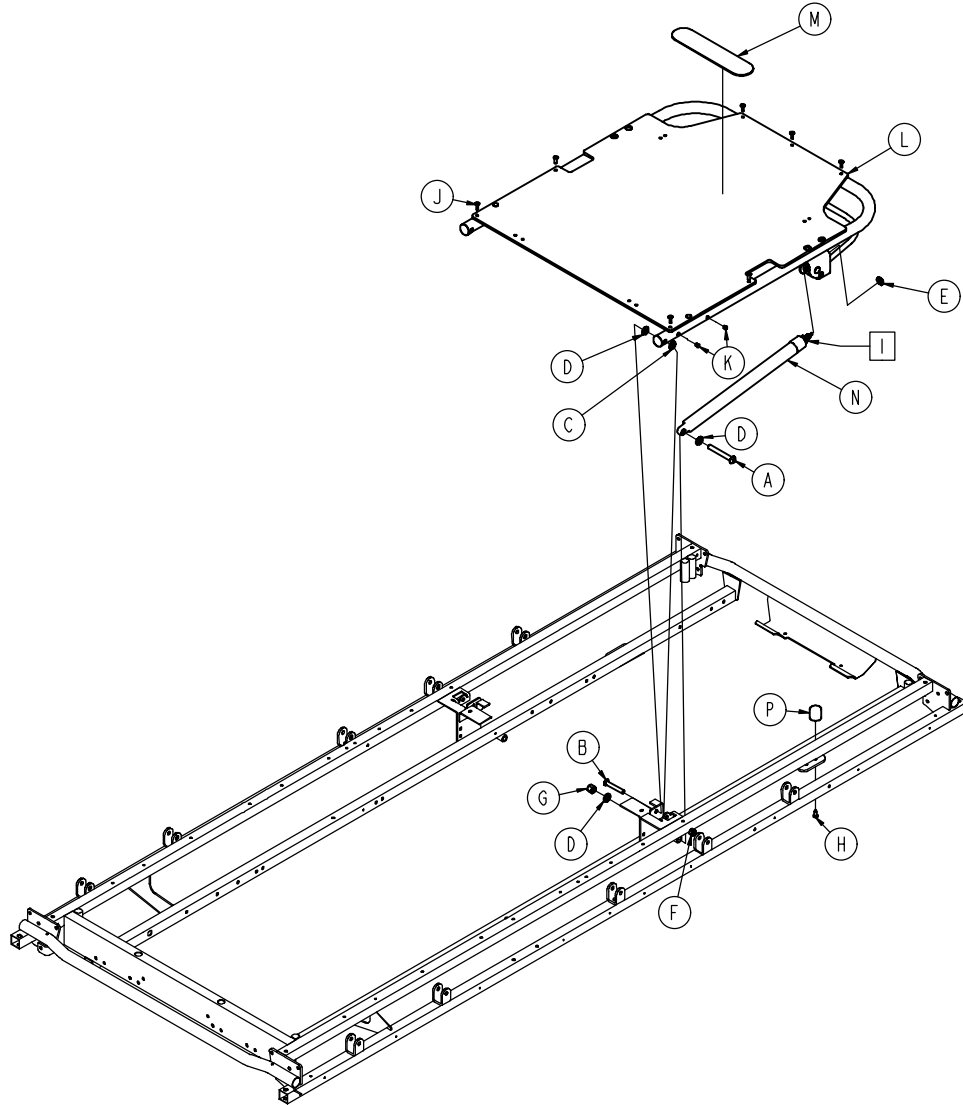

Item	Part No.	Part Name	Qty.
A	0004-182-000	Button Hd. Cap Screw	2
B	0004-183-000	Button Hd. Cap Screw	2
C	0014-020-000	Washer	2
D	0014-021-000	Washer	6
E	0015-060-000	Nylock Hex Nut	2
F	0016-036-000	Nylock Hex Nut	2
G	0016-117-000	Stover Hex Lock Nut	2
H	0023-256-000	PanHead Sheet Metal Screw	2
J	0025-050-000	Rivot	7
K	0721-031-065	Hole Plug	4
L	(page 46)	Pneumatic Fowler Assembly	1
M	7900-001-102	Velcro Pile	1
N	1010-031-078	Gas Cyclinder	2
P	1211-031-031	Pneumatic Fowler Rest	2

Pneumatic Fowler Outer Housing Assembly

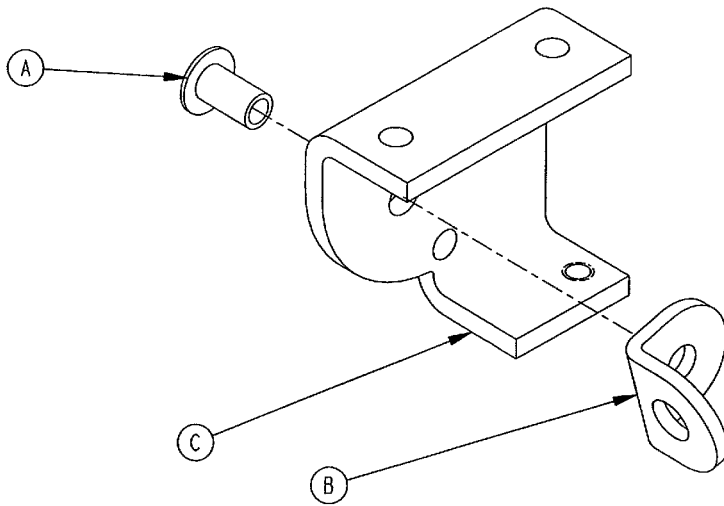

**Assembly part number
1210-031-106 (Right)**

Item	Part No.	Part Name	Qty.
A	0025-144-000	Semi-Tubular Rivet	1
B	1210-031-103	Pivot Tab	1
C	1210-031-104	Outer Housing, Right	1

**Assembly part number
1210-031-107 (Left)**

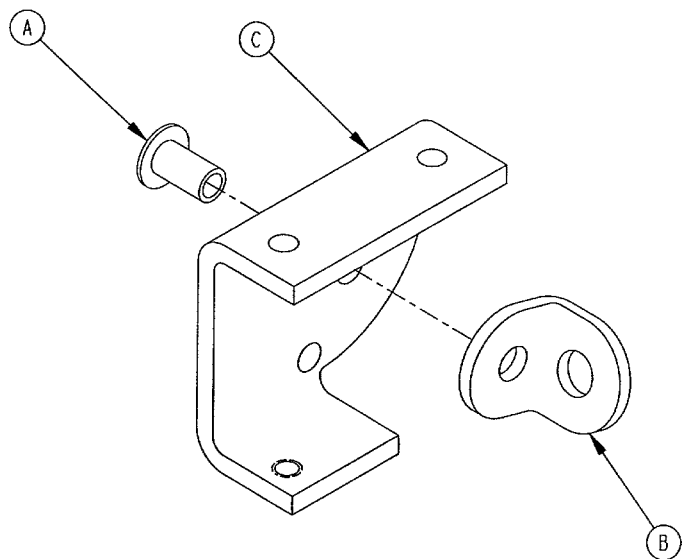

Item	Part No.	Part Name	Qty.
A	0025-144-000	Semi-Tubular Rivet	1
B	1210-031-103	Pivot Tab	1
C	1210-031-105	Outer Housing, Left	1

0390-025-010 Standard, Removable I.V. Pole Assembly

Item	Part No.	Part Name	Qty.
A	0024-023-000	Plastic Knob	1
B	0390-003-053	Double IV Ass'y	1
C	0393-003-043	Tube Assembly	1
D	0004-496-000	Soc. Hd. Cap Screw	1

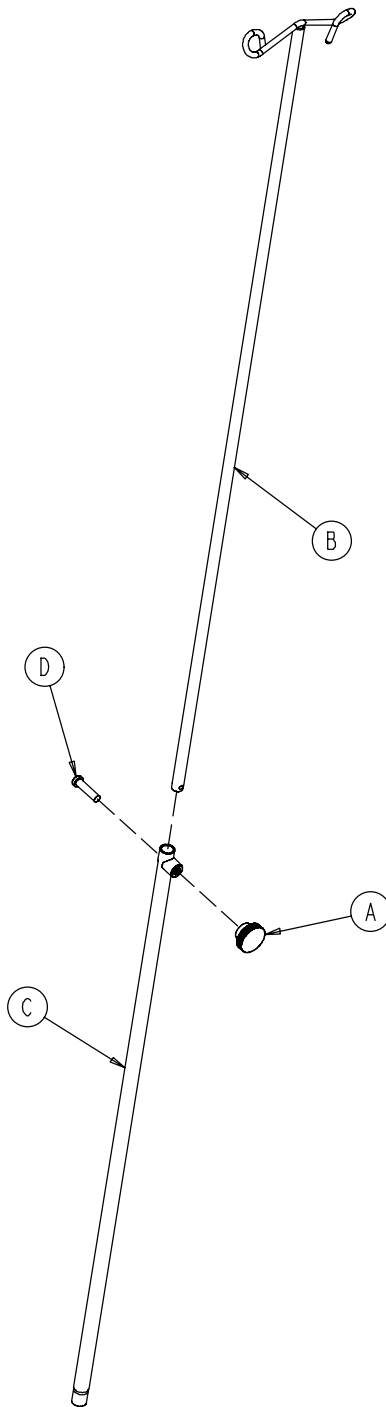

Corner Cover Assembly

Assembly part number (reference only)

0736-035-010 Head End

0736-035-060 Foot End

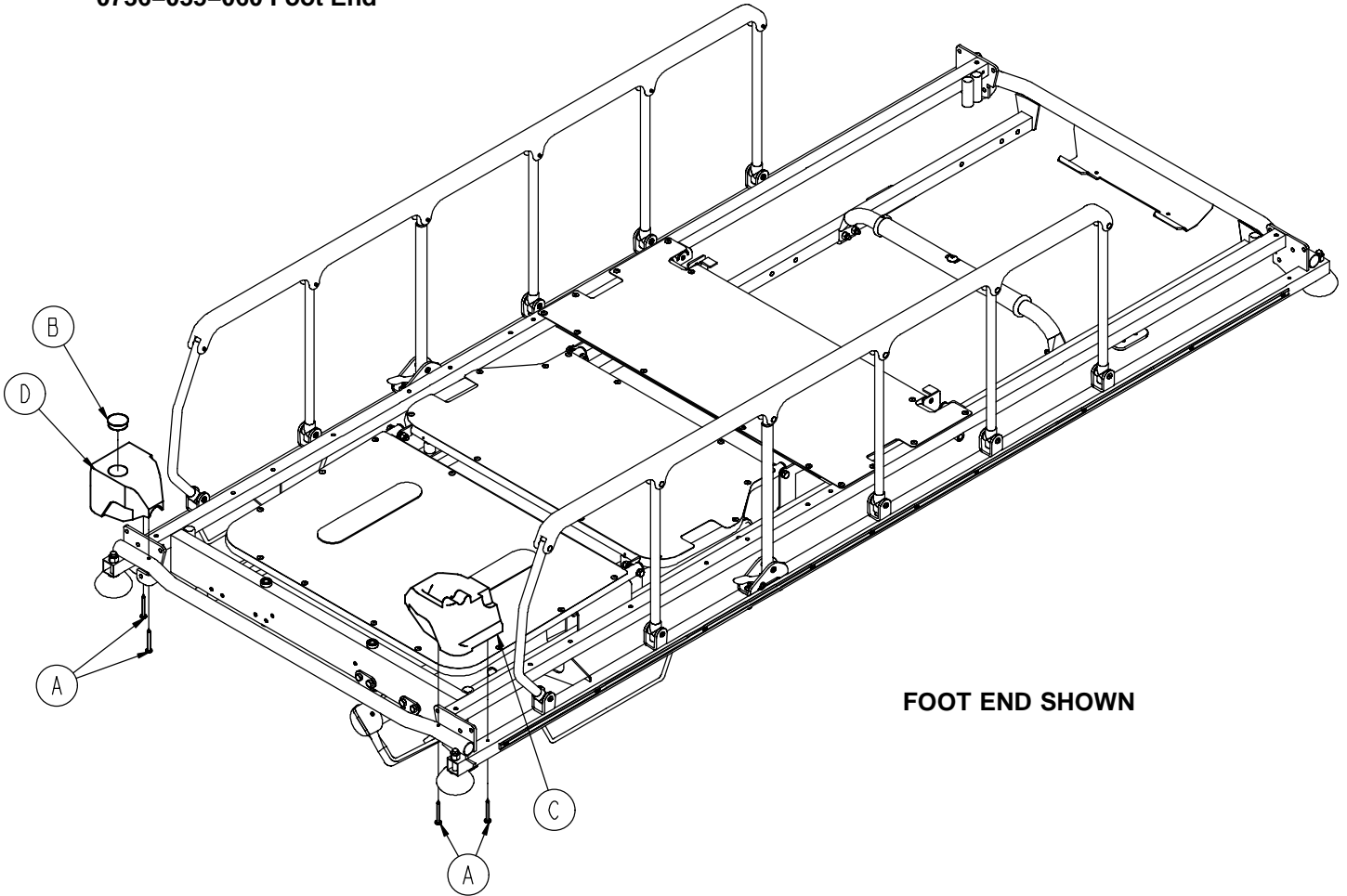

Item	Part No.	Part Name	Qty
A	0023-104-000	Pan Head Screw	4
B	0037-059-000	Hole Plug	1
C	1010-201-238	Corner Cover/Slot	1
D	1010-201-239	Corner Cover/Hole	1

Corner Cover, Push Handle Assembly

Assembly part number (reference only)

0736-035-015 Head End

0736-035-065 Foot End

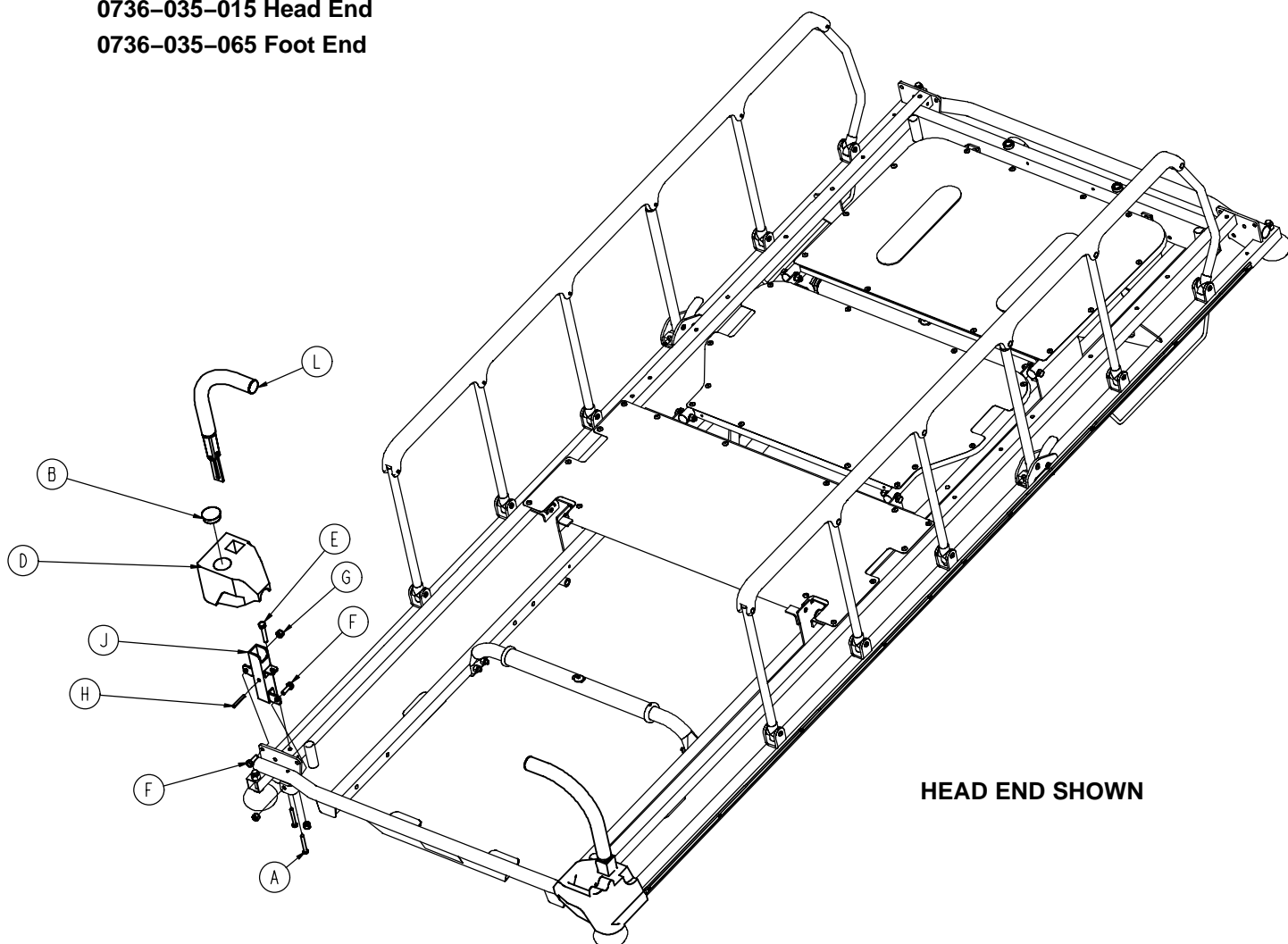

Item	Part No.	Part Name	Qty
A	0023-104-000		4
B	0037-059-000	Hole Plug	1
C	1010-201-236	Corner Cover Hole/Slot	1
D	1010-201-237	Corner Cover Hole/Hole	1
E	0003-047-000	Hex Head Cap Screw	2
F	0003-050-000	Hex Head Cap Screw	4
G	0016-028-000	Fiberlock Hex Nut	6
H	0026-012-000	Slotted Spring Pin	2
J	1010-254-004	Handle Socket, LH	1
K	1010-254-006	Handle Socket, RH	1
L	(page 56)	Push Handle Assembly	2

Corner Cover, 2-Stage I.V. Assembly

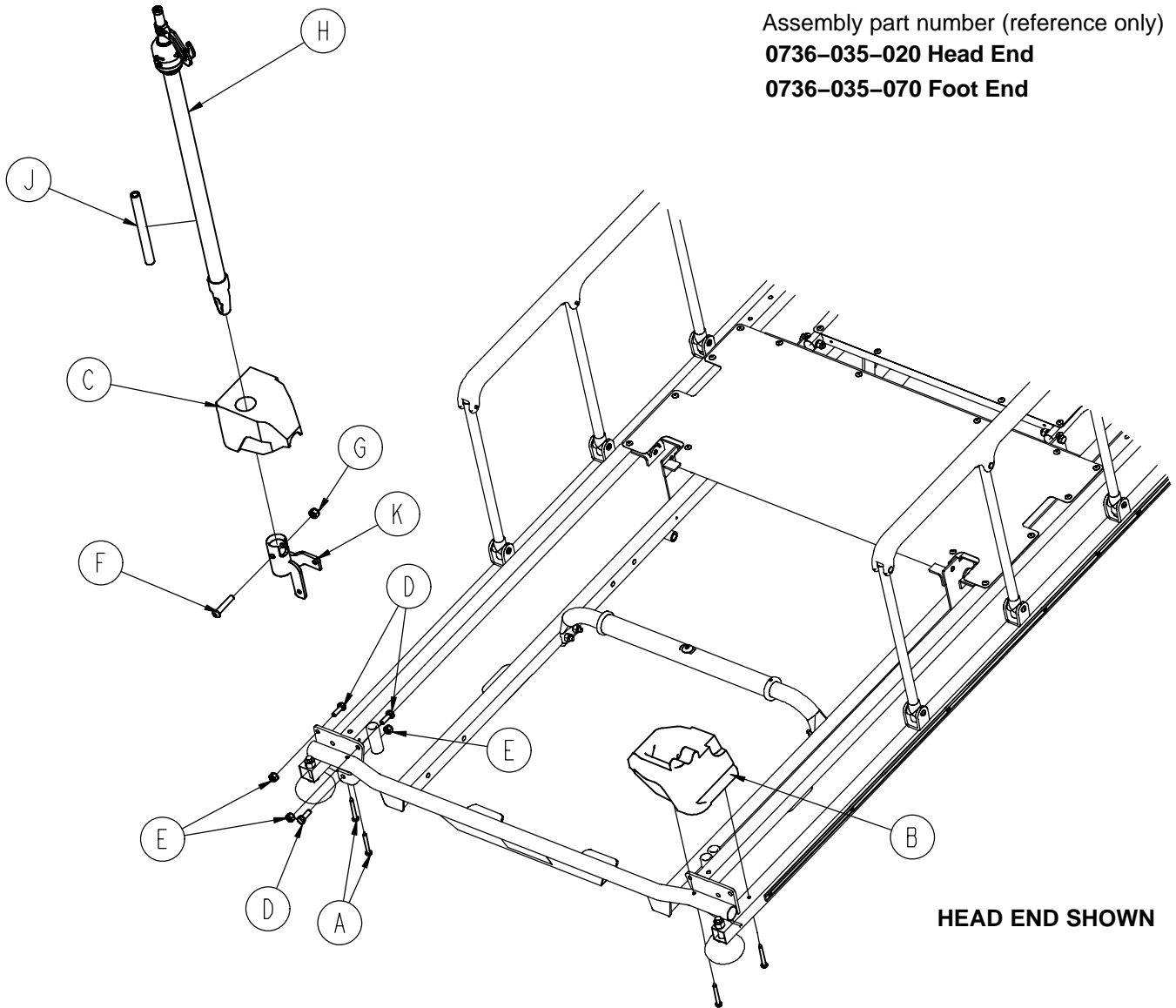

Assembly part number (reference only)
0736-035-020 Head End
0736-035-070 Foot End

Item	Part No.	Part Name	Qty
A	0023-104-000	Pan Head Screw	4
B	1010-201-238	Corner Cover Slot	1
C	1010-201-239	Corner Cover Hole	1
D	0003-050-000	Hex Head Cap Screw	3
E	0016-028-000	Fiberlock Hex Nut	3
F	0004-199-000	Button Head Cap Screw	1
G	0016-036-000	Nylock Hex Nut	1
H	(page 57)	2-Stage IV Pole Assembly	1
J	1509-110-001	IV Plug	1
K	1001-259-103	IV Pivot	1

Corner Cover, 2-Stage I.V., Push Handle Assembly

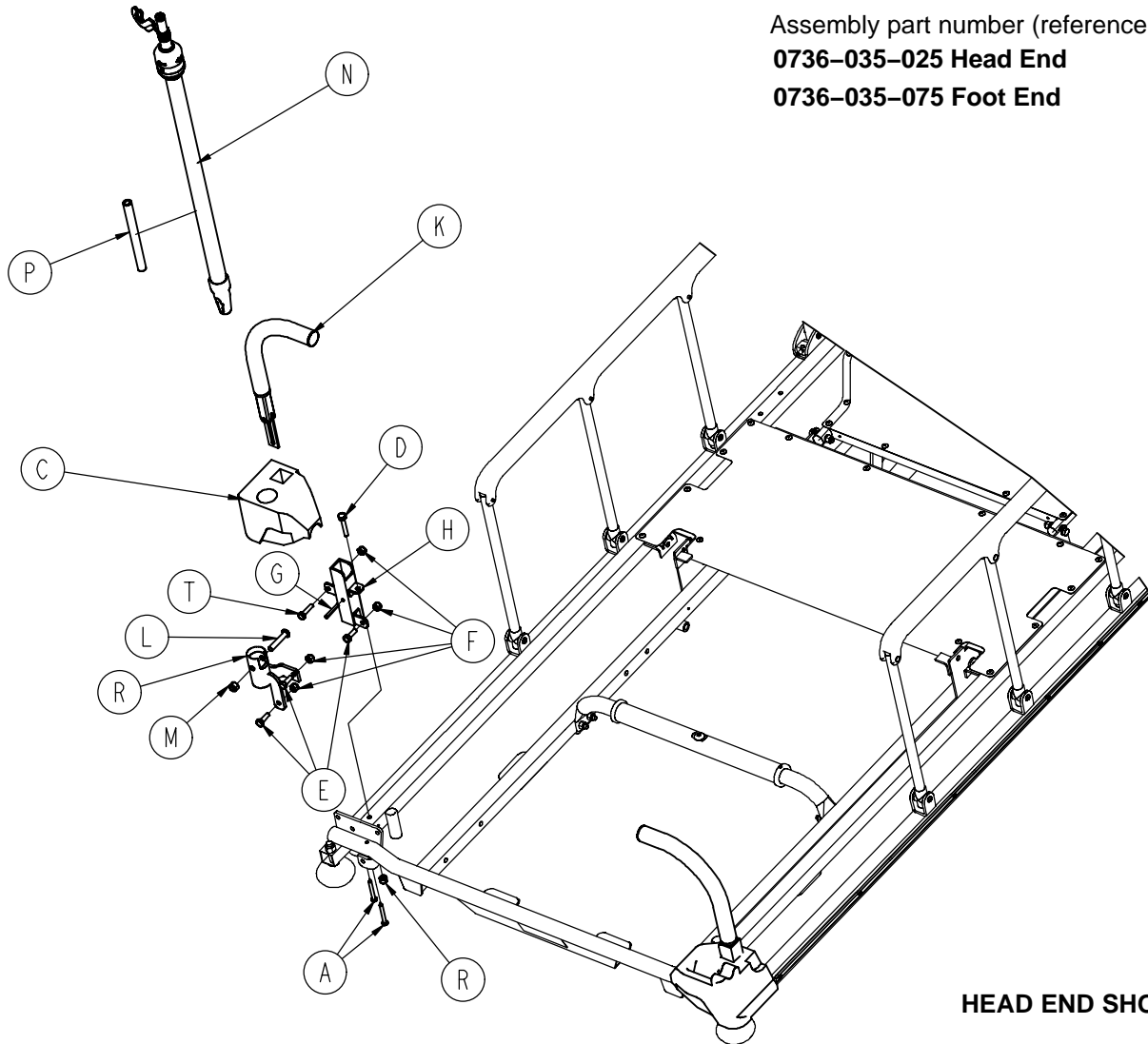

Assembly part number (reference only)
0736-035-025 Head End
0736-035-075 Foot End

Item	Part No.	Part Name	Qty
A	0023-104-000	Pan Head Screw	4
B	1010-201-238	Corner Cover Slot	1
C	1010-201-239	Corner Cover Hole	1
D	0003-047-000	Hex Head Cap Screw	2
E	0003-050-000	Hex Head Cap Screw	5
F	0016-028-000	Fiberlock Hex Nut	8
G	0026-012-000	Slotted Spring Pin	2
H	1010-254-004	Push Handle Socket, LH	1
J	1010-254-006	Push Handle Socket, RH	1
K	(page 56)	Push Handle Assembly	2
L	0004-199-000	Button Head Cap Screw	1
M	0016-036-000	Nylock Hex Nut	1
N	(page 57)	2-Stage IV Pole Assembly	1
P	1509-110-001	IV Plug	1
R	1001-259-103	IV Pivot	1
T	0003-054-000	Hex Head Cap Screw	1

Corner Cover, 3-Stage I.V. Assembly

Assembly part number (reference only)
0736-035-030 Head End
0736-035-080 Foot End

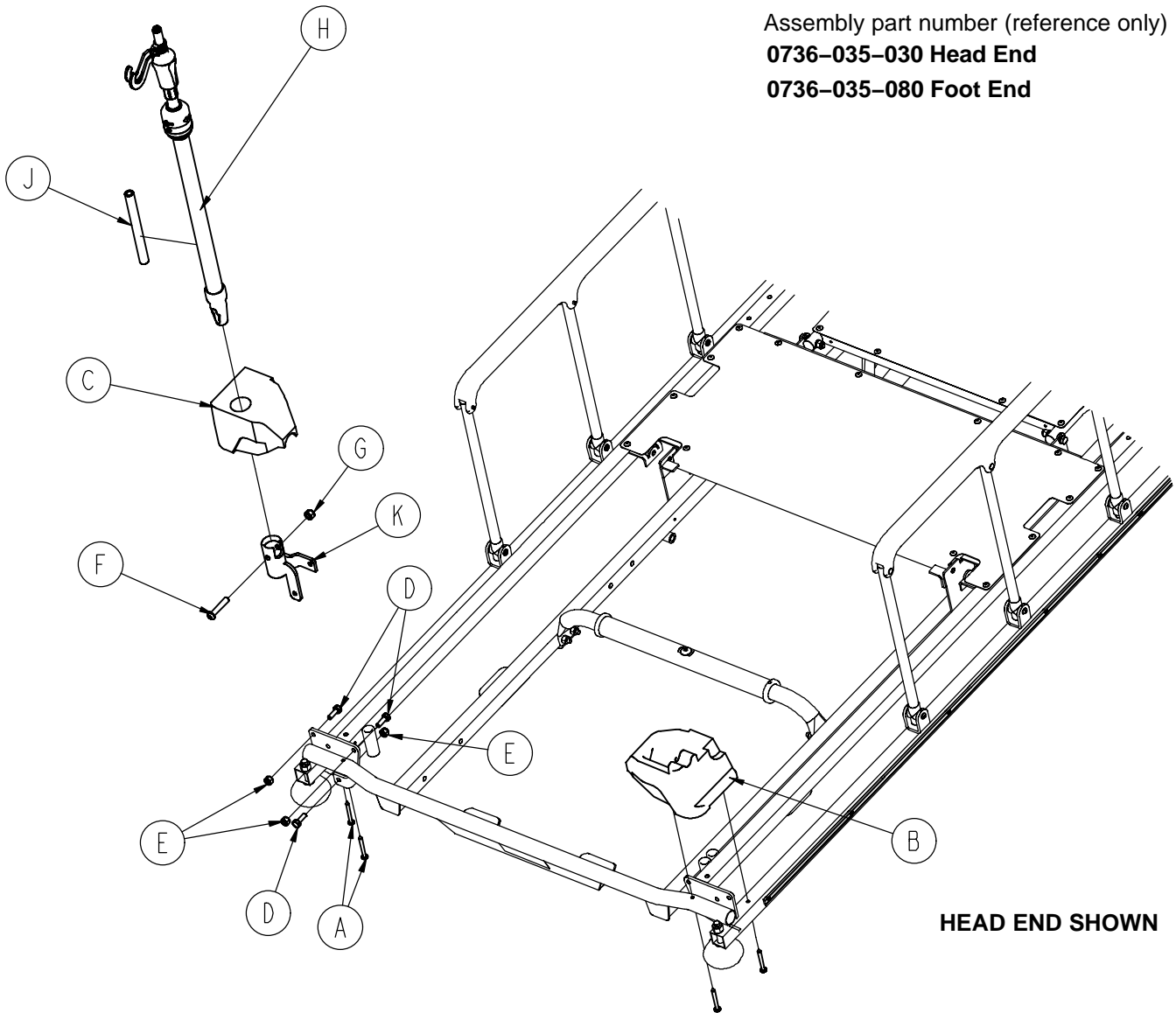

Item	Part No.	Part Name	Qty
A	0023-104-000	Pan Head Screw	4
B	1010-201-238	Corner Cover Slot	1
C	1010-201-239	Corner Cover Hole	1
D	0003-050-000	Hex Head Cap Screw	3
E	0016-028-000	Fiberlock Hex Nut	3
F	0004-199-000	Button Head Cap Screw	1
G	0016-036-000	Nylock Hex Nut	1
H	(page 58)	3-Stage IV Pole Assembly	1
J	1509-110-001	IV Plug	1
K	1001-259-103	IV Pivot	1

Corner Cover, 3-Stage I.V., Push Handle Assembly

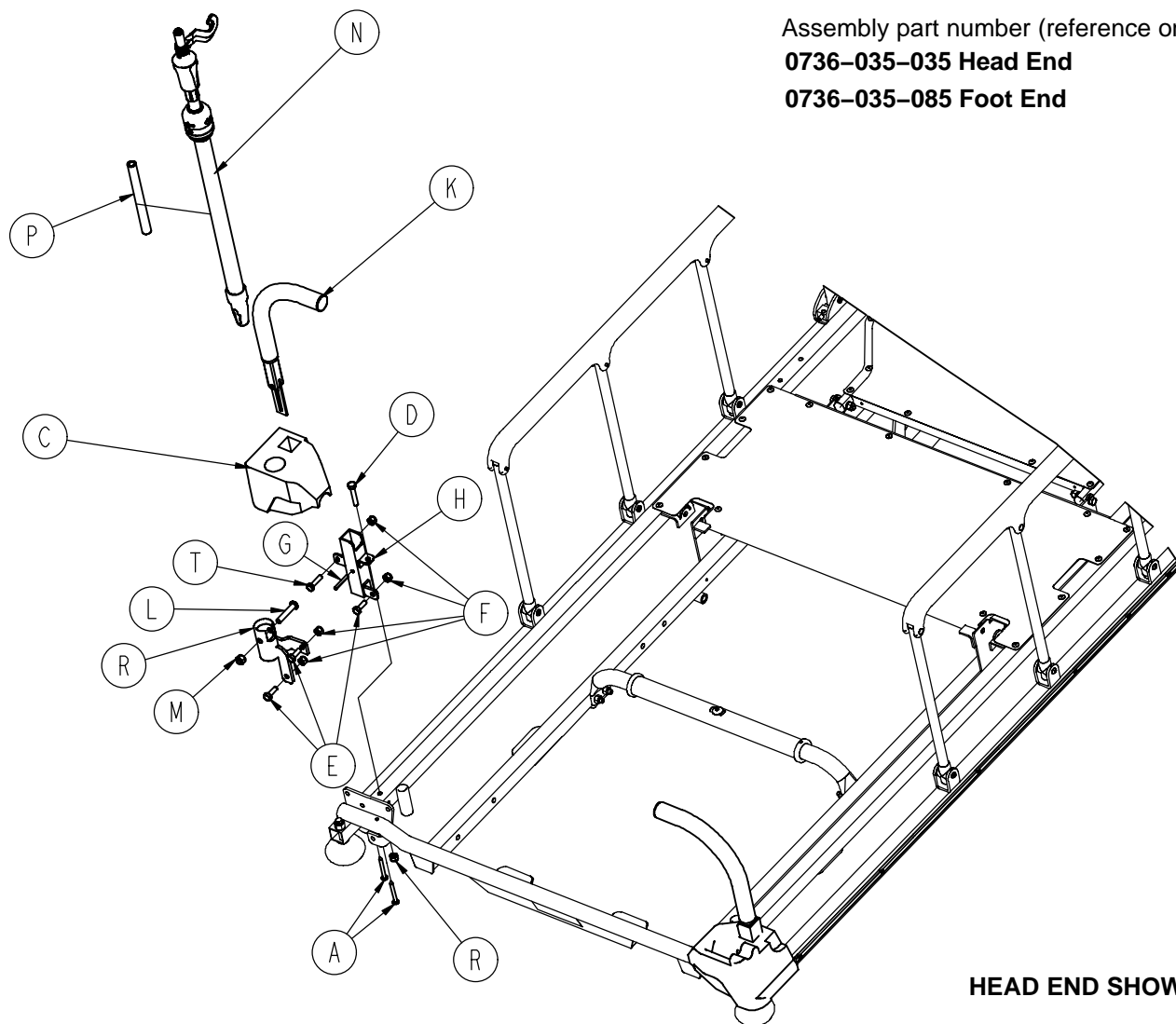

Assembly part number (reference only)
0736-035-035 Head End
0736-035-085 Foot End

Item	Part No.	Part Name	Qty
A	0023-104-000	Pan Head Screw	4
B	1010-201-238	Corner Cover Slot	1
C	1010-201-239	Corner Cover Hole	1
D	0003-047-000	Hex Head Cap Screw	2
E	0003-050-000	Hex Head Cap Screw	5
F	0016-028-000	Fiberlock Hex Nut	8
G	0026-012-000	Slotted Spring Pin	2
H	1010-254-004	Push Handle Socket, LH	1
J	1010-254-006	Push Handle Socket, RH	1
K	(page 56)	Push Handle Assembly	2
L	0004-199-000	Button Head Cap Screw	1
M	0016-036-000	Nylock Hex Nut	1
N	(page 58)	3-Stage IV Pole Assembly	1
P	1509-110-001	IV Plug	1
R	1001-259-103	IV Pivot	1
T	0003-054-000	Hex Head Cap Screw	1

1211-351-010 Push Handle Assembly

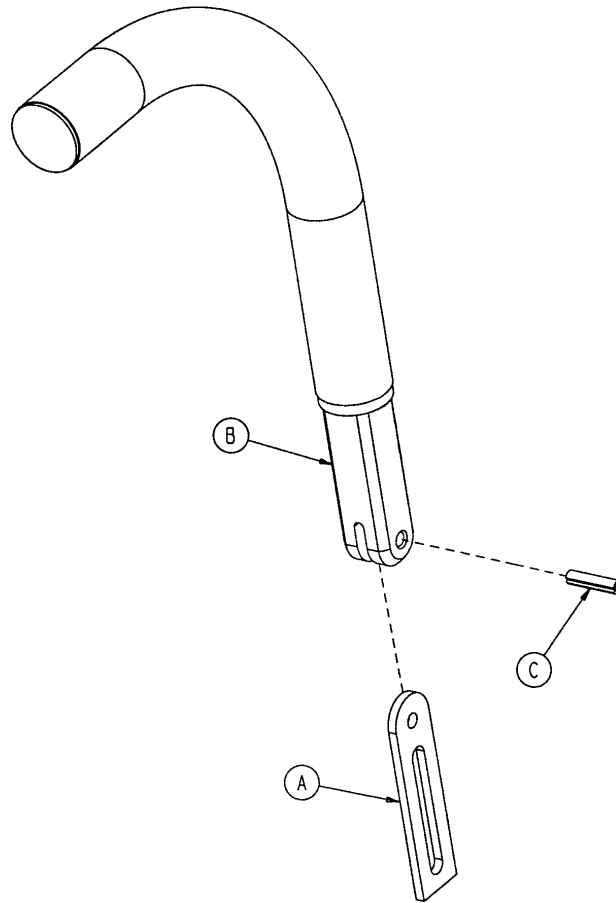

Item	Part No.	Part Name	Qty.
A	1010-354-024	Stop Link	1
B	1211-151-018	Sleeve Assembly	1
C	0026-118-000	Roll Pin	1

1211-210-010 Optional 2-Stage I.V. Pole Assembly

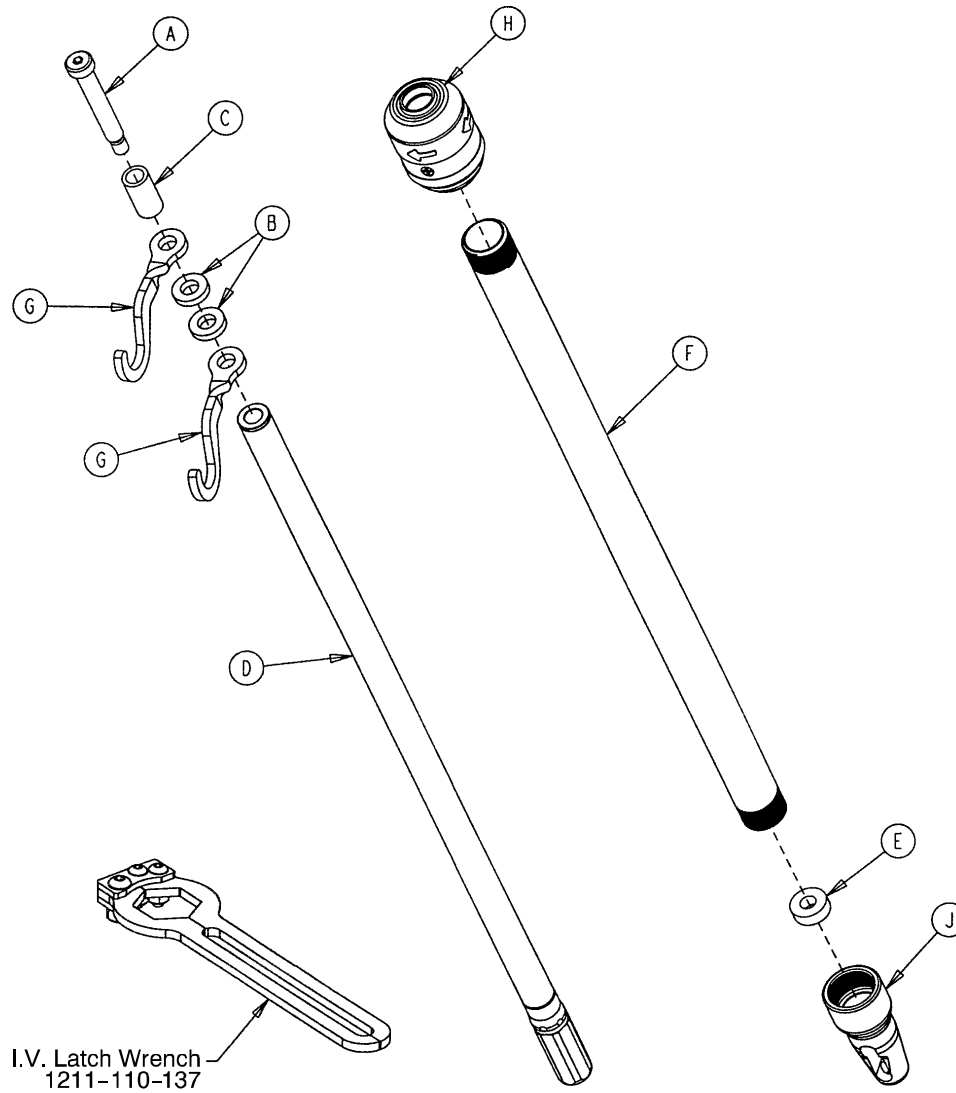

Item	Part No.	Part Name	Qty.
A	0008-031-000	Soc. Hd. Cap Screw	1
B	0052-017-000	Washer	2
C	0926-400-162	Spacer	1
D	1211-210-029	2nd Stage Assembly	1
E	1001-359-013	Dampener	1
F	1001-159-028	Base Tube	1
G	1010-059-016	I.V. Hook	2
H	(page 60)	I.V. Pole Latch	1
J	1001-359-112	Pivot	1

1211-211-010 Optional 3-Stage I.V. Pole Assembly

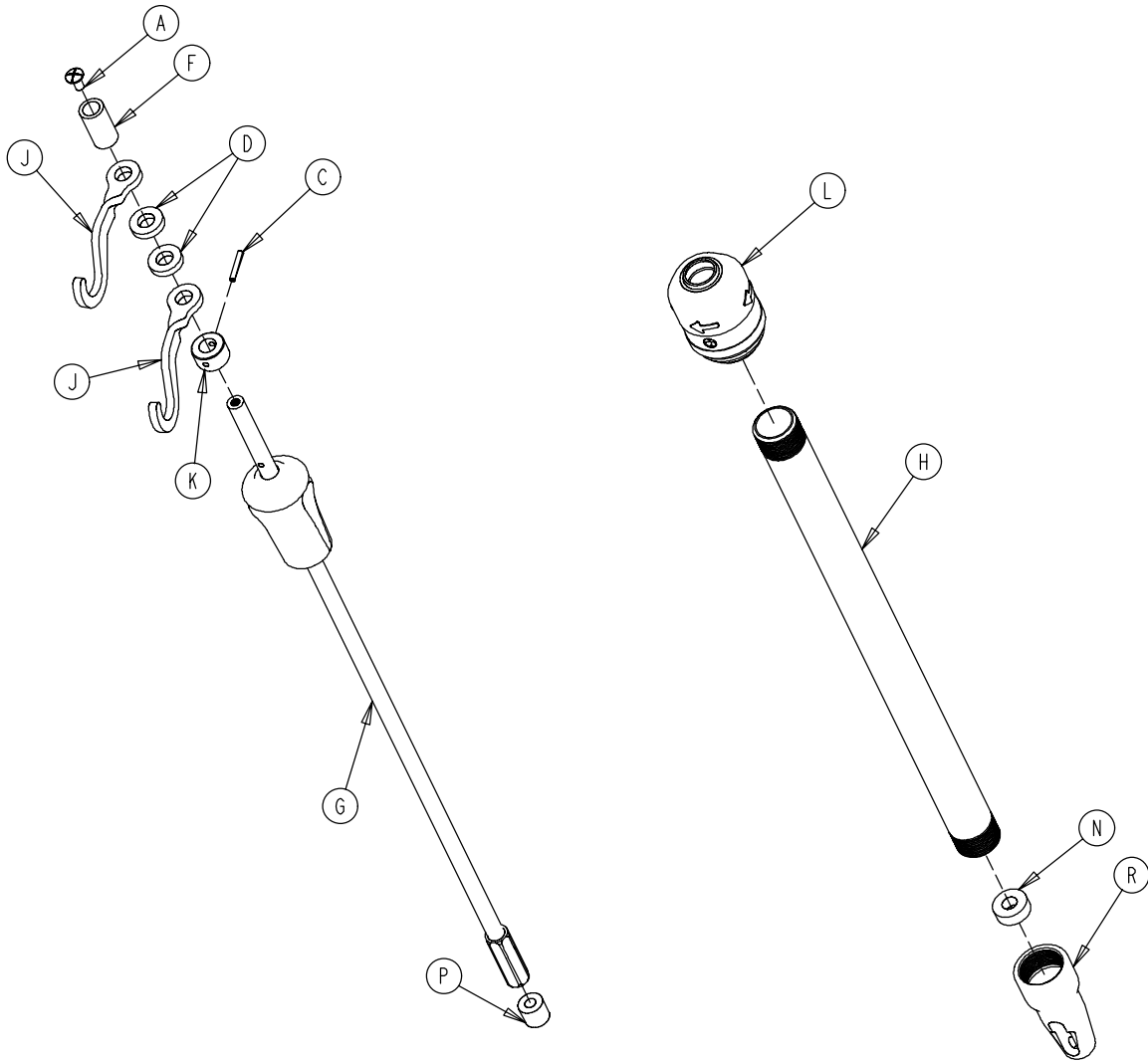

Item	Part No.	Part Name	Qty.
A	0007-004-000	Truss Hd. Machine Screw	1
C	0026-076-000	Roll Pin	1
D	0052-017-000	Spacer	2
F	0926-400-162	Spacer	1
G	(page 59)	3rd Stage Assembly	1
H	1001-161-023	Base Tube	1
J	1010-059-016	I.V. Hook	2
K	1010-061-014	Collar	1
L	(page 60)	I.V. Pole Latch	1
N	1001-359-013	Dampener	1
P	1001-359-014	Dampener	1
R	1001-359-112	Pivot	1

3-Stage I.V. Pole 3rd Stage Assembly

Assembly part number 1211-110-032
(reference only)

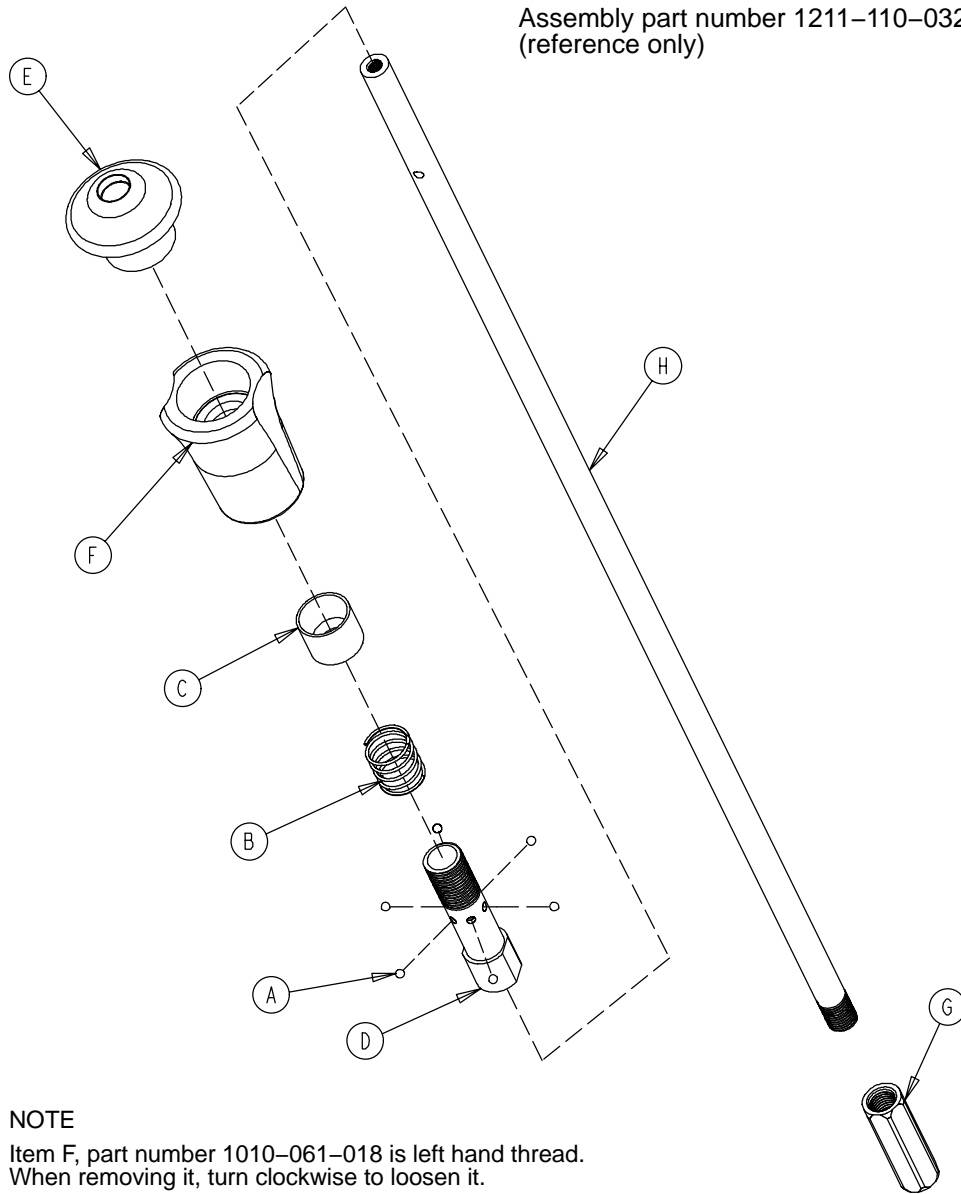

NOTE

Item F, part number 1010-061-018 is left hand thread.
When removing it, turn clockwise to loosen it.

Item	Part No.	Part Name	Qty.
A	0031-021-000	Ball	6
B	0038-303-000	Compression Spring	1
C	1010-061-013	Ball Retainer	1
D	1010-061-016	Retaining Shaft	1
E	1010-061-017	Thumb Knob	1
F	1010-061-018	Hand Guard	1
G	1211-110-117	Nut	1
H	1211-110-033	3rd Extension Rod	1

1211-210-026 I.V. Pole Latch Assembly

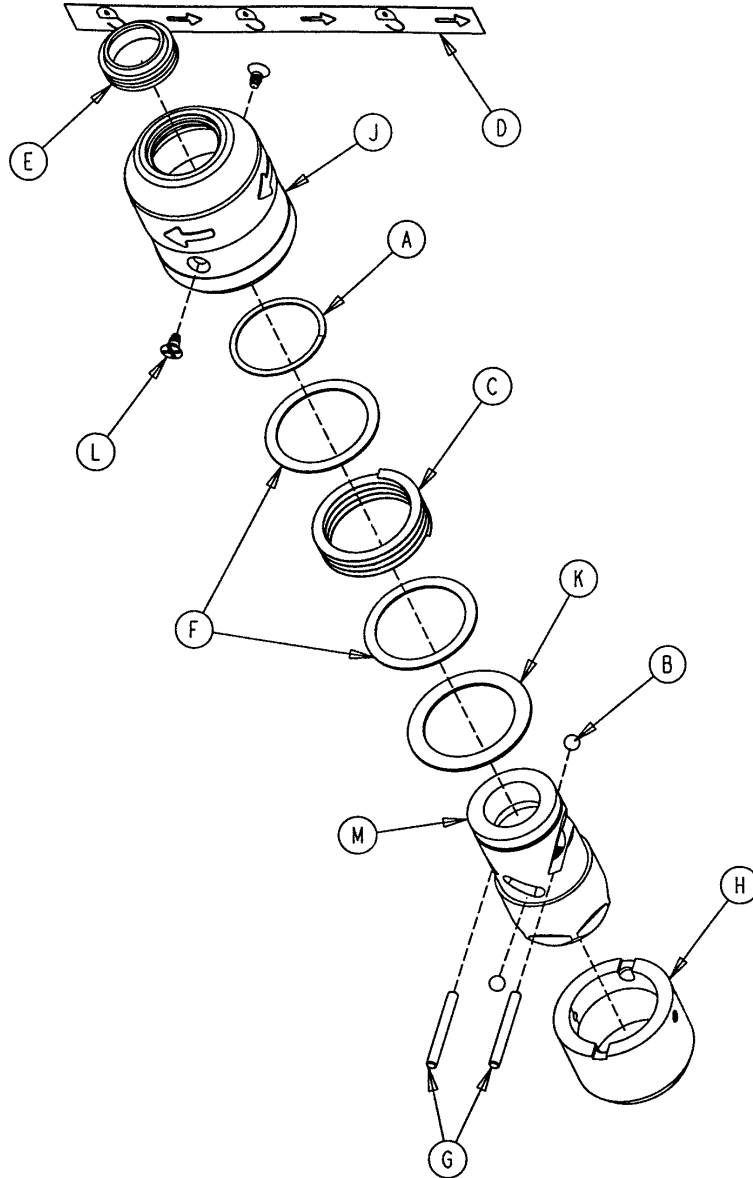

Item	Part No.	Part Name	Qty.
A	0028-167-000	Retaining Ring	1
B	0031-004-000	Steel Ball	2
C	0038-392-000	Crest-to-Crest Spring	1
D	1211-091-034	Release Label	1
E	1211-110-018	I.V. Latch Seal	1
F	1211-110-020	Washer	2
G	1211-110-021	I.V. Latch Locking Pin	2
H	1211-110-022	I.V. Latch Guide	1
J	1211-110-024	I.V. Latch O.D. Housing	1
K	1211-110-035	Washer	1
L	1211-110-036	Self-Tapping Screw	2
M	1211-210-023	I.V. Latch I.D. Housing	1

0785-045-200 Optional Defibrillator Tray Assembly

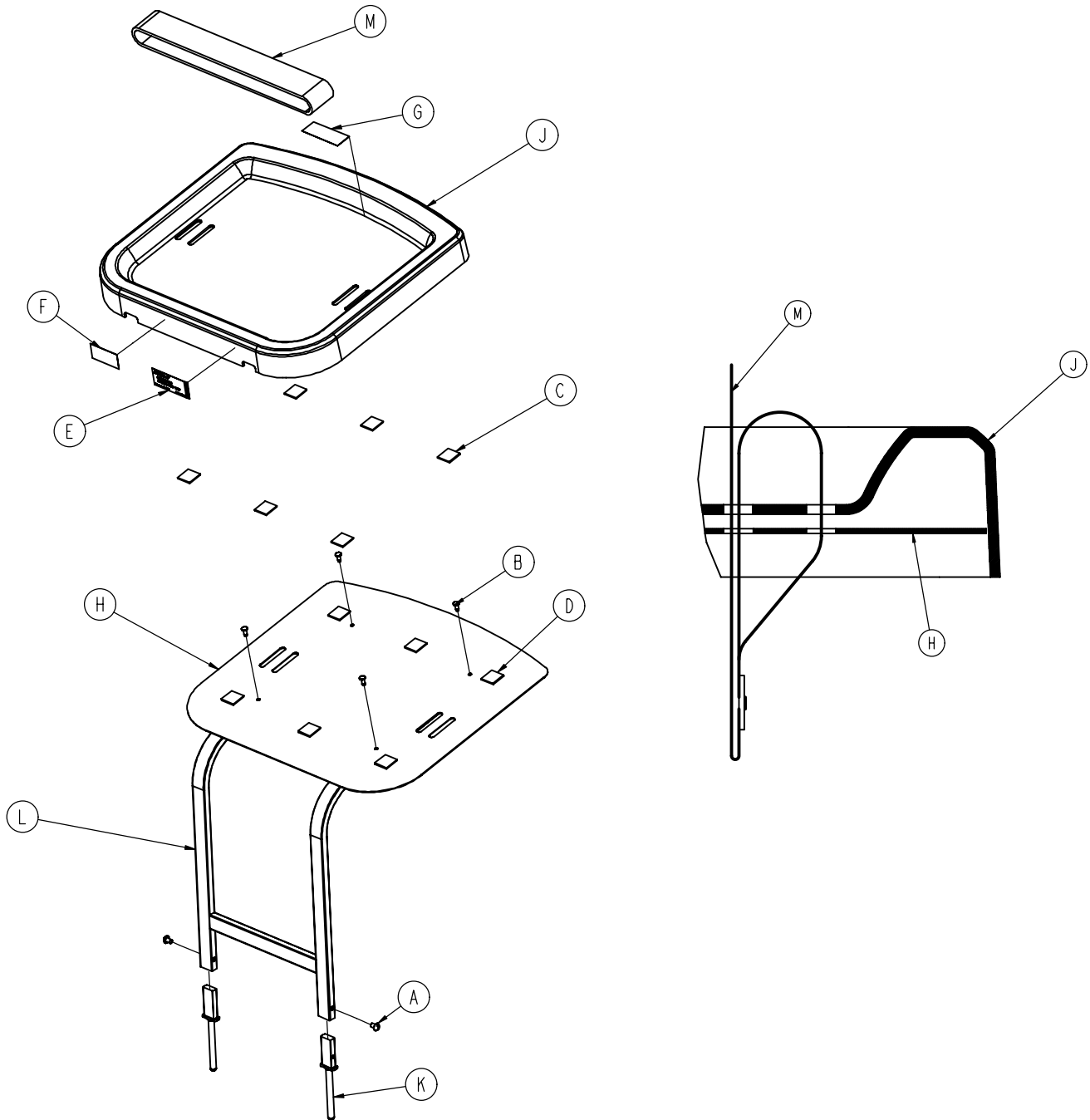

Item	Part No.	Part Name	Qty.	Item	Part No.	Part Name	Qty.
A	0002-044-000	Machine Screw	2	G	0785-045-703	Weight Capacity Label	1
B	0025-055-000	Blind Hole Rivot	4	H	0785-045-204	Tray Support	1
C	0029-008-000	Dual Lock	6	J	0785-045-207	Tray	1
D	0029-010-000	Dual Lock	6	K	0785-045-208	Bayonet	2
E	0785-045-201	Defib Tray Label	1	L	0785-045-210	Defib Tray Frame	1
F	0785-045-402	"Push/Pull" Label	1	M	1010-050-021	Long Strap	1

0785-045-400 Foot Extension/Defibrillator Tray Ass'y

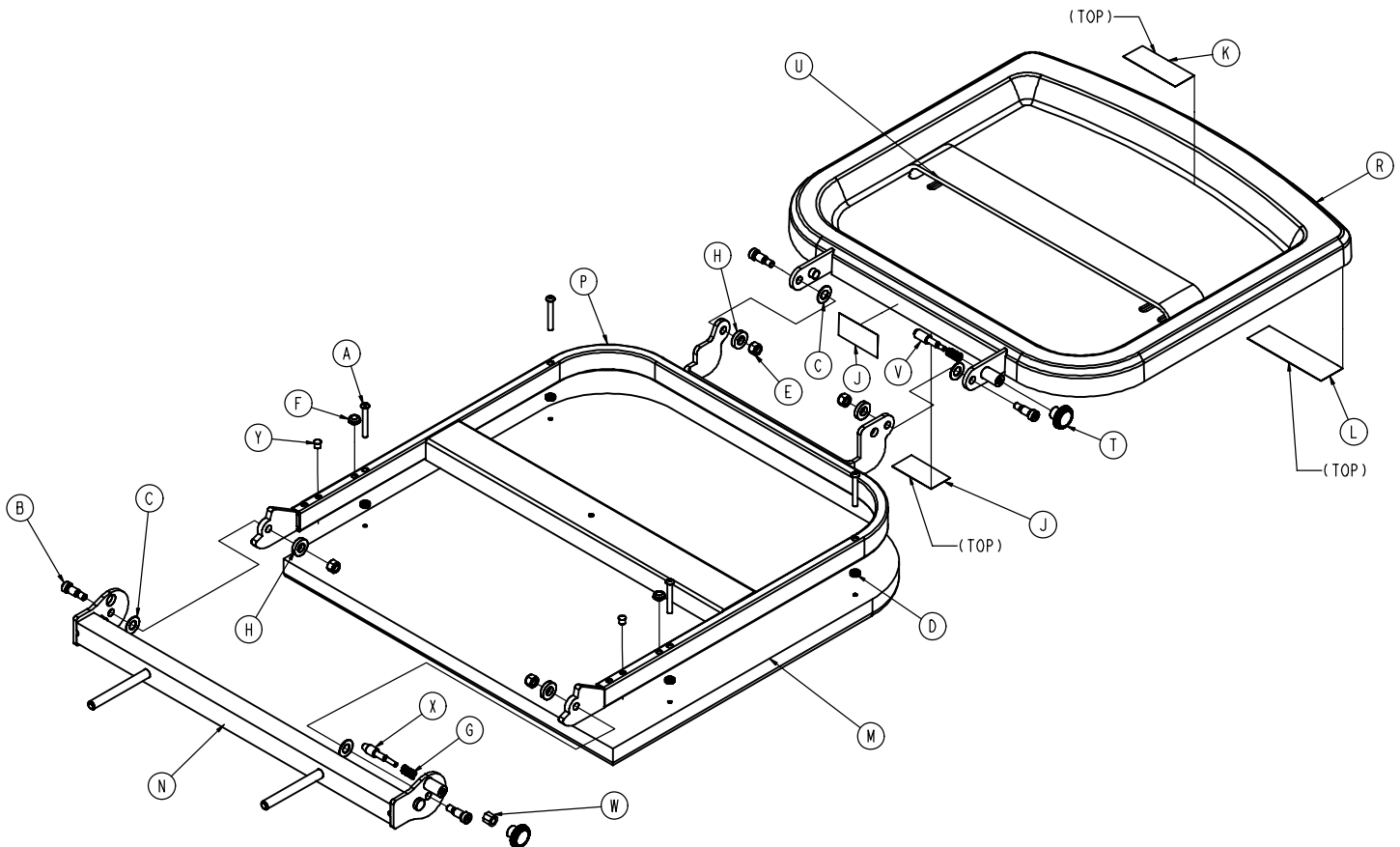

Item	Part No.	Part Name	Qty.	Item	Part No.	Part Name	Qty.
A	0004-215-000	Button Head Cap Screw	4	L	0785-045-401	Foot Ext/Defib Tray Label	1
B	0008-049-000	Shoulder Bolt	4	M	0785-045-405	Cushion	1
C	0014-020-000	Washer	4	N	0785-045-410	Base MTG. Wldmt.	1
D	0014-120-000	Washer	4	P	0785-045-420	Frame-Pivot Wldmt.	1
E	0016-028-000	Hex Nut	4	R	0785-045-430	Tray Assembly	1
F	0037-052-000	Rubber Bumper	2	T	0785-045-450	Knob	2
G	0038-133-000	Compression Spring	2	U	1010-050-021	Long Strap	1
H	0052-017-000	Spacer	4	V	1010-050-242	Pin Lock	1
J	0785-045-402	"Push/Pull" Label	2	W	1010-050-250	Lock Adjuster	1
K	0785-045-403	Weight Capacity Label	1	X	1010-050-248	Lower Pin Lock	1
				Y	0721-031-065	Hole Plug	2

0785-045-500 Foot Board/Chartholder Assembly

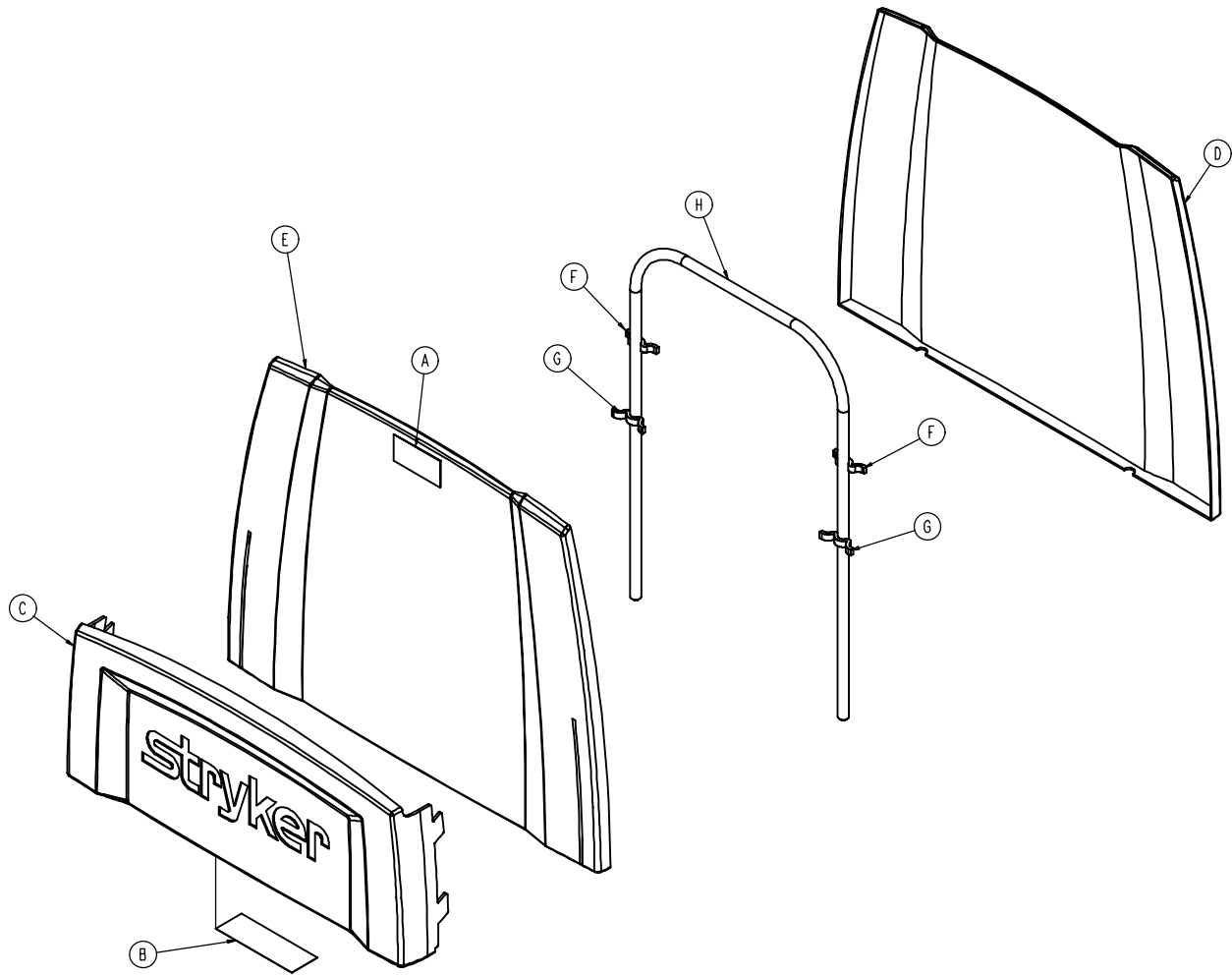

Item	Part No.	Part Name	Qty.
A	0785-045-402	Push/Pull Label	1
B	0785-045-501	Foot Board Label	1
C	0785-45-511	Chart Holder Thermoform	1
D	0785-045-512	Foot Board, Back	1
E	0785-045-513	Foot Board, Front	1
F	0785-045-514	Standoff, Small	2
G	0785-045-515	Standoff, Large	2
H	0946-029-010	Support	1

1020-030-000 Upright O₂ Bottle Holder Assembly

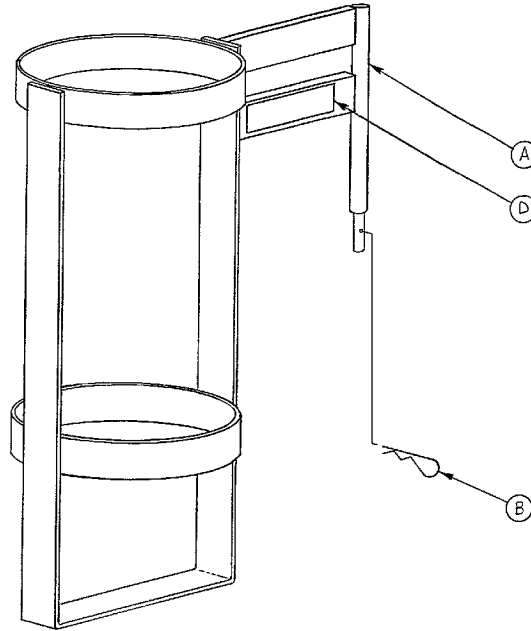

Item	Part No.	Part Name	Qty.
A	1020-030-011	Upright Bottle Holder	1
B	0027-012-000	Cotter Pin	1
D	1020-030-017	Specification Label	1

1040-010-090 Optional O₂ Bottle Retainer Assembly

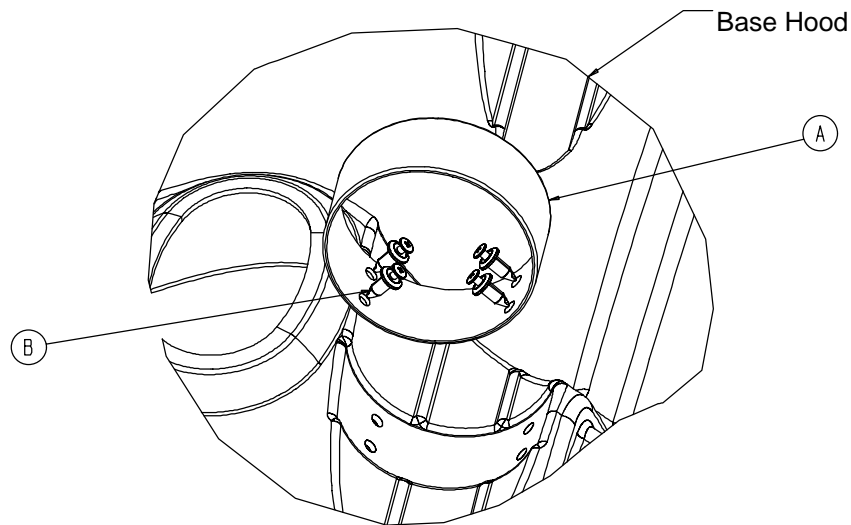

Item	Part No.	Part Name	Qty.
A	1040-010-091	Bottle Retainer	1
B	1040-010-092	Scrulok Fastener	4

Mattresses and Siderail Pads

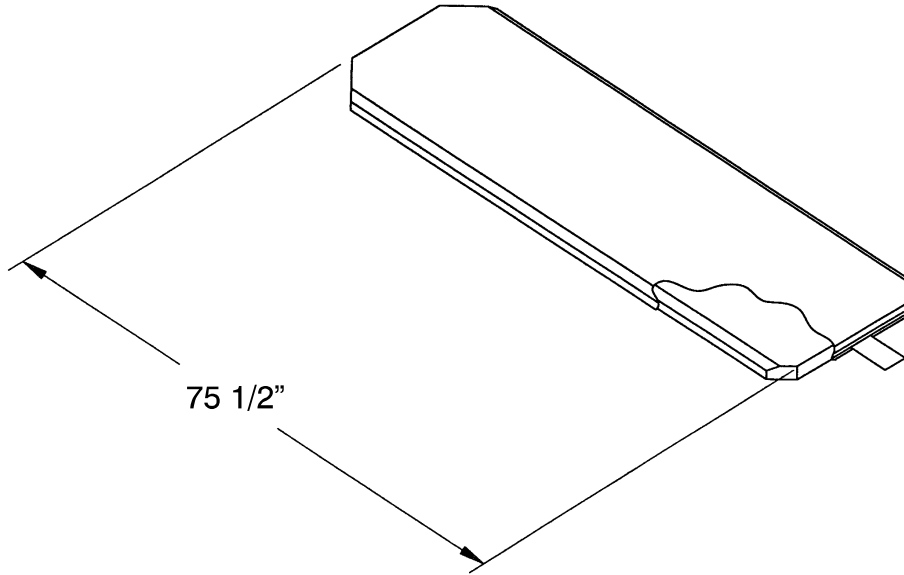

- Mattress, 4" Thick x 30" Wide, Enhanced Comfort part # 0785-034-323
- Mattress, 4" Thick x 30" Wide, Ultra Comfort part # 0785-034-303
- Mattress, 5" Thick x 30" Wide, Ultra Comfort part # 0785-034-333

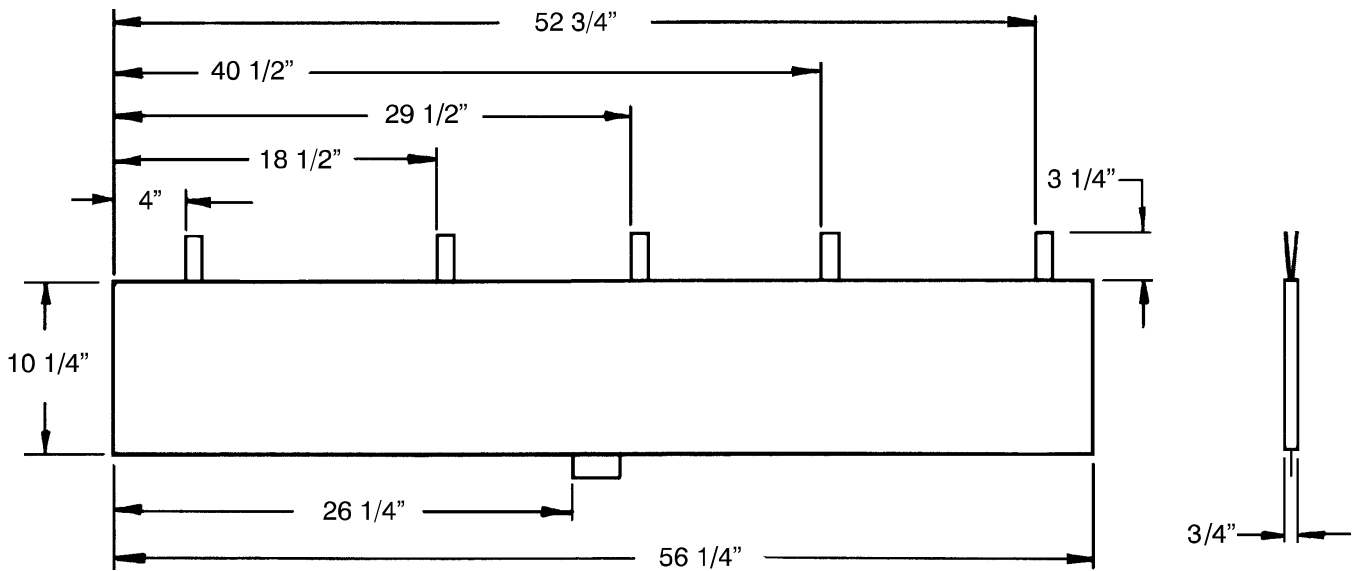

- Siderail Pad Set part # 1010-052-000

Warranty

Limited Warranty:

Stryker Medical Division, a division of Stryker Corporation, warrants to the original purchaser that its products should be free from defects in material and workmanship for a period of one (1) year after date of delivery. Stryker's obligation under this warranty is expressly limited to supplying replacement parts and labor for, or replacing, at its option, any product which is, in the sole discretion of Stryker, found to be defective. If requested by Stryker, products or parts for which a warranty claim is made shall be returned prepaid to Stryker's factory. Any improper use or any alteration or repair by others in such manner as in Stryker's judgement affects the product materially and adversely shall void this warranty. Any repair of Stryker products using parts not provided or authorized by Stryker shall void this warranty. No employee or representative of Stryker is authorized to change this warranty in any way.

Stryker Medical stretcher products are designed for a 10 year expected service life under normal use, conditions, and with appropriate periodic maintenance as described in the maintenance manual for each device. Stryker warrants to the original purchaser that the welds on its stretcher products will be free from structural defects for the expected 10 year life of the stretcher product as long as the original purchaser owns the product.

This statement constitutes Stryker's entire warranty with respect to the aforesaid equipment. STRYKER MAKES NO OTHER WARRANTY OR REPRESENTATION, EITHER EXPRESSED OR IMPLIED, EXCEPT AS SET FORTH HEREIN. THERE IS NO WARRANTY OF MERCHANTABILITY AND THERE ARE NO WARRANTIES OF FITNESS FOR ANY PARTICULAR PURPOSE. IN NO EVENT SHALL STRYKER BE LIABLE HEREUNDER FOR INCIDENTAL OR CONSEQUENTIAL DAMAGES ARISING FROM OR IN ANY MANNER RELATED TO SALES OR USE OF ANY SUCH EQUIPMENT.

To Obtain Parts and Service:

Stryker products are supported by a nationwide network of dedicated Stryker Field Service Representatives. These representatives are factory trained, available locally, and carry a substantial spare parts inventory to minimize repair time. Simply call your local representative, or call Stryker Customer Service at (800) 327-0770.

Service Contract Coverage:

Stryker has developed a comprehensive program of service contract options designed to keep your equipment operating at peak performance at the same time it eliminates unexpected costs. We recommend that these programs be activated *before* the expiration of the new product warranty to eliminate the potential of additional equipment upgrade charges.

A SERVICE CONTRACT HELPS TO:

- Ensure equipment reliability
- Stabilize maintenance budgets
- Diminish downtime
- Establish documentation for JCAHO
- Increase product life
- Enhance trade-in value
- Address risk management and safety

Warranty

Stryker offers the following service contract programs:

SPECIFICATIONS	GOLD	SILVER	PM* ONLY
Annually scheduled preventative maintenance	X		X
All parts,** labor, and travel	X	X	
Unlimited emergency service calls	X	X	
Priority one contact; two hour phone response	X	X	X
Most repairs will be completed within 3 business days	X	X	
JCAHO documentation	X	X	X
On-site log book w/ preventative maintenance & emergency service records	X		
Factory-trained Stryker Service Technicians	X	X	X
Stryker authorized parts	X	X	X
End of year summary	X		
Stryker will perform all service during regular business hours (9-5)	X	X	X

* Replacement parts and labor for products under PM contract will be discounted.

** Does not include any disposable items, I.V. poles (except for Stryker HD permanent poles), mattresses, or damage resulting from abuse.

Stryker Medical also offers *personalized* service contracts.

Pricing is determined by age, location, model and condition of product.

***For more information on our service contracts,
please call your local representative or call (800) 327-0770 (option #2).***

Return Authorization:

Merchandise cannot be returned without approval from the Stryker Customer Service Department. An authorization number will be provided which must be printed on the returned merchandise. Stryker reserves the right to charge shipping and restocking fees on returned items.

SPECIAL, MODIFIED, OR DISCONTINUED ITEMS NOT SUBJECT TO RETURN.

Damaged Merchandise:

ICC Regulations require that claims for damaged merchandise must be made with the carrier within fifteen (15) days of receipt of merchandise. **DO NOT ACCEPT DAMAGED SHIPMENTS UNLESS SUCH DAMAGE IS NOTED ON THE DELIVERY RECEIPT AT THE TIME OF RECEIPT.** Upon prompt notification, Stryker will file a freight claim with the appropriate carrier for damages incurred. Claim will be limited in amount to the actual replacement cost. In the event that this information is not received by Stryker within the fifteen (15) day period following the delivery of the merchandise, or the damage was not noted on the delivery receipt at the time of receipt, the customer will be responsible for payment of the original invoice in full.

Claims for any short shipment must be made within thirty (30) days of invoice.

International Warranty Clause:

This warranty reflects U.S. domestic policy. Warranty outside the U.S. may vary by country. Please contact your local Stryker Medical representative for additional information.



3800 E. Centre Ave., Portage, MI 49002
(800) 327-0770
www.stryker.com