

**stryker<sup>®</sup>**  
**Medical**

---

---

*Trauma Series*

---

*1020 Full-Length X-Ray Stretcher  
Maintenance Manual*

*For stretchers with serial numbers of 9803034840 and above*

*For Parts or Technical Assistance  
800-327-0770*

# Table of Contents

---

Introduction	
Specifications .....	3
Warning / Caution / Note Definition .....	3
Preventative Maintenance	
Checklist .....	4
Cleaning .....	5
Service Information	
Caster Assembly Replacement .....	6
Fifth Wheel Replacement .....	6
Caster Cover Installation And Removal .....	7
Brake Cam Replacement .....	8
Brake Ring Replacement .....	8
Brake Adjustment .....	9
Base Side Control Pedal Linkage Adjustment .....	9
Base Side Control Brake/Steer Gear Replacement .....	10
Uni-Pedal Replacement .....	10
Jack Replacement .....	11
Jack Torque Specifications .....	12
Hydraulic Troubleshooting .....	12
Removal Of Excess Air (Vacuum) From The Hydraulic System .....	12
Checking Hydraulic Fluid Level .....	13
Jack Descent Rate Adjustment .....	13
Hydraulic Check Valve Replacement	
Replacement Of Valve #1 .....	14
Replacement Of Valve #2 .....	15
Replacement Of Valve (Poppet) #3 .....	15
Base Lubrication .....	16
Pneumatic Fowler Adjustment .....	17
Transfer Board Counterbalance Adjustment .....	17
Siderail Latch Adjustment .....	17
Replacement Parts .....	18
Assembly Drawings and Parts Lists	
Side Control Base Assembly .....	19-22
End Control Base Assembly .....	23-26
Brake Adjuster Assembly .....	27
Brake Cam Assembly .....	28
Side Control Pump Pedal Assembly .....	29
End Control Pump Pedal Assembly, Foot End .....	30
End Control Pump Pedal Assembly, Head End .....	31
Base Assembly with Steerlock Caster Option .....	32
Caster Assembly with Steerlock .....	33
Standard Caster Assembly .....	34
Base Assembly with Fifth Wheel Option .....	35
Pivot Rod Assembly .....	36
Wheel Arm Assembly .....	37

# Table of Contents

---

## Assembly Drawings and Parts Lists (Continued)

Jack Assembly	38
Jack Base Assembly	39
Base Assembly with Side Control Brakes	40, 41
Base Assembly with Uni-Lower Pedal	42
Base Assembly with Dual Lowering Pedals	43
Base Labeling Assembly	44-46
Litter Assembly	47-49
Litter Corner Cover Assembly	50,51
Transfer System Assembly, Left	52
Transfer System Assembly, Right	53
Arm Board Support Assembly	54
Siderail Assembly, Right & Left	55
Manual Fowler to Frame Assembly	56
Manual Fowler Assembly	57
Pneumatic Fowler to Frame Assembly	58
Pneumatic Fowler Assembly	59
Foot Section Assembly	60
Push Handle Assembly	61-63
X-Ray Tray Assembly	64-67
Grid Holder Assembly	68
Centering Device Option Assembly	69
Fowler X-Ray Cassette Assembly	70
Removable I.V. Pole Assembly	71
Tethered I.V. Assembly	72
Tethered I.V. Pole Assembly	73
2-Stage I.V. Assembly	74
2-Stage I.V. Pole Assembly	75
I.V. Pole Latch Assembly	76
3-Stage I.V. Assembly	77
3-Stage I.V. Pole Assembly	78
3rd Stage Assembly	79
Foot Board/Chartholder	80
Upright Oxygen Bottle Holder	80
Defibrillator Tray Assembly	81
Foot Extension/Defibrillator Tray Assembly	82
Heel Stirrup and Support Assembly	83
Stirrup Support Assembly	84
Heel Stirrup Assembly	85
C-Spine Cassette Holder Assembly	86
C-Spine Support Pole Assembly	87
C-Spine Storage Bracket Assembly	88
O <sub>2</sub> Bottle Retainer	89
Mattresses and Siderail Pads	90, 91
Warranty	
Obtaining Parts and Service	92
Supplemental Warranty Coverage	92
Return Authorization	93
Freight Damage Claims	93

# Introduction

---

## INTRODUCTION

This manual is designed to assist you with the maintenance of the 1020 Full-Length X-Ray Emergency Room Stretcher. Read it thoroughly before using the equipment or beginning any maintenance on it.

## SPECIFICATIONS

Maximum Weight Capacity	400 pounds
Overall Bed Length/Width	86.5"/31.25"
Minimum/Maximum Bed Height	26"/39.25"
Bed Weight w/Accessories	290 pounds
Fowler Angle	0 to 90 degrees
Trendelenburg/Reverse Trendelenburg	-15 degrees to +18 degrees

Stryker reserves the right to change specifications without notice.

## WARNING / CAUTION / NOTE DEFINITION

The words WARNING, CAUTION and NOTE carry special meanings and should be carefully reviewed.

---

### WARNING

The personal safety of the patient or user may be involved. Disregarding this information could result in injury to the patient or user.

---

---

### CAUTION

These instructions point out special procedures or precautions that must be followed to avoid damaging the equipment.

---

### NOTE

This provides special information to make maintenance easier or important instructions clearer.

---

### WARNING

Patients should be discouraged from sitting directly on the ends of the stretcher. Excessive weight will cause the litter surface to tip up, possibly causing patient injury. Always apply the caster brakes when a patient is getting on or off the stretcher. Push on the stretcher to ensure the brakes are securely locked. Always engage the brakes unless the stretcher is being moved. Injury could result if the stretcher moves while a patient is getting on or off the stretcher.

---

# Preventative Maintenance

---

## CHECKLIST

- \_\_\_\_\_ All fasteners secure (reference all assembly prints)
- \_\_\_\_\_ Siderails move and latch properly (page 17)
- \_\_\_\_\_ Engage brake pedal and push on the stretcher to ensure all casters lock securely (page 9)
- \_\_\_\_\_ Steer function working properly
- \_\_\_\_\_ All casters secure and swivel properly
- \_\_\_\_\_ Body restraints working properly
- \_\_\_\_\_ I.V. pole intact and operating properly (page 71- 79)
- \_\_\_\_\_ Oxygen bottle holder intact and operating properly
- \_\_\_\_\_ Fowler operates and latches properly
- \_\_\_\_\_ Trendelenberg/Reverse Trendelenberg operating properly
- \_\_\_\_\_ No rips or cracks in mattress cover
- \_\_\_\_\_ Transfer boards intact and operating properly (page 52 & 53)
- \_\_\_\_\_ Arm board support levers intact and operating properly (page 54)
- \_\_\_\_\_ Ground chain intact
- \_\_\_\_\_ No leaks at hydraulic connections
- \_\_\_\_\_ Hydraulic jacks holding properly (page 12)
- \_\_\_\_\_ Hydraulic drop rate set properly (page 13)
- \_\_\_\_\_ Hydraulic oil level sufficient (page 13)
- \_\_\_\_\_ Lubricate where required (page 16)
- \_\_\_\_\_ X-Ray Tray slide tracks cleaned of dust and debris
- \_\_\_\_\_ Accessories and mounting hardware in good condition and working properly

Serial No. \_\_\_\_\_  
\_\_\_\_\_  
\_\_\_\_\_  
\_\_\_\_\_  
\_\_\_\_\_

Completed By: \_\_\_\_\_ Date: \_\_\_\_\_

## NOTE

Preventative maintenance should be performed at a minimum of annually. A preventative maintenance program should be established for all Stryker Medical equipment. Preventative maintenance may need to be performed more frequently based on the usage level of the product.

## NOTE

References to the right or left side of the stretcher refer to the right and left sides of a patient lying face up on the stretcher.

# Cleaning

Hand wash all surfaces of the stretcher with warm water and mild detergent. Dry thoroughly. **DO NOT STEAM CLEAN, PRESSURE WASH, HOSE OFF OR ULTRASONICALLY CLEAN.** Using these methods of cleaning is **not** recommended and may void this product's warranty.

Clean Velcro **AFTER EACH USE**. Saturate Velcro with disinfectant and allow disinfectant to evaporate. (Appropriate disinfectant for nylon Velcro should be determined by the hospital.)

In general, when used in those concentrations recommended by the manufacturer, either phenolic type or quaternary type disinfectants can be used. Iodophor type disinfectants are not recommended for use because staining may result. The following products have been tested and have been found not to have a harmful effect **WHEN USED IN ACCORDANCE WITH MANUFACTURERS RECOMMENDED DILUTION.\***

TRADE NAME	DISINFECTANT TYPE	MANUFACTURER	*MANUFACTURER'S RECOMMENDED DILUTION
A33	Quaternary	Airwick (Professional Products Division)	2 ounces/gallon
A33 (dry)	Quaternary	Airwick (Professional Products Division)	1/2 ounce/gallon
Beaucoup	Phenolic	Huntington Laboratories	1 ounce/gallon
Blue Chip	Quaternary	S.C. Johnson	2 ounces/gallon
Elimstaph	Quaternary	Walter G. Legge	1 ounce/gallon
Franklin Phenomysan F2500	Phenolic	Purex Corporation	1 1/4 ounce/gallon
Franklin Sentinel	Quaternary	Purex Corporation	2 ounces/gallon
Galahad	Phenolic	Puritan Churchill Chemical Company	1 ounce/gallon
Hi-Tor	Quaternary	Huntington Laboratories	1/2 ounce/gallon
LPH	Phenolic	Vestal Laboratories	1/2 ounce/gallon
Matar	Phenolic	Huntington Laboratories	1/2 ounce/gallon
Omega	Quaternary	Airwick (Professional Products Division)	1/2 ounce/gallon
Quanto	Quaternary	Huntington Laboratories	1 ounce/gallon
Sanikleen	Quaternary	West Chemical Products	2 ounces/ gallon
Sanimaster II	Quaternary	Service Master	1 ounce/gallon
Vesphene	Phenolic	Vestal Laboratories	1 1/4 ounce/ gallon

Quaternary Germicidal Disinfectants, used as directed, and/or Chlorine Bleach products, typically 5.25% Sodium Hypochlorite in **dilutions ranging between 1 part bleach to 100 parts water, and 2 parts bleach to 100 parts water are not considered mild detergents. These products are corrosive in nature and may cause damage to your stretcher if used improperly.** If these types of products are used to clean Stryker patient handling equipment, measures must be taken to insure the stretchers are rinsed with clean water and thoroughly dried following cleaning. Failure to properly rinse and dry the stretchers will leave a corrosive residue on the surface of the stretcher, possibly causing premature corrosion of critical components.

## NOTE

Failure to follow the above directions when using these types of cleaners may void this product's warranty.

## REMOVAL OF IODINE COMPOUNDS

This solution may be used to remove iodine stains from mattress cover and foam footrest pad surfaces.

1. Use a solution of 1-2 tablespoons Sodium Thiosulfate in a pint of warm water to clean the stained area. Clean as soon as possible after staining occurs. If stains are not immediately removed, allow solution to soak or stand on the surface.
2. Rinse surfaces which have been exposed to the solution in clear water before returning bed to service.

# Service Information

---

## CASTER ASSEMBLY REPLACEMENT

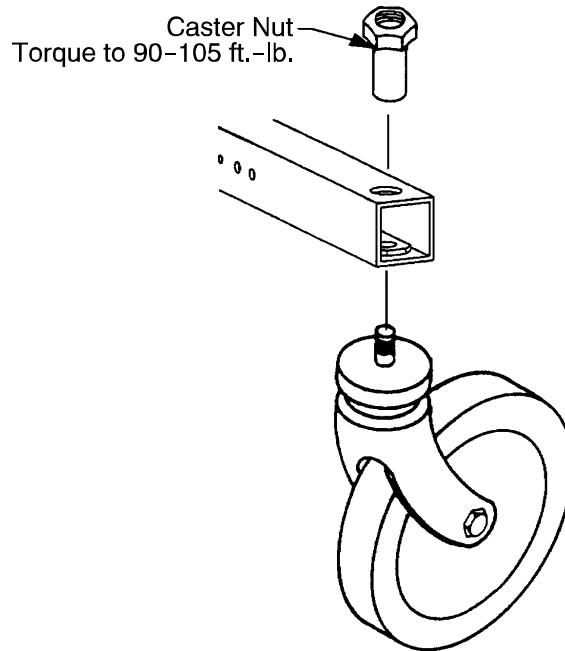

1. Remove the old caster assembly.
2. Install the replacement caster and caster nut. Tighten the caster nut to 90-105 ft.-lb. with a torque wrench.

### NOTE

A new caster assembly with a 3M patch does not require the application of Loctite at assembly. However, the patch is appropriate for only one installation. If the caster is removed and reassembled for any reason, apply Loctite 242 to two or three threads of both the bolt and caster nut and tighten to 90-105 ft.-lb. with a torque wrench.

## FIFTH WHEEL REPLACEMENT

### Required Tools:

Pliers  
(2) 9/16" Box End Wrenches

String or Bungee Cord

3/16" Allen Wrench

### Procedure:

1. Apply the stretcher brakes.
2. Pump the litter up to full height.
3. Lift and support the base hood using string or bungee cord.
4. Using pliers, remove the cotter pin from the end of the fifth wheel pivot rod and remove the two washers.
5. Pull up on the fifth wheel arm and pull down on the tension spring to release the pressure on the arm.
6. Using a 3/16" Allen wrench, remove the hex Allen bolt from the center of the pivot rod and pull the pivot rod out of the wheel arm.
7. Reverse the above steps to install a new fifth wheel assembly.

### NOTE

To replace the wheel only, use two 9/16" box end wrenches to remove the bolt and nut holding it to the wheel arm.

# Service Information

## CASTER COVER INSTALLATION AND REMOVAL

1.

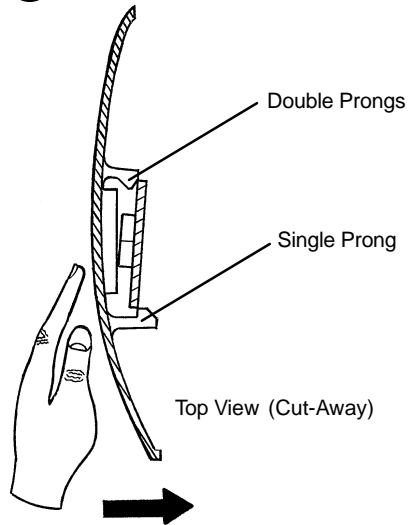

Looking through the larger of the two side cut-outs, align cover with axle nut or bolt head, as shown. Push down on the opposite side of the cover until single prong engages with caster horn.

Push with palm on cover until double prongs engage.

2.

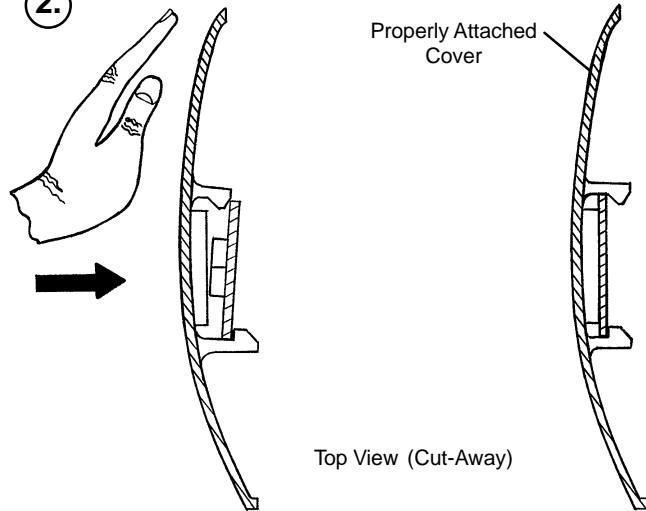

3.

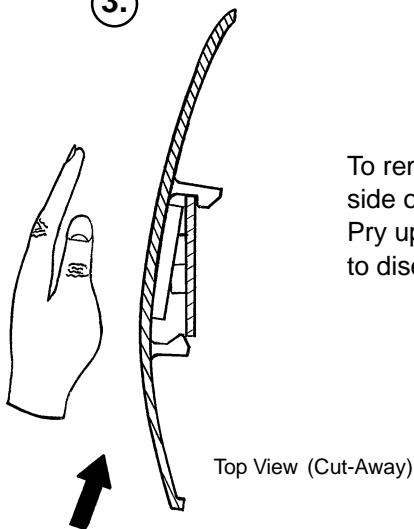

To remove wheel cover, insert large screwdriver into cut-out in side of wheel cover and into the space between the double prongs. Pry up cover to disengage double prongs and push sharply upward to disengage single prong.



# Service Information

---

## BRAKE CAM REPLACEMENT

Brake Cam Part Number 715-201-213

### Required Tools:

Phillips Screwdriver	String or Bungee Cord	3/32" Allen Wrench
1/8" Allen Wrench		

### Procedure:

1. Remove the four Phillips screws holding the base hood to the frame. Lift and support the base hood using string or bungee cord.
2. Using a 3/32" Allen wrench, loosen the set screw holding the brake adjuster to the brake ring and turn the adjuster clockwise to remove it.
3. Using a 1/8" Allen wrench, remove the shoulder bolt and nut holding the brake link on the cam and remove the cam.
4. Reverse steps 3 and 4 to install the new cam. Verify the brakes are operating properly. If adjustment is required, see page 9. Reinstall the base hood.

## BRAKE RING REPLACEMENT

Brake Ring Part Number 715-1-61

### Required Tools:

Phillips Screwdriver	String or Bungee Cord	Floor Jack, Small Crate (or equiv.)
Large Standard Screwdriver	3/32" Allen Wrench	11/16" Socket & Ratchet
5/8" Wrench	Needle-Nose Pliers	(2) 7/16" Wrenches

### Procedure:

1. Remove the four Phillips screws holding the base hood to the frame. Lift and support the base hood using string or bungee cord. Put the brake/steer pedal in the neutral position. Lift the end of the base needing service until the casters are approximately 12" off the floor and support it with a jack or the equivalent.
2. Using a 3/32" Allen wrench, loosen the set screw holding the brake adjuster to the brake ring and turn the adjuster clockwise to remove it.
3. Remove the caster covers on both casters (see page 7).
4. Remove one of the casters (see page 6). On the other caster, use an 11/16" socket and ratchet and a 5/8" wrench to remove the nut and bolt holding the wheel on the caster horn and remove only the wheel.
5. Using needle-nose pliers, carefully squeeze and remove the spring between the brake cam and the brake ring.

---

### WARNING

The spring is tightly compressed. Use caution when removing it or personal injury could result.

---

6. If you are working on an end control base, remove the spring from the pump pedal.
7. Lower the brake ring and remove it from the base. Remove the brake pads and bushings and install them on the new brake ring.
8. Reverse the above steps to install the new brake ring and reinstall the caster and wheel. Apply and release the brakes to verify they operate properly. If adjustment is required, see page 9. Reinstall the base hood.

# Service Information

## BRAKE ADJUSTMENT

### Required Tools:

3/32" Hex Allen Wrench  
Pry Bar  
Thread "Locktite"

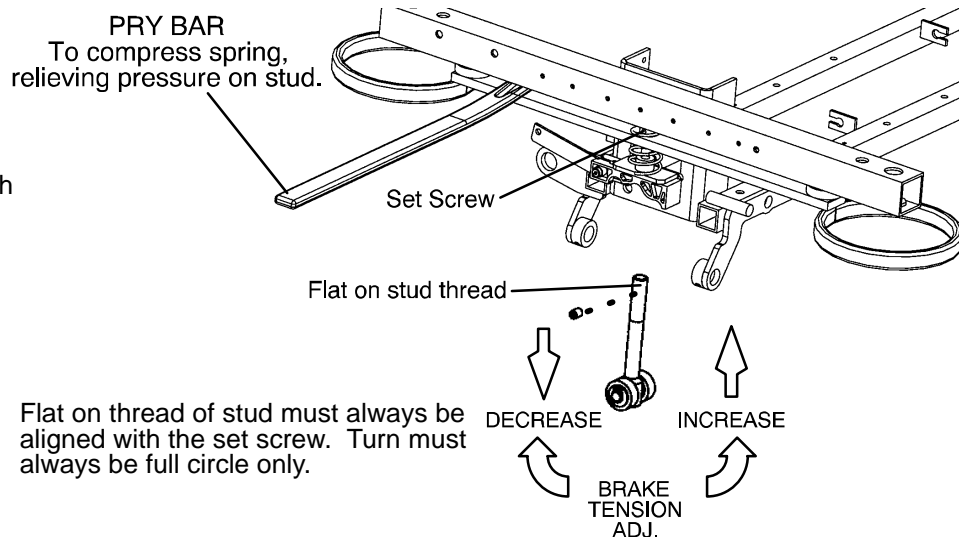

## BASE SIDE CONTROL PEDAL LINKAGE ADJUSTMENT

### Required Tools:

3/8" Wrench

5/32" Hex Allen Wrench

7/16" Wrench

Bungee Cords

### Adjustment Procedure:

1. Place 150-200 pounds on the litter and pump the litter up to full height.
2. Lift the base hood, separating the hood from the base frame. Using the bungee cords, support the base hood.
3. Using a 3/8" wrench and a 5/32" hex Allen wrench, loosen the appropriate pedal linkage adjustment nut until the jack stops "drifting". Raise the litter to full up.
4. Tighten the pedal linkage adjustment nut until the jack begins to slowly descend.
5. Using a 7/16" wrench, back the pedal linkage adjustment nut out four full turns. Raise the litter to full up.
6. Loosen the pedal linkage adjustment nut and ensure no drift occurs. If the jack drifts, repeat procedure.

# Service Information

---

## BASE SIDE CONTROL BRAKE/STEER GEAR REPLACEMENT

### Required Tools:

Pliers	String or Bungee Cord	Floor Jack or Equivalent
1/8" Allen Wrench	5/32" Allen Wrench	3/8" Box End Wrench
(2) 9/16" Box End Wrenches	3/16" Punch	1/4" Punch
Hammer		

### Procedure:

1. Apply the stretcher brakes.
2. Pump the litter up to full height.
3. Lift and support the base hood using string or bungee cord.
4. Using pliers, remove the cotter pins from both jack pump pistons and the pump linkage.
5. Using the 9/16" box end wrenches, remove the two bearing plate bolts.
6. Remove the cotter pin on the side brake bar.
7. Remove the bearing plate and pull out the idler gear rod while holding onto the gear. Lift the gear out.
8. Slide the miter gear away from the rod spacer and remove the dowel pin.
9. Using the floor jack, raise the side of the base you are working on approximately four inches.
10. Rotate the brake bar so the pedals are upside down.
11. Using a 1/4" punch and a hammer, remove the groove pin from the side brake rod.
12. Using a 3/16" punch and hammer, remove the 3/16" groove pin from the pedal.
13. Using a 5/32" Allen wrench, remove the set screw from the collar inside the gear box.
14. Remove the brake rod while holding the gear on the rod.
15. Using a 1/8" Allen wrench and a 3/8" box end wrench, remove the nuts and bolts holding the brake link to the rod.
16. Using a 5/32" Allen wrench, remove the set screw from the collar outside of the gear box.
17. Using a 1/4" punch, remove the roll pin from the cam and brake link collar.
18. Reverse the above steps to install the replacement gear.
19. Inspect each gear for wear. Lube with MPG-2 grease or the equivalent if necessary.

## UNI-PEDAL REPLACEMENT

### Required Tools:

Drill w/3/16" Drill Bit	Floor Jack	Pop Rivet Tool
-------------------------	------------	----------------

### Replacement Procedure:

1. Set the stretcher brake and pump the litter up fully.
2. Use the floor jack to raise the side of the base frame off the floor approximately four inches.
3. Using a drill with a 3/16" drill bit, drill out the rivets on the bottom of the pedal to be replaced.
4. Using a pop rivet tool and rivets, install the replacement pedal.
5. Lower the stretcher to the floor. Test the operation of the pedal before returning the stretcher to service.

# Service Information

---

## JACK REPLACEMENT (WITHOUT COMPRESSION SPRING)

### Required Tools:

3/8" Wrench

1/2" Socket

1/2" Wrench

Needle-Nosed Pliers

### Replacement Procedure:

1. Apply stretcher brakes. Raise litter to full up. Raise Fowler to full up and raise siderails.
2. Use a 3/8" wrench to remove the bolt in the litter support tube above black bellows on both ends.
3. With the assistance of another person, lift off the stretcher litter and set it aside, taking care not to damage the siderails, etc.
4. Push down on the jack actuator to put the jack in the full down position.
5. Lift off the plastic base hood, separating the Velcro holding it to the base frame.
6. Using a 1/2" socket and 1/2" wrench, remove the four bolts, washers and nuts holding the jack support straps to the base frame.
7. Using needle-nosed pliers, remove the two cotter keys on the pump link and remove the pump link.
8. Using a 1/2" socket and a 1/2" wrench, remove the four bolts holding the jack base to the base frame (using a 3" extension may be required). Remove the jack from the base frame.
9. Reverse steps 6-8 to install the replacement jack. Reinstall the base hood and the stretcher litter.

## JACK REPLACEMENT (WITH COMPRESSION SPRING)

### Required Tools:

3/8" Wrench

Needle-Nosed Pliers

Straight Screwdriver

Spring Compression Tool

### Replacement Procedure:

1. Apply stretcher brakes. Raise litter to full up. Raise Fowler to full up and raise siderails.
2. Use a 3/8" wrench to remove the bolt in the litter support tube above black bellows on both ends.
3. With the assistance of another person, lift off the stretcher litter and set it aside, taking care not to damage the siderails, etc.
4. Push down on the jack actuator to put the jack in the full down position.
5. Lift off the plastic base hood, separating the Velcro holding it to the base frame.
6. Using needle-nosed pliers, pull cotter pin from pump cylinder.
7. Using a straight screwdriver and pump spring compression tool (available upon request), compress the pump spring and pry the pump link out of the pump cylinder.

---

### CAUTION

Be sure not to let the pump piston come out of the jack or damage may occur.

8. Remove and replace jack as described in the procedure above.
9. Replace pump spring and pump link using the straight screwdriver and the pump compression tool.
10. Reinstall the base hood and the stretcher litter.

# Service Information

## JACK ASSEMBLY TORQUE SPECIFICATION

### Jack Assembly with Threads Oiled

- |   |                      |
|---|----------------------|
| 1. Jack Cap Assembly to Jack Actuator Cylinder  | 75 to 85 Foot Pounds |
| 2. Jack Actuator Cylinder to Jack Base Assembly | 55 to 65 Foot Pounds |

### Jack Base Assembly with Threads Oiled

- |   |                      |
|---|----------------------|
| 1. Jack Pump Cylinder to Jack Base Machined | 45 to 55 Foot Pounds |
| 2. Jack Pin Housing to Jack Base Machined   | 35 to 45 Foot Pounds |
| 3. Jack Base Plugs to Jack Base Machined    | 8 to 12 Foot Pounds  |
| 4. Jack Valve Plug to Jack Base Machined    | 8 to 12 Foot Pounds  |
| 5. Flow Control Valve to Jack Base Machined | 16-20 Foot Pounds    |

## HYDRAULIC TROUBLESHOOTING

PROBLEM/SYMPTOM	SOLUTION
Jack will not raise to full height.	Add hydraulic fluid (see p.13). Check for leaks.
Jack will not hold in raised position.	Close the needle valve completely. If the jack holds, replace the release valve (see p. 15).
Jack will not pump up and the jack actuator rod <b>does not</b> move.	Close the needle valve. If the jack will now pump up, replace the release valve (see p. 15). If the jack still will not pump up after closing the needle valve, replace the poppet valve (see p. 15).
Jack will not pump up but the jack actuator rod <b>does</b> move when the pump pedal is activated.	Replace the check valve (see p. 14).
Jack will not pump up and the jack actuator rod may or may not move.	Remove excess air (vacuum) in system (see below).

Be sure the pedal linkage has been adjusted properly before beginning service on the jacks (see page 9).

Contact Stryker technical service at 1-800-327-0770 for further assistance.

## REMOVAL OF EXCESS AIR (VACUUM) FROM THE HYDRAULIC SYSTEM

### Procedure:

1. Verify all hydraulic linkages are secure and operating properly (see pedal linkage adjustment procedure page 9).
2. Using pump pedal, actuate system several times. This will force the air through the system and the jack should now pump up.

# Service Information

---

## CHECKING HYDRAULIC FLUID LEVEL

### Required Tools:

3/8 Open End Wrench                      3/4 Open End Wrench

### Procedure:

---

#### WARNING

To avoid personal injury or damage to the stretcher, remove the litter and the base hood before beginning service on the jacks.

---

1. Using a 3/8 open end wrench, remove square head set screws from both head and foot end jack support tubes. Remove litter top and set aside.
  2. Lift base hood off base frame and set aside.
  3. Be sure there are no hydraulic leaks. If there are, jack replacement will be necessary.
  4. Lower the jack to the full down position.
  5. Using a 3/4 open end wrench, slowly turn the fill plug located on the side of the reservoir counterclockwise to allow excess system pressure to vent. Remove the fill plug.
  6. The hydraulic fluid should be visible at the bottom of the fill hole. If it is not, add Mobil Aero HFA hydraulic fluid (Stryker part number 2020-70-475) until the fluid is visible at the bottom of the fill hole. Replace the fill plug.
- 

#### CAUTION

Use of other types of oil may damage hydraulic units.

7. Replace the hood and the litter.

## JACK DESCENT RATE ADJUSTMENT

### Required Tools:

Screwdriver                                      Bungee Cords (or equivalent)

### Adjustment Procedure:

1. Pump the litter up to full height.
2. Lift the base hood, separating the hood from the base frame. Using the bungee cords, support the base hood.
3. The descent rate needle valve is located on the base of the jack. Turning the needle valve clockwise, with a screwdriver, will decrease the rate of descent. Turning it counterclockwise will increase the rate of descent.
4. Adjust the needle valve so that the foot end of the stretcher descends slightly faster than the head end.

#### NOTE

The larger percentage of a patient's weight is located in the torso area. Adjust descent rate accordingly.

5. Remove the bungee cords supporting the base hood and secure the hood to the base frame.

#### NOTE

The jack descent rate was preset at the factory to drop the foot end faster than the head. It is recommended that the foot drop faster to avoid patient disorientation.

# Service Information

---

## CONSTANT FLOW JACK DESCENT RATE ADJUSTMENT

### Required Tools:

Bungee Cords

### Adjustment Procedure:

1. Pump the litter up to full height
2. Lift the base hood, separating the Velcro holding it to the base frame.
3. The adjustable descent valve is located on the base of the jack and has a blue knob on the end. To adjust, loosen the silver locking ring by turning it counterclockwise. Turning the blue knob clockwise will increase the rate of litter descent. Turning it counterclockwise will decrease the rate of descent.
4. Adjust the valve so that the jack at the foot end of the stretcher will descend slightly faster than the jack at the head end.
5. Remove the bungee cords supporting the base hood and secure the hood to the base frame.

## ADJUSTABLE PRESSURE COMPENSATED (P.C.) VALVE REPLACEMENT

P.C. Valve Part Number 5050-70-50

---

### WARNING

To avoid personal injury or damage to the stretcher, always remove the litter and the base hood before beginning service on the jacks. Lower the jack rod completely to relieve the pressure on the pump piston side of the jack.

---

### Required Tools:

3/8" Wrench

13/16" Wrench

### Replacement Procedure:

### NOTE

It requires two people to safely perform this procedure.

1. Apply the stretcher brakes. Raise the litter to full up. Raise the Fowler and the siderails.
2. Using a 3/8" wrench, remove the bolts in the litter support tubes above the black bellows on both ends of the litter.
3. With the assistance of another person, lift the litter off the base and set it aside, taking care not to damage the leg section linkages and other litter components.
4. Push down on the jack actuator to put the jack in the full down position.
5. Lift off the plastic base hood, separating the Velcro holding it to the base frame.
6. Using a 13/16" wrench, remove the adjustable P.C. valve (see page 39.3 for part reference).
7. Check for any contaminants in the valve as well as in the jack base.

# Service Information

---

## ADJUSTABLE PRESSURE COMPENSATED (P.C.) VALVE REPLACEMENT (CONTINUED)

8. Install the replacement P.C. valve. Moisten the O-ring seal with hydraulic fluid to ensure a tight seal.
9. Tighten the valve manually and then an additional 1/8-1/4 turn with a 13/16" wrench. **Do not over-tighten** or damage may occur to the O-ring seal.
10. Pump up the jack to the maximum height and press the release pedal to lower it to check the jack's operation.
11. Check for any hydraulic fluid leaks before replacing the base hood and litter.

### NOTE

The jack descent rate was preset at the factory to lower the foot end 3-7 seconds faster than the head. It is recommended to have the foot end lower faster to avoid patient disorientation.



# Service Information

## HYDRAULIC CHECK VALVE REPLACEMENT

### Required Tools:

3/8 Open End Wrench  
3/4 Open End Wrench

Stiff Wire (with bent, pointed end)  
Torque Wrench (with Ft. Lbs. adjust.)

Small Needle Nose Pliers  
7/32 Hex Allen Wrench

### Replacement of Check Valve

#### WARNING

To avoid personal injury or damage to the stretcher, remove the litter and the base hood before beginning service on the jacks. Lower the jack rod completely to relieve the pressure on the pump piston side of the jack. This will prevent large hydraulic fluid loss and possible damage when the base plugs are removed.

1. Remove the base plug (3) and the seal (4).
2. Remove the valve plug (5).
3. Using a stiff wire with a bent, pointed end, remove the valve (1).
4. Install the new valve (1) with the beveled end up (as shown in the illustration).
5. Reinstall the valve plug (5) with the beveled end down toward valve (1) and tighten to 10 foot-pounds torque.
6. Reinstall the seal (4) and the base plug (3) and tighten to 10 foot-pounds torque.
7. Pump up the jack to the maximum height.
8. Be sure there are no hydraulic leaks before replacing the base hood and the litter.

ITEM	PART NO.	PART NAME
1	926-20-153	Check Valve
2	715-1-341	Poppet
3	715-1-301	Base Plug
4	926-20-156	Seal
5	715-1-309	Valve Plug
6	926-20-154	Seal
7	715-1-301	Base Plug
8	926-20-156	Seal
9	390-2-134	Compression Spring
10	715-270-100	Valve Assembly*
10	2025-700-26	Valve Assembly**
11	715-100-325	Pump Piston

\* Used on jack part number 1231-70-10.  
\*\* Used on jack part number 1231-70-210.  
(See label on side of jack reservoir for jack part number).

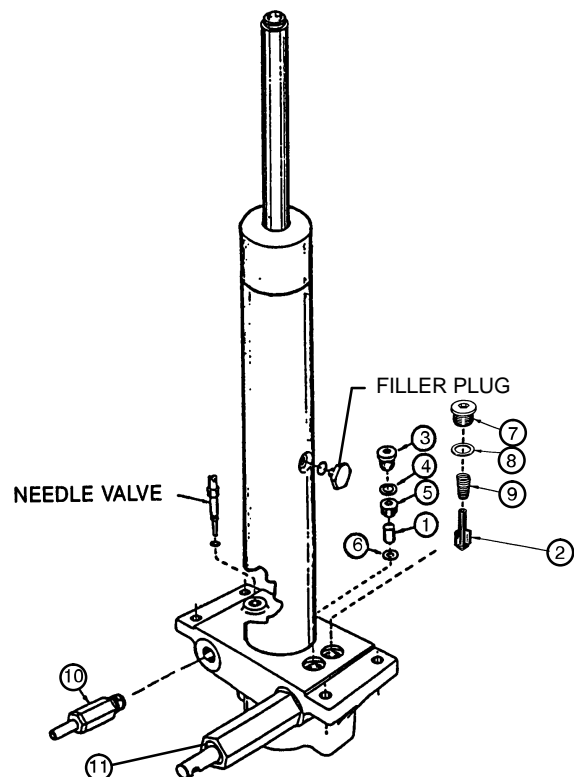

# Service Information

---

## HYDRAULIC CHECK VALVE REPLACEMENT (CONTINUED)

### Replacement of Release Valve

---

#### **WARNING**

To avoid personal injury or damage to the stretcher, remove the litter and the base hood before beginning service on the jacks. Lower the jack rod completely to relieve the pressure on the pump piston side of the jack. This will prevent large hydraulic fluid loss and possible damage when the base plugs are removed.

---

1. Remove the release valve (10).
2. Install the new release valve (10).
3. Pump up the jack to the maximum height.
4. Be sure there are no hydraulic leaks before replacing the base hood and the litter.

### Replacement of Poppet Valve

---

#### **WARNING**

To avoid personal injury or damage to the stretcher, remove the litter and the base hood before beginning service on the jacks. Lower the jack rod completely to relieve the pressure on the pump piston side of the jack. This will prevent large hydraulic fluid loss and possible damage when the base plugs are removed.

---

1. Remove the base plug (7) and the seal (8).
2. Remove the compression spring (9).
3. Using small needle nose pliers, remove the poppet valve (2).
4. Install the new poppet valve (2).
5. Reinstall the compression spring (9).
6. Reinstall the seal (8) and the base plug (7) and tighten to 10 foot-pounds torque.
7. Pump up the jack to the maximum height to check its operation.
8. Check for hydraulic leaks before replacing the base hood and the litter.

# Service Information

## BASE LUBRICATION

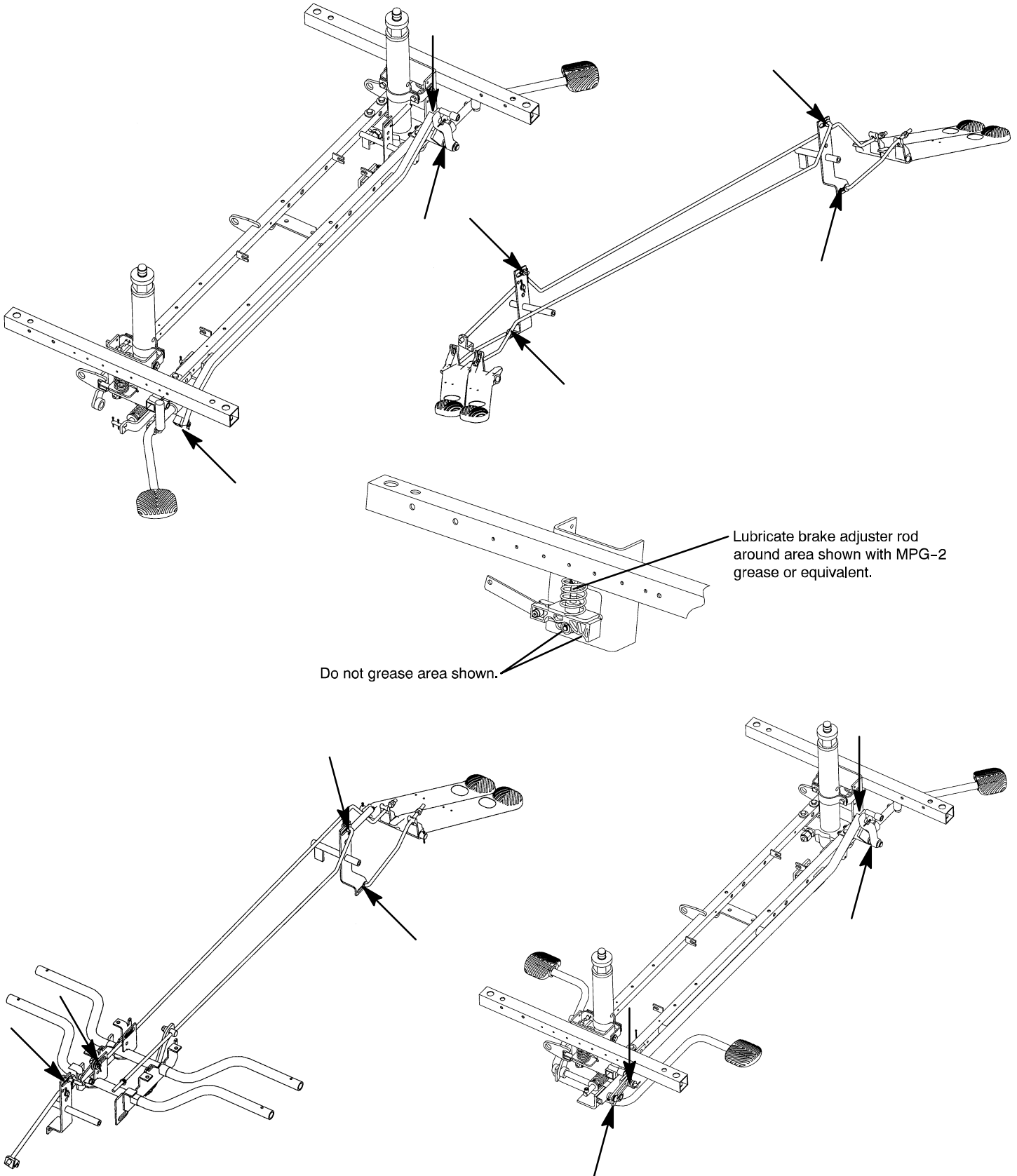

# Service Information

---

## PNEUMATIC FOWLER ADJUSTMENT

**Required Tools:** 5/32" Hex Allen Wrench 1/2" Open End Wrench

### Adjustment Procedure:

1. For easier access, move Fowler to 75° or higher.
2. Using a 1/2" open end wrench, loosen the nuts in the actuator arms on the end of the trip bar.
3. To adjust the Fowler, use a 5/32" hex Allen wrench to turn the Allen screws 1 to 2 turns counter-clockwise if the Fowler will not move or 1 to 2 turns clockwise if the Fowler will not hold its position.
4. Retighten the nuts. Be sure the Fowler will travel from flat to 90° and down again and will hold its position when weight is applied before returning the stretcher to service.

## TRANSFER BOARD COUNTERBALANCE ADJUSTMENT

**Required Tools:** 7/16 Open End Wrench

### Adjustment Procedure:

1. Raise the transfer board to the full up position.
2. Unhook the extension spring at the eye bolt.
3. Using a 7/16 open end wrench, loosen the jam nut at the eye bolt and adjust the eye bolt to the desired position.
4. Tighten the jam nut.
5. Hook the extension spring to the eye bolt. Allow the transfer board to lower on its own.
6. Repeat until the desired counterbalance is achieved.

## SIDERAIL LATCH ADJUSTMENT

**Required Tools:** 1/8 Hex Allen Wrench

---

### WARNING

The siderail latch adjustment is pre-set at the factory, and should not normally need adjustment. If adjustment must be done, it is important to follow the procedure below. If it is not done properly, injury could occur.

---

### Adjustment Procedure:

1. Using a 1/8 hex Allen wrench, adjust the hex Allen screw located on the latch assembly opposite the latch. Turning the screw clockwise will **DECREASE** the amount of "play" in the latching mechanism. Turning counterclockwise will **INCREASE** the amount.

### NOTE

The amount of "play" in the siderail, when in full up engaged position, should be approximately 1/8 to 3/16".

---

### CAUTION

Too much "play" when the siderail is in the full up engaged position will give the siderail the appearance of being unstable and could also cause premature wearing of the latch system.

Too little "play" will obstruct the latch and keep it from engaging completely in the full up position, which may cause damage to the latch and/or injury to the patient or user.

# Service Information

---

## BIG WHEEL/BEARING REPLACEMENT

### Required Tools:

15/16" Wrench or Socket & Ratchet                      (2) Bungee Cords                      Torque Wrench  
Small Standard Screwdriver

### Procedure:

1. Apply the stretcher brakes.
2. Pump the litter up to full height.
3. Lift the base hood and support it from the litter frame using bungee cords.
4. Using a small standard screwdriver, remove the big wheel hub cap, being careful not to damage the outer surface of the hub cap (see page 37.4 for part reference).
5. Using a 15/16" wrench or socket and ratchet, remove the nut holding the big wheel to the frame. Remove the bearing and sleeve (see page 37.13 for part reference).
6. Install the replacement bearing and the sleeve onto the wheel bolt. Install the big wheel and outer bearing.
7. Install the nut and tighten it to 30 foot-pounds using a torque wrench.
8. Remove the bungee cords and reinstall the base hood.
9. Verify the brake and steer functions are working properly before returning the bed to service.

## BIG WHEEL ADJUSTMENT

### Required Tools:

9/16" Wrench                      (2) Bungee Cords                      Small Ruler or Tape Measure

### Procedure:

1. Apply the stretcher brakes.
2. Pump the litter up to full height.
3. Lift the base hood and support it from the litter frame using bungee cords.
4. Using a 9/16" wrench, remove the two side bolts on the cam adjuster block (see page 37.4 for part reference).
5. Release the brakes and engage the big wheel.
6. Adjust the two top bolts on the adjuster block equal amounts so the foot end casters are raised off the floor 1/4". Reinstall the two side bolts on the cam adjuster block after applying Loctite to both bolts.
7. Apply the stretcher brakes.
8. Remove the bungee cords and reinstall the base hood.
9. Verify the brake and steer functions are working properly before returning the bed to service.

# Service Information

---

## BIG WHEEL RETURN SPRING ADJUSTMENT

### Required Tools:

1/2" Deep Well Socket & Ratchet      (2) Bungee Cords

### Procedure:

1. Apply the stretcher brakes.
2. Pump the litter up to full height.
3. Lift the base hood and support it from the litter frame using bungee cords.
4. Using a 1/2" deep well socket and ratchet, loosen the nut on the eyebolt to the end of the threads. Remove the spring from the frame and eyebolt (see page 37.4 for part reference).
5. Install the new spring and tighten the nut on the eyebolt.
6. Check for proper operation.
7. Apply the stretcher brakes.
8. Remove the bungee cords and reinstall the base hood.
9. Verify the brake and steer functions are working properly before returning the bed to service.

## BIG WHEEL HUBCAP REMOVAL

### Required Tools:

Large Standard Screwdriver

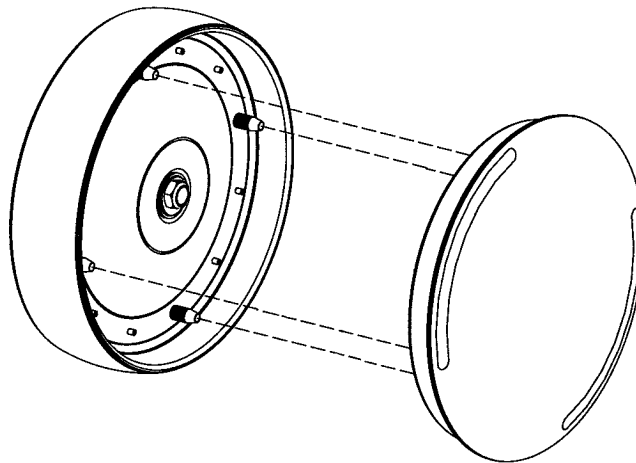

### Removal Procedure:

1. Using a large standard screwdriver, pry evenly around the entire edge of the Big Wheel hubcap until it pops off the mounting studs on the wheel.

---

### CAUTION

Do not attempt to pull off the hubcap after prying up only one side. Damage to the slots on the hubcap or the mounting studs on the wheel could result.

2. To reinstall the hubcap, place it on the wheel, aligning the slots in the hubcap with the mounting studs on the wheel. Press down evenly on the edges of the hubcap until it snaps into place.

# Replacement Parts and Kits

---

<b><u>PART NAME</u></b>	<b><u>PART NUMBER</u></b>
Brake Adjuster Service Tool .....	715-700-150
Caster Cover Kit .....	1010-56-100
Centering Label, X-Ray Tray .....	1020-19-5
C-Spine Cassette Holder .....	1020-70-100
Defibrillator Tray .....	741-48
Fowler X-Ray Cassette .....	1020-23
Full-Length X-Ray Tray, Left Side Load .....	1020-21-10
Full-Length X-Ray Tray, Right Side Load .....	1020-22-10
Foot Board/Chartholder .....	741-34-100
Foot Board/Defibrillator Tray .....	1010-50-100
Head/Foot Board .....	741-29-100
Heel Stirrups .....	1020-55
Hydraulic Jack, Constant Descent .....	1231-70-210
Hydraulic Jack, Variable Descent .....	1231-70-10
Hydraulic Oil, Mobil Aero HFA - 1 Quart .....	2020-70-475
Instrument/Serving Tray .....	1052-129
I.V. Caddy .....	1050-1-100
I.V. Caddy w/Mounting Clip .....	1050-2
I.V. Pole, 2-Stage, Permanent, Foot End .....	1010-80-100
I.V. Pole, 2-Stage, Permanent, Head End .....	1010-81-100
I.V. Pole, 3-Stage, Permanent, Head End .....	1020-61
I.V. Pole, 3-Stage, Permanent, Foot End .....	1020-62
I.V. Pole, Tethered .....	1010-22-100
I.V. Pole, Standard, Removable .....	390-25
Mattress, 3" Standard .....	1059-326-140
Mattress, 4" Standard .....	1059-426-140
Mattress, 3" Enhanced Comfort .....	1001-48-106
Mattress, 4" Enhanced Comfort .....	1001-47-106
Mattress, 4" Ultra Comfort .....	1210-40
Mattress, 5" Ultra Comfort .....	1210-50
Oxygen Bottle Holder .....	1020-30
Paint, Touch-Up, Gloss Black, Bottle w/Brush .....	7000-1-322
Paint, Touch-Up, Gloss Black, Spray Can .....	7000-1-319
Paint, Touch-Up, Gray, Bottle w/Brush .....	7000-1-320
Paint, Touch-Up, Gray, Spray Can .....	7000-1-317
Push Handles, Foot End .....	1020-51
Restraint Strap, Ankle .....	946-43-100
Restraint Strap, Body .....	390-19
Restraint Strap, Chest .....	1010-58
Restraint Strap, Wrist .....	946-44-100
Restraint Straps, Full Patient Security Package .....	1010-77
Siderail Pads .....	1010-52
X-Ray Grid Holder .....	1020-27

# Side Control Base Assembly

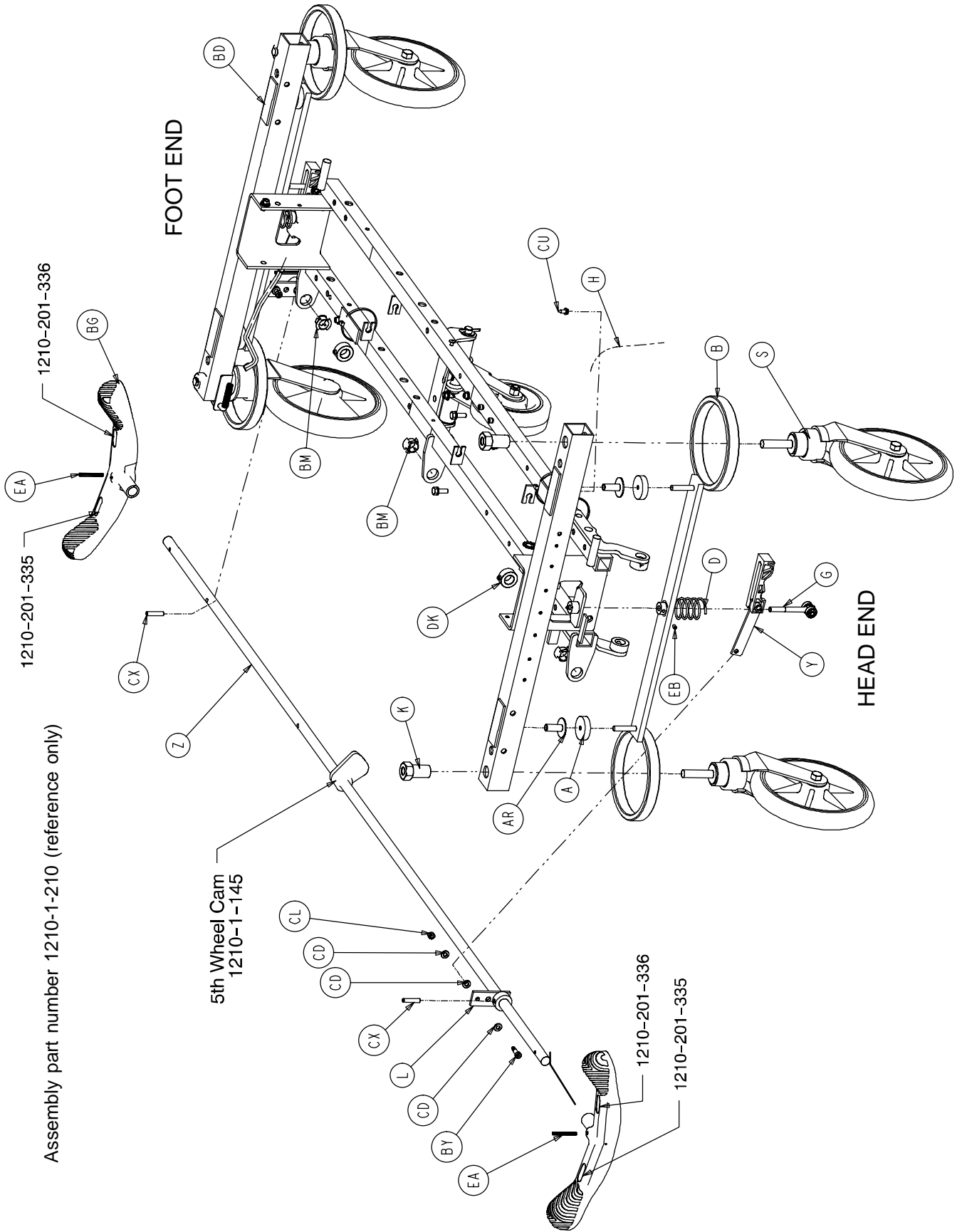

Assembly part number 1210-1-210 (reference only)



# Side Control Base Assembly

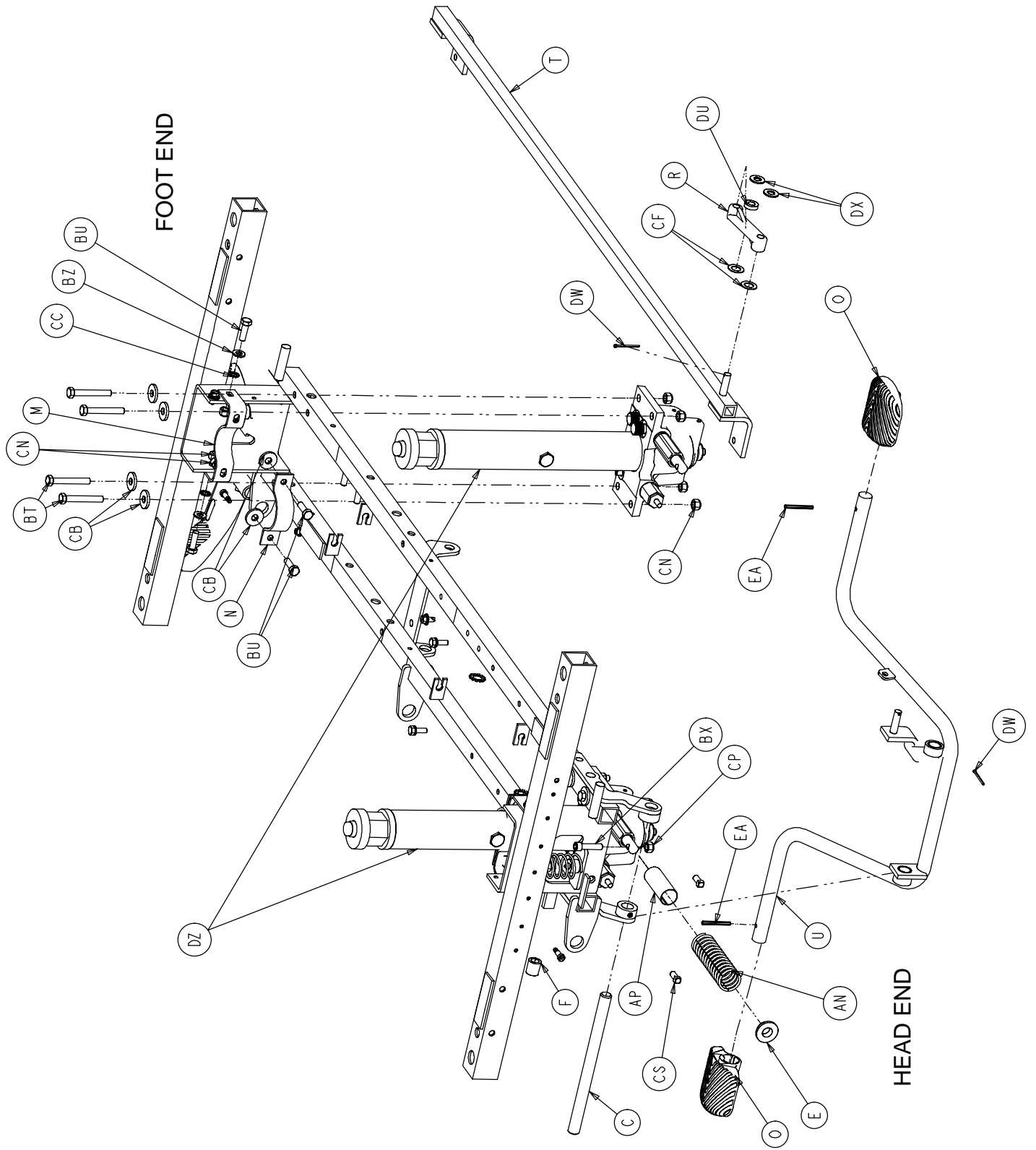

# Side Control Base Assembly

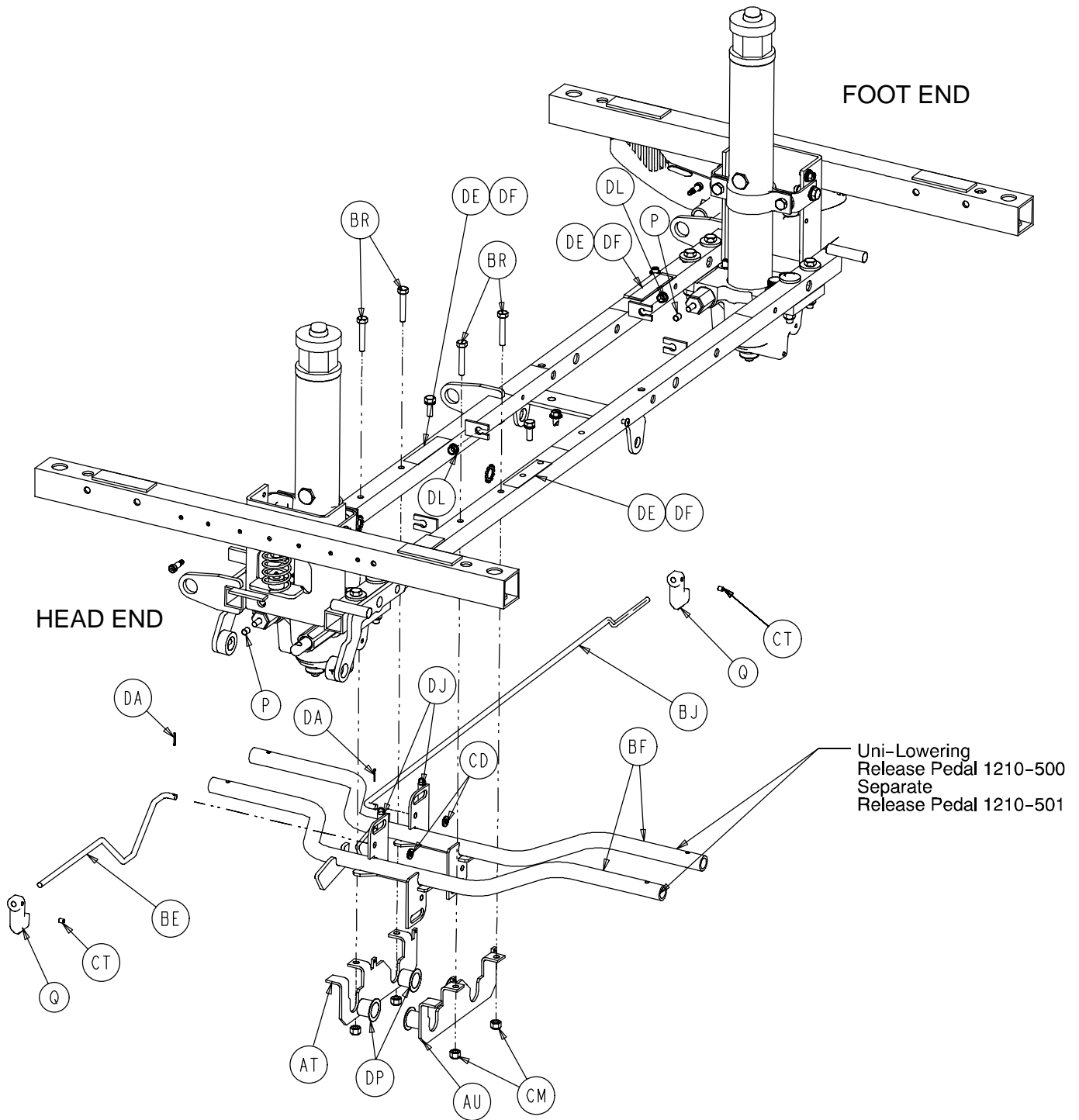

# Side Control Base Assembly

---

Item	Part No.	Part Name	Qty.	Item	Part No.	Part Name	Qty.
A	715-1-1 1	Brake Cushion	4	BR	3-47	Hex Hd. Cap Screw	4
B	715-1-61	Caster Brake Weldment	2	BT	3-62	Hex Hd. Cap Screw	8
C	715-1-92	Pump Pedal Shaft	1	BU	3-85	Hex Hd. Cap Screw	8
D	715-201-94	Compression Spring	2	BX	4-146	Soc. Hd. Cap Screw	2
E	715-1-133	Collar	1	BY	8-17	Shoulder Bolt	2
F	715-1-140	Vinyl Tube	1	BZ	11-3	Washer	12
G	(page 27)	Brake Adjuster	2	CB	11-262	Washer	12
H	715-1-156	Ground Chain	1	CC	13-38	Ext. Tooth Lock Washer	4
K	715-1-158	Caster Nut	4	CD	14-2	Washer	8
L	715-1-165	Actuator Plate Weldment	2	CF	14-9	Washer	2
M	715-1-192	Jack Support	2	CL	16-59	Hex Nut	2
N	715-1-193	Jack Support Clamp	2	CM	16-28	Hex Nut	4
O	715-201-126	Slip-On Pump Pedal	2	CN	16-36	Hex Nut	16
P	715-1-333	Release Rod Stop Sleeve	2	CP	16-48	Hex Nut	2
Q	715-1-346	Release Paddle	2	CS	46-2	Square Hd. Set Screw	2
R	715-1-214	Connecting Link	1	CT	21-50	Set Screw	2
S	(page 34)	Caster Assembly	*	CU	23-25	Self-Tapping Screw	1
T	715-201-27	Pump Rod Assembly	1	CX	26-13	Spring Pin	2
U	(page 29)	Pump Pedal Assembly	1	DA	27-4	Cotter Pin	2
Y	(page 28)	Brake Cam Assembly	2	DE	29-12	Velcro Loop	3
Z	715-201-230	Brake Bar	1	DF	29-14	Velcro Hook	3
AN	38-246	Jack Spring	1	DJ	38-355	Extension Spring	2
AP	763-1-16	Spring Holder	1	DK	42-20	Collar	2
AR	946-1-1 16	Brake Bar Bushing	4	DL	52-245	Nyliner	2
AT	1210-1-1 15	Pedal Pivot, Left	1	DP	52-747	Flange Bearing	4
AU	1210-1-1 14	Pedal Pivot, Right	1	DU	52-284	Spacer Washer	1
BD	1210-201-120	Base Frame Weldment	1	DW	27-3	Cotter Pin	2
BE	1210-201-139	Pull Release Rod, Head	1	DX	11-4	Washer	2
BF	1210-201-152	Release Pedal Weldment	2	DZ	(p. 38 or 39.2)	Jack Assembly	2
BG	1210-201-153	Butterfly "V" Pedal	2	EA	26-143	Groove Pin	4
BJ	1210-201-222	Push Release Rod	1	EB	21-151	Set Screw	2
BM	1210-201-251	Insert	3				

\* Caster assembly is quantity of 4 if the fifth wheel option is present on the stretcher and quantity of 3 if the steering caster option is present.

# End Control Base Assembly

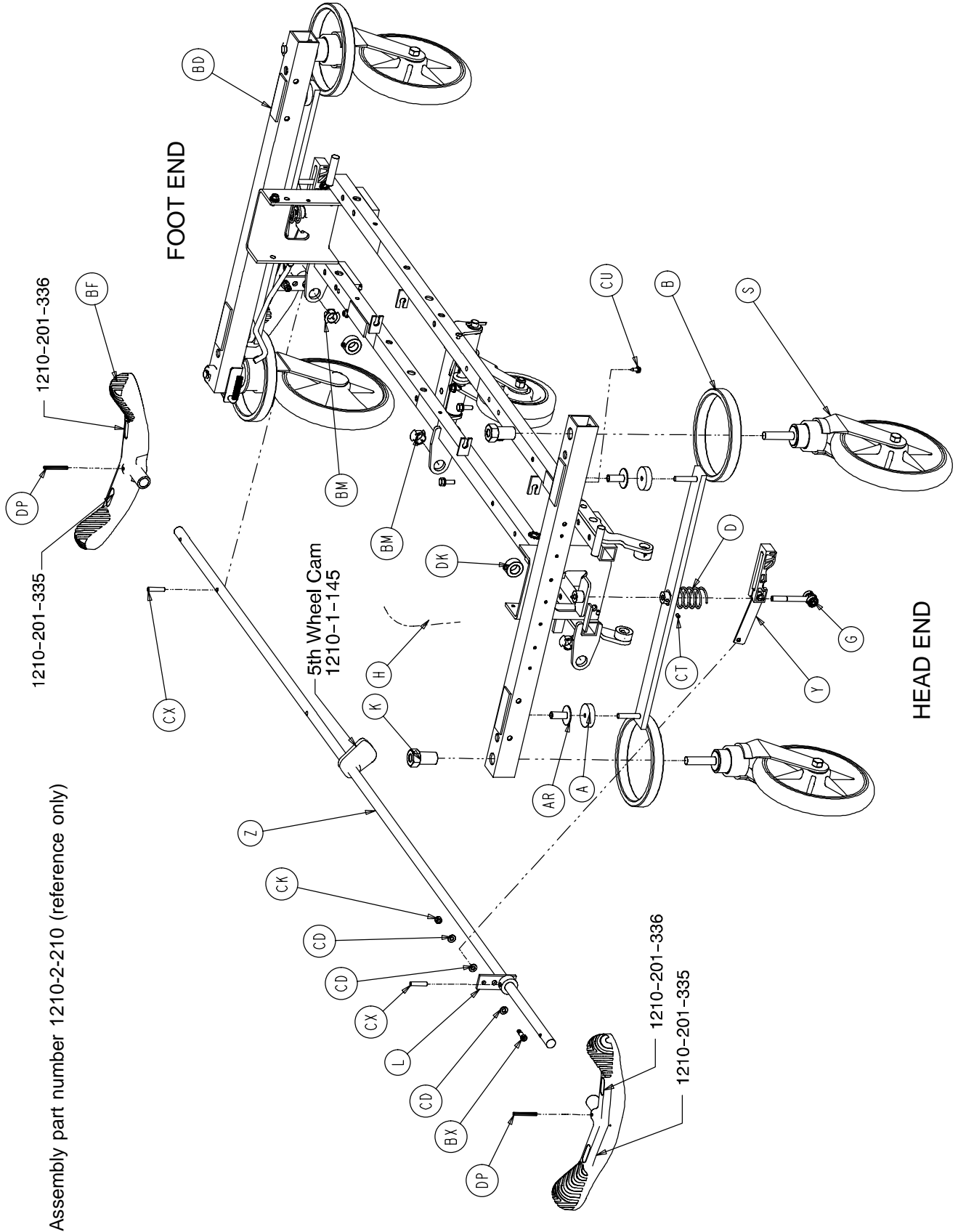

Assembly part number 1210-2-210 (reference only)

# End Control Base Assembly

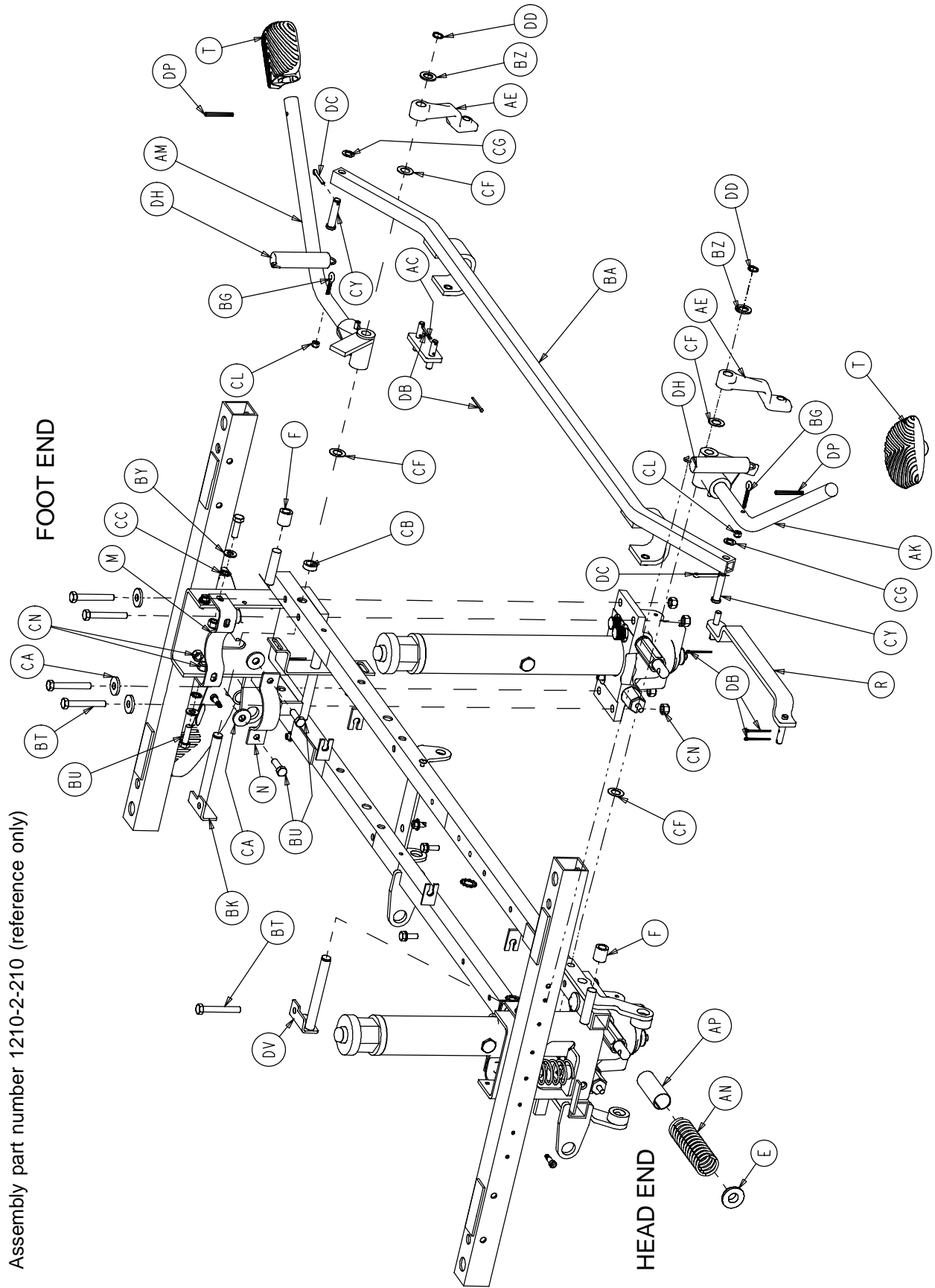

Assembly part number 1210-2-210 (reference only)

# End Control Base Assembly

Assembly part number 1210-2-210 (reference only)

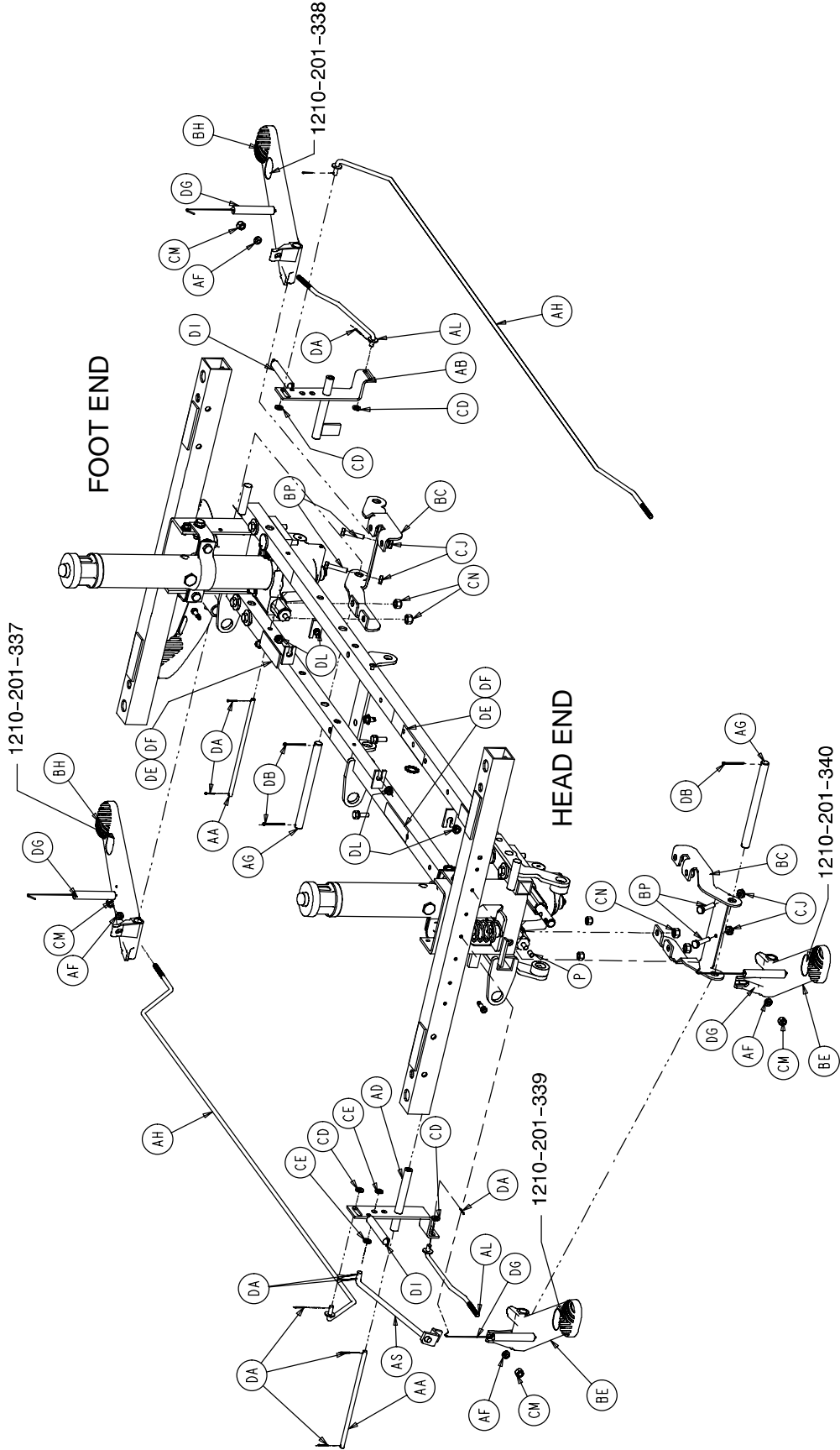

# End Control Base Assembly

Item	Part No.	Part Name	Qty.	Item	Part No.	Part Name	Qty.
A	715-1-1 1	Brake Cushion	4	BH	1210-201-155	Foot Rel. Pedal, Offset, Lt	2
B	715-1-61	Caster Brake Weldment	2	BK	1210-201-201	Pivot Pin Bracket, Foot End	1
D	715-201-94	Compression Spring	2	BM	1210-201-251	Insert	3
E	715-1-133	Collar	2	BP	3-3	Hex Cap Screw	4
F	715-1-140	Vinyl Tube	2	BT	3-62	Hex Hd. Cap Screw	8
G	(page 27)	Brake Adjuster	2	BU	3-85	Hex Hd. Cap Screw	8
H	715-1-156	Ground Chain	1	BX	8-17	Shoulder Bolt	2
K	715-1-158	Caster Nut	4	BY	11-3	Washer	4
L	715-1-165	Actuator Plate Weldment	2	BZ	11-13	Washer	2
M	715-1-192	Jack Support	2	CA	11-262	Washer	10
N	715-1-193	Jack Support Clamp	2	CB	11-350	Spacer Washer	1
P	715-1-333	Release Rod Stop Sleeve	2	CC	13-38	Ext. Tooth Lock Washer	4
R	716-1-109	Head End Pump Link	1	CD	14-2	Washer	10
S	(page 34)	Caster Assembly	*	CE	14-3	Washer	2
T	715-201-26	Slip-On Pump Pedal	2	CF	14-7	Washer	4
Y	(page 28)	Brake Cam Assembly	2	CG	14-9	Washer	2
Z	715-201-230	Brake Bar	1	CJ	15-1 1	Hex Nut	4
AA	716-1-15	Release Pivot Bar	2	CK	16-2	Hex Nut	2
AB	716-1-52	Pivot Assembly, Foot End	1	CL	16-14	Nylock Nut	2
AC	716-1-102	Pump Link Weldment, Ft.	1	CM	16-102	Hex Nut	4
AD	716-1-1 19	Pivot Assembly, Head End	1	CN	16-36	Hex Nut	16
AE	716-201-281	Pump Idler Link	2	CT	21-151	Set Screw	2
AF	716-1-286	Release Ball Spacer	4	CU	23-25	Self-Tapping Screw	1
AG	716-201-61	Release Pedal Pivot Rod	2	CX	26-13	Spring Pin	2
AH	716-201-70	Long Release Rod	2	CY	26-195	Clevis Pin	2
AK	(page 31)	Head End Pump Pedal	1	DA	27-4	Cotter Pin	9
AL	716-201-74	Release Rod	2	DB	27-7	Cotter Pin	9
AM	(page 30)	Foot End Pump Pedal	1	DC	27-16	Cotter Pin	2
AN	763-1-15	Jack Spring	1	DD	28-97	Ext. Tooth Retaining Ring	2
AP	763-1-16	Spring Holder	1	DE	29-12	Velcro Loop	3
AR	946-1-1 16	Brake Bar Bushing	4	DF	29-14	Velcro Hook	3
AS	1210-1-1 12	Rel. Rod, Head End, Lt.	1	DG	38-235	Desc. Pedal Return Spring	4
BA	1210-201-27	Pump Connecting Rod	1	DH	38-251	Pump Return Spring	2
BC	1210-201-1 11	End Release Pedal Brkt.	2	DI	38-326	Extension Spring	2
BD	1210-201-120	Base Frame Weldment	1	DK	42-20	Collar	2
BE	1210-201-154	Head Rel. Pedal, Offset, Rt.	2	DL	52-245	Nyliner	4
BF	1210-201-153	Butterfly "V" Pedal	2	DM	(p. 38 or 39.2)	Jack Assembly	2
BG	1210-201-551	Eye Bolt	2	DP	26-143	Groove Pin	4

\* Caster assembly is quantity of 4 if the fifth wheel option is present on the stretcher and quantity of 3 if the steering caster option is present.

# 715-201-150 Brake Adjuster Assembly

---

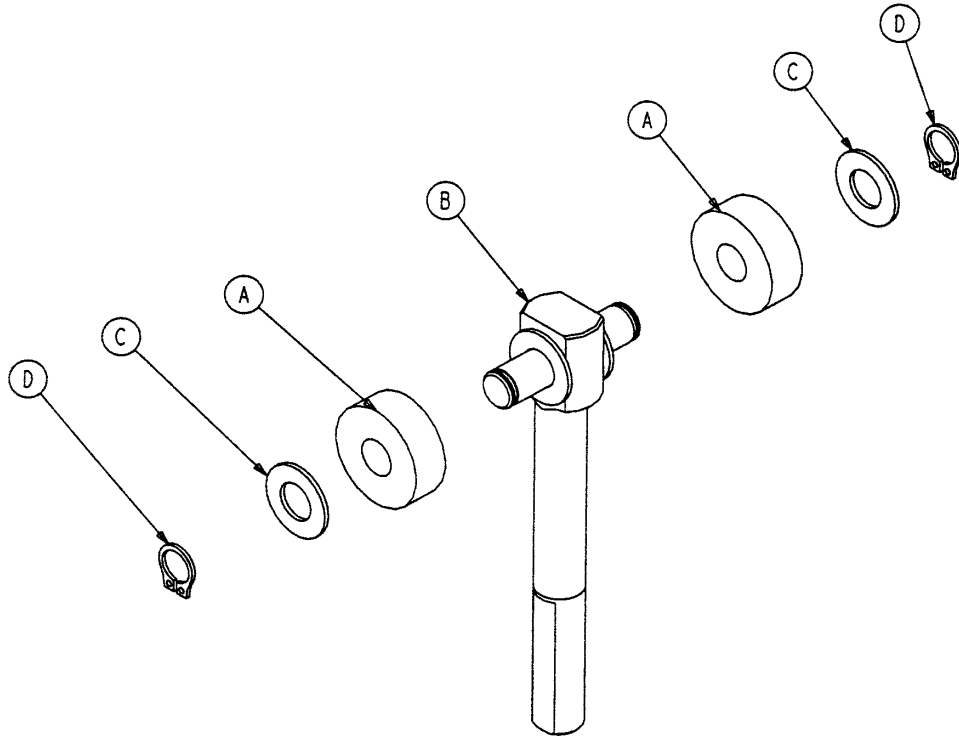

Item	Part No.	Part Name	Qty.
A	715-1-180	Cam Bearing	2
B	715-201-62	Threaded Stud Assembly	1
C	14-4	Nylon Washer	4
D	28-8	External Retaining Ring	2



# 715-201-213 Brake Cam Assembly

---

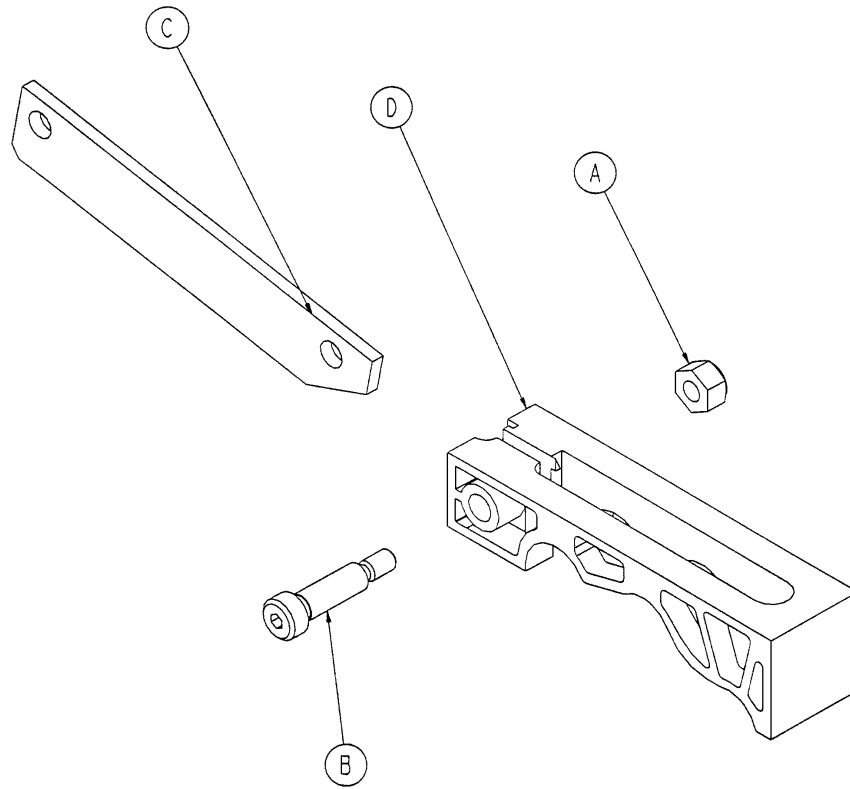

Item	Part No.	Part Name	Qty.
A	16-59	Hex Nut	1
B	8-21	Soc. Hd. Shoulder Screw	1
C	715-201-173	Brake Connecting Link	1
D	715-301-221	Brake Cam	1

# Side Control Pump Pedal Assembly

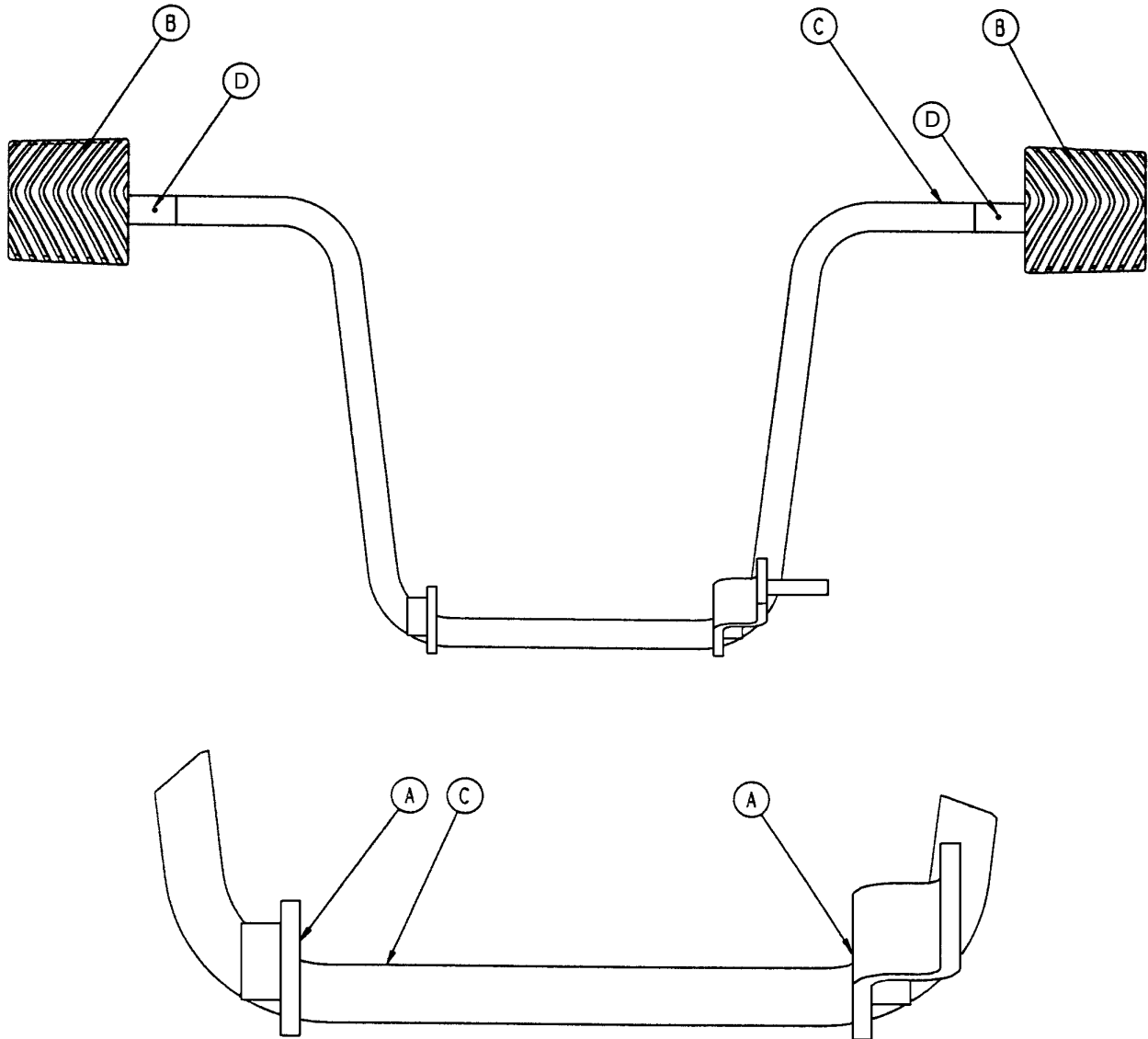

Item	Part No.	Part Name	Qty.
A	81-44	Bronze Bearing	2
B	715-201-126	Slip-On Pedal Pad	2
C	715-201-83	Pump Pedal Weldment	1
D	26-143	Groove Pin	2

# 716-201-288 Foot End Pump Pedal Assembly

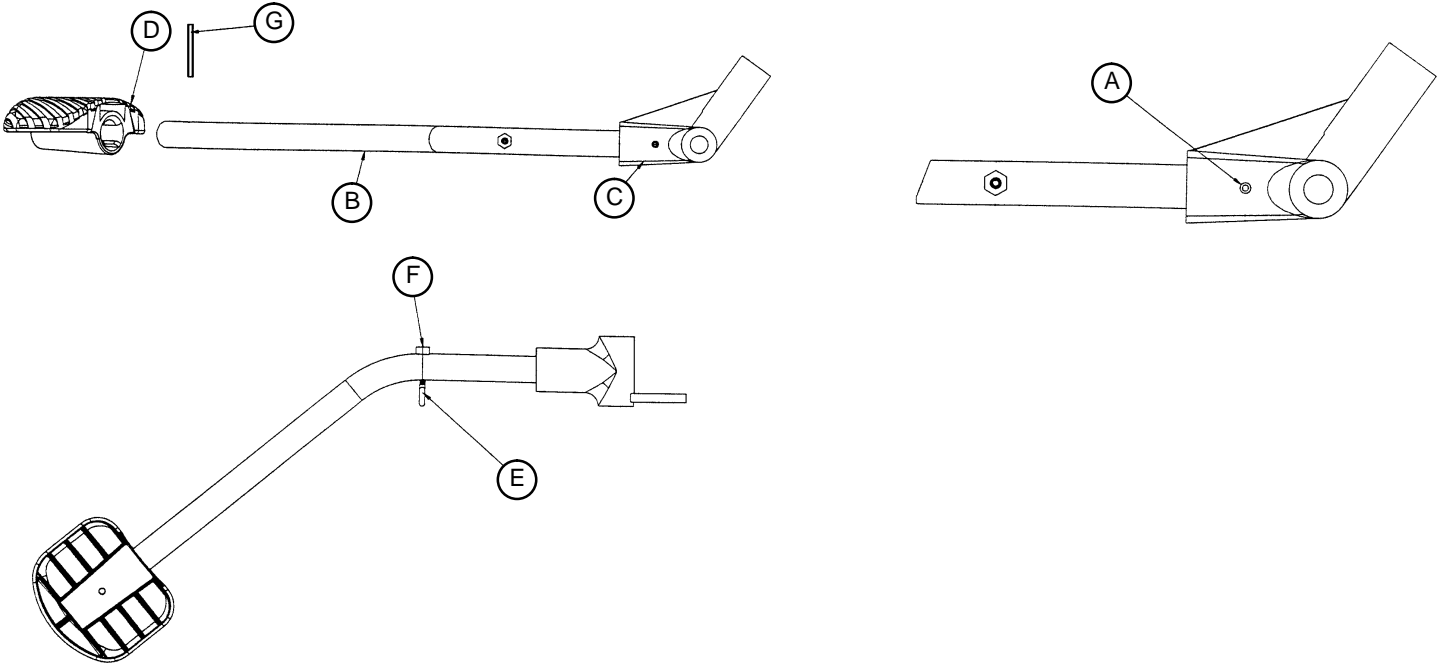

Item	Part No.	Part Name	Qty.
A	26-145	Spring Pin	1
B	716-201-14	Foot End Pump Rod	1
C	716-1-283	Pump Pivot Housing	1
D	715-201-126	Pedal	1
E	1210-201-551	Eye Bolt	1
F	16-14	Nylock Nut	1
G	26-261	Groove Pin	1

# 716-201-292 Head End Pump Pedal Assembly

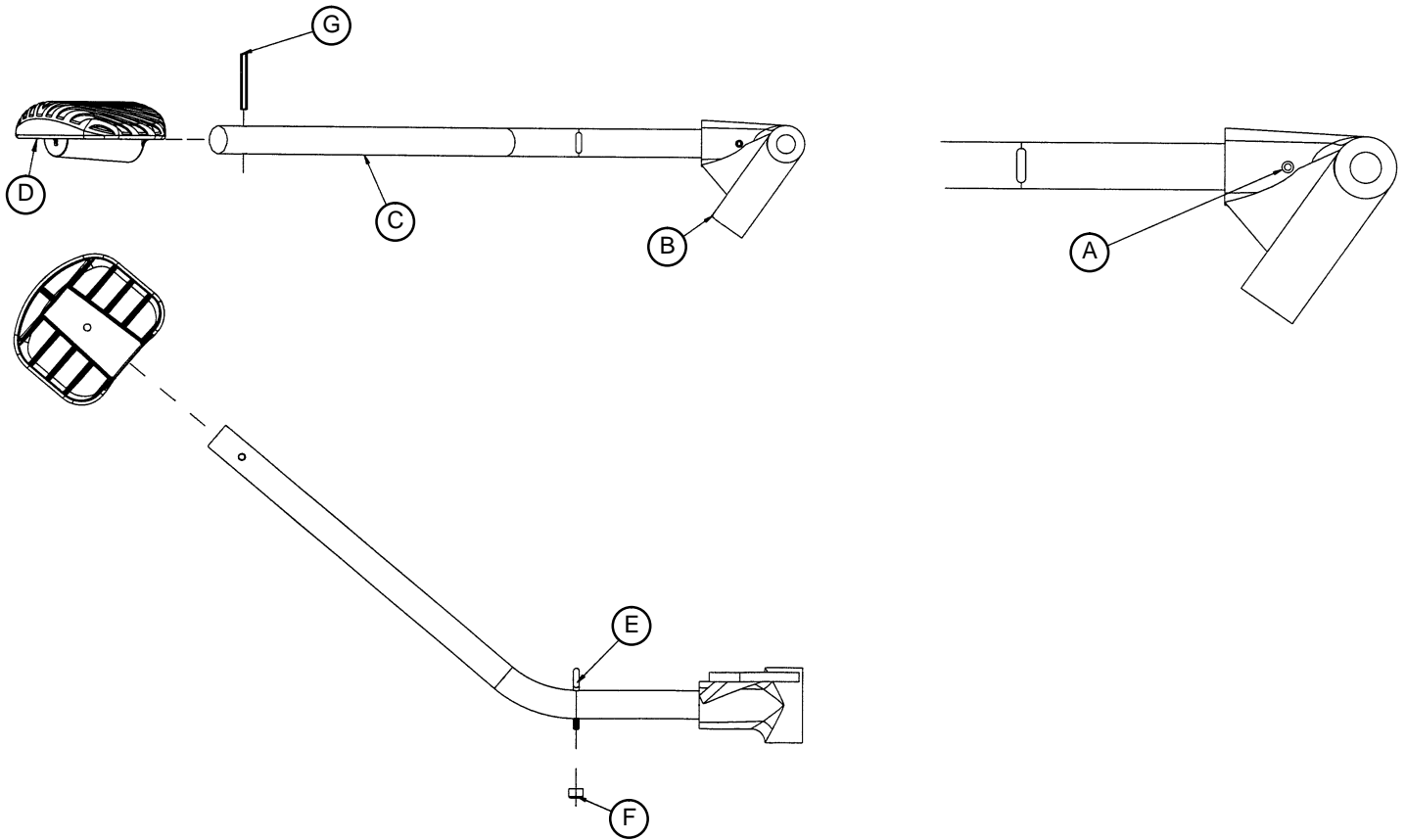

Item	Part No.	Part Name	Qty.
A	26-145	Spring Pin	1
B	716-1-285	Pump Pivot Housing, Hd. End	1
C	716-201-14	Head End Pump Rod	1
D	715-201-126	Pedal	1
E	1210-201-551	Eye Bolt	1
F	16-14	Nylock Nut	1
G	26-261	Groove Pin	1

# Base Assembly w/Steerlock Caster Option

Assembly part number 1000-159  
(reference only)

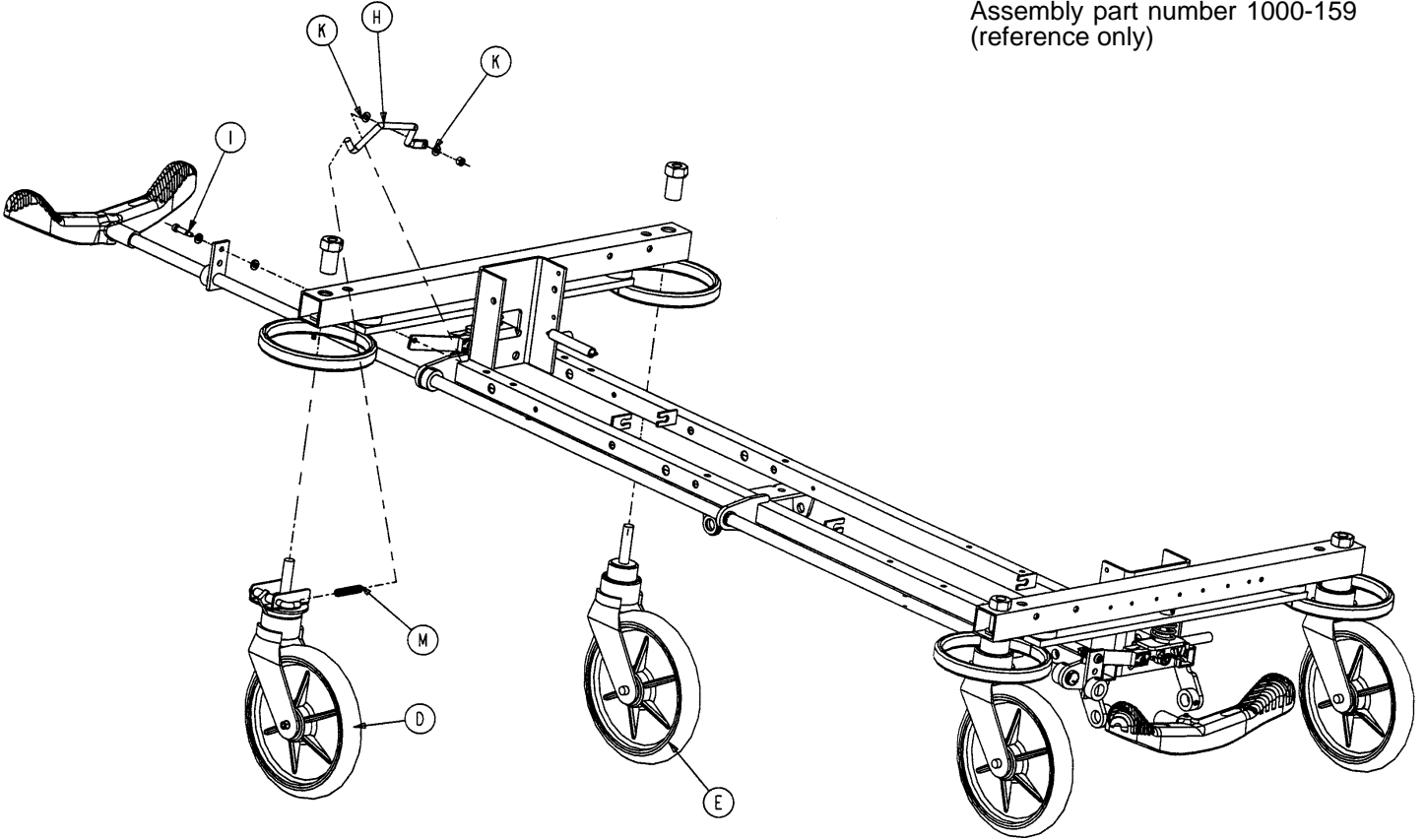

Item	Part No.	Part Name	Qty.
D	(page 33)	Steer Caster Assembly	1
E	(page 34)	Caster Assembly	3
H	1000-210-62	Steer Lock Linkage Bar	1
I	8-21	Shoulder Bolt	1
K	14-2	Washer	2
M	38-21 1	Spring	1

# 715-269-100 Caster Assembly w/Steerlock

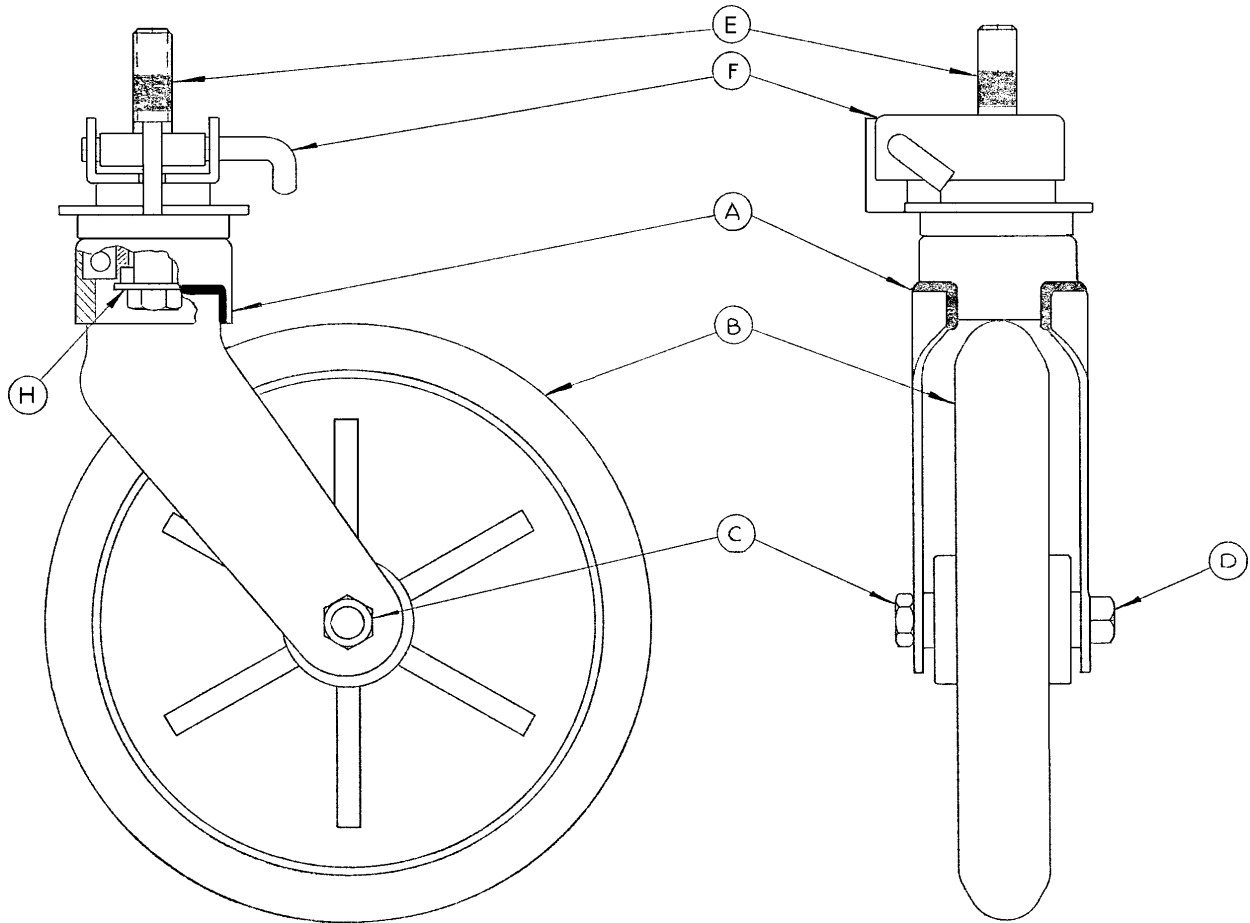

Assembly part number 715-2-21 (reference only)

Item	Part No.	Part Name	Qty.
A	700-10-50	Steer Lock Caster Weldment	1
B	715-2-25	Caster Wheel	1
C	16-60	Hex Nut	1
D	3-99	Hex Bolt	1
E	715-3-96	Hex Bolt	1
F	1000-59-10	Latch Assembly	1
H	11-310	Flat Washer	1

# Standard Caster Assembly

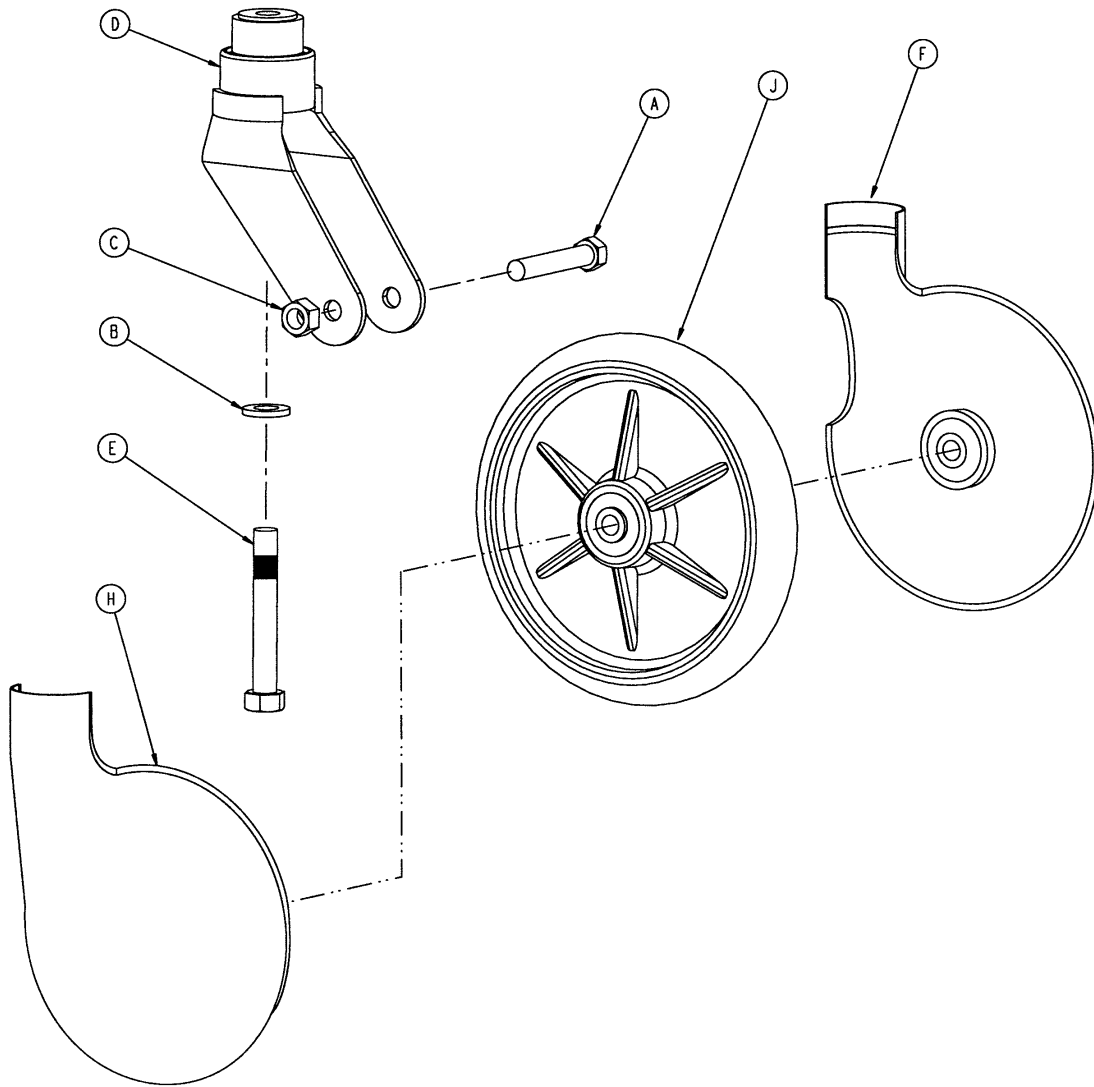

Item	Part No.	Part Name	Qty.
A	3-99	Hex Hd. Cap Screw	1
B	11-310	Washer	1
C	16-60	Hex Nut	1
D	715-2-16	Horn Assembly	1
E	715-3-96	Hex Hd. Cap Screw	1
F	715-1-265	Wheel Cover, Right	1
H	715-1-266	Wheel Cover, Left	1
J	715-2-25	Wheel	1
	715-1-158	Caster Nut (not shown)	1

p/n 715-259-400 - Kit to replace 4 standard caster assemblies with hardware - no caster covers.

p/n 715-269-400 - Kit to replace 3 standard caster assemblies and 1 steerlock caster with hardware - no caster covers.

p/n 715-259-100 - Kit to replace 1 standard caster assembly with hardware - no caster covers.

p/n 1010-56-200 - Kit to replace both caster covers on all four wheels.

# Base Assembly w/Fifth Wheel Option

Assembly part number 1010-260 (reference only)

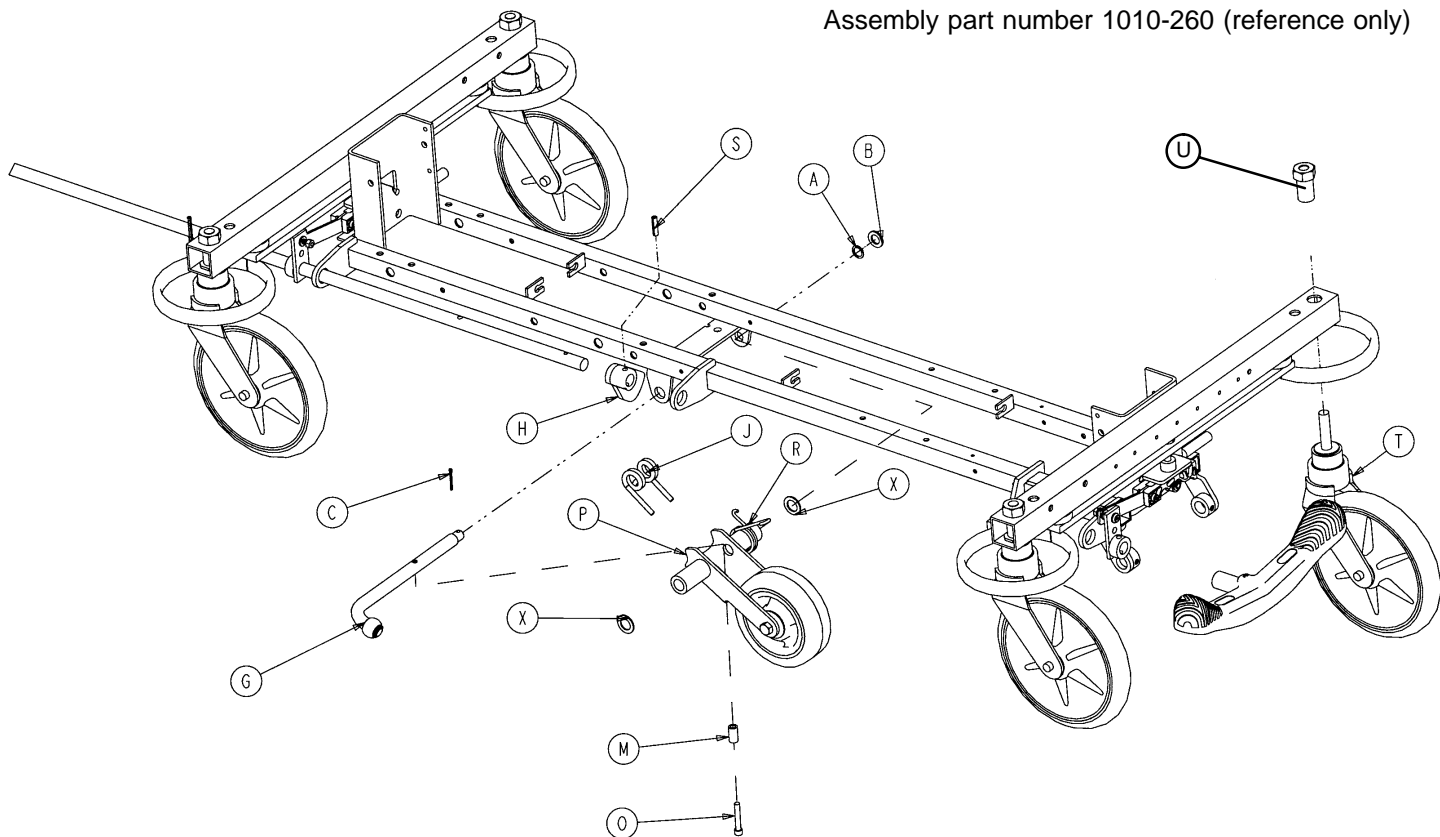

Item	Part No.	Part Name	Qty.
A	14-79	Nylon Washer	1
B	11-13	Washer	1
C	27-16	Cotter Pin	1
G	(page 36)	Pivot Rod Assembly	1
H	1210-1-145	Cam	1
J	1210-1-148	Torsion Spring	1
M	1210-201-149	Spring Spacer	1
O	4-10	Bolt	1
P	(page 37)	Wheel Arm Assembly	1
R	1210-1-146	Torsion Spring	1
S	26-35	Roll Pin	1
T	(page 34)	Caster Assembly	4
U	715-1-158	Caster Nut	4
X	14-80	Nylon Washer	2



# Pivot Rod Assembly

Assembly part number 1210-201-2  
(reference only)

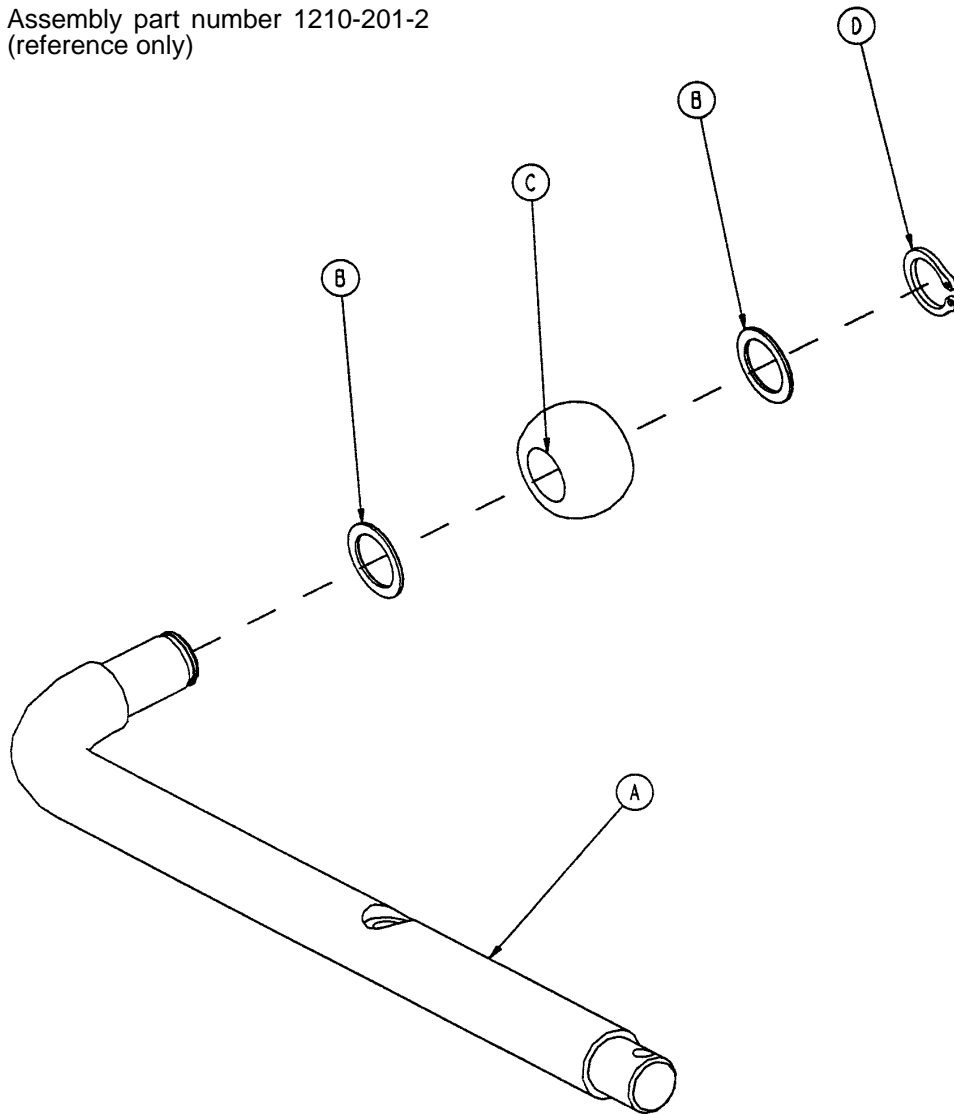

Item	Part No.	Part Name	Qty.
A	1210-1-143	Pivot Rod	1
B	14-79	Nylon Washer	2
C	1210-1-144	Roller	1
D	28-131	Snap Ring	1
E	27-16	Cotter Pin	1

# 715-201-125 Wheel Arm Assembly

---

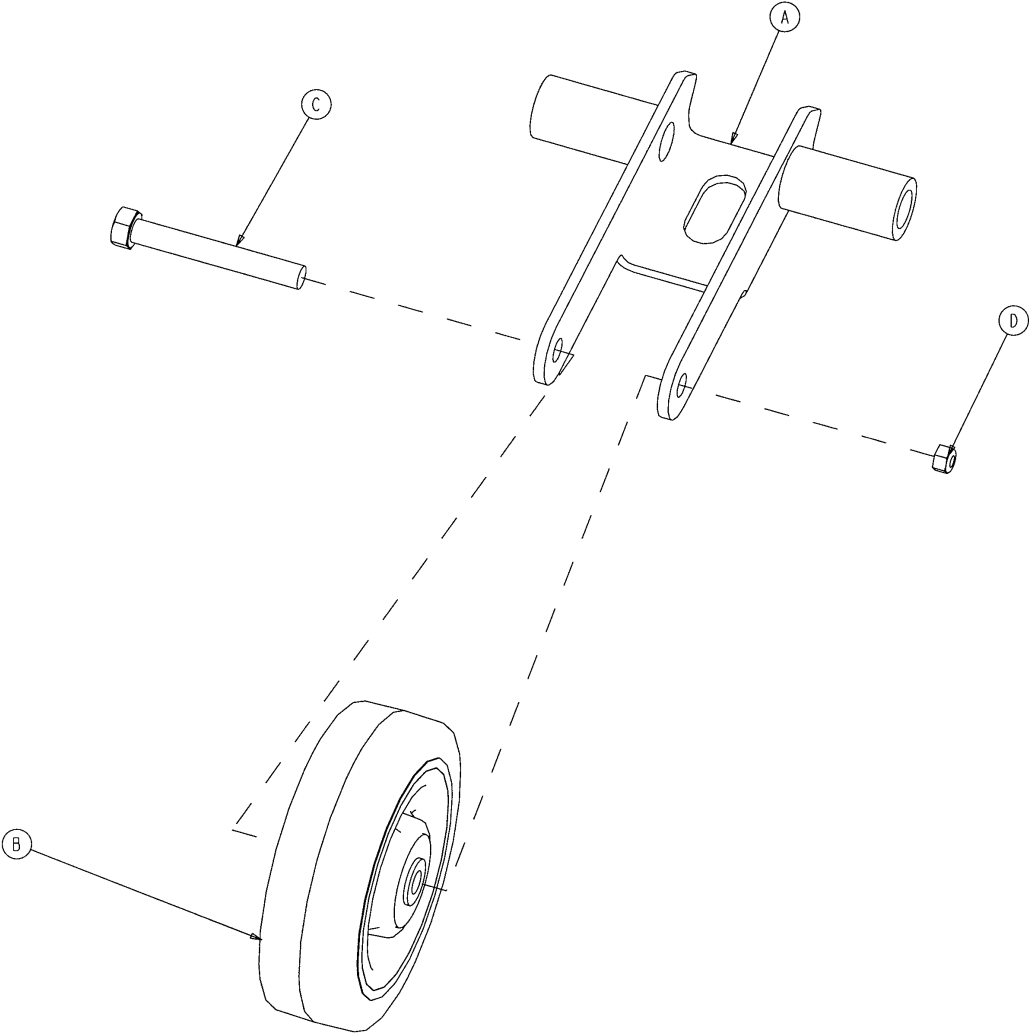

Item	Part No.	Part Name	Qty.
A	1210-201-553	Wheel Arm	1
B	1210-1-147	Fifth Wheel	1
C	3-31	Hex Hd. Cap Screw	1
D	16-35	Nylock Nut	1

# Optional Side Control Big Wheel Base Assembly

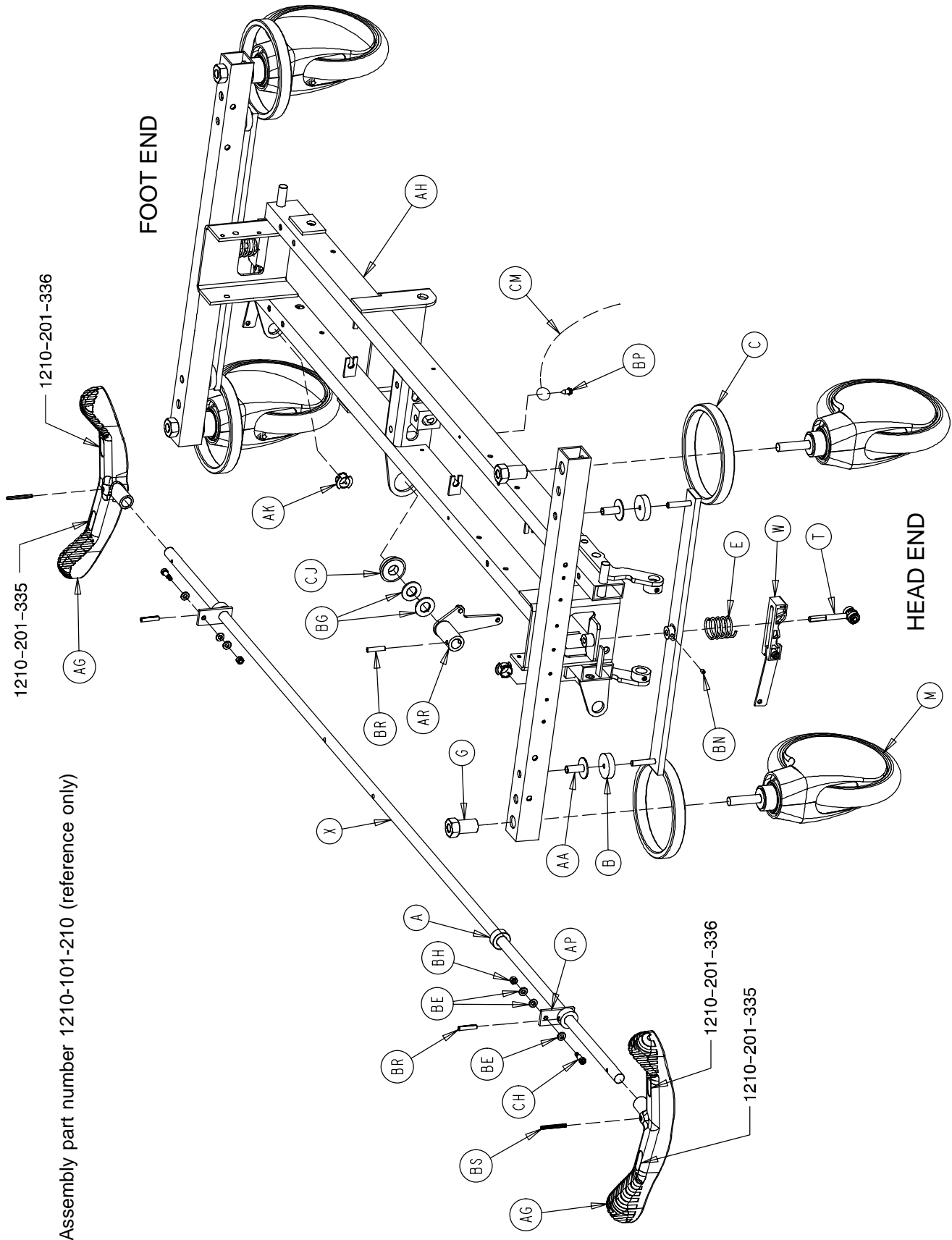

Assembly part number 1210-101-210 (reference only)

# Optional Side Control Big Wheel Base Assembly

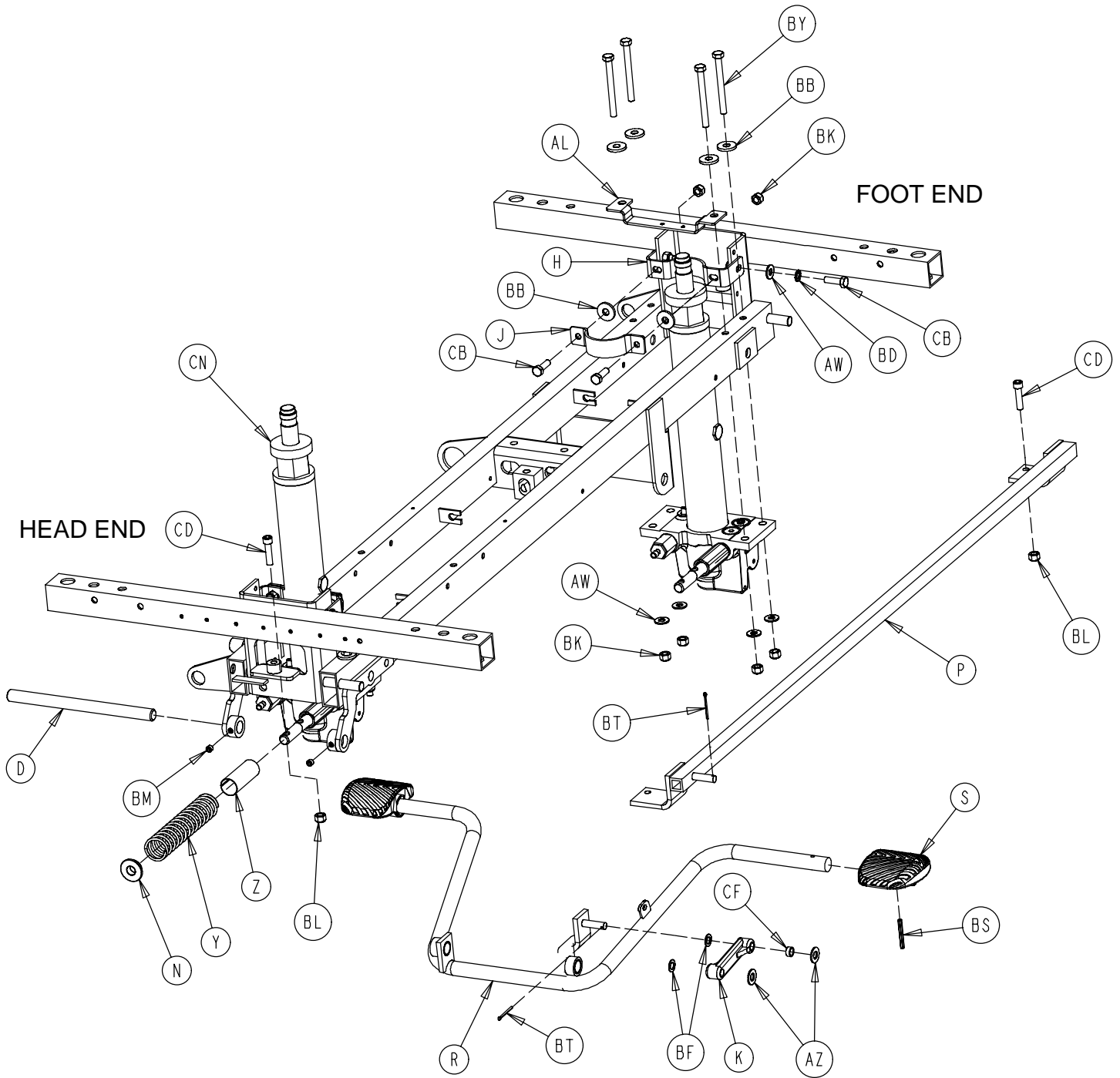

# Optional Side Control Big Wheel Base Assembly

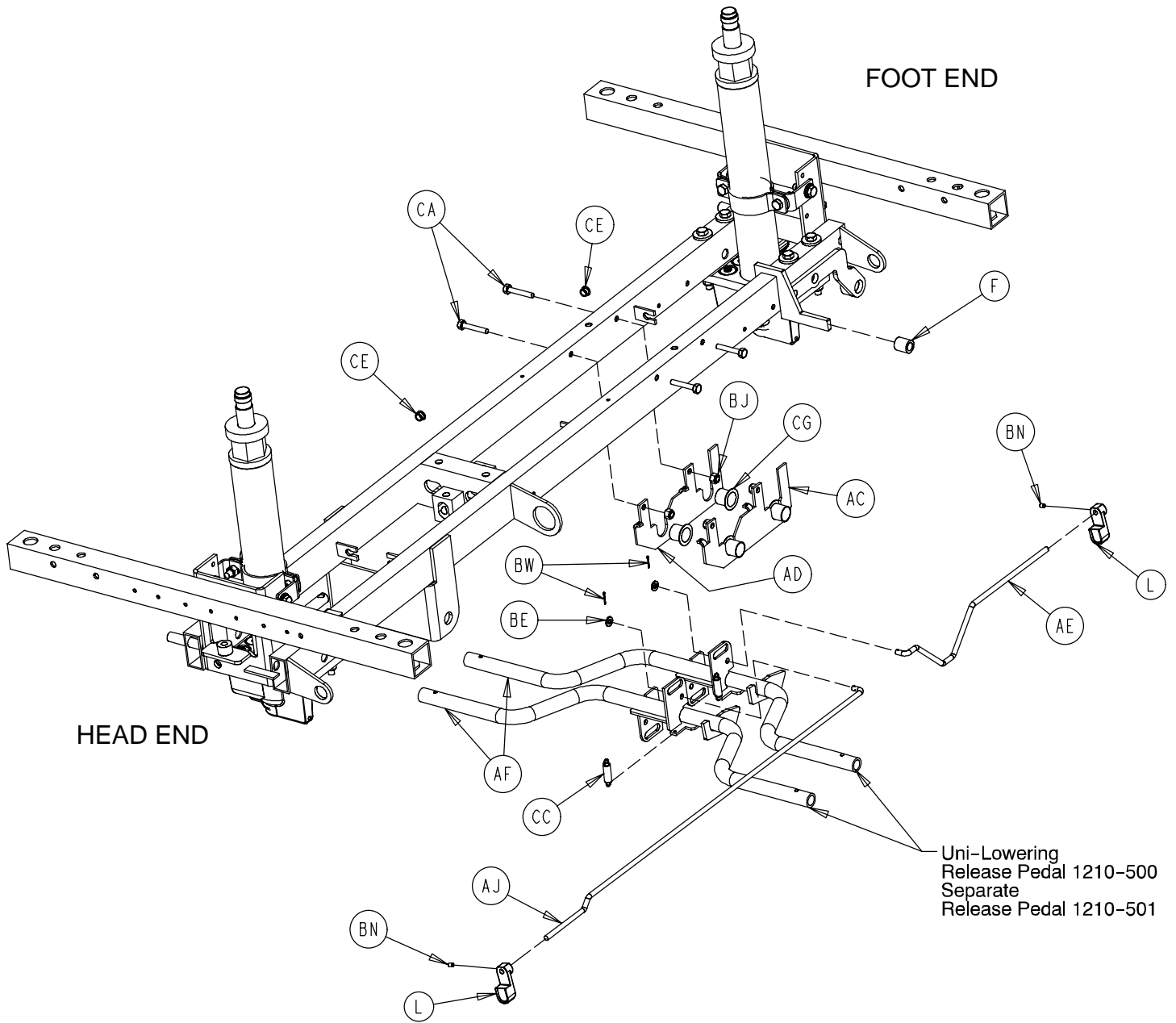

# Optional Side Control Big Wheel Base Assembly

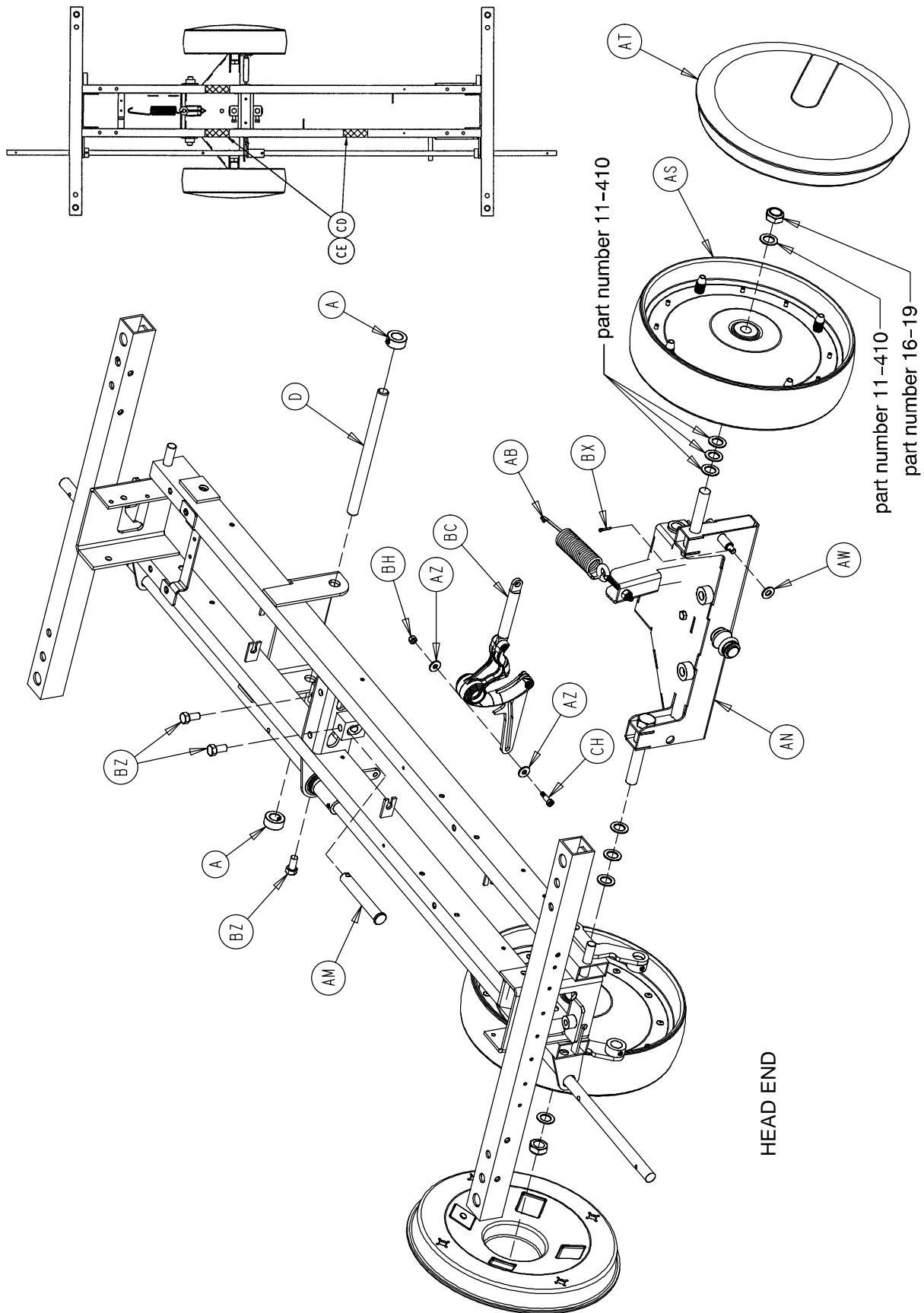

# Optional Side Control Big Wheel Base Assembly

Item	Part No.	Part Name	Qty.	Item	Part No.	Part Name	Qty.
A	42-20	Collar	3	AT	1210-301-653	Wheel Cover Assembly	2
B	715-1-1 1	Brake Cushion	4	AW	11-3	Washer	11
C	715-1-61	Caster Brake Weldment	2	AZ	11-4	Washer	2
D	715-1-92	Pump Pedal Shaft	2	BA	11-224	Washer	2
E	715-1-94	Compression Spring	2	BB	11-262	Washer	12
F	715-1-140	Vinyl Tube	1	BC	(page 37.14)	Cam Assembly	1
G	715-1-158	Caster Nut	4	BD	13-38	Lock Washer	4
H	715-1-192	Jack Support	2	BE	14-2	Washer	8
J	715-1-193	Jack Support Clamp	2	BF	14-9	Washer	2
K	715-1-214	Connecting Link	1	BG	14-71	Washer	2
L	715-1-346	Release Paddle	2	BH	16-2	Hex Nut	3
M	(page 34)	Caster Assembly	4	BJ	16-28	Hex Nut	4
N	715-1-133	Collar	1	BK	16-36	Hex Nut	16
P	715-201-27	Pump Rod Weldment	1	BL	16-48	Hex Nut	2
R	715-201-108	Pump Pedal	1	BM	21-22	Set Screw	2
S	715-201-126	Slip On Pump Pedal	2	BN	21-50	Set Screw	4
T	(page 27)	Brake Adjuster Assembly	2	BP	23-25	Hex Washer Hd. Tap. Screw	1
W	(page 28)	Brake Cam Assembly	2	BR	26-13	Spring Pin	3
X	715-201-230	Brake Rod	1	BS	26-143	Groove Pin	4
Y	763-1-15	Jack Spring	1	BT	27-3	Cotter Pin	2
Z	763-1-16	Spring Guide	1	BW	27-4	Cotter Pin	2
AA	946-1-1 16	Brake Bar Bushing	4	BX	27-13	Cotter Pin	1
AB	1210-1-151	Interface Spring	1	BY	3-1 1	Hex Cap Screw	8
AC	1210-201-1 14	Pedal Pivot, Left	1	BZ	3-21	Hex Cap Screw	4
AD	1210-201-1 15	Pedal Pivot, Right	1	CA	3-47	Hex Cap Screw	4
AE	1210-201-139	Pull Release Rod, Hd. End	1	CB	3-85	Hex Cap Screw	8
AF	1210-201-152	Side Release Pedal Wldmt.	2	CC	38-355	Extension Spring	2
AG	1210-201-153	Butterfly "V" Pedal	2	CD	4-146	Soc. Hd. Cap Screw	2
AH	1210-201-220	Base Frame Weldment	1	CE	52-245	Nyliner	2
AJ	1210-201-222	Push Release Rod, Hd. End	1	CF	52-284	Washer	1
AK	1210-201-251	Insert	2	CG	52-747	Flange Bearing	4
AL	1210-201-330	Spring Support	1	CH	8-10	Shoulder Bolt	3
AM	1210-201-412	Roller Pin	1	CJ	81-301	Bearing	1
AN	(page 37.11)	Interface Assembly	1	CK	29-12	Velcro Loop	3
AP	1210-201-620	Actuator Weldment	2	CL	29-14	Velcro Hook	3
AR	1210-201-630	Horn Weldment	1	CM	715-1-156	Ground Chain	1
AS	(page 37.13)	Wheel Assembly	2	CN	(p. 38 or 39.2)	Jack Assembly	2





# Optional End Control Big Wheel Base Assembly

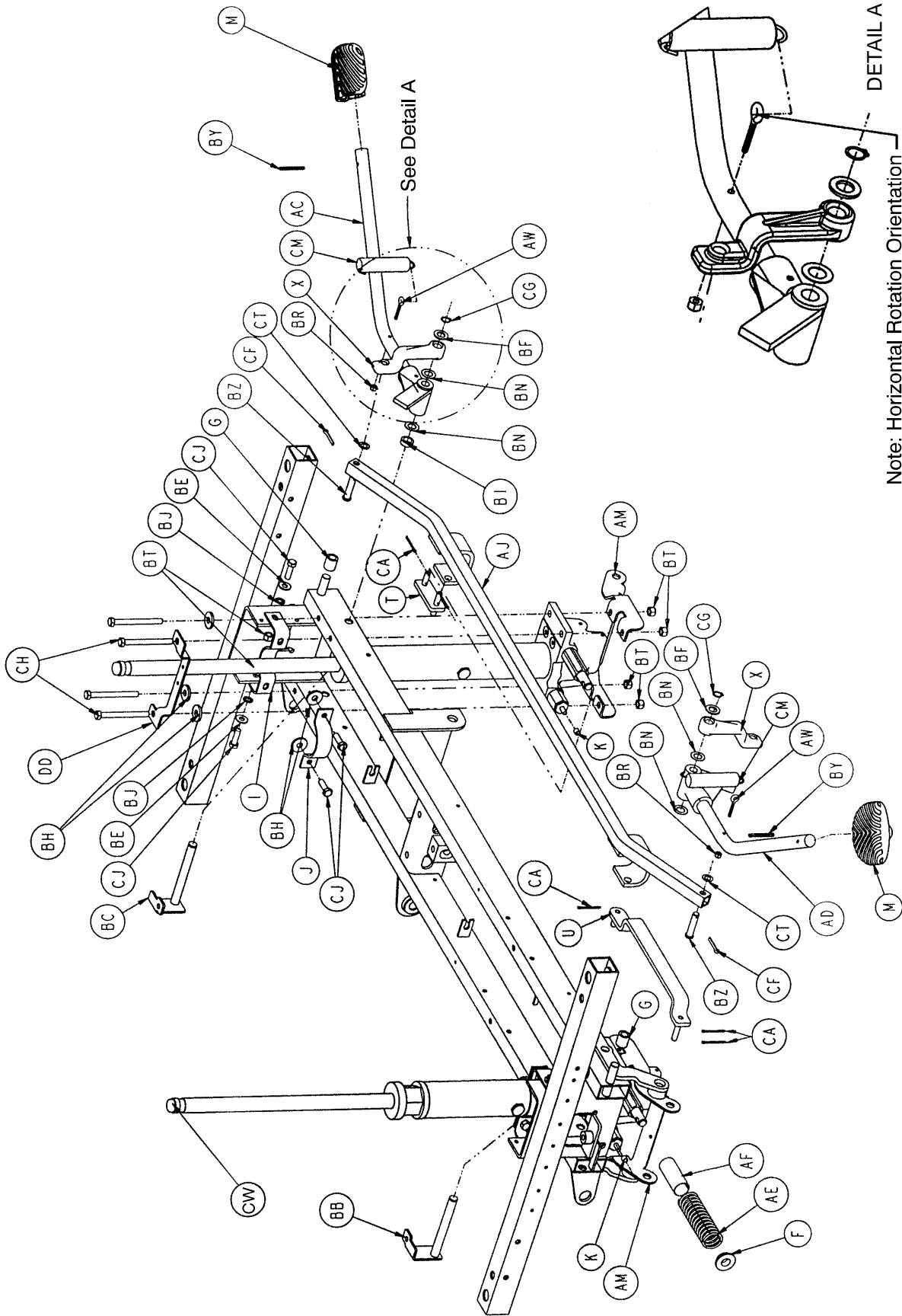



# Optional End Control Big Wheel Base Assembly

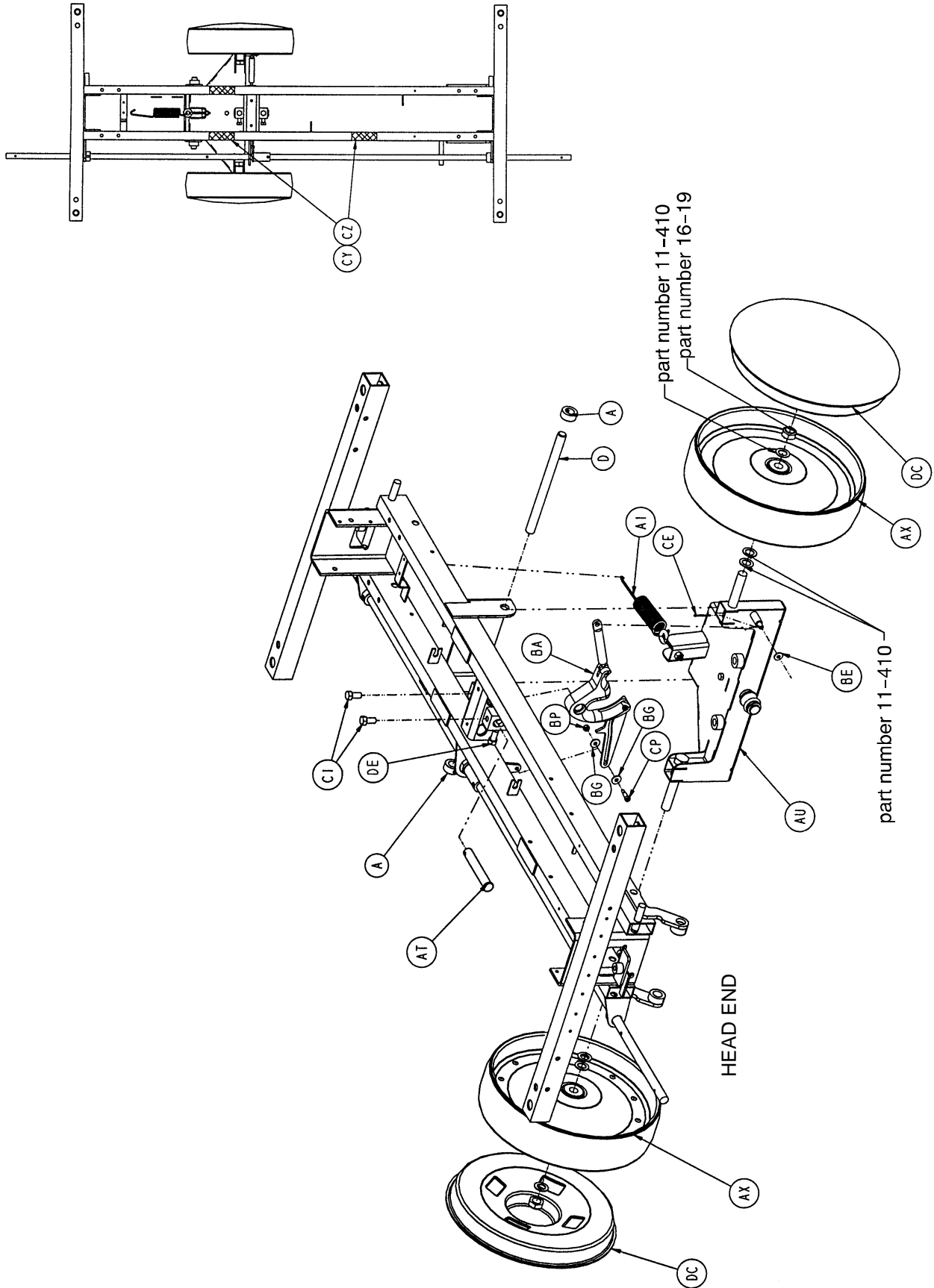

# Optional End Control Big Wheel Base Assembly

Item	Part No.	Part Name	Qty.	Item	Part No.	Part Name	Qty.
A	42-20	Collar	4	BB	1210-301-200	Hd. End Pin Brkt. Pivot	1
B	715-1-1 1	Brake Cushion	4	BC	1210-301-201	Ft. End Pin Brkt. Pivot	1
C	715-1-61	Caster Brake Weldment	2	BE	11-3	Washer	5
D	715-1-92	Pump Pedal Shaft	2	BF	11-13	Washer	2
E	715-1-94	Compression Spring	2	BG	11-224	Washer	2
F	715-1-133	Jack Spring Collar	1	BH	11-262	Washer	10
G	715-1-140	Vinyl Tube	2	BI	11-350	Washer	1
H	715-1-158	Caster Nut	4	BJ	13-38	Lock Washer	4
I	715-1-192	Jack Support	2	BK	14-2	Washer	6
J	715-1-193	Jack Support Clamp	2	BM	14-3	Washer	2
K	715-1-333	Release Rod Stop Sleeve	2	BN	14-7	Washer	4
M	715-201-126	Slip On Pump Pedal	2	BO	15-1 1	Hex Nut	4
N	(page 27)	Brake Adjuster Assembly	2	BP	16-2	Hex Nut	3
O	(page 28)	Brake Cam Assembly	2	BR	16-14	Hex Nut	2
P	715-201-230	Brake Rod	1	BS	16-102	Hex Nut	4
R	716-1-15	Release Pivot Bar	2	BT	16-36	Hex Nut	16
S	716-1-52	Pivot Assembly, Ft. End	1	BU	21-151	Set Screw	2
T	716-1-102	Pump Link Wldmt., Ft. End	1	BW	23-25	Hex Washer Hd. Tap. Screw	1
U	716-1-109	Pump Link Wldmt., Hd. End	1	BX	26-13	Spring Pin	3
W	716-1-1 19	Pivot Assembly, Hd. End	1	BY	26-143	Groove Pin	4
X	716-1-281	Pump Idler Link	2	BZ	26-195	Clevis Pin	2
Y	716-1-286	Ball Release Spacer	4	CA	27-3	Cotter Pin	8
Z	716-201-61	Release Pedal Pivot Rod	2	CB	27-4	Cotter Pin	8
AA	716-201-70	Long Release Rod	2	CE	27-13	Cotter Pin	1
AB	716-301-74	Release Rod	2	CF	27-16	Cotter Pin	2
AC	(page 30)	Pump Pedal Ass'y, F t.End	1	CG	28-97	External Retaining Ring	2
AD	(page 31)	Pump Pedal Ass'y, Hd. End	1	CH	3-1 1	Hex Cap Screw	8
AE	763-1-15	Jack Spring	1	CI	3-21	Hex Cap Screw	2
AF	763-1-16	Spring Guide	1	CJ	3-85	Hex Cap Screw	8
AG	946-1-1 16	Brake Bar Bushing	4	CK	38-235	Desc. Pedal Return Spring	4
AH	1210-101-1 12	Release Rod, Hd. End, Lt.	1	CM	38-451	Pump Return Spring	2
AI	1210-1-151	Interface Spring	1	CN	38-326	Extension Spring	2
AJ	1210-201-27	Pump Rod Ass'y Angle	1	CO	52-245	Nyliner	4
AM	1210-201-1 11	End Release Pedal Bracket	2	CP	8-17	Shoulder Bolt	3
AN	1210-201-153	Butterfly "V" Pedal	2	CR	81-301	Bearing	1
AO	1210-201-154	Rel. Pedal, Hd., Offset, Rt.	2	CS	715-1-156	Ground Chain	1
AP	1210-201-155	Rel. Pedal, Ft., Offset, Lt.	2	CT	14-9	Washer	2
AR	1210-201-220	Base Frame Weldment	1	CW	(p. 38 or 39.2)	Jack Assembly	2
AS	1210-201-251	Insert	2	CX	3-3	Hex Bolt	4
AT	1210-201-412	Roller Pin	1	CY	29-12	Velcro Loop	3
AU	(page 37.11)	Interface Assembly	1	CZ	29-14	Velcro Hook	3
AW	1210-201-551	Eye Bolt	2	DA	14-71	Washer	2
AX	(page 37.13)	Wheel Assembly	2	DB	(page 34)	Caster Assembly	4
AY	1210-201-620	Actuator Weldment	2	DC	1210-201-650	Wheel Cover Assembly	2
AZ	1210-201-630	Horn Weldment	1	DD	1210-201-330	Spring Support	1
BA	(page 37.14)	Cam Assembly	1	DE	3-351	Hex Hd. Cap Screw	2

# Optional Big Wheel Interface Assembly

Assembly part number 1210-201-450 (reference only)

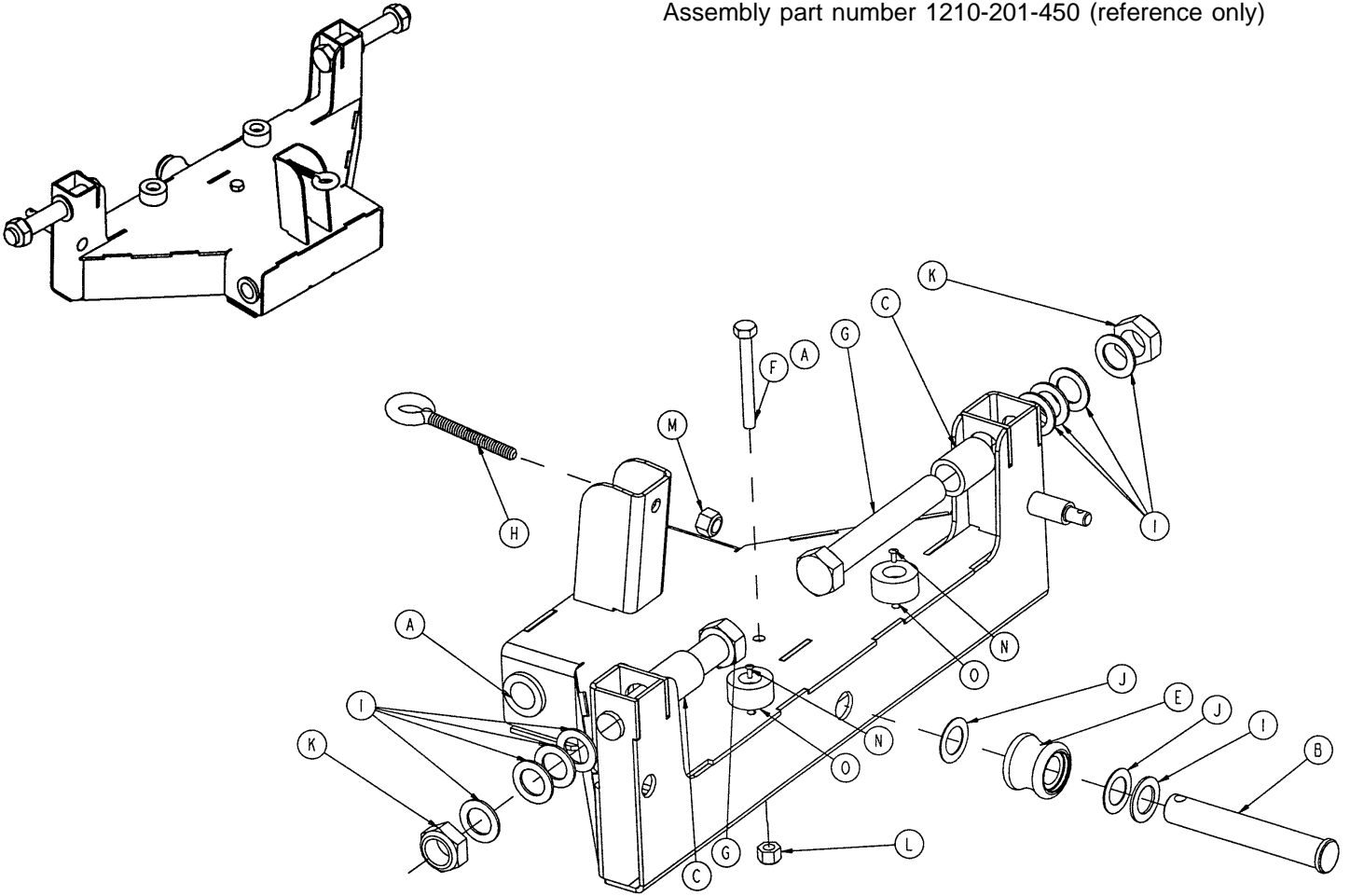

Item	Part No.	Part Name	Qty.
A	81-303	Flange Bushing	2
B	1210-201-412	Roller Pin	1
C	1210-201-625	Interface Sleeve	2
D	1210-201-445	Interface Weldment	1
E	(page 37.12)	Roller Assembly	1
F	3-32	Hex Hd. Cap Screw	1
G	3-345	Hex Hd. Cap Screw	2
H	10-4	Eye Bolt	1
I	11-410	Washer	9
J	14-80	Washer	2
K	16-19	Hex Nut	2
L	16-28	Hex Nut	1
M	16-36	Hex Nut	1
N	25-133	Rivet	2
O	56-16	Bumper Pad	2

# 1210-301-641 Optional Big Wheel Roller Assembly

---

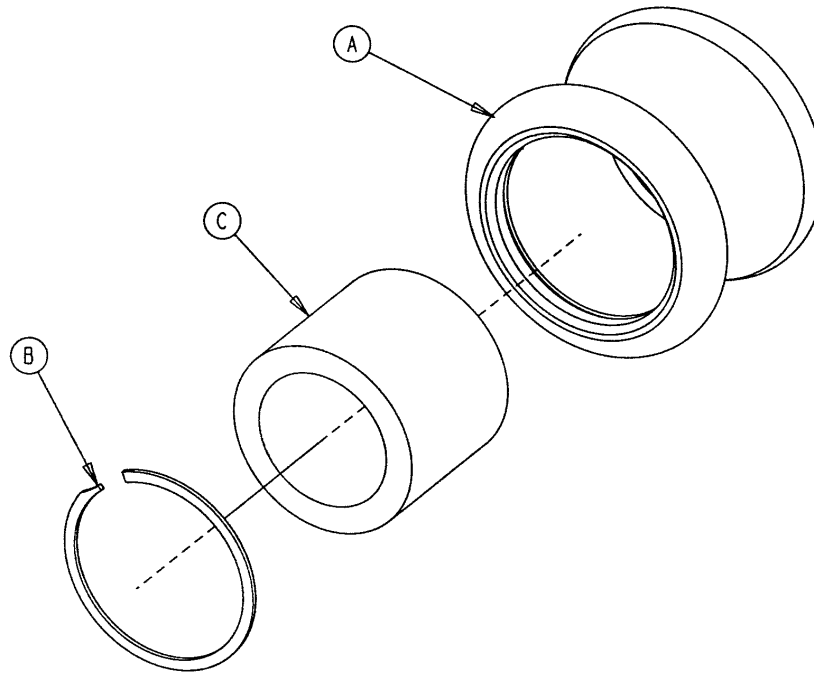

Item	Part No.	Part Name	Qty.
A	1210-301-640	Roller	1
B	28-184	Snap Ring	1
C	81-299	Bearing	1

# 1210-301-619 Optional Big Wheel Assembly

---

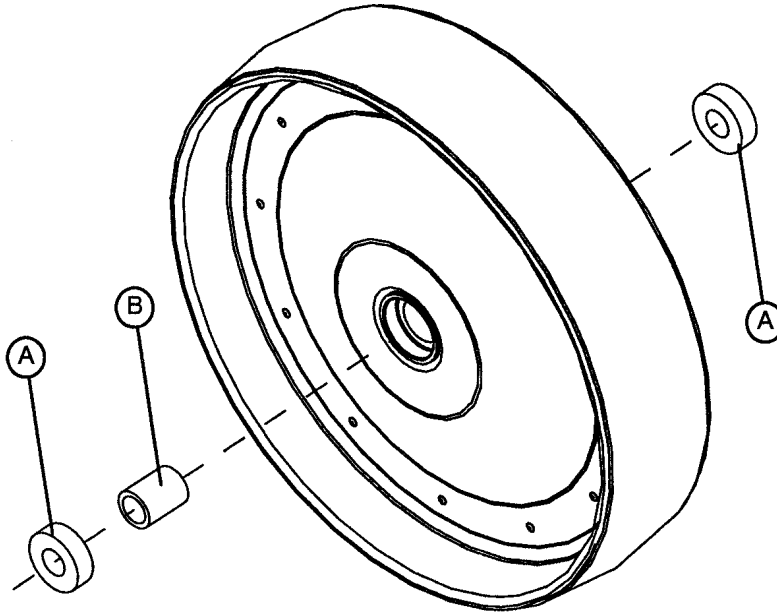

Item	Part No.	Part Name	Qty.
A	81-226	Bearing	2
B	1210-201-625	Wheel Inner Sleeve	1

# 1210-301-900 Optional Big Wheel Cam Assembly

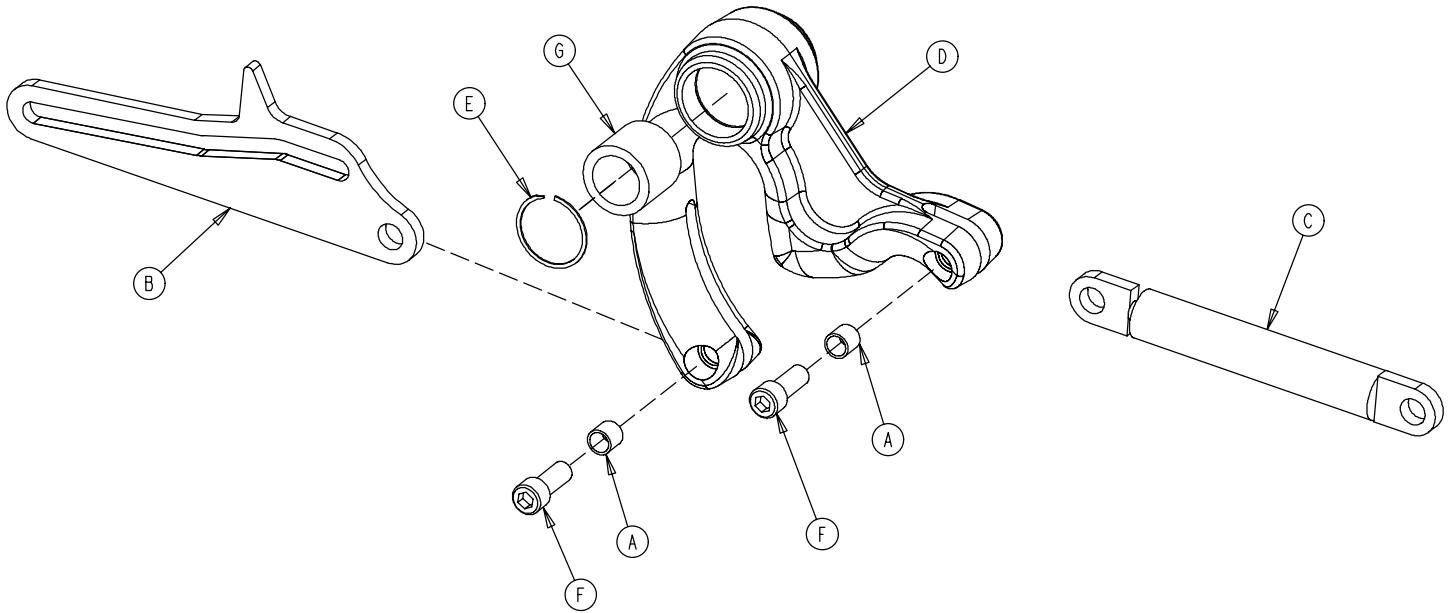

Item	Part No.	Part Name	Qty.
A	715-1-333	Release Valve Stop Sleeve	2
B	1210-201-610	Connecting Link	1
C	1210-201-671	Dampener	1
D	1210-301-901	Cam	1
E	28-184	Snap Ring	1
F	4-328	Soc. Hd. Cap Screw	2
G	81-299	Needle Bearing	1



# 1231-70-10 Jack Assembly

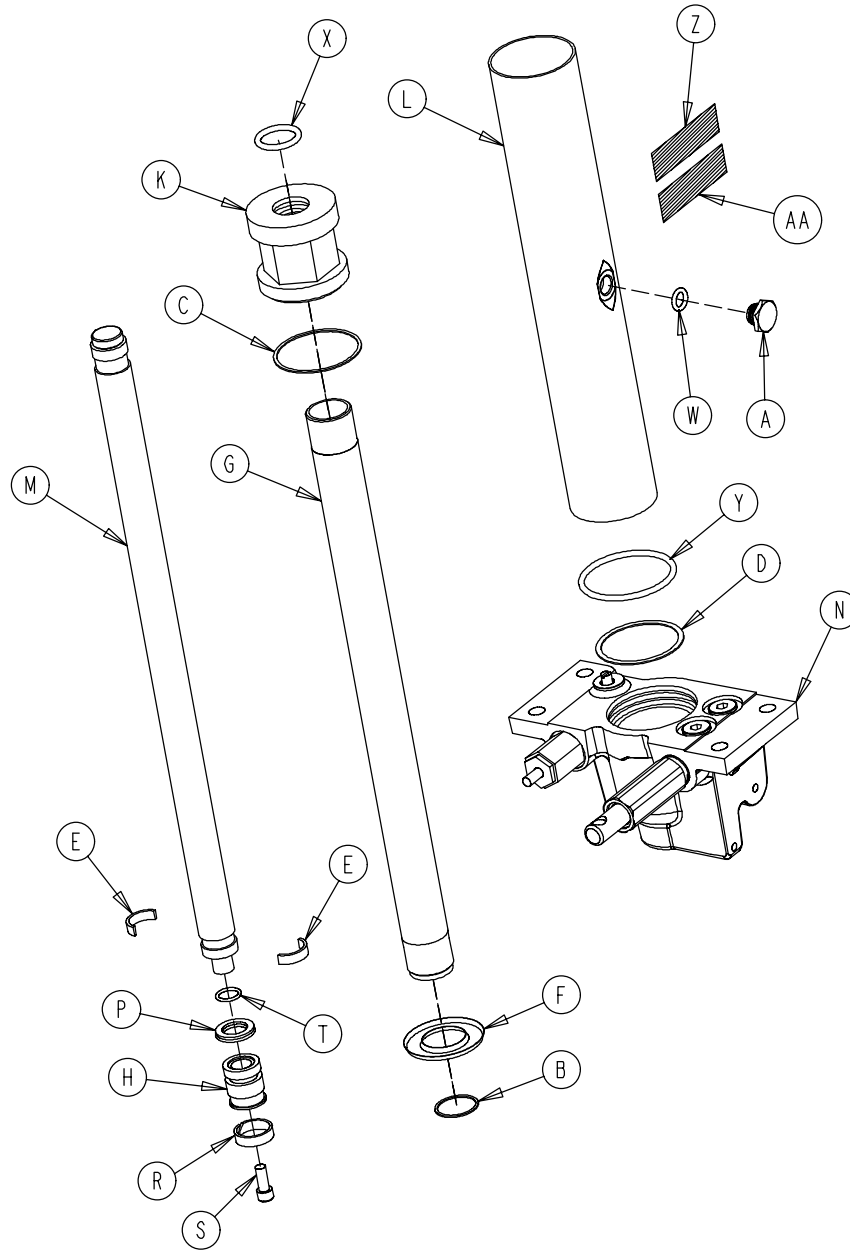

Item	Part No.	Part Name	Qty.	Item	Part No.	Part Name	Qty.
A	388-100-38	Plug	1	N	(page 39)	Jack Base Ass'y	1
B	390-1-238	Actuator Gasket	1	P	926-20-161	Parker Packing	1
C	390-1-243	Gasket	1	R	926-20-162	Wear Ring	1
D	390-1-244	Base Gasket	1	S	4-14	Soc. Hd. Cap Screw	1
E	390-2-139	Retaining Ring	2	T	45-14	O-Ring	1
F	715-1-320	Jack Screen	1	W	45-110	O-Ring	1
G	715-1-323	Actuator Cylinder	1	X	45-904	O-Ring	1
H	715-1-331	Piston End	1	Y	45-978	O-Ring	1
K	715-1-340	Jack Cap Assembly	1	Z	1231-70-110	Label	1
L	715-1-422	Reservoir	1	AA	921-1-252	Serial Number Label	1
M	715-1-325	Actuator Rod	1				

# Jack Base Assembly

Assembly part number 1231-70-5 (reference only)

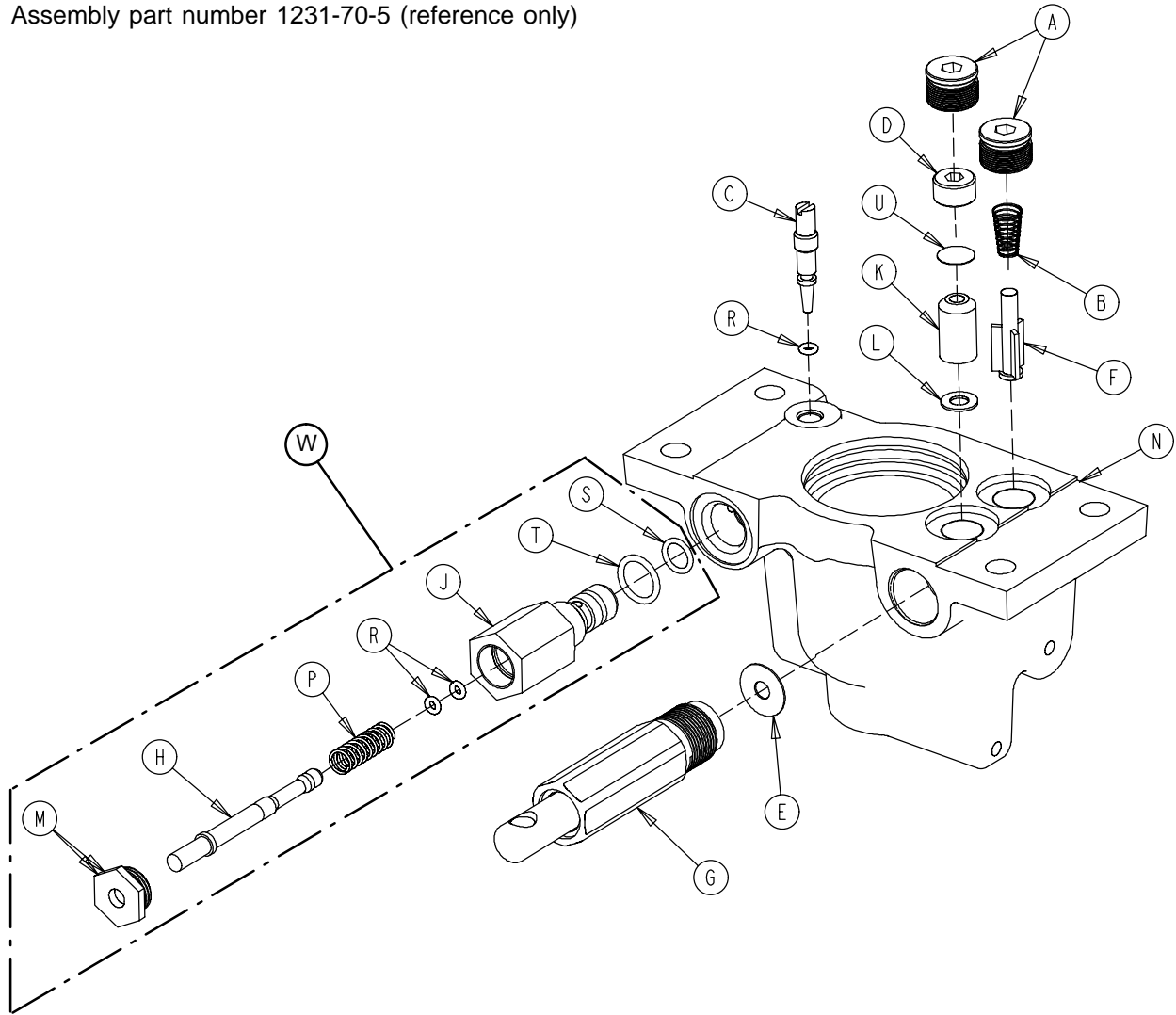

Item	Part No.	Part Name	Qty.	Item	Part No.	Part Name	Qty.
A	48-147	Base Plug	2	L	926-20-154	Seal	1
B	390-2-134	Conical Comp. Spring	1	M	1210-170-13	Base Plug	1
C	715-1-307	Needle Valve	1	N	1210-270-12	Jack Base	1
D	715-1-309	Valve Plug	1	P	38-31 1	Compression Spring	1
E	715-1-329	Pump Seal	1	R	45-6	O-Ring	3
F	715-1-341	Poppet	1	S	45-966	O-Ring	1
G	(page 39.1)	Pump Piston Assembly	1	T	45-967	O-Ring	1
H	715-270-1	Pin	1	U	715-1-321	Check Valve Screen	1
J	715-270-2	Pin Housing	1	W	715-270-100	Relief Valve Assembly	1
K	926-20-153	Check Valve	1				

# 715-100-425 Jack Pump Piston Assembly

Assembly part number 715-201-325 (reference only)

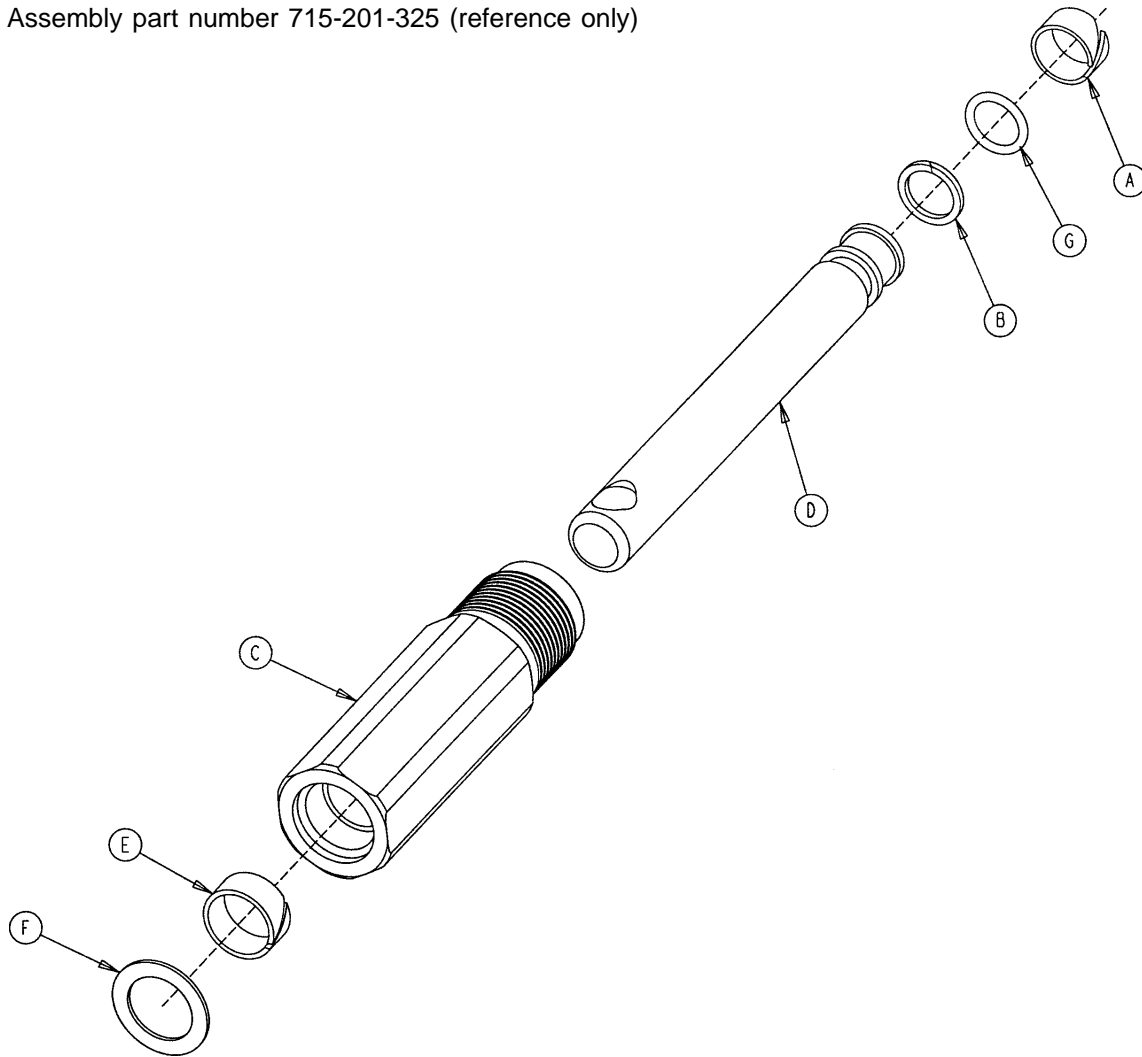

Item	Part No.	Part Name	Qty.
A	715-1-328	Piston Wear Ring	1
B	715-1-400	O-Ring Back Up	1
C	715-200-316	Pump Cylinder	1
D	715-201-318	Pump Piston	1
E	715-201-327	Cylinder Wear Ring	1
F	14-50	Bearing Retainer	1
G	45-1 10	O-Ring	1
	715-1-329	Pump Seal (not shown)	1

# 1231-70 210 Constant Flow Jack Assembly

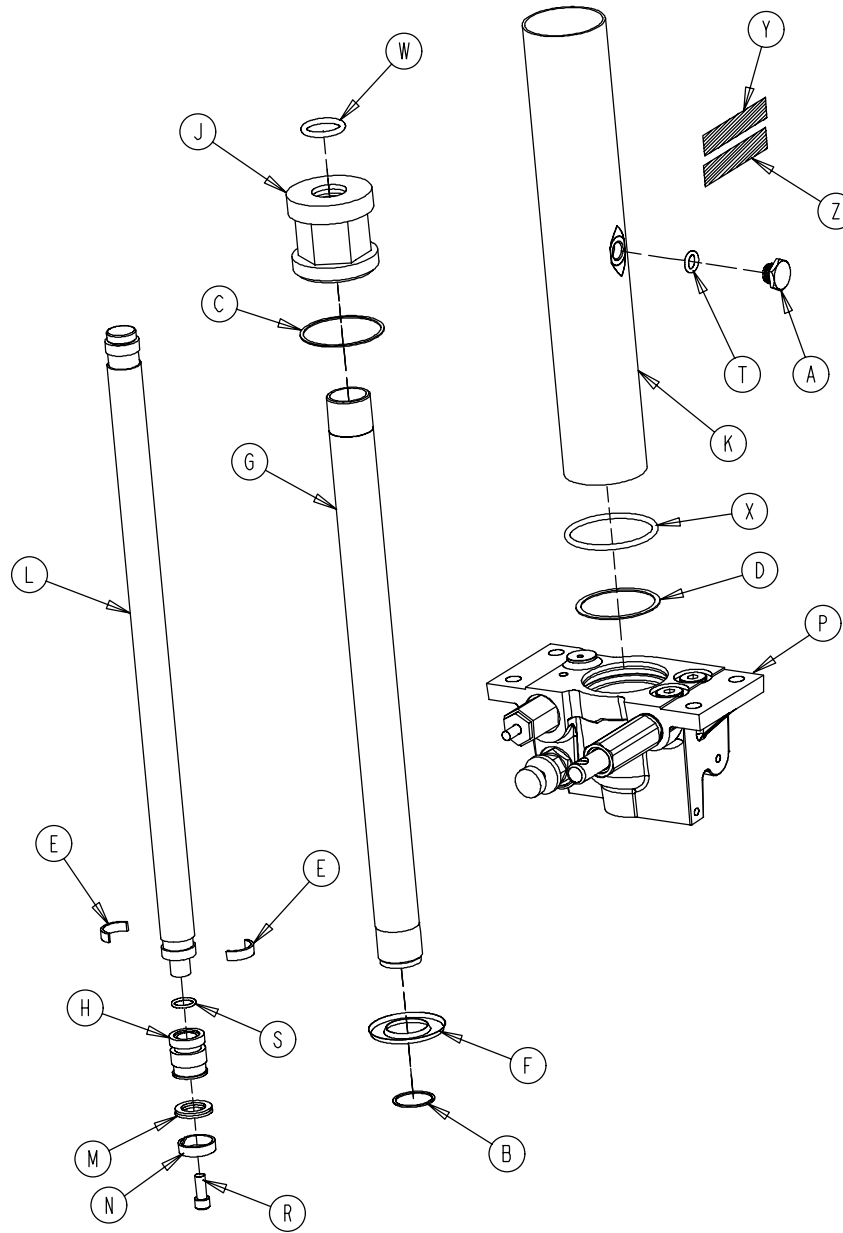

Item	Part No.	Part Name	Qty.	Item	Part No.	Part Name	Qty.
A	388-100-38	Plug	1	M	926-20-161	Parker Packing	1
B	390-1-238	Actuator Gasket	1	N	926-20-162	Wear Ring	1
C	390-1-243	Gasket	1	P	(page 39.3)	Jack Base Ass'y	1
D	390-1-244	Base Gasket	1	R	4-14	Soc. Hd. Cap Screw	1
E	390-2-139	Retaining Ring	2	S	45-14	O-Ring	1
F	715-1-320	Jack Screen	1	T	45-1 10	O-Ring	1
G	715-1-323	Actuator Cylinder	1	W	45-904	O-Ring	1
H	715-1-331	Piston End	1	X	45-978	O-Ring	1
J	715-1-340	Jack Cap Assembly	1	Y	1231-70-211	Label	1
K	715-1-422	Reservoir	1	Z	921-1-252	Serial Number Label	1
L	715-1-325	Actuator Rod	1				

# Constant Flow Jack Base Assembly

Assembly part number 5050-370-100 (reference only)

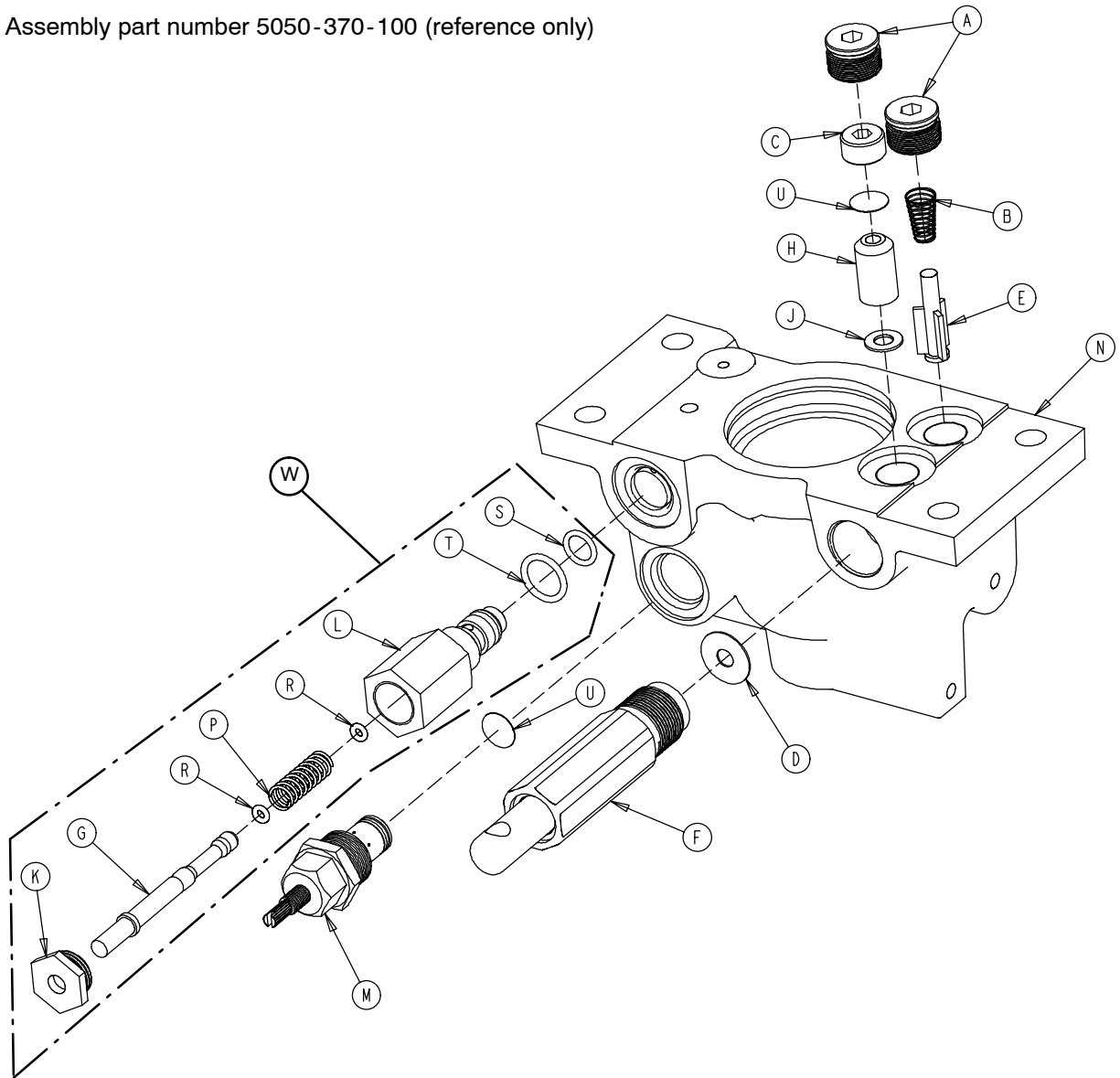

Item	Part No.	Part Name	Qty.	Item	Part No.	Part Name	Qty.
A	48-147	Base Plug	2	L	2025-75-87	Pin Housing	1
B	390-2-134	Conical Comp. Spring	1	M	5050-170-50	Adj. P.C. Valve Cartridge	1
C	715-1-309	Valve Plug	1	N	5050-370-110	Jack Base	1
D	715-1-329	Pump Seal	1	P	38-311	Compression Spring	1
E	715-1-341	Poppet	1	R	45-6	O-Ring	2
F	(page 39.1)	Pump Piston Assembly	1	S	45-966	O-Ring	1
G	715-270-1	Pin	1	T	45-967	O-Ring	1
H	926-20-153	Check Valve	1	U	715-1-321	Check Valve Screen	2
J	926-20-154	Seal	1	W	2025-700-26	Relief Valve Assembly	1
K	1210-170-13	Base Plug	1				

# Notes

---

# Optional Side Control Brake Assembly

Assembly part number 1001-400 (reference only)

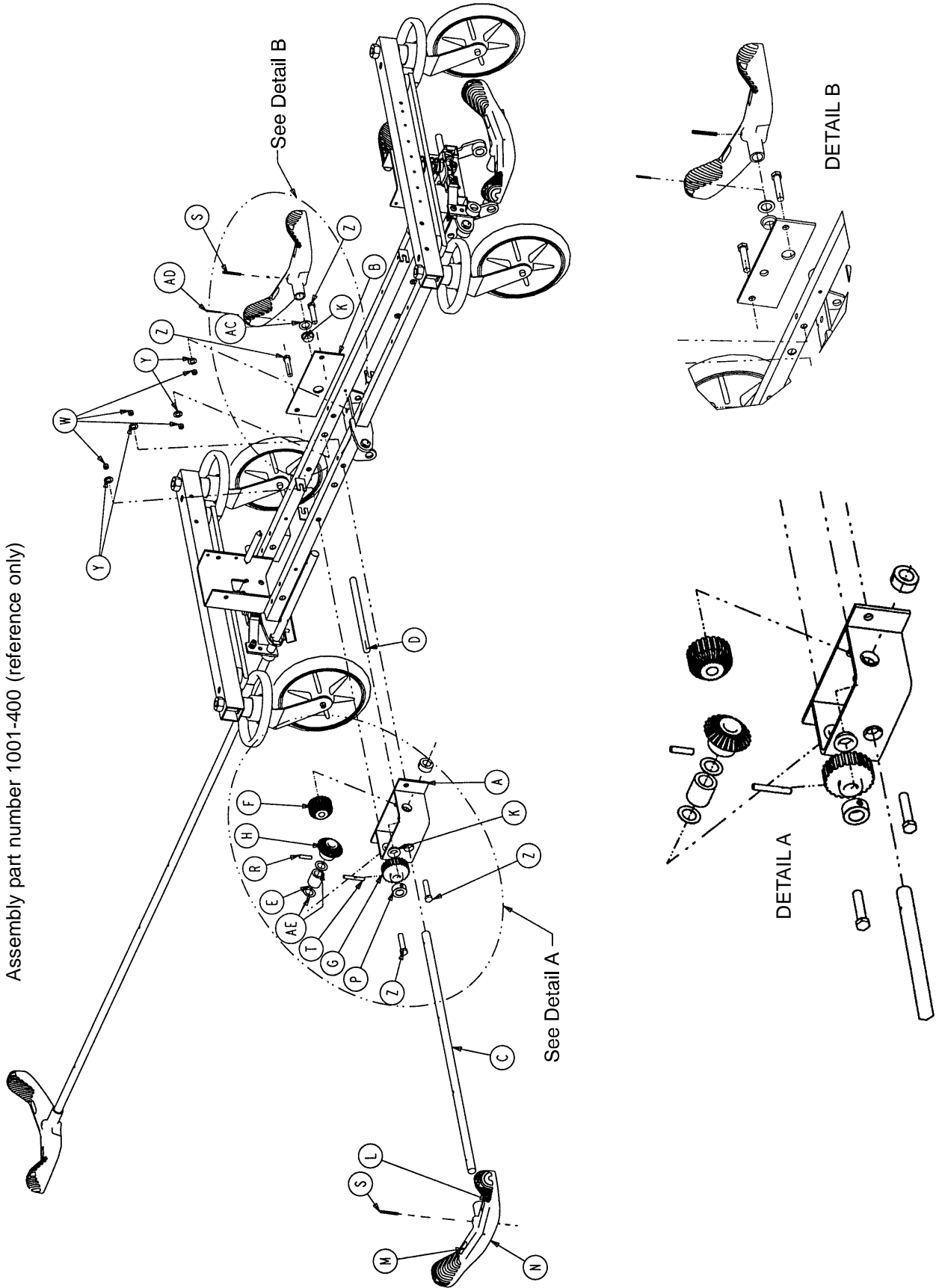

# Optional Side Control Brake Assembly

---

Item	Part No.	Part Name	Qty.
A	1210-301-400	Gear Box Weldment	1
B	1210-301-412	Support	1
C	1210-201-409	Side Control Brake/Steer Rod	1
D	1210-201-407	Pin	1
E	1210-301-406	Spacer	1
F	1210-301-405	Miter/Spur Gear	1
G	1210-301-404	Spur Gear	1
H	1210-301-403	Miter Gear	1
K	1210-201-401	Flange Bearing	5
L	1210-201-336	Steer Label	2
M	1210-201-335	Brake Label	2
N	1210-201-153	Butterfly "V" Pedal	2
P	42-20	Collar	1
R	26-265	Gear Dowel Pin	1
S	26-143	Pedal Dowel Pin	2
T	26-166	Groove Pin	1
W	16-35	Lock Nut	4
Y	11-4	Flat Washer	4
Z	3-45	Hex Hd. Cap Screw	4
AA	1210-201-341	Brake/Steer Label, Right	1
AB	1210-201-342	Brake/Steer Label, Left	1
AC	14-71	Washer	1
AD	27-16	Cotter Pin	1
AE	14-80	Washer	2



# Optional Uni-Lower Pedal Assembly

Assembly part number 1210-500 (reference only)

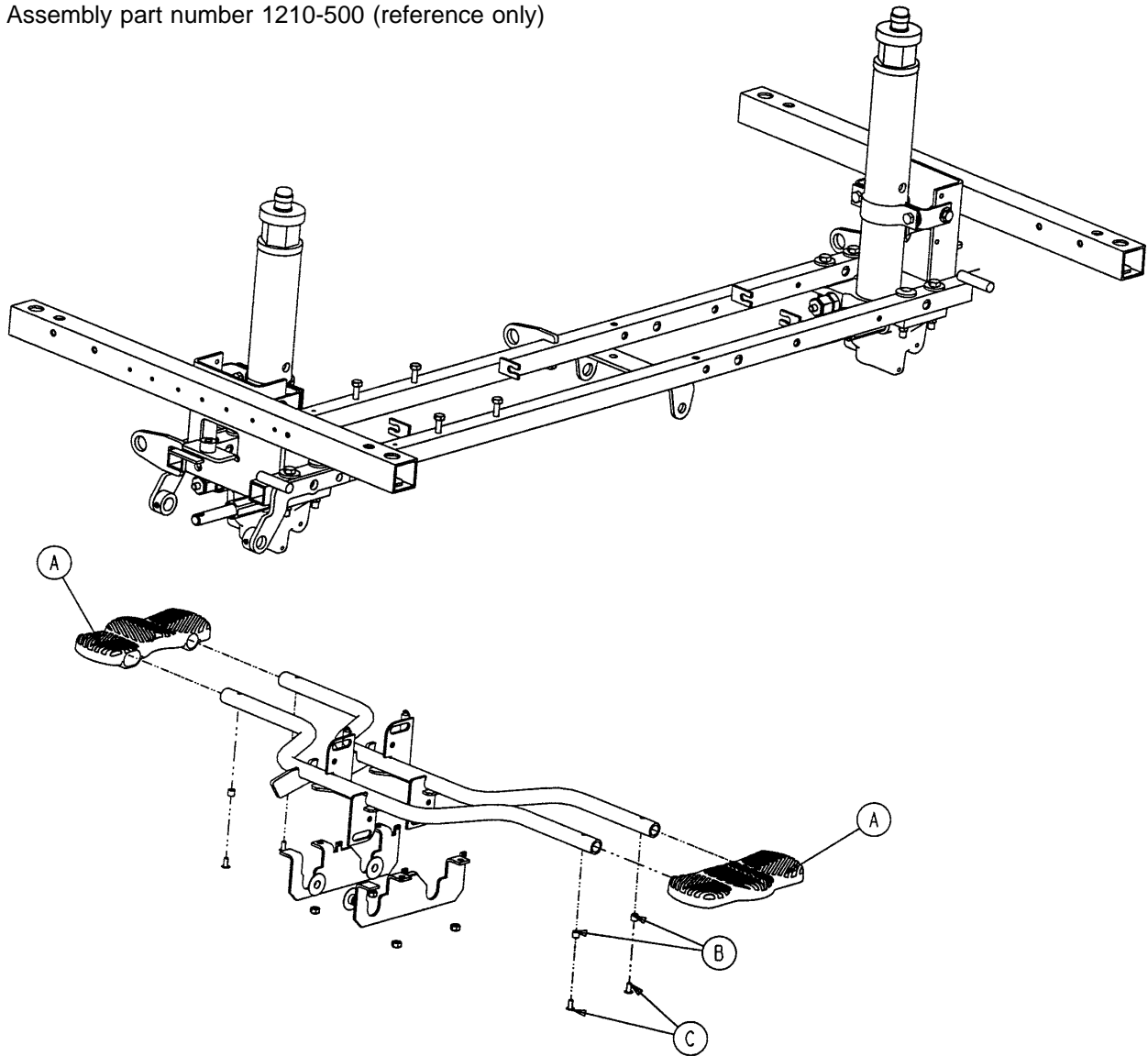

Item	Part No.	Part Name	Qty.
A	715-201-127	Uni-Lowering Pedal	2
B	715-1-333	Release Rod Stop Sleeve	4
C	25-50	Pop Rivet	4

# Optional Dual Lowering Pedal Assembly

Assembly part number 1210-501 (reference only)

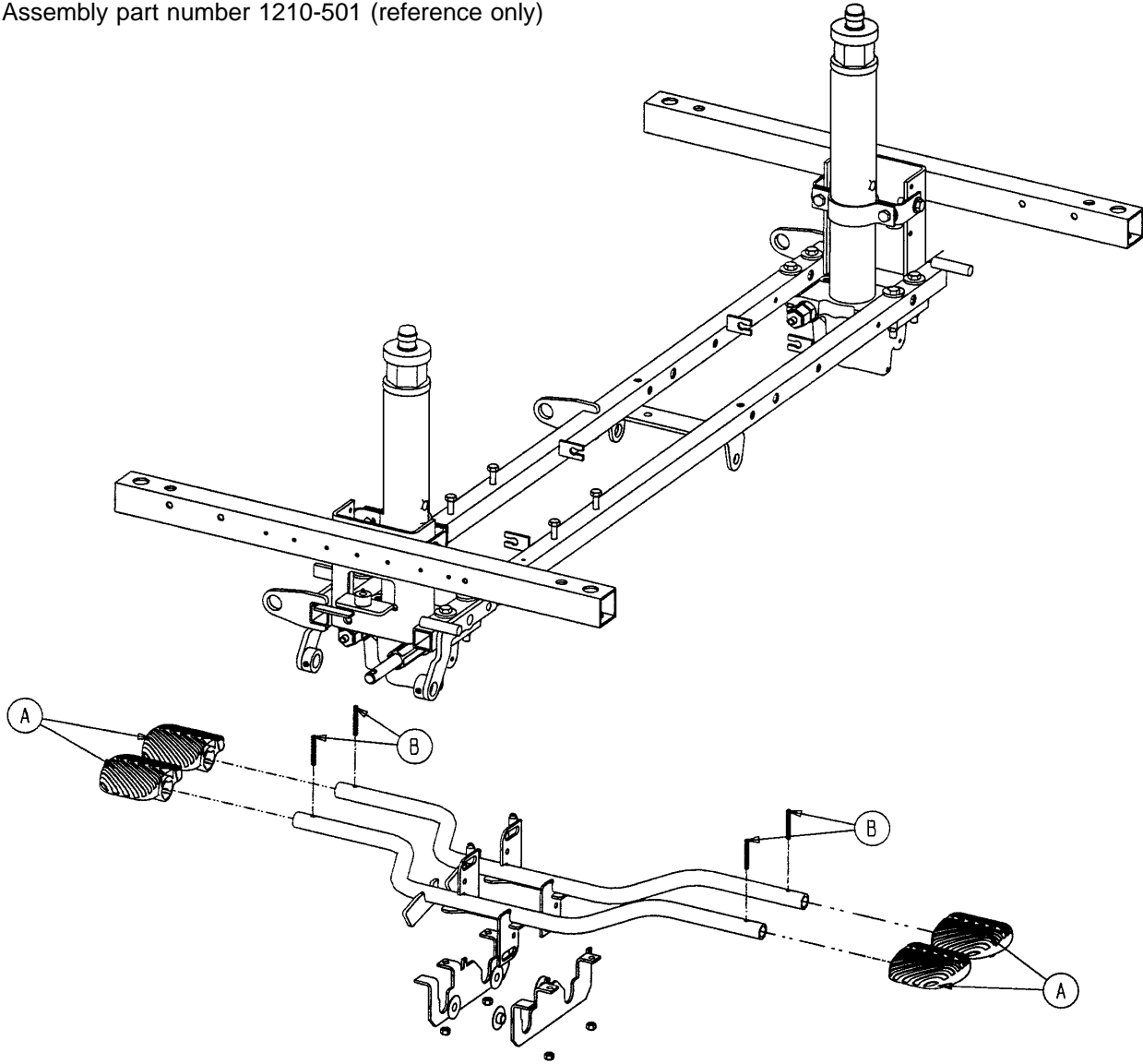

Item	Part No.	Part Name	Qty.
A	715-201-126	Pump Pedal	4
B	26-143	Groove Pin	4

# Side Control Base Labeling Assembly

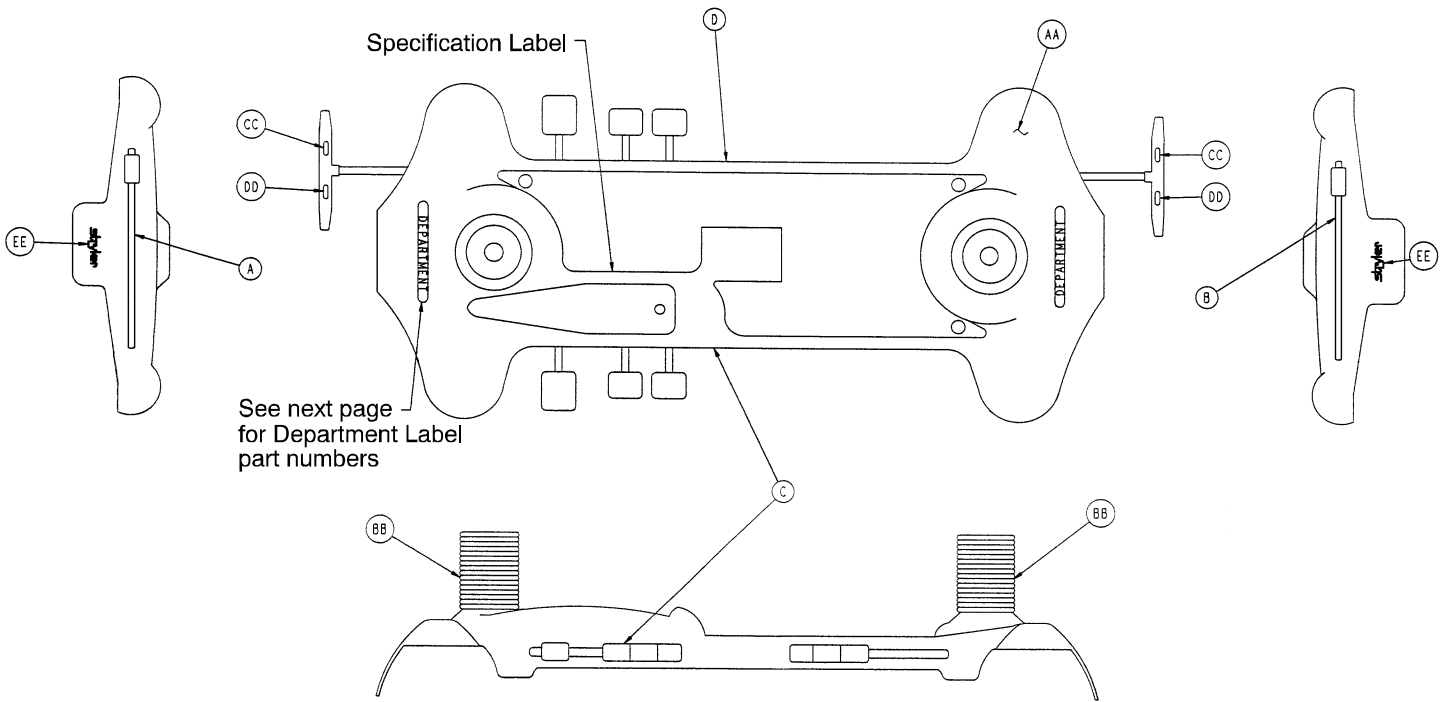

Item	Part No.	Part Name	Qty.
AA	1001-200-1	Base Hood	1
BB	715-1-134	Bellows	2
CC	1210-201-335	Red Brake Label	2
DD	1210-201-336	Green Steer Label	2
EE	946-201-60	Stryker Logo Label	4

Color Set P/N	Item A Control Label, Head End	Item B Control Label, Foot End	Item C Control Label, Right	Item D Control Label, Left	Litter Bumper Strip
RED 1001-700-1 10	1001-700-1 13	1001-700-1 14	1001-700-21 1	1001-700-212	1010-700-15
PURPLE 1001-700-120	1001-700-123	1001-700-124	1001-700-221	1001-700-222	1010-700-25
GREEN 1001-700-130	1001-700-133	1001-700-134	1001-700-231	1001-700-232	1010-700-35
GRAY 1001-700-140	1001-700-143	1001-700-144	1001-700-241	1001-700-242	1010-700-45
TEAL 1001-700-150	1001-700-153	1001-700-154	1001-700-251	1001-700-252	1010-700-55
PINK 1001-700-160	1001-700-163	1001-700-164	1001-700-261	1001-700-262	1010-700-65
BLUE 1001-700-170	1001-700-173	1001-700-174	1001-700-271	1001-700-272	1010-700-75

# Department Labels

---

## BASE HOOD DEPARTMENT LABELS

Department	Label Part Number
Emergency	1010-900-215
PACU	1010-900-220
Transport	1010-900-225
Surgery	1010-900-230
Extended Stay	1010-900-235
Maternity	1010-900-240
Endoscopy	1010-900-245
Radiology	1010-900-250
Nuclear Medicine	1010-900-255
Ambulatory Surgery	1010-900-260
G.I. Lab	1010-900-265
Cath. Lab	1010-900-270
Same Day Surgery	1010-900-275
Cardio.	1010-900-280
Ultrasound	1010-900-285

### NOTE

All base hood department labels are quantity of two.

## FOOT BOARD DEPARTMENT LABELS

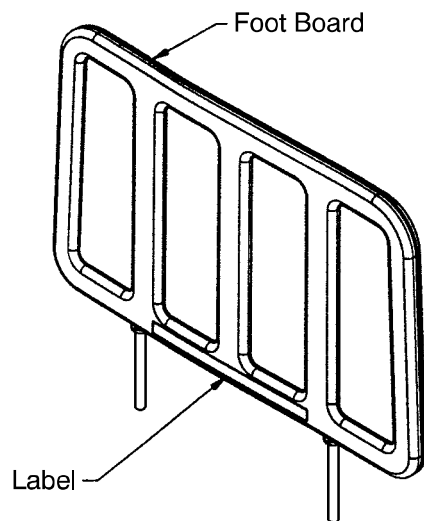

Department	Label Part No.
Demo Stryker	1010-900-186
Ophthalmology	1010-900-187
Outpatient Surgery	1010-900-188
Recovery	1010-900-189
Trauma	1010-900-190
Urgence	1010-900-191
Special (Blank)	1010-900-192

# End Control Base Labeling Assembly

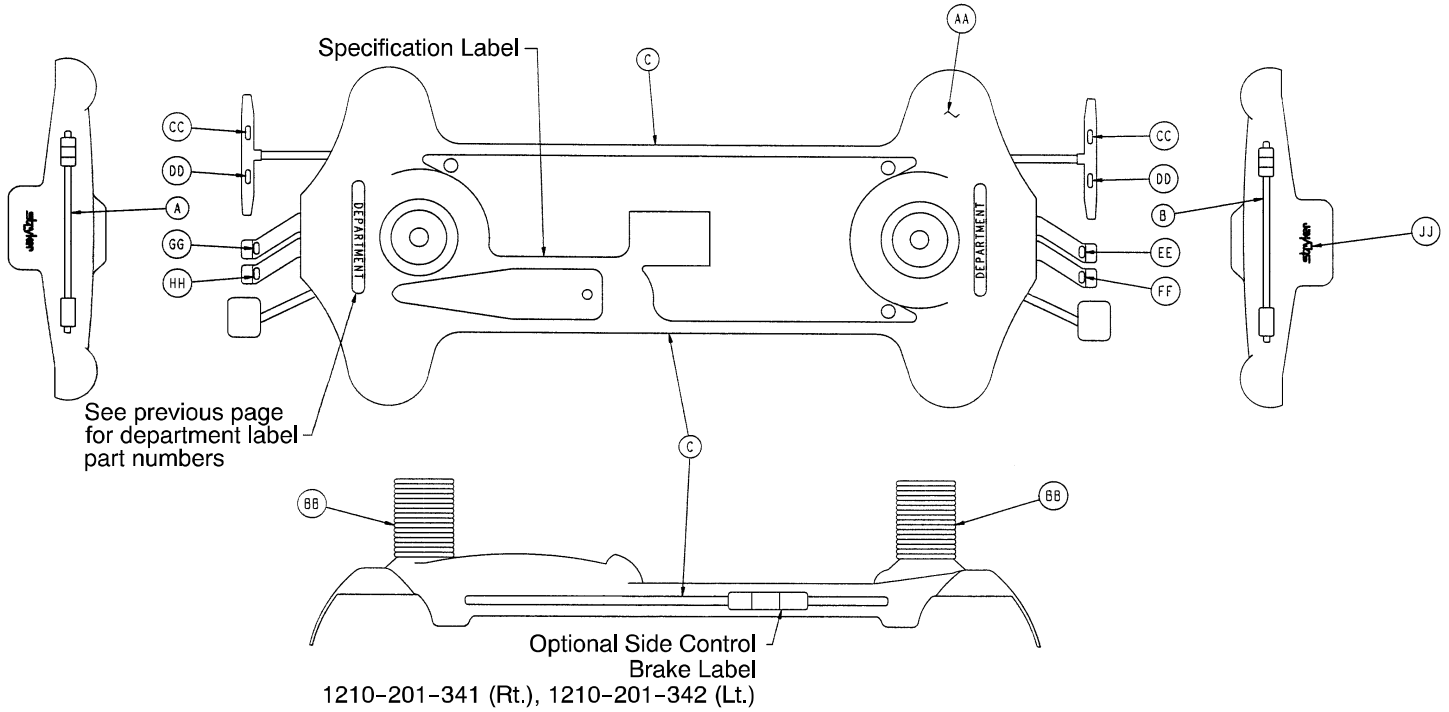

Item	Part No.	Part Name	Qty.
AA	1001-200-1	Hood	1
BB	715-1-134	Bellows	2
CC	1210-201-335	Brake Label	2
DD	1210-201-336	Steer Label	2
EE	1210-201-337	Head Down Label, Foot End	1
FF	1210-201-338	Foot Down Label, Foot End	1
GG	1210-201-339	Head Down Label, Head End	1
HH	1210-201-340	Foot Down Label, Head End	1
JJ	946-201-6	Stryker Logo Label	2

Color Set P/N	Item A Control Label, Head End	Item B Control Label, Foot End	Item C Side Control Label	Litter Bumper Strip
RED 1001-800-1 10	1001-800-1 11	1001-800-1 12	1001-800-13	1010-700-15
PURPLE 1001-800-120	1001-800-121	1001-800-122	1001-800-23	1010-700-25
GREEN 1001-800-130	1001-800-131	1001-800-132	1001-800-33	1010-700-35
GRAY 1001-800-140	1001-800-141	1001-800-142	1001-800-43	1010-700-45
TEAL 1001-800-150	1001-800-151	1001-800-152	1001-800-53	1010-700-55
PINK 1001-800-160	1001-800-161	1001-800-162	1001-800-63	1010-700-65
BLUE 1001-800-170	1001-800-171	1001-800-172	1001-800-73	1010-700-75

# Optional Big Wheel Side Control Base Labeling Ass'y

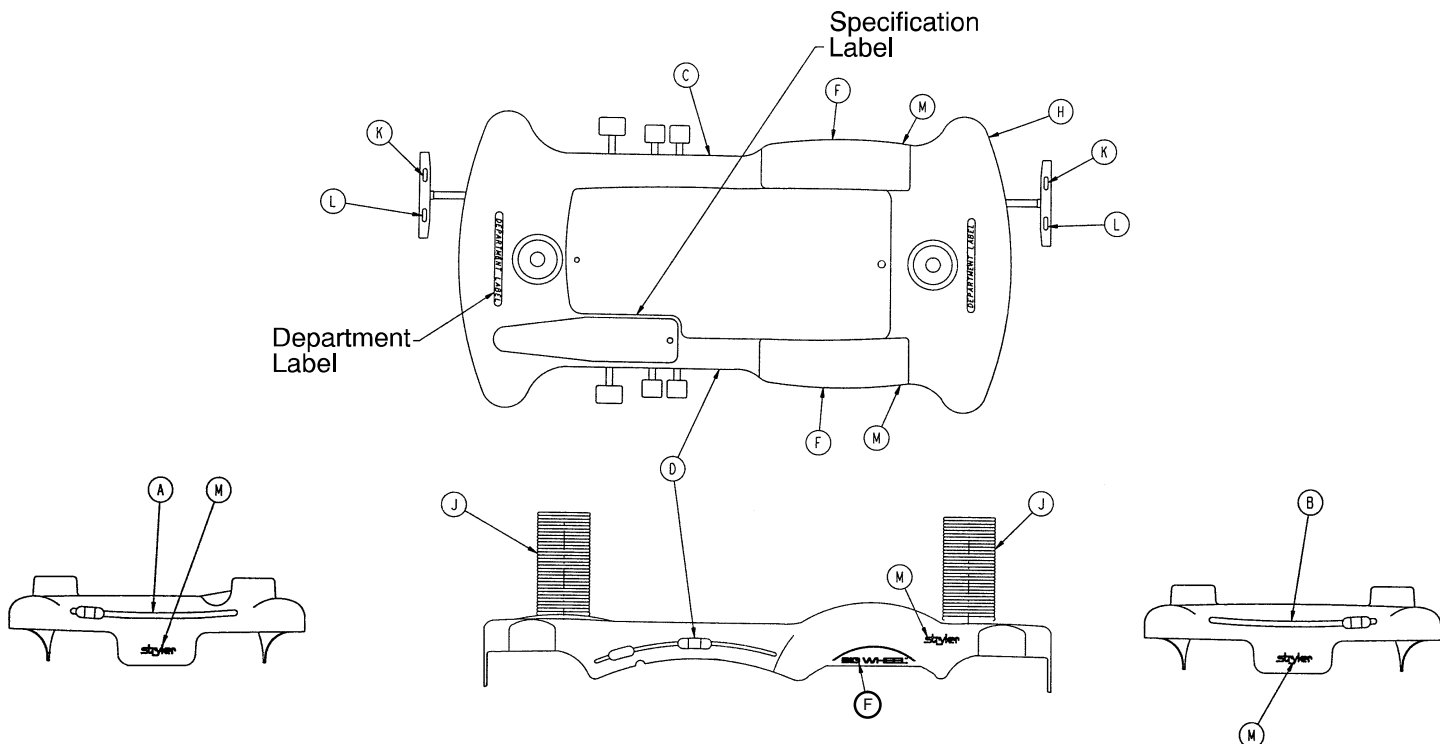

Color Set P/N	Item A Control Label, Head End	Item B Control Label, Foot End	Item C Control Label, Right	Item D Control Label, Left	Litter Bumper Strip
RED 1001-700-315	1210-800-1 13	1210-850-1 16	1210-800-1 14	1210-800-1 15	1010-700-15
PURPLE 1001-700-325	1210-800-123	1210-850-126	1210-800-124	1210-800-125	1010-700-25
GREEN 1001-700-335	1210-800-133	1210-850-136	1210-800-134	1210-800-135	1010-700-35
GRAY 1001-700-345	1210-800-143	1210-850-146	1210-800-144	1210-800-145	1010-700-45
TEAL 1001-700-355	1210-800-153	1210-850-156	1210-800-154	1210-800-155	1010-700-55
PINK 1001-700-365	1210-800-163	1210-850-166	1210-800-164	1210-800-165	1010-700-65
BLUE 1001-700-375	1210-800-173	1210-850-176	1210-800-174	1210-800-175	1010-700-75

Item	Part No.	Part Name	Qty.
F	1210-201-651	Big Wheel Label	2
H	1210-245-25	Base Hood	1
J	715-1-134	Bellows	2
K	1210-201-335	Red Brake Label	2
L	1210-201-336	Green Steer Label	2
M	946-201-60	Stryker Logo Label	4

# Optional Big Wheel End Control Base Labeling Ass'y

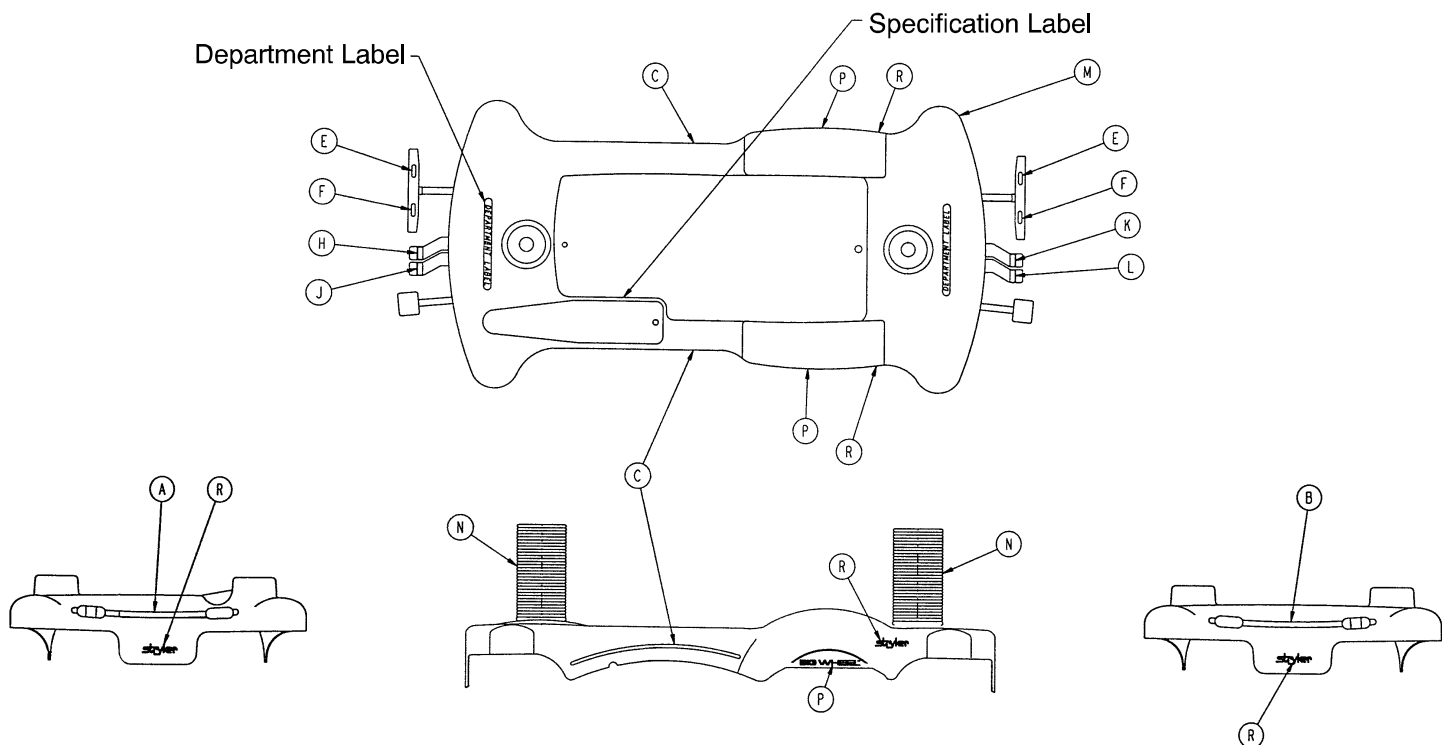

Color Set P/N	Item A Control Label, Head End	Item B Control Label, Foot End	Item C Side Control Label	Litter Bumper Strip
RED 1001-800-315	1210-800-1 17	1210-850-1 15	1210-850-1 13	1010-700-15
PURPLE 1001-800-325	1210-800-127	1210-850-125	1210-850-123	1010-700-25
GREEN 1001-800-335	1210-800-137	1210-850-135	1210-850-133	1010-700-35
GRAY 1001-800-345	1210-800-147	1210-850-145	1210-850-143	1010-700-45
TEAL 1001-800-355	1210-800-157	1210-850-155	1210-850-153	1010-700-55
PINK 1001-800-365	1210-800-167	1210-850-165	1210-850-163	1010-700-65
BLUE 1001-800-375	1210-800-177	1210-850-175	1210-850-173	1010-700-75

Item	Part No.	Part Name	Qty.
E	1210-201-335	Brake Label	2
F	1210-201-336	Steer Label	2
H	1210-201-339	Head Down Label, Head End	1
J	1210-201-340	Foot Down Label, Head End	1
K	1210-201-337	Head Down Label, Foot End	1
L	1210-201-338	Foot Down Label, Foot End	1
M	1210-245-25	Hood	1
N	715-1-134	Bellows	2
P	1210-201-651	Big Wheel Label	2
R	946-201-60	Stryker Logo Label	4

# Litter Assembly

Assembly part number 1020-1-10 (reference only)

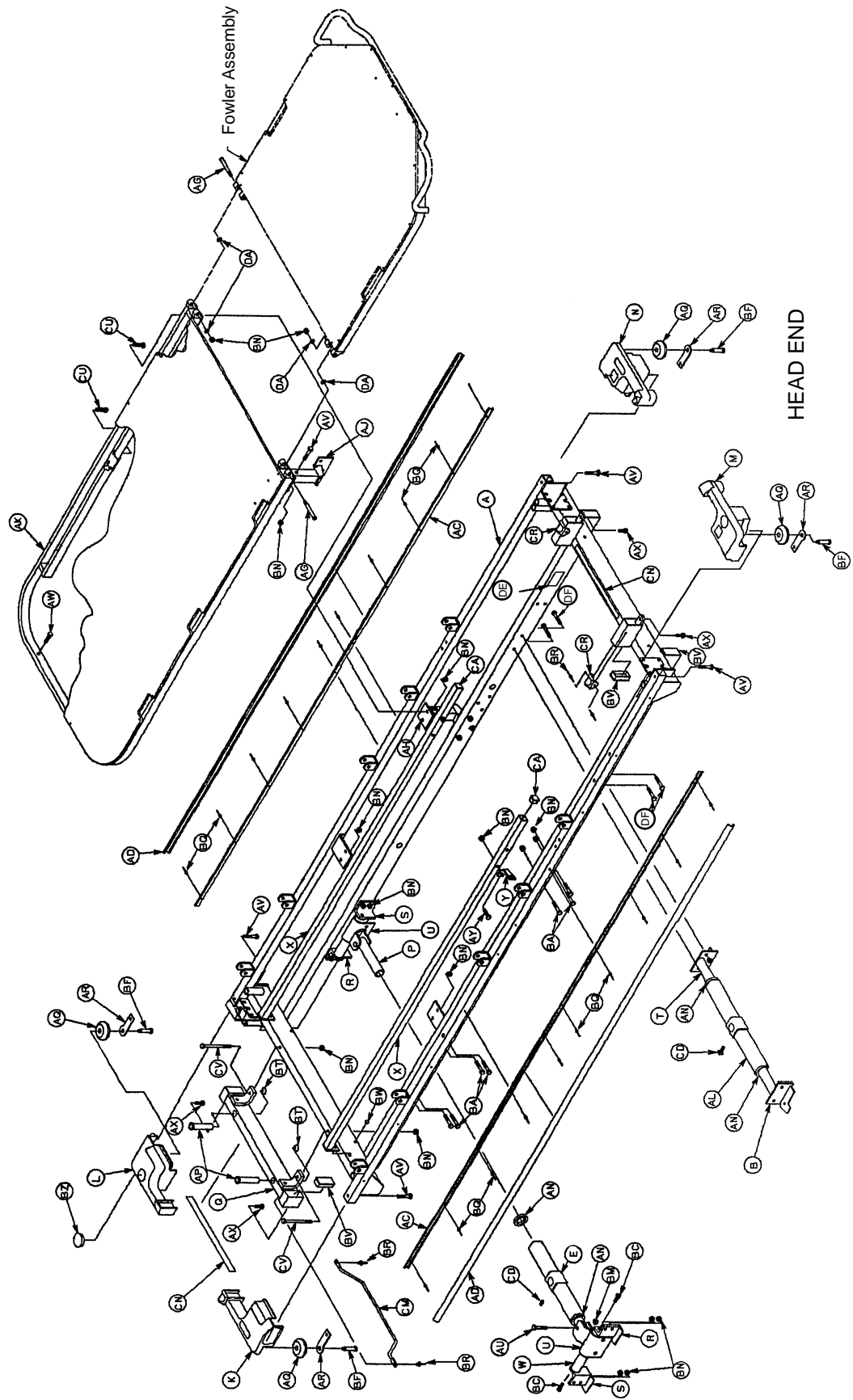



# Litter Assembly

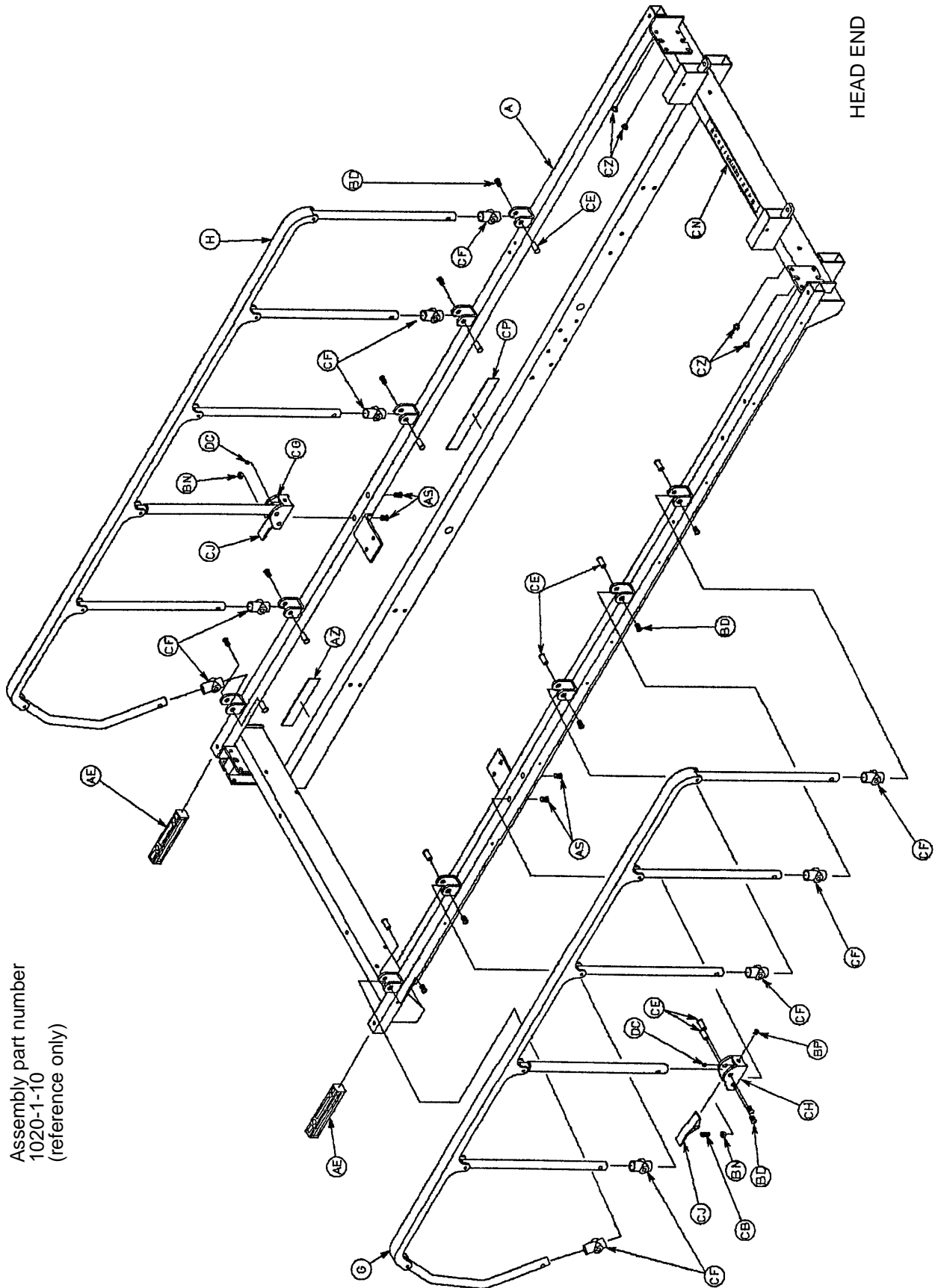

Assembly part number  
1020-1-10  
(reference only)

# Litter Assembly

Item	Part No.	Part Name	Qty.	Item	Part No.	Part Name	Qty.
A	1020-1-61	Litter Frame Ass'y	1	AY	3-74	Hex Hd. Cap Screw	2
B	1020-28-14	Jack Supt. Ass'y, Lt.	1	AZ	1020-22-28	Release Label	1
E	1010-32-85	Support Tube Ass'y	1	BA	3-78	Hex Hd. Cap Screw	14
G	(page 55)	Folddown Siderail, Lt.	1	BC	4-21	Soc. Hd. Cap Screw	4
H	(page 55)	Folddown Siderail, Rt.	1	BD	4-136	Hex Soc. But. Hd. Scr.	14
K	1010-1-14	Cover, Foot, Left	1	BF	8-24	Hex Soc. Sh. Bolt	4
L	1010-1-13	Cover, Foot, Right	1	BM	16-11	Flexlock Nut	2
M	(page 50-51)	Cover, Head, Left	1	BN	16-28	Nylock Nut	40
N	(page 50-51)	Cover, Head, Right	1	BP	21-104	Set Screw	2
P	1010-32-64	Carrier Tube	2	BQ	25-38	Rivet	20
Q	1020-1-40	Footboard Supt. Ass'y	1	BR	25-79	Rivet	6
R	1020-1-42	Roller Supt. Ass'y, Lt.	2	BT	28-23	Retaining Ring	2
S	1020-1-43	Roller Supt. Ass'y, Rt.	2	BV	37-49	Hole Plug	8
T	1020-28-13	Jack Supt. Ass'y, Rt.	1	BW	37-52	Rubber Bumper	8
U	1020-1-49	Supt. Tube & Roller Ass'y	2	BZ	37-59	Hole Plug	1
W	1020-1-59	Trend Roller Bar	2	CA	37-63	Rect. Hole Plug	2
X	1020-22-23	Guide Tube Assembly	2	CB	38-220	Compression Spring	2
Y	1020-22-26	Adjustment Bracket	2	CD	46-1	Set Screw	2
AC	1020-26-21	Bumper Channel	2	CE	721-26-66	Pivot Screw	14
AD	(page 44)	Siderail Bumper	2	CF	721-26-69	Upright Sleeve	10
AE	1010-26-69	Lock Support	2	CG	1010-26-81	Lock Hsg. Ass'y, Lt.	1
AG	1020-32-19	Pivot Bolt	2	CH	1010-26-80	Lock Hsg. Ass'y, Rt.	1
AH	1020-32-31	Litter Riser, Right	1	CJ	721-26-74	Plated Lock Handle	2
AJ	1020-32-32	Litter Riser, Left	1	CM	1010-32-92	Foley Bag Rack	1
AK	(page 60)	Footsection Ass'y	1	CN	1020-91-52	Center Label	2
AL	1510-32-20	Support Tube Ass'y	1	CP	1020-1-53	Film Label	1
AN	938-1-401	Collar Assembly	4	CU	4-161	H. Soc. But. Hd. C. Scr.	4
AP	721-40-26	Foot Bd. Receptacle	2	CV	3-35	Hex Hd. Cap Screw	2
AQ	721-32-49	Bumper Roller	4	CZ	37-35	Hole Plug	4
AR	1010-1-17	Roller Plate	4	DA	14-3	Thrust Washer	4
AS	1-96	Flat Head Screw	4	DB	4-32	Soc. Hd. Cap Screw	2
AU	3-40	Hex Hd. Cap Screw	2	DC	37-74	Hole Plug	2
AV	3-47	Hex Hd. Cap Screw	14	DE	1210-800-8	Patent Label	1
AW	3-50	Hex Hd. Cap Screw	2	DF	3-47	Hex Hd. Cap Screw	4
AX	3-54	Hex Hd. Cap Screw	4				

# Head End Litter Covers - No I.V. & No Push Handles

Assembly part number 1020-151-1

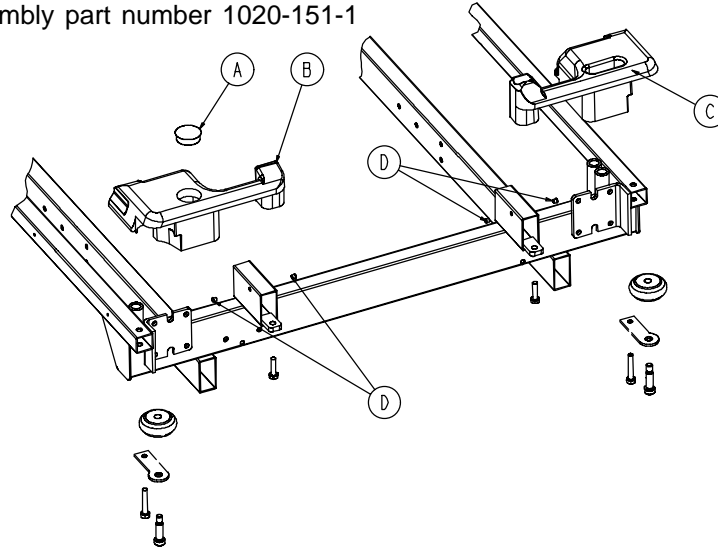

Item	Part No.	Part Name	Qty.
A	37-59	Hole Plug	1
B	1010-1-13	Cover, Head, Left, Hole	1
C	1010-1-14	Cover, Head, Right, Slot	1
D	37-74	Hole Plug	4

# Head End Litter Covers - With I.V. & No Push Handles

Assembly part number 1020-151-4

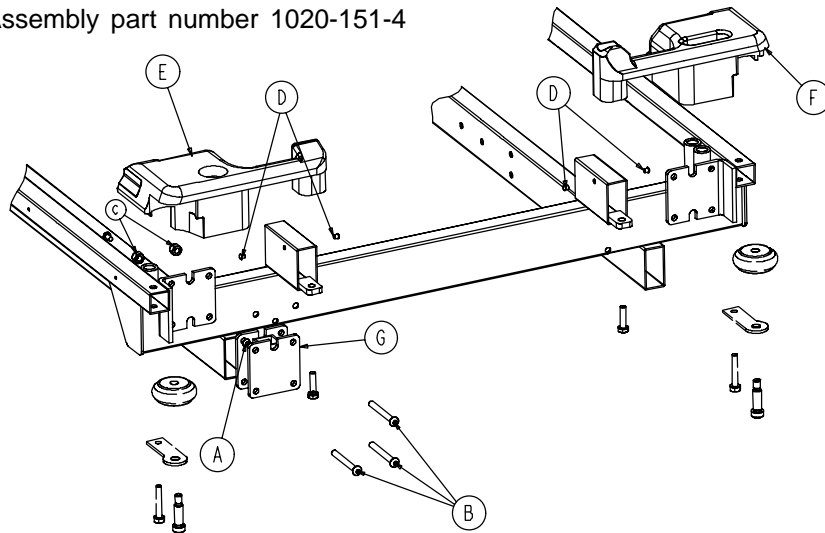

Item	Part No.	Part Name	Qty.	Item	Part No.	Part Name	Qty.
A	4-97	But Hd. Cap Screw	1	E	1010-1-13	Cover, Head, Left, Hole	1
B	4-163	But. Hd. Cap Screw	3	F	1010-1-14	Cover, Head, Right, Slot	1
C	16-28	Hex Nut	4	G	1020-54-67	I.V. Spacer	1
D	37-74	Hole Plug	4				

# Head End Litter Covers - With Push Handles & No I.V.

Assembly part number 1020-151-3

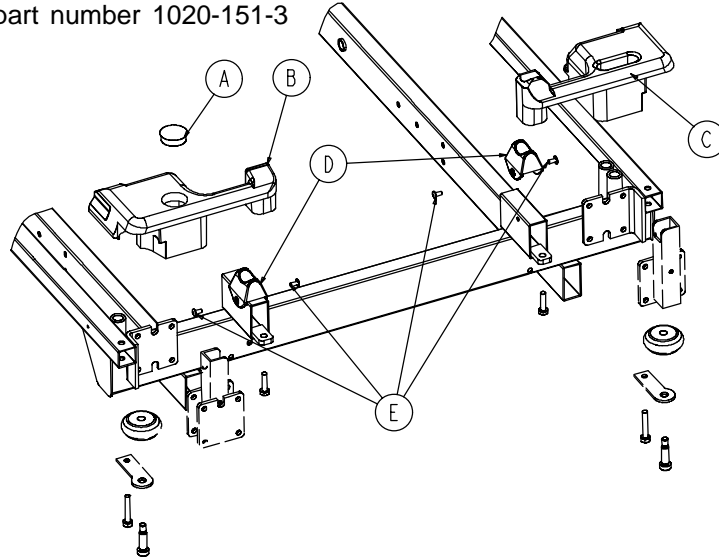

Item	Part No.	Part Name	Qty.
A	37-59	Hole Plug	1
B	1010-1-15	Cover, Head, Left, Hole/Hole	1
C	1010-1-16	Cover, Head, Left, Hole/Slot	1
D	1010-1-35	Handle Rest	2
E	25-79	Pop Rivet	4

# Head End Litter Covers - With I.V. & Push Handles

Assembly part number 1020-151-2

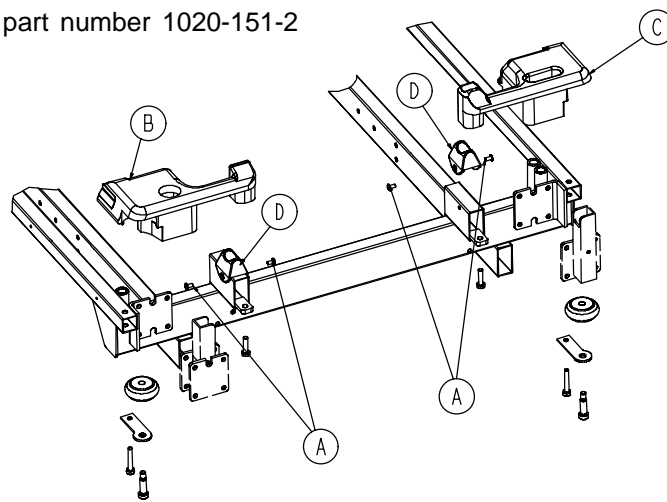

Item	Part No.	Part Name	Qty.
A	25-79	Pop Rivet	4
B	1010-1-15	Cover, Head, Left, Hole/Hole	1
C	1010-1-16	Cover, Head, Left, Hole/Slot	1
D	1010-1-35	Handle Rest	2

# Transfer System Assembly

Assembly part number 1020-24-20 (reference only)

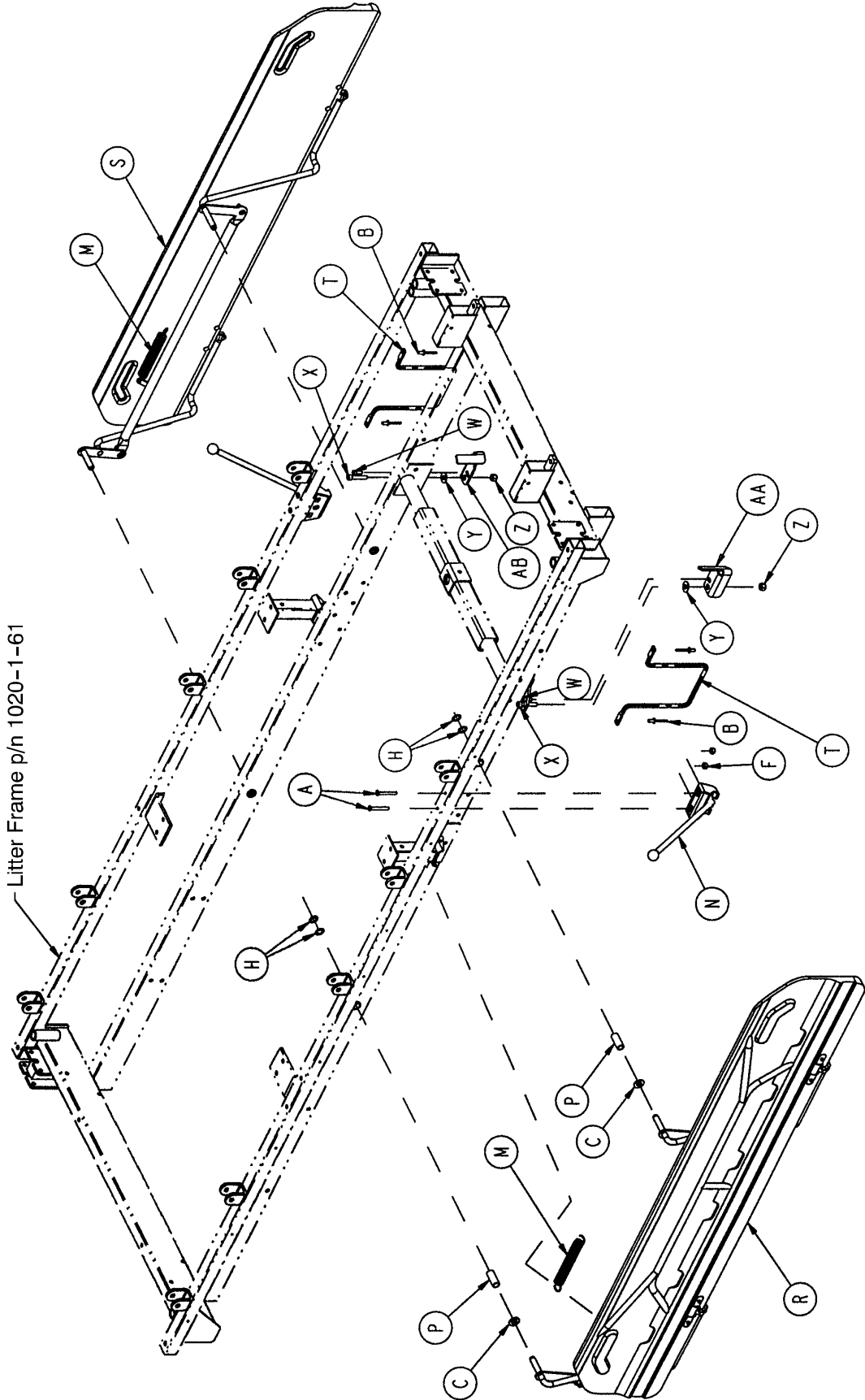

# Transfer System Assembly

---

Item	Part No.	Part Name	Qty.
A	2-100	Pan Hd. Machine Screw	4
B	25-79	Pop Rivet	4
C	14-21	Washer	4
F	16-3	Fiberlock Hex Nut	4
H	28-93	Retaining Ring	8
M	38-252	Extension Spring	2
N	(page 54)	Board Support Assembly	2
P	1020-1-29	Bearing	4
R	(page 52)	Transfer Board Ass'y, Left	1
S	(page 53)	Transfer Board Ass'y, Right	1
T	1020-24-121	Board Retainer	2
W	4-32	Soc. Hd. Cap Screw	2
X	4-142	Soc. Hd. Cap Screw	2
Y	11-179	Nylon Washer	2
Z	16-28	Nylock Nut	2
AA	1020-24-34	Support Plate, Left	1
AB	1020-24-35	Support Plate, Right	1

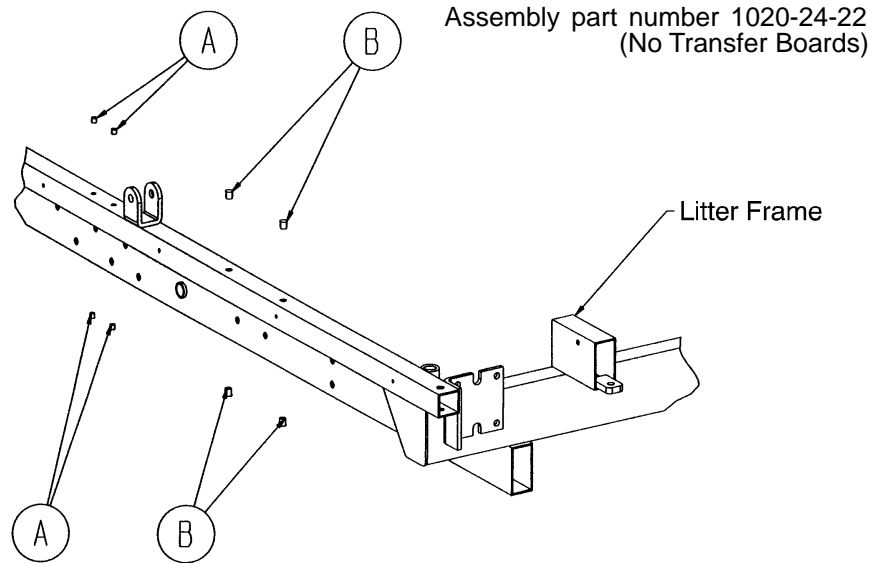

Item	Part No.	Part Name	Qty.
A	37-74	Hole Plug	8
B	721-31-65	Hole Plug	8

# 1020-24-10 Transfer System Assembly, Left

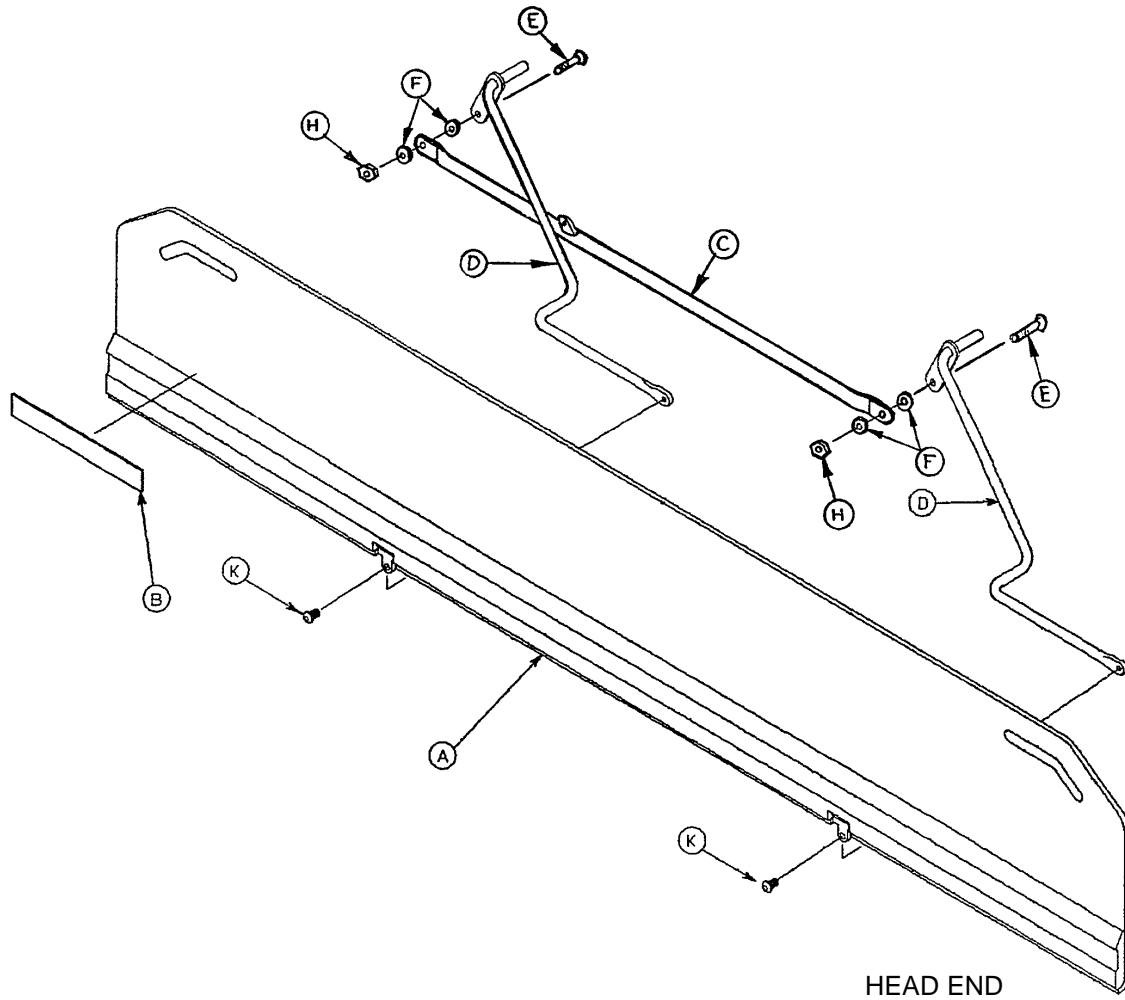

Item	Part No.	Part Name	Qty.
A	1020-32-100	Transfer Board Assembly	1
B	721-24-46	Label	1
C	1020-24-38	Connecting Link Assembly	1
D	1020-24-12	Pivot Arm Assembly, Left	2
E	1-25	Flat Hd. Machine Screw	2
F	11-224	Nylon Flat Washer	4
H	16-28	Nylock Hex Nut	2
K	4-156	Button Hd. Cap Screw	2

# 1020-24-1 1 Transfer System Assembly, Right

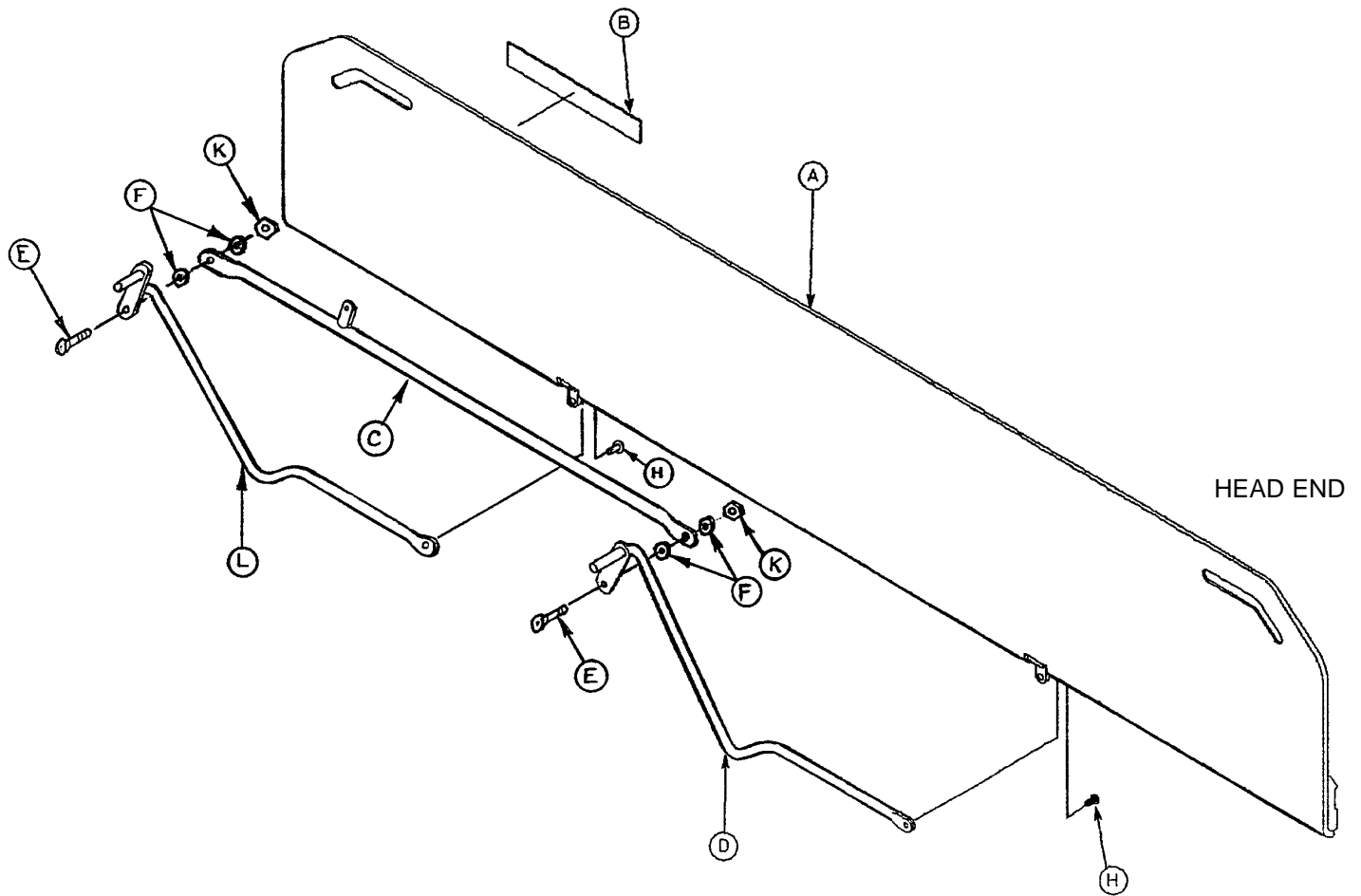

Item	Part No.	Part Name	Qty.
A	1020-32-100	Transfer Board Assembly	1
B	721-24-46	Label	1
C	1020-24-37	Connecting Link Assembly	1
D	1020-24-13	Pivot Arm Ass'y Head, Rt.	1
E	1-25	Flat Hd. Machine Screw	2
F	11-224	Nylon Flat Washer	4
H	4-156	Button Hd. Cap Screw	2
K	16-28	Nylock Hex Nut	2
L	1020-24-33	Pivot Arm Ass'y, Right	1



# 1010-24-30 Arm Board Support Assembly

---

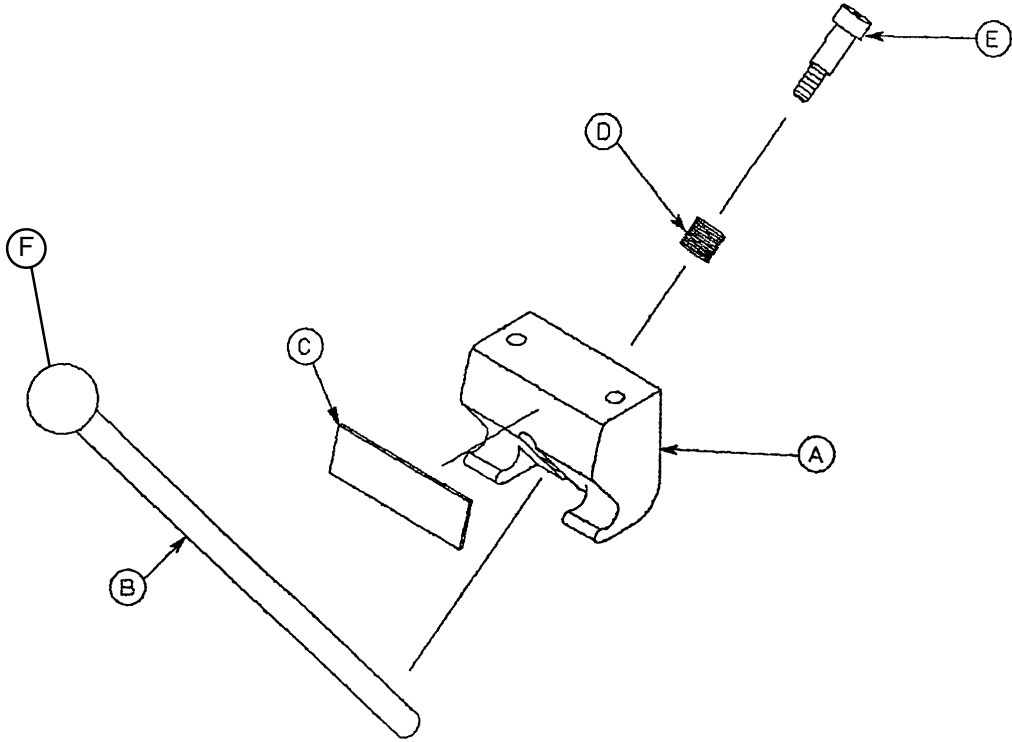

Item	Part No.	Part Name	Qty.
A	1010-24-15	Support Block	1
B	1010-24-16	Support Arm	1
C	1010-24-14	Warning Label	1
D	38-263	Spring	1
E	8-17	Shoulder Bolt	1
F	1010-26-46	Ball Knob	1

# Siderail Assembly, Right & Left

Assembly part numbers  
 1010-26-17 (Right)  
 1010-26-19 (Left)  
 (reference only)

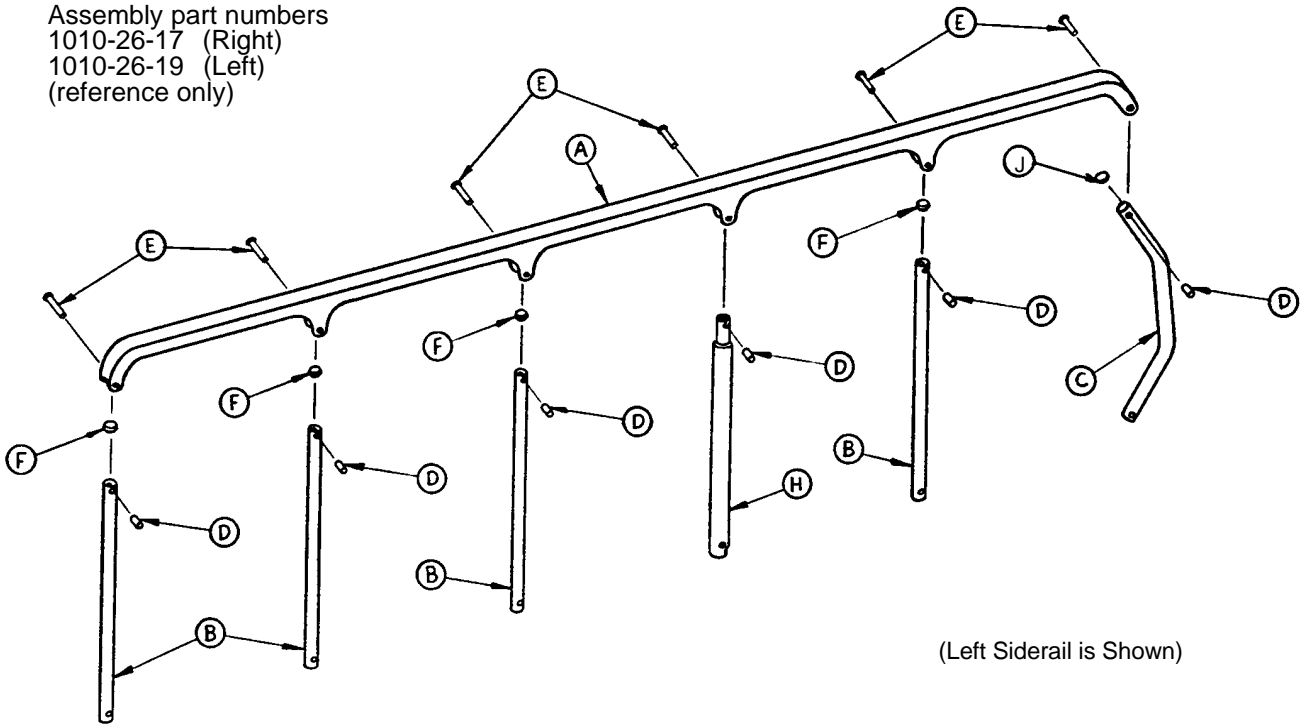

Item	Part No.	Part Name	Qty.
A	1010-26-15	Top Rail	1
B	1010-26-83	Upright	4
C	1010-26-84	Upright, Bent	1
D	1010-26-82	Sleeve Bearing	6
E	25-106	Semi-Tubular Rivet	6
F	1010-26-10	Round Hole Plug	4
H	1010-26-85	Upright, Latch	1
J	1010-26-12	Bent Spindle Rest	1

# Manual Fowler to Frame Assembly

Assembly part number 1020-32-59 (reference only)

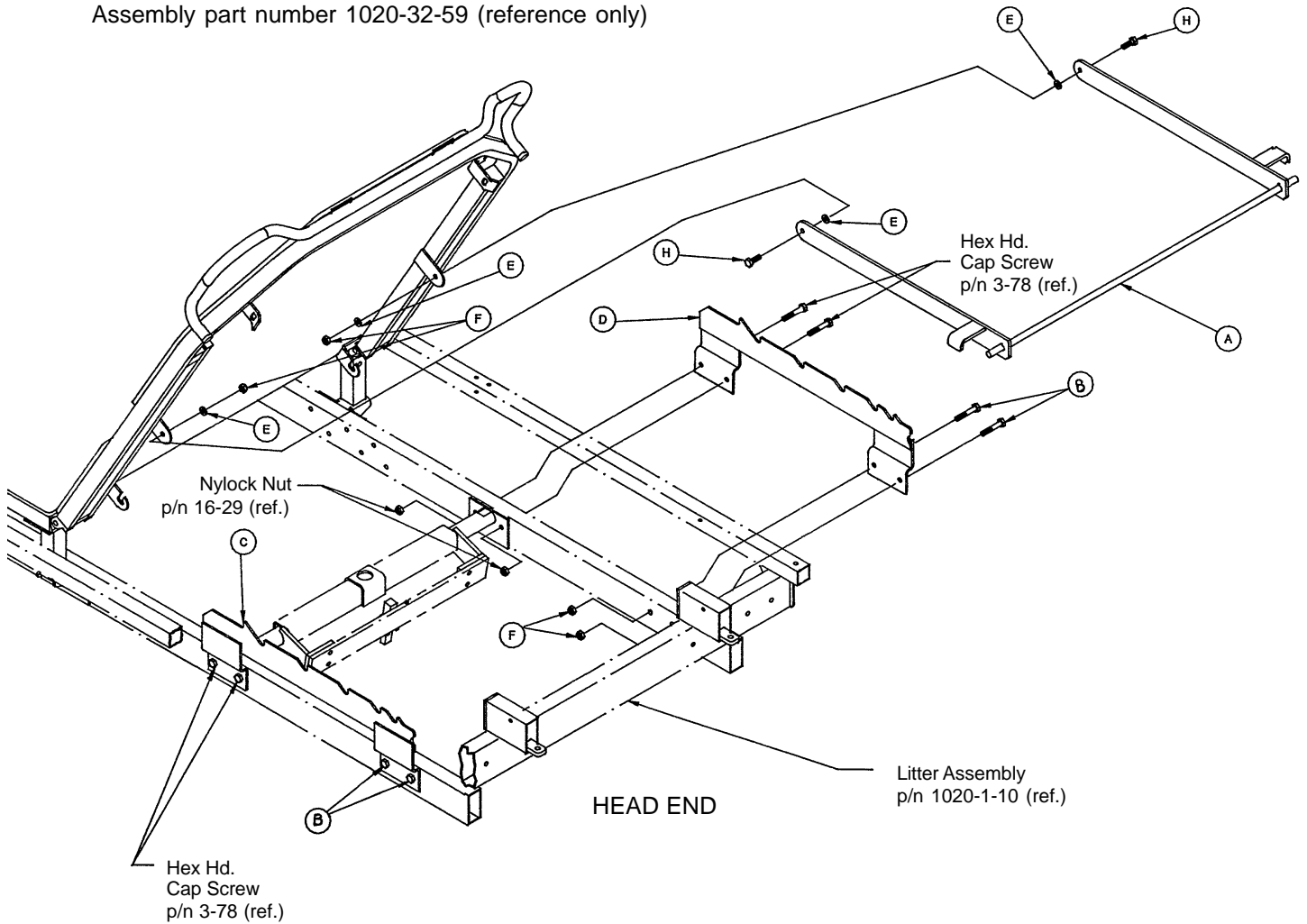

Item	Part No.	Part Name	Qty.
A	1020-32-54	Pivot Leg Assembly	1
B	3-78	Hex Hd. Cap Screw	4
C	1020-32-56	Left Bracket Weldment	1
D	1020-32-55	Right Bracket Weldment	1
E	14-2	Nylon Flat Washer	4
F	16-28	Nylock Nut	6
H	3-50	Hex Hd. Cap Screw	2

# Manual Fowler Assembly

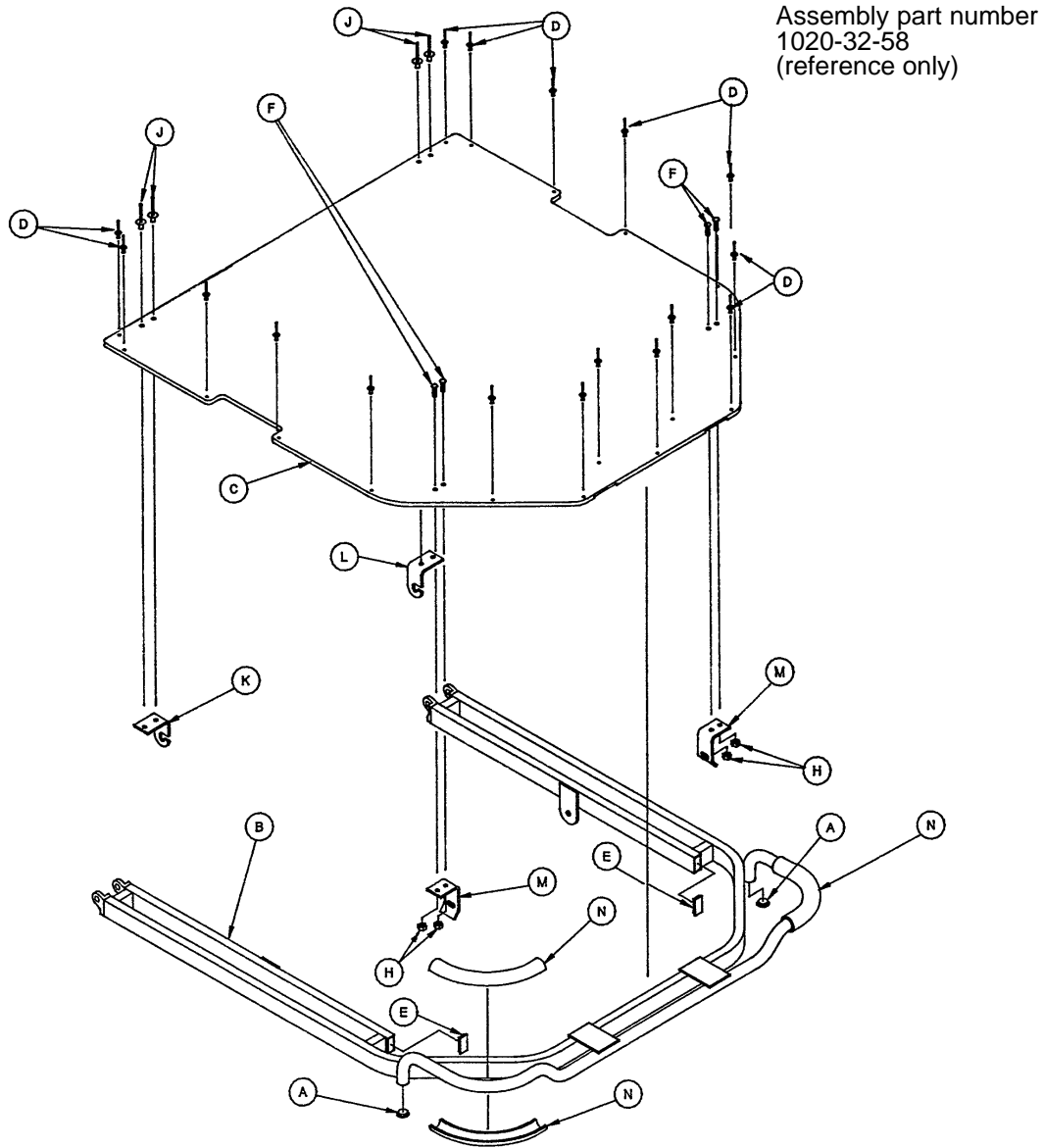

Item	Part No.	Part Name	Qty.
A	37-65	Hole Plug	2
B	1020-32-57	Fowler Weldment	1
C	1020-31-39	Fowler Skin	1
D	25-99	Pop Rivet	17
E	1010-32-66	Hole Plug	2
F	4-149	But. Hd. Cap Screw	4
H	16-3	Self-Locking Nut	4
J	25-69	Pop Rivet	4
K	1020-23-12	Tray Hinge, Left	1
L	1020-23-13	Tray Hinge, Right	1
M	1020-23-14	Tray Hinge	2
N	1020-1-65	Fowler Handle Cover	4

# Pneumatic Fowler to Frame Assembly

Assembly part number 1020-31-11 (reference only)

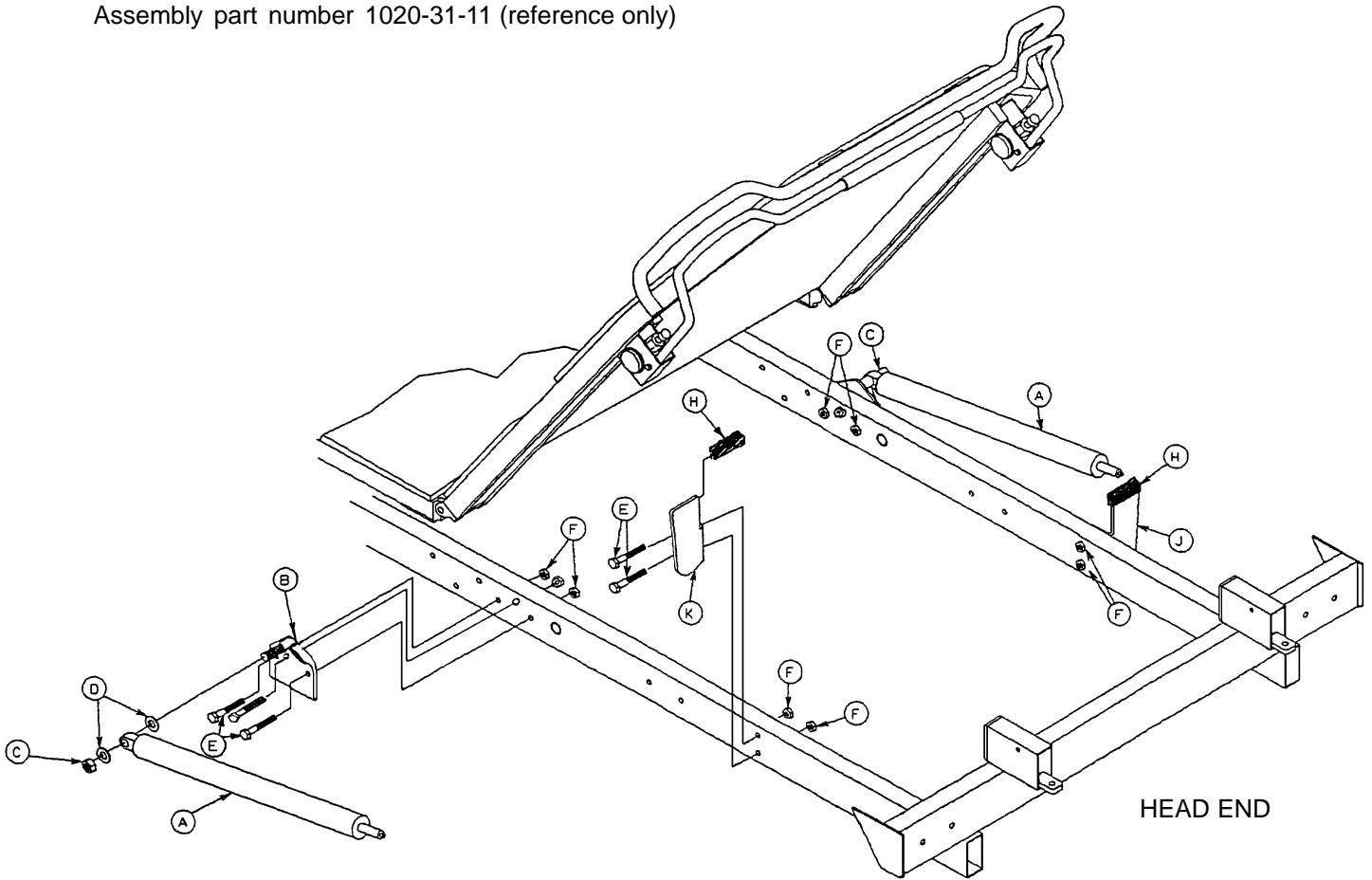

Item	Part No.	Part Name	Qty.
A	1010-31-78	Gas Cylinder	2
B	1020-31-25	Cylinder Mount	2
C	16-35	Nylock Hex Nut	2
D	14-29	Flat Washer	4
E	3-78	Hex Hd. Cap Screw	10
F	16-28	Nylock Hex Nut	10
H	1020-31-38	Fowler Rest Bumper	2
J	1020-31-17	Fowler Rest, Right	1
K	1020-31-19	Fowler Rest, Left	1

# Pneumatic Fowler Assembly

Assembly part number 1020-31-10 (reference only)

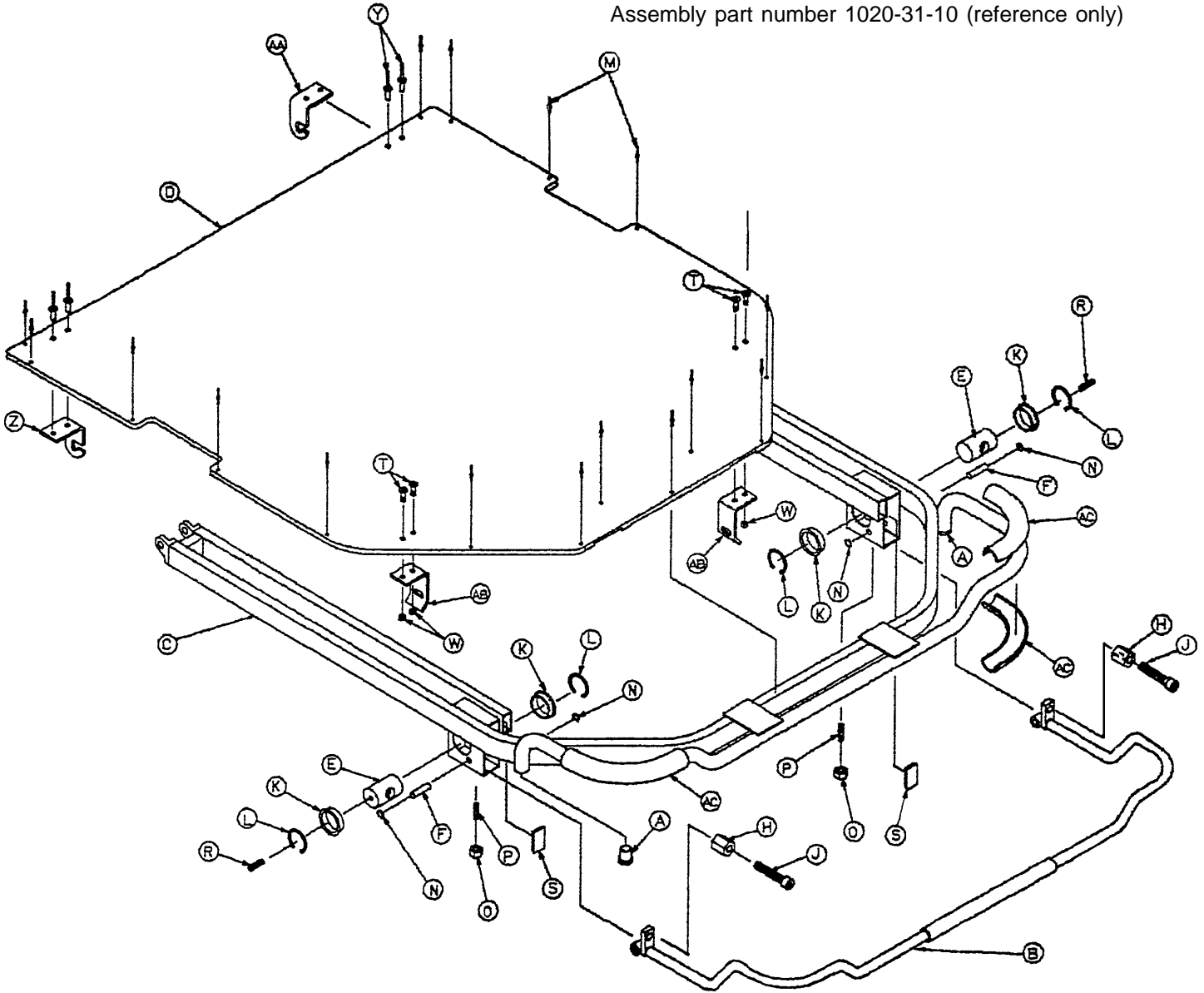

Item	Part No.	Part Name	Qty.	Item	Part No.	Part Name	Qty.
A	37-65	Hole Plug	2	O	15-37	Jam Nut	2
B	1020-31-20	Handle Assembly	1	P	21-104	Set Screw	2
C	1020-31-15	Fowler Weldment	1	R	21-1 19	Set Screw	2
D	1020-31-39	Fowler Skin	1	S	1010-32-66	Hole Plug	2
E	1510-31-28	Yoke	2	T	4-149	But. Hd. Cap Screw	4
F	1510-31-37	Pivot	2	W	16-3	Self-Locking Nut	4
H	15-50	Hex Nut	2	Y	25-69	Pop Rivet	4
J	21-126	Set Screw	2	Z	1020-23-12	Tray Hinge, Left	1
K	946-35-25	Liner	4	AA	1020-23-13	Tray Hinge, Right	1
L	28-76	Retaining Ring	4	AB	1020-23-14	Tray Latch	2
M	25-99	Pop Rivet	17	AC	1020-1-65	Fowler Handle Cover	4
N	28-8	Retaining Ring	4				

# Foot Section Assembly

Assembly part number  
1020-32-35 (reference only)

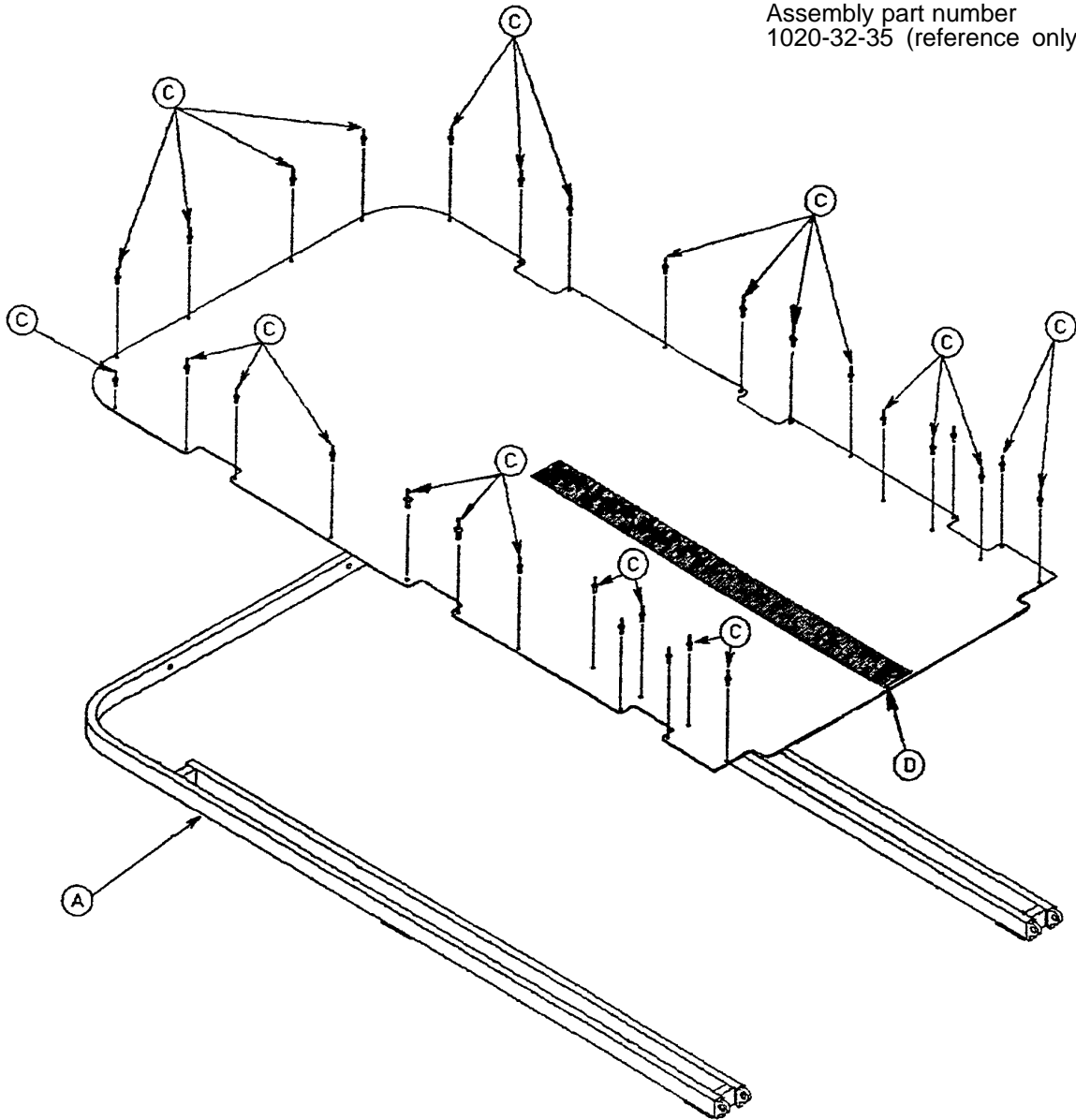

Item	Part No.	Part Name	Qty.
A	1020-32-25	Footsection Weldment	1
B	1020-32-26	Footsection Skin	1
C	25-99	Pop Rivet	30
D	381-24-7	Velcro	1

# 1020-151 Optional Head End Push Handles Assembly

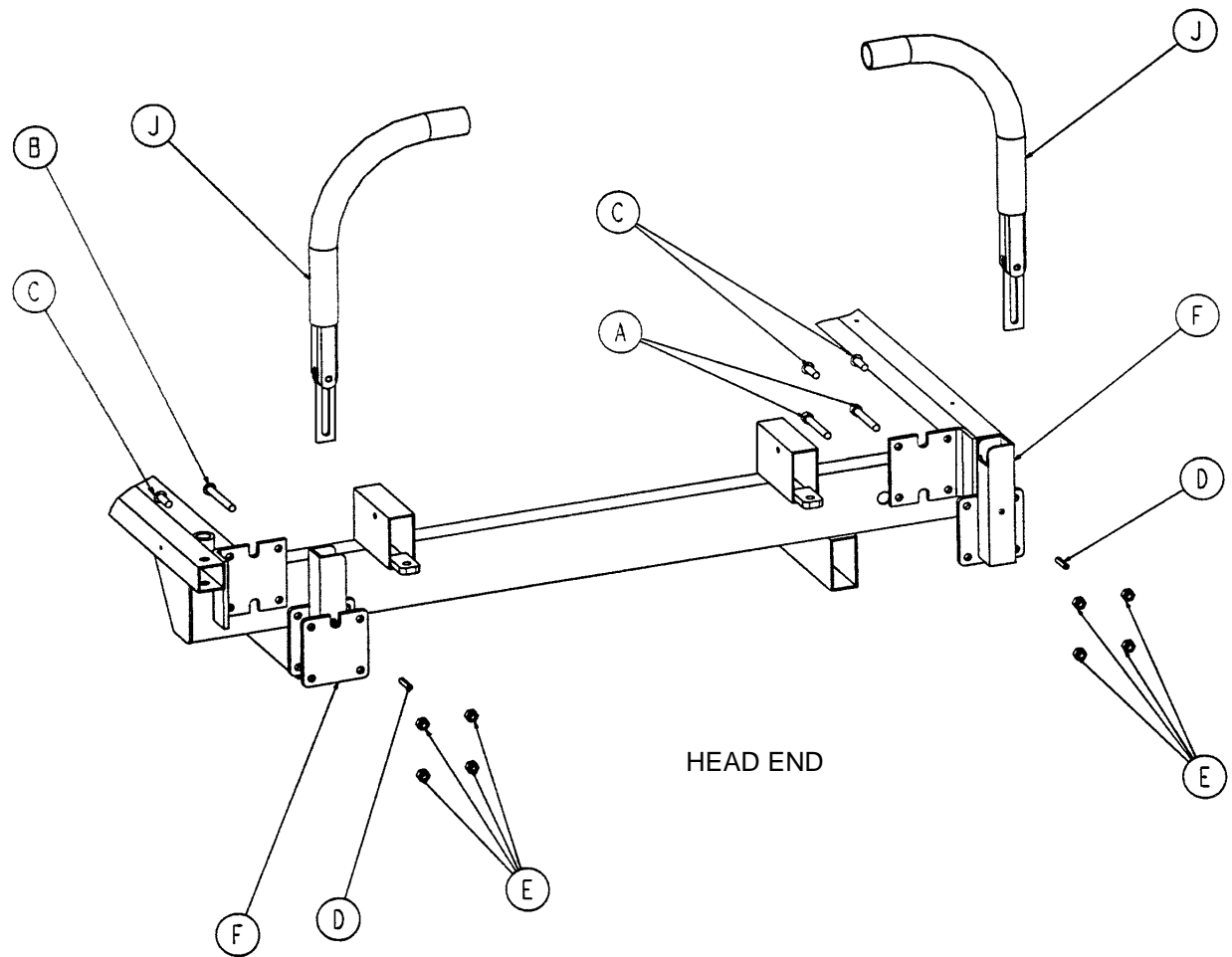

Item	Part No.	Part Name	Qty.
A	4-9	Soc. Hd. Cap Screw	2
B	4-97	But. Hd. Cap Screw	3
C	4-161	But. Hd. Cap Screw	3
D	26-11	Spring Pin	2
E	16-28	Hex Nut	8
F	1010-54-70	Socket Assembly, Left	1
H	1010-54-71	Socket Assembly, Right	1
J	(page 62)	Handle Assembly	2



# 1211-351-10 Push Handle Assembly

---

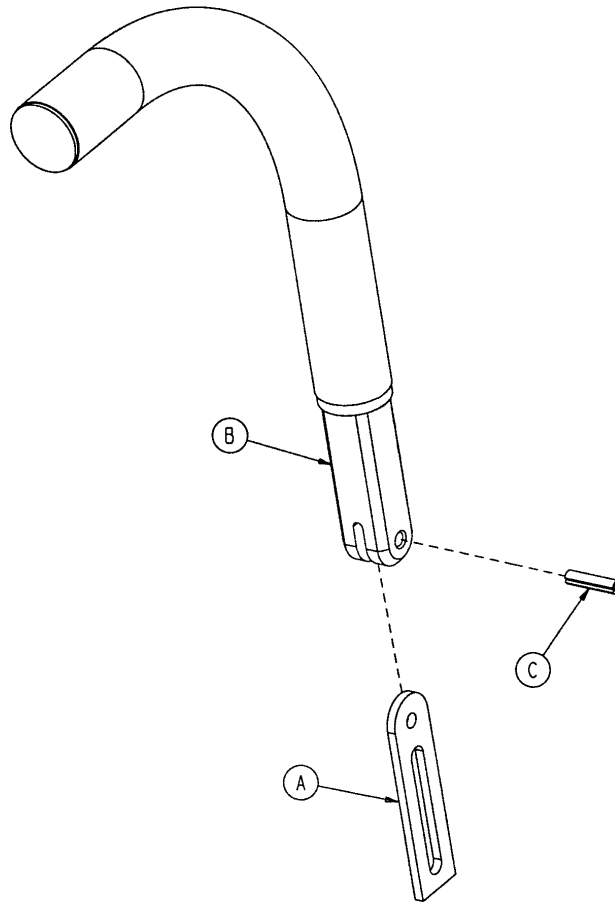

Item	Part No.	Part Name	Qty.
A	1010-354-24	Stop Link	1
B	1211-151-18	Sleeve Assembly	1
C	26-1 18	Roll Pin	1

# 1020-51 Optional Foot End Push Handles Assembly

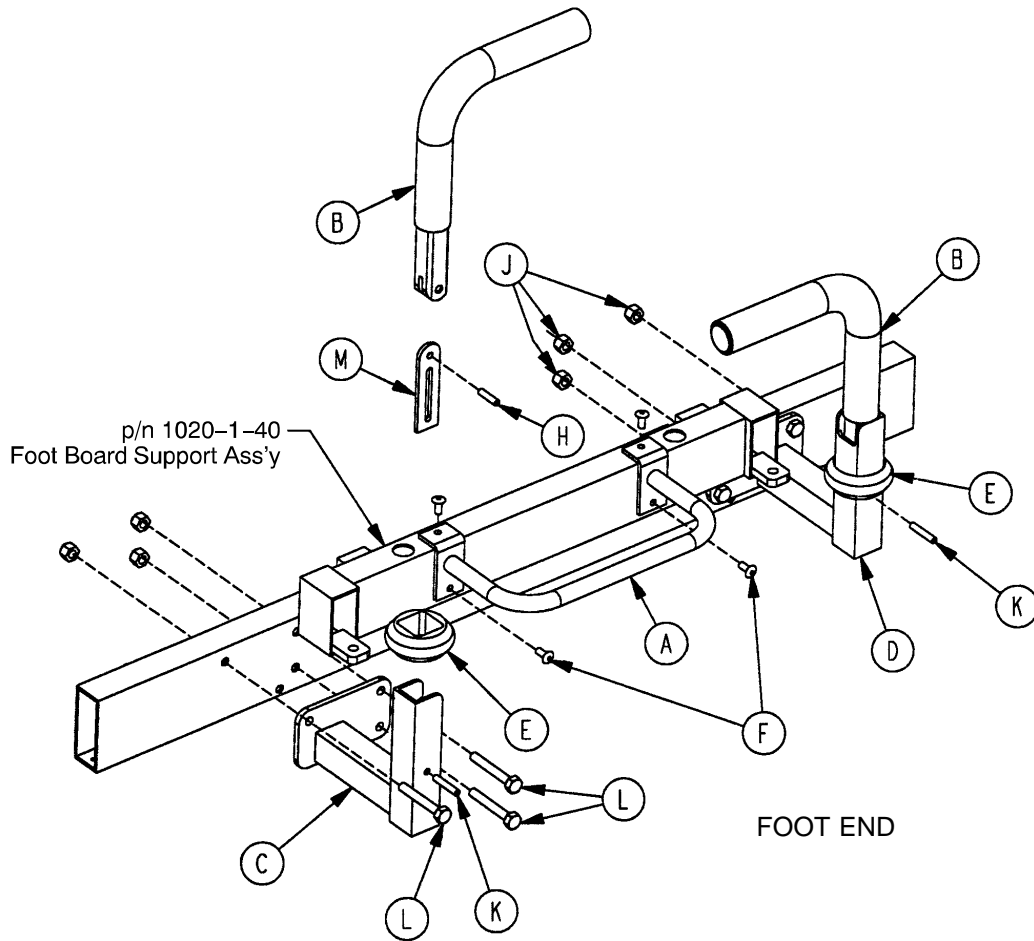

Item	Part No.	Part Name	Qty.
A	1010-51-19	Guard	1
B	1000-58-19	Push Handle	2
C	1020-51-15	Handle Socket	1
D	1020-51-17	Handle Socket	1
E	1010-51-18	Rubber Bumper	2
F	25-79	Pop Rivet	4
H	26-10	Roll Pin	2
J	16-28	Nylock Nut	6
K	26-11	Roll Pin	2
L	3-78	Hex Hd. Bolt	6
M	1010-354-24	Stop Link	2

# 1020-22-10 X-Ray Tray Assembly, Right Side Loading

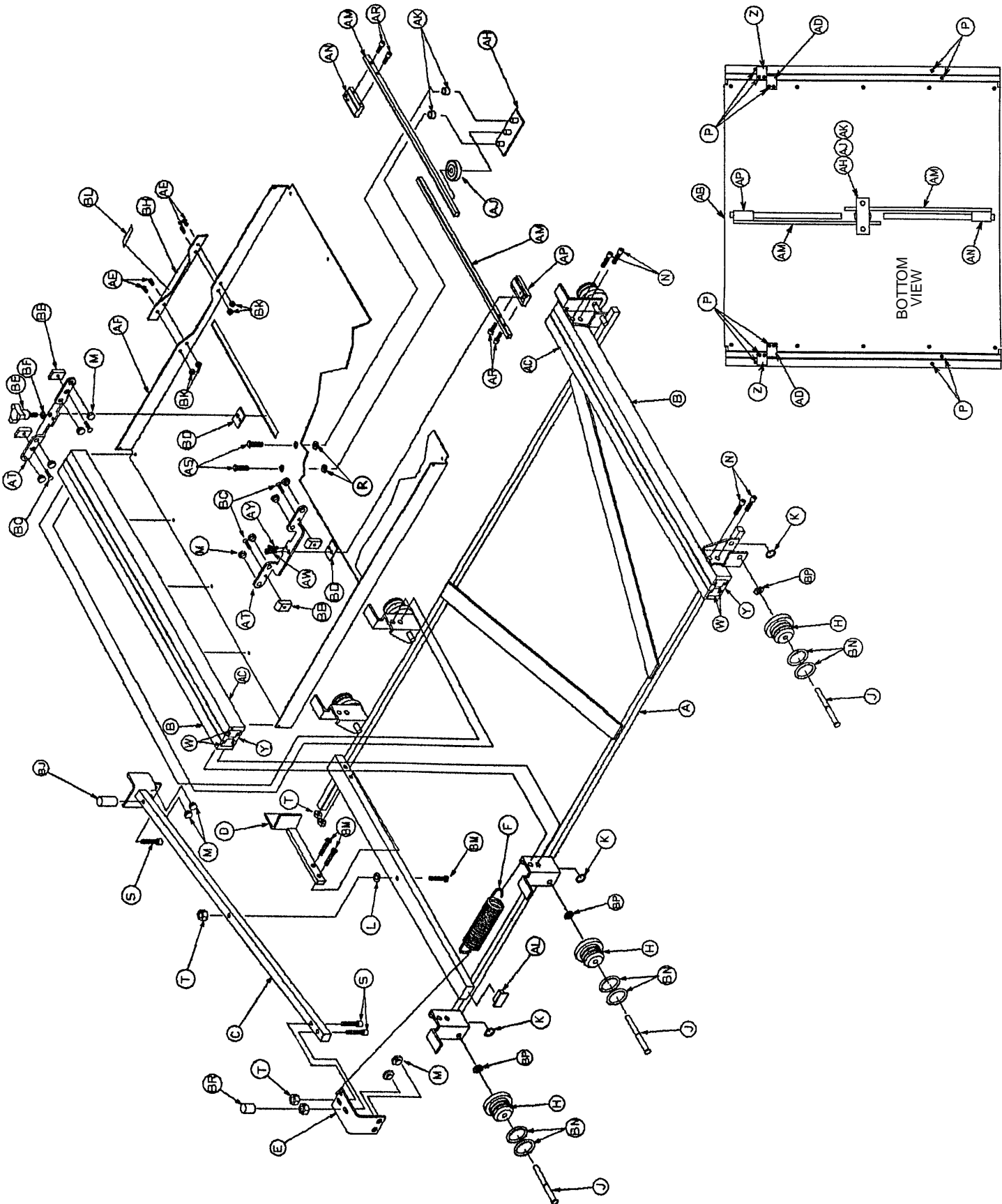

# 1020-22-10 X-Ray Tray Assembly, Right Side Loading

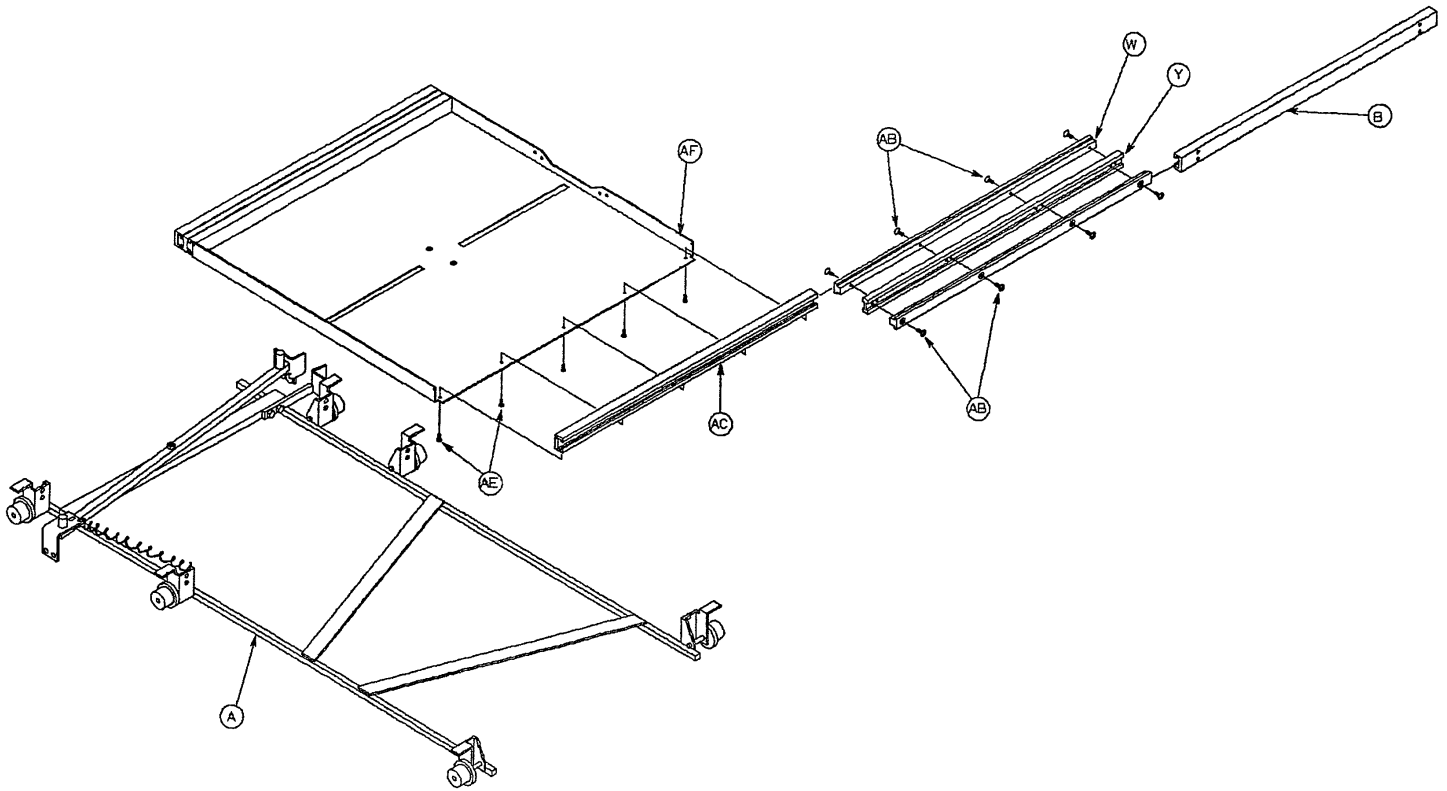

Item	Part No.	Part Name	Qty.	Item	Part No.	Part Name	Qty.
A	1020-22-44	Tray Frame Ass'y	1	AJ	1020-22-41	Spur Gear	1
B	1020-22-1	Outer Slide, Mach'd	2	AK	52-250	Spacer	2
C	1020-22-15	Pivot Tube Ass'y	1	AL	1010-32-66	Hole Plug	2
D	1020-22-7	Brake Handle	1	AM	1020-22-43	Rack, Modified	2
E	1020-22-36	Brake Adj. Bracket	1	AN	1020-22-58	Rack Connector Ass'y	1
F	38-253	Extension Spring	1	AP	1020-22-57	Left Rack Connector	1
H	1020-22-59	Tray Wheel	6	AR	4-127	Soc. Hd. Cap Screw	4
J	1020-22-25	Wheel Axle	6	AS	1-26	Flat Hd. Mach. Screw	2
K	28-98	Retaining Ring	6	AT	1020-22-56	Centering Plate	2
L	11-146	Nylon Washer	1	AW	4-169	But. Hd. Cap Screw	1
M	37-64	Rubber Bumper	12	AY	4-170	But. Hd. Cap Screw	1
N	4-136	Soc. Hd. Cap Screw	8	BB	1020-22-21	Slide Block	4
P	4-101	Soc. Hd. Cap Screw	18	BC	1-85	Flat Hd. Screw	4
R	11-11	Fiber Washer	2	BD	1020-22-55	Slide Pad	2
S	4-26	Soc. Hd. Cap Screw	3	BE	24-51	Three-Arm Knob	1
T	16-3	Nylock Hex Nut	5	BF	11-132	Nylon Washer	1
W	1020-22-13	Inner Slide, Mach'd	4	BH	1020-22-29	Handle	1
Y	1020-22-12	Support, Mach'd	2	BJ	1010-22-35	Retention Spacer, Rt.	1
Z	1020-22-45	Stop, First Stage	2	BK	16-23	Nylock Hex Nut	4
AB	1-87	Flat Hd. Screw	16	BL	1020-22-60	Label	1
AC	1020-22-47	Tray Slide, Mach'd	2	BM	4-171	But. Hd. Cap Screw	3
AD	1020-22-46	Stop-2nd Stage	2	BN	45-952	O-Ring	12
AE	4-167	But. Hd. Cap Screw	14	BP	14-4	Nylon Flat Washer	6
AF	1020-22-14	Tray Pan	1	BR	1010-22-36	Retention Spacer, Lt.	1
AH	1020-22-52	Guide Plate Ass'y	1				

# 1020-21-10 X-Ray Tray Assembly, Left Side Loading

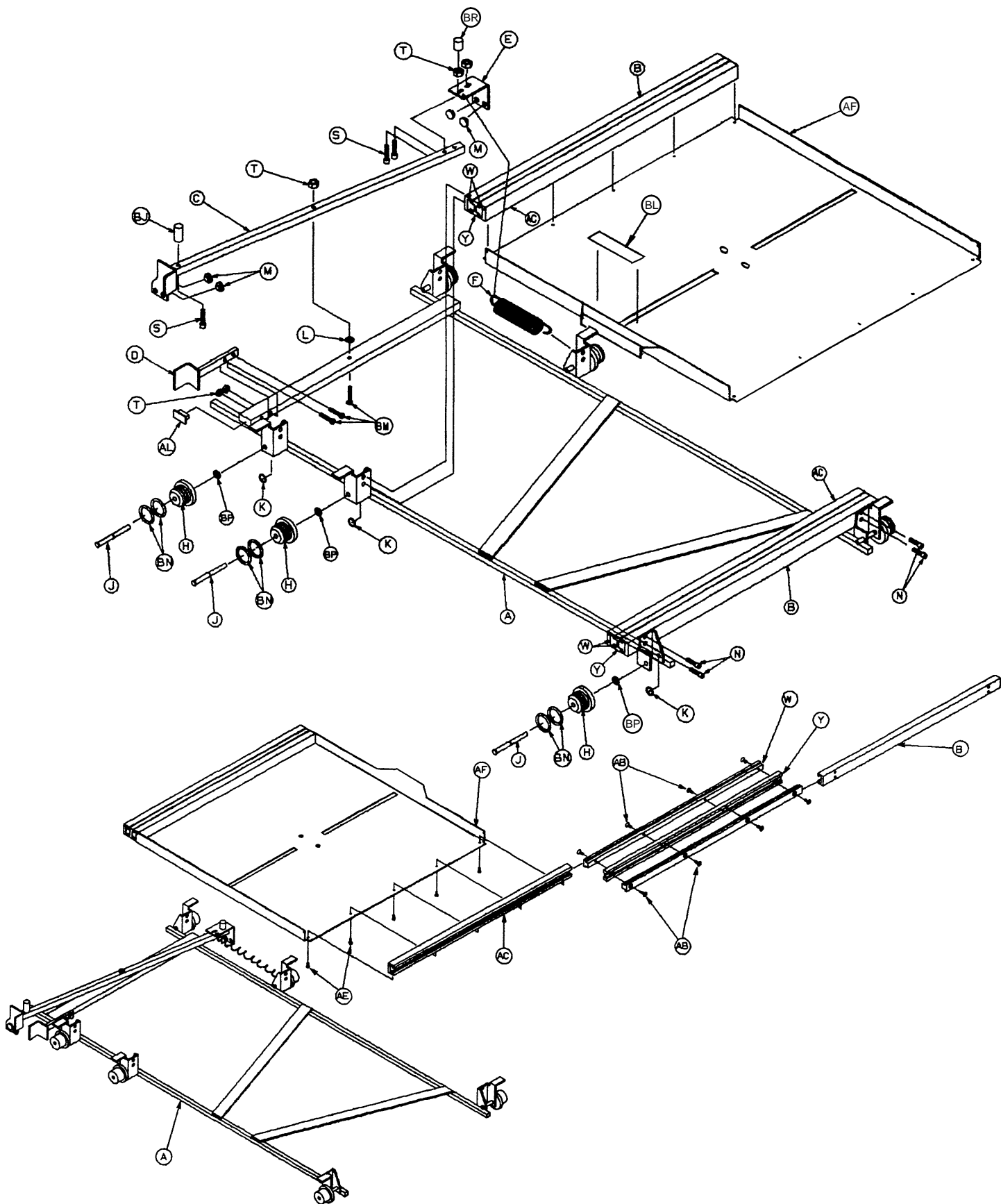

# 1020-21-10 X-Ray Tray Assembly, Left Side Loading

Item	Part No.	Part Name	Qty.	Item	Part No.	Part Name	Qty.
A	1020-21-44	Tray Frame Ass'y	1	W	1020-22-13	Inner Slide, Mach'd	4
B	1020-22-1	Outer Slide, Mach'd	2	Y	1020-22-12	Support, Mach'd	2
C	1020-21-15	Pivot Tube Ass'y	1	Z	1020-22-45	Stop, First Stage	2
D	1020-21-7	Brake Handle	1	AB	1-87	Flat Hd. Screw	16
E	1020-21-36	Brake Adj. Bracket	1	AC	1020-22-47	Tray Slide, Mach'd	2
F	38-253	Extension Spring	1	AD	1020-22-46	Stop-2nd Stage	2
H	1020-22-59	Tray Wheel	6	AE	4-167	But. Hd. Cap Screw	10
J	1020-22-25	Wheel Axle	6	AF	1020-21-14	Tray Pan	1
K	28-98	Retaining Ring	6	AL	1010-32-66	Hole Plug	2
L	11-146	Nylon Washer	1	BJ	1010-22-35	Retention Spacer, Rt.	1
M	37-64	Rubber Bumper	4	BL	1020-22-60	Label	1
N	4-136	Soc. Hd. Cap Screw	8	BM	4-171	But. Hd. Cap Screw	3
P	4-101	Soc. Hd. Cap Screw	18	BN	45-952	O-Ring	12
S	4-26	Soc. Hd. Cap Screw	3	BP	14-4	Nylon Flat Washer	6
T	16-3	Nylock Hex Nut	5	BR	1010-22-36	Retention Spacer, Lt.	1

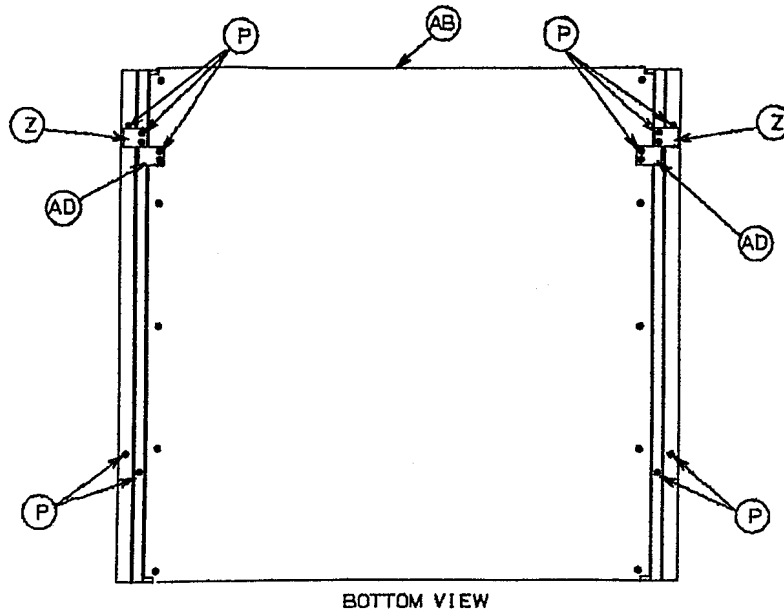

# 1020-27 Grid Holder Assembly

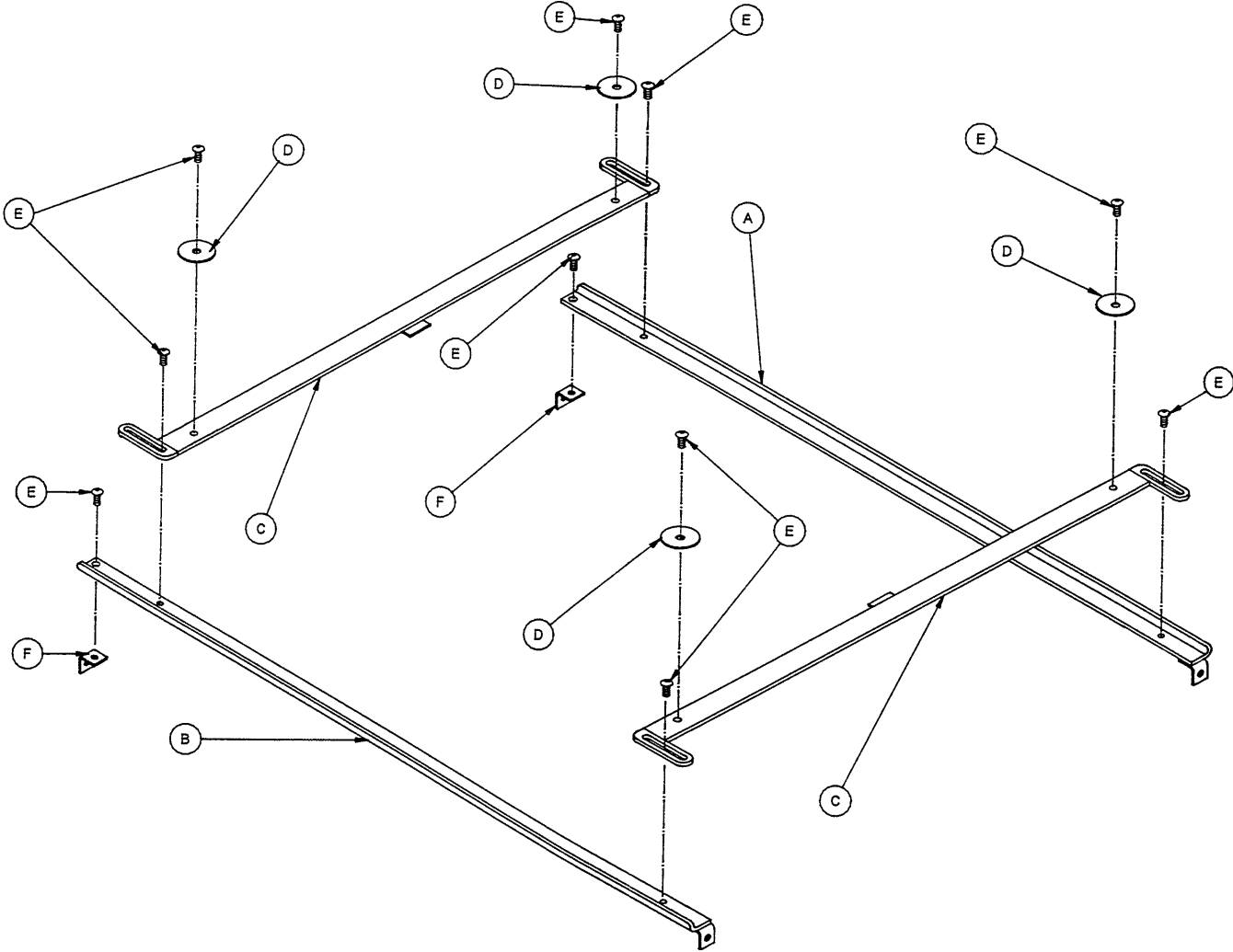

Item	Part No.	Part Name	Qty.
A	1020-27-21	Guide Weldment, Rt.	1
B	1020-27-22	Guide Weldment, Lt.	1
C	1020-27-1	Slider Weldment	2
D	11-271	Fender Washer	4
E	4-131	Button Hd. Cap Screw	10
F	1020-27-24	"L" Bracket	2

# 1020-20 Centering Device Option Assembly

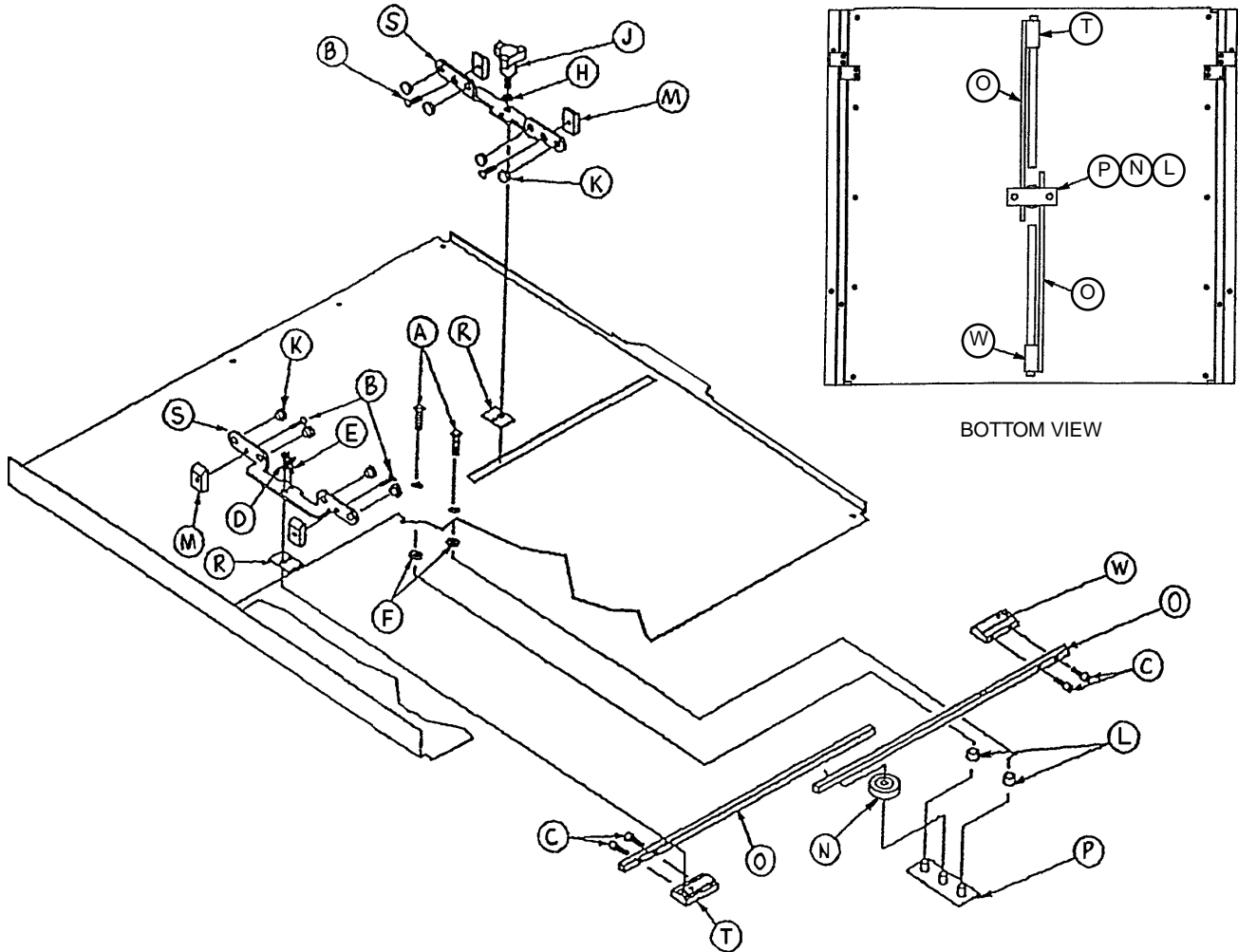

Item	Part No.	Part Name	Qty.
A	1-22	Flat Hd. Mach. Screw	2
B	1-85	Flat Hd. Mach. Screw	4
C	4-127	Soc. Hd. Cap Screw	4
D	4-169	But. Hd. Cap Screw	1
E	4-170	But. Hd. Cap Screw	1
F	11-146	Nylon Washer	2
H	11-132	Nylon Washer	1
J	24-51	Three Arm Knob	1
K	37-64	Rubber Bumper	8
L	52-250	Spacer	2
M	1020-22-21	Slide Block	4
N	1020-22-41	Spur Gear	1
P	1020-22-52	Guide Plate	1
R	1020-22-55	Slide Pad	2
S	1020-22-56	Centering Plate	2
T	1020-22-57	Left Rack Connector	1
W	1020-22-58	Rack Connector Ass'y	1
X	1020-19-5	Centering Label (not shown)	1



# 1020-23 Fowler X-Ray Cassette Assembly

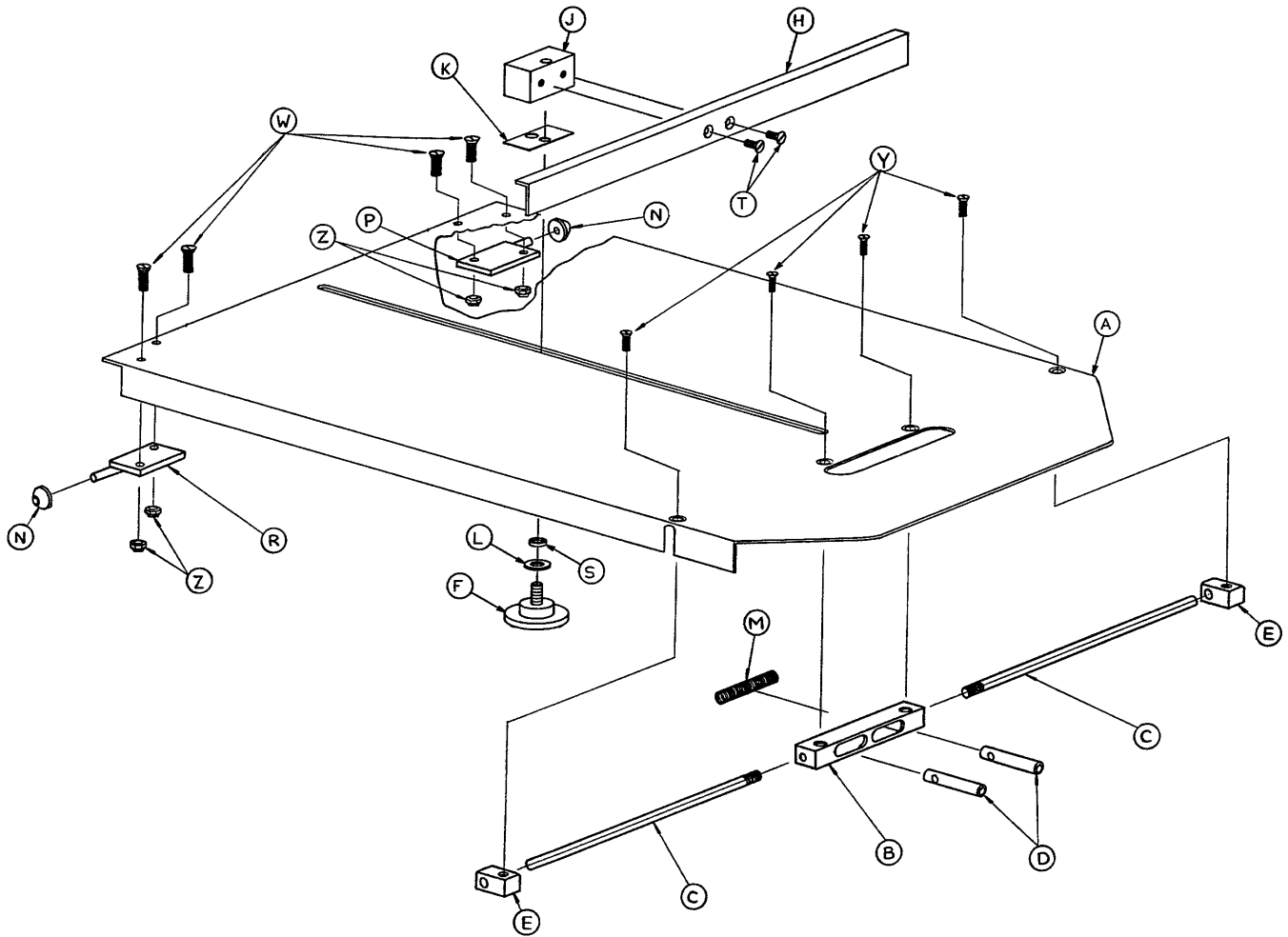

Item	Part No.	Part Name	Qty.
A	1020-23-1	Tray	1
B	1020-23-16	Post Housing	1
C	1020-23-25	Actuating Rod	2
D	926-23-64	Post	2
E	1010-23-37	Rod Guide	2
F	1020-23-21	Knob	1
H	1010-23-28	Tray Angle	1
J	926-23-70	Block Assembly	1
K	926-23-69	Washer	1
L	14-3	Washer	1
M	38-122	Compression Spring	1
N	1020-23-26	Spacer	2
P	1020-23-19	Tray Hinge, Right	1
R	1020-23-20	Tray Hinge, Left	1
S	926-23-71	Bushing	1
T	1-20	Flat Hd. Mach. Screw	2
W	4-149	Hex Soc. But. Hd. Cap Screw	4
Y	1-22	Flat Hd. Screw	4
Z	16-3	Nylock Nut	4
AA	1010-23-19	Tray Removal Label	1
AB	1020-23-27	Specification Label	1

# 390-25 Standard, Removable I.V. Pole Assembly

---

Item	Part No.	Part Name	Qty.
A	24-23	Plastic Knob	1
C	390-3-53	Double I.V. Ass'y	1
D	393-3-43	Tube Assembly	1

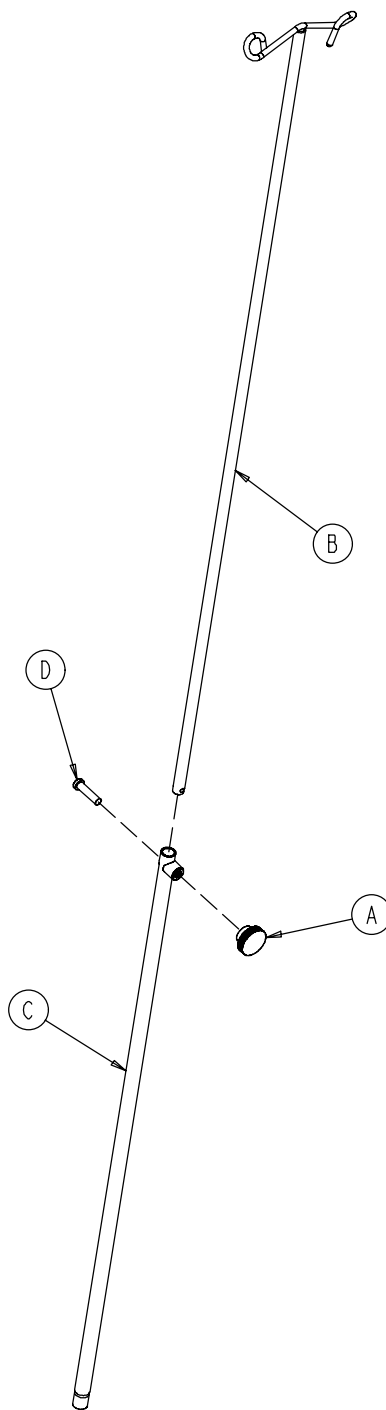

# 1010-22-100 Tethered I.V. Assembly

---

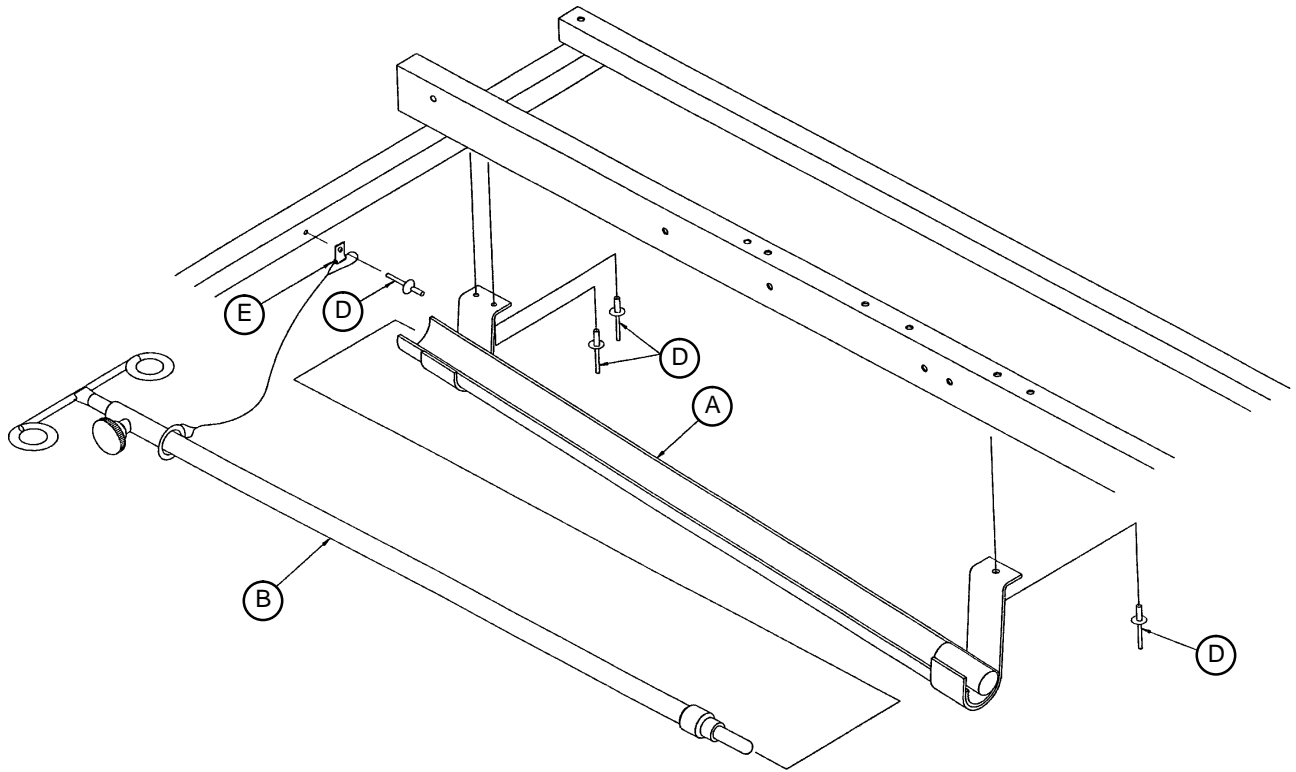

Item	Part No.	Part Name	Qty.
A	1010-22-25	Trough Assembly	1
B	(Page 73)	Tethered I.V. Assembly	1
D	25-92	Pop Rivet	4
E	34-22	Loop Clamp	1

# 1001-87-18 Tethered I.V. Pole Assembly

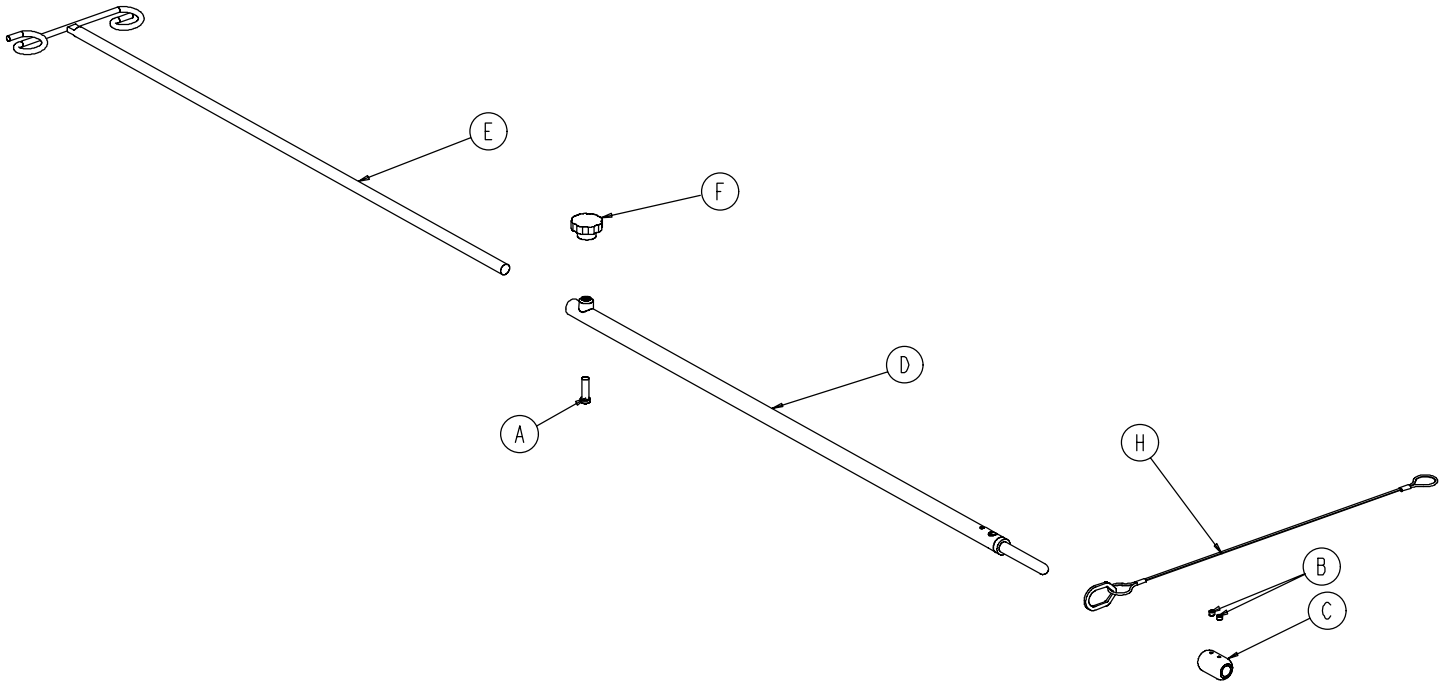

Item	Part No.	Part Name	Qty.
A	4-495	Soc. Hd. Cap Screw	1
B	21-16	Set Screw	2
C	741-47-14	Retainer	1
D	938-1-305	Pole Socket Assembly	1
E	938-1-308	Pole Assembly	1
F	1211-1 17-16	Plastic Knob	1
C	1211-1 17-20	Cable Assembly	1

# 1010-80 2-Stage I.V. Mounting Ass'y - Foot End, Right

# 1010-81 2-Stage I.V. Mounting Ass'y - Head End, Left

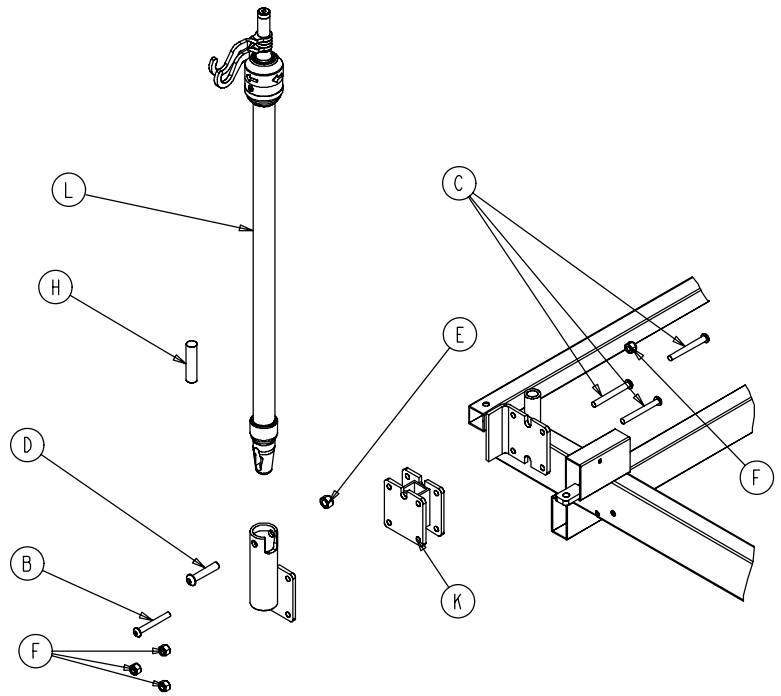
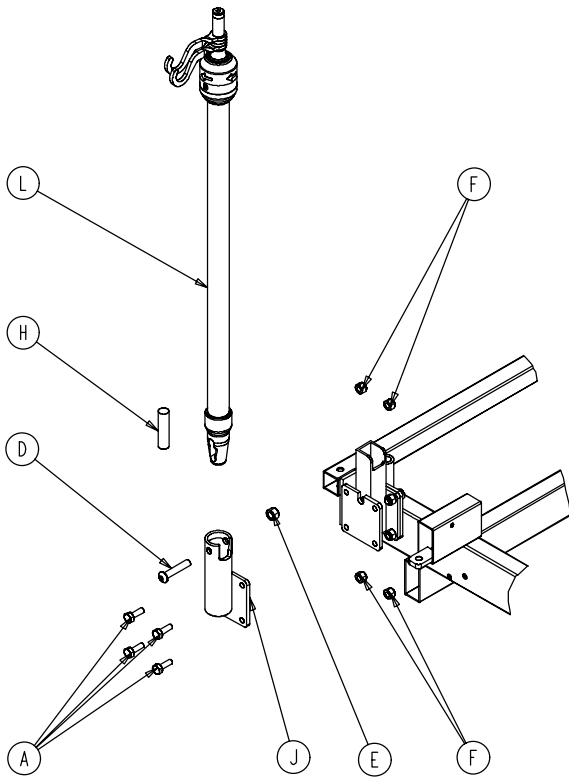

Item	Part No.	Part Name	Qty.
A	3-50	But. Hd. Cap Screw	4
B	4-97	But. Hd. Cap Screw	1
C	4-163	But. Hd. Cap Screw	3
D	4-199	But. Hd. Cap Screw	1
E	16-11	Flexlock Nut	1
F	16-28	Nylock Nut	4
H	1001-59-42	I.V. Plug	1
J	1001-259-1 11	I V. Socket Ass'y	1
K	1020-54-67	Spacer Weldment	3
B	(page 75)	2-Stage I.V. Pole Ass'y	1

# 1211-210-10 Optional 2-Stage I.V. Pole Assembly

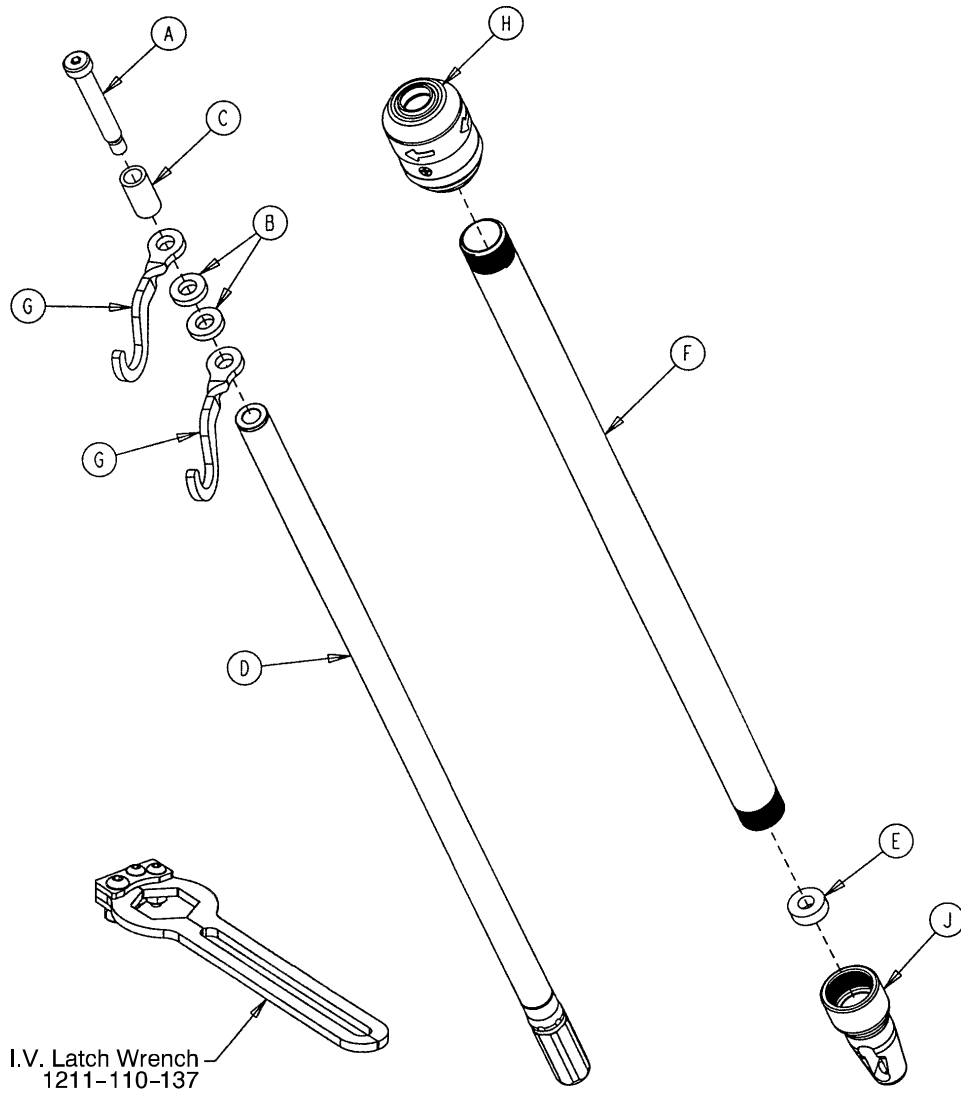

Item	Part No.	Part Name	Qty.
A	8-31	Soc. Hd. Cap Screw	1
B	52-17	Washer	2
C	926-400-162	Spacer	1
D	1211-210-29	2nd Stage Assembly	1
E	1001-359-13	Dampener	1
F	1001-159-28	Base Tube	1
G	1010-259-16	I.V. Hook	2
H	(page 76)	I.V. Pole Latch	1
J	1001-359-1 12	Pivot	1

# 1211-210-26 Optional I.V. Pole Latch Assembly

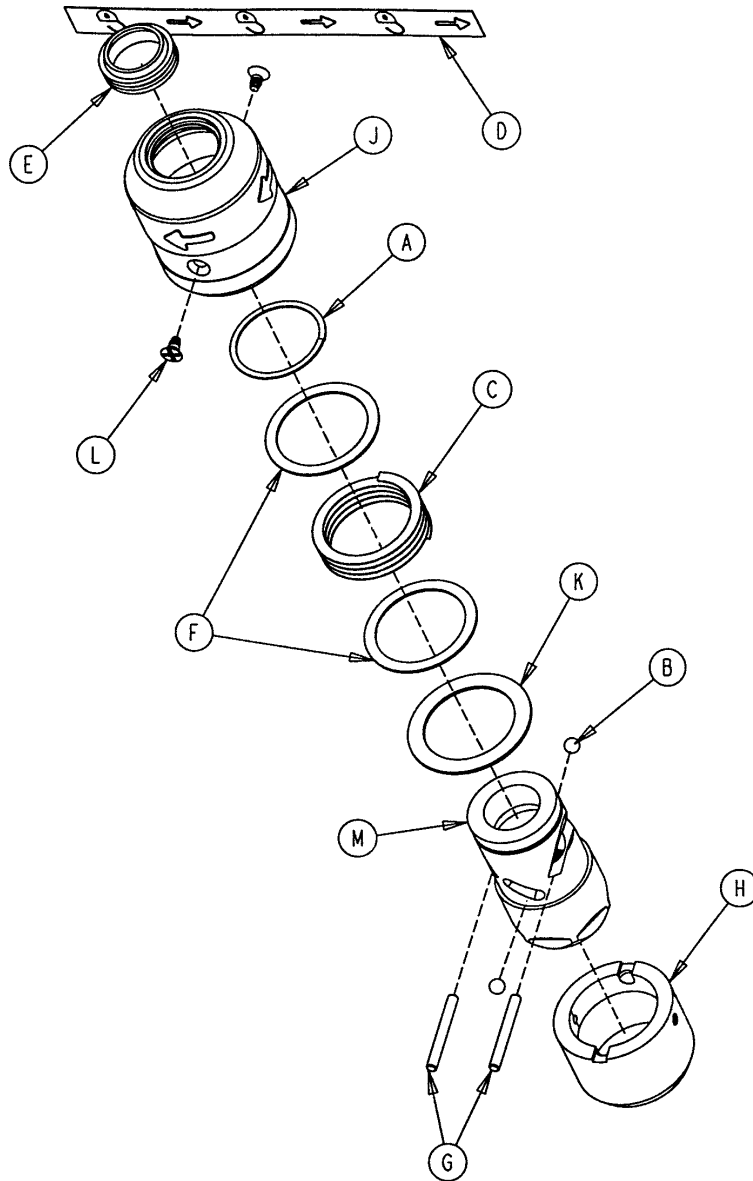

Item	Part No.	Part Name	Qty.
A	28-167	Retaining Ring	1
B	31-4	Steel Ball	2
C	38-392	Crest-to-Crest Spring	1
D	1211-91-34	Release Label	1
E	1211-1 10-18	I.V. Latch Seal	1
F	1211-1 10-20	Washer	2
G	1211-1 10-21	I.V. Latch Locking Pin	2
H	1211-1 10-22	I.V. Latch Guide	1
J	1211-1 10-24	I.V. Latch O.D. Housing	1
K	1211-1 10-35	Washer	1
L	1211-1 10-36	Self-Tapping Screw	2
M	1211-210-23	I.V. Latch I.D. Housing	1

# 1020-62 3-Stage I.V. Mounting Ass'y - Foot End, Right

# 1020-61 3-Stage I.V. Mounting Ass'y - Head End, Left

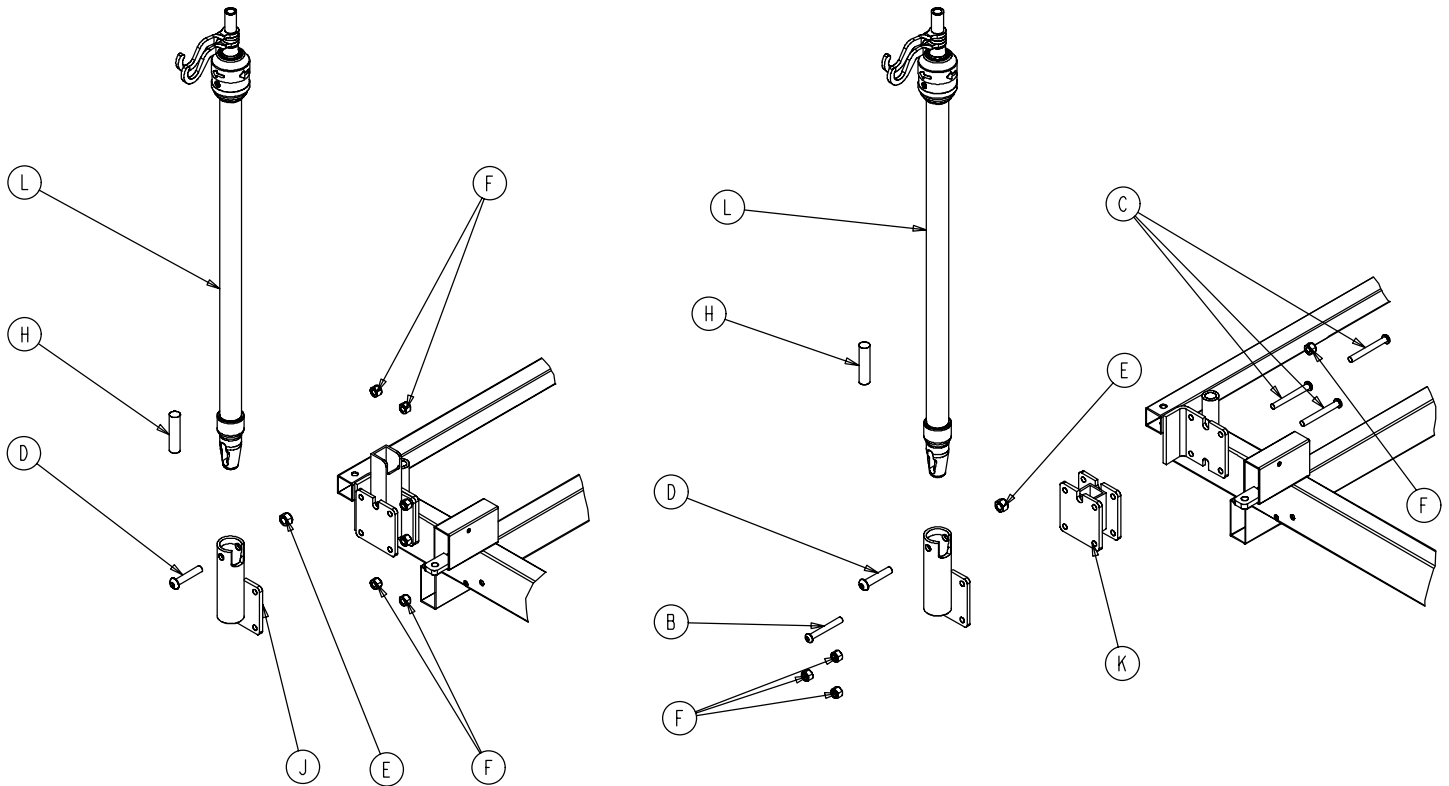

Item	Part No.	Part Name	Qty.
A	3-50	But. Hd. Cap Screw	4
B	4-97	But. Hd. Cap Screw	1
C	4-163	But. Hd. Cap Screw	3
D	4-199	But. Hd. Cap Screw	1
E	16-11	Flexlock Nut	1
F	16-28	Nylock Nut	4
H	1001-59-42	Plug	3
J	1001-259-1 11	I.V. Pivot Weldment	1
K	1020-54-67	Spacer Weldment	3
L	(page 78)	I.V. Pole Assembly	1



# 1211-211-10 Optional 3-Stage I.V. Pole Assembly

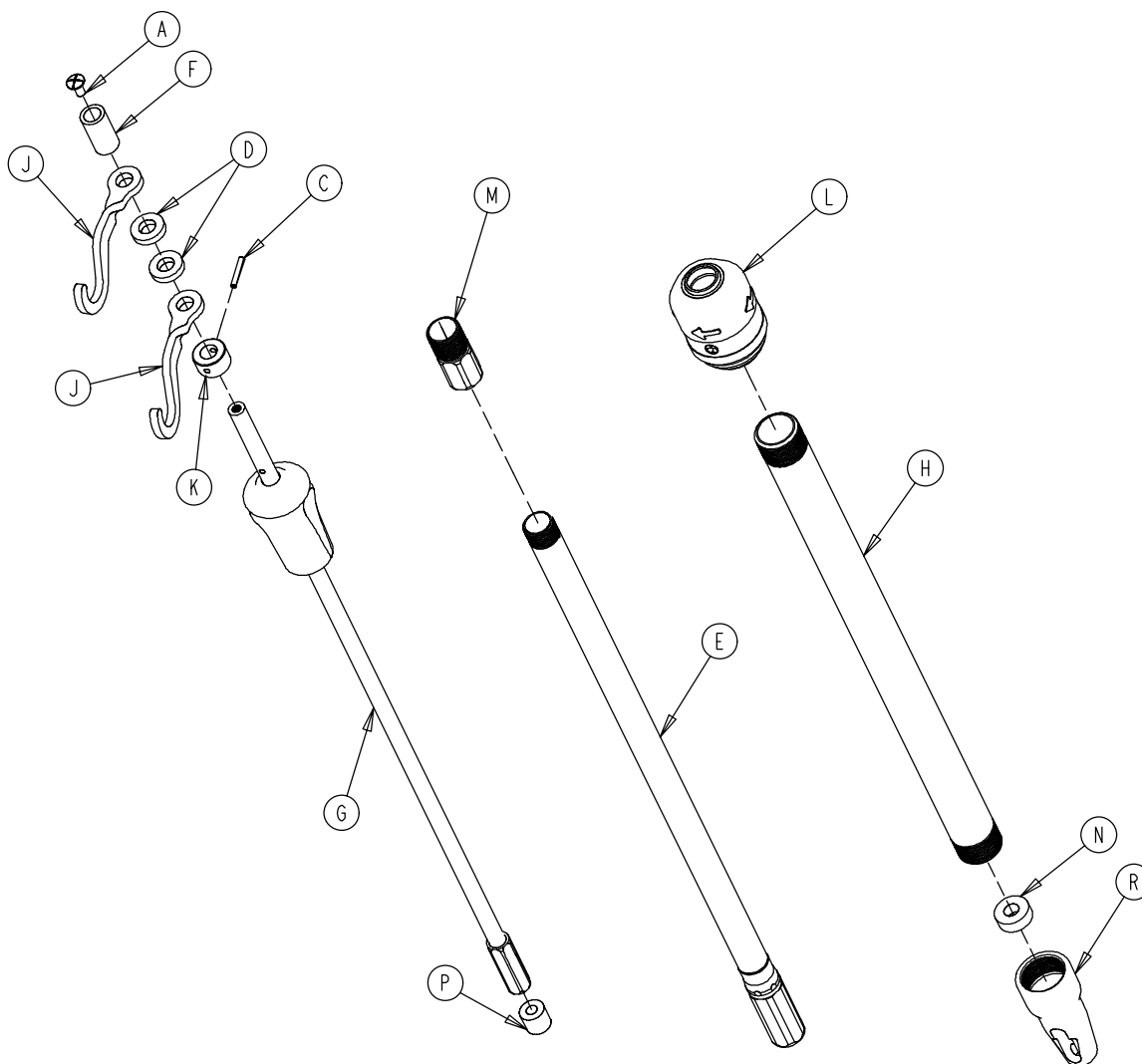

Item	Part No.	Part Name	Qty.
A	7-4	Truss Hd. Machine Screw	1
C	26-76	Roll Pin	1
D	52-17	Spacer	2
E	1211-210-31	2nd Stage Assembly	1
F	926-400-162	Spacer	1
G	(page 79)	3rd Stage Assembly	1
H	1001-161-23	Base Tube	1
J	1010-259-16	I.V. Hook	2
K	1010-61-14	Collar	1
L	(page 76)	I.V. Pole Latch	1
M	1211-1 10-16	Threaded Adaptor	1
N	1001-359-13	Dampener	1
P	1001-359-14	Dampener	1
R	1001-359-1 12	Pivot	1

# 1211-110-32 Optional 3rd Stage Assembly

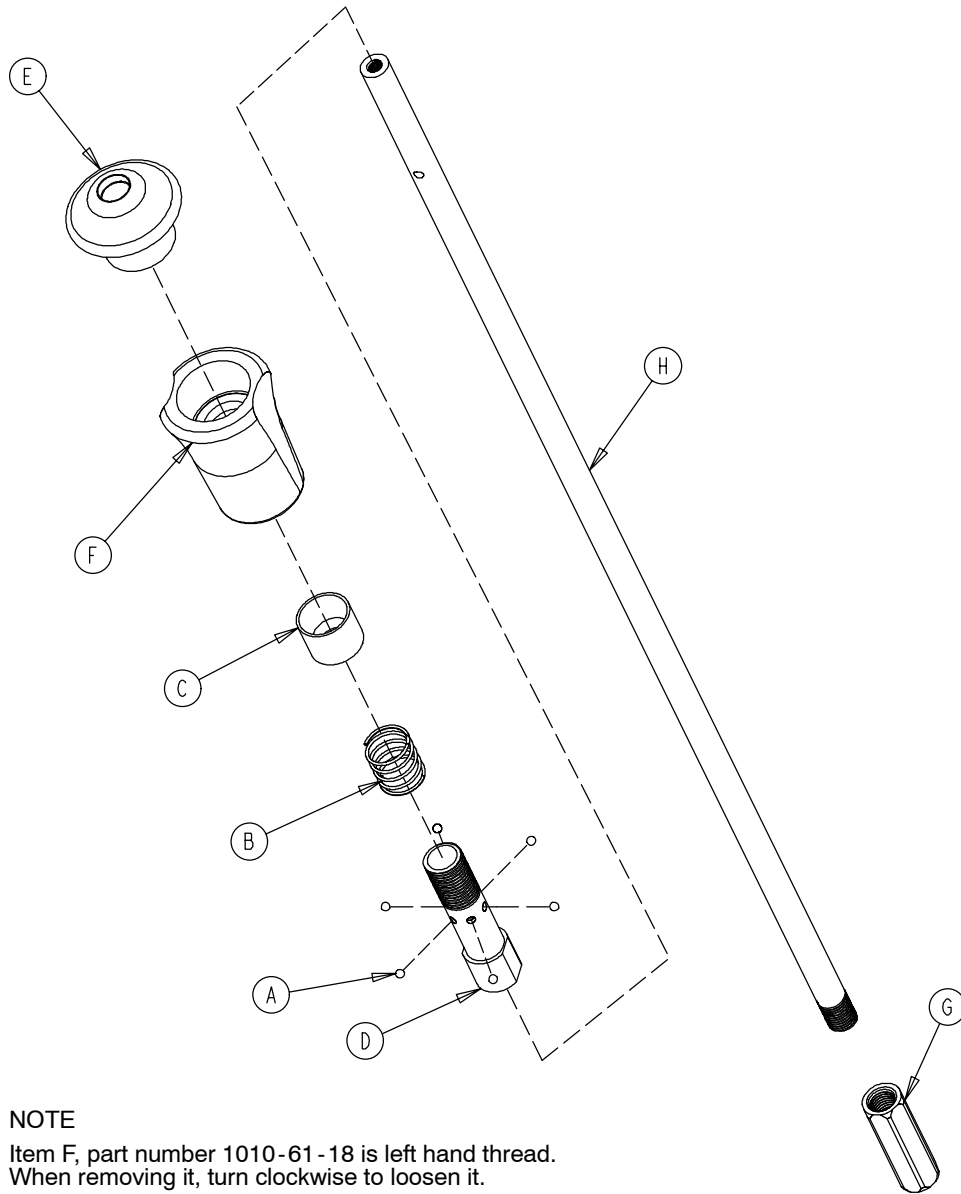

Item	Part No.	Part Name	Qty.
A	31-21	Ball	6
B	38-303	Compression Spring	1
C	1010-61-13	Ball Retainer	1
D	1010-61-16	Retaining Shaft	1
E	1010-61-17	Thumb Knob	1
F	1010-61-18	Hand Guard	1
G	1211-110-117	Nut	1
H	1211-110-33	3rd Extension Rod	1

## 741-34-100 Foot Board/Chartholder

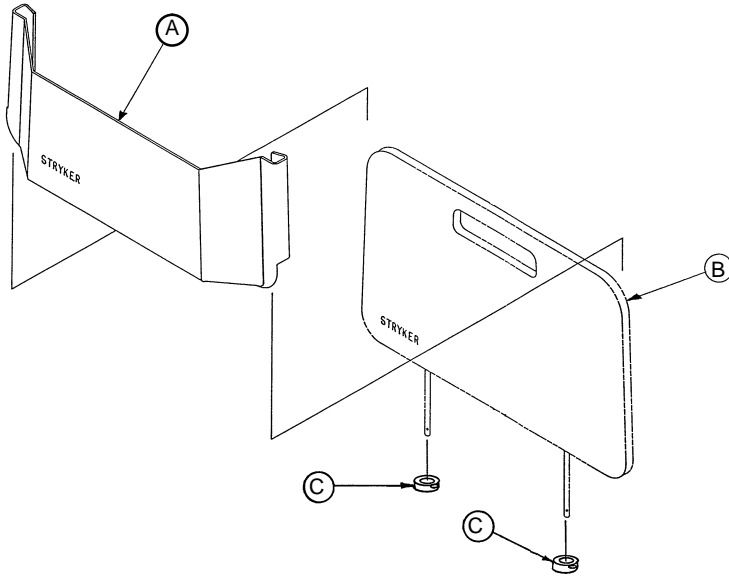

Item	Part No.	Part Name	Qty.
A	946-28-1	Chart Holder	1
B	741-29-18	Head/Foot Board	1
C	42-6	Collar	2

## 1020-30 Upright Oxygen Bottle Holder

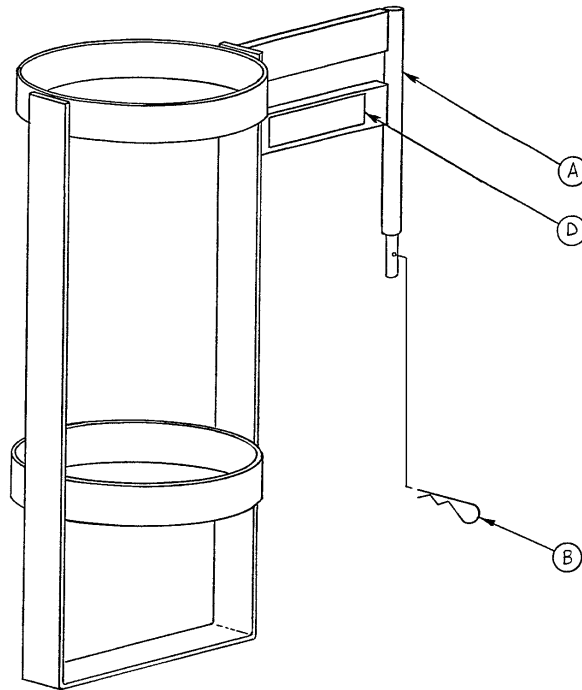

Item	Part No.	Part Name	Qty.
A	1020-30-1	Upright Bottle Holder	1
B	27-12	Cotter Pin	1
D	1020-30-17	Specification Label	1

# 741-48 Defibrillator Tray Assembly

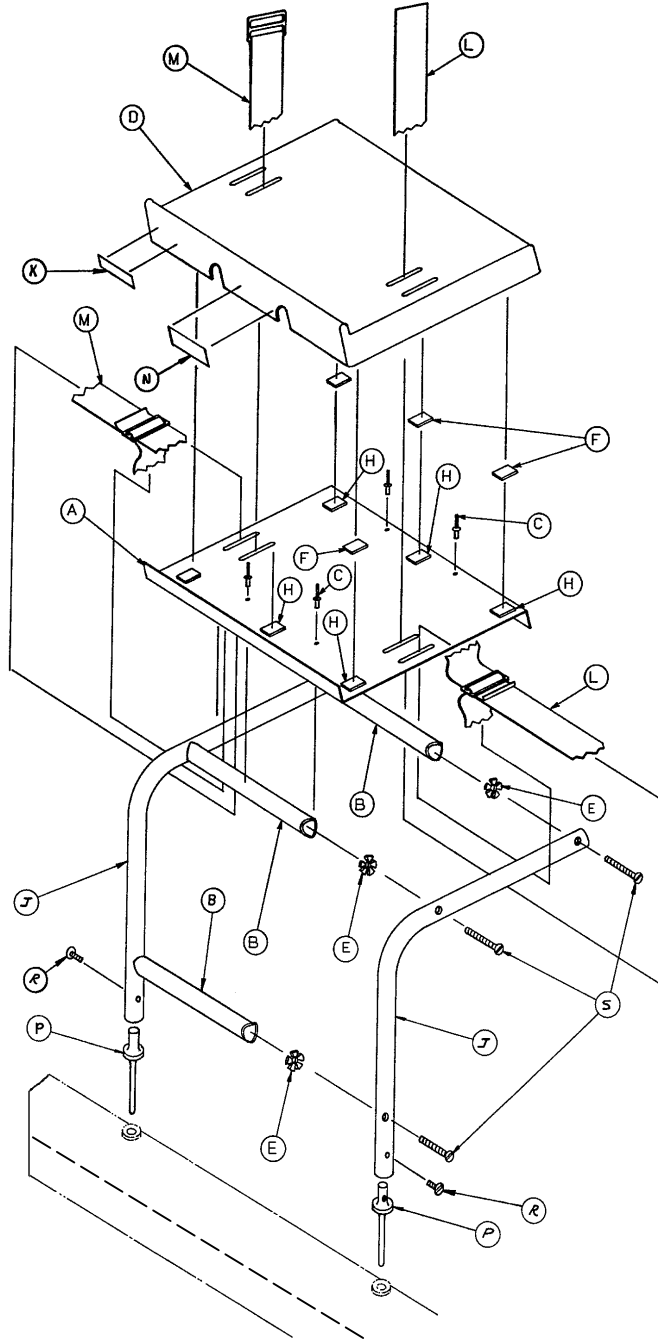

Item	Part No.	Part Name	Qty.	Item	Part No.	Part Name	Qty.
A	946-39-4	Tray	1	K	741-48-12	Label	1
B	926-39-16	Crosstube	3	L	390-57-12	Long Strap	1
C	25-55	Rivet	4	M	390-57-13	Short Strap	1
D	926-39-9	Cover	1	N	946-1-283	Label	1
E	18-6	Umbrella Nut	6	P	711-48-20	Holder	2
F	29-8	Dual Lock	6	R	2-44	Screw	2
H	29-10	Dual Lock	6	S	2-105	Rd. Hd. Mach. Screw	6
J	946-39-3	Support Tube	2				

# 1010-50-100 Foot Extension/Defibrillator Tray Ass'y

Assembly part number 1010-50-210 (reference only)

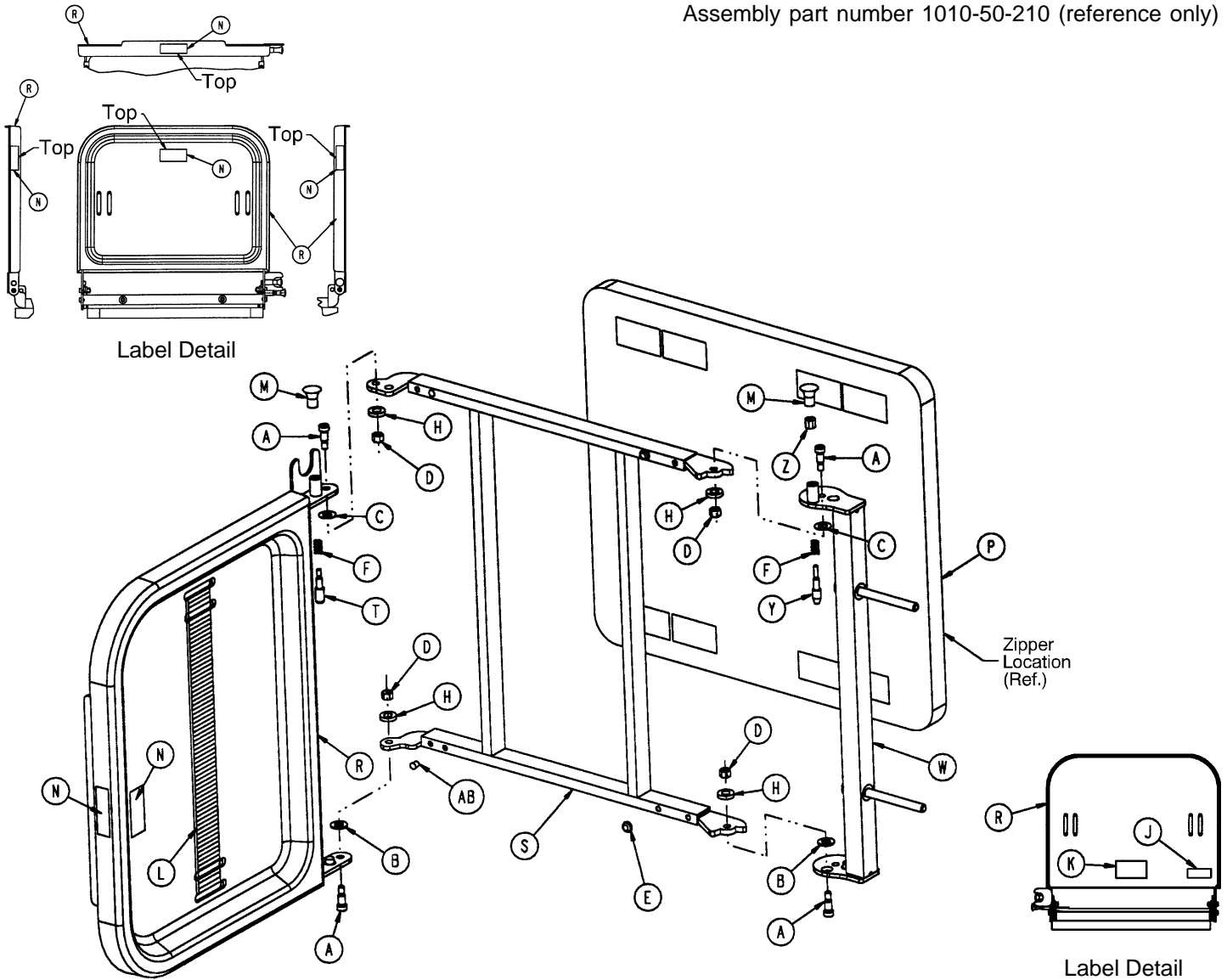

Item	Part No.	Part Name	Qty.	Item	Part No.	Part Name	Qty.
A	8-49	Socket Hd. Shoulder Bolt	4	M	1010-50-50	Knob	2
B	14-20	Nylon Washer	2	N	1010-50-57	"Max. Weight" Label	4
C	14-21	Nylon Washer	2	P	1010-50-205	Cushion Assembly	1
D	16-28	Fiberlock Nut	4	R	1010-50-218	Foot & Tray Board	1
E	37-52	Rubber Bumper	2	S	1010-50-225	Pivot Frame Weldment	1
F	38-133	Spring	2	T	1010-50-242	Pin Lock	1
H	52-17	Spacer	4	W	1010-50-246	Base Mounting Ass'y	1
J	1010-50-17	Specification Label	1	Y	1010-50-248	Lower Pin Lock	1
K	1010-50-19	"Push/Pull" Label	1	Z	1010-50-250	Pin Adjuster	1
L	1010-50-21	Long Strap	1	AB	721-31-65	Hole Plug	2

# 1020-55 Heel Stirrup and Support Assembly

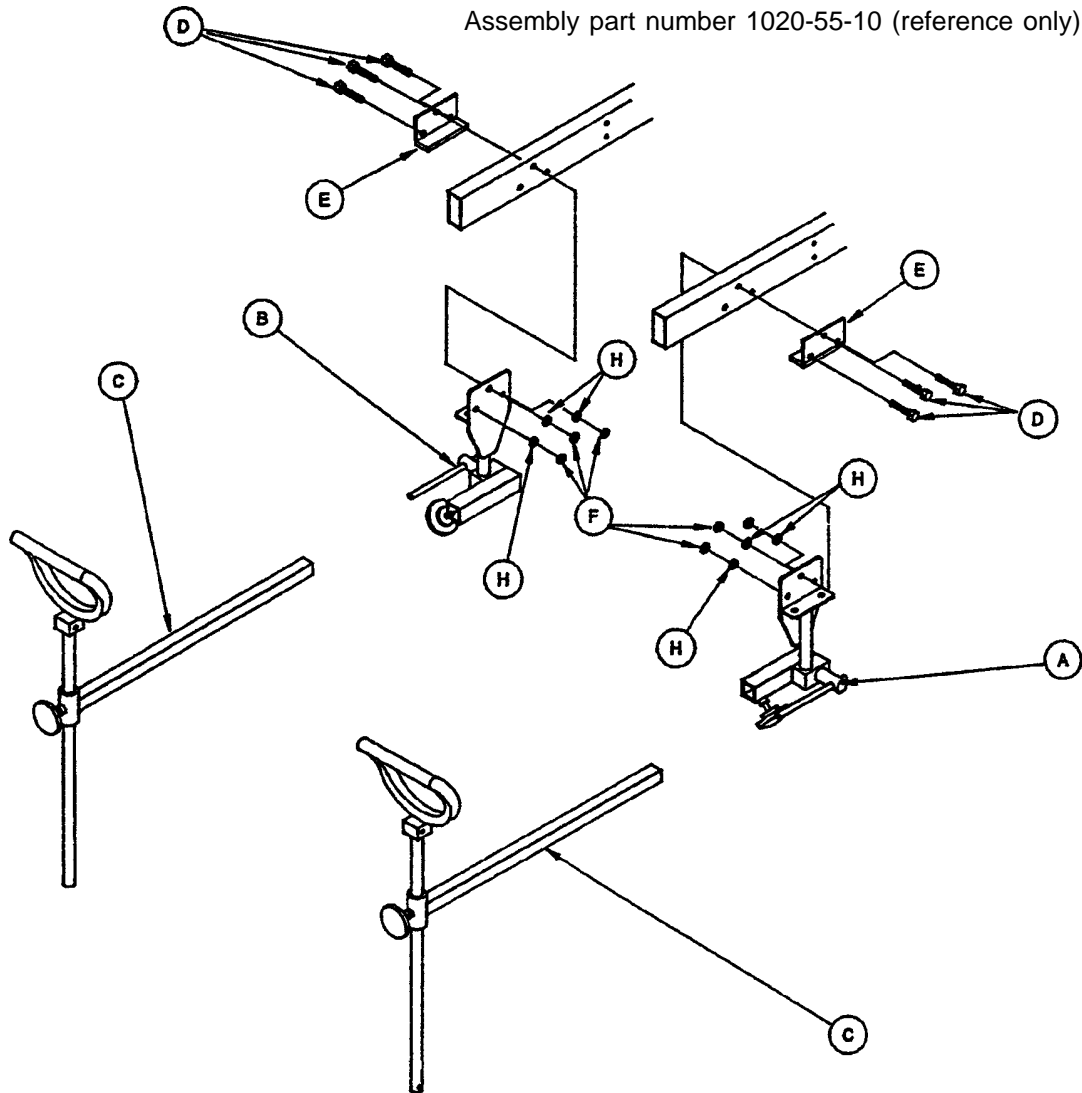

Item	Part No.	Part Name	Qty.
A	(page 84)	Stirrup Support Ass'y, Rt.	1
B	(page 84)	Stirrup Support Ass'y, Lt.	1
C	(page 85)	Stirrup Assembly	2
D	3-78	Hex Hd. Cap Screw	6
E	1020-55-15	Backer Assembly	2
F	16-28	Nylock Hex Nut	6
F	11-158	Flat Washer	6

# 1010-55-15 (Rt.) & 1010-55-25 (Lt.) Stirrup Support Ass'y

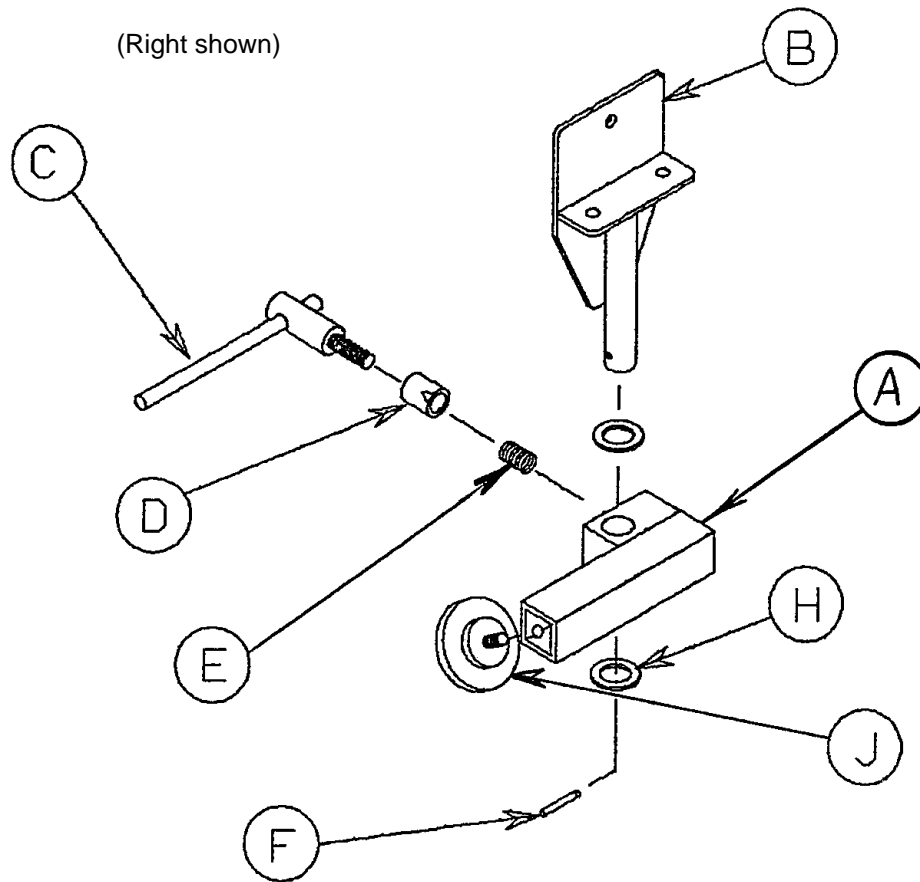

Item	Part No.	Part Name	Qty.
A	1010-55-16	Right Support Tube Ass'y	1
	1010-55-26	Left Support Tube Ass'y	1
B	1010-55-20	Mounting Bracket	1
C	650-2-32	Lock Screw Assembly	1
D	966-51-19	Wedge Lock, Modified	1
E	38-171	Compression Spring	1
F	26-7	Roll Pin	1
H	14-40	Nylon Flat Washer	2
J	24-11	Knob	1

# 1010-55-29 Heel Stirrup Assembly

---

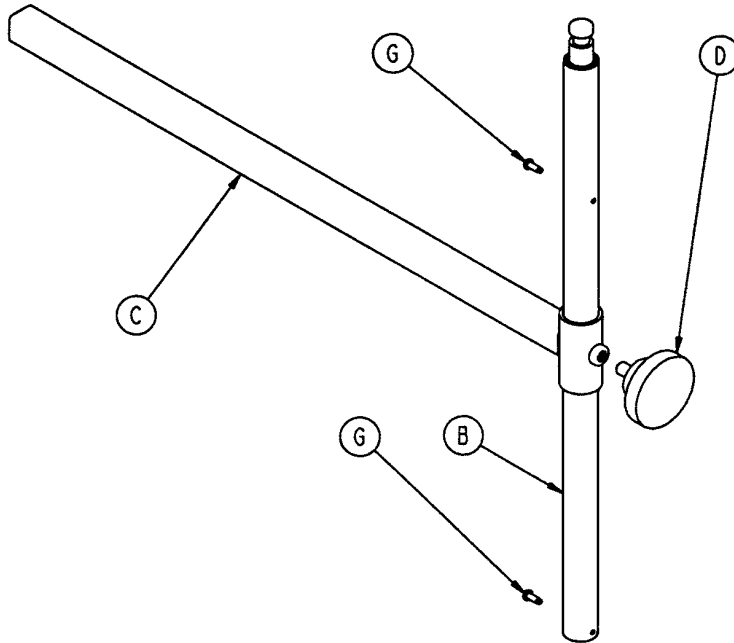
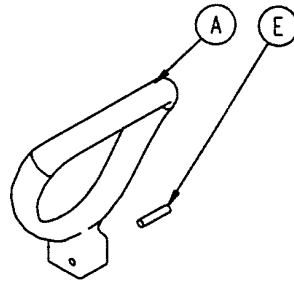

Item	Part No.	Part Name	Qty.
A	390-20-13	Stirrup	1
B	390-20-9	Stirrup Holder Assembly	1
C	1010-55-30	Extension Tube Assembly	1
D	24-11	Knob	1
E	26-43	Roll Pin	1
G	22-8	Drive Screw	2



# 1020-70 C-Spine Cassette Holder Assembly

Assembly part number  
1020-70-10  
(reference only)

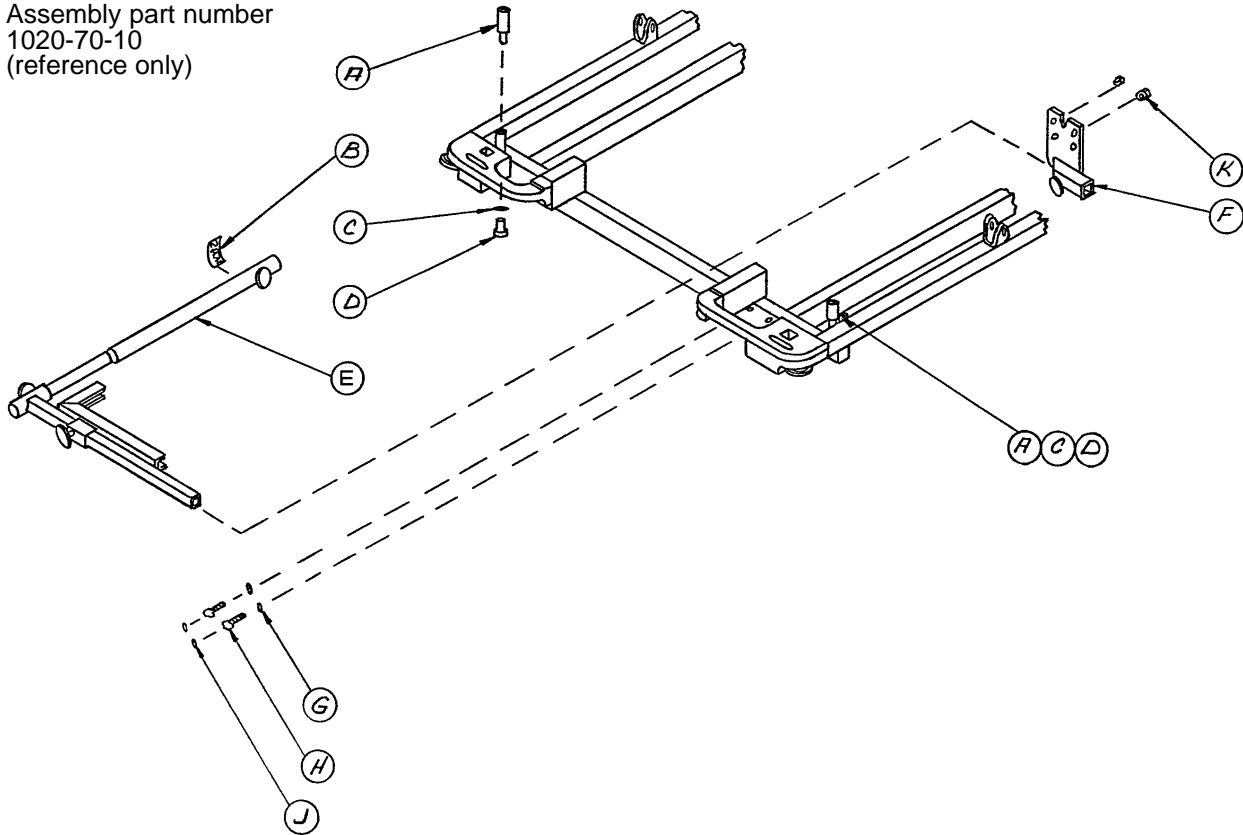

Item	Part No.	Part Name	Qty.
A	1010-70-25	I.V. Adaptor	2
B	1020-70-18	Specification Label	1
C	11-3	Flat Washer	2
D	4-91	Soc. Hd. Cap Screw	2
E	(page 87)	Support Pole Ass'y	1
F	(page 88)	Storage Bracket Ass'y	1
G	37-56	Washer	2
H	3-47	Hex Hd. Cap Screw	2
J	37-55	Cap	2
K	16-28	Nylock Nut	2

# C-Spine Support Pole Assembly

Assembly part number  
1010-70-10  
(reference only)

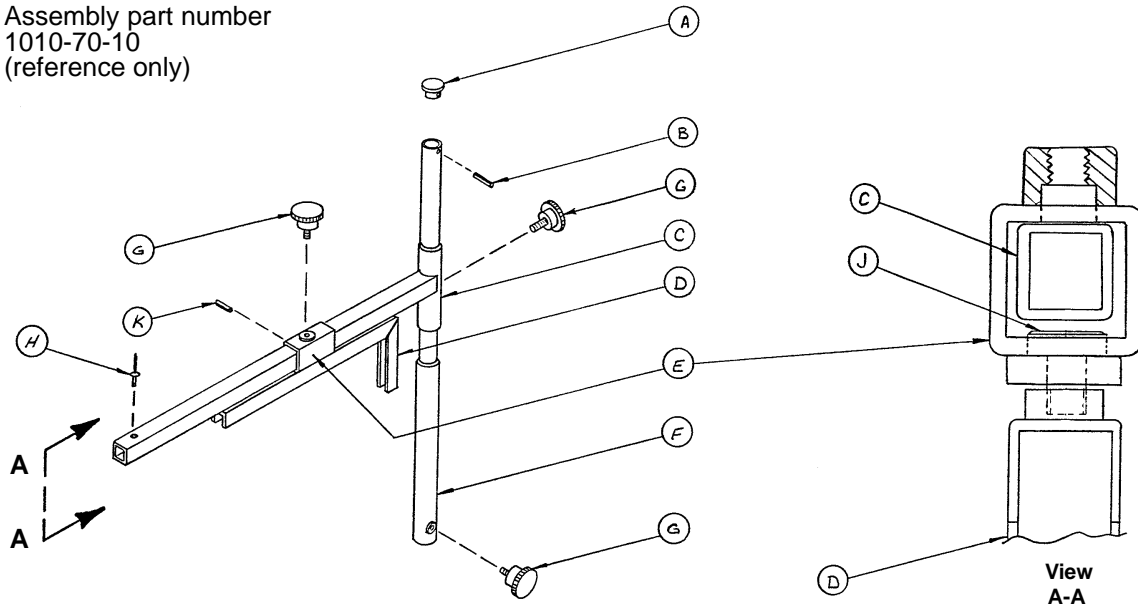

Item	Part No.	Part Name	Qty.
A	1010-70-33	Support Tube Cap	1
B	26-6	Roll Pin	1
C	1010-70-34	Support Arm Weldment	1
D	1010-70-42	Cassette Holder Weldment	1
E	1010-70-50	Adjustment Tube Weldment	1
F	1010-70-30	Base Tube Weldment	1
G	1010-70-45	Knob	3
H	25-55	Pop Rivet	1
J	1010-70-44	Pivot Pin	1
K	26-5	Roll Pin	1

# 1020-70-19 C-Spine Storage Bracket Assembly

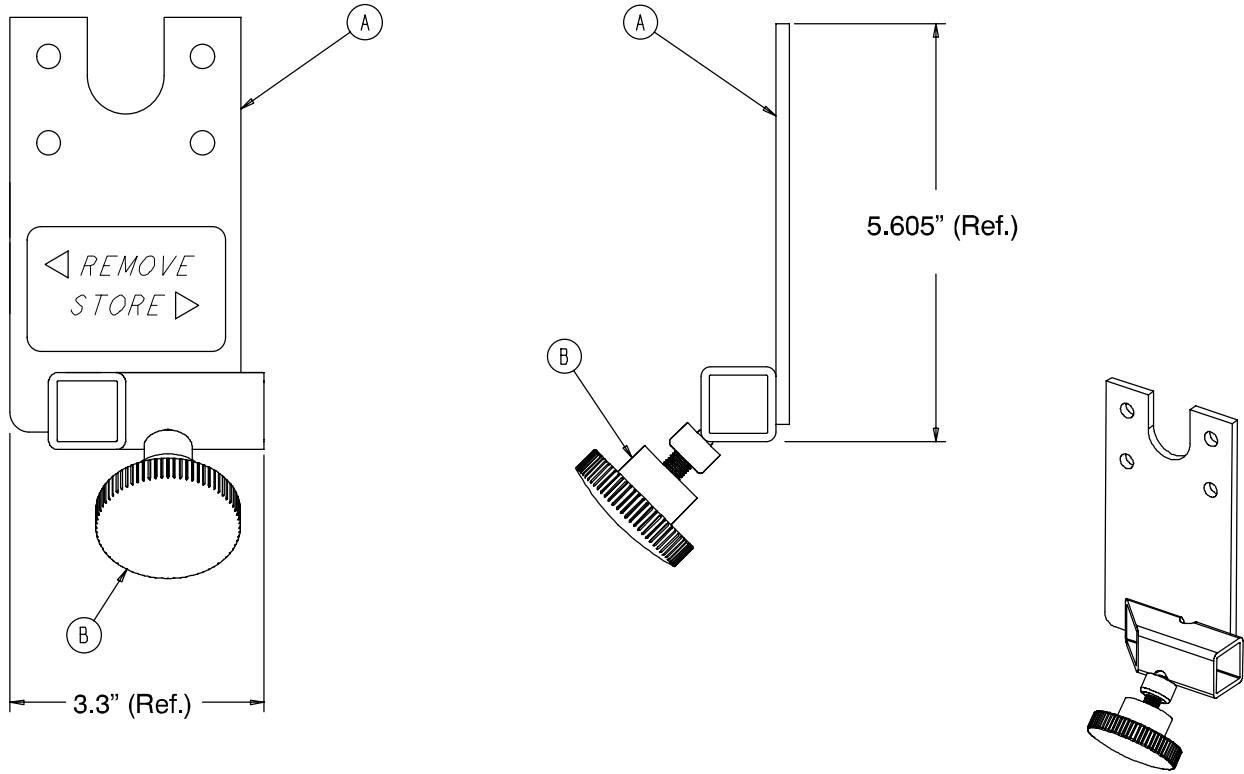

Item	Part No.	Part Name	Qty.
A	1020-70-20	Storage Bracket Weldment	1
B	1010-70-45	Knob	1
C	1010-70-23	Storage Label	1

# 1040-10-90 Optional O<sub>2</sub> Bottle Retainer Assembly

---

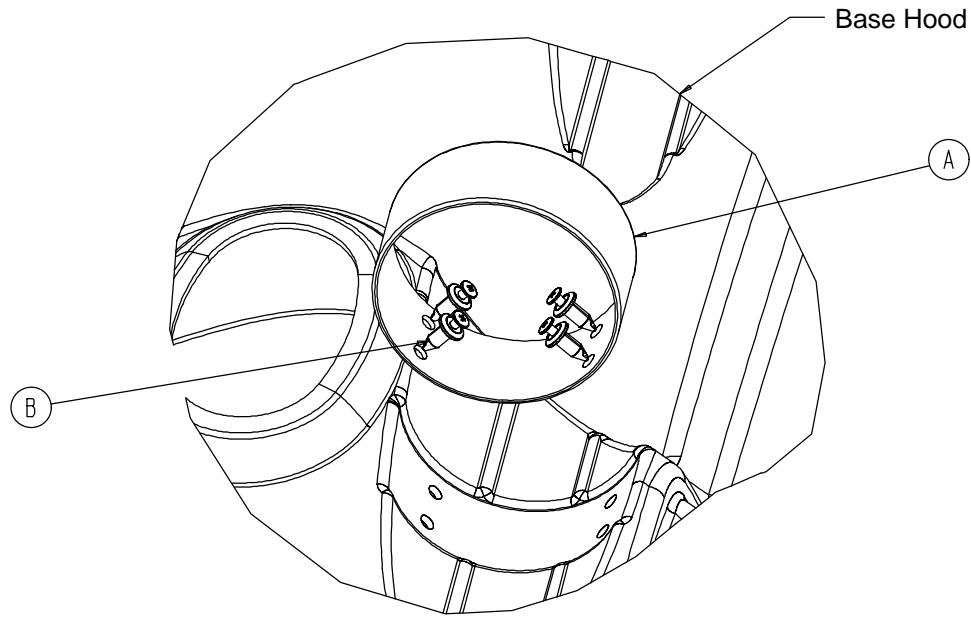

Item	Part No.	Part Name	Qty.
A	1040-10-91	Bottle Retainer	1
B	1040-10-92	Scrulok Fastener	4

# Mattresses and Siderail Pads

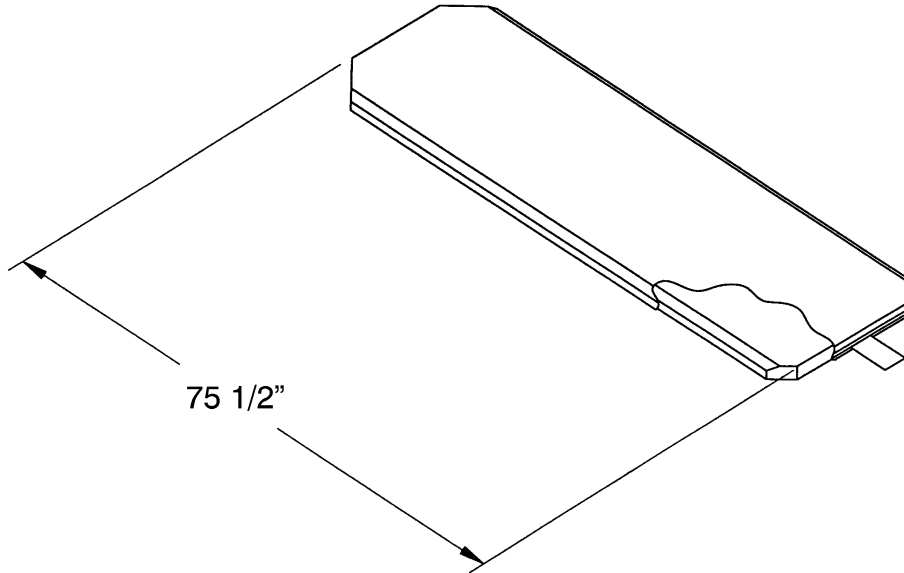

- Mattress, 2" Thick x 24" Wide, Standard ..... part # 1059-226-140
- Mattress, 3" Thick x 26" Wide, Standard ..... part # 1059-326-140
- Mattress, 3" Thick x 26" Wide, Enhanced Comfort ..... part # 1001-48-106
- Mattress, 4" Thick x 26" Wide, Enhanced Comfort ..... part # 1001-47-106
- Mattress, 4" Thick x 26" Wide, Ultra Comfort ..... part # 1210-40
- Mattress, 5" Thick x 26" Wide, Ultra Comfort ..... part # 1210-50

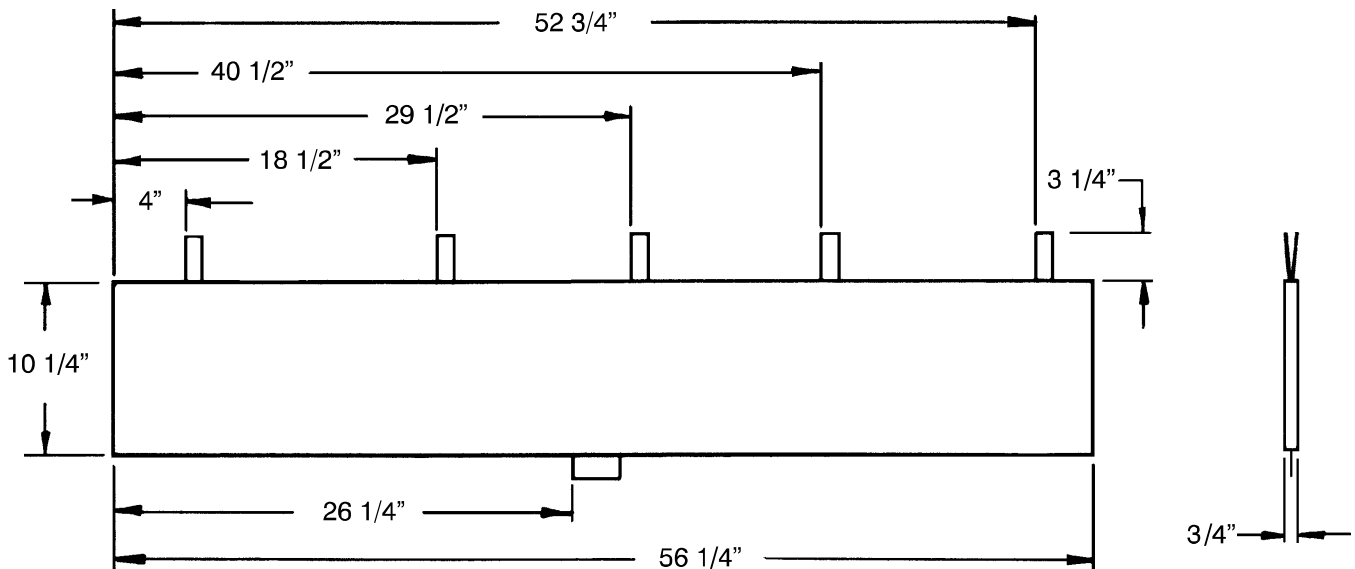

- Siderail Pad Set ..... part # 1010-52

# Echo Mattresses

---

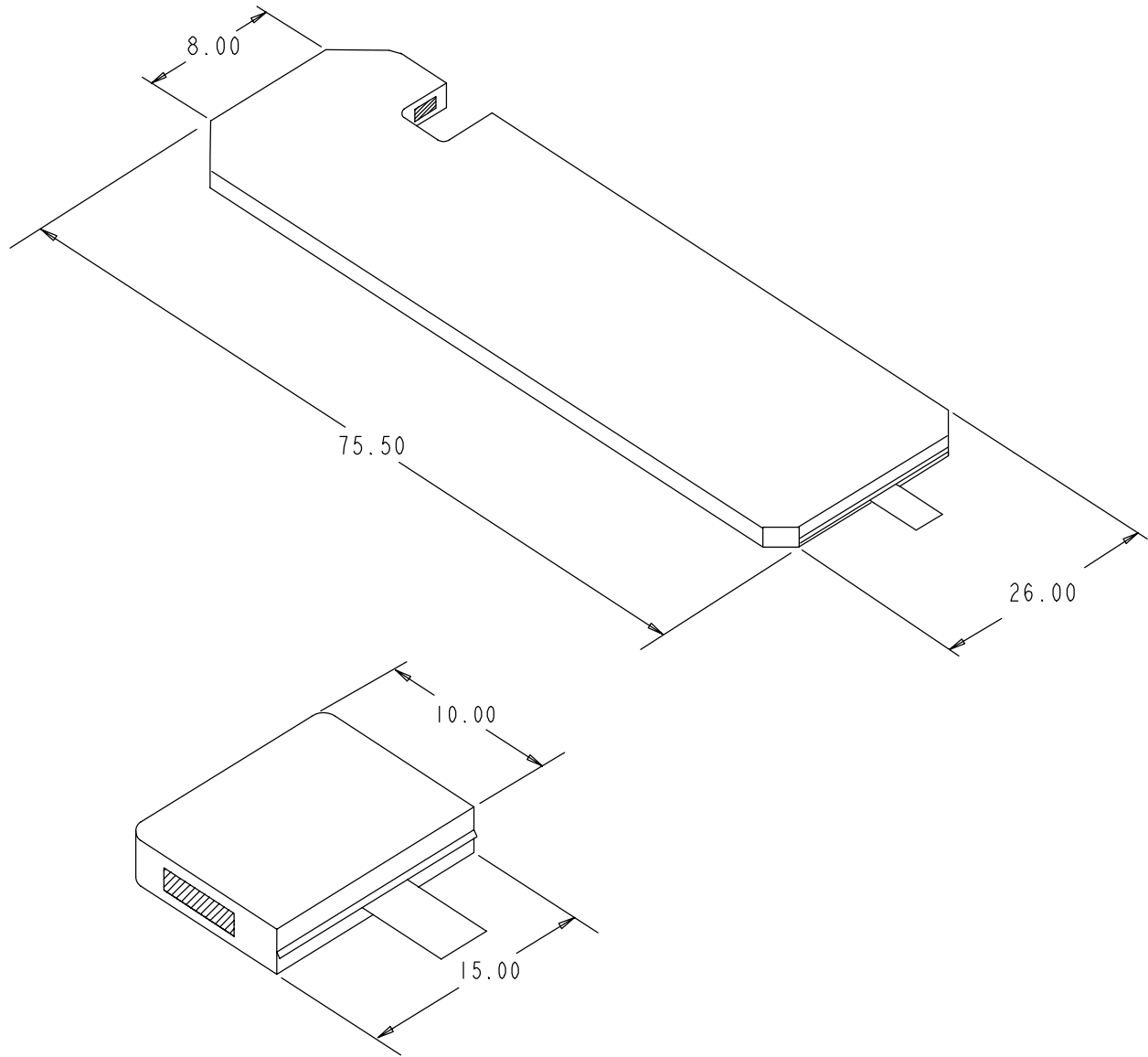

Mattress, 26" Wide ..... part # 1059-459-10  
Cut-Out Mattress ..... part # 1059-426-28

# Warranty

---

## Limited Warranty:

Stryker Medical Division, a division of Stryker Corporation, warrants to the original purchaser that its products should be free from defects in material and workmanship for a period of one (1) year after date of delivery. Stryker's obligation under this warranty is expressly limited to supplying replacement parts and labor for, or replacing, at its option, any product which is, in the sole discretion of Stryker, found to be defective. Stryker warrants to the original purchaser that the frame and welds on its beds will be free from structural defects for as long as the original purchaser owns the bed. If requested by Stryker, products or parts for which a warranty claim is made shall be returned prepaid to Stryker's factory. Any improper use or any alteration or repair by others in such manner as in Stryker's judgement affects the product materially and adversely shall void this warranty. Any repair of Stryker products using parts not provided or authorized by Stryker shall void this warranty. No employee or representative of Stryker is authorized to change this warranty in any way.

Stryker Medical stretchers are designed for a 10 year expected life under normal use conditions and appropriate periodic maintenance as described in the maintenance manual for each device.

This statement constitutes Stryker's entire warranty with respect to the aforesaid equipment. STRYKER MAKES NO OTHER WARRANTY OR REPRESENTATION, EITHER EXPRESSED OR IMPLIED, EXCEPT AS SET FORTH HEREIN. THERE IS NO WARRANTY OF MERCHANTABILITY AND THERE ARE NO WARRANTIES OF FITNESS FOR ANY PARTICULAR PURPOSE. IN NO EVENT SHALL STRYKER BE LIABLE HEREUNDER FOR INCIDENTAL OR CONSEQUENTIAL DAMAGES ARISING FROM OR IN ANY MANNER RELATED TO SALES OR USE OF ANY SUCH EQUIPMENT.

## To Obtain Parts and Service:

Stryker products are supported by a nationwide network of dedicated Stryker Field Service Representatives. These representatives are factory trained, available locally, and carry a substantial spare parts inventory to minimize repair time. Simply call your local representative, or call Stryker Customer Service at (800) 327-0770.

## Service Contract Coverage:

Stryker has developed a comprehensive program of service contract options designed to keep your equipment operating at peak performance at the same time it eliminates unexpected costs. We recommend that these programs be activated *before* the expiration of the new product warranty to eliminate the potential of additional equipment upgrade charges.

## **A SERVICE CONTRACT HELPS TO:**

- Ensure equipment reliability
- Stabilize maintenance budgets
- Diminish downtime
- Establish documentation for JCAHO
- Increase product life
- Enhance trade-in value
- Address risk management and safety

# Warranty

**Stryker offers the following service contract programs:**

SPECIFICATIONS	GOLD	SILVER	PM* ONLY
Annually scheduled preventative maintenance	X		X
All parts,** labor, and travel	X	X	
Unlimited emergency service calls	X	X	
Priority one contact; two hour phone response	X	X	X
Most repairs will be completed within 3 business days	X	X	
JCAHO documentation	X	X	X
On-site log book w/ preventative maintenance & emergency service records	X		
Factory-trained Stryker Service Technicians	X	X	X
Stryker authorized parts	X	X	X
End of year summary	X		
Stryker will perform all service during regular business hours (9-5)	X	X	X

\* Replacement parts and labor for products under PM contract will be discounted.

\*\* Does not include any disposable items, I.V. poles (except for Stryker HD permanent poles), mattresses, or damage resulting from abuse.

**Stryker Medical also offers *personalized* service contracts.**

**Pricing is determined by age, location, model and condition of product.**

**For more information on our service contracts,  
please call your local representative or call (800) 327-0770 (option #2).**

## **Return Authorization:**

Merchandise cannot be returned without approval from the Stryker Customer Service Department. An authorization number will be provided which must be printed on the returned merchandise. Stryker reserves the right to charge shipping and restocking fees on returned items.

SPECIAL, MODIFIED, OR DISCONTINUED ITEMS NOT SUBJECT TO RETURN.

## **Damaged Merchandise:**

ICC Regulations require that claims for damaged merchandise must be made with the carrier within fifteen (15) days of receipt of merchandise. **DO NOT ACCEPT DAMAGED SHIPMENTS UNLESS SUCH DAMAGE IS NOTED ON THE DELIVERY RECEIPT AT THE TIME OF RECEIPT.** Upon prompt notification, Stryker will file a freight claim with the appropriate carrier for damages incurred. Claim will be limited in amount to the actual replacement cost. In the event that this information is not received by Stryker within the fifteen (15) day period following the delivery of the merchandise, or the damage was not noted on the delivery receipt at the time of receipt, the customer will be responsible for payment of the original invoice in full.

Claims for any short shipment must be made within thirty (30) days of invoice.

## **International Warranty Clause:**

This warranty reflects U.S. domestic policy. Warranty outside the U.S. may vary by country. Please contact your local Stryker Medical representative for additional information.





## **European Representative**

Stryker EMEA RA/QA Director  
Stryker France  
ZAC Satolas Green Pusignan  
Av. De Satolas Green  
69881 MEYZIEU Cedex  
France

**stryker<sup>®</sup>**  
**Medical**

6300 S. Sprinkle Road, Kalamazoo, MI 49001 - 9799

(800) 327-0770  
[www.strykermedical.com](http://www.strykermedical.com)



DH 7/03 1020-032-134 REV L