

Prime TC®



















Operations Manual

REF 1460

Transport Chair



Symbols

	Consult instructions for use
	General warning
	Caution
	Warning; crushing of hands
	No pushing
	Catalogue number
	Serial number
	For US Patents see www.stryker.com/patents
	CE mark
	Authorized representative in the European Community
	UK Conformity Assessment mark
	Importer
	Unique device identifier
	Authorized representative in Switzerland
	European medical device
	Manufacturer
	Date of manufacture
	Safe working load





	Lubricate
	Fragile, handle with care
	Keep dry
	This way up
	Do not stack

Table of Contents

Warning/Caution/Note Definition	2
Summary of safety precautions	2
Pinch points	4
Introduction	5
Product description	5
Intended use	5
Clinical benefits	5
Expected service life	5
Disposal/recycle	6
Contraindications	6
Specifications	6
Product illustration	8
Contact information	9
Serial number location	9
Date of manufacture	9
Setup	10
Operation	11
Applying or releasing the brake	11
Transferring an occupant	12
Removing an occupant	12
Positioning the flip-up footrest	13
Stowing the flip-up footrest	14
Positioning the swing-away footrest	14
Stowing the swing-away footrest	15
Raising or lowering the flip-up armrests	16
Storing records in the chart holder	17
Transporting an occupant	18
Securing an oxygen bottle in the oxygen bottle holder	19
Accessories and parts	21
Securing the foley bag to the optional foley bag hook	21
Securing an IV bag to the optional IV pole	22
Fastening the lap belt	23
Positioning the leg rest	24
Stowing the leg rest	25
Optional ground chain	26
Cleaning and disinfecting with wipes	28
Cleaning	29
Preventive maintenance	30

Warning/Caution/Note Definition

The words **WARNING**, **CAUTION**, and **NOTE** carry special meanings and should be carefully reviewed.

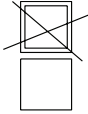
WARNING

Alerts the reader about a situation which, if not avoided, could result in death or serious injury. It may also describe potential serious adverse reactions and safety hazards.

CAUTION

Alerts the reader of a potentially hazardous situation which, if not avoided, may result in minor or moderate injury to the user or patient or damage to the product or other property. This includes special care necessary for the safe and effective use of the device and the care necessary to avoid damage to a device that may occur as a result of use or misuse.

Note - Provides special information to make maintenance easier or important instructions clearer.

Summary of safety precautions

Always read and strictly follow the warnings and cautions listed on this page. Service only by qualified personnel.

WARNING

- Always apply the brake when an occupant is getting in the product or out of the product to avoid instability.
 - Do not overload the product above the safe working load of 500 lb (226.8 kg).
 - Do not allow the occupant to lean outside of the perimeter of the product to avoid tipping.
 - Do not use the product on ramps or slopes that are greater than 5.7 degrees to avoid instability.
 - Do not lift the product or lower the product while occupied.
 - Always properly secure the oxygen bottle to the oxygen bottle holder before moving the product.
 - Do not activate the leg rest release latch with an occupant's leg on the leg rest.
-

CAUTION

- Improper usage of the product can cause injury to the occupant or operator. Operate the product only as described in this manual.
- Do not modify the product or any components of the product. Modifying the product can cause unpredictable operation resulting in injury to occupant or operator. Modifying the product also voids its warranty.
- Always apply the brake to prevent unintended movement.
- Do not apply the brake pedal to stop a moving product.
- Do not place car seats, infant carriers, or other objects on the product seat or on the occupant's lap.
- Always keep occupant extremities and operator extremities away from the flip-up armrest when raising or lowering the armrest to avoid the risk of pinching.
- Do not hang items on the push handles, chart holder, optional oxygen bottle holder, or flip-up armrests to avoid instability.
- Always clear the path of the swing-away footrests before activation to avoid entrapment.
- Do not sit, stand, or lean on the flip-up armrests, footrest, leg rest, or seat back to avoid instability.
- Do not use the flip-up armrests, chart holder, optional oxygen bottle holder, or the optional IV pole as a push or pull device.
- Always clear fingers from the armrest release latch before releasing the latch to avoid the risk of pinching.
- Always transport the occupant with their feet on the footrests.
- Always avoid the pinch point between the flip-up armrest, seat back, and seat when repositioning the flip-up armrest. The flip-up armrest should remain down (in the forward position) when the chair is occupied and should only be in the stowed position to assist with getting in the product or getting out of the product.
- Do not put items weighing more than 6 lb (2.72 kg) in the chart holder.
- Do not roll the product on the anti-tip wheels.
- Do not transport with more than one occupant in the product to avoid instability.

- Always carefully transport the product over thresholds and small ledges to make sure that the wheels roll smoothly and the product is stable.
 - Always keep occupant extremities and operator extremities away from the flip-up armrest when raising the armrest or lowering the armrest to avoid the risk of pinching.
 - Do not operate the product on soft or unstable surfaces, such as sand, grass, or gravel, to avoid instability or difficult mobility.
 - Always use safe lifting techniques with two operators when lifting the empty product over a barrier. Lift the product by the main frame tubes only. Do not lift the product by the armrests, footrests, accessories, or seating surfaces.
 - The optional oxygen bottle holder is designed for type E class oxygen bottles only.
 - Always make sure that you only attach foley bags to the optional foley bag hook.
 - Always properly secure the IV bags to the hooks on the optional IV pole or the foley bags to the optional foley bag hook before moving the product.
 - Do not hang a foley bag over the safe working load of 10 lb (4.53 kg) on the optional foley bag hook.
 - Always make sure that you only attach standard IV bags to the optional IV pole.
 - Do not load the optional IV pole above the safe working load of 6 lb (2.72 kg) (3 lb (1.36 kg) per hook).
 - Do not load the leg rest above the safe working load of 40 lb (18.14 kg).
 - Do not steam clean the product.
 - Always make sure that all labels are intact, brake pedal and go pedal lock properly in both positions, and check all components for proper lubrication before you return the product to service after cleaning.
 - Always make sure that you wipe each product with clean water and thoroughly dry each product after cleaning. Some cleaning products are corrosive in nature and may cause damage to the product if you use them improperly. If you do not properly rinse and dry the product, a corrosive residue may be left on the surface of the product that could cause premature corrosion of critical components. Failure to follow these cleaning instructions may void your warranty.
-

Pinch points

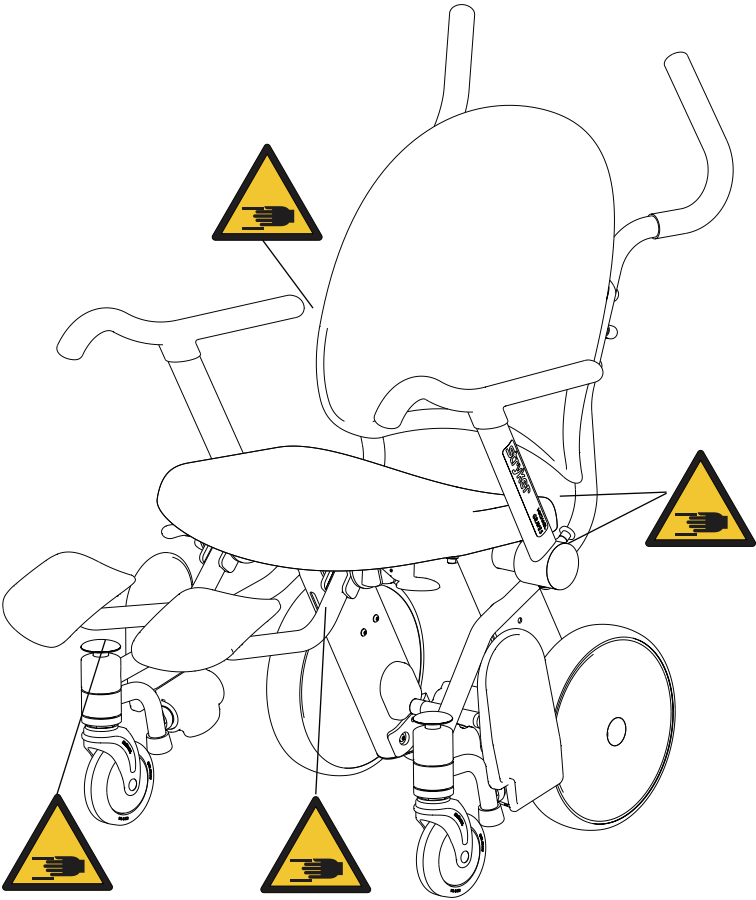

Figure 1 – Pinch points

Introduction

This manual assists you with the operation or maintenance of your Stryker product. Read this manual before operating or maintaining this product. Set methods and procedures to educate and train your staff on the safe operation or maintenance of this product.

CAUTION

- Improper usage of the product can cause injury to the occupant or operator. Operate the product only as described in this manual.
 - Do not modify the product or any components of the product. Modifying the product can cause unpredictable operation resulting in injury to occupant or operator. Modifying the product also voids its warranty.
-

Note

- This manual is a permanent part of the product and should remain with the product even if the product is sold.
- Stryker continually seeks advancements in product design and quality. This manual contains the most current product information available at the time of printing. There may be minor discrepancies between your product and this manual. If you have any questions, contact Stryker Customer Service or Technical Support at 1-800-327-0770.

Product description

The Stryker Model 1460 **Prime TC**® is a manual, operator-propelled chair that is designed to transport occupants in the seated position with their associated medical equipment (such as an oxygen bottle, IV fluid bags, or a foley catheter bag). The product is equipped with a brake mechanism that immobilizes the rear wheels for increased stability and assists with occupant entry and exit.

Intended use

Prime TC is a transport chair that is intended for medical purposes to assist a person in performing an activity that the person would find difficult to do or be unable to do. **Prime TC** is intended for occupants who have the ability to hold themselves in an upright, seated position, unassisted, and in compliance with facility guidelines for transporting.

Expected use of **Prime TC** is to support the occupant in an upright, seated position with their back against the seat back and their feet and arms on the provided resting surfaces. For transport, the operator pushes the chair from behind by gripping the provided handles. Users should not sit on the arms, stand upright on any surface, or lean on the arms or seat back from a standing position. Intended operators include healthcare transporters (escorts), nurses, other healthcare professionals, family members, and individuals who accompany the occupant.

Prime TC is intended for use inside healthcare facilities and outside healthcare facilities, and in adjacent locations, including parking lots. Transport activity includes curbside admissions and discharge, interdepartmental and intradepartmental transport, and transport in elevators. **Prime TC** has a safe working load of 500 lb (226.8 kg), including occupant and accessories. The typical duration of use can vary from several minutes to up to an hour. However, occupant wait time for certain events (for example, awaiting CT scan, MRI scan, or an X-ray) may exceed an hour.

Clinical benefits

Occupant transport and facilitate treatment (IV pole permanently attached)

Expected service life

Prime TC has a five year expected service life under normal use, conditions, and with appropriate periodic maintenance.

Disposal/recycle

Always follow the current local recommendations and/or regulations governing environmental protection and the risks associated with recycling or disposing of the equipment at the end of its useful life.

Contraindications

None known.

Specifications

		500 lb	226.8 kg
Note - Safe working load indicates the sum of the occupant and accessory weight.			
Base model weight (without options)		90.7 lb	41.14 kg
Note - Weight may vary by 1 lb.			
Width	Overall width	28.3 in.	71.8 cm
	Seat width	21.5 in.	54.6 cm
Seat height	From footrests	15 in.	38.1 cm
	From floor	21 in.	53.3 cm
Height	With IV pole	73 in.	185.4 cm
	Without IV pole	45 in.	114.3 cm
Push handle grip range	Width	16 - 20.5 in.	40.6 - 52.1 cm
	Height from floor	35 - 45 in.	88.9 - 114.3 cm
Nesting	First chair length	39.8 in.	101.0 cm
	First chair length with footrest stowed	33.4 in.	84.8 cm
	Length added by each additional nested chair	20.5 in.	52.1 cm

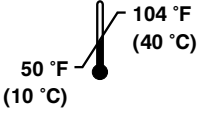
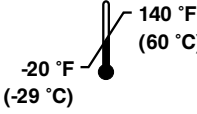
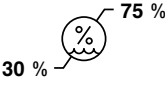
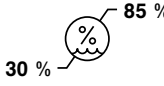
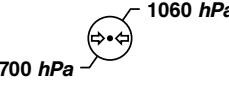
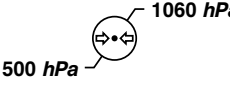
Environmental Conditions	Operation	Storage and Transportation
Temperature		
Relative Humidity		
Atmospheric Pressure		

Specifications listed are approximate and may vary slightly from product to product.

Stryker reserves the right to change specifications without notice.

Product illustration

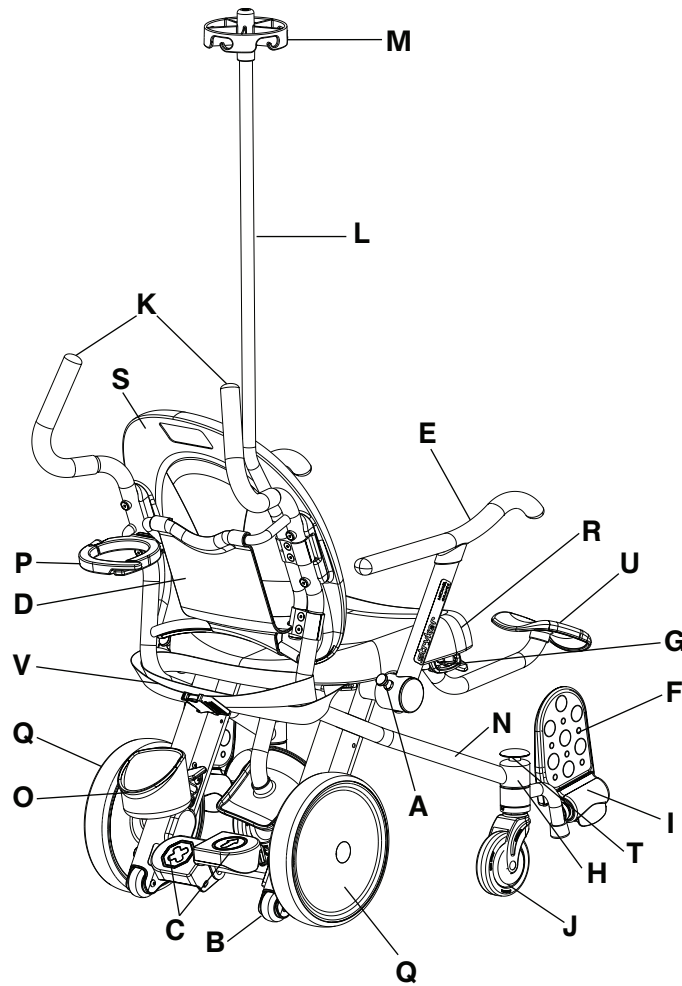

Figure 2 – Prime TC

A	Armrest release	L	IV pole, optional
B	Anti-tip wheels	M	IV pole topper, optional
C	BackSmart™ brake/go pedals	N	Main frame tubes
D	Chart holder	O	BackSmart oxygen bottle holder bottom, optional
E	BackSmart flip-up armrest	P	BackSmart oxygen bottle holder top, optional
F	BackSmart flip-up footrest	Q	Rear wheel
G	Foley bag hook, optional	R	Seat
H	Footrest assembly, swing-away	S	Seat back
I	Footrest lever	T	Swing-away footrest release
J	Front caster	U	Leg rest, optional
K	BackSmart handles	V	Lap belt, optional

Contact information

Contact Stryker Customer Service or Technical Support at: 1-800-327-0770.

Stryker Medical
3800 E. Centre Avenue
Portage, MI 49002
USA

Note - The user and/or the occupant should report any serious product-related incident to both the manufacturer and the Competent authority of the European Member State where the user and/or occupant is established.

To view your operations or maintenance manual online, see <https://techweb.stryker.com/>.

Have the serial number (A) of your Stryker product available when calling Stryker Customer Service or Technical Support. Include the serial number in all written communication.

Serial number location

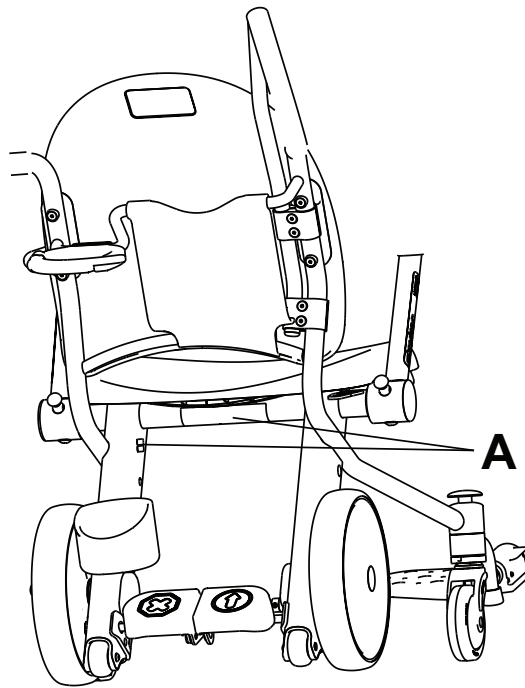

Date of manufacture

The year of manufacture is the first four digits of the serial number.

Setup

Before placing the product into service, make sure that these components are working properly:

1. Visually inspect the product for any signs of shipping damage.
2. Push down on the brake pedal and push on the chair to make sure that the rear wheels are locked.
3. Raise and lower the flip-up armrests to make sure that they move smoothly and lock in the forward position.
4. Make sure that the flip-up footrests automatically raise when feet are removed from the footrests and flip down when the footrest lever is pushed up.
5. Press the yellow swing-away footrest release button and make sure that the footrests rotate into the stowed position.
6. Return the swing-away footrest to the use position and make sure that the footrest locks in place.
7. Make sure that any optional accessories are installed and operate as described in the operation instructions.

Operation

Applying or releasing the brake

WARNING - Always apply the brake when an occupant is getting in the product or out of the product to avoid instability.

CAUTION

- Always apply the brake to prevent unintended movement.
 - Do not apply the brake pedal to stop a moving product.
-

The brake pedal and go pedal are located on the back of the chair between the rear wheels (Figure 3). When you apply the brake, the rear wheels are locked, but you can still move the front casters.

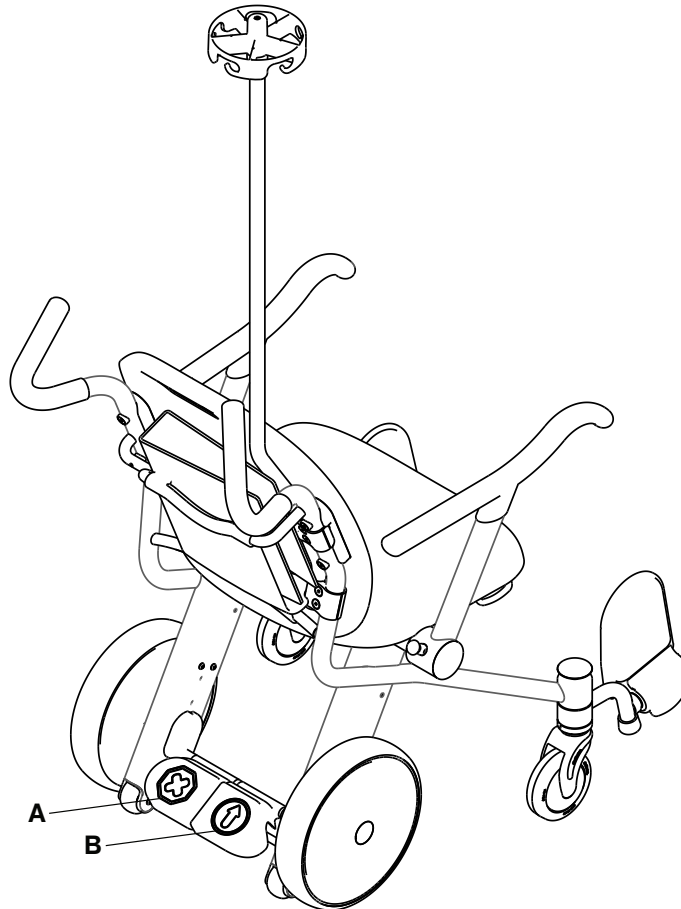

Figure 3 – Brake pedal and go pedal

To apply the brake, push down on the brake pedal (A).

To release the brake, push down on the go pedal (B).

Note - The rear wheel locking brake mechanism prevents rear wheel rotation only. The brake mechanism does not prevent the chair from sliding on the floor surface.

Transferring an occupant

WARNING

- Always apply the brake when an occupant is getting in the product or out of the product to avoid instability.
 - Do not overload the product above the safe working load of 500 lb (226.8 kg).
 - Do not allow the occupant to lean outside of the perimeter of the product to avoid tipping.
-

CAUTION

- Always apply the brake to prevent unintended movement.
 - Do not place car seats, infant carriers, or other objects on the product seat or on the occupant's lap.
 - Always keep occupant extremities and operator extremities away from the flip-up armrest when raising or lowering the armrest to avoid the risk of pinching.
 - Do not hang items on the push handles, chart holder, optional oxygen bottle holder, or flip-up armrests to avoid instability.
 - Always clear the path of the swing-away footrests before activation to avoid entrapment.
 - Do not sit, stand, or lean on the flip-up armrests, footrest, leg rest, or seat back to avoid instability.
 - Do not use the flip-up armrests, chart holder, optional oxygen bottle holder, or the optional IV pole as a push or pull device.
-

Only use **Prime TC** for single occupants who have the ability to hold themselves in an upright, seated position, unassisted, and in compliance with facility guidelines for transporting occupants.

To transfer an occupant (see *Stowing the flip-up footrest* (page 14)):

Note - Keep the footrest in the stowed position when there is no occupant in **Prime TC**.

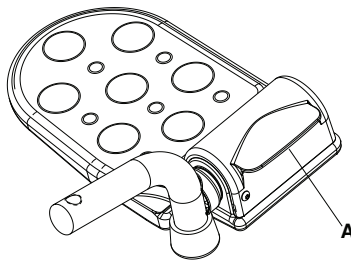

Figure 4 – Flip-up footrest lever

1. Position the chair near the occupant.
2. Push down on the brake pedal to apply the brake. Push on the product to make sure that the brake is working.
3. Assist the occupant in getting into **Prime TC**. Make sure that the occupant is seated in an upright position against the seat back.
4. Using your foot, lower the flip-up footrest to the transport position by lifting up on the footrest lever (A) (Figure 4).
5. Position the occupant's feet fully on the footrests.
6. Put the flip-up armrests down and make sure that the occupant's arms are fully positioned on the armrests.

Removing an occupant

WARNING

- Always apply the brake when an occupant is getting in the product or out of the product to avoid instability.
 - Do not allow the occupant to lean outside of the perimeter of the product to avoid tipping.
-

CAUTION

- Always apply the brake to prevent unintended movement.
 - Always clear the path of the swing-away footrests before activation to avoid entrapment.
 - Always keep occupant extremities and operator extremities away from the flip-up armrest when raising or lowering the armrest to avoid the risk of pinching.
 - Always clear fingers from the armrest release latch before releasing the latch to avoid the risk of pinching.
 - Do not sit, stand, or lean on the flip-up armrests, footrest, leg rest, or seat back to avoid instability.
-

To remove an occupant:

1. Push down on the brake pedal to apply the brake. Push on the product to make sure that the brake is working.
2. Make sure that the occupant's feet are clear of the flip-up footrests and that the flip-up footrests have moved to the stowed position.
3. Remove the occupant from the product following facility protocol.

Positioning the flip-up footrest

CAUTION

- Always apply the brake to prevent unintended movement.
 - Always transport the occupant with their feet on the footrests.
-

To position the flip-up footrest in place for use (Figure 5):

1. Push down on the brake pedal to apply the brake. Push on the product to make sure that the brake is working.
2. Make sure that the occupant's feet are clear of the flip-up footrests (A).

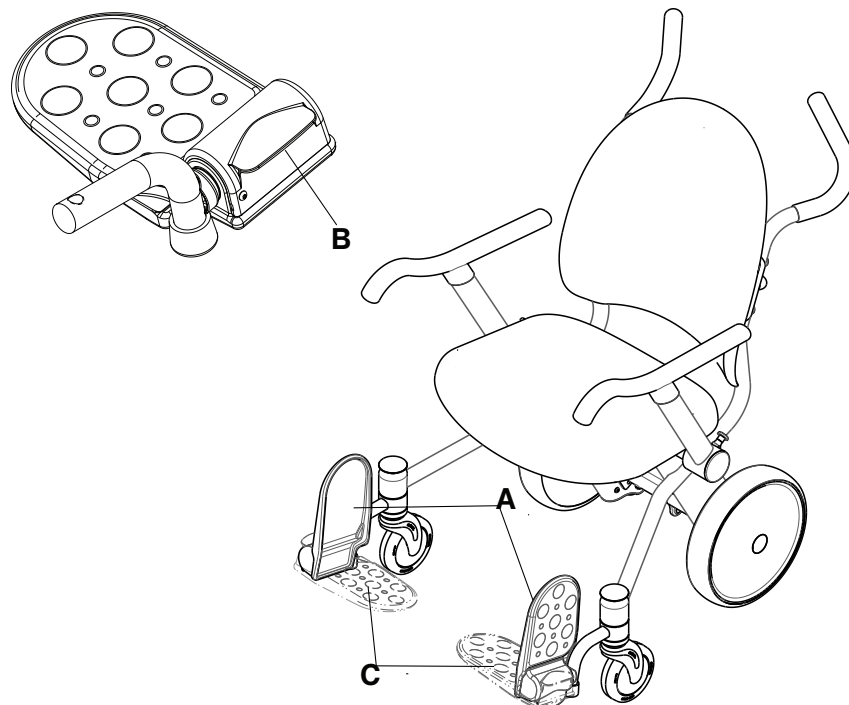

Figure 5 – Flip-up footrest transport position

3. Using your foot, lower the flip-up footrest to the transport position by lifting up on the footrest lever (B).
4. Position the occupant's feet fully on the flip-up footrests (C).

Stowing the flip-up footrest

CAUTION

- Always apply the brake to prevent unintended movement.
 - Always transport the occupant with their feet on the footrests.
-

To stow the flip-up footrest:

1. Make sure that the occupant's feet are clear of the flip-up footrests.

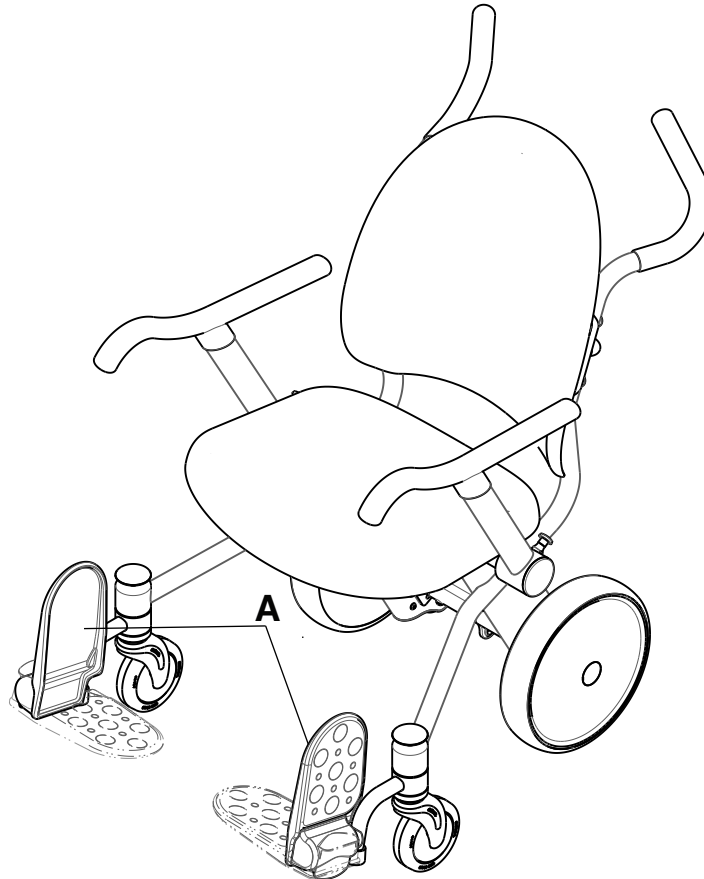

Figure 6 – Flip-up footrests stowed position

2. Make sure that the flip-up footrests raise to the stowed position (A) (Figure 6).

Positioning the swing-away footrest

CAUTION

- Always apply the brake to prevent unintended movement.
 - Always clear the path of the swing-away footrests before activation to avoid entrapment.
-

To position the swing-away footrest for use (Figure 7):

1. Push down on the brake pedal to apply the brake. Push on the product to make sure that the brake is working.
2. Make sure that the occupant's feet are clear of the swing-away footrest.
3. Swing each swing-away footrest into the use position and make sure that the footrest is locked in place.
4. Make sure that the occupant's feet are clear of the flip-up footrest (A).

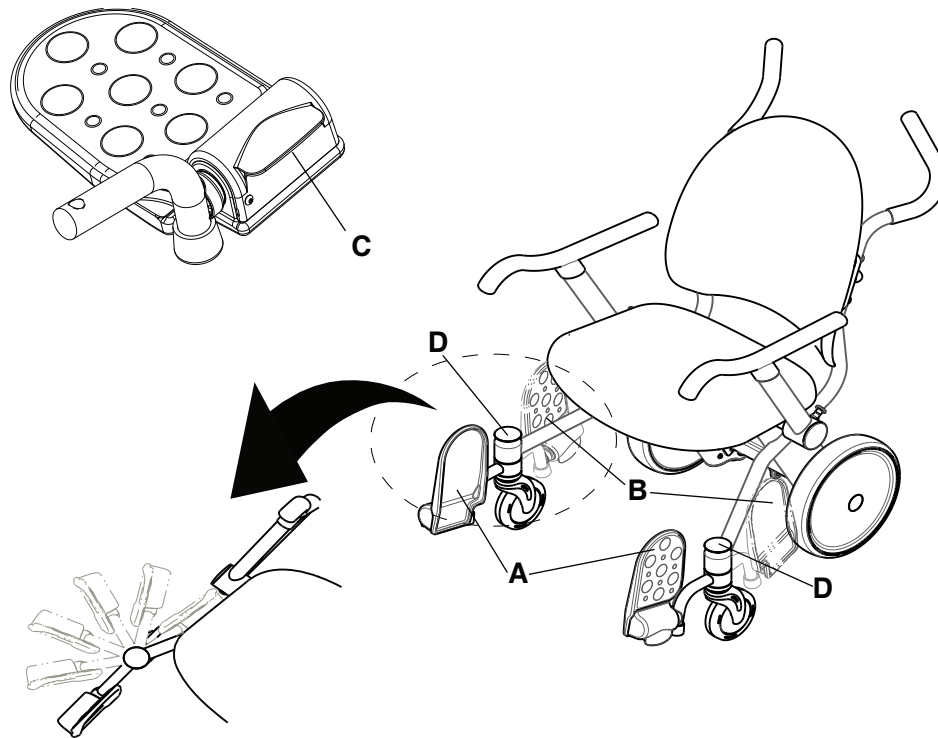

Figure 7 – Swing-away footrest use position

5. Using your foot, lower the flip-up footrest to the transport position by lifting up on the footrest lever (C).
6. Position the occupant's feet fully on the flip-up footrests (A).

Stowing the swing-away footrest

CAUTION

- Always apply the brake to prevent unintended movement.
- Always clear the path of the swing-away footrests before activation to avoid entrapment.

To stow the swing-away footrests (Figure 8):

1. Make sure that the occupant's feet are clear of the flip-up footrests.
2. Make sure that the flip-up footrests raise to the stowed position (A).

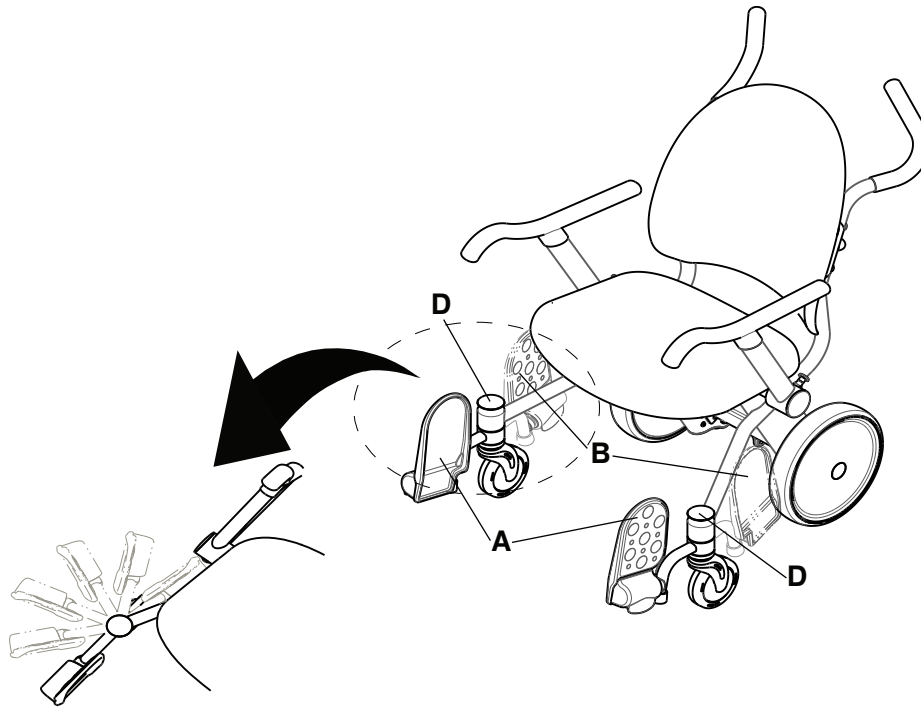

Figure 8 – Swing-away footrest stowed position

3. Clear the path of the swing-away footrests.
4. Using your foot, press the yellow swing-away footrest release button (D) on the top of the swing-away footrest and put the swing-away footrest in the stowed position (B).

Raising or lowering the flip-up armrests

CAUTION

- Always keep occupant extremities and operator extremities away from the flip-up armrest when raising or lowering the armrest to avoid the risk of pinching.
 - Always clear fingers from the armrest release latch before releasing the latch to avoid the risk of pinching.
 - Always avoid the pinch point between the flip-up armrest, seat back, and seat when repositioning the flip-up armrest. The flip-up armrest should remain down (in the forward position) when the chair is occupied and should only be in the stowed position to assist with getting in the product or getting out of the product.
 - Do not sit, stand, or lean on the flip-up armrests, footrest, leg rest, or seat back to avoid instability.
 - Do not hang items on the push handles, chart holder, optional oxygen bottle holder, or flip-up armrests to avoid instability.
 - Do not use the flip-up armrests, chart holder, optional oxygen bottle holder, or the optional IV pole as a push or pull device.
-

Use both hands when raising the armrests or lowering the armrests. Use one hand to operate the armrest release button and the other hand to position the flip-up armrests.

To raise the flip-up armrests (rear position), pull outward on the yellow armrest release button (A) and raise the flip-up armrest until the armrest reaches the hard stop (Figure 9).

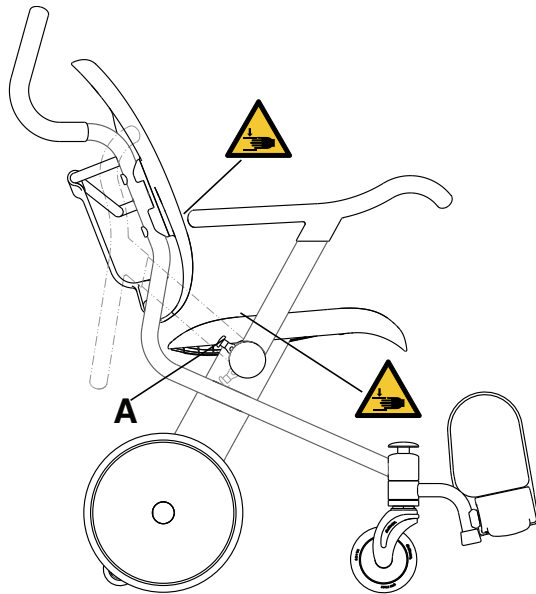

Figure 9 – Pinch points when raising armrests and lowering armrests

To lower the flip-up armrests (forward position), make sure that the occupant is clear of the flip-up armrest. Lower the flip-up armrest into the forward position until the armrest latches securely (Figure 9).

Storing records in the chart holder

CAUTION

- Do not hang items on the push handles, chart holder, optional oxygen bottle holder, or flip-up armrests to avoid instability.
 - Do not put items weighing more than 6 lb (2.72 kg) in the chart holder.
 - Do not use the flip-up armrests, chart holder, optional oxygen bottle holder, or the optional IV pole as a push or pull device.
-

Use the chart holder to store and transport occupant records (A) (Figure 10). The chart holder holds a 3-inch, three-ring binder.

Note - The sides of the chart holder are open for ease of cleaning. Do not put loose paperwork in the chart holder.

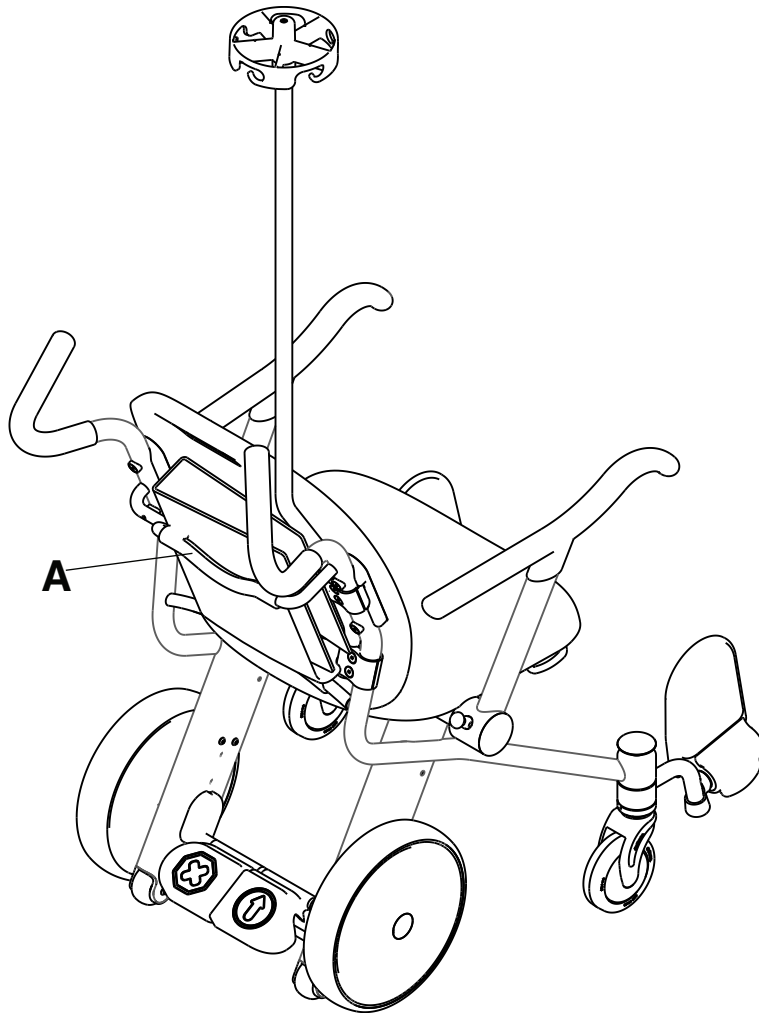

Figure 10 – Storing records in the chart holder

Transporting an occupant

WARNING

- Do not use the product on ramps or slopes that are greater than 5.7 degrees to avoid instability.
 - Do not overload the product above the safe working load of 500 lb (226.8 kg).
 - Do not allow the occupant to lean outside of the perimeter of the product to avoid tipping.
 - Do not lift the product or lower the product while occupied.
-

CAUTION

- Always apply the brake to prevent unintended movement.
- Do not apply the brake pedal to stop a moving product.
- Do not roll the product on the anti-tip wheels.
- Do not transport with more than one occupant in the product to avoid instability.
- Do not place car seats, infant carriers, or other objects on the product seat or on the occupant's lap.
- Always transport the occupant with their feet on the footrests.
- Always carefully transport the product over thresholds and small ledges to make sure that the wheels roll smoothly and the product is stable.
- Always keep occupant extremities and operator extremities away from the flip-up armrest when raising the armrest or lowering the armrest to avoid the risk of pinching.

- Do not operate the product on soft or unstable surfaces, such as sand, grass, or gravel, to avoid instability or difficult mobility.
 - Do not hang items on the push handles, chart holder, optional oxygen bottle holder, or flip-up armrests to avoid instability.
 - Always use safe lifting techniques with two operators when lifting the empty product over a barrier. Lift the product by the main frame tubes only. Do not lift the product by the armrests, footrests, accessories, or seating surfaces.
 - Do not use the flip-up armrests, chart holder, optional oxygen bottle holder, or the optional IV pole as a push or pull device.
-

Only use **Prime TC** for single occupants who have the ability to hold themselves in an upright, seated position, unassisted, and in compliance with facility guidelines for transporting occupants.

Note - When attempting to operate a heavily loaded product, the startup movement and mobility may be difficult.

To transport an occupant:

1. Face the back of the chair.
2. Grip the push handles with two hands.
3. Apply the go pedal.

Securing an oxygen bottle in the oxygen bottle holder

WARNING - Always properly secure the oxygen bottle to the oxygen bottle holder before moving the product.

CAUTION

- Do not use the flip-up armrests, chart holder, optional oxygen bottle holder, or the optional IV pole as a push or pull device.
 - Do not hang items on the push handles, chart holder, optional oxygen bottle holder, or flip-up armrests to avoid instability.
 - The optional oxygen bottle holder is designed for type E class oxygen bottles only.
-

To secure an oxygen bottle (Figure 11):

1. Make sure that the optional oxygen bottle holder bottom (B) is empty.

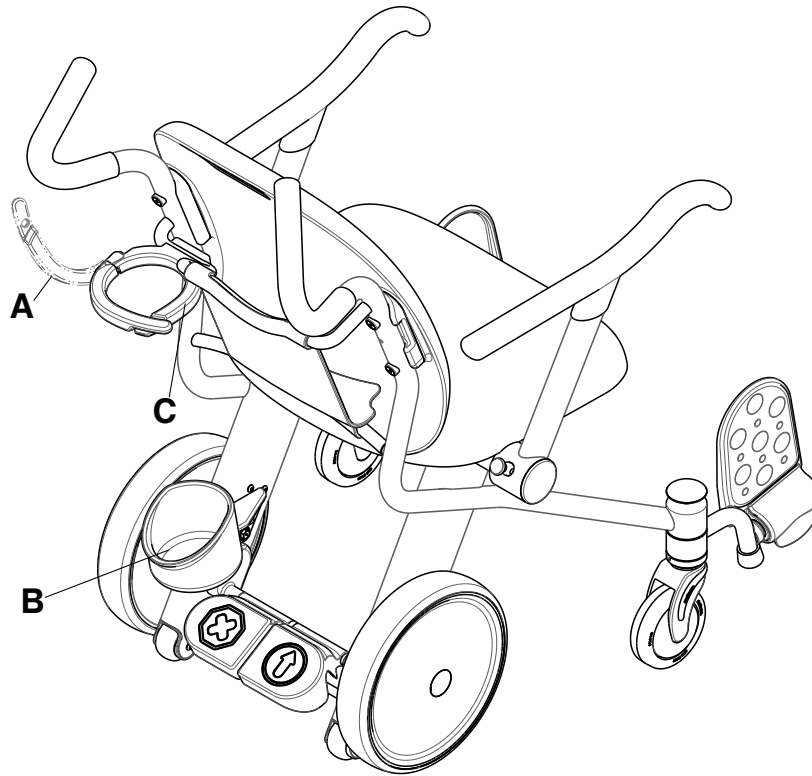

Figure 11 – Optional oxygen bottle holder top positions

2. Raise the yellow arm (A) on the optional oxygen bottle holder top.
3. Position the oxygen bottle in the optional oxygen bottle holder bottom (B). Make sure that the oxygen bottle is fully seated in the optional oxygen bottle holder.
4. Lower the yellow arm (A) on the optional oxygen bottle holder top (C) to secure the oxygen bottle.
5. Verify that the top latch is closed properly before moving the chair.

Accessories and parts

These accessories may be available for use with your product. Confirm availability for your configuration or region. Call Stryker Customer Service: 1-800-327-0770.

Name		Number
Foley bag hook option		1460-101-150
Foley bag hook with leg rest option		1460-001-200
Ground chain option		1460-075-000
Ground chain, none		1460-075-100
IV pole		1460-035-000
IV pole topper	Red	1460-035-024
	Dark lilac	1460-035-025
	Navy	1460-035-026
	Powder blue	1460-035-027
	Cool grey	1460-035-028
	Yellow	1460-035-029
Lap belt		1460-013-100
Leg rest option		1460-166-030
Oxygen bottle holder		1460-045-000
Oxygen bottle holder		1460-145-000
Padded seat option		1460-013-050

Securing the foley bag to the optional foley bag hook

CAUTION

- Always make sure that you only attach foley bags to the optional foley bag hook.
- Always properly secure the IV bags to the hooks on the optional IV pole or the foley bags to the optional foley bag hook before moving the product.
- Do not hang a foley bag over the safe working load of 10 lb (4.53 kg) on the optional foley bag hook.

To secure a foley bag to the optional foley bag hook, place the hook of the foley bag on the optional foley bag hook (A) (Figure 12). Make sure that you have securely attached the foley bag.

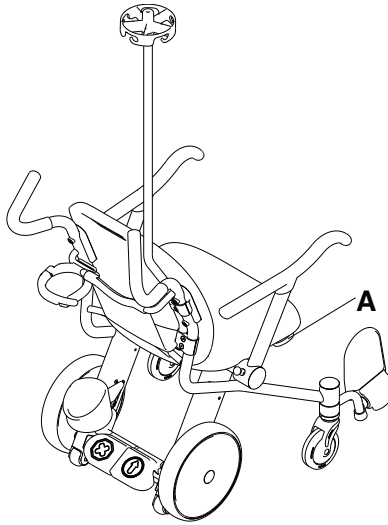

Figure 12 – Foley bag hook location

Securing an IV bag to the optional IV pole

CAUTION

- Always make sure that you only attach standard IV bags to the optional IV pole.
 - Do not load the optional IV pole above the safe working load of 6 lb (2.72 kg) (3 lb (1.36 kg) per hook).
 - Always properly secure the IV bags to the hooks on the optional IV pole or the foley bags to the optional foley bag hook before moving the product.
 - Do not use the flip-up armrests, chart holder, optional oxygen bottle holder, or the optional IV pole as a push or pull device.
-

To secure IV bags to optional IV pole:

1. Pull on the optional IV pole (A) to make sure that it is secure (Figure 13).

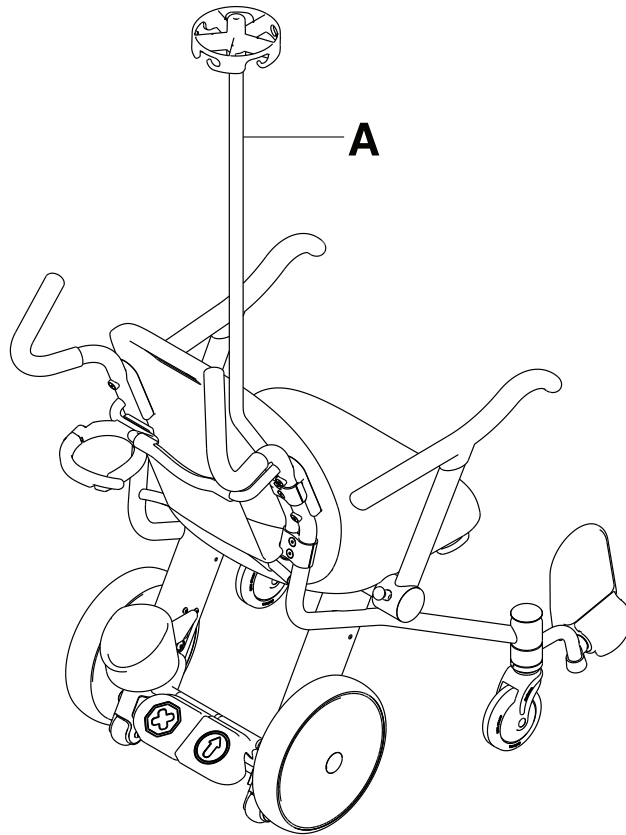

Figure 13 – IV pole

2. Place the IV bags onto the hooks and make sure that the bags are secure.

Fastening the lap belt

Open the lap belt straps and place them at either side of the chair while you position the occupant on the chair. Lengthen the lap belt straps, buckle them around the occupant, and shorten to the desired length.

1. To open the lap belt, grasp and squeeze the tabs (A) on the buckle latch. Pull on the buckle receiver (B) and the buckle latch (C) to separate them (Figure 14).

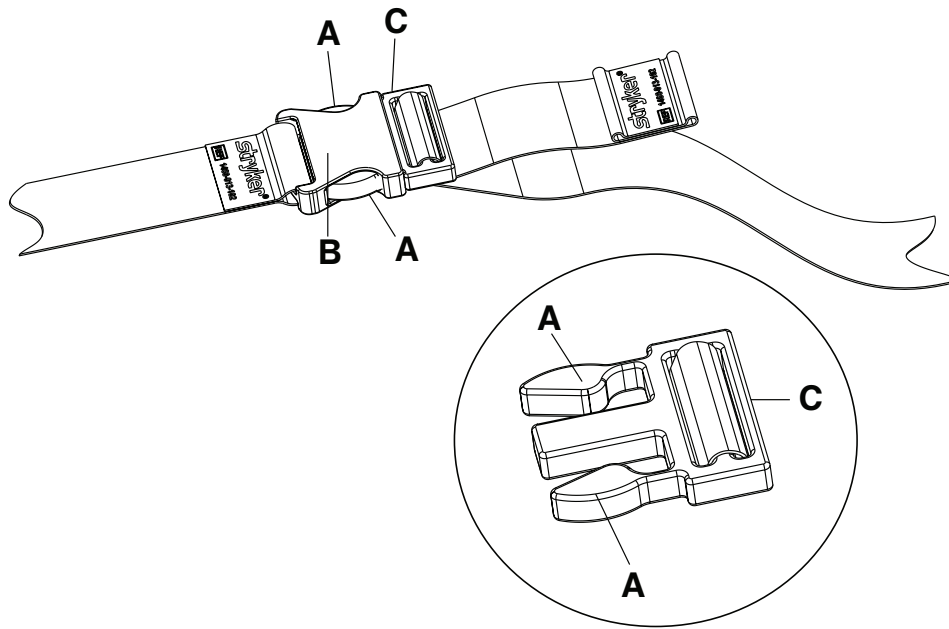

Figure 14 – Open the lap belt

2. To close the lap belt (Figure 15), push the buckle latch (C) into the buckle receiver (B) until you hear a click.

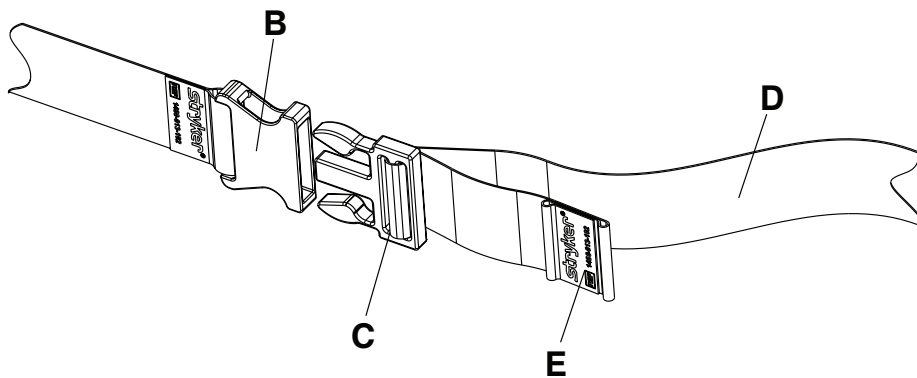

Figure 15 – Close the lap belt

3. To lengthen the lap belt, with one hand, grasp the buckle latch (C) and with the other hand, grasp the strap (D). Pull the strap out through the buckle latch (C) until you achieve the desired length.
4. To shorten the lap belt, with one hand, grasp the buckle receiver (B) and with the other hand, grasp the hemmed end of the strap (E). Pull the strap through the buckle receiver (B) until you achieve the desired length.
5. Make sure that the buckle latch (C) is secure. Do not allow any extra strap to hang loose or tangle in the wheels.
6. Inspect the lap belt at least once a month (more frequently if used more often). Check for a bent or broken receiver or buckle latch, or torn or frayed straps. Immediately replace any worn or inoperable lap belt strap.

Positioning the leg rest

WARNING - Do not activate the leg rest release latch with an occupant's leg on the leg rest.

CAUTION

- Always apply the brake to prevent unintended movement.
- Do not sit, stand, or lean on the flip-up armrests, footrest, leg rest, or seat back to avoid instability.

- Do not load the leg rest above the safe working load of 40 lb (18.14 kg).
-

To position the leg rest for use (Figure 16):

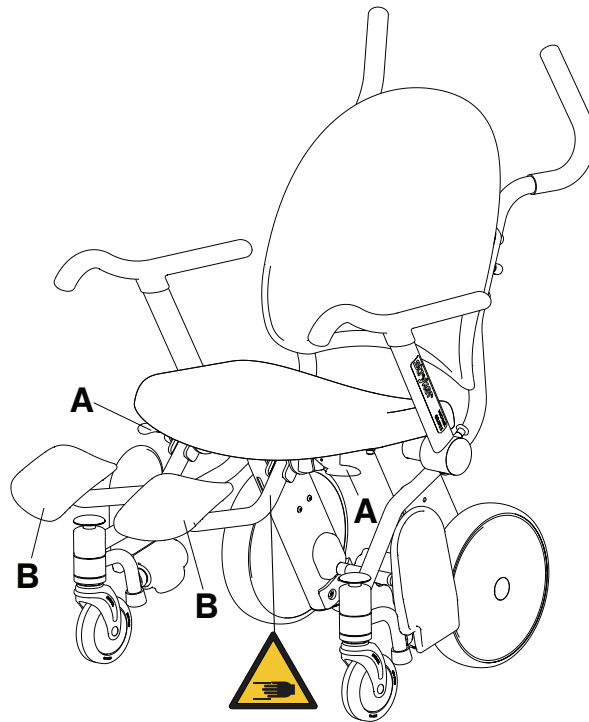

Figure 16 – Leg rest use position

1. Push down on the brake pedal to apply the brake. Push on the product to make sure that the brake is working.
2. Make sure that the occupant's legs are clear of the leg rest.
3. Pull up on the yellow release handle (A) below the seat on the appropriate side.
4. Pull up on the leg rest (B) until it clicks and locks in the use position. Push down on the leg rest to make sure that it is secure.
5. Position the occupant's leg on the leg rest (B).

Stowing the leg rest

WARNING - Do not activate the leg rest release latch with an occupant's leg on the leg rest.

CAUTION

- Always apply the brake to prevent unintended movement.
 - Do not sit, stand, or lean on the flip-up armrests, footrest, leg rest, or seat back to avoid instability.
 - Do not load the leg rest above the safe working load of 40 lb (18.14 kg).
-

To stow the leg rest (Figure 17):

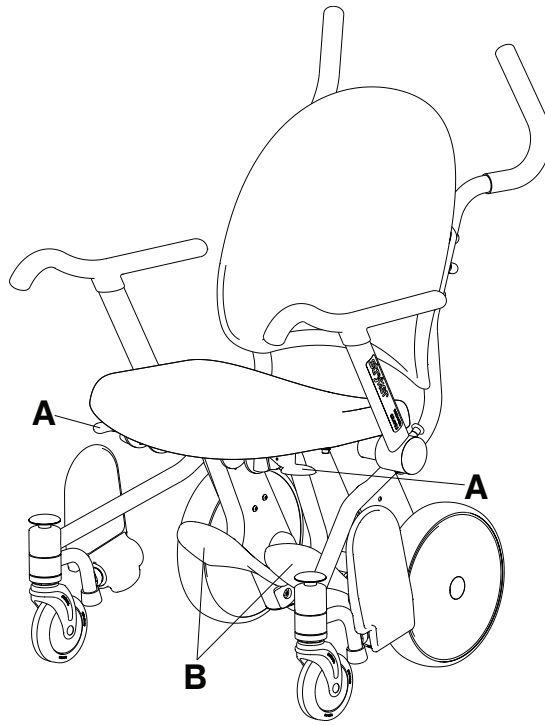

Figure 17 – Leg rest stowed position

1. Make sure that the occupant's legs are clear of the leg rest.
2. Pull up on the yellow release handle (A) under the seat on the appropriate side.
3. Push the leg rest (B) toward the back of the chair until it clicks. Push the leg rest (B) toward the back of the chair to make sure that it is secure.

Optional ground chain

The optional ground chain reduces static discharge during transport.

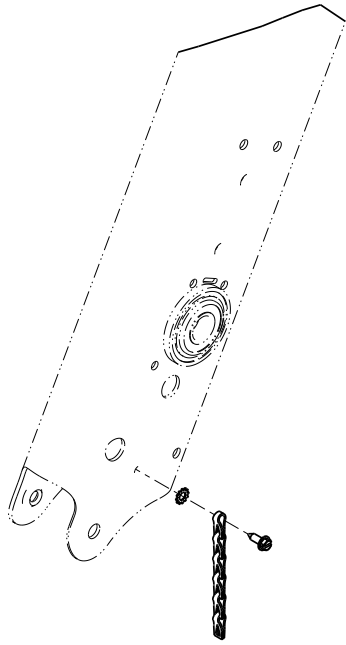

Figure 18 – Optional ground chain

Cleaning and disinfecting with wipes

For United States only. Confirm availability for your configuration or region. Call Stryker Customer Service: 1-800-327-0770.

Stryker's preferred wipes (2060-000-001 6" x 10" or 2060-000-002 9" x 12") include the following active ingredients:

- n-Alkyl (60% C14, 30% C16, 5% C12, 5% C18) dimethyl benzyl ammonium chloride - 0.154%
- n-Alkyl (68% C12, 32% C14) dimethyl ethylbenzyl ammonium chloride - 0.154%
- Isopropanol - 21.000%

Non-active ingredient: Ethylene Glycol Monobutyl Ether – < 3%

Note - For safety information, read the product label.

To clean or disinfect the external product surface:

1. To clean, wipe external surfaces with a fresh, clean wipe to remove all visible soils. Repeat as necessary until the product is clean.

Note

- Use as many wipes as necessary.
 - Complete step 1 before you disinfect.
2. To disinfect, wipe external surfaces with a fresh, clean wipe until wet. Allow the external surface to remain wet for two minutes at room temperature.
 3. Allow the product to dry before you return it to service.

Cleaning

CAUTION

- Do not steam clean the product.
 - Always make sure that all labels are intact, brake pedal and go pedal lock properly in both positions, and check all components for proper lubrication before you return the product to service after cleaning.
 - Always make sure that you wipe each product with clean water and thoroughly dry each product after cleaning. Some cleaning products are corrosive in nature and may cause damage to the product if you use them improperly. If you do not properly rinse and dry the product, a corrosive residue may be left on the surface of the product that could cause premature corrosion of critical components. Failure to follow these cleaning instructions may void your warranty.
-

Note

- Direct skin contact with visibly soiled, permeable material may increase the risk of infection.
- Do not power wash the padded seat option. If the product is equipped with the padded seat option, remove the padded seat before power washing.

These instructions are intended to provide recommended cleaning methods for Model 1460 **Prime TC**.

Prime TC is power washable. The product may show some signs of oxidation or discoloration from continuous washing. However, no degradation of the product's performance characteristics or functionality will occur due to power washing as long as the proper procedures are followed.

Recommended cleaning method

To wipe down the product with disinfectant between uses, follow these steps:

1. Follow the cleaning solution manufacturer's dilution recommendations exactly.
2. Hand-wash all surfaces of the product with a recommended disinfectant between uses.
3. Apply the recommended disinfectant solution by spray or pre-soaked wipes.
4. Make sure that you disinfect all surfaces. Pay attention to high contact areas, such as the flip-up armrest, seat, seat back, push handles, and oxygen bottle holder option.
5. Follow the cleaning solution manufacturer's instructions for appropriate contact time and rinsing requirements.
6. Dry thoroughly before you return the product to service.

Recommended cleaners

Quaternary cleaners (active ingredient - ammonium chloride) that contain less than 3% glycol ether
Phenolic cleaners (active ingredient - o-phenylphenol)
Chlorinated bleach solution (5.25% bleach diluted 1 part bleach to 100 parts water which equals 520 ppm available chlorine (40 mL of a 5.25% bleach solution per 4000 mL water))
21% isopropyl alcohol

Avoid over saturation and make sure that the product does not stay wet longer than recommended by the cleaning solution manufacturer's guidelines for proper disinfecting.

Preventive maintenance

Remove the product from service before you perform the preventive maintenance inspection. Check all items listed during annual preventive maintenance for all Stryker Medical products. You may need to perform preventive maintenance checks more often based on your level of product usage. Service only by qualified personnel.

Note - Clean and disinfect the product before inspection, if applicable.

Inspect the following items:

- _____ All welds
- _____ All fasteners are secure
- _____ Seat and seat back are not cracked or damaged
- _____ Chart holder is not cracked or damaged
- _____ Flip-up armrests raise, lower, and latch
- _____ Casters are secure and swivel
- _____ Casters are free of wax and debris
- _____ Wheels operate and rotate without resistance
- _____ Brake mechanism functions
- _____ Both rear wheels lock when the brake is applied
- _____ Rear wheels are not loose and do not wobble
- _____ Anti-tip wheels are intact
- _____ Footrest pivots up when not in use
- _____ Swing-away footrest locks in the use position
- _____ Swing-away footrest pivots to the stowed position when you depress the swing-away footrest release
- _____ IV pole option is intact and the topper is secure and is not broken
- _____ Oxygen bottle holder option is intact and can be latched and unlatched
- _____ Lap belt option is free of damage
- _____ Padded seat option is not torn or damaged
- _____ Leg rest option locks in the stowed position
- _____ Leg rest option pivots and locks in the use position
- _____ Lubricate leg rest option release latch

Product serial number:
Completed by:
Date:

stryker



Stryker Medical
3800 E. Centre Avenue
Portage, MI 49002
USA