

IsoAir™

REF 2940

stryker®

Operation/Maintenance Manual



Stryker Customer Service: 1-800-327-0770





















Table of Contents

Symbols and Definitions	
- Symbols.....	3
- Warnings / Cautions / Acronyms.....	5
Introduction	
- Intended Use / Contraindications / Product Description / Product & Therapy Overview / IsoAir System Components.....	6
- Specifications.....	7
- Contact Information & Serial Number Location	9
Summary of Safety Precautions	11
Support Surface Assembly.....	15
Pump Assembly.....	17
Pump Controls & Indicators.....	18
Installation and Operation Procedures	
Installation:	
- Support Surface.....	22
- Pump.....	23
- Connecting Support Surface to the Pump.....	24
Operation.....	25
CPR.....	26
Pressure Adjustment.....	27
Patient Handling:	
- Transferring a Patient from one Support Platform to Another.....	28
- Transporting a Patient on the IsoAir™ System.....	28
- Managing Incontinence / Drainage	28
Troubleshooting.....	29
Alarm and Alert Indications.....	32
Power Failure.....	33
Cleaning and Disinfection	
- Cleaning/Disinfection of Pump.....	34
- Cleaning/Disinfection of Support Surface.....	35
Service Information.....	37
Preventive Maintenance.....	40
Product Labeling.....	42
Quick Reference Replacement Parts List.....	45
Product Compliance Declarations.....	46
Warranty.....	49
QUICK REFERENCE GUIDE	50

*** FIND A QUICK REFERENCE GUIDE ON PAGE 50-51 ***

Symbols and Definitions

SYMBOLS

	Warning
	Caution
	Electrical Safety Mark
	Refer to Instruction Manual
	Type B Applied Part; Applied Part is the Mattress
	Safe Working Load (SWL)
	Do Not Iron
	Machine Wash
	Tumble Dry
	Do Not Bleach
	Chlorinated Bleach Allowed (See Page 34)
	Do Not Tumble Dry
	Do Not Dry Clean
	Do Not Wash
	Drip Dry
	Consult Instructions for Use
IP21	Ingress Protection Rating
	Equipment Emits Electromagnetic Energy
	Manufacturer
	Date of Manufacture
	Li Ion Battery
	Model Number

Symbols and Definitions

SYMBOLS

	Serial Number
	Double Insulated
	Product Weight
	Power (ON/STANDBY)
	Lock
	Alarm Silence
	Pressure Alarm Indicator
	Alarm Indicator
	Moisture Management (MM)
	Pressure Redistribution (Static) Mode
	Alternating Low Pressure (ALP) Mode
	Increase Pressure
	Decrease Pressure
	Active Sensor Technology (AST)
	MAX Inflate
*	AST Contact Indicator
	Battery Alert
	Choking Hazard
	Do Not Dispose as Unsorted Municipal Waste

Symbols and Definitions

WARNING / CAUTION

The words **WARNING** and **CAUTION** carry special meanings and should be carefully reviewed.

WARNING

Alerts the reader about a situation which, if not avoided, could result in death or serious injury. It may also describe potential serious adverse reactions and safety hazards.

CAUTION

Alerts the reader of a potentially hazardous situation which, if not avoided, may result in minor or moderate injury to the user or patient or damage to the equipment or other property. This includes special care necessary for the safe and effective use of the device and the care necessary to avoid damage to a device that may occur as a result of use or misuse.

ACRONYMS

ALP	Alternating Low Pressure
AST	Active Sensor Technology
CPR	Cardio-Pulmonary Resuscitation
HOB	Head of Bed
LCD	Liquid Crystal Display
LED	Light Emitting Diode
MM	Moisture Management (Low Air Loss)
SWL	Safe Working Load = Maximum load that the equipment can support without breaking. NOTE! SWL is not the <u>Therapeutic Weight Range</u> for this product. See Specifications Section on Page 7 for the Therapeutic Weight Range.

Introduction

This manual is designed to assist with the operation and maintenance of the Stryker IsoAir™ System (“IsoAir™”). Carefully read this entire manual before using or beginning maintenance on the Pump or Support Surface. To ensure safe operation of this equipment, it is recommended that methods and procedures are established for educating and training staff on the safe operation of the Pump and Support Surface.

INTENDED USE OF THE PRODUCT

The IsoAir™ is a therapeutic support system used to assist in the prevention and treatment of all categories/stages of pressure ulcers (including stages I, II, III, IV, Un-stageable, and Deep Tissue Injury).

This system is intended for use in acute care and long-term care, not including the home environment.

CONTRAINDICATIONS

The IsoAir™ System is intended for use as prescribed by a licensed physician. The IsoAir™ System is contraindicated for use with certain medical conditions and treatments. Always consult with the patient’s physician before commencing therapy with the IsoAir™ System.

PRODUCT DESCRIPTION

The IsoAir™ System offers Alternating Low Pressure (ALP) and Moisture Management (MM) on demand. The system consists of a main control unit (Pump), which provides a pressure source for inflating and deflating the air cells in the support surface. The support surface consists of a series of air cells that run laterally across the surface to support the patient, and side bolsters.

The AST feature is an auto-sensing function that is used to provide optimal immersion.

PRODUCT & THERAPY OVERVIEW

The IsoAir™ helps to prevent and treat pressure ulcers. The air cells in the support surface are positioned every 4 inches (10 cm) from the head to the foot. Two types of therapy are available, Pressure Redistribution and ALP. Pressure Redistribution therapy fills the cells with just enough air to deeply immerse the patient into the surface. This immersion distributes pressure to support the patient as evenly as possible. ALP therapy will alternately inflate and deflate every other cell to relieve pressure and allow blood to flow into the tissue more easily. This function will continue to cycle every 6 minutes.

An additional feature called Moisture Management (MM) is available. MM enhances patient comfort and helps to prevent and treat pressure ulcers by removing moisture through the top cover. Air is pumped into the surface in the seat and torso areas to evaporate the moisture.

The Pump is connected to the air cells through flexible hoses. The Pump monitors and adjusts the air in the air cells automatically. If less air is required then the Pump opens a valve to vent some out. If more air is required then the Pump turns on its air compressor and opens a valve to direct more air into the cell.

There are two ways that the firmness / softness of the surface can be set. Manual mode allows the user to select one of five preset levels. AST mode utilizes sensors in the seat area of the surface. These sensors determine the amount of immersion of the patient. If the mattress is too soft and the patient is immersed too much, the Pump will increase the air pressure in the surface. Conversely, if it is too hard the Pump will decrease the air pressure in the surface.

ISOAIR™ SYSTEM COMPONENTS

The IsoAir™ System is composed of a Support Surface (Mattress) and a Pump. The Surface has a built in Hose Assembly that connects to the Pump via the CPR Connector.



The Pump is supplied with two power cords, a long cord and a short cord. The long cord is for wall connection and the short cord is for connecting directly to the power socket built into some Stryker bedframes.

The system is accompanied by an Operation/Maintenance Manual.

Introduction

SPECIFICATIONS

The table below lists the specifications for the IsoAir™ System:

PUMP	
Model	12SM-SRLVC
Dimensions	Height: 8.5 in / 21.6 cm Width: 8 in / 20.3 cm Depth: 5 in / 12.7 cm
Input Voltage AC	120 Volts +10%/-15%
Input Frequency	60 Hz +/- 5%
Current Consumption	0.4 Amps
Power Consumption	< 50 Watts
Circuit Protection	Fuses (Qty. 2), 250V, 1.6A, 5 x 20 mm, Fast blow (1500A)
Protection Against Electrical Shock ¹	Class II Class II Medical Equipment provides electrical safety by the means of insulation without the use of grounding (protective earthing). 
Applied Part	Type B A type B rating indicates that the device may have electrical contact with the patient and the electrical contact may be connected to earth ground. 
Pressure Display Accuracy	±2 mmHg
Pressure Settings (mmHg)	10 to 30 mmHg in 5 mmHg Increments
Power Cord	3 ft / 1m (For Bed Frame Outlet) & 15 ft / 5m (For Wall Outlet)
Air Hose	34 in / 86 cm
Air Hose Connections	5/16 Inch Flow Quick Coupling
AST Plug	¼ in Phono Jack
AST Cable	35 in / 89 cm
Packaging	1 Pump per Box
Latex Content	User accessible parts (mattress, Pumps and accessories) are not made with natural rubber latex.
Pump Weight	11 lb / 5 kg
Alarms (See Page 32):	
Maximum Sound Pressure Level	61.2 dB
Protection Against Harmful Ingress of Liquids:	
Ingress Protection	IP21 (with CPR and AST plug attached) 2 Protected against solid objects over 12.5mm e.g. hands, large tools. 1 Protected against vertically falling drops of water or condensation.
Applied Parts:	
Support Surfaces	See Part Number listing in the following <i>Support Surface Specifications Table</i> .
Expected Life:	
IsoAir™ Pump	5 Years

¹ The ground connection of the power cord is used to provide suppression of electronic noise that may interfere with other equipment. It does NOT provide electrical safety protection.

Introduction

SPECIFICATIONS

SUPPORT SURFACE		
Support Surface Coverlet Material	Equilibrium 2 by Dartex®	
Support Surface Sizes:		
Model		
45A-SR5-3584	84" x 35" x 7.0"	213.4 cm x 88.9 cm x 17.8 cm
Maximum Support Surface Weight	28 lb	12.7 kg
Safe Working Load	550 lb	250 kg
Therapeutic Weight Range	50 lb - 350 lb	22.7 kg - 158.7 kg
Flammability Standards	16 CFR 1632 16 CFR 1633 CAL TB 129 UNI 9175 Boston BFD IX-11 Canada - Method CAN/CGSB-4.2 No. 27.7-2013 BS 597-1, BS 597-2, BS7177/BS6807 (Crib 5)	
Compatible Bed Frames	2030-000-000 Epic / Epic II Critical Care bed 2035-000-000 Apex Critical Care Bed FL27 InTouch Critical Care bed 3002-000-000 Secure II MedSurg Bed 3005-000-000 S3 MedSurg Bed	
Biocompatibility Standards	ISO 10993-1, ISO 10993-5, ISO 10993-10	
System Operating Conditions		
Ambient Temperature	5 to 38 °C	
Relative Humidity	15 to 93 % Non-Condensing	
Atmospheric Pressure	700 to 1060 hPa	
System Storage and Shipping Conditions:		
Ambient Temperature	-20 to 60 °C	
Relative Humidity	10 to 95 %, Non-Condensing	
Atmospheric Pressure (hPa)	500 to 1060 hPa	
Product Compliance:		
Medical Equipment	IEC 60601-1 (3 rd edition) AAMI ES60601-1 CAN/CSA C22.2 NO. 60601-1 (3 rd Edition)	
Collateral Standards	Electromagnetic Compatibility, IEC 60601-1-2 (See Pages 46-48) Usability, IEC 60601-1-6 Alarms, IEC 60601-1-8	
Expected Life:		
IsoAir™ Support Surface	Coverlet 2 Years Support Surface without Coverlet 5 years	

Stryker reserves the right to change specifications without notice.

Introduction

CONTACT INFORMATION

Contact Stryker Customer Service at **1-800-327-0770** for assistance in setting up, using or maintaining the IsoAir™ System, or if you encounter any unexpected events/operation.

Stryker Medical

3800 E. Centre Avenue
Portage, MI 49002
USA

Please have the serial number of your Stryker product available when calling Stryker Customer Service. Include the serial number in all written communication.

PUMP SERIAL NUMBER LOCATION

The serial number is located on the back of the Pump as shown in the label example to the right.

SERIAL NUMBER FORMAT (8 CHARACTERS):

Serial Number Example: 14J00234

1	4	J	0	0	2	3	4
Y	Y	M	N	N	N	N	N

Manufacture Date (YY/M): 2014 September
Sequential Number (N): 00234

SN	14J00234
	2014
12SM-SRXX-XX	

Year Legend (Y)	
2014	14
2015	15
2016	16
2017	17
2018	18

Month Legend (M)	
January	A
February	B
March	C
April	D
May	E
June	F
July	G
August	H
September	J
October	K
November	L
December	M

Sequential # Legend (N)
00001 - 99999

Introduction

SUPPORT SURFACE SERIAL NUMBER LOCATION

The serial number is located inside the support surface on the patient right side at the foot end near the corner.



COVERLET SERIAL NUMBER LOCATION

The serial number is located on the patient right side at the foot end of the coverlet.

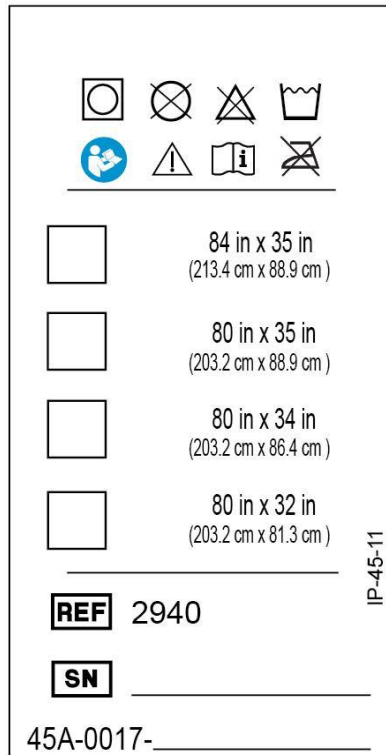

Summary of Safety Precautions

Before operating this medical equipment, carefully read and strictly follow the Warnings and Cautions presented in the following sections.



General

- Read this manual to understand the operating instructions and safety precautions. Failure to do this could result in patient injury and/or damage to the product.
- To avoid the risk of electric shock inspect the Pump and power cord for damage. If damage is observed, take the Pump out of operation immediately and contact Customer Service. (See **Page 9** for Contact Information).
- Entrapment & Falls: Evaluate patients for the risk of entrapment & falls according to facility protocols. Ensure side rails are fully locked when in the raised position. Failure to do this could result in death or injury.
- The patient should be evaluated for suitability of the device to treat the patient's condition.
- It is the responsibility of the operator to monitor the patient and the patient's skin condition at regular intervals, per medical protocols, to ensure patient safety and proper support surface performance. Consult a physician if irritation or skin breakdown occurs.
- Do not modify or change this device. There are no user-serviceable parts inside the Pump. Service should only be completed by qualified personnel. Failure to do so could result in injury and void warranty.
- Connect only items that have been specified as part of the device, or specified as being compatible with the device.
- Pressure in support surface is under automated control and may adjust without notice. Use care when performing medical procedures on patient.
- Smoking in bed or improper use of radiant heaters may cause a fire. Doing so could result in death or injury.

Support Surface

- To avoid the risk of patient injury, do not use the support surface on a bed frame of a larger or smaller size. The risk of entrapment can develop when the support surface is placed on bed frames that leave gaps between the support surface and the headboard, footboard, and side rails. The support surface is not to be used when such gaps are present.
 - To avoid risk of severe injury, properly secure support surface to the frame according to the instructions for use.
 - Initiate deflation of the Support Surface before starting CPR. Failure to do so may result in ineffective CPR. Refer to **Page 26**.
 - The hose sleeve is a safety feature. Do not operate the equipment without the sleeve in place.
 - Risk of entanglement if hose sleeve is not secured to the back plate of the CPR connector.
 - Risk of asphyxiation due to entanglement with hoses. Ensure hose sleeve is correctly installed.
 - Ensure that all side rails are fully latched when in the raised position. Failure to do so could result in serious injury or death including patient falls.
 - To avoid the risk of patient injury and equipment damage, do not use the support surface handles or straps to lift, or move the support surface with a patient on it.
 - To avoid the risk of patient and operator injury, a minimum of two (2) operators is required when transferring a patient. Operators need to be positioned so that they can control patient positioning.
 - To avoid the risk of patient injury, ensure the opposite side rail is raised when placing a patient on the support surface.
-

Summary of Safety Precautions



Pump

- Risk of Electric Shock. Do not open or attempt to repair or service the electronic Pump. Repairs and service should only be done by authorized personnel. If the Pump is not functioning properly, or has been damaged, unplug the Pump and take it out of service immediately and contact Customer Service. (See **Page 9** for contact information).
- Electrical-safety testing of your Pump should be performed at least annually. Failure to do so may result in death or injury. Contact Customer Service, **Page 9**, for service information.
- Medical Electrical Equipment needs special precautions regarding Electro-Magnetic Compatibility (EMC) between devices and needs to be installed and put into service according to the EMC information provided in this manual (See **Pages 46-48**). However, there is no guarantee that interference will not occur in a particular installation. If the pump causes harmful interference to other devices or other equipment causes harmful interference to the pump, which can be determined by turning equipment ON and OFF, the user is encouraged to try to correct the interference by one or more of the following measures:
 1. Reorient or relocate the receiving device.
 2. Increase the separation between the Pump and other equipment.
 3. Connect the equipment into an outlet on a circuit different from that to which other device(s) are connected.

Consult with Stryker Customer Service for assistance.

- The Pump should not be used adjacent to or stacked with other equipment, doing so may cause abnormal operation in either device. If adjacent or stacked use is necessary, the Pump and other equipment should be observed to verify normal operation in the configuration in which it will be used.
- Portable and mobile RF communications equipment, such as wireless home network devices, mobile phones, cordless telephones, their base stations, and walkie-talkies can affect this and other Medical Electrical Equipment. See **Pages 46-48** for guidance.
- The use of accessories and cables other than those specified, with the exception of those sold by the manufacturer as replacement parts, may result in increased emissions and/or decreased immunity of the device.
- The Pump hangers are not intended to be in patient contact. Extended patient contact with the Pump hangers may cause injury.
- Do not use in the presence of flammable anesthetics, nitrous oxide, or oxygen-rich environments. Risk of explosion, burns and asphyxiation can result.
- Exposure of the electronic Pump to any liquid while it is plugged in could result in a severe electrical hazard.
- To avoid risk of injury do not place objects on the surface of the Pump.
- The AST cable ONLY connects to the AST-socket. Connecting it anywhere else may result in severe electrical shock.
- If “Key-Click” sound is not heard, DO NOT use the Pump.
- Pressure in support surface is under automated control and may adjust without notice. Use care when performing medical procedures on patient.
- The device is not compatible for use in MRI.
- AC mains power must be connected to provide therapy. If power is lost, therapy provided will be discontinued.
- Good filter maintenance is critical in keeping your IsoAir™ Pump in optimal operating condition. Failure to clean the filter may cause damage to the Pump. A damaged Pump may not provide proper support pressures resulting in patient injury.

Summary of Safety Precautions



Electrical Connections & Power Cord

- Plug the power cord into a properly grounded outlet. Failure to do so may cause electronic noise that may interfere with other equipment e.g. ECG, EKG, or EEG.
- Do not use multiple socket outlets or extensions. This may result in an electrical hazard.
- Power cord may cause tripping hazard. Route cord under bed frame.
- Before plugging in the Pump, check the power cord for damage, e.g. cuts, exposed wires, worn insulation, etc. If hazards are present, take the Pump out of operation immediately and contact Customer Service. (See **Page 9** for Contact Information)
- Improper use or handling of the power cord could result in damage. If damage of power cord is present, do not use and call qualified maintenance personnel for replacement (See Parts list on **Page 45**). To avoid risk of electric shock use approved power cords only.
- The power cord to the Pump should be positioned to avoid a tripping and strangulation hazard and/or damage to the cord. Stryker recommends placing the cord under the bed frame and plugging it into an electrical outlet by the head end of the bed, or the integral electric outlet on the bed frame using the shorter cord provided.
- Orient power cord so that it is not difficult to disconnect.
- Risk of asphyxiation due to entanglement with cords. Route cord under bed frame.

Disinfection

- Disinfect the Pump and Surface between patient installations and when servicing, utilizing standard hospital protocol and disinfectants. Failure to disinfect may risk cross-contamination and infection.
 - When disinfecting is required, check disinfectant manufacturer's instructions before use, and use disinfectant and personal protective equipment in accordance with the manufacturer's instructions.
 - Do not spray disinfectant directly on the electrical Pump, or immerse the Pump in any type of liquid. This could result in a severe electrical hazard.
 - All disinfection should be done using a "hospital-grade" disinfectant.
 - DO NOT spray disinfectant directly on the electrical Pump, or immerse the Pump in any type of liquid. This could result in a severe electrical hazard.
 - Check patient medical history for allergies to the disinfectants listed on **Page 34**.
-

Summary of Safety Precautions



General

- Check the system and surrounding area for pests that may damage the system causing harm to the patient.
- Do not return a Pump for any reason without first contacting Customer Service to obtain authorization.
- Do not leave children and pets unattended while the IsoAir™ System is in use. They may damage the system that may cause bodily harm to themselves and/or the patient.
- DO NOT service or perform maintenance while the product is in use. May result in patient injury.

Support Surface

- Use care when using sharp objects, such as needles, as these can damage the air cells in the support surface.
- Do not use harsh cleansers, solvents, or detergents on the Pump/Surface. Equipment damage could occur.
- To avoid the risk of equipment damage, when cleaning the underside of the support surface, ensure that no liquid is allowed to seep into the zipper area and watershed cover barrier; fluids allowed to come in contact with the zipper may leak into the support surface.
- AST sensor cells (light blue) can be wiped down, but not laundered.
- Cap the air cell connectors before laundering (See **Page 36**. Failure to cap the connectors will lead to liquid ingress inside of the air cell and the risk of damage or mold growth through incomplete drying.
- The Mattress includes straps at the bottom center that are intended for storage use. Do not use these to tie the Mattress to the bedframe. May result in equipment damage.

Pump

- When hanging the Pump on the foot board, ensure the hangers are seated as they are not spring loaded and may become dislodged if not properly hung.
- The Pump is a precision electronic product. Use care when handling or transporting. Dropping, or other sudden impacts, may result in damage to the Pump.
- After exposure to extreme high or low temperatures, allow the Pump to equilibrate for at least one (1) hour before operating.
- The Pump circulates room air during operation. Exposure to smoke may cause the Pump to fail. Therefore, smoking by patients, or visitors, while using this product should be avoided.
- DO NOT autoclave the Pump OR the Hosing Assembly. May result in equipment damage.
- Unplug the Pump from its source prior to cleaning. Failure to do so may result in an electrical hazard.

Environmental

- To prevent the materials in this product from contributing to potentially serious health and/or environmental hazards:
 1. Consult your local regulations to safely dispose of electronic equipment, batteries, and/or any biohazardous waste.
 2. Do not dispose of as unsorted municipal waste. See your local distributor for return or collection systems available in your country.

Support Surface Assembly

The location of features and connections on the Support Surface are presented below. Please refer to these during installation, set up and operation of the Support Surface.

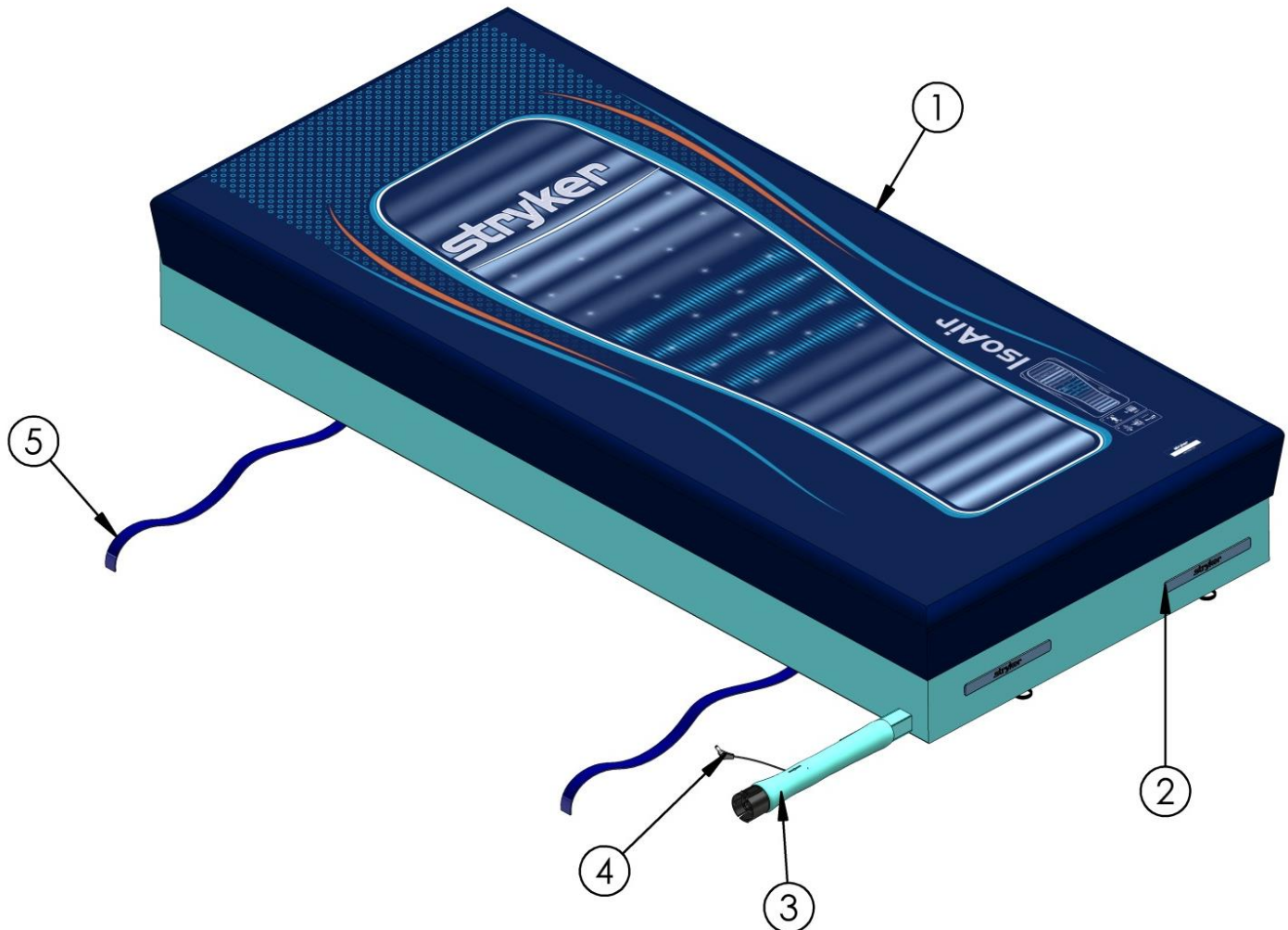

- 1 COVERLET
- 2 STRAP HANDLES (FOOT END SHOWN)
- 3 CPR CONNECTOR
- 4 AST CABLE
- 5 TIE DOWN STRAPS

 The Mattress includes straps at the bottom center (not shown) that are intended for storage use. Do not use these to tie the Mattress to the bedframe. May result in equipment damage.

Support Surface Assembly

7.0" AIR CELL (AIR/FOAM) SUPPORT SURFACE

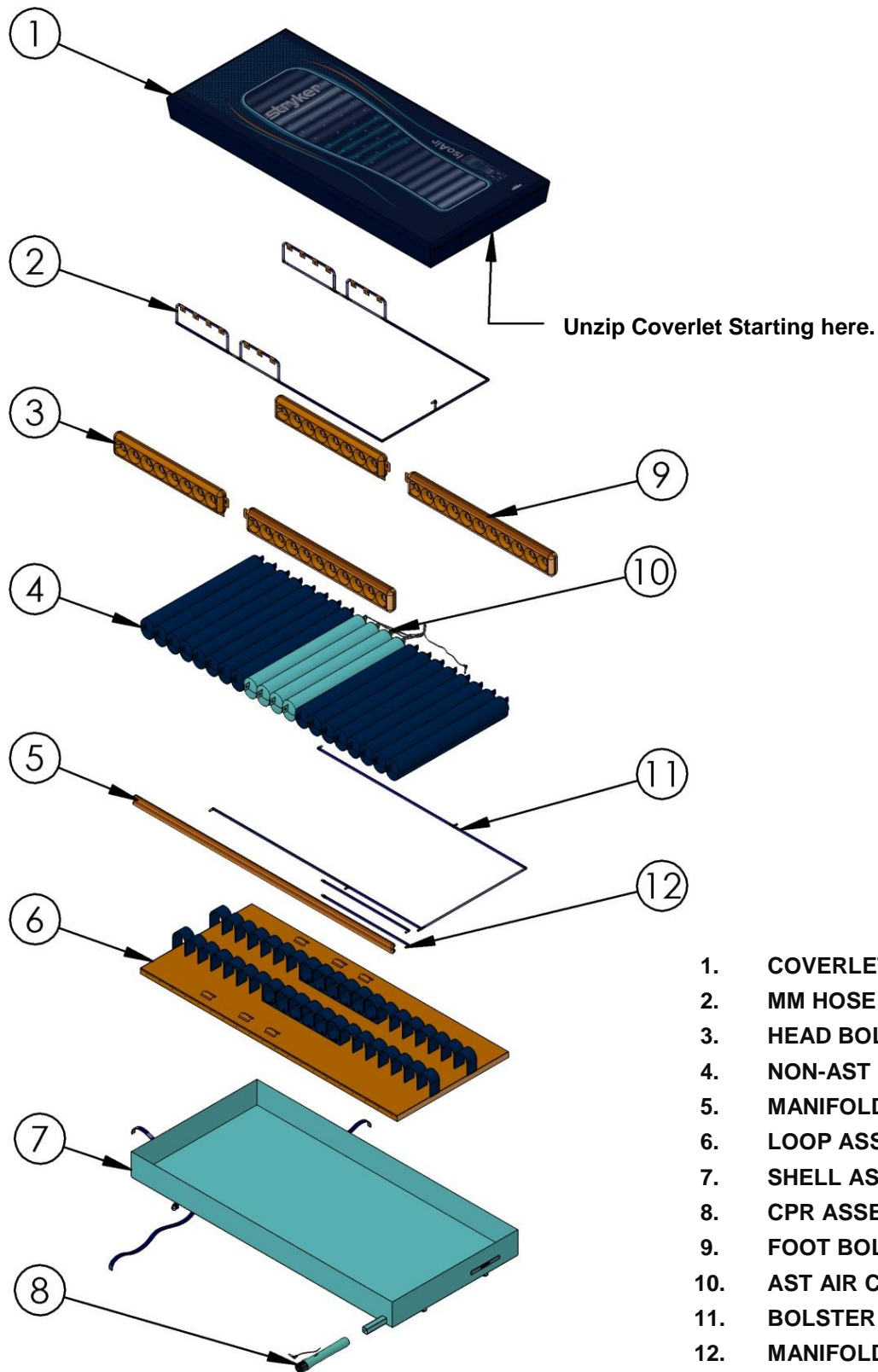

1. COVERLET ASSEMBLY
2. MM HOSE ASSEMBLY
3. HEAD BOLSTER
4. NON-AST AIR CELLS
5. MANIFOLD
6. LOOP ASSEMBLY
7. SHELL ASSEMBLY
8. CPR ASSEMBLY
9. FOOT BOLSTER
10. AST AIR CELL PACK
11. BOLSTER HOSE ASSEMBLY
12. MANIFOLD HOSE ASSEMBLY

Pump Assembly

The location of features and connections on the Pump are presented below. Please refer to these during installation, set up and operation of the Pump.

FRONT VIEW



BACK VIEW

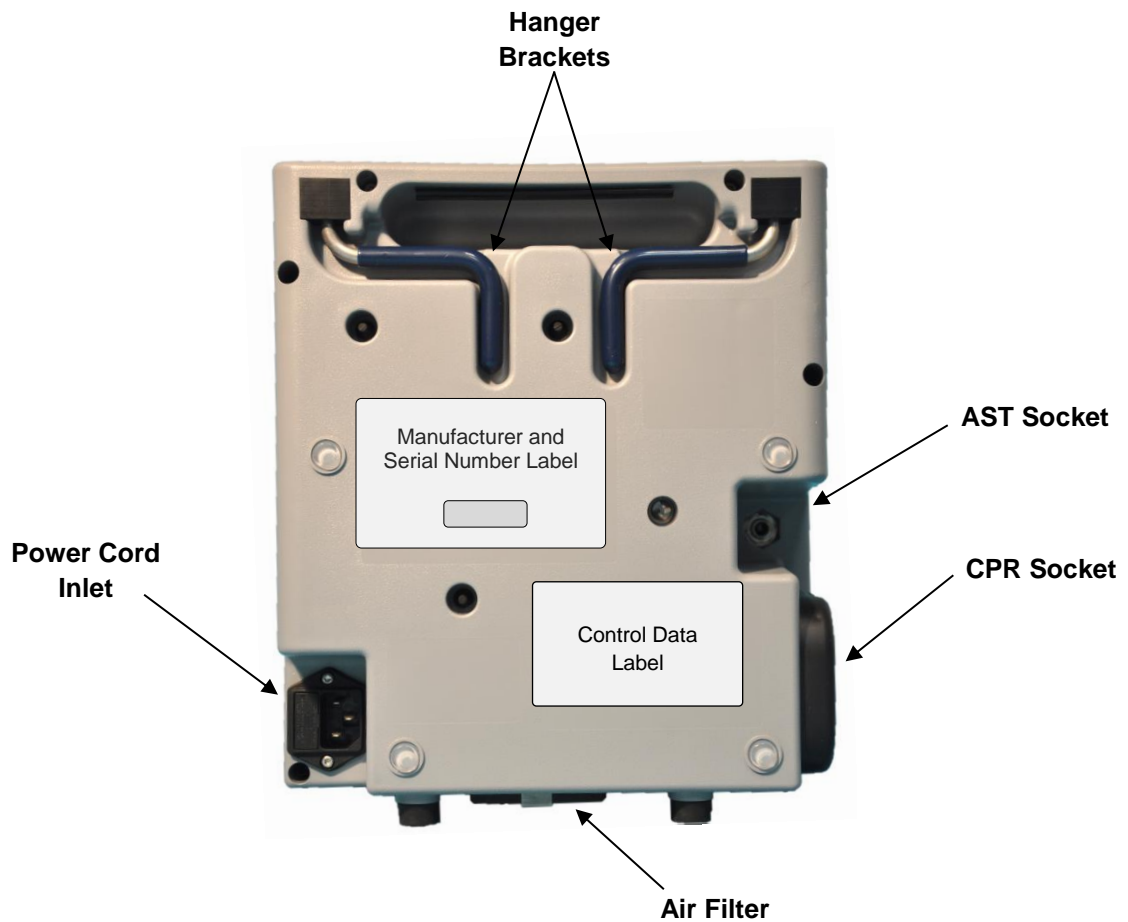

Pump Controls & Indicators

CONTROL PANEL

The Control Panel of the Pump is shown in the picture below.

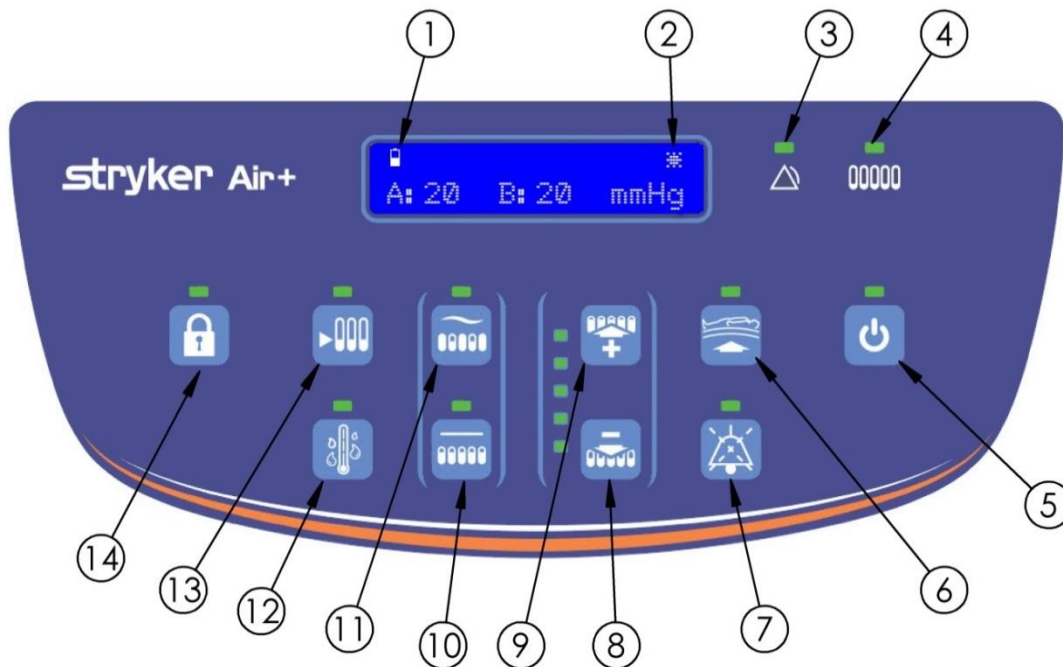

- | | | | |
|---|--------------------------|----|---------------------------------------|
| 1 | Battery Alert | 8 | Pressure Down (Decrease) |
| 2 | AST Contact Indicator | 9 | Pressure Up (Increase) |
| 3 | Alarm Signal Indicator | 10 | Pressure Redistribution (Static) Mode |
| 4 | Pressure Alarm Indicator | 11 | ALP Mode |
| 5 | Power | 12 | MM Mode |
| 6 | MAX Inflate | 13 | AST Mode |
| 7 | Alarm Silence | 14 | Lock |

LCD ICONS

1. BATTERY ALERT

If there is a fault detected in the Battery charging circuit, or the battery charge is below the acceptable range the Battery Alert icon  will appear in the upper left corner of the LCD. This will not affect the operation of the system unless there is a Power Fail condition.

2. AST CONTACT INDICATOR

When the system is in AST mode and the AST Sensor is in contact, and asterisk (*) will appear in the upper right corner of the LCD.

LEDs

As shown above, each key has a corresponding LED that is lit if the key is selected. Additionally, two other LED's provide information related to the Pump.

3. ALARM SIGNAL INDICATOR

4. The Pump is equipped with an Alarm Signal Indicator which flashes to alert the user that an alarm is active and requires resolution before continuing use (See **Pages 31-32**, Alarms and Alert Indications).

5. PRESSURE ALARM INDICATOR

6. The Pump is equipped with a Pressure Indicator LED to alert the user that the actual pressure is out of the specified range (See **Pages 31-32**, Alarms and Alert Indications).

Pump Controls & Indicators

KEY FUNCTIONS

The control panel has ten (10) keys as shown in the picture above: Each key will light up the associated LED indicator(s) when activated.

1. **POWER**
Turns Pump ON or to STANDBY. When Unit is plugged in and in STANDBY, the LED indicator is white. When the Unit is ON, the LED indicator is green.
2. **MAX INFLATE**
Activates Max Inflate override mode.
3. **ALARM SILENCE**
Stops ALARM sound.
4. **PRESSURE UP**
Increases Pressure setting in 5 mmHg Increments (Illuminated LED indicators increase with each key press).
5. **PRESSURE DOWN**
Decreases Pressure setting in 5 mmHg Decrements (Illuminated LED indicators decrease with each key press).
6. **PRESSURE REDISTRIBUTION (STATIC)**
Activates Pressure Redistribution therapy mode.
7. **ALP**
Activates ALP therapy mode.
8. **MM**
Activates Moisture Management supplementary therapy mode.
9. **AST**
Activates AST therapy mode.
10. **LOCK**
Locks settings and prevents keys from functioning.

Pump Controls & Indicators

PUMP FUNCTIONS:

ALARM FUNCTION

The Pump is equipped with a flashing/audible alarm to alert the user that the actual pressure is out of the specified range. This typically indicates a leak or a kinked hose and requires resolution before continuing use (See **Page 29**), Troubleshooting Guide and Alarm Priority Table).

LOCK FUNCTION

Pressing and holding the **LOCK** Key for three (3) seconds will lock the current settings to avoid unintended changes. Pressing and holding the **LOCK** Key for three (3) seconds again will allow setting(s) to be changed. Note, LOCK function does not lock the ALARM SILENCE function.

ALARM SILENCE FUNCTION

Pressing the **ALARM SILENCE** Key disables Alarm sounds for 10 minutes. Note that this only affects currently active alarms, it cannot be used to silence possible future alarms.

PRESSURE UP FUNCTION

Pressing the **PRESSURE UP** Key will increase the pressure level from 1 to 5 (from 10 to 30 mmHg) while in Pressure Redistribution or ALP modes.

PRESSURE DOWN FUNCTION

Pressing the **PRESSURE DOWN** Key will decrease the pressure level between 5 and 1 (from 30 to 10 mmHg) while in Pressure Redistribution or ALP modes.

MAX INFLATE FUNCTION

MAX INFLATE is used for any procedure in which a firm surface is required. Pressing the **MAX INFLATE** Key activates the Max Inflate override mode. The Max Inflate override mode inflates all cells to maximum pressure and disables manual adjustment of cell pressure (**PRESSURE UP** and **PRESSURE DOWN** Keys will be inoperable while this mode is active). The cells will remain inflated to maximum pressure for 15 minutes. A countdown timer is displayed on the display, indicating the time remaining in Max Inflate override mode. An alert tone is emitted when the Max Inflate override mode times out.

While the Max Inflate override mode is active, activating either main therapy mode (via the **ALP** or **PRESSURE REDISTRIBUTION** Keys) will disable Max Inflate override mode. Pressing the **AST** key does not affect the MAX Inflate operation.

After Max Inflate override mode times out or is disabled, the Pump resumes operation based on the therapy mode setting and pressure settings in effect prior to initiating the Max Inflate Override mode.

PRESSURE REDISTRIBUTION (STATIC) FUNCTION

Pressing the Pressure Redistribution Key activates the Pressure Redistribution therapy mode, which keeps all cells at constant pressure and allows for manual adjustment of cell pressure (**PRESSURE UP** and **PRESSURE DOWN** Keys will function normally while this mode is active). Activating MAX INFLATE or ALP mode (via their respective Keys) will disable Pressure Redistribution therapy mode.

Pump Controls & Indicators

ALP FUNCTION

Pressing the **ALP** Key activates the ALP therapy mode, which alternately inflates and deflates cells to relieve pressure and allows for manual adjustment of cell pressure (**PRESSURE UP** and **PRESSURE DOWN** Keys will function normally while this mode is active). Activating MAX INFLATE or Pressure Redistribution (Static) mode (via their respective Keys) will disable ALP therapy mode.

AST FUNCTION

Pressing the **AST** Key activates the AST mode. AST mode works to automatically adjust air cell pressures to control patient immersion. Enabling AST disables manual adjustment of cell pressures (**PRESSURE UP** and **PRESSURE DOWN** Keys will be inoperable while this mode is active). AST mode can be active while either Pressure Redistribution or ALP mode is active. Activating Max Inflate mode (via the **MAX INFLATE** Key) will disable AST mode.

MM FUNCTION

Pressing the **MM** Key activates the Moisture Management therapy mode. Moisture Management mode can be active while any other mode is active (AST, ALP, Pressure Redistribution, or Max Inflate), and will only be disabled by pressing the **MM** Key a second time.

LCD DISPLAY

The following information is displayed on the LCD Display:

AIR CELL PRESSURE

Measured pressure values for Zone A and Zone B air cells are displayed in mmHg.

HOURLY METER

When the **ALARM SILENCE** key is pressed for more than 3 seconds, the accrued time for hours of operation will be displayed for 30 seconds.



MAX INFLATE COUNTDOWN TIMER

While the MAX INFLATE function is active a countdown timer will be displayed. The countdown timer will indicate the fifteen (15) minute countdown for the MAX INFLATE function. If the MAX INFLATE function is deactivated, the countdown timer is removed from the display.

Installation & Operation Procedures

Follow the procedures below for the installation and operation of the Pump and Support Surface:

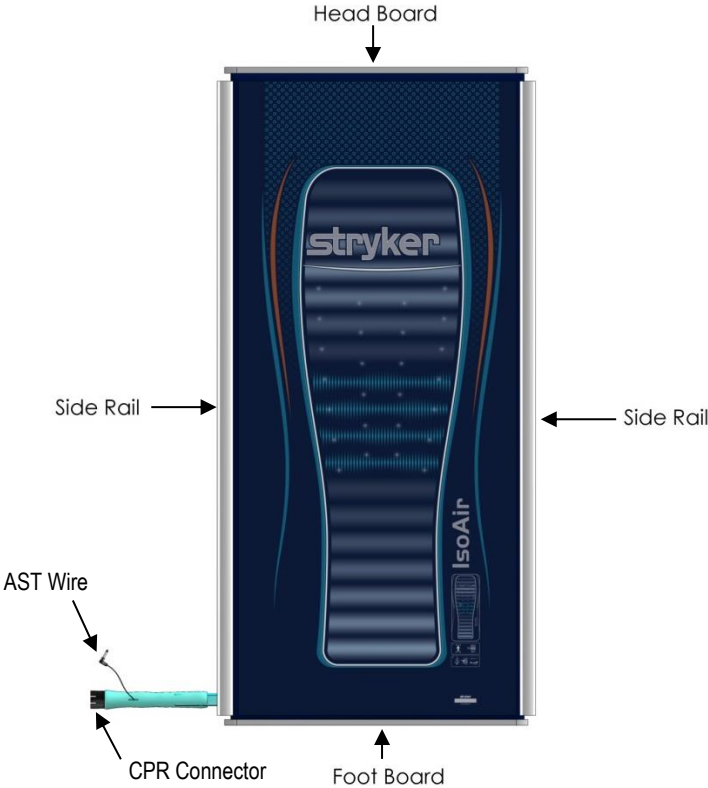
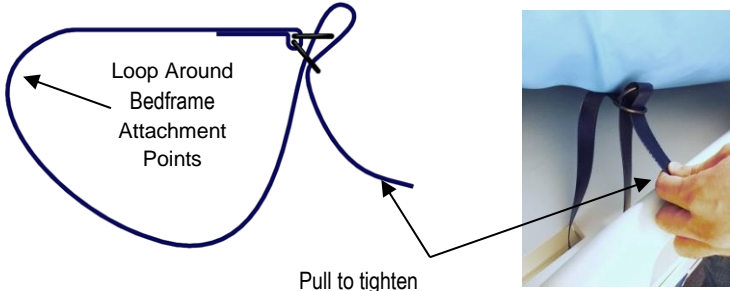
INSTALLATION OF SUPPORT SURFACE:

Procedure	Cautions & Warnings
<p>1. Ensure that the support surface properly fits the bed frame on which it is being placed.</p>  <p>2. The support surface is designed to be used with a non-fitted sheet. Do not pull linens too tight over the product to avoid the hammock effect that will reduce the effectiveness of the product.</p> <p>3. Secure the support surface to the bedframe using the straps provided.</p>  <p>4. Before attempting to inflate the support surface, unzip the cover and ensure that all of the air cells, especially the four AST sensor cells (the light blue cells in the center section) are upright, and free to rotate within their retaining loops.</p>	 <ul style="list-style-type: none"> - To avoid risk of severe injury, properly secure support surface to the frame according to the instructions for use. - Support surface handles are not intended to carry patient. - The risk of entrapment can develop when the support surface is placed on bed frames that leave gaps of even a few inches between the support surface and the headboard, footboard, and side rails. The support surface is not to be used when such gaps are present. - To avoid the risk of patient injury, do not use the support surface on a bed frame of a larger or smaller size than the stated size as this may cause the support surface to slide. - Ensure that all side rails are fully latched when in the raised position. Failure to do so could result in serious injury or death including patient falls. <hr/>  <ul style="list-style-type: none"> - To avoid the risk of equipment damage, do not put accessories inside the coverlet or on top of the support surface. Doing so may reduce pressure redistribution performance. - Use care when using sharp objects, such as needles, as these can damage the air cells in the support surface.



Installation & Operation Procedures

INSTALLATION OF PUMP:

Procedure	Cautions & Warnings
<p>1. The Pump is equipped with a detachable power cord. To apply power, the cord must be attached to the Pump and an electrical outlet. To disconnect power, the cord may be detached from either the Pump or the outlet.</p> <p>2. Determine which electrical outlet you will use for the Pump. Use the short cord to connect to an outlet on the bed frame; use the long cord to connect to a wall outlet.</p> <p>3. Insert the power cord into the Pump Power Inlet.</p>  <p>4. Hang the Pump on the foot panel of the bed.</p>  <p>5. If you are using a wall outlet, stretch the power cord beneath the bed to an outlet at the head end of the bed, making sure the cord is out of the way. Use the long (5m/15ft) power cord provided.</p> <p>6. If you are installing the support surface on a Stryker bed frame equipped with an outlet, use the optional power outlet located under the foot end of the frame and the short (1m/3ft) power cord provided. Consult the bed frame manual for the location of the outlet.</p>	<div data-bbox="917 304 966 346"> </div> <ul style="list-style-type: none"> - When hanging the Pump on the foot board, ensure the hangers are seated as they are not spring loaded and may come dislodged if not properly hung. - The Pump hangers are not intended to be in patient contact. Extended patient contact with the Pump hangers may cause injury. - Do not use in the presence of flammable anesthetics, nitrous oxide, or oxygen-rich environments. Risk of explosion. - Exposure of the electronic Pump to any liquid while it is plugged in could result in a severe electrical hazard. - Plug the power cord into a properly grounded outlet or electronic noise may interfere with other equipment e.g. ECG, EKG, or EEG. - The Pump should not be used adjacent to or stacked with other equipment, doing so may cause abnormal operation in either device. If adjacent or stacked use is necessary, the Pump and other equipment should be observed to verify normal operation in the configuration in which it will be used. - Medical Electrical Equipment needs special precautions regarding Electro-Magnetic Compatibility (EMC) between devices and needs to be installed and put into service according to the EMC information provided in this manual (See Pages 46-48). - Portable and mobile RF communications equipment, such as wireless home network devices, mobile phones, cordless telephones, their base stations, and walkie-talkies can affect this and other Medical Electrical Equipment. See Pages 46-48 for guidance. - To avoid risk of injury do not place objects on the surface of the Pump. - Risk of asphyxiation due to entanglement with cords. Route cord under bed frame. - Power cord may cause tripping hazard. Route cord under bed frame. - Before plugging in the Pump, check power cord for damage, e.g. cuts, exposed wires, worn insulation, etc. If hazards are present, take the Pump out of operation immediately and contact Customer Service - Orient power cord so that it is not difficult to disconnect. <hr/> <div data-bbox="933 1774 982 1816"> </div> <ul style="list-style-type: none"> - After exposure to extreme high or low temperatures, allow the Pump to equilibrate for at least one (1) hour before operating.

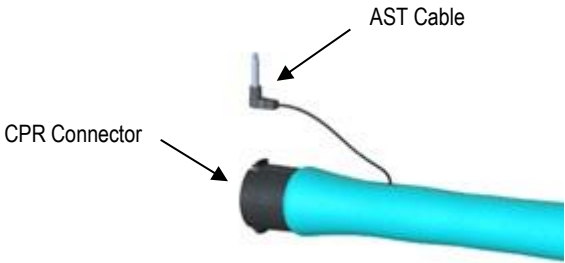
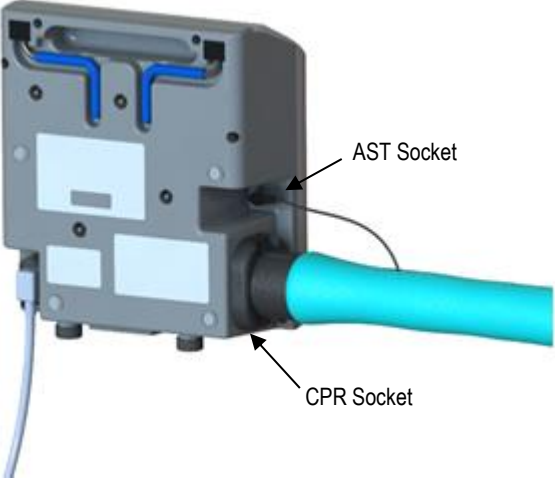

Installation & Operation Procedures

CONNECTING THE SUPPORT SURFACE TO THE PUMP:

Procedure	Cautions & Warnings
<p>1. Locate the CPR Connector and the AST Cable at the end of the hose sleeve on the support surface. The CPR Connector and AST Cable are shown below.</p>  <p>2. Firmly push the CPR Connector into the mating CPR Socket on the Pump, and connect the AST Cable to the AST Socket on the Pump.</p> 	<p></p> <ul style="list-style-type: none">- The AST cable-ONLY connects to the AST Socket. Connecting it anywhere else may result in severe electrical shock.- The hose sleeve is a safety feature; do not operate the equipment without the sleeve in place.- Risk of asphyxiation due to entanglement with hoses. Ensure hose sleeve is correctly installed.- Risk of entanglement if hose sleeve is not secured to the back plate of the CPR connector.- Before plugging in the Pump, check the power cord for electrical hazards, e.g. cuts, exposed wires, worn insulation, etc. If hazards are present, take the Pump out of operation immediately and contact Customer Service. (See Page 9 for Contact Information).- Improper use, or handling, of the power cord could result in damage. If damage has occurred to the power cord, do not use and call qualified maintenance personnel for replacement (See Parts list on Page 45). To avoid risk of electric shock use approved power cords only.- The power cord to the Pump should be positioned to avoid a tripping and strangulation hazard and/or damage to the cord. Stryker recommends placing the cord under the bed frame and plugging it into an electrical outlet by the head end of the bed, or the integral electric outlet on the bed.- Orient power cord so that it is not difficult to disconnect.- Risk of asphyxiation due to entanglement with cords. Route cord under bed frame.



Installation & Operation Procedures

PUMP OPERATION:

Procedure	Cautions & Warnings
<p>1. While standing in front of the Pump, press the POWER key located on the Control Panel to turn the Pump ON. Listen for a “Key-Click” sound to verify operation of audio-alarm system. If Pump lights do not come on, see Troubleshooting Page 29.</p> <p>NOTE! When powered on, the Pump will revert to the previous MODE and PRESSURE settings.</p> <p>2. PRESSURE REDISTRIBUTION Mode: Press the Pressure Redistribution MODE key. The LED will illuminate and the Pump will start inflating the support surface. The support surface will inflate in approximately 10 minutes. Start with the MAX INFLATE setting.</p> <p>3. Pressure Adjustment: The Pump is capable of adjusting the cushion pressure to five set points over a range of 10 to 30 mmHg. The five set points can be adjusted directly by the PRESSURE UP Key and the PRESSURE DOWN Key, which will increase and decrease the pressure of the cells, respectively.</p> <p>4. ALP Mode: To activate the ALP therapy mode press the ALP key. ALP Therapy Mode will alternately inflate and deflate the cells in the support surface at three minute intervals. To deactivate ALP therapy mode, press the PRESSURE REDISTRIBUTION key to change to Pressure Redistribution Mode.</p> <p>5. MM Function: To activate the MM function, press the MM key. The MM function provides a constant stream of air between the support surface and the coverlet to keep the patient dry. To deactivate the MM function, press the MM key again.</p> <p>6. AST Function: To activate the AST function, press the AST Key. The AST function disables manual adjustment of the pressure setting. To deactivate the AST function press the MANUAL key.</p> <p>7. MAX INFLATE Function: To activate the MAX INFLATE function press the MAX INFLATE key. The MAX INFLATE function will inflate all cells in the support surface to the maximum pressure. Manual adjustment of pressure settings is not allowed in MAX INFLATE mode.</p> <p>The MAX INFLATE function is intended to be used when the mattress should not be moving, such as when the patient is entering or leaving the bed, or a procedure is being performed on the patient.</p> <p>MAX INFLATE mode will last for 15 minutes. At the completion of MAX INFLATE time or if MAX INFLATE is deactivated, the system will automatically revert to the mode and pressure settings previously selected.</p> <p>While the MAX INFLATE mode is active, a countdown timer, indicating the time remaining in MAX INFLATE mode, will be displayed.</p> <p>To deactivate MAX INFLATE prior to the automatic deactivation, press the MAX INFLATE key, or initiate ALP or PRESSURE REDISTRIBUTION therapy modes.</p> <p>8. LOCK Function: To prevent inadvertent changes of the Pump settings, the control panel can be locked by pressing and holding the LOCK key for three (3) seconds. When the control panel is locked, the LOCK LED will be illuminated.</p> <p>While the control panel is locked, pressing any other key, except the LOCK key and Alarm Silence key will result in a LOCK Alert being generated.</p>	<div style="border-top: 1px solid black; border-bottom: 1px solid black; padding: 5px 0;">  <ul style="list-style-type: none"> - If “Key-Click” sound is not heard, DO NOT use the Pump. - Pressure in support surface is under automated control and may adjust without notice. Use care when performing medical procedures on patient. - AC mains power must be connected to provide therapy. If power is lost, therapy provided will be discontinued. - Do not use multiple socket outlets or extensions. This may result in an electrical hazard. </div> <div style="border-top: 1px solid black; padding: 5px 0;">  <ul style="list-style-type: none"> - The Pump is a precision electronic product. Use care when handling or transporting. Dropping, or other sudden impacts, may result in damage to the Pump. - After exposure to extreme high or low temperatures, allow the Pump to equilibrate for at least one (1) hour before operating. - The Pump circulates room air during operation. Exposure to smoke may cause the Pump to fail. Therefore, smoking by patients, or visitors, while using this product is contraindicated. - To ensure optimal performance electrical-safety testing of your Pump should be performed at least annually. Contact Customer Service, Page 9, for service information. - Do not leave children and pets unattended while the IsoAir™ System is in use. They may damage the system that may cause bodily harm to themselves and/or the patient. - Check the system and surrounding area for pests that may damage the system causing harm to the patient. </div>

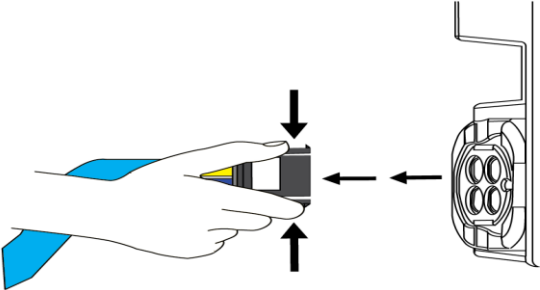

Installation & Operation Procedures

CPR ACTIVATION:

Procedure	Cautions & Warnings
<p>Disconnect hose from the Pump by pushing in the TABS on the CPR Connector and pulling the connector away from the Pump.</p> 	<p></p> <ul style="list-style-type: none">- Initiate deflation of the Support Surface before starting CPR. Failure to do so may result in ineffective CPR.

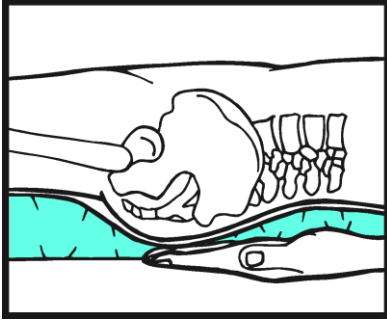
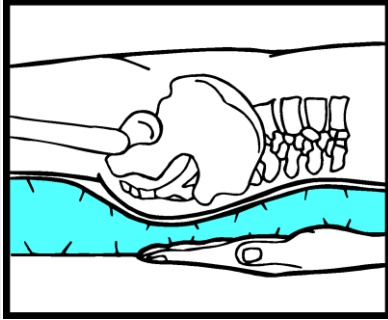

Installation & Operation Procedures

PRESSURE ADJUSTMENT CHECK:

Procedure	Cautions & Warnings
<p>1. To ensure the patient is getting the proper therapy, periodically use HAND CHECKS to check for proper inflation.</p> <p>2. When the mattress is in the Manual Mode a HAND CHECK should be performed to establish the correct pressure setting. Perform a HAND CHECK whenever the patient is repositioned.</p> <p>Underinflated:  Properly Inflated: </p> <p>3. Slide your hand, palm up, with fingers flat, between the bed surface and the mattress at the patient's lower back or hip.</p> <p>NOTE! Do not lean on the product or lift at the side as these actions can lead to false readings.</p> <p>Adjust the pressure setpoint until you can no longer feel the patient's lower back or hip. If you can feel the bony prominence inflate the product using the PRESSURE UP key on the Pump.</p> <p>Wait two minutes and repeat the HAND CHECK until you have adequate inflation.</p>	<p></p> <p>– It is the responsibility of the operator to monitor the patient and the patient's skin condition at regular intervals, per hospital protocols, to ensure patient safety and proper support surface performance. Consult a physician if erythema or skin breakdown occurs.</p>

Installation & Operation Procedures

PATIENT HANDLING:

Procedure	Cautions & Warnings
<p>TRANSFERRING A PATIENT FROM ONE SUPPORT PLATFORM TO ANOTHER:</p> <p>1. To transfer a patient from one support platform to another, e.g. bed frame, stretcher, gurney, operating table:</p> <p>2. Prerequisites: Two operators will be required for this task.</p> <ol style="list-style-type: none"> 1) Position the patient along the center line of the support surface. 2) It is recommended that the surface be placed in MAX INFLATE mode, unless otherwise contraindicated. 3) Position the patient support platforms alongside each other, as closely as possible. 4) Set the brakes to “ON” for both support platforms. Ensure that the two support surfaces are level with each other. 5) Raise the bed side rail located opposite the patient transfer. <p>Move ONLY the patient. DO NOT attempt to move the IsoAir™ surface with a patient on it.</p>	<div style="text-align: center;"></div> <ul style="list-style-type: none"> – To avoid the risk of patient injury, do not transfer the patient from one bed to another using the support surface with a patient on it. – To avoid the risk of patient and equipment damage, do not use the support surface straps to lift or move the support surface with a patient on it. – To avoid the risk of patient and operator injury, a minimum of two (2) operators is required when transferring a patient. Operators need to be positioned so that they can control patient positioning. – To avoid the risk of patient injury, ensure the opposite side rail is raised when placing a patient on the support surface.
<p>TRANSPORTING A PATIENT ON THE ISOAIR™ SYSTEM:</p> <p>1. To transport the patient while he/she is on the IsoAir™ System perform the following steps –</p> <ol style="list-style-type: none"> 1) Adjust the bed and mattress to the desired transport position. 2) Allow the pressures to stabilize. 3) Press POWER key to place Pump into Standby. 4) Unplug the Pump power cord (unless plugged into bedframe power outlet). 5) Secure the power cord to avoid rolling the bed frame over it and to eliminate tripping hazard. 6) Transport patient to the desired location. 7) Plug the power cord into a power outlet. 8) Press POWER key to turn Pump back on. <p>2 The system will resume the previous modes and settings.</p> <p>NOTE! While the IsoAir™ System is not plugged in, a power fail condition exists. The system will not deflate for at least two hours.</p>	<div style="text-align: center;"></div> <ul style="list-style-type: none"> – To avoid the risk of patient injury, ensure both side rails are raised when transporting the patient. – Power cord may cause tripping hazard. Secure to bed frame prior to initiating transport.

INCONTINENCE / DRAINAGE

This support surface is NOT intended to manage incontinence. Therefore, it is recommended to use incontinence management devices when appropriate. Disposable diapers or incontinence pads may be used. Ensure appropriate skin care is provided following each episode.

Troubleshooting

Troubleshooting Guide

Condition	Problem	Recommended Action
Stuck Key	<ul style="list-style-type: none"> - An audible alarm is present - The ALARM LED is blinking - The LED for one of the Keys is flashing (identifying the Stuck Key) 	<ul style="list-style-type: none"> - Press and release the key with the flashing LED to clear the stuck key. - If condition persists contact Stryker Customer Service Page 9, or authorized service personnel.
AST Connection	<ul style="list-style-type: none"> - An audible alarm is present - The ALARM LED is blinking - The AST LED is blinking 	<ul style="list-style-type: none"> - Check that the AST plug is completely inserted into the AST socket. - Toggle the AST key (OFF/ON) to see if condition clears. - If condition persists contact Stryker Customer Service Page 9, or authorized service personnel.
AST Sensor	<p>If the AST Sensor remains in contact for more than 15 minutes while operating in AST mode:</p> <ul style="list-style-type: none"> - An audible alarm is present - The ALARM LED is blinking - The AST Key LED is blinking and Pressure Indicator LED is blinking 	<ul style="list-style-type: none"> - If patient is in fowler, reduce HOB angle. - Unzip cover and check that AST air cells are correctly positioned underneath patient. - Perform a hand check to ensure that the patient is not bottoming out. - If condition persists contact Stryker Customer Service Page 9, or authorized service personnel.
Pressure Alarm	<p>A high or low air pressure condition exists; an air cell pressure is outside the allowable range.</p> <ul style="list-style-type: none"> - An audible alarm is present - The ALARM LED is blinking - The Pressure LED is blinking 	<ul style="list-style-type: none"> - Check that the CPR connector is correctly plugged into the Pump. - Check for kinks in hoses from the CPR connector to the support surface. - Unzip the top cover. Reach inside the support surface and check air cells, hoses and connections for possible leaks. - If condition persists contact Stryker Customer Service Page 9, or authorized service personnel.
MM Low Flow (Low Air Loss)	<p>The MM air flow is below the minimum expected threshold for 5 seconds.</p> <ul style="list-style-type: none"> - An audible alarm is present - The ALARM LED is blinking - The MM LED is blinking - The Pressure LED is blinking 	<ul style="list-style-type: none"> - Check the CPR hose bundle is free from pinches - Unzip the top cover. Check for air flow blockage by following the MM hoses inside the support surface (See Page 16). - If condition persists contact Stryker Customer Service Page 9, or authorized service personnel.
System Error	<p>In the event of a hardware failure:</p> <ul style="list-style-type: none"> - An audible alarm is present - The ALARM LED flashing - The LCD backlight is blinking 	<ul style="list-style-type: none"> - Cycle the power. - If condition persists contact Stryker Customer Service Page 9, or authorized service personnel.

Troubleshooting

Troubleshooting Guide (Continued)

Condition	Problem	Recommended Action
Power Fail	May be caused by: <ul style="list-style-type: none"> - AC power outage - disconnected power cord - blown fuse - internal damage 	<ul style="list-style-type: none"> - Make sure the power cord is plugged in, AC power is ON and the Power LED is lit (white for standby, green for unit turned on). - If condition persists contact Stryker Customer Service Page 9, or authorized service personnel.
Pump Does Not Turn On	May be caused by: <ul style="list-style-type: none"> - AC power outage - disconnected power cord - blown fuse - internal damage - Power On “stuck key” 	<ul style="list-style-type: none"> - Make sure the power cord is plugged in, AC power is ON and the Power LED is lit (white for standby, green for unit turned on). - See recommended action for Keys not responding - If condition persists contact Stryker Customer Service Page 9, or authorized service personnel.
Keys not responding	May be caused by: <ul style="list-style-type: none"> - LOCK function - Stuck Key 	<ul style="list-style-type: none"> - Make sure the power cord is plugged in and the unit is turned ON (not in Standby). Power LED should be green. - Check LOCK key for activation. If the LOCK key indicator is ON, Press and hold the LOCK key for three seconds to deactivate. - In case of a Stuck Key, press and release key with the flashing LED to clear the stuck key. - If condition persists contact Stryker Customer Service Page 9, or authorized service personnel.
Support Surface does not inflate	May be caused by: <ul style="list-style-type: none"> - the Pump not being plugged into a power outlet - The unit being in Standby (Power LED is white), but not turned ON (Power LED is green) - internal damage or failure 	<ul style="list-style-type: none"> - Make sure the power cord is plugged in and the unit is turned ON (not in Standby). Power LED should be green. - Check that the CPR hose is properly connected. - If condition persists contact Stryker Customer Service Page 9, or authorized service personnel.
Air Leak	<ul style="list-style-type: none"> - If the support surface is not fully inflated in 15 minutes it may indicate an air leak. 	<ul style="list-style-type: none"> - Check that the CPR hose connector is properly attached to the Pump. - Check the CPR hose bundle for possible damage - Unzip the top cover and check the air cells and tubing for air leaks. - If condition persists contact Stryker Customer Service Page 9, or authorized service personnel.
Battery Alert Icon appears on LCD display	<ul style="list-style-type: none"> - Battery charge is low 	<ul style="list-style-type: none"> - Ensure power is connected for at least five hours. - If condition persists contact Stryker Customer Service Page 9, or authorized service personnel.
Interference on other equipment (e.g. ECG, EKG, or EEG)	<ul style="list-style-type: none"> - the Pump is not plugged into a properly grounded power outlet. 	<ul style="list-style-type: none"> - Ensure power outlet is properly grounded. - Disconnect the AST connector and run the unit in Manual Pressure mode. - If condition persists contact Stryker Customer Service Page 9, or authorized service personnel.

Alarm and Alert Indicators

All alarms are indicated by a flashing LED and accompanied by an audible alarm. Only the highest priority alarm is sounded.

ALARM & ALERTS LEDs

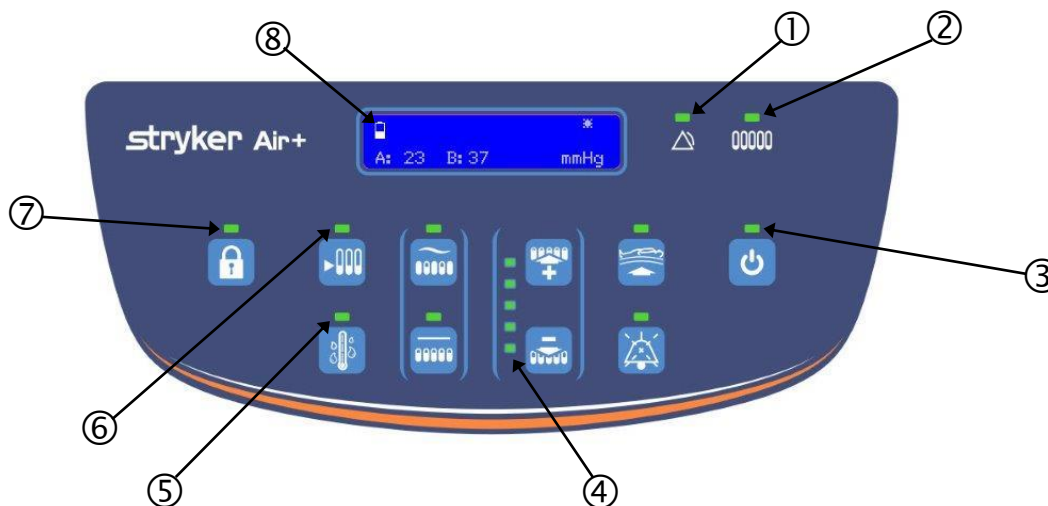

- | | | | |
|---|-----------------------|---|--------------------|
| 1 | Alarm | 5 | MM |
| 2 | Pressure | 6 | AST |
| 3 | Power | 7 | Lock |
| 4 | Manual Pressure Level | 8 | Battery Alert Icon |

ALARM PRIORITY AND CAUSE TABLE

Alarm ¹	Notification Priority	Cause	Alarm May Stop If:
Power Fail	1	The Pump is not receiving electricity.	<ul style="list-style-type: none"> - The system is turned off OR - Power is applied
Hardware Failure	2	The Pump has detected one of the internal hardware faults listed below: <ul style="list-style-type: none"> - Problem with the reading/writing operation of the parameters for Pressure Calibration, User Settings, User Timers or an invalid Hour Meter reading has been detected. - Failure of clock electronics - Failure of LED electronics - Failure of compressor electronics - Problem with power supply voltage levels - Failure of LCD electronics - Failure of Audio electronics 	<ul style="list-style-type: none"> - The system is powered off OR - The condition is corrected
Stuck Key	3	The Pump has detected that a key has been continuously activated for more than 15 seconds	<ul style="list-style-type: none"> - The system is powered off OR - The condition is corrected
AST Connection Error	4	The Pump has detected that either the AST cable is disconnected or there is an electrical failure in the support surface for 1 second	<ul style="list-style-type: none"> - The system is powered off OR - Max Inflate is turned on OR - AST Connection has been restored
AST Sensor	4	Patient contact activates the AST Sensor for more than 15 minutes while operating in AST mode	<ul style="list-style-type: none"> - The system is powered off OR - Max Inflate is turned on OR - No contact is detected for 5 seconds
Pressure Alarm	5	The system has been turned on for more than 15 minutes AND A high or low pressure condition exists in any support cell for 10 minutes OR a low pressure condition exists in the bolster for 10 minutes	<ul style="list-style-type: none"> - The system is powered off OR - Pressure returns to the specified range for 5 seconds
MM Low Flow	6	The Manifold pressure is greater than > 65 mmHg for 5 seconds.	<ul style="list-style-type: none"> - The system is powered off OR - MM Mode is turned off OR - The manifold pressure is below 60 mmHg for 5 seconds

1 - All alarms are classified as Medium Priority per IEC 60601-1-8.

Alarm and Alert Indicators

ALARM and ALERT INDICATIONS TABLE

Alarm/ Alert ¹	LCD Display	Control Panel Indicator					
		Alarm Signal LED	Pressure Indicator LED	Power LED	AST LED	Lock LED	MM LED
Power Fail	N/A	Blinking ²	Off	Blinking	Off	Off	Off
Hardware Failure	Blinking	Blinking	N/A	N/A	N/A	N/A	N/A
Stuck Key	N/A	Blinking	N/A	Flashes ³ the LED for the Stuck Key			
AST Connection Error	N/A	Blinking	N/A	N/A	Blinking	N/A	N/A
AST Sensor	N/A	Blinking	Blinking	N/A	Blinking	N/A	N/A
Pressure Alarm	N/A	Blinking	Blinking	N/A	N/A	N/A	N/A
MM Low Flow	N/A	Blinking	Blinking	N/A	N/A	N/A	Blinking
Lock Alert	N/A	N/A	N/A	N/A	N/A	Flashing	N/A
Battery Alert	Battery Icon ON	N/A	N/A	N/A	N/A	N/A	N/A

1 - All alarms are classified as Medium Priority per *IEC 60601-1-8*

2 - Blinking = every 2 seconds

3 - Flashing = 10 times per second

OPERATORS POSITION

The operator is intended to be standing directly in front of the Pump during operation.

SILENCING AN ALARM

Pressing the **ALARM SILENCE** Key disables Alarm sounds. The **ALARM SILENCE** LED will be on. The ALARM SILENCE will end if any of the following conditions occur:

- The power fails or the cord is disconnected
- 10 minutes have elapsed since an alarm was silenced
- No alarms are active
- The ALARM SILENCE key is pressed again
- The Power key is pressed

Power Failure

POWER FAIL CONDITIONS

A power fail condition can occur under three cases:

- Plug detached from the power outlet
- Power outage has occurred
- Fuse has blown

OPERATION DURING POWER FAILURE

During a power fail condition, the LCD is off, the Alarm and Power LEDs are blinking, and the air cells will not inflate/deflate (no therapy will be delivered). During this time, the air cells will remain inflated for at least two (2) hours.

SHORT POWER INTERRUPTIONS

All therapy modes, pressures and settings are retained after a power fail condition that lasts less than 30 seconds.

If the power fail condition lasts for more than 30 seconds the system saves all settings and therapy modes, with the exception of Max Inflate.

The system will return to normal operation after any power failure that lasts less than 30 minutes.

EXTENDED POWER INTERRUPTIONS

If the power failure lasts for more than 30 minutes, the audio and visual power fail indications will stop and the Pump will power off.

If power is restored after thirty (30) minutes, the system will return to the state it was in prior to the power interruption. Therapy mode and settings are retained.

Cleaning and Disinfection



- Disinfect the Pump and Surface between patient installations and when servicing, utilizing *standard hospital protocol and disinfectants*. *Failure to disinfect may risk cross-contamination and infection.*
- When disinfecting is required, check disinfectant manufacturer's instructions before use, and use disinfectant and personal protective equipment.
- Use Personal Protection Equipment in accordance with the manufacturer's instructions to reduce the likelihood of cross-contamination during cleaning.
- All disinfection should be done using a "hospital-grade" disinfectant.
- Check patient medical history for allergies to the Suggested Disinfectants listed below

SUGGESTED DISINFECTANTS

- Quaternary Cleaners
- Phenolic Cleaners
- Chlorinated Bleach Solution (5.25% bleach diluted 1 part bleach to 10 parts water)
- 70% Isopropyl Alcohol
- Accelerated Hydrogen Peroxide (AHP)

CLEANING and DISINFECTION of the PUMP



- DO NOT spray disinfectant directly on the electrical Pump, or immerse the Pump in any type of liquid. This could result in a severe electrical hazard.



- DO NOT autoclave the Pump OR the Hosing Assembly. Equipment damage could occur.
- Unplug Pump from its source prior to cleaning. Failure to do so may result in an electrical hazard.
- Do not use harsh cleansers, solvents, or detergents on the Pump. Equipment damage could occur.

The exterior of the Pump and Hosing Assembly should be wiped down between patients. Always inspect Pump components during Preventive Maintenance (**Page 40**) and replace as necessary.

When cleaning and disinfecting the Pump, the following procedure is advised:

1. Unplug the power cord prior to cleaning/disinfecting.
2. Dampen a clean cloth with disinfectant according to manufacturer's recommendations.
3. Wipe down the Pump and Hosing Assembly to remove any foreign material/fluid/dirt.
4. Dry completely before using the Pump.

Cleaning and Disinfection

CLEANING and DISINFECTION of the SUPPORT SURFACE



- To avoid the risk of equipment damage, do not immerse support surface in cleaning or disinfectant solutions.
- Do not allow liquid to pool on the support surface.
- To avoid the risk of patient injury, coverlet and shell should be inspected for tears, punctures, excessive wear, and misaligned zippers each time the coverlets are cleaned. If a support surface coverlet becomes compromised, the support surface coverlet should be removed from service immediately and replaced to prevent cross-contamination.



- Do not use harsh cleansers, solvents, or detergents on the Surface. Equipment damage could occur.
- To avoid the risk of equipment damage, when cleaning the underside of the support surface, ensure that no liquid is allowed to seep into the zipper area or under the watershed cover; fluids allowed to come in contact with the zipper may leak into the support surface.

The useful life of the support surface components (shell, air cells & coverlet) may be shortened by the number of times it is cleaned/disinfected. The number of cleanings/disinfections is “patient-dependent” and it is the responsibility of the caregiver to ensure the support surface is clean and sanitary for the patient, including determining the frequency of cleaning/disinfection. Generally, the presence of foreign material/fluids/odors would indicate the need to clean/disinfect the surface. Always inspect Surface components during Preventive Maintenance (**Page 40**) and replace as necessary.

When cleaning and disinfecting the Support Surface, the following procedure is advised:

1. Using a clean, soft, damp cloth, wipe down the support surface with a mild soap and water solution to remove foreign material.
2. Wipe down the support surface with a clean, dry cloth to remove any excess liquid or cleaning agent.
3. Disinfect with a hospital grade disinfectant AFTER cleaning has been completed. Refer to “Suggested Disinfectants” on **Page 34**.

Cleaning and Disinfection

CLEANING and DISINFECTION AIR CELLS

All Air Cells (AST and Non-AST) can be wiped down and disinfected. The following procedure is advised:

1. Using a clean, soft, damp cloth, wipe down the air cells with a mild soap and water solution to remove foreign material.
2. Wipe down the air cells with a clean, dry cloth to remove any excess liquid or cleaning agent.
3. Disinfect with a hospital grade disinfectant AFTER cleaning has been completed. Refer to "Suggested Disinfectants" on **Page 34**.



- The AST Sensor Cells (light blue, with attached wires) can be wiped down, **but not laundered**. Equipment damage could occur.

LAUNDERING of NON-AST AIR CELLS

The Non-AST Air Cells (dark blue without wires) may be laundered. The following procedure is advised:

1. Remove Non-AST air cells to be laundered. See under Air Cell Replacement (**Page 37**) for instructions.
2. Cap the air cell connectors with Air Cell Laundry Caps (2940-002-062) as shown.
3. Launder at a maximum water temperature of 60°C using standard hospital grade laundry detergents. **DO NOT ADD CHLORINE BLEACH.**
4. The air cells may be air dried or machine dried at a temperature not to exceed 60°C.



Air Cells may be laundered as many as 25 times over the life of the product.



- Cap the air cell connectors before laundering. Failure to cap the connectors will lead to liquid ingress inside of the air cell and the risk of damage or mold growth through incomplete drying.

LAUNDERING of the COVERLET

When Laundering the Coverlets, the following procedure is advised:

1. Coverlets can be machine washed at a maximum water temperature of 70°C using standard hospital grade laundry detergents. **DO NOT ADD CHLORINE BLEACH WHEN LAUNDERING.**
2. Coverlets can be air dried or machine dried at temperatures not to exceed 75°C.

Laundering can be performed up to 130 times over the life of the product.

NOTE! If storing the Support Surface and/or Pump between uses, store according to Storage Conditions presented in the table on **Page 8**.

Service Information

For service and/or technical information other than specified in this manual, including fuse replacement, circuit diagrams and isolation of mains, see IsoAir Service Manual AO-SM-70-SR.



- There are no “user-serviceable” parts inside the Pump. Service should only be performed by authorized maintenance personnel only. Equipment damage could occur.
- Disinfect the Pump and Hosing Assembly between patient installations and before servicing, use standard hospital protocol and disinfectants. Failure to disinfect may risk cross-contamination and infection.



- Do not service or perform maintenance while product is in use. May cause harm to the patient.
- Do not return a Pump for any reason without first contacting Customer Service to obtain authorization.
- Consult your local regulations to properly dispose of electronic equipment.
- Do not dispose of as unsorted municipal waste. See your local distributor for return or collection systems available in your country.

BATTERY

The battery is only for visual and audible alarming during power failure. It does not power the Pump for therapy purposes. It is not user-serviceable and must only be serviced by authorized service personnel. The typical service life of the battery is the life of the device. The system recharges the battery when the device is connected to a power outlet and power is available.

AIR CELL REPLACEMENT

Tools/Parts Required:

- Non-AST Aircell (2940-002-033)
- Air Plug Assembly (2940-002-001)

Procedure:

1. Unzip and remove the coverlet.
2. Identify the air cell to be replaced.
3. Disconnect the air cell from the manifold connector.
4. Cap the manifold connector (Air Plug Assemblies are stored in the pocket inside the Surface at the foot end of the bed).

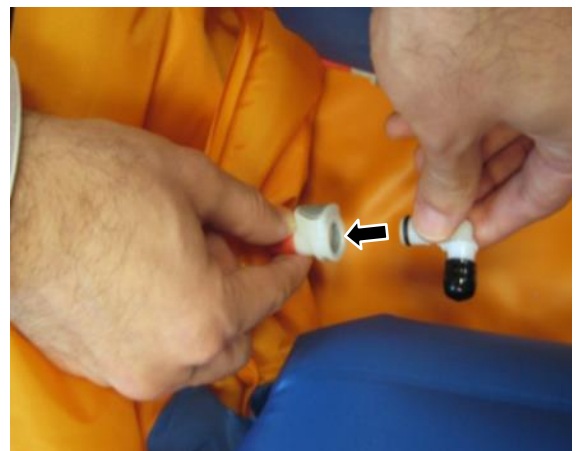

Service Information

AIR CELL REPLACEMENT (Continued)

5. Unbutton both sides of the air cell.

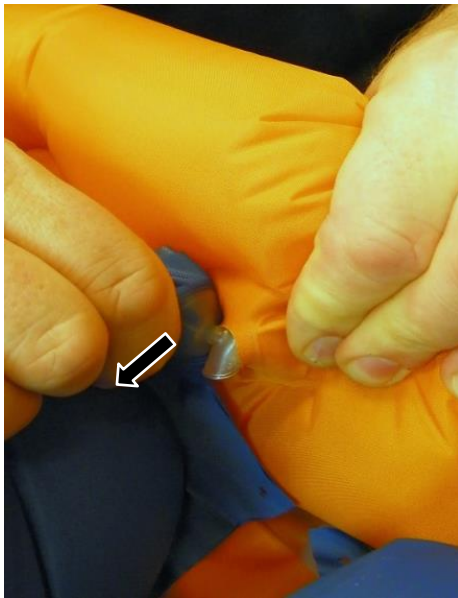

6. Slide the air cell out of the restraining loops.
7. Insert the new air cell through the loops.

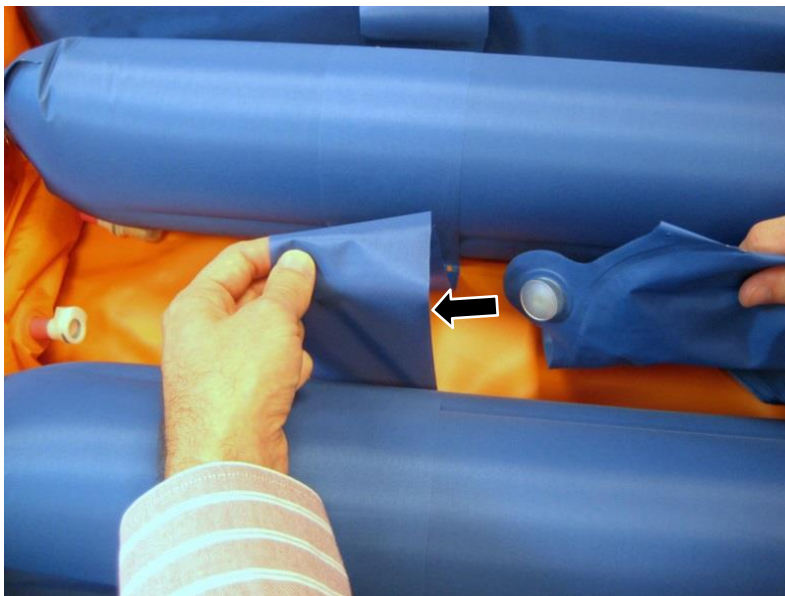

8. Button both sides of the new cell.
9. Uncap the manifold connector and connect the new air cell.
10. Place Air Plug Assemblies back into shell pocket.
11. Inflate and verify air cell properly inflates.
12. Re-zip the coverlet.

Service Information

CLEANING PUMP FILTER



Good filter maintenance is critical in keeping your IsoAir™ Pump in optimal operating condition. Failure to clean the filter may cause damage to the Pump. The damaged Pump may not provide proper support pressures resulting in patient injury.

Tools/Parts Required:

- Flat-bladed screwdriver
- Air Filter (2940-002-052)

Procedure:

The Pump filter should be checked every 30 days. If dirty, the filter can be dusted or vacuumed without removal. The filter may also be periodically removed and washed, or replaced as follows:

1. Unplug the electronic Pump.
2. Open the filter grill cover and remove the filter. This can be gently pried open using a flat-bladed screwdriver or similar from the opposite side to the hinge. The filter cover will swing open. DO NOT unscrew the filter assembly.
3. Clean the filter by washing in a mild detergent and allow to air dry. If replacing with a new filter discard instead of washing.
4. Insert the new or cleaned filter back into the filter housing and replace the grill cover.

If the filter cannot be cleaned or becomes damaged, contact Stryker Customer Service for information, see **Page 9**.

SUPPORT SURFACE COVERLET REPLACEMENT

Tools/Parts Required:

- Replacement Coverlet (2940-002-036)

Procedure:

1. Raise the bed height to the full up position.
2. Lower the fowler and gatch sections to the full down positions.
3. Unzip both zippers on the coverlet. Start at the foot end of the support surface and stop at the head end.
4. Attach the new coverlet by starting both zippers at the head end.
5. Zip the coverlet to close. Start at the head end and stop at the foot end.
6. Make sure the new coverlet aligns properly with the support surface.

Preventive Maintenance

PREVENTIVE MAINTENANCE OF THE SUPPORT SURFACE



- DO NOT service or perform maintenance while the product is in use. May result in patient injury.

At a minimum, check all items listed during annual preventive maintenance for all Stryker Medical products. You may need to perform preventive maintenance checks more frequently based on the level of patient usage and the number of times the Surface is cleaned/disinfected. Service should only be performed by qualified personnel.

Remove product from service before you perform preventive maintenance inspection.

Note: Clean and disinfect the exterior of the support surface before inspection, if applicable.

CHECKLIST

- _____ Inspect coverlet; if tears, rips, holes, cracks, or excessive wear are observed, it is strongly recommended to replace the coverlet
- _____ Verify that the coverlet zipper opens and closes properly and has no visible damage.
- _____ Unzip coverlet to view the air cells; inspect the air cells and the bolster to ensure that there are no holes, cracks or signs of excessive wear. Replace as required.
- _____ Inspect fire barrier for rips, cracks or excessive wear.
- _____ Check labels as specified in this manual (**Page 42**) for legibility, proper adherence, and integrity.
- _____ Inspect handles and stitching to ensure that there are no rips or cracks.
- _____ Inspect hose sleeve for tears, rips or damage.
- _____ Inspect surface straps and ensure that they are intact and are not damaged.
- _____ During installation, confirm that straps properly secure the support surface assembly to the bed frame.

SERIAL NUMBERS

System Component	Serial Number
Support Surface	
Coverlet	

MAINTENANCE RECORD

Completed By	Date

Preventive Maintenance

PREVENTIVE MAINTENANCE OF THE PUMP



Electrical safety testing of the Pump should be performed at least annually. Failure to do so may result in death or injury. Contact Stryker Customer Service for information, see **Page 9**.

Preventive maintenance should be performed annually, at a minimum. A preventive maintenance program should be established for all Stryker Medical equipment. Preventive maintenance may need to be performed more frequently based on the level of usage and the number of times the Pump is cleaned/disinfected. Use this sheet for your records and keep on file.

CHECKLIST

- Verify that there are no cracks, holes or damages on the Pump Housing, or its components (Hoses, Power Cord, and Case)
- Verify the hooks used to hang the Pump on the bed frame are intact and not damaged.
- Verify the POWER Key is working properly.
- While in operation, verify there are no air leaks from the Pump or the attached connectors/hosing.
- Check Air Filter (See **Page 39**).

SERIAL NUMBERS

System Component	Serial Number
Air Pump	

MAINTENANCE RECORD

Completed By	Date

Product Labeling

Support Surface Labels

Labels attached to the Support Surface are shown below are:
(Images are representative, actual labels may vary.)

1) Care Label

STITCHING TO BE ABOVE THIS LINE

MODEL
2940-ISOAIR

This product made with urethane, polyurethane foam, polyurethane, vinyl, nylon, and pvc

CONFORMS WITH
FLAMMABILITY STANDARD
USA-16 CFR 1633, 1632
BOSTON-BFD IX-11, CANADA-METHOD 27.7-1979 of CAN 2-4.2 M77, CALIFORNIA-TB 129, EUROPE BS-7177, ITALY UNI-9175 WHEN USED WITHOUT A FOUNDATION.

SERIAL NUMBER IS LOCATED INSIDE THE MATTRESS AT THE FOOT END

WARNING
DO NOT TRANSFER PATIENT FROM ONE BED TO ANOTHER USING THE SUPPORT SURFACE WITH THE PATIENT ON IT

1/2 ENGLISH IP-45-06 D

STITCHING TO BE ABOVE THIS LINE

CARE LABEL

MATTRESS OPTIONS

- 84 in LENGTH 84 in x 35 in x 7.0 in (213.4 cm x 88.9 cm x 17.8 cm)
- 80 in LENGTH 80 in x 35 in x 7.0 in (203.2 cm x 88.9 cm x 17.8 cm)
- 80 in LENGTH 80 in x 34 in x 7.0 in (203.2 cm x 86.4 cm x 17.8 cm)
- 80 in LENGTH 80 in x 32 in x 7.0 in (203.2 cm x 81.3 cm x 17.8 cm)
- 80 in LENGTH 80 in x 35 in x 7.7 in (203.2 cm x 88.9 cm x 19.6 cm)
- 80 in LENGTH 80 in x 34 in x 7.7 in (203.2 cm x 86.4 cm x 19.6 cm)
- 80 in LENGTH 80 in x 32 in x 7.7 in (203.2 cm x 81.3 cm x 19.6 cm)

2/2 ENGLISH IP-45-06 D

2) Law Label

STITCHING TO BE ABOVE THIS LINE

Not to be removed until delivered to the consumer
Ne pas enlever avant la livraison au consommateur

This article contains
NEW MATERIAL ONLY
Cet article contient des
MATERIAUX NEUFS SEULEMENT

This label is affixed in compliance with Provincial Law
Cette étiquette est apposée conformément à la loi de la province

Made by Reg. No. Fabriqué par No. de permis:

CANADA REG. NO. 03T-1633009

Content
Urethane
Polyurethane Foam
Polyester
Vinyl
Nylon
PVC

Contenu
Urethane
Mousse de polyuréthane
Polyuréthane
Vinyle
Nylon
PVC

IP-45-07-CAN

3) Coverlet Label

- 84 in x 35 in (213.4 cm x 88.9 cm)
- 80 in x 35 in (203.2 cm x 88.9 cm)
- 80 in x 34 in (203.2 cm x 86.4 cm)
- 80 in x 32 in (203.2 cm x 81.3 cm)

REF 2940

SN _____

45A-0017-_____

IP-45-11

4) Shell Label

STITCHING TO BE ABOVE THIS LINE

Stryker Medical
3800 E. Centre Ave.
Portage, MI 49002
USA

84 in x 35 in
(213.4 cm x 88.9 cm)

REF 2940

SN _____

45A-SR _____

IP-45-12-CAN C

5) Shell Pocket - Choking Hazard Label:

Stryker Medical
3800 E. Centre Ave.,
Portage, MI 49002 USA

REF 2940-002-001

0-3

Product Labeling

Pump Labels

Labels attached to the Pump are shown below are:
(Images are representative, actual labels may vary.)

1) Manufacturer Label:

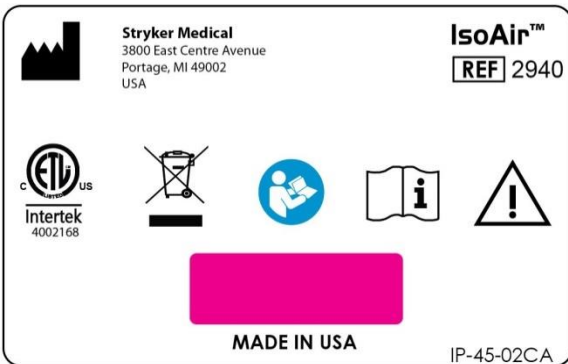

2) Part & Serial Number Label:

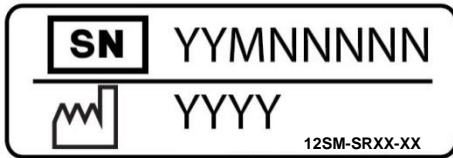

3) Control Data Label:

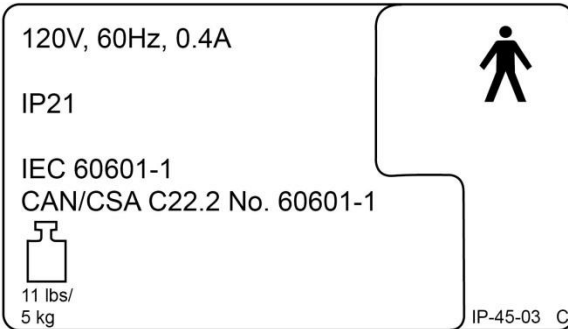

4) Fuse Label:

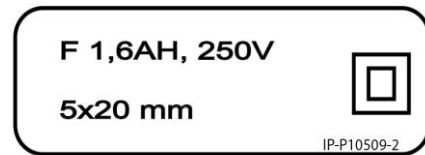

3) Stryker Name Label:



Product Labeling

Hosing/Tubing Assembly and Power Cord Labeling

Labels attached to the hosing/tubing assembly & the power cords are shown below:
(Images are representative, actual labels may vary.)

1) CPR Hose Label:



2) Power Cord Label:

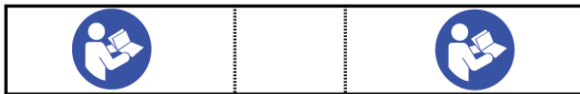

Quick Reference Replacement Parts List

The parts and accessories listed on this page are currently available for purchase. Some of the parts identified on the assembly drawing in this manual may not be individually available for purchase. Please call *Stryker Customer Service* at **1-800-327-0770** for availability and pricing.

Stryker Part Number	Part Description
2940-002-103	Kit, Controller, Power Cords, CAN
2940-001-101	Power Cord, 3 ft, US/CAN, B
2940-001-102	Power Cord, 15 ft, US/CAN, B
2940-002-001	Assembly, Air Plug
2940-002-062	Cap, Air Cell Laundry
2940-002-036	Coverlet, 35x84 (88.9 cm x 213.4 cm)
2940-002-033	Non-AST Air Cell, 35x5.5 (88.9 cm x 17.8 cm)
2940-002-052	Air Filter

Product Compliance Declarations

GUIDANCE AND MANUFACTURER'S DECLARATION – ELECTROMAGNETIC EMISSIONS

Guidance and Manufacturer's Declaration – Electromagnetic Emissions		
The IsoAir™ 2940 is intended for use in the electromagnetic environment specified below. The customer or the user of the IsoAir™ 2940 should assure that it is used in such an environment.		
Emissions Test	Compliance	Electromagnetic Environment – Guidance
RF emissions CISPR 11	Group 1	The IsoAir™ 2940 uses RF energy only for its internal function. Therefore, its RF emissions are very low and are not likely to cause any interference in nearby electronic equipment.
RF emissions CISPR 11	Class A	The IsoAir™ 2940 is suitable for use in all establishments other than domestic and those directly connected to the public low-voltage power supply network that supplies buildings used for domestic purposes.
Harmonic emissions IEC 61000-3-2	Not Applicable	
Voltage fluctuations/ flicker emissions IEC 61000-3-3	Not Applicable	

GUIDANCE AND MANUFACTURER'S DECLARATION – ELECTROMAGNETIC IMMUNITY

Guidance and Manufacturer's Declaration – Electromagnetic Immunity			
The IsoAir™ 2940 is intended for use in the electromagnetic environment specified below. The customer or the user of the IsoAir™ 2940 should assure that it is used in such an environment.			
Immunity Test	IEC 60601 Test Level	Compliance Level	Electromagnetic Environment – Guidance
Electrostatic discharge (ESD) IEC 61000-4-2	± 6 kV contact ± 8 kV air	± 6 kV contact ± 8 kV air	Floors should be wood, concrete, or ceramic tile. If floors are covered with synthetic material, the relative humidity should be at least 30 %.
Electrical fast transient/burst IEC 61000-4-4	± 2 kV for power supply lines ± 1 kV for input/output lines	± 2 kV for power supply lines ± 1 kV for input/output lines	Mains power quality should be that of a typical commercial or hospital environment.
Surge IEC 61000-4-5	± 1 kV line(s) to line(s) ± 2 kV line(s) to earth	± 1 kV line(s) to line(s) ± 2 kV line(s) to earth	Mains power quality should be that of a typical commercial or hospital environment.
Voltage dips, short interruptions and voltage variations on power supply input lines IEC 61000-4-11	<5 % U_T (>95 % dip in U_T) for 0,5 cycle 40 % U_T (60 % dip in U_T) for 5 cycles 70 % U_T (30 % dip in U_T) for 25 cycles <5 % U_T (>95 % dip in U_T) for 5 s	<5 % U_T (>95 % dip in U_T) for 0,5 cycle 40 % U_T (60 % dip in U_T) for 5 cycles 70 % U_T (30 % dip in U_T) for 25 cycles <5 % U_T (>95 % dip in U_T) for 5 s	Mains power quality should be that of a typical commercial or hospital environment. If the user of the IsoAir™ 2940 requires continued operation during power mains interruptions, it is recommended that the IsoAir™ 2940 be powered from an uninterruptible power supply or a battery.
Power frequency (50/60 Hz) magnetic field IEC 61000-4-8	3 A/m	3 A/m	Power frequency magnetic fields should be at levels characteristic of a typical location in a typical commercial or hospital environment.
NOTE U_T is the a.c. mains voltage prior to application of the test level.			

Product Compliance Declarations

GUIDANCE AND MANUFACTURER'S DECLARATION – ELECTROMAGNETIC IMMUNITY - NOT LIFE-SUPPORTING

Guidance and Manufacturer's Declaration – Electromagnetic Immunity			
The IsoAir™ 2940 is intended for use in the electromagnetic environment specified below. The customer or the user of the IsoAir™ 2940 should assure that it is used in such an environment.			
Immunity Test	IEC 60601 Test Level	Compliance Level	Electromagnetic Environment – Guidance
<p>Conducted RF IEC 61000-4-6</p> <p>Radiated RF IEC 61000-4-3</p>	<p>3 V_{RMS} 150 kHz to 80 MHz</p> <p>3 V/m 80 MHz to 2.5 GHz</p>	<p>$V_1 = 3 V_{RMS}$</p> <p>$E_1 = 3 V/m$</p>	<p>Portable and mobile RF communications equipment should be used no closer to any part of the IsoAir™ 2940, including cables, than the recommended separation distance calculated from the equation applicable to the frequency of the transmitter.</p> <p>Recommended separation distance</p> $d = \left[\frac{3.5}{V_1} \right] \sqrt{P}$ $d = \left[\frac{3.5}{E_1} \right] \sqrt{P} \quad 80 \text{ MHz to } 800 \text{ MHz}$ $d = \left[\frac{7}{E_1} \right] \sqrt{P} \quad 800 \text{ MHz to } 2.5 \text{ GHz}$ <p>where P is the maximum output power rating of the transmitter in watts (W) according to the transmitter manufacturer and d is the recommended separation distance in meters (m).</p> <p>Field strengths from fixed RF transmitters, as determined by an electromagnetic site survey,^a should be less than the compliance level in each frequency range.^b</p> <p>Interference may occur in the vicinity of equipment marked with the following symbol:</p> 
<p>NOTE 1 At 80 MHz and 800 MHz, the higher frequency range applies.</p> <p>NOTE 2 These guidelines may not apply in all situations. Electromagnetic propagation is affected by absorption and reflection from structures, objects, and people.</p>			
<p>^a Field strengths from fixed transmitters, such as base stations for radio (cellular/cordless) telephones and land mobile radios, amateur radio, AM and FM radio broadcast and TV broadcast cannot be predicted theoretically with accuracy. To assess the electromagnetic environment due to fixed RF transmitters, an electromagnetic site survey should be considered. If the measured field strength in the location in which the IsoAir™ 2940 is used exceeds the applicable RF compliance level above, the IsoAir™ 2940 should be observed to verify normal operation. If abnormal performance is observed, additional measures may be necessary, such as re-orienting or relocating the IsoAir™ 2940.</p> <p>^b Over the frequency range 150 kHz to 80 MHz, field strengths should be less than 3 V/m.</p>			

Product Compliance Declarations

GUIDANCE AND MANUFACTURER'S DECLARATION – RECOMMENDED SEPARATION DISTANCES BETWEEN PORTABLE AND MOBILE RF COMMUNICATIONS EQUIPMENT AND THE IsoAir™ 2940

Recommended Separation Distances Between Portable and Mobile RF Communications Equipment and the IsoAir™ 2940			
The IsoAir™ 2940 is intended for use in an electromagnetic environment in which radiated RF disturbances are controlled. The customer or the user of the IsoAir™ 2940 can help prevent electromagnetic interference by maintaining a minimum distance between portable and mobile RF communications equipment (transmitters) and the IsoAir™ 2940 as recommended below, according to the maximum output power of the communications equipment.			
Rated Maximum Output Power of Transmitter (in Watts)	Separation Distance According to Frequency of Transmitter (in meters)		
	150 kHz to 80 MHz $d = \left[\frac{3.5}{V_1} \right] \sqrt{P}$	80 MHz to 800 MHz $d = \left[\frac{3.5}{E_1} \right] \sqrt{P}$	800 MHz to 2.5 GHz $d = \left[\frac{7}{E_1} \right] \sqrt{P}$
0.01	0.12	0.12	0.23
0.1	0.37	0.37	0.74
1	1.2	1.2	2.3
10	3.7	3.7	7.4
100	12	12	23
For transmitters rated at a maximum output power not listed above, the recommended separation distance d in meters (m) can be estimated using the equation applicable to the frequency of the transmitter, where P is the maximum output power rating of the transmitter in watts (W) according to the transmitter manufacturer.			
NOTE 1 At 80 MHz and 800 MHz, the separation distance for the higher frequency range applies.			
NOTE 2 These guidelines may not apply in all situations. Electromagnetic propagation is affected by absorption and reflection from structures, objects, and people.			

Warranty

LIMITED WARRANTY

The Stryker IsoAir™ System has a warranty of **TWO (2) YEARS** under normal use, conditions, and with appropriate periodic maintenance as described in this manual.

This statement constitutes Stryker's entire warranty with respect to the aforesaid equipment. **Stryker makes no other warranty or representation, either expressed or implied, except as set forth herein. There is no warranty of merchantability and there are no warranties of fitness for any particular purpose. In no event shall Stryker be liable here under for incidental or consequential damages arising from or in any manner related to sales or use of any such equipment.**

CONDITIONS AND LIMITATIONS

This statement constitutes Stryker's entire warranty with respect to the aforesaid equipment. Stryker makes no other warranty or representation, either expressed or implied, except as set forth herein. There is no warranty of merchantability and there are no warranties of fitness for any particular purpose. This warranty does not extend to, nor cover:

- Normal wear and tear; or
- Damage or product failure due to causes beyond Stryker's control such as, but not limited to abuse, theft, fire, flood, wind, lightning, freezing, clogging of support surface pores due to tobacco smoke, unusual atmosphere conditions, material degradation due to exposure to moisture; or
- Damage to support surface or support surface handles through the use of the support surface for patient transfer or transport.

Normal use is defined as normal hospital or facility usage. Damages arising from abnormal use such as those caused by needle punctures, burns, chemicals, negligent use or improper care or improper cleaning or staining resulting from it are exempt from warranty coverage.

TO OBTAIN PARTS AND SERVICE

Stryker products are supported by a nationwide network of dedicated Stryker Field Service Representatives. These representatives are factory trained, available locally, and carry a substantial spare parts inventory to minimize repair time. Simply call your local representative or call Stryker Customer Service at **1-800-327-0770**.

RETURN AUTHORIZATION

Merchandise cannot be returned without approval from the Stryker Customer Service Department. An authorization number will be provided which must be printed on the returned merchandise. Stryker reserves the right to charge shipping and restocking fees on returned items. **Special, modified, or discontinued items not subject to return.**

DAMAGED MERCHANDISE

ICC Regulations require that claims for damaged merchandise must be made with the carrier within fifteen (15) days of receipt of merchandise. **Do not accept damaged shipments unless such damage is noted on the delivery receipt at the time of receipt.** Upon prompt notification, Stryker will file a freight claim with the appropriate carrier for damages incurred. Claim will be limited in amount to the actual replacement cost. In the event that this information is not received by Stryker within the fifteen (15) day period following the delivery of the merchandise, or the damage was not noted on the delivery receipt at the time of receipt, the customer will be responsible for payment of the original invoice in full. Claims for any short shipment must be made within thirty (30) days of invoice.

ISOAIR™ QUICK REFERENCE GUIDE

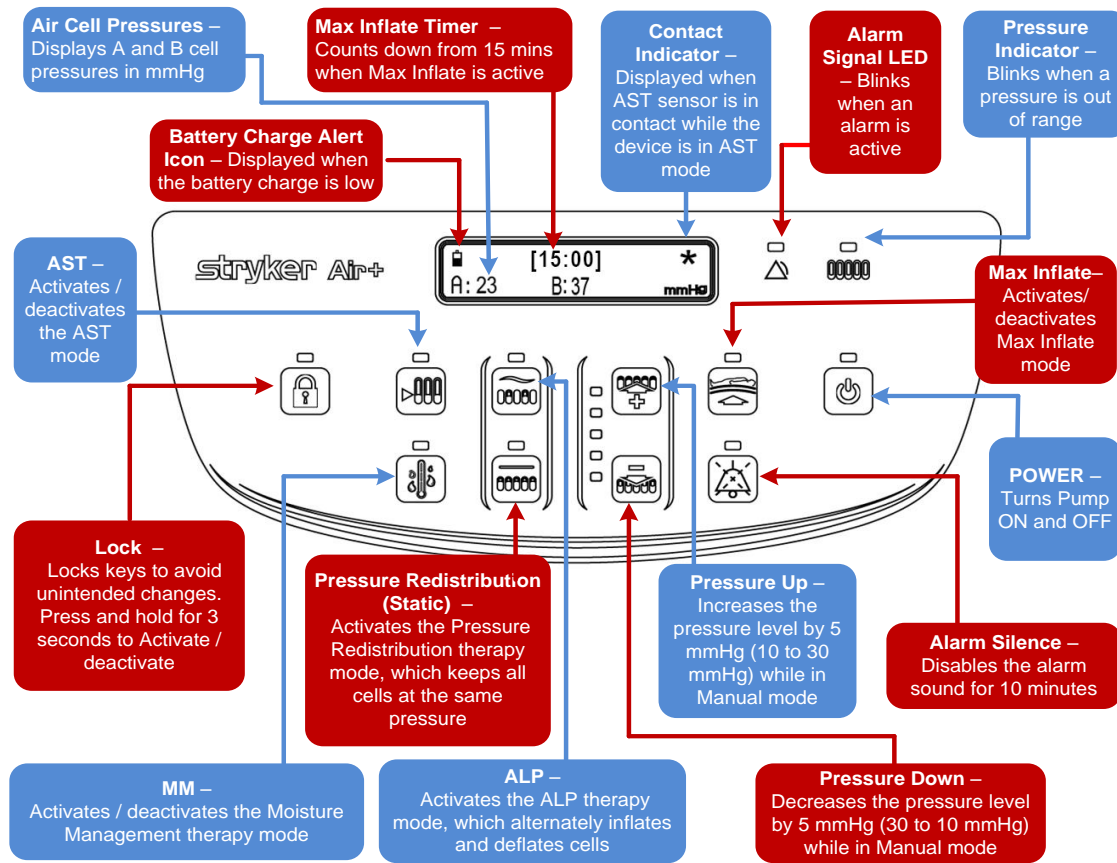



Alarms / Alerts (In Order of Notification Priority)	Symptoms	Recommended Action ⁴
1. Power Failure - The controller is not receiving power due to a power outage, disconnected power cord, blown fuse, or possible internal damage.	<ul style="list-style-type: none"> - Controller does not turn on. - Support surface does not inflate - Keys not responding - Alarm Signal LED blinks and Power Key LED blinks². 	<ul style="list-style-type: none"> - Make sure the power cord is plugged in, mains AC power is ON and the Power LED is lit (white for standby, green for unit turned on).
2. Hardware Failure - The controller has detected an internal hardware failure.	<ul style="list-style-type: none"> - Alarm Signal LED blinks and Power Key LED continuously lit. 	<ul style="list-style-type: none"> - Cycle power
3. Stuck Key - The controller has detected that a key has been activated for more than 15 seconds.	<ul style="list-style-type: none"> - Keys not responding - Alarm Signal LED blinks² and LED for affected stuck key flashes³ 	<ul style="list-style-type: none"> - Press and release the key with the flashing LED to clear the stuck key.
4. AST Connection Error - The controller has detected that the AST cable is disconnected.	<ul style="list-style-type: none"> - Alarm Signal LED blinks² and AST Key LED blinks 	<ul style="list-style-type: none"> - Check that the AST plug is completely inserted into the AST socket. - Toggle the AST key (OFF/ON) to see if condition clears.
5. AST Sensor – The AST Sensor remains in contact for more than 15 minutes while operating in AST mode.	<ul style="list-style-type: none"> - Alarm Signal LED blinks², AST Key LED blinks and Pressure Indicator LED blinks 	<ul style="list-style-type: none"> - If patient is in fowler, reduce HOB angle. - Unzip cover and check that AST air cells are correctly positioned underneath patient. - Perform a hand check to ensure that the patient is not bottoming out.
6. Pressure Alarm - A high or low pressure condition exists in a support cell or bolster.	<ul style="list-style-type: none"> - Alarm Signal LED blinks² and Pressure Indicator LED blinks 	<ul style="list-style-type: none"> - Check that the CPR connector is correctly plugged into the controller. - Check for kinks in tubes from the CPR connector to the support surface. - Unzip the mattress cover, check air cells, tubing and connections for possible leaks.
7. MM Low Flow – flow is below minimum expected threshold for 5 seconds.	<ul style="list-style-type: none"> - Alarm Signal LED blinks², the MM Key LED blinks and the Pressure LED blinks 	<ul style="list-style-type: none"> - Unzip the mattress cover. Check for air flow blockage along the MM hoses inside the mattress (See Page 16).
8. Lock Alert - A key is pressed while the LOCK function is active.	<ul style="list-style-type: none"> - Keys not responding - Lock Key LED flashes³ 	<ul style="list-style-type: none"> - If required, deactivate the LOCK function by pressing and holding the LOCK key for 3 seconds.
9. Battery Fault Alert - A fault with the battery was detected.	<ul style="list-style-type: none"> - Battery icon is displayed on LCD 	<ul style="list-style-type: none"> - Ensure power is connected for at least five hours.

1 - All alarms are classified as Medium Priority per IEC 60601-1-8

2 - Blinking = every 2 seconds

3 - Flashing = 10 times per second

4 - If alarm condition persists, contact Stryker Customer Service

Stryker Customer Service – 1-800-327-0770

Distributed By:
Stryker Medical
3800 E. Centre Ave.
Portage, Michigan 49002
USA

stryker[®]
