

**Impression™**  
**Non-Powered Mattress**  
Model 2980

# stryker®

## Operations/Maintenance Manual



For Parts or Technical Assistance:  
USA: 1-800-327-0770 (option 2)  
Canada: 1-888-233-6888



# Table of Contents

---

Introduction . . . . .	<a href="#">4</a>
Intended Use of Manual . . . . .	<a href="#">4</a>
Intended Use of Product . . . . .	<a href="#">4</a>
Product Description . . . . .	<a href="#">4</a>
Product Serial Number Identification . . . . .	<a href="#">4</a>
Specifications . . . . .	<a href="#">5</a>
Warning /Caution / Note Definition . . . . .	<a href="#">6</a>
Symbols . . . . .	<a href="#">6</a>
Summary of Safety Precautions. . . . .	<a href="#">7</a>
Product Inspection . . . . .	<a href="#">8</a>
Nursing Care . . . . .	<a href="#">8</a>
Transferring a Patient to and from the Impression™ Non-Powered Mattress . . . . .	<a href="#">8</a>
Incontinence / Drainage . . . . .	<a href="#">8</a>
Preventative Maintenance Checklist . . . . .	<a href="#">9</a>
Checklist . . . . .	<a href="#">9</a>
Cleaning . . . . .	<a href="#">10</a>
Routine Care . . . . .	<a href="#">10</a>
Suggested Cleaners for Hard to Clean Areas and Disinfection . . . . .	<a href="#">10</a>
Service Information . . . . .	<a href="#">11</a>
Cover Removal and Replacement . . . . .	<a href="#">11</a>
Pods Assembly Removal and Replacement . . . . .	<a href="#">11</a>
Crib Removal and Replacement . . . . .	<a href="#">11</a>
Flame Barrier Replacement . . . . .	<a href="#">11</a>
Mattress Cover, Sloped Heel, with Flame Barrier Assembly . . . . .	<a href="#">13</a>
Mattress Cover, Flat Heel, with Flame Barrier Assembly . . . . .	<a href="#">14</a>
Mattress Cover, Sloped Heel, without Flame Barrier Assembly. . . . .	<a href="#">15</a>
Mattress Cover, Flat Heel, without Flame Barrier Assembly . . . . .	<a href="#">16</a>
Mattress Assembly, Sloped Heel . . . . .	<a href="#">17</a>
Mattress Assembly, Flat Heel . . . . .	<a href="#">19</a>
Mattress Cover . . . . .	<a href="#">21</a>
Cover Options - Sloped Heel. . . . .	<a href="#">21</a>
Cover Options - Flat Heel . . . . .	<a href="#">21</a>
Warranty. . . . .	<a href="#">22</a>
Limited Lifetime Warranty . . . . .	<a href="#">22</a>
To Obtain Parts and Service . . . . .	<a href="#">22</a>
Return Authorization . . . . .	<a href="#">22</a>
Damaged Merchandise. . . . .	<a href="#">22</a>

# Introduction

## INTENDED USE OF MANUAL

This manual is designed to assist with the operation of the Impression™ non-powered mattress system, model 2980. Carefully read this manual thoroughly before using or beginning maintenance on the mattress. To ensure safe operation of this equipment, it is recommended that methods and procedures be established for educating and training staff on the safe operation of the mattress.

## INTENDED USE OF PRODUCT

The Impression™ non-powered mattress is recommended for use in the prevention of pressure ulcers. It is intended for use on Stryker frames and on other frames supporting a 84" x 35" x 6" mattress.

## PRODUCT DESCRIPTION

Impression™ is a non-powered surface for improved patient outcomes, focusing on equalizing pressure, reducing moisture and enhancing comfort.

The mattress is compatible with any frame that supports a 84" x 35" x 6" mattress.

## PRODUCT SERIAL NUMBER IDENTIFICATION

**Location:** attached to the foam crib at the footend of the mattress. Unzip the cover to access the foam crib.

**Format:**

Y	Y	M	M	S#	S#	S#	S#	S#	S#	<ul style="list-style-type: none"> <li>• Y (first Y) = <b>Year</b></li> <li>• Y (second Y) = <b>Year</b></li> <li>• M (first M) = <b>Month</b> product built</li> <li>• M (second M) = Product <b>Model</b></li> <li>• S# - Sequence number assigned to product</li> </ul>
0	9	B	A	0	0	0	1	5	0	<ul style="list-style-type: none"> <li>• 09 = Year (see year legend below)</li> <li>• B = February (see month legend below)</li> <li>• A = Impression (see model legend below)</li> <li>• 000150 = Sequence number (unit number)</li> </ul>





Year Legend	
2008	08
2009	09
2010	10
2011	11

Month Legend	
January	A
February	B
March	C
April	D
May	E
June	F
July	G
August	H
September	J
October	K
November	L
December	M

Models Legend	
Impression (non-powered)	A

# Introduction

## SPECIFICATIONS

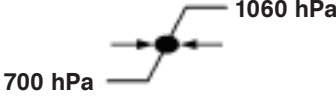
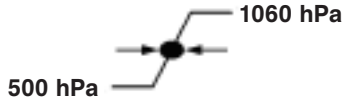
Non-Powered Mattress		
<b>Model 2980 - L59-001 - (Sloped Heel)</b> <b>Model 2980 - L59-014 - (Flat Heel)</b>		
• Dimensions	• 84" x 35" x 6"	213,4 cm x 88,9 cm x 15,2 cm
• Weight of mattress and cover	• 37 lbs	16,78 kg
• Safe Working Load	• 500 lbs	226,8 kg
		
Mattress Cover		
Sloped Heel	Dartex Silver - 59-0413	Polyamide Fabric with Silver, Water Penetration Resistance, No Latex
Flat Heel	Dartex Silver - 59-0555	
Sloped Heel	Goretex 59-0412	Nylon, Polyetrafluoroethylene Membrane, Waterproof, Breathable, No Latex
Flat Heel	Goretex 59-0552	
Environmental Conditions	Operation	Storage and Transportation
Ambient Temperature		
Relative Humidity (Non-Condensing)		
Atmospheric Pressure		
<b>Product Compliance (with Flame Barrier Option)</b>	CAL TB 603 16 CFR 1632 16 CFR 1633 BS EN 597-1 BS EN 597-2 CAL TB 129	

*Stryker reserves the right to change specifications without notice.*

[Return To Table of Contents](#)

# Introduction

---

## WARNING /CAUTION / NOTE DEFINITION

These words carry special meanings and should be carefully reviewed.

---

### **WARNING**

Alerts the reader about the situation which if not avoided, could result in death or serious injury. It may also describe potential serious adverse reactions and safety hazards.

---

---

### **CAUTION**

Alerts the reader of a potentially hazardous situation, which if not avoided, may result in minor or moderate injury to the user or patient or damage to the equipment or other property. This includes special care necessary for the safe and effective use of the device and the care necessary to avoid damage to a device that may occur as a result of use or misuse.

---

### **NOTE**

This provides special information to make maintenance easier or important instructions clearer.

# Symbols

---



Warning/Warning, consult accompanying documentation



Safe Working Load Symbol



Moisture Management



Non-Powered Envelopment

# Summary of Safety Precautions

---

Before operating or servicing the Impression™ non-powered mattress system, it is important to read and understand all information in this manual. Carefully read and strictly follow these guidelines. The warnings and cautions are repeated throughout the manual, where applicable.

To ensure safe operation, methods and procedures must be established for educating and training the staff.

---

## WARNING

- Do not transfer the patient from one bed to another using the mattress with a patient on it. Doing so can result in serious patient injury.
  - Do not use the mattress cover straps to lift or move the mattress with a patient on it. Doing so can result in a serious patient injury and can cause physical damage to the product.
  - It is the responsibility of the caregiver to monitor the patient and skin condition at regular intervals (every 8 hours, or once per shift) to ensure patient safety and proper mattress performance.
  - Disinfect the mattress between patients. Failure to do so could result in cross-contamination and infection.
  - Patient stability and siderails coverage may be compromised with the use of an overlay.
  - Siderails must be up and head/foot board in place during litter operation.
  - Discontinue use if the mattress cover is ripped, torn or damaged in any way. Degradation represents end of life of the cover.
  - To reduce risk of patient or user injury and equipment damage, do not exceed the safe working load of the hospital bed frame when supporting both the patient and the mattress
  - A sheet (or equivalent) must be positioned between the patient's skin and the mattress surface prior to use.
- 

---

## CAUTION

- The mattress cover must be completely dry before storage or adding linens. Failure to remove excess disinfectant could cause degradation of the cover material.
  - Follow all applicable safety rules and protocols concerning patient and care giving safety.
  - Monitor the patient's skin condition regularly to ensure skin integrity.
  - Avoid contact of sharp objects with mattress. Punctures, cuts and tears in the cover could result in contamination of the cushions, prevent proper air pressure control and compromise therapy and safety.
  - Be aware of devices or equipment placed on the top of the mattress. The weight, heat generated, or a sharp edge of a device or equipment could damage the mattress.
  - It is the responsibility of the caregiver team to evaluate the appropriate CPR protocol to be used with the surface.
- 

## CONTRAINDICATIONS

Stryker promotes the clinical assessment of each patient and appropriate usage by the caregiver. Air support therapy is not recommended for patients with, but not limited to:

- Unstable spinal cord injury.
- Cervical, thoracic, and/or lumbar fracture.
- Cervical traction.

# Product Inspection

---

The condition of the Impression™ non-powered mattress is the responsibility of the owner. There is no setup required to use this product only an inspection of the mattress and cover prior to **first time use**. A qualified service technician should inspect the product thoroughly and confirm the items listed below are free from damage prior to putting into service. Product inspection is recommended during routine care.

\_\_\_\_\_ Verify there are no rips, cracks, tears or holes in the mattress cover.

\_\_\_\_\_ Verify the mattress cover straps are intact and not damaged.

## Nursing Care

---

### TRANSFERRING A PATIENT TO AND FROM THE IMPRESSION™ NON-POWERED MATTRESS

---

#### **WARNING**

Do not transfer the patient from one bed to another using the mattress with a patient on it. Doing so can result in serious patient injury.

---

1. Position the patient along the center line of the mattress.
2. Lock the brakes on both bed surfaces.
3. Adjust the height of the bed to the same level as the surface to which (or from which) the patient is to transfer.
4. Transfer the patient following all applicable safety rules and institution protocols to ensure patient and caregiver safety.



### INCONTINENCE / DRAINAGE

Disposable diapers or incontinence pads may be used. Ensure to provide appropriate skin care following each episode.

---

#### **WARNING**

It is the caregiver's responsibility to monitor the patient's condition at regular intervals to ensure patient safety. Consult physician if erythema or skin breakdown occurs.

---



# Preventative Maintenance Checklist

---

The Impression™ non-powered mattress requires an effective maintenance program, we recommend checking these items annually. Use this sheet for your records. Keep on file.

## CHECKLIST

- Cover zipper opens and closes properly and has no visible damage.
- Cover is free from tears, rips, holes, cuts or other openings.
- If excessive wear is observed on the cover, it is strongly recommended to replace this cover.
- Mattress cover straps are intact and not damaged.
- Straps are properly securing mattress assembly to the crib.
- Mattress has no visible signs of sagging in the mid section.
- Foam and other components do not degrade or come apart.
- Flame barrier (if option present) has no visible sign of damage. If excessive wear is observed, it is recommended to replace it.

## Mattress Serial No.

Completed by: \_\_\_\_\_ Date: \_\_\_\_\_

# Cleaning

---

## ROUTINE CARE

Wipe down the entire Impression™ non-powered mattress surface with a mild soap and lukewarm water solution and a clean, soft cloth. Rinse and dry. Apply a disinfectant to the entire mattress outer surface. Lift up the head section of the mattress to clean the bottom surface.

To clean the bottom of the foot section, carefully lift up the foot section and fold it over the seat section. Clean as described above. Allow the surface to completely dry then gently lower the foot section back into its original position.



### CAUTION

- The mattress cover must be completely dry before storage or adding linens. Failure to remove excess disinfectant could cause degradation of the cover material.
  - Internal components of this mattress are not cleanable. If there is contamination inside the mattress it should be discarded.
- 

### Note (Applicable for Silver cover only)

The mattress cover contains an antimicrobial agent to help prevent bacteria and fungus from destroying the cover. If stains, discoloration, brittleness, stickiness or unpleasant odors become noticeable, the antimicrobial agent may have become ineffective and the mattress cover should be replaced.

## SUGGESTED CLEANERS FOR HARD TO CLEAN AREAS AND DISINFECTION

- Quaternary Cleaners (active ingredient - ammonium chloride).
  - Phenolic Cleaners (active ingredient - o-phenylphenol).
  - Chlorinated Bleach Solution (5.25% - less than 1 part bleach to 100 parts water).
- 



### CAUTION

- Iodophor type disinfectants (Betadine, for example) will stain fabrics.
  - Prolonged contact with bleach solutions, improper dilution ratios for any cleaning agent, or poor rinsing of fabric surface after disinfecting and cleaning may cause damage to both the appearance and performance of the fabric.
  - Laundering is not recommended.
  - Do not use harsh cleaners or solvents.
- 

### Note

All cleaning agents must first be spot tested on an inconspicuous part of the fabric to ensure that they do not damage the fabric. User must dilute cleaning agent in accordance with manufacturer's instructions.

# Service Information

---

## COVER REMOVAL AND REPLACEMENT

1. Unzip the Impression™ non-powered mattress cover and remove the old cover.
2. Replace with the new cover.  
**Note:** Make sure that the foot section of the cover and of the crib are located in the same direction (labels are located at the foot section). Make sure that the pods assembly is located at the bottom of the mattress.
3. Put the mattress back into service.

## PODS ASSEMBLY REMOVAL AND REPLACEMENT

1. Unzip the Impression™ non-powered mattress cover and remove.
2. Unbutton the pods assembly from the crib.
3. Remove the pods assembly.
4. Place the new pods assembly under the crib.
5. Attach the Low Air Loss system in the pods Assembly.
6. Attach the pods assembly to the crib by attaching all of the buttons.
7. Reinstall flame barrier and secure the velcro together  
**Note:** The flame barrier should be installed with the velcro positioned on the foot end.
8. Replace the mattress cover.
9. Make sure that all components are correctly attached, so that no components move freely. Ensure that there are no foreign objects inside of the mattress.  
**Note:** Make sure that the foot section of the cover and of the crib are located in the same direction (labels are located at the foot sections). Make sure that the pods assembly is located at the bottom of the mattress.
10. Put the mattress back into service.

## FLAME BARRIER REPLACEMENT

1. Unzip the Impression™ non-powered mattress cover and remove.
2. Detach the velcro holding the flame barrier together. Remove flame barrier.
3. Install new flame barrier and secure the velcro together  
**Note:** The flame barrier should be installed with the velcro positioned on the foot end.
4. Reinstall mattress cover.  
**Note:** Make sure that the foot section of the cover and of the crib are located in the same direction (labels are located at the foot sections). Make sure that the pods assembly is located at the bottom of the mattress.
5. Put the mattress back into service.

# Notes

---

# Mattress Cover, Sloped Heel, with Flame Barrier Assembly

Assembly Part Number Options: (reference only)

2980-000-002 Rev C (with Goretex Cover)

2980-000-004 Rev C (with Dartex Cover)

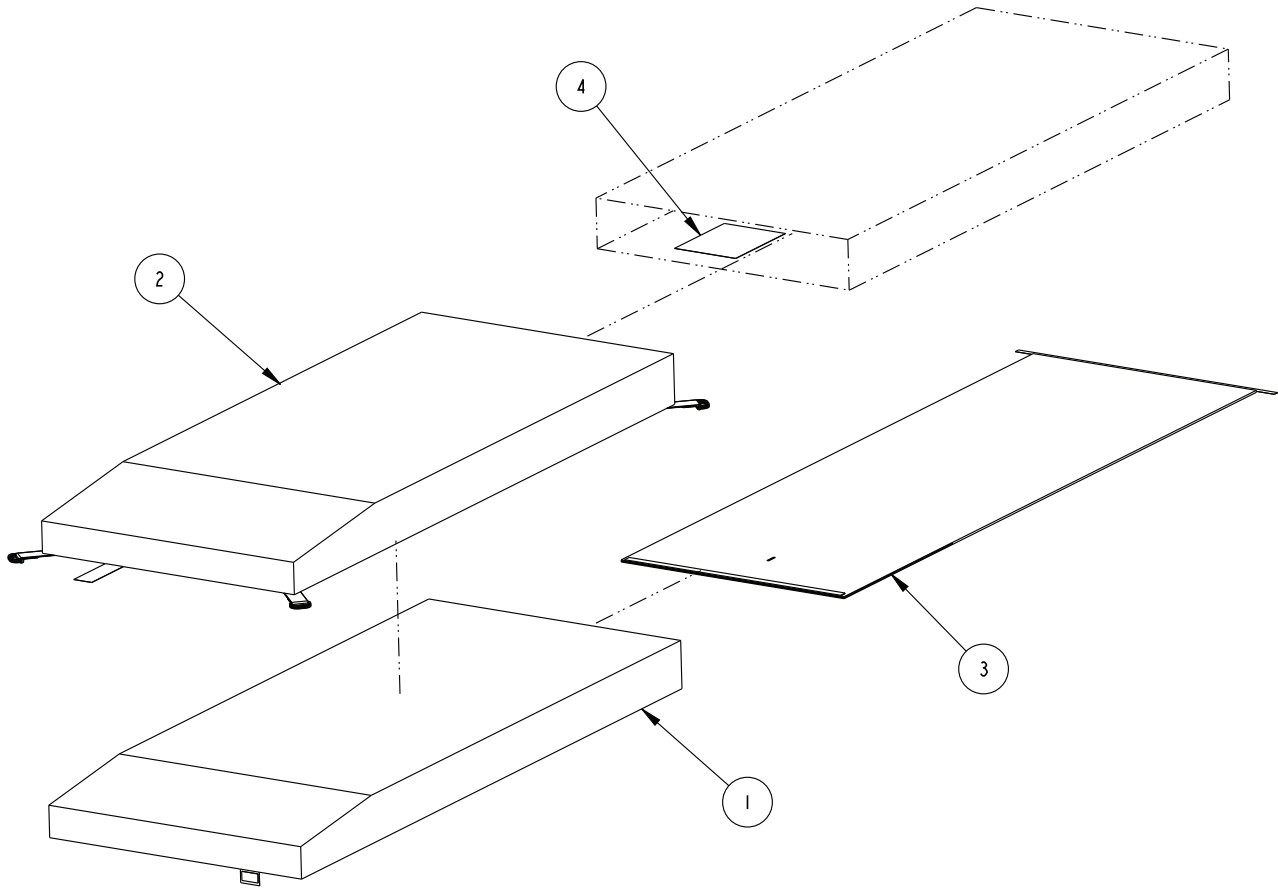

Item	Part No.	Part Name	Qty.
1	L59-001	Mattress Assembly ( <a href="#">see page 17</a> )	1
2	OL590001	Goretex Cover ( <a href="#">see page 21</a> )	1 or
	OL590002	Dartex Cover ( <a href="#">see page 21</a> )	1
3	OL590006	Flame Barrier	1
4	OL590007	Packaging	1

[Return To Table of Contents](#)

# Mattress Cover, Flat Heel, with Flame Barrier Assembly

Assembly Part Number Options: (reference only)

2980-000-022 Rev A (with Goretex Cover)

2980-000-024 Rev A (with Dartex Cover)

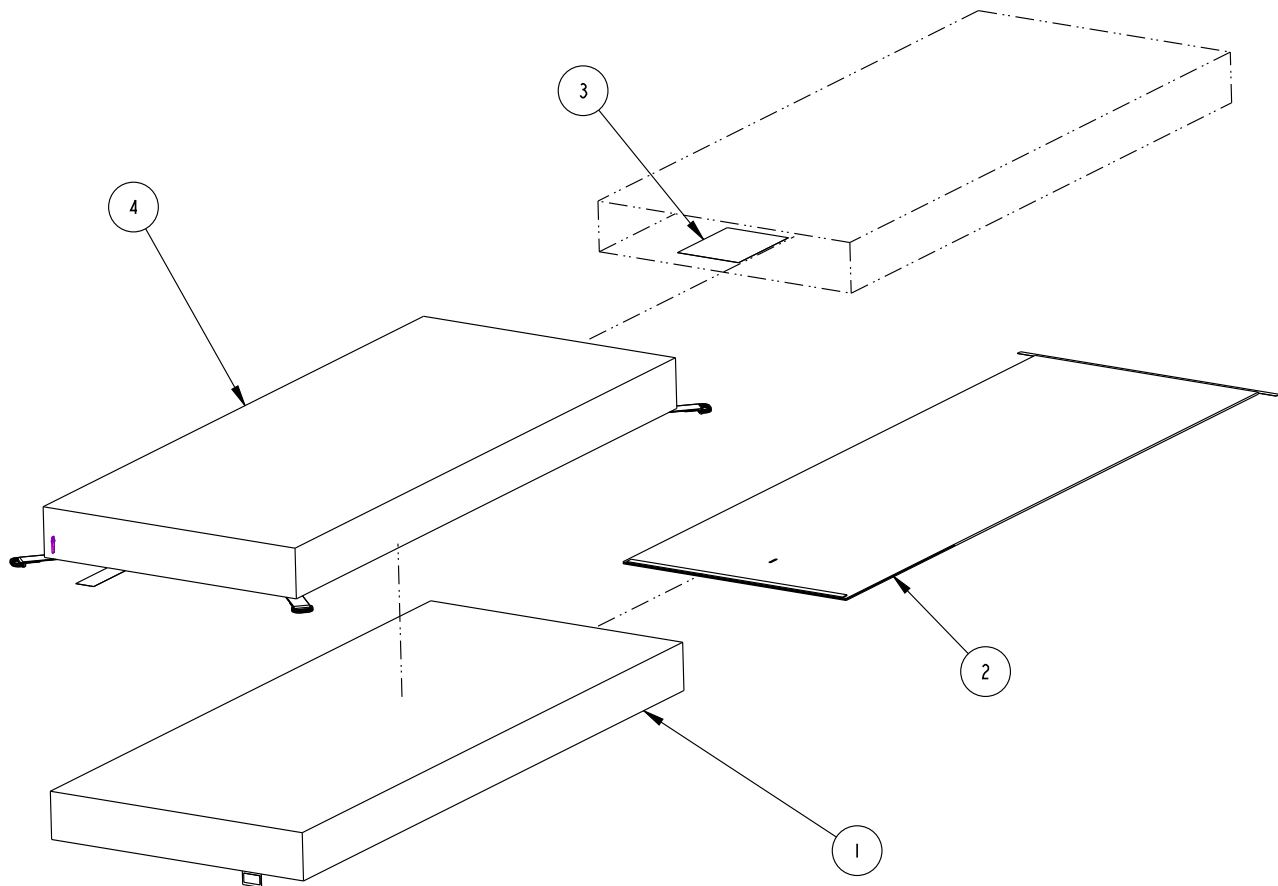

Item	Part No.	Part Name	Qty.
1	L59-014	Mattress Assembly ( <a href="#">see page 19</a> )	1
2	OL590006	Flame Barrier	1
3	OL590007	Packaging	1
4	OL590024	Goretex Cover ( <a href="#">see page 21</a> )	1 or
	OL590025	Dartex Cover ( <a href="#">see page 21</a> )	1

# Mattress Cover, Sloped Heel, without Flame Barrier Assembly

Assembly Part Number Options: (reference only)

2980-000-001 Rev C (with Goretex Cover)

2980-000-003 Rev C (with Dartex Cover)

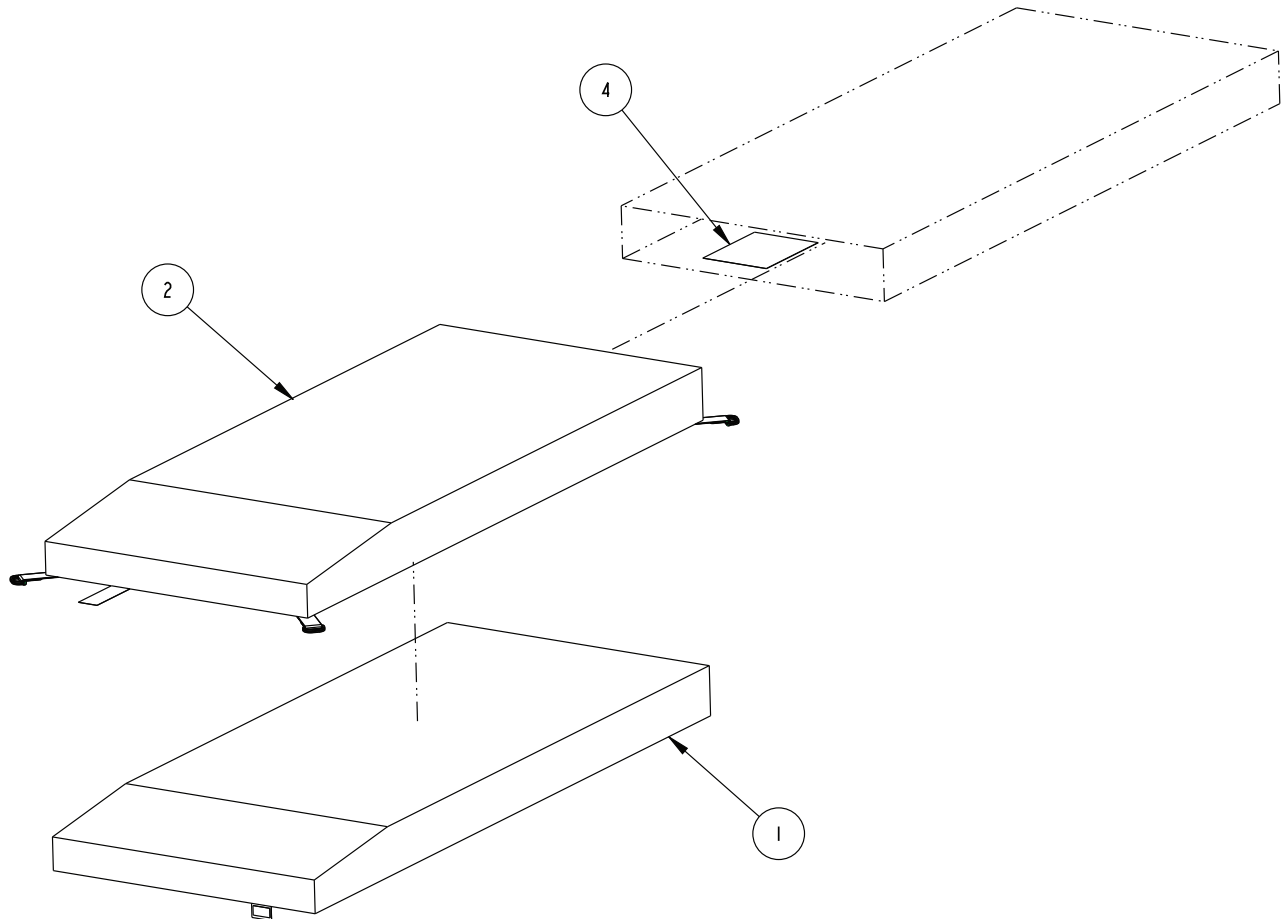

Item	Part No.	Part Name	Qty.
1	L59-001	Mattress Assembly ( <a href="#">see page 17</a> )	1
2	OL590001	Goretex Cover ( <a href="#">see page 21</a> )	1 or
	OL590002	Dartex Cover ( <a href="#">see page 21</a> )	1
4	OL590007	Packaging	1

[Return To Table of Contents](#)

# Mattress Cover, Flat Heel, without Flame Barrier Assembly

Assembly Part Number Options: (reference only)

2980-000-021 Rev A (with Goretex Cover)

2980-000-023 Rev A (with Dartex Cover)

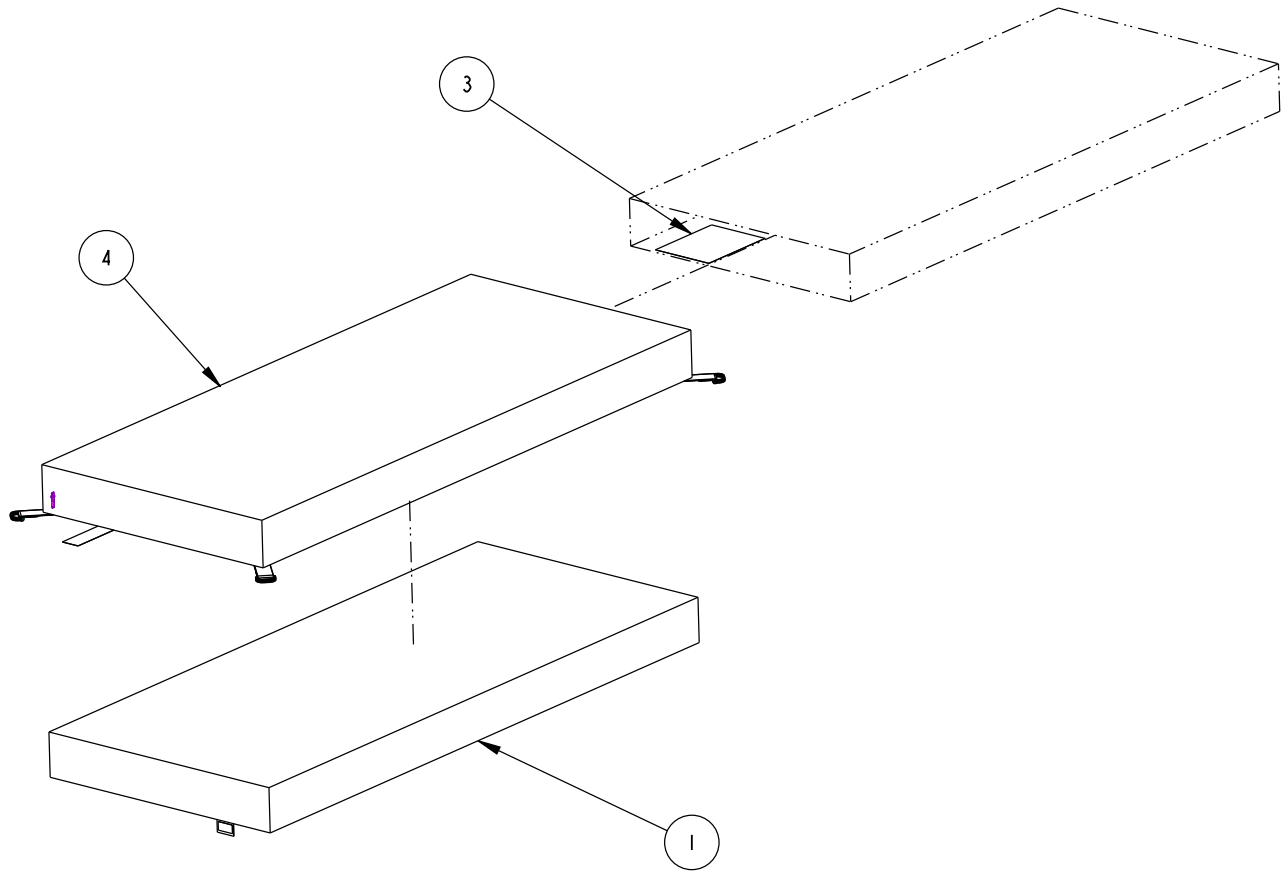

Item	Part No.	Part Name	Qty.
1	L59-014	Mattress Assembly ( <a href="#">see page 19</a> )	1
3	OL590007	Packaging	1
4	OL590024	Goretex Cover ( <a href="#">see page 21</a> )	1 or
	OL590025	Dartex Cover ( <a href="#">see page 21</a> )	1



# Mattress Assembly, Sloped Heel

Assembly Part Number: L59-001 Rev E (reference only)

Slide the Tubing between the Pods and secure with the straps.

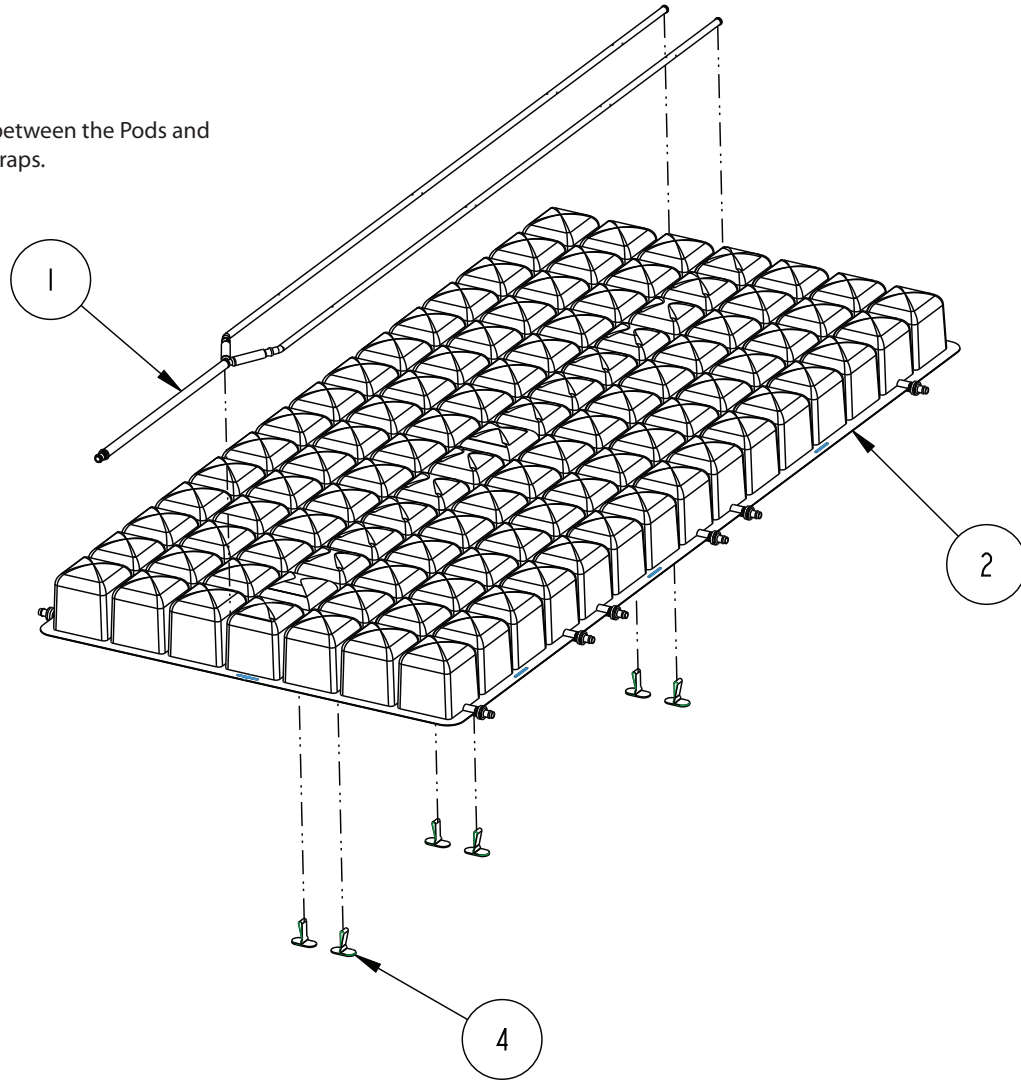

Adjust the Tubing Assembly so there is a hole visible on both sides of the strap.

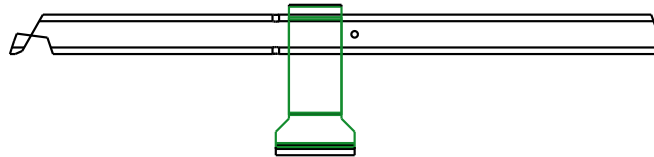

[Return To Table of Contents](#)

# Mattress Assembly, Sloped Heel

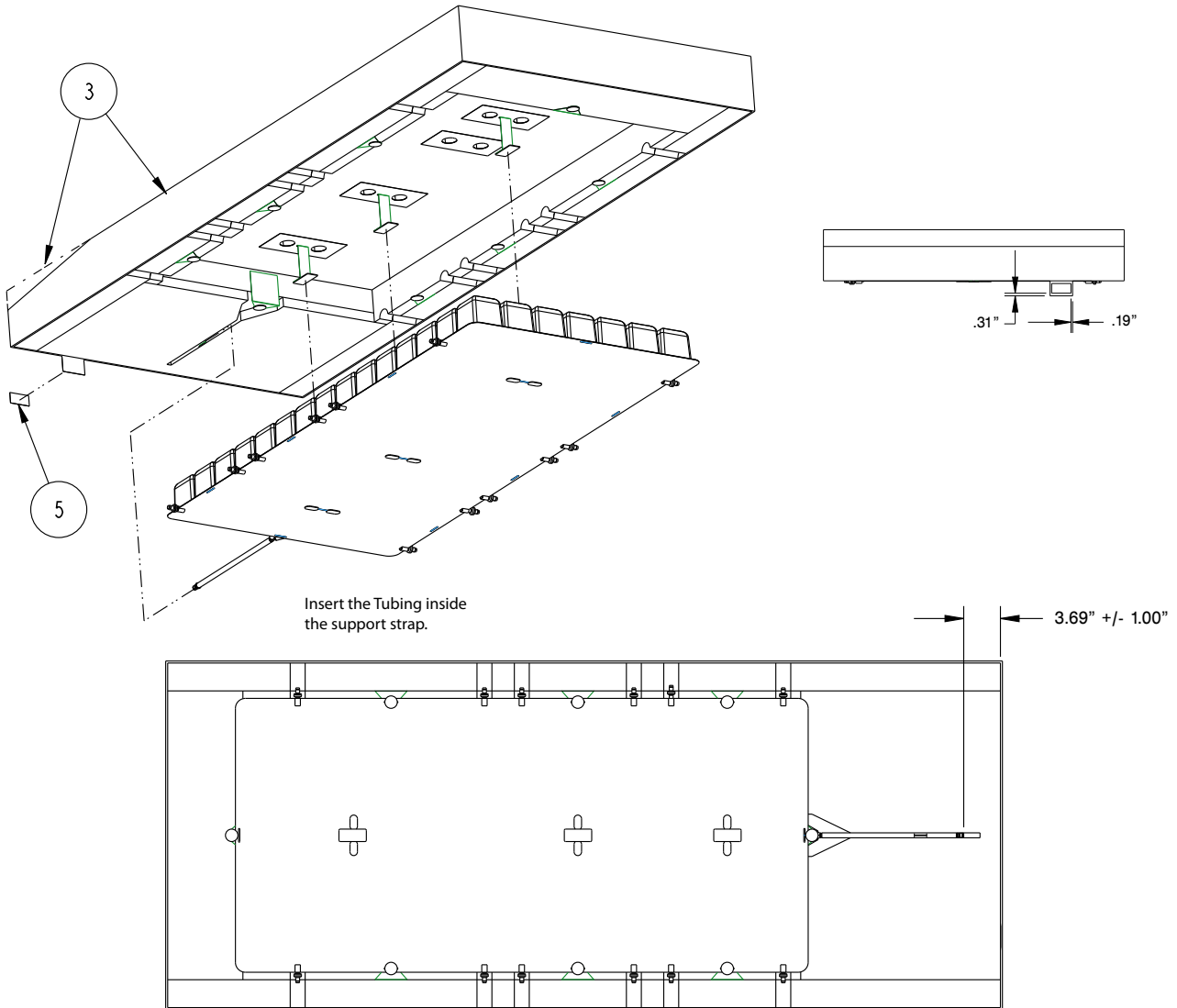

## Mattress Assembly - L59-001 Rev E (reference only)

Item	Part No.	Part Name	Qty.
1	59-0488	LAL Tubing Assembly	1
2	QDF59-0115	Pods Assembly	1
3	QDF59-0166	Foam Crib Assembly	1
4	QDF59-0393	Tie Tube	6
5	QE71-1205-T	Stryker Serial Number	1

# Mattress Assembly, Flat Heel

Assembly Part Number: L59-014 Rev A (reference only)

Slide the Tubing between the Pods and secure with the straps.

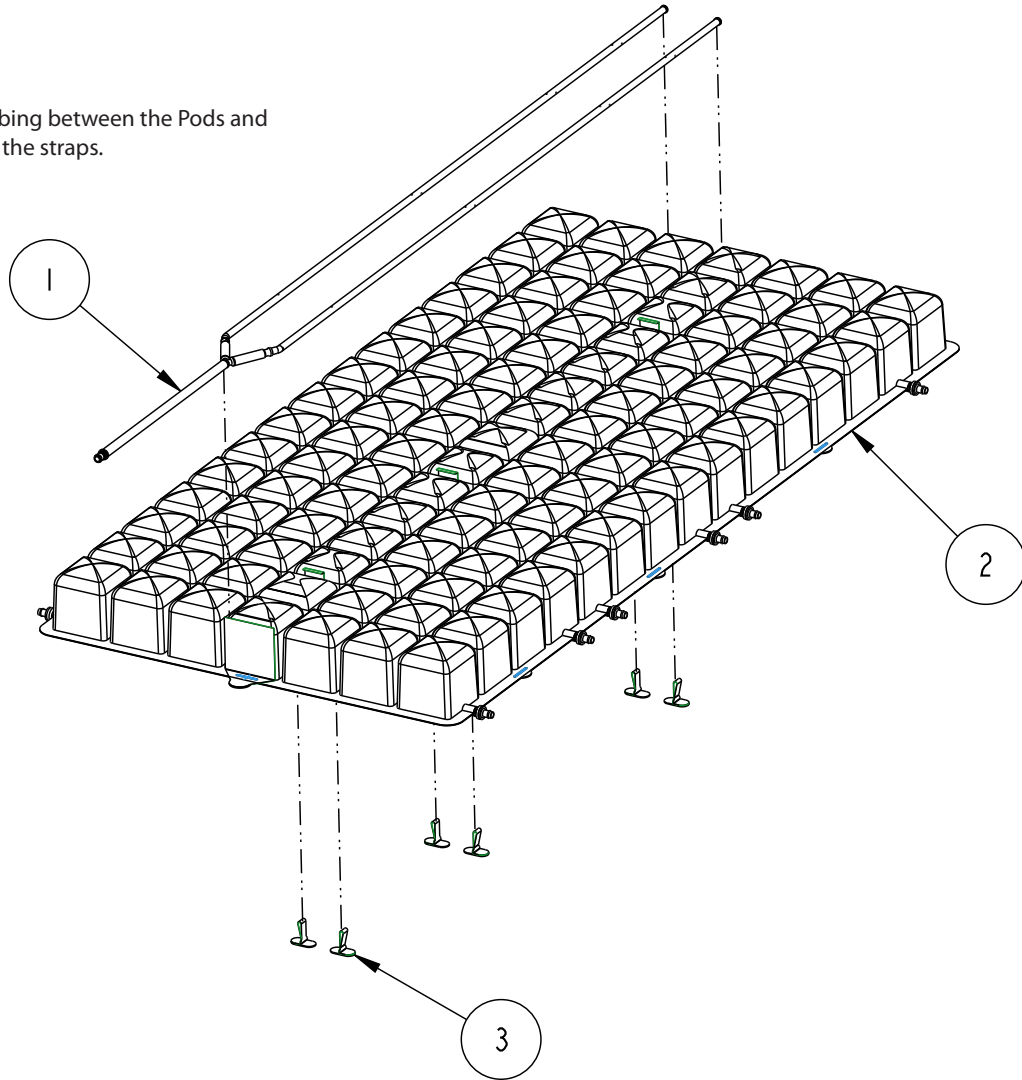

Adjust the Tubing Assembly so there is a hole visible on both sides of the strap.

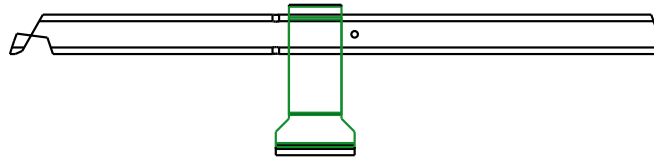

# Mattress Assembly, Flat Heel

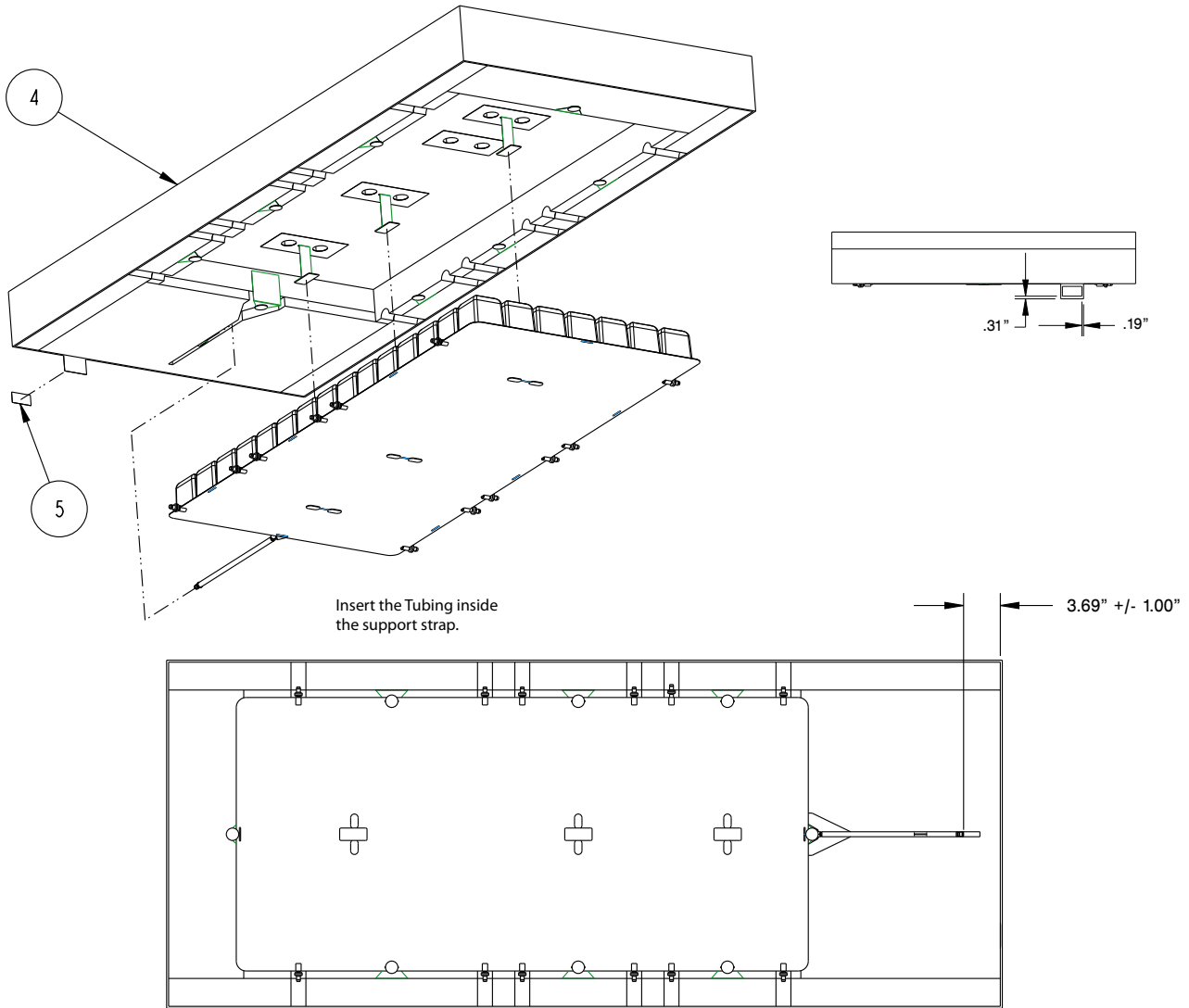

## Mattress Assembly - L59-014 Rev A (reference only)

Item	Part No.	Part Name	Qty.
1	59-0488	LAL Tubing Assembly	1
2	QDF59-0115	Pods Assembly	1
3	QDF59-0393	Tie Tube	6
4	QDF59-0546	Foam Crib Assembly	6
5	QE71-1205-T	Stryker Serial Number	1

# Mattress Cover

## COVER OPTIONS - SLOPED HEEL

Cover Type	Part Number
Dartex Silver	59-0413
Goretex	59-0412

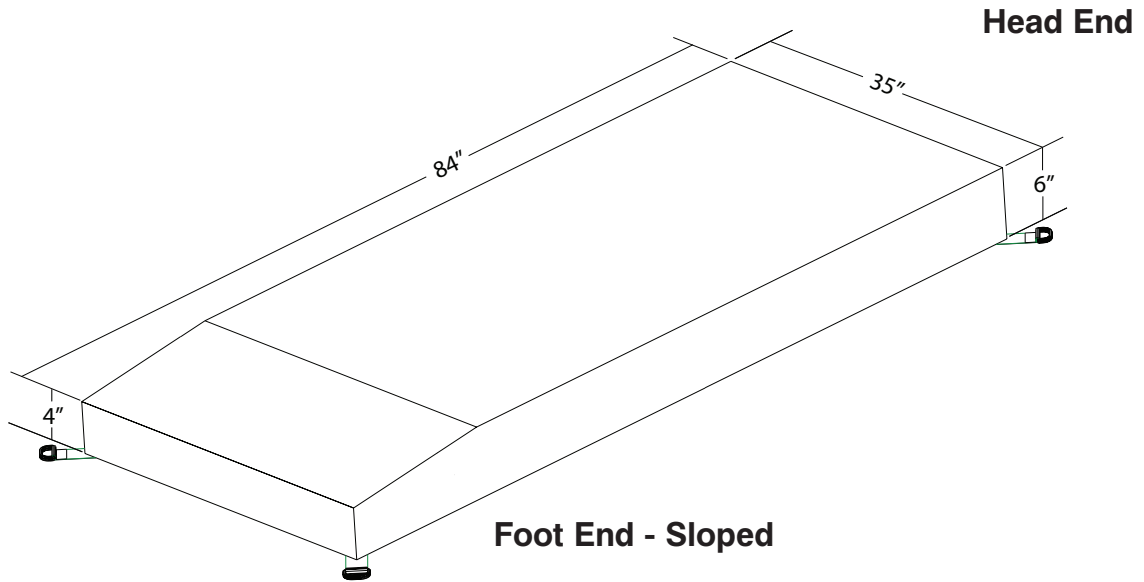

## COVER OPTIONS - FLAT HEEL

Cover Type	Part Number
Dartex Silver	59-0555
Goretex	59-0552

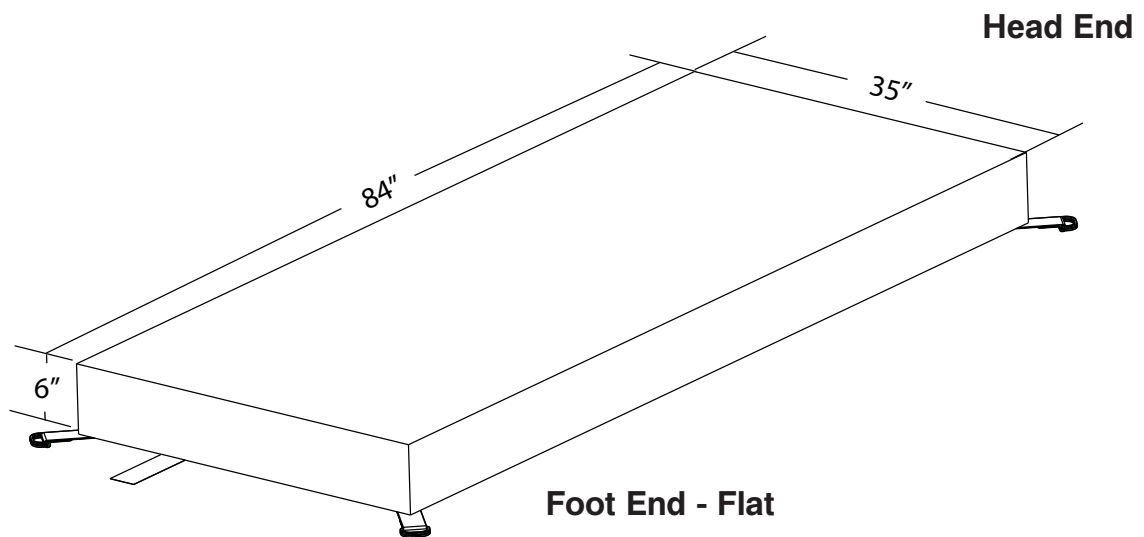

# Warranty

---

## LIMITED LIFETIME WARRANTY

Stryker Medical Division, a division of Stryker Corporation, warrants to the original purchaser the Impression™ Non-Powered Mattress to be free from defects in material and workmanship for a period of five (5) years after date of delivery. Stryker's obligation under this warranty is expressly limited to supplying replacement parts and labor for, or replacing, at its option, any product which is, in the sole discretion of Stryker, found to be defective. If requested by Stryker, products or parts for which a warranty claim is made shall be returned prepaid to the factory. Any improper use or any alteration or repair by others in such manner as in Stryker's judgment affects the product materially and adversely shall void this warranty. Any repair of Stryker products using parts not provided or authorized by Stryker shall void this warranty. No employee or representative of Stryker is authorized to change this warranty in any way.

Stryker Medical Mattress products are designed for a 5 year expected service life under normal use, conditions, and proper care. Subject to the limitations set below, Stryker will repair or, at our option, replace defective merchandise free of charge.

- Three (3) years, non-prorated warranty on mattress cover.
- Five (5) years, non-prorated limited warranty on mattress.

The Limited Lifetime Warranty is void in cases of modifications, misuse, improper assembly or maintenance, accidents, damage caused by a carrier other than Stryker Medical, and the use of customer's own material.

## TO OBTAIN PARTS AND SERVICE

Stryker products are supported by a nationwide network of dedicated Stryker Field Service Representatives. These representatives are factory trained, available locally, and carry a substantial spare parts inventory to minimize repair time. Simply call your local representative, or call Stryker Customer Service USA at 1-800-327-0770, Canada 1-888-233-6888.

## RETURN AUTHORIZATION

Merchandise cannot be returned without approval from the Stryker Customer Service Department. An authorization number will be provided which must be printed on the returned merchandise. Stryker reserves the right to charge shipping and restocking fees on returned items. **Special, modified, or discontinued items not subject to return.**

## DAMAGED MERCHANDISE

Claims for damaged merchandise must be made with the carrier within fifteen (15) days of receipt of merchandise. **Do not accept damaged shipments unless such damage is noted on the delivery receipt at the time of receipt.** Upon prompt notification, Stryker will file a freight claim with the appropriate carrier for damages incurred. Claim will be limited in amount to the actual replacement cost. In the event that this information is not received by Stryker within the fifteen (15) day period following the delivery of the merchandise, or the damage was not noted on the delivery receipt at the time of receipt, the customer will be responsible for payment of the original invoice in full. Claims for any short shipment must be made within thirty (30) days of invoice.



UNITED STATES  
Stryker Medical  
3800 E. Centre Ave.,  
Portage, Michigan 49002  
USA

CANADA  
Stryker Canada  
45 Innovation Drive  
Hamilton, Ontario L9H 7L8  
Canada

QUEBEC  
Stryker Medical Quebec LP  
230, Boul. Nilus-Leclerc  
L'Islet, Quebec G0R 2C0  
Canada

**stryker**<sup>®</sup>