stryker[®] Medical



Epic™ & Epic+™ Critical Care Bed

Model 2030/2031

MAINTENANCE MANUAL

For Parts or Technical Assistance
1-800-327-0770

INTRODUCTION AND SET-UP INFORMATION

Introduction 1-1

Specifications 1-1

Warning/Caution/Note Information 1-1

Warranty 1-2, 1-3

Safety Tips and Guidelines 1-4, 1-5

Set-Up Procedures 1-6

Bed Symbols 1-7 – 1-14

PREVENTIVE MAINTENANCE

Cleaning 2-2

Preventive Maintenance Checklist 2-3

General Information 2-4

TROUBLESHOOTING

Troubleshooting Guide 3-2

Optional Dynamic Mattress System Troubleshooting Guide 3-3

Optional Epic+ Battery Backup Troubleshooting Guide 3-4

ELECTRICAL SYSTEM INFORMATION

CPU Board 4-2, 4-3

Power Supply 4-4

Optional DMS Control Board 4-5

Optional StryKair Power Supply 4-6

Optional Smart TV Circuit Board 4-7, 4-8

Optional Epic+ Display CPU Board 4-9

Optional Epic+ AC Crossover Board 4-10

Optional Bed Communications Tester 4-11

Head Wall Output Configuration 4-12

Optional Inverter Protection Features and Voltage Points 4-13

QUICK REFERENCE REPLACEMENT PARTS LIST

Quick Reference Replacement Parts List 5-1

BASE MAINTENANCE

Static Discharge Precautions 6-2

Brake Pedal Replacement 6-3

Lift Motor and Capacitor Removal and Replacement 6-4

Lift Housing Removal and Replacement 6-5, 6-6

Lift Potentiometer Replacement and Adjustment 6-7, 6-8

Lift Potentiometer “Burn-In” Procedure 6-8

Lift Motor Coupler Replacement 6-9

Power and Sensor Coil Cord Replacement 6-10, 6-11

LITTER MAINTENANCE

Scale System Diagnostics and Calibration 7-2 – 7-4

Load Cell Replacement 7-4

Head Motor Removal and Replacement 7-5

Knee Motor Removal and Replacement 7-6

Power Supply Removal and Replacement 7-7

CPU Board Removal and Replacement 7-7

Fowler and Lift Potentiometer “Burn-In” Procedure 7-8

SIDERAIL MAINTENANCE

Head and Foot End Siderail Cover Removal 8-2

Head and Foot Molded Siderail Replacement 8-3

Head End Siderail Cable Replacement 8-4, 8-5

FOOT BOARD MAINTENANCE

Foot Board Hinge Removal 9-2

Foot Board Module Replacement 9-3

Foot Board Interface Plug Replacement 9-4

OPTIONAL DYNAMIC MATTRESS SYSTEM MAINTENANCE

Mattress Cover Replacement 10-2

Air Bladder Replacement 10-3

Foam Base Assembly Replacement 10-3

Control Unit Circuit Board Replacement 10-4

Control Unit Air Compressor Replacement 10-4, 10-5

Control Unit Replacement 10-5

ASSEMBLY DRAWINGS AND PARTS LISTS

Base Assembly 11-3 – 11-11

Lift Assembly 11-12

Common Lift Assembly 11-13 – 11-15

Isolation Plate Assembly 11-16

Brake Crank Assembly 11-17

Brake Bar Assembly 11-18

Brake Shaft Assembly 11-19

6" Caster Assembly 11-20

6" Steer Caster Assembly 11-21

6" Wheel Assembly 11-22

8" Caster Assembly 11-23

8" Steer Caster Assembly 11-24

8" Wheel Assembly 11-25

Litter Assembly 11-26 – 11-38

Epic+ Litter Assembly 11-38.1 – 11-38.6

Fowler Brake Kit Assembly 11-38.7

Head End Siderail Assembly 11-39 – 11-53

Head End Siderail Timing Link Assembly 11-54, 11-55

Head End Siderail Inner Panel Assembly 11-56

Head End Siderail Outer Panel Assembly 11-57

Head End Siderail DMS Module Assembly 11-58

Head End Siderail Smart TV Module Assembly 11-59, 11-60

ASSEMBLY DRAWINGS AND PARTS LISTS (CONTINUED)

Head End Siderail TV Control Module Assembly	11-61, 11-62
Foot End Siderail Assembly	11-63 – 11-66
Foot End Siderail Timing Link Assembly	11-67, 11-68
Head Board Assembly	11-69
Foot Board Assembly	11-70 – 11-75
Foot Board Main Module Assembly	11-76
Foot Board CPR Drop/Cardiac Chair Module Assembly	11-77
Foot Board Bed Exit Module Assembly	11-78
Pendant Assembly	11-79
Removable I.V. Pole Assembly	11-80
2-Stage I.V. Mounting Assembly, Foot End	11-81
2-Stage I.V. Mounting Assembly, Head End	11-82
2-Stage I.V. Mounting Assembly, Dual Head End	11-83
2-Stage I.V. Pole Assembly	11-84
I.V. Pole Latch Assembly	11-85
Fowler X-Ray Cassette Holder Assembly	11-86
Siderail Transducer Mount Assembly	11-87
I.V. Pole Transducer Mount Assembly	11-88
Upright Oxygen Bottle Holder Assembly	11-89
Defibrillator Tray Assembly	11-90
Optional Bed Extender Pad	11-91

INTRODUCTION

This manual is designed to assist you with the maintenance of the Model 2030 Stryker **EPIC** Critical Care Bed. Read it thoroughly before beginning any maintenance on the equipment .

SPECIFICATIONS

Maximum Weight Capacity	500 pounds or 227 kilograms
Weigh System Capacity (optional equipment)	patients weighing up to 500 pounds or patients weighing up to 227 kilograms
Weigh System Accuracy (optional equipment)	± 1% of total patient weight
Overall Bed Length/Width	L-91" /W-42.5" or L-231 cm. /W-108 cm.
Minimum/Maximum Bed Height	19.5" to 32.5" or 50 cm. to 83 cm. (8" caster option) 17.5" to 30.5" or 45 cm. to 77 cm. (6" caster option)
Knee Gatch Angle	0° to 35°
Back Angle	0° to 90°
Trendelenburg/Reverse Trendelenburg	-14° to +14°
Electrical Requirements	115 VAC, 60 Hz, 7.0 Amps
Noise Level	> 65 Decibels

Stryker reserves the right to change specifications without notice.

WARNING / CAUTION / NOTE DEFINITION

The words WARNING, CAUTION and NOTE carry special meanings and should be carefully reviewed.

WARNING

The personal safety of the patient or user may be involved. Disregarding this information could result in injury to the patient or user.

CAUTION

These instructions point out special procedures or precautions that must be followed to avoid damaging the equipment.

NOTE

This provides special information to make important instructions clearer.

WARNING

Always apply the caster brakes when a patient is getting on or off the bed. Push on the bed to ensure the brakes are securely locked. Always engage the brakes unless the bed is being moved. Injury could result if the bed moves while a patient is getting on or off the bed.

Warranty

Limited Warranty:

Stryker Medical Division, a division of Stryker Corporation, warrants to the original purchaser that its products should be free from defects in material and workmanship for a period of one (1) year after date of delivery. Stryker's obligation under this warranty is expressly limited to supplying replacement parts and labor for, or replacing, at its option, any product which is, in the sole discretion of Stryker, found to be defective. Stryker warrants to the original purchaser that the frame and welds on its beds will be free from structural defects for as long as the original purchaser owns the bed. If requested by Stryker, products or parts for which a warranty claim is made shall be returned prepaid to Stryker's factory. Any improper use or any alteration or repair by others in such manner as in Stryker's judgement affects the product materially and adversely shall void this warranty. No employee or representative of Stryker is authorized to change this warranty in any way.

This statement constitutes Stryker's entire warranty with respect to the aforesaid equipment. STRYKER MAKES NO OTHER WARRANTY OR REPRESENTATION, EITHER EXPRESSED OR IMPLIED, EXCEPT AS SET FORTH HEREIN. THERE IS NO WARRANTY OF MERCHANTABILITY AND THERE ARE NO WARRANTIES OF FITNESS FOR ANY PARTICULAR PURPOSE. IN NO EVENT SHALL STRYKER BE LIABLE HEREUNDER FOR INCIDENTAL OR CONSEQUENTIAL DAMAGES ARISING FROM OR IN ANY MANNER RELATED TO SALES OR USE OF ANY SUCH EQUIPMENT.

To Obtain Parts and Service:

Stryker products are supported by a nationwide network of dedicated Stryker Field Service Representatives. These representatives are factory trained, available locally, and carry a substantial spare parts inventory to minimize repair time. Simply call your local representative, or call Stryker Customer Service at (800) 327-0770.

Supplemental Warranty Coverage:

Stryker has developed a comprehensive program of extended warranty options designed to keep your equipment operating at peak performance at the same time it eliminates unexpected costs. We recommend that these programs be activated *before* the expiration of the new product warranty to eliminate the potential of additional equipment upgrade charges. Stryker offers the following Supplemental Warranties:

Extended (Parts and Labor)

- All replacement parts (excluding mattresses and consumable items)
- Labor and travel for *all* scheduled and unscheduled calls
- Annual Preventive Maintenance Inspections and repairs
- JCAHO paperwork for preventive maintenance
- Priority Emergency Service

Standard (Labor Only):

- Labor and travel for *all* scheduled and unscheduled calls
- Annual Preventive Maintenance Inspections and repairs
- JCAHO paperwork for preventive maintenance
- Priority Emergency Service

Basic (Parts Only):

- All replacement parts (excluding mattresses and consumable items)
- Priority Emergency Service

Please call your local representative, or call (800) 327-0770 for further information

Warranty

Return Authorization:

Merchandise cannot be returned without approval from the Stryker Customer Service Department. An authorization number will be provided which must be printed on the returned merchandise. Stryker reserves the right to charge shipping and restocking fees on returned items.

SPECIAL, MODIFIED, OR DISCONTINUED ITEMS NOT SUBJECT TO RETURN.

Damaged Merchandise:

ICC Regulations require that claims for damaged merchandise must be made with the carrier within fifteen (15) days of receipt of merchandise. **DO NOT ACCEPT DAMAGED SHIPMENTS UNLESS SUCH DAMAGE IS NOTED ON THE DELIVERY RECEIPT AT THE TIME OF RECEIPT.** Upon prompt notification, Stryker will file a freight claim with the appropriate carrier for damages incurred. Claim will be limited in amount to the actual replacement cost. In the event that this information is not received by Stryker within the fifteen (15) day period following the delivery of the merchandise, or the damage was not noted on the delivery receipt at the time of receipt, the customer will be responsible for payment of the original invoice in full.

Claims for any short shipment must be made within thirty (30) days of invoice.

International Warranty Clause:

This warranty reflects U.S. domestic policy. Warranty outside the U.S. may vary by country. Please contact your local Stryker Medical representative for additional information.

Safety Tips and Guidelines

Before operating the 2030, it is important to read and understand all information in this manual. Carefully read and strictly follow the safety guidelines listed on this page.

It is important that all users have been trained and educated on the inherent hazards associated with the usage of electric beds.



WARNING

- The 2030 is not intended for use with patients less than two years of age.
 - Powered bed mechanisms can cause serious injury. Operate bed only when all persons are clear of the mechanisms.
 - To help reduce the number and severity of falls by patients, always leave the bed in the lowest position when the patient is unattended.
 - Leave the siderails fully up and locked when the patient is unattended. When raising the siderails, listen for the "click" that indicates the siderail has locked in the up position. Pull firmly on the siderail to ensure it is locked into position.
Siderails are not intended to be a patient restraint device. It is the responsibility of the attending medical personnel to determine the degree of restraint necessary to ensure a patient will remain safely in bed.
 - Always keep the caster brakes applied when a patient is on the bed (except during transport). Serious injury could result if the bed moves while a patient is getting in or out of bed. After the brake pedal is applied, push on the bed to ensure the brakes are locked. When moving the bed, toggle the steer pedal to put the bed in the steer mode. This locks the swivel motion of the right foot end caster and makes the bed easier to move.
 - When large spills occur in the area of the circuit boards, 110 volt cables and motors, immediately unplug the bed power cord from the wall socket. Remove the patient from the bed and clean up the fluid. Have maintenance completely check the bed. Fluids can affect the operational capabilities of any electrical product. **DO NOT** put the bed back into service until it is completely dry and has been thoroughly tested for safe operation.
 - Do not steam clean or hose off the bed. Do not immerse any part of the bed. The internal electric parts may be damaged by exposure to water. Hand wash all surfaces of the bed with warm water and mild detergent. Dry thoroughly. Quaternary Germicidal Disinfectants, used as directed, and/or Chlorine Bleach products, typically 5.25% Sodium Hypochlorite in dilutions ranging between 1 part bleach to 100 parts water, and 2 parts bleach to 100 parts water are **not** considered mild detergents. **THESE PRODUCTS ARE CORROSIVE IN NATURE AND MAY CAUSE DAMAGE TO YOUR BED IF USED IMPROPERLY.** If these types of products are used to clean Stryker patient care equipment, measures must be taken to insure the beds are wiped with clean water and thoroughly dried following cleaning. Failure to properly rinse and dry the beds will leave a corrosive residue on the surface of the bed, possibly causing premature corrosion of critical components. Failure to follow the above directions when using these types of cleaners may void this product's warranty.
Clean Velcro **AFTER EACH USE**. Saturate Velcro with disinfectant and allow disinfectant to evaporate. (Appropriate disinfectant for nylon Velcro should be determined by the hospital.)
 - Preventative maintenance should be performed at a minimum of biannually to ensure all bed features are functioning properly. Close attention should be given to safety features including, but not limited to: safety side latching mechanisms, frayed electrical cords and components, all electrical controls return to off or neutral position when released, caster braking systems, no controls or cabling entangled in bed mechanisms, leakage current 100 MA maximum, scale and bed exit systems calibrated properly.
 - Always unplug bed during service or cleaning. When working under the bed with the bed in the high position, always place blocks under the litter frame and set the brakes to prevent injury in case the Bed Down switch is accidentally pressed.
 - Explosion Hazard – do not use bed in the presence of flammable anesthetics.
-

Safety Tips and Guidelines

 **WARNING**

If your bed is equipped with the Epic+ Option:

- Always unplug the power cord and push the battery power on/off switch to the “OFF” position before service or cleaning. When working under the transport frame, always place blocks under the litter frame to prevent injury in case the Litter Down switch is accidentally activated.
- The battery tray assembly weighs 50 pounds. Take care when removing the two hex head screws securing it to the base frame or personal injury could result.
- Battery posts, terminals and related accessories contain lead and lead compounds, chemicals known to the State of California to cause cancer and birth defects or other reproductive harm. **Wash hands after handling.**



 **WARNING**

Potential pinch points

Set-Up Procedures

It is important that the 2030 is working properly before it is put into service. The following list will help ensure that each part of the bed is tested.

- Plug the bed into a properly grounded, hospital grade wall receptacle and ensure the "Power" LED light at the foot end of the bed comes on.



WARNING

The 2030 is equipped with a hospital grade plug for protection against shock hazard. It must be plugged directly into a properly grounded three-prong receptacle. Grounding reliability can be achieved only when a hospital grade receptacle is used.

- Plug the optional interface cable into the 37 pin connector under the litter frame at the head end of the bed, and into the "Patient Station", "Head Wall", "Dock Station", or equivalent (whichever applies). Test the interface cable to verify it is functioning properly.



WARNING

Use only a Stryker supplied interface cable. Use of any other cable may cause the bed to function improperly which may result in patient or user injury.

- Ensure the siderails raise, lower and store smoothly and lock in the up and intermediate positions
- Ensure that all four casters lock when the brake pedal is engaged

NOTE

Ensure that the "Brake Not Set" LEDs located on the outside of the head end siderails and on the foot board control panel come on when the brakes are disengaged.

- Run through each function on the foot board control panel to ensure that each function is working properly.
- Run through each function on both head end siderails to ensure that each is working properly.

If your bed is equipped with the Epic+ Option:

- Unplug the power cord from the wall socket. Push the battery power switch located on the lower left corner of the head end to the "ON" position. Again, verify each function on the foot board and siderails is operating properly.

If any problems are found during bed set-up, contact Stryker Customer Service at 800-327-0770.

Damaged Merchandise

ICC Regulations require that claims for damaged merchandise must be made with the carrier within fifteen (15) days of receipt of merchandise. **DO NOT ACCEPT DAMAGED SHIPMENTS UNLESS SUCH DAMAGE IS NOTED ON THE DELIVERY RECEIPT AT THE TIME OF RECEIPT.** Stryker Customer Service must be notified immediately. Stryker will aid the customer in filing a freight claim with the appropriate carrier for damages incurred. Claim will be limited in amount to the actual replacement cost. In the event that this information is not received by Stryker within the fifteen (15) day period following the delivery of the merchandise, or the damage was not noted on the delivery receipt at the time of receipt, the customer will be responsible for payment of the original invoice in full.

Claims for any short shipment must be made within thirty (30) days of invoice.

Bed Symbols



Warning, Refer to Service/Maintenance Manual



Alternating Current



Type B Equipment: equipment providing a particular degree of protection against electric shock, particularly regarding allowable leakage current and reliability of the protective earth connection.

Class 1 Equipment: equipment in which protection against electric shock does not rely on BASIC INSULATION only, but which includes an additional safety precaution in that means are provided for the connection of the EQUIPMENT to the protective earth conductor in the fixed wiring of the installation in such a way that ACCESSIBLE METAL PARTS cannot become live in the event of a failure of the BASIC INSULATION.

IPX4: Protection from liquid splash



Dangerous Voltage Symbol



Protective Earth Terminal



Potential Equalization Symbol



Medical Equipment Classified by Underwriters Laboratories Inc. with Respect to Electric Shock, Fire, Mechanical and Other Specified Hazards Only in Accordance with UL 2601-1 and CAN/CSA C22.2 No. 601.1

Bed Symbols

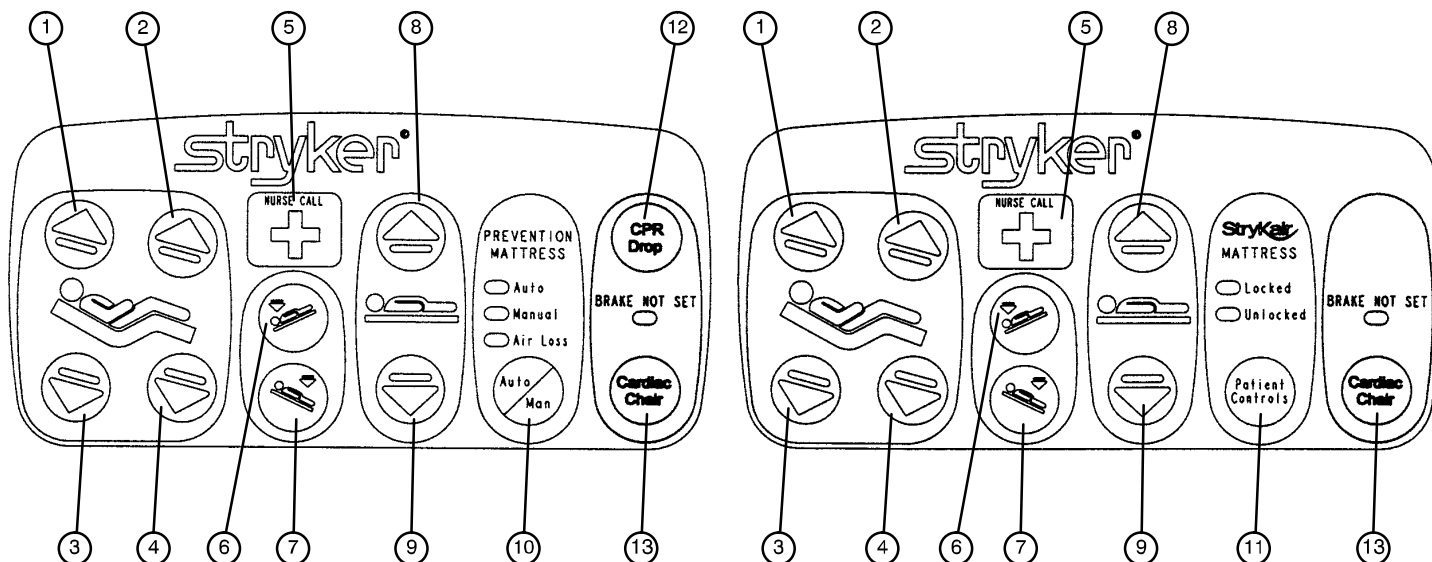

1. Press to raise back section.
2. Press to raise knee section.
3. Press to lower back section.
4. Press to lower knee section.
5. Press to activate nurse call.
6. Press to lower the head end of the bed (Trendelenburg).
7. Press to lower the foot end of the bed (Reverse Trendelenburg).
8. Press to raise the litter.
9. Press to lower the litter.
10. If the bed is equipped with a Dynamic Mattress System™, press to activate the automatic or manual operation of the DMS.
11. If the bed is equipped with a StryKair™ Mattress, press to lock out patient control of the StryKair™ Mattress.
12. Press to activate emergency CPR positioning.
13. Press to activate emergency Cardiac Chair positioning.

Bed Symbols

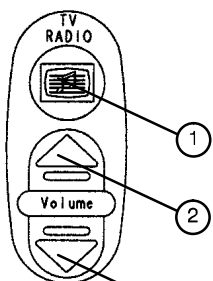

1. Press to turn on the TV or radio. Press again to change TV channels and to turn off the TV.

2. Press to increase the TV or radio volume.

3. Press to decrease the TV or radio volume.

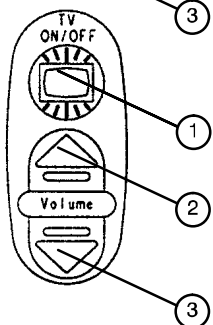

4. Press to change the TV channel up.

5. Press to change the TV channel down.

6. Press to mute the TV sound. Press again to turn the sound back on.

7. Press to display TV closed captioning.

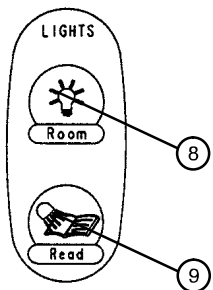
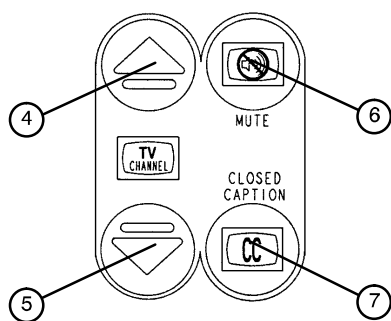

8. Press to turn on the room lights. Press again to turn off.

9. Press to turn on the reading light. Press again to turn off.

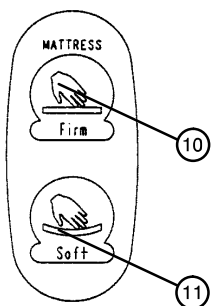

10. Press to increase the firmness of the mattress.

11. Press to decrease the firmness of the mattress.

Bed Symbols

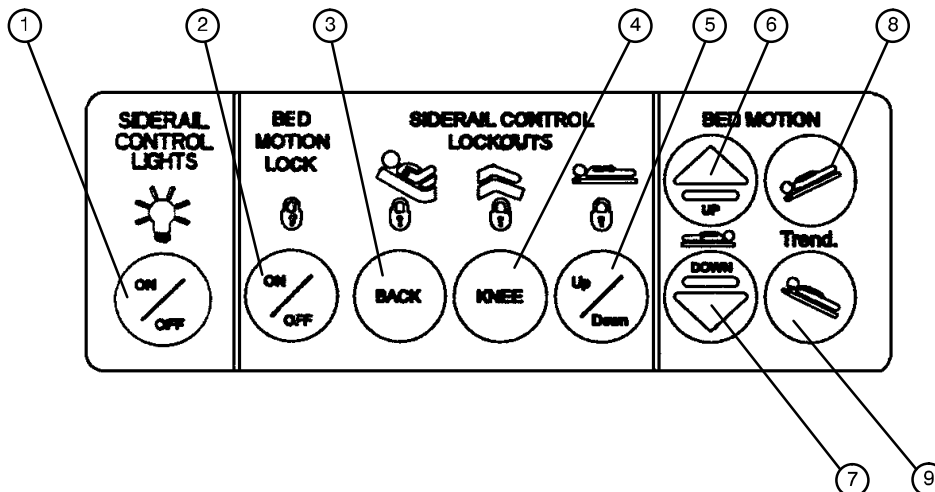

1. Press repeatedly for low, medium and high settings for the siderail control lights. Continue to press this switch to turn off the siderail control lights and the nurse call indicator light.
2. Press to lock out all bed motion controls on the siderails. Press again to unlock.
3. Press to lock out Back motion control on the siderails. Press again to unlock.
4. Press to lock out Knee motion control on the siderails. Press again to unlock.
5. Press to lock out bed up/down motion controls on the siderails. Press again to unlock.
6. Press to raise bed.
7. Press to lower bed.
8. Press to lower head end of bed (Trendelenburg).
9. Press to lower foot end of bed (Reverse Trendelenburg).

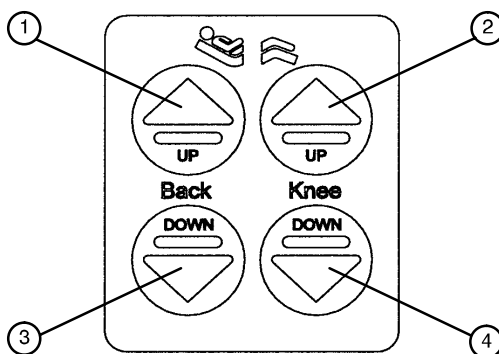

1. Press to raise back section.
2. Press to raise knee section.
3. Press to lower back section.
4. Press to lower knee section.

Bed Symbols

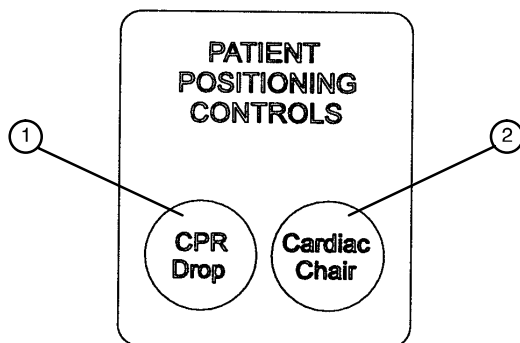

1. Press to activate the emergency CPR drop function. The bed will level from Trendelenburg/reverse Trendelenburg, the Fowler will lower to flat, the Knee will lower to flat and the litter will lower to full down.
2. Press to activate the emergency Cardiac Chair function. The Knee will raise, the Fowler will raise or lower to 51° and the bed will tilt to -10° reverse Trendelenburg (foot end down). Release the button to stop bed movement: hold the button until movement stops to complete the function.

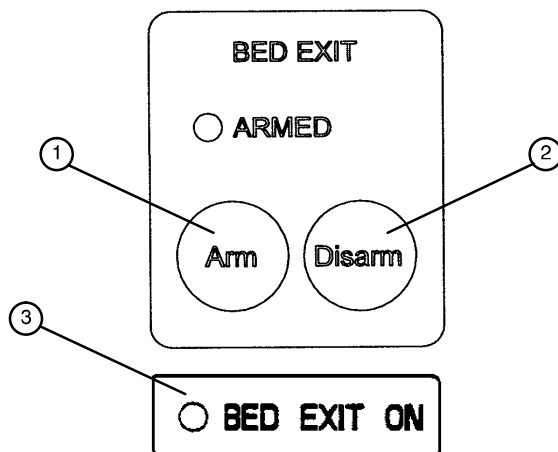

1. Press to arm the Bed Exit function.
2. Press to disarm the Bed Exit function.
3. "BED EXIT ON" LED – will light when the BED EXIT function is armed.

Bed Symbols

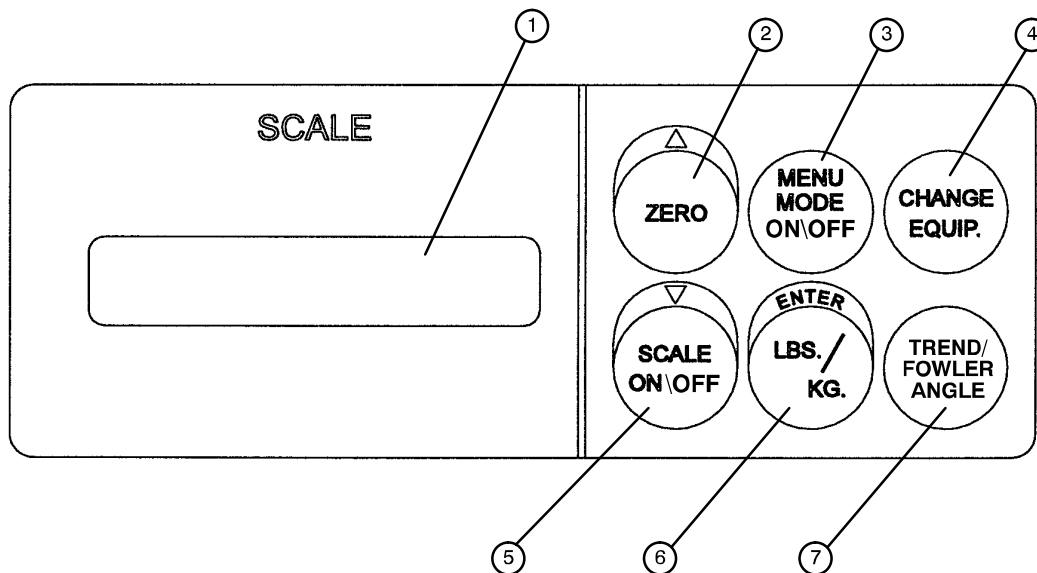

1. LCD – displays patient weight. Trendelenburg angle is displayed when the scale is not active.
2. Press to zero bed. Also press to scroll while Menu Mode is active.
3. Press to enter and exit the Menu Mode.
4. Press when adding or removing equipment to the bed.
5. Press to turn weigh system on and off. Also press to scroll while Menu Mode is active.
6. Press to change weight from pounds to kilograms or back. Also press while using the Menu Mode.
7. Press to display the Trendelenburg or Fowler angle of the bed.

Bed Symbols

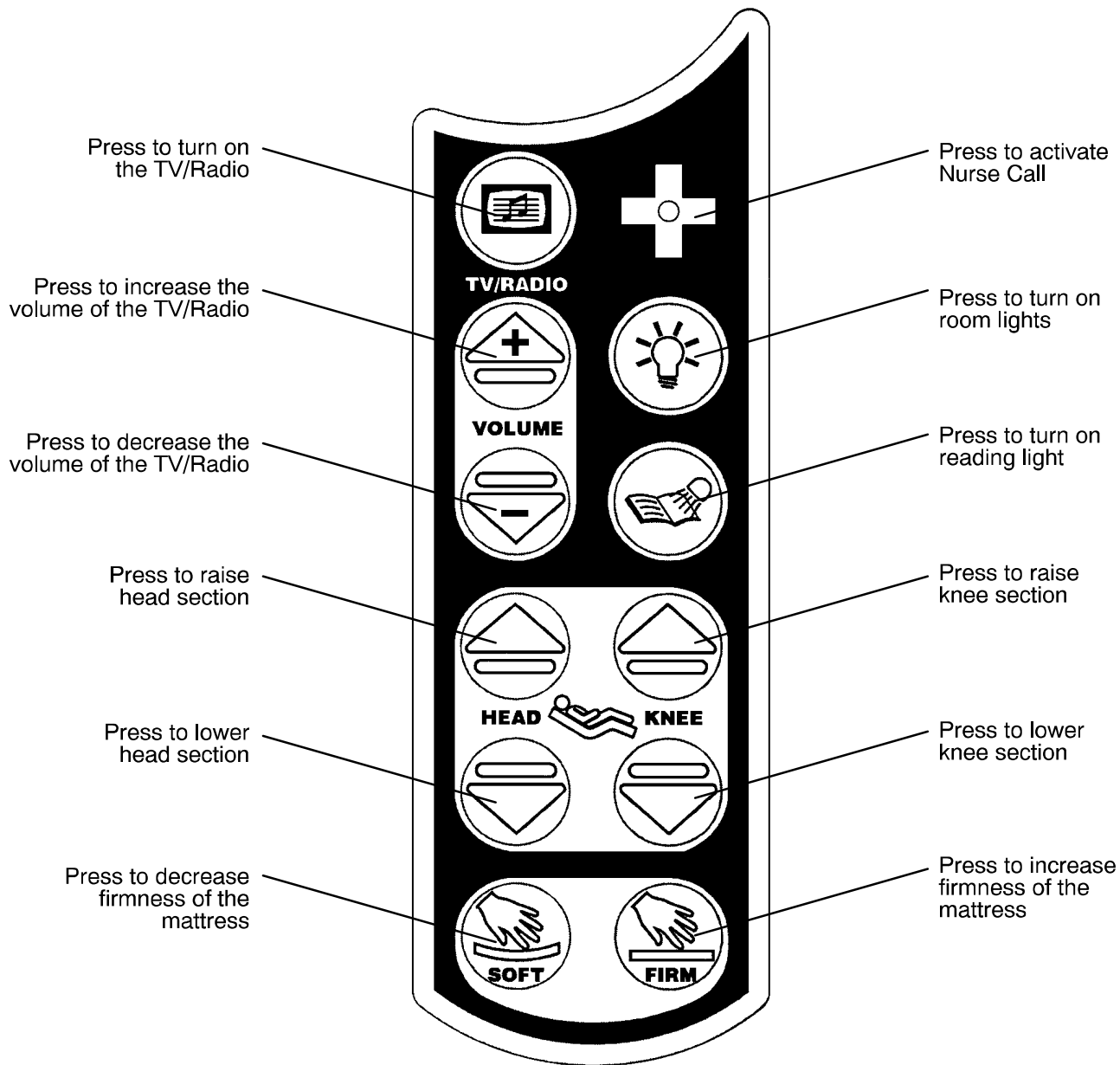

Bed Symbols

OPTIONAL EPIC+ CONTROL PANEL

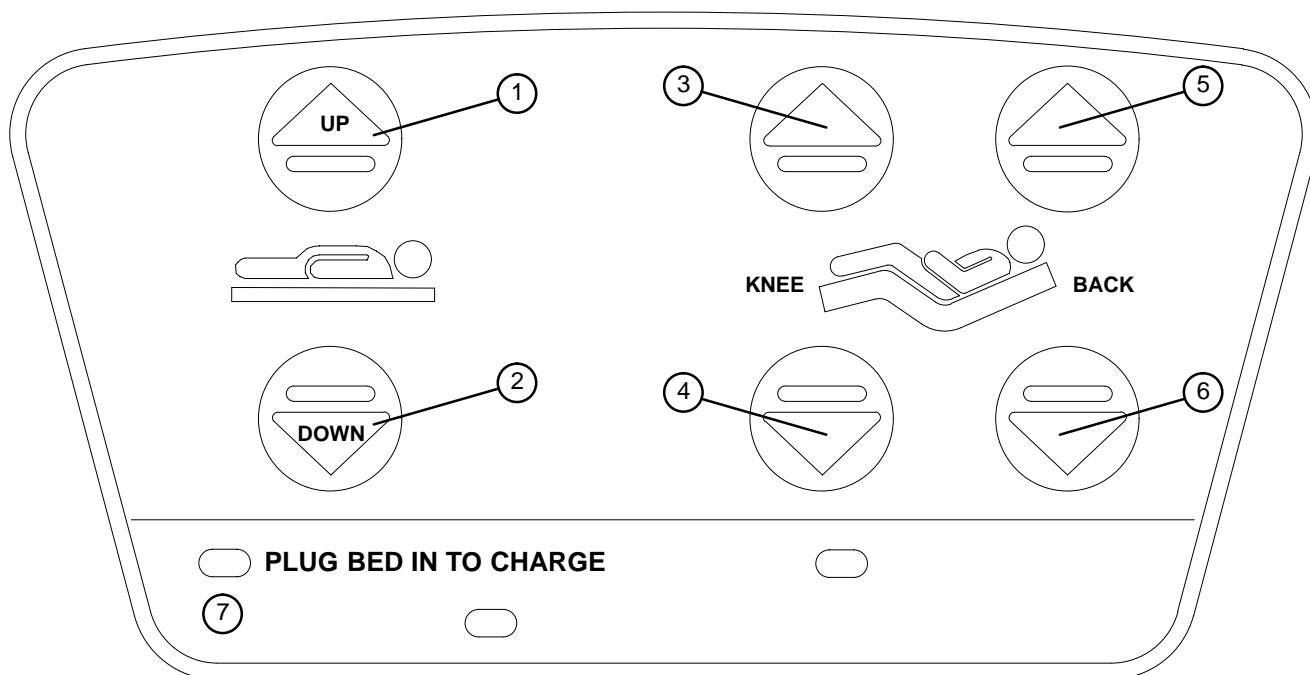

1. Press and hold to raise the litter.
2. Press and hold to lower the litter
3. Press to raise the Knee section.
4. Press to lower the Knee section.
5. Press to raise the Back section.
6. Press to lower the Back section.
7. The "Plug Bed In To Charge" LED will be illuminated while the battery power switch is on if the battery level is low. Plug the bed power cord into the wall socket to charge the batteries.

GENERAL INFORMATION

This section contains cleaning instructions and a checklist to assist with the routine preventive maintenance and cleaning of your equipment.

In the text, the words “right” and “left” refer to the right and left sides of a patient lying face up on the bed.

PREVENTIVE MAINTENANCE CONTENTS

Cleaning 2-2

Preventive Maintenance Checklist 2-3

General Information 2-4

Cleaning

Hand wash all surfaces of the bed with warm water and mild detergent. Dry thoroughly. **DO NOT STEAM CLEAN, PRESSURE WASH, HOSE OFF OR ULTRASONICALLY CLEAN.** Using these methods of cleaning is **not** recommended and may void this product's warranty.

Clean Velcro **AFTER EACH USE**. Saturate Velcro with disinfectant and allow disinfectant to evaporate. (Appropriate disinfectant for nylon Velcro should be determined by the hospital.)

In general, when used in those concentrations recommended by the manufacturer, either phenolic type or quaternary type disinfectants can be used with Staph–Chek fabrics. Iodophor type disinfectants are not recommended for use on Staph–Chek fabrics because staining may result. The following products have been tested by the Herculite Laboratory and have been found not to have a harmful effect on Staph–Chek fabrics **WHEN USED IN ACCORDANCE WITH MANUFACTURERS RECOMMENDED DILUTION.***

TRADE NAME	DISINFECTANT TYPE	MANUFACTURER	*MANUFACTURER'S RECOMMENDED DILUTION
A33	Quaternary	Airwick (Professional Products Division)	2 ounces/gallon
A33 (dry)	Quaternary	Airwick (Professional Products Division)	1/2 ounce/gallon
Beaucoup	Phenolic	Huntington Laboratories	1 ounce/gallon
Blue Chip	Quaternary	S.C. Johnson	2 ounces/gallon
Elimstaph	Quaternary	Walter G. Legge	1 ounce/gallon
Franklin Phenomysan F2500	Phenolic	Purex Corporation	1 1/4 ounce/gallon
Franklin Sentinel	Quaternary	Purex Corporation	2 ounces/gallon
Galahad	Phenolic	Puritan Churchill Chemical Company	1 ounce/gallon
Hi–Tor	Quaternary	Huntington Laboratories	1/2 ounce/gallon
LPH	Phenolic	Vestal Laboratories	1/2 ounce/gallon
Matar	Phenolic	Huntington Laboratories	1/2 ounce/gallon
Omega	Quaternary	Airwick (Professional Products Division)	1/2 ounce/gallon
Quanto	Quaternary	Huntington Laboratories	1 ounce/gallon
Sanikleen	Quaternary	West Chemical Products	2 ounces/ gallon
Sanimaster II	Quaternary	Service Master	1 ounce/gallon
Vesphene	Phenolic	Vestal Laboratories	1 1/4 ounce/ gallon

Quaternary Germicidal Disinfectants, used as directed, and/or Chlorine Bleach products, typically 5.25% Sodium Hypochlorite in dilutions ranging between 1 part bleach to 100 parts water, and 2 parts bleach to 100 parts water are not considered mild detergents. These products are corrosive in nature and may cause damage to your stretcher if used improperly. If these types of products are used to clean Stryker patient handling equipment, measures must be taken to insure the stretchers are rinsed with clean water and thoroughly dried following cleaning. Failure to properly rinse and dry the stretchers will leave a corrosive residue on the surface of the stretcher, possibly causing premature corrosion of critical components. Failure to follow the above directions when using these types of cleaners may void this product's warranty.

REMOVAL OF IODINE COMPOUNDS

This solution may be used to remove iodine stains from mattress cover and foam footrest pad surfaces.

1. Use a solution of 1–2 tablespoons Sodium Thiosulfate in a pint of warm water to clean the stained area. Clean as soon as possible after staining occurs. If stains are not immediately removed, allow solution to soak or stand on the surface.
2. Rinse surfaces which have been exposed to the solution in clear water before returning bed to service.

Preventive Maintenance Checklist

- _____ All fasteners secure
- _____ Engage brake pedal and push on the bed to ensure all casters lock securely
- _____ Optional locking steer caster engages and disengages properly
- _____ Siderails move, latch and stow properly
- _____ All functions on siderails working properly (including LED's)
- _____ Head End Control Panel working properly (including LED) – optional equipment
- _____ Confirm battery powered functionality – optional equipment
- _____ CPR release working properly
- _____ Foot prop intact and working properly
- _____ I.V. pole working properly
- _____ Optional Foley bag hooks intact
- _____ Optional chart rack intact and working properly
- _____ Optional CPR board not cracked or damaged and stores properly
- _____ No cracks or splits in head and foot boards
- _____ All functions on footboard working properly (including LED's)
- _____ No rips or cracks in mattress cover
- _____ Power cord not frayed
- _____ No cables worn or pinched
- _____ All electrical connections tight
- _____ All grounds secure to the frame
- _____ Ground impedance not more than 100 milliohms
- _____ Current leakage not more than 100 microamps

Bed Serial No. _____

Completed By: _____ Date: _____

NOTE

Preventative maintenance should be performed at a minimum of annually. A preventative maintenance program should be established for all Stryker Medical equipment. Preventative maintenance may need to be performed more frequently based on the usage level of the product.

General Information

NOTE

To prevent a low battery condition when the bed is not plugged in, position the cord out switch at the head end of the bed to the off position. The switch is identified by the label shown below. If the switch is not positioned as shown below and the bed power cord and pendant cord are unplugged, the life of the back-up battery will be significantly reduced.

If the power light (located on the foot board) is flashing, the Nurse Call battery needs to be replaced. The battery is located on the patient's left side at the head end of the bed. No tools are required to replace the battery. Unplug the bed power cord from the wall socket and replace the battery.

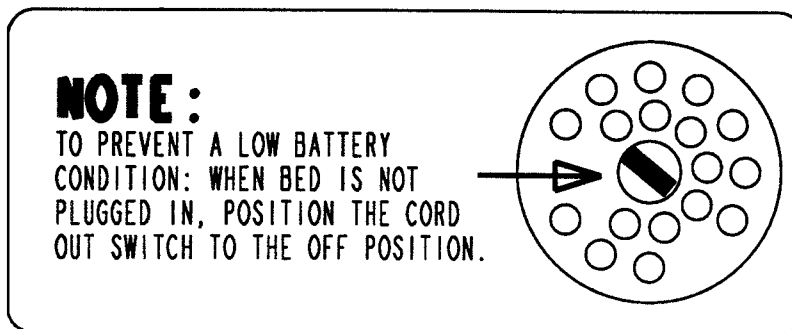

BATTERY CHARGER CIRCUIT BREAKER (EPIC+ OPTION)

If the battery charger circuit breaker(s) located under the litter on the patient's head end, left side are tripped, refer to the troubleshooting section of the maintenance manual.

GENERAL INFORMATION

This section contains troubleshooting charts to assist with the diagnosis of a problem with your equipment. In the text, the words “right” and “left” refer to the right and left sides of a patient lying face up on the bed.

TROUBLESHOOTING CONTENTS

Troubleshooting Guide 3-2

Optional Dynamic Mattress System Troubleshooting Guide 3-3

Troubleshooting Guide

DEFINITIONS:

DMM = Digital Multi-Meter
 PCB = Printed Circuit Board
 CPU = Central Processing Unit

NOTE

See page 4–2 through page 4–7 for an outline of bed PCB's and voltage test points.

PROBLEM/FAILURE	RECOMMENDED ACTION
No power to bed	<p>A. Check circuit breaker on bed.</p> <p>B. Check for 120 VAC power at J1 on power supply. See page 4–4 for power supply voltage test points.</p> <p>C. Check for DC voltages on J2 (Pins 1,2,3 & 6) on power supply. See page 4–4 for power supply voltage test points.</p>
No bed down motion.	<p>A. Enter diagnostics, (see page 7–2) and press bed down. If motion is present, re-burn lift potentiometers. Monitor Pin 3 and Pin 2 of HDR7 and HDR12 on the CPU PCB using DMM. Verify voltage changes on Pin 3 with changes in lift motion. See page 7–8 for voltage parameters for low and high limits.</p> <p>B. If no down motion in diagnostic, check for 120 VAC power on HDR33 and HDR34, Pin 1 and Pin 3, of the CPU.</p> <p>C. Check for 1.1–1.5 VDC signal on O6 and O8 Pin 1 and HDR2 Pin 5 of the CPU PCB.</p> <p>D. Check for motion interrupt jumper on HDR3.</p>
No bed up motion.	<p>A. Check 120 VAC power on HDR33 and HDR34, Pin 1 and Pin 6, of the CPU board.</p> <p>B. Check for 1.1–1.5 VDC signal on O5 and O7 Pin 1 and HDR2 Pin 5 of the CPU PCB.</p>
No Gatch down motion.	<p>A. Check for 120 VAC power on HDR30 Pin 1 and Pin 3 of the CPU board.</p> <p>B. Check for 1.1–1.5 VDC signal on O3 Pin 1 and HDR2 Pin 5 of the CPU PCB.</p>
No Gatch up motion.	<p>A. Check for 120 VAC on HDR30, Pin 1 and Pin 2 of the CPU board.</p> <p>B. Check for 1.1–1.5 VDC on O1 Pin 1 and HDR2 Pin 5 of the CPU PCB.</p>
No Fowler down motion.	<p>A. Check for 120 VAC power on HDR29 Pin 3 and Pin 1 of the CPU board.</p> <p>B. Check for 1.1–1.5 VDC signal on O4 Pin 1 and HDR2 Pin 5 of the CPU PCB.</p>
No Fowler up motion.	<p>A. Check for 120 VAC on HDR29, Pin 1 and Pin 3 of the power supply.</p> <p>B. Check for 1.1–1.5 VDC on O2 Pin 1 and HDR2 Pin 5 of the CPU PCB.</p>

Optional Dynamic Mattress System Troubleshooting Guide

PROBLEM/SYMPTOM	SOLUTION(S)
AIR LOSS LED on.	<p>A. Check air connections between bladder and control unit.</p> <p>B. Check for leak in bladder.</p> <p>C. Unplug transformer from wall socket and plug back in.</p> <p>D. Replace bladder (page 10–3).</p> <p>E. Replace control unit (page 10–5).</p>
Auto LED does not light when plugged in.	<p>A. Plug into another wall socket.</p> <p>B. Open control unit and check for 12 VDC at power supply connector.</p> <p>C. Replace power supply assembly</p> <p>D. Replace control unit (page 10–5).</p>
Cover stained, upper foam layer stained.	<p>A. Check cleaning solution and protocol.</p> <p>B. Replace outer cover (page 10–2).</p> <p>C. Replace upper foam topper.</p>

Optional Epic+ Battery Backup Troubleshooting Guide

This section of the troubleshooting guide includes the battery backup functions. When using this guide, assume the bed is functioning properly when powered by the AC line cord with the exception of the battery charging components.

PROBLEM/FAILURE	POSSIBLE CAUSE	RECOMMENDED ACTION
ON/OFF switch is in the on position but the power LED is off and the bed does not function.	No DC voltage from the batteries.	A. Check the fuse (F1) on the power board (see page 4–4) – replace if necessary (p/n 59–730). B. Check battery + to battery – on the power board for greater than 22VDC. C. Verify the battery voltage is greater than 22 VDC. D. Check the battery fuse – replace if necessary (p/n 2040–1–802). E. Check the cable connections from the batteries to the display board. F. Check the ON/OFF switch and cabling.
ON/OFF switch is in the on position, the power LED is on but the bed does not function.	Display board is not functioning or is locking out all functions.	A. Check the safety switches on the drive bar. B. Verify the battery voltage is greater than 22 VDC. C. Verify the display board is functioning. D. Check all cable connections on the display and power boards.
The bed power cord is plugged in but the battery does not charge.	The battery charger is not functioning.	A. Check the circuit breakers on the litter. B. Check the battery charger. C. Check all cable connections on the charger.

GENERAL INFORMATION

This section contains circuit board layouts and other information on the electrical system of the bed.

ELECTRICAL SYSTEM INFORMATION CONTENTS

CPU Board 4-2, 4-3

Power Supply 4-4

Optional DMS Control Board 4-5

Optional StryKair Power Supply 4-6

Optional Smart TV Circuit Board 4-7, 4-8

Optional Epic+ Display/CPU Board 4-9

Optional Epic+ AC Crossover Board 4-10

Optional Bed Communications Tester 4-11

Head Wall Output Configuration 4-12

Optional Inverter Protection Features and Voltage Points 4-13

CPU Board (Continued)

CPU KIT (SCALE ONLY) – 2030-700-001

CPU KIT (BED EXIT ONLY) – 2030-700-002

CPU KIT (SCALE & BED EXIT) – 2030-700-003

CONNECTOR LOCATION	CABLE LOCATION	VOLTAGE	POSITIVE LEAD	NEGATIVE LEAD	DESCRIPTION
HDR 2	W	+12 VDC	Pin 1	Pin 4 or 5	Relays & Siderails Light Voltage
HDR 2	W	+5 VDC	Pin 2 & 3	Pin 4 or 5	+5 VDC from Power Supply
HDR 2	W	-12 VDC	Pin 6	Pin 4 or 5	Relays & Siderails Light Voltage
HDR 6	ZZ	+5 VDC	Pin 1	Pin 4	+5 VDC for Fowler Pot
HDR 6	ZZ	0 – 5 VDC	Pin 3	Pin 4	Fowler Pot Wiper
HDR 7	J	0 – 5 VDC	Pin 3	Pin 2	Head Lift Pot Wiper
HDR 7	J	+5 VDC	Pin 4	Pin 2	+5 VDC for Head Lift Pot
HDR 12	C	+5 VDC	Pin 1	Pin 2	+5 VDC for Foot Lift Pot
HDR 12	C	0 – 5 VDC	Pin 3	Pin 2	Foot Lift Pot Wiper
HDR 29	CC	0 VAC w/o Switch 110 VAC w/Switch	Neutral Pin 1	Pin 2	Gatch Up
HDR 29	CC	0 VAC w/o Switch 110 VAC w/Switch	Neutral Pin 1	Pin 3	Gatch Down
HDR 30	GG	0 VAC w/o Switch 160 VAC w/ Switch	Neutral Pin 3	Pin 1	Fowler Up
HDR 30	GG	0 VAC w/o Switch 120 VAC w/ Switch	Neutral Pin 3	Pin 2	Fowler Down
HDR 32	O	110 VAC	Pin 1	Pin 2	Line Voltage to Bed
HDR 33	N	0 VAC w/o Switch 120 VAC w/ Switch	Neutral Pin 1 or 4	Pin 3	Head Lift Down
HDR 33	N	0 VAC w/o Switch 120 VAC w/ Switch	Neutral Pin 1 or 4	Pin 6	Head Lift Up
HDR 34	G	0 VAC w/o Switch 120 VAC w/ Switch	Neutral Pin 1 or 4	Pin 3	Foot Lift Down
HDR 34	G	0 VAC w/o Switch 120 VAC w/ Switch	Neutral Pin 1 or 4	Pin 6	Foot Lift Up

Power Supply

POWER SUPPLY – P/N 59-157

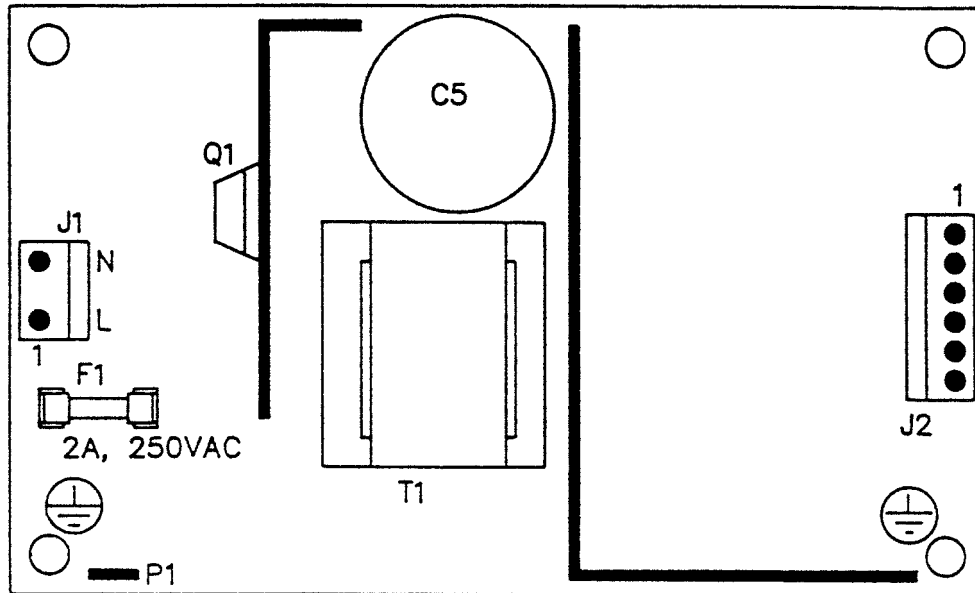

CONNECTOR LOCATION	VOLTAGE	POSITIVE LEAD	NEGATIVE LEAD
J1	110V	Pin 1	Pin 2
J2	12V	Pin 1	Pin 4 or 5
J2	5V	Pin 2	Pin 4 or 5
J2	5V	Pin 3	Pin 4 or 5
J2	GND	Pin 4	Pin 4 or 5
J2	GND	Pin 5	Pin 4 or 5
J2	-12V	Pin 6	Pin 4 or 5

DMS Control Board

OPTIONAL INTEGRATED DMS CONTROL BOARD – P/N 2500-402-900

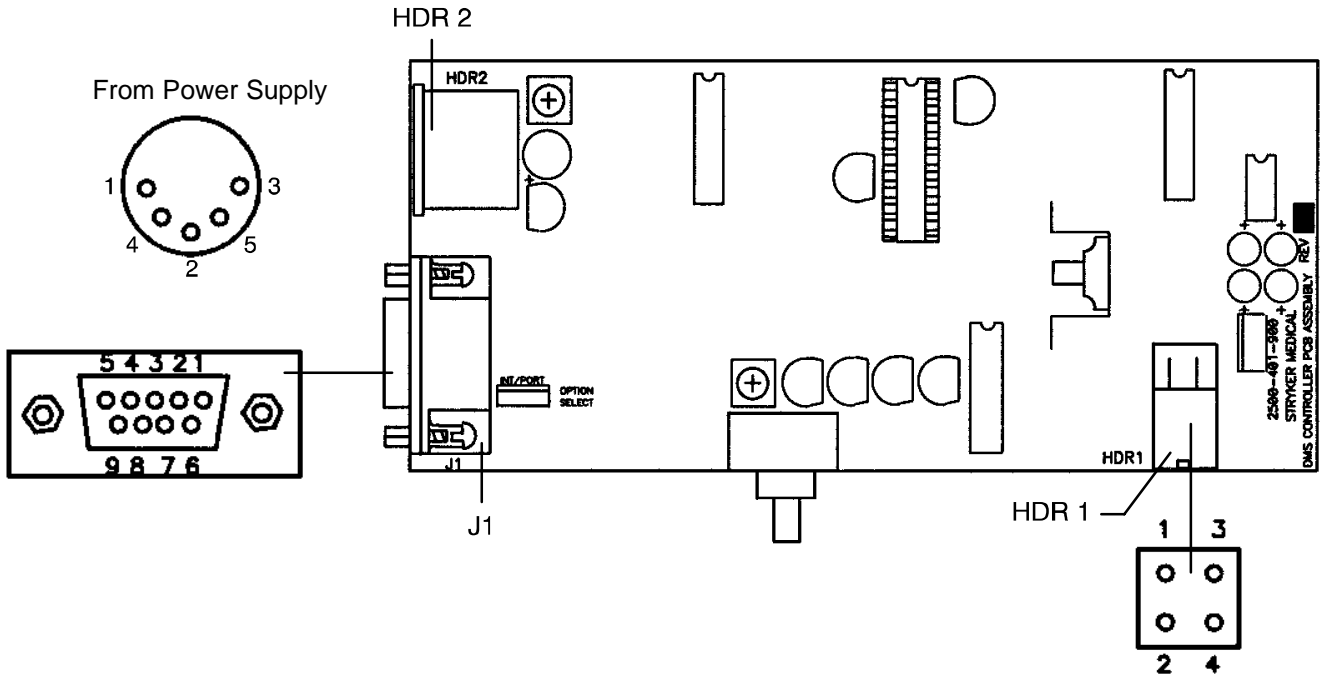

CONNECTOR LOCATION	VOLTAGE	POSITIVE LEAD	NEGATIVE LEAD	DESCRIPTION
PS	+12 – +14 VDC	Pin 1	Pin 3	Power Supply
PS	+12 – +14 VDC	Pin 4	Pin 3	Power Supply
HDR 1	+12 – +14 VDC	Pin 4	Pin 3	Air Compressor
J1	+5 VDC	Pin 2	Pin 3	Hand Pendant
J1	Digital (Ref.)	Pin 6	Pin 3	Manual LED
J1	Digital (Ref.)	Pin 7	Pin 3	Auto LED
J1	Digital (Ref.)	Pin 8	Pin 3	Error LED
J1	+12 – +14 VDC	Pin 9	Pin 3	Power Supply

StryKair Power Supply

OPTIONAL STRYKAIR POWER SUPPLY – P/N 2600-300-900

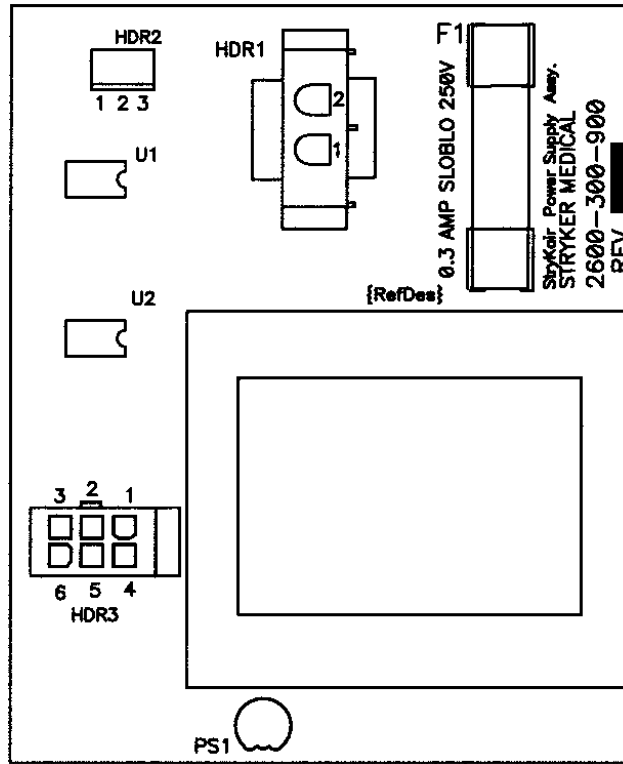

CONNECTOR LOCATION	VOLTAGE	POSITIVE LEAD	NEGATIVE LEAD	DESCRIPTION
HDR 1	120 VAC	Pin 1	Pin 2	AC power to board
HDR 3	12-16 VAC	Pin 1	Pin 2	AC power to mattress
HDR 3	+ 5 VDC	Pin 4	Pin 3	DC power returned to board
HDR 2	+ 5 VDC	Pin 1	Pin 3	S/R switch voltage with firm switch pressed
HDR 2	+ 5 VDC	Pin 2	Pin 3	S/R switch voltage with soft switch pressed

Smart TV Circuit Board

OPTIONAL SMART TV CIRCUIT BOARD – P/N 3001–330–950

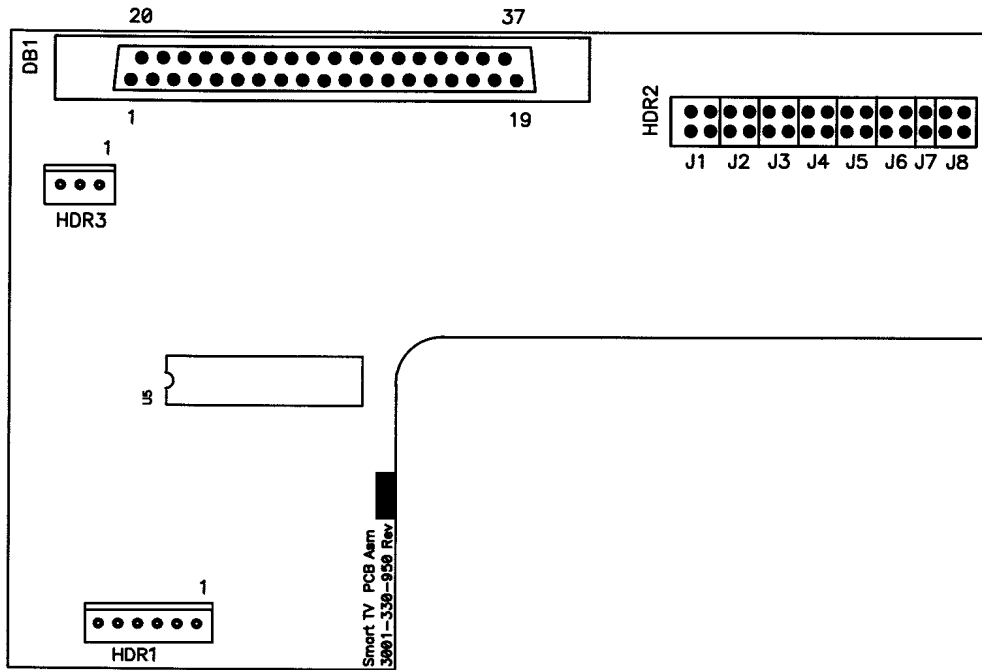

CONNECTOR LOCATION	VOLTAGE	POSITIVE LEAD	NEGATIVE LEAD	DESCRIPTION
HDR 1	5 VDC	Pin 2	Pin 1	Regulated 5 VDC Power to the board
HDR 1	Digital Control	Pin 3–5	Pin 1	Serial control lines
HDR 1	5 VDC	Pin 6	Pin 1	5 VDC for option relay
HDR 3	+5 or +12 VDC	2	Pin 1	Power/control line from the TV Note: This header provides TV control to a non–Stryker pendant
DB1	+5 or +12 VDC	Pin 34	Pin 33	Power/Control line from the TV Note: If this polarity is reversed, place the shunts of J8 in the alternate position

Smart TV Circuit Board

OPTIONAL SMART TV CIRCUIT BOARD – P/N 3001-330-970

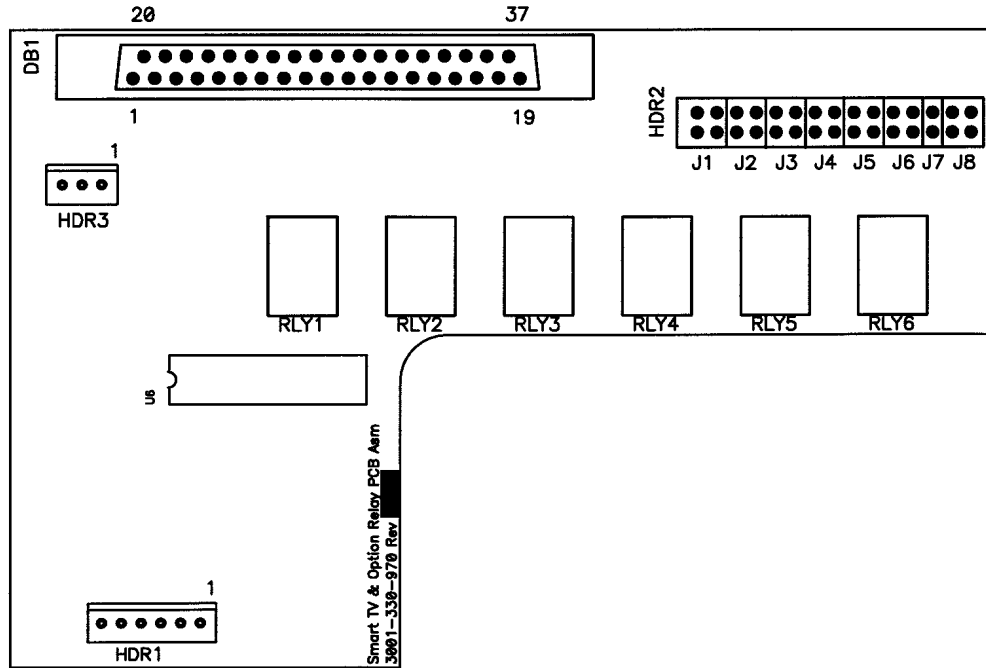

CONNECTOR LOCATION	VOLTAGE	POSITIVE LEAD	NEGATIVE LEAD	DESCRIPTION
HDR 1	5 VDC	Pin 2	Pin 1	Regulated 5 VDC Power to the board
HDR 1	Digital Control	Pin 3-5	Pin 1	Serial control lines
HDR 1	5 VDC	Pin 6	Pin 1	5 VDC for option relay
HDR 3	+5 or +12 VDC	2	Pin 1	Power/control line from the TV Note: This header provides TV control to a non-Stryker pendant
DB1	+5 or +12 VDC	Pin 34	Pin 33	Power/Control line from the TV Note: If this polarity is reversed, place the shunts of J8 in the alternate position

Optional Epic+ Display/CPU Diagram

OPTIONAL EPIC+ DISPLAY/CPU – P/N 2030–31–910

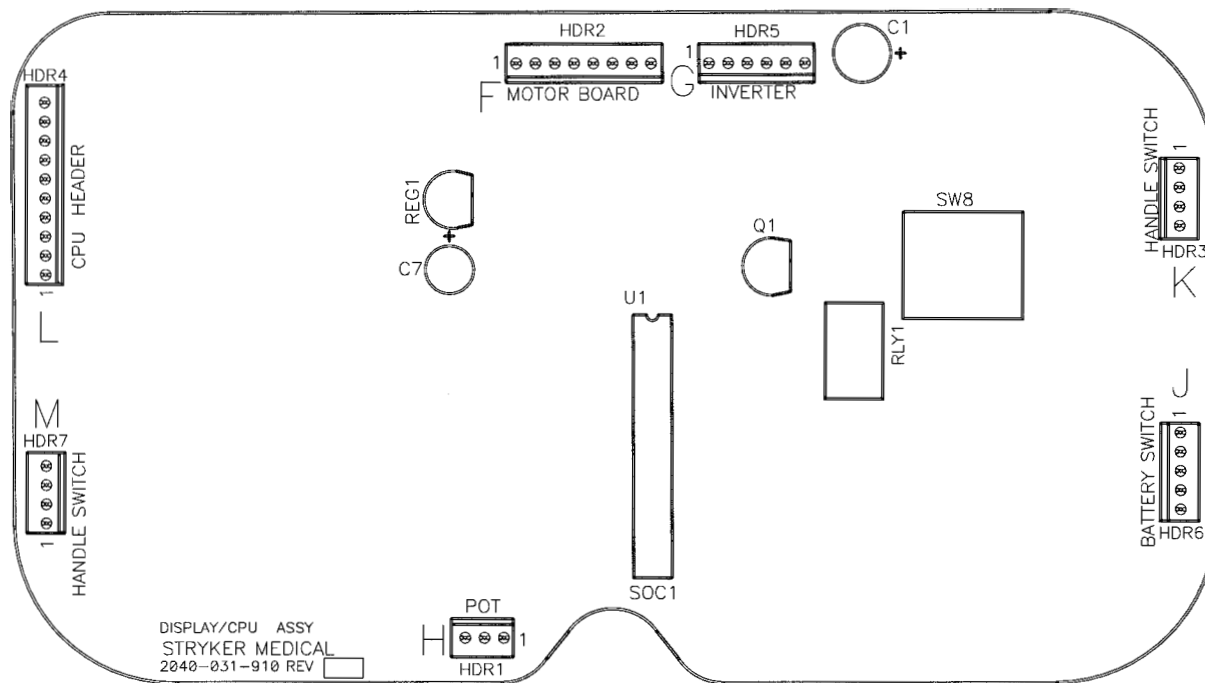

CONNECTOR LOCATION	VOLTAGE	POSITIVE LEAD	NEGATIVE LEAD	DESCRIPTION
HDR 4 (L)	Battery voltage around 24VDC	Pin 3	Pin 1	Battery Voltage into the Display/CPU Board
HDR 1 (H)	0–5VDC	Pin 2	Pin 1	Control Pot Wiper Voltage
HDR 6 (J)	Battery voltage around 24VDC	Pin 1	Pin 5	Battery Voltage Return from On/Off Switch

Optional Epic+ AC Crossover Board Diagram

OPTIONAL EPIC+ AC CROSSOVER BOARD – P/N 2040–31–900

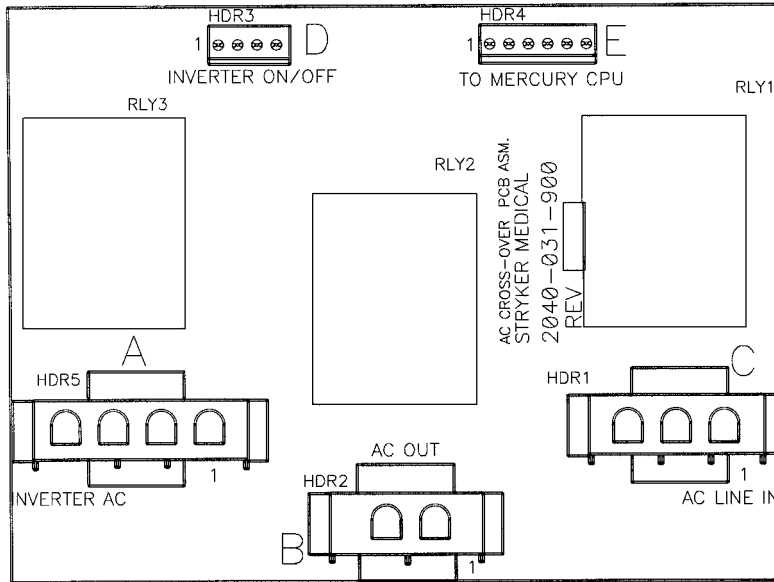

CONNECTOR LOCATION	VOLTAGE	POSITIVE LEAD	NEGATIVE LEAD	DESCRIPTION
HDR 5 (A)	120VAC	Pin 4	Pin 1	AC Input to Board from the Inverter with the Power Cord Unplugged
HDR 1 (C)	120VAC	Pin 3	Pin 1	AC Input to Board from the Wall Receptacle
HDR 2 (B)	120VAC	Pin 2	Pin 1	AC Output of Board to Main Power
HDR 4 (E)	+5VDC	Pin 4	Pin 1	+5VDC when AC is Unplugged from the Wall Receptacle
HDR 3 (D)	Continuity	Pin 3	Pin 1	Relay Contacts. Closed when Power Cord is Unplugged. Turns on the Inverter

Bed Communications Tester

OPTIONAL BED COMMUNICATIONS TESTER – P/N 3001-303-165

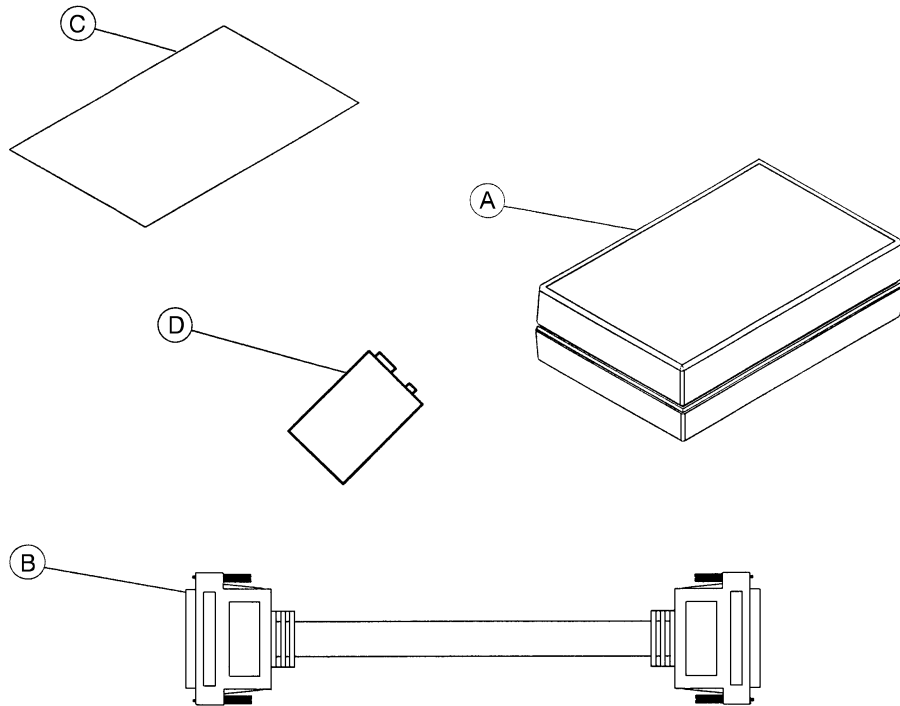

Item	Part No.	Part Name	Qty.
A	3001-303-160	BCT Unit	1
B	3001-303-825	37-Pin Cable	1
C	3001-303-162	Instructions	1
D	3000-303-871	9V Battery	1

Head Wall Output Configuration

37-PIN CONNECTOR

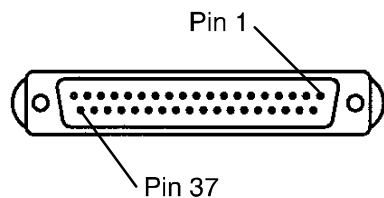

Pin 1	Option 2 Common
Pin 2	Read Light
Pin 3	Room Light
Pin 4	Speaker High
Pin 5	Pot Wiper
Pin 6	Radio Common
Pin 7	Nurse Call Interlock
Pin 8	Audio Transfer –
Pin 9	Audio Transfer +
Pin 10	Interlock +
Pin 11	Interlock –
Pin 12	Spare
Pin 13	Options 3 Common
Pin 14	Pot Low Common
Pin 15	Pot High Common
Pin 16	Nurse Answer Light +
Pin 17	Option 1 NO/NC
Pin 18	Option 1 Common
Pin 19	Nurse Call Light +
Pin 20	Option 2 NO/NC
Pin 21	Option 3 NO/NC
Pin 22	Option 3A NO/NC
Pin 23	Option 2A Common
Pin 24	Option 2A NO/NC
Pin 25	Nurse Call +
Pin 26	Nurse Call NO/NC
Pin 27	Room/Read Light Common
Pin 28	Nurse Call Light –
Pin 29	Nurse Answer Light –
Pin 30	Priority NO/NC
Pin 31	Priority Common
Pin 32	Option 3A Common
Pin 33	TV –
Pin 34	TV +
Pin 35	Speaker Low Common
Pin 36	Audio Shield
Pin 37	Radio NO/NC

STRYKER PENDANT PORT

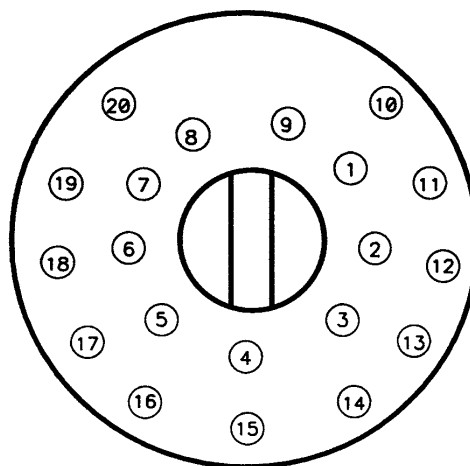

1	Scan Line
2	Audio (–)
3	Nurse Call (+)
4	+5 VDC
5	Scan Line
6	Scan Line
7	Nurse Call (–)
8	TV Channel Up
9	Backlight
10	Audio (+)
11	Gatch Up/Fowler In/Foot Up/DMS Firm
12	Gatch Down/Fowler Out/Foot Out/DMS Soft
13	Fowler Up/Trend In
14	Fowler Down/Trend Out
15	Audio Shield
16	Not Used – Socket Filled
17	Bed Up
18	Ground
19	Read Light/Bed Down
20	Room Light

Optional Inverter Protection Features and Voltage Points

The optional Epic+ inverter has several features to prevent internal damage:

1. **Low Battery Voltage** – If the battery voltage at the inverter drops below the low voltage cut-off, an alarm will sound and the inverter will shut off. When battery voltage increases to 95% of nominal battery voltage, the inverter will restart.
2. **High Battery Voltage** – If the battery voltage input rises above the high voltage cut-off, the inverter will shut off. When the battery voltage input drops back within the normal voltage range, the inverter will restart.
3. **Over-Temperature** – If the inverter gets too hot, it will shut off. The overheating may be caused by high ambient temperature, blocked air flow or an overload condition. When the inverter reaches an acceptable temperature, it will restart.
4. **Over-Power** – The inverter will source up to its maximum power rating. If the load requires more, the output voltage will be lowered to supply no more than its maximum power so the maximum power from the inverter is reduced to a safe amount.

⚠ WARNING

The optional inverter generates 115VAC, the same as a wall receptacle. To prevent injury, do not put anything into the electrical outlets other than an appliance power cord. Keep the outlets covered when not in use. Do not submerge the unit or subject it to moisture.

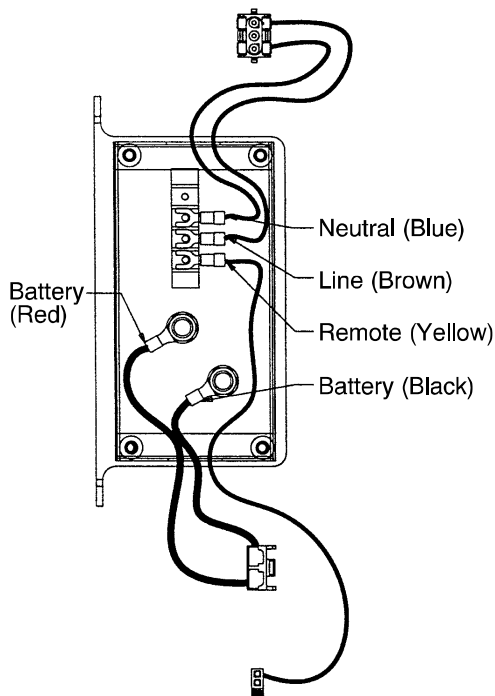

VOLTAGE	POSITIVE LEAD	NEGATIVE LEAD
Approximately 24VDC	Battery Red	Battery Black
Approximately 120VAC	Line Brown	Neutral Blue

ELECTRICAL COMPONENTS

AC CROSSOVER BOARD (OPTIONAL)	2040-31-900
CPU KIT (SCALE ONLY)	2030-700-1
CPU KIT (BED EXIT ONLY)	2030-700-2
CPU KIT (SCALE & BED EXIT)	2030-700-3
DISPLAY/CPU BOARD (OPTIONAL)	2030-31-910
FOOT BOARD KEYBOARD (S/R LIGHTS, LOCKOUTS, ETC.)	3001-500-930
FOOT BOARD SCALE DISPLAY	3001-507-900
FOOT BOARD SCALE KEYBOARD	3001-507-910
FOOT BOARD BED EXIT KEYBOARD	3001-508-900
POWER SUPPLY	59-157
SMART TV CIRCUIT BOARD	3001-330-950
SMART TV CIRCUIT BOARD	3001-330-970

SIDERAIL BOARDS

DMS BOARD	3001-402-900
INSIDE BOARD	3001-400-930
OUTSIDE BOARD	3001-400-910
SMART TV BOARD, RIGHT	5000-400-920
SMART TV BOARD, LEFT	5000-400-930
SPEAKER W/CABLE	3000-403-831

OTHER COMPONENTS

CAPACITOR, FOWLER & GATCH	59-779
CAPACITOR, FOWLER & GATCH, 230V	59-153
CAPACITOR, LIFT	59-778
CAPACITOR, LIFT, 230V	3221-200-243
CASTER, 6"	3001-200-60
CASTER, STEER, 6"	3001-200-50
CASTER, 8", OPTIONAL	3001-200-90
CASTER, STEER, 8", OPTIONAL	3001-200-80
COIL CORD, LIFT POWER	3001-200-864
COIL CORD, LIFT SENSOR	3001-200-815
COMMUNICATIONS TESTER	3001-303-165
ISOLATION PLATE KIT, LIFT MOTOR	3000-200-723
LOAD CELL	3001-307-57
MOTOR COUPLER KIT, LIFT	3000-200-725
MOTOR, FOWLER & GATCH W/CLUTCH	3001-300-705
MOTOR, FOWLER & GATCH W/CLUTCH, 230V	3221-300-705
MOTOR, LIFT (SAME FOR HEAD AND FOOT END)	3000-200-213
MOTOR, LIFT, 230V (SAME FOR HEAD AND FOOT END)	3221-200-213

OTHER COMPONENTS (CONTINUED)

PAINT, TOUCH-UP, OPAL, BOTTLE W/BRUSH	7000-1-321
PAINT, TOUCH-UP, OPAL, SPRAY CAN	7000-1-318
POTENTIOMETER, FOOT END	3001-200-230
POTENTIOMETER, FOWLER W/CABLE	2035-32-803
POTENTIOMETER, HEAD END	3001-200-240
POWER CORD	39-254
SINGLE TUBE OF GREASE	3000-200-700

GENERAL INFORMATION

This section contains tool lists and step-by-step procedures to assist with the maintenance and servicing of the base portion of your equipment.

In the text, the words “right” and “left” refer to the right and left sides of a patient lying face up on the bed.

BASE MAINTENANCE CONTENTS

Static Discharge Precautions 6-2

Brake Pedal Replacement 6-3

Lift Motor and Capacitor Removal and Replacement 6-4

Lift Housing Removal and Replacement 6-5, 6-6

Lift Potentiometer Replacement and Adjustment 6-7, 6-8

Lift Potentiometer “Burn-In” Procedure 6-8

Lift Motor Coupler Replacement 6-9

Power and Sensor Coil Cord Replacement 6-10, 6-11

Optional Inverter Removal and Replacement 6-12

Optional Battery Charger Removal and Replacement 6-12

Optional Battery Removal and Replacement 6-13

Static Discharge Precautions

The electronic circuits in the 2030 are completely protected from static electricity damage only while the bed is assembled. It is extremely important that all service personnel always use adequate static protection when servicing the electronic systems of the 2030. *Whenever you are touching wires, you should be using static protection.*

Static Protection Equipment

The necessary equipment for proper static protection is:

- 1 static wrist strap; 3M part number 2214 or equivalent,
- 1 grounding plug; 3M part number 61038 or equivalent,
- 1 test lead with a banana plug on one end and an alligator clip on the other; Smith part number N132B699 or equivalent.

Stryker has available the following equipment for proper static protection:

- Complete static protection system – part number 3000-000-753
- 1 grounding plug – part number 3000-000-754
- 1 static wrist strap – part number 3000-000-755
- 1 test lead – part number 3000-000-756

CAUTION

All electronic service parts will be shipped in static shielding bags. Do not open the bags until you have completed steps 2 and 3 of the following procedure. Do not place unprotected circuit boards on the floor. All circuit boards to be returned to Stryker Medical should be shipped in the static shielding bags the new boards were shipped in.

Static Protection Procedure

1. Unplug the power cord from the wall receptacle.
2. Insert the grounding plug into a properly grounded hospital grade wall receptacle. Plug the banana plug of the test lead into the receptacle on the grounding plug. Connect the alligator clip on the other end of the test lead to a ground point on the bed.
3. Place the static control wrist strap on your wrist. Connect the alligator clip at the other end of the wrist strap cord to a ground point on the bed.

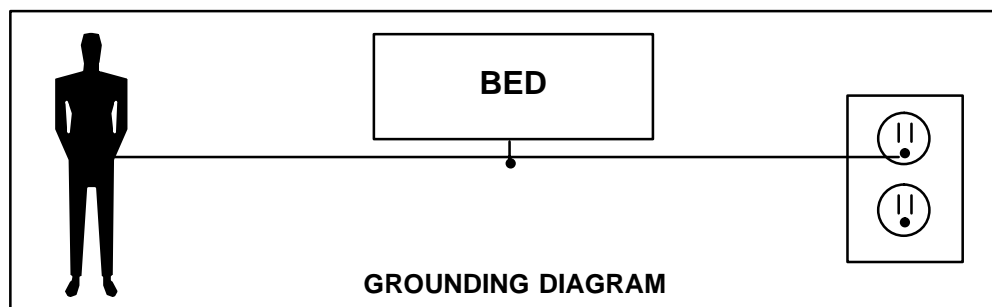

Brake Pedal Replacement

Required Tools:

5/16" Hex Allen Wrench

Torque Wrench

Loctite 242

Hammer

Punch

#2 Phillips Screwdriver

Bungee Cords (or Equivalent)

Procedure:

5. Raise the litter to the full up position.
6. Unplug the bed power cord from the wall socket.
7. Using a #2 Phillips screwdriver, remove the three screws holding both the head end and the foot end upper lift covers. If you want, hold the covers out of the way by using bungee cords (or the equivalent) to secure them to the litter top.
8. Using a 5/16" hex Allen wrench, remove the two bolts holding the brake pedal to the brake rod.
9. Using a hammer and punch, remove the roll pins holding the brake shaft crank to the brake rod on both the head and the foot end.
10. Push the brake rod through the frame until the brake pedal is clear. Remove the brake pedal.
11. Reverse the above steps to attach the new brake pedal.

NOTE

Use Loctite 242 when reinstalling the bolts and torque the bolts to 25 foot-pounds.

Lift Motor and Capacitor Removal and Replacement

Required Tools:

3/8" Socket Wrench w/Extension
Side Cutters

5/16" Socket Wrench
7/16" Open End Wrench

Floor Jack
2x4 (or Equivalent)

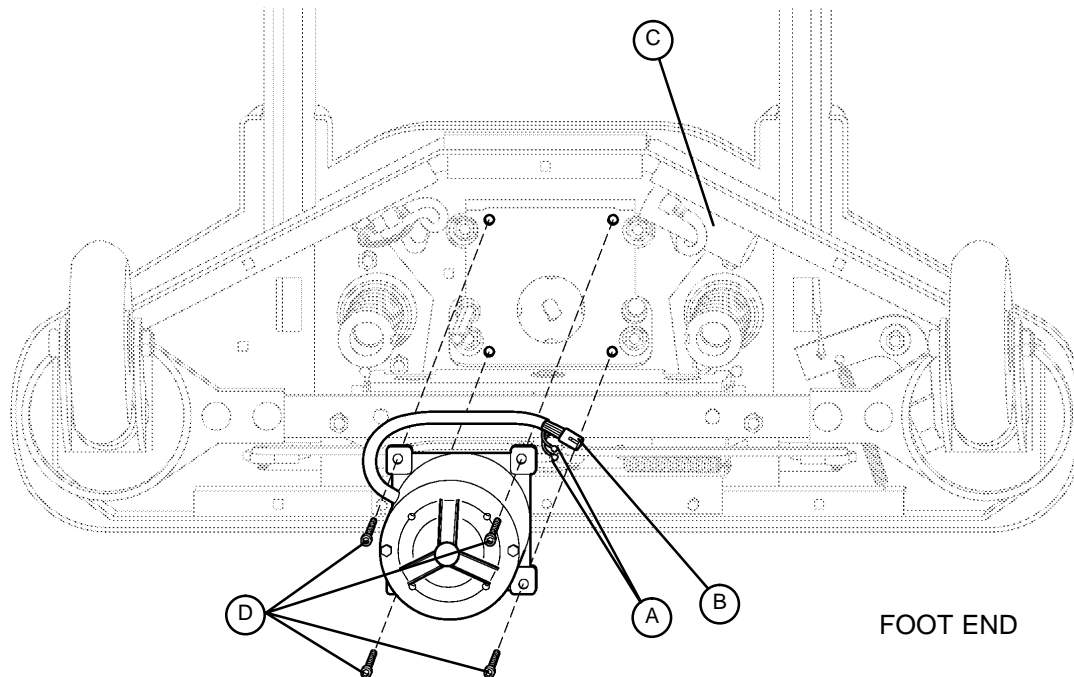

Procedure:

NOTE

If you need more space to work under the base frame, place a 2x4 across the base frame rails and use a floor jack to raise the base frame off the floor.

1. Unplug the bed power cord from the wall socket. Using a 5/16" socket wrench, remove the six bolts holding the lower lift cover to the base and remove the cover.
2. Disconnect the two connectors (A) at the motor capacitor.
3. Disconnect the white connector (B) from the power cord.
4. Using side cutters, cut the cable ties holding the capacitor (C) to the base and remove the capacitor.
5. Using a 3/8" socket wrench, remove the four screws (D) holding the motor assembly in the lift housing and remove the motor assembly.
6. Reverse the above steps to install the new motor.

NOTE

The drive shaft on the new motor probably will have to be turned to be aligned with the coupler. Use a 7/16" open end wrench to turn the drive shaft of the motor.

The procedure for lift motor and capacitor removal and replacement is the same for both ends of the bed.

Lift Housing Removal and Replacement

Required Tools:

#2 Phillips Screwdriver	Bungee Cord (or Equivalent)	5/16" Socket Wrench
Side Cutters	9/16" Socket Wrench	Floor Jack
7/32" Hex Allen Socket Wrench	Sawhorses (or Equivalent)	2x4 (or Equivalent)
3/8" Socket Wrench (w/ 6" extension)		

Procedure:

NOTE

If you need more space to work under the base frame, place a 2x4 across the base frame rails and use a floor jack to raise the base frame off the floor.

1. Unplug the bed power cord from the wall socket.
2. Using a 5/16" socket wrench, remove the six bolts holding the lower lift cover to the base and remove the cover.
3. Using a #2 Phillips screwdriver, remove the three screws holding the upper lift cover to the base. If you want, hold the covers out of the way by using bungee cords (or the equivalent) to secure them to the litter top.
4. Remove the lift motor and capacitor (refer to procedure on page 6-4).
5. Remove lift potentiometer (refer to procedure on page 6-7).
6. Using a 5/16" socket wrench, remove the cable clamps holding the power and sensor coil cords on top of the lift housing assembly. Cut the cable ties and disconnect the coil cords from under the lift housing. The power and sensor coil cords are now free of the lift housing assembly. Drape them up out of the way.
7. Using a 7/32" hex Allen socket, remove the two screws holding the lift screws to the header crossbar plate.
8. Lift the litter top up and support it about 6" above the lift screws with sawhorses or the equivalent.

Lift Housing Removal and Replacement (Continued)

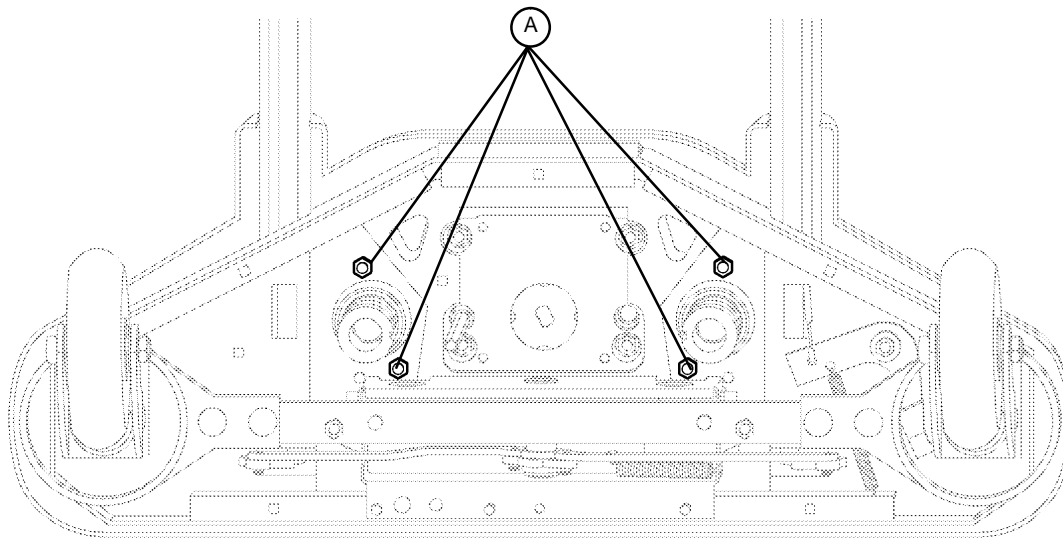

FOOT END – BOTTOM VIEW

9. Under the base, using a 9/16" socket, remove the four nuts (A) holding the lift housing to the base.
10. Lift up and out on the lift housing assembly to remove it from the base.

 **CAUTION**

To ensure proper reattachment of the power and sensor coil cords, refer to the procedure on page 6–10. Refer to the procedure on page 6–7 for reattachment of the lift potentiometer.

11. Reverse the above steps to reinstall the lift housing assembly after service is completed.

NOTE

The procedure for lift housing removal and replacement is the same for both ends of the bed.

Lift Potentiometer Replacement and Adjustment

Required Tools:

#2 Phillips Screwdriver
3/8" Open End Wrench

Bungee Cord (or equivalent)
Side Cutters

5/16" Socket Wrench

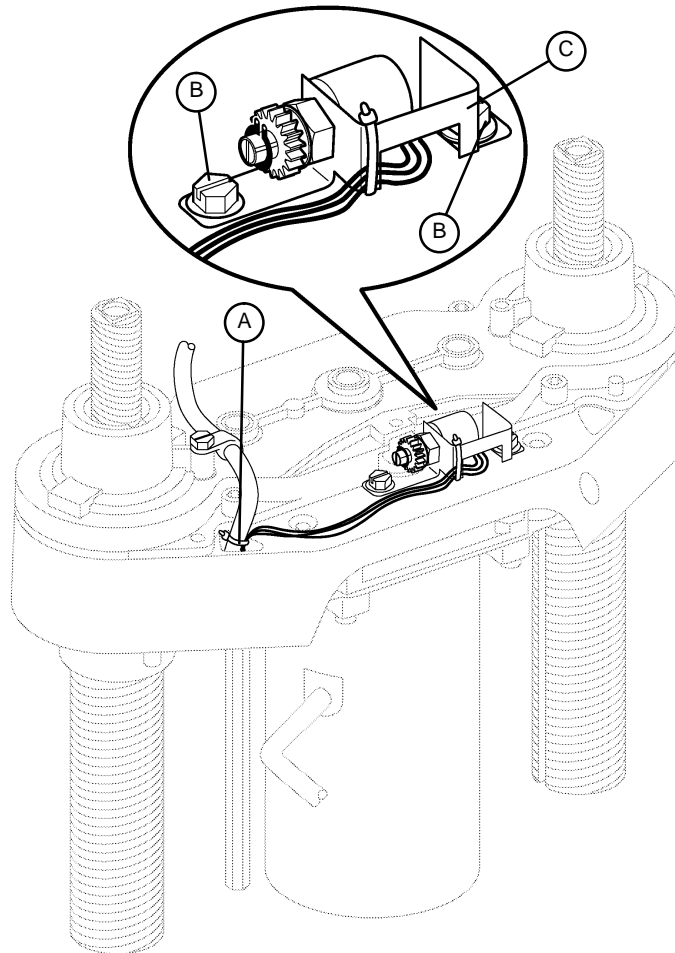

Procedure:

1. Raise the litter to the full up position.
2. Unplug the bed power cord from the wall socket.
3. Using a 5/16" socket wrench, remove the six bolts holding the lower lift cover to the base and remove the cover. If you want, hold the covers out of the way by using bungee cords (or the equivalent) to secure them to the litter top.
4. Using a #2 Phillips screwdriver, remove the three screws holding the upper lift cover to the base. If you want, hold the covers out of the way by using bungee cords (or the equivalent) to secure them to the litter top.
5. Using side cutters, cut the cable tie (A) holding the pot cable to the coil cord.
6. Unplug the pot cable from the sensor coil cord. If replacing a pot at the head end of the bed, unplug the cables attached to the brake sensor switch.
7. Pull the pot cable up through the base.
8. Using a 3/8" open end wrench, remove the two bolts (B) holding the pot housing (C) to the lift housing.

Lift Potentiometer Replacement and Adjustment (Continued)

9. Lift up and out on the pot housing assembly to remove it from the lift housing.
10. Before installing the new pot on the bed, turn it clockwise until it stops. Turn it back counterclockwise two full (360°) revolutions. This allows a "window" position for proper upper and lower limits.
11. Reverse steps 4–8 to install the new pot and pot housing assembly.
12. After installing the new pot, the "burn-in" procedure below must be followed.

NOTE

Be sure to maintain the pot position while installing.

Lift Potentiometer "Burn-In" Procedure

1. Unplug the bed power cord from the wall socket.
2. On the foot board control panel, hold down the Bed Motion Lock and Knee Lock Out buttons simultaneously.
3. While holding down the above two buttons, plug the power cord into the wall socket. Release the two buttons. The Siderail Control Lights LED on the foot board control panel should be flashing, indicating the bed is in the diagnostics mode.
4. From the foot board, run the litter full up to a "hard stop".
5. Hold down the Bed Motion Lock button until the light flashes.
6. Release the button and unplug the power cord from the wall socket.
7. Plug the power cord back in to the wall socket. Run the bed to full down, then full up to verify the bed limits.
8. The distance between the floor and the top of the litter seat section (without a mattress) should be approximately 17 1/2" with the litter fully down and 30 1/2" with the litter fully up.

NOTE

These values are for beds equipped with 6 inch casters. Add two inches to both measurements for beds equipped with 8 inch casters.

Lift Motor Coupler Replacement

Required Tools:

5/16" Socket Wrench
2x4 (or Equivalent)

3/8" Socket Wrench (w/6" Extension)

Floor Jack

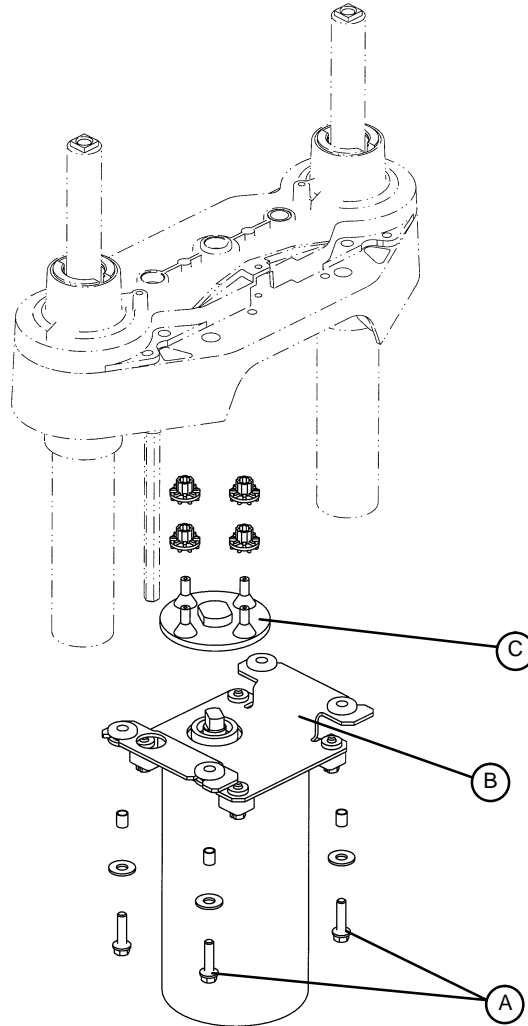

Procedure:

NOTE

If you need more space to work under the base frame, place a 2x4 across the base frame rails and use a floor jack to raise the base frame off the floor.

1. Unplug the bed power cord from the wall socket.
2. Using a 5/16" socket wrench, remove the six bolts holding the lower lift cover to the base and remove the cover.
3. Using a 3/8" socket with an extension, remove the four bolts (A) holding the isolation plate (B) to the lift housing and lower the lift motor and isolation plate assembly to allow access to the coupler (C).
4. The motor coupler can now be removed from the lift housing.
5. Reverse the above steps to install the new motor coupler and bushings.

Power and Sensor Coil Cord Replacement

Required Tools:

#2 Phillips Screwdriver	Side Cutters	5/16" Socket Wrench
Bungee Cord (or equivalent)	5/16" Nut Driver	Floor Jack
2x4 (or Equivalent)		

Procedure:

NOTE

If you need more space to work under the base frame, place a 2x4 across the base frame rails and use a floor jack to raise the base frame off the floor.

1. Unplug the bed power cord from the wall socket.
2. Using a 5/16" socket wrench, remove the six bolts holding the lower lift cover to the base and remove the cover.
3. Using a #2 Phillips screwdriver, remove the three screws holding the upper lift cover to the base. If you want, hold the covers out of the way by using bungee cords (or the equivalent) to secure them to the litter top.
4. Using side cutters, cut the cable ties holding the power and sensor coil cords to the base. Remove the ground wire coming from the sensor cord that is attached to the base (note the star washer arrangement).
5. Disconnect the cables going to the motor and the lift potentiometer (at the head end, the sensor cord is also attached to the brake switch sensor).
6. Pull both cords up through the frame of the bed and the lift housing.
7. Using a 5/16" socket wrench, remove the two screws (A) holding the cable clamps* to the top of the lift housing.
8. Using a 5/16" socket wrench, remove the two screws (B) securing the cable clamps* to the underside of the header crossbar assembly.
9. Pull both coil cords up through the header crossbar assembly.
10. Disconnect the power and sensor coil cords from the connectors.
11. The cords should now be completely removed from the bed. Reverse the above steps to install the new power and sensor cords.*

CAUTION

* When the power and sensor coil cords are being replaced, secure the cable clamps to the cords at the first coil both on the top and on the bottom to assure there is not too much slack in the cords between the top of the lift housing assembly and the bottom of the header crossbar. Be sure the clamps are fastened at exactly the correct angle, as shown by the arrows in the illustration. Arrange the cords exactly as shown in the illustration (left in front of right). **If this is not done correctly, damage to the cords will result.**

Power and Sensor Coil Cord Replacement Illustration

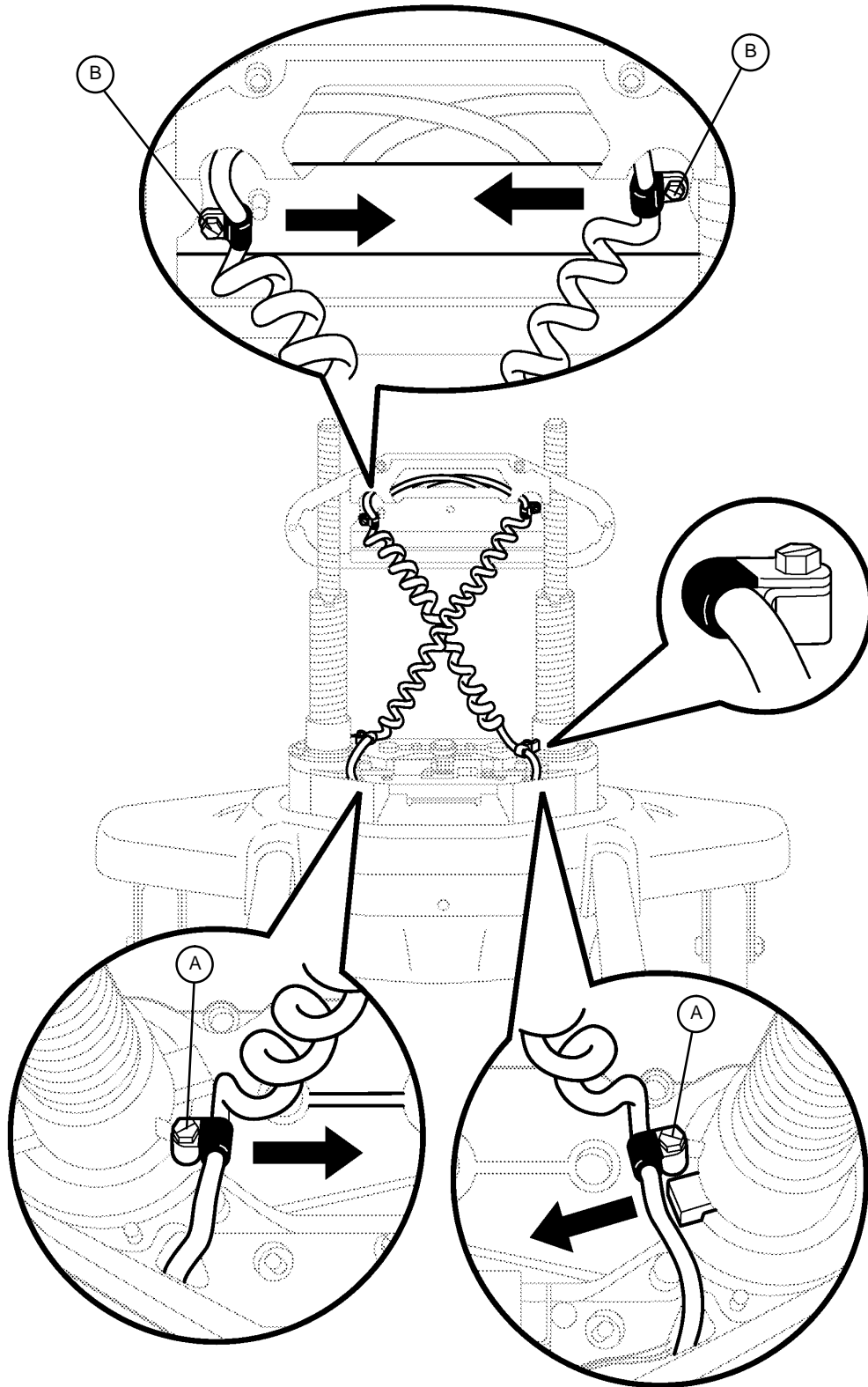

VIEW FROM CENTER OF BED

Optional Inverter Removal and Replacement

Required Tools:

Phillips Screwdriver

Bungee Cords

T27 Torx

Procedure:

1. Raise the litter to full up. Unplug the power cord from the wall socket and push the battery power on/off switch to the “OFF” position.
2. Using a Phillips screwdriver, remove the four screws holding the base hood to the base frame.
3. Lift the base hood and support it from the litter frame using bungee cords or the equivalent.
4. Properly ground yourself (see page 6–2 for static discharge precautions).
5. Open the cable clamp at the head end, left side of the base frame and remove the cables from the clamp.
6. Using a T27 Torx, remove the four screws holding the electronics box cover and remove the cover.
7. Remove all cables from the inverter.

NOTE

Notice the cable connections so you can connect them properly to the new inverter.

8. Using a Phillips screwdriver, remove the four screws holding the inverter to the box. Lift the inverter up and out of the box.
9. Reverse steps 1 – 8 to install the new inverter.

Optional Battery Charger Removal and Replacement

Required Tools:

Phillips Screwdriver

T27 Torx

Bungee Cords

Procedure:

1. Raise the litter to the full up position.
2. Unplug the power cord from the wall socket and push the battery power on/off switch to the “OFF” position.
3. Using a Phillips screwdriver, remove the four screws holding the base hood to the base frame.
4. Lift the base hood and support it from the litter frame using bungee cords or the equivalent.
5. Properly ground yourself (see page 6–2 for static discharge precautions).
6. Open the cable clamp at the head end, left side of the base frame and remove the cables from the clamp.
7. Using a T27 Torx, remove the four screws holding the electronics box cover and remove the cover.
8. Unplug all the cables from the battery charger and lift out the charger.

NOTE

Notice the cable routing and connections so you can connect them properly to the new battery charger.

9. Reverse steps 1 – 8 to install the new battery charger.

Optional Battery Removal and Replacement

Required Tools:

Torx T27	7/16" Wrench
1/2" Socket Wrench	Bungee Cords
Phillips Screwdriver	

Procedure:

1. Raise the litter to full up. Unplug the power cord from the wall socket and push the battery power on/off switch to the "OFF" position.
2. Using a Phillips screwdriver, remove the four screws holding the base hood to the base frame.
3. Lift the base hood and support it from the litter frame using bungee cords or the equivalent.
4. Properly ground yourself (see page 6–2 for static discharge precautions).
5. Open the cable clamp at the head end, left side of the base frame and remove the cables from the clamp.
6. Using a Torx T27, remove the four screws (A) holding the electronics box cover and remove the cover.
7. Disconnect the three battery cables (B).

WARNING

The battery tray assembly weighs 50 pounds. Use caution when removing the two hex head screws securing it to the base frame or personal injury could result. Battery posts, terminals and related accessories contain lead and lead compounds, chemicals known to the State of California to cause cancer and birth defects or other reproductive harm. **Wash hands after handling.**

8. Support the battery tray assembly from the bottom. Using a 7/16" hex socket or wrench, remove the two screws (C) supporting the battery tray.
9. The back of the battery tray assembly has a lip which catches on the electronics box. Lift up and out to remove the battery tray assembly.
10. Reverse steps 1 – 9 to install the new batteries. Complete the last four items of the set-up procedures on page 1–6.

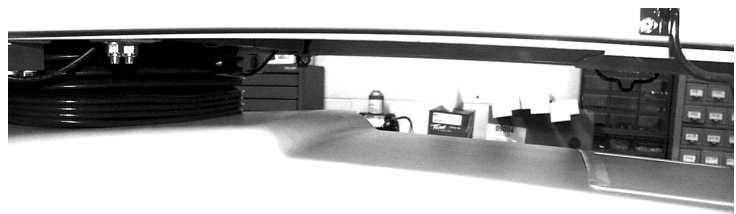

A

B

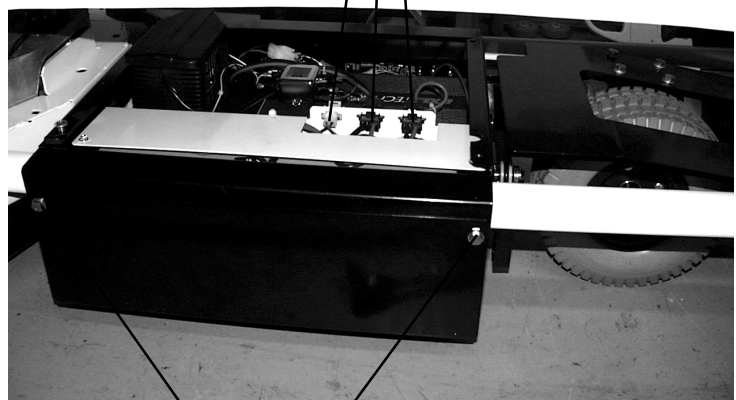
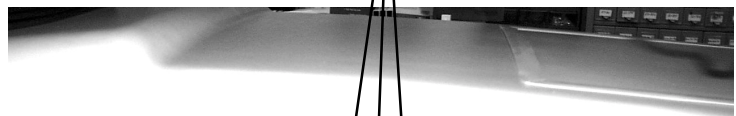

C

GENERAL INFORMATION

This section contains tool lists and step-by-step procedures to assist with the maintenance and servicing of the litter portion of your equipment.

In the text, the words “right” and “left” refer to the right and left sides of a patient lying face up on the bed.

LITTER MAINTENANCE CONTENTS

Scale System Diagnostics and Calibration 7-2 – 7-4

Load Cell Replacement 7-4

Head Motor Removal and Replacement 7-5

Knee Motor Removal and Replacement 7-6

Power Supply Removal and Replacement 7-7

CPU Board Removal and Replacement 7-7

Fowler and Lift Potentiometer “Burn-In” Procedure 7-8

Optional Smart TV Interface “Burn-In” Procedure 7-9

Optional Epic+ AC Crossover Board Replacement 7-10, 7-11

Optional Display/CPU Board Replacement 7-12

Scale System Diagnostics and Calibration

Diagnostic Mode Functions:

1. **Calibrate Scale:** This is required in the field if a CPU board or a load cell is replaced.
2. **Display Corner:** This function displays the individual reference numbers for each load cell assembly and can be used to isolate a defective load cell.
3. **Init. to Defaults:** This may be required in the field when replacing a CPU board or a load cell.
4. **Erase E-prom:** This is a factory setting not used in the field.
5. **Display Factor:** This is a factory setting not used in the field.
5. **Exit Diagnostics:** Changes made in the diagnostic mode **must** be saved in permanent memory using this function. Switching off power without saving will reset all variables to their previous values.

Diagnostic Mode:

NOTE

It requires **two people** to enable the diagnostic mode for the scale system.

1. To enter diagnostic mode, unplug the bed's power cord from the wall socket.
2. Press and **hold down** the LBS/KGS button.
3. While still holding the LBS/KGS button, plug the bed's power cord into the wall socket.
4. After two seconds, release the LBS/KGS button. The LCD should display "CALIBRATE SCALE". The diagnostic mode is now active.

Displaying Individual Load Cell Outputs:

A defective load cell can be detected by entering diagnostics and displaying individual load cell outputs.

1. Enter the diagnostic mode. The LCD will display "CALIBRATE SCALE" when the diagnostic mode is activated.
2. Repeatedly press and release the up or down arrow button (ZERO or SCALE ON/OFF) until the LCD displays "DISPLAY CORNER".
3. Press and release the ENTER button (LBS/KGS). The LCD should display "PICK CORNER NOW".

The four buttons listed in the group below function as POSITION buttons corresponding with the four corners of the bed's litter. Whenever the LCD displays "PICK CORNER NOW", press one of these buttons to select the load cell assembly at the desired corner.

- A. ZERO = head end, patient's left side
 - B. CHANGE EQUIP. = head end, patient's right side
 - C. TREND/FOWLER ANGLE = foot end, patient's right side
 - D. LBS/KGS = foot end, patient's left side
4. Press and release the position button that corresponds with the load cell to be checked. The LCD should display "X/X=NNN.N". "X/X" represents the initials of the selected corner, i.e. H/R will be displayed for the patient's head end, right side. "NNN.N" represents the resistance of the load cell.
 5. Repeat step four for each corner. Head end weight readings will normally be lower than foot end weights. Weight readings should be constant. A drifting 000.0 or 999.9 weight, or a reading that does not change when weight is applied to that corner of the bed indicates a problem with the selected load cell assembly or load cell cable.
 6. When all the load cell outputs have been checked, repeatedly press and release the SCALE ON/OFF button until the LCD displays "EXIT DIAGNOSTICS". Press the ENTER button (LBS/KGS) to exit diagnostics.

Scale System Diagnostics and Calibration

Verifying Scale Accuracy:

1. Zero the empty bed. Place a known weight on the center of the bed; the heavier the better and no less than 100 pounds. The displayed weight should be within 1% of the actual weight.
2. If the displayed weight is not accurate, remove the weight from the bed and proceed to the Scale Calibration section.

Scale Calibration:

NOTE

It requires **two people** to enable the calibration mode for the scale system.

Calibrate the scale system with a known 200 pound weight. If exactly 200 pounds is not available, the factory default for calibration will have to be changed as described in step 8.

1. To enter the calibration mode, unplug the bed's power cord from the wall socket.
2. Press and **hold down** the LBS/KGS button.
3. While still holding the LBS/KGS button, plug the bed's power cord into the wall socket.
4. After two seconds, release the LBS/KGS button. The LCD should read "CALIBRATE SCALE". The calibration mode is now active.
5. Using the up or down arrow button (ZERO or SCALE ON/OFF), toggle through the menu until "INIT. TO DEFAULTS" is displayed. Press and hold the ENTER button (LBS/KGS) until "SAVING DEFAULTS" is displayed. Release the ENTER button.
6. Using the up or down arrow buttons (ZERO or SCALE ON/OFF), toggle through the menu until "CALIBRATE SCALE" is displayed.
7. Press and hold the ENTER button (LBS/KGS). Zero the bed, following the displayed instructions. When the bed is zeroed, the LCD should display "REF X100=<2 0000". This is the factory default for 200 pounds. If 200 pounds will be used to calibrate the scale, proceed to step 9.
8. If exactly 200 pounds is not available, change the display to match the weight you are using. Pressing the TREND/FOWLER ANGLE button will move the cursor position to the right. Pressing the up arrow (ZERO) button will increase the numbers. Pressing the down arrow (SCALE ON/OFF) button will decrease the numbers. Scroll through the numbers until they match the weight you will use for calibration.
9. Press and release the ENTER button (LBS/KGS). The LCD will display "ADD H/L, HIT ON". Place the known weight on the litter over the head, left load cell.
10. Press the SCALE ON/OFF button. The LCD will display "RELEASE TO CAL." Release the button. The display should read "DO NOT TOUCH BED".
11. The LCD will display "ADD H/R, HIT ON". Place the known weight on the litter over the head, right load cell.
12. Press the SCALE ON/OFF button. The LCD will display "RELEASE TO CAL." Release the button. The display should read "DO NOT TOUCH BED".
13. The LCD will display "ADD F/R, HIT ON". Place the known weight on the litter over the foot, right load cell.
14. Press the SCALE ON/OFF button. The LCD will display "RELEASE TO CAL." Release the button. The display should read "DO NOT TOUCH BED".
15. The LCD will display "ADD F/L, HIT ON". Place the known weight on the litter over the foot, left load cell.
16. Press the SCALE ON/OFF button, the LCD will display "RELEASE TO CAL." Release the button. The display should read "DO NOT TOUCH BED".

Scale System Diagnostics and Calibration

Scale Calibration (Continued):

17. After all four corners have been calibrated, the LCD will display “CENTER WT ON BED”.
18. Remove the weight from the foot, left corner and position it on the center of the bed.
19. Press and release the SCALE ON/OFF button and the LCD will display “PRESS REV. TREND”. Press the button with the Reverse Trendelenburg symbol (feet down/head up) until the bed reaches full reverse Trend. Release the button and the LCD will display “DO NOT TOUCH BED”.
20. The LCD will display “PRESS TREND.” Press the button with the Trendelenburg symbol (feet up/head down) until the bed reaches full trend. Release the button and the LCD will display “DO NOT TOUCH BED”.
21. The LCD will display “CALIBRATE SCALE”. This indicates the calibration procedure is complete.
22. Exit scale calibration by pressing the up arrow button (ZERO) until the LCD displays “EXIT DIAGNOSTICS”. Press the ENTER (LBS/KGS) button to exit.
23. Level the bed at a full up or full down position. Remove the weight and zero the bed.
24. Verify scale accuracy and functionality before returning the bed to service.

Load Cell Replacement

Required Tools:

9/16” Socket Wrench
Wire Cutters

9/16” Open End Wrench

Saw Horse (or Equivalent)

Replacement Procedure:

1. Raise the Fowler or knee section, depending which end of the litter needs service.
2. Unplug the load cell connector from the load cell cable.
3. Using wire cutters, remove the wire ties holding the cable to the frame.
4. Using a 9/16” socket and a 9/16” open end wrench, remove the two bolts holding the load cell to the litter cross tube and remove the load cell.
5. Using a saw horse, support the litter at the end where the load cell was removed. Reverse the above procedure to install the new load cell.

NOTE

Scale calibration procedure must be performed after the load cell is replaced (see page 7–3).

Head Motor Removal and Replacement

Required Tools:

T27 Torx

7/16" Socket Wrench

3/8" Socket Wrench

Wire Cutters

Procedure:

1. Run the litter to the full up position and remove the mattress from the bed.
2. Fold the foot section back toward the head end of the bed. Electrically run the knee section to full up. If the knee section will not move electrically, pull the foot section toward the head end of the bed while pulling the CPR release handle (located at the head end of the bed). The knee section will raise.
3. Using a T27 torx, remove the four screws holding the cover to the actuator box and remove the cover.
4. Remove the two CPR release cables from the CPR release bracket. Using a 3/8" socket wrench underneath the actuator box, remove the two bolts holding the release bracket to the actuator box and remove the bracket from the actuator box.
5. Disconnect all the electrical connections going to the head motor and move aside any wiring that could interfere with the removal of the motor.
6. Using a 3/8" socket wrench underneath the actuator box, remove the four bolts holding the motor mounting bracket to the actuator box. Lift up and out on the motor to remove it.
7. Remove the motor mounting bracket from the old motor and install it on the replacement motor.
8. Reverse steps 3 through 6 to install the replacement motor.
9. Verify the bed is working properly before returning it to service.

Knee Motor Removal and Replacement

Required Tools:

T27 Torx

7/16" Socket Wrench

3/8" Socket Wrench

Wire Cutters

Procedure:

1. Run the litter to the full up position and remove the mattress from the bed.
2. Fold the foot section back toward the head end of the bed. Electrically run the knee section to full up. If the knee section will not move electrically, pull the foot section toward the head end of the bed while pulling the CPR release handle (located at the head end of the bed). The knee section will raise.
3. Using a 7/16" socket wrench, remove the mounting bolt on the litter for the knee dampening cylinder. This leaves the knee dampener mounted only to the seat panel.
4. Using a T27 torx, remove the four screws holding the cover to the actuator box and remove the cover.
5. Remove the two CPR release cables from the CPR release bracket. Using a 3/8" socket wrench underneath the actuator box, remove the two bolts holding the release bracket to the actuator box and remove the bracket from the actuator box.
6. Disconnect all the electrical connections going to the knee motor and move aside any wiring that could interfere with the removal of the motor.
7. Pull the foot panel toward the head end of the bed. This causes the knee motor linkage to roll past center and allows the motor to be removed without supporting the knee section.
8. Using a 3/8" socket wrench underneath the actuator box, remove the four bolts holding the motor mounting bracket to the actuator box. Lift up and out on the motor to remove it.
9. Remove the motor mounting bracket from the old motor and install it on the replacement motor.
10. Install the replacement motor.
11. Reverse step 3 – 5 to reinstall the knee dampener, CPR bracket and actuator box cover.
12. Pull the foot panel toward the foot end of the bed. This causes the knee motor linkage to roll back past center. If this step is not done, damage to the motor or linkage will occur.
13. Verify the bed is working properly before returning it to service.

Fowler and Lift Potentiometer "Burn-In" Procedure

NOTE

It requires **two people** to enable the diagnostics mode for the bed.

1. Unplug the bed power cord from the wall socket.
2. On the foot board control panel, hold down the bed motion lock button and the button to lock out the side-rail controls for the knee. While still holding the buttons, plug the bed power cord into the wall socket. Release the foot board buttons. The siderail control lights LED should be flashing to indicate the bed is in diagnostics mode.
3. Using the foot board controls, run the Fowler up to 90°. Press and hold the button on the foot board to lock out the siderail controls for the back until the padlock LED flashes. Release the button.
4. Using the foot board controls, run the Fowler down to 0°. Press and hold the button on the foot board to lock out the siderail controls for the knee until the padlock LED flashes. Release the button..
5. To "burn in" the Bed Up/Down limits, raise the bed completely up until it can't go any farther. Press and hold the "Bed Motion Lock" button. The "Bed Motion Lock" LED will light. Continue to hold the "Bed Motion Lock" button until the "Bed Motion Lock" LED flashes. The flashing LED indicates the limits have been set. Release the "Bed Motion Lock" button and unplug the bed power cord from the wall socket to complete the "burn-in" mode.
6. Plug the bed power cord into the wall socket and verify the back and bed lift limits are set properly before returning the bed to service.

NOTE

The distance between the floor and the top of the litter seat section (without a mattress) should be approximately 17" with the litter fully down and approximately 30 1/2" with the litter fully up.

Optional Smart TV Interface "Burn-In" Procedure

This procedure is used for selecting the style of TV interface desired for your bed. If traditional TV is desired, select the "No Flash" setting. If optional Smart TV is available on the bed, select one of the TV manufacturers listed in the table below.

SET-UP

- Ensure the communication cable is connected between the bed and the Db37 wall port or the pillow speaker port of the nurse call system. If available, a bed communication tester can be used instead of the hospital wiring.

PROCEDURE

1. Place the bed in the Fowler potentiometer burn-in mode (see page 7–8).
2. Notice the Nurse Call LED (yellow) is not flashing. This represents the traditional TV mode. Notice the Nurse Answer LED (green) is flashing on/off slowly.
3. Press and release the TV ON/OFF switch on the bed's siderail. Notice the Nurse Call LED flashes once. This is the first selection of TV manufacturers for the Smart TV mode. Notice the Nurse Answer LED (green) is flashing on/off slowly. The Nurse Answer LED will only light when the Nurse Call LED (yellow) is flashing.
4. Press and release the TV ON/OFF switch on the bed's siderail to scroll to other TV manufacturers. Notice the number of times the Nurse Call LED flashes matches the number listed in the table below and represents the TV manufacturer selected.
5. When the desired TV manufacturer has been selected, unplug the bed power cord from the wall socket and plug it back in to complete the Smart TV burn-in procedure.

NOTE

If the bed is connected to a television during the burn-in procedure, the television will turn on when the correct setting is selected.

TV MANUFACTURER SELECTION FOR SMART TV BURN-IN PROCEDURE		
Press and release TV ON/OFF switch:	Nurse Call LED (Yellow)	TV Manufacturer
No press	No flash	Traditional TV
Once	One flash	RCA 1
Twice	Two flashes	RCA 2
Three times	Three flashes	Zenith 1
Four times	Four flashes	Zenith 2
Five times	Five flashes	Phillips/Magnavox
Six Times	Six flashes	Magnavox (models 9120, 9220, 9320)

Optional Epic+ AC Crossover Board Replacement

Required Tools:

T27 Torx

1/2" Box End Wrench

#2 Phillips Screwdriver

Wire Cutters

Small Flat Blade Screwdriver

Needle Nose Pliers

5/16" Nut Driver

Replacement Procedure:

1. Raise the litter and the head end to the full up position.
2. Remove the head board from the bed.
3. Unplug the power cord from the wall socket and push the battery power on/off switch to the "OFF" position.
4. Using a #2 Phillips screwdriver, remove the two screws (A) holding the plastic cover over the nurse call port at the head end (see Figure 1).
5. Using a 5/16" nut driver, remove the screw (B) holding the power cord clamp to the bumper weldment and remove the clamp from the bumper.
6. Remove the plastic cover at the head end covering the nurse call port.

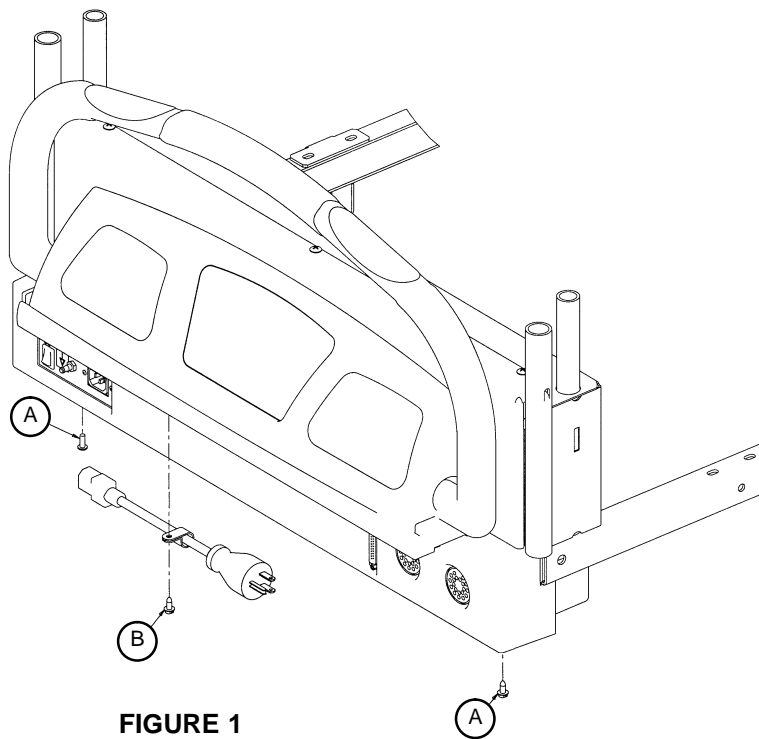

Optional Epic+ AC Crossover Board Replacement

7. Using a T27 Torx, remove the four bolts (C) at the head end of the bed holding the control bar mounting bracket to the head end (see Figure 2).
8. Using a #2 Phillips screwdriver, remove the three screws (D) holding the control bar cover to the head end of the bed (see Figure 3).

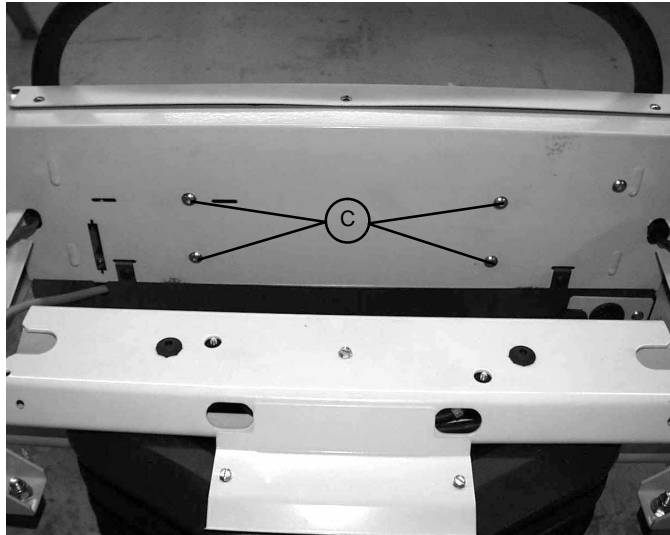

FIGURE 2

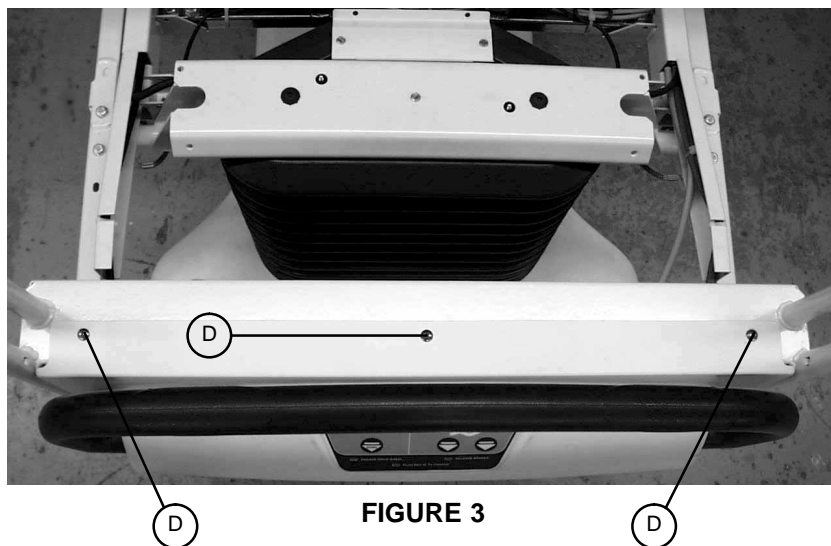

FIGURE 3

9. Using a T-27 Torx, remove the 2 bolts holding the AC crossover board cover to the head end frame and remove the cover.
10. Disconnect all wires from the AC crossover board.
11. Using needle nose pliers, release the four mounting stand-offs from the board and remove the board.
12. Reverse steps 9 – 12 to install the new board.
13. Reverse steps 1 – 8 of the control bar potentiometer replacement procedure on page 7-11 to reassemble the bed.

Optional Epic+ Display/CPU Board Replacement

Required Tools:

T27 Torx

1/2" Box End Wrench

#2 Phillips Screwdriver

Wire Cutters

Small Flat Blade Screwdriver

Needle Nose Pliers

5/16" Nut Driver

Replacement Procedure:

1. Follow steps 1 – 8 of the AC Crossover Board replacement procedure on page 7–10 & page 7–11.
2. Disconnect all wires from the display/CPU board.
3. Using a #2 Phillips screwdriver, remove the six screws holding the display/CPU board to the control bar cover and remove the board.
4. Reverse steps 2 & 3 to install the new board.
5. Reverse steps 1 – 8 of the AC Crossover Board replacement procedure on page 7–10 & page 7–11 to reassemble the bed.

GENERAL INFORMATION

This section contains tool lists and step-by-step procedures to assist with the maintenance and servicing of the siderail portion of your equipment.

In the text, the words “right” and “left” refer to the right and left sides of a patient lying face up on the bed.

SIDERAIL MAINTENANCE CONTENTS

Head and Foot End Siderail Cover Removal 8-2

Head and Foot Molded Siderail Replacement 8-3

Head End Siderail Cable Replacement 8-4, 8-5

Head and Foot Siderail Cover Removal

Required Tools:

#2 Phillips Screwdriver

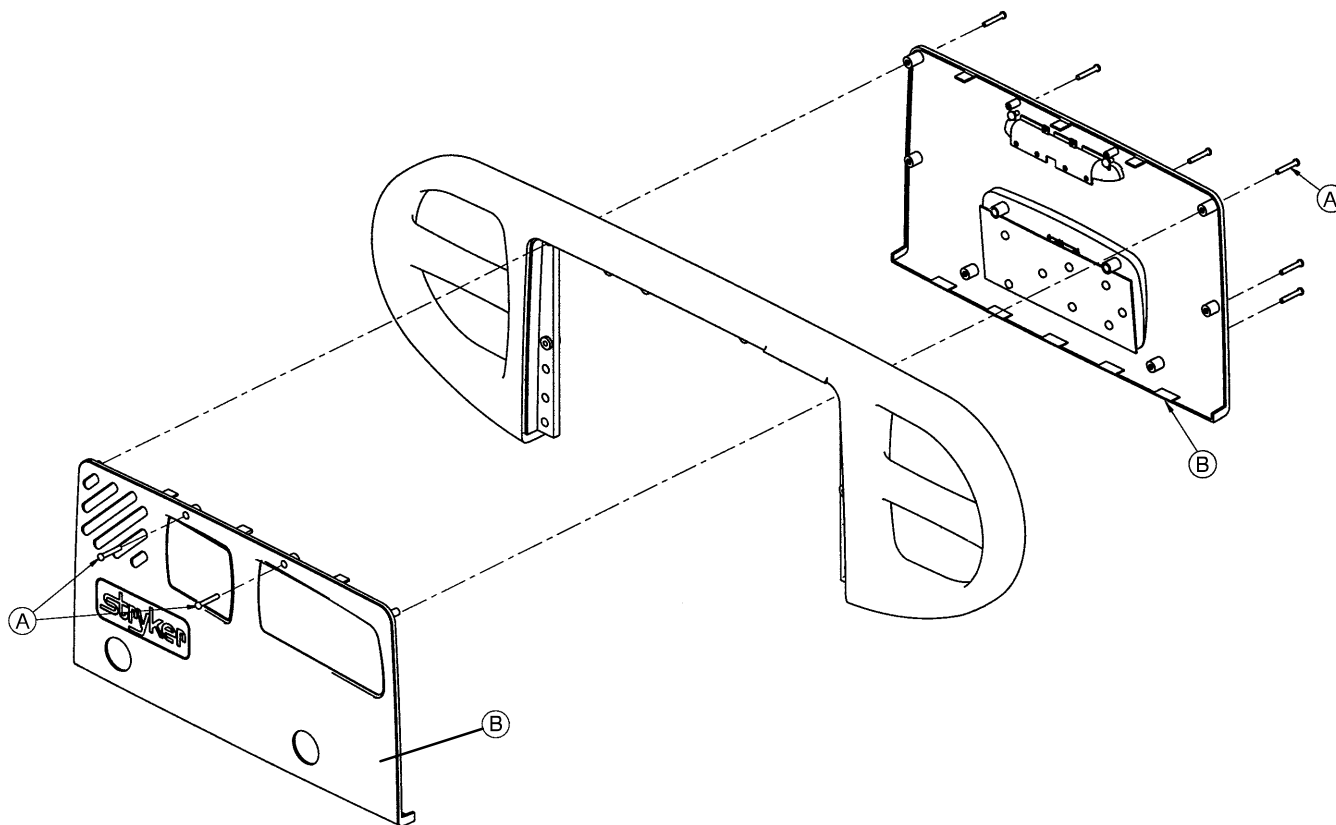

Removal Procedure:

1. Unplug the power cord from the wall receptacle.
2. Using a #2 Phillips screwdriver, remove the 8 phillips screws (A) holding the covers (B) to the siderail.

CAUTION

There are two cables connecting the outside cover to the head end siderail. Be careful not to pull on them when removing the cover.

3. Remove the cables from the siderail. Make note of the proper location for the cables.
4. Reverse the above steps to reattach the cover.

CAUTION

Do not snag the cables when installing the siderail cover.

NOTE

Follow the same procedure for siderail cover removal for the foot end rails.

Head and Foot Molded Siderail Replacement

Required Tools:

#2 Phillips Screwdriver

3/8" Nut Driver

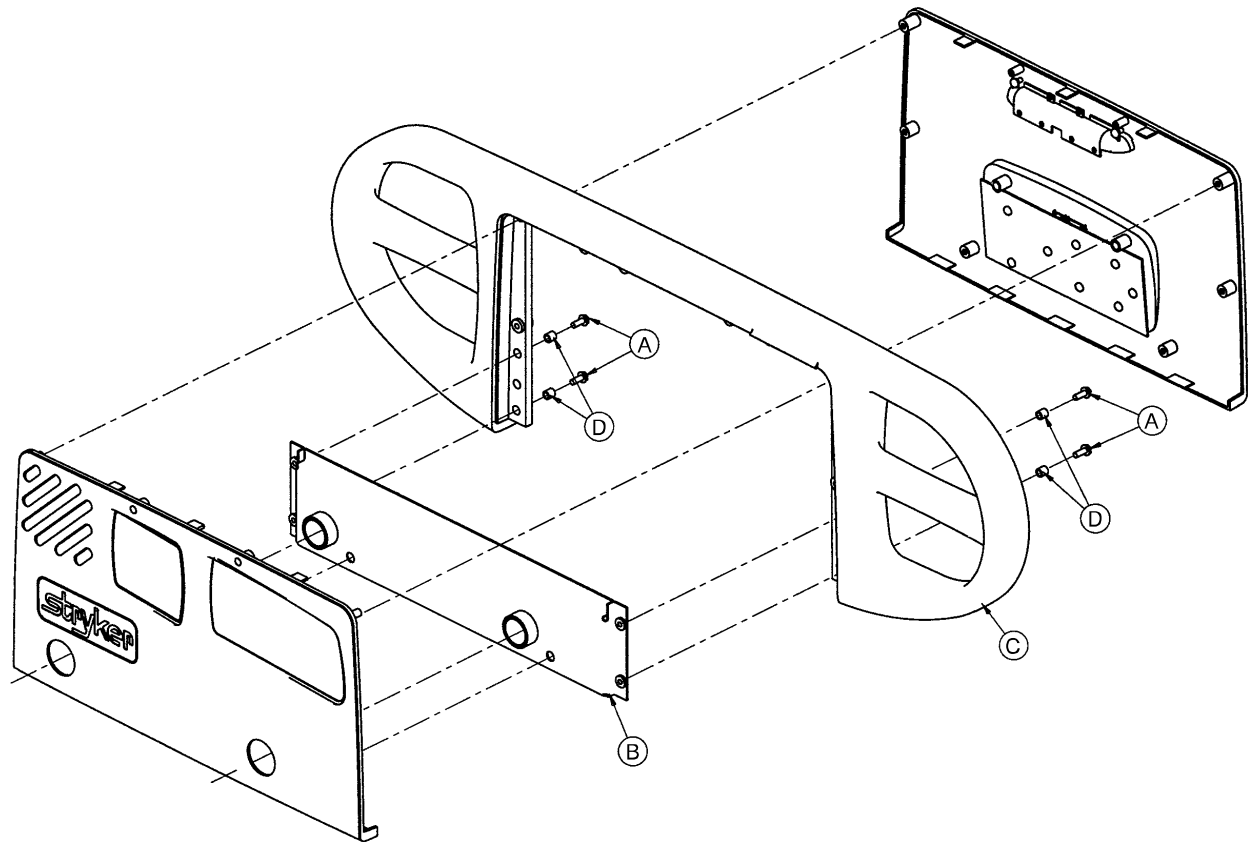

Procedure:

1. Unplug the bed power cord from the wall socket.
2. Remove the siderail cover (see page 8-2).
3. Using a 3/8" nut driver, remove the four screws (A) holding the molded rail (C) to the siderail support assembly (B).

NOTE

Note the location of the spacers (D) for re-assembly purposes.

4. Pull up on the molded rail (C) to remove it from the siderail assembly.
5. Reverse the above steps to install the new molded rail.

Head End Siderail Cable Replacement

Required Tools:

#2 Phillips Screwdriver

Side Cutters

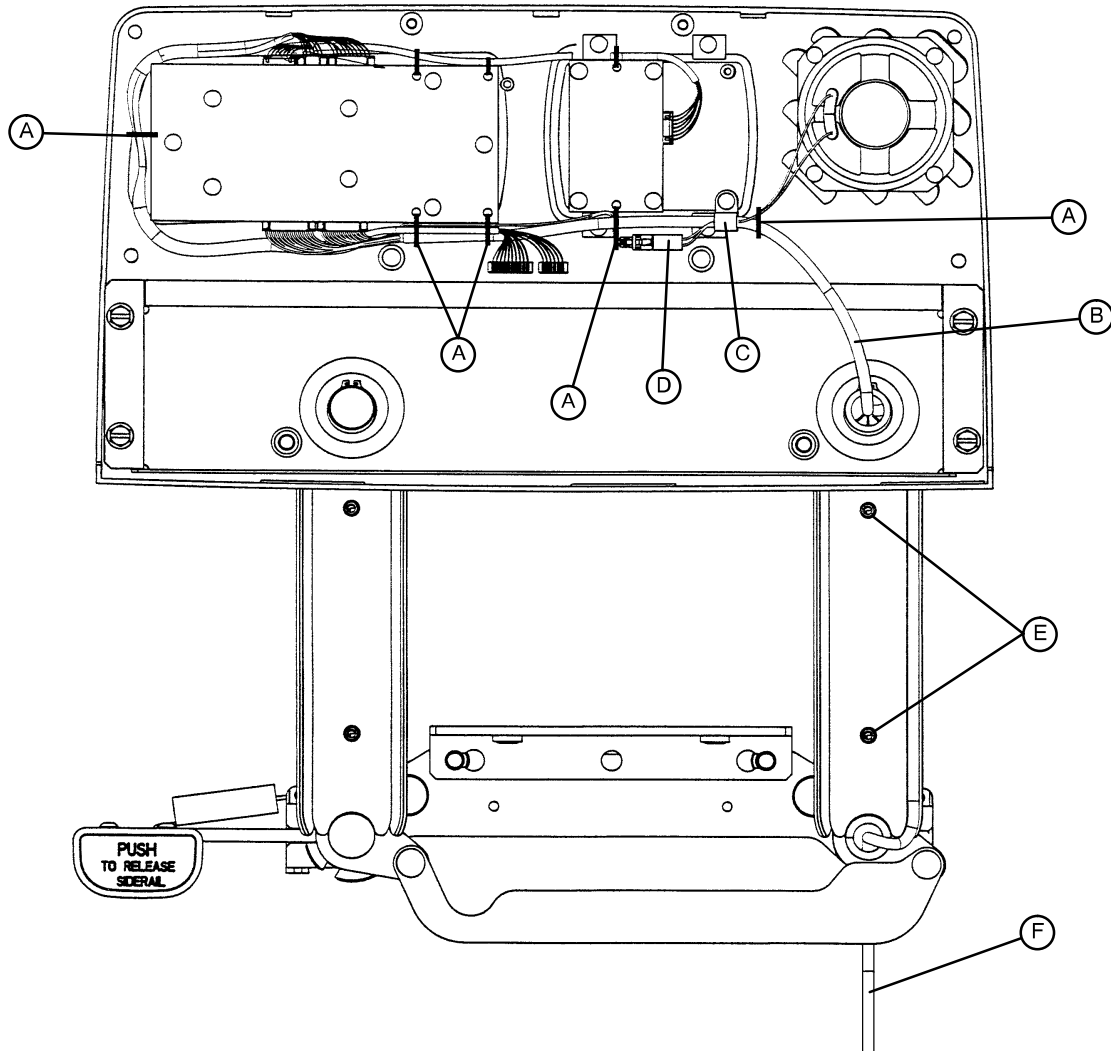

Procedure:

1. Run the head section fully up.
2. Unplug the bed power cord from the wall socket.
3. Using a #2 Phillips screwdriver, remove the eight screws holding the siderail cover and remove the cover.
4. Put the siderail in the down position.
5. Using a #2 Phillips screwdriver, remove the two screws (E) holding the rear siderail pivot arm cover to the pivot arm. Remove the cover to expose the siderail cables.

Head End Siderail Cable Replacement (Continued)

6. Using side cutters, clip the cable ties (A) holding the cables together.
7. Using a #2 Phillips screwdriver, remove the cable clamp (C) from the siderail.
8. Disconnect cable (B) from the circuit board and cable (D) from the speaker.

NOTE

The speaker and nurse call are optional equipment and may not be in the siderail as shown.

9. Pull the cables through the siderail (toward the center of the bed).
10. Unplug the cable assembly (F) underneath the head section.
11. Reverse the above steps to install the new cable.



CAUTION

Be sure to position the cables on both sides of the pivot arm, as shown in the illustration on page 8-4, before reattaching the pivot arm cover. If not done properly, the cover will not fit tightly and damage could occur to the cables.

GENERAL INFORMATION

This section contains tool lists and step-by-step procedures to assist with the maintenance and servicing of the foot board portion of your equipment.

FOOT BOARD MAINTENANCE CONTENTS

Foot Board Hinge Removal 9-2

Foot Board Module Replacement 9-3

Foot Board Interface Plug Replacement 9-4

Foot Board Hinge Removal

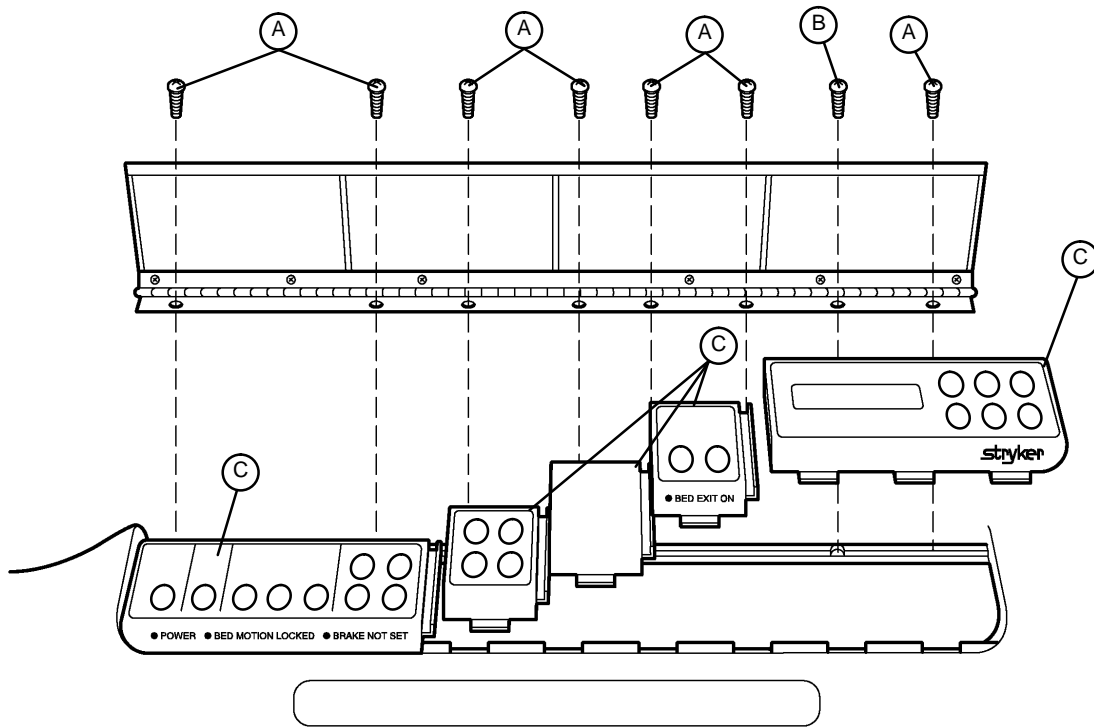

Required Tools:

#2 Phillips Screwdriver

Procedure:

1. Using a #2 Phillips screwdriver, remove the screws (A & B) holding the door and hinge assembly to the foot board.
2. If replacing the hinge only, use a Phillips screwdriver to remove the screws holding the hinge to the door.
3. Reverse the above steps to attach the replacement door and/or hinge.

NOTE

Screw (B) is a machine screw and must be reinstalled in the proper hole.

Foot Board Module Replacement

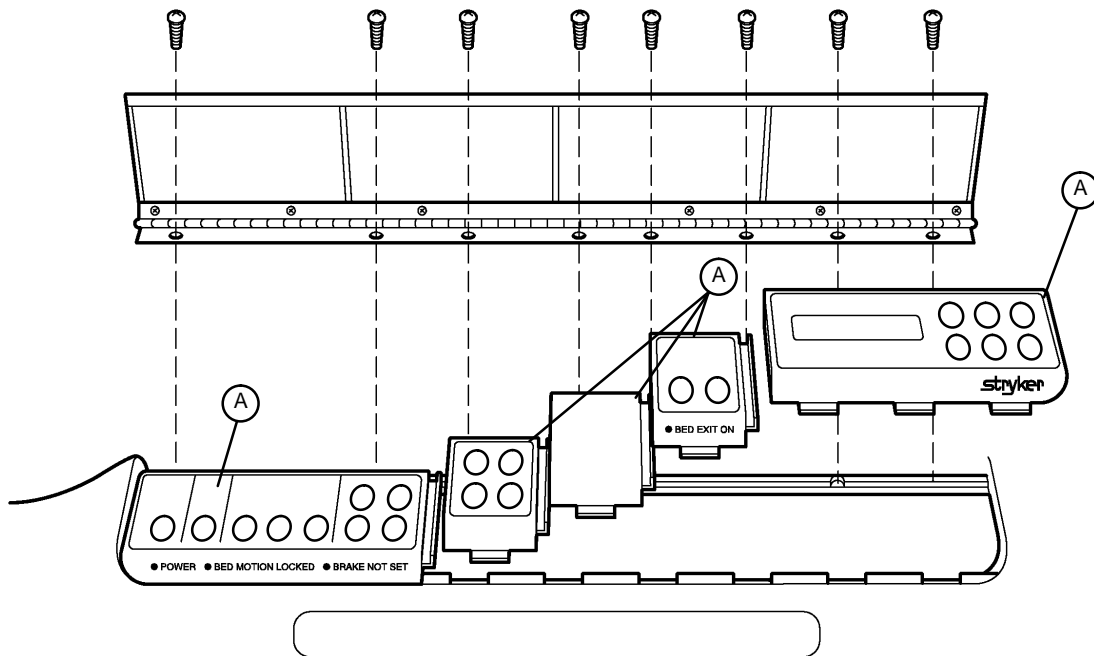

Required Tools:

#2 Phillips Screwdriver

Procedure:

1. Unplug the bed power cord from the wall socket. Remove the foot board hinge (see above).

NOTE

Regardless of which module is being replaced, the farthest module to the right must be removed first.

2. Pull the module out of the foot board and disconnect the cable from the module (A).
3. Reverse the above steps to install the new module.

CAUTION

The modules must be overlapped as shown in the illustration to prevent fluids from entering the board cavity and causing damage.

Foot Board Interface Plug Replacement

Required Tools:

#2 Phillips Screwdriver

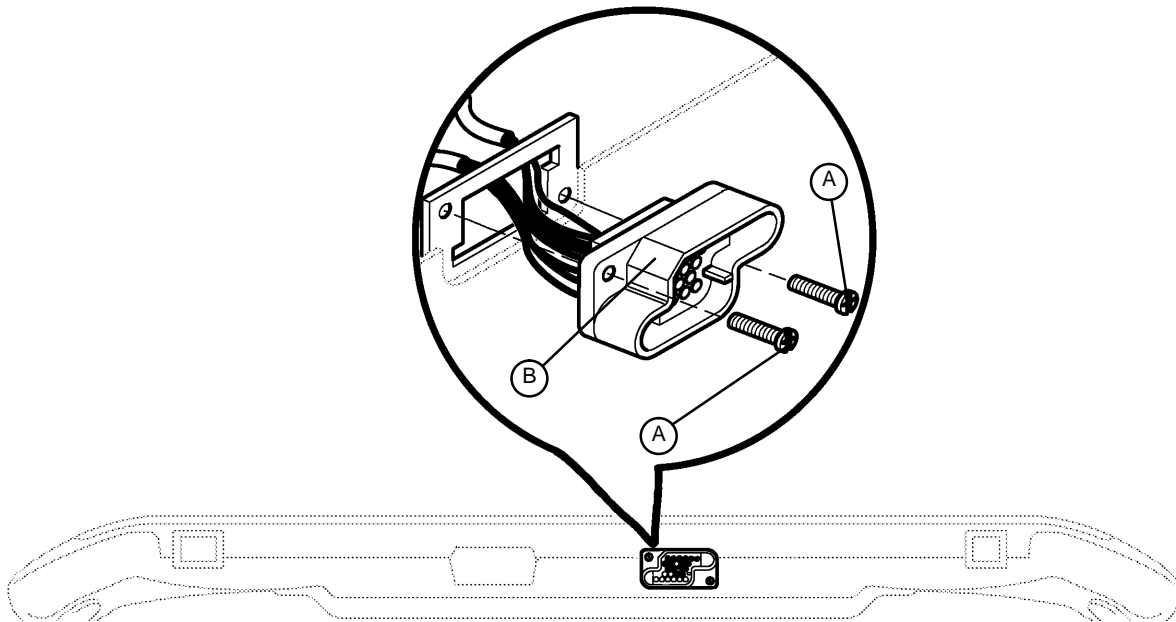

BOTTOM VIEW OF FOOT BOARD

Procedure:

1. Unplug the bed power cord from the wall socket.
2. Remove the foot board from the bed to access the bottom of the board.
3. Properly ground yourself (see page 6–2 for static discharge precautions).
4. Using a #2 Phillips screwdriver, remove the eight screws holding the foot board door to the foot board and remove the door.
5. Using a #2 Phillips screwdriver, remove the two screws (A) holding the plug to the foot board.
6. Disconnect the cable from the foot board module cable. Note proper placement of the cable so it will be reconnected properly.
7. Reverse the above steps to install the new interface plug.

CAUTION

Be sure to install the plug with the flat edge (B) at the top left, as shown in the illustration, or the foot board interface plug will not mate properly with the bed and damage to the plug or foot board could result.

GENERAL INFORMATION

This section contains tool lists and step-by-step procedures to assist with the maintenance and servicing of the optional Dynamic Mattress System.

In the text, the words “right” and “left” refer to the right and left sides of a patient lying face up on the bed.

DYNAMIC MATTRESS SYSTEM MAINTENANCE CONTENTS

Mattress Cover Replacement 10-2

Air Bladder Replacement 10-3

Foam Base Assembly Replacement 10-3

Control Unit Circuit Board Replacement 10-4

Control Unit Air Compressor Replacement 10-4, 10-5

Control Unit Replacement 10-5

Mattress Cover Replacement

Required Tools:

Wire Cutters

Static Protection Equipment (see page 6–2)

Replacement Procedure:

1. Unplug the power supply from the wall socket.
2. Unzip and remove the upper mattress cover.
3. Remove and set aside the upper foam layer.
4. Properly ground yourself. (See page 6–2 for static discharge precautions).
5. Unplug the cables from the control unit.
6. Remove the remaining foam assembly from the bottom cover and set aside.
7. Cut the cable ties securing the cables through the bottom cover grommet.
8. Remove the cables from the bottom cover.
9. Spread out the new bottom cover on a flat surface.
10. Replace the cables through the grommet in the bottom cover.
11. Place the foam assembly containing the air bladder and control unit into the bottom cover being sure the control unit is at the foot end of the new bottom cover.
12. Route the cables along the patient left side of the foam assembly to the control unit.
13. Reconnect the cables to the control unit.
14. Push the cables down into the slit in the base foam assembly.
15. Lift the head end of the foam assembly and pull the cable slack out of the mattress.
16. Fold the grommet material around the cable and replace the cable ties where they were located prior to disassembly.
17. Place the foam assembly back into the bottom cover.
18. Reinstall the upper foam layer with the *pink side down*.
19. Place the upper cover on the mattress with the “Head End” stamp at the head end of the mattress.
20. Zip the upper mattress cover onto the lower cover.
21. Plug the power supply into the wall socket and test the mattress for proper operation.

To replace the upper cover only:

1. Unzip and remove the old upper cover.
2. Unpack the new upper cover and lay it flat on the mattress, aligning the zipper properly.
3. Zip the upper cover onto the lower cover.

Air Bladder Replacement

Required Tools: None

Replacement Procedure:

1. Unplug the power supply from the wall socket.
2. Unzip and remove the upper mattress cover.
3. Remove and set aside the upper foam layer.
4. Unplug the hoses from the air bladder fittings.
5. Remove the air bladder from the mattress.
6. Install the new air bladder into the foam frame.
7. Install the hoses on the fittings of new air bladder.
8. Reinstall the upper foam layer, with the *pink side down*.
9. Reinstall the upper cover on the mattress with the “Head End” stamp at the head end of the mattress.
10. Zip the upper cover onto the lower cover.
11. Plug the power supply into the wall socket and test the mattress for proper operation.

Foam Base Assembly Replacement

Required Tools: Static Protection Equipment (see page 6–2)

Replacement Procedure:

1. Unplug the power supply from the wall socket.
2. Unzip and remove the upper mattress cover.
3. Remove and set aside the upper foam layer.
4. Disconnect the hoses from the air bladder. Remove the air bladder from the mattress and set it aside.
5. Properly ground yourself (see page 6–2 for static discharge precautions).
6. Disconnect the cables from the control unit. Remove the control unit and set it aside.
7. Remove entire foam base assembly.
8. Install the new foam base assembly with the cut–out for the control unit at the foot end of the cover.
9. Install the control unit into the new foam base.
10. Install the air bladder into the new base foam.
11. Reconnect the hoses to the fittings on the air bladder.
12. Route the cables along the patient left side of the foam assembly to the control unit.
13. Reconnect the cables to the control unit.
14. Push the cables down into the slit in the base foam assembly.
15. Reinstall the upper foam layer, *pink side down*.
16. Reinstall the upper cover on the mattress with the “Head End” stamp at the head end of the mattress.
17. Zip the upper cover onto the lower cover.
18. Plug the power supply into the wall socket and test the mattress for proper operation.

Control Unit Circuit Board Replacement

Required Tools:

Static Protection Equipment (see page 6–2) Standard Screwdriver Needle Nose Pliers
5/16" Socket Wrench or Nut Driver 3/16" Socket Wrench or Nut Driver

Replacement Procedure:

1. Unplug the power supply from the wall socket.
2. Unzip and remove the upper mattress cover.
3. Remove and set aside the upper foam layer.
4. Properly ground yourself (see page 6–2 for static discharge precautions).
5. Disconnect the cables from the control unit.
6. Disconnect the hoses from the air bladder.
7. Remove the control unit from the mattress.
8. Using a standard screwdriver, unsnap the cover of the control unit.
9. Unplug the power connector for the air compressor.
10. Remove the two 5/16" nuts holding the circuit board cover to the bottom cover of the control unit.
11. Remove the two 3/16" modified standoff screws holding the circuit board hand pendant port to the side of the bottom cover.
12. Remove the pressure switch hose from the circuit board.
13. Using needle nose pliers, squeeze the two standoffs holding the circuit board in place and lift up slightly on the circuit board from the circuit board end to remove the circuit board.
14. Reverse the above procedure to install the new circuit board.
15. Plug the power supply into the wall socket and test the mattress for proper operation.

Control Unit Air Compressor Replacement

Required Tools:

Standard Screwdriver

Replacement Procedure:

1. Unplug the power supply from the wall socket.
2. Unzip and remove the upper mattress cover.
3. Remove and set aside the upper foam layer.
4. Disconnect the cables from the control unit.
5. Disconnect the hoses from the air bladder.
6. Remove the control unit from the mattress.
7. Using a standard screwdriver, unsnap the cover of the control unit.
8. Unplug the power connector for the air compressor.
9. Unplug the pressure switch hose from the air compressor.

Control Unit Air Compressor Replacement (Continued)

10. Firmly grip the air compressor and lift it out of the control unit box (the air compressor is held down with double-faced tape).
11. Clean the double-faced tape off the bottom cover.
12. Remove the protective coating from the double-faced tape on the replacement air compressor.
13. Install the replacement air compressor into the control unit box. Press down firmly to secure the double-faced tape.
14. Reconnect the pressure switch hose to the air compressor.
15. Reconnect the power connector to the inside of the control unit box.
16. Snap the top cover onto the control unit.
17. Reinstall the control unit into the mattress.
18. Reconnect the hoses to the air bladder.
19. Reconnect the cables to the control unit.
20. Reinstall the upper foam layer.
21. Zip the upper cover onto the lower cover.
22. Plug the power supply into the wall socket and test the mattress for proper operation.

Control Unit Replacement

Required Tools:

Static Protection Equipment (see page 6–2)

Replacement Procedure:

1. Unplug the power supply from the wall socket.
2. Unzip and remove the upper mattress cover.
3. Remove and set aside the upper foam layer.
4. Properly ground yourself (see page 6–2 for static discharge precautions).
5. Disconnect the cables from the control unit.
6. Disconnect the hoses from the air bladder.
7. Remove the control unit from the mattress.
8. Install the new control unit into the mattress.
9. Connect the cables to the new control unit.
10. Reconnect the hoses to the air bladder.
11. Push the cables down into the slit in the base foam assembly.
12. Reinstall the upper foam layer, *pink side down*.
13. Reinstall the upper cover on the mattress with the “Head End” stamp at the head end of the mattress.
14. Zip the upper cover onto the lower cover.
15. Plug in the power supply and test the mattress for proper operation.

GENERAL INFORMATION

This section contains assembly drawings and parts lists to assist with the identification of individual components of the equipment and accessories.

In the parts lists, the words “right” and “left” refer to the right and left sides of a patient lying face up on the bed.

ASSEMBLY DRAWINGS AND PARTS LISTS CONTENTS

Base Assembly 11-3 – 11-11

Lift Assembly 11-12

Common Lift Assembly 11-13 – 11-15

Isolation Plate Assembly 11-16

Brake Cam Assembly 11-16

Brake Crank Assembly 11-17

Brake Bar Assembly 11-18

Brake Shaft Assembly 11-19

6” Caster Assembly 11-20

6” Steer Caster Assembly 11-21

6” Wheel Assembly 11-22

8” Caster Assembly 11-23

8” Steer Caster Assembly 11-24

8” Wheel Assembly 11-25

Litter Assembly 11-26 – 11-38

Head End Siderail Assembly 11-39 – 11-53

Head End Siderail Timing Link Assembly 11-54, 11-55

Head End Siderail Inner Panel Assembly 11-56

Head End Siderail Outer Panel Assembly 11-57

Head End Siderail DMS Module Assembly 11-58

Head End Siderail Smart TV Module Assembly 11-59, 11-60

Head End Siderail TV Control Module Assembly 11-61, 11-62

Foot End Siderail Assembly 11-63 – 11-66

Foot End Siderail Timing Link Assembly 11-67, 11-68

Head Board Assembly 11-69

ASSEMBLY DRAWINGS AND PARTS LISTS CONTENTS (CONTINUED)

Foot Board Assembly	11-70 – 11-75
Foot Board Main Module Assembly	11-76
Foot Board CPR Drop/Cardiac Chair Module Assembly	11-77
Foot Board Bed Exit Module Assembly	11-78
Pendant Assembly	11-79
Removable I.V. Pole Assembly	11-80
2-Stage I.V. Mounting Assembly, Foot End	11-81
2-Stage I.V. Mounting Assembly, Head End	11-82
2-Stage I.V. Mounting Assembly, Dual Head End	11-83
2-Stage I.V. Pole Assembly	11-84
I.V. Pole Latch Assembly	11-85
Fowler X-Ray Cassette Holder Assembly	11-86
Siderail Transducer Mount Assembly	11-87
I.V. Pole Transducer Mount Assembly	11-88
Upright Oxygen Bottle Holder Assembly	11-89
Defibrillator Tray Assembly	11-90
Optional Bed Extender Pad	11-91

Base Assembly – Epic & Epic+

Assembly part number 3001-200-3 (reference only)

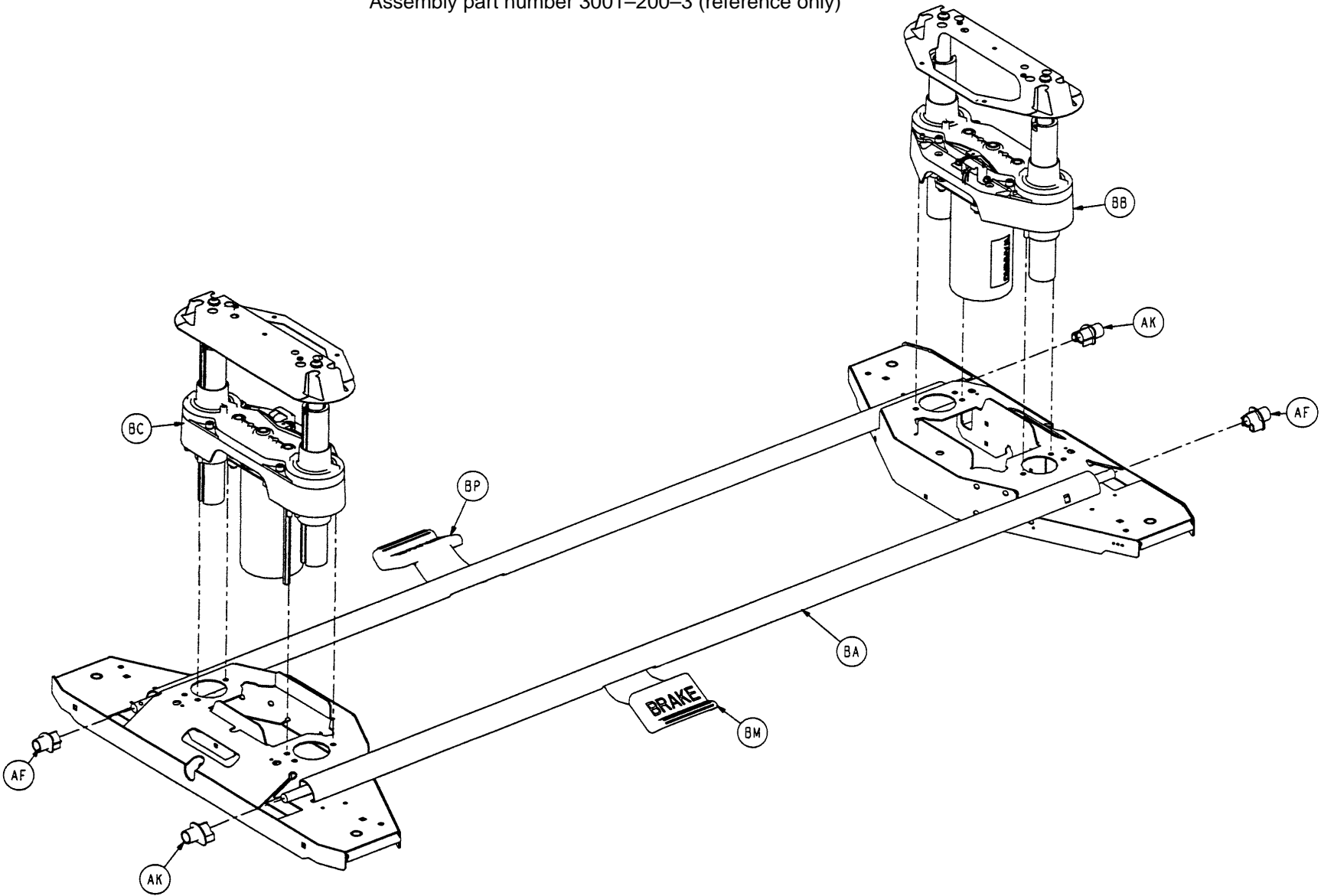

Base Assembly

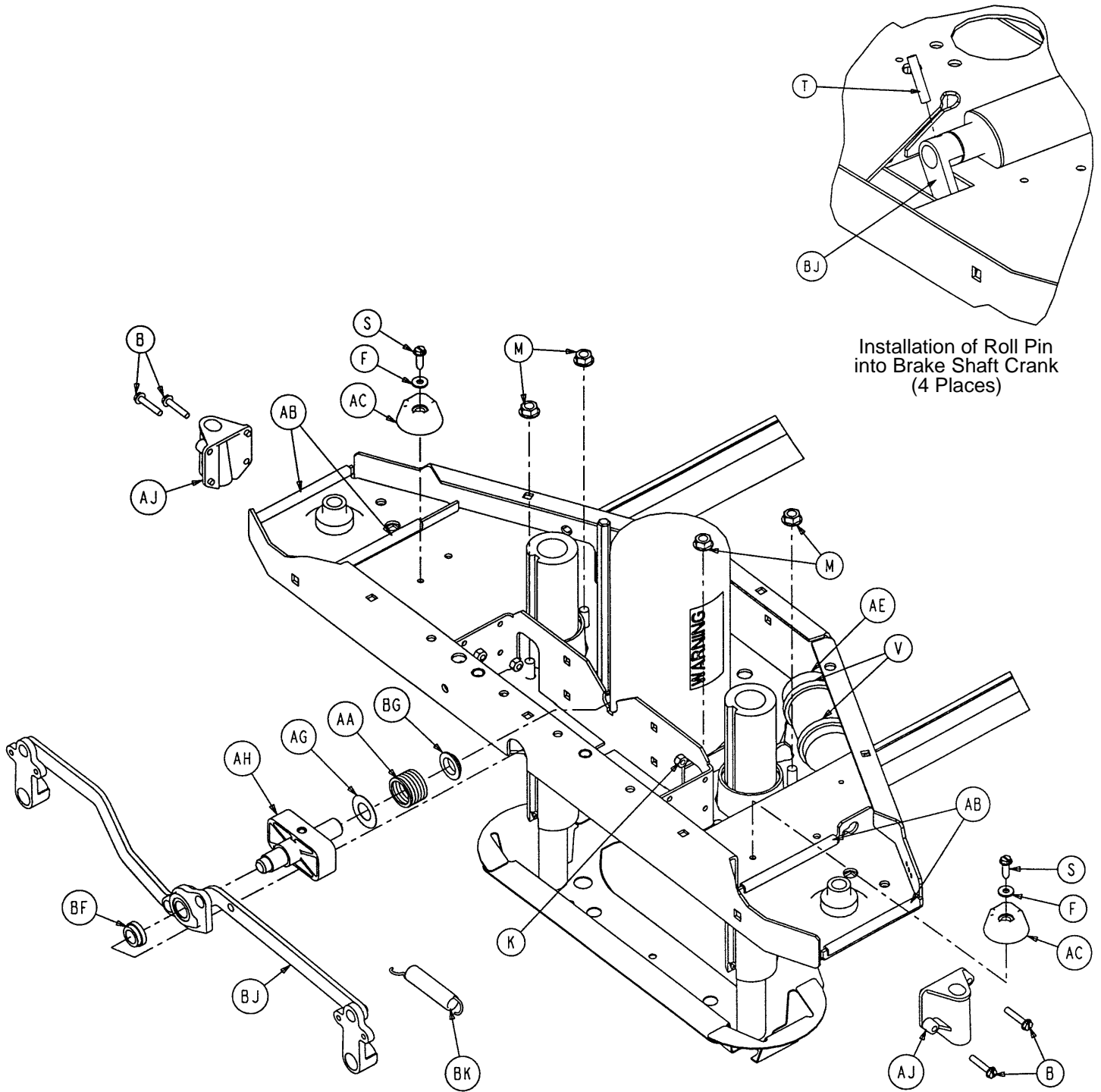

Base Assembly - Epic & Epic+

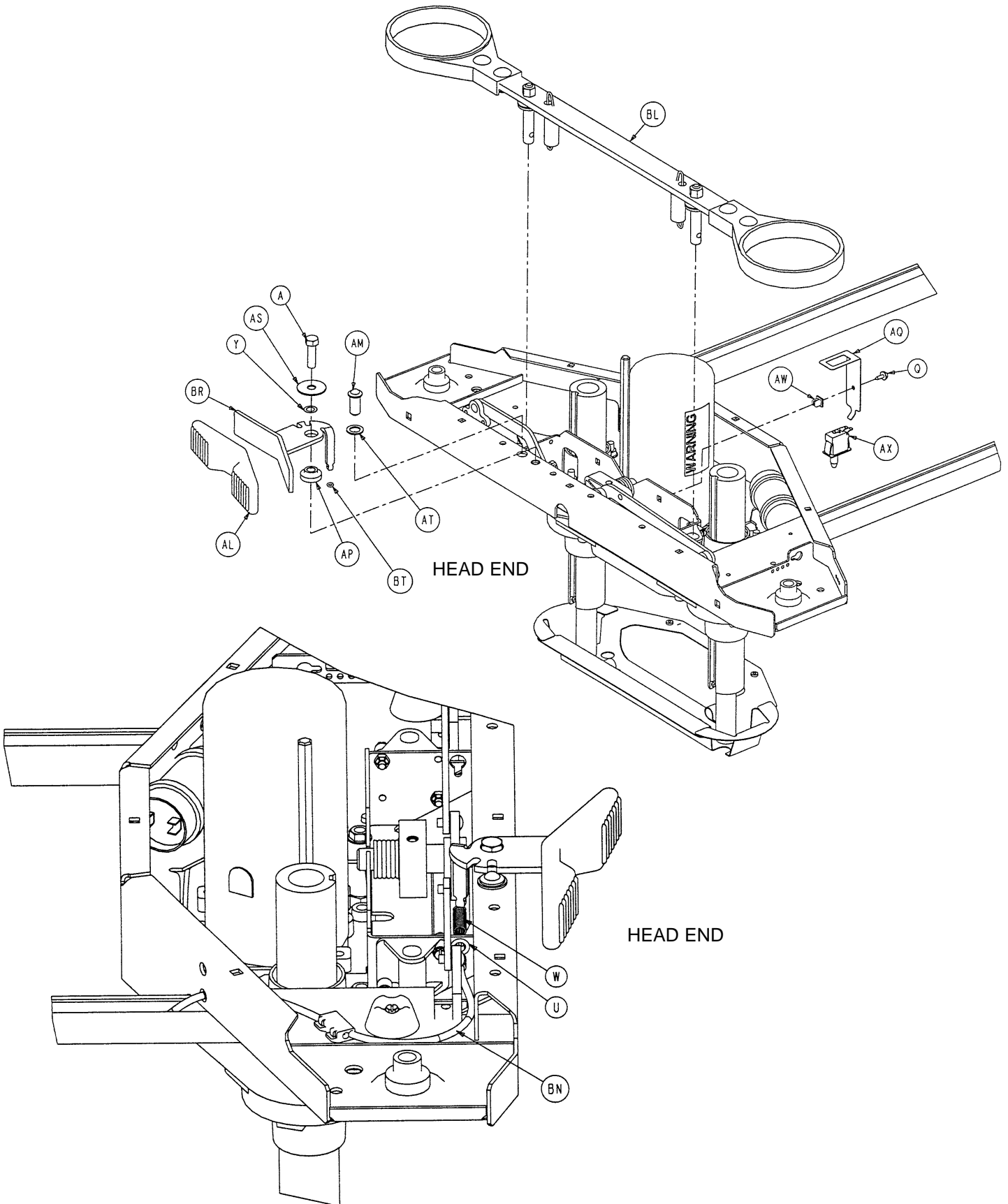

Base Assembly

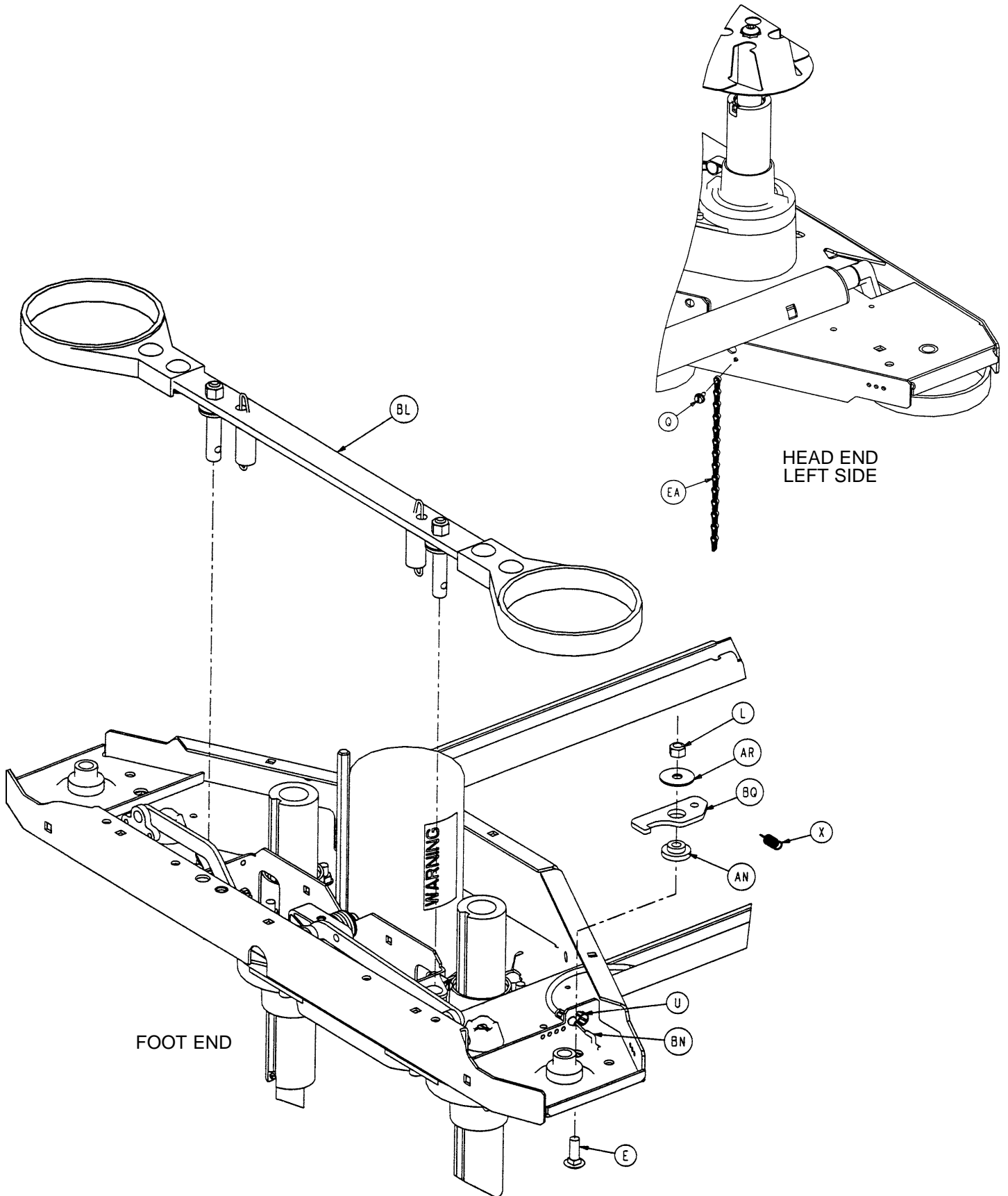

Base Assembly – Epic & Epic+

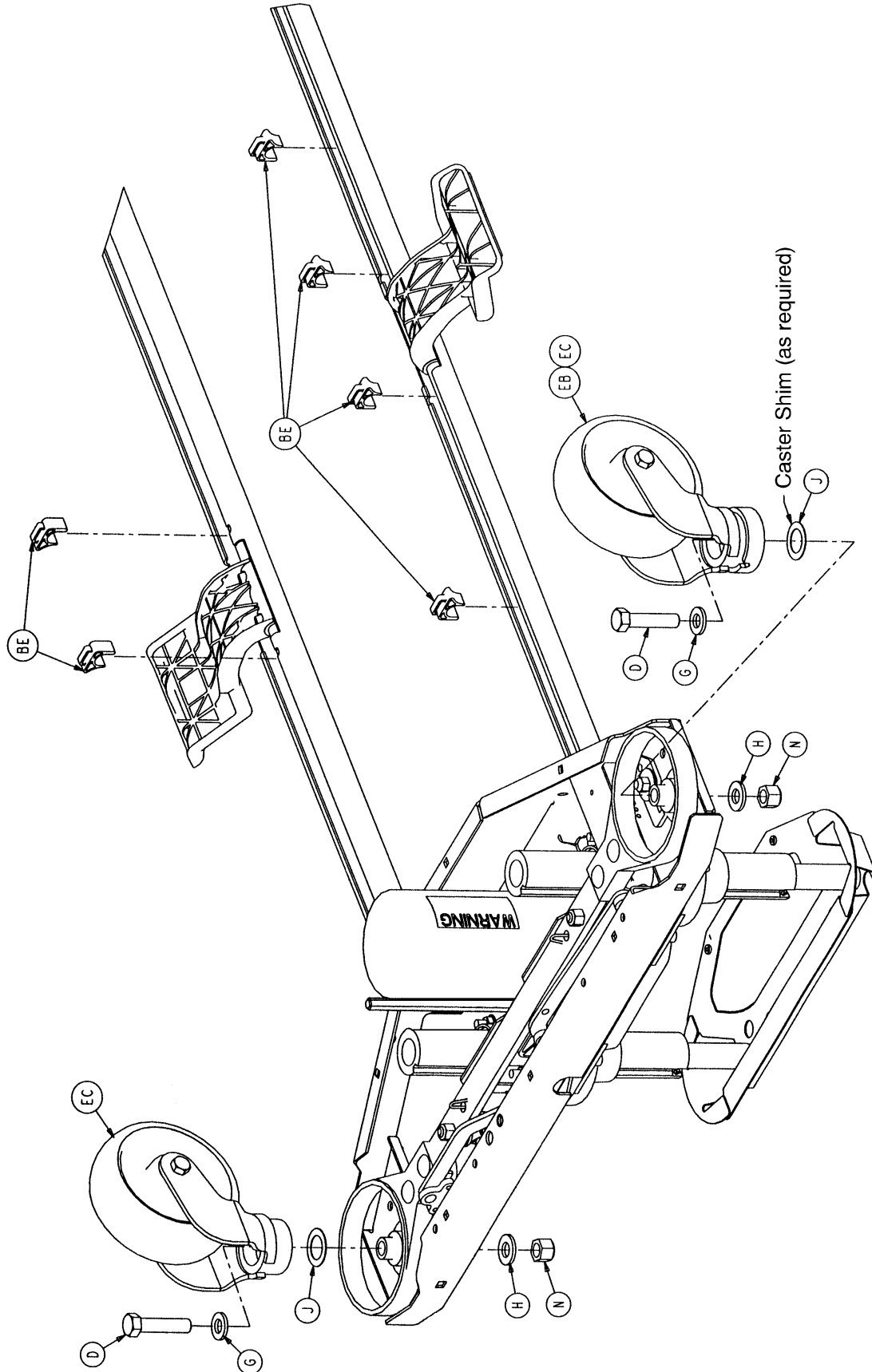

Base Assembly

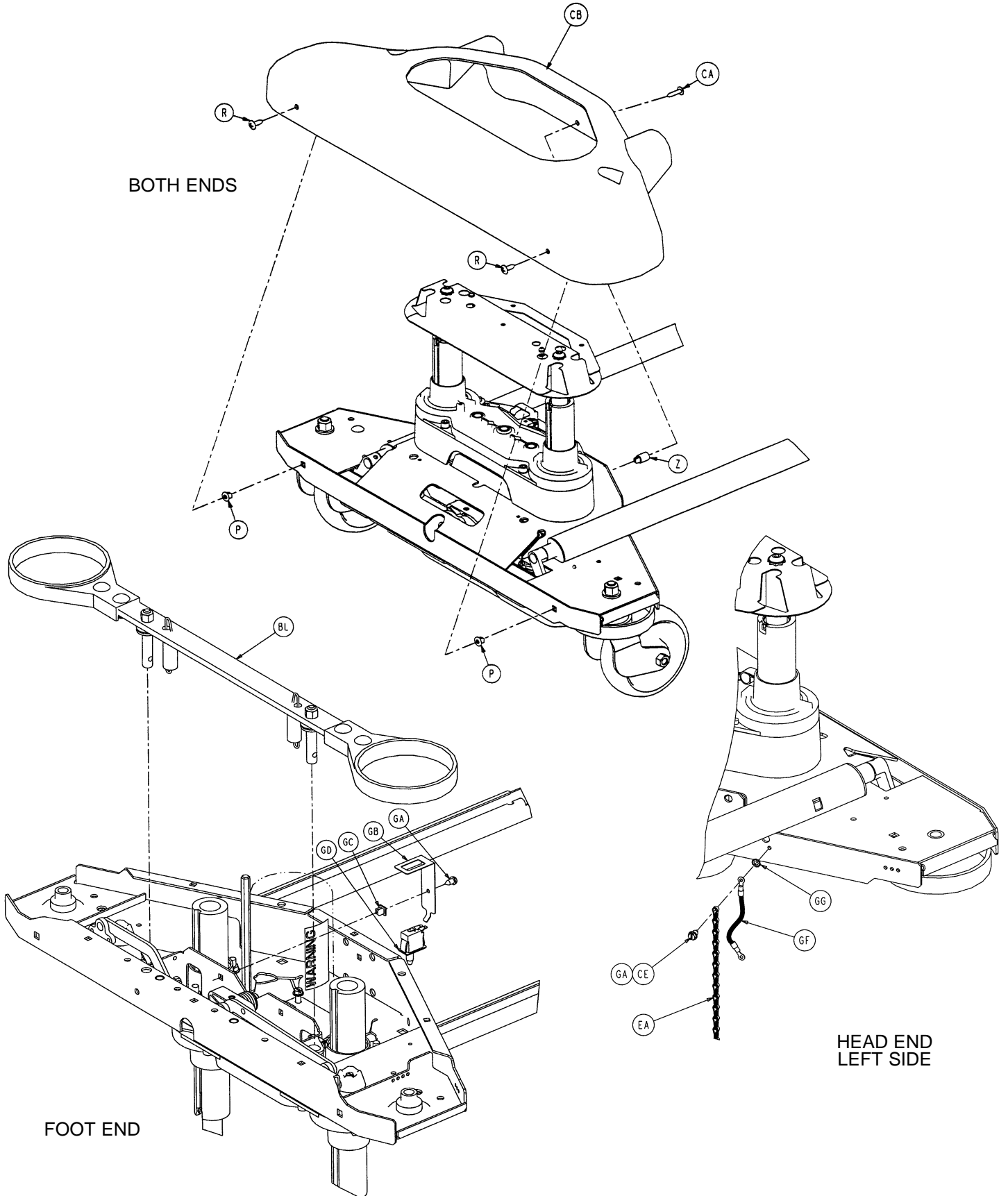

Base Assembly - Epic & Epic+

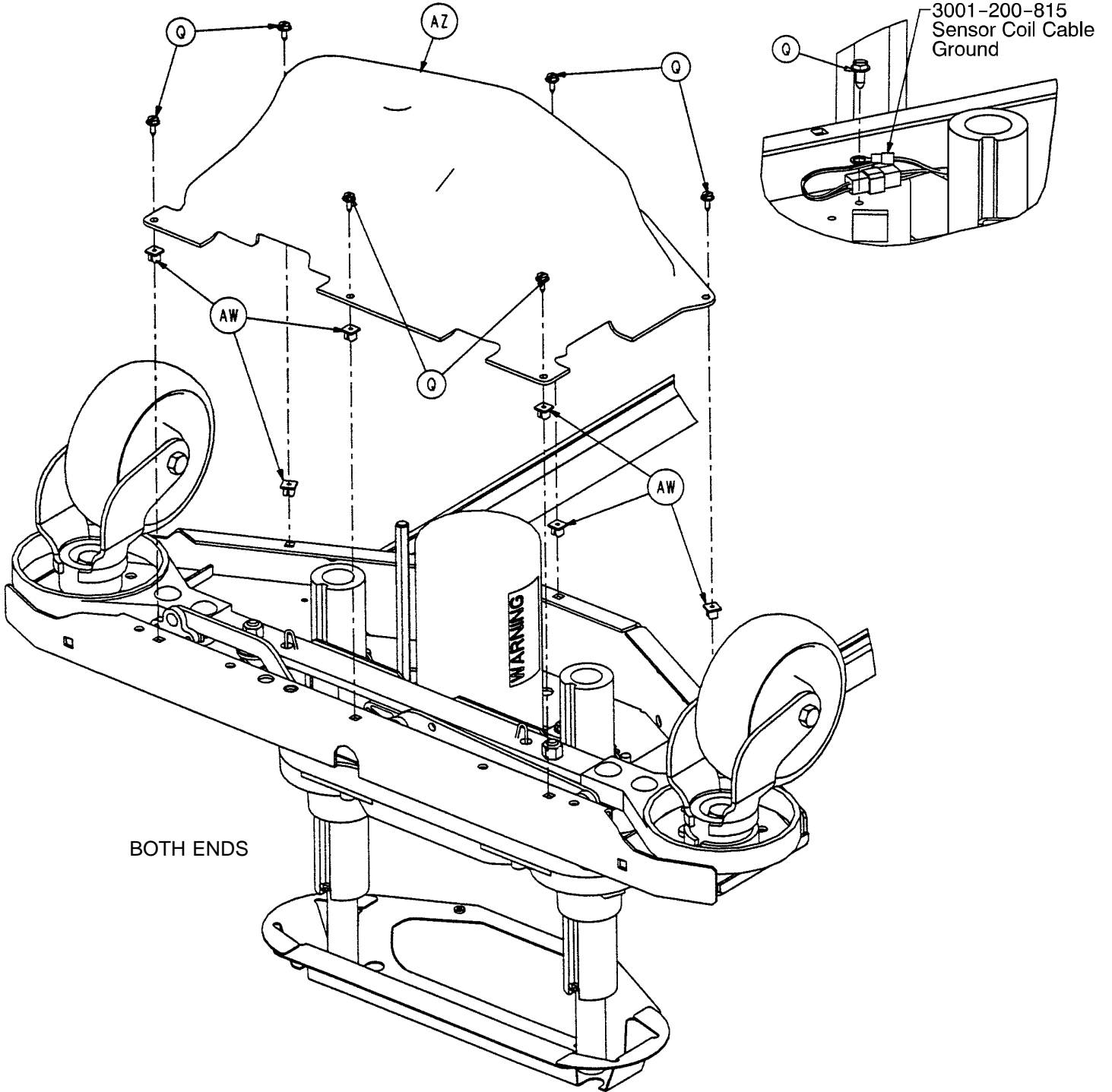

Base Assembly

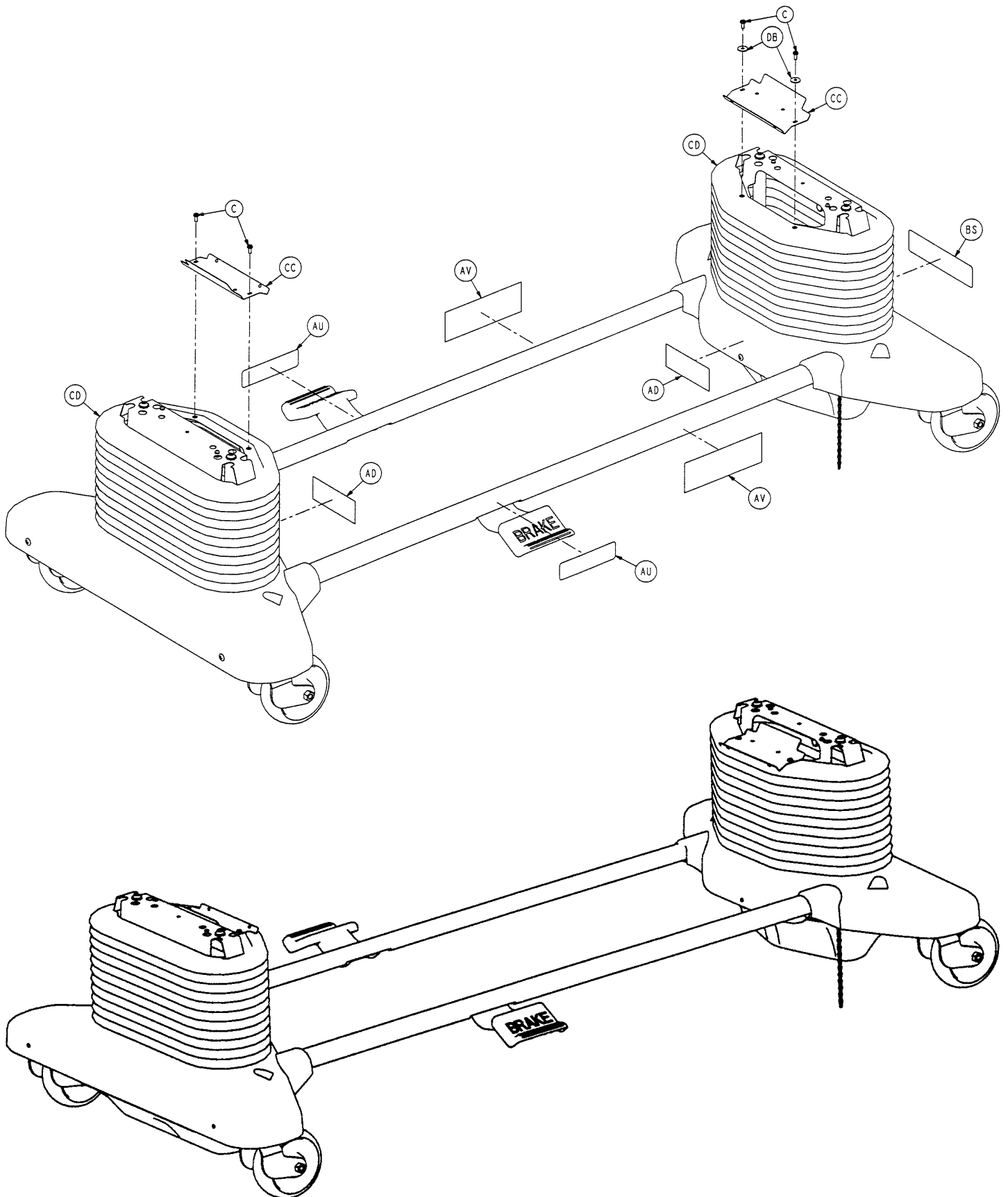

Base Assembly – Epic & Epic+

Item	Part No.	Part Name	Qty.	Item	Part No.	Part Name	Qty.
A	3-349	Hex Hd. Cap Screw	1	AU	3000-200-601	Brake Pedal Label	2
B	3-122	Hex Washer Hd. Screw	8	AV	3000-200-602	Stryker Logo Label	2
C	3-224	Hex Washer Hd. Screw	4	AW	3000-300-2	Plastic Clip Nut	13
D	3-333	Hex Hd. Cap Screw	4	AX	3000-300-58	Plunger Switch	1
E	5-20	Carriage Bolt	1	AY	3000-300-113	Cable Tie	6
F	11-302	Flat Washer	4	AZ	3001-200-20	Bottom Cover	2
G	11-310	Washer	4	BA	3001-200-102	Base Weldment	1
H	11-333	Flat Washer	4	BB	(page 11-12)	Head End Lift Ass'y	1
J	11-417	Washer	4	BC	(page 11-12)	Foot End Lift Ass'y	1
K	16-2	Nylock Nut	8	BE	3001-200-306	Brake Pedal Shaft Brg.	6
L	16-11	Nylock Nut	1	BF	3001-200-317	Brake Cam Shaft Bshg.	2
M	16-98	Hex Flange Nut	8	BG	3001-200-321	Brake Cam Shaft Bshg.	2
N	16-104	Nylock Nut	4	BJ	(page 11-17)	Brake Crank Ass'y	2
P	18-36	Plastic Clip Nut	4	BK	3001-200-334	Brake Return Spring	2
Q	23-25	Hex Washer Hd. Screw	16	BL	(page 11-18)	Brake Bar Assembly	2
R	23-92	Phillips Truss Hd. Screw	4	BM	(page 11-19)	Brake Shaft Ass'y, Left	1
S	23-101	Hex Washer Hd. Screw	4	BN	3001-200-342	Steer Cable Assembly	1
T	26-14	Roll Pin	4	BP	(page 11-19)	Brake Shaft Ass'y, Right	1
U	30-52	Snap Bushing	2	BQ	3001-200-370	Steer Lock Lever	1
V	38-151	Cable Tie	4	BR	3001-200-371	Steer Pedal Arm	1
W	38-414	Pedal Extension Spring	1	BS	5000-90-13	Steer Label	1
X	38-416	Lever Extension Spring	1	BT	45-8	O-Ring	1
Y	52-305	Flat Washer	1	CA	23-264	Truss Hd. Screw	2
Z	52-800	Mounting Standoff	2	CB	3000-200-9	Uni-Pan Cover	2
AA	52-812	Cam Shaft Spring	2	CC	3001-200-8	Bellows Bracket	2
AB	3001-200-14	Edge Strip	8	CD	2030-000-101	Bellows	2
AC	59-746	Mounting Feet	4	EA	715-1-156	6" Ground Chain	1
AD	988-2-708	Caution Label	2		3001-200-53	8" Ground Chain (Option)	1
AE	59-778	Lift Motor Capacitor	2	EB	(page 11-21)	6" Steer Caster	1
AF	3000-200-305	Brake Shaft Bshg., Rt.	2		(page 11-24)	8" Steer Caster (Option)	1
AG	3000-200-311	Cam Shaft Thrust Washer	2	EC	(page 11-20)	6" Caster	3
AH	(page 11-16)	Brake Cam Assembly	2		(page 11-23)	8" Caster (Option)	3
AJ	3000-200-328	Brake Guide Bushing	4	FA	2025-1-47	Caster Cover, Right	4
AK	3000-200-331	Brake Shaft Bshg., Lt.	2	FB	2025-1-48	Caster Cover, Left	4
AL	3000-200-336	Rubber Steer Pedal	1	GA	23-25	Hex Washer Hd. Screw	2
AM	3000-200-337	Push Fit Ball Plunger	1	GB	3000-200-343	Brake Switch Bracket	1
AN	3000-200-339	Steer Lock Lever Bshg.	1	GC	3000-300-2	Plastic Clip Nut	1
AP	3000-200-341	Steer Pedal Bushing	1	GD	3000-300-58	Plunger Switch	1
AQ	3000-200-343	Brake Switch Bracket	1	GE	3001-200-306	Brake Pedal Shaft Brg.	2
AR	3000-200-347	Special Washer	1	GF	2025-31-805	Ground Strap	1
AS	3000-200-348	Special Wide Washer	1	GG	13-18	Ext. Tooth Lock Washer	1
AT	3000-200-349	Special Narrow Washer	1				

Epic+ Base Option Assembly

Assembly part number
2030-1-210 (reference only)

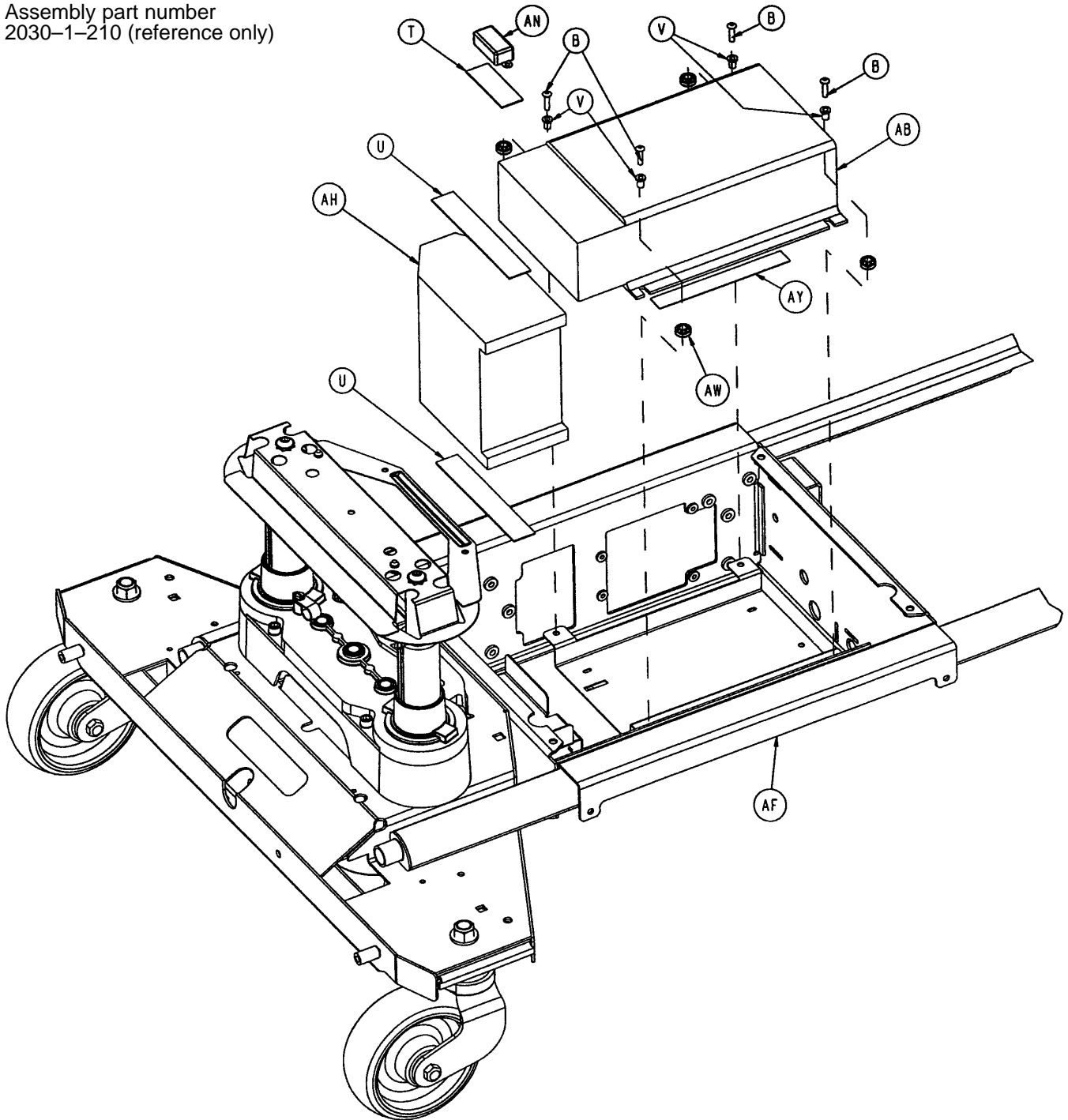

Epic+ Base Option Assembly

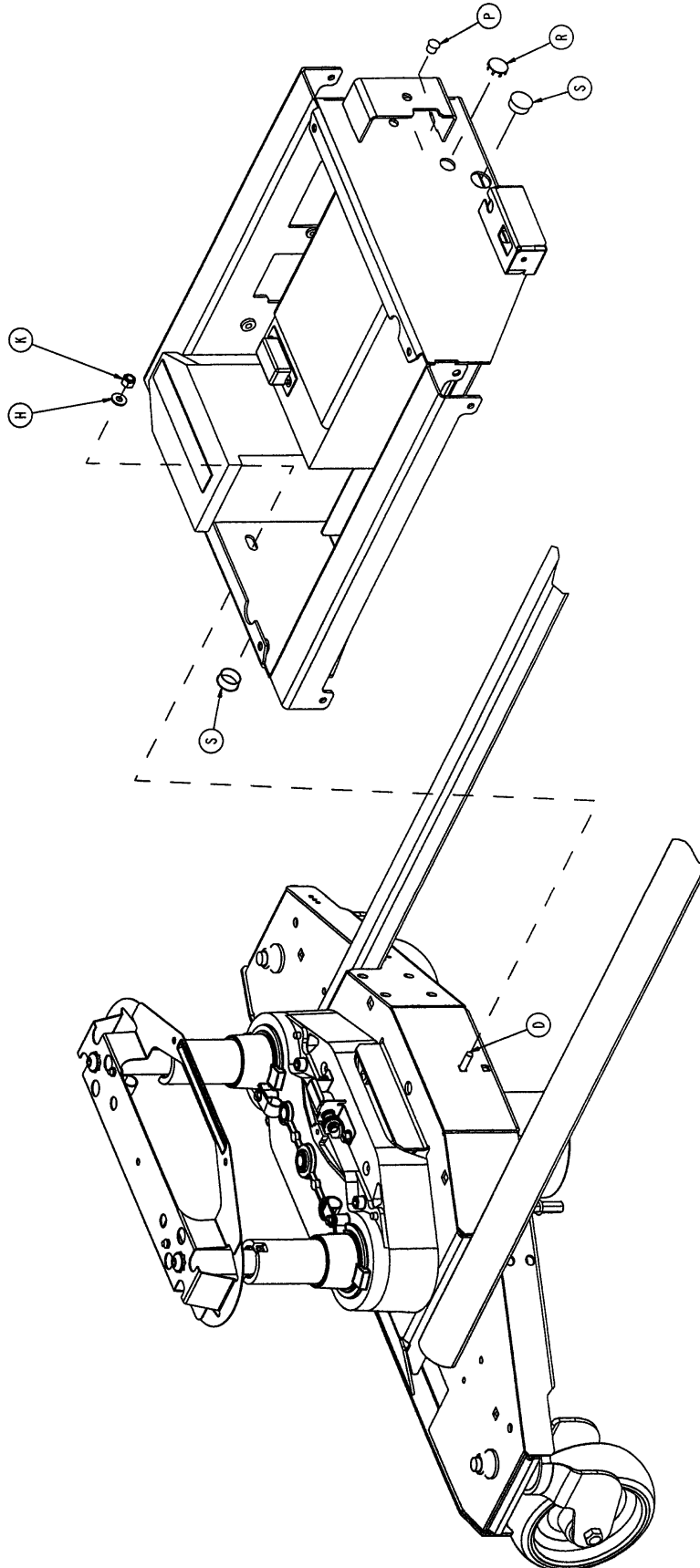

Epic+ Base Option Assembly

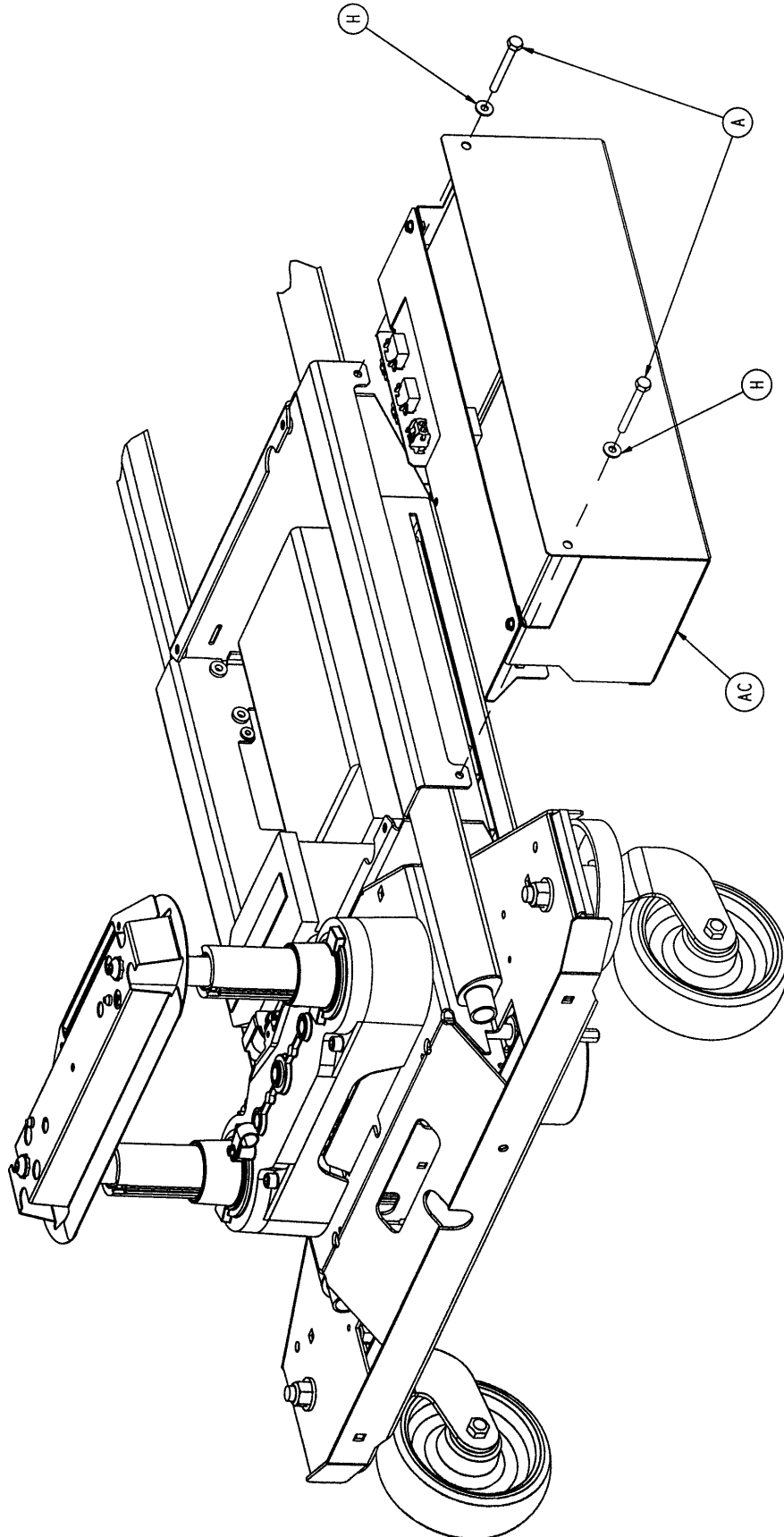

Epic+ Base Option Assembly

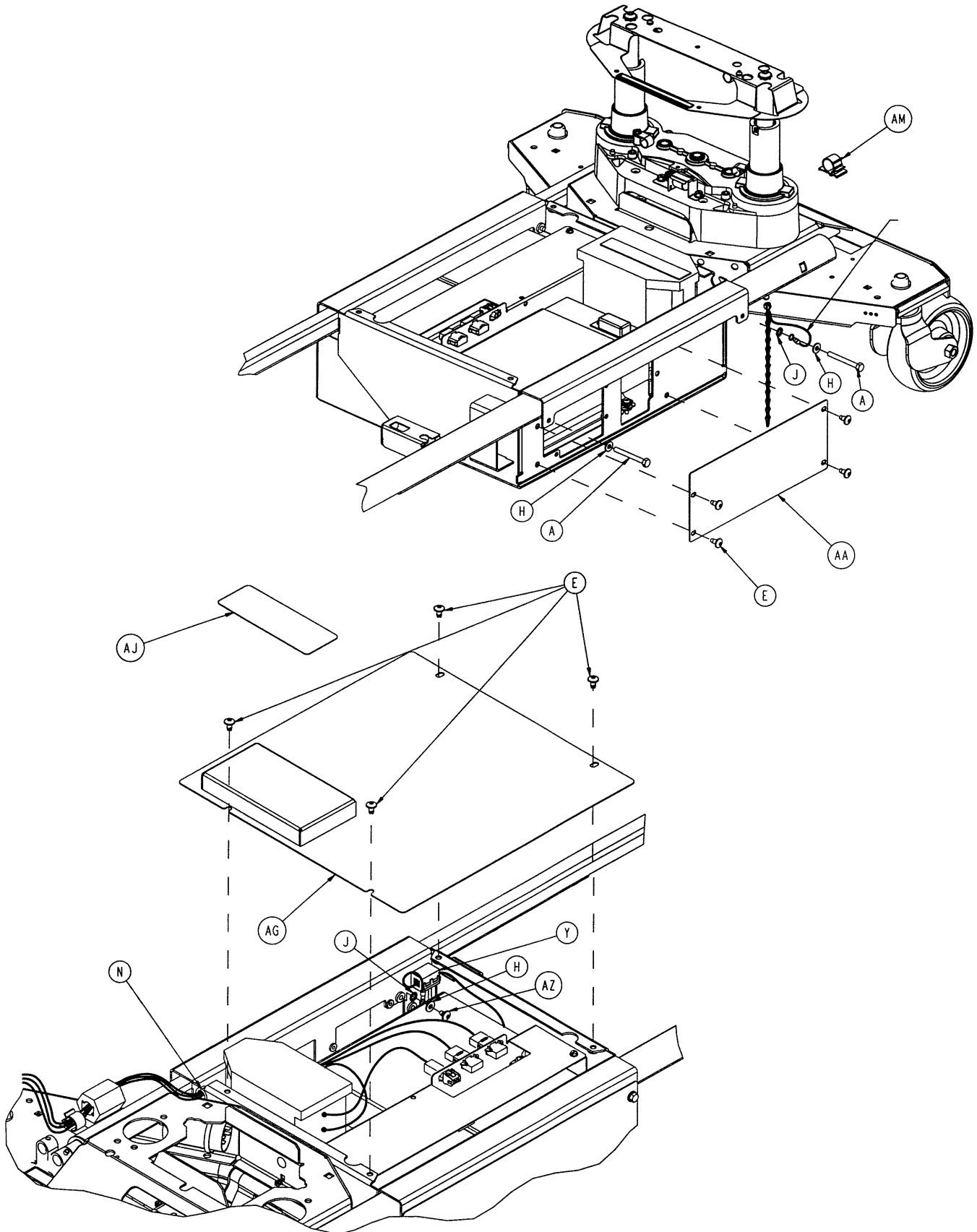

Epic+ Base Option Assembly

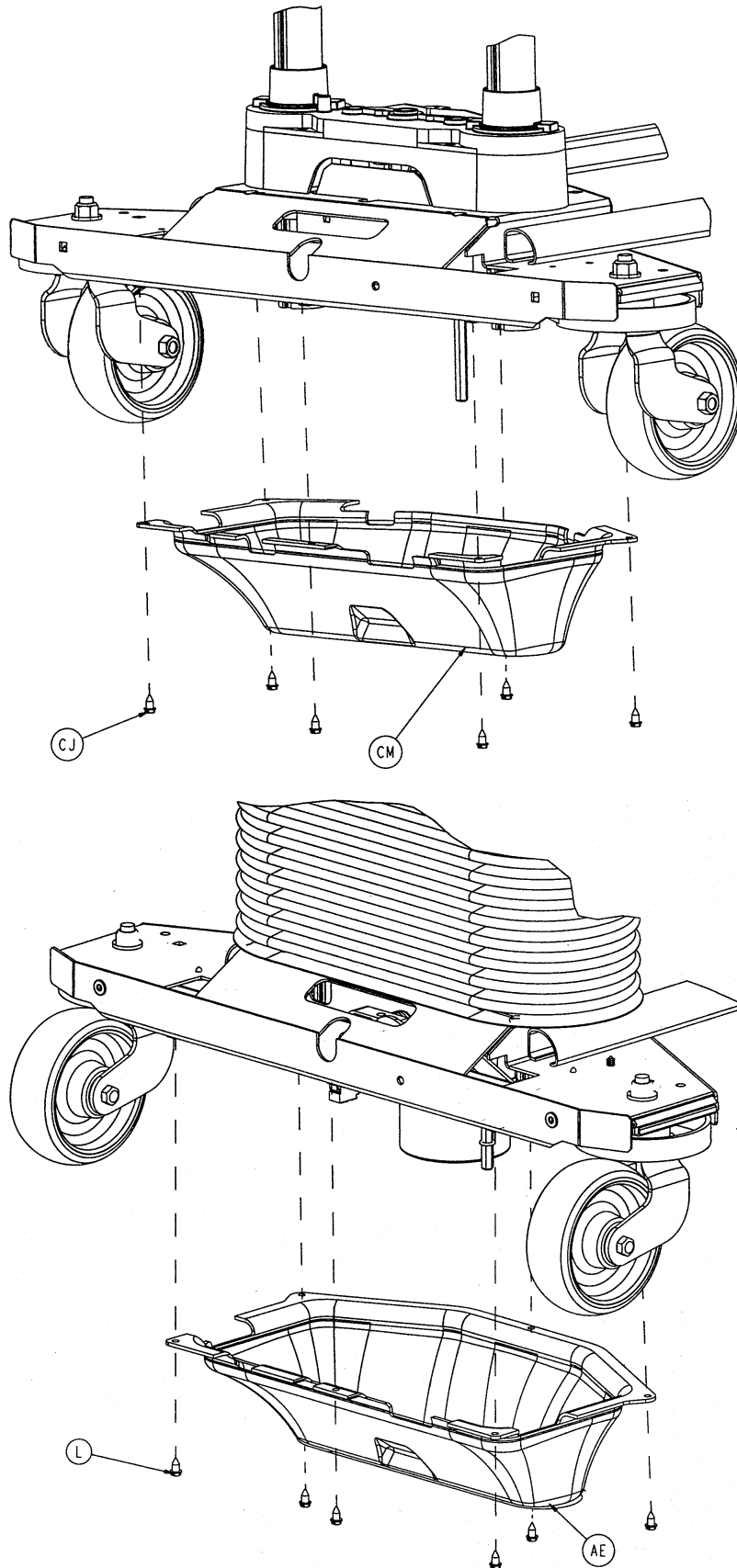

Epic+ Base Option Assembly

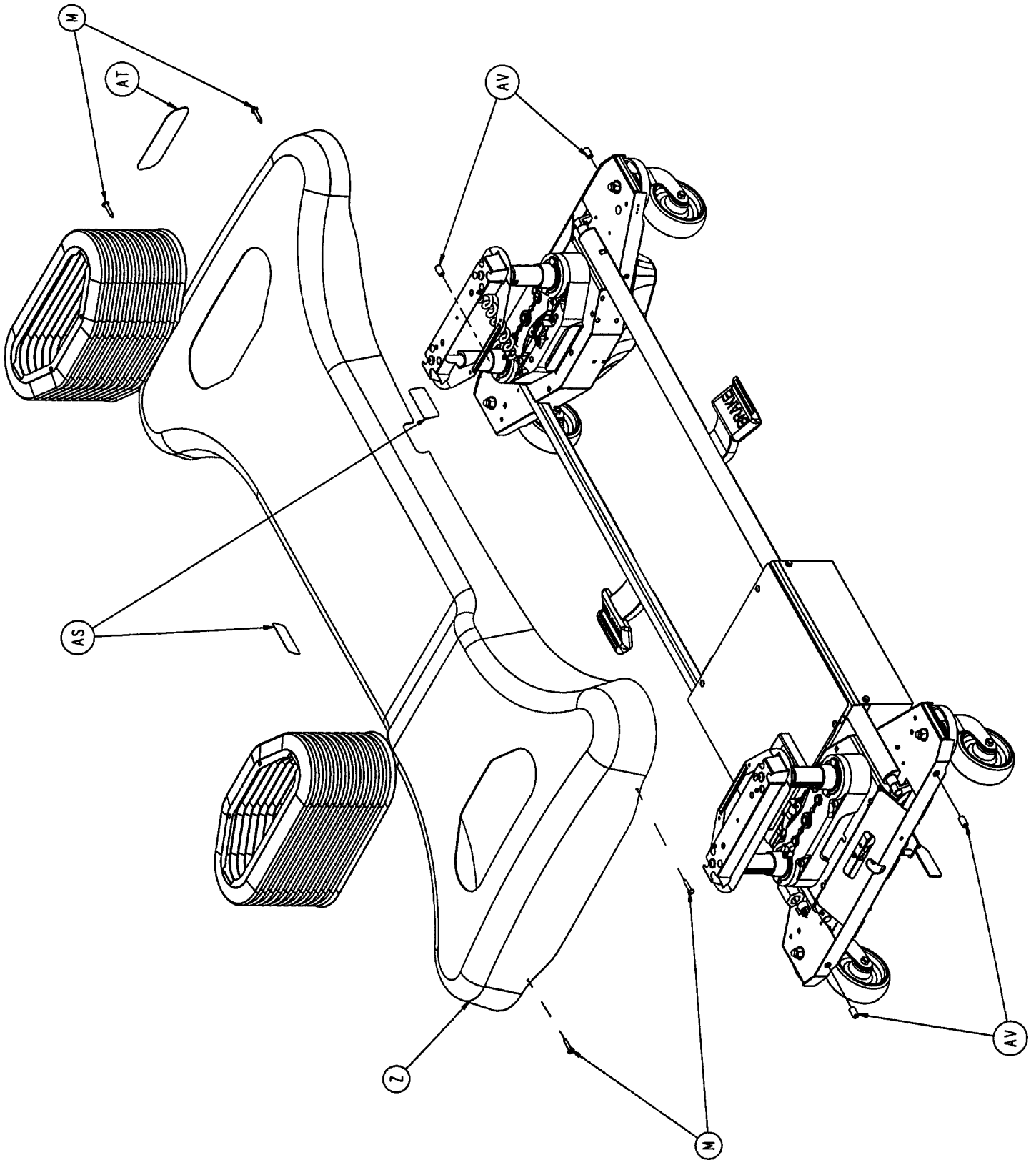

Epic+ Base Option Assembly

Item	Part No.	Part Name	Qty.
A	3-32	Hex Hd. Cap Screw	4
B	4-278	But. Hd. Cap Screw	4
C	4-307	Socket But. Hd. Cap Screw	1
D	5-17	Carriage Bolt	1
E	7-52	Truss Hd. Torx	8
F	7-58	Truss Hd. Torx	2
G	11-4	Washer	6
H	11-63	Washer	7
J	13-10	External Tooth Star Washer	3
K	16-28	Nylock Nut	1
L	23-25	Hex Washer Hd. Screw	10
M	23-281	Truss Hd. Self Tapping Screw	4
N	30-38	Split Bushing	1
P	37-35	Hole Plug	1
R	37-221	Hole Plug	1
S	37-230	Hole Plug	2
T	44-29	Double-Sided Foam Tape (2.75")	1
U	44-29	Double-Sided Foam Tape (6")	2
V	52-313	Finishing Shoulder Washer	4
W	59-133	Push-Mount Wire Clip	1
X	59-192	Split Ferrite	2
Y	59-194	Split Ferrite	3
Z	2030-1-5	Hood	1
AA	2030-1-6	Electrical Cover Plate	1
AB	(page 11-11.8)	Inverter Assembly	1
AC	(page 11-11.9)	Battery Tray Assembly	1
AD	(page 11-11.11)	Foot End Bottom Cover	1
AE	(page 11-11.11)	Head End Bottom Cover	1
AF	2040-1-50	Charger Box Weldment	1
AH	2040-1-66	Battery Charger Assembly	1
AJ	2040-1-101	Charger Box Cover Label	1
AK	2040-1-103	Charger Box Switch Bracket Cover	1
AL	2040-1-104	Power Board Insulator Label	1
AM	2040-1-804	Power Board DC Power Cable	1
AN	2040-1-811	Inverter Filter Cable Assembly	1
AP	2040-200-5	Base Assembly	1
AR	2040-201-809	Umbilical Cable Assembly	1
AS	3000-200-601	Brake Label	2
AT	3000-200-602	Stryker Label	1
AU	3000-300-113	Wire Tie	4
AV	3000-300-428	Gatch Link Sleeve	4
AW	3000-300-442	EAR Grommet	4
AX	7000-1-326	Single-Sided Foam Tape (10")	2
AY	7000-1-326	Single-Sided Foam Tape (6")	1
AZ	7-53	Truss Hd. Torx	1

2040-1-11 Inverter Assembly

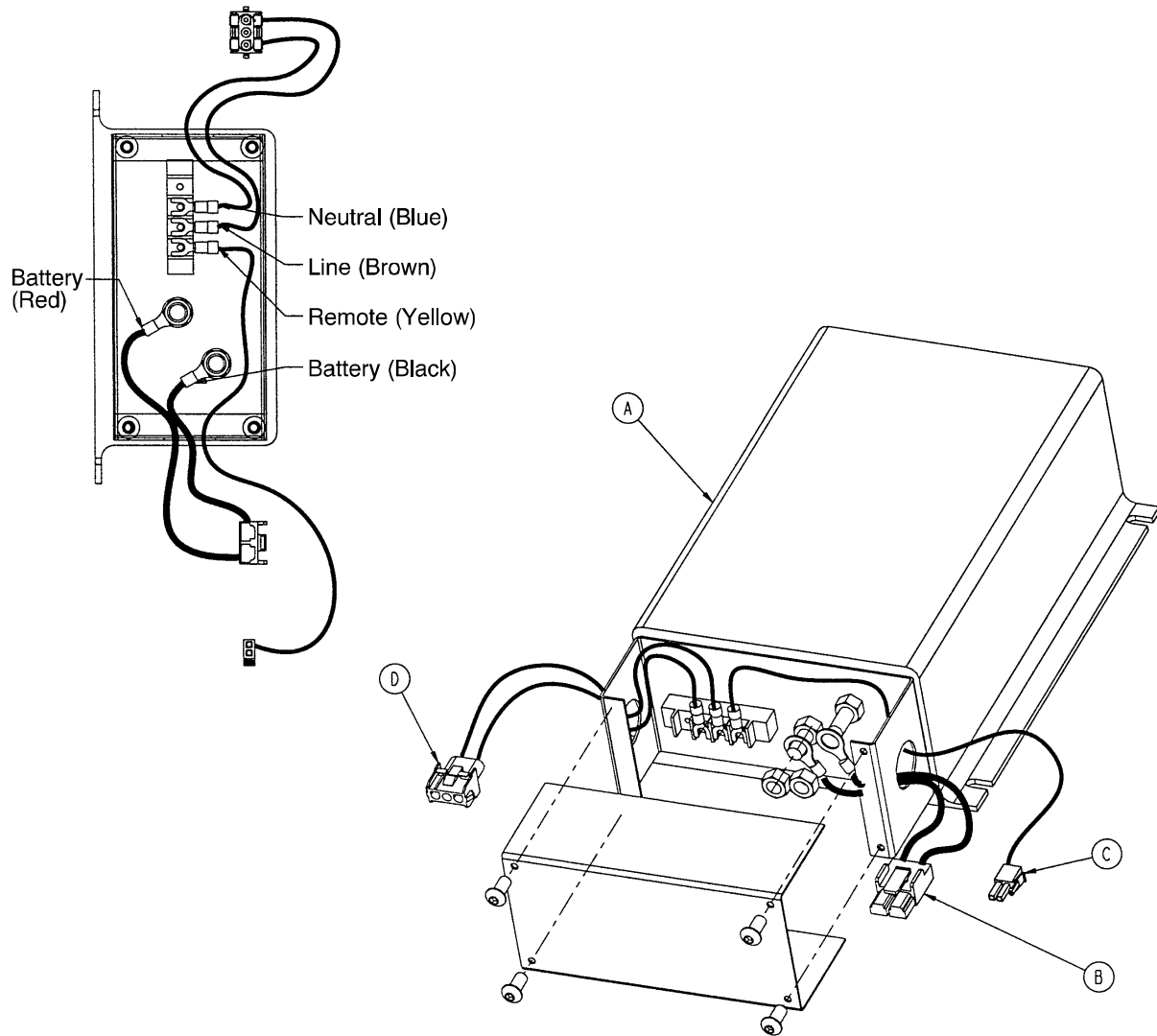

Item	Part No.	Part Name	Qty.
A	2040-1-76	Inverter	1
B	2040-1-805	Inverter DC Power Cable	1
C	2040-1-807	Inverter Remote Cable	1
D	2040-1-808	Inverter AC Jumper	1

2040-1-15 Battery Tray Assembly

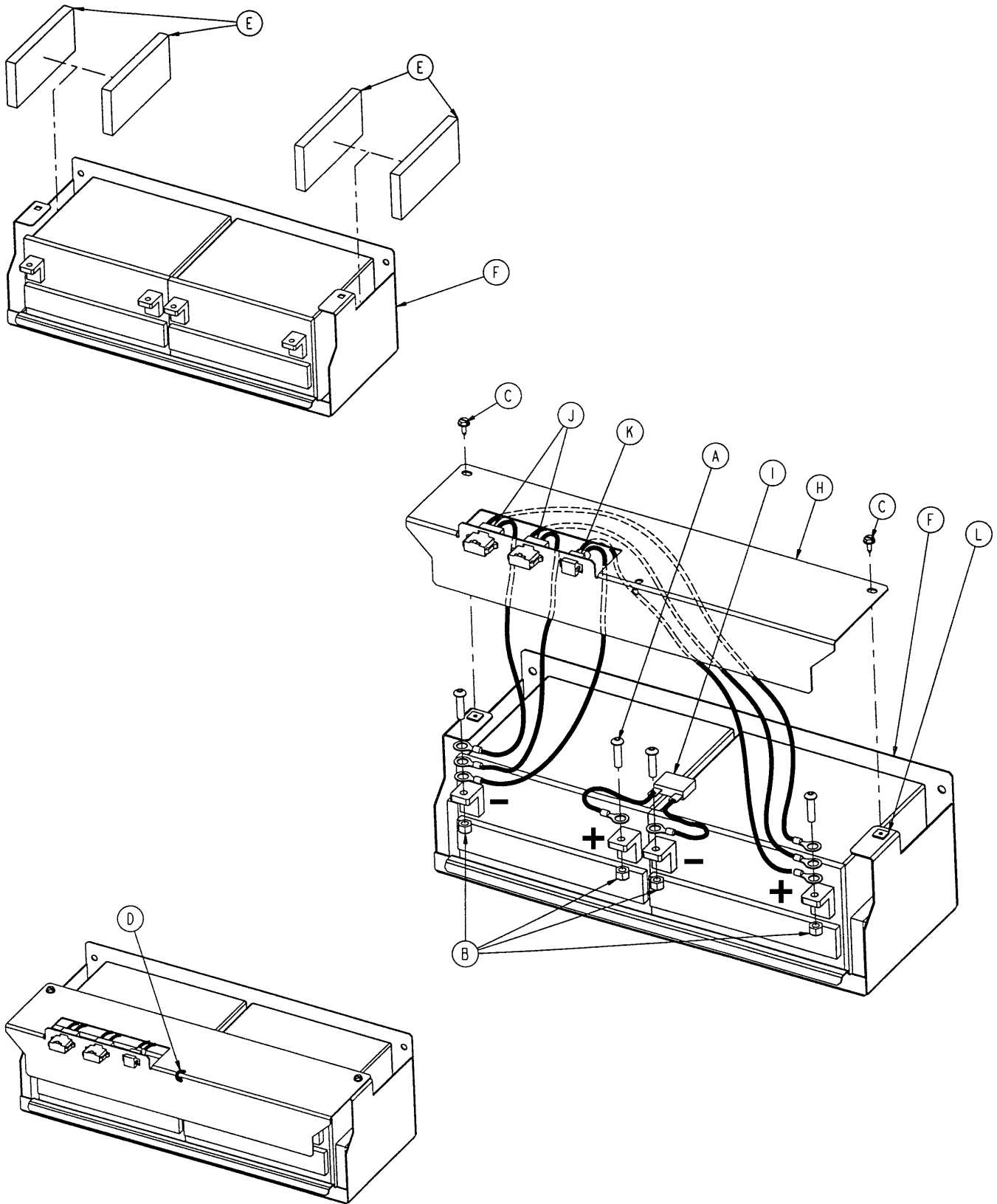

2040–1–15 Battery Tray Assembly

Item	Part No.	Part Name	Qty.
A	4–46	But. Hd. Cap Screw	4
B	16–28	Nylock Nut	4
C	23–25	Hex Washer Hd. Tap. Screw	2
D	38–151	Cable Tie	1
E	5000–101–43	Foam Block	4
F	2040–1–69	Battery Tray	1
H	2040–1–91	Terminal Guard	1
I	2040–1–802	Battery Jumper Cable	1
J	2040–1–803	Battery Harness Cable	2
K	2040–1–810	Charger DC Jumper Cable	1
L	3000–300–2	#10 Screw Push Nut	2

Note: complete assembly (part number 2040–1–15) must be ordered if battery replacement is required.

2040-1-16 Foot End Bottom Cover

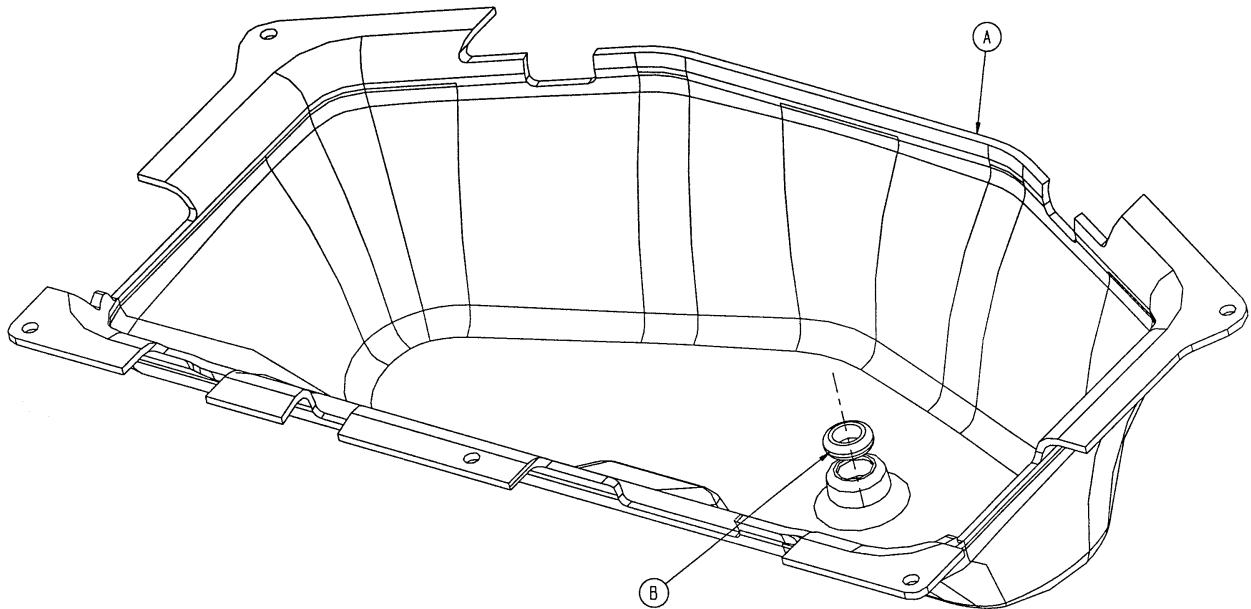

Item	Part No.	Part Name	Qty.
A	2040-1-78	Foot End Bottom Cover	1
B	3000-000-039	Grommet	1

2040-1-17 Head End Bottom Cover

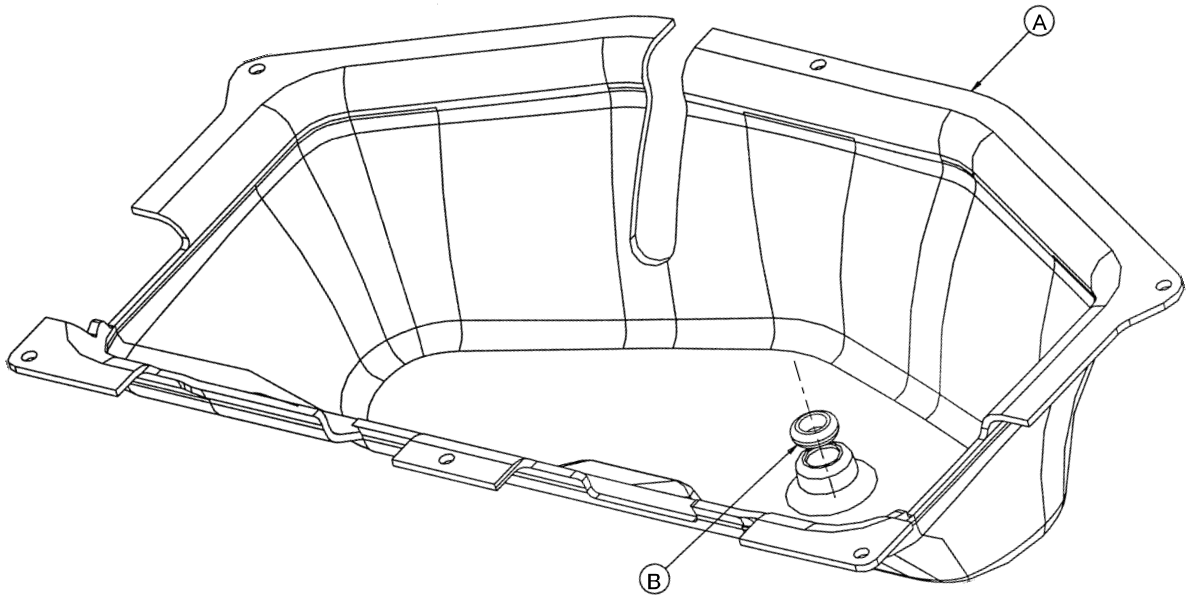

Item	Part No.	Part Name	Qty.
A	2040-1-79	Head End Bottom Cover	1
B	3000-000-039	Grommet	1

Notes

Lift Assembly (Head and Foot End)

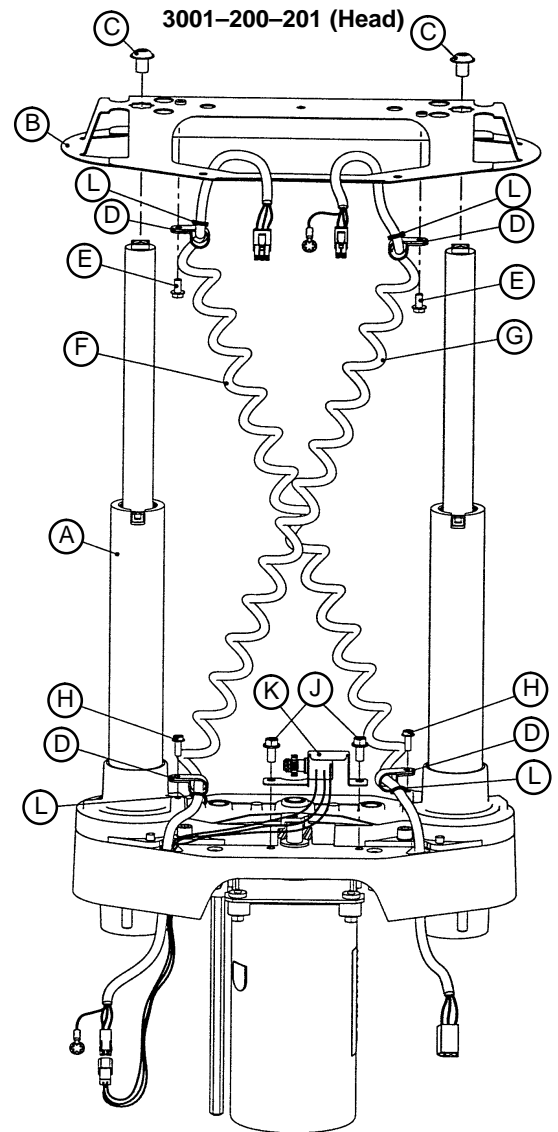
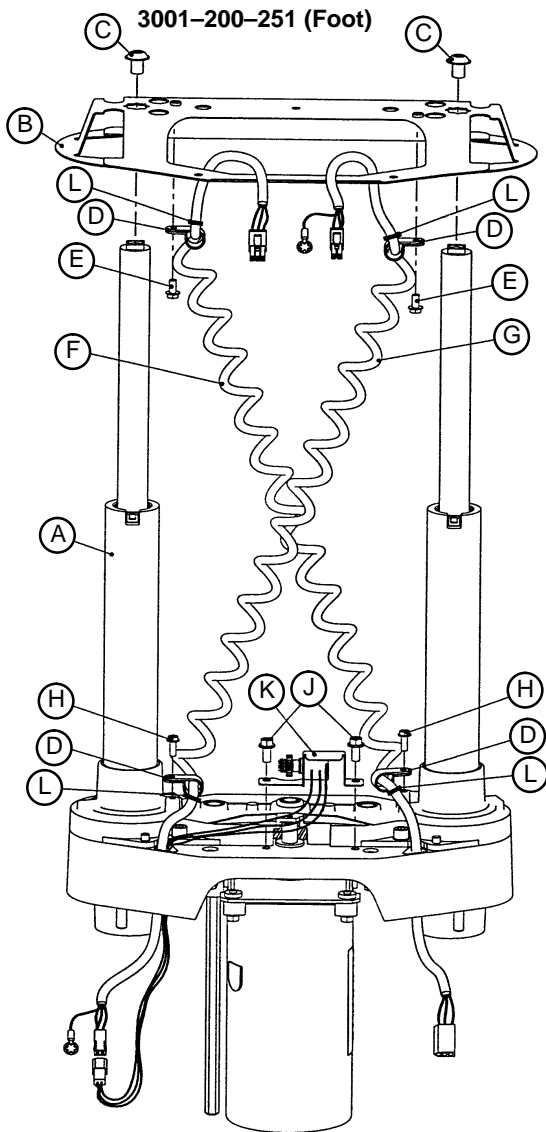
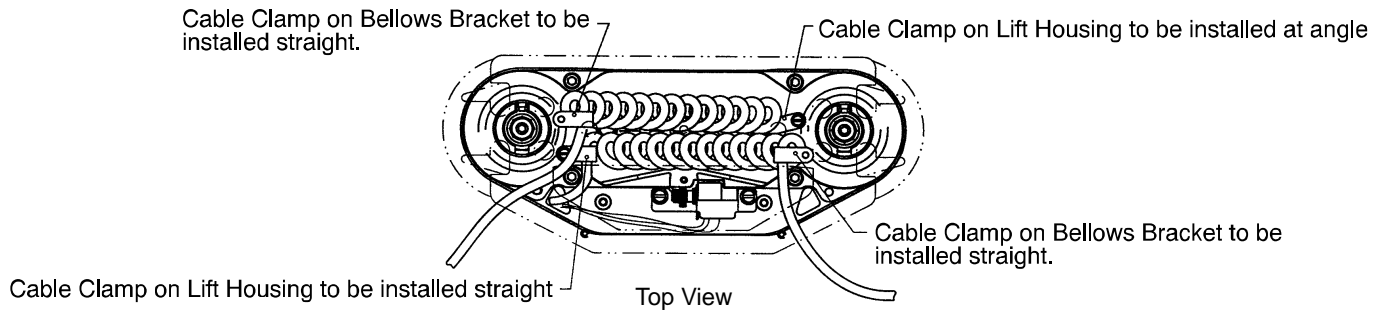

Item	Part No.	Part Name	Qty.	Item	Part No.	Part Name	Qty.
A	(page 11-13)	Common Lift Assembly	1	G	3001-200-815	Sensor Coil Cord	1
B	3000-200-52	Bellows Bracket	1	H	3-128	Hex Washer Hd. Screw	2
C	4-245	Flanged But. Hd. Screw	2	J	3-121	Hex Washer Hd. Screw	2
D	34-22	Cord Clamp	4	K	3001-200-240	Head End Pot. Ass'y	1
E	3-123	Hex Washer Hd. Screw	2	K	3001-200-230	Foot End Pot. Ass'y	1
F	3001-200-864	Power Coil Cord	1	L	3000-300-113	Cable Tie	4

Lift Assembly (Common)

Assembly part number 3000-200-275 (reference only)

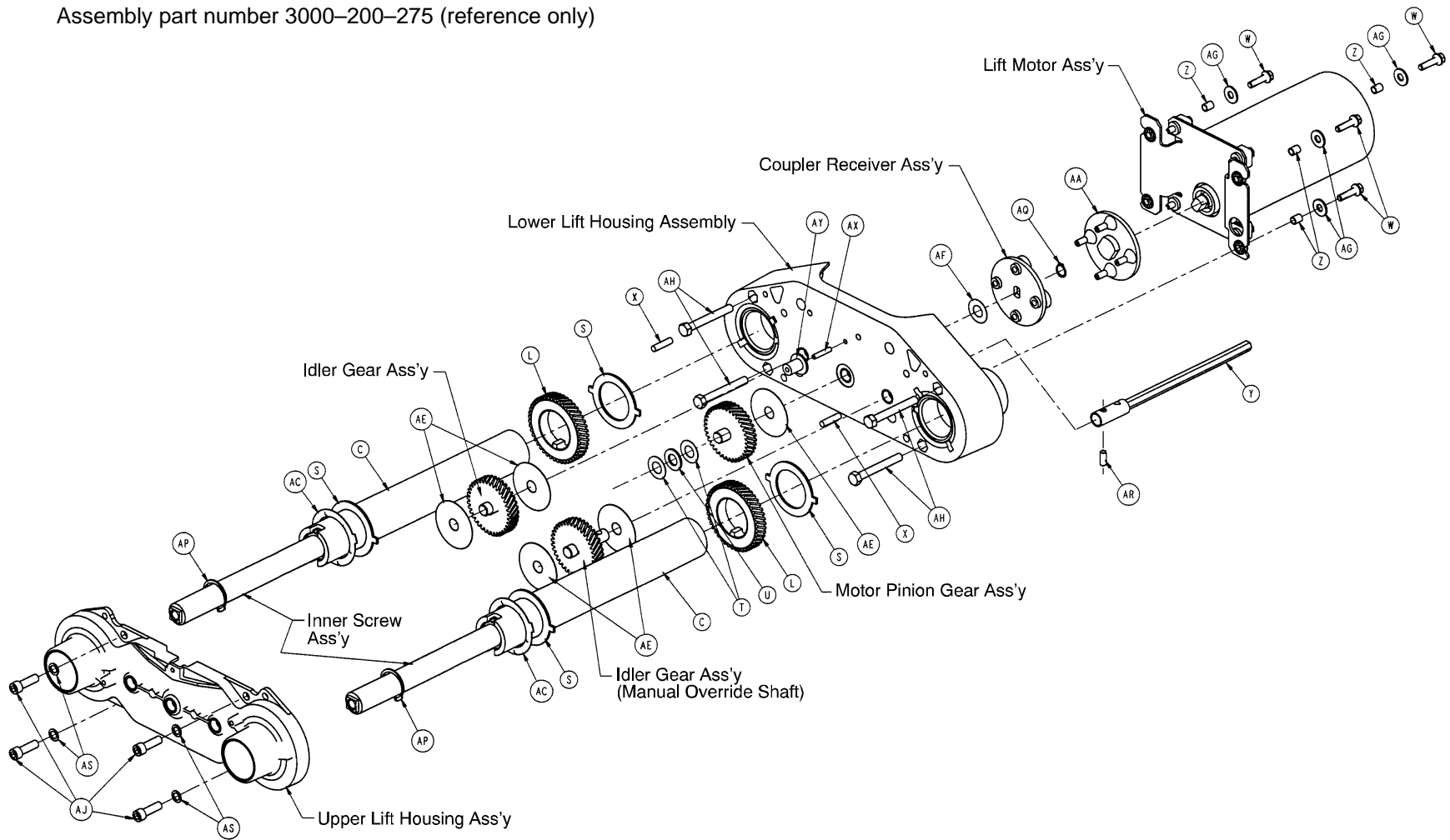

Lift Assembly (Common)

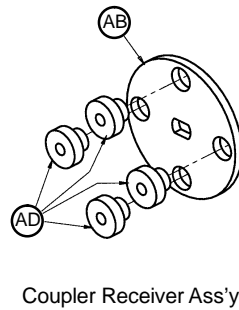
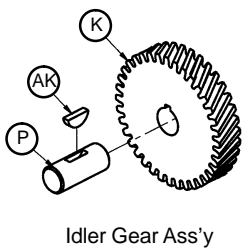
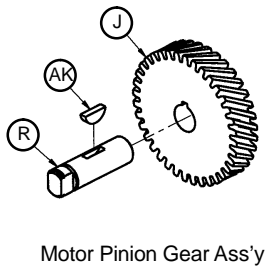
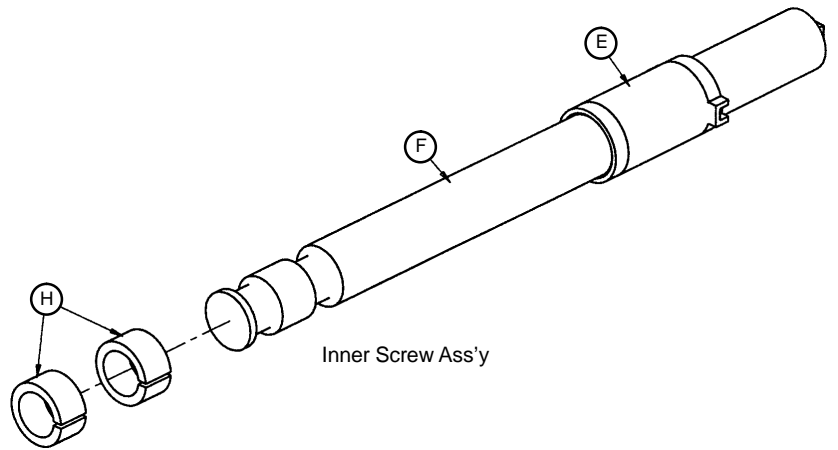
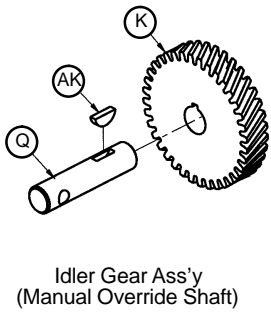
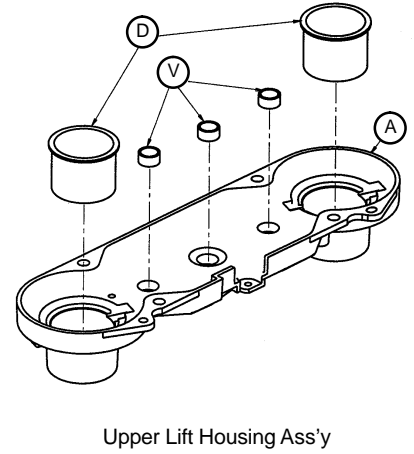
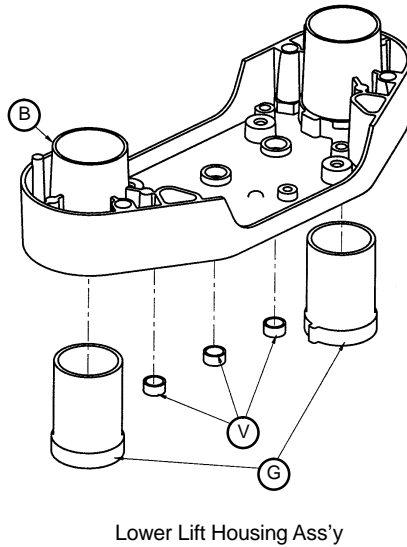
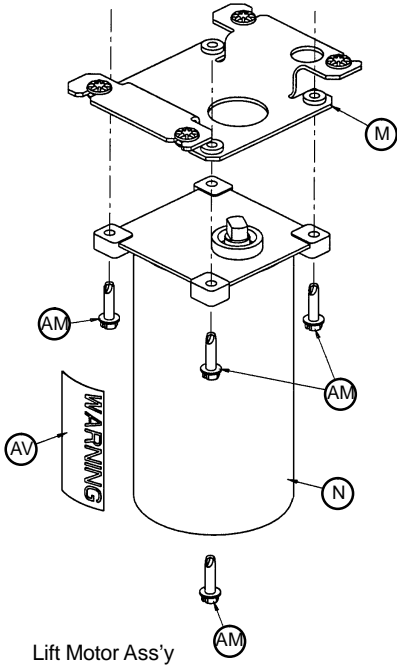

Lift Assembly (Common)

Item	Part No.	Part Name	Qty.
A	3000-200-201	Upper Lift Housing	1
B	3000-200-202	Lower Lift Housing	1
C	3000-200-251	Outer Screw	2
D	3000-200-204	Upper Housing Sleeve	2
E	3000-200-205	Upper Stage Nut	2
F	3000-200-249	Inner Screw	2
G	3000-200-207	Lower Stage Nut	2
H	3000-200-208	Glide Bushing	4
J	3000-200-209	Motor Pinion Gear	1
K	3000-200-210	Idler Gear	2
L	3000-200-252	Output Gear	2
M	(page 11-16)	Motor Isolation Plate Ass'y	1
N	3000-200-213	Lift Motor	1
	3221-200-213	230V Lift Motor	1
P	3000-200-218	Idler Shaft, Lift	1
Q	3000-200-219	Idler Man. Over. Shaft	1
R	3000-200-220	Input Pinion Shaft	1
S	3000-200-223	Output Gear Thr. Washer	4
T	3000-200-224	Input Gear Thr. Washer	2
U	3000-200-225	Input Pinion Thr. Bearing	1
V	3000-200-226	Pinion Shaft Bushing	6
W	3001-200-228	Mounting Standoff	4
X	26-231	Dowel Pin	2
Y	3001-200-235	Man. Override Shaft Ass'y	1
Z	3001-300-19	Isolation Sleeve	4
AA	3000-200-233	Lift Motor Coupler	1
AB	3000-200-234	Coupler Receiver	1
AC	3000-200-241	Crush Washer	2
AD	3000-300-455	Isolation Bushing	4
AE	3000-200-245	Gear Washer	5
AF	3000-200-246	Nylon Washer	1
AG	11-408	Flat Washer	4
AH	3-82	Hex Hd. Cap Screw	4
AJ	4-213	Soc. Hd. Cap Screw	4
AK	58-44	Woodruff Key	3
AM	3-331	Hex Washer Hd. Screw	4
AP	28-121	Retaining Ring	2
AQ	28-97	Retaining Ring	1
AR	26-178	Roll Pin	1
AS	11-308	Serrated Belleville Washer	4
AV	3000-300-604	Warning Label	1
AX	3000-200-239	Pot. Drive Gear Shaft	1
AY	3000-200-216	Potentiometer Drive Gear	1

3000–200–723 Isolation Plate Assembly

Assembly part number 3001–200–214 (reference only)

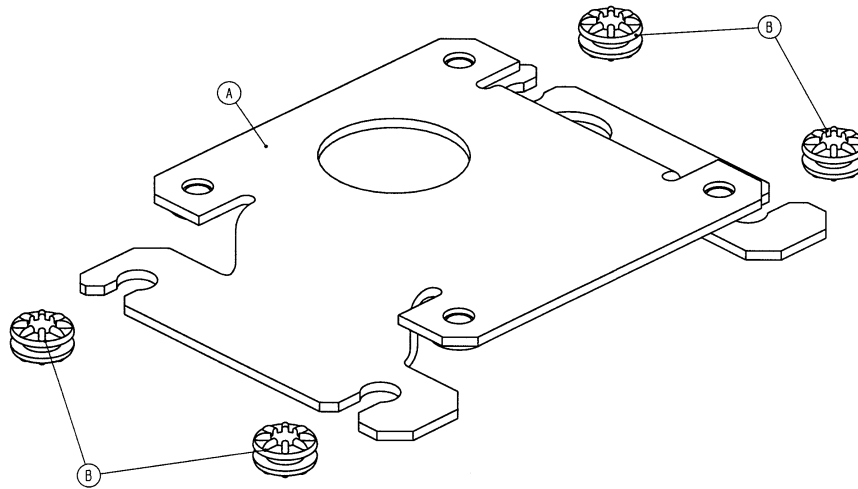

Item	Part No.	Part Name	Qty.
A	3001–200–213	Isolation Plate	1
B	3000–300–442	Grommet	4

3001–200–305 Brake Cam Assembly

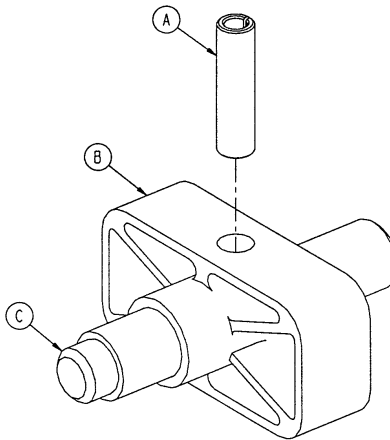

Item	Part No.	Part Name	Qty.
A	3000–200–313	Slotted Roll Pin	1
B	3001–200–304	Plastic Brake Cam	1
C	3001–200–323	Brake Cam Shaft	1

3001–200–330 Brake Crank Assembly

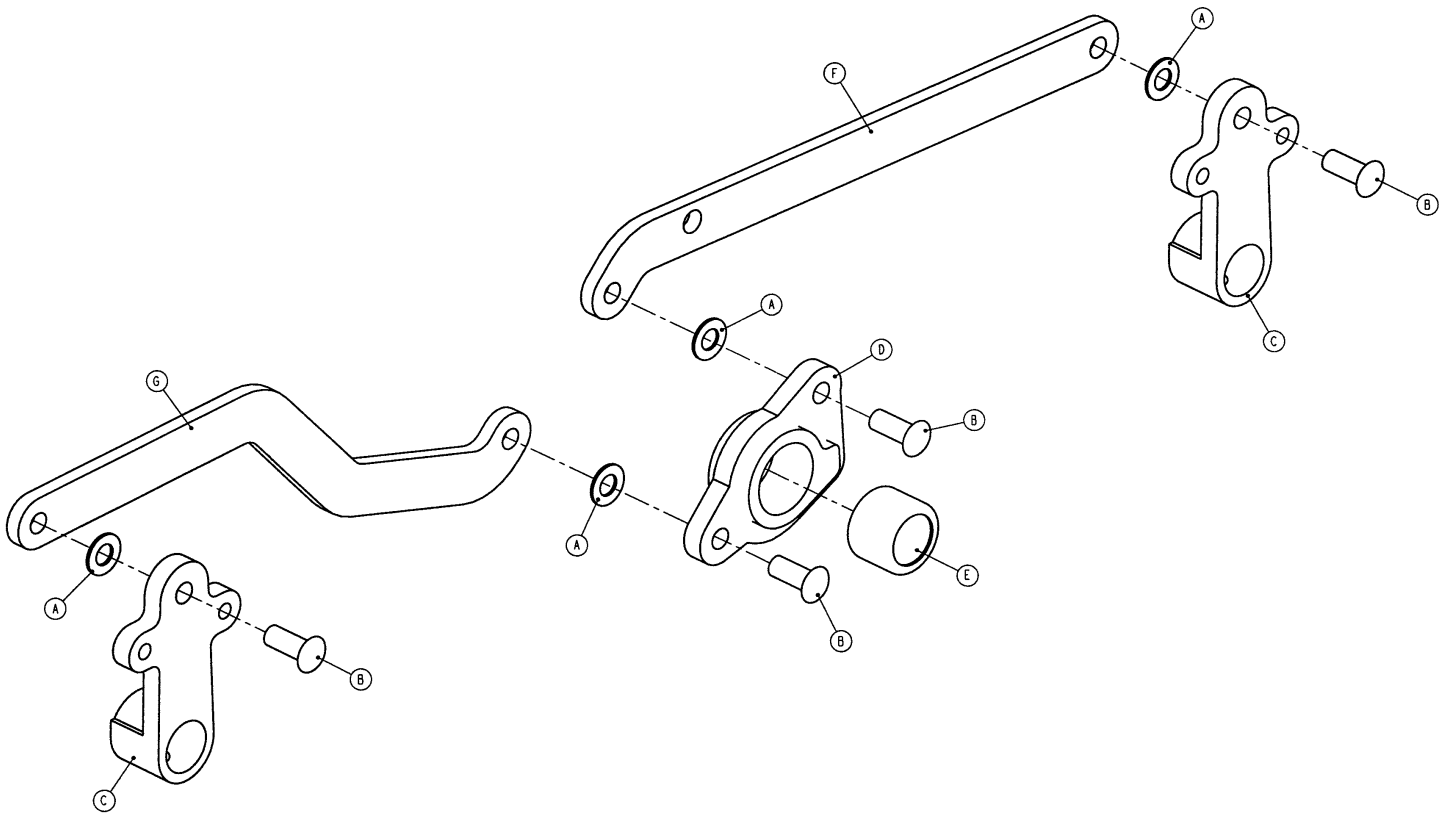

Item	Part No.	Part Name	Qty.
A	14-4	Nylon Washer	4
B	25-146	Rivet	4
C	3000-200-302	Brake Shaft Crank	2
D	3000-200-322	Brake Crank Wheel	1
E	3000-200-338	Drawn Cup Roller Clutch	1
F	3001-200-311	Brake Link	1
G	3001-200-312	Dog Leg Brake Link	1

Brake Bar Assembly

Assembly part number 3001-200-335
(reference only)

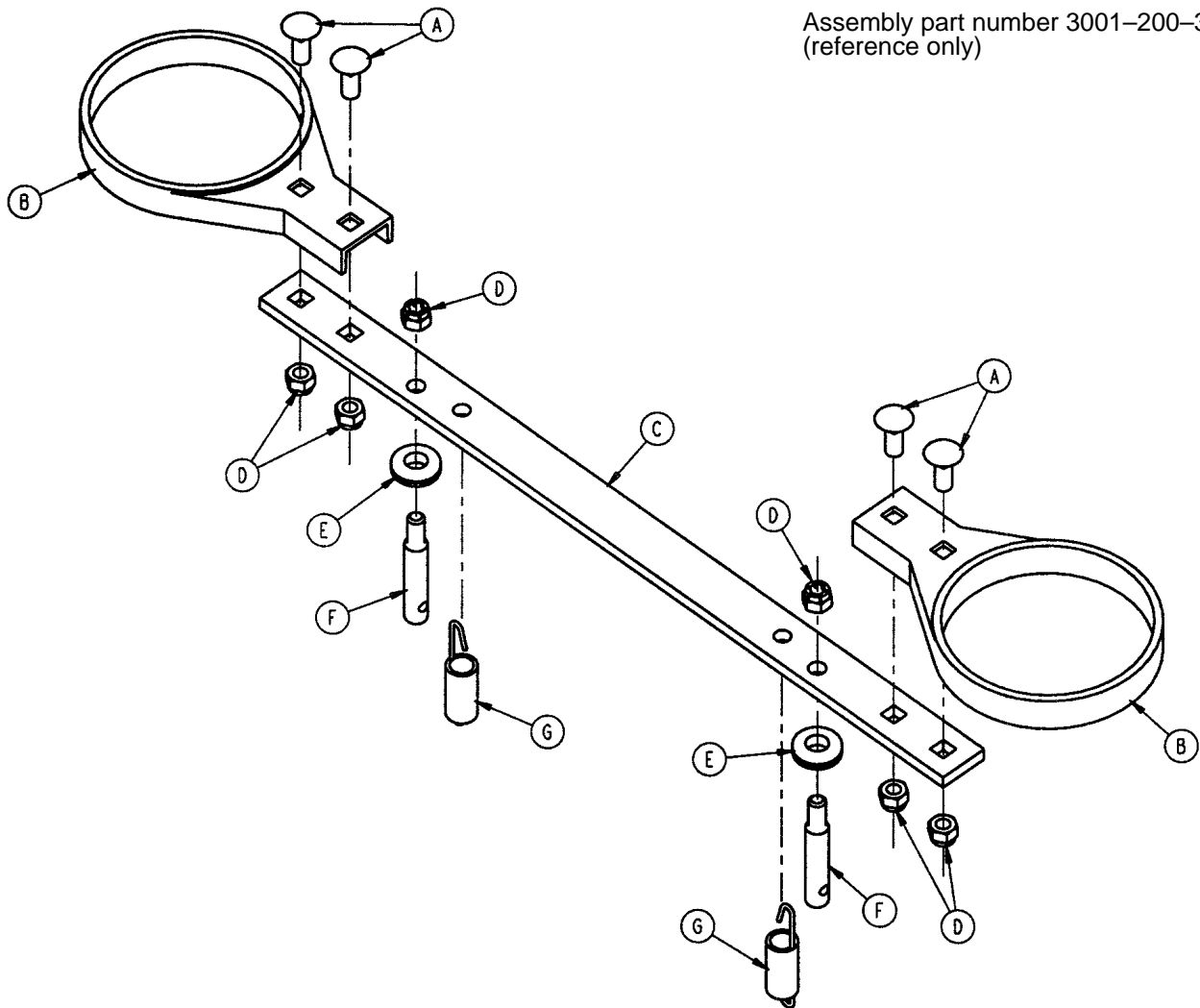

Item	Part No.	Part Name	Qty.
A	5-18	Carriage Bolt	4
B	3000-200-321	Brake Ring	2
C	3000-200-323	Brake Bar	1
D	16-35	Nylock Nut	6
E	3000-200-324	Brake Bar Bumper	2
F	3000-200-318	Guide Pin	2
G	3000-200-352	Brake Bar Return Spring	2

Brake Shaft Assembly, Left and Right

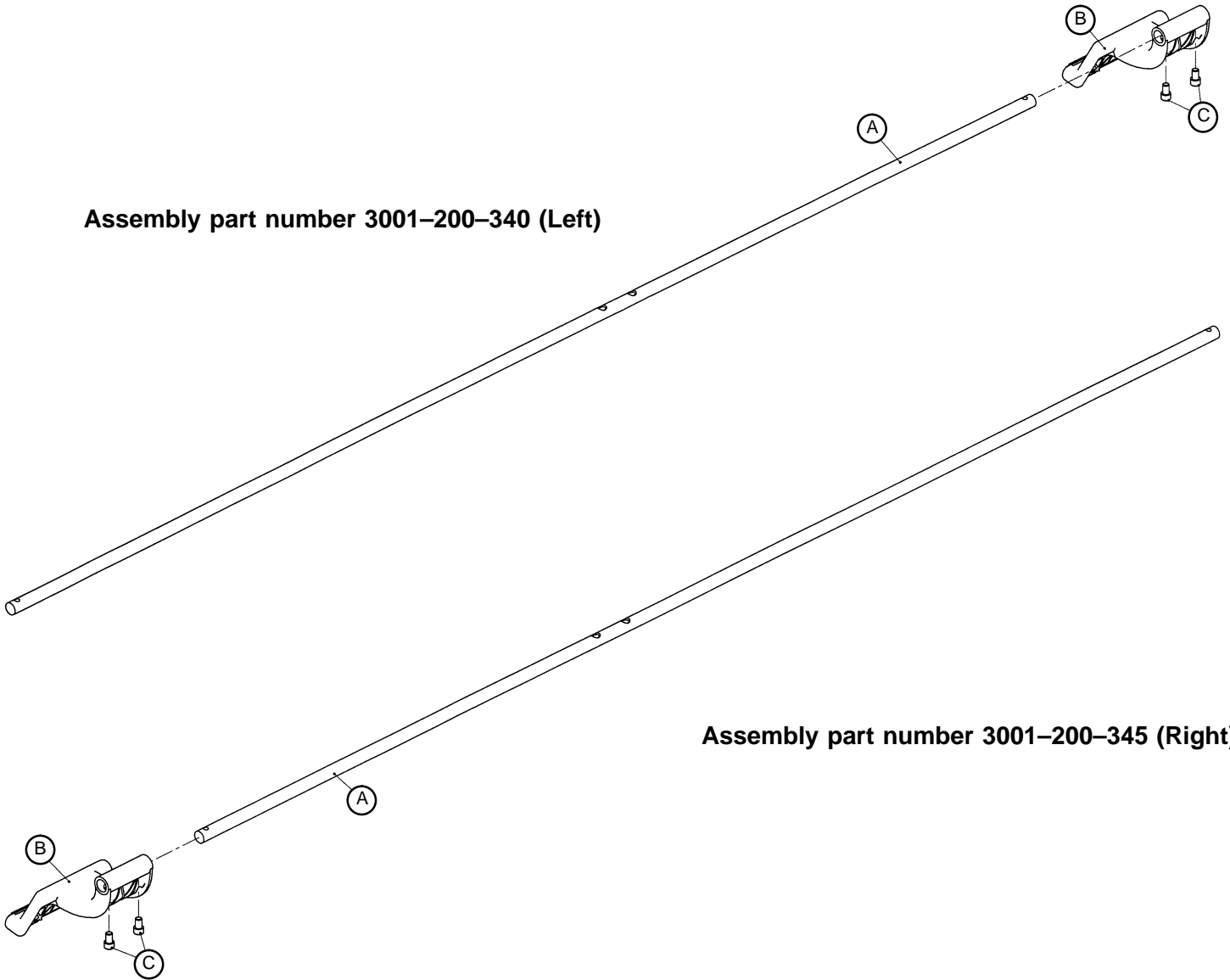

Item	Part No.	Part Name	Qty.
A	3000-200-314	Brake Shaft	1
B	3001-200-325	Brake Pedal	1
C	4-270	Soc. Hd. Cap Screw	2

3001-200-60 6" Caster Assembly

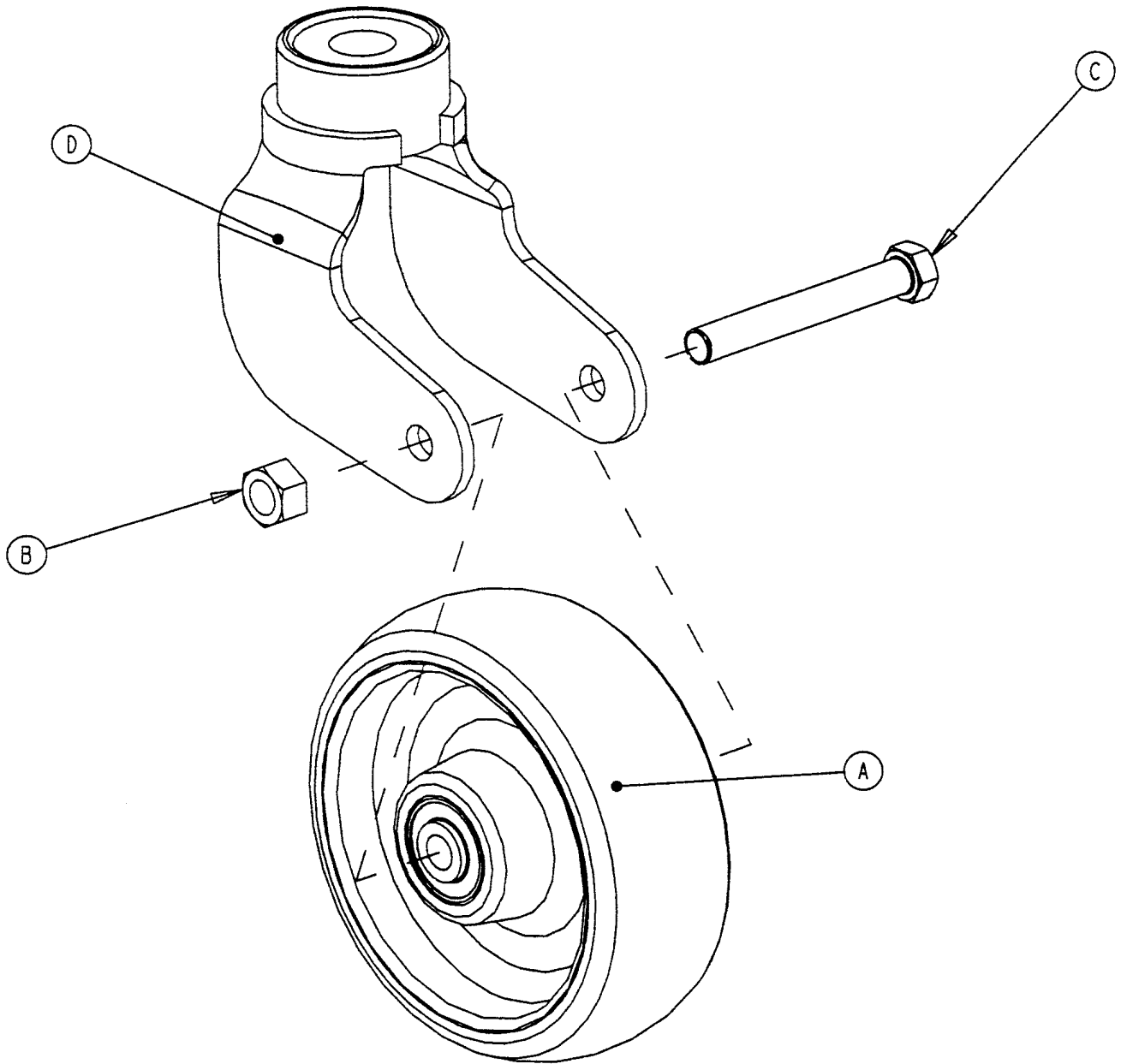

Item	Part No.	Part Name	Qty.
A	(page 11-22)	Wheel Assembly	1
B	16-60	Lock Nut	1
C	3-342	Hex Hd. Cap Screw	1
D	3001-200-61	Caster Horn w/Bearing	1

3001-200-50 6" Steer Caster Assembly

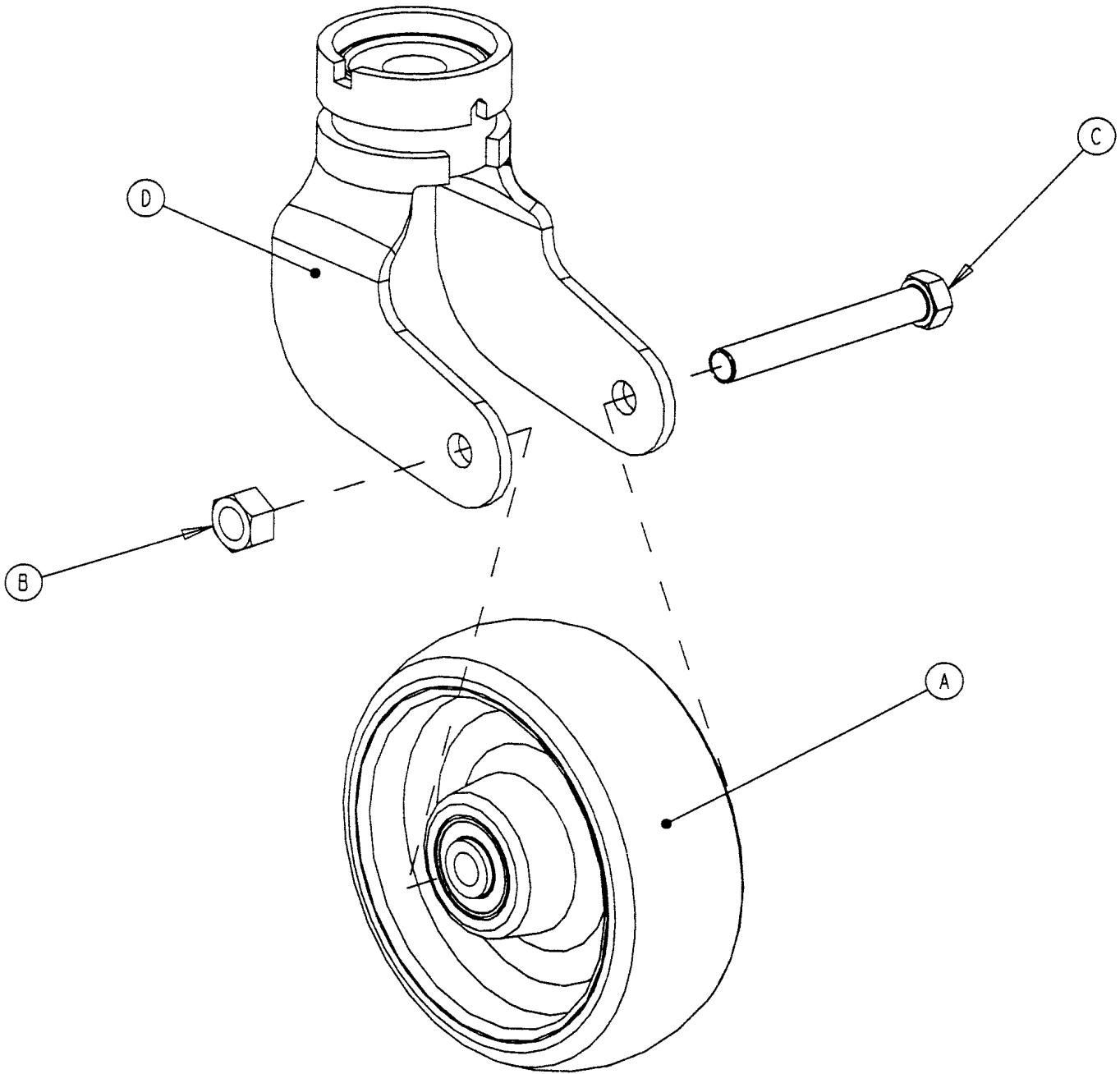

Item	Part No.	Part Name	Qty.
A	(page 11-22)	Wheel Assembly	1
B	16-60	Lock Nut	1
C	3-342	Hex Hd. Cap Screw	1
D	3001-200-51	Steer Caster Horn w/Bearing	1

5000-2-10 6" Molded Wheel Assembly

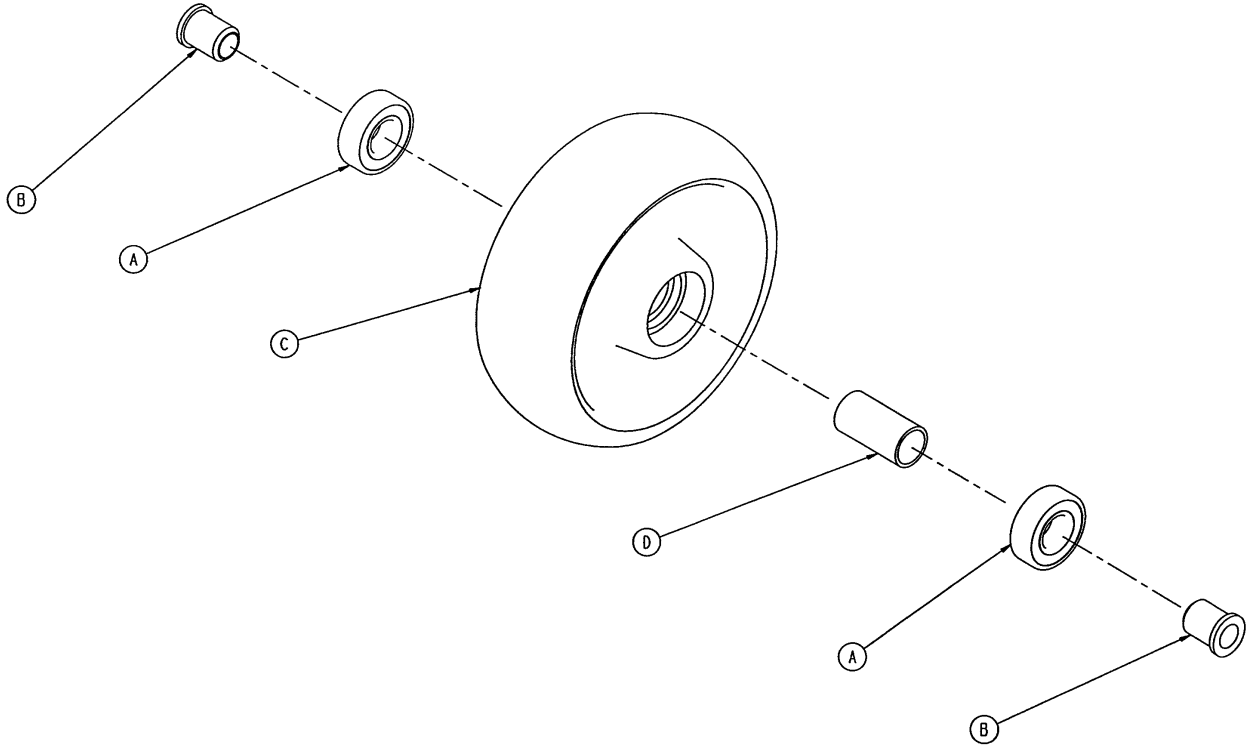

Item	Part No.	Part Name	Qty.
A	81-226	Bearing	2
B	715-1-255	Wheel Bushing	2
C	5000-2-20	Molded Wheel	1
D	6060-2-46	Bearing Spacer	1

3001–200–90 Optional 8” Caster Assembly

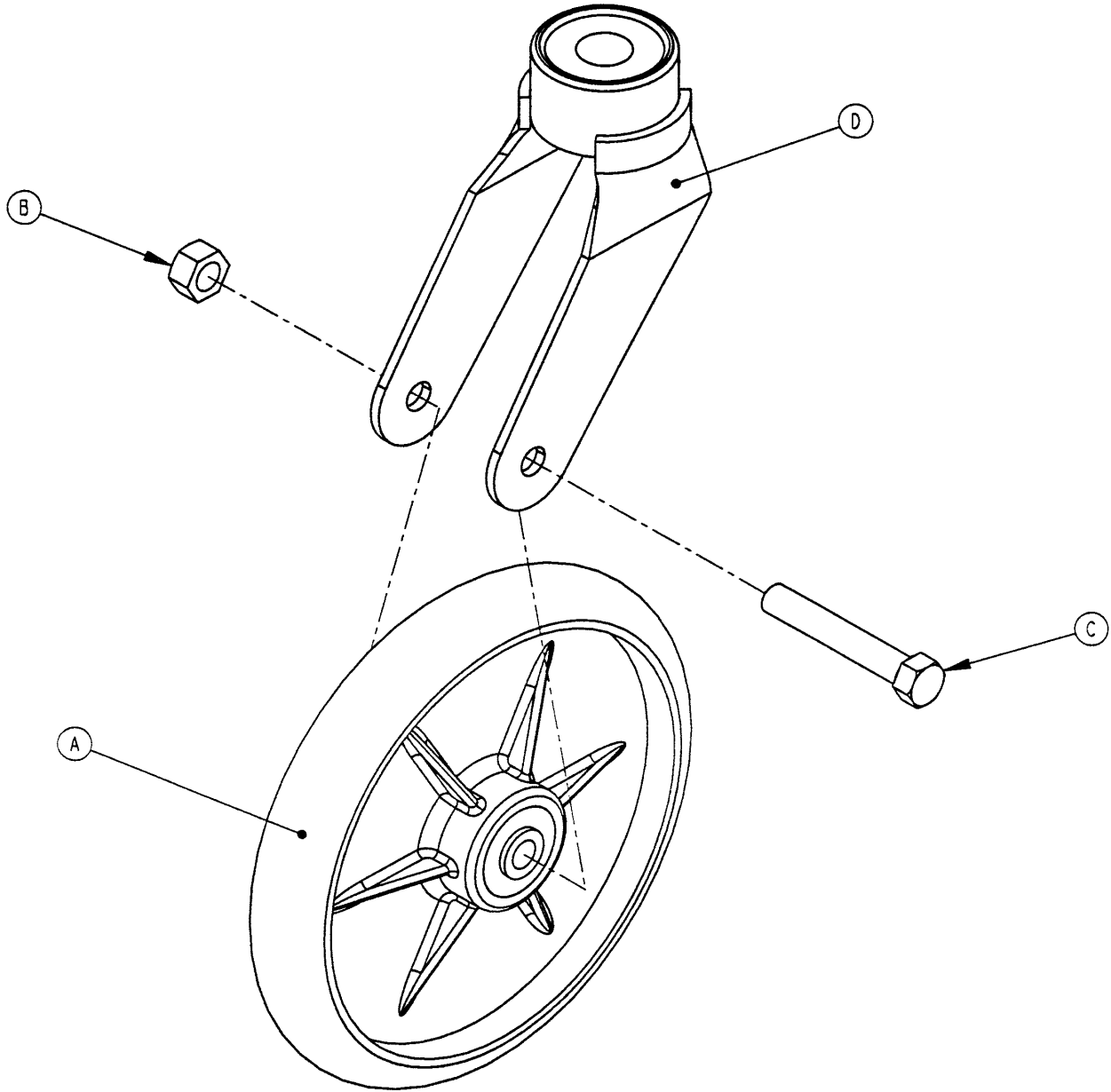

Item	Part No.	Part Name	Qty.
A	(page 11–25)	Wheel Assembly	1
B	16–60	Hex Nut	1
C	3–99	Hex Hd. Cap Screw	1
D	3001–200–76	Caster Horn	1

NOTE

The hex head cap screw (item C) must be threaded through the caster horn in the direction shown to avoid damaging the plastic caster covers.

3001–200–80 Optional 8” Steer Caster Assembly

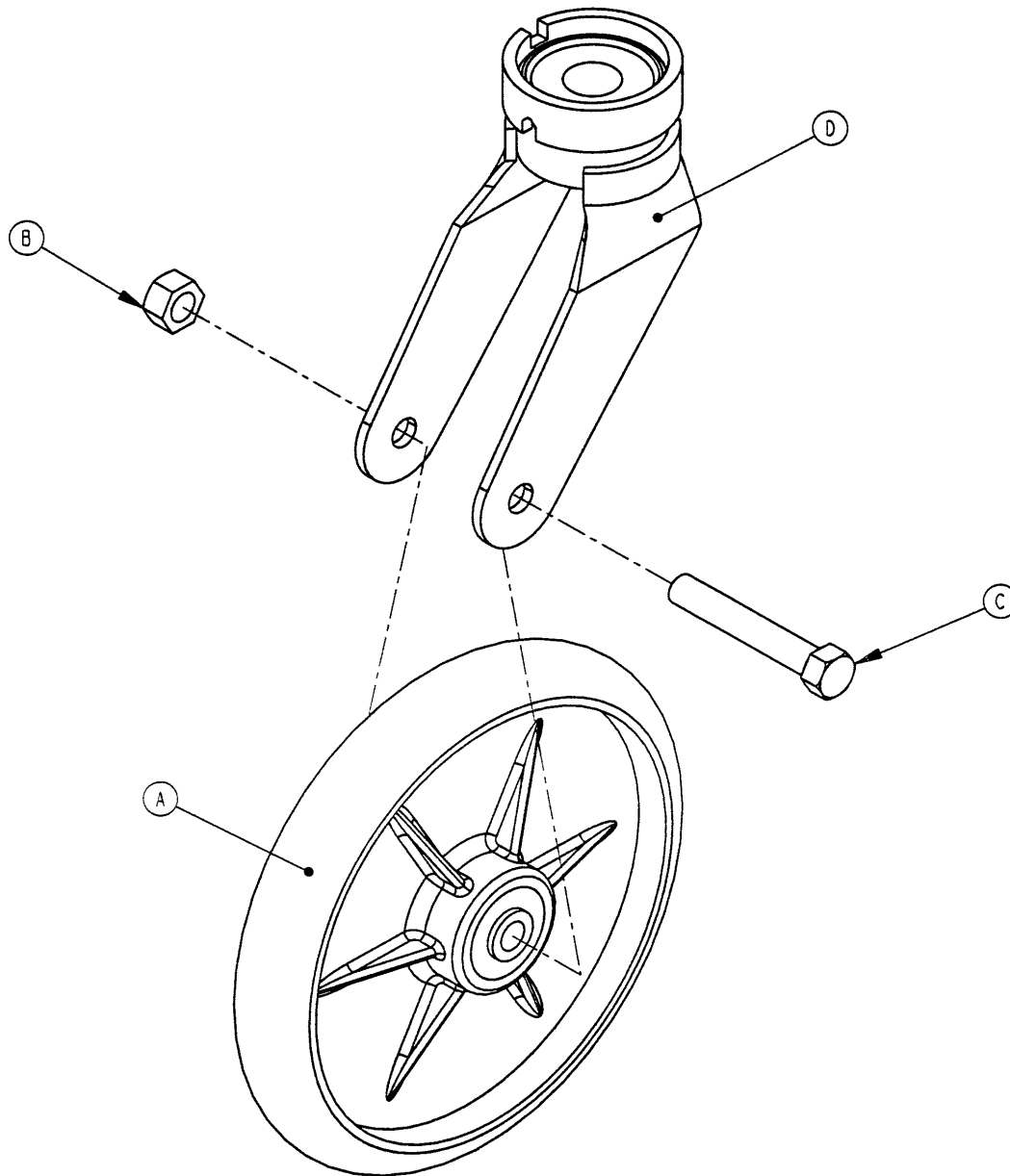

Item	Part No.	Part Name	Qty.
A	(page 11–25)	Wheel Assembly	1
B	16–60	Hex Nut	1
C	3–99	Hex Hd. Cap Screw	1
D	3001–200–81	Caster Horn	1

NOTE

The hex head cap screw (item C) must be threaded through the caster horn in the direction shown to avoid damaging the plastic caster covers.

2025-1-49 Optional 8" Wheel Assembly

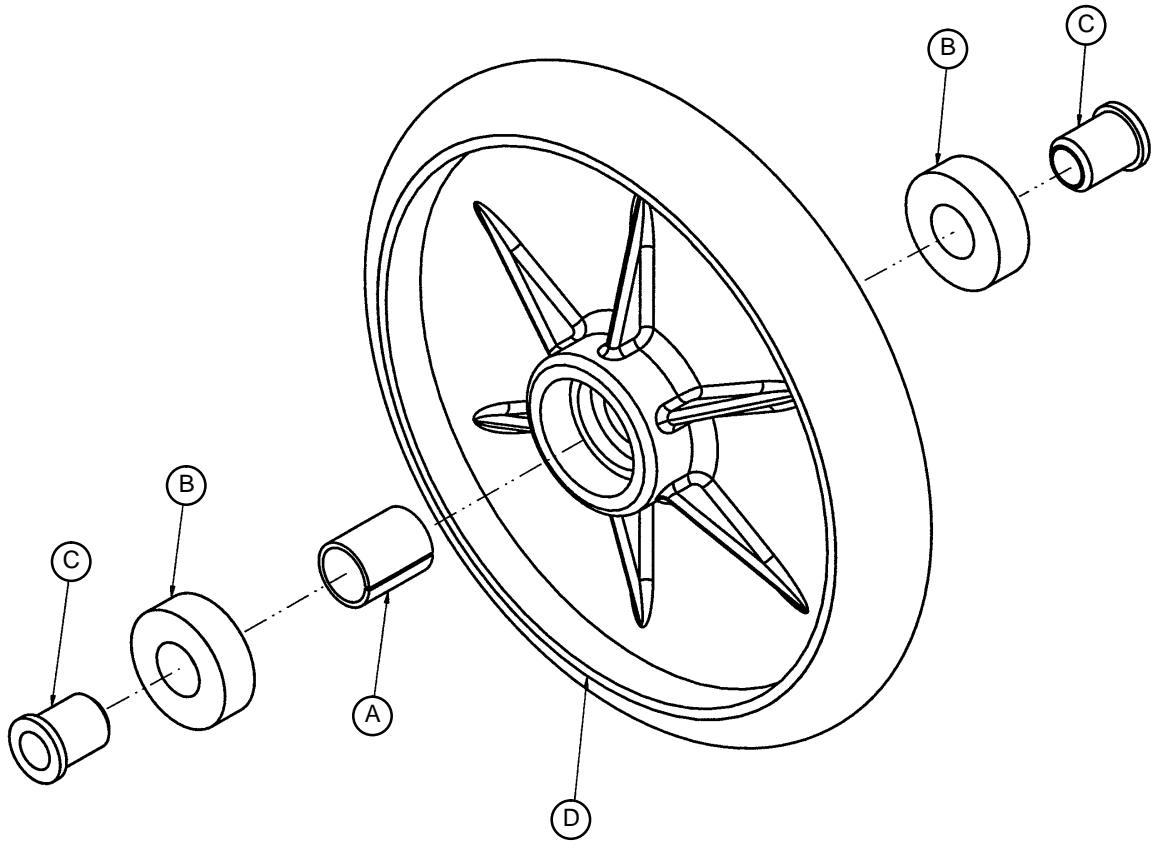

Item	Part No.	Part Name	Qty.
A	52-503	Bearing Spacer	1
B	81-226	Bearing	2
C	715-1-255	Wheel Bearing	2
D	2025-1-46	Wheel	1

Litter Assembly

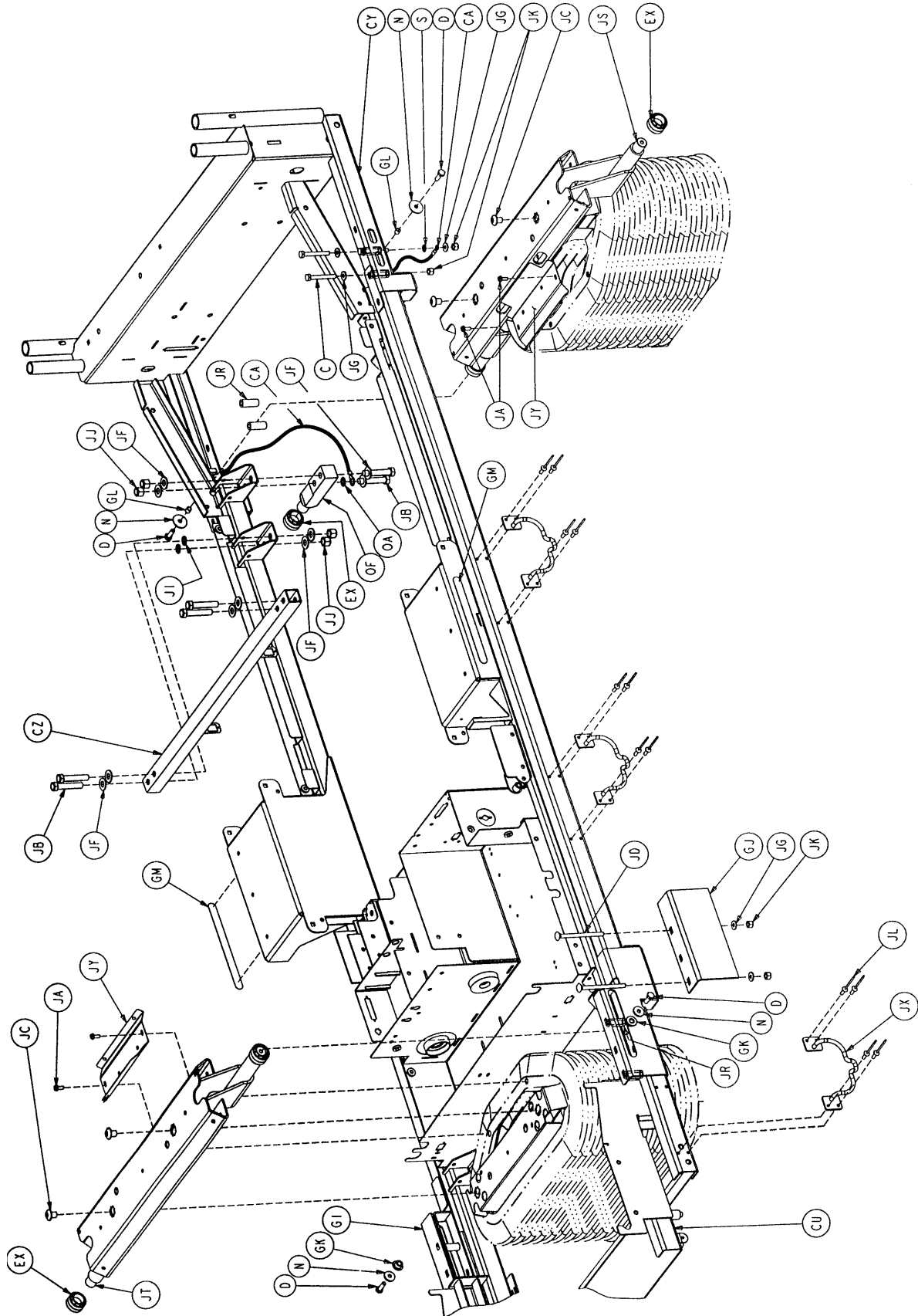

Litter Assembly

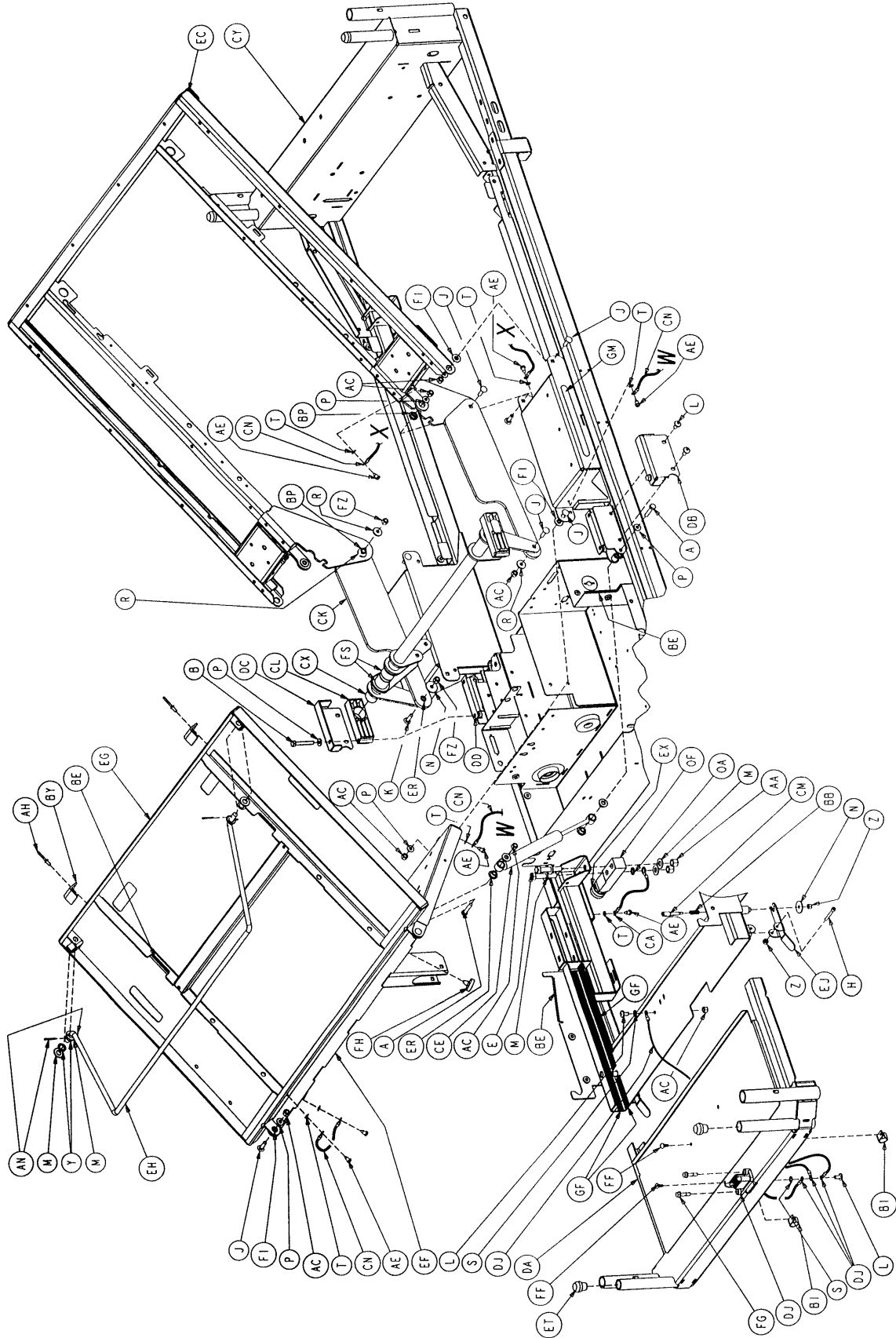

Litter Assembly

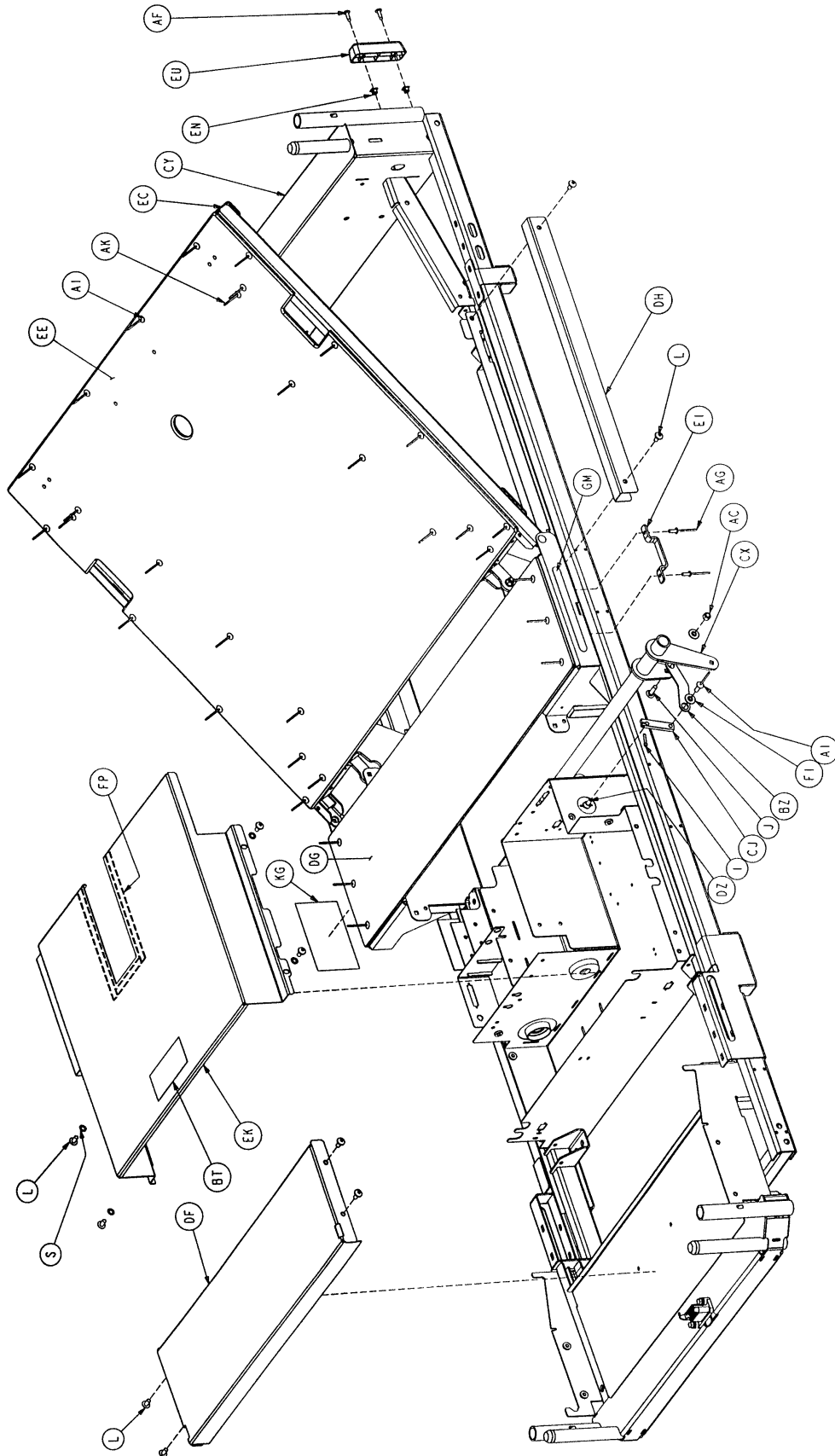

Litter Assembly

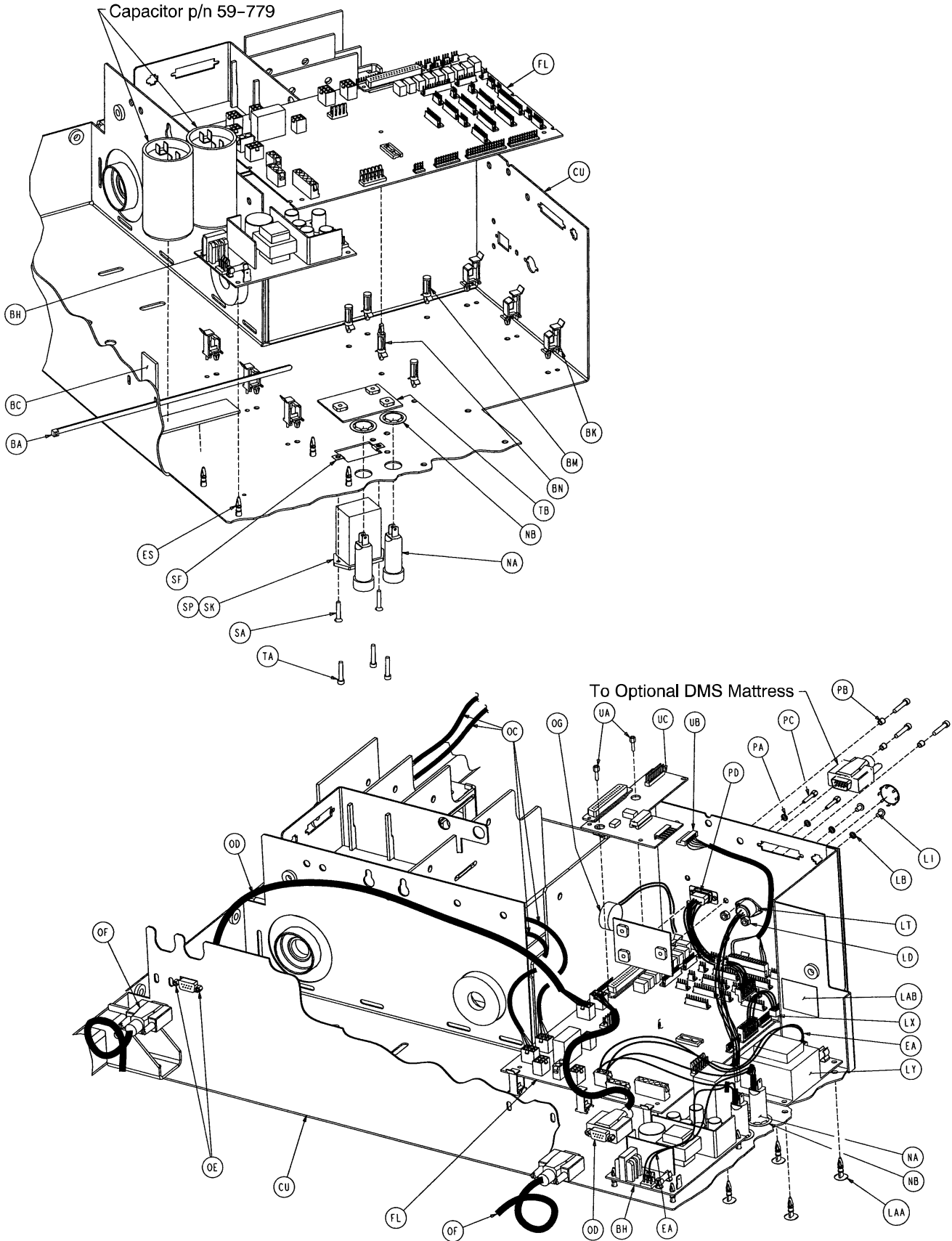

Litter Assembly

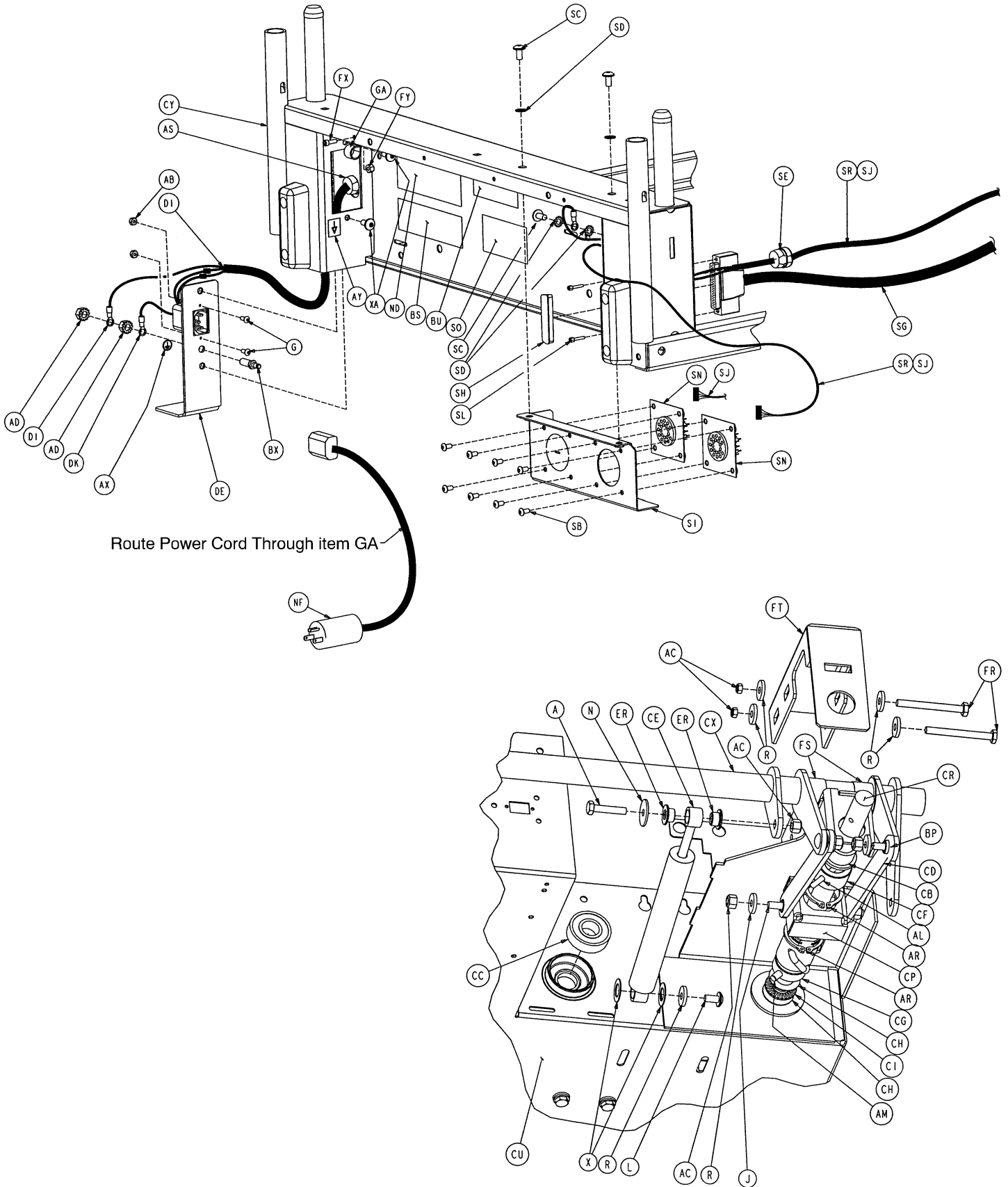

Litter Assembly

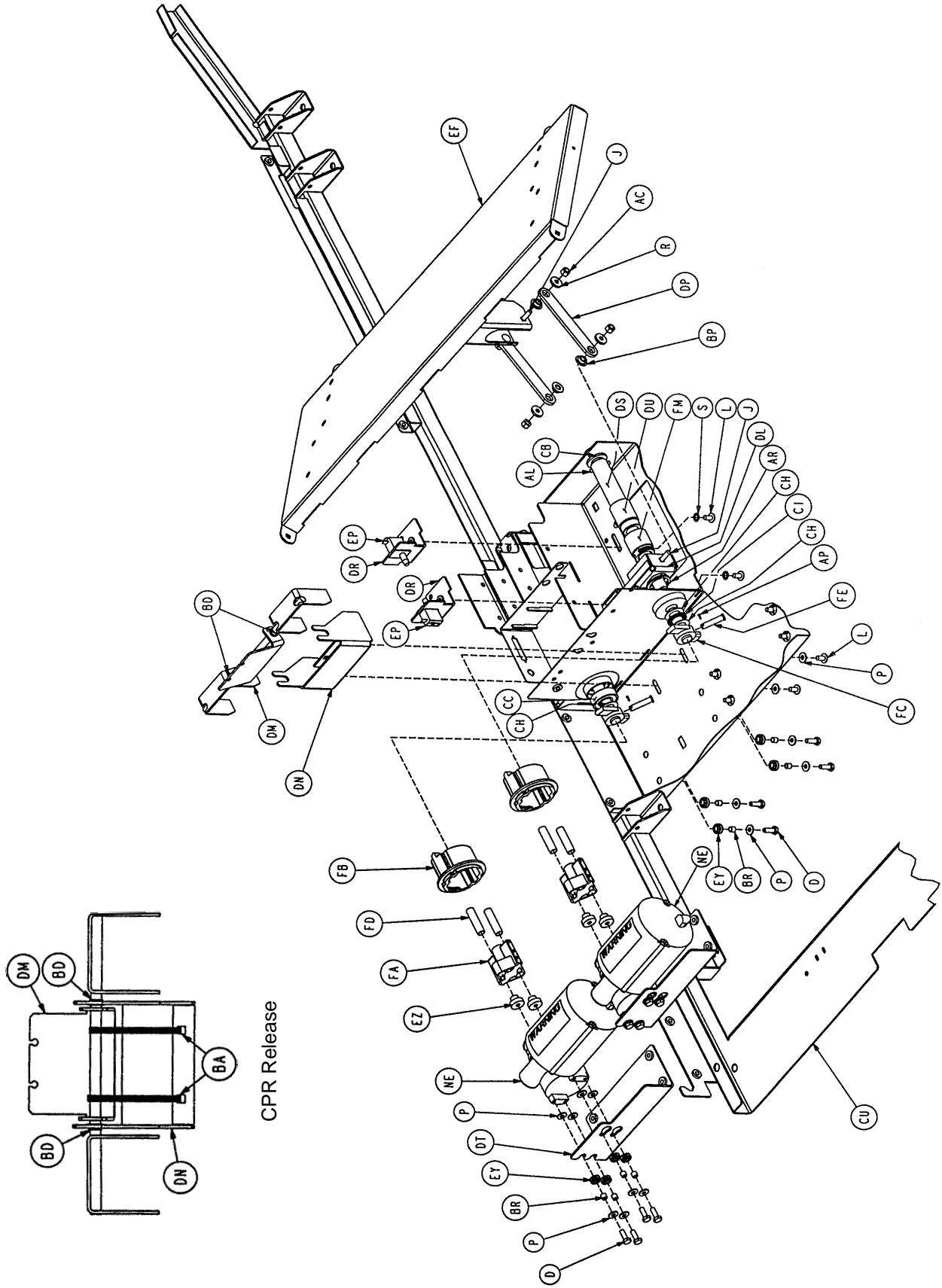

CPR Release

Litter Assembly

Integated StryKair Option Assembly
part number 2600-331-10

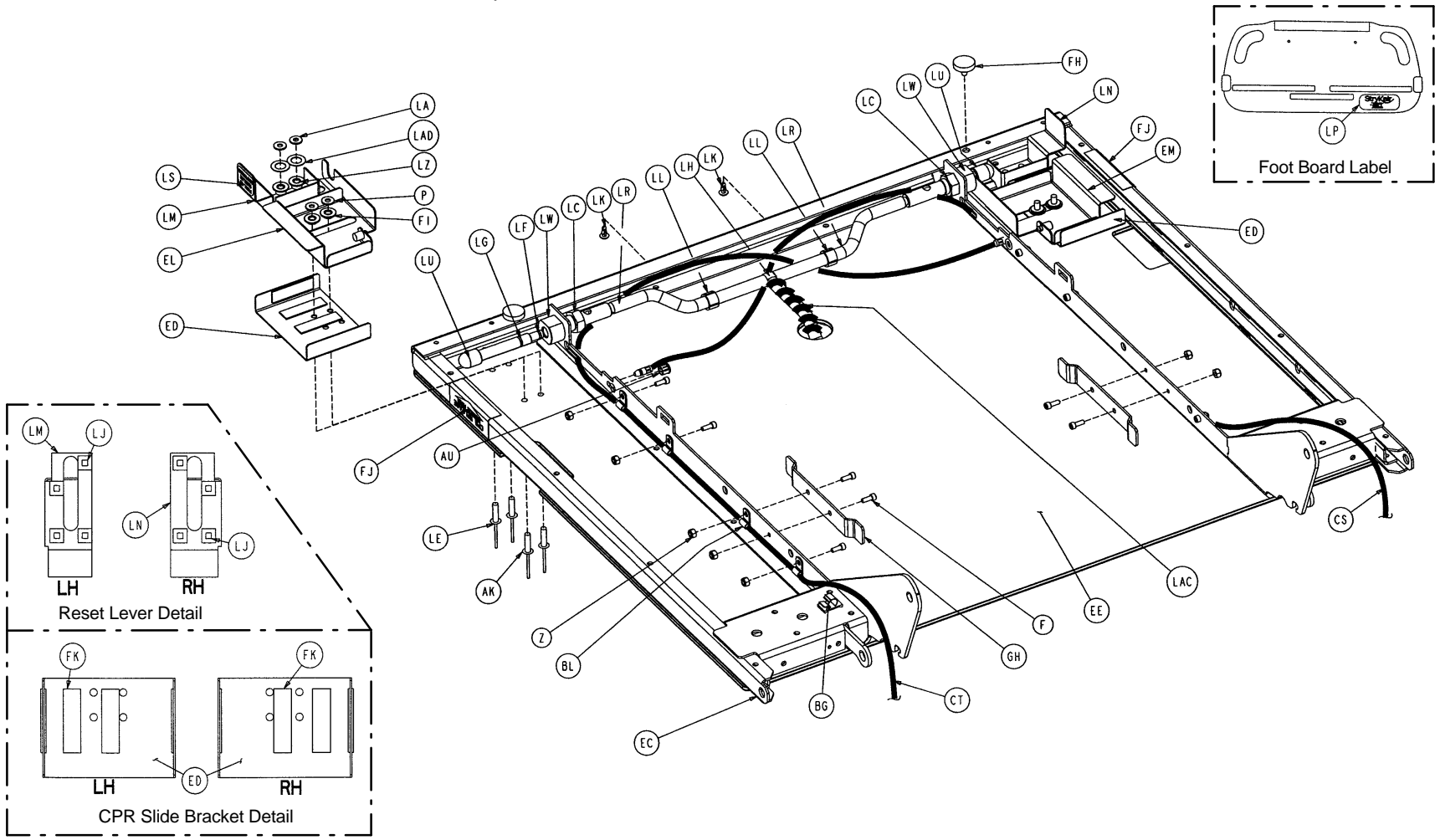

Litter Assembly

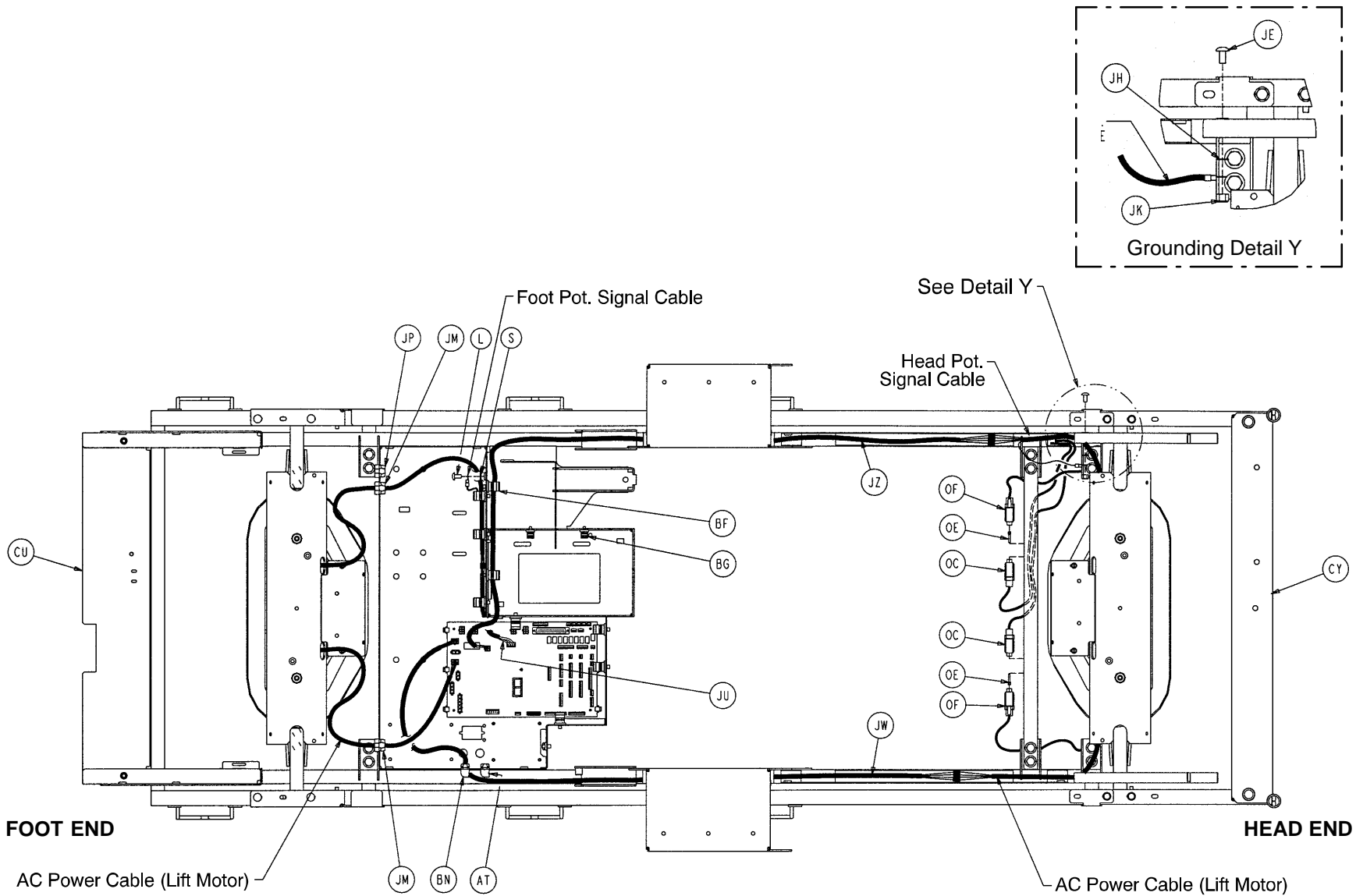

Litter Assembly

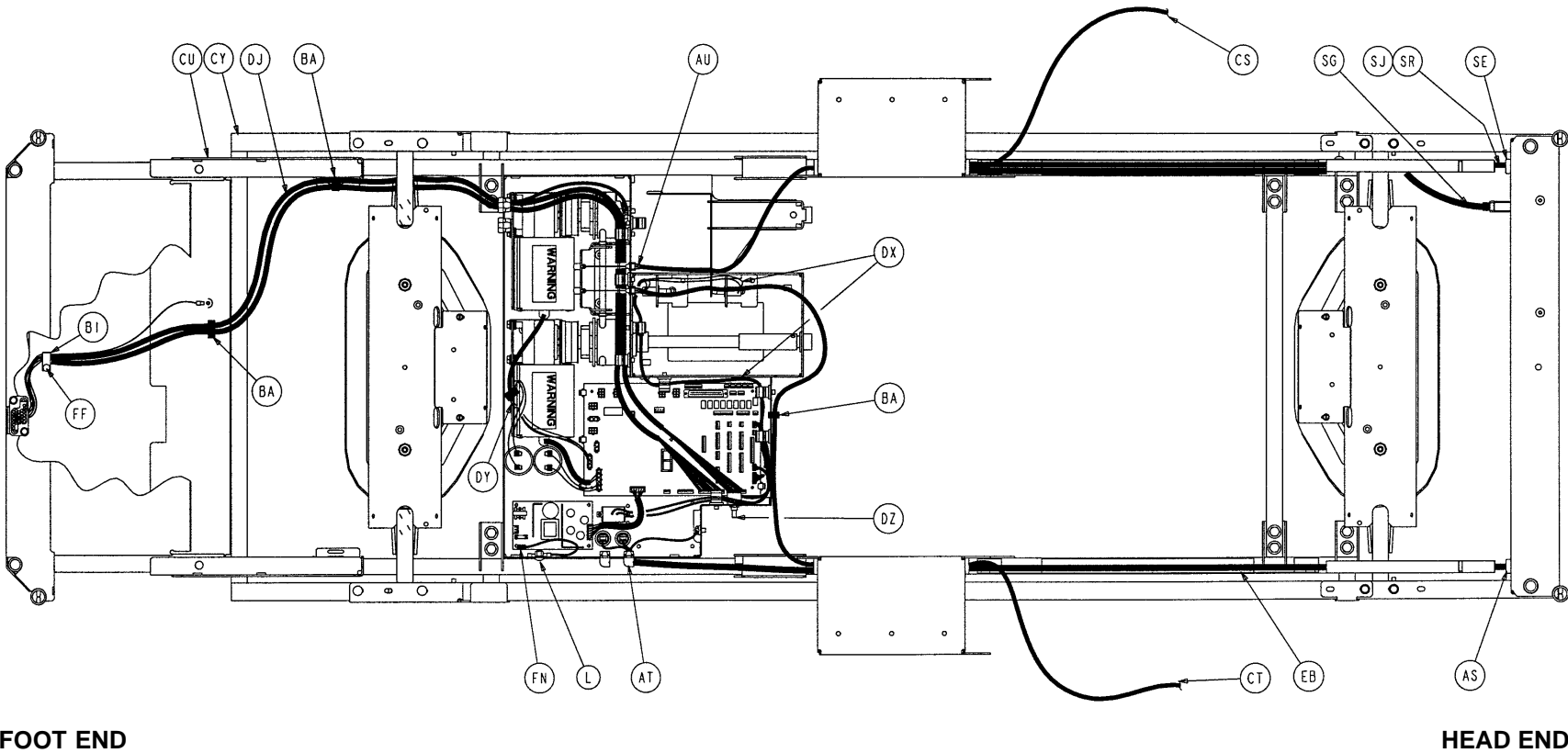

FOOT END

HEAD END

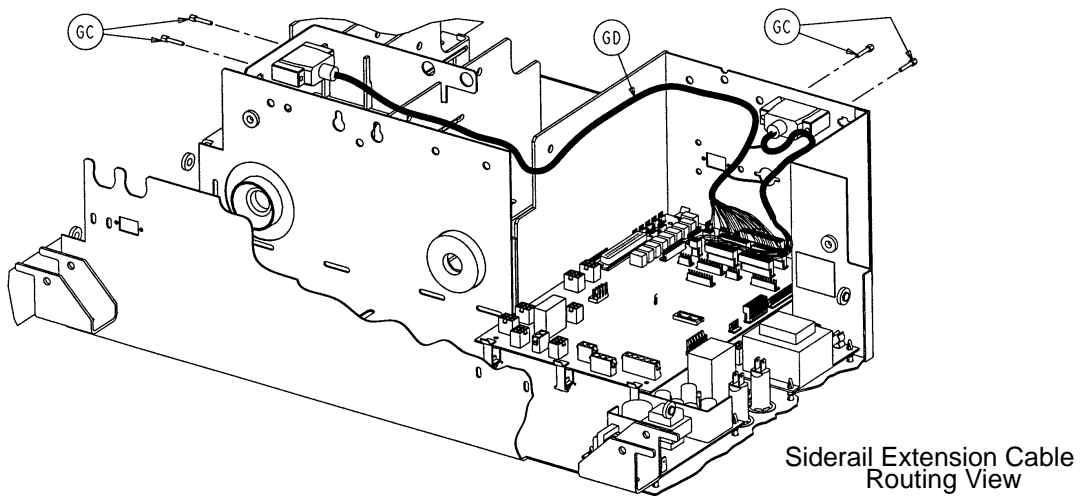

Siderail Extension Cable Routing View

Litter Assembly

Item	Part No.	Part Name	Qty.	Item	Part No.	Part Name	Qty.
A	3-4	Hex Hd. Cap Screw	3	BU	2011-1-104	Danger Label	1
B	3-78	Hex Hd. Cap Screw	2	BX	2011-1-215	Grounding Lug	1
C	3-20	Hex Hd. Cap Screw	4	BY	2020-34-758	Calf Section Rest	2
D	3-214	Hex Hd. Cap Screw	20	BZ	2025-31-62	Pot. Actuator Link	1
E	3-347	Hex Hd. Cap Screw	4	CA	2025-31-804	Ground Jumper	4
F	4-32	Soc. Hd. Cap Screw	10	CB	2025-32-68	Flange Bearing	2
G	4-49	Soc. Hd. Cap Screw	2	CC	2025-32-76	Ball Bearing	2
H	4-85	Soc. Hd. Cap Screw	2	CD	2025-32-77	Fowler Actuator Link	2
I	4-101	Soc. Hd. Cap Screw	1	CE	2025-32-82	Hydraulic Dampener	2
J	5-19	Carriage Bolt	20	CF	2025-32-84	Fowler Screw Up Stop	1
K	5-23	Carriage Bolt	1	CG	2025-32-85	Fowler Screw Down Stop	1
L	7-58	Truss Hd. Torx	23	CH	2025-32-86	Thrust Washer	5
M	11-4	Washer	12	CI	2025-32-87	Big Roller Cage Bearing	2
N	11-53	Washer	8	CJ	2025-231-61	Pot. Timing Clamp	1
P	11-63	Washer	41	CK	2025-231-88	Fowler Link	2
R	11-158	Washer	18	CL	2025-231-90	Torque Tube Pivot Brg.	2
S	13-10	Ext. Tooth Lock Washer	12	CM	2025-231-112	Bed Extender Pin Lock	2
T	13-18	Ext. Tooth Lock Washer	14	CN	2025-31-805	Ground Strap	6
U	13-32	Ext. Tooth Lock Washer	2	CP	2025-232-89	Fowler Nut Box	1
X	14-7	Washer	2	CR	2025-232-90	Fowler Ball Screw	1
Y	14-8	Washer	4	CS	2035-31-48	Short CPR Cable Ass'y	1
Z	16-3	Nylock Nut	14	CT	2035-31-49	Long CPR Cable Ass'y	1
AA	16-35	Nylock Nut	8	CU	2035-31-50	Scale Frame Weldment	1
AB	16-23	Nylock Nut	2	CX	2035-31-51	Torque Tube Weldment	1
AC	16-28	Nylock Nut	25	CY	2035-31-54	Isolated Frame Wldmt.	1
AD	16-33	Kep Nut	2	CZ	2035-31-55	H/E Crosstube Wldmt.	1
AE	23-25	Hex Washer Hd. Screw	14	DA	2035-31-57	Bed Extender Weldment	1
AF	23-80	Truss Hd. Screw	4	DB	2035-31-64	Torq. Tube Ret. Brkt., Lt.	1
AG	25-50	Rivet	4	DC	2035-31-65	Torq. Tube Ret. Brkt., Rt.	1
AH	25-79	Rivet	2	DD	2035-31-66	Torque Block Channel	2
AI	25-142	Rivet	29	DE	2035-231-70	Mounting Plate A/C Filter	1
AK	25-147	Rivet	4	DF	2035-31-94	Foot Support Cover	1
AL	26-12	Roll Pin	2	DG	2035-31-97	Seat Section Skin	1
AM	26-168	Spiral Pin	2	DH	2035-31-100	Litter Wire Channel Cover	2
AN	27-15	Cotter Pin	4	DI	2035-31-801	Inlet Cable	1
AP	27-17	Cotter Pin	2	DJ	2035-31-802	Foot Board CPU Cable	1
AR	28-120	Ext. Retaining Ring	3	DK	2035-31-803	Power Inlet Cable	1
AS	30-27	Strain Relief	1	DL	2035-32-52	Gatch Trigger Weldment	1
AT	30-47	Right Angle Strain Relief	1	DM	2035-32-54	CPR Rel. Brkt. Wldmt.	1
AU	30-52	Snap Bushing	4	DN	2035-32-72	CPR Rel. Pivot Bracket	1
AX	36-46	220V Ground Label	1	DP	2035-32-77	Gatch Actuator Link	2
AY	36-115	Earth Ground Label	1	DR	2035-32-79	Act. Box Switch Bracket	2
AZ	38-111	Cable Tie	10	DS	2035-32-85	Gatch Screw Down Stop	1
BA	38-151	Long Cable Tie	17	DT	2035-32-88	Act. Box Motor Mtg. Brkt.	2
BB	38-382	Compression Spring	2	DU	2035-32-90	Gatch Ball Screw Ass'y	1
BC	44-29	Black Foam Tape	1	DX	2035-32-801	Gatch Limit Switch Cable	1
BD	52-759	Flange Bearing	2	DY	2035-32-802	Fow./CPU Jumper Cable	1
BE	58-56	Black Edge Trim	.5'	DZ	2035-32-803	Fowler Pot. Cable	1
BF	59-135	Big Push Mount Wire Clip	8	EA	2035-32-804	Fuse/PCB Cable	1
BG	8815-001-100	Wire Mount Clip	4	EB	2035-32-805	CPU/Power Supply Cable	1
BH	59-157	Power Supply	1	EC	2035-33-50	Fowler Frame Weldment	1
BI	59-743	Wire Harness Clip	2	ED	2035-33-62	CPR Rel. Slide Bracket	2
BK	59-751	Circuit Bd. Locking Supt.	6	EE	2035-33-63	Fowler Skin	1
BL	59-767	Cable Clamp	8	EF	2035-34-50	Thigh Section Weldment	1
BM	59-773	Push Spacer	4	EG	2035-35-50	Foot Section Weldment	1
BN	59-774	PCB Locking Support	1	EH	2035-35-96	Foot Prop Rod	1
BP	81-268	Flange Bearing	14	EI	2035-53-20	Restraint Strap Bracket	2
BR	715-1-333	Rel. Valve Stop Sleeve	16	EJ	2035-231-99	Bed Extender Rel. Lever	2
BS	1550-90-1	Hospital Grade Plug Label	1	EK	2035-232-75	Actuator Box Cover	1
BT	1550-90-13	Shock Caution Label	1	EL	2035-233-64	Quick Drop Rel. Brkt., Lt.	1

Litter Assembly

Item	Part No.	Part Name	Qty.	Item	Part No.	Part Name	Qty.
EM	2035-233-65	Quick Drop Rel. Brkt., Rt.	1	FM	5000-30-366	Fowler Nut Adapter	1
EN	3000-300-2	Plastic Clip Nut	4	FN	5010-80-7	Power Supply Gd. Cable	1
EP	3000-300-58	Switch Plunger	2	FP	8800-380-000	Neoprene Sponge	1.5'
ER	3000-300-99	Fowler Modified Bushing	10	FR	3-23	Hex Hd. Cap Screw	2
ES	3000-300-115	Standoff	4	FS	52-762	Nyliner Bushing	2
ET	3000-300-349	Hd/Ft Board Post Cap	4	FT	2035-32-96	Ball Screw Cover	1
EU	3000-300-350	Head End Bumper Strip	2	FX	4-5	Soc. Hd. Cap Screw	1
EX	3000-300-353	Roller	8	FY	16-14	Nylock Nut	1
EY	3000-300-442	Fowler Drive Grommet	16	FZ	16-102	Nylock Jam Nut	3
EZ	3000-300-455	CPR Isolation Bushing	4	GA	34-22	Cord Clamp	1
FA	3000-300-456	CPR Isolator	2	GC	59-727	Jack Screw	4
FB	3000-300-461	CPR Decoupler	2	GD	3001-300-877	Siderail Extension Cable	1
FC	3000-300-462	CPR Wing	2	GE	59-133	Push-Mount Wire Clip	1
FD	3000-300-464	CPR Engagement Spring	4	GF	44-32	1" Poly Tape	50"
FE	3000-300-473	Clevis Pin	2	GG	2035-32-84	Gatch Screw Up Stop	1
FF	58-76	Drive Fastener	2	GH	2035-400-565	Siderail Guide Bracket	2
FG	3001-200-228	Mounting Standoff	2	GI	2035-31-115	Roller Bracket Cover, Rt.	1
FH	3001-300-8	Thigh Section Bumper	4	GJ	2035-31-116	Roller Bracket Cover, Lt.	1
FI	3001-300-99	Flange Bearing	10	GL	715-1-333	Stop Sleeve	2
FJ	3001-300-603	CPR Release Label	2	GM	6080-90-106	"500 Lb. Max." Label	2
FK	3001-300-663	Velcro Strip	10	XA	7-58	Truss Hd. Torx	2
FL	*	CPU Board	1				

* 2035-700-1 – CPU Kit – Scale Only

2035-700-2 – CPU Kit – Bed Exit Only

2035-700-3 – CPU Kit – Scale and Bed Exit

2030-32-10 Epic Litter Components

Item	Part No.	Part Name	Qty.	Item	Part No.	Part Name	Qty.
JA	3-224	Hex Washer Hd. Screw	4	JM	30-27	Strain Relief	2
JB	3-347	Hex Hd. Cap Screw	8	JN	30-47	Right Angle Strain Relief	1
JC	4-245	But. Hd. Screw	4	JP	59-106	Strain Relief	1
JD	5-29	Rd. Hd. Sq. Neck Bolt	4	JR	3001-300-4	Spacer	8
JE	7-58	Truss Hd. Torx	1	JS	2030-331-52	Head End Header Wldmt.	1
JF	11-4	Washer	16	JT	2030-331-53	Foot End Header Wldmt.	1
JG	11-63	Washer	10	JU	2030-31-801	Foot Pot. Exten. Cable	1
JH	13-10	Ext. Tooth Lock Washer	1	JW	2030-31-803	Head Lift Motor Extension	1
JI	13-32	Ext. Tooth Lock Washer	4	JX	2035-31-56	Short Foley Weldment	6
JJ	16-35	Nylock Nut	8	JY	3001-200-8	Bellows Retainer Bracket	2
JK	16-28	Nylock Nut	9	JZ	2030-31-802	Head Pot. Exten. Cable	1
JL	25-50	Rivet	24				

2030-32-15 Litter Domestic Components

Item	Part No.	Part Name	Qty.
NA	59-179	Circuit Breaker	2
NB	59-181	Clip Retainer	2
NC	59-779	Capacitor	2
ND	2030-231-125	Specification Label	1
NE	2035-300-705	Fowler Drive Assembly	2
NF	39-254	Power Cord	1

2031-32-15 Litter International Components

Item	Part No.	Part Name	Qty.
NA	59-178	Circuit Breaker	2
NB	59-181	Clip Retainer	2
NC	59-153	Capacitor	2
ND	2031-231-125	Specification Label	1
NE	3221-300-705	Fowler Drive Assembly	2

2031-32-16 Litter European Comp. – No Scale

Item	Part No.	Part Name	Qty.
NA	59-178	Circuit Breaker	2
NB	59-181	Clip Retainer	2
NC	59-153	Capacitor	2
ND	2031-231-126	Specification Label	1
NE	3221-300-705	Fowler Drive Assembly	2

2031-32-17 Litter European Comp. – Scale

Item	Part No.	Part Name	Qty.
NA	59-178	Circuit Breaker	2
NB	59-181	Clip Retainer	2
NC	59-153	Capacitor	2
ND	2031-231-127	Specification Label	1
NE	3221-300-705	Fowler Drive Assembly	2

Litter Assembly

2600–331–10 Litter Assembly – Integrated StryKair Option

Item	Part No.	Part Name	Qty.	Item	Part No.	Part Name	Qty.
LA	11–63	Washer	4	LP	2600–22–46	Foot Board Logo Label	1
LB	12–30	Ext. Tooth Star Washer	2	LR	2600–40–1	Hose	2
LC	15–61	Hex Jam Nut	2	LS	2600–90–99	Reset Label	2
LD	16–23	Nylock Nut	2	LT	2600–242–801	StryKair Port Cable	1
LE	25–147	Pop Rivet	4	LU	2600–300–98	Plunger	2
LF	45–993	O–Ring	2	LW	2600–300–99	Guide Tube	2
LG	45–994	O–Ring	2	LX	2600–300–802	StryKair Signal Cable	1
LH	48–171	Tee Fitting	1	LY	2600–300–900	StryKair Power Supply	1
LI	50–38	Pan Hd. Mach. Screw	2	LZ	3000–300–99	Bushing	4
LJ	58–75	Flat Tie Holder	8	LAA	3000–300–115	Standoff	4
LK	58–76	Drive Fastener	2	LAB	2600–320–606	Fuse Label	1
LL	59–743	Wire Harness Clip	2	LAC	34–273	Slit Harness Wrap	24"
LM	2035–233–66	Left Reset Lever	1	LAD	14–7	Washer	4
LN	2035–233–67	Right Reset Lever	1				

2035–30–100 No Scale or Bed Exit Options

Item	Part No.	Part Name	Qty.
	(page 11–72)	Foot Board, No Scale/BE	1
OF	3001–300–511	"Imitation" Load Cell	4

2035–30–125 Scale Option Only

Item	Part No.	Part Name	Qty.
OA	13–32	Ext. Tooth Lock Washer	4
	(page 11–74)	Foot Board, Scale Option	1
OC	2035–31–804	Load Cell Cable, Head	2
OD	2035–31–805	Load Cell Cable, Foot	2
OE	3001–300–7	M/F Screw	8
OF	3001–307–57	Load Cell	4

2035–30–175 Bed Exit Option Only

Item	Part No.	Part Name	Qty.
OA	13–32	Ext. Tooth Lock Washer	4
	(page 11–73)	Foot Board, BE Option	1
OC	2035–31–804	Load Cell Cable, Head	2
OD	2035–31–805	Load Cell Cable, Foot	2
OE	3001–300–7	M/F Screw	8
OF	3001–307–57	Load Cell	4
OG	3001–508–869	BE Beeper	1

2035–30–150 Scale w/Bed Exit Options

Item	Part No.	Part Name	Qty.
OA	13–32	Ext. Tooth Lock Washer	4
	(page 11–75)	Foot Board, Scale & BE	1
OC	2035–31–804	Load Cell Cable, Head	2
OD	2035–31–805	Load Cell Cable, Foot	2
OE	3001–300–7	M/F Screw	8
OF	3001–307–57	Load Cell	4
OG	3001–508–869	BE Beeper	1

2035–42 Integrated DMS Option

Item	Part No.	Part Name	Qty.
PA	12–30	Ext Tooth Lock Washer	2
PB	37–74	Hole Plug	3
PC	59–727	Jack Screw	2
PD	2035–42–801	DMS Port Cable	1

2035–30–205 No Nurse Call Option

Item	Part No.	Part Name	Qty.
TA	4–101	Soc. Hd. Cap Screw	3
TB	2025–32–74	DMS Cover Plate	1

2035–30–206 Smart TV Option

Item	Part No.	Part Name	Qty.
UA	59–176	Jack Screw	2
UB	2035–232–806	STV Option Control Cable	1
UC	3001–330–950	STV Comm. Board	1

2035–30–207 Smart TV W/Relays Option

Item	Part No.	Part Name	Qty.
UA	59–176	Jack Screw	2
UB	2035–232–806	STV Option Control Cable	1
UC	3001–330–970	STV Comm. Board	1

Litter Assembly

2035-30-200 Head Wall Communication Option

Item	Part No.	Part Name	Qty.
SG	59-175	Head Wall Interface Cable	1
SH	59-710	Static Cap	1
SL	3001-300-7	M/F Screw	2

2035-30-201 Head Wall Comm. w/Nurse Call

Item	Part No.	Part Name	Qty.
SA	1-87	Flat Hd. Mach. Screw	2
SF	52-783	U Clip	2
SG	59-175	Head Wall Interface Cable	1
SH	59-710	Static Cap	1
SK	3000-303-871	Battery	1
SL	3001-300-7	M/F Screw	2
SP	5010-80-20	9V Battery Box w/Cable	1

2035-30-202 HW Comm. w/NC & 1 Stryker Port

Item	Part No.	Part Name	Qty.
SA	1-87	Flat Hd. Mach. Screw	2
SB	4-307	But. Hd. Cap Screw	4
SC	7-58	Truss Hd. Torx	3
SD	13-10	Ext. Tooth Lock Washer	4
SE	3-27	Strain Relief Grommet	1
SF	52-783	U Clip	2
SG	59-175	Head Wall Interface Cable	1
SH	59-710	Static Cap	1
SI	2035-30-99	Pend. Port Head Wall Brkt.	1
SJ	2035-30-804	Pendant Port Cable	1
SK	3000-303-871	Battery	1
SL	3001-300-7	M/F Screw	2
SN	3001-314-920	Head Wall Pend. Port PCB	1
SO	5000-90-28	Cord Out Label	1
SP	5010-80-20	9V Battery Box w/Cable	1

2035-30-203 HW Comm. w/NC & 2 Stryker Ports

Item	Part No.	Part Name	Qty.
SA	1-87	Flat Hd. Mach. Screw	2
SB	4-307	But. Hd. Cap Screw	8
SC	7-58	Truss Hd. Torx	3
SD	13-10	Ext. Tooth Lock Washer	4
SE	3-27	Strain Relief Grommet	1
SF	52-783	U Clip	2
SG	59-175	Head Wall Interface Cable	1
SH	59-710	Static Cap	1
SI	2035-30-99	Pend. Port Head Wall Brkt.	1
SJ	2035-30-805	Pend. Port Cable, 2 Ports	1
SK	3000-303-871	Battery	1
SL	3001-300-7	M/F Screw	2
SN	3001-314-920	Head Wall Pend. Port PCB	2
SO	5000-90-28	Cord Out Label	1
SP	5010-80-20	9V Battery Box w/Cable	1

Epic+ Litter Option Assembly

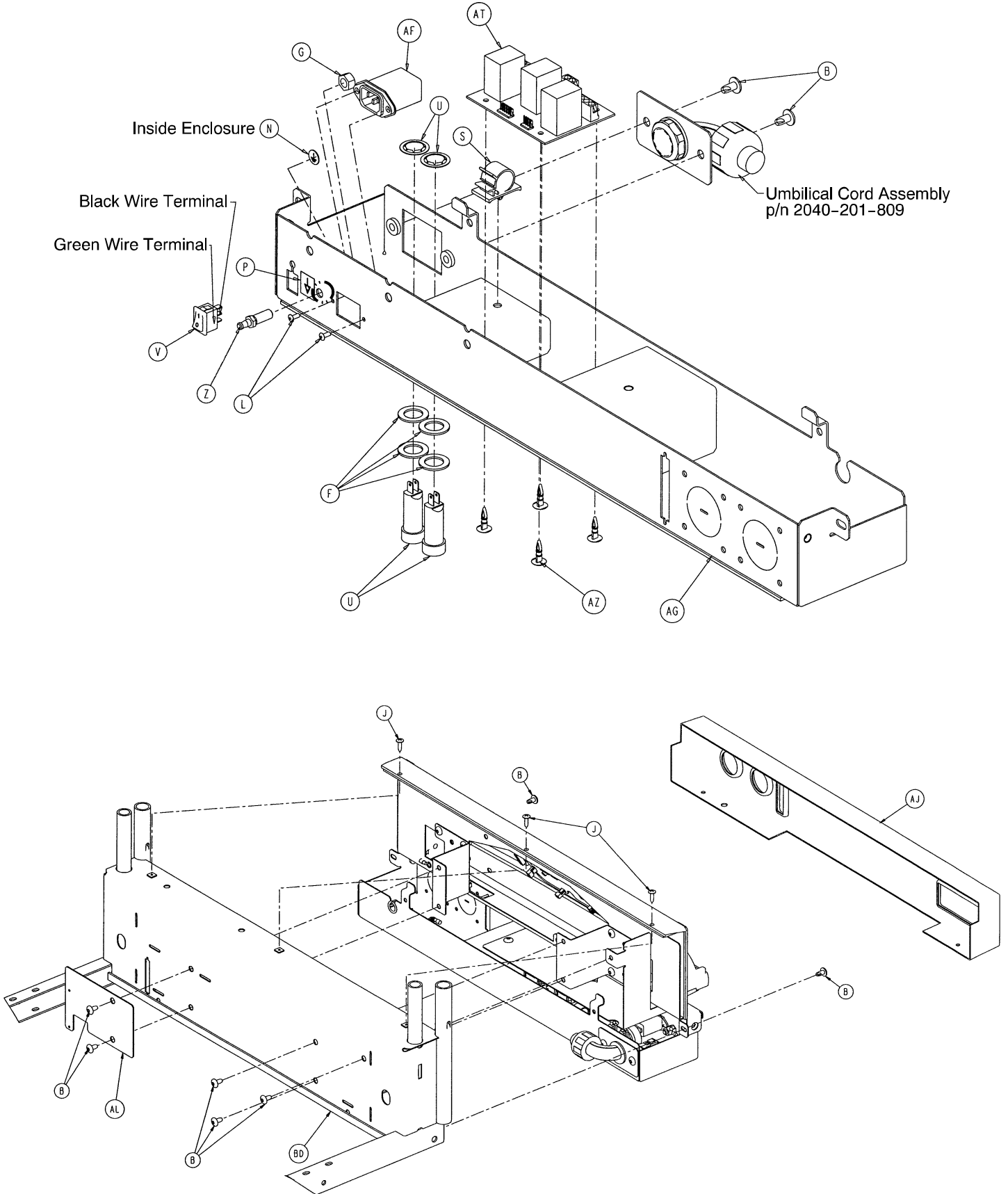

Epic+ Litter Option Assembly

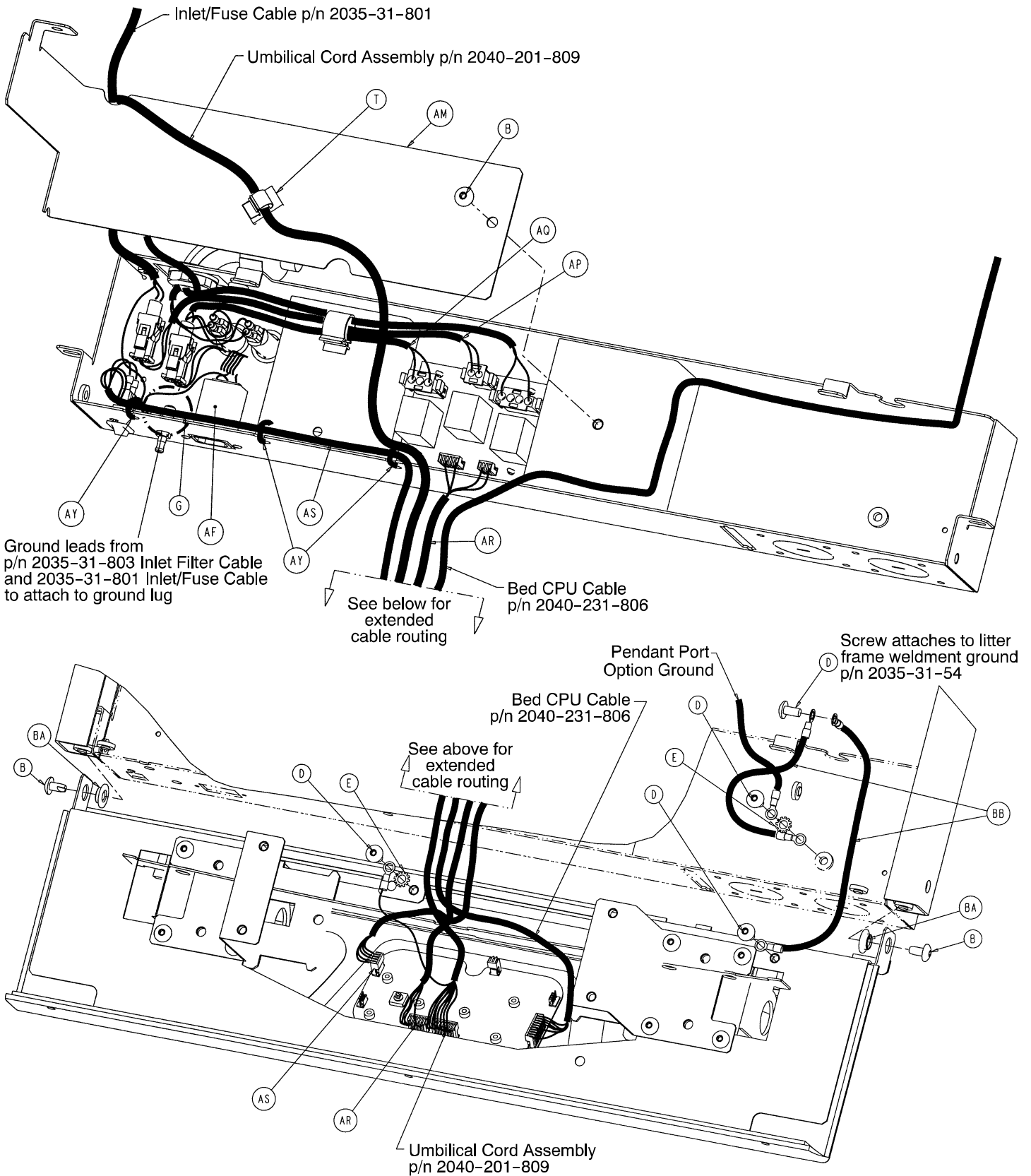

Epic+ Litter Option Assembly

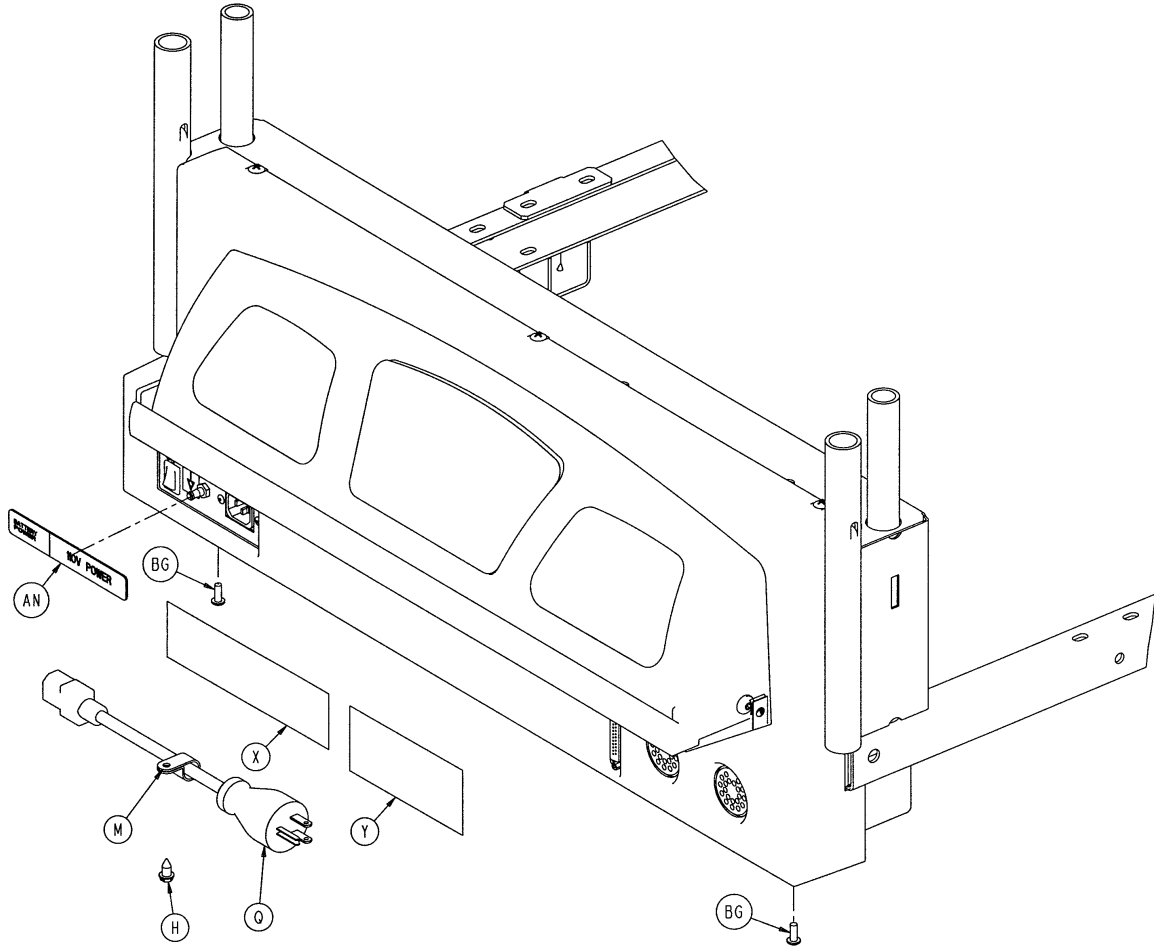

Epic+ Litter Option Assembly

Item	Part No.	Part Name	Qty.
A	4-142	Soc. Hd. Cap Screw	2
B	7-52	Truss Hd. Torx	20
C	7-56	Truss Hd. Torx	4
D	7-58	Truss Hd. Torx	4
E	13-10	External Tooth Lock Washer	5
F	14-40	Washer	4
G	16-33	Kep Nut	2
H	23-25	Hex Washer Hd. Screw	1
J	23-80	Truss Hd. Screw	3
K	23-112	Pan Hd. Screw	6
L	25-40	Rivet	2
M	34-22	Cord Clamp	1
N	36-46	Ground Label	1
P	36-115	Ground Label	1
Q	39-254	Power Cord	1
R	55-27	“U” Type Nut	4
S	59-133	Push-Mount Wire Clip	1
T	59-136	Push-Mount Wire Clip	1
U	59-190	1.0A Circuit Breaker	2
V	59-191	On/Off Switch	1
W	59-781	4-Position Connector	2
X	1550-90-1	Hospital Plug Label	1
Y	2011-1-104	Anesthetics Danger Label	1
Z	2011-1-215	Grounding Lug	1
AA	2030-31-7	Epic+ Logo Label	2
AB	2030-31-9	Instruction Label	1
AC	2030-31-10	Epic+ Head End Label	1
AD	2030-31-208	Top Display Housing	1
AE	2030-31-910	Display/CPU Board	1
AF	2035-31-803	Inlet Filter Cable	1
AG	2040-31-53	Bottom Head End Enclosure	1
AH	2040-31-54	Bumper Attachment Weldment	1
AJ	2040-31-61	Bottom Display Housing	1
AK	2040-31-63	Top Head End Enclosure	1
AL	2040-31-77	Cover Plate	1
AM	2040-31-92	Head End Electronics Cover	1
AN	2040-31-103	Power Label	1
AP	2040-31-807	Bed AC Power Jumper Cable	1
AQ	2040-31-808	Charger AC Jumper Cable	1
AR	2040-31-809	CPU/Crossover PCB Jumper Cable	1
AS	2040-31-810	On/Off Cable	1
AT	2040-31-900	AC Switchover PCB	1
AU	2040-231-75	Head End Reinforcement Bracket	2
AV	2040-31-110	Pivot Bracket, Right	1
AW	2040-31-111	Pivot Bracket, Left	1
AX	2040-231-69	Display Bumper	1
AY	3000-300-114	4” Wire Tie	3
AZ	3000-300-115	Standoff	4
BA	3001-300-99	Pivot Bearing	2
BB	3001-300-870	8” Ground Strap	2
BC	3001-400-953	Switch Cap	6
BD	7000-1-326	Foam Tape (26.75”)	1
BE	8800-380-000	Foam Tape (26.25”)	1
BF	8800-380-000	Foam Tape (1.25”)	2
BG	8800-233-500	Phillips Pan Hd. Tapping Screw	2

Epic+ Litter Option Assembly

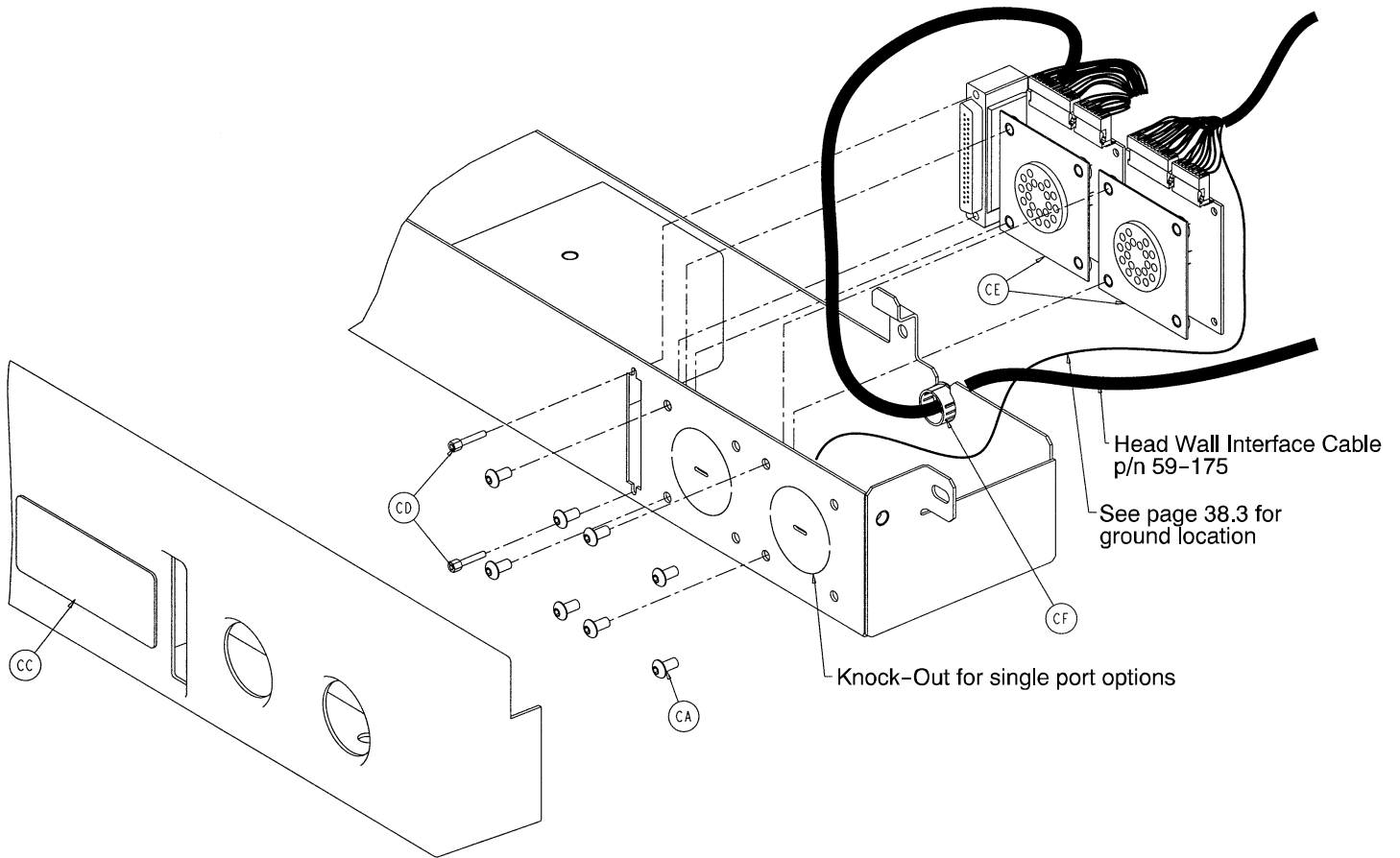

2030-31-200 Head Wall Communication Option

Item	Part No.	Part Name	Qty.
CD	3001-300-7	M/F Screw	2
CF	30-38	Grommet	1

2030-31-201 Head Wall Comm. w/Nurse Call

Item	Part No.	Part Name	Qty.
CD	3001-300-7	M/F Screw	2
CF	30-38	Grommet	1

2030-31-202 HW Comm. w/NC & 1 Stryker Port

Item	Part No.	Part Name	Qty.
CA	4-307	But. Hd. Cap Screw	4
CB	13-10	Ext. Tooth Lock Washer	2
CC	2040-31-104	Cord Out Label	1
CD	3001-300-7	M/F Screw	2
CE	3001-314-920	Head Wall Pend. Port PCB	1
CF	30-38	Grommet	1

2030-31-203 HW Comm. w/NC & 2 Stryker Ports

Item	Part No.	Part Name	Qty.
CA	4-307	But. Hd. Cap Screw	8
CB	13-10	Ext. Tooth Lock Washer	2
CC	2040-31-104	Cord Out Label	1
CD	3001-300-7	M/F Screw	2
CE	3001-314-920	Head Wall Pend. Port PCB	2
CF	30-38	Grommet	1

3001–300–775 Fowler Brake Kit Assembly

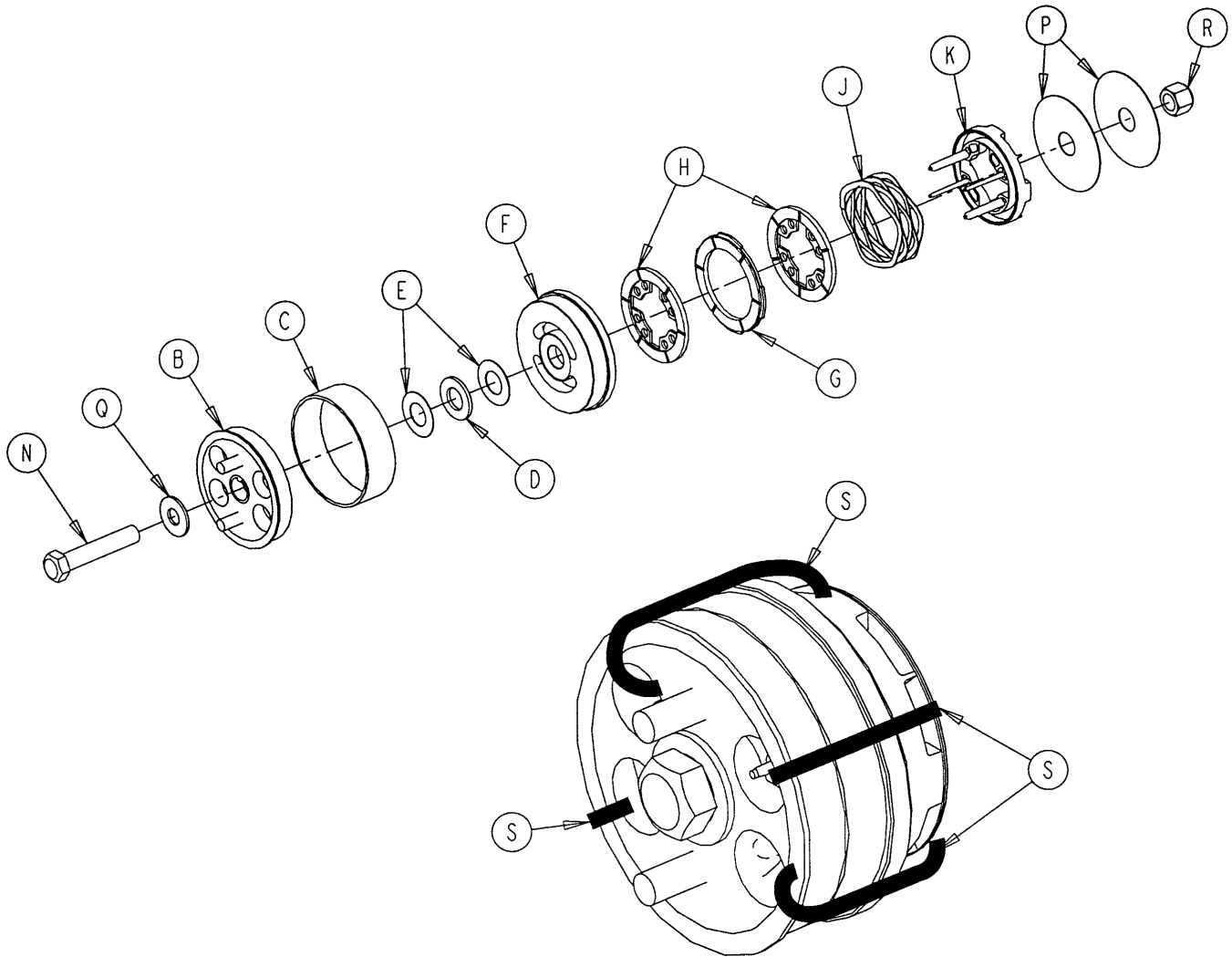

Item	Part No.	Part Name	Qty.
B	3001–300–455	CPR Coupler Assembly	1
C	3000–300–465	CPR Clutch Spring	1
D	3000–200–225	CPR Thrust Bearing	1
E	3000–200–224	Idler Gear Thrust Washer	2
F	3001–300–569	Brake Cup	1
G	3001–300–552	CPR Brake Disc	1
H	3001–300–551	CPR Spring Cup	2
J	3001–300–563	CPR Brake Spring	1
K	3001–300–570	CPR Spring Cup	1
N	3–64	Hex Hd. Cap Screw	1
P	3000–200–245	Flat Washer	2
Q	11–193	Heavy Flat Washer	1
R	16–12	Nylock Nut	1
S	3000–300–113	8" Wire Tie	4

Notes

Head End Siderail Assembly

Assembly part number
2035-400-105 (Left) & 2035-400-205 (Right)
(reference only)

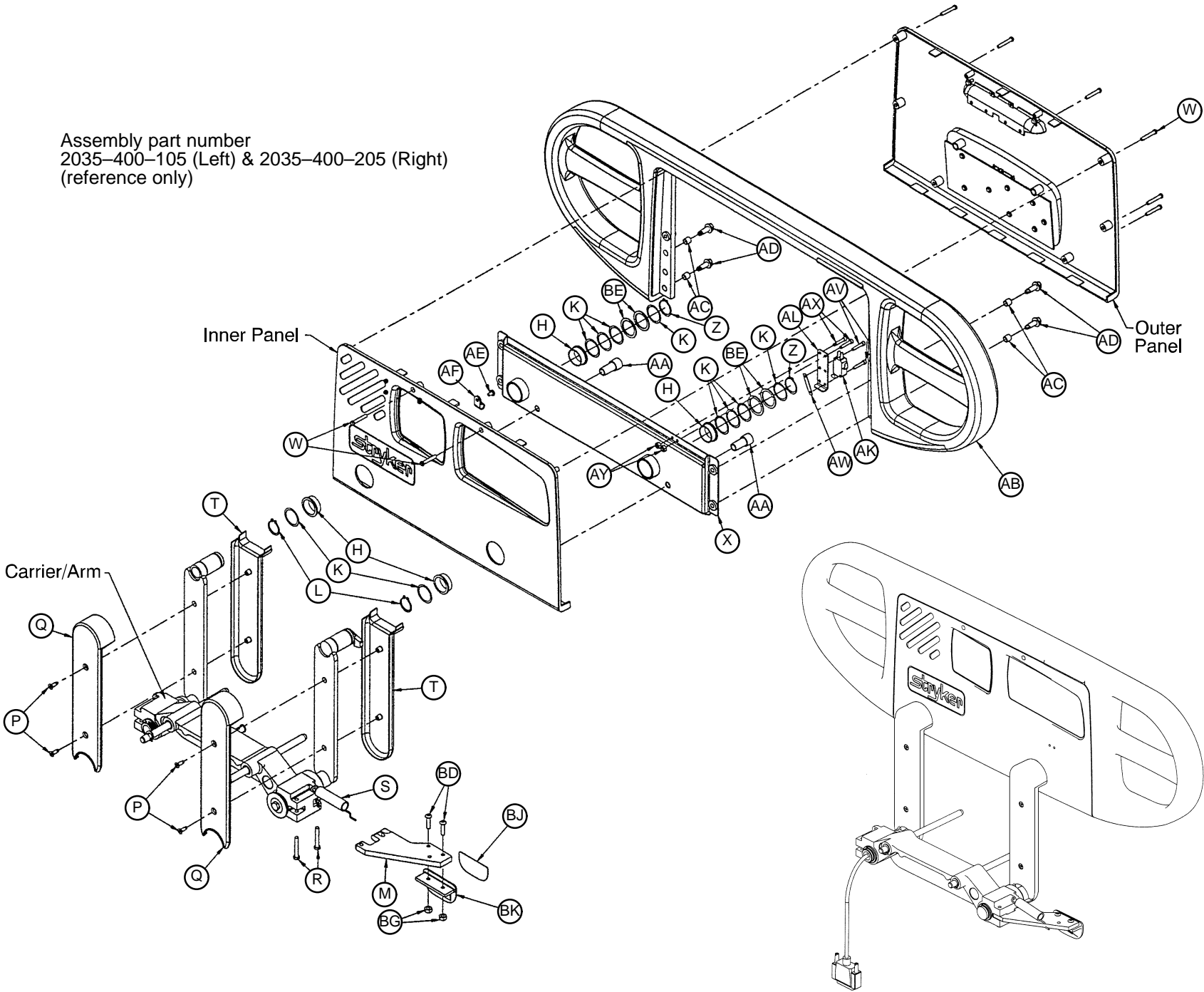

Head End Siderail Assembly

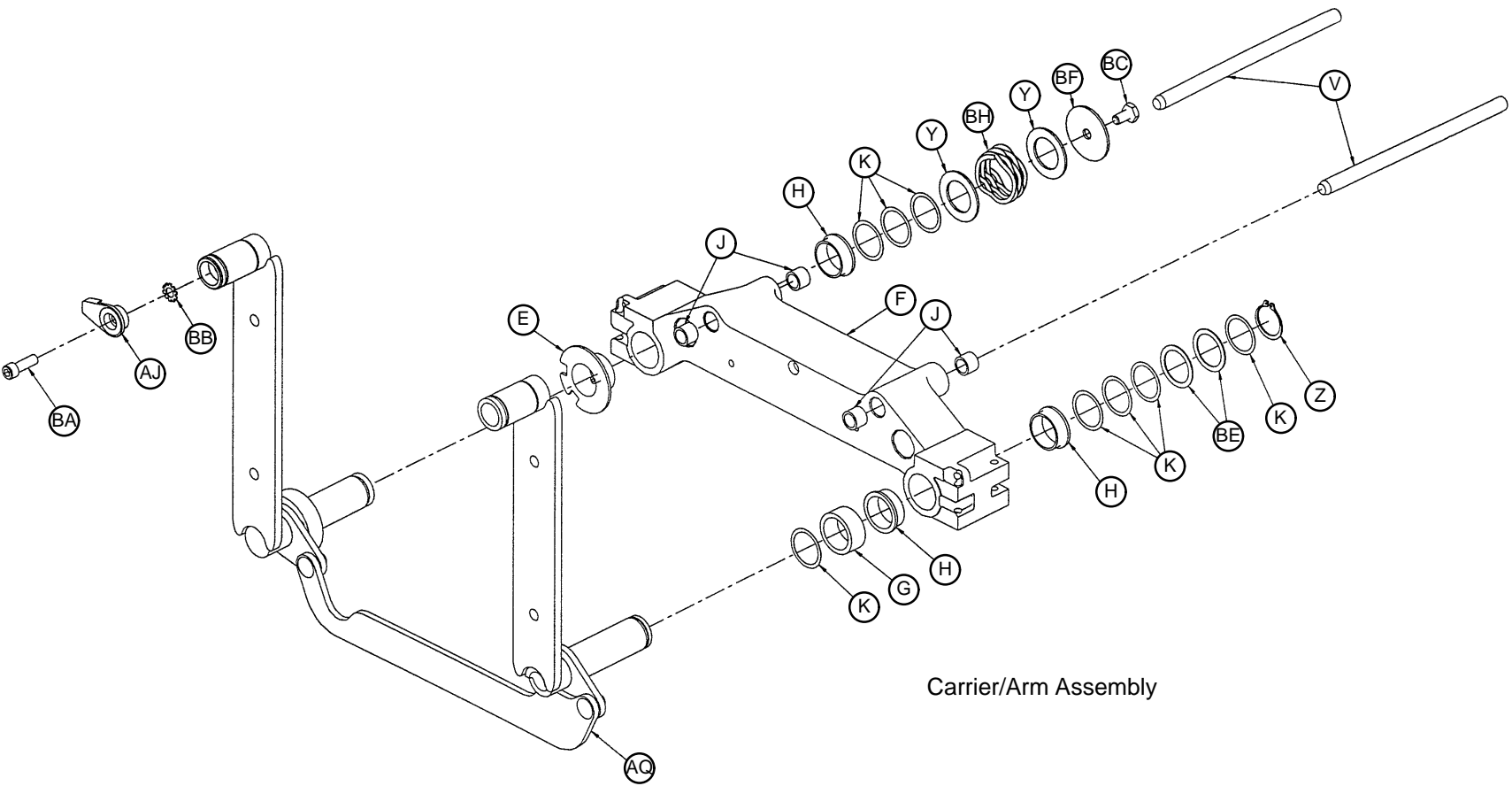

Head End Siderail Assembly

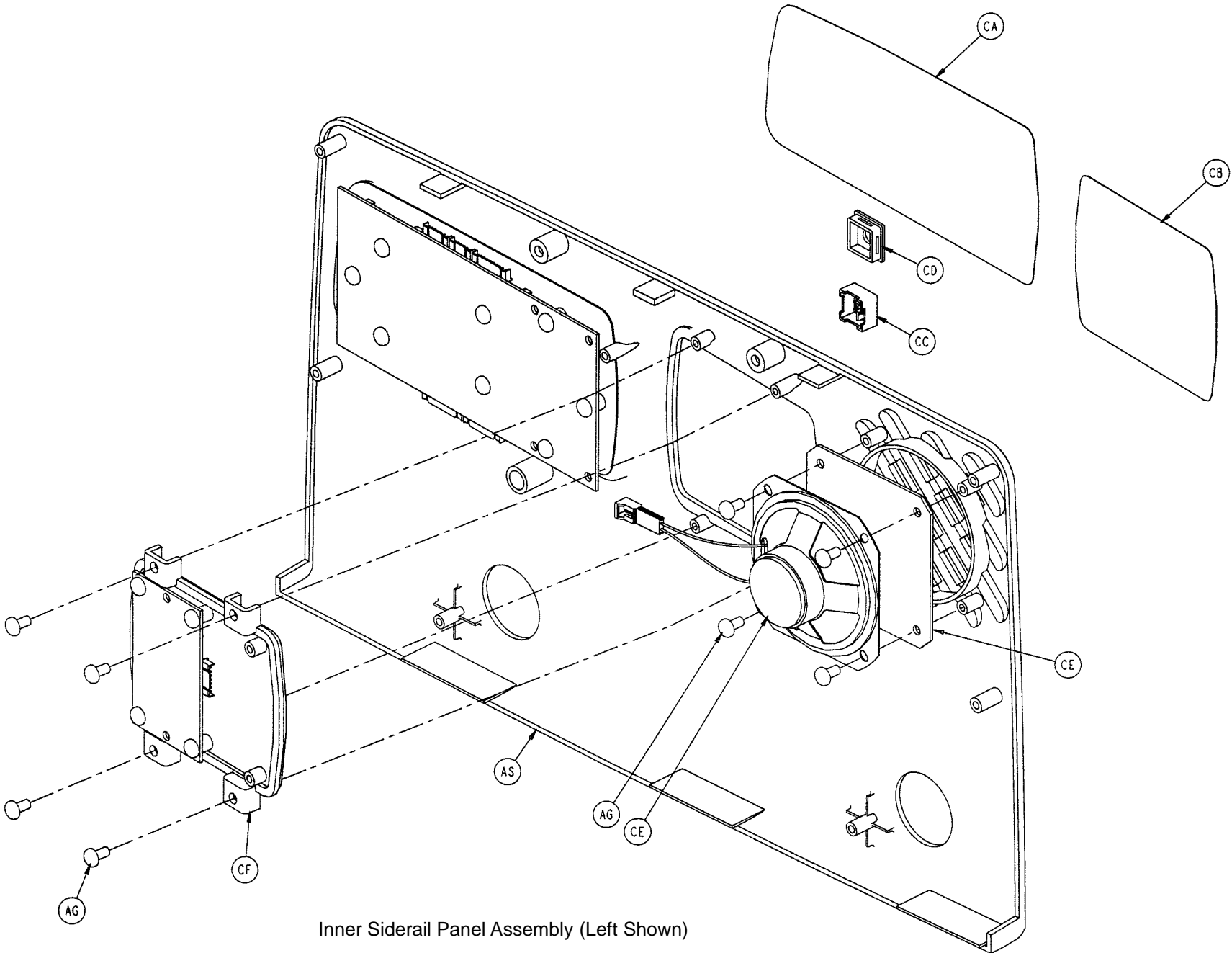

Inner Siderail Panel Assembly (Left Shown)

Head End Siderail Assembly

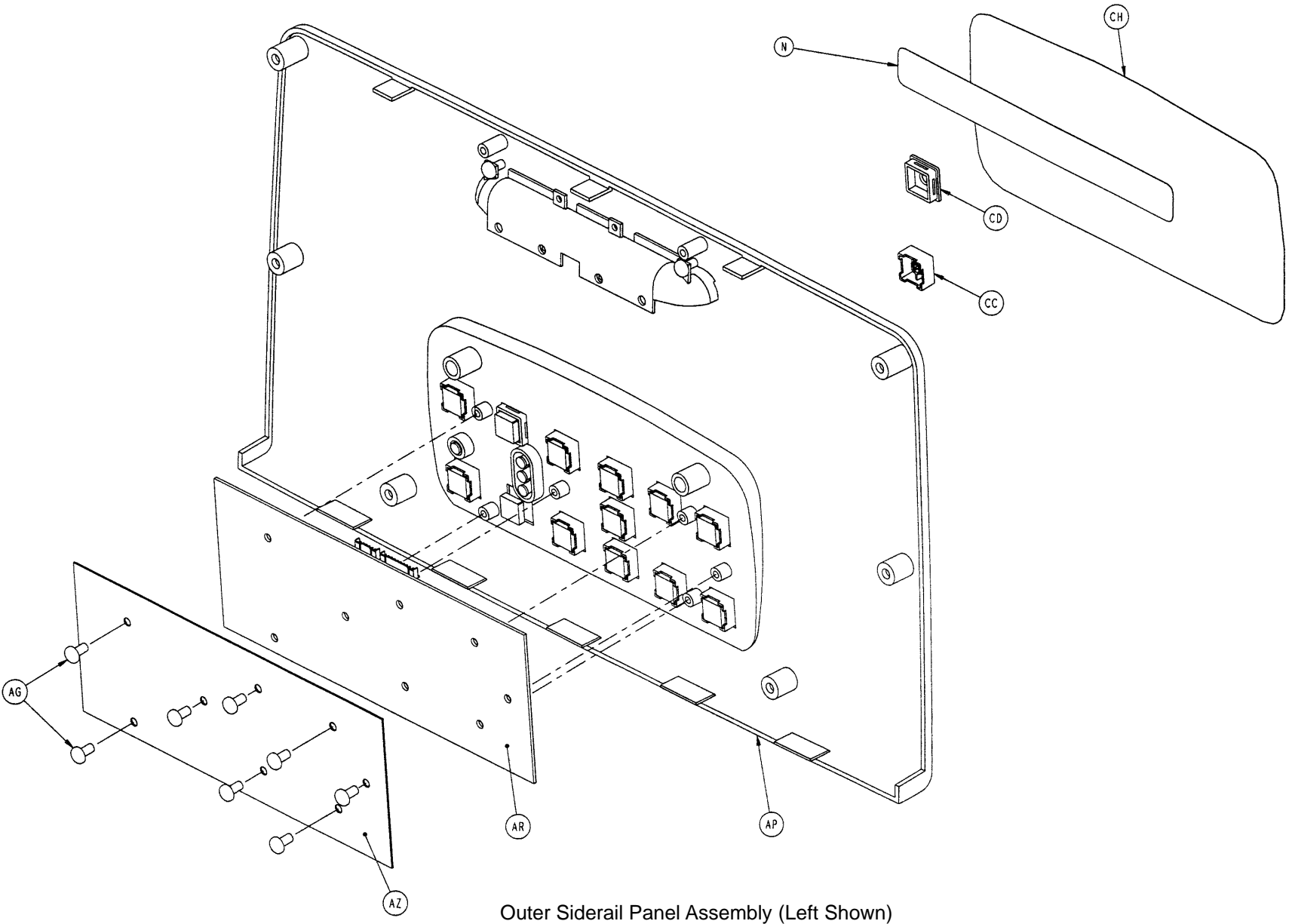

Outer Siderail Panel Assembly (Left Shown)

Head End Siderail Assembly

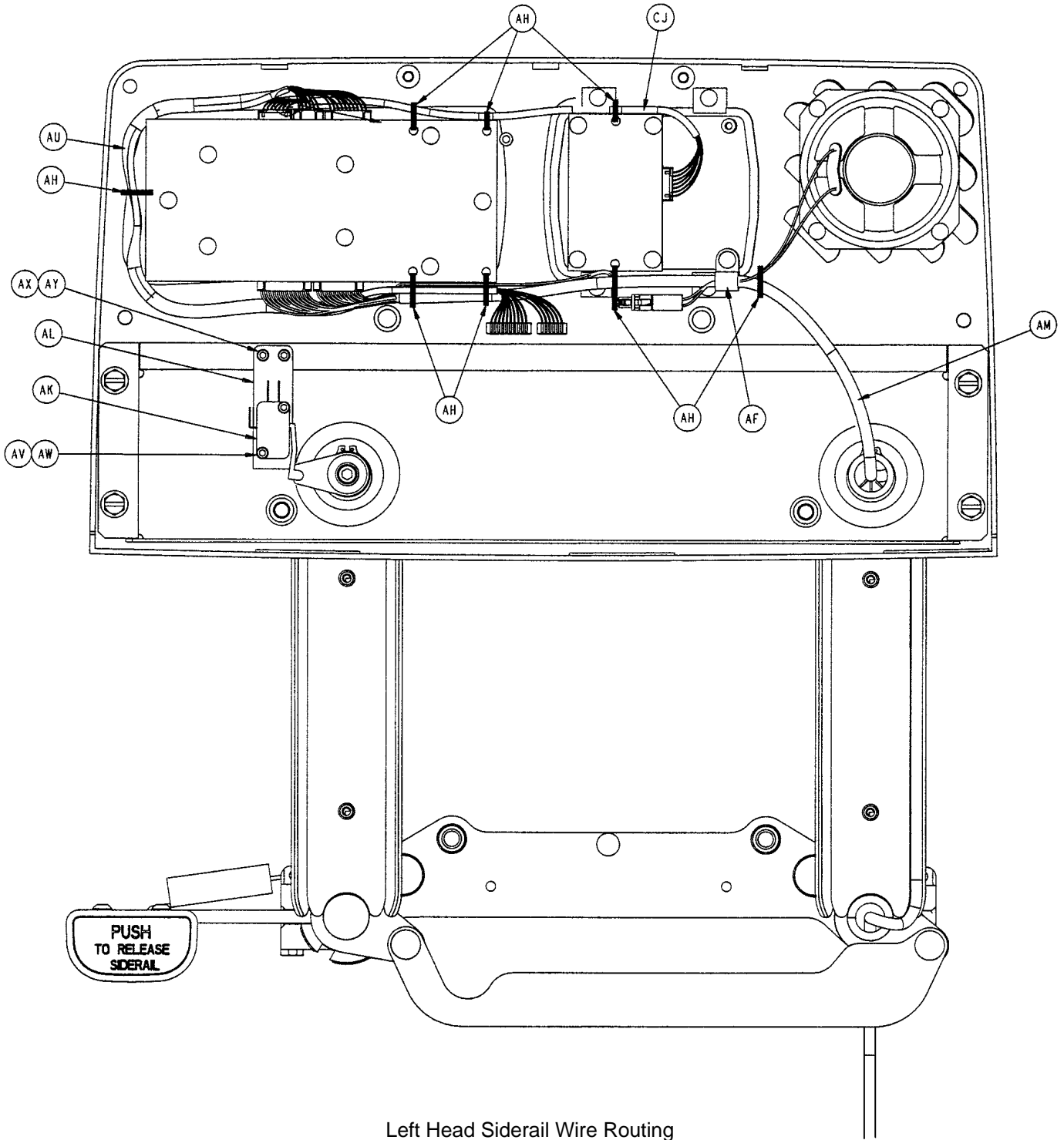

Left Head Siderail Wire Routing

Head End Siderail Assembly

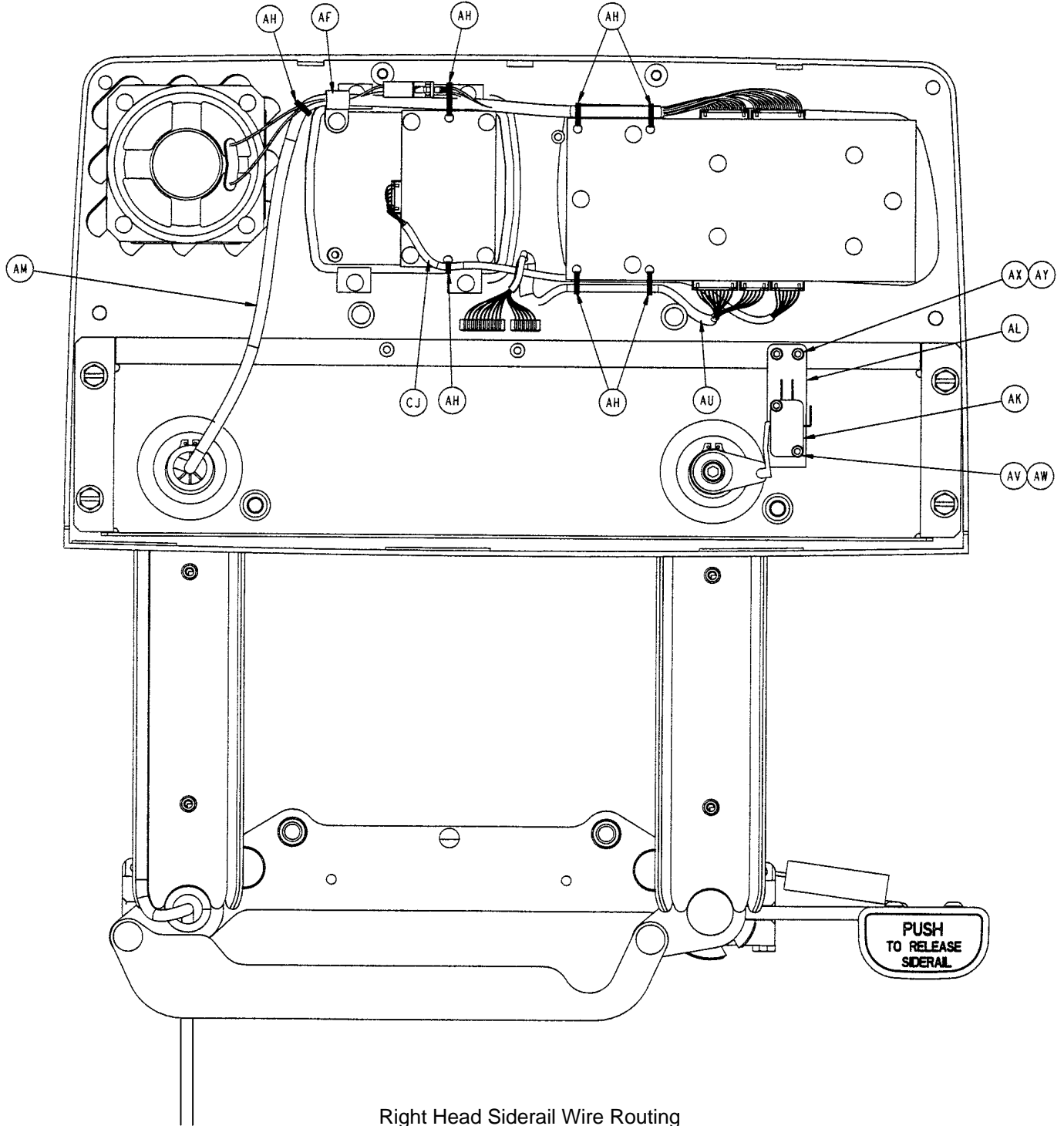

Right Head Siderail Wire Routing

Head End Siderail Assembly

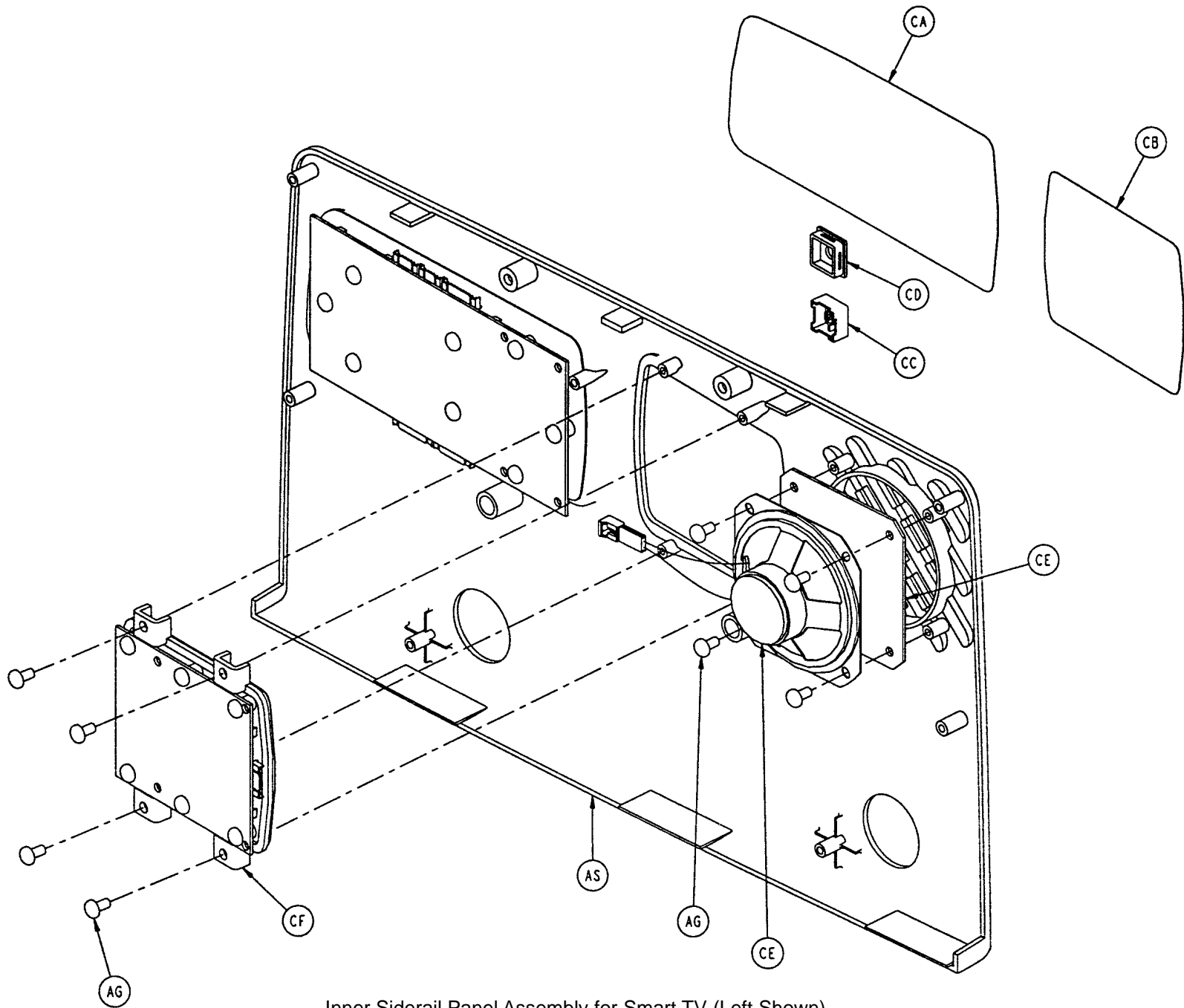

Inner Siderail Panel Assembly for Smart TV (Left Shown)

Head End Siderail Assembly

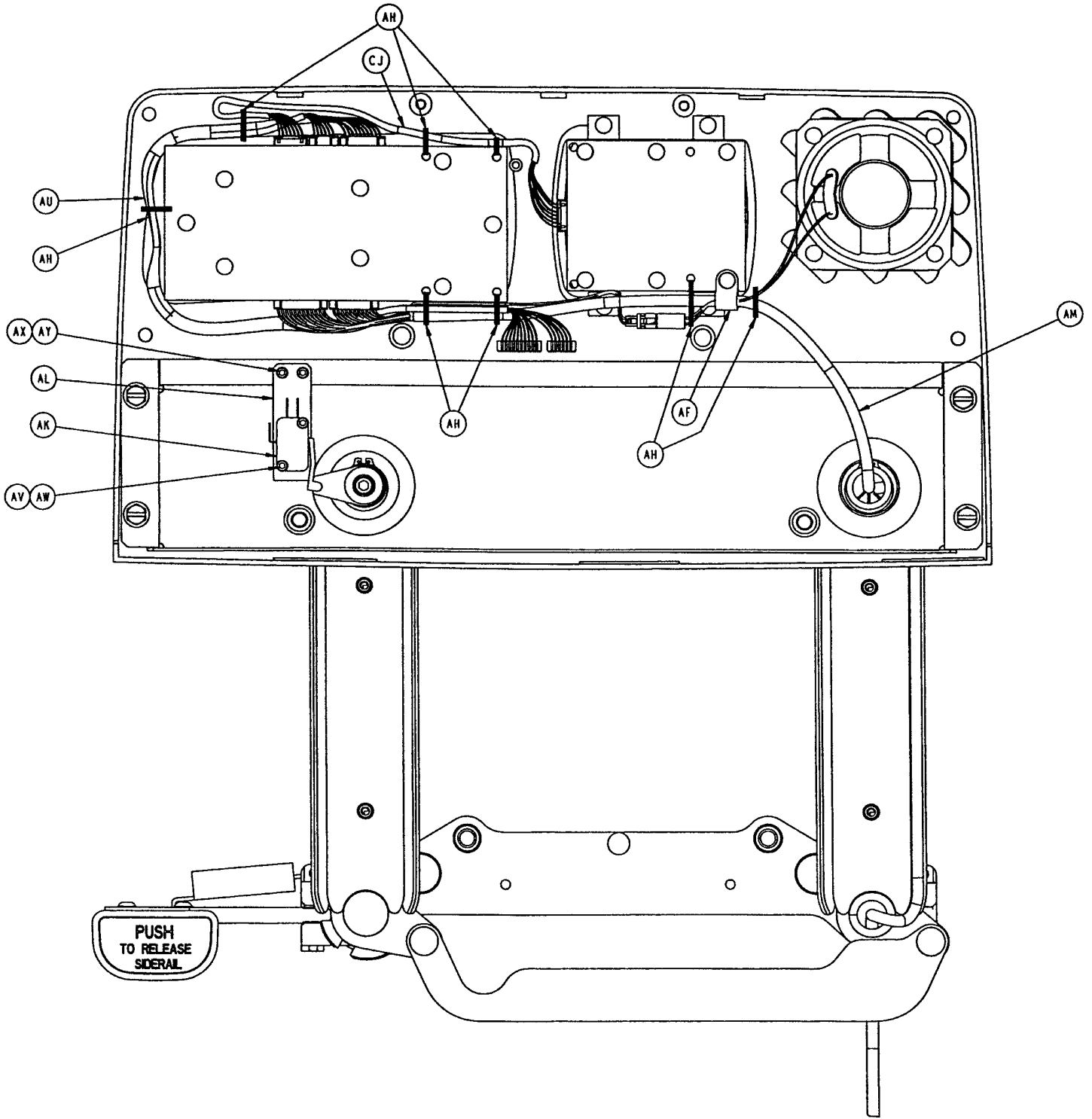

Left Head Siderail Wire Routing for Smart TV Option

Head End Siderail Assembly

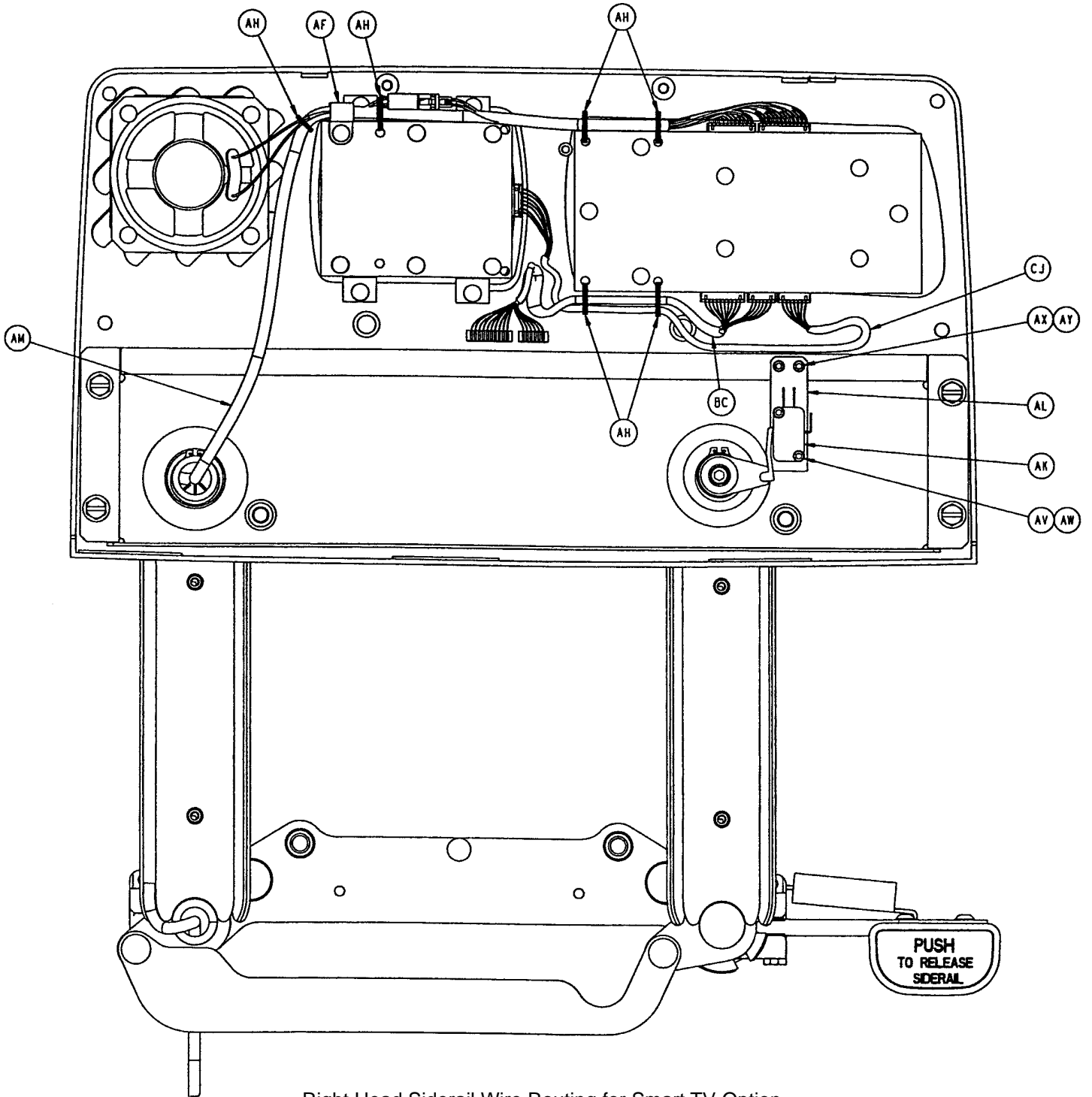

Right Head Siderail Wire Routing for Smart TV Option

Head End Siderail Assembly

2035-400-105 Left Standard Components

Item	Part No.	Part Name	Qty.
E	3001-400-513	Wear Bushing	1
F	2035-400-531	Siderail Carrier	1
G	3001-400-530	Siderail Arm Spacer	1
H	3000-400-513	Flange Bearing	7
J	3000-400-557	Sleeve Bearing	4
K	11-353	Shim Washer	18
L	28-128	Retaining Ring	2
M	2035-400-553	Release Lever, Head Rail	1
N	3000-400-556	Warning Label	1
P	23-280	High-Low Tapping Screw	4
Q	5000-20-5	Inner Arm Cover	2
R	3-344	Hex Hd. Mach. Screw	2
S	3000-200-334	Extension Spring	1
T	5000-20-6	Outer Arm Cover	2
V	2035-400-570	Glide Rod	2
W	23-90	High-Low Tapping Screw	8
X	3001-400-130	Supt. Weldment, Hd., Lt.	1
Y	11-434	Shim	2
Z	28-132	Bowed Retaining Ring	3
AA	3000-400-523	Panel Spacer	2
AB	3001-400-515	Head Rail	1
AC	3001-400-558	Siderail Spacer	4
AD	3-226	Hex Washer Hd. Screw	4
AE	23-86	High-Low Tapping Screw	1
AF	3000-300-478	CPR Conduit Clamp	1
AG	23-112	High-Low Tapping Screw	16
AH	3000-300-114	4" Cable Tie	8
AJ	2035-20-60	Limit Switch Cam	1
AK	3000-300-41	Micro Switch	1
AL	2035-20-62	Limit Switch Bracket	1
AM	2035-20-802	Siderail Cable	1
AN	2035-32-801	Limit Switch Cable	1
AP	(page 11-57)	Outer Panel Assembly	1
AQ	(page 11-55)	Timing Link Ass'y, Hd., Lt.	1
AR	2035-400-900	Siderail Outside PCB	1
AS	(page 11-56)	Inner Panel Assembly	1
AU	2035-20-804	Main Outside Cable, Lt.	1
AV	4-127	Soc. Hd. Cap Screw	2
AW	16-69	Twin Fastener	1
AX	4-101	Soc. Hd. Cap Screw	2
AY	16-23	Fiberlock Nut	2
AZ	2035-20-61	Insulation Card	1
BA	4-9	Soc. Hd. Cap Screw	1
BB	13-10	Ext. Tooth Lock Washer	1
BC	3-75	Hex Hd. Cap Screw	1
BD	4-278	Hex But. Hd. Cap Screw	2
BE	11-338	Wave Washer	6
BF	11-344	Washer	1
BG	16-2	Nylock Nut	2
BH	38-435	Wave Washer	1
BJ	3001-400-505	Release Pad Label	1
BK	3001-400-514	Release Lever Pad	1

2035-400-205 Right Standard Components

Item	Part No.	Part Name	Qty.
E	3001-400-513	Wear Bushing	1
F	2035-400-531	Siderail Carrier	1
G	3001-400-530	Siderail Arm Spacer	1
H	3000-400-513	Flange Bearing	7
J	3000-400-557	Sleeve Bearing	4
K	11-353	Shim Washer	18
L	28-128	Retaining Ring	2
M	2035-400-553	Release Lever, Head Rail	1
N	3000-400-556	Warning Label	1
P	23-280	High-Low Tapping Screw	4
Q	5000-20-5	Inner Arm Cover	2
R	3-344	Hex Hd. Mach. Screw	2
S	3000-200-334	Extension Spring	1
T	5000-20-6	Outer Arm Cover	2
V	2035-400-570	Glide Rod	2
W	23-90	High-Low Tapping Screw	8
X	3001-400-230	Supt. Weldment, Hd., Rt.	1
Y	11-434	Shim	2
Z	28-132	Bowed Retaining Ring	3
AA	3000-400-523	Panel Spacer	2
AB	3001-400-515	Head Rail	1
AC	3001-400-558	Siderail Spacer	4
AD	3-226	Hex Washer Hd. Screw	4
AE	23-86	High-Low Tapping Screw	1
AF	3000-300-478	CPR Conduit Clamp	1
AG	23-112	High-Low Tapping Screw	16
AH	3000-300-114	4" Cable Tie	7
AJ	2035-20-60	Limit Switch Cam	1
AK	3000-300-41	Micro Switch	1
AL	2035-20-62	Limit Switch Bracket	1
AM	2035-20-802	Siderail Cable	1
AN	2035-32-801	Limit Switch Cable	1
AP	(page 11-57)	Outer Panel Assembly	1
AQ	(page 11-54)	Timing Link Ass'y, Hd., Rt.	1
AR	2035-400-900	Siderail Outside PCB	1
AS	(page 11-56)	Inner Panel Assembly	1
AU	2035-20-803	Main Outside Cable, Rt.	1
AV	4-127	Soc. Hd. Cap Screw	2
AW	16-69	Twin Fastener	1
AX	4-101	Soc. Hd. Cap Screw	2
AY	16-23	Fiberlock Nut	2
AZ	2035-20-61	Insulation Card	1
BA	4-9	Soc. Hd. Cap Screw	1
BB	13-10	Ext. Tooth Lock Washer	1
BC	3-75	Hex Hd. Cap Screw	1
BD	4-278	Hex But. Hd. Cap Screw	2
BE	11-338	Wave Washer	6
BF	11-344	Washer	1
BG	16-2	Nylock Nut	2
BH	38-435	Wave Washer	1
BJ	3001-400-505	Release Pad Label	1
BK	3001-400-514	Release Lever Pad	1

Head End Siderail Assembly

2030-20-11 Standard Siderail

Item	Part No.	Part Name	Qty.
CA	2035-000-100	Label, Standard, Left	1
CA	2035-000-200	Label, Standard, Right	1
CC	3001-400-953	Switch Cap	28
CD	3001-400-522	Filler Cap	18
CE	3001-400-517	Speaker Seal	2
CF	3001-400-535	Inner Panel Blank Module	2
CH	2030-000-300	Label, Standard, Left	1
CH	2030-000-400	Label, Standard, Right	1

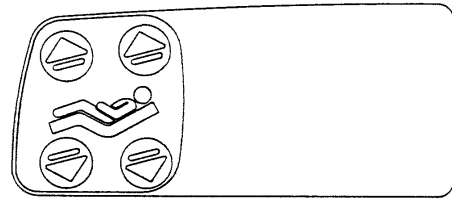

Right Inner Siderail Label

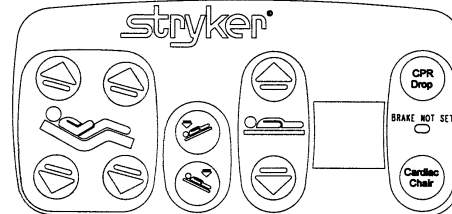

Right Outer Siderail Label

2030-20-12 Standard Siderail with Nurse Call

Item	Part No.	Part Name	Qty.
CA	2035-000-101	Label, Standard, NC, Left	1
CA	2035-000-201	Label, Standard, NC, Right	1
CC	3001-400-953	Switch Cap	32
CD	3001-400-522	Filler Cap	14
CE	3001-403-831	Speaker with Cable	2
CF	3001-400-535	Inner Panel Blank Module	2
CH	2030-000-301	Label, Standard, NC, Left	1
CH	2030-000-401	Label, Standard, NC, Right	1

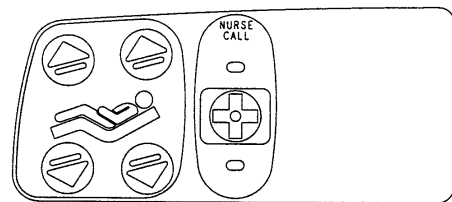

Right Inner Siderail Label

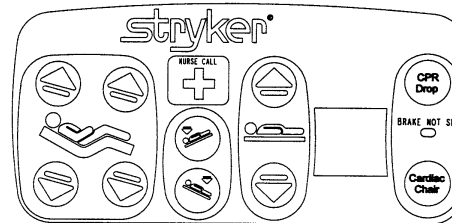

Right Outer Siderail Label

2030-20-16 Standard Siderail with DMS

Item	Part No.	Part Name	Qty.
AN	3000-300-114	Cable Tie	3
CA	2035-000-100	Label, Standard, Left	1
CA	2035-000-200	Label, Standard, Right	1
CB	2035-000-104	Label, Mattress, Left	1
CB	2035-000-204	Label, Mattress, Right	1
CC	3001-400-953	Switch Cap	36
CD	3001-400-522	Filler Cap	14
CE	3001-400-517	Speaker Seal	2
CF	(page 11-58)	DMS Module Assembly	2
CH	2030-000-303	Label, Standard, DMS, Lt.	1
CH	2030-000-403	Label, Standard, DMS, Rt.	1
CJ	3001-402-803	Main to Opt. PCB Cable, Rt.	1
CJ	3001-402-804	Main to Opt. PCB Cable, Lt.	1

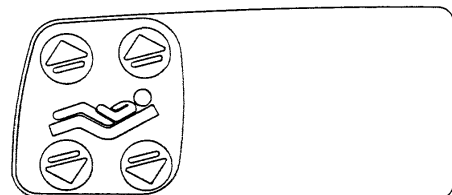

Right Inner Siderail Label



Inner Mattress Label

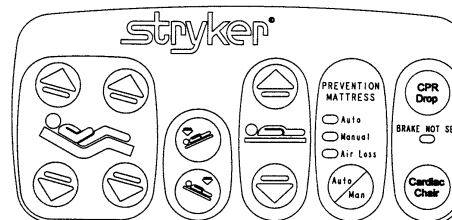

Right Outer Siderail Label

Head End Siderail Assembly

2030-20-19 Standard Siderail with StryKair

Item	Part No.	Part Name	Qty.
AN	3000-300-114	Cable Tie	3
CA	2035-000-100	Label, Standard, Left	1
CA	2035-000-200	Label, Standard, Right	1
CB	2035-000-104	Label, Mattress, Left	1
CB	2035-000-204	Label, Mattress, Right	1
CC	3001-400-953	Switch Cap	36
CD	3001-400-522	Filler Cap	14
CE	3001-400-517	Speaker Seal	2
CF	(page 11-58)	DMS Module Assembly	2
CH	2030-000-305	Label, Std., StryKair, Lt.	1
CH	2030-000-405	Label, Std., StryKair, Rt.	1
CJ	3001-402-803	Main to Opt. PCB Cable, Rt.	1
CJ	3001-402-804	Main to Opt. PCB Cable, Lt.	1

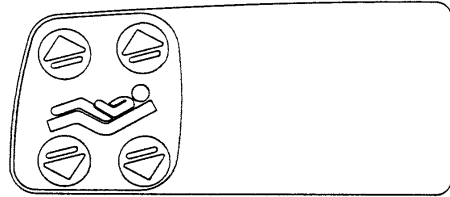

Right Inner Siderail Label



Inner Mattress Label

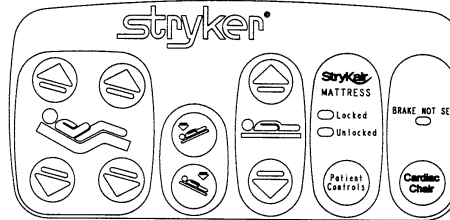

Right Outer Siderail Label

2030-20-32 Std. Siderail/StryKair Capable

Item	Part No.	Part Name	Qty.
AN	3000-300-114	Cable Tie	3
CA	2035-000-100	Label, Standard, Left	1
CA	2035-000-200	Label, Standard, Right	1
CB	2035-000-105	Label, Mattress, Blank	2
CC	3001-400-953	Switch Cap	32
CD	3001-400-522	Filler Cap	18
CE	3001-400-517	Speaker Seal	2
CF	(page 11-58)	DMS Module Assembly	2
CH	2030-000-307	Label, StryKair Capable, Lt.	1
CH	2030-000-407	Label, StryKair Capable, Rt.	1
CJ	3001-402-803	Main to Opt. PCB Cable, Rt.	1
CJ	3001-402-804	Main to Opt. PCB Cable, Lt.	1

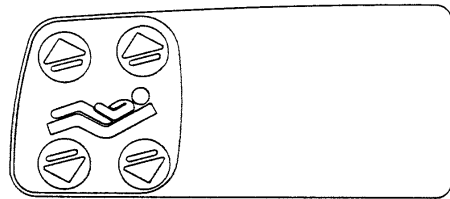

Right Inner Siderail Label

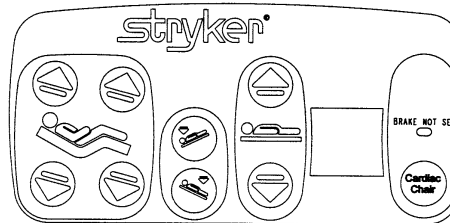

Right Outer Siderail Label

2030-20-13 Standard Siderail w/NC & DMS

Item	Part No.	Part Name	Qty.
AN	3000-300-114	Cable Tie	3
CA	2035-000-101	Label, Standard, NC, Left	1
CA	2035-000-201	Label, Standard, NC, Right	1
CB	2035-000-104	Label, Mattress, Left	1
CB	2035-000-204	Label, Mattress, Right	1
CC	3001-400-953	Switch Cap	38
CD	3001-400-522	Filler Cap	12
CE	3001-403-831	Speaker with Cable	2
CF	(page 11-58)	DMS Module Assembly	2
CH	2030-000-302	Label, Std., NC, DMS, Lt.	1
CH	2030-000-402	Label, Std., NC, DMS, Rt.	1
CJ	3001-402-803	Main to Opt. PCB Cable, Rt.	1
CJ	3001-402-804	Main to Opt. PCB Cable, Lt.	1

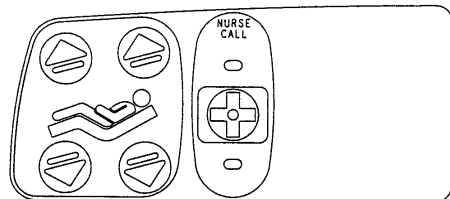

Right Inner Siderail Label

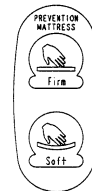

Inner Mattress Label

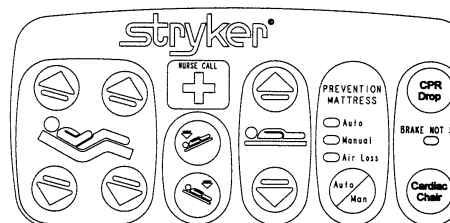

Right Outer Siderail Label

Head End Siderail Assembly

2030-20-17 Std. Siderail w/NC & StryKair

Item	Part No.	Part Name	Qty.
AN	3000-300-114	Cable Tie	3
CA	2035-000-101	Label, Standard, NC, Left	1
CA	2035-000-201	Label, Standard, NC, Right	1
CB	2035-000-104	Label, Mattress, Left	1
CB	2035-000-204	Label, Mattress, Right	1
CC	3001-400-953	Switch Cap	40
CD	3001-400-522	Filler Cap	10
CE	3001-403-831	Speaker with Cable	2
CF	(page 11-58)	DMS Module Assembly	2
CH	2030-000-304	Label, Std., NC, StryKair, Lt.	1
CH	2030-000-404	Label, Std., NC, StryKair, Rt.	1
CJ	3001-402-803	Main to Opt. PCB Cable, Rt.	1
CJ	3001-402-804	Main to Opt. PCB Cable, Lt.	1

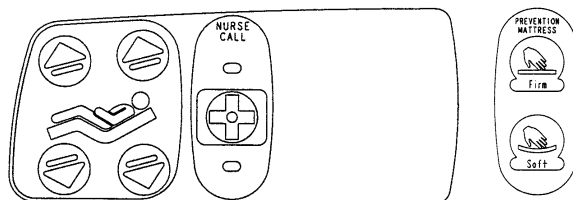

Right Inner Siderail Label

Inner Mattress Label

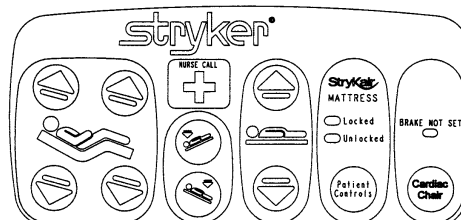

Right Outer Siderail Label

2030-20-30 Std. Rail w/NC/StryKair Capable

Item	Part No.	Part Name	Qty.
AN	3000-300-114	Cable Tie	3
CA	2035-000-101	Label, Standard, NC, Left	1
CA	2035-000-201	Label, Standard, NC, Right	1
CB	2035-000-105	Label, Mattress, Blank	2
CC	3001-400-953	Switch Cap	38
CD	3001-400-522	Filler Cap	12
CE	3001-403-831	Speaker with Cable	2
CF	(page 11-58)	DMS Module Assembly	2
CH	2030-000-306	Label, NC, StryKair Cap., Lt.	1
CH	2030-000-406	Label, NC, StryKair Cap., Rt.	1
CJ	3001-402-803	Main to Opt. PCB Cable, Rt.	1
CJ	3001-402-804	Main to Opt. PCB Cable, Lt.	1

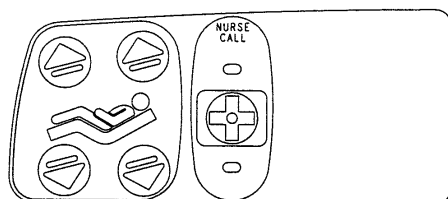

Right Inner Siderail Label

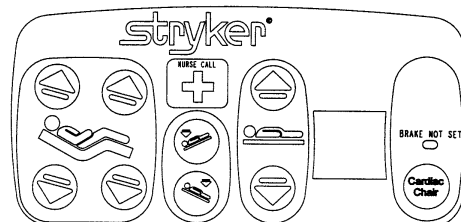

Right Outer Siderail Label

2030-20-15 Standard Siderail w/NC & Comm.

Item	Part No.	Part Name	Qty.
CA	2035-000-102	Label, Standard, Left	1
CA	2035-000-202	Label, Standard, Right	1
CC	3001-400-953	Switch Cap	42
CD	3001-400-522	Filler Cap	4
CE	3001-403-831	Speaker with Cable	2
CF	3001-400-535	Inner Panel Blank Module	2
CH	2030-000-301	Label, Standard, NC, Lt.	1
CH	2030-000-401	Label, Standard, NC, Rt.	1

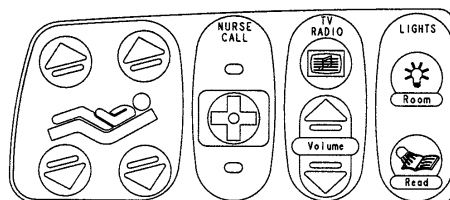

Right Inner Siderail Label

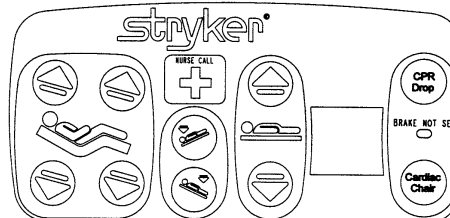

Right Outer Siderail Label

Head End Siderail Assembly

2030-20-21 Std. Siderail w/NC & STV

Item	Part No.	Part Name	Qty.
AN	3000-300-114	Cable Tie	3
CA	2035-000-106	Label, Std., NC, STV., Lt.	1
CA	2035-000-206	Label, Std., NC, STV., Rt.	1
CB	2035-000-109	Label, CC & Mute, Left	1
CB	2035-000-209	Label, CC & Mute, Right	1
CC	3001-400-953	Switch Cap	42
CD	3001-400-522	Filler Cap	4
CE	3001-403-831	Speaker with Cable	2
CF	(page 11-59)	STV Module, Left	1
CF	(page 11-60)	STV Module, Right	1
CH	2030-000-301	Label, Standard, NC, Lt.	1
CH	2030-000-401	Label, Standard, NC, Rt.	1
CJ	3001-402-803	Main to Opt. PCB Cable	2

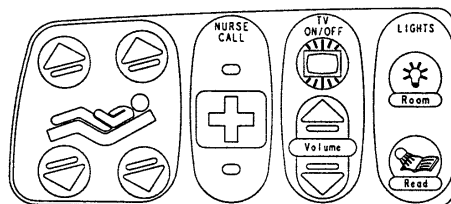

Right Inner Siderail Label

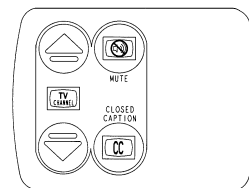

Inner STV Label

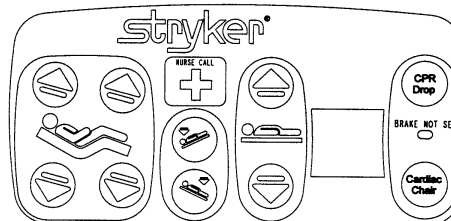

Right Outer Siderail Label

2030-20-14 Std. Rail w/NC, DMS & Comm.

Item	Part No.	Part Name	Qty.
AN	3000-300-114	Cable Tie	3
CA	2035-000-102	Label, Std., NC, Comm., Lt.	1
CA	2035-000-202	Label, St., NC, Comm. Rt.	1
CB	2035-000-104	Label, Mattress, Left	1
CB	2035-000-204	Label, Mattress, Right	1
CC	3001-400-953	Switch Cap	48
CD	3001-400-522	Filler Cap	2
CE	3001-403-831	Speaker with Cable	2
CF	(page 11-58)	DMS Module Assembly	2
CH	2030-000-302	Label, Std., NC, DMS, Lt.	1
CH	2030-000-402	Label, Std., NC, DMS, Rt.	1
CJ	3001-402-803	Main to Opt. PCB Cable, Rt.	1
CJ	3001-402-804	Main to Opt. PCB Cable, Lt.	1

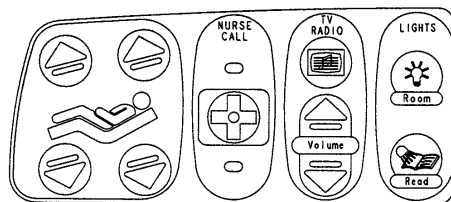

Right Inner Siderail Label



Inner Mattress Label

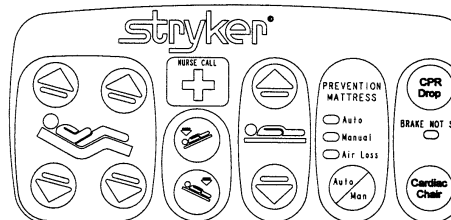

Right Outer Siderail Label

2030-20-20 Std. Rail w/NC, DMS & STV

Item	Part No.	Part Name	Qty.
AN	3000-300-114	Cable Tie	3
CA	2035-000-106	Label, Std., NC, STV., Lt.	1
CA	2035-000-206	Label, Std., NC, STV., Rt.	1
CC	3001-400-953	Switch Cap	48
CB	2035-000-110	Label, Matt., CC & Mute, Lt.	1
CB	2035-000-210	Label, Matt., CC & Mute, Rt.	1
CC	3001-400-953	Switch Cap	48
CD	3001-400-522	Filler Cap	2
CE	3001-403-831	Speaker with Cable	2
CF	(page 11-61)	Module Assembly, Lt.	1
CF	(page 11-62)	Module Assembly, Rt.	1
CH	2030-000-302	Label, Std., NC, DMS, Lt.	1
CH	2030-000-402	Label, Std., NC, DMS, Rt.	1
CJ	3001-402-803	Main to Opt. PCB Cable, Rt.	2

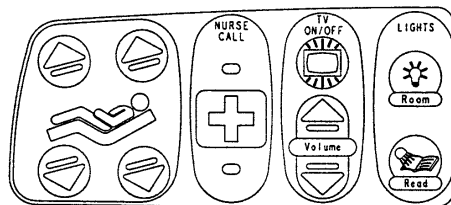

Right Inner Siderail Label

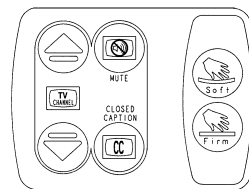

Inner Mattress/STV Label

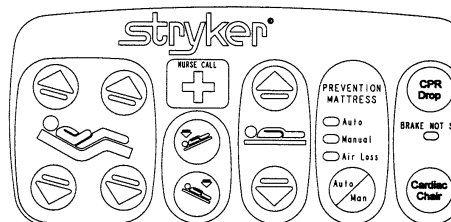

Right Outer Siderail Label

Head End Siderail Assembly

2030-20-18 Std. Rail w/NC, StryKair & Comm.

Item	Part No.	Part Name	Qty.
AN	3000-300-114	Cable Tie	3
CA	2035-000-102	Label, Std., NC, Comm., Lt.	1
CA	2035-000-202	Label, Std., NC, Comm. Rt.	1
CB	2035-000-104	Label, Mattress, Left	1
CB	2035-000-204	Label, Mattress, Right	1
CC	3001-400-953	Switch Cap	50
CE	3001-403-831	Speaker with Cable	2
CF	(page 11-58)	DMS Module Assembly	2
CH	2030-000-304	Label, Std., NC, StryKair, Lt.	1
CH	2030-000-404	Label, Std., NC, StryKair, Rt.	1
CJ	3001-402-803	Main to Opt. PCB Cable, Rt.	1
CJ	3001-402-804	Main to Opt. PCB Cable, Lt.	1

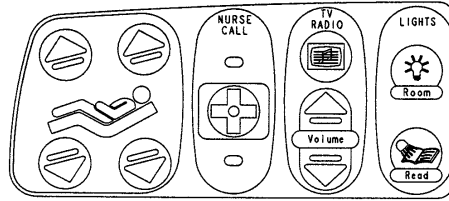

Right Inner Siderail Label



Inner Mattress Label

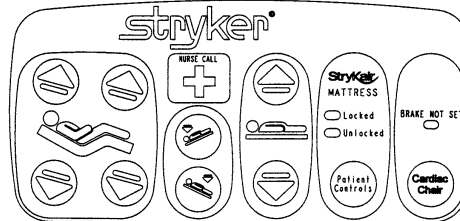

Right Outer Siderail Label

2030-20-22 Std. Rail w/NC, StryKair & STV

Item	Part No.	Part Name	Qty.
AN	3000-300-114	Cable Tie	3
CA	2035-000-106	Label, Std., NC, STV., Lt.	1
CA	2035-000-206	Label, Std., NC, STV., Rt.	1
CB	2035-000-110	Label, Matt., CC & Mute, Lt.	1
CB	2035-000-210	Label, Matt., CC & Mute, Rt.	1
CC	3001-400-953	Switch Cap	46
CD	3001-400-522	Filler Cap	4
CE	3001-403-831	Speaker with Cable	2
CF	(page 11-61)	Module Assembly, Lt.	1
CF	(page 11-62)	Module Assembly, Rt.	1
CH	2030-000-304	Label, Std., NC, StryKair, Lt.	1
CH	2030-000-404	Label, Std., NC, StryKair, Rt.	1
CJ	3001-402-803	Main to Opt. PCB Cable, Rt.	2

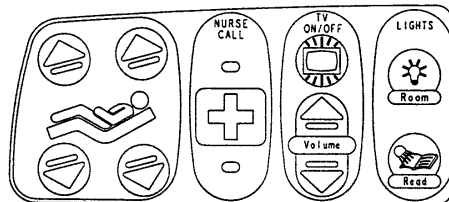

Right Inner Siderail Label

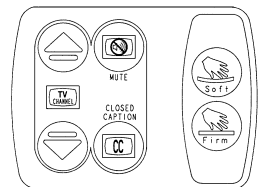

Inner Mattress/STV Label

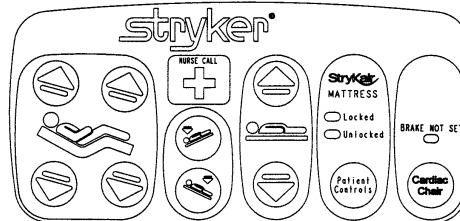

Right Outer Siderail Label

2030-20-31 Rail w/NC, StryKair Cap. & Comm.

Item	Part No.	Part Name	Qty.
AN	3000-300-114	Cable Tie	3
CA	2035-000-102	Label, Standard, Left	1
CA	2035-000-202	Label, Standard, Right	1
CB	2035-000-105	Label, Mattress, Blank	2
CC	3001-400-953	Switch Cap	46
CD	3001-400-522	Filler Cap	4
CE	3001-403-831	Speaker with Cable	2
CF	(page 11-58)	DMS Module Assembly	2
CH	2030-000-306	Label, NC, StryKair Cap., Lt.	1
CH	2030-000-406	Label, NC, StryKair Cap., Rt.	1
CJ	3001-402-803	Main to Opt. PCB Cable, Rt.	1
CJ	3001-402-804	Main to Opt. PCB Cable, Lt.	1

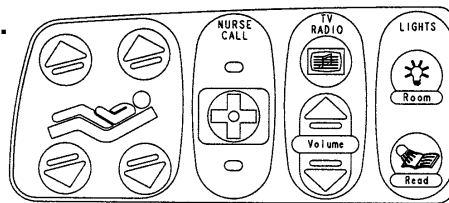

Right Inner Siderail Label

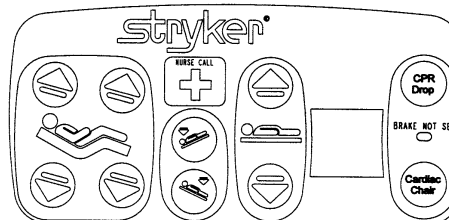

Right Outer Siderail Label

2035-400-228 Head End Siderail Timing Link Assembly, Right

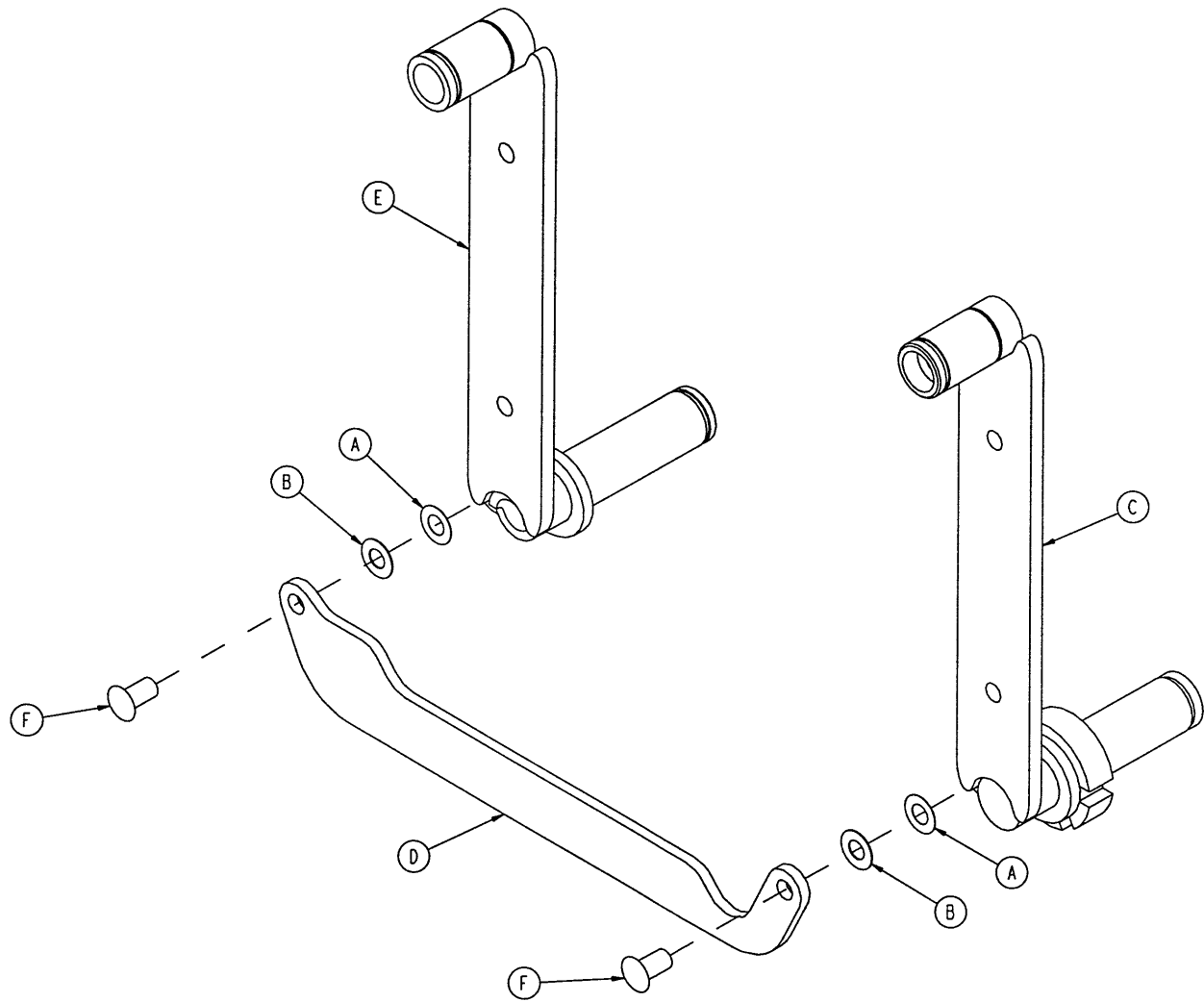

Item	Part No.	Part Name	Qty.
A	11-377	Nylon Washer	2
B	11-403	Shim Washer	2
C	2035-400-227	Arm Wldmt., Right, Head, Foot	1
D	3001-400-11	Head End Timing Link	1
E	3001-400-228	Arm Wldmt., Right, Head, Head	1
F	3001-400-501	Siderail Linkage Rivet	2

2035-400-128 Head End Siderail Timing Link Assembly, Left

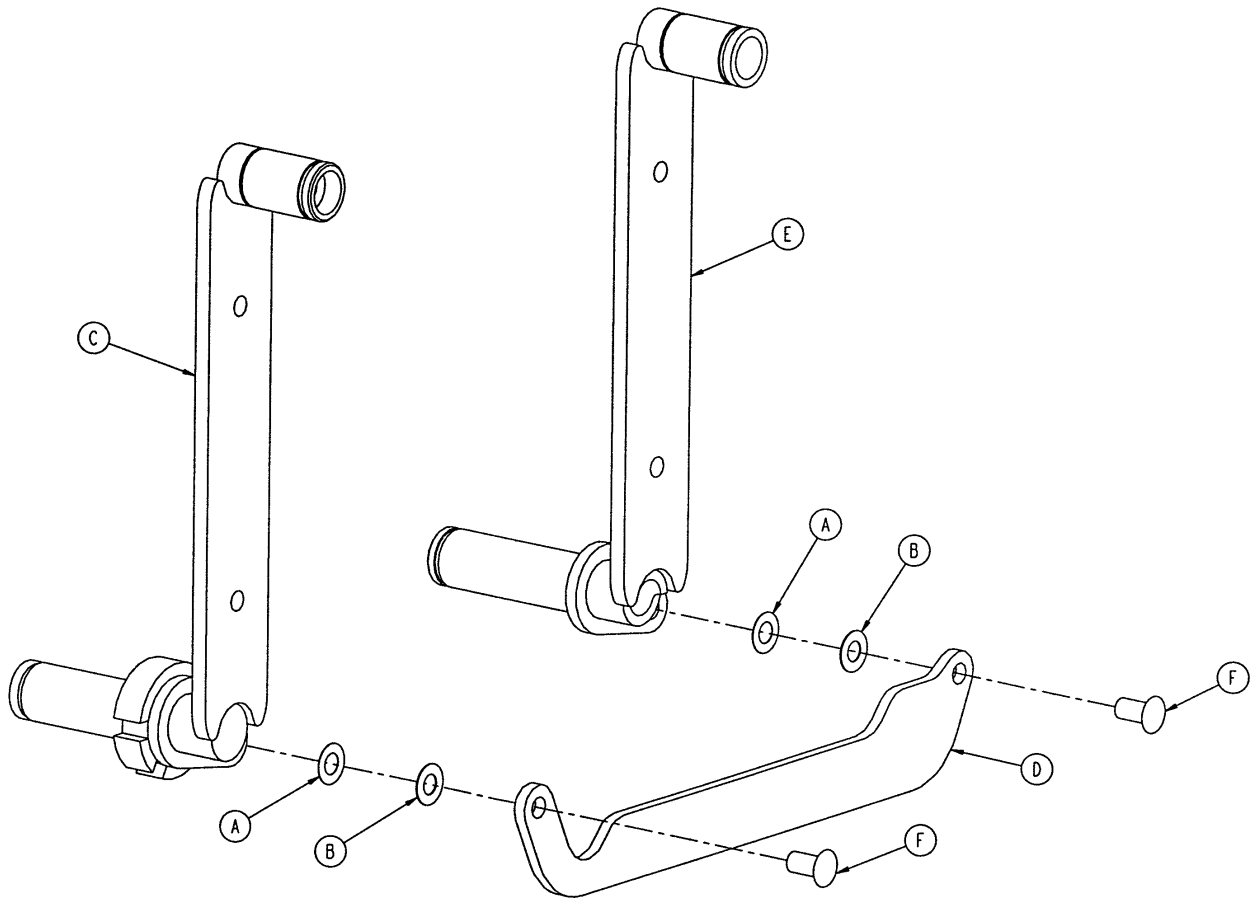

Item	Part No.	Part Name	Qty.
A	11-377	Nylon Washer	2
B	11-403	Shim Washer	2
C	2035-400-127	Arm Wldmt., Left, Head, Foot	1
D	3001-400-11	Head End Timing Link	1
E	3001-400-128	Arm Wldmt., Left, Head, Head	1
F	3001-400-501	Siderail Linkage Rivet	2

Head End Siderail Inner Panel Assembly

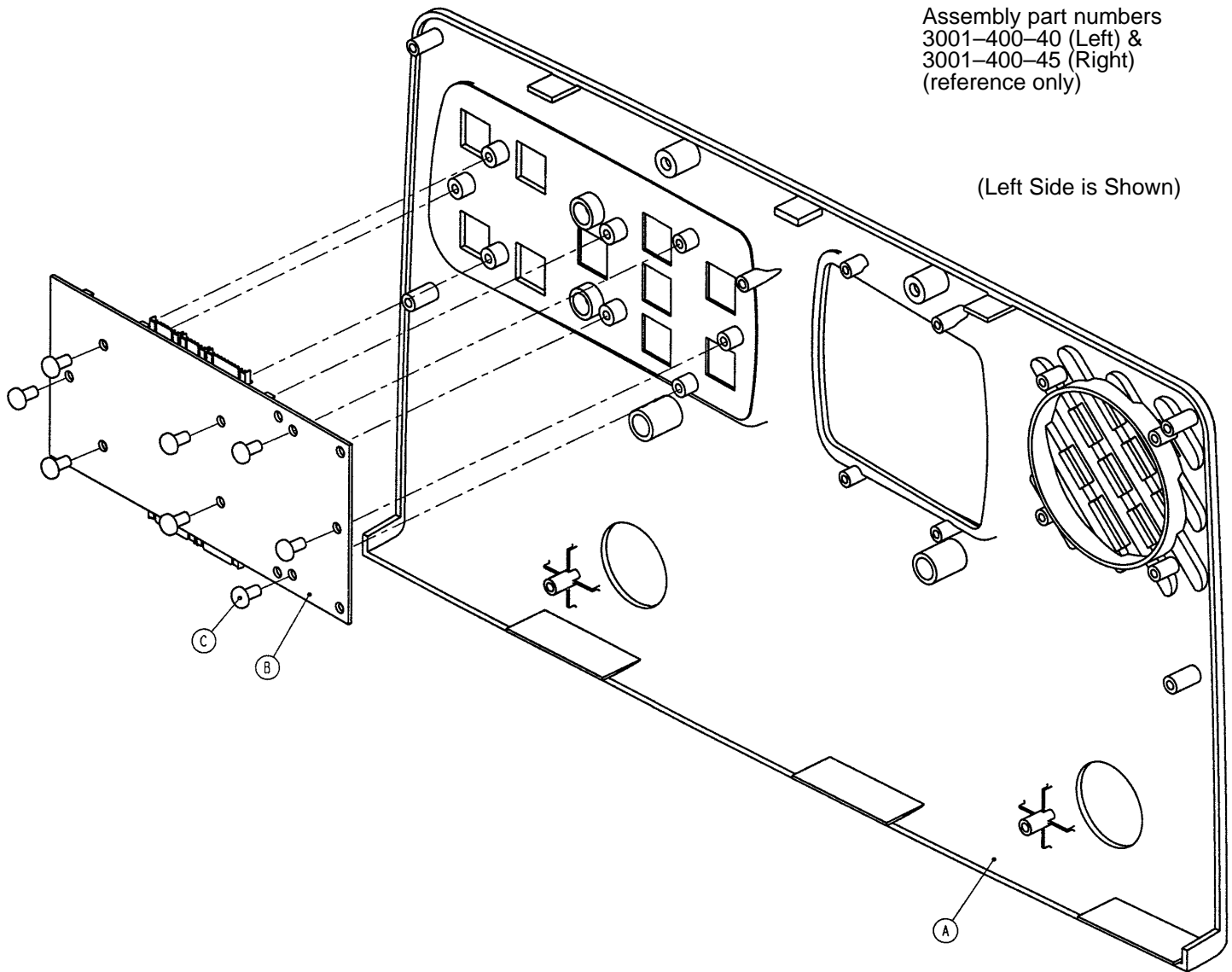

Item	Part No.	Part Name	Qty.
A	3001-400-101	Left Inner Panel	1
	3001-400-201	Right Inner Panel	1
B	3001-400-900	Inner Siderail PCB Assembly	1
C	23-112	Hi-Low Tapping Screw	8

Head End Siderail Outer Panel Assembly, Right & Left

Assembly part number 2035-400-50
(reference only)

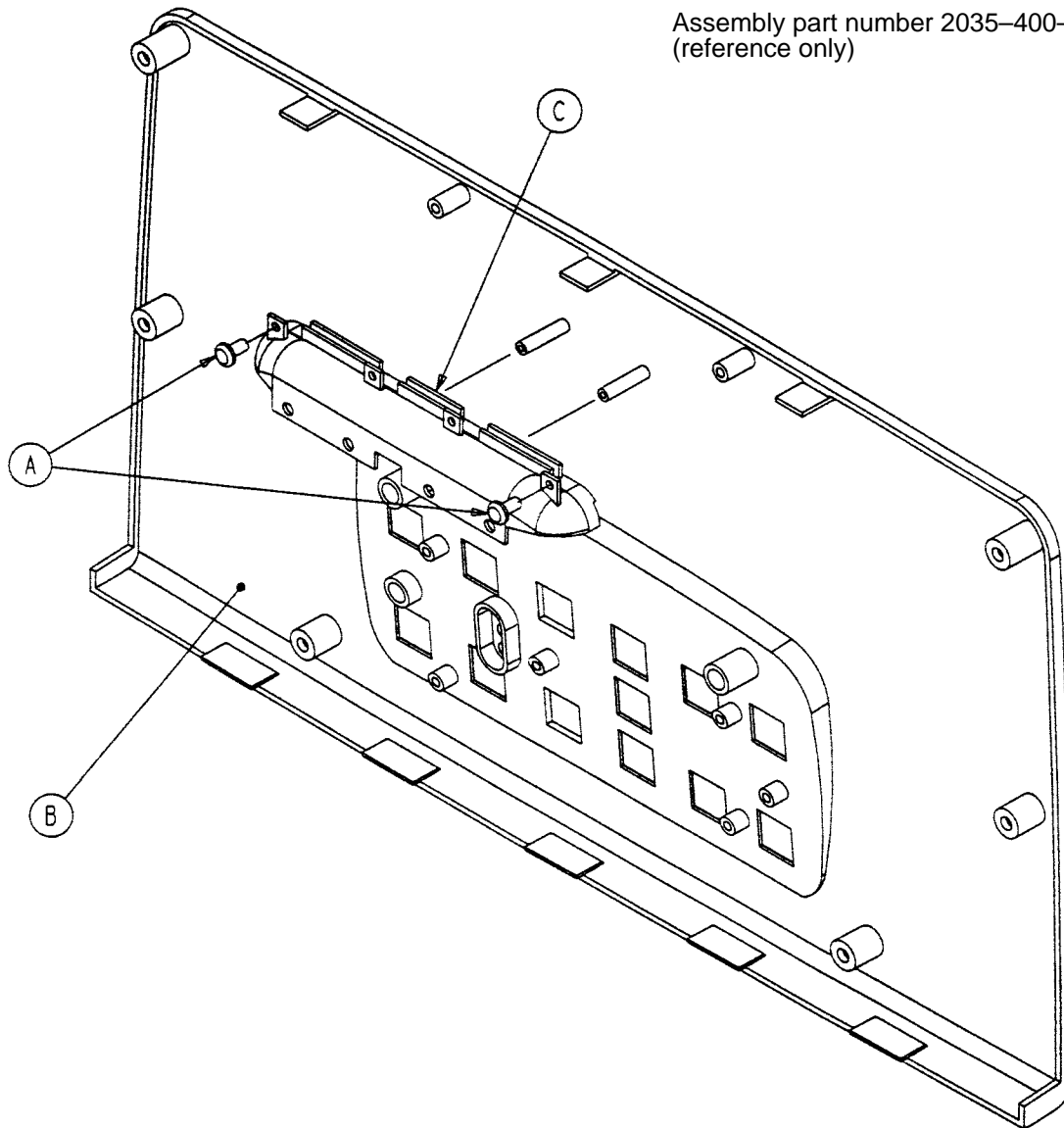

Item	Part No.	Part Name	Qty.
A	23-112	Hi-Low Tapping Screw	2
B	2035-400-102	Outer Panel	1
C	3001-400-599	Handle Insert	1

Optional DMS Siderail Module Assembly, Right & Left

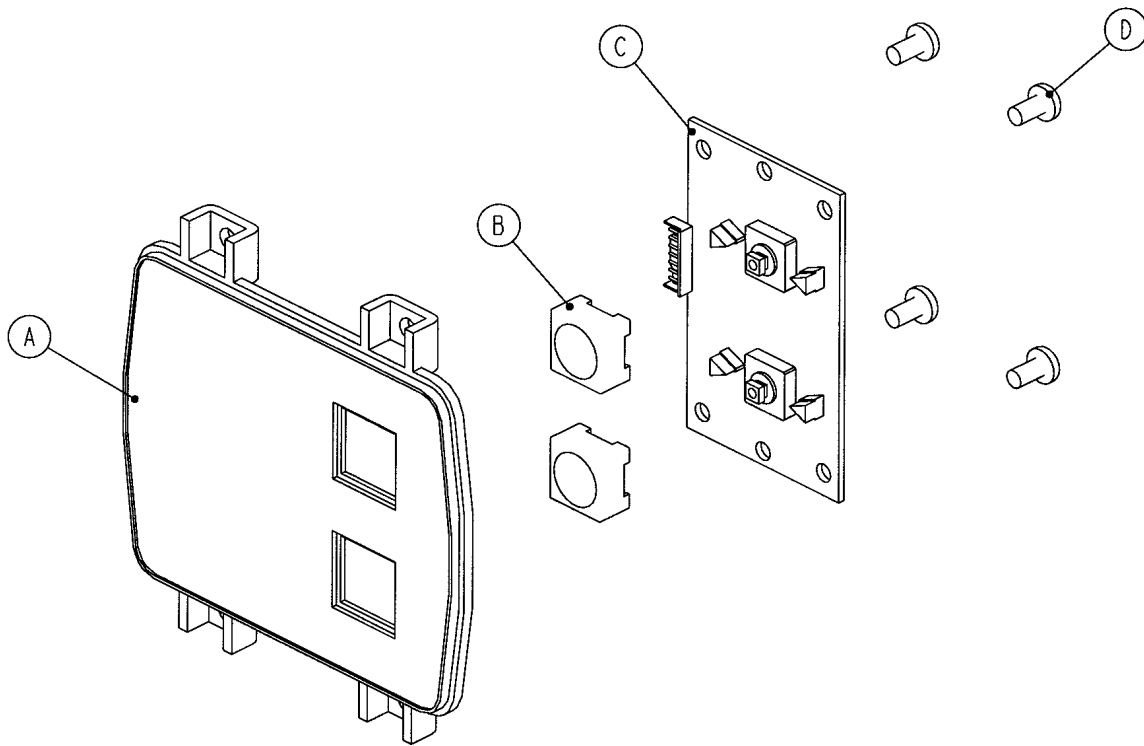

Item	Part No.	Part Name	Qty.
A	3001-400-521	DMS Module	1
B	3001-400-953	Switch Cap	2
C	3001-402-900	DMS Keypad PCB	1
D	23-112	Tapping Screw	4

2035–400–53 Optional Smart TV Siderail Module, Right

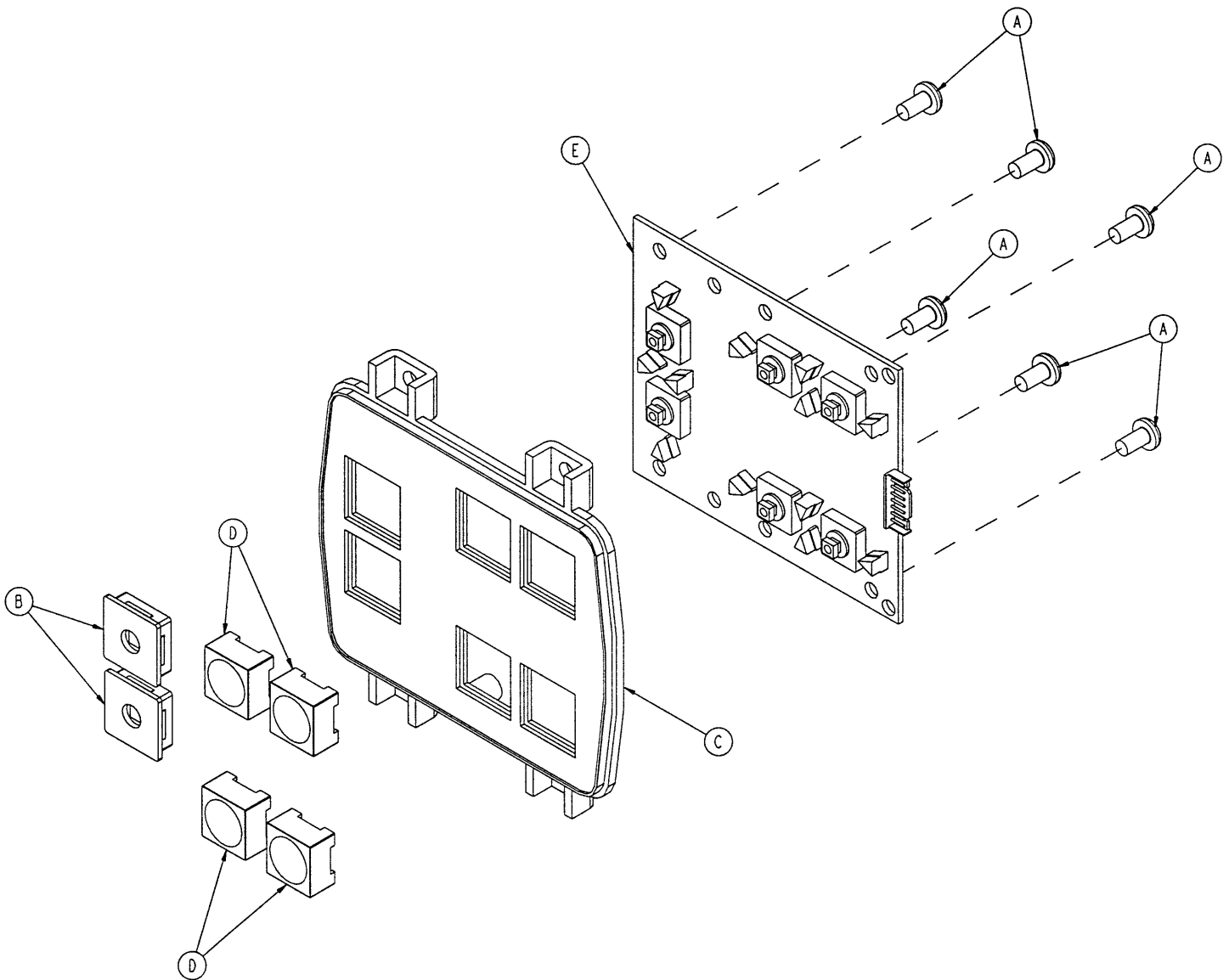

Item	Part No.	Part Name	Qty.
A	23-112	Ph. Hd. Hi-Lo Tapping Screw	6
B	3001-400-522	Filler Cap	2
C	3001-400-524	Module	1
D	3001-400-953	Switch Cap	4
E	5000-400-930	Keypad PCB, Left	1

2035–400–51 Optional Smart TV Siderail Module, Left

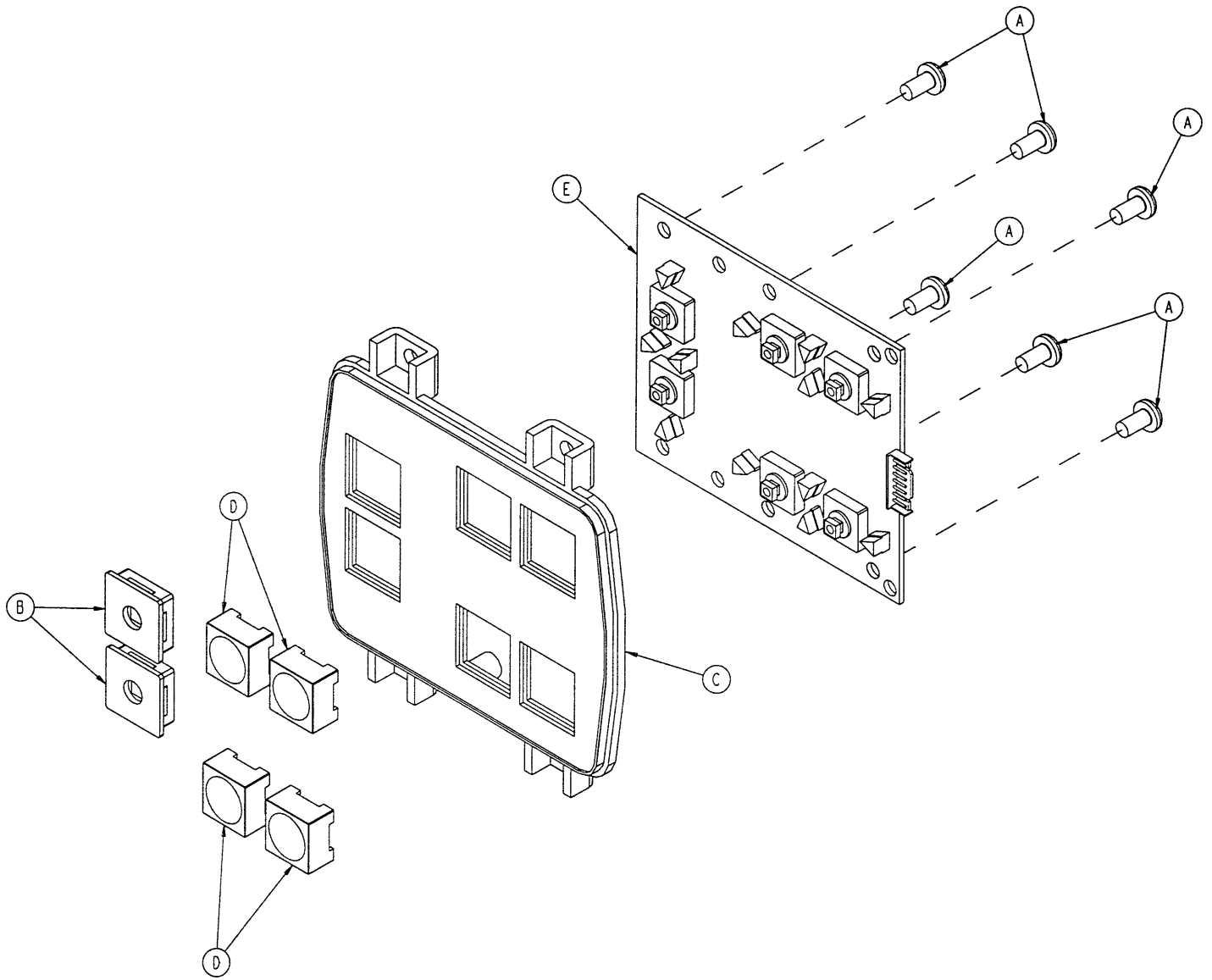

Item	Part No.	Part Name	Qty.
A	23-112	Ph. Hd. Hi-Lo Tapping Screw	6
B	3001-400-522	Filler Cap	2
C	3001-400-524	Module	1
D	3001-400-953	Switch Cap	4
E	5000-400-920	Keypad PCB, Right	1

5000–20–27 Optional Smart TV & Mattress Control Module, Right

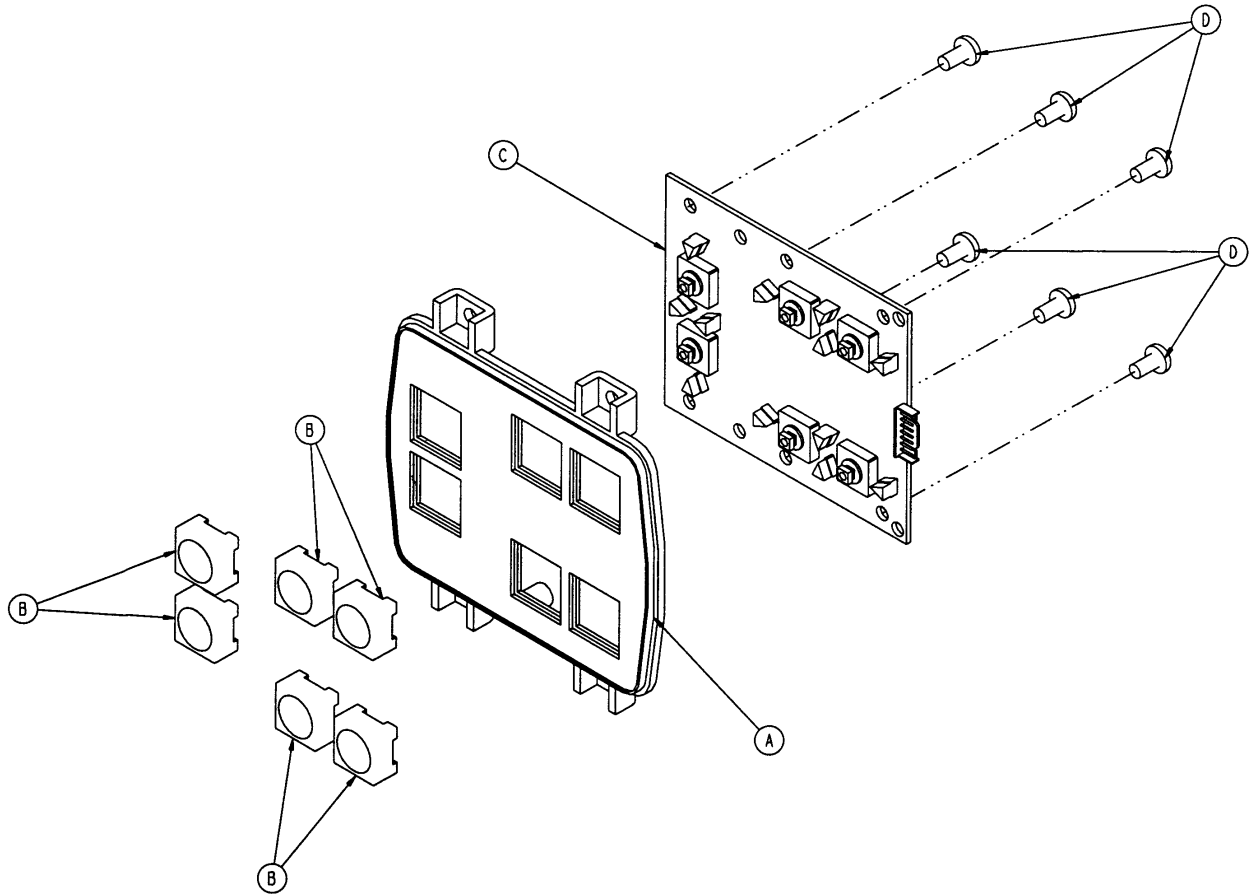

Item	Part No.	Part Name	Qty.
A	3001–400–524	Lumbar Module	1
B	3001–400–953	Switch Cap	6
C	5000–400–930	Lumbar Keypad PCB, Left	1
D	23–112	Tapping Screw	6

5000–20–26 Optional Smart TV & Mattress Control Module, Left

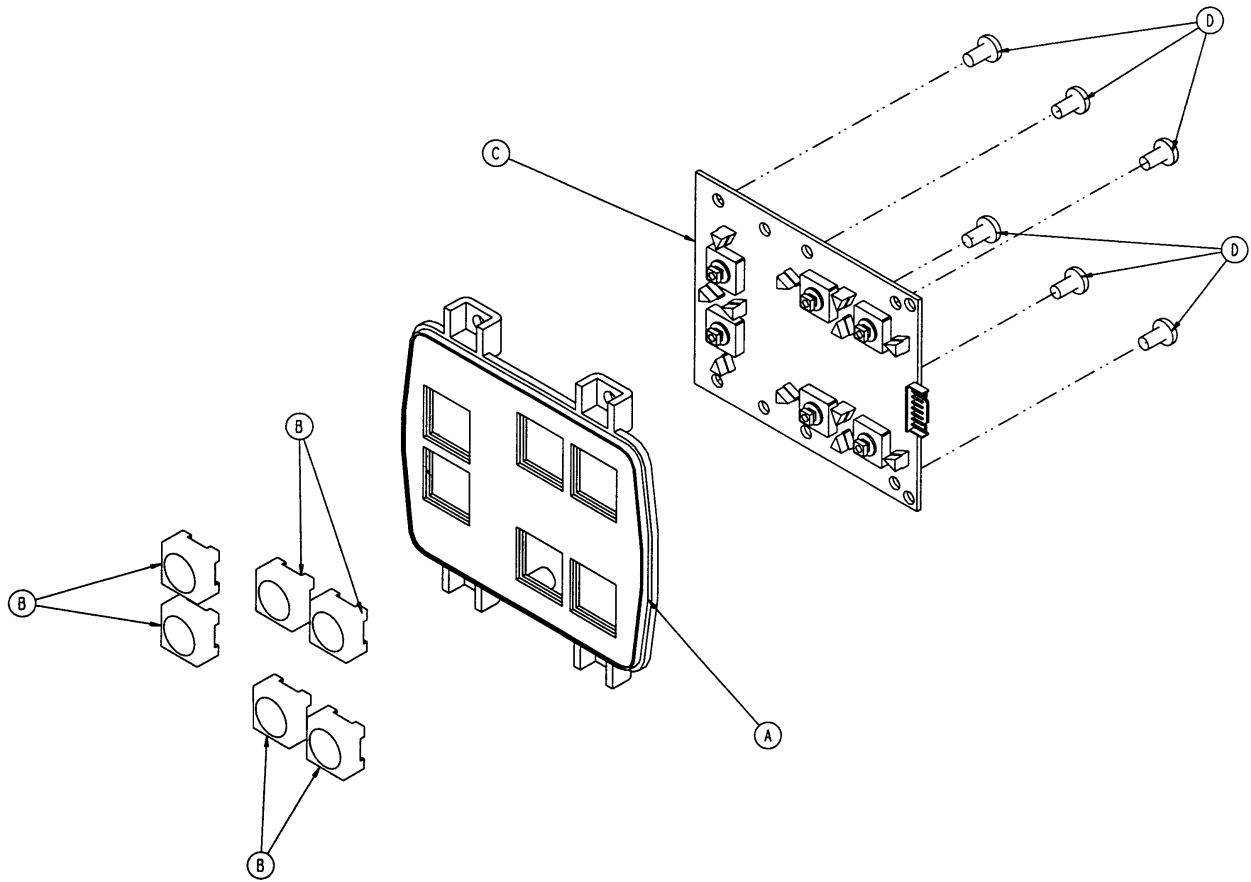

Item	Part No.	Part Name	Qty.
A	3001–400–524	Lumbar Module	1
B	3001–400–953	Switch Cap	6
C	5000–400–920	Lumbar Keypad PCB, Right	1
D	23–112	Tapping Screw	6

Foot End Siderail Assembly

Assembly part number 2035-400-405 (Left)
Assembly part number 2035-400-305 (Right)
(Reference Only)

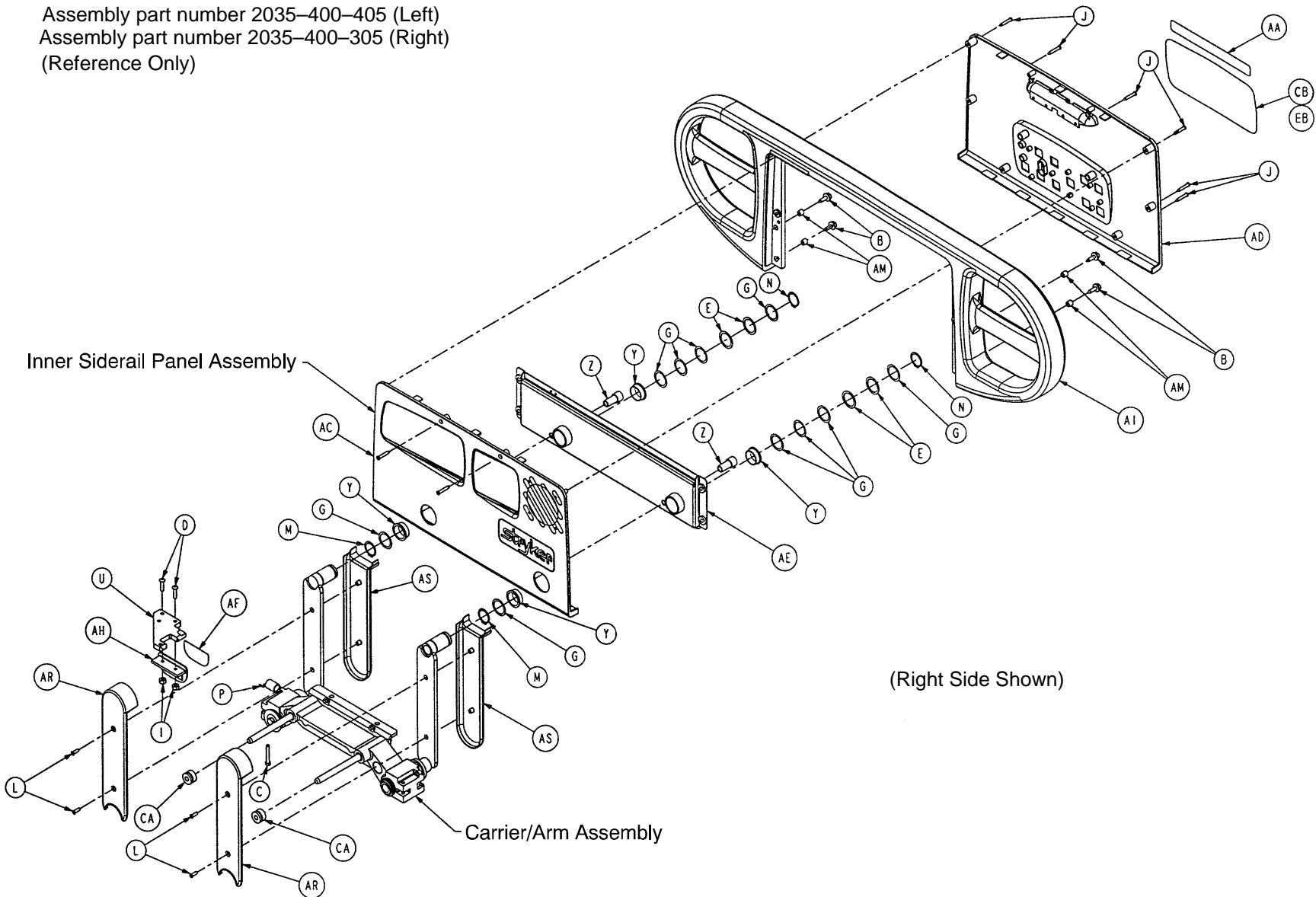

Foot End Siderail Assembly

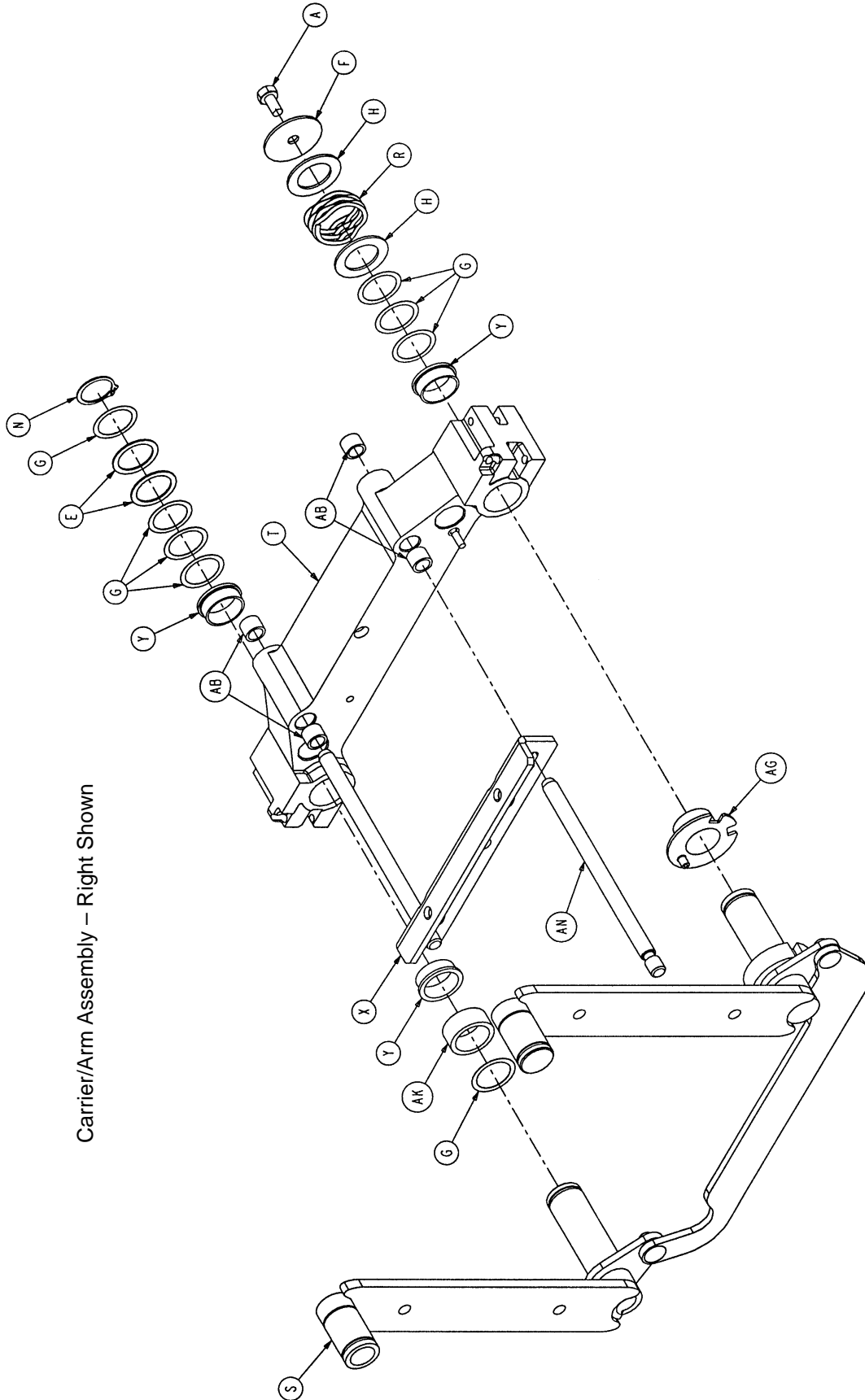

Carrier/Arm Assembly – Right Shown

Foot End Siderail Assembly

Inner Panel Assembly – Right Shown

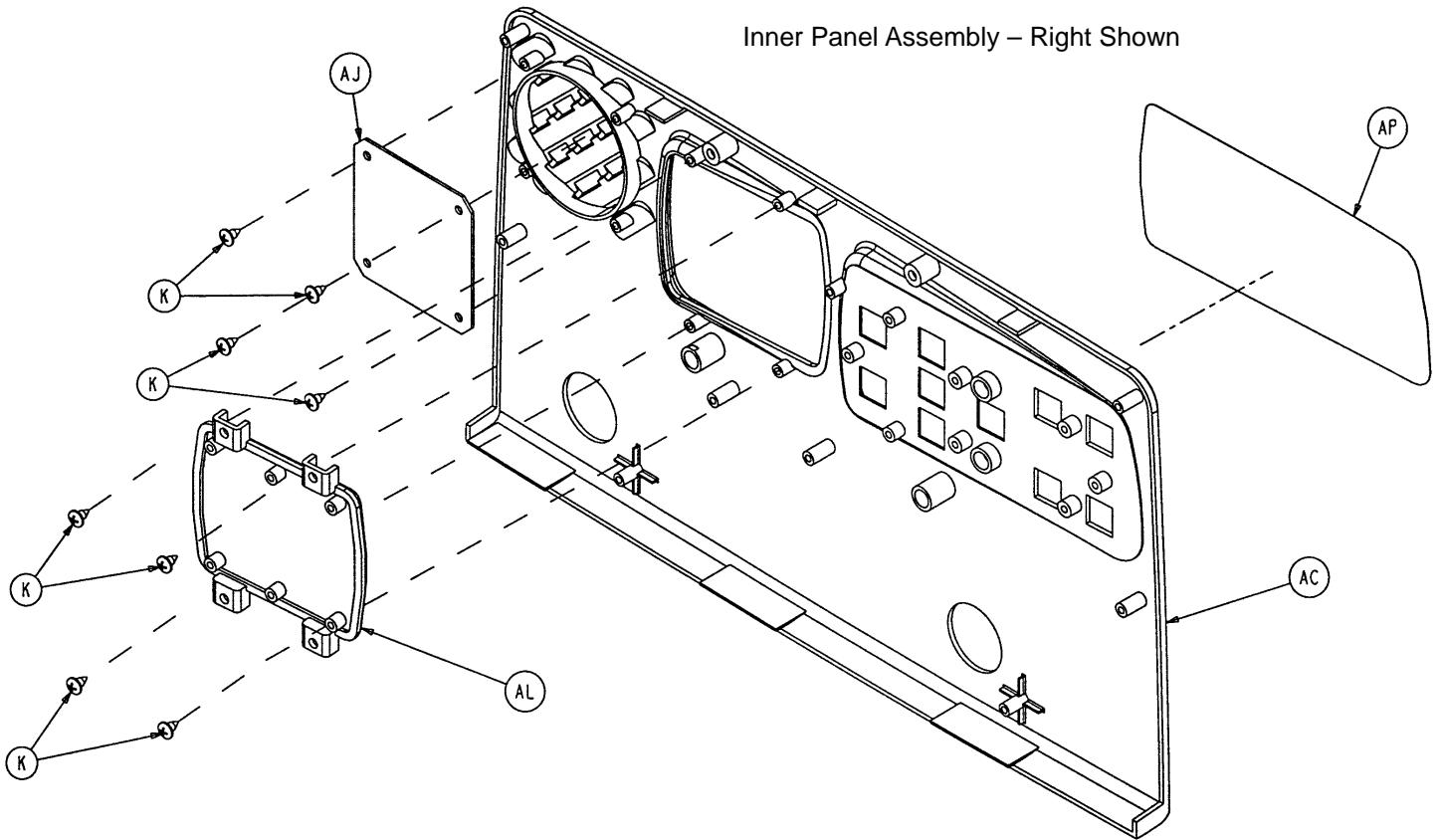

Foot End Siderail Assembly

2035-400-305 Right Siderail Components

Item	Part No.	Part Name	Qty.
A	3-75	Hex Hd. Cap Screw	1
B	3-226	Hex Washer Hd. Screw	4
C	3-330	Hex Hd. Cap Screw	1
D	4-278	Button Hd. Screw	2
E	11-338	Wave Washer	6
F	11-344	Washer	1
G	11-353	Washer	18
H	11-434	Washer	2
I	16-2	Nylock Nut	2
J	23-90	Pan Hd. Tapping Screw	8
K	23-112	Pan Hd. Tapping Screw	8
L	23-261	Flat Hd. Screw	4
M	28-128	Retaining Ring	2
N	28-132	Bowed Retaining Ring	3
P	38-433	Extension Spring	1
R	38-435	Wave Washer	1
S	(page 11-67)	Timing Link Ass'y, Right	1
T	2035-400-531	Siderail Carrier	1
U	2035-400-552	Release Lever	1
X	2035-400-556	Glide Rod Assembly	1
Y	3000-400-513	Flange Bearing	7
Z	3000-400-523	Panel Spacer	2
AA	3000-400-556	Warning Label	1
AB	3000-400-557	Sleeve Bearing	4
AC	3001-400-201	Inner Panel, Right	1
AD	3001-400-50	Outer Panel	1
AE	3001-400-230	Head, Right Supt. Wldmt.	1
AF	3001-400-505	Pad Label	1
AG	3001-400-513	Wear Bushing	1
AH	3001-400-514	Release Lever Pad	1
AI	3001-400-515	Head Rail	1
AJ	3001-400-517	Speaker Seal	1
AK	3001-400-530	Siderail Arm Spacer	1
AL	3001-400-535	Inner Panel Blank Module	1
AM	3001-400-558	Siderail Spacer	4
AN	3001-400-564	Glide Rod	1
AP	3001-445-611	Blank Label, Right	1
AR	5000-20-5	Inner Arm Cover	2
AS	5000-20-6	Outer Arm Cover	2
CA	30-40	Grommet	2
CB	2030-000-90	Epic Logo Label	1
EB	2030-31-8	Epic+ Logo Label	1

2035-400-405 Left Siderail Components

Item	Part No.	Part Name	Qty.
A	3-75	Hex Hd. Cap Screw	1
B	3-226	Hex Washer Hd. Screw	4
C	3-330	Hex Hd. Cap Screw	1
D	4-278	Button Hd. Screw	2
E	11-338	Wave Washer	6
F	11-344	Washer	1
G	11-353	Washer	18
H	11-434	Washer	2
I	16-2	Nylock Nut	2
J	23-90	Pan Hd. Tapping Screw	8
K	23-112	Pan Hd. Tapping Screw	8
L	23-261	Flat Hd. Screw	4
M	28-128	Retaining Ring	2
N	28-132	Bowed Retaining Ring	3
P	38-433	Extension Spring	1
R	38-435	Wave Washer	1
S	(page 11-68)	Timing Link Ass'y, Left	1
T	2035-400-531	Siderail Carrier	1
U	2035-400-552	Release Lever	1
X	2035-400-556	Glide Rod Assembly	1
Y	3000-400-513	Flange Bearing	7
Z	3000-400-523	Panel Spacer	2
AA	3000-400-556	Warning Label	1
AB	3000-400-557	Sleeve Bearing	4
AC	3001-400-101	Inner Panel, Left	1
AD	3001-400-50	Outer Panel	1
AE	3001-400-130	Head, Left Supt. Wldmt.	1
AF	3001-400-505	Pad Label	1
AG	3001-400-513	Wear Bushing	1
AH	3001-400-514	Release Lever Pad	1
AI	3001-400-515	Head Rail	1
AJ	3001-400-517	Speaker Seal	1
AK	3001-400-530	Siderail Arm Spacer	1
AL	3001-400-535	Inner Panel Blank Module	1
AM	3001-400-558	Siderail Spacer	4
AN	3001-400-564	Glide Rod	1
AP	3001-445-621	Blank Label, Left	1
AR	5000-20-5	Inner Arm Cover	2
AS	5000-20-6	Outer Arm Cover	2
CA	30-40	Grommet	2
CB	2030-000-90	Epic Logo Label	1
EB	2030-31-8	Epic+ Logo Label	1

2035-400-428 Foot End Siderail Timing Link Ass'y, Rt.

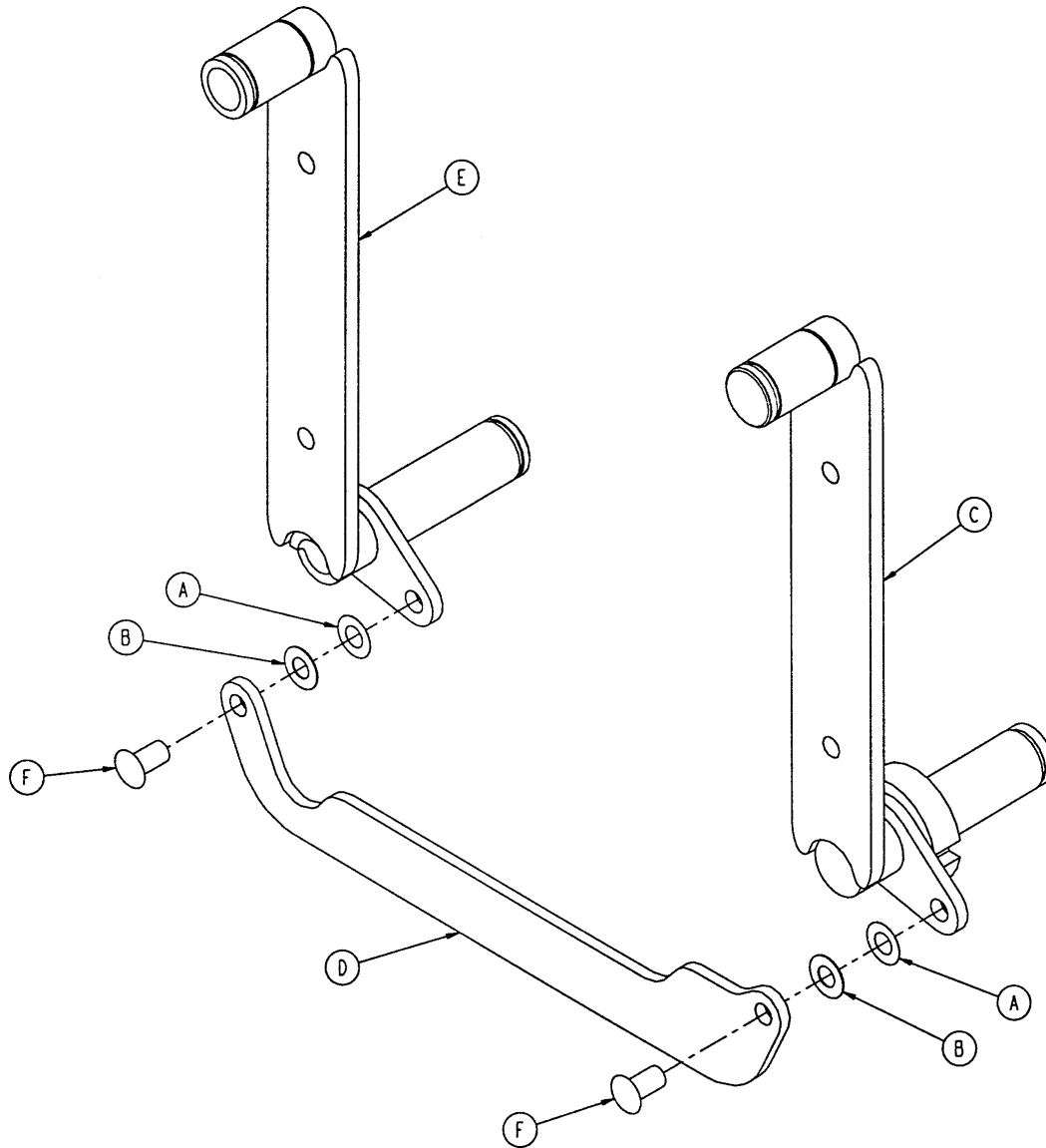

Item	Part No.	Part Name	Qty.
A	11-377	Nylon Washer	2
B	11-403	Shim Washer	2
C	2035-400-427	Arm Wldmt., Right, Foot, Foot	1
D	3001-400-11	Head End Timing Link	1
E	3001-400-128	Arm Wldmt., Left, Foot, Head	1
F	3001-400-501	Siderail Linkage Rivet	2

2035-400-328 Foot End Siderail Timing Link Ass'y, Lt.

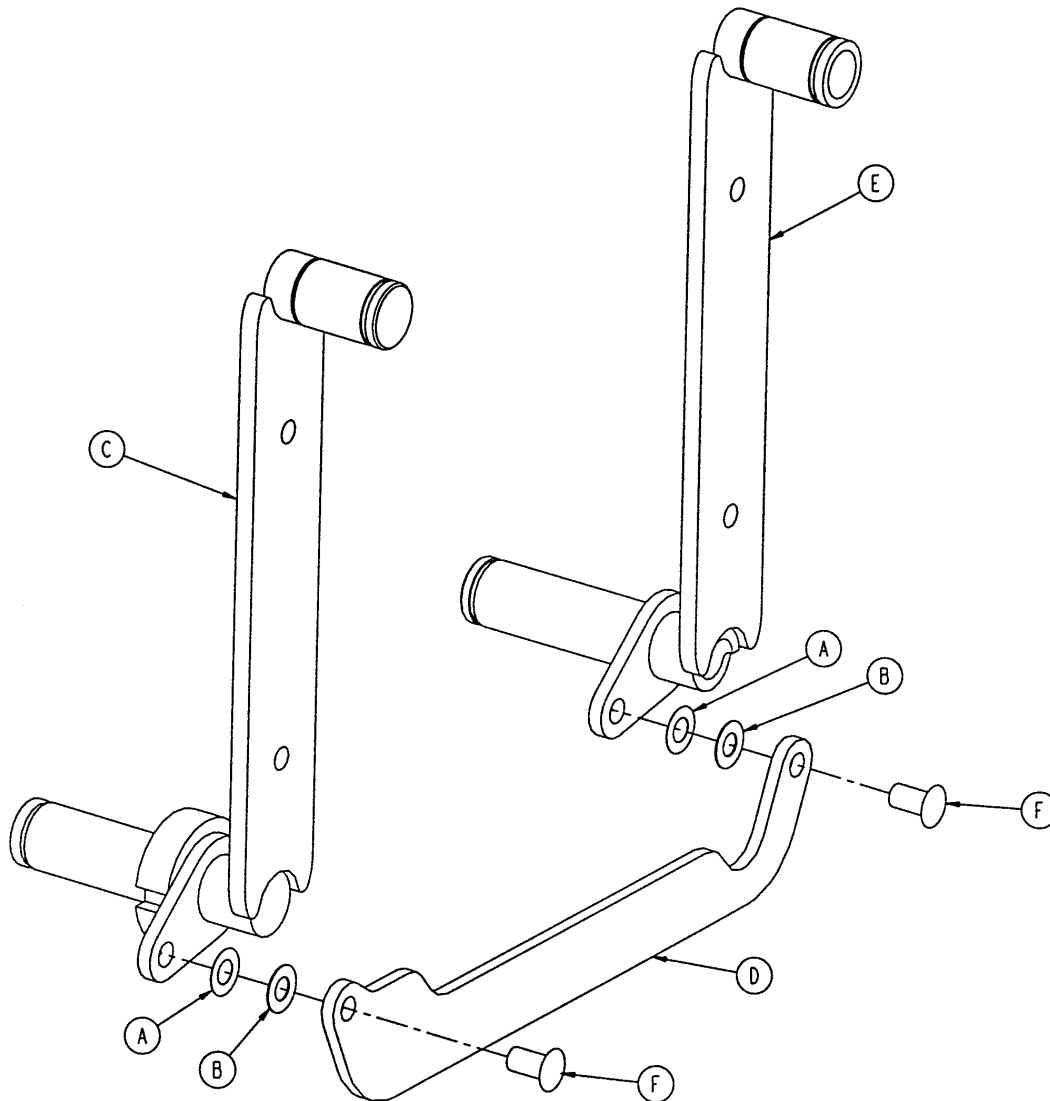

Item	Part No.	Part Name	Qty.
A	11-377	Nylon Washer	2
B	11-403	Shim Washer	2
C	2035-400-327	Arm Wldmt., Left, Foot, Foot	1
D	3001-400-11	Head End Timing Link	1
E	3001-400-228	Arm Wldmt., Right, Foot, Head	1
F	3001-400-501	Siderail Linkage Rivet	2

2035–130–10 Head Board Assembly

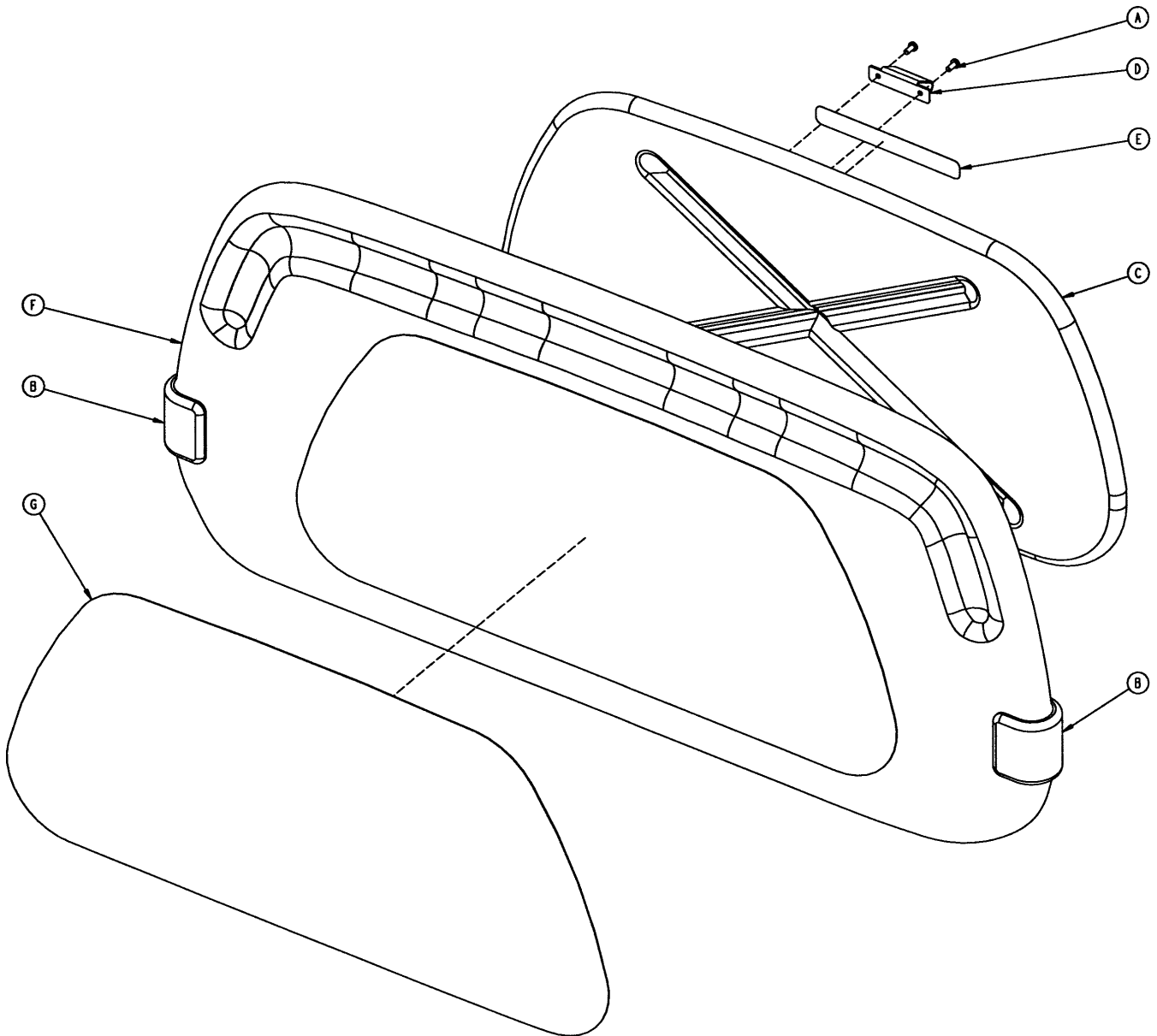

Item	Part No.	Part Name	Qty.
A	23–88	Pan Hd. Screw	2
B	2035–500–7	Dark Blue “C” Bumper	2
C	3000–526–1	CPR Board	1
D	3000–526–2	CPR Board Clip	1
E	3000–526–3	CPR Board Label	1
F	3000–600–10	Head Board Clam Shell Ass’y	1
G	3000–600–56	Beige Head Board Laminate	1
H	72–2–71	“C” Bumper Adhesive	N/A

Foot Board Assembly

part number 2035-000-151

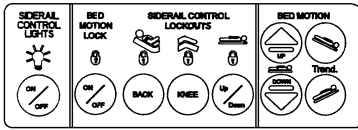

POWER BED MOTION LOCKED

part number 2035-000-155

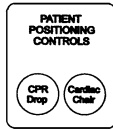

part number 2035-000-153

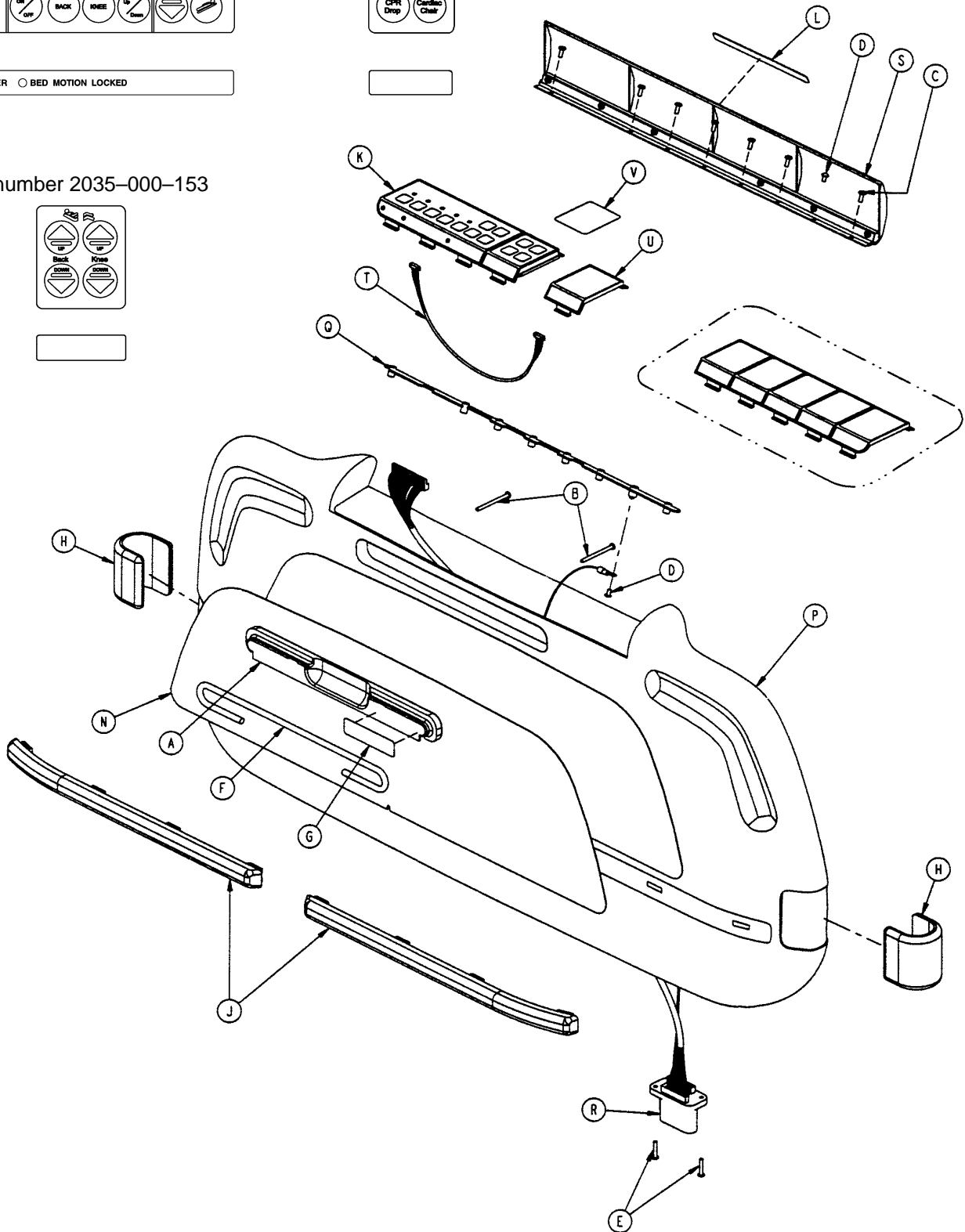
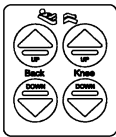

Foot Board Assembly

2035–135–10 Foot Board Assembly – Standard Components

Item	Part No.	Part Name	Qty.
A	3000–525–1	Chart Rack	1
B	23–99	Pan Hd. Screw	2
C	23–103	Pan Hd. Screw	7
D	50–38	Pan Hd. Machine Screw	2
E	50–39	Pan Hd. Machine Screw	2
F	3000–525–2	Chart Rod	1
G	3000–525–4	Pull Handle Label	1
H	2035–500–7	Blue “C” Bumper	2
J	2035–500–8	Bumper Strip	2
K	(page 11–76)	Main Module Assembly	1
L	3000–500–25	Lid Label	1
M	3000–500–29	Caution Fire Hazard Label	1
N	3000–500–56	Beige Laminate	1
P	3001–500–10	Foot Board Clam Shell Ass’y	1
Q	3001–500–64	Hinge Plate	1
R	3001–500–801	Foot Board Cable	1
S	3001–500–1	Lid Assembly	1
T	2025–136–801	E–Drop/Card. Chair Cable	1
U	(page 11–77)	E–Drop/Card. Chair Module	1
V	2035–000–155	E–Drop/Card. Chair Label	1
W	72–2–71	“C” Bumper Adhesive	N/A

Foot Board Assembly

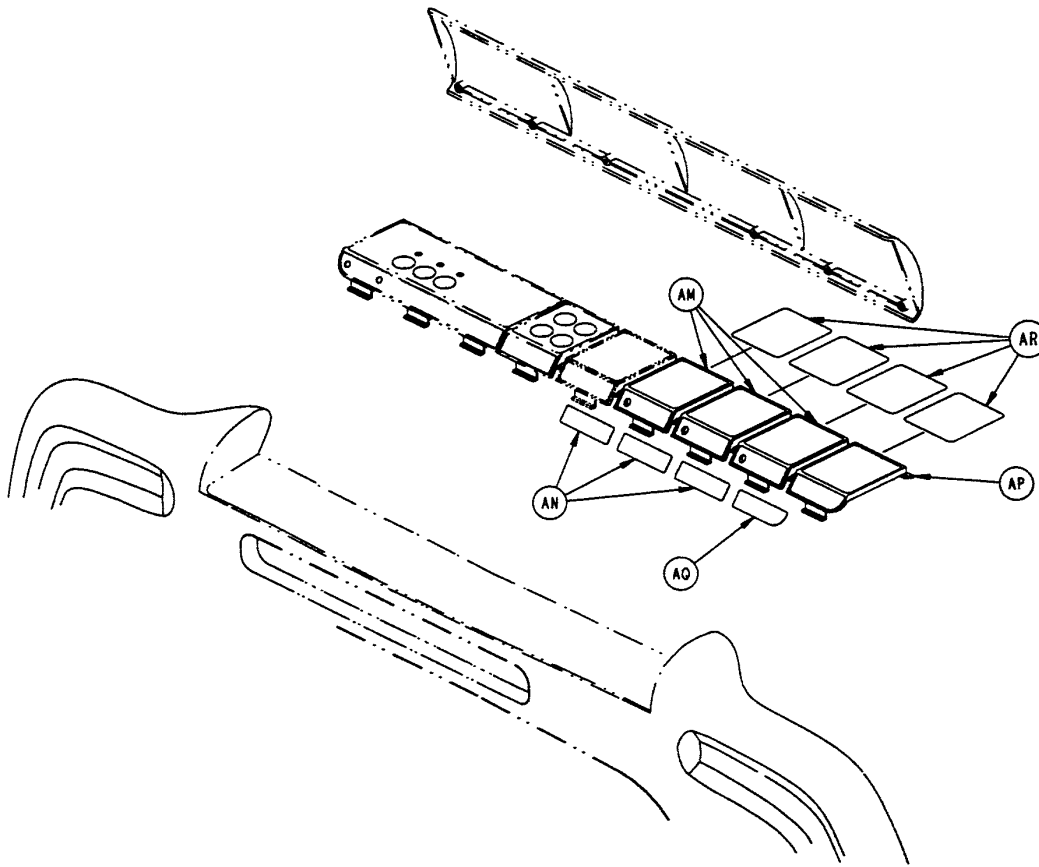

2035-30-101 Foot Board Assembly – No Scale & No Bed Exit

Item	Part No.	Part Name	Qty.
AM	3001-500-3	Blank Module	3
AN	3000-500-26	Blank Module Label	3
AP	3000-500-4	End Module	1
AQ	3000-500-27	Blank End Label	1
AR	2035-500-101	Foot Board Blank Label	4

Foot Board Assembly

part number 2035-000-154

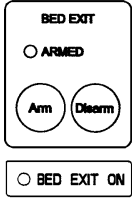
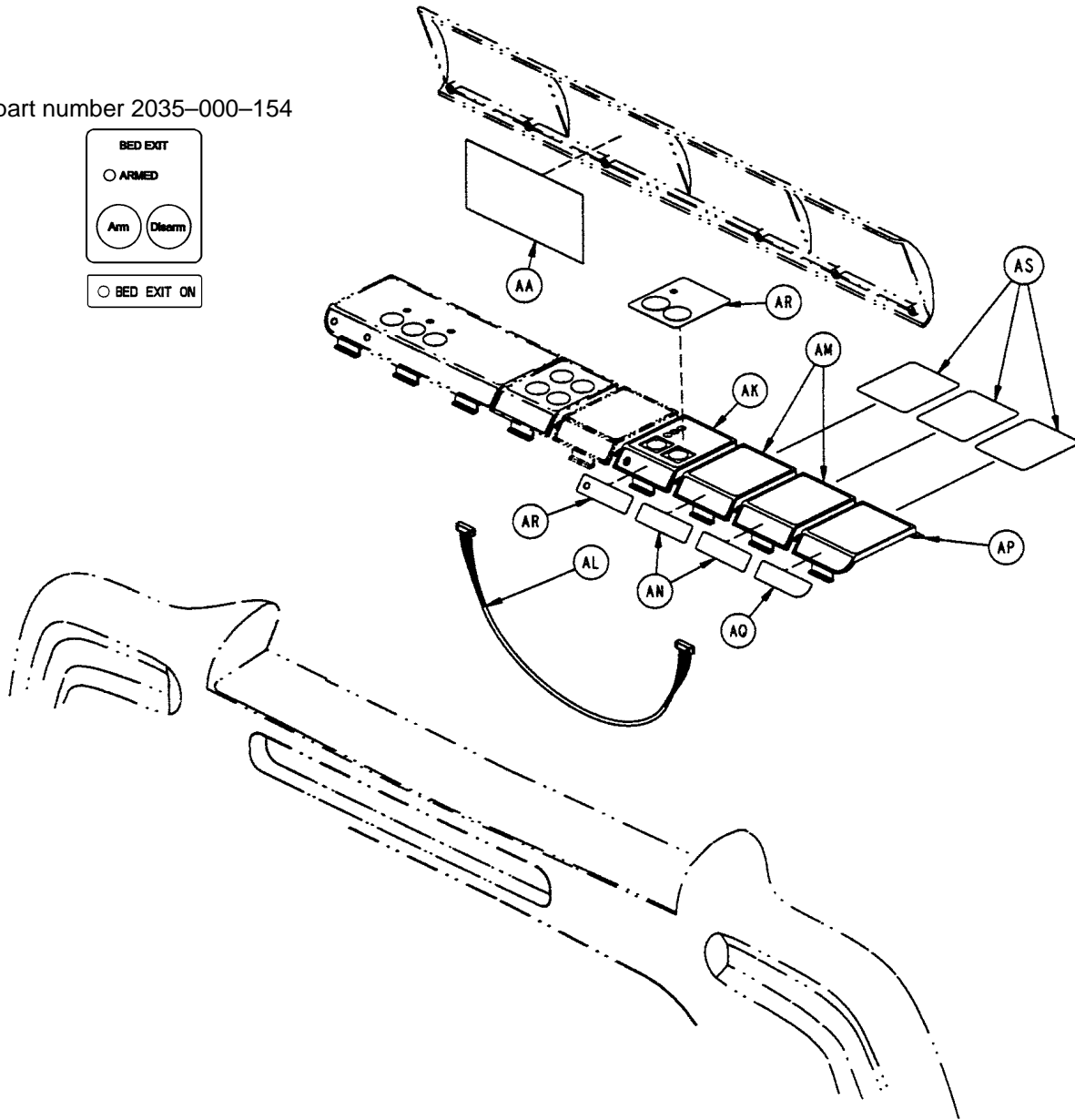

2035-30-176 Foot Board Assembly – Bed Exit Option Only

Item	Part No.	Part Name	Qty.
AA	2025-30-177	Bed Exit Label	1
AD	3001-400-953	Switch Cap	2
AK	(page 11-78)	Bed Exit Module Assembly	1
AL	3001-508-800	Bed Exit Keypad Cable	1
AM	3001-500-3	Blank Module	2
AN	3000-500-26	Blank Module Label	2
AP	3000-500-4	End Module	1
AQ	3000-500-27	Blank End Label	1
AR	2035-000-154	Bed Exit Label	1
AS	2035-500-101	Foot Board Blank Label	3

Foot Board Assembly

part number 2035-000-152

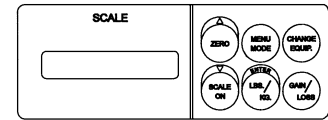

stryker®

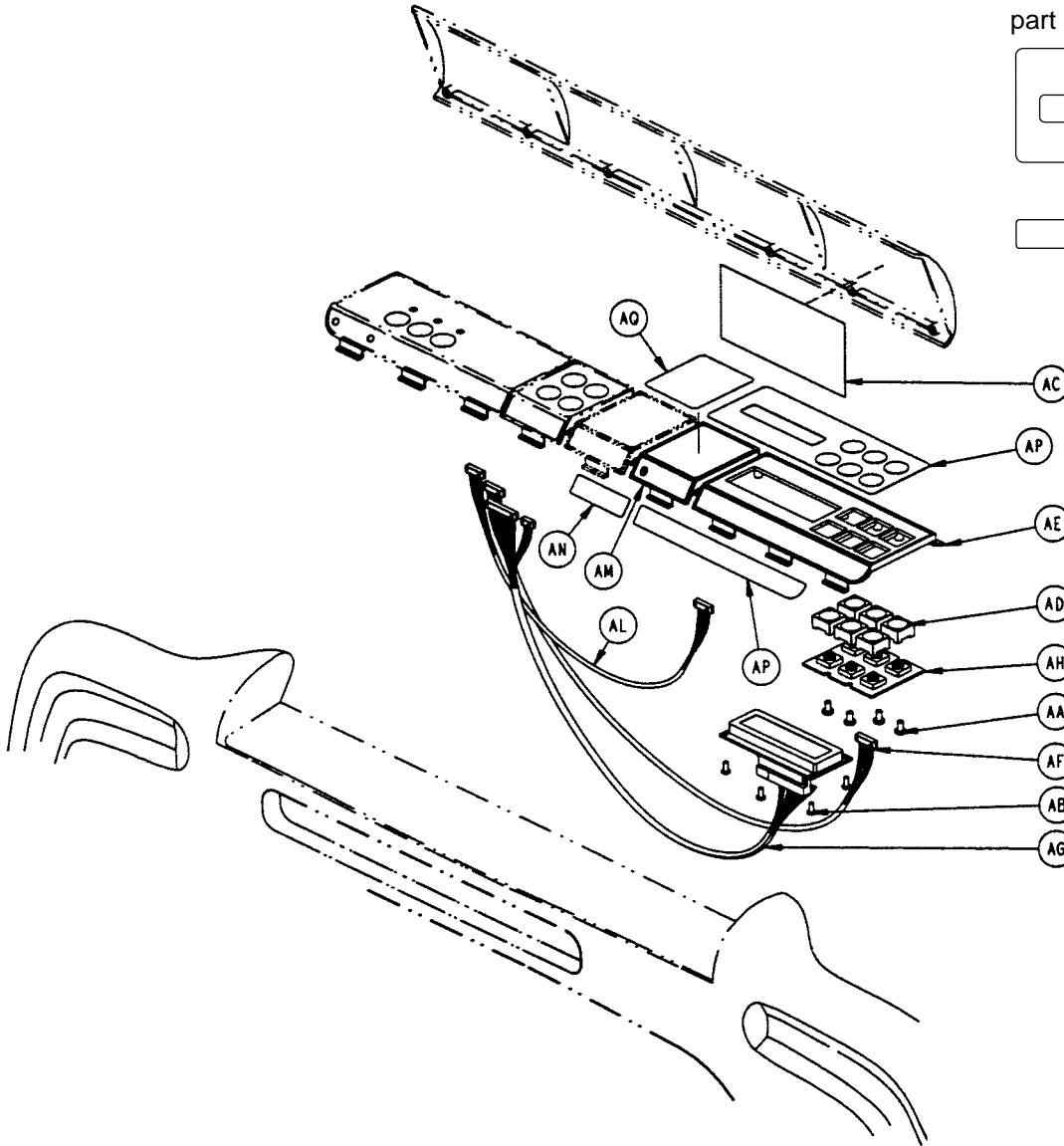

2035-30-126 Foot Board Assembly – Scale Option Only

Item	Part No.	Part Name	Qty.
AA	23-87	Pan Hd. Tapping Screw	4
AB	23-91	Pan Hd. Tapping Screw	4
AC	2025-30-127	Scale Lid Label	1
AD	3001-400-953	Switch Cap	6
AE	3001-507-1	Scale Module	1
AF	3001-507-800	Scale Keypad Cable	1
AG	3001-507-900	Scale LCD Display Cable	1
AH	3001-507-910	Scale Keypad PCB	1
AM	3001-500-3	Blank Panel	1
AN	3000-500-26	Blank Module Label	1
AP	2035-000-152	Scale Label	1
AQ	2035-500-101	Foot Board Blank Label	1

Foot Board Assembly

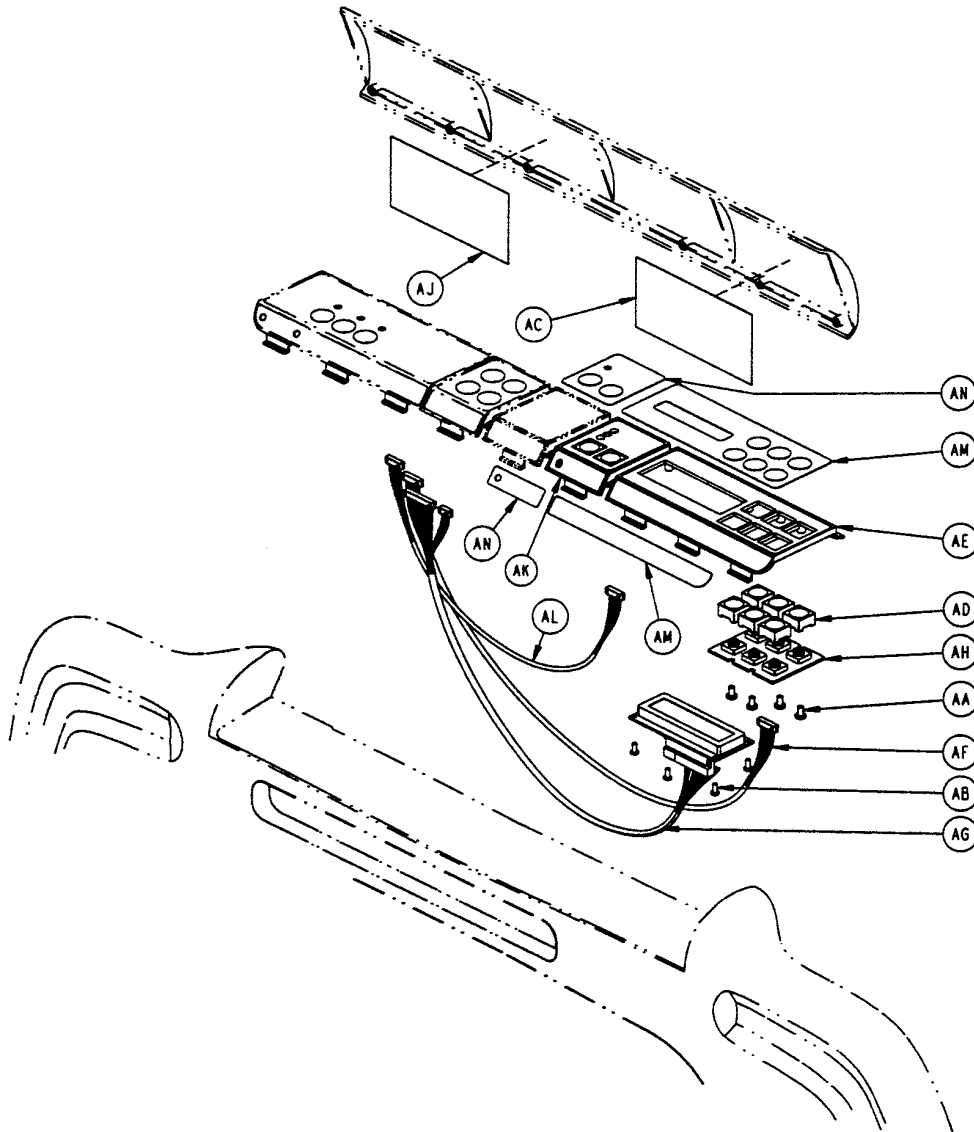

part number 2035-000-152

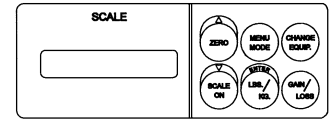

stryker®

part number 2035-000-154

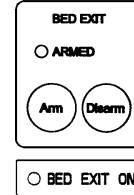

2035-30-151 Foot Board Assembly – Scale and Center of Gravity Bed Exit Options

Item	Part No.	Part Name	Qty.
AA	23-87	Pan Hd. Tapping Screw	4
AB	23-91	Pan Hd. Tapping Screw	4
AC	2025-30-127	Scale Lid Label	1
AD	3001-400-953	Switch Cap	6
AE	3001-507-1	Scale Module	1
AF	3001-507-800	Scale Keypad Cable	1
AG	3001-507-900	Scale LCD Display Cable	1
AH	3001-507-910	Scale Keypad PCB	1
AJ	2025-30-177	Bed Exit Lid Label	1
AK	(page 11-78)	Bed Exit Module Assembly	1
AL	3001-508-800	Bed Exit Keypad Cable	1
AM	2035-000-152	Scale Label	1
AN	2035-000-154	Bed Exit Label	1

2035–235–20 Foot Board Main Module Assembly

part number 2035–000–151

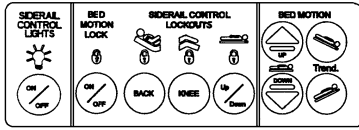

○ POWER ○ BED MOTION LOCKED

part number 2035–000–153

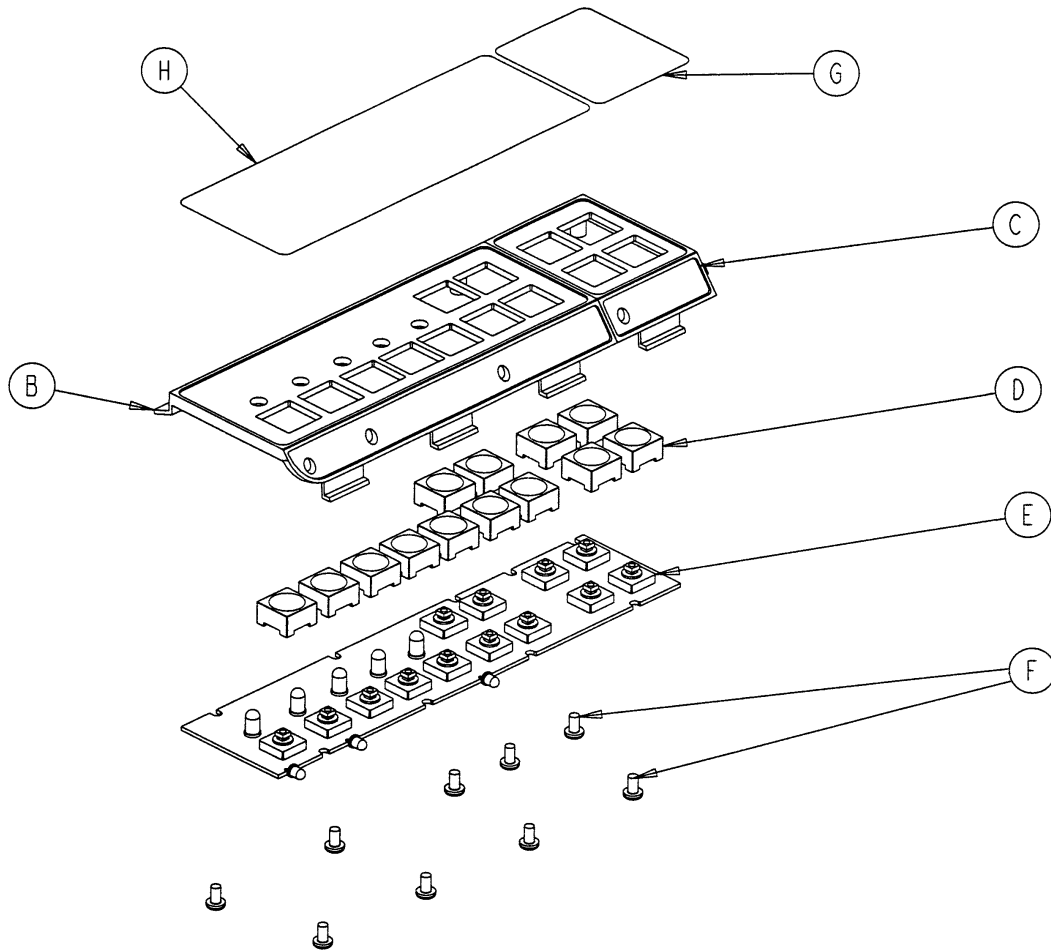
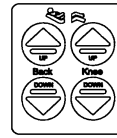

Item	Part No.	Part Name	Qty.
B	3000–500–2	Foot Board Standard Module	1
C	3000–501–1	Gatch/Fowler Module	1
D	3001–400–953	Switch Cap	13
E	3001–500–930	Main Foot Board PCB	1
F	23–87	Pan Hd. Tapping Screw	9
G	2035–000–153	Gatch/Fowler Label	1
H	2035–000–151	Foot Board Std. Module Label	1

2025–136–21 Foot Board CPR Drop/Cardiac Chair Module Ass’y

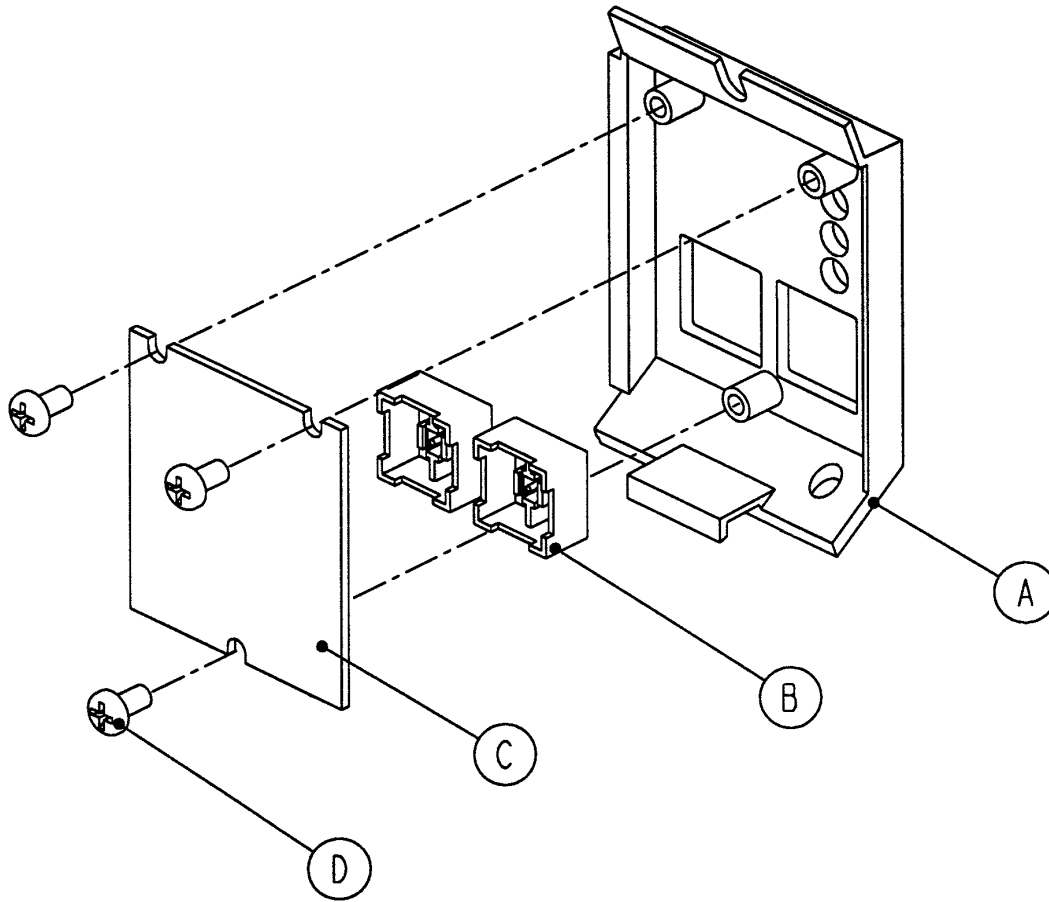

Item	Part No.	Part Name	Qty.
A	3000–508–1	Bed Exit Module Panel	1
B	3001–400–953	Switch Cap	2
C	2025–136–900	CPR Drop/Card. Ch. Keypad	1
D	23–87	Hi-Low Tapping Screw	3

2025–136–22 Foot Board Bed Exit Module Assembly

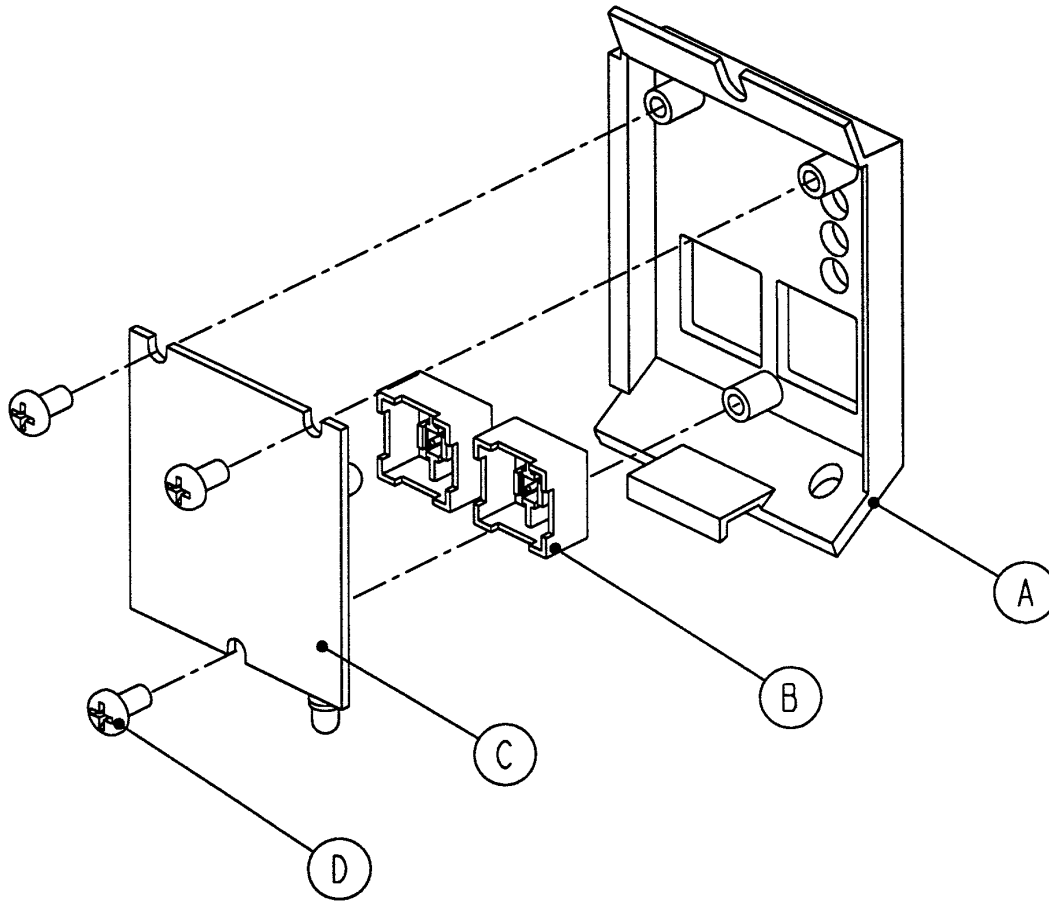

Item	Part No.	Part Name	Qty.
A	3000–508–1	Bed Exit Module Panel	1
B	3001–400–953	Switch Cap	2
C	3001–508–910	Bed Exit Keypad Ass'y	1
D	23–87	Hi–Low Tapping Screw	3

Optional Pendant Assembly

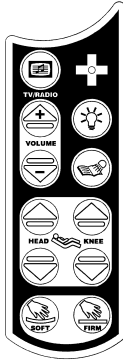

**3001-315-11 Combination Pendant
Motion/Comm./DMS**

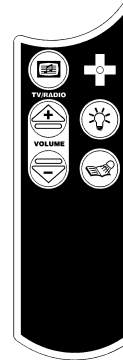

**3001-315-16 Combination Pendant
Communication Only**

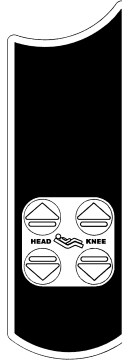

**3001-315-14 Combination Pendant
Motion Only**

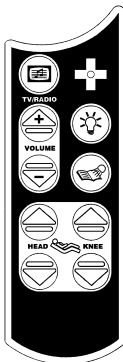

**3001-315-12 Combination Pendant
Motion/Communication**

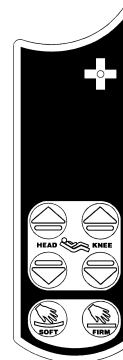

**3001-315-17 Combination Pendant
Motion/DMS/NC**



**3001-315-15 Combination Pendant
Communication/DMS**

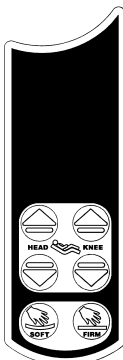

**3001-315-13 Combination Pendant
Motion/DMS**

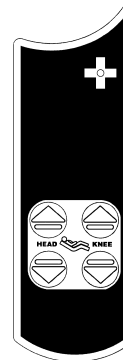

**3001-315-18 Combination Pendant
Motion/NurseCall**

3000–300–80 Removable I.V. Pole Assembly

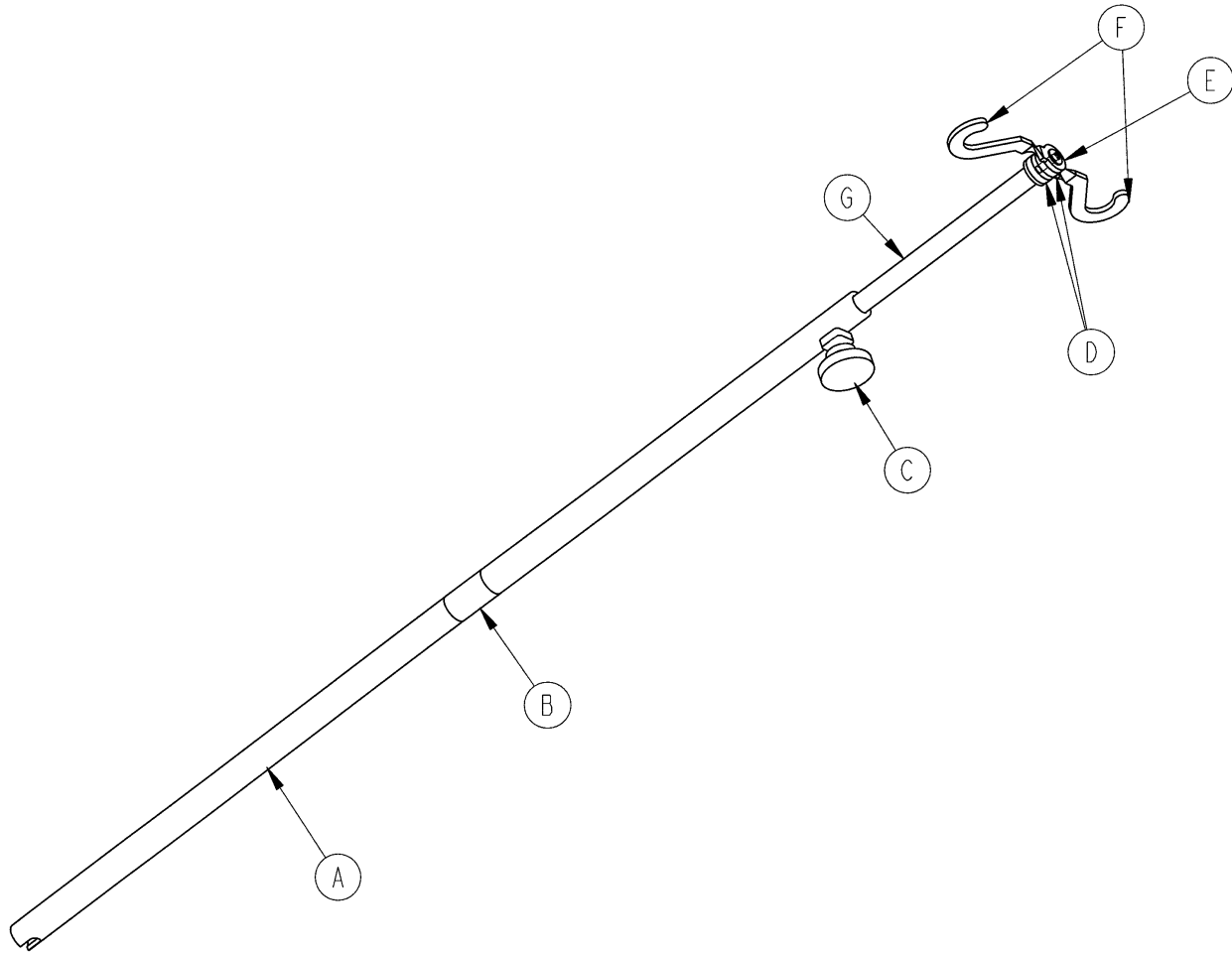

Item	Part No.	Part Name	Qty.
A	3000–300–81	Outer Tube	1
B	3000–300–89	Label	1
C	24–50	Fluted Knob	1
D	52–17	Spacer	2
E	7–40	Phillips Truss Hd. Screw	1
F	1010–59–16	I.V. Hook	2
G	3000–300–85	Inner Tube Assembly	1

2035-111 Optional 2-Stage I.V. Mounting Assembly, Foot End

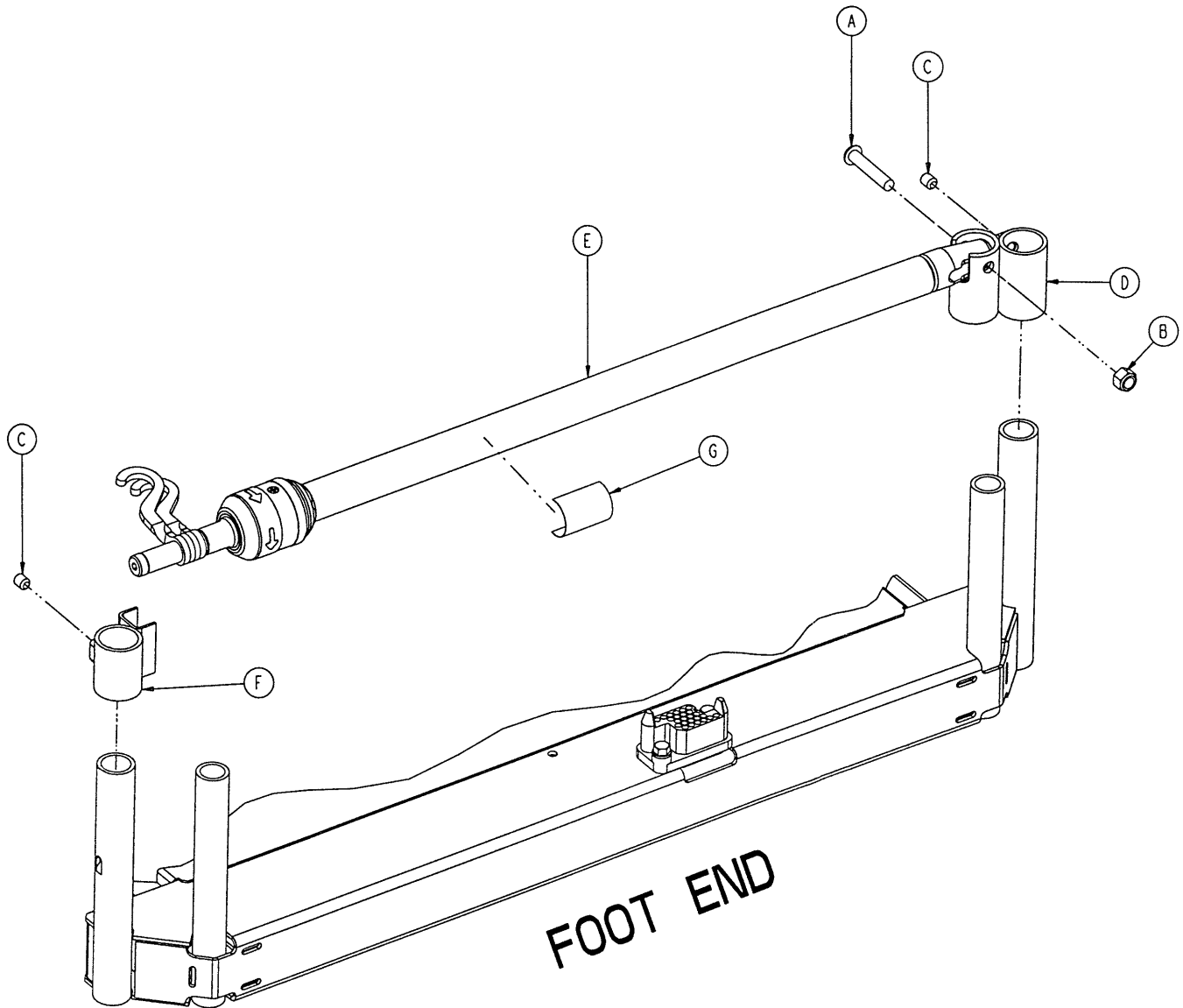

Item	Part No.	Part Name	Qty.
A	4-199	But. Hd. Cap Screw	1
B	16-11	Flexlock Nut	1
C	21-140	Set Screw	2
D	2035-111-1	I.V. Receptacle, Foot, Left	1
E	(page 11-84)	I.V. Pole Assembly, Left	1
F	3000-312-35	I.V. Cradle	1
G	2035-112-110	Specification Label	1

2035–112 Optional 2–Stage I.V. Mounting Assembly, Head End

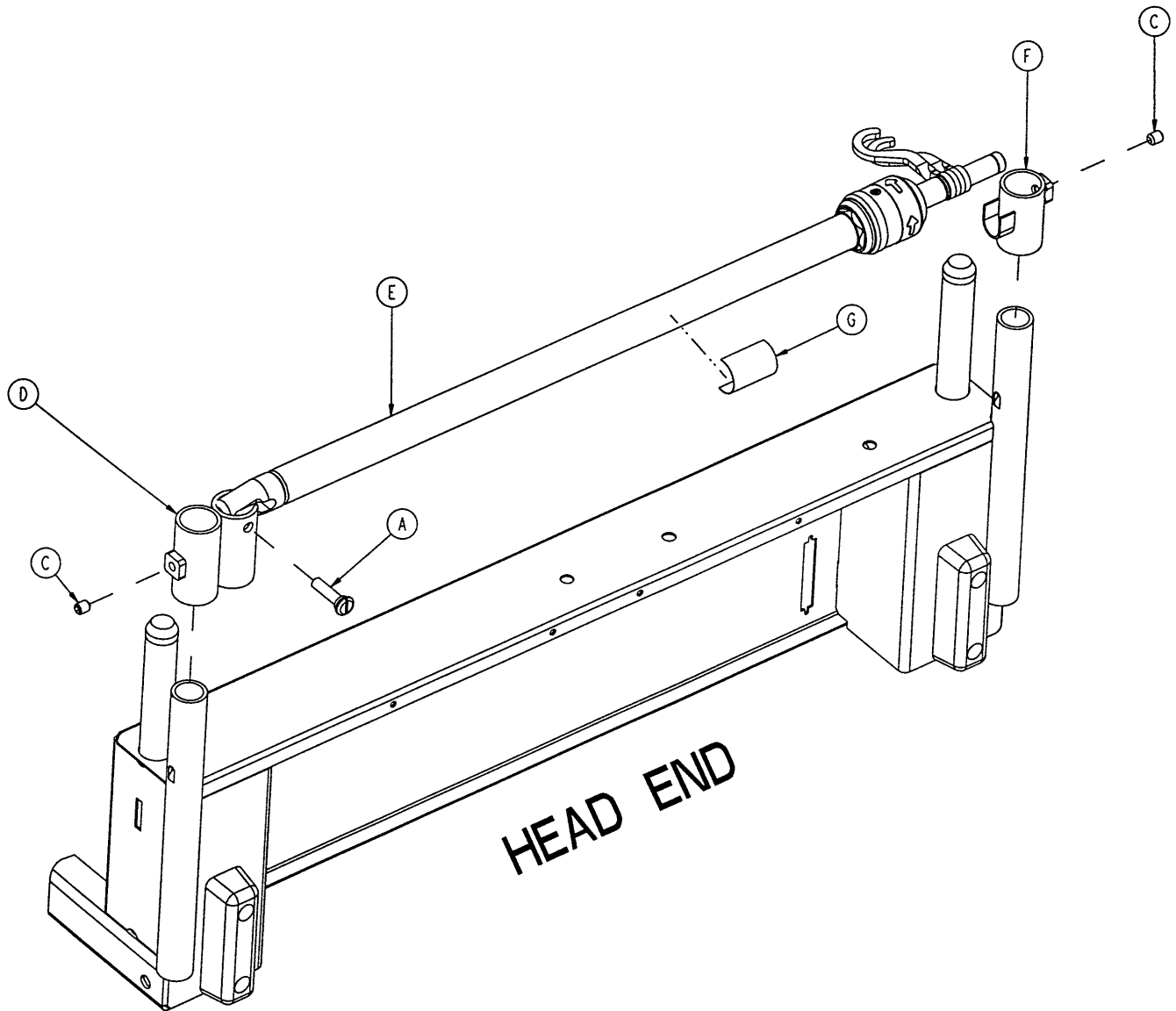

Item	Part No.	Part Name	Qty.
A	1015–24–35	Retaining Pin	1
C	21–140	Set Screw	2
D	2035–112–1	I.V. Receptacle, Head, Left	1
E	(page 11–84)	I.V. Pole Assembly, Left	1
F	3000–311–16	I.V. Rest	1
G	2035–112–110	Specification Label	1

2035-113 Optional 2-Stage I.V. Mounting Ass'y, Dual Head End

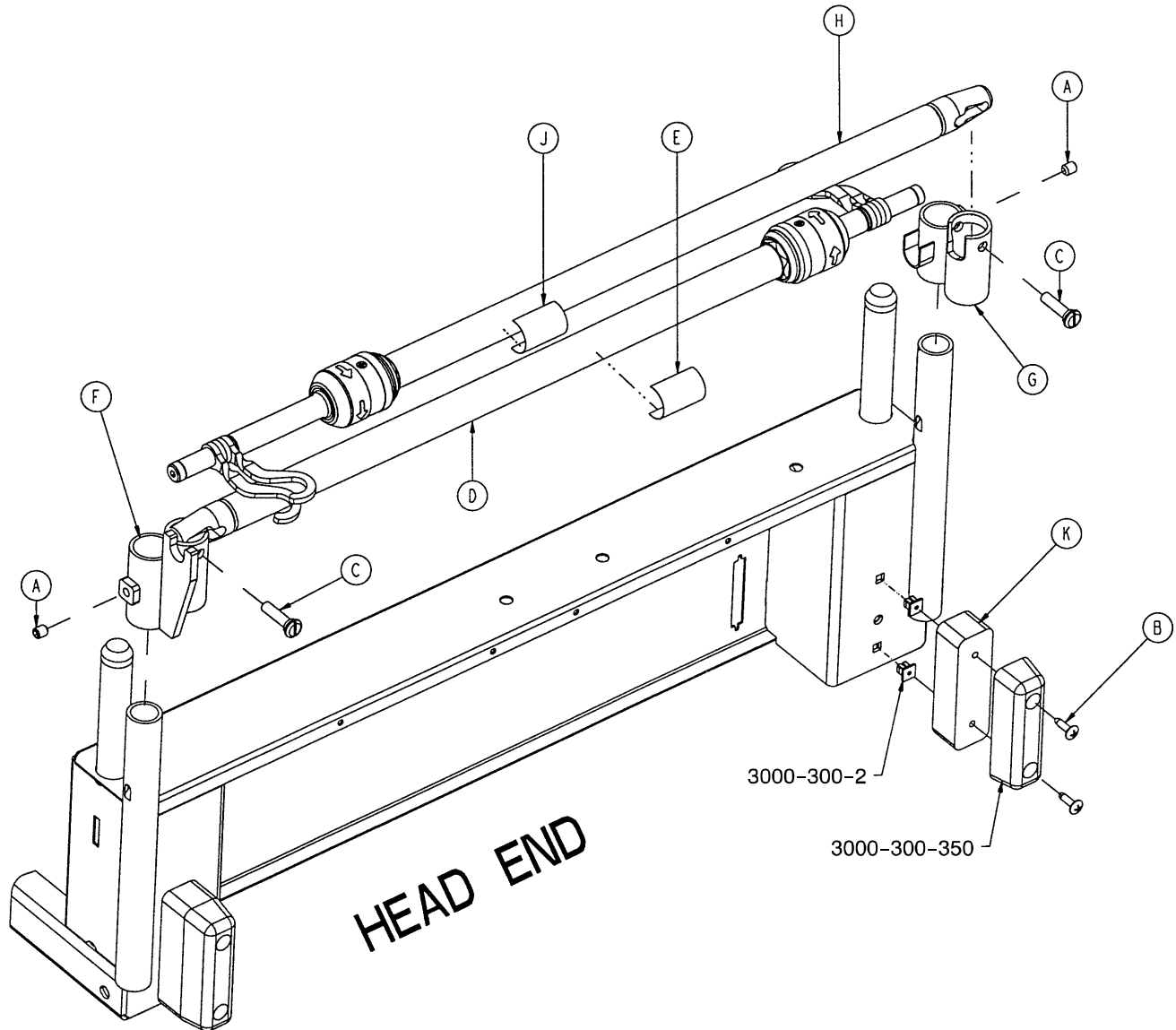

Item	Part No.	Part Name	Qty.
A	21-140	Set Screw	2
B	23-277	Truss Hd. Screw	4
C	1015-24-35	Retaining Pin	2
D	(page 11-84)	I.V. Pole Assembly, Left	1
E	2035-112-110	Specification Label	1
F	2035-113-1	I.V. Receptacle, Dual Head, Lt.	1
G	2035-113-2	I.V. Receptacle, Dual Head, Rt.	1
H	(page 11-84)	I.V. Pole Assembly, Right	1
J	2035-113-111	Specification Label	1
K	2035-113-6	Head End Bumper Spacer	2

2035-112-10 & 2035-113-11 Optional 2-Stage I.V. Ass’y, Hd. & Ft.

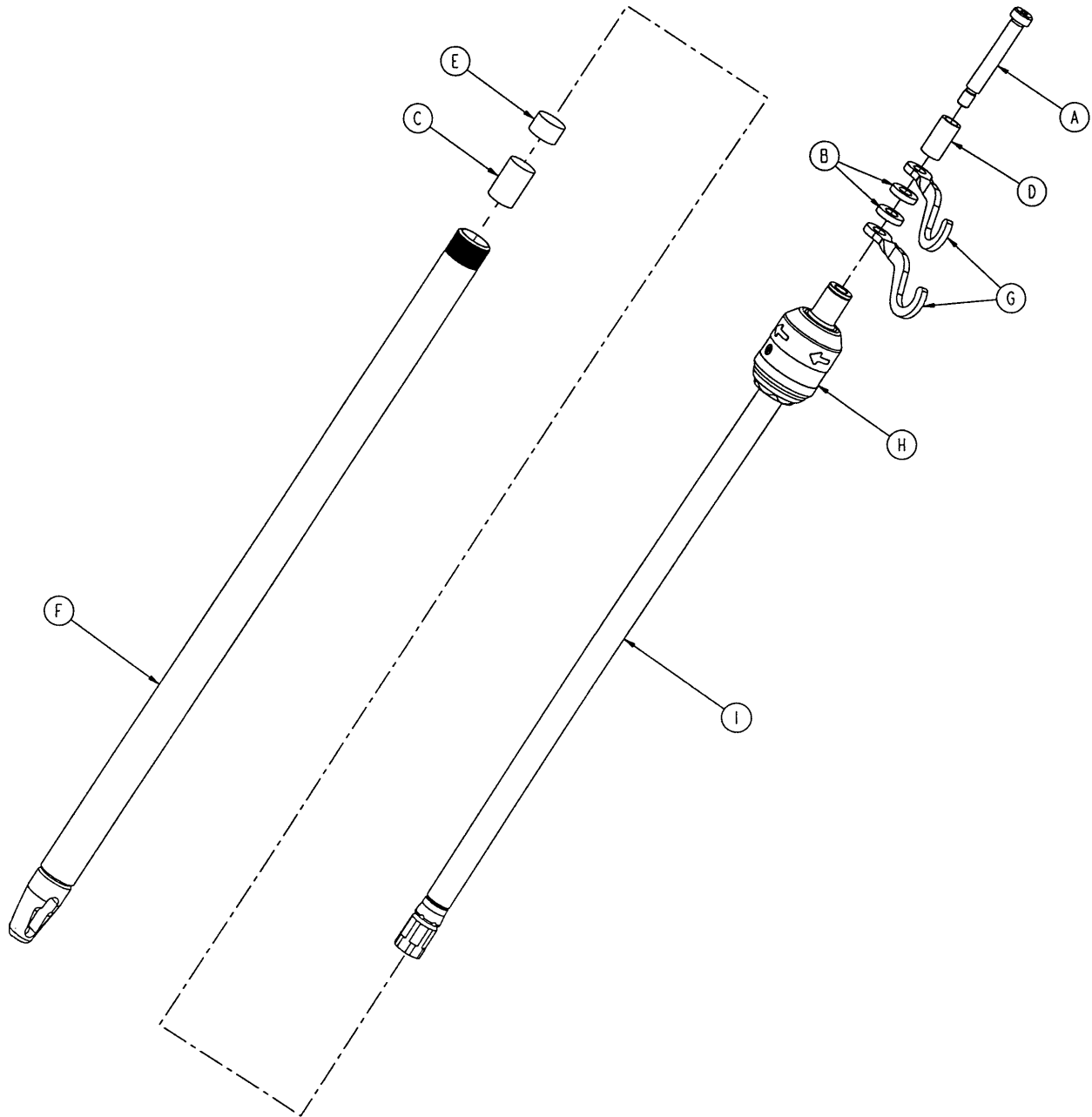

2035-112-10 Head End, Left

2035-113-11 Foot End, Right

Item	Part No.	Part Name	Qty.
A	8-31	Soc. Hd. Shoulder Screw	1
B	52-17	Washer	2
C	52-310	Spacer	1
D	926-400-162	Spacer	1
E	1001-259-13	Dampener	1
F	1001-259-32	Base Tube Weldment	1
G	1010-259-16	I.V. Hook	2
H	(page 11-85)	I.V. Pole Latch	1
I	1211-110-29	2nd Stage Assembly	1

Item	Part No.	Part Name	Qty.
A	8-31	Soc. Hd. Shoulder Screw	1
B	52-17	Washer	2
C	52-311	Spacer	1
D	926-400-162	Spacer	1
E	1001-259-13	Dampener	1
F	1001-259-32	Base Tube Weldment	1
G	1010-259-16	I.V. Hook	2
H	(page 11-85)	I.V. Pole Latch	1
I	1211-110-29	2nd Stage Assembly	1

1211-210-26 I.V. Pole Latch Assembly

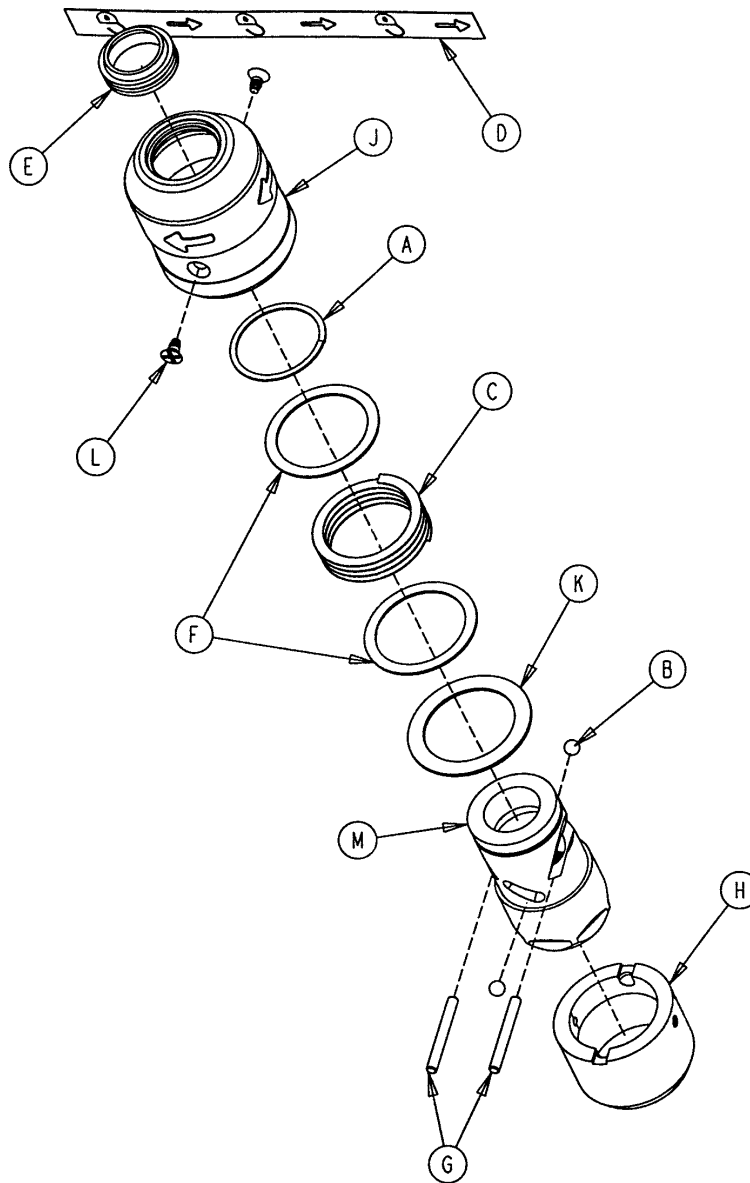

Item	Part No.	Part Name	Qty.
A	28-167	Retaining Ring	1
B	31-4	Steel Ball	2
C	38-392	Crest-to-Crest Spring	1
D	1211-91-34	Release Label	1
E	1211-110-18	I.V. Latch Seal	1
F	1211-110-20	Washer	2
G	1211-110-21	I.V. Latch Locking Pin	2
H	1211-110-22	I.V. Latch Guide	1
J	1211-110-24	I.V. Latch O.D. Housing	1
K	1211-110-35	Washer	1
L	1211-110-36	Self-Tapping Screw	2
M	1211-210-23	I.V. Latch I.D. Housing	1

2035-140 Optional Fowler X-Ray Cassette Holder Assembly

Assembly part number
2035-140-10
(reference only)

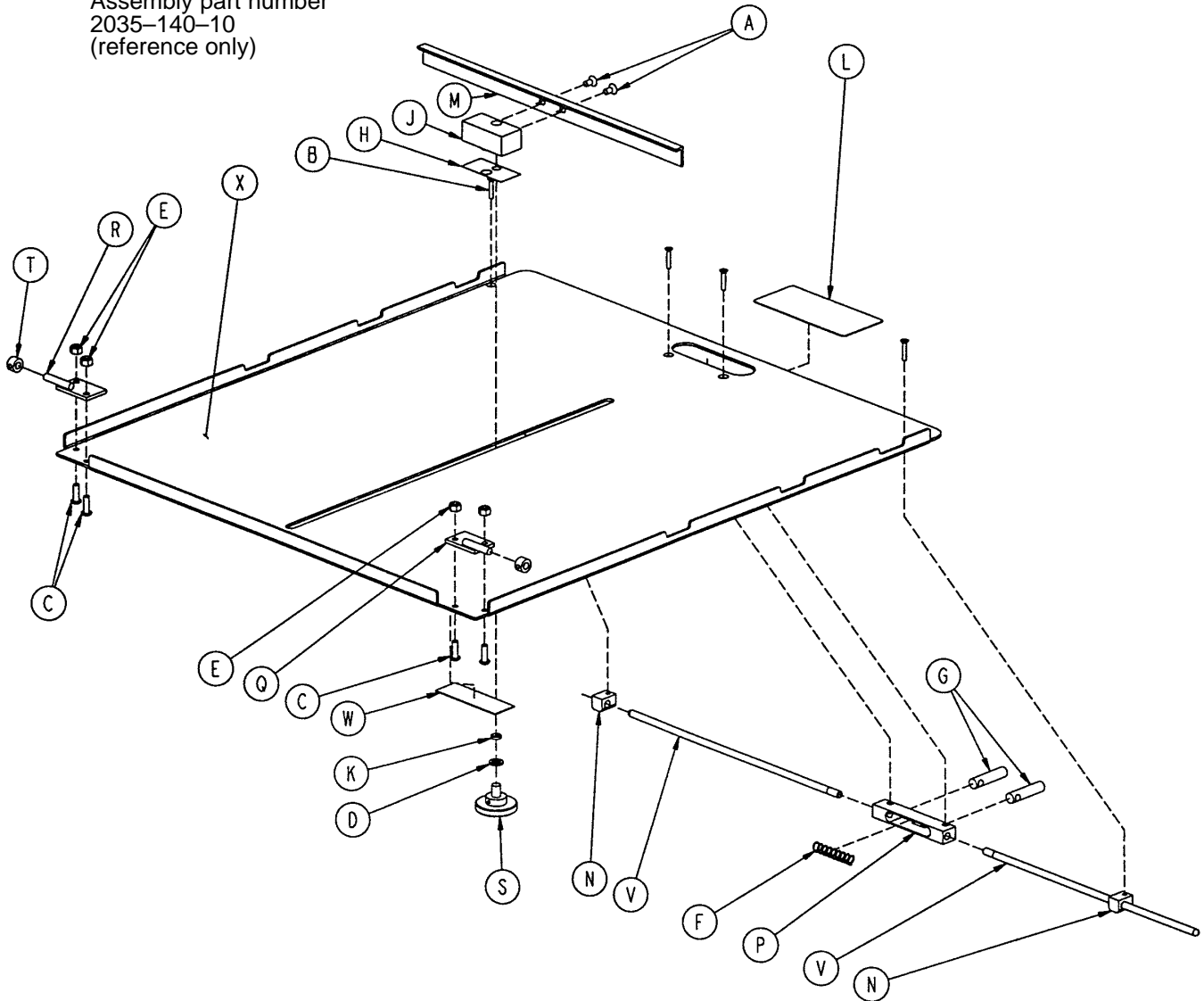

Item	Part No.	Part Name	Qty.	Item	Part No.	Part Name	Qty.
A	1-20	Flat C'sunk Hd. Mach Scr.	2	M	1010-23-28	Tray Angle	1
B	1-22	Flat C'sunk Hd. Mach Scr.	4	N	1010-23-37	Cassette Rod Guide	2
C	4-149	H. Soc. But. Hd. Cap Scr.	4	P	1020-23-16	Cassette Post Housing	1
D	14-3	Washer	1	Q	1020-23-19	Tray Hinge Wldmt., Rt.	1
E	16-3	Hex Nut	4	R	1020-23-20	Tray Hinge Wldmt., Lt.	1
F	38-122	Spring	1	S	1020-23-21	Knob	1
G	926-23-64	Tray Post	2	T	42-13	Collar w/Set Screw	2
H	926-23-69	Cassette Washer	1	V	2025-140-2	Cassette Actuating Rod	2
J	926-23-70	Cassette Block Subass'y	1	W	2035-140-25	Specification Label	1
K	926-23-71	Cassette Bushing	1	X	2035-140-99	Cassette Tray	1
L	1010-23-19	Instruction Label	1				

2035-19-10 Optional Siderail Transducer Mount Assembly

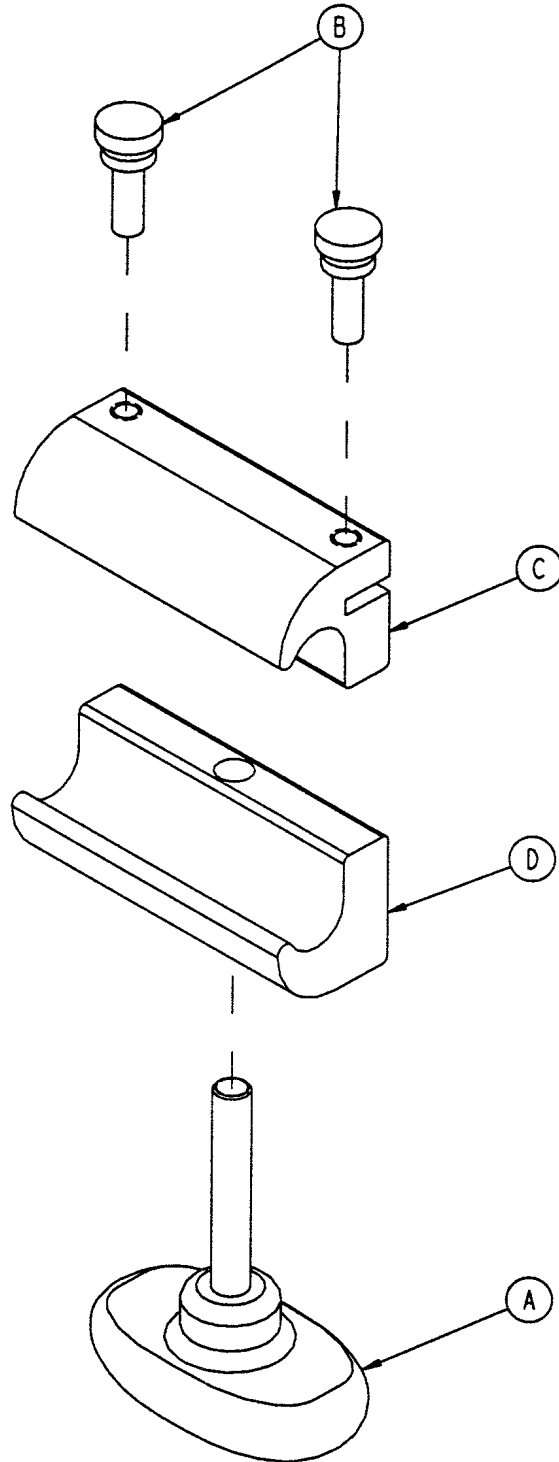

Item	Part No.	Part Name	Qty.
A	24-63	T-Knob	1
B	24-64	Thumb Screw	2
C	2035-19-11	Transducer Mount, Top	1
D	2035-19-12	Transducer Mount, Bottom	1

2035–18–10 Optional I.V. Pole Transducer Mount Assembly

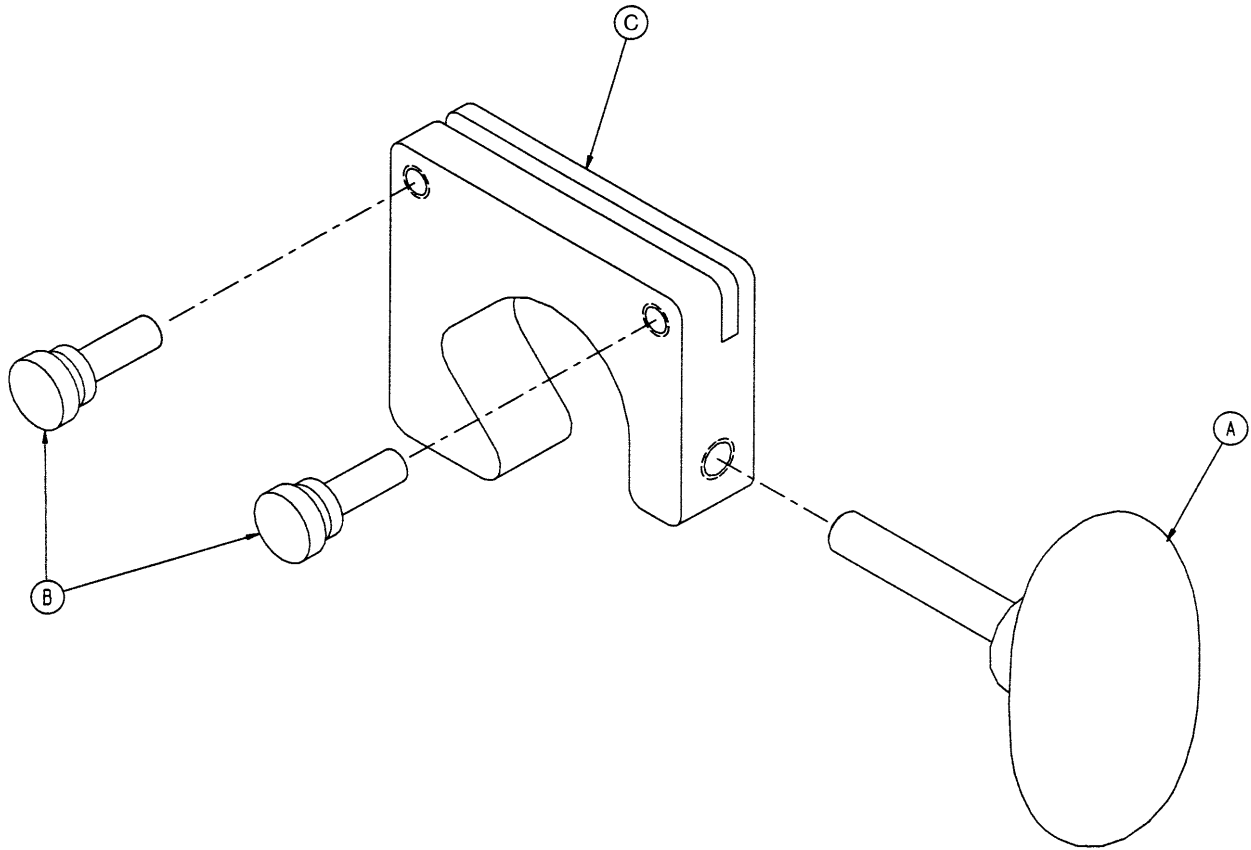

Item	Part No.	Part Name	Qty.
A	24-63	T-Knob	1
B	24-64	Thumb Screw	2
C	2035-18-11	Transducer Mount	1

2025–150–10 Optional Upright O2 Bottle Holder Assembly

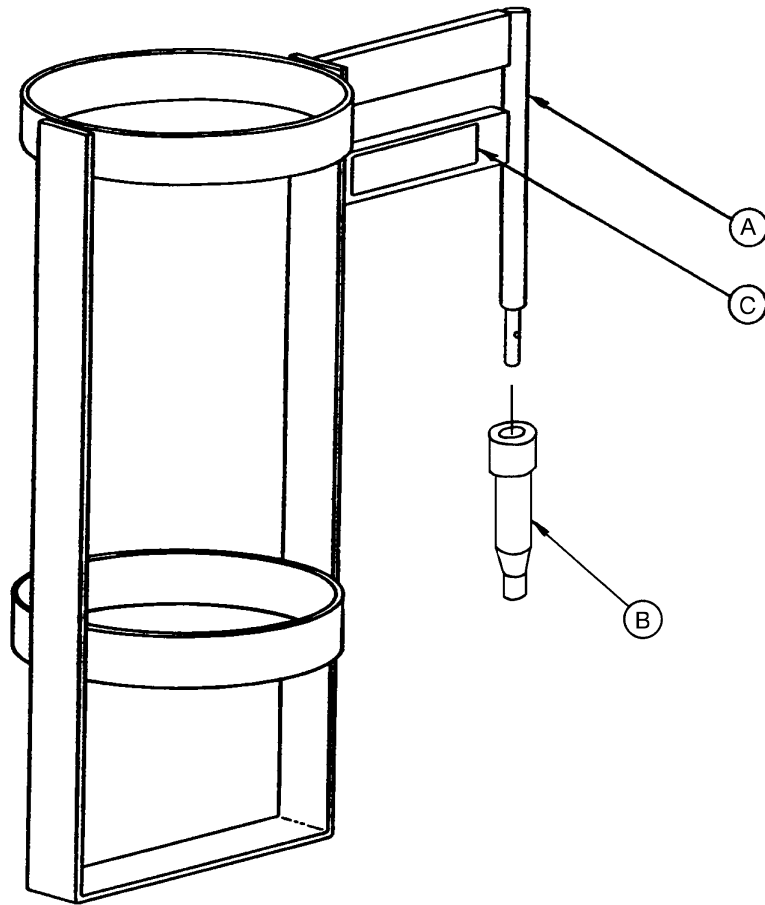

Item	Part No.	Part Name	Qty.
A	1010–30–11	Upright Bottle Holder	1
B	2025–150–1	Bottle Holder Adapter	1
C	2025–150–2	Specification Label	1

2025-120 Optional Defibrillator Tray Assembly

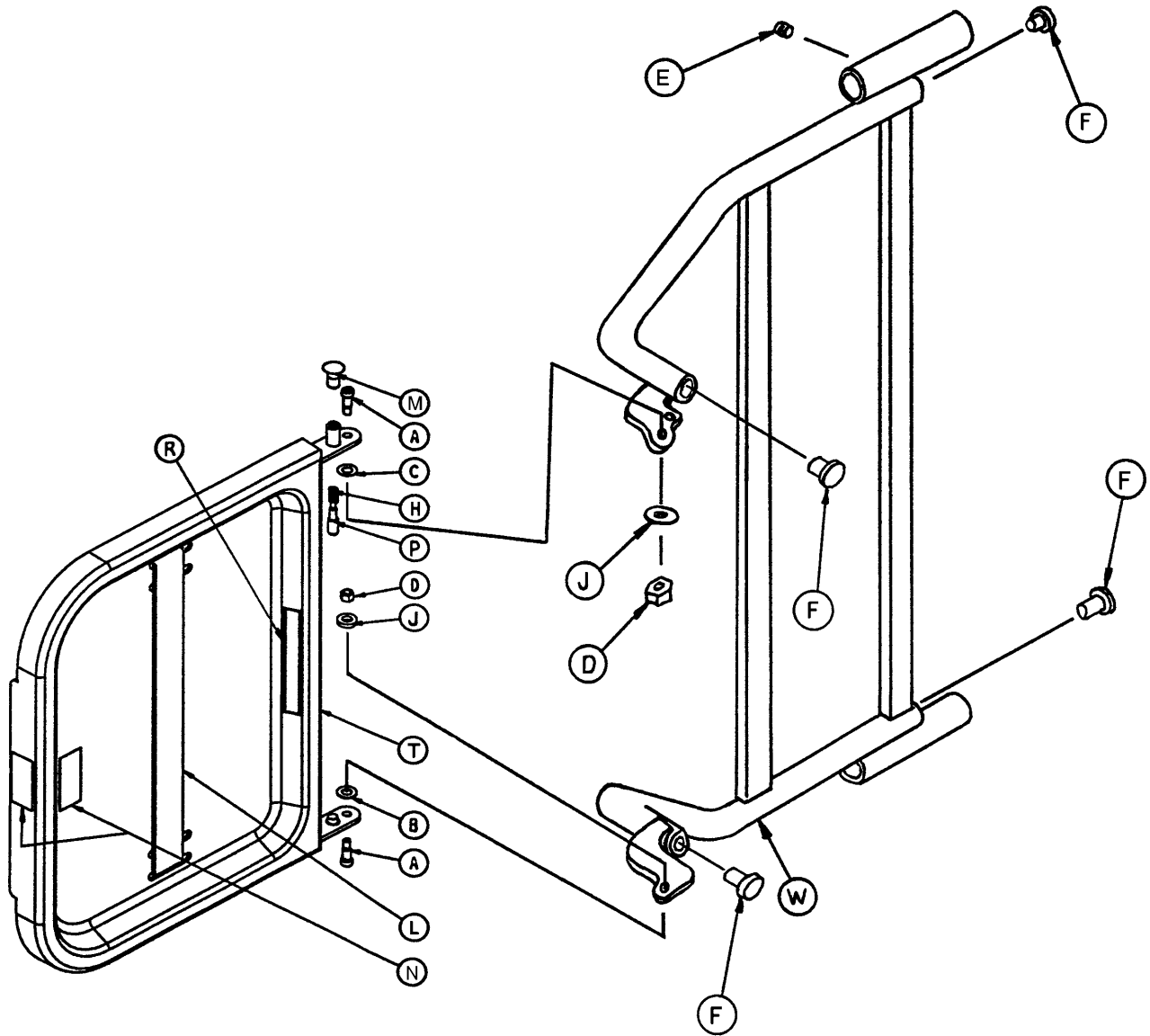

Item	Part No.	Part Name	Qty.	Item	Part No.	Part Name	Qty.
A	8-49	Soc. Hd. Shoulder Bolt	2	L	1010-50-21	Long Strap	1
B	14-20	Thrust Washer	1	M	1010-50-50	Knob	1
C	14-21	Thrust Washer	1	N	1010-50-57	Max. Weight Label	4
D	16-28	Fiberlock Nut	2	P	1010-50-242	Lock Pin	1
E	21-17	Set Screw	4	R	2025-120-5	Equipment Label	1
F	37-214	Hole Plug	4	S	2025-120-6	Specification Label	1
H	38-133	Spring	1	T	2025-120-18	Tray Assembly	1
J	52-17	Spacer	2	W	2025-120-25	Pivot Weldment Frame	1
K	1010-50-19	"Push/Pull" Label	1				

2025-40 Optional Bed Extender Pad Assembly

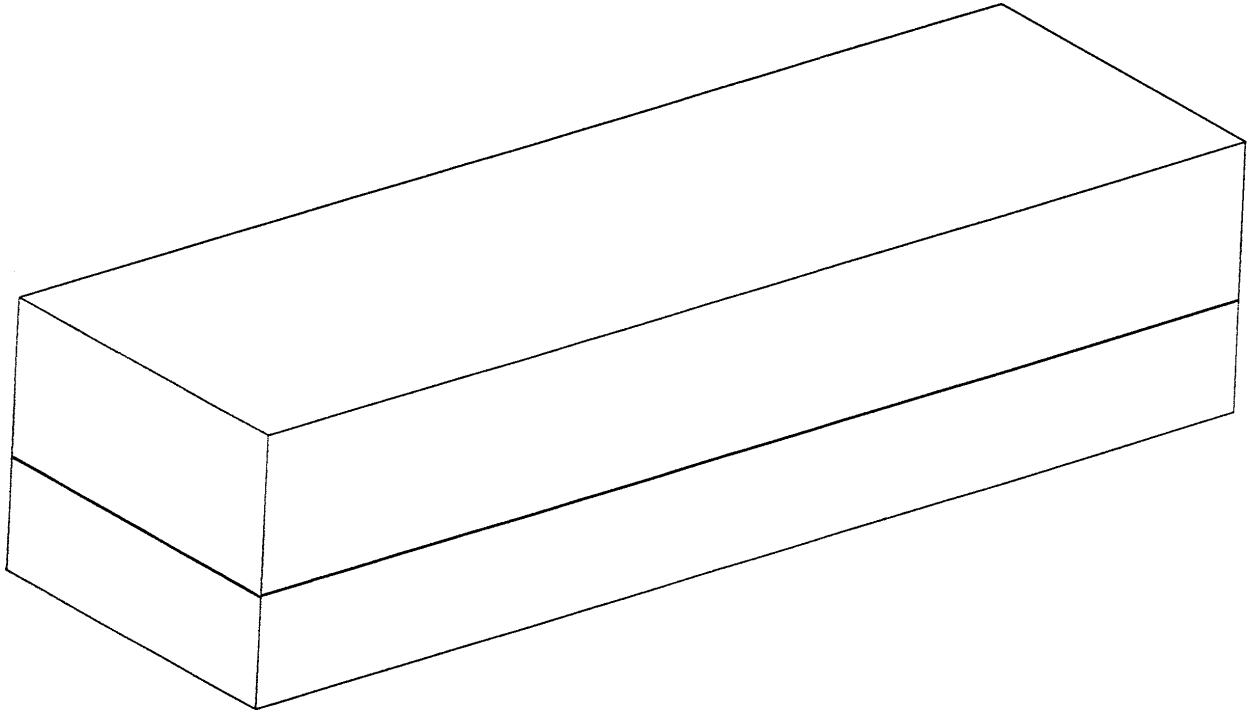



European Representative

Stryker France
BP 50040-95946 Roissy Ch. de Gaulle
Cedex-France

Phone: 33148632290
Fax: 33148632175

stryker[®]
Medical

6300 Sprinkle Road, Kalamazoo, MI 49001-9799 USA

(800) 327-0770



DH 5/00 2030-100-2 REV A