

Power-PRO 2 Cot

Service Manual

- REF 650700000000
- REF 650700080301
- REF 650700450301
- REF 650705550001
- REF 650705550002
- REF 650705550003



Table of Contents

Warning/Caution/Note Definition	5
Summary of safety precautions	5
Introduction for service	6
Expected service life	6
Contact information	6
Serial number location - Power-PRO 2	6
Serial number location - Alvarium	6
Preventive maintenance	8
Lubrication	8
Regular inspection and adjustments	8
Every month or two hours	8
Every three months or six hours	8
Every six months or 12 hours	9
Every 12 months or 24 hours	10
Maintenance record	10
Training record	11
Troubleshooting	13
Stryker Service Tool	13
Error code information	15
Battery charger (BC)	15
Head base control (HBC)	18
Foot end interface board (FEIB)	25
Charger does not charge the battery	31
A fully charged battery does not provide sufficient power to operate the cot	31
HBC PCBA assembly	32
FEIB PCBA assembly	33
Battery charger PCBA assembly	34
Service	35
Protecting against electrostatic discharge (ESD)	35
Cot calibration	35
Power-LOAD unloading adjustment	35
12 VDC automotive cable fuse replacement	37
Backrest adjustment	38
Fowler cylinder assembly replacement	39
Head section replacement	41
Manual release cable replacement	42
Manual release cable adjustment	45
Battery power/comm cable assembly replacement	47
Cot retaining post installation and replacement	48
Cot retaining post screw replacement	49
Hydraulic cylinder assembly replacement	50
Siderail assembly replacement (standard)	52
Siderail assembly replacement (XPS option)	53
Ratchet assembly replacement (XPS option)	55
Release handle assembly replacement (XPS option)	55
Spring handle assembly replacement (XPS option)	56
Hydrogen base control (HBC) board replacement	56
Wireless module replacement	58
Near field module inductive charger (NFMIC) replacement	60
Regulatory notes	61
Wheel replacement	62
Caster horn replacement (non-brake base tube)	63
Caster horn and base tube replacement (brake base tube)	65
X-frame base leg guard replacement	66
MTS sensor replacement	67
Cot foot end interface board (FEIB) replacement	68
Battery charger board replacement	70
Inner tube (X-frame) replacement - foot end	71
Inner tube (X-frame) replacement - head end	72
Inductive power cable assembly replacement	74
User interface button replacement	74
Power and comm cable replacement	76
HBC enclosure and cable replacement	79
HBC strain gauge external cable assembly replacement	82
Slider roller replacement	84
Foot section replacement	86
Slider magnet assembly replacement	87
Head extension option replacement	89

Cot wireless configuration	91
Wireless router configuration	93
Cot assembly, common components	95
Power-LOAD fastener	103
Performance-LOAD fastener	105
Power-LOAD and Performance-LOAD fastener	107
Lift assembly	109
Two wheel lock option - 650709990109	114
Four wheel lock option - 650709990110	115
Lock base assembly, right	117
Lock base assembly, left	119
Non-lock base assembly, left	122
Inner lift legs assembly	123
Base leg assembly, foot end	125
Base leg assembly, head end	126
Actuator lift assembly	127
Manual release bracket assembly	129
Outer rail assembly, left	130
Outer rail assembly, right	132
Hitch bracket assembly, foot end	134
Hitch assembly, foot end	136
Foot end interface board (FEIB) assembly	139
Birdcage assembly, no NFMIC, no Wi-Fi	146
Birdcage assembly, NFMIC, no Wi-Fi	149
Birdcage assembly, NFMIC, Wi-Fi	152
Birdcage assembly, no NFMIC, Wi-Fi	156
HBC enclosure assembly	160
Foot section assembly	162
Housing assembly, foot end, right	167
Latch assembly, foot end, right	168
Housing assembly, foot end, left	169
Latch assembly, foot end, left	170
Wagon handle assembly	171
Head section assembly	172
Standard siderail option - 650709990102	175
XPS siderail option - 650709990101	176
XPS assembly, left	177
XPS assembly, right	178
Fowler assembly	179
Fowler frame assembly	181
Fowler cylinder assembly	182
Fowler handle assembly	183
Gatch assembly	184
Gatch support assembly	186
Telescoping Gatch assembly	187
Thigh assembly	188
Foot assembly	189
Head extension mounting body assembly	190
Head extension frame assembly	191
Head extension option - 650700450045	192
IV pole, two-stage, right - 650700350101	193
IV pole, three-stage, right - 650700350102	194
IV pole, two-stage, left - 650700350105	195
IV pole, three-stage, left - 650700350106	196
HAVASU IV pole assembly, two-stage, left	197
HAVASU IV pole assembly, two-stage, right	198
HAVASU IV pole assembly, three-stage, left	199
HAVASU IV pole assembly, three-stage, right	200
IV pole assembly, two-stage	201

IV pole assembly, three-stage	202
Battery assembly	203
Battery charger assembly	204
X-restraint package option - 6500-001-430	205
X-restraint package option, cobalt blue - 6500-001-431	206
XPR restraint package option - 650600030010	207
Foot barrier option - 650700450201	208
Belt extension option - 6082-160-050	209
Base storage net option- 6500-160-000	210
Head end storage flat option - 6500-128-000	211
Storage pouch, backrest, dual-sided - 650700450134	212
Storage pouch, backrest, single-sided - 650700450142	213
Oxygen bottle holder, Fowler - 650700450153	214
Oxygen bottle holder, head section - 650700450154	215
Mattress option, knee Gatch bolster - 6506-034-000	216
Mattress option, knee Gatch bolster, grey - 6506-033-000	217
Mattress option, knee Gatch bolster, XPS - 6500-003-130	218
Mattress option, knee Gatch bolster, grey, XPS - 6506-041-000	219
In-fastener shut-off assembly option - 6500-001-027	220
Safety hook, short - 6060-036-017/Safety hook, long - 6060-036-018/Safety hook, J - 6092-036-018	221
MTS - Power-PRO 2 assembly, high config - 650705550001	222
MTS - Power-PRO 2 assembly, mid config - 650705550002	223
MTS - Power-PRO 2 assembly, high config, no Wi-Fi - 650705550003	224
EMC information	225
Recycling passport	229
650700080301	229
650700450301	230
650700450102	231
650700450103	232
650700450104	233
650700450105	234
650700450106	235
650700450107	236
650700450108	237
650700450109	238
650700450210	239
650700450211	240
650700450212	241
650700450101	242
650700080806	243
650700080009	244
650700080009	245
650700080800	246
650700080900	247
650700080810	248
650700080910	249
650700080820	250
650700080920	251
650700080202	252
650700080203	253
650700080860	254
650700080862	255
650700080863	256
650700080864	257
650700080865	258
650700080866	259
650700080867	260
650700080868	261
650700080869	262

650700080870.....	263
650700080871.....	264
650700080872.....	265
650700080873.....	266
650700080875.....	267
650700080876.....	268
650700080877.....	269
650700080878.....	270
650700080879.....	271
650700080880.....	272
650700080890.....	273
650700080891.....	274
650700080892.....	275
650700080893.....	276

Warning/Caution/Note Definition

The words **WARNING**, **CAUTION**, and **NOTE** carry special meanings and should be carefully reviewed.

WARNING

Alerts the reader about a situation which, if not avoided, could result in death or serious injury. It may also describe potential serious adverse reactions and safety hazards.

CAUTION

Alerts the reader of a potentially hazardous situation which, if not avoided, may result in minor or moderate injury to the user or patient or damage to the product or other property. This includes special care necessary for the safe and effective use of the device and the care necessary to avoid damage to a device that may occur as a result of use or misuse.

Note - Provides special information to make maintenance easier or important instructions clearer.

Summary of safety precautions

Always read and strictly follow the warnings and cautions listed on this page. Service only by qualified personnel.

WARNING

- Do not use bare hands to check for hydraulic leaks.
 - Do not allow the sensor lead to bend when you remove the lead from the box or install the lead. The MTS sensor arrives in a custom box to protect the sensor lead from bending.
 - Portable RF communications equipment, including peripherals such as antenna cables and external antennas, should be used no closer than 12 inches (30 cm) to any part of **Power-PRO 2**, including cables specified by the manufacturer.
 - Avoid stacking or placing other equipment adjacent to **Power-PRO 2** to prevent improper operation of the products. If such use is necessary, carefully observe the cot and the other equipment to verify proper operation.
 - The use of accessories, transducers, and cables, other than those specified or provided by the manufacturer, could result in increased electromagnetic emissions or decreased electromagnetic immunity and result in improper operation.
-

CAUTION

- Always use authorized parts to avoid the risk of product damage.
 - Do not lubricate the bearings in the X-frame as it will degrade the performance of the cot and may void its warranty.
 - Always use electrostatic discharge (ESD) protective equipment before you open antistatic bags and service electronic parts.
 - Do not place unprotected circuit boards on the floor.
 - Always remove the cot battery before you upgrade or service the cot to reduce the risk of shock.
 - Always remove the cot battery before you service or upgrade the cot to reduce the risk of shock.
 - Always use care when you lift and support the cot. The cot may move while you tip the cot onto the head section.
 - Always use assistance from another person when you flip the cot onto the backrest.
 - Do not use the head extension option as a push/pull device or to steer the product.
 - Do not hang equipment from the head extension option.
 - Changes or modifications to the **Alvarium** Battery Management System, not expressly approved by Stryker, could void the user's authority to operate the equipment.
-

Introduction for service

This manual assists you with the service of your Stryker product. Read this manual to service this product. This manual does not address the operation of this product. To view your instructions for use online, see <https://ifu.stryker.com/>.

Expected service life

Power-PRO 2 has a 7 year expected service life under normal use conditions and with appropriate periodic maintenance.

Alvarium charger has a 7 year expected service life under normal use conditions.

Alvarium battery has a 2 year expected service life under normal use conditions.

Contact information

Contact Stryker Customer Service or Technical Support at: 1-800-327-0770.

Stryker Medical
3800 E. Centre Avenue
Portage, MI 49002
USA

Note - The user and/or the patient should report any serious product-related incident to both the manufacturer and the Competent authority of the European Member State where the user and/or patient is established.

To view your operations or maintenance manual online, see ifu.stryker.com.

Have the serial number (A) of your Stryker product available when calling Stryker Customer Service or Technical Support. Include the serial number in all written communication.

Serial number location - Power-PRO 2

See below for the cot (A) serial number location (Figure 1).

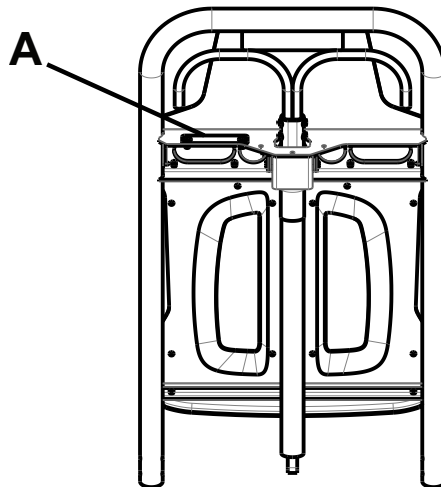

Figure 1 – Power-PRO 2 serial number location

Serial number location - Alvarium

See below for the battery (B) and charger (C) serial number locations (Figure 2 and Figure 3).

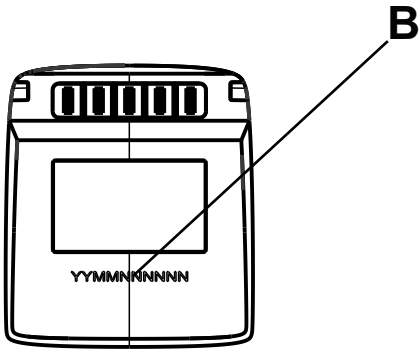

Figure 2 – Alvarium battery serial number location

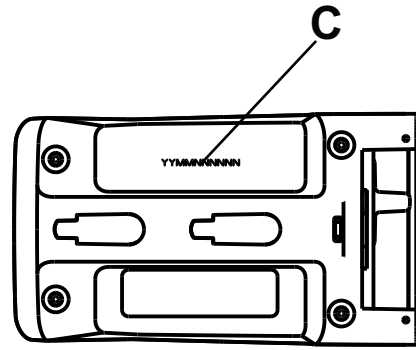

Figure 3 – Alvarium charger serial number location

Preventive maintenance

WARNING - Do not use bare hands to check for hydraulic leaks.

CAUTION - Always use authorized parts to avoid the risk of product damage.

Establish and follow a maintenance schedule and keep records of the maintenance activity. Remove the product from service before you perform the preventive maintenance inspection. You may need to perform preventive maintenance checks more often based on your level of product usage. Service only by qualified personnel.

When using maintenance products, follow the directions of the manufacturer and reference all Material Safety Data Sheets (MSDS).

Lubrication

CAUTION - Do not lubricate the bearings in the X-frame as it will degrade the performance of the cot and may void its warranty.

The cot has been designed to operate without the need for lubrication.

Regular inspection and adjustments

The following schedule is a general guide to maintenance. Factors such as weather, terrain, geographical location, and individual usage will alter the required maintenance schedule. If you are unsure how to perform these checks, contact your Stryker service technician. If you are in doubt as to what intervals to follow to maintain your product, consult your Stryker service technician. Check each routine and replace worn parts if necessary.

Every month or two hours

Inspect these items every month or two hours of motor run time, whichever comes first.

Item	Inspect
Settings	In-fastener shutoff configuration
Cylinder	Extend cylinder rod and wipe with a soft cloth and household cleaner
Cables and wires	No hanging wires from routings or connections
	Hand tighten foot end electronics cable
Manual back-up release handle	Manual back-up release handle functions
Litter	Frame and litter
Base	Frame and base
Wheels	All wheels are secure, roll, and swivel
Head section	Pull toward the head section to check that the safety bar swings and rotates and pulls back to the home position
Foot section	Extend and retract
	Functions and latches
Restraint	Function with no excessive wear (such as a bent or broken receiver or latch plate or torn or frayed webbing)
Battery	Housing and terminal area for cracks or damage before first and every use
Charger	For cuts in the cord, bent pins or contacts, or cracks in the housing before first and every use

Every three months or six hours

Inspect these items every three months or six hours of motor run time, whichever comes first.

Item	Inspect
Hydraulics	Motor mount fasteners are secure
	No hydraulic fluid leaks

Item	Inspect
	No leaks from reservoir
Cables and wires	No damage or pinching of wiring harness, cable, or lines
	No damaged connectors
Manual back-up release handle	Base extends and retracts when you pull the manual back-up release handle
Litter	All fasteners are secure
	Backrest cylinder operates
	Adjust pneumatic cylinder for full range of motion, if required
Base	All fasteners are secure
X-frame	X-frame expands and retracts
Head section	All fasteners are secure
	Head section extends and locks
Foot section	Transport handle extends and locks in 90 degree upright position
	All fasteners are secure
	Foot section extends and locks in the retracted, mid, and extended positions
	Stow and lock transport handle
	Foot end guide lights operate
Accessories and parts	All accessories and parts operate

Every six months or 12 hours

Inspect these items every six months or 12 hours of motor run time, whichever comes first.

Item	Inspect
Electronic controls/functions	Extend cot to raised position, measure and check load height
	Jog function operates
	High speed retract and extend operates
	Bumper detection operates
	Press the release or transport height button and confirm correct height
	Measure load height and confirm correct height
Switches	No damage or wear to the switches
	All switches operate
Litter	No bent, broken, or damaged components
	No damage or tears on cot grips
	Siderails operate and latch
	Footrest operates
Mattress	No cracks or tears
Base	No bent, broken, or damaged components
	Cot retaining post is secure. If not, replace the screw.
	No excessive damage to X-frame guards

	Training date		
Trainee name	Basic training	Refresher update	Owner's manual, in-service, formal class, etc.

Troubleshooting

Stryker Service Tool

The Stryker Service Tool allows you to retrieve status and diagnostic data from the cot.

Tools required:

- Stryker Service Tool (521205080001)
- Microsoft Windows PC
- USB A to USB micro-B cable
- T10 Torx driver

Procedure:

1. Using a T10 Torx driver, loosen the T10 Torx screw that secures the USB port cover. Allow the USB port cover to swing down enough so you can access the USB port.
2. Plug the USB cable into the cot and the computer.
3. Open the Stryker Service Tool (521205080001).
4. Select **Connect via USB**, located under **Power-PRO 2 (6507)** (Figure 4).

Note - The Stryker Service Tool will show a found device. The product will take a few seconds to make the full connection.

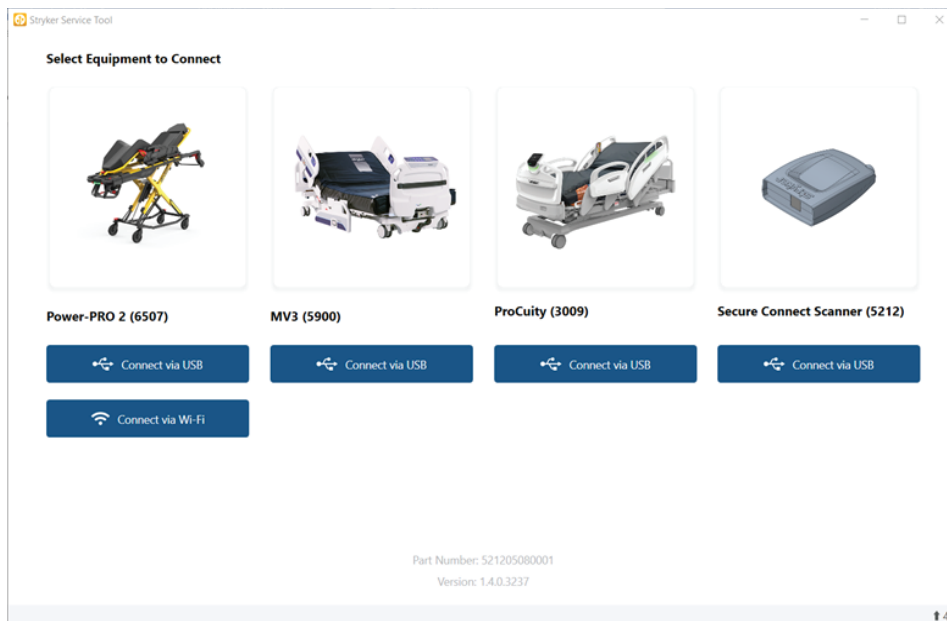

Figure 4 – USB Connection to Power-PRO 2 (6507)

5. After the Diagnostics button highlights blue, select **Diagnostics** to access Equipment Details (Figure 5).

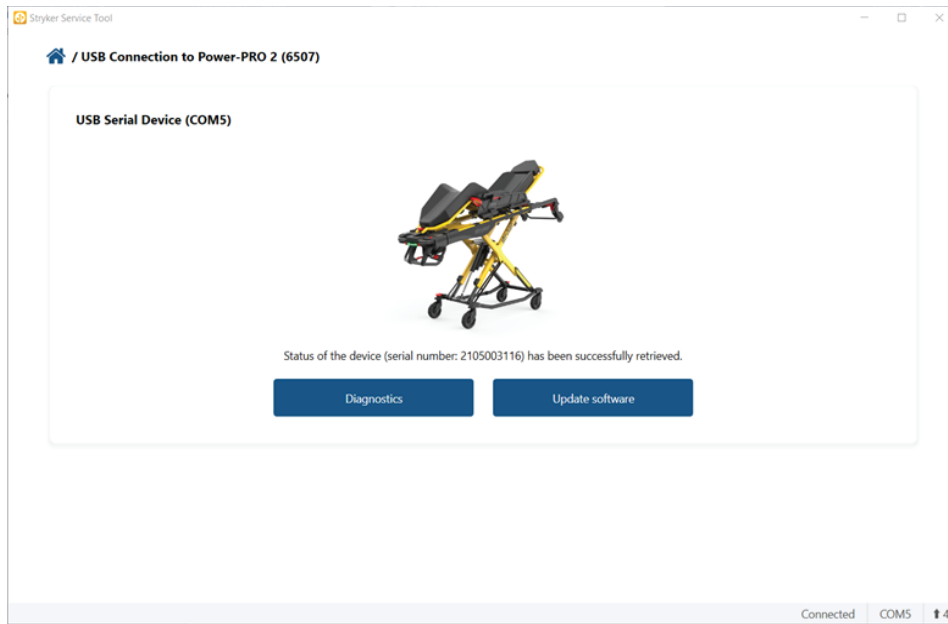

Figure 5 – Diagnostics

6. Use the tabs in the Equipment Details main screen to access different data from the cot (Figure 6).

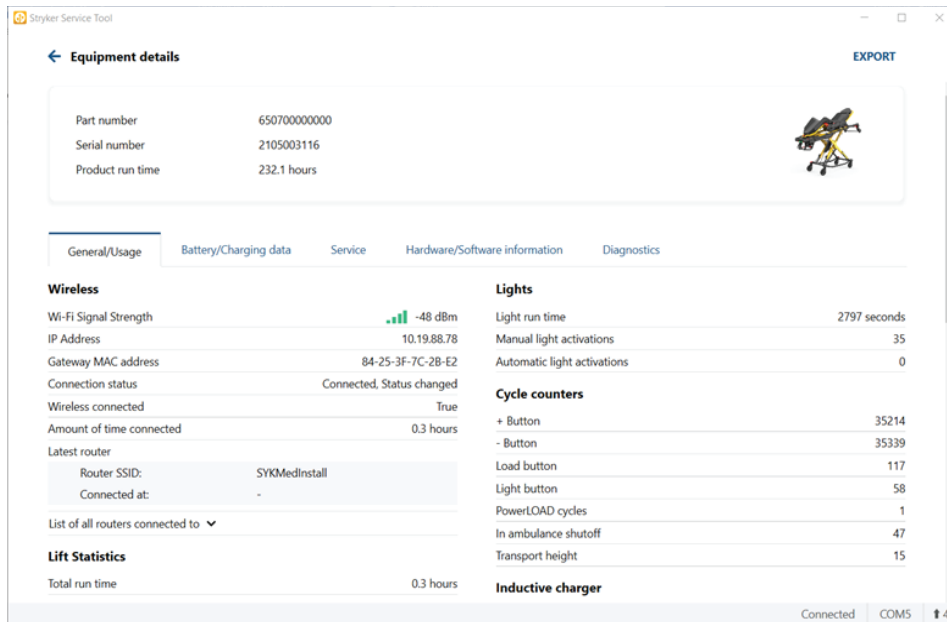

Figure 6 – Equipment Details main screen

Error code information

Battery charger (BC)

Error code ID	Fault description and possible cause	Troubleshooting
6507-825-01-1 MicroP On-chip data memory levels exhausted	The data storage leveling algorithm has run out of space. <ul style="list-style-type: none"> Product is at the end of life Memory is worn out 	<ol style="list-style-type: none"> 1. No actions needed - the cot is still operational but will no longer collect service or operational data. 2. Replace the battery charger board or leave as is.
6507-825-01-2 MicroP On-chip data memory file system corrupted	The data memory is corrupted and cannot be recovered. <ul style="list-style-type: none"> Flash memory defect 	<ol style="list-style-type: none"> 1. Power cycle the cot. 2. Recalibrate the cot. 3. Replace the battery charger board.
6507-825-02-1 Logic power DC over voltage	The primary DC power supply is operating above the permissible range. <ul style="list-style-type: none"> Short from battery bus to 12V_SYSTEM bus FEIB PS failure 	Replace the battery charger board.

Error code ID	Fault description and possible cause	Troubleshooting
6507-825-02-2 Logic power DC under voltage	<p>The primary DC power supply is operating below the permissible range.</p> <ul style="list-style-type: none"> Battery charger board fault HBC board fault External sensor fault (pressure transducer or motor hall fault) 	<ol style="list-style-type: none"> Verify that the logic power voltage is between 4-14VDC. Cycle power and confirm that the error is still present. <ol style="list-style-type: none"> If the error is still present and voltage is correct, replace the battery charger board. If the voltage is not correct, unplug battery charger board power cable. Verify that the +12V system voltage at FEIB is above 9V (FEIB board J10.8 to J10.1). <ol style="list-style-type: none"> If the voltage recovers, replace the battery charger board. If the voltage is still low, verify the corresponding FEIB fault. Unplug the system bus cable from FEIB (J10). Cycle power and confirm that the fault goes away and the voltage is above 9V. <ol style="list-style-type: none"> If the fault goes away and voltage is above 9V, follow HBC +12V_system bus under voltage diagnosis steps. If the fault is still present and the voltage is still below 9V, replace the FEIB.
6507-825-04-1 Battery over temperature - not charging	<p>The attached smart battery has set the over temperature flag in the BatteryStatus register while discharging.</p> <ul style="list-style-type: none"> Battery failure Bad thermistor 	Replace the battery.
6507-825-04-2 Battery over temperature - charging	<p>The attached smart battery has set the over temperature flag in the BatteryStatus register while charging.</p> <ul style="list-style-type: none"> Battery failure Bad thermistor 	Replace the battery.
6507-825-04-3 Charger over temperature	<p>The temperature measured on the charging circuit has risen above a threshold.</p> <ul style="list-style-type: none"> Charger over current Damaged sensor/board 	Replace the battery charger board.
6507-825-04-4 Charger over current - major	<p>The measured charge current has risen above a major threshold.</p> <ul style="list-style-type: none"> Damaged battery Damaged battery charger board Short to ground Damaged sensor 	<ol style="list-style-type: none"> Replace the battery. <ol style="list-style-type: none"> If the fault goes away, replace the battery. If the fault does not go away, verify that the short to ground is not present. Measure J1.1 to J1.2. <ol style="list-style-type: none"> If you measure a fault, determine the fault location by unplugging wires until the fault goes away. <p>Note - The fault may be on the board.</p> Replace the battery charger board.

Error code ID	Fault description and possible cause	Troubleshooting
6507-825-04-5 Charger open circuit	Charging is enabled but no charge current is measured. <ul style="list-style-type: none"> Damaged battery charger board Short to ground Damaged sensor 	<ol style="list-style-type: none"> Replace the battery. <ol style="list-style-type: none"> If the fault goes away, replace the battery. If the fault does not go away, verify that there is no open wire on the battery harness or charger harness. If you measure a fault, replace the appropriate harness. Replace the battery charger board.
6507-825-04-6 Charger over voltage	The measured charge voltage has risen above a threshold. <ul style="list-style-type: none"> Damaged board 	<ol style="list-style-type: none"> Replace the battery. <ol style="list-style-type: none"> If the fault goes away, replace the battery. Replace the battery charger board.
6507-825-08-1 Battery voltage sensing error	The battery voltage does not correlate to the other assemblies on the board measuring the battery voltage. PCB A/D input disagrees with the voltage reported by the battery. <ul style="list-style-type: none"> Damaged wiring Loose cable/wire connection Battery failure Sensor error 	<ol style="list-style-type: none"> Measure the battery voltage at the battery. Measure the voltage at the terminal block. <ol style="list-style-type: none"> If the battery voltage does not match the Stryker Service Tool, verify continuity of wires and connections from the battery to the battery charger board. Measure the voltage on the battery charger board from J1.1 to J1.2. All voltages should be within 0.25V of each other. Replace the harnesses as appropriate. <ol style="list-style-type: none"> If the battery voltage is not the same as the other two, replace the battery. If the battery charger board voltage is not the same as the other two, replace the battery charger board.
6507-825-08-2 MCP4725 output voltage error	MCP4725 digital-to-analog converter accepted a new voltage command but the measured feedback from its output does not match the command. <ul style="list-style-type: none"> Damaged board 	Replace the battery charger board.
6507-825-08-3 Thermistor reading out of range	The thermistor reading is beyond typical temperature. <ul style="list-style-type: none"> Defective thermistor or circuit 	<ol style="list-style-type: none"> Allow the control to cool (wait approximately 30 minutes). <ol style="list-style-type: none"> If the fault is no longer present, the fault was likely due to continued use under heavy load. If the fault is still present, replace battery charger board.
6507-825-13-1 CAN bus error	The CAN controller is going bus-off and will not recover. <ul style="list-style-type: none"> Intermittent connection 	<ol style="list-style-type: none"> Cycle power. Check that the CAN bus (BC J4.2 and J4.3) is not shorted to the ground (J4.1). Disconnect the boards/cables until fault goes away. Replace the boards/cables as needed. Wiggle the wires in case of an intermittent open wire. <ol style="list-style-type: none"> If the other nodes are offline, perform a similar cable check on the other CAN cables (wireless module and HBC).
6507-825-13-2 Master node is offline	BC is not getting a master node CAN heartbeat message. <ul style="list-style-type: none"> Intermittent connection Error could be logged during a SW update and not show up until after update completed 	<ol style="list-style-type: none"> Cycle power. Check that the CAN bus (BC J4.2 and J4.3) is not shorted to the ground (J4.1). Disconnect the boards/cables until fault goes away. Replace the boards/cables as needed. Wiggle the wires in case of an intermittent open wire.

Error code ID	Fault description and possible cause	Troubleshooting
6507-825-13-3 MCP4725 I2C error	I2C communication error detected with MCP4725 digital to analog converter IC. <ul style="list-style-type: none">Damaged board	Replace the battery charger board.
6507-825-13-4 Smart battery SMBus error	SMBus communication error detected with attached smart battery. <ul style="list-style-type: none">Defective batteryOpen wire on harness/board	1. Replace the battery. a. If the fault does not go away, verify continuity of the SMB harness (J3.1, J3.2, J3.3) to battery connections. b. If you do not find the fault, replace the battery charger board.
6507-825-14-1 Battery end of life	Smart battery cycle count has risen above the rated threshold for the cells. <ul style="list-style-type: none">Battery at end of life	Replace the battery.

Head base control (HBC)

Error code ID	Fault description and possible cause	Troubleshooting
6507-805-01-1 MicroP On-chip data memory levels exhausted	The data storage leveling algorithm has run out of space. <ul style="list-style-type: none">Product is at end of lifeMemory is worn out	1. No actions needed - the cot is still operational but will no longer collect service or operational data. 2. Replace the HBC board.
6507-805-01-2 MicroP On-chip data memory file system corrupted	The data memory is corrupted and cannot be recovered. <ul style="list-style-type: none">Flash memory defect	1. Cycle power. 2. Recalibrate the cot. 3. Replace the HBC board.
6507-805-02-1 Battery DC over voltage	The primary DC power supply is operating above the permissible range. <ul style="list-style-type: none">Battery is overchargedInductive charging voltage is too highBack EMF spike	1. Check the battery voltage. 2. Replace the battery if the voltage is over 28V. a. If the battery voltage is OK, and if inductive charging works, check the inductive charge output voltage. b. If the output voltage is over 28V, verify the voltages on Power-LOAD . 3. The foot end hitch is not damaged. Make sure that they are operating within specifications. 4. If not inductively charging or the inductive charge voltages look good, verify that the motor phase cables and motor hall cables do not have an intermittent connection. Wiggle the wires while doing a continuity check on each wire measured from each end.

Error code ID	Fault description and possible cause	Troubleshooting
<p>6507-805-02-2</p> <p>Battery DC under voltage</p>	<p>The primary DC power supply is operating above the permissible range.</p> <ul style="list-style-type: none"> • Low battery • Battery cell damaged • Inductive charging voltage too low 	<ol style="list-style-type: none"> 1. Check the battery voltage. 2. Replace the battery if the voltage is under 18V. <p>Note - You may need to run the cot under load.</p> <ol style="list-style-type: none"> 3. Run the cot under heavy load. 4. Verify that the battery is not cutting out by monitoring the battery for an error code. <ol style="list-style-type: none"> a. See the over current fault for more checks and possible diagnosis. b. If the battery voltage is OK, and if inductive charging works, check the inductive charge output voltage. c. If the output voltage is under 18V, verify the voltages on Power-LOAD. Make sure that the voltages are operating within specifications. 5. Verify that the battery cables are not shorted.
<p>6507-805-02-4</p> <p>+12V SW under voltage</p>	<p>Switched +12V bus is operating below the permissible range.</p> <ul style="list-style-type: none"> • FEIB circuit pulling CAN bus low • Pressure transducer short • Motor hall cable short (including cable coming from motor) • Motor hall sensor short • HBC blown fuse or damaged FET 	<ol style="list-style-type: none"> 1. Verify that the +12V SW voltage is correct (J2.1 to J2.2). <p>Note - The voltage should be between 9-14VDC.</p> <ol style="list-style-type: none"> 2. Cycle power and confirm that the error is still present. <ol style="list-style-type: none"> a. If the error is still present and the voltage is correct, replace the HBC board. 3. Unplug the system bus cable from the HBC board. 4. Verify that the +12V system voltage at the FEIB is correct (FEIB board J10.8 to J10.1). <ol style="list-style-type: none"> a. If the voltage is still low, check the FEIB +12V system bus faults. b. If the voltage is above 9V, reattach the system bus cable to the HBC board. 5. Unplug the pressure transducer cable. <ol style="list-style-type: none"> a. Cycle power and confirm that the fault goes away and the voltage is above 9V. If the fault goes away and voltage is above 9V, replace the pressure transducer. <ol style="list-style-type: none"> i. If the fault is still present and the voltage is still below 9V, unplug the motor hall cable. If the fault goes away and the voltage is above 9V, replace the hydraulic assembly. b. If the fault does not go away, check for shorts between the motor hall cable wires. <ol style="list-style-type: none"> i. If the cable has a short, replace the cable. 6. If the fault is still present and the voltage is still below 9V, replace the HBC board. <ol style="list-style-type: none"> a. Confirm that the fuse F6 on HBC board is not blown, if possible. If blown, verify that the fault is not on the board. Confirm J6.1 and J2.3 are not shorted to ground (J2.1 or TP1) on the board. <ol style="list-style-type: none"> i. If shorted, replace the HBC board. ii. If not shorted, there is a short elsewhere in the system. 7. Double check the system. With no power to the unit, reattach all wires and the original board. <ol style="list-style-type: none"> a. Confirm that there are no shorts on the motor hall, pressure transducer, or HBC board by checking J6.1 or J2.3 to all other wires on all other connectors.

Error code ID	Fault description and possible cause	Troubleshooting
6507-805-02-5 +3.3V switched power supply over voltage	3.3V bus is operating above the permissible range. <ul style="list-style-type: none"> 1. 3.3V bus shorted to +12V or battery bus Most likely cause is exposed wires from two different cables touching causing short Other possibility includes short on board 	1. Verify that all cables from the HBC board are intact with no abrasions or similar wear in which the bare wires are exposed. <ol style="list-style-type: none"> If you find damaged cables, replace all damaged cables and confirm that the error goes away. 2. Replace the HBC board.
6507-805-02-6 Bulk V bus over voltage	Bulk V Bus is operating above the permissible range. <ul style="list-style-type: none"> Switched_Batt+ bus on when it should not be Battery overcharged Inductive charging voltage too high Back EMF spike 	1. Run DC (battery) over voltage fault checks. 2. If DC battery over voltage checks are good, replace the HBC board.
6507-805-02-8 Battery over current	Excessive battery current to the motor and solenoid. <ul style="list-style-type: none"> Motor stall Motor windings shorted Bulk cap charge circuit not working 	1. Verify that the motor load current is within limits (unweighted cot - should be less than 20A). <ol style="list-style-type: none"> If over 20A, replace the hydraulic assembly. If less than 20A but the motor stops right away, replace the HBC board. Note - Make sure that there are no obstructions in the slider block or X-frame area.
6507-805-02-9 +3.3V switched power supply under voltage	3.3V bus is operating below the permissible range. <ul style="list-style-type: none"> Strain gauge/strain gauge cable failure - short to ground Regulator damaged 	1. Unplug the strain gauge cable at the enclosure. <ol style="list-style-type: none"> If the fault goes away, replace the strain gauge (strain gauge fault may appear). 2. Confirm low voltage on the 3.3V line (press the light button to make sure that the circuit is ON before measuring - 20 seconds before the circuit will turn off again). <ol style="list-style-type: none"> If the voltage level is above 2.5V, then it is a false detection. 3. If the fault is still present, unplug the strain gauge cable at board. <ol style="list-style-type: none"> If the fault goes away, replace the interior strain gauge cable (strain gauge fault may appear). 4. Replace the HBC board.
6507-805-02-10 Bulk V bus under voltage	Bulk V Bus is operating below the permissible range. <ul style="list-style-type: none"> Bulk charge circuit not working (HBC board) Short to ground (solenoid or HBC) Gating FET did not turn ON (HBC board) 	1. Verify that the battery voltage is within acceptable limits and there is no battery error. <ol style="list-style-type: none"> If battery voltage is below 18V or battery under voltage error is shown, perform battery under voltage checks as listed above. If battery voltage is acceptable, replace the HBC board.
6507-805-02-11 Battery under current	Below normal current to the motor and solenoid. <ul style="list-style-type: none"> Back EMF 	1. Look for obstructions in the X-frame or slider block. 2. Verify that the motor hall cables or motor cables do not have intermittent connection. 3. Replace the HBC board (assumes that the on board current measurement circuit is bad).

Error code ID	Fault description and possible cause	Troubleshooting
6507-805-02-12 +12V_SYSTEM over voltage	+12V system bus is operating above the permissible range. <ul style="list-style-type: none"> Short from battery bus to 12V_SYSTEM bus FEIB PS failure 	<ol style="list-style-type: none"> Verify that all cables from the HBC board are intact with no abrasions or similar wear in which the bare wires are exposed. <ol style="list-style-type: none"> If you find damaged cables, replace all damaged cables and confirm that the error goes away. With power removed, perform a continuity check from the HBC cable J12.8 or FEIB board J10.8 to 24V bus terminal block or HBC J11.1. <ol style="list-style-type: none"> If you find a continuity, unplug the cables to every component until the fault goes away. <p>Note - Start with down stream components first.</p> <ol style="list-style-type: none"> Replace the component or cable until the fault goes away. If the continuity check shows no short circuit path, measure 12V output from FEIB (J10.8). <ol style="list-style-type: none"> If the continuity check is above 14V, replace the FEIB.
6507-805-02-13 +12V_SYSTEM under voltage	+12V system bus is operating below the permissible range. <ul style="list-style-type: none"> High load on 12V bus (+12V_System or +12V_SW) Short to GND on 12V bus (+12V_System or +12V_SW) 	<ol style="list-style-type: none"> Verify that all cables from the HBC board are intact with no abrasions or similar wear in which the bare wires are exposed. <ol style="list-style-type: none"> If you find damaged cables, replace all damaged cables and confirm that the error goes away. Verify that the +12V_System voltage is between 9-14VDC (J12.1 to J12.8). Cycle power and confirm error is still present. <ol style="list-style-type: none"> If the error is still present and the voltage is correct, disconnect the system bus cable. Measure the 12V output from FEIB (J10.8). If the voltage is below 7V, replace the FEIB. If the voltage goes to the correct level, perform diagnostics from the +12V_SW Undervoltage Section.
6507-805-13-1 Bus-off condition	CAN controller is going bus-off and will not recover. <ul style="list-style-type: none"> Intermittent connection 	<ol style="list-style-type: none"> Cycle power. Check that the CAN bus (HBC J12.2 and J12.3) is not shorted to ground (HBC J12.1). <ol style="list-style-type: none"> Disconnect the boards/cables until fault goes away. Replace boards/cables as needed. <p>Note - Wiggle the wires in case of an intermittent open wire.</p>
6507-805-13-2 Master node is offline	HBC is not getting any CAN message from master node. <ul style="list-style-type: none"> Intermittent connection 	<ol style="list-style-type: none"> Cycle power. Check that the CAN bus (HBC J12.2 and J12.3) is not shorted to ground (HBC J12.1). <ol style="list-style-type: none"> Disconnect the boards/cables until the fault goes away. Replace the boards/cables as needed. <p>Note - Wiggle the wires in case of an intermittent open wire.</p>
6507-805-13-3 DRV8305 com failure	Communication with DRV8305 failed. <ul style="list-style-type: none"> Defective HBC motor drive circuitry 	<ol style="list-style-type: none"> If the motor/cot is still working, the fault is most likely a false error and can be ignored. If the motor does not work, replace the HBC board.

Error code ID	Fault description and possible cause	Troubleshooting
6507-805-13-4 NFMIC invalid	Communication with NFMIC device invalid. <ul style="list-style-type: none"> • EMI or other electronic device blocking signal • Improper cot configuration • NFMIC board or cable damaged • HBC board damaged 	<ol style="list-style-type: none"> 1. Ignore if no NFMIC device. 2. Verify that other electronic devices (iPad or similar) are not near the NFMIC control on the cot or on Power-LOAD. 3. Determine if issue is at the cot or Power-LOAD. <ol style="list-style-type: none"> a. Use other cots/Power-LOAD to determine where issues are located. 4. Visually verify that the NFMIC cable is not damaged and is physically connected to the HBC board. 5. Verify 9V signal from HBC board J10.2 to J10.1 (ground). <ol style="list-style-type: none"> a. If there is voltage, replace the NFMIC board. b. If there is no signal, replace the HBC board.
6507-805-04-1 HS_FETA failure	Motor driver IC reports a fault (GATE DRIVE). <ul style="list-style-type: none"> • HBC board driver fault • Motor short 	<ol style="list-style-type: none"> 1. Replace the hydraulic assembly. 2. If the problem persists, replace the HBC board.
6507-805-04-2 LS_FETA failure	Motor driver IC reports a fault (GATE DRIVE). <ul style="list-style-type: none"> • HBC board driver fault • Motor short 	<ol style="list-style-type: none"> 1. Replace the hydraulic assembly. 2. If the problem persists, replace the HBC board.
6507-805-04-3 HS_FETB failure	Motor driver IC reports a fault (GATE DRIVE). <ul style="list-style-type: none"> • HBC board driver fault • Motor short 	<ol style="list-style-type: none"> 1. Replace the hydraulic assembly. 2. If the problem persists, replace the HBC board.
6507-805-04-4 LS_FETB failure	Motor driver IC reports a fault (GATE DRIVE). <ul style="list-style-type: none"> • HBC board driver fault • Motor short 	<ol style="list-style-type: none"> 1. Replace the hydraulic assembly. 2. If the problem persists, replace the HBC board.
6507-805-04-5 HS_FETC failure	Motor driver IC reports a fault (GATE DRIVE). <ul style="list-style-type: none"> • HBC board driver fault • Motor short 	<ol style="list-style-type: none"> 1. Replace the hydraulic assembly. 2. If the problem persists, replace the HBC board.
6507-805-04-6 LS_FETC failure	Motor driver IC reports a fault (GATE DRIVE). <ul style="list-style-type: none"> • HBC board driver fault • Motor short 	<ol style="list-style-type: none"> 1. Replace the hydraulic assembly. 2. If the problem persists, replace the HBC board.
6507-805-04-7 Motor driver over temp	Motor driver IC reports a fault. <ul style="list-style-type: none"> • HBC board driver fault • Motor short 	<ol style="list-style-type: none"> 1. Allow the motor to cool (wait approximately 30 minutes). <ol style="list-style-type: none"> a. Perform five lift/lowers with no weight. b. If the cot runs OK, the issue is most likely due to continued use under heavy load. 2. If the fault persists, verify the current for each phase. <ol style="list-style-type: none"> a. Current for unloaded lift/lower should be under 20A. b. If above 20A, verify no obstructions/debris in roller guide or other similar areas that might restrict movement. 3. If not, replace the hydraulic assembly. 4. If fault persists, replace the HBC board.

Error code ID	Fault description and possible cause	Troubleshooting
<p>6507-805-03-1</p> <p>SG1 strain gauge fault</p>	<p>SG1 Strain gauge input error.</p> <ul style="list-style-type: none"> • Strain gauge cable short/open • Strain gauge drift (excess weight/stress on cot) • HBC board damaged 	<ol style="list-style-type: none"> 1. While the cot is unloaded at transport (or load) height, and cot is not suspended, the Stryker Service Tool values should be within 0.75V to 2.0V. <ol style="list-style-type: none"> a. Move the cot up and down. The values should remain in the same range. b. Suspend the cot. The values should drop to the 0.25V to 1.0V range. c. If the values do not drop, replace the strain gauge/strain gauge bracket. 2. Unplug the strain gauge cable from enclosure. The Stryker Service Tool value should go to 0.1V. <ol style="list-style-type: none"> a. Measure the resistance across each pin combination of strain gauge connector, values will vary between 225Ω and 350Ω. b. If any reading is outside these values, replace the strain gauge/strain gauge bracket. c. If resistance check is OK, verify continuity of the HBC enclosure internal harness. d. If open wire, replace cable. 3. Replace the HBC board.
<p>6507-805-03-2</p> <p>Pressure transducer fault</p>	<p>Pressure transducer out of range.</p> <ul style="list-style-type: none"> • Pressure transducer cable open • Pressure transducer damaged • HBC board damaged 	<ol style="list-style-type: none"> 1. Perform lift and lower. <ol style="list-style-type: none"> a. Verify that the fault still exists. 2. While the cot is unloaded and not at minimum height, read the pressure transducer value from the Stryker Service Tool. <ol style="list-style-type: none"> a. If value is low (>0.8V), perform continuity check. b. If open, verify cable is not open. c. If cable is OK, replace the pressure transducer/hydraulic assembly. 3. If the issue from step 1 still exists or value reads high (>3.25V), replace the pressure transducer/hydraulic assembly. 4. If steps 1 and 2 do not resolve the problem, replace the HBC board.
<p>6507-805-03-3</p> <p>Motor hall-effect sensor fault</p>	<p>Hall effect sensor out of range.</p> <ul style="list-style-type: none"> • Motor hall cable open • Motor/motor halls damaged • Motor drive circuitry damaged 	<ol style="list-style-type: none"> 1. Measure continuity from all pins on the HBC board connector J2 to backside of motor connector. <ol style="list-style-type: none"> a. If you detect an open circuit, move the probe up and down to the different connectors to determine which connection is causing the issue. 2. Verify the +12V signal on the HBC board from J2.2 to J2.1 ground. <ol style="list-style-type: none"> a. If you have a +12V signal, replace the hydraulic assembly. b. If +12V is not present: Verify no short is present between any pins on the HBC board J2 (keep all cable connections in place). c. If a short is detected, disconnect cables/change probe locations to determine location of short. 3. Replace the HBC board.
<p>6507-805-03-4</p> <p>Motor board temperature sensor fault</p>	<p>PCB Temperature sensor is malfunctioning.</p> <ul style="list-style-type: none"> • Sensor damaged 	<ol style="list-style-type: none"> 1. Allow the motor to cool (wait approximately 30 minutes). 2. Perform five lift lowers with no weight. <ol style="list-style-type: none"> a. If the motor/cot is still working, verify Stryker Service Tool value. If value is less than 2V, most likely due to continued use under heavy load. b. If the value remains above 2V (fault still present), replace the HBC board.

Error code ID	Fault description and possible cause	Troubleshooting
<p>6507-805-03-5</p> <p>Motor temperature sensor fault</p>	<p>Motor temperature sensor is malfunctioning.</p> <ul style="list-style-type: none"> • Sensor open • Motor temp wire harness open • HBC board damaged 	<ol style="list-style-type: none"> 1. Allow the motor to cool (wait approximately 30 minutes). 2. Read the Stryker Service Tool value. <ol style="list-style-type: none"> a. If > 3.1V, a sensor or cable is open. Disconnect the motor connector. b. Verify continuity of sensor at motor connector. If open, replace the hydraulic assembly. c. If the sensor at the motor connector is not open (resistance value between 40Ω and 500Ω), reattach the motor cable to the harness, and perform a continuity check from the motor connector side to the HBC connector. Move the probes and disconnect the cables as appropriate to find the open source. d. If the value remains above 3.1V (fault still present), replace the HBC board.
<p>6507-805-03-7</p> <p>Position sensor fault</p>	<p>Position sensor is disconnected or defective.</p> <ul style="list-style-type: none"> • Wire harness open/shorted • Sensor is damaged 	<ol style="list-style-type: none"> 1. Monitor the Stryker Service Tool position sensor value. <ol style="list-style-type: none"> a. Perform the lift/lower cot movement. If the value does not move or if the value remains below 100 mV, make sure that all cables are connected and check continuity of cable wires (open/short). b. Replace the cable harness as needed. c. If no harness fault is found, replace the MTS sensor. 2. Monitor the Stryker Service Tool position sensor value. <ol style="list-style-type: none"> a. Perform the lift/lower cot movement. Watch the value to see if the reading jumps more than 1000 mV. b. If the value jumps, replace the MTS sensor. 3. Monitor the Stryker Service Tool position sensor value. <ol style="list-style-type: none"> a. Perform the lift/lower cot movement. Verify that the value does not exceed 4950 mV or less than 100 mV. b. If the value is outside this range, replace the MTS sensor. c. If the fault persists, replace the FEIB.
<p>6507-805-14-1</p> <p>Motor stall</p>	<p>Motor does not activate</p> <ul style="list-style-type: none"> • Motor hall cable open • Motor cable open • Motor/motor halls damaged • Motor drive circuitry damaged 	<ol style="list-style-type: none"> 1. Verify there are no obstructions or debris in the roller guide or other similar areas that might restrict movement. 2. Verify continuity of motor phase cables. 3. Measure continuity from all pins on the HBC board connector J2 to backside of motor connector. <ol style="list-style-type: none"> a. If you detect an open circuit, move the probe up and down to the different connectors to determine which connection is causing the issue. 4. Verify the +12V signal on the HBC board from J2.2 to J2.1 ground. <ol style="list-style-type: none"> a. If +12V signal, replace the hydraulic assembly. b. If +12V is not present, verify no short is present between any pins on the HBC board J2 (keep all cable connections in place). c. If a short is detected, disconnect the cables/change probe locations to determine the location of the short. 5. Replace the HBC board.

Error code ID	Fault description and possible cause	Troubleshooting
6507-805-14-2 Motor board over temperature	Motor PCB temperature exceeds a threshold. <ul style="list-style-type: none"> Excessive load Motor stall Motor windings partially shorted 	<ol style="list-style-type: none"> Allow the motor to cool (wait approximately 30 minutes). Perform five lift/lowers with no weight. <ol style="list-style-type: none"> If the motor/cot is still working, verify the Stryker Service Tool value. If the value is less than 1.5V, the fault is most likely due to continued use under heavy load. If the fault persists, verify the current for each phase. <ol style="list-style-type: none"> Current for unloaded lift/lower should be under 20A. If the current is above 20A, verify there are no obstructions or debris in the roller guide or other similar areas that might restrict movement. If not, replace the hydraulic assembly. If the fault persists, replace the HBC board.
6507-805-14-3 Motor over temperature	Motor temperature exceeds a threshold. <ul style="list-style-type: none"> Excessive load Motor stall Motor windings partially shorted 	<ol style="list-style-type: none"> Allow the motor to cool (wait approximately 30 minutes). Perform five lift/lowers with no weight. <ol style="list-style-type: none"> If the motor/cot is still working, verify the Stryker Service Tool value. If the value is less than 1V, the fault is most likely due to continued use under heavy load. If the fault persists, verify the current for each phase. <ol style="list-style-type: none"> Current for unloaded lift/lower should be under 20A. If the current is above 20A, verify there are no obstructions or debris in the roller guide or other similar areas that might restrict movement. If not, replace the hydraulic assembly. If the fault persists, replace the HBC board.

Foot end interface board (FEIB)

Error code ID	Fault description and possible cause	Troubleshooting
6507-815-01-6 NVRAM data memory file system corrupted	Data memory is corrupted and cannot be recovered. <ul style="list-style-type: none"> Memory IC defect 	<ol style="list-style-type: none"> Power cycle the cot. Recalibrate the cot. Replace the battery charger board.
6507-815-02-1 DC over voltage	The primary DC power supply is operating above the permissible range. <ul style="list-style-type: none"> Battery overcharged Inductive charging voltage too high Back EMF spike DC power supply defect 	<ol style="list-style-type: none"> Check the battery voltage. <ol style="list-style-type: none"> Replace the battery if voltage is over 28V. If the battery voltage is OK, and if inductive charging, check the inductive charge output voltage. If the output voltage is over 28V: <ol style="list-style-type: none"> Verify the voltages on Power-LOAD. The foot end hitch is not damaged. Make sure that the cot and Power-LOAD are operating within specifications. If not inductively charging or the inductive charge voltages look good: <ol style="list-style-type: none"> Verify that the motor phase cables and the motor hall cables do not have intermittent connection. Wiggle the wires while doing a continuity check on each wire measured from each end.

Error code ID	Fault description and possible cause	Troubleshooting
6507-815-02-3 +12V over voltage	<p>Voltage rating for +12V is over the acceptable range.</p> <ul style="list-style-type: none"> Issue caused by system bus cable or HBC board Issue caused by light module Buck converter on the FEIB unable to control the voltage Short from Batt bus to 12V_SW bus 	<ol style="list-style-type: none"> 1. Remove the connection from J10 on the FEIB and confirm that the fault goes away. 2. Disconnect the UI coil cable on the FEIB enclosure and confirm that the fault goes away. 3. Replace the FEIB board. 4. Remove the connection from J11 on the FEIB and confirm that the fault goes away.
6507-815-02-4 +12V under voltage	<p>Voltage rating for +12V is under the acceptable range.</p> <ul style="list-style-type: none"> Short to ground on HBC or the system bus cable Short to ground or any of the line of the UI/light module Load on the FEIB buck converter too high/buck converter failure/12V bus short to ground Short to ground on the battery charger board 	<ol style="list-style-type: none"> 1. Remove the connection from J10 on the FEIB and confirm that the fault goes away. 2. Disconnect the UI coil cable on the FEIB enclosure and confirm that the fault goes away. 3. Replace the FEIB board. 4. Remove the connection from J11 on the FEIB and confirm that the fault goes away.
6507-815-02-5 +12V high current	<p>Current rating for +12V is over the acceptable range.</p> <ul style="list-style-type: none"> HBC board drawing more current than expected UIs shorted to ground The inductor on the output of the buck converter damaged 	<ol style="list-style-type: none"> 1. Disconnect the J10 connector from the FEIB and confirm that the fault goes away. 2. Disconnect the UI coil cable from the FEIB and confirm that the fault goes away. 3. Replace the FEIB.
6507-815-02-7 +5V over voltage	<p>Voltage rating for +5V is over of acceptable range.</p> <ul style="list-style-type: none"> Short to 12V bus LDO of the buck converter not working 	<ol style="list-style-type: none"> 1. Disconnect the in-ambulance sensor and the MTS sensor and confirm that the fault goes away. <ol style="list-style-type: none"> a. If so, replace one or both of the sensors. 2. Replace the FEIB.
6507-815-02-8 +5V under voltage	<p>Voltage rating for +5V is under of acceptable range.</p> <ul style="list-style-type: none"> Short to ground Short to 3.3V line 	<ol style="list-style-type: none"> 1. Disconnect the in-ambulance sensor and the MTS sensor and confirm that the fault goes away. <ol style="list-style-type: none"> a. If so, replace one or both of the sensors. 2. Replace the FEIB.
6507-815-02-9 Task light current out of range	<p>Current supplied to the TASK_LIGHT_PWR current is out of the expected range.</p> <ul style="list-style-type: none"> Task Light shorted to ground Coil cable shorted to ground or 12V One or both of the UIs is shorted to ground or 12V 	<ol style="list-style-type: none"> 1. Replace the task light and confirm that the fault goes away. 2. Replace the coil cable and confirm that the fault goes away. 3. Disconnect the top UI and confirm that the fault goes away. 4. Disconnect the bottom UI and confirm that the fault goes away.

Error code ID	Fault description and possible cause	Troubleshooting
6507-815-02-10 Charge current too high	<p>Current supplied to the CHRG_I_SNS is exceeding a threshold.</p> <ul style="list-style-type: none"> The wires soldered on the inductive coil is shorted Metallic debris between the primary and secondary coil The diodes of rectifier on the FEIB Board shorted Current monitor IC failure 	<ol style="list-style-type: none"> Replace the inductive coil assembly and confirm that the fault goes away. Visually inspect to see if any debris exists between the primary and secondary coils. <ol style="list-style-type: none"> Blow air over the coils to clean it. Reconnect and confirm that the fault goes away. Replace the FEIB.
6507-815-02-11 +12V HBC over voltage	<p>Voltage supplying the HBC is over the acceptable range.</p> <ul style="list-style-type: none"> The 12 V Line is shorted to the 24V bus The wires in the system bus cable shorted Buck converter not able to regulate/failed 	<ol style="list-style-type: none"> Disconnect the J10 connector from the FEIB and confirm that the fault goes away. Replace the FEIB.
6507-815-02-12 +12V HBC under voltage	<p>Voltage supplying the HBC is under the acceptable range.</p> <ul style="list-style-type: none"> The 12V line is shorted to ground Charger comm cable shorted with ground wire or CAN wires Buck converter on the FEIB failed 	<ol style="list-style-type: none"> Disconnect the J10 connector from the FEIB and confirm that the fault goes away. Visually inspect to see if the J10 connector is secured to the header. <ol style="list-style-type: none"> Inspect the pins of the connector in the system bus cable to make sure that the pins have not backed out. Replace the FEIB.
6507-815-02-13 +12V BC over voltage	<p>Voltage supplying the BC is over the acceptable range.</p> <ul style="list-style-type: none"> The 12V line is shorted to ground System bus cable not connected/ making intermittent contact/ disconnected Buck converter on the FEIB failed 	<ol style="list-style-type: none"> Disconnect the charger comm cable from the J11 of the FEIB and confirm that the fault goes away. Visually inspect the charger comm cable to verify a secure connection. <ol style="list-style-type: none"> Verify that the pins of the J11 connector are secured to of the FEIB. Replace the FEIB.
6507-815-02-14 +12V BC under voltage	<p>Voltage supplying the BC is under the acceptable range.</p> <ul style="list-style-type: none"> The 12V line is shorted to ground Charger comm cable shorted with ground wire or CAN wires Buck converter on the FEIB failed 	<ol style="list-style-type: none"> Disconnect the charger comm cable from the J11 of the FEIB and confirm that the fault goes away. Replace the charger comm cable and confirm that the fault goes away. Replace the FEIB.

Error code ID	Fault description and possible cause	Troubleshooting
6507-815-13-1 CAN bus offline	<p>CAN controller is going bus-off and will not recover.</p> <ul style="list-style-type: none"> CAN connections on the system bus cable is shorted CAN lines on the HBC shorted CAN connections on the charger comm cables is shorted CAN lines on the BC shorted CAN controller completely failed 	<ol style="list-style-type: none"> Disconnect the J10 connector from the FEIB and confirm that the fault goes away. <ol style="list-style-type: none"> If so, replace the cable. If the fault persists after replacing the cable, replace the HBC board to confirm that the fault goes away. Disconnect the J11 connector from the FEIB and confirm that the fault goes away. <ol style="list-style-type: none"> If so, replace the charger comm cable. If the fault persists after replacing the charger comm cable, replace the HBC board and confirm that the fault goes away. Replace the FEIB.
6507-815-13-2 HBC offline	<p>FEIB is not getting HBC heartbeat.</p> <ul style="list-style-type: none"> Cable not connected on either the FEIB or the HBC end CAN line of the system bus cable shorted/open CAN controller on the HBC board failed 	<ol style="list-style-type: none"> Make sure that the connectors of the system bus cable are secured on both the FEIB and the HBC ends. Replace the system bus cable and confirm that the fault goes away. Replace the FEIB.
6507-815-13-3 BC offline	<p>FEIB is not getting JB heartbeat.</p> <ul style="list-style-type: none"> Cable not connected on either the FEIB or the HBC end CAN line of the system bus cable shorted/open CAN controller on the BC board failed 	<ol style="list-style-type: none"> Make sure that the connectors of the charger comm cable are secured on both the FEIB and the BC ends. Replace the charger comm cable and confirm that the fault goes away. Replace the FEIB.
6507-815-13-4 Gateway offline	<p>FEIB is not getting Gateway heartbeat.</p> <ul style="list-style-type: none"> Gateway cable on HBC end disconnected Gateway board failed Gateway not getting 12V from HBC CAN lines on the system bus cable shorted/open/damaged/disconnected 	<ol style="list-style-type: none"> Make sure that the Gateway connection to the HBC end is secure and the connector is not damaged. Replace the Gateway board and confirm that the fault goes away (may take up to 10 minutes). Check to see if the 12V on pins 5 and 4 of the HBC J13 connector are secure. Replace the system bus cable and confirm that the fault goes away (may take up to 10 minutes).
6507-815-13-6 Accelerometer IC is not responding	<p>Invalid information is being returned from the IC, suggesting that it is not communicating.</p> <ul style="list-style-type: none"> Accelerometer IC lost communication with the FEIB micro 	<ol style="list-style-type: none"> Cycle power and confirm that the fault goes away. <ol style="list-style-type: none"> If the fault persists, replace the FEIB.
6507-815-13-7 GPS IC is not responding	<p>No information is being returned from the IC, suggesting that it is not communicating.</p> <ul style="list-style-type: none"> GPS module lost communication with the FEIB micro 	<ol style="list-style-type: none"> Cycle power and confirm that the fault goes away. <ol style="list-style-type: none"> If the fault persists, replace the FEIB.

Error code ID	Fault description and possible cause	Troubleshooting
6507-815-16-0 FEIB up-switch failure	<p>A valid up button signal is decoded with no valid switch common signal detected.</p> <ul style="list-style-type: none"> • UI coil cable (650700080862) damaged where the purple wire is shorted to 3.3V • UI internal cable (650700080876) wire is shorted to 3.3V • The trace on the board is shorted to 3.3V 	<ol style="list-style-type: none"> 1. Replace the UI coil cable and confirm that the fault goes away. 2. Replace the UI internal cable and confirm that the fault goes away. 3. Replace the FEIB board and confirm that the fault goes away. 4. Replace the UI one at a time until the fault goes away.
6507-815-16-1 FEIB down-switch failure	<p>A valid down button signal is decoded with no valid switch common signal detected.</p> <ul style="list-style-type: none"> • UI coil cable (650700080862) damaged where the gray wire is shorted to 3.3V • UI internal cable (650700080876) wire is shorted to 3.3V • The trace on the board is shorted to 3.3V 	<ol style="list-style-type: none"> 1. Replace the UI coil cable and confirm that the fault goes away. 2. Replace the UI internal cable and confirm that the fault goes away. 3. Replace the FEIB board and confirm that the fault goes away. 4. Replace the UI one at a time until the fault goes away.
6507-815-16-2 FEIB release-switch failure	<p>A valid release button signal is decoded with no valid switch common signal detected.</p> <ul style="list-style-type: none"> • UI coil cable (650700080862) damaged where the yellow wire is shorted to 3.3V • UI internal cable (650700080876) wire is shorted to 3.3V • The trace on the board is shorted to 3.3V 	<ol style="list-style-type: none"> 1. Replace the UI coil cable and confirm that the fault goes away. 2. Replace the UI internal cable and confirm that the fault goes away. 3. Replace the FEIB board and confirm that the fault goes away. 4. Replace the UI one at a time until the fault goes away.
6507-815-16-3 FEIB switch common mismatch error	<p>The decoded state of the switch common signal on the FEIB does not match the CAN reported state by the HBC.</p> <ul style="list-style-type: none"> • UI coil cable (650700080862) damaged where the brown wire is shorted to 3.3V • UI internal cable (650700080876) wire is shorted to 3.3V • The trace on the board is shorted to 3.3V 	<ol style="list-style-type: none"> 1. Replace the UI coil cable and confirm that the fault goes away. 2. Replace the UI internal cable and confirm that the fault goes away. 3. Replace the FEIB board and confirm that the fault goes away. 4. Replace the UI one at a time until the fault goes away.

Error code ID	Fault description and possible cause	Troubleshooting
6507-815-16-4 Work light switch	The push button is stuck in the pressed state. <ul style="list-style-type: none"> • UI coil cable (650700080862) damaged where the brown wire is shorted to 3.3V • UI internal cable (650700080876) wire is shorted to 3.3V • The trace on the board is shorted to 3.3V 	<ol style="list-style-type: none"> 1. Replace the UI coil cable and confirm that the fault goes away. 2. Replace the UI internal cable and confirm that the fault goes away. 3. Replace the FEIB board and confirm that the fault goes away. 4. Replace the light module and confirm that the fault goes away.
6507-815-16-5 FEIB up-switch stuck	The push button is stuck in the pressed state. <ul style="list-style-type: none"> • UI coil cable (650700080862) damaged where the purple wire is shorted to 3.3V • UI internal cable (650700080876) wire is shorted to 3.3V • The trace on the board is shorted to 3.3V • The UI + button is damaged 	<ol style="list-style-type: none"> 1. Replace the UI coil cable and confirm that the fault goes away. 2. Replace the UI internal cable and confirm that the fault goes away. 3. Replace the FEIB board and confirm that the fault goes away. 4. Replace the light module and confirm that the fault goes away.
6507-815-16-6 FEIB down-switch stuck	The push button is stuck in the pressed state. <ul style="list-style-type: none"> • UI coil cable (650700080862) damaged where the gray wire is shorted to 3.3V • UI internal cable (650700080876) wire is shorted to 3.3V • The trace on the board is shorted to 3.3V • The UI - button is damaged 	<ol style="list-style-type: none"> 1. Replace the UI coil cable and confirm that the fault goes away. 2. Replace the UI internal cable and confirm that the fault goes away. 3. Replace the FEIB board and confirm that the fault goes away. 4. Replace the light module and confirm that the fault goes away.
6507-815-16-7 FEIB release-switch stuck	The push button is stuck in the pressed state. <ul style="list-style-type: none"> • UI coil cable (650700080862) damaged where the yellow wire is shorted to 3.3V • UI internal cable (650700080876) wire is shorted to 3.3V • The trace on the board is shorted to 3.3V • The RLS button is damaged 	<ol style="list-style-type: none"> 1. Replace the UI coil cable and confirm that the fault goes away. 2. Replace the UI internal cable and confirm that the fault goes away. 3. Replace the FEIB board and confirm that the fault goes away. 4. Replace the light module and confirm that the fault goes away.

Error code ID	Fault description and possible cause	Troubleshooting
6507-815-16-10 FEIB switch common stuck	<p>The switch common is stuck in the pressed state.</p> <ul style="list-style-type: none"> • UI coil cable (650700080862) damaged where the brown wire is shorted to 3.3V • UI internal cable (650700080876) wire is shorted to 3.3V • The trace on the board is shorted to 3.3V • The UI carbon dome on any one or multiple buttons has collapsed 	<ol style="list-style-type: none"> 1. Replace the UI coil cable and confirm that the fault goes away. 2. Replace the UI internal cable and confirm that the fault goes away. 3. Replace the FEIB board and confirm that the fault goes away. 4. Replace the light module and confirm that the fault goes away.
6507-815-8-1 Ambient out of range temperature fault	<p>Ambient temperature reading is out of range.</p> <ul style="list-style-type: none"> • Defective thermistor on the FEIB board 	Replace the FEIB board.
6507-815-8-2 In-ambulance sensor fault	<p>In-ambulance sensor is disconnected or defective.</p> <ul style="list-style-type: none"> • The in-ambulance sensor is disconnected • The in-ambulance sensor panel mount connector is broken shorting the pins • In-ambulance sensor is disconnected from J13 of the FEIB • Wires directly attached to the in-ambulance sensor are damaged 	<ol style="list-style-type: none"> 1. Make sure that the in-ambulance sensor panel mount connector is connected. 2. Visually inspect the in-ambulance sensor panel mount connector for any damage. <ol style="list-style-type: none"> a. If damaged, replace the cable. 3. Make sure that the in-ambulance sensor cable is connected to the FEIB. 4. Replace the in-ambulance sensor.

Charger does not charge the battery

1. Verify that the battery power LED is illuminated.
2. Make sure that the battery does not have a fault condition. Push the button on the battery.
 - a. If the two outer LEDs flash five times and pause (repeated three times and then stop), the battery needs to be replaced.
 - b. If the LEDs illuminate as expected, there may be a problem with the charger.
3. Using a voltmeter, measure for 3.3 VDC between (-) negative and (D, C, or T) on the charger side of the connector.

A fully charged battery does not provide sufficient power to operate the cot

1. Make sure that the battery does not have a fault condition. Push the button on the battery.
 - a. If the two outer LEDs flash five times and pause (repeated three times and then stop), the battery needs to be replaced.
 - b. If the LEDs illuminate as expected, there may be a problem with the charger.
2. Using a voltmeter, measure for 3.3 VDC between (-) negative and (D, C, or T) on the battery.

HBC PCBA assembly

650700080800 Rev AM

650700080900 Rev AG

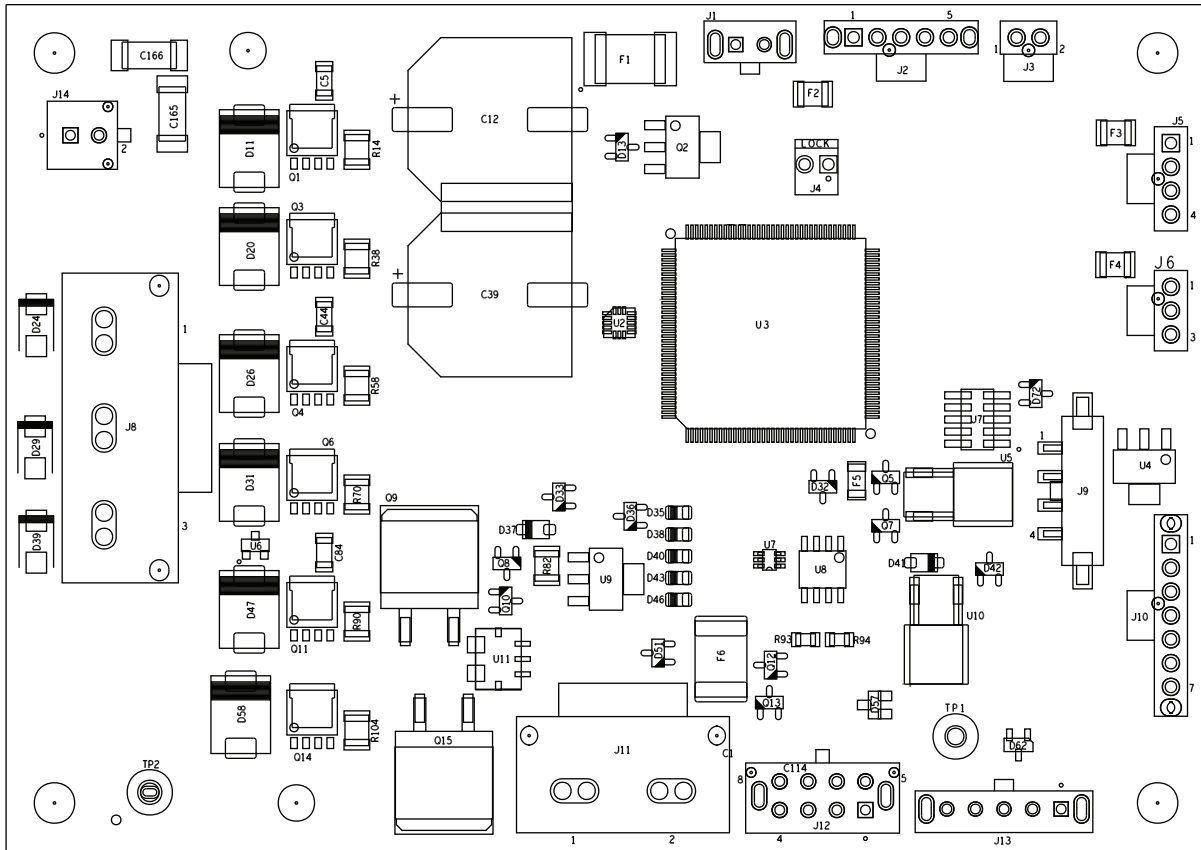

FEIB PCBA assembly

650700080810 Rev AM

650700080910 Rev AG

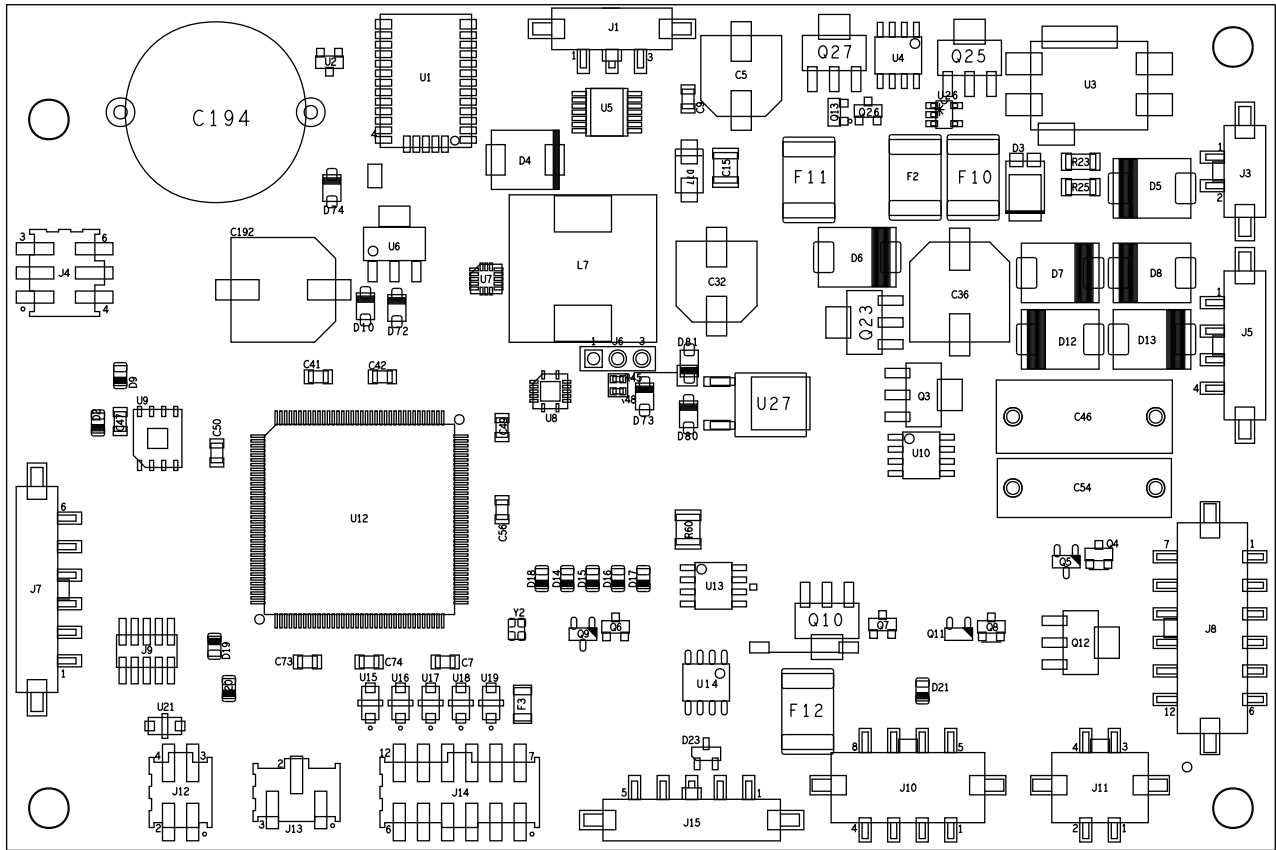

Battery charger PCBA assembly

650700080820 Rev AL

650700080920 Rev AE

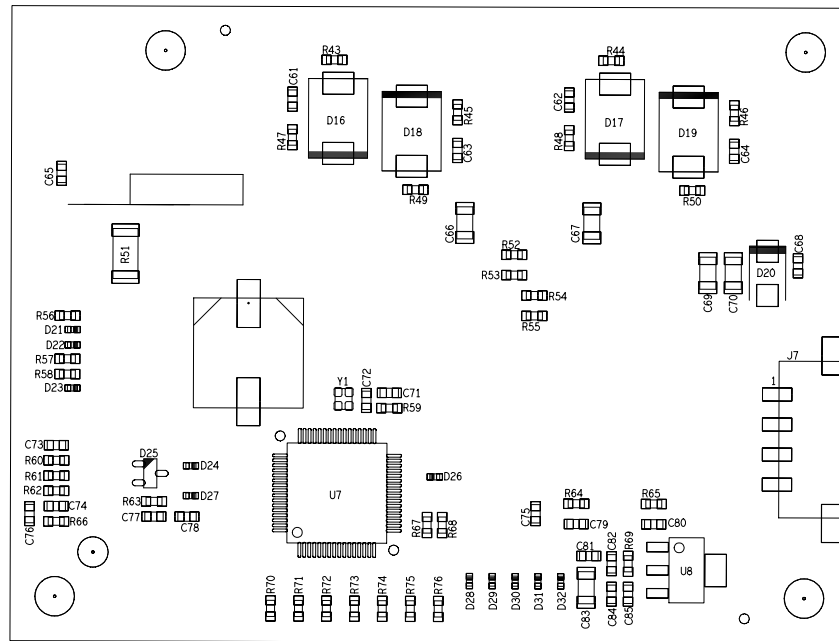
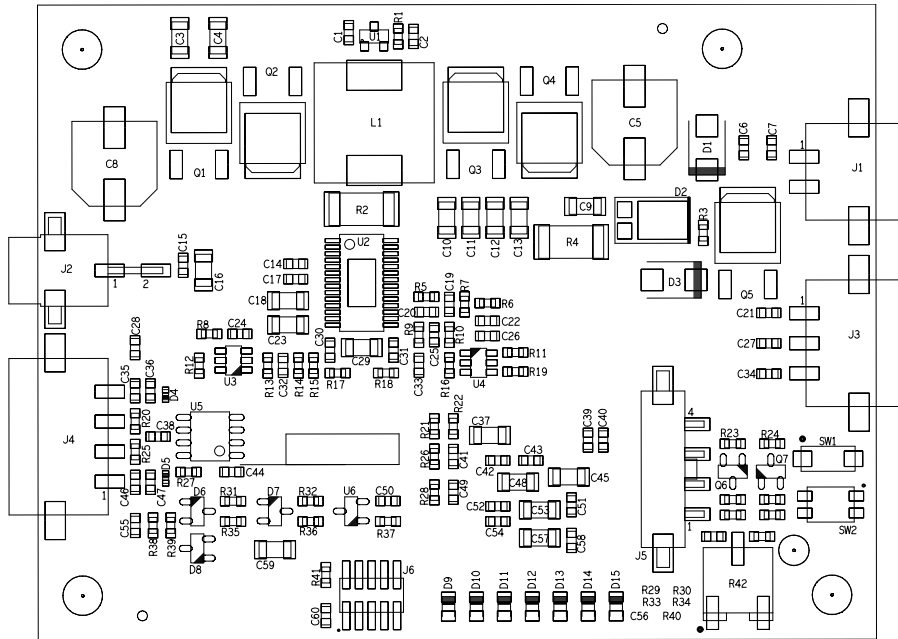

Service

Protecting against electrostatic discharge (ESD)

CAUTION

- Always use electrostatic discharge (ESD) protective equipment before you open antistatic bags and service electronic parts.
 - Do not place unprotected circuit boards on the floor.
-

Note - Always ship the circuit boards back to Stryker. Use the antistatic bag that the new board was originally shipped in.

The electronic circuits in the product are completely protected from static electricity damage when factory assembled. Always use adequate static protection when you service the electronic systems of the product. All service personnel must use static protection whenever they touch wires.

Sample antistatic protection equipment includes:

- Antistatic wrist strap
- Grounding plug
- Test lead with a banana plug on one end and an alligator clip on the other end

Make sure that you follow the ESD manufacturer's instructions for appropriate protection against static discharge.

Cot calibration

Tools required:

- Magnet

Procedure:

1. Using a magnet, cover the in-fastener shut-off magnet.

Note - The in-fastener shut-off magnet is located behind the foot end right side cover. There is a molded triangle to indicate where to place the magnet.

2. While you hold the magnet over the in-fastener shut-off magnet, push and hold the transport height button and the (+) button for five seconds.

Note - The LED will flash when in calibration mode.

3. Press the (-) button until the litter is all the way down.
4. Press the (+) button until the litter is all the way up.
5. Using a load surface, support the cot so all four casters do not touch the ground.
6. Press the cot into the loading position.
7. Press the (-) button for one second to retract the base a little.
8. Press the transport height button to save the calibration.

Note - The transport height lights will flash after calibration if the calibration failed. The cot will default to slow speed motion until calibration is successful.

9. Verify proper operation of the high speed retract and high speed extend before you set the cot down.

Note - To change the default cot load height, raise or lower the cot to the desired height and press the (+) and (-) buttons for three to five seconds. The cot load height LED will flash twice when the new cot load height is saved.

Power-LOAD unloading adjustment

Tools required:

- T10 Torx driver
- Stryker Service Tool 521205080001 v2.2.0.118 or higher

Note

- Before you start this procedure, the software board versions for the head end base controller (HBC) and foot end interface board (FEIB) must be v2.2.0.118 or higher.
- If the software for either board is not at the required version, you will need to update the software.

1. Calibrate the cot. See *Cot calibration* (page 35).
2. Raise the cot to the highest height position.
3. Using a T10 Torx driver, loosen the screw (CH) that secures the USB port cover (CK) to the foot end enclosure. Allow the cover to swing down for access to the USB port (Figure 7).

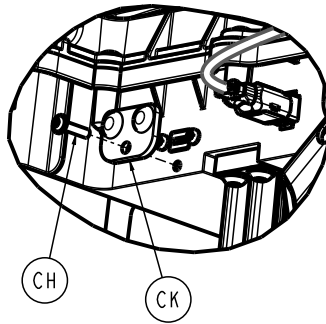

Figure 7 – Remove the USB port cover

4. Open the Stryker Service Tool.
5. Plug the USB cable into the USB port on the cot.
6. Plug the other end of the USB cable into the computer.
7. For Power-PRO 2 (6507), click **Connect via USB** (Figure 8). Then, click **Diagnostics**.

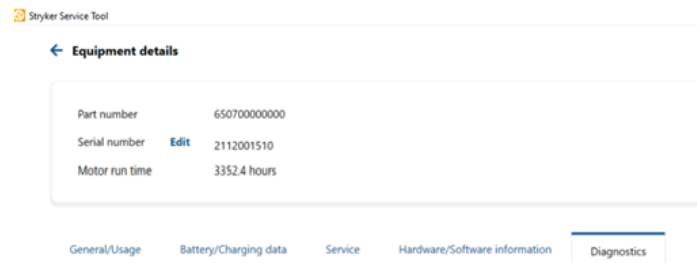

Figure 8 – Connect via USB

8. Scroll down and click **PL Unloading Adjustment** (Figure 9).

Calibration Data (ADC)

Max Height	53800
Load Height	3200
Position Window	2605
Transport Window	65535
Min Height	2700
Indeterminate Height	4000
Strain Gauge Treshold	0
Change PL Unloading Adjustment	0
Calibration Count	0



Figure 9 – Power-LOAD Unloading Adjustment

9. Load the cot into **Power-LOAD** and move the trolley into the loading position.
10. Press and hold the retract (-) button on the cot control switch to retract the cot undercarriage.
11. Press and hold the extend (+) button on the cot control switch to extend the cot undercarriage until the cot wheels are on the ground.
12. Release the extend (+) button after the cot is no longer supported by the lifting arms. The **Power-LOAD** lifting arms will continue moving until fully lowered. Do not unlock the cot from **Power-LOAD**.
13. Make sure that the head end casters do not touch the ground.
 - a. If the head end casters move freely, increase the PL Unloading Adjustment value to decrease the distance between the wheels and the ground.
 - b. If the head end casters do not move at all, decrease the PL Unloading Adjustment value to increase the distance between the wheels and the ground.

Note - Changing the PL Unloading Adjustment value by 5,000 = approximately a 2.5" distance.

14. When you are done changing the PL Unloading Adjustment value, click **Set** to save the configuration (Figure 10).

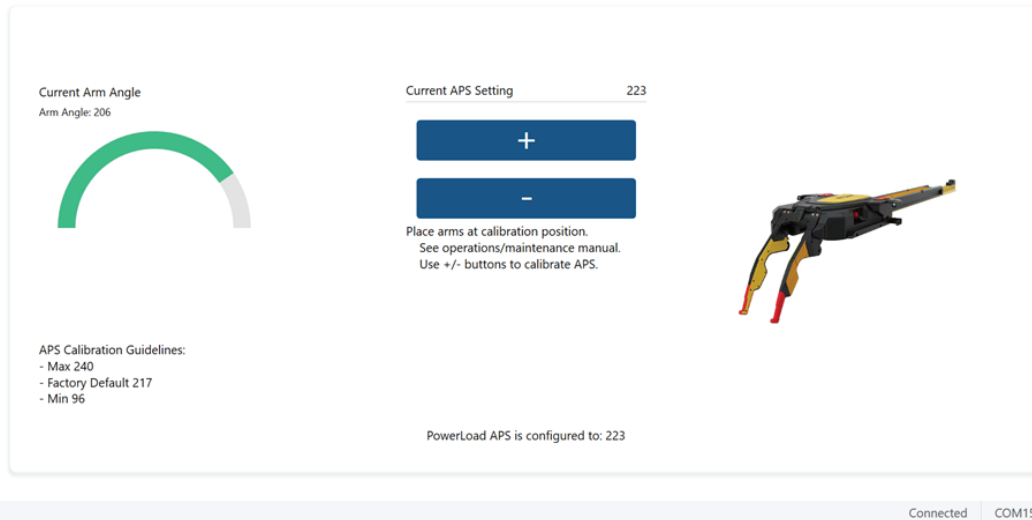

Figure 10 – Save the new configuration

15. Repeat steps 9-14 until the back caster is firmly on the ground.
16. Unlock the cot from the **Power-LOAD** and make sure that:
 - The head section load pins do not rub on the trolley.
 - The load pins do not have too much pressure on them.
17. Close the Stryker Service Tool.
18. Unplug the USB cable from the USB ports on the cot and your computer.
19. Using a T10 Torx driver, reinstall the screw (removed in step 3) to secure the USB port cover.
20. Verify proper operation before you return the product to service.

12 VDC automotive cable fuse replacement

Tools required:

- None

Procedure:

1. Unplug the adaptor cable from the plug (B) and the plug connector (A) (Figure 11).
2. Unscrew the tip on the source end and remove the fuse.

Note - The source tip and the fuse tension spring are loose and could be dropped.
3. Install the supplied 10A 250V fuse into the source end of the adaptor cable and screw the tip back on.
4. Plug both ends back into the source and the charger.
5. Test for functionality before you return the charger to service.



Figure 11 – 12 VDC automotive cable

Backrest adjustment

Tools required:

- Loctite®
- 1/2" combination wrench
- 5/32" hex wrench
- 3/32" hex wrench
- Small slotted screwdriver
- T25 Torx driver
- Torque wrench (in-lb)

Procedure:

1. Apply the brakes.
2. Remove the mattress from the cot.
3. Place the cot and Fowler in the highest height positions.
4. Check that the gas cylinder (B) is threaded into the gas spring yoke (E) so that no threads are visible on the gas cylinder shaft (Figure 12).
5. If threads are visible, complete these steps:

- a. Using a T25 Torx driver, remove the two button head cap screws (K) that secure the gas spring yoke end (G) to the yoke on the patient left side (Figure 13). Save the screws.

Note - Using a torque wrench, torque the button head cap screws to 3.40 - 4.60 ft-lb when you reinstall.

- b. Using a 3/32" hex wrench, remove the set screw (A) from the center of the gas spring yoke (E) (Figure 12 and Figure 13). Save the screw.

Note - Using a torque wrench, torque the set screw to 1.70 - 2.30 ft-lb when you reinstall.

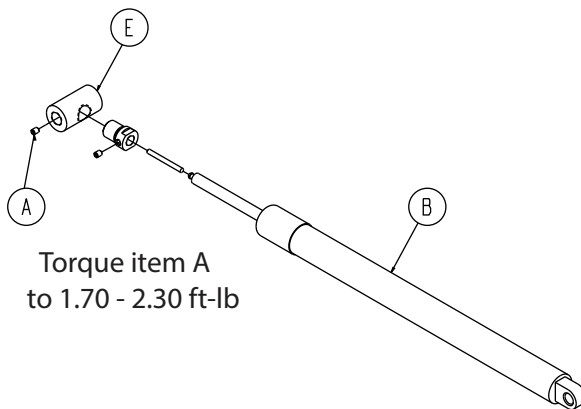

Figure 12 – Fowler cylinder components

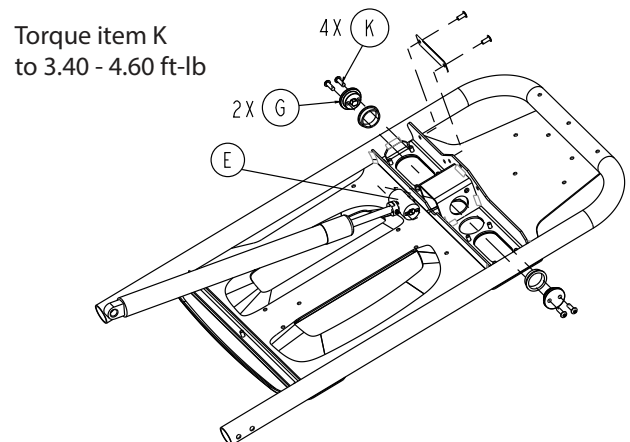

Figure 13 – Remove the button head cap screws

- c. Using a small slotted screwdriver, remove the truarc ring (G) and Fowler cylinder pin (J) that secure the bottom of the gas cylinder to the mount (Figure 14). Save the truarc ring and Fowler cylinder pin.

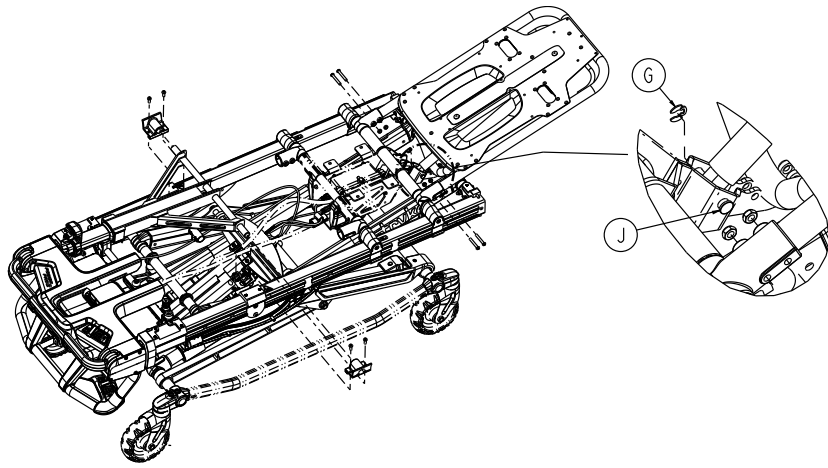

Figure 14 – Remove the truarc ring and Fowler cylinder pin

- d. Thread the gas cylinder into the gas spring yoke until no threads are visible on the gas cylinder shaft.
 - e. Using a small slotted screwdriver, reinstall the truarc ring and Fowler cylinder pin (removed in step 3c).
 - f. Using **Loctite®** and a 3/32" hex wrench, reinstall the set screw (removed in step 3b).
6. Using a 1/2" combination wrench, loosen the hex nut (A) on the Fowler release handle pivot while using a 5/32" hex wrench to hold the set screw (B) fixed in the pivot (Figure 15).
 7. Using a 5/32" hex wrench, turn the set screw until there is no movement between the Fowler release handle (E) and the pneumatic cylinder release button (Figure 15).

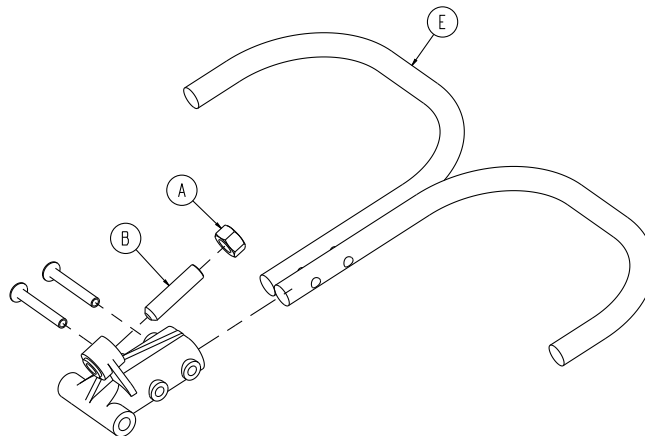

Figure 15 – Loosen the hex nut

8. Check that the backrest travels from flat to the highest height position. If it does not, turn the set screw clockwise half of a turn. Repeat until the backrest can achieve at least 75 degrees of movement.
9. Verify proper operation before you return the product to service.

Fowler cylinder assembly replacement

Tools required:

- 1/2" combination wrench
- 5/32" hex wrench
- Small slotted screwdriver
- T25 Torx driver
- Torque wrench (in-lb)

Procedure:

1. Apply the brakes.
2. Remove the mattress from the cot.
3. Place the cot and Fowler in the highest height positions.
4. Using a T25 Torx driver, remove the two button head cap screws (K) that secure the gas spring yoke end (G) to the gas spring yoke (E) on the patient left side (Figure 16). Save the screws.

Note - Using a torque wrench, torque the button head cap screws to 3.40 - 4.60 ft-lb when you reinstall.

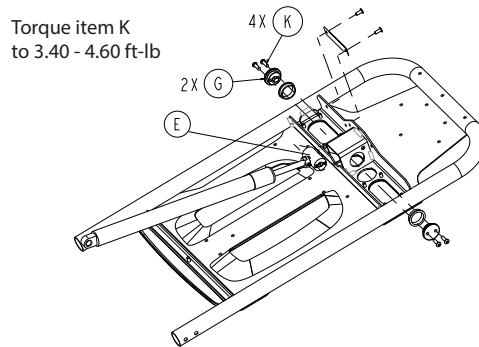

Figure 16 – Remove the button head cap screws

5. Repeat step 2 on the patient right side.
6. Using a small slotted screwdriver, remove the truarc ring (G) and Fowler cylinder pin (J) that secure the bottom of the gas cylinder to the mount (Figure 17). Save the truarc ring and Fowler cylinder pin.

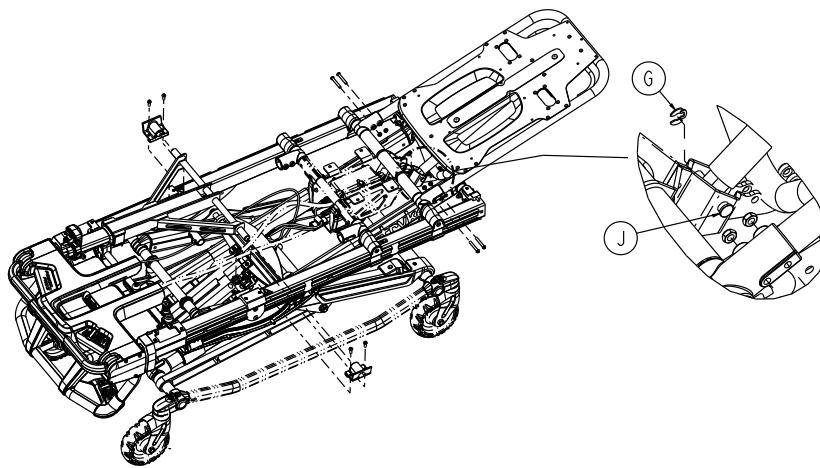

Figure 17 – Remove the truarc ring and Fowler cylinder pin

7. Hold the Fowler up and pull out the bottom of the gas cylinder (B) (Figure 18).

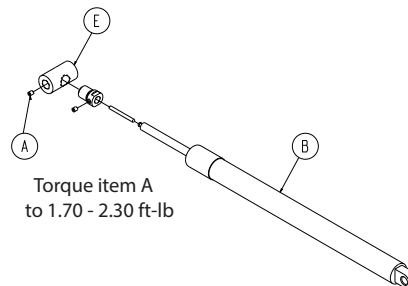

Figure 18 – Fowler cylinder components

8. Lower the gas cylinder and gas spring yoke out of the backrest. Discard the gas cylinder and gas spring yoke.
9. Reverse steps to install the supplied Fowler cylinder assembly.
10. Using a 1/2" combination wrench, loosen the hex nut (A) on the Fowler release handle pivot while using a 5/32" hex wrench to hold the set screw (B) fixed in the pivot (Figure 19).
11. Using a 5/32" hex wrench, turn the set screw until there is no movement between the Fowler release handle (E) and the pneumatic cylinder release button (Figure 19).
12. Check that the backrest travels from flat to the highest height position. If it does not, turn the set screw clockwise half of a turn. Repeat until the backrest can achieve at least 75 degrees of movement.
13. Lower the backrest to a 5-10 degree angle and release the handle. Apply approximately 50 lb of downward force to the end of the backrest. If the backrest drifts down, turn the set screw counterclockwise. Repeat until the backrest does not drift down.

14. Using a 1/2" combination wrench, tighten the hex nut (A) while you hold the set screw (B) fixed in the pivot (Figure 19).

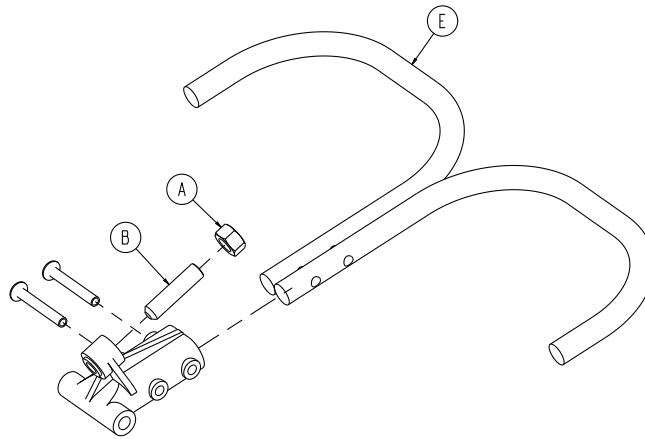

Figure 19 – Loosen the hex nut

15. Verify proper operation before you return the product to service.

Head section replacement

Tools required:

- 7/16" combination wrench
- 3/16" hex wrench
- Torque wrench (in-lb)

Procedure:

1. Apply the brakes.
2. Place the cot and Fowler in the highest height positions.
3. Using a 7/16" combination wrench and a 3/16" hex wrench, remove the two socket head cap screws (BJ) and Fiberlock hex nuts (E) that secure the cap bearings to the base litter interface bracket (one on each side) (Figure 20). Save the screws and nuts.

Note - Using a torque wrench, torque the socket head cap screws to 2.29 - 3.09 ft-lb when you reinstall.

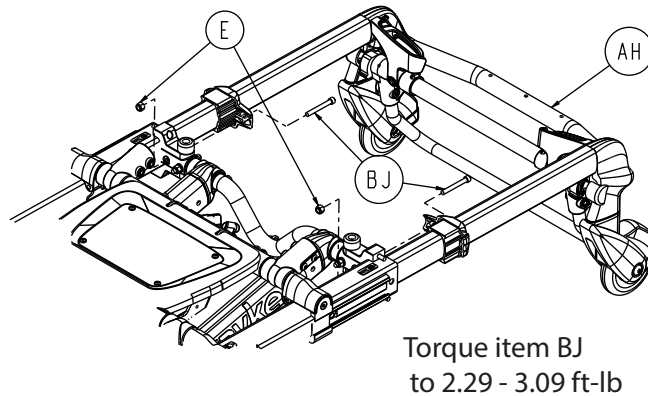

Figure 20 – Head section components

4. Squeeze the head section release handles and remove the head section assembly (AH) (Figure 20).
5. Reverse steps to reinstall.
6. Verify proper operation before you return the product to service.

Manual release cable replacement

Tools required:

- T10 Torx driver
- T20 Torx driver
- T30 Torx driver
- Pick
- Torque wrench (in-lb)
- 10 mm combination wrench
- Bungee cord
- Drop cloth

Procedure:

1. Apply the brakes.
2. Remove the mattress from the cot.
3. Place the cot and Fowler in the highest height positions.
4. Raise and lock the foot section in the highest height position. Then, fold the foot section toward the backrest and secure with the bungee cord.
5. Remove the cot battery.

CAUTION - Always remove the cot battery before you upgrade or service the cot to reduce the risk of shock.

6. Using a 10 mm combination wrench, loosen the manual release cable lock nut (A) (Figure 21).
7. Using a T10 Torx driver, remove the two button head cap screws (CH) that secure the manual release cable bracket to the hydraulic assembly (Figure 22). Save the screws.

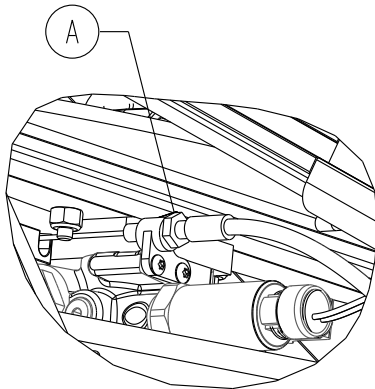

Figure 21 –

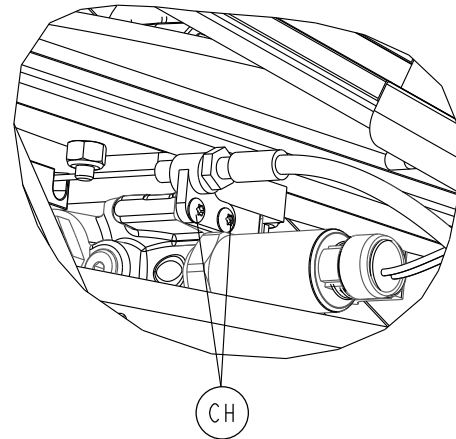

Figure 22 –

8. Disconnect the manual release cable from the manual release bracket assembly (650700020008).
9. Remove the manual release cable bracket (650700020161) from the manual release cable. Save the manual release cable bracket.

Note - When you reinstall, route the manual release cable (650700020228) between the lift motor cable assembly and the cable bundle (system bus cable, solenoid/transducer external cable assembly, and strain gauge external cable assembly).

10. Using a T20 Torx driver, remove the five round washer head tapping screws that secure the top mini loop (650700080251) to the bottom mini loop (650700080252). Remove the top mini loop and the manual release cable from the bottom mini loop.

Note - When you reinstall, align the cable grommet with the bottom of the supplied bottom mini loop.

11. Extend the foot section to access the outer rail end cap screws.
12. Remove the FEIB to status external module coil cable assembly (650700080862) (Figure 23).
13. Using a T30 Torx driver, remove the pan head machine screw (BG) that secures the outer rail end cap (F) to the outer rail (Figure 24). Repeat on the other side. Discard the screws.

Note - Using a torque wrench, torque the two supplied pan head machine screws (700000719305) to 4.48 - 6.06 ft-lb when you reinstall.

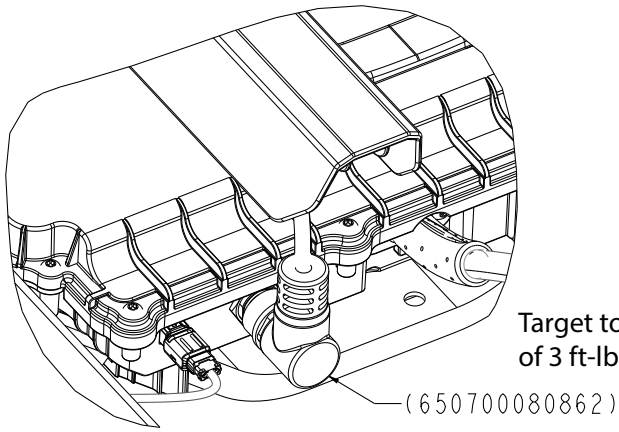

Figure 23 –

Target torque
of 3 ft-lb

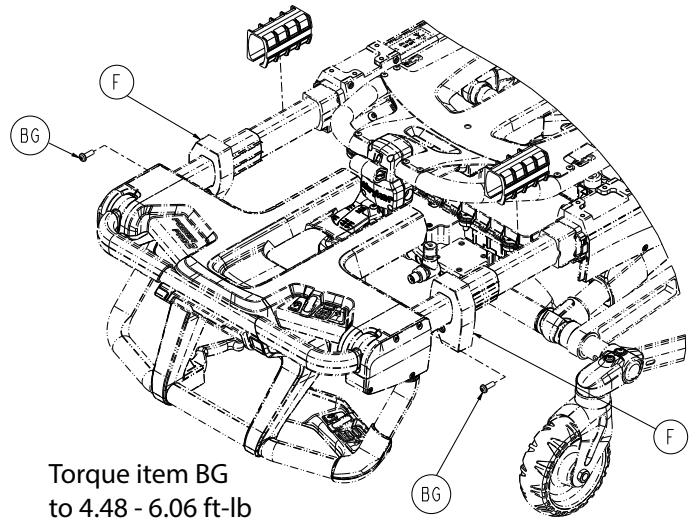

Figure 24 –

Torque item BG
to 4.48 - 6.06 ft-lb

14. Extend the wagon handle to the upright position.
15. Place a drop cloth on the ground.
16. Remove the foot section from the cot and place it on the drop cloth.
17. Using a T10 Torx driver, remove the round washer head tapping screws (AJ) from the foot section. Then, remove the cable clamps (D) from the manual release cable (Figure 25). Save the cable clamps and screws.

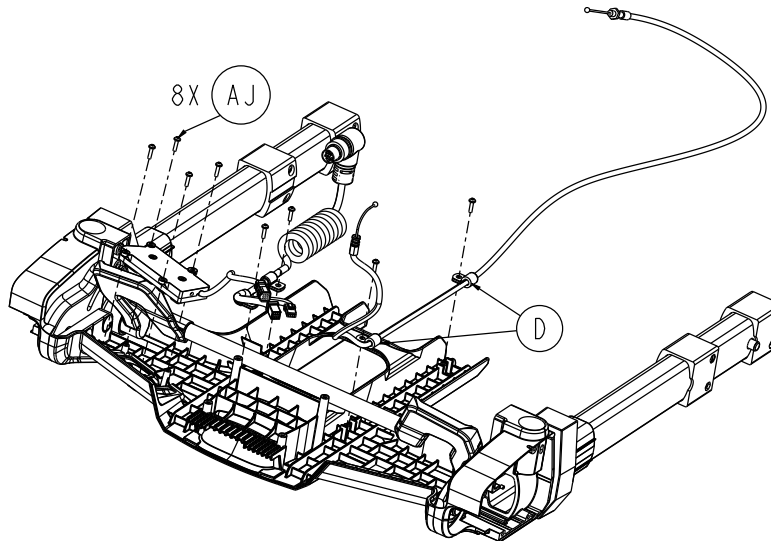

Figure 25 –

18. Using a T20 Torx driver, remove the six round washer head tapping screws (AK) from the back of the foot end housing (Figure 26). Save the screws.

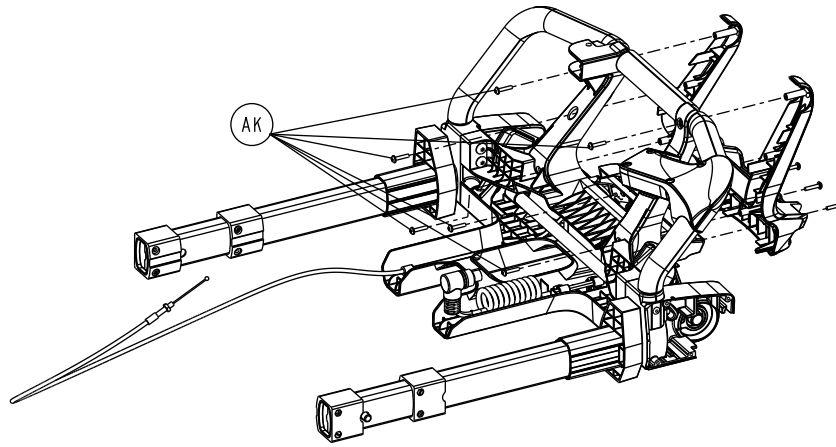

Figure 26 –

19. Using a T20 Torx driver, remove the three round washer head tapping screws (AK) from the foot end enclosure (S) (Figure 27). Remove the front foot end housing. Save all parts.

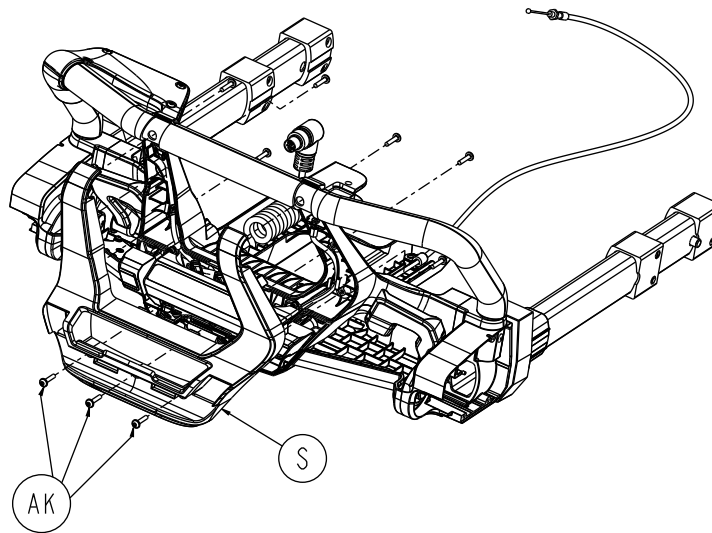

Figure 27 –

20. Using a T10 Torx driver, remove the five round washer head tapping screws (AJ) that secure the light module cable assembly (AF) (Figure 28). Save the screws. Remove and save the light module cable assembly.

21. Using a pick, remove the round hole plug (AR) from the foot section assembly (Figure 29).

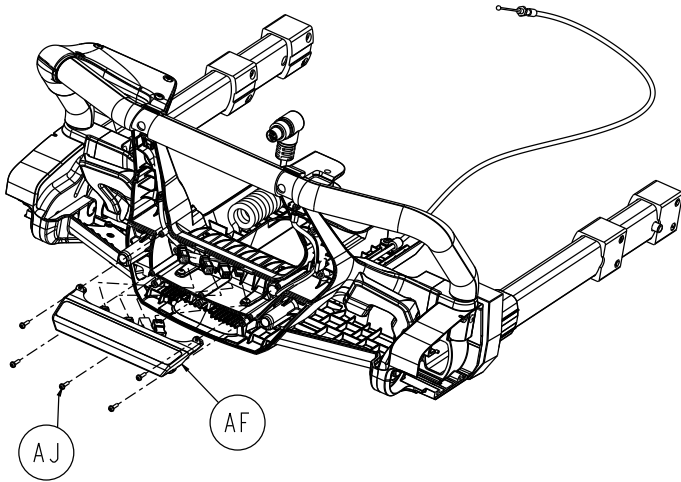

Figure 28 –

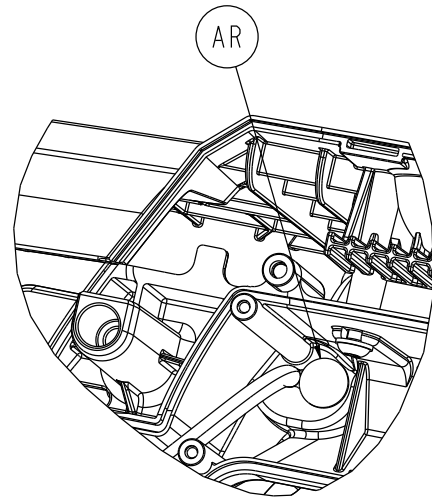

Figure 29 –

22. Using a T20 Torx driver, loosen (do not remove) the pan head tapping screw (A), then remove the manual release pivot pin (G) from the quick-release handle assembly (AB) (Figure 30).

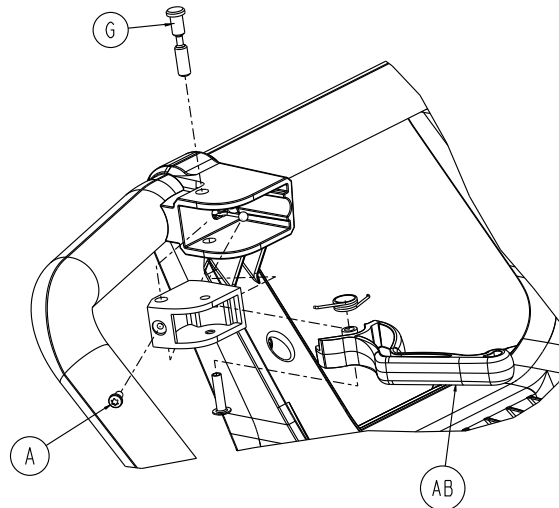

Figure 30 –

23. Remove the manual release cable from the foot section assembly. Discard the manual release cable.

24. Install the supplied manual release cable (650700020228) through the foot section.

Note - The supplied manual release cable has a line painted on it. Make sure that the painted line aligns with the clip.

25. Reverse steps to reinstall.

26. Verify proper operation before you return the product to service.

Manual release cable adjustment

Tools required:

- 8 mm combination wrench
- 10 mm combination wrench

Procedure:

1. Apply the brakes.
2. Remove the mattress from the cot.
3. Place the cot and Fowler in the highest height positions.
4. Extend the foot section assembly.
5. Using a 10 mm combination wrench, loosen the manual release cable lock nut (A) (Figure 31).

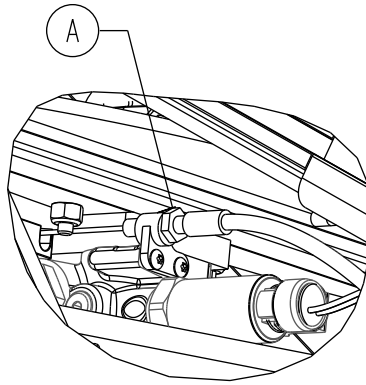

Figure 31 – Loosen the manual release cable lock nut

6. Using an 8 mm combination wrench, thread the manual release cable through the bracket until the cable is flush with the bracket (Figure 32).
7. Using an 8 mm combination wrench, adjust the tension on the manual release cable.

Note - Do not let the cable rotate during adjustment. Hold the cable flat while you adjust tension.

8. Using a 10 mm combination wrench, tighten the jam nut (C) after slack in the manual release cable is gone (Figure 33).

Note - This occurs when the manual release finger begins to move toward the manual release valve.

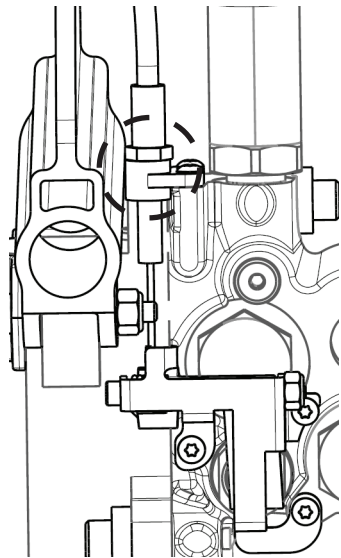

Figure 32 – Cable flush with bracket

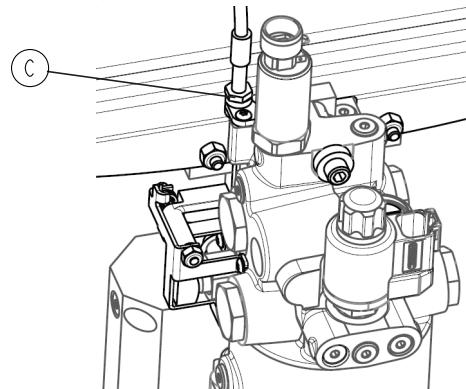

Figure 33 – Tighten the jam nut

9. Make sure that the maximum distance between the cable jam nut and the manual release cable stem is 0.578" (Figure 34).

Note - The load height must read 34.5" - 35.5".

10. Suspend the head end and foot end of the cot.
11. Press the minus (-) button to retract the base.
12. Press and hold the minus (-) button until the motor times out (approximately two seconds).
13. Pull the manual release handle. Make sure that the cot legs extend.
14. Make sure that there is a visible gap between the manual release finger (D) and the manual release valve (E) (Figure 35).

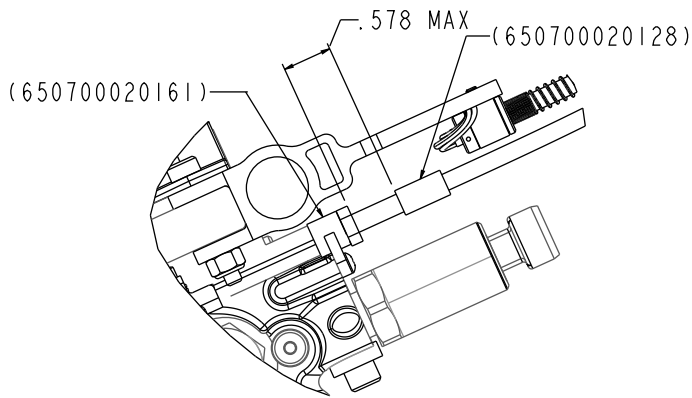

Figure 34 – Maximum distance

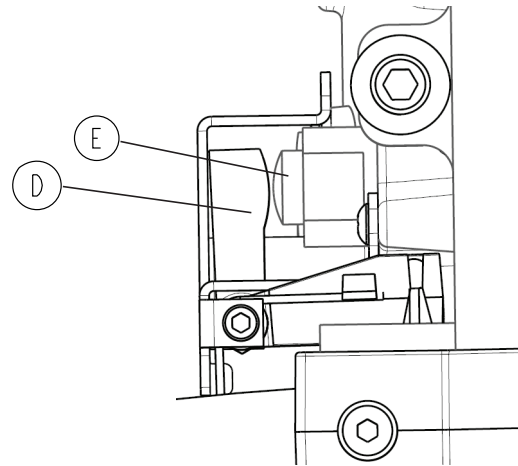

Figure 35 – Visible gap

15. Verify proper operation before you return the product to service.

Battery power/comm cable assembly replacement

Tools required:

- T20 Torx driver
- T27 Torx driver
- Torque screwdriver (in-lb)

Procedure:

1. Apply the brakes.
2. Remove the mattress from the cot.
3. Place the cot and foot section in the highest height positions.
4. Extend and lock the foot section assembly.
5. Remove the cot battery.

CAUTION - Always remove the cot battery before you service or upgrade the cot to reduce the risk of shock.

6. Using a T20 Torx driver, remove the two pan head tapping screws (AF) that secure the battery mount back cover (L) to the foot end interface assembly (FEIB) (Figure 36). Save the screws.

Note - Fully seat the power/comm cable assembly when you reinstall.

7. Using a T20 Torx driver, remove the two pan head tapping screws (AF) that secure the battery power/comm cable assembly (U) (Figure 37). Save the screws.

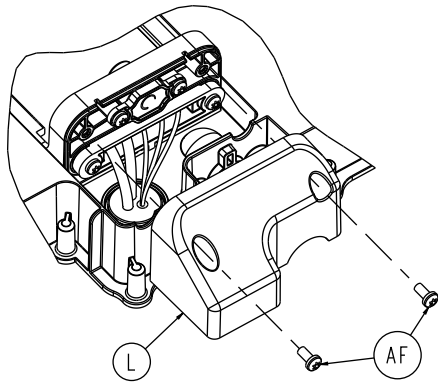

Figure 36 – Remove the battery mount back cover screws

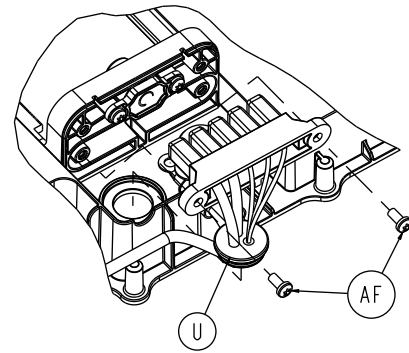

Figure 37 – Remove the battery power/comm cable assembly screws

8. Using a T27 Torx driver, remove the two button head cap screws (CD) that secure the Gatch bumper housing (CA) to the hitch bracket (Figure 38). Remove and save the Gatch bumper housing. Save the screws. Repeat on the other side.

Note - Using a torque screwdriver, torque the button head cap screws to 3.91 - 5.29 ft-lb when you reinstall.

9. Unscrew the FEIB status external module coil cable assembly from the bottom FEIB enclosure. Fold the cable assembly toward the foot end of the cot.

10. Using a T20 Torx driver, remove the thirteen round washer head tapping screws (AV) that secure the top FEIB enclosure (AL) to the bottom FEIB enclosure (Figure 39). Save the screws.

Note - Using a torque screwdriver, torque the round washer head tapping screws to 0.95 - 1.16 ft-lb when you reinstall.

Torque item CD
to 3.91 - 5.29 ft-lb

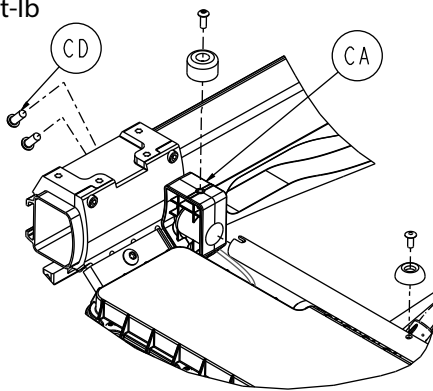

Figure 38 – Remove the Gatch bumper housing

Torque item AV
to 0.95 - 1.16 ft-lb

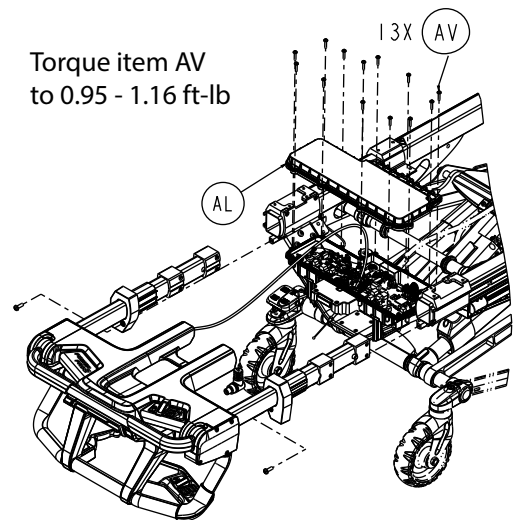

Figure 39 – Remove the FEIB cover screws

11. Remove the top FEIB enclosure from the bottom FEIB enclosure.
12. Using a T20 Torx driver, remove the two pan head tapping screws that secure the positive and negative cables to the charging board. Save the screws.
13. Remove the connection J3 cable at the charging board.
14. Remove the cables and plug from the bottom of the FEIB.
15. Remove the battery power/comm cable assembly from the holder and discard.
16. Reverse steps to reinstall.

Note - Fully seat the power/comm cable assembly when you reinstall.

17. Verify proper operation before you return the product to service.

Cot retaining post installation and replacement

Tools required:

- T27 Torx driver

- T30 Torx driver
- Torque wrench (in-lb)

Procedure:

1. Apply the brakes.
2. Remove the mattress from the cot.
3. Place the cot and Fowler in the highest height positions.
4. Tilt the cot onto the patient left side.

Note

- Use caution when you place the cot on its side as it is heavy and could move.
- Locate and note the arrow or groove in the bottom bracket. Assemble the supplied retaining post bracket to this same orientation.
- The cot retaining post is set for an X-frame cot if the arrow on the bottom bracket of the retaining post points toward the head end of the cot or if the groove in the bottom bracket is located on the inside of the patient left side of the base tube.

5. Using a T30 Torx driver, remove the two socket head cap screws (AE) that secure the cot retaining post to the base tube (Figure 40). Discard the screws and cot retaining post.
6. Assemble the supplied cot retaining post across the base tube. Align the holes of the brackets and insert two supplied socket head cap screws into the threaded holes of the bottom pin bracket.
7. Using a torque wrench, tighten the socket head cap screws (AE) to 6.38 ft-lb (minimum).
8. Insert the button head cap screw (AC) through the retaining post cap (V) and retaining post body (U), and then into the top pin bracket (AA).
9. Using a T27 Torx driver, tighten the button head cap screw to secure the retaining post cap and retaining post body to the bottom bracket (Y).

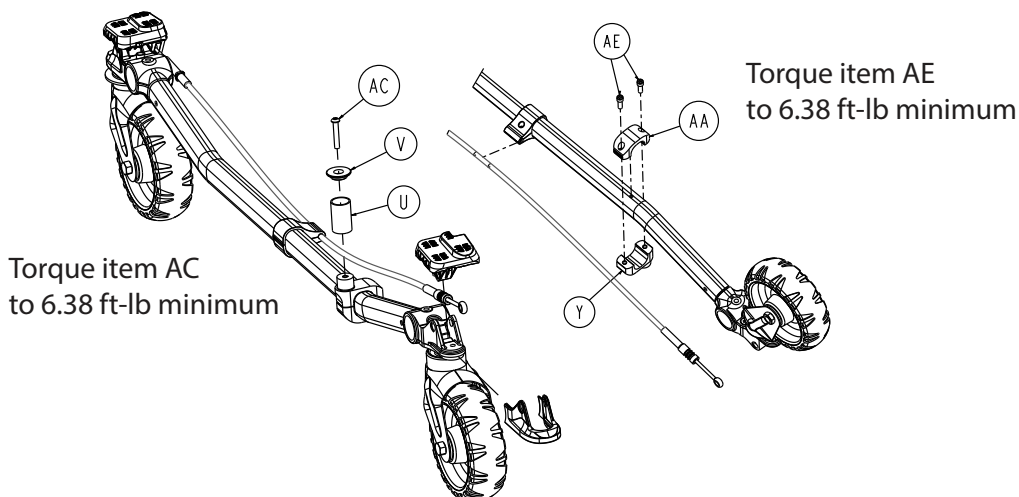

Figure 40 – Cot retaining post components

10. Using a torque wrench, torque the screw (AC) to 6.38 ft-lb (minimum).
11. Verify proper operation before you return the product to service.

Note - You may need to adjust the rail clamp assembly to compensate for any variation in cot retaining post position, depending on the ambulance cot manufacturer and model number.

Cot retaining post screw replacement

Tools required:

- T27 Torx driver
- Torque wrench (in-lb)

Procedure:

1. Using a T27 Torx driver, remove the button head cap screw (AC) that secures the retaining post cap (V) and retaining post body (U) to the top bracket (Figure 41). Discard the screw.

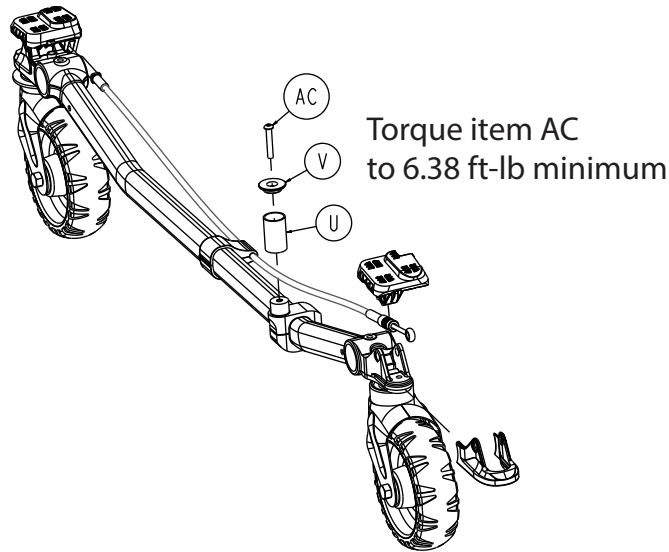

Figure 41 – Remove and discard the button head cap screw

2. Using a T27 Torx driver, install and tighten the supplied button head cap screw to secure the retaining post cap and retaining post body to the top portion of the lock base assembly.
3. Using a torque wrench, torque the screw to 6.38 ft-lb (minimum).

Note - If you cannot torque the screw to 6.38 ft-lb (minimum), then you must replace the entire cot retaining post. See *Cot retaining post installation and replacement* (page 48).

4. Verify proper operation before you return the product to service.

Hydraulic cylinder assembly replacement

CAUTION

- Always use electrostatic discharge (ESD) protective equipment before you open antistatic bags and service electronic parts.
 - Do not place unprotected circuit boards on the floor.
-

Tools required:

- 9/16" combination wrench
- 3/4" combination wrench
- T10 Torx driver
- 3/8" combination wrench
- 1/8" hex wrench
- T20 Torx driver
- T25 Torx driver
- Torque wrench (in-lb)

Procedure:

1. Apply the brakes.
2. Remove the mattress from the cot.
3. Place the cot and Fowler in the highest height positions.
4. Remove the cot battery.

CAUTION - Always remove the cot battery before you service or upgrade the cot to reduce the risk of shock.

5. Raise XPS siderails (if equipped) to the upright and locked position.
6. Using a T10 Torx driver, remove the two button head cap screws (A) that secure the manual release cable bracket (G) to the X-frame cross brace (Figure 42). Save the screws and bracket.

Note - Using a torque wrench, torque the button head cap screws to 1.39 - 1.87 ft-lb when you reinstall.

7. Remove the manual release cable from the manual release bracket assembly (E) (Figure 42).

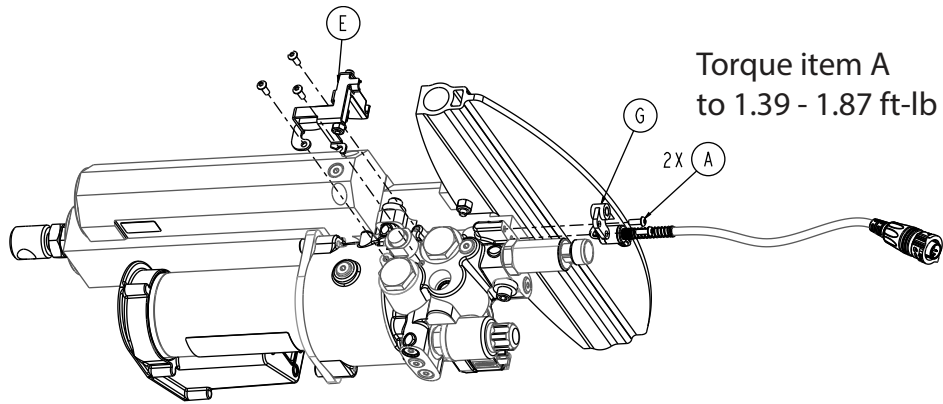

Figure 42 – Actuator lift assembly components

8. Unplug the two valve cables from the valves on the hydraulic cylinder.

Note - Use an ESD system when you unplug the cable connectors.

9. Stand at the foot end and tilt the cot onto its head section.

CAUTION - Always use care when you lift and support the cot. The cot may move while you tip the cot onto the head section.

Note - Make sure that the head section is retracted and locked.

10. Pull the manual release handle to relieve any pressure in the hydraulic system.

11. Using a T20 Torx driver, remove the five round washer head tapping screws (AV) that secure the actuator end cap (AD) to the hydraulic assembly electrical box (Figure 43). Save the screws and end cap.

Note - Using a torque wrench, torque the round washer head tapping screws to 1.28 - 1.73 ft-lb when you reinstall.

12. Unlock and unplug both cable connections in the electrical box.

13. Using a T25 Torx driver, remove the four button head torx screws (A) that secure the lift motor cable assembly to the actuator cover (Figure 43). Remove and save the lift motor cable assembly. Save the screws.

Note - Using a torque wrench, torque the button head torx screws to 1.28 - 1.73 ft-lb when you reinstall.

14. Using a 1/8" hex wrench and 3/8" combination wrench, remove the two socket head shoulder bolts (J) and Fiberlock nuts (C) that secure the actuator assembly to the X-frame cross brace (Figure 44). Save the bolts and nuts.

Note - Using a torque wrench, torque the socket head shoulder bolts to 1.75 - 2.37 ft-lb when you reinstall.

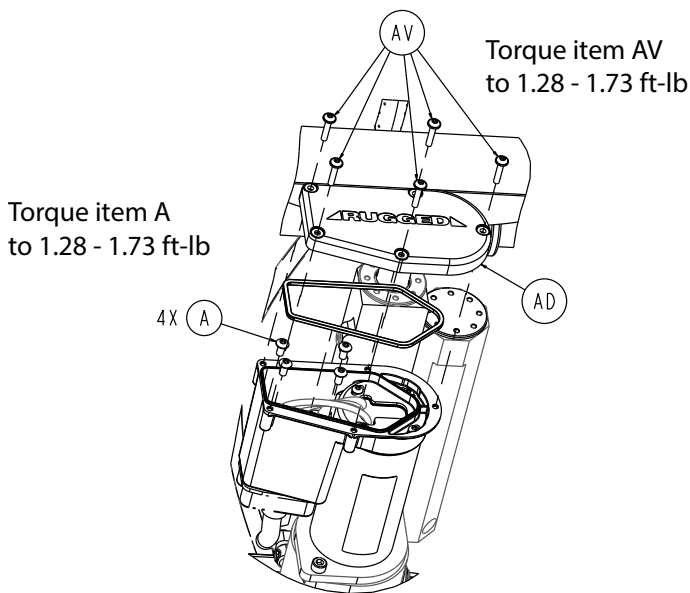

Figure 43 – Lift motor cable assembly components

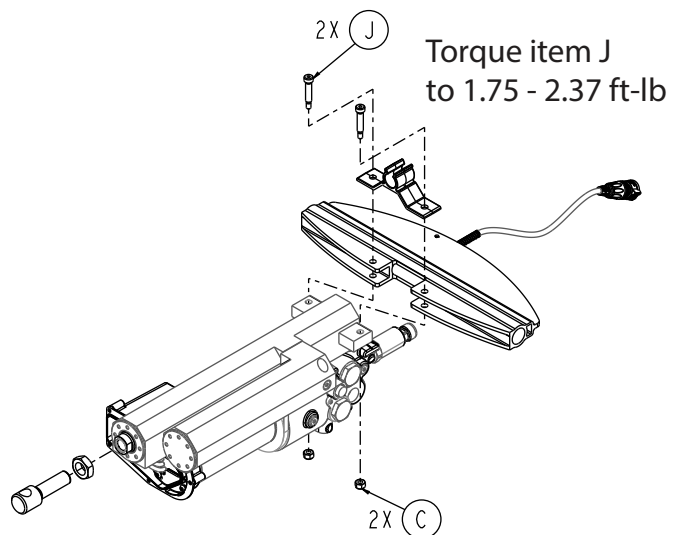

Figure 44 – Remove the actuator assembly bolts and nuts

15. Using a 3/4" combination wrench and a 9/16" combination wrench, remove the rod attachment pin (R), flat washer (B), and Nylock hex nut (E) that secure the hydraulic cylinder to the base (Figure 45). Save all parts.

Note - Using a torque wrench, torque the rod attachment pin to 9.61 - 13.00 ft-lb when you reinstall.

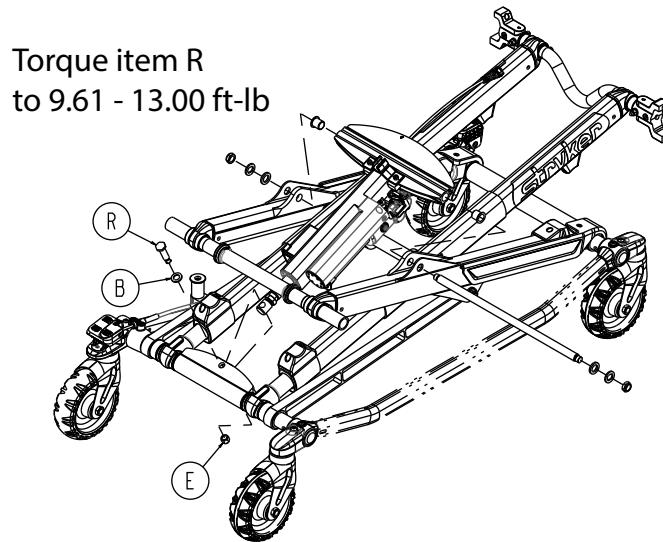

Figure 45 – Lift assembly components

16. Remove and discard the hydraulic cylinder assembly.
17. Reverse steps to reinstall.
18. Calibrate the cot. See *Cot calibration* (page 35).
19. Raise and lower the cot several times to check functionality.
20. Verify proper operation before you return the product to service.

Siderail assembly replacement (standard)

Tools required:

- T25 Torx driver
- 3/16" hex driver
- Torque wrench (in-lb)

Procedure:

1. Apply the brakes.
2. Remove the mattress from the cot.
3. Place the product in the highest height position.
4. Raise the siderail to the up and locked position.
5. Using a T25 Torx driver and a 3/16" hex driver, remove the three button head cap screws (H) and siderail nuts (E) that secure the siderail assembly to the cot (Figure 46). Save the screws and nuts.

Note - Using a torque wrench, torque the button head cap screws and siderail nuts to 4.05 - 5.49 ft-lb when you reinstall.

6. Remove and discard the siderail (B) (Figure 46).

Torque items E and H
to 4.05 - 5.49 ft-lb

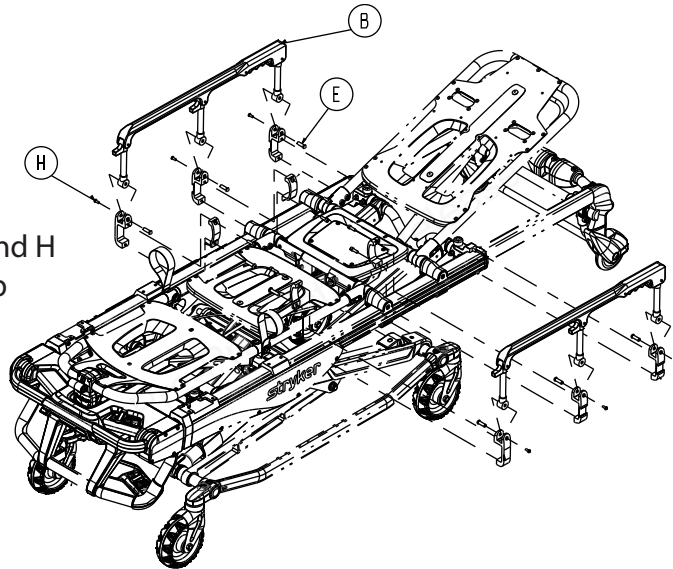

Figure 46 – Standard siderail components

7. Reverse steps to reinstall.
8. Verify proper operation before you return the product to service.

Siderail assembly replacement (XPS option)

Tools required:

- T25 Torx driver
- 3/16" hex wrench
- Rubber mallet
- Slotted screwdriver
- Torque wrench (in-lb)

Procedure:

1. Apply the brakes.
2. Remove the mattress from the cot.
3. Place the product in the highest height position.
4. Using a T25 Torx driver, remove the four round washer head tapping screws (AV) and slider block cover (Y or AA) on the side where you are replacing the siderail (Figure 47). Save the screws and slider block cover.

Note - Using a torque wrench, torque the round washer head tapping screws to 1.70 - 2.30 ft-lb when you reinstall.

5. Using a slotted screwdriver, remove the outer rail bumper (AN) (Figure 47). Save the outer rail bumper.

Note - Use a rubber mallet to reinstall the outer rail bumper.

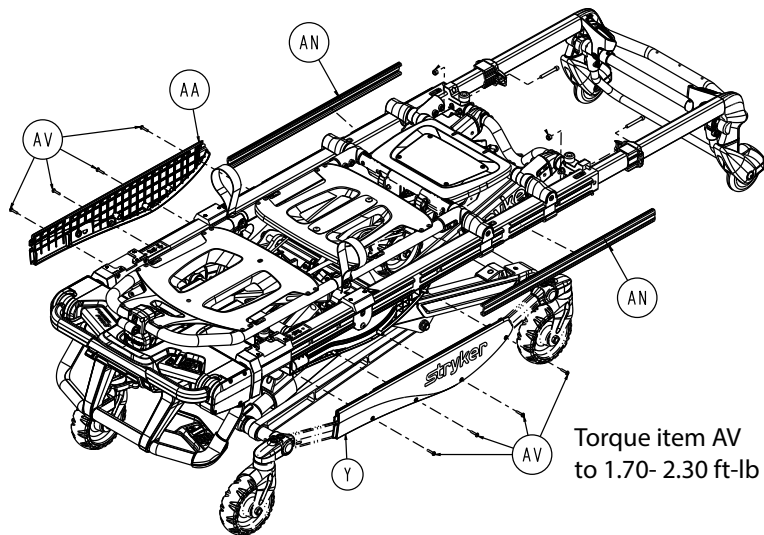

Figure 47 – Remove the screws and slider block cover

Note

- Hold on to the siderail main assembly when you remove the outer rail bumper to prevent the outer rail bumper from falling off.
- The head end and middle siderail pivots may be loose and could fall off of the main assembly.

6. Using a 3/16" hex wrench, remove the hex socket button head cap screw (A), socket head cap screw (B) and XPS inner bracket (F) that secure the ratchet assembly at the foot end of the main assembly (Figure 48). Save the screws and bracket.

Note

- Using a torque wrench, torque both of the supplied screws to 6.89 - 13.00 ft-lb when you reinstall.
- The siderail will be loose; do not operate or pull on the siderail.

7. Using a 3/16" hex wrench, remove the two socket head cap screws (G) that secure the siderail clamp (C) to the outer rail assembly (Figure 48). Save the screws and clamp.

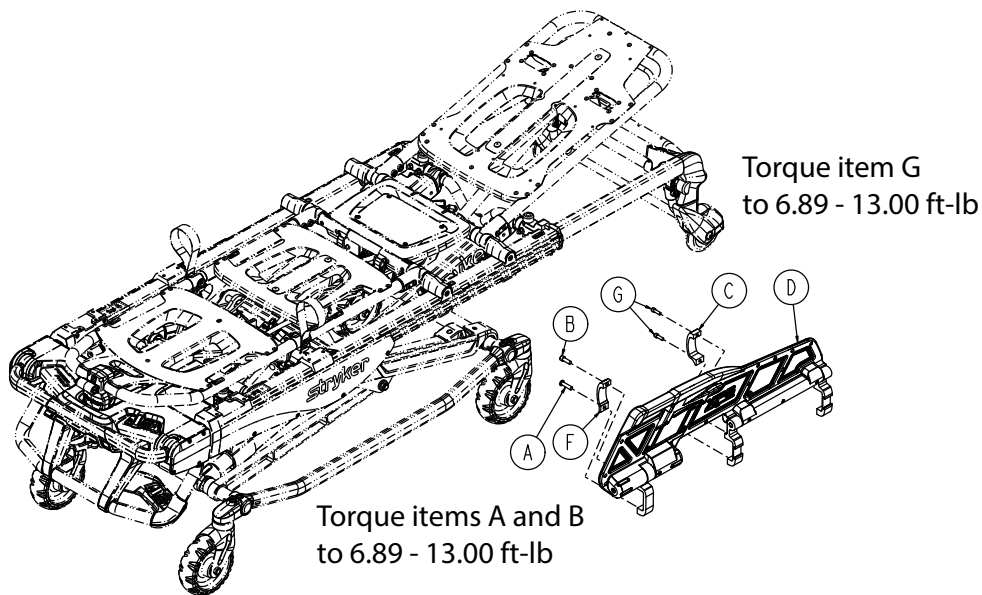

Figure 48 – Replace the XPS siderail

8. Remove and discard the XPS assembly (D) (Figure 48).
9. Reverse steps to reinstall.
10. Verify proper operation before you return the product to service.

Ratchet assembly replacement (XPS option)

Tools required:

- 3/32" hex wrench
- 1/4" hex wrench
- 3/16" hex wrench
- Torque wrench (in-lb)

Procedure:

1. Apply the brakes.
2. Remove the mattress from the cot.
3. Place the product in the highest height position.
4. Raise the siderail to the up and locked position.
5. Using a 3/32" hex wrench, remove the two socket head cap screws (M) that secure the ratchet cover (G) to the ratchet assembly (J) (Figure 49). Remove and save the ratchet cover. Save the screws.
6. Using a 1/4" hex wrench, remove the socket head cap screws (P) that secure the siderail clamp (D) to the ratchet assembly at the foot end of the main assembly. Save the screws.
7. Using a 3/16" hex wrench, remove the four socket head cap screws (T) that secure the ratchet assembly to the overmold assembly (K). Remove and discard the ratchet assembly. Save the screws.

Note - Using a torque wrench, torque the socket head cap screws to 9.00 - 11.00 ft-lb when you reinstall.

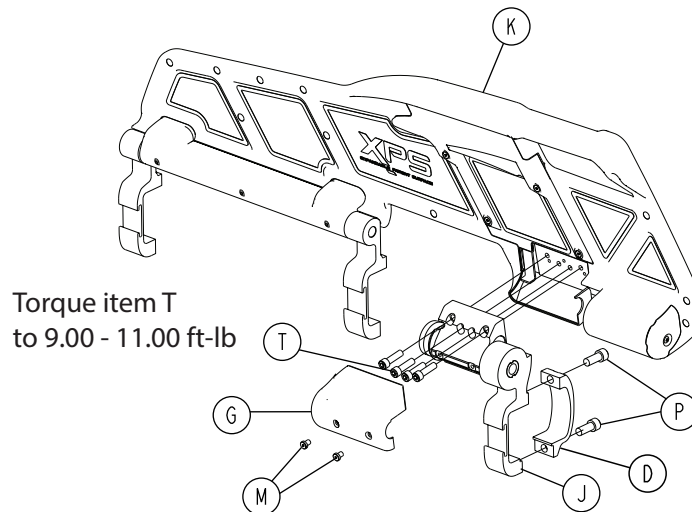

Figure 49 – Ratchet assembly components (XPS)

8. Grasp the ratchet assembly and pull toward the head end of the cot to remove. Discard the ratchet assembly.
9. Reverse steps to reinstall.
10. Verify proper operation before you return the product to service.

Release handle assembly replacement (XPS option)

Tools required:

- 3/32" hex wrench
- Small slotted screwdriver

Procedure:

1. Apply the brakes.
2. Remove the mattress from the cot.
3. Place the product in the highest height position.
4. Raise the siderail to the up and locked position.
5. Using a 3/32" hex wrench, remove the four socket head cap screws (N and P) that secure the release cover (L) to the overmold assembly (K) (Figure 50). Remove and save the release cover. Save the screws.

6. Using a small slotted screwdriver, pry the handle spring (D) up. Remove and save the spring.
7. Grasp the handle assembly (B) and lift the handle spring side to remove from the cover. Discard the handle assembly.

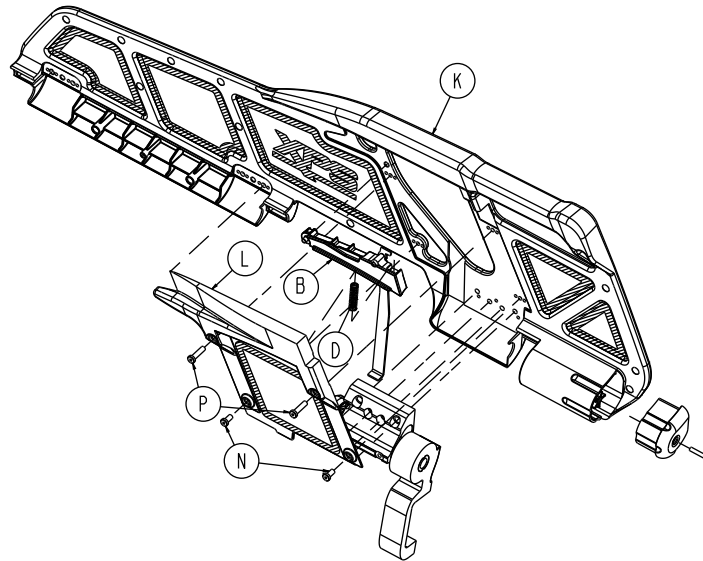

Figure 50 – Release/spring handle assembly components (XPS)

8. Reverse steps to reinstall.
9. Verify proper operation before you return the product to service.

Spring handle assembly replacement (XPS option)

Tools required:

- 3/32" hex wrench
- Small slotted screwdriver

Procedure:

1. Apply the brakes.
2. Remove the mattress from the cot.
3. Place the product in the highest height position.
4. Raise the siderail to the up and locked position.
5. Using a 3/32" hex wrench, remove the four socket head cap screws (N and P) that secure the release cover (L) to the overmold assembly (K) (Figure 50). Remove and save the release cover. Save the screws.
6. Using a small slotted screwdriver, pry the handle spring (D) up. Remove and discard the spring.
7. Reverse steps to reinstall.
8. Verify proper operation before you return the product to service.

Hydrogen base control (HBC) board replacement

CAUTION

- Always use electrostatic discharge (ESD) protective equipment before you open antistatic bags and service electronic parts.
- Do not place unprotected circuit boards on the floor.

Tools required:

- T20 Torx driver
- T25 Torx driver
- 3/8" combination wrench
- Torque screwdriver (in-lb)
- ESD system

Procedure:

1. Apply the brakes.

2. Remove the mattress from the cot.
3. Place the product in the highest height position.
4. Remove the cot battery.

CAUTION - Always remove the cot battery before you service or upgrade the cot to reduce the risk of shock.

5. Using a T25 Torx driver, remove the four pan head thread rolling screws (BD) that secure the seat skin (AM) to the cot (Figure 51). Remove and save the seat skin. Save the screws.

Note - Using a torque screwdriver, torque the pan head thread rolling screws to 4.67 - 6.31 ft-lb when you reinstall.

6. Using a T20 Torx driver, remove the three pan head tapping screws (M) that secure the HBC enclosure assembly (A) to the birdcage (E) (Figure 52). Save the screws.

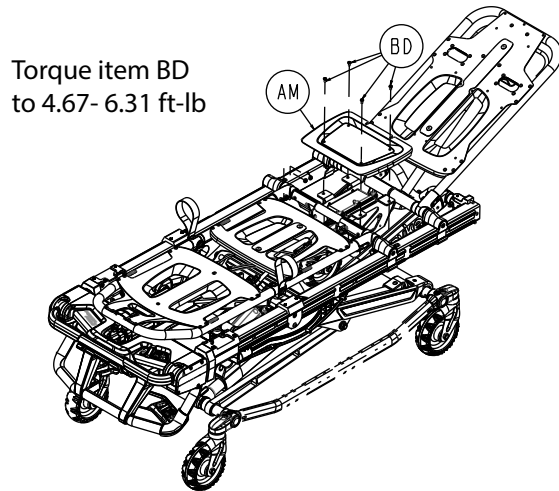

Figure 51 – Remove the seat skin screws

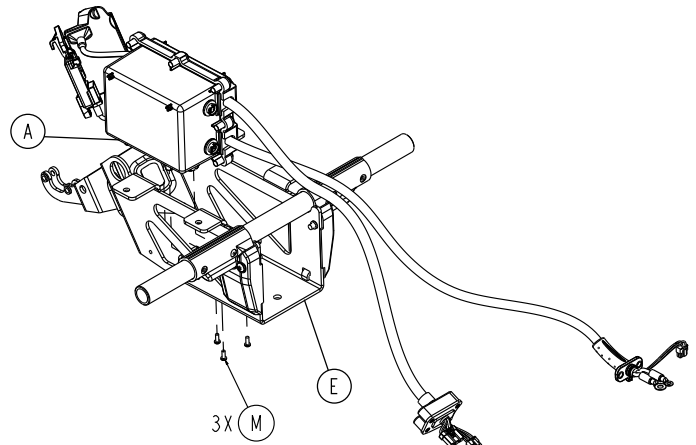

Figure 52 – Remove the HBC enclosure assembly screws

7. Using a T25 Torx driver and a 3/8" combination wrench, remove the button head cap screw (N) and Fiberlock nut (R) that secure the wireless module, if equipped, and the NFMIC module to the cot, if equipped (Figure 53). Save the screw and nut.
8. Unhook the wireless and NFMIC module(s), if equipped, from the frame and drop the wireless module out of the bottom of the cot.
9. Lift the HBC enclosure assembly up through the seat section to access the screws that secure the HBC top cover.
10. Using a T20 Torx driver, remove the seven round washer head tapping screws (S) that secure the top cover (F) to the HBC enclosure assembly (Figure 54). Remove and save the top cover. Save the screws.

Note - Using a torque screwdriver, torque the round washer head tapping screws to 1.49 - 1.83 ft-lb when you reinstall.

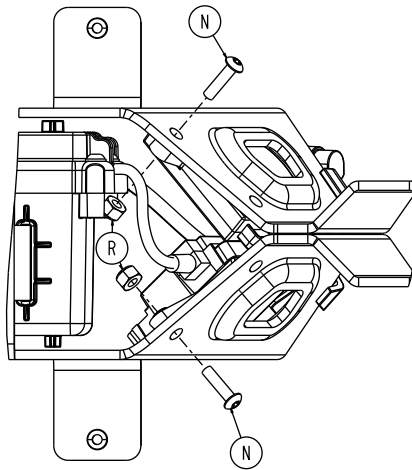

Figure 53 – Remove the wireless module screw and nut

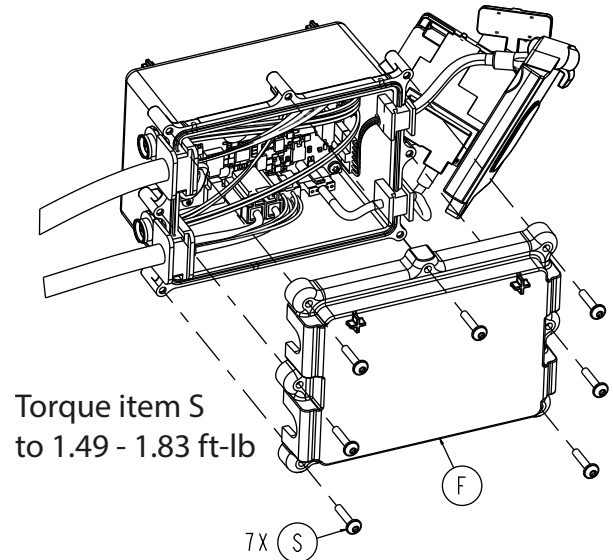

Figure 54 – Remove the HBC top cover screws

11. Unplug the cable connectors from the HBC board.

Note - Use an ESD system when you unplug the cable connectors and remove and install the HBC board.

12. Using a T20 Torx driver, remove the four pan head tapping screws (E) that secure the HBC board (B) to the HBC board enclosure assembly (A) (Figure 55). Discard the HBC board.

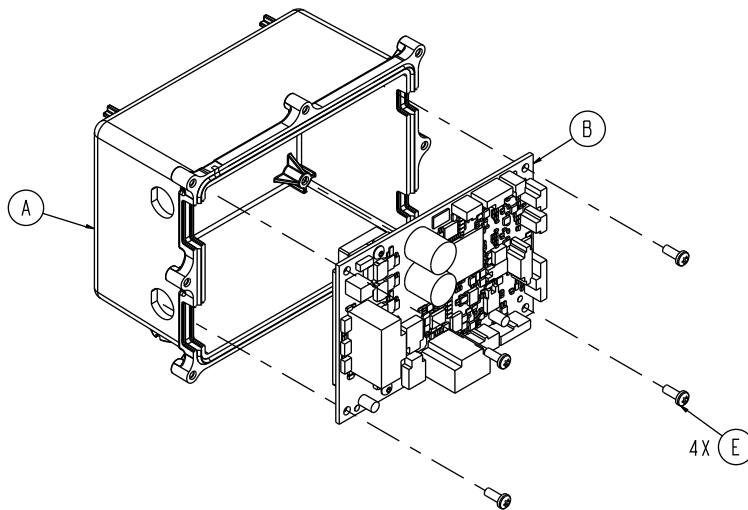

Figure 55 – Remove the HBC board screws

13. Reverse steps to reinstall.

Note - Push the rubber grommets from the cables into the HBC enclosure assembly pockets.

14. Calibrate the cot. See *Cot calibration* (page 35).

15. Verify proper operation before you return the product to service.

Wireless module replacement

CAUTION

- Always use electrostatic discharge (ESD) protective equipment before you open antistatic bags and service electronic parts.
- Do not place unprotected circuit boards on the floor.

Tools required:

- T20 Torx driver
- T25 Torx driver
- 3/8" combination wrench
- Torque screwdriver (in-lb)
- ESD system
- Wireless configuration tool (5212-502-003)

Procedure:

1. Apply the brakes.
2. Remove the mattress from the cot.
3. Place the product in the highest height position.
4. Remove the cot battery.

CAUTION - Always remove the cot battery before you service or upgrade the cot to reduce the risk of shock.

5. Using a T25 Torx driver, remove the four pan head thread rolling screws (BD) that secure the seat skin (AM) to the cot (Figure 56). Remove and save the seat skin. Save the screws.

Note - Using a torque screwdriver, torque the pan head thread rolling screws to 4.67 - 6.31 ft-lb when you reinstall.

6. Using a T20 Torx driver, remove the three pan head tapping screws (M) that secure the HBC enclosure assembly (A) to the birdcage (E) (Figure 57). Save the screws.

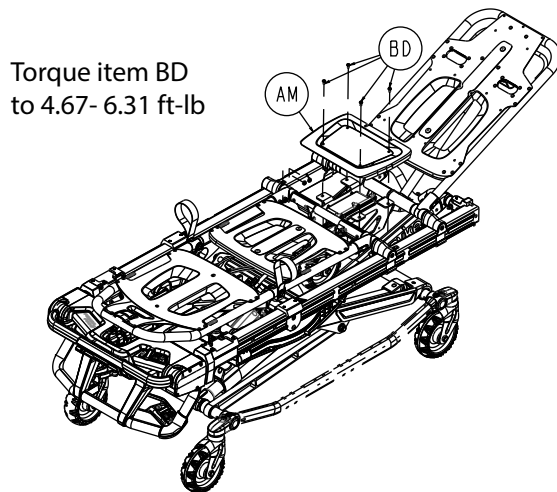

Figure 56 – Remove the seat skin screws

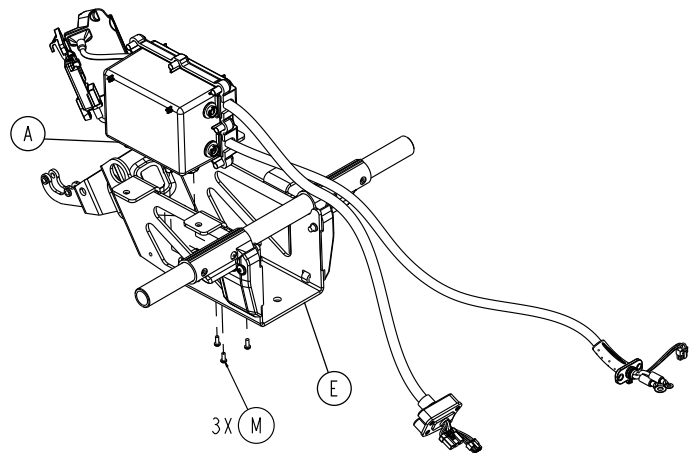

Figure 57 – Remove the HBC enclosure assembly screws

7. Using a T25 Torx driver and a 3/8" combination wrench, remove the button head cap screw (N) and Fiberlock nut (R) that secure the wireless module, if equipped, and the NFMIC module to the cot, if equipped (Figure 58). Save the screw and nut.
8. Unhook the wireless and NFMIC module(s), if equipped, from the frame and drop the wireless module out of the bottom of the cot.
9. Lift the NFMIC module and HBC enclosure assembly up through the seat section to access the screws that secure the HBC enclosure assembly top cover.

Note - Keep the NFMIC module tight against the HBC enclosure assembly so you can remove them together.

10. Using a T20 Torx driver, remove the seven round washer head tapping screws (S) that secure the top cover (F) to the HBC enclosure assembly (Figure 59). Remove and save the top cover. Save the screws.

Note - Using a torque screwdriver, torque the round washer head tapping screws to 1.49 - 1.83 ft-lb when you reinstall.

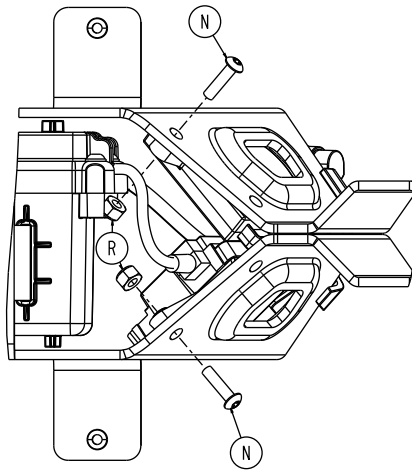

Figure 58 – Remove the wireless module screw and nut

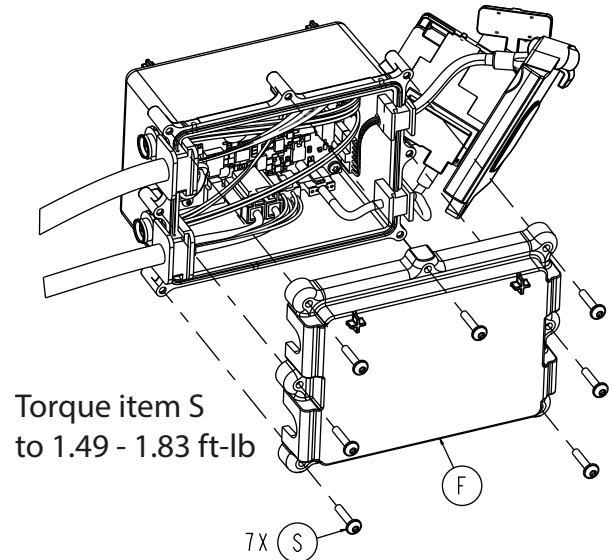

Figure 59 – Remove the HBC top cover screws

11. Unplug the wireless module cable from J13 connector on the HBC board. Discard the wireless module.

Note - Use an ESD system when you unplug the cable connectors.

12. Reverse steps to reinstall.

Note - Push the rubber grommets from the cables into the HBC enclosure assembly pockets.

13. Using the 5212-502-003 wireless configuration tool and other required items, configure the wireless module for the required networks.

14. Verify proper operation before you return the product to service.

Near field module inductive charger (NFMIC) replacement

CAUTION

- Always use electrostatic discharge (ESD) protective equipment before you open antistatic bags and service electronic parts.
- Do not place unprotected circuit boards on the floor.

Tools required:

- T20 Torx driver
- T25 Torx driver
- 3/8" combination wrench
- Torque screwdriver (in-lb)
- ESD system

Procedure:

1. Apply the brakes.
2. Remove the mattress from the cot.
3. Place the product in the highest height position.
4. Remove the cot battery.

CAUTION - Always remove the cot battery before you service or upgrade the cot to reduce the risk of shock.

5. Using a T25 Torx driver, remove the four pan head thread rolling screws (BD) that secure the seat skin (AM) to the cot (Figure 60). Remove and save the seat skin. Save the screws.

Note - Using a torque screwdriver, torque the pan head thread rolling screws to 4.67 - 6.31 ft-lb when you reinstall.

6. Using a T20 Torx driver, remove the three pan head tapping screws (M) that secure the HBC enclosure assembly (A) to the birdcage (E) (Figure 61). Save the screws.

Torque item BD
to 4.67- 6.31 ft-lb

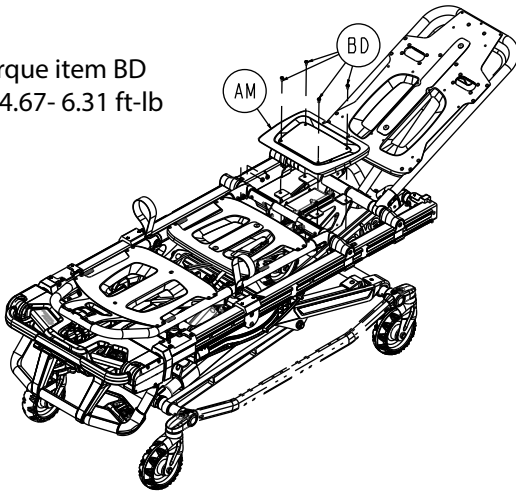

Figure 60 – Remove the seat skin screws

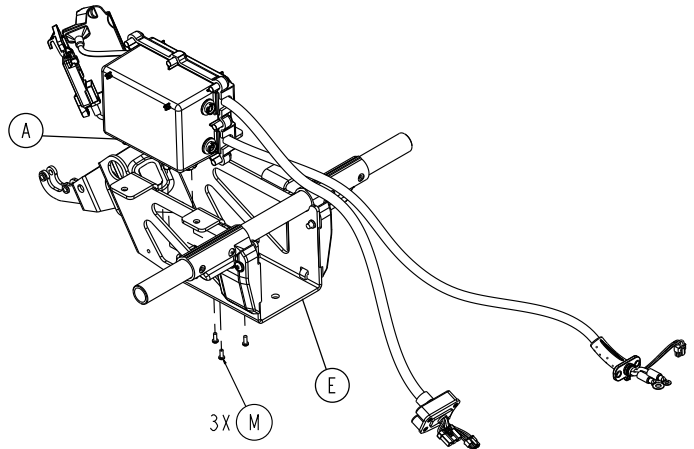

Figure 61 – Remove the HBC enclosure assembly screws

7. Using a T25 Torx driver and a 3/8" combination wrench, remove the button head cap screw (N) and Fiberlock nut (R) that secure the wireless module, if equipped, and the NFMIC module to the cot, if equipped (Figure 62). Save the screw and nut.
8. Unhook the wireless and NFMIC module(s), if equipped, from the frame and drop the wireless module from the bottom of the cot.
9. Lift the NFMIC module and HBC enclosure assembly up through the seat section to access the screws that secure the HBC top cover.

Note - Keep the NFMIC module tight against the HBC enclosure assembly so you can remove them together.

10. Using a T20 Torx driver, remove the seven round washer head tapping screws (S) that secure the top cover (F) to the HBC enclosure assembly (Figure 63). Remove and save the top cover. Save the screws.

Note - Using a torque screwdriver, torque the round washer head tapping screws to 1.49 - 1.83 ft-lb when you reinstall.

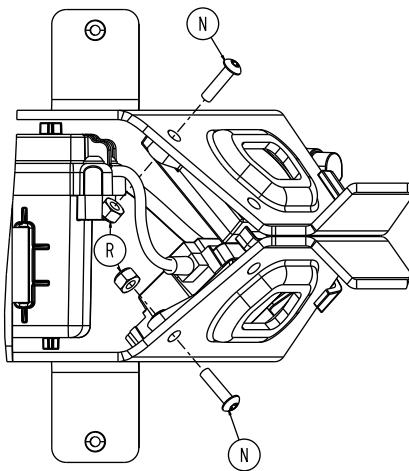
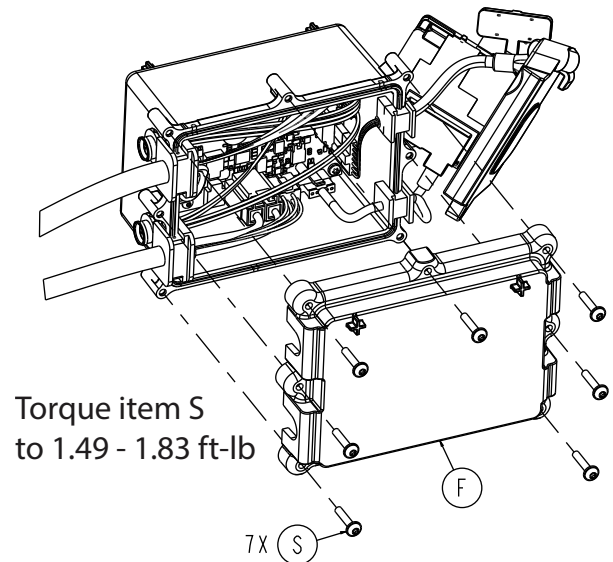

Figure 62 – Remove the wireless module screw and nut



Torque item S
to 1.49 - 1.83 ft-lb

Figure 63 – Remove the HBC top cover screws

11. Unplug the NFMIC module cable from J10 connector on the HBC board.

Note - Use an ESD system when you unplug the cable connectors.

12. Reverse steps to reinstall.

Note - Push the rubber grommets from the cables into the HBC enclosure assembly pockets.

13. Verify proper operation before you return the product to service.

Regulatory notes

- The NFMIC module is limited to use in devices manufactured by Stryker.

- The NFMIC module is never connected to AC Mains.
- The NFMIC module is labeled with the FCC and IC IDs, which are visible when the module is installed according to the installation instructions provided.

United States – Federal Communication Commission (FCC)

FCC ID: Z7A-6507

This device complies with part 15 of the FCC Rules. Operation is subject to the following two conditions:

1. This device may not cause harmful interference, and
2. This device must accept any interference received, including interference that may cause undesired operation. Changes or modifications not expressly approved by Stryker could void the user's authority to operate the equipment.

Canada – Innovation, Science and Economic Development (ISED)

IC: 4919E-6507

This device complies with Innovation, Science, and Economic Development Canada's license-exempt RSSs. Operation is subject to the following two conditions:

1. This device may not cause interference, and
2. This device must accept any interference, including interference that may cause undesired operation of the device.

Le présent appareil est conforme aux CNR d'Industrie Canada applicables aux appareils radio exempts de licence. L'exploitation est autorisée aux deux conditions suivantes:

1. L'appareil ne doit pas produire de brouillage, et
2. L'utilisateur de l'appareil doit accepter tout brouillage radioélectrique subi, même si le brouillage est susceptible d'en compromettre le fonctionnement.

South Korea

Applicant: Stryker Korea Co Ltd.

Taiwan

Without permission granted by the NCC, any company, enterprise, or user is not allowed to change frequency, enhance transmitting power or alter original characteristic as well as performance to a approved low power radio-frequency devices. The low power radio-frequency devices shall not influence aircraft security and interfere legal communications; If found, the user shall cease operating immediately until no interference is achieved. The said legal communications means radio communications is operated in compliance with the Telecommunications Management Act. The low power radio-frequency devices must be susceptible with the interference from legal communications or ISM radio wave radiated devices.

取得審驗證明之低功率射頻器材，非經核准，公司、商號或使用者均不得擅自變更頻率、加大功率或變更原設計之特性及功能。低功率射頻器材之使用不得影響飛航安全及干擾合法通信；經發現有干擾現象時，應立即停用，並改善至無干擾時方得繼續使用。前述合法通信，指依電信管理法規定作業之無線電通信。低功率射頻器材須忍受合法通信或工業、科學及醫療用電波輻射性電機設備之干擾。

Wheel replacement

Tools required:

- Sawhorse (2)
- Ratchet
- 5/8" combination wrench
- 11/16" socket wrench
- Torque wrench (in-lb)

Procedure:

1. Apply the brakes.
2. Remove the mattress from the cot.
3. Using two sawhorses:
 - a. Foot end – place the cot in the highest height position. Lift and support the foot end below the foot section.
 - b. Head end – place the cot in the mid-height position. Extend and lock the head section, then lift and support the head section.
4. Using a ratchet, 11/16" socket wrench, and 5/8" combination wrench, remove the hex head cap screw (A) and toplock hex thin nut (C) that secure the 6 inch molded wheel assembly (E) to the caster horn (Figure 64). Remove and discard the wheel. Save the screw and nut.

Note - Using a torque wrench, torque the hex head cap screw to 17.85 - 24.15 ft-lb when you reinstall.

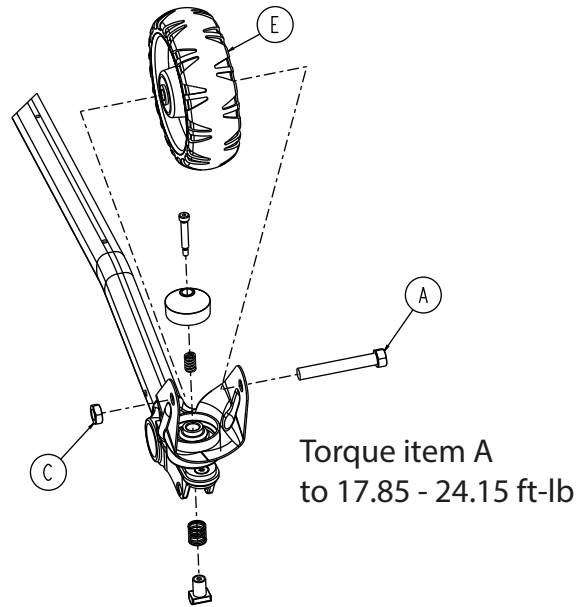

Figure 64 – Transport wheel components

5. Reverse steps to reinstall.
6. Verify proper operation before you return the product to service.

Caster horn replacement (non-brake base tube)

Tools required:

- Sawhorse (2)
- 5/8" combination wrench
- 1" combination wrench
- Ratchet
- 11/16" socket wrench
- T30 Torx driver
- Torque wrench (in-lb)

Procedure:

1. Apply the brakes.
2. Remove the mattress from the cot.
3. Using two sawhorses:
 - a. Foot end – place the cot in the highest height position. Lift and support the foot end below the foot section.
 - b. Head end – place the cot in the mid-height position. Extend and lock the head section, then lift and support the head section.
4. Using a ratchet, 11/16" socket wrench, and 5/8" combination wrench, remove the hex head cap screw (A) and toplock hex thin nut (C) that secure the 6 inch molded wheel assembly (E) to the caster horn (Figure 65). Remove and discard the wheel. Save the screw and nut.

Note - Using a torque wrench, torque the hex head cap screw to 17.85 - 24.15 ft-lb when you reinstall.

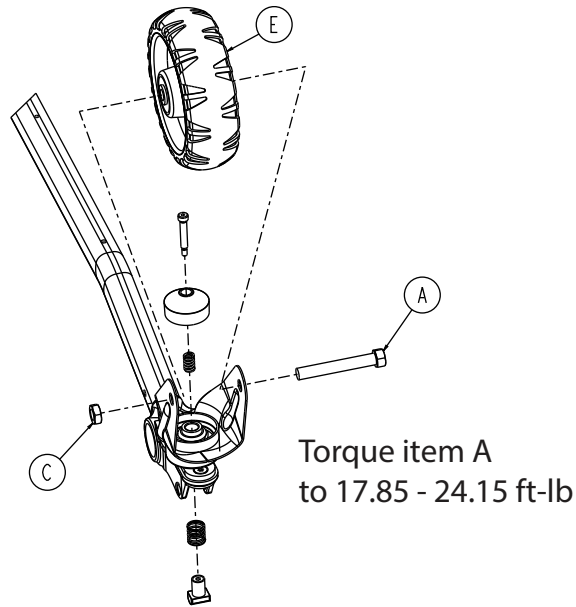

Figure 65 – Transport wheel components

- Using a T30 Torx driver, remove the pan head machine screw (C) that secures the caster mount cover (F) to the base tube (Figure 66). Remove and save the caster mount cover. Save the screw.

Note - Using a torque wrench, torque the pan head machine screw to 2.15 - 2.91 ft-lb when you reinstall.

- Using a 1" combination wrench, remove the flat head/hex socket bolt (B) and caster nut (E) that secure the caster horn (J) to the base tube weldment (H) (Figure 66). Remove and discard the caster horn. Save the bolt and nut.

Note - Using a torque wrench, torque the caster nut to 76.73 - 93.78 ft-lb when you reinstall.

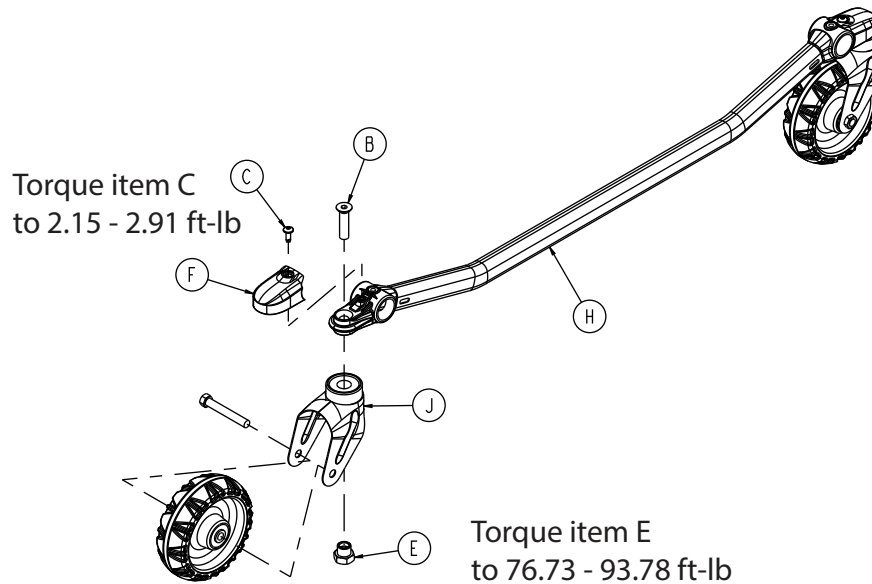

Figure 66 – Caster horn components (non-brake base tube)

- Reverse steps to reinstall.
- Verify proper operation before you return the product to service.

Caster horn and base tube replacement (brake base tube)

Tools required:

- Sawhorse (2)
- Ratchet
- 5/8" combination wrench
- 3/8" combination wrench
- 11/16" socket wrench
- Slotted screwdriver
- T27 Torx driver
- Torque wrench (in-lb)

Procedure:

1. Apply the brakes.
 2. Remove the mattress from the cot.
 3. Using two sawhorses:
 - a. Foot end – place the cot in the highest height position. Lift and support the foot end below the foot section.
 - b. Head end – place the cot in the mid-height position. Extend and lock the head section, then lift and support the head section.
 4. Using a ratchet, 11/16" socket wrench, and 5/8" combination wrench, remove the hex head cap screw (A) and toplock hex thin nut (C) that secure the 6 inch molded wheel assembly (E) to the caster horn (Figure 67). Remove and discard the wheel. Save the screw and nut.
- Note** - Using a torque wrench, torque the hex head cap screw to 17.85 - 24.15 ft-lb when you reinstall.
5. Using a slotted screwdriver, remove the slic pin (W) from the brake pedal (J) that secures the cable (on the side that goes through cross-tube) (Figure 68). Save the slic pin.

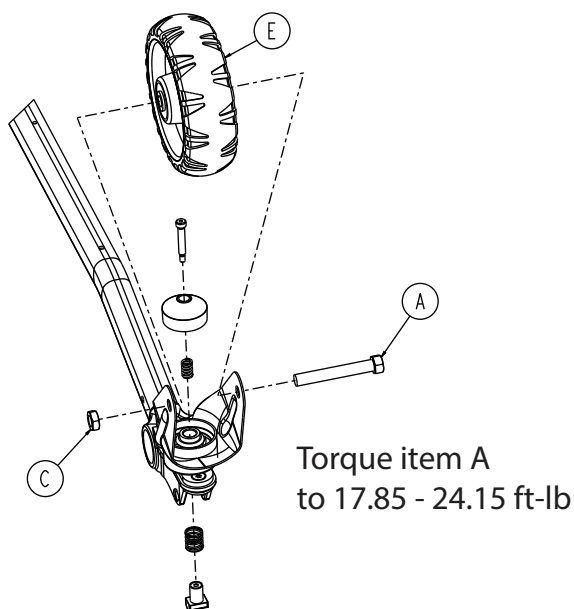

Figure 67 – Transport wheel components

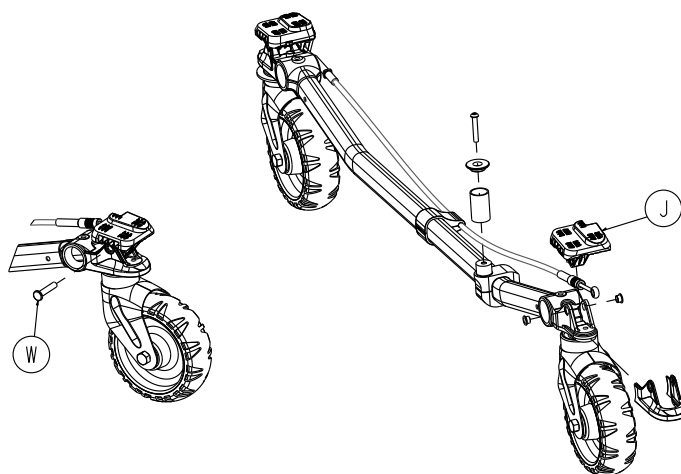

Figure 68 – Brake pedal components

6. Carefully flex the cable out of the pedal.
7. Unthread the cable end and hold the cable to the cross tube to remove the nut. Pull the cable through the cross tube and remove the base tube from the cot. Save the nut.
8. Using a T27 Torx driver and a 3/8" combination wrench, remove the two caster mount bolts (J), washers (C), and fiberlock nuts (D) that secure the base tube assembly to the cot (Figure 69). Save all parts.

Note - Using a torque wrench, torque the caster mount bolts to 4.09 - 5.53 ft-lb when you reinstall.

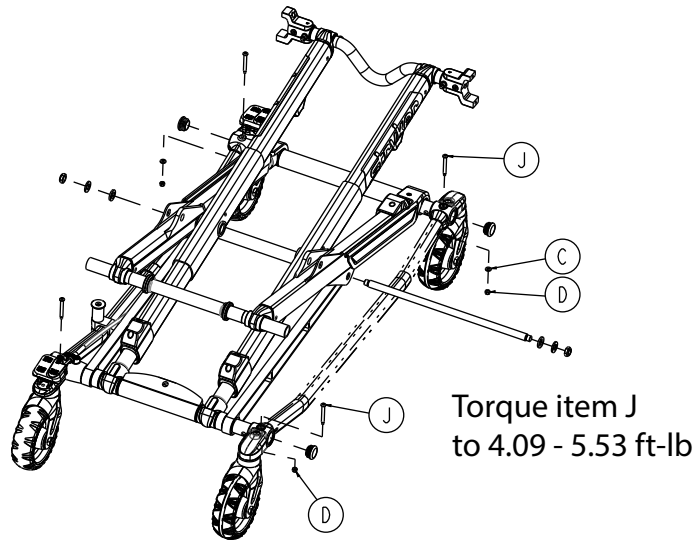

Figure 69 – Remove the base tube assembly

9. Remove and discard the base tube assembly.
10. Reverse steps to reinstall.
11. Verify proper operation before you return the product to service.

X-frame base leg guard replacement

Tools required:

- T25 Torx driver
- Torque wrench (in-lb)

Procedure:

1. Apply the brakes.
2. Remove the mattress from the cot.
3. Place the product in the highest height position.
4. Using a T25 Torx driver, remove the two button head cap screws (BD) that secure the roller cover (AW, AY) to the outer lift tube (Figure 70). Remove and save the roller cover. Save the screws.

Note - Using a torque wrench, torque the button head cap screws to 1.63 - 2.21 ft-lb when you reinstall.

5. Using a T25 Torx driver, remove the button head cap screw (BD) that secures the base leg guard (BA, BB) to the inner lift tube. Remove and discard the base leg guard. Save the screw.

Note - Using a torque wrench, torque the button head cap screw to 1.63 - 2.21 ft-lb when you reinstall.

Torque item BD
to 1.63 - 2.21 ft-lb

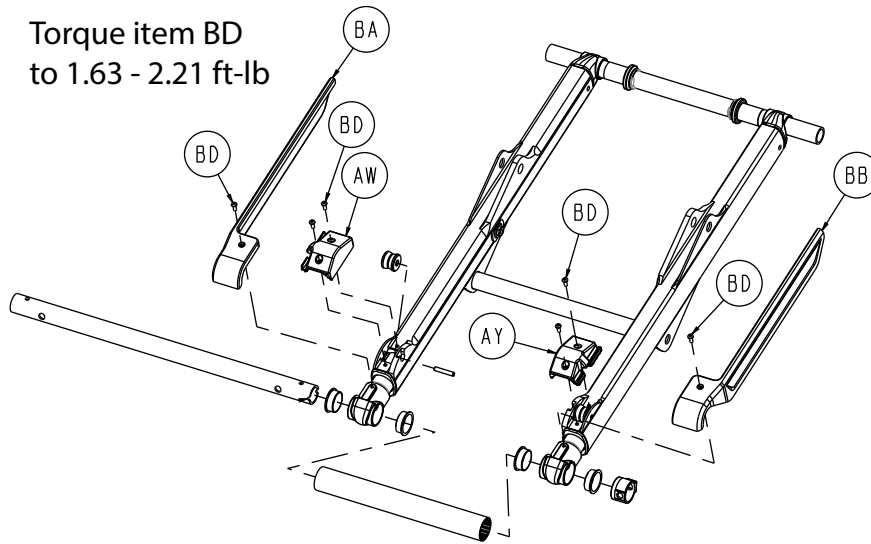

Figure 70 – Lift assembly components

6. Reverse steps to reinstall.
7. Verify proper operation before you return the product to service.

MTS sensor replacement

CAUTION

- Always use electrostatic discharge (ESD) protective equipment before you open antistatic bags and service electronic parts.
 - Do not place unprotected circuit boards on the floor.
-

Tools required:

- T25 Torx driver
- Pick
- ESD system
- Torque screwdriver (in-lb)

Procedure:

1. Apply the brakes.
2. Remove the mattress from the cot.
3. Place the product in the highest height position.
4. Remove the cot battery.

CAUTION - Always remove the cot battery before you service or upgrade the cot to reduce the risk of shock.

5. Raise the left XPS siderail to the up and locked position, if equipped.
6. Using a pick, remove the hole plug (BL) from the back of the slider block (Figure 71). Save the hole plug.
7. Using a pick, unplug the connector for the MTS sensor from the foot end box.

Note - Use an ESD system when you unplug the cable connectors.

8. Using a T25 Torx driver, remove the four round washer head tapping screws (AV) that secure the slider block cover (Y) to the slider block (Figure 72). Save the screws.

Note - Using a torque screwdriver, torque the round washer head tapping screws to 1.70 - 2.30 ft-lb when you reinstall.

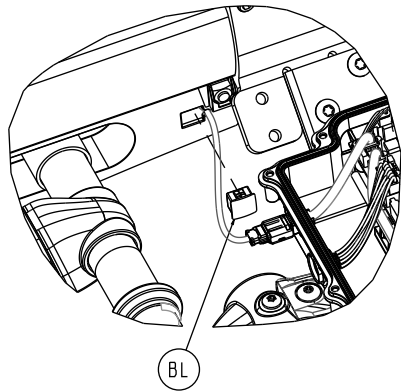

Figure 71 – Remove the hole plug

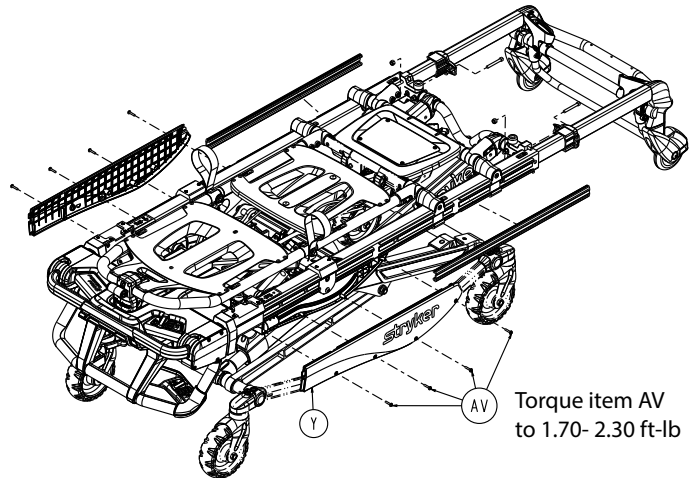

Figure 72 – Remove the slider block cover screws

9. Pivot the head end down and out to remove the slider block cover. Save the cover.
10. Remove the MTS sensor (CE) (Figure 73).

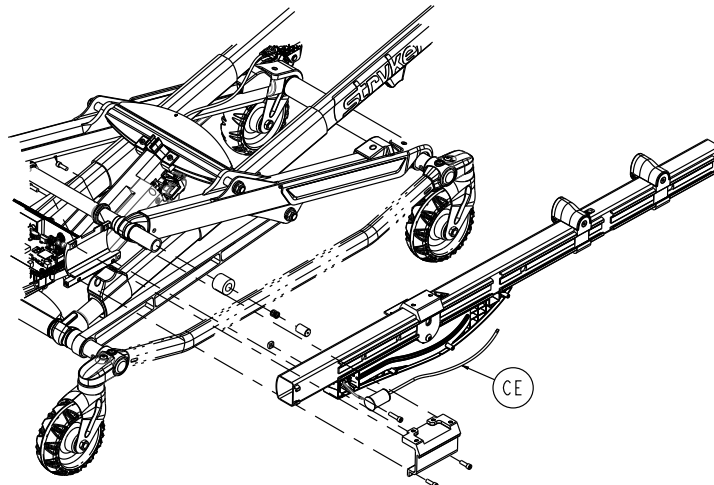

Figure 73 – Remove the MTS sensor

11. Reverse steps to reinstall.

WARNING - Do not allow the sensor lead to bend when you remove the lead from the box or install the lead. The MTS sensor arrives in a custom box to protect the sensor lead from bending.

12. Calibrate the cot. See *Cot calibration* (page 35).
13. Verify proper operation before you return the product to service.

Cot foot end interface board (FEIB) replacement

CAUTION

- Always use electrostatic discharge (ESD) protective equipment before you open antistatic bags and service electronic parts.
 - Do not place unprotected circuit boards on the floor.
-

Tools required:

- T27 Torx driver
- T20 Torx driver
- Bungee cord
- Torque screwdriver (in-lb)
- ESD system

Procedure:

1. Remove the mattress from the cot.
2. Place the product in the highest height position.
3. Raise and lock the foot section to the highest position. Fold the foot section toward the backrest and secure with the bungee cord.
4. Extend and lock the foot section assembly.
5. Remove the cot battery.

CAUTION - Always remove the cot battery before you service or upgrade the cot to reduce the risk of shock.

6. Using a T27 Torx driver, remove the two button head cap screws (CD) that secure the Gatch bumper housing (CA) to the hitch bracket (Figure 74). Remove and save the Gatch bumper housing. Save the screws. Repeat on the other side.

Note - Using a torque screwdriver, torque the button head cap screws to 3.91 - 5.29 ft-lb when you reinstall.

7. Unscrew the FEIB status external module coil cable assembly from the bottom FEIB enclosure. Fold the cable assembly toward the foot end of the cot.

Note - Full seat the cable connector when you reinstall.

8. Using a T20 Torx driver, remove the thirteen round washer head tapping screws (AV) that secure the top FEIB enclosure (AL) to the bottom FEIB enclosure (Figure 75). Save the screws.

Note - Using a torque screwdriver, torque the round washer head tapping screws to 0.95 - 1.16 ft-lb when you reinstall.

Torque item CD
to 3.91 - 5.29 ft-lb

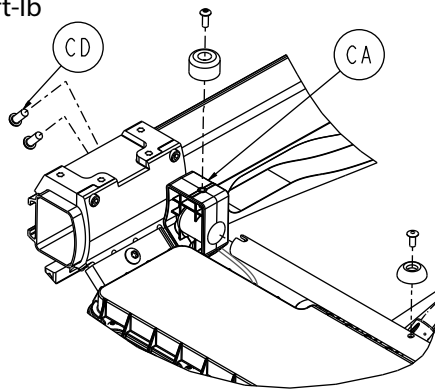

Figure 74 – Remove the Gatch bumper housing

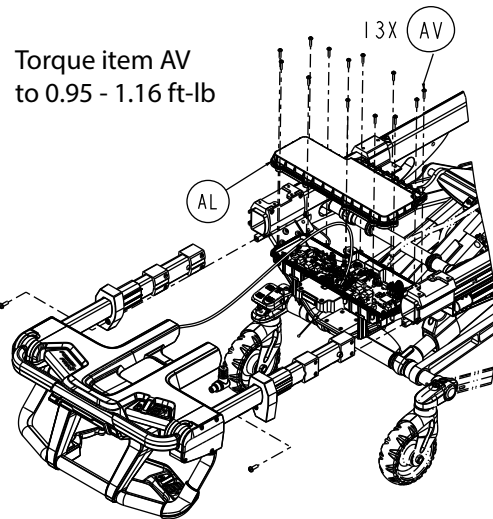

Figure 75 – Remove the FEIB enclosure screws

9. Remove the top FEIB enclosure from the bottom FEIB enclosure.
10. Unplug all cables from the FEIB board.

Note - Use an ESD system when you unplug the cable connectors.

11. Using a T20 Torx driver, remove the four pan head tapping screws (AF) that secure the cot FEIB board (R) to the bottom FEIB enclosure (Figure 76). Save the screws.

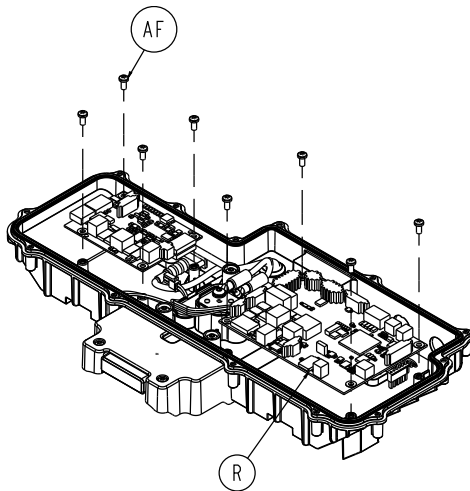

Figure 76 – Remove the FEIB board screws

12. Remove and discard the cot FEIB board.
13. Reverse steps to reinstall.
14. Calibrate the cot. See *Cot calibration* (page 35).
15. Verify proper operation before you return the product to service.

Battery charger board replacement

CAUTION

- Always use electrostatic discharge (ESD) protective equipment before you open antistatic bags and service electronic parts.
 - Do not place unprotected circuit boards on the floor.
-

Tools required:

- T27 Torx driver
- T20 Torx driver
- Bungee cord
- Torque screwdriver (in-lb)
- ESD system

Procedure:

1. Apply the brakes.
2. Remove the mattress from the cot.
3. Place the product in the highest height position.
4. Raise and lock the foot section to the highest position. Fold the foot section toward the backrest and secure with the bungee cord.
5. Extend and lock the foot section assembly.
6. Remove the cot battery.

CAUTION - Always remove the cot battery before you service or upgrade the cot to reduce the risk of shock.

7. Using a T27 Torx driver, remove the two button head cap screws (CD) that secure the Gatch bumper housing (CA) to the hitch bracket (Figure 77). Remove and save the Gatch bumper housing. Save the screws. Repeat on the other side.

Note - Using a torque screwdriver, torque the button head cap screws to 3.91 - 5.29 ft-lb when you reinstall.

8. Unscrew the FEIB status external module coil cable assembly from the bottom FEIB enclosure. Fold the cable assembly toward the foot end of the cot.

Note - Full seat the cable connector when you reinstall.

9. Using a T20 Torx driver, remove the thirteen round washer head tapping screws (AV) that secure the top FEIB enclosure (AL) to the bottom FEIB enclosure (Figure 78). Save the screws.

Note - Using a torque screwdriver, torque the round washer head tapping screws to 0.95 - 1.16 ft-lb when you reinstall.

Torque item CD
to 3.91 - 5.29 ft-lb

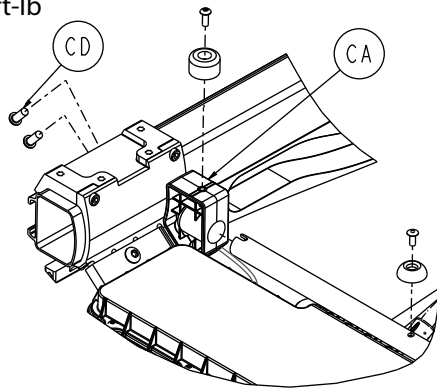

Figure 77 – Remove the Gatch bumper housing

Torque item AV
to 0.95 - 1.16 ft-lb

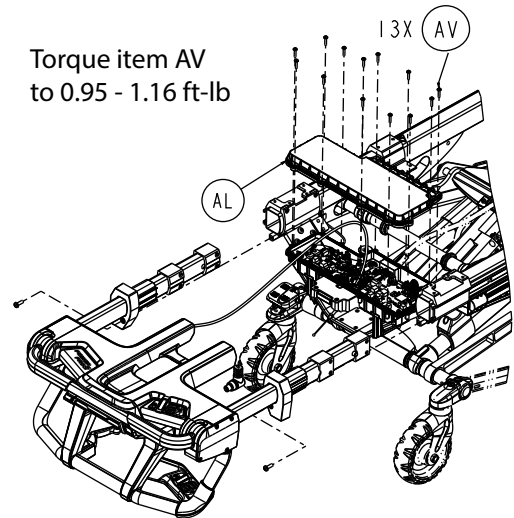

Figure 78 – Remove the FEIB enclosure screws

10. Remove the top FEIB enclosure from the bottom FEIB enclosure.

11. Unplug all cables from the battery charger board.

Note - Use an ESD system when you unplug the cables.

12. Using a T20 Torx driver, remove the four pan head tapping screws (AF) that secure the cot FEIB board (R) to the bottom FEIB enclosure (Figure 79). Save the screws.

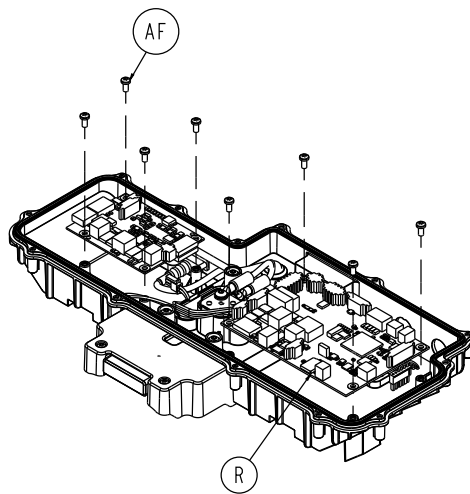

Figure 79 – Remove the FEIB board screws

13. Remove and discard the battery charger board.

14. Reverse steps to reinstall.

15. Verify proper operation before you return the product to service.

Inner tube (X-frame) replacement - foot end

Note - Always replace both right and left sides of the head end or foot end inner lift tubes, even if only one is bent. This will allow the lift system to operate properly and prevent further damage to the product.

Tools required:

- T25 Torx driver
- T27 Torx driver
- 3/8" combination wrench
- Rubber hammer
- Small punch
- Torque wrench (in-lb)

Procedure:

1. Apply the brakes.
2. Remove the mattress from the cot.
3. Place the product in the highest height position.
4. Raise the backrest and foot section to the highest position.
5. Make sure that the head extension is retracted and locked.
6. Raise the cot from the foot end. Tilt the cot up so it rests on the backrest.

CAUTION - Always use assistance from another person when you flip the cot onto the backrest.

7. Work from the foot end with the damaged tube (left or right).
8. Using a T25 Torx driver, remove the two button head cap screws (BD) that secure the roller cover (AW, AY) to the outer lift A-frame weldment (AP) (Figure 80). Save the screws.

Note - Using a torque wrench, torque the button head cap screws to 1.63 - 2.21 ft-lb when you reinstall.

9. Using a T27 Torx driver and a 3/8" combination wrench, remove the caster mount bolt (J) and fiberlock nut (D) that secure the outer base tube (Figure 81). Save the bolt and nut. Repeat on the head end.

Note - Using a torque wrench, torque the caster mount bolt to 4.09 - 5.53 ft-lb when you reinstall.

10. Using a rubber hammer, tap out on the foot end and head end of the outer base tube. Remove and save the outer base tube.

Note - Remove and save the base spacers from the foot and head end cross tubes when you repair the non-brake side of the cot.

11. Using a rubber hammer, tap out on the opposite base tube to move the base cross tubes out of the inner tube. Separate the X-frame supports and remove the cross tube spacer from the foot end only. Save all parts.
12. Using a small punch, push the dowel pin (BG) through the external roller assembly (AN) (Figure 80). Remove and save the dowel pin and external roller assembly.

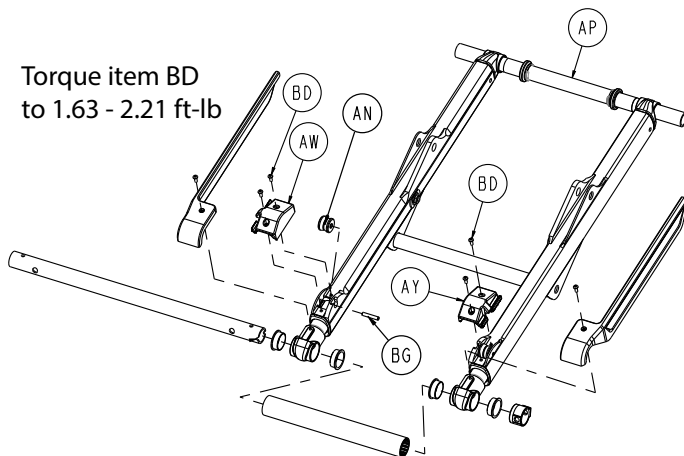

Figure 80 – Lift assembly components

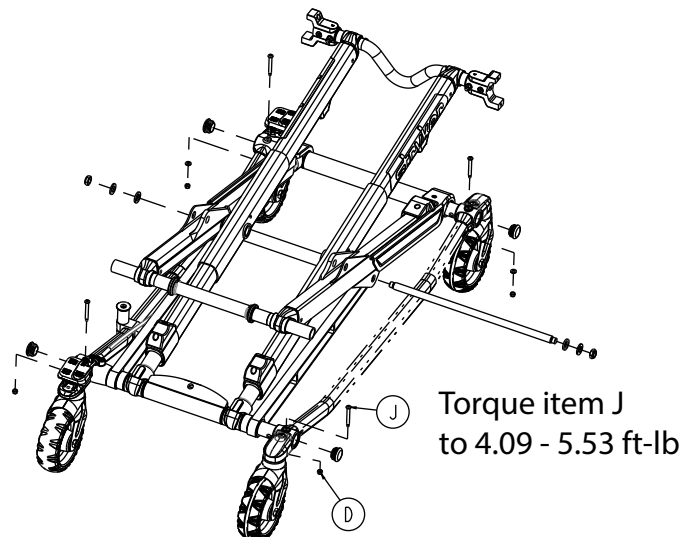

Figure 81 – Remove the foot end bolt and nut

13. Grasp the inner tube to remove it from the outer tube. Discard the inner tube.
14. Reverse steps to reinstall.
15. Verify proper operation before you return the product to service.

Inner tube (X-frame) replacement - head end

Note - Always replace both right and left sides of the head end or foot end inner lift tubes, even if only one is bent. This will allow the lift system to operate properly and prevent further damage to the product.

Tools required:

- T25 Torx driver
- T27 Torx driver
- 3/8" combination wrench
- Rubber hammer
- Small punch
- Torque wrench (in-lb)

Procedure:

1. Apply the brakes.
2. Remove the mattress from the cot.
3. Place the product in the highest height position.
4. Raise the backrest and foot section to the highest position.
5. Make sure that the head extension is retracted and locked.
6. Raise the cot from the foot end. Tilt the cot up so it rests on the backrest.

CAUTION - Always use assistance from another person when you flip the cot onto the backrest.

7. Work from the head end with the damaged tube (left or right).
 8. Using a T25 Torx driver, remove the two button head cap screws (BD) that secure the roller cover (AW, AY) to the outer lift A-frame weldment (AP) (Figure 82). Save the screws.
- Note** - Using a torque wrench, torque the button head cap screws to 1.63 - 2.21 ft-lb when you reinstall.
9. Using a T27 Torx driver and a 3/8" combination wrench, remove the caster mount bolt (J) and fiberlock nut (D) that secure the outer base tube (Figure 83). Save the bolt and nut. Repeat on the foot end.

Note - Using a torque wrench, torque the caster mount bolt to 4.09 - 5.53 ft-lb when you reinstall.

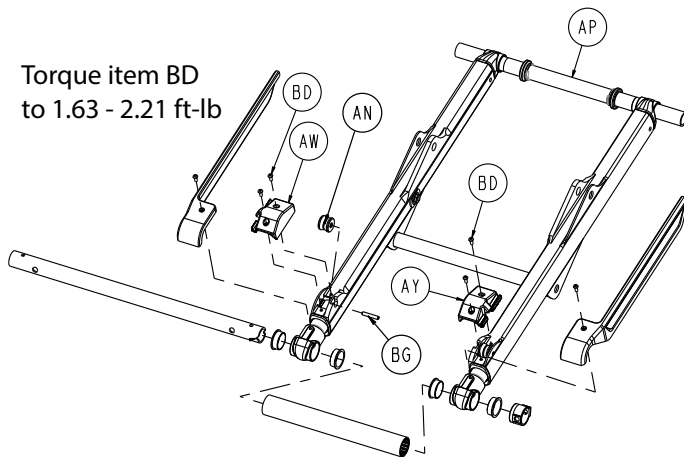

Figure 82 – Lift assembly components

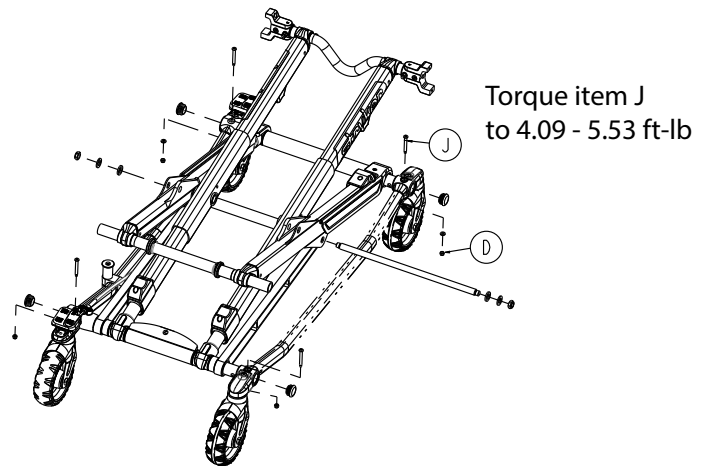
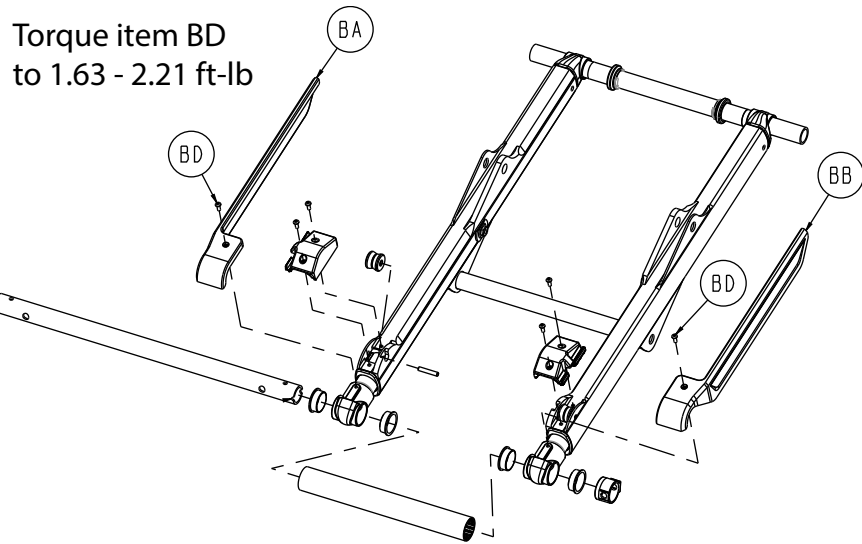

Figure 83 – Remove the head end bolt and nut

10. Using a rubber hammer, tap out on the foot end and head end of the outer base tube. Remove and save the outer base tube.
11. Using a rubber hammer, tap out on the opposite base tube to move the base cross tubes out of the inner tube. Separate the X-frame supports and remove the cross tube spacer from the foot end only. Save all parts.
12. Using a small punch, push the dowel pin (BG) through the external roller assembly (AN) (Figure 82). Remove and save the pin and roller assembly.
13. Grasp the inner tube to remove it from the outer tube. Discard the inner tube.
14. Using a T25 Torx driver, remove the screw (BD) that secures the base leg guard (BA, BB) (Figure 84). Remove and save the base leg guard. Save the screw.

Note - Guide the base leg guard through the guide bracket on the outer tube when you install the supplied inner tube.



Torque item BD
to 1.63 - 2.21 ft-lb

Figure 84 – Remove the base leg guard

15. Reverse steps to reinstall.
16. Verify proper operation before you return the product to service.

Inductive power cable assembly replacement

Tools required:

- T40 Torx driver
- 5/32" hex wrench
- Torque wrench (in-lb)

Procedure:

1. Apply the brakes.
2. Remove the mattress from the cot.
3. Place the product in the highest height position.
4. Remove the cot battery.

CAUTION - Always use assistance from another person when you flip the cot onto the backrest.

5. Pull the foot section out.
6. Unplug the inductive power cable from the foot section box.
7. Using a T40 Torx driver, remove the four button head cap screws that secure the foot end hitch assembly. Remove and save the foot end hitch assembly and cover. Save the screws.
8. Using a 5/32" hex wrench, remove the two socket head shoulder screws that secure the hitch body to the foot end hitch inductive support. Remove and save the hitch body. Save the screws.

Note - Using a torque wrench, torque the socket head shoulder screws to 3.90 - 4.76 ft-lb when you reinstall.

9. Remove and discard the inductive power cable assembly.
10. Reverse steps to reinstall.
11. Verify proper operation before you return the product to service.

User interface button replacement

Follow this procedure to replace the upper or lower UI button.

Tools required:

- T10 Torx driver
- T20 Torx driver

Procedure:

1. Apply the brakes.
2. Remove the mattress from the cot.

3. Place the product in the highest height position.
4. Remove the cot battery.

Note - Always remove the cot battery before you service or upgrade the cot to reduce the risk of shock.

5. Using a T20 Torx driver, remove the four round washer head tapping screws (AK) that secure the back UI cover (Y) to the button housing (Figure 85). Save the screws and cover.
6. Using a T10 Torx driver, remove the two round washer head tapping screws (AJ) that secure the UI cable assembly (AG) to the button housing (Figure 86). Save the screws and cable assembly.

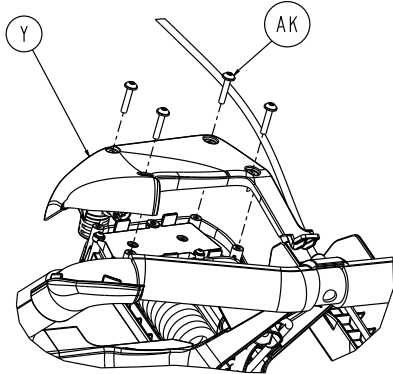

Figure 85 – Remove the back UI button screws

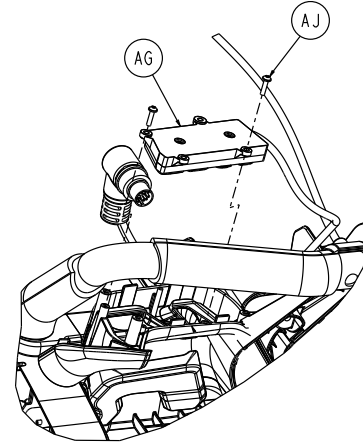

Figure 86 – Remove the UI cable assembly and screws

7. Using a T20 Torx driver, loosen the manual release pivot pin (G) on the quick release handle (AB) (Figure 87). Remove and save the pin and quick release handle assembly.

Note - Use caution when you remove the manual release handle. If you pull the manual release cable, the cot could lower during service.

8. Using a T20 Torx driver, remove the six round washer head tapping screws (AK) from the back of the foot end housing (Figure 88). Save the screws.

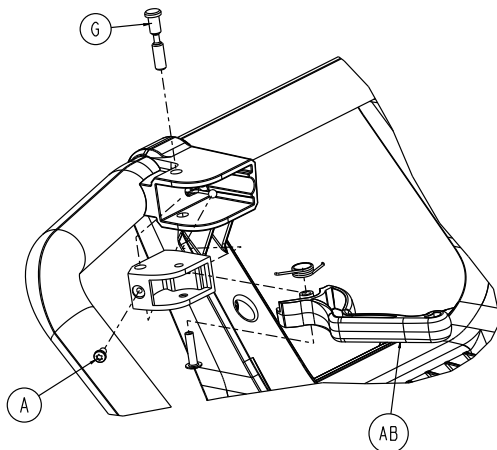

Figure 87 – Remove the manual release pivot pin

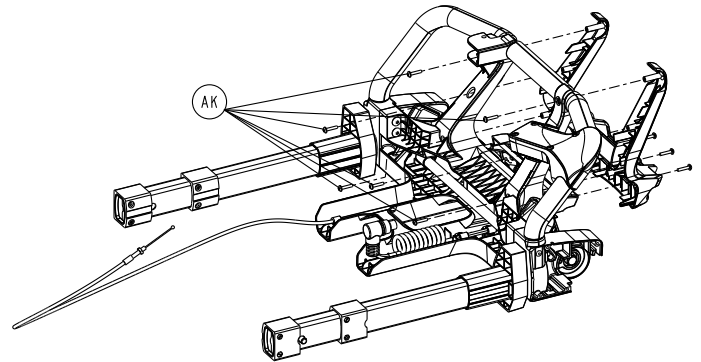

Figure 88 – Remove the foot end housing screws

9. Using a T20 Torx driver, remove the three round washer head tapping screws (AK) from the foot end enclosure (S) (Figure 89). Remove the front foot end housing. Save all parts.
10. Using a T10 Torx driver, remove the five round washer head tapping screws (AJ) that secure the light module cable assembly (AF) (Figure 90). Remove and save the light module cable assembly. Save the screws.

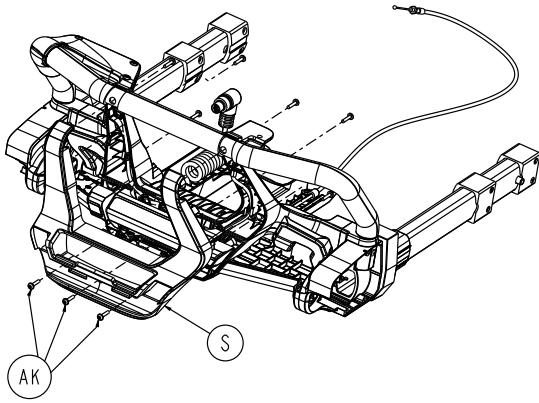

Figure 89 – Remove the foot end enclosure

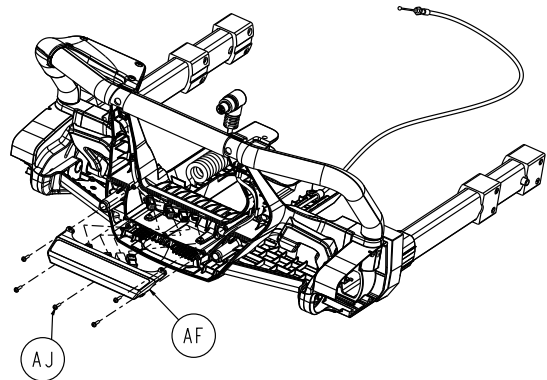

Figure 90 – Remove the light module cable assembly

11. Unplug the user interface cable connection to replace the button. Discard the cable.
12. Reverse steps to reinstall.
13. Make sure that the foot end button and latch operate.
14. Verify proper operation before you return the product to service.

Power and comm cable replacement

CAUTION

- Always use electrostatic discharge (ESD) protective equipment before you open antistatic bags and service electronic parts.
 - Do not place unprotected circuit boards on the floor.
-

Tools required:

- T15 Torx driver
- T20 Torx driver
- T25 Torx driver
- T27 Torx driver
- 3/8" combination wrench
- Torque screwdriver (in-lb)
- ESD system

Procedure:

1. Apply the brakes.
2. Remove the mattress from the cot.
3. Raise the product to the highest height position.
4. Raise and lock the foot section in the highest position.
5. Extend and lock the foot section assembly.
6. Remove the cot battery.

CAUTION - Always remove the cot battery before you service or upgrade the cot to reduce the risk of shock.

7. Using a T27 Torx driver, remove the two button head cap screws (CD) that secure the Gatch bumper housing (CA) to the hitch bracket (Figure 91). Remove and save the Gatch bumper housing. Save the screws. Repeat on the other side.

Note - Using a torque screwdriver, torque the screws to 3.91 - 5.29 ft-lb when you reinstall.

8. Unscrew the FEIB status external module coil cable assembly from the bottom FEIB enclosure. Fold the cable assembly toward the foot end of the cot.
9. Using a T20 Torx driver, remove the thirteen round washer head tapping screws (AV) that secure the top FEIB enclosure (AL) to the bottom FEIB enclosure (Figure 92). Save the screws.

Note - Using a torque screwdriver, torque the round washer head tapping screws to 0.95 - 1.16 ft-lb when you reinstall.

Torque item CD
to 3.91 - 5.29 ft-lb

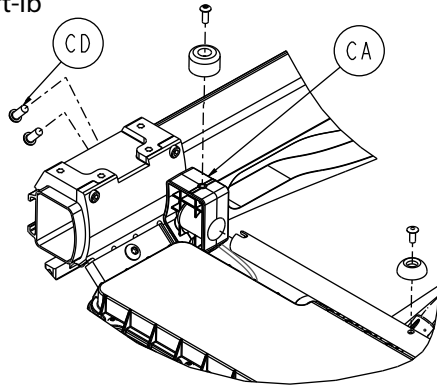

Figure 91 – Remove the Gatch bumper housing

Torque item AV
to 0.95 - 1.16 ft-lb

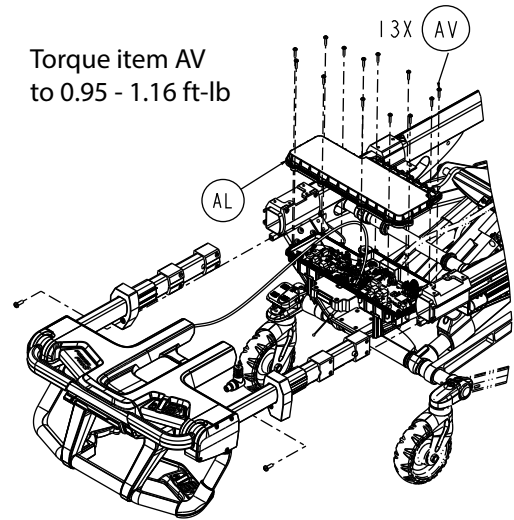

Figure 92 – Remove the FEIB enclosure screws

10. Remove the top FEIB enclosure from the bottom FEIB enclosure.
11. Using a T25 Torx driver, remove the two pan head tapping screws that secure the system bus cable assembly to the back of the FEIB assembly. Save the screws.
12. Using a T27 Torx driver, remove the pan head machine screw that secures the negative wire connection to the FEIB grounding block. Save the screw.
13. Using a T25 Torx driver, remove the pan head machine screw that secures the positive wire connection to the FEIB grounding block. Save the screw.
14. Remove the two other connections from the cot FEIB PCBA to the system bus cable assembly.
15. Remove the system bus cable assembly from the back of the bottom FEIB enclosure.

Note

- Always use care when you lift and support the cot. The cot may move while you tip the cot onto the head section.
- Retract and lock the head section and make sure that the Fowler is in the up position before you tip the cot.

16. Stand at the foot end and tilt the cot onto its head section.
17. Using a T20 Torx driver, remove the five round washer head tapping screws (AV) that secure the actuator end cap (AD) to the hydraulic assembly electrical box (Figure 93). Save the screws and end cap.

Note - Using a torque wrench, torque the round washer head tapping screws to 1.28 - 1.73 ft-lb when you reinstall.

18. Unlock and unplug both cable connections in the electrical box.
19. Using a T15 Torx driver, remove the four button head torx screws (A) that secure the lift motor cable assembly to the actuator cover (Figure 93). Save the screws.

Note - Using a torque wrench, torque the button head torx screws to 1.28 - 1.73 ft-lb when you reinstall.

20. Remove the lift motor cable assembly through the back of the electrical box.
21. Stand at the foot end and lower the cot back onto the four wheels.
22. Using a T25 Torx driver, remove the four pan head thread rolling screws (BD) that secure the seat skin (AM) to the cot (Figure 94). Remove and save the seat skin. Save the screws.

Note - Using a torque wrench, torque the pan head thread rolling screws to 4.67 - 6.31 ft-lb when you reinstall.

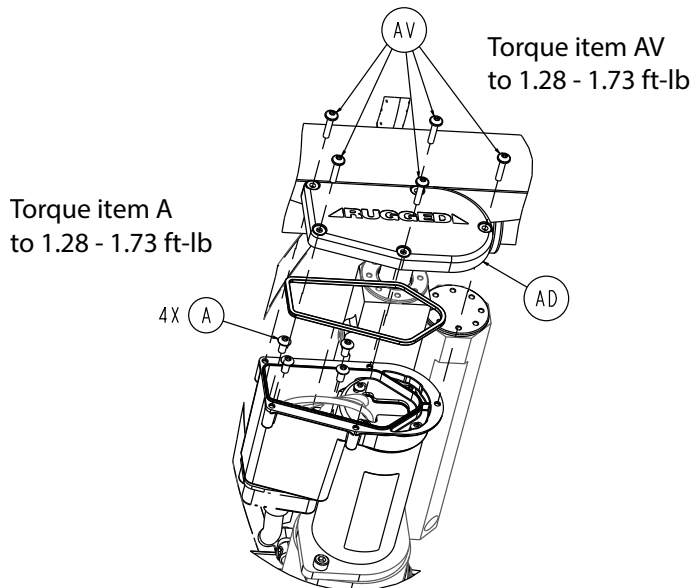

Figure 93 – Lift motor cable assembly components

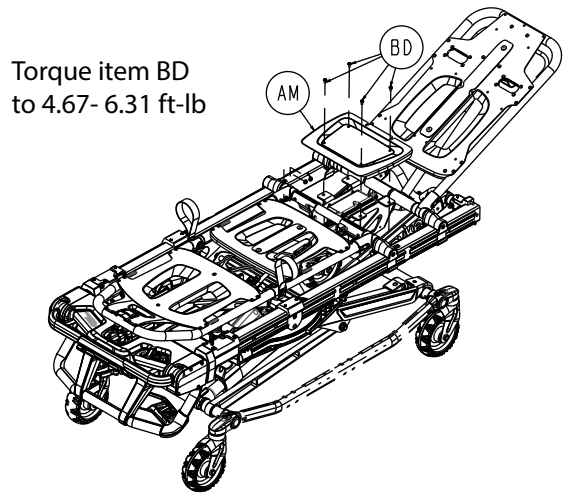

Figure 94 – Remove the screws and seat skin

23. Disconnect the two quick disconnect connections (HBC strain gauge external cable assembly and the solenoid/transducer external cable assembly) from the HBC enclosure assembly.
24. Using a T25 Torx driver, remove the three pan head tapping screws (M) that secure the HBC enclosure assembly (A) to the bird cage (E) (Figure 95). Save the screws.
25. Using a T25 Torx driver and a 3/8" combination wrench, remove the button head cap screw (N) and Fiberlock nut (R) that secure the wireless module, if equipped, and the NFMIC module to the cot, if equipped (Figure 96). Save the screw and nut.

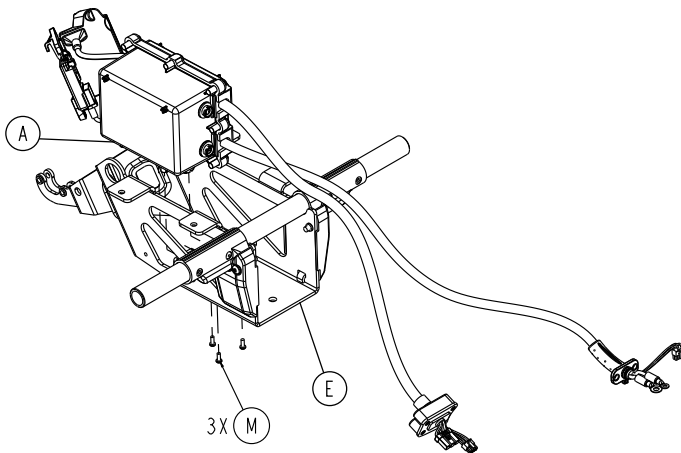

Figure 95 – Remove the HBC enclosure assembly screws

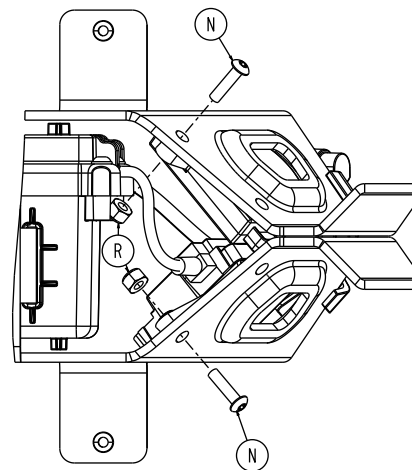

Figure 96 – Remove the wireless module screw and nut

26. Lift the HBC enclosure assembly up through the seat section to access the screws that secure the HBC top cover.
27. Using a T20 Torx driver, remove the seven round washer head tapping screws (S) that secure the top cover (F) to the HBC enclosure assembly (Figure 97). Remove and save the top cover. Save the screws.

Note - Using a torque screwdriver, torque the screws to 1.49 - 1.83 ft-lb when you reinstall.

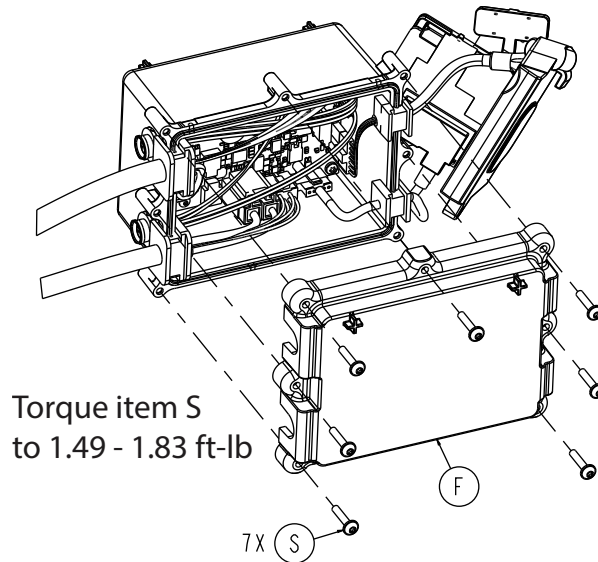

Figure 97 – Remove the HBC top cover screws

28. Unplug the cable connectors from the HBC board.

Note - Use an ESD system when you unplug the cable connectors.

29. Remove HBC enclosure and cable assemblies.

30. Reverse steps to reinstall.

Note

- See *Cot assembly, common components* (page 95) for cable routing views.
- Push the rubber grommets from the cables into the HBC enclosure assembly pockets.

31. Calibrate the cot. See *Cot calibration* (page 35).

32. Verify proper operation before you return the product to service.

HBC enclosure and cable replacement

CAUTION

- Always use electrostatic discharge (ESD) protective equipment before you open antistatic bags and service electronic parts.
 - Do not place unprotected circuit boards on the floor.
-

Tools required:

- T15 Torx driver
- T20 Torx driver
- T25 Torx driver
- T27 Torx driver
- 3/8" combination wrench
- Torque screwdriver (ft-lb)
- ESD system

Procedure:

1. Apply the brakes.
2. Remove the mattress from the cot.
3. Raise the product to the highest height position.
4. Raise and lock the foot section in the highest position.
5. Extend and lock the foot section assembly.
6. Remove the cot battery.

CAUTION - Always remove the cot battery before you service or upgrade the cot to reduce the risk of shock.

7. Using a T27 Torx driver, remove the two button head cap screws (CD) that secure the Gatch bumper housing (CA) to the hitch bracket (Figure 98). Remove and save the Gatch bumper housing. Save the screws. Repeat on the other side.

Note - Using a torque screwdriver, torque the screws to 3.91 - 5.29 ft-lb when you reinstall.

8. Unscrew the FEIB status external module coil cable assembly from the bottom FEIB enclosure. Fold the cable assembly toward the foot end of the cot.

9. Using a T20 Torx driver, remove the thirteen round washer head tapping screws (AV) that secure the top FEIB enclosure (AL) to the bottom FEIB enclosure (Figure 99). Save the screws.

Note - Using a torque screwdriver, torque the round washer head tapping screws to 0.95 - 1.16 ft-lb when you reinstall.

Torque item CD
to 3.91 - 5.29 ft-lb

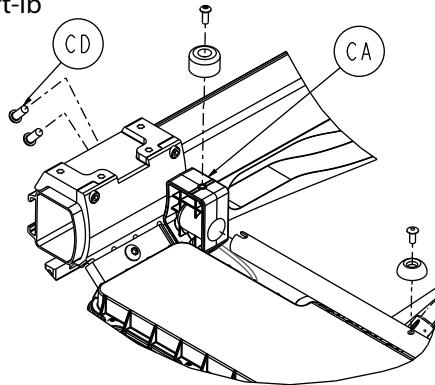

Figure 98 – Remove the Gatch bumper housing

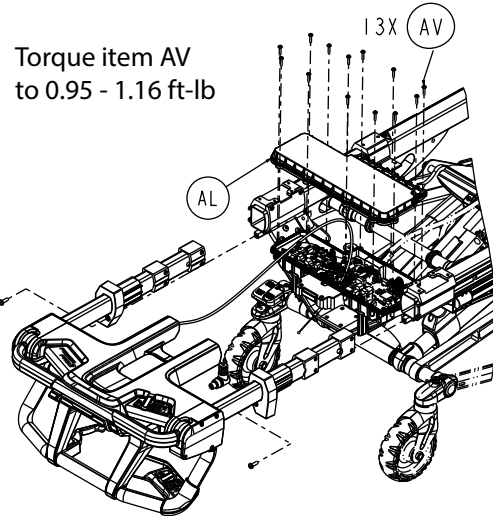

Figure 99 – Remove the FEIB enclosure screws

10. Remove the top FEIB enclosure from the bottom FEIB enclosure.
11. Using a T25 Torx driver, remove the two pan head tapping screws that secure the system bus cable assembly to the back of the FEIB assembly. Save the screws.
12. Using a T27 Torx driver, remove the pan head machine screw that secures the negative wire connection to the FEIB grounding block. Save the screw.
13. Using a T25 Torx driver, remove the pan head machine screw that secures the positive wire connection to the FEIB grounding block. Save the screw.
14. Remove the two other connections from the cot FEIB PCBA to the system bus cable assembly.
15. Remove system bus cable assembly from the back of the bottom FEIB enclosure.

Note

- Always use care when you lift and support the cot. The cot may move while you tip the cot onto the head section.
- Retract and lock the head section and make sure that the Fowler is in the up position before you tip the cot.

16. Stand at the foot end and tilt the cot onto its head section.
17. Using a T20 Torx driver, remove the five round washer head tapping screws (AV) that secure the actuator end cap (AD) to the hydraulic assembly electrical box (Figure 100). Save the screws and end cap.

Note - Using a torque wrench, torque the round washer head tapping screws to 1.28 - 1.73 ft-lb when you reinstall.

18. Unlock and unplug both cable connections in the electrical box.
19. Using a T15 Torx driver, remove the four button head torx screws (A) that secure the lift motor cable assembly to the actuator cover (Figure 100). Save the screws.

Note - Using a torque wrench, torque the button head torx screws to 1.28 - 1.73 ft-lb when you reinstall.

20. Remove the lift motor cable assembly through the back of the electrical box.
21. Stand at the foot end and lower the cot back onto the four wheels.
22. Using a T25 Torx driver, remove the four pan head thread rolling screws (BD) that secure the seat skin (AM) to the cot (Figure 101). Remove and save the seat skin. Save the screws.

Note - Using a torque wrench, torque the pan head thread rolling screws to 4.67 - 6.31 ft-lb when you reinstall.

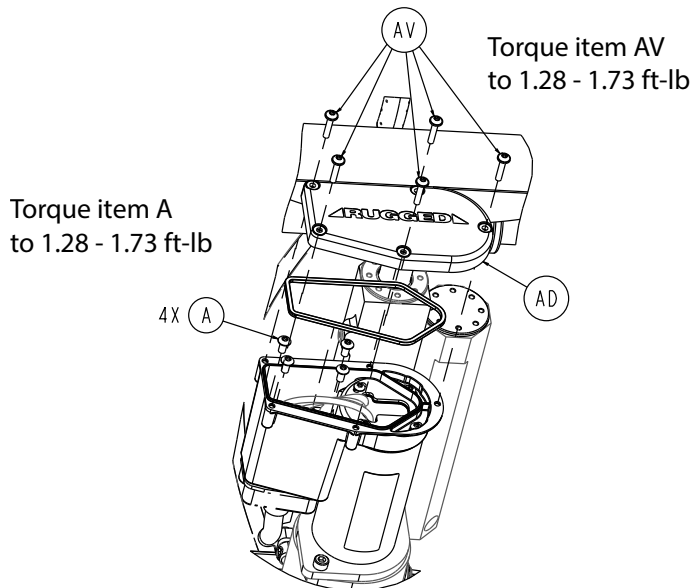

Figure 100 – Lift motor cable assembly components

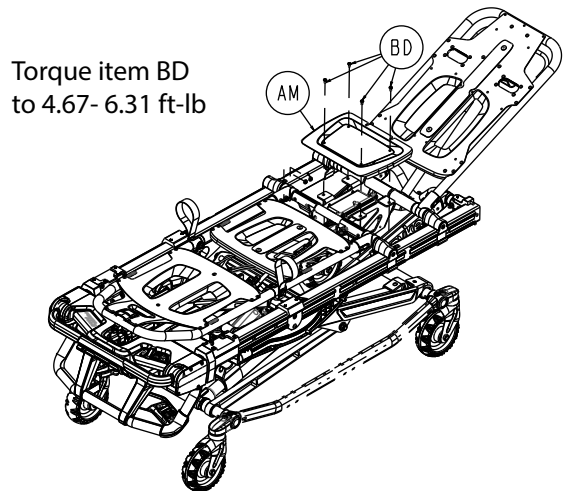

Figure 101 – Remove the screws and seat skin

23. Disconnect the two quick disconnect connections (HBC strain gauge external cable assembly and the solenoid/transducer external cable assembly) from the HBC enclosure assembly.
24. Using a T25 Torx driver, remove the three pan head tapping screws (M) that secure the HBC enclosure assembly (A) to the bird cage (E) (Figure 102). Save the screws.
25. Using a T25 Torx driver and a 3/8" combination wrench, remove the button head cap screw (N) and Fiberlock nut (R) that secure the wireless module, if equipped, and the NFMIC module to the cot, if equipped (Figure 103). Save the screw and nut.

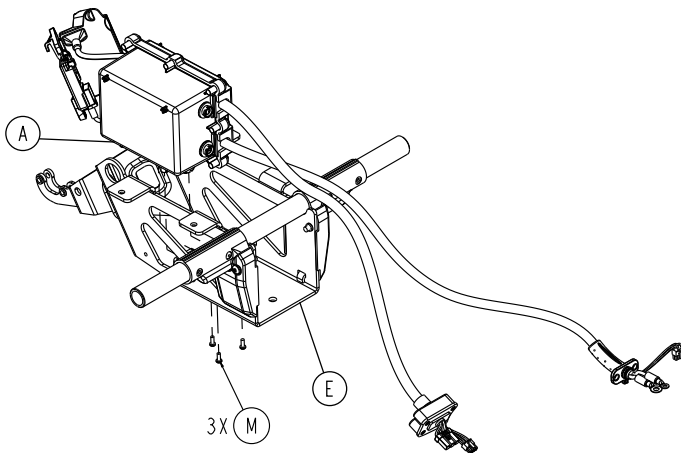

Figure 102 – Remove the HBC enclosure assembly screws

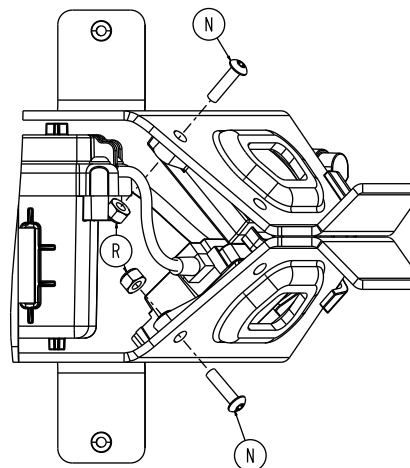

Figure 103 – Remove the wireless module screw and nut

26. Lift the HBC enclosure assembly up through the seat section to access the screws that secure the HBC top cover.
27. Using a T20 Torx driver, remove the seven round washer head tapping screws (S) that secure the top cover (F) to the HBC enclosure assembly (Figure 104). Remove and save the top cover. Save the screws.

Note - Using a torque screwdriver, torque the screws to 1.49 - 1.83 ft-lb when you reinstall.

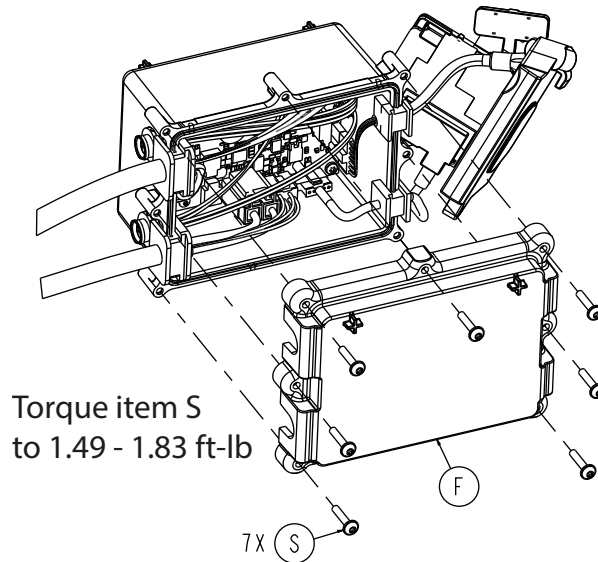

Figure 104 – Remove the HBC top cover screws

28. Unplug the cable connectors from the HBC board.

Note - Use an ESD system when you unplug the cable connectors.

29. Remove HBC enclosure and cable assemblies.

30. Reverse steps to reinstall.

Note - Push the rubber grommets from the cables into the HBC enclosure assembly pockets.

31. Calibrate the cot. See *Cot calibration* (page 35).

32. Verify proper operation before you return the product to service.

HBC strain gauge external cable assembly replacement

Tools required:

- 3/4" combination wrench (2)
- 1/8" hex wrench
- 3/8" combination wrench
- Saw horse (2)
- Small punch
- Torque screwdriver (in-lb)

Procedure:

1. Apply the brakes.
2. Remove the mattress from the cot.
3. Raise the product to the highest height position.
4. Remove the cot battery.

CAUTION - Always remove the cot battery before you service or upgrade the cot to reduce the risk of shock.

5. Extend and lock the head section.
6. Retract and lock the foot section.
7. Using two sawhorses:
 - a. Foot end – place the cot in the highest height position. Lift and support the foot end below the foot section.
 - b. Head end – place the cot in the mid-height position. Extend and lock the head section, then lift and support the head section.
8. Remove the solenoid/transducer (AP) at the HBC via the quick disconnect (Figure 105).
9. Using a 1/8" hex wrench and 3/8" combination wrench, remove the two socket head shoulder bolts (J) and Fiberlock hex nuts (C) that secure the hydraulic cylinder assembly to the X-frame cross brace (Figure 106). Save the bolts and nuts.

Note - Using a torque screwdriver, torque the socket head shoulder bolts to 1.75 - 2.37 ft-lb when you reinstall.

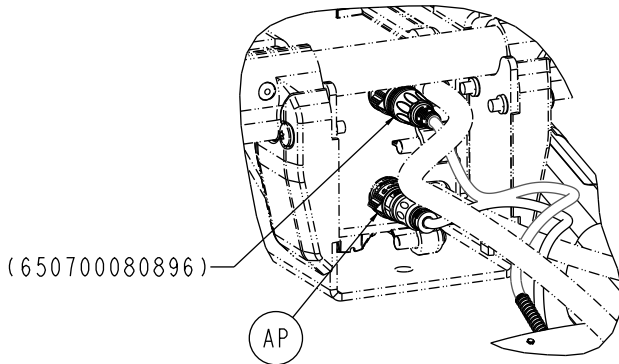

Figure 105 – Remove the solenoid/transducer external cable assembly

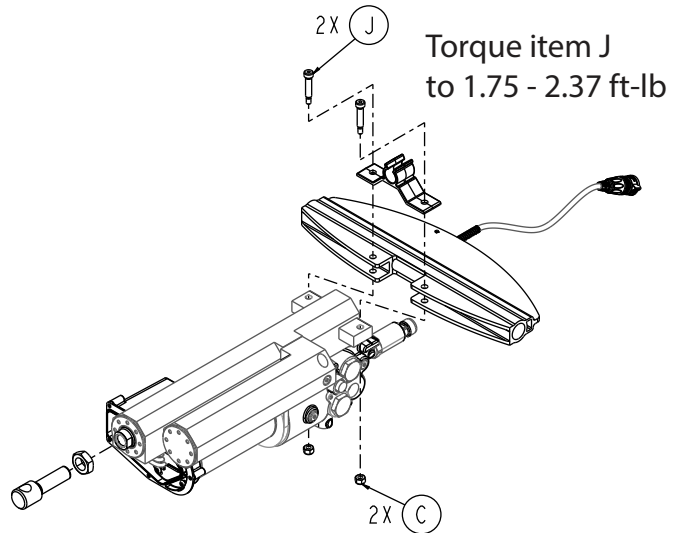

Figure 106 – Remove the actuator assembly bolts and nuts

10. Using two 3/4" combination wrenches, remove the Nylock hex nut (F), D washer (U), and washer (BH) (Figure 107). Save all parts.

Note - Using a torque screwdriver, torque the Nylock hex nut to 13.09 - 17.71 ft-lb when you reinstall.

11. Using a small punch, push the stiffener bar cross tube (T) through the HBC strain gauge external cable assembly (AM) (Figure 107). Remove and save stiffener bar cross tube and flange bearings (L).

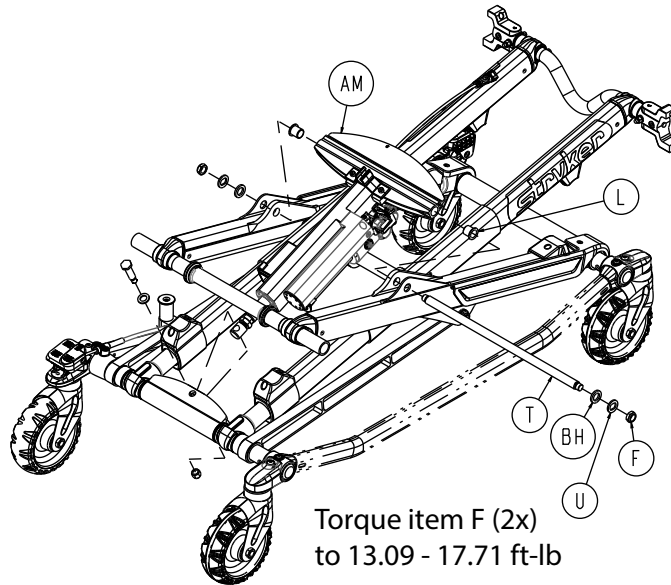

Figure 107 – Lift assembly components

12. Remove HBC strain gauge external cable assembly and discard.

13. Reverse steps to reinstall.

Note - Push the rubber grommets from the cables into the HBC enclosure assembly pockets.

14. Calibrate the cot. See *Cot calibration* (page 35).

15. Verify proper operation before you return the product to service.

Slider roller replacement

Tools required:

- T25 Torx driver
- 3/16" hex wrench
- 1/2" combination wrench
- Pick
- Torque wrench (in-lb)

Procedure:

1. Apply the brakes.
2. Place the product in the highest height position.
3. Remove the cot battery.

CAUTION - Always remove the cot battery before you service or upgrade the cot to reduce the risk of shock.

4. Raise the left XPS siderail to the up and locked position, if equipped.
5. Raise the backrest and foot section to the highest height position.
6. Retract and lock the head section.
7. Raise the cot from the foot end. Tilt the cot up so it rests on the backrest.

CAUTION - Always use assistance from another person when you flip the cot onto the backrest.

8. Using a pick, remove the hole plug (BL) for the MTS sensor from the back of the slider block (Figure 108). Save the hole plug.
9. Using a pick, unplug the connector for the MTS sensor from the foot end box.
10. Using a T25 Torx driver, remove the four round washer head tapping screws (AV) that secure the slider block cover (Y) to the slider block (Figure 109). Save the screws.

Note - Using a torque wrench, torque the round washer head tapping screws to 1.70 - 2.30 ft-lb when you reinstall.

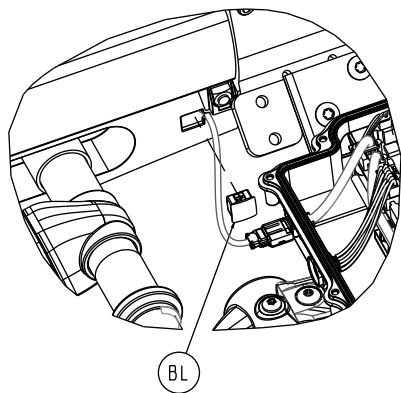

Figure 108 – Remove the hole plug

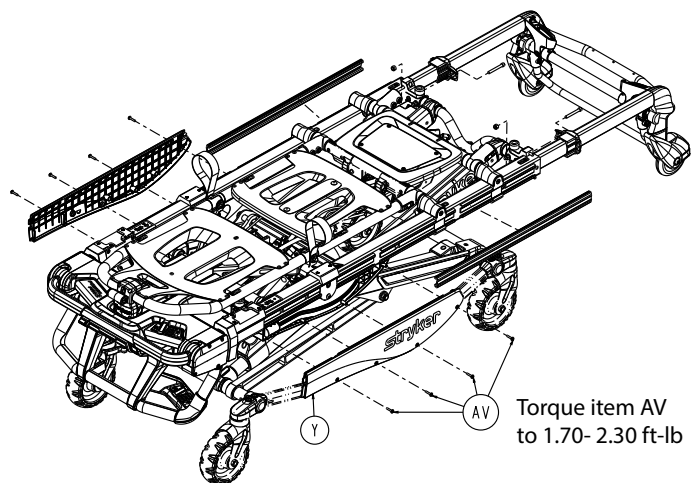

Figure 109 – Remove the slider block cover screws

11. Pivot the head end down and out to remove and save the slider block cover.
12. Using a 3/16" hex wrench and a 1/2" combination wrench, remove the button head cap screw (A) and Nylock hex nut (B) that secure the slider block (F) to the outer rail (E) (Figure 110). Save all parts.

Note - Using a torque wrench, torque the button head cap screw to 4.25 - 5.75 ft-lb when you reinstall.

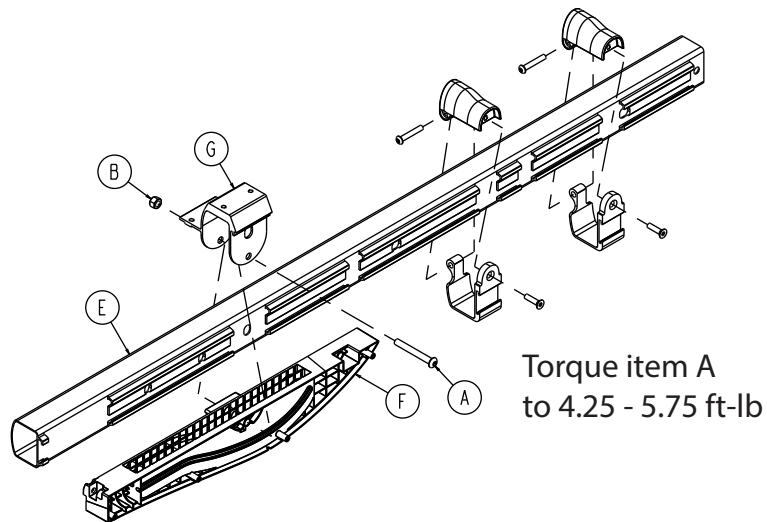

Figure 110 – Remove the slider block

13. Using a 3/16" hex wrench, remove the hex socket button head cap screw (B) that secures the XPS inner bracket (F) to the slider block (Figure 111). Save the screw.

Note - Using a torque wrench, torque the hex socket button head cap screw (B) to 6.89 - 13.00 ft-lb when you reinstall.

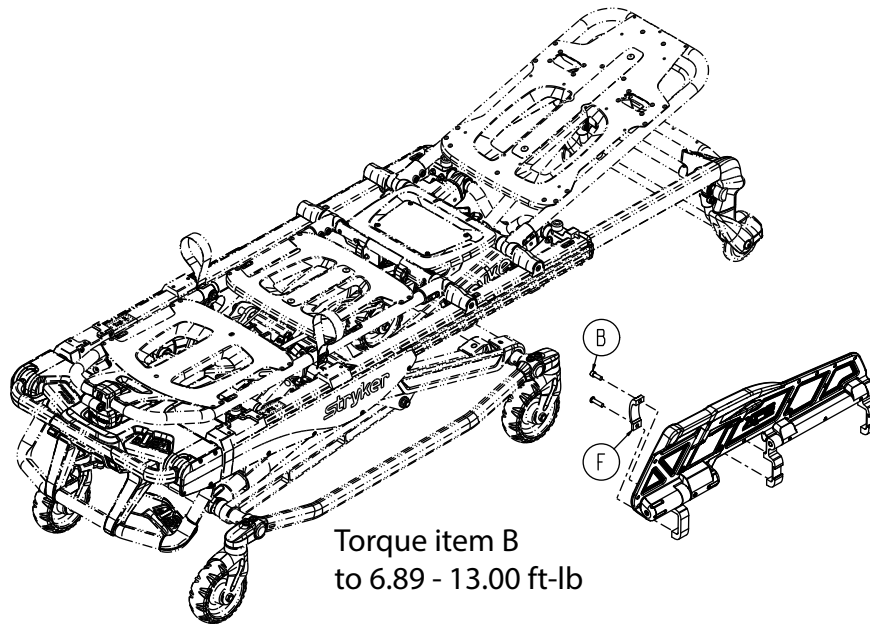

Figure 111 – Remove the hex socket button head cap screw

14. Using a 3/16" hex wrench, remove the socket head cap screw (BK) that secures the slider block to the hitch bracket I-clamp (W) to the outer rail (U) (Figure 112). Save the screw.

Note - Using a torque wrench, torque the socket head cap screw to 1.70 - 2.30 ft-lb when you reinstall.

15. Lift up and provide pressure on foot end to separate to outer rail from the slider block.

16. Remove slider roller (AC), slide magnet assembly (T), and compression wire (BM) (Figure 112). Save the slide magnet assembly and compression wire. Discard slider roller.

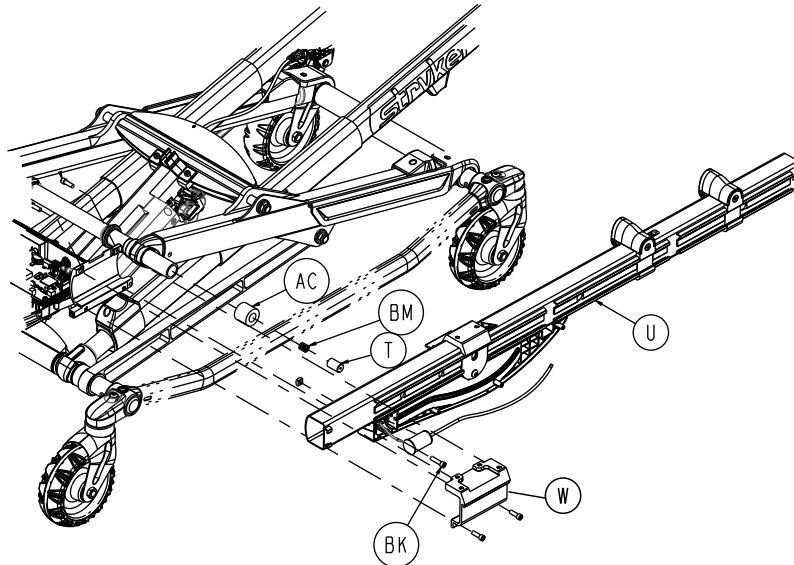

Torque item BK
to 1.70 - 2.30 ft-lb

Figure 112 – Discard the slider roller

17. Reverse steps to reinstall.

18. Verify proper operation before you return the product to service.

Foot section replacement

Tools required:

- T10 Torx driver
- T30 Torx driver
- Torque wrench (in-lb)

Procedure:

1. Apply the brakes.
2. Remove the mattress from the cot.
3. Place the cot and foot section in the highest height position.
4. Remove the cot battery.

CAUTION - Always remove the cot battery before you service or upgrade the cot to reduce the risk of shock.

5. Using a T10 Torx driver, remove the two round washer head tapping screws (CH) that secure the manual release cable bracket to the hydraulic assembly (Figure 113). Save the screws.
6. Raise the knee Gatch to the Trendelenburg position.
7. Remove the FEIB to status external module coil cable assembly (650700080862) (Figure 114).

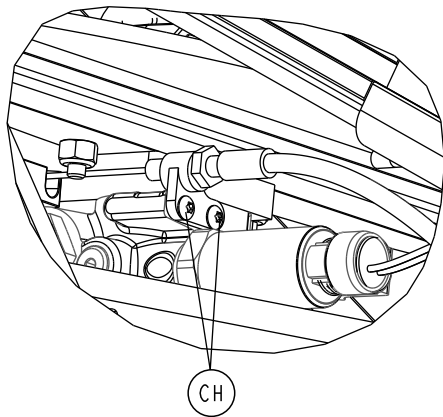

Figure 113 –

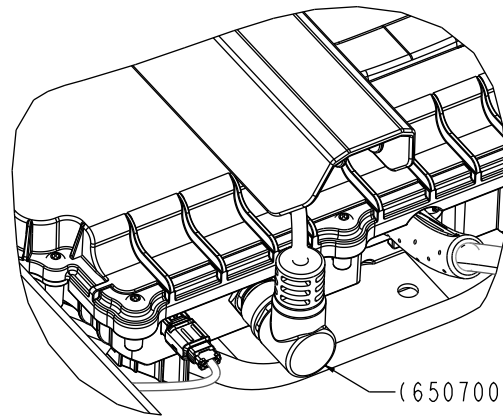

Figure 114 –

8. Extend the foot section to access the outer rail end cap screws.
9. Using a T30 Torx driver, remove the pan head machine screw (BG) that secures the outer rail end cap (F) to the outer rail (Figure 115). Repeat on the other side. Save the screws.

Note - Using a torque wrench, torque the pan head machine screws to 4.48 - 6.06 ft-lb when you reinstall.

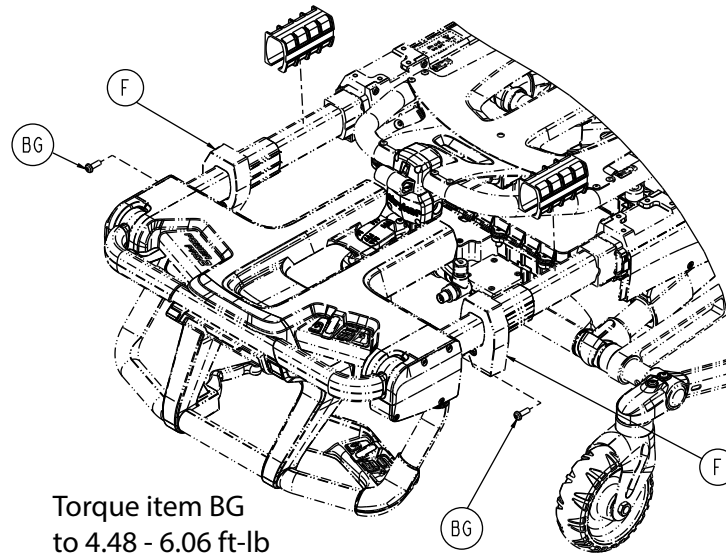

Figure 115 –

10. Remove and discard the foot section.
11. Reverse steps to reinstall.
12. Verify proper operation before you return the product to service.

Slider magnet assembly replacement

CAUTION

- Always use electrostatic discharge (ESD) protective equipment before you open antistatic bags and service electronic parts.
- Do not place unprotected circuit boards on the floor.

Tools required:

- T20 Torx driver
- T30 Torx driver
- Slotted screwdriver
- 1/2" combination wrench
- ESD system
- Torque wrench (in-lb)

Procedure:

1. Apply the brakes.
2. Remove the mattress from the cot.
3. Retract the retractable head section.
4. Place the cot and Fowler in the highest height position.
5. Remove the cot battery.

CAUTION - Always remove the cot battery before you service or upgrade the cot to reduce the risk of shock.

6. Tilt the cot onto its head end.
7. Using a T20 Torx driver, remove the four round washer head tapping screws (AV) from the patient left slider block cover (Y) (Figure 116). Save the screws and cover.

Note - Using a torque wrench, torque the round washer head tapping screws to 1.70 - 2.30 ft-lb when you reinstall.

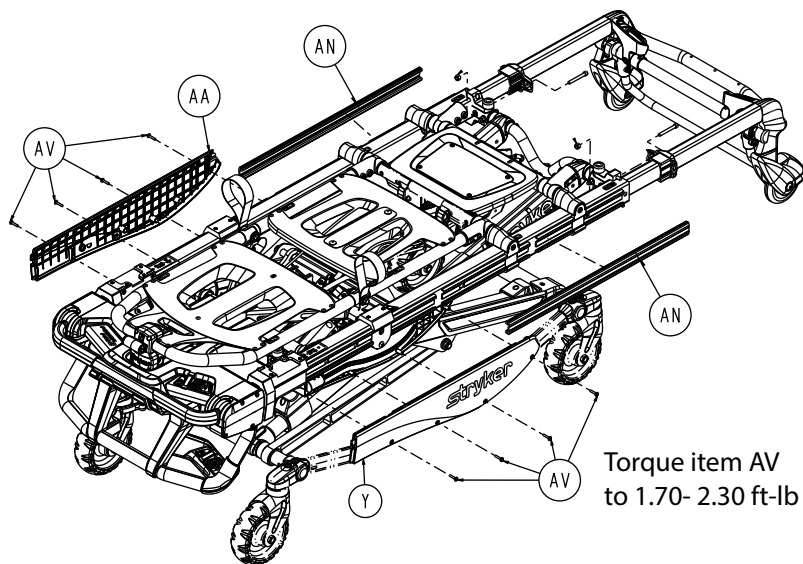

Figure 116 – Remove the slider block cover

8. Using a T30 Torx driver and a 1/2" combination wrench, remove the button head cap screw (A) that secures the patient left slider block (F) to the outer rail (E) (Figure 117). Save the screw and slider block.

Note - Using a torque wrench, torque the button head cap screw to 4.25 - 5.75 ft-lb when you reinstall.

9. Unplug the MTS sensor assembly (CE) (Figure 118).

Note - Use an ESD system when you unplug the cable connectors.

10. Using a T30 Torx driver, remove the socket head cap screw (BK) from the outer rail assembly (U) (Figure 118). Save the screw.

Note - Using a torque wrench, torque the socket head cap screw to 1.70 - 2.30 ft-lb when you reinstall.

11. Remove the slider magnet assembly (T), slider roller (AC), and compression wire (BM) (Figure 118). Discard all parts.

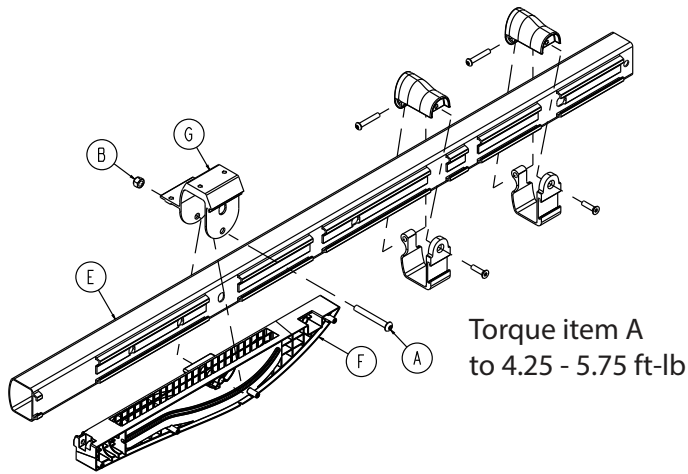

Figure 117 – Remove the slider block

Torque item A
to 4.25 - 5.75 ft-lb

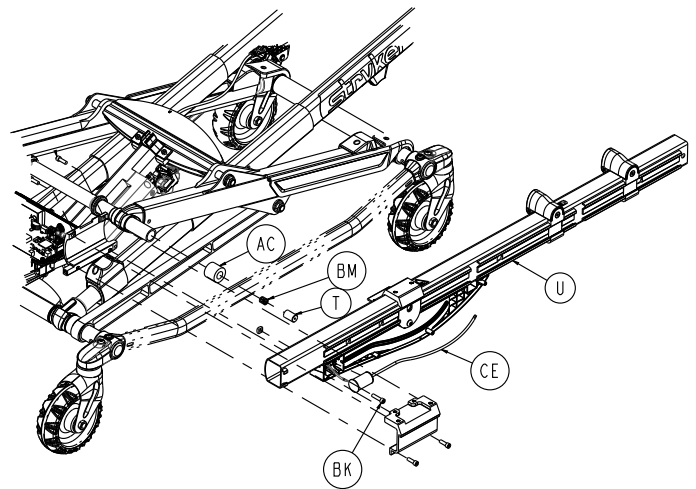

Figure 118 – Remove the slider magnet assembly

Torque item BK
to 1.70 - 2.30 ft-lb

12. Reverse steps to reinstall

13. Verify proper operation before you return the product to service.

Head extension option replacement

CAUTION

- Do not use the head extension option as a push/pull device or to steer the product.
 - Do not hang equipment from the head extension option.
-

Tools required:

- T25 Torx driver
- Torque wrench (ft-lb)

Procedure:

1. Apply the brakes.
2. Remove the mattress from the cot.
3. Place the cot in the highest height position.
4. Place the Fowler in the mid-height position.
5. Remove the cot battery.

CAUTION - Always remove the cot battery before you service or upgrade the cot to reduce the risk of shock.

6. Remove and discard the head extension pillow sleeve. Save the pillow.
7. Using a T25 Torx driver, remove the four button head cap screws (E) that secure the head extension mounting body (B) and head extension assembly (C) to the head section skin (Figure 119). Save the screws. Discard the head extension assembly.

Note - Using a torque wrench, torque the button head cap screws to 3.17 - 4.29 ft-lb when you reinstall.

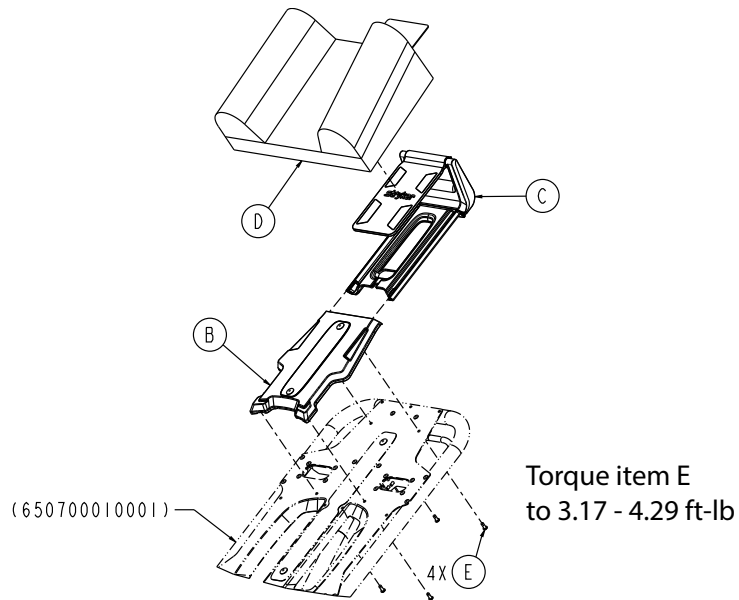

Figure 119 – Head extension option components

8. Reverse steps to install the supplied head extension assembly and pillow (D).
9. Verify proper operation before you return the product to service.
 - a. Extend and retract the head extension assembly. Make sure that the head extension assembly locks in both positions.
 - b. Flip the pillow up and out of the way.

Note

- The head extension pillow is a Type BF applied part.
- Do not use the head section oxygen bottle holder option (650700450054) and Fowler oxygen bottle holder option (650700450053) with the head extension option (650700450045).

Cot wireless configuration

Tools required:

- Wireless Configuration Tool (5212-503-001)
- Microsoft Windows PC running Windows 10 (minimum)
- Wireless router (with Stryker's SSID and security settings loaded) (*Wireless router configuration* (page 93))

Procedure:

1. Plug in the wireless router (Programmed with Stryker's SSID).
2. Connect the PC to the wireless router SSID SYKMedicalInstall.
3. Open the Stryker Wireless Configuration Tool (Figure 120).

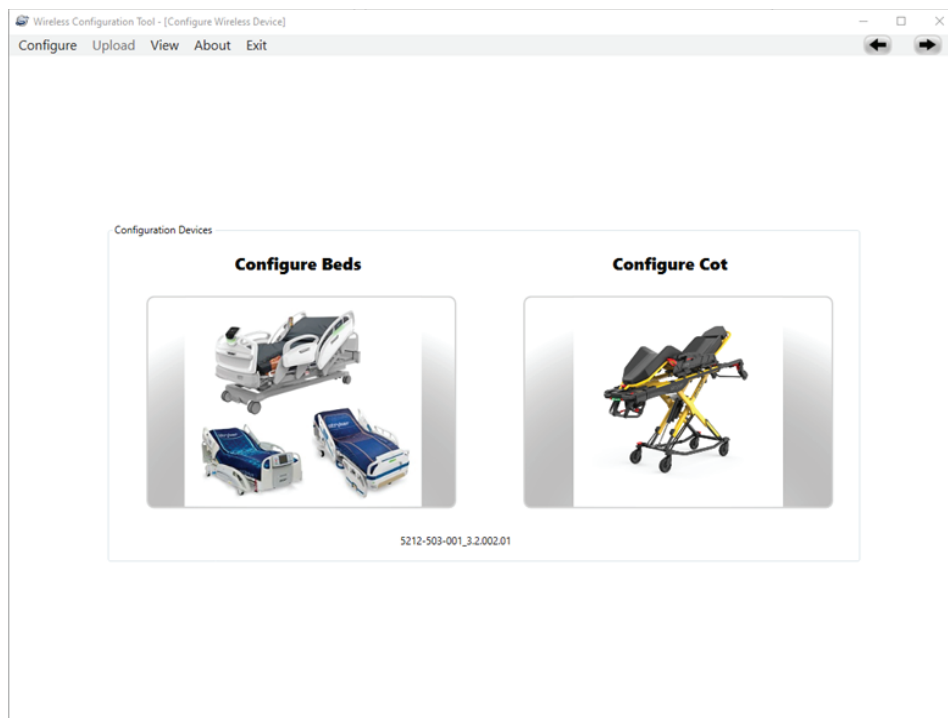

Figure 120 –

4. Click **Configure Cot**.
5. Insert the battery or press a button on the cot to turn the power on. This will power the wireless radio on the cot.
6. Select the Auto Scan box.
7. As the devices start to connect and populate Auto Scan table, select the cot to be activated. The serial number and radio MAC will be listed in the window (Figure 121).

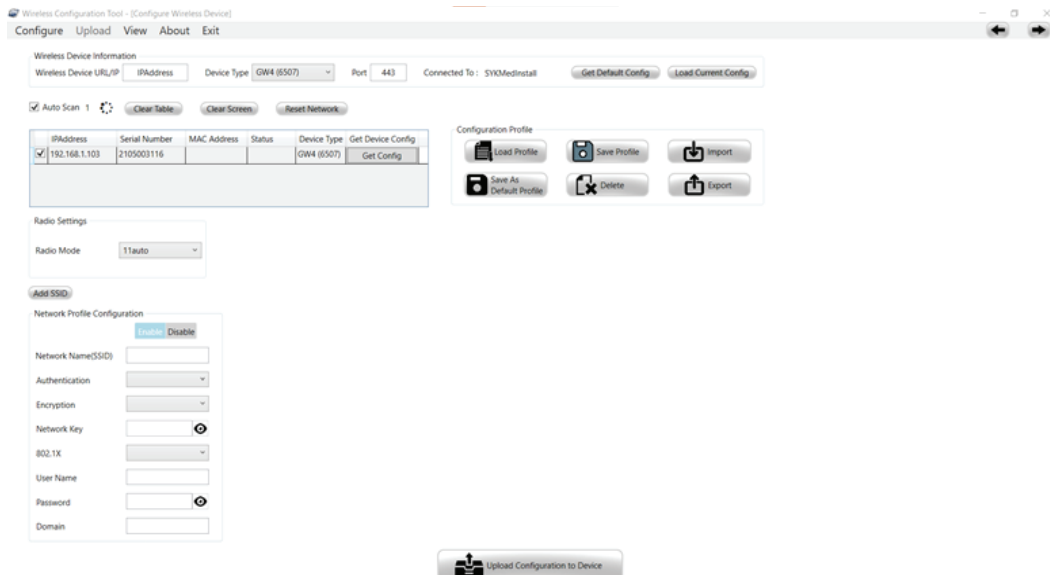

Figure 121 –

8. For the selected device, click **Get Config** in the Auto Scan window and wait for the device info window to pop up (Figure 122).

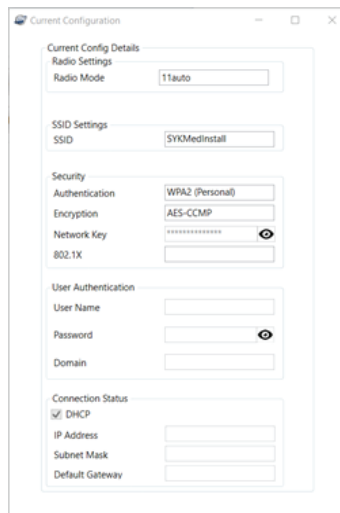

Figure 122 –

9. Close the pop-up window. This is the confirmation of the connection to the cot.

10. In the bottom of the Wireless Configuration Tool window, enter the SSID information for the SSID to be added to the cot (Figure 123).

Note - Click **Add SSID** and enter the next SSID information if more than one SSID is required for the cot to connect to multiple wireless networks. The cot can support up to ten SSIDs.

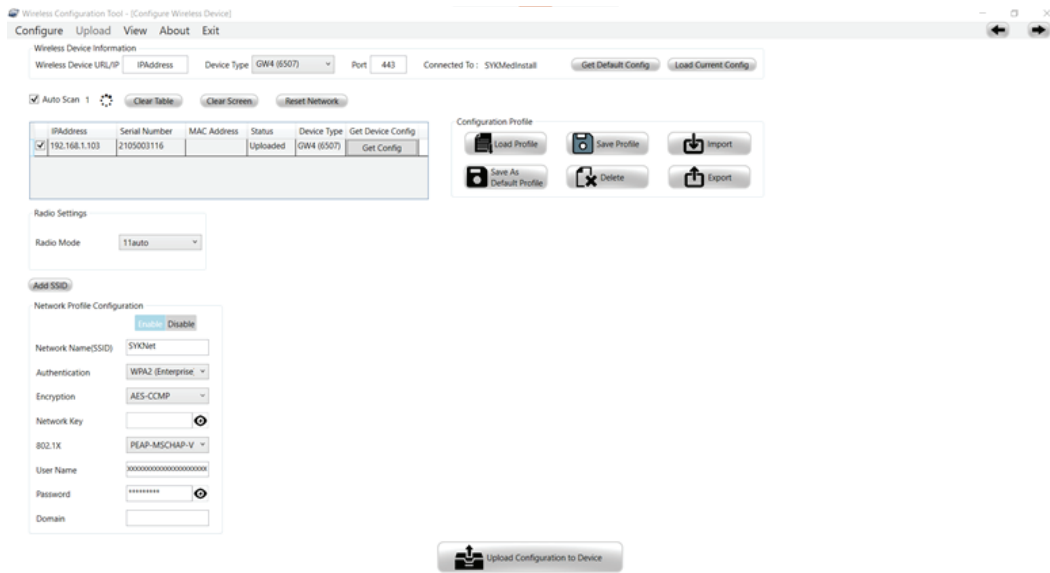

Figure 123 –

11. Click **Upload Configuration to Device** to upload the SSID settings to the cot.

Note - Use this tool to reconnect if any SSIDs need to be added, deleted, or modified. When you receive the Get Device Config pop-up, you will be able to see and edit the programmed SSIDs.

Wireless router configuration

Linksys AC1200 Dual-Band Wi-Fi 5 Router, Model EA6350 (recommended) or any dual-band homestyle (Figure 124):

2.4 GHz network name: syk_med_install

Network password: Stryk3r1#TfWxP

5 GHz network name: SYKMedInstall

Network password: Stryk3r1#TfWxP

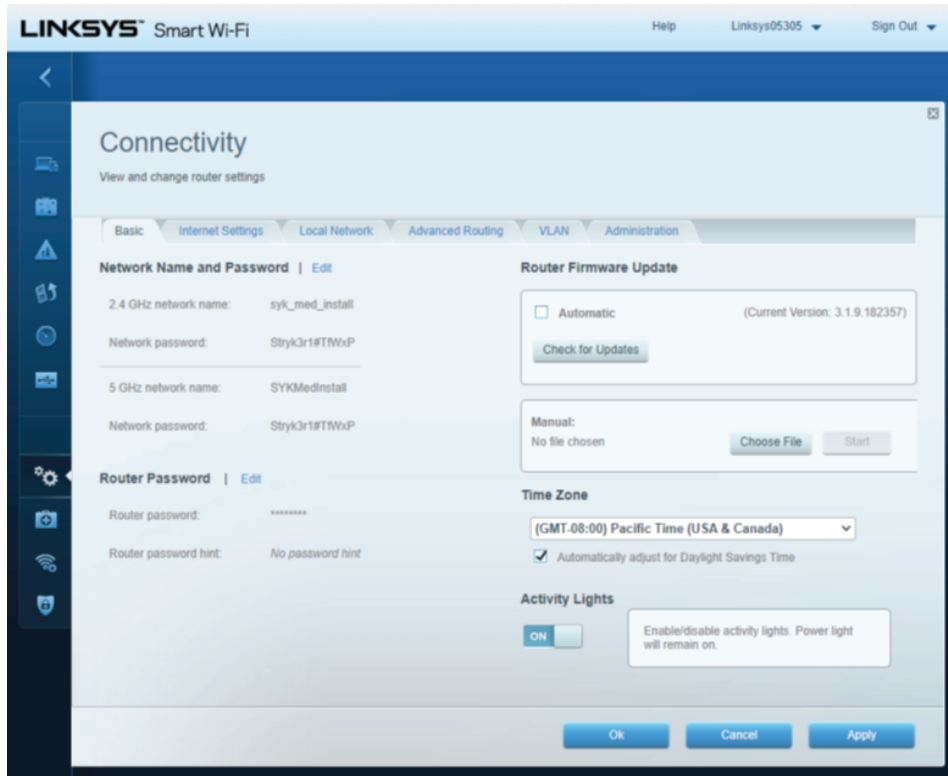
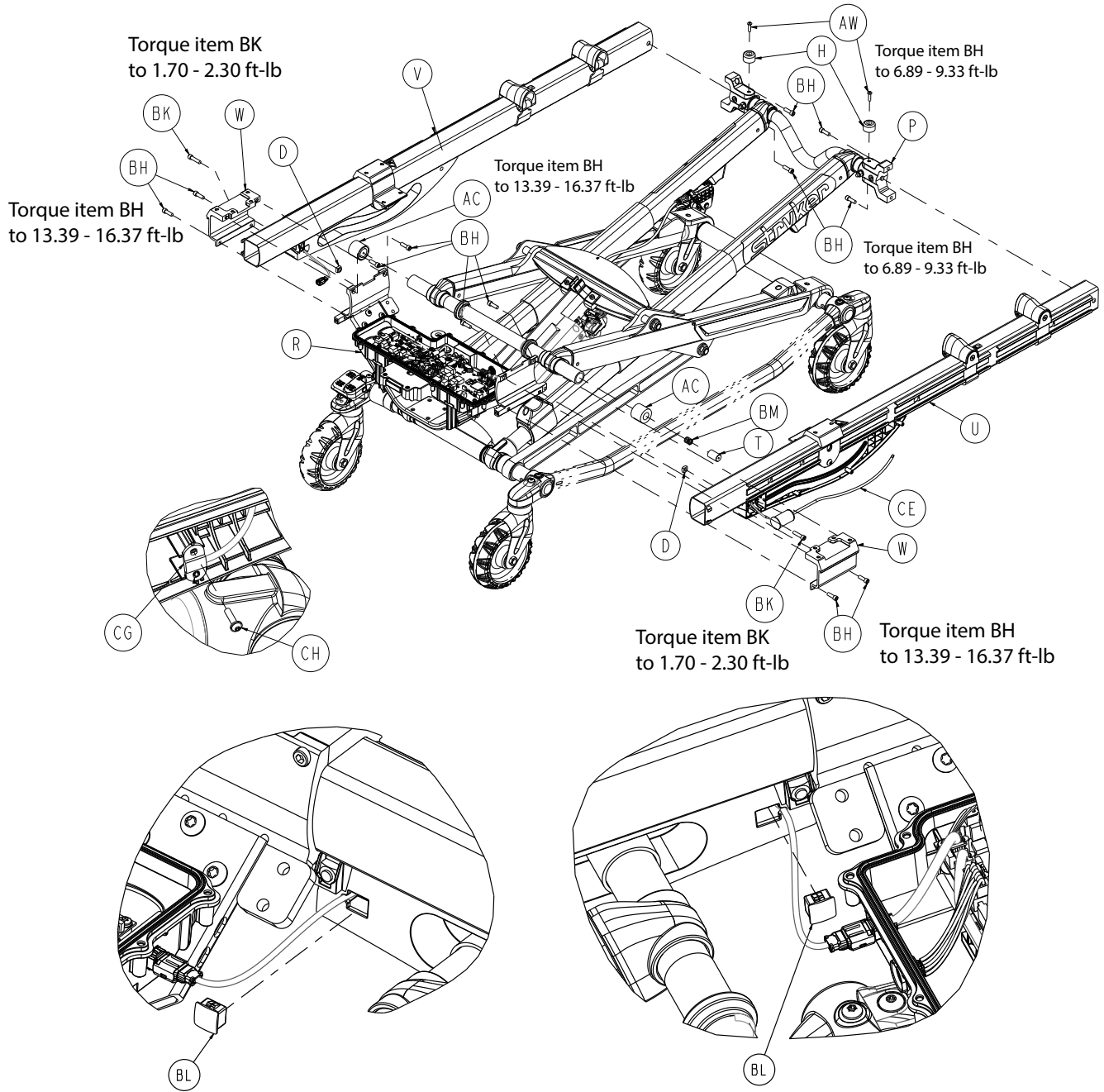

Figure 124 –

Cot assembly, common components

650700010001 Rev AP (Reference only)



Torque item BC
to 1.70 - 2.30 ft-lb

Torque item BF
to 1.70 - 2.30 ft-lb

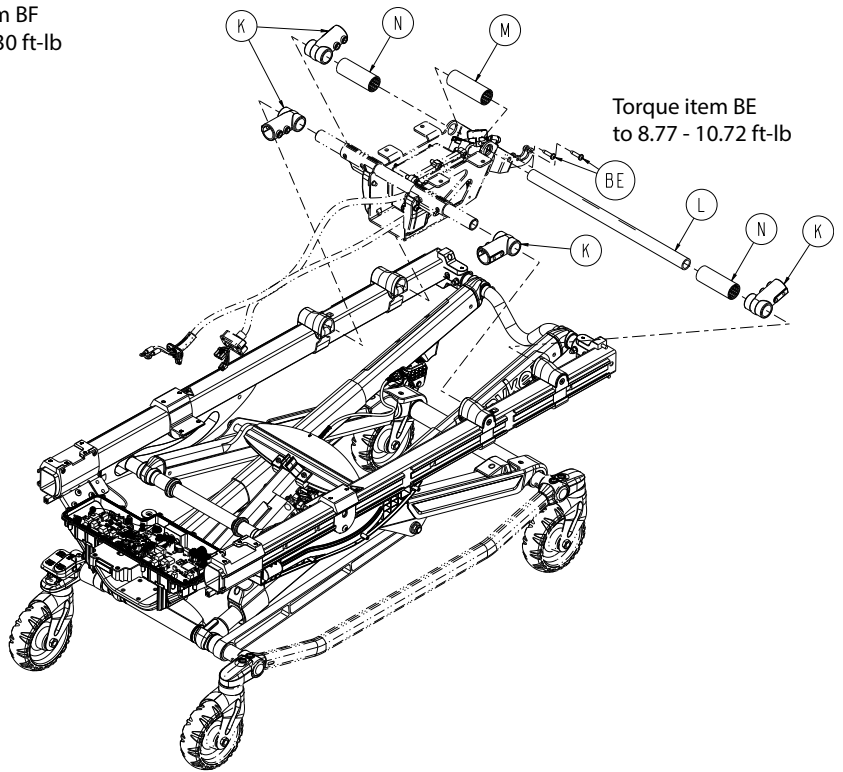
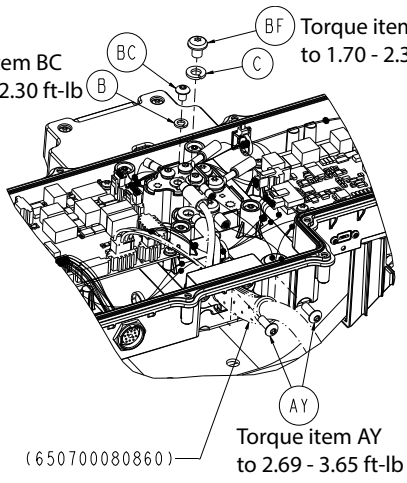

Torque item AV
to 1.28 - 1.73 ft-lb

Torque item A
to 1.28 - 1.73 ft-lb
4X

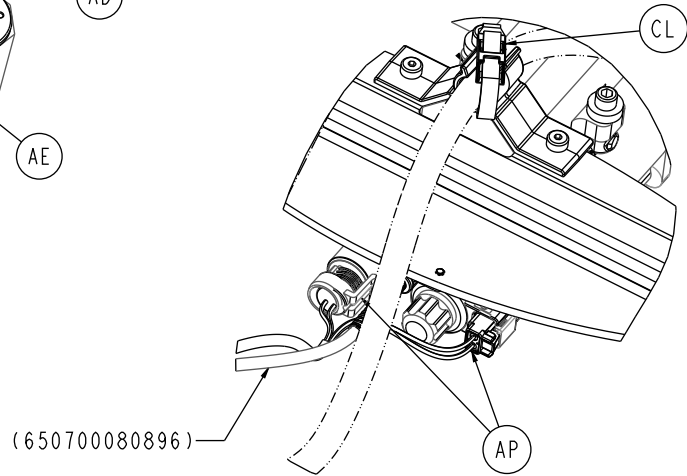
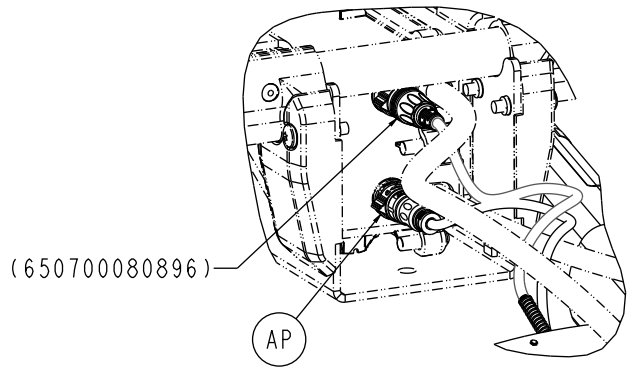
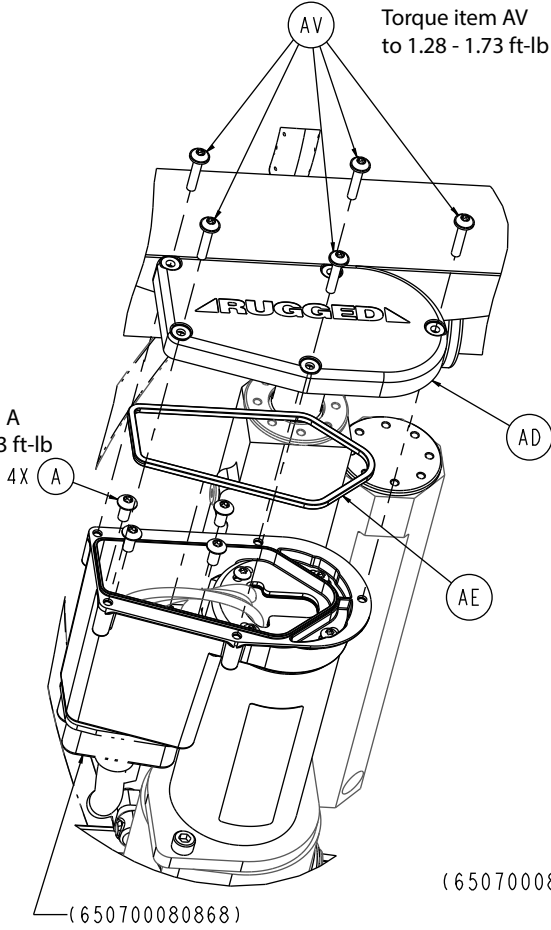

Torque item CD
to 3.91 - 5.29 ft-lb

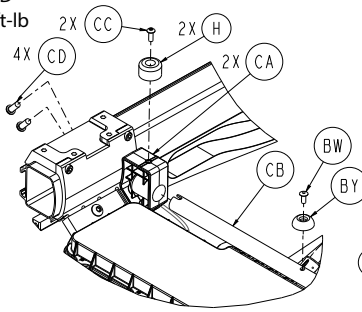

Torque item AV
to 0.95 - 1.16 ft-lb

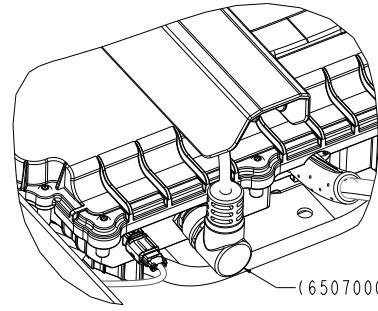
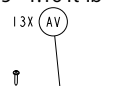

Target torque
of 3 ft-lb

(650700080862)

Torque item BG
to 4.48 - 6.06 ft-lb

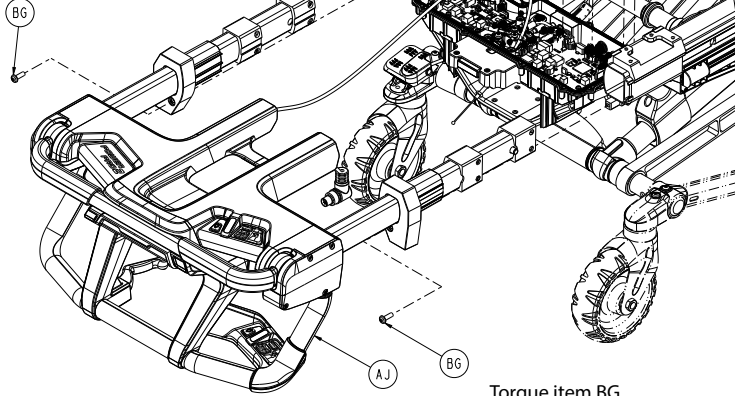

Torque item BG
to 4.48 - 6.06 ft-lb

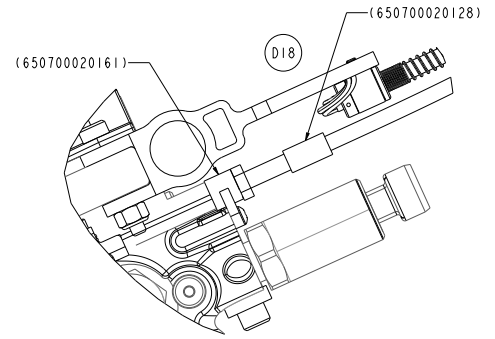

(650700020161)

(650700020128)

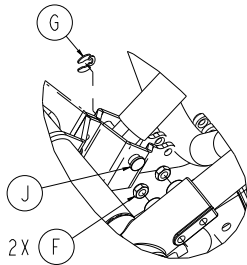

DETAIL A

Torque item BB
to 4.48 - 6.06 ft-lb

Torque item BA
to 3.40 - 4.60 ft-lb

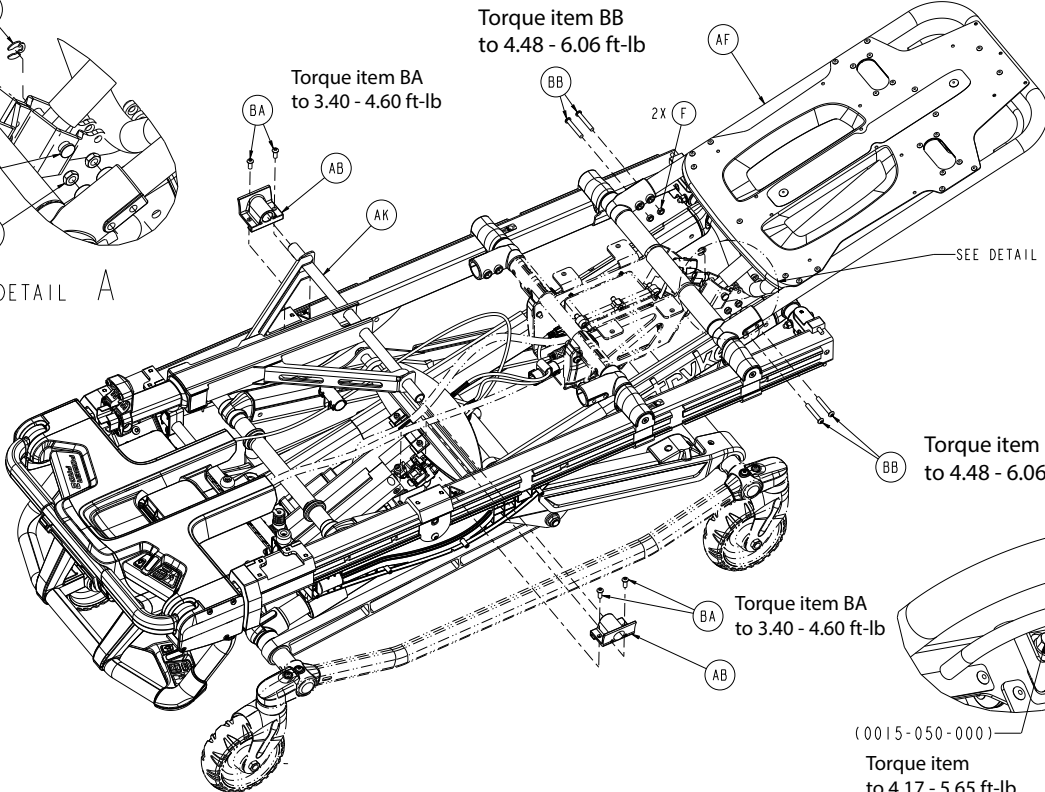

Torque item BB
to 4.48 - 6.06 ft-lb

SEE DETAIL A

Torque item BA
to 3.40 - 4.60 ft-lb

(0015-050-000)
Torque item
to 4.17 - 5.65 ft-lb

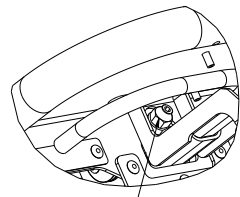

ROUTE 650700080894 AND 650700080889
 UNDERNEATH 650700080868 AND ABOVE
 650700080860

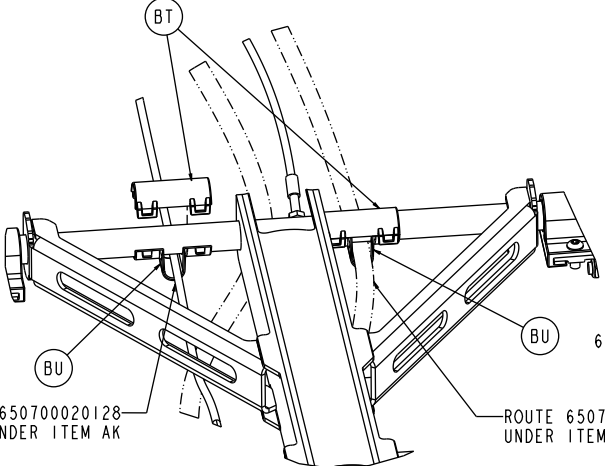
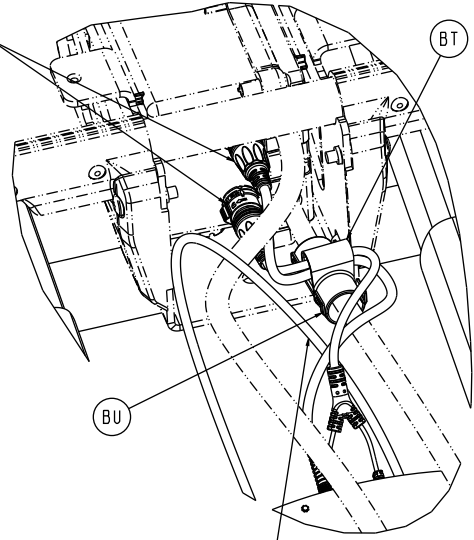

ROUTE 650700020128 BETWEEN
 650700080868 AND 650700080860 /
 650700080894 / 650700080889

ROUTE 650700020128
 UNDER ITEM AK

ROUTE 650700080860
 UNDER ITEM AK

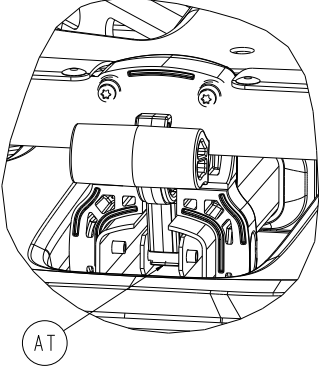

Torque item BD
 to 4.67 - 6.31 ft-lb

Torque item BB
 to 4.48 - 6.06 ft-lb

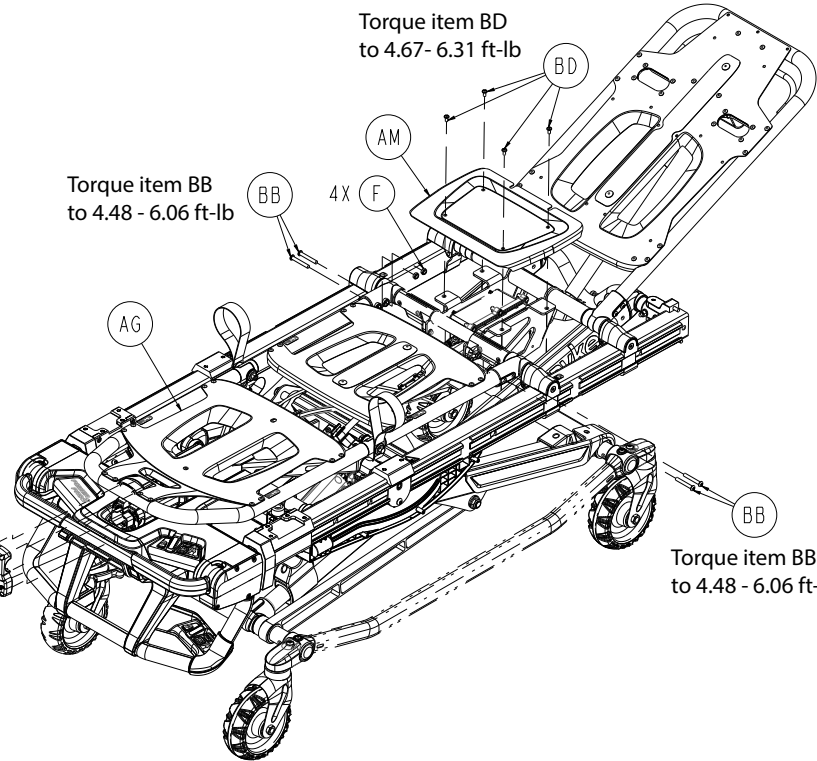

Torque item BB
 to 4.48 - 6.06 ft-lb

Torque item AU
 to 2.69 - 3.65 ft-lb

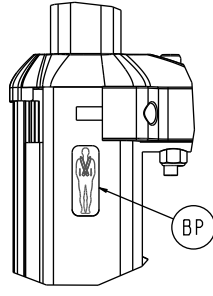
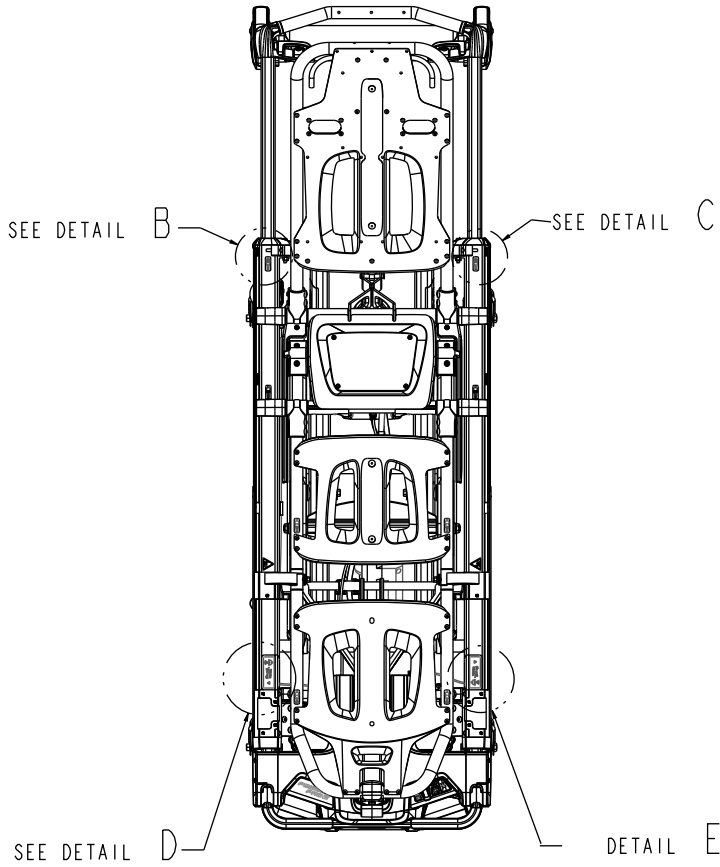
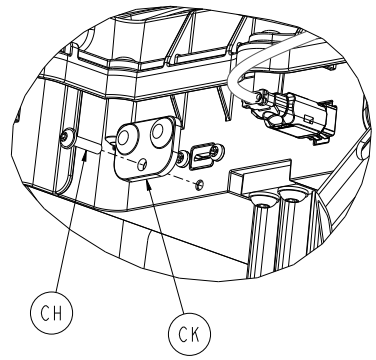
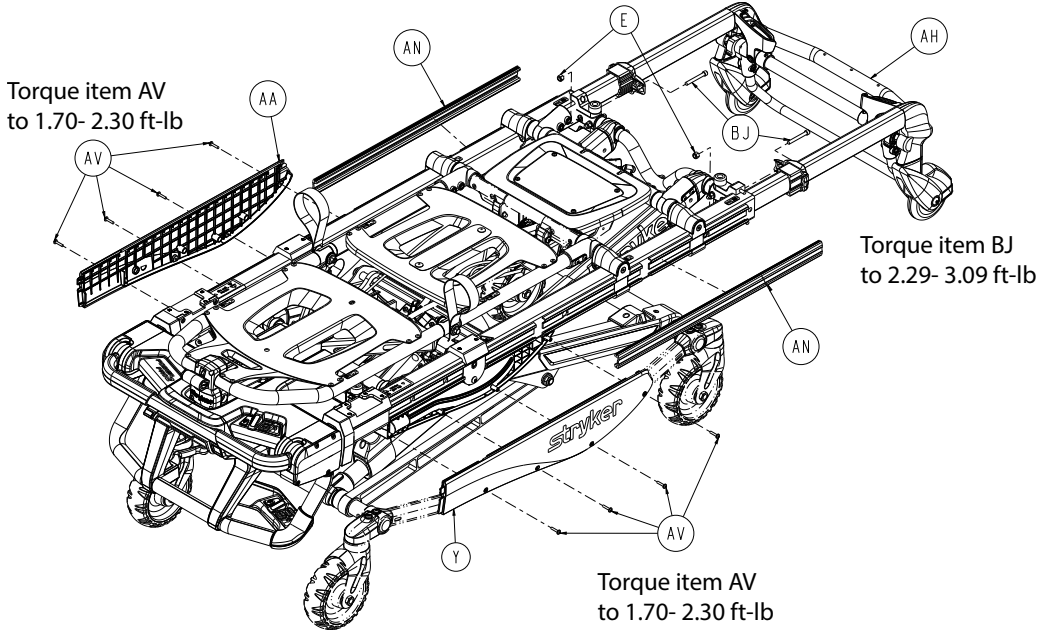

DETAIL B

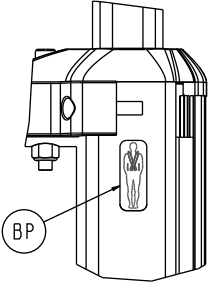

DETAIL C

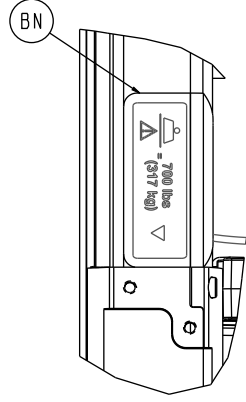

DETAIL D

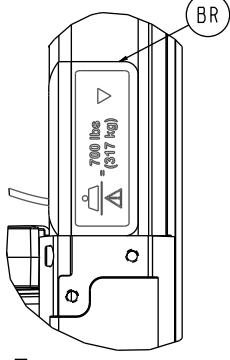

DETAIL E

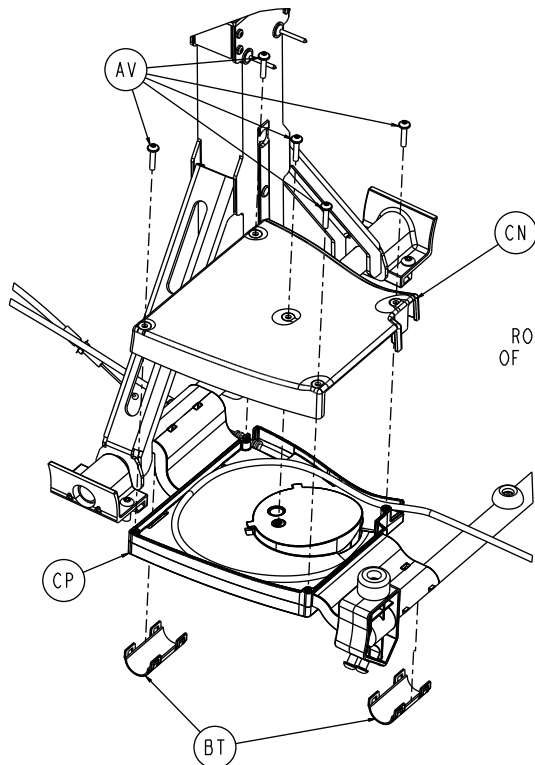

ROUTE ONE GROMMET ON EACH SIDE
OF 650700080251 AND 650700080252

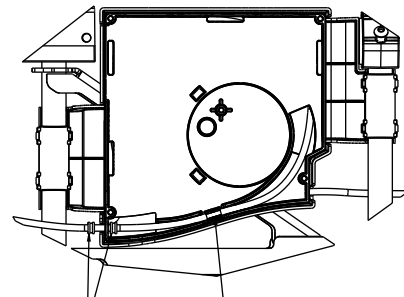

ROUTE 650700020228 INTO
SNAPS OF 650700080252

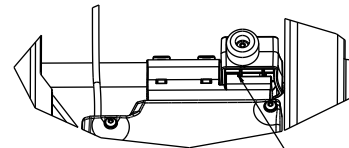

LOCK TAB OF 650700080252
INTO 650700020129

Item	Number	Name	Quantity
A	0004-442-000	Button head torx screw	4
B	0012-005-000	Lock washer	1
C	0012-012-000	Lock washer	1
D	0015-096-000	Square nut	2
E	0016-028-000	Fiberlock hex nut	2
F	0016-102-000	Nylock nut	8
G	0028-181-000	Truarc ring	1
H	0056-028-000	Bumper, black TPR	4
J	6085-101-143	Fowler cylinder pin	1
K	6100-003-125	Straight T pivot	4
L	6500-001-105	Litter support cross tube	1
M	6500-001-249	Spacer, litter, outside	1
N	6500-001-250	Spacer, litter, inside	2
P	650700010002	Lift assembly (page 109)	1
R	650700020001	Hitch bracket assembly, foot end (page 134)	1
T	650700020002	Slider magnet assembly	1
U	650700020012	Outer rail assembly, left (page 130)	1
V	650700020013	Outer rail assembly, right (page 132)	1
W	650700020137	Hitch bracket o-clamp	2
Y	650700020142	Slider block cover, left	1
AA	650700020143	Slider block cover, right	1
AB	650700020146	Gatch cross tube housing	2
AC	650700020248	Slider roller	2
AD	650700020192	Actuator end cap	1
AE	650700020196	Actuator end cap seal	1

Item	Number	Name	Quantity
AF	650700080002	<i>Fowler assembly</i> (page 179)	1
AG	650700080006	<i>Gatch assembly</i> (page 184)	1
AH	650700080007	<i>Head section assembly</i> (page 172)	1
AJ	650700080008	<i>Foot section assembly</i> (page 162)	1
AK	650700080011	<i>Gatch support assembly</i> (page 186)	1
AL	650700080113	FEIB enclosure, top	1
AM	650700080172	Seat skin	1
AN	650700080188	Outer rail bumper	2
AP	650700080894	Solenoid/transducer external cable assembly	1
AR	6550-001-124	Gatch release, front	1
AT	6550-001-126	Gatch release lever	1
AU	700000687300	Pan head thread forming screw	4
AV	700000687745	Round washer head tapping screw	31
AW	700000689468	Button head cap screw	2
AY	700000689483	Button head cap screw	2
BA	700000689546	Button head cap screw	4
BB	700000689592	Button head cap screw	8
BC	700000715613	Button head cap screw	1
BD	700000717902	Pan head thread rolling screw	4
BE	700001726578	Pan head thread rolling screw	2
BF	700000719304	Pan head machine screw	1
BG	700000719305	Pan head machine screw	2
BH	700000721221	Socket head cap screw	12
BJ	700000721224	Socket head cap screw	2
BK	700000740914	Socket head cap screw	2
BL	700000765285	Rectangular hole plug	2
BM	700000770647	Compression wire	1
BN	650700010906	Label, weight capacity, right	1
BP	650700010909	Label, restraint, frame, shoulder	2
BT	650700080218	Cable clip, top	4
BU	650700080219	Cable clip, bottom	2
BV	650700080301	<i>Battery assembly</i> (page 203)	1
BW	0025-079-000	Dome head pop rivet	1
BY	0946-001-155	Bumper	1
CA	650700020129	Gatch bumper housing	2
CB	650700020131	Gatch bumper tube	1
CC	700000689499	Button head cap screw	2
CD	700001315681	Button head cap screw	4
CE	650700020198	MTS sensor assembly	1
CG	650700080875	Cable assembly, in-ambulance sensor internal	1
CH	700000687744	Round washer head tapping screw	2
CK	650700080208	FEIB USB cover	1
CL	0059-211-000	Nylon cable tie	1
CM	6507-009-030	Extension limiter kit memo (not shown)	1

Item	Number	Name	Quantity
CN	650700080251	Mini loop, top	1
CP	650700080252	Mini loop, bottom	1

Power-LOAD fastener

650709990104 Rev AC (Reference only)

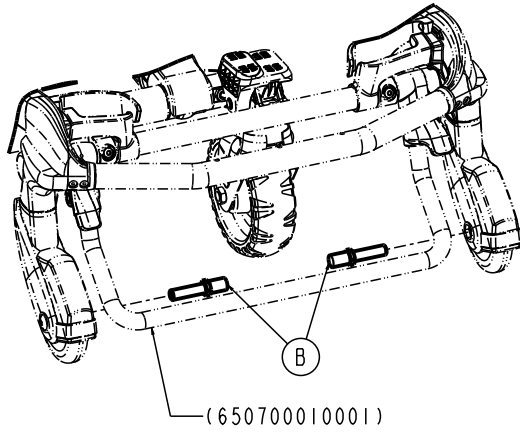

Torque item J
to 1.77 - 2.39 ft-lb

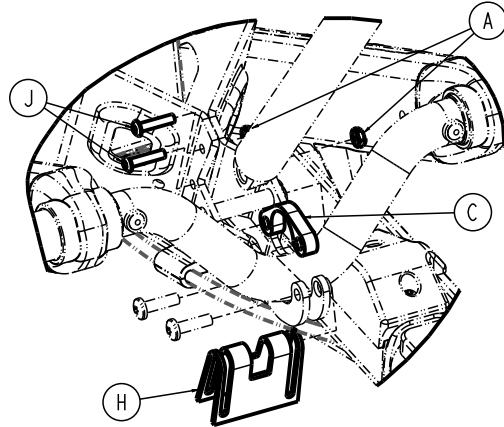

Torque item L
to 13.61 - 16.63 ft-lb

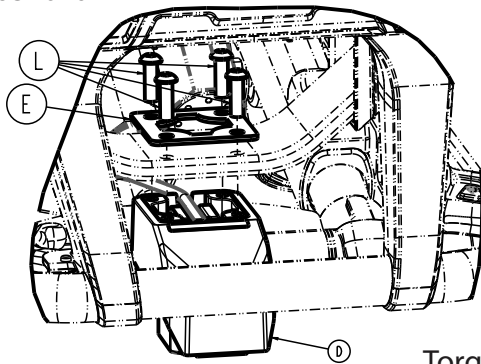

Torque item K
to 3.40 - 4.60 ft-lb

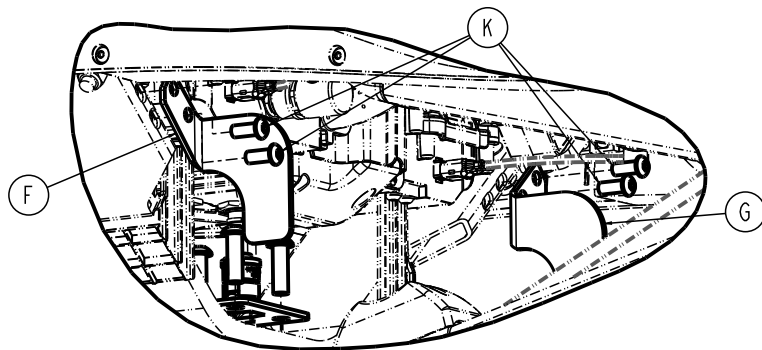
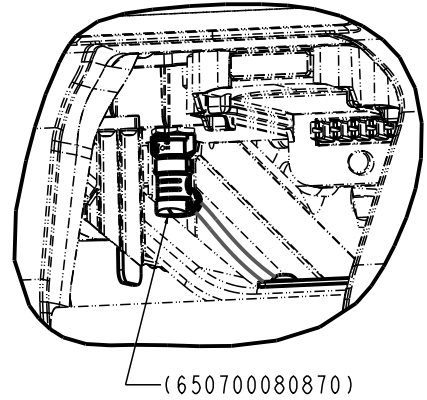

Item	Number	Name	Quantity
A	0016-131-000	Nylock hex nut	2
B	6500-002-104	Load wheel pin	2
C	6500-002-195	Collar	1
D	650700020011	Hitch assembly, foot end (page 136)	1

Item	Number	Name	Quantity
E	650700020136	Hitch bracket plate	1
F	650700020187	Foot end hitch bracket hook, left	1
G	650700020188	Foot end hitch bracket hook, right	1
H	650700080189	Gas spring spacer	1
J	700000715614	Button head cap screw	2
K	700000689546	Button head cap screw	4
L	700000715617	Button head cap screw	4

Performance-LOAD fastener

650709990105 Rev AC (Reference only)

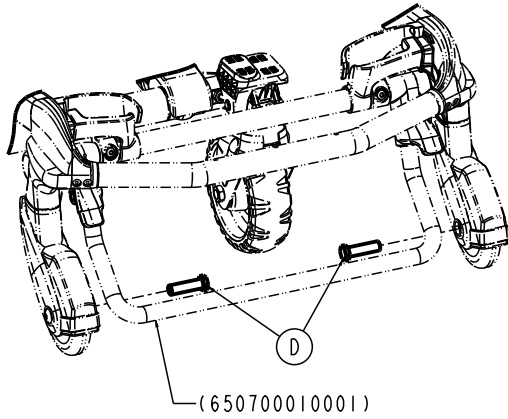

Torque item L
to 1.77 - 2.39 ft-lb

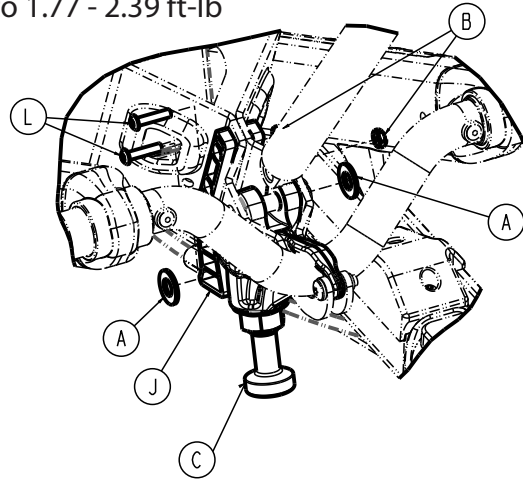

Torque item M
to 13.61 - 16.63 ft-lb

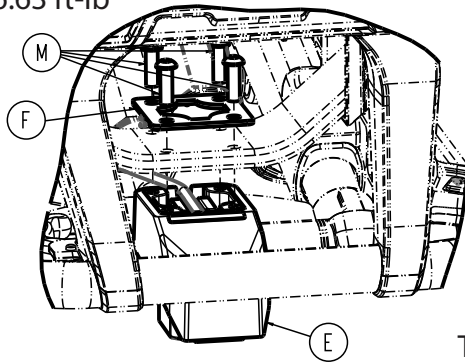

Torque item K
to 3.40 - 4.60 ft-lb

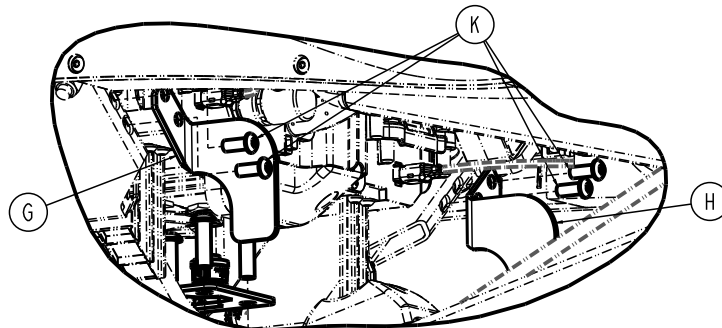
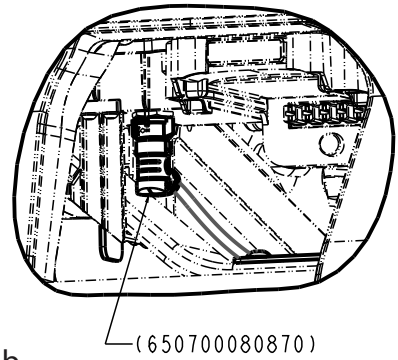

Item	Number	Name	Quantity
A	0011-004-000	Flat washer	2
B	0016-131-000	Nylock hex nut	2
C	6392-001-062	Head end forging assembly	1

Item	Number	Name	Quantity
D	6500-002-106	Load wheel fastener	2
E	650700020011	<i>Hitch assembly, foot end (page 136)</i>	1
F	650700020136	Hitch bracket plate	1
G	650700020187	Foot end hitch bracket hook, left	1
H	650700020188	Foot end hitch bracket hook, right	1
J	650700080192	Head end pin stop	1
K	700000689546	Button head cap screw	4
L	700000715614	Button head cap screw	2
M	700000715617	Button head cap screw	4

Power-LOAD and Performance-LOAD fastener

650709990106 Rev AB (Reference only)

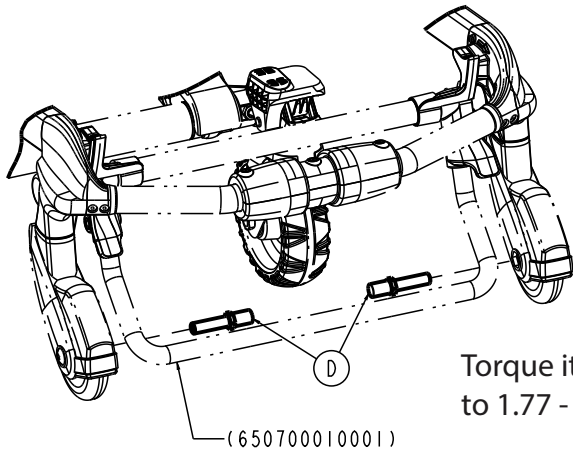

Torque item L
to 1.77 - 2.39 ft-lb

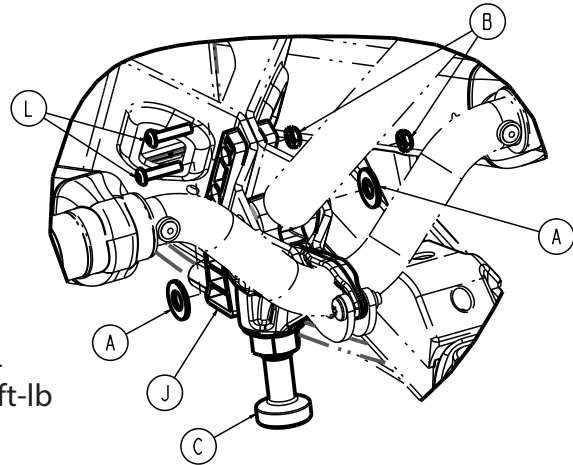

Torque item M
to 13.61 - 16.63 ft-lb

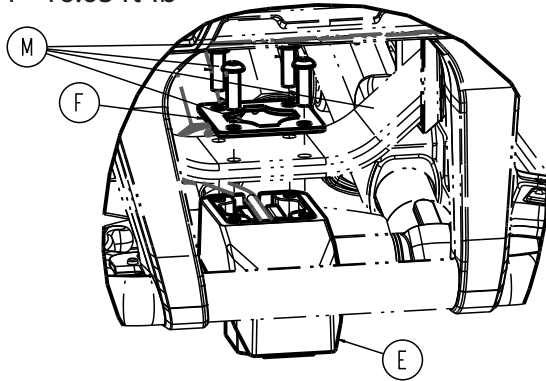

Torque item K
to 3.40 - 4.60 ft-lb

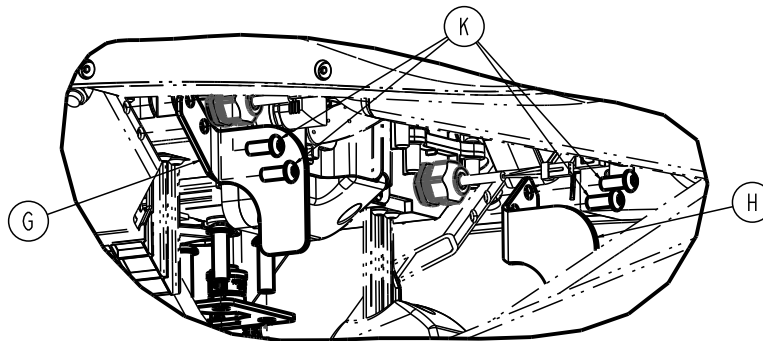
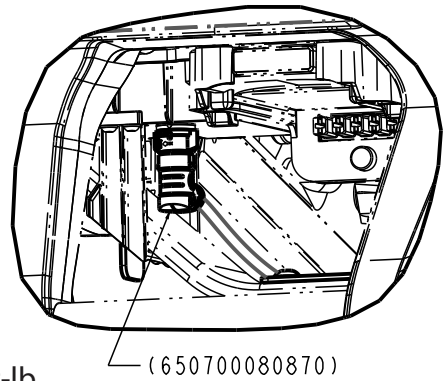

Item	Number	Name	Quantity
A	0011-004-000	Flat washer	2
B	0016-131-000	Nylock hex nut	2
C	6392-001-062	Head end forging assembly	1
D	6500-002-104	Load wheel pin	2
E	650700020011	Hitch assembly, foot end (page 136)	1
F	650700020136	Hitch bracket plate	1
G	650700020187	Foot end hitch bracket hook, left	1
H	650700020188	Foot end hitch bracket hook, right	1

Item	Number	Name	Quantity
J	650700080192	Head end pin stop	1
K	700000689546	Button head cap screw	4
L	700000715614	Button head cap screw	2
M	700000715617	Button head cap screw	4

Lift assembly

650700010002 Rev AG (Reference only)

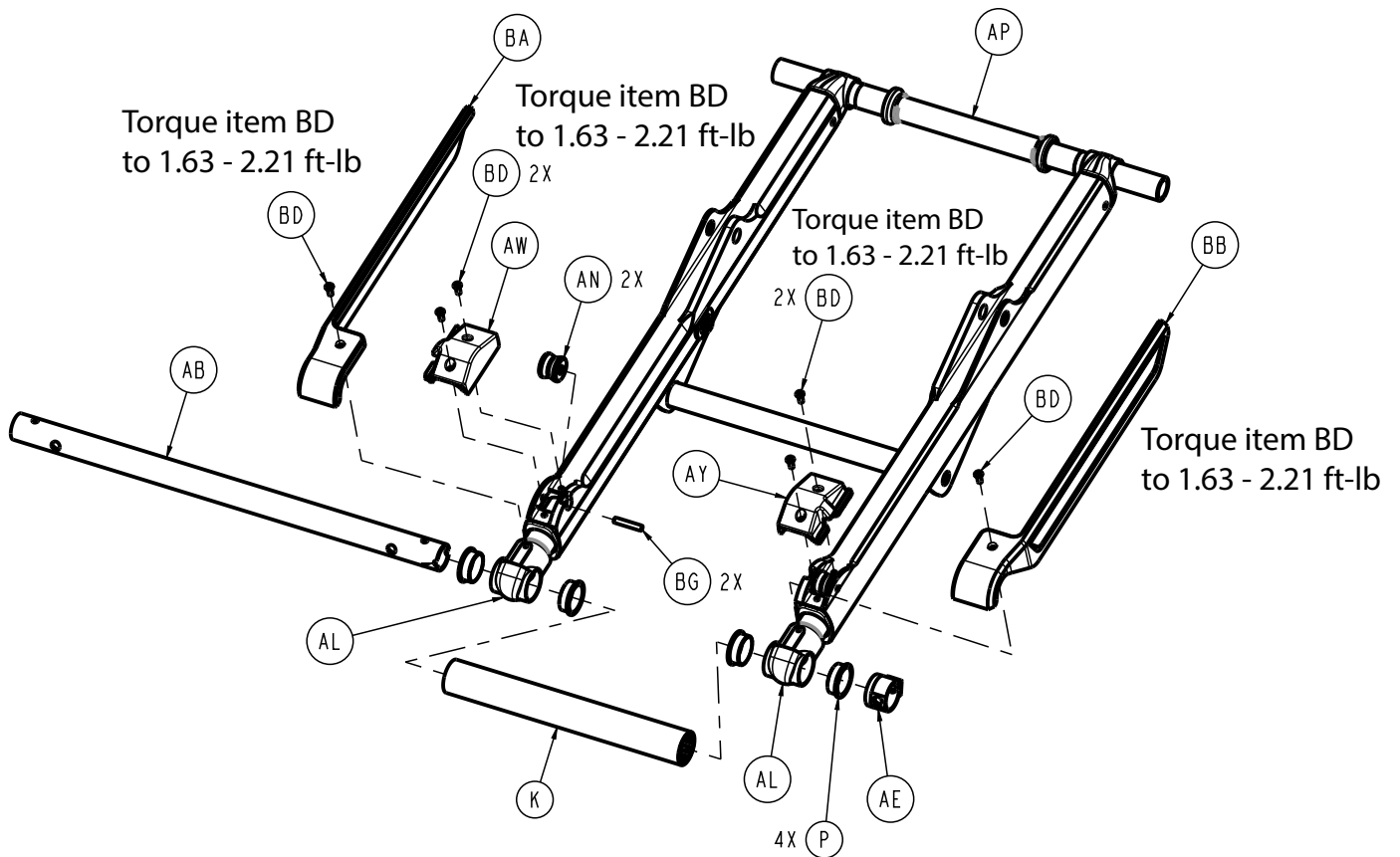
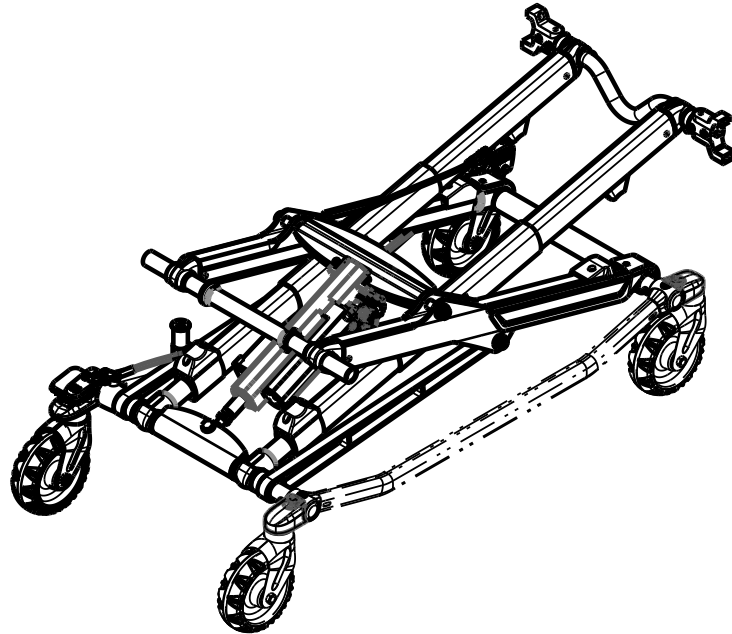

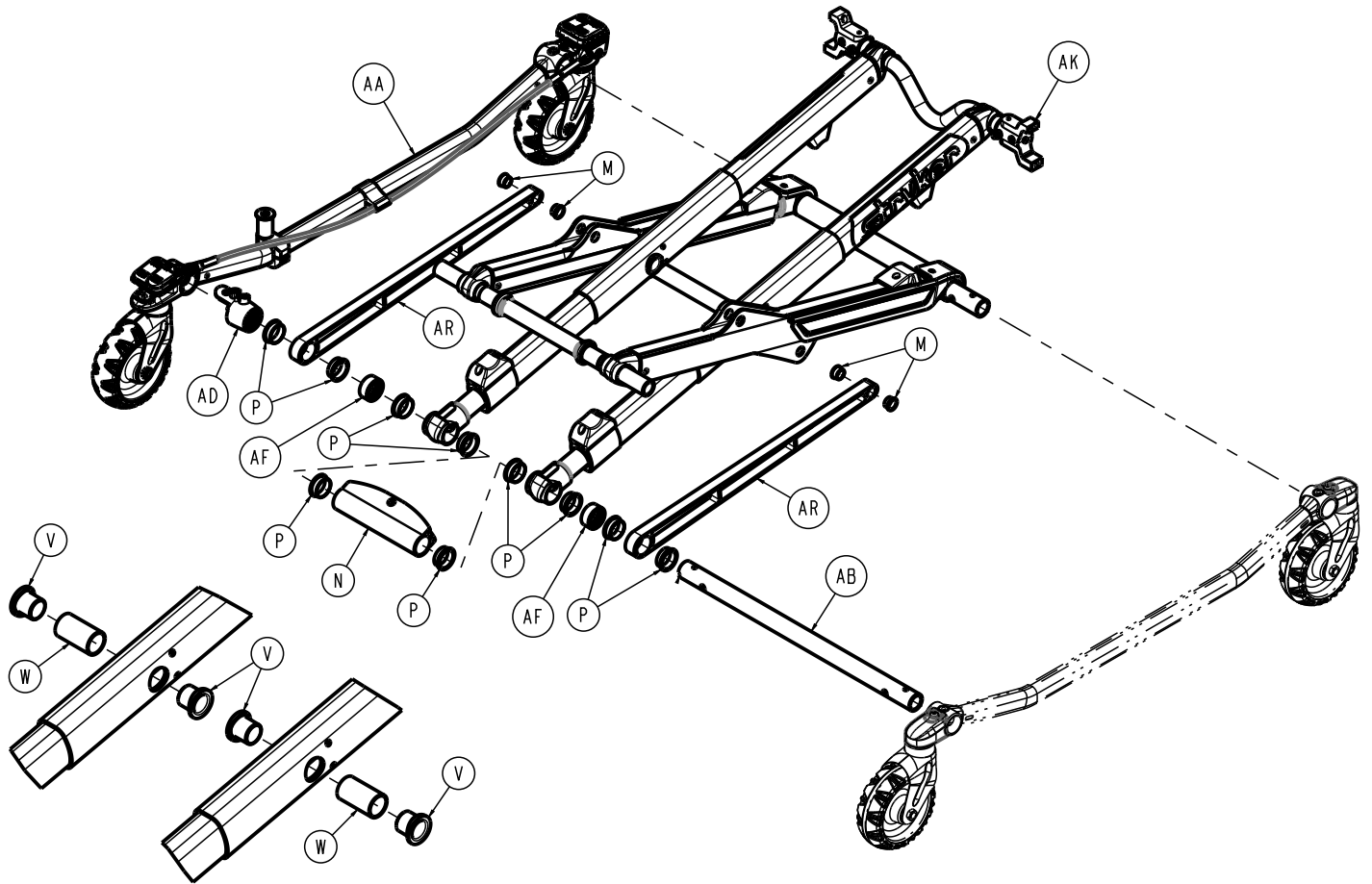

Torque item BE
to 6.54 - 8.84 ft-lb

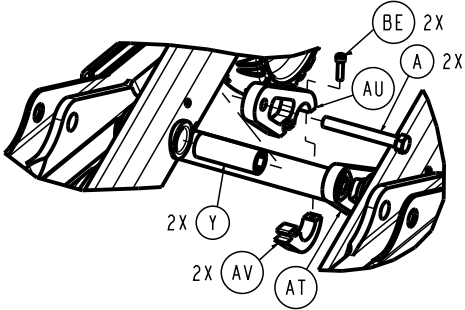

Torque item F (2x)
to 13.09 - 17.71 ft-lb

Torque item A
to 15.12 - 20.46 ft-lb

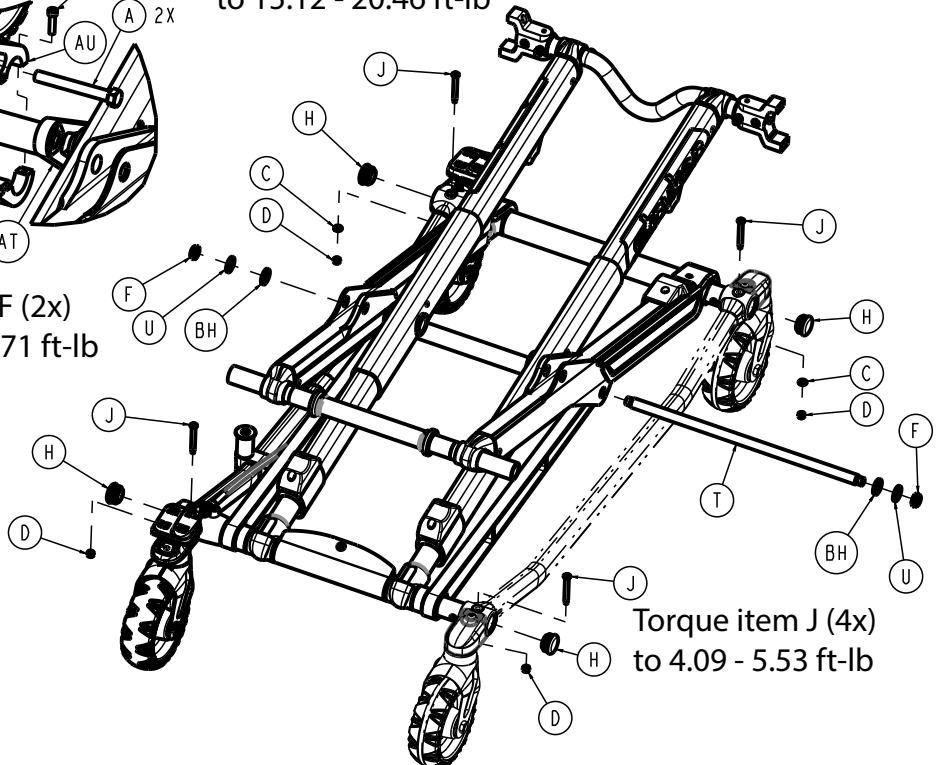

Torque item J (4x)
to 4.09 - 5.53 ft-lb

Torque item F (2x)
to 13.09 - 17.71 ft-lb

Torque item R
to 9.61 - 13.00 ft-lb

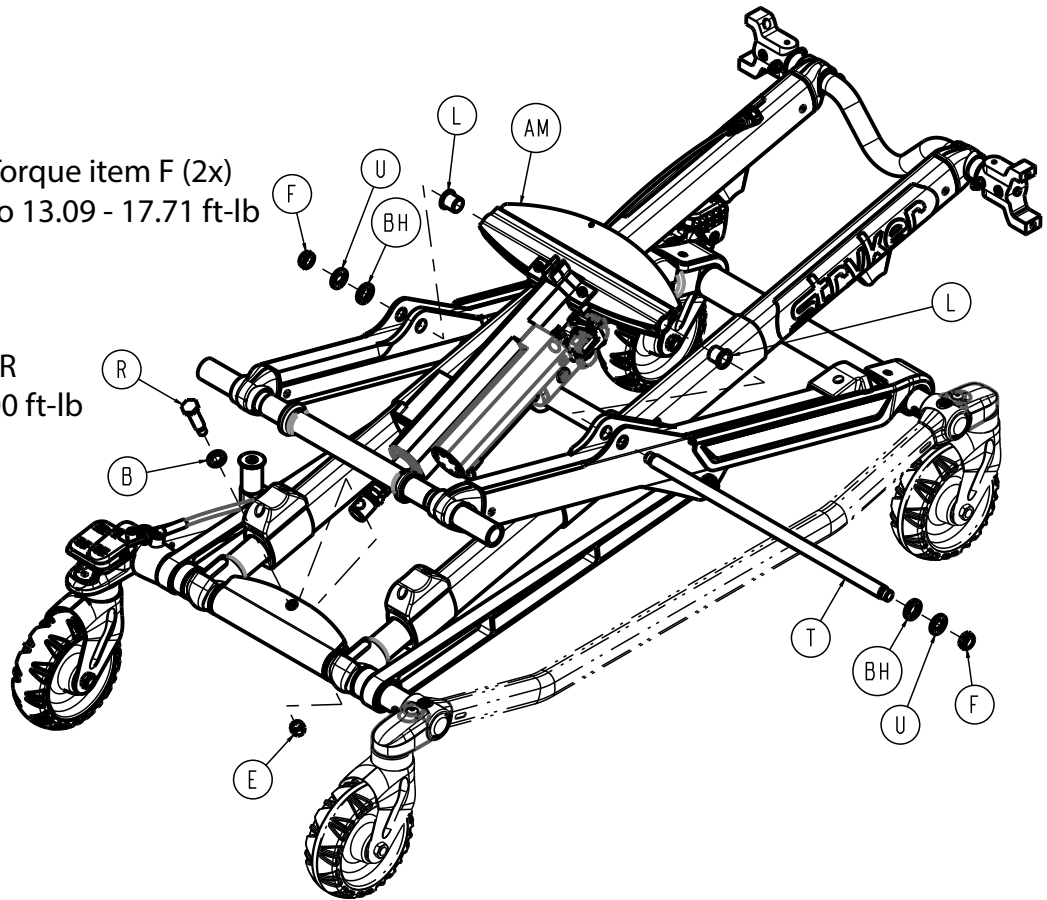

Torque item G
to 6.38 - 8.63 ft-lb

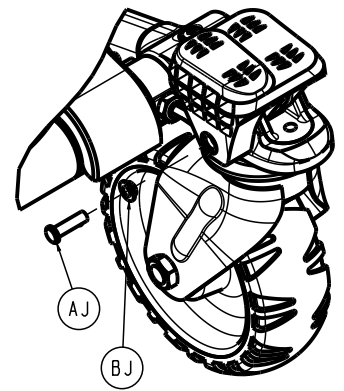
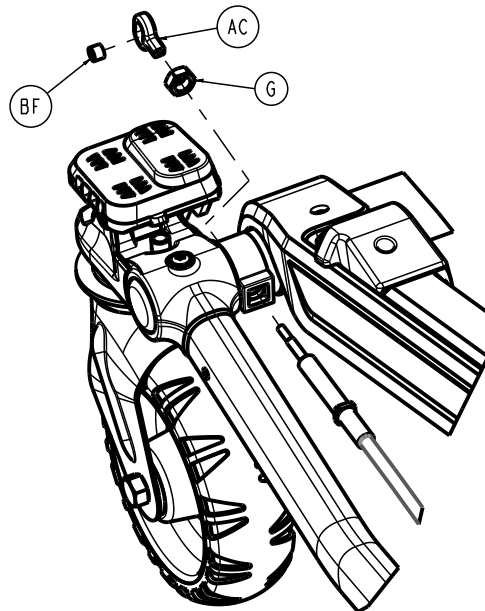
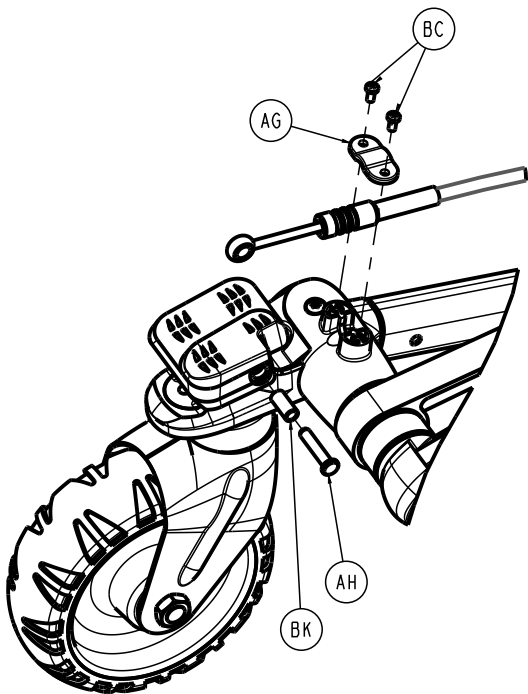

Item	Number	Name	Quantity
A	0003-388-000	Hex head cap screw	2
B	0011-013-000	Flat washer	1
C	0014-002-000	Washer	2
D	0016-002-000	Fiberlock nut	4
E	0016-035-000	Nylock hex nut	1
F	0016-049-000	Nylock hex nut	4
G	0016-089-000	Centerlock hex nut	1
H	0037-083-000	Tube plug	4
J	6085-001-097	Caster mount bolt	4
K	6500-001-129	Plastic extrusion - spacer	1
L	6500-001-157	Flange bearing	2
M	6500-001-162	Flange bearing	4
N	6500-001-165	Cylinder mount, pivot, bottom	1
P	6500-001-166	Flange bearing	14
R	6500-001-168	Rod attachment pin	1
T	6500-001-182	Stiffener bar cross tube	2
U	6500-001-225	D washer	4
V	6500-001-226	Bearing, pivot, base tube	4
W	6500-001-227	Post, pivot, base tube	2
Y	6500-001-341	Post, pivot, base tube	2
AA	650700010003	<i>Lock base assembly, right (page 117)</i>	1
AB	650700010104	Base cross tube, head end	2
AC	650700010117	Slotted eye end	1
AD	650700010123	Brake cable mount, foot end, right	1
AE	650700010124	Brake cable mount, head end	1
AF	650700010131	Base spacer, small	2
AG	650700010138	Brake cable mount cover	1
AH	650700010146	Slic pin	1
AJ	650700010147	Slic pin	1
AK	650700020003	<i>Inner lift legs assembly (page 123)</i>	1
AL	650700020006	<i>Base leg assembly, head end (page 126)</i>	2
AM	650700020007	<i>Actuator lift assembly (page 127)</i>	1
AN	650700020009	External roller assembly	2
AP	650700020105	Outer lift A-frame weldment	1
AR	650700020113	Timing link	2
AT	650700020116	Pivot support, left	1
AU	650700020117	Pivot support, right	1
AV	650700020118	Pivot support, base	2
AW	650700020121	Roller cover, head end, left	1
AY	650700020122	Roller cover, head end, right	1
BA	650700020018	Base leg guard, left	1
BB	650700020019	Base leg guard, right	1
BC	700000687304	Pan head tapping screw	2
BD	700000689499	Button head cap screw	6
BE	700000721218	Socket head cap screw	2

Item	Number	Name	Quantity
BF	70000738011	Bearing, sleeve	1
BG	700001174627	Dowel pin	2
BH	70000757370	Washer	4
BJ	70000828751	Bearing, flange	1
BK	700001288868	Bearing, sleeve	1

Two wheel lock option - 650709990109

Rev AB (Reference only)

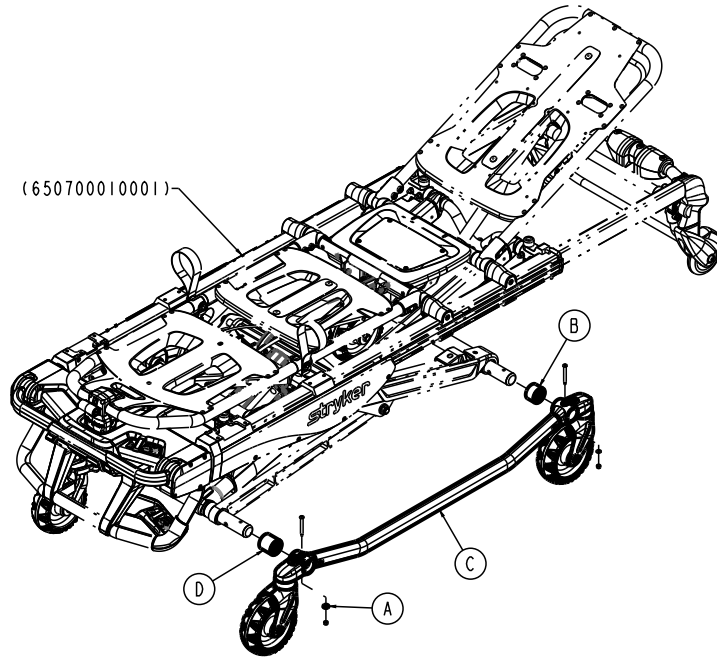

Item	Number	Name	Quantity
A	0014-002-000	Washer	1
B	6500-001-178	Plastic extrusion - spacer	1
C	650700010004	Non-lock base assembly, left (page 122)	1
D	650700010129	Base spacer, large	1

Four wheel lock option - 650709990110

Rev AD (Reference only)

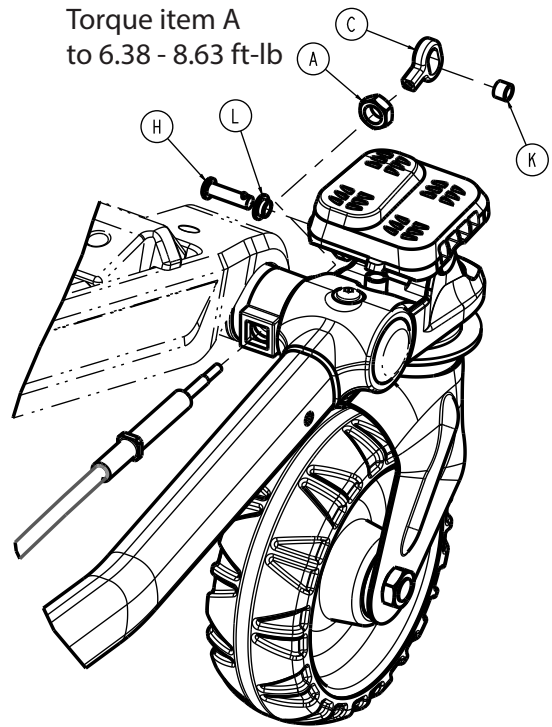
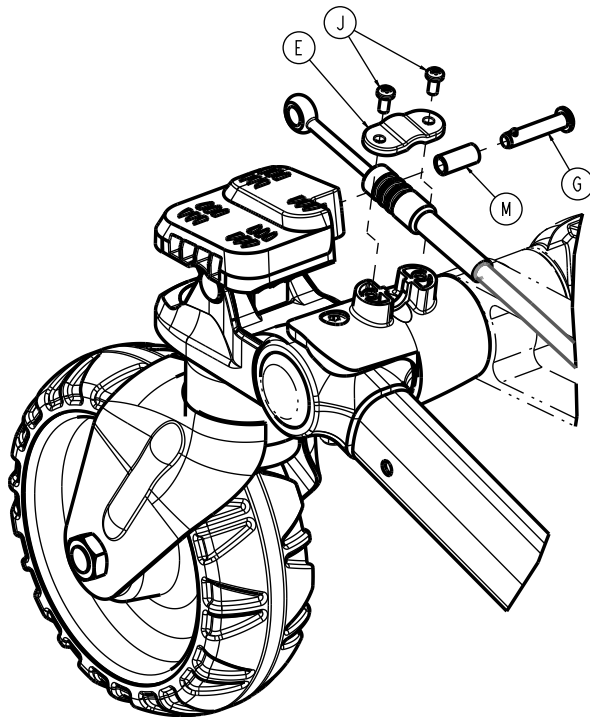
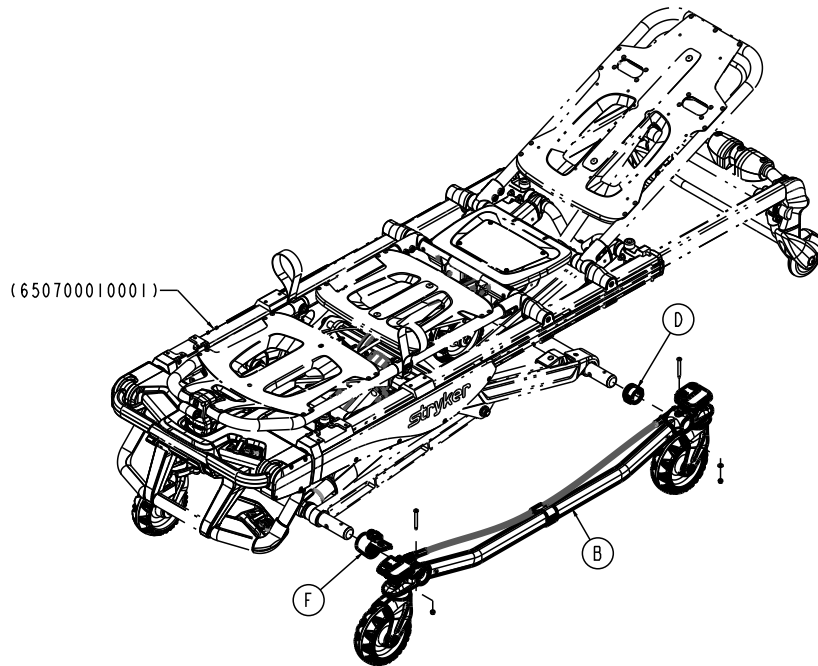

Item	Number	Name	Quantity
A	0016-089-000	Centerlock hex nut	1
B	650700010006	Lock base assembly, left (page 119)	1
C	650700010117	Slotted eye end	1
D	650700010124	Brake cable mount, head end, left	1
E	650700010138	Brake cable mount, cover	1
F	650700010143	Brake cable mount, foot end, left	1

Item	Number	Name	Quantity
G	650700010146	Slic pin	1
H	650700010147	Slic pin	1
J	700000687304	Pan head tapping screw	2
K	700000738011	Bearing, sleeve	1
L	700000828751	Bearing, flange	1
M	700001288868	Bearing, sleeve	1

Lock base assembly, right

650700010003 Rev AG (Reference only)

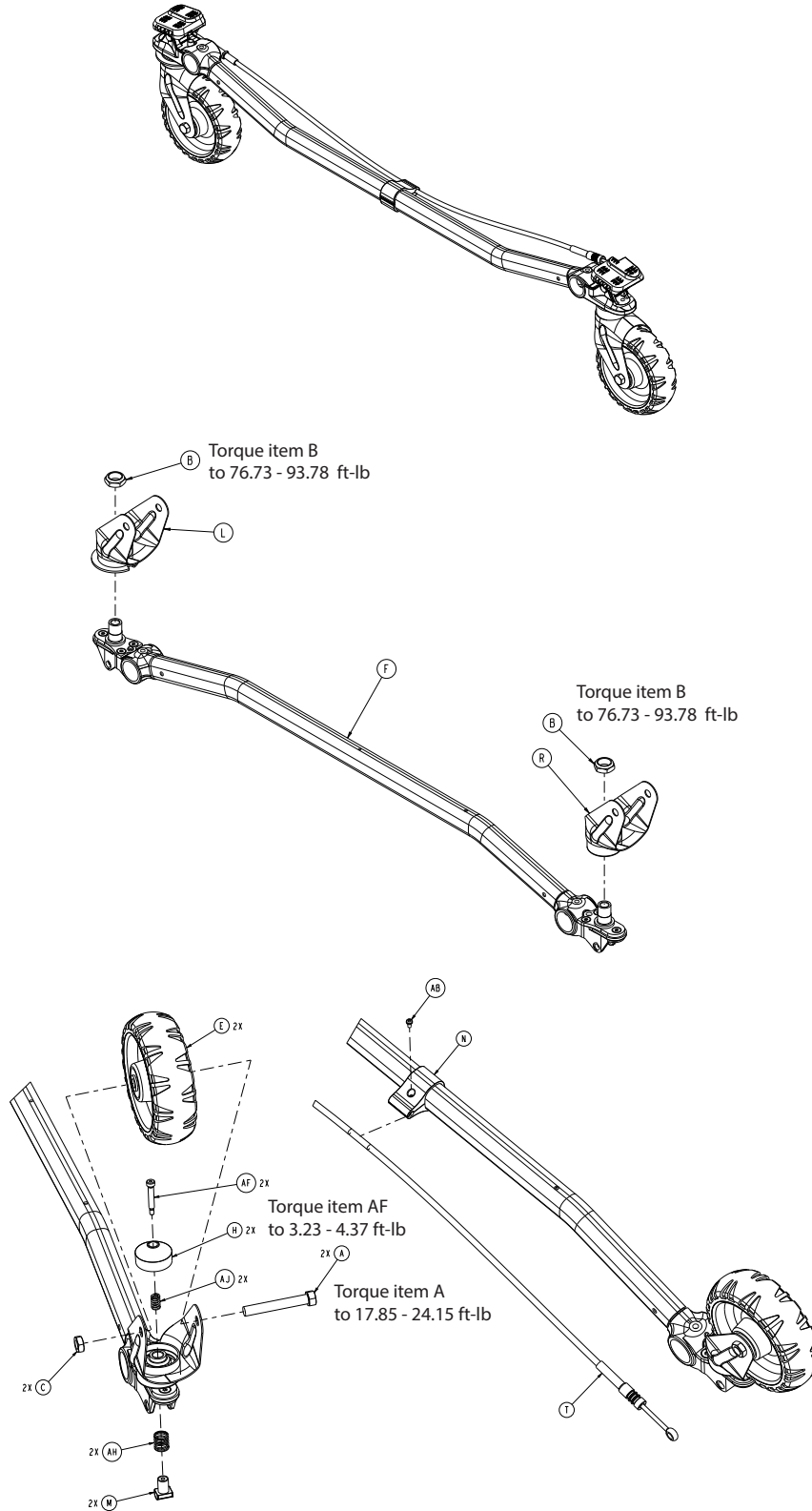

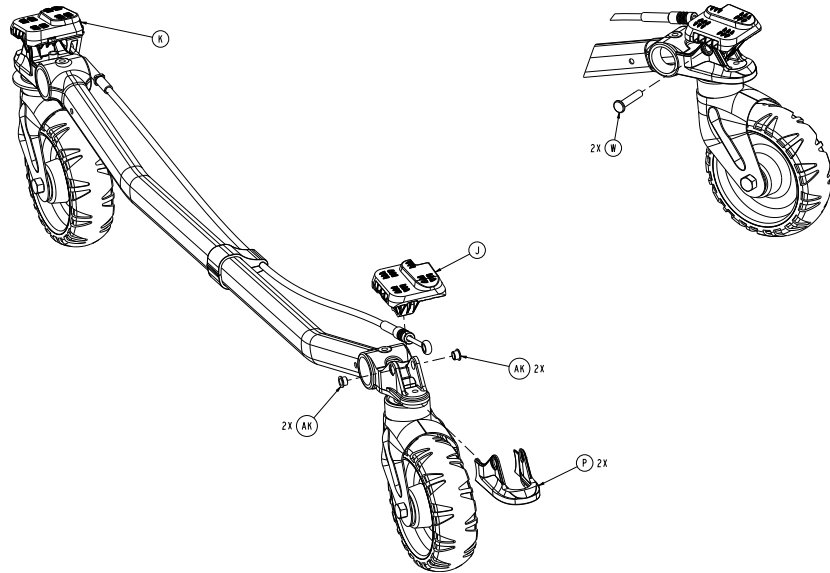

Item	Number	Name	Quantity
A	0003-205-000	Hex head cap screw	2
B	700000887054	Nylock hex thin nut	2
C	0016-060-000	Toplock hex jam nut	2
E	6060-002-010	6 in. molded wheel assembly	2
F	650700010013	Base tube lock assembly	1
H	650700010107	Brake pad	2
J	650700010108	Brake pedal, foot end, right	1
K	650700010109	Brake pedal, head end, right	1
L	650700010115	Steer-Lock caster weldment	1
M	650700010116	Caster plunger, overmolded	2
N	650700010126	Brake cable guide	1
P	650700010128	Caster mount cover, lock	2
R	650700010130	Peening, caster, black	1
T	650700010132	Brake cable	1
W	650700010144	Slic pin	2
AB	700000687304	Pan head tapping screw	1
AF	700000721316	Socket head shoulder bolt	2
AH	700001303528	Compression wire	2
AJ	700001345315	Compression wire	2
AK	700000737997	Flange bearing	4

Lock base assembly, left

650700010006 Rev AF (Reference only)

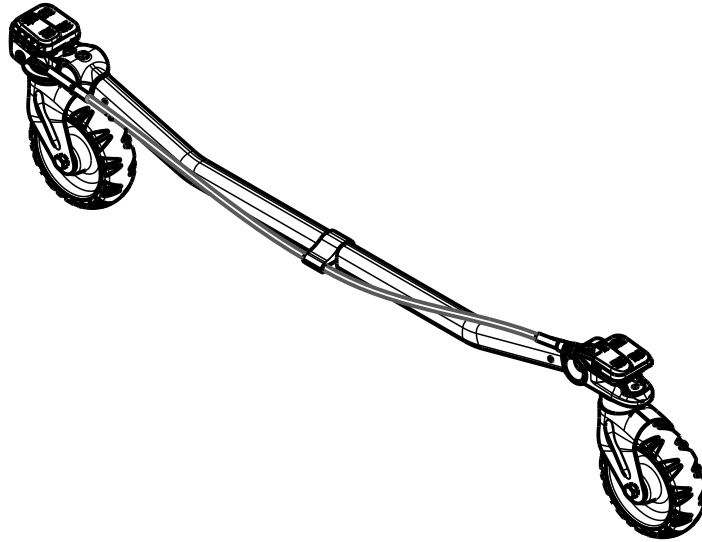

Torque item B
to 76.13 - 93.78 ft-lb

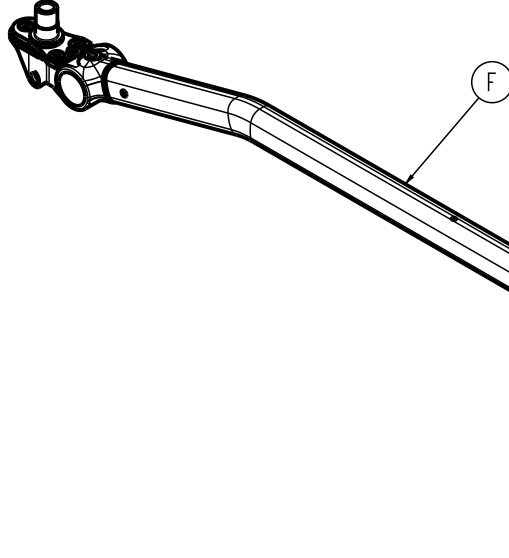
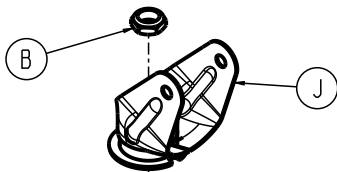

Torque item B
to 76.13 - 93.78 ft-lb

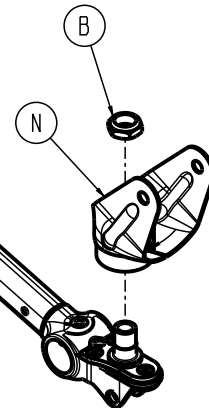

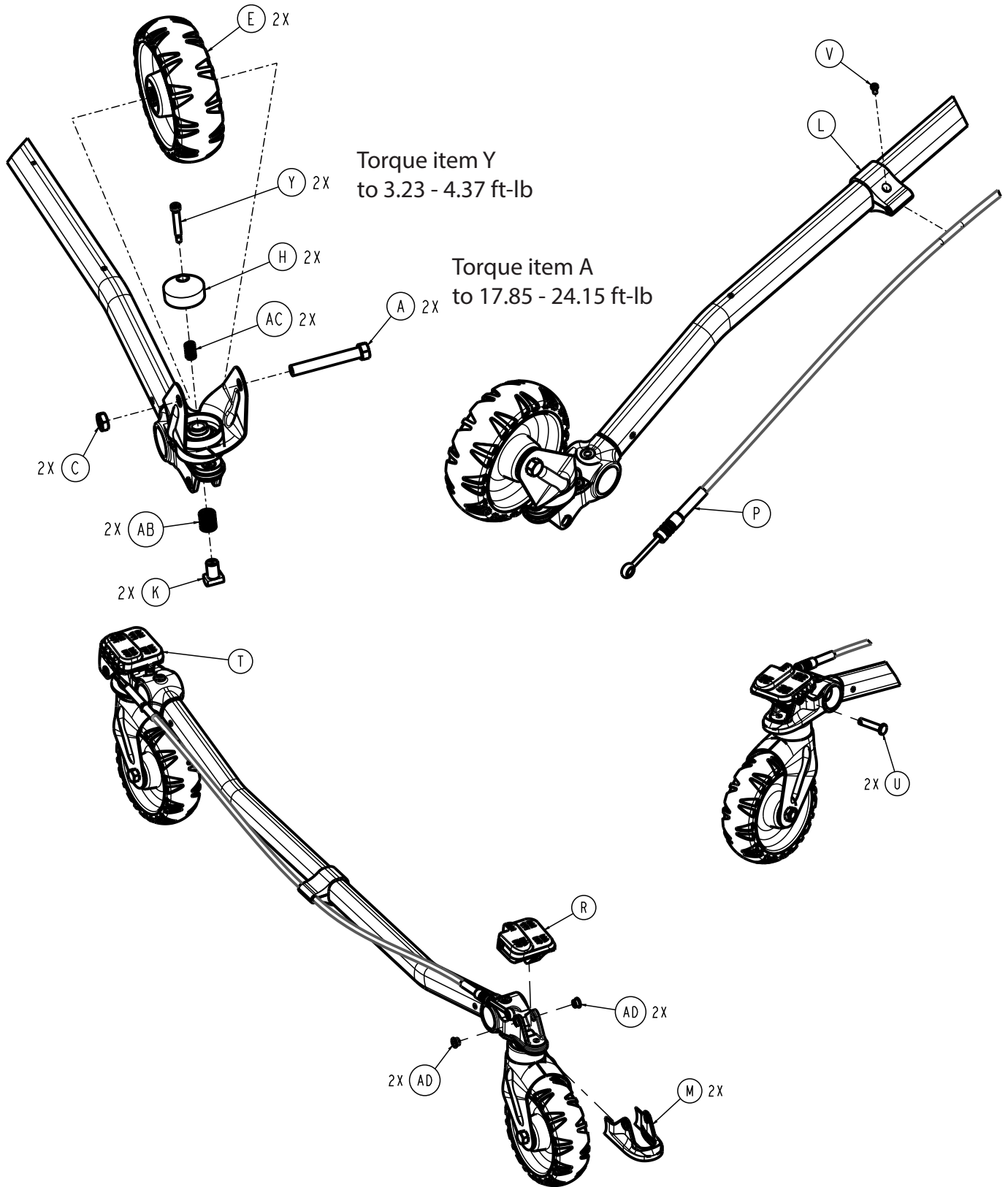

Item	Number	Name	Quantity
A	0003-205-000	Hex head cap screw	2
B	700000887054	Nylock hex thin nut	2
C	0016-060-000	Toplock hex jam nut	2
E	6060-002-010	6 in. molded wheel assembly	2

Item	Number	Name	Quantity
F	650700010013	Base tube lock assembly	1
H	650700010107	Brake pad	2
J	650700010115	Steer-Lock caster weldment	1
K	650700010116	Caster plunger, overmolded	2
L	650700010126	Brake cable guide	1
M	650700010128	Caster mount cover, lock	2
N	650700010130	Peening, caster, black	1
P	650700010132	Brake cable	1
R	650700010141	Brake pedal, foot end, left	1
T	650700010142	Brake pedal, head end, left	1
U	650700010144	Slic pin	2
V	700000687304	Pan head tapping screw	1
Y	700000721316	Socket head shoulder bolt	2
AB	700001303528	Compression wire	2
AC	700001345315	Compression wire	2
AD	700000737997	Flange bearing	4

Non-lock base assembly, left

650700010004 Rev AD (Reference only)

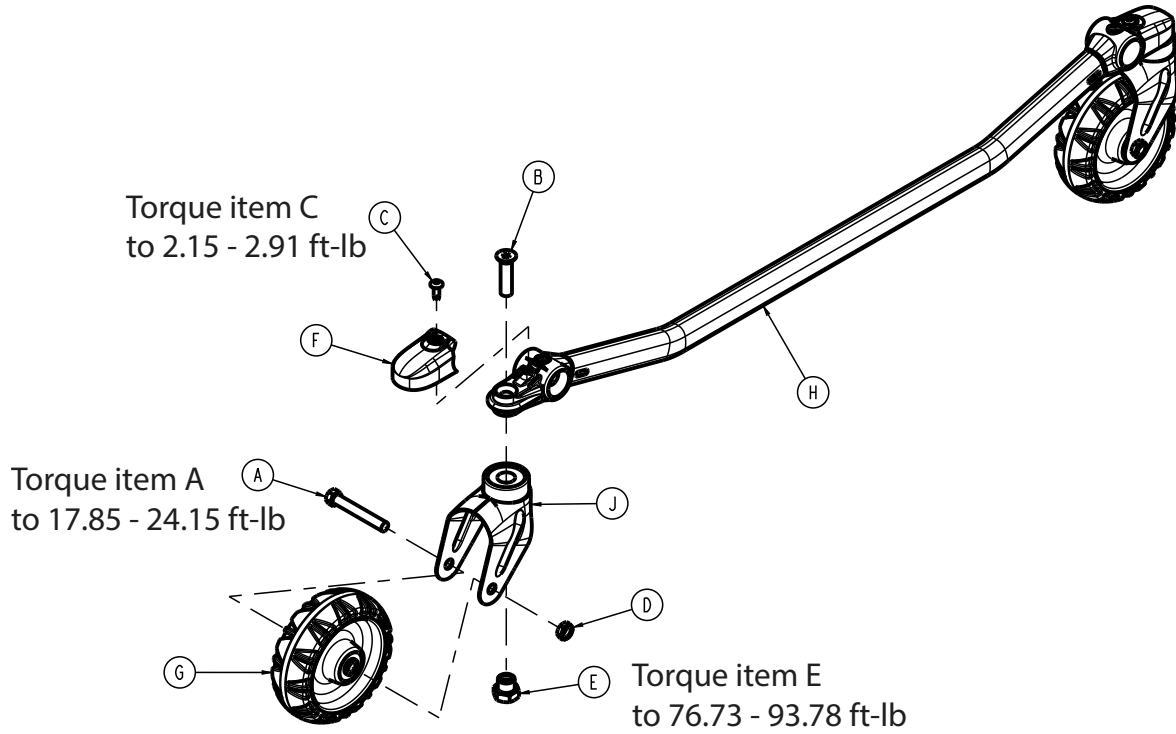

Item	Number	Name	Quantity
A	0003-205-000	Hex head cap screw	2
B	0004-319-000	Flat head/hex socket bolt	2
C	700000719305	Pan head machine screw	2
D	0016-060-000	Toplock hex jam nut	2
E	6090-001-009	Caster nut	2
F	6500-001-177	Caster mount cover	2
G	6060-002-010	6 in. molded wheel assembly	2
H	650700010125	Non-lock base tube weldment	1
J	650700010130	Peening, caster, black	2

Inner lift legs assembly

650700020003 Rev AD (Reference only)

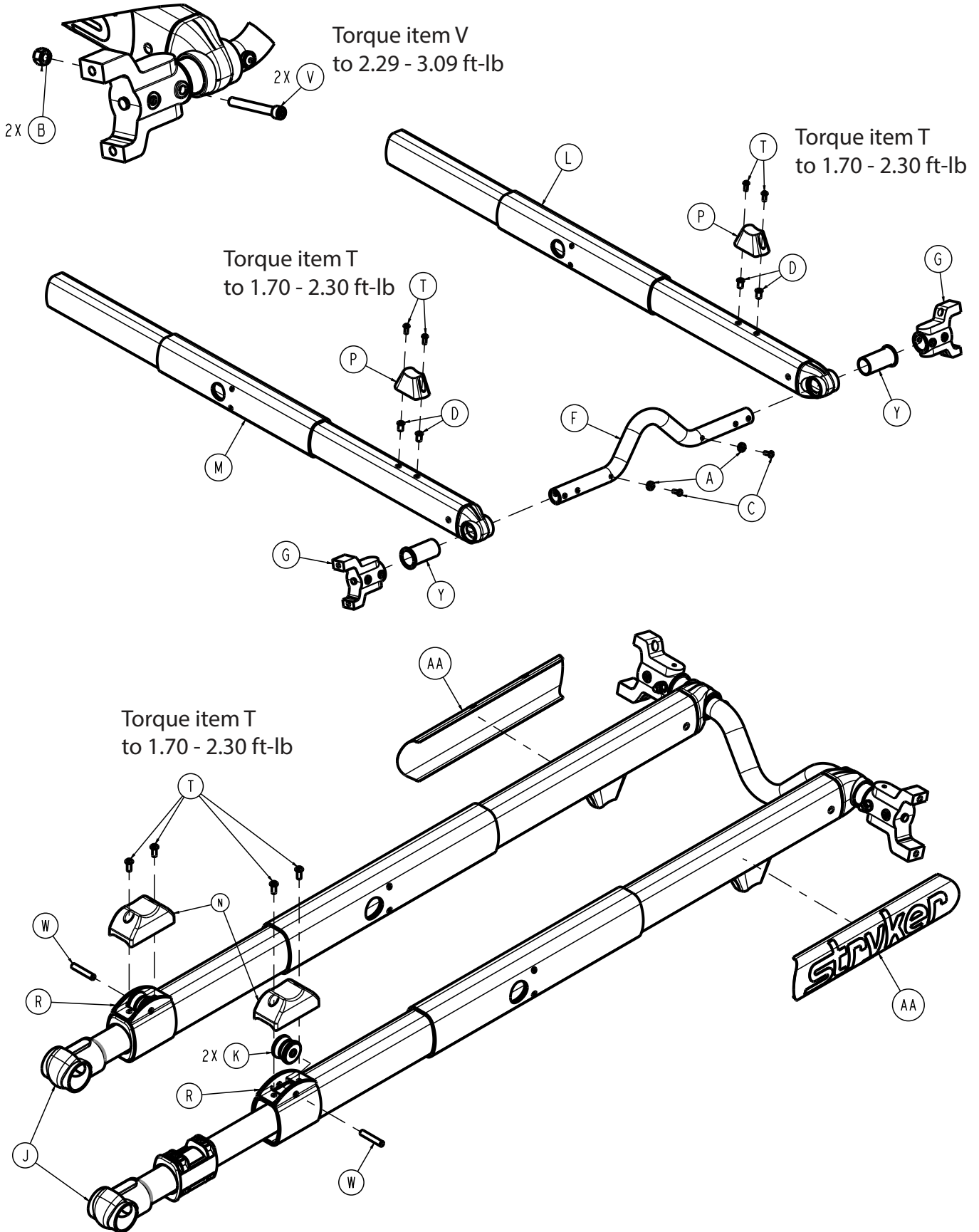

Item	Number	Name	Quantity
A	0014-115-000	Washer	2
B	0016-028-000	Fiberlock hex nut	2
C	0025-133-000	Dome head pop rivet	2
D	0055-100-075	Riv nut	4
F	6500-001-090	Head end cross tube	1
G	6500-001-102	Base/litter interface bracket	2
J	650700020004	<i>Base leg assembly, foot end (page 125)</i>	2
K	650700020009	External roller assembly	2
L	650700020110	Inner lift leg weldment, left	1
M	650700020115	Inner lift leg weldment, right	1
N	650700020119	Foot end roller cover	2
P	650700020152	Dead stop	2
R	650700020153	External roller cover	2
T	700000689499	Button head cap screw	8
V	700000721224	Socket head cap screw	2
W	700001174627	Dowel pin	2
Y	650700020112	Lift flange bearing	2
AA	650700010908	Label, Stryker	2

Base leg assembly, foot end

650700020004 Rev AA (Reference only)

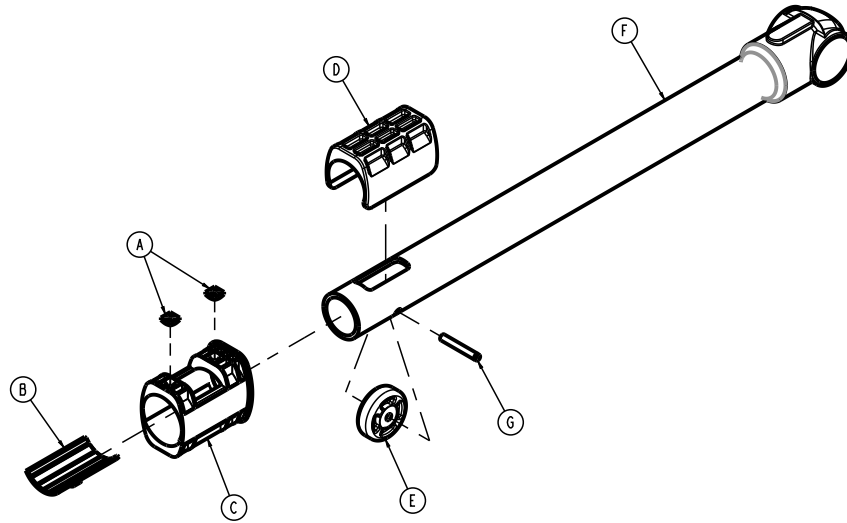

Item	Number	Name	Quantity
A	0015-051-000	Square nut	2
B	6500-101-327	Half shell bearing	1
C	650700020107	Bearing housing	1
D	650700020108	Internal bearing	1
E	650700020109	Internal roller	1
F	650700020130	Inner base leg weldment	1
G	700000755477	Dowel pin	1

Base leg assembly, head end

650700020006 Rev AA (Reference only)

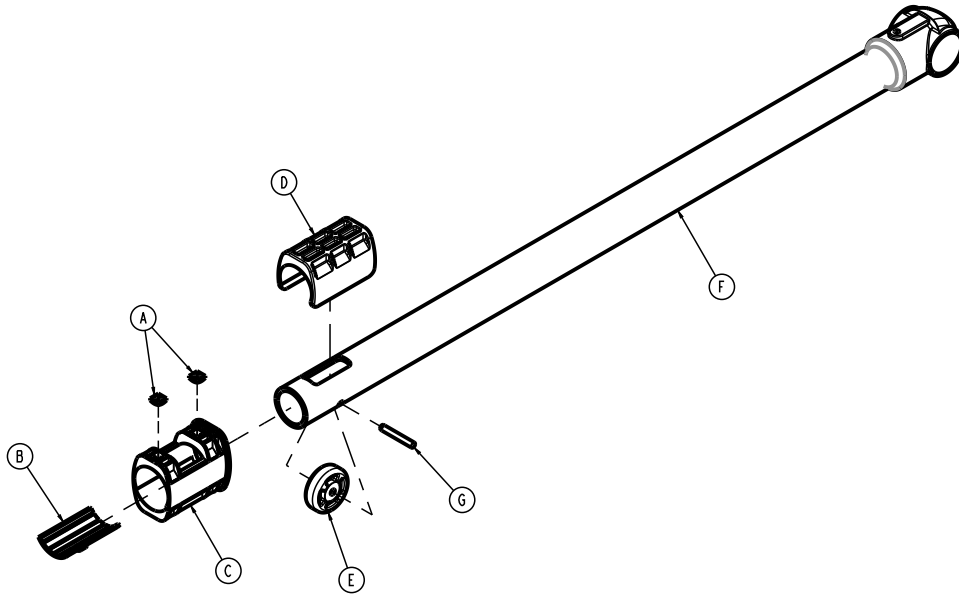

Item	Number	Name	Quantity
A	0015-051-000	Square nut	2
B	6500-101-327	Half shell bearing	1
C	650700020107	Bearing housing	1
D	650700020108	Internal bearing	1
E	650700020109	Internal roller	1
F	650700020135	Outer base leg weldment	1
G	700000755477	Dowel pin	1

Actuator lift assembly

650700020007 Rev AG (Reference only)

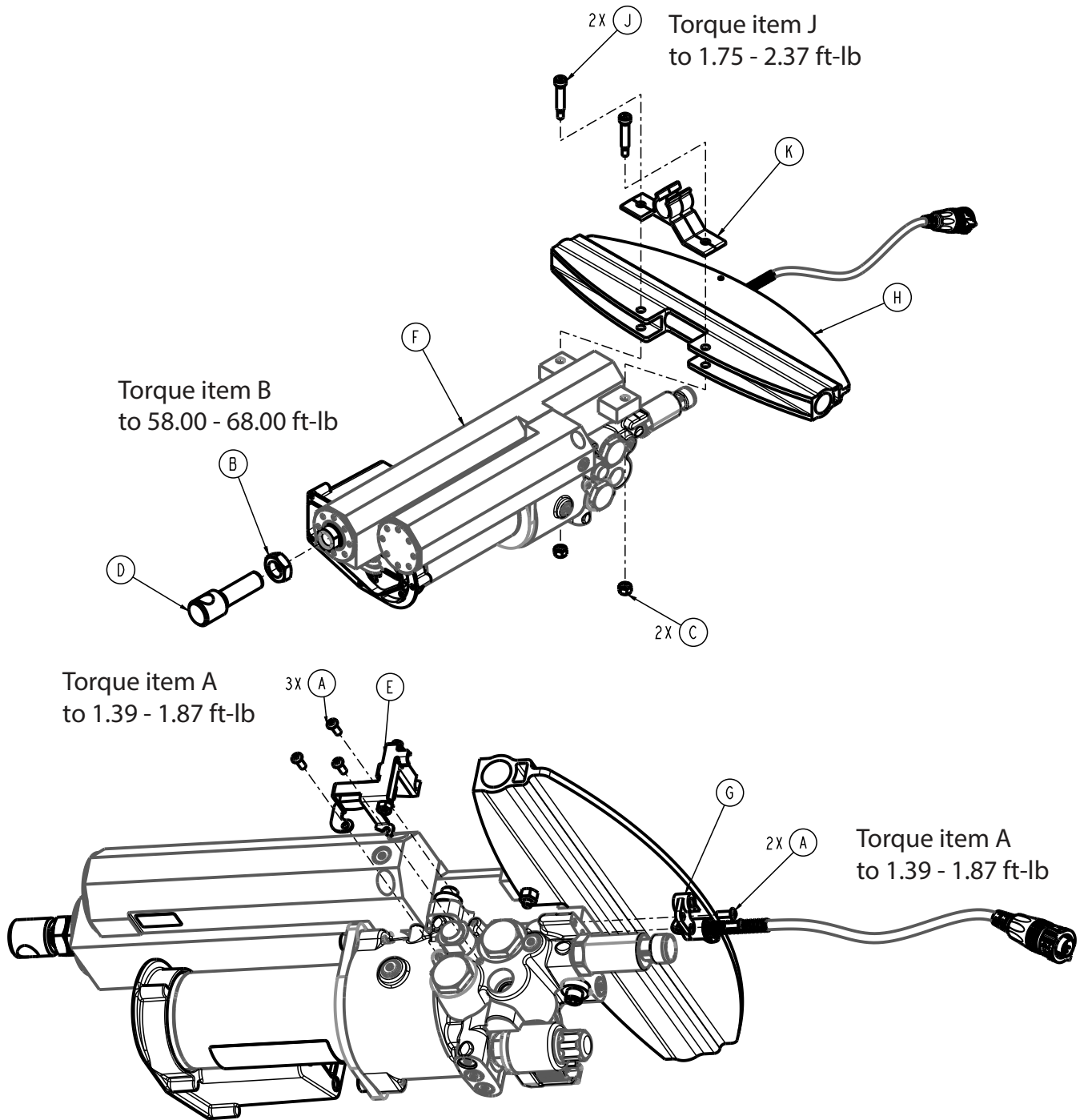

Item	Number	Name	Quantity
A	700000875213	Button head cap screw	5
B	0015-052-000	Hex jam nut	1
C	0016-002-000	Fiberlock nut	2
D	6500-001-169	Rod end, cylinder	1
E	650700020008	Manual release bracket assembly (page 129)	1
F	650700020027	Actuator assembly	1
G	650700020161	Manual release cable bracket	1

Item	Number	Name	Quantity
H	650700080896	Strain gauge cable assembly	1
J	0008-030-000	Socket head shoulder bolt	2
K	650700020211	Motor cable clip	1

Manual release bracket assembly

650700020008 Rev AB (Reference only)

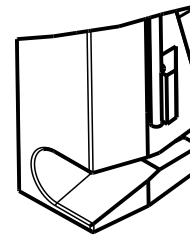
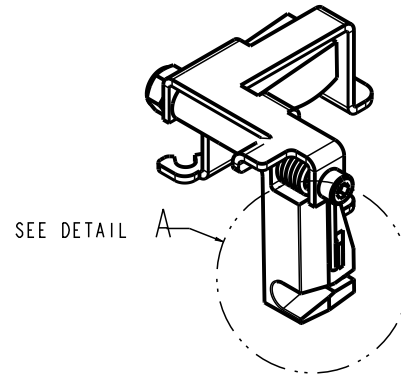
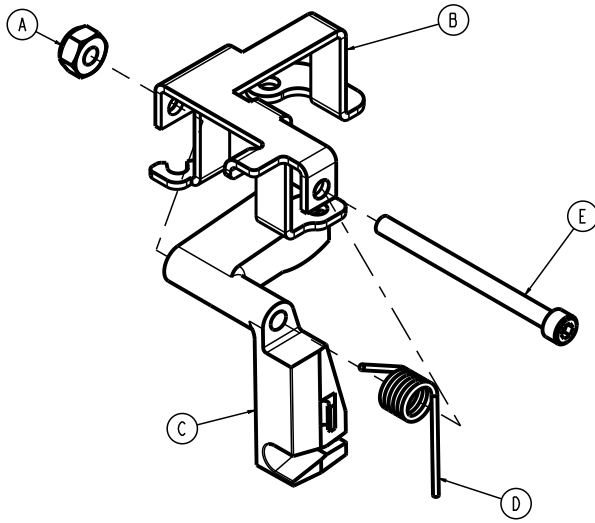

DETAIL A

Item	Number	Name	Quantity
A	0016-023-000	Nylon hex nut	1
B	650700020157	Manual release bracket	1
C	650700020158	Manual release finger	1
D	650700020159	Manual release spring	1
E	700000721239	Socket head cap screw	1

Outer rail assembly, left

650700020012 Rev AD (Reference only)

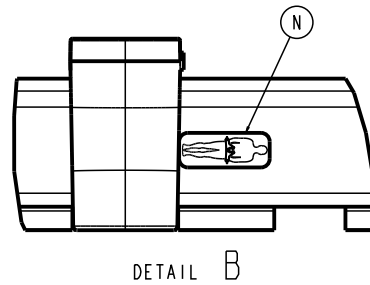
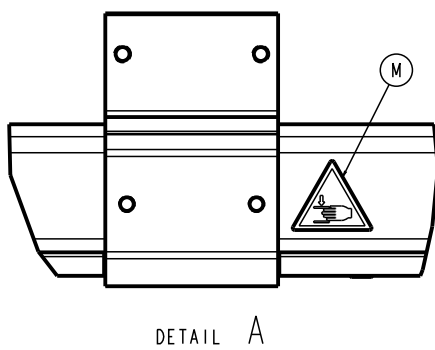
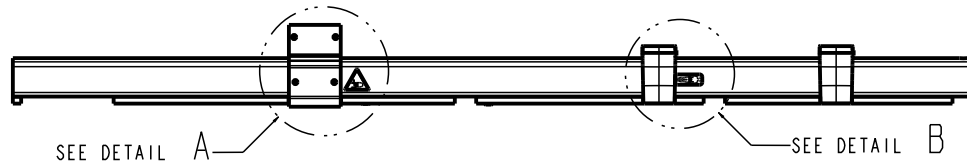
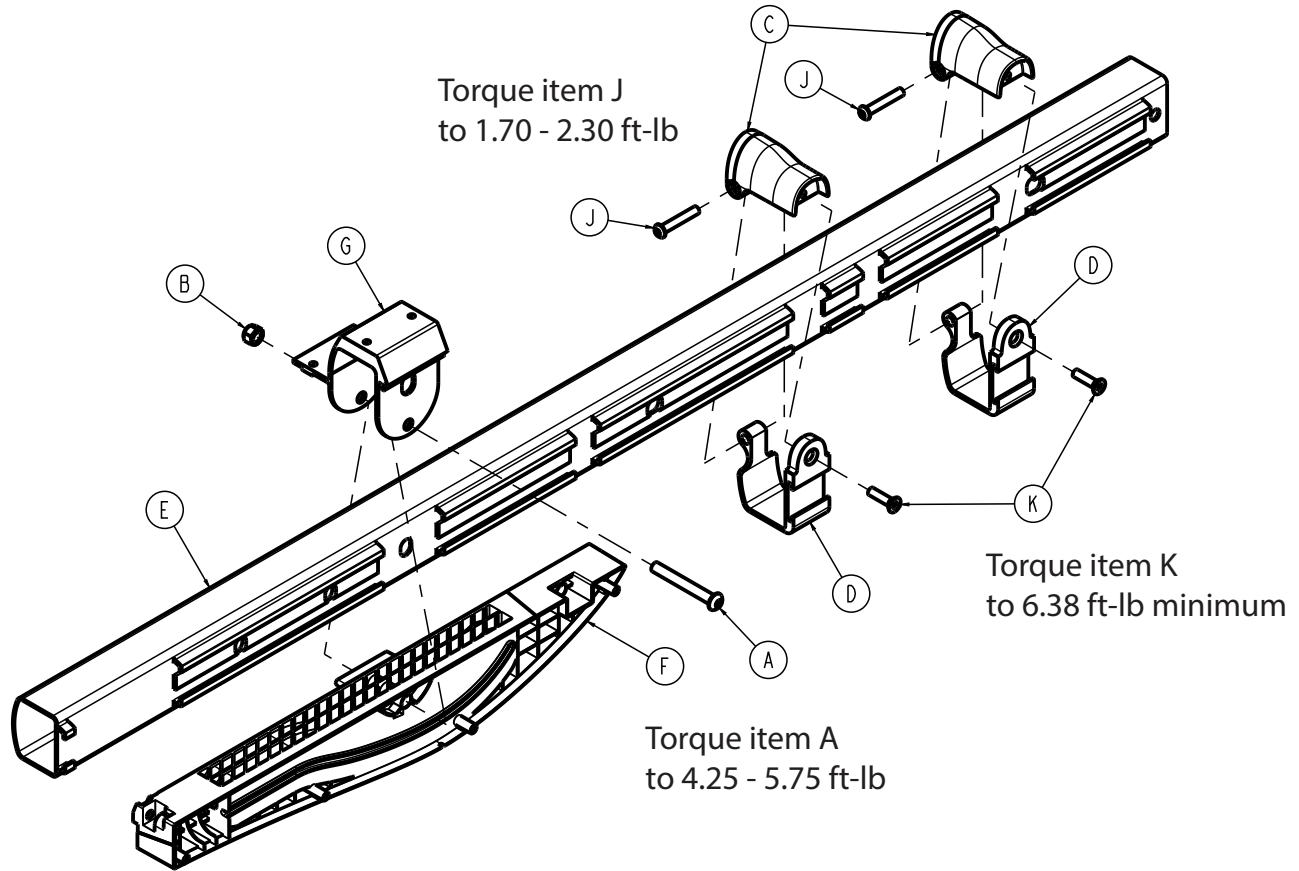

Item	Number	Name	Quantity
A	0004-512-000	Button head cap screw	1
B	0016-036-000	Nylock hex nut	1
C	6500-002-130	Litter support bracket, machined	2
D	6500-002-131	Litter support bracket, inner, machining	2

Item	Number	Name	Quantity
E	650700020127	Outer rail	1
F	650700020139	Slider block, left	1
G	650700020144	Gatch cross tube bracket	1
J	700000689591	Button head cap screw	2
K	700000718346	Socket flat countersunk head cap screw	2
M	650700010903	Label, pinch point	1
N	650700010910	Label, restraint, frame, waist	1

Outer rail assembly, right

650700020013 Rev AD (Reference only)

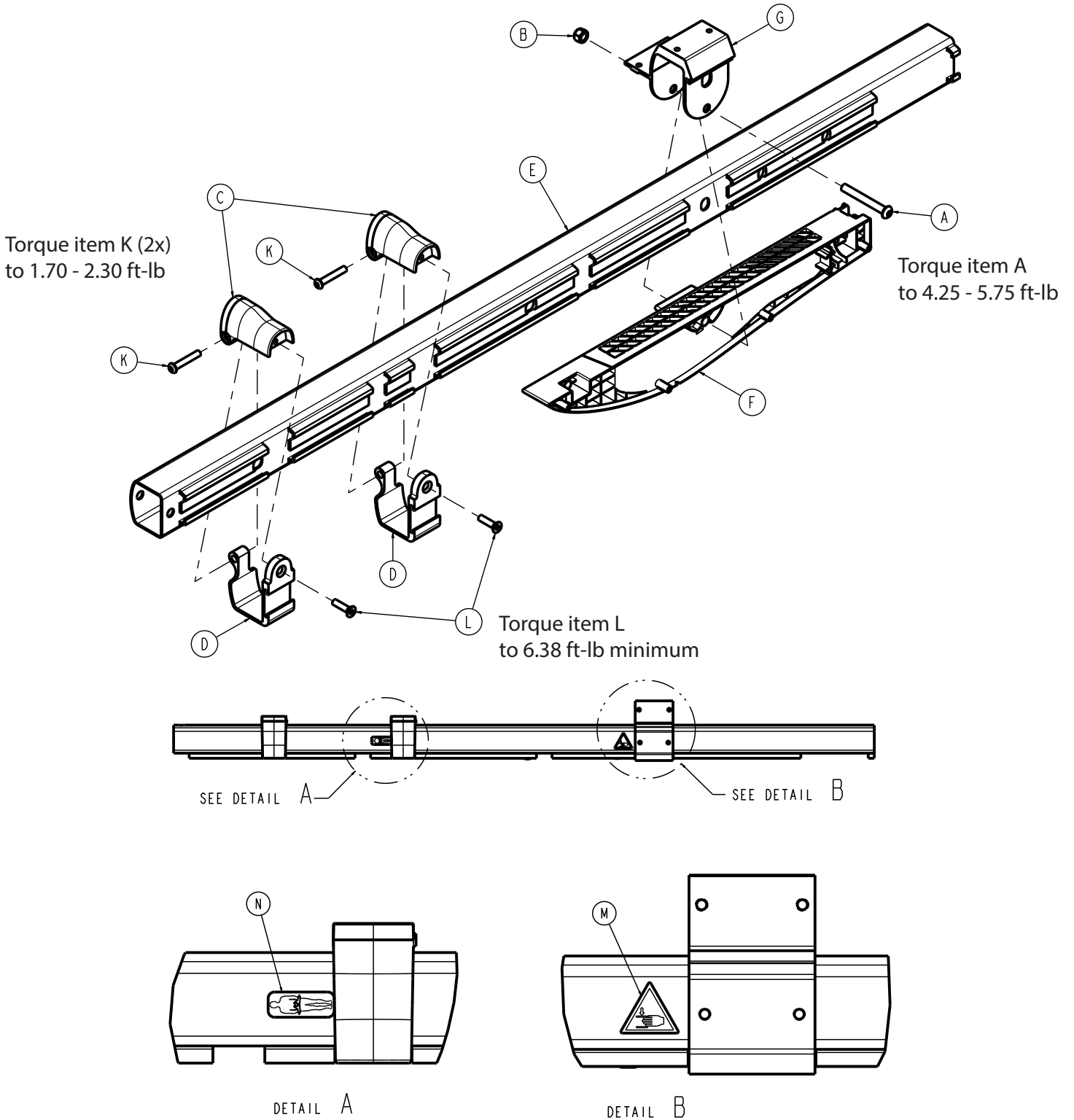

Item	Number	Name	Quantity
A	0004-512-000	Button head cap screw	1
B	0016-036-000	Nylock hex nut	1
C	6500-002-130	Litter support bracket, machined	2

Item	Number	Name	Quantity
D	6500-002-131	Litter support bracket, inner, machining	2
E	650700020127	Outer rail	1
F	650700020141	Slider block, right	1
G	650700020144	Gatch cross tube bracket	1
K	700000689591	Button head cap screw	2
L	700000718346	Socket flat countersunk head cap screw	2
M	650700010903	Label, pinch point	1
N	650700010910	Label, restraint, frame, waist	1

Hitch bracket assembly, foot end

650700020001 Rev AD (Reference only)

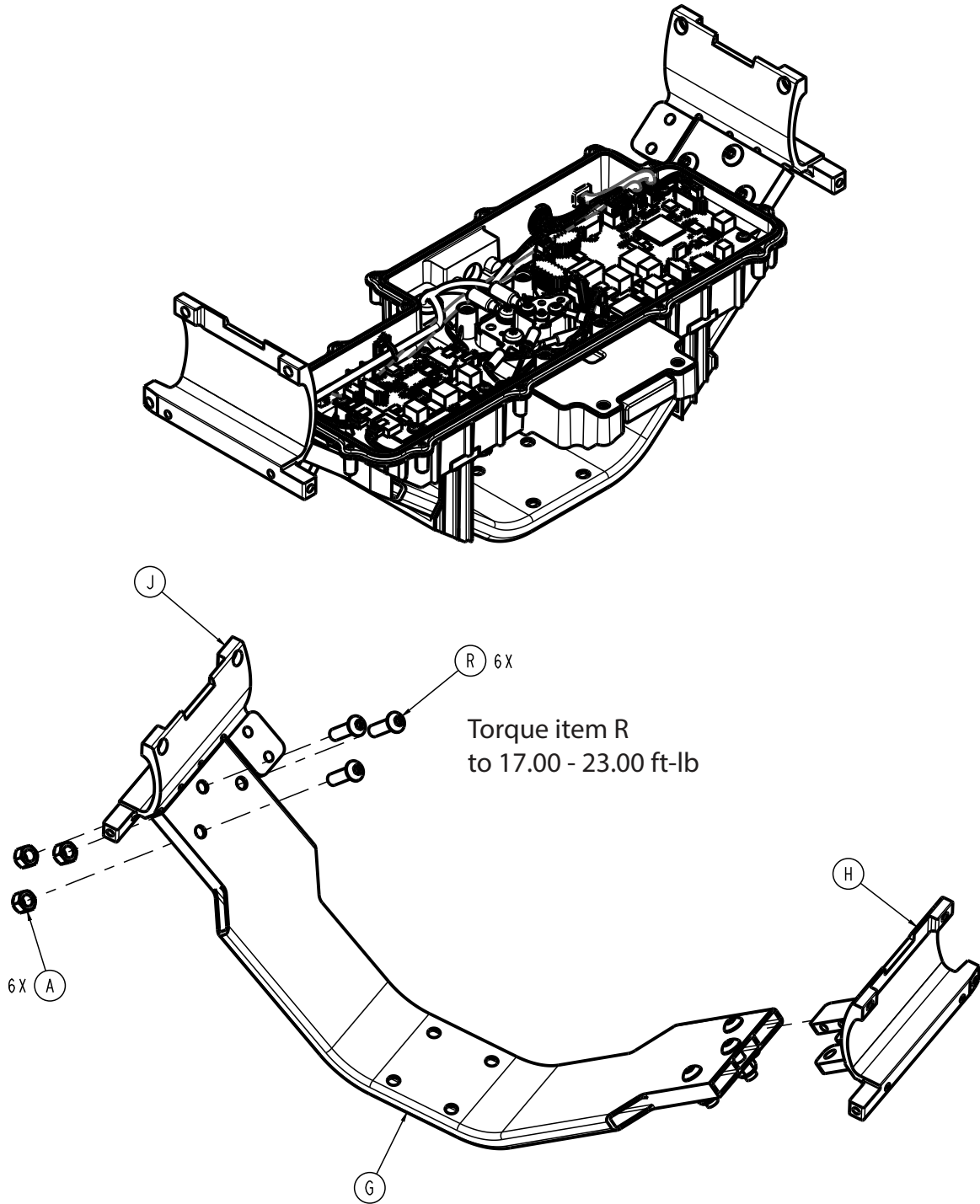

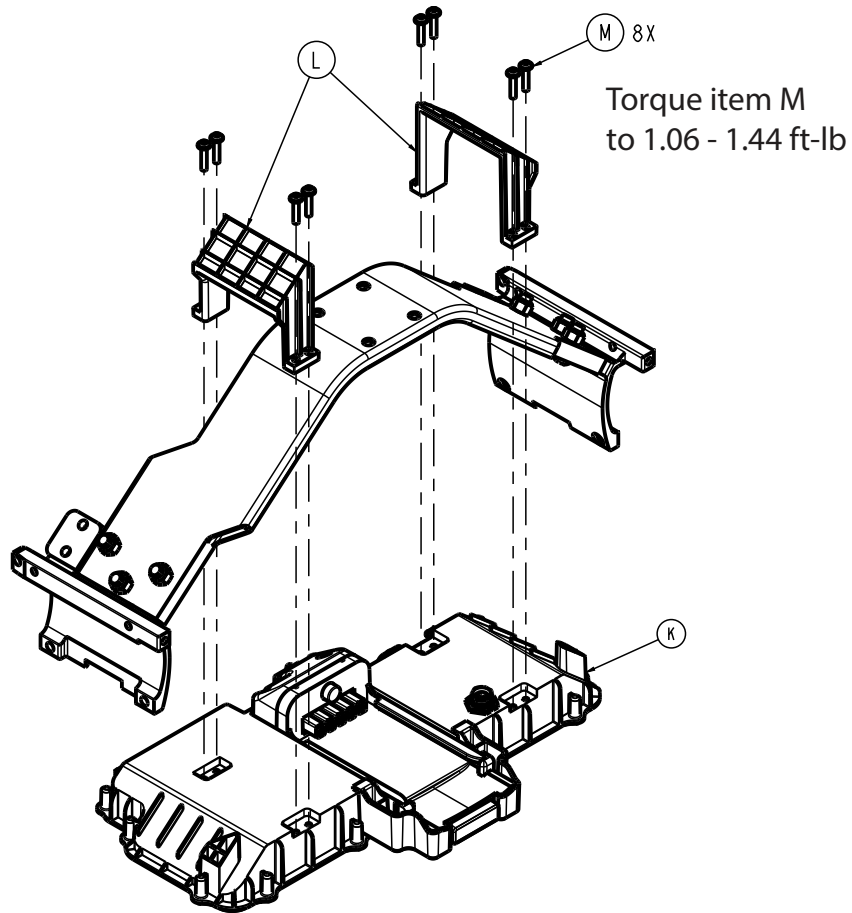

Item	Number	Name	Quantity
A	0016-036-000	Nylock hex nut	6
G	650700020132	Hitch bracket	1
H	650700020133	Hitch bracket, I-clamp, left	1
J	650700020134	Hitch bracket, I-clamp, right	1
K	650700080009	Foot end interface board (FEIB) assembly (page 139)	1
L	650700080127	FEIB mounting bracket	2
M	700000687745	Round washer head tapping screw	8
R	700000715617	Button head cap screw	6

Hitch assembly, foot end

650700020011 Rev AE (Reference only)

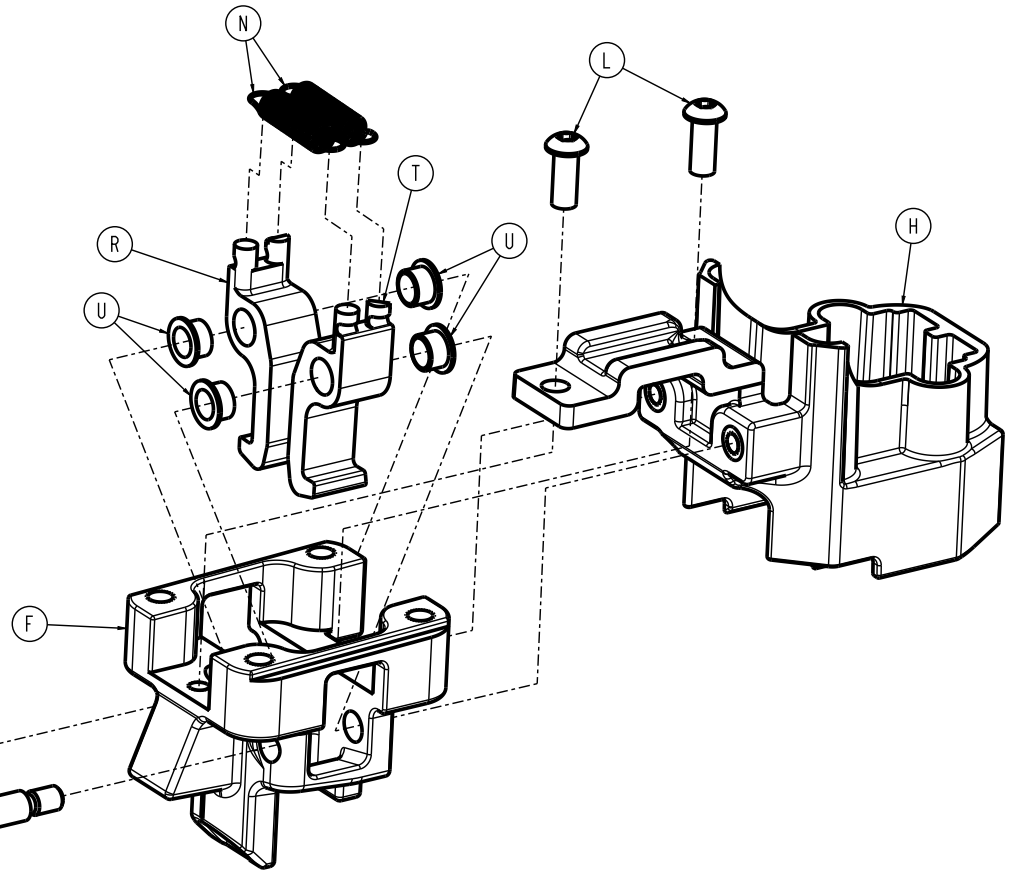
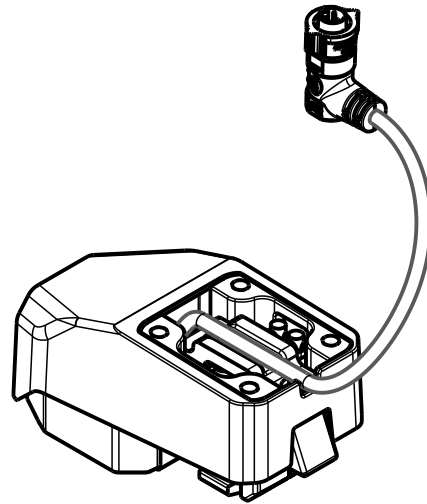

Torque item A
to 3.90 - 4.76 ft-lb

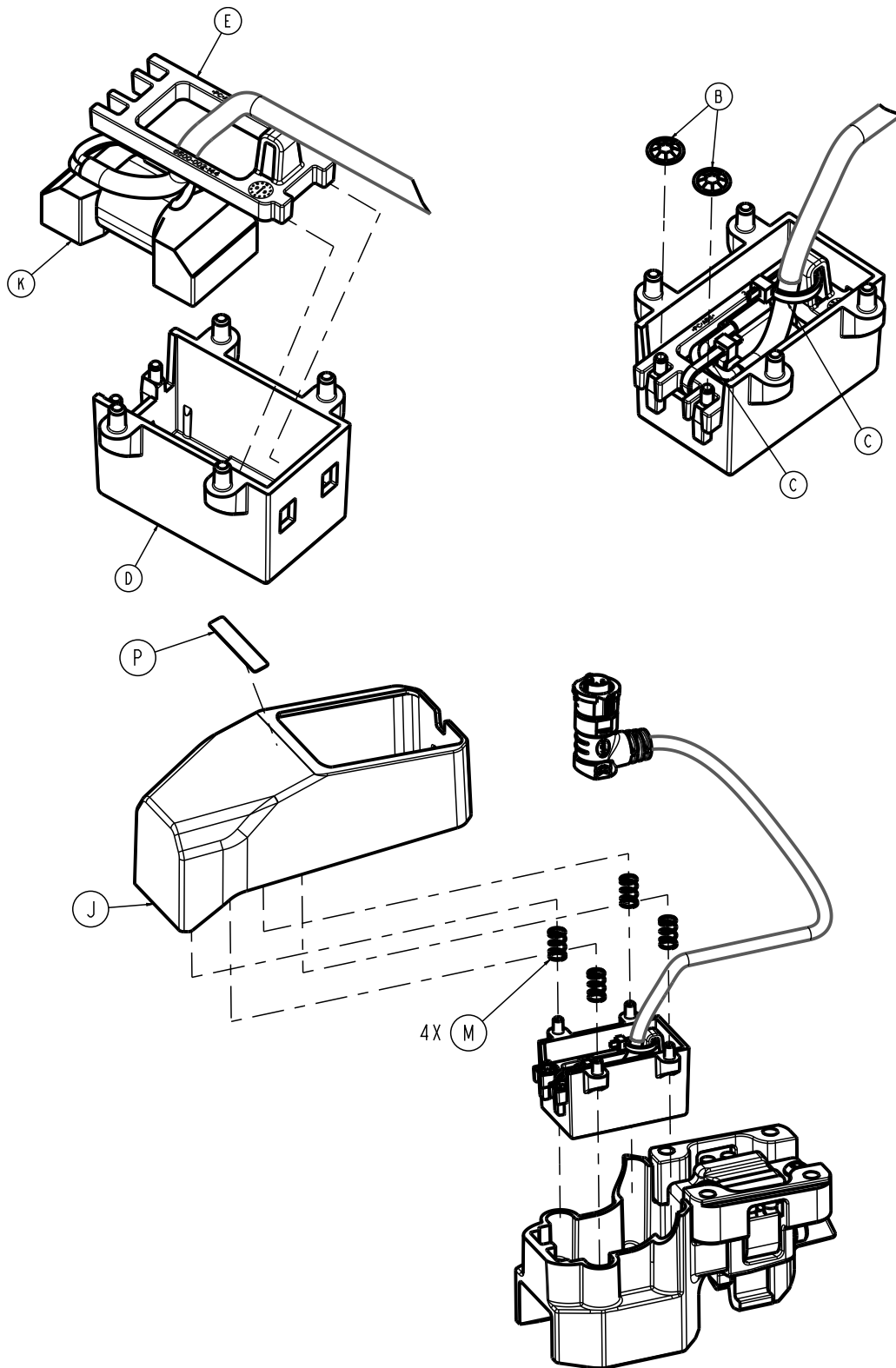

Item	Number	Name	Quantity
A	7000001682962	Socket head shoulder screw	2
B	0028-217-000	Push nut	2
C	0038-111-000	Cable tie	2
D	6500-002-135	Cot foot end fastener coil holder	1
E	6500-002-144	Cot tie down coil strap	1

Item	Number	Name	Quantity
F	650700020179	Foot end hitch body	1
H	650700020183	Foot end hitch inductive support	1
J	650700020186	Foot end hitch cover	1
K	650700080870	Inductive power cable assembly	1
L	700000689546	Button head cap screw	2
M	700000759852	Compression wire	4
N	700000759904	Extension wire	2
P	650700010969	Label, hitch, charging	1
R	650700020213	Foot end hitch hook, left	1
T	650700020214	Foot end hitch hook, right	1
U	700000737997	Flange bearing	4

Foot end interface board (FEIB) assembly

650700080009 Rev AH (Reference only)

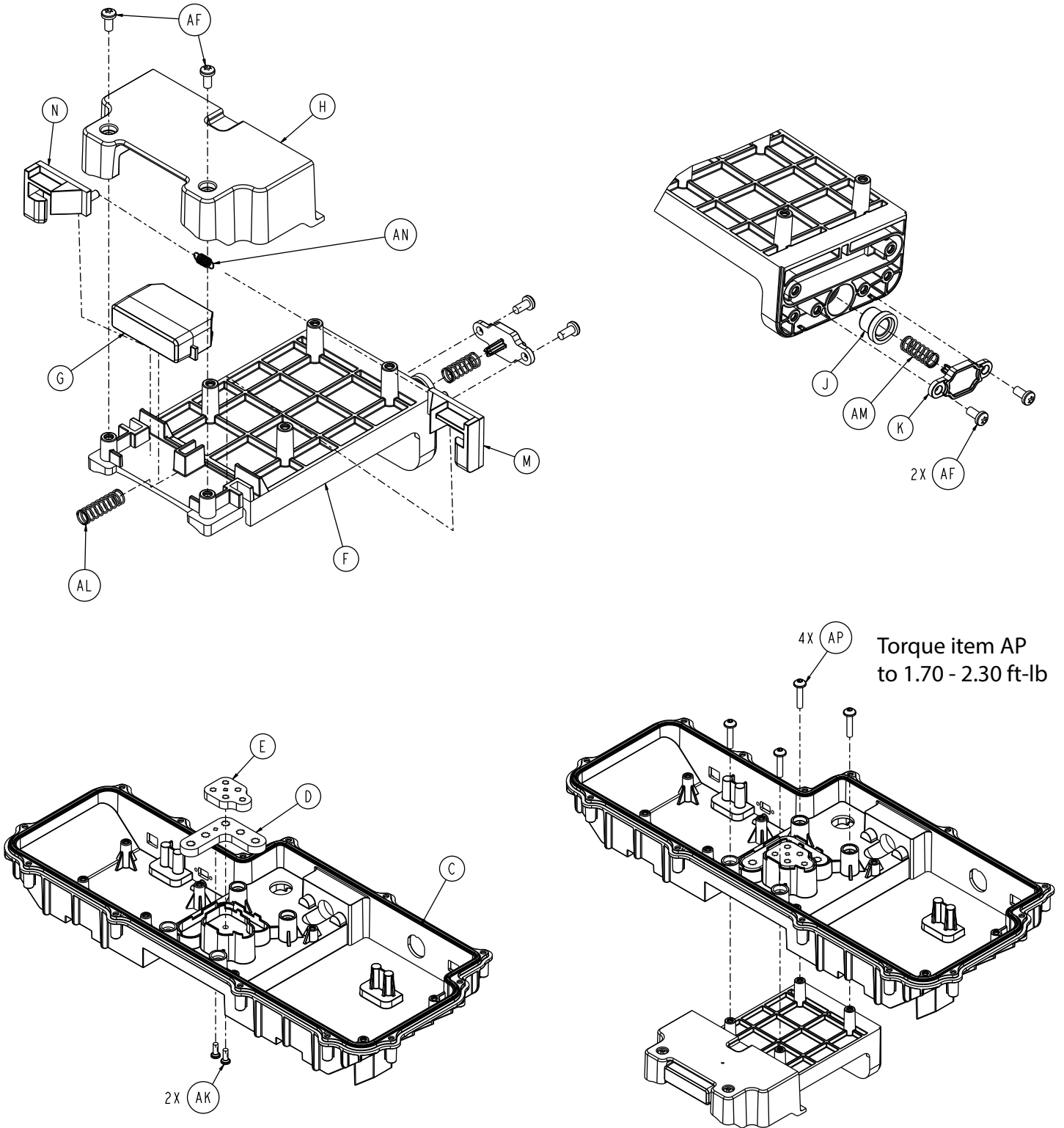

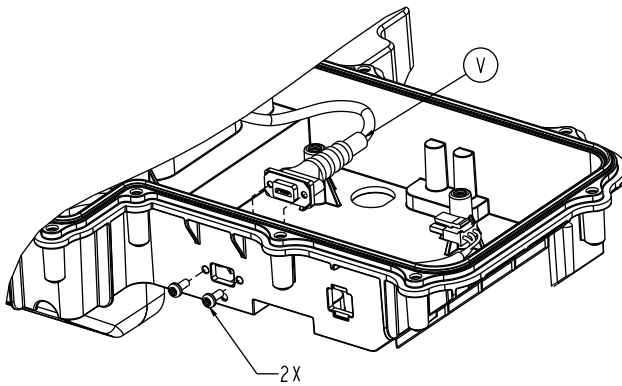
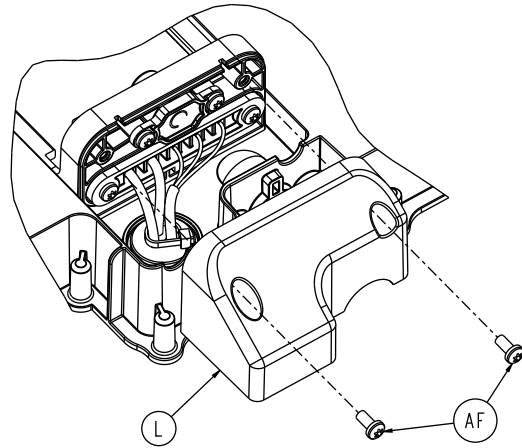
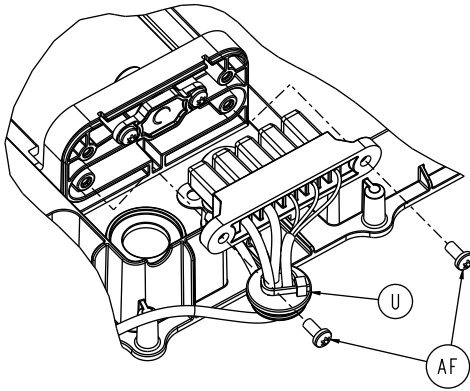

Torque screws
to .12 - .16 ft-lb

Torque items AH and AJ
to 1.70 - 2.30 ft-lb

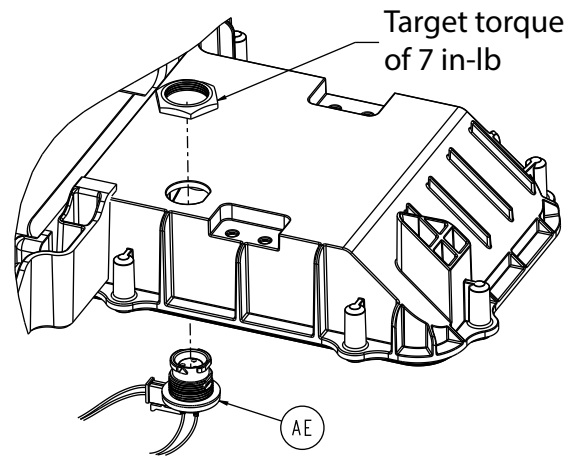
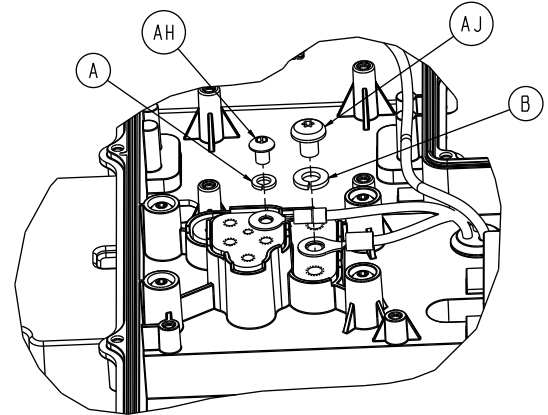

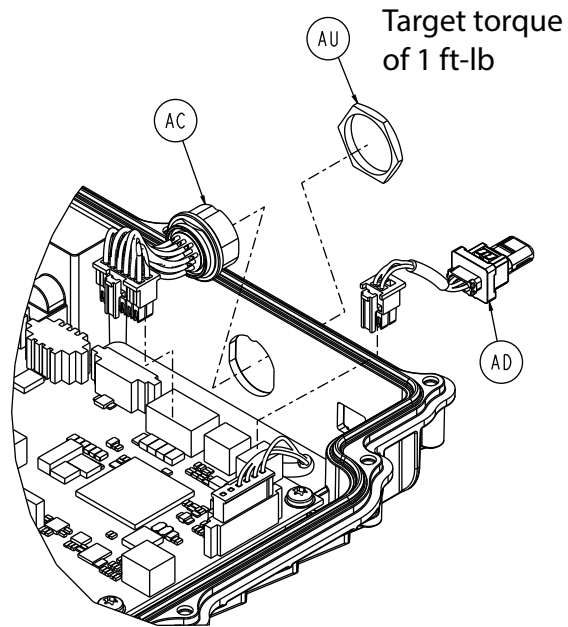
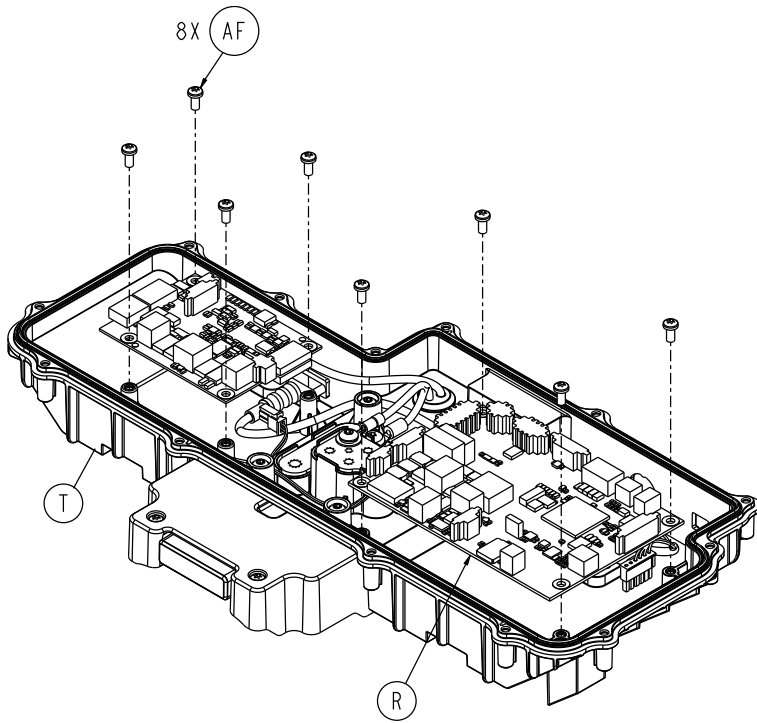

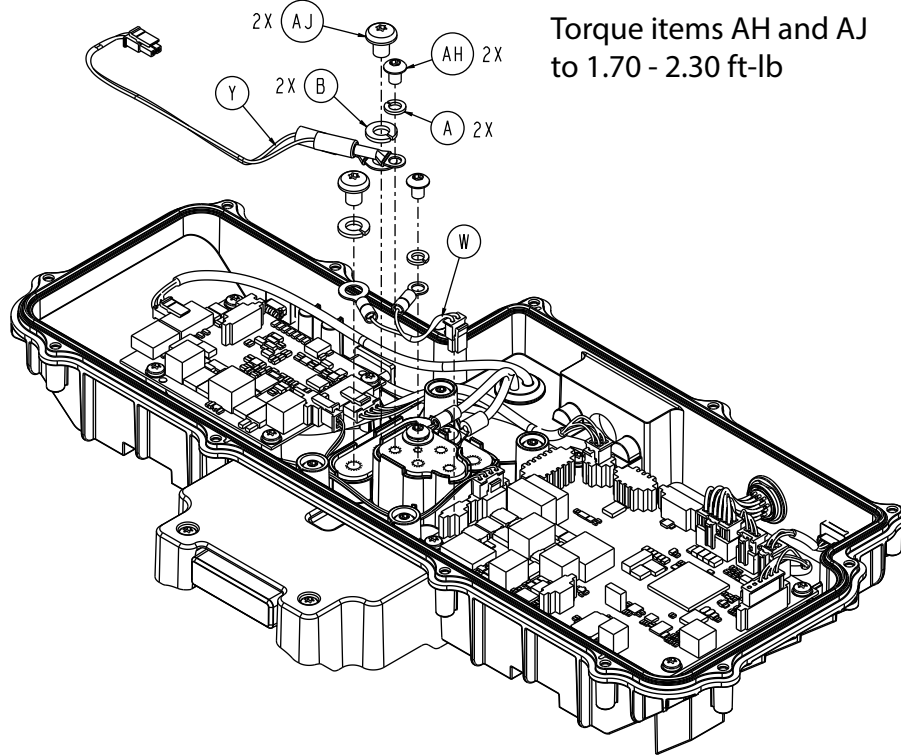
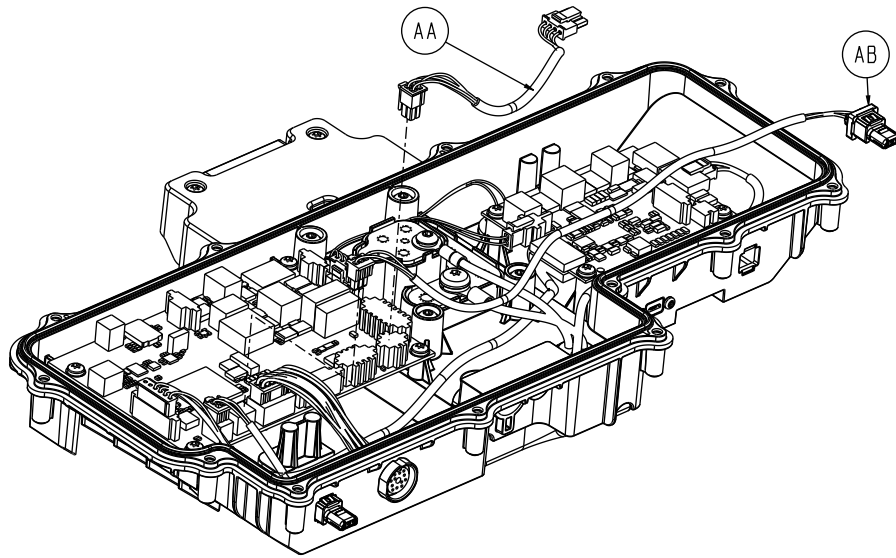

Torque items AH and AJ
to 1.70 - 2.30 ft-lb

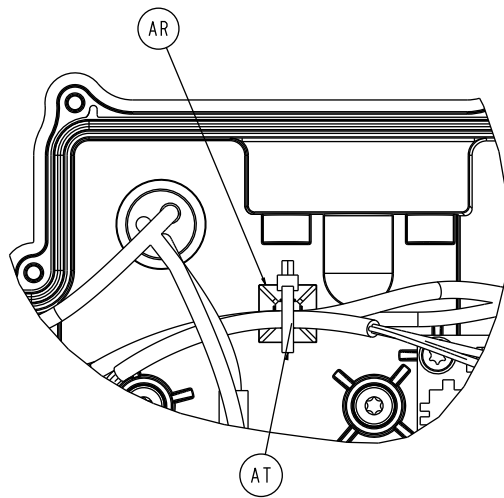
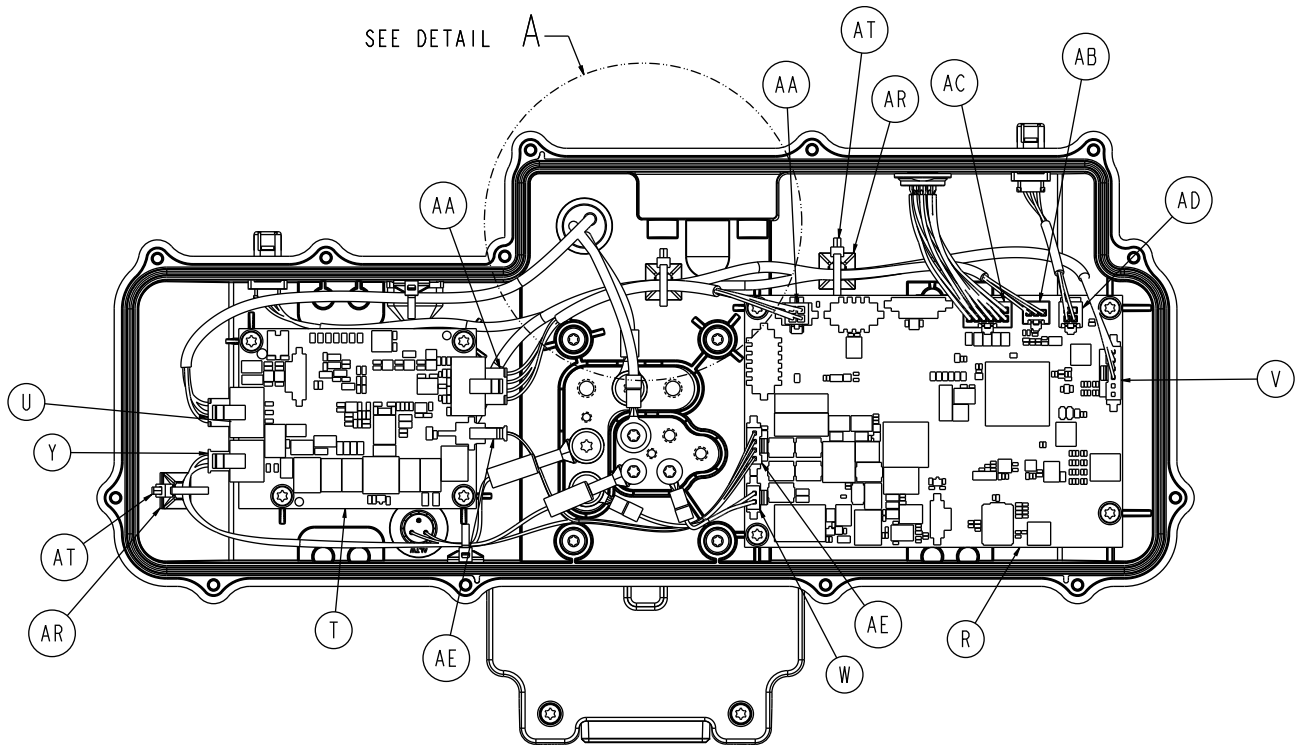

DETAIL A

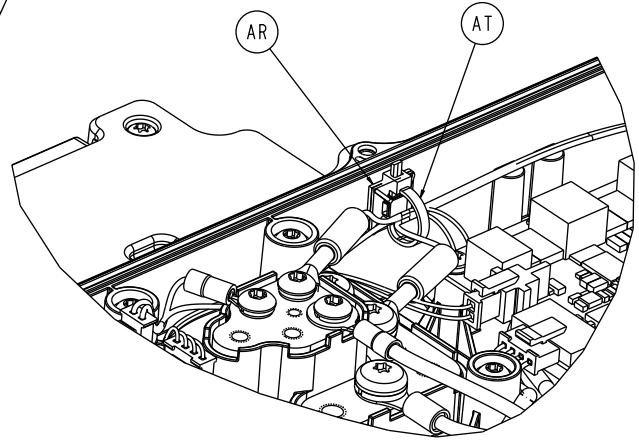
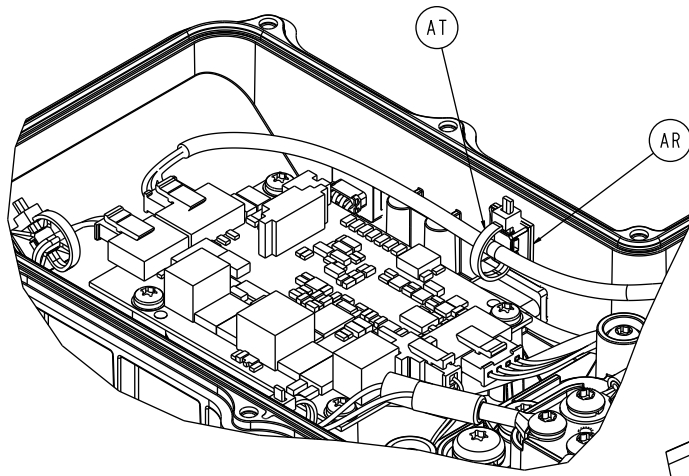

Item	Number	Name	Quantity
A	0012-005-000	Lock washer	3
B	0012-012-000	Lock washer	3
C	650700080112	FEIB enclosure, bottom overmolded	1
D	650700080114	FEIB terminal block	1
E	650700080116	FEIB grounding block	1
F	650700080117	Battery mount	1
G	650700080118	Battery release button	1
H	650700080119	Battery release button cover	1
J	650700080121	Battery pusher	1
K	650700080122	Battery pusher cover	1
L	650700080123	Battery mount back cover	1
M	650700080124	Battery lock pin, left	1
N	650700080126	Battery lock pin, right	1
R	650700080816	Cot FEIB PCBA with software	1
T	650700080926	Battery charger PCBA with software	1
U	650700080861	Battery power/comm cable assembly	1
V	650700080864	USB cable assembly	1
W	650700080865	FEIB to terminal block cable assembly	1
Y	650700080866	Charger to terminal block cable assembly	1
AA	650700080867	Charger comm cable assembly	1
AB	650700080873	In-ambulance sensor cable assembly	1
AC	650700080876	FEIB coil internal cable assembly	1
AD	650700080877	FEIB height sensor internal cable assembly	1
AE	650700080880	Internal inductive power cable assembly	1
AF	700000687304	Pan head tapping screw	16
AH	700000715613	Button head cap screw	3

Item	Number	Name	Quantity
AJ	700000719304	Pan head machine screw	3
AK	700000721347	Pan head machine screw	2
AL	700000734208	Compression wire	1
AM	700000734224	Compression wire	1
AN	700000740590	Extension wire	1
AP	700000778629	Round washer head tapping screw	4
AR	0058-143-000	Adhesive backed mounting tab	5
AT	0038-111-000	Cable tie	5
AU	700000913037	Hex nut	1

Birdcage assembly, no NFMIC, no Wi-Fi

650700080027 Rev AF (Reference only)

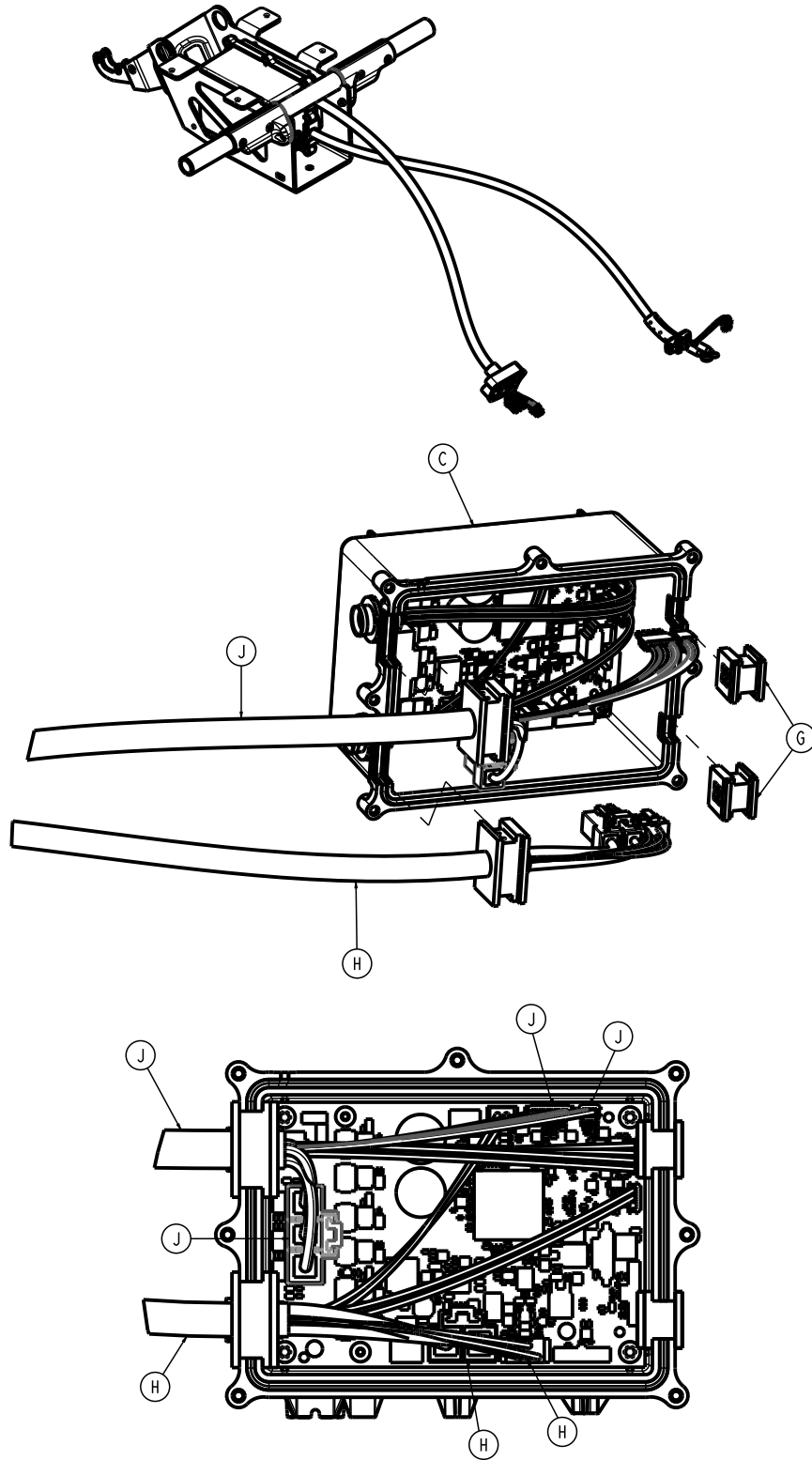

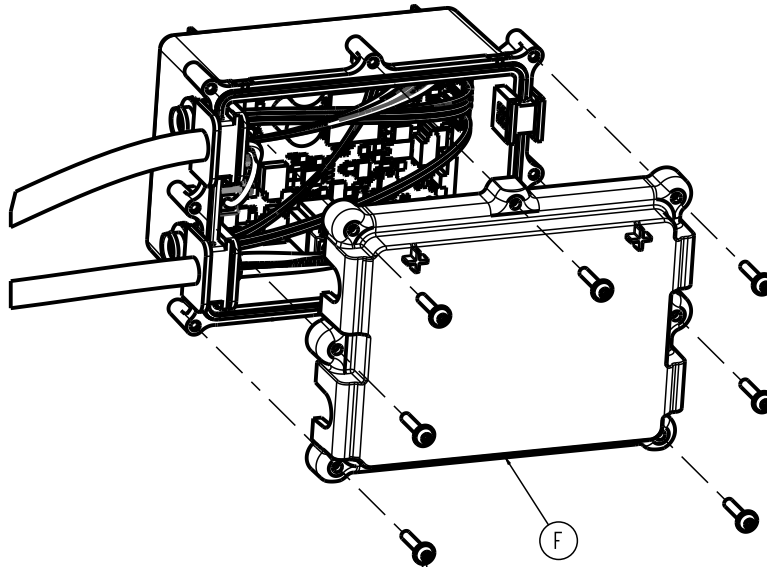

Torque item M
to 1.49 - 1.83 ft-lb

7X M

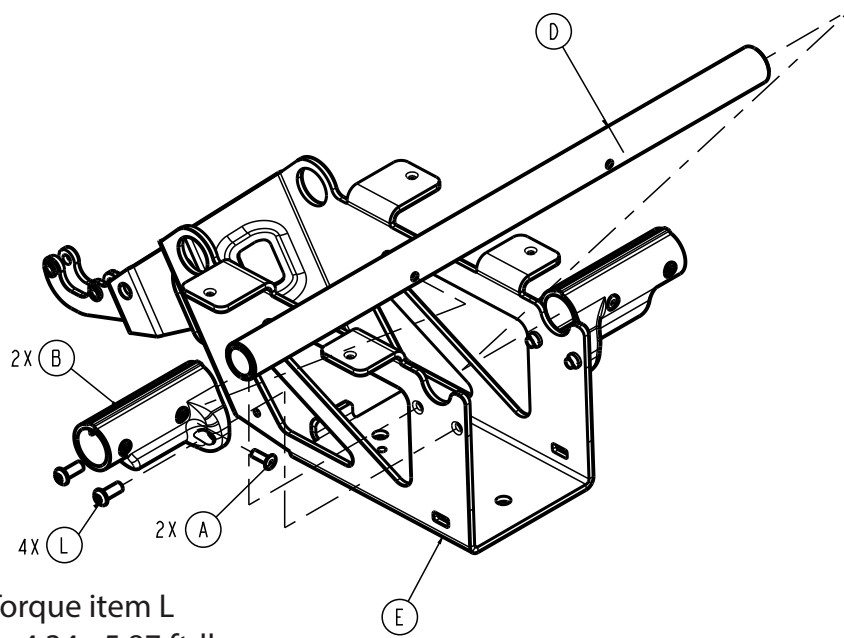

Torque item L
to 4.34 - 5.87 ft-lb

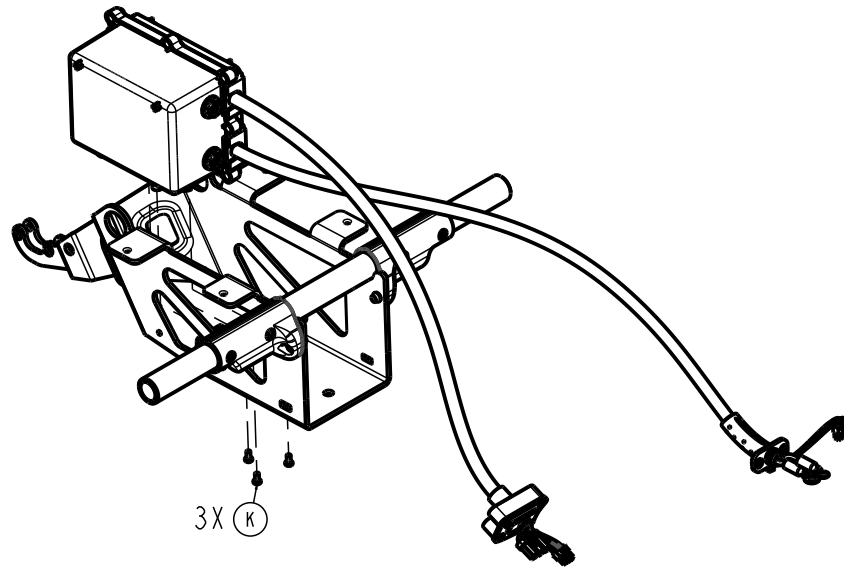

Item	Number	Name	Quantity
A	0025-133-000	Dome head pop rivet	2
B	6500-001-195	Motor mount casting	2
C	650700080032	HBC enclosure assembly (page 160)	1
D	650700080104	Gatch cross brace	1
E	650700080106	Birdcage bracket	1
F	650700080108	HBC enclosure, top	1
G	650700080196	HBC plug	2
H	650700080860	System bus cable assembly	1
J	650700080868	Lift motor cable assembly	1
K	700000837095	Pan head tapping screw	3
L	700000717877	Button head thread rolling screw	4
M	700000687745	Round washer head tapping screw	7

Birdcage assembly, NFMIC, no Wi-Fi

650700080028 Rev AJ (Reference only)

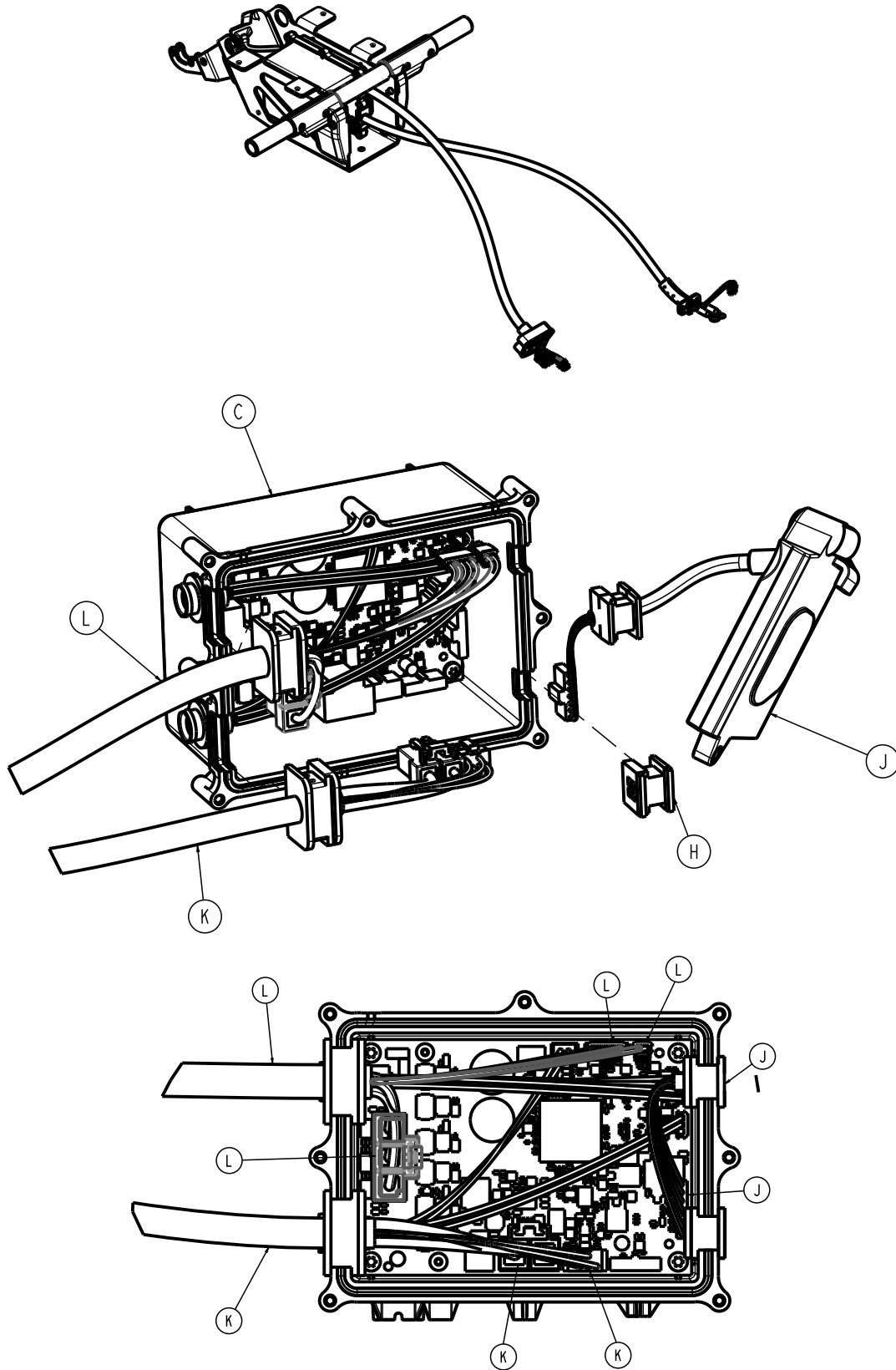

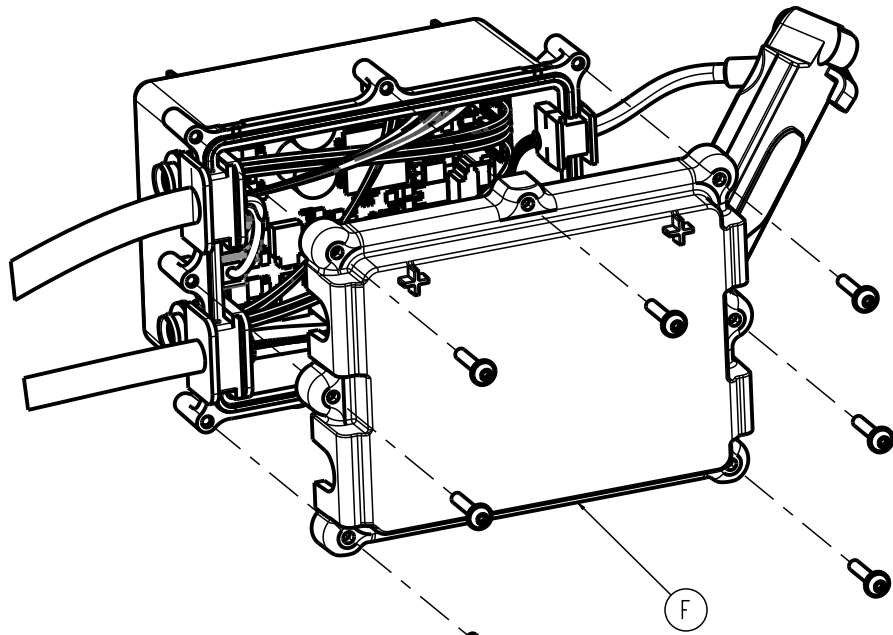

Torque item S
to 1.49 - 1.83 ft-lb 7X S

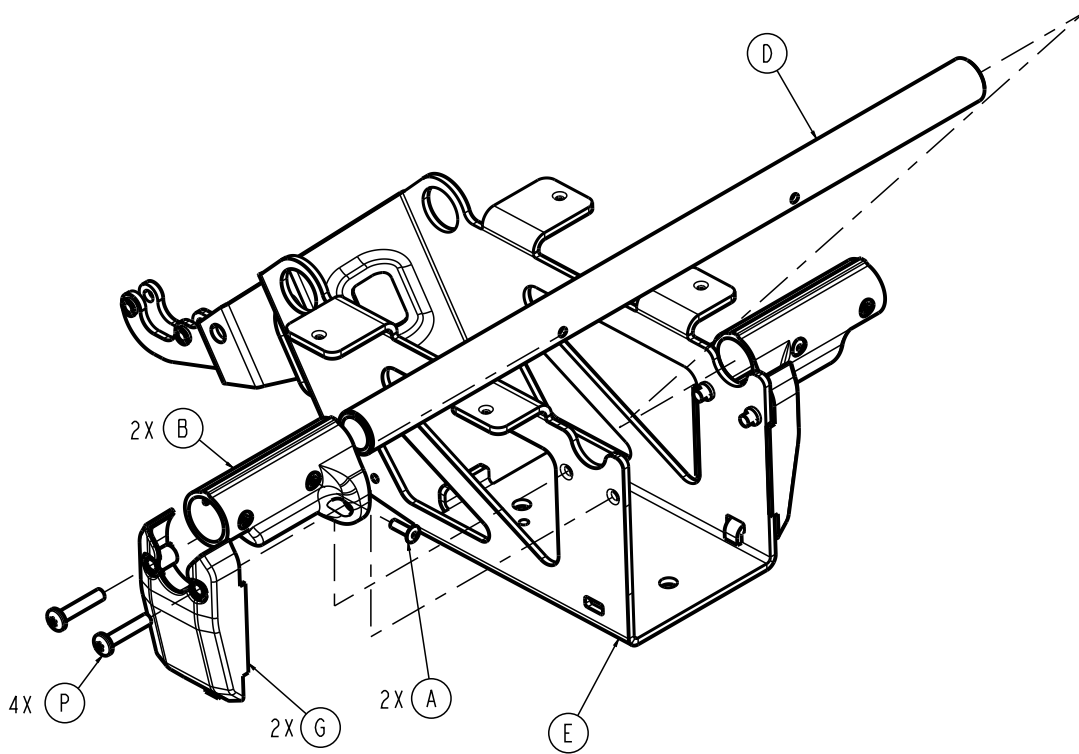

Torque item P
to 4.34 - 5.87 ft-lb

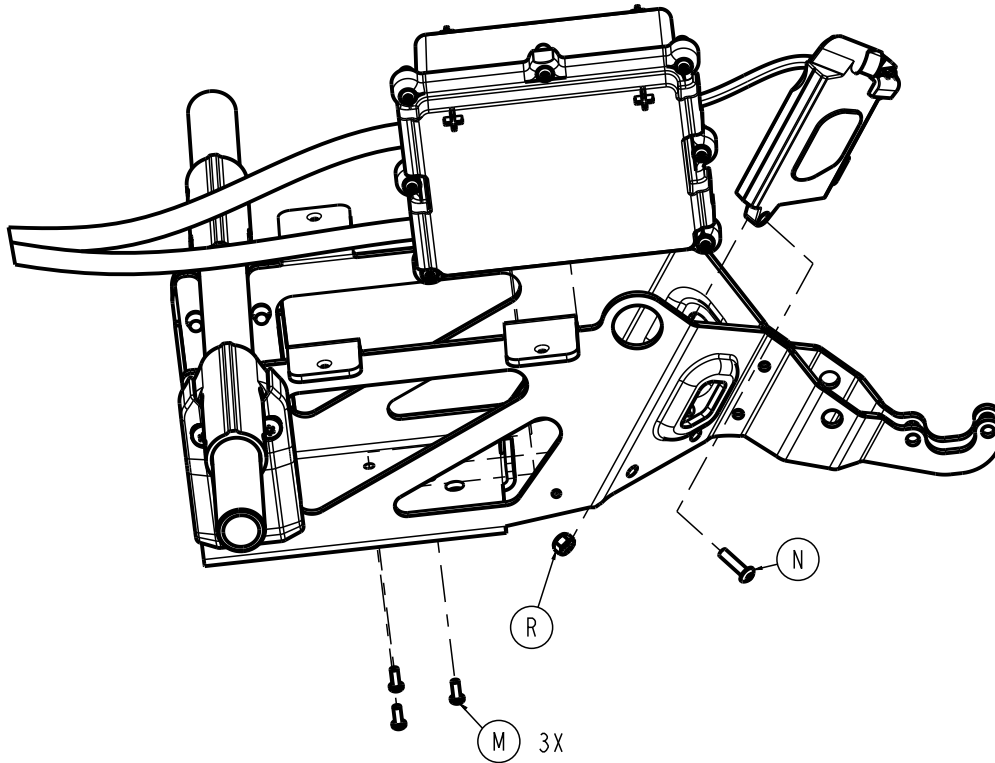

Item	Number	Name	Quantity
A	0025-133-000	Dome head pop rivet	2
B	6500-001-195	Motor mount casting	2
C	650700080032	HBC enclosure assembly (page 160)	1
D	650700080104	Gatch cross brace	1
E	650700080106	Birdcage bracket	1
F	650700080108	HBC enclosure, top	1
G	650700080191	Power-LOAD guide	2
H	650700080196	HBC plug	1
J	650700080203	Cot comm board	1
K	650700080860	System bus cable assembly	1
L	650700080868	Lift motor cable assembly	1
M	700000837095	Pan head tapping screw	3
N	700000689468	Button head cap screw	1
P	700000717908	Pan head thread rolling screw	4
R	0016-002-000	Fiberlock nut	1
S	700000687745	Round washer head tapping screw	7

Birdcage assembly, NFMIC, Wi-Fi

650700080029 Rev AK (Reference only)

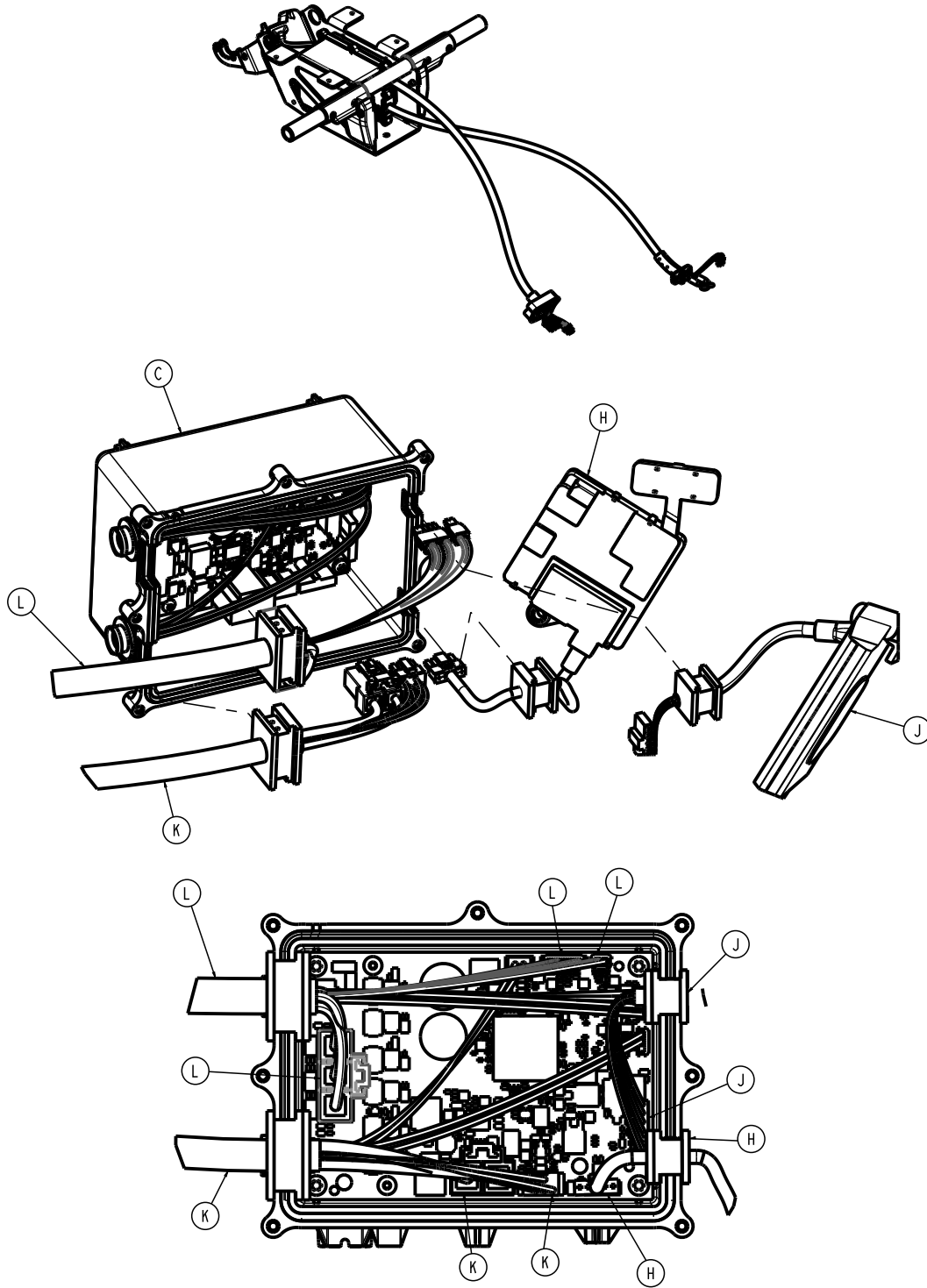

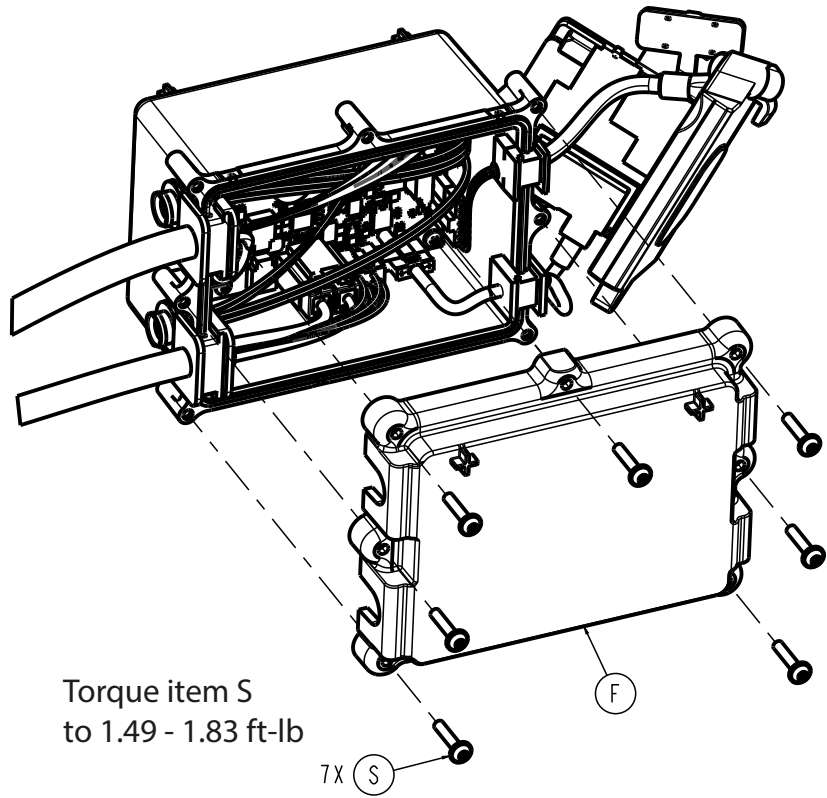

Torque item S
to 1.49 - 1.83 ft-lb

7X S

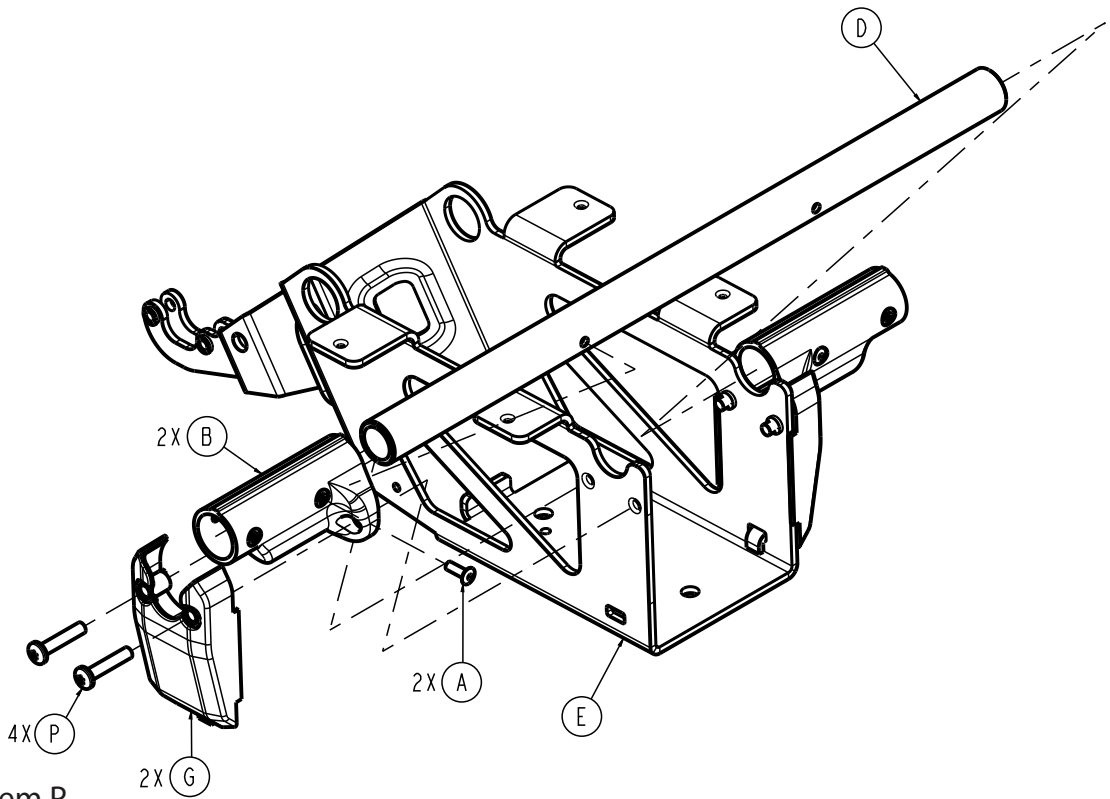

Torque item P
to 4.34 - 5.87 ft-lb

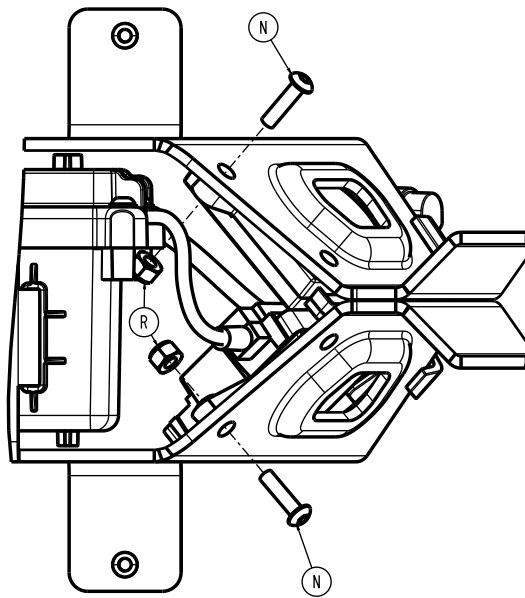
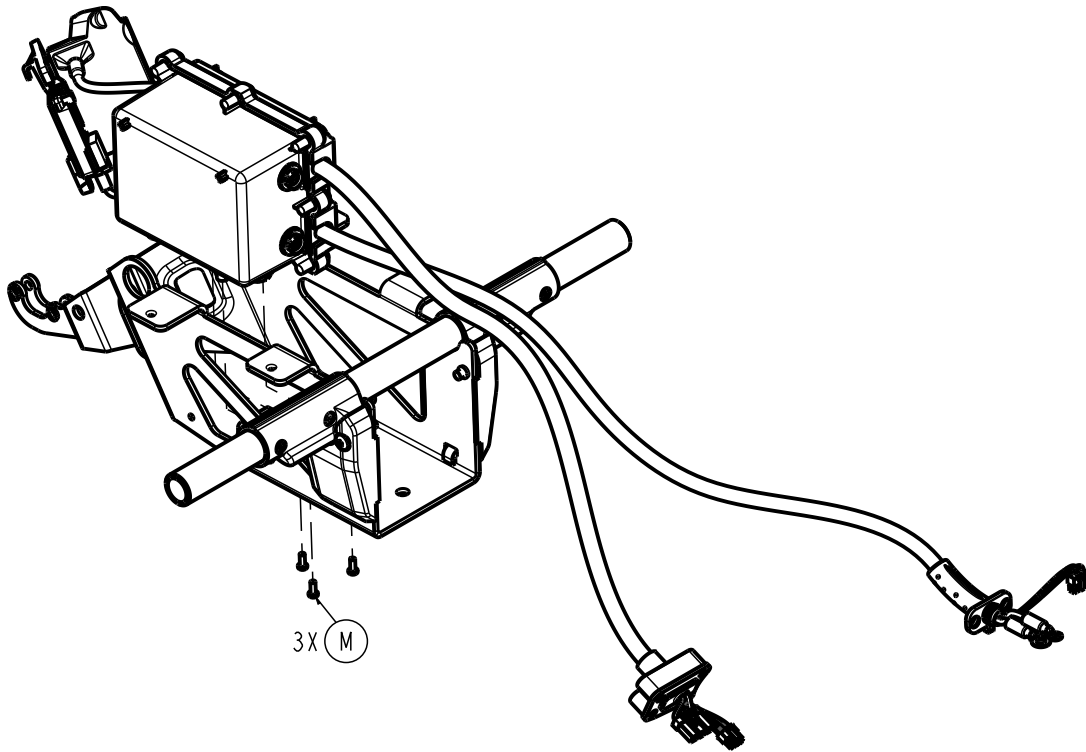

Item	Number	Name	Quantity
A	0025-133-000	Dome head pop rivet	2
B	6500-001-195	Motor mount casting	2
C	650700080032	HBC enclosure assembly (page 160)	1
D	650700080104	Gatch cross brace	1
E	650700080106	Birdcage bracket	1
F	650700080108	HBC enclosure, top	1
G	650700080191	Power-LOAD guide	2
H	650700080202	Wi-Fi module, cot	1
J	650700080203	Cot comm board	1
K	650700080860	System bus cable assembly	1

Item	Number	Name	Quantity
L	650700080868	Lift motor cable assembly	1
M	700000837095	Pan head tapping screw	3
N	700000689468	Button head cap screw	2
P	700000717908	Pan head thread rolling screw	4
R	0016-002-000	Fiberlock nut	2
S	700000687745	Round washer head tapping screw	7

Birdcage assembly, no NFMIC, Wi-Fi

650700080031 Rev AK (Reference only)

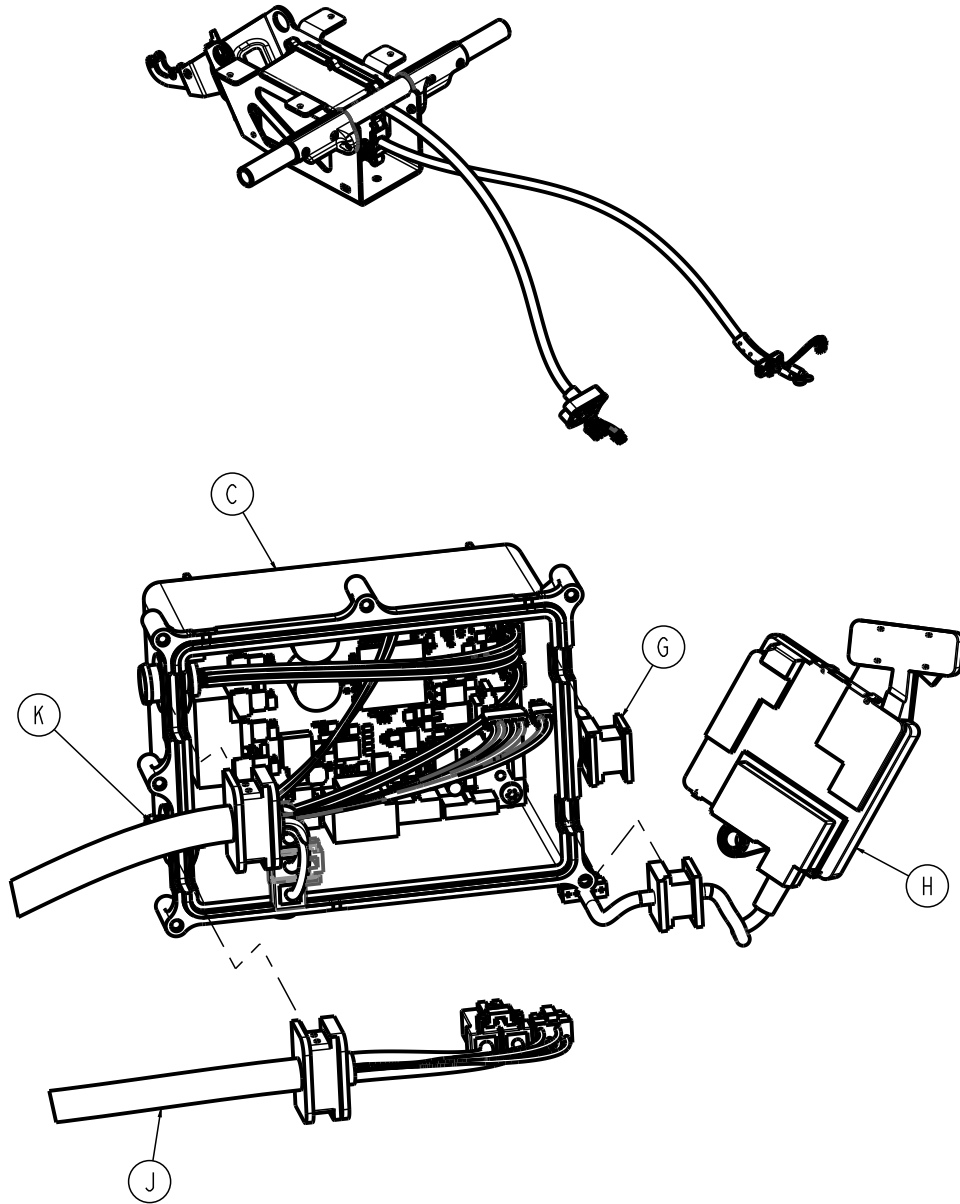

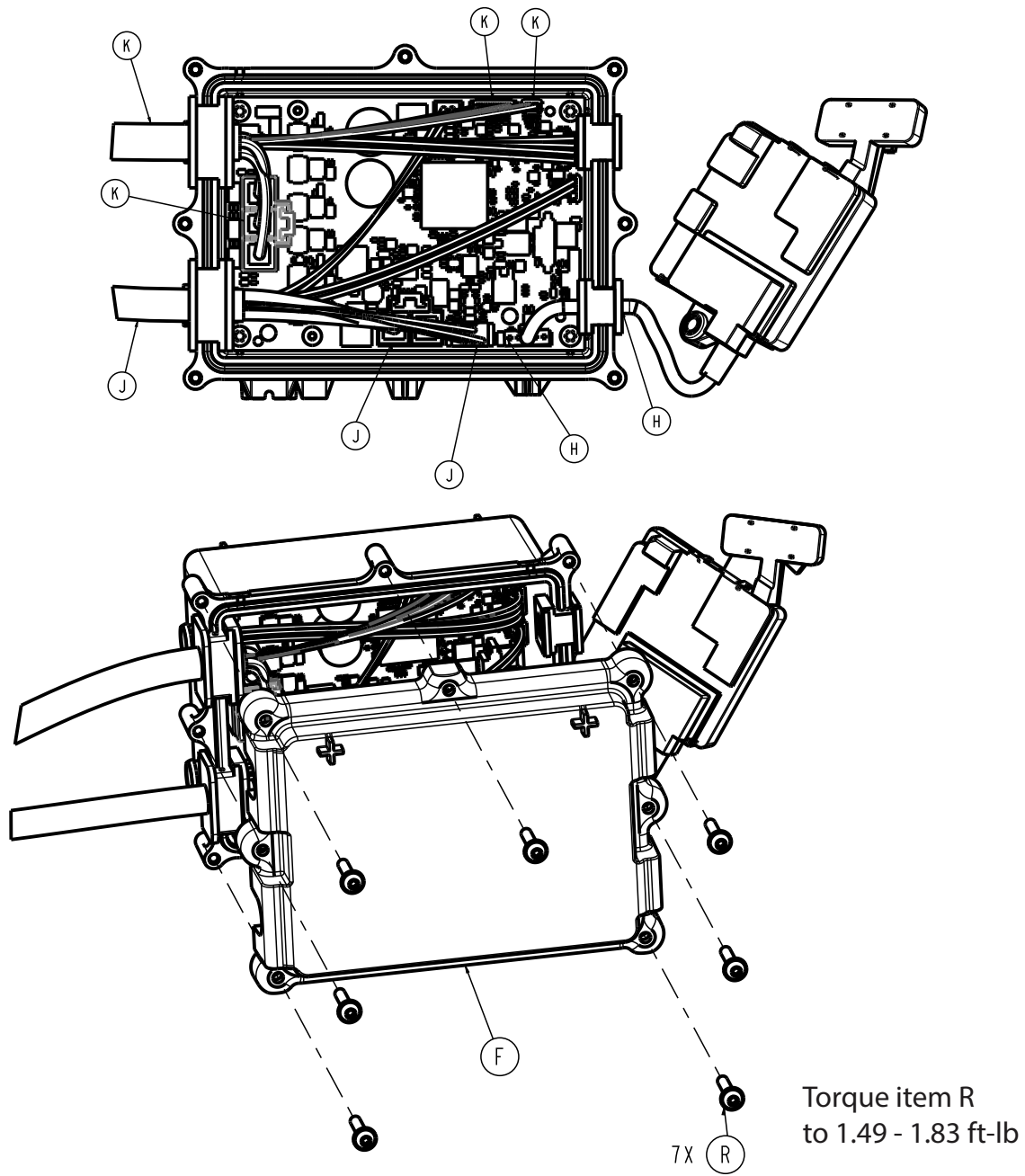

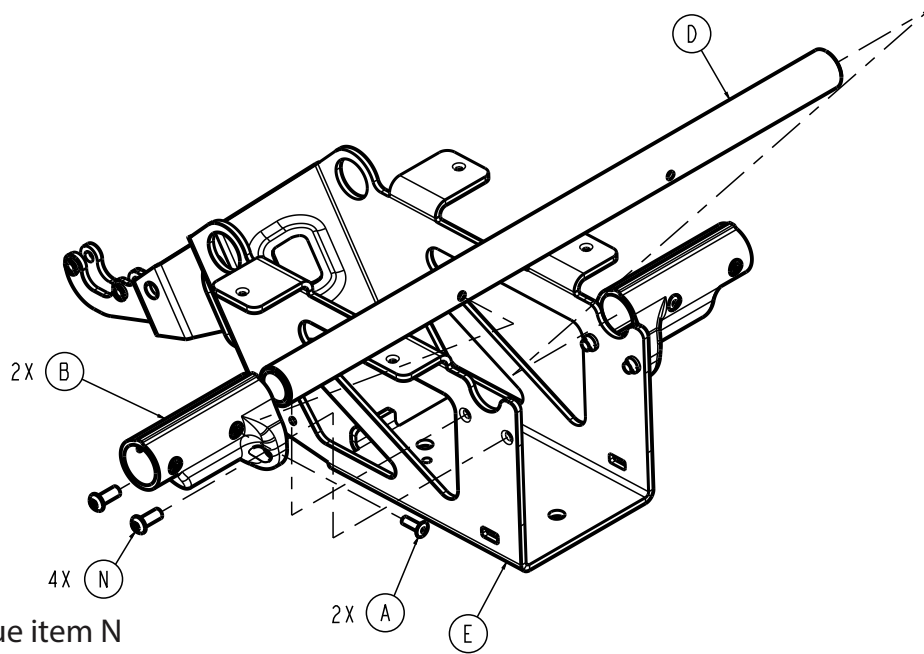

Torque item N
to 4.34 - 5.87 ft-lb

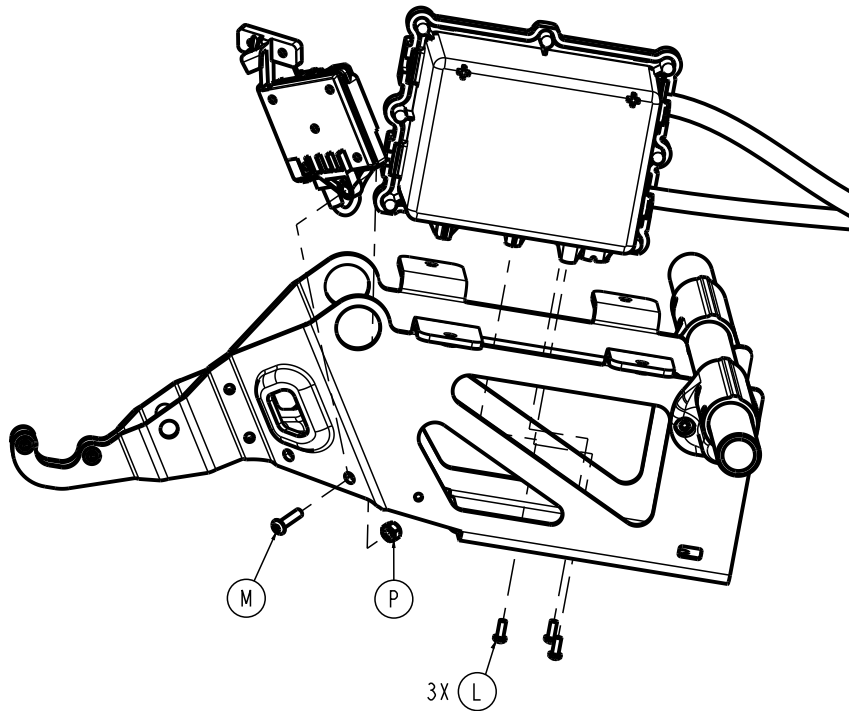

Item	Number	Name	Quantity
A	0025-133-000	Dome head pop rivet	2
B	6500-001-195	Motor mount casting	2
C	650700080032	HBC enclosure assembly (page 160)	1
D	650700080104	Gatch cross brace	1
E	650700080106	Birdcage bracket	1
F	650700080108	HBC enclosure, top	1
G	650700080196	HBC plug	1
H	650700080202	Wi-Fi module, cot	1
J	650700080860	System bus cable assembly	1

Item	Number	Name	Quantity
K	650700080868	Lift motor cable assembly	1
L	700000837095	Pan head tapping screw	3
M	700000689468	Button head cap screw	1
N	700000717877	Button head thread rolling screw	4
P	0016-002-000	Fiberlock nut	1
R	700000687745	Round washer head tapping screw	7

HBC enclosure assembly

650700080032 Rev AC (Reference only)

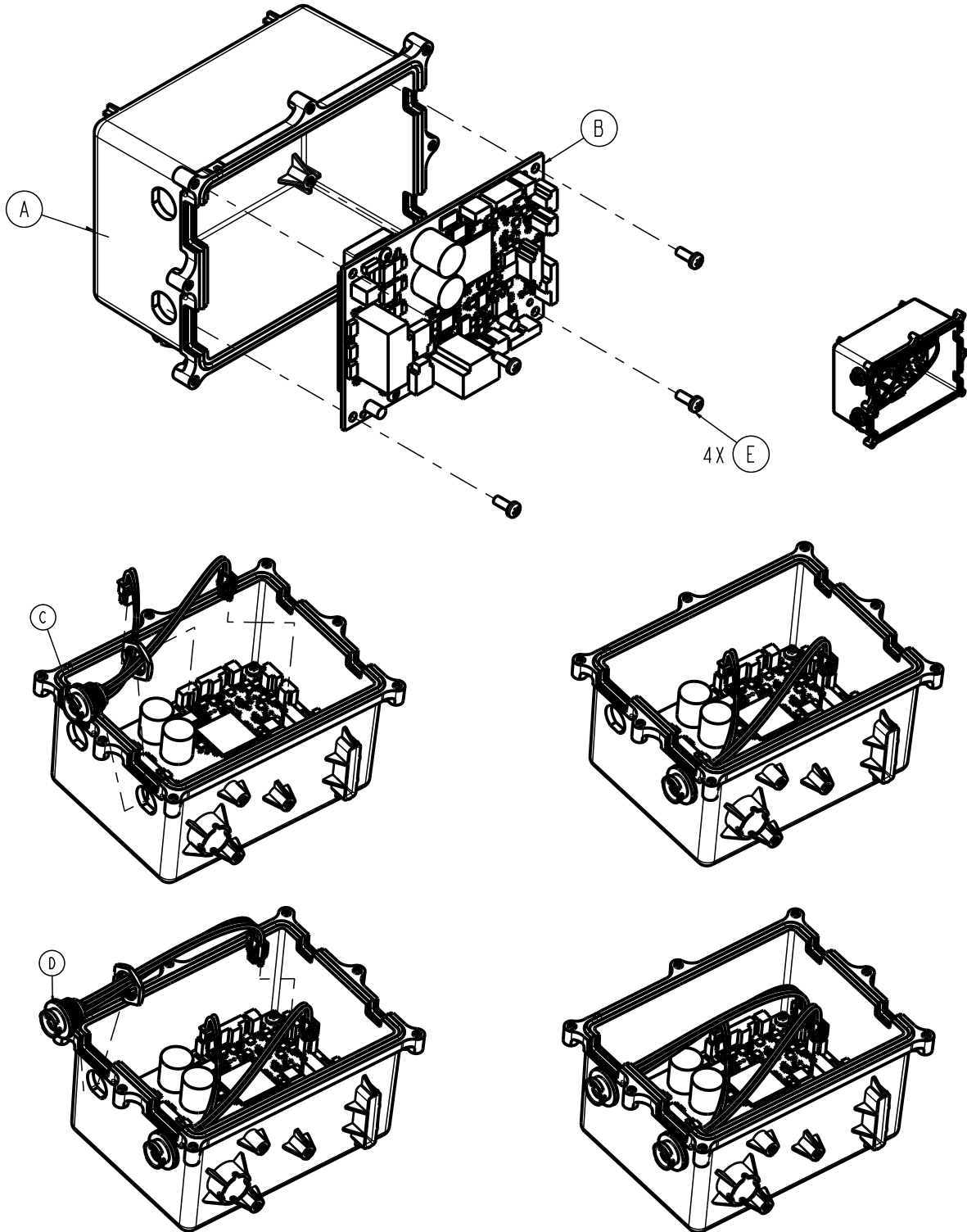

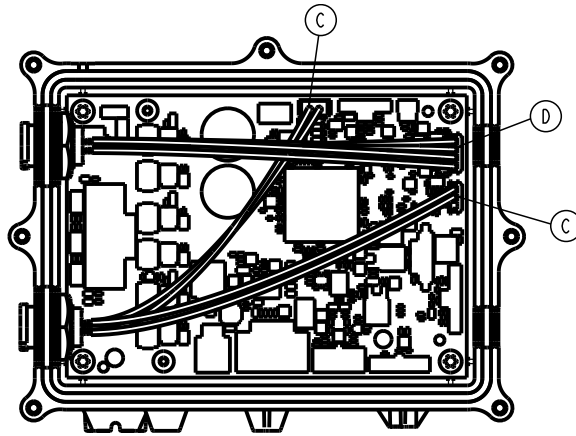

Item	Number	Name	Quantity
A	650700080107	HBC enclosure, bottom overmolded	1
B	650700080806	Base controller PCBA assembly with software	1
C	650700080878	Solenoid/transducer internal cable assembly	1
D	650700080879	HBC strain gauge internal cable assembly	1
E	700000837095	Pan head tapping screw	4

Foot section assembly

650700080008 Rev AK (Reference only)

Torque item AP
to 1.67 - 2.25 ft-lb

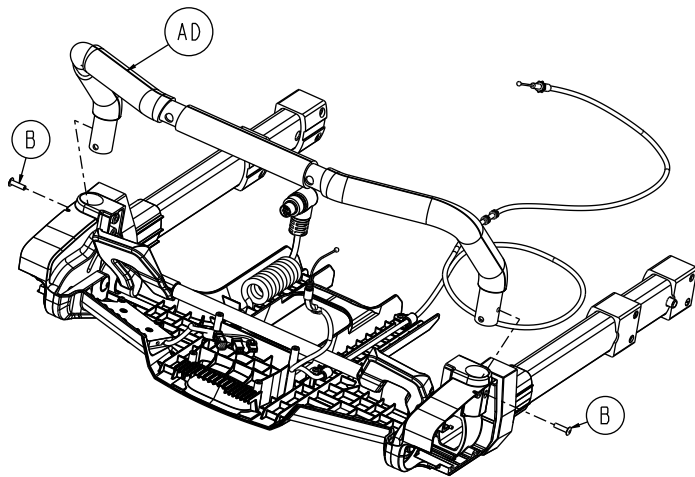
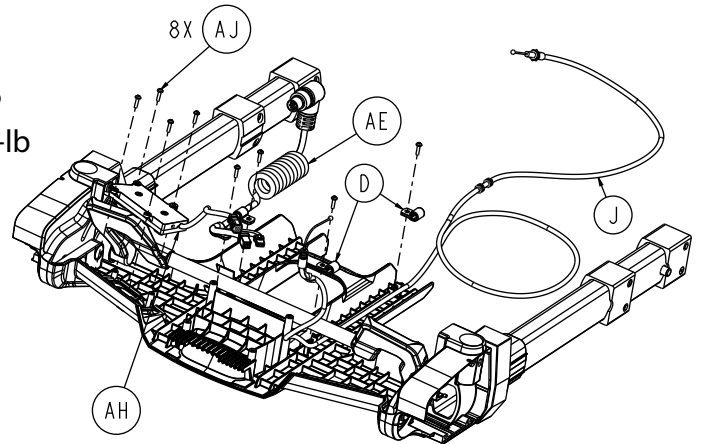
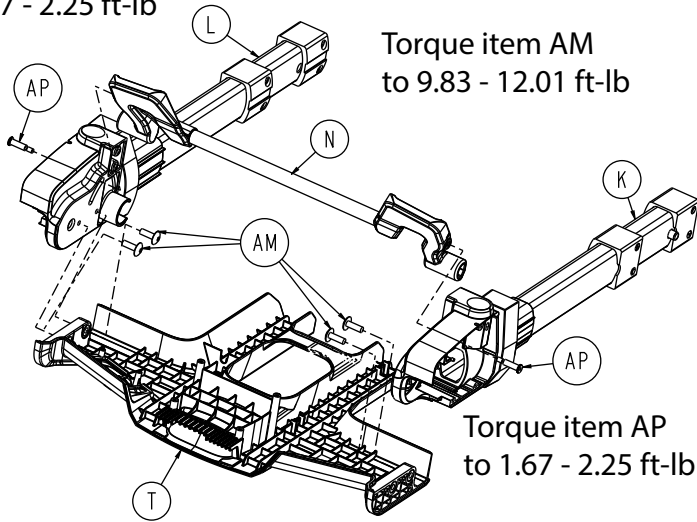

Torque item AN
to 9.83 - 12.01 ft-lb

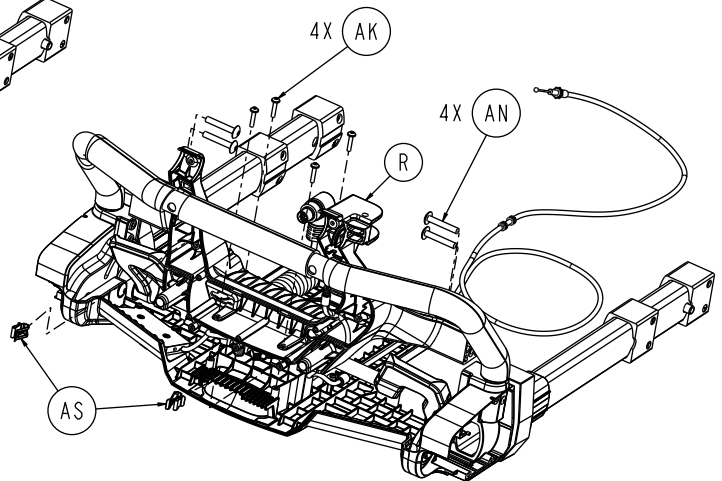

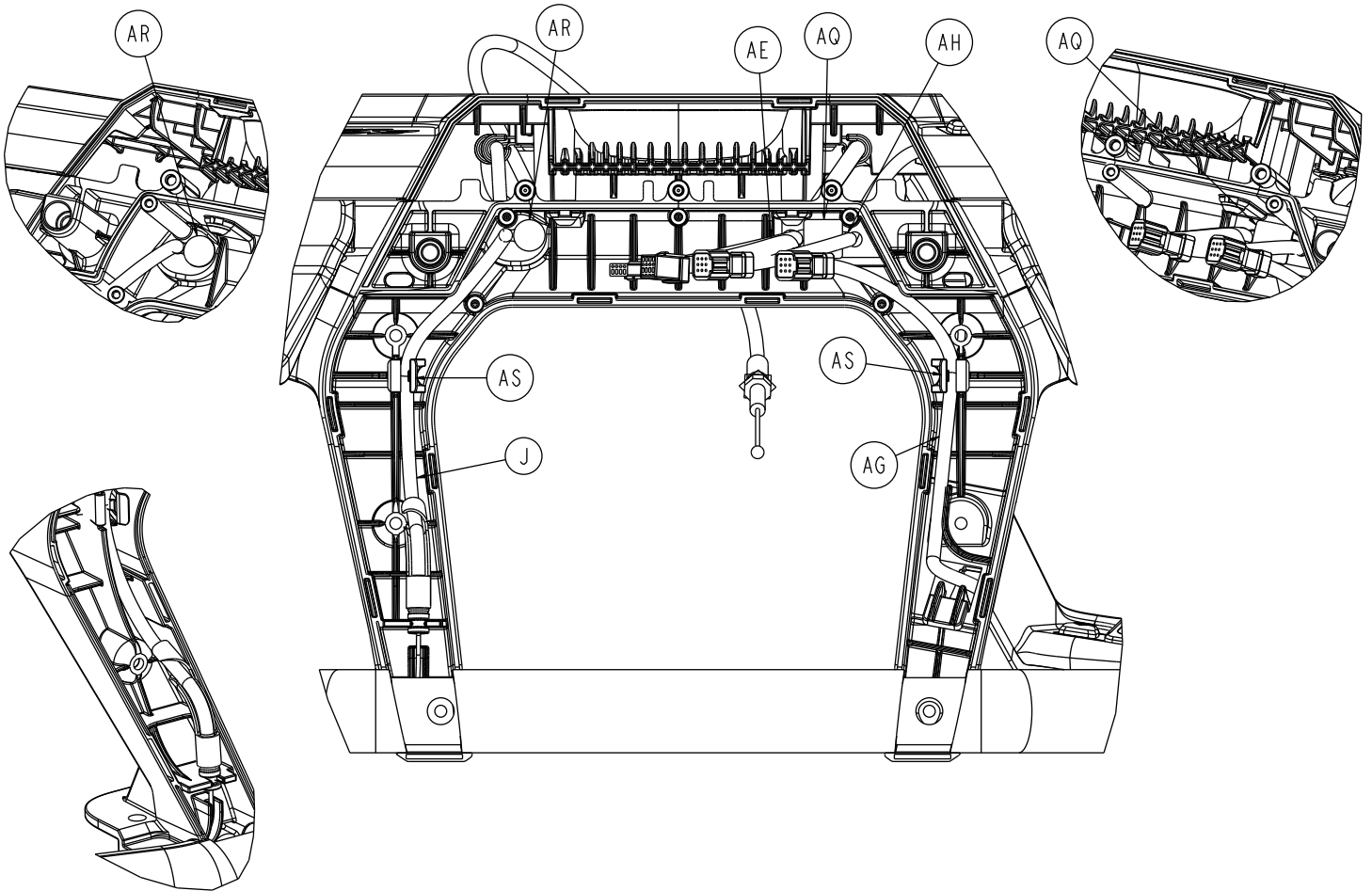
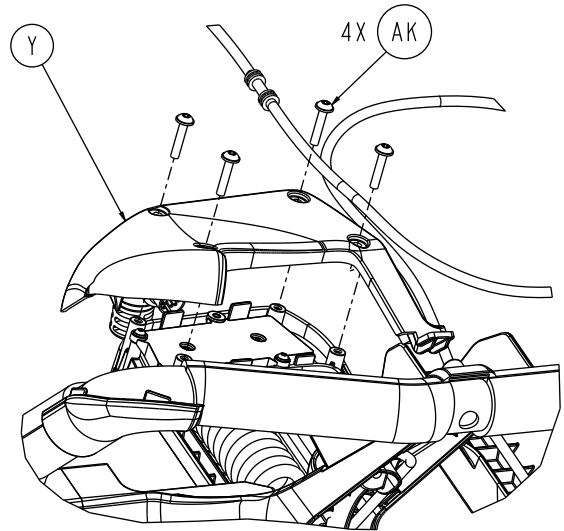
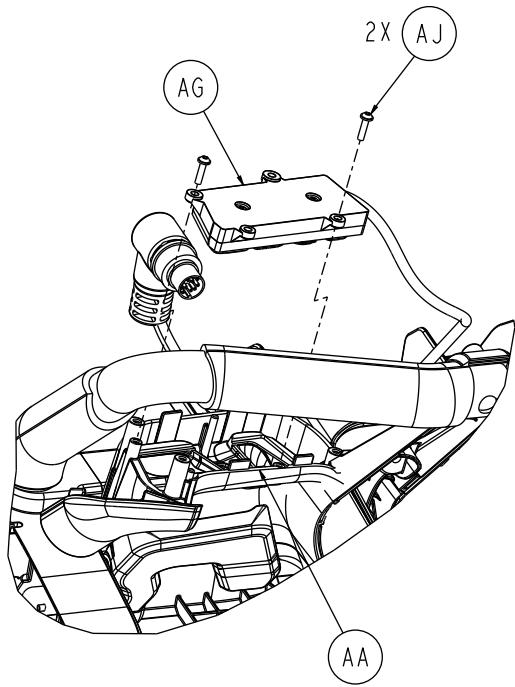

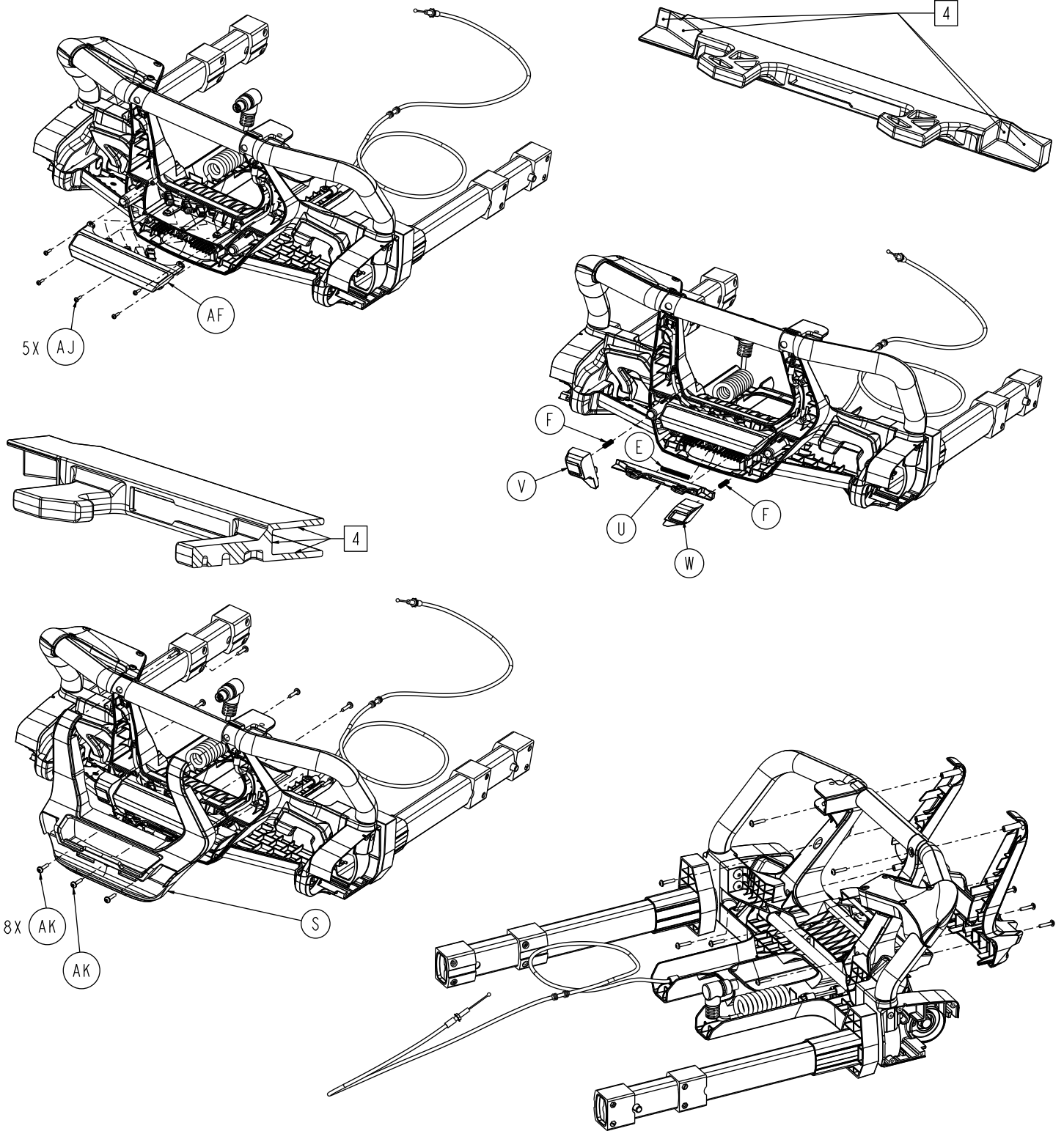

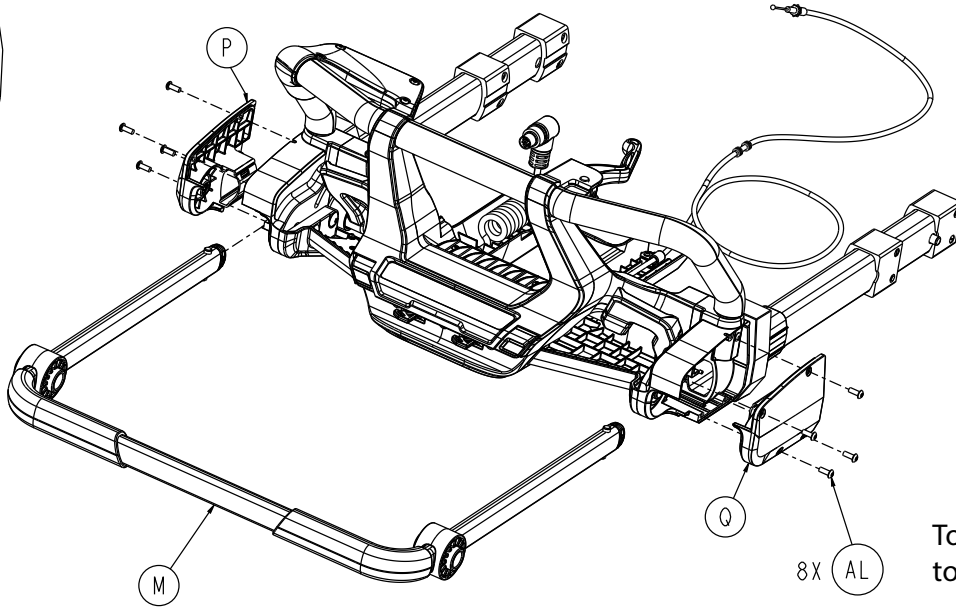
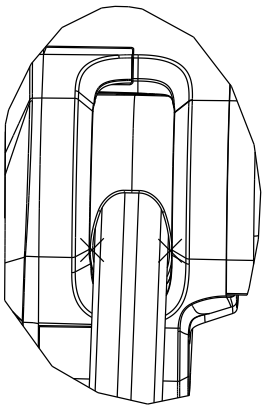
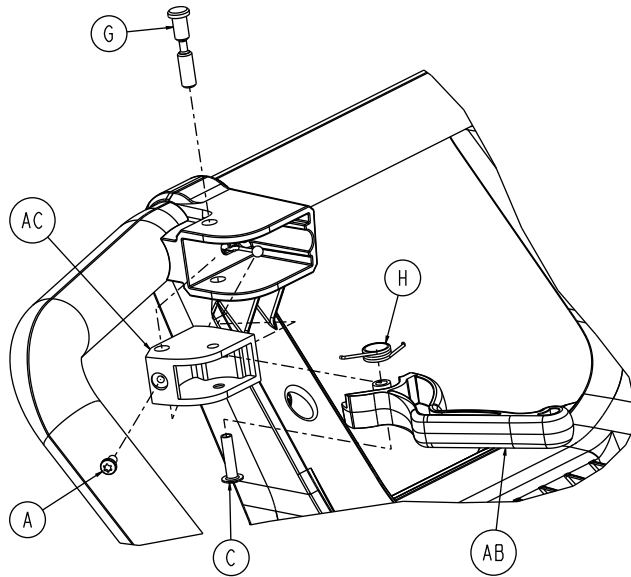

Torque item AL
to 2.62 - 3.55 ft-lb

Item	Number	Name	Quantity
A	0023-163-000	Pan head tapping screw	1
B	0025-086-000	Dome head, open pop rivet	2
C	0025-113-000	Truss head semi-tubular rivet	1
D	0034-381-000	Cable clamp	2
E	0038-134-000	Compression wire	1
F	0038-570-000	Compression wire	2
G	6500-001-146	Manual release pivot pin	1
H	6500-001-147	Manual release torsion spring	1
J	650700020228	Manual release cable	1
K	650700080014	Housing assembly, foot end, right (page 167)	1

Item	Number	Name	Quantity
L	650700080016	Housing assembly, foot end, left (page 169)	1
M	650700080017	Wagon handle assembly (page 171)	1
N	650700080135	Activation bonding, foot end	1
P	650700080156	Foot end housing body cover, left	1
Q	650700080157	Foot end housing body cover, right	1
R	650700080248	Foot end enclosure, back	1
S	650700080249	Foot end enclosure, front	1
T	650700080247	Foot end enclosure, top	1
U	650700080221	Wagon handle release latch	1
V	650700080164	Wagon handle release button, left	1
W	650700080166	Wagon handle release button, right	1
Y	650700080167	UI cover, back	1
AA	650700080168	UI cover, front	1
AB	650700080193	Quick release handle	1
AC	650700080194	Quick release handle housing	1
AD	650700080206	Foot end lift bar overmold	1
AE	650700080862	FEIB to status external module coil cable assembly	1
AF	650700080890	Light module cable assembly	1
AG	650700080891	UI bottom cable assembly	1
AH	650700080892	UI top cable assembly	1
AJ	700000687744	Round washer head tapping screw	15
AK	700000687745	Round washer head tapping screw	17
AL	700000689483	Button head cap screw	8
AM	700000711191	Truss head machine screw	4
AN	700000711194	Truss head machine screw	4
AP	700002801177	Socket head shoulder bolt	2
AQ	700000765285	Rectangular hole plug	1
AR	700000765287	Round hole plug	1
AS	700000765290	Heyco wire clip	2

Housing assembly, foot end, right

650700080014 Rev AD (Reference only)

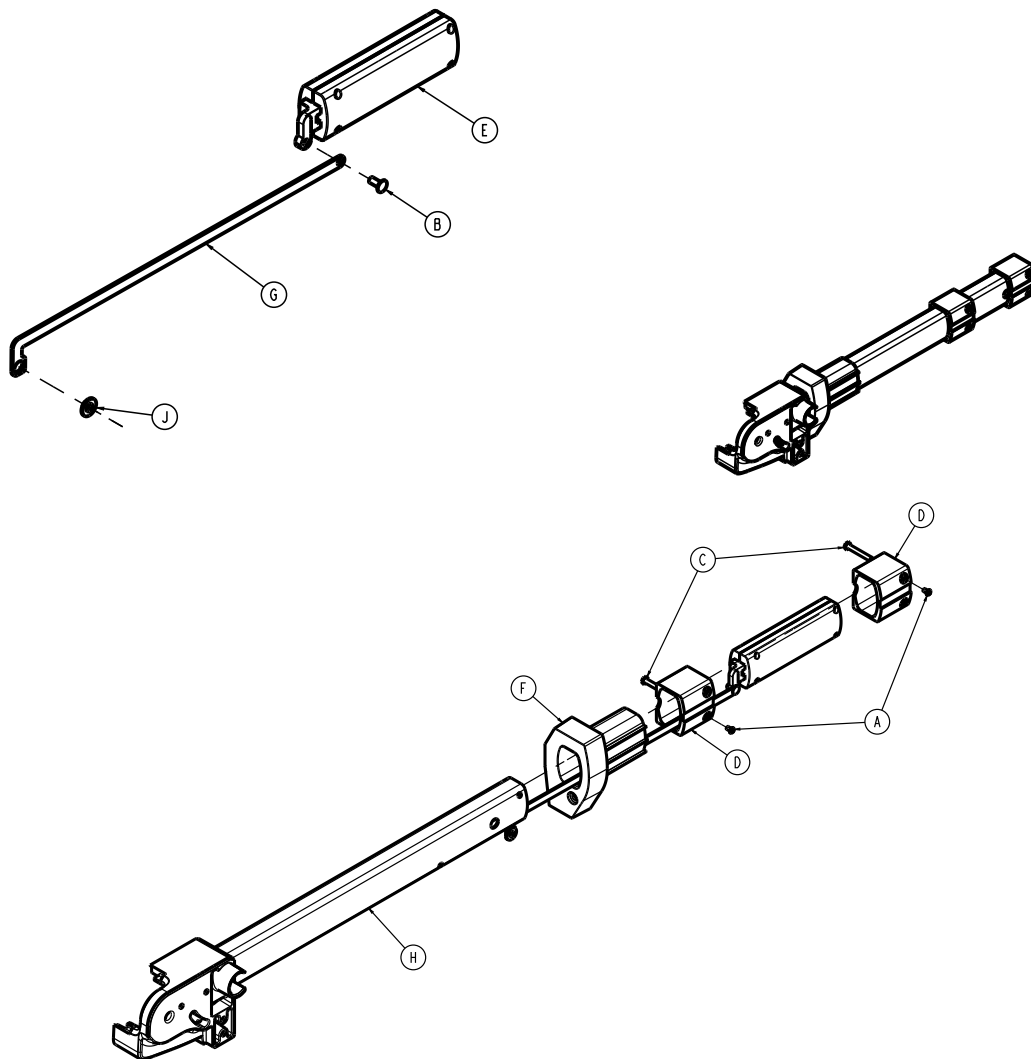

Item	Number	Name	Quantity
A	0004-883-000	Button head cap screw	2
B	0025-126-000	Semi-tubular rivet	1
C	6085-001-169	Head section nut	2
D	6085-001-170	Internal bearing	2
E	650700080022	Latch assembly, foot end, right (page 168)	1
F	650700080133	Outer rail end cap, foot end, right	1
G	650700080142	Extension release latch link	1
H	650700080165	Foot end housing bonding, right	1
J	700001235118	Flange bearing	1

Latch assembly, foot end, right

650700080022 Rev AA (Reference only)

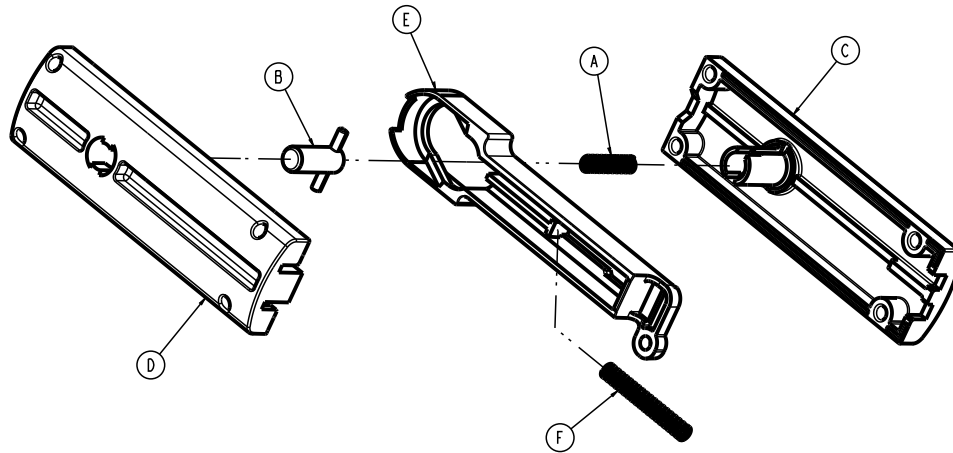

Item	Number	Name	Quantity
A	0038-570-000	Compression wire	1
B	6500-001-025	Latch assembly	1
C	6500-001-091	Housing latch, top	1
D	6500-001-092	Housing latch, bottom	1
E	650700080138	Extension release latch, right	1
F	700000763860	Compression wire	1

Housing assembly, foot end, left

650700080016 Rev AD (Reference only)

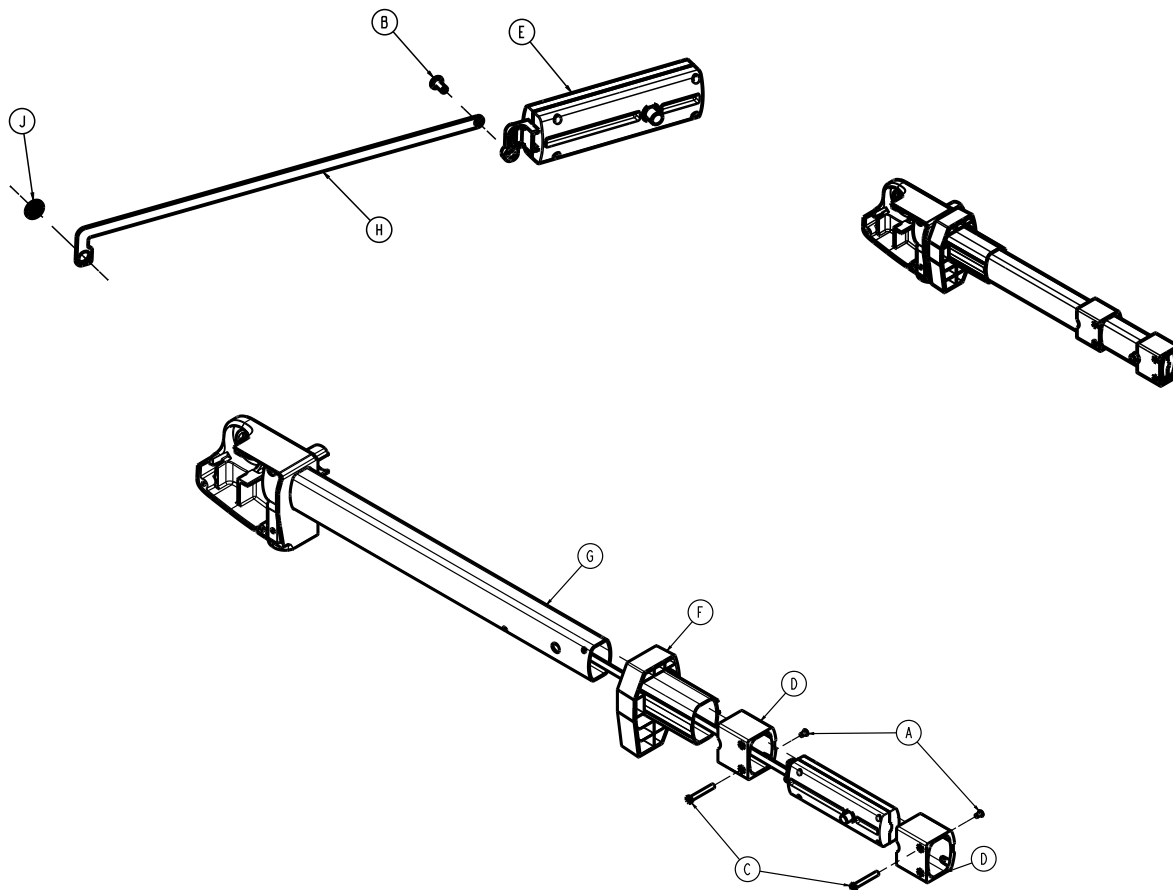

Item	Number	Name	Quantity
A	0004-883-000	Button head cap screw	2
B	0025-126-000	Semi-tubular rivet	1
C	6085-001-169	Head section nut	2
D	6085-001-170	Internal bearing	2
E	650700080023	Latch assembly, foot end, left (page 170)	1
F	650700080132	Outer rail end cap, foot end, left	1
G	650700080160	Foot end housing bonding, left	1
H	650700080142	Extension release latch link	1
J	700001235118	Flange bearing	1

Latch assembly, foot end, left

650700080023 Rev AA (Reference only)

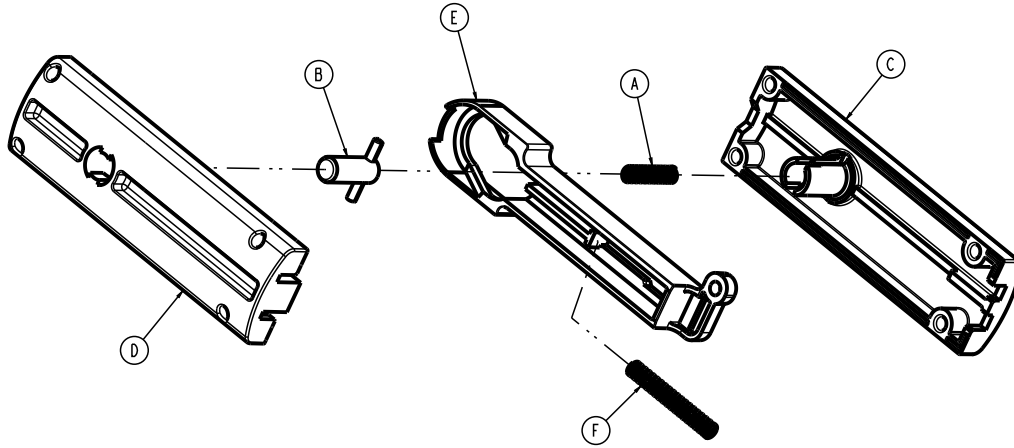

Item	Number	Name	Quantity
A	0038-570-000	Compression wire	1
B	6500-001-025	Latch assembly	1
C	6500-001-091	Housing latch, top	1
D	6500-001-092	Housing latch, bottom	1
E	650700080139	Extension release latch, left	1
F	700000763860	Compression wire	1

Wagon handle assembly

650700080017 Rev AA (Reference only)

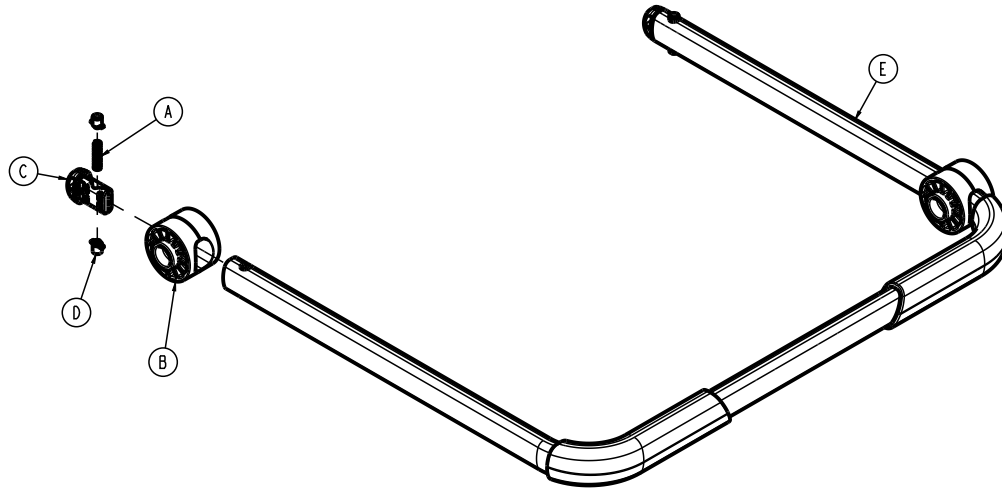

Item	Number	Name	Quantity
A	0038-570-000	Compression wire	2
B	650700080144	Wagon handle joint	2
C	650700080147	Wagon handle bar cap	2
D	650700080148	Wagon handle bar pin	4
E	650700080204	Wagon handle bar, overmold	1

Head section assembly

650700080007 Rev AE (Reference only)

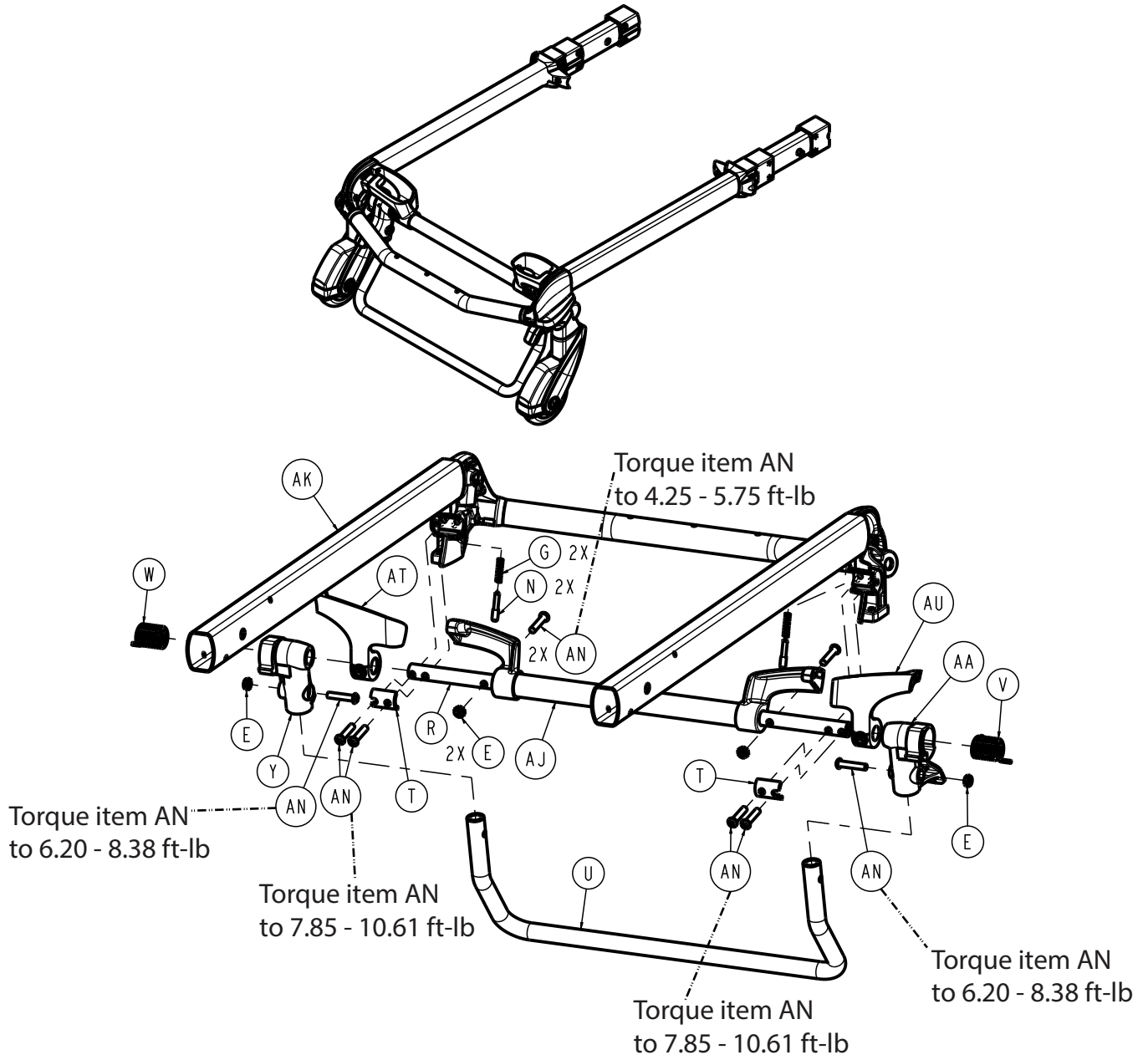

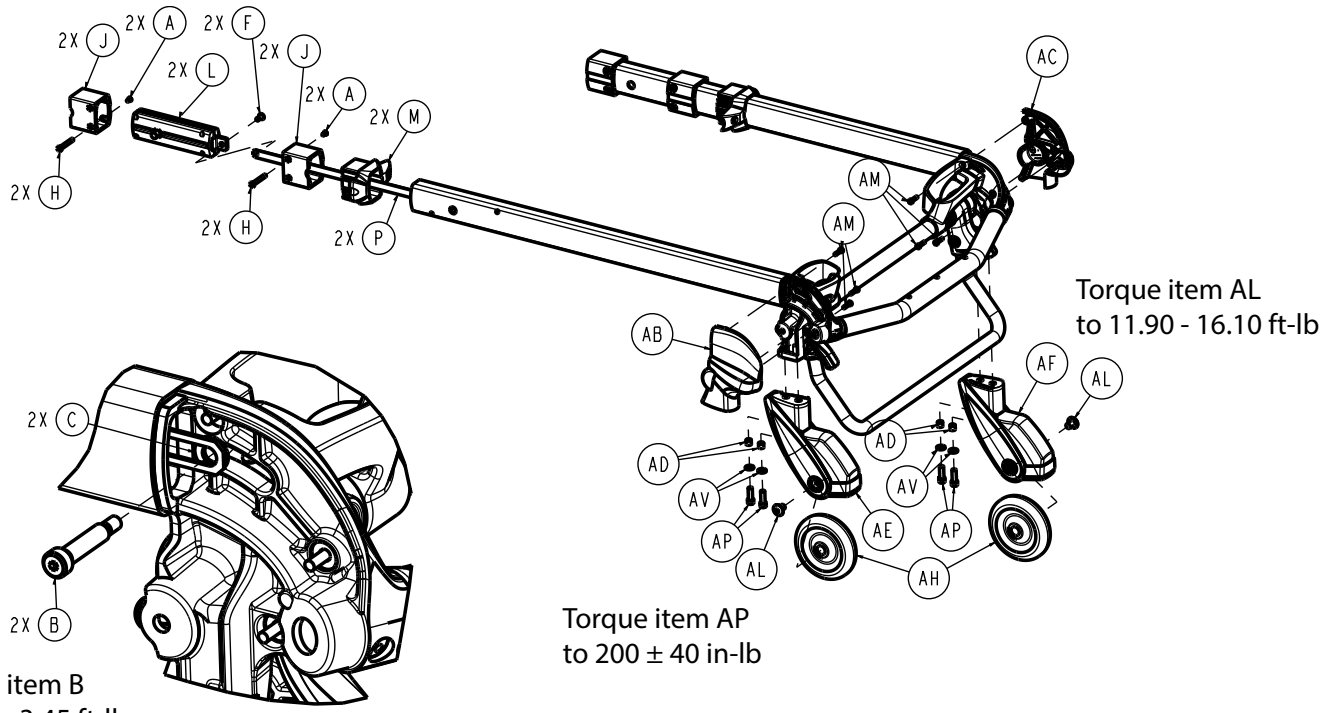

Item	Number	Name	Quantity
A	0004-883-000	Button head cap screw	4
B	0008-030-000	Socket head shoulder bolt	2
C	0014-002-000	Washer	2
E	0016-102-000	Nylock nut	4
F	0025-126-000	Semi-tubular rivet	2
G	0038-570-000	Compression wire	2
H	6085-001-169	Head section nut	4
J	6085-001-170	Internal bearing	4
L	6500-001-026	Head section lock assembly	2
M	6500-001-087	Cap bearing	2
N	6500-001-093	Safety bar lock pin	2
P	6500-001-096	Head section release link	2
R	6500-001-220	Head section pivot cross tube	1
T	6500-001-221	Cross tube clamp	2
U	6500-001-322	Sliding head section safety bar	1
V	6500-001-325	Safety bar torsion spring, left	1
W	6500-001-326	Safety bar torsion spring, right	1
Y	6500-002-107	Safety bar pivot, right	1
AA	6500-002-108	Safety bar pivot, left	1
AB	6500-002-109	Load wheel horn cover, left	1
AC	6500-002-110	Load wheel horn cover, right	1
AD	6500-002-114	Compression limiter sleeve	4
AE	6500-002-120	Load wheel horn, left	1
AF	6500-002-121	Load wheel horn, right	1
AH	6500-101-086	Load wheel, hard	2
AJ	650700080155	Activation bonding, head end	1

Item	Number	Name	Quantity
AK	650700080150	Head section bonding	1
AL	700000686337	Truss head machine screw	2
AM	700000687300	Pan head tapping screw	6
AN	700000689588	Button head cap screw	8
AP	700000721221	Socket head cap screw	4
AT	6500-001-280	Head section guard, right	1
AU	6500-001-281	Head section guard, left	1
AV	700001671948	Flat washer	4

Standard siderail option - 650709990102

Rev AD (Reference only)

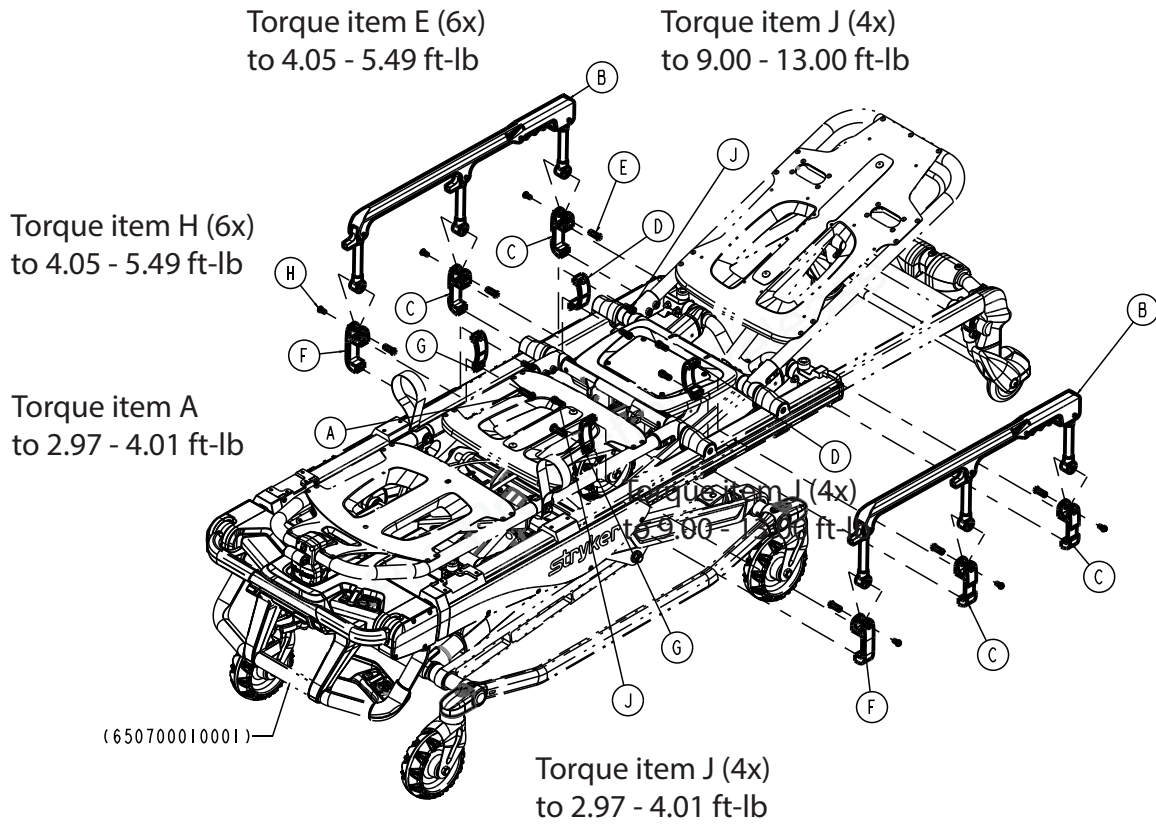

Item	Number	Name	Quantity
A	0004-130-000	Hex socket button head cap screw	2
B	6082-026-010	Siderail assembly	2
C	6500-001-116	Siderail bracket	4
D	6500-001-117	Siderail clamp	2
E	6500-001-118	Siderail nut	6
F	650700020169	Standard siderail mounting bracket	2
G	650700020171	Standard siderail inner bracket	2
H	700000689483	Button head cap screw	6
J	700000721221	Socket head cap screw	6

XPS siderail option - 650709990101

Rev AC (Reference only)

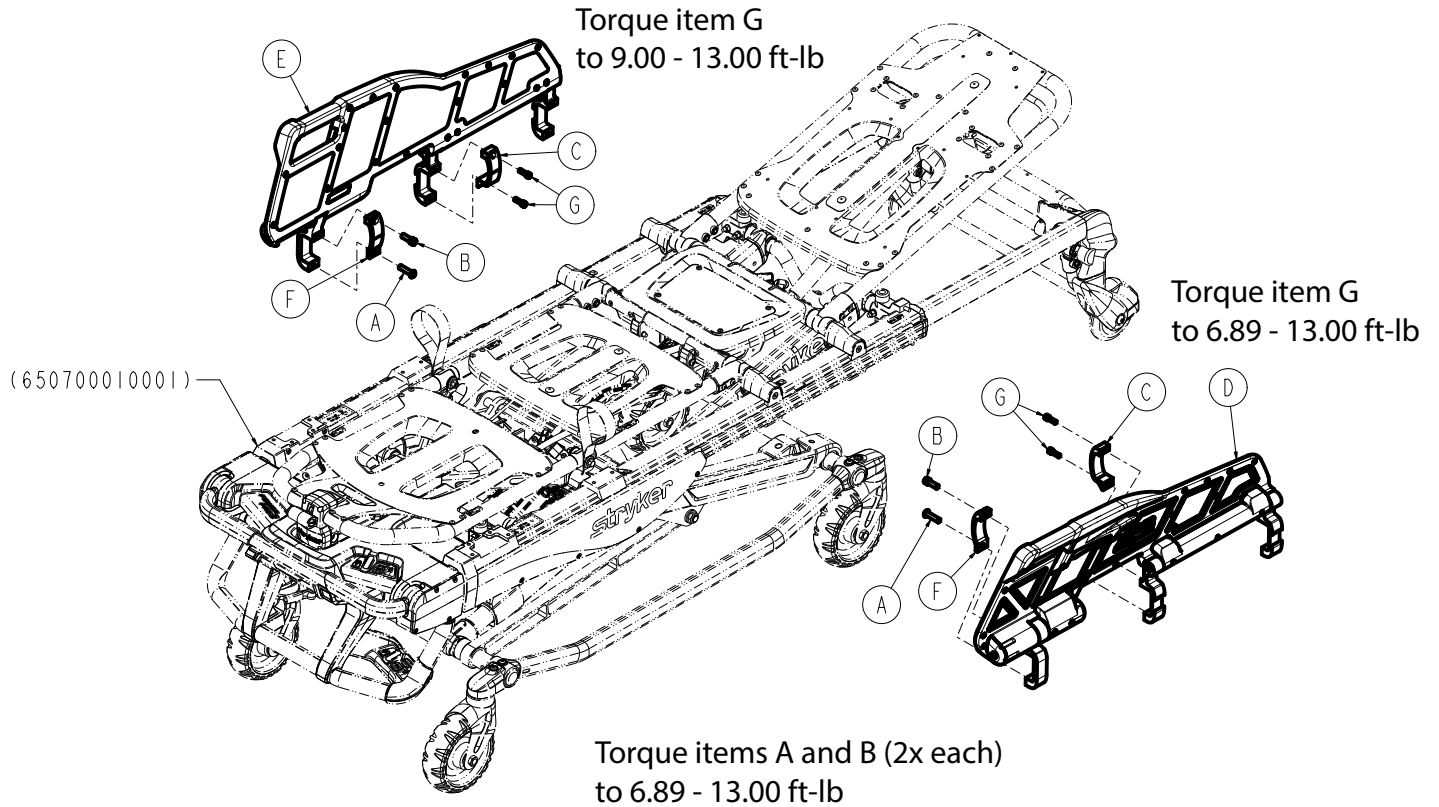

Item	Number	Name	Quantity
A	0004-130-000	Hex socket button head cap screw	2
B	0004-213-000	Socket head cap screw	2
C	6500-001-117	Siderail clamp	2
D	650700020021	XPS assembly, left (page 177)	1
E	650700020022	XPS assembly, right (page 178)	1
F	650700020168	XPS inner bracket	2
G	700000721221	Socket head cap screw	4

XPS assembly, left

650700020021 Rev AB (Reference only)

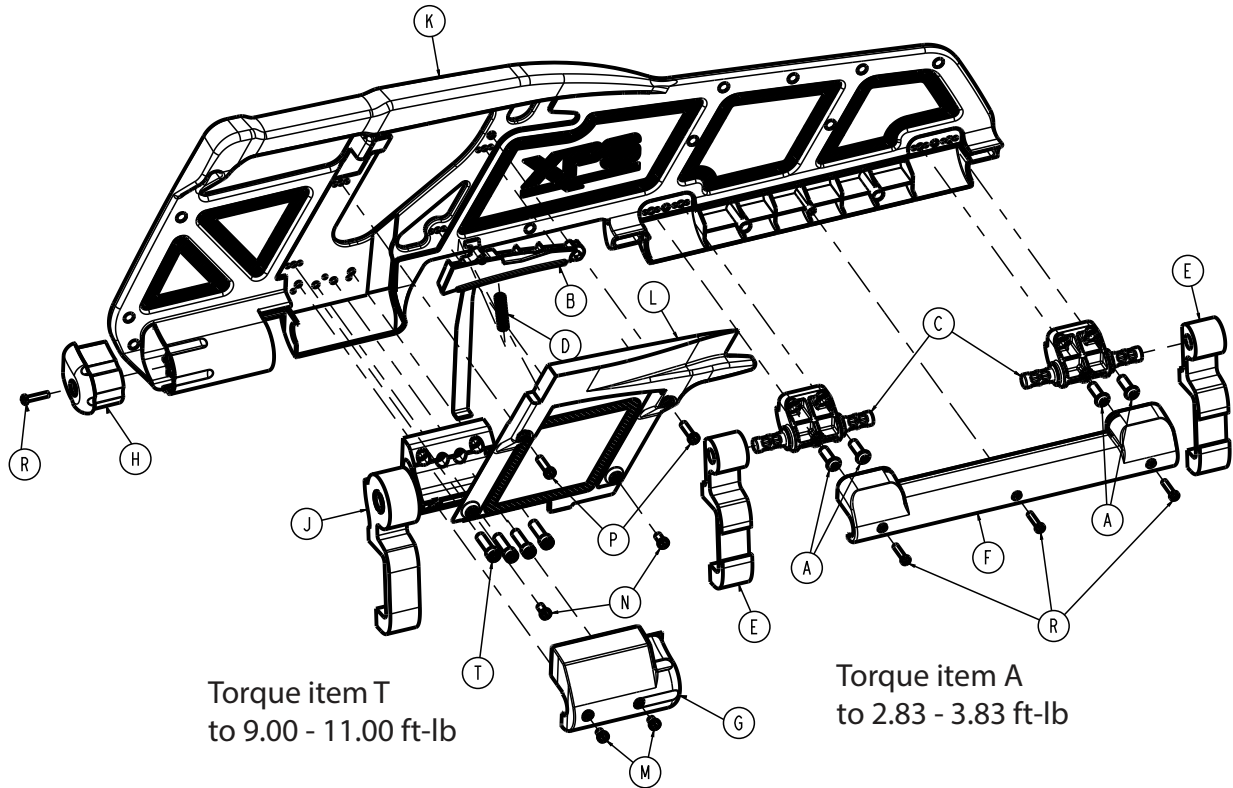

Item	Number	Name	Quantity
A	0004-468-000	Button head cap screw	4
B	6500-003-045	XPS handle assembly, left	1
C	6500-003-084	Support pivot	2
D	6500-003-085	XPS handle spring	1
E	6500-003-086	XPS siderail pivot	2
F	6500-003-097	XPS pivot cover	1
G	6500-003-120	Ratchet cover, left	1
H	6500-003-122	Cap end cover	1
J	650700020023	XPS ratchet assembly, left	1
K	650700020201	XPS overmold assembly, left	1
L	650700020203	XPS release cover, right	1
M	700000718375	Socket head cap screw	2
N	700000718378	Socket head cap screw	2
P	700000718380	Socket head cap screw	2
R	700000719623	Pan head tapping screw	4
T	700000721223	Socket head cap screw	4

XPS assembly, right

650700020022 Rev AB (Reference only)

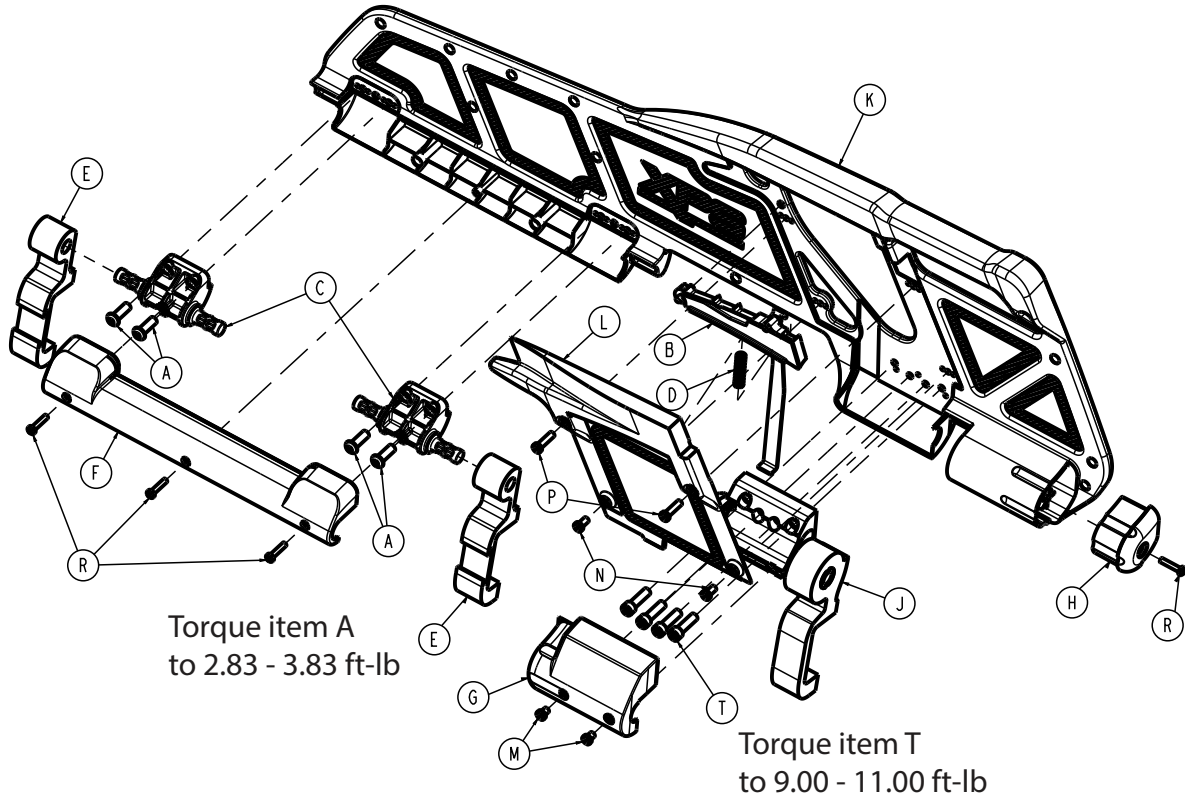

Item	Number	Name	Quantity
A	0004-468-000	Button head cap screw	4
B	6500-003-043	XPS handle assembly, right	1
C	6500-003-084	Support pivot	2
D	6500-003-085	XPS handle spring	1
E	6500-003-086	XPS siderail pivot	2
F	6500-003-097	XPS pivot cover	1
G	6500-003-119	Ratchet cover, right	1
H	6500-003-121	Cap end cover	1
J	650700020024	XPS ratchet assembly, right	1
K	650700020202	XPS overmold assembly, right	1
L	650700020204	XPS release cover, right	1
M	700000718375	Socket head cap screw	2
N	700000718378	Socket head cap screw	2
P	700000718380	Socket head cap screw	2
R	700000719623	Pan head tapping screw	4
T	700000721223	Socket head cap screw	4

Fowler assembly

650700080002 Rev AH (Reference only)

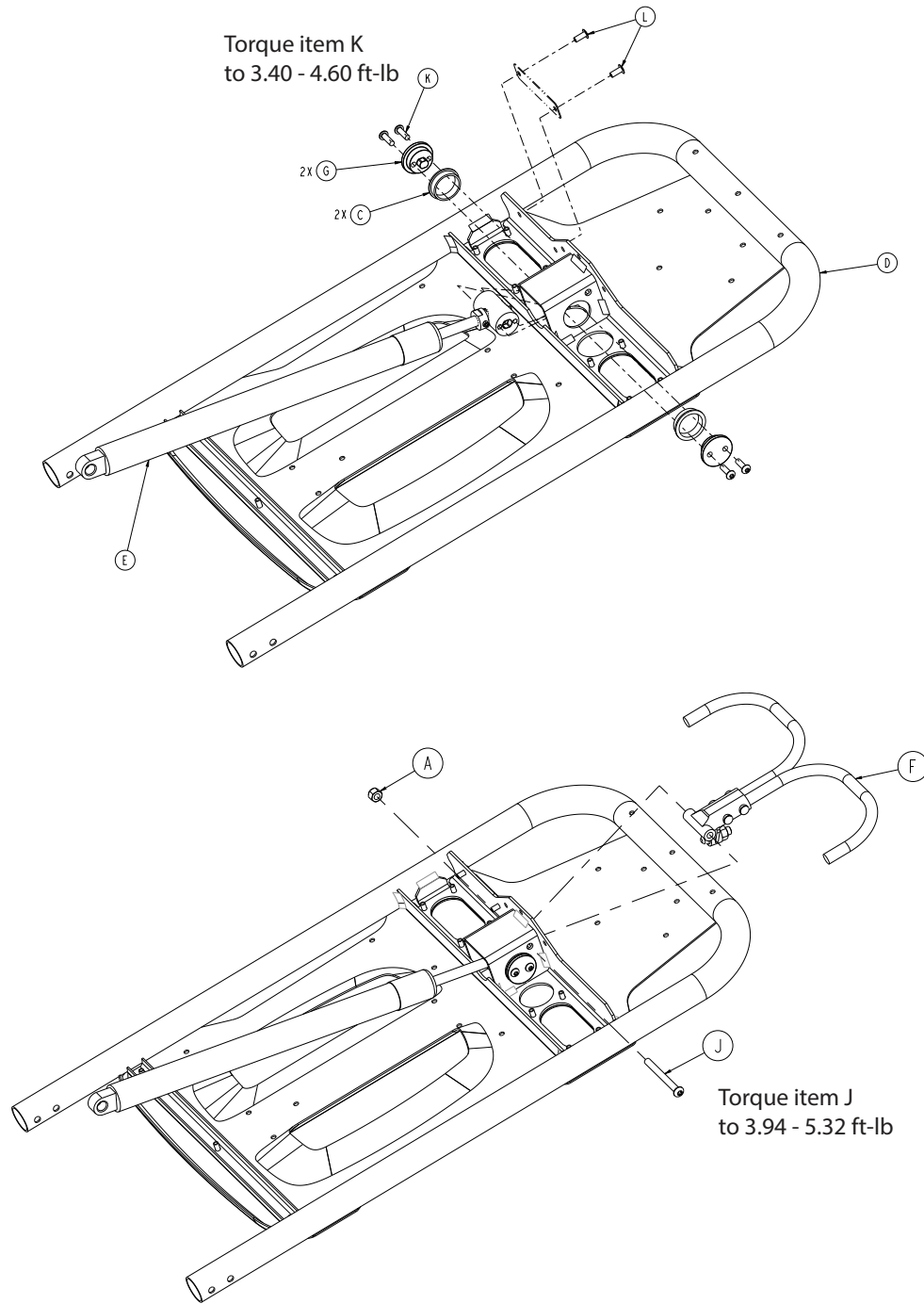

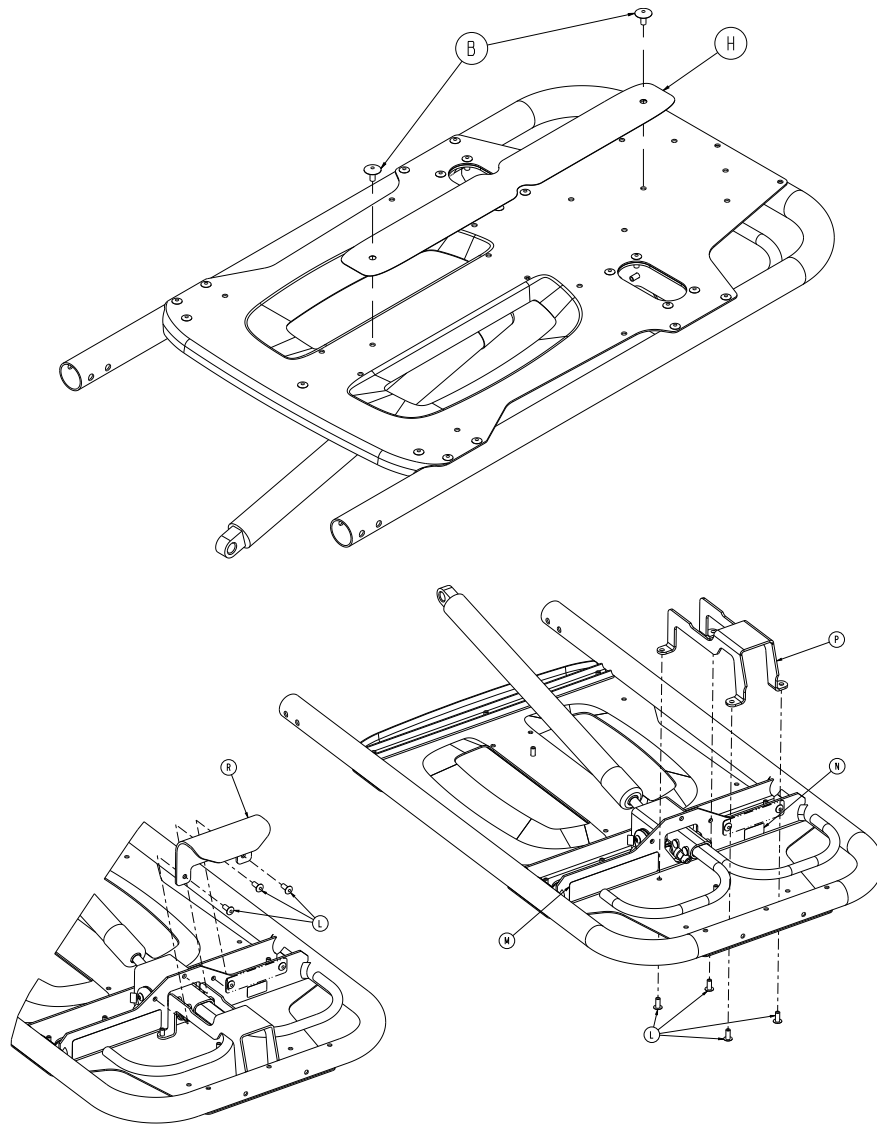

Item	Number	Name	Quantity
A	0016-028-000	Fiberlock hex nut	1
B	0025-132-000	Large flange rivet	2
C	0946-035-025	Liner	2
D	650700080001	<i>Fowler frame assembly (page 181)</i>	1
E	650700080012	<i>Fowler cylinder assembly (page 182)</i>	1
F	650700080013	<i>Fowler handle assembly (page 183)</i>	1
G	650700080179	Gas spring yoke end	2
H	650700080182	Fowler mattress loop	1
J	700000689600	Button head cap screw	1
K	700000689500	Button head cap screw	4
L	0025-079-000	Dome head pop rivet	9
M	650700010901	Label, specification	1
N	123400010900	Label, eIFU	1
P	650700080228	Fowler release guard	1
R	6500-001-237	Equipment hook	1

Fowler frame assembly

650700080001 Rev AD (Reference only)

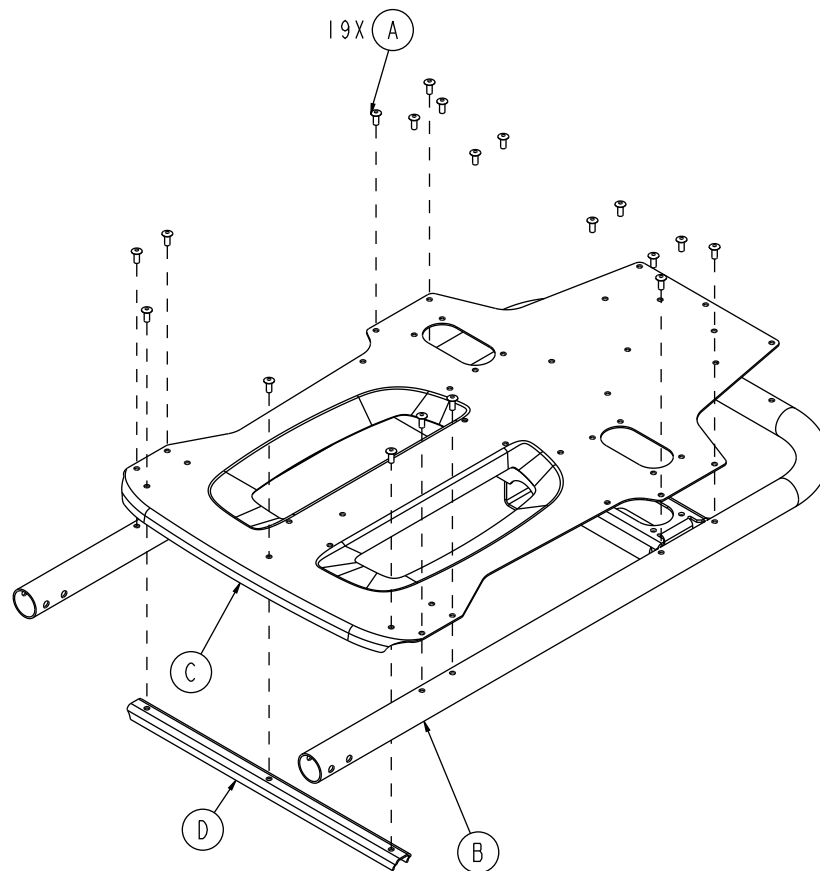

Item	Number	Name	Quantity
A	0025-079-000	Dome head blind rivet	19
B	650700080110	Fowler weldment	1
C	650700080171	Fowler skin	1
D	650700080222	Fowler cross brace	1

Fowler cylinder assembly

650700080012 Rev AC (Reference only)

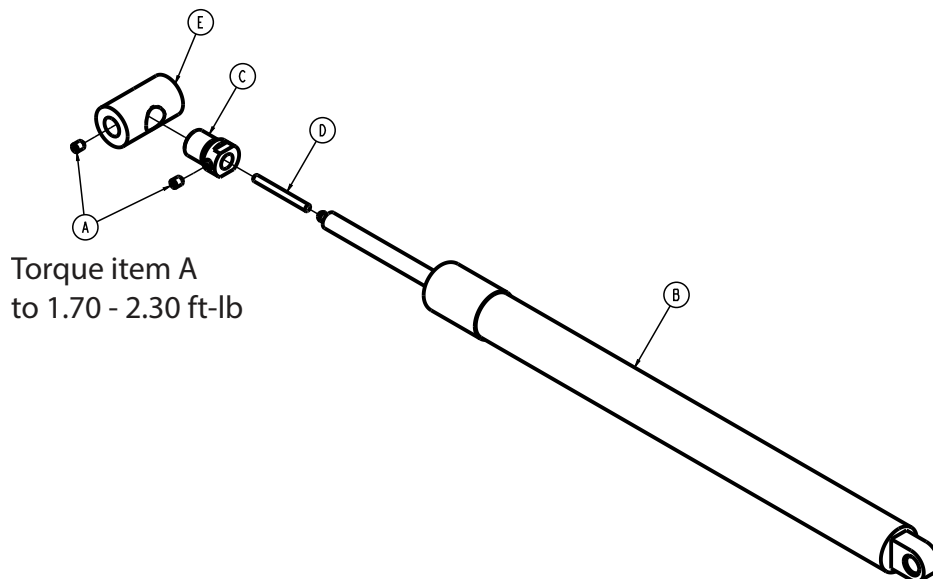

Item	Number	Name	Quantity
A	0021-050-000	Set screw	2
B	6500-031-077	Gas cylinder	1
C	6506-012-001	Fowler extension sleeve, ambulance cot	1
D	6506-012-002	Fowler plunger, ambulance cot	1
E	650700080178	Gas spring yoke	1

Fowler handle assembly

650700080013 Rev AA (Reference only)

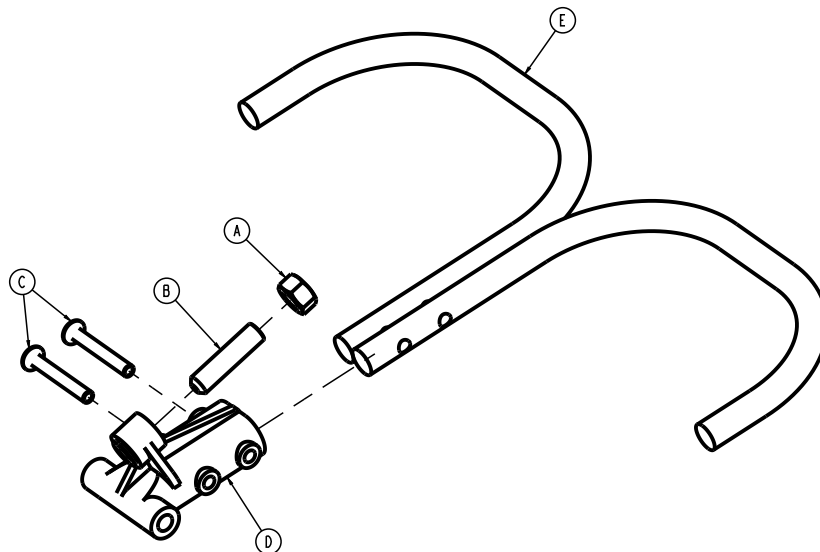

Item	Number	Name	Quantity
A	0015-050-000	Hex nut	1
B	0021-138-000	Set screw	1
C	0025-131-000	Type S (oval) head semi-tubular rivet	2
D	6060-032-040	Pivot Fowler lift - ambulance cot	1
E	6082-032-052	Release handle weldment - Fowler	1

Gatch assembly

650700080006 Rev AC (Reference only)

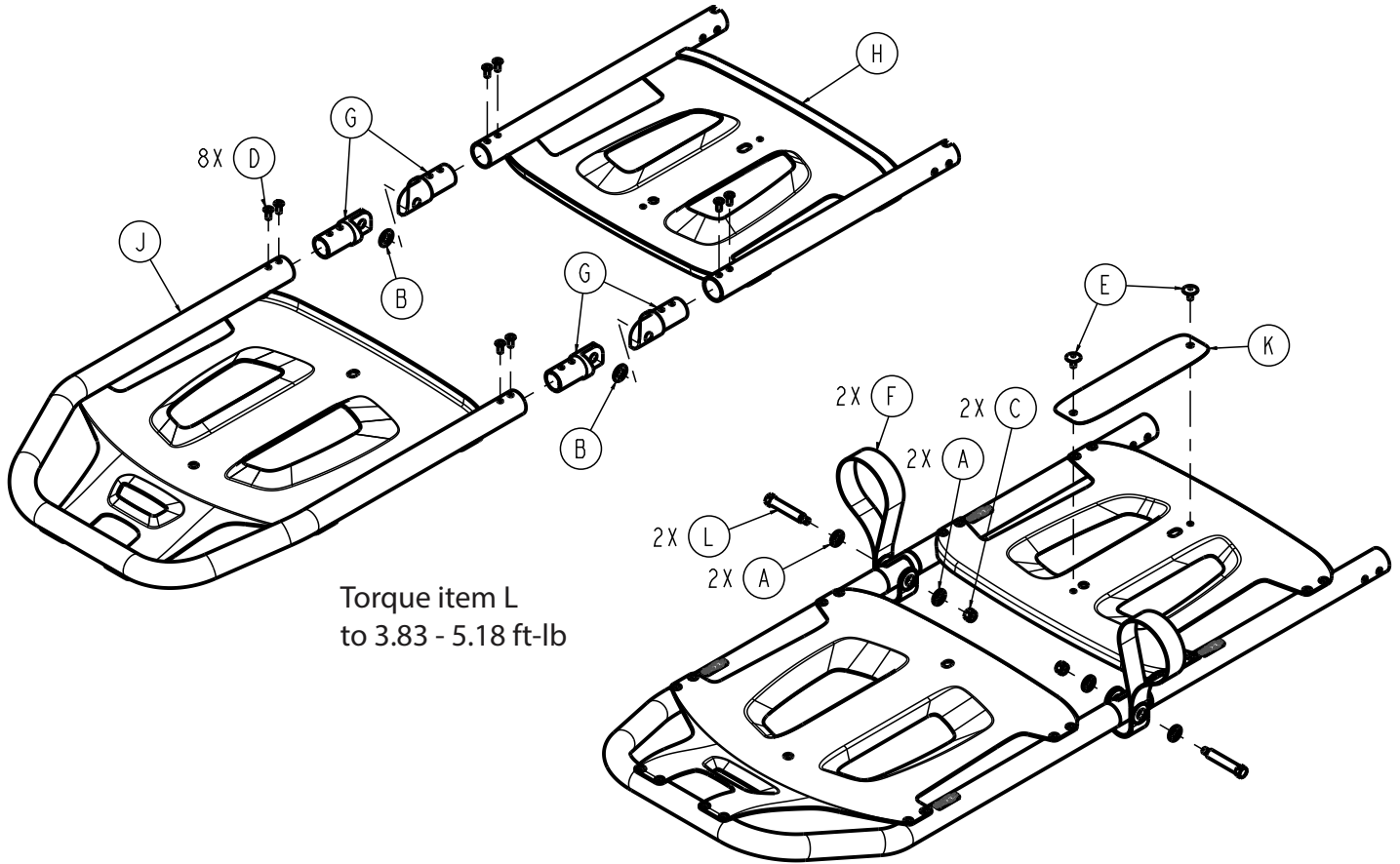

Torque item L
to 3.83 - 5.18 ft-lb

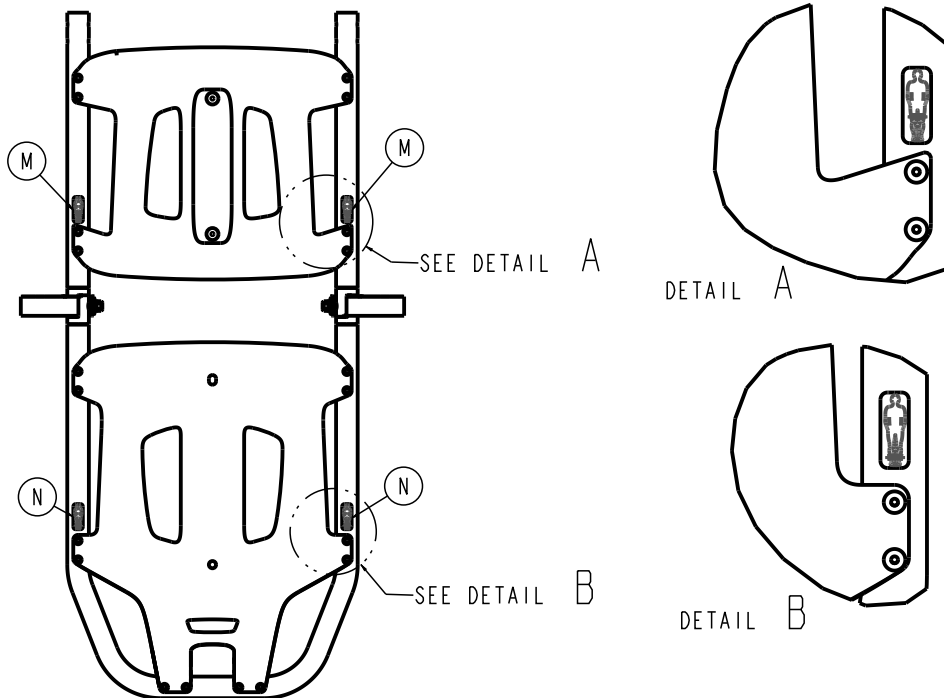

Item	Number	Name	Quantity
A	0011-448-000	Plain washer	4
B	0014-020-000	Flat washer	2
C	0016-028-000	Fiberlock hex nut	2
D	0025-079-000	Dome head pop rivet	8
E	0025-132-000	Large flange rivet	2
F	6100-031-096	Trend lift strap	2
G	6100-031-108	Gatch pivot	4
H	650700080003	<i>Thigh assembly (page 188)</i>	1
J	650700080004	<i>Foot assembly (page 189)</i>	1
K	650700080187	Thigh mattress loop	1
L	6550-001-186	Gatch pivot pin	2
M	650700010911	Label, restraint, frame, thigh	2
N	650700010912	Label, restraint, frame, ankle	2

Gatch support assembly

650700080011 Rev AD (Reference only)

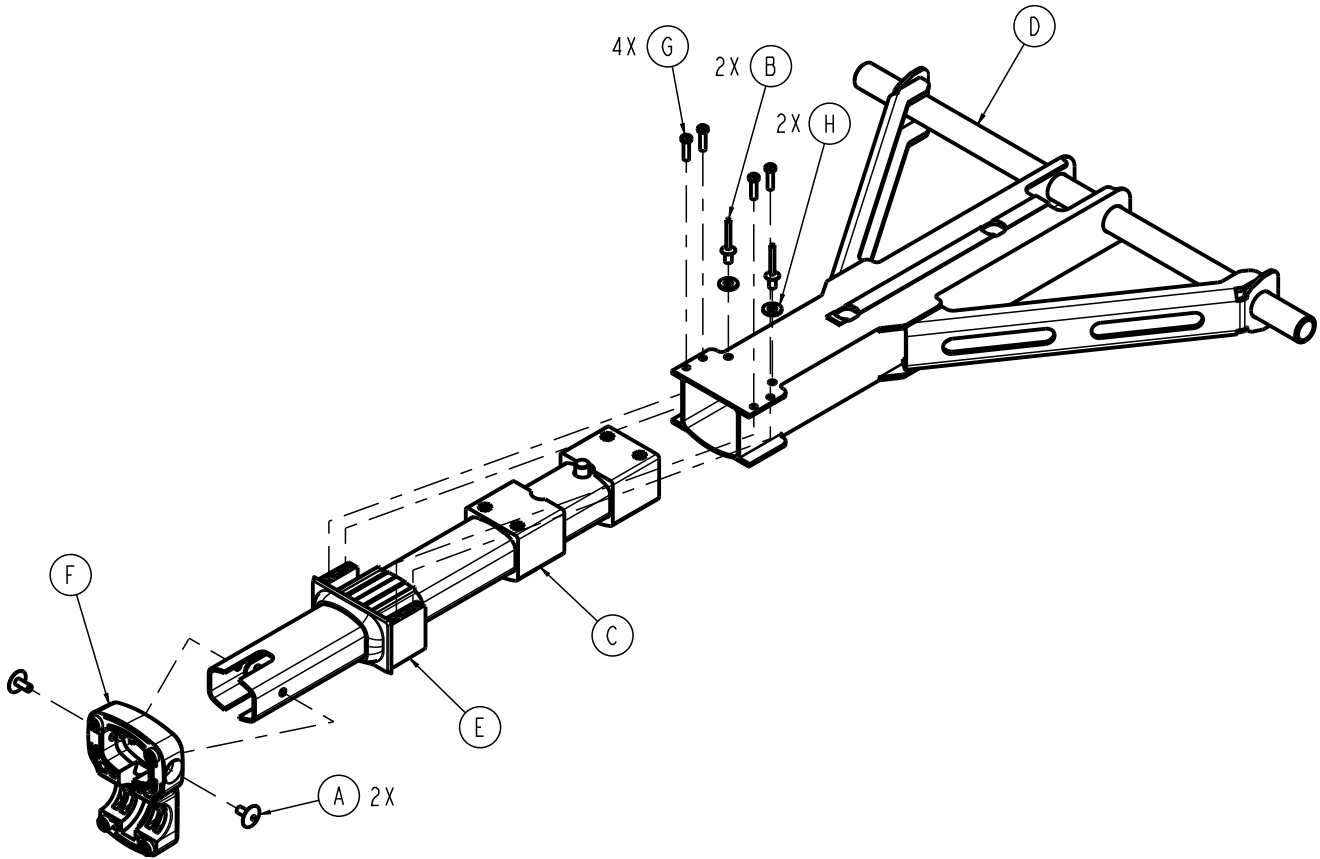

Item	Number	Name	Quantity
A	0025-132-000	Large flange rivet	2
B	0025-271-000	Closed end blind rivet, dome head	2
C	650700080018	Telescoping Gatch assembly (page 187)	1
D	650700080105	Gatch support weldment	1
E	650700080186	Gatch bearing end cap	1
F	6550-001-125	Gatch release, back	1
G	700000687300	Pan head tapping screw	4
H	0011-453-000	Plain washer	2

Telescoping Gatch assembly

650700080018 Rev AC (Reference only)

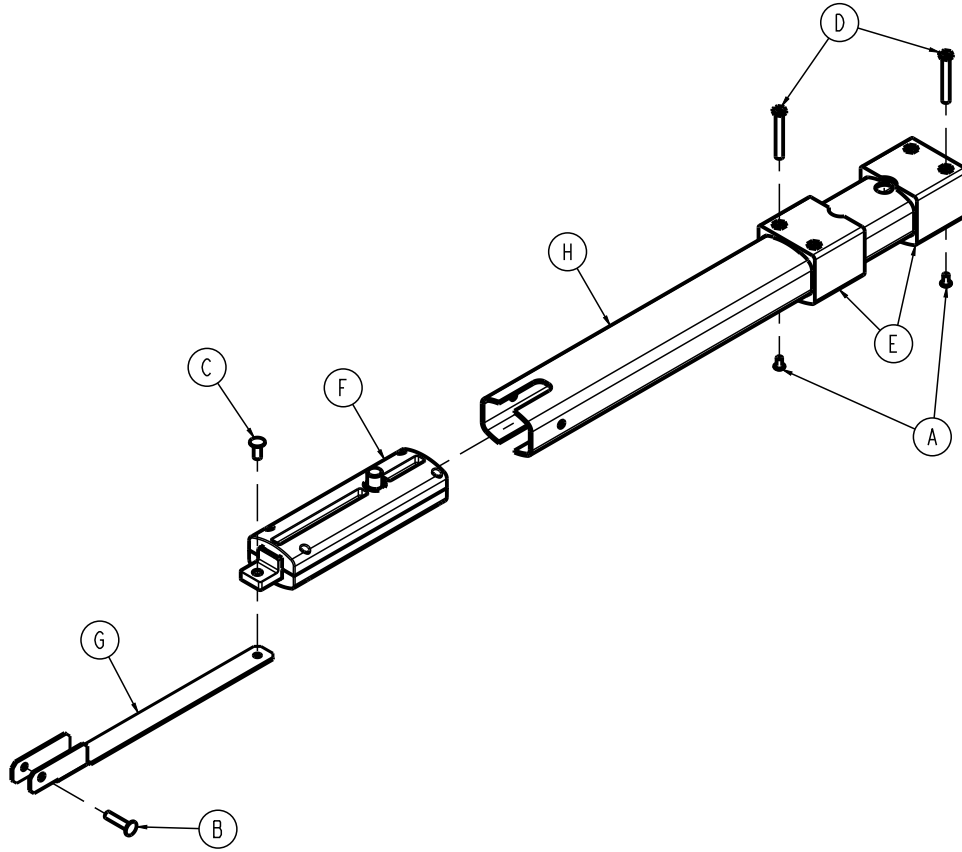

Item	Number	Name	Quantity
A	0004-883-000	Button head cap screw	2
B	0025-125-000	Semi-tubular steel	1
C	0025-126-000	Semi-tubular rivet	1
D	6085-001-169	Head section nut	2
E	6085-001-170	Internal bearing	2
F	6500-001-026	Head section lock assy	1
G	6550-001-115	Gatch link	1
H	6550-001-119	Gatch inner tube	1

Thigh assembly

650700080003 Rev AA (Reference only)

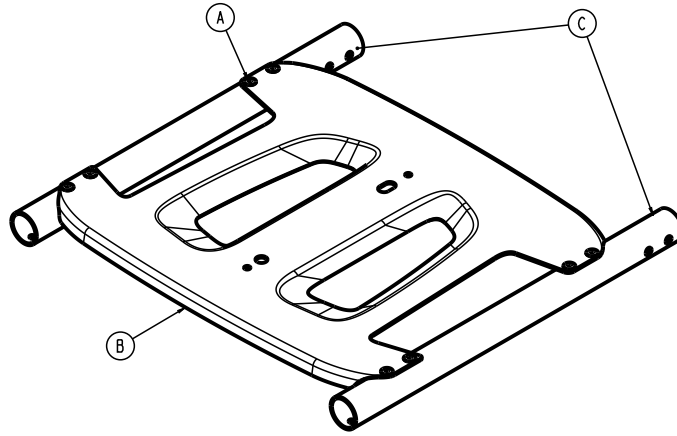

Item	Number	Name	Quantity
A	0025-079-000	Dome head pop rivet	8
B	650700080173	Thigh skin	1
C	650700080183	Thigh frame	2

Foot assembly

650700080004 Rev AA (Reference only)

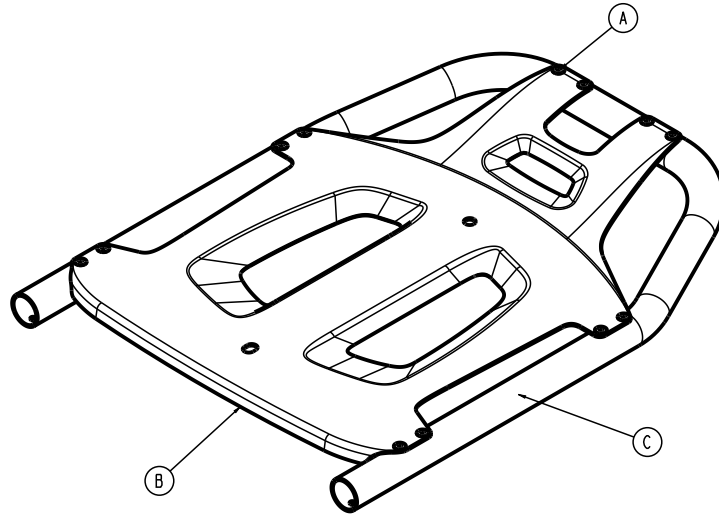

Item	Number	Name	Quantity
A	0025-079-000	Dome head pop rivet	12
B	650700080169	Foot skin	1
C	650700080184	Foot frame	1

Head extension mounting body assembly

650700450041 Rev AA (Reference only)

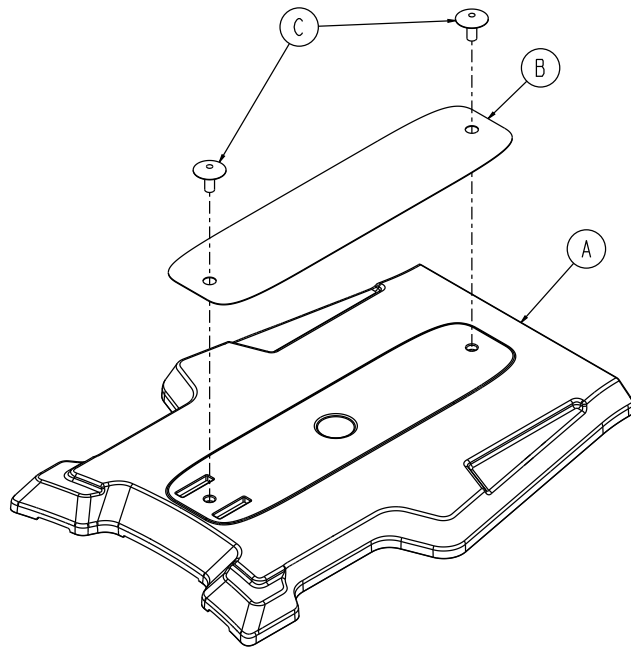

Item	Number	Name	Quantity
A	650700450156	Head extension mounting body	1
B	650700450158	Head extension mounting body loop	1
C	0025-132-000	Dome head blind rivet	2

Head extension frame assembly

650700450043 Rev AA (Reference only)

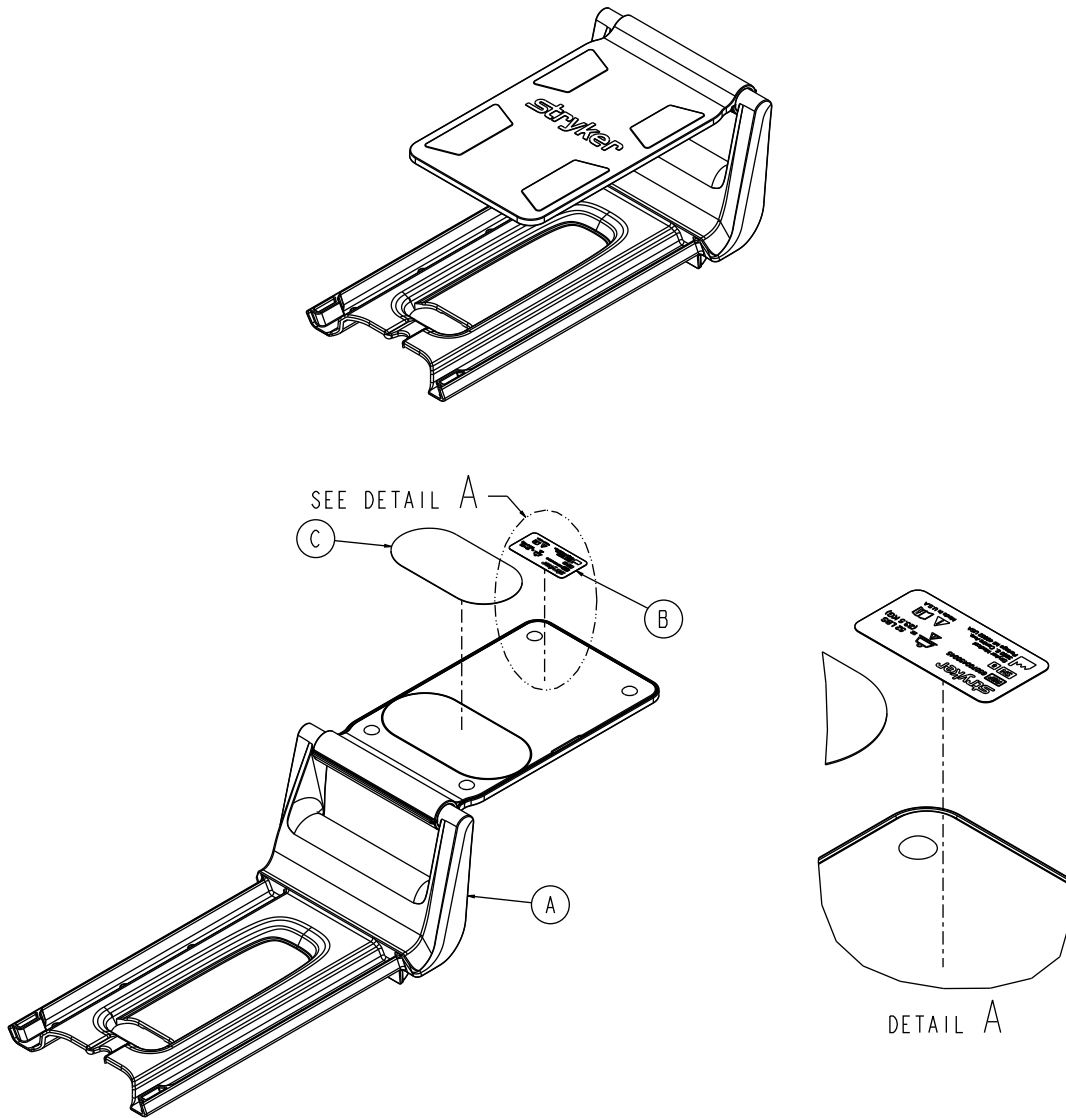

Item	Number	Name	Quantity
A	650700450042	Head extension frame and plate	1
B	650700010924	Label, head extension	1
C	650700450159	Head extension plate hook	1

Head extension option - 650700450045

Rev AA (Reference only)

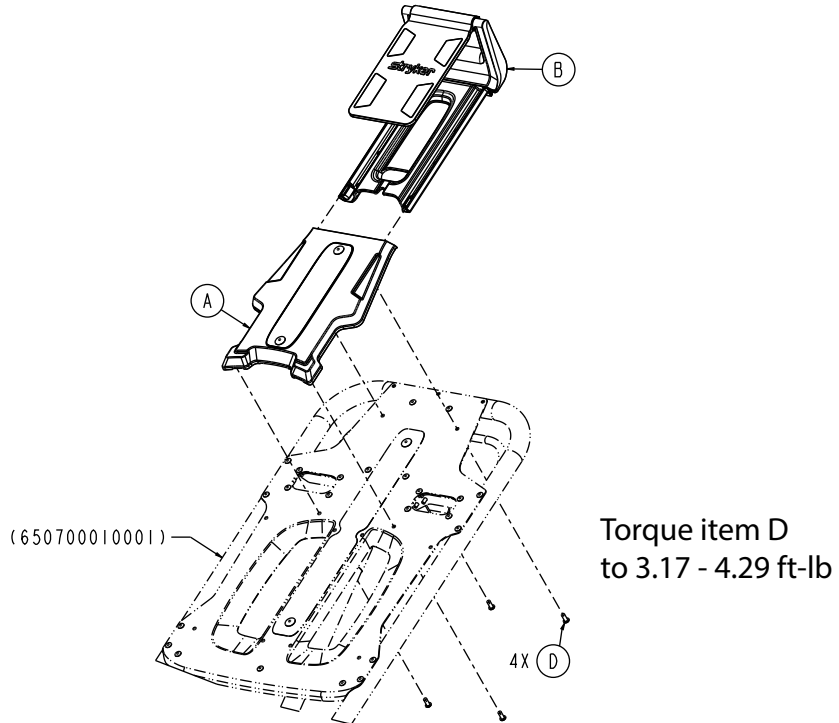

Item	Number	Name	Quantity
A	650700450041	Head extender mounting body	1
B	650700450043	Head extender frame assembly	1
C	6100-041-030	Pillow (not shown)	1
D	700000689483	Button head cap screw	4

IV pole, two-stage, right - 650700350101

Rev AE (Reference only)

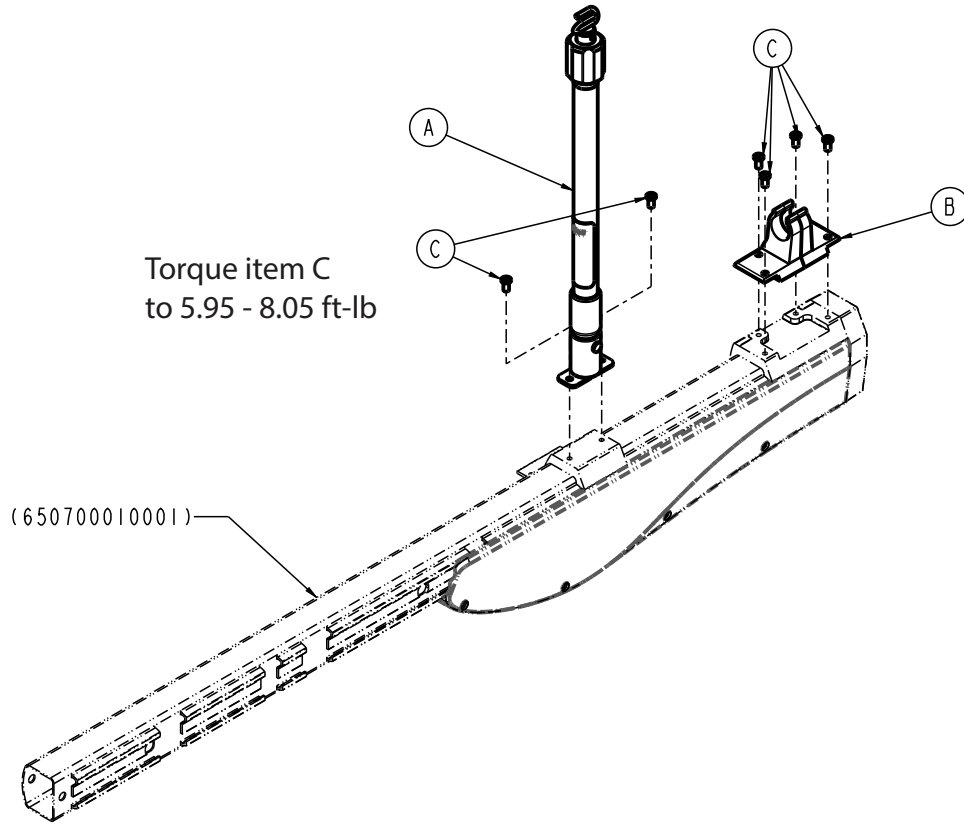

Item	Number	Name	Quantity
A	650700450033	HAVASU IV pole assembly, two-stage, right (page 1 198)	1
B	650700450133	IV pole clip	1
C	700000913363	Button head cap screw	6

IV pole, three-stage, right - 650700350102

Rev AD (Reference only)

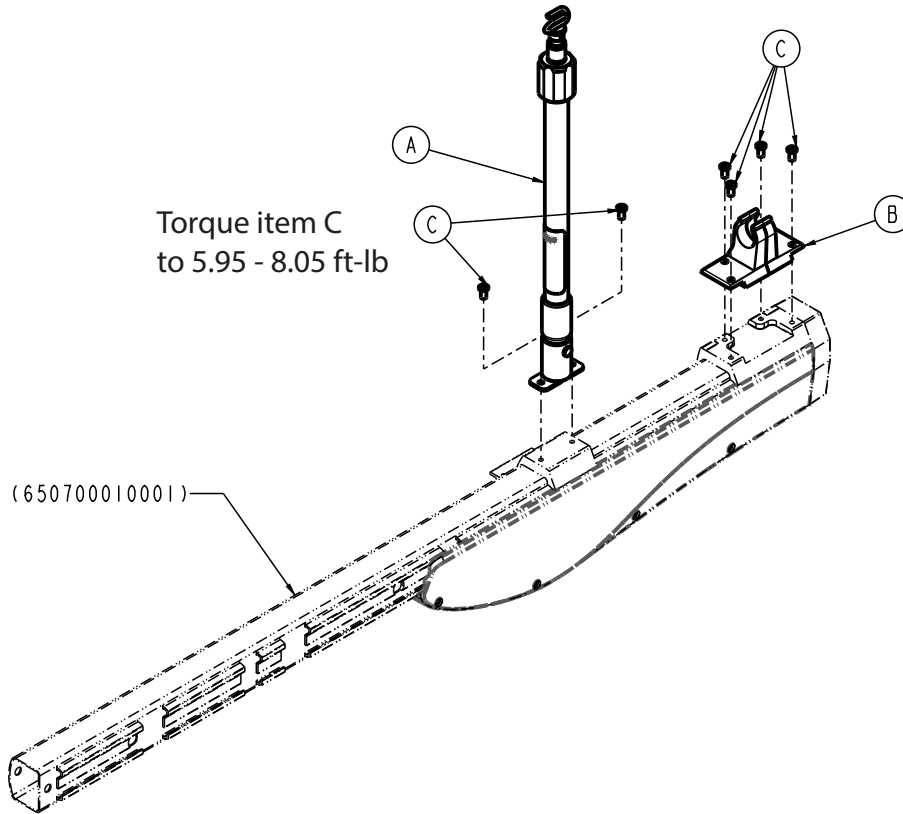

Item	Number	Name	Quantity
A	650700450034	HAVASU IV pole assembly, three-stage, right (page 200)	1
B	650700450133	IV pole clip	1
C	700000913363	Button head cap screw	6

IV pole, two-stage, left - 650700350105

Rev AD (Reference only)

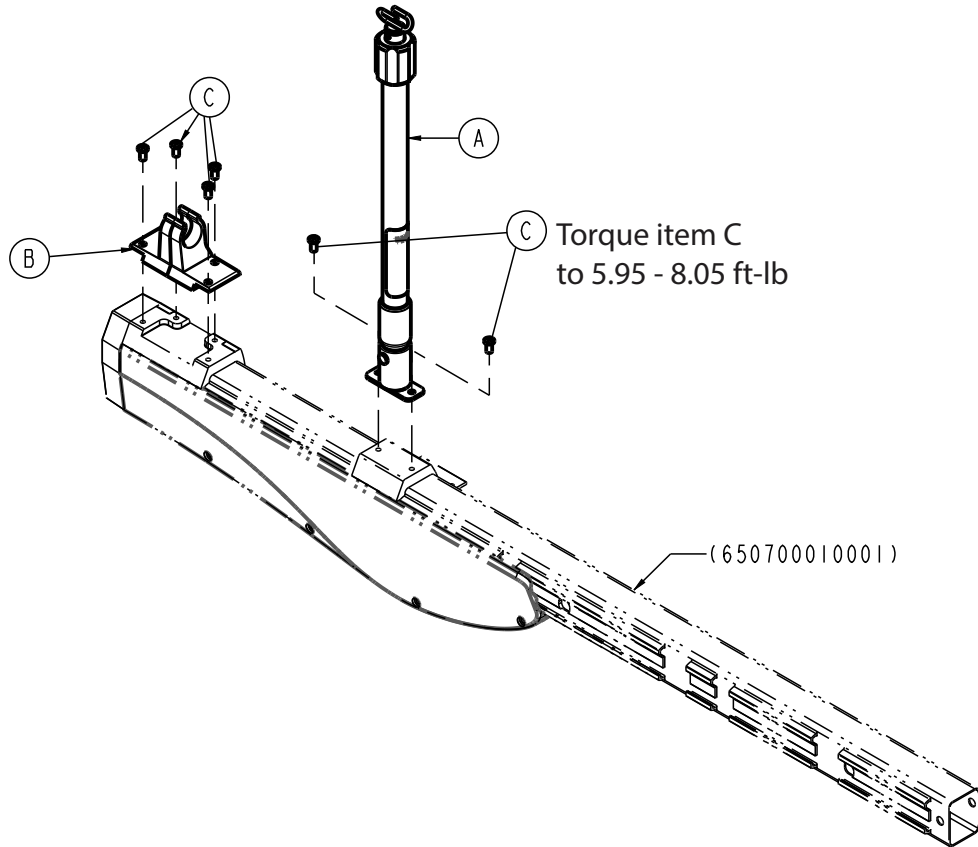

Item	Number	Name	Quantity
A	650700450035	HAVASU IV pole assembly, two-stage, left (page 197)	1
B	650700450133	IV pole clip	1
C	700000913363	Button head cap screw	6

IV pole, three-stage, left - 650700350106

Rev AD (Reference only)

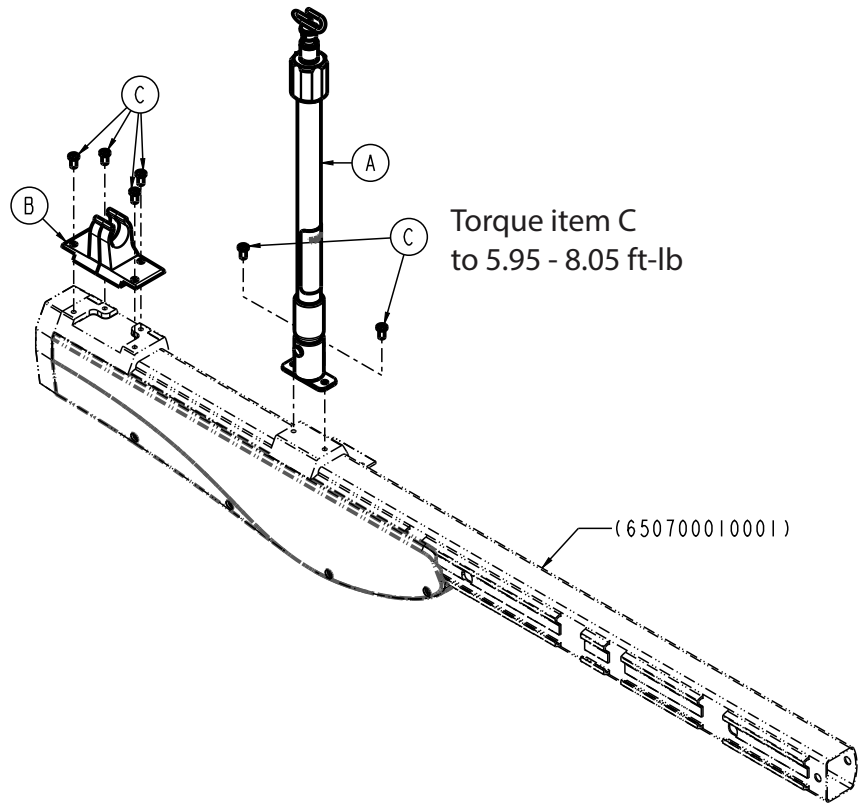

Item	Number	Name	Quantity
A	650700450036	HAVASU IV pole assembly, three-stage, left (page 199)	1
B	650700450133	IV pole clip	1
C	700000913363	Button head cap screw	6

HAVASU IV pole assembly, two-stage, left

650700450035 Rev AC (Reference only)

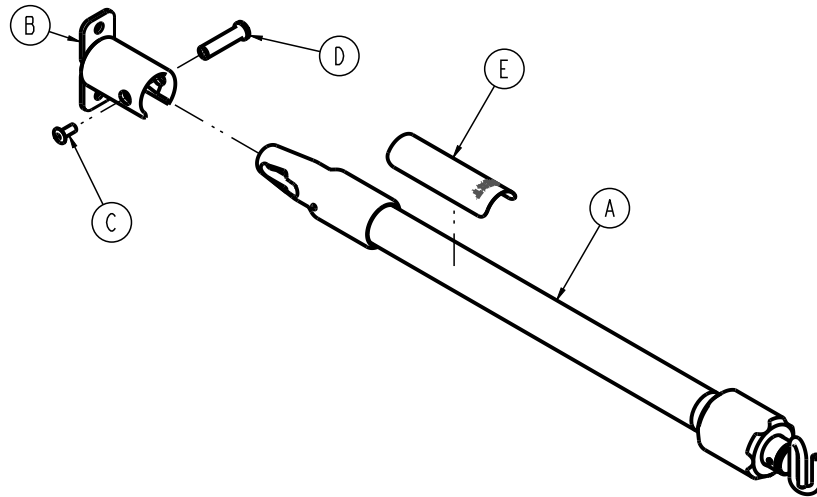

Item	Number	Name	Quantity
A	6070-210-070	IV pole assembly, two-stage (page 201)	1
B	6100-115-051	Socket weldment, Euro IV	1
C	0025-079-000	Dome head pop rivet	1
D	6070-110-037	IV pivot pin	1
E	650700010953	Label, IV pole, two-stage, left	1

HAVASU IV pole assembly, two-stage, right

650700450033 Rev AD (Reference only)

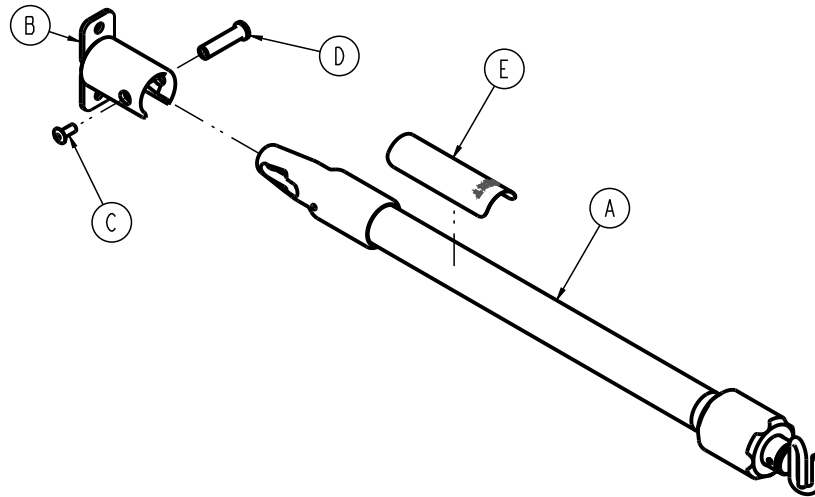

Item	Number	Name	Quantity
A	6070-210-070	IV pole assembly, two-stage (page 201)	1
B	6100-115-051	Socket weldment, Euro IV	1
C	0025-079-000	Dome head pop rivet	1
D	6070-110-037	IV pivot pin	1
E	650700010951	Label, IV pole, two-stage, right	1

HAVASU IV pole assembly, three-stage, left

650700450036 Rev AC (Reference only)

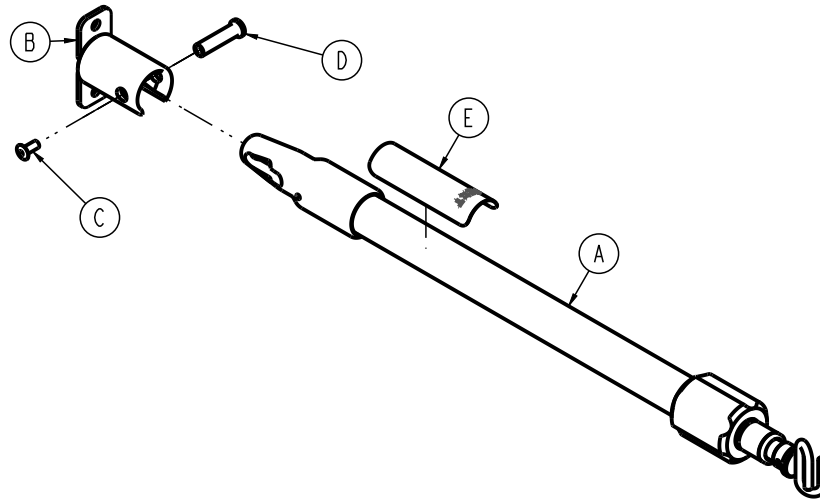

Item	Number	Name	Quantity
A	6070-215-070	IV pole assembly, three-stage (page 202)	1
B	6100-115-051	Socket weldment, Euro IV	1
C	0025-079-000	Dome head pop rivet	1
D	6070-110-037	IV pivot pin	1
E	650700010954	Label, IV pole, three-stage, left	1

HAVASU IV pole assembly, three-stage, right

650700450034 Rev AC (Reference only)

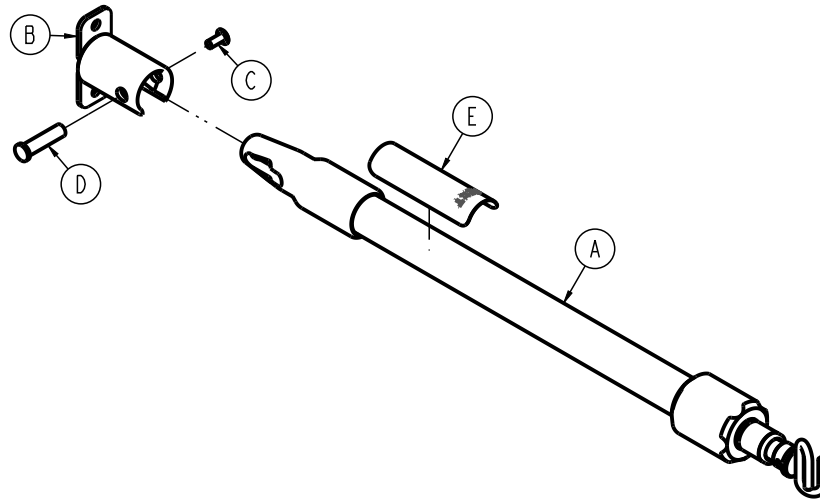

Item	Number	Name	Quantity
A	6070-215-070	IV pole assembly, three-stage (page 202)	1
B	6100-115-051	Socket weldment, Euro IV	1
C	0025-079-000	Dome head pop rivet	1
D	6070-110-037	IV pivot pin	1
E	650700010952	Label, IV pole, three-stage, right	1

IV pole assembly, two-stage

6070-210-070 Rev AA (Reference only)

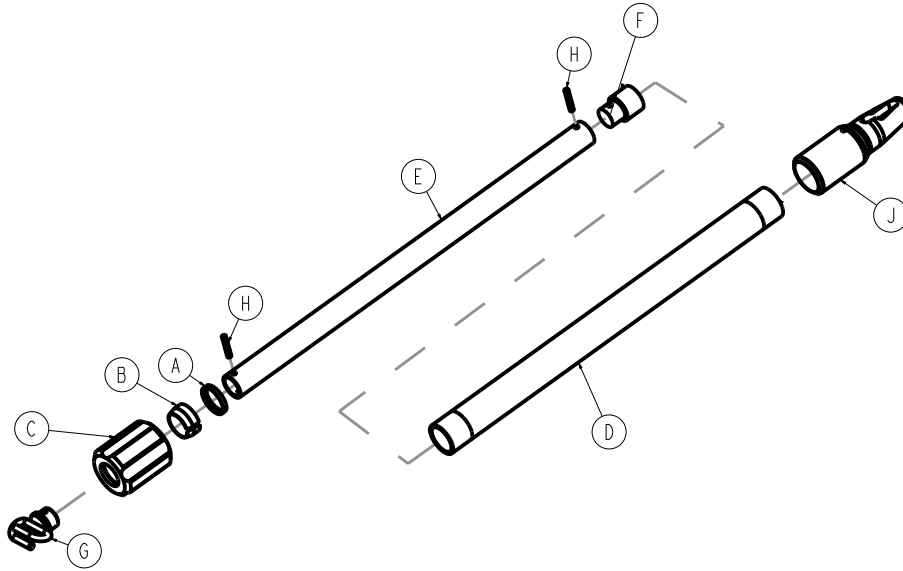

Item	Number	Name	Quantity
A	1210-110-046	Back-up ring	1
B	1210-110-047	Lock ring	1
C	1210-110-049	IV pole actuator (locking collar)	1
D	6070-210-051	Base tube, cot IV	1
E	6070-110-042	2nd stage tube, cot IV	1
F	6070-110-051	2nd stage slide plug	1
G	6070-110-050	Hook weldment, cot IV	1
H	0026-006-000	Roll pin	1
J	6070-110-012	IV pole pivot	1

IV pole assembly, three-stage

6070-215-070 Rev AA (Reference only)

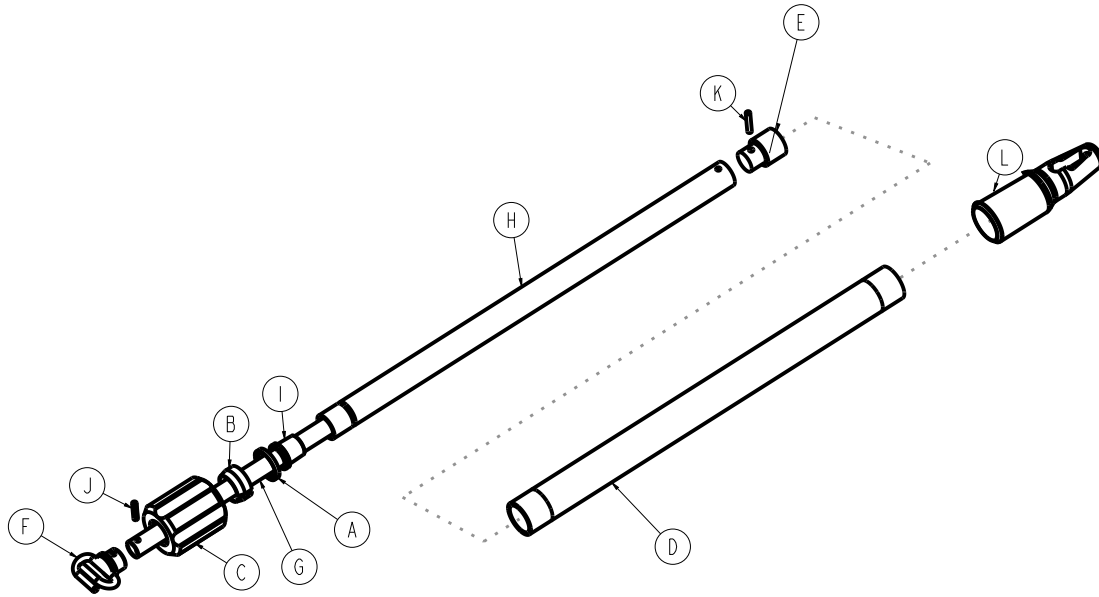

Item	Number	Name	Quantity
A	1210-110-046	Back-up ring	1
B	1210-110-047	Lock ring	1
C	1210-110-049	IV pole actuator (locking collar)	1
D	6070-210-051	Base tube, cot IV	1
E	6070-110-051	2nd stage slide plug	1
F	6070-110-050	Hook weldment, cot IV	1
G	6070-115-030	3rd stage assembly, cot IV	1
H	6070-115-042	2nd stage tube, cot IV	1
I	6070-115-045	Bearing plug, IV pole	1
J	0026-005-000	Roll pin	1
K	0026-006-000	Roll pin	1
L	6070-110-012	IV pole pivot	1

Battery assembly

650700080301 Rev AM (Reference only)

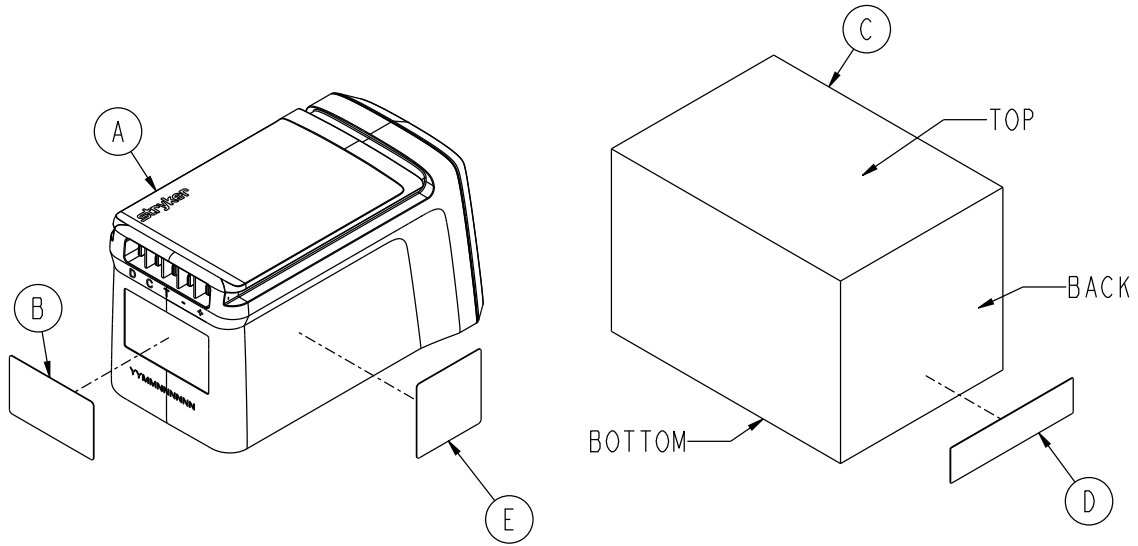

Item	Number	Name	Quantity
A	650700080401	Battery assembly	1
B	650700010930	Label, battery	1
C	650700190011	Packaging, battery, individual box	1
D	650700010940	Label, GSI barcode, battery	1
E	650700010949	Label, battery, trash bin	1

Battery charger assembly

650700450301 Rev AJ (Reference only)

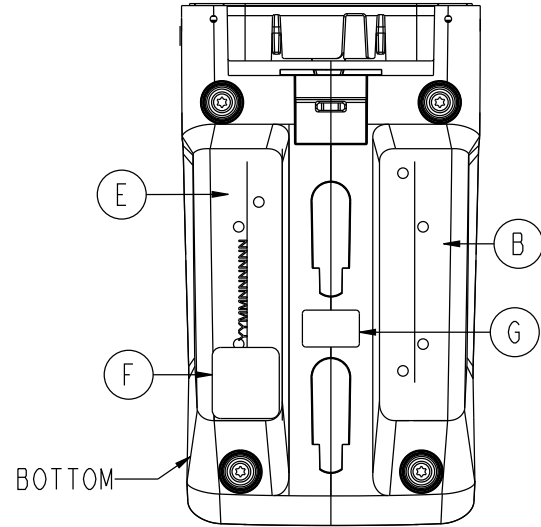
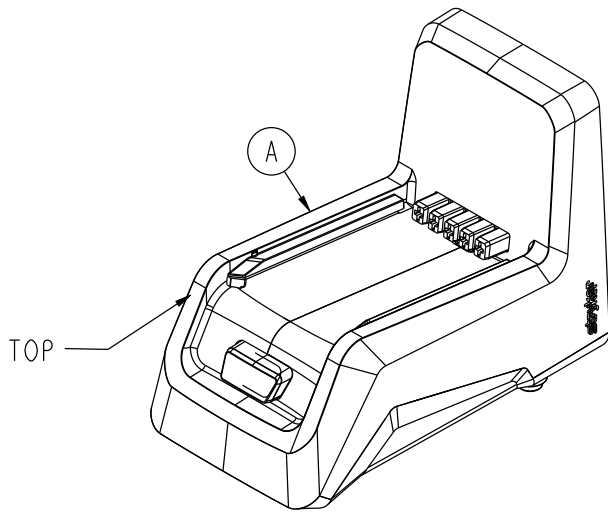

Item	Number	Name	Quantity
A	650700450401	Battery charger assembly	1
B	650700010931	Label, charger	1
E	650700010943	Label, charger, FCC	1
F	650700010942	Label, charger, Cal Prop 65	1
G	650700010948	Label, charger, EU/UK	1

X-restraint package option - 6500-001-430

Rev AA (Reference only)

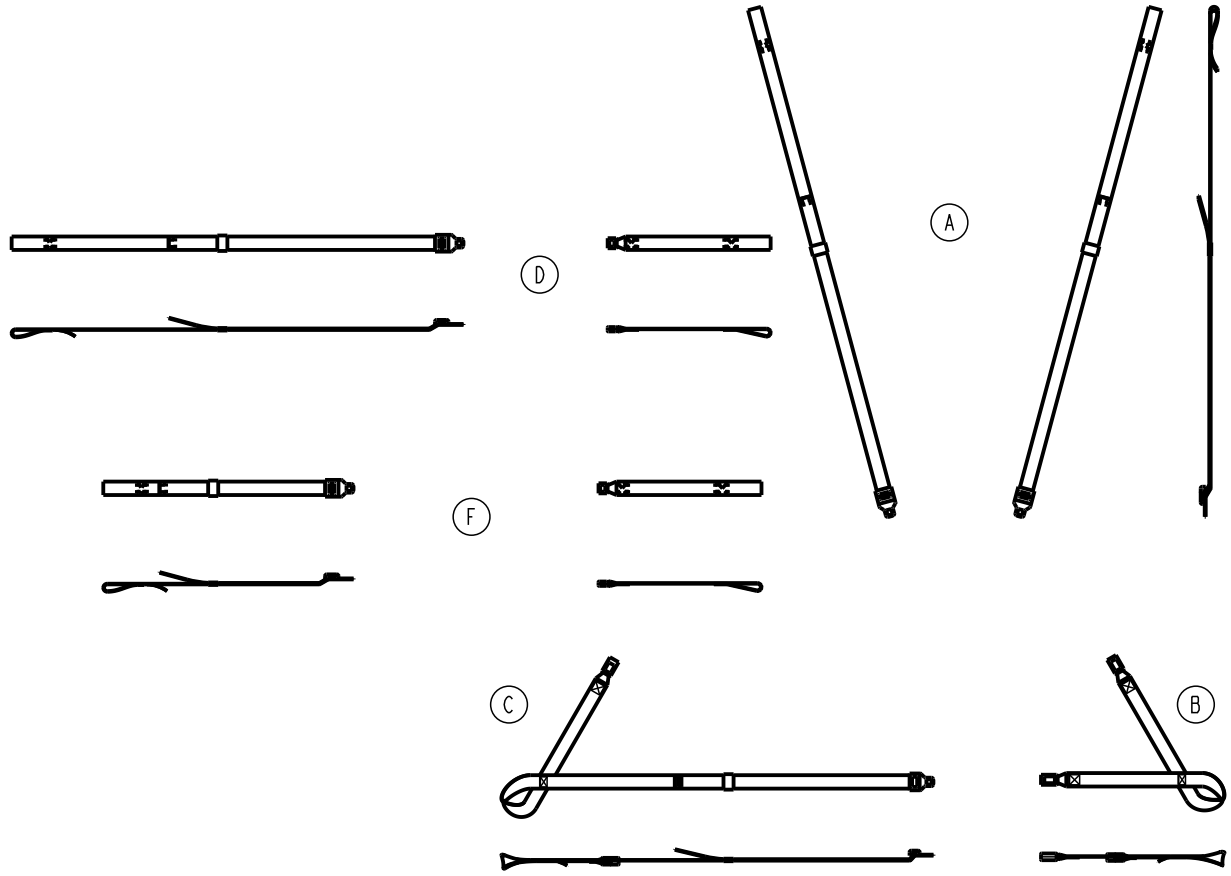

Item	Number	Name	Quantity
A	6500-001-401	Shoulder restraint	2
B	6500-001-402	X-double buckle strap	1
C	6500-001-403	X-buckle and tongue strap	1
D	6500-001-404	Thigh restraint	1
F	6500-001-405	Ankle restraint	1

X-restraint package option, cobalt blue - 6500-001-431

Rev B (Reference only)

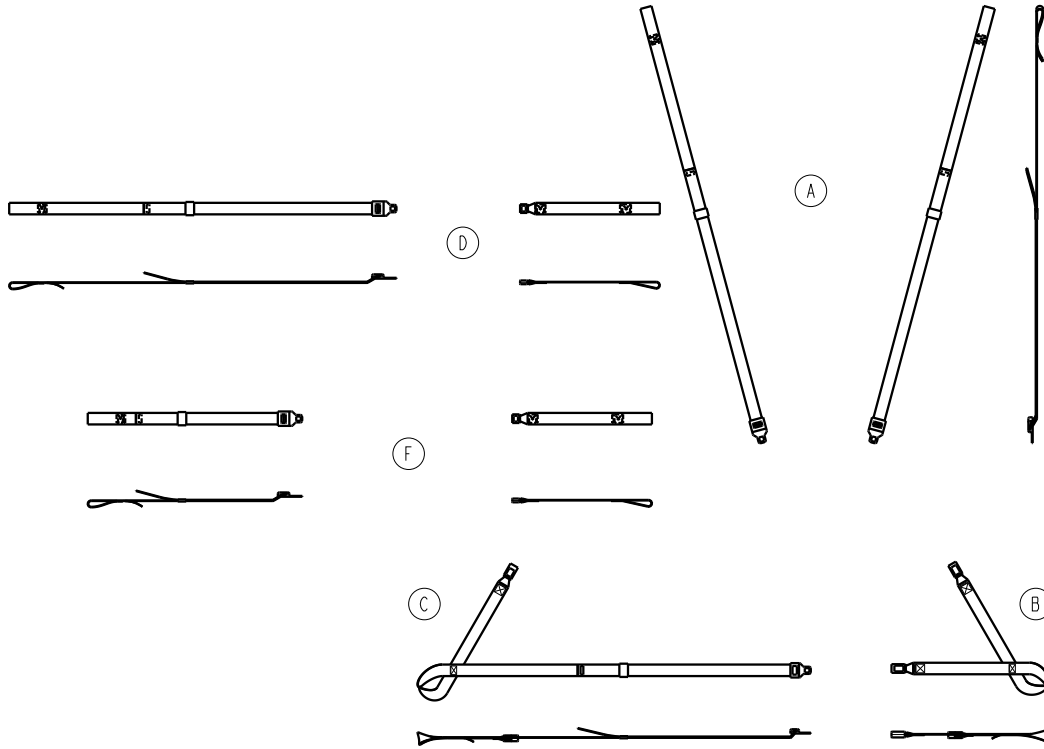

Item	Number	Name	Quantity
A	6500-001-411	Shoulder restraint, cobalt blue	2
B	6500-001-412	X-double buckle strap, cobalt blue	1
C	6500-001-413	X-buckle and tongue strap, cobalt blue	1
D	6500-001-414	Thigh restraint, cobalt blue	1
F	6500-001-415	Ankle restraint, cobalt blue	1

XPR restraint package option - 650600030010

Rev AC (Reference only)

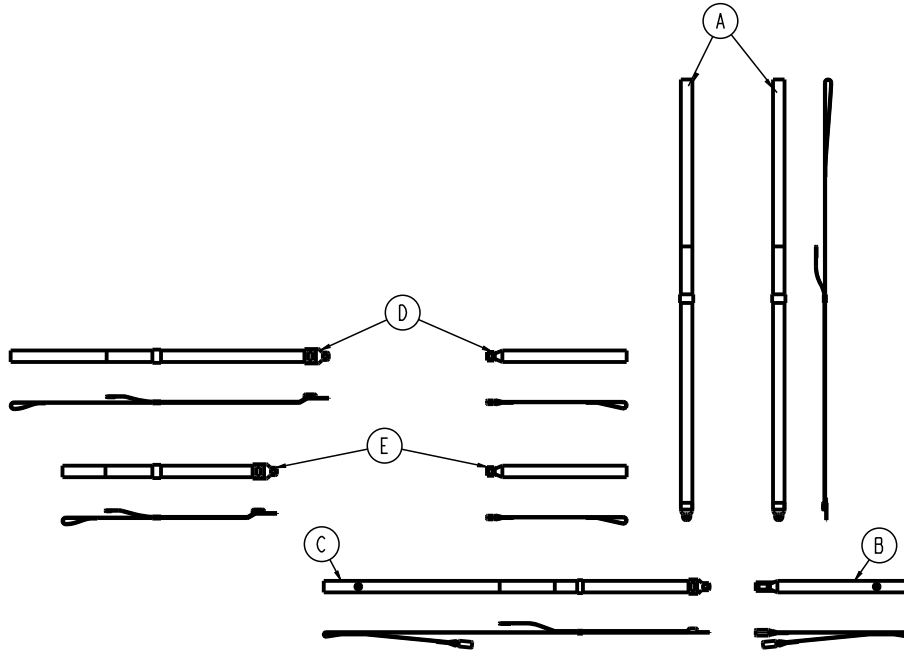

Item	Number	Name	Quantity
A	650600030001	XPR shoulder restraint	2
B	650600030002	XPR waist double buckle restraint	1
C	650600030003	XPR waist single buckle long restraint	1
D	650600030004	XPR thigh restraint	1
E	650600030005	XPR ankle restraint	1
G	650600030011	Label, XPR restraint package	1

Foot barrier option - 650700450201

650700450203 Rev AD (Reference only)

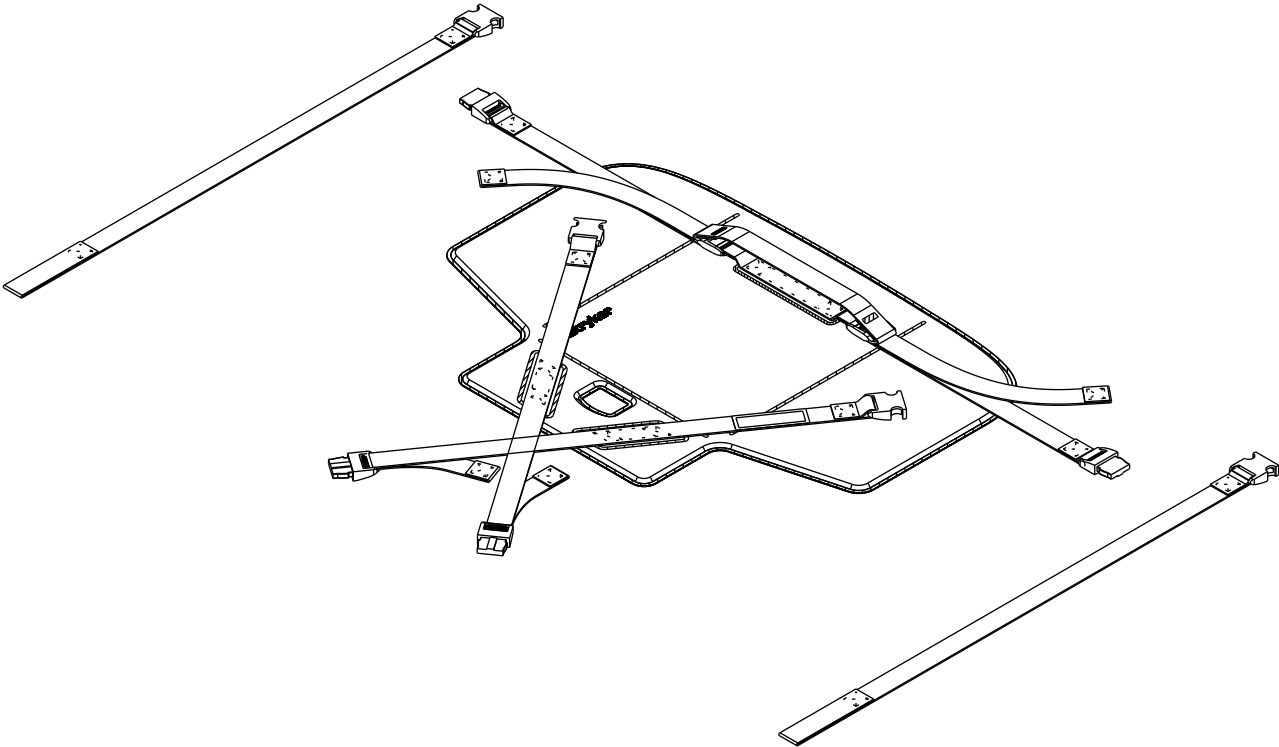

Belt extension option - 6082-160-050

Rev C (Reference only)

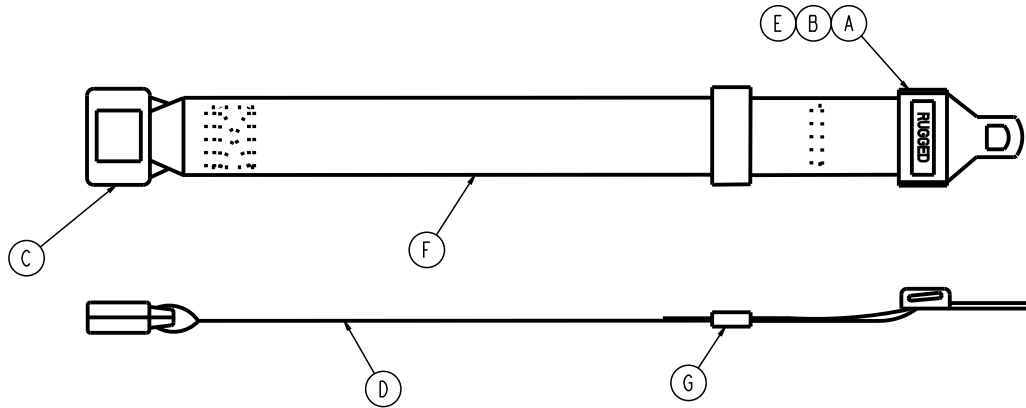

Item	Number	Name	Quantity
A		Tongue (Intertek p/n 2122681)	
B		Cap (Intertek p/n 2122525)	
C		Buckle (Intertek p/n 2122682)	
D	6082-090-001	Label, belt extension	1
E	6060-090-011	Label, RUGGED	1
F		Belt, 2" wide, black	
G		Belt retainer	

Base storage net option- 6500-160-000

6500-001-126 Rev AB (Reference only)

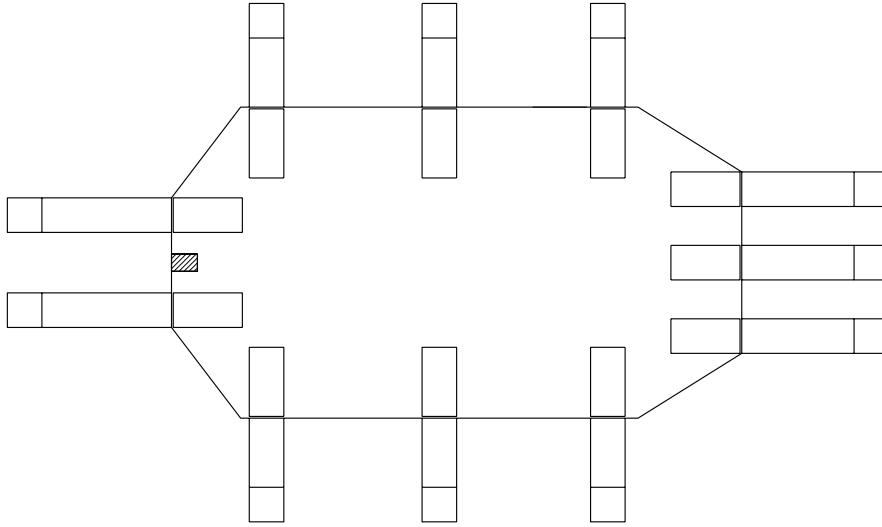

Head end storage flat option - 6500-128-000

Rev A (Reference only)

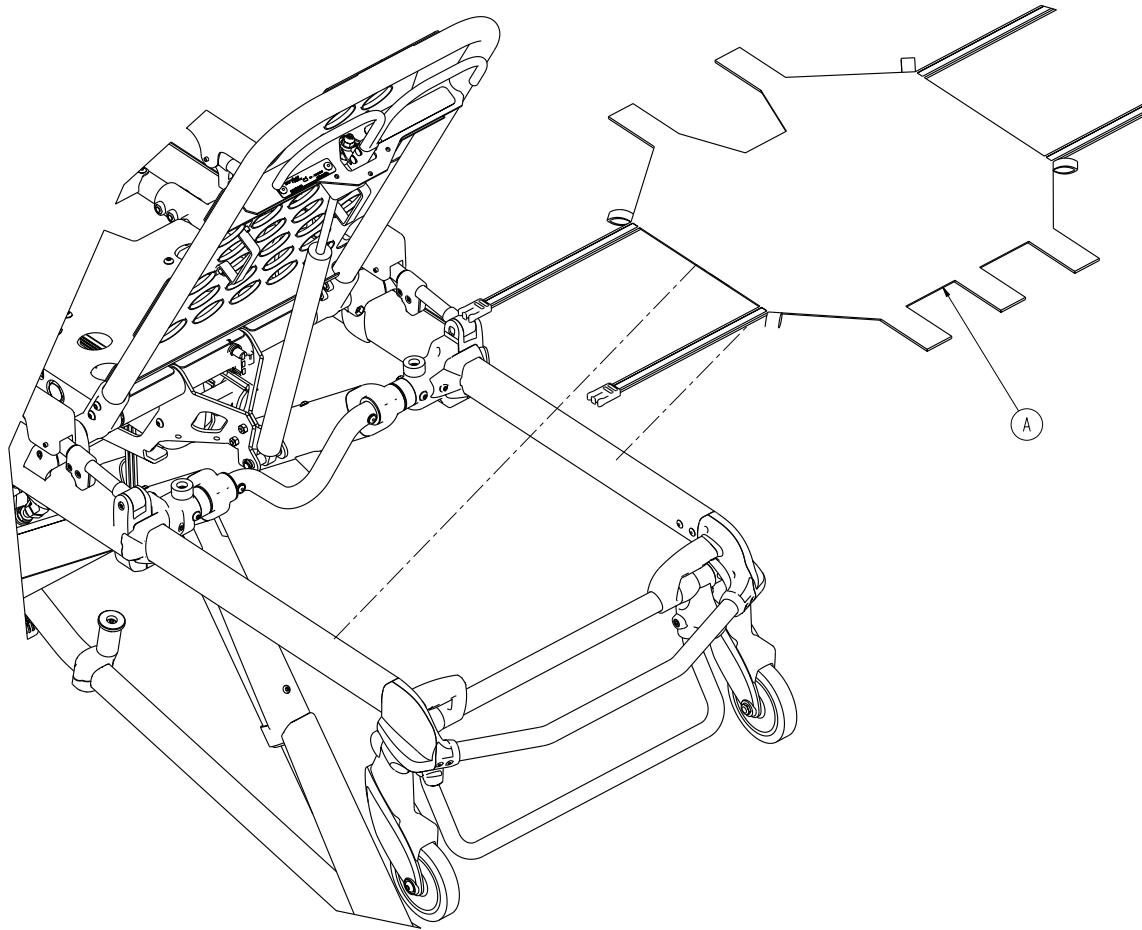

Item	Number	Name	Quantity
A	6500-001-232	Head end storage flat	1

Storage pouch, backrest, dual-sided - 650700450134

Rev AC (Reference only)

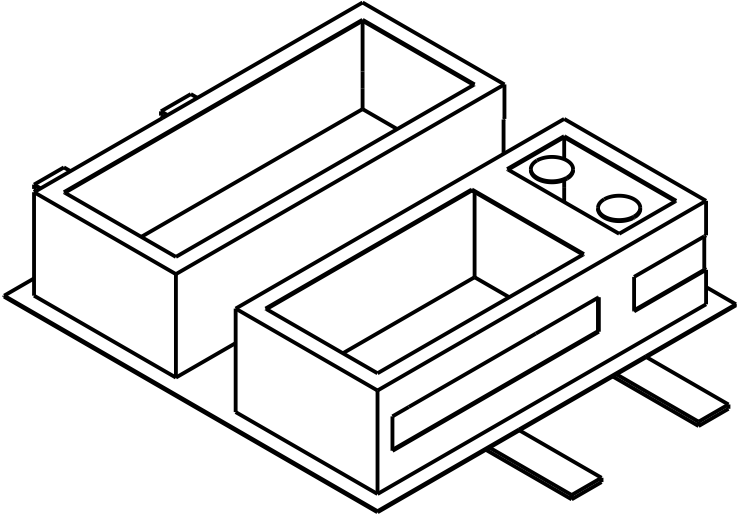

Storage pouch, backrest, single-sided - 650700450142

Rev AB (Reference only)

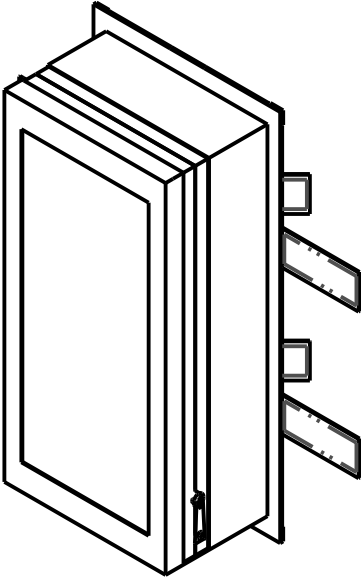

Oxygen bottle holder, Fowler - 650700450153

Rev AC (Reference only)

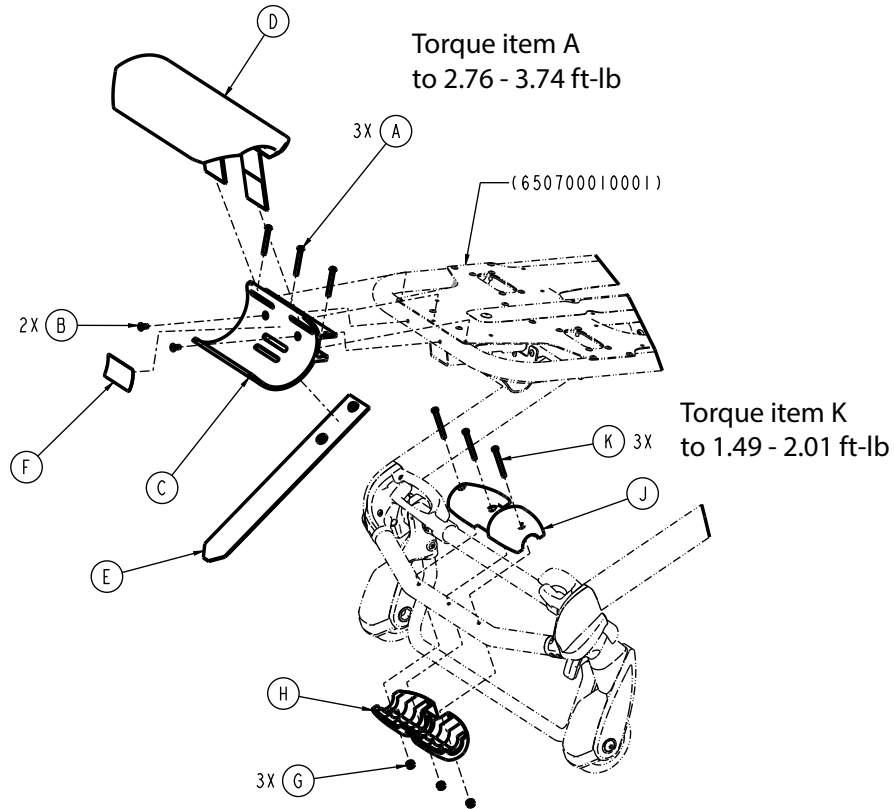

Item	Number	Name	Quantity
A	0004-636-000	Button head cap screw	3
B	0025-079-000	Dome head pop rivet	2
C	6500-011-119	Bracket, oxygen holder, backrest	1
D	6500-001-260	Fowler oxygen bottle holder cover	1
E	6500-001-261	Fowler oxygen bottle holder strap	1
F	6500-101-231	Label, Fowler oxygen bottle holder	1
G	0016-002-000	Fiberlock nut	3
H	6085-001-174	Oxygen bottle holder, bottom	1
J	6500-002-156	Guide, head end, top	1
K	700000721220	Socket head cap screw	3

Oxygen bottle holder, head section - 650700450154

Rev AB (Reference only)

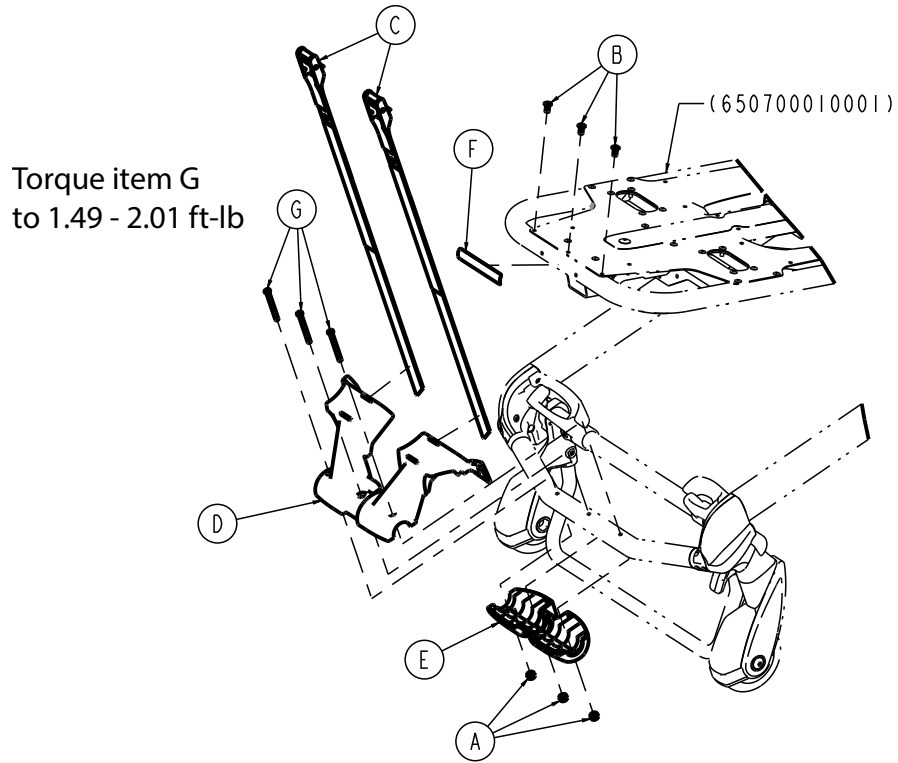

Item	Number	Name	Quantity
A	0016-002-000	Fiberlock nut	3
B	0025-079-000	Dome head pop rivet	3
C	6085-001-171	Strap, head end	2
D	6085-001-173	Oxygen bottle holder, top	1
E	6085-001-174	Oxygen bottle holder, bottom	1
F	650700010904	Label, Power-PRO 2	1
G	700000721220	Socket head cap screw	3

Mattress option, knee Gatch bolster - 6506-034-000

6500-002-150 Rev AB (Reference only)

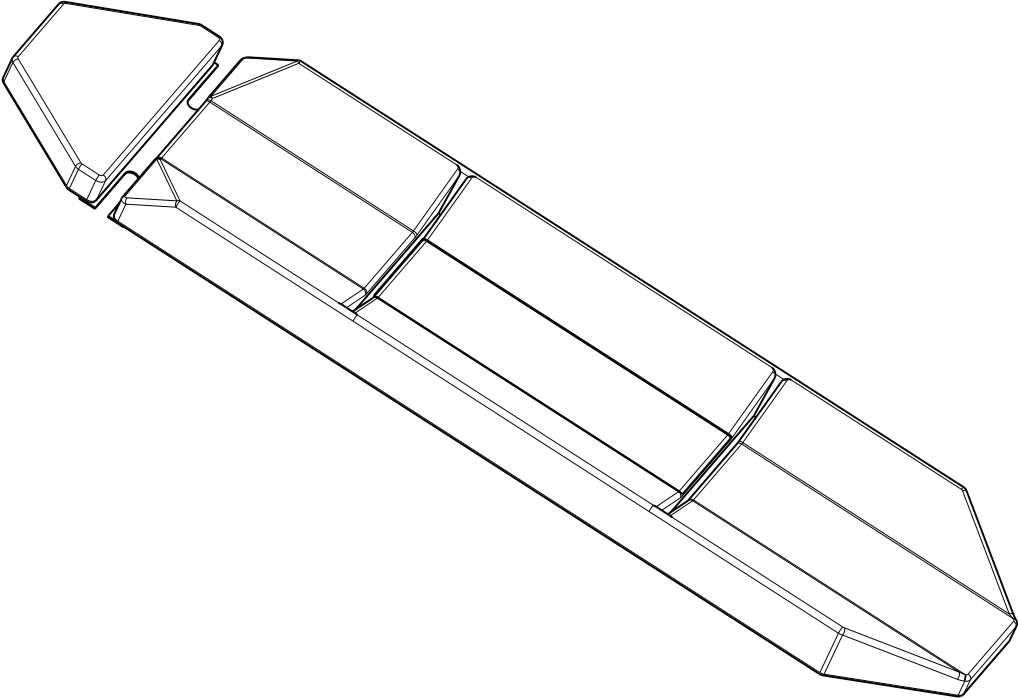

Mattress option, knee Gatch bolster, grey - 6506-033-000

6506-002-150 Rev AB (Reference only)

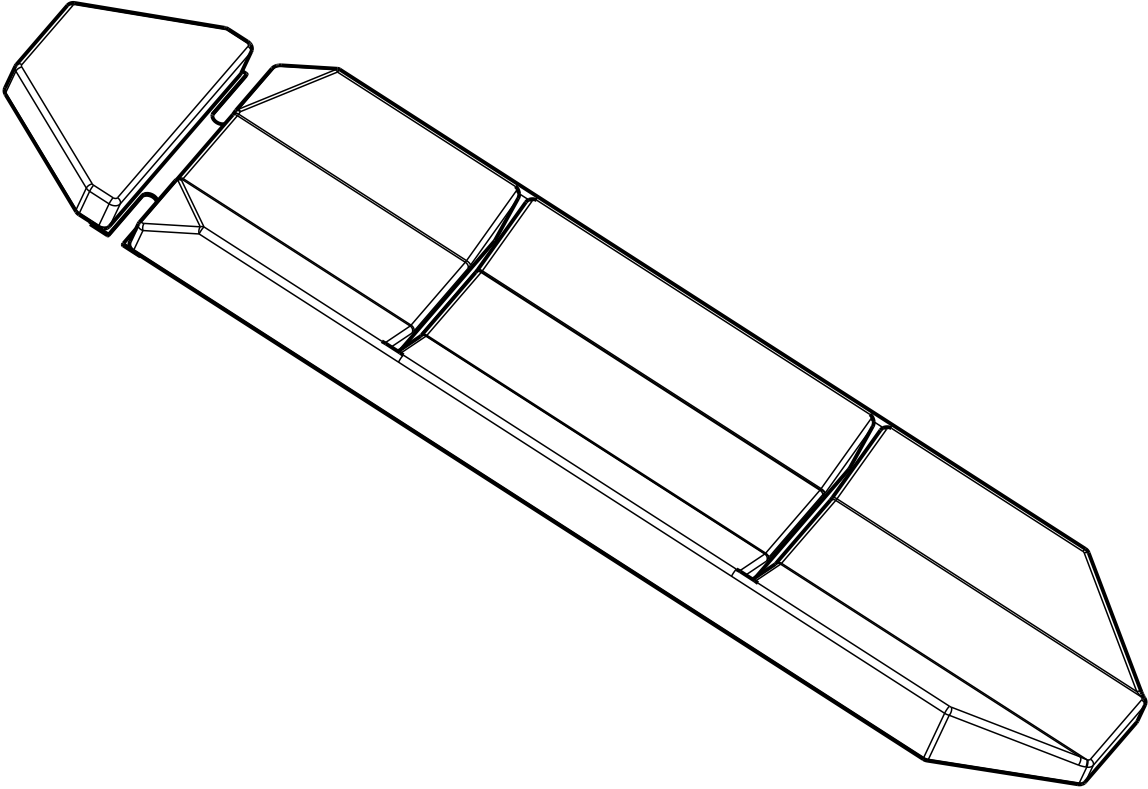

Mattress option, knee Gatch bolster, XPS - 6500-003-130

Rev AB (Reference only)

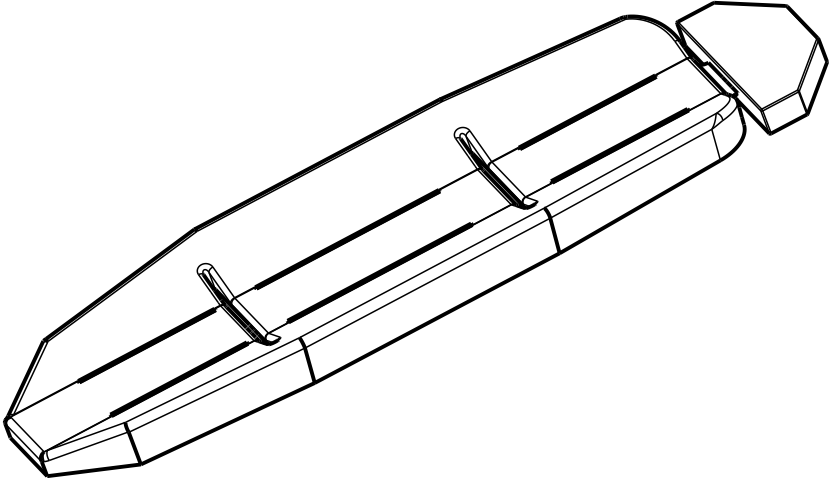

Mattress option, knee Gatch bolster, grey, XPS - 6506-041-000

6506-003-130 Rev AB (Reference only)

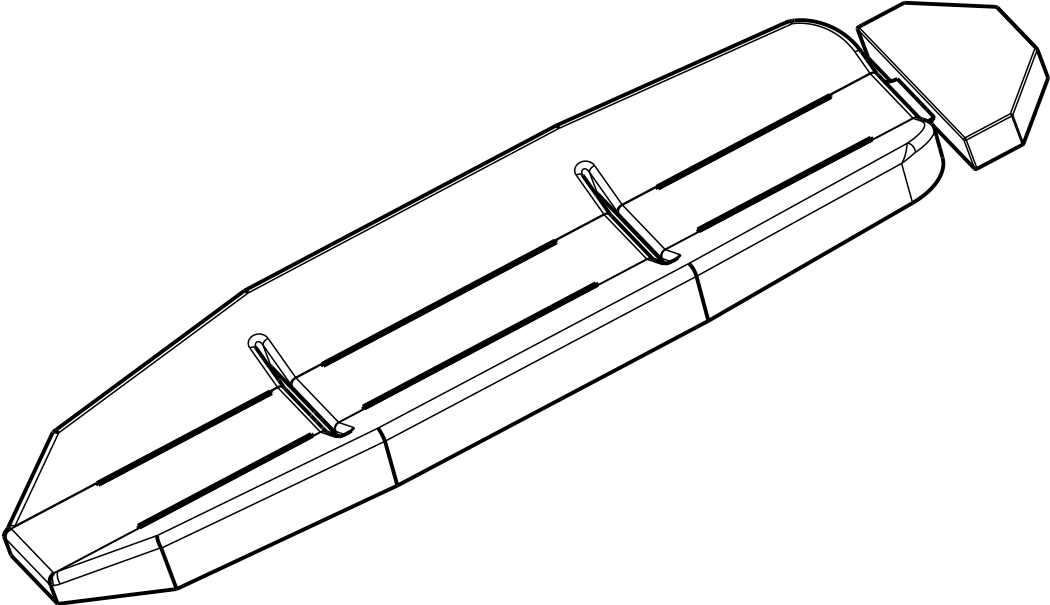

In-fastener shut-off assembly option - 6500-001-027

Rev AA (Reference only)

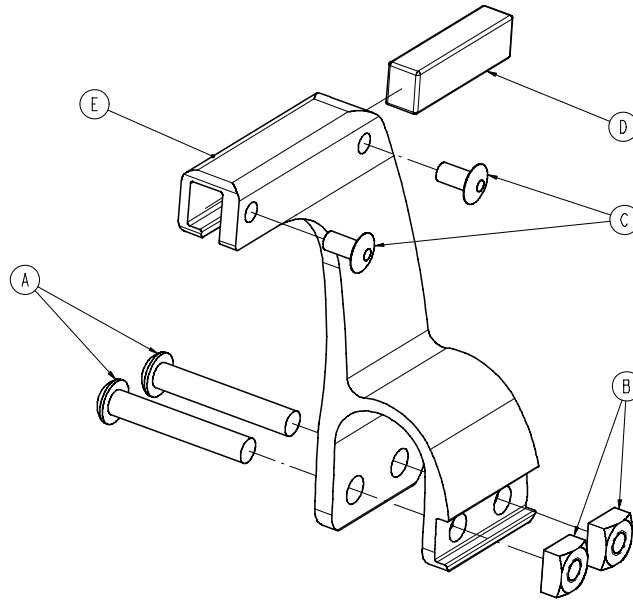

Item	Number	Name	Quantity
A	0004-376-000	Button head cap screw	2
B	0015-016-000	Square nut	2
C	0025-079-000	Dome head rivet	2
D	6500-001-271	Ambulance shut-off magnet	1
E	6500-001-272	Fastener shut-off magnet holder	1
F	0054-200-808	Box (not shown)	1

Safety hook, short - 6060-036-017/Safety hook, long - 6060-036-018/Safety hook, J - 6092-036-018

Safety hook, short - 6060-036-017 Rev A (Reference only)

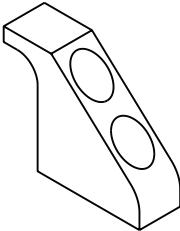

Safety hook, long - 6060-036-018 Rev D (Reference only)

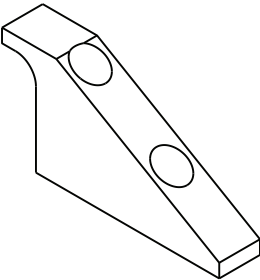

Safety hook, J - 6092-036-018 Rev A (Reference only)

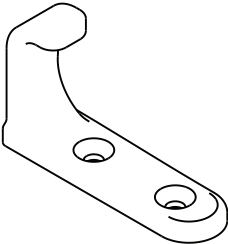

MTS - Power-PRO 2 assembly, high config - 650705550001

Rev AE (Reference only)

Item	Number	Name	Quantity
A	6500-001-232	Head end storage flat option - 6500-128-000 (page 211)	1
B	6500-003-130	Mattress option, knee Gatch bolster, XPS - 6500-003-130 (page 218)	1
C	6507-073-005	Power-PRO 2 Operations/Maintenance Manual - Model 6507	1
D	650700010001	Cot assembly, common components (page 95)	1
E	650700010880	Wi-Fi setting, US	1
F	650700010927	Label, serial number, 001	1
G	650700080029	Birdcage assembly, NFMIC, Wi-Fi (page 152)	1
H	650700190212	Packaging assembly, boxed	1
J	650700350102	IV pole, three-stage, right - 650700350102 (page 194)	1
K	650700450142	Storage pouch, backrest, single-sided - 650700450142 (page 213)	1
L	650700450154	Oxygen bottle holder, head section - 650700450154 (page 215)	1
M	650709990101	XPS siderail option - 650709990101 (page 176)	1
N	650709990104	Power-LOAD fastener (page 103)	1
P	650709990110	Four wheel lock option - 650709990110 (page 115)	1
R	650700020959	Assembly, labels, Wi-Fi - NFMIC, US setting	1
T	6500-001-430	X-restraint package	1
U	1234-009-001	Electronic instructions for use (eIFU) leaflet	1

MTS - Power-PRO 2 assembly, mid config - 650705550002

Rev AE (Reference only)

Item	Number	Name	Quantity
A	6500-001-232	Head end storage flat option - 6500-128-000 (page 211)	1
B	6500-002-150	Mattress option, knee Gatch bolster - 6506-034-000 (page 216)	1
C	6507-073-005	Power-PRO 2 Operations/Maintenance Manual - Model 6507	
D	650700010001	Cot assembly, common components (page 95)	1
E	650700010880	Wi-Fi setting, US	1
F	650700010928	Label, serial number, 002	1
G	650700080029	Birdcage assembly, NFMIC, Wi-Fi (page 152)	1
H	650700190212	Packaging assembly, boxed	1
J	650700350102	IV pole, three-stage, right - 650700350102 (page 194)	1
K	650700450154	Oxygen bottle holder, head section - 650700450154 (page 215)	1
L	650709990102	Standard siderail option - 650709990102 (page 175)	1
M	650709990104	Power-LOAD fastener (page 103)	1
N	650709990109	Two wheel lock option - 650709990109 (page 114)	1
P	650700020959	Assembly, labels, Wi-Fi - NFMIC, US setting	1
R	6500-001-430	X-restraint package	1
T	1234-009-001	Electronic instructions for use (eIFU) leaflet	1

MTS - Power-PRO 2 assembly, high config, no Wi-Fi - 650705550003

Rev AC (Reference only)

Item	Number	Name	Quantity
A	6500-001-232	Head end storage flat option - 6500-128-000 (page 211)	1
B	6500-003-130	Mattress option, knee Gatch bolster, XPS - 6500-003-130 (page 218)	1
C	6507-073-005	Power-PRO 2 Operations/Maintenance Manual - Model 6507	1
D	650700010001	Cot assembly, common components (page 95)	1
E	650700010929	Label, serial number, 003	1
F	650700020961	Assembly, labels, NFMIC, US setting	1
G	650700080028	Birdcage assembly, NFMIC, no Wi-Fi (page 149)	1
H	650700190212	Packaging assembly, boxed	1
J	650700350102	IV pole, three-stage, right - 650700350102 (page 194)	1
K	650700450134	Storage pouch, backrest, dual-sided - 650700450134 (page 212)	1
L	650700450154	Oxygen bottle holder, head section - 650700450154 (page 215)	1
M	650709990101	XPS siderail option - 650709990101 (page 176)	1
N	650709990106	Power-LOAD and Performance-LOAD fastener (page 107)	1
P	650709990110	Four wheel lock option - 650709990110 (page 115)	1
R	6500-001-430	X-restraint package	1
T	1234-009-001	Electronic instructions for use (eIFU) leaflet	1

EMC information

WARNING

- Portable RF communications equipment, including peripherals such as antenna cables and external antennas, should be used no closer than 12 inches (30 cm) to any part of **Power-PRO 2**, including cables specified by the manufacturer.
- Avoid stacking or placing other equipment adjacent to **Power-PRO 2** to prevent improper operation of the products. If such use is necessary, carefully observe the cot and the other equipment to verify proper operation.
- The use of accessories, transducers, and cables, other than those specified or provided by the manufacturer, could result in increased electromagnetic emissions or decreased electromagnetic immunity and result in improper operation.

Guidance and manufacturer's declaration - electromagnetic emissions		
Emissions test	Compliance	Electromagnetic environment
Power-PRO 2 is intended for use in the electromagnetic environment specified below. The customer or the user of Power-PRO 2 should assure that they are used in such an environment.		
RF emissions CISPR 11	Group 2	Power-PRO 2 with the Power-LOAD compatibility option must emit electromagnetic energy in order to perform its intended function. Nearby electronic equipment may be affected.
RF emissions CISPR 11	Group 1	The emissions characteristics of this equipment make it suitable for use in professional healthcare facilities, emergency medical services, and home healthcare environments. If it is used in other environments, this equipment might not offer adequate protection to radio-frequency communication services and power supply networks. The user might need to take mitigation measures, such as relocating or reorienting the equipment.
RF emissions CISPR 11	Class B	

Recommended separation distances between portable and mobile RF communications equipment and Power-PRO 2			
Band (MHz)	Service	Maximum power (W)	Minimum separation distance (m)
Power-PRO 2 is intended for use in an electromagnetic environment in which radiated RF disturbances are controlled. The customer or the user of Power-PRO 2 can help prevent electromagnetic interferences by maintaining a minimum distance between portable and mobile RF communications equipment (transmitters), Power-PRO 2 , and cables, as recommended below, according to the maximum output power of the communications equipment.			
380-390	TETRA 400	1.8	0.3
430-470	GMRS 460 FRS 460	2.0	0.3
704-787	LTE band 13, 17	0.2	0.3
800-960	GSM 800/900 TETRA 800 iDEN 820 CDMA 850 LTE band 5	2.0	0.3
1,700-1,990	GSM 1800 CDMA 1900 GSM 1900 DECT LTE band 1, 3, 4, 25 UMTS	2.0	0.3

Recommended separation distances between portable and mobile RF communications equipment and Power-PRO 2			
Band (MHz)	Service	Maximum power (W)	Minimum separation distance (m)
2,400-2,570	Bluetooth WLAN 802.11 b/g/n RFID 2450 LTE band 7	2.0	0.3
5,100-5,800	WLAN 802.11 a/n	0.2	0.3

For transmitters rated at a maximum output power not listed above, the recommended separation distance d in meters (m) can be estimated using the equation applicable to the frequency of the transmitter, where P is the maximum output power rating of the transmitter in watts (W) according to the transmitter manufacturer.

Note: These guidelines may not apply in all situations. Electromagnetic propagation is affected by absorption and reflection from structures, objects, and people.

Guidance and manufacturer's declaration - electromagnetic immunity			
<p>Power-PRO 2 is suitable for use in a professional healthcare facility, home, and EMS environments. Power-PRO 2 is not suitable for use in environments exceeding immunity test conditions that the product was evaluated to, such as near high frequency (HF) surgical equipment and inside of the radio frequency (RF) shielded room of magnetic resonance imaging (MRI) equipment. The customer or the user of Power-PRO 2 should assure that it is used in such an environment and that the electromagnetic environment guidance listed below is followed.</p>			
Immunity test	IEC 60601 test level	Compliance level	Electromagnetic environment-guidance
Electrostatic discharge (ESD) IEC 61000-4-2	± 8 kV contact ± 15 kV air	± 8 kV contact ± 15 kV air	Floors should be wood, concrete or ceramic tile. If floors are covered with synthetic material, the relative humidity should be at least 30%.
Power frequency (50/60 Hz) magnetic field IEC 61000-4-8	30 A/m	30 A/m	Power frequency magnetic fields should be at levels characteristic of a typical location in a typical commercial or hospital environment.

Guidance and manufacturer's declaration - electromagnetic immunity

<p align="center">Radiated RF IEC 61000-4-3</p>	<p align="center">10 V/m 80 MHz to 2.7 GHz</p>	<p align="center">10 V/m</p>	<p>Portable and mobile RF communications equipment should follow the guidance in the table titled Recommended separation distances between portable and mobile RF communication equipment and Power-PRO 2. If the mobile service is not listed in the table, the recommended separation distance should be calculated from the equation appropriate for the frequency of the transmitter.</p> <p>Recommended separation distance: $D=(0.6) (\sqrt{P})$</p> <p>where P is the maximum output power rating of the transmitter in watts (W) according to the transmitter manufacturer and d is the recommended separation distance in meters (m).</p> <p>Field strengths from fixed RF transmitters, as determined by an electromagnetic site survey^a should be less than the compliance level in each frequency range.^b</p> <p>Interference may occur in the vicinity of equipment marked with the following symbol:</p> 						
<p align="center">Proximity Magnetic Fields IEC 61000-4-39</p>	<table border="1"> <tr> <td align="center">8 A/m 30 kHz</td> </tr> <tr> <td align="center">65 A/m 134.2 kHz</td> </tr> <tr> <td align="center">7.5 A/m 13.56 MHz</td> </tr> </table>	8 A/m 30 kHz	65 A/m 134.2 kHz	7.5 A/m 13.56 MHz	<table border="1"> <tr> <td align="center">8 A/m</td> </tr> <tr> <td align="center">65 A/m</td> </tr> <tr> <td align="center">7.5 A/m</td> </tr> </table>	8 A/m	65 A/m	7.5 A/m	<p>RFID readers and similar generators of magnetic fields should not be operated closer than 50 mm from the electronics or cables of Power-PRO 2.</p>
8 A/m 30 kHz									
65 A/m 134.2 kHz									
7.5 A/m 13.56 MHz									
8 A/m									
65 A/m									
7.5 A/m									

Note - These guidelines may not apply in all situations. Electromagnetic propagation is affected by absorption and reflection from structures, objects, and people.

^a Field strengths from fixed transmitters, such as base stations for radio (cellular/cordless) telephones and land mobile radios, amateur radio, AM and FM radio broadcast, and TV broadcast cannot be predicted theoretically with accuracy. To assess the electromagnetic environment due to fixed RF transmitters, an electromagnetic site survey should be considered. If the measured field strength in the location in which **Power-PRO 2** is used exceeds the applicable RF compliance level above, the **Power-PRO 2** system should be observed to verify normal operation. If abnormal performance is observed, additional measures may be necessary, such as reorienting or relocating **Power-PRO 2**.

^b Over the frequency range 150 kHz to 80 MHz, field strengths are less than 10 V/m.

CAUTION - Changes or modifications to the **Alvarium** Battery Management System, not expressly approved by Stryker, could void the user's authority to operate the equipment.

For United States only:

Alvarium Battery Management System: Model 650700080301 (battery) and Model 650700450301 (charger)

Note - This equipment has been tested and found to comply with the limits for a Class B digital device, pursuant to part 15 of the FCC Rules. These limits are designed to provide reasonable protection against harmful interference in a residential installation. This equipment generates, uses and can radiate radio frequency energy and, if not installed and used in accordance with the instructions, may cause harmful interference to radio communications. However, there is no guarantee that interference will not occur in a particular installation. If this equipment does cause harmful interference to radio or television reception, which can be determined by turning the equipment off and on, the user is encouraged to try to correct the interference by one or more of the following measures:

- Reorient or relocate the receiving antenna
- Increase the separation between the equipment and receiver
- Connect the equipment into an outlet on a circuit different from that to which the receiver is connected
- Consult the dealer or an experienced radio or TV technician for help

Recycling passport

650700080301

Rev AM

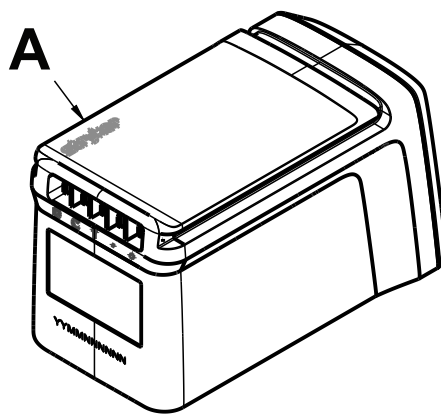

Item	Recyclable part number	Description	Important information	Quantity
A	650700080401	LiFePO ₄ (lithium iron phosphate) battery	No SVHC present	1



The Rechargeable Battery Recycling Corporation (RBRC) is a non-profit, public service organization that promotes the recycling of portable rechargeable batteries. Batteries must be delivered to a battery collection site. Visit the RBRC website (www.rbrc.org) to find a nearby collection site or call the phone number shown on the recycling symbol.

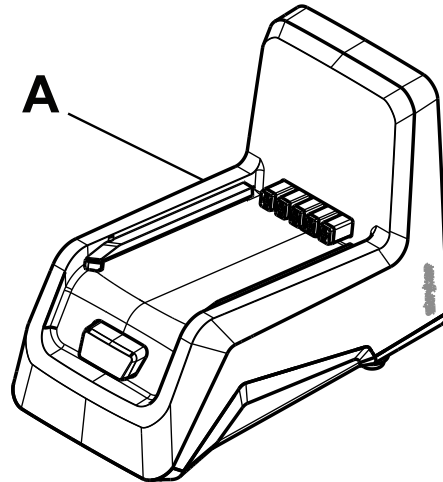

Item	Recyclable part number	Description	Important information	Quantity
A	650700450401	Battery charger assembly	Lead, lead compounds, diboron trioxide, bisphenol A (BPA), antimony oxide (antimony trioxide), molybdenum trioxide, precious metals, antimony trioxide in plastic materials	1

650700450102

Rev AC

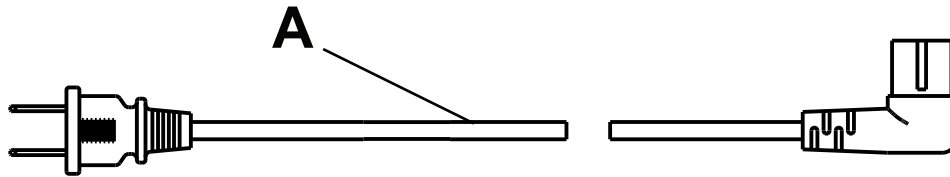

Item	Recyclable part number	Description	Important information	Quantity
A	650700450002	Power cord assembly, North America	No SVHCs present	1

650700450103

Rev AC

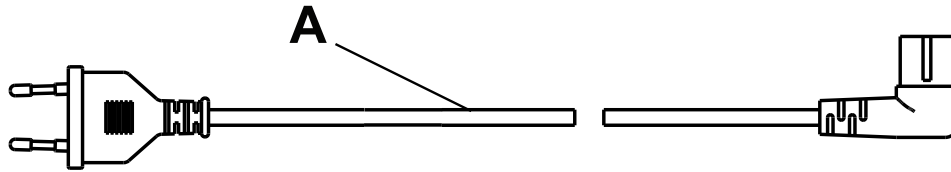

Item	Recyclable part number	Description	Important information	Quantity
A	650700450003	Power cord assembly, Europe	No SVHCs present	1

650700450104

Rev AC

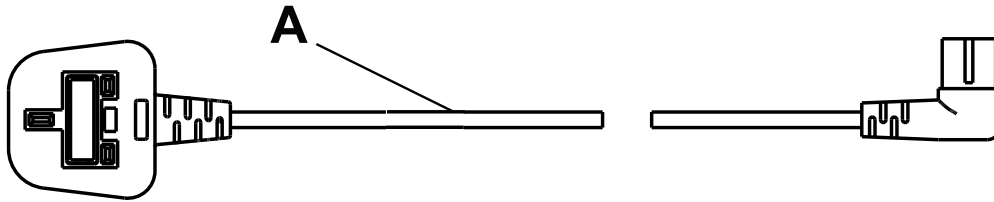

Item	Recyclable part number	Description	Important information	Quantity
A	650700450004	Power cord assembly, UK	No SVHCs present	1

650700450105

Rev AC

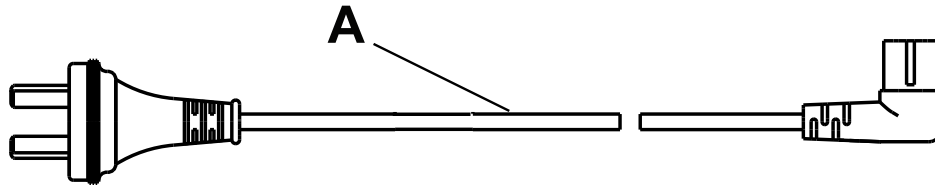

Item	Recyclable part number	Description	Important information	Quantity
A	650700450005	Power cord assembly, Australia	No SVHCs present	1

650700450106

Rev AC

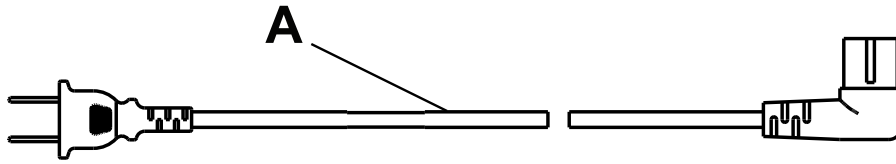

Item	Recyclable part number	Description	Important information	Quantity
A	650700450006	Power cord assembly, Japan	No SVHCs present	1

650700450107

Rev AC

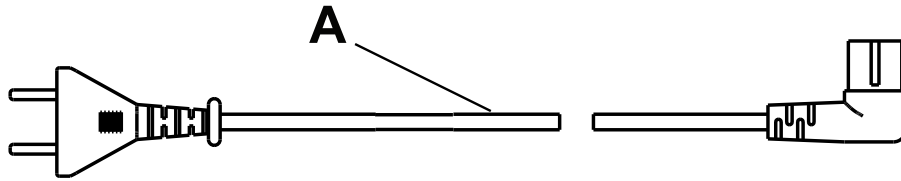

Item	Recyclable part number	Description	Important information	Quantity
A	650700450007	Power cord assembly, Switzerland	No SVHCs present	1

650700450108

Rev AC

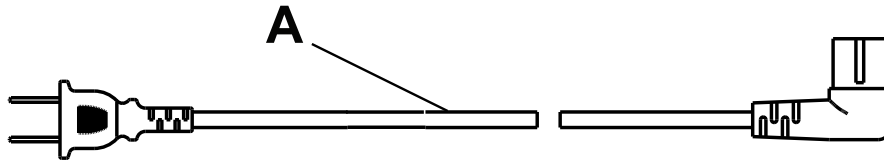

Item	Recyclable part number	Description	Important information	Quantity
A	650700450008	Power cord assembly, China	No SVHCs present	1

650700450109

Rev AA

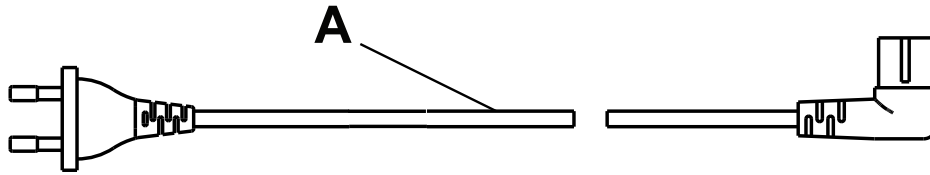

Item	Recyclable part number	Description	Important information	Quantity
A	650700450009	Power cord assembly, Brazil	No SVHCs present	1

650700450210

Rev AA

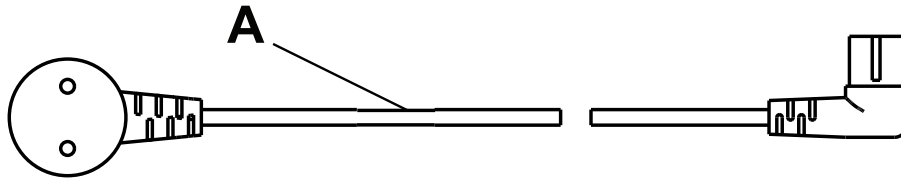

Item	Recyclable part number	Description	Important information	Quantity
A	650700450010	Power cord assembly, Israel	No SVHCs present	1

650700450211

Rev AA

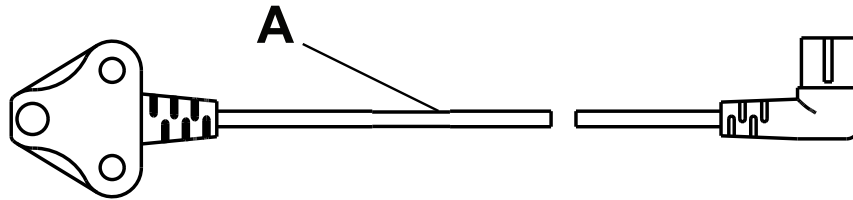

Item	Recyclable part number	Description	Important information	Quantity
A	650700450011	Power cord assembly, South Africa	No SVHCs present	1

650700450212

Rev AA

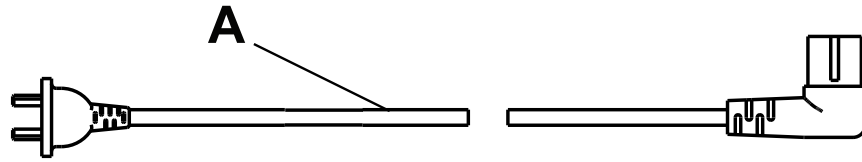

Item	Recyclable part number	Description	Important information	Quantity
A	650700450012	Power cord assembly, Argentina	No SVHCs present	1

650700450101

Rev AA

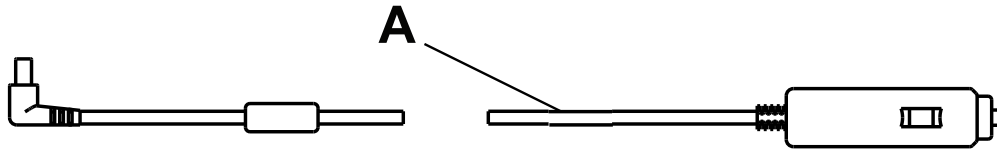

Item	Recyclable part number	Description	Important information	Quantity
A	6500-201-147	12 VDC cable, automotive	Lead, fatty acids, C16-18, lead salts, diarsenic pentaoxide	1

650700080806

Rev AF

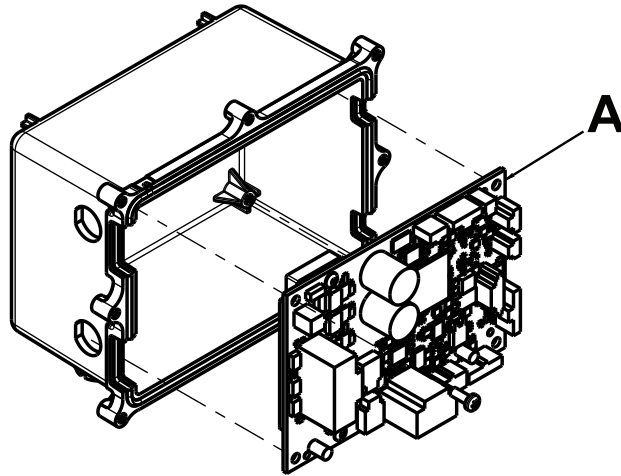

Item	Recyclable part number	Description	Important information	Quantity
A	650700080800	HBC PCBA with software	Lead, lead monoxide (lead oxide), diboron trioxide, 2-methyl-1-(4-methylthiophenyl)-2-morpholinopropan-1-one	1

650700080009

Rev AH

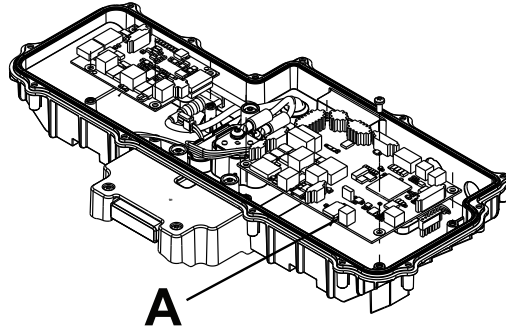

Item	Recyclable part number	Description	Important information	Quantity
A	650700080816	FEIB PCBA with software	No SVHCs present	1

650700080009

Rev AH

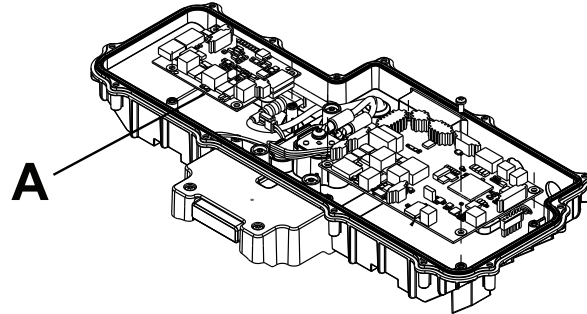

Item	Recyclable part number	Description	Important information	Quantity
A	650700080826	Battery charger PCBA with software	No SVHCs present	1

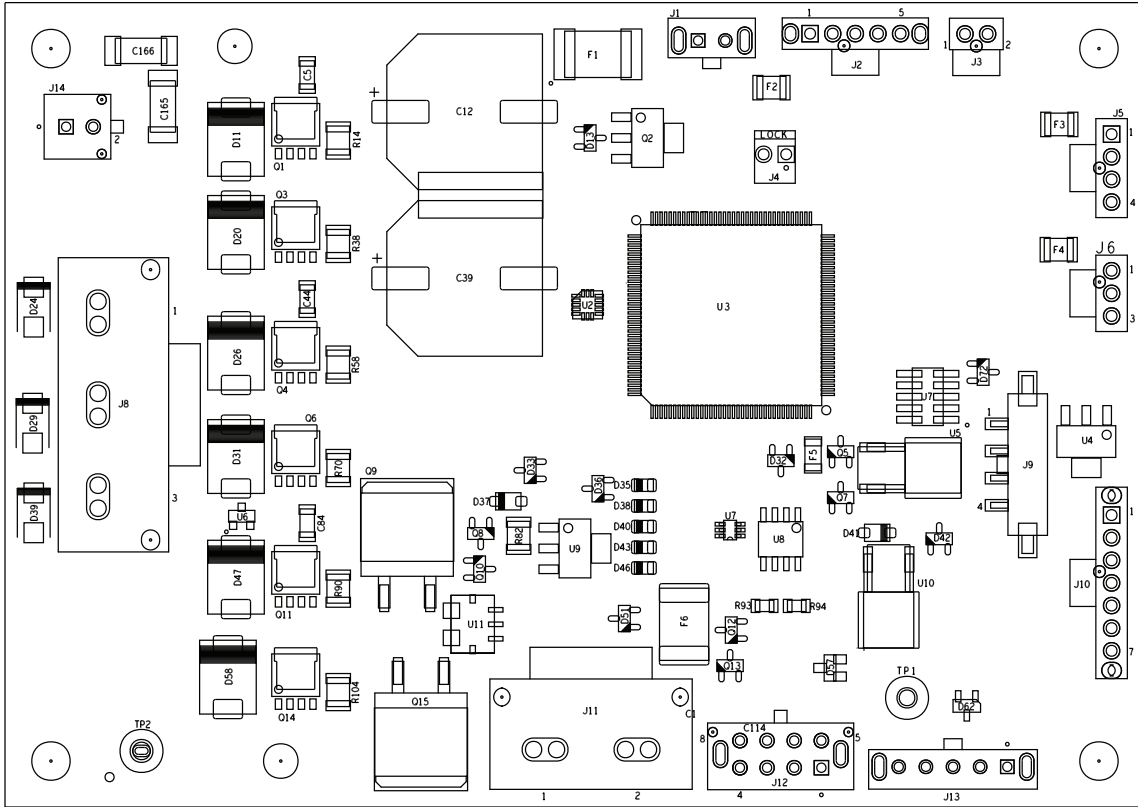

Item	Recyclable part number	Description	Important information	Quantity
A	650700080800	HBC PCBA assembly	Lead, lead monoxide (lead oxide), diboron trioxide, 2-methyl-1-(4-methylthiophenyl)-2-morpholinopropan-1-one	1

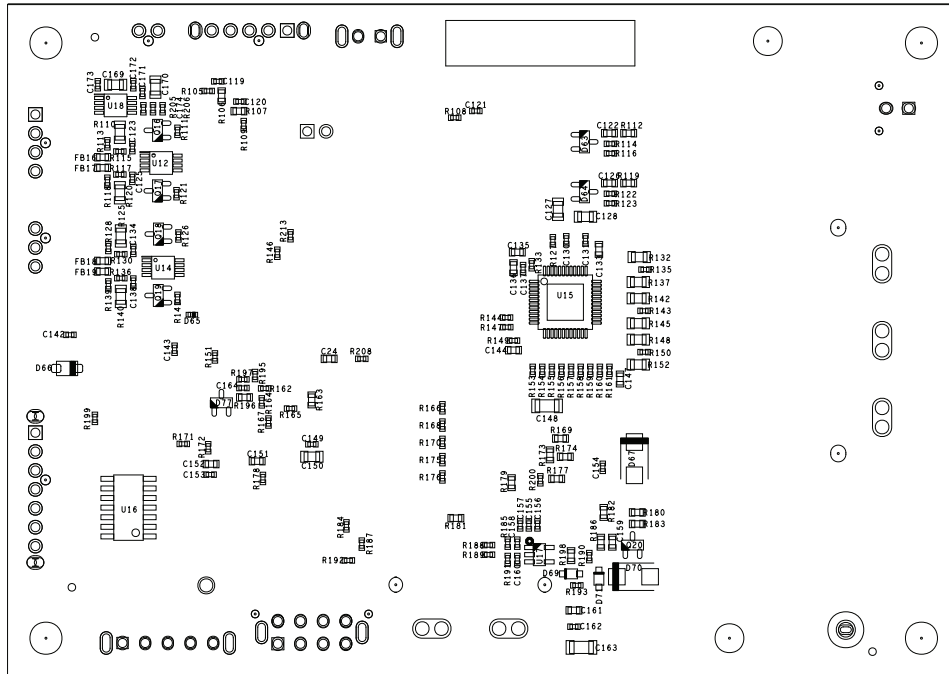

Item	Recyclable part number	Description	Important information	Quantity
A	650700080900	HBC PCBA assembly	Lead, lead monoxide (lead oxide), diboron trioxide, 2-methyl-1-(4-methylthiophenyl)-2-morpholinopropan-1-one	1

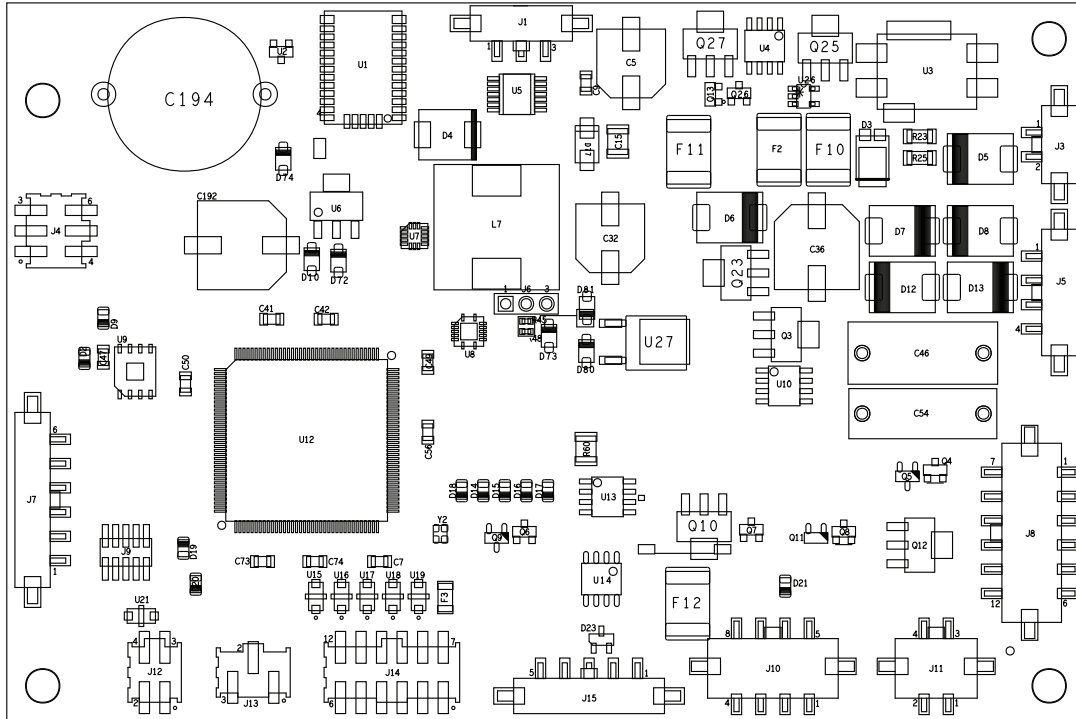

Item	Recyclable part number	Description	Important information	Quantity
A	650700080810	FEIB PCBA assembly	Lead, lead monoxide (lead oxide), diboron trioxide	1

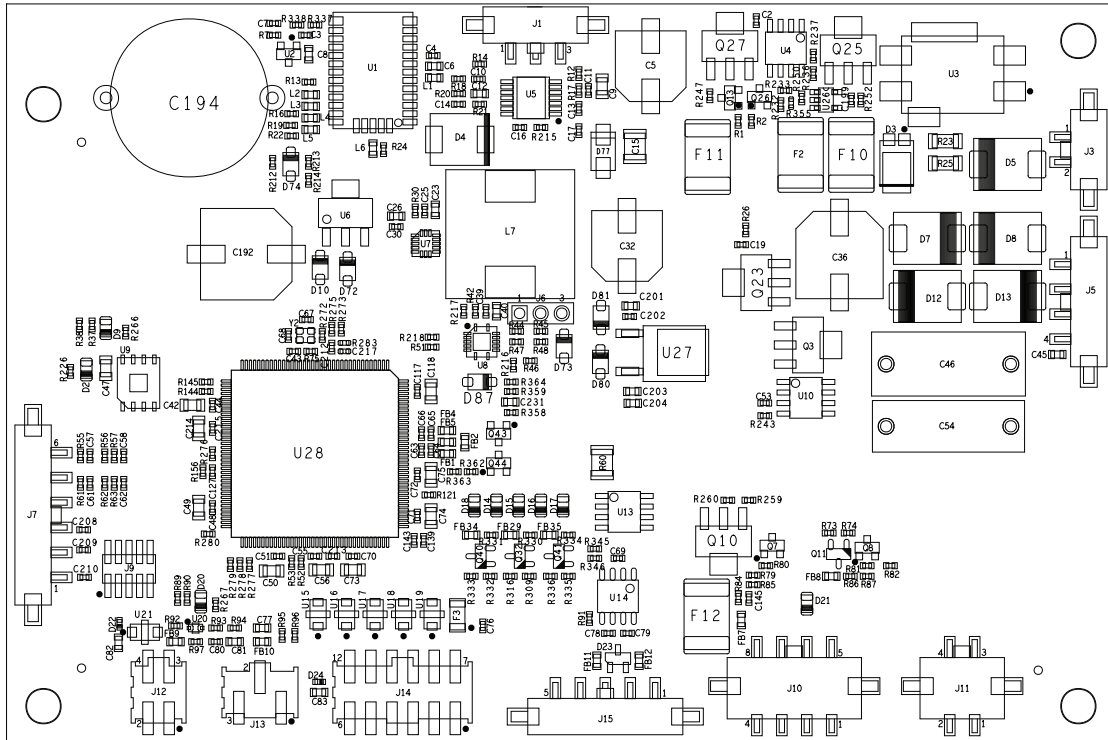

Item	Recyclable part number	Description	Important information	Quantity
A	650700080910	FEIB PCBA assembly	Lead, lead monoxide (lead oxide), diboron trioxide, lead components, precious metals, antimony oxide (antimony trioxide), antimony trioxide in plastic materials	1

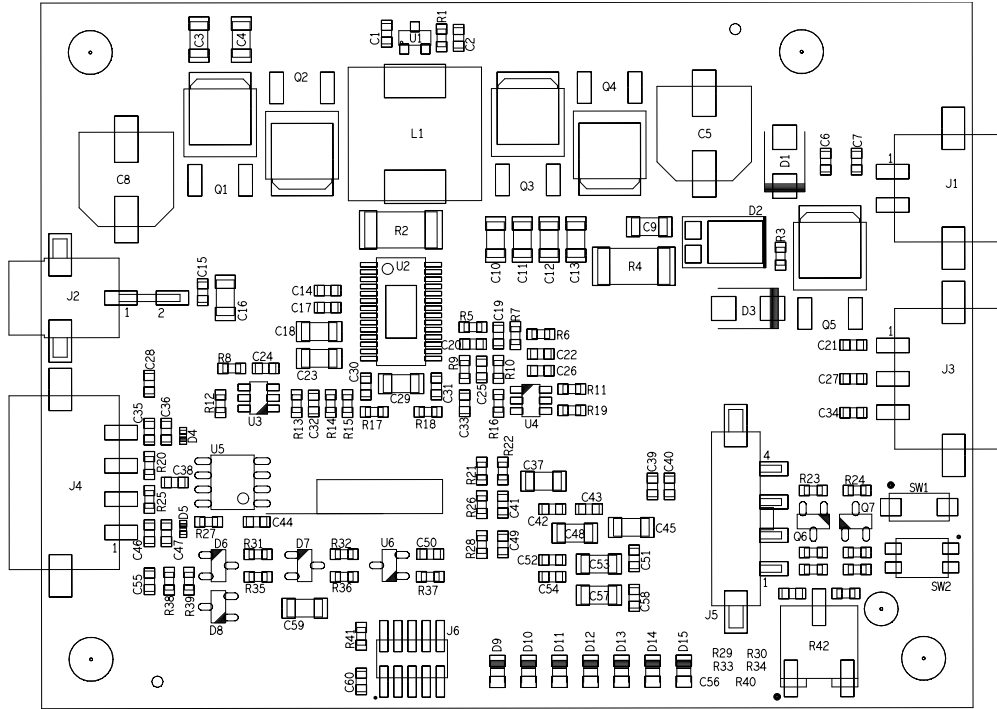

Item	Recyclable part number	Description	Important information	Quantity
A	650700080820	Battery charger PCBA	Lead, lead monoxide (leadoxide), lead compounds, precious metals, diboron trioxide	1

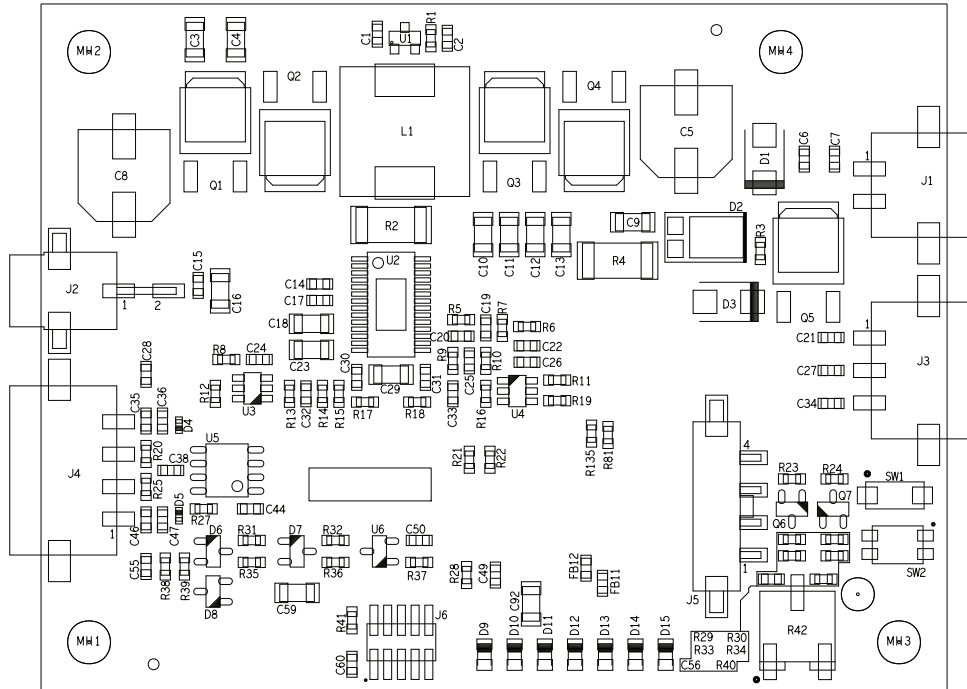

Item	Recyclable part number	Description	Important information	Quantity
A	650700080920	Battery charger PCBA	Lead, lead monoxide (leadoxide), lead compounds, precious metals, diboron trioxide	1

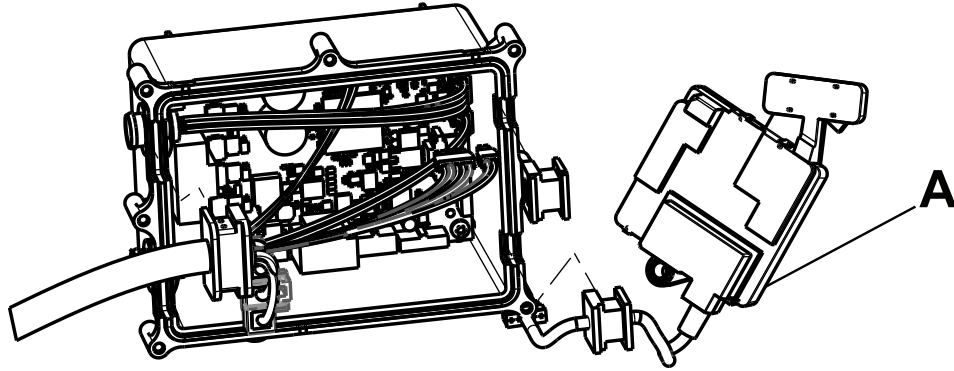

Item	Recyclable part number	Description	Important information	Quantity
A	521206000900	Gateway PCBA 4.0	No SVHCs present	1

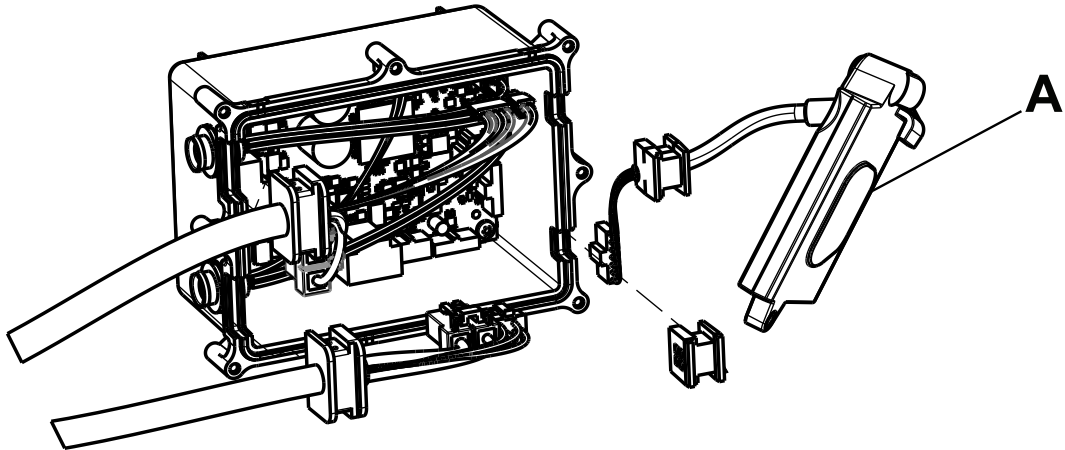

Item	Recyclable part number	Description	Important information	Quantity
A	650700080830	NFMIC - shielded PCBA assembly	Lead, lead monoxide (lead oxide), diboron trioxide	1

650700080860

Rev AF

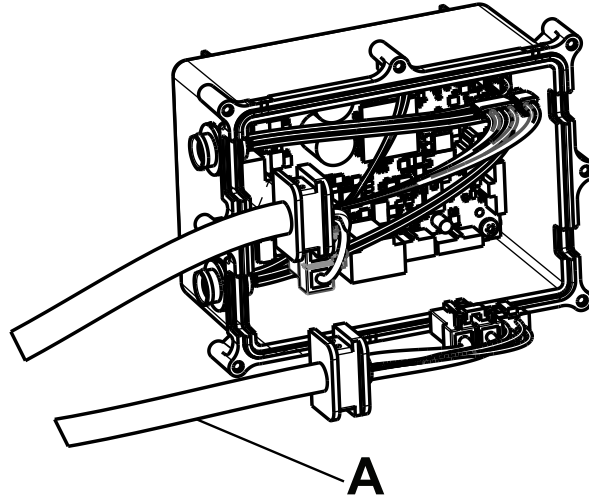

Item	Recyclable part number	Description	Important information	Quantity
A	650700080860	Cable assembly, system bus cable	No SVHCs present	1

650700080862

Rev AG

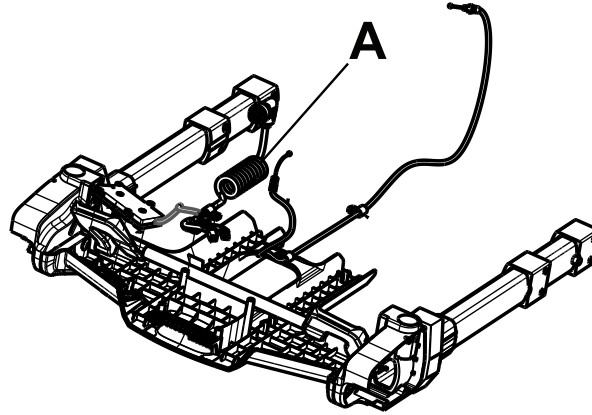

Item	Recyclable part number	Description	Important information	Quantity
A	650700080862	Cable assembly, FEIB to status external module coil cable	No SVHCs present	1

650700080863

Rev AG

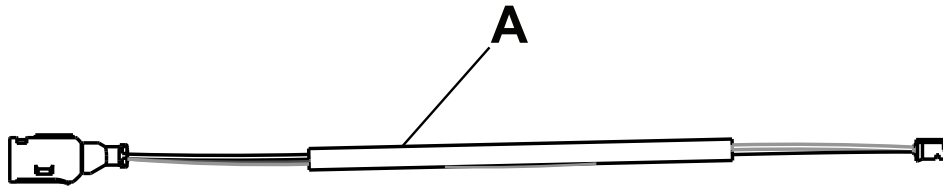

Item	Recyclable part number	Description	Important information	Quantity
A	650700080863	Cable assembly, height sensor cable	No SVHCs present	1

650700080864

Rev AD

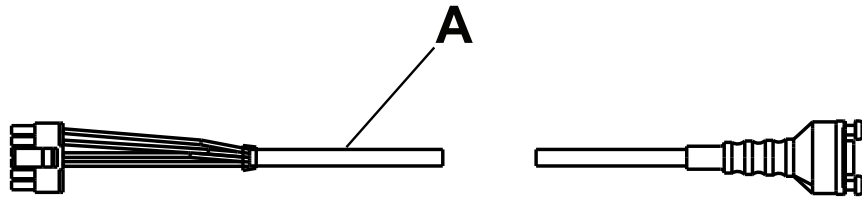

Item	Recyclable part number	Description	Important information	Quantity
A	650700080864	Cable assembly, USB cable	No SVHCs present	1

650700080865

Rev AE

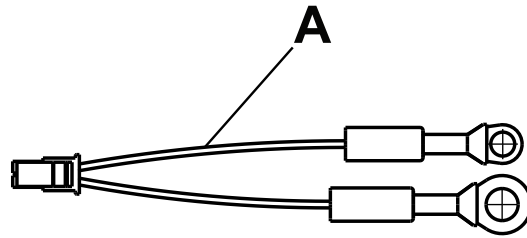

Item	Recyclable part number	Description	Important information	Quantity
A	650700080865	Cable assembly, FEIB to terminal block cable	No SVHCs present	1

650700080866

Rev AC

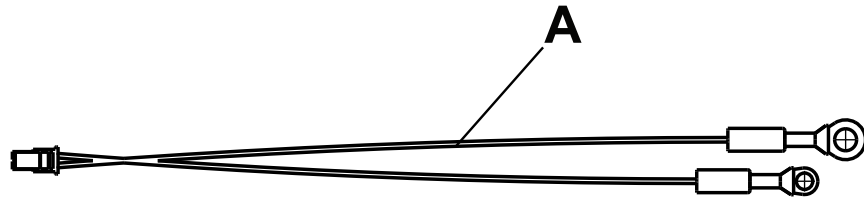

Item	Recyclable part number	Description	Important information	Quantity
A	650700080866	Cable assembly, charger to terminal block cable	No SVHCs present	1

650700080867

Rev AD

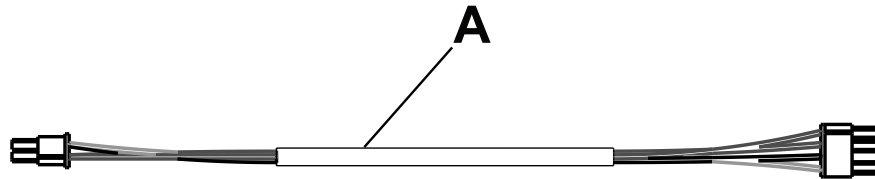

Item	Recyclable part number	Description	Important information	Quantity
A	650700080867	Cable assembly, charger comm cable	No SVHCs present	1

650700080868

Rev AH

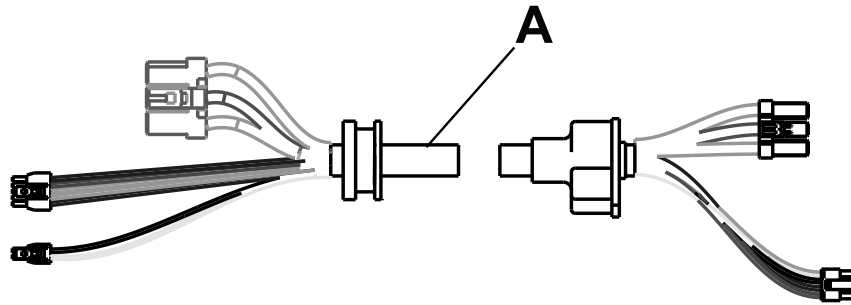

Item	Recyclable part number	Description	Important information	Quantity
A	650700080868	Cable assembly, lift motor cable	No SVHCs present	1

650700080869

Rev AJ

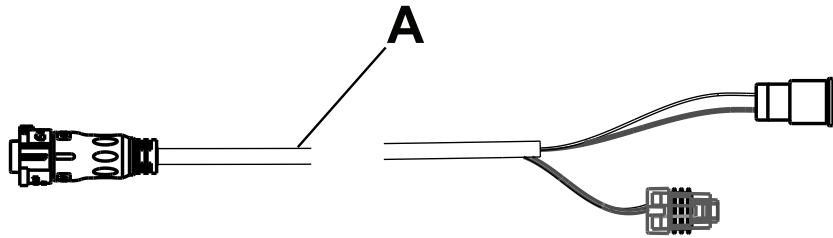

Item	Recyclable part number	Description	Important information	Quantity
A	650700080869	Cable assembly, solenoid/ transducer external cable	No SVHCs present	1

650700080870

Rev AG

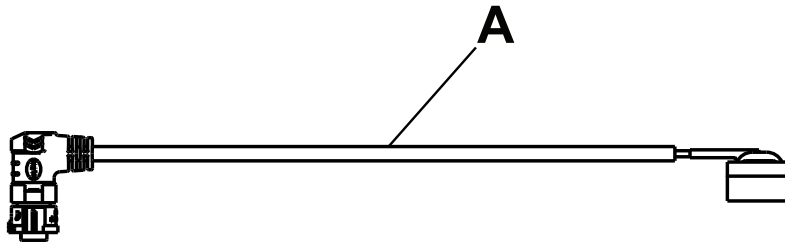

Item	Recyclable part number	Description	Important information	Quantity
A	650700080870	Cable assembly, inductive power cable	No SVHCs present	1

650700080871

Rev AE

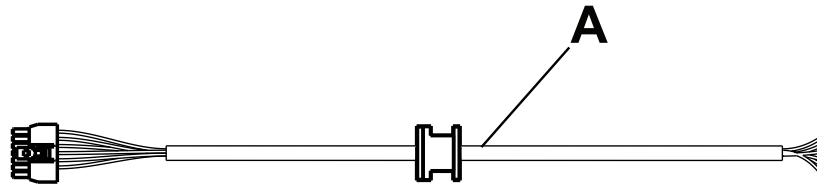

Item	Recyclable part number	Description	Important information	Quantity
A	650700080871	Cable assembly, NFMIC cable	No SVHCs present	1

650700080872

Rev AD

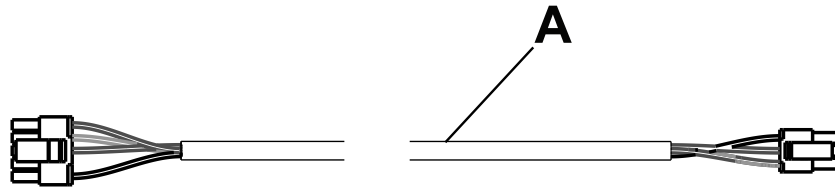

Item	Recyclable part number	Description	Important information	Quantity
A	650700080872	Cable assembly, Mackinac cable	No SVHCs present	1

650700080873

Rev AE

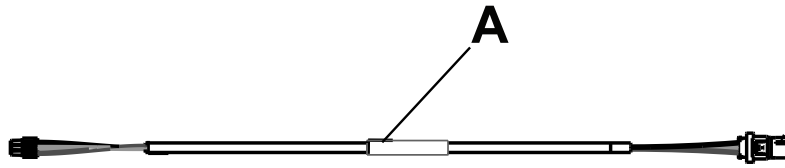

Item	Recyclable part number	Description	Important information	Quantity
A	650700080873	Cable assembly, in-ambulance sensor cable	No SVHCs present	1

650700080875

Rev AE

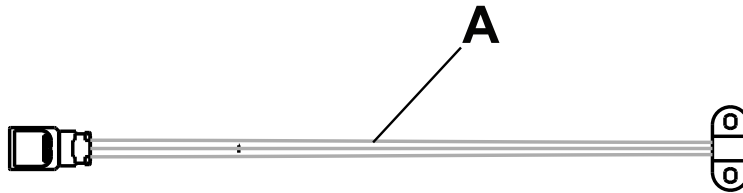

Item	Recyclable part number	Description	Important information	Quantity
A	650700080875	Cable assembly, in-ambulance sensor internal cable	No SVHCs present	1

650700080876

Rev AD

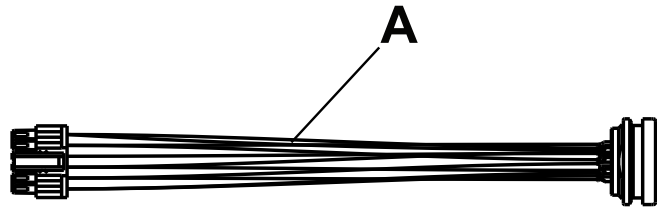

Item	Recyclable part number	Description	Important information	Quantity
A	650700080876	Cable assembly, FIEB coil internal cable	No SVHCs present	1

650700080877

Rev AD

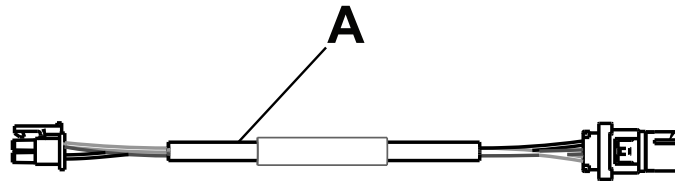

Item	Recyclable part number	Description	Important information	Quantity
A	650700080877	Cable assembly, FEIB height sensor internal cable	No SVHCs present	1

650700080878

Rev AB

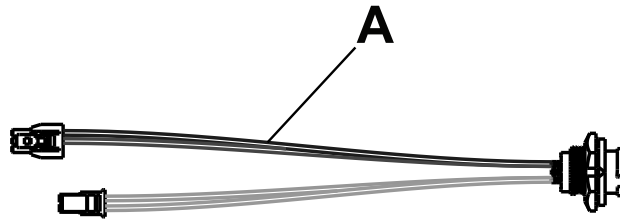

Item	Recyclable part number	Description	Important information	Quantity
A	650700080878	Cable assembly, solenoid/ transducer internal cable	No SVHCs present	1

650700080879

Rev AA

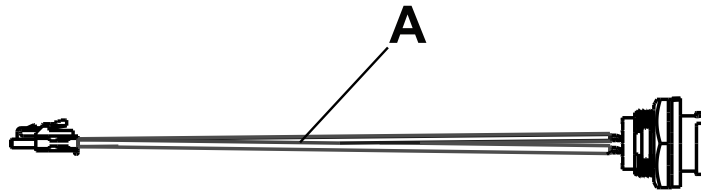

Item	Recyclable part number	Description	Important information	Quantity
A	650700080879	Cable assembly, HBC strain gauge internal cable	No SVHCs present	1

650700080880

Rev AB

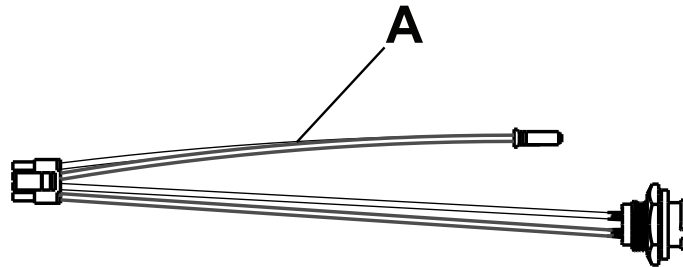

Item	Recyclable part number	Description	Important information	Quantity
A	650700080880	Cable assembly, internal inductive power cable	No SVHCs present	1

650700080890

Rev AG

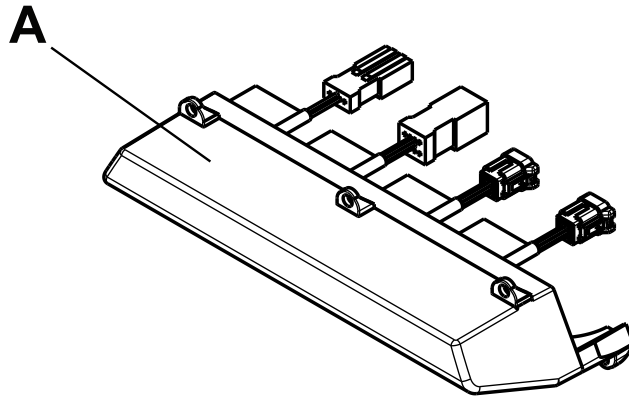

Item	Recyclable part number	Description	Important information	Quantity
A	650700080890	Cable assembly, light module cable	No SVHCs present	1

650700080891

Rev AD

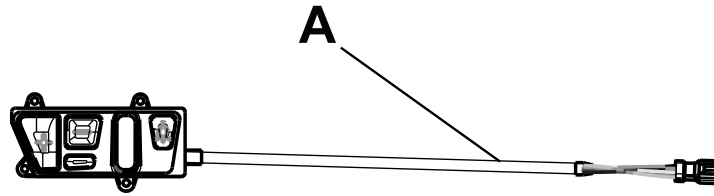

Item	Recyclable part number	Description	Important information	Quantity
A	650700080891	Cable assembly, UI bottom	No SVHCs present	1

650700080892

Rev AD

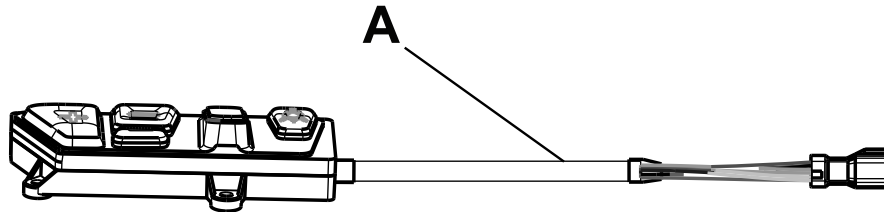

Item	Recyclable part number	Description	Important information	Quantity
A	650700080892	Cable assembly, UI top	No SVHCs present	1

650700080893

Rev AC

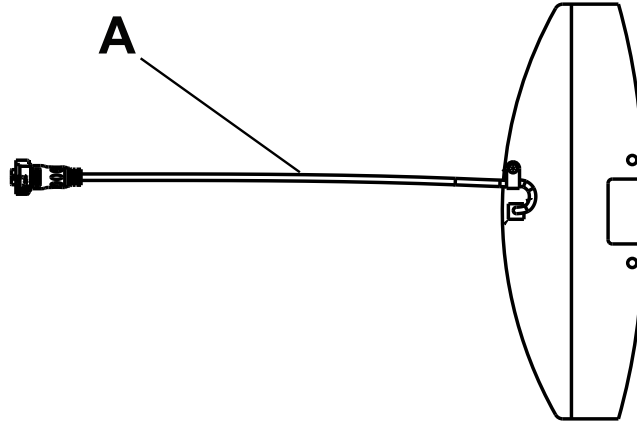

Item	Recyclable part number	Description	Important information	Quantity
A	650700080893	Cable assembly, HBC strain gauge external cable	No SVHCs present	1

Stryker Corporation or its divisions or other corporate affiliated entities own, use or have applied for the following trademarks or service marks: **Alvarium, HAVASU, Performance-LOAD, Power-LOAD, Power-PRO, ProCare, Steer-Lock, Stryker, XPS, XPR**. All other trademarks are trademarks of their respective owners or holders.



Stryker Medical
3800 E. Centre Avenue
Portage, MI 49002
USA