

Power-PRO™ TL Cot

Maintenance Manual

REF 6550



Table of Contents

Warning/Caution/Note Definition	4
Summary of safety precautions	4
Pinch points	4
Mechanical stability	5
Introduction for service	7
Expected service life	7
Contact information	7
Serial number location - Power-PRO	7
Serial number location - SMRT	7
Preventive maintenance	8
Lubrication	8
Regular inspection and adjustments	8
Every month or two hours	8
Every three months or six hours	9
Every six months or 12 hours	10
Every 12 months or 24 hours	10
Maintenance record	11
Training record	11
Troubleshooting	13
Electronic and hydraulics locator	13
Hydraulic manifold components locator	14
Wiring schematics	14
Electrical system block diagram - lower and retract functions	15
Electrical system block diagram - lift and extend functions	16
Troubleshooting guide	16
Litter drifts (without patient weight)	16
Base drifts (without patient weight)	16
Litter does not lower in the powered mode	16
Litter does not extend in powered mode - check the power indicator LED	17
Litter does not extend in the powered mode - check motor	17
Base does not retract in the powered mode	17
Base does not extend in the manual mode	18
Base does not retract in the manual mode	18
Litter does not retract in the manual mode (with patient weight)	18
Litter does not extend in the manual mode	18
High speed retract does not engage	18
Main cable assembly	18
Electronics assembly	19
Electronics assembly wiring schematics	20
SMRT charger power LED is NOT illuminated	20
SMRT charger will not charge the SMRT Pak	21
SMRT charger indicator LEDs are NOT illuminated when the Pak is inserted	21
A fully charged SMRT Pak does not provide sufficient power for cot operation	21
SMRT charger indicates a SMRT Pak error (amber LED), but the Pak performs well on the cot	22
Charger indicates a temperature delay (flashing amber LED), but the Pak is within the normal operating temperature range	22
Service	23
Accessing the hydraulic subassembly (6550-001-030)	23
Manual release cable adjustment	24
Filling the hydraulics assembly reservoir	24
Wheel locking force adjustment	25
Siderail assembly replacement (standard)	25
Siderail assembly replacement (XPS option)	26
Ratchet assembly replacement (XPS option)	27
Release handle assembly replacement (XPS option)	28

Spring handle assembly replacement (XPS option)	29
12 VDC automotive cable fuse replacement	29
Cot assembly	31
Base assembly	37
Two wheel lock option	42
Four wheel lock option	43
Caster horn assembly - 6082-002-012	44
Adjustable caster Steer-Lock assembly	45
Inner lift tube assembly, litter pivot, right - 6550-001-034	46
Inner lift tube assembly, litter pivot, left - 6550-001-035	47
Hitch assembly, head end	48
Standard siderail	51
Siderail assembly	52
Outer rail, right	53
Outer rail, left	54
Optional siderail (XPS option)	55
XPS main assembly, right - 6500-003-034	56
XPS main assembly, left - 6500-003-044	57
Oxygen bottle holder option - 6550-150-000	58
Mounted hydraulics assembly	59
Hydraulics subassembly	61
Hitch assembly, foot end	62
Switch assembly	65
Switch housing assembly	66
Telescoping foot end - 6550-001-015	67
Telescoping head section - 6550-001-020	69
Fowler assembly	71
Gatch assembly	72
Gatch telescoping assembly - 6550-001-017	75
Optional push bar - 6550-040-000	76
Optional corner handle assembly	77
XPR restraint package - 650600030010	78
EMS restraint package - 6060-160-010	79
Belt extension - 6082-160-050	80
Battery pack, SMRT - 6500-033-000	81
Defibrillator platform - 6550-170-000	82
Defibrillator platform assembly - 6082-170-000	83
Defibrillator platform common components	84
Equipment hook option - 6500-147-000	86
No IV pole assembly option	87
Two-stage IV pole, right - 6550-310-000	88
HAVASU™ IV pole assembly, two-stage, right - 6500-101-041	89
Two-stage IV pole, left - 6550-311-000	90
HAVASU IV pole assembly, two-stage, left - 6500-101-042	91
Two-stage IV pole, dual - 6550-312-000	92
Three-stage IV pole, right - 6550-315-000	93

HAVASU IV pole assembly, three-stage, right - 6500-101-043	94
Three-stage IV pole, left - 6550-316-000.....	95
HAVASU IV pole assembly, three-stage, left - 6500-101-044	96
Three-stage IV pole, dual - 6550-317-000	97
Oxygen bottle holder.....	98
Removable oxygen bottle holder - 6080-140-000	99
Base storage net - 6500-160-000.....	100
Backrest pouch - 6500-130-000	101
Knee Gatch bolster mattress - 6550-001-084	102
Flat knee Gatch mattress - 6550-001-295.....	103
Knee Gatch bolster mattress, XPS - 6500-003-130.....	104
Knee Gatch bolster mattress grey, XPS - 6506-041-000.....	105
EMC information	106
Recycling passport	110
6500-101-010	110
6500-201-010	111
6550-101-036	112
6550-001-172	113
6550-101-014	114
6500-001-214	115
6500-201-148	116

Warning/Caution/Note Definition

The words **WARNING**, **CAUTION**, and **NOTE** carry special meanings and should be carefully reviewed.

WARNING

Alerts the reader about a situation which, if not avoided, could result in death or serious injury. It may also describe potential serious adverse reactions and safety hazards.

CAUTION

Alerts the reader of a potentially hazardous situation which, if not avoided, may result in minor or moderate injury to the user or patient or damage to the product or other property. This includes special care necessary for the safe and effective use of the device and the care necessary to avoid damage to a device that may occur as a result of use or misuse.

Note - Provides special information to make maintenance easier or important instructions clearer.

Summary of safety precautions

Always read and strictly follow the warnings and cautions listed on this page. Service only by qualified personnel.

WARNING

- Always keep your hands clear of the red safety bar pivots when you load, unload, or change the height position of the cot.
 - Always use both hands when transporting the cot.
 - Always relieve pressure before you disconnect hydraulic or other lines. Escaping fluid under pressure can penetrate the skin and cause serious injury. Tighten all connections before you apply pressure. If an accident occurs, see a doctor immediately.
 - Do not use bare hands to check for hydraulic leaks.
-

CAUTION

- Always use authorized parts to avoid the risk of product damage.
 - Always check hoses and lines regularly to avoid damage to the cot. Check and tighten loose connections. Hydraulic lines, hoses, and connections can fail or loosen due to physical damage, kinks, age, and environment exposure.
 - Do not tip the cot onto its load wheels and actuate the product as this will allow air to enter the hydraulic system.
 - Do not lubricate the bearings in the X-frame as it will degrade the performance of the cot and may void its warranty.
 - The use of accessories, transducers, and cables, other than those specified or provided by the manufacturer, could result in increased electromagnetic emissions or decreased electromagnetic immunity and result in improper operation.
 - The emissions characteristics of this equipment make it suitable for use in industrial areas and hospitals (CISPR 11 class A). If it is used in a residential environment, for which CISPR 11 class B is normally required, this equipment might not offer adequate protection to radio frequency communication services. The user might need to take mitigation measures, such as relocating or reorienting the equipment.
 - Portable RF communications equipment, including peripherals such as antenna cables and external antennas, should be used no closer than 12 inches (30 cm) to any part of **Power-PRO** and **SMRT** charger, including cables specified by the manufacturer.
 - Avoid stacking or placing other equipment adjacent to **Power-PRO** and **SMRT** charger to prevent improper operation of the products. If such use is necessary, carefully observe **Power-PRO** and **SMRT** charger and the other equipment to make sure that they are operating properly.
-

Pinch points

WARNING - Always keep your hands clear of the red safety bar pivots when you load, unload, or change the height position of the cot.

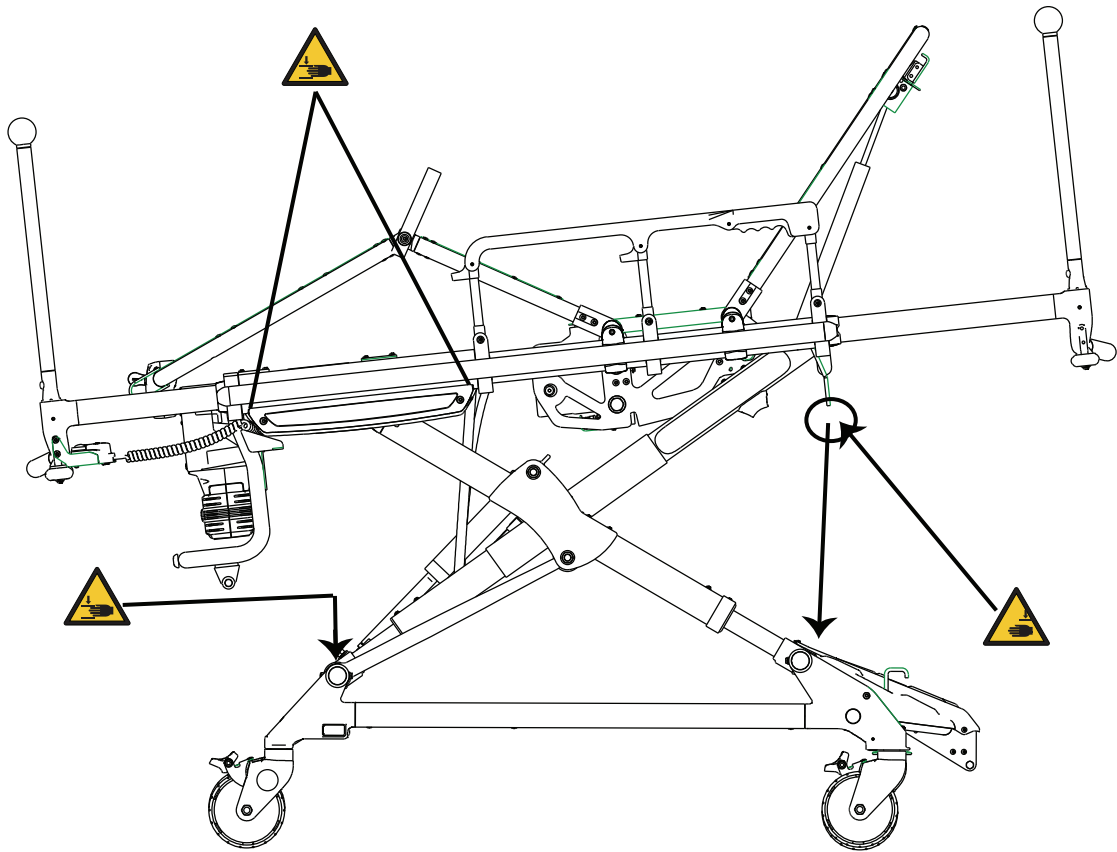


Figure 1 – Pinch points

Mechanical stability

WARNING - Always use both hands when transporting the cot.

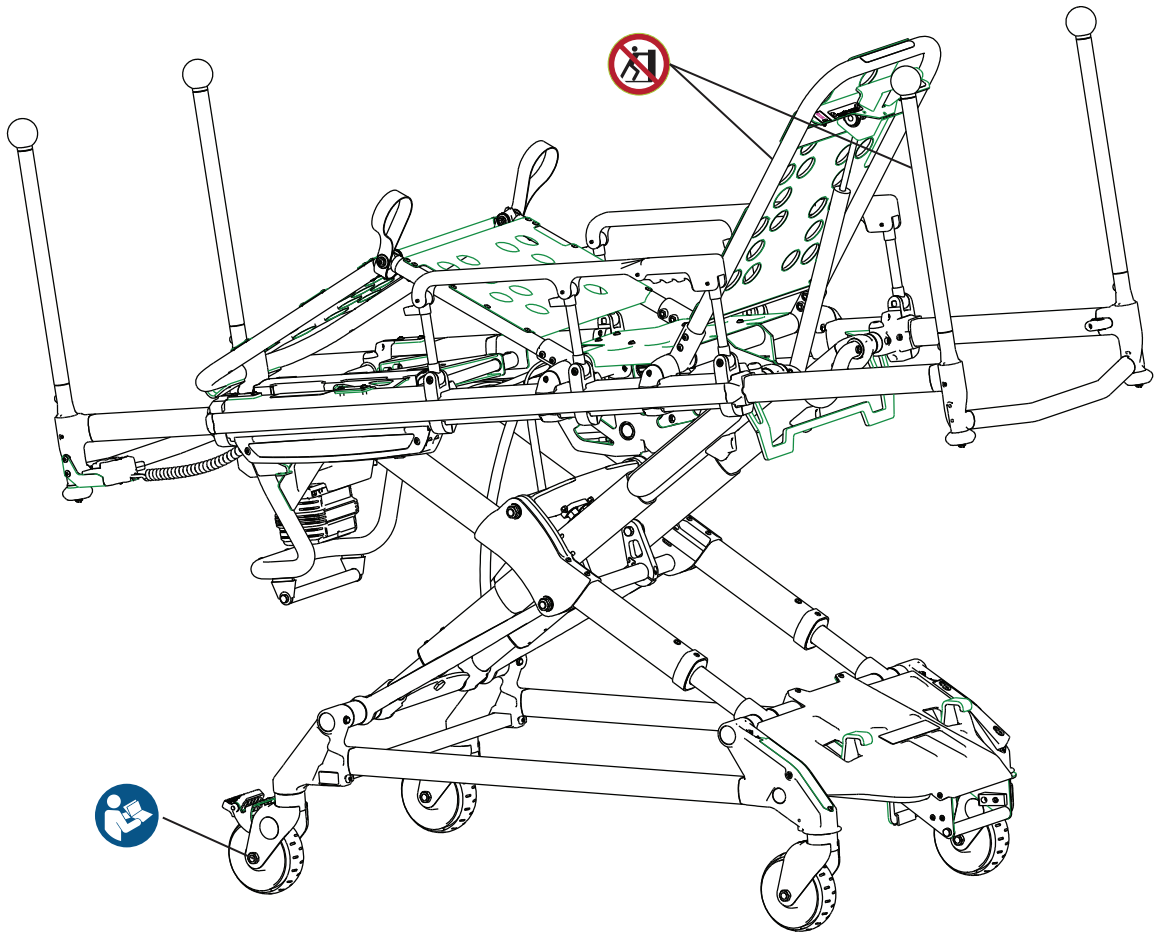


Figure 2 – Mechanical stability

Note - If the cot is on a plane steeper than five degrees, place the cot in the lowest position.

Introduction for service

This manual assists you with the service of your Stryker product. Read this manual to service this product. This manual does not address the operation of this product. See the Operations Manual for operating and use instructions. To view your Operations Manual online, see <https://techweb.stryker.com/>.

Expected service life

Power-PRO has a seven year expected service life under normal use conditions and with appropriate periodic maintenance.

The **SMRT** charger has a seven year expected service life under normal use conditions and with appropriate periodic maintenance.

The **SMRT** Pak battery has a two year expected service life under normal use conditions.

Contact information

Contact Stryker Customer Service or Technical Support at: 1-800-327-0770.

Stryker Medical
3800 E. Centre Avenue
Portage, MI 49002
USA

Note - The user and/or the patient should report any serious product-related incident to both the manufacturer and the Competent authority of the European Member State where the user and/or patient is established.

To view your operations or maintenance manual online, see <https://techweb.stryker.com/>.

Have the serial number (A) of your Stryker product available when calling Stryker Customer Service or Technical Support. Include the serial number in all written communication.

Serial number location - Power-PRO

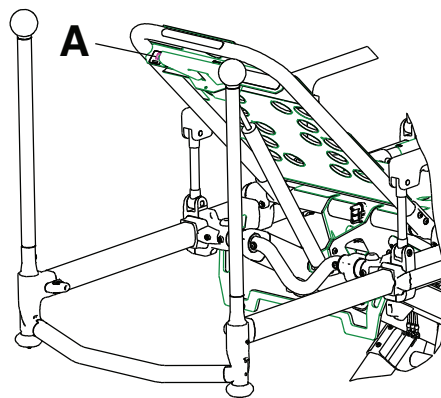


Figure 3 – Serial number location

Serial number location - SMRT

The serial number for the **SMRT** charger is located on the bottom of the unit. The lot number for the **SMRT** Pak is located on the top of the **SMRT** Pak above the red release button.

Preventive maintenance

WARNING

- Always relieve pressure before you disconnect hydraulic or other lines. Escaping fluid under pressure can penetrate the skin and cause serious injury. Tighten all connections before you apply pressure. If an accident occurs, see a doctor immediately.
 - Do not use bare hands to check for hydraulic leaks.
-

CAUTION

- Always use authorized parts to avoid the risk of product damage.
 - Always check hoses and lines regularly to avoid damage to the cot. Check and tighten loose connections. Hydraulic lines, hoses, and connections can fail or loosen due to physical damage, kinks, age, and environment exposure.
 - Do not tip the cot onto its load wheels and actuate the product as this will allow air to enter the hydraulic system.
-

Establish and follow a maintenance schedule and keep records of the maintenance activity. Remove product from service before you perform the preventive maintenance inspection. You may need to perform preventive maintenance checks more often based on your level of product usage. Service only by qualified personnel.

When using maintenance products, follow the directions of the manufacturer and reference all material safety data sheets (MSDS).

Lubrication

CAUTION - Do not lubricate the bearings in the X-frame as it will degrade the performance of the cot and may void its warranty.

The cot has been designed to operate without the need for lubrication.

Regular inspection and adjustments

The following schedule is a general guide to maintenance. Factors such as weather, terrain, geographical location, and individual usage will alter the required maintenance schedule. If you are unsure how to perform these checks, contact your Stryker service technician. If you are in doubt as to what intervals to follow to maintain your product, consult your Stryker service technician. Check each routine and replace worn parts if necessary.

Every month or two hours

Inspect these items every month or two hours, whichever comes first.

Item	Inspect
Settings	In-fastener shutoff configuration
Cylinder	Extend cylinder rod. Wipe the cylinder rod with a soft cloth and household cleaner.
Cables and wires	No hanging wires from routings or connections
Manual backup release handle	Manual backup release handle functions
Litter	Frame and litter
Base	Frame and base
Wheels	All wheels are secure, roll, and swivel
Head section	Safety bar operates. Pull toward the head section to make sure that the safety bar swings and rotates freely and pulls back to the home position

Item	Inspect
Restraint	Restraints function with no excessive wear (such as a bent or broken receiver or latch plate or torn or frayed webbing)
Battery	SMRT Pak housing and terminal area for cracks or damage before first and every use
Charger	SMRT charger and parts for cuts in the cord, bent pins or contacts, or cracks in the housing before first and every use

Every three months or six hours

Inspect these items every three months or six hours, whichever comes first.

Item	Inspect
Cylinder	All fasteners are secure
	No hydraulic fluid (red) leaks
	Loose fittings - tighten, if needed
Hydraulics	Motor mount fasteners are secure
	No hydraulic fluid leaks
	No leaks from reservoir
Cables and wires	No damage or pinching of wiring harness, cable, or lines
	No damaged connectors
Manual backup release handle	Base extends and retracts when you pull the manual backup release handle
	Cot does not lower when you pull the manual backup release handle with 100 lb (45 kg) or more on the cot
Litter	All fasteners are secure
	Backrest cylinder operates
	Adjust pneumatic cylinder for full range of motion, if required
Base	All fasteners are secure
X-frame	X-frame expands and retracts
Head section	All fasteners are secure
	Head section extends and locks
Accessories and parts (optional)	All accessories and parts operate (such as IV pole, restraint extender, push bars, and oxygen bottle holder)

Every six months or 12 hours

Inspect these items every six months or 12 hours, whichever comes first.

Item	Inspect
Hydraulics	Hoses and fittings for damage or wear
	Hydraulic velocity fuse - place a weight of approximately 50 lb (23 kg) on the cot, raise the cot, lift the cot with two operators, pull the manual backup release handle, rapidly set the cot down, and make sure that the cot does not drop
Electronic controls	Extend cot to raised position, measure and check load height
	Jog function operates
	High speed retract works
Switches	No damage or wear to either switch
	Both switches operate
Litter	No bent, broken, or damaged components
	No damage or tears on cot grips
	Siderails operate and latch
	Foot rest operates
Mattress	No cracks or tears
Base	No bent, broken, or damaged components
Wheels	Free of debris
Head section	No bent, broken, or damaged components
	Grip bar has no excessive damage or tears
	Load wheels are secure and roll
Kickstand (optional)	Lubricate the kickstand spring and internal spring housing (optional) using Tri-Flow® lubrication.

Every 12 months or 24 hours

Inspect these items every 12 months or 24 hours, whichever comes first.

Item	Inspect
Settings	Cot and fastener fit and function
Cylinder	Cylinder is adjusted - lock nut is tight and the cot stops moving when it hits the dead stops
Manual backup release handle	Returns to the stowed position
Litter	All welds are intact, not cracked, or broken
	Warning labels present, legible
Base	All welds are intact, not cracked, or broken

Item	Inspect
Wheels	Check and adjust wheel locks
Retractable head section oxygen bottle holder (optional)	Straps and clips for wear
Defibrillator platform (optional)	Straps not frayed or torn
	Latch hooks are intact and secure

Maintenance record

Date	Maintenance operation performed	By	Hours

Training record

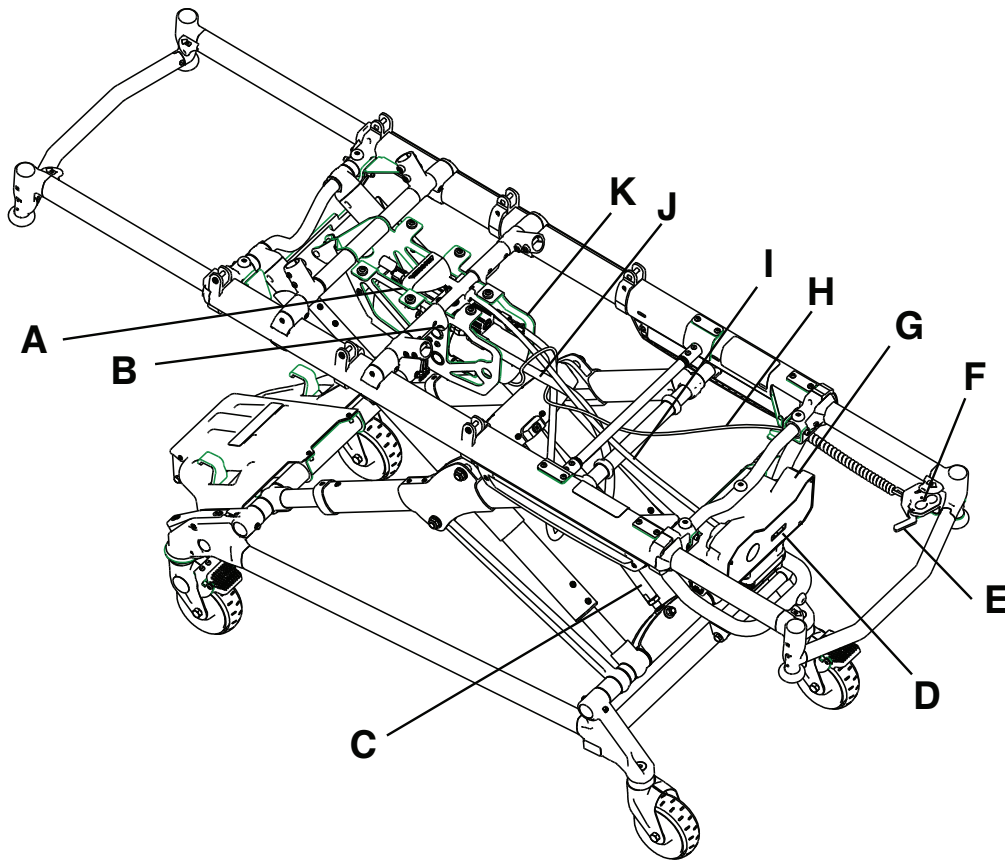
Trainee name	Training date		Owner's manual, in-service, formal class, etc.
	Basic training	Refresher update	

	Training date		
Trainee name	Basic training	Refresher update	Owner's manual, in-service, formal class, etc.

Troubleshooting

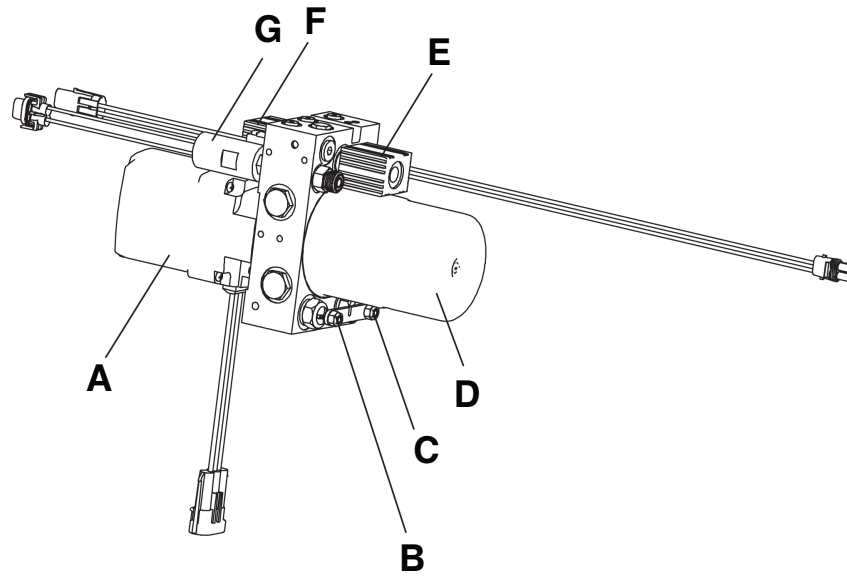
Electronic and hydraulics locator

Note - Some components have been removed for clarity.



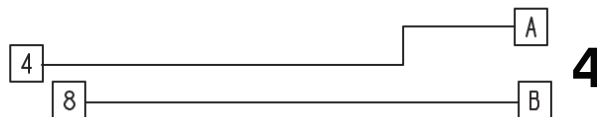
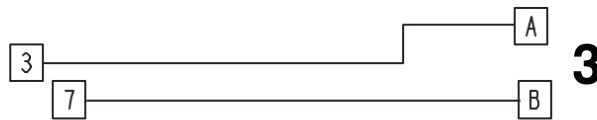
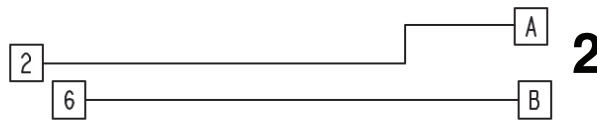
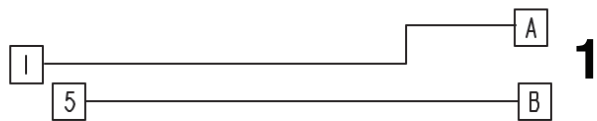
A	Hydraulic manifold assembly (see <i>Hydraulic manifold components locator</i> (page 14))
B	Motor mount
C	Hydraulic cylinder
D	LCD screen
E	Manual release handle
F	Switch
G	Electronic housing (control board inside)
H	Manual release cable
I	Main cable (see <i>Wiring schematics</i> (page 14))
J	Cap-side hydraulic hose
K	Rod-side hydraulic hose

Hydraulic manifold components locator



A	Motor
B	Cap-side (locking) manual valve
C	Rod-side (non-locking) manual valve
D	Reservoir
E	B-valve
F	A-valve
G	Pressure switch

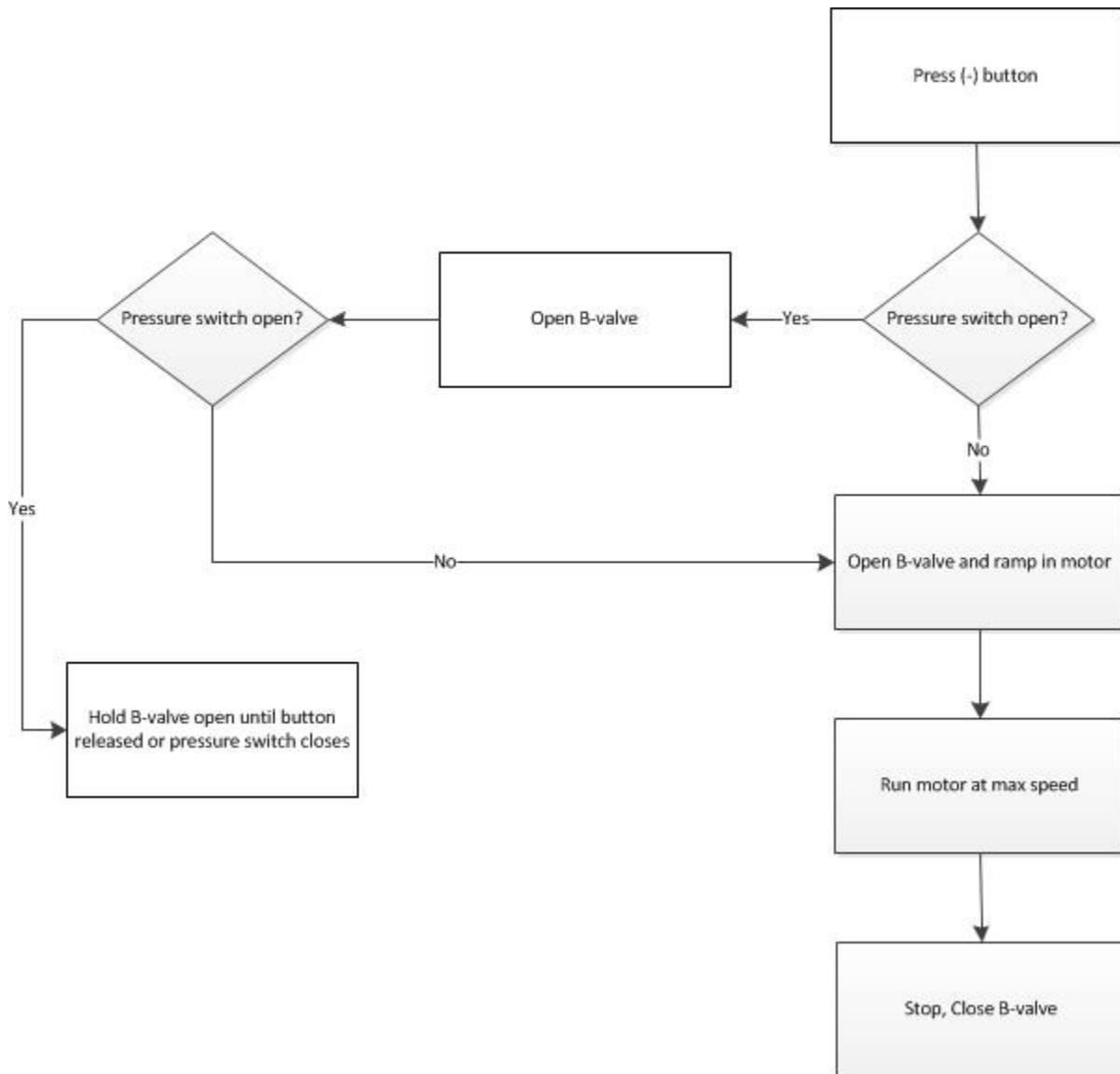
Wiring schematics



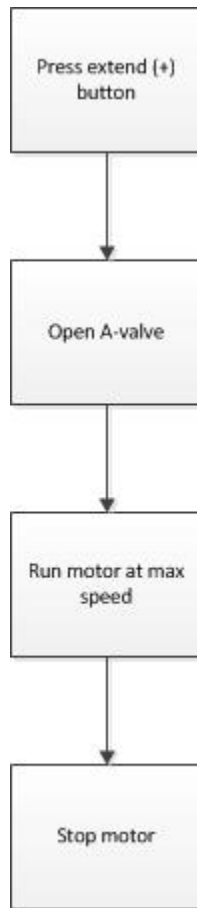
Wiring schematics main cable 8-pin connector

Item	Connection	Link
1	A-valve	1 to A = orange
		5 to B = blue
2	B-valve	2 to A = red
		6 to B = white
3	Pressure switch	3 to A = green
		7 to B = brown
4	Wireless expansion port	4 to A = black
		8 to B = yellow

Electrical system block diagram - lower and retract functions



Electrical system block diagram - lift and extend functions



Troubleshooting guide

Check for proper operation after each step. When the problem is fixed return the cot to service. If assistance is needed at any time during troubleshooting, contact your Stryker service technician.

Litter drifts (without patient weight)

1. Check the manual release cable adjustment.
2. Change the locking manual valve.
3. Change "B" valve.

Base drifts (without patient weight)

1. Check the manual release cable adjustment.
2. Change non-locking manual valve.
3. Change "A" valve.

Litter does not lower in the powered mode

Check the power indicator LED.

1. If blinking constant RED, change the battery.

2. If blinking a patterned AMBER short, short, long flash:
 - a. Check for broken or disconnected wires.
 - b. Check for 24 VDC at connector (C) on the main cable by the motor while pressing the retract (-) button. If voltage is present, replace (in order) the solenoid and/or "B" valve. If voltage is not present, go to step c.
 - c. Check for 24 VDC on electronics assembly pins, 1 blue and 5 orange, on (F) while you press the retract (-) button. If voltage is not present, replace the electronics assembly. If voltage is present, replace the wire harness.
3. If the GREEN light turns on, but does not lower the litter, try the other switch. If the other switch works, replace the bad switch.

Litter does not extend in powered mode - check the power indicator LED

Check the power indicator LED.

1. If blinking constant RED, change the battery.
2. If blinking a patterned AMBER short, short, long flash:
 - a. Check for broken or disconnected wires.
 - b. Check for 24 VDC at connector (B) on the main cable by the motor while you press the extend (+) button. If voltage is present, replace (in order) the solenoid and/or "A" valve. If voltage is not present, go to step c.
 - c. Check for 24 VDC on the electronics assembly pins, 2 white and 6 red, on (F) while you press the extend (+) button. If voltage is not present, replace the electronics assembly. If voltage is present replace the wire harness.
3. If the GREEN light turns on, but does not lower, try the other switch. If the other switch works, replace the bad switch.

Litter does not extend in the powered mode - check motor

Check the motor.

1. If the motor runs, but does not raise the cot:
 - a. Check the manual release cable for too much tension.
 - b. Lightly tap the manual locking valve.
 - c. Replace the manual locking valve.
2. If the motor is stalled, replace the "A" valve.
3. If the light is GREEN, but the motor does not run:
 - a. Check for 24 VDC at connector (E) on the main cable. If voltage is present and the motor does not run, replace the hydraulic sub-assembly. If voltage is not present, go to step b.
 - b. Check for 24 VDC on electronics assembly connection (H) (-) lead on black (+) lead on green while you press the extend (+) button. If voltage is not present, replace the electronics assembly. If voltage is present, replace the main cable.

Base does not retract in the powered mode

Check the power indicator LED.

1. If blinking constant RED, change the battery.
2. If blinking a patterned AMBER short, short, long flash:
 - a. Check for broken or disconnected wires.
 - b. Check for 24 VDC at connector (B) on the main cable by the motor while you press the extend (+) button. If voltage is present, replace (in order) the solenoid and/or "A" valve. If voltage is not present, go to step c.
 - c. Check for 24 VDC on electronics assembly pins, 2 white and 6 red, on (F) while you press the extend (+) button. If voltage is not present, replace the electronics assembly. If voltage is present, replace the wire harness.

Base does not extend in the manual mode

1. Check manual cable adjustment.
2. Change the non-locking manual valve.

Base does not retract in the manual mode

1. Check manual release cable adjustment.
2. Change locking manual valve.

Litter does not retract in the manual mode (with patient weight)

1. Make sure that the weight is off of the casters before you lower the cot.
2. Check the manual cable adjustment.
3. Replace the locking manual valve.

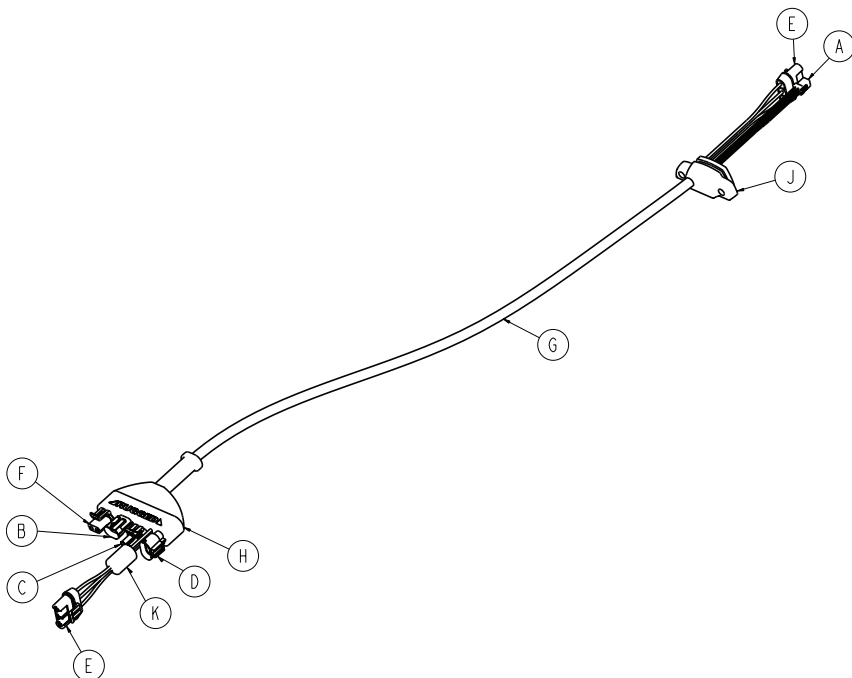
Litter does not extend in the manual mode

1. Check the manual cable adjustment.
2. Change the non-locking manual valve.

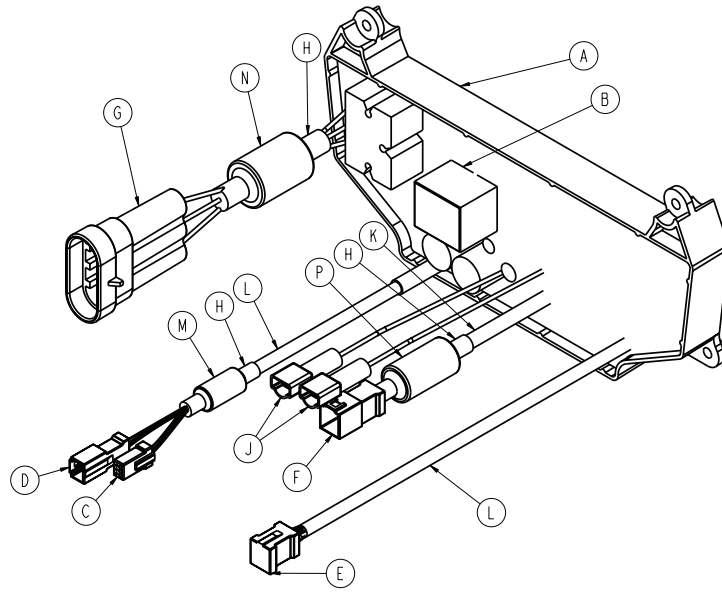
High speed retract does not engage

1. Check that the weight is off of the casters.
2. Change the pressure switch.

Main cable assembly



Electronics assembly



Electronics assembly wiring schematics

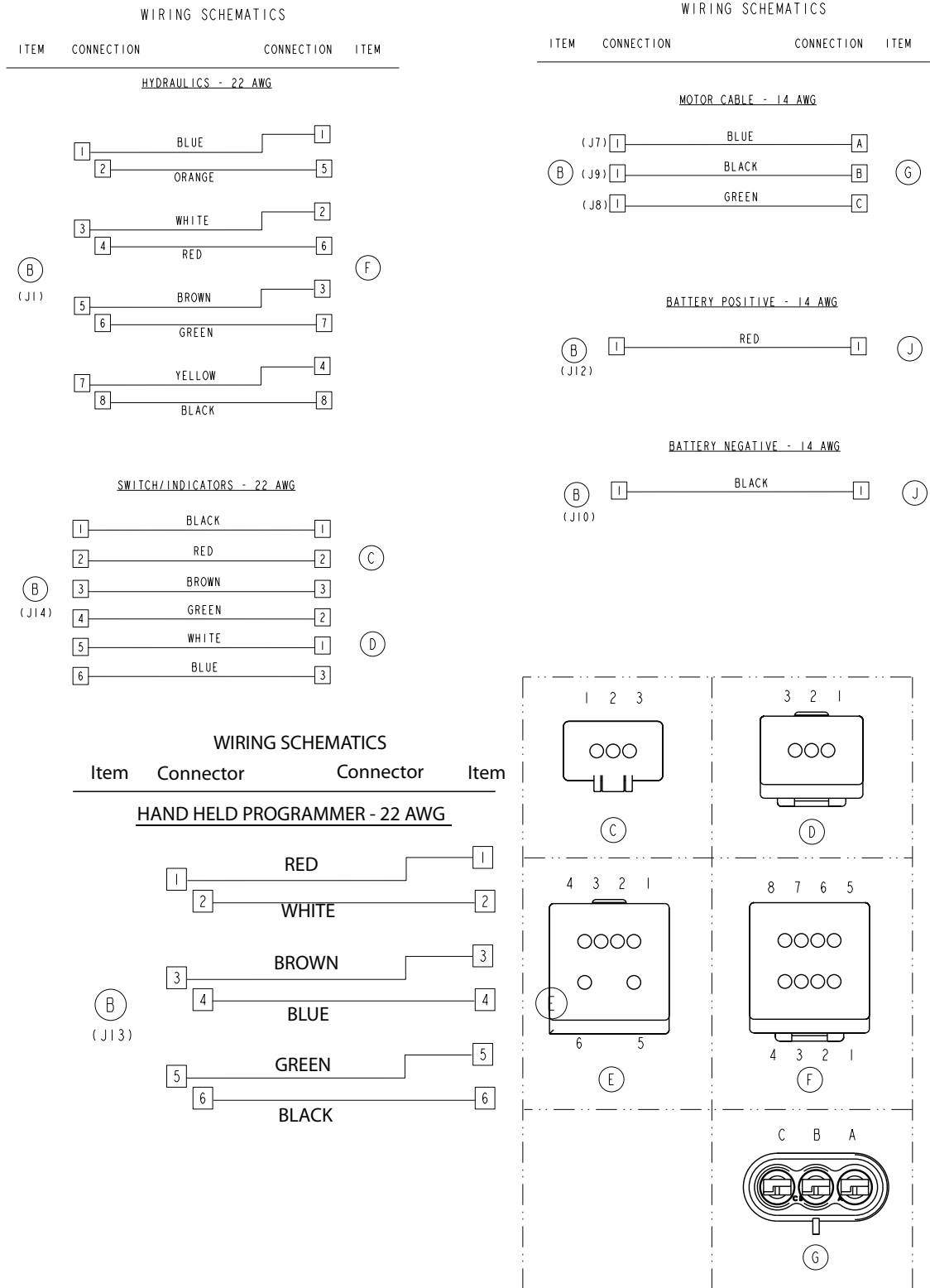


Figure 4 – Wiring Schematics

SMRT charger power LED is NOT illuminated

Make sure that the AC power supply or DC cable is connected properly.

1. If using an AC power supply, make sure that the:

- a. AC power cord is plugged into a wall outlet and the wall outlet has AC power.
 - b. AC power cord is plugged into the power supply.
 - c. AC power supply output cord is plugged into the charger.
2. If using a DC cable, make sure that the:
- a. DC cable is plugged into a power source with 12.5 - 16 VDC
Note - The DC power supply output cord adaptor LED should be illuminated.
 - b. Power cord adaptor internal fuse has continuity. If not, replace the fuse. See *12 VDC automotive cable fuse replacement* (page 29).
 - c. DC cable is plugged into the charger.
3. Check for 12.5 to 16 VDC at the power supply output cord that plugs into the charger.
- a. If 12.5 to 16 VDC is not present, replace the power supply assembly.
 - b. If 12.5 to 16 VDC is present, replace the charger.

SMRT charger will not charge the SMRT Pak

1. Make sure that the charger power LED is illuminated.
 - a. If not, see *SMRT charger indicator LEDs are NOT illuminated when the Pak is inserted* (page 21).
2. Make sure that the charger indicator LEDs flash when the charger is first powered.
 - a. If the LEDs flash at start up, go to step 3.
 - b. If the LEDs do not flash at start up, replace the charger.
3. Reinsert the **SMRT** Pak on the charger and check the charger indicator LEDs for the status of the **SMRT** Pak:
 - a. Solid amber = a **SMRT** Pak error. See *A fully charged SMRT Pak does not provide sufficient power for cot operation* (page 21).
 - b. Flashing amber = a temperature delay. Allow the **SMRT** Pak time to get to normal operating temperature. Reinstall the **SMRT** Pak and recheck step 3.
 - c. Solid green = a fully charged and ready **SMRT** Pak. See *A fully charged SMRT Pak does not provide sufficient power for cot operation* (page 21).

SMRT charger indicator LEDs are NOT illuminated when the Pak is inserted

1. Unplug the charger, wait five seconds, and plug the charger back into the wall outlet.
2. Make sure that the charger power LED is illuminated. If not, see *SMRT charger power LED is NOT illuminated* (page 20).
3. Make sure that the **SMRT** Pak is fully inserted into the charger. If not, reinsert the **SMRT** Pak fully, listen for an audible click, and make sure that the charger indicator LEDs illuminate.
4. Try another **SMRT** Pak to identify any issues.
Note - Separate and label **SMRT** Paks during troubleshooting.
 - a. If the charger indicator LEDs do not illuminate, replace the charger.
 - b. If the charger indicator LEDs illuminate, replace the original **SMRT** Pak.

A fully charged SMRT Pak does not provide sufficient power for cot operation

1. Fully charge the **SMRT** Pak for two hours.

- a. If the charger indicator LED is solid green, indicating a fully charged and ready **SMRT Pak**, go to step 2.
 - b. If the charger indicator LED is solid amber, indicating a **SMRT Pak** error, replace the **SMRT Pak**.
2. Immediately following a full charge, remove the **SMRT Pak** from the charger and check the voltage at the power terminals on the Pak for 26 VDC minimum.
 - a. If the Pak has a 26 VDC minimum, go to step 3.
 - b. If the VDC is less than 26 VDC, replace the Pak.
 3. Wait exactly one hour and charge the **SMRT Pak** again.
 - a. If the charger indicator LED turns solid green (indicating a fully charged and ready **SMRT Pak**) in less than one minute, call Stryker Technical Support.
 - b. If the charger indicator LED flashes green for longer than one minute, replace the Pak.

SMRT charger indicates a SMRT Pak error (amber LED), but the Pak performs well on the cot

1. Fully discharge the **SMRT Pak** by powering a cot until the cot indicator LED flashes red.
2. Recharge the Pak.
 - a. If the charger indicator LED is solid green, indicating a fully charged and ready Pak, then the Pak is ready for use.
 - b. If the charger indicator LED is solid amber, indicating a Pak error, call Stryker Technical Support.

Charger indicates a temperature delay (flashing amber LED), but the Pak is within the normal operating temperature range

1. Remove the **SMRT Pak** from the charger and allow the Pak to cool for at least four hours at room temperature.
2. Insert the Pak into the charger.
 - a. If the charger indicator LED is flashing green, then the Pak is charging.
 - b. If the charger indicator LED is flashing amber, indicating a temperature delay, replace the Pak.

Service

Accessing the hydraulic subassembly (6550-001-030)

Tools required:

- T27 Torx driver

Procedure:

1. Using a T27 Torx driver, remove the six button head cap screws (0004-592-000) from the six well nuts (0055-100-074) that hold the mid-section (6550-001-111) to the motor mounts (6500-001-194 and 6500-001-294). Save the screws.
2. Remove and save the mid-section skin (6550-001-111). The six well nuts will stay with the two motor mounts (6500-01-194 and 6500-001-294).
3. Remove the four button head cap screws (0004-596-000) and the four Nylock hex nuts (0016-102-000) from the two straight "T" pivots (6100-003-125) that hold the Gatch assembly (6550-001-019) to the litter cross brace (6500-001-196).
4. Flip the Gatch assembly (6550-001-019) toward the foot end of the cot until it rests on the telescoping foot end (6550-001-015).
5. Reverse steps to reinstall.
6. Verify proper operation before you return the product to service.

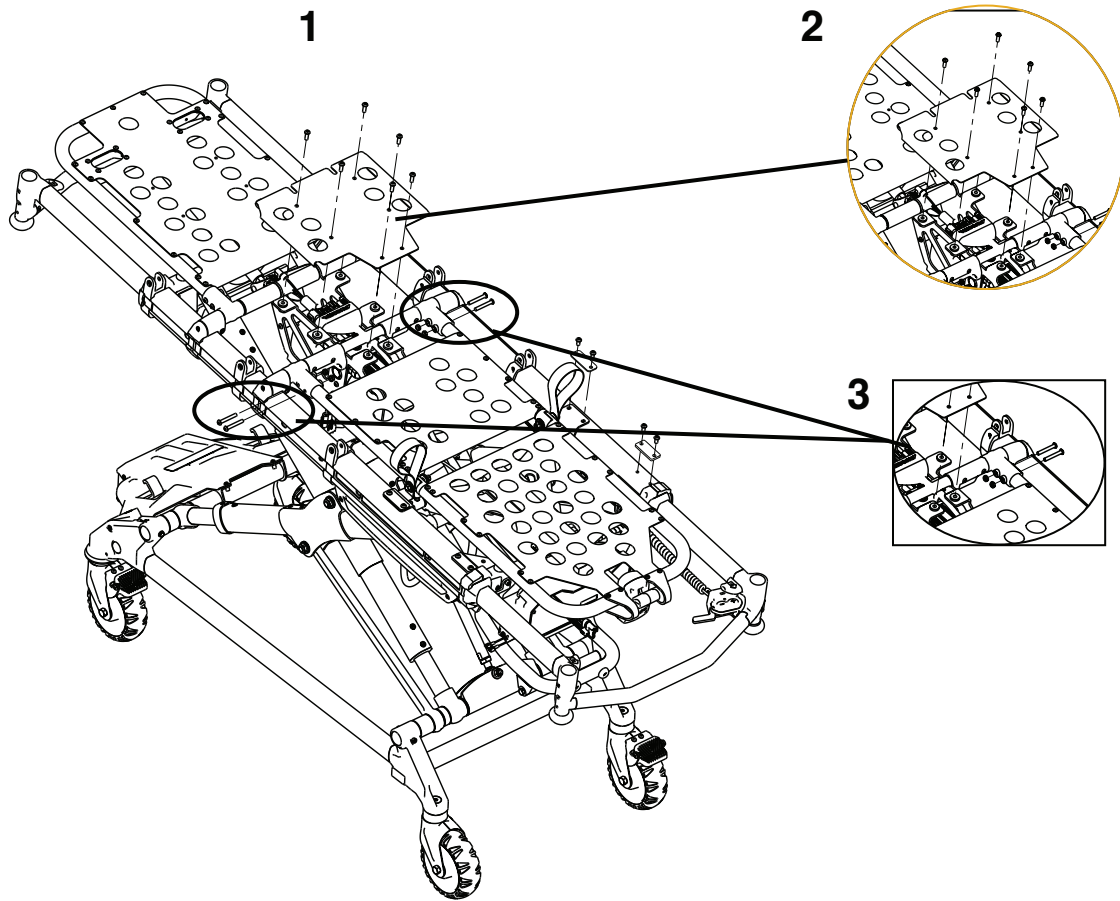


Figure 5 – Accessing the hydraulic subassembly

Manual release cable adjustment

Tools required:

- 8 mm combination wrench
- 10 mm combination wrench

Procedure:

1. Support the litter so no weight is on the base.
2. Make sure that the manual release cable is intact.
3. Using a 10 mm combination wrench, loosen the cable lock nut.
4. Using an 8 mm combination wrench, adjust the tension on the manual release cable.
5. Tighten the cable lock nut.
6. Verify proper operation before you return the product to service.

Filling the hydraulics assembly reservoir

Use only Mobil Mercon® V Synthetic Blend Oil (6500-001-293) when you fill the hydraulics assembly reservoir.

Note - Any time you work with the hydraulics you may lose some oil.

Tools required:

- 3/16" hex wrench

Procedure:

1. Raise the product to the highest height position.
2. Make sure that the fill port is horizontal and lined up with the hole in the motor mount.
3. Using a 3/16" hex wrench, remove the port plug (A) (Figure 6).
4. Fill the reservoir up to the bottom of the fill port.
5. Replace the plug and raise and lower the cot a few times.
6. Verify proper operation before you return the product to service.

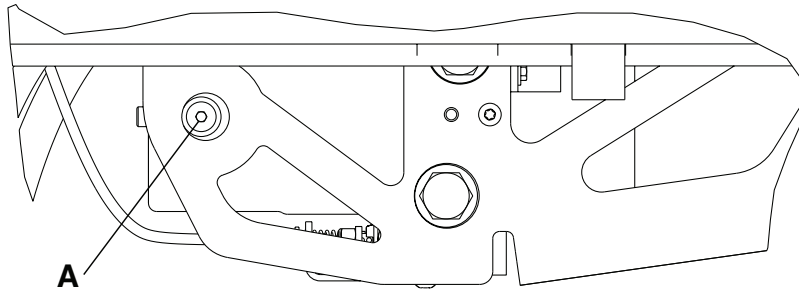


Figure 6 – Hydraulic assembly reservoir

Wheel locking force adjustment

Tools required:

- 5/32" hex wrench
- 7/16" combination wrench or socket

Procedure:

1. Using the 5/32" hex wrench and 7/16" combination wrench or socket, remove the socket screw from the center of the lock pedal. Save the screw. The wheel lock is initially assembled with the pedal set at the minimum locking force. The marker on the pedal (A) is aligned with the marker on the octagonal sleeve (B) (*Wheel locking force adjustment* (page 25)).
2. Remove the sleeve (B). Rotate the sleeve counterclockwise to increase the pedal locking force and clockwise to decrease the locking force. Insert the sleeve into the pedal (*Wheel locking force adjustment* (page 25)).
3. Using the 5/32" hex wrench and 7/16" combination wrench or socket, reinstall the socket screw (removed in step 1).
4. Test the pedal locking force and make sure that the pedal holds before you return the product to service.

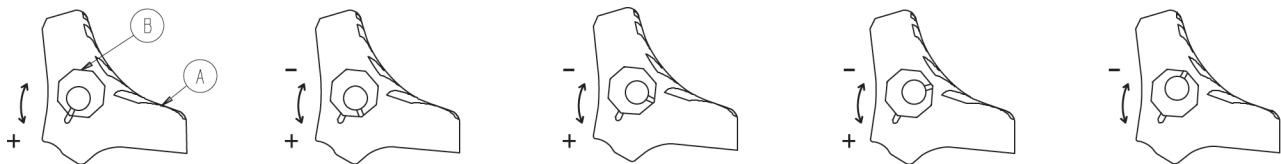


Figure 7 – Wheel locking force adjustment

Siderail assembly replacement (standard)

Tools required:

- T25 Torx driver

Procedure:

1. Raise the product to the highest height position.
2. Raise the siderail to the up and locked position.

3. Using a T25 Torx driver, remove the three spindle screws that secure the siderail assembly.
4. Remove the siderail.
5. Reverse steps to install the new siderail assembly.
6. Verify proper operation before you return the product to service.

Siderail assembly replacement (XPS option)

Tools required:

- T25 Torx driver
- 1/4" hex wrench
- 3/16" hex wrench
- Slotted screwdriver
- Torque wrench (ft-lb)
- Rubber mallet

Procedure:

1. Raise the product to the highest height position.
2. Remove the mattress.
3. Using a T25 Torx driver, remove the button head cap screw (A) and black bumper (B) on the side where you are replacing the siderail (Figure 8). Save the screw and bumper.

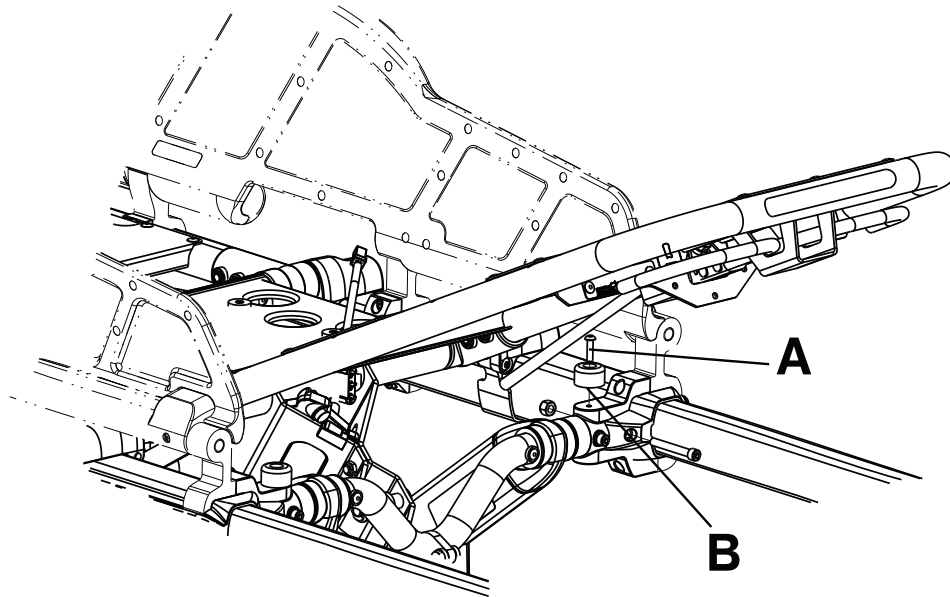


Figure 8 – Siderail assembly replacement (XPS)

4. Using a slotted screwdriver, remove the outer rail bumper.

Note

- Hold on to the siderail main assembly when you remove the outer rail bumper to prevent the outer rail bumper from falling off.
 - The head end and middle siderail pivots may be loose and could fall off of the main assembly.
5. Using a 1/4" hex wrench, remove the socket head cap screws (C) that secure the siderail clamp (D) to the ratchet assembly at the foot end of the main assembly (Figure 9). When you reinstall, use a torque wrench to torque both new screws to 22 ± 3.3 ft-lb.

Note - The siderail will be loose, so do not operate or pull on the siderail.

- Using a 3/16" hex wrench, remove the two socket head cap screws (E) that secure the middle siderail clamp (F) to the outer rail assembly (Figure 9).
- Using a 3/16" hex wrench, remove the two socket head cap screws (G) that secure the top and bottom of the base/litter interface bracket to the outer rail assembly (Figure 9).

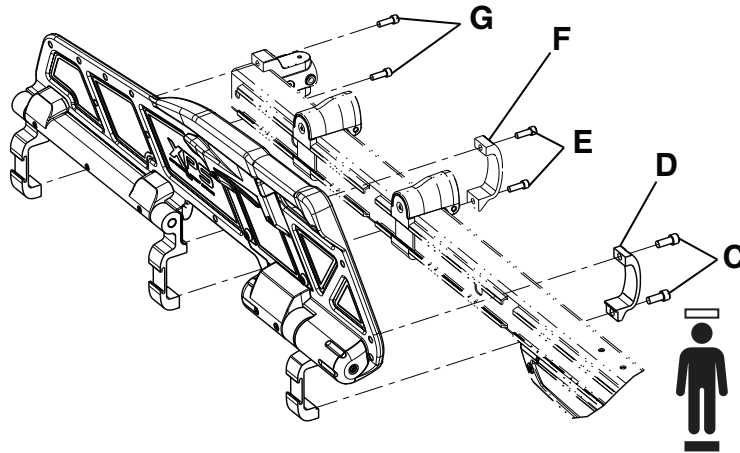


Figure 9 – Remove the siderail assembly

- Reverse steps to reinstall. Use a rubber mallet to reinstall the outer rail bumper.
- Verify proper operation before you return the product to service.

Ratchet assembly replacement (XPS option)

Tools required:

- 3/32" hex wrench
- 1/4" hex wrench
- 3/16" hex wrench
- Torque wrench (ft-lb)

Procedure:

- Raise the product to the highest height position.
- Raise the siderail to the up and locked position.
- Using a 3/32" hex wrench, remove the two screws (A) that secure the ratchet cover (B) to the ratchet assembly. Remove the cover (Figure 10).
- Using a 1/4" hex wrench, remove the socket head cap screws (C) that secure the siderail clamp (D) to the ratchet assembly at the foot end of the main assembly (Figure 10). When you reinstall, use a torque wrench to torque both new screws to 22 ± 3.3 ft-lb.
- Using a 3/16" hex wrench, remove the four screws (E) that secure the ratchet assembly (F) to the overmold assembly and discard. Remove the ratchet assembly (Figure 10). When you reinstall, use a torque wrench to torque the four new screws to 9.5 ± 1.5 ft-lb.

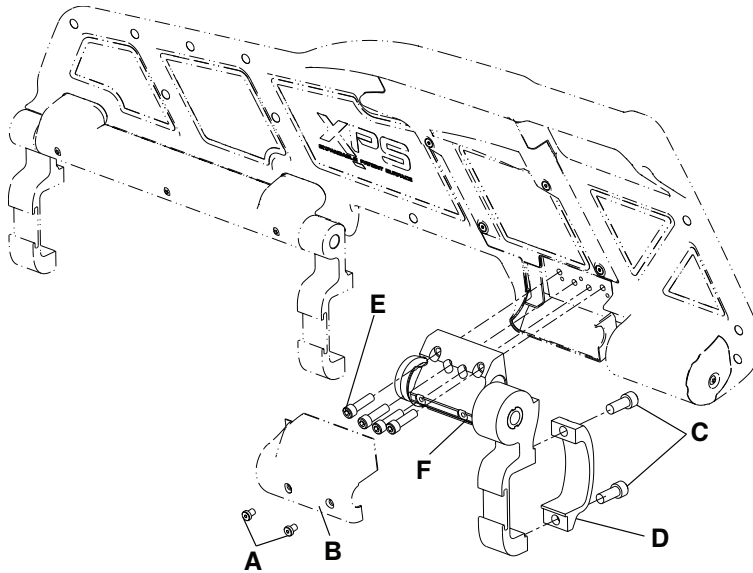


Figure 10 – Ratchet assembly replacement (XPS)

6. Grasp the ratchet assembly and pull toward the head end of the cot to remove.
7. Reverse steps to reinstall.
8. Verify proper operation before you return the product to service.

Release handle assembly replacement (XPS option)

Tools required:

- 3/32" hex wrench
- Small slotted screwdriver

Procedure:

1. Raise the product to the highest height position.
2. Raise the siderail to the up and locked position.
3. Using a 3/32" hex wrench, remove the four screws (A) that secure the release cover (B) to the overmold assembly to remove the release cover (Figure 11).
4. Using a small slotted screwdriver, pry the release handle return spring (C) up to remove the spring (Figure 11).
5. Grasp the release handle assembly (D), and hinge upward on the spring side to remove from the cover (Figure 11).

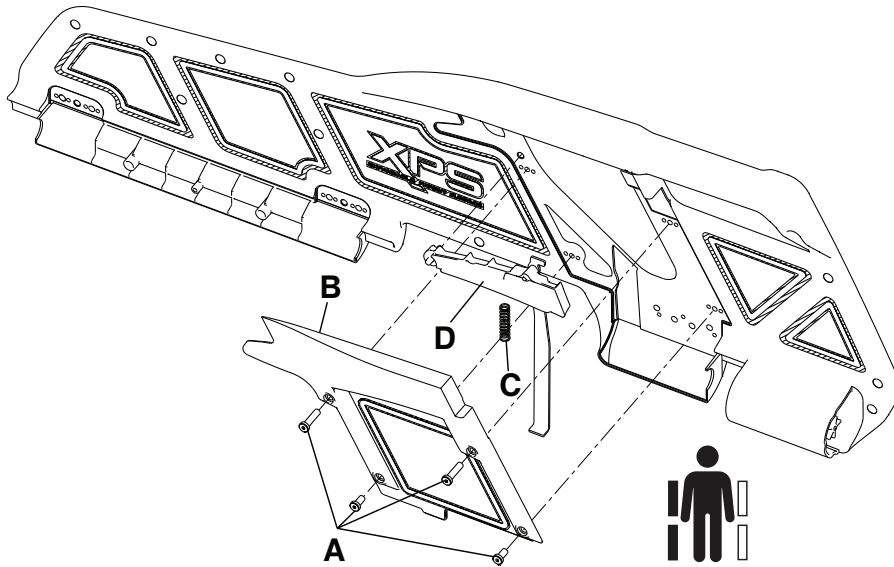


Figure 11 – Release/spring handle assembly replacement (XPS)

6. Reverse steps to reinstall.
7. Verify proper operation before you return the product to service.

Spring handle assembly replacement (XPS option)

Tools required:

- 3/32" hex wrench
- Small slotted screwdriver

Procedure:

1. Raise the product to the highest height position.
2. Raise the siderail to the up and locked position.
3. Using a 3/32" hex wrench, remove the four screws (A) that secure the release cover (B) to the overmold assembly to remove the release cover (Figure 11).
4. Using a small slotted screwdriver, pry the release handle return spring (C) up to remove the spring (Figure 11).
5. Reverse steps to reinstall.
6. Verify proper operation before you return the product to service.

12 VDC automotive cable fuse replacement

Tools required:

- None

Procedure:

1. Unplug the adaptor cable from the plug (B) and the plug connector (A).
2. Unscrew the tip on the source end and remove the fuse (*12 VDC automotive cable fuse replacement (page 29)*).

Note - The source tip and the fuse tension spring are loose and could be dropped.

3. Install the new 10A 250V fuse into the source end of the adaptor cable and screw the tip back on.
4. Plug both ends back into the source and the charger.

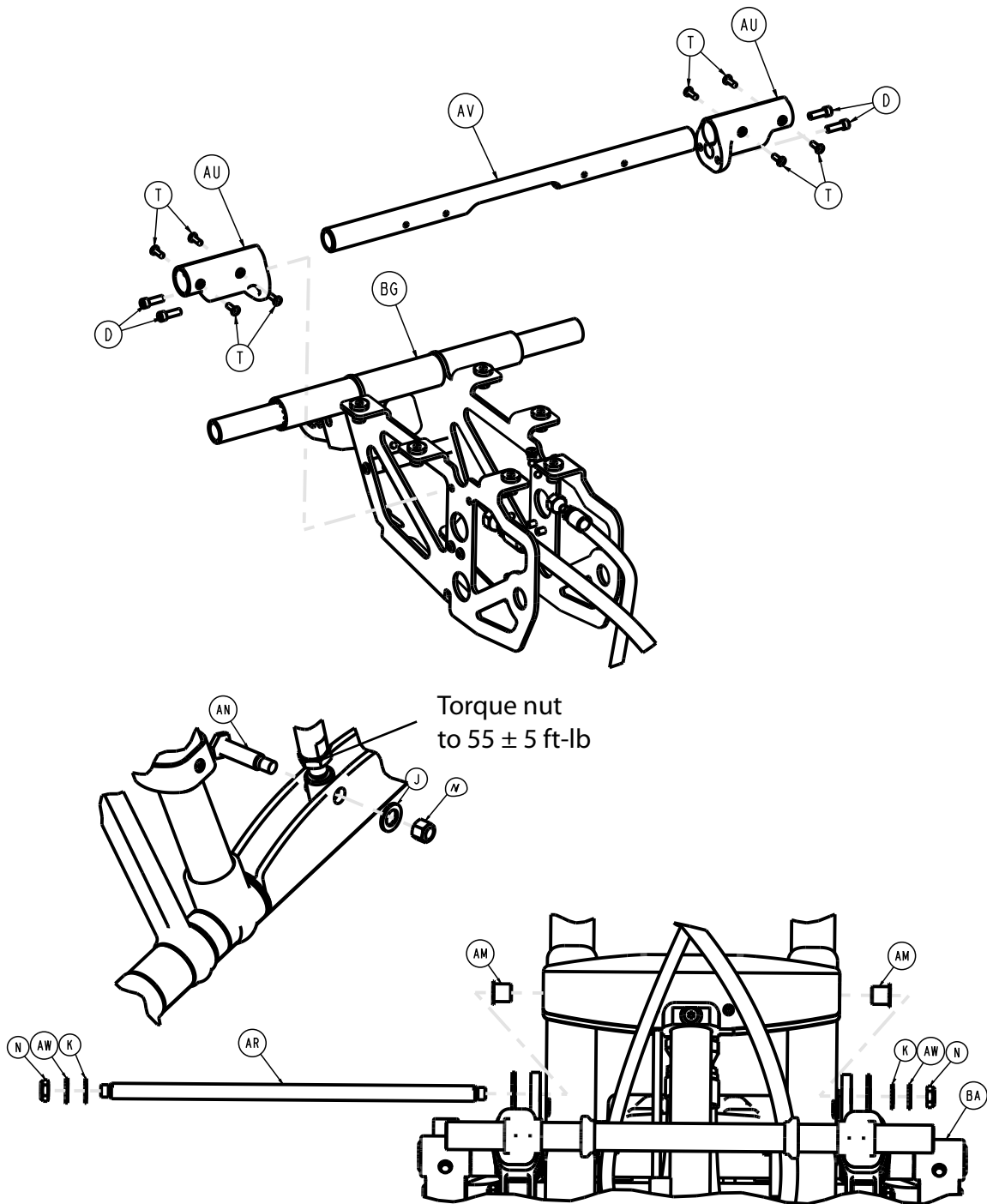
5. Test for functionality before you return the charger to service.

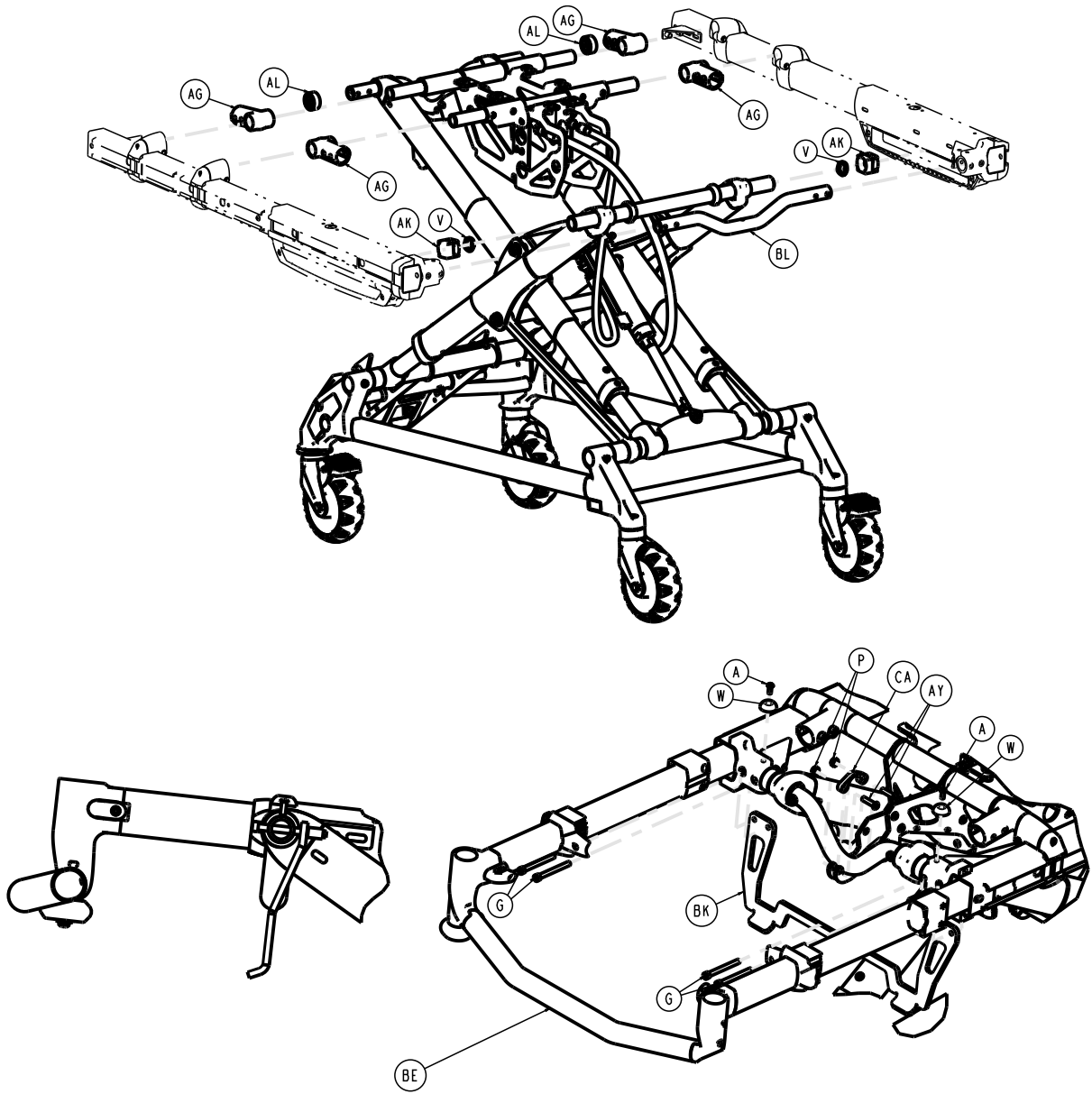


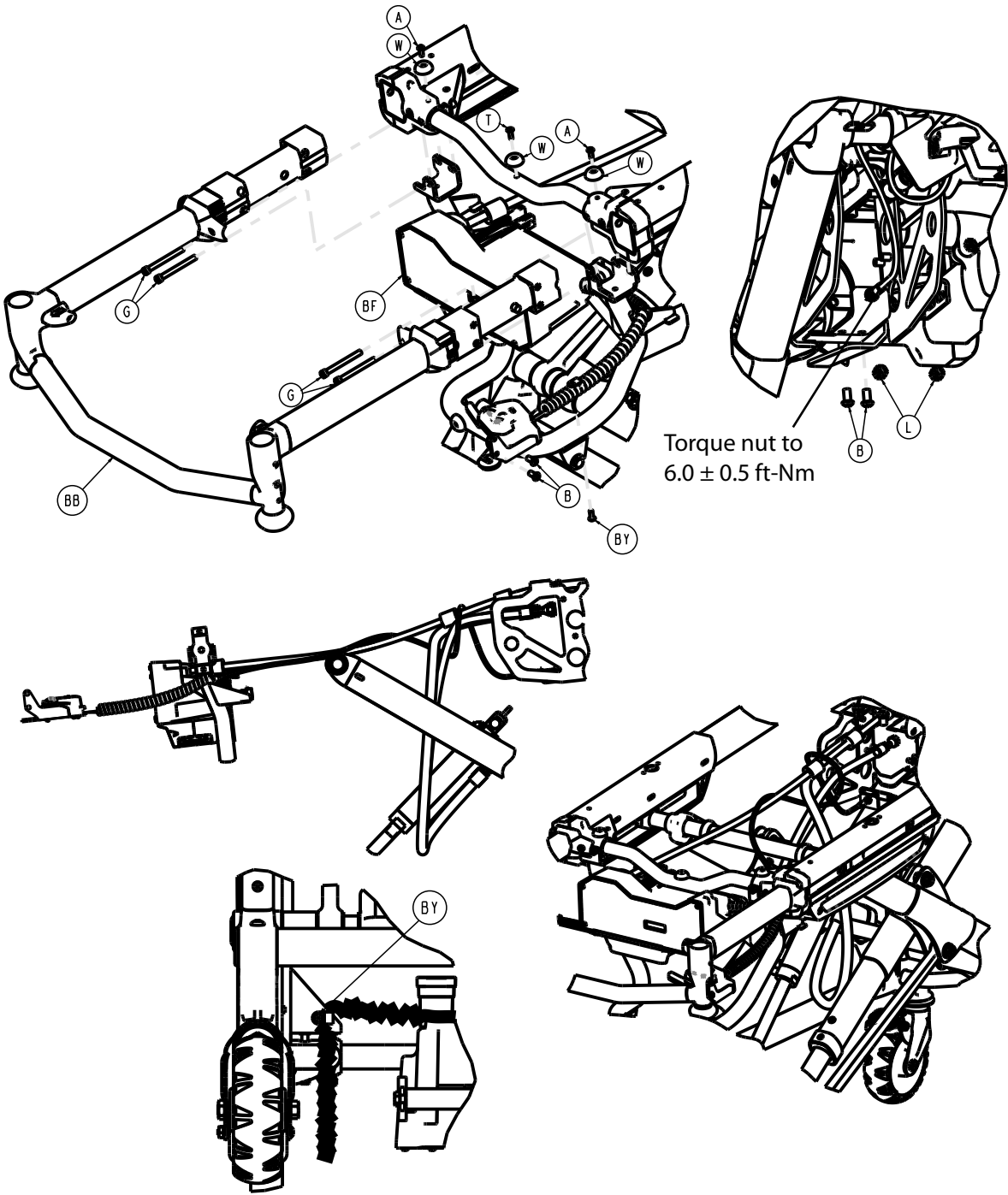
Figure 12 – 12 VDC automotive cable

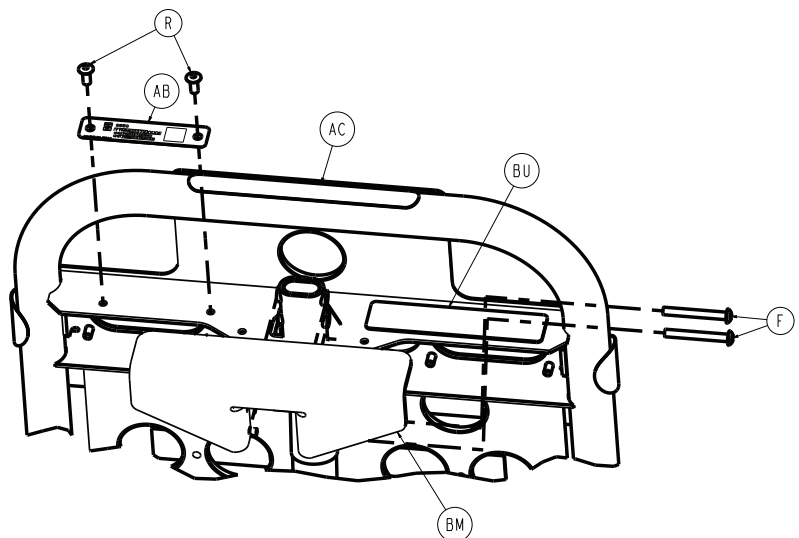
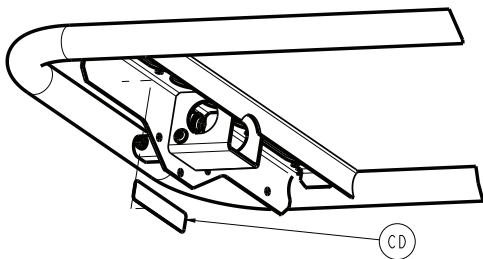
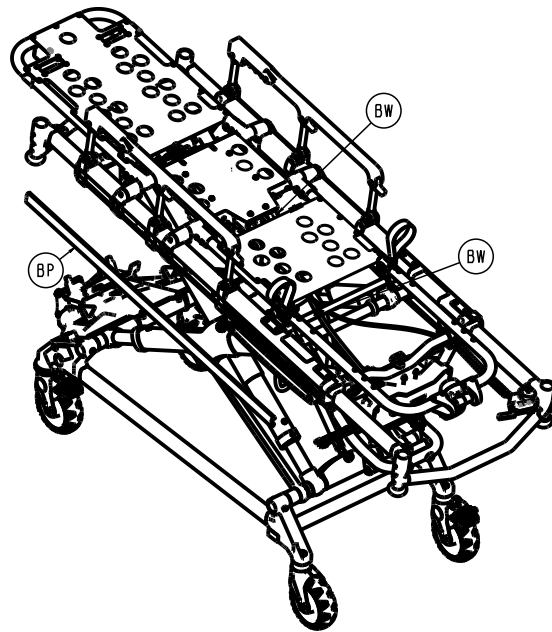
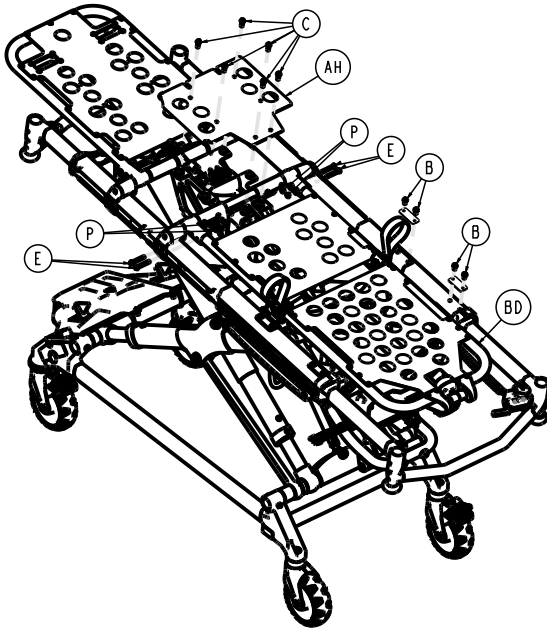
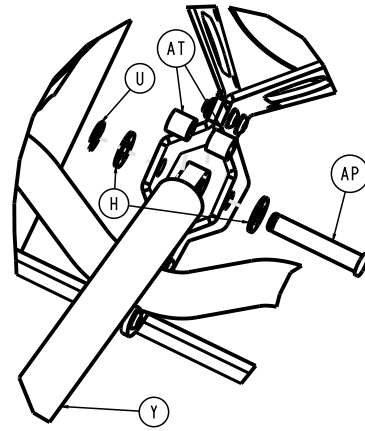
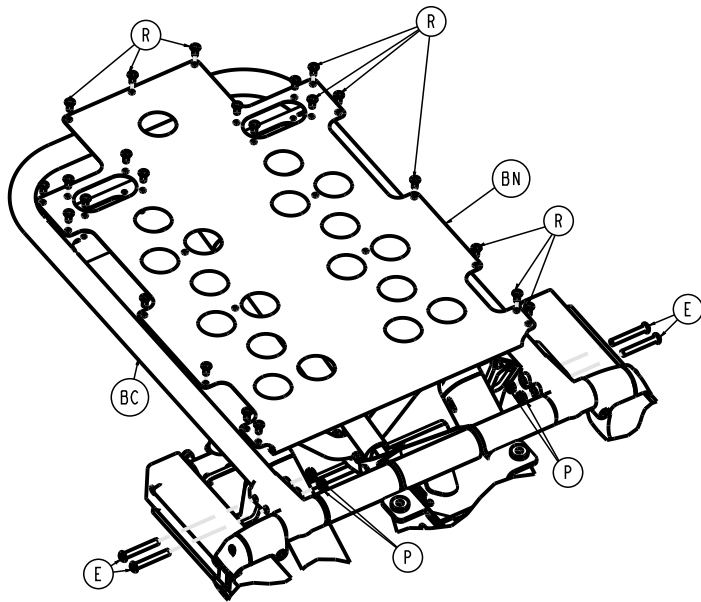
Cot assembly

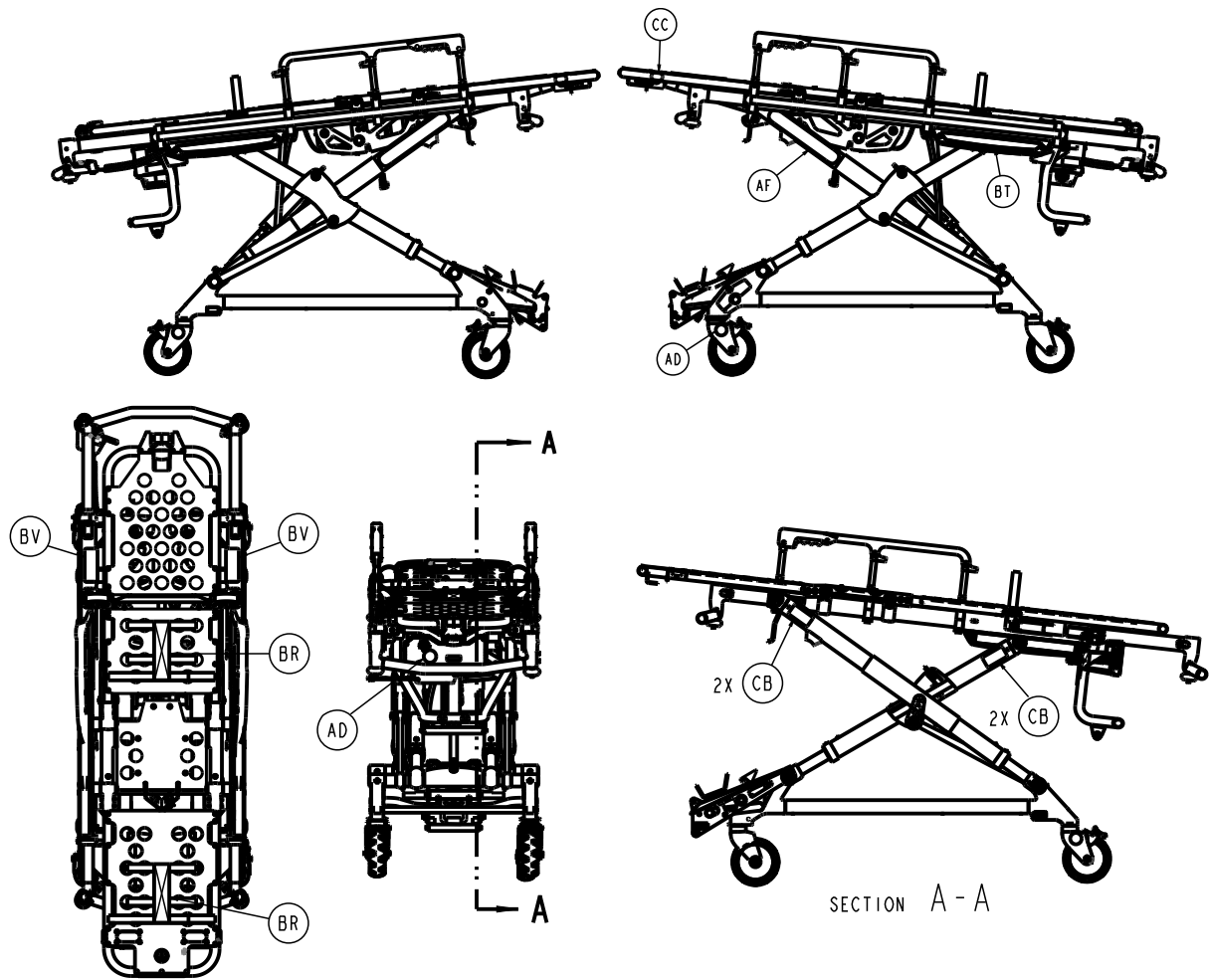
6550-001-010 Rev AB (Reference only)









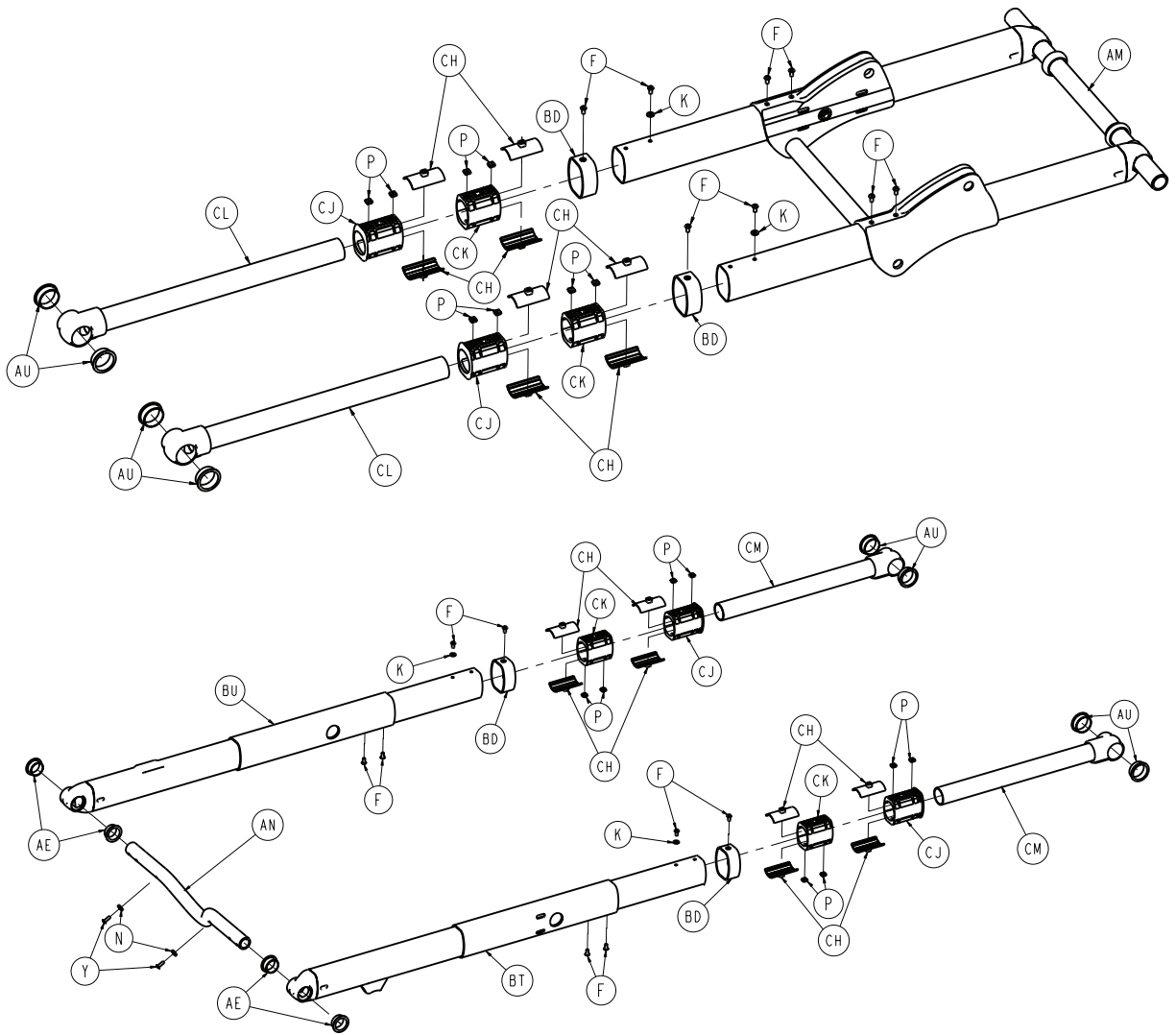


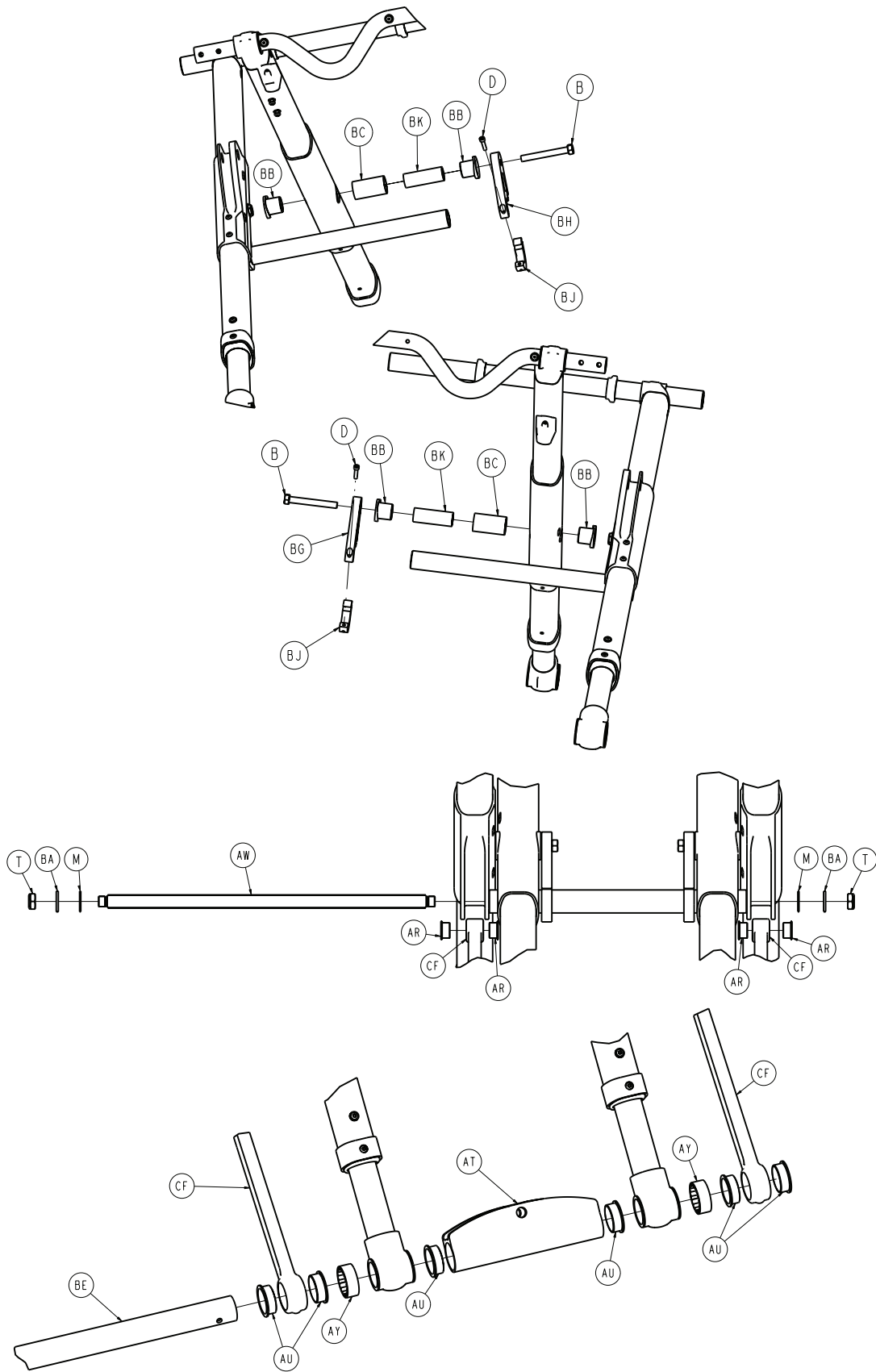
Item	Number	Name	Quantity
A	0004-585-000	Button head cap screw	4
B	0004-589-000	Button head cap screw	12
C	0004-592-000	Button head cap screw	6
D	0004-591-000	Socket head cap screw	4
E	0004-596-000	Button head cap screw	8
F	0004-636-000	Button head cap screw	2
G	0004-852-000	Socket head cap screw	8
H	0011-004-000	Washer	2
J	0011-013-000	Washer	1
K	0014-040-000	Washer	2
L	0016-028-000	Nylock hex nut	2
M	0016-035-000	Nylock hex nut	1
N	0016-049-000	Nylock hex nut	2
P	0016-102-000	Nylock hex nut	10
R	0025-079-000	Dome head rivet	25
T	0025-133-000	Dome head pop rivet	9
U	0028-181-000	Truarc ring	1
V	0038-574-000	Crest-to-crest spring	2
W	0946-001-155	Bumper	5
Y	6500-031-077	Gas spring	1
AB	6550-001-926	6550 serial number tag	1

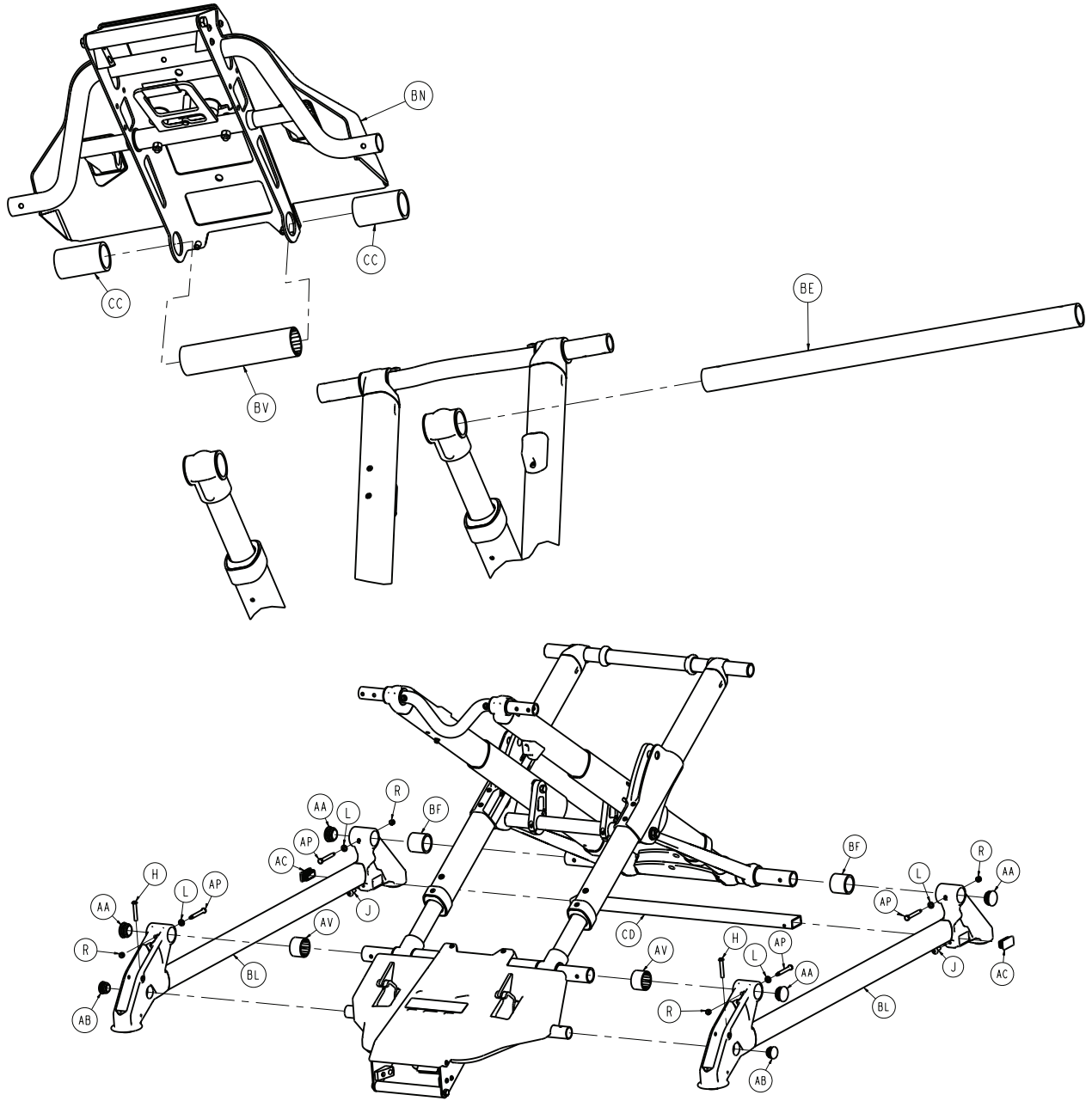
Item	Number	Name	Quantity
AC	6060-090-004	Label, RUGGED small	1
AD	6506-001-900	Label, refer to instruction manual	5
AF	6082-090-043	Label, 11" Stryker	2
AG	6100-003-125	Straight T pivot	4
AH	6500-001-111	Mid-section skin	1
AK	6500-001-123	Hall effects slider	2
AL	6500-001-128	Plastic extrusion spacer	2
AM	6500-001-157	Flange bearing	2
AN	6500-001-168	Rod attachment pin	1
AP	6085-101-143	Fowler cylinder pin	1
AR	6500-001-171	Cylinder mount cross tube	1
AT	6500-001-191	Fowler cylinder spacer	2
AU	6500-001-195	Motor mount casting	2
AV	6500-001-196	Litter cross brace	1
AW	6500-001-225	"D" washer	2
AY	0004-594-000	Button head cap screw	2
BA	6550-001-012	<i>Base assembly (page 37)</i>	1
BB	6550-001-015	Telescoping foot end	1
BC	6550-001-018	Fowler assembly	1
BD	6550-001-019	Gatch assembly	1
BE	6550-001-020	Telescoping head section	1
BF	6550-001-022	<i>Hitch assembly, foot end (page 62)</i>	1
BG	6550-101-031	<i>Mounted hydraulics assembly (page 59)</i>	1
BK	6550-001-090	Litter hitch interface, head end	1
BL	6550-001-091	Litter cross tube, foot end	1
BM	6550-001-099	Fowler release handle	1
BN	6550-001-102	Backrest skin	1
BP	6550-001-170	Outer rail bumper	2
BR	6550-001-197	Velcro® strap	2
BT	6550-101-233	Label, sensor housing	2
BU	6550-101-234	Label, Power-PRO TL specification	1
BV	6085-101-155	Label, weight capacity	2
BW	0059-211-000	11" nylon cable tie	3
BY	0004-634-000	Button head cap screw	1
CA	6500-002-195	Collar	1
CB	6252-101-139	Label, do not lubricate	4
CC	6506-001-901	Label, no pushing	2
CD	639000010901	Label, EAR	1

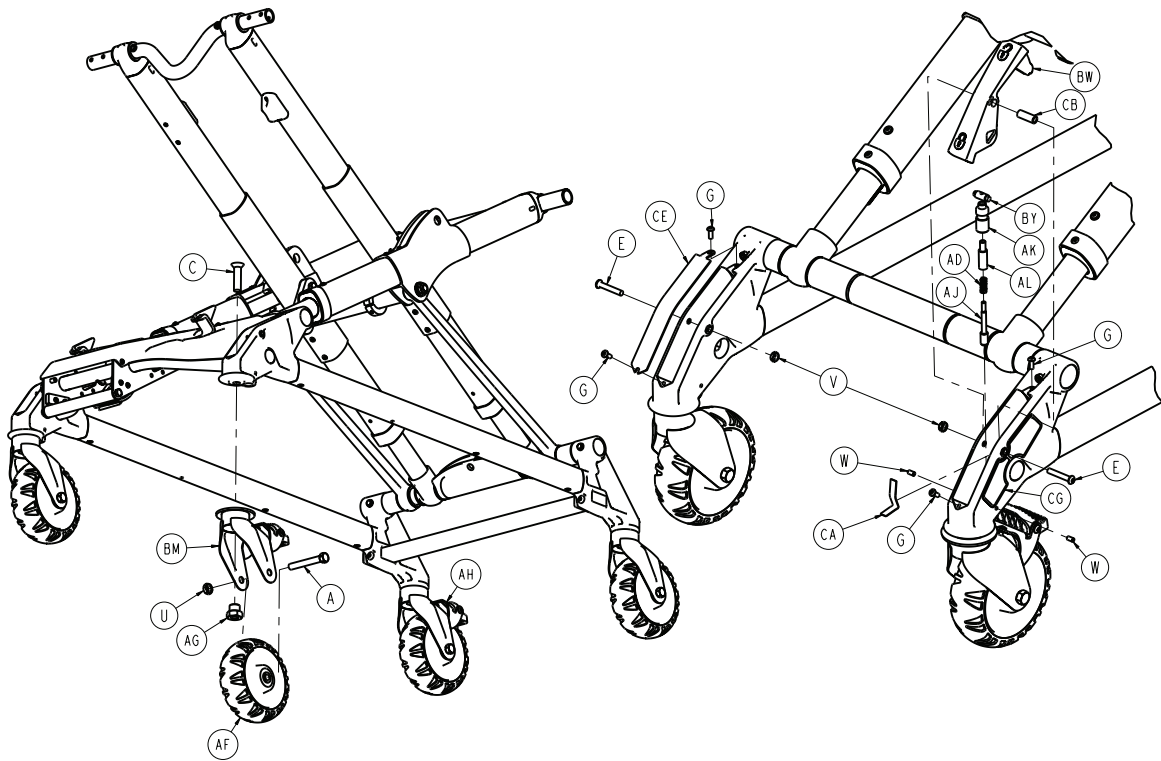
Base assembly

6550-001-012 Rev J (Reference only)









Item	Number	Name	Quantity
A	0003-205-000	Hex head cap screw	4
B	0003-388-000	Hex head cap screw	2
C	0004-319-000	Flat head socket screw	4
D	0004-659-000	Socket head cap screw	2
E	0004-376-000	Button head cap screw	2
F	0004-587-000	Button head cap screw	16
G	0004-634-000	Button head cap screw	4
H	0004-848-000	Button head cap screw	2
J	0007-086-000	Truss head screw	2
K	0011-062-000	Washer	4
L	0014-002-000	Washer	4
M	0014-040-000	Washer	2
N	0014-115-000	Washer	2
P	0015-051-000	Square nut	16
R	0016-002-000	Fiberlock hex nut	4
T	0016-049-000	Nylock hex nut	2
U	0016-060-000	Toplock hex jam nut	4
V	0016-102-000	Nylock hex nut	2
W	0021-180-000	Set screw	2
Y	0025-133-000	Dome head pop rivet	2
AA	0037-083-000	Tube plug	4
AB	0037-243-000	Tube plug	2
AC	0037-244-000	Rectangular hole plug	2
AD	0038-382-000	Compression spring	1
AE	0081-244-000	Flange bearing	4
AF	6060-002-010	6" molded wheel assembly	4
AG	6090-001-009	Caster nut	4
AH	6100-003-022	Brake and caster assembly	1

Item	Number	Name	Quantity
AJ	6100-003-136	Steer-Lock pin	1
AK	6100-203-135	Pin sleeve, Steer-Lock	1
AL	6100-203-136	Steer-Lock plastic bushing	1
AM	6500-001-056	Inner tube base frame	1
AN	6500-001-090	Cross tube, head end	1
AP	6500-001-145	Caster mount spacer	4
AR	6500-001-162	Flange bearing	4
AT	6500-001-165	Cylinder mount pivot, bottom	1
AU	6500-001-166	Flange bearing	14
AV	6500-001-178	Base spacer, outer	2
AW	6500-001-182	Stiffener bar cross tube	1
AY	6500-001-183	Base spacer, outer	2
BA	6500-001-225	"D" washer	2
BB	6500-001-226	Base tube pivot bearing	4
BC	6500-001-227	Base tube pivot post	2
BD	6500-001-228	Inner lift tube sleeve	4
BE	6500-001-229	Base tube, foot	2
BF	6550-001-203	Solid spacer, foot end	2
BG	6500-001-308	Base strap, right	1
BH	6500-001-309	Base strap, left	1
BJ	6500-001-310	Base strap clamp	2
BK	6500-001-341	Base tube pivot post	2
BL	6550-001-013	Outer base tube assembly	2
BM	6550-001-016	Wheel lock caster, Steer-Lock	1
BN	6550-001-021	<i>Hitch assembly, head end (page 48)</i>	1
BT	6550-001-034	Inner lift tube assembly, litter pivot, right	1
BU	6550-001-035	Inner lift tube assembly, litter pivot, left	1
BV	6550-001-085	Base spacer, outer	1
BW	6550-001-103	Steer-Lock pedal	1
BY	6550-001-104	Steer-Lock cross piece	1
CA	6550-001-105	Steer-Lock spring	1
CB	6550-001-107	Steer-Lock pivot	1
CC	6550-001-204	Solid spacer, head end	2
CD	6550-001-171	Rectangular cross tube, foot end	1
CE	6550-001-179	Steer-Lock cover	1
CF	6550-001-200	Support link	2
CG	6550-001-106	Label, Steer-Lock	1
CH	6500-101-327	Half shell bearing	16
CJ	6500-001-328	Lower bearing carrier	4
CK	6500-001-329	Middle bearing carrier	4
CL	6500-301-051	Base pivot lift tube weldment	2
CM	6550-101-066	Base pivot inner lift tube weldment	2

Two wheel lock option

6550-500-000 Rev A (Reference only)

Item	Number	Name	Quantity
A	6082-002-012	<i>Caster horn assembly - 6082-002-012</i> (page 44)	2

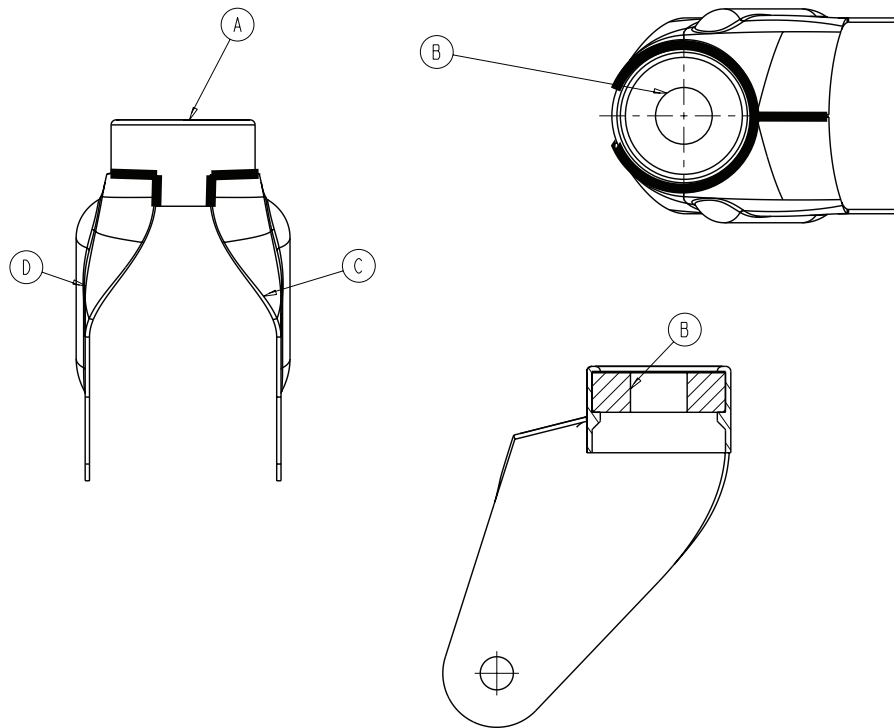
Four wheel lock option

6550-501-000 Rev B (Reference only)

Item	Number	Name	Quantity
A	6100-003-022	<i>Adjustable caster Steer-Lock assembly</i> (page 45)	2
B	6506-001-900	Label	4

Caster horn assembly - 6082-002-012

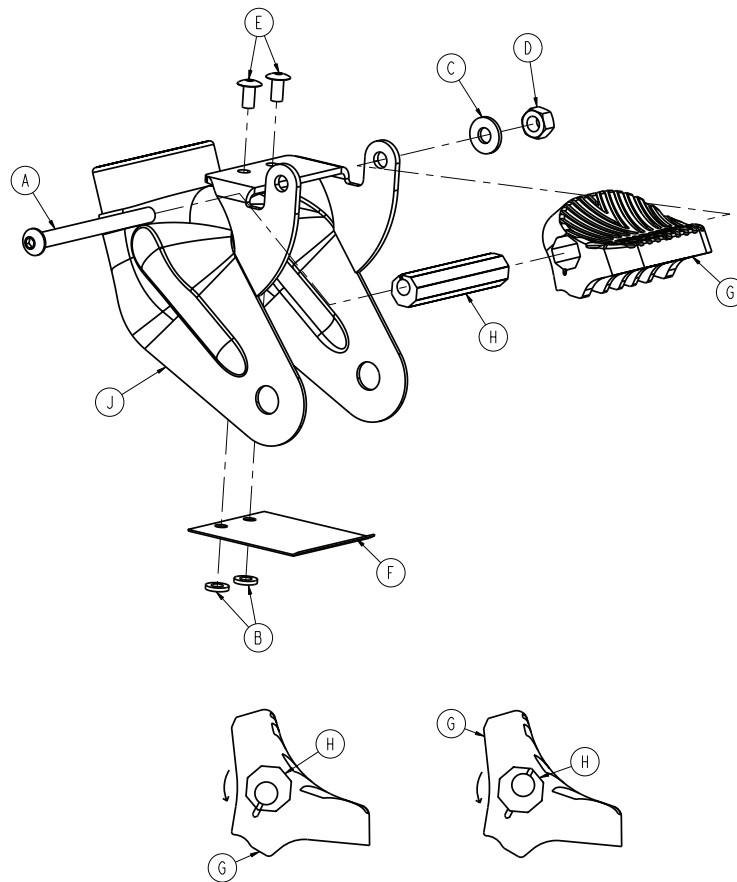
Rev C (Reference only)



Item	Number	Name	Quantity
A	6082-002-039	Bearing retainer	1
B	0081-227-000	Bearing	1
C	6082-002-042	Caster horn plate, left	1
D	6082-002-043	Caster horn plate, right	1

Adjustable caster Steer-Lock assembly

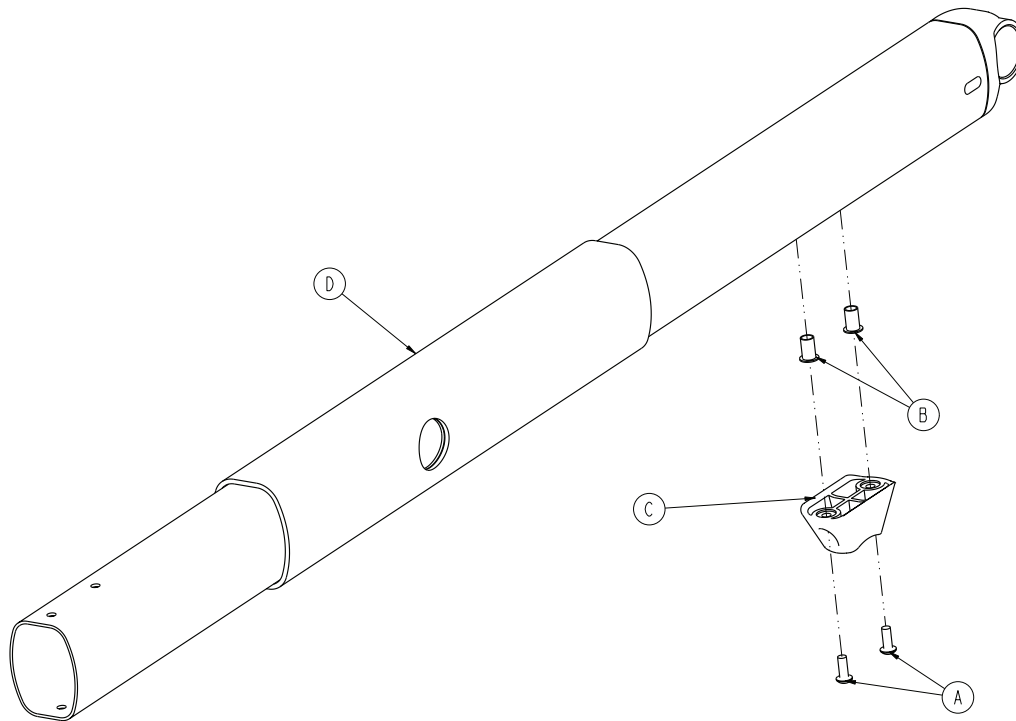
6100-003-022 Rev C (Reference only)



Item	Number	Name	Quantity
A	0004-098-000	Button head cap screw	1
B	0011-454-000	Washer	2
C	0011-456-000	Washer	1
D	0016-118-000	Stover hex lock nut	1
E	0025-079-000	Dome head rivet	2
F	6080-100-032	Spring	1
G	6080-300-030	Pedal	1
H	6080-200-041	Octagonal sleeve	1
J	6100-003-055	Foot end caster weldment	1

Inner lift tube assembly, litter pivot, right - 6550-001-034

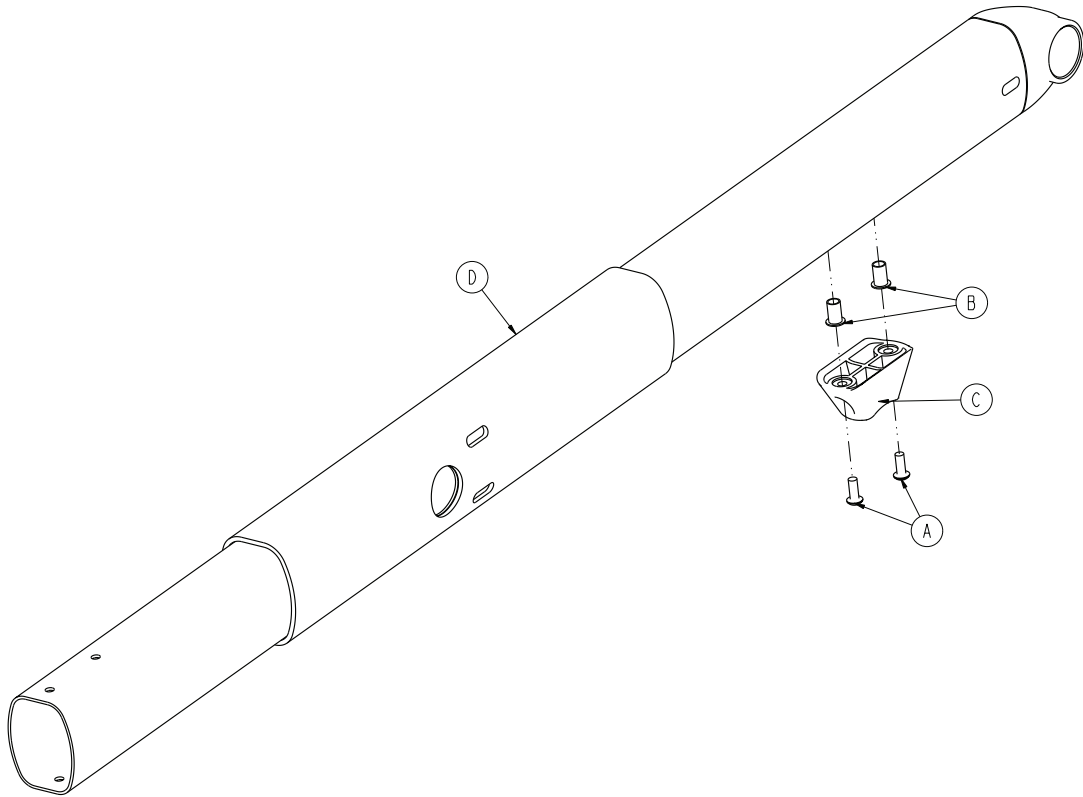
Rev C (Reference only)



Item	Number	Name	Quantity
A	0004-634-000	Button head cap screw	2
B	0055-100-075	Riv nut	2
C	6500-001-125	Base dead stop	1
D	6550-001-260	Litter pivot inner lift tube weldment	1

Inner lift tube assembly, litter pivot, left - 6550-001-035

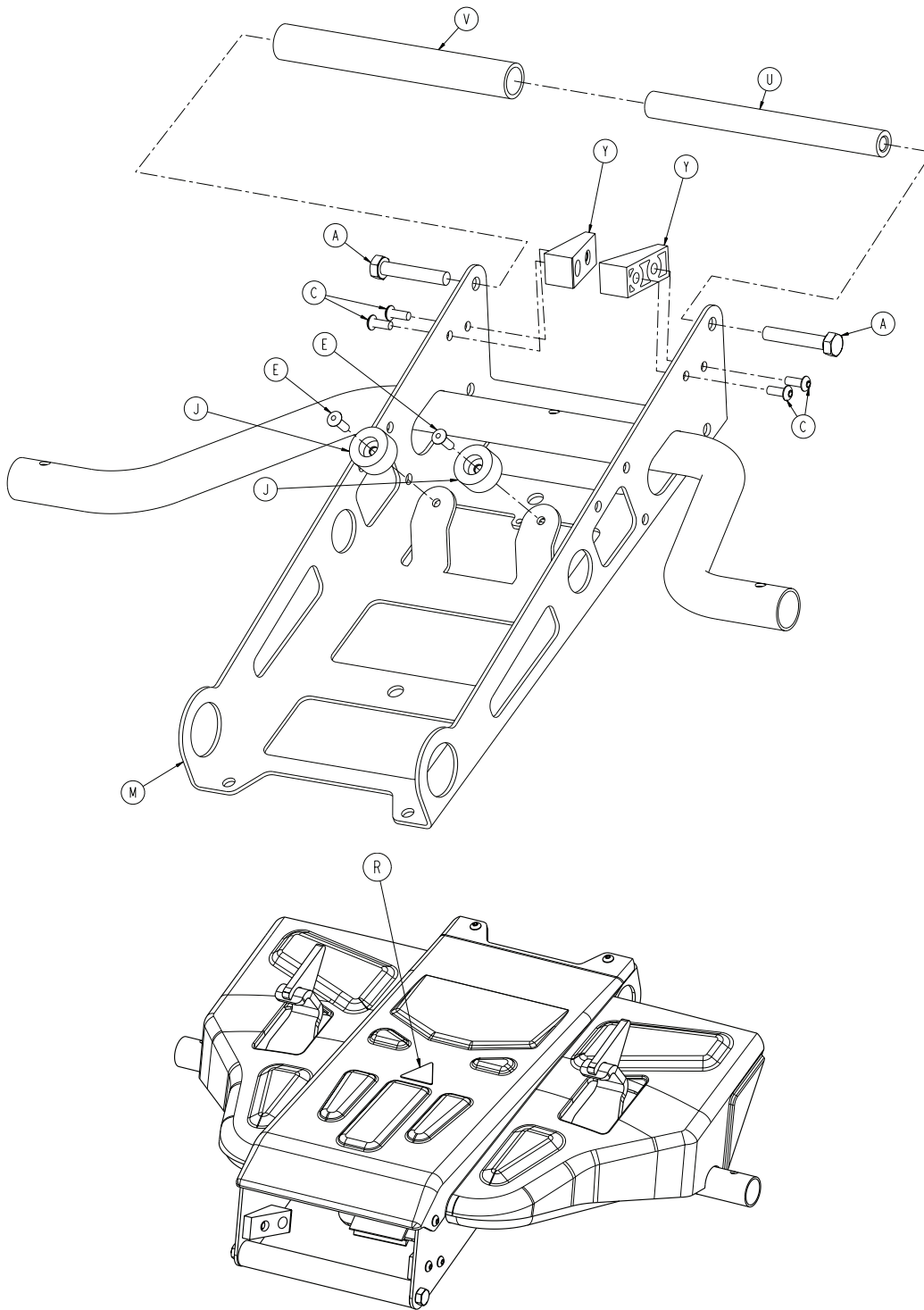
Rev C (Reference only)

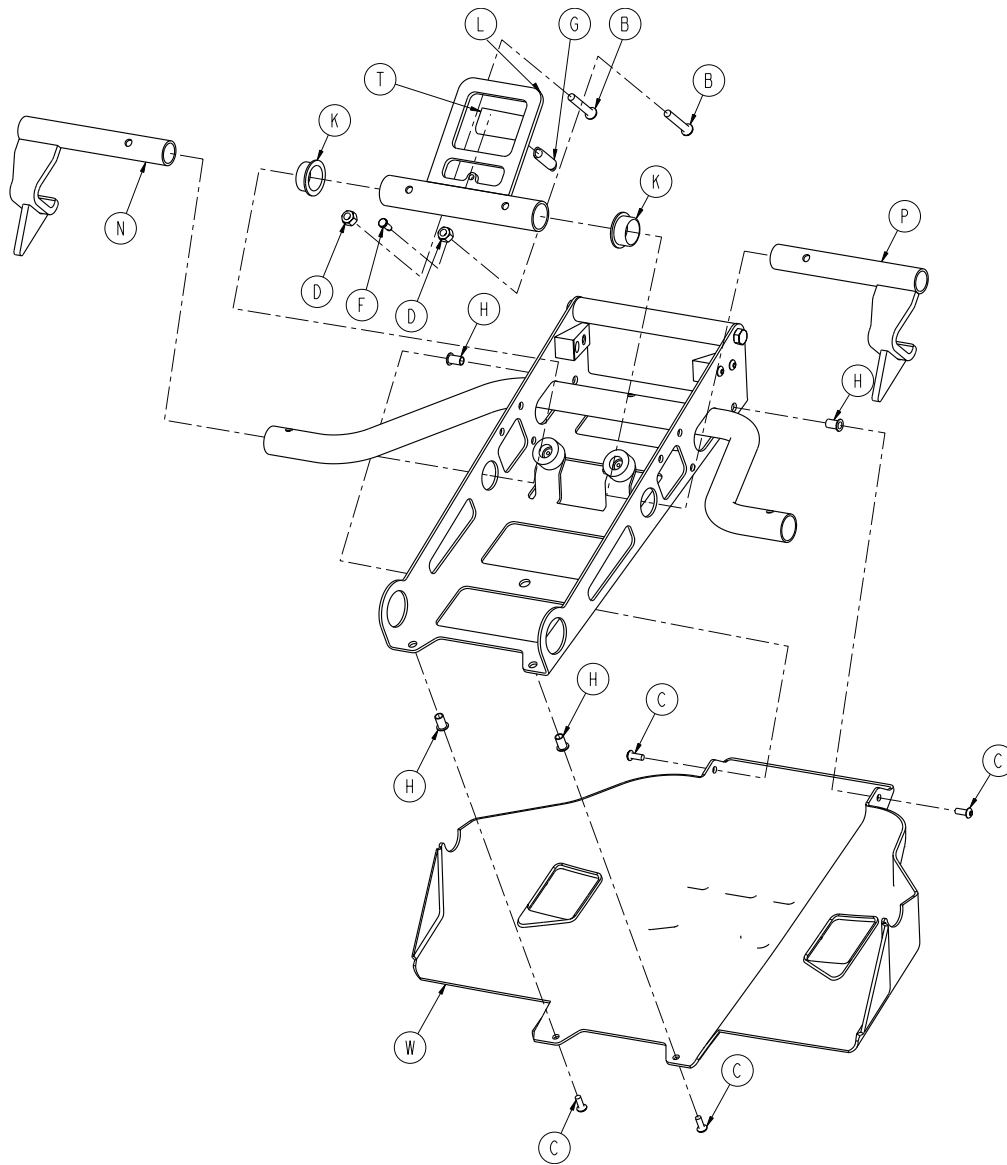


Item	Number	Name	Quantity
A	0004-634-000	Button head cap screw	2
B	0055-100-075	Riv nut	2
C	6500-001-125	Base dead stop	1
D	6550-101-058	Litter pivot inner lift tube weldment	1

Hitch assembly, head end

6550-001-021 Rev AA (Reference only)



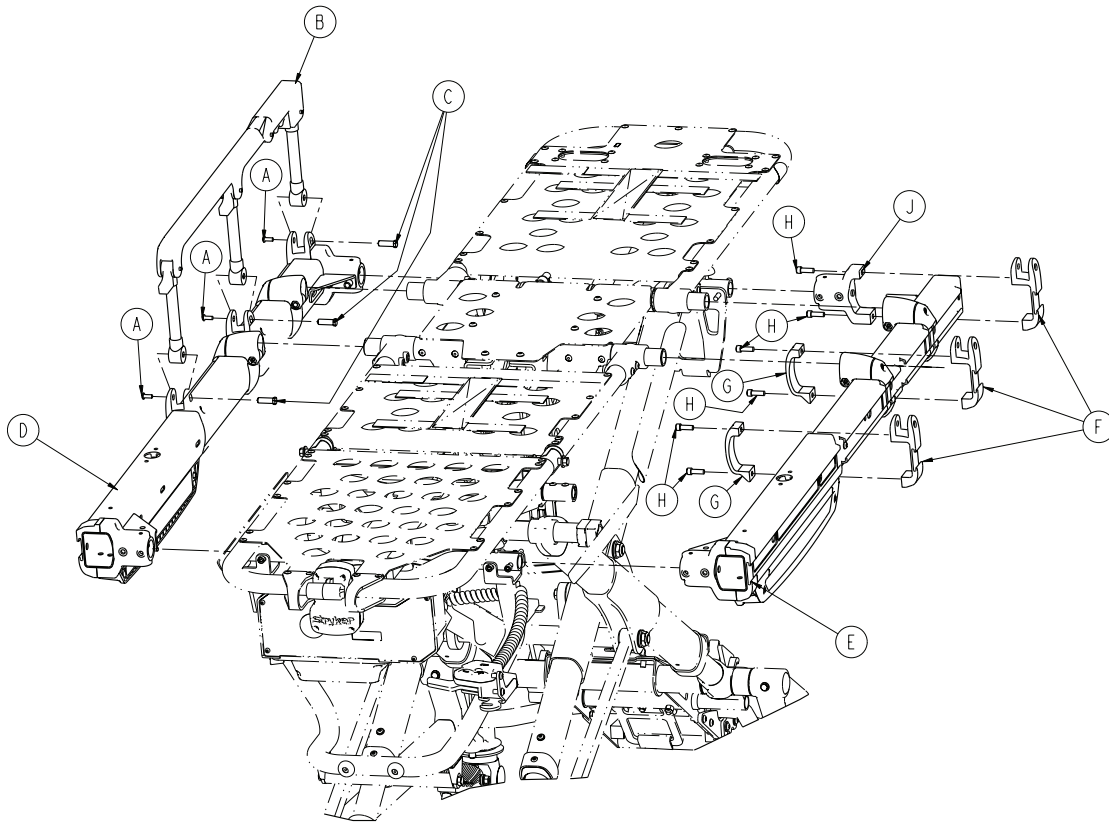


Item	Number	Name	Quantity
A	0003-391-000	Hex head cap screw	2
B	0004-376-000	Button head cap screw	2
C	0004-634-000	Button head cap screw	8
D	0016-028-000	Fiberlock hex nut	2
E	0025-133-000	Dome head pop rivet	2
F	0026-385-000	Clevis pin	1
G	0038-588-000	Extension spring	1
H	0055-100-075	Riv nut	4
J	0056-016-000	Black SBR	2
K	0081-012-002	Flange bearing	2
L	6550-001-054	Crash connect center weldment	1
M	6550-001-055	Cage weldment, head end hitch	1
N	6550-001-059	Crash connect outer weldment, left	1
P	6550-001-063	Crash connect outer weldment, right	1
R	6506-001-905	Label, warning: crushing of hands	1
T	6550-001-087	Head end hitch wear strip	1
U	6550-001-134	Cot fastener bar, head end	1

Item	Number	Name	Quantity
V	6550-001-140	Head end hitch bar sleeve	1
W	6550-001-174	Head end hitch cover	1
Y	6550-001-175	Head end hitch guide	2

Standard siderail

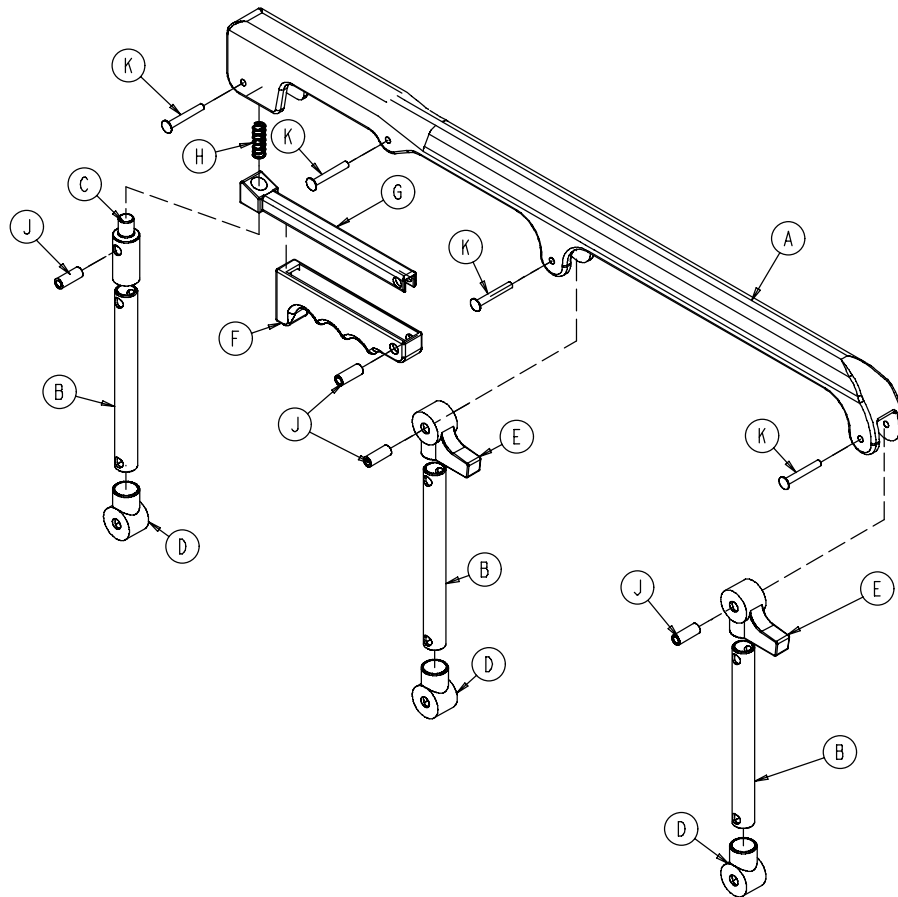
6550-034-000 Rev A (Reference only)



Item	Number	Name	Quantity
A	0004-585-000	Button head cap screw	6
B	6082-026-010	Siderail assembly (page 52)	2
C	6500-001-118	Siderail nut	6
D	6550-101-032	Outer rail, right (page 53)	1
E	6550-101-033	Outer rail, left (page 54)	1
F	6500-001-116	Siderail bracket	6
G	6500-001-117	Siderail clamp	4
H	0004-591-000	Socket head cap screw	12
J	6500-001-102	Base/litter interface bracket	2

Siderail assembly

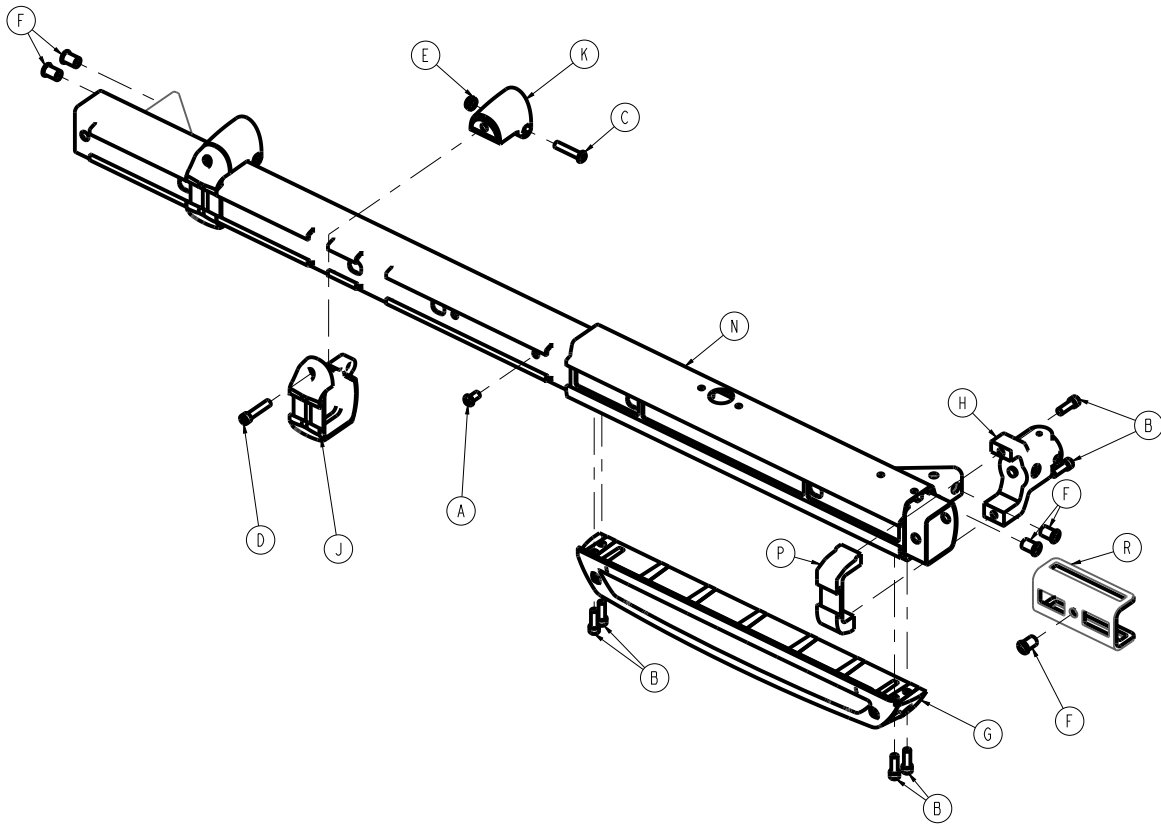
6082-026-010 Rev B (Reference only)



Item	Number	Name	Quantity
A	6060-025-024	Top rail	1
B	6060-025-043	Spindle	3
C	6060-025-047	Spindle lock	1
D	6060-025-041	Spindle pivot	3
E	6060-025-040	Spindle pivot stop	2
F	6060-025-029	Lock release grip	1
G	6061-125-030	Lock bar casting	1
H	0038-344-000	Lock release compression spring	1
J	6060-025-035	Pivot bushing	4
K	0025-131-000	Rivet	4

Outer rail, right

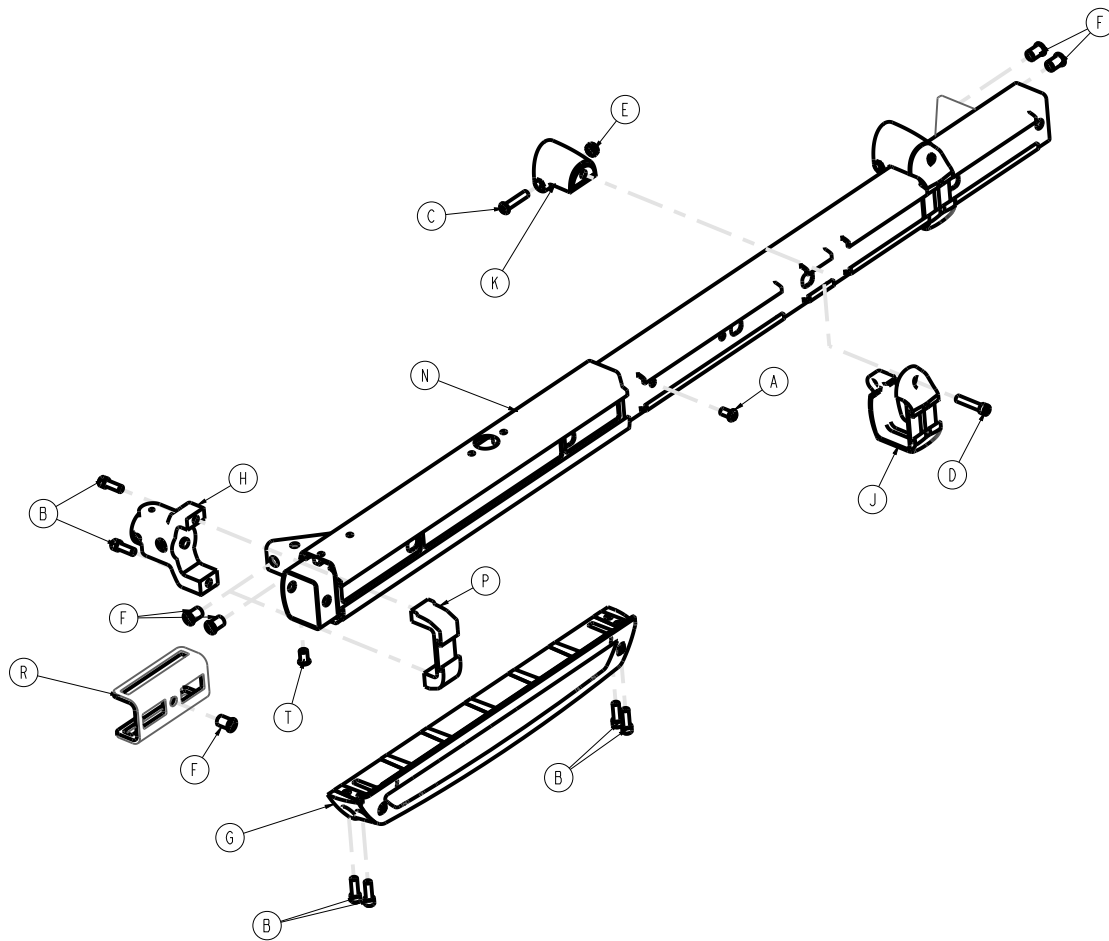
6550-101-032 Rev AA (Reference only)



Item	Number	Name	Quantity
A	0004-589-000	Button head cap screw	1
B	0004-591-000	Socket head cap screw	6
C	0004-612-000	Button head cap screw	2
D	0004-613-000	Socket head cap screw	2
E	0016-102-000	Nylock nut	2
F	0055-100-076	Riv nut	5
G	6500-001-029	Empty sensor housing	1
H	6500-001-102	Base/litter interface bracket	1
J	6500-001-104	Litter support bracket, outside	2
K	6500-001-106	Litter support bracket, inside	2
N	6550-101-064	Outer rail weldment, right	1
P	6550-001-096	Outer rail clamp	1
R	6550-001-166	Dead stop	1

Outer rail, left

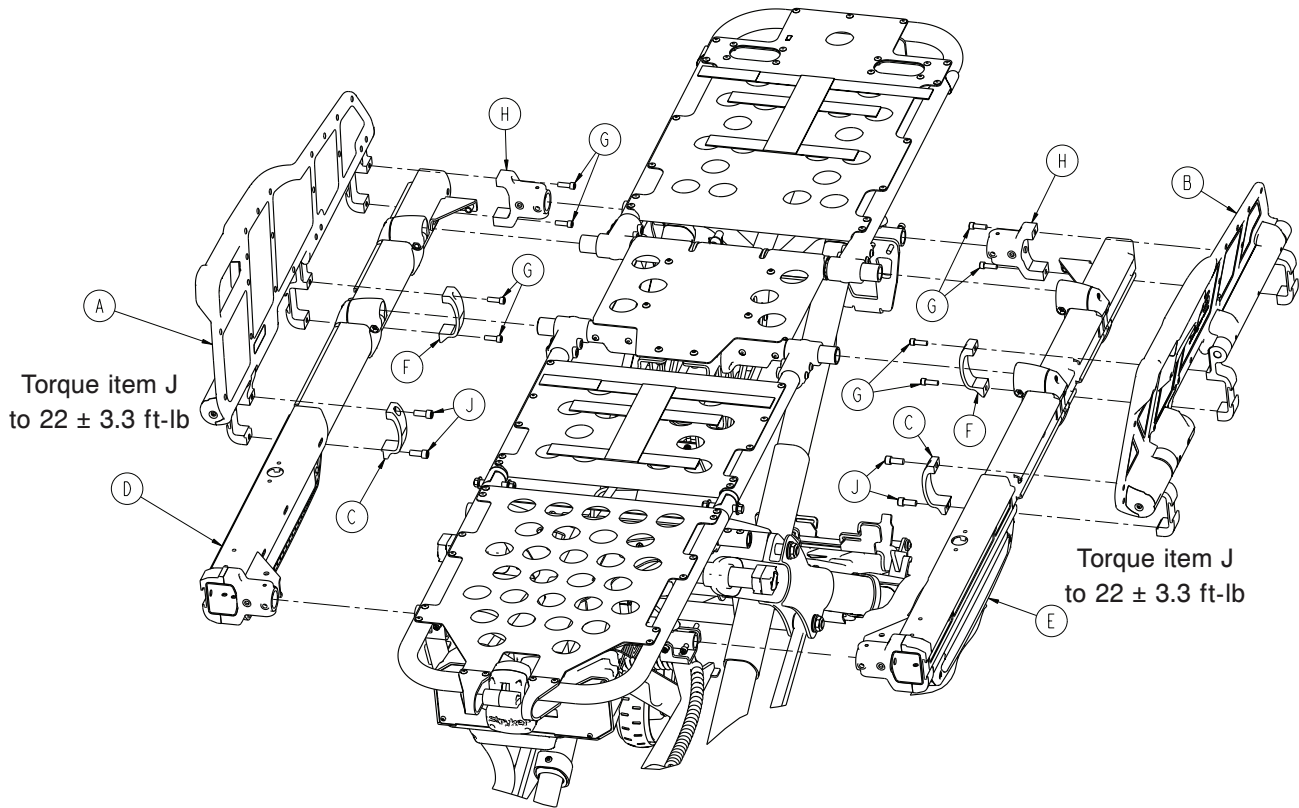
6550-101-033 Rev AA (Reference only)



Item	Number	Name	Quantity
A	0004-589-000	Button head cap screw	1
B	0004-591-000	Socket head cap screw	6
C	0004-612-000	Button head cap screw	2
D	0004-613-000	Socket head cap screw	2
E	0016-102-000	Nylock hex nut	2
F	0055-100-076	Riv nut	5
G	6500-001-029	Empty sensor housing	1
H	6500-001-102	Base/litter interface bracket	1
J	6500-001-104	Litter support bracket, outside	2
K	6500-001-106	Litter support bracket, inside	2
N	6550-101-065	Outer rail weldment, left	1
P	6550-001-096	Outer rail clamp	1
R	6550-001-166	Dead stop	1
T	0055-100-075	Riv nut	1

Optional siderail (XPS option)

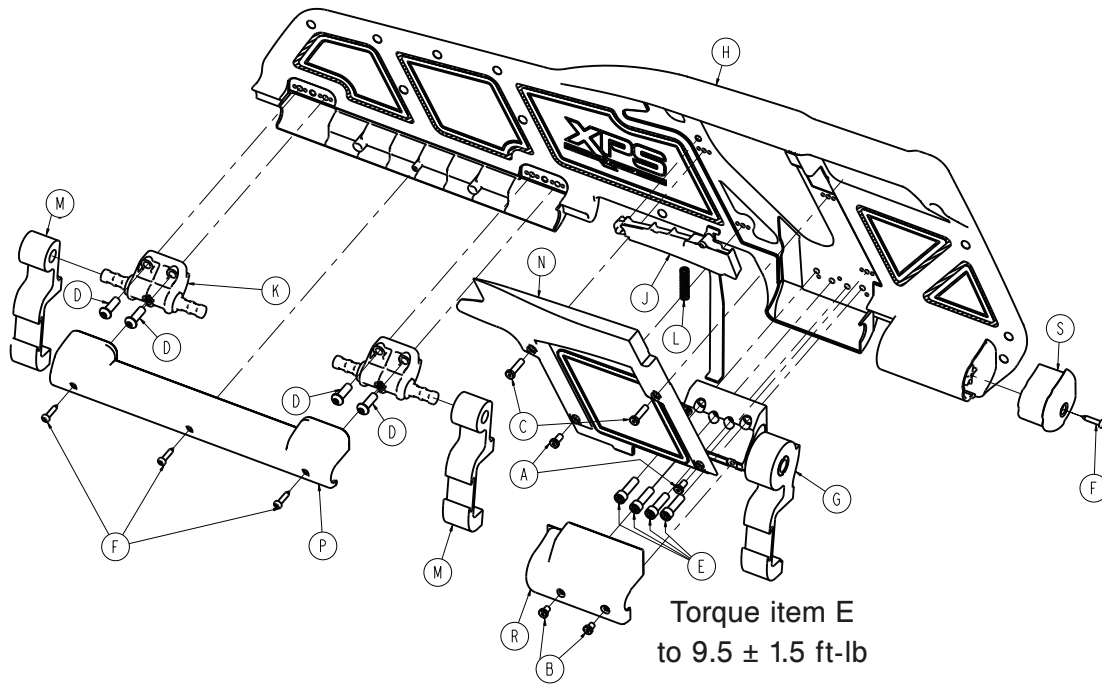
6550-031-000 Rev A (Reference only)



Item	Number	Name	Quantity
A	6500-003-034	XPS main assembly, right - 6500-003-034 (page 56)	1
B	6500-003-044	XPS main assembly, left - 6500-003-044 (page 57)	1
C	6500-003-099	XPS siderail clamp	2
D	6550-101-032	Outer rail, right (page 53)	1
E	6550-101-033	Outer rail, left (page 54)	1
F	6500-001-117	Siderail clamp	2
G	0004-591-000	Socket head cap screw	8
H	6500-001-102	Base/litter interface bracket	2
J	0004-900-000	Socket head cap screw	4

XPS main assembly, right - 6500-003-034

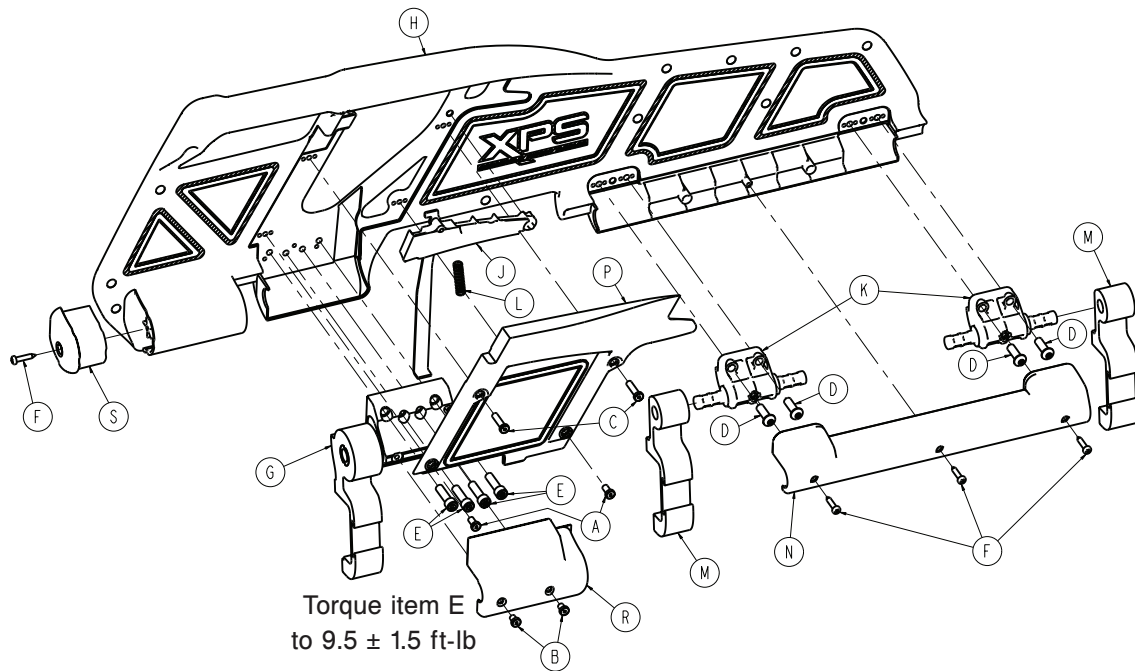
Rev C (Reference only)



Item	Number	Name	Quantity
A	0004-400-000	Socket head cap screw	2
B	0004-402-000	Socket head cap screw	2
C	0004-403-000	Socket head cap screw	2
D	0004-468-000	Button head cap screw	4
E	0004-661-000	Socket head cap screw	4
F	0023-297-000	Delta screw	4
G	6500-003-035	XPS ratchet assembly, right	1
H	6500-003-037	XPS overmold assembly, right	1
J	6500-003-043	XPS handle assembly, right	1
K	6500-003-084	Support pivot	2
L	6500-003-085	XPS spring handle	1
M	6500-003-086	XPS siderail pivot	2
N	6500-003-094	XPS release cover, right	1
P	6500-003-097	XPS pivot cover	1
R	6500-003-119	XPS ratchet cover, right/left	1
S	6500-003-121	End cap cover, right	1

XPS main assembly, left - 6500-003-044

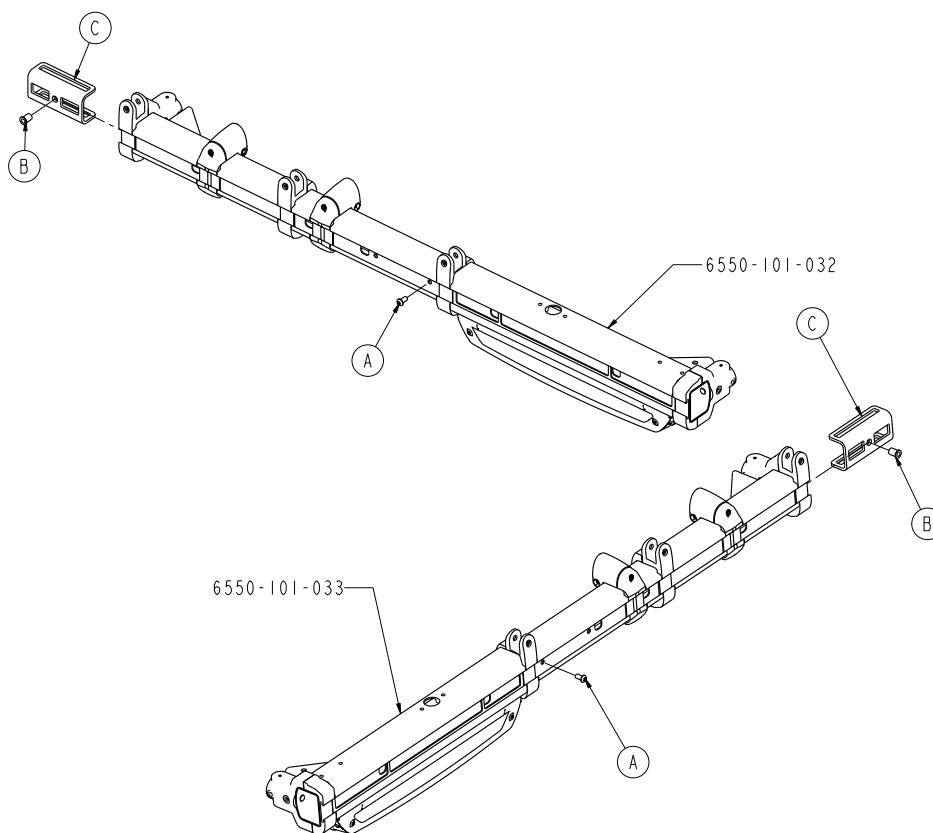
Rev C (Reference only)



Item	Number	Name	Quantity
A	0004-400-000	Socket head cap screw	2
B	0004-402-000	Socket head cap screw	2
C	0004-403-000	Socket head cap screw	2
D	0004-468-000	Button head cap screw	4
E	0004-661-000	Socket head cap screw	4
F	0023-297-000	Delta screw	4
G	6500-003-036	XPS ratchet assembly, right	1
H	6500-003-038	XPS overmold assembly, right	1
J	6500-003-045	XPS handle assembly, right	1
K	6500-003-084	Support pivot	2
L	6500-003-085	XPS spring handle	1
M	6500-003-086	XPS siderail pivot	2
N	6500-003-097	XPS pivot cover	1
P	6500-003-102	XPS release cover, left	1
R	6500-003-120	XPS ratchet cover, right/left	1
S	6500-003-122	End cap cover, right	1

Oxygen bottle holder option - 6550-150-000

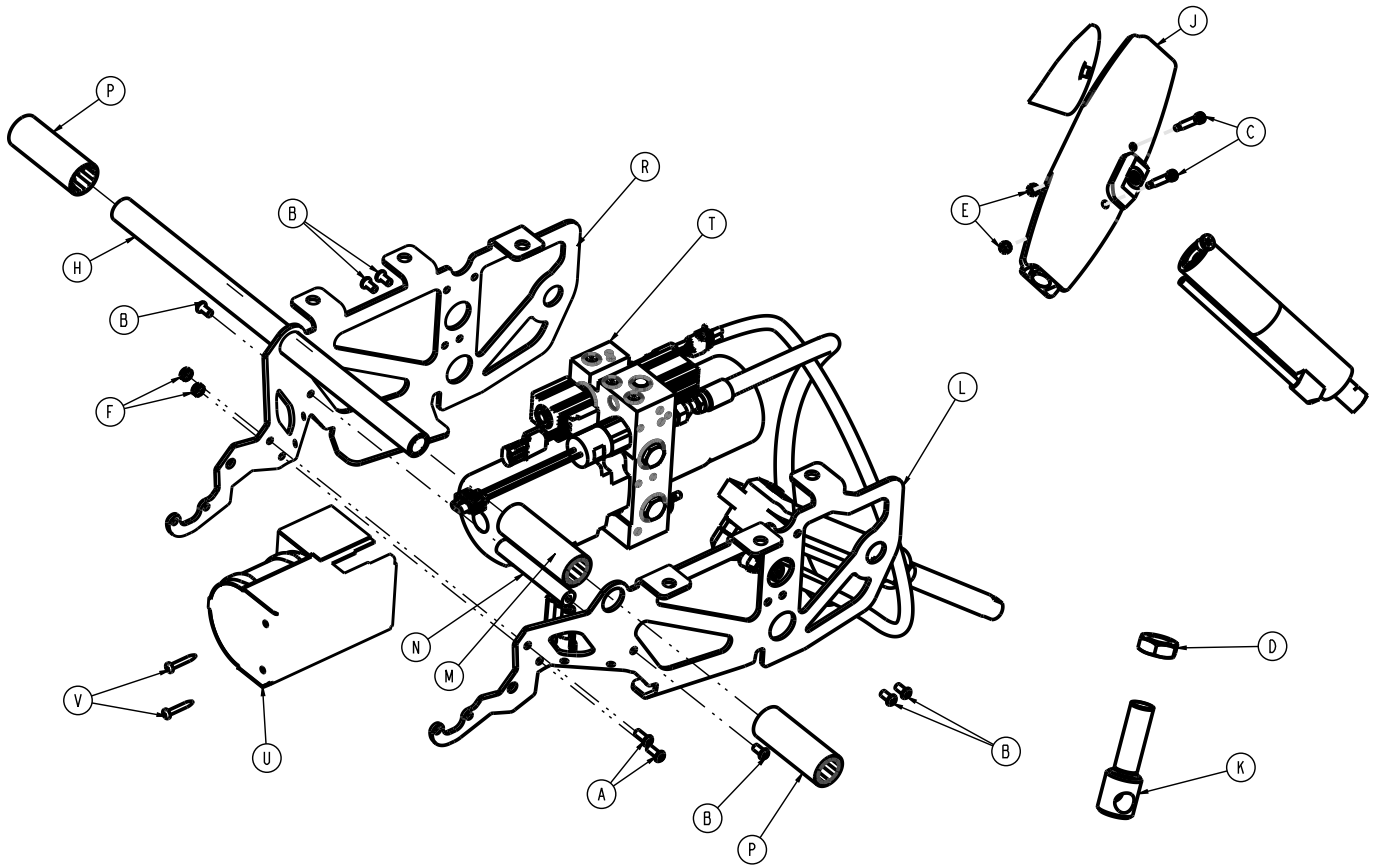
Rev A (Reference only)

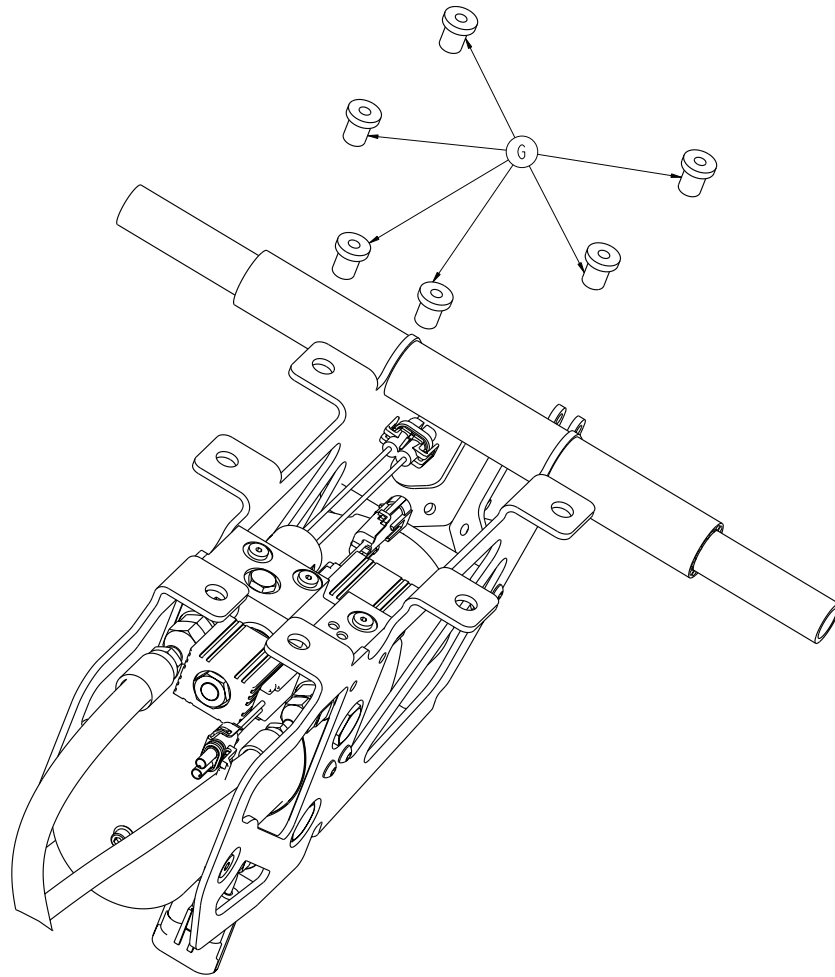


Item	Number	Name	Quantity
A	0004-589-000	Button head cap screw	2
B	0055-100-076	Riv nut	2
C	6550-001-166	Dead stop	2
D	6550-102-020	Oxygen bottle holder (page 98) (not shown)	1

Mounted hydraulics assembly

6550-101-031 Rev C (Reference only)

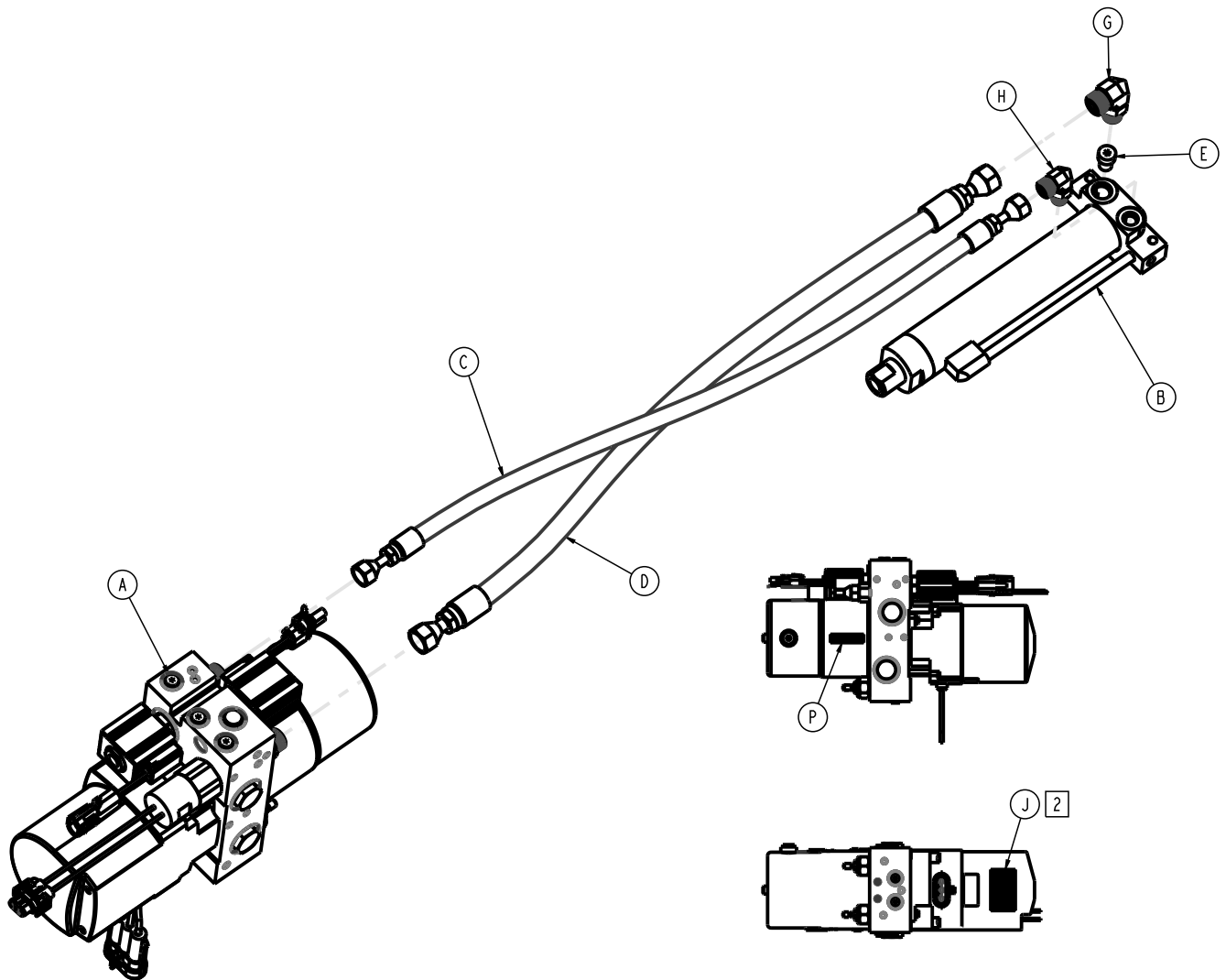




Item	Number	Name	Quantity
A	0004-577-000	Button head cap screw	2
B	0004-589-000	Button head cap screw	6
C	0008-030-000	Socket head shoulder screw	2
D	0015-052-000	Hex jam nut	1
E	0016-002-000	Fiberlock hex nut	2
F	0016-102-000	Nylock hex nut	2
G	0055-100-074	Well nut	6
H	6500-001-105	Cross tube, litter support	1
J	6500-001-164	Pivot, cylinder mount, top	1
K	6500-001-169	Rod end, cylinder	1
L	6500-002-194	Motor mount	1
M	6500-001-212	Cross bar, motor mount	1
N	6500-001-249	Plastic extrusion, spacer	1
P	6500-001-250	Plastic extrusion, spacer	2
R	6500-002-294	Motor mount	1
T	6550-101-030	<i>Hydraulics subassembly (page 61)</i>	1
U	6506-001-820	PP motor can weldment	1
V	0023-333-000	Pan head sheet metal screw	2

Hydraulics subassembly

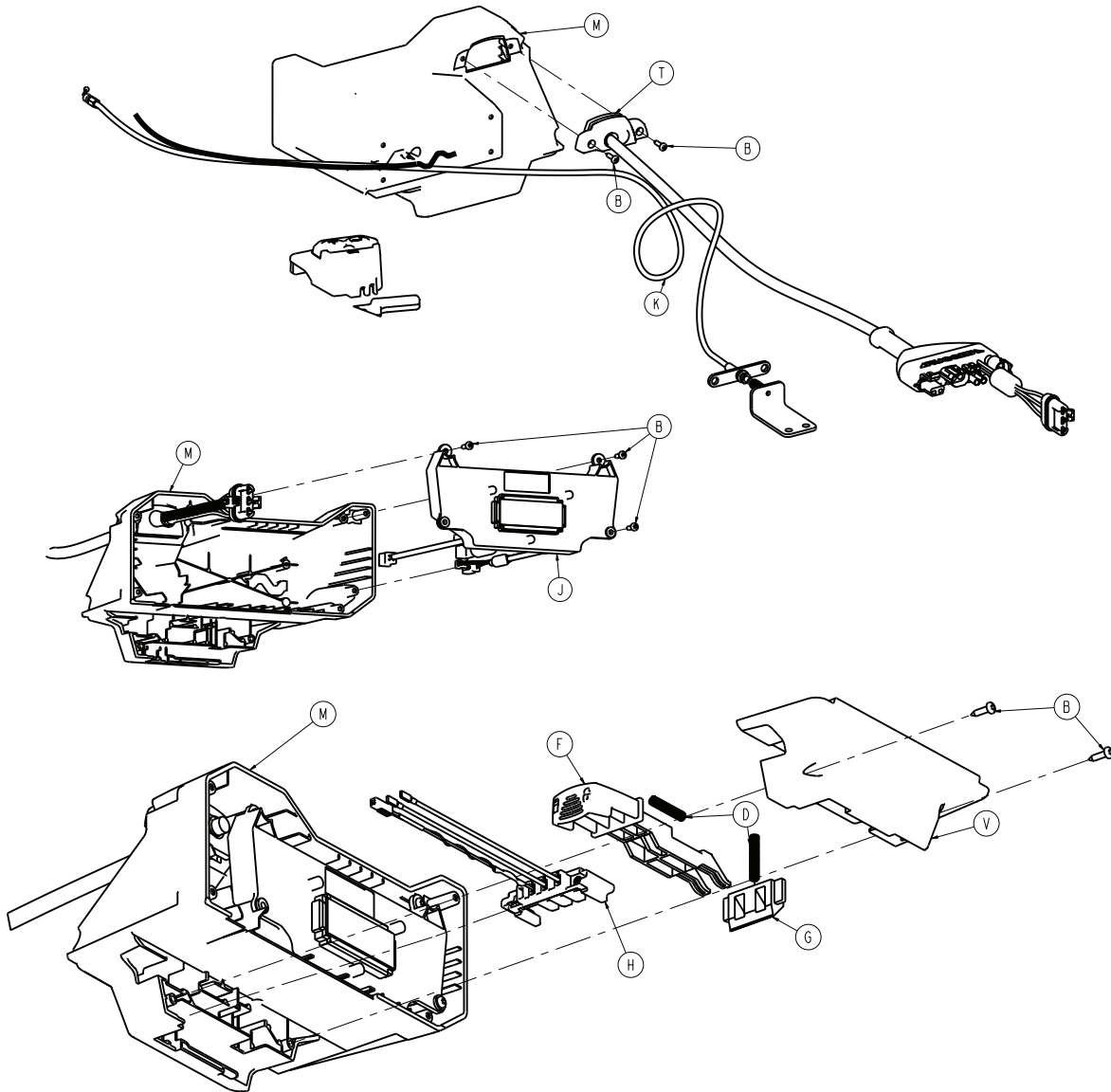
6550-101-030 Rev AB (Reference only)

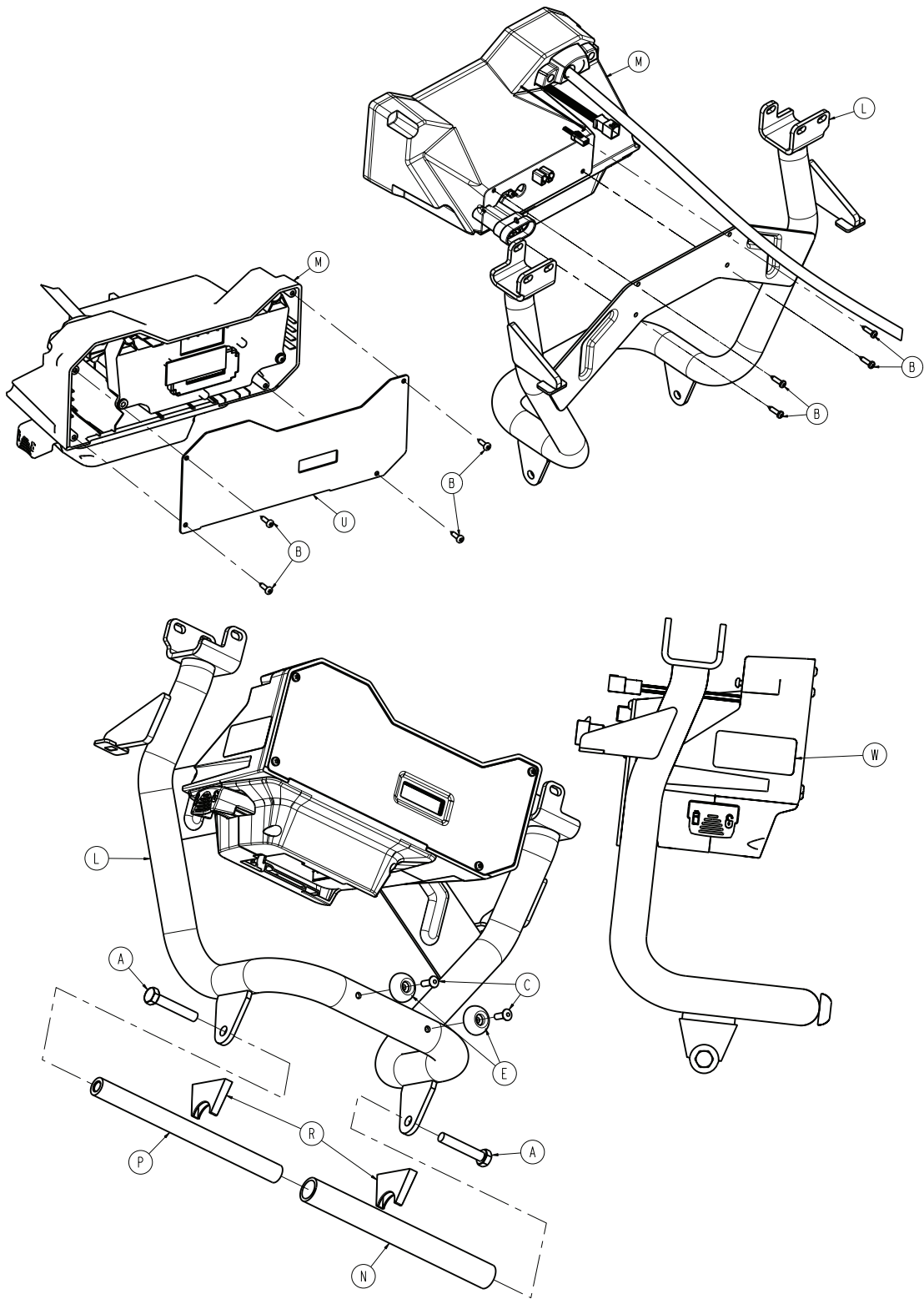


Item	Number	Name	Quantity
A	6500-101-214	Manifold assembly	1
B	6550-002-034	Hydraulic cylinder assembly	1
C	6500-001-211	Hydraulic hose assembly	1
D	6500-001-210	Hydraulic hose	1
E	Depatie 8506 - 1.9	Velocity fuse, Vonberg	1
F	Depatie PPTL bar code label	Serial number label	1
G	6500-001-296	Cap side hose fitting, cylinder	1
H	6500-001-297	Rod side hose fitting, cylinder	1
J	Depatie PPQC label	Quality control label	1

Hitch assembly, foot end

6550-001-022 Rev E (Reference only)



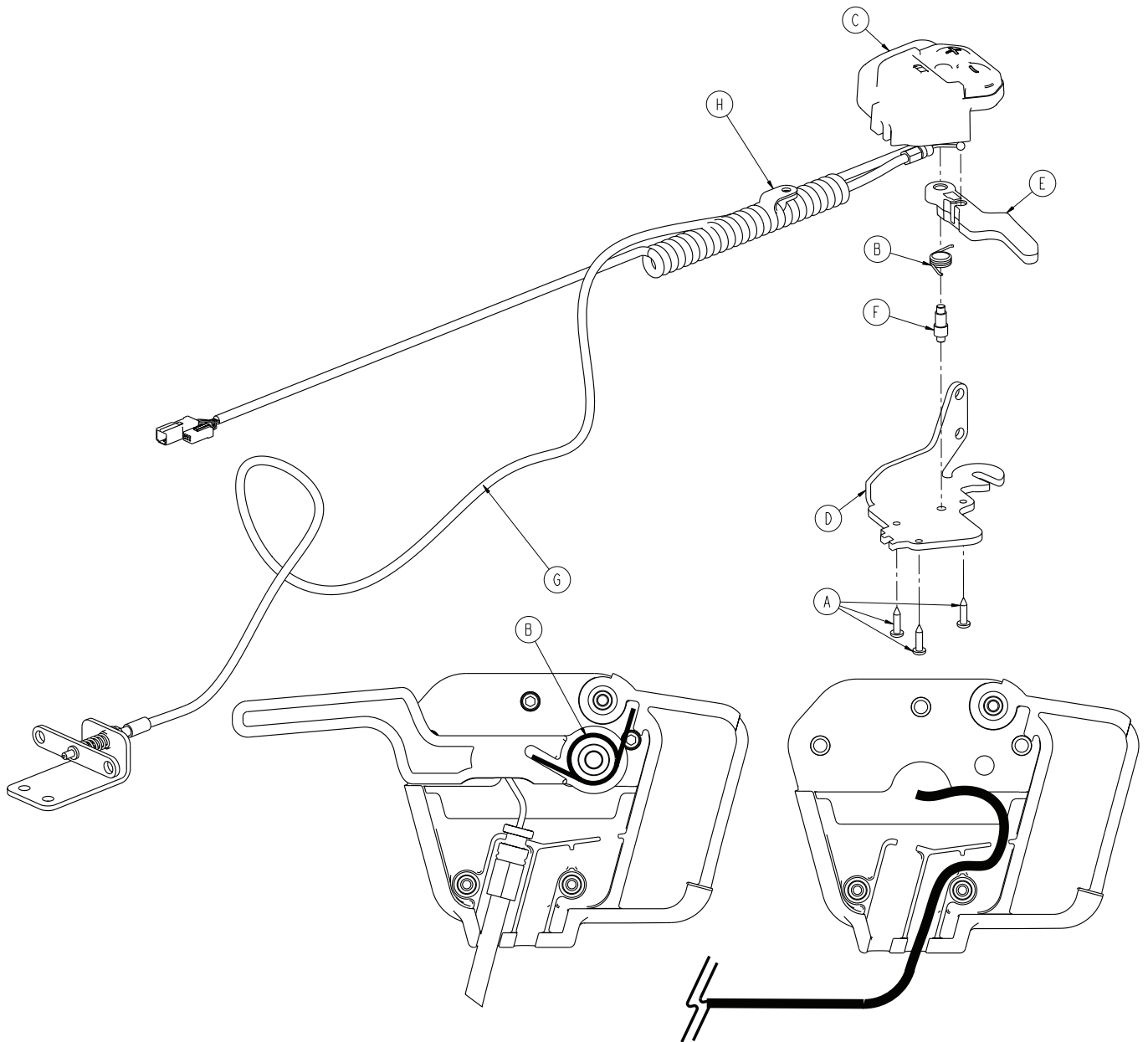


Item	Number	Name	Quantity
A	0003-391-000	Hex head cap screw	2
B	0023-162-000	Delta screw	15
C	0025-133-000	Dome head pop rivet	2
D	0038-572-000	Compression spring	2
E	0946-001-155	Bumper	2
F	6500-001-138	Battery release button	1

Item	Number	Name	Quantity
G	6500-001-139	Battery release lock	1
H	6500-102-216	Cot connector cable assembly	1
J	6550-101-014	Electronics assembly	1
K	6550-001-029	<i>Switch assembly</i> (page 65)	1
L	6550-001-060	Hitch tube weldment, foot end	1
M	6550-001-092	Board enclosure	1
N	6550-001-141	Hitch bar sleeve, foot end	1
P	6550-001-146	Hitch bar, foot end	1
R	6550-001-167	Hitch wear guard, foot end	2
T	6550-001-172	Cable assembly	1
U	6550-101-173	Housing cover, foot end	1
V	6550-001-178	Bottom plate enclosure, foot end	1
W	6500-001-356	Label, SMRT power	1

Switch assembly

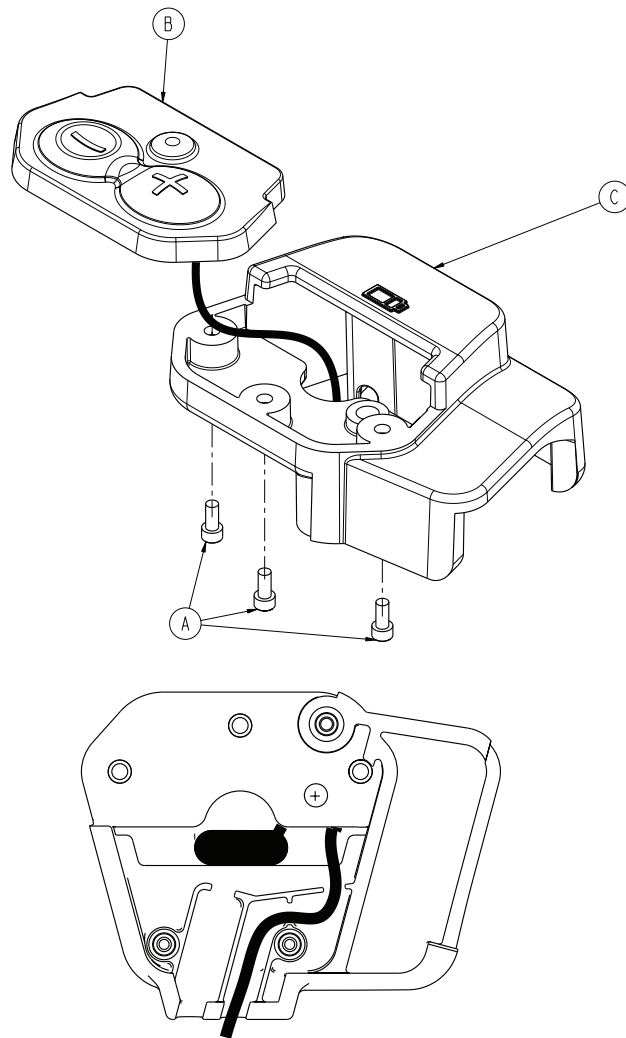
6550-001-029 Rev F (Reference only)



Item	Number	Name	Quantity
A	0023-162-000	Delta screw	3
B	6500-001-147	Manual release torsion spring	1
C	6550-101-036	Switch housing assembly (page 66)	1
D	6550-001-153	Switch housing bracket	1
E	6550-001-155	Manual release handle	1
F	6550-001-168	Manual release pivot	1
G	6550-001-177	Manual release cable assembly	1
H	0052-116-000	Cable clamp	1

Switch housing assembly

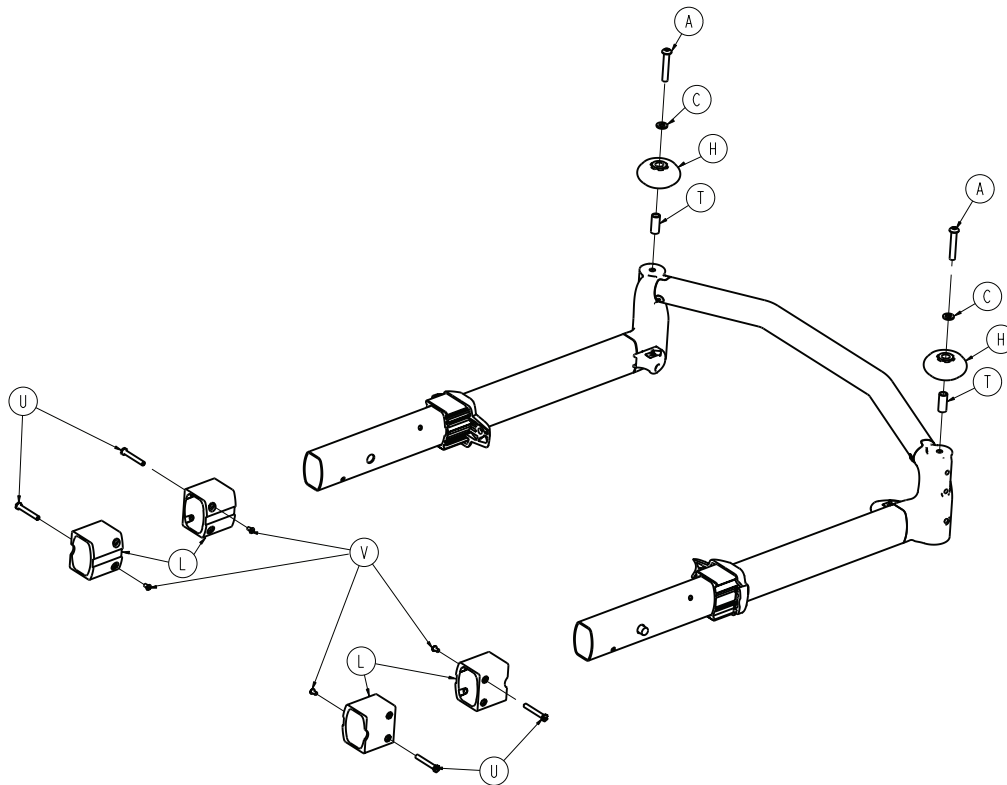
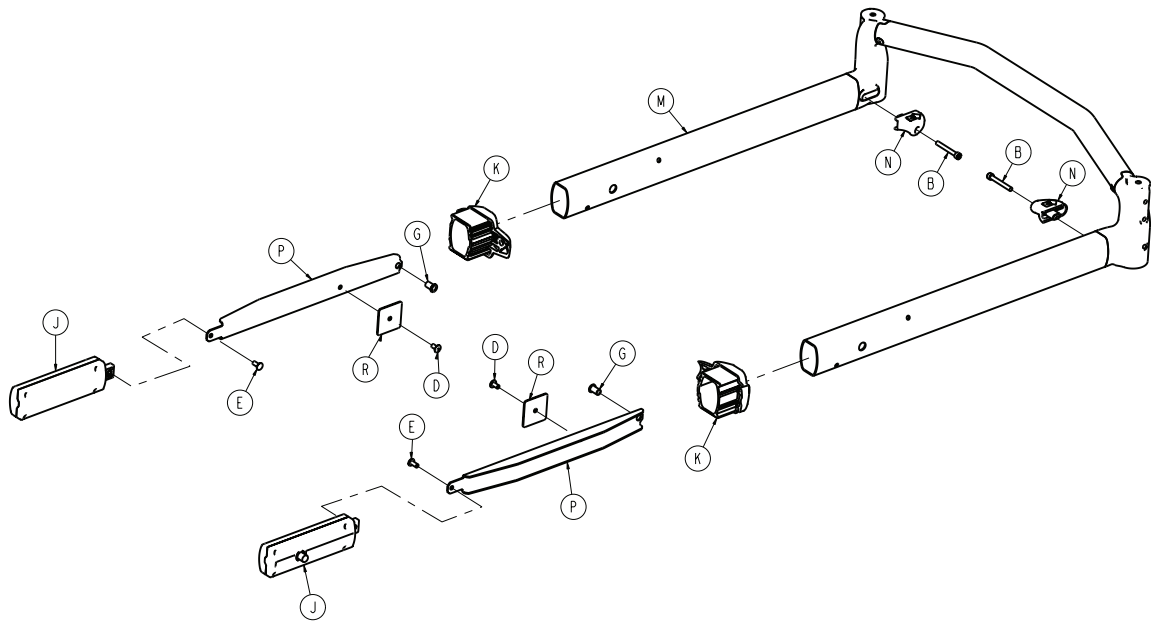
6550-101-036 Rev C (Reference only)



Item	Number	Name	Quantity
B	6550-101-152	Switch with LED	1
C	6550-001-154	Switch housing	1

Telescoping foot end - 6550-001-015

Rev B (Reference only)

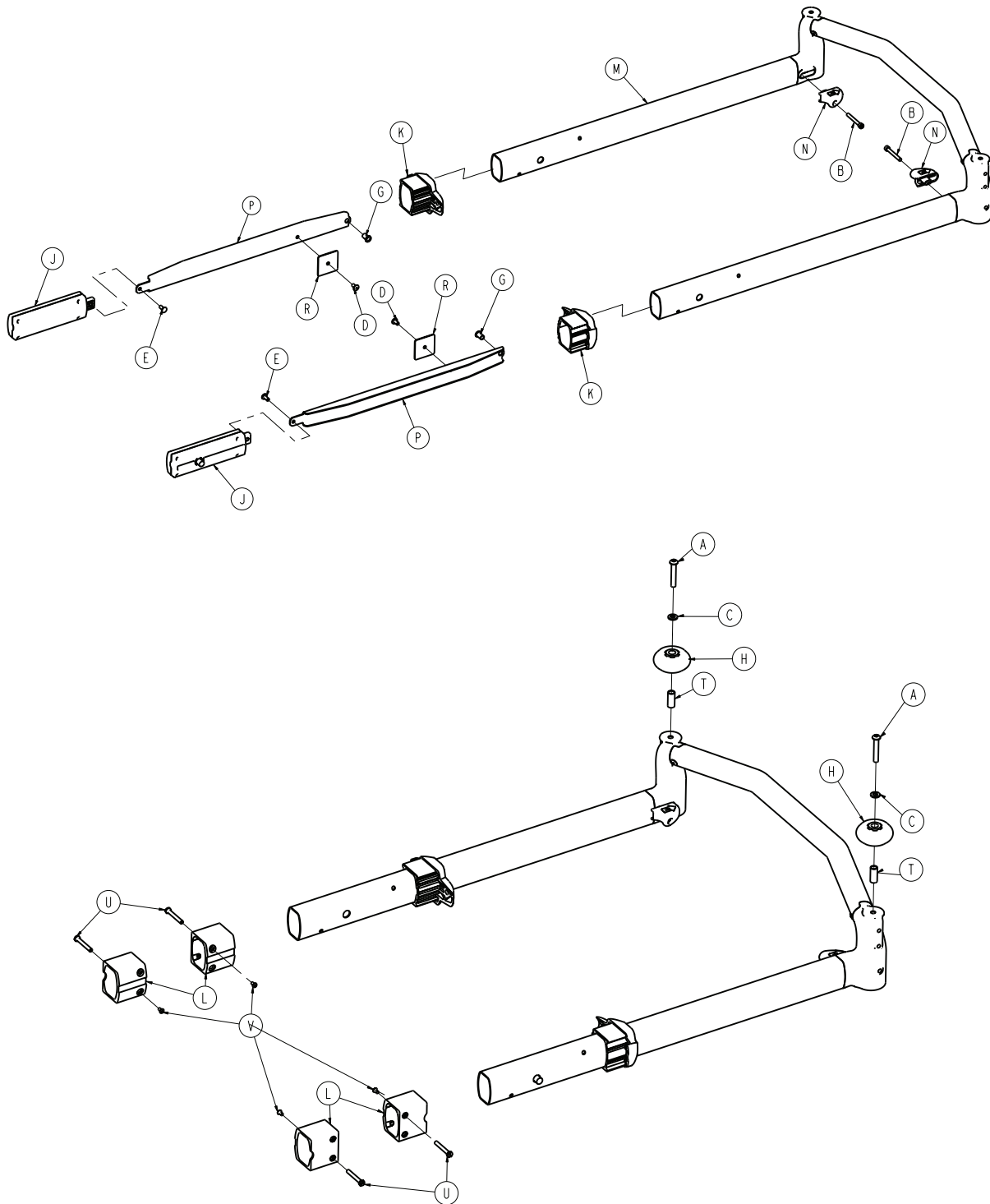


Item	Number	Name	Quantity
A	0004-848-000	Button head cap screw	2
B	0004-849-000	Socket head cap screw	2
C	0011-065-000	Washer	2
D	0025-079-000	Dome head rivet	2
E	0025-126-000	Semi-tubular rivet	2
G	0055-100-075	Riv nut	2

Item	Number	Name	Quantity
H	0721-032-049	Bumper roller	2
J	6500-001-026	Head section lock assembly	2
K	6500-001-087	Cap bearing	2
L	6085-001-170	Internal bearing	4
M	6550-001-025	Bonded frame, foot end	1
N	6550-001-156	Section release trigger	2
P	6550-001-162	Link release, foot end	2
R	6550-001-163	Link guide	2
T	6550-001-169	Bumper pivot	2
U	6085-001-169	Head section nut	4
V	0004-168-000	Button head cap screw	4

Telescoping head section - 6550-001-020

Rev B (Reference only)

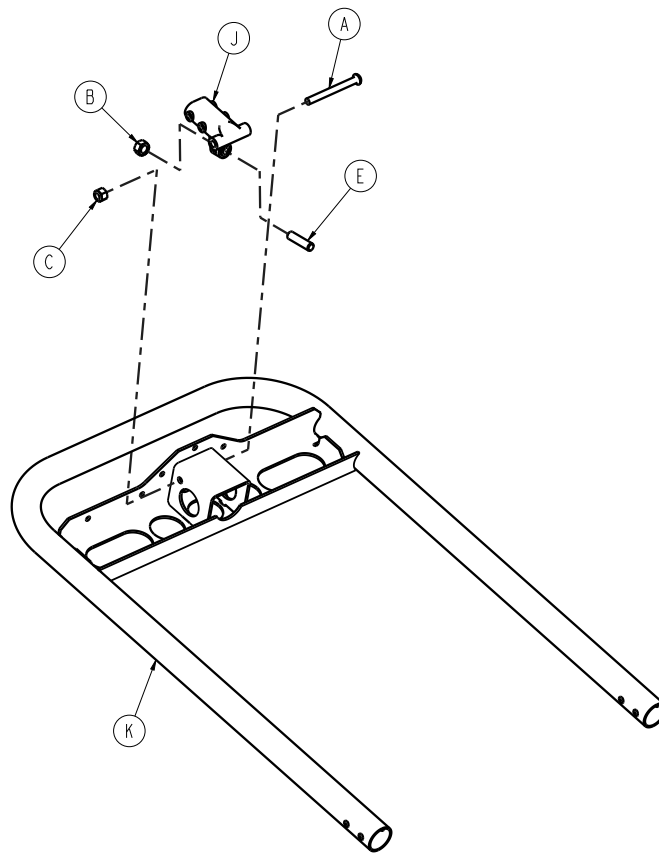


Item	Number	Name	Quantity
A	0004-848-000	Button head cap screw	2
B	0004-849-000	Socket head cap screw	2
C	0011-065-000	Washer	2
D	0025-079-000	Dome head rivet	2
E	0025-126-000	Semi-tubular rivet	2

Item	Number	Name	Quantity
G	0055-100-075	Riv nut	2
H	0721-032-049	Bumper roller	2
J	6500-001-026	Head section lock assembly	2
K	6500-001-087	Cap bearing	2
L	6085-001-170	Internal bearing	4
M	6550-001-024	Bonded frame, head end	1
N	6550-001-156	Section release trigger	2
P	6550-001-161	Link release, head end	2
R	6550-001-163	Link guide	2
T	6550-001-169	Bumper pivot	2
U	6085-001-169	Headsection nut	4
V	0004-168-000	Button head cap screw	4

Fowler assembly

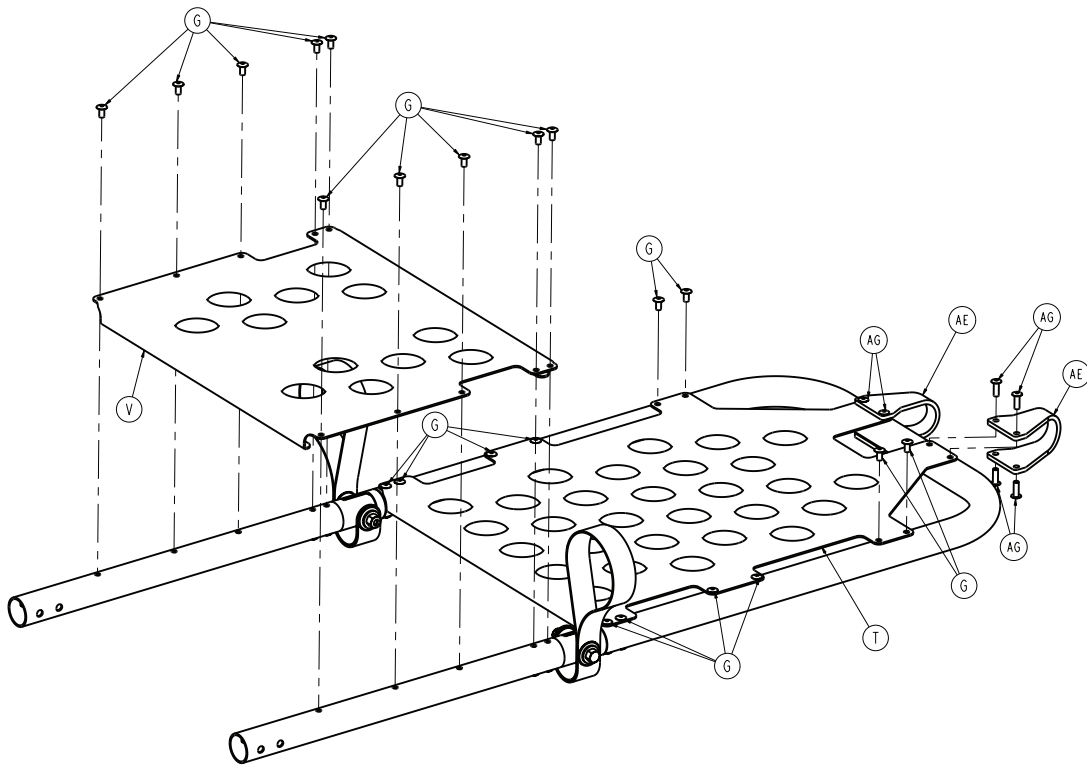
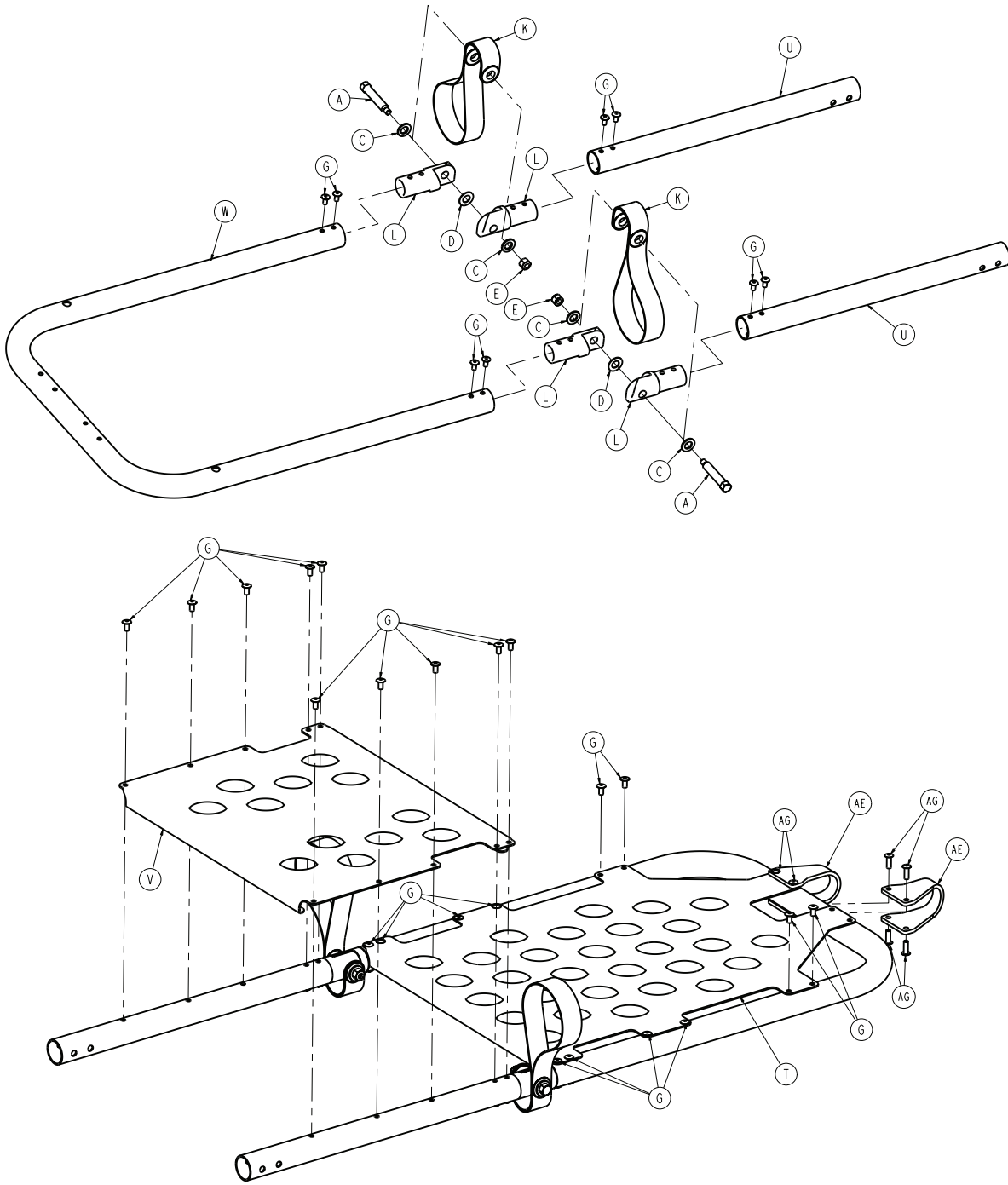
6550-001-018 Rev C (Reference only)

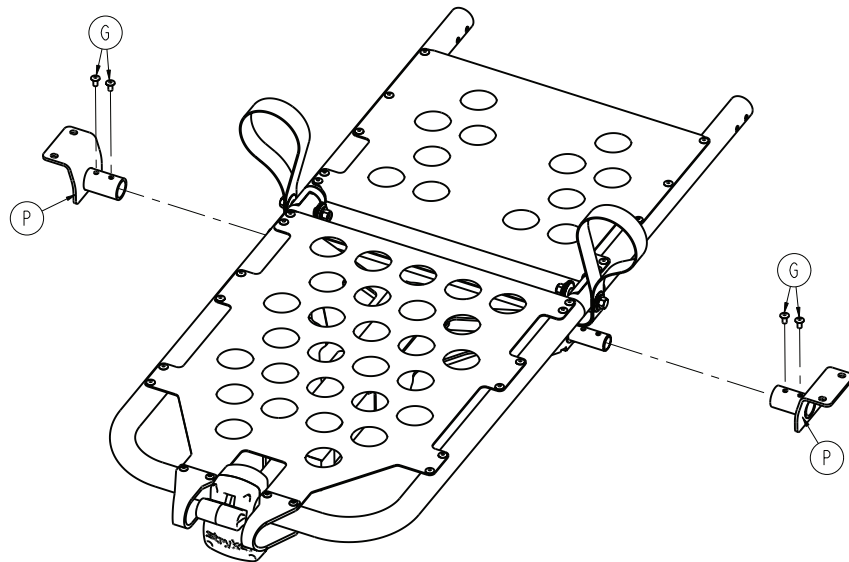
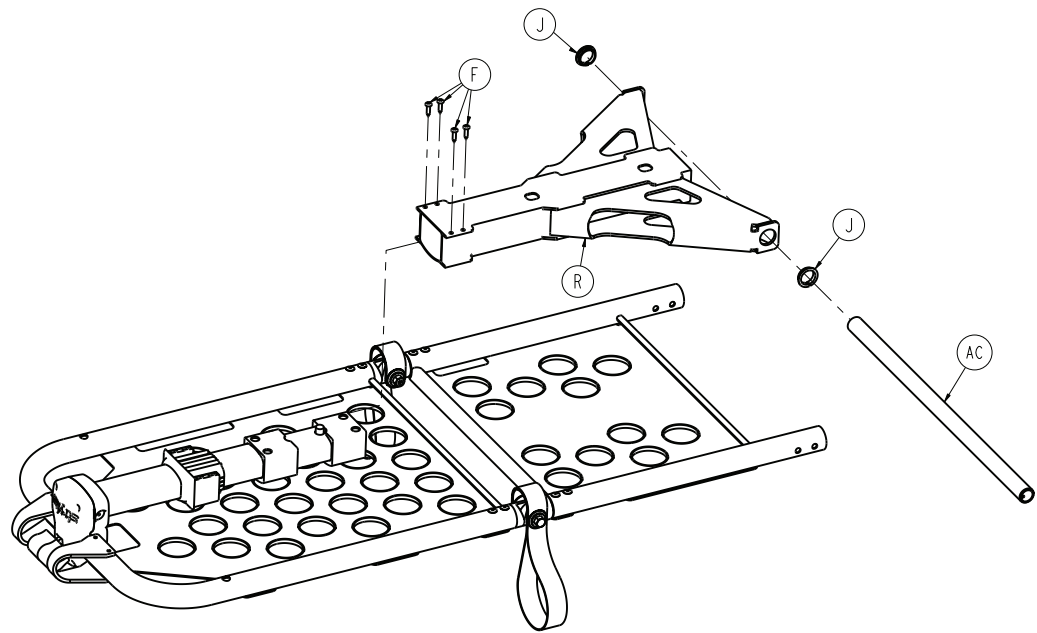
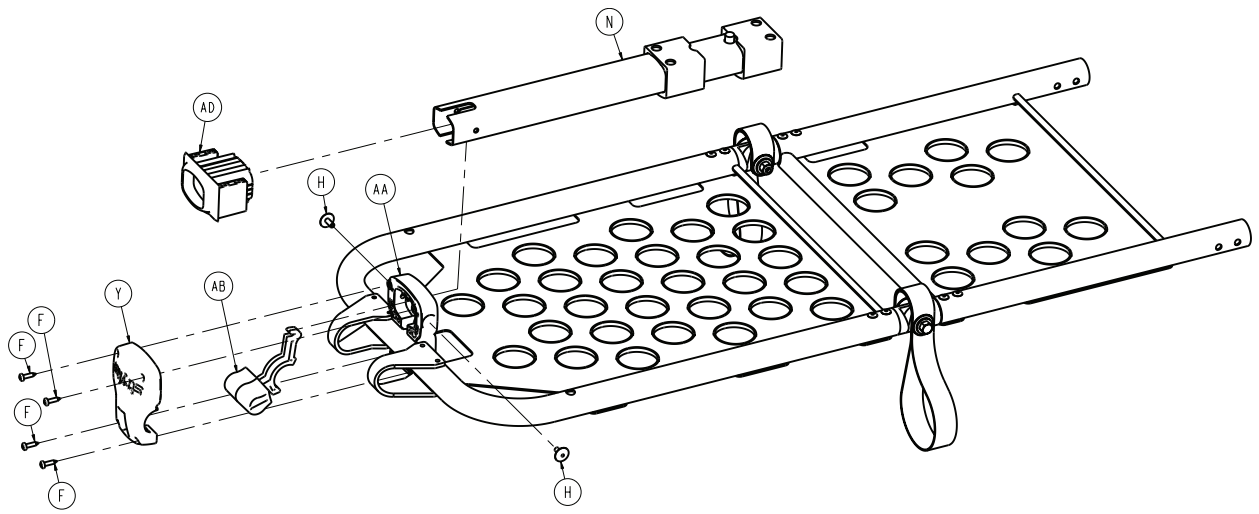


Item	Number	Name	Quantity
A	0004-597-000	Button head cap screw	1
B	0015-050-000	Hex nut	1
C	0016-028-000	Fiberlock hex nut	1
E	0021-138-000	Set screw	1
J	6060-032-040	Fowler lift pivot	1
K	6550-001-051	Fowler weldment	1

Gatch assembly

6550-001-019 Rev F (Reference only)

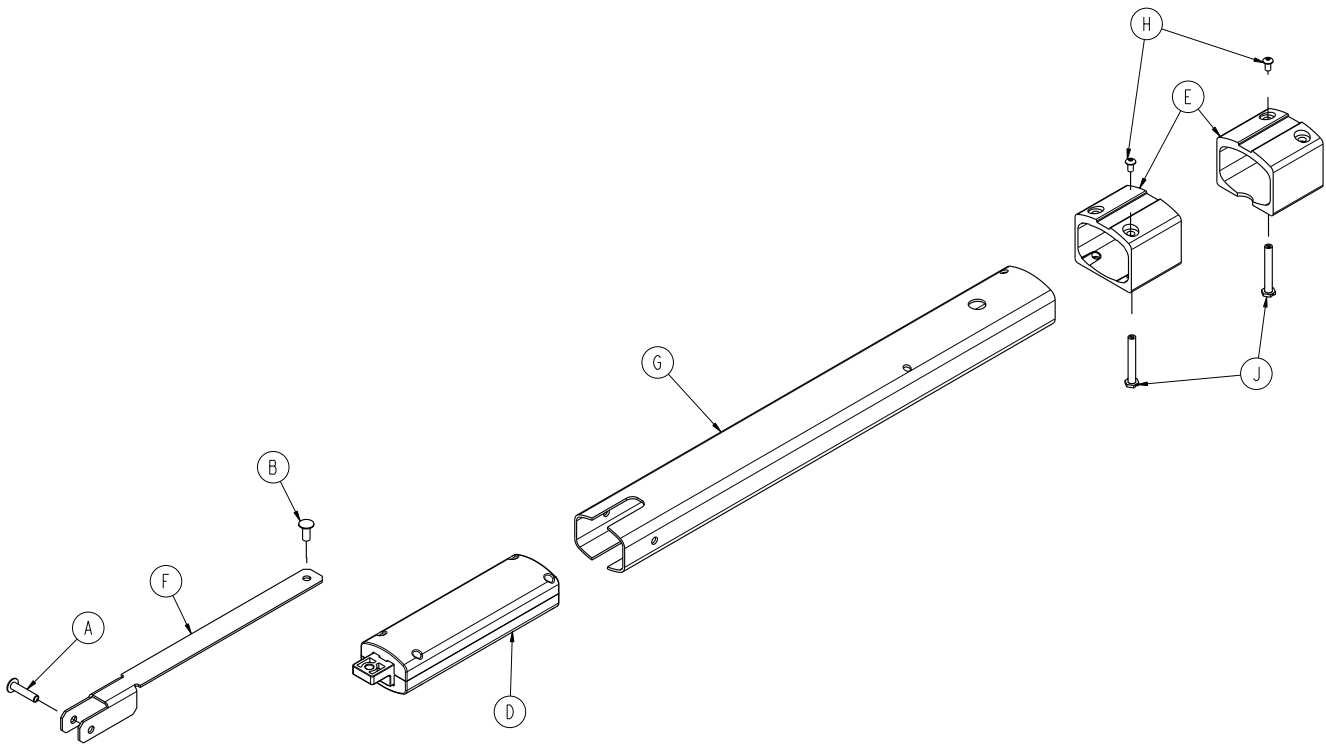




Item	Number	Name	Quantity
A	6550-001-186	Gatch pivot pin	2
B	0025-271-000	Dome head rivet	2
C	0011-448-000	Plain washer	4
D	0014-020-000	Washer	2
E	0016-028-000	Fiberlock hex nut	2
F	0023-162-000	Delta screw	8
G	0025-079-000	Dome head rivet	34
H	0025-132-000	Dome head rivet	2
J	0081-255-000	Split bearing	2
K	6100-031-096	Trend lift strap	2
L	6100-031-108	Litter knee pivot	4
M	0011-062-000	Washer	2
N	6550-001-017	<i>Gatch telescoping assembly - 6550-001-017 (page 75)</i>	1
P	6550-001-053	Gatch pivot weldment	2
R	6550-001-057	Gatch lock tube weldment	1
T	6550-001-110	Foot section skin	1
U	6550-001-111	Thigh section tube	2
V	6550-001-112	Thigh section skin	1
W	6550-001-116	Telescoping foot section u-tube	1
Y	6550-001-124	Front Gatch release	1
AA	6550-001-125	Back Gatch release	1
AB	6550-001-126	Lever front Gatch release	1
AC	6550-001-129	Gatch pivot cross tube	1
AD	6550-001-131	Gatch bearing end cap	1
AE	6550-001-193	Gatch handle guard	2
AG	0025-133-000	Dome head pop rivet	8

Gatch telescoping assembly - 6550-001-017

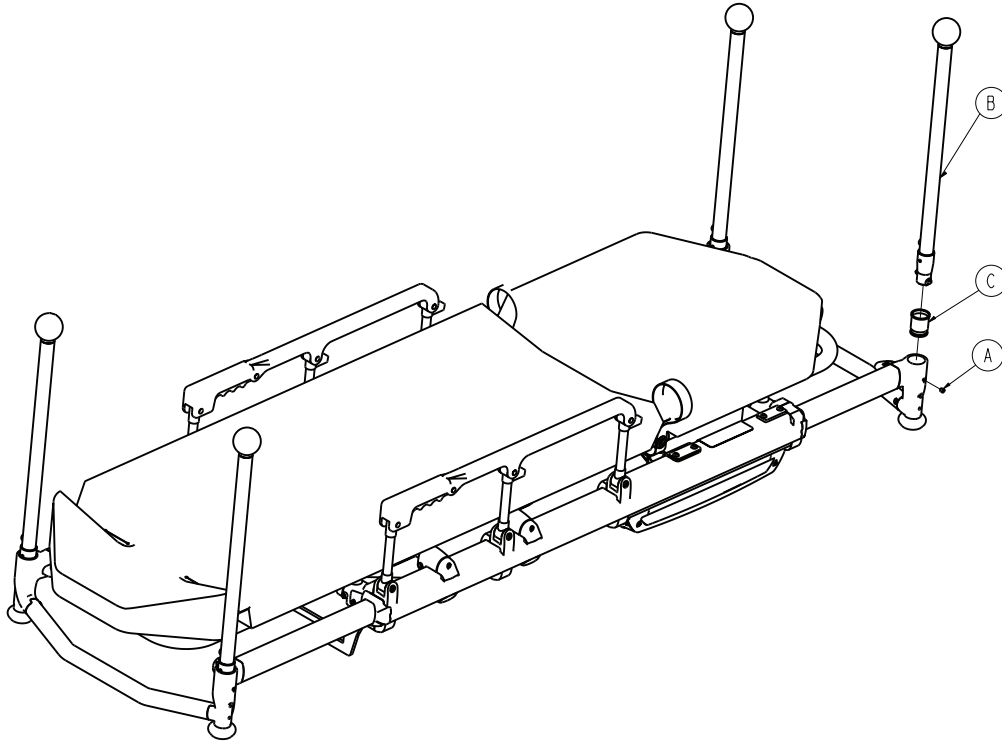
Rev B (Reference only)



Item	Number	Name	Quantity
A	0025-125-000	Semi-tubular rivet	1
B	0025-126-000	Semi-tubular rivet	1
D	6500-001-026	Head section lock assembly	1
E	6085-001-170	Internal bearing	2
F	6550-001-115	Gatch link	1
G	6550-001-119	Gatch inner tube	1
H	0004-168-000	Button head cap screw	2
J	6085-001-169	Head section nut	2

Optional push bar - 6550-040-000

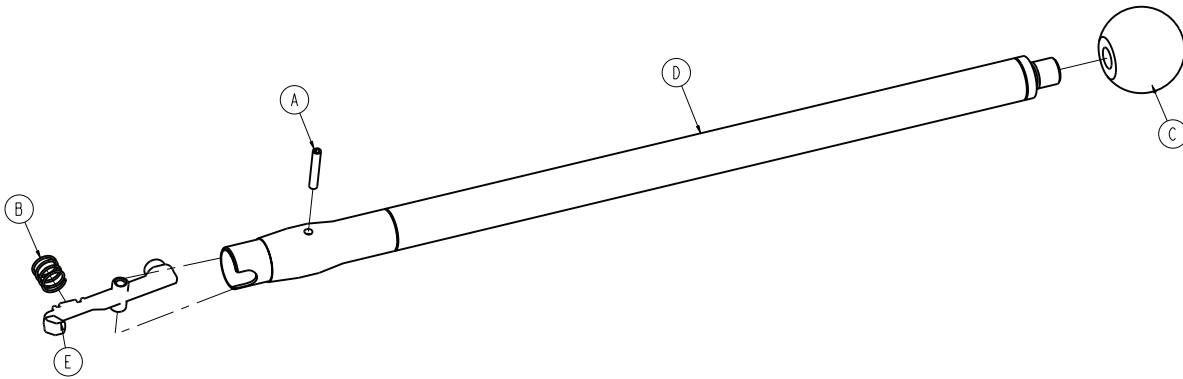
Rev A (Reference only)



Item	Number	Name	Quantity
A	0021-179-000	Set screw	4
B	6550-001-026	Optional corner handle assembly (page 4 77)	4
C	6550-001-108	Push bar sleeve	4
D	6550-001-199	Push bar storage pouch	1

Optional corner handle assembly

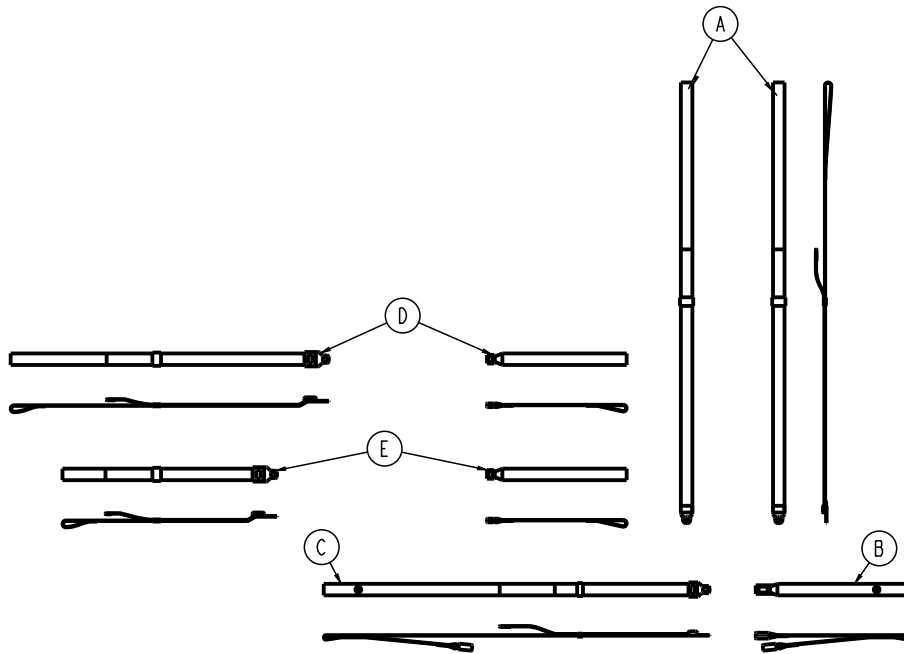
6550-001-026 Rev AA (Reference only)



Item	Number	Name	Quantity
A	0026-387-000	Slotted spring pin	1
B	0038-589-000	Compression spring	1
C	6510-001-119	Handle ball	1
D	6550-001-067	Handle weldment	1
E	655000010100	Push bar lock button	1

XPR restraint package - 650600030010

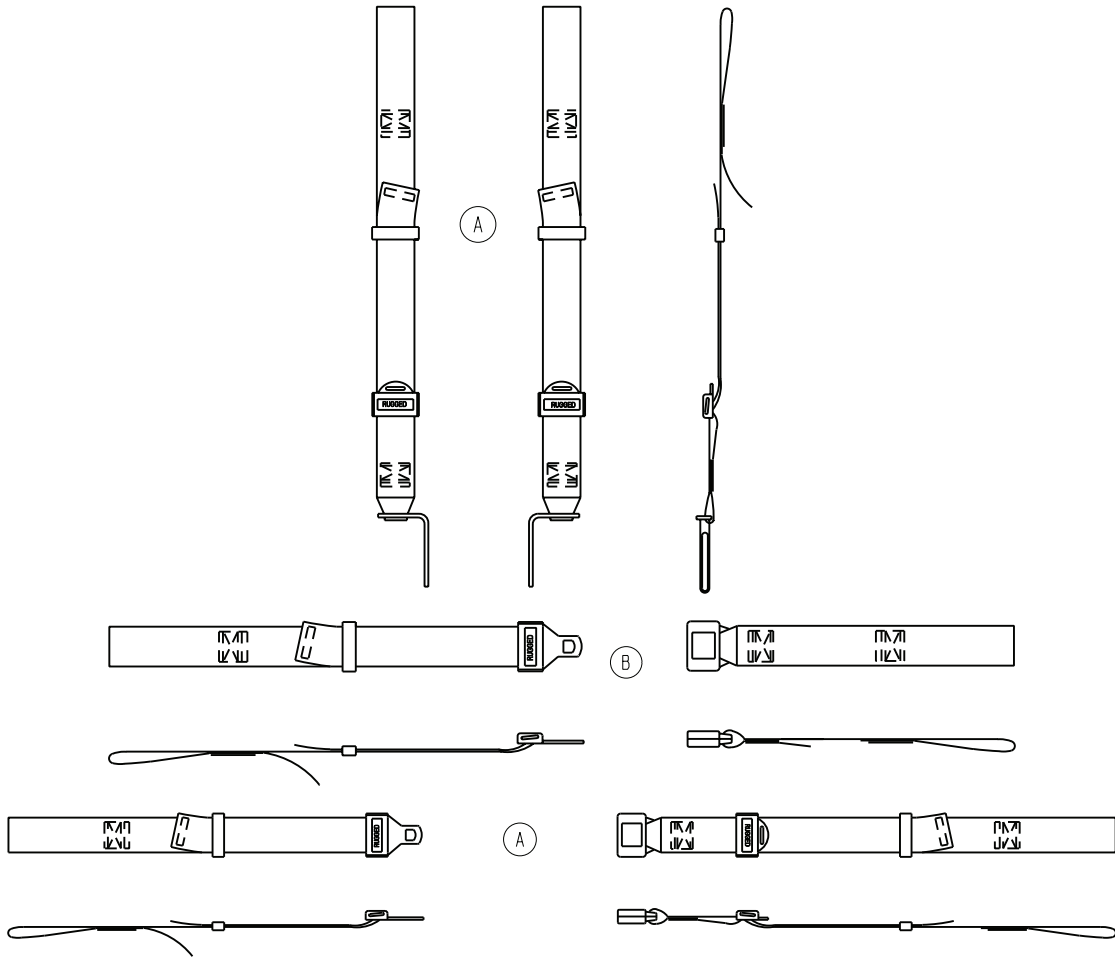
Rev AC (Reference only)



Item	Number	Name	Quantity
A	650600030001	XPR shoulder restraint	2
B	650600030002	XPR waist double buckle restraint	1
C	650600030003	XPR waist single buckle long restraint	1
D	650600030004	XPR thigh restraint	1
E	650600030005	XPR ankle restraint	1
G	650600030011	Label, XPR restraint package	1

EMS restraint package - 6060-160-010

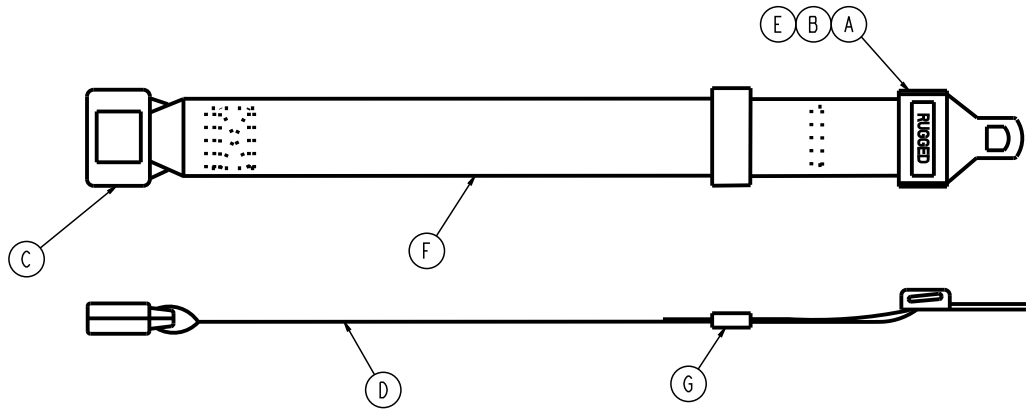
Rev D (Reference only)



Item	Number	Name	Quantity
A	6060-160-045	Four point harness	1
B	6060-160-050	Waist restraint	2

Belt extension - 6082-160-050

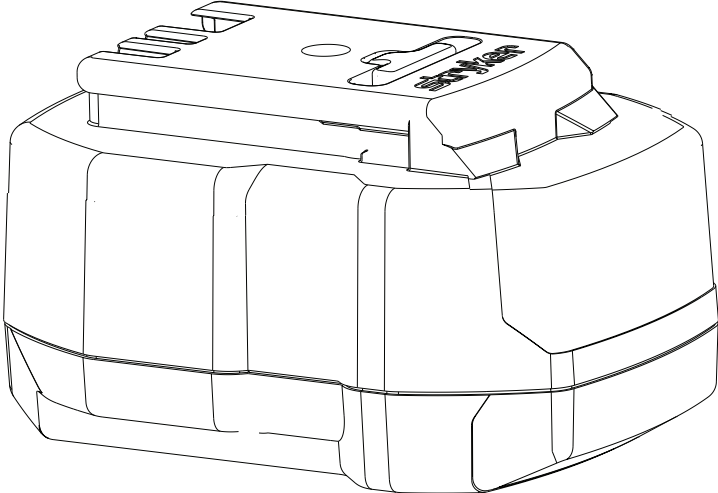
Rev C (Reference only)



Item	Number	Name	Quantity
A		Tongue (Intertek p/n 2122681)	
B		Cap (Intertek p/n 2122525)	
C		Buckle (Intertek p/n 2122682)	
D	6082-090-001	Label, belt extension	1
E	6060-090-011	Label, RUGGED	1
F		Belt, 2" wide, black	
G		Belt retainer	

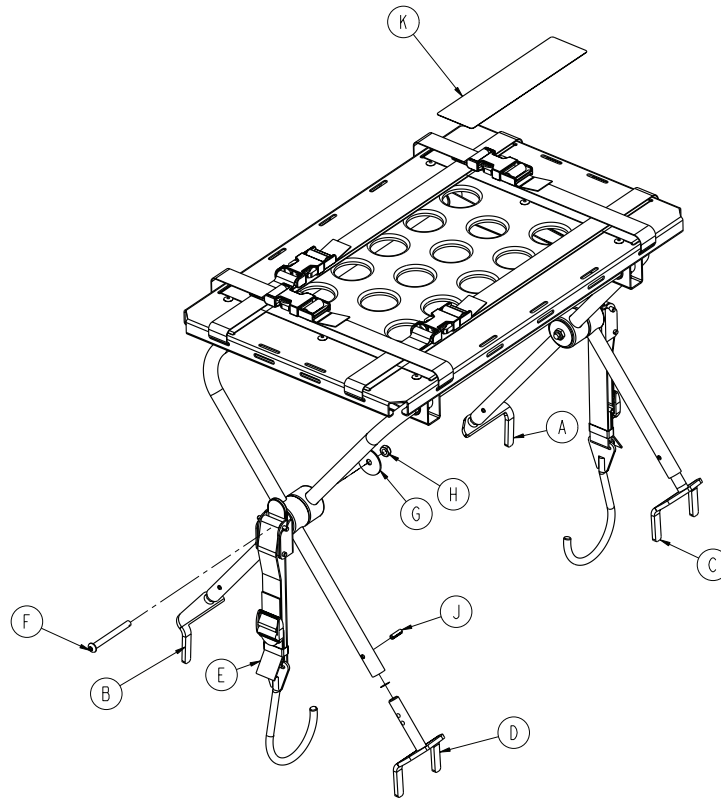
Battery pack, SMRT - 6500-033-000

6500-101-010 Rev AB (Reference only)



Defibrillator platform - 6550-170-000

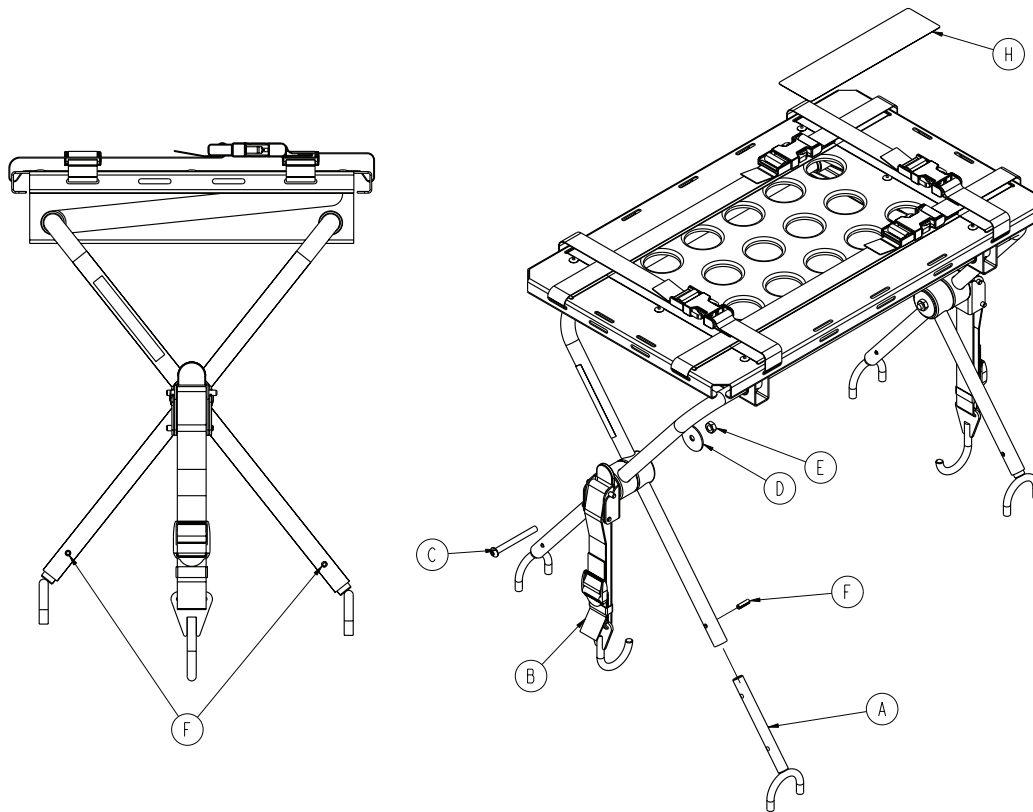
Rev A / 6550-170-010 Rev A (Reference only)



Item	Number	Name	Quantity
A	6100-170-050	Head end bracket weldment, left	1
B	6100-170-051	Head end bracket weldment, right	1
C	6100-170-052	Foot end bracket weldment, left	1
D	6100-170-053	Foot end bracket weldment, right	1
E	6100-170-020	Defibrillator latch strap assembly	2
F	0004-234-000	Button head cap screw	2
G	0011-355-000	Washer	2
H	0016-102-000	Nylock nut	2
J	0026-172-000	Slotted spring pin	4
K	6100-190-023	Label, specification and warning	1
L	6082-170-020	<i>Defibrillator platform common components (page 84)</i>	1

Defibrillator platform assembly - 6082-170-000

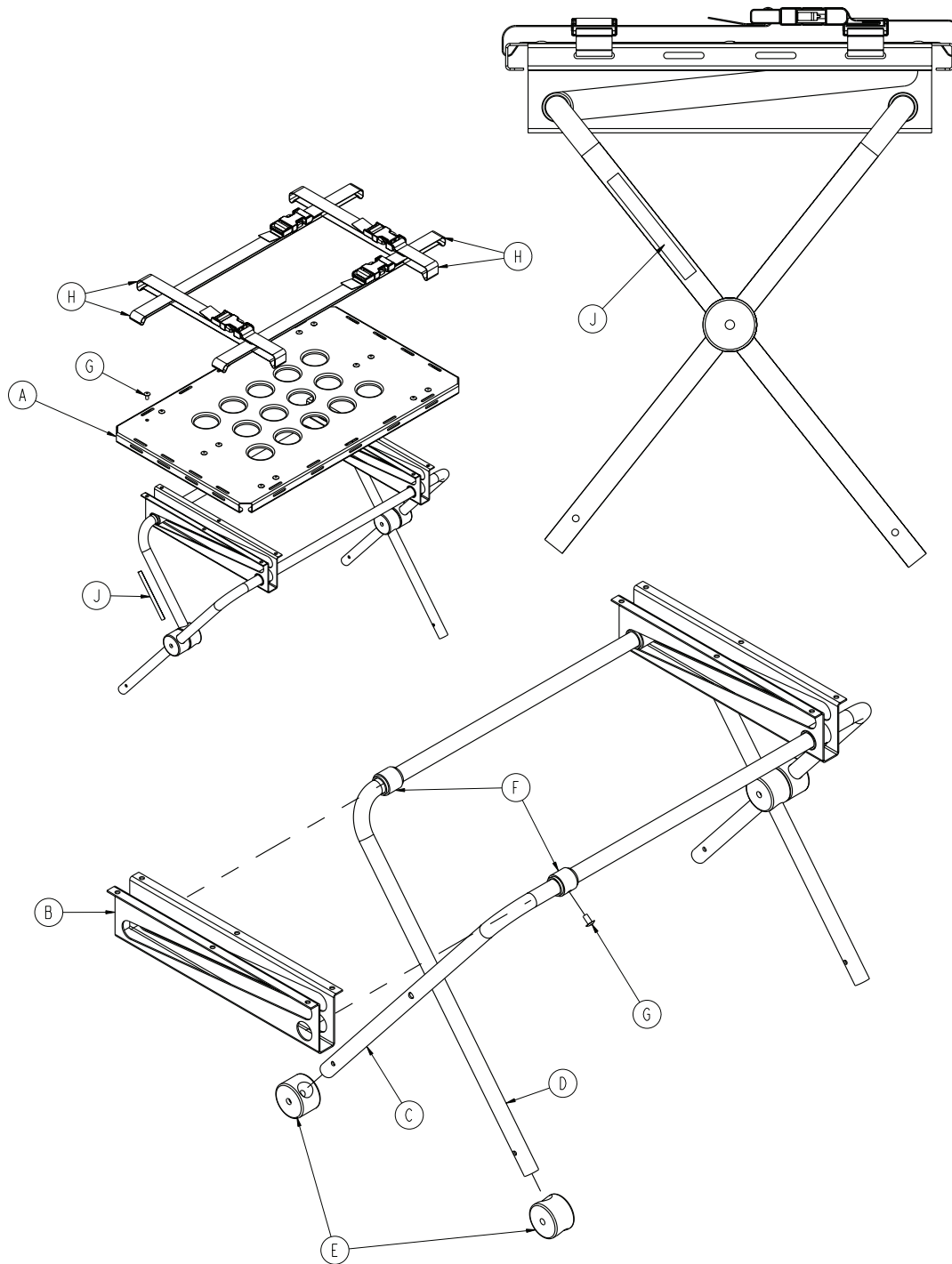
Rev F / 6082-170-010 Rev E (Reference only)



Item	Number	Name	Quantity
A	6082-170-050	Defibrillator U-foot weldment	4
B	6080-170-020	Defibrillator latch strap assembly	2
C	0004-234-000	Button head cap screw	2
D	0011-355-000	Washer	2
E	0016-102-000	Nylock nut	2
F	0026-172-000	Slotted spring pin	4
H	6082-090-022	Label, specification and warning	1
J	6082-170-020	Defibrillator platform common components	1

Defibrillator platform common components

6082-170-020 Rev B (Reference only)

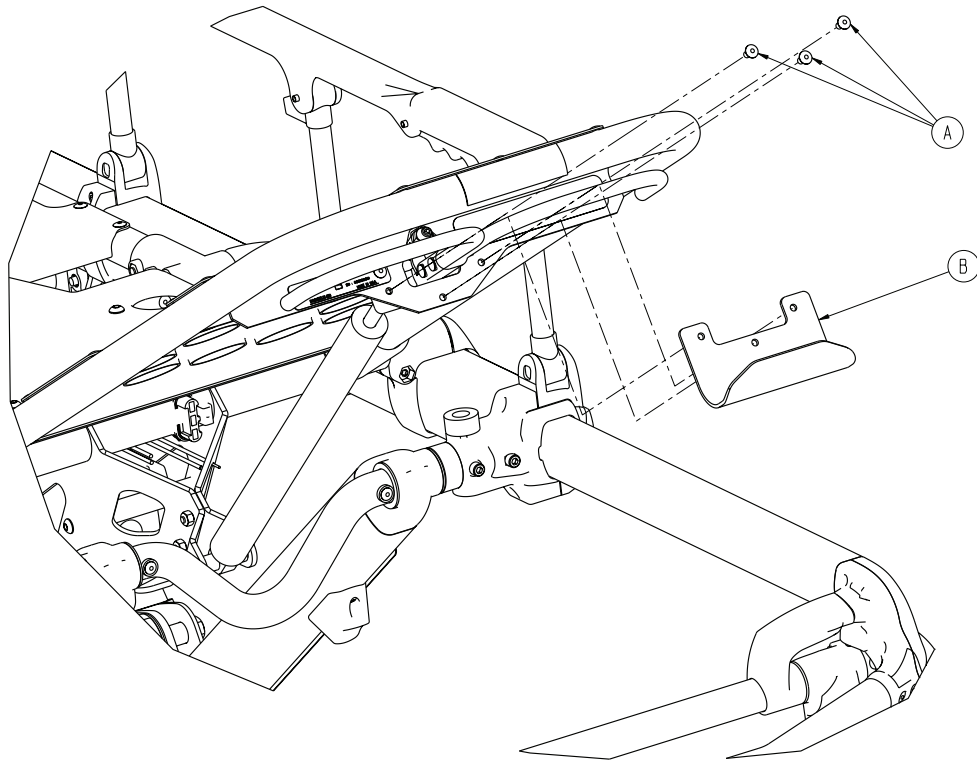


Item	Number	Name	Quantity
A	6080-170-011	Top panel	1
B	6080-170-012	Leg support	2
C	6080-170-013	Stationary defibrillator leg	1
D	6080-170-014	Sliding defibrillator leg	1
E	6080-170-015	Support pivot leg	4
F	6080-170-016	Leg collar	4

Item	Number	Name	Quantity
G	0025-079-000	Dome head rivet	16
H	6060-170-022	Defibrillator platform strap, long	4
J	6080-090-023	Label	2

Equipment hook option - 6500-147-000

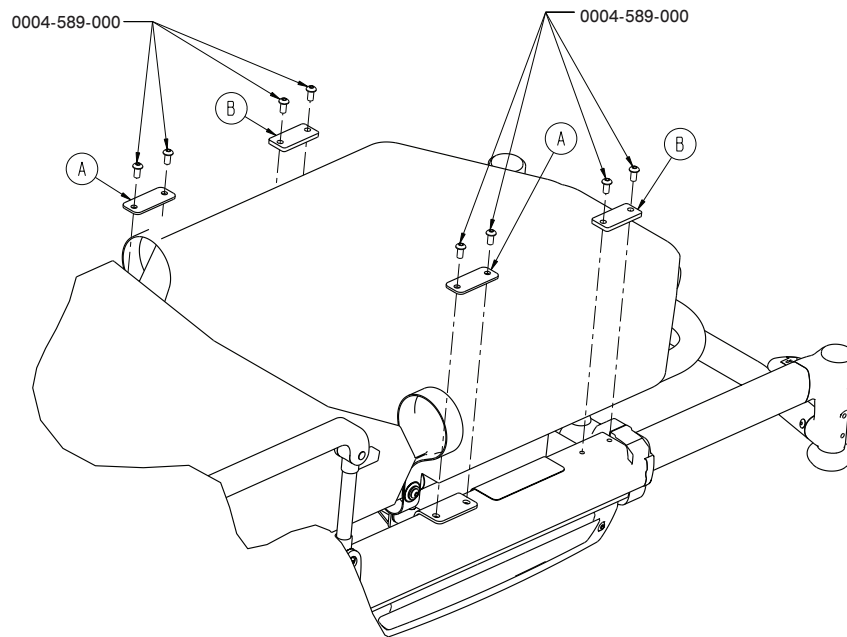
Rev B (Reference only)



Item	Number	Name	Quantity
A	0025-079-000	Dome head rivet	3
B	6500-001-237	Equipment hook	1

No IV pole assembly option

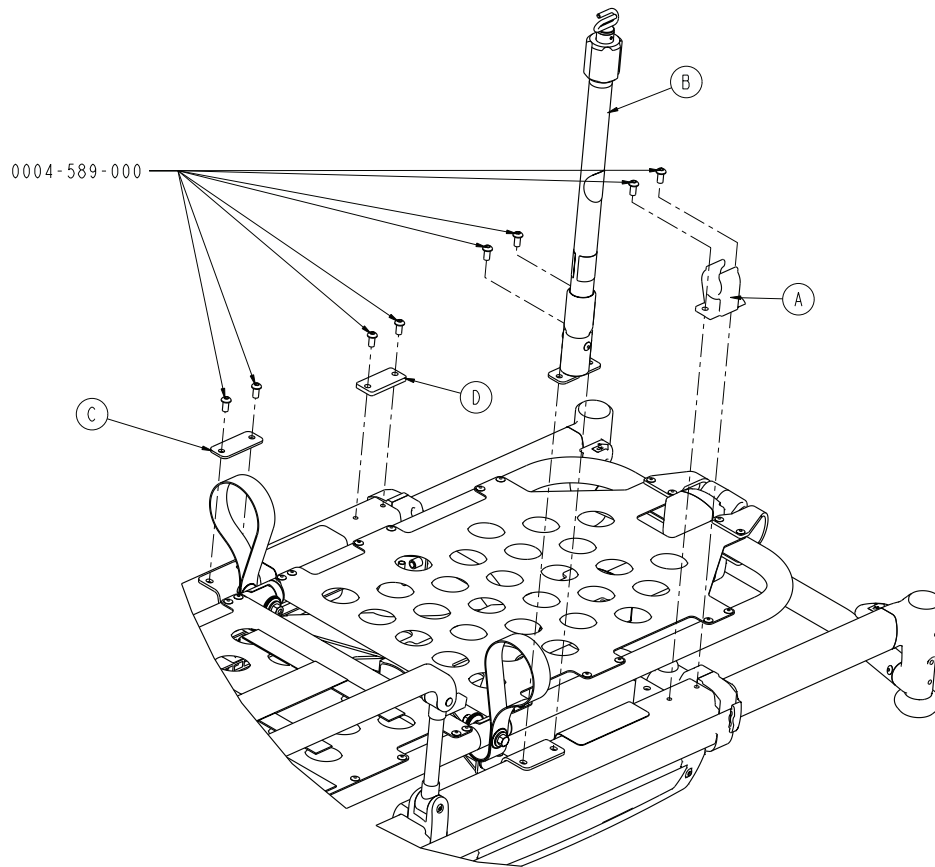
6550-218-000 Rev A (Reference only)



Item	Number	Name	Quantity
A	6550-001-117	IV pole spacer plate	2
B	6550-001-118	IV clip spacer plate	2

Two-stage IV pole, right - 6550-310-000

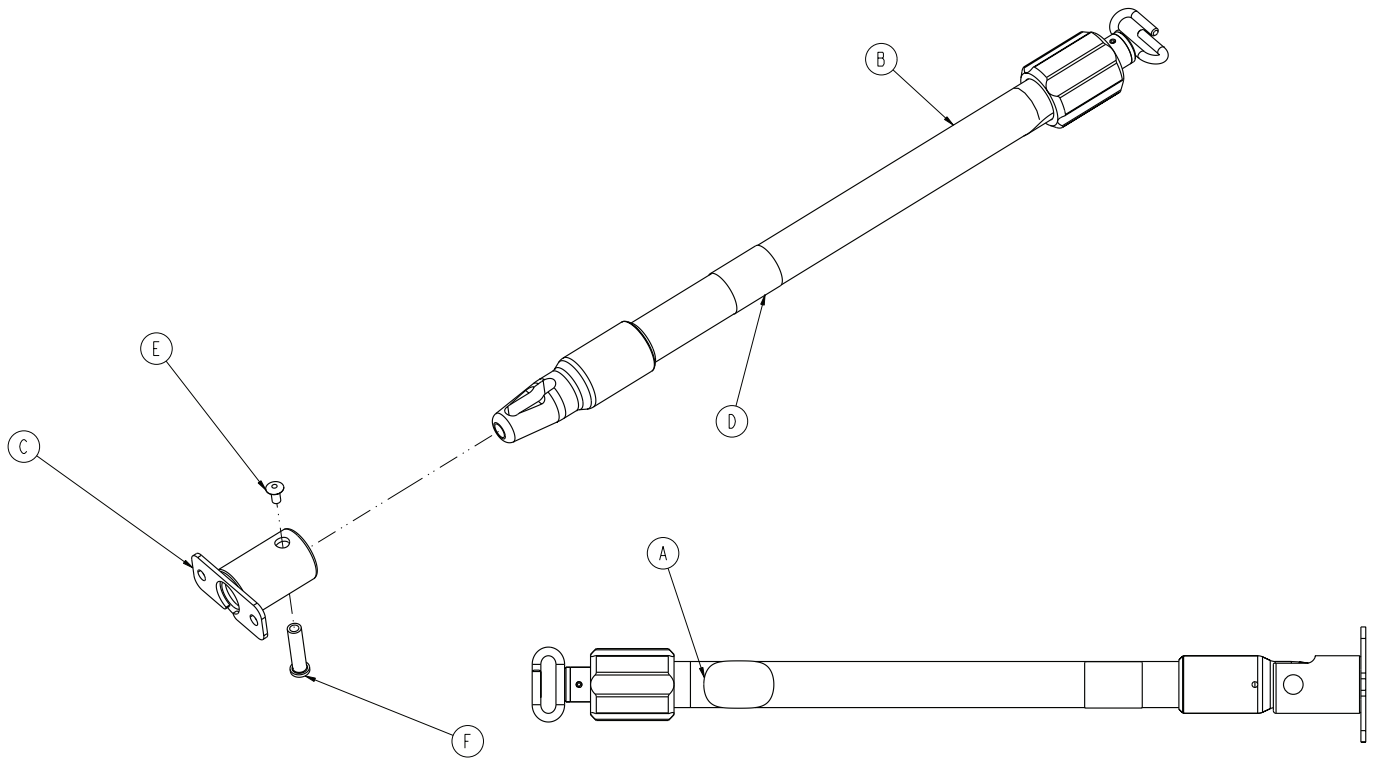
Rev A (Reference only)



Item	Number	Name	Quantity
A	6100-115-060	IV pole clip	1
B	6500-101-041	HAVASU™ IV pole assembly, two-stage, right - 6500-101-041 (page 89)	1
C	6550-001-117	IV pole spacer plate	1
D	6550-001-118	IV clip spacer plate	1

HAVASU™ IV pole assembly, two-stage, right - 6500-101-041

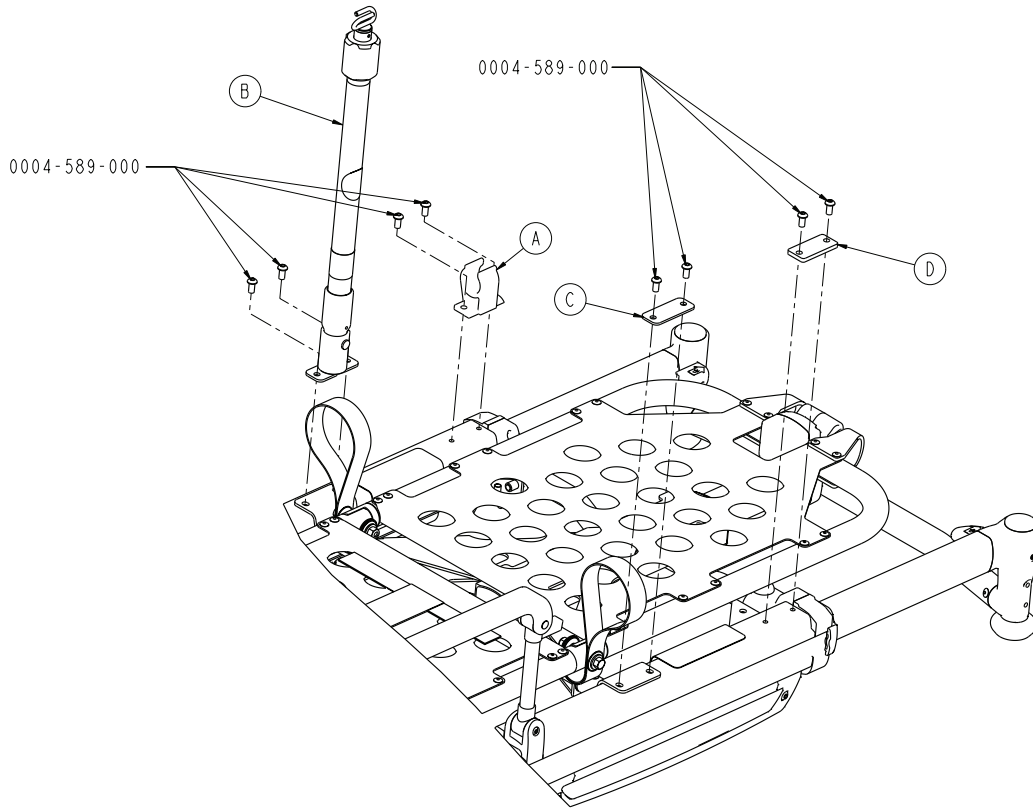
Rev AA (Reference only)



Item	Number	Name	Quantity
A	650600350901	Label, EAR	1
B	6070-210-070	Pole assembly	1
C	6100-115-051	Socket weldment	1
D	6500-101-253	Label, two-stage IV pole, right	1
E	0025-079-000	Dome head pop rivet	1
F	6070-110-037	IV pivot pin	1

Two-stage IV pole, left - 6550-311-000

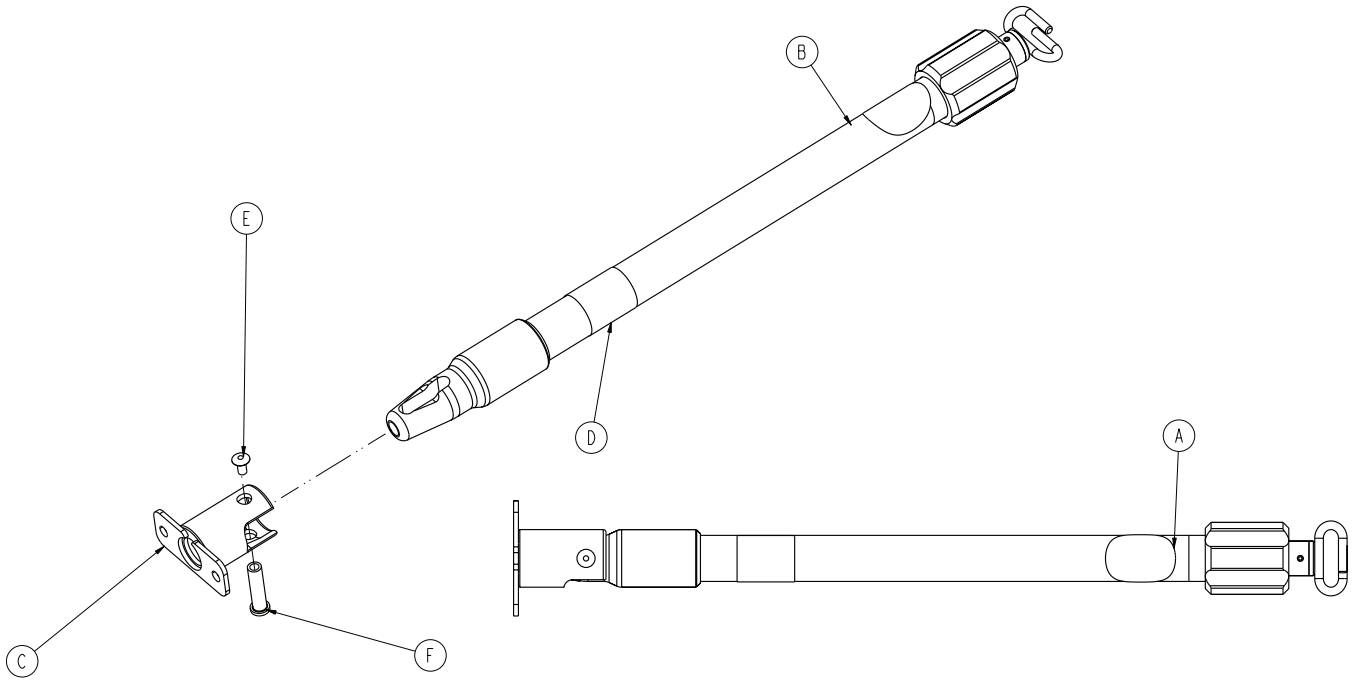
Rev A (Reference only)



Item	Number	Name	Quantity
A	6100-115-060	IV pole clip	1
B	6500-101-042	HAVASU IV pole assembly, two-stage, left - 6500-101-042 (page 91)	1
C	6550-001-117	IV pole spacer plate	1
D	6550-001-118	IV clip spacer plate	1

HAVASU IV pole assembly, two-stage, left - 6500-101-042

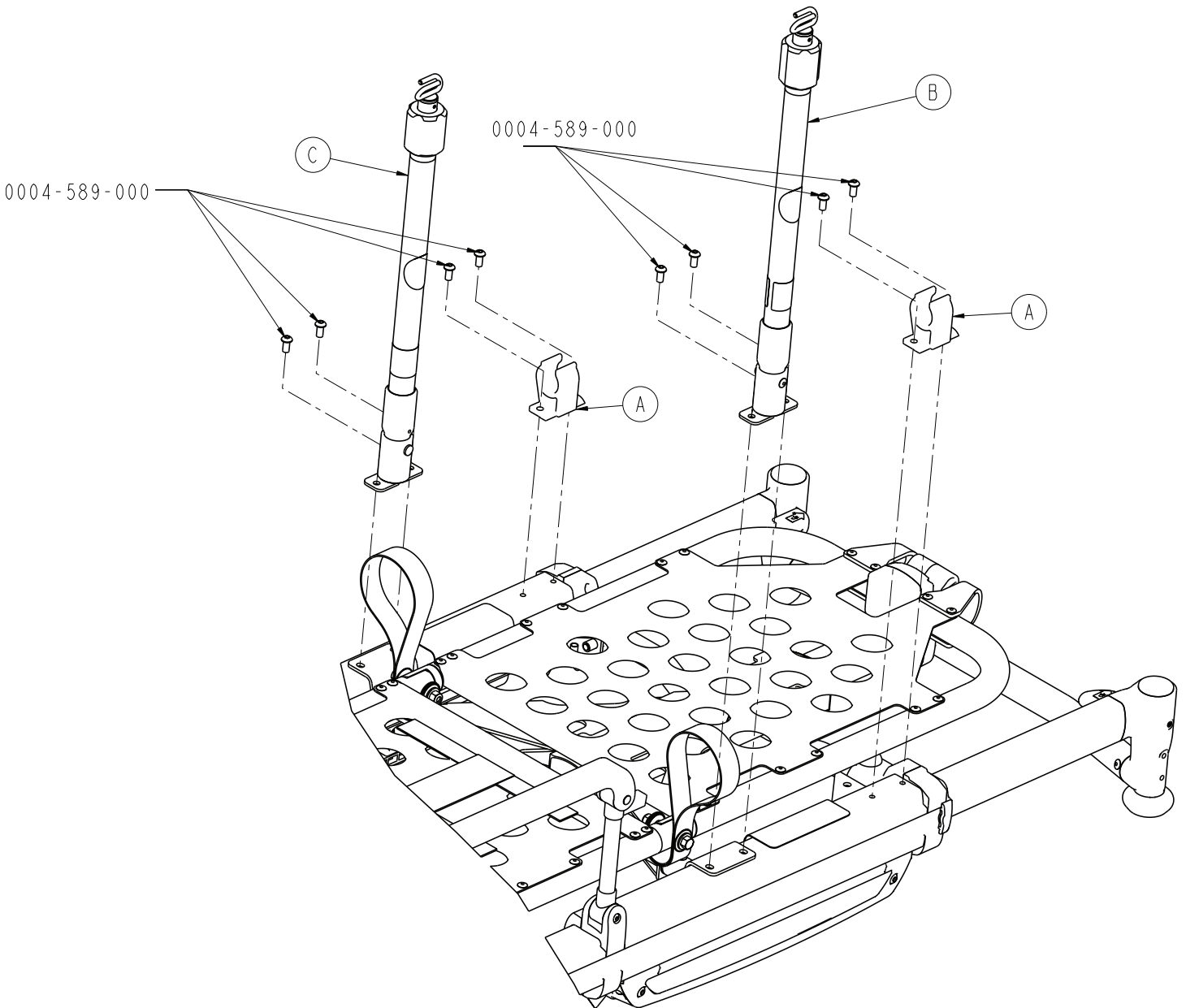
Rev AA (Reference only)



Item	Number	Name	Quantity
A	650600350901	Label, EAR	1
B	6070-210-070	Pole assembly	1
C	6100-115-051	Socket weldment	1
D	6500-101-254	Label, two-stage IV pole, left	1
E	0025-079-000	Dome head pop rivet	1
F	6070-110-037	IV pivot pin	1

Two-stage IV pole, dual - 6550-312-000

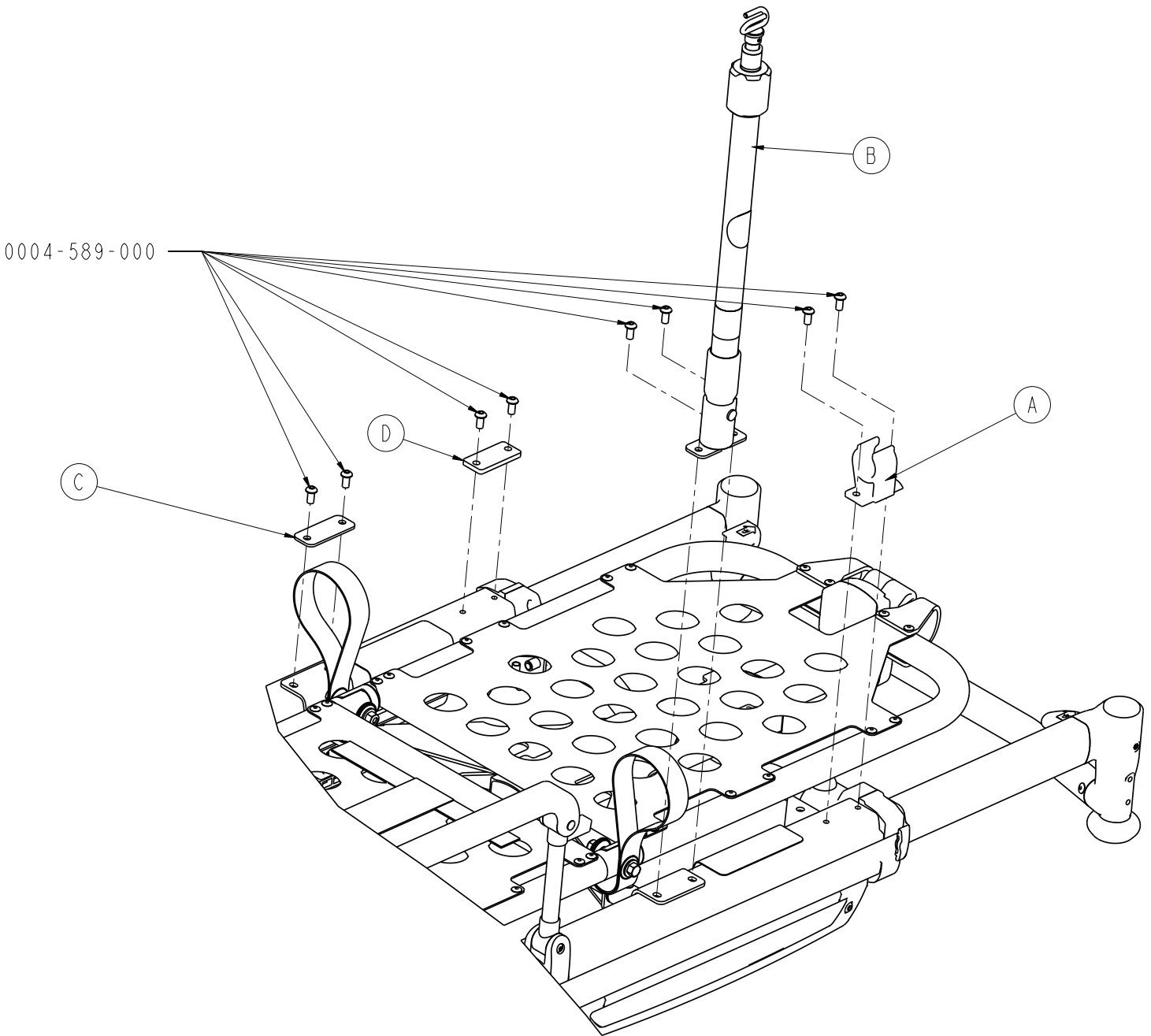
Rev A (Reference only)



Item	Number	Name	Quantity
A	6100-115-060	IV pole clip	1
B	6500-101-041	HAVASU™ IV pole assembly, two-stage, right - 6500-101-041 (page 89)	1
C	6500-101-042	HAVASU IV pole assembly, two-stage, left - 6500-101-042 (page 91)	1

Three-stage IV pole, right - 6550-315-000

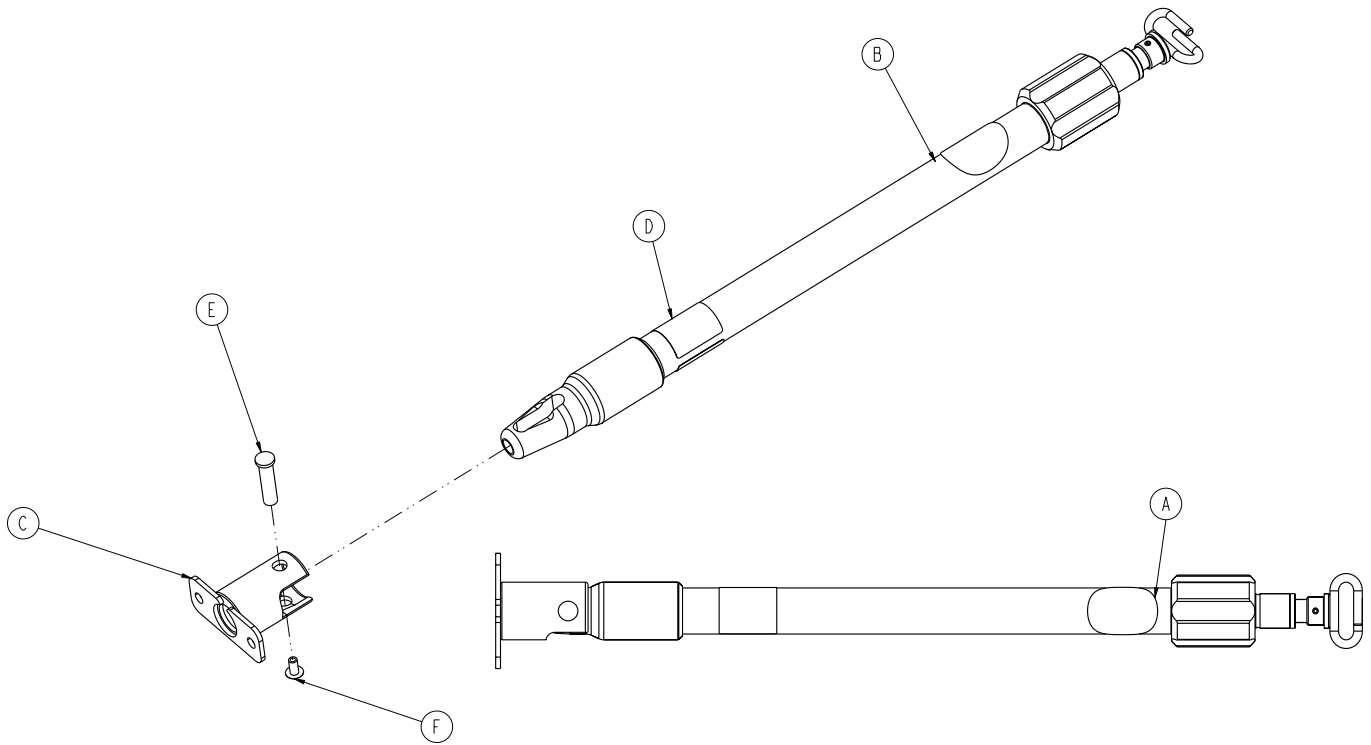
Rev A (Reference only)



Item	Number	Name	Quantity
A	6100-115-060	IV pole clip	1
B	6500-101-043	HAVASU IV pole assembly, three-stage, right - 6500-101-043 (page 94)	1
C	6550-001-117	IV pole spacer plate	1
D	6550-001-118	IV clip spacer plate	1

HAVASU IV pole assembly, three-stage, right - 6500-101-043

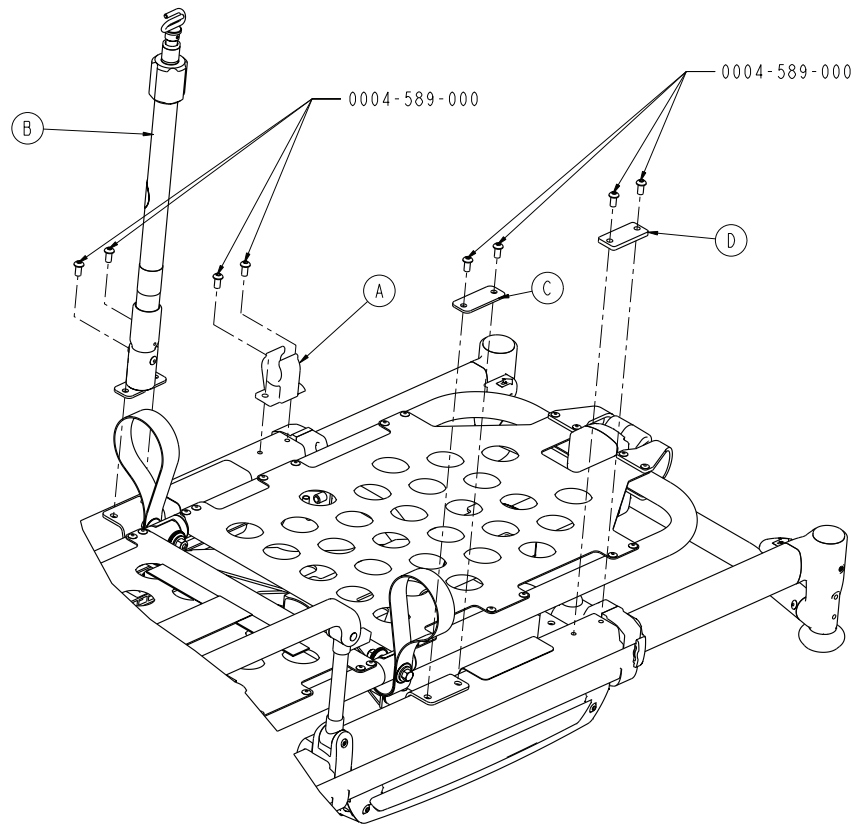
Rev AA (Reference only)



Item	Number	Name	Quantity
A	650600350901	Label, EAR	1
B	6070-215-070	Pole assembly	1
C	6100-115-051	Socket weldment	1
D	6500-101-255	Label, three-stage IV pole, right	1
E	6070-110-037	IV pivot pin	1
F	0025-079-000	Dome head pop rivet	1

Three-stage IV pole, left - 6550-316-000

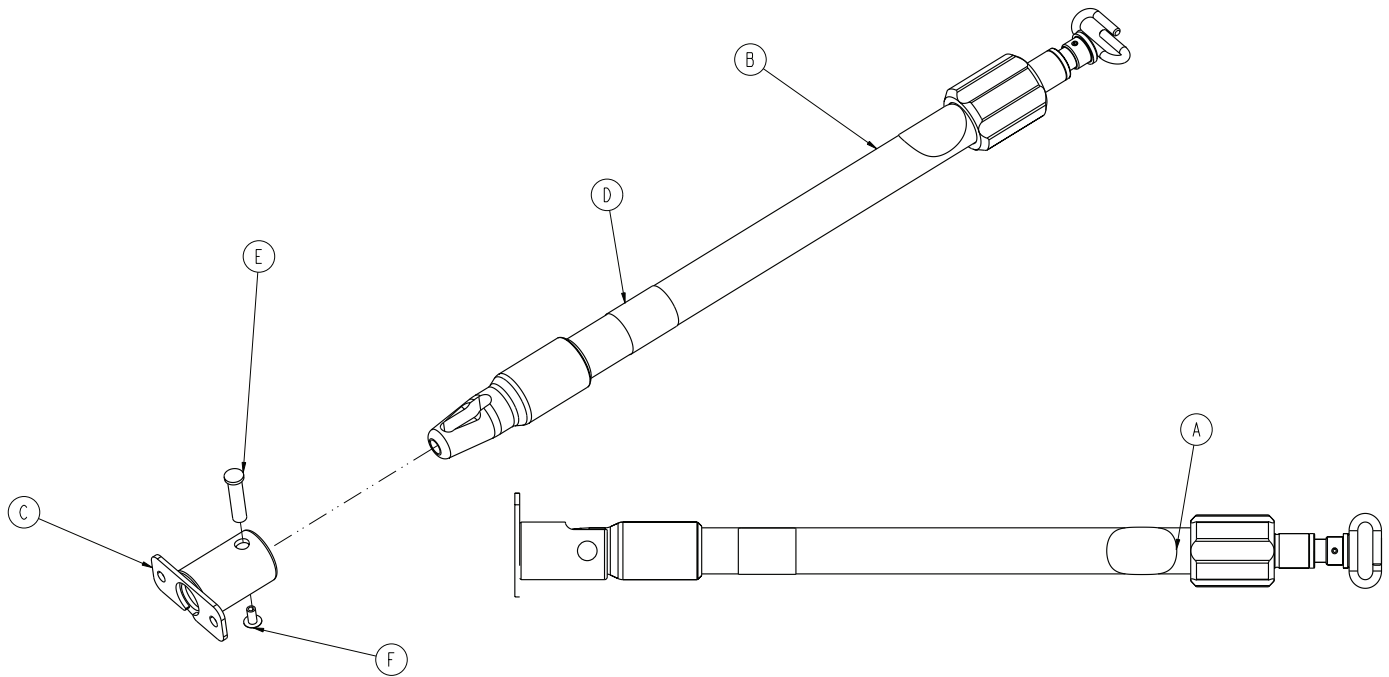
Rev A (Reference only)



Item	Number	Name	Quantity
A	6100-115-060	IV pole clip	1
B	6500-101-044	HAVASU IV pole assembly, three-stage, left - 6500-101-044 (page 96)	1
C	6550-001-117	IV pole spacer plate	1
D	6550-001-118	IV clip spacer plate	1

HAVASU IV pole assembly, three-stage, left - 6500-101-044

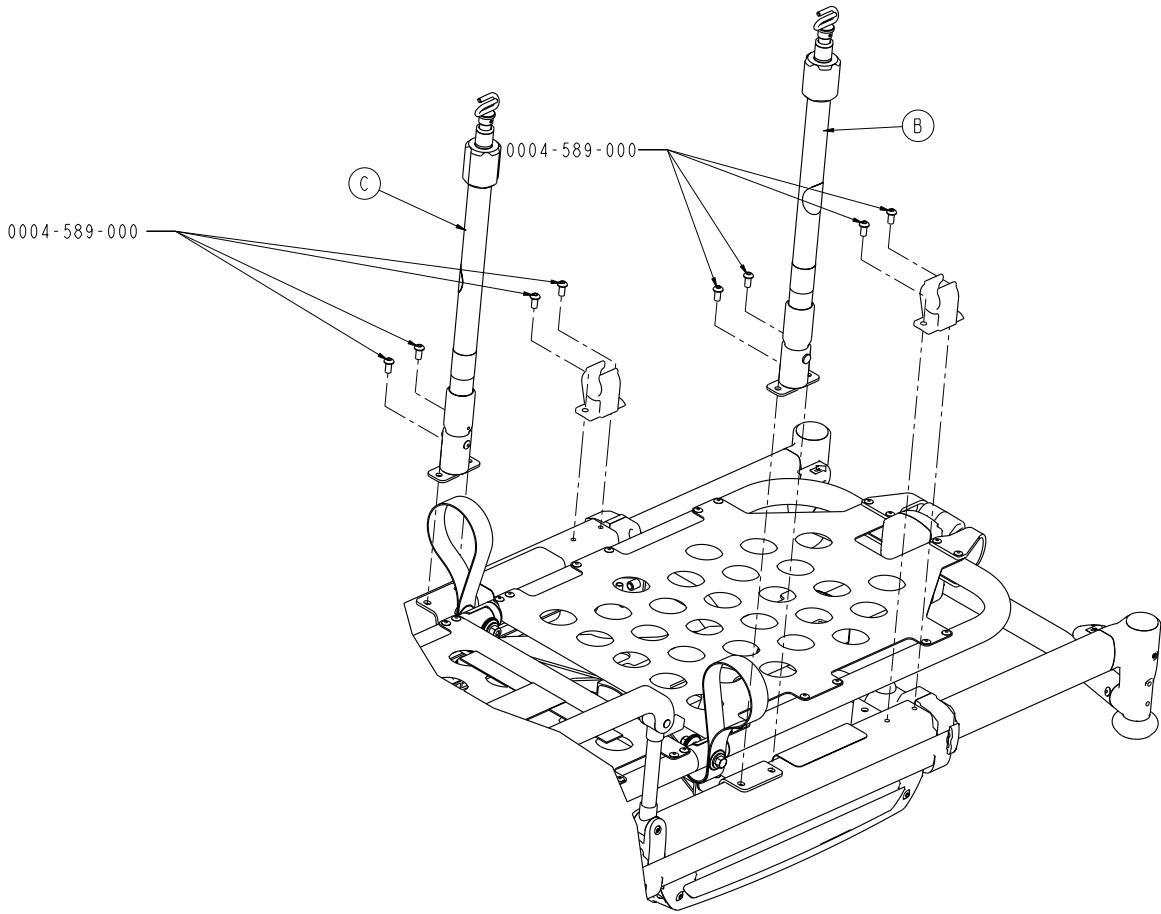
Rev AA (Reference only)



Item	Number	Name	Quantity
A	650600350901	Label, EAR	1
B	6070-215-070	Pole assembly	1
C	6100-115-051	Socket weldment	1
D	6500-101-256	Label, three-stage IV pole, left	1
E	6070-110-037	IV pivot pin	1
F	0025-079-000	Dome head pop rivet	1

Three-stage IV pole, dual - 6550-317-000

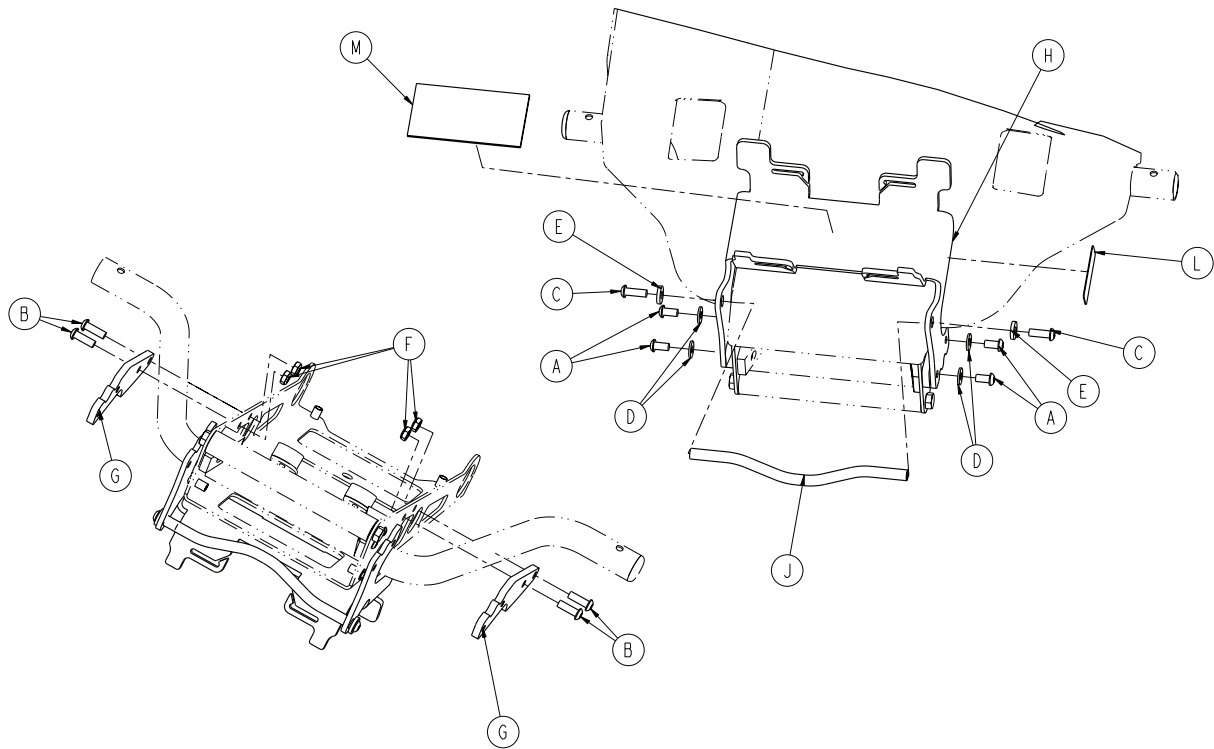
Rev A (Reference only)



Item	Number	Name	Quantity
A	6100-115-060	IV pole clip	2
B	6500-101-043	HAVASU IV pole assembly, three-stage, 1 right - 6500-101-043 (page 94)	
C	6550-101-044	HAVASU IV pole assembly, three-stage, 1 left - 6500-101-044 (page 96)	

Oxygen bottle holder

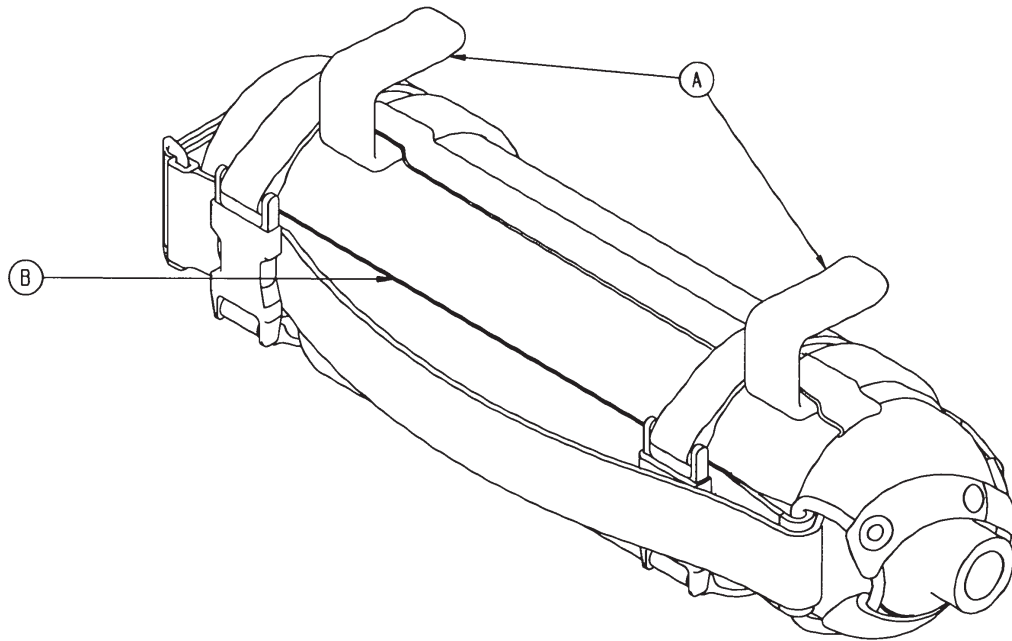
6550-102-020 Rev A (Reference only)



Item	Number	Name	Quantity
A	0004-589-000	Button head cap screw	4
B	0004-592-000	Button head cap screw	4
C	0004-593-000	Button head cap screw	2
D	0011-063-000	Washer	4
E	0011-209-000	Washer	2
F	0016-102-000	Nylock nut	4
G	6550-002-001	Oxygen bracket	2
H	6550-002-002	Oxygen tray	1
J	6550-002-003	Oxygen rod	1
K	6550-002-004	Oxygen bottle strap	1
L	6550-102-009	Label, oxygen bottle holder	1
M	6500-001-262	Neoprene pad	1

Removable oxygen bottle holder - 6080-140-000

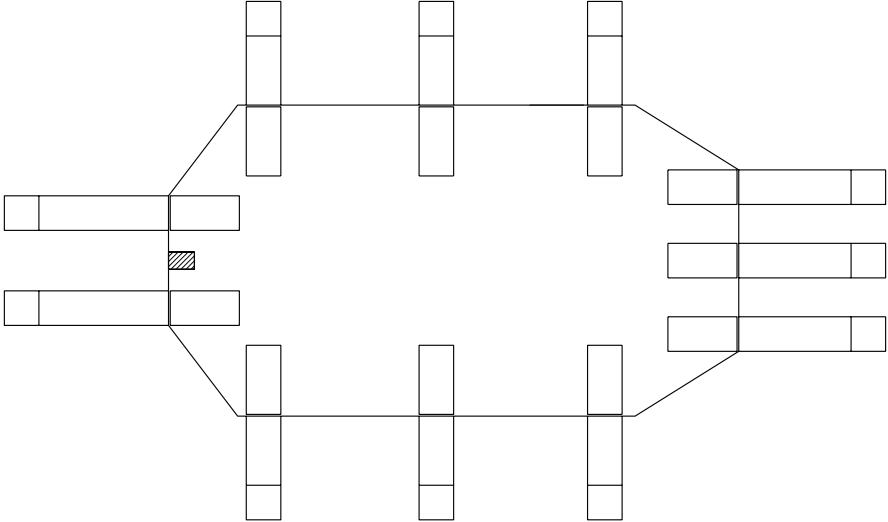
Rev A / 6080-140-010 Rev A (Reference only)



Item	Number	Name	Quantity
A	6080-140-011	Oxygen bottle holder hanger	2
B	6080-140-012	Oxygen bottle holder	1

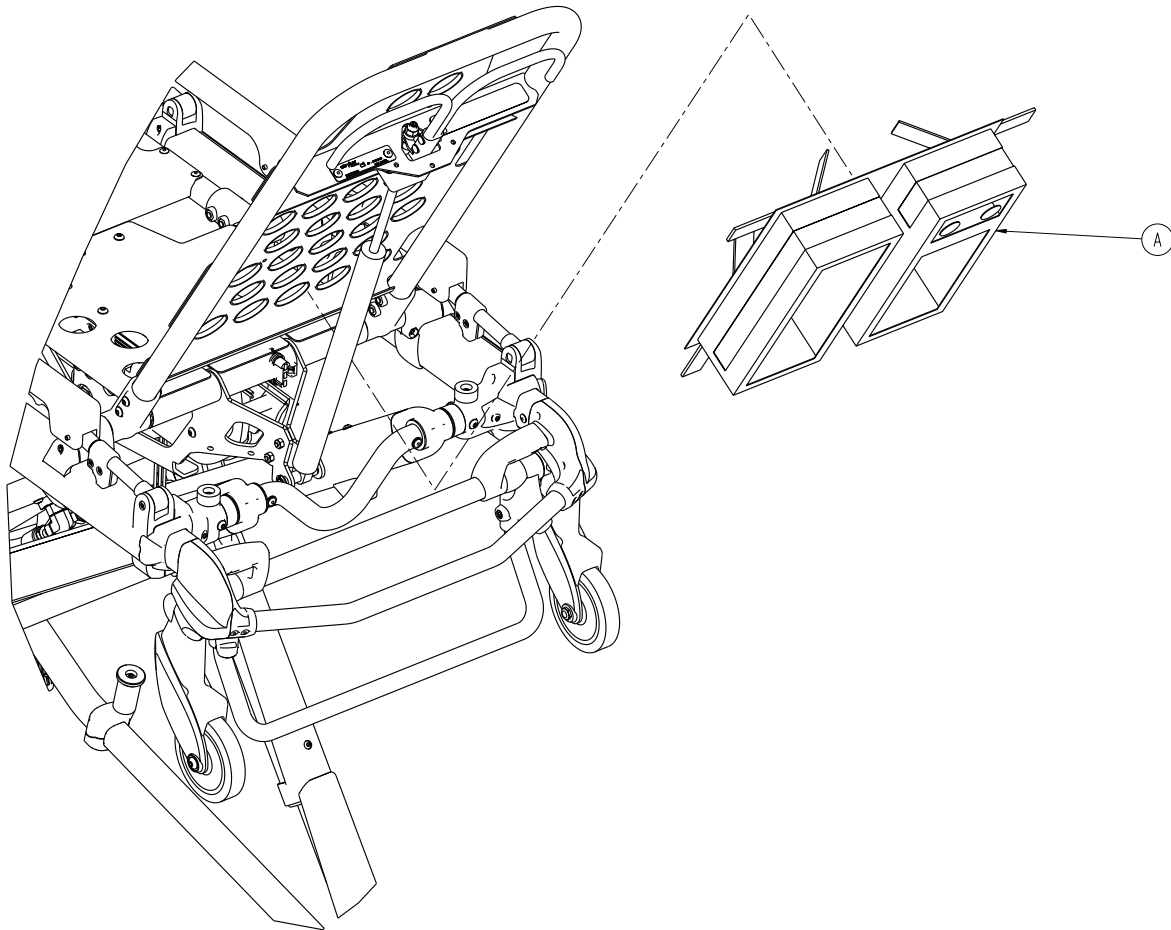
Base storage net - 6500-160-000

6500-001-126 Rev AA (Reference only)



Backrest pouch - 6500-130-000

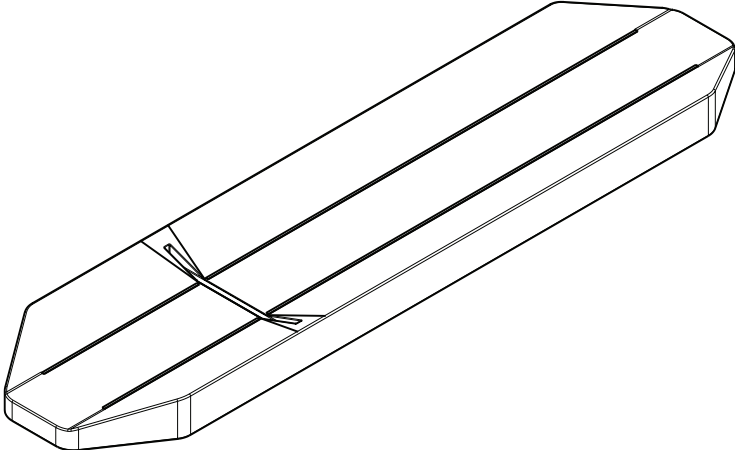
Rev A (Reference only)



Item	Number	Name	Quantity
A	6500-001-241	Pocketed backrest storage pouch	1

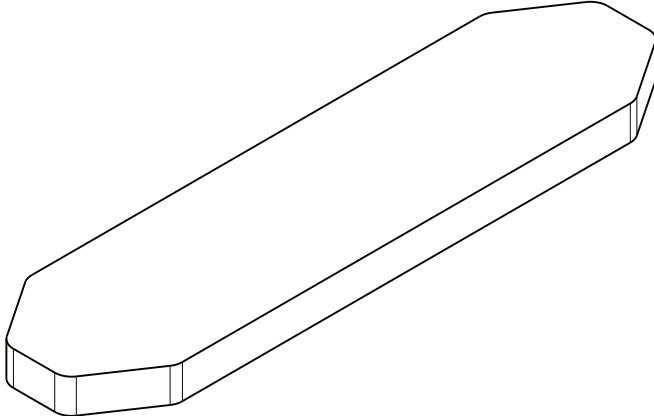
Knee Gatch bolster mattress - 6550-001-084

Rev AA (Reference only)



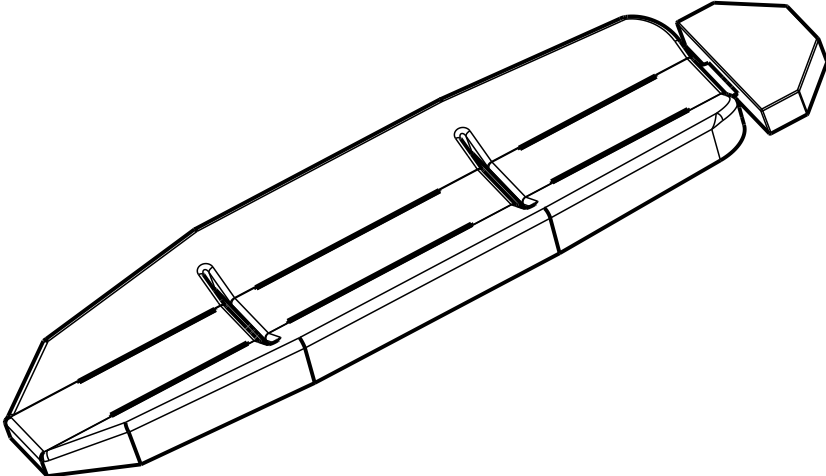
Flat knee Gatch mattress - 6550-001-295

Rev C (Reference only)



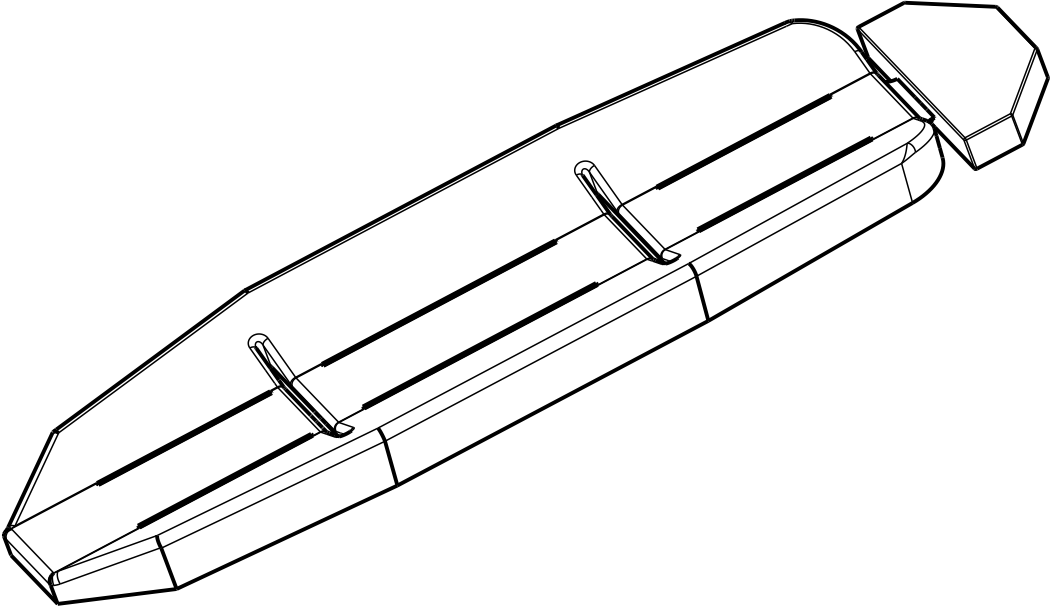
Knee Gatch bolster mattress, XPS - 6500-003-130

Rev AB (Reference only)



Knee Gatch bolster mattress grey, XPS - 6506-041-000

6506-003-130 Rev AB (Reference only)



EMC information

CAUTION

- The use of accessories, transducers, and cables, other than those specified or provided by the manufacturer, could result in increased electromagnetic emissions or decreased electromagnetic immunity and result in improper operation.
- The emissions characteristics of this equipment make it suitable for use in industrial areas and hospitals (CISPR 11 class A). If it is used in a residential environment, for which CISPR 11 class B is normally required, this equipment might not offer adequate protection to radio frequency communication services. The user might need to take mitigation measures, such as relocating or reorienting the equipment.

Guidance and manufacturer's declaration - electromagnetic emissions

Power-PRO and **SMRT** charger are intended for use in the electromagnetic environment specified below. The customer or the user of **Power-PRO** and **SMRT** charger should assure that they are used in such an environment.

Emissions test	Compliance	Electromagnetic environment
RF Emissions CISPR 11	Group 1	Power-PRO and SMRT charger use RF energy only for its internal function. Therefore, its RF emissions are very low and are not likely to cause any interference in nearby electronic equipment.
RF Emissions CISPR 11	Power-PRO : Class A	Power-PRO is suitable for use in all establishments other than domestic and those directly connected to the public low-voltage power supply network that supplies buildings used for domestic purposes.
	SMRT charger (6500-201-010): Class B	The SMRT charger is suitable for use in all establishments, including domestic establishments and those directly connected to the public low-voltage power supply network that supplies buildings used for domestic purposes.
Harmonic Emissions IEC 61000-3-2	Power-PRO : N/A SMRT charger (6500-201-010): Class A	The SMRT charger is suitable for use in all establishments, including domestic establishments and those directly connected to the public low-voltage power supply network that supplies buildings used for domestic purposes.
Voltage Fluctuations Flicker Emissions IEC 61000-3-3	Power-PRO : N/A SMRT charger (6500-201-010): complies	The SMRT charger is suitable for use in all establishments, including domestic establishments and those directly connected to the public low-voltage power supply network that supplies buildings used for domestic purposes.

CAUTION

- Portable RF communications equipment, including peripherals such as antenna cables and external antennas, should be used no closer than 12 inches (30 cm) to any part of **Power-PRO** and **SMRT** charger, including cables specified by the manufacturer.
- Avoid stacking or placing other equipment adjacent to **Power-PRO** and **SMRT** charger to prevent improper operation of the products. If such use is necessary, carefully observe **Power-PRO** and **SMRT** charger and the other equipment to make sure that they are operating properly.

Recommended separations distances between portable and mobile RF communications equipment and Power-PRO and SMRT charger

Power-PRO and **SMRT** charger are intended for use in an electromagnetic environment in which radiated RF disturbances are controlled. The customer or the user of **Power-PRO** and **SMRT** charger can help prevent electromagnetic interferences by maintaining a minimum distance between portable and mobile RF communications equipment (transmitters) and **Power-PRO** and **SMRT** charger as recommended below, according to the maximum output power of the communications equipment.

Rated maximum output power of transmitter W	Separation distance according to frequency of transmitter m		
	150 kHz to 80 MHz $D=(1.2) (\sqrt{P})$	80 MHz to 800 MHz $D=(0.35) (\sqrt{P})$	800 MHz to 2.7 GHz $D=(0.70) (\sqrt{P})$
0.01	0.12	0.04	0.07
0.1	0.38	0.11	0.22
1	1.20	0.35	0.70
10	3.79	1.11	2.21
100	12	3.50	7

For transmitters rated at a maximum output power not listed above, the recommended separation distance d in meters (m) can be estimated using the equation applicable to the frequency of the transmitter, where P is the maximum output power rating of the transmitter in watts (W) according to the transmitter manufacturer. Note 1: At 80 MHz and 800 MHz, the separation distance for the higher frequency range applies. Note 2: These guidelines may not apply in all situations. Electromagnetic propagation is affected by absorption and reflection from structures, objects, and people.

Guidance and manufacturer's declaration - electromagnetic immunity

Power-PRO and **SMRT** charger are suitable for use in the electromagnetic environment specified below. The customer or the user of **Power-PRO** and **SMRT** charger should assure that they are used in such an environment.


Immunity test	IEC 60601 test level	Compliance level	Electromagnetic environment-guidance
Electrostatic discharge (ESD) IEC 61000-4-2	± 8 kV contact ± 15 kV air	± 8 kV contact ± 15 kV air	Floors should be wood, concrete or ceramic tile. If floors are covered with synthetic material, the relative humidity should be at least 30%.
Electrostatic fast Transient/ burst IEC 61000-4-4	± 2 kV for power supply lines ± 1 kV for input/output lines	Power-PRO: N/A SMRT Charger (6500-201-010): ± 2 kV for power supply lines ± 1 kV for input/output lines	Mains power quality should be that of a typical commercial or hospital environment.

Guidance and manufacturer's declaration - electromagnetic immunity

<p>Surge IEC 61000-4-5</p>	<p>± 1 kV line(s) to line(s) ± 2 kV line(s) to earth</p>	<p>Power-PRO: N/A SMRT Charger (6500-201-010): ± 1 kV line(s) to line(s) ± 2 kV line(s) to earth</p>	<p>Mains power quality should be that of a typical commercial or hospital environment.</p>
<p>Voltage dips, voltage variations and short interruptions on power supply input lines IEC 61000-4-11</p>	<p>0% U_T for 0.5 cycle at 0°, 45°, 90°, 135°, 180°, 225°, 270°, and 315° 0% U_T for 1 cycle 70% U_T (30% dip in U_T) for 25 cycles 0% U_T for 250 cycles</p>	<p>Power-PRO: N/A SMRT charger (6500-201-010): 0% U_T for 0.5 cycle at 0°, 45°, 90°, 135°, 180°, 225°, 270°, and 315° 0% U_T for 1 cycle 70% U_T (30% dip in U_T) for 25 cycles 0% U_T for 250 cycles</p>	<p>Mains power quality should be that of a typical commercial or hospital environment. If the user of the SMRT charger requires continued operation during power main interruptions, it is recommended that the device be powered from an uninterrupted power supply or a battery.</p>
<p>Power frequency (50/60Hz) magnetic field IEC 61000-4-8</p>	<p>30 A/m</p>	<p>30 A/m</p>	<p>Power frequency magnetic fields should be at levels characteristic of a typical location in a typical commercial or hospital environment.</p>
<p>Electrical transient conduction along supply lines ISO 7637-2</p>	<p>per ISO 7637-2</p>	<p>Power-PRO: N/A SMRT Charger (6500-201-010): per ISO 7637-2</p>	<p>N/A</p>

Note: U_T is the a.c. mains voltage before applications of the test level.

Guidance and manufacturer's declaration - electromagnetic immunity

<p>Conducted RF IEC 61000-4-6</p> <p>Radiated RF IEC 61000-4-3</p>	<p align="center">3 Vrms</p> <p>6 Vrms in ISM and amateur radio bands 150kHz to 80MHz</p> <p align="center">10 V/m</p> <p>80 MHz to 2.7 GHz</p>	<p align="center">3 V</p> <p>6 Vrms in ISM and amateur radio bands</p> <p align="center">10 V/m</p>	<p>Portable and mobile RF communications equipment should be used no closer to any part of Power-PRO or SMRT charger, including cables, than the recommended separation distance calculated from the equation appropriate for the frequency of the transmitter.</p> <p>Recommended separation distance</p> <p>$D=(1.2) (\sqrt{P})$</p> <p>$D=(.35) (\sqrt{P})$</p> <p>80 MHz to 800 MHz</p> <p>$D=(0.70) (\sqrt{P})$</p> <p>800 MHz to 2.7 GHz</p> <p>where <i>P</i> is the maximum output power rating of the transmitter in watts (W) according to the transmitter manufacturer and <i>d</i> is the recommended separation distance in meters (m).</p> <p>Field strengths from fixed RF transmitters, as determined by an electromagnetic site ^a should be less than the compliance level in each frequency range.^b</p> <p>Interference may occur in the vicinity of equipment marked with the following symbol:</p> 
--	---	---	---

Note 1: At 80 MHz and 800 MHz, the higher frequency range applies.

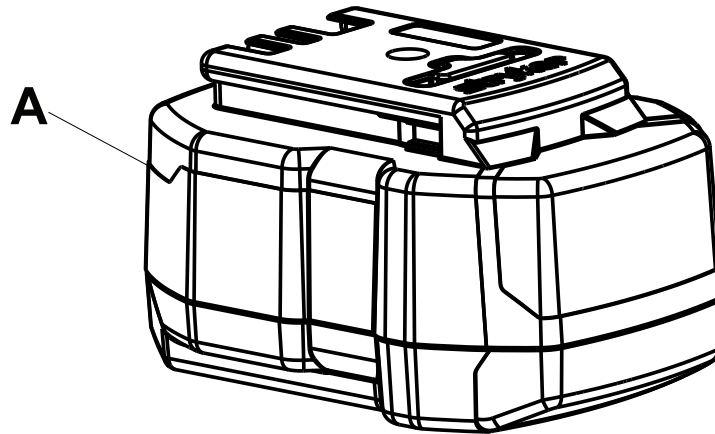
Note 2: These guidelines may not apply in all situations. Electromagnetic propagation is affected by absorption and reflection from structures, objects, and people.

Note 3: The ISM (industrial, scientific and medical) bands between 0.15 MHz and 80 MHz are 6.765 MHz to 6.795 MHz; 13.553 MHz to 13.567 MHz; 26.957 MHz to 27.283 MHz; and 40.66 MHz to 40.70 MHz. The amateur radio bands between 0.15 MHz and 80 MHz are 1.8 MHz to 2.0 MHz, 3.5 MHz to 4.0 MHz, 5.3 MHz to 5.4 MHz, 7 MHz to 7.3 MHz, 10.1 MHz to 10.15 MHz, 14 MHz to 14.2 MHz, 18.07 MHz to 18.17 MHz, 21.0 MHz to 21.4 MHz, 24.89 MHz to 24.99 MHz, 28.0 MHz to 29.7 MHz and 50.0 MHz to 54.0 MHz.

Recycling passport

6500-101-010

Rev AB



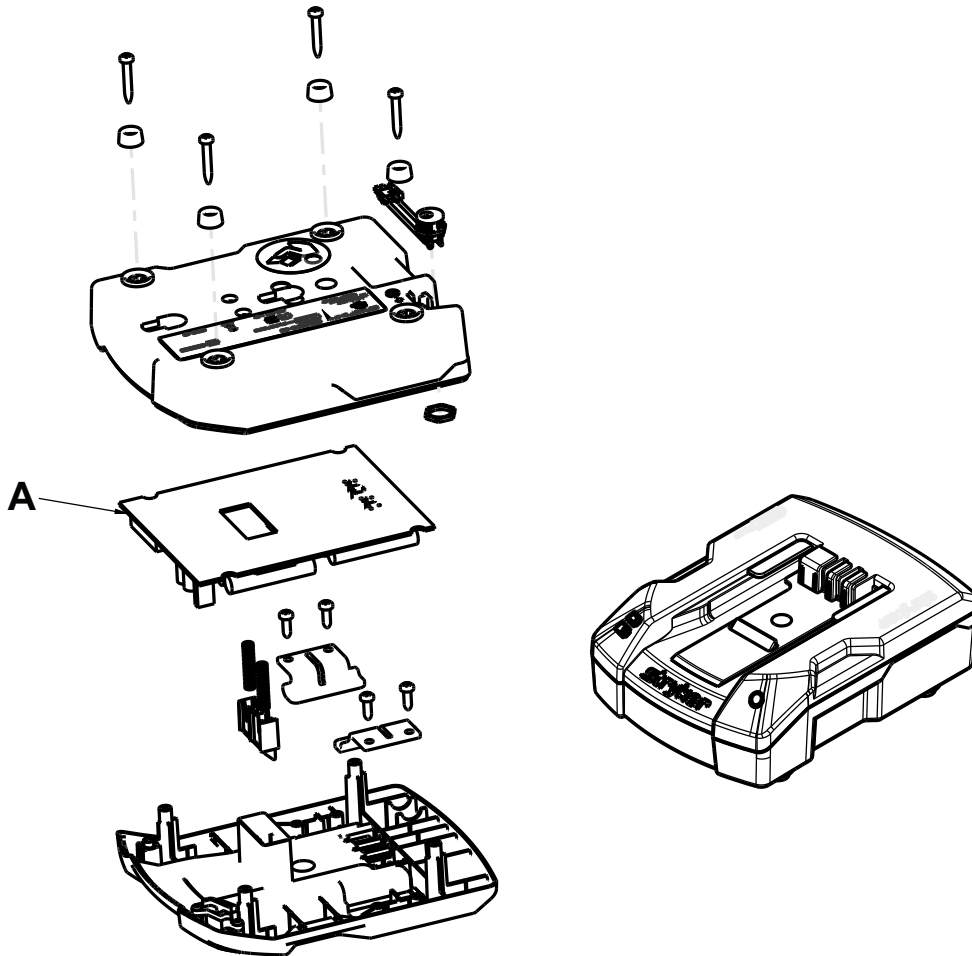
Item	Recyclable part number	Material code	Important information	Quantity
A	6500-101-010	NiCd		2



The Rechargeable Battery Recycling Corporation (RBRC) is a non-profit, public service organization that promotes the recycling of portable rechargeable batteries. Batteries must be delivered to a battery collection site. Visit the RBRC website (www.rbcc.org) to find a nearby collection site or call the phone number shown on the recycling symbol.

6500-201-010

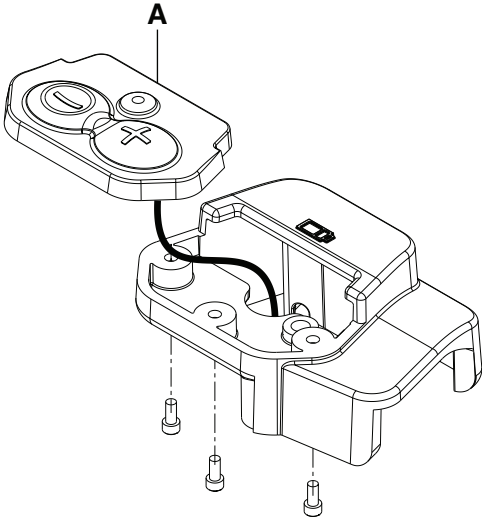
Rev AA



Item	Recyclable part number	Material code	Important information	Quantity
A	6500-201-140	Charger PCB		1

6550-101-036

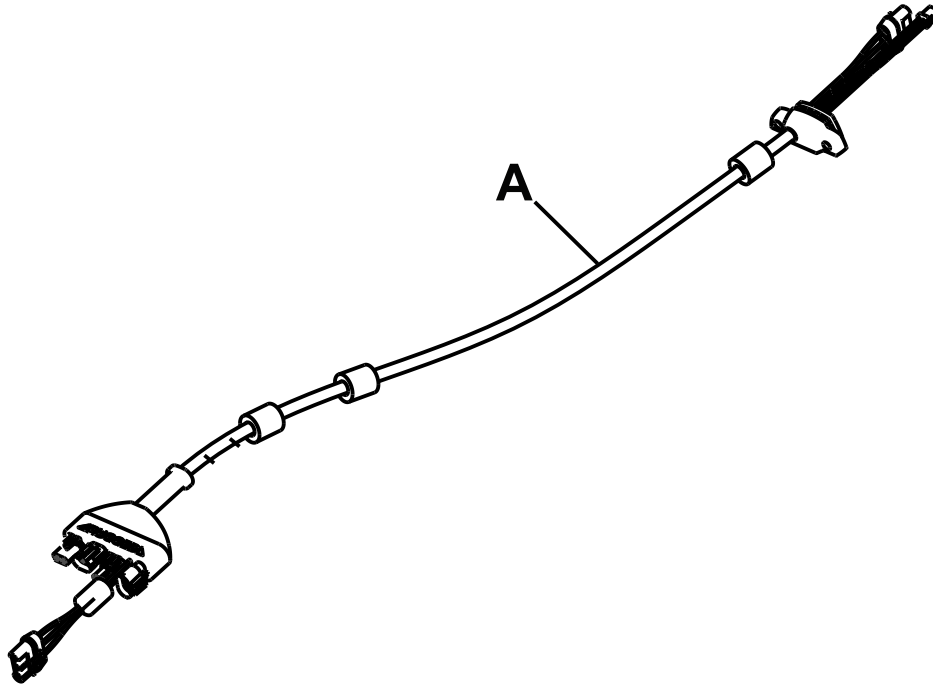
Rev C



Item	Recyclable part number	Important information	Quantity
A	6550-101-152		1

6550-001-172

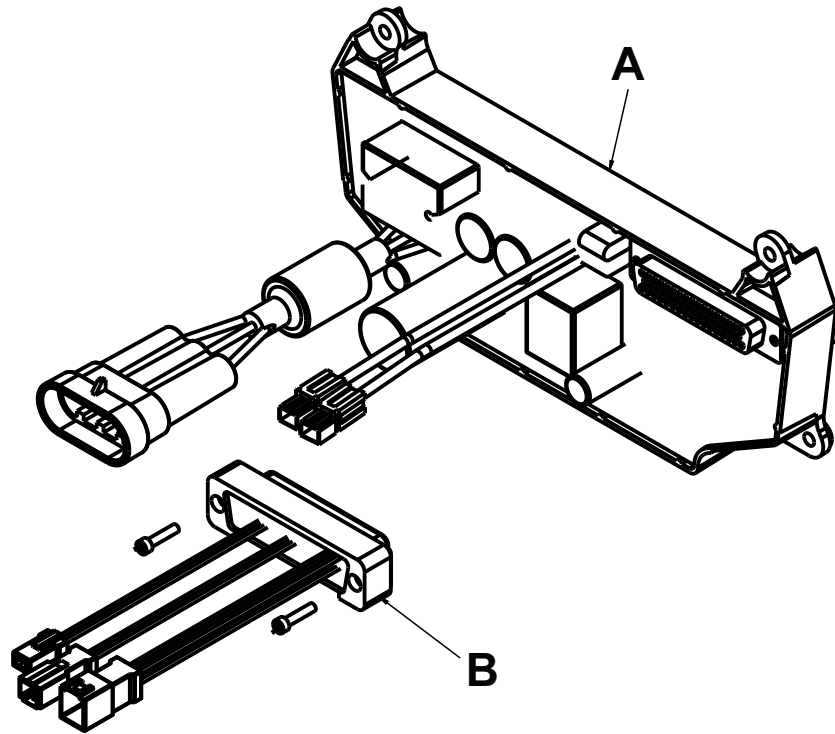
Rev AA



Item	Recyclable part number	Important information	Quantity
A	6550-001-172		1

6550-101-014

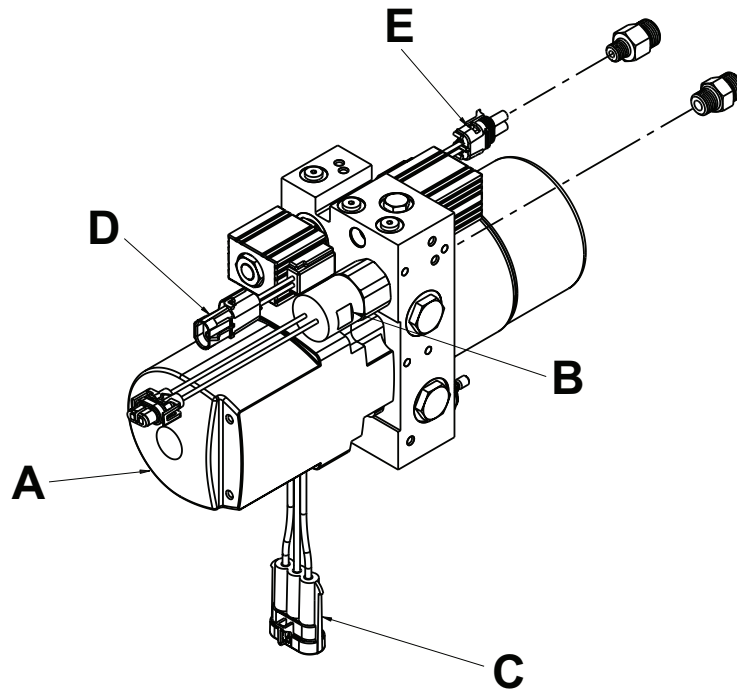
Rev B



Item	Recyclable part number	Important information	Quantity
A	6550-101-014		1
B	6550-002-103		1

6500-001-214

Rev N

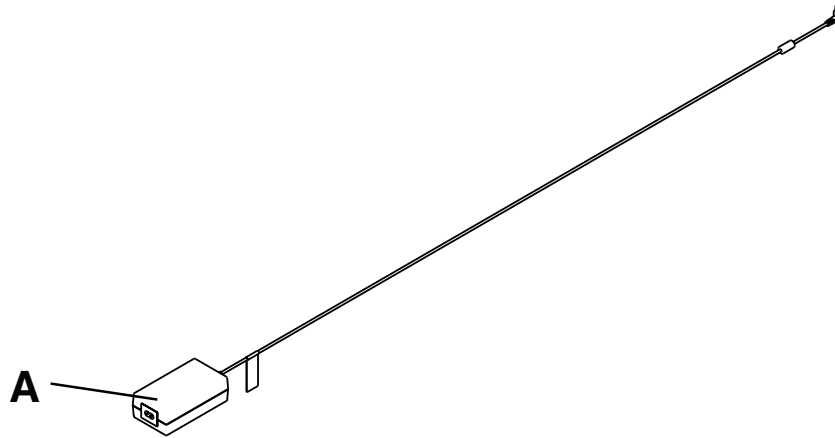


Item	Recyclable part number	Material code	Important information	Quantity
A	413768	Motor	Contains automatic transmission fluid*	1
B	6500-001-290	External electrical cable		1
C	12264	External electrical cable		1
D	12010973	External electrical cable		1
E	12015792	External electrical cable		1

*Mobil Mercon V Synthetic blend or equivalent

6500-201-148

Rev AA



Item	Recyclable part number	Material code	Important information	Quantity
A	6500-201-248	Power supply		1

stryker



Stryker Medical
3800 E. Centre Avenue
Portage, MI 49002
USA