

Power-LOAD™  
Cot Fastener System

REF 6390

# stryker®















## Operations/Maintenance Manual





CE



# Symbols

	Refer to instruction manual/booklet
	Operating instructions
	CE Mark
	Manufacturer
	Safe working load
	Class II electrical equipment: equipment in which protection against electric shock does not rely on basic insulation only, but in which additional safety precautions such as double insulation or reinforced insulation are provided, there being no provision for protective earthing or reliance upon installation conditions.
	Direct current
	General warning sign
	Caution
	Warning; Crushing of hands
	Warning; non-ionizing radiation
	Medical Equipment Recognized by Underwriters Laboratories LLC With Respect to Electric Shock, Fire, and Mechanical Hazards only in accordance with ANSI/AAMI ES60601-1: 2005 and CAN/CSA-C22.2 No. 60601-1:08.
<b>IPX6</b>	Protection from powerful water jets
	The Rechargeable Battery Recycling Corporation (RBRC) is a non-profit, public service organization that promotes the recycling of portable rechargeable batteries. Batteries must be delivered to a battery collection site. Visit the RBRC website ( <a href="http://www.rbrc.org">www.rbrc.org</a> ) to find a nearby collection site or call the phone number shown on the recycling symbol.
	In accordance with European Directive 2002/96/EC on Waste Electrical and Electronic Equipment, this symbol indicates that the product must not be disposed of as unsorted municipal waste, but should be collected separately. Refer to your local distributor for return and/or collection systems available in your country.

# Symbols

	This device complies with Part 18 of the FCC Rules
 or <b>THIS SIDE UP</b>	This way up  <b>Note:</b> "THIS SIDE UP" verbiage is provided for the domestic market and is duplicate information as the international symbol is also provided.

# Table of Contents

---

Symbols . . . . .	<a href="#">3</a>
Definitions . . . . .	<a href="#">8</a>
Warning/Caution/Note Definition . . . . .	<a href="#">8</a>
Introduction . . . . .	<a href="#">9</a>
Product Description . . . . .	<a href="#">9</a>
Intended Use of Product. . . . .	<a href="#">9</a>
Product Illustration . . . . .	<a href="#">10</a>
Important Contact Information . . . . .	<a href="#">11</a>
Stryker Contact Information . . . . .	<a href="#">11</a>
Serial Number Location . . . . .	<a href="#">11</a>
Specifications . . . . .	<a href="#">12</a>
Summary of Safety Precautions . . . . .	<a href="#">14</a>
Pinch Points . . . . .	<a href="#">17</a>
Cot Compatibility Information . . . . .	<a href="#">18</a>
Installation Set Up Procedures . . . . .	<a href="#">19</a>
Floor Plate Assembly Installation Component Checklist. . . . .	<a href="#">19</a>
Power-LOAD Assembly Installation Component Checklist . . . . .	<a href="#">20</a>
Optional Wheel Guide Assembly Installation Component Checklist . . . . .	<a href="#">21</a>
Quality System Regulation for Installation . . . . .	<a href="#">22</a>
Quality System Regulation . . . . .	<a href="#">22</a>
Floor Plate Installation Guidelines . . . . .	<a href="#">23</a>
Installation Guide . . . . .	<a href="#">25</a>
Installing the Floor Plate. . . . .	<a href="#">25</a>
Installing the Power-LOAD System . . . . .	<a href="#">31</a>
Installing The Optional Wheel Guide. . . . .	<a href="#">41</a>
Installing Cot Wheel Covers . . . . .	<a href="#">45</a>
Power-LOAD Installation Checklist . . . . .	<a href="#">46</a>
User Set Up Procedures . . . . .	<a href="#">48</a>
User Controls and LED Indicators . . . . .	<a href="#">49</a>
Manual User Controls. . . . .	<a href="#">51</a>
Power-PRO Cot User Controls. . . . .	<a href="#">52</a>
Using the Cot Control Switches . . . . .	<a href="#">52</a>
Checking the Cot Battery Power Level . . . . .	<a href="#">53</a>
Powered Operations Instructions. . . . .	<a href="#">54</a>
Manual Operations Instructions. . . . .	<a href="#">55</a>
Operation Guide. . . . .	<a href="#">56</a>
Operating Guidelines . . . . .	<a href="#">56</a>
Checking the Battery Power Level . . . . .	<a href="#">57</a>
Charging the Battery . . . . .	<a href="#">57</a>
Storing Power-LOAD . . . . .	<a href="#">57</a>
Setting the Cot Load Height . . . . .	<a href="#">57</a>
Using a Non-Upgraded X-Frame Cot for a Mass Casualty Incident . . . . .	<a href="#">58</a>
Extending Power-LOAD from the Vehicle without a Cot . . . . .	<a href="#">58</a>
Loading a Performance-PRO Cot into a Vehicle (Model 6085/6086 with the Power-LOAD Option) . . . . .	<a href="#">59</a>
Unloading a Performance-PRO Cot from a Vehicle (Model 6085/6086 with the Power-LOAD Option) . . . . .	<a href="#">61</a>

# Table of Contents

---

Loading a Power-PRO Cot into a Vehicle (Model 6500/6506 & 6510/6516 with the Power-LOAD Option) . . . . .	<a href="#">63</a>
Unloading a Power-PRO Cot from a Vehicle (Model 6500/6506 & 6510/6516 with the Power-LOAD Option) . . .	<a href="#">65</a>
Unloading a Cot From a Vehicle Manually after loading with Power-LOAD (Power-LOAD Power Loss or System Error). . . . .	<a href="#">67</a>
Loading a Cot into a Vehicle Manually (Power-LOAD Power Loss or System Error) . . . . .	<a href="#">69</a>
Unloading a Cot from a Vehicle Manually . . . . .	<a href="#">70</a>
Removing a Cot from a Vehicle for Repair . . . . .	<a href="#">71</a>
Loading a Cot into a Vehicle Manually (Power-PRO Power Loss). . . . .	<a href="#">72</a>
Cleaning. . . . .	<a href="#">74</a>
Cleaning Procedure . . . . .	<a href="#">74</a>
Cleaning Limitations. . . . .	<a href="#">74</a>
Removal of Iodine Compounds . . . . .	<a href="#">75</a>
Preventative Maintenance. . . . .	<a href="#">76</a>
Regular Inspection and Adjustments . . . . .	<a href="#">76</a>
Maintenance Record. . . . .	<a href="#">78</a>
Quick Reference Replacement Parts List . . . . .	<a href="#">79</a>
Transfer Service Information . . . . .	<a href="#">81</a>
Transfer Removal. . . . .	<a href="#">81</a>
Trolley Service Information . . . . .	<a href="#">82</a>
Trolley Removal . . . . .	<a href="#">82</a>
Cover Removal and Replacement. . . . .	<a href="#">84</a>
Manual Release Button Assembly Removal and Replacement. . . . .	<a href="#">85</a>
Control Board Assembly Removal and Replacement . . . . .	<a href="#">86</a>
Master On/Off Switch Replacement . . . . .	<a href="#">87</a>
Trolley Actuator Assembly Replacement . . . . .	<a href="#">88</a>
Hydraulic Assembly Removal and Replacement . . . . .	<a href="#">89</a>
Hydraulic Cylinder Rod End Replacement . . . . .	<a href="#">91</a>
Communication Board Replacement. . . . .	<a href="#">92</a>
Inductive Coil Replacement . . . . .	<a href="#">93</a>
Trolley Position Sensor (TPS) Replacement . . . . .	<a href="#">94</a>
Flat Roller and V-Guide Roller Replacement . . . . .	<a href="#">95</a>
Hydraulic Cylinder Removal and Replacement . . . . .	<a href="#">96</a>
Velocity Fuse Removal and Replacement . . . . .	<a href="#">98</a>
Non-Locking Manual Valve Removal and Replacement . . . . .	<a href="#">99</a>
Hose Removal and Replacement . . . . .	<a href="#">100</a>
Pump/Motor Assembly Replacement. . . . .	<a href="#">101</a>
Motor Cable Removal and Replacement . . . . .	<a href="#">102</a>
Motor Replacement . . . . .	<a href="#">103</a>
Pressure Compensated Flow Control Valve Replacement . . . . .	<a href="#">104</a>
Battery Replacement . . . . .	<a href="#">105</a>
Filling the Reservoir . . . . .	<a href="#">105</a>
Anchor Service Information. . . . .	<a href="#">106</a>
Primary Coil Replacement, Foot End . . . . .	<a href="#">106</a>
Primary Coil Replacement, Head End . . . . .	<a href="#">109</a>
Transfer Lock Bearing Removal and Replacement . . . . .	<a href="#">111</a>

# Table of Contents

---

Troubleshooting Guide . . . . .	<a href="#">112</a>
Power-LOAD Assembly . . . . .	<a href="#">124</a>
Assembly Kit, Floor Plate - 6390-001-055 . . . . .	<a href="#">127</a>
Assembly Kit, Power-LOAD - 6390-001-054 . . . . .	<a href="#">128</a>
Anchor Assembly . . . . .	<a href="#">129</a>
Anchor Pawl Assembly, Head End . . . . .	<a href="#">132</a>
Anchor Plunger Assembly, Middle . . . . .	<a href="#">136</a>
Transfer Assembly . . . . .	<a href="#">137</a>
Foot End Fastener Assembly. . . . .	<a href="#">143</a>
Foot End Fastener Assembly. . . . .	<a href="#">144</a>
Transfer Trolley Lock Assembly. . . . .	<a href="#">145</a>
Trolley Assembly . . . . .	<a href="#">146</a>
Trolley Main Frame. . . . .	<a href="#">151</a>
Trolley/Transfer Interface Mechanism . . . . .	<a href="#">166</a>
Wing Assembly, Left . . . . .	<a href="#">167</a>
Hydraulics Assembly. . . . .	<a href="#">168</a>
Manifold Assembly . . . . .	<a href="#">169</a>
Trolley Manual Release Assembly. . . . .	<a href="#">170</a>
Trolley Arm Assembly . . . . .	<a href="#">172</a>
Arm, Left . . . . .	<a href="#">173</a>
Arm, Right . . . . .	<a href="#">174</a>
Trolley Actuator Assembly - 6390-001-028 . . . . .	<a href="#">175</a>
Optional Wheel Guide. . . . .	<a href="#">176</a>
Optional Wheel Guide Assembly - 6390-001-017 . . . . .	<a href="#">177</a>
EMC Information. . . . .	<a href="#">178</a>
Warranty . . . . .	<a href="#">181</a>
Stryker EMS Return Policy . . . . .	<a href="#">182</a>
Return Authorization. . . . .	<a href="#">182</a>
Damaged Merchandise . . . . .	<a href="#">182</a>
International Warranty Clause. . . . .	<a href="#">182</a>
Patent Information . . . . .	<a href="#">182</a>
Recycling Passport. . . . .	<a href="#">183</a>

# Definitions

---

## WARNING/CAUTION/NOTE DEFINITION

The words WARNING, CAUTION and Note carry special meanings and should be carefully reviewed.

---

### **WARNING**

Alerts the reader about a situation which, if not avoided, could result in death or serious injury. It may also describe potential serious adverse reactions and safety hazards.

---

### **CAUTION**

Alerts the reader of a potentially hazardous situation which, if not avoided, may result in minor or moderate injury to the user or patient or damage to the equipment or other property. This includes special care necessary for the safe and effective use of the device and the care necessary to avoid damage to a device that may occur as a result of use or misuse.

---

### **Note**

Provides special information to make maintenance easier or important instructions clearer.



# Introduction

---

This manual is designed to provide instructions for the operation and maintenance of the Stryker 6390 **Power-LOAD™**. Read it thoroughly before installing or using the equipment or beginning any maintenance on it.

## **PRODUCT DESCRIPTION**

The Stryker 6390 Power-LOAD is designed to assist the user in loading the cot into a vehicle, unloading the cot from the vehicle, and to restrict the movement of the cot as it is being transported in the vehicle patient compartment under normal conditions. Usage of this product in any other way becomes the complete responsibility of the owner/user. Caution must be used at all times during placement of the cot into the vehicle patient compartment.

## **INTENDED USE OF PRODUCT**

The Stryker 6390 Power-LOAD cot fastening system is intended to assist with loading and unloading of a compatible wheeled stretcher (ambulance cot) to and from a transport vehicle and to secure the ambulance cot during transport. The device has a maximum safe working load of 870 lb, which includes the weight of the ambulance cot, patient, and equipment attached to the cot (i.e. oxygen bottles, monitors, and/or pumps). The intended users of the device will be trained professionals, including emergency medical service and medical care center personnel, as well as medical first responders, service technicians and installers. The expected service life of the product is 7 years.

## **CONTRAINDICATIONS**

There are no known contraindications to use for this product.

# Introduction

## PRODUCT ILLUSTRATION

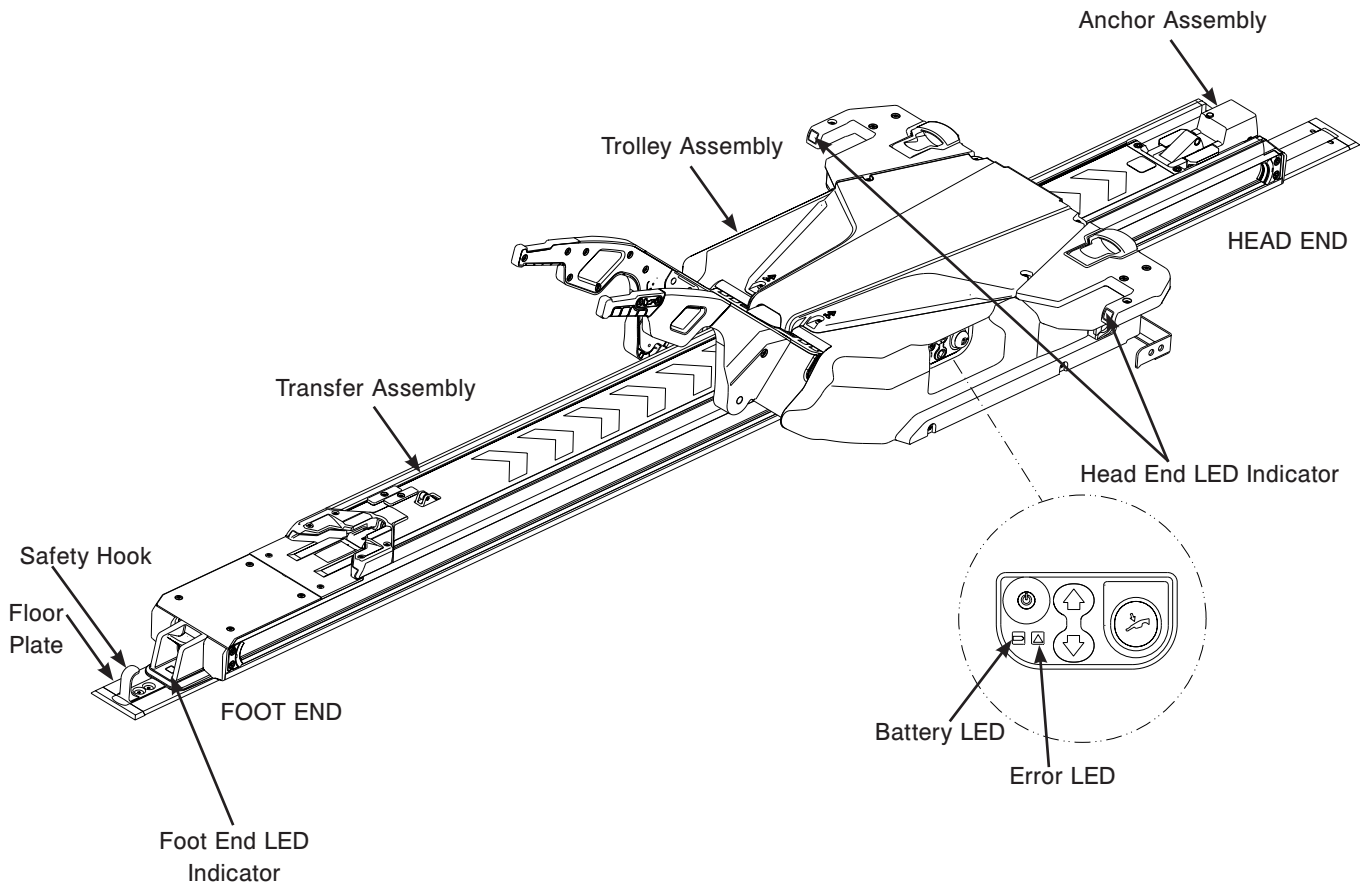

Figure 1: Product Illustration

# Introduction

## IMPORTANT CONTACT INFORMATION

For information about Federal Ambulance Specification KKK-A-1822F, contact:  
Chief, Automotive & Commodity Management Branch (QMDAA)  
Office of Motor Vehicle Management  
General Services Administration  
2200 Crystal Drive, Suite 1006  
Arlington, VA 22202  
Telephone: 703-605-2277

For more information about AMD standards, contact:  
Ambulance Manufacturers Division  
(National Truck Equipment Association)  
37400 Hills Tech Drive  
Farmington Hills, MI 48331-3414

## STRYKER CONTACT INFORMATION

Contact Stryker Customer Service or Technical Support at (800) 327-0770.  
Stryker Medical  
3800 E. Centre Avenue  
Portage, MI 49002  
USA

Please have the serial number (A) of your Stryker product available when calling Stryker Customer Service or Technical Support. Include the serial number in all written communication.

## SERIAL NUMBER LOCATION

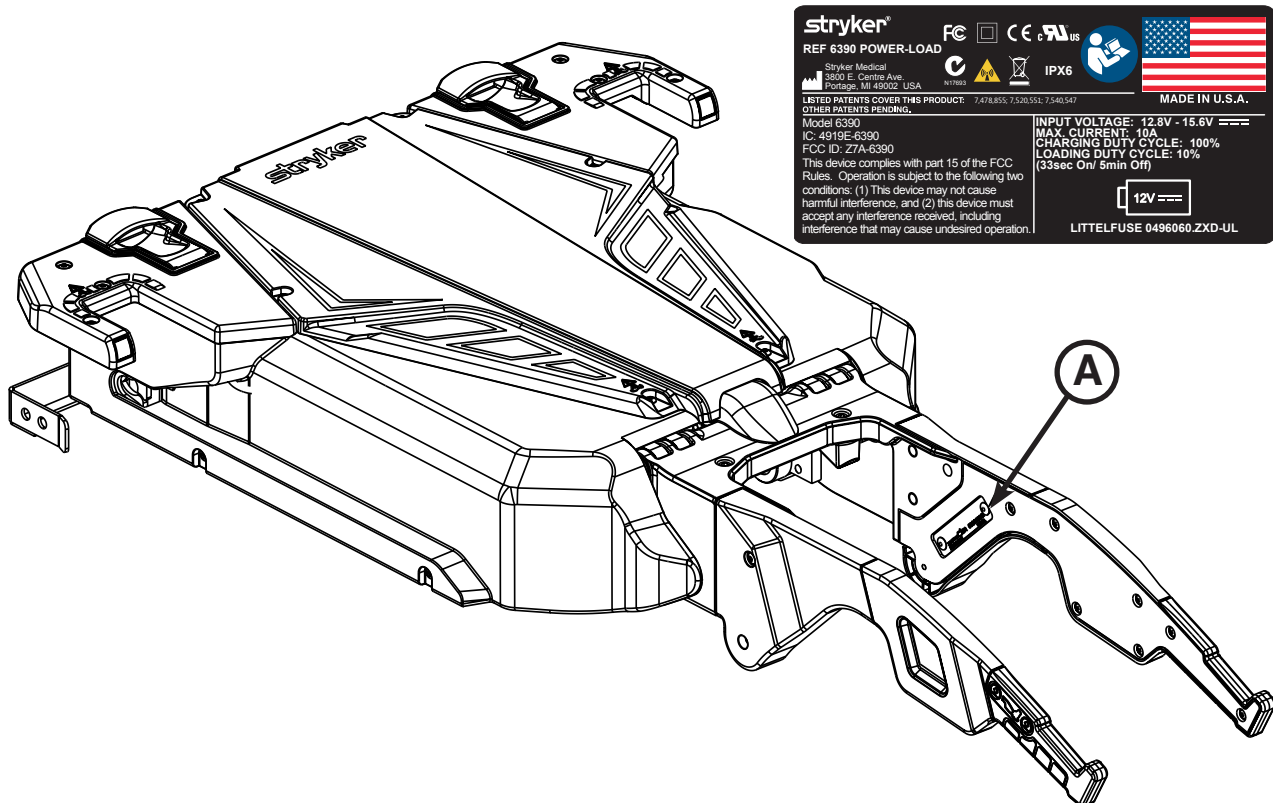



Figure 2: Serial Number Location

# Introduction

## SPECIFICATIONS

 Safe Working Load <b>Note:</b> Safe Working Load represents the sum of the cot total weight and patient	870 lb	395 kg
Maximum Lift Capacity (patient and accessories)	700 lb	318 kg
Overall Length/Minimum Length/Width	95 in / 85 in / 24.5 in	241 cm / 216 cm / 62 cm
Weight		
Floor Plate Assembly	16.5 lb	7.5 kg
Anchor Assembly	23 lb	10.5 kg
Transfer Assembly	67 lb	30.5 kg
Trolley Assembly	105 lb	48 kg
Minimum Operators Required for Loading/ Unloading an Occupied Cot	2	
Minimum Operators Required for Loading/ Unloading an Unoccupied Cot	1	
Recommended Loading Height	22 in to 36 in	56 cm to 91 cm
Hydraulic Oil	Mobil Mercon® V Blend ATF Oil (6500-001-293) <b>Note:</b> See the Mobil Mercon® V Blend ATF Oil material safety data sheet (MSDS) for safety information.	
Electrical Requirements	12.8V-15.6V $\overline{DC}$ , 15A fuse/breaker, 2 conductor 10 AWG cable	
Battery Duty Cycle, Charging	100%	
Battery Duty Cycle, Loading	10% (33 sec On / 5 min Off)	
Battery	12V $\overline{DC}$ , 5 Ah Lead Acid Battery (6390-001-468)	
Fuse	LITTELFUSE 0496060.ZXD-UL	
Standards	ANSI/AAMI ES60601-1 (2005, 3rd ed.) and CAN/CSA-C22.2 No. 60601-1 (2008) BS EN 1789:2007 AS/NZS 4535:1999 KKK-A-1822F	

Stryker reserves the right to change specifications without notice.

Patents pending.

**The yellow and black color scheme is a proprietary trademark of Stryker Corporation.**

Stryker hereby declares that this **Power-LOAD™** cot fastening system (model 6390) is in compliance with the essential requirements and other relevant provisions of Directive 1999/5/EC. A copy of the original declaration of conformity can be obtained by contacting Stryker Medical at 3800 E. Centre Ave. Portage, MI 49002 Attn. Regulatory Affairs.

### WARNING

- Do not operate Power-LOAD using a voltage inconsistent with the rating on the unit.
- To avoid the risk of equipment damage or smoke hazard, do not use Power-LOAD above its duty cycle.
- To ensure performance and prevent power hazards, connect Power-LOAD to a 12.8V-15.6V DC vehicle circuit that is on a 15A fuse/breaker. Do not connect Power-LOAD to a 24V DC vehicle circuit.
- Power-LOAD operates at 13.56 MHz when using Power-LOAD controls with a powered cot (Power-PRO XT or Power-PRO IT) that could interfere with other equipment that operate at this frequency band.
- To meet BS EN 1789:2007 and AS/NZS 4535:1999 crash-test standards with the use of a crash-rated fastener, such as Power-LOAD (Model 6390), you must install the EMS restraint package (6500-002-030) and knee gatch bolster mattress (6500-002-150) on your Power-LOAD compatible cot. Call Stryker Customer Service USA at 1-800-327-0770 for availability and pricing. Power-LOAD does not meet BS EN 1789:2007 or AS/NZS 4535:1999 crash-test standards for use with the Power-LOAD compatible model 6510 or 6516 Power-PRO IT cot and does not meet AS/NZS 4535:1999 crash test standards for use with the 6085 or 6086 Performance-PRO XT.

# Introduction

## SPECIFICATIONS (CONTINUED)

Environmental Conditions	Operation	Storage and Transportation
Temperature	<p>-30°F (-34°C) to 130°F (54°C)</p>	<p>-30°F (-34°C) to 158°F (70°C)</p>
Relative Humidity	<p>0% to 93%</p>	<p>0% to 93%</p>
Atmospheric Pressure	<p>700 to 1060 hPa</p>	<p>700 to 1060 hPa</p>

### CAUTION

- Changes or modifications to the Power-LOAD system not expressly approved by Stryker could void the user's authority to operate the system.
- This equipment has been tested and found to comply with the limits for a Class A digital device, pursuant to part 15 of the FCC Rules. These limits are designed to provide reasonable protection against harmful interference when the equipment is operated in a commercial environment. This equipment generates, uses, and can radiate radio frequency energy and, if not installed and used in accordance with the instruction manual, may cause harmful interference to radio communications. Operation of this equipment in a residential area is likely to cause harmful interference in which case the user will be required to correct the interference at their expense. In the event of interference, please relocate or reorient the Power-LOAD system or interfering product.
- This device complies with Part 18 of the FCC Rules. In the event of interference, relocate or reorient the Power-LOAD system or interfering product.

### Notes:

- This device is compliant to European Directive 2002/95/EC Restriction of Hazardous Substances (RoHS) as it does not contain any of the restricted substances in excess of the acceptable threshold in electrical and electronic equipment.
- This device is considered an "article" as defined in Article 3(3) of the European Registration, Evaluation, Authorization and restriction of Chemicals (REACH) Regulation (EC) 1907/2006, and it does not release substances under its normal use. Suppliers of articles are not required to register with the European Chemicals Agency (ECHA), but must provide recipients with information on Substances of Very High Concern (SVHC) if those are present above a concentration limit of 0.1 % weight on an article level. Based on a diligent review of information provided by our suppliers, this device does not contain above 0.1% weight (w/w) threshold of any (SVHC) as listed by the ECHA as of the 30MAR2010 release. Stryker will continue to monitor REACH regulations for any SVHC that may be included in subsequent ECHA candidate lists and will communicate this information to customers.

# Summary of Safety Precautions

---

Carefully read and strictly follow the warnings and cautions listed on this page. Service only by qualified personnel.

---

## WARNING

- Do not operate Power-LOAD using a voltage inconsistent with the rating on the unit.
- To avoid the risk of equipment damage or smoke hazard, do not use Power-LOAD above its duty cycle.
- To ensure performance and prevent power hazards, connect Power-LOAD to a 12.8V-15.6V DC vehicle circuit that is on a 15A fuse/breaker. Do not connect Power-LOAD to a 24V DC vehicle circuit.
- Power-LOAD operates at 13.56 MHz when using Power-LOAD controls with a powered cot (Power-PRO XT or Power-PRO IT) that could interfere with other equipment that operate at this frequency band.
- To meet BS EN 1789:2007 and AS/NZS 4535:1999 crash-test standards with the use of a crash-rated fastener, such as Power-LOAD (Model 6390), you must install the EMS restraint package (6500-002-030) and knee gatch bolster mattress (6500-002-150) on your Power-LOAD compatible cot. Call Stryker Customer Service USA at 1-800-327-0770 for availability and pricing. Power-LOAD does not meet BS EN 1789:2007 or AS/NZS 4535:1999 crash-test standards for use with the Power-LOAD compatible model 6510 or 6516 Power-PRO IT cot and does not meet AS/NZS 4535:1999 crash test standards for use with the 6085 or 6086 Performance-PRO XT.
- Power-LOAD is designed to be compatible with the Performance-PRO XT, Power-PRO XT, and Power-PRO IT cots with the Power-LOAD option only. In certain situations, you can use Power-LOAD as a standard antler for most X-frame cots, but a rail clamp assembly is required for all cots without the Power-LOAD option.
- It is the responsibility of the cot operator to ensure that the cot being used in the Stryker Model 6390 Power-LOAD system is a Power-LOAD compatible cot. Injury may result if a non-compatible cot is used in the Stryker Model 6390 Power-LOAD system.
- Improper installation can result in injury. Install the Stryker Model 6390 Power-LOAD system as described in this manual. Ensure that, at a minimum, your configuration with Power-LOAD is tested to meet the National Truck Equipment Association/Ambulance Manufacturer's Division Standard 004, Litter Retention System Static Test (AMD-004).
- Take special precautions regarding electromagnetic compatibility (EMC) when using medical electrical equipment like Power-LOAD. Install and place Power-LOAD into service according to the EMC information in this manual. Portable and mobile RF communications equipment can affect the function of Power-LOAD.
- The use of accessories, transducers and cables other than those specified, with the exception of transducers and cables sold by Stryker as replacement parts for internal components may result in increased emissions or decreased immunity of the Power-LOAD system.
- The Power-LOAD system and the Power-PRO cot should not be used adjacent to or stacked with other equipment. If adjacent or stacked use is necessary, observe the Power-LOAD system to verify normal operation in the configuration in which it will be used.
- Power-LOAD operates at the following frequencies: 70 - 125 kHz for inductive charging and 13.56 MHz±7 kHz, Amplitude Modulated (OOK), ERP: -82.37 dBm. The Power-LOAD system may be interfered with by other equipment, even if that other equipment complies with CISPR emission requirements.
- To avoid the risk of personal injury or equipment damage during installation, properly secure the item that you are cutting and be aware of the area around your cutting location. Always wear appropriate eye protection while operating a saw.
- During installation, always wear safety glasses and a face mask while operating a router.
- To avoid the risk of personal injury or vehicle damage, be aware of items around and below the electrical inlet during floor plate installation. Consult the vehicle manufacturer before installing. Make sure that you do not damage or interfere with brake lines, oxygen lines, fuel lines, fuel tank or electrical wiring of the vehicle.
- Ensure that all gaps to the exterior of the vehicle are sealed to prevent exhaust fumes from entering the vehicle patient compartment.
- To prevent exhaust fumes from entering the vehicle patient compartment, route the drain tube under the vehicle away from the exhaust system.
- To avoid the risk of personal injury or vehicle damage, be aware of items around and below the anchor-to-vehicle cable during floor plate installation.
- Failure to install the safety hook can cause injury to the patient or operator. Install and use the safety hook as described in this manual.
- Inadequate bumper clearance could result in patient or operator injury.
- To avoid the risk of injury, two installers are required when lifting and positioning the transfer assembly.
- To avoid the risk of injury, keep hands and fingers clear of all moving mechanisms.

---

[Return To Table of Contents](#)

# Summary of Safety Precautions

---

## WARNING (CONTINUED)

- To avoid the risk of injury, two installers are required when lifting and positioning the trolley assembly.
- To avoid the risk of patient injury, adjust the cot load wheel height to match the vehicle deck height as described in the appropriate cot operations/maintenance manual for your cot model.
- Improper usage of the Power-LOAD system or any accessory can cause injury to the patient or operator. Operate the Power-LOAD system and accessories only as described in the manuals.
- For manual operations, the operator must support the weight at the foot end of the cot.
- Failure to ensure proper Power-LOAD functionality prior to use may result in patient and/or operator injury.
- Use caution while moving around in the vehicle patient compartment to avoid tripping on Power-LOAD.
- To avoid the risk of operator and/or patient injury, use caution when operating Power-LOAD in adverse weather conditions (for example, rain, ice, snow).
- Entanglement in powered cot and/or Power-LOAD mechanisms can cause serious injury. Operate the cot and/or Power-LOAD only when all persons are clear of the mechanisms.
- Practice loading and unloading the cot with Power-LOAD until operation of the product is fully understood. Improper use can cause injury.
- Do not allow untrained personnel to assist in the operation of Power-LOAD. Untrained technicians/personnel can cause injury to the patient or themselves.
- To reduce the risk of patient injury and/or equipment damage, do not drive the vehicle with the trolley in the mid position. This position does not lock and is not intended for driving.
- Power-LOAD is only an assisting device. Operators are responsible for evaluating each situation to determine how to distribute and lift the weight being transported. Always use both hands when handling the cot.
- When handling weights over 400 lb (181 kg), ensure there are enough operators to handle the forces required for loading or unloading. To increase safety, users should attempt to perform loading or unloading on flat surfaces. For 36 in (91 cm) vehicle deck heights, you may need to use the manual release button on the Power-LOAD control panel or the manual cot release handles at the head end of Power-LOAD to manually unload.
- Keep hands and extremities clear of the Power-LOAD trolley lifting arms and the cot base during powered loading and unloading.
- Return damaged batteries to a service center for recycling. Do not dispose of as unsorted municipal waste. Refer to your local distributor for return and/or collection systems available in your country.
- To reduce the risk of electric shock, do not remove the battery when Power-LOAD is in operation.
- Before servicing Power-LOAD, unplug the shoreline (if applicable), disconnect the vehicle battery, press the main power button to turn the unit off, and then place the trolley into the loading position.
- Do not press the main power button to turn the unit off during normal use as it will prevent battery charging.
- To prevent the rail jaws from releasing the cot frame, the space between the rail clamp and the rail stationary jaw must never exceed 1 in (2.5 cm). To prevent the rail jaws from releasing the cot frame and causing possible injury to the patient or user, the rail clamp must not overlap the red adjustment limit label on the rail tube.
- The rail clamp fastener closes with a strong spring action. To avoid injury, do not use hand or fingers to press the release button when the rail jaws are open.
- Loading and/or unloading an occupied cot into a vehicle requires a minimum of two (2) trained operators.
- Make sure that all occupants enter the vehicle patient compartment after the Power-LOAD compatible cot has been loaded into the vehicle patient compartment.
- When unloading the cot, ensure that the cot base is extended before pressing any buttons on the Power-LOAD control panel.
- As the cot is unlocked for removal from the vehicle patient compartment, the Power-LOAD lifting arms will slightly raise the cot. If the lifting arms do not raise the cot, then the operators must be ready to accept the entire weight of the cot and patient to avoid injury.
- When unloading a cot from the vehicle patient compartment while Power-LOAD is experiencing a power loss or system error, the operators must be ready to accept the entire weight of the cot and patient.
- Removing a cot from a vehicle for repair requires a minimum of two (2) trained operators.
- Always press the main power button to turn the unit off before service or cleaning.
- When cleaning, use any appropriate personal safety equipment, such as goggles or respirator, to avoid the risk of inhaling contagion. Use of power washing equipment can aerate contamination collected during the use of the unit.

# Summary of Safety Precautions

---

## **WARNING (CONTINUED)**

- SOME CLEANING PRODUCTS ARE CORROSIVE IN NATURE AND MAY CAUSE DAMAGE TO THE PRODUCT IF USED IMPROPERLY. If the products described above are used to clean Stryker patient care equipment, measures must be taken to insure the units are wiped with clean water and thoroughly dried following cleaning. Failure to properly rinse and dry the units will leave a corrosive residue on the surface of the units, possibly causing premature corrosion of critical components.
  - To avoid the risk of injury, replace Power-LOAD if it has been involved in an accident. A fastener that has been involved in an accident may be damaged, possibly causing failure to operate properly.
  - While servicing or installing covers, do not pinch cables.
  - Use only Mobil Mercon® V Blend ATF Oil (6500-001-293) in the specified quantity. Do not overfill the reservoir with oil. See the Mobil Mercon® V Blend ATF Oil material safety data sheet (MSDS) issued by the manufacturer for safety information (Exxon Mobil Corporation, 1-(800) 947-9147, <http://www.exxon.com>, <http://www.mobil.com>, product code: 20103020B010, 525147-00, 97X826).
- 

## **CAUTION**

- Changes or modifications to the Power-LOAD system not expressly approved by Stryker could void the user's authority to operate the system.
  - This equipment has been tested and found to comply with the limits for a Class A digital device, pursuant to part 15 of the FCC Rules. These limits are designed to provide reasonable protection against harmful interference when the equipment is operated in a commercial environment. This equipment generates, uses, and can radiate radio frequency energy and, if not installed and used in accordance with the instruction manual, may cause harmful interference to radio communications. Operation of this equipment in a residential area is likely to cause harmful interference in which case the user will be required to correct the interference at their expense. In the event of interference, please relocate or reorient the Power-LOAD system or interfering product.
  - This device complies with Part 18 of the FCC Rules. In the event of interference, relocate or reorient the Power-LOAD system or interfering product.
  - When installing the anchor assembly, ensure that the wires rest inside of the floor plate assembly channel and are not pinched by the anchor assembly.
  - When installing the transfer assembly, slowly slide the transfer assembly to avoid breaking the cot inductive charge housing.
  - To avoid the risk of vehicle damage, be aware of items around your selected drill hole locations during installation.
  - The manual overrides allow the Power-LOAD system to move freely.
  - To avoid the risk of equipment damage, do not slam the cot into the trolley when loading.
  - To avoid the risk of equipment damage, do not push the cot into the vehicle patient compartment until the cot base is fully retracted.
  - Do not let go of the manual release until the cot locks into position at the foot end. If you let go too early, then the cot base may prevent the cot from properly locking into Power-LOAD.
  - **DO NOT STEAM CLEAN OR ULTRASONICALLY CLEAN THE UNIT.**
  - Maximum water temperature should not exceed 180°F/82°C.
  - Allow unit to air dry prior to use.
  - Maximum water pressure should not exceed 1500 psi/130.5 bar. If a hand held wand is being used to wash the unit, the pressure nozzle must be kept a minimum of 24 inches (61 cm) from the unit.
  - When hosing down or power washing the unit, do not spray directly underneath the trolley up into the trolley mechanism or water could gain ingress into the trolley housing which could accelerate long-term corrosion and degrade operation.
  - Failure to comply with these instructions may invalidate any/all warranties.
  - To reduce the risk of damage to the electronics assembly, ESD precautions should be taken when handling the control board. For more information about ESD protection, contact Stryker Technical Support at (800) 327-0770.
  - While replacing the rollers, make sure that the trolley is on a flat and level work surface. Pay attention to the trolley positioning when loosening or tightening the pivot bolts.
  - When replacing the motor, damage may occur if motor armature or stator are bumped around.
  - When replacing the battery, do not touch the negative and positive battery terminals together on any metal surface.
-



# Summary of Safety Precautions

## PINCH POINTS

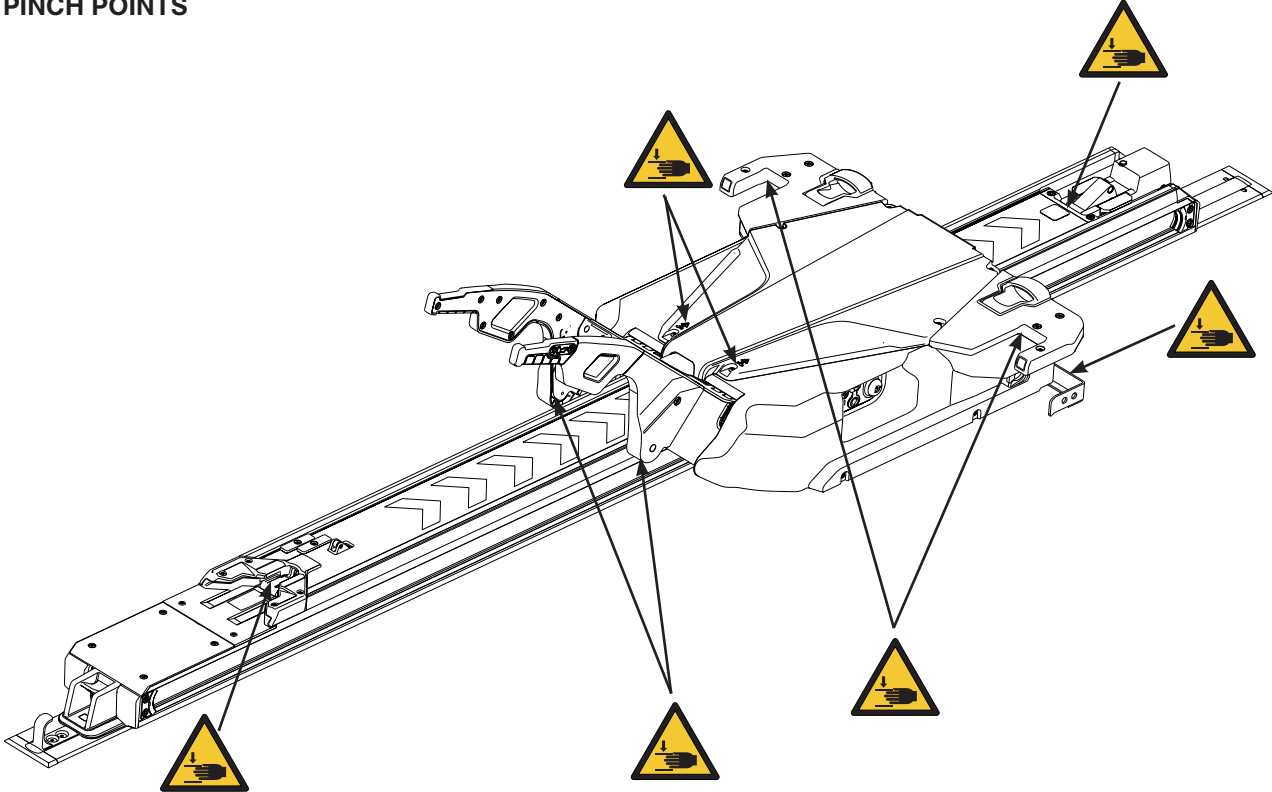

Figure 3: Pinch Points

# Cot Compatibility Information

---

The Stryker Model 6390 Power-LOAD system is designed to be fully compatible with cots with the Power-LOAD compatible option only. Cots which currently meet these specifications are:

- Model 6085 **Performance-PRO™** XT with the Power-LOAD compatibility kit (6085-700-010)
- Model 6086 **Performance-PRO™** XT with the Power-LOAD option or compatibility kit (6086-700-001)
- Model 6500 **Power-PRO™** XT with the Power-LOAD compatibility kit (6500-700-049)
- Model 6506 **Power-PRO™** XT with the Power-LOAD option or compatibility kit (6506-700-001)
- Model 6510 **Power-PRO™** IT with the Power-LOAD compatibility kit (6510-700-001)
- Model 6516 **Power-PRO™** IT with the Power-LOAD option or compatibility kit (6516-700-001)

---

## **WARNING**

- Power-LOAD is designed to be compatible with the Performance-PRO XT, Power-PRO XT, and Power-PRO IT cots with the Power-LOAD option only. In certain situations, you can use Power-LOAD as a standard antler for most X-frame cots, but a rail clamp assembly is required for all cots without the Power-LOAD option.
  - It is the responsibility of the cot operator to ensure that the cot being used in the Stryker Model 6390 Power-LOAD system is a Power-LOAD compatible cot. Injury may result if a non-compatible cot is used in the Stryker Model 6390 Power-LOAD system.
  - To meet BS EN 1789:2007 and AS/NZS 4535:1999 crash-test standards with the use of a crash-rated fastener, such as Power-LOAD (Model 6390), you must install the EMS restraint package (6500-002-030) and knee gatch bolster mattress (6500-002-150) on your Power-LOAD compatible cot. Call Stryker Customer Service USA at 1-800-327-0770 for availability and pricing. Power-LOAD does not meet BS EN 1789:2007 or AS/NZS 4535:1999 crash-test standards for use with the Power-LOAD compatible model 6510 or 6516 Power-PRO IT cot and does not meet AS/NZS 4535:1999 crash test standards for use with the 6085 or 6086 Performance-PRO XT.
-

# Installation Set Up Procedures

## FLOOR PLATE ASSEMBLY INSTALLATION COMPONENT CHECKLIST

Follow this component checklist to ensure that you have all of the required components to properly install the Power-LOAD system. For installation instructions, see "Installing the Floor Plate" on [page 25](#).

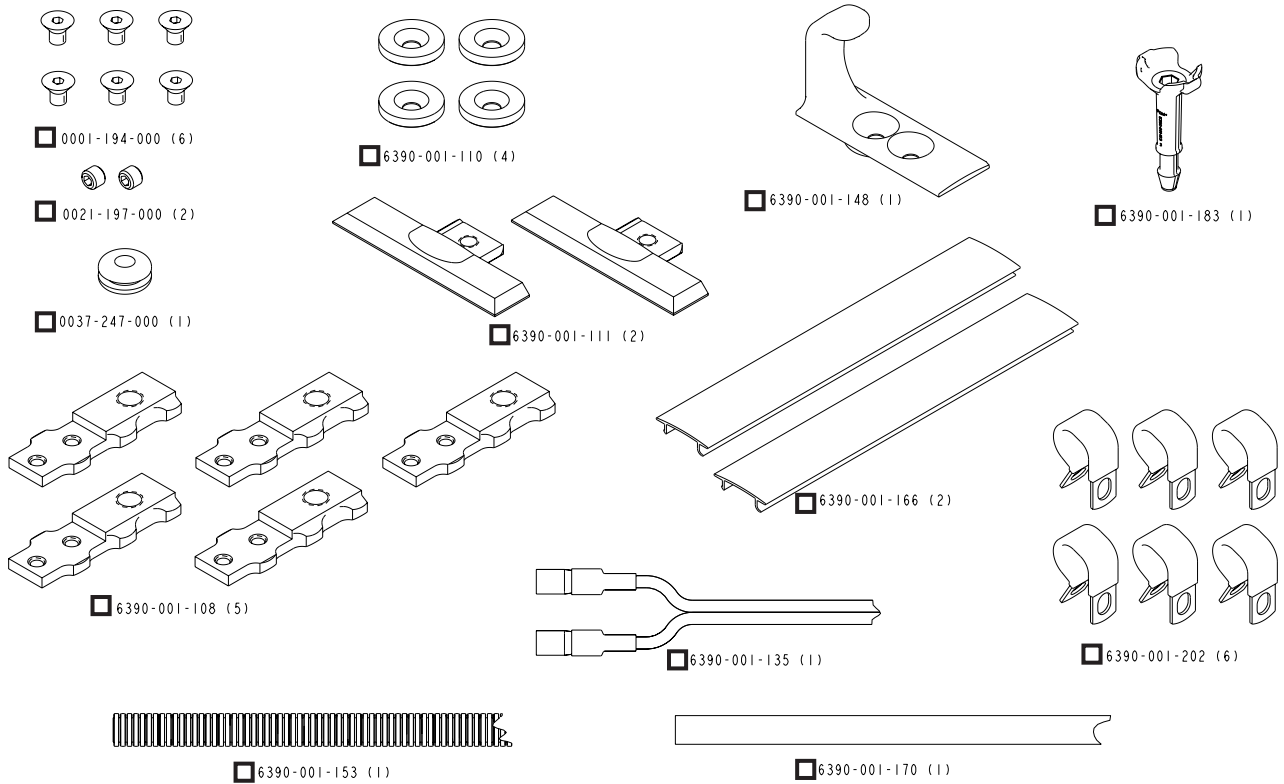

Figure 4: Floor Plate Installation Kit Components (6390-001-055)

# Installation Set Up Procedures

## POWER-LOAD ASSEMBLY INSTALLATION COMPONENT CHECKLIST

Follow this component checklist to ensure that you have all of the required components to properly install the Power-LOAD system. For installation instructions, see “Installing the Power-LOAD System” on [page 31](#).

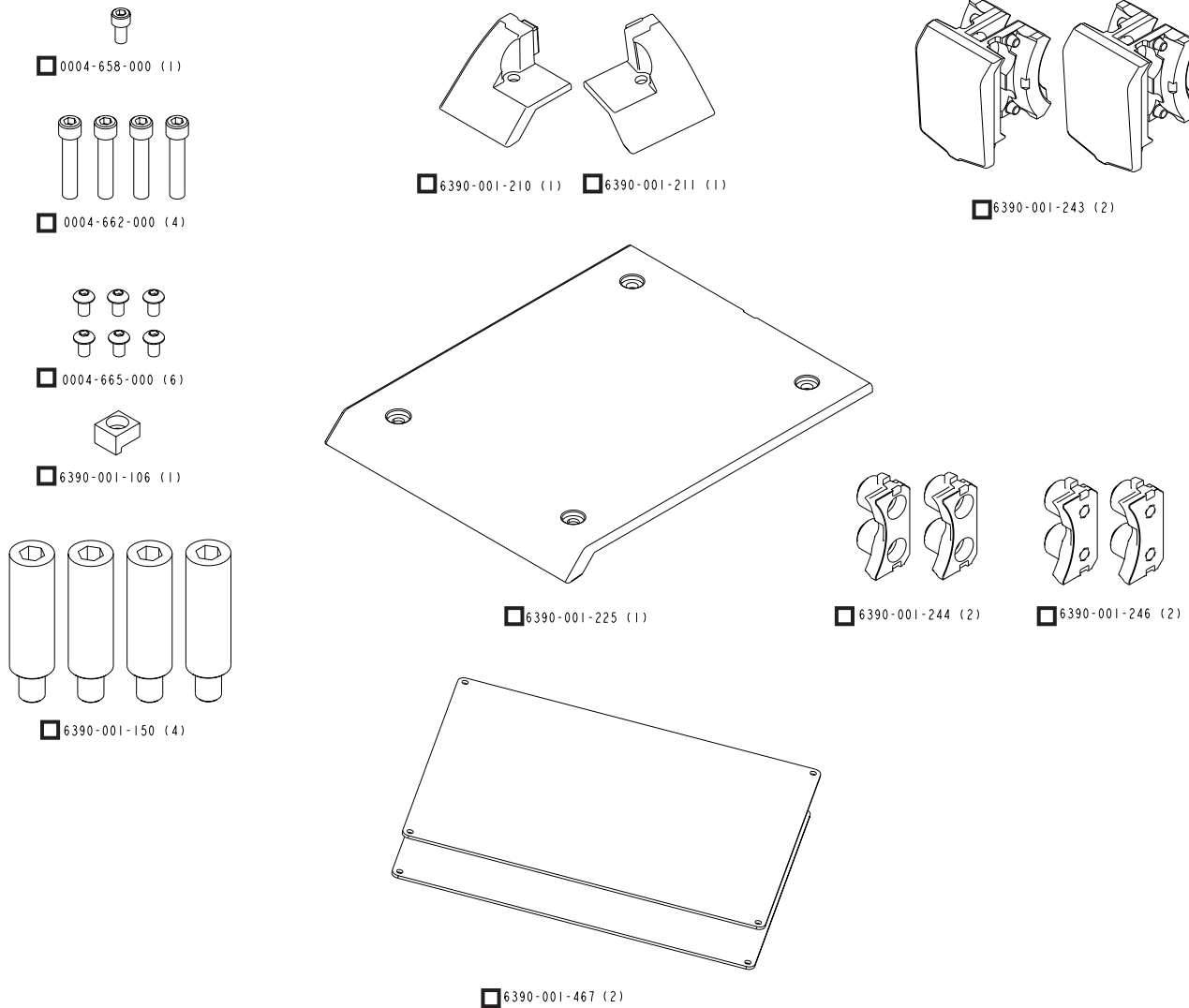
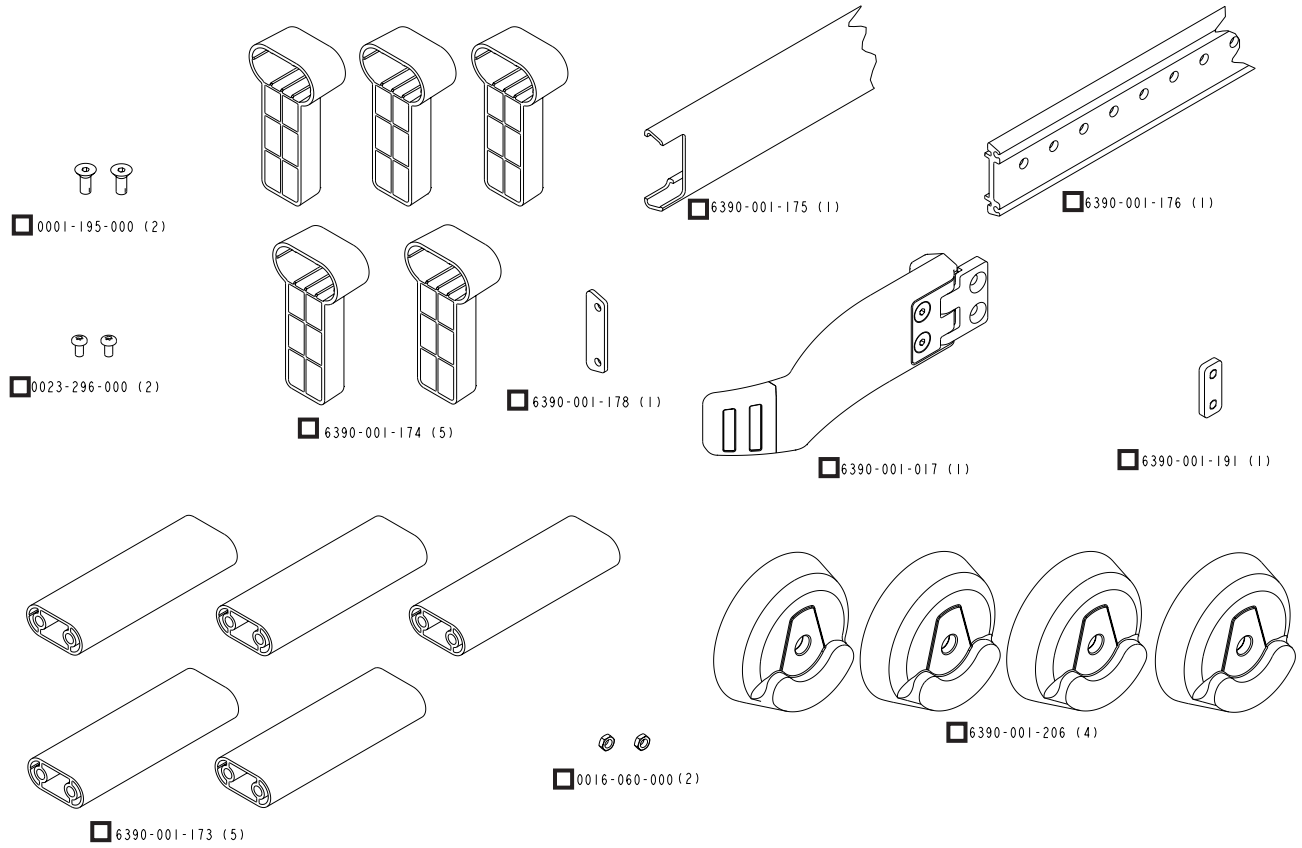

Figure 5: Power-LOAD Assembly Installation Kit Components (6390-001-054)

# Installation Set Up Procedures

## OPTIONAL WHEEL GUIDE ASSEMBLY INSTALLATION COMPONENT CHECKLIST

Follow this component checklist to ensure that you have all of the required components to properly install the Power-LOAD system. For installation instructions, see “Installing The Optional Wheel Guide” on [page 41](#).



**Figure 6: Optional Wheel Guide Assembly Installation Kit Components (6390-027-000)**

# Quality System Regulation for Installation

---

## QUALITY SYSTEM REGULATION

The U.S. Food and Drug Administration (FDA) Code of Federal Regulations (CFR) Title 21 provides guidance regarding the installation of devices, such as Power-LOAD. To comply with these federal regulations, each device must be verified to have been properly installed by trained\* individuals by following the inspection criteria in the “Power-LOAD Installation Checklist” on [page 46](#). This document must be maintained for a minimum of 7 years for each serial number/installation.

\*the Power-LOAD installation facility must maintain their own training records showing that the installer was qualified.

## CFR 21 SEC. 820.170 INSTALLATION

(a) Each manufacturer of a device requiring installation shall establish and maintain adequate installation and inspection instructions, and where appropriate test procedures. Instructions and procedures shall include directions for ensuring proper installation so that the device will perform as intended after installation. The manufacturer shall distribute the instructions and procedures with the device or otherwise make them available to the person(s) installing the device.

(b) The person installing the device shall ensure that the installation, inspection, and any required testing are performed in accordance with the manufacturer’s instructions and procedures and shall document the inspection and any test results to demonstrate proper installation.

## CFR 21 SEC. 820.180 GENERAL REQUIREMENTS

All records required by this part shall be maintained at the manufacturing establishment or other location that is reasonably accessible to responsible officials of the manufacturer and to employees of FDA designated to perform inspections. Such records, including those not stored at the inspected establishment, shall be made readily available for review and copying by FDA employee(s). Such records shall be legible and shall be stored to minimize deterioration and to prevent loss. Those records stored in automated data processing systems shall be backed up.

(a) Confidentiality. Records deemed confidential by the manufacturer may be marked to aid FDA in determining whether information may be disclosed under the public information regulation in part 20 of this chapter.

(b) Record retention period. All records required by this part shall be retained for a period of time equivalent to the design and expected life of the device, but in no case less than 2 years from the date of release for commercial distribution by the manufacturer.

---

### WARNING

- Improper installation can result in injury. Install the Stryker Model 6390 Power-LOAD system as described in this manual. Ensure that, at a minimum, your configuration with Power-LOAD is tested to meet the National Truck Equipment Association/Ambulance Manufacturer’s Division Standard 004, Litter Retention System Static Test (AMD-004).
  - Take special precautions regarding electromagnetic compatibility (EMC) when using medical electrical equipment like Power-LOAD. Install and place Power-LOAD into service according to the EMC information in this manual. Portable and mobile RF communications equipment can affect the function of Power-LOAD.
-

# Floor Plate Installation Guidelines

---

Select your configuration (see Figure 7 or Figure 8 on [page 24](#)). All measurements are shown in inches.

**Note:** Five sets of 3/8-16 UNC flat head cap screws (ASTM-F835 or SAE grade 8), flat washers, and lock nuts are required, but are not included with your installation kit. Examine your vehicle support structure to determine the best length bolt hardware for your floor plate installation. Use these bolts to secure the floor plate as described in step 17.

- 1 The foot end of the floor plate should be 2-3/4 in (7 cm) from the location where the door sill first drops off.
- 2 Floor plate may be cut shorter, if necessary (minimum 89.50 in (227.33 cm)).
- 3 Router depth is 9/16 in (1.4 cm) for the floor plate pocket. Floor plate pocket width is approximately 2-5/8 in (6.5 cm).
- 4 Floor mount plate - 28-7/8 in (73.3 cm) / Wall mount plate - 25-1/4 in (64.1 cm)

**Notes:**

- Dimension 4 should match the dimension above when you install the Power-LOAD anchor on the Power-LOAD floor plate in the rear most location (toward cot foot end). If you install the Power-LOAD anchor forward of the rear most location, dimension 4 will increase by the same amount.
- For a pre-existing rail clamp plate, if dimension 4 measures shorter than the above values, move the rail clamp plate to the appropriate location.

- 5 Choose one hole to drill through  $\varnothing$  1/2 in (1.3 cm) for electrical input.
- 6 The fifth hole from the foot end will be drilled through  $\varnothing$  9/16 in (1.4 cm) for the drain tube assembly.
- 7 Select any one bolt location from each of the five bolt patterns.
- 8 This dimension is measured from the sill edge to the floor plate pocket.

**Notes:**

- Use 3/8-16 UNC flat head cap screws, ASTM-F835 or SAE grade 8 bolts. Each bolt should have a flat washer and lock nut.
- Install each bolt with a minimum of 40 ft-lb (54.3 N-m) torque.
- Each bolt and support structure must be able to withstand 2,750 lbf (12,230 N) in upward tension and 600 lbf (2,669 N) in shear in all horizontal directions.
- Alternatively, you can install a tap plate. Secure the 3/8-16 flat head cap screws directly into the tap plate (tap plate must meet the strength requirements). Use an appropriate thread locker to prevent the screws from loosening.
- Electrical requirements: 12.8V-15.6V  $\overline{=}$ , 15A fuse/breaker, 2 conductor 10 AWG cable (see [page 29](#)).
- Ensure that minimum clearance is provided from the captain's seat. Refer to KKK-A-1822F Federal Specification for the Star-of-Life Ambulance, section 3.10.4, for further guidance.
- You should install the optional wheel guide (6390-027-000) if the cot center line is 17-1/2" or less from the vehicle wall (see [page 41](#)).

# Floor Plate Installation Guidelines

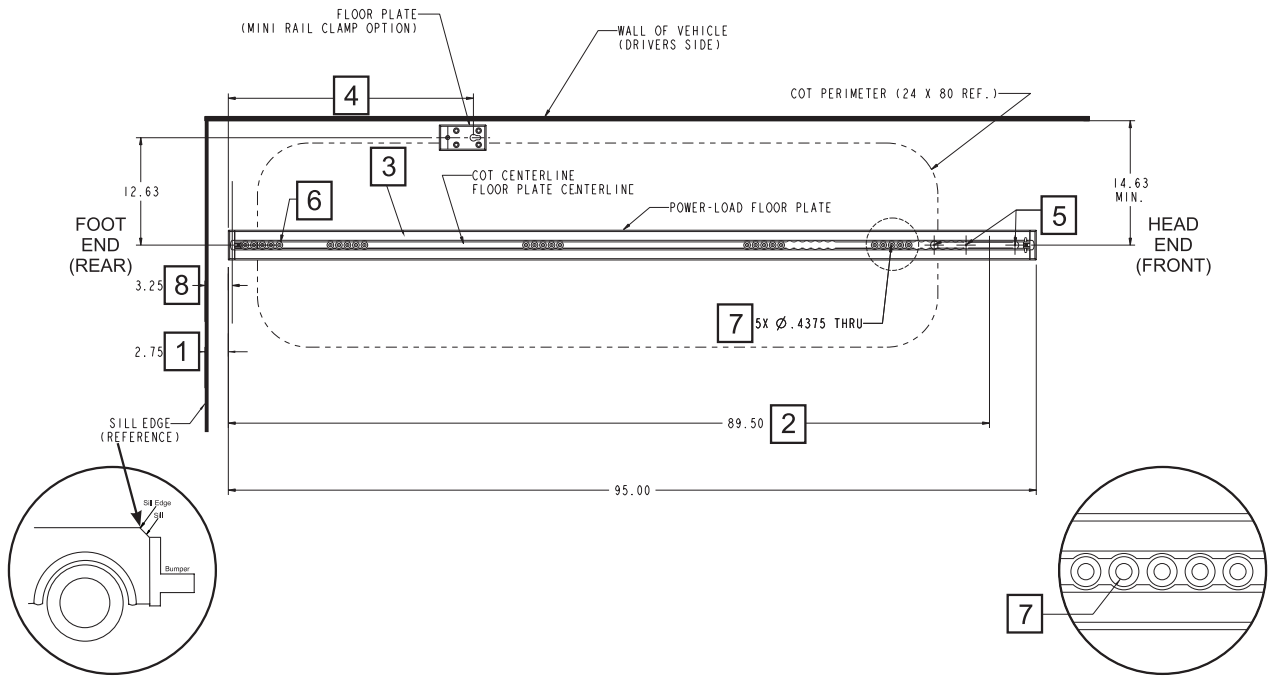

**Figure 7: Power-LOAD Floor Plate with Single Standard Floor Mount Cot Fastener Floor Plate (Optional)**

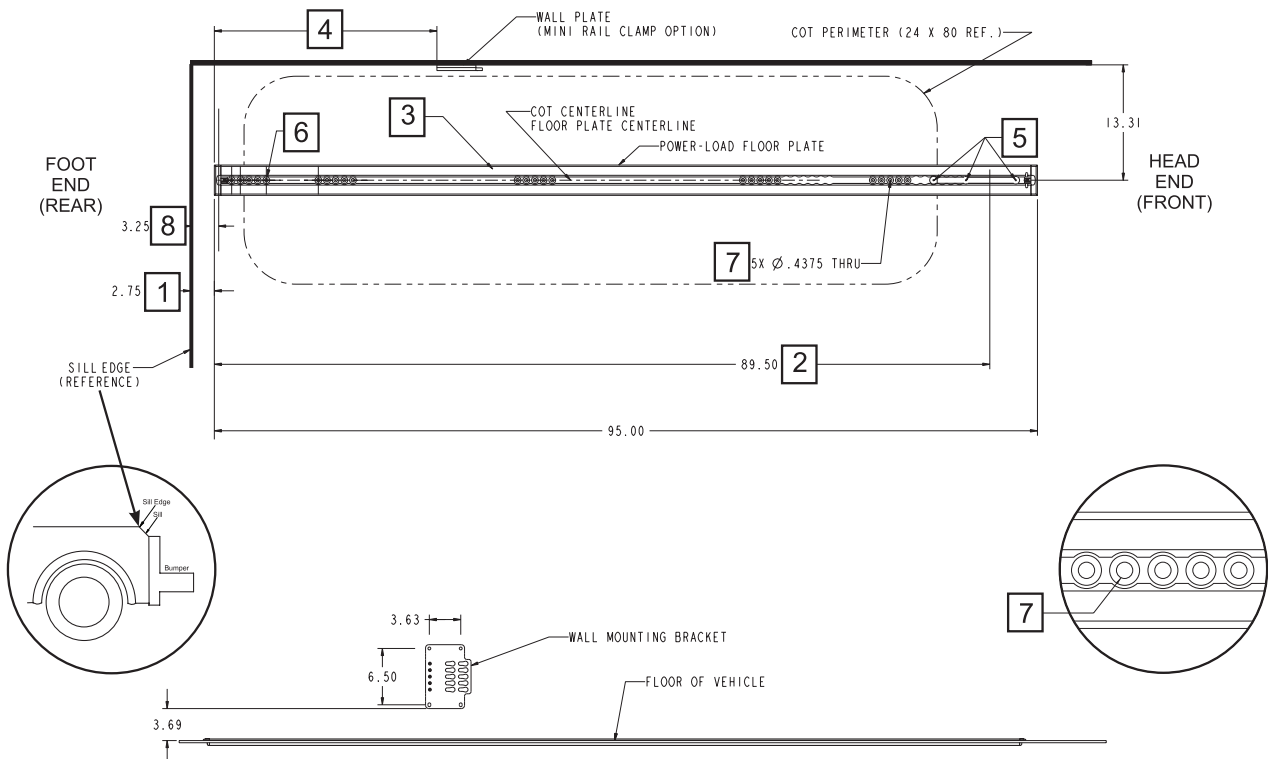

**Figure 8: Power-LOAD Floor Plate with Standard Wall Mount Cot Fastener Wall Plate (Optional)**



# Installation Guide

## INSTALLING THE FLOOR PLATE

**Note:** This procedure shows you how to install the floor plate with a wood floor. There are many different vehicle configurations and you should plan your installation accordingly.

### Floor Plate Assembly Kit Components (6390-001-055)

- (6) Flat Head Cap Screw (p/n 0001-194-000)
- (4) Sub Anchor Attachment Bracket Retainer (p/n 6390-001-110)
- (1) Rubber Grommet (p/n 0037-247-000)
- (1) Anchor-to-Vehicle Cable (p/n 6390-001-135)
- (1) Wire Protection Loom (p/n 6390-001-153)
- (1) Drain Tube (p/n 6390-001-170)
- (6) P-Style Clamp (p/n 6390-001-202)
- (2) Set Screw (p/n 0021-197-000)
- (5) Floor Plate Attachment Bracket (p/n 6390-001-108)
- (2) Floor Plate End Cap (p/n 6390-001-111)
- (1) Power-LOAD Safety Hook (p/n 6390-001-148)
- (2) Floor Plate Cover, Short (p/n 6390-001-166)
- (1) Floor Plate Drain Tube (p/n 6390-001-183)

### Additional Parts Used

- (1) Floor Plate (p/n 6390-001-107)

### Additional Parts Used (not included)

- **Five sets of 3/8-16 UNC flat head cap screws (ASTM-F835 or SAE grade 8), flat washers, and lock nuts**
- **15A fuse/breaker (for vehicle)**
- **1/4" screws (for wire protection loom)**

### Tools Required:

- Pencil
- Router
- Drill
- Tape Measure
- 1/2" Drive 7/32" Hex
- Face Mask
- Multimeter
- Saw
- 1/2" to 1" Router Bit
- 1/2" Drill Bit
- 7/16" Drill Bit
- 9/16" Drill Bit
- 1/4" Hex Wrench
- 1/2" Drive Torque Wrench (ft-lb) > 40 ft-lb (54.3 N-m)
- 5/32" Hex Wrench
- Shop Vacuum
- Silicone Sealant
- Rubber Hammer
- Safety Glasses
- Extension Cord

### Procedure:

**Note:** Five sets of 3/8-16 UNC flat head cap screws (ASTM-F835 or SAE grade 8), flat washers, and lock nuts are required, but are not included with your installation kit. Examine your vehicle support structure to determine the best length bolt hardware for your floor plate installation. Use these bolts to secure the floor plate as described in step 17.

1. Identify the back-to-front mounting location relative to the door sill. Start at the location where the door sill first drops off as shown in Figure 7 or Figure 8 on [page 24](#) and measure 2-3/4 in (7 cm) inwards. Use a pencil to mark the location along the width of the vehicle patient compartment.
2. Using a 5/32" hex wrench, install the set screw (0021-197-000) to attach the floor plate end caps (6390-001-111) on the rear end and front end of the floor plate (6390-001-107).

# Installation Guide

---

## INSTALLING THE FLOOR PLATE (CONTINUED)

3. Position the floor plate the desired distance from the vehicle patient compartment walls (see Figure 7 or Figure 8 on [page 24](#)).
  - Align the edge of the installed end cap with the marked location at 2-3/4 in (7 cm).
  - Use a pencil to mark the center location of the floor plate on the vehicle floor at the rear end and front end of the end caps.
  - Measure from these marks to the vehicle wall to ensure that they are parallel.

**Note:** You should install the optional wheel guide (6390-027-000) if the cot center line is 17-1/2" or less from the vehicle wall (see [page 41](#)).

---

### WARNING

To avoid the risk of personal injury or equipment damage during installation, properly secure the item that you are cutting and be aware of the area around your cutting location. Always wear appropriate eye protection while operating a saw.

---

**Note:** If the floor plate does not fit lengthwise in the vehicle patient compartment, use a saw to shorten the floor plate (see Figure 7 or Figure 8 on [page 24](#)). Before cutting the floor plate, remove the front end floor plate end cap. Replace the cap after cutting the floor plate.

4. Securely hold the floor plate in place. Using the floor plate as a template, trace the inset edge of the floor plate and end caps onto the vehicle patient compartment floor as shown in Figure 9.

**Note:** If you are installing multiple Power-LOAD systems, you can make a template to expedite installation.

5. Remove the floor plate and inspect the trace. Follow this trace when cutting the floor plate pocket for the floor plate.

**Notes:**

- Slightly oversize the cutout to ensure that the floor plate fits into the floor plate pocket. The flange of the floor plate will cover any minor widening of the floor plate pocket.
- It may be necessary to notch your sill plate, so your floor plate sits flat on the floor.



**Figure 9**

# Installation Guide

## INSTALLING THE FLOOR PLATE (CONTINUED)

**Note:** Steps 6 - 8 explain the process for creating the floor plate pocket in the vehicle floor to accept the floor plate. These instructions assume the vehicle has a wood floor with a thickness of at least 9/16 in (1.4 cm).

Here are a few alternative installations:

Vehicle Patient Compartment Floor Thickness	Action Required
Less than 7/16 in (1.1 cm)	Build up your floor to a thickness of at least 9/16 in (1.4 cm).
7/16 in (1.1 cm) to 9/16 in (1.4 cm)	Route (or cut) down to the vehicle support structure. When you install the floor plate, there will be a gap of not more than 1/8 in (0.32 cm) between the bottom of the flange of the floor plate and the floor. Fill this gap with silicone sealant.
Greater than 9/16 in (1.4 cm) or with a foam structure	Route (or cut) the floor plate pocket to the depth of the solid vehicle support structure and then use spacers (for example, . 3/8 in (0.95 cm) washers – not provided) to build the vehicle support structure up to the bottom of the floor plate. For example, if your vehicle floor is 3/4 in (1.9 cm), you need to install 3/16 in (0.5 cm) spacers or washers to support the floor plate at the five mounting holes. This has the following advantages: <ul style="list-style-type: none"><li>• Easier identification of the patient vehicle compartment support structure</li><li>• Less cutting of the patient vehicle compartment</li><li>• May eliminate the need to router an additional floor plate pocket for the electrical rubber grommet (see step 14)</li></ul>

### **WARNING**

During installation, always wear safety glasses and a face mask while operating a router.

- Using a router and 1/2" to 1" router bit, router out the floor by following the lines marked onto the floor in step 4.  
**Note:** Set the router bit depth to 9/16 in (1.4 cm). Use a firm stance when using the router to avoid damaging the floor.
- Set the floor plate into the floor plate pocket to check the fit. Make any adjustments, as necessary.  
**Note:** The flange of the floor plate will cover any minor widening of the floor plate pocket.
- Identify and mark at least one of the five mounting holes in each of the five (5) five-hole patterns that align with the vehicle support structure. If none of the five mounting holes in any one hole pattern lines up with a support structure, you need to create a support structure for that location, such as a plate or bracket.

#### **Notes:**

- These mounting holes will be drilled out to 7/16 in (1.1 cm) diameter.
- Each bolt and support structure must be able to withstand 2,750 lbf (12,230 N) in upward tension and 600 lbf (2,669 N) in shear in all horizontal directions.
- Consider any restrictions due to clearances with any vehicle component.

# Installation Guide

## INSTALLING THE FLOOR PLATE (CONTINUED)

### WARNING

To avoid the risk of personal injury or vehicle damage, be aware of items around and below the electrical inlet during floor plate installation. Consult the vehicle manufacturer before installing. Make sure that you do not damage or interfere with brake lines, oxygen lines, fuel lines, fuel tank or electrical wiring of the vehicle.

**Note:** The electrical inlet hole and drain tube assembly hole do not need to align with the support structure.

- Identify and mark the electrical inlet hole (see Figure 7 or Figure 8 on [page 24](#)). This hole will be drilled to 1/2 in (1.3 cm) diameter.
- Identify and mark the fifth hole from the foot end for the drain tube assembly (see Figure 7 or Figure 8 on [page 24](#)). This hole will be drilled to 9/16 in (1.4 cm) diameter.

**Note:** If this hole location will not work for your drain tube installation, determine the anchor assembly mounting position before selecting an unused drain tube hole. Make sure that the drain does not interfere with the anchor attachment mechanism.

- Remove the floor plate from the floor plate pocket.
- Using a drill and appropriate drill bit, drill the following marked holes through the floor plate:

Hole	Quantity	Diameter	Drill Bit
Mounting	5	7/16 in (1.1 cm)	7/16 in
Electrical Inlet	1	1/2 in (1.3 cm)	1/2 in
Drain Tube	1	9/16 in (1.4 cm)	9/16 in

- Install the floor plate into the floor plate pocket. Transfer holes onto the floor plate pocket in the vehicle patient compartment floor. Remove the floor plate. Drill the corresponding holes into the vehicle patient compartment floor.
- Using a drill or router, cut a 1 in (2.54 cm) diameter hole to a depth of 1/4 in (.635 cm) below the floor plate pocket for the electrical rubber grommet.
- Insert the supplied electrical rubber grommet (0037-247-000) into the floor plate at the electrical input location.
- Apply silicone sealant to the underside of the floor plate flange, and press the floor plate firmly into the floor plate pocket.

### WARNING

Ensure that all gaps to the exterior of the vehicle are sealed to prevent exhaust fumes from entering the vehicle patient compartment.

- Install the appropriate length 3/8-16 UNC flat head cap screws, ASTM-F835 or SAE grade 8 with a flat washer and lock nut.

**Note:** This hardware is required, but not included with your installation kit, because vehicle support structures vary.

- Using a 1/2" drive torque wrench with a 1/2" drive 7/32" hex, tighten the floor plate tie-down bolts to a minimum torque of 40 ft-lb (54.3 N-m) in at least a two-step tightening process.
- Attach the drain tube (6390-001-170) to the floor plate drain tube (6390-001-183) and insert it into the floor plate drain tube assembly hole.

#### Notes:

- You can cut the 10 ft (3 m) drain tube to meet the needs of your installation.
- Alternatively, you can install the drain tube from the underside of the vehicle.

# Installation Guide

---

## INSTALLING THE FLOOR PLATE (CONTINUED)

20. Using a 1/4" hex wrench, turn the drain a quarter turn to lock the drain in place.
21. Route the drain tube under the vehicle away from the exhaust system ensuring that the open end of the tube is lower than the drain for proper drainage. Secure the drain tube to the vehicle using appropriate tie downs (not supplied).

---

### WARNING

To prevent exhaust fumes from entering the vehicle patient compartment, route the drain tube under the vehicle away from the exhaust system.

---

**Electrical Note:** The Power-LOAD system contains two inductive couplers that supply power for charging both the cot and Power-LOAD trolley batteries and provide power to the foot end sensor and LED indicator located in the Power-LOAD anchor. The vehicle system provides the power to run these electronics through the connection established in the following steps. See step 22 for the connection electrical requirements. Select where to make the electrical connection within the vehicle system.

To determine where the Power-LOAD system resides within the vehicle's electrical system, consider how and if the Power-LOAD electrical connection will interface with the following:

- Modular disconnect switch
- DC power provided by the AC/DC converter from the shoreline
- Ignition switch
- Direct vehicle battery connection
- Dedicated switch

**Note:** The Power-LOAD inductive charging system and foot end indicator LED will only operate when the system is receiving power according to the limits below. For example, if the system is installed on the ignition switch, the system will only receive power when the ignition is on.

The Power-LOAD system is equipped with safeguards to protect its power source, such as:

- Charging will not start if the  $V_{source} < 12.8V$
- Charging will be limited to a 2 hour time limit if  $V_{source} < 12.4V$
- Charging will cease if  $V_{source} < 11.6V$
- Anchor electronics will enter "sleep-mode" if  $V_{source} < 11.1V$

22. Identify the point of connection between the supplied anchor-to-vehicle cable (6390-001-135) and the vehicle electrical system (Electrical requirements: 12.8V-15.6V DC, 15A fuse/breaker, 2 conductor 10 AWG cable).

**Note:** To prevent the possibility of draining the vehicle batteries to the limits above, you can wire Power-LOAD so that power is only supplied to Power-LOAD when the vehicle ignition is turned on or the shoreline is plugged in.

---

### WARNING

To ensure performance and prevent power hazards, connect Power-LOAD to a 12.8V-15.6V DC vehicle circuit that is on a 15A fuse/breaker. Do not connect Power-LOAD to a 24V DC vehicle circuit.

---

23. Install the anchor-to-vehicle cable (6390-001-135) through the electrical rubber grommet in the electrical inlet. Leave enough slack (approximately 6 in (15 cm)), so you can connect the spade-connector end of the anchor-to-vehicle cable to the Power-LOAD anchor cable.

---

### WARNING

To avoid the risk of personal injury or vehicle damage, be aware of items around and below the anchor-to-vehicle cable during floor plate installation.

---

# Installation Guide

---

## INSTALLING THE FLOOR PLATE (CONTINUED)

24. Route the anchor-to-vehicle cable back to the vehicle connection point. Twelve feet of wire protection loom (6390-001-153) and six p-clamps (6390-001-202) are provided.
25. Connect the anchor-to-vehicle cable to the vehicle electrical system. Place the Power-LOAD system on a dedicated 15A fuse/breaker.
26. Using a multimeter, check the voltage at the spade-connector end of the anchor-to-vehicle cable (6390-001-135) to ensure that the voltage is 12.8V-15.6V DC.

### Notes:

- Before checking for voltage, engage any additional interconnects (turn on the vehicle ignition, modular connection, or dedicated switch), if applicable.
- If your installation uses DC power, provided by the AC/DC converter from the shoreline, check the voltage at the spade end of the anchor-to-vehicle cable in the configuration in which you will most often use the shoreline (such as shore power attached, vehicle ignition off, or modular disconnect open).



### WARNING

Ensure that all gaps to the exterior of the vehicle are sealed to prevent exhaust fumes from entering the vehicle patient compartment.

---

# Installation Guide

## INSTALLING THE POWER-LOAD SYSTEM

### Install the Anchor Assembly

27. Insert a floor plate attachment bracket (6390-001-108) at the foot end of the vehicle patient compartment to install the safety hook (6390-001-148) (Figure 10). Line the notches with the tabs to insert, then slide the bracket into the floor plate assembly.

### WARNING

Failure to install the safety hook can cause injury to the patient or operator. Install and use the safety hook as described in this manual.

28. Using a 5/32" hex wrench, install two flat head cap screws (0001-194-000) to secure the safety hook to the floor plate assembly (Figure 11).

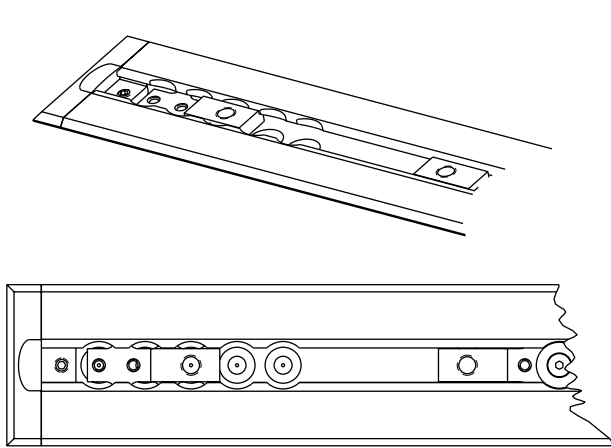

Figure 10: Insert Floor Plate Attachment Bracket

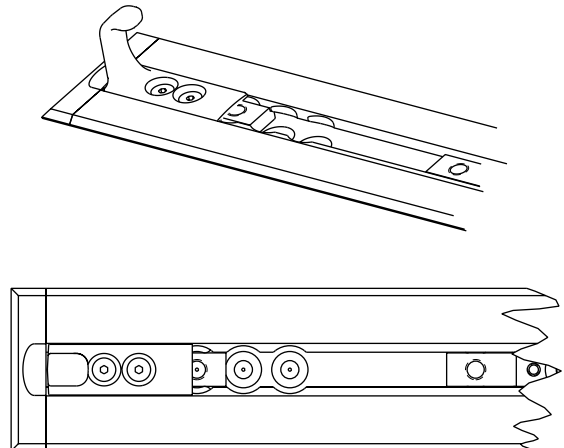

Figure 11: Secure Safety Hook

29. Lift the vehicle bumper to the raised position (if equipped).
30. Measure from the end of the floor plate to the end of the bumper to determine how far you can move the anchor in towards the head end (Figure 12).

**Note:** If the distance measured is less than 18 in (46 cm), you can shift Power-LOAD in closer to the head end of the vehicle patient compartment by a maximum of the difference of 18 in (46 cm) and the measured distance.

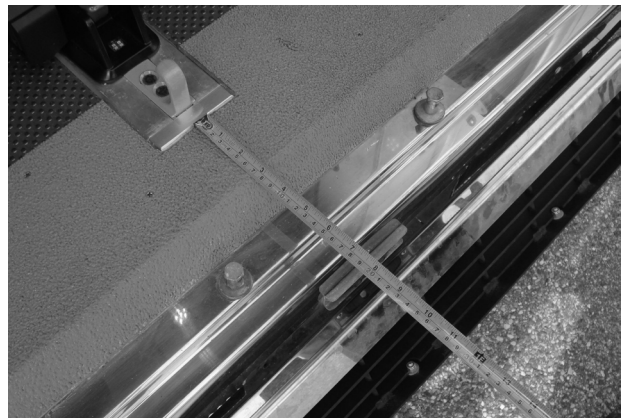

Figure 12: Measure for Anchor Installation

### WARNING

Inadequate bumper clearance could result in patient or operator injury.

# Installation Guide

## INSTALLING THE POWER-LOAD SYSTEM (CONTINUED)

31. Locate the first floor plate attachment bracket (Figure 13) location (near the foot end). This location provides the most wheel clearance.

### Notes:

- To shift the cot closer to the head end of the vehicle patient compartment, select another location.
- Each successive location shifts the cot one inch toward the head end.
- Make sure that the location is not further from the first location than the value calculated in step 30. Leave enough room for the cot base to clear the vehicle bumper.
- Flipping the bracket as shown in Figure 14 moves the mounting location an additional two inches toward the head end.
- Figure 13 shows the location for the most wheel clearance from the bumper. Figure 14 shows the location for the least wheel clearance from the bumper and represents a 8 in (20.3 cm) shift in from the first location. Select the location that provides the appropriate wheel clearance for your set up.

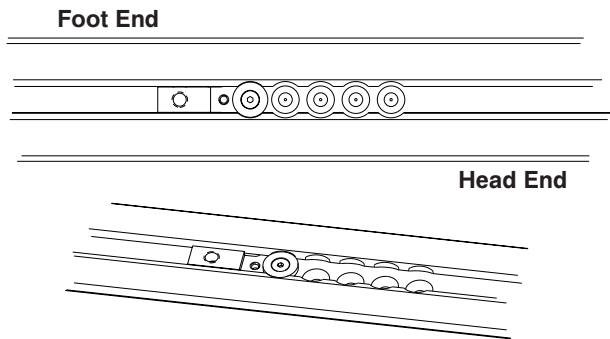

Figure 13: Most Wheel Clearance

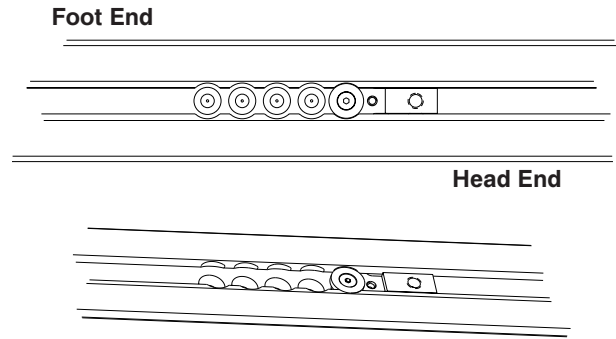

Figure 14: Flipping the Bracket

32. Using a 5/32" hex wrench, install a flat head cap screw (0001-194-000) to the sub anchor attachment bracket retainer (6390-001-110) to secure the floor plate attachment bracket (6390-001-108).
33. Repeat steps 31-32 for three other locations in the floor plate assembly.

**Note:** The position of these three floor plate attachment brackets must match the location selected in step 31.

34. Connect the red wire to the red wire and the black wire to the black wire to connect the anchor assembly to the anchor-to-vehicle cable. Position the anchor over its mounting holes. Feed any excess wire through the electrical rubber grommet. Place the connectors into the floor plate pocket.

**Note:** Apply silicone sealant to the electrical rubber grommet to completely seal the electrical pass through.

### WARNING

Ensure that all gaps to the exterior of the vehicle are sealed to prevent exhaust fumes from entering the vehicle patient compartment.

35. After power is applied to the anchor, make sure that the foot end LED indicator is flashing amber to ensure proper functionality.

**Note:** If the foot end LED indicator is not flashing amber, ensure that there is power to the anchor.



# Installation Guide

## INSTALLING THE POWER-LOAD SYSTEM (CONTINUED)

36. Carefully place the anchor assembly (A) on top of the floor plate assembly (B) as shown in Figure 15, laying the excess wire into the floor plate pocket. Align the four holes with the floor plate attachment brackets.

### ⚠ CAUTION

When installing the anchor assembly, ensure that the wires rest inside of the floor plate pocket and are not pinched by the anchor assembly.

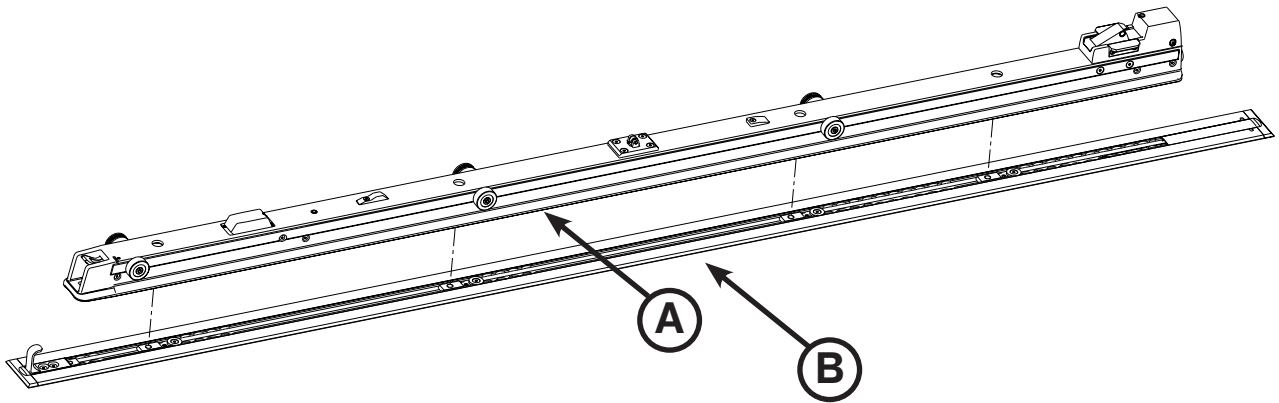

Figure 15: Anchor Assembly and Floor Plate Assembly

37. Measure the exposed pocket at the head end and the foot end of the floor plate to customize the floor plate covers.

### ⚠ WARNING

To avoid the risk of personal injury or equipment damage during installation, properly secure the item that you are cutting and be aware of the area around your cutting location. Always wear appropriate eye protection while operating a saw.

38. Using a saw, cut the two floor plate covers (6390-001-166) (A) to fit the measured length on both ends (Figure 16). The floor plate cover does not fit over the floor plate attachment bracket.

**Note:** If the anchor is assembled over the foot end or head end of the floor plate, then no floor plate cover is needed on that end.

39. Using a rubber hammer, snap each floor plate cover into the floor plate (hook side (B) first).

**Note:** To unsnap the floor plate cover, use a screwdriver on the side of the cover with a raised edge.

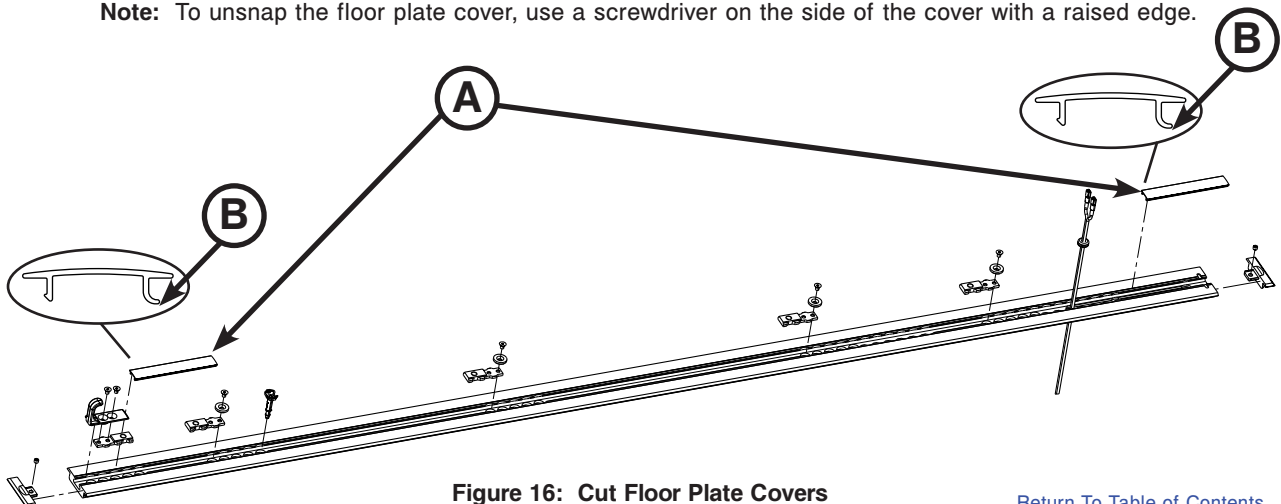

Figure 16: Cut Floor Plate Covers

[Return To Table of Contents](#)

# Installation Guide

## INSTALLING THE POWER-LOAD SYSTEM (CONTINUED)

### Power-LOAD Assembly Kit Components (6390-001-054)

- (1) Socket Head Cap Screw (p/n 0004-658-000)
- (6) Button Head Cap Screw (p/n 0004-665-000)
- (4) Anchor Mounting Post (p/n 6390-001-150)
- (1) Transfer Trim, HE, Right (p/n 6390-001-211)
- (2) Dead Stop Bumper (p/n 6390-001-243)
- (2) Dead Stop Block, Threaded (p/n 6390-001-246)
- (4) Socket Head Cap Screw (p/n 0004-662-000)
- (1) Trolley Magnet Activator (p/n 6390-001-106)
- (1) Transfer Trim, HE, Left (p/n 6390-001-210)
- (1) Transfer Wear Pad, Foot End (p/n 6390-001-225)
- (2) Dead Stop Block, Thru Hole (p/n 6390-001-244)

### Tools Required:

- 3/8" Hex Wrench
- 5/32" Hex Wrench
- 3/16" Hex Wrench
- T25 Torx Driver
- 1/2" Drive Torque Wrench (ft-lb) > 60 ft-lb

### Procedure:

1. Using a 3/8" hex wrench, install the four supplied anchor mounting posts (6390-001-150) (A) into the four holes in the anchor assembly as shown in Figure 17.

**Note:** Do not fully tighten the posts until all four posts are aligned and started.

2. Using a torque wrench, tighten each post to 60±10 ft-lb.

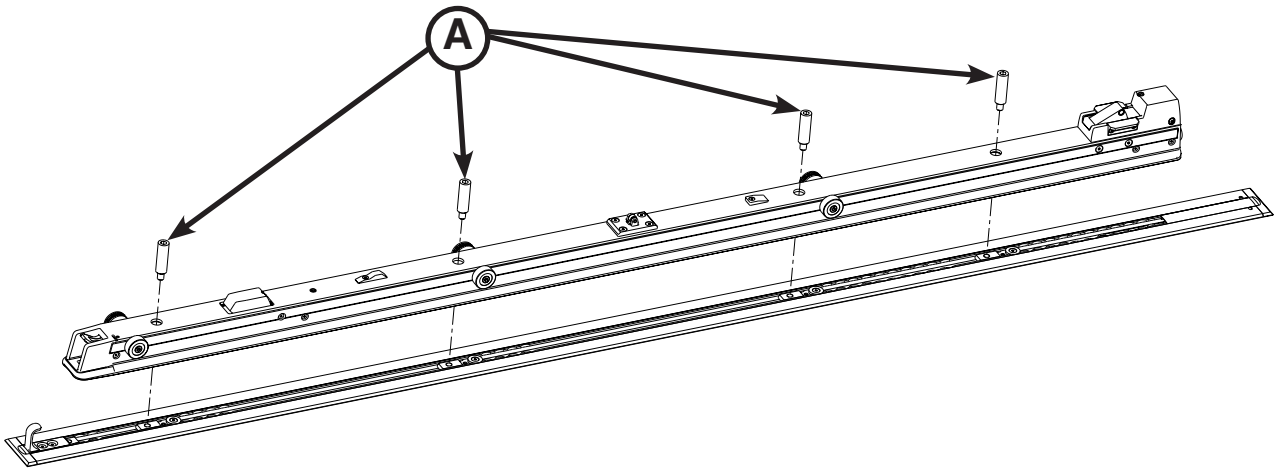

Figure 17: Install Anchor Mounting Posts

# Installation Guide

---

## INSTALLING THE POWER-LOAD SYSTEM (CONTINUED)

### Install the Transfer Assembly

---

#### WARNING

To avoid the risk of injury, two installers are required when lifting and positioning the transfer assembly.

---

3. Position the transfer assembly (A), so the open end is facing the anchor assembly (B) as shown in Figure 18.

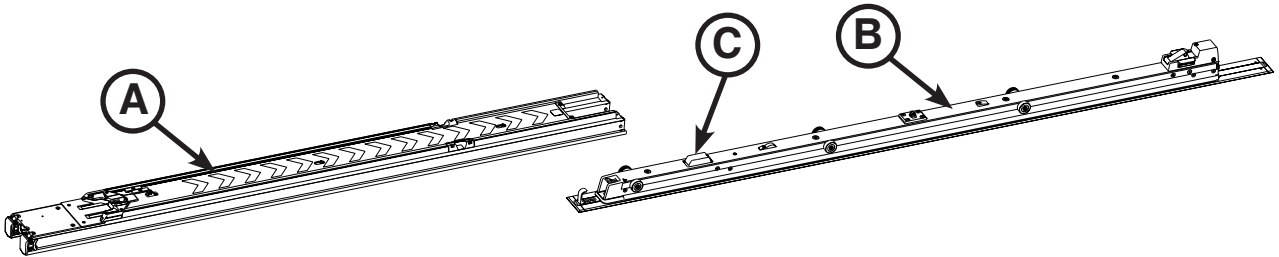

Figure 18: Install Transfer Assembly

---

#### WARNING

To avoid the risk of injury, keep hands and fingers clear of all moving mechanisms.

---

4. Installer 1 (Foot End) lifts the transfer assembly and slides the transfer lock triggers (E) (Figure 19) toward the foot end of the transfer to disengage the transfer locks. Keep the transfer lock triggers pulled toward the foot end until the transfer is seated on the anchor as shown in Figure 19. Installer 2 (Head End) slides and centers the open end of the transfer assembly over the rollers in the anchor assembly.

**Note:** You may notice slight resistance while rolling over the second set of rollers; push past the resistance to the position shown in Figure 19.

---

#### CAUTION

When installing the transfer assembly, slowly slide the transfer assembly to avoid breaking the cot inductive charge housing (C) (as shown in Figure 18).

---

# Installation Guide

## INSTALLING THE POWER-LOAD SYSTEM (CONTINUED)

### Install the Trolley Assembly

5. Using a 5/32" hex wrench, install the supplied socket head cap screw (0004-658-000) (A) to secure the supplied trolley magnet activator (6390-0001-106) (B) as shown in Figure 19.
6. Using a T25 Torx driver, install four supplied button head cap screws (0004-665-000) (C) to attach the supplied foot end transfer wear pad (6390-001-225) (D) to the transfer assembly as shown in Figure 19.
7. Slide the transfer lock triggers (closest to the foot end) (E) as shown in Figure 19 toward the foot end of the transfer assembly to unlock.

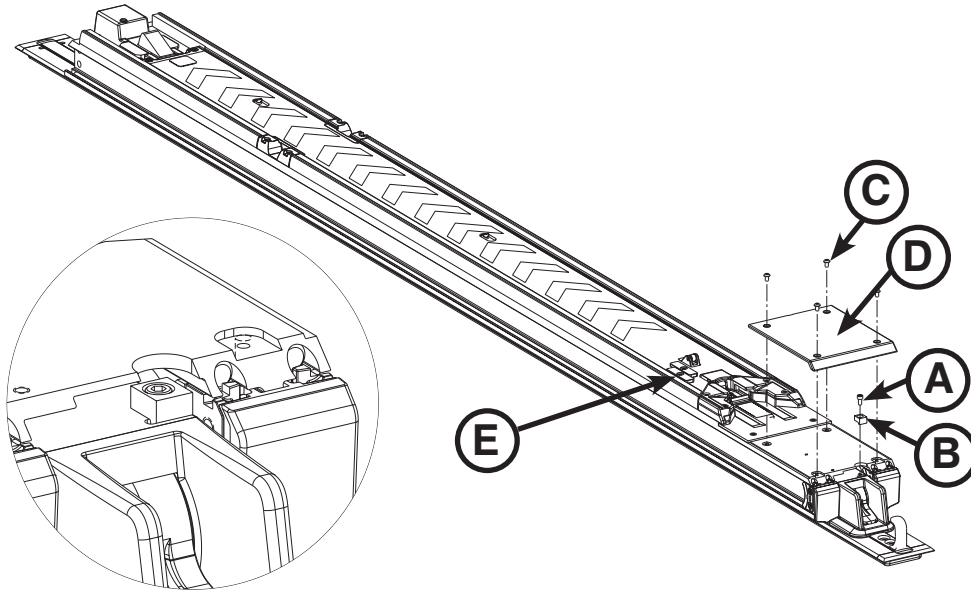

Figure 19: Attach the Foot End Transfer Wear Pad

8. Move the transfer assembly into its mid position as shown in Figure 20.

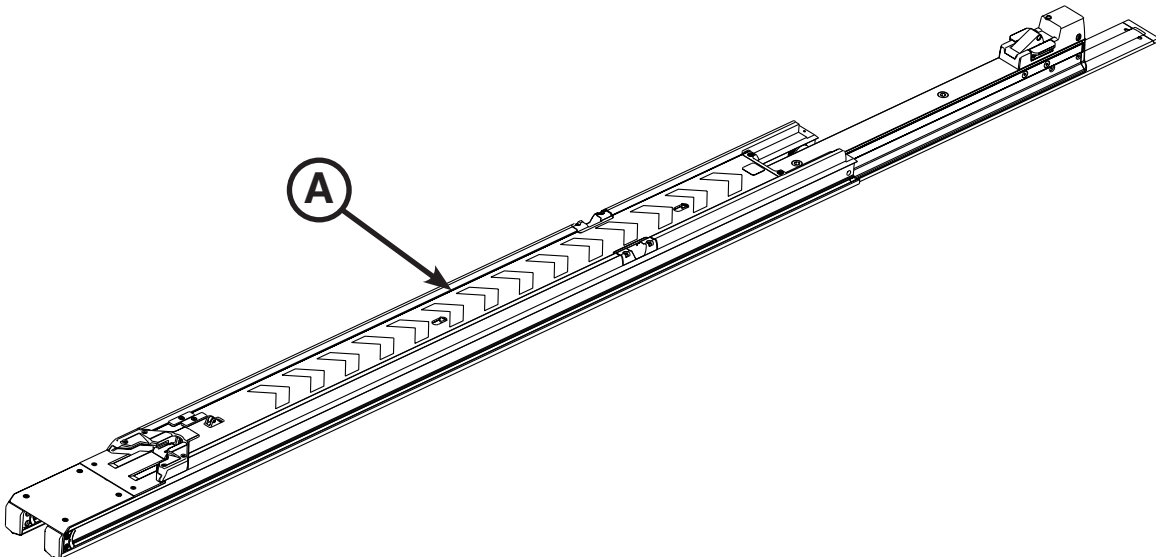

Figure 20: Position the Transfer Assembly

# Installation Guide

## INSTALLING THE POWER-LOAD SYSTEM (CONTINUED)

### WARNING

To avoid the risk of injury, two installers are required when lifting and positioning the trolley assembly.

- Carefully lift the trolley assembly by its arm and wing. Do not lift the trolley by the manual cot release handles. Lift only where indicated. Installer 1, position hands at A1 and A2. Installer 2, position hands at B1 and B2 as shown in Figure 21.

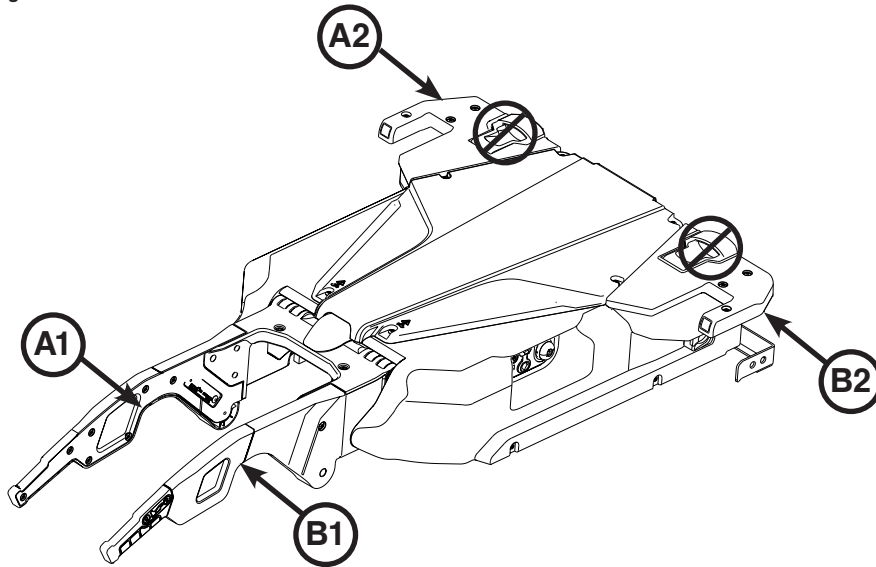

Figure 21: Trolley Assembly

- Position the trolley assembly (A) between the transfer assembly (B) and head end of the anchor assembly (C) on the floor as shown in Figure 22.
- Installer 1 (Foot End) - Slide the rollers of the trolley assembly into the side channel of the transfer assembly.
- Installer 2 (Head End) - Lift the trolley assembly to align the second set of rollers and slide the rollers until the trolley is near the middle of the transfer.

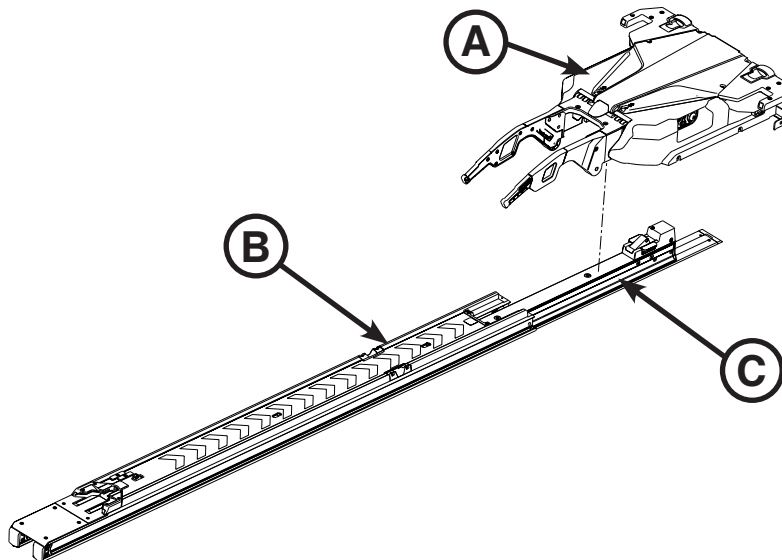

Figure 22: Position the Trolley Assembly

# Installation Guide

## INSTALLING THE POWER-LOAD SYSTEM (CONTINUED)

- Carefully push the transfer assembly forward toward the head end until it locks into position.
- Assemble the bumper block by aligning the supplied dead stop block (6390-001-244) (with through holes) (A) with the supplied dead stop bumper (6390-001-243) (B) and the supplied inner dead stop block (6390-001-246) (with threaded holes) (C) as shown in Figure 23.

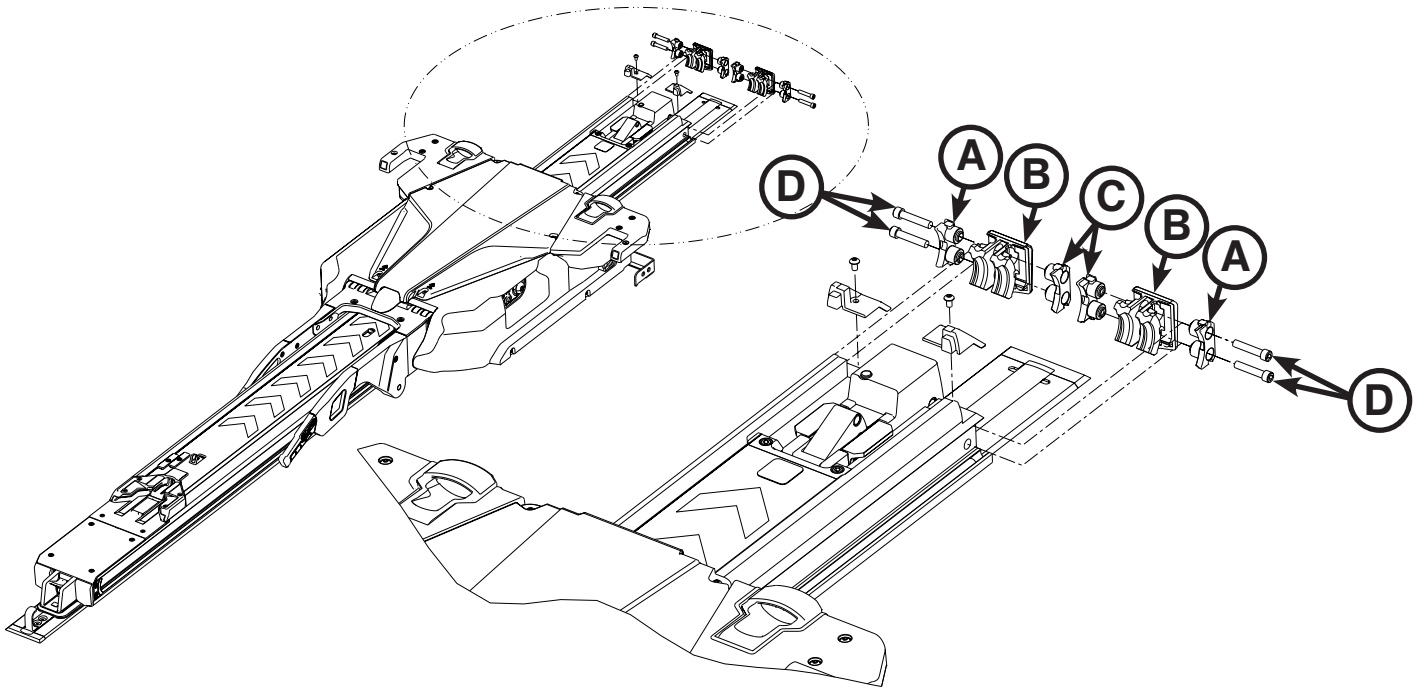

Figure 23: Assemble Bumper Block

- Slide the assembled dead stop bumper into the end of the transfer assembly.

**Note:** Position the dead stop bumper, so that the hump (A) is on the bottom as shown in Figure 24.

- Repeat steps 14-15 to assemble and install the second dead stop bumper.
- Using a 3/16" hex wrench, install the four supplied socket head cap screws (0004-662-000) (two for each side) (D) into the transfer assembly as shown in Figure 23.
- Visually inspect the head end transfer bumpers to ensure that they are installed flush to the outer edge of the transfer assembly with no signs of misalignment or improper installation.

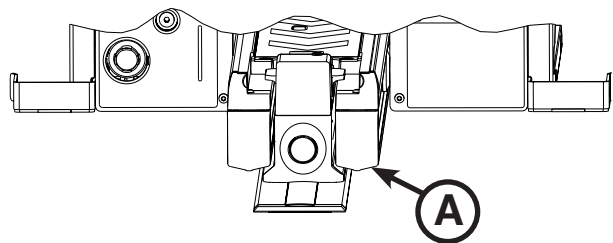

Figure 24: Dead Stop Bumper Hump

# Installation Guide

## INSTALLING THE POWER-LOAD SYSTEM (CONTINUED)

- Using a T25 Torx driver, install the two supplied button head cap screws (0004-665-000) (A) to attach the supplied patient left transfer head end trim (6390-001-210) and supplied patient right transfer head end trim (6390-001-211) (B) to the transfer assembly as shown in Figure 25.

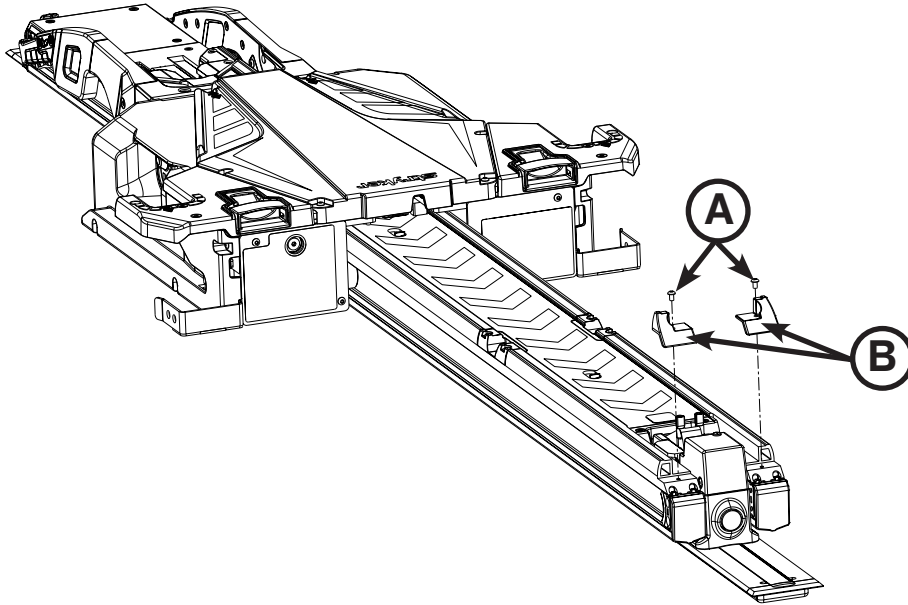

Figure 25: Attach Head End Trim

# Installation Guide

## INSTALLING THE POWER-LOAD SYSTEM (CONTINUED)

20. Press the main power button (A), as shown in Figure 26, on the patient left side of the trolley assembly to turn power on to the unit.

**Notes:**

- If you wired Power-LOAD into a circuit with a switch, make sure that the switch is turned on.
- When pressing the main power button, a green battery power LED (B) also turns on to indicate that the Power-LOAD system is on. If the trolley battery is low, a flashing amber error LED (C) may also appear.

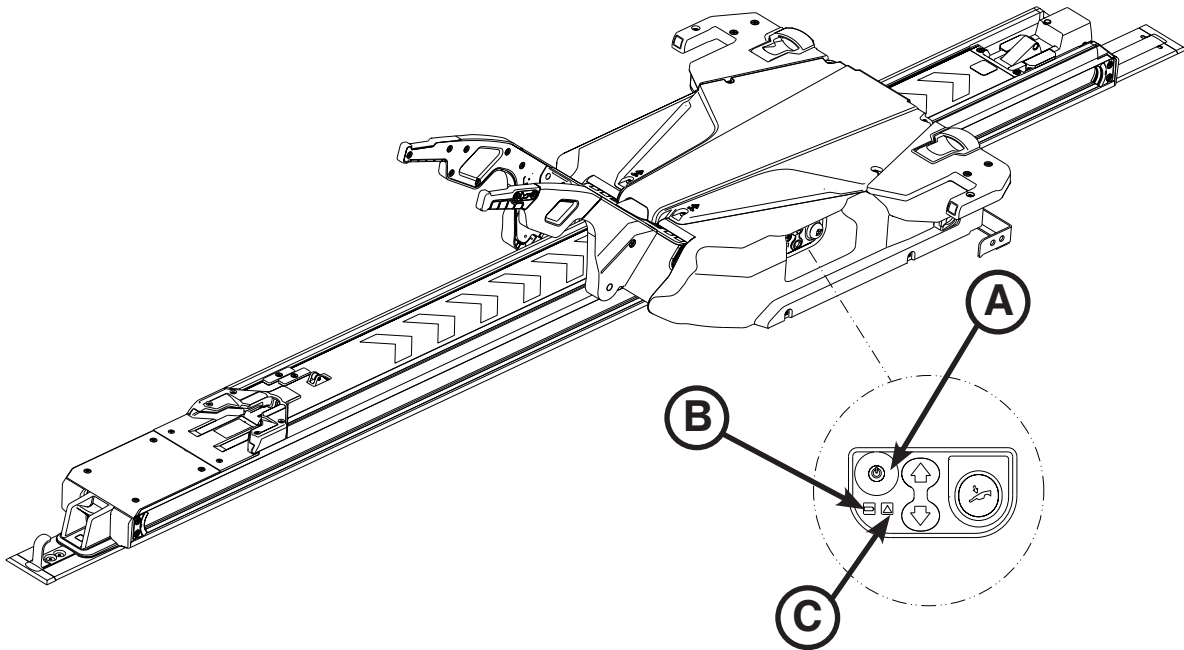

**Figure 26: Power-LOAD Control Panel**

21. Raise the lifting arms and manually push the trolley into the head end of the vehicle patient compartment to charge the battery.

**Note:** The battery power LED (B) flashes green when charging.

22. Affix the operation labels to the door or wall where it is visible to Power-LOAD operators. See “Powered Operations Instructions” on [page 54](#) and “Manual Operations Instructions” on [page 55](#) for label details.

**Note:** Ensure that you apply the label to a smooth surface or the supplied sheet metal plate (6390-001-467) that you can screw or rivet into the vehicle.

23. Complete the installation checklist on [page 46](#).



# Installation Guide

## INSTALLING THE OPTIONAL WHEEL GUIDE

### Optional Wheel Guide Kit Components (6390-027-000)

- (2) Flat Head Cap Screw (p/n 0001-195-000)
- (1) Wheel Guide Assembly (p/n 6390-001-017)
- (5) Wheel Guide Support (p/n 6390-001-174)
- (1) Wheel Guide Rail (p/n 6390-001-176)
- (1) Wheel Guide Nut (p/n 6390-001-191)
- (2) Toplock Locknut (p/n 0016-060-000)
- (2) Pan Head Machine Screw (p/n 0023-296-000)
- (5) Spacer (p/n 6390-001-173)
- (1) Wheel Guide Rail Bumper (p/n 6390-001-175)
- (1) Wheel Guide Cap (p/n 6390-001-178)
- (4) Wheel Cover (p/n 6390-001-206)

### Additional Parts Used (not included)

- (10) 1/4-20 hex head cap screws (ASTM-F835 or SAE grade 8)

### Tools Required:

- Tape Measure
- Drill
- 3/8" Drive Ratchet
- 5/32" Hex Wrench
- Saw (or equivalent)
- 1/4" Drill Bit
- 7/16" Combination Wrench
- Pencil
- 7/16" Socket
- T25 Torx Driver

### Procedure:

**Note:** Ten 1/4-20 hex head cap screws (ASTM-F835 or SAE grade 8) are required, but are not included with your installation kit. Examine your vehicle to determine the best length bolt hardware for your installation. Use these bolts to secure the wheel guide as described in step 11. While installing the wheel guide, see [page 43](#) for component assembly detail.

1. Using a tape measure, measure from the center line of the floor plate to the wall (cabinet) on the driver's side of the vehicle patient compartment (reference Figure 27 and Figure 28).

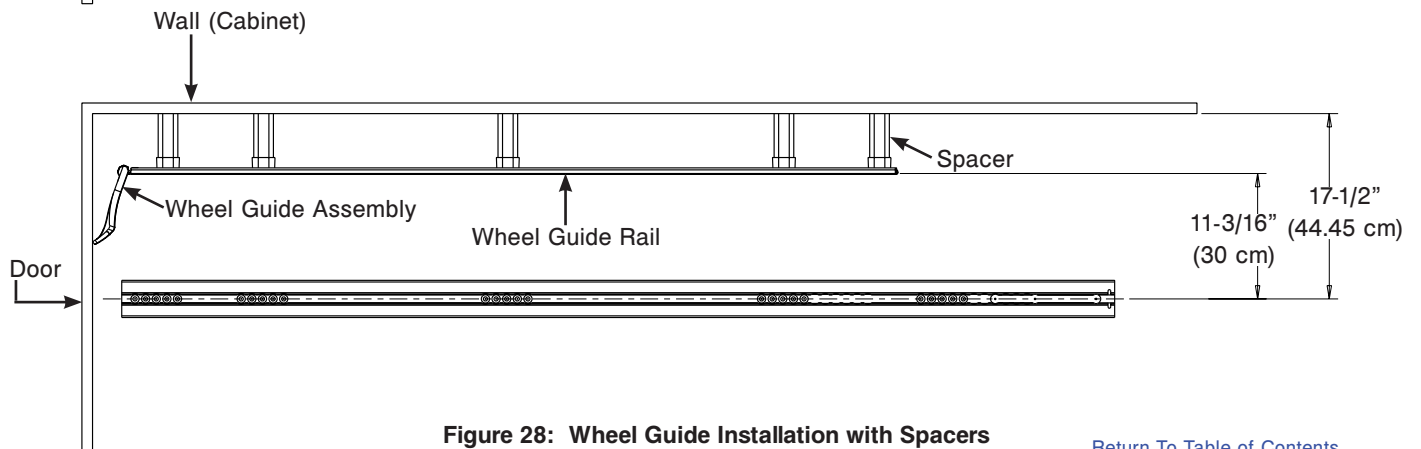
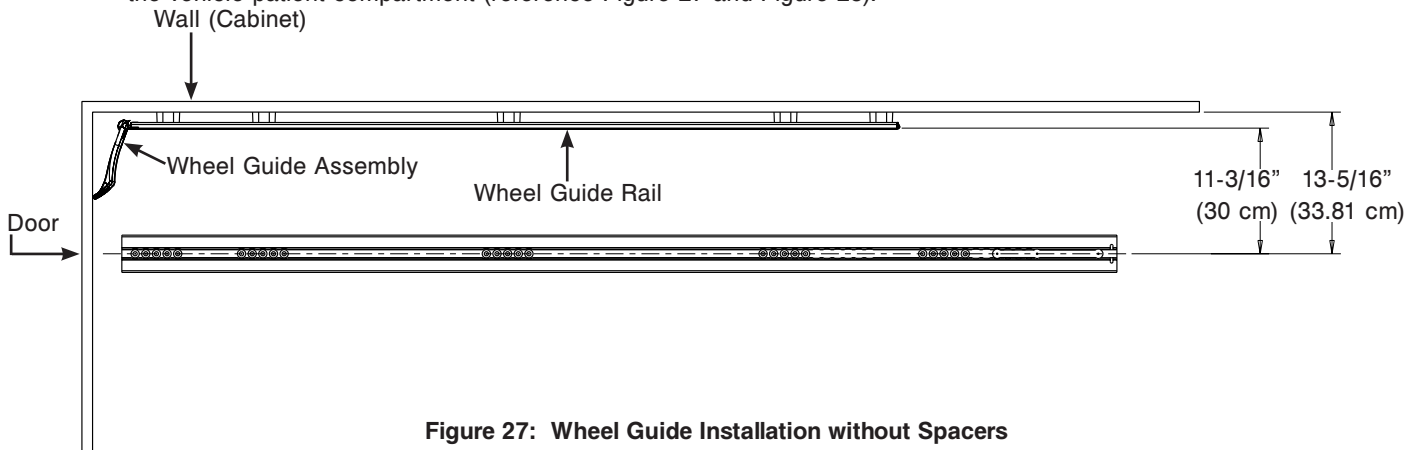

[Return To Table of Contents](#)

# Installation Guide

## INSTALLING THE OPTIONAL WHEEL GUIDE (CONTINUED)

- Using the measurement from step 1, determine if you will need to install the spacers (6390-001-173) (D) for the wheel guide assembly.

Measurement from the Center Line (Floor Plate)	Action Required
Greater than 17-1/2 in (44.45 cm) from the wall	The optional wheel guide is not required.
13-5/16 in (33.81 cm) to 17-1/2 in (44.45 cm)	Spacers (6390-001-173) (D) are required. Subtract 13-5/16 in (33.81 cm) from the measurement in step 1 to determine the size of each spacer. Use a saw (or equivalent) to cut each spacer to fit.
Exactly 17-1/2 in (44.45 cm)	Spacers (6390-001-173) (D) are required, but they do not need to be cut to fit.
Exactly 13-5/16 in (33.81 cm)	Spacers (6390-001-173) (D) are NOT required. Discard all five spacers.

### WARNING

To avoid the risk of personal injury or equipment damage during installation, properly secure the item that you are cutting and be aware of the area around your cutting location. Always wear appropriate eye protection while operating a saw.

- With the vehicle door closed, align the wheel guide rail (6390-001-176) (G) against the wall (cabinet).
- Using a tape measure, measure 1-1/2 in (3.81 cm) from the foot end of the wheel guide rail to the door panel.
- Using a pencil, make a small mark on the wall (cabinet) noting the location of the back of the wheel guide rail.
- With the assistance of someone else, place all five wheel guide supports (6390-001-174) (E) in the approximate mounting locations.
- Set the wheel guide rail on top of the wheel guide supports by referencing the mark made in step 5 for location of the wheel guide rail.

#### Notes:

- Ensure that the holes in the wheel guide rail align with the open areas in the vehicle patient compartment for adequate wheel guide rail support.
- Each hole is spaced 1 in (2.54 cm) apart for multiple installation options.
- Space all five wheel guide supports as evenly as possible. Install all five wheel guide supports.

# Installation Guide

## INSTALLING THE OPTIONAL WHEEL GUIDE (CONTINUED)

- Using a pencil, mark each of the holes in the five areas where a wheel guide support (E) will be located on the wall (cabinet) (Figure 29).

**Note:** Make sure that the wheel guide rail does not move during this process or holes could be made in the wrong position.

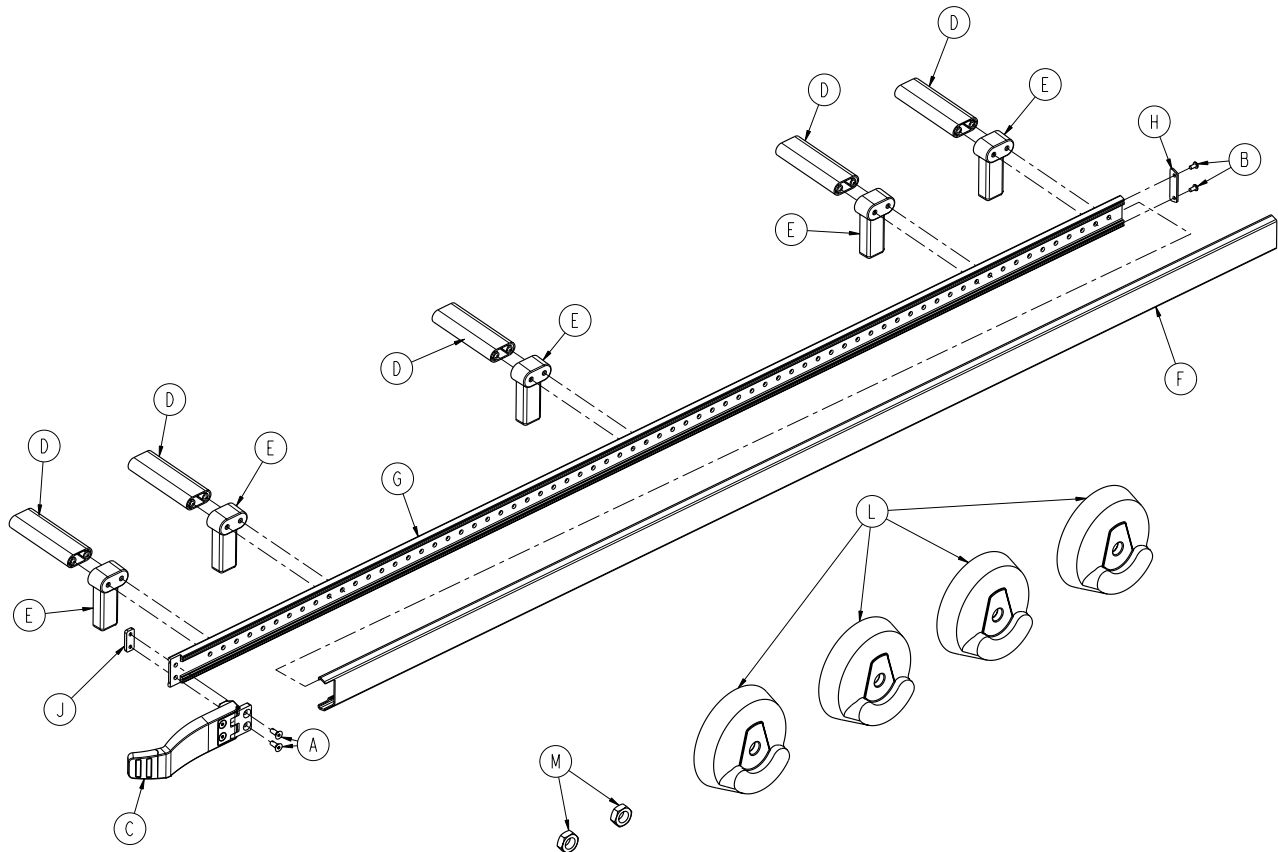

Figure 29: Optional Wheel Guide Kit Components - 6390-027-000

- Remove the wheel guide rail and wheel guide supports.
- Using a drill and a 1/4" drill bit, drill each of the marked hole locations (marked in step 8) into the wall (cabinet).

### ⚠ CAUTION

To avoid the risk of vehicle damage, be aware of items around your selected drill hole locations during installation.

- Select the appropriate length 1/4-20 hex head cap screws, ASTM-F835 or SAE grade 8 (not supplied), for your wheel guide rail installation.
- Using a 7/16" socket with a 3/8" drive ratchet and a 7/16" combination wrench, install the screws (selected in step 11) to secure the wheel guide rail to the wheel guide support through the spacer (6390-001-173) (D), if required, then to the wall of the vehicle patient compartment as shown in "Figure 27: Wheel Guide Installation without Spacers" on [page 41](#) or "Figure 28: Wheel Guide Installation with Spacers" on [page 41](#).
- Using a T25 Torx driver, install the two pan head machine screws (0023-296-000) (B) to secure the wheel guide cap (6390-001-178) (H) to the head end of the wheel guide rail.

[Return To Table of Contents](#)

# Installation Guide

---

## INSTALLING THE OPTIONAL WHEEL GUIDE (CONTINUED)

14. Slide the wheel guide rail bumper (6390-001-175) (F) over the wheel guide rail from the foot end of the vehicle patient compartment to the head end.
15. Using a 5/32" hex wrench, install the two flat head cap screws (0001-195-000) (A) through the wheel guide assembly (6390-001-017) (C) hinge and the wheel guide rail to the wheel guide nut (6390-001-191) (J) as shown in "Figure 29: Optional Wheel Guide Kit Components - 6390-027-000" on [page 43](#).
16. Install the two toplock locknuts (0016-060-000) (M) and four wheel covers (6390-001-206) (L) to the patient right side of the cot that is to be used with the wheel guide assembly. See "Installing Cot Wheel Covers" on [page 45](#).

# Installation Guide

## INSTALLING COT WHEEL COVERS

### Tools Required:

- 5/8" Socket
- 3/8" Drive Ratchet
- 11/16" Combination Wrench

### Procedure:

1. Tilt the cot onto its head end.

**Note:** Make sure that the head section is extended and locked.

2. Using a 5/8" socket with 3/8" drive ratchet and a 11/16" combination wrench, remove the hex head cap screw (A) and nut (B) that secure the wheel (C) to the caster horn (Figure 30) on the patient right side at the foot end of the cot that is to be used with the installed wheel guide assembly. Save the screw for reinstallation. Discard the nut.
3. Remove the two bushings (D) from the wheel (Figure 30). Discard both bushings.
4. Align two wheel covers (6390-001-206) (D) around the wheel, so that the wheel covers match on both sides (Figure 31).
5. Using a 5/8" socket with a 3/8" drive ratchet and a 11/16" combination wrench, install the hex head cap screw (A) and toplock locknut (B) (0016-060-000) to secure the wheel (C) with the wheel covers (D) to the caster horn (Figure 31).

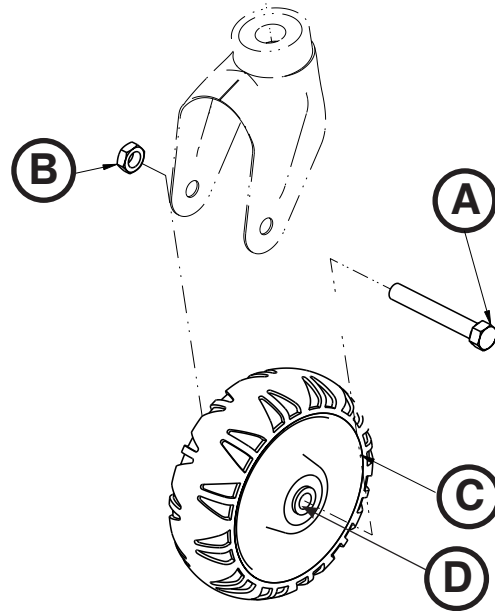

Figure 30: Cot Wheel without Wheel Covers

**Note:** Pay attention to the orientation of the wheel covers during installation to ensure that the two sides are aligned. Do not overtighten the nut. Ensure that the wheel spins freely.

6. Tilt the cot onto its foot end.
7. Repeat steps 2-5 on the patient right side at the head end of the cot.
8. Ensure that both wheels roll smoothly.

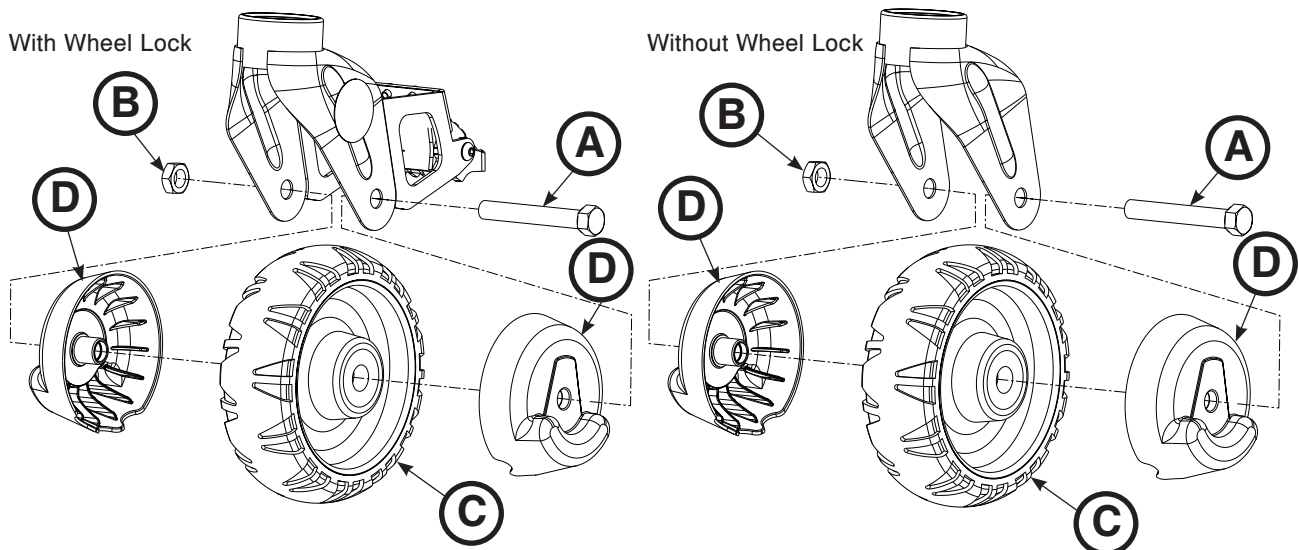

Figure 31: Cot Wheels with Wheel Covers

# Installation Guide

---

## POWER-LOAD INSTALLATION CHECKLIST

**Note:** Allow the battery to charge for a minimum of 20 minutes prior to starting the Power-LOAD functional check. The battery will only charge when the trolley is locked at the head end of the vehicle patient compartment. The battery power LED should flash green while charging.

Before starting the Power-LOAD functional check, ensure that the:

- Check is performed with a Power-LOAD compatible Power-PRO cot (model 6500, 6506, 6510, 6516)
- Power-LOAD is locked at the foot end of the vehicle with the lifting arms down (see “Extending Power-LOAD from the Vehicle without a Cot” on [page 58](#))
- Power is turned on
- LEDs on the trolley assembly wings flash amber

**Note:** When pressing the main power button, the battery power LED also illuminates to indicate that the Power-LOAD system is on. If the trolley battery is low, a flashing amber error LED may appear.

**Note:** Check both the upper and lower cot control switches when checking the cot button functionality.

- \_\_\_\_\_ 1. Lift the vehicle bumper to the raised position (if equipped).
- \_\_\_\_\_ 2. Lock the Power-LOAD compatible cot into Power-LOAD.
- \_\_\_\_\_ 3. Check that both cot load wheel pins are locked into Power-LOAD (latches).
- \_\_\_\_\_ 4. Check that LEDs change from flashing amber to solid green.
- \_\_\_\_\_ 5. Press and hold the retract (-) button on the cot control switch to fully retract the cot undercarriage.
- \_\_\_\_\_ 6. Push the cot into the vehicle patient compartment until it locks at the head end of the vehicle patient compartment. Ensure that the lifting arms lower until the cot wheels are on the vehicle patient compartment floor and the cot foot end locks into the fastener.
- \_\_\_\_\_ 7. Check the foot end LED indicator to ensure that the cot is ready to transport.
  - If the LED is solid green, then the cot foot end is in position or ready to transport.
  - If the LED is flashing amber, then the cot foot end is not in position or not ready to transport.
- \_\_\_\_\_ 8. Ensure that the cot is locked into Power-LOAD by firmly pulling side to side on the foot end of the cot.
- \_\_\_\_\_ 9. Press and hold the extend (+) button on the cot control switch to verify that the cot does not extend in the vehicle. The cot legs should not attempt to lift in the transport position.

**Note:** Pressing the retract (-) button on the cot control switch will allow motion in some conditions.
- \_\_\_\_\_ 10. Press and hold the release lever at the foot end of the Power-LOAD system and pull to remove the cot from the vehicle patient compartment. Ensure that the lifting arms raise the cot until the cot wheels are off the vehicle patient compartment floor.
- \_\_\_\_\_ 11. Ensure that the head end LED indicators are solid green. Press and hold the extend (+) button on the cot control switch to extend the cot until the cot wheels rest on the ground and the cot is no longer supported by the Power-LOAD lifting arms. **Note:** The lifting arms should remain in the full down position after the cot is released from Power-LOAD.
- \_\_\_\_\_ 12. Press the up (↑) button on the Power-LOAD control panel to raise the lifting arms and cot to the highest position.

**Note:** The cot legs do not retract.
- \_\_\_\_\_ 13. Press the down (↓) button on the Power-LOAD control panel to lower the lifting arms and cot.
- \_\_\_\_\_ 14. Press the release button on the cot control switch to release the cot from Power-LOAD. The head end LED indicators will flash amber.
- \_\_\_\_\_ 15. Lock the cot into Power-LOAD again.
- \_\_\_\_\_ 16. Press the up (↑) button on the Power-LOAD control panel to lift the cot up to the highest position.

**Note:** The cot legs do not retract.
- \_\_\_\_\_ 17. Press the manual release button on the Power-LOAD control panel to lower the cot. Continue holding the button until the lifting arms are clear of the cot.

# Installation Guide

---

## POWER-LOAD INSTALLATION CHECKLIST (CONTINUED)

- \_\_\_\_\_ 18. Lift one of the two manual cot release handles at the head end of the trolley to unlock the cot.
- \_\_\_\_\_ 19. Roll the cot away from Power-LOAD.
- \_\_\_\_\_ 20. Raise the lifting arms and push the trolley into the vehicle patient compartment to the transport position. With the trolley at the head end, allow the arms to lower.
- \_\_\_\_\_ 21. Load the Power-LOAD compatible cot without using the LOAD functions to simulate manual loading of cots into the vehicle patient compartment. Ensure that the cot locks into place. See “Loading a Cot into a Vehicle Manually (Power-LOAD Power Loss or System Error)” on [page 69](#).
- \_\_\_\_\_ 22. Press and hold the release lever at the foot end of the Power-LOAD system and pull to remove the cot from the vehicle patient compartment. Ensure that the safety bar engages the safety hook.  
**Note:** Only the cot will unlock. The trolley should remain at the head end of Power-LOAD.
- \_\_\_\_\_ 23. To unlock the trolley, raise the lifting arms and press the trolley release button at the head end of the Power-LOAD system. Slide the trolley only a few inches toward the foot end.
- \_\_\_\_\_ 24. Slide the manual lock override closest to the foot end on the transfer and push the transfer out toward the foot end. Ensure that the transfer can be unlocked.
- \_\_\_\_\_ 25. Fully extend Power-LOAD out of the vehicle patient compartment.
- \_\_\_\_\_ 26. Slide the manual lock override closest to the head end on the transfer and push the transfer in toward the head end. Ensure that the transfer can be unlocked. See “Figure 22: Position the Trolley Assembly” on [page 37](#).
- \_\_\_\_\_ 27. Visually inspect the head end transfer bumpers to ensure that they are installed flush to the outer edge of the transfer assembly with no signs of misalignment or improper installation.
- \_\_\_\_\_ 28. Visually check that all bolts and screws are properly tightened with no signs of protruding or missing fasteners.
- \_\_\_\_\_ 29. Push on the head end pawl and use the foot end release lever to activate the head end pin to ensure that they move freely and do not bind upon letting go.
- \_\_\_\_\_ 30. For Type II ambulances or if the cot center line is 17-1/2” or less from the vehicle wall, verify that the optional wheel guide assembly (6390-027-000) is installed. Mark N/A if the wheel guide is not required.
- \_\_\_\_\_ 31. Press the main power button to turn the unit off. You may need to turn the unit on and then off to ensure that Power-LOAD is off and not in sleep mode.

---

 **CAUTION**

The manual overrides allow the Power-LOAD system to move freely.

---

**Note:** If Power-LOAD will not be in use for a week or more, press the main power button to turn the unit off and avoid draining the battery. You may need to turn the unit on and then off to ensure that Power-LOAD is off and not in sleep mode.

Power-LOAD Serial Number: \_\_\_\_\_

Installed by: \_\_\_\_\_ Date: \_\_\_\_\_

Inspected by: \_\_\_\_\_ Date: \_\_\_\_\_

**Note:** Maintain a copy of this record for at least seven years.

# User Set Up Procedures

---

## POWER-LOAD SET UP

The condition of Power-LOAD is the responsibility of the user. It is important that Power-LOAD is working properly before the product is placed into service. Have a qualified service person use the following list and the operation guide instructions to check Power-LOAD functionality before the product is placed into service.

1. Raise the lifting arms and manually push the Power-LOAD trolley into the head end of the transfer assembly to charge the battery. **To ensure proper operation, the battery should be charged for a minimum of two hours before Power-LOAD is put into service for its first use.**

**Note:** The battery power LED flashes green when charging.

2. Confirm that the installation checklist is complete (see “Power-LOAD Installation Checklist” on [page 46](#)).
3. If the installation checklist was completed by a third-party installer, the installation checklist should be repeated by the end user. Do not place Power-LOAD into service if the installation checklist cannot be completed.

## POWER-LOAD COMPATIBLE COT SET UP

The condition of the Power-LOAD compatible cot is the responsibility of the user. It is important that the Power-LOAD compatible cot is working properly before the product is placed into service. Ensure that the cot is set up according to the requirements specified in the appropriate cot operations/maintenance manual for your cot model.

---

### **WARNING**

To avoid the risk of patient injury, adjust the cot load wheel height to match the vehicle deck height as described in the appropriate cot operations/maintenance manual for your cot model.

---



# User Controls and LED Indicators

Power-LOAD LED indicators, located on the side Power-LOAD control panel and at the head end and foot end of Power-LOAD display trolley battery and system status. This figure and table highlight all Power-LOAD buttons and LED indicators.

**Note:** If Power-LOAD will not be in use for a week or more, press the red main power button (2) to turn the unit off and avoid draining the battery. You may need to turn the unit on and then off to ensure that Power-LOAD is off and not in sleep mode.

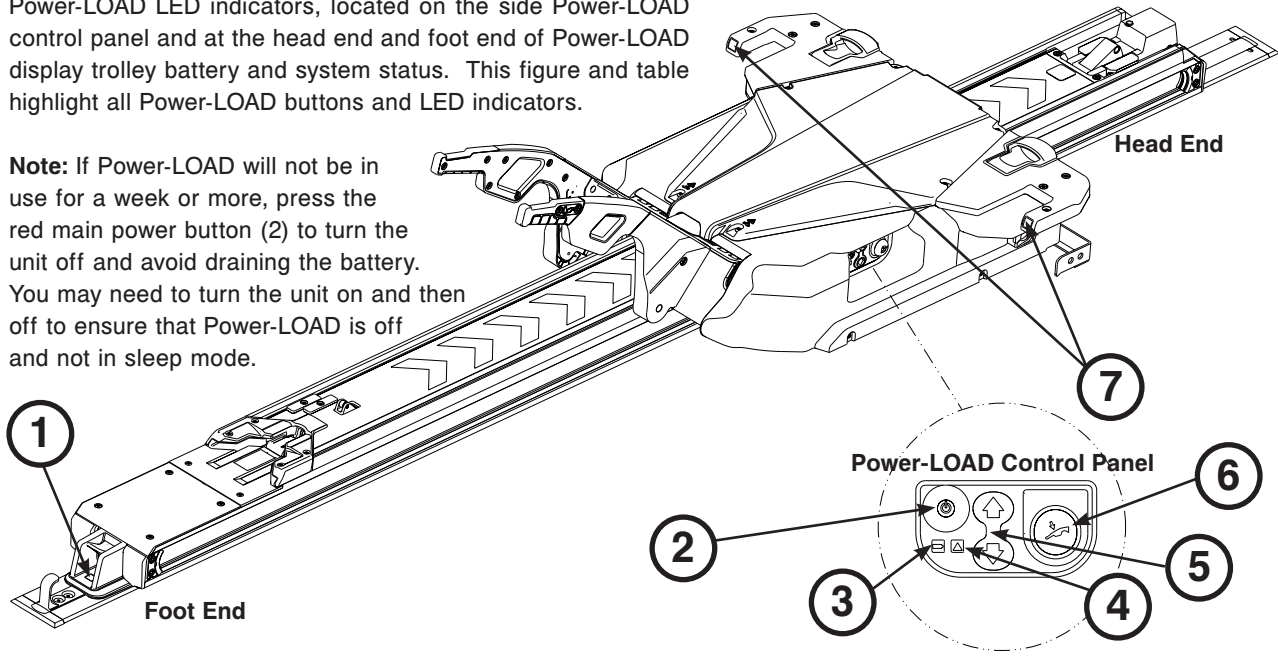

Ref	Icon/Button	Name	Description	Type	Location
1		Foot End LED Indicator	If LED is solid green, the cot foot end is in position or ready to transport. If LED is flashing amber, the cot foot end is not in position or not ready to transport.	LED	Trolley
2		Main Power	Press to power the unit on or off. <b>Note:</b> The battery power LED also illuminates to indicate that the Power-LOAD system is on. If the trolley battery is low, a flashing amber LED may appear.	Button	Power-LOAD Control Panel
3		Battery Power	If LED is solid green, the Power-LOAD system is on and not charging. If LED is flashing green, the battery is charging. <b>Note:</b> The battery will only charge when the trolley is locked at the head end of the vehicle patient compartment.	LED	Power-LOAD Control Panel
4		Error	If LED is solid amber, there is a Power-LOAD error. Press the main power button twice to reset the unit. If the LED remains solid amber, contact technical support. If LED is flashing amber, the trolley battery power is low.	LED	Power-LOAD Control Panel
5		Up/Down	Press up (↑) to raise the lifting arms to the highest position. <b>Note:</b> The cot legs do not retract. Press down (↓) to lower the lifting arms and cot. <b>Note:</b> Extend the cot base before pressing.	Button	Power-LOAD Control Panel
6		Manual Release	Press to unload the cot in the event of a Power-LOAD power failure. Continue holding the button until the lifting arms are clear of the cot. <b>Note:</b> Extend the cot base before pressing.	Button	Power-LOAD Control Panel
7		Head End LED Indicator	If LEDs are solid green, the cot head end is in position. If LEDs are flashing amber, the cot head end is not in position.	LED	Trolley

[Return To Table of Contents](#)

# User Controls and LED Indicators

These Power-LOAD LED indicators are located at the head end of the Power-LOAD trolley.

The oil reservoir location is shown for your reference.

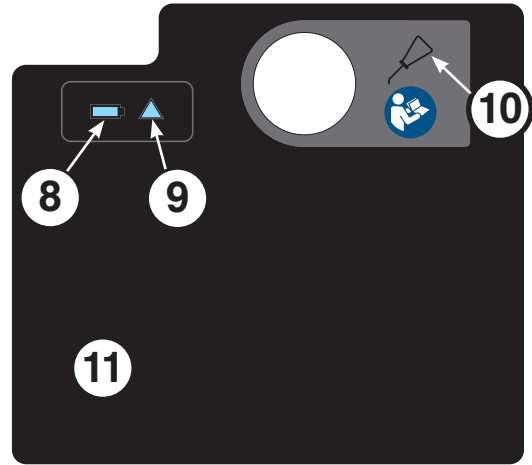

Trolley Head End Label





Ref	Icon/Button	Name	Description	Type	Location
8		Battery Power	If LED is solid green, the Power-LOAD system is on and not charging. If LED is flashing green, the battery is charging. <b>Note:</b> The battery will only charge when the trolley is locked at the head end of the patient compartment.	LED	Trolley Head End
9		Error	If LED is solid amber, there is a Power-LOAD error. Press the red main power button twice to reset the unit. If the LED remains solid amber, contact technical support. If LED is flashing amber, the trolley battery power is low.	LED	Trolley Head End
10		Oil Reservoir	Add Mobil Mercon® V Blend ATF Oil (6500-001-293) here until full. To avoid the risk of a unit malfunction or leak, do not overfill the reservoir with oil. See “Filling the Reservoir” on <a href="#">page 105</a> .	Not Applicable	Trolley Head End
11	Not Applicable	USB Port	Remove plate to access the USB port for input/output diagnostics. Service only by qualified personnel.	Not Applicable	Trolley Head End

# Manual User Controls

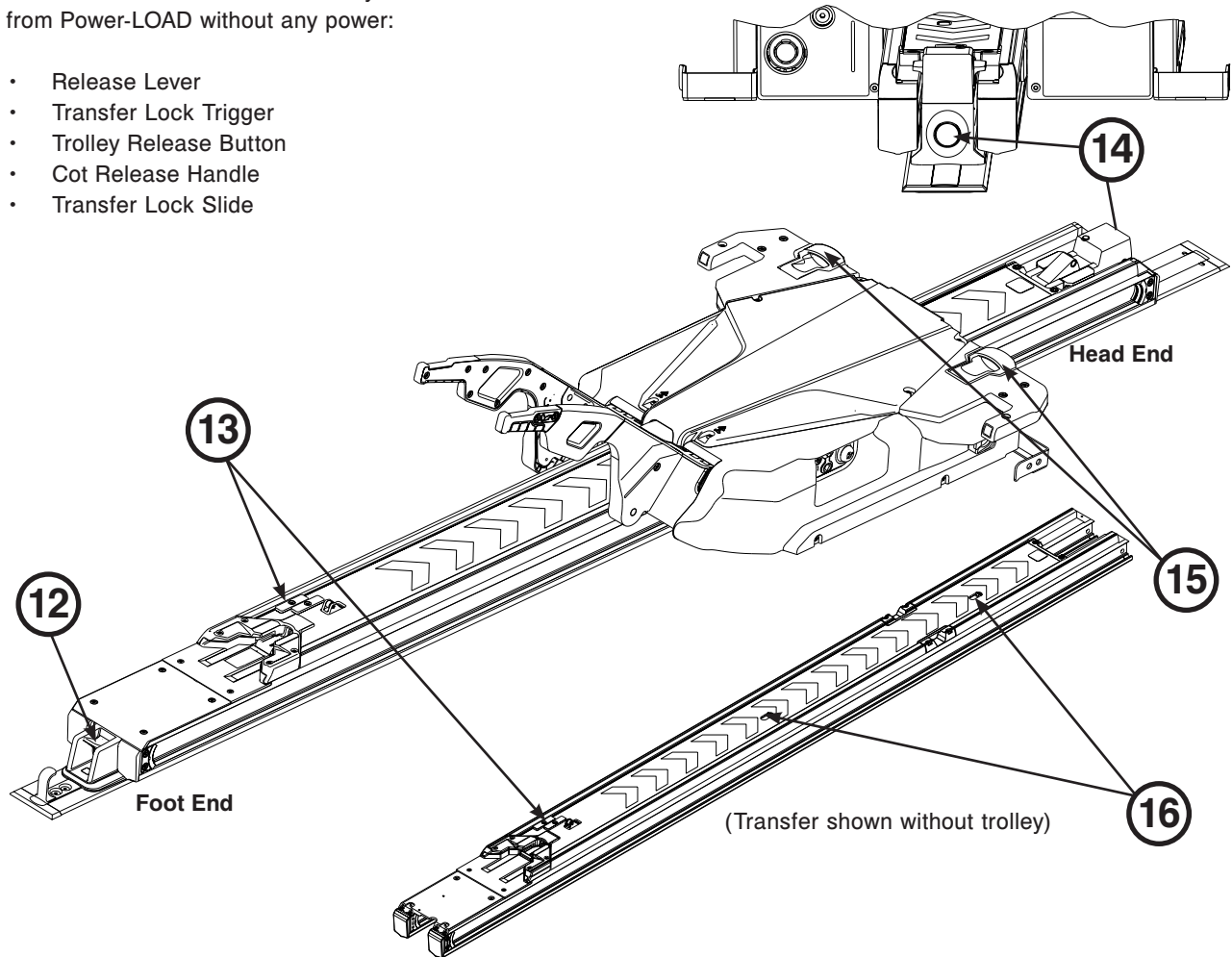
These manual user controls allow you to release a cot from Power-LOAD without any power:

- Release Lever
- Transfer Lock Trigger
- Trolley Release Button
- Cot Release Handle
- Transfer Lock Slide

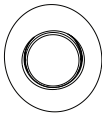

Ref	Manual Control	Name	Description	Location
12		Release Lever	Press and hold to disengage the cot from the patient compartment.	Foot End
13		Transfer Lock Trigger	Slide to disengage the transfer from a locked position.	Transfer
14		Trolley Release Button	Press while raising the lifting arms to release and extend Power-LOAD from the vehicle patient compartment without a cot. Then, pull the trolley out of the vehicle patient compartment.	Head End
15		Cot Release Handle	Lift to unlock the cot from Power-LOAD when the cot base is fully extended.	Trolley
16		Transfer Lock Slide	Slide to disengage the transfer from a locked position.	Transfer

[Return To Table of Contents](#)

# Power-PRO Cot User Controls

## USING THE COT CONTROL SWITCHES

There are two identical cot control switches located on the Power-PRO cots (models 6500/6506 and 6510/6516). Press the buttons on either of these switches to extend the cot, retract the cot, or release the cot from Power-LOAD.

This figure and table highlight the three buttons located on the cot control switch.

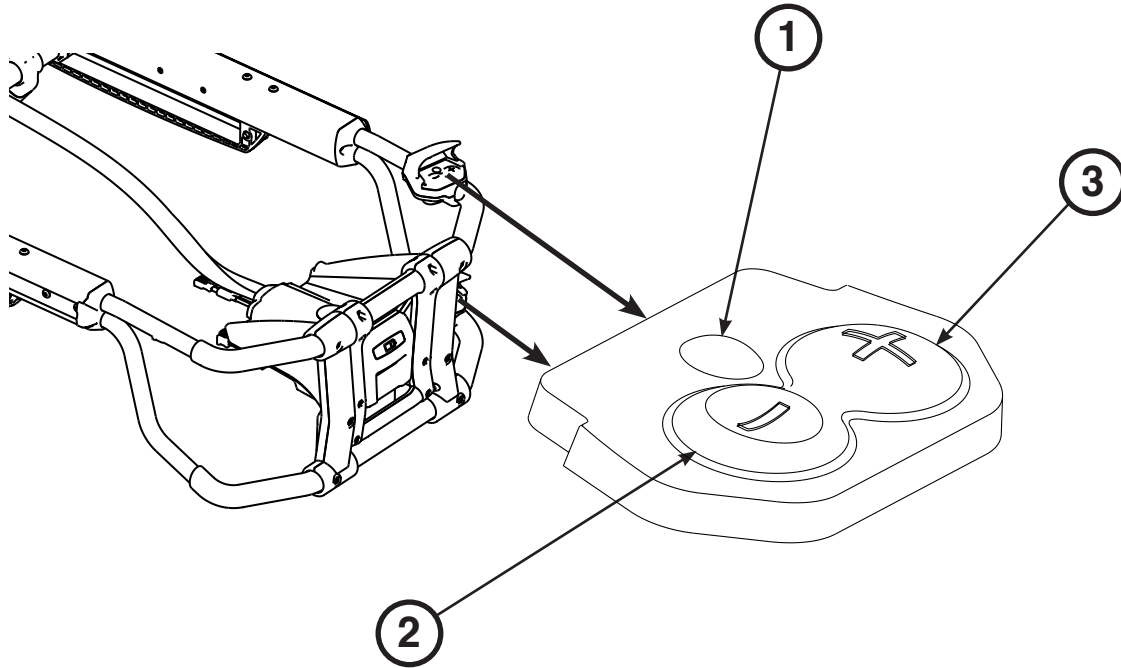

Ref	Name	Description
1	Release	Press to unlock the cot from Power-LOAD.
2	Retract (-)	Press and hold to fully retract the cot undercarriage until the cot is supported.
3	Extend (+)	Press and hold to fully extend the cot undercarriage until the cot wheels are on the ground.

# Power-PRO Cot User Controls

## CHECKING THE COT BATTERY POWER LEVEL

Power-LOAD automatically charges the Power-PRO **SMRT™** Pak battery when the cot is locked into Power-LOAD in the transport position (no cable or connectors required). The cot battery LED indicator momentarily flashes green to signify that it is charging.

To check the battery power level, press the retract (–) button (2) on the cot control switch to activate the cot battery LED indicator (A) as shown in Figure 32.

The cot battery LED indicator is located at the Power-PRO foot end control enclosure (shown as a battery symbol).

- The LED is solid green when the battery is fully charged or has adequately charged battery power.
- The LED flashes amber when the battery needs to be recharged or replaced.
- The LED is solid amber to indicate a battery error.

See the SMRT Power System Operations/Maintenance manual for additional SMRT Pak and SMRT Charger information.

See the Power-PRO Operations/Maintenance manual for additional cot battery information.

### Notes:

- Automatic charging will only occur with SMRT Pak batteries.
- Only use Stryker-approved batteries with Power-PRO.

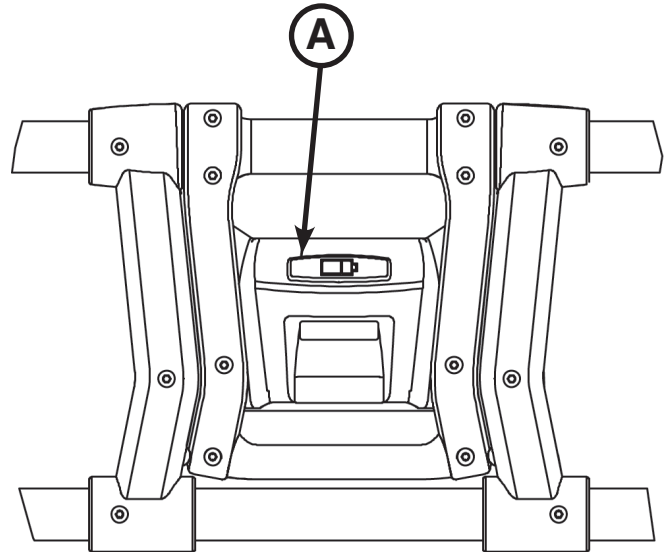

**Figure 32: Battery Power LED Indicator**

# Powered Operations Instructions

Adhere this Powered Operation instruction label to the plate (6390-001-467) and mount the plate on the inside door panel or wall of the vehicle patient compartment where visible to users. See “User Controls and LED Indicators” on [page 49](#) for button and LED locations.

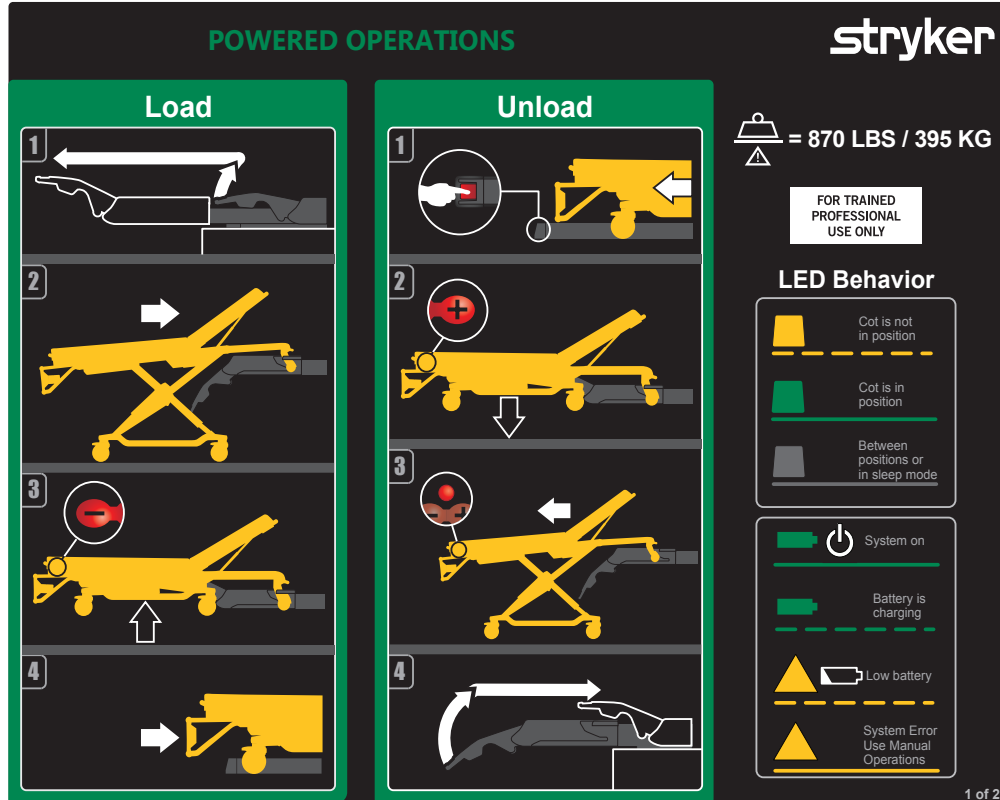

## To unload Power-LOAD:

1. Press and hold the release lever at the foot end of the Power-LOAD system and pull to remove the cot from the vehicle patient compartment.
2. Press and hold the extend (+) button on the cot control switch to extend the cot until the cot wheels rest on the ground.
3. Press the release button on the cot control switch to unlock the cot from Power-LOAD.
4. Raise the lifting arms and guide the trolley into the vehicle patient compartment until the arms are far enough in to not interfere with the vehicle doors.
5. For additional unloading instructions, see “Unloading a Power-PRO Cot from a Vehicle (Model 6500/6506 & 6510/6516 with the Power-LOAD Option)” on [page 65](#).

## To load Power-LOAD:

1. Raise the lifting arms to guide and pull the trolley out of the vehicle patient compartment.
2. Push the cot into Power-LOAD until the cot load wheel pins lock into position. Ensure that the cot is aligned with the lifting arms when loading.
3. Press and hold the retract (–) button on the cot control switch to fully retract the cot undercarriage until the cot is supported.
4. Push the cot into the vehicle patient compartment until the lifting arms lower and the cot locks into Power-LOAD.
5. Check the foot end LED indicator to ensure that the cot is ready to transport.
  - If the LED is solid green, then the cot foot end is in position or ready to transport.
  - If the LED is flashing amber, then the cot foot end is not in position or not ready to transport.
6. Ensure that the cot is locked into Power-LOAD by firmly pulling side to side on the foot end of the cot.
7. For additional unloading instructions, see “Loading a Power-PRO Cot into a Vehicle (Model 6500/6506 & 6510/6516 with the Power-LOAD Option)” on [page 63](#).

**Note:** If Power-LOAD will not be in use for a week or more, press the main power button to turn the unit off and avoid draining the battery. You may need to turn the unit on and then off to ensure that Power-LOAD is off and not in sleep mode.

# Manual Operations Instructions

Adhere this Manual Operation instruction label to the plate (6390-001-467) and mount the plate on the inside door panel or wall of the vehicle patient compartment where visible to users. See “User Controls and LED Indicators” on [page 49](#) for button and LED locations.

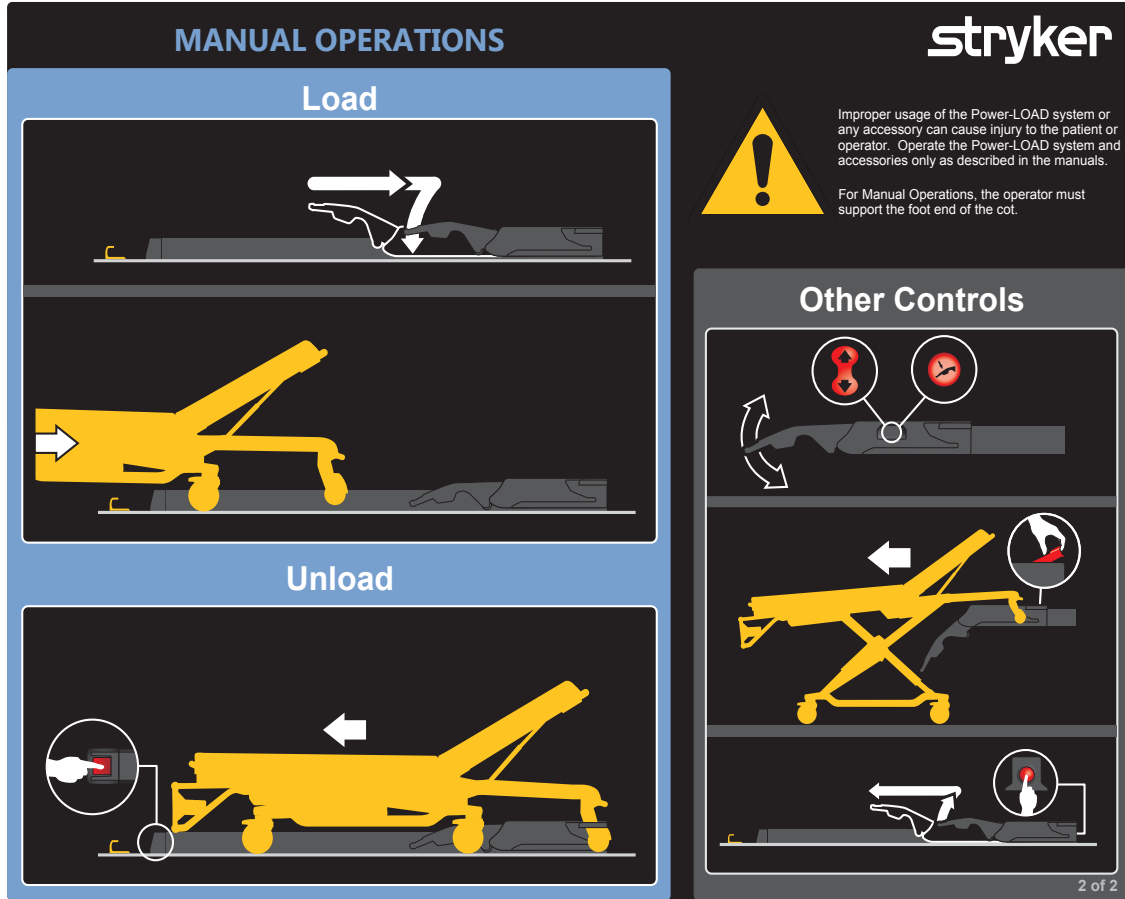

## To load Power-LOAD:

1. Ensure that Power-LOAD is located at the head end of the vehicle patient compartment with the lifting arms down.
2. Push the cot into the vehicle patient compartment until the cot locks into Power-LOAD.
3. Ensure that the cot is locked into Power-LOAD by firmly pulling side to side on the foot end of the cot.
4. For additional loading instructions, see “Loading a Cot into a Vehicle Manually (Power-LOAD Power Loss or System Error)” on [page 69](#).

## To unload Power-LOAD:

Press and hold the release lever at the foot end of the Power-LOAD system and pull to remove the cot from the vehicle patient compartment. For additional unloading instructions, “Unloading a Cot from a Vehicle Manually” on [page 70](#).

## Notes:

- Without power, the lifting arms will not raise the cot. Operators must be ready to accept the entire weight of the cot.
- If Power-LOAD will not be in use for a week or more, press the main power button to turn the unit off and avoid draining the battery. You may need to turn the unit on and then off to ensure that Power-LOAD is off and not in sleep mode.

## WARNING

- Improper usage of the Power-LOAD system or any accessory can cause injury to the patient or operator. Operate the Power-LOAD system and accessories only as described in the manuals.
- For manual operations, the operator must support the weight at the foot end of the cot.

# Operation Guide

---

## OPERATING GUIDELINES

- Check Power-LOAD for proper functionality before starting each shift (the lifting arms should slightly raise the cot as the cot is unlocked, check the battery power level, etc.). If the unit does not seem to be operating properly, remove the vehicle from service to diagnose and repair Power-LOAD.
- Do not operate Power-LOAD with weights greater than 700 lb (318 kg), which includes patient weight and accessories. The safe working load of Power-LOAD is 870 lb (395 kg), which includes the weight of the cot.
- Do not turn off the main power button during normal use as it will prevent battery charging.
- Do not drive the vehicle with the trolley in the mid position. This position does not lock and is not intended for driving.
- Power-LOAD is only an assisting device. Operators are responsible for evaluating each situation to determine how to distribute and lift the weight being transported. Always use both hands when handling the cot.
- When handling weights over 400 lb (181 kg), ensure there are enough operators to handle the forces required for loading or unloading. To increase safety, users should attempt to perform loading or unloading on flat surfaces. For 36 in (91 cm) vehicle deck heights, you may need to use the manual release button on the Power-LOAD control panel or the manual cot release handles at the head end of Power-LOAD to manually unload. Keep hands and extremities clear of the Power-LOAD trolley lifting arms and the cot base during powered loading and unloading.
- Use caution when operating Power-LOAD in adverse weather conditions (for example, rain, ice, snow) to avoid operator and/or patient injury.
- Operate Power-LOAD with the vehicle on a flat surface, if possible.
- If you are unable to unload an occupied cot from the vehicle patient compartment, use a backboard to unload the patient.
- Stryker recommends periodic training (at least once per year) on manual backup procedures. See “Unloading a Cot From a Vehicle Manually after loading with Power-LOAD (Power-LOAD Power Loss or System Error)” on [page 67](#), “Loading a Cot into a Vehicle Manually (Power-LOAD Power Loss or System Error)” on [page 69](#), “Unloading a Cot from a Vehicle Manually” on [page 70](#) “Unloading a Cot from a Vehicle Manually” on [page 70](#), “Loading a Cot into a Vehicle Manually (Power-PRO Power Loss)” on [page 72](#). See [www.stryker.com](http://www.stryker.com) or contact your Stryker sales representative for an additional training checklist example (Mkt Lit-676).

---

### WARNING

- Improper usage of the Power-LOAD system or any accessory can cause injury to the patient or operator. Operate the Power-LOAD system and accessories only as described in the manuals.
  - Failure to ensure proper Power-LOAD functionality prior to use may result in patient and/or operator injury.
  - Use caution while moving around in the vehicle patient compartment to avoid tripping on Power-LOAD.
  - To avoid the risk of operator and/or patient injury, use caution when operating Power-LOAD in adverse weather conditions (for example, rain, ice, snow).
  - Entanglement in powered cot and/or Power-LOAD mechanisms can cause serious injury. Operate the cot and/or Power-LOAD only when all persons are clear of the mechanisms.
  - Practice loading and unloading the cot with Power-LOAD until operation of the product is fully understood. Improper use can cause injury.
  - Do not allow untrained personnel to assist in the operation of Power-LOAD. Untrained technicians/personnel can cause injury to the patient or themselves.
  - To reduce the risk of patient injury and/or equipment damage, do not drive the vehicle with the trolley in the mid position. This position does not lock and is not intended for driving.
  - Power-LOAD is only an assisting device. Operators are responsible for evaluating each situation to determine how to distribute and lift the weight being transported. Always use both hands when handling the cot.
  - When handling weights over 400 lb (181 kg), ensure there are enough operators to handle the forces required for loading or unloading. To increase safety, users should attempt to perform loading or unloading on flat surfaces. For 36 in (91 cm) vehicle deck heights, you may need to use the manual release button on the Power-LOAD control panel or the manual cot release handles at the head end of Power-LOAD to manually unload.
  - Keep hands and extremities clear of the Power-LOAD trolley lifting arms and the cot base during powered loading and unloading.
-



# Operation Guide

---

## CHECKING THE BATTERY POWER LEVEL

Ensure that the trolley power is turned on and check the battery power level on the Power-LOAD control panel (shown as a battery symbol).

- The battery power LED is solid green when the Power-LOAD system is on and not charging.
- The battery power LED flashes green when the battery is charging.
- The error LED flashes amber when the battery is low.

To charge the battery, see “Charging the Battery”.

---

### WARNING

- Return damaged batteries to a service center for recycling. Do not dispose of as unsorted municipal waste. Refer to your local distributor for return and/or collection systems available in your country.
- To reduce the risk of electric shock, do not remove the battery when Power-LOAD is in operation.
- Before servicing Power-LOAD, unplug the shoreline (if applicable), disconnect the vehicle battery, press the main power button to turn the unit off, and then place the trolley into the loading position.

---

## CHARGING THE BATTERY

Ensure that the battery is sufficiently charged for the Power-LOAD to operate properly. When fully discharged, the battery requires a minimum of 10 hours to recharge. The batteries charge whenever the trolley is locked into the head end of the vehicle patient compartment.

To charge the battery:

1. Raise the lifting arms and manually push the trolley into the head end of the vehicle patient compartment.
2. Lock the trolley at the head end of the vehicle patient compartment.

**Note:** The battery power LED flashes green when the battery is charging.

To check the battery power level, see “Checking the Battery Power Level”.

**Note:** If Power-LOAD will not be in use for a week or more, press the main power button to turn the unit off and avoid draining the battery. You may need to turn the unit on and then off to ensure that Power-LOAD is off and not in sleep mode.

---

### WARNING

Do not press the main power button to turn the unit off during normal use as it will prevent battery charging.

---

## STORING POWER-LOAD

All batteries lose charge during storage or periods of inactivity. If Power-LOAD will not be in use for a week or more, press the main power button to turn the unit off and avoid draining the battery. You may need to turn the unit on and then off to ensure that Power-LOAD is off and not in sleep mode.

## SETTING THE COT LOAD HEIGHT

You must set the cot load height for the cot with the Power-LOAD option before placing the vehicle into service. For a list of compatible cots, see “Cot Compatibility Information” on [page 18](#). See the Operations/Maintenance Manual for your cot for more information about how to set the appropriate cot height.

# Operation Guide

## USING A NON-UPGRADED X-FRAME COT FOR A MASS CASUALTY INCIDENT

Some non-compatible cots, including most X-frame cots, may be used in a mass casualty incident. The loading and unloading operations are similar to the instructions for manual loading and unloading of a cot (see [page 69](#)), however, a rail clamp assembly is used instead of a foot end cot lock. When loading a non-compatible cot, lock the cot retaining post into the rail clamp assembly.

The mass casualty option contains a rail assembly for wall or floor mount. You should store this rail assembly in a cabinet in case of emergency for quick attachment in the vehicle patient compartment.

### WARNING

- To prevent the rail jaws from releasing the cot frame, the space between the rail clamp and the rail stationary jaw must never exceed 1 in (2.5 cm). To prevent the rail jaws from releasing the cot frame and causing possible injury to the patient or user, the rail clamp must not overlap the red adjustment limit label on the rail tube.
- The rail clamp fastener closes with a strong spring action. To avoid injury, do not use hand or fingers to press the release button when the rail jaws are open.

## EXTENDING POWER-LOAD FROM THE VEHICLE WITHOUT A COT

To extend Power-LOAD from the vehicle patient compartment without a cot:

1. Walk to the head end of the Power-LOAD system.
2. While raising the lifting arms, press the trolley release button at the head end of the Power-LOAD system as shown in Figure 33.
3. Pull the trolley out of the vehicle patient compartment as shown in Figure 34.



Figure 33: Press Trolley Release Button



Figure 34: Pull Trolley Out

# Operation Guide

## LOADING A PERFORMANCE-PRO COT INTO A VEHICLE (MODEL 6085/6086 WITH THE POWER-LOAD OPTION)

### WARNING

- Loading and/or unloading an occupied cot into a vehicle requires a minimum of two (2) trained operators.
- Make sure that all occupants enter the vehicle patient compartment after the Power-LOAD compatible cot has been loaded into the vehicle patient compartment.

1. Lift the vehicle bumper to the raised position (if equipped).
2. Raise the lifting arms to guide and pull the trolley out of the vehicle patient compartment as shown in Figure 35.
3. Raise the cot to the load position.
4. Push the cot into Power-LOAD until the cot load wheel pins lock into position as shown in Figure 36. Ensure that the cot is aligned with the lifting arms when loading.

### CAUTION

To avoid the risk of equipment damage, do not slam the cot into the trolley when loading.



Figure 35

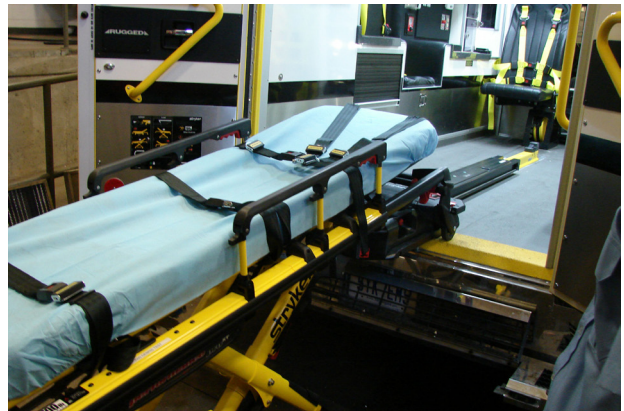

Figure 36

5. Check the head end LED indicators to ensure that the cot is ready to load.
  - If the LEDs are solid green, then the cot head end is in position.
  - If the LEDs are flashing amber, then the cot head end is not in position.

# Operation Guide

---

## LOADING A PERFORMANCE-PRO COT INTO A VEHICLE (MODEL 6085/6086 WITH THE POWER-LOAD OPTION) (CONTINUED)

6. Press the up (↑) button on the Power-LOAD control panel to raise the lifting arms to the highest position as shown in Figure 37.

**Note:** The cot legs do not retract.

7. Operator 1 (Foot End) – Grasp the cot frame at the foot end. Squeeze and hold the cot manual release.
8. Operator 2 (Side) – Stabilize the cot by placing one hand on the outer rail. Grasp the base frame as shown in Figure 38. After the foot end operator has lifted the cot and squeezed the cot manual release, retract the undercarriage with one hand and hold it in place.



Figure 37



Figure 38

9. Operator 1 (Foot End) - Release the cot manual release to lock the undercarriage in the retracted position. Ensure that the cot manual release is released. If it is not released, the cot base will extend preventing the cot from locking in the fastener.

---

### CAUTION

To avoid the risk of equipment damage, do not push the cot into the vehicle patient compartment until the cot base is fully retracted.

---

10. Push the cot into the vehicle patient compartment until the lifting arms lower and the cot locks into Power-LOAD.
11. Check the foot end LED indicator to ensure that the cot is ready to transport.
  - If the LED is solid green, then the cot foot end is in position or ready to transport.
  - If the LED is flashing amber, then the cot foot end is not in position or not ready to transport.
12. Ensure that the cot is locked into Power-LOAD by firmly pulling side to side on the foot end of the cot.

# Operation Guide

---

## UNLOADING A PERFORMANCE-PRO COT FROM A VEHICLE (MODEL 6085/6086 WITH THE POWER-LOAD OPTION)

---

### WARNING

Loading and/or unloading an occupied cot into a vehicle requires a minimum of two (2) trained operators.

---

1. Lift the vehicle bumper to the raised position (if equipped).
  2. Press and hold the release lever at the foot end of the Power-LOAD system and pull to remove the cot from the vehicle patient compartment.
- 

### WARNING

As the cot is unlocked for removal from the vehicle patient compartment, the Power-LOAD lifting arms will slightly raise the cot. If the lifting arms do not raise the cot, then the operators must be ready to accept the entire weight of the cot and patient to avoid injury.

---

3. Grasp the cot frame at the foot end to pull the cot out of the vehicle patient compartment.

**Note:** The head end LED indicators turn solid green only when the cot is ready to unload.

4. Operator 1 (Foot End) – Grasp the cot frame as shown in Figure 39. Squeeze and hold the cot manual release.
  5. Operator 2 (Side) – Grasp the base frame where indicated in Figure 39, lift slightly, and lower the base frame to its fully extended position. Verify that the cot wheels are on the ground.
- 

### WARNING

When unloading the cot, ensure that the cot base is extended before pressing any buttons on the Power-LOAD control panel.

---

6. Operator 1 (Foot End) – Release the cot manual release to lock the undercarriage into the extended position.



Figure 39

# Operation Guide

---

## UNLOADING A PERFORMANCE-PRO COT FROM A VEHICLE (MODEL 6085/6086 WITH THE POWER-LOAD OPTION) (CONTINUED)

7. Press the down (↓) button on the Power-LOAD control panel to lower the lifting arms and cot as shown in Figure 40.
8. Lift one of the two manual cot release handles at the head end of the trolley to unlock the cot as shown in Figure 41.



Figure 40



Figure 41

9. Raise the lifting arms and guide the trolley into the vehicle patient compartment until the arms are far enough in to not interfere with the vehicle doors.

# Operation Guide

## LOADING A POWER-PRO COT INTO A VEHICLE (MODEL 6500/6506 & 6510/6516 WITH THE POWER-LOAD OPTION)

### WARNING

- Loading and/or unloading an occupied cot into a vehicle requires a minimum of two (2) trained operators.
- Make sure that all occupants enter the vehicle patient compartment after the Power-LOAD compatible cot has been loaded into the vehicle patient compartment.

1. Lift the vehicle bumper to the raised position (if equipped).
2. Raise the lifting arms to guide and pull the trolley out of the vehicle patient compartment as shown in Figure 42.
3. Press and hold the extend (+) button on the cot control switch to extend the cot undercarriage to the set load height. (Figure 43).



Figure 42



Figure 43

4. Push the cot into Power-LOAD until the cot load wheel pins lock into position as shown in Figure 44. Ensure that the cot is aligned with the lifting arms when loading.

### CAUTION

To avoid the risk of equipment damage, do not slam the cot into the trolley when loading.

5. Check the head end LED indicators to ensure that the cot is ready to load.
  - If the LEDs are solid green, then the cot head end is in position.
  - If the LEDs are flashing amber, then the cot head end is not in position.



Figure 44

# Operation Guide

---

## LOADING A POWER-PRO COT INTO A VEHICLE (MODEL 6500/6506 & 6510/6516 WITH THE POWER-LOAD OPTION) (CONTINUED)

6. Press and hold the retract (–) button on the cot control switch, as shown in Figure 45, to fully retract the cot undercarriage until the cot is supported.
7. Push the cot into the vehicle patient compartment until the lifting arms lower and the cot locks into Power-LOAD.
8. Check the foot end LED indicator to ensure that the cot is ready to transport.
  - If the LED is solid green, then the cot foot end is in position or ready to transport.
  - If the LED is flashing amber, then the cot foot end is not in position or not ready to transport.
9. Ensure that the cot is locked into Power-LOAD by firmly pulling side to side on the foot end of the cot.



Figure 45



# Operation Guide

## UNLOADING A POWER-PRO COT FROM A VEHICLE (MODEL 6500/6506 & 6510/6516 WITH THE POWER-LOAD OPTION)

### WARNING

Loading and/or unloading an occupied cot into a vehicle requires a minimum of two (2) trained operators.

1. Lift the vehicle bumper to the raised position (if equipped).
2. Press and hold the release lever at the foot end of the Power-LOAD system and pull to remove the cot from the vehicle patient compartment as shown in Figure 46.

### WARNING

As the cot is unlocked for removal from the vehicle patient compartment, the Power-LOAD lifting arms will slightly raise the cot. If the lifting arms do not raise the cot, then the operators must be ready to accept the entire weight of the cot and patient to avoid injury.

3. Grasp the cot frame at the foot end to pull the cot out of the vehicle patient compartment as shown in Figure 47.

**Note:** The head end LED indicators turn solid green only when the cot is ready to unload.



Figure 46



Figure 47

4. Press and hold the extend (+) button on the cot control switch to extend the cot until the cot wheels rest on the ground.
5. Release the extend (+) button after the cot is no longer supported by the lifting arms. The lifting arms will continue moving until they have fully lowered.

# Operation Guide

---

## UNLOADING A POWER-PRO COT FROM A VEHICLE (MODEL 6500/6506 & 6510/6516 WITH THE POWER-LOAD OPTION) (CONTINUED)

6. Press the release button (Figure 48) on the cot control switch at the foot end of the cot or lift one of the two manual cot release handles at the head end of the trolley to unlock the cot (Figure 49).



**Figure 48**



**Figure 49**

7. Raise the lifting arms and guide the trolley into the vehicle patient compartment until the arms are far enough in to not interfere with the vehicle doors.

# Operation Guide

---

## UNLOADING A COT FROM A VEHICLE MANUALLY AFTER LOADING WITH POWER-LOAD (POWER-LOAD POWER LOSS OR SYSTEM ERROR)

---

### WARNING

- Loading and/or unloading an occupied cot into a vehicle requires a minimum of two (2) trained operators.
  - When unloading a cot from the vehicle patient compartment while Power-LOAD is experiencing a power loss or system error, the operators must be ready to accept the entire weight of the cot and patient.
- 

If Power-LOAD loses power or experiences a system error after a cot has already been loaded, follow these steps to unload the cot:

**Note:** The lifting arms will be in the up position.

1. Press and hold the release lever at the foot end of the Power-LOAD system and pull to remove the cot from the vehicle patient compartment as shown in Figure 50.

**Note:** The lifting arms will not raise the cot. Operators must be ready to accept the entire weight of the cot.

2. Grasp the cot frame at the foot end to pull the cot out of the vehicle patient compartment.



**Figure 50**

### **For models 6500/6506 and 6510/6516 with the Power-LOAD option:**

- Operator 1 - Grasp the cot frame at the foot end. While supporting the weight of the cot, guide and pull the cot out of the vehicle patient compartment. Press and hold the extend (+) button on the cot control switch to extend the cot until the cot wheels rest on the ground.
- Operator 2 - Stabilize the cot during the unloading operation by securely grasping the outer rail.

### **For models 6085/6086 with the Power-LOAD option:**

- Operator 1 – Grasp the cot frame.
  - Operator 2 – Grasp the base frame where indicated, lift slightly, and lower the base frame to its fully extended position while Operator 1 squeezes and holds the cot manual release. Verify that the cot wheels are on the ground.
  - Operator 1 (Foot End) – Release the cot manual release to lock the undercarriage into the extended position.
- 

### WARNING

When unloading the cot, ensure that the cot base is extended before pressing any buttons on the Power-LOAD control panel.

---

# Operation Guide

---

## UNLOADING A COT FROM A VEHICLE MANUALLY AFTER LOADING WITH POWER-LOAD (POWER-LOAD POWER LOSS OR SYSTEM ERROR) (CONTINUED)

3. Press the manual release button on the Power-LOAD control panel as shown in Figure 51 to lower the lifting arms until they are clear of the cot.
4. Lift one of the manual cot release handles at the head end of Power-LOAD to unlock the cot as shown in Figure 52.



Figure 51



Figure 52

5. Raise the lifting arms and guide the trolley into the vehicle patient compartment until the arms are far enough in to not interfere with the vehicle doors.
6. Following the call, remove the vehicle from service to diagnose and repair Power-LOAD.

# Operation Guide

## LOADING A COT INTO A VEHICLE MANUALLY (POWER-LOAD POWER LOSS OR SYSTEM ERROR)

### WARNING

- Loading and/or unloading an occupied cot into a vehicle requires a minimum of two (2) trained operators.
- Make sure that all occupants enter the vehicle patient compartment after the Power-LOAD compatible cot has been loaded into the vehicle patient compartment.

1. Lift the vehicle bumper to the raised position (if equipped).
2. Ensure that the trolley is located at the head end of the vehicle patient compartment with the lifting arms down. If not, raise the lifting arms and guide the trolley into the vehicle patient compartment until Power-LOAD locks into position with the lifting arms down.
3. Make sure that the cot retractable head section is fully extended and locked.
4. Place the cot in a loading position (any position where the loading wheels meet the vehicle patient compartment floor height).
5. Roll the cot to the open vehicle patient compartment.
6. Push the cot forward until the loading wheels are on the vehicle patient compartment floor and the safety bar passes the safety hook as shown in Figure 53.



Figure 53

**Note:** For maximum clearance to lift the base, pull the cot out until the safety bar engages the safety hook.

#### For models 6500/6506 and 6510/6516 with the Power-LOAD option:

- Grasp the cot frame at the foot end.
- Lift the foot end of the cot and press and hold the retract (-) button on the cot control switch to fully retract the cot undercarriage.

**Note:** The cot undercarriage will retract in less than three seconds.

#### For models 6085/6086 with the Power-LOAD option:

- Operator 1 (Foot End) – Grasp the cot frame at the foot end. Squeeze and hold the cot manual release.
- Operator 2 (Side) – Stabilize the cot by placing one hand on the outer rail. Grasp the base frame. After the foot end operator has lifted the cot and squeezed the cot manual release, retract the undercarriage with one hand and hold it in place.
- Operator 1 (Foot End) - Release the cot manual release to lock the undercarriage in the retracted position.

### CAUTION

To avoid the risk of equipment damage, do not push the cot into the vehicle patient compartment until the cot base is fully retracted.

7. Push the cot into the vehicle patient compartment until the cot locks into Power-LOAD.
8. Ensure that the cot is locked into Power-LOAD by firmly pulling side to side on the foot end of the cot.
9. Following the call, remove the vehicle from service to diagnose and repair Power-LOAD.

# Operation Guide

## UNLOADING A COT FROM A VEHICLE MANUALLY

### WARNING

- Loading and/or unloading an occupied cot into a vehicle requires a minimum of two (2) trained operators.
- Power-LOAD is only an assisting device. Operators are responsible for evaluating each situation to determine how to distribute and lift the weight being transported. Always use both hands when handling the cot.
- When handling weights over 400 lb (181 kg), ensure there are enough operators to handle the forces required for loading or unloading. To increase safety, users should attempt to perform loading or unloading on flat surfaces. For 36 in (91 cm) vehicle deck heights, you may need to use the manual release button on the Power-LOAD control panel or the manual cot release handles at the head end of Power-LOAD to manually unload.

1. Lift the vehicle bumper to the raised position (if equipped).
2. Press and hold the release lever at the foot end of the Power-LOAD system and pull to remove the cot from the vehicle patient compartment as shown in Figure 54.
3. Grasp the cot frame at the foot end to pull the cot out of the vehicle patient compartment.

#### For models 6500/6506 and 6510/6516 with the Power-LOAD option:

- Operator 1 - Grasp the cot frame at the foot end. While supporting the weight of the cot, guide and pull the cot out of the vehicle patient compartment until the safety bar engages the safety hook. Press and hold the extend (+) button on the cot control switch to extend the cot until the cot wheels rest on the ground.
- Operator 2 - Verify that the safety bar engages the safety hook and stabilize the cot during the unloading operation by securely grasping the outer rail. Push the safety bar release lever forward to disengage the safety bar from the safety hook in the vehicle patient compartment.

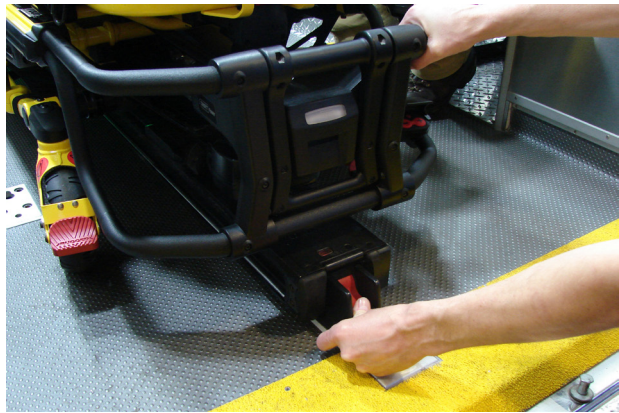

Figure 54

#### For models 6085/6086 with the Power-LOAD option:

- Operator 1 (Foot End) – Grasp the cot frame at the foot end. While supporting the weight of the cot, guide and pull the cot out of the vehicle patient compartment until the safety bar engages the safety hook.
- Operator 2 (Side) – Grasp the base frame where indicated, lift slightly, and lower the base frame to its fully extended position while Operator 1 squeezes and holds the cot manual release.
- Operator 1 (Foot End) – Let go of the cot manual release and ensure that the undercarriage locks into place. Set the cot onto the ground.
- Operator 2 (Side) – Disengage the safety bar from the safety hook by pushing the safety bar release lever forward.

### WARNING

When unloading the cot, ensure that the cot base is extended before pressing any buttons on the Power-LOAD control panel.

**Note:** In the unlikely case that the cot foot end fails and the cot cannot be removed from the vehicle, remove the patient by alternate means (for example, by using a backboard or field cot).

# Operation Guide

---

## REMOVING A COT FROM A VEHICLE FOR REPAIR

---

 **WARNING**

Removing a cot from a vehicle for repair requires a minimum of two (2) trained operators.

---

To remove a cot from a vehicle for repair:

1. Operator 1 - Press and hold the trolley release button at the head end of the Power-LOAD system. Operator 2 - Slide both transfer lock triggers (closest to the foot end) toward the foot end of the transfer assembly to unlock and with the help of Operator 1, push the cot and transfer firmly out of the vehicle compartment.
  2. Operator 1 - With a screwdriver or similar tool, push on the hook assembly underneath the transfer while Operator 2 pushes the transfer forward toward the head end of the vehicle compartment to disengage the cot from the lock.
  3. After the cot is unlocked, pull the cot all the way out.
- 

 **WARNING**

Power-LOAD is only an assisting device. Operators are responsible for evaluating each situation to determine how to distribute and lift the weight being transported. Always use both hands when handling the cot.

---

4. Ensure that the cot base is extended, then lift one of the manual cot release handles at the head end of Power-LOAD to unlock the cot.
- 

 **WARNING**

When unloading the cot, ensure that the cot base is extended before pressing any buttons on the Power-LOAD control panel.

---

# Operation Guide

## LOADING A COT INTO A VEHICLE MANUALLY (POWER-PRO POWER LOSS)

### WARNING

- Loading and/or unloading an occupied cot into a vehicle requires a minimum of two (2) trained operators.
- Make sure that all occupants enter the vehicle patient compartment after the Power-LOAD compatible cot has been loaded into the vehicle patient compartment.

1. Lift the vehicle bumper to the raised position (if equipped).
2. Raise the lifting arms to guide and pull the trolley out of the vehicle patient compartment as shown in Figure 55.
3. Raise the cot to the load position.
4. Push the cot into Power-LOAD until the cot load wheel pins lock into position as shown in Figure 56. Ensure that the cot is aligned with the lifting arms when loading.



Figure 55

### CAUTION

To avoid the risk of equipment damage, do not slam the cot into the trolley when loading.

5. Check the head end LED indicators to ensure that the cot is ready to load.
  - If the LEDs are solid green, then the cot head end is in position.
  - If the LEDs are flashing amber, then the cot head end is not in position.
6. Press the up (↑) button on the Power-LOAD control panel as shown in Figure 57 to raise the lifting arms to the highest position.

**Note:** The cot legs do not retract.

7. Operator 1 (Foot End) – Grasp the cot frame at the foot end. Squeeze and hold the cot manual release.
8. Operator 2 (Side) – Grasp the base frame. After the foot end operator squeezes the cot manual release, retract the undercarriage with one hand and stabilize the cot with your other hand.

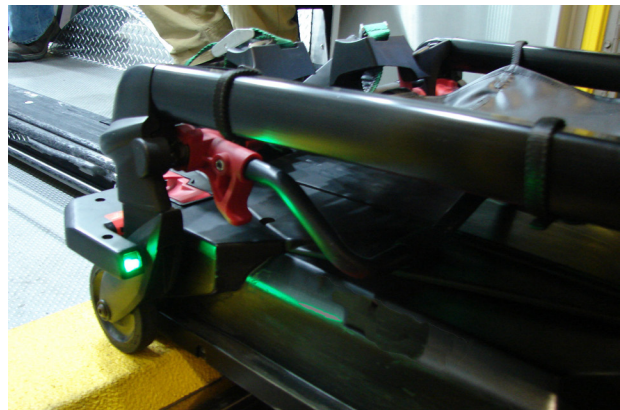

Figure 56

### CAUTION

To avoid the risk of equipment damage, do not push the cot into the vehicle patient compartment until the cot base is fully retracted.



Figure 57



# Operation Guide

---

## LOADING A COT INTO A VEHICLE MANUALLY (POWER-PRO POWER LOSS) (CONTINUED)

9. Both Operators - Push the cot into the vehicle patient compartment, until the lifting arms lower and the cot locks into Power-LOAD.
10. Operator 1 - Continue to squeeze and hold the cot manual release.

---

 **CAUTION**

Do not let go of the manual release until the cot locks into position at the foot end. If you let go too early, then the cot base may prevent the cot from properly locking into Power-LOAD.

---

11. Ensure that the cot is locked into Power-LOAD by firmly pulling side to side on the foot end of the cot.
12. Following the call, remove the cot from service to diagnose and repair the Power-PRO cot.

**Note:** Power-LOAD automatically charges the Power-PRO SMRT Pak battery when the cot is locked into Power-LOAD in the transport position (no cable or connectors required). The cot battery LED indicator momentarily flashes green to signify that it is charging.

# Cleaning

---

## **WARNING**

Always press the main power button to turn the unit off before service or cleaning.

---

The Power-LOAD is designed to be power washable. The unit may show some signs of oxidation or discoloration from continuous washing, however, no degradation of the unit's performance characteristics or functionality will occur due to power washing as long as the proper procedures are followed.

## **CLEANING PROCEDURE**

- Follow the cleaning solution manufacturer's dilution recommendations exactly.
- Stryker Medical recommends power washing Power-LOAD with recommended cleaners, hosing down the unit, and towel drying the transfer rails and arm hinges. Alternatively, you can power wash Power-LOAD with a hand held wand unit or wipe the unit with a clean cloth and recommended cleaner as listed in "Cleaning" on [page 75](#).
- When hosing down or power washing the unit, do not spray directly underneath the trolley up into the trolley mechanism or water could gain ingress into the trolley housing which could accelerate long-term corrosion and degrade operation.
- Using a soft cloth and brush, clean the transfer roller channels to prevent debris accumulation according to the Preventative Maintenance checklist on [page 76](#).
- Remove the trolley top cover and patient left side cover assembly to towel dry the control board assembly. See "Cover Removal and Replacement" on [page 84](#).
- Disconnect the motor and battery connectors and towel dry the connectors.
- Towel dry the transfer rails and arm hinges.

While cleaning, park the ambulance uphill and fully extend the transfer and trolley so that the water will drain out of the rear end of the patient compartment.

**Note:** Water that gets into the Power-LOAD system will drain through the drain tube to the underside of the ambulance.

---

## **WARNING**

When cleaning, use any appropriate personal safety equipment, such as goggles or respirator, to avoid the risk of inhaling contagion. Use of power washing equipment can aerate contamination collected during the use of the unit.

---

## **CLEANING LIMITATIONS**

### **CAUTION**

- DO NOT STEAM CLEAN OR ULTRASONICALLY CLEAN THE UNIT.
  - Maximum water temperature should not exceed 180°F/82°C.
  - Allow unit to air dry prior to use.
  - Maximum water pressure should not exceed 1500 psi/130.5 bar. If a hand held wand is being used to wash the unit, the pressure nozzle must be kept a minimum of 24 inches (61 cm) from the unit.
  - When hosing down or power washing the unit, do not spray directly underneath the trolley up into the trolley mechanism or water could gain ingress into the trolley housing which could accelerate long-term corrosion and degrade operation.
  - Failure to comply with these instructions may invalidate any/all warranties.
-

# Cleaning

---

In general, when used in those concentrations recommended by the manufacturer, either phenolic type or quaternary (**excluding Virex® TB**) type disinfectants can be used. Iodophor type disinfectants are not recommended for use because staining may result.

Suggested cleaners for the Power-LOAD surfaces:

- Quaternary Cleaners (active ingredient - ammonium chloride)
- Phenolic Cleaners (active ingredient - o-phenylphenol)
- Chlorinated Bleach Solution (5.25% - less than 1 part bleach to 100 parts water)

Avoid over saturation and ensure that the product does not stay wet longer than the chemical manufacturer's guidelines for proper disinfecting.

---

## **WARNING**

SOME CLEANING PRODUCTS ARE CORROSIVE IN NATURE AND MAY CAUSE DAMAGE TO THE PRODUCT IF USED IMPROPERLY. If the products described above are used to clean Stryker patient care equipment, measures must be taken to insure the units are wiped with clean water and thoroughly dried following cleaning. Failure to properly rinse and dry the units will leave a corrosive residue on the surface of the units, possibly causing premature corrosion of critical components.

---

**Note:** Failure to follow the above directions when using these types of cleaners may void this product's warranty.

## **REMOVAL OF IODINE COMPOUNDS**

Use a solution of 1/2 Tablespoon Sodium Thiosulfate in a pint of warm water to clean the stained area. Clean as soon as possible after staining occurs. If stains are not immediately removed, allow solution to soak or stand on the surface. Rinse surfaces which have been exposed to the solution in clear water before returning unit to service.

# Preventative Maintenance

## REGULAR INSPECTION AND ADJUSTMENTS

### Maintenance Intervals

The following schedule is intended as a general guide to maintenance. Call volume, weather, terrain, geographical location, and individual usage will alter the required maintenance schedule. If you are unsure as to how to perform these checks or are in doubt as to what intervals to follow in maintaining your unit, contact your Stryker Service Technician. See the “Quick Reference Replacement Parts List” on [page 79](#) for any part numbers that you may need to replace.

When performing Power-LOAD preventive maintenance checks, you must perform a preventive maintenance check on its corresponding Power-LOAD compatible cot and the optional wheel guide assembly (if applicable) to ensure operability of the entire system.

#### Power-LOAD Compatible Cot Maintenance

Wear items that may require replacement on the Power-LOAD compatible cot include the cot arm spacer (6500-002-123), base dead stop (6085-001-094), and load wheel pin (6500-002-104).

#### Optional Wheel Guide Assembly Maintenance (if applicable)

To preserve Power-LOAD fastener functionality, ensure that the wheel guide is functional and its structure has not been compromised. The wheel guide rail system is designed to assist the Power-LOAD system in loading the cot. If the wheel guide has been compromised, replace it immediately.

**Note:** The Power-LOAD maintenance schedule is based on 10 calls per day. Adjust the following schedule to your actual service usage.

### WARNING

To avoid the risk of injury, replace Power-LOAD if it has been involved in an accident. A fastener that has been involved in an accident may be damaged, possibly causing failure to operate properly.

Routine	Every			
	1 Month	3 Months	6 Months	12 Months
Check for loose fasteners. Replace if loose. Reference all assembly drawings.		X		
Check that the battery terminal screws are tight (torque to 9 in-lb)		X		
Check the battery. Replace if lifting is sluggish.				X
Check and replace any worn parts, including arm covers, arm wear pads, trolley top and side covers, cot release handle springs, anchor lever cover, or cot guides, if necessary				X
Check the dead stop bumpers. Replace if the corner is damaged.				X
Check the motor. Replace when no motor motion exists.				X
Check the cylinder rod end. Replace if Power-LOAD functions in manual mode and the error LED is illuminated.				X
Clean debris from the foot end lock location on the transfer	X			
Clean debris from the top of the transfer assembly and anchor assembly		X		
Clean transfer roller channels to prevent debris accumulation		X		
Check full functionality according to the “Power-LOAD Installation Checklist” on <a href="#">page 46</a>				X
<b><i>Routines continued on <a href="#">page 77</a></i></b>				

# Preventative Maintenance

## REGULAR INSPECTION AND ADJUSTMENTS (CONTINUED)

Routine	Every			
	1 Month	3 Months	6 Months	12 Months
Check for hydraulic leaks				X
Replace the transfer lock bearing once per year. See the replacement schedule on <a href="#">page 77</a> for more information. <b>Note:</b> During bearing replacement, ensure that the surrounding area is clean (anchor) and apply molybdenum disulfide grease to the transfer lock pin.				X
Check the load and unload functionality for Power-LOAD. If the unit is difficult to roll or wear is noticeable in the transfer roller channel beyond the inner rod, replace the V-guide rollers on the trolley and switch the patient right, outside, bottom transfer rod with the patient right, outside top transfer rod. Check all remaining rollers for damage or excessive wear. Replace, if necessary. <b>Note:</b> See the replacement schedule on <a href="#">page 77</a> for more information.				X

### Flat Roller and V-Guide Roller Part Replacement Schedule

You must replace the flat roller and V-guide roller parts every 14,110 calls to ensure that Power-LOAD remains fully functional. Follow this time table, based on call volume, to plan appropriate service intervals to comply with this requirement.

Calls per day	Months
6	80
7-8	60
9-10	48
11-12	40
13	36
14-15	30

### Transfer Lock Bearing Part Replacement Schedule

You must replace the transfer lock bearing parts every 3,653 calls to ensure that Power-LOAD remains fully functional. Follow this time table, based on call volume, to plan appropriate service intervals to comply with this requirement.

Calls per day	Months
2	60
3	40
4-5	24
6	20
7-8	15
9-10	12
11-12	10
13-15	8



# Quick Reference Replacement Parts List

The parts and accessories listed on this page are all currently available for purchase. Some of the parts identified on the assembly drawing parts in this manual may not be individually available for purchase. Please call Stryker Customer Service USA at 1-800-327-0770 for availability and pricing.

Part Name	Part Number
Actuator Assembly, Trolley	6390-001-028
Battery	6390-001-468
Board, Comm, Trolley	6390-001-378
Board, Inductive Primary, Anchor	6390-001-147
Board Assembly, Trolley Control	6390-001-014
Bronze Bearing (Anchor Lock Bearing)	0081-439-000
Bumper Block, Mid Position	6390-001-322
Coil Assembly, Middle, Anchor	6390-001-030
Coil Assembly, Primary, Anchor	6390-001-071
Coil Assembly, Trolley	6390-001-066
Cot Release Handle Spring	0038-376-000
Cover, Top	6390-101-420
Cover Assembly, Side, Patient Right	6390-001-041
Cover Assembly, Side, Patient Left	6390-001-042
Cover Assembly, Wing, Patient Right	6390-101-047
Cover Assembly, Wing, Patient Left	6390-101-048
Cover, Arm, Mid, Patient Right	6390-001-369
Cover, Arm, Mid, Patient Left	6390-001-370
Cover, Arm, Head End, Patient Right	6390-001-371
Cover, Arm, Head End, Patient Left	6390-001-372
Grip, Arm, Patient Left	6390-001-341
Grip, Arm, Patient Right	6390-001-368
Dead Stop Block, Threaded	6390-001-246
Dead Stop Block, Thru Hole	6390-001-244
Dead Stop Bumper	6390-001-243
Hydraulics Assembly	6390-001-039
Hydraulic Fluid	6500-001-293
Hydraulic Cylinder Rod End	6390-001-040
Label, Powered Operations Instructions	6390-101-498
Label, Manual Operations Instructions	6390-001-499
Motor	6390-001-132

# Quick Reference Replacement Parts List

---

<b>Part Name</b>	<b>Part Number</b>
Power-LOAD Mass Casualty Fastener, Wall Mounted Fastener (Model 6391)	6391-000-000
Power-LOAD Mass Casualty Fastener, Floor Mounted Fastener (Model 6391)	6391-000-000
Release Lever Housing	6390-001-105
Roller Assembly, Flat	6390-001-027
Roller Assembly, V-Guide	6390-001-025
Sensor, Angle Position (APS)	6390-001-397
Sensor, Trolley Position (TPS)	6390-001-361
Switch, Master On/Off	6390-001-450
Wheel Guide Rail Bumper	6390-001-175
Wheel Guide Rail	6390-001-176



# Transfer Service Information

---

## TRANSFER REMOVAL

### Tools Required:

- T25 Torx Driver
- 5/32" Hex Wrench

### Procedure:

1. Remove the trolley. See "Trolley Removal" on [page 82](#).
2. Put the transfer into the transport position all the way into the vehicle compartment.
3. Using a T25 Torx driver, remove the four screws (A) that secure the foot end transfer wear pad (B) to the transfer extrusion to remove the foot end transfer wear pad (Figure 58).
4. Using a 5/32" hex wrench, remove the screw (C) that secures the trolley magnet activator (D) to the anchor extrusion to remove the trolley magnet activator (Figure 58).
5. Slide both transfer lock triggers (E) to extend and pull the transfer off of the anchor completely (Figure 58).

**Note:** The transfer assembly is heavy and may require assistance to remove.

6. Reverse steps to reinstall.
7. Verify proper operation of the unit before returning it to service.

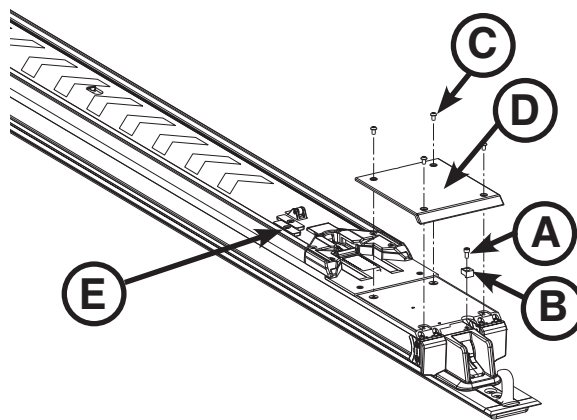

Figure 58

# Trolley Service Information

## TROLLEY REMOVAL

### Tools Required:

- 3/16" Hex Wrench
- T25 Torx Driver

### Procedure:

1. Raise the lifting arms (A), press the trolley release button at the head end of the anchor (B), and pull the trolley toward the foot end to the middle of the transfer assembly (Figure 59).
2. Slide the patient right transfer lock trigger (C) to extend and pull the transfer towards the foot end until the transfer stops at its first lock position (Figure 59).

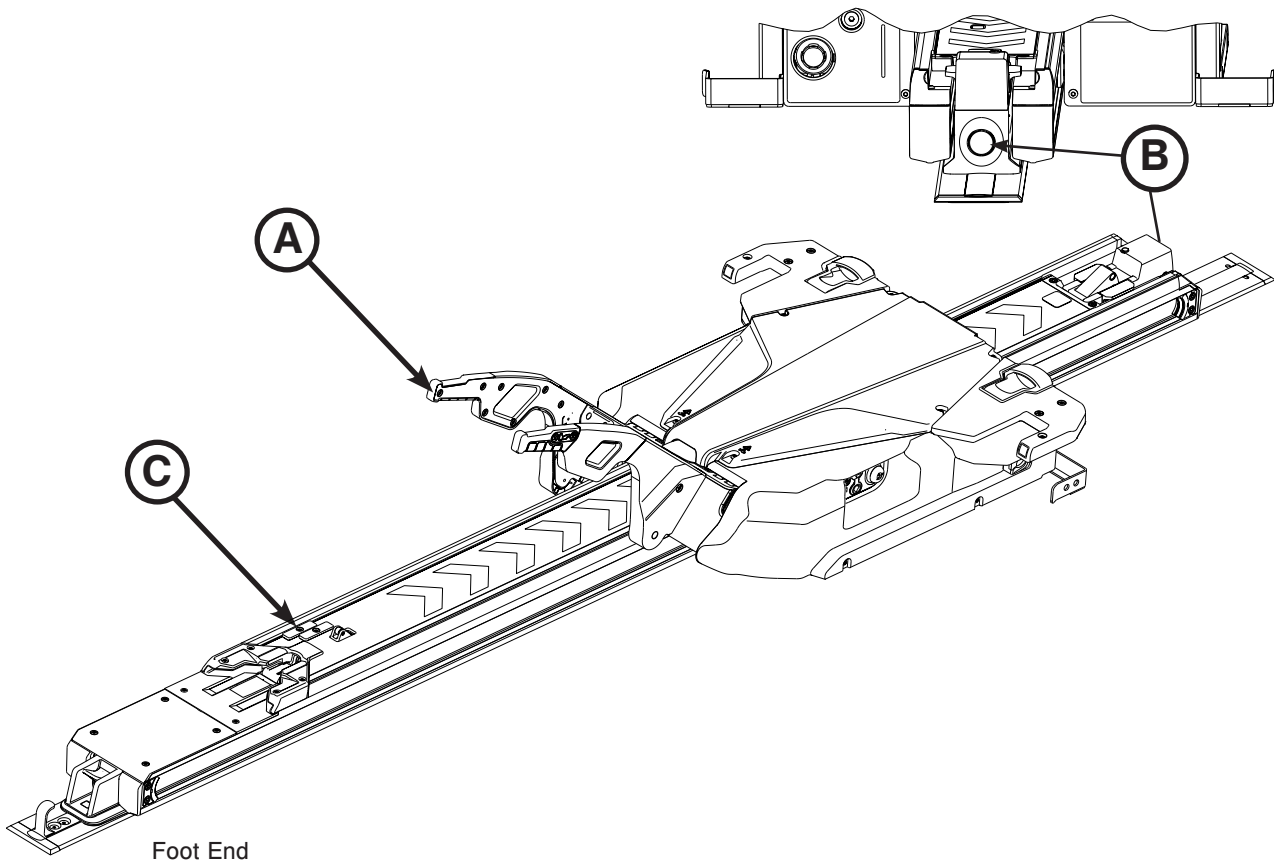

Figure 59

# Trolley Service Information

## TROLLEY REMOVAL (CONTINUED)

- Using a T25 Torx driver, remove the two screws that secure the transfer trim (E) (Figure 60).
- Using a 3/16" hex wrench, loosen (do not remove) the four socket head cap screws (two on each side) (D) that secure the dead stops to the transfer assembly (Figure 60).
- Push on the screws (loosened in step 4) to loosen the dead stops from the transfer.

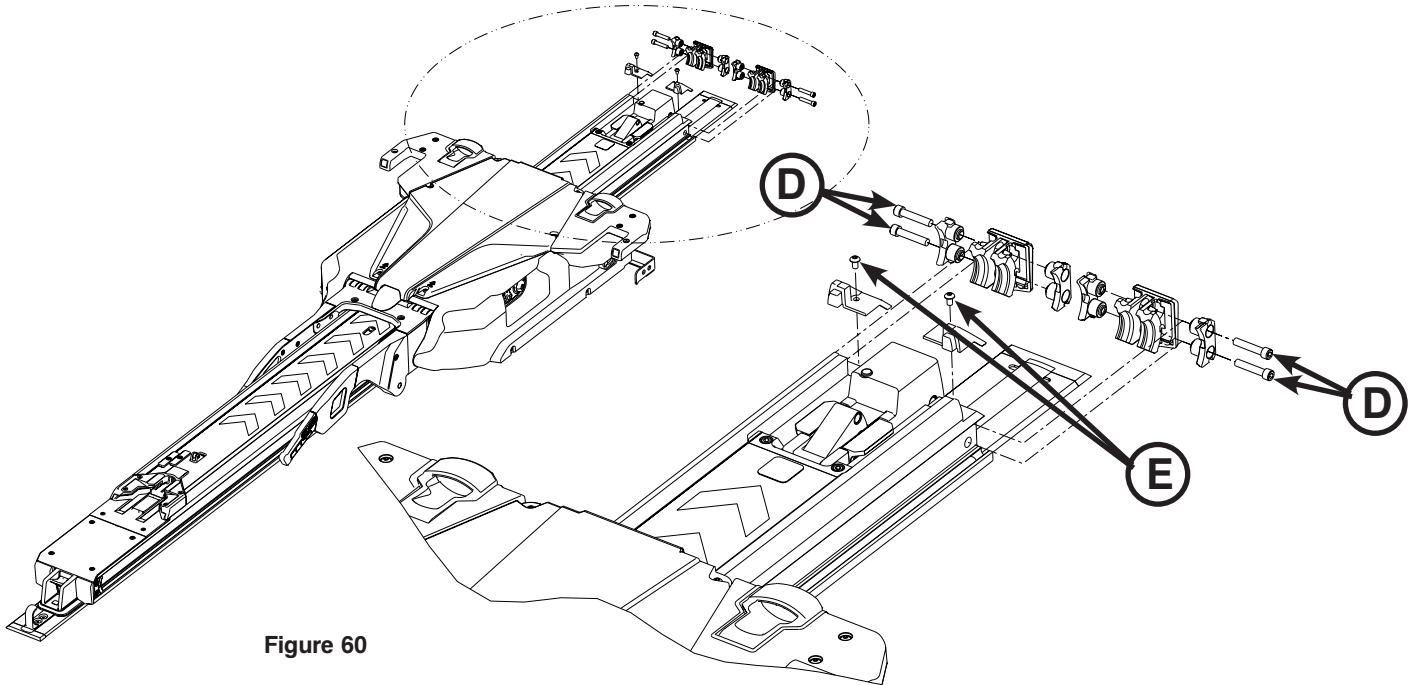

Figure 60

- Remove the dead stop bumpers. Save the bumpers for reinstallation.

### WARNING

To avoid the risk of injury, two installers are required when lifting and positioning the trolley assembly.

**Note:** The trolley will drop down slightly as you remove it from the transfer. Do not tip the trolley upside down, forward or onto its side.

- Carefully lift the trolley assembly by its arm and wing. Do not lift the trolley by the manual cot release handles. Lift only where indicated. Installer 1, position hands at A1 and A2. Installer 2, position hands at B1 and B2 as shown in Figure 61. Move the trolley toward the head end until it is off of the transfer. Remove the trolley from the anchor. Place the trolley in a suitable work area.
- Reverse steps to reinstall.
- Verify proper operation of the unit before returning it to service.

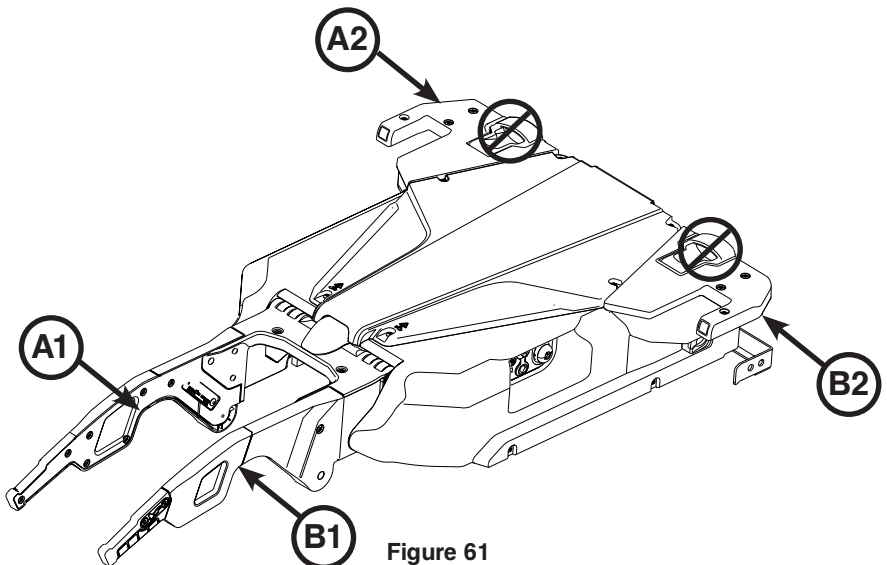

Figure 61

# Trolley Service Information

## COVER REMOVAL AND REPLACEMENT

### Tools Required:

- T25 Torx Driver
- 5/32" Hex Wrench

### Procedure:

1. Using a T25 Torx driver, remove the six screws (A) that secure the trolley top cover (B) (Figure 62).
2. Using a T25 Torx driver, remove the three screws (C) left side cover (D) (Figure 63).
3. Using a 5/32" hex wrench, remove one Allen screw (E) from the top of the left side cover (D) (Figure 63).
4. Remove the cover. Save the side cover, left and all screws for reinstallation.
5. Repeat steps 2-4 to remove the side cover, right (F) (Figure 63).
6. Reverse steps to reinstall.

### WARNING

While servicing or installing covers, do not pinch cables.

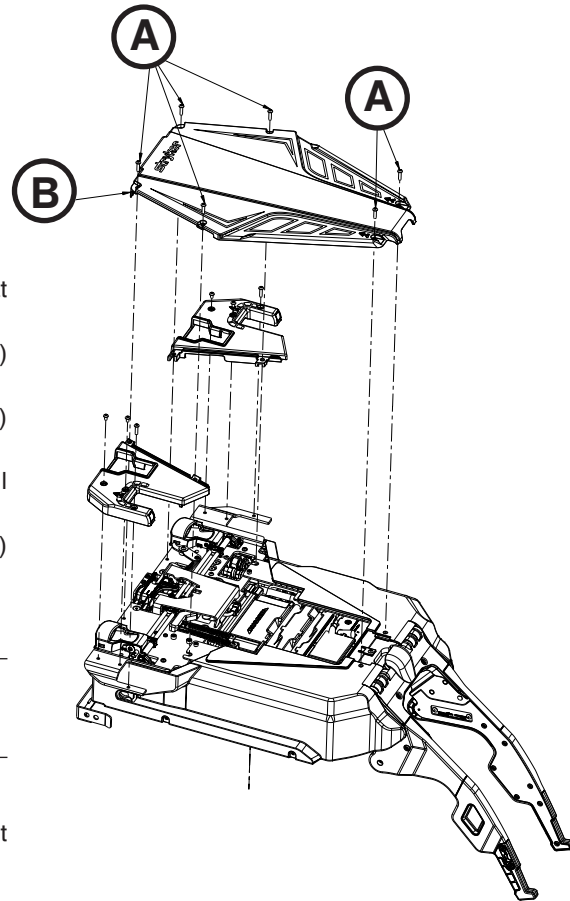

Figure 62

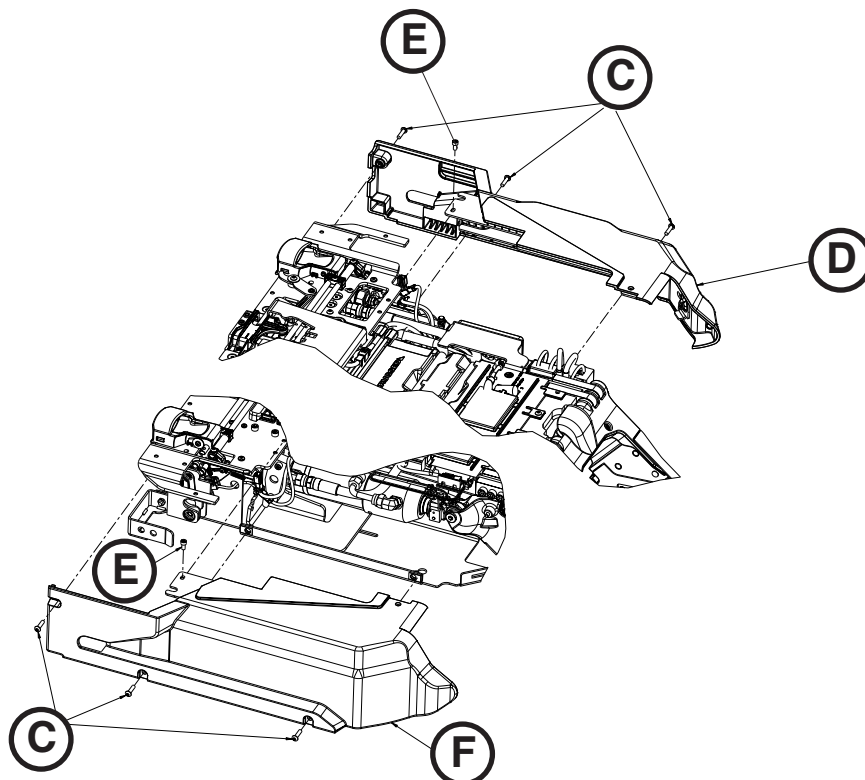

Figure 63

# Trolley Service Information

## MANUAL RELEASE BUTTON ASSEMBLY REMOVAL AND REPLACEMENT

### Tools Required:

- T25 Torx Driver
- 5/32" Hex Wrench

### Procedure:

1. Pull the trolley assembly out of the patient compartment until it locks into the loading position.
2. Remove the trolley covers. See "Cover Removal and Replacement" on [page 84](#).
3. Press the main power button to turn the unit off.
4. Remove the slic pin (A) from the switch/bracket assembly (Figure 64).
5. Using a T25 Torx driver, remove the two button head cap screws (B) that secure the manual release button bracket to the trolley frame (Figure 64).
6. Using a 5/32" hex wrench, loosen (do not remove) the socket head cap screw (C) that secures the manual release button bracket to the trolley frame (Figure 64).
7. Unplug the cables from the master On/Off switch (D) and remove the manual release button assembly (Figure 65).

**Note:** Verify cable connection locations, so they do not get mixed up.

8. Reverse steps to reinstall.
9. Verify proper operation of the unit before returning it to service.

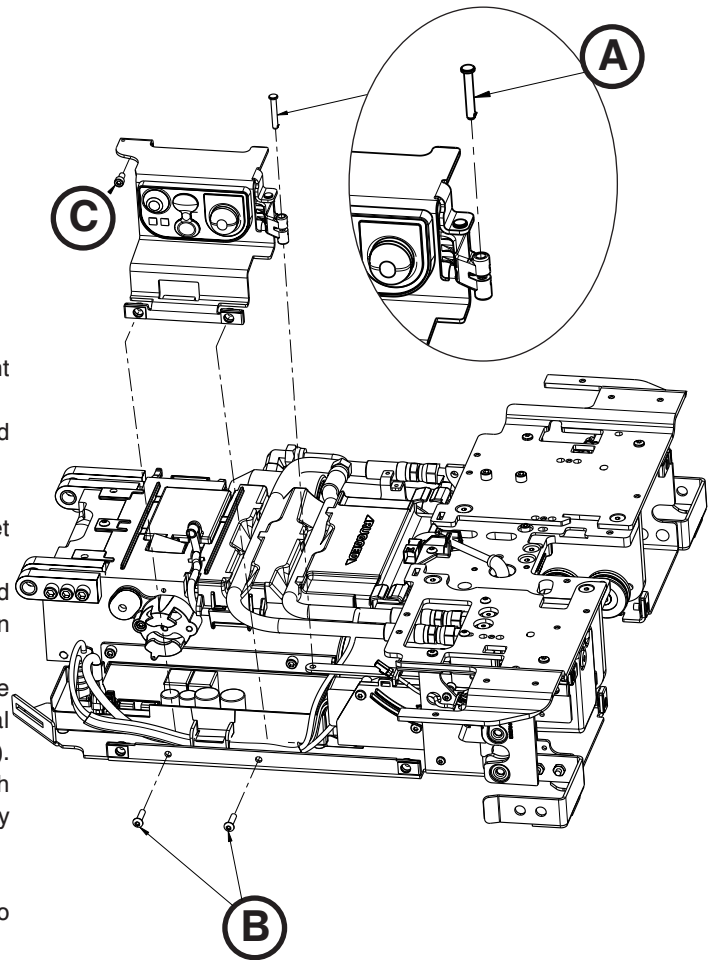

Figure 64

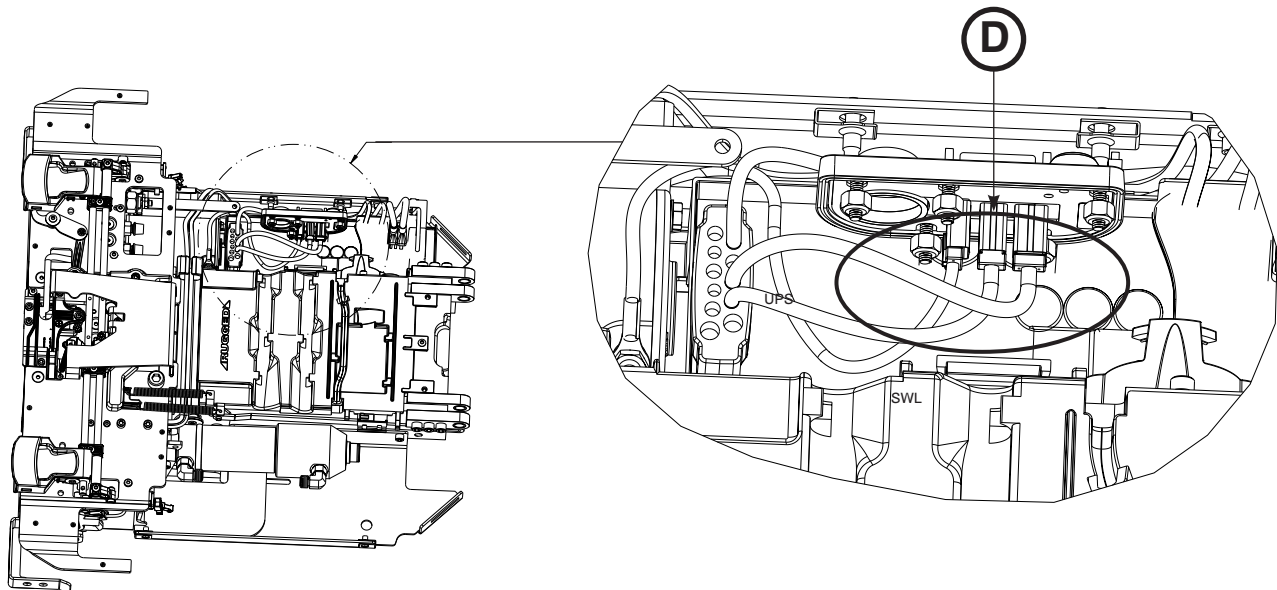

Figure 65

[Return To Table of Contents](#)

# Trolley Service Information

## CONTROL BOARD ASSEMBLY REMOVAL AND REPLACEMENT

### Tools Required:

- 3/32" Hex Wrench

### ⚠ CAUTION

To reduce the risk of damage to the electronics assembly, ESD precautions should be taken when handling the control board. For more information about ESD protection, contact Stryker Technical Support at (800) 327-0770.

### Procedure:

1. Remove the manual release button assembly. See "Manual Release Button Assembly Removal and Replacement" on [page 85](#).
2. Using a 3/32" hex wrench, loosen (do not remove) the two screws (A) that secure the main cable assembly (B) to the control board assembly (Figure 66).
3. Unplug all of the other cables from the control board assembly (C) and then remove the control board assembly (Figure 66). Discard the control board assembly.

**Note:** Do not dispose of as unsorted municipal waste. Refer to your local distributor for return and/or collection systems available in your country.

4. Align the control board assembly tabs with the holes in bottom pan, left to install the new control board assembly. Ensure that all of the cables are routed correctly.
5. Reverse steps to reinstall.
6. Verify proper operation of the unit before returning it to service.

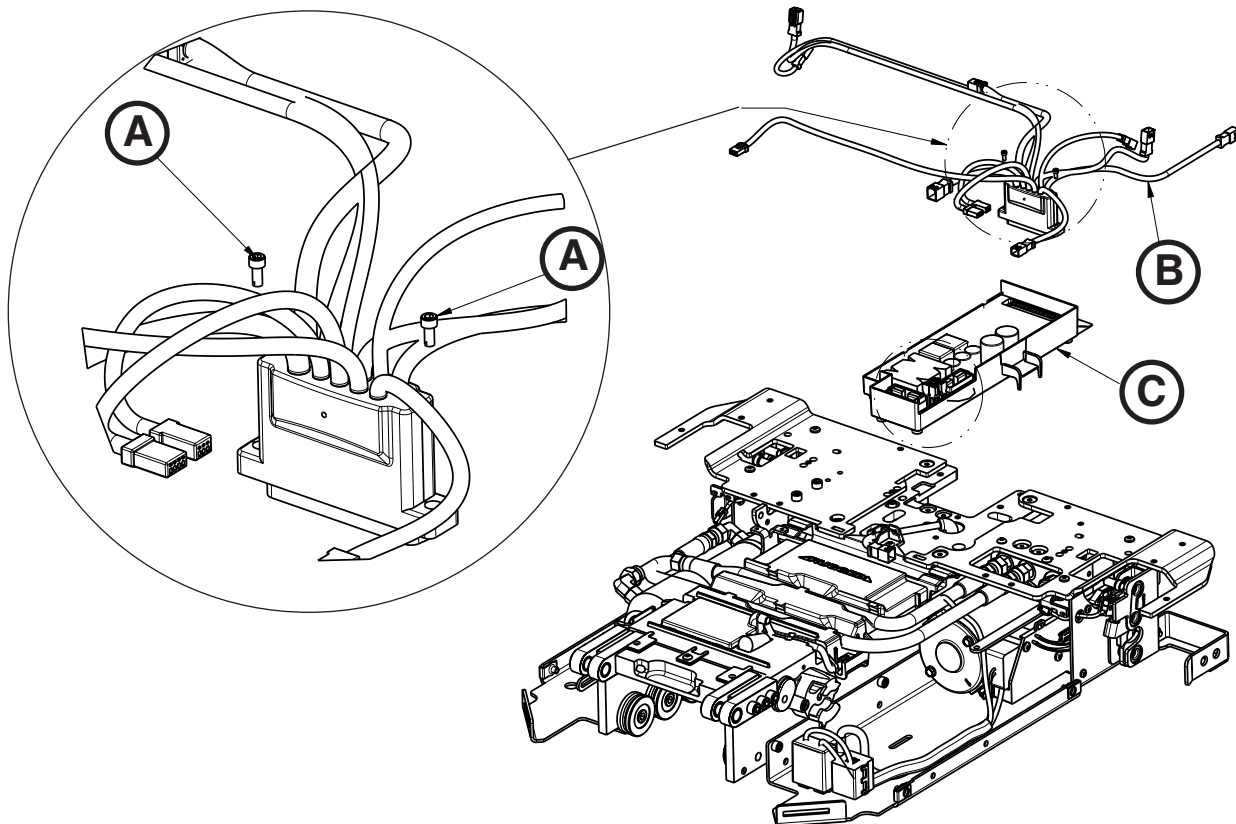

Figure 66

# Trolley Service Information

## MASTER ON/OFF SWITCH REPLACEMENT

### Tools Required:

- 11/32" Nut Driver

### Procedure:

1. Remove the manual release button assembly. See "Manual Release Button Assembly Removal and Replacement" on [page 85](#).
2. Using a 11/32" nut driver, remove the five Fiberlock hex nuts (A) that secure the master On/Off switch (B) to the manual release button bracket (C). Discard the master On/Off switch (Figure 67).

**Note:** Do not dispose of as unsorted municipal waste. Refer to your local distributor for return and/or collection systems available in your country.

3. Reverse steps to reinstall.

**Note:** Do not overtighten the nuts.

4. Verify proper operation of the unit before returning it to service.

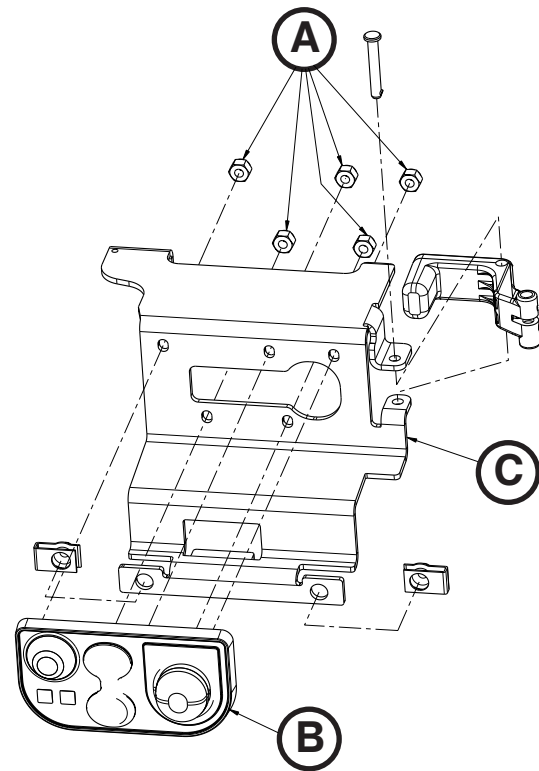

Figure 67

# Trolley Service Information

## TROLLEY ACTUATOR ASSEMBLY REPLACEMENT

### Tools Required:

- T20 Torx Driver

### Procedure:

1. Remove the manual release button assembly. See “Manual Release Button Assembly Removal and Replacement” on [page 85](#).
2. Using a T20 Torx driver, remove the three delta screws (A) that secure the trolley actuator (B) to the trolley frame (Figure 68).
3. Unplug the cable (C) from the trolley actuator to the main cable assembly (Figure 69).
4. Pull the actuator out and up towards the trolley control board to remove.
5. Reverse steps to install.

**Note:** Ensure that the cables are seated and routed correctly.

6. Verify proper operation of the unit before returning it to service.

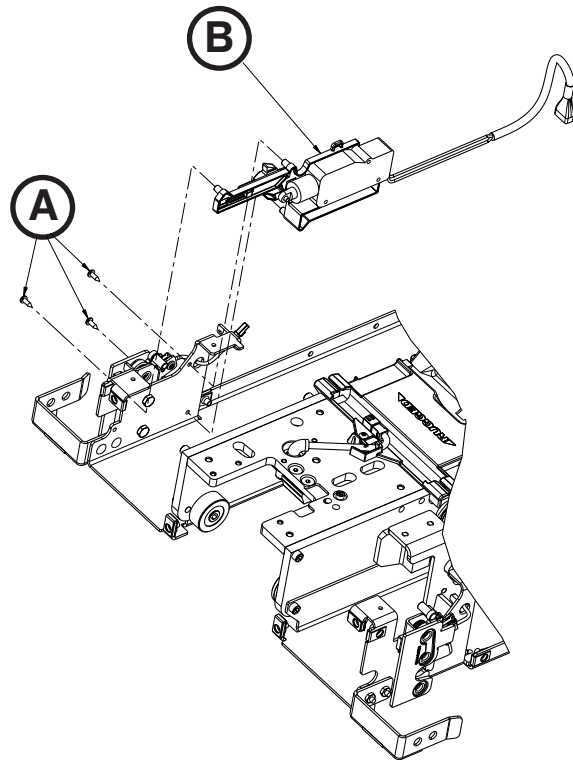

Figure 68

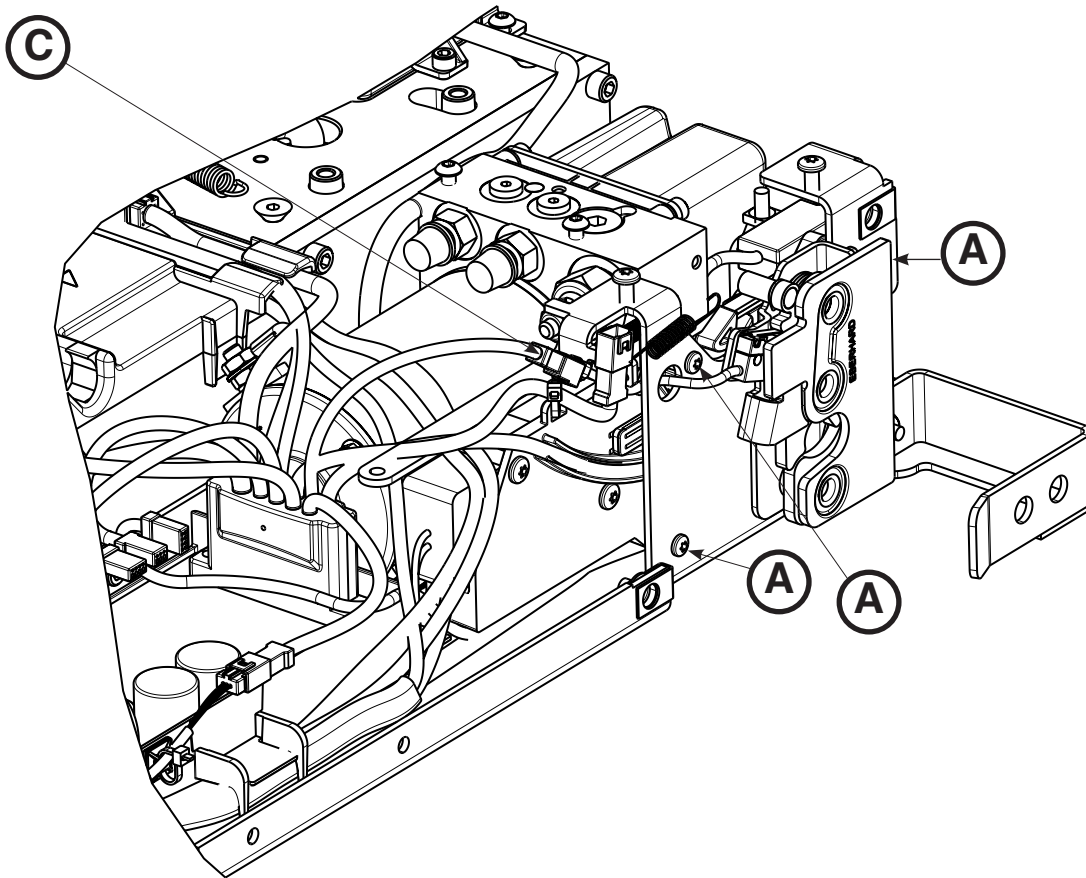

Figure 69



# Trolley Service Information

## HYDRAULIC ASSEMBLY REMOVAL AND REPLACEMENT

### Tools Required:

- T20 Torx Driver
- T25 Torx Driver
- 1/4" Hex Wrench
- 3/16" Hex Wrench
- 1/2" Combination Wrench
- Diagonal Pliers

### Procedure:

1. Remove the control board assembly. See "Control Board Assembly Removal and Replacement" on [page 86](#).
2. Remove the trolley actuator assembly. See "Trolley Actuator Assembly Replacement" on [page 88](#).
3. Unclip the cables from the trolley routing tray and the hydraulic hoses.
4. Unplug the USB quick connect and the D+L-L lock switch cable from the main cable.
5. Position the main cable assembly towards the center of the trolley to allow clearance.
6. Using a T25 Torx driver, remove the two screws (A) that secure the hydraulic assembly (B) to the wing plate, left (C) (Figure 70).
7. Pull outward to remove the pump assembly and set the pump assembly on top of the wing plate, left.
8. Using a 1/4" hex wrench and a 1/2" combination wrench, remove the end cap cylinder pin (D) and nut (E) (Figure 71).

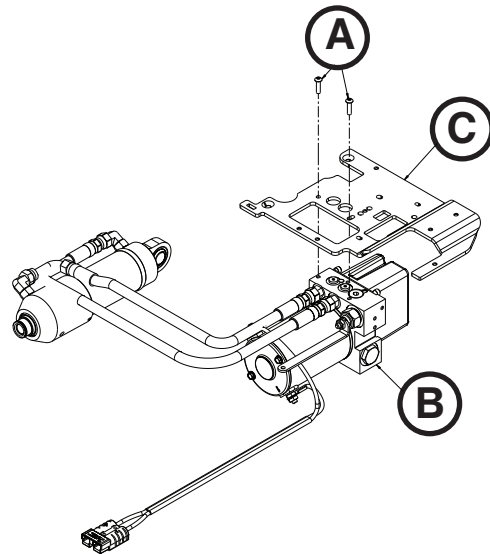

Figure 70

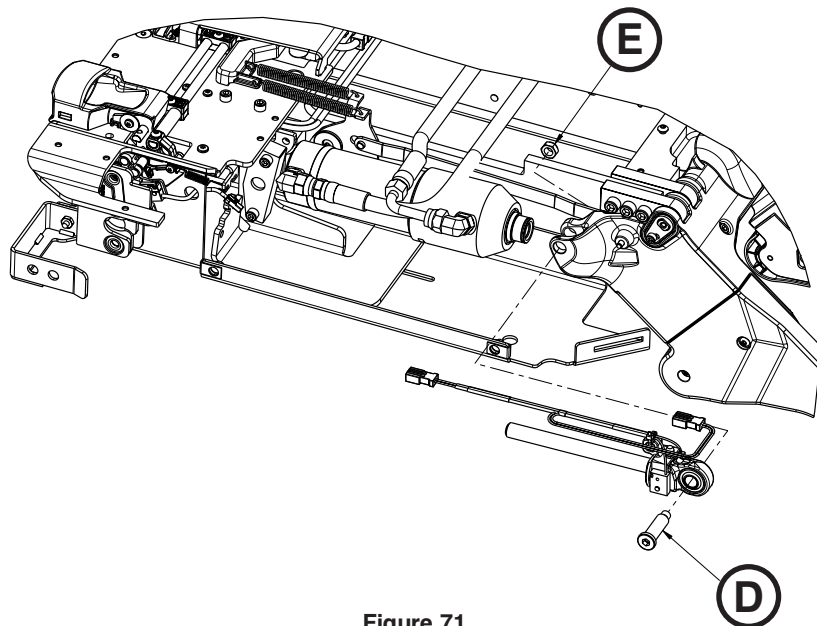

Figure 71

# Trolley Service Information

## HYDRAULIC ASSEMBLY REMOVAL AND REPLACEMENT (CONTINUED)

- Using diagonal pliers, cut the zip ties (F) that secure the hydraulic cylinder rod end assembly cable to the plastic cover (Figure 72).

**Note:** Pay attention to the location of all cable ties for reinstallation.

- While lifting up on the cylinder, pull the hydraulic cylinder rod end assembly out. Save the hydraulic cylinder rod end assembly for reinstallation.
- Using a 3/16" hex wrench, remove the two screws (G) that secure the pin bracket (H) to the trolley (Figure 73).
- Remove the pin (I) and lift the hydraulic cylinder out (Figure 73).
- Remove the hydraulic assembly and properly discard.

**Note:** Do not dispose of as unsorted municipal waste. Refer to your local distributor for return and/or collection systems available in your country.

- Reverse steps to reinstall.
- Verify proper operation of the unit before returning it to service.

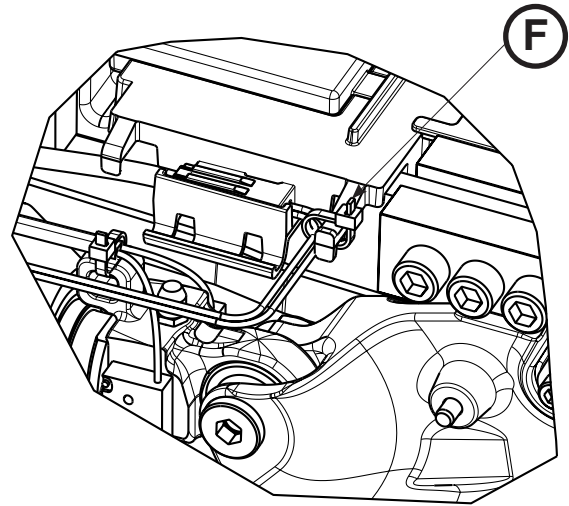

Figure 72

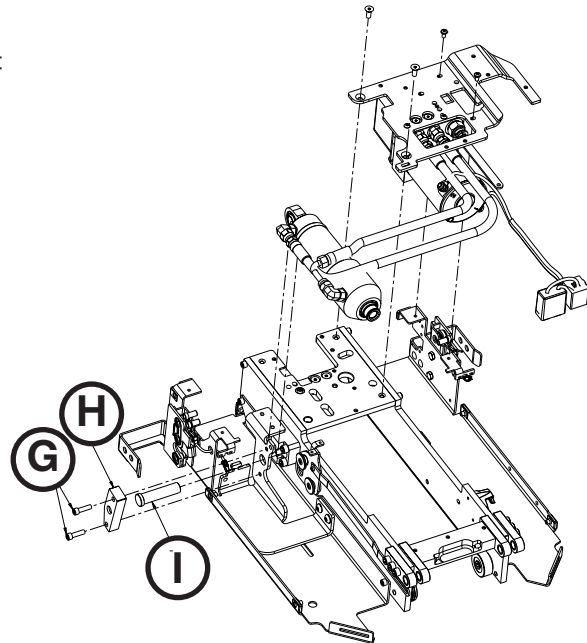

Figure 73

# Trolley Service Information

## HYDRAULIC CYLINDER ROD END REPLACEMENT

### Tools Required:

- 1/4" Hex Wrench
- 1/2" Combination Wrench
- Diagonal Pliers

### Procedure:

1. Pull the trolley assembly out of the patient compartment until it locks into the loading position.
2. Remove the trolley covers. See "Cover Removal and Replacement" on [page 84](#).
3. Press the main power button to turn the unit off.
4. Using a 1/4" hex wrench and a 1/2" combination wrench, remove the cylinder clevis pin (A) and nut (B) (Figure 75).
5. Using diagonal pliers, cut the zip ties (C) that secure the hydraulic cylinder rod end assembly cable to the plastic cover (Figure 74).

**Note:** Pay attention to the location of all cable ties for reinstallation.

6. While lifting up on the cylinder, pull the hydraulic cylinder rod end assembly (D) out and discard (Figure 75).
7. Reverse steps to reinstall.
8. Verify proper operation of the unit before returning it to service.

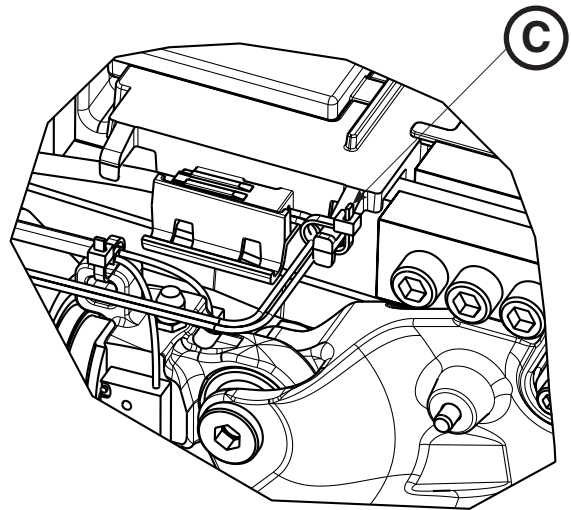

Figure 74

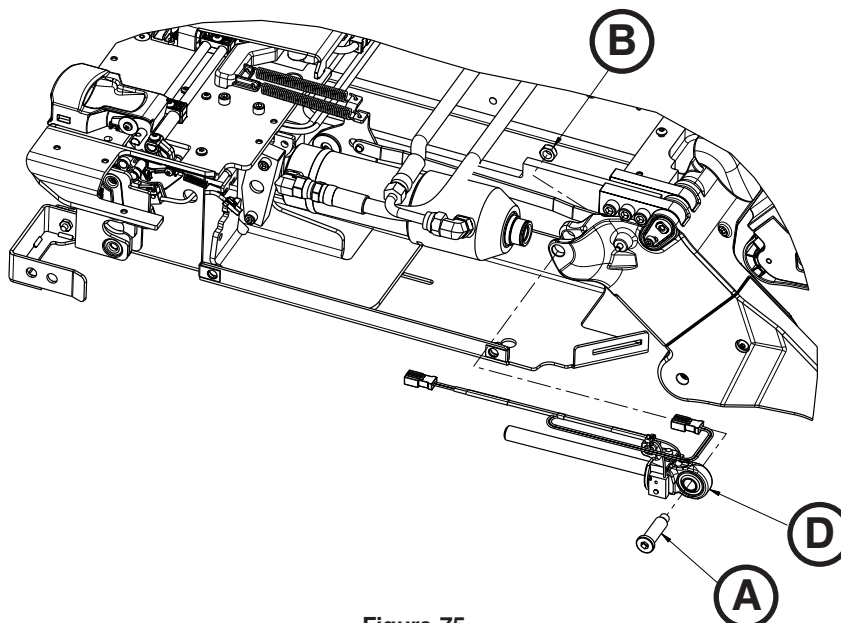

Figure 75

# Trolley Service Information

## COMMUNICATION BOARD REPLACEMENT

### Tools Required:

- Diagonal Pliers

### Procedure:

1. Pull the trolley assembly out of the patient compartment until it locks into the loading position.
2. Remove the trolley covers. See “Cover Removal and Replacement” on [page 84](#).
3. Using diagonal pliers, cut the zip tie that secures the communication cable to the plastic cover.
4. Lift up on the trolley communication board (A) to remove (Figure 76). Discard the communication board.

**Note:** Do not dispose of as unsorted municipal waste. Refer to your local distributor for return and/or collection systems available in your country.

5. Reverse steps to reinstall.
6. Verify proper operation of the unit before returning it to service.

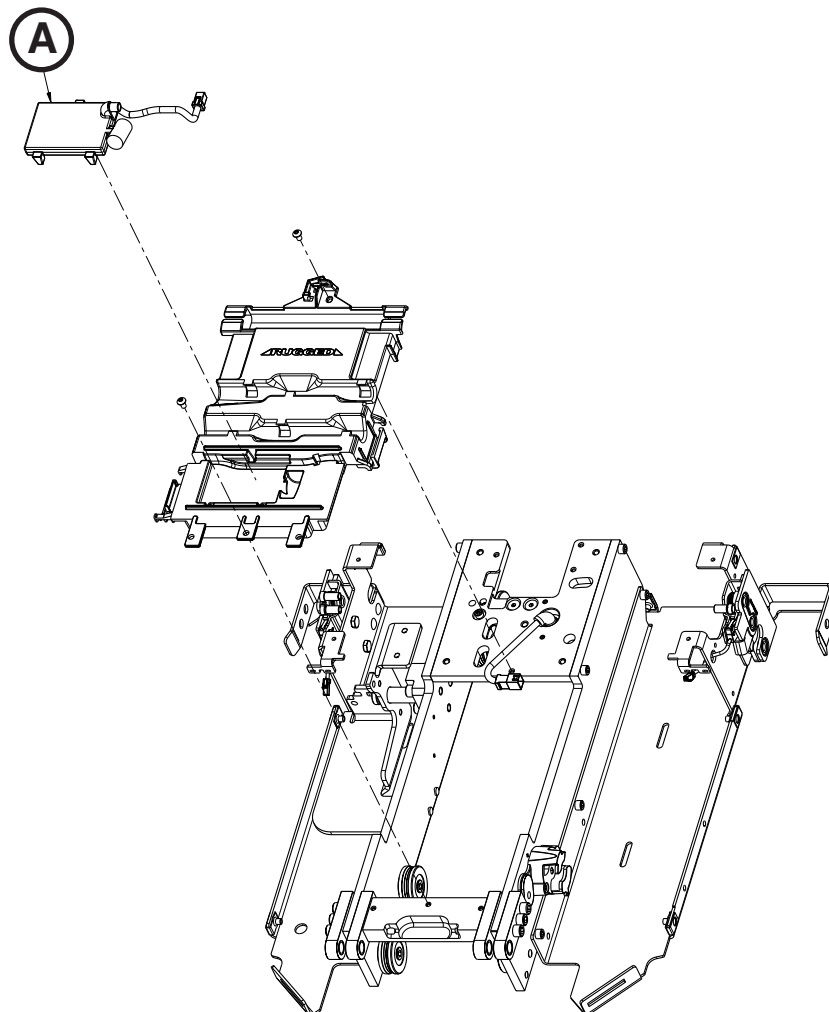

Figure 76

# Trolley Service Information

## INDUCTIVE COIL REPLACEMENT

### Tools Required:

- 5/32" Hex Wrench
- 3/16" Hex Wrench
- T25 Torx Driver

### Procedure:

1. Remove the manual release button assembly. See "Manual Release Button Assembly Removal and Replacement" on [page 85](#).
2. Using a 5/32" hex wrench, remove the screw (A) that secures the inductive coil assembly to the frame (Figure 78).
3. Using a 3/16" hex wrench, remove the screw (B) that secures the inductive coil assembly to the frame (Figure 78).
4. Remove the cover (C) (Figure 78). Save for reinstallation.
5. Remove the return spring (D) (Figure 79). Save for reinstallation.
6. Using a T25 Torx driver, remove the screws (E) that secure the charge bracket (Figure 78).
7. Using a 5/32" hex wrench, remove the screw (F) that secures the charge bracket (Figure 78).
8. Using a T25 Torx driver, remove the two screws that secure the back left wing cover.
9. Unplug the cable (G) from the trolley control board, and remove the inductive coil (H) (Figure 78). Discard the inductive coil.

### Notes:

- Lift up on the trolley control board to pull the cable through.
- Pay attention to the cable routing for reinstallation.
- Do not dispose of as unsorted municipal waste. Refer to your local distributor for return and/or collection systems available in your country.

10. Reverse steps to reinstall.
11. Verify proper operation of the unit before returning it to service.

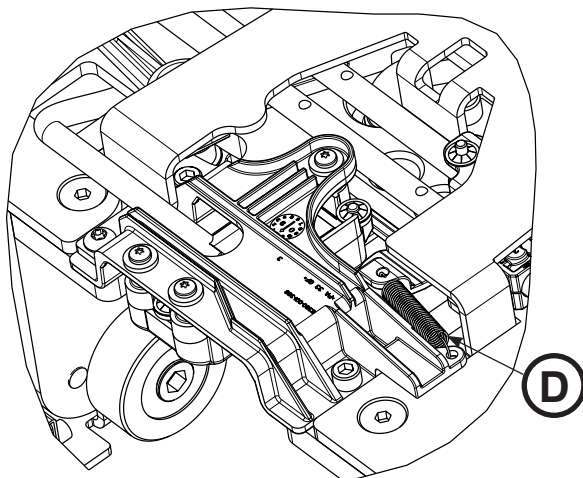

Figure 77

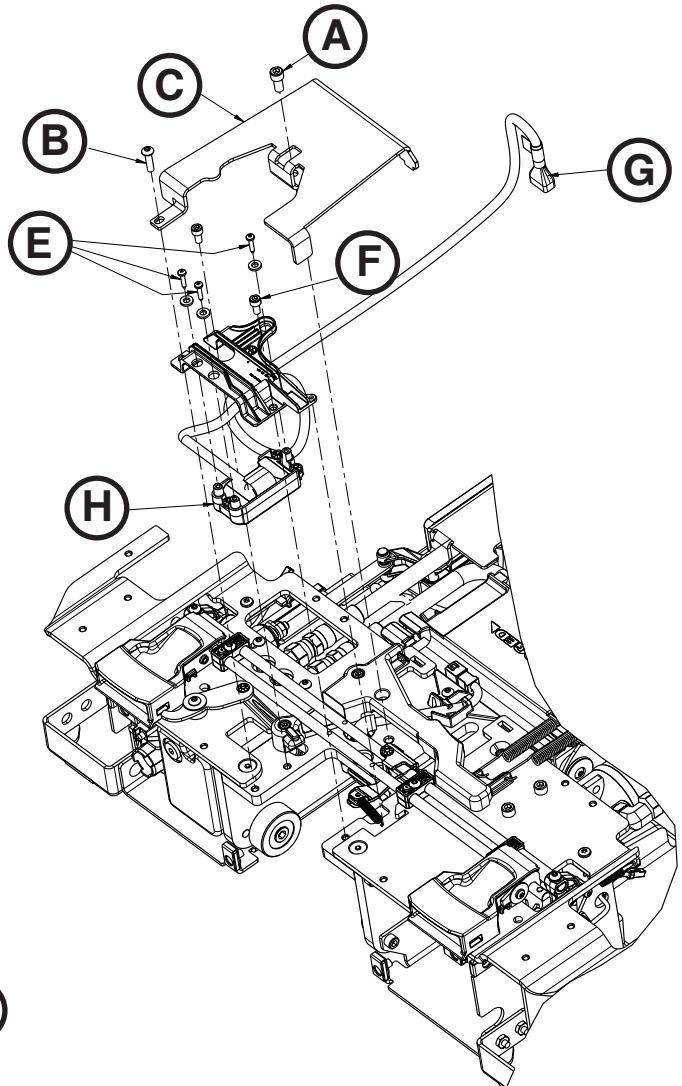

Figure 78

[Return To Table of Contents](#)

# Trolley Service Information

## TROLLEY POSITION SENSOR (TPS) REPLACEMENT

### Tools Required:

- T25 Torx Driver
- 1/8" Hex Wrench
- 5/32" Hex Wrench
- 1/4" Ratchet

### Procedure:

1. Remove the trolley. See "Trolley Removal" on [page 82](#).
2. Remove the trolley covers. See "Cover Removal and Replacement" on [page 84](#).
3. Unplug the TPS cable (A) from the main cable assembly (Figure 79).
4. Using a 5/32" hex wrench, loosen (do not remove) the socket head cap screw (B) that secures the trolley mechanism arm (Figure 80).
5. Using 1/8" hex wrench, remove the flat head cap screw (C) that secures the link to the trolley mechanism arm and remove the trolley mechanism pivot pillar (D) (Figure 80).
6. Using a 1/8" hex wrench, loosen (do not remove) the flat head cap screw (E) that secures the front link (F) to the trolley mechanism arm and swing it out of the way (Figure 80).

**Note:** Rotate the link to remove the pivot pillar. During removal, pay attention to the orientation of the pivot pillar.

7. Using a 1/4" ratchet and a T25 Torx driver, remove the two button head cap screws (G) that secure the TPS assembly (H) (Figure 81).

### Notes:

- Slightly lift up on the trolley mechanism arm to pull the cable through to remove the TPS. Discard the TPS.
- Do not dispose of as unsorted municipal waste. Refer to your local distributor for return and/or collection systems available in your country.

8. Reverse steps to reinstall.
9. Verify proper operation of the unit before returning it to service.

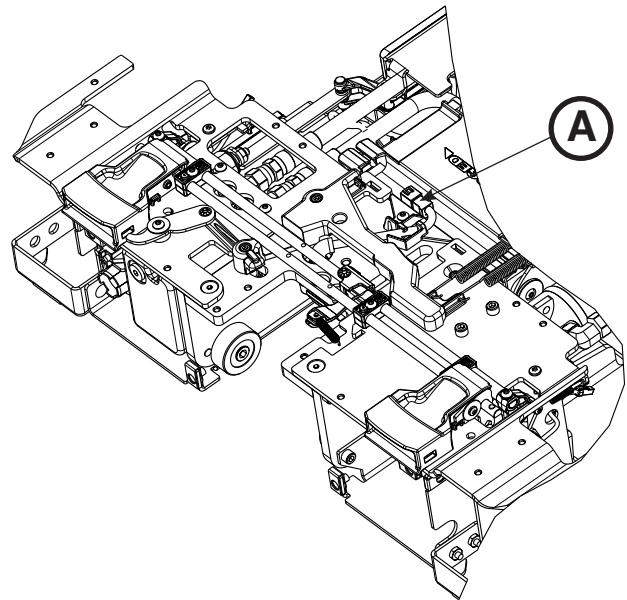

Figure 79

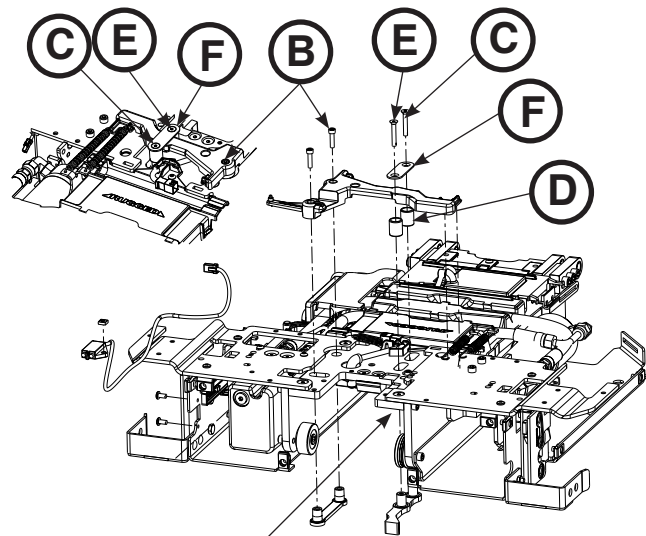

Figure 80

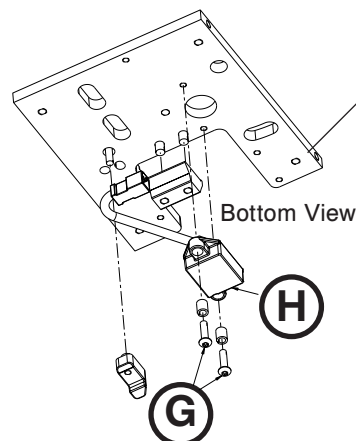

Figure 81

# Trolley Service Information

## FLAT ROLLER AND V-GUIDE ROLLER REPLACEMENT

### Tools Required:

- 1/4" Socket
- 3/8" Drive Ratchet
- Torque Wrench (in-lb) > 317 in-lb

### Procedure:

#### CAUTION

While replacing the rollers, make sure that the trolley is on a flat and level work surface. Pay attention to the trolley positioning when loosening or tightening the pivot bolts.

1. Remove the trolley. See "Trolley Removal" on [page 82](#).
2. Carefully set the trolley upright as shown in Figure 82.

**Note:** Do not tip the trolley upside down, forward or onto its side.

3. Using a 1/4" socket with a 3/8" drive ratchet, loosen (do not remove) the pivot bolt that secures the bad roller to the trolley.

**Note:** The V-guide rollers are on the patient right side (five rollers) (A) and the flat rollers are on the patient left side (two rollers) (B) (Figure 82).

4. Reverse steps to reinstall. When reinstalling, torque all bolts to 235-317 in-lb.
5. Verify proper operation of the unit before returning it to service.

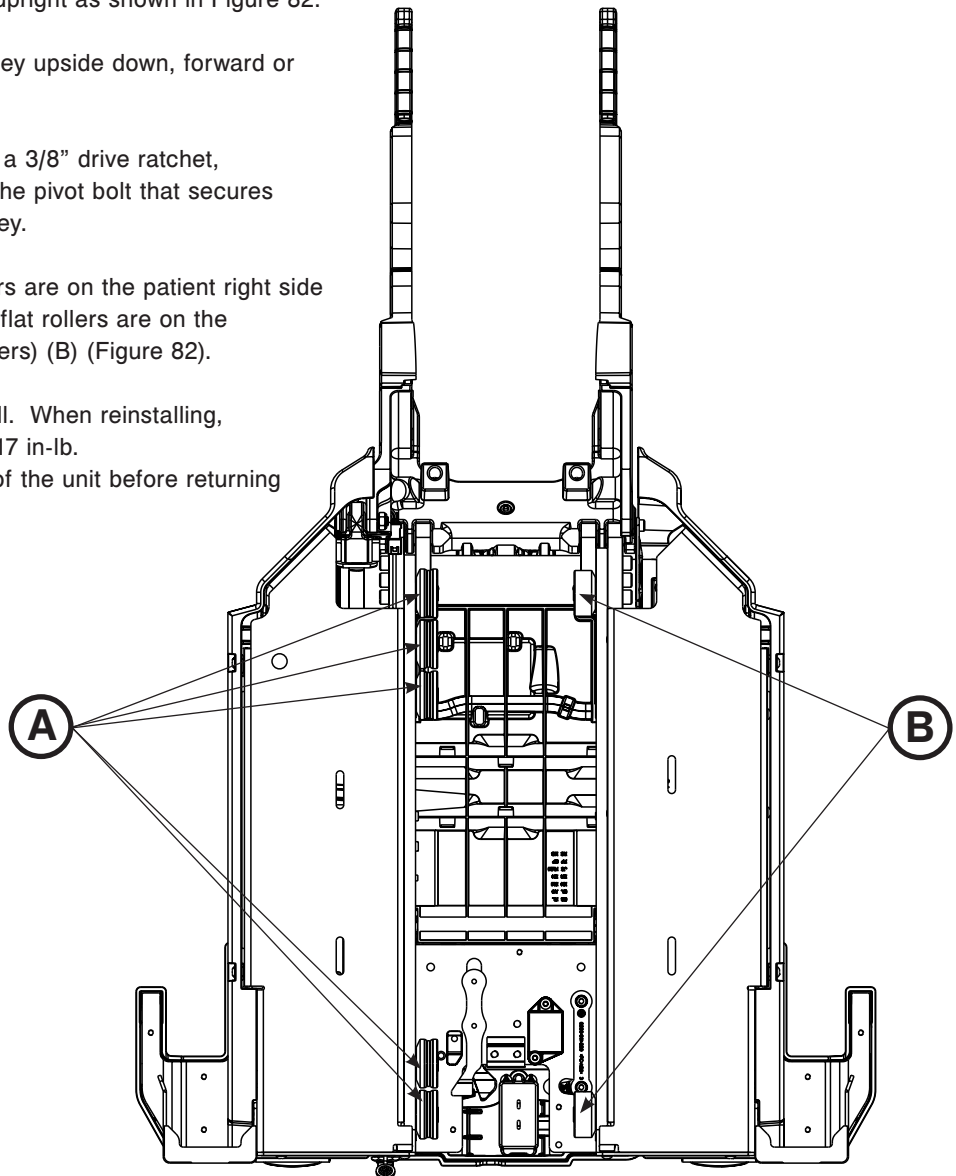

Figure 82

# Trolley Service Information

## HYDRAULIC CYLINDER REMOVAL AND REPLACEMENT

### Tools Required:

- 1/4" Hex Wrench
- 1/8" Hex Wrench
- 1/2" Combination Wrench
- Diagonal Pliers
- 5/8" Combination Wrench
- 3/16" Hex Wrench
- 11/16" Combination Wrench

### Procedure:

1. Pull the trolley assembly out of the patient compartment until it locks into the loading position.

**Note:** This makes it easier to work on the unit, but is not required.

2. Press the manual release button on the Power-LOAD control panel until the lifting arms are in the lowest position.
3. Remove the trolley covers. See "Cover Removal and Replacement" on [page 84](#).
4. Using a 1/4" hex wrench and a 1/2" combination wrench, remove the end cap cylinder pin (A) and nut (B) (Figure 83).
5. Using diagonal pliers, cut the zip ties (D) (Figure 84) that secure the hydraulic cylinder rod end assembly (C) cable to the plastic cover (Figure 83).

**Note:** Pay attention to the location of all of the cable ties for reinstallation.

6. While lifting up on the cylinder, remove the hydraulic cylinder rod end assembly (C) (Figure 83). Save the hydraulic cylinder rod end assembly for reinstallation.
7. Using an 11/16" combination wrench, disconnect both hoses from the cylinder. Reference "Velocity Fuse Removal and Replacement" on [page 98](#).

**Note:** Hydraulic fluid will leak from the cylinder and hoses. Lay down towels to catch fluid.

8. Using a 5/8" combination wrench, loosen (do not remove) the jam nuts on both of the cylinder hose fittings, and unthread the fitting from the hydraulic cylinder. Save all parts for reinstallation.

**Note:** Pay attention to the hose routing and location for reinstallation.

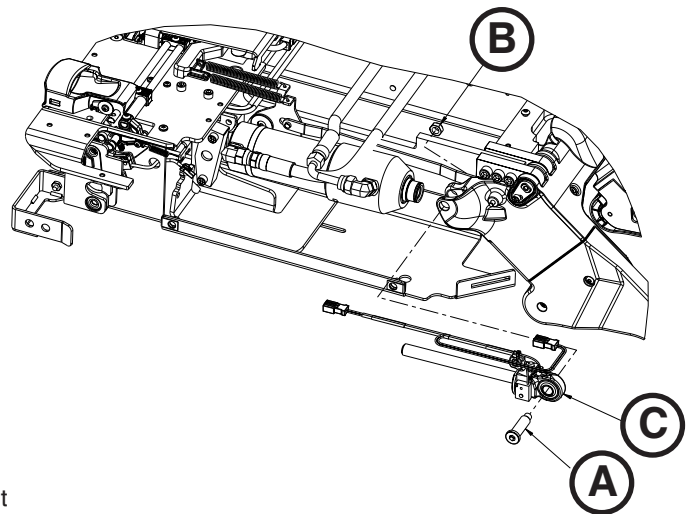

Figure 83

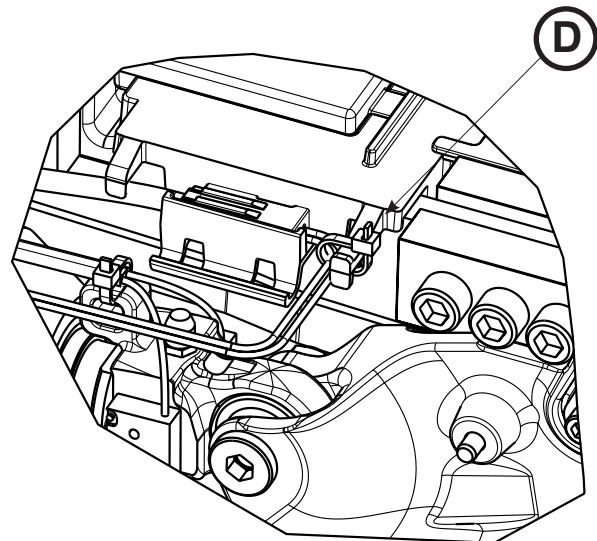

Figure 84



# Trolley Service Information

## HYDRAULIC CYLINDER REMOVAL AND REPLACEMENT (CONTINUED)

9. Using a 1/8" hex wrench, remove the velocity fuse from the hydraulic cylinder. Save the fuse for reinstallation.
10. Using a 3/16" hex wrench, remove the two screws (E) that secure the cylinder bracket (F) to the trolley and remove the end cap cylinder pin (G) (Figure 85).
11. Remove the hydraulic assembly and discard.
12. Using a 1/8" hex wrench, install the velocity fuse into the cylinder.
13. Reverse steps to reinstall.
14. Check the fluid level before returning the unit to service. See "Filling the Reservoir" on [page 105](#).
15. Verify proper operation of the unit before returning it to service.

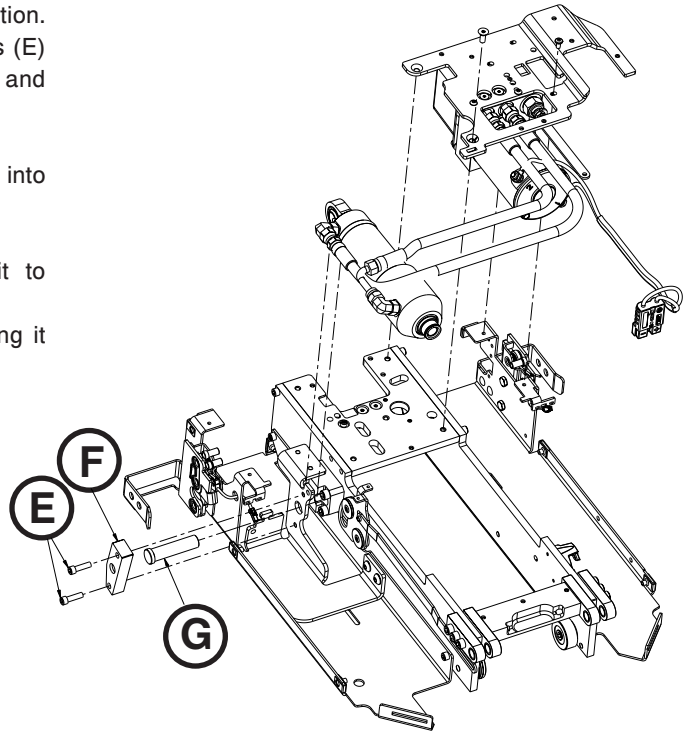

Figure 85

# Trolley Service Information

## VELOCITY FUSE REMOVAL AND REPLACEMENT

### Tools Required:

- 1/8" Hex Wrench
- 11/16" Combination Wrench
- 5/8" Combination Wrench
- Torque Wrench (in-lb)

### Procedure:

1. Pull the trolley assembly out of the patient compartment until it locks into the loading position.

**Note:** This makes it easier to work on the unit, but is not required.

2. Remove the trolley covers. See "Cover Removal and Replacement" on [page 84](#).
3. Using an 11/16" combination wrench, disconnect the hydraulic hose (A) closest to the mounting bracket at the head end of the trolley (Figure 86).

**Note:** Hydraulic fluid will leak from the cylinder and hoses. Lay down towels to catch fluid.

4. Using a 5/8" combination wrench loosen (do not remove) the jam nut on the cylinder hose fitting (B) and unthread the fitting from the hydraulic cylinder (C) (Figure 86). Save all parts for reinstallation.
5. Using a 1/8" hex wrench remove the velocity fuse (D) from the hydraulic cylinder (C) (Figure 86). Discard the fuse.
6. Reverse steps to reinstall.

**Note:** When reinstalling the cylinder hose fitting (B) lubricate the o-ring with ATF and only thread the fitting in until you feel resistance. When aligning the fitting for proper position, do not back out more the 340 degrees from where resistance was felt. Using a torque wrench, torque the jam nut of the fitting to 190±10 in-lb.

7. Check the fluid level before returning the unit to service. See "Filling the Reservoir" on [page 105](#).
8. Verify proper operation of the unit before returning it to service.

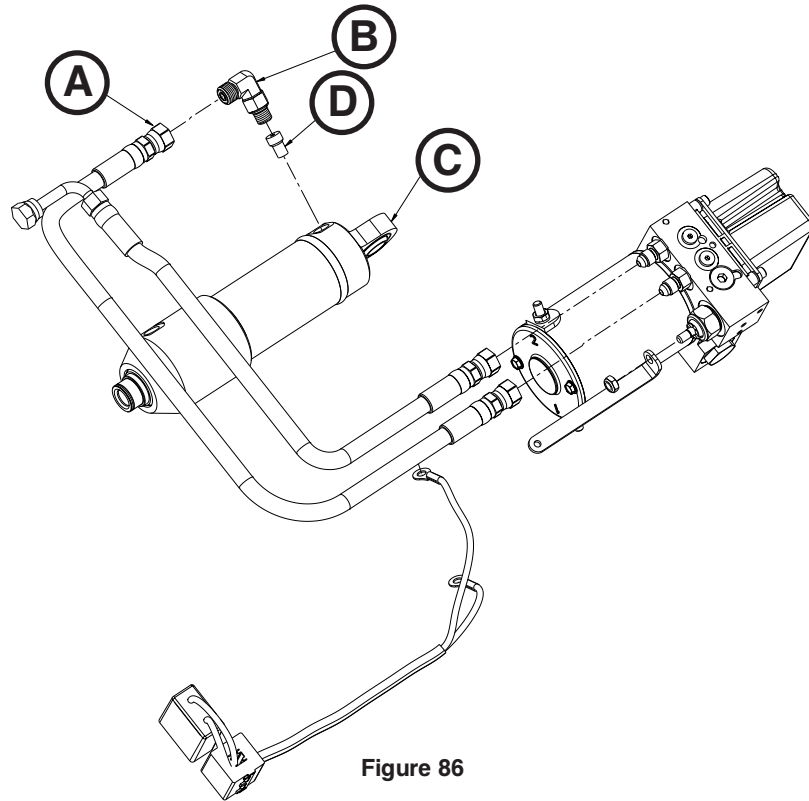

Figure 86

# Trolley Service Information

## NON-LOCKING MANUAL VALVE REMOVAL AND REPLACEMENT

### Tools Required:

- 7/16" Deep Well Socket
- 7/8" Deep Well Socket
- 3/8" Drive Ratchet
- 1/16" Hex Wrench

### Procedure:

1. Pull the trolley assembly out of the patient compartment until it locks into the loading position.

**Note:** This makes it easier to work on the unit, but is not required.

2. Lower the lifting arms down.
3. Remove the trolley covers. See "Cover Removal and Replacement" on [page 84](#).
4. Remove the manual release button assembly. See "Manual Release Button Assembly Removal and Replacement" on [page 85](#).
5. Using a 7/16" deep well socket and 3/8" drive ratchet, remove the Nylock Hex nut (A) that secures the non-locking manual valve (B) to the manual release link (C) (Figure 87).

**Note:** Place a 1/16" hex wrench through the slot on the non-locking manual valve (B) to keep it from turning (Figure 87).

6. Using a 7/8" deep well socket and 3/8" drive ratchet, remove the non-locking manual valve (B) (Figure 87). Discard the valve.

**Note:** Hydraulic fluid will leak from the cylinder and hoses. Lay down towels to catch fluid.

7. Reverse steps to reinstall.
8. Check the fluid level before returning the unit to service. See "Filling the Reservoir" on [page 105](#).
9. Verify proper operation of the unit before returning it to service.

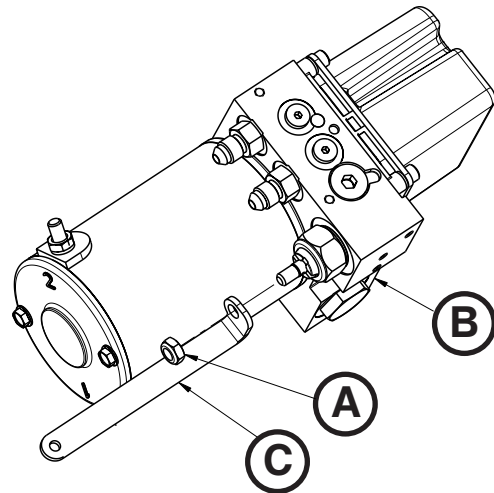

Figure 87

# Trolley Service Information

## HOSE REMOVAL AND REPLACEMENT

### Tools Required:

- 11/16" Combination Wrench
- (2) 9/16" Combination Wrench
- T25 Torx Driver

### Procedure:

1. Pull the trolley assembly out of the patient compartment.

**Note:** This makes it easier to work on the unit, but is not required.

2. Remove the trolley covers. See "Cover Removal and Replacement" on [page 84](#).
3. Using an 11/16" combination wrench, disconnect the bad hose from the cylinder.

**Note:** Hydraulic fluid will leak from the cylinder and hoses. Lay down towels to catch fluid.

4. Using a T25 Torx driver, loosen (do not remove) the two screws (A) that secure the manifold fitting to the left wing plate (Figure 89).

**Note:** Do not remove the manifold fitting, just loosen the screws to gain better access to the nuts.

5. Using two 9/16" combination wrenches, disconnect the bad hose from the manifold fitting. Discard the hose.

**Note:** Hydraulic fluid will leak from the cylinder and hoses. Lay down towels to catch fluid.

6. Reverse steps to reinstall.
7. Check the fluid level before returning the unit to service. See "Filling the Reservoir" on [page 105](#).
8. Verify proper operation of the unit before returning it to service.

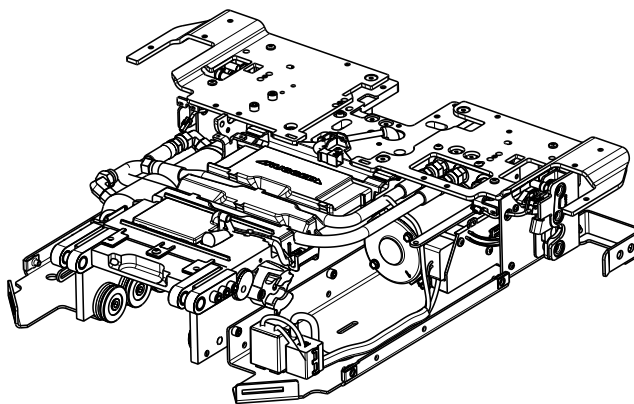

Figure 88

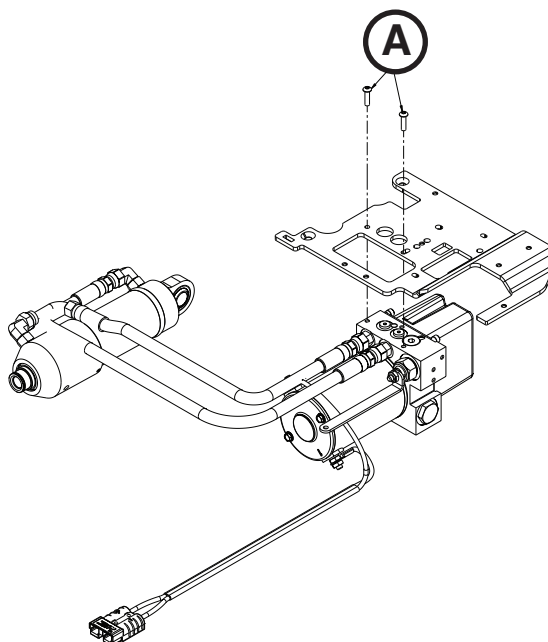

Figure 89

# Trolley Service Information

---

## PUMP/MOTOR ASSEMBLY REPLACEMENT

### Tools Required:

- (2) 9/16" Combination Wrench

### Procedure:

1. Pull the trolley assembly out of the patient compartment until it locks into the loading position.

**Note:** This makes it easier to work on the unit, but is not required.

2. Remove the hydraulic assembly. See "Hydraulic Assembly Removal and Replacement" on [page 89](#).
3. Using two 9/16" combination wrenches, loosen (do not remove) the hose end connectors (A) from the manifold to remove both hoses (Figure 90).

**Note:** Hydraulic fluid will leak from the cylinder and hoses. Lay down towels to catch fluid.

4. Reverse steps to reinstall.
5. Verify proper operation of the unit before returning it to service.

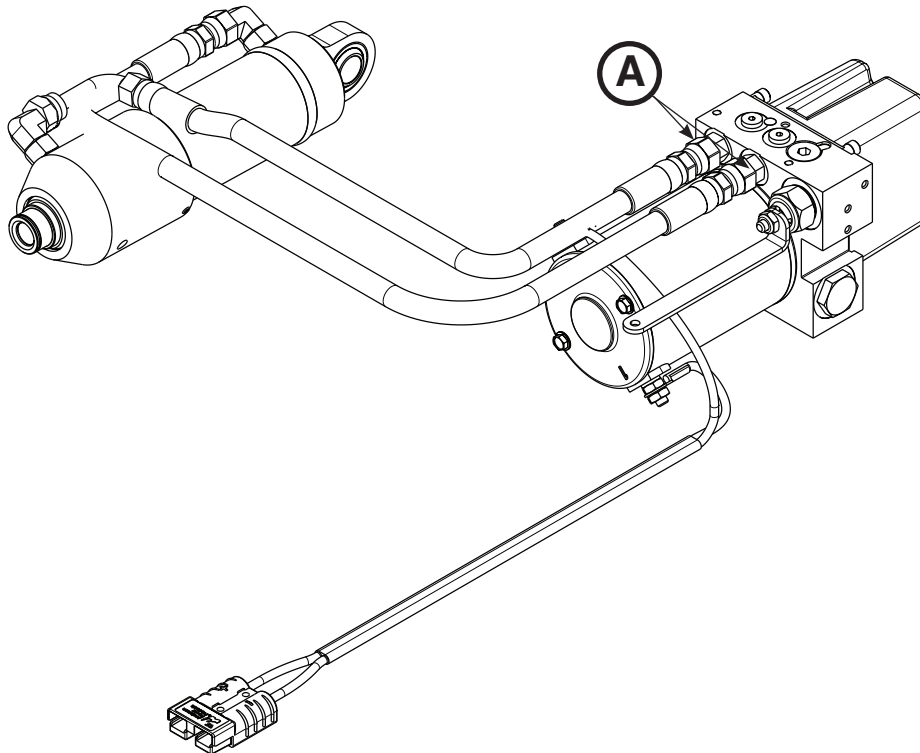

Figure 90

# Trolley Service Information

## MOTOR CABLE REMOVAL AND REPLACEMENT

### Tools Required:

- 7/16" Combination Wrench

### Procedure:

1. Pull the trolley assembly out of the patient compartment until it locks into the loading position.

**Note:** This makes it easier to work on the unit, but is not required.

2. Remove the trolley covers. See "Cover Removal and Replacement" on [page 84](#).
3. Remove the hydraulic assembly. See "Hydraulic Assembly Removal and Replacement" on [page 89](#).
4. Using a 7/16" combination wrench, remove the two nuts (A) and star washers (B) that secure the motor cable (C) to the motor assembly (Figure 91).

**Note:** Pay attention to the cable routing and terminal orientation for reinstallation.

5. Reverse steps to reinstall.
6. Verify proper operation of the unit before returning it to service.

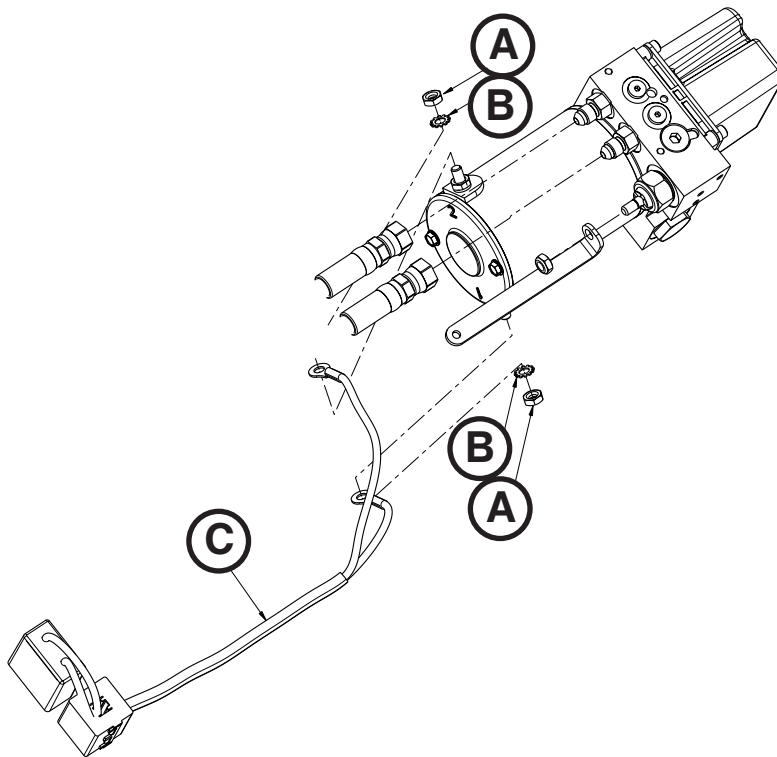

Figure 91

# Trolley Service Information

---

## MOTOR REPLACEMENT

### Tools Required:

- 7/16" Combination Wrench
- 1/4" Drive Ratchet
- 9/32" Socket

### Procedure:

1. Pull the trolley assembly out of the patient compartment until it locks into the loading position.

**Note:** This makes it easier to work on the unit, but is not required.

2. Remove the trolley covers. See "Cover Removal and Replacement" on [page 84](#).
3. Remove the motor cable. See "Motor Cable Removal and Replacement" on [page 102](#).
4. Using a 9/32" socket and 1/4" drive ratchet, remove the two bolts (A) that secure the motor (B) to the hydraulic manifold assembly (C) (Figure 92).

**Note:** During reinstallation, do not overtighten the bolts.

5. Reverse steps to reinstall.

---

### CAUTION

When replacing the motor, damage may occur if motor armature or stator are bumped around.

---

6. Verify proper operation of the unit before returning it to service.

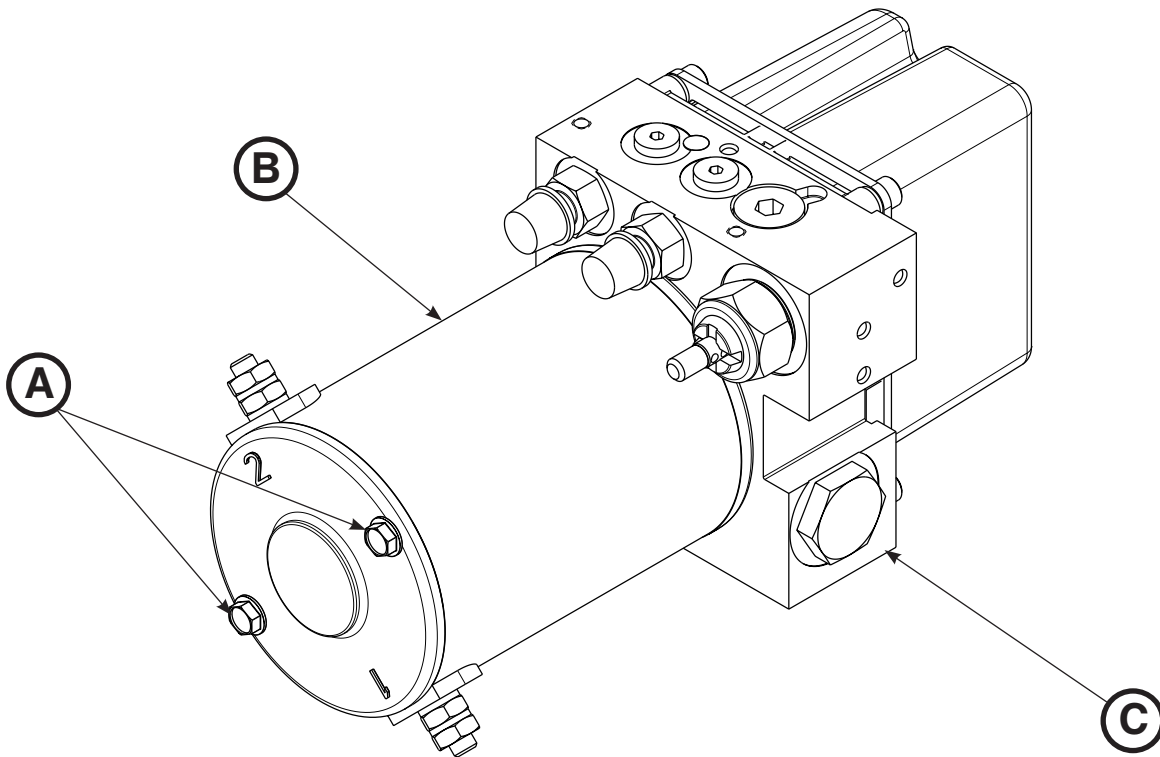

Figure 92

# Trolley Service Information

## PRESSURE COMPENSATED FLOW CONTROL VALVE REPLACEMENT

### Tools Required:

- 1/4" Hex Wrench
- Needle Nose Pliers

### Procedure:

1. Pull the trolley assembly out of the patient compartment until it locks into the loading position.

**Note:** This makes it easier to work on the unit, but is not required.

2. Remove the trolley covers. See "Cover Removal and Replacement" on [page 84](#).
3. Remove the hydraulic assembly. See "Hydraulic Assembly Removal and Replacement" on [page 89](#).
4. Using a 1/4" hex wrench, remove the hex plug (A) from the top of the hydraulic manifold assembly (Figure 93).
5. Using needle nose pliers, remove the pressure compensated flow control valve.

**Note:** Pay attention to the orientation of the valve for reinstallation.

6. Install the replacement pressure compensated flow control valve.

**Note:** Install the o-ring side of the valve down into the port.

7. Reverse steps to reinstall.
8. Check the fluid level before returning the unit to service. See "Filling the Reservoir" on [page 105](#).
9. Verify proper operation of the unit before returning it to service.

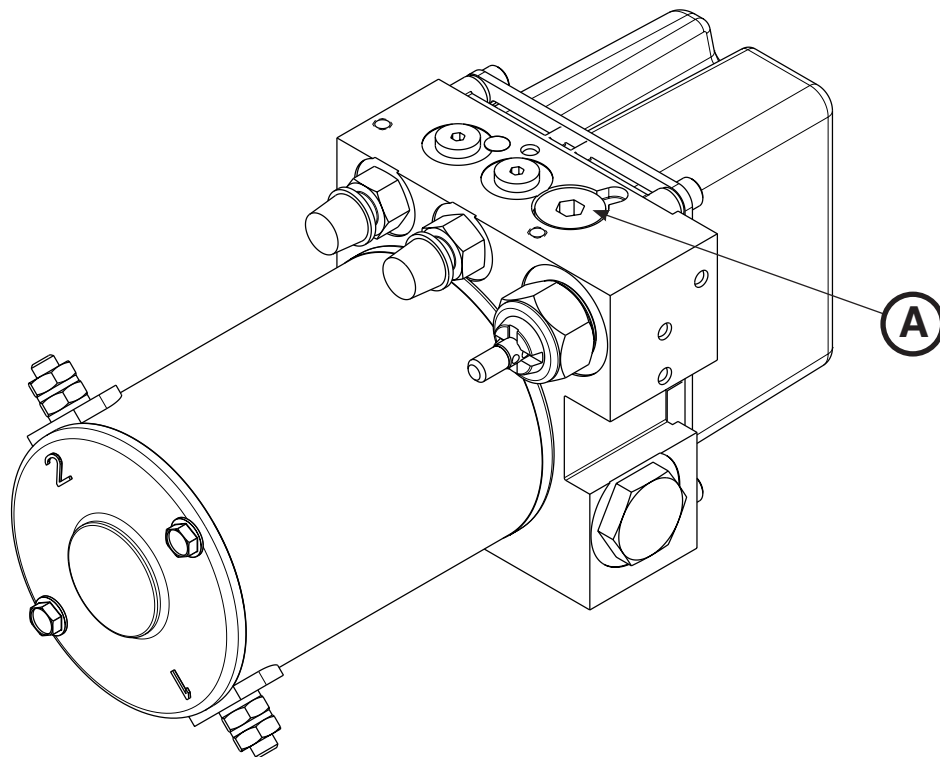

Figure 93



# Trolley Service Information

## BATTERY REPLACEMENT

### Tools Required:

- T25 Torx Driver

### Procedure:

1. Press the main power button to turn the unit off.
2. Using a T25 Torx driver, remove the two button head cap screws (A) that secure the rear trolley plate cover (B) to the trolley frame (Figure 94). Remove the cover.
3. Pull to remove the battery housing assembly (C) (Figure 94).
4. Remove and discard the battery.

**Note:** Do not dispose of as unsorted municipal waste. Refer to your local distributor for return and/or collection systems available in your country.

### CAUTION

When replacing the battery, do not touch the negative and positive battery terminals together on any metal surface.

5. Reverse steps to reinstall.
6. Verify proper operation of the unit before returning it to service.

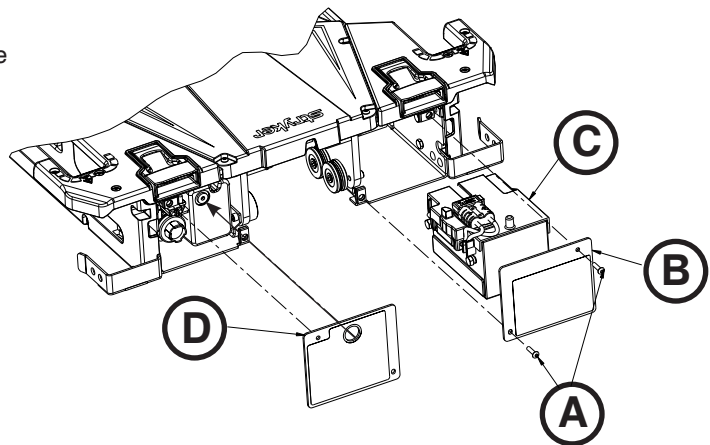

Figure 94

## FILLING THE RESERVOIR

### Tools Required:

- 3/16" Hex Wrench

### Procedure:

1. Pull the trolley assembly out of the patient compartment until it locks into the loading position.
2. Ensure that the lifting arms are in the down position before filling the reservoir.
3. Using a 3/16" hex wrench, remove the fill plug (D) (Figure 94).
4. Fill the reservoir up to the bottom of the fill port with Mobil Mercon® V Blend ATF Oil (6500-001-293).
5. Reinstall the plug.

### WARNING

Use only Mobil Mercon® V Blend ATF Oil (6500-001-293) in the specified quantity. Do not overfill the reservoir with oil. See the Mobil Mercon® V Blend ATF Oil material safety data sheet (MSDS) issued by the manufacturer for safety information (Exxon Mobil Corporation, 1-(800) 947-9147, <http://www.exxon.com>, <http://www.mobil.com>, product code: 20103020B010, 525147-00, 97X826).

# Anchor Service Information

## PRIMARY COIL REPLACEMENT, FOOT END

### Tools Required:

- 5/32" Hex Wrench
- (2) 1/8" Hex Wrench
- 1/4" Hex Wrench
- 3/8" Allen Driver
- Torque Wrench (ft-lb) > 60 ft-lb

### Procedure:

1. Remove the trolley. See "Trolley Removal" on [page 82](#).
2. Remove the transfer. See "Transfer Removal" on [page 81](#).
3. Using a 5/32" hex wrench, remove the two screws that secure the safety hook to the floor plate and remove the safety hook.
4. Using a 3/8" Allen driver, remove the four anchor mounting posts (A) that secure the anchor to the floor plate (Figure 95).

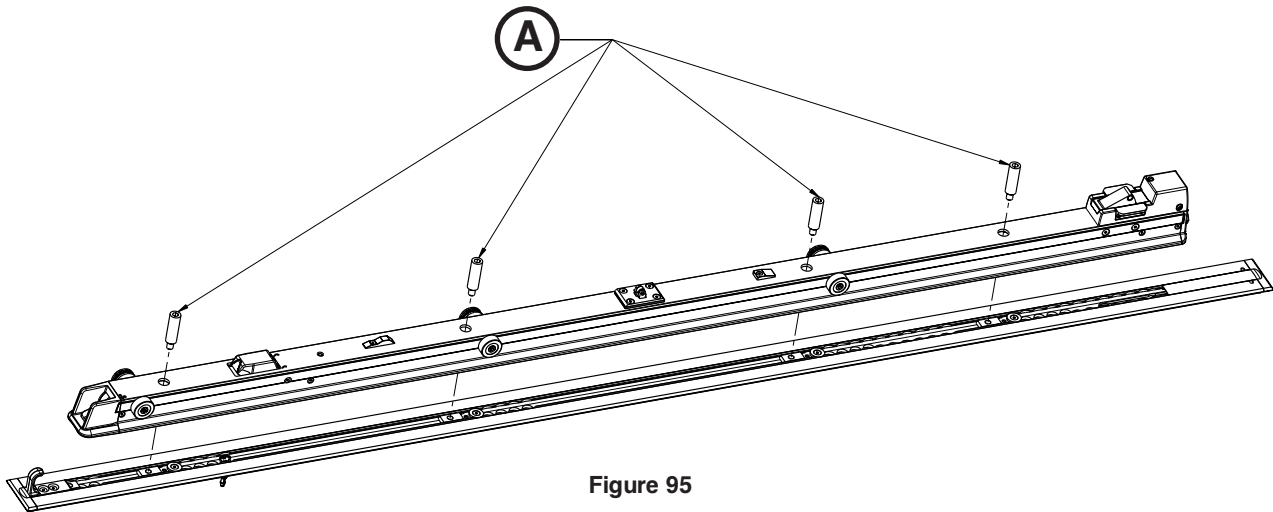

Figure 95

5. Flip the anchor on its side and unplug the anchor plunger assembly cables from the patient compartment main power cable (at the head end).
6. Using a 1/8" hex wrench, remove one of the two flat head cap screws (B) that secure the release lever housing (F) to the anchor (Figure 96).

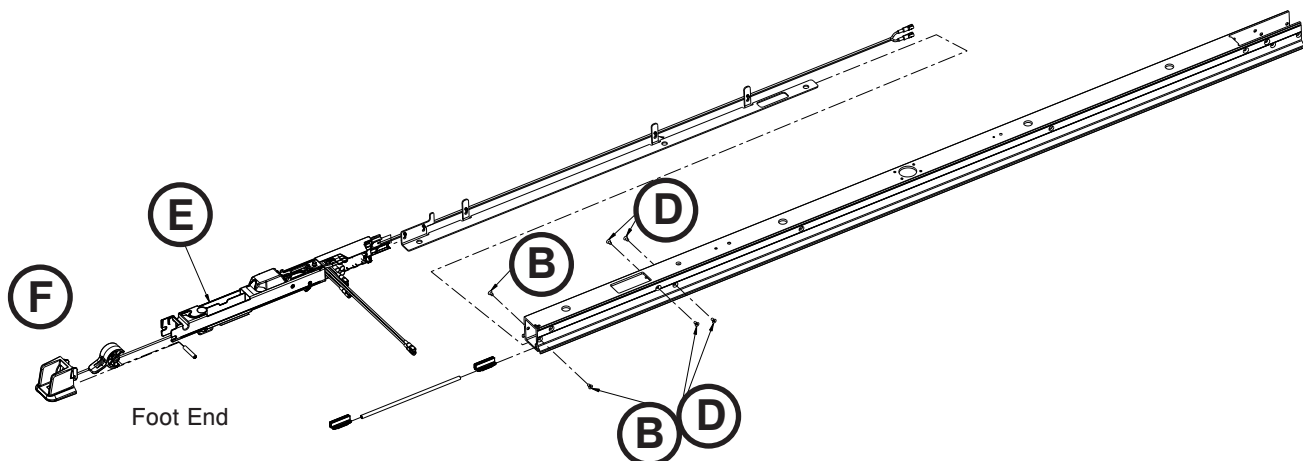

Figure 96

# Anchor Service Information

## PRIMARY COIL REPLACEMENT, FOOT END (CONTINUED)

- Using the second 1/8" hex wrench, insert the wrench into the anchor pivot pin to remove the other screw and remove the anchor trigger assembly.

**Note:** The LED cable will still be attached. Do not pull the parts to prevent damage.

- Using a 1/4" hex wrench, remove the two screws (C) that secure the flat roller assembly and the V-guide roller assembly on the foot end of the anchor assembly (Figure 97). Save all parts for reinstallation.

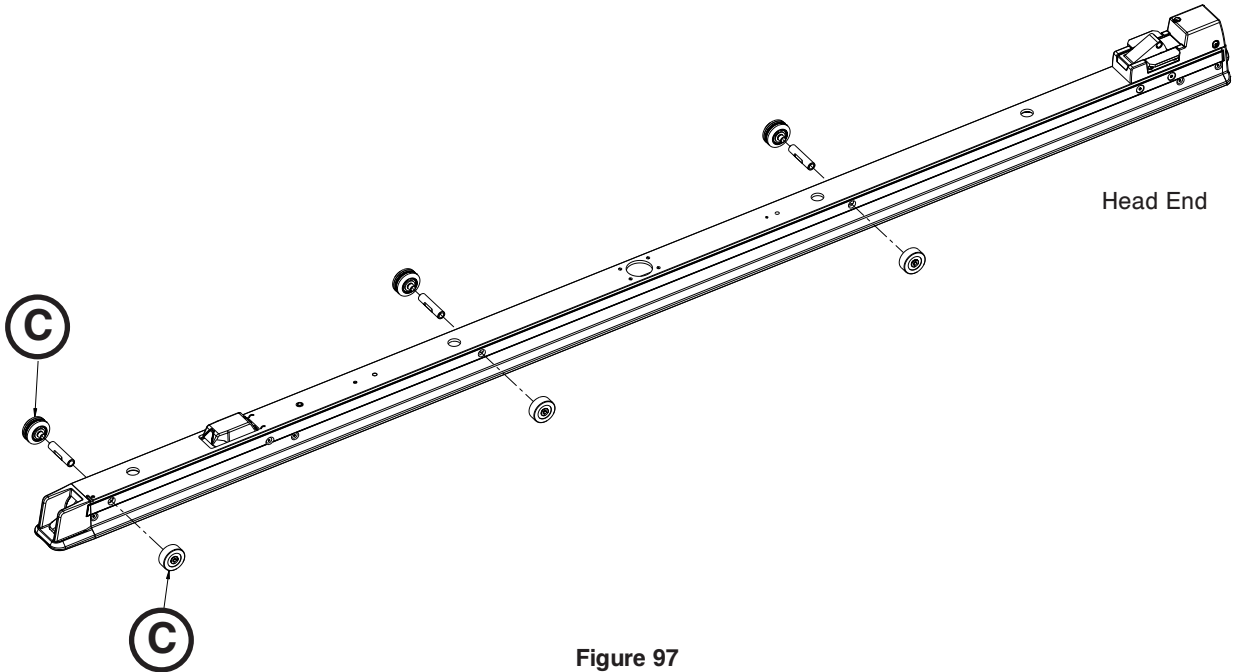

Figure 97

- Using a 1/8" hex wrench, remove two of the four flat head cap screws (D) from one side of the anchor plunger assembly, mid (Figure 96)). Save all parts for reinstallation.
- Using the second 1/8" hex wrench, insert the wrench into the anchor pivot pin to remove the other two of the four flat head cap screws (D) (Figure 96). Save screws for reinstallation.
- Unplug the power cables from the extension cable from the underside of the anchor.
- Carefully remove the anchor plunger assembly, mid (E) from the anchor (Figure 96).

# Anchor Service Information

## PRIMARY COIL REPLACEMENT, FOOT END (CONTINUED)

13. Remove the anchor pivot pin (G) that holds the anchor coil assembly (H) to the anchor housing (J) (Figure 98).
14. Unplug the coil wires from the inductive primary board (I) (Figure 98). Discard the anchor coil assembly.

**Note:** Do not dispose of as unsorted municipal waste. Refer to your local distributor for return and/or collection systems available in your country.

15. Reverse steps to reinstall. Torque the V-guide roller assembly and flat roller assembly to 235-317 in-lb. Torque the anchor mounting posts to  $60 \pm 10$  ft-lb.
16. Verify proper operation of the unit before returning it to service.

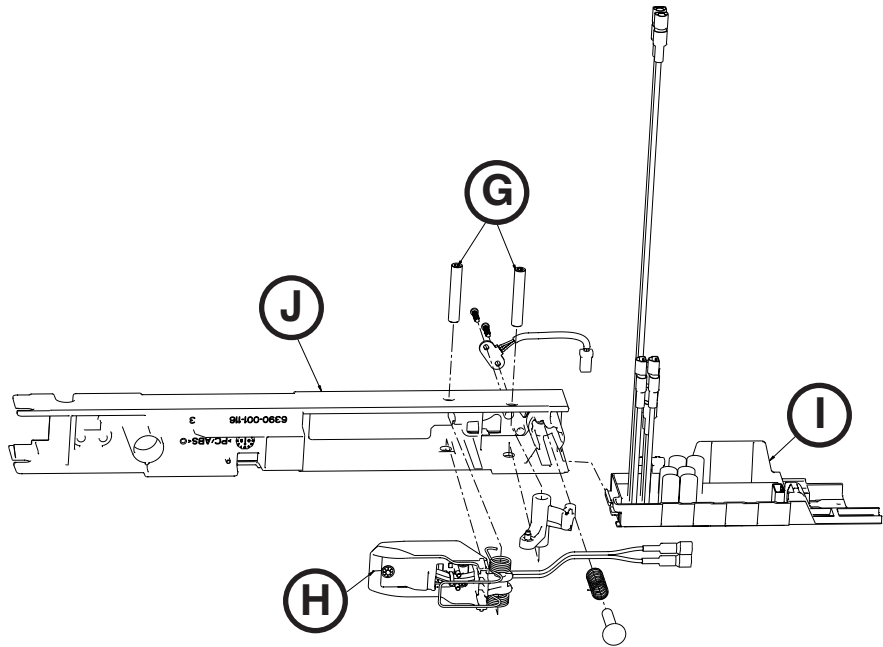

Figure 98

# Anchor Service Information

## PRIMARY COIL REPLACEMENT, HEAD END

### Tools Required:

- 5/32" Hex Wrench
- (2) 1/8" Hex Wrench
- 3/8" Allen Driver
- T25 Torx Driver
- Diagonal Pliers
- Torque Wrench (ft-lb) > 60 ft-lb

### Procedure:

1. Remove the trolley. See "Trolley Removal" on [page 82](#).
2. Remove the transfer. See "Transfer Removal" on [page 81](#).
3. Using a 5/32" hex wrench, remove the two screws that secure the safety hook to the floor plate and remove the safety hook.
4. Using a 3/8" Allen driver, remove four the anchor mounting bolts that secure the anchor to the floor plate.
5. Unplug the main power cable from the patient compartment to the anchor assembly at the head end.
6. Using a 5/32" hex wrench, remove the four screws (A) (Figure 99).
7. Using two 1/8" hex wrenches, remove the four flat head cap screws (B) that secure the anchor pawl assembly to the anchor (Figure 99). Save all parts for reinstallation.
8. Carefully remove the anchor pawl assembly (C) from the anchor by pulling toward the head end of the anchor (Figure 99).

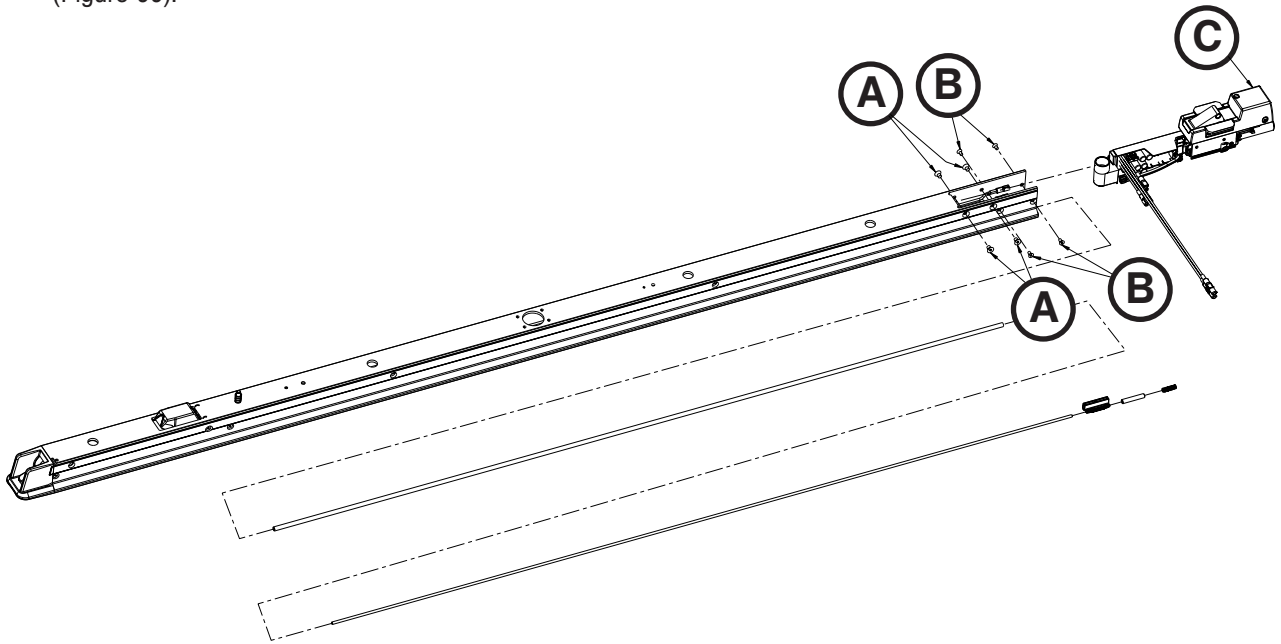

Figure 99

9. Unplug the power cables from the extension cable from the anchor.

# Anchor Service Information

## PRIMARY COIL REPLACEMENT, HEAD END (CONTINUED)

10. Unplug the two coil wires from the inductive primary board.
11. Using diagonal pliers, cut the zip ties (D) that secure the coil wires to the wire management strap (Figure 100).
12. Using a T25 Torx driver, remove the four button head cap screws (E) that secure the two retainer wings and remove the retainer wings (Figure 101). Save all parts for reinstallation.
13. Using a 1/8" hex wrench, remove the two button head cap screws (F) that secure the anchor housing assembly, head end to the anchor pawl assembly and remove the anchor housing assembly (G) (Figure 102).
14. Carefully remove the anchor housing. Discard the anchor housing.

**Note:** Do not dispose of as unsorted municipal waste. Refer to your local distributor for return and/or collection systems available in your country.

15. Reverse steps to reinstall. When reinstalling, use a torque wrench to tighten each anchor mounting post to  $60 \pm 10$  ft-lb.
16. Verify proper operation of the unit before returning it to service.

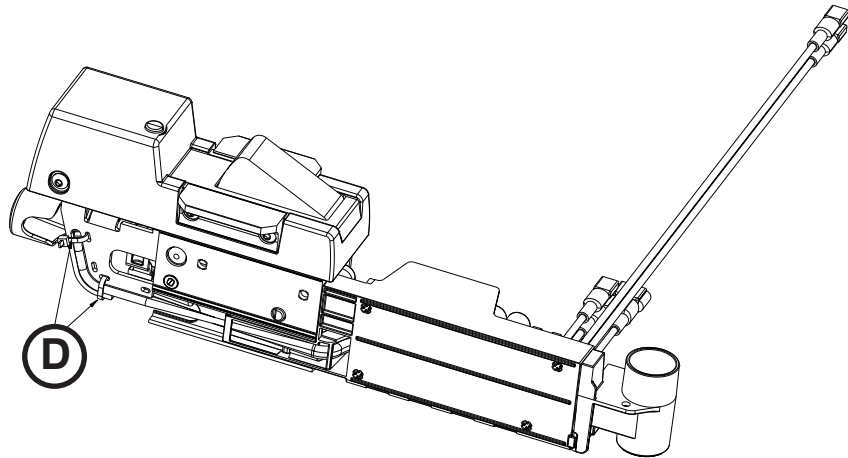

Figure 100

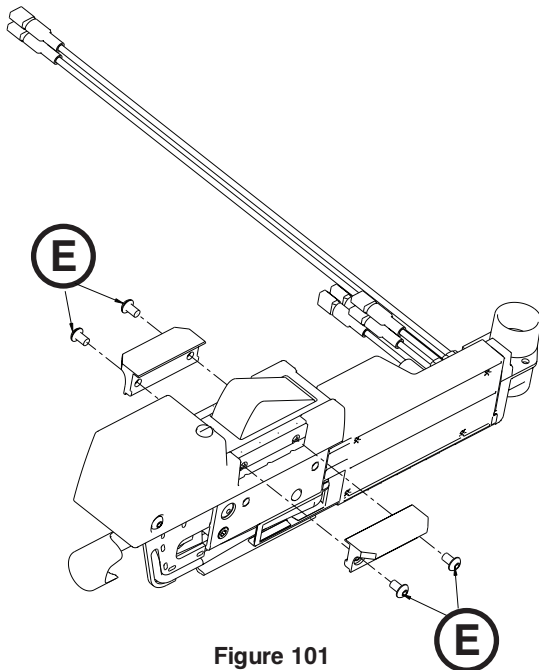

Figure 101

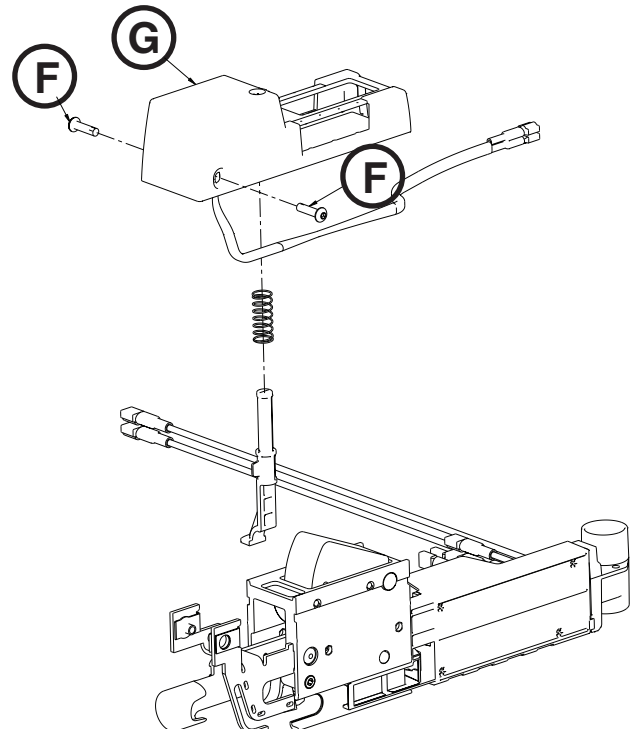

Figure 102

# Anchor Service Information

## TRANSFER LOCK BEARING REMOVAL AND REPLACEMENT

### Tools Required:

- 5/32" Hex Wrench

### Procedure:

1. Remove the trolley. See "Trolley Removal" on [page 82](#).
2. Remove the transfer. See "Transfer Removal" on [page 81](#).
3. Using a 5/32" hex wrench, remove the four flat head cap screws (A) that secure the transfer lock cap to the anchor extrusion (Figure 103).
4. Remove the transfer lock cap (B) (Figure 103).
5. Remove the transfer lock pin assembly (C), compression spring (D), and bronze bearing (E) from the anchor extrusion (Figure 103). Discard the bronze bearing.
6. Clean the transfer lock pin assembly (C) and spring (D) thoroughly (Figure 103).
7. Install the new bronze bearing (E), compression spring (D), transfer lock pin assembly (C) into the anchor extrusion (Figure 103).

**Note:** Prior to reinstallation, grease the transfer lock pin assembly with molybdenum disulfide lubricant (6390-001-263).

8. Using a 5/32" hex wrench, reinstall the four flat head cap screws that secure the transfer lock cap (B) to the anchor extrusion by just starting each screw first and then tightening all four (Figure 103).
9. Reverse steps to reinstall.
10. Verify proper operation of the unit before returning it to service.

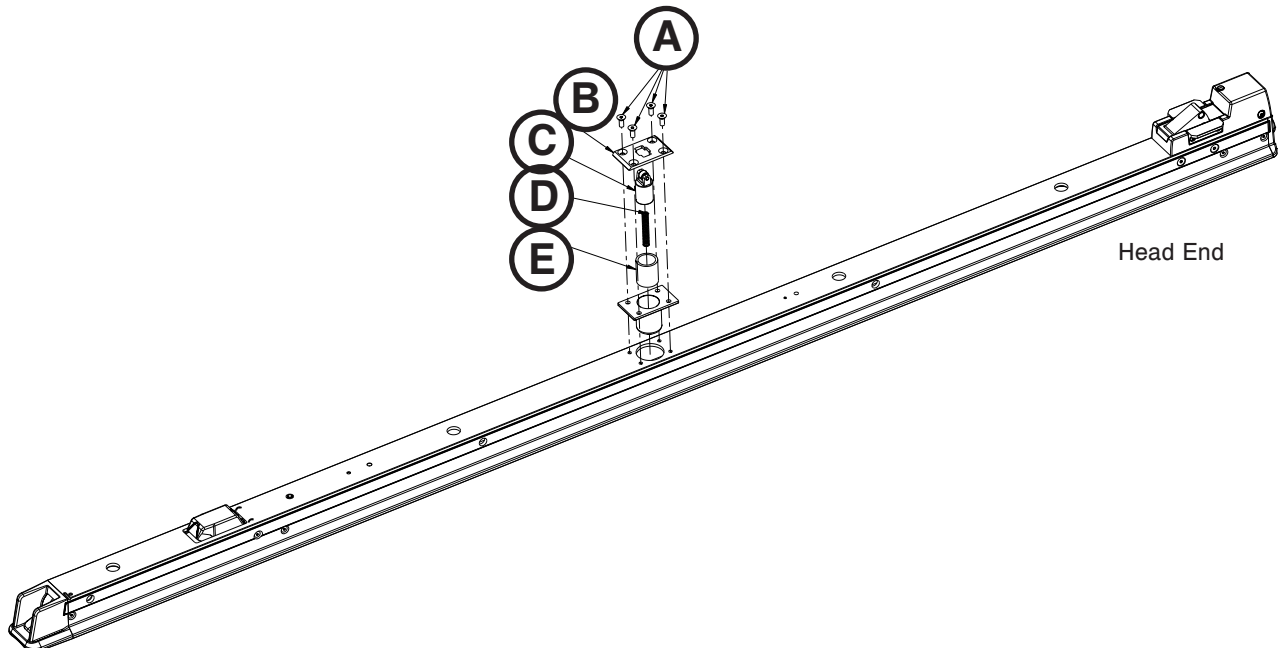

Figure 103

# Troubleshooting Guide

Check for proper operation after each step. When the problem is fixed, return the unit to service. If assistance is needed at any time during troubleshooting, please contact a service technician at (800) 327-0770 or (269) 389-6500.

PROBLEM/FAILURE	RECOMMENDED ACTION
Transfer/cot does not move out of the transport position when you press the release lever at the foot end of the anchor	<ol style="list-style-type: none"> <li>1. Verify If the lifting arms are over the base tube:               <ol style="list-style-type: none"> <li>a. If the lifting arms are over the base tube:                   <ol style="list-style-type: none"> <li>i. Press the transfer release lever and the trolley release button at the head end of the anchor at the same time with the help of another person.                       <ol style="list-style-type: none"> <li>1. If the cot is free, then investigate the head end anchor mechanism.</li> </ol> </li> <li>ii. If the cot still will not move, then repeat step i while simultaneously pulling on the patient right transfer lock trigger at the foot end of the transfer. This should allow the cot to be pulled out while it is still locked into the trolley and transfer. After it is pulled out, look at the underside of the transfer. About 15 inches from the foot end, you will see the metal hook with a semi-circle cutout at its head end. Push up on the semi-circle and the cot should be free to move (have someone help pull the cot at this point).                       <ol style="list-style-type: none"> <li>1. If the cot is free, then check the foot end anchor mechanism.                           <ol style="list-style-type: none"> <li>a. Remove the transfer to inspect the foot end anchor pin and remove the anchor mechanism from the foot end of the anchor.</li> </ol> </li> </ol> </li> </ol> </li> <li>b. If the lifting arms are under the base tube:                   <ol style="list-style-type: none"> <li>i. With the help of another person, press the transfer release lever and lift up on one of the cot release handles on the trolley same time.                       <ol style="list-style-type: none"> <li>1. If the cot is free, remove the cot and verify if the black pin will extend up from the anchor head end cover.                           <p><b>Note:</b> The trolley must be in the mid position and the release lever to elevate the pin.</p> <ol style="list-style-type: none"> <li>a. If the pin extends out without signs of damage, check the casting in the trolley release handle mechanism (6390-001-328) or the plastic lever in the trolley middle mechanism.</li> <li>b. If the pin does not extend out, check the head end anchor mechanism for damage.</li> </ol> </li> </ol> </li> <li>ii. If the cot still will not move, insert a screwdriver into each notch at the head end of the trolley side covers to release the cot head section latches.                       <ol style="list-style-type: none"> <li>1. After the latches are unlocked, use the release lever at the foot end to release the cot.</li> <li>2. After the cot is removed, investigate the release handle mechanism in the trolley.</li> </ol> </li> </ol> </li> </ol> </li> </ol>
Trolley does not roll smoothly	<ol style="list-style-type: none"> <li>1. If rolling is difficult while the trolley is rolling on the transfer:               <ol style="list-style-type: none"> <li>a. Check the rods in the channels on the outside of the transfer extrusion for debris or foreign material and remove.</li> <li>b. If step a does not solve the problem, check if the transfer extrusion is worn around the channels. If so, replace the V-guide rollers on the trolley</li> </ol> </li> <li>2. If rolling is difficult while the transfer is rolling on the anchor:               <ol style="list-style-type: none"> <li>a. Check the metal dead stops (6390-001-246) at the head end of the transfer to ensure they are fully seated and not rubbing on the anchor extrusion.</li> <li>b. Check the rods in the channels on the inside of the transfer extrusion and remove any debris or foreign material.</li> <li>c. If neither step a or b solve the problem, check to see if the transfer extrusion is worn around the channels. If so, replace the V-guide rollers on the anchor.</li> </ol> </li> </ol>
Trolley rolls part of the way and stops	<ol style="list-style-type: none"> <li>1. Check the transfer lock bearing in the anchor:               <ol style="list-style-type: none"> <li>a. Clean the transfer lock pin, replace the bearing and apply molybdenum disulfide lubricant (6390-001-263) to the inside of the new bearing.</li> </ol> </li> <li>2. Check the transfer lock override slides (6390-001-261) for excessive wear.</li> </ol>



# Troubleshooting Guide

## TROUBLESHOOTING GUIDE (CONTINUED)

PROBLEM/FAILURE	RECOMMENDED ACTION
Trolley makes noise while rolling	<ol style="list-style-type: none"> <li>1. If the noise occurs when the trolley is rolling on the transfer:               <ol style="list-style-type: none"> <li>a. When rolling the system out of the transport position, does the trolley get to the foot end of the transfer before the transfer moves?                   <ol style="list-style-type: none"> <li>i. If no, the transfer lock pin in the anchor, or its return spring, is most likely the problem. The pin should return to the full up position after it is pressed. Check the transfer lock pin for cleaning or replacement of the spring or bearing.</li> <li>ii. If yes, remove any debris or foreign objects from the transfer and vehicle floor. Inspect the transfer extrusion for wear. Remove the trolley from the transfer and check that the trolley rollers are free of debris. If this does not solve the problem, or if the transfer extrusion is worn around the rods, replace the V-guide rollers on the trolley.</li> </ol> </li> </ol> </li> <li>2. If the noise occurs when the transfer is rolling on the anchor:               <ol style="list-style-type: none"> <li>a. The noise is likely caused by either the detent roller (usually a high pitched squeak), or the transfer lock pin (usually more of a grinding sound).</li> </ol> </li> </ol>
Trolley LEDs stay off when the trolley reaches the loading position	<ol style="list-style-type: none"> <li>1. Confirm that the trolley is on and the battery is charged.</li> <li>2. Check that the magnet activator (6390-001-106) is present and that it is properly fastened at the foot end of the anchor.</li> <li>3. Confirm that if you push on the trolley (with the lifting arms down), the system does not roll away from the loading position and is locked in this position.</li> <li>4. Remove the transfer and confirm that the magnet mover trigger (6390-001-205) is intact and undamaged.</li> <li>5. Remove the magnet mover trigger (6390-001-205). Remove the foot end latch assembly from the transfer and pull out the link in the channel on the patient left side. Check that the magnet nested into that link is present and intact. Check that the return spring on the link is in good condition.</li> <li>6. Remove the trolley covers and check the connection of the trolley position sensor (TPS) cable (6390-001-361).</li> <li>7. Check the connection of the trolley main cable (6390-001-391) to the control board assembly (6390-001-014).</li> <li>8. Check the connection of the trolley LED cables (6390-001-396).</li> <li>9. Replace the trolley position sensor (TPS) (6390-001-361).</li> <li>10. Replace one of the trolley LEDs (6390-001-396).</li> <li>11. Replace the trolley control board assembly (6390-001-014).</li> <li>12. Replace the trolley main cable (6390-001-391).</li> </ol>

# Troubleshooting Guide

## TROUBLESHOOTING GUIDE (CONTINUED)

PROBLEM/FAILURE	RECOMMENDED ACTION
Cot release button does not unlock the cot from the trolley	<ol style="list-style-type: none"> <li>1. Confirm that both the cot and trolley have power, no errors, and are operational independently.</li> <li>2. Confirm that the cot release handles on the trolley are able to release the cot from Power-LOAD.</li> <li>3. Confirm that communication exists between the cot and Power-LOAD by lifting the cot using the cot controls.</li> <li>4. Try the release button on the second switch. If this works, the issue is with the first switch or a bad connection in the cot.</li> <li>5. In a quiet area, press the release button and listen for a clicking sound at the head end patient left side of the trolley. You may need to push the button twice if the cot is asleep.               <ol style="list-style-type: none"> <li>a. If there is a sound, the problem is likely a broken part in the actuator assembly or an improperly installed actuator assembly (6390-001-478).</li> <li>b. If there is not a sound, remove the trolley top and patient left side covers and check the following:                   <ol style="list-style-type: none"> <li>i. Confirm that the connection of the actuator (6390-001-478) to the circuit board is good and the contacts appear to be in good condition.</li> <li>ii. Confirm that the connection of the trolley main cable (6390-001-391) to the control board assembly (6390-001-014) is good, the connector screws are tight, and the contacts appear to be in good condition.</li> <li>iii. Test Power-LOAD with a new actuator (6390-001-478).</li> <li>iv. Test Power-LOAD with a new control board assembly (6390-001-014).</li> </ol> </li> </ol> </li> </ol>
Trolley release handles do not release the cot from the trolley	<ol style="list-style-type: none"> <li>1. Confirm that the system is in the loading position with the cot wheels on the ground and head section locked into the trolley.</li> <li>2. Confirm that the lifting arms are in the full down position.</li> <li>3. Are the release handles on the trolley free to rotate (they should rotate about 20 degrees)?               <ol style="list-style-type: none"> <li>a. If yes, inspect the release handle mechanism. Pay particular attention to the activation cams (6390-001-329). Also inspect the trolley latches (6390-001-318 and 6390-001-319).</li> <li>b. If no, remove the trolley covers and inspect the following:                   <ol style="list-style-type: none"> <li>i. In the mechanism in the center of the trolley at the head end, check the trolley arm (6390-001-334) or its return spring, which could be broken or jammed by debris.</li> <li>ii. The trolley arm mechanism (6390-001-045) in the trolley could be jammed.</li> <li>iii. The trolley latches (6390-001-318 and 6390-001-319) could be stuck or broken.</li> </ol> </li> </ol> </li> </ol>

# Troubleshooting Guide

## TROUBLESHOOTING GUIDE (CONTINUED)

PROBLEM/FAILURE	RECOMMENDED ACTION
Trolley does not lock in the loading position	<ol style="list-style-type: none"> <li>1. Confirm where the system is unlocking from:               <ol style="list-style-type: none"> <li>a. If the trolley is unlocking from the transfer:                   <ol style="list-style-type: none"> <li>i. Remove the cot. Put the trolley in the middle of the transfer.                       <ol style="list-style-type: none"> <li>1. On the extended transfer, locate just to the head end of the foot end fastener, the transfer to trolley lock pawl (6390-001-073), which should be sticking out of the transfer about 1/2". If the pawl is not sticking up or does not return when pressed, check its return spring, or look for debris binding it down.</li> <li>2. Check that the pin of the roller in the pawl is not sticking out on either side.</li> <li>3. Remove the transfer head end dead stops, and remove the transfer from the anchor. Clear any debris or foreign material from the top of the anchor and the channels in the transfer. Foreign objects that do not allow the trolley to reach the full out position could cause this mechanism to not operate properly.</li> <li>4. Inspect the trolley stop ramp (6390-001-325) on the underside of the trolley middle mechanism to ensure it is present and secured.</li> </ol> </li> <li>b. If the transfer is unlocking from the anchor:                   <ol style="list-style-type: none"> <li>i. Remove the cot. Move the trolley to the mid position. Check for debris around the transfer lock trigger (6390-001-231).                       <ol style="list-style-type: none"> <li>1. Push the transfer all the way to the transport position. Pull on the transfer to check if it is locked. If the transfer is not locked, the problem is likely that the transfer lock pin in the anchor is stuck or broken. Check the return spring, and look for burrs or debris.</li> </ol> </li> </ol> </li> </ol> </li> </ol> </li> </ol>
Trolley will not unlock from the transfer position	<ol style="list-style-type: none"> <li>1. Remove the cot. Using the head end transfer lock override slide (6390-001-261), move the transfer in, and put the trolley in the mid position.</li> </ol>
Trolley pump runs for and extended time after cot jog up	<ol style="list-style-type: none"> <li>1. Check the angle position sensor (APS) (6390-001-397) calibration set point. Call Stryker Service.</li> <li>2. Check that the hydraulic cylinder is not "over-stroking". Over stroke condition is evidenced by a ~1/8" back settle in the rod of the hydraulic cylinder at full extension. <b>Note:</b> The patient right side cover must be removed to observe.</li> <li>3. Check for damage of components in the chain of load bearing parts from the lifting arms to the patient right side plate (6390-001-344).</li> </ol>

# Troubleshooting Guide

## TROUBLESHOOTING GUIDE (CONTINUED)

PROBLEM/FAILURE	RECOMMENDED ACTION
Cot does not lock into the trolley and the LEDs flash red	<ol style="list-style-type: none"> <li>1. Remove the cot from Power-LOAD. Ensure that the cot is a Power-LOAD compatible cot and that the load wheel horns and pins (6500-002-104) are present, properly tightened, and in good condition.</li> <li>2. Check that the handle release mechanism (6390-001-046) moves freely and the release handles return to the full down position. Debris under the release handles could cause this issue.</li> <li>3. Remove the trolley covers and check the connection of the trolley latch switch cables (6390-001-318 and 6390-001-319).</li> <li>4. Check the connection of the trolley main cable (6390-001-391) to the control board assembly (6390-001-014).</li> <li>5. Remove and inspect the actuator assembly (6390-001-028) from the trolley.</li> <li>6. Check the return springs connecting the release cams (6390-001-329) to the trolley bottom pans.</li> <li>7. Examine the trolley latches (6390-001-318 and 6390-001-319). Ensure that when the latch is locked, the electronic switch is being compressed. This could be impeded by cables obstructing the pin on top of the latch, or a broken spring internal to the latch.               <ol style="list-style-type: none"> <li>a. Replace each latch.</li> <li>b. Replace the trolley control board assembly (6390-001-014).</li> <li>c. Replace the trolley main cable (6390-001-391).</li> </ol> </li> </ol>
Cot locks into the trolley at the loading position but the LEDs are not on	<ol style="list-style-type: none"> <li>1. Confirm that the trolley is on and the battery is charged.</li> <li>2. Check that the magnet activator (6390-001-106) is present and that it is properly fastened at the foot end of the anchor.</li> <li>3. Confirm that if you push on the trolley (with the lifting arms down) the system does not roll away from the loading position.</li> <li>4. Remove the transfer and confirm that the magnet mover trigger (6390-001-205) is not damaged.</li> <li>5. Remove the magnet mover trigger (6390-001-205). Remove the foot end latch assembly from the transfer and pull out the link in the channel on the patient right side. Check that the magnet nested into that link is present and intact. Check that the return spring on the link is in good condition.</li> <li>6. Remove the trolley covers and check the connection of the trolley position sensor (TPS) cable (6390-001-361).</li> <li>7. Check the connection of the trolley main cable to the control board assembly (6390-001-014).</li> <li>8. Check the connection of the trolley LED cables (6390-001-396).</li> <li>9. Replace the trolley position sensor (TPS) (6390-001-361).</li> <li>10. Replace one of the trolley LEDs (6390-001-396).</li> <li>11. Replace the trolley control board assembly (6390-001-014).</li> <li>12. Replace the trolley main cable (6390-001-391).</li> </ol>

# Troubleshooting Guide

## TROUBLESHOOTING GUIDE (CONTINUED)

PROBLEM/FAILURE	RECOMMENDED ACTION
Cot will not jog up when released from the transport position	<ol style="list-style-type: none"> <li>1. Check the trolley control panel LEDs. They should be solid green without any solid amber error indication.               <ol style="list-style-type: none"> <li>a. If there are no trolley control panel LEDs illuminated:                   <ol style="list-style-type: none"> <li>i. Press the main power button to turn the unit on. You may need to turn the unit on and then off to ensure that Power-LOAD is not in sleep mode</li> </ol> </li> <li>b. If the trolley control panel LEDs are illuminated:                   <ol style="list-style-type: none"> <li>i. Flashing amber means the battery is low. Return the trolley to the transport position. Ensure that the unit begins to charge as indicated by a flashing green battery LED. Low battery indication (flashing amber) may continue for as the battery recharges.</li> <li>ii. Solid green battery LED and solid amber LED means - System Error: Call Stryker Service for advanced troubleshooting. The following may be attempted:                       <ol style="list-style-type: none"> <li>1. If you hear the motor run as you pull the unit from the transport toward the loading position, the problem is most likely with the hydraulic unit.                           <ol style="list-style-type: none"> <li>a. Replace the hydraulics assembly (6390-001-039).</li> <li>b. Replace the motor cable (6390-001-397).</li> <li>c. Replace the angle position sensor (APS) (6390-001-397).</li> <li>d. Replace the trolley position sensor (TPS) (6390-001-361).</li> <li>e. Replace the control board assembly (6390-001-014).</li> </ol> </li> </ol> </li> </ol> </li> </ol> </li> </ol>
Cot will not jog up high enough when released from the transport position	<ol style="list-style-type: none"> <li>1. Check the angle position sensor (APS) (6390-001-397) calibration set point. Call Stryker Service.</li> <li>2. Check that the hydraulic cylinder is not "over-stroking". Over stroke condition is evidenced by a ~1/8" back settle in the rod of the hydraulic cylinder at full extension. <b>Note:</b> The patient right side cover must be removed to observe.</li> <li>3. Check for damage of components in the chain of load bearing parts from the lifting arms to the patient right side plate (6390-001-344).</li> </ol>
Cot takes a long time to jog up	<ol style="list-style-type: none"> <li>1. Check that the battery voltage is 12.2V DC.</li> <li>2. Check the battery cable connections for damage.</li> <li>3. Check the cable connections to the control board.</li> <li>4. Replace the hydraulics assembly (6390-001-039).</li> <li>5. Replace the control board assembly (6390-001-014).</li> </ol>

# Troubleshooting Guide

## TROUBLESHOOTING GUIDE (CONTINUED)

PROBLEM/FAILURE	RECOMMENDED ACTION
Lifting arms do not lower but the cot legs extend when you press the extend (+) button	<ol style="list-style-type: none"> <li>1. Ensure that the trolley is powered on and that Power-LOAD recognizes the loading position by checking that the head end LED indicators are green.               <ol style="list-style-type: none"> <li>a. If the head end LED indicators are not on:                   <ol style="list-style-type: none"> <li>i. Check the trolley control panel LEDs to ensure that the unit is on. The LEDs should appear as a solid green battery symbol with no illumination of error indication.</li> <li>ii. If the trolley control panel LED illuminates solid green only, then the trolley may not see what position it is in.                       <ol style="list-style-type: none"> <li>1. Check that the magnet activator (6390-001-106) is present and that it is properly fastened at the foot end of the anchor.</li> </ol> </li> </ol> </li> <li>b. If the head end LED indicators are on:                   <ol style="list-style-type: none"> <li>i. Check if the trolley motor is running when you press the cot switch.                       <ol style="list-style-type: none"> <li>1. If the trolley motor is audible, then the problem is with the low pressure relief valve in the trolley hydraulic assembly. Extend the cot legs and use the trolley manual release to drop the lifting arms until they are no longer supporting the cot. Press the down button on the trolley side panel to complete lowering the arms. If the arm moves, replace the hydraulics assembly (6390-001-039).</li> <li>2. If the trolley motor is not audible.                           <ol style="list-style-type: none"> <li>a. Check the motor and voltage to the motor. If voltage is present, replace the motor (6390-001-132).</li> <li>b. Check the motor and voltage to the motor. If voltage is not present, replace the motor cable (6390-001-431) or control board assembly (6390-001-014).</li> <li>c. Run the lifting arms down using the trolley control panel. If the unit lowers, the issue is likely with communication. Check both sides of the communication link. Replace the communication boards (6390-001-378 or 6500-002-100), as necessary.</li> </ol> </li> </ol> </li> </ol> </li> <li>c. If the trolley control panel LED error indication is illuminated.                   <ol style="list-style-type: none"> <li>i. Call Stryker Service for advanced troubleshooting.</li> </ol> </li> </ol> </li> </ol>
Lifting arms lower but the cot legs do not extend when you press the extend (+) button	<ol style="list-style-type: none"> <li>1. Check that the cot battery has sufficient power to drive the cot (no amber battery indicator).</li> <li>2. Check if the cot pump motor is audible.               <ol style="list-style-type: none"> <li>a. If yes, the problem is with the cot hydraulic unit.</li> <li>b. If no, check for error codes on the cot LCD. Also check all cable connections at the control board and hydraulic unit.</li> <li>c. Replace the cot control board (6500-002-014).</li> <li>d. Replace the cot hydraulics assembly (6500-001-030).</li> <li>e. Replace the cot main cable (6500-002-159).</li> </ol> </li> </ol>
Lifting arms lower cot too quickly when you press the extend (+) button	<ol style="list-style-type: none"> <li>1. Check for proper operation of the support sensor (6390-001-452). Make sure that both switches have continuity when weight &lt; 100 lb is on the lifting arms.               <ol style="list-style-type: none"> <li>a. If no continuity, replace the rod end assembly (6390-001-040).</li> </ol> </li> <li>2. Check for loose cable connections from support sensors to control board.</li> </ol>

# Troubleshooting Guide

## TROUBLESHOOTING GUIDE (CONTINUED)

PROBLEM/FAILURE	RECOMMENDED ACTION
Lifting arms lower cot too slowly when you press the extend (+) button	<ol style="list-style-type: none"> <li>1. Check the trolley control panel LEDs for low battery.</li> <li>2. Check for false closure of velocity fuse.</li> <li>3. Raise the cot by using the trolley control panel.               <ol style="list-style-type: none"> <li>a. If cot does not raise, check for a loose or bad trolley pump motor connection.</li> </ol> </li> <li>4. Lower the cot by using the trolley control panel.               <ol style="list-style-type: none"> <li>a. Does cot lower at correct rate?                   <ol style="list-style-type: none"> <li>i. If yes, replace the hydraulic velocity fuse (6390-001-381).</li> <li>ii. If no, replace the hydraulic motor (6390-001-132).</li> </ol> </li> </ol> </li> </ol>
Trolley does not lower smoothly when you press the extend (+) button	<ol style="list-style-type: none"> <li>1. Check that the trolley hydraulics have sufficient oil in the reservoir when the lifting arms are all the way down. The oil level should be just below the fill port. Look for any leaks and repair.</li> <li>2. Cycle the lifting arms up and down a few times without a cot by closing the docked/locked latch and using the trolley control panel.</li> <li>3. Check for proper operation of the support sensor (6390-001-452). Make sure that both switches have continuity when weight &lt; 100 lb is on the lifting arms.               <ol style="list-style-type: none"> <li>a. If no continuity, replace the rod end assembly (6390-001-040).</li> </ol> </li> <li>2. Check for loose cable connections from support sensors to control board.</li> <li>3. Replace the hydraulics assembly (6390-001-039).</li> </ol>
Trolley hydraulic motor is noisy when you press the extend (+) or retract (-) button	<ol style="list-style-type: none"> <li>1. Check that the trolley hydraulics have sufficient oil in the reservoir when the lifting arms are all the way down. The oil level should be just below the fill port. Look for any leaks and repair.</li> <li>2. Cycle the lifting arms up and down a few times without a cot by closing the docked/locked latch and using the trolley control panel.</li> <li>3. Cycle the unit up and down 3 to 5 times, especially if this phenomena happens right after a repair.</li> <li>4. Replace the motor (6390-001-132) on the hydraulic unit.</li> <li>5. Replace the hydraulics assembly (6390-001-039).</li> </ol>
Lifting arms do not lower the cot low enough when you press the extend (+) button	<ol style="list-style-type: none"> <li>1. Check the trolley control panel for errors.               <ol style="list-style-type: none"> <li>a. If an error occurs when the lifting arms are loaded:                   <ol style="list-style-type: none"> <li>i. The safety limit for loaded operation of the arms has been reached. This can happen at high load heights (&gt;34") with heavy loads (&gt;=400 lb).                       <ol style="list-style-type: none"> <li>1. Check the Support Sensor (6390-001-452) or angle position sensor (APS) (6390-001-397) for damage.</li> </ol> </li> </ol> </li> <li>b. If an error occurs when arms are unloaded or become unloaded:                   <ol style="list-style-type: none"> <li>i. Check that arms are not being held up on/by cot legs.</li> <li>ii. Check for a broken angle position sensor (APS) (6390-001-397) or angle position sensor (APS) attachment hardware.</li> <li>iii. Check for loose cable connections from the angle position sensor to the control board.</li> </ol> </li> </ol> </li> <li>2. Replace the control board.</li> </ol>

# Troubleshooting Guide

## TROUBLESHOOTING GUIDE (CONTINUED)

PROBLEM/FAILURE	RECOMMENDED ACTION
Cot drift down or goes into high speed retract when you press the retract (-) button	<ol style="list-style-type: none"> <li>1. Check that the trolley is on and functions without errors.</li> <li>2. Check that cot and trolley communication modules are connected, undamaged, and working properly.               <ol style="list-style-type: none"> <li>a. To do this, try the cot with a known good Power-LOAD and/or the trolley with a known good cot.</li> </ol> </li> <li>3. Check all cable connections associated with communication leading back to the control board.</li> <li>4. Replace the communication board (6390-001-378 or 6500-002-100).</li> <li>5. Replace the control board assembly (6390-001-014 or 6500-002-014).</li> </ol>
Cot legs are retracted but cot is not lifted by the lifting arms when you press the retract (-) button	<ol style="list-style-type: none"> <li>1. Check that the trolley is on and functions without errors.</li> <li>2. Check that cot and trolley communication modules are connected, undamaged, and working properly.               <ol style="list-style-type: none"> <li>a. To do this, try the cot with a known good Power-LOAD and/or the trolley with a known good cot.</li> </ol> </li> <li>3. Check all cable connections associated with communication leading back to the control board.</li> <li>4. Replace the communication board (6390-001-378 or 6500-002-100).</li> <li>5. Replace the control board assembly (6390-001-014 or 6500-002-014).</li> </ol>
Cot is lifted by the lifting arms but the cot legs do not retract when you press the retract (-) button	<ol style="list-style-type: none"> <li>1. Check the support sensor (6390-001-397) on the trolley or the cable and connections to the control board.</li> <li>2. Check for an error on the trolley control panel.               <ol style="list-style-type: none"> <li>a. If there is an error, call Stryker Service.</li> </ol> </li> <li>3. Check the cot by itself for proper functionality.</li> <li>4. Ensure the cot indicates a good battery and no errors are present on the cot LCD. If you have an error consult the cot manual to troubleshoot.</li> <li>5. Press the retract (-) button on the cot:               <ol style="list-style-type: none"> <li>a. If you hear the cot pump motor run, the issue is a stuck rod-side manual valve (patient left manual valve) on the cot.</li> </ol> </li> <li>6. Check for a faulty pressure switch by removing the pressure switch connection from the cot main cable at the end, closest to the hydraulics.               <ol style="list-style-type: none"> <li>a. Jumper the cable to simulate a closed switch and press the retract (-) button.                   <ol style="list-style-type: none"> <li>i. If you do not hear the motor, the issue is either with cable connections or a bad pump motor.</li> <li>ii. Fix the connection or replace the pump motor.</li> </ol> </li> </ol> </li> <li>7. Check and/or replace the cot control board (6500-002-014).</li> </ol>
Trolley lifts the cot to slowly when you press the retract (-) button	<ol style="list-style-type: none"> <li>1. Check that the trolley battery voltage is &gt; 12.2V DC.               <ol style="list-style-type: none"> <li>a. If the battery is charged and the voltage sags &lt; 10.0V DC when you press the retract (-) button, replace the trolley battery.</li> </ol> </li> <li>2. Check for an error on the trolley control panel LEDs while moving the lifting arms with the trolley control panel.               <ol style="list-style-type: none"> <li>a. If an error is active only when using the lifting arms, replace the support sensor (6390-001-452).</li> </ol> </li> <li>2. Replace the hydraulics assembly (6390-001-039).</li> <li>3. Replace the trolley control board assembly (6390-001-014).</li> </ol>



# Troubleshooting Guide

## TROUBLESHOOTING GUIDE (CONTINUED)

PROBLEM/FAILURE	RECOMMENDED ACTION
Lifting arms lift the cot to quickly when you press the retract (-) button	<ol style="list-style-type: none"> <li>1. Check for a faulty or broken support sensor cable (6390-001-452).</li> <li>2. Check for a faulty cabling connection to the control board.</li> </ol>
Trolley does not lift smoothly when you press the retract (-) button	<ol style="list-style-type: none"> <li>1. Check that the trolley hydraulics have sufficient oil in the reservoir when the lifting arms are all the way down. The oil level should be just below the fill port. Look for any leaks and repair.</li> <li>2. Cycle the lifting arms up and down a few times without a cot by closing the docked/locked latch and using the trolley control panel.</li> <li>3. Check for proper operation of the support sensor (6390-001-452). Make sure that both switches have continuity when weight &lt; 100 lb is on the lifting arms.               <ol style="list-style-type: none"> <li>a. If no continuity, replace the rod end assembly (6390-001-040).</li> </ol> </li> <li>4. Check for loose cable connections from support sensors to control board.</li> <li>5. Replace the hydraulics assembly (6390-001-039).</li> </ol>
Cot does not lift high enough	<ol style="list-style-type: none"> <li>1. Check the angle position sensor (APS) (6390-001-397) calibration set point. Call Stryker Service.</li> <li>2. Check that the hydraulic cylinder is not “over-stroking”. Over stroke condition is evidenced by a ~1/8” back settle in the rod of the hydraulic cylinder at full extension.               <p><b>Note:</b> The patient right side cover must be removed to observe.</p> </li> <li>3. Check for damage of components in the chain of load bearing parts from the lifting arms to the patient right side plate (6390-001-344).</li> </ol>
Cot does not jog down once in the transport position	<ol style="list-style-type: none"> <li>1. Check the trolley control panel LEDs. They should be solid green without any solid amber error indication.               <ol style="list-style-type: none"> <li>a. If no trolley control panel LEDs are illuminated:                   <ol style="list-style-type: none"> <li>i. Press the main power button to turn the unit on. You may need to turn the unit on and then off to ensure that Power-LOAD is not in sleep mode.</li> </ol> </li> <li>b. If trolley control panel LEDs are illuminated:                   <ol style="list-style-type: none"> <li>i. Flashing amber means the battery is low. Return the trolley to the transport position. Ensure that the unit begins to charge as indicated by a flashing green battery LED. Low battery indication (flashing amber) may continue for as the battery recharges.</li> <li>ii. Solid green battery LED and solid amber LED means - System Error: Call Stryker Service for advanced troubleshooting.</li> </ol> </li> </ol> </li> <li>2. Check the following items: hydraulics assembly (6390-001-039), motor cable (6390-001-431), angle position sensor (APS) (6390-001-397), and control board assembly (6390-001-014).               <ol style="list-style-type: none"> <li>a. Pull the trolley from the transport position. If you hear the motor running as you pull the unit from the transport position toward the loading position, the problem is with the hydraulic unit.</li> </ol> </li> <li>3. Check the magnet in the anchor pawl at the head end that initiates “jog down”. Make sure the pawl is fully engaging the catch on the trolley when the trolley is in the transport position and that it is not stuck. This can be done by visual inspection, but a good indicator of full engagement is that the release lever at the foot end of the anchor is fully up and not pushed part way in.</li> </ol>

# Troubleshooting Guide

## TROUBLESHOOTING GUIDE (CONTINUED)

PROBLEM/FAILURE	RECOMMENDED ACTION
Trolley manual release button does not lower the lifting arms	<ol style="list-style-type: none"> <li>1. Check that the linkages of the manual release that attaches to the side controls are properly connected and actuating the manual release valve on the hydraulic pump. To do this you will need to remove the patient right side cover.               <ol style="list-style-type: none"> <li>a. If the manual release valve is actuating, then the problem is a faulty velocity fuse. The velocity fuse (6390-001-381) is located in the cap end cylinder port under the elbow fitting. Remove and replace it.</li> <li>b. If this does not fix the issue, replace the pressure compensated flow control (6390-001-151).</li> <li>c. Replace the hydraulics assembly (6390-001-039).</li> </ol> </li> </ol>
Trolley manual release button lowers the lifting arms but not smoothly	<ol style="list-style-type: none"> <li>1. Replace the velocity fuse (6390-001-381). The velocity fuse is located in the cap end cylinder port under the elbow fitting. Remove and replace it.</li> <li>2. If this does not fix the issue replace the pressure compensated flow control (6390-001-151).</li> <li>3. Replace the hydraulics assembly (6390-001-039).</li> </ol>
Trolley error LED indicates an error (solid amber)	<ol style="list-style-type: none"> <li>1. Call Stryker Service.</li> </ol>
Trolley control panel does not move the lifting arms	<ol style="list-style-type: none"> <li>1. Check that the unit displays a solid green LED on the trolley control panel, indicating that power is on.</li> <li>2. The trolley control panel will only work if the trolley is in the loading position and the latches are engaged. When the lifting arms are supporting weight, they only lower to a certain angle. These are safety features.</li> <li>3. Check that the unit is in the loading position and that both latches are engaged. This is shown as a solid green LED on the head end indicators.               <ol style="list-style-type: none"> <li>a. If there is no head end indicator LED activity, then the unit is not in the loading position.</li> <li>b. If the head end indicator LEDs are flashing amber, one or both of the latches are not closed. Check the status of the latches. If the problem persists, then check the switches and connectivity back to the control board.</li> </ol> </li> <li>3. Check for connectivity from the trolley control panel back to the control board.</li> <li>4. Replace the trolley control panel board (6390-001-450).</li> </ol>
Trolley stops part way while rolling to the transport position	<ol style="list-style-type: none"> <li>1. Remove the transfer from the anchor.               <ol style="list-style-type: none"> <li>a. Check and remove any debris from the anchor and the channels on the inside of the transfer.</li> <li>b. Examine the trolley to transfer lock release ramp (6390-001-144) located about 24" from the foot end of the anchor. Ensure that it is intact, tightly fastened, and not excessively worn.</li> <li>c. Examine the trolley to transfer lock pawl assembly (6390-001-021). Ensure that the pawl is allowed to rotate freely and, when pressed, it can rotate fully below the surface of the transfer.</li> <li>d. Examine the V-guide rollers and flat rollers on the trolley and anchor. Replace any rollers that do not roll smoothly or are excessively worn.</li> </ol> </li> </ol>

# Troubleshooting Guide

## TROUBLESHOOTING GUIDE (CONTINUED)

PROBLEM/FAILURE	RECOMMENDED ACTION
Trolley makes noises while rolling	<ol style="list-style-type: none"> <li>1. Check and remove any debris or foreign objects found inside transfer channels.</li> <li>2. Check the transfer for wear around the channels. Replace if needed.</li> <li>3. Remove the trolley from the transfer and check that the trolley rollers are free of debris.</li> <li>4. Replace the V-guide rollers on the trolley (6390-001-025).</li> </ol>
Trolley is in the transport position with a cot and the trolley LEDs are not illuminated (green)	<ol style="list-style-type: none"> <li>1. Pull the trolley out of transport position. Inspect the trolley head end pawl. It should return firmly when pressed down. If it does not, check the following:               <ol style="list-style-type: none"> <li>a. Ensure the pawl is free of debris or foreign objects that may stop it from returning.</li> <li>b. Ensure the head end anchor release button is free from debris inhibiting motion.</li> <li>c. Check the return springs on the pawl (0038-885-000).</li> </ol> </li> <li>2. Check the trolley stop ramp (6390-001-325) on the underside of the trolley middle mechanism.</li> <li>3. Remove the transfer from the anchor. Ensure that the channels where the trolley and anchor rollers travel are free from debris or foreign objects that could limit the range of motion.</li> </ol>
Trolley is in the transport position and the cot is not locked in at the foot end	<ol style="list-style-type: none"> <li>1. Check if the cot foot end casters are on the vehicle floor:               <ol style="list-style-type: none"> <li>a. If yes, pull the cot manual release and push down on the foot end of the cot. If the cot still does not drop into the lock, pull the cot all the way out and push the cot retract (-) button to fully retract the cot base. Load the cot again without using the manual release lever. If the cot is still held up by foot end casters, then the problem is in the cot hydraulic system.</li> <li>b. If no, did Power-LOAD run the motor to jog the cot down when the cot reached the transport position at the head end? If no, see "Cot does not jog down once in the transport position" section for further troubleshooting. If yes, check that the cot foot end guide (6500-002-111) is aligned with the transfer foot end guide (6390-001-220). To ensure alignment, firmly move the cot foot end back and forth and the cot should drop into place. Also, remove the cot and look for debris located in the transfer guide which may be preventing the cot from locking.</li> </ol> </li> </ol>
Transfer does not lock to the anchor	<ol style="list-style-type: none"> <li>1. Push the transfer in by hand to check if the transfer goes all the way in against the bumper stops.               <ol style="list-style-type: none"> <li>a. If yes, then the problem is likely the transfer lock bearing in the anchor. Clean the transfer lock pin, replace the bearing, and apply molybdenum disulfide lubricant (6390-001-263) to the inside of the new bearing. Inspect the transfer lock override slides (6390-001-261) for excessive wear.</li> <li>b. If no, remove the transfer head end dead stops, and remove the transfer from the anchor. Clear any debris from the top of the anchor and the channels in the transfer. Foreign objects that do not allow the trolley to reach the full out position could cause this mechanism to not operate properly.</li> </ol> </li> </ol>

# Power-LOAD Assembly

6390-001-010 Rev B (Reference Only)

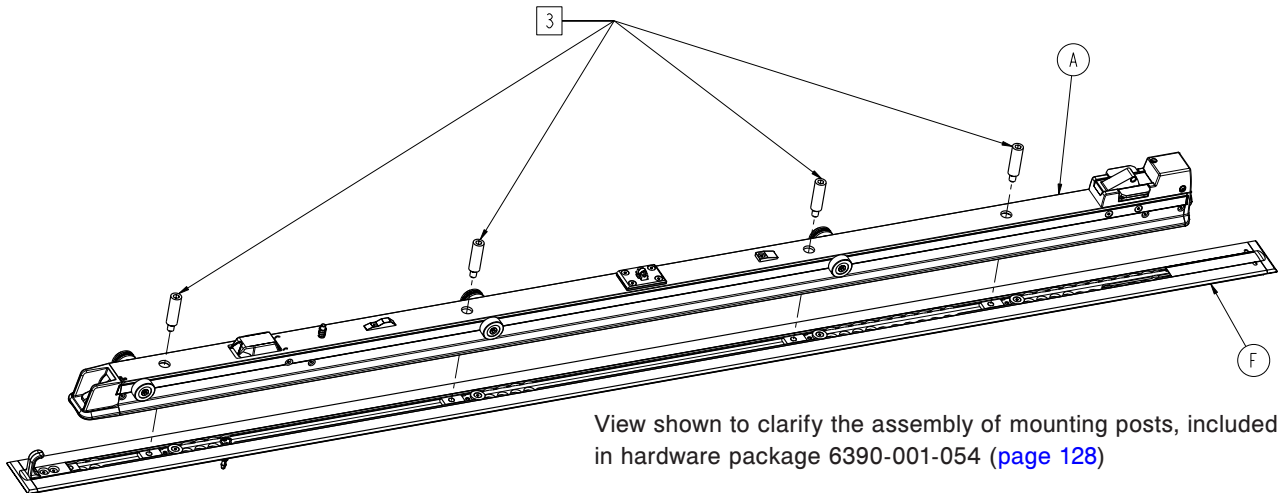

View shown to clarify the assembly of mounting posts, included in hardware package 6390-001-054 ([page 128](#))

## Notes:

1 Cut piece(s) to desired length to cover void at either end, as needed.

2 Drill .400/.450 diameter hole through Item F for assembly. Hole to be drilled at pre-machined counter-sunk locations only.

3 Torque to 60±10 ft-lb

4 Drill .600/.656 diameter hole through item F for assembly hole to be drilled at one of pre-machined pocket locations only.

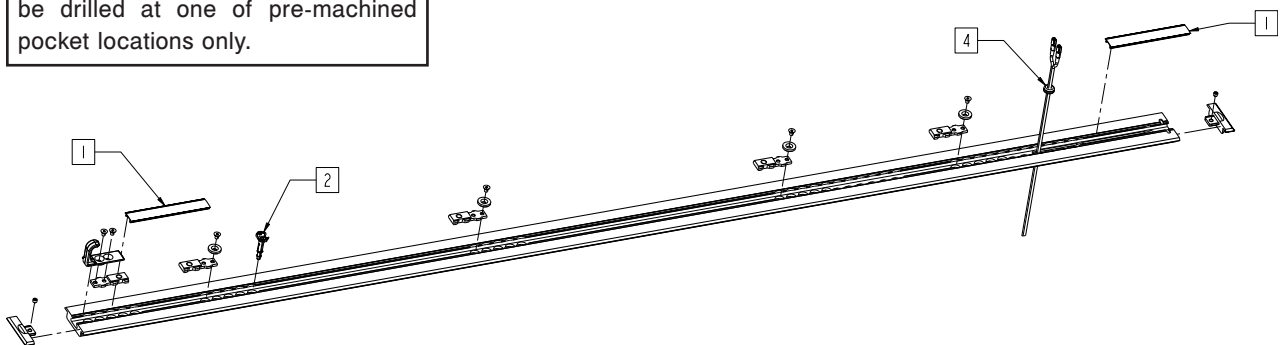

View shown to clarify the assembly of hardware package 6390-001-055 ([page 127](#))

# Power-LOAD Assembly

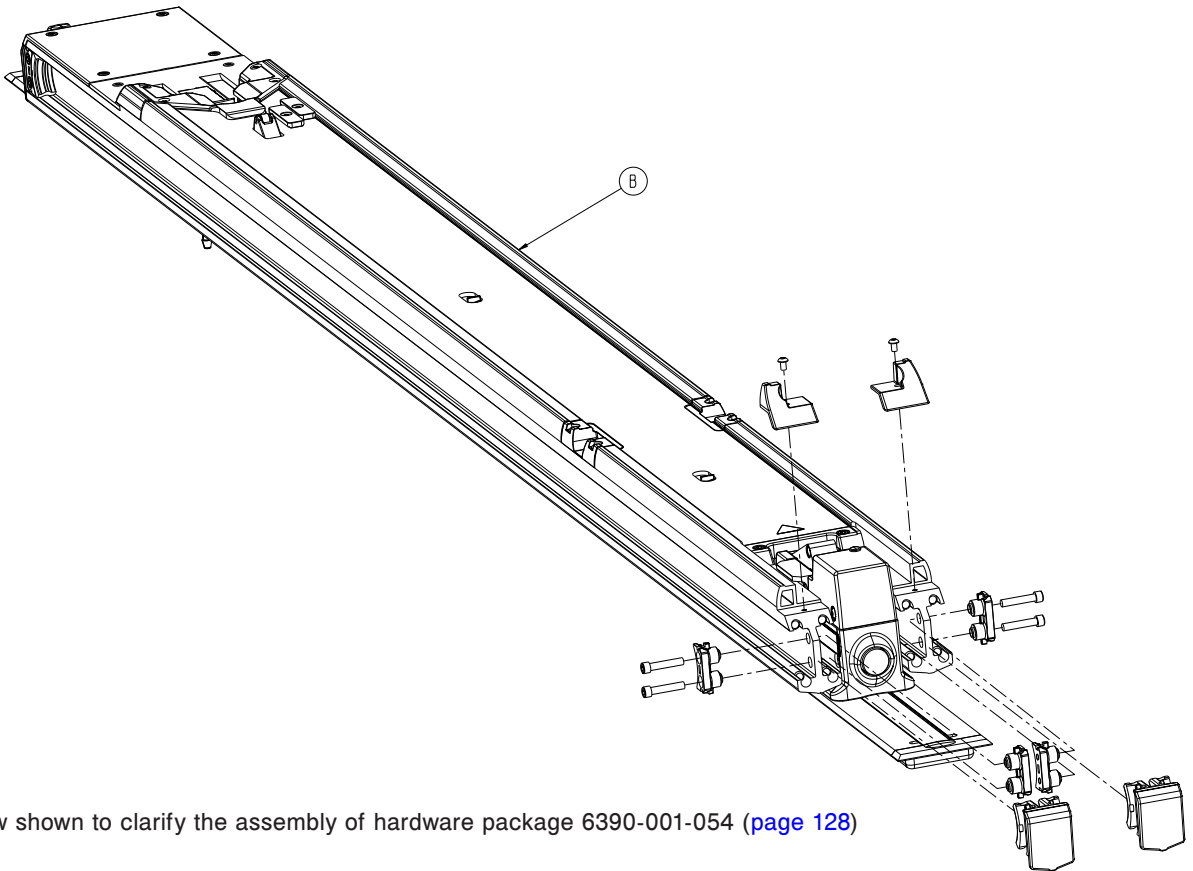

View shown to clarify the assembly of hardware package 6390-001-054 ([page 128](#))

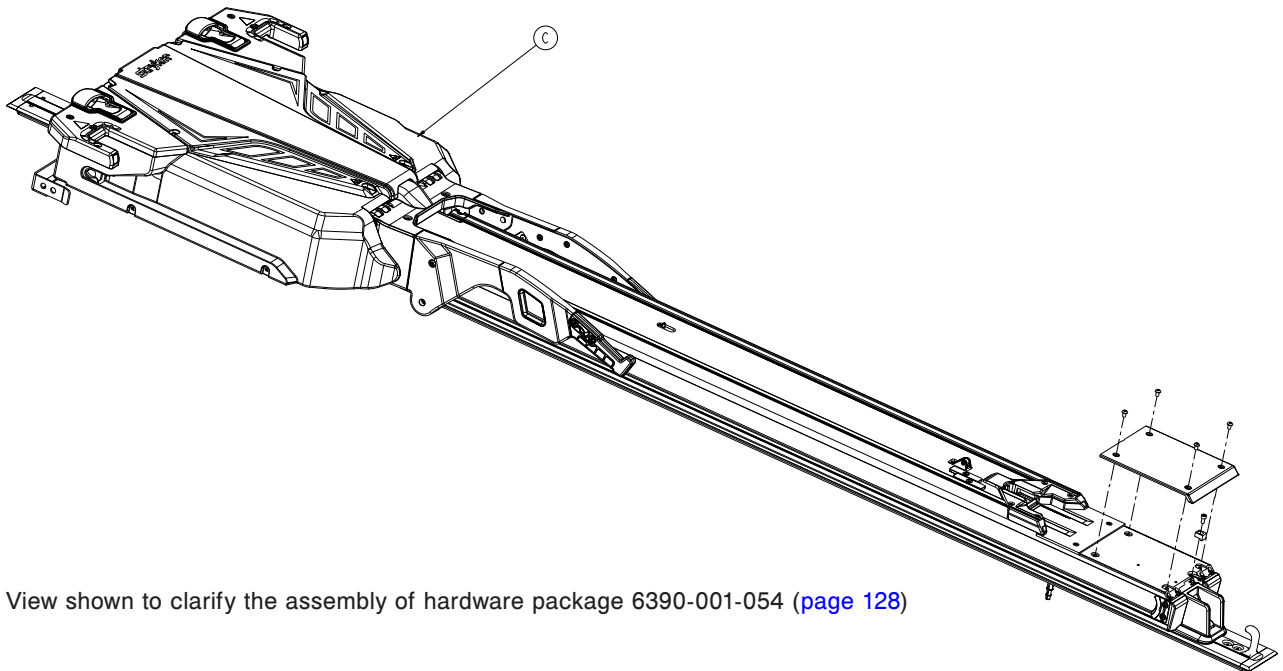

View shown to clarify the assembly of hardware package 6390-001-054 ([page 128](#))

# Power-LOAD Assembly

---

## Power-LOAD Assembly - 6390-001-010 Rev B (Reference Only)

Item	Part No.	Part Name	Qty.
A	6390-001-011	Anchor Assembly ( <a href="#">page 129</a> )	1
B	6390-101-012	Transfer Assembly ( <a href="#">page 137</a> )	1
C	6390-001-013	Trolley Assembly ( <a href="#">page 146</a> )	1
D	6390-001-054	Assembly Kit, Power-LOAD ( <a href="#">page 128</a> )	1
E	6390-001-055	Assembly Kit, Floor Plate ( <a href="#">page 127</a> )	1
F	6390-001-107	Floor Plate	1

# Assembly Kit, Floor Plate - 6390-001-055

Rev A

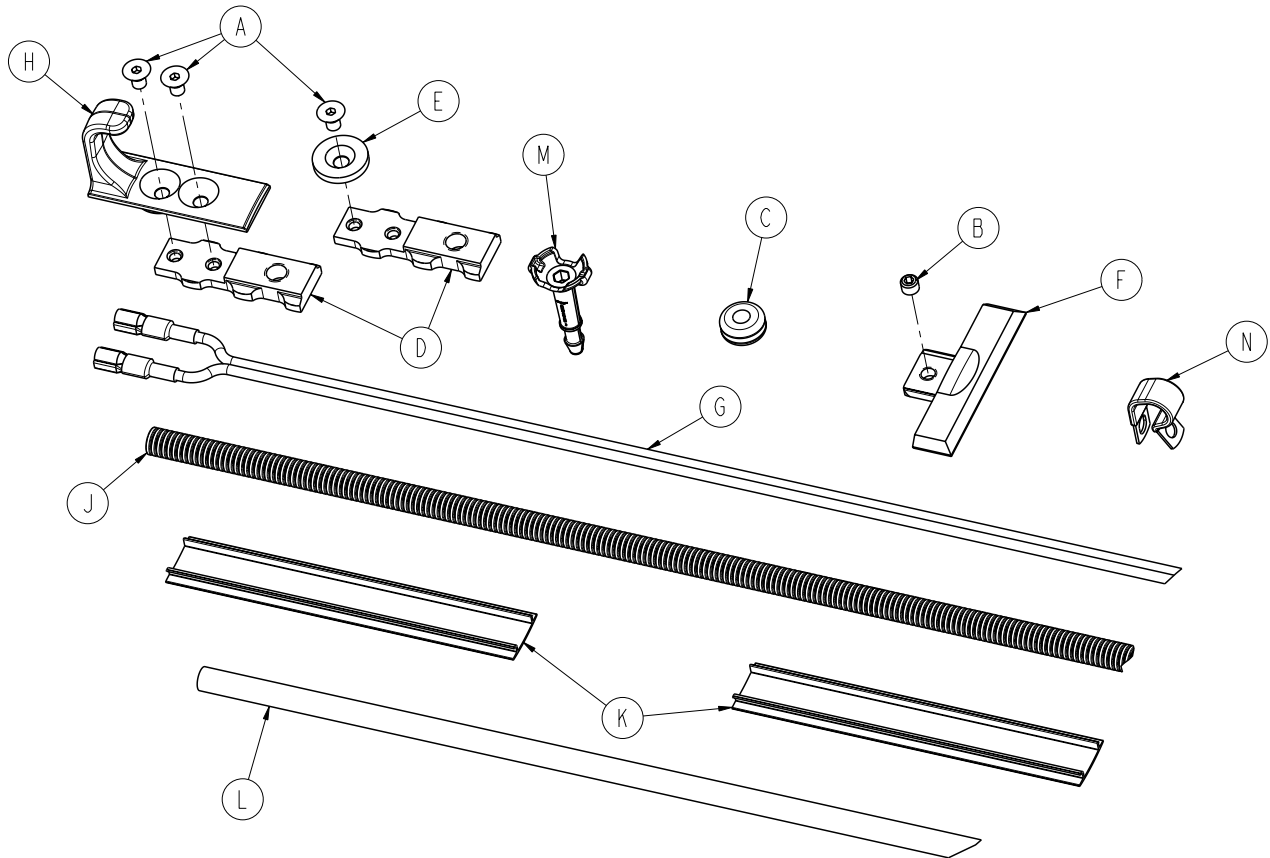

Item	Part No.	Part Name	Qty.
A	0001-194-000	Flat Head Cap Screw	6
B	0021-197-000	Set Screw	2
C	0037-247-000	Rubber Grommet	1
D	6390-001-108	Floor Plate Attachment Bracket	5
E	6390-001-110	Sub Anchor Attach Bracket Retainer	4
F	6390-001-111	Machined Floor Plate End Cap	2
G	6390-001-135	Anchor-to-Vehicle Cable	1
H	6390-001-148	Power-LOAD Safety Hook	1
J	6390-001-153	Under Ambulance Wire Protector	1
K	6390-001-166	Floor Plate Cover, Short	2
L	6390-001-170	Drain Tube	1
M	6390-001-183	Drain Tube, Floor Plate	1
N	6390-001-202	P-Style Clamp (Rubber Coated)	6

[Return To Table of Contents](#)

# Assembly Kit, Power-LOAD - 6390-001-054

Rev B

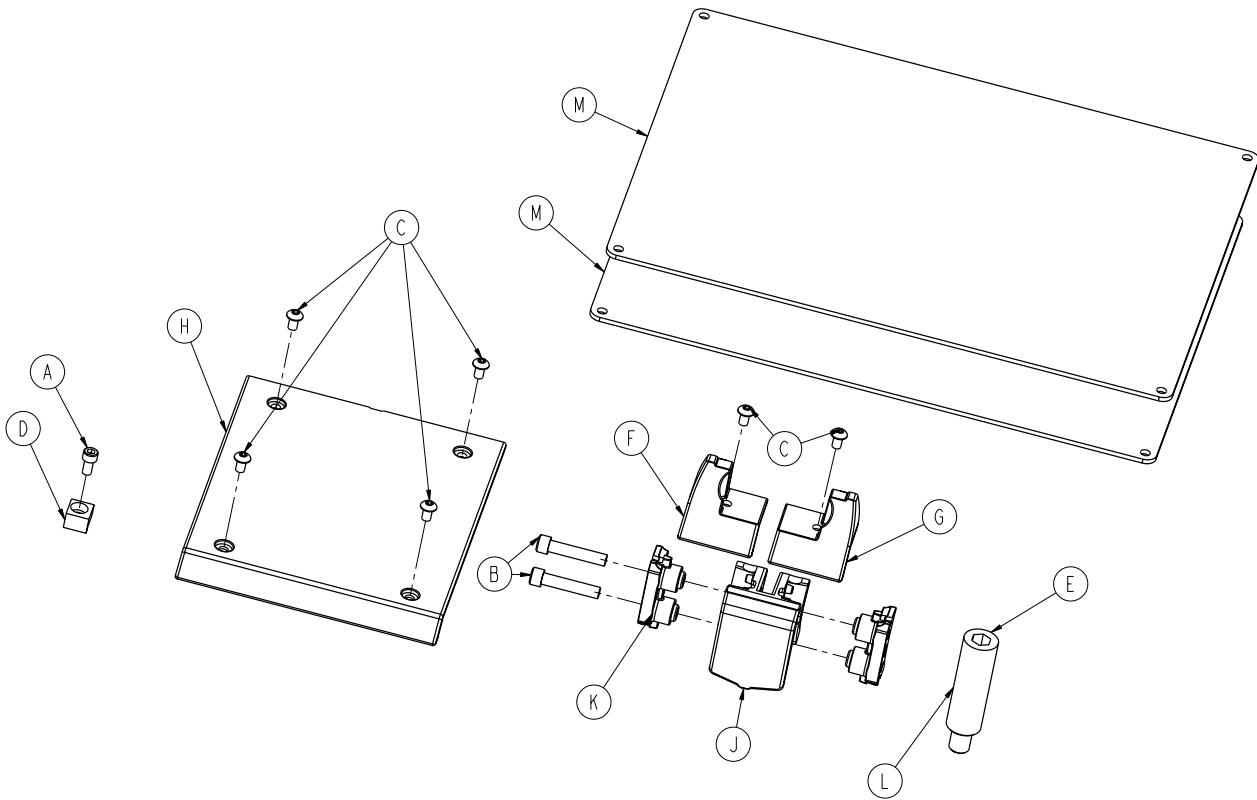

Item	Part No.	Part Name	Qty.
A	0004-658-000	Socket Head Cap Screw	1
B	0004-662-000	Socket Head Cap Screw	4
C	0004-665-000	Button Head Cap Screw	6
D	6390-001-106	Trolley Magnet Activator	1
E	6390-001-150	Anchor Mounting Post	4
F	6390-001-210	Transfer Trim, Head End, Left	1
G	6390-001-211	Transfer Trim, Head End, Right	1
H	6390-001-225	Transfer Wear Pad, Foot End	1
J	6390-001-243	Dead Stop Bumper	2
K	6390-001-244	Dead Stop Block, Thru Hole	2
L	6390-001-246	Dead Stop Block, Threaded	2
M	6390-001-467	Plate, IFU Label	2



# Anchor Assembly

6390-001-011 Rev D (Reference Only)

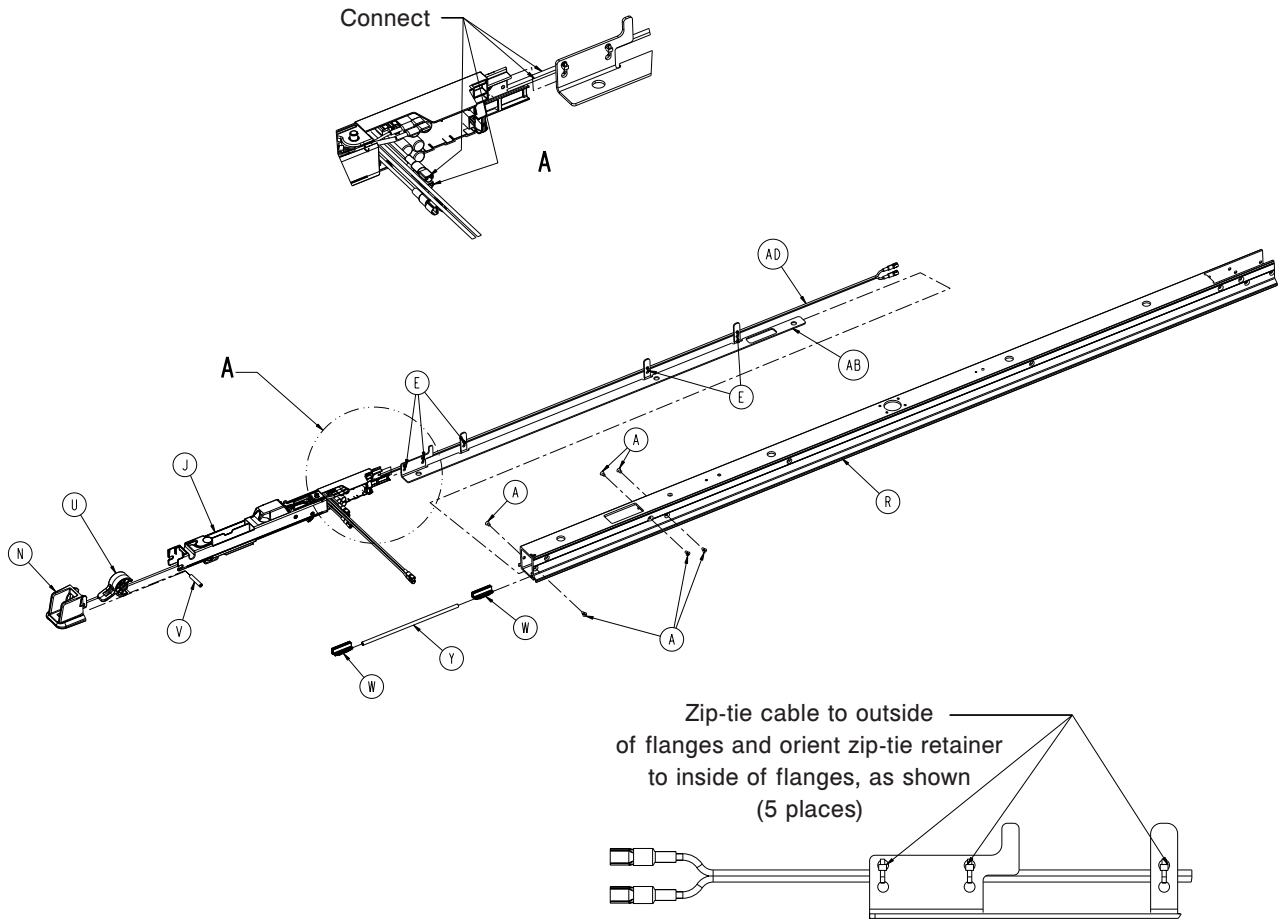

# Anchor Assembly

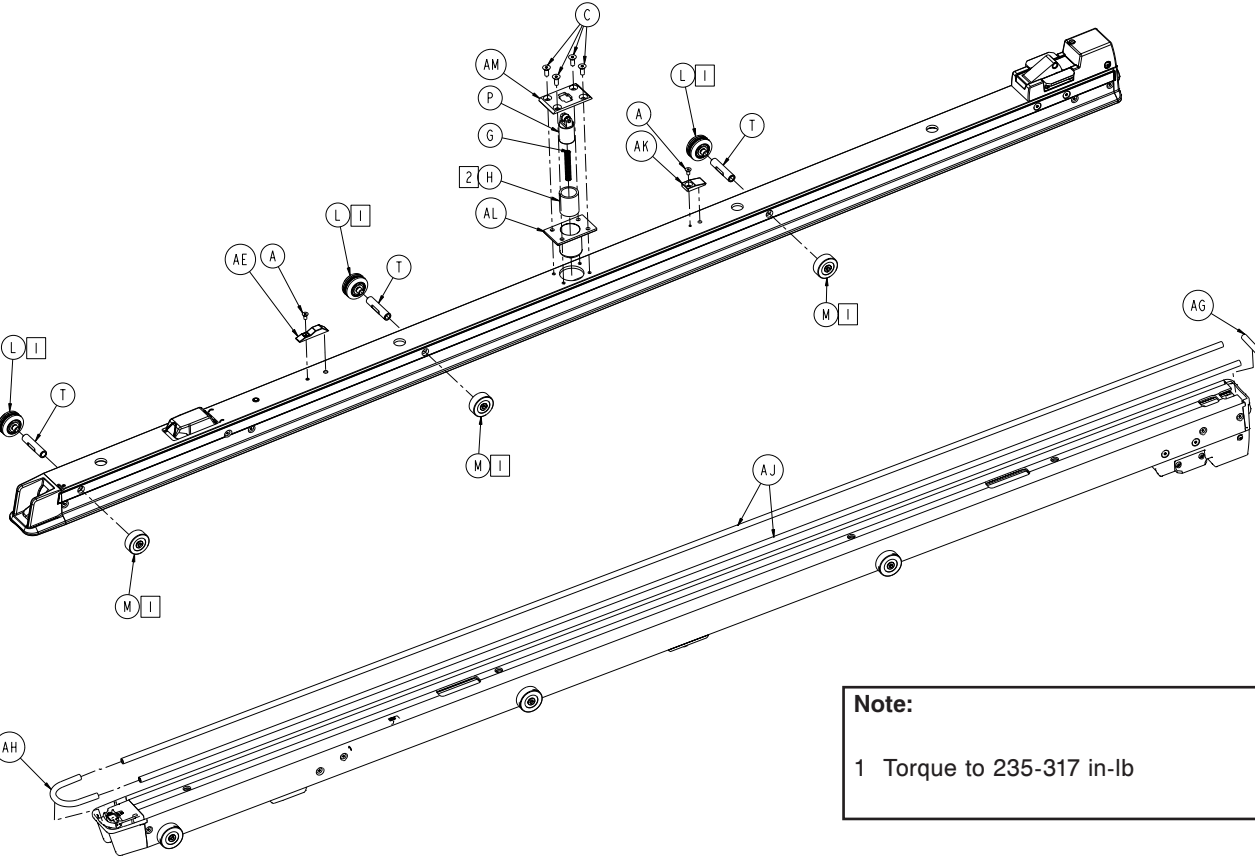
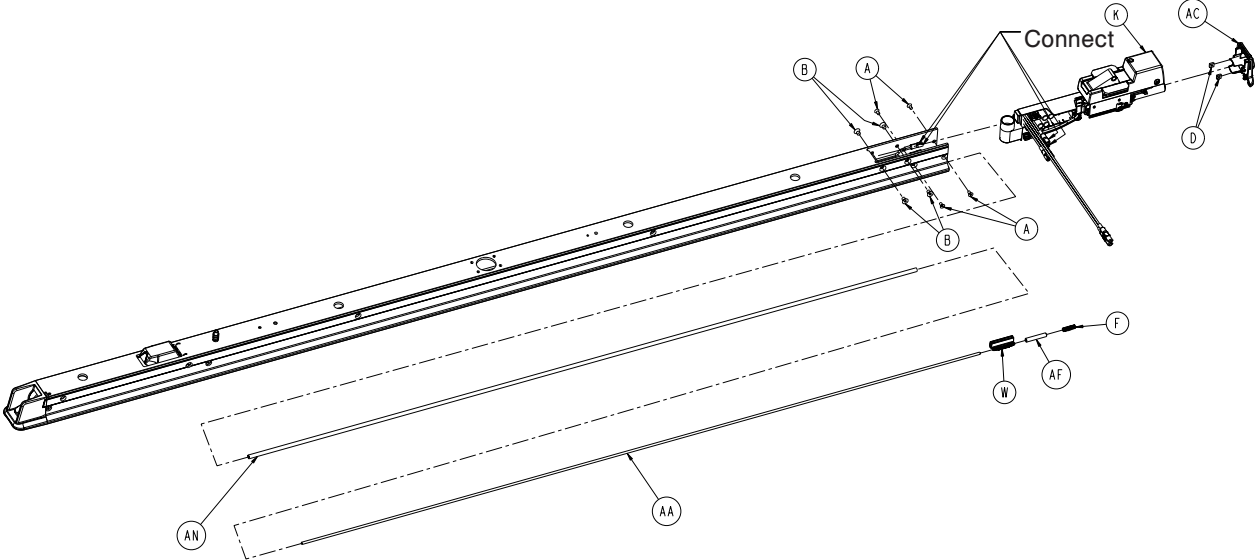

**Note:**  
1 Torque to 235-317 in-lb

# Anchor Assembly

## Anchor Assembly - 6390-001-011 Rev D (Reference Only)

Item	Part No.	Part Name	Qty.
A	0001-193-000	Flat Head Cap Screw	12
B	0001-194-000	Flat Head Cap Screw	4
C	0001-195-000	Flat Head Cap Screw	4
D	0015-087-000	Square Nut	2
E	0038-111-000	Zip Tie	5
F	0038-887-000	Compression Spring	1
G	0038-606-000	Compression Spring	1
H	0081-439-000	Bronze Bearing	1
J	6390-001-023	Anchor Plunger Assembly, Mid ( <a href="#">page 136</a> )	1
K	6390-001-024	Anchor Pawl Assembly, Head End ( <a href="#">page 132</a> )	1
L	6390-001-025	V-Guide Roller Assembly	3
M	6390-001-027	Flat Roller Assembly	3
N	6390-001-067	Anchor Housing Assembly, Foot End	1
P	6390-001-074	Transfer Lock Pin Assembly	1
R	6390-001-100	Machined Anchor Extrusion	1
T	6390-001-103	Anchor Roller Axle	3
U	6390-001-104	Anchor Trigger	1
V	6390-001-112	Anchor Pivot Pin, Threaded	1
W	6390-001-113	Anchor Drive Block	3
Y	6390-001-114	Anchor Drive Rod, Medium	1
AA	6390-001-186	Anchor Drive Rod, Long	1
AB	6390-001-120	Wire Routing and Washer Bracket	1
AC	6390-001-136	Anchor End Cap, Rear	1
AD	6390-001-139	Cot Charging Cable	1
AE	6390-001-144	Trolley to Trans Lock Ramp	1
AF	6390-001-152	Anchor Rod Drive, Rear	1
AG	6390-001-179	Anchor Seal, Head End	1
AH	6390-001-180	Anchor Seal, Head End	1
AJ	6390-001-181	Anchor Seal, Side	2
AK	6390-001-193	Detent Spring Ramp	1
AL	6390-001-195	Transfer Lock Housing, Machined	1
AM	6390-001-196	Transfer Lock Cap	1
AN	6390-001-190	Anchor Drive Rod, Bearing Sleeve, Long	1

# Anchor Pawl Assembly, Head End

6390-001-024 Rev B (Reference Only)

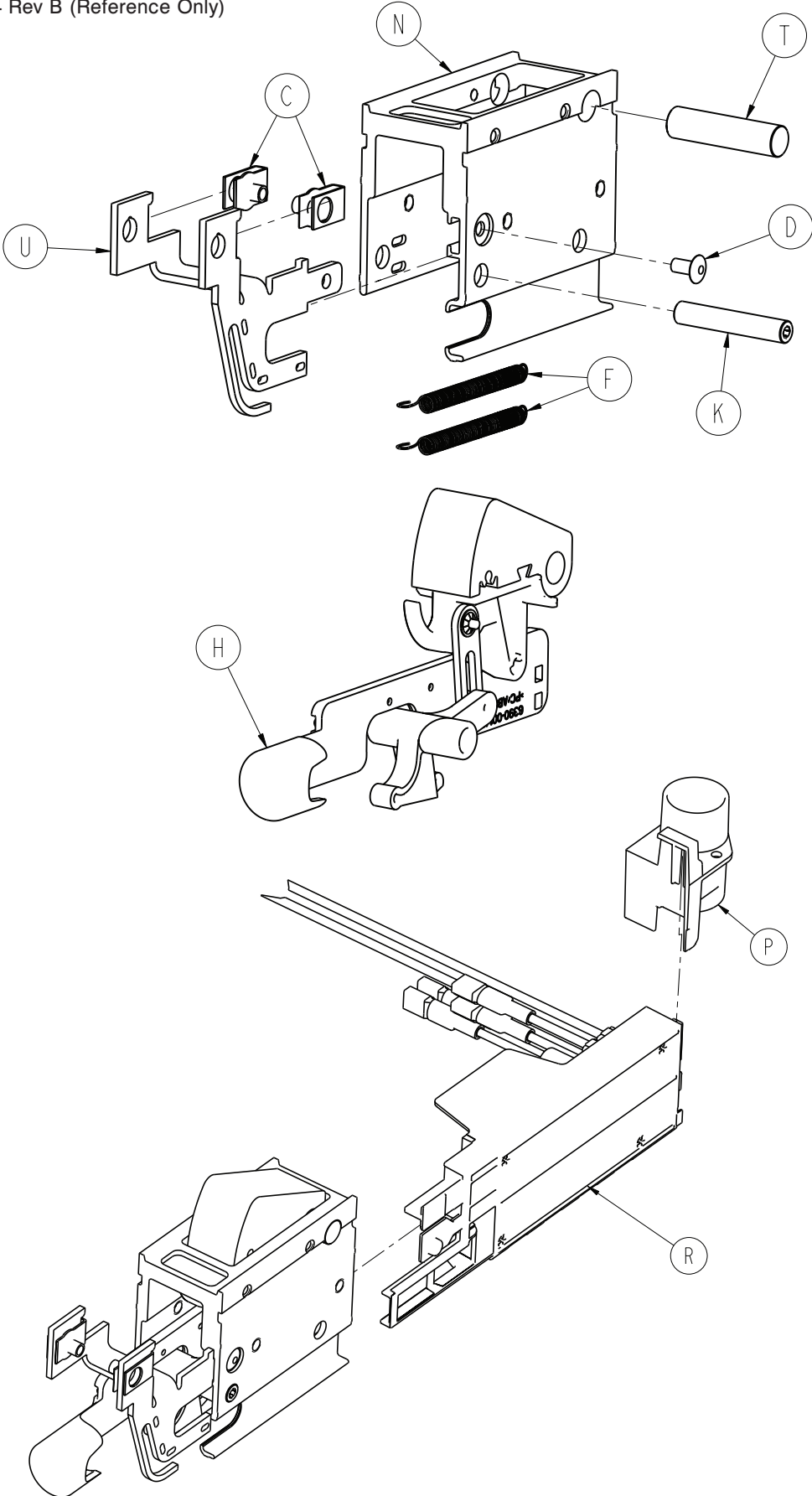

# Anchor Pawl Assembly, Head End

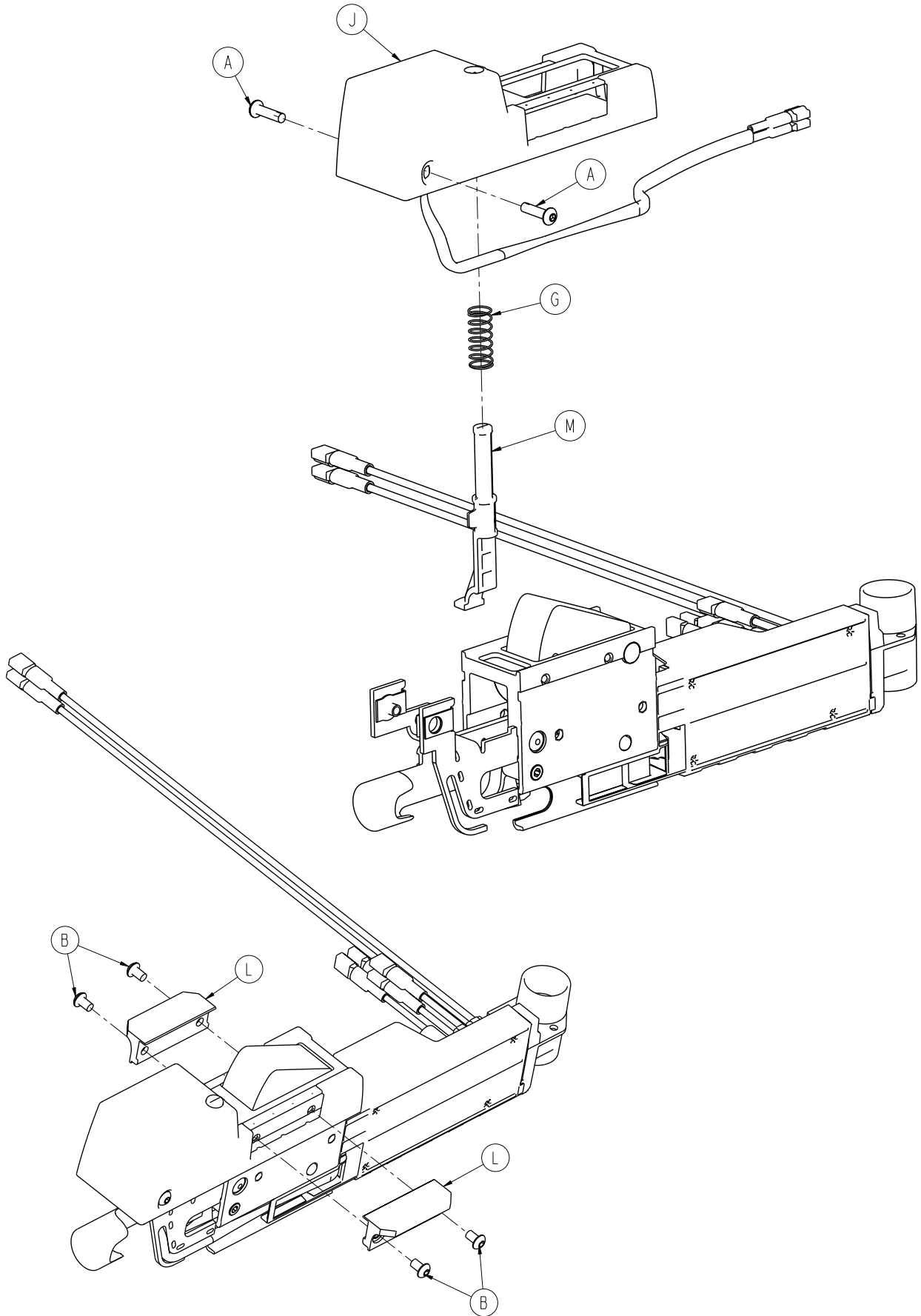

# Anchor Pawl Assembly, Head End

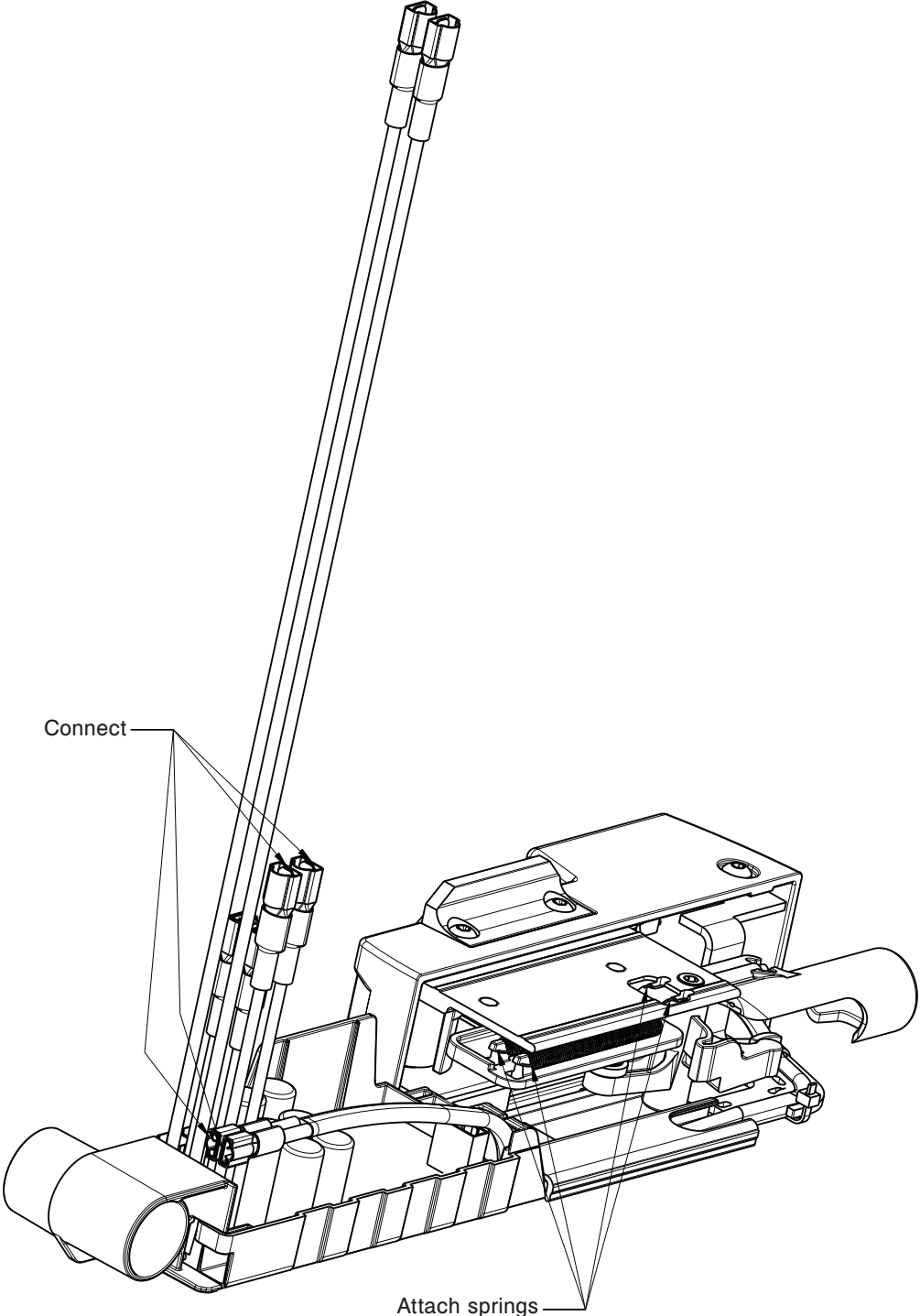

Spring attachment  
(some components removed for clarity)

# Anchor Pawl Assembly, Head End

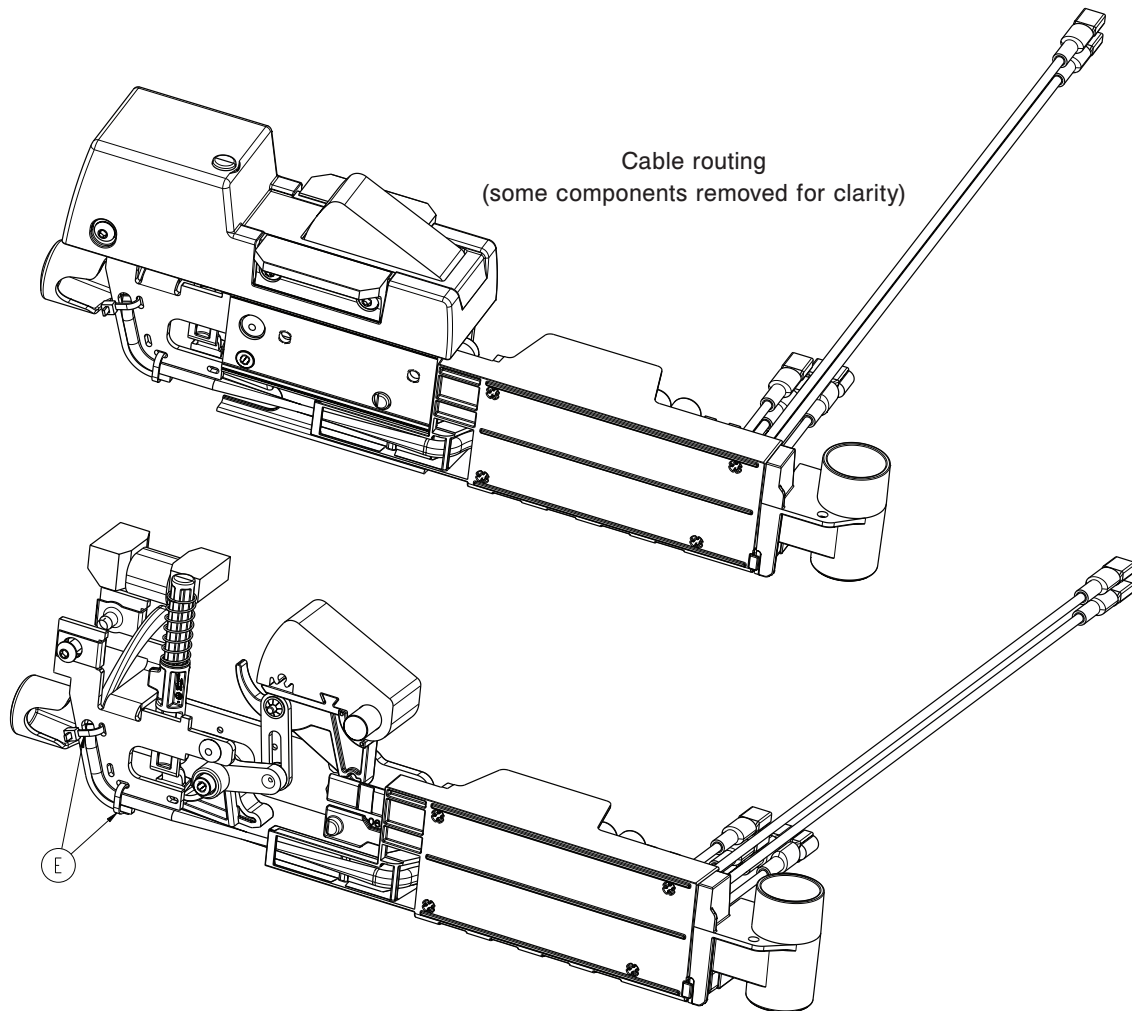

Anchor Pawl Assembly, Head End - 6390-001-024 Rev B (Reference Only)

Item	Part No.	Part Name	Qty.
A	0004-396-000	Button Head Cap Screw	2
B	0004-665-000	Button Head Cap Screw	4
C	0018-009-000	Extruded "U" Nut	2
D	0025-079-000	Dome Head Rivet	1
E	0038-111-000	Zip Tie	2
F	0038-885-000	Pawl Return Spring	2
G	0038-888-000	Compression Spring	1
H	6390-001-070	Manual Release Mechanism	1
J	6390-001-071	Anchor Housing Assembly, Head End	1
K	6390-001-112	Anchor Pivot Pin, Threaded	1
L	6390-001-123	Retainer Wing	2
M	6390-001-124	Anchor Actuator Pin, Head End	1
N	6390-001-125	Anchor Housing, Head End	1
P	6390-001-137	Wire Protector	1
R	6390-001-147	Inductive Primary Board	1
T	6390-001-149	Pawl Pivot Pin	1
U	6390-001-164	Wire Management Strap, Head End	1

# Anchor Plunger Assembly, Middle

6390-001-023 Rev C (Reference Only)

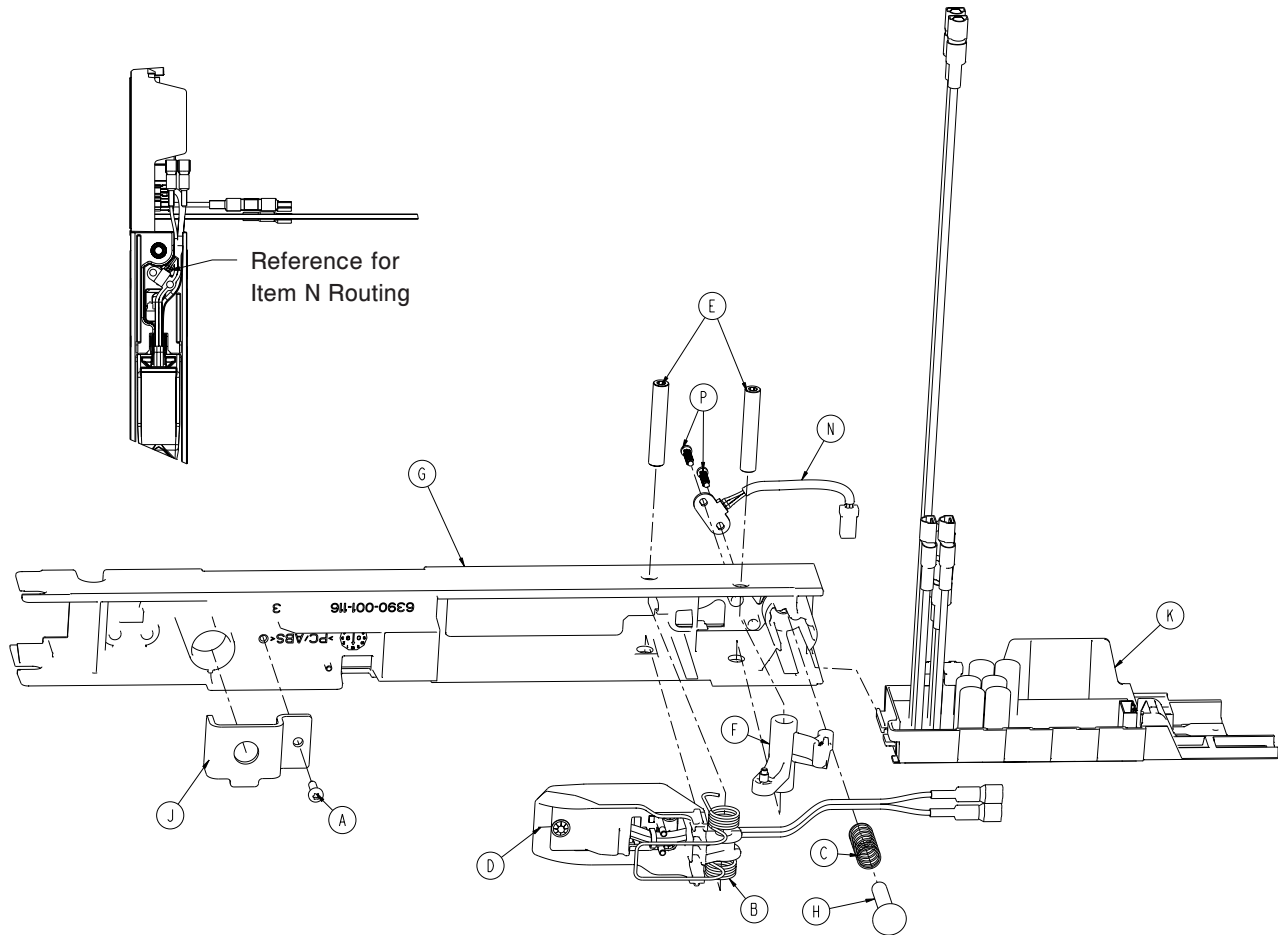

Item	Part No.	Part Name	Qty.
A	0023-163-000	Screw	1
B	0038-886-000	Torsion Spring - Anchor Coil Housing	1
C	0038-888-000	Compression Spring	1
D	6390-001-030	Anchor Coil Assembly, Mid	1
E	6390-001-112	Anchor Pivot Pin, Threaded	2
F	6390-001-115	Pivot Actuator	1
G	6390-001-116	Anchor Housing, Middle	1
H	6390-001-117	Anchor Actuator Pin, Middle	1
J	6390-001-127	Anchor Bolster Plate, Foot End	1
K	6390-001-147	Inductive Primary Board	1
N	6390-001-189	Anchor Hall-Effect Cable	1
P	6500-101-128	Press Fit Fastener	2



# Transfer Assembly

6390-101-012 Rev A (Reference Only)

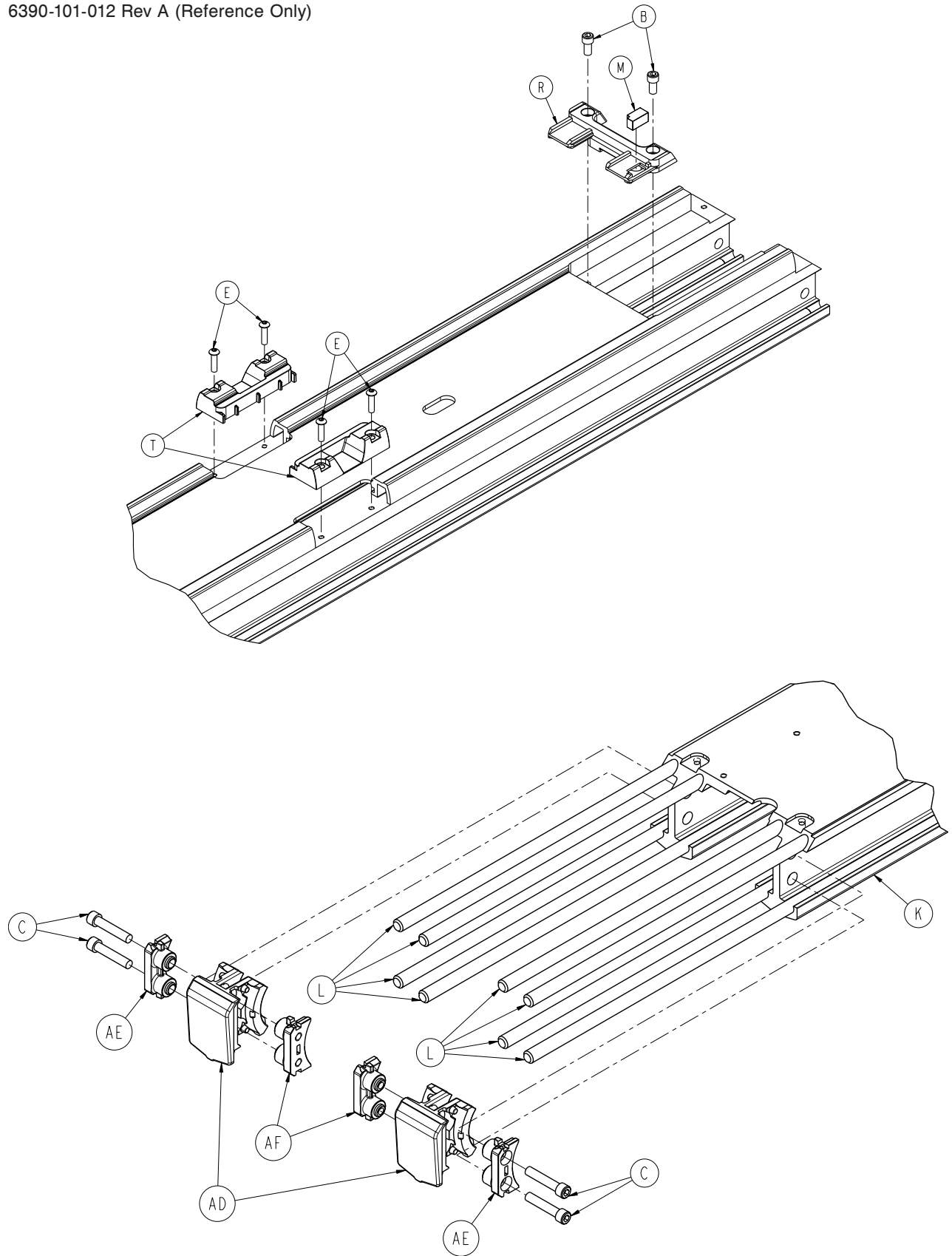

[Return To Table of Contents](#)

# Transfer Assembly

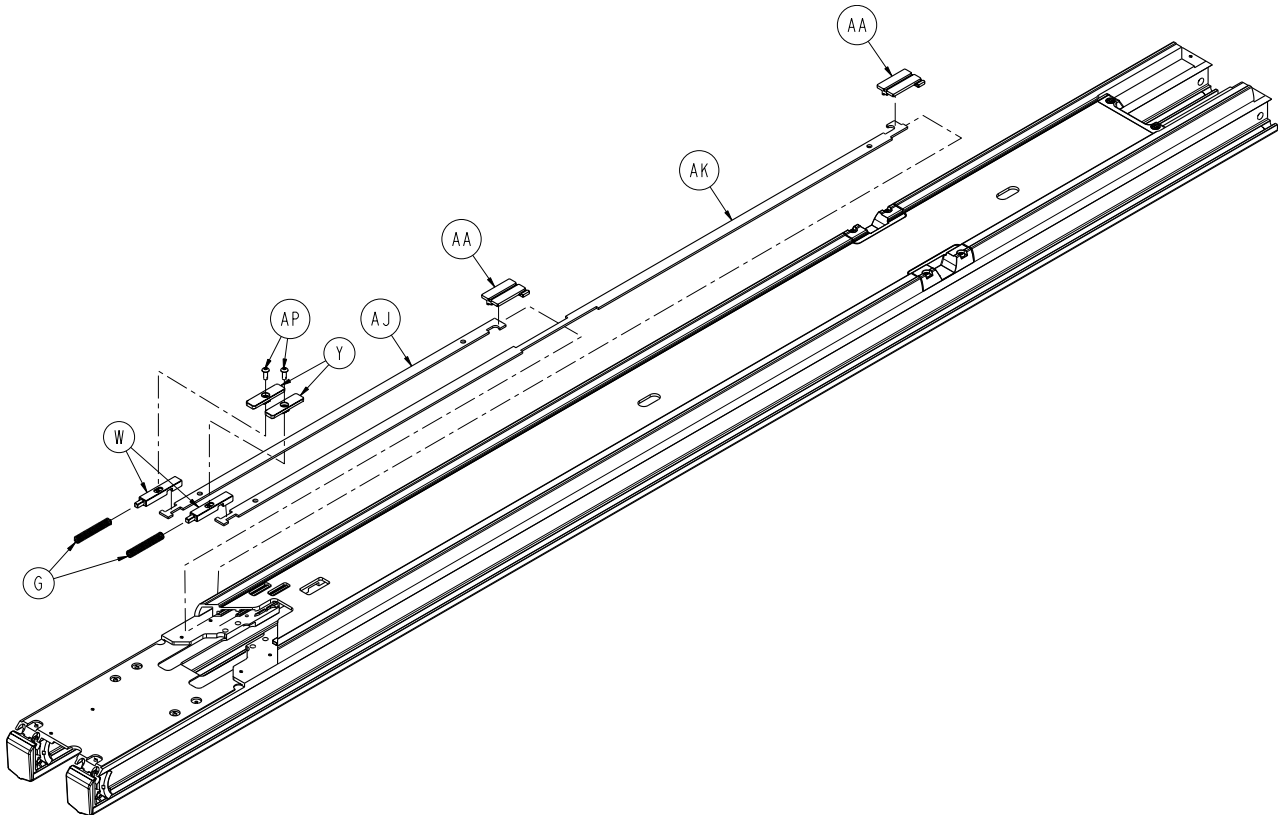
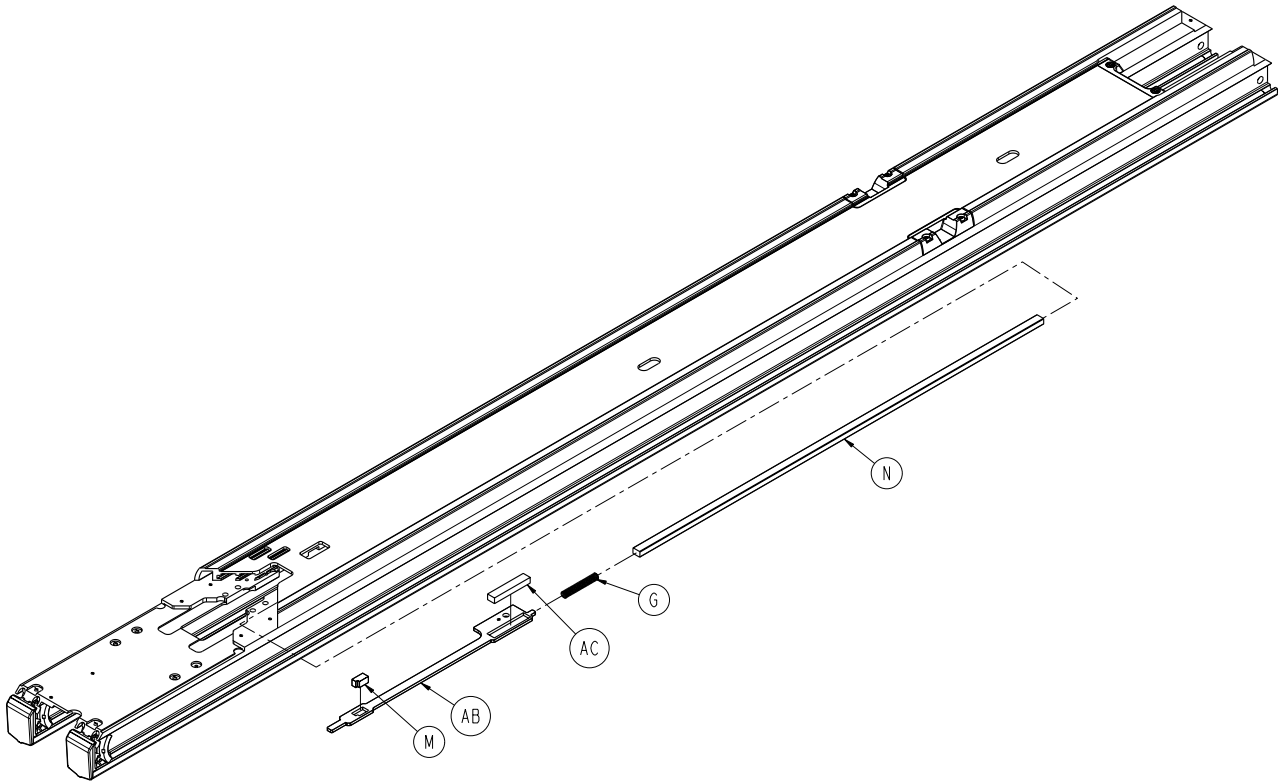

# Transfer Assembly

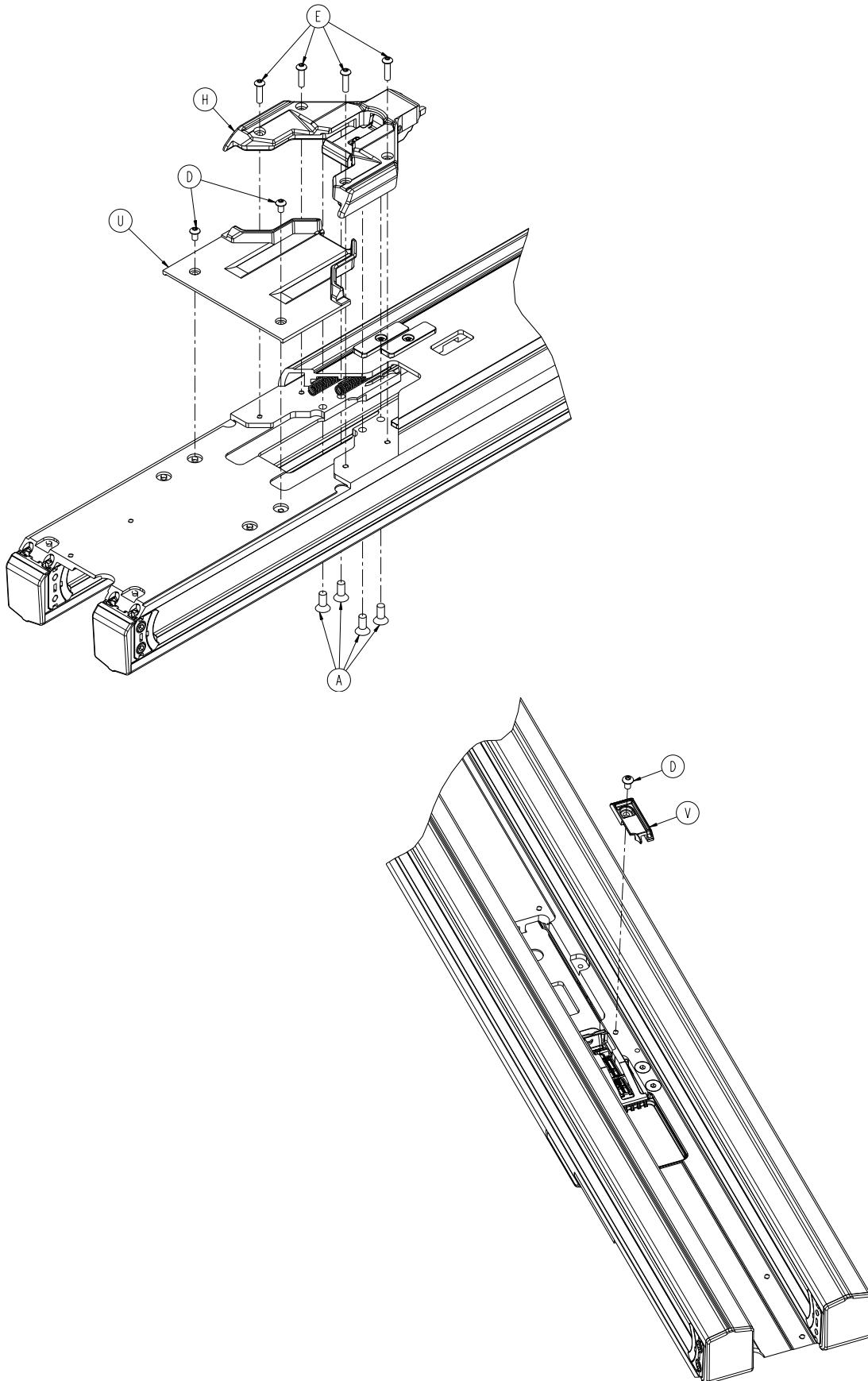

# Transfer Assembly

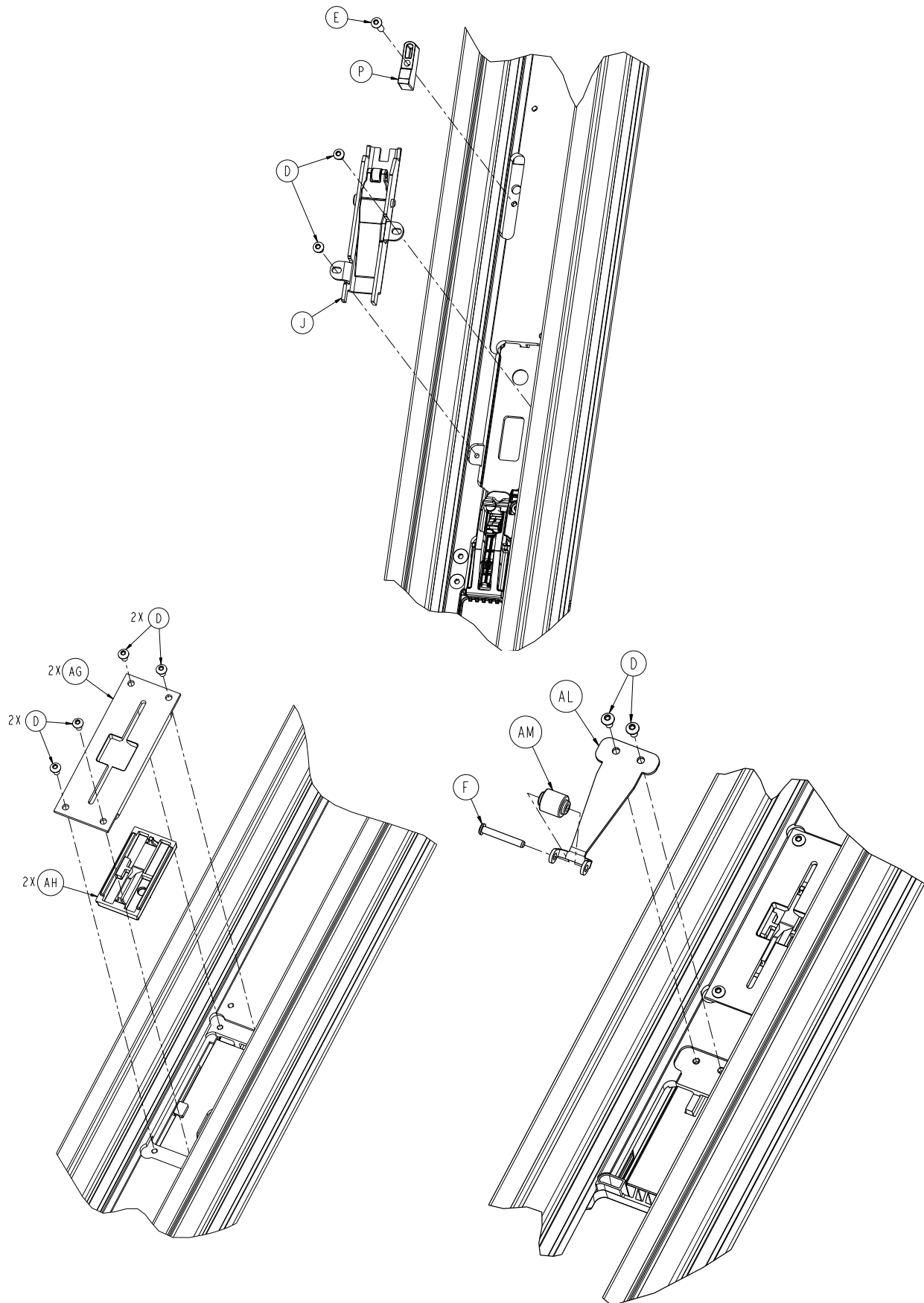

# Transfer Assembly

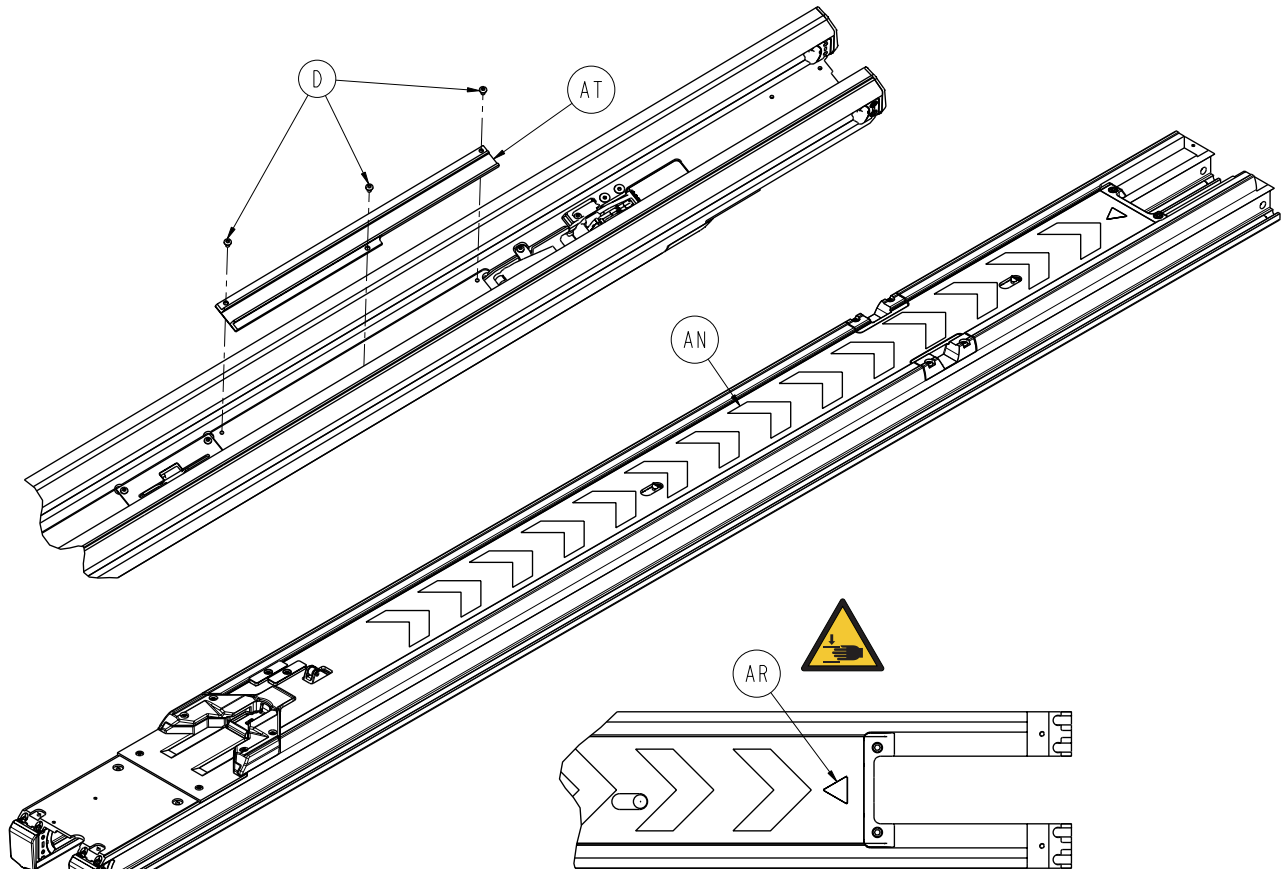

Transfer Assembly - 6390-101-012 Rev A (Reference Only)

Item	Part No.	Part Name	Qty.
A	0001-195-000	Flat Head Cap Screw	4
B	0004-660-000	Socket Head Cap Screw	2
C	0004-662-000	Socket Head Cap Screw	4
D	0004-665-000	Button Head Cap Screw	18
E	0004-666-000	Button Head Cap Screw	9
F	0027-778-000	Slic Pin	1
G	0038-606-000	Compression Spring	3
H	6390-001-018	Foot End Fastener Assy ( <a href="#">page 143</a> )	1
J	6390-001-021	Transfer Trolley Lock Assy ( <a href="#">page 145</a> )	1
K	6390-001-200	Transfer Extrusion	1
L	6390-001-201	Roller Rail Rod	8
M	6390-001-203	Transfer Magnet	2
N	6390-001-204	Transfer Magnet Spacer	1
P	6390-001-205	Magnet Mover Trigger	1
R	6390-001-207	Transfer Back Cover	1
T	6390-001-208	Mid Position Head End Cutout Cap	2
U	6390-001-213	Inductive Charger Cover Plate	1
V	6390-001-217	Lock Latch Indicator Slide Block	1
W	6390-001-230	Transfer Lock Trigger Base	2
Y	6390-001-231	Transfer Lock Trigger	2
AA	6390-001-233	Transfer Lock Slide	2
AB	6390-001-240	Magnet Mover	1
AC	6390-001-242	Magnet Mover Glide	1

# Transfer Assembly

---

## Transfer Assembly - 6390-101-012 Rev A (Reference Only) (Continued)

AD	6390-001-243	Dead Stop Bumper	2
AE	6390-001-244	Dead Stop Block, Thru Hole	2
AF	6390-001-246	Dead Stop Block, Threaded	2
AG	6390-001-260	Transfer Lock Plate	2
AH	6390-001-261	Transfer Lock Override Slide	2
AJ	6390-001-266	Transfer Lock Link, Short	1
AK	6390-001-267	Transfer Lock Link, Long	1
AL	6390-001-269	Detent Spring	1
AM	6390-001-270	Detent Roller	1
AN	6390-001-299	Label, Chevron	1
AP	0004-585-000	Button Head Cap Screw	2
AR	6506-001-114	Label, Warning, Crushing of Hands	1
AT	6390-001-276	Transfer Wear Pad	1

# Foot End Fastener Assembly

6390-001-018 Rev C (Reference Only)

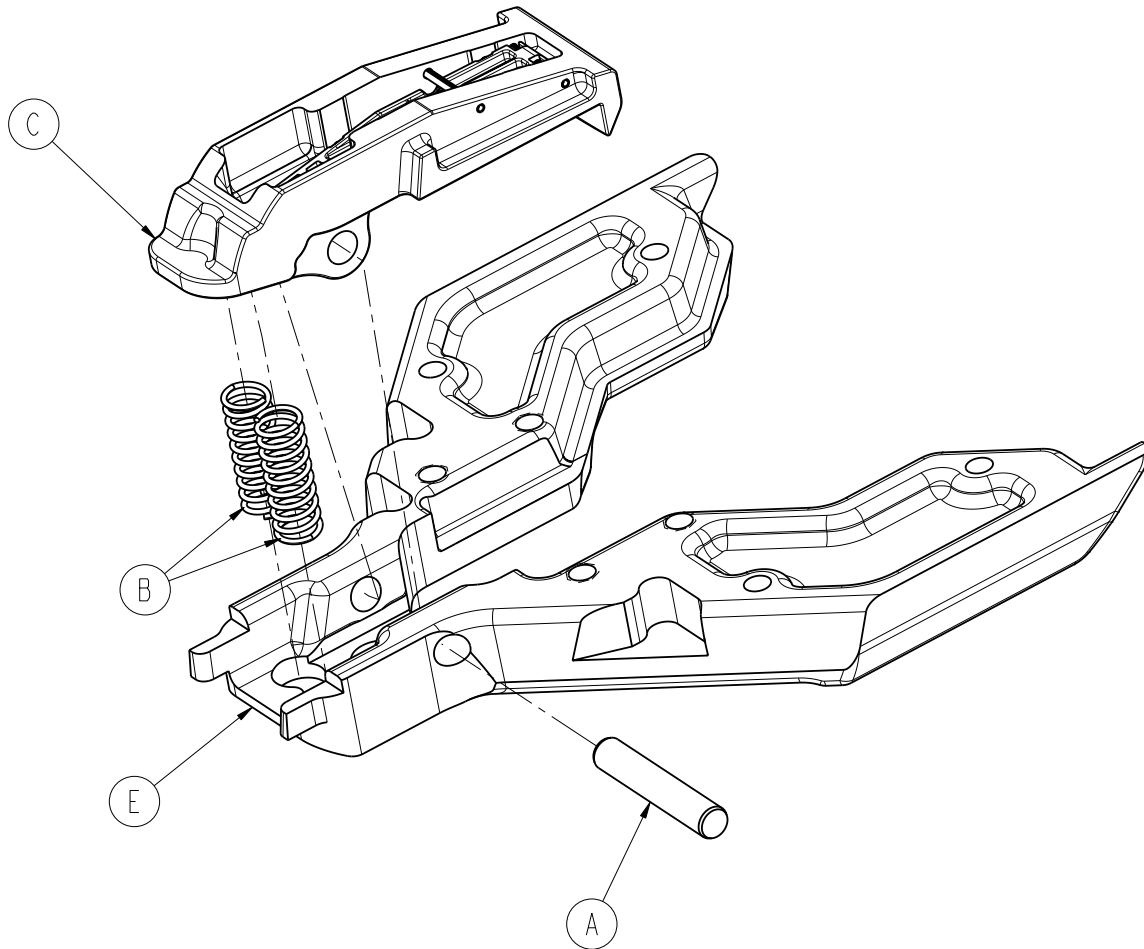

Item	Part No.	Part Name	Qty.
A	0026-556-000	Dowel Pin	1
B	0038-890-000	Compression Spring	2
C	6390-001-072	Foot End Fastener Assy ( <a href="#">page 144</a> )	1
E	6390-001-220	Foot End Fastener Guide	1

# Foot End Fastener Assembly

6390-001-072 Rev C (Reference Only)

**Notes:**

- 1 Item F to be inserted into slot on Item H
- 2 Item D to be inserted through end hoop of item E

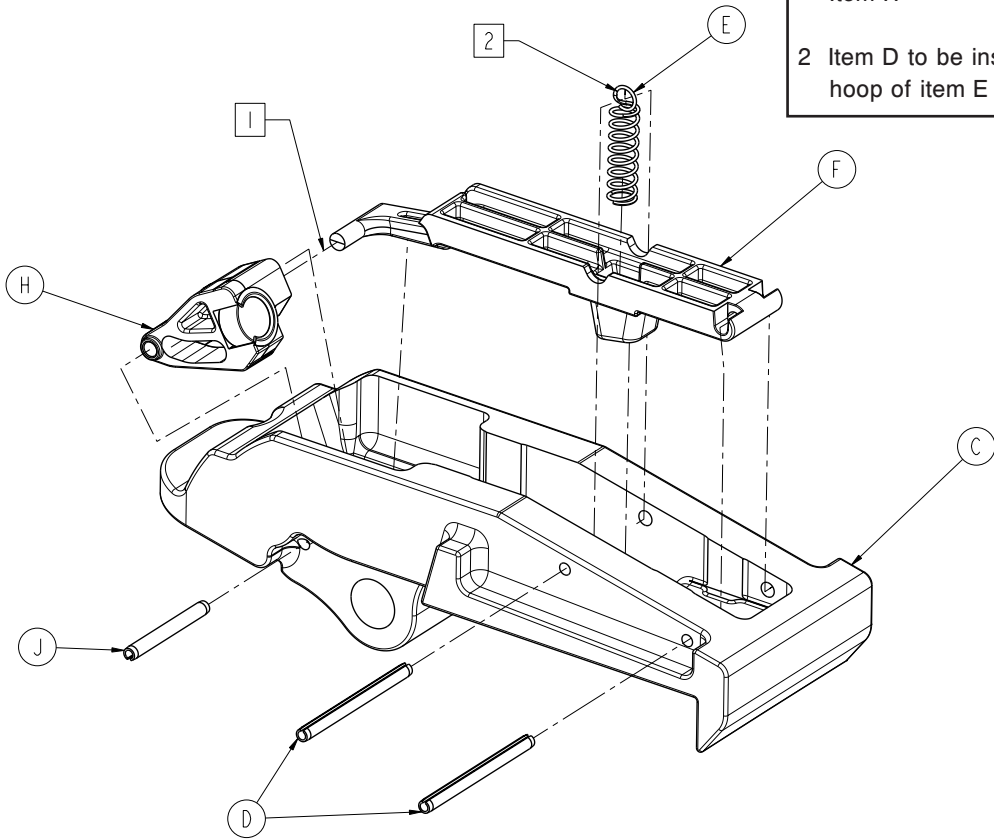

Item	Part No.	Part Name	Qty.
C	6390-001-224	Foot End Fastener Hook	1
D	0026-402-000	Spring Pin	2
E	0038-902-000	Compression Spring	1
F	6390-001-291	Hall Paddle	1
H	6390-001-290	Foot End Indicator Pivot	1
J	0026-559-000	Spring Pin	1



# Transfer Trolley Lock Assembly

6390-001-021 Rev A (Reference Only)

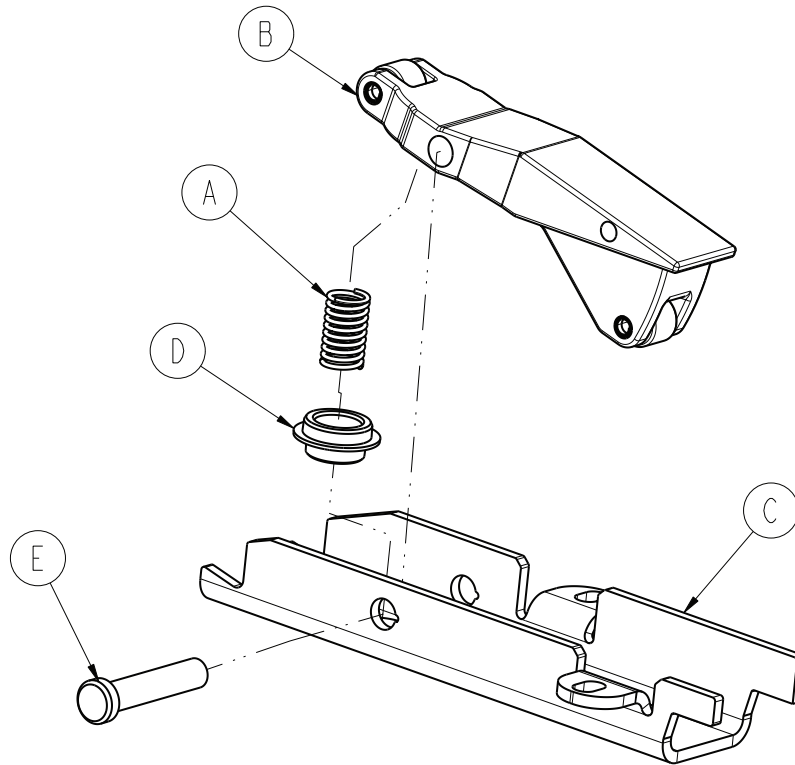

Item	Part No.	Part Name	Qty.
A	0038-890-000	Compression Spring	1
B	6390-001-073	Transfer Trolley Lock Assembly	1
C	6390-001-250	Transfer Trolley Bracket	1
D	6390-001-252	Transfer Trolley Lock Spring Cap	1
E	6390-001-259	Trolley Lock Pivot Pin	1

# Trolley Assembly

6390-001-013 Rev F (Reference Only)

## Notes:

1 Angle sensor to be connected to Item AD with indicating dot oriented to top.

2 Item H orientation.

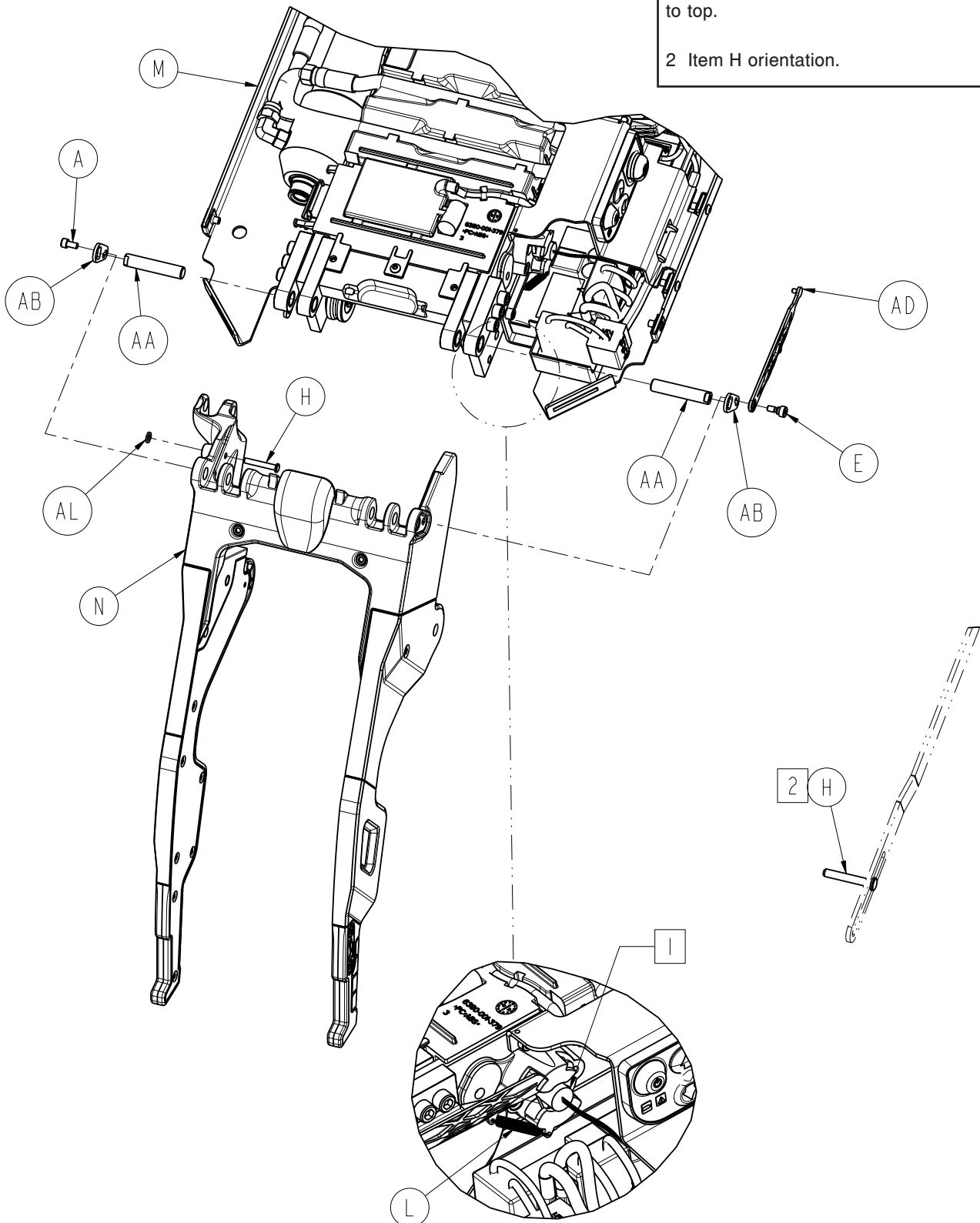

# Trolley Assembly

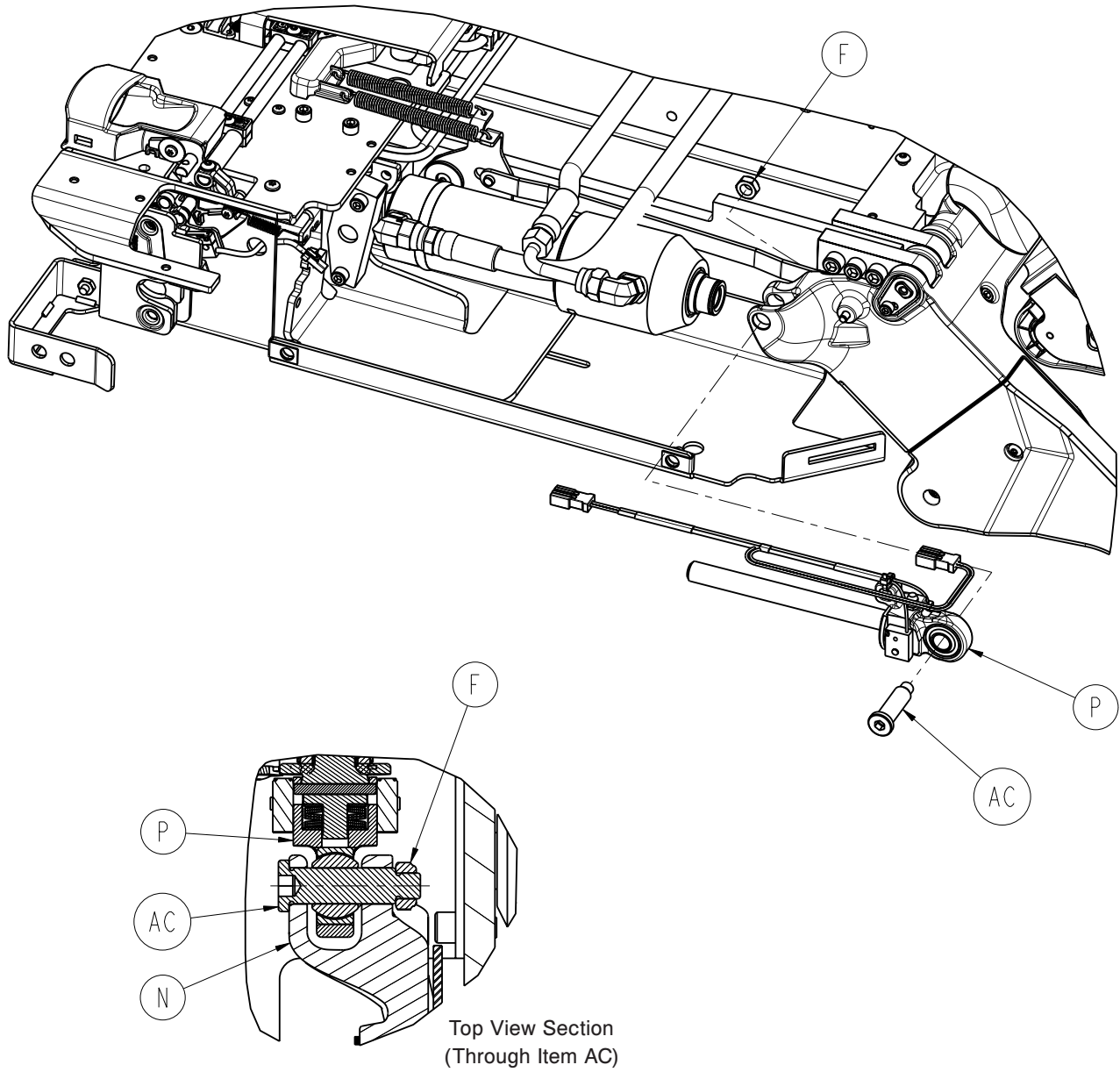

Top View Section  
(Through Item AC)

# Trolley Assembly

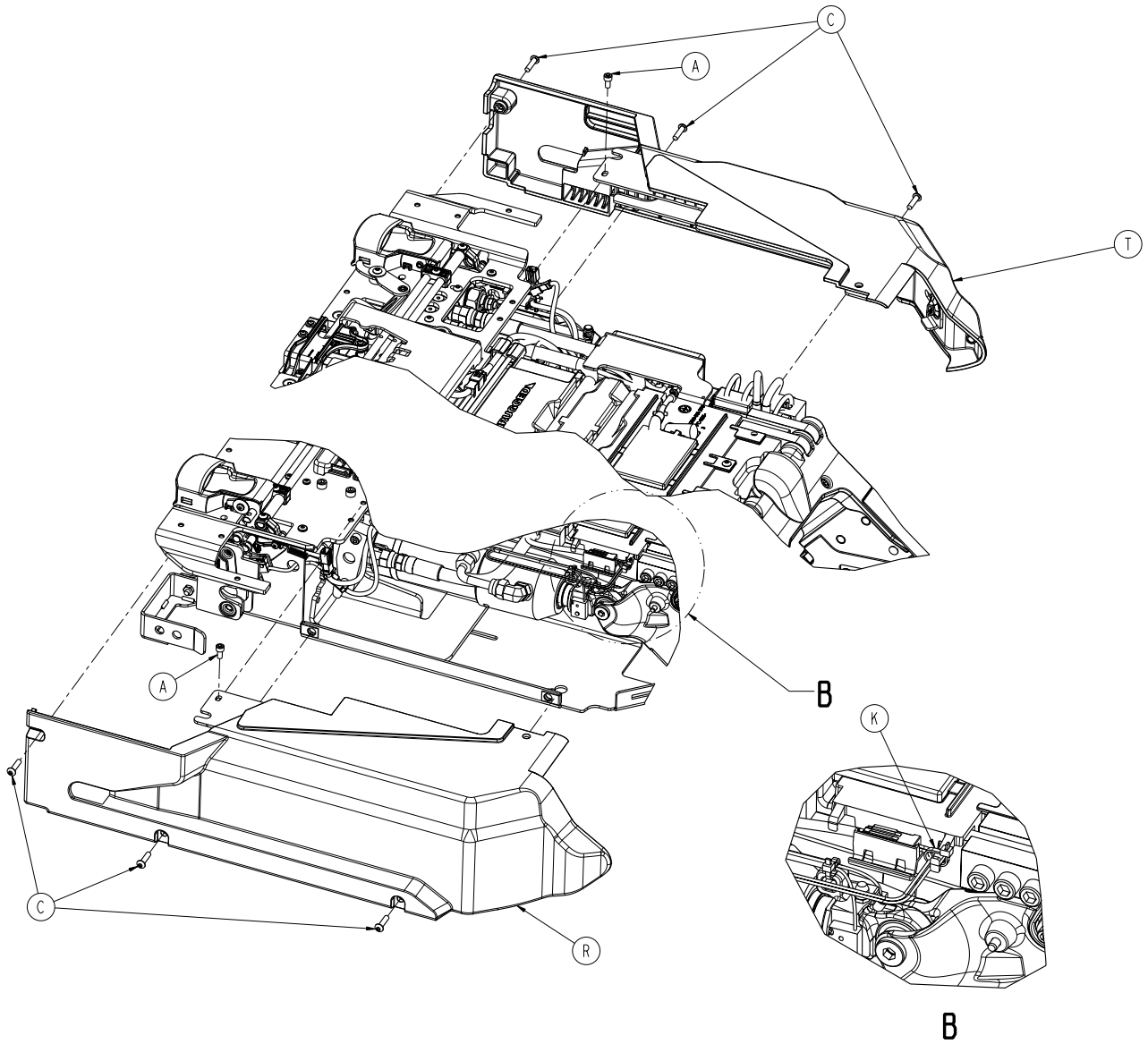

# Trolley Assembly

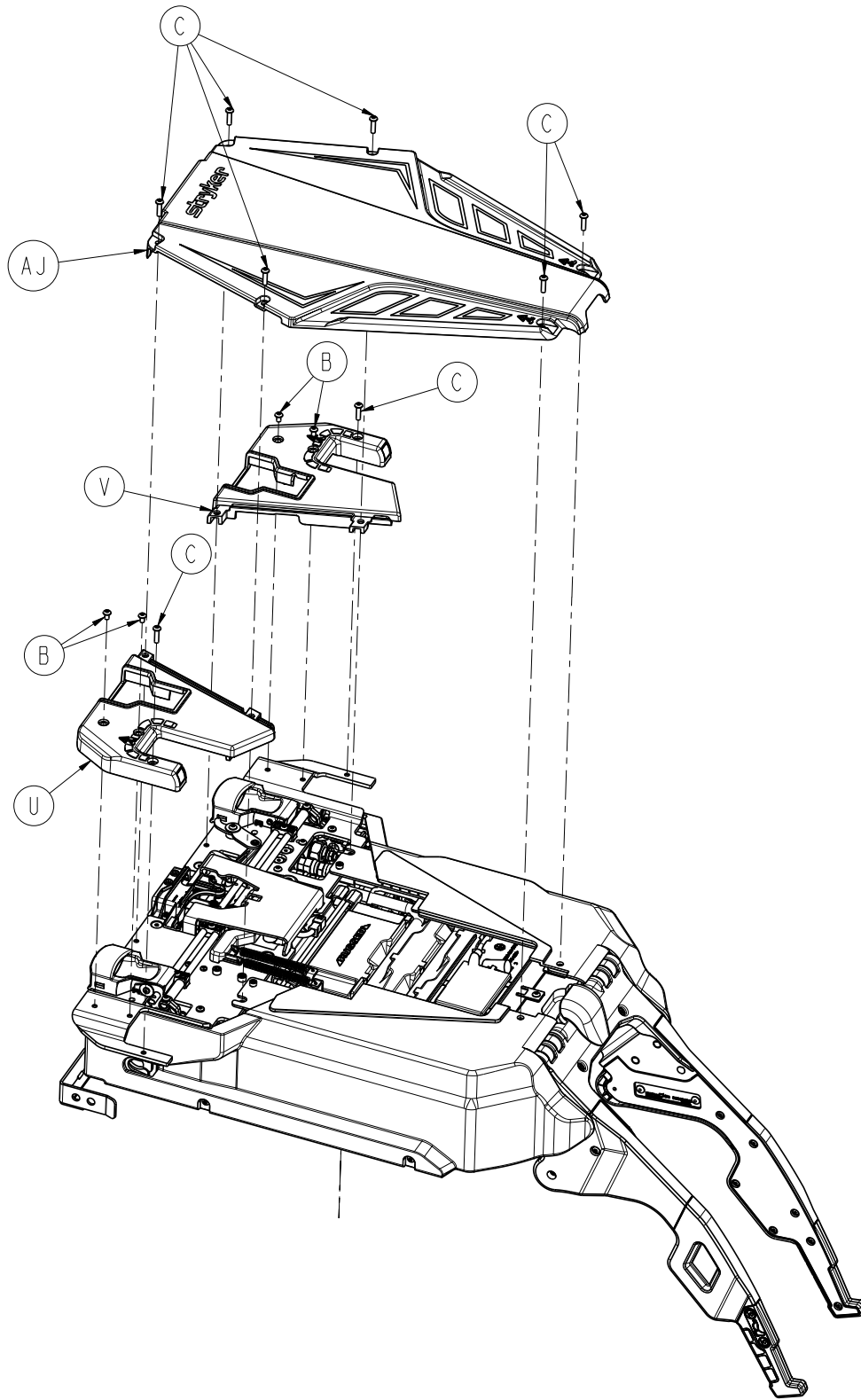

# Trolley Assembly

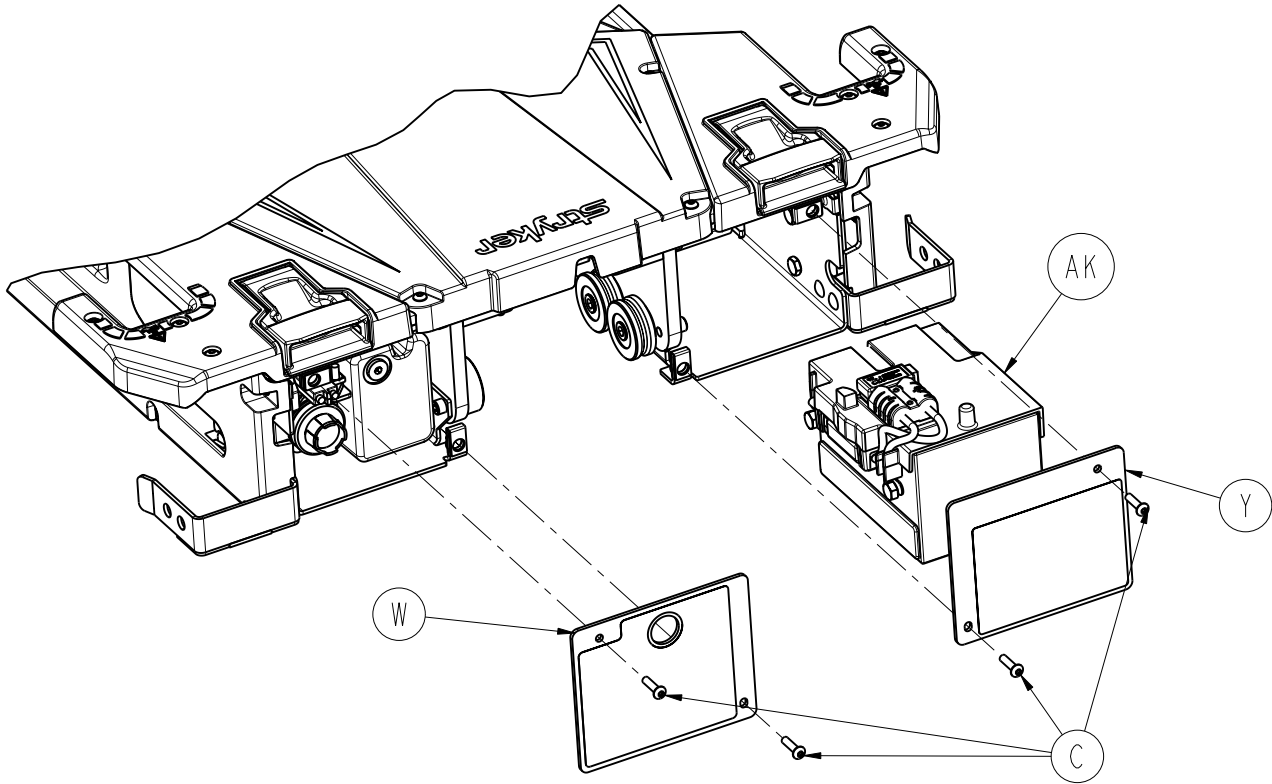

Trolley Assembly - 6390-001-013 Rev F (Reference Only)

Item	Part No.	Part Name	Qty.
A	0004-658-000	Socket Head Cap Screw	3
B	0004-665-000	Button Head Cap Screw	4
C	0004-666-000	Button Head Cap Screw	18
E	0008-082-000	Socket Head Set Screw	1
F	0016-132-000	Nylock Hex Nut	1
H	0027-778-000	Slit Pin	1
K	0038-111-000	Zip Tie	1
L	0038-896-000	Extension Spring	1
M	6390-001-015	Trolley Main Frame ( <a href="#">page 151</a> )	1
N	6390-001-016	Trolley Arm Assembly ( <a href="#">page 172</a> )	1
P	6390-001-040	Hydraulic Cylinder Rod End Assembly	1
R	6390-001-041	Side Cover, Right	1
T	6390-001-042	Side Cover, Left	1
U	6390-101-047	Wing Cover, Right	1
V	6390-101-048	Wing Cover, Left	1
W	6390-101-062	Trolley Rear Cover Plate, Left	1
Y	6390-101-063	Trolley Rear Cover Plate, Right	1
AA	6390-001-309	Arm Hinge Pin	2
AB	6390-001-311	Hinge Cover Plate	2
AC	6390-001-313	Cylinder Clevis Pin	1
AD	6390-001-377	Angle Sensor Link	1
AJ	6390-101-420	Trolley Top Cover	1
AK	6390-001-026	Battery Assembly	1
AL	0011-454-000	Plain Washer	1

# Trolley Main Frame

6390-001-015 Rev K (Reference Only)

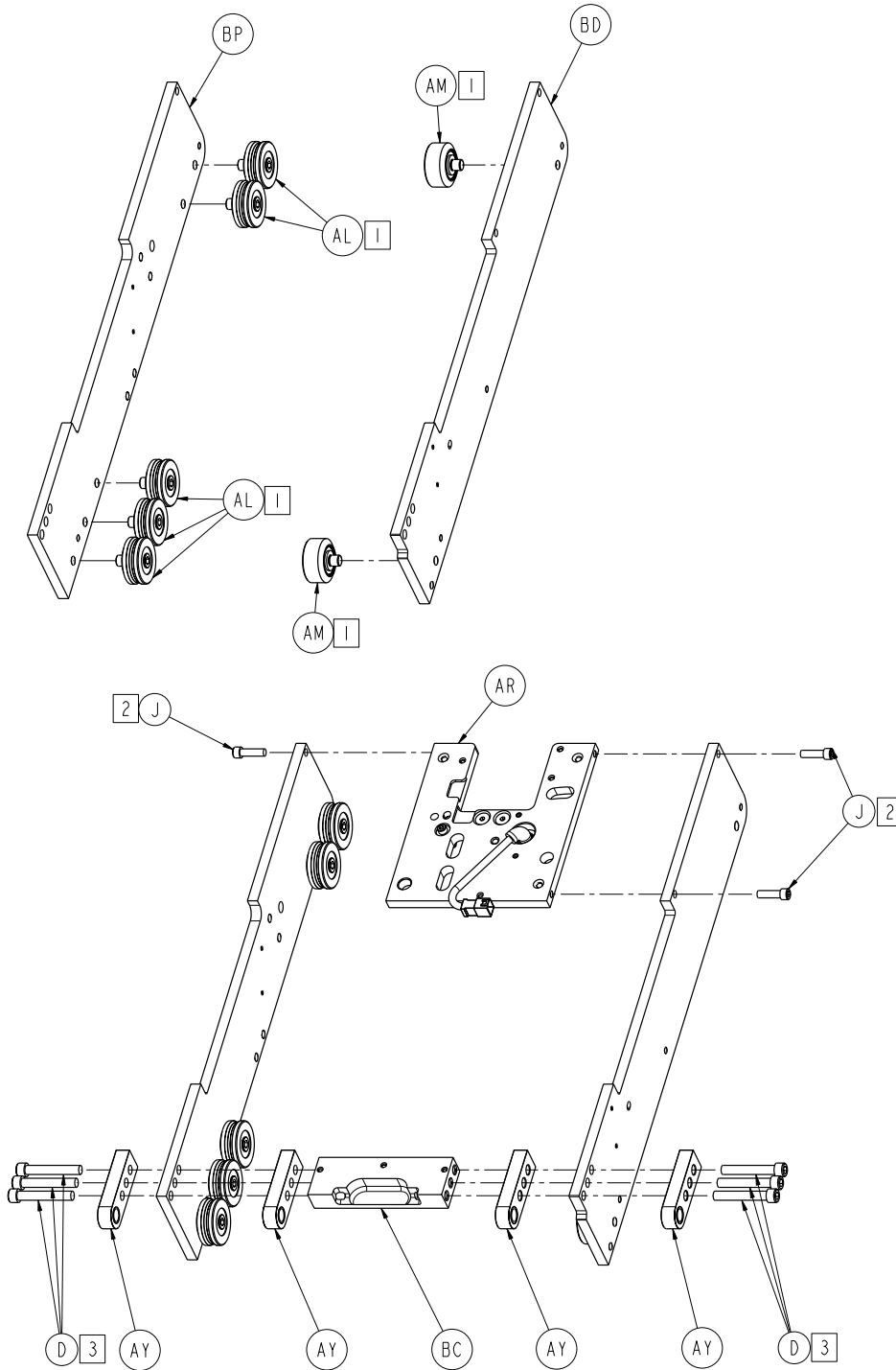

## Notes:

- 1 Torque to 235-317 in-lb
- 2 Torque to 13-19 ft-lb
- 3 Torque to 219-297 in-lb
- 4 Torque to 68-92 in-lb
- 5 Feed wire from latch through hole, as shown
- 6 Torque to 20-28 ft-lb
- 7 Torque to 12-18 in-lb
- 8 Zip tie (AC) to land on heat shrink portion of angle sensor cable (CJ)
- 9 Torque to 45 max in-ozs
- 10 Torque to 480-600 in-lb
- 11 Indicated springs must be oriented as shown

# Trolley Main Frame

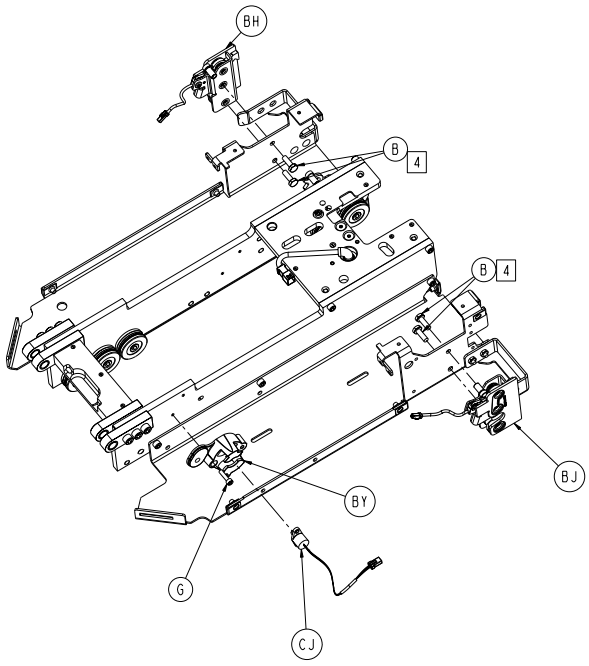
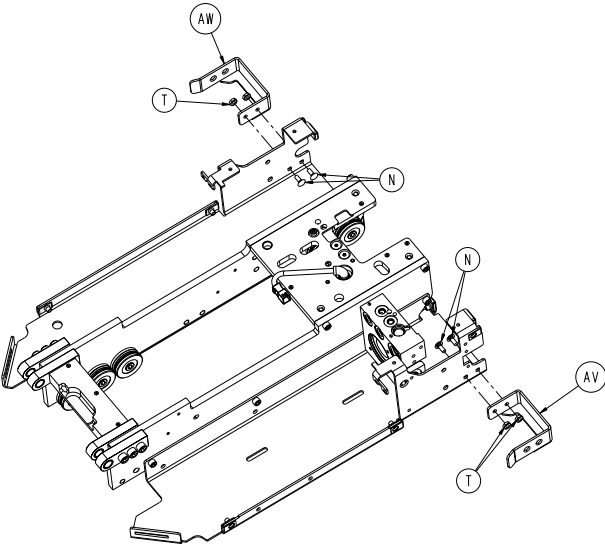
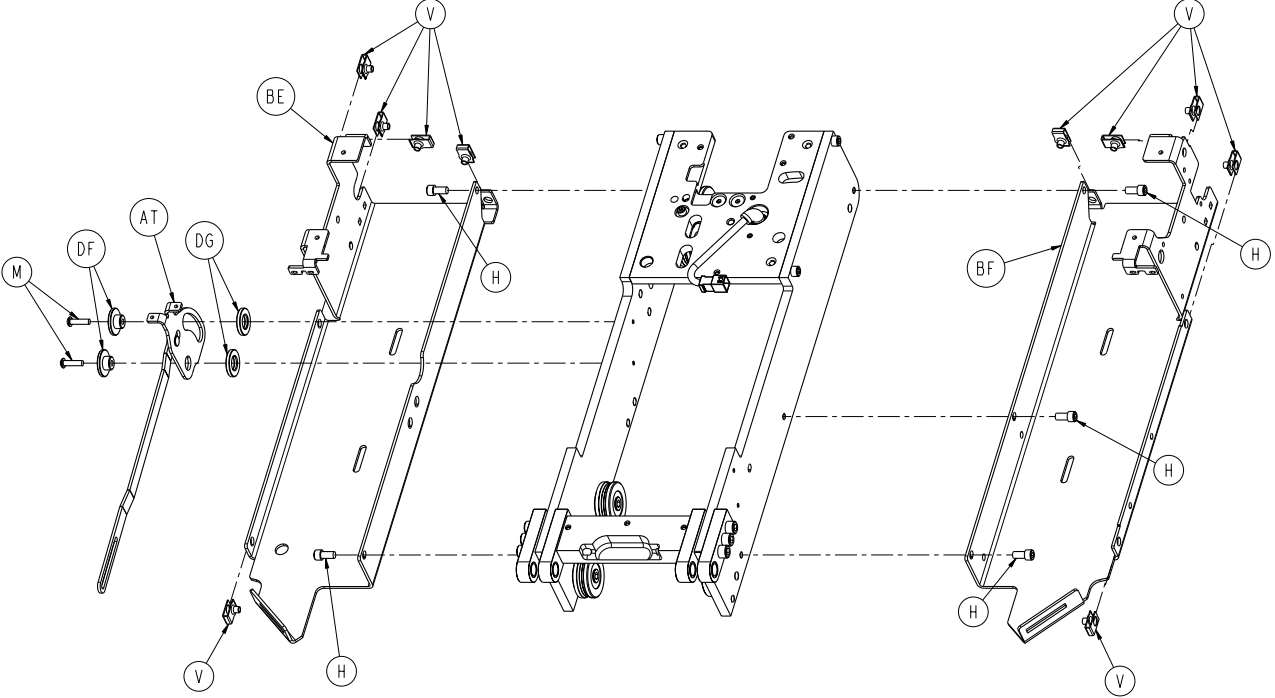



# Trolley Main Frame

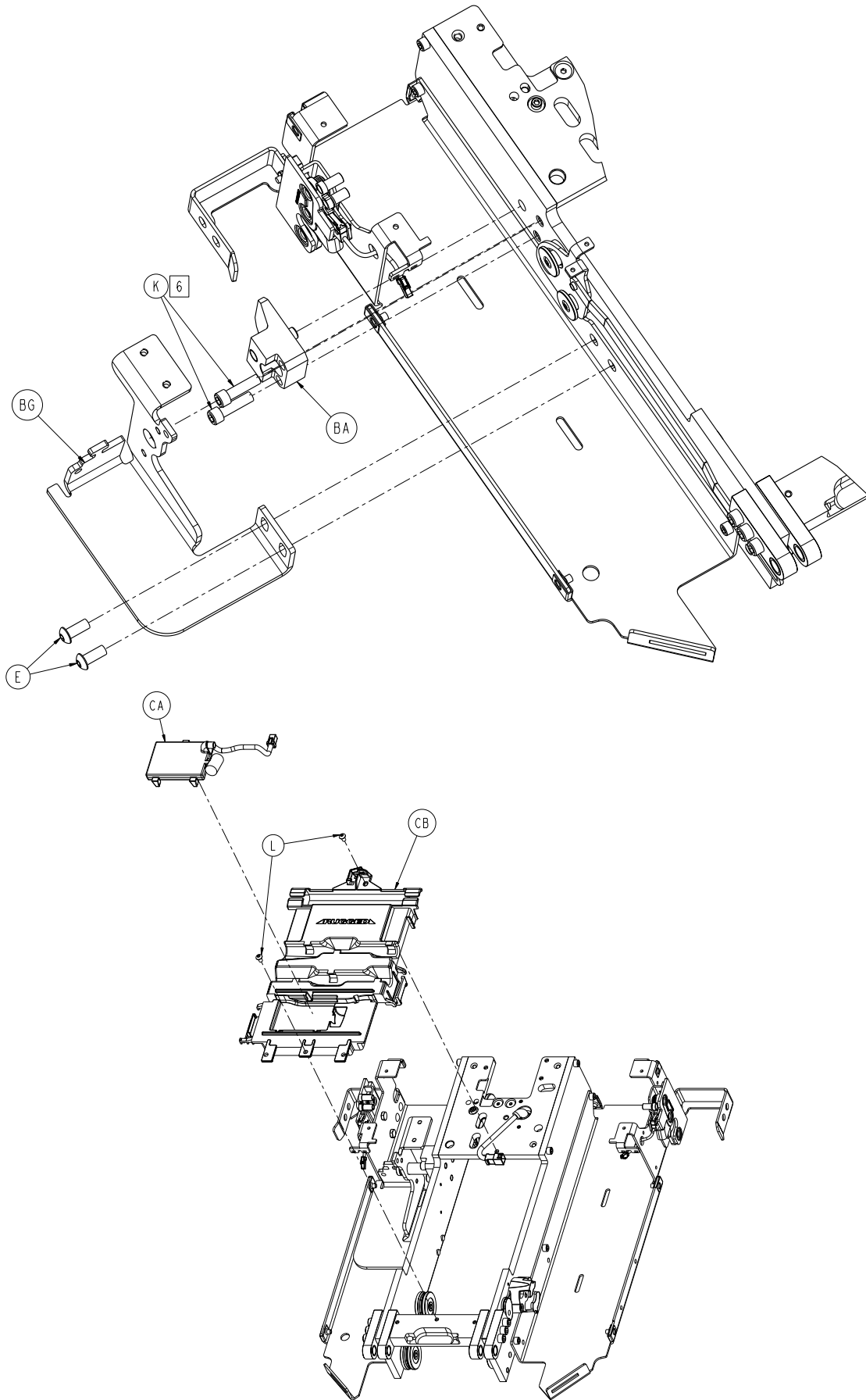

# Trolley Main Frame

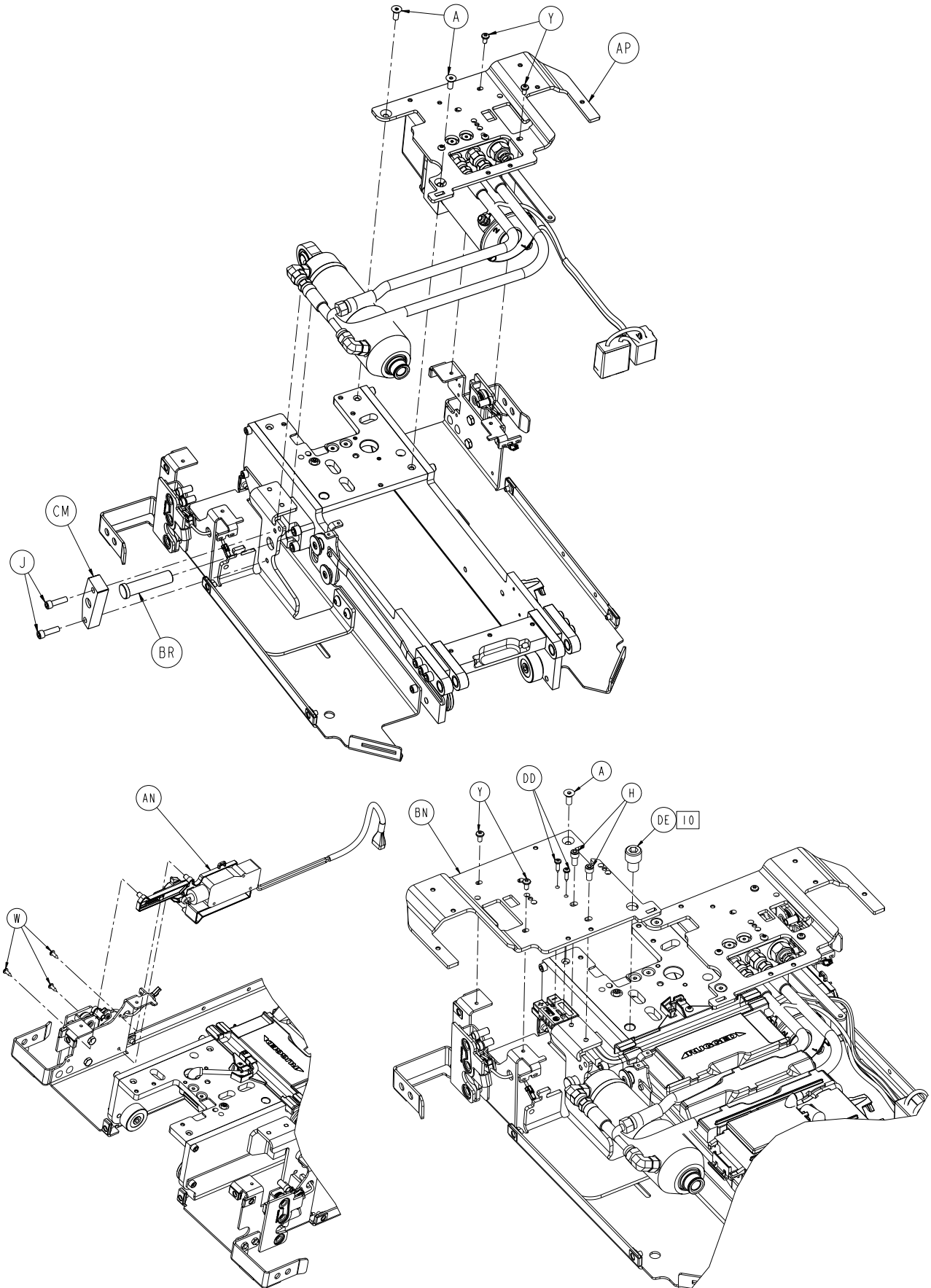

# Trolley Main Frame

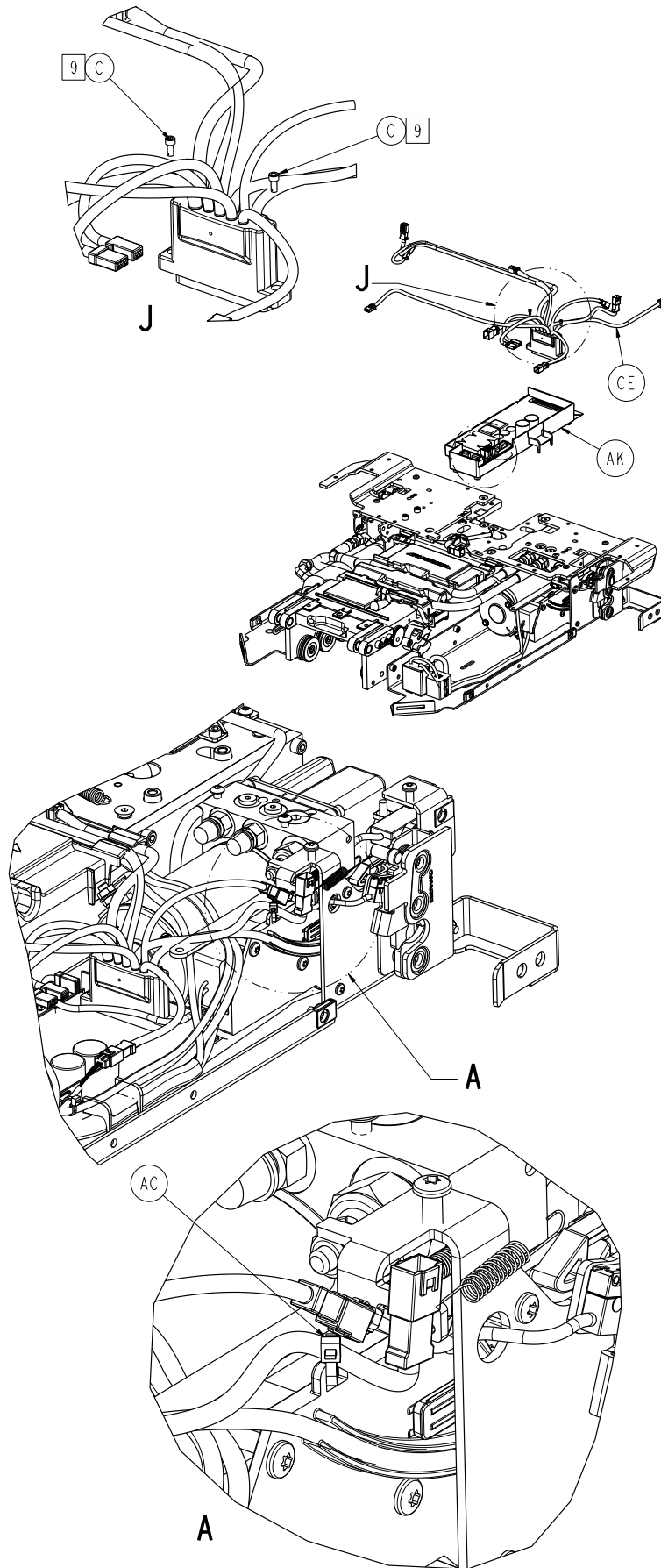

# Trolley Main Frame

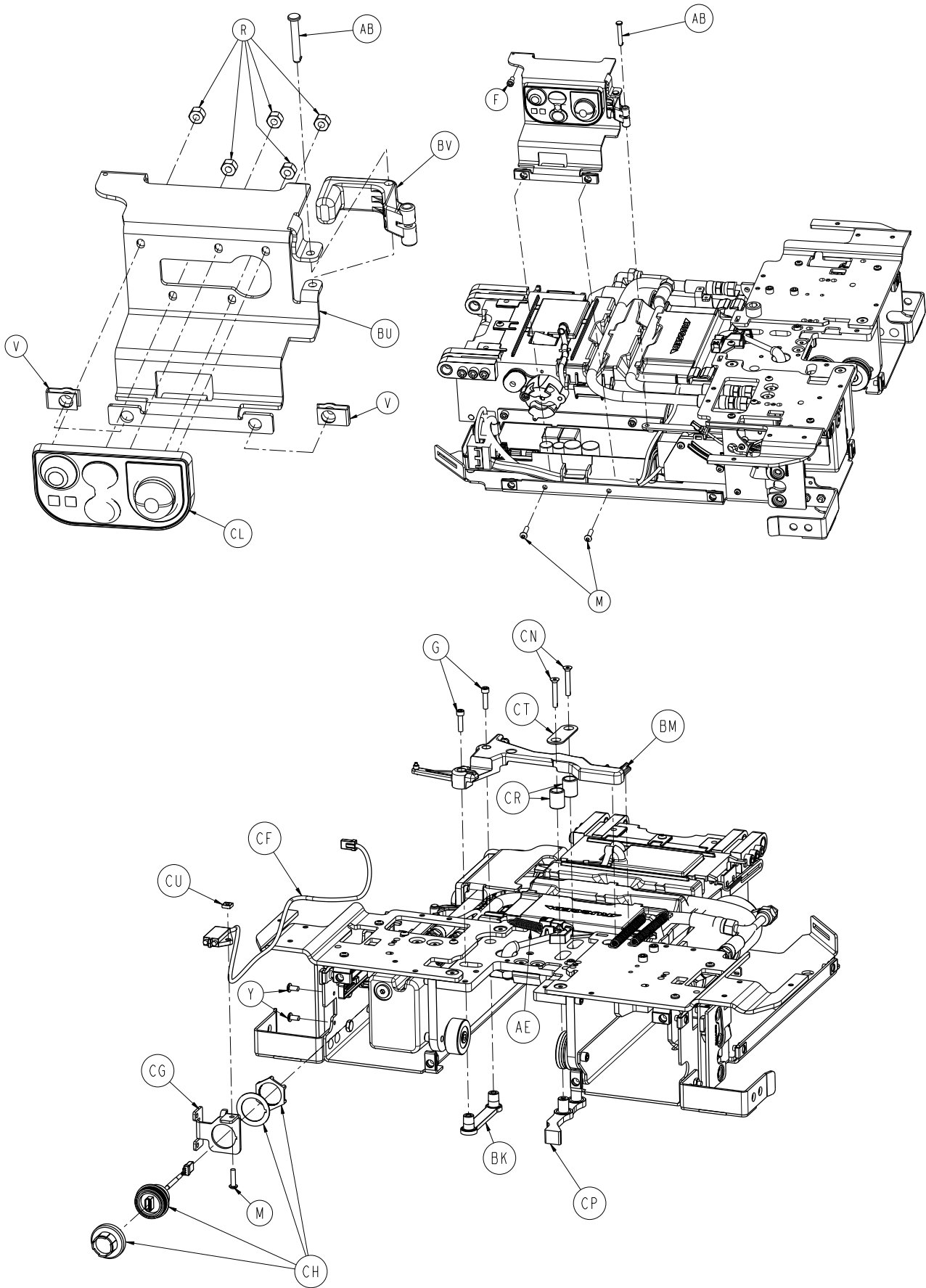

# Trolley Main Frame

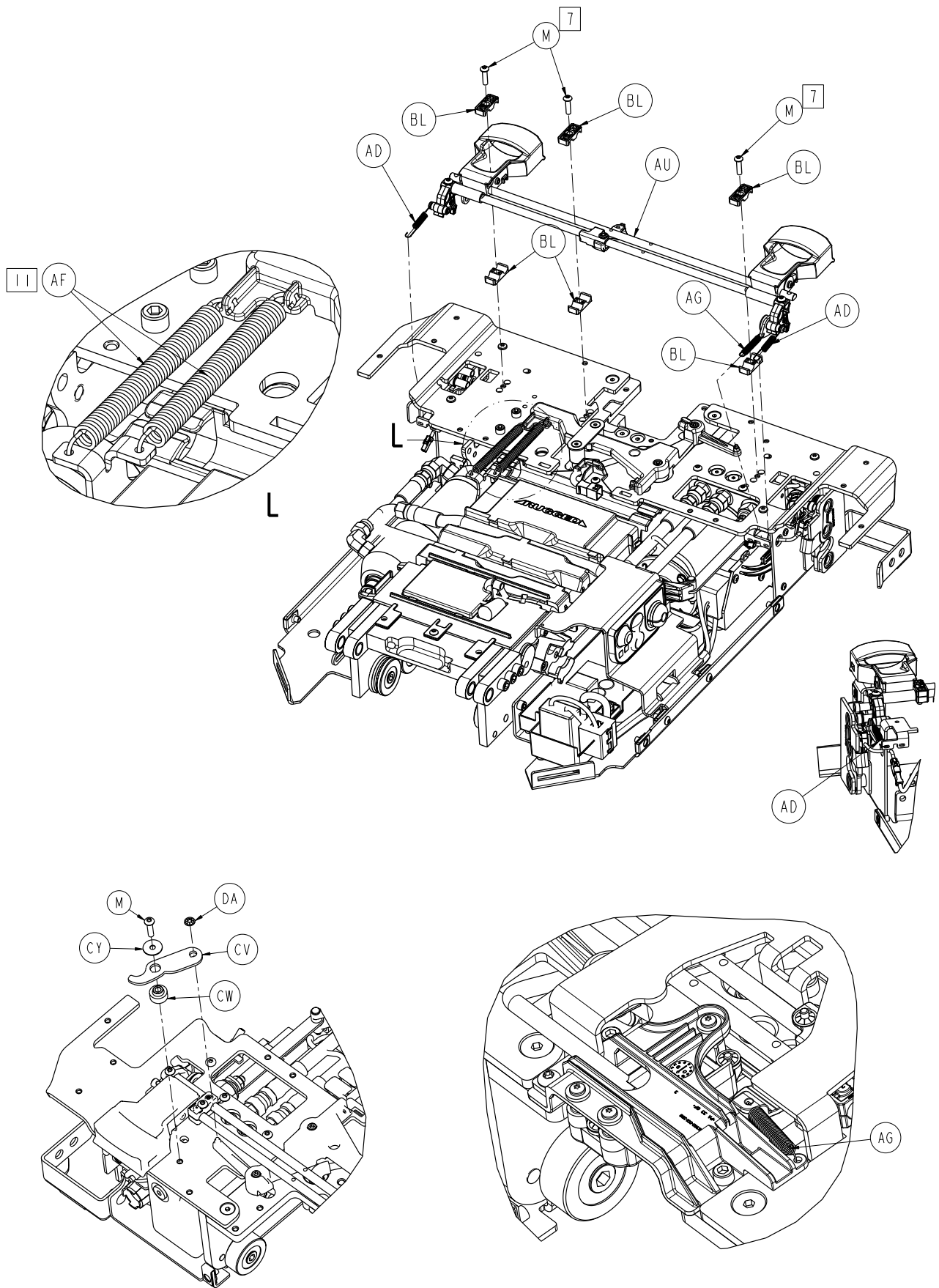

[Return To Table of Contents](#)

# Trolley Main Frame

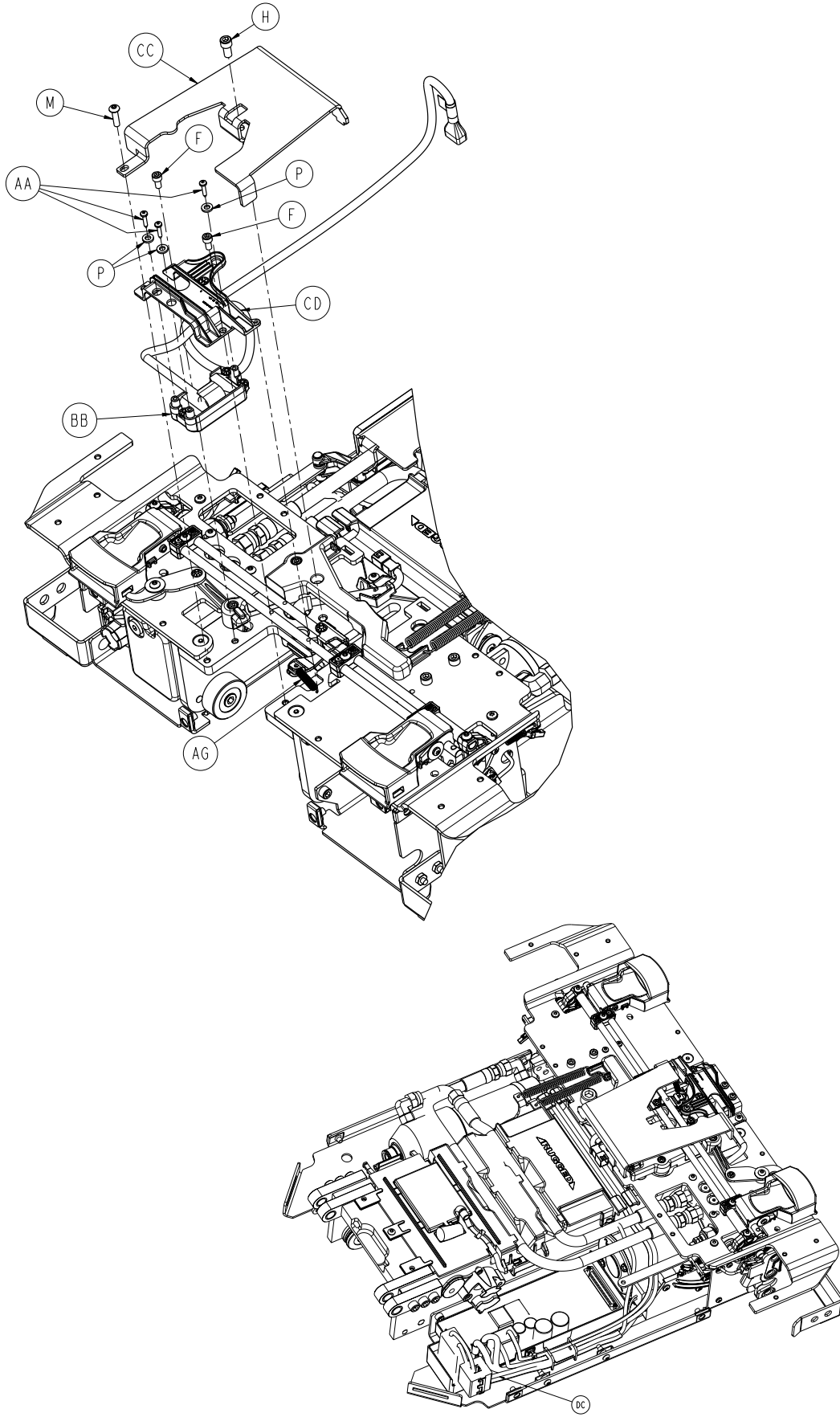

# Trolley Main Frame

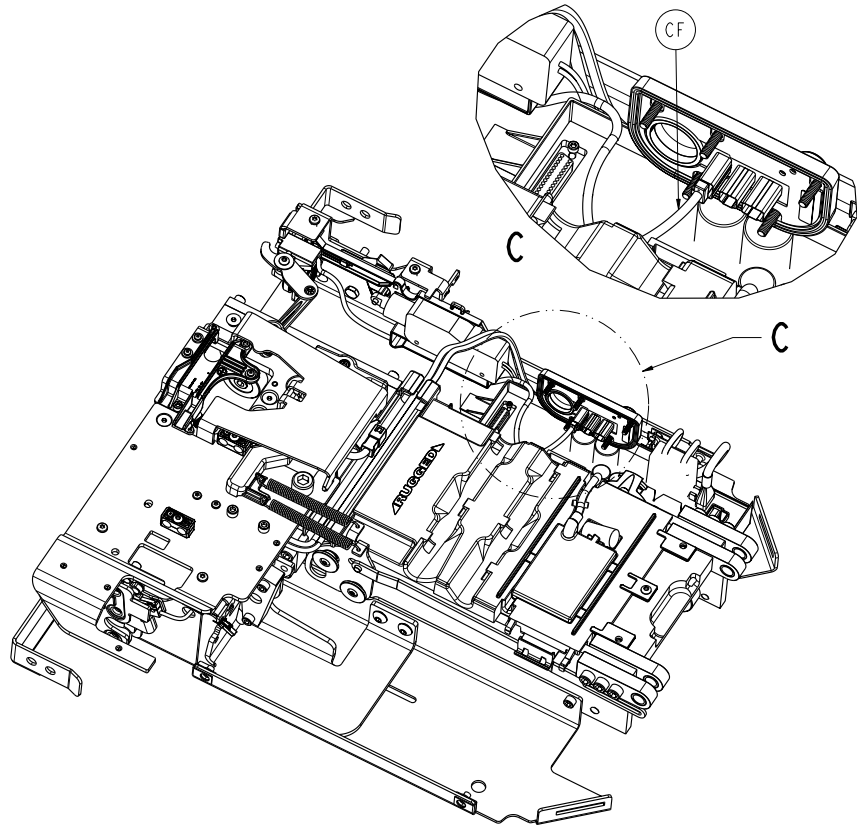

Routing for rear LED  
cable item "CF"

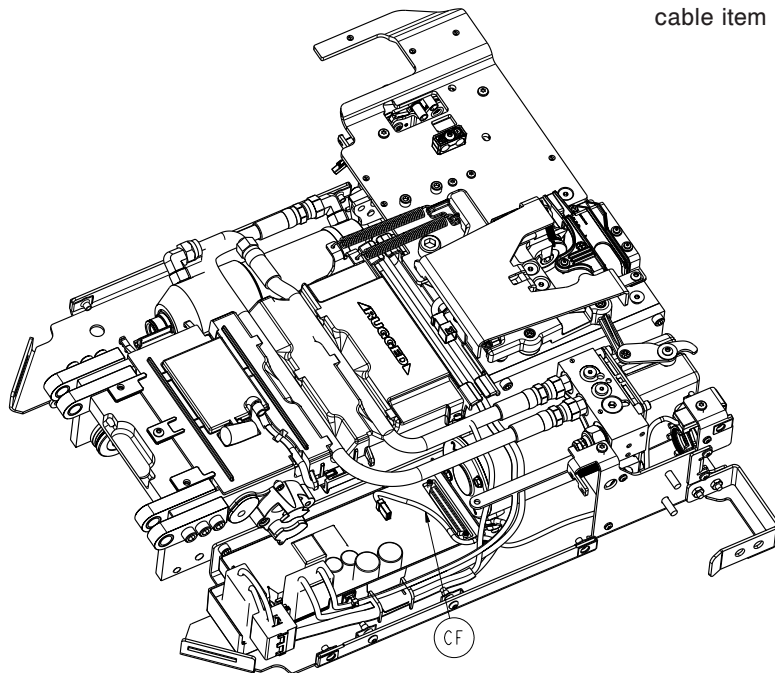

# Trolley Main Frame

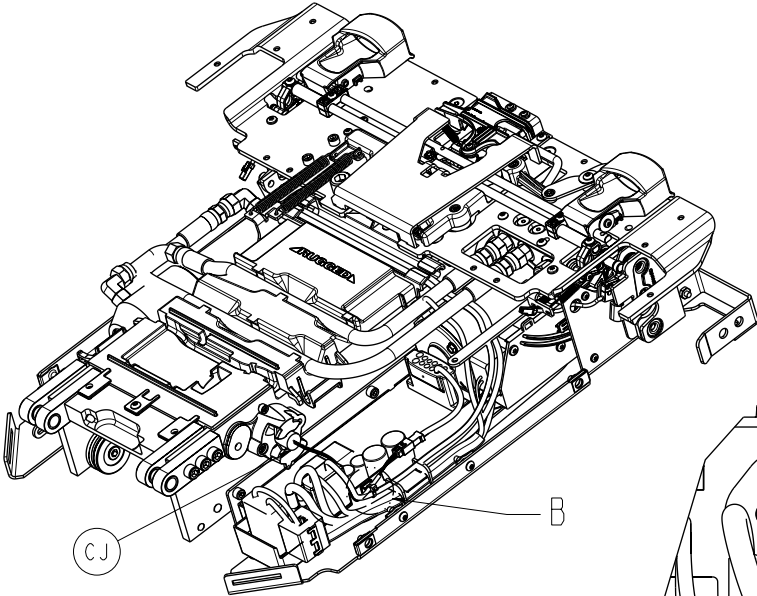

Routing for angle sensor cable item "CJ"

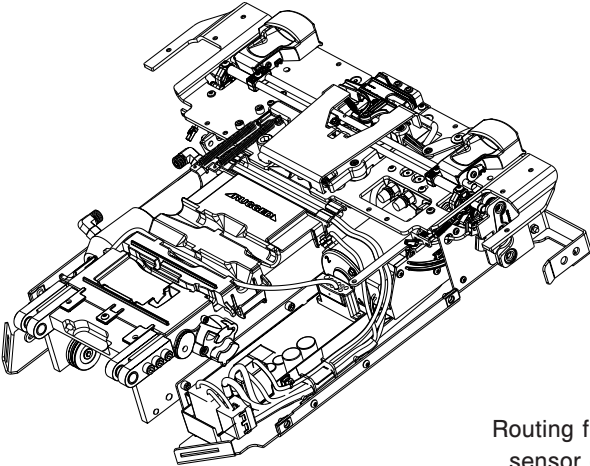
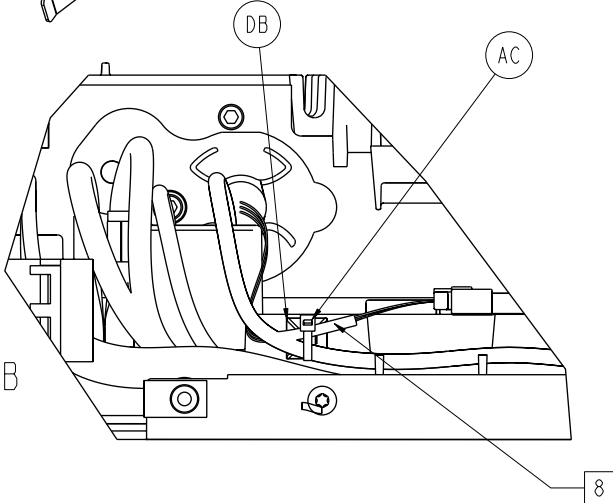

Routing for load sensor cable

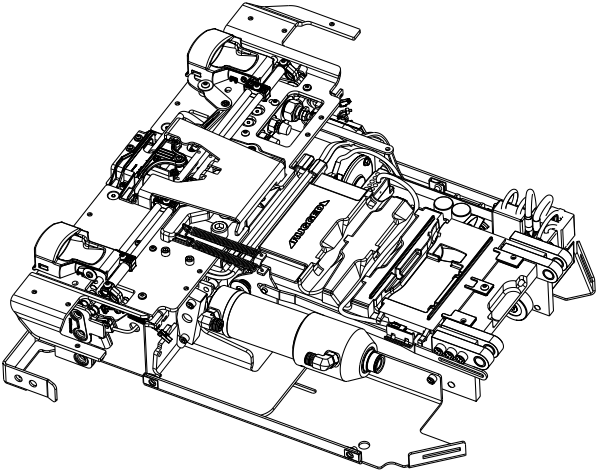



# Trolley Main Frame

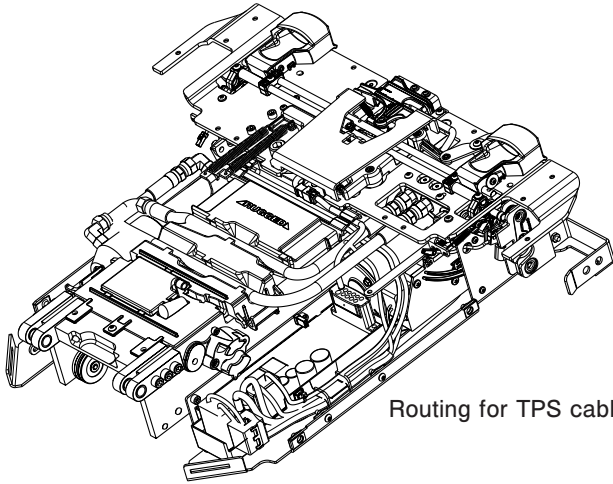

Routing for TPS cable

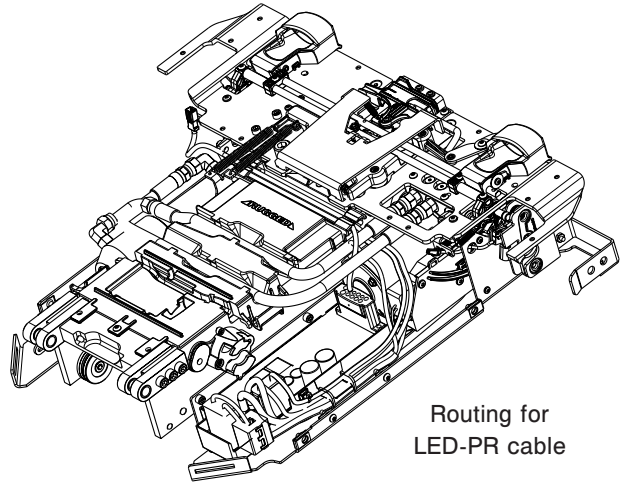

Routing for LED-PR cable

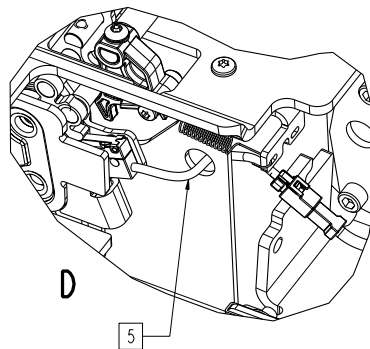
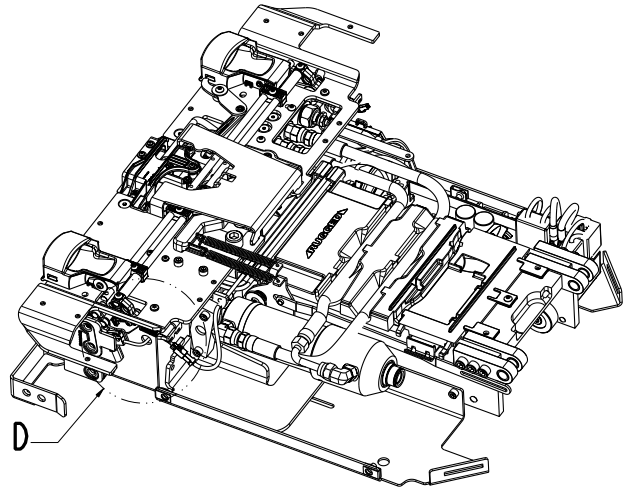
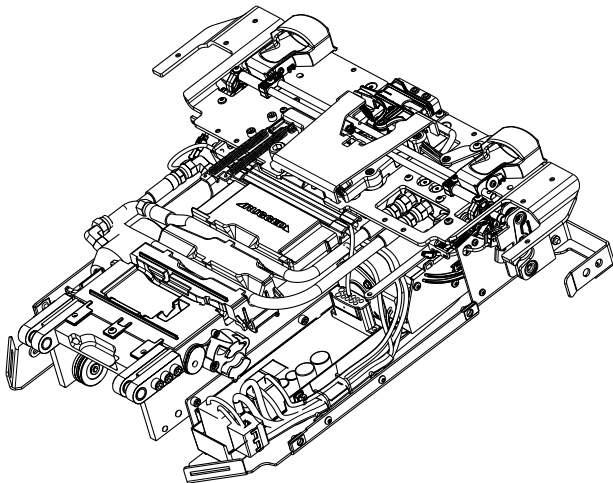

Routing for latch - PR cable

# Trolley Main Frame

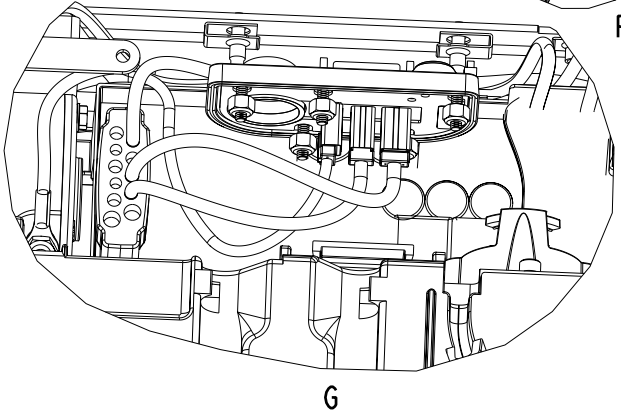
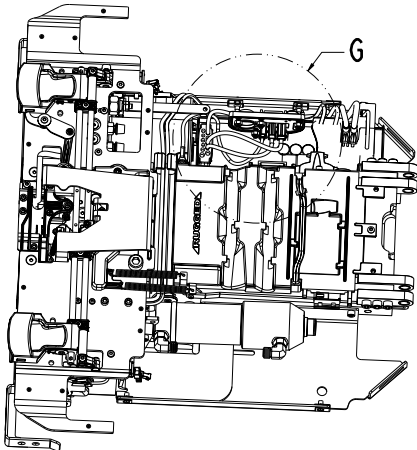
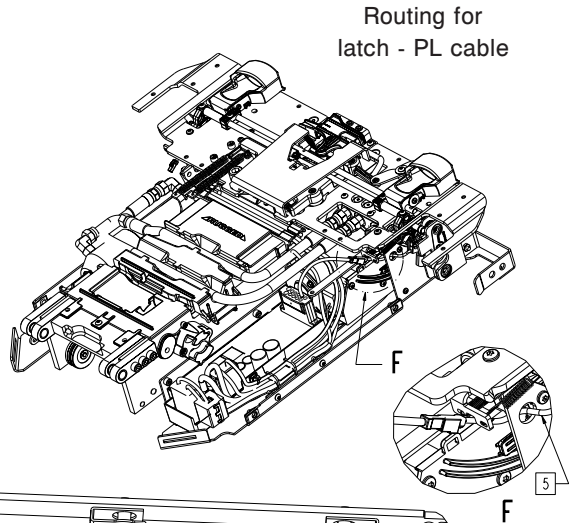
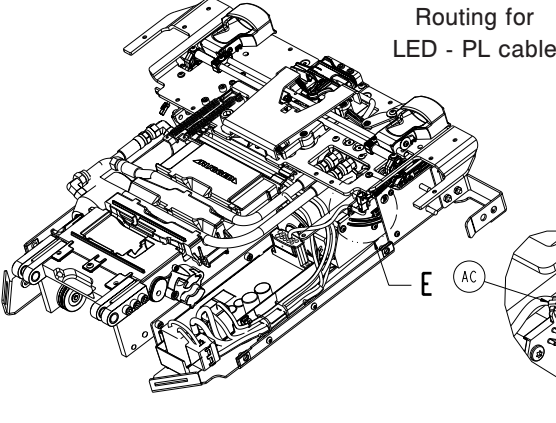

Routing for switch panel cables

# Trolley Main Frame

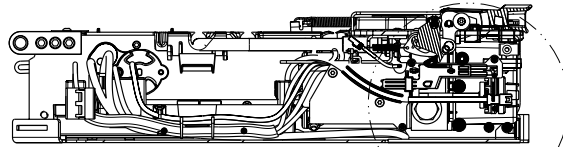
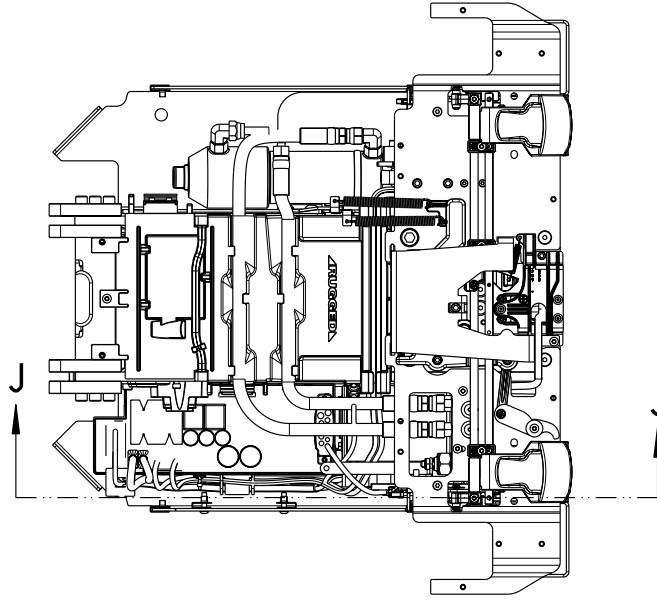

J - J

H

Press cable firmly  
into trough

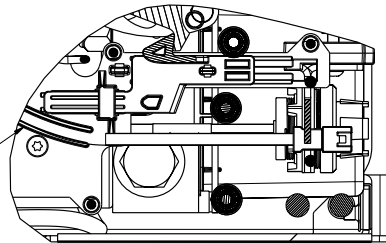

H

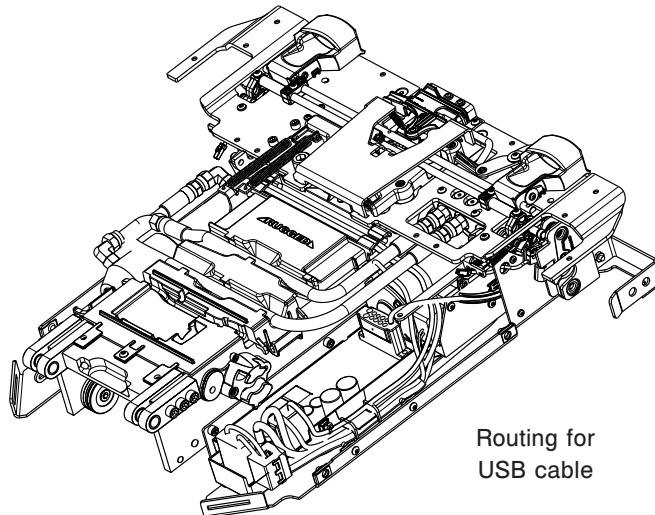

Routing for  
USB cable

# Trolley Main Frame

## Trolley Main Frame - 6390-001-015 Rev K (Reference Only)

Item	Part No.	Part Name	Qty.
A	0001-195-000	Flat Head Cap Screw	3
B	0003-148-000	Hex Head Cap Screw	4
C	0004-874-000	Socket Head Cap Screw	2
D	0004-352-000	Socket Head Cap Screw	6
E	0004-652-000	Button Head Cap Screw	2
F	0004-658-000	Socket Head Cap Screw	3
G	0004-659-000	Socket Head Cap Screw	3
H	0004-660-000	Socket Head Cap Screw	8
J	0004-661-000	Socket Head Cap Screw	5
K	0004-397-000	Socket Head Cap Screw	2
L	0004-665-000	Button Head Cap Screw	2
M	0004-666-000	Button Head Cap Screw	10
N	0005-047-000	Carriage Bolt	4
P	0011-436-000	Washer	3
R	0016-014-000	Fiberlock Hex Nut	5
T	0015-003-000	Hex Nut	4
V	0018-009-000	Extruded "U" Nut	12
W	0023-167-000	Delta Screw	3
Y	0023-296-000	Pan Head Machine Screw	6
AA	0023-321-000	Delta Screw	3
AB	0027-778-000	Slic Pin	2
AC	0038-111-000	Zip Tie	2
AD	0038-376-000	Extension Spring	2
AE	0038-894-000	Extension Spring	1
AF	0038-895-000	Extension Spring	2
AG	0038-896-000	Extension Spring	2
AK	6390-001-014	Control Board Assembly	1
AL	6390-001-025	V-Guide Roller Assembly	5
AM	6390-001-027	Flat Roller Assembly	2
AN	6390-001-028	Trolley Actuator Assembly ( <a href="#">page 175</a> )	1
AP	6390-001-035	Wing Assembly, Left ( <a href="#">page 167</a> )	1
AR	6390-001-043	Trolley/Transfer Interface Mechanism ( <a href="#">page 166</a> )	1
AT	6390-001-045	Trolley Arm Mechanism	1
AU	6390-001-046	Trolley Manual Release Assembly ( <a href="#">page 170</a> )	1
AV	6390-001-052	Load Wheel Horn Guide Weldment, Left	1
AW	6390-001-053	Load Wheel Horn Guide Weldment, Right	1
AY	6390-001-064	Hinge Plate Assembly	4
BA	6390-001-065	Cylinder Support Block Assembly	1
BB	6390-001-066	Coil Housing Assembly	1
BC	6390-001-301	Trolley Main Frame Front Block	1
BD	6390-001-304	Trolley Main Frame Side Block, Left	1
BE	6390-001-314	Bottom Pan, Right	1
BF	6390-001-315	Bottom Pan, Left	1
BG	6390-001-316	Cylinder Support Bracket	1
BH	6390-001-318	Custom Eberhard Latch, Right	1
BJ	6390-001-319	Custom Eberhard Latch, Left	1
BK	6390-001-320	Bottom Release Arm	1
BL	6390-001-333	Release Rod Support Block	6

# Trolley Main Frame

---

## Trolley Main Frame - 6390-001-015 Rev K (Reference Only) (Continued)

Item	Part No.	Part Name	Qty.
BM	6390-001-334	Trolley Mechanism Arm	1
BN	6390-001-340	Wing Plate, Right	1
BP	6390-001-344	Trolley Main Frame Side Plate, Right	1
BR	6390-001-360	End Cap Cylinder Pin	1
BU	6390-001-365	Manual Release Button Bracket	1
BV	6390-001-366	Manual Release Button - Pump	1
BY	6390-001-375	Angle Sensor Housing	1
CA	6390-001-378	Trolley Comm Board	1
CB	6390-001-379	Trolley Routing Tray	1
CC	6390-001-385	Center Metal Cover	1
CD	6390-001-388	Charge Bracket Trolley Ind.	1
CE	6390-001-391	Main Cable Assembly	1
CF	6390-001-392	Trolley Rear LED Assembly	1
CG	6390-001-393	USB Mounting Bracket	1
CH	6390-001-395	USB Connector	1
CJ	6390-001-397	Angle Position Sensor	1
CL	6390-001-450	Master On/Off Switch	1
CM	6390-001-352	Cylinder Bracket	1
CN	0001-196-000	Flat Head Cap Screw	2
CP	6390-001-351	Trolley Release Actuator	1
CR	6390-001-343	Trolley Mechanism Pivot Pillar	2
CT	6390-001-336	Link	1
CU	0015-087-000	Square Nut	1
CV	6390-001-412	Handle Lock Pawl	1
CW	6390-001-413	Handle Lock Pivot Base	1
CY	0011-518-000	Washer	1
DA	0028-217-000	Pushnut	1
DB	0058-143-000	Adhesive Backed Mounting Tab	1
DC	6390-001-545	Battery Fuse Extension Cable	1
DD	0023-162-000	Delta Screw	2
DE	0004-404-000	Socket Head Cap Screw	1
DF	6390-001-574	Trolley Lock Mechanism Actuator	
		Bushing	2
DG	6390-001-573	Actuator Thrust Washer	2

# Trolley/Transfer Interface Mechanism

6390-001-043 Rev C (Reference Only)

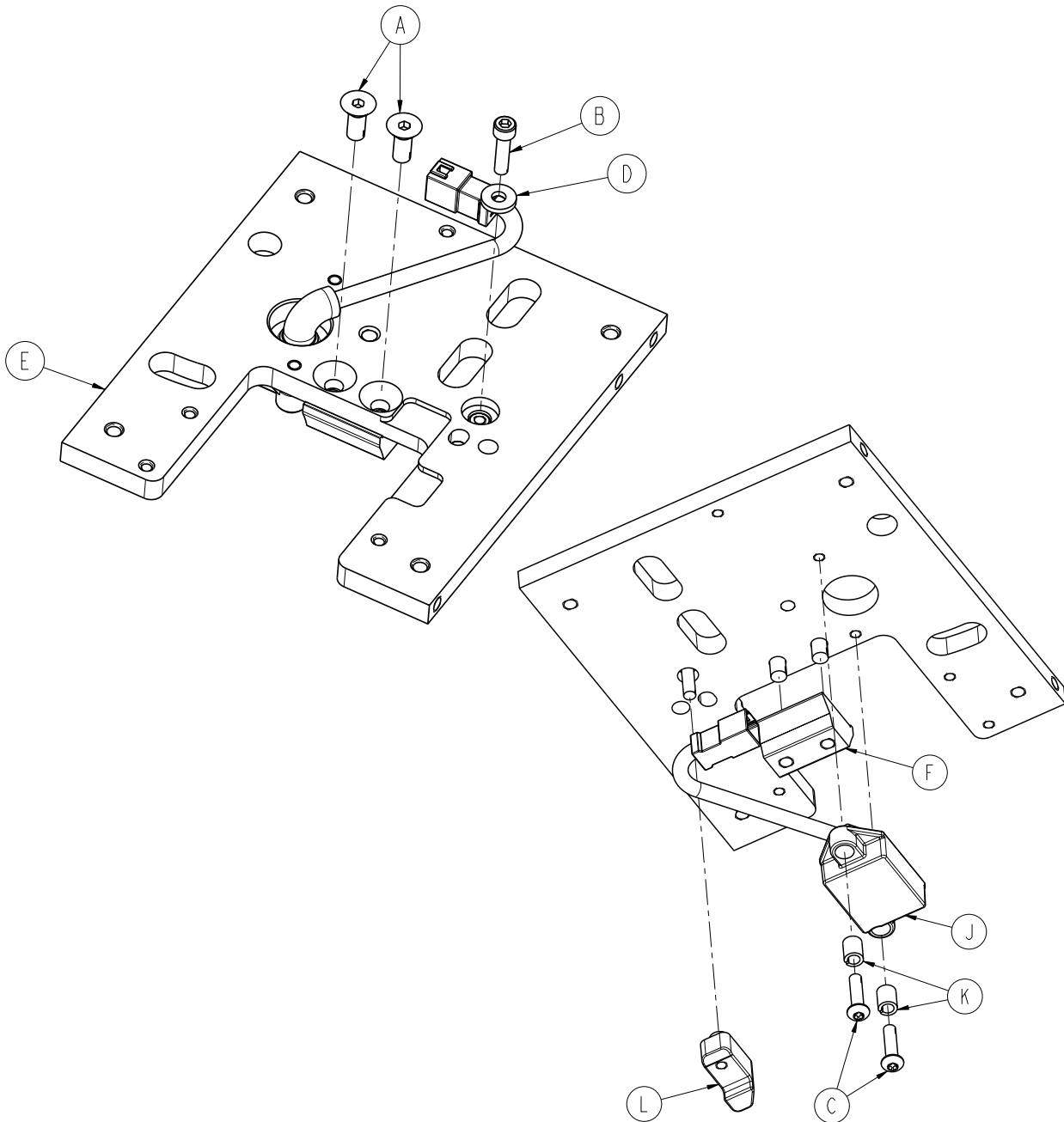

Item	Part No.	Part Name	Qty.
A	0001-195-000	Flat Head Cap Screw	2
B	0004-659-000	Socket Head Cap Screw	1
C	0004-666-000	Button Head Cap Screw	2
D	0011-517-000	Washer	1
E	6390-001-303	Trolley Main Frame Top Plate	1
F	6390-001-325	Trolley Stop Ramp	1
J	6390-001-361	TPS Sensor Assembly	1
K	6390-001-362	TPS Compression Limiter	2
L	6390-001-404	Transfer to Anchor Release Plug	1

# Wing Assembly, Left

6390-001-035 Rev A (Reference Only)

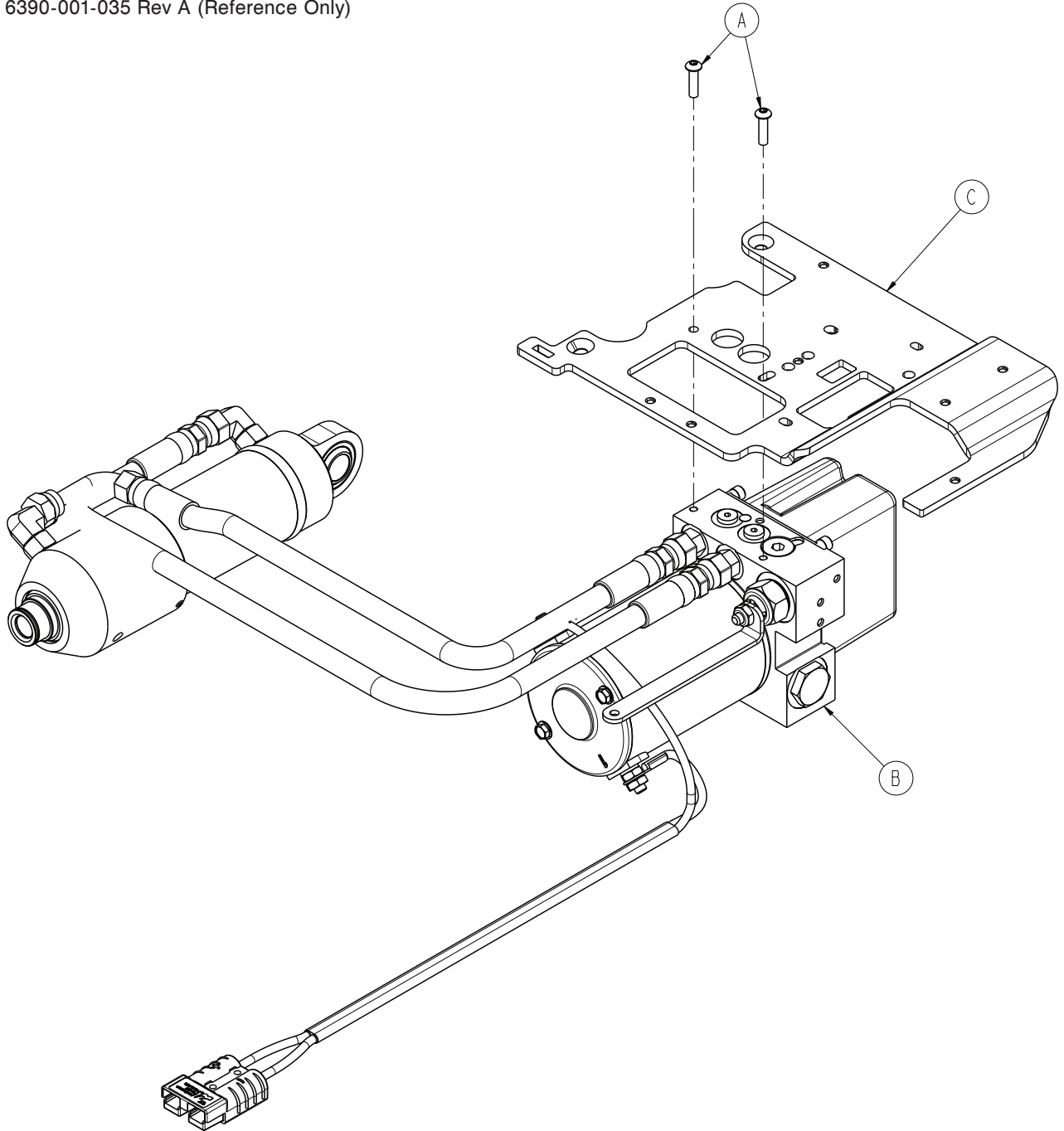

Item	Part No.	Part Name	Qty.
A	0004-666-000	Button Head Cap Screw	2
B	6390-001-039	Hydraulics Assembly ( <a href="#">page 168</a> )	1
C	6390-001-339	Wing Plate, Left	1

# Hydraulics Assembly

6390-001-039 Rev K (Reference Only)

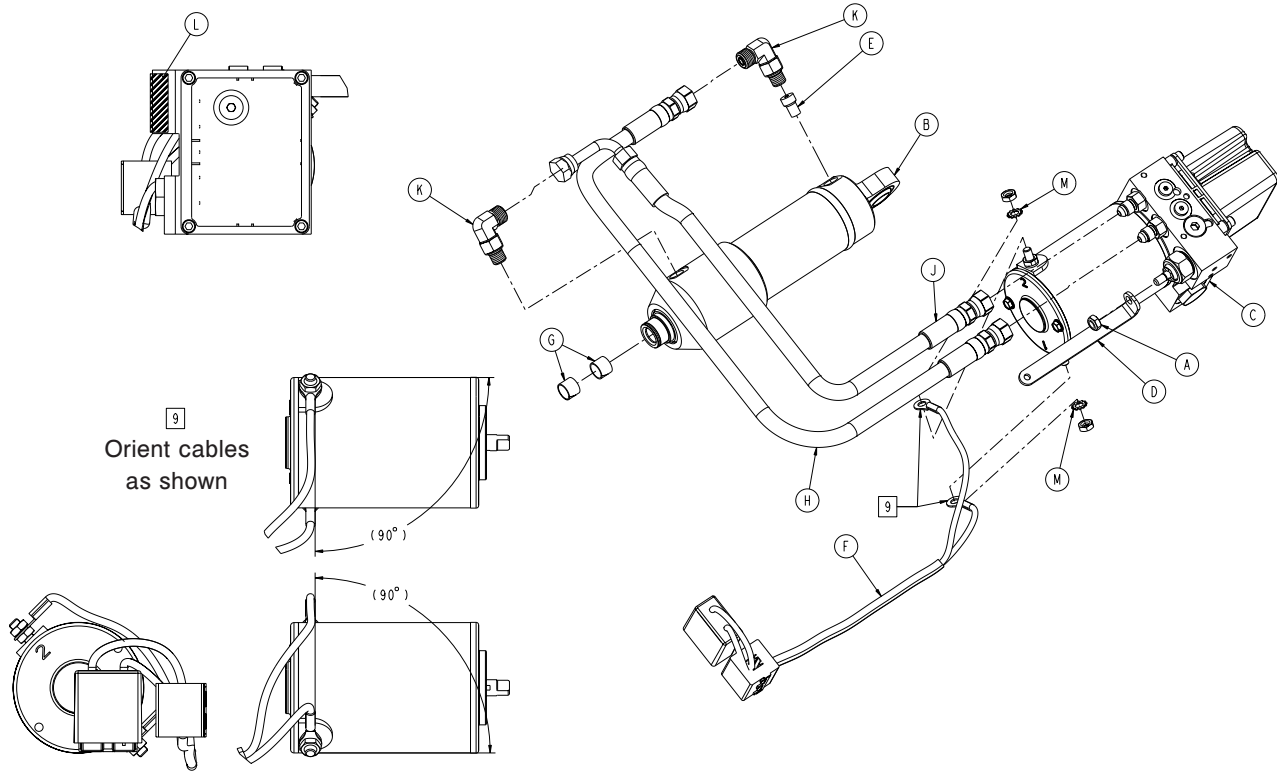

Item	Part No.	Part Name	Qty.
A	0016-102-000	Nylock Hex Nut	1
B	6390-001-029	Hydraulic Cylinder	1
C	6390-001-038	Manifold Assembly ( <a href="#">page 169</a> )	1
D	6390-001-167	Manual Release Link	1
E	6390-001-381	Velocity Fuse	1
F	6390-001-431	Motor Cable	1
G	6390-001-433	Inner Rod Bearing	2
H	6390-001-436	Hydraulic Hose, Cap End	1
J	6390-001-437	Hydraulic Hose, Rod End	1
K	6500-001-297	Cylinder Rod Side Hose Fitting	2
L	NA	2 Min Polyester Label	1
M	0013-010-000	External Tooth Lock Washer	2



# Manifold Assembly

---

6390-001-038 Rev H (Reference Only)

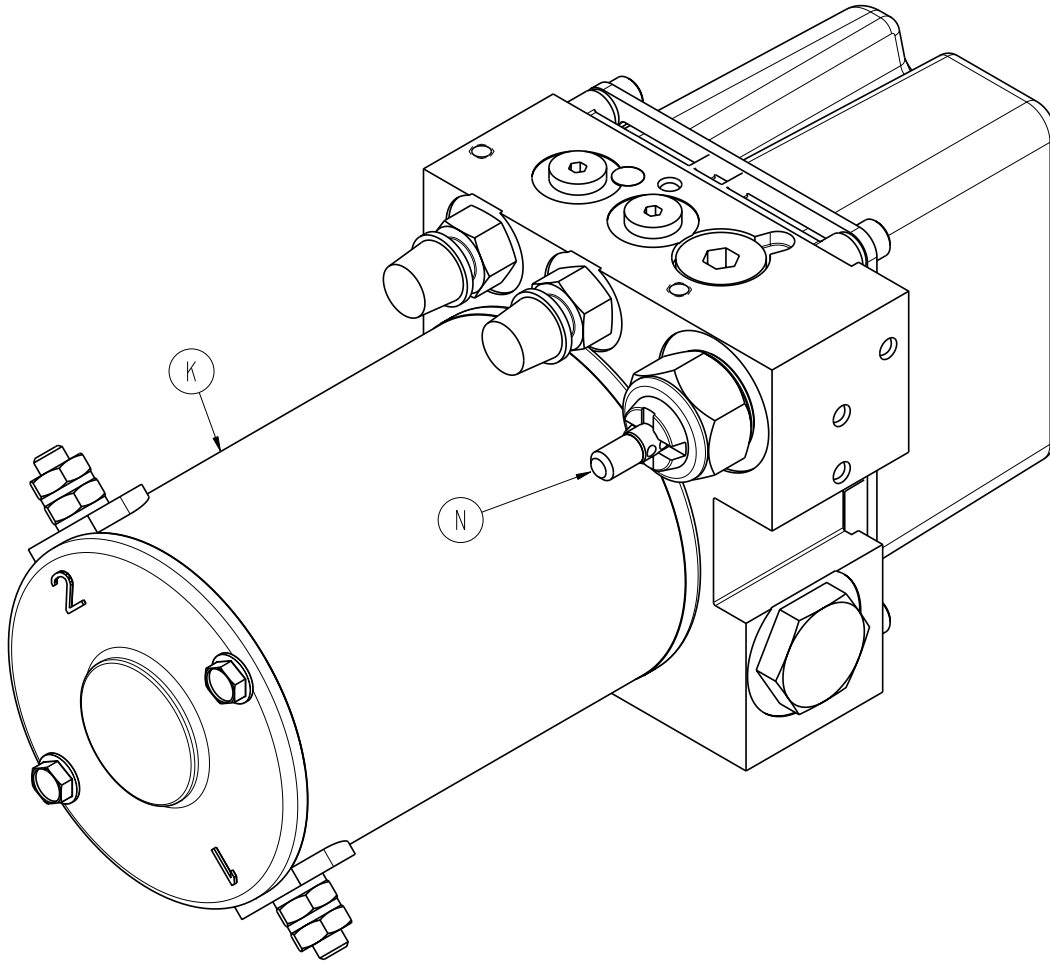

Item	Part No.	Part Name	Qty.
K	6390-001-132	Motor 12DC 109/165 AY	1
N	6500-001-289	Non-Locking Manual Valve	1

# Trolley Manual Release Assembly

6390-001-046 Rev C (Reference Only)

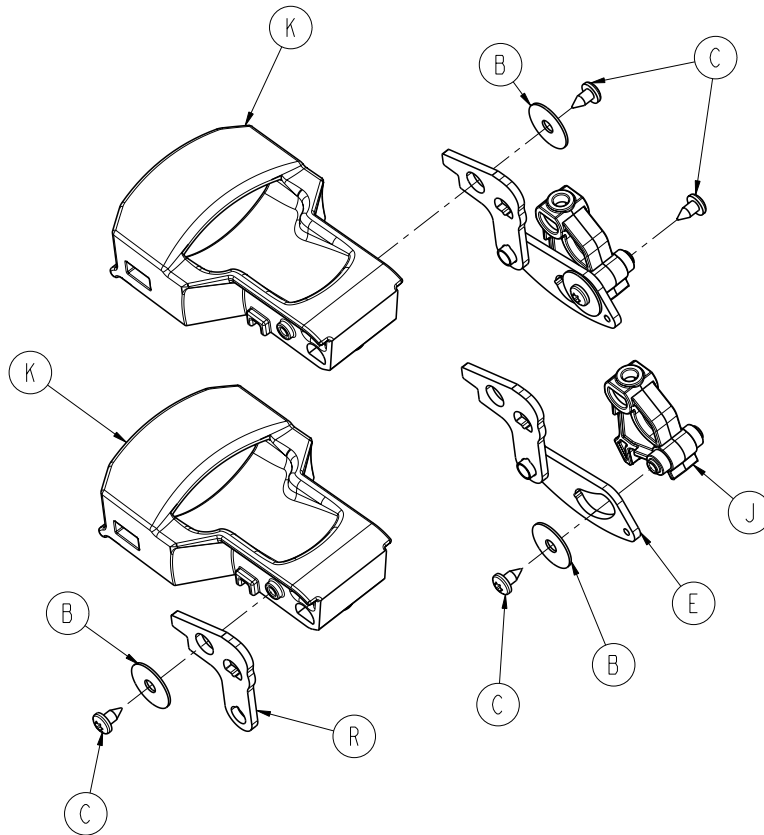

# Trolley Manual Release Assembly

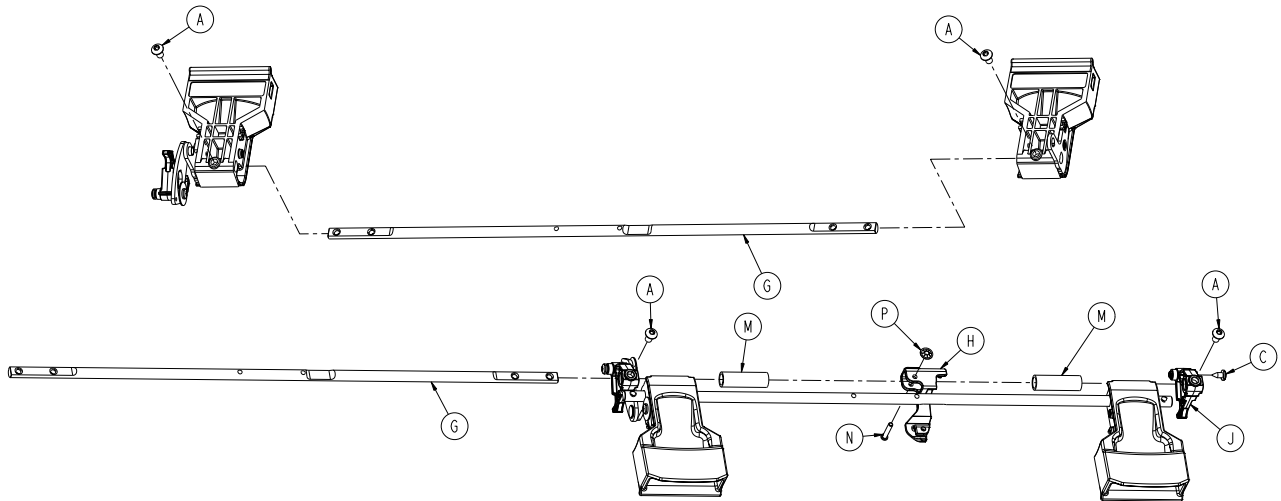

## Trolley Manual Release Assembly - 6390-001-046 Rev C (Reference Only)

Item	Part No.	Part Name	Qty.
A	0004-665-000	Button Head Cap Screw	4
B	0011-518-000	Washer	3
C	0023-163-000	Delta Screw	5
E	6390-001-060	Manual Release Linkage Assy, Left	1
G	6390-001-326	Actuation Rod	2
H	6390-001-328	Manual Cot Release Slider Block	1
J	6390-001-329	Actuation Cam	2
K	6390-001-332	Trolley Release Handle	2
M	6390-001-387	Release Handle Retainer	2
N	6390-001-323	Cot Manual Release Pin	1
P	0028-217-000	Pushnut	1
R	6390-001-382	Trolley Release Handle Link Arm	1

# Trolley Arm Assembly

6390-001-016 Rev C (Reference Only)

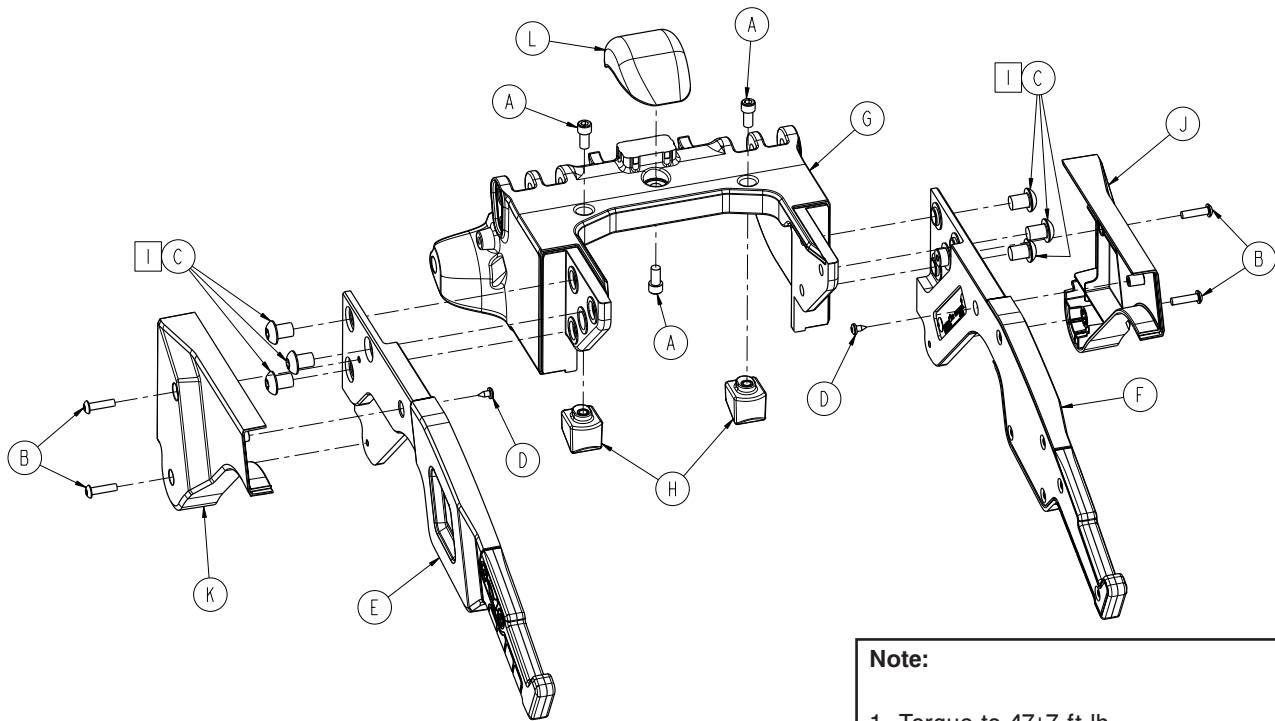

**Note:**  
1 Torque to 47±7 ft-lb

Item	Part No.	Part Name	Qty.
A	0004-660-000	Socket Head Cap Screw	3
B	0004-666-000	Button Head Cap Screw	4
C	0004-668-000	Button Head Cap Screw	6
D	0023-163-000	Delta Screw	2
E	6390-001-036	Arm, Right ( <a href="#">page 174</a> )	1
F	6390-001-037	Arm, Left ( <a href="#">page 173</a> )	1
G	6390-001-305	Middle Arm	1
H	6390-001-322	Mid Position Bumper Lock Block	2
J	6390-001-372	Arm Cover, Head End, Left	1
K	6390-001-371	Arm Cover, Head End, Right	1
L	6390-001-440	Trolley Cot Ramp	1

# Arm, Left

6390-001-037 Rev C (Reference Only)

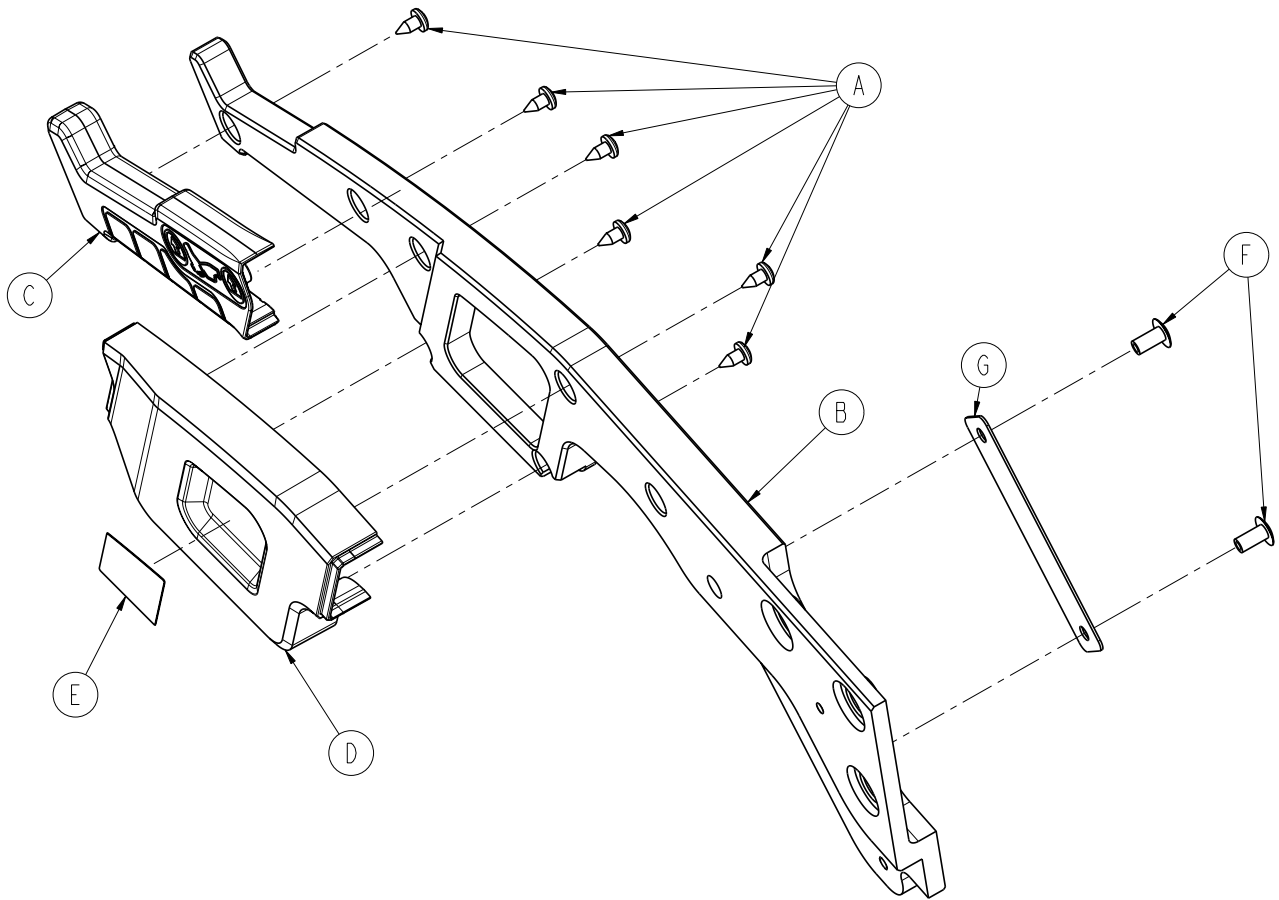

Item	Part No.	Part Name	Qty.
A	0023-163-000	Delta Screw	6
B	6390-001-417	Arm, Left	1
C	6390-001-341	Arm Grip, Left	1
D	6390-001-370	Arm Cover, Foot End, Left	1
E	6390-001-410	Label, Arm, Left	1
F	0025-079-000	Dome Head Rivet	2
G	6060-090-002	Serial Number Tag	1

# Arm, Right

6390-001-036 Rev C (Reference Only)

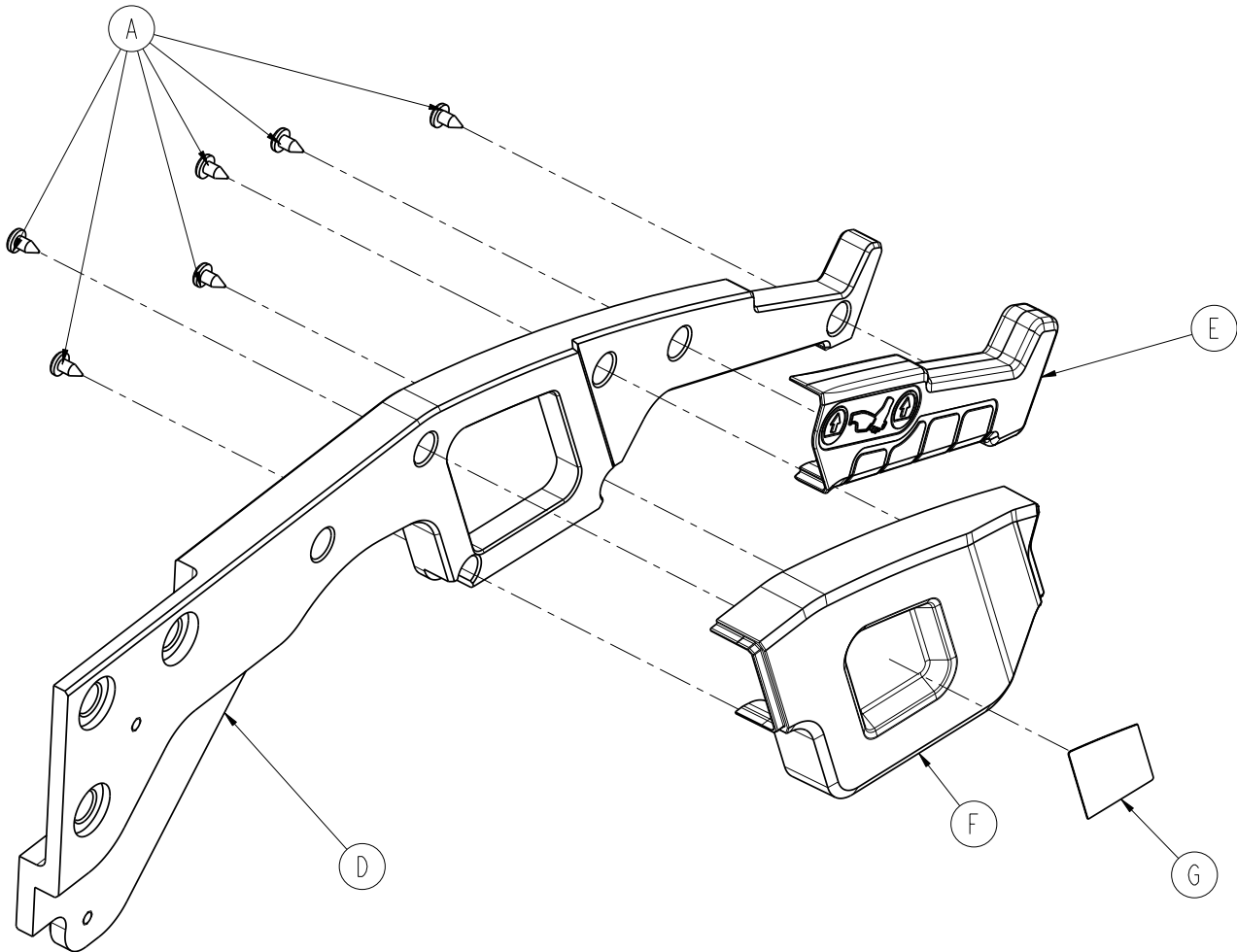

Item	Part No.	Part Name	Qty.
A	0023-163-000	Delta Screw	6
D	6390-001-418	Arm, Right	1
E	6390-001-368	Arm Grip, Right	1
F	6390-001-369	Arm Cover, Foot End, Right	1
G	6390-001-411	Label, Arm, Right	1

# Trolley Actuator Assembly - 6390-001-028

Rev A

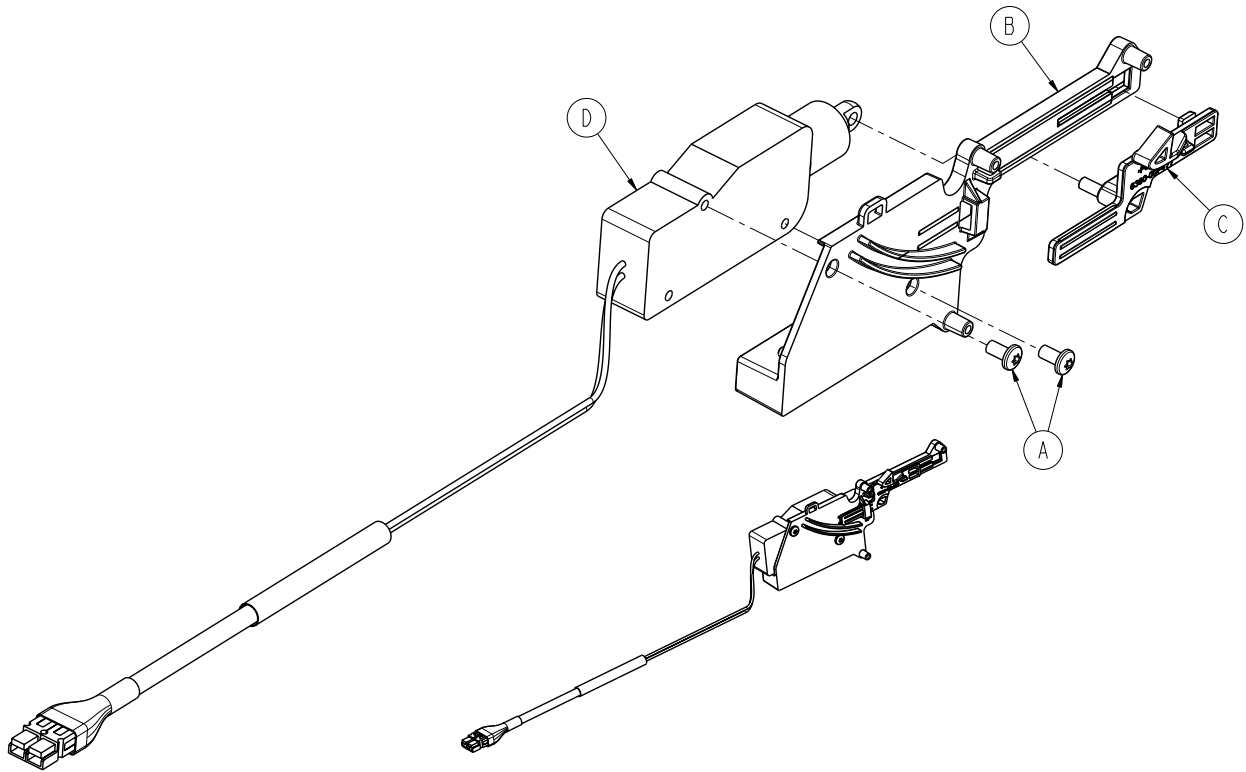

Item	Part No.	Part Name	Qty.
A	0023-296-000	Pan Head Machine Screw	2
B	6390-001-476	Lock Release Actuator Housing	1
C	6390-001-477	Lock Release Actuator Slide	1
D	6390-001-478	Actuator	1

# Optional Wheel Guide

6390-027-000 Rev C (Reference Only)

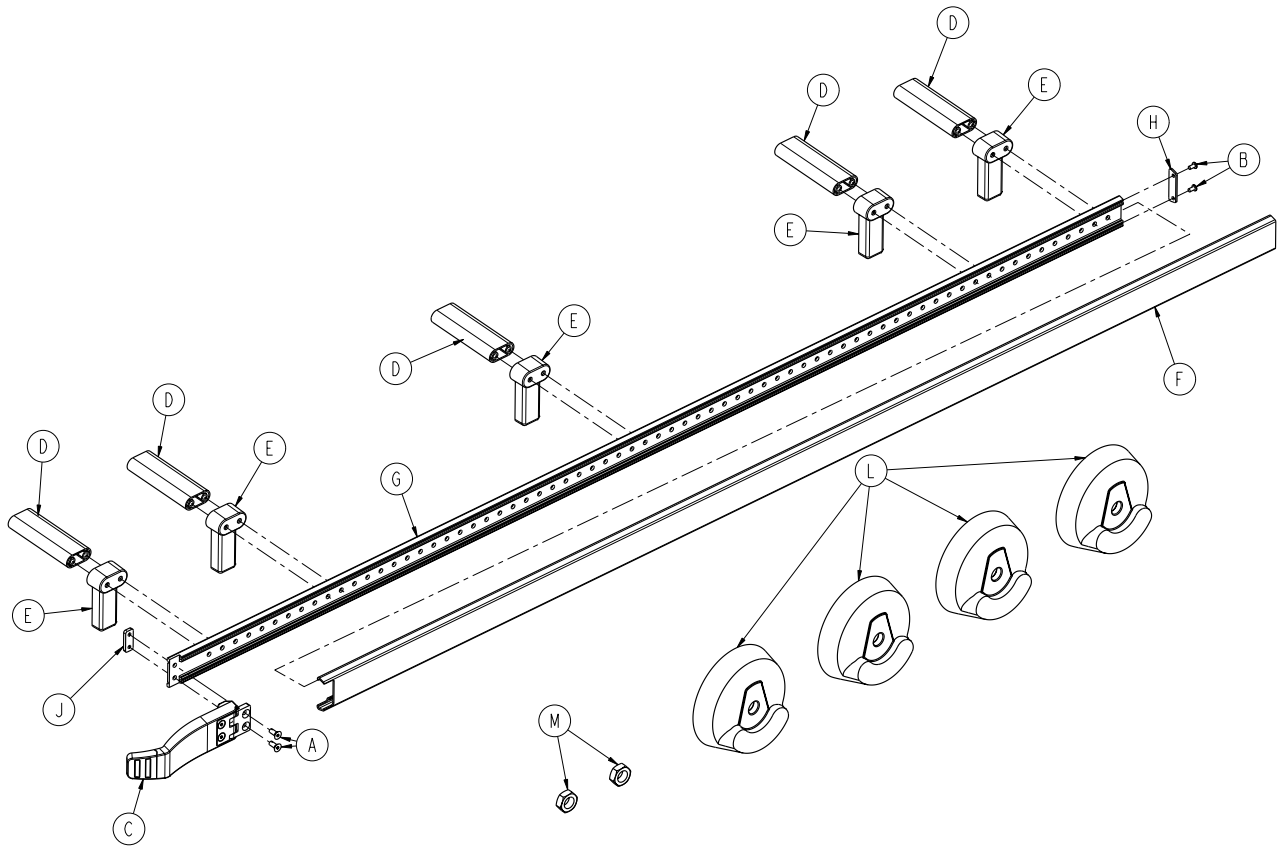

Item	Part No.	Part Name	Qty.
A	0001-195-000	Flat Head Cap Screw	2
B	0023-296-000	Pan Head Machine Screw	2
C	6390-001-017	Wheel Guide Assembly ( <a href="#">page 177</a> )	1
D	6390-001-173	Spacer	5
E	6390-001-174	Wheel Guide Support	5
F	6390-001-175	Wheel Guide Rail Bumper	1
G	6390-001-176	Wheel Guide Rail	1
H	6390-001-178	Wheel Guide Cap	1
J	6390-001-191	Wheel Guide Nut	1
L	6390-001-206	Wheel Cover	4
M	0016-060-000	Toplock Locknut	2



# Optional Wheel Guide Assembly - 6390-001-017

Rev C

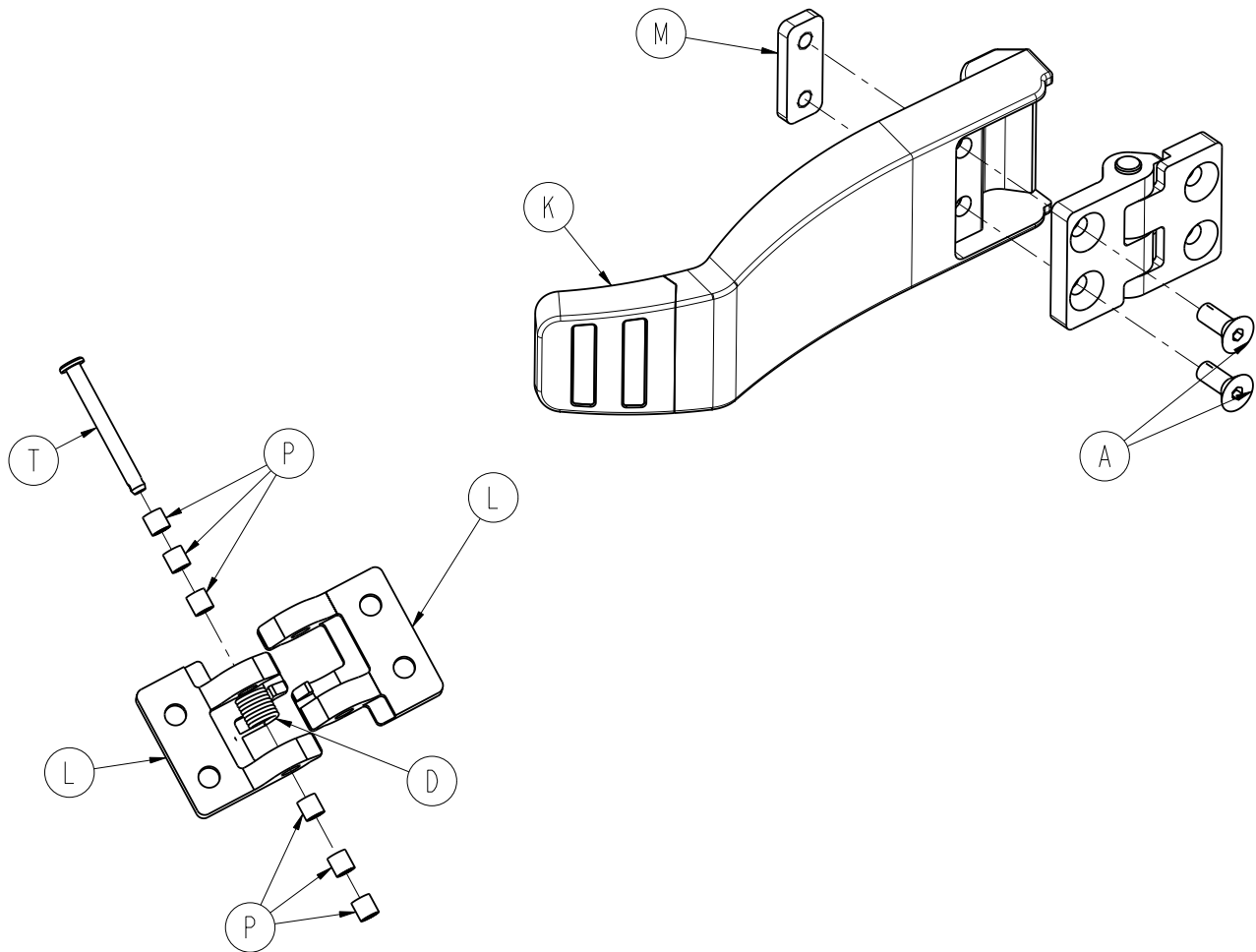

Item	Part No.	Part Name	Qty.
A	0001-195-000	Flat Head Cap Screw	2
D	0038-377-000	Torsion Spring	1
K	6390-001-185	Wheel Guide	1
L	6390-001-188	Wheel Guide Hinge	2
M	6390-001-191	Wheel Guide Nut	1
P	0081-500-000	Bearing	6
T	0026-403-000	Clevis Pin	1

# EMC Information

## POWER-LOAD

<b>Guidance and manufacturer's declaration - electromagnetic emissions</b>		
The Model 6390 Power-LOAD system is intended for use in the electromagnetic environment specified below. The customer or the user of the Model 6390 Power-LOAD system should assure that it is used in such an environment.		
<b>Emissions test</b>	<b>Compliance</b>	<b>Electromagnetic environment - guidance</b>
RF emissions CISPR 11	Group 1	The Model 6390 Power-LOAD system uses RF energy only for its internal function. Therefore, its RF emissions are very low and are not likely to cause any interference in nearby electronic equipment.
RF emissions CISPR 11	Group 2	The Model 6390 Power-LOAD system must emit electromagnetic energy in order to perform its intended function. Nearby electronic equipment may be affected.
RF emissions CISPR 11	Class A	The Model 6390 Power-LOAD system is suitable for use in all establishments other than domestic and those directly connected to the public low-voltage power supply network that supplies buildings used for domestic purposes.

<b>Guidance and manufacturer's declaration - electromagnetic immunity</b>			
The Model 6390 Power-LOAD system is intended for use in the electromagnetic environment specified below. The customer or the user of the Model 6390 Power-LOAD system should assure that it is used in such an environment.			
<b>IMMUNITY test</b>	<b>EN/IEC 60601 test level</b>	<b>Compliance level</b>	<b>Electromagnetic environment - guidance</b>
Electrostatic discharge (ESD) EN/IEC 61000-4-2	$\pm 6$ kV contact $\pm 8$ kV air	$\pm 6$ kV contact $\pm 8$ kV air	Floors should be wood, concrete or ceramic tile. If floors are covered with synthetic material, the relative humidity should be at least 30%.
Power frequency (50/60Hz) magnetic field EN/IEC 61000-4-8	3 A/m	3 A/m	Power frequency magnetic fields should be at levels characteristic of a typical location in a typical commercial or hospital environment.

# EMC Information

## POWER-LOAD (CONTINUED)

<b>Guidance and manufacturer's declaration - electromagnetic immunity</b>			
The Model 6390 Power-LOAD system is intended for use in the electromagnetic environment specified below. The customer or the user of the Model 6390 Power-LOAD system should assure that it is used in such an environment.			
IMMUNITY test	EN/IEC 60601 test level	Compliance level	Electromagnetic environment - guidance
<p>Conducted RF EN/IEC 61000-4-6</p> <p>Radiated RF EN/IEC 61000-4-3</p>	<p>3 Vrms 150 kHz to 80 MHz</p> <p>20 V/m 80 MHz to 2,5 GHz</p>	<p>3 Vrms</p> <p>20 V/m</p>	<p>Portable and mobile RF communications equipment should be used no closer to any part of the Model 6390 Power-LOAD system, including cables, than the recommended separation distance calculated from the equation applicable to the frequency of the transmitter.</p> <p><b>Recommended separation distance</b></p> <p><math>D=(1.2)(\sqrt{P})</math></p> <p><math>D=(0.18)(\sqrt{P})</math> 80 MHz to 800 MHz</p> <p><math>D=(0.35)(\sqrt{P})</math> 800 MHz to 2,5 GHz</p> <p>where <math>P</math> is the maximum output power rating of the transmitter in watts (W) according to the transmitter manufacturer and <math>d</math> is the recommended separation distance in meters (m).</p> <p>Field strengths from fixed RF transmitters, as determined by an electromagnetic site survey,<sup>a</sup> should be less than the compliance level in each frequency range.<sup>b</sup></p> <p>Interference may occur in the vicinity of equipment with the following symbol:</p> <div style="text-align: center;">  </div>
NOTE 1: At 80 MHz and 800 MHz, the higher frequency range applies.			
NOTE 2: These guidelines may not apply in all situations. Electromagnetic propagation is affected by absorption and reflection from structures, objects and people.			
<p><sup>a</sup> Field strengths from fixed transmitters, such as base stations for radio (cellular/cordless) telephones and land mobile radios, amateur radio, AM and FM radio broadcast, and TV broadcast cannot be predicted theoretically with accuracy. To assess the electromagnetic environment due to fixed RF transmitters, an electromagnetic site survey should be considered. If the measured field strength in the location in which the Model 6390 Power-LOAD system is used exceeds the applicable RF compliance level above, the Model 6390 Power-LOAD system should be observed to verify normal operation. If abnormal performance is observed, additional measures may be necessary, such as re-orienting or relocating the Model 6390 Power-LOAD system.</p> <p><sup>b</sup> Over the frequency range 150 kHz to 80 MHz, field strengths should be less than 20 V/m.</p>			

[Return To Table of Contents](#)

# EMC Information

## POWER-LOAD (CONTINUED)

<b>Recommended separations distances between portable and mobile RF communication equipment and the Model 6390 Power-LOAD system</b>			
The Model 6390 Power-LOAD system is intended for use in an electromagnetic environment in which radiated RF disturbances are controlled. The customer or the user of the Model 6390 Power-LOAD system can help prevent electromagnetic interference by maintaining a minimum distance between portable and mobile RF communications equipment (transmitters) and the Model 6390 Power-LOAD system as recommended below, according to the maximum output power of the communications equipment.			
Rated maximum output power of transmitter W	Separation distance according to frequency of transmitter m		
	150 kHz to 80 MHz $D=(1.2)(\sqrt{P})$	80 MHz to 800 MHz $D=(0.18)(\sqrt{P})$	800 MHz to 2,5 GHz $D=(0.35)(\sqrt{P})$
0.01	0.12	0.018	0.035
0.1	0.38	0.57	0.11
1	1.2	0.18	0.35
10	3.8	0.57	1.1
100	12	1.8	3.5
For transmitters rated at a maximum output power not listed above, the recommended separation distance $d$ in meters (m) can be estimated using the equation applicable to the frequency of the transmitter, where $P$ is the maximum output power rating of the transmitter in watts (W) according to the transmitter manufacturer.			
NOTE 1: At 80 MHz and 800 MHz, the separation distance for the higher frequency range applies.			
NOTE 2: These guidelines may not apply in all situations. Electromagnetic propagation is affected by absorption and reflection from structures, objects and people.			

# Warranty

---

Stryker EMS, a division of the Stryker Corporation, offers two distinct warranty options in the United States:

One (1) year parts and labor. Under this option, Stryker EMS warrants to the original purchaser that its products should be free from manufacturing non-conformances that affect product performance and customer satisfaction for a period of one (1) year after date of delivery. Stryker's obligation under this warranty is expressly limited to supplying replacement parts and labor for, or replacing, at its option, any product that is, in the sole discretion of Stryker, found to be defective.

Two (2) year parts. Under this option, Stryker EMS warrants to the original purchaser that non-expendable components of its products should be free from manufacturing non-conformances that affect product performance and customer satisfaction for a period of two (2) years after date of delivery. Stryker's obligation under this warranty is expressly limited to supplying replacement parts for, or replacing, at its option, any product which is, in the sole discretion of Stryker, found to be defective. Expendable components, i.e. mattresses, restraints, I.V. poles, storage nets, storage pouches, oxygen straps, batteries, and other soft goods, have a one (1) year limited warranty with this option.

Under either warranty option, Power-LOAD is designed for a 7 year expected service life under normal use, conditions, and with appropriate periodic maintenance as described in the maintenance manual for the device. Stryker warrants to the original purchaser that the welds on Power-LOAD will be free from structural defects for the expected 7 year life of Power-LOAD as long as the original purchaser owns the product.

If Stryker requests products or parts for which an original purchaser makes a warranty claim, the purchaser shall return the product or part prepaid freight to Stryker's factory.

Any improper use or alteration or repair by unauthorized service providers in such a manner as in Stryker's judgement affects the product materially and adversely, shall void this warranty. Any repair of Stryker products using parts not provided or authorized by Stryker shall void this warranty. No employee or representative of Stryker is authorized to change this warranty in any way.

This statement constitutes Stryker EMS's entire warranty with respect to the aforesaid equipment. STRYKER MAKES NO OTHER WARRANTY OR REPRESENTATION EITHER EXPRESSED OR IMPLIED, EXCEPT AS SET FORTH HEREIN. THERE IS NO WARRANTY OF MERCHANTABILITY AND THERE ARE NO WARRANTIES OF FITNESS FOR ANY PARTICULAR PURPOSE. IN NO EVENT SHALL STRYKER BE LIABLE HEREUNDER FOR INCIDENTAL OR CONSEQUENTIAL DAMAGES ARISING FROM OR IN ANY MANNER RELATED TO SALES OR USE OF ANY SUCH EQUIPMENT.

# Warranty

---

## **STRYKER EMS RETURN POLICY**

Cots, Stair Chairs, Evacuation Chairs, Power-LOAD and Aftermarket Accessories may be returned up to 180 days of receipt if they meet the following guidelines:

### **Prior to 30 Days**

- 30 day money back guarantee in effect
- Stryker EMS is responsible for all charges
- Returns will not be approved on modified items

### **Prior to 90 Days**

- Product must be **unused, undamaged** and in the original packaging
- Customer is responsible for a 10% restocking fee

### **Prior to 180 Days**

- Product must be **unused, undamaged** and in the original packaging
- Customer is responsible for a 25% restocking fee

## **RETURN AUTHORIZATION**

Merchandise cannot be returned without approval from the Stryker Customer Service Department. An authorization number will be provided which must be printed on the returned merchandise. Stryker reserves the right to charge shipping and restocking fees on returned items.

**SPECIAL, MODIFIED, OR DISCONTINUED ITEMS NOT SUBJECT TO RETURN.**

## **DAMAGED MERCHANDISE**

ICC Regulations require that claims for damaged merchandise must be made with the carrier within fifteen (15) days of receipt of merchandise. **DO NOT ACCEPT DAMAGED SHIPMENTS UNLESS SUCH DAMAGE IS NOTED ON THE DELIVERY RECEIPT AT THE TIME OF RECEIPT.** Upon prompt notification, Stryker will file a freight claim with the appropriate carrier for damages incurred. Claim will be limited in amount to the actual replacement cost. In the event that this information is not received by Stryker within the fifteen (15) day period following the delivery of the merchandise, or the damage was not noted on the delivery receipt at the time of receipt, the customer will be responsible for payment of the original invoice in full.

Claims for any short shipment must be made within thirty (30) days of invoice.

## **INTERNATIONAL WARRANTY CLAUSE**

This warranty reflects U.S. domestic policy. Warranty outside the U.S. may vary by country. Please contact your local Stryker Medical representative for additional information.

## **PATENT INFORMATION**

Power-LOAD is covered by one or more of the following patents:

United States 7,478,855 7,520,551 7,540,547

Other Patents Pending

# Recycling Passport

Assembly Part Number: 6390-001-023 (Reference Only)

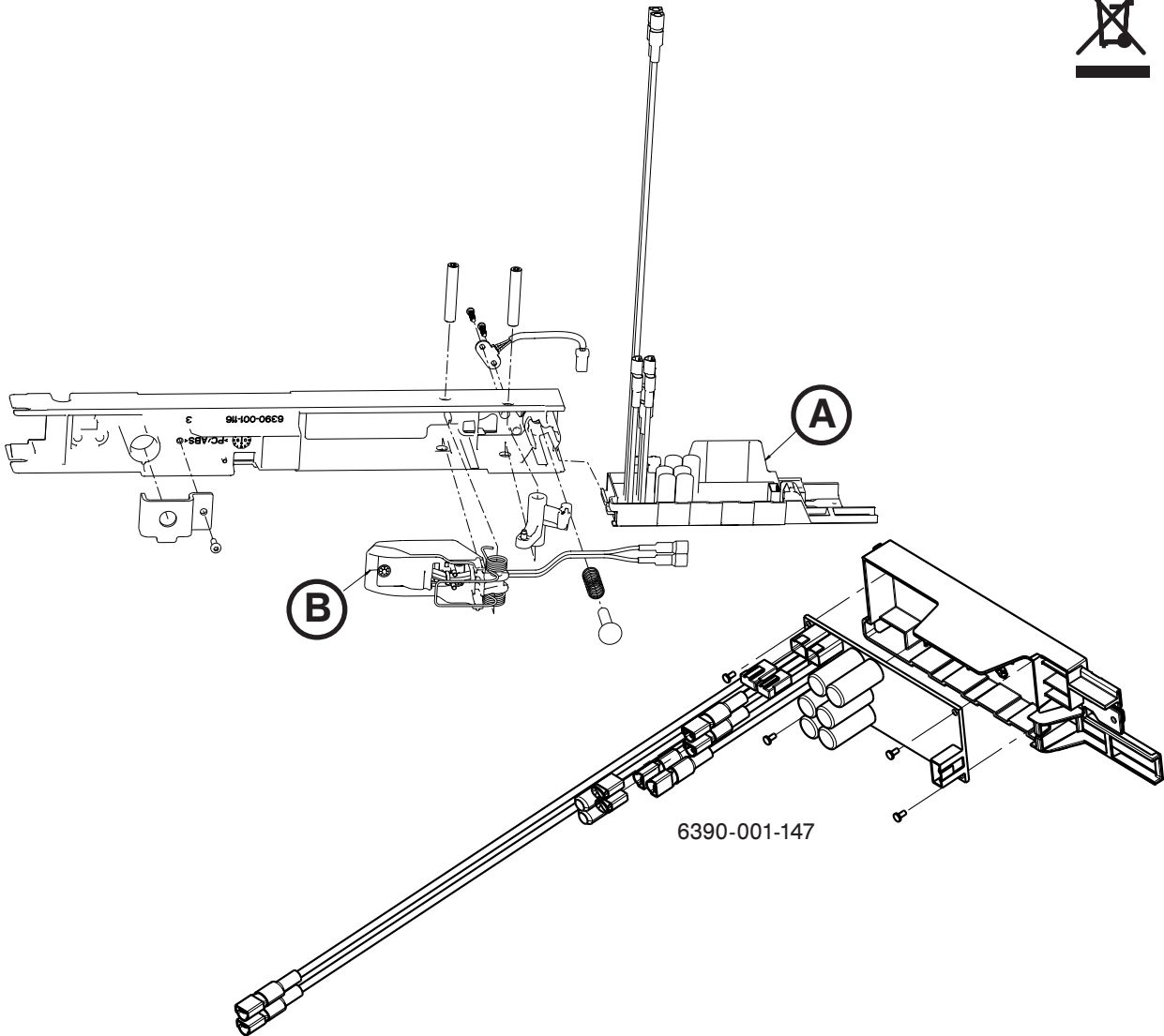

Item	Recycling/Material Code	Important Information	Qty
A	6390-001-147 (Inductive Primary Board)		1
B	6390-001-030 (Anchor Coil Assembly, Middle)		1

# Recycling Passport

Assembly Part Number: 6390-001-024 (Reference Only)

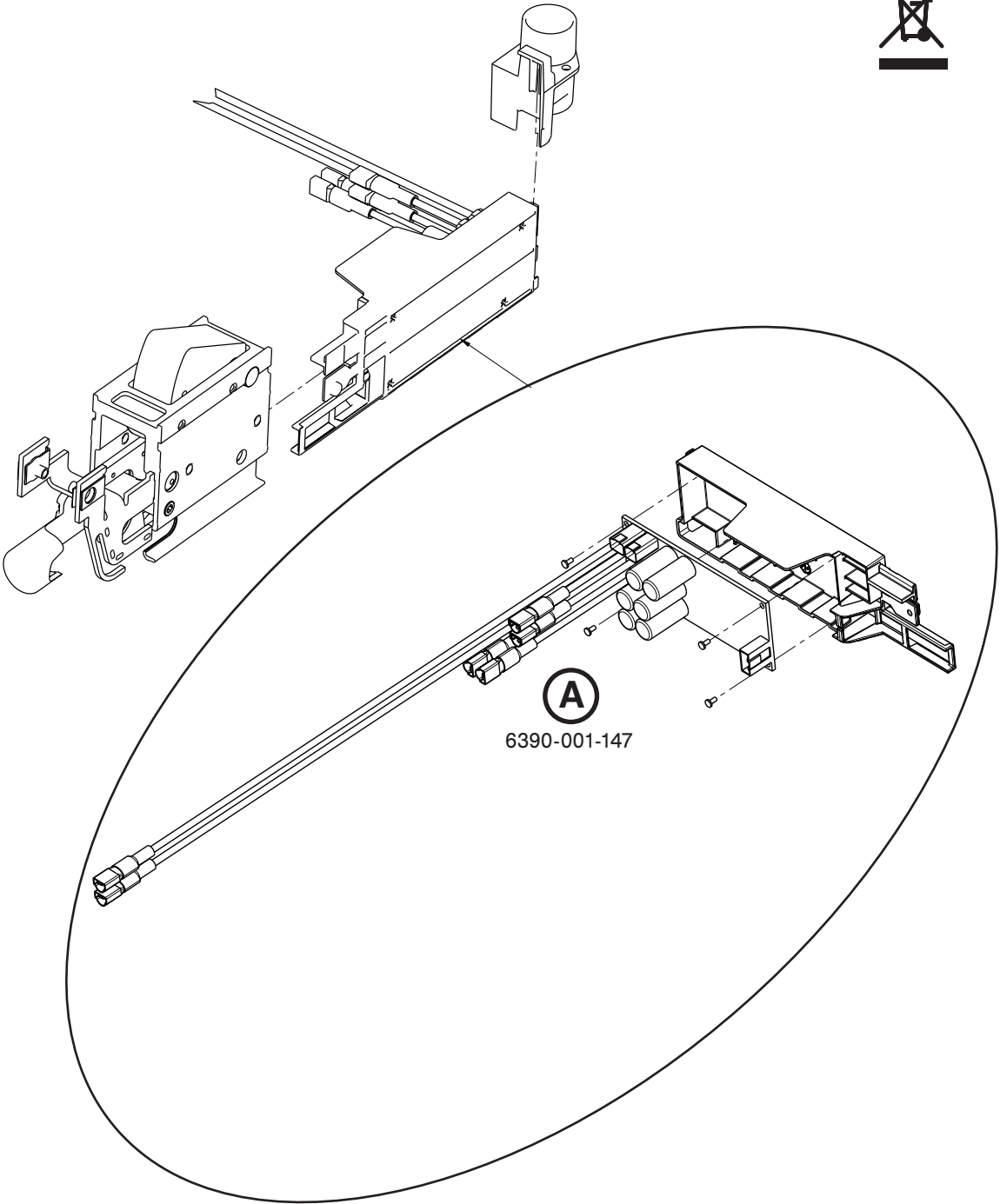

Item	Recycling/Material Code	Important Information	Qty
A	6390-001-147 (Inductive Primary Board)		1



# Recycling Passport

Assembly Part Number: 6390-001-066 (Reference Only)

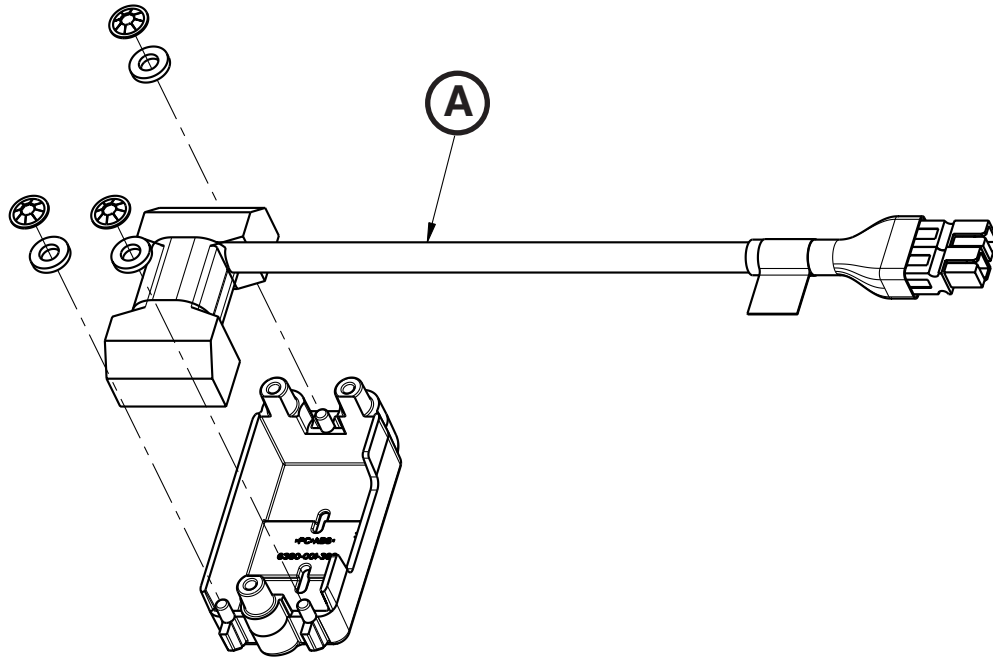

Item	Recycling/Material Code	Important Information	Qty
A	6390-001-337 (Trolley Secondary Coil)		1

# Recycling Passport

Assembly Part Number: 6390-001-013 (Reference Only)

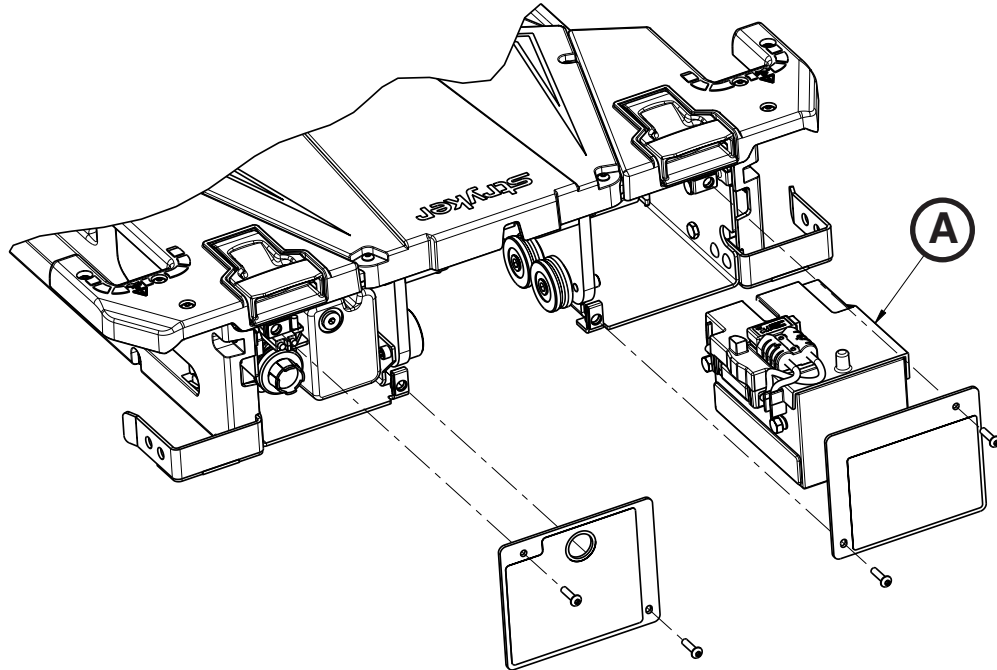

Item	Recycling/Material Code	Important Information	Qty
A	6390-001-026 (12V, 5 Ah Lead Acid Battery)		1



The Rechargeable Battery Recycling Corporation (RBRC) is a non-profit, public service organization that promotes the recycling of portable rechargeable batteries. Batteries must be delivered to a battery collection site. Visit the RBRC website ([www.rbcc.org](http://www.rbcc.org)) to find a nearby collection site or call the phone number shown on the recycling symbol.

# Recycling Passport

Assembly Part Number: 6390-001-015 (Reference Only)

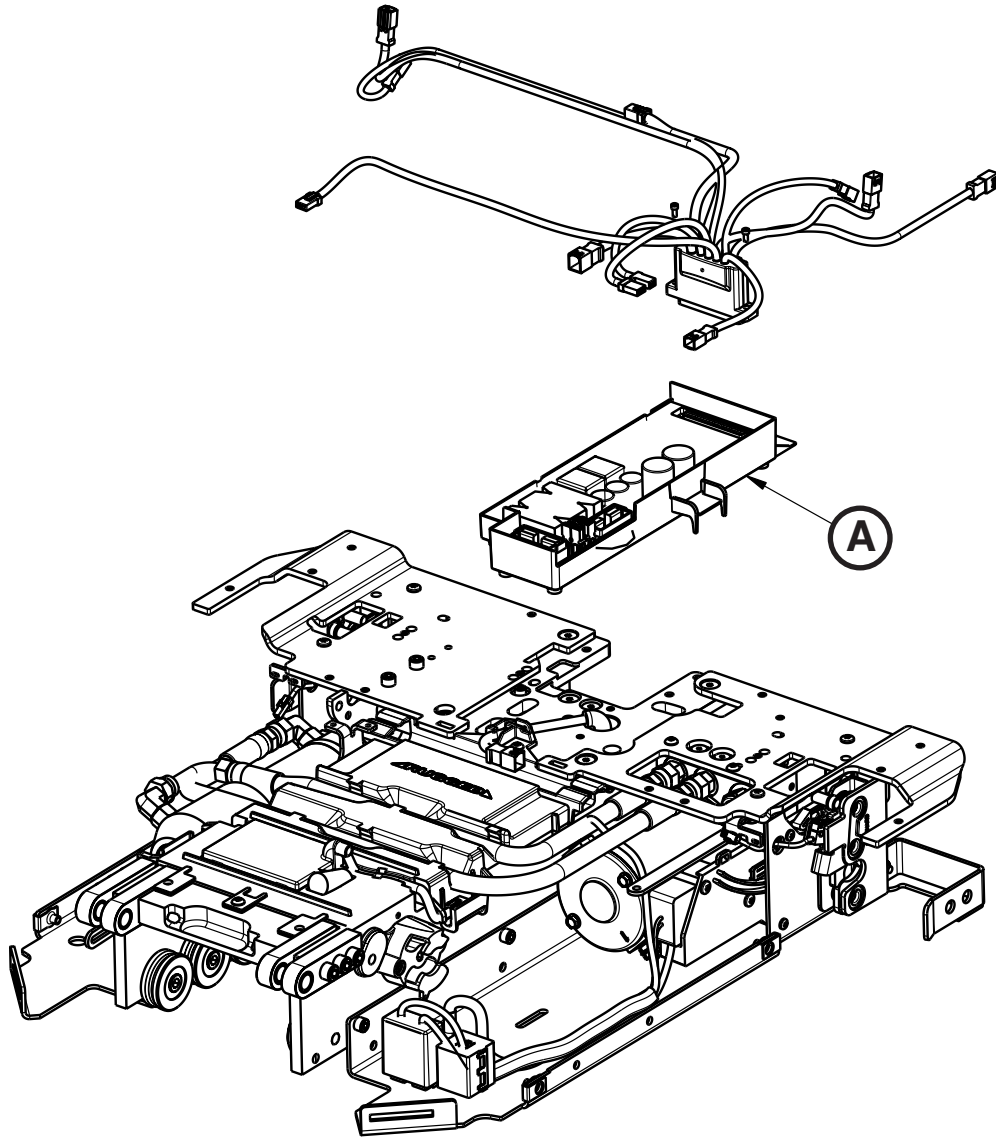

Item	Recycling/Material Code	Important Information	Qty
A	6390-001-014 (Control Board Assembly)		1

# Recycling Passport

Assembly Part Number: 6390-001-015 (Reference Only)

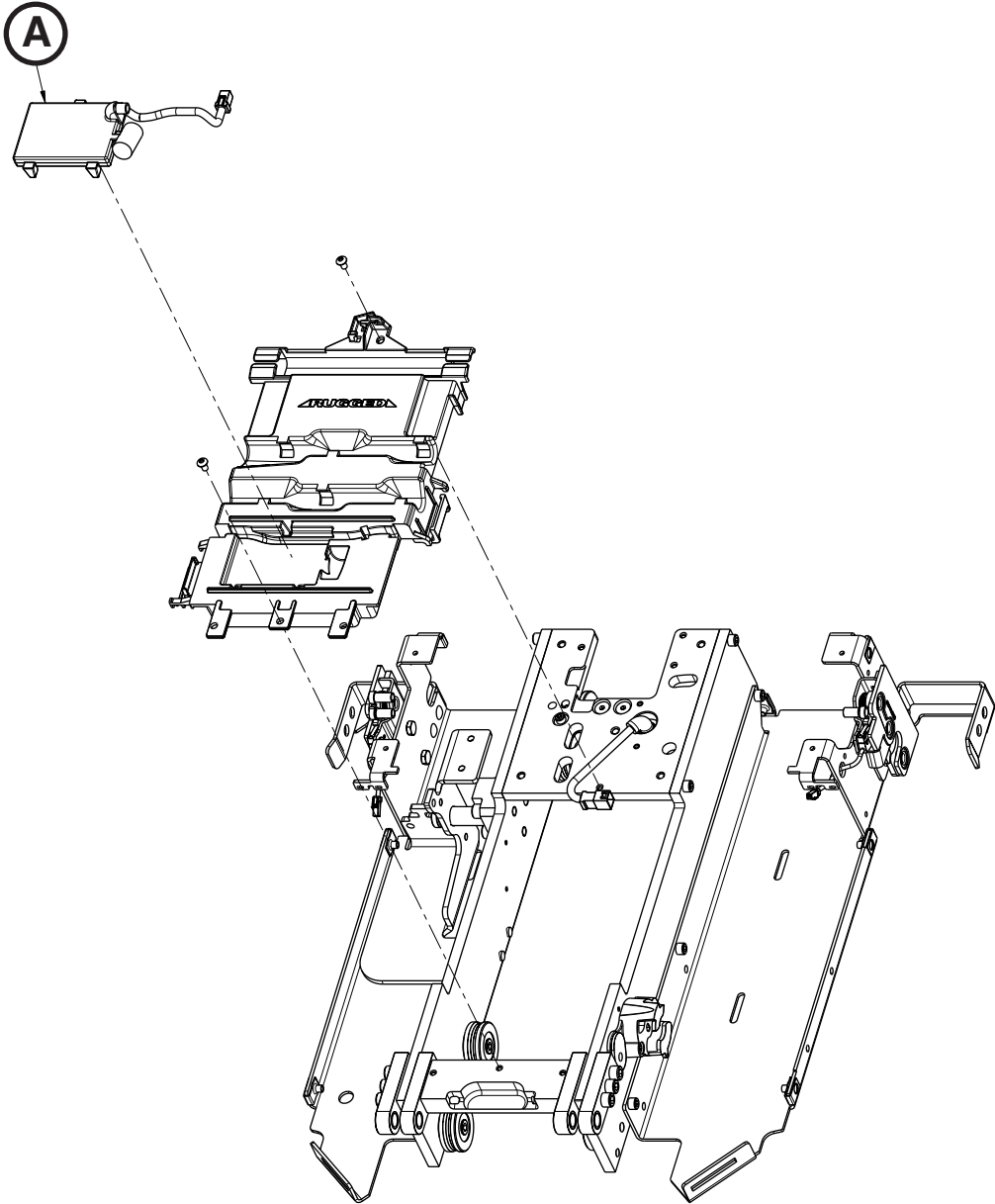

Item	Recycling/Material Code	Important Information	Qty
A	6390-001-378 (Trolley Comm Board)		1

# Recycling Passport

Assembly Part Number: 6390-001-043 (Reference Only)

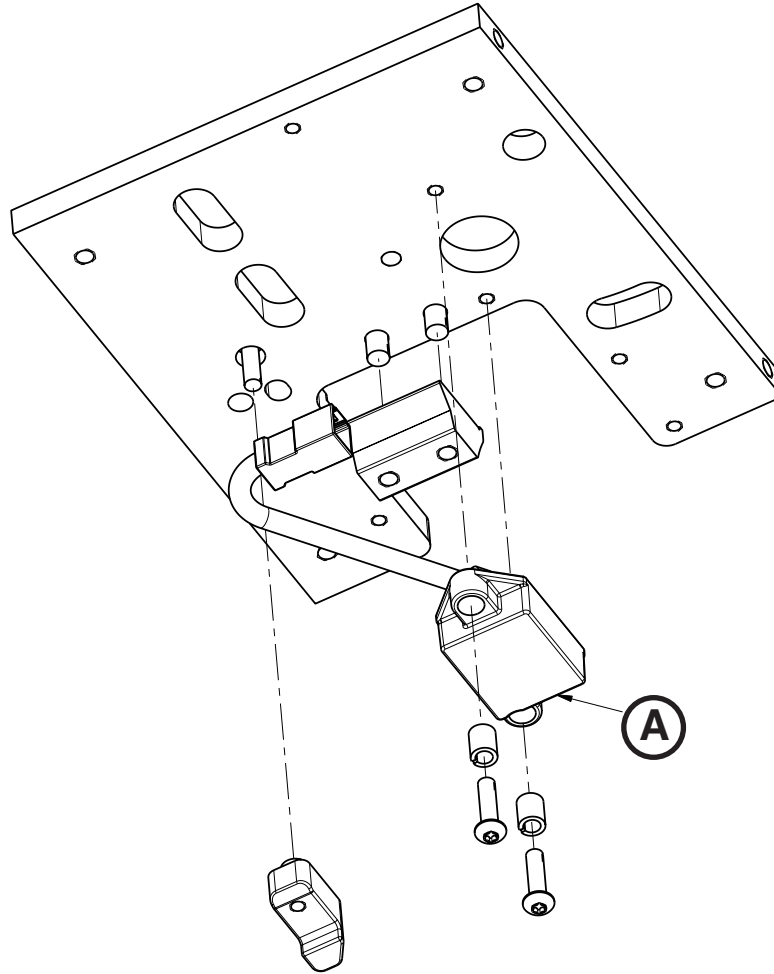

Item	Recycling/Material Code	Important Information	Qty
A	6390-001-361 (TPS Sensor Assembly)		1

# Recycling Passport

Assembly Part Number: 6390-001-035 (Reference Only)

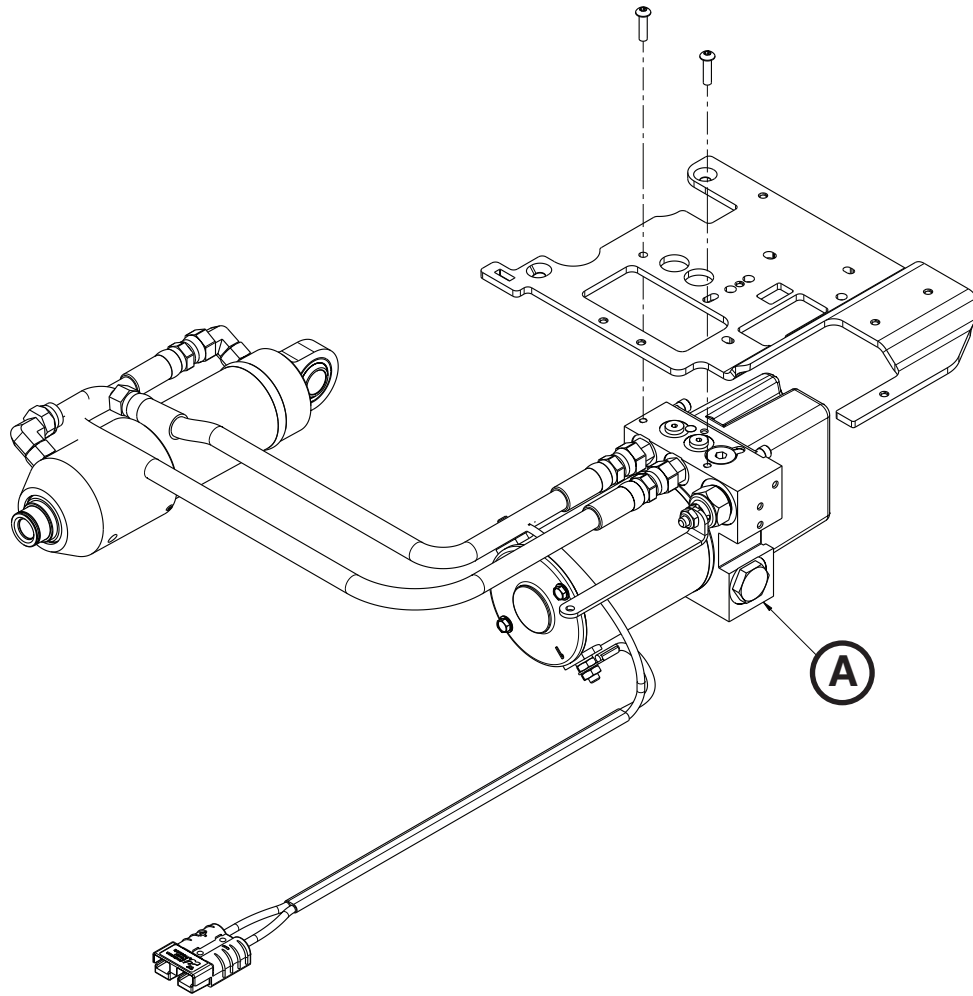

Item	Recycling/Material Code	Important Information	Qty
A	6390-001-039 (Hydraulics Assembly)		1

# Recycling Passport

Assembly Part Number: 6390-001-015 (Reference Only)

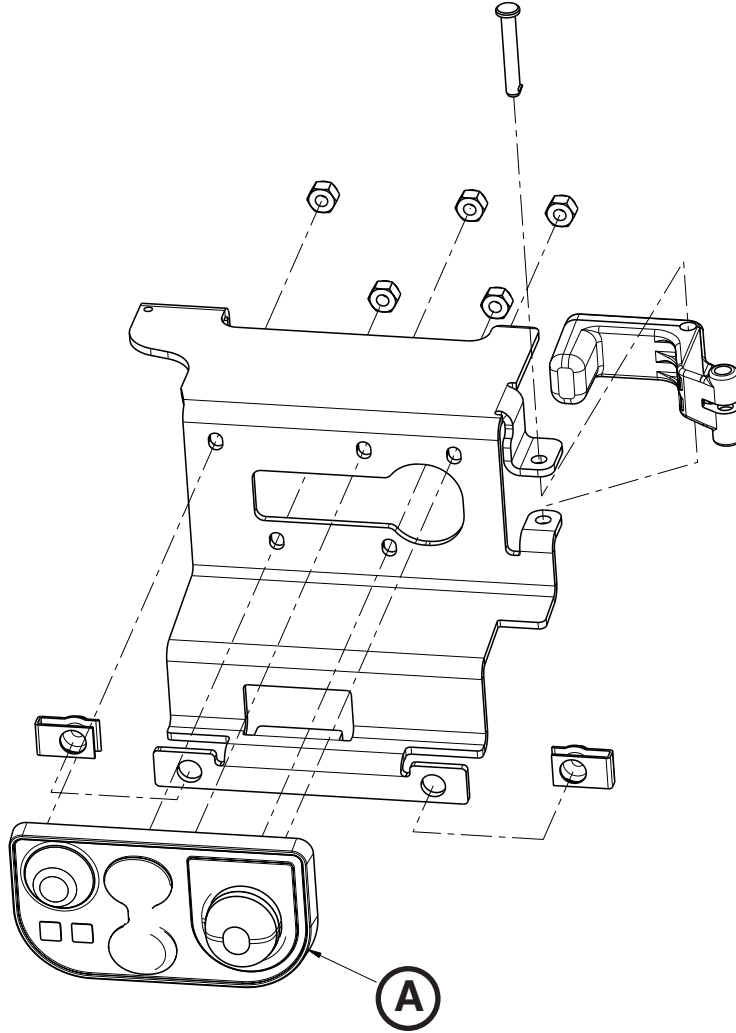

Item	Recycling/Material Code	Important Information	Qty
A	6390-001-450 (Master On/Off Switch)		1







Stryker Medical  
3800 E. Centre Ave.  
Portage, Michigan 49002  
USA



Stryker EMEA RA/QA Director  
ZAC – Avenue de Satolas Green  
69881 MEYZIEU Cedex  
France



**stryker**<sup>®</sup>