

## Performance-LOAD® Cot Fastener System



















Maintenance Manual





REF 6392





# Symbols

	Refer to instruction manual/booklet
	Consult instructions for use
	General warning
	Caution
	Two person lift
	Catalogue number
	Serial number
	For US Patents see <a href="http://www.stryker.com/patents">www.stryker.com/patents</a>
	Authorized representative in the European Community
	European medical device
	Manufacturer
	Date of manufacture
	CE mark
	Class II electrical equipment: equipment in which protection against electric shock does not rely on basic insulation only, but in which additional safety precautions such as double insulation or reinforced insulation are provided, there being no provision for protective earthing or reliance upon installation conditions.
	Direct current
	Medical Equipment Recognized by Underwriters Laboratories LLC With Respect to Electric Shock, Fire, and Mechanical Hazards only in accordance with ANSI/AAMI ES60601-1: 2005 and CAN/CSA-C22.2 No. 60601-1:08.
<b>IP26</b>	Protection from objects greater than 12.5 mm and powerful water jets
	Medical Equipment Classified by Underwriters Laboratories Inc. With Respect to Electric Shock, Fire, and Mechanical Hazards Only in Accordance with ANSI/AAMI ES60601-1: 2005 and CAN/CSA-C22.2 No. 60601-1:08.
	In accordance with European Directive 2012/19/EU on Waste Electrical and Electronic Equipment (WEEE) as amended, this symbol indicates that the product should be collected separately for recycling. Do not dispose of as unsorted municipal waste. Contact local distributor for disposal information. Ensure infected equipment is decontaminated prior to recycling.

	This way up
	Fragile, handle with care
	Keep dry
	Stacking limit by number

# Table of Contents

Warning/Caution/Note Definition .....	2
Summary of safety precautions .....	2
Introduction .....	3
Product description .....	3
Indications for use .....	3
Expected service life .....	3
Disposal/recycle .....	3
Contraindications .....	4
Specifications .....	4
Standards with required options .....	5
Product illustration .....	5
Contact information .....	6
Serial number location .....	6
Date of manufacture .....	6
Preventive maintenance .....	7
Maintenance record .....	7
Training record .....	8
Troubleshooting .....	9
Inductive charging system does not charge the cot battery .....	9
Service .....	10
Head end interface assembly replacement .....	10
Foot end interface assembly replacement .....	10
Inductive primary board replacement (optional) .....	11
Head end plunger replacement .....	12
Foot end lock pawl replacement .....	13
Safety bar rail support replacement .....	13
Foot end cover assembly replacement .....	14
Performance-LOAD assembly .....	16
Center cover assembly .....	19
Floor plate bolt assembly .....	20
Install kit assembly .....	21
Inductive charging option .....	22
Foot end cover assembly .....	23
Foot end interface assembly .....	24
Foot end nose assembly .....	25
Head end cover assembly .....	27
Head end interface assembly .....	28
Inductive charging assembly .....	29
Head end hitch assembly .....	30
Head end forging assembly .....	31
EMC information .....	32

# Warning/Caution/Note Definition

The words **WARNING**, **CAUTION**, and **NOTE** carry special meanings and should be carefully reviewed.

## **WARNING**

Alerts the reader about a situation which, if not avoided, could result in death or serious injury. It may also describe potential serious adverse reactions and safety hazards.

## **CAUTION**

Alerts the reader of a potentially hazardous situation which, if not avoided, may result in minor or moderate injury to the user or patient or damage to the product or other property. This includes special care necessary for the safe and effective use of the device and the care necessary to avoid damage to a device that may occur as a result of use or misuse.

**Note** - Provides special information to make maintenance easier or important instructions clearer.

## Summary of safety precautions

Always read and strictly follow the warnings and cautions listed on this page. Service only by qualified personnel.

---

### **CAUTION**

- Improper usage of the product can cause injury to the patient or operator. Operate the product only as described in this manual.
  - Do not modify the product or any components of the product. Modifying the product can cause unpredictable operation resulting in injury to patient or operator. Modifying the product also voids its warranty.
  - The use of accessories and cables, other than those specified, with the exception of cables that are sold by Stryker as replacement parts for internal components, may result in increased emissions or decreased immunity of the **Performance-LOAD** system.
  - Do not use the **Performance-LOAD** system and the **Power-PRO** cot adjacent to or stacked with other equipment. If adjacent or stacked use is necessary, observe the **Performance-LOAD** system to confirm normal operation in the configuration where it will be used.
  - Do not use portable RF communications equipment (including peripherals such as antenna cables and external antennas) no closer than 30 cm (12 in.) to any part of the **Performance-LOAD** system, including cables specified by the manufacturer. Otherwise, degradation of the performance of this equipment could result.
  - The emissions characteristics of this equipment make it suitable for use in industrial areas and hospitals (CISPR 11 class A). This equipment generates, uses, and can radiate radio frequency energy and, if not installed and used in accordance with the instruction manual, may cause harmful interference to radio communications. Operation of this equipment in a residential area (for which CISPR 11 class B is normally required) is likely to cause harmful interference in which case the user will be required to correct the interference at their expense. In the event of interference, please relocate or reorient the **Performance-LOAD** system or interfering product.
-

# Introduction

This manual assists you with the operation or maintenance of your Stryker product. Read this manual before operating or maintaining this product. Set methods and procedures to educate and train your staff on the safe operation or maintenance of this product.

---

## CAUTION

- Improper usage of the product can cause injury to the patient or operator. Operate the product only as described in this manual.
  - Do not modify the product or any components of the product. Modifying the product can cause unpredictable operation resulting in injury to patient or operator. Modifying the product also voids its warranty.
- 

## Note

- This manual is a permanent part of the product and should remain with the product even if the product is sold.
- Stryker continually seeks advancements in product design and quality. This manual contains the most current product information available at the time of printing. There may be minor discrepancies between your product and this manual. If you have any questions, contact Stryker Customer Service or Technical Support at 1-800-327-0770.

## Product description

**Performance-LOAD** is a manual cot fastener designed to secure compatible ambulance cots into a ground-based transport vehicle for patient transportation purposes and to allow for the insertion and removal of the compatible ambulance cots.

When the compatible cot is secured in the transport position, **Performance-LOAD** can inductively charge compatible model ambulance cots with an inductive charging option. In the event of loss of charging, **Performance-LOAD** remains functional for guiding into, securing within, and removing the cot from the vehicle.

## Indications for use

**Performance-LOAD** is intended to guide the loading and unloading of a compatible ambulance cot (wheeled stretcher) to and from a ground-based transport vehicle and to secure the ambulance cot during transport in a fastened position while also providing an optional inductive charging platform for charge-compatible ambulance cots.

## Expected service life

The **Performance-LOAD** cot fastener has a seven year expected service life under normal use conditions and with appropriate periodic maintenance.

## Disposal/recycle

Always follow the current local recommendations and/or regulations governing environmental protection and the risks associated with recycling or disposing of the equipment at the end of its useful life.

## Contraindications

None known.

## Specifications

Length	70 in.	178 cm
Width	19 in.	48 cm
Height	6 in.	15 cm
Floor plate assembly weight	16.5 lb	7.5 kg
Fastener assembly weight	46 lb	21 kg
Minimum operators required for loading/unloading an occupied cot	2	
Minimum operators required for loading/unloading an unoccupied cot	1	
Recommended loading height	22 in. to 36 in.	56 cm to 91 cm
Electrical requirements - inductive charging (optional)	12.8 VDC-15.6 VDC, 15A fuse/breaker, 2 conductor 10 AWG cable	
Standards	KKK-A-1822F With inductive charging: IEC 60601-1 Edition 3.0, IEC 60601-1 Edition 3.1, IEC 60601-1-2 Edition 3.0, IEC 60601-1-2 Edition 4.0, IEC 60601-1-12 Edition 1.0, ANSI/AAMI ES60601-1: 2005/(R)2012, CSA-C22.2 No. 60601-1 (2014) For standards that require specific options, see <i>Standards with required options</i> (page 5).	

Stryker reserves the right to change specifications without notice. Patents pending.

The yellow and black color scheme is a proprietary trademark of Stryker Corporation.

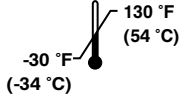
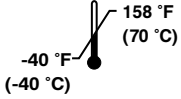
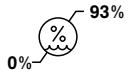
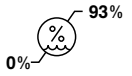
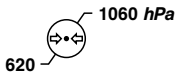
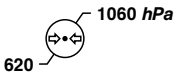
Environmental conditions	Operation	Storage and transportation
Temperature		
Relative humidity		
Atmospheric pressure		

### CAUTION

- The use of accessories and cables, other than those specified, with the exception of cables that are sold by Stryker as replacement parts for internal components, may result in increased emissions or decreased immunity of the **Performance-LOAD** system.
- Do not use the **Performance-LOAD** system and the **Power-PRO** cot adjacent to or stacked with other equipment. If adjacent or stacked use is necessary, observe the **Performance-LOAD** system to confirm normal operation in the configuration where it will be used.



- Do not use portable RF communications equipment (including peripherals such as antenna cables and external antennas) no closer than 30 cm (12 in.) to any part of the **Performance-LOAD** system, including cables specified by the manufacturer. Otherwise, degradation of the performance of this equipment could result.
- The emissions characteristics of this equipment make it suitable for use in industrial areas and hospitals (CISPR 11 class A). This equipment generates, uses, and can radiate radio frequency energy and, if not installed and used in accordance with the instruction manual, may cause harmful interference to radio communications. Operation of this equipment in a residential area (for which CISPR 11 class B is normally required) is likely to cause harmful interference in which case the user will be required to correct the interference at their expense. In the event of interference, please relocate or reorient the **Performance-LOAD** system or interfering product.

## Standards with required options

To be compliant with the standards, you must use **Performance-LOAD** with the following compatible cots. See the Operations Manual for your cot model for more information.

**Note** - Compatible cot is loaded into **Performance-LOAD** in powered mode for crash testing.

Standard	Performance-LOAD compatible cot models
SAE J3027	6506, 6086
BS EN 1789:2007 +A2:2014 and AS/NZS-4535:1999 applicable clauses	6506

## Product illustration

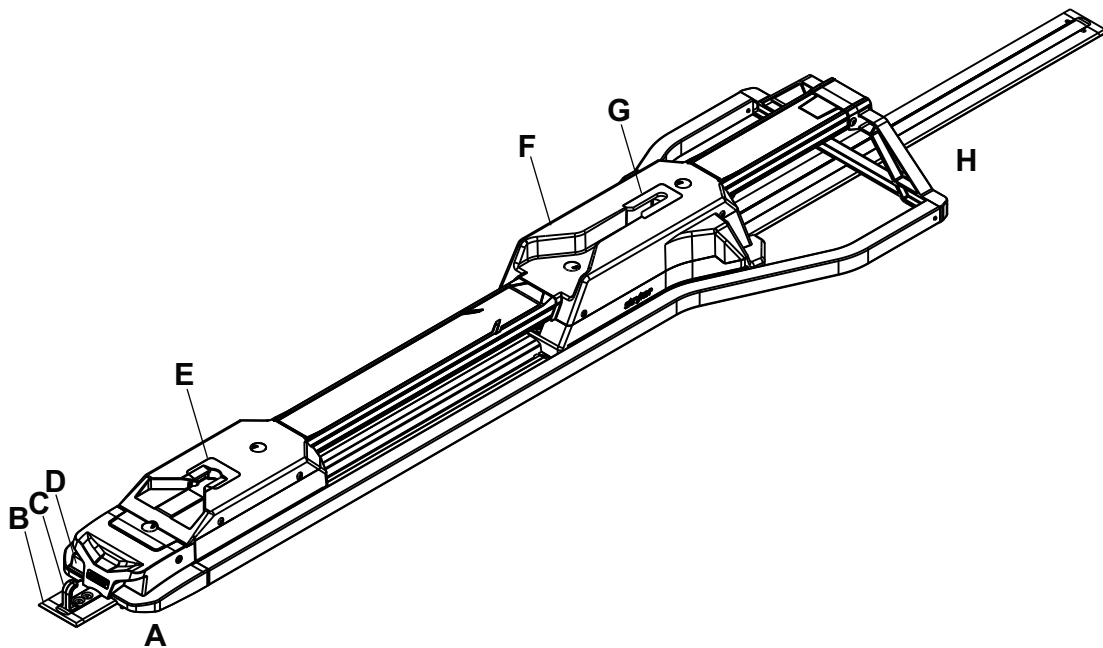

A	Foot end
B	Floor plate
C	Safety hook
D	Release button

E	Foot end interface
F	Cot fastener
G	Head end interface
H	Head end

## Contact information

Contact Stryker Customer Service or Technical Support at: 1-800-327-0770.

Stryker Medical  
3800 E. Centre Avenue  
Portage, MI 49002  
USA

**Note** - The user and/or the patient should report any serious product-related incident to both the manufacturer and the Competent authority of the European Member State where the user and/or patient is established.

To view your operations or maintenance manual online, see <https://techweb.stryker.com/>.

Have the serial number (A) of your Stryker product available when calling Stryker Customer Service or Technical Support. Include the serial number in all written communication.

## Serial number location

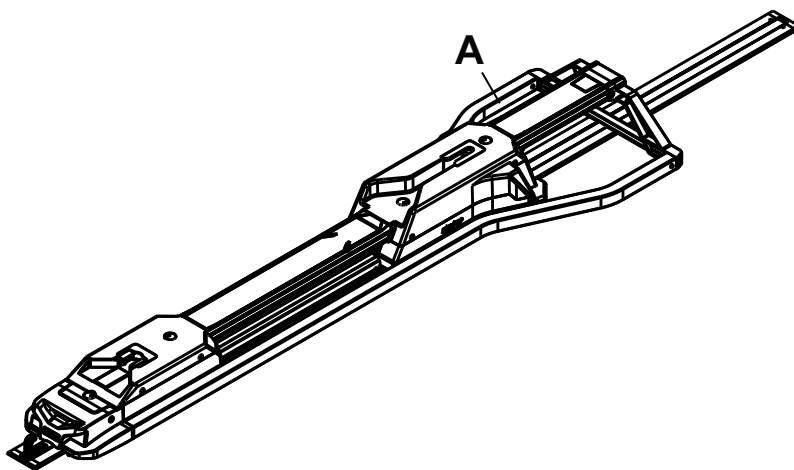

Figure 1 – Serial number location

## Date of manufacture

The year of manufacture is the first four digits of the serial number.

## Preventive maintenance

Establish and follow a maintenance schedule and keep records of the maintenance activity. Remove product from service before you perform the preventive maintenance inspection. You may need to perform preventive maintenance checks more often based on your level of product usage. Service only by qualified personnel.

### Every month

Check	Routine
Foot end interface and head end interface	Clean debris

### Every three months

Check	Routine
Loose fasteners	Replace if loose

### Every twelve months

Check	Routine
All parts	Replace any worn parts, including covers, cot guides, and latch assembly, if necessary
Full functionality	See the Installation checklist in the Operations Manual

## Maintenance record

Date	Maintenance operation performed	By	Hours

Date	Maintenance operation performed	By	Hours

**Training record**

Trainee name	Training date		Owner’s manual, in-service, formal class, etc.
	Basic training	Refresher update	

# Troubleshooting

## Inductive charging system does not charge the cot battery

Inductive charging system does not charge the cot battery when you load the cot into the fastener.

**Note** - Before you service the cot, disconnect the vehicle's battery starting with the negative lead.

1. Make sure that a **SMRT Pak** battery is used on the cot and that the cot is equipped with inductive charging hardware.
2. Check for proper connection between the anchor-to-vehicle cable and the inductive primary board.

- a. Check for 12.8V to 15.6V at the **Performance-LOAD** end of the anchor-to-vehicle cable (6390-001-135) connection.

- b. If present, continue to step 3.

- c. If not present, make sure that the vehicle meets the following electrical requirements: 12.8V - 15.6V, 15A fuse/breaker and two conductor 10 AWG cable.

3. Reattach the anchor-to-vehicle cable to the mating side of the inductive primary board.

**Note** - Check that like-colored wires are connected (red to red; black to black).

4. After making the connection, verify proper functionality as follows:

- a. Load a **Power-PRO** cot (with a **SMRT Pak** battery) into the fastener, check that the **Power-PRO** battery indicator is OFF prior to loading the cot into **Performance-LOAD**.

- b. If the unit is functioning properly, the cot light panel orb will turn on within five seconds of being loaded into **Performance-LOAD**. The light indicates that the unit is receiving power and that the electrical installation is correct and complete.

- c. If the light panel orb does not turn ON, check all connection points and replace the inductive coil and/or the primary board.

# Service

## Head end interface assembly replacement

### Tools required:

- T27 Torx driver
- 1/4" hex wrench
- Torque wrench (in-lb)

### Procedure:

1. Using a T27 Torx driver, remove the four screws that secure the head end top cover to the head end bottom covers. Save the screws.
2. Using a 1/4" hex wrench, remove the four screws (A) that secure the head end interface assembly (P) to the head end weldment (T) (Figure 2). Save the screws.

**Note** - Torque item (A) to  $300 \pm 15$  in-lb.

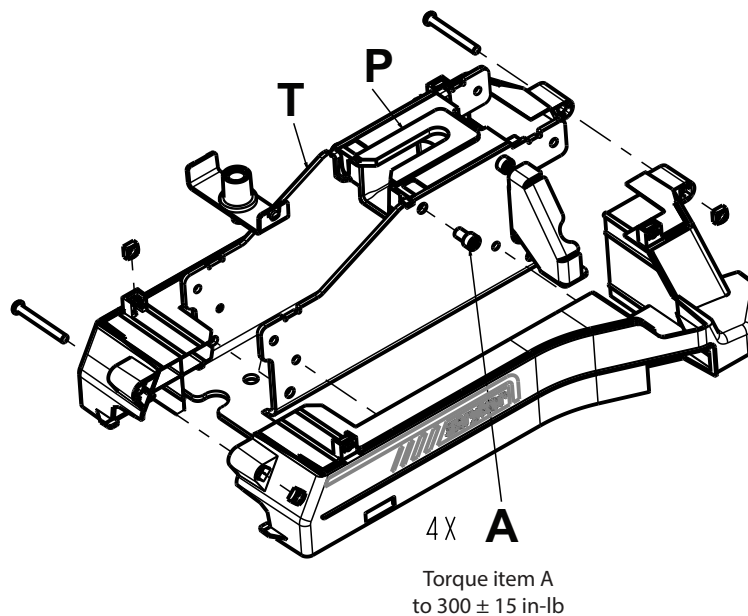

**Figure 2 – Replacing the head end interface assembly**

3. Remove and discard the head end interface assembly.
4. Reverse steps to reinstall.
5. Verify proper operation before you return the product to service.

## Foot end interface assembly replacement

### Tools required:

- T27 Torx driver
- 1/4" hex wrench
- Torque wrench (in-lb)

### Procedure:

1. Using a T27 Torx driver, remove the six screws that secure the foot end top cover to the foot end bottom cover. Save the screws.

- Using a 1/4" hex wrench, remove the six screws (A) that secure the foot end interface assembly (K) to the foot end weldment (R) (Figure 3). Save the screws.

**Note** - Torque item (A) to  $300 \pm 15$  in-lb.

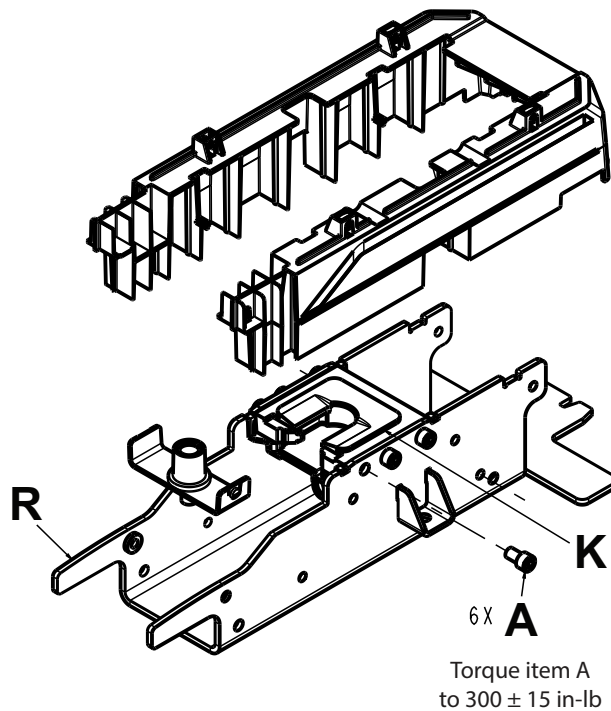

**Figure 3 – Replacing the foot end interface assembly**

- Remove the foot end interface from the lower release link by sliding it toward the head end. Discard the foot end interface.
- Reverse steps to reinstall.
- Verify proper operation before you return the product to service.

## Inductive primary board replacement (optional)

### Tools required:

- T27 Torx driver

### Procedure:

- Unsnap the floor plate cover to gain access to the electrical connection.
- Disconnect the red and black wires from the cable harness.
- Using a T27 Torx driver, remove the six screws that secure the foot end top cover to the foot end bottom cover. Save the screws.
- Using a T27 Torx driver, remove the two screws (A) that secure the inductive charging assembly (C) to the foot end weldment (Figure 4). Save the screws.
- Remove the inductive charging assembly.
- Remove the inductive primary board from the charging enclosure. Discard the inductive primary board.

**Note** - Do not dispose of as unsorted municipal waste. Refer to your local distributor for return or collection systems available in your country.

- Reverse steps to reinstall.
- Verify proper operation before you return the product to service.

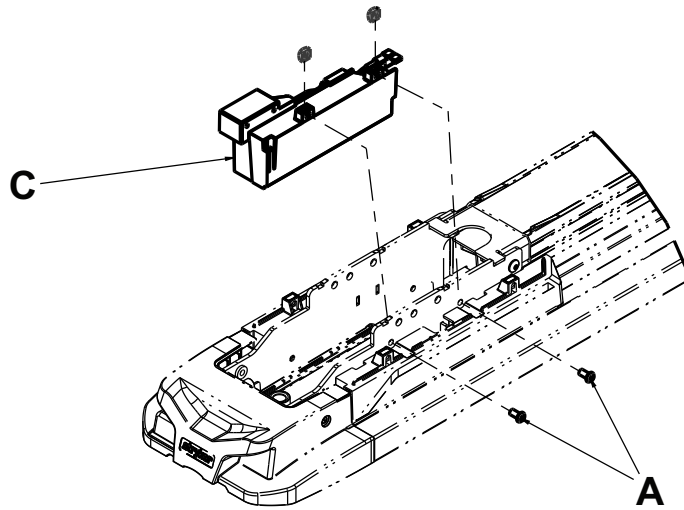

Figure 4 – Replacing the inductive primary board

## Head end plunger replacement

### Tools required:

- T27 Torx driver

### Procedure:

1. Remove the head end interface assembly (see *Head end interface assembly replacement* (page 10)).
2. Using a T27 Torx driver, remove the four screws (A) that secure the pin enclosure (C) to the head end interface (B) (Figure 5). Save the screws.
3. Remove and save the two plunger springs (D) (Figure 5).
4. Remove and save the plunger bracket (F) (Figure 5).
5. Remove and discard the plunger (E) (Figure 5).

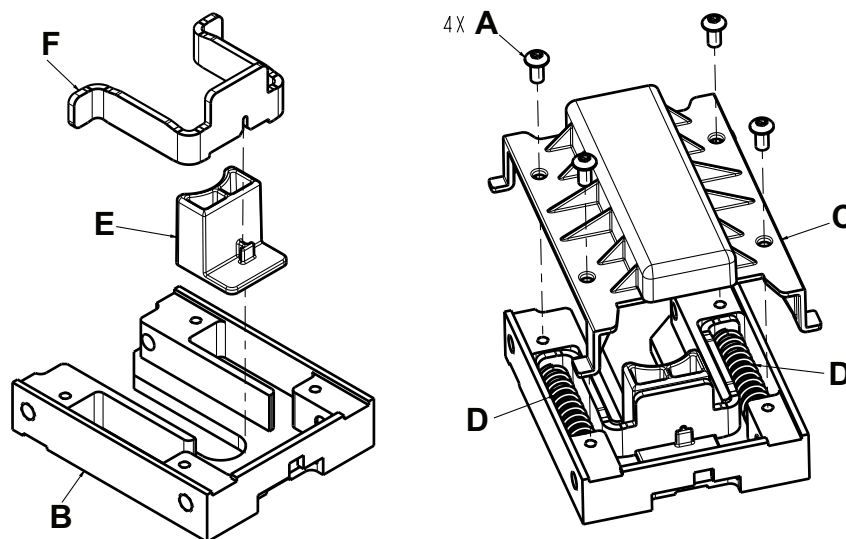

Figure 5 – Replacing the head end plunger

6. Reverse steps to reinstall.
7. Verify proper operation before you return the product to service.



## Foot end lock pawl replacement

### Tools required:

- T25 Torx driver
- 1/8" punch

### Procedure:

1. Remove the foot end interface assembly (see *Foot end interface assembly replacement* (page 10)).
2. Using a 1/8" punch, push the dowel pin (B) out of the release latch arm (G) (Figure 6). Save the dowel pin.
3. Using a T25 Torx driver, remove the six screws (A) that secure the pivot bracket to the foot end interface (C) (Figure 6). Save the screws.
4. Remove and discard the lock pawl (D) (Figure 6).

**Note** - Make sure that the pawl spring (F) remains in place when you remove the lock pawl.

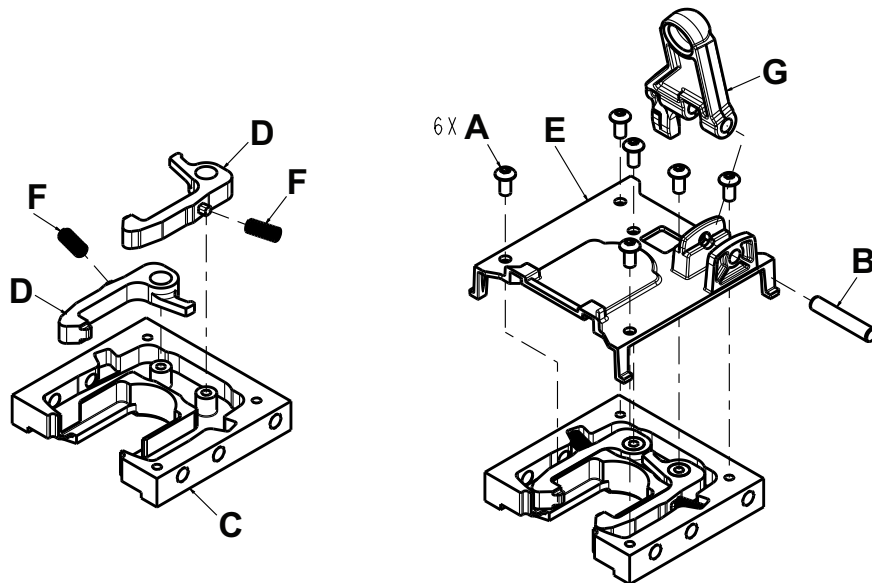

Figure 6 – Replacing the foot end lock pawl

5. Reverse steps to reinstall.

**Note** - Fully insert the dowel pin during reassembly.

6. Verify proper operation before you return the product to service.

## Safety bar rail support replacement

### Tools required:

- T27 Torx driver

### Procedure:

1. Using a T27 Torx driver, remove the two screws (A) that secure the safety bar rail support (B) to the safety bar rail (C) (Figure 7). Save the screws.

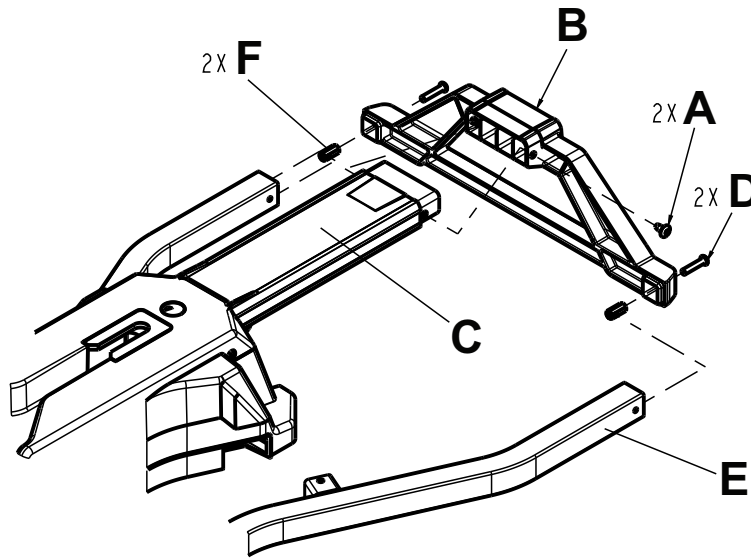

**Figure 7 – Replacing the safety bar rail support**

2. Using a T27 Torx driver, remove the two screws (D) that secure the safety bar rail support (B) to the guide rails (E) (Figure 7). Save the screws. Discard the safety bar rail support.
3. Reverse steps to reinstall.
 

**Note** - Make sure that the two hex couplers (F) are centered in the guide rails (E) before you reinstall (Figure 7).
4. Verify proper operation before you return the product to service.

## Foot end cover assembly replacement

### Tools required:

- T27 Torx driver
- 15/16" hex wrench
- 3/8" Allen wrench

### Procedure:

1. Using a T27 Torx driver, remove the four socket head cap screws (A) that secure the foot end cover assembly (B) to the transfer (Figure 8). Save the screws.
2. Using a T27 Torx driver, remove the two button head cap screws (C) that secure the foot end cover assembly to the foot end nose assembly (D) (Figure 8). Save the screws.
3. Remove the foot end cover assembly by sliding it toward the head end of the vehicle patient compartment. Discard the foot end cover assembly.
4. Reverse steps 1-3 to reinstall the foot end cover assembly.

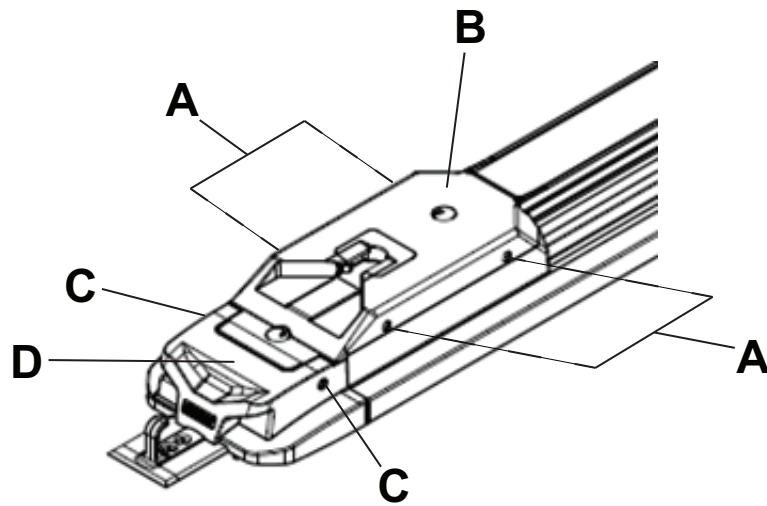

**Figure 8 – Foot end cover assembly**

5. Using a 15/16" hex wrench, loosen the locknut (E) that secures the pin (F) to the head end forging assembly (Figure 9).

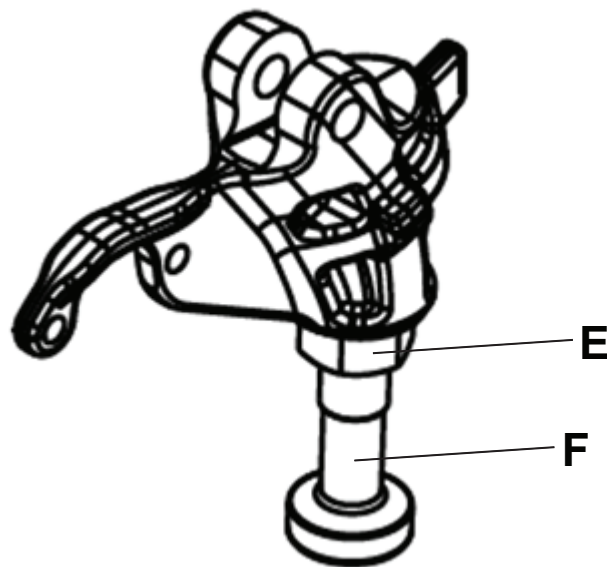

**Figure 9 – Head end forging assembly**

6. Using a 3/8" Allen wrench, adjust the pin so there is maximum clearance between the foot end cover assembly during loading and unloading.

**Note** - The pin must lock into the head end of the fastener while loaded.

7. Using a 15/16" hex wrench, tighten the locknut that secures the pin to the head end forging assembly.
8. Verify proper operation before you return the product to service.

**Note** - You must repair the cot and **Performance-LOAD** to avoid recurring damage to the foot end cover assembly.

# Performance-LOAD assembly

6392-001-010 Rev AA (Reference only)

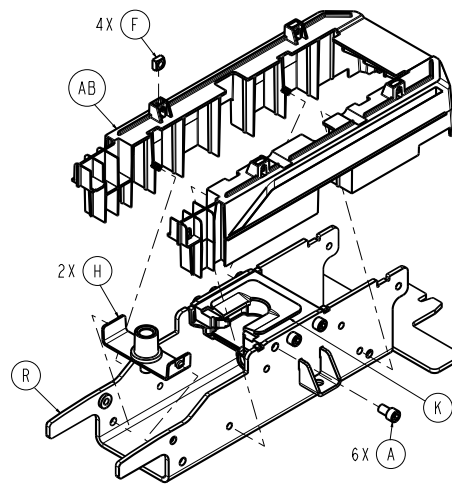
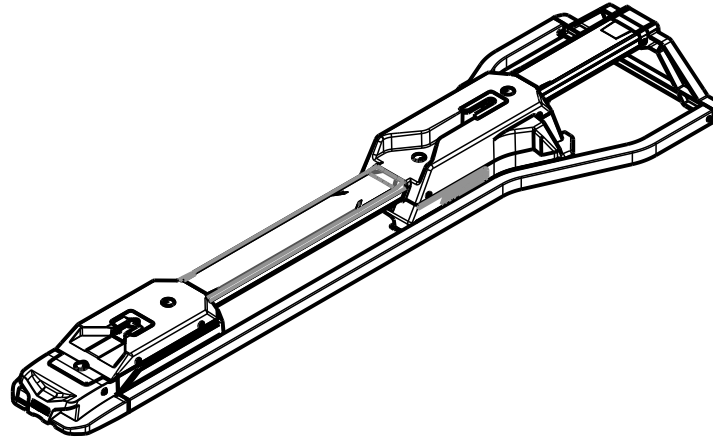

Torque item A  
to  $300 \pm 15$  in-lb

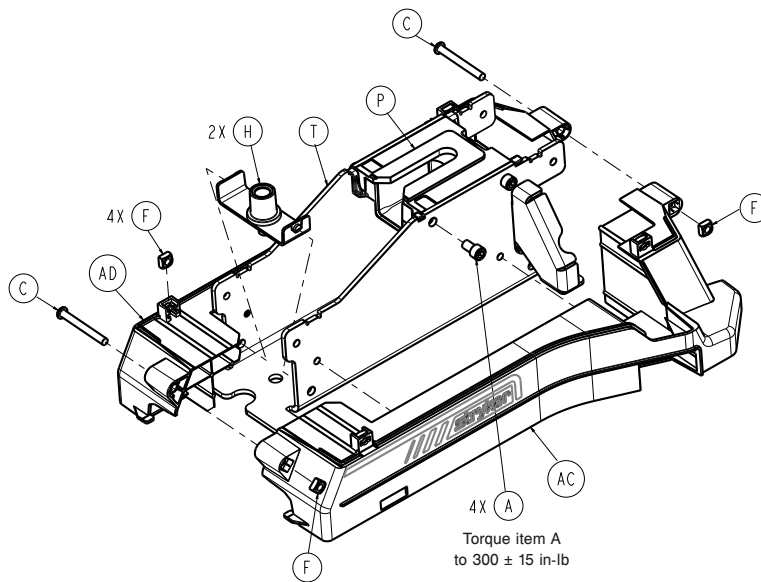

Torque item A  
to  $300 \pm 15$  in-lb

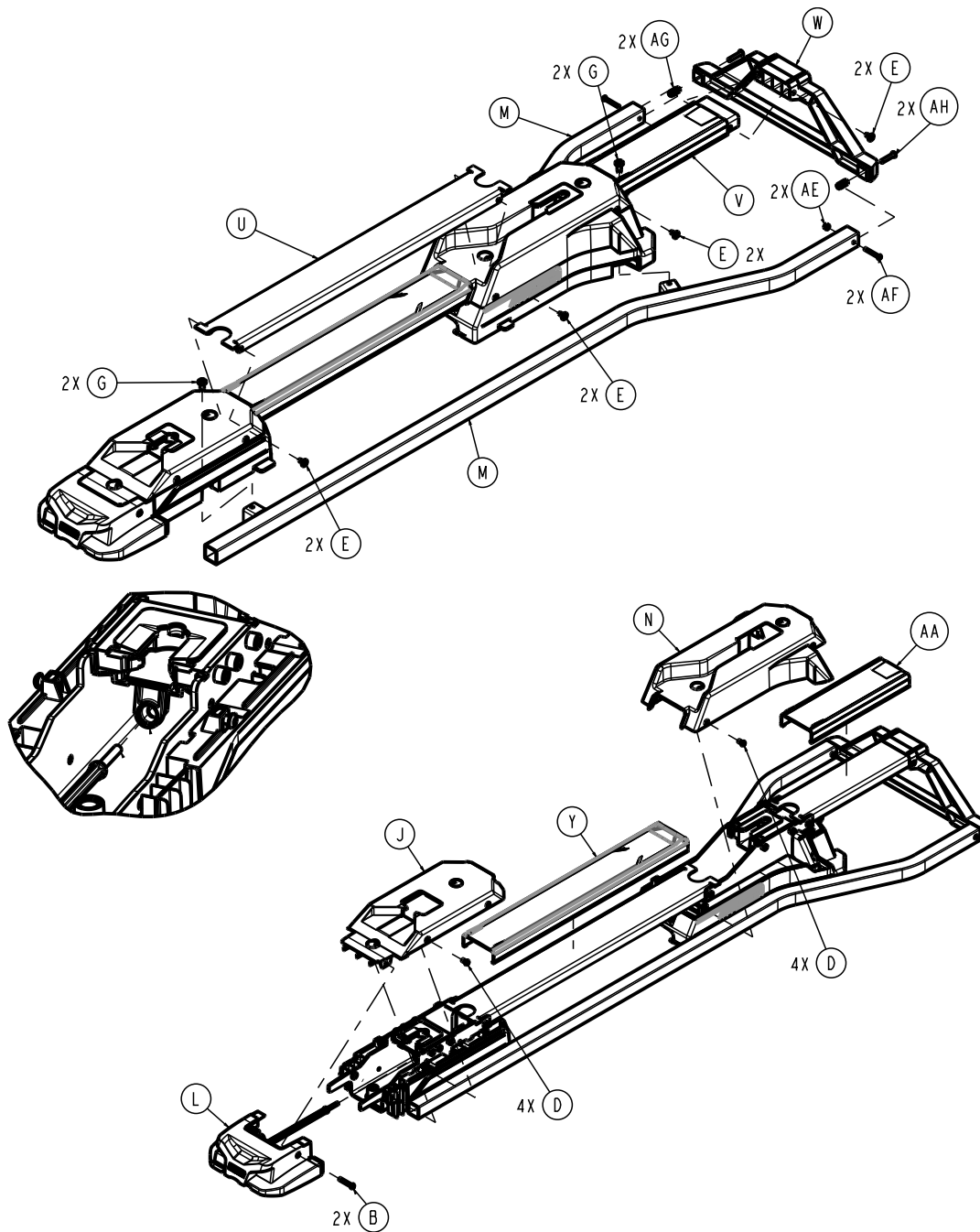

Item	Number	Name	Quantity
A	0004-270-000	Socket head cap screw	10
B	0004-376-000	Button head cap screw	2
C	0004-387-000	Button head cap screw	2
D	0004-589-000	Button head cap screw	8
E	0007-052-000	Truss head Torx screw	8
F	0015-096-000	Square nut	10
G	0023-350-000	Pan head thread-cutting tapping screw	4
H	6392-001-012	Floor plate bolt assembly (page 20)	4
J	6392-001-021	Foot end cover assembly (page 23)	1
K	6392-001-022	Foot end interface assembly (page 24)	1
L	6392-001-023	Foot end nose assembly (page 25)	1
M	639201010050	Weldment, guide rail	2

Item	Number	Name	Quantity
N	6392-001-031	<i>Head end cover assembly (page 27)</i>	1
P	6392-001-032	<i>Head end interface assembly (page 28)</i>	1
R	6392-001-052	Weldment, foot end	1
T	6392-001-053	Weldment, head end	1
U	6392-001-102	Safety bar rail, long	1
V	6392-001-103	Safety bar rail, short	1
W	6392-001-104	Safety bar rail support	1
Y	6392-001-105	Safety bar rail cover, long	1
AA	6392-001-106	Safety bar rail cover, short	1
AB	6392-001-208	Foot end cover, bottom	1
AC	6392-001-303	Head end cover, patient left	1
AD	6392-001-304	Head end cover, patient right	1
AE	0016-003-000	Nylon hex nut	2
AF	0004-171-000	Button head cap screw	2
AG	639200010001	Hex coupler	2
AH	0004-198-000	Button head cap screw	2

# Center cover assembly

6392-001-011 Rev A (Reference only)

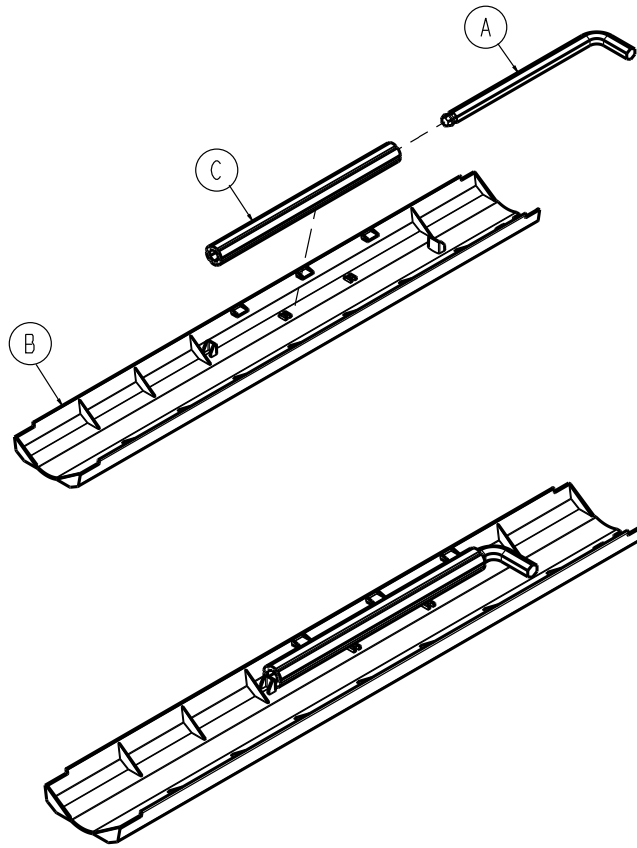

Item	Number	Name	Quantity
A	0057-011-000	3/8" hex wrench, ball end	1
B	6392-001-403	Floor plate cover	1
C	6392-001-406	Removal tool extension	1

# Floor plate bolt assembly

6392-001-012 Rev A (Reference only)

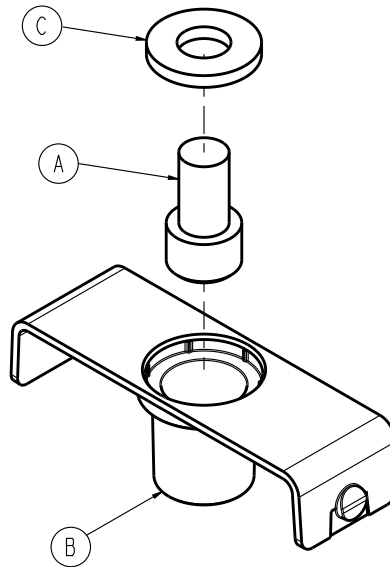

Item	Number	Name	Quantity
A	0004-910-000	Socket head cap screw	1
B	6392-001-142	Floor plate bolt holder	1
C	6392-001-143	Washer, bolt holder	1



# Install kit assembly

6392-001-014 Rev A (Reference only)

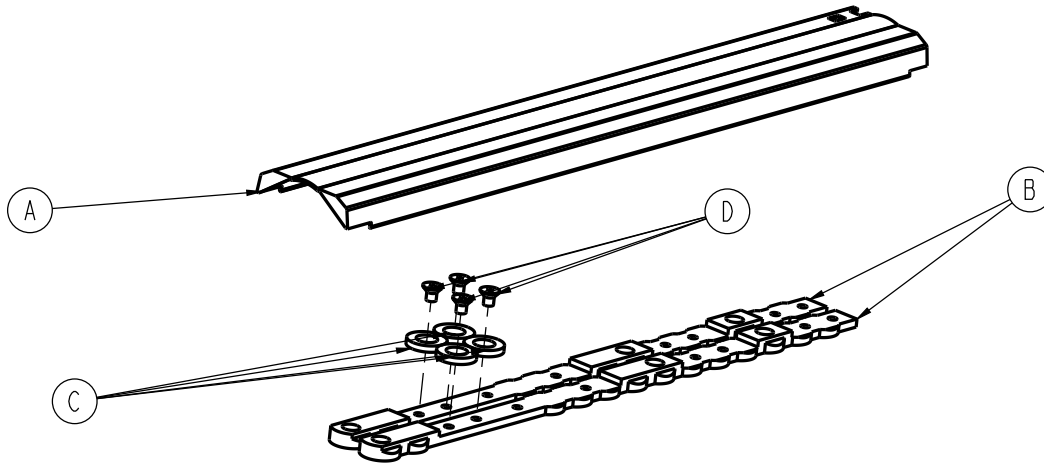

Item	Number	Name	Quantity
A	6392-001-011	Center cover assembly	1
B	6392-001-400	Cleat	2
C	6392-001-401	Cleat locator washer	4
D	0001-194-000	Flat head cap screw	4

# Inductive charging option

6392-001-015 Rev B (Reference only)

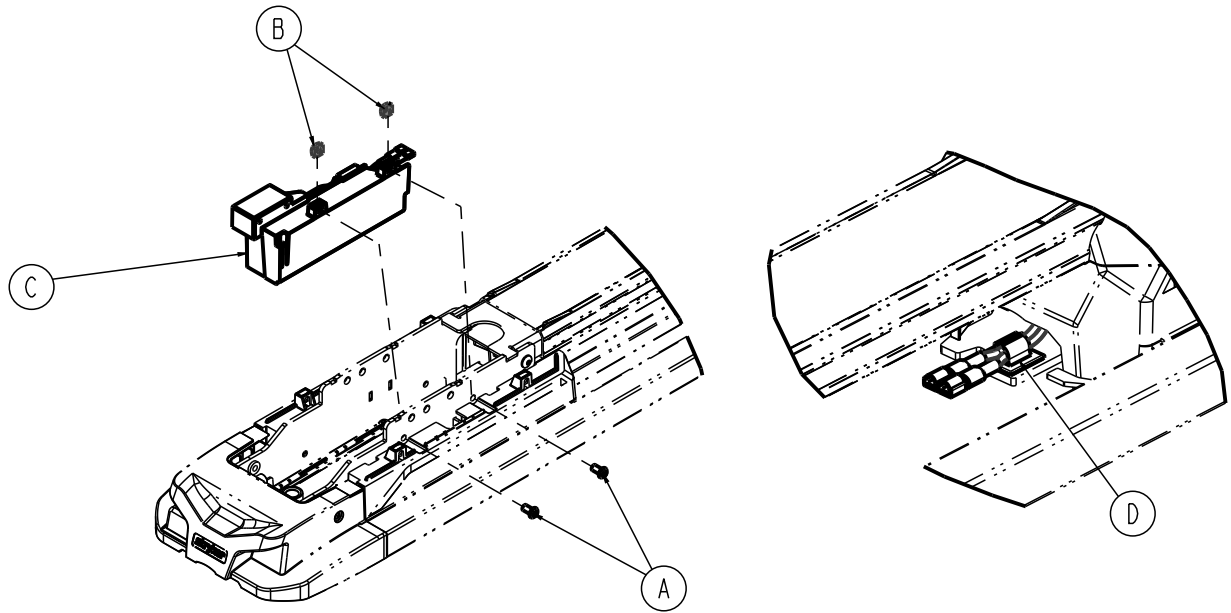

Item	Number	Name	Quantity
A	0004-589-000	Button head cap screw	2
B	0015-096-000	Square nut	2
C	6392-001-041	Inductive charging assembly	1
D	0058-394-000	Cable clip	1

# Foot end cover assembly

6392-001-021 Rev A (Reference only)

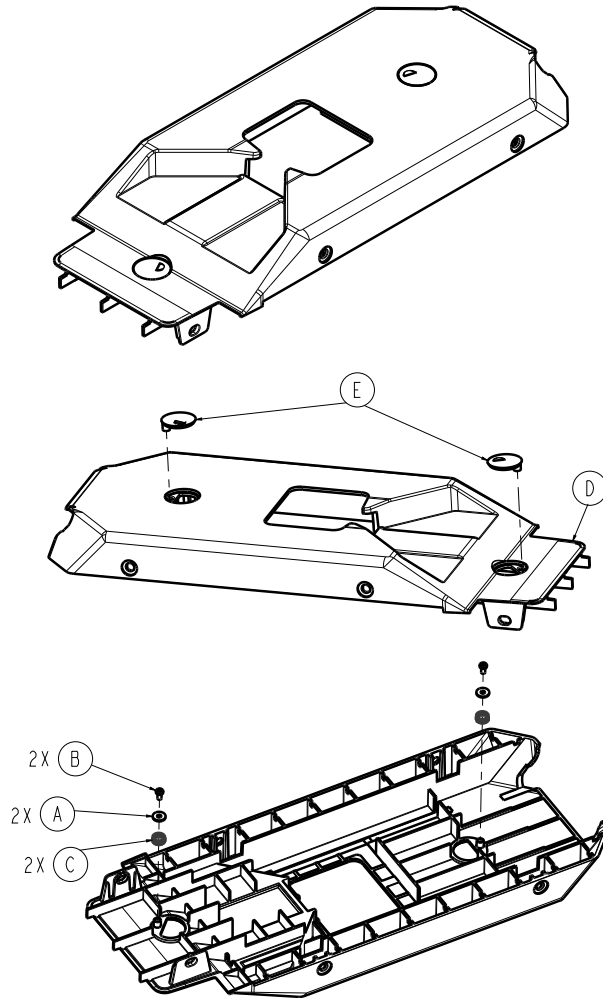

Item	Number	Name	Quantity
A	0011-642-000	Plain washer	2
B	0023-349-000	Pan head thread forming screw	2
C	0038-905-000	Spin cap spring	2
D	6392-001-108	Top cover, foot end	1
E	6392-001-309	Spin cap	2

# Foot end interface assembly

6392-001-022 Rev A (Reference only)

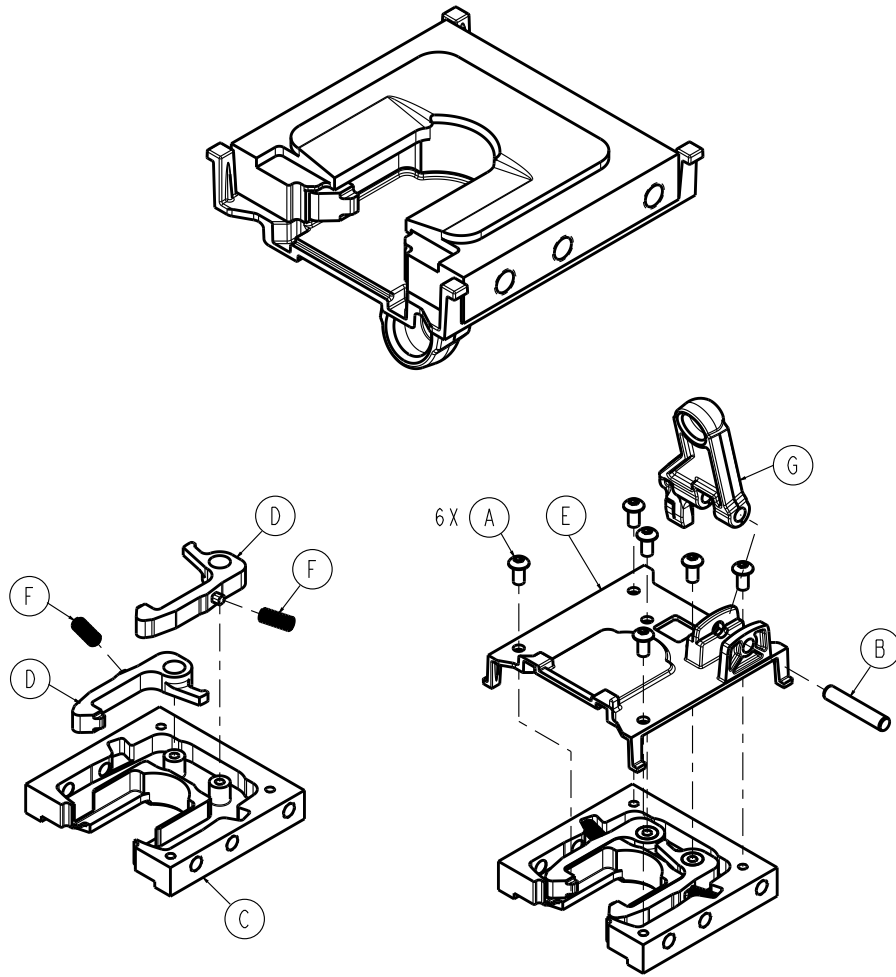

Item	Number	Name	Quantity
A	0004-442-000	Button head cap screw	6
B	0026-556-000	Dowel pin	1
C	6392-001-202	Interface, foot end	1
D	6392-001-250	Lock pawl, foot end	2
E	6392-001-251	Pivot bracket, foot end interface	1
F	6392-001-252	Pawl spring	2
G	6392-001-257	Release latch link arm	1

# Foot end nose assembly

6392-001-023 Rev A (Reference only)

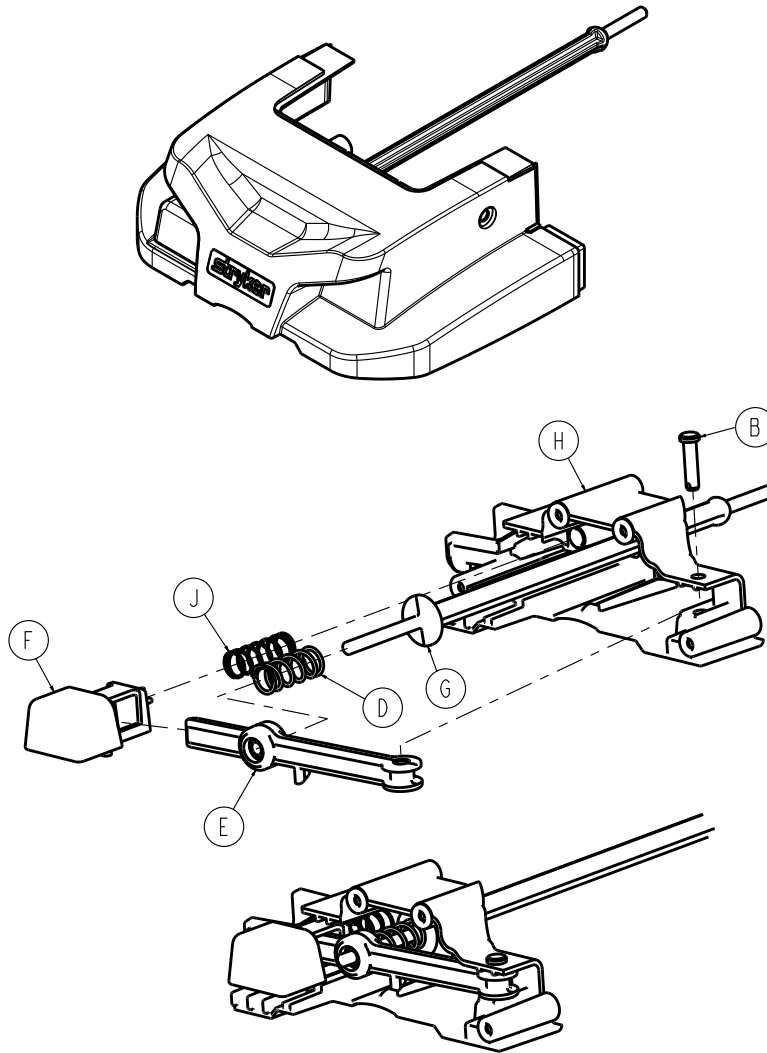

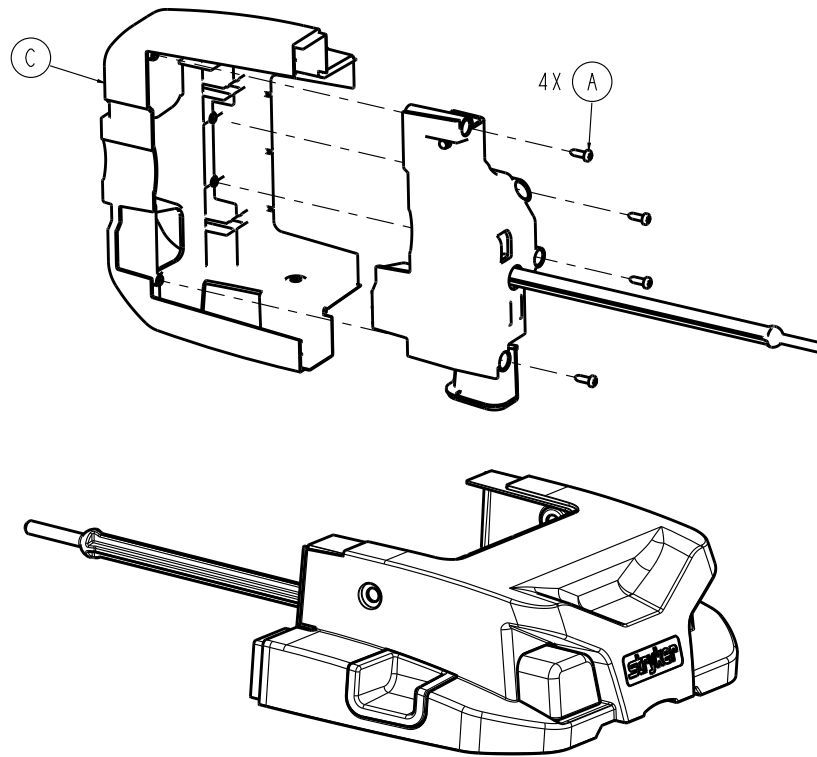

Item	Number	Name	Quantity
A	0023-167-000	Pan head thread forming screw	4
B	0026-316-000	Clevis pin	1
C	6392-001-205	Nose cover	1
D	6392-001-253	Thick release spring	1
E	6392-001-254	Release pivot arm	1
F	6392-001-255	Release button	1
G	6392-001-256	Release lower link	1
H	6392-001-258	Release housing	1
J	6392-001-259	Thin long release spring	1

# Head end cover assembly

6392-001-031 Rev A (Reference only)

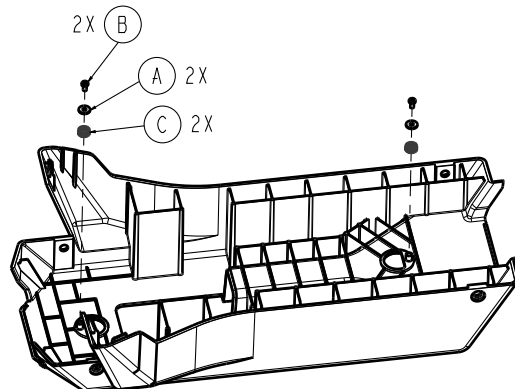
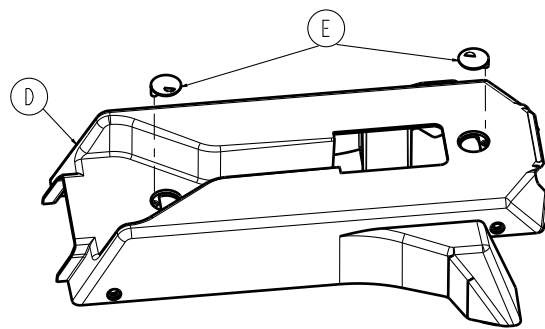
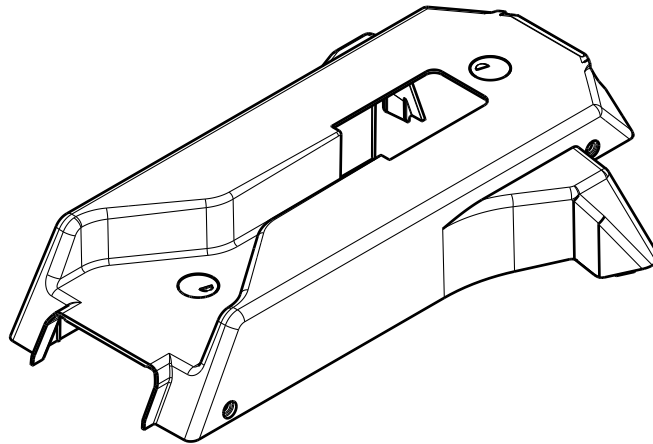

Item	Number	Name	Quantity
A	0011-642-000	Plain washer	2
B	0023-349-000	Pan head thread forming screw	2
C	0038-905-000	Spin can spring	2
D	6392-001-109	Head end top cover	1
E	6392-001-309	Spin cap	2

# Head end interface assembly

6392-001-032 Rev A (Reference only)

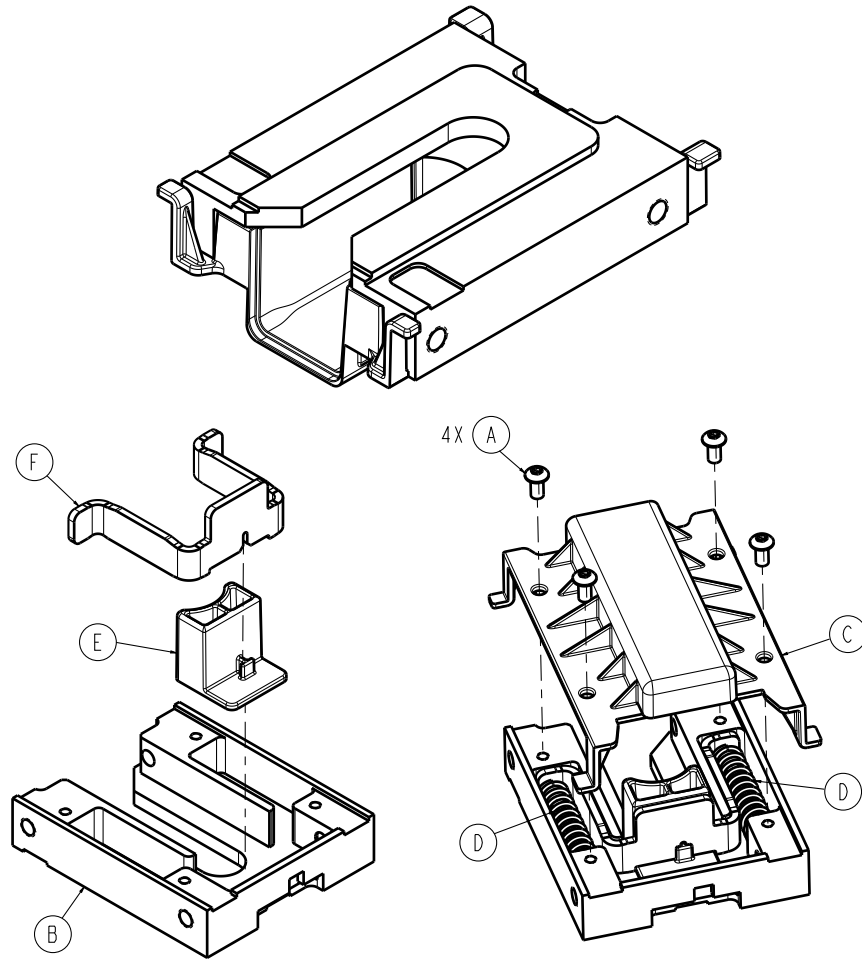

Item	Number	Name	Quantity
A	0004-442-000	Button head cap screw	4
B	6392-001-302	Head end interface	1
C	6392-001-305	Head end pin closure	1
D	6392-001-306	Plunger spring	2
E	6392-001-307	Head end plunger	1
F	6392-001-308	Head end plunger bracket	1



# Inductive charging assembly

6392-001-041 Rev B (Reference only)

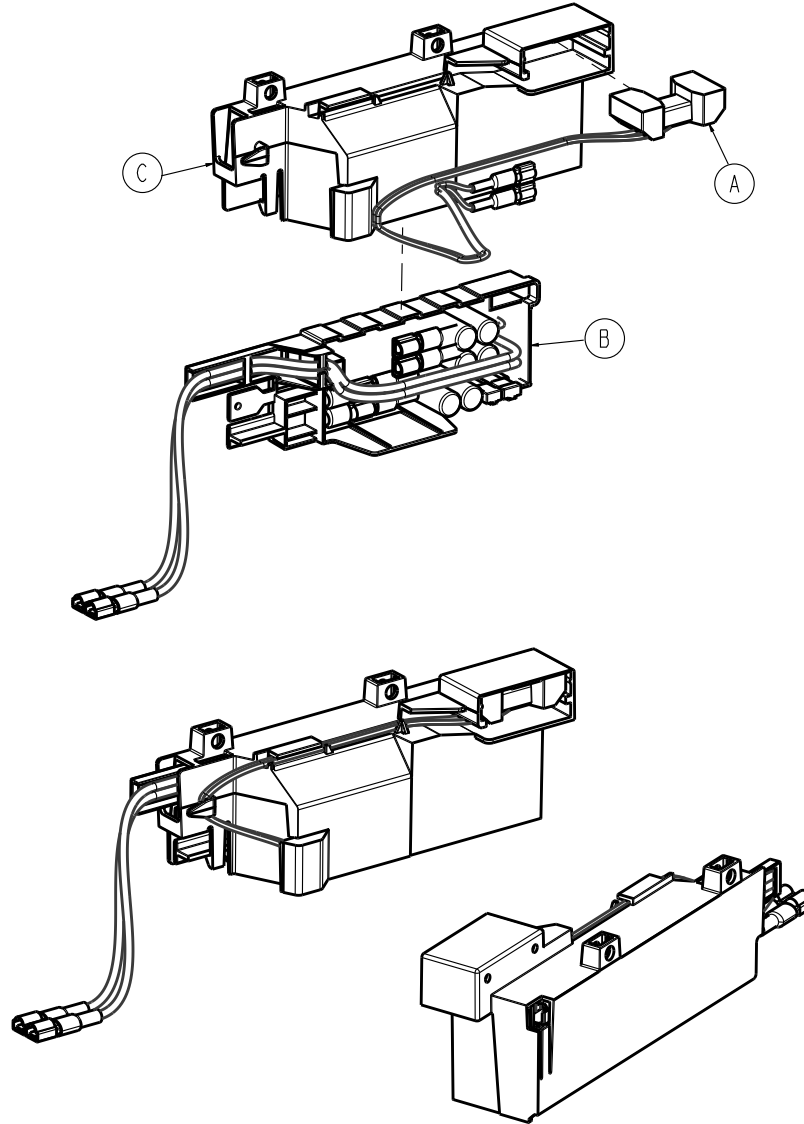

Item	Number	Name	Quantity
A	6390-001-133	Anchor primary coil	1
B	6390-001-147	Inductive primary board	1
C	6392-001-150	Inductive charging enclosure	1

# Head end hitch assembly

6392-001-061 Rev A (Reference only)

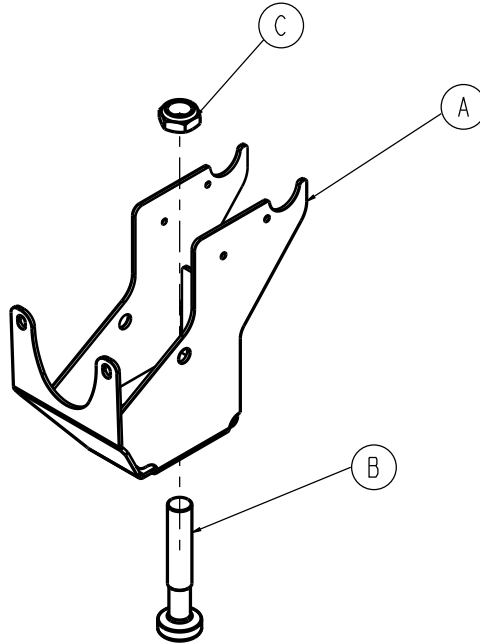

Item	Number	Name	Quantity
A	6392-001-054	Head end hitch weldment	1
B	6392-001-500	Head end hitch pin	1
C	0016-019-000	Nylock hex nut	1

# Head end forging assembly

6392-001-062 Rev A (Reference only)

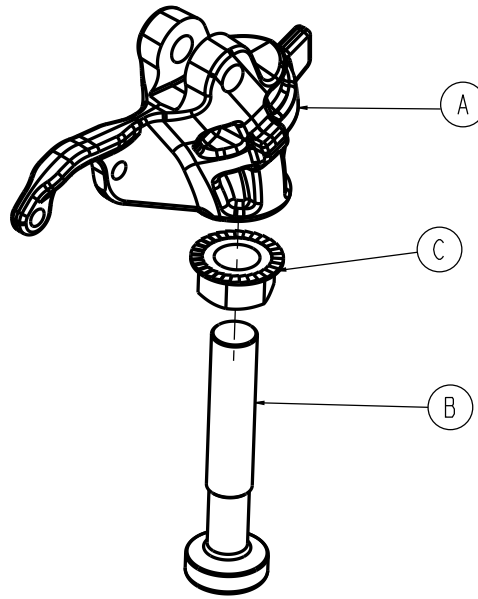

Item	Number	Name	Quantity
A	6392-001-510	Machined forging	1
B	6392-001-500	Head end hitch pin	1
C	0016-323-000	Hex flange serrated lock nut	1

## EMC information

Guidance and manufacturer's declaration - electromagnetic emissions		
<p><b>Performance-LOAD</b> is intended for use in the electromagnetic environment specified below. The customer or the user of <b>Performance-LOAD</b> should assure that it is used in such an environment.</p>		
Emissions test	Compliance	Electromagnetic environment
RF Emissions CISPR 11	Group 2	The <b>Performance-LOAD</b> system must emit electromagnetic energy in order to perform its intended function. Nearby electronic equipment may be affected.
RF Emissions CISPR 11	Class A	The <b>Performance-LOAD</b> system is suitable for use in all establishments other than domestic and those directly connected to the public low-voltage power supply network that supplies buildings used for domestic purposes.

Recommended separations distances between portable and mobile RF communications equipment and Performance-LOAD			
<p><b>Performance-LOAD</b> is intended for use in an electromagnetic environment in which radiated RF disturbances are controlled. The customer or the user of <b>Performance-LOAD</b> can help prevent electromagnetic interferences by maintaining a minimum distance between portable and mobile RF communications equipment (transmitters) and <b>Performance-LOAD</b> as recommended below, according to the maximum output power of the communications equipment.</p>			
Rated maximum output power of transmitter  W	Separation distance according to frequency of transmitter  m		
	150 kHz to 80 MHz  $d=(1.2) (\sqrt{P})$	80 MHz to 800 MHz  $d=(.18) (\sqrt{P})$	800 MHz to 2.5 GHz  $d=(.35) (\sqrt{P})$
0.01	0.12	0.035	0.07
0.1	0.38	0.11	0.22
1	1.2	0.35	0.7
10	3.8	1.1	2.2
100	12	3.5	7
<p>For transmitters rated at a maximum output power not listed above, the recommended separation distance <math>d</math> in meters (m) can be estimated using the equation applicable to the frequency of the transmitter, where <math>P</math> is the maximum output power rating of the transmitter in watts (W) according to the transmitter manufacturer. Note 1: At 80 MHz and 800 MHz, the separation distance for the higher frequency range applies. Note 2: These guidelines may not apply in all situations. Electromagnetic propagation is affected by absorption and reflection from structures, objects, and people.</p>			

Guidance and manufacturer's declaration - electromagnetic immunity			
<p><b>Performance-LOAD</b> is suitable for use in the electromagnetic environment specified below. The customer or the user of <b>Performance-LOAD</b> should assure that it is used in such an environment.</p>			
Immunity test	EN/IEC 60601 test level	Compliance level	Electromagnetic environment-guidance

**Guidance and manufacturer's declaration - electromagnetic immunity**

Electrostatic discharge (ESD) IEC 61000-4-2	±8 kV contact ±15 kV air	±8 kV contact ±15 kV air	Floors should be wood, concrete, or ceramic tile. If floors are covered with synthetic material, the relative humidity should be at least 30%.
Power frequency (50/60 Hz) magnetic field IEC 61000-4-8	30 A/m	30 A/m	Power frequency magnetic fields should be at levels characteristic of a typical location in a typical commercial or hospital environment.

**Note:**  $U_T$  is the a.c. mains voltage before applications of the test level.

Conducted RF IEC 61000-4-6  Radiated RF IEC 61000-4-3	3 Vrms 150 kHz to 80 MHz  10 V/m 80 MHz to 2.5 GHz	3 Vrms  10 V/m	Portable and mobile RF communications equipment should be used no closer to any part of <b>Performance-LOAD</b> , including cables, than the recommended separation distance calculated from the equation appropriate for the frequency of the transmitter.  Recommended separation distance $D = (.35) (\sqrt{P})$ 80 MHz to 800 MHz $D = (0.70) (\sqrt{P})$ 800 MHz to 2.5 GHz  where $P$ is the maximum output power rating of the transmitter in watts (W) according to the transmitter manufacturer and $d$ is the recommended separation distance in meters (m).  Field strengths from fixed RF transmitters, as determined by an electromagnetic site <sup>a</sup> should be less than the compliance level in each frequency range. <sup>b</sup>  Interference may occur in the vicinity of equipment marked with the following symbol:  
---	--	----------------------	--

## Guidance and manufacturer's declaration - electromagnetic immunity

**Note 1:** At 80 MHz and 800 MHz, the higher frequency range applies.

**Note 2:** These guidelines may not apply in all situations. Electromagnetic propagation is affected by absorption and reflection from structures, objects, and people.

<sup>a</sup> Field strengths from fixed transmitters, such as base stations for radio (cellular/cordless) telephones and land mobile radios, amateur radio, AM and FM radio broadcast, and TV broadcast cannot be predicted theoretically with accuracy. To assess the electromagnetic environment due to fixed RF transmitters, an electromagnetic site survey should be considered. If the measured field strength in the location in which **Performance-LOAD** is used exceeds the applicable RF compliance level above, the **Performance-LOAD** system should be observed to verify normal operation. If abnormal performance is observed, additional measures may be necessary, such as reorienting or relocating **Performance-LOAD**.

<sup>b</sup> Over the frequency range 150 kHz to 80 MHz, field strengths should be less than 3 V/m.



# stryker



Stryker Medical  
3800 E. Centre Avenue  
Portage, MI 49002  
USA