

Performance-LOAD® Cot Fastener System

Maintenance Manual

REF 6392



Table of Contents

Warning/Caution/Note Definition	2
Introduction for service	3
Expected service life	3
Contact information	3
Serial number location	3
Preventive maintenance	4
Maintenance record	4
Training record	5
Troubleshooting	6
Inductive charging system does not charge the cot battery	6
Service	7
Head end interface assembly replacement	7
Foot end interface assembly replacement	7
Inductive primary board replacement (optional)	8
Head end plunger replacement	9
Foot end lock pawl replacement	10
Safety bar rail support replacement	10
Foot end cover assembly replacement	11
Performance-LOAD assembly	13
Center cover assembly	16
Floor plate bolt assembly	17
Install kit assembly	18
Inductive charging option	19
Foot end cover assembly	20
Foot end interface assembly	21
Foot end nose assembly	22
Head end cover assembly	24
Head end interface assembly	25
Inductive charging assembly	26
Head end hitch assembly	27
Head end forging assembly	28
Floor plate, assembly kit	29
EMC information	30

Warning/Caution/Note Definition

The words **WARNING**, **CAUTION**, and **NOTE** carry special meanings and should be carefully reviewed.

WARNING

Alerts the reader about a situation which, if not avoided, could result in death or serious injury. It may also describe potential serious adverse reactions and safety hazards.

CAUTION

Alerts the reader of a potentially hazardous situation which, if not avoided, may result in minor or moderate injury to the user or patient or damage to the product or other property. This includes special care necessary for the safe and effective use of the device and the care necessary to avoid damage to a device that may occur as a result of use or misuse.

Note - Provides special information to make maintenance easier or important instructions clearer.

Introduction for service

This manual assists you with the service of your Stryker product. Read this manual to service this product. This manual does not address the operation of this product. See the Operations Manual for operating and use instructions. To view your Operations Manual online, see <https://techweb.stryker.com/>.

Expected service life

The **Performance-LOAD** cot fastener has a seven year expected service life under normal use conditions and with appropriate periodic maintenance.

Contact information

Contact Stryker Customer Service or Technical Support at: 1-800-327-0770.

Stryker Medical
3800 E. Centre Avenue
Portage, MI 49002
USA

Note - The user and/or the patient should report any serious product-related incident to both the manufacturer and the Competent authority of the European Member State where the user and/or patient is established.

To view your operations or maintenance manual online, see <https://techweb.stryker.com/>.

Have the serial number (A) of your Stryker product available when calling Stryker Customer Service or Technical Support. Include the serial number in all written communication.

Serial number location

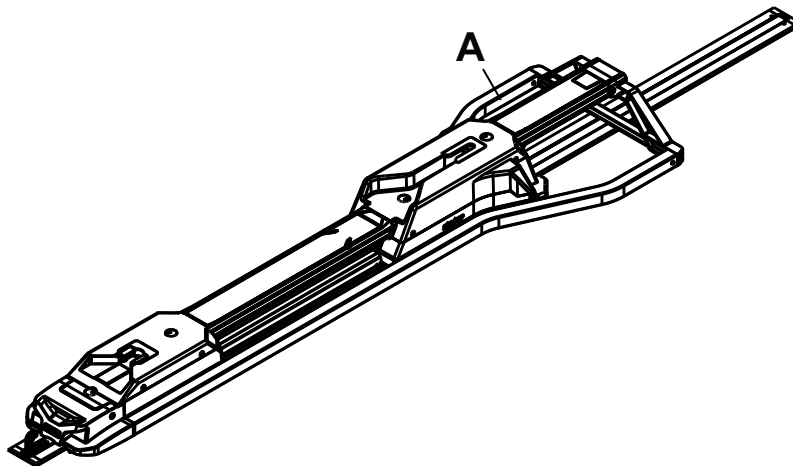

Figure 1 – Serial number location

Troubleshooting

Inductive charging system does not charge the cot battery

Inductive charging system does not charge the cot battery when you load the cot into the fastener.

Note - Before you service the cot, disconnect the vehicle's battery starting with the negative lead.

1. Make sure that a **SMRT Pak** battery is used on the cot and that the cot is equipped with inductive charging hardware.
2. Check for proper connection between the anchor-to-vehicle cable and the inductive primary board.
 - a. Check for 12.8V to 15.6V at the **Performance-LOAD** end of the anchor-to-vehicle cable (639000010135) connection.
 - b. If present, continue to step 3.
 - c. If not present, make sure that the vehicle meets the following electrical requirements: 12.8V - 15.6V, 15A fuse/breaker and two conductor 10 AWG cable.
3. Reattach the anchor-to-vehicle cable to the mating side of the inductive primary board.
4. After making the connection, verify proper functionality:
 - a. Load a **Power-PRO** cot (with a **SMRT Pak** battery) into the fastener, check that the **Power-PRO** battery indicator is OFF prior to loading the cot into **Performance-LOAD**.
 - b. If the unit is functioning properly, the cot light panel orb will turn on within five seconds of being loaded into **Performance-LOAD**. The light indicates that the unit is receiving power and that the electrical installation is correct and complete.
 - c. If the light panel orb does not turn ON, check all connection points and replace the inductive coil and/or the primary board.

Service

Head end interface assembly replacement

Tools required:

- T27 Torx driver
- 1/4" hex wrench
- Torque wrench (in-lb)

Procedure:

1. Using a T27 Torx driver, remove the four screws that secure the head end top cover to the head end bottom covers. Save the screws.
2. Using a 1/4" hex wrench, remove the four screws (A) that secure the head end interface assembly (P) to the head end weldment (T) (Figure 2). Save the screws.

Note - Torque item (A) to 300 ± 15 in-lb.

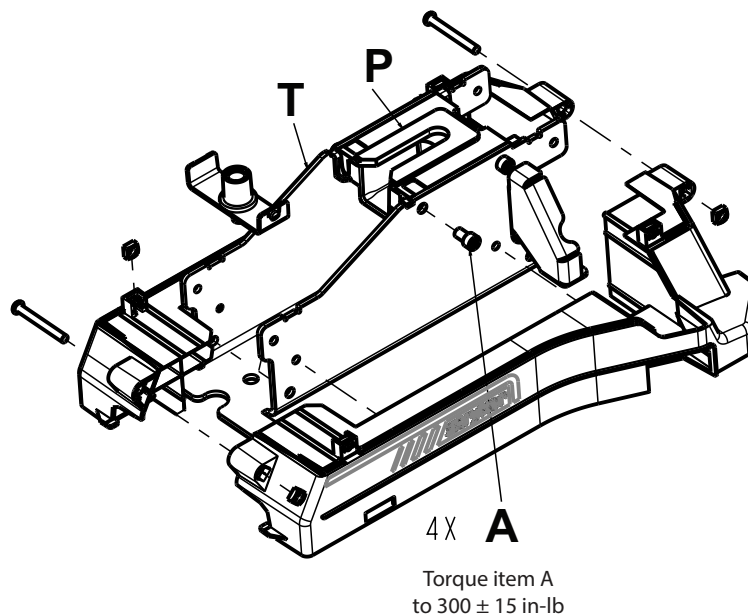

Figure 2 – Replacing the head end interface assembly

3. Remove and discard the head end interface assembly.
4. Reverse steps to reinstall.
5. Verify proper operation before you return the product to service.

Foot end interface assembly replacement

Tools required:

- T27 Torx driver
- 1/4" hex wrench
- Torque wrench (in-lb)

Procedure:

1. Using a T27 Torx driver, remove the six screws that secure the foot end top cover to the foot end bottom cover. Save the screws.

- Using a 1/4" hex wrench, remove the six screws (A) that secure the foot end interface assembly (K) to the foot end weldment (R) (Figure 3). Save the screws.

Note - Torque item (A) to 300 ± 15 in-lb.

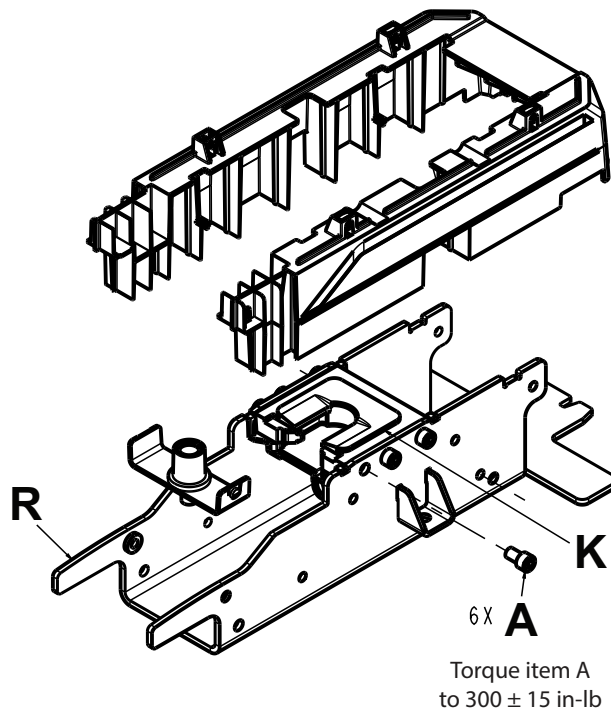

Figure 3 – Replacing the foot end interface assembly

- Remove the foot end interface from the lower release link by sliding it toward the head end. Discard the foot end interface.
- Reverse steps to reinstall.
- Verify proper operation before you return the product to service.

Inductive primary board replacement (optional)

Tools required:

- T27 Torx driver

Procedure:

- Unsnap the floor plate cover to gain access to the electrical connection.
- Disconnect the red and black wires from the cable harness.
- Using a T27 Torx driver, remove the six screws that secure the foot end top cover to the foot end bottom cover. Save the screws.
- Using a T27 Torx driver, remove the two screws (A) that secure the inductive charging assembly (C) to the foot end weldment (Figure 4). Save the screws.
- Remove the inductive charging assembly.
- Remove the inductive primary board from the charging enclosure. Discard the inductive primary board.

Note - Do not dispose of as unsorted municipal waste. Refer to your local distributor for return or collection systems available in your country.

- Reverse steps to reinstall.
- Verify proper operation before you return the product to service.

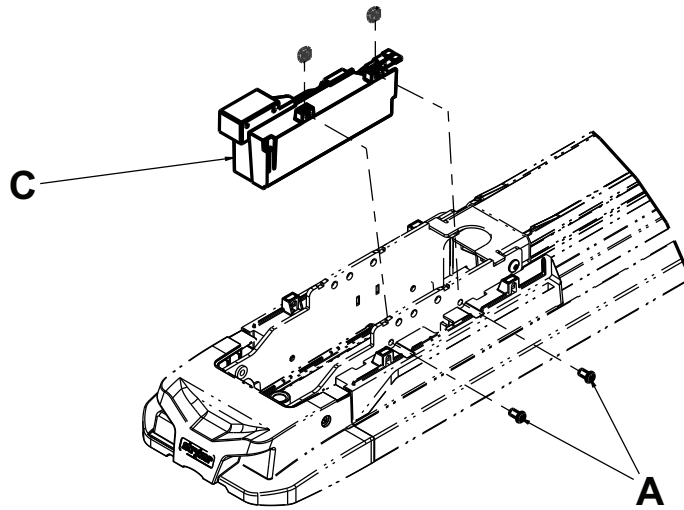

Figure 4 – Replacing the inductive primary board

Head end plunger replacement

Tools required:

- T27 Torx driver

Procedure:

1. Remove the head end interface assembly (see *Head end interface assembly replacement* (page 7)).
2. Using a T27 Torx driver, remove the four screws (A) that secure the pin enclosure (C) to the head end interface (B) (Figure 5). Save the screws.
3. Remove and save the two plunger springs (D) (Figure 5).
4. Remove and save the plunger bracket (F) (Figure 5).
5. Remove and discard the plunger (E) (Figure 5).

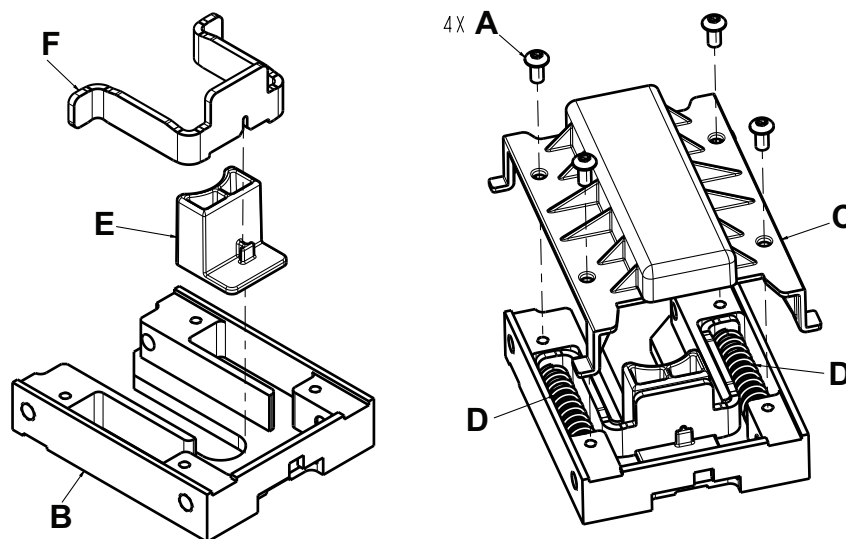

Figure 5 – Replacing the head end plunger

6. Reverse steps to reinstall.
7. Verify proper operation before you return the product to service.

Foot end lock pawl replacement

Tools required:

- T25 Torx driver
- 1/8" punch

Procedure:

1. Remove the foot end interface assembly (see *Foot end interface assembly replacement* (page 7)).
2. Using a 1/8" punch, push the dowel pin (B) out of the release latch arm (G) (Figure 6). Save the dowel pin.
3. Using a T25 Torx driver, remove the six screws (A) that secure the pivot bracket to the foot end interface (C) (Figure 6). Save the screws.
4. Remove and discard the lock pawl (D) (Figure 6).

Note - Make sure that the pawl spring (F) remains in place when you remove the lock pawl.

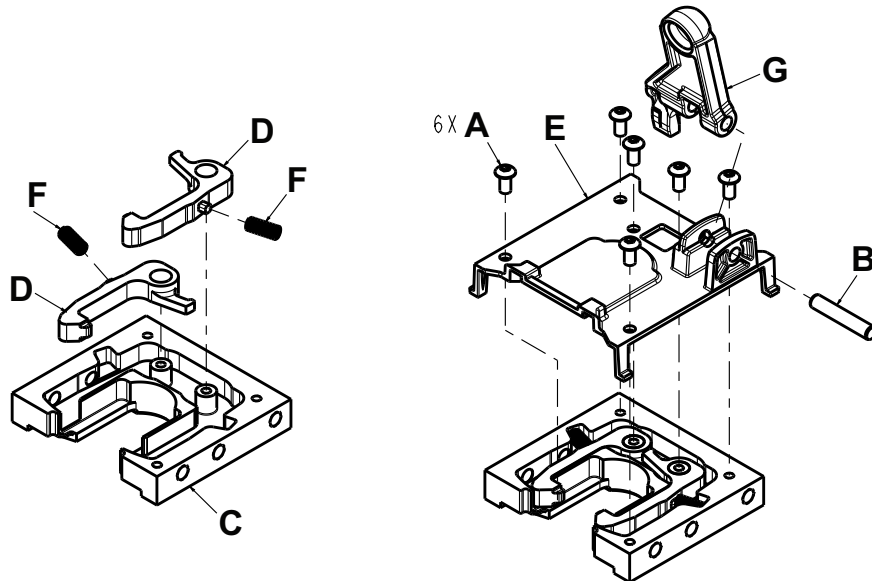

Figure 6 – Replacing the foot end lock pawl

5. Reverse steps to reinstall.

Note - Fully insert the dowel pin during reassembly.

6. Verify proper operation before you return the product to service.

Safety bar rail support replacement

Tools required:

- T27 Torx driver

Procedure:

1. Using a T27 Torx driver, remove the two screws (A) that secure the safety bar rail support (B) to the safety bar rail (C) (Figure 7). Save the screws.

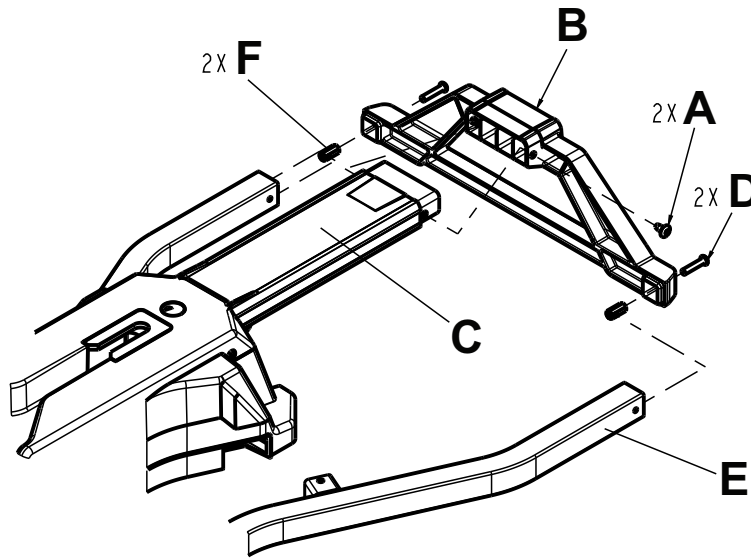

Figure 7 – Replacing the safety bar rail support

2. Using a T27 Torx driver, remove the two screws (D) that secure the safety bar rail support (B) to the guide rails (E) (Figure 7). Save the screws. Discard the safety bar rail support.
3. Reverse steps to reinstall.

Note - Make sure that the two hex couplers (F) are centered in the guide rails (E) before you reinstall (Figure 7).
4. Verify proper operation before you return the product to service.

Foot end cover assembly replacement

Tools required:

- T27 Torx driver
- 15/16" hex wrench
- 3/8" Allen wrench

Procedure:

1. Using a T27 Torx driver, remove the four socket head cap screws (A) that secure the foot end cover assembly (B) to the transfer (Figure 8). Save the screws.
2. Using a T27 Torx driver, remove the two button head cap screws (C) that secure the foot end cover assembly to the foot end nose assembly (D) (Figure 8). Save the screws.
3. Remove the foot end cover assembly by sliding it toward the head end of the vehicle patient compartment. Discard the foot end cover assembly.
4. Reverse steps 1-3 to reinstall the foot end cover assembly.

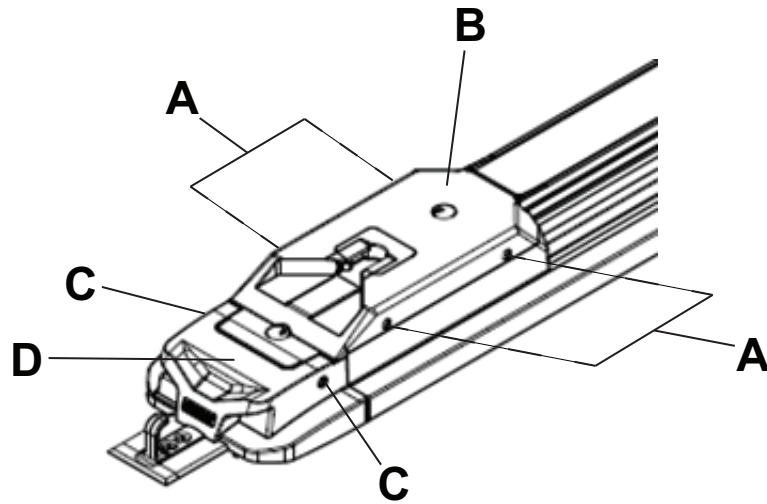

Figure 8 – Foot end cover assembly

- Using a 15/16" hex wrench, loosen the locknut (E) that secures the pin (F) to the head end forging assembly (Figure 9).

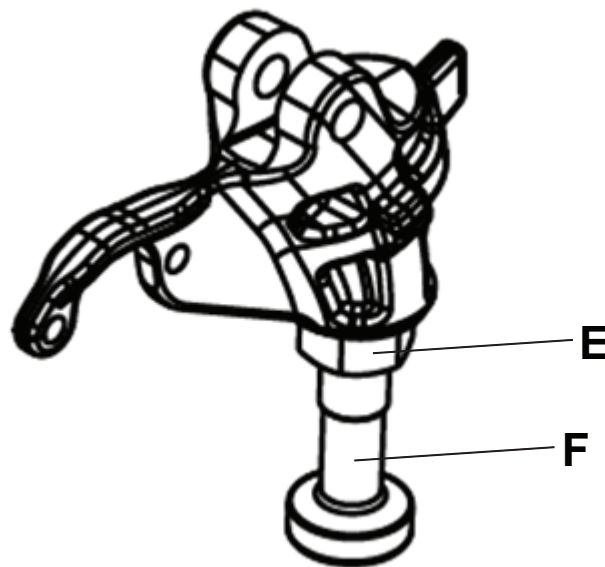

Figure 9 – Head end forging assembly

- Using a 3/8" Allen wrench, adjust the pin so there is maximum clearance between the foot end cover assembly during loading and unloading.

Note - The pin must lock into the head end of the fastener while loaded.

- Using a 15/16" hex wrench, tighten the locknut that secures the pin to the head end forging assembly.
- Verify proper operation before you return the product to service.

Note - You must repair the cot and **Performance-LOAD** to avoid recurring damage to the foot end cover assembly.

Performance-LOAD assembly

6392-001-010 Rev AA (Reference only)

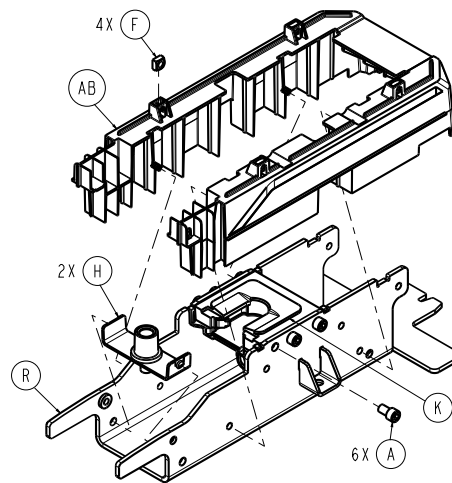
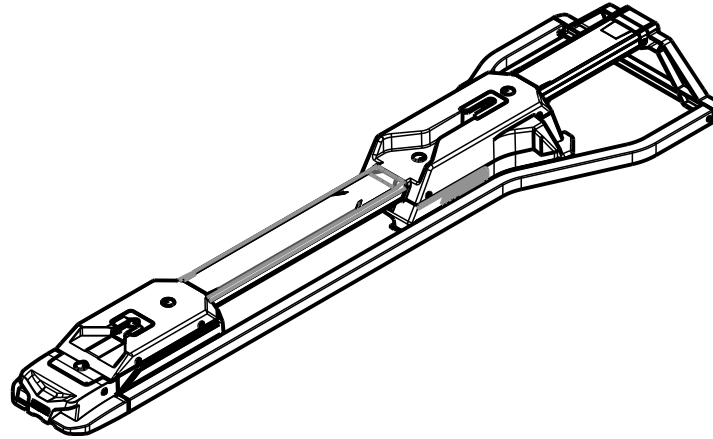

Torque item A
to 300 ± 15 in-lb

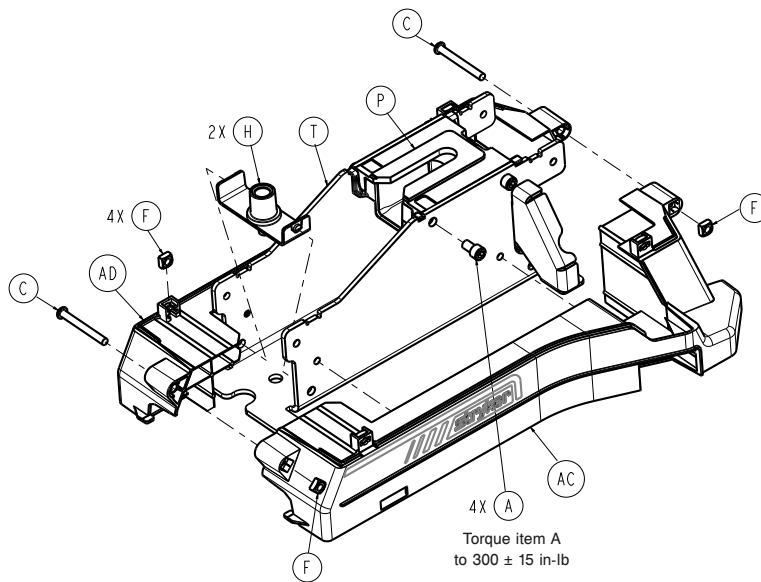

Torque item A
to 300 ± 15 in-lb

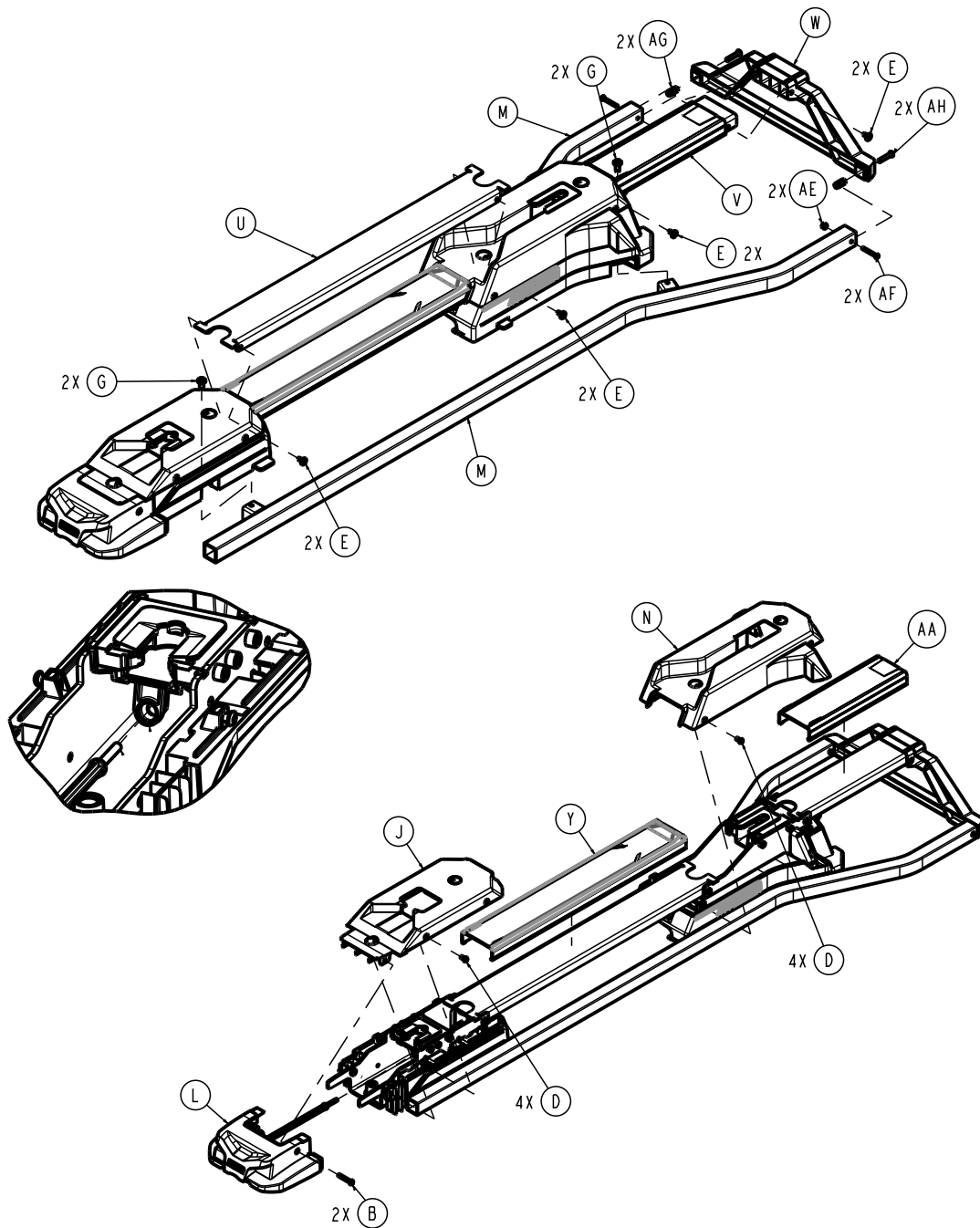

Item	Number	Name	Quantity
A	0004-270-000	Socket head cap screw	10
B	0004-376-000	Button head cap screw	2
C	0004-387-000	Button head cap screw	2
D	0004-589-000	Button head cap screw	8
E	0007-052-000	Truss head Torx screw	8
F	0015-096-000	Square nut	10
G	0023-350-000	Pan head thread-cutting tapping screw	4
H	6392-001-012	Floor plate bolt assembly (page 17)	4
J	6392-001-021	Foot end cover assembly (page 20)	1
K	6392-001-022	Foot end interface assembly (page 21)	1
L	6392-001-023	Foot end nose assembly (page 22)	1
M	639201010050	Weldment, guide rail	2

Item	Number	Name	Quantity
N	6392-001-031	<i>Head end cover assembly (page 24)</i>	1
P	6392-001-032	<i>Head end interface assembly (page 25)</i>	1
R	6392-001-052	Weldment, foot end	1
T	6392-001-053	Weldment, head end	1
U	6392-001-102	Safety bar rail, long	1
V	6392-001-103	Safety bar rail, short	1
W	6392-001-104	Safety bar rail support	1
Y	6392-001-105	Safety bar rail cover, long	1
AA	6392-001-106	Safety bar rail cover, short	1
AB	6392-001-208	Foot end cover, bottom	1
AC	6392-001-303	Head end cover, patient left	1
AD	6392-001-304	Head end cover, patient right	1
AE	0016-003-000	Nylon hex nut	2
AF	0004-171-000	Button head cap screw	2
AG	639200010001	Hex coupler	2
AH	0004-198-000	Button head cap screw	2

Center cover assembly

6392-001-011 Rev A (Reference only)

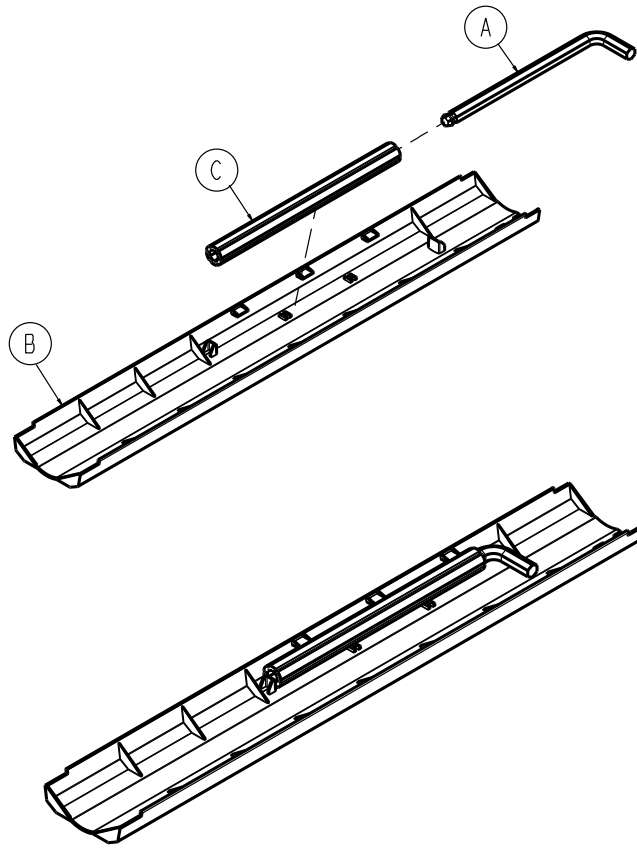

Item	Number	Name	Quantity
A	0057-011-000	3/8" hex wrench, ball end	1
B	6392-001-403	Floor plate cover	1
C	6392-001-406	Removal tool extension	1

Floor plate bolt assembly

6392-001-012 Rev A (Reference only)

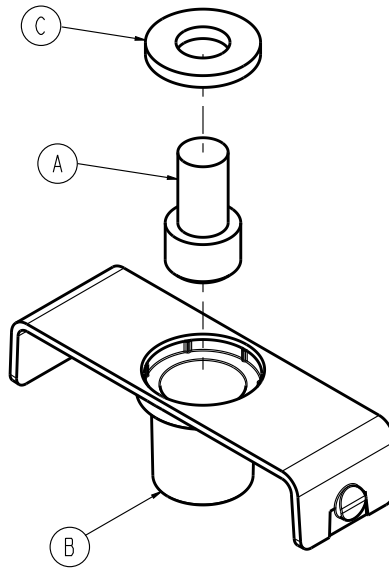

Item	Number	Name	Quantity
A	0004-910-000	Socket head cap screw	1
B	6392-001-142	Floor plate bolt holder	1
C	6392-001-143	Washer, bolt holder	1

Install kit assembly

6392-001-014 Rev A (Reference only)

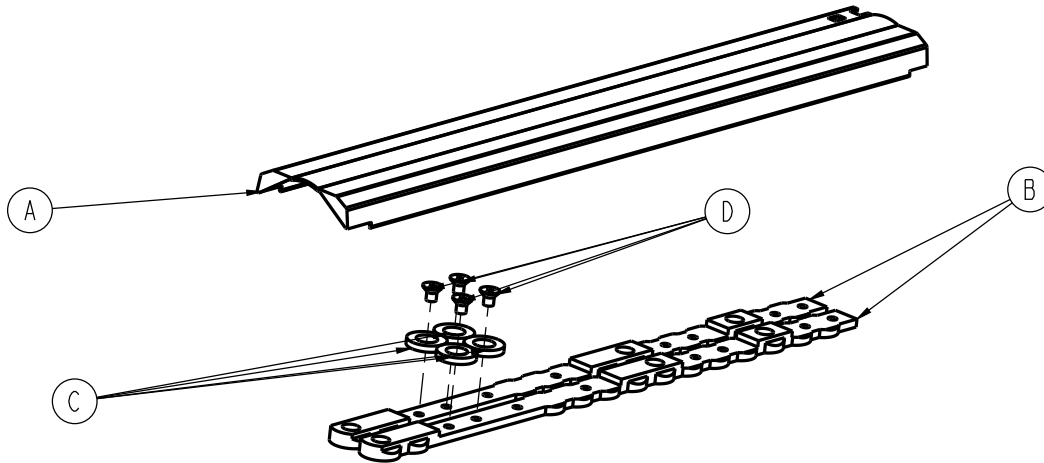

Item	Number	Name	Quantity
A	6392-001-011	Center cover assembly	1
B	6392-001-400	Cleat	2
C	6392-001-401	Cleat locator washer	4
D	0001-194-000	Flat head cap screw	4

Inductive charging option

6392-001-015 Rev AA (Reference only)

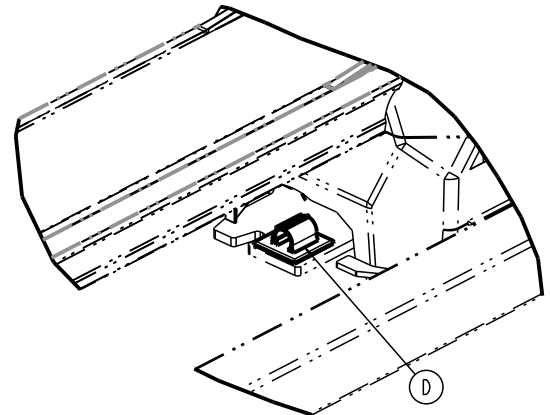
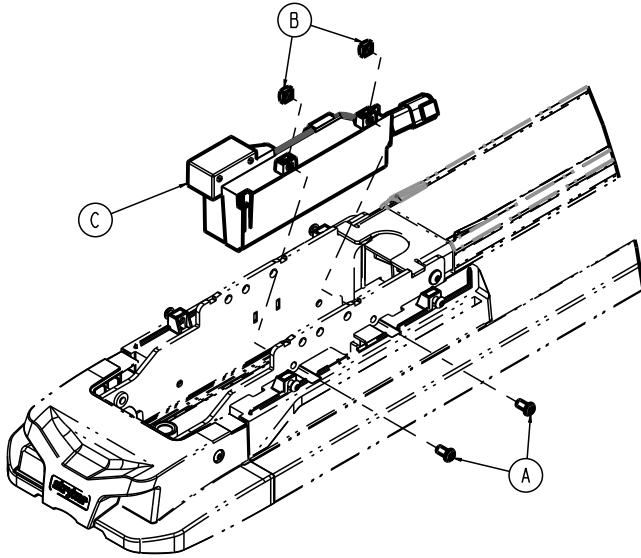

Item	Number	Name	Quantity
A	0004-589-000	Button head cap screw	2
B	0015-096-000	Square nut	2
C	639200010041	<i>Inductive charging assembly</i> (page 26)	1
D	0058-394-000	Cable clip	1

Foot end cover assembly

6392-001-021 Rev A (Reference only)

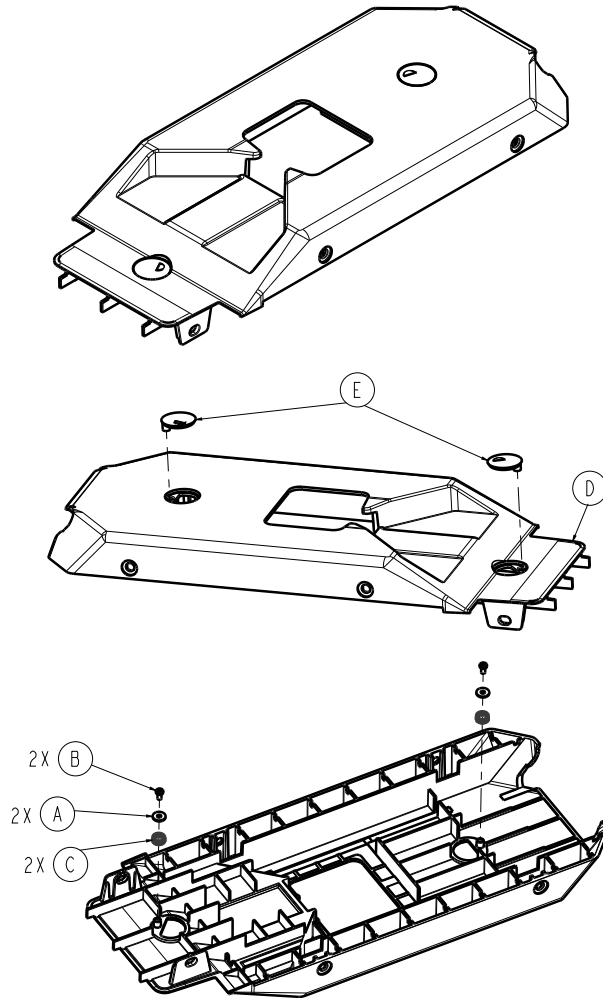

Item	Number	Name	Quantity
A	0011-642-000	Plain washer	2
B	0023-349-000	Pan head thread forming screw	2
C	0038-905-000	Spin cap spring	2
D	6392-001-108	Top cover, foot end	1
E	6392-001-309	Spin cap	2

Foot end interface assembly

6392-001-022 Rev A (Reference only)

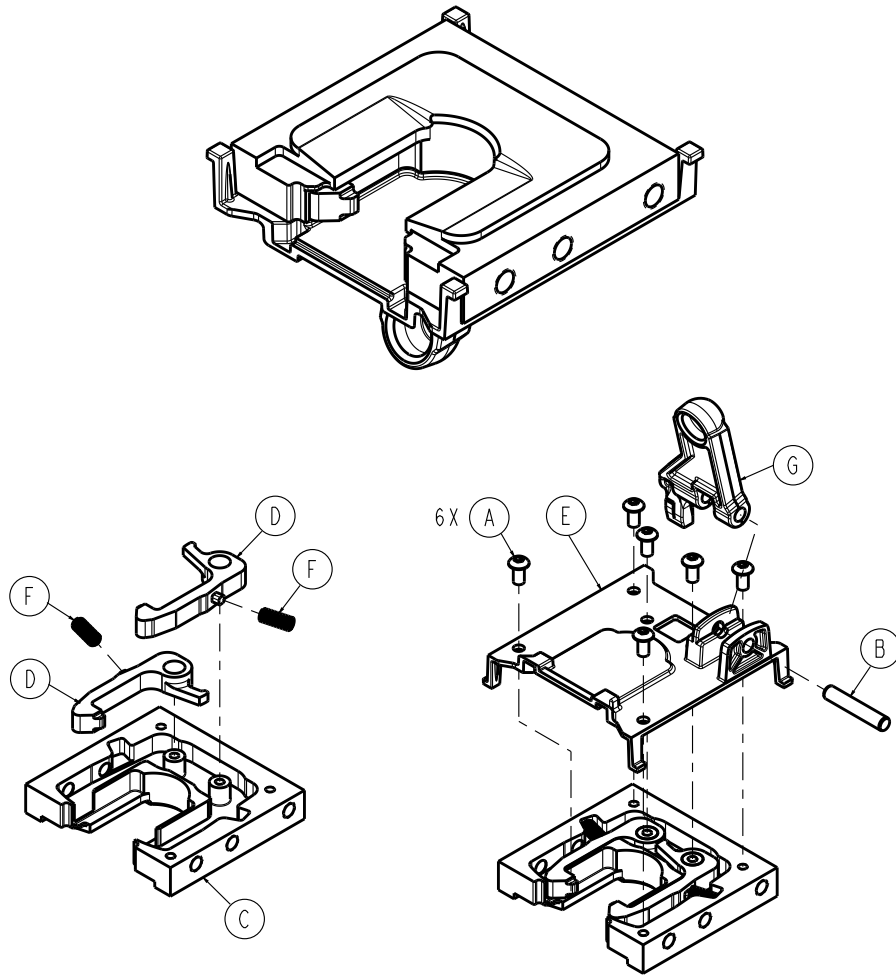

Item	Number	Name	Quantity
A	0004-442-000	Button head cap screw	6
B	0026-556-000	Dowel pin	1
C	6392-001-202	Interface, foot end	1
D	6392-001-250	Lock pawl, foot end	2
E	6392-001-251	Pivot bracket, foot end interface	1
F	6392-001-252	Pawl spring	2
G	6392-001-257	Release latch link arm	1

Foot end nose assembly

6392-001-023 Rev A (Reference only)

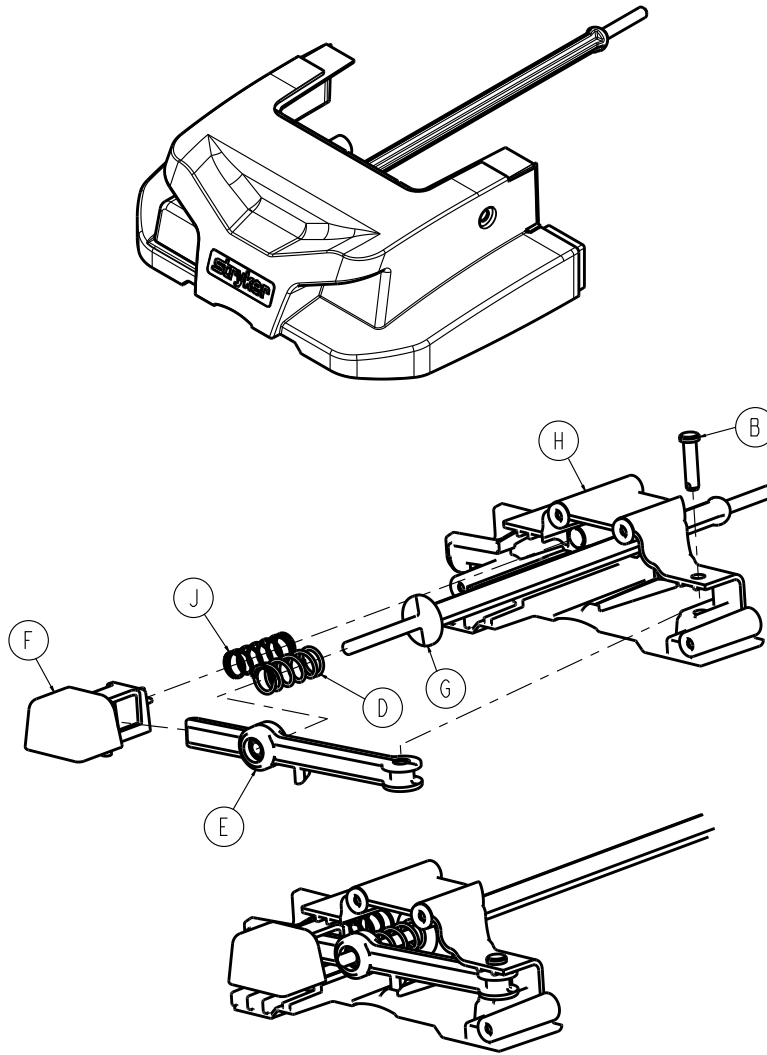

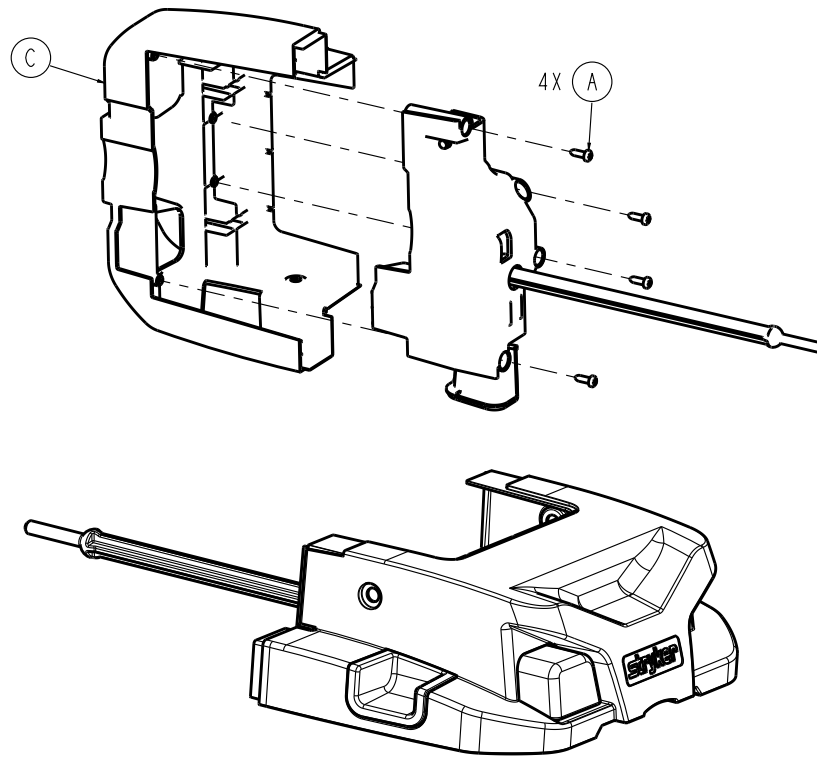

Item	Number	Name	Quantity
A	0023-167-000	Pan head thread forming screw	4
B	0026-316-000	Clevis pin	1
C	6392-001-205	Nose cover	1
D	6392-001-253	Thick release spring	1
E	6392-001-254	Release pivot arm	1
F	6392-001-255	Release button	1
G	6392-001-256	Release lower link	1
H	6392-001-258	Release housing	1
J	6392-001-259	Thin long release spring	1

Head end cover assembly

6392-001-031 Rev A (Reference only)

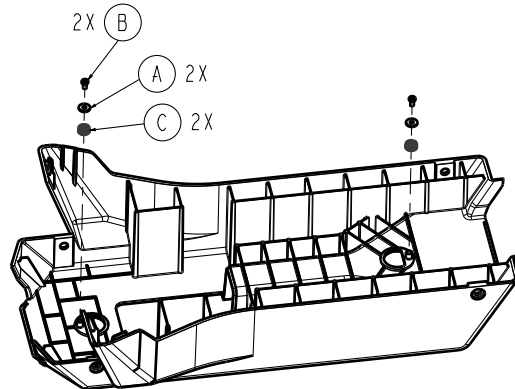
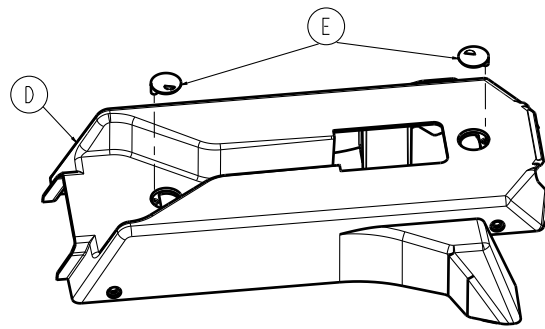
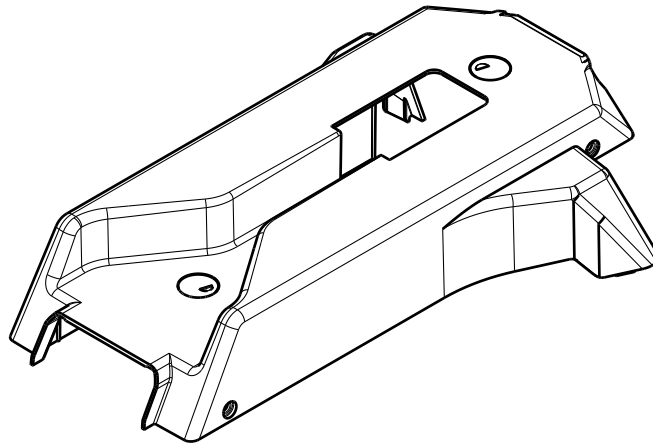

Item	Number	Name	Quantity
A	0011-642-000	Plain washer	2
B	0023-349-000	Pan head thread forming screw	2
C	0038-905-000	Spin can spring	2
D	6392-001-109	Head end top cover	1
E	6392-001-309	Spin cap	2

Head end interface assembly

6392-001-032 Rev A (Reference only)

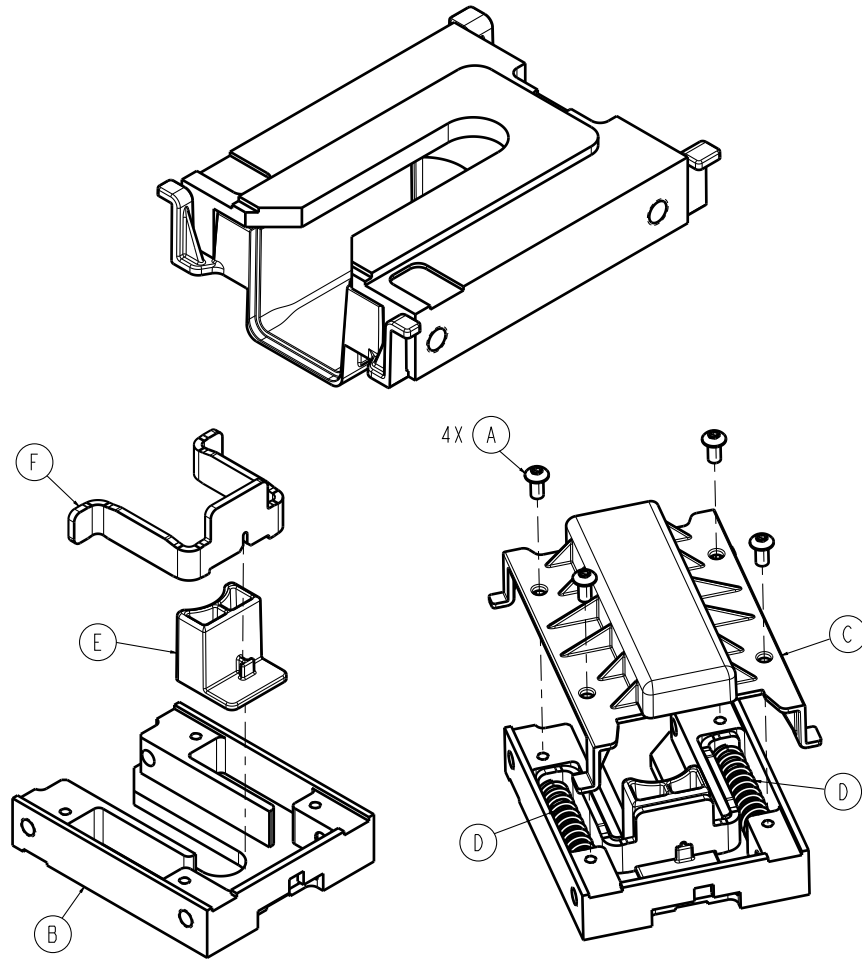

Item	Number	Name	Quantity
A	0004-442-000	Button head cap screw	4
B	6392-001-302	Head end interface	1
C	6392-001-305	Head end pin closure	1
D	6392-001-306	Plunger spring	2
E	6392-001-307	Head end plunger	1
F	6392-001-308	Head end plunger bracket	1

Inductive charging assembly

639200010041 Rev AA (Reference only)

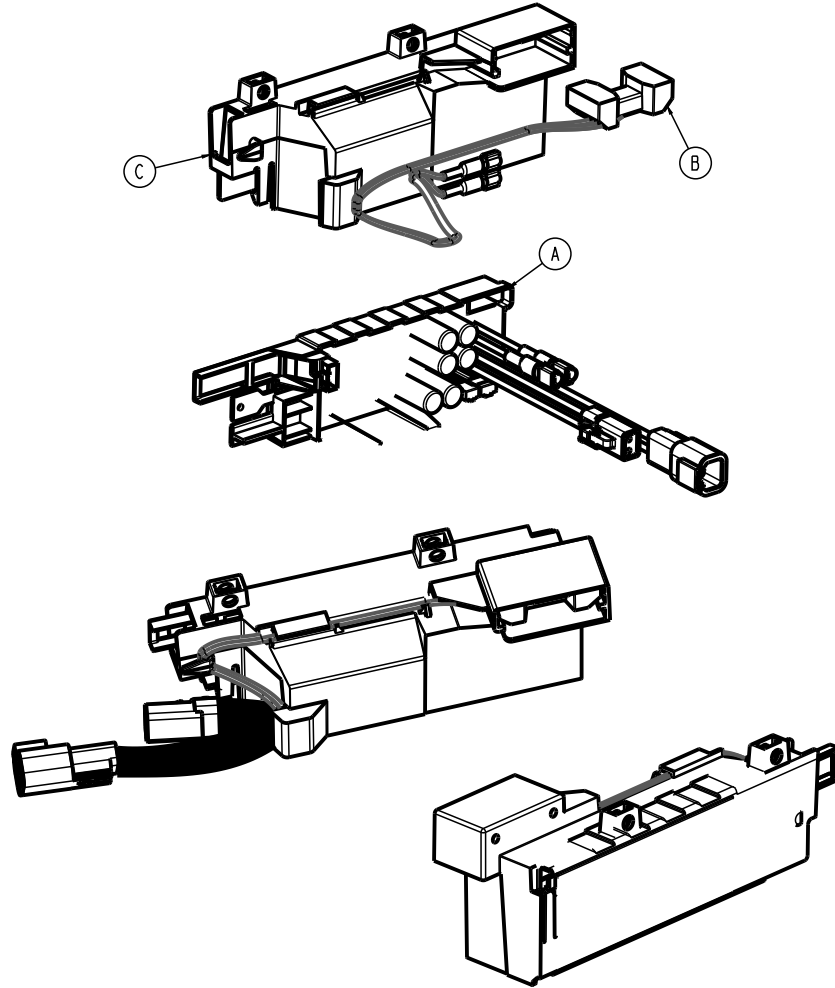

Item	Number	Name	Quantity
A	639002010147	Inductive primary board	1
B	6390-001-133	Anchor primary coil	1
C	6392-001-150	Inductive charging enclosure	1

Head end hitch assembly

6392-001-061 Rev A (Reference only)

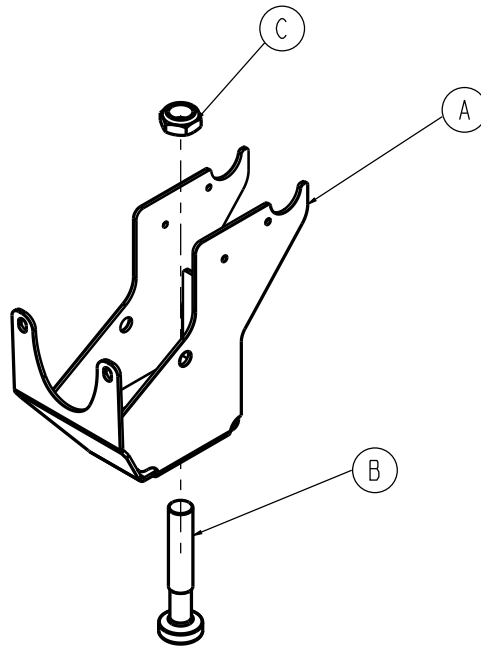

Item	Number	Name	Quantity
A	6392-001-054	Head end hitch weldment	1
B	6392-001-500	Head end hitch pin	1
C	0016-019-000	Nylock hex nut	1

Head end forging assembly

6392-001-062 Rev A (Reference only)

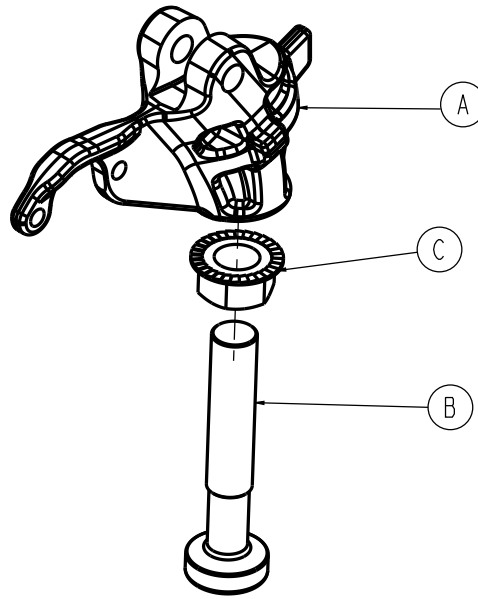

Item	Number	Name	Quantity
A	6392-001-510	Machined forging	1
B	6392-001-500	Head end hitch pin	1
C	0016-323-000	Hex flange serrated lock nut	1

Floor plate, assembly kit

639207000001 Rev AA (Reference only)

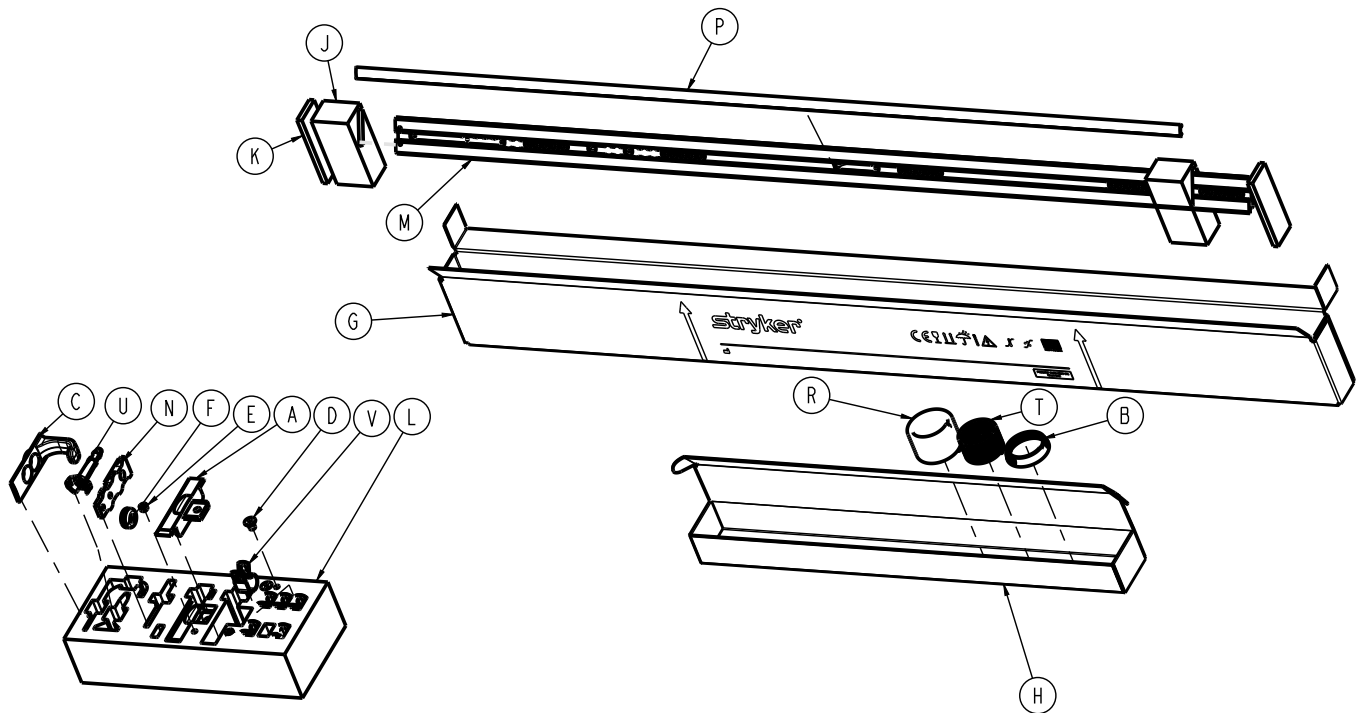

Item	Number	Name	Quantity
A	639000010111	Floor plate end cap, machined	1
B	639000010135	Anchor-to-vehicle cable	1
C	639000010148	Power-LOAD safety hook	1
D	0001-194-000	Flat head cap screw	2
E	0021-197-000	Set screw	2
F	0037-247-000	Rubber grommet	1
G	0054-200-372	Floor plate/wheel guide shipping box	1
H	0054-200-375	Component shipping box	1
J	0054-200-380	Floor plate shipping foam	2
K	0054-200-383	Wheel guide end cap	2
L	0054-401-003	Floor plate foam pack	1
M	6390-001-107	Floor plate	1
N	6390-101-108	Floor plate attachment bracket	1
P	6390-001-109	Floor plate cap	1
R	6390-001-153	Wire protection loom, under ambulance	1
T	6390-001-170	Drain tube	1
U	6390-001-183	Drain tube, floor plate	1
V	6390-001-202	Clamp, rubber coated, p style	6
W	6390-009-044	Model 6390 wiring update memo (not shown)	1
Y	6390-109-020	Floor plate installation instructions (not shown)	1

EMC information

Guidance and manufacturer's declaration - electromagnetic emissions		
<p>Performance-LOAD is intended for use in the electromagnetic environment specified below. The customer or the user of Performance-LOAD should assure that it is used in such an environment.</p>		
Emissions test	Compliance	Electromagnetic environment
RF Emissions CISPR 11	Group 2	The Performance-LOAD system must emit electromagnetic energy in order to perform its intended function. Nearby electronic equipment may be affected.
RF Emissions CISPR 11	Class A	The Performance-LOAD system is suitable for use in all establishments other than domestic and those directly connected to the public low-voltage power supply network that supplies buildings used for domestic purposes.

Recommended separations distances between portable and mobile RF communications equipment and Performance-LOAD			
<p>Performance-LOAD is intended for use in an electromagnetic environment in which radiated RF disturbances are controlled. The customer or the user of Performance-LOAD can help prevent electromagnetic interferences by maintaining a minimum distance between portable and mobile RF communications equipment (transmitters) and Performance-LOAD as recommended below, according to the maximum output power of the communications equipment.</p>			
Rated maximum output power of transmitter W	Separation distance according to frequency of transmitter m		
	150 kHz to 80 MHz $d=(1.2) (\sqrt{P})$	80 MHz to 800 MHz $d=(.18) (\sqrt{P})$	800 MHz to 2.5 GHz $d=(.35) (\sqrt{P})$
0.01	0.12	0.035	0.07
0.1	0.38	0.11	0.22
1	1.2	0.35	0.7
10	3.8	1.1	2.2
100	12	3.5	7
<p>For transmitters rated at a maximum output power not listed above, the recommended separation distance d in meters (m) can be estimated using the equation applicable to the frequency of the transmitter, where P is the maximum output power rating of the transmitter in watts (W) according to the transmitter manufacturer. Note 1: At 80 MHz and 800 MHz, the separation distance for the higher frequency range applies. Note 2: These guidelines may not apply in all situations. Electromagnetic propagation is affected by absorption and reflection from structures, objects, and people.</p>			

Guidance and manufacturer's declaration - electromagnetic immunity			
<p>Performance-LOAD is suitable for use in the electromagnetic environment specified below. The customer or the user of Performance-LOAD should assure that it is used in such an environment.</p>			
Immunity test	EN/IEC 60601 test level	Compliance level	Electromagnetic environment-guidance

Guidance and manufacturer's declaration - electromagnetic immunity

Electrostatic discharge (ESD) IEC 61000-4-2	±8 kV contact ±15 kV air	±8 kV contact ±15 kV air	Floors should be wood, concrete, or ceramic tile. If floors are covered with synthetic material, the relative humidity should be at least 30%.
Power frequency (50/60 Hz) magnetic field IEC 61000-4-8	30 A/m	30 A/m	Power frequency magnetic fields should be at levels characteristic of a typical location in a typical commercial or hospital environment.

Note: U_T is the a.c. mains voltage before applications of the test level.

Conducted RF IEC 61000-4-6	3 Vrms 150 kHz to 80 MHz	3 Vrms	Portable and mobile RF communications equipment should be used no closer to any part of Performance-LOAD , including cables, than the recommended separation distance calculated from the equation appropriate for the frequency of the transmitter.
Radiated RF IEC 61000-4-3	10 V/m 80 MHz to 2.5 GHz	10 V/m	Recommended separation distance $D = (.35) (\sqrt{P})$ 80 MHz to 800 MHz $D = (0.70) (\sqrt{P})$ 800 MHz to 2.5 GHz
			where P is the maximum output power rating of the transmitter in watts (W) according to the transmitter manufacturer and d is the recommended separation distance in meters (m).
			Field strengths from fixed RF transmitters, as determined by an electromagnetic site ^a should be less than the compliance level in each frequency range. ^b
			Interference may occur in the vicinity of equipment marked with the following symbol: 

Guidance and manufacturer's declaration - electromagnetic immunity

Note 1: At 80 MHz and 800 MHz, the higher frequency range applies.

Note 2: These guidelines may not apply in all situations. Electromagnetic propagation is affected by absorption and reflection from structures, objects, and people.

^a Field strengths from fixed transmitters, such as base stations for radio (cellular/cordless) telephones and land mobile radios, amateur radio, AM and FM radio broadcast, and TV broadcast cannot be predicted theoretically with accuracy. To assess the electromagnetic environment due to fixed RF transmitters, an electromagnetic site survey should be considered. If the measured field strength in the location in which **Performance-LOAD** is used exceeds the applicable RF compliance level above, the **Performance-LOAD** system should be observed to verify normal operation. If abnormal performance is observed, additional measures may be necessary, such as reorienting or relocating **Performance-LOAD**.

^b Over the frequency range 150 kHz to 80 MHz, field strengths should be less than 3 V/m.

stryker



Stryker Medical
3800 E. Centre Avenue
Portage, MI 49002
USA