

IMPORTANT
File in your
maintenance
records

stryker[®]
Medical

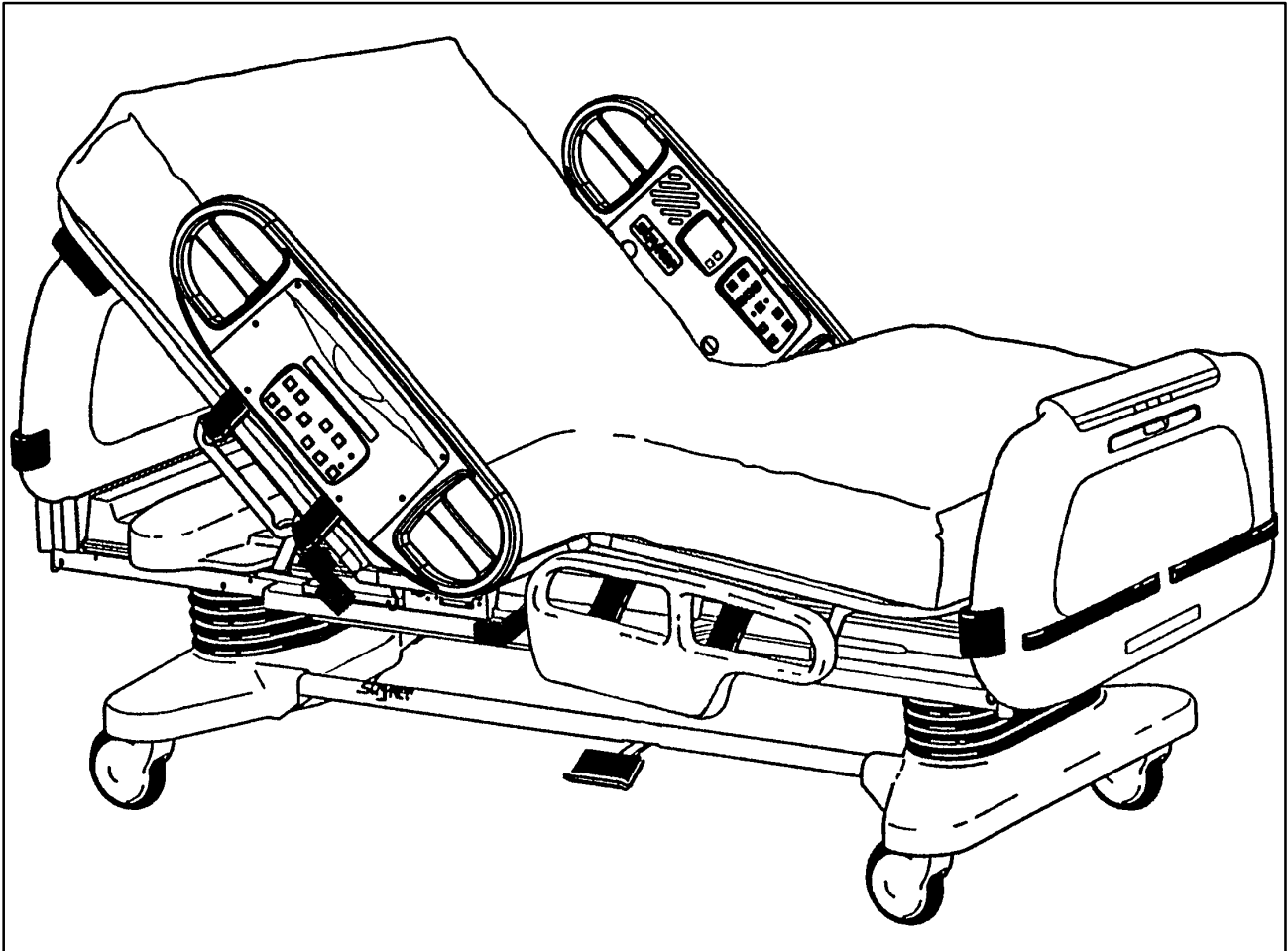

Secure 3000 Bed

MAINTENANCE MANUAL

For beds with serial numbers 980515174 and above.

For Parts or Technical Assistance
1-800-327-0770

Table of Contents

Introduction	
Specifications	4
Warning / Caution / Note Definition	4
Safety Tips And Guidelines	5
Limited Warranty	
Obtaining Parts and Service	6
Return Authorization	6
Freight Damage Claims	7
Service Contract Coverage	7
Preventative Maintenance	
Cleaning	8
Maintenance Checklist	9
Set-Up Procedures	10
Bed Illustration	11
Brake Pedal Operation	12
Steer Pedal Operation	12
CPR Emergency Release Usage	13
Foley Bag Hooks Usage	13
Foot Prop Usage	13
Fracture Frame Usage	13
I.V. Poles	14
Night Light Usage	15
Patient Restraint Strap Locations	15
Chart Rack Usage	16
CPR Board Usage	16
Positioning Siderails	17
Siderail Control Panel Lights	17
Inside Siderail Function Guide	18
Outside Siderail Function Guide	19
Dynamic Mattress System Usage	20
Foot Board Control Panel Guide	21–23
Weigh System Operation Guide	24–27
Static Discharge Precautions	28
Troubleshooting	
Troubleshooting Guide	29–30
Bed Circuit Boards	31–34.2
Head Wall Output Configuration	35
Replacement Parts List	36, 37
Maintenance Procedures	
Brake Pedal Replacement	38
Lift Motor and Capacitor Removal and Replacement	39
Lift Motor Isolation Plate Replacement	40
Lift Housing Removal and Replacement	41, 42
Lift Potentiometer Replacement and Adjustment	43, 44
Lift Potentiometer “Burn-In” Procedure	44
Lift Motor Coupler Replacement	45

Table of Contents

Maintenance Procedures (Continued)

Power and Sensor Coil Cord Replacement	46, 47
Knee Motor Removal and Replacement	48
Head Motor Cam and Cam Guide Replacement	49
Head Motor Limit Setting	50
Head Motor Removal and Replacement	51
Head Motor Drive Isolator and CPR Decoupler Removal and Replacement	52
Head Motor Drive Screw and Ball Nut Replacement	53, 54
Scale System Diagnostic Procedure	55, 56
Load Cell Replacement	57, 58
Power Board Replacement	58
CPU Board Replacement	59
Potentiometer “Burn-In” Procedure	59
Siderail Cover Removal	60
Molded Siderail Replacement	61
Head End Siderail Cable Replacement	62, 63
Siderail Assembly Removal	64
Foot Board Hinge Removal	65
Foot Board Module Replacement	65
Foot Board Interface Plug Replacement	66
DMS Cover Replacement	67
DMS Air Bladder Replacement	68
DMS Foam Base Assembly Replacement	68
DMS Pendant Replacement	69
DMS Power Supply Replacement	70
DMS Control Unit Circuit Board Replacement	71
DMS Control Unit Air Compressor Replacement	71, 72
DMS Control Unit Replacement	72

Assembly Drawings and Parts Lists

Bed Assembly	73, 74
Base Assembly	75–83
Lift Assembly	84–87
Isolation Plate Assembly	88
Brake Crank Assembly	89
Brake Bar Assembly	90
Brake Shaft Assembly	91
6” Caster Assembly	92–94
8” Caster Assembly	95–97
Litter Assembly	98–106
CPU Cover Assembly	107
Foot Cover Assembly	108
Litter Assembly, Electrical	109–115
Litter Assembly, Mechanical	116–119
Lift Header Assemblies	120, 121
230V Surge Suppressor Assembly	122
Gatch Motor Assembly	123

Table of Contents

Assembly Drawings and Parts Lists (Continued)

Fowler Drive Assembly	124, 125
Fowler Limit Switch Assembly	126, 127
Litter Assembly, Optional 110V Outlet	128, 129
Outlet Box Assembly	130
Litter Assembly, Optional Scale and/or Bed Exit	132, 133
Litter Assembly, 12V DMS Option	134, 135
Litter Assembly, 24V Hybrid DMS Option	136, 137
Optional DMS Mattress Assembly	138, 139
Litter Assembly, StryKair Mattress Option	140, 141
Litter Assembly, Optional HWI w/Communication	142, 143
Litter Assembly, Optional HWI w/Communication and Ports	144–146
Battery Enclosure Assembly	147
Litter Assembly, Optional Night Light	148, 149
Head End Siderail Assembly	150–156
Siderail Panel Assembly	157, 158
Head End Siderail Options	159–180
Siderail DMS Module Assembly	181
Foot End Siderail Assembly	182–184
Siderail Release Lever Assembly	185, 186
Siderail Support Assembly	187, 188
Foot Board Assembly	189–193
Foot Board Standard Module Assembly	194
Foot Board Optional Bed Exit Module Assembly	195
Head Board Assembly	196
Optional CPR Board Assembly	197
Optional Pendant Assembly	198
Removable I.V. Pole Mounting Assembly	199
Removable I.V. Pole Assembly	200
Permanent I.V. Pole Mounting Assembly, Head End	201
Permanent I.V. Pole Mounting Assembly, Foot End	202
Permanently Mounted I.V. Pole Assembly	203
Litter Roller Option	204
90° Power Cord Option	205
Accessory Adapter Frame Option	206, 207
Bed Extender Option	208–211
Bed Extender Mattress	212
Telephone Mounting Bracket Option	213
Optional Traction Socket Extension	214
Optional Urine Bottle Hanger	215
Optional Padded Siderail Cover Kits	216

Introduction

INTRODUCTION

This manual is designed to assist you with the maintenance of the Secure 3000 Bed. Read it thoroughly before beginning any maintenance on the equipment.

SPECIFICATIONS

Maximum Weight Capacity	500 pounds (227 kilograms)
Overall Bed Length/Width	93" x 42-1/2" (with siderails up) – 36" (with siderails down) 238 cm. x 109 cm. (with siderails up) – 92 cm. (with siderails down)
Patient Sleep Surface	84" x 35" – 215 cm. x 90 cm.
Bed Height (to top of seat litter)	16" (Low) x 29-1/2" (High) – 41 cm. (Low) x 76 cm. (High)
Knee Gatch Angle	0° to 40°
Fowler Angle	0° to 60°
Trendelenburg/Reverse Trendelenburg	-11° to +11°
Weigh System Accuracy (optional equipment)	± 1% of total patient weight while the bed is level and up to a 4° or -4° angle ± 3% of total patient weight from 5° to 11° angle or -5° to -11° angle
Electrical Requirements – all electrical requirements meet UL 544 specifications.	115 VAC, 60 Hz, 7.0 Amp. w/o outlet 115 VAC, 60 Hz, 12.0 Amp. w/outlet 230 VAC, 50/60 Hz, 4.0 Amp.

Stryker reserves the right to change specifications without notice.

WARNING / CAUTION / NOTE DEFINITION

The words WARNING, CAUTION and NOTE carry special meanings and should be carefully reviewed.

WARNING

The personal safety of the patient or user may be involved. Disregarding this information could result in injury to the patient or user.

CAUTION

These instructions point out special procedures or precautions that must be followed to avoid damaging the equipment.

NOTE

This provides special information to make important instructions clearer.

WARNING

Always apply the caster brakes when a patient is getting on or off the bed. Push on the bed to ensure the brakes are securely locked. Always engage the brakes unless the bed is being moved. Injury could result if the bed moves while a patient is getting on or off the bed.

Introduction

SAFETY TIPS AND GUIDELINES

Before operating the Secure Bed, it is important to read and understand all information in this manual. Carefully read and strictly follow the safety guidelines listed on this page.

It is important that all users have been trained and educated on the inherent hazards associated with the usage of electric beds.

WARNING

- The Secure 3000 Bed is not intended for use with patients less than two years of age.
 - Powered bed mechanisms can cause serious injury. Operate bed only when all persons are clear of the mechanisms.
 - To help reduce the number and severity of falls by patients, always leave the bed in the lowest position when the patient is unattended.
 - Leave the siderails fully up and locked when the patient is unattended. When raising the siderails, listen for the "click" that indicates the siderail has locked in the up position. Pull firmly on the siderail to ensure it is locked into position.
Siderails are not intended to be a patient restraint device. It is the responsibility of the attending medical personnel to determine the degree of restraint necessary to ensure a patient will remain safely in bed.
 - Always keep the caster brakes applied when a patient is on the bed (except during transport). Serious injury could result if the bed moves while a patient is getting in or out of bed. After the brake pedal is applied, push on the bed to ensure the brakes are locked. When moving the bed, toggle the steer pedal to put the bed in the steer mode. This locks the swivel motion of the right foot end caster and makes the bed easier to move.
 - Do not attempt to move the foot end of the bed laterally when the steer pedal is activated. When the steer pedal is activated, the steer caster at the foot end of the bed cannot swivel. Attempting to move the bed laterally when the steer pedal is activated may cause injury to the user.
 - When large spills occur in the area of the circuit boards, 110 volt cables and motors, immediately unplug the bed power cord from the wall socket. Remove the patient from the bed and clean up the fluid. Have maintenance completely check the bed. Fluids can affect the operational capabilities of any electrical product. **DO NOT** put the bed back into service until it is completely dry and has been thoroughly tested for safe operation.
 - Do not steam clean or hose off the bed. Do not immerse any part of the bed. The internal electric parts may be damaged by exposure to water. Hand wash all surfaces of the bed with warm water and mild detergent. Dry thoroughly. Quaternary Germicidal Disinfectants, used as directed, and/or Chlorine Bleach products, typically 5.25% Sodium Hypochlorite in dilutions ranging between 1 part bleach to 100 parts water, and 2 parts bleach to 100 parts water are **not** considered mild detergents. **THESE PRODUCTS ARE CORROSIVE IN NATURE AND MAY CAUSE DAMAGE TO YOUR BED IF USED IMPROPERLY.** If these types of products are used to clean Stryker patient care equipment, measures must be taken to insure the beds are wiped with clean water and thoroughly dried following cleaning. Failure to properly rinse and dry the beds will leave a corrosive residue on the surface of the bed, possibly causing premature corrosion of critical components. Failure to follow the above directions when using these types of cleaners may void this product's warranty.
Clean Velcro **AFTER EACH USE**. Saturate Velcro with disinfectant and allow disinfectant to evaporate. (Appropriate disinfectant for nylon Velcro should be determined by the hospital.)
 - Preventative maintenance should be performed at a minimum of biannually to ensure all bed features are functioning properly. Close attention should be given to safety features including, but not limited to: safety side latching mechanisms, frayed electrical cords and components, all electrical controls return to off or neutral position when released, caster braking systems, no controls or cabling entangled in bed mechanisms, leakage current 100 MA maximum, scale and bed exit systems calibrated properly.
 - Always unplug bed during service or cleaning. When working under the bed with the bed in the high position, always place blocks under the litter frame and set the brakes to prevent injury in case the Bed Down switch is accidentally pressed.
-

Warranty

Limited Warranty:

Stryker Medical Division, a division of Stryker Corporation, warrants to the original purchaser that its products should be free from defects in material and workmanship for a period of either: one (1) year parts and labor or two (2) years for parts only, after date of delivery. Stryker's obligation under this warranty is expressly limited to supplying replacement parts for, or replacing, at its option, any product which is, in the sole discretion of Stryker, found to be defective. Stryker warrants to the original purchaser that the frame and welds on its beds will be free from structural defects for as long as the original purchaser owns the bed. If requested by Stryker, products or parts for which a warranty claim is made shall be returned prepaid to Stryker's factory. Any improper use or any alteration or repair by others in such manner as in Stryker's judgement affects the product materially and adversely shall void this warranty. No employee or representative of Stryker is authorized to change this warranty in any way.

This statement constitutes Stryker's entire warranty with respect to the aforesaid equipment. STRYKER MAKES NO OTHER WARRANTY OR REPRESENTATION, EITHER EXPRESSED OR IMPLIED, EXCEPT AS SET FORTH HEREIN. THERE IS NO WARRANTY OF MERCHANTABILITY AND THERE ARE NO WARRANTIES OF FITNESS FOR ANY PARTICULAR PURPOSE. IN NO EVENT SHALL STRYKER BE LIABLE HEREUNDER FOR INCIDENTAL OR CONSEQUENTIAL DAMAGES ARISING FROM OR IN ANY MANNER RELATED TO SALES OR USE OF ANY SUCH EQUIPMENT.

To Obtain Parts and Service:

Stryker products are supported by a nationwide network of dedicated Stryker Field Service Representatives. These representatives are factory trained, available locally, and carry a substantial spare parts inventory to minimize repair time. Simply call your local representative, or call Stryker Customer Service at (800) 327-0770.

Extended Warranty Coverage:

Stryker offers warranties to provide an extension of the above stated warranty, that are available upon the purchase of the Model 3000 Bed.

Covered under these warranties:

- All replacement parts, as set forth in the limited warranty statement above (excluding mattresses and consumable items)
NOTE: mattresses carry a separate warranty plan. Refer to mattress documentation.
- Labor and Travel for all scheduled and unscheduled calls (if labor option is chosen).

The following extended options are available at a nominal charge:

- 3 years parts – no labor (1 year extension to standard 2 year parts warranty).
- 4 years parts – no labor (2 year extension to standard 2 year parts warranty).
- 5 years parts – no labor (3 year extension to standard 2 year parts warranty).

- 2 years parts and labor (1 year extension to standard 1 year parts and labor warranty).
- 3 years parts and labor (2 year extension to standard 1 year parts and labor warranty).
- 4 years parts and labor (3 year extension to standard 1 year parts and labor warranty).
- 5 years parts and labor (4 year extension to standard 1 year parts and labor warranty).

Warranty

Return Authorization:

Merchandise cannot be returned without approval from the Stryker Customer Service Department. An authorization number will be provided which must be printed on the returned merchandise. Stryker reserves the right to charge shipping and restocking fees on returned items.

SPECIAL, MODIFIED, OR DISCONTINUED ITEMS NOT SUBJECT TO RETURN.

Damaged Merchandise:

ICC Regulations require that claims for damaged merchandise must be made with the carrier within fifteen (15) days of receipt of merchandise. **DO NOT ACCEPT DAMAGED SHIPMENTS UNLESS SUCH DAMAGE IS NOTED ON THE DELIVERY RECEIPT AT THE TIME OF RECEIPT.** Stryker Customer Service must be notified immediately. Stryker will aid the customer in filing a freight claim with the appropriate carrier for damages incurred. Claim will be limited in amount to the actual replacement cost. In the event that this information is not received by Stryker within the fifteen (15) day period following the delivery of the merchandise, or the damage was not noted on the delivery receipt at the time of receipt, the customer will be responsible for payment of the original invoice in full.

Claims for any short shipment must be made within thirty (30) days of invoice.

International Warranty Clause:

This warranty reflects U.S. domestic policy. Warranty outside the U.S. may vary by country. Please contact your local Stryker Medical representative for additional information.

Service Contract Coverage (Optional):

Stryker has developed a comprehensive program of service contract options designed to keep your equipment operating at peak performance at the same time it eliminates unexpected costs. We recommend that these programs be activated *before* the expiration of the new product warranty to eliminate the potential of additional equipment upgrade charges. Stryker offers the following contract coverages at a nominal fee:

Extended (Parts and Labor)

- All replacement parts (excluding mattresses and consumable items)
- Labor and travel for *all* scheduled and unscheduled calls
- Annual Preventive Maintenance Inspections and repairs
- JCAHO paperwork for preventive maintenance
- Priority Emergency Service

Standard (Labor Only):

- Labor and travel for *all* scheduled and unscheduled calls
- Annual Preventive Maintenance Inspections and repairs
- JCAHO paperwork for preventive maintenance
- Priority Emergency Service

Basic (Parts Only):

- All replacement parts (excluding mattresses and consumable items)
- Priority Emergency Service

Please call your local representative, or call (800) 327-0770 for further information

Preventative Maintenance

Hand wash all surfaces of the bed with warm water and mild detergent. Dry thoroughly. **DO NOT STEAM CLEAN, PRESSURE WASH, HOSE OFF OR ULTRASONICALLY CLEAN.** Using these methods of cleaning is **not** recommended and may void this product's warranty.

Clean Velcro **AFTER EACH USE**. Saturate Velcro with disinfectant and allow disinfectant to evaporate. (Appropriate disinfectant for nylon Velcro should be determined by the hospital.)

In general, when used in those concentrations recommended by the manufacturer, either phenolic type or quaternary type disinfectants can be used with Staph–Chek fabrics. Iodophor type disinfectants are not recommended for use on Staph–Chek fabrics because staining may result. The following products have been tested by the Herculite Laboratory and have been found not to have a harmful effect on Staph–Chek fabrics **WHEN USED IN ACCORDANCE WITH MANUFACTURERS RECOMMENDED DILUTION.***

TRADE NAME	DISINFECTANT TYPE	MANUFACTURER	*MANUFACTURER'S RECOMMENDED DILUTION
A33	Quaternary	Airwick (Professional Products Division)	2 ounces/gallon
A33 (dry)	Quaternary	Airwick (Professional Products Division)	1/2 ounce/gallon
Beaucoup	Phenolic	Huntington Laboratories	1 ounce/gallon
Blue Chip	Quaternary	S.C. Johnson	2 ounces/gallon
Elimstaph	Quaternary	Walter G. Legge	1 ounce/gallon
Franklin Phenomysan F2500	Phenolic	Purex Corporation	1 1/4 ounce/gallon
Franklin Sentinel	Quaternary	Purex Corporation	2 ounces/gallon
Galahad	Phenolic	Puritan Churchill Chemical Company	1 ounce/gallon
Hi–Tor	Quaternary	Huntington Laboratories	1/2 ounce/gallon
LPH	Phenolic	Vestal Laboratories	1/2 ounce/gallon
Matar	Phenolic	Huntington Laboratories	1/2 ounce/gallon
Omega	Quaternary	Airwick (Professional Products Division)	1/2 ounce/gallon
Quanto	Quaternary	Huntington Laboratories	1 ounce/gallon
Sanikleen	Quaternary	West Chemical Products	2 ounces/ gallon
Sanimaster II	Quaternary	Service Master	1 ounce/gallon
Vesphene	Phenolic	Vestal Laboratories	1 1/4 ounce/ gallon

Quaternary Germicidal Disinfectants, used as directed, and/or Chlorine Bleach products, typically 5.25% Sodium Hypochlorite in **dilutions ranging between 1 part bleach to 100 parts water, and 2 parts bleach to 100 parts water are not considered mild detergents. These products are corrosive in nature and may cause damage to your stretcher if used improperly.** If these types of products are used to clean Stryker patient handling equipment, measures must be taken to insure the stretchers are rinsed with clean water and thoroughly dried following cleaning. Failure to properly rinse and dry the stretchers will leave a corrosive residue on the surface of the stretcher, possibly causing premature corrosion of critical components.

NOTE

Failure to follow the above directions when using these types of cleaners may void this product's warranty.

REMOVAL OF IODINE COMPOUNDS

This solution may be used to remove iodine stains from mattress cover and foam footrest pad surfaces.

1. Use a solution of 1–2 tablespoons Sodium Thiosulfate in a pint of warm water to clean the stained area. Clean as soon as possible after staining occurs. If stains are not immediately removed, allow solution to soak or stand on the surface.
2. Rinse surfaces which have been exposed to the solution in clear water before returning bed to service.

Preventative Maintenance

CHECKLIST

- _____ All fasteners secure (reference all assembly prints)
- _____ Engage brake pedal and push on the bed to ensure all casters lock securely
- _____ "Brake Not Set" LED (on foot board) blinks when brakes are not engaged
- _____ Locking steer caster engages and disengages properly
- _____ Siderails move, latch and stow properly
- _____ CPR release working properly
- _____ Foot prop intact and working properly
- _____ I.V. pole working properly
- _____ Foley bag hooks intact
- _____ Optional chart rack intact and working properly
- _____ Optional CPR board not cracked or damaged and stores properly
- _____ No cracks or splits in head and foot boards
- _____ No rips or cracks in mattress cover
- _____ All functions on head end siderails working properly (including LED's)
- _____ All functions on footboard working properly (including LED's)
- _____ Scale and Bed Exit system calibrated properly
- _____ Motion Interrupt switches working properly
- _____ Optional night light working properly
- _____ Power cord not frayed
- _____ No cables worn or pinched
- _____ All electrical connections tight
- _____ All grounds secure to the frame
- _____ Ground impedance not more than 100 milliohms
- _____ Current leakage not more than 100 microamps
- _____ Apply grease to litter grease points

Bed Serial No. _____

Completed By: _____ Date: _____

NOTE

Preventative maintenance should be performed at a minimum of annually. A preventative maintenance program should be established for all Stryker Medical equipment. Preventative maintenance may need to be performed more frequently based on the usage level of the product.

LITTER GREASE POINTS

1. All litter pivot joint bushings – "Syntech" synthetic grease.
2. All Gatch and Fowler pivot link bushings – "Syntech" synthetic grease.
3. Fowler drive screw – "Mobil 28" grease.

Set-Up Procedures

SET-UP PROCEDURES

It is important that the Secure 3000 Bed is working properly before it is put into service. The following list will help ensure that each part of the bed is tested.

- Plug the bed into a properly grounded, hospital grade wall receptacle and ensure the "Power" LED light at the foot end of the bed comes on.

WARNING

The 3000 is equipped with a hospital grade plug for protection against shock hazard. It must be plugged directly into a properly grounded three-prong receptacle. Grounding reliability can be achieved only when a hospital grade receptacle is used.

-
- Plug the optional interface cable into the 37 pin connector under the litter frame at the head end of the bed, and into the "Patient Station", "Head Wall", "Dock Station", or equivalent (whichever applies). Test the interface cable to verify it is functioning properly.

WARNING

Use only a Stryker supplied interface cable. Use of any other cable may cause the bed to function improperly which may result in patient or user injury.

-
- Ensure the siderails raise, lower and store smoothly and lock in the up and intermediate positions (page 17).
 - Ensure that all four casters lock when the brake pedal is engaged (page 12).

NOTE

Ensure that the "Brake Not Set" LEDs located on the outside of the head end siderails and on the foot board control panel come on when the brakes are disengaged.

- Run through each function on the foot board control panel to ensure that each function is working properly (page 21–23).
- Run through each function on both head end siderails to ensure that each is working properly (page 18–20).
- Activate the motion stop system to ensure it is functioning properly: press and hold down the BED DOWN key. As the bed lowers, lift up on the motion interrupt pan (page 11) and ensure the downward motion stops. Release the pan and allow the downward motion to continue.

NOTE

The bed's upward motion or other functions are not disrupted by the motion stop system.

If any problems are found during bed set-up, contact Stryker Customer Service at 800–327–0770.

Damaged Merchandise

ICC Regulations require that claims for damaged merchandise must be made with the carrier within fifteen (15) days of receipt of merchandise. **DO NOT ACCEPT DAMAGED SHIPMENTS UNLESS SUCH DAMAGE IS NOTED ON THE DELIVERY RECEIPT AT THE TIME OF RECEIPT.** Stryker Customer Service must be notified immediately. Stryker will aid the customer in filing a freight claim with the appropriate carrier for damages incurred. Claim will be limited in amount to the actual replacement cost. In the event that this information is not received by Stryker within the fifteen (15) day period following the delivery of the merchandise, or the damage was not noted on the delivery receipt at the time of receipt, the customer will be responsible for payment of the original invoice in full.

Claims for any short shipment must be made within thirty (30) days of invoice.

Bed Illustration

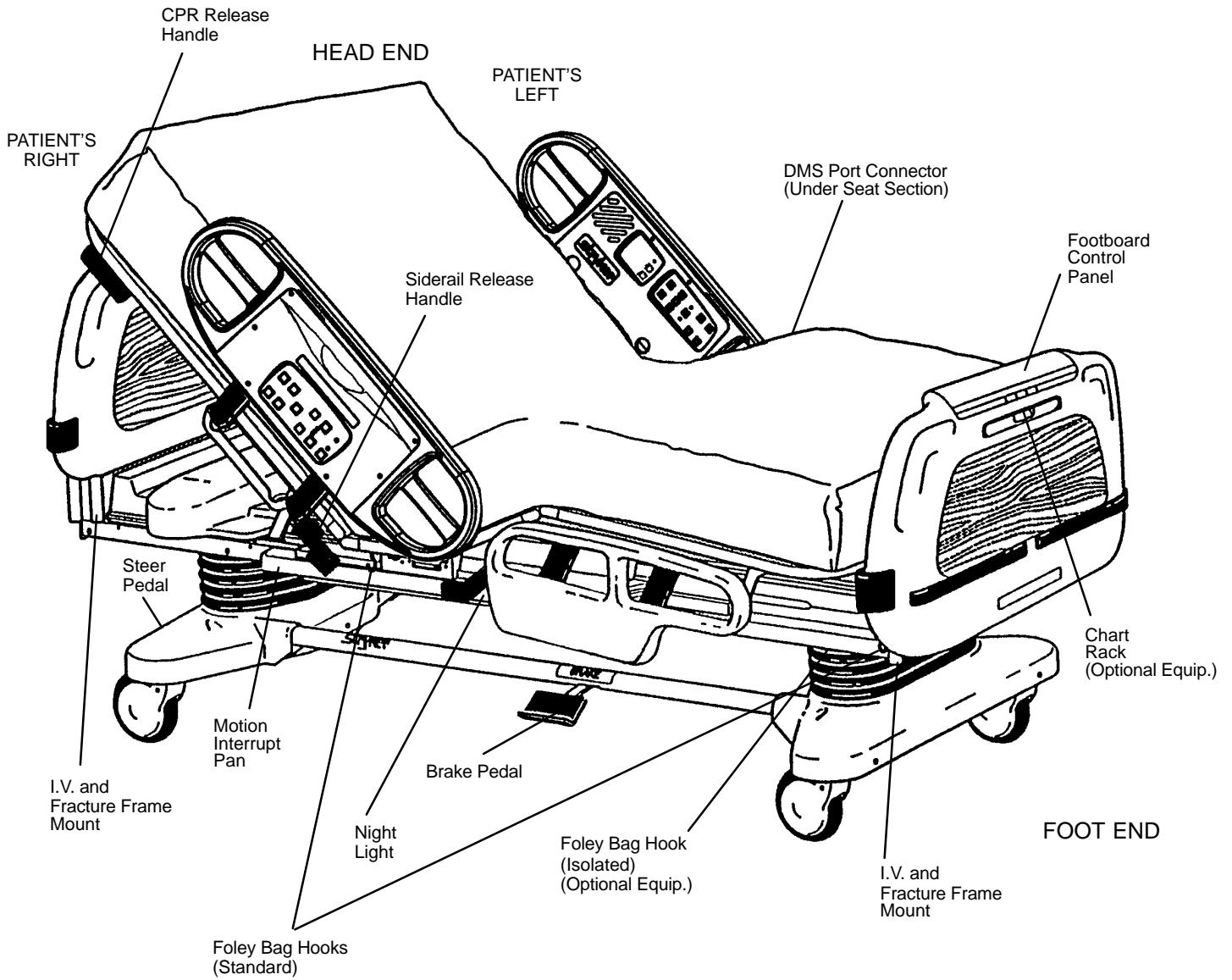

Base Operation Guide

BRAKE PEDAL OPERATION

WARNING

Always apply the caster brakes when a patient is getting on or off the bed. Push on the bed to ensure the brakes are securely locked. Always engage the brakes unless the bed is being moved. Injury could result if the bed moves while a patient is getting on or off the bed.

To activate the brakes, push down once on the pedal identified by the label at right (located at the midpoint of the bed on both sides). To disengage, push down once.



NOTE

There are LED lights on the outside of the head end siderails and on the foot end control panel that will blink when the brakes are not engaged only if the bed is plugged into a wall socket (see pages 20 & 21). The brakes will still operate properly when the bed is not plugged in.

STEER PEDAL OPERATION

The purpose of the steer caster is to help guide the bed along a straight line and to help with pivoting at corners when the bed is moved.

To activate the steer caster, move the pedal located at the head end of the bed to your left as shown on the label.



NOTE

For proper "tracking" of the steer caster, push the bed approximately 10 feet to allow the wheels to face the direction of travel before engaging the steer pedal. If this is not done, proper "tracking" will not occur and the bed will be difficult to steer.

WARNING

Do not attempt to move the foot end of the bed laterally when the steer pedal is activated. When the steer pedal is activated, the steer caster at the foot end of the bed cannot swivel. Attempting to move the bed laterally when the steer pedal is activated may cause injury to the user.

Litter Operation Guide

CPR EMERGENCY RELEASE USAGE

When quick access to the patient is needed, and the Fowler is raised, squeeze one of the two red release handles (see illustration, page 11) and the Fowler can be guided down to a flat position.

NOTE

The handle can be released at any time to stop the Fowler from lowering.

FOLEY BAG HOOKS USAGE, STANDARD AND ISOLATED (Isolated Optional Equipment)

The standard Foley bag hooks are found at two locations on both sides of the bed, under the frame rail below the seat section and at the extreme foot end of the bed.

NOTE

The patient weight reading on the bed scale system will be affected by using the standard Foley bag hooks.

The optional isolated Foley bag hooks are located under the litter frame at the top of the foot end bellows.

CAUTION

The Foley bag hooks move when the Fowler is raised or lowered. Fowler motion must be locked out when using these hooks to avoid inadvertent movement of the hooks.

NOTE

The patient weight reading on the bed scale system will not be affected by usage of the isolated Foley bag hooks.

FOOT PROP USAGE

To prop the foot end of the Knee Gatch up, grasp the handle (A) at the end of the Knee Gatch and lift upward, allowing the latch arm to engage at the desired height. To release the prop, (B) lift up on the handle (A) and swing the foot prop (B) toward the head end of the bed to disengage the hinge and allow the foot end to lower.

WARNING

The purpose of the foot prop is to elevate a patient's feet. To avoid injury while cleaning or servicing under the foot section, secure the foot section with string or bungee cords or hold it up out of the way.

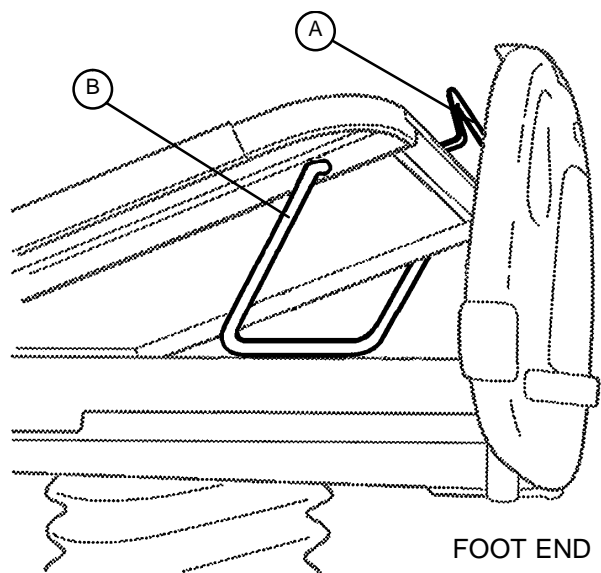

FRACTURE FRAME USAGE

A standard fracture frame can be mounted on the bed using the I.V. sockets located on all four corners of the bed. I.V. poles can be used in conjunction with a fracture frame if I. V. pole adaptor sockets are purchased.

WARNING

Use only retractable traction or fracture frames. Failure to use a retractable frame may result in injury to the patient and/or damage to the equipment.

Litter Operation Guide

I.V. POLES

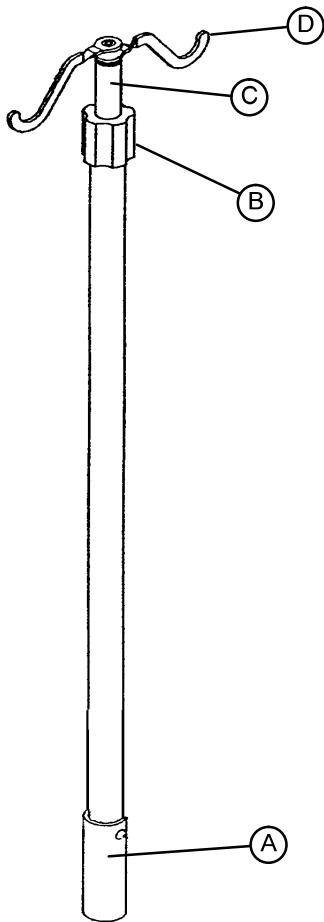

To use the Permanently Attached I.V. pole (optional equipment):

1. Lift and pivot the pole from the storage position and push down until it is locked into receptacle (A).
2. To raise the height of the pole, turn the lock actuator (B) counter-clockwise and pull up on the telescoping portion (C) of the pole to raise it to the desired height.
3. Turn the lock actuator (B) clockwise to lock the telescoping portion in place.
4. Rotate the I.V. hangers (D) to desired position and hang I.V. bags.

CAUTION

The weight of the I.V. bags should not exceed 40 pounds.

To use the "Removable" I.V. pole (optional equipment):

1. Remove the pole from its storage position located at the foot end of the bed, under the foot board, or at the left side of the bed below the litter.
2. Install the pole at any of the six receptacles on the bed top (located on all four corners of the bed and at the midpoint of the bed, on both sides.)
3. To raise the height of the pole, turn knob (A) counterclockwise and pull up on the telescoping portion (B) of the pole and raise it to the desired height.
4. Turn knob (A) clockwise to tighten the telescoping portion in place.

CAUTION

The weight of the I.V. bags should not exceed 40 pounds.

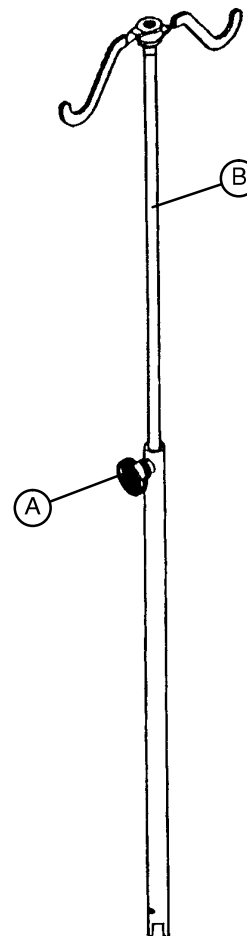

Litter Operation Guide

NIGHT LIGHT USAGE (Optional Equipment)

The bed may be equipped with two optional night lights (A) to illuminate the floor area around the bed.

There is a master switch at the foot end of the bed on the right side that controls both lights. Each light also has a switch to control the individual light.

NOTE

If the switch is turned off on either of the individual lights, the master switch will not control that light.

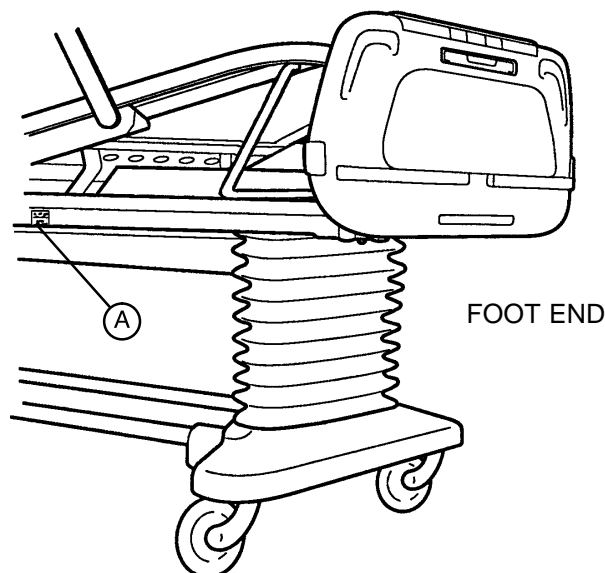

PATIENT RESTRAINT STRAP LOCATIONS

The bed is equipped with 12 separate locations for installing patient restraint straps. The "cutouts" in the bed top are located directly across from each other (on both sides of the bed).

WARNING

Improperly adjusted restraint straps can cause serious injury to a patient. The clinician must use her/his judgement to determine proper use of restraint straps and restraint strap locations.

Clean Velcro **AFTER EACH USE**. Saturate Velcro with disinfectant and allow disinfectant to evaporate. (Appropriate disinfectant for nylon Velcro should be determined by the hospital.)

NURSE CALL BACK-UP BATTERY

To prevent a low battery condition when the bed is not plugged in, position the cord out switch at the head end of the bed to the off position. The switch is identified by the label shown below. If the switch is not positioned as shown below and the bed power cord and pendant cord are unplugged, the life of the back-up battery will be significantly reduced.

If the power light (located on the foot board) is flashing, the Nurse Call battery needs to be replaced. The battery is located on the patient's left side at the head end of the bed. No tools are required to replace the battery. Unplug the bed power cord from the wall socket and replace the battery.

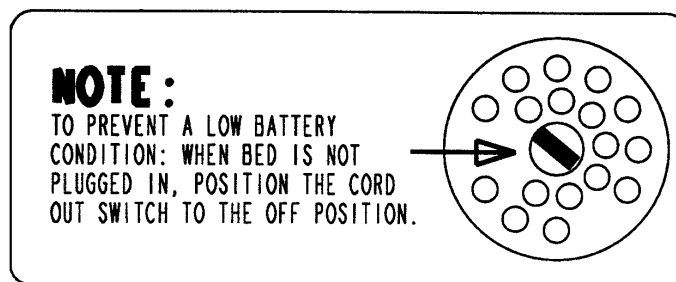

Head Board/Foot Board Operation Guide

CHART RACK USAGE (Optional Equipment)

To use the optional foot board chart rack, pull the handle rod (A) downward. To store, push the handle back to its storage position until it locks in place.

CAUTION

Do not use the handle rod (A) as a device for pulling the bed. Doing so may cause damage to the chart rack and foot board.

The weight of items placed on the chart rack should not exceed 5 pounds or damage to the chart rack and foot board could occur.

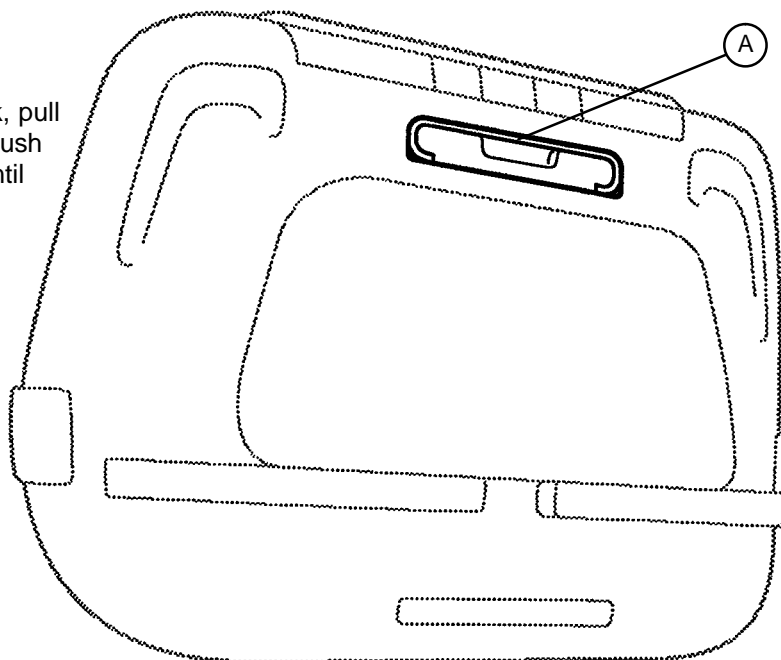

FOOT BOARD

CPR BOARD USAGE (Optional Equipment)

The optional CPR board is stored on the bed's head board. To remove, pull away from the head board and lift out of storage position. If the CPR board option was not purchased, the head board can also be removed and used as an emergency CPR board.

Siderail Operation Guide

POSITIONING SIDERAILS

NOTE

The siderails can be locked at two heights (intermediate & full).

The siderails can be tucked away under the bed when not in use. To remove the rail from the tucked position, grasp the top of the rail and pull outward.

To engage the head end siderail, grasp the rail and swing it upward toward the head end of the bed until it rests in the "intermediate" position. To continue to full height, push in the blue release handle (A) and rotate the siderail until full height is reached.

To engage the foot end siderail, grasp the rail and swing it upward toward the foot end of the bed.

WARNING

Be sure rail is locked securely into position. Siderails are not intended to keep patients from exiting the bed. They are designed to keep a patient from inadvertently rolling off the bed. Proper restraint methods should be utilized to ensure the patient remains in bed. The siderails are not intended to be used as a push device.

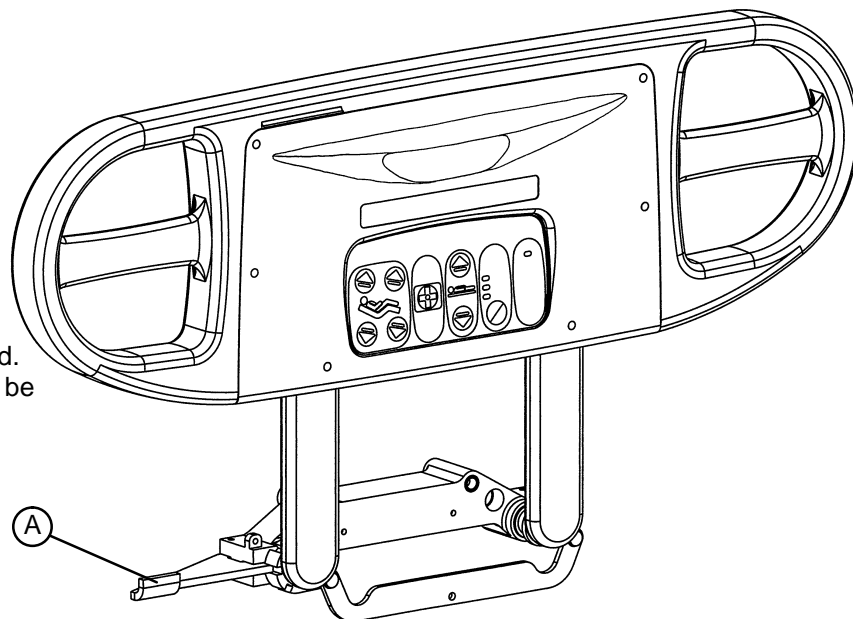

To disengage the rail, push in the blue release handle (A) and swing rail down to desired height. Tuck away siderails by pushing the rails under the bed. Rails must be in the full down position before they can be tucked.

SIDERAIL CONTROL PANEL LIGHTS

The bed is equipped with lights to illuminate the head end siderail control panel and the red nurse call switches. Both can be activated at the foot board control panel. Three settings are available for the control panel lights: low, medium and high intensity. When all lights are off, push the siderail control light button at the foot board once to turn on both the control lights and the nurse call light at the siderail. Push again to change from low to medium setting, and a third time to change to the high setting. The nurse call light intensity is not affected. Pushing the button a fourth time will turn off the siderail control panel lights and pushing it a fifth time will turn off the red nurse call light as well (see control panel guide page 21).

CAUTION

The purpose of the red nurse call light on the siderails is to ensure the patient can immediately identify where to push to contact the nurse station. Turning this light off will compromise this ability, especially in a darkened room.

Siderail Operation Guide

INSIDE SIDERAIL FUNCTION GUIDE

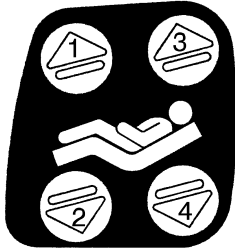

(Patient's Right Rail)

1. Push to raise Knee Gatch.
2. Push to lower Knee Gatch.
3. Push to raise Fowler.
4. Push to lower Fowler.

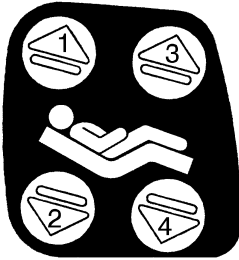

(Patient's Left Rail)

1. Push to raise Fowler.
2. Push to lower Fowler.
3. Push to raise Knee Gatch.
4. Push to lower Knee Gatch.



1. Push to activate Nurse Call.

NOTE

Yellow LED will light when button is pushed. Red LED will light with Nurse Station acknowledgment.

► This panel is optional equipment.

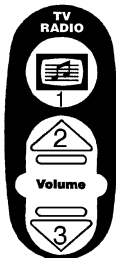

1. Push to turn TV or radio on and to select a channel.
2. Push to increase volume.
3. Push to decrease volume.

► This panel is optional equipment.

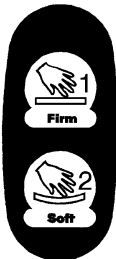

1. Push to increase firmness of mattress
2. Push to decrease firmness of mattress.
(See page 20 for system instructions).

► This panel is optional equipment.

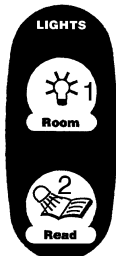

1. Push to turn the room light on.
2. Push to turn the bed overhead light on.

► This panel is optional equipment.

Siderail Operation Guide

INSIDE SIDERAIL FUNCTION GUIDE (CONTINUED)



1. Push to turn TV on or off.
2. Push to raise the TV volume.
3. Push to lower the TV volume.

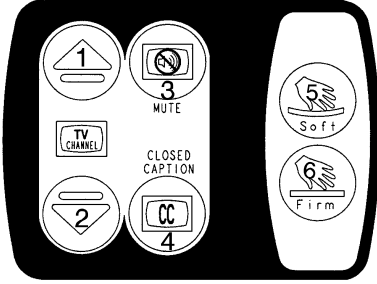

1. Push to change the TV channel up.
2. Push to change the TV channel down.
3. Push to mute the TV volume. Push again to turn the sound back on.
4. Push to display closed captioning. Push again to turn off closed captioning.
5. Press to decrease the firmness of the mattress.
6. Press to increase the firmness of the mattress.

► These panels are optional equipment.

OUTSIDE SIDERAIL FUNCTION GUIDE

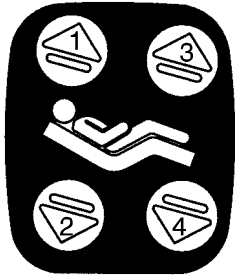

(Patient's Right Rail)

1. Push to raise Fowler.
2. Push to lower Fowler.
3. Push to raise Knee Gatch.
4. Push to lower Knee Gatch.

► This panel is optional equipment.

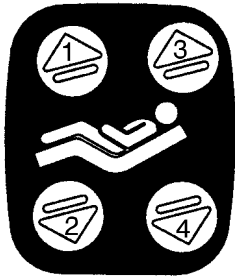

(Patient's Left Rail)

1. Push to raise Knee Gatch.
2. Push to lower Knee Gatch.
3. Push to raise Fowler.
4. Push to lower Fowler.

► This panel is optional equipment.



1. Push to raise bed height.

2. Push to lower bed height.

Siderail Operation Guide

OUTSIDE SIDERAIL FUNCTION GUIDE (CONTINUED)



Push to activate Nurse Call.

▶ This panel is optional equipment.



LED will blink when the brakes are not set.



Push to activate auto or manual mode of the Dynamic Mattress System. LED will light to indicate selected mode and/or possible air leak.

▶ This panel is optional equipment.

DYNAMIC MATTRESS SYSTEM USAGE (OPTIONAL EQUIPMENT)

1. The DMS system can be set in either "AUTOMATIC" or "MANUAL" modes. The "AUTO/MAN" switch is used to activate both modes. When Automatic mode is selected, the "AUTOMATIC" LED on the siderail control panel will be on. When Manual mode is selected, the "MANUAL" LED on the siderail control panel will be on. The "AUTO/MAN" switches are located on the control panels on the outside of the head end siderails (see above).
2. When the Automatic mode is selected, the firmness of the mattress will adjust automatically as needed. When the Manual mode is selected, the firmness of the mattress can be adjusted by the patient or the hospital clinical staff. The "FIRM" and "SOFT" switches are located on the control panels on the inside of the head end siderails (see page 18).

NOTE

The mattress power cord must be plugged into the bed for the mattress to operate. See page 11 for "DMS Port" location.

Foot Board Operation Guide

FOOT BOARD CONTROL PANEL GUIDE

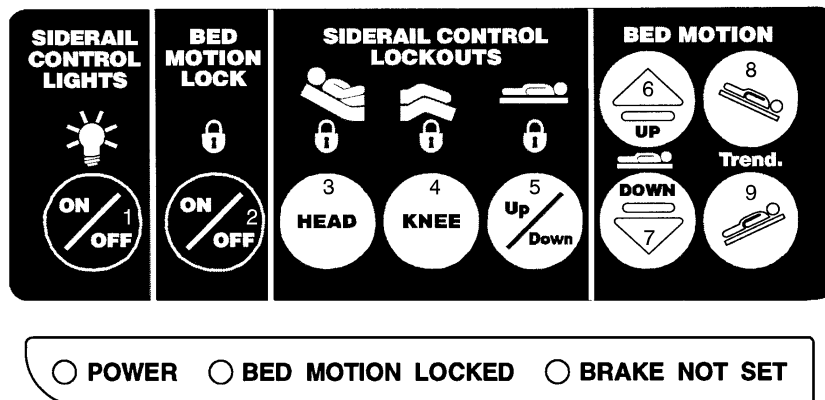

1. Push repeatedly for low, medium and high settings for siderail control lights. Pushing a fourth and fifth time will turn off the siderail control lights and the red nurse call light respectively (see page 17).

CAUTION

The intent of the red nurse call light on the siderails is to ensure the patient has immediate understanding of which button to push to contact the nurse station. Turning the red light off may compromise this ability, especially in a darkened room.

2. Push to lock out all bed motions. The MOTION lock icon and the "BED MOTION LOCKED" LED will light. Push again to unlock.
3. Push to lock out Back Rest controls at both siderails. The HEAD lock icon will light. Push again to unlock.
4. Push to lock out Knee Gatch controls at both siderails. The KNEE lock icon will light. Push again to unlock.
5. Push to lock out bed height movement at both siderails. The UP/DOWN lock icon will light. Push again to unlock.
6. Push to raise bed height.
7. Push to lower bed height.
8. Push to lower head end/raise foot end of bed (Trendelenberg position).
9. Push to lower foot end/raise head end of bed (Reverse Trendelenberg position).

FUNCTION LOCKOUT SYSTEM USAGE

1. To lock out the bed movement functions on the siderails and prevent the patient from changing the positioning of the bed, push the "HEAD", "KNEE" and/or "UP/DOWN" switches in the "Siderail Control Lockouts" module on the foot board control panel.

NOTE

The foot board controls for these motions are not affected by the lockout switches.

The "padlock" symbol on the control panel will be lighted when that function is locked out.

2. To lock out the entire bed motion for all switches on the bed (siderails and foot board), push the "ON/OFF" switch in the "Bed Motion Lock" module on the foot board control panel.

Foot Board Operation Guide

FOOT BOARD CONTROL PANEL GUIDE (CONTINUED)

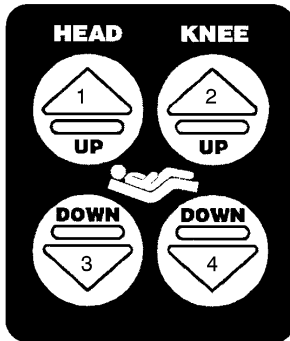

1. Push to raise Fowler.
 2. Push to raise Knee Gatch.
 3. Push to lower Fowler.
 4. Push to lower Knee Gatch.
- ▶ This panel is optional equipment.

LED DISPLAY PANEL GUIDE

The LED Display Panel is located at the foot end of the bed, under the Control Panel.



"POWER" – will light when the bed is plugged into the wall receptacle.

"BED MOTION LOCKED" – will light when the Bed Motion Lock has been activated.

"BRAKE NOT SET" – will blink when the brakes have not been set.

"BED EXIT ON" – will light when the Bed Exit function has been activated (optional equipment).

Foot Board Operation Guide

CENTER OF GRAVITY BED EXIT (OPTIONAL EQUIPMENT)

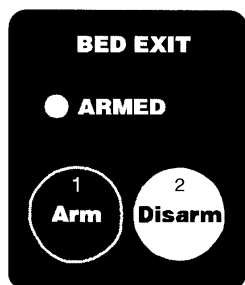

1. Push to activate Bed Exit function.
2. Push to deactivate Bed Exit function.



NOTE

If the scale system is in use, it will switch to "off" when Bed Exit is armed. Bed Exit will be temporarily disarmed when the scale system is activated and will re-arm when the scale system shuts off. When the bed is equipped with scales, the scales must be properly zeroed for the Bed Exit System to function properly (see page 26 for scale system usage instructions). If bed is not equipped with a scale system, follow the procedure below.

1. Before putting a new patient on the bed: prepare bed for patient stay by adding linens and equipment to the bed. Press and hold "ARM" and "DISARM" keys together for 5 seconds – "ARMED" light will begin to flash. Release "ARM" and "DISARM" keys and do not touch the bed until "ARMED" light stops flashing.
2. Once the new patient is on the bed: push "ARM" key and release ("ARMED" light will come on).
3. To deactivate Bed Exit, push "DISARM". The "ARMED" and "BED EXIT ON" LED's will turn off.

WARNING

The Bed Exit System is intended only to aid in the detection of a patient exiting the bed. It is NOT intended to replace patient monitoring protocol. It signals when a patient is about to exit. Adding or subtracting objects from the bed after arming the bed exit system may cause a reduction in the sensitivity of the bed exit system.

Foot Board Operation Guide

WEIGH SYSTEM CONTROL PANEL GUIDE

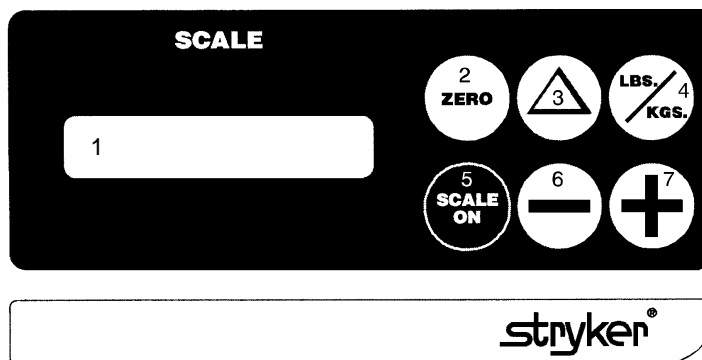

1. LCD – displays patient weight.
2. Push to zero bed.
3. Push when changing equipment on the bed.
4. Push to change weight from pounds to kilograms or back.
5. Push to turn weight system on.
6. Push to decrease numerical value of displayed weight.
7. Push to increase numerical value of displayed weight.





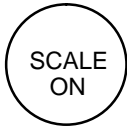
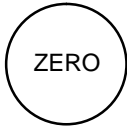





NOTE

After approximately 30 seconds of idle time, the scale display will turn off and will show the Trendelenberg angle of the bed. Press “SCALE ON” to return to the weight display.

SYMBOL	ACTION	DISPLAY
	To prepare bed for new patient:	
	Press and hold “SCALE ON”. Release the button <i>after</i> the display reads: “LET GO FOR SCALE”	“LET GO FOR SCALE” “WEIGHING...” “XXX.X LB”
	Press and hold “ZERO” Release “ZERO”	“HOLD TO ZERO WT.” “RELEASE TO ZERO” “DO NOT TOUCH BED” “0.0 LB”

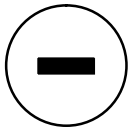
Foot Board Operation Guide

WEIGH SYSTEM CONTROL PANEL GUIDE (CONTINUED)

SYMBOL	ACTION	DISPLAY
	<p>To add or remove equipment during patient stay without affecting registered patient weight:</p> <p>Press and release "SCALE ON"</p>	<p>"WEIGHING..." "XXX.X LB"</p>
	<p>Press </p> <p>Release </p> <p>Add or remove equipment.</p>	<p>"HOLD TO START" "RELEASE TO START" "DO NOT TOUCH BED" "ADD/REMOVE EQUIP."</p>
	<p>Press </p> <p>Release </p>	<p>"RELEASE TO FIN." "DO NOT TOUCH BED" "XXX.X LB"</p>
	<p>To convert the patient's weight:</p>	
	<p>To convert the patient's weight to kilograms, press and release "LBS./KG."</p> <p>Repeat the procedure to return to pounds.</p>	<p>"WEIGHT NOW KGS" "XXX.X KG"</p>
	<p>To change the numerical value of displayed weight:</p>	
	<p>Press  and hold to scroll to desired weight.</p>	<p>"HOLD TO DEC. WT." "XXX.X LB"</p>
	<p>Press  and hold to scroll to desired weight.</p>	<p>"HOLD TO INC. WT." "XXX.X LB"</p>

Weigh System Usage

OPERATING THE SCALE BEFORE PUTTING A NEW PATIENT IN BED





- Prepare bed for patient stay (linens, pillows, etc.).
- Press and hold "SCALE ON". Release the button *after* the display reads "LET GO FOR SCALE". (This will turn off the Trend. angle display and activate the scale). The scale monitor will read:
"LET GO FOR SCALE"
"WEIGHING"
"XXX.X LB"
- Press and hold "ZERO". The scale monitor will read:
"HOLD TO ZERO WT."
"RELEASE TO ZERO"
- Release "ZERO". The scale monitor will now read:
"DO NOT TOUCH BED"
"0.0 LB"

The bed is now ready for the patient.

NOTE

Do not zero the bed while a patient is in bed. Inaccurate patient weight reading will result. If this should occur, remove the patient and zero the bed.

OPERATING THE SCALE IF PATIENT IS ALREADY IN BED

- If it is necessary to add or remove special equipment (monitors, pumps, etc.) during the patient's stay, press and release "SCALE ON" to activate the weigh system. After the scale monitor reads "XXX.X LB", press and hold . The scale monitor will read:
"HOLD TO START"
"RELEASE TO START"
- Release . The scale monitor will read:
"DO NOT TOUCH BED"
"ADD/REMOVE EQUIP"
- Add or remove the equipment and press . The scale monitor will read:
"RELEASE TO FIN."
- Release . The scale monitor will read:
"DO NOT TOUCH BED"
"XXX.X LB"

The weight displayed will be that of the patient only.

Weigh System Usage

CONVERTING THE PATIENT'S WEIGHT

- To convert the patient's weight from pounds to kilograms, press and release "SCALE ON" to activate the weigh system. After the scale monitor reads "XXX.X LB", press and release the "LBS/KGS" button. The scale monitor will read:

"WEIGHT NOW KGS"

"XXX.X KG"

- Repeat the procedure to return to pounds. The display will read:

"WEIGHT NOW LBS"

"XXX.X LB"

CHANGING THE NUMERICAL VALUE OF DISPLAYED WEIGHT

- To decrease the numerical value of the displayed weight, press and hold "-". The scale monitor will read:

"HOLD TO DEC. WT."

"XXX.X LB"

- Hold "-" until desired value is achieved.

- To increase the numerical value of the displayed weight, press and hold "+". The scale monitor will read:

"HOLD TO INC. WT."

"XXX.X LB"

- Hold "+" until desired value is achieved.

NOTE

The weigh system will shut off approximately one minute after a function has been used, if another function is not activated. Display light will shut off and display will read "SCALE OFF".

The weigh system will retain all patient weight information in its memory even when the scale monitor is off or when the bed is unplugged from the wall socket.

Static Discharge Precautions

The electronic circuits in the 3000 are completely protected from static electricity damage only while the bed is assembled. It is extremely important that all service personnel always use adequate static protection when servicing the electronic systems of the 3000. *Whenever you are touching wires, you should be using static protection.*

Static Protection Equipment

The necessary equipment for proper static protection is:

- 1 static wrist strap; 3M part number 2214 or equivalent,
- 1 grounding plug; 3M part number 61038 or equivalent,
- 1 test lead with a banana plug on one end and an alligator clip on the other; Smith part number N132B699 or equivalent.

Stryker has available the following equipment for proper static protection:

- Complete static protection system – part number 3000–000–753
- 1 grounding plug – part number 3000–000–754
- 1 static wrist strap – part number 3000–000–755
- 1 test lead – part number 3000–000–756

CAUTION

All electronic service parts will be shipped in static shielding bags. Do not open the bags until you have completed steps 2 and 3 of the following procedure. Do not place unprotected circuit boards on the floor. All circuit boards to be returned to Stryker Medical should be shipped in the static shielding bags the new boards were shipped in.

Static Protection Procedure

1. Unplug the power cord from the wall receptacle.
2. Insert the grounding plug into a properly grounded hospital grade wall receptacle. Plug the banana plug of the test lead into the receptacle on the grounding plug. Connect the alligator clip on the other end of the test lead to a ground point on the bed.
3. Place the static control wrist strap on your wrist. Connect the alligator clip at the other end of the wrist strap cord to a ground point on the bed.

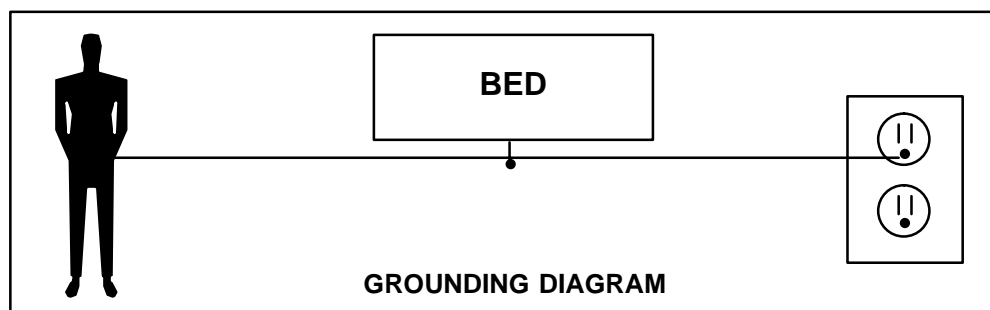

Troubleshooting

TROUBLESHOOTING GUIDE

DEFINITIONS:

DMM = Digital Multi-Meter

PCB = Printed Circuit Board

CPU = Central Processing Unit

NOTE

See pages 31–34 for an outline of bed PCB's and voltage test points.

PROBLEM/FAILURE	RECOMMENDED ACTION
No power to bed	<p>A. Unplug bed power cord and check continuity of fuses F1 and F2 with DMM.</p> <p>B. Check for 120 VAC power at J1 on power supply. See page 33 for power supply voltage test points.</p> <p>C. Check for DC voltages on J2 (Pins 1,2,3 & 6) on power supply. See page 33 for power supply voltage test points.</p>
No bed down motion.	<p>A. Enter diagnostics, (see page 55) and press bed down. If motion is present, re-burn lift potentiometers. Monitor Pin 3 (Red) and Pin 2 (Black) of HDR7 and HDR12 on the CPU PCB using DMM. Verify voltage changes on Pin 3 with changes in lift motion. See page 59 for voltage parameters for low and high limits.</p> <p>B. If no down motion in diagnostic, check for 120 VAC power on HDR33 and HDR34, Pin 1 and Pin 3, of the CPU.</p> <p>C. Check for 1.1–1.5 VDC signal on O6 and O8 Pin 1 and HDR2 Pin 5 of the CPU PCB.</p> <p>D. Check if motion interrupt cable is connected on HDR3.</p>
No bed up motion.	<p>A. Check 120 VAC power on HDR33 and HDR34, Pin 1 and Pin 6, of the CPU board.</p> <p>B. Check for 1.1–1.5 VDC signal on O5 and O7 Pin 1 and HDR2 Pin 5 of the CPU PCB.</p>
No Gatch down motion.	<p>A. Check for 120 VAC power on HDR29 Pin 1 and Pin 3 of the CPU board.</p> <p>B. Check for 1.1–1.5 VDC signal on O3 Pin 1 and HDR2 Pin 5 of the CPU PCB.</p>
No Gatch up motion.	<p>A. Check for 120 VAC on HDR29, Pin 1 and Pin 2 of the CPU board.</p> <p>B. Check for 1.1–1.5 VDC on O1 Pin 1 and HDR2 Pin 5 of the CPU PCB.</p>
No Fowler down motion.	<p>A. Check for 120 VAC power on HDR30 Pin 3 and Pin 1 of the CPU board.</p> <p>B. Check for 1.1–1.5 VDC signal on O4 Pin 1 and HDR2 Pin 5 of the CPU PCB.</p>
No Fowler up motion.	<p>A. Check for 120 VAC on HDR30, Pin 1 and Pin 3 of the power supply.</p> <p>B. Check for 1.1–1.5 VDC on O2 Pin 1 and HDR2 Pin 5 of the CPU PCB.</p>

Troubleshooting – Optional DMS Mattress

TROUBLESHOOTING GUIDE

PROBLEM/SYMPTOM	SOLUTION(S)
AIR LOSS LED on.	A. Check air connections between bladder and control unit. B. Check for leak in bladder. C. Unplug transformer from wall socket and plug back in. D. Replace bladder (page 68). E. Replace control unit (page 72).
Auto LED does not light when plugged in.	A. Plug into another wall socket. B. Open control unit and check for 12 VDC at power supply connector. C. Replace power supply assembly (page 69). D. Replace control unit (page 72).
Cannot switch from AUTO to MANUAL mode, otherwise system functions properly.	A. Check pendant cord and connector. B. Replace pendant (page 69).
Cannot adjust FIRM or SOFT, otherwise system functions properly.	A. Check pendant cord and connector. B. Replace pendant (page 69).
Cover stained, upper foam layer stained.	A. Check cleaning solution and protocol. B. Replace outer cover (page 67). C. Replace upper foam topper.

Bed Circuit Boards

CPU KIT (NO OPTIONS) – 3001-300-760

CPU KIT (COMMUNICATION ONLY) – 3001-303-760

CPU KIT (SCALE AND COMMUNICATION ONLY) – 3001-307-760

CPU KIT (BED EXIT AND COMMUNICATION ONLY) – 3001-308-760

CPU KIT (SCALE, BED EXIT, AND COMMUNICATION) – 3001-307-762

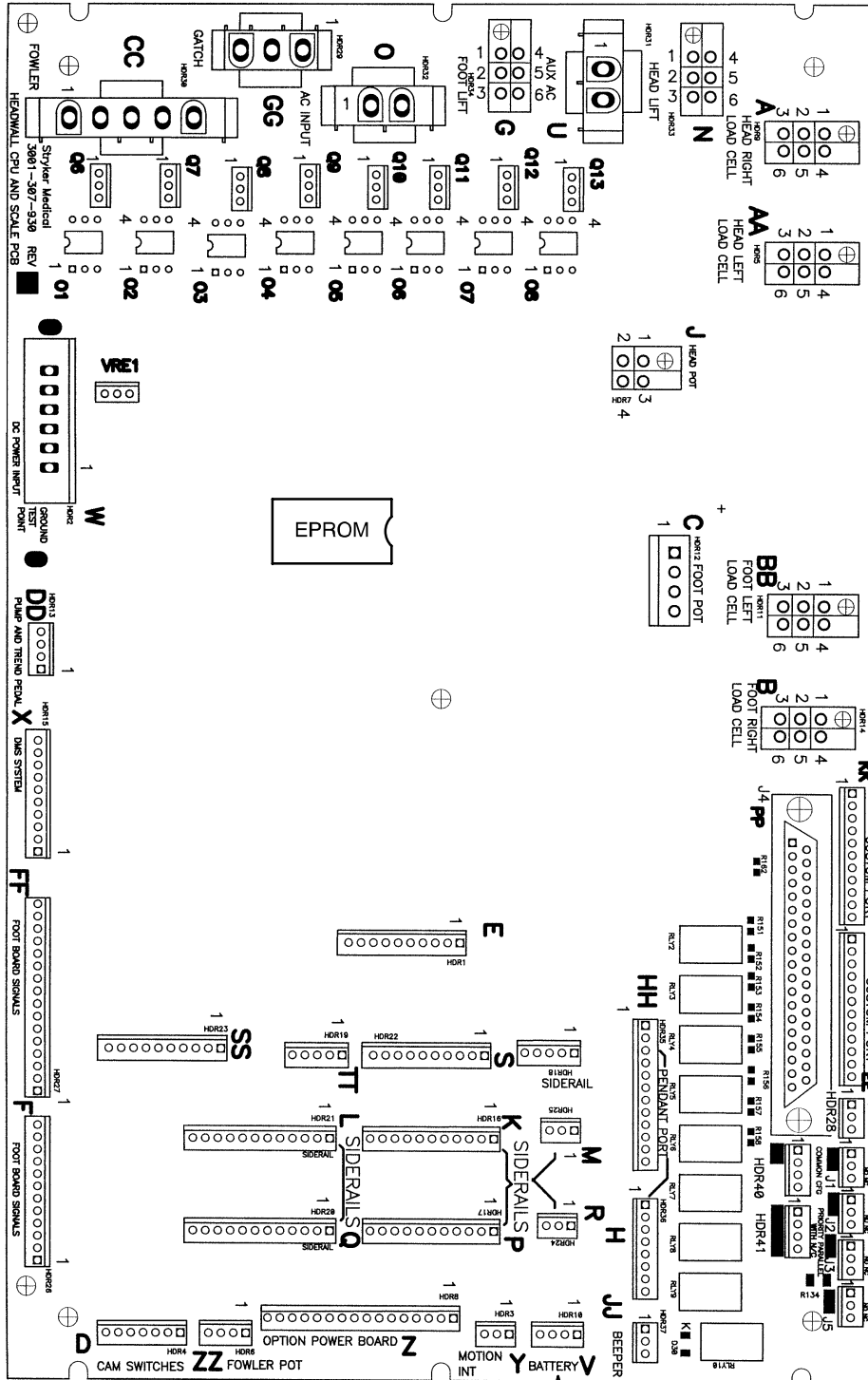

59-137
Shunt for
No Nurse Call



Bed Circuit Boards

CPU KIT (NO OPTIONS) – 3001–300–760

CPU KIT (COMMUNICATION ONLY) – 3001–303–760

CPU KIT (SCALE AND COMMUNICATION ONLY) – 3001–307–760

CPU KIT (BED EXIT AND COMMUNICATION ONLY) – 3001–308–760

CPU KIT (SCALE, BED EXIT, AND COMMUNICATION) – 3001–307–762

CONNECTOR LOCATION	CABLE LOCATION	VOLTAGE	POSITIVE LEAD	NEGATIVE LEAD	DESCRIPTION
HDR 2	W	+12 VDC	Pin 1	Pin 4 or 5	Relays & Siderails Light Voltage
HDR 2	W	+5 VDC	Pin 2 & 3	Pin 4 or 5	+5 VDC from Power Supply
HDR 2	W	-12 VDC	Pin 6	Pin 4 or 5	Relays & Siderails Light Voltage
HDR 7	J	0 – 5 VDC	Pin 3	Pin 2	Head Lift Pot Wiper
HDR 7	J	+5 VDC	Pin 4	Pin 2	+5 VDC for Head Lift Pot
HDR 12	C	+5 VDC	Pin 1	Pin 2	+5 VDC for Foot Lift Pot
HDR 12	C	0 – 5 VDC	Pin 3	Pin 2	Foot Lift Pot Wiper
HDR 29	GG	0 VAC w/o Switch 110 VAC w/Switch	Neutral Pin 1	Pin 2	Gatch Up
HDR 29	GG	0 VAC w/o Switch 110 VAC w/Switch	Neutral Pin 1	Pin 3	Gatch Down
HDR 30	CC	0 VAC w/o Switch 160 VAC w/ Switch	Neutral Pin 3	Pin 1	Fowler Up
HDR 30	CC	0 VAC w/o Switch 120 VAC w/ Switch	Neutral Pin 3	Pin 2	Fowler Down
HDR 32	O	110 VAC	Pin 1	Pin 2	Line Voltage to Bed
HDR 33	N	0 VAC w/o Switch 120 VAC w/ Switch	Neutral Pin 1 or 4	Pin 3	Head Lift Down
HDR 33	N	0 VAC w/o Switch 120 VAC w/ Switch	Neutral Pin 1 or 4	Pin 6	Head Lift Up
HDR 34	G	0 VAC w/o Switch 120 VAC w/ Switch	Neutral Pin 1 or 4	Pin 3	Foot Lift Down
HDR 34	G	0 VAC w/o Switch 120 VAC w/ Switch	Neutral Pin 1 or 4	Pin 6	Foot Lift Up

Bed Circuit Boards

POWER SUPPLY – P/N 59-157

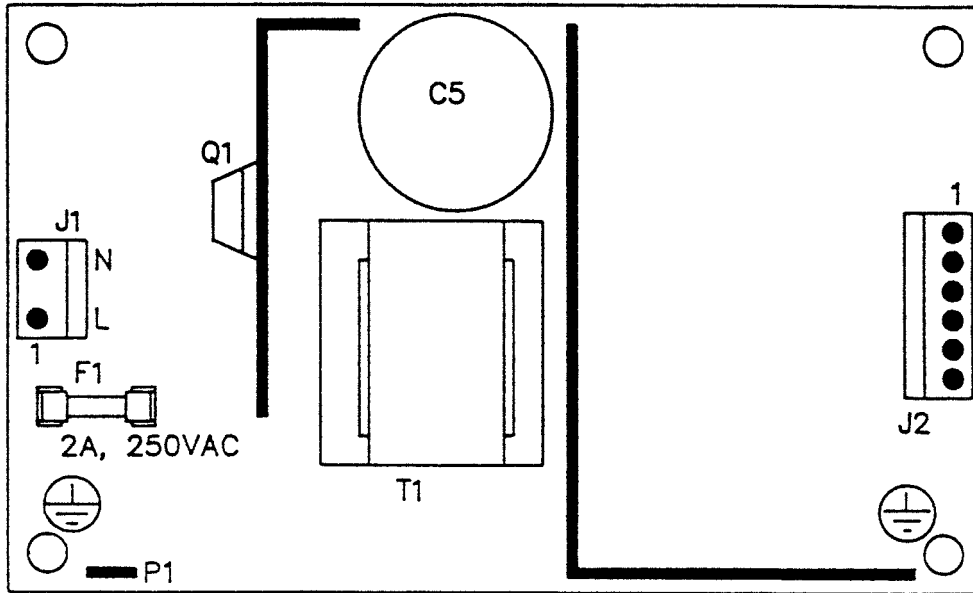

CONNECTOR LOCATION	VOLTAGE	POSITIVE LEAD	NEGATIVE LEAD
J1	110V	Pin 1	Pin 2
J2	12V	Pin 1	Pin 4 or 5
J2	5V	Pin 2	Pin 4 or 5
J2	5V	Pin 3	Pin 4 or 5
J2	GND	Pin 4	Pin 4 or 5
J2	GND	Pin 5	Pin 4 or 5
J2	-12V	Pin 6	Pin 4 or 5

Bed Circuit Boards

OPTIONAL HYBRID DMS CONTROL BOARD – P/N 2500–401–900

OPTIONAL INTEGRATED DMS CONTROL BOARD – P/N 2500–402–900

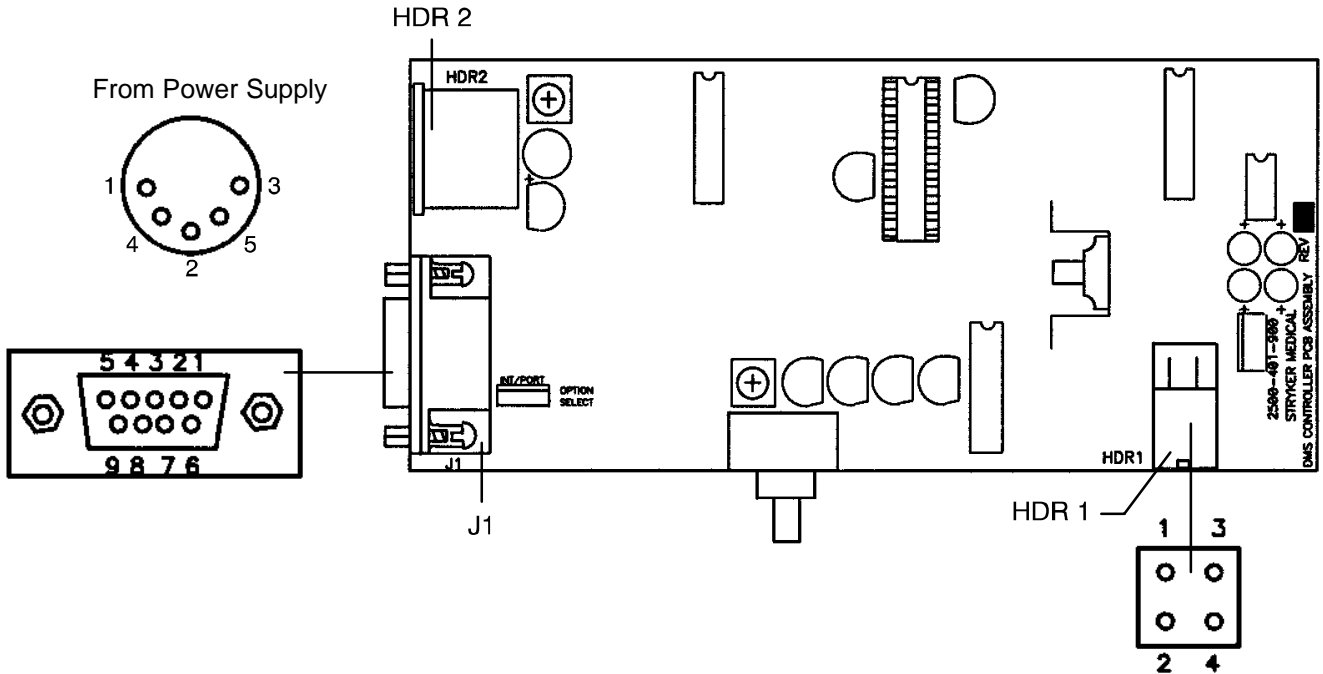

CONNECTOR LOCATION	VOLTAGE	POSITIVE LEAD	NEGATIVE LEAD	DESCRIPTION
PS	+12 – +14 VDC	Pin 1	Pin 3	Power Supply
PS	+12 – +14 VDC	Pin 4	Pin 3	Power Supply
HDR 1	+12 – +14 VDC	Pin 4	Pin 3	Air Compressor
J1	+5 VDC	Pin 2	Pin 3	Hand Pendant
J1	Digital (Ref.)	Pin 6	Pin 3	Manual LED
J1	Digital (Ref.)	Pin 7	Pin 3	Auto LED
J1	Digital (Ref.)	Pin 8	Pin 3	Error LED
J1	+12 – +14 VDC	Pin 9	Pin 3	Power Supply

Bed Circuit Boards

OPTIONAL STRYKAIR POWER SUPPLY – P/N 2600–300–900

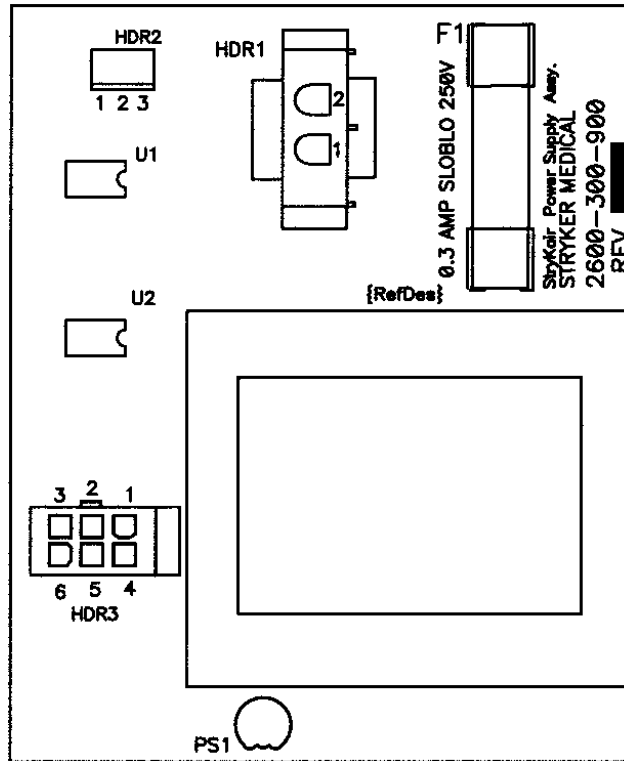

CONNECTOR LOCATION	VOLTAGE	POSITIVE LEAD	NEGATIVE LEAD	DESCRIPTION
HDR 1	120 VAC	Pin 1	Pin 2	AC power to board
HDR 3	12–16 VAC	Pin 1	Pin 2	AC power to mattress
HDR 3	+ 5 VDC	Pin 4	Pin 3	DC power returned to board
HDR 2	+ 5 VDC	Pin 1	Pin 3	S/R switch voltage with firm switch pressed
HDR 2	+ 5 VDC	Pin 2	Pin 3	S/R switch voltage with soft switch pressed

Bed Circuit Boards

OPTIONAL SMART TV CIRCUIT BOARD – P/N 3001–330–940

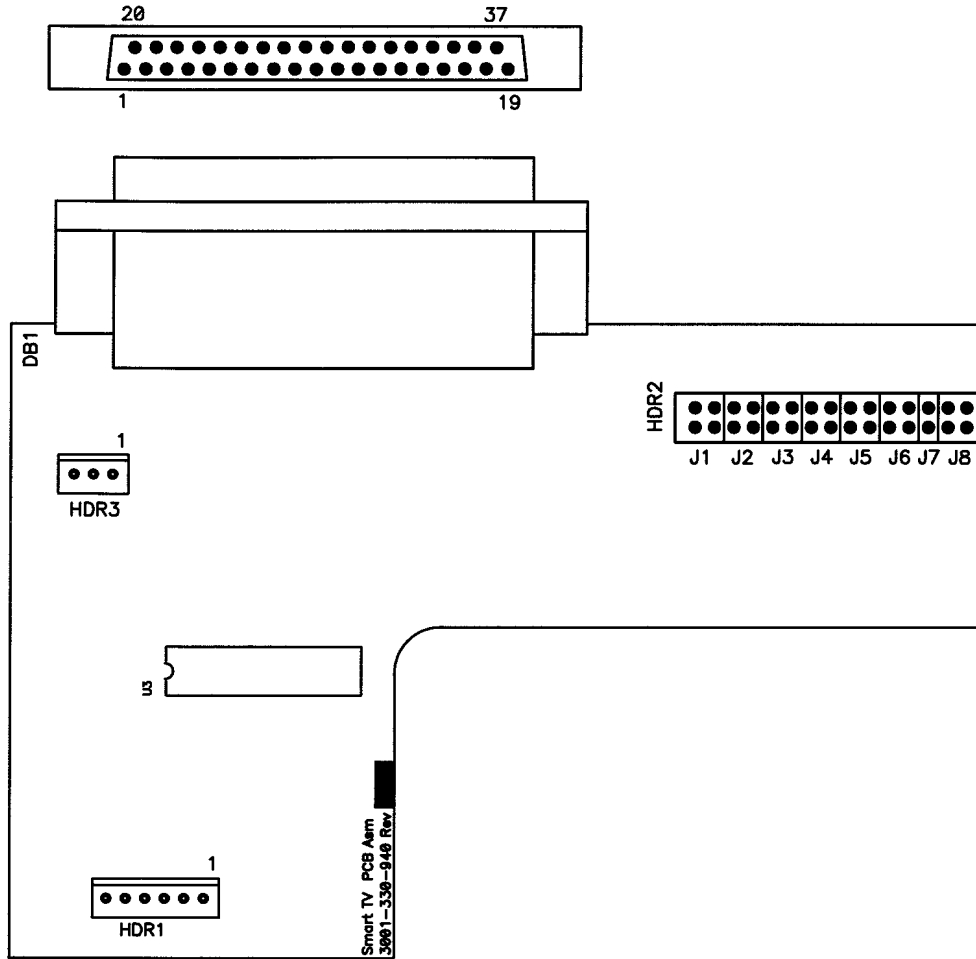

CONNECTOR LOCATION	VOLTAGE	POSITIVE LEAD	NEGATIVE LEAD	DESCRIPTION
HDR 1	5 VDC	Pin 2	Pin 1	Regulated 5 VDC Power to the board
HDR 1	Digital Control	Pin 3–5	Pin 1	Serial control lines
HDR 1	5 VDC	Pin 6	Pin 1	5 VDC for option relay
HDR 3	+5 or +12 VDC	2	Pin 1	Power/control line from the TV Note: This header provides TV control to a non-Stryker pendant
DB1	+5 or +12 VDC	Pin 34	Pin 33	Power/Control line from the TV Note: If this polarity is reversed, place the shunts of J8 in the alternate position

Bed Circuit Boards

OPTIONAL SMART TV CIRCUIT BOARD – P/N 3001–330–960

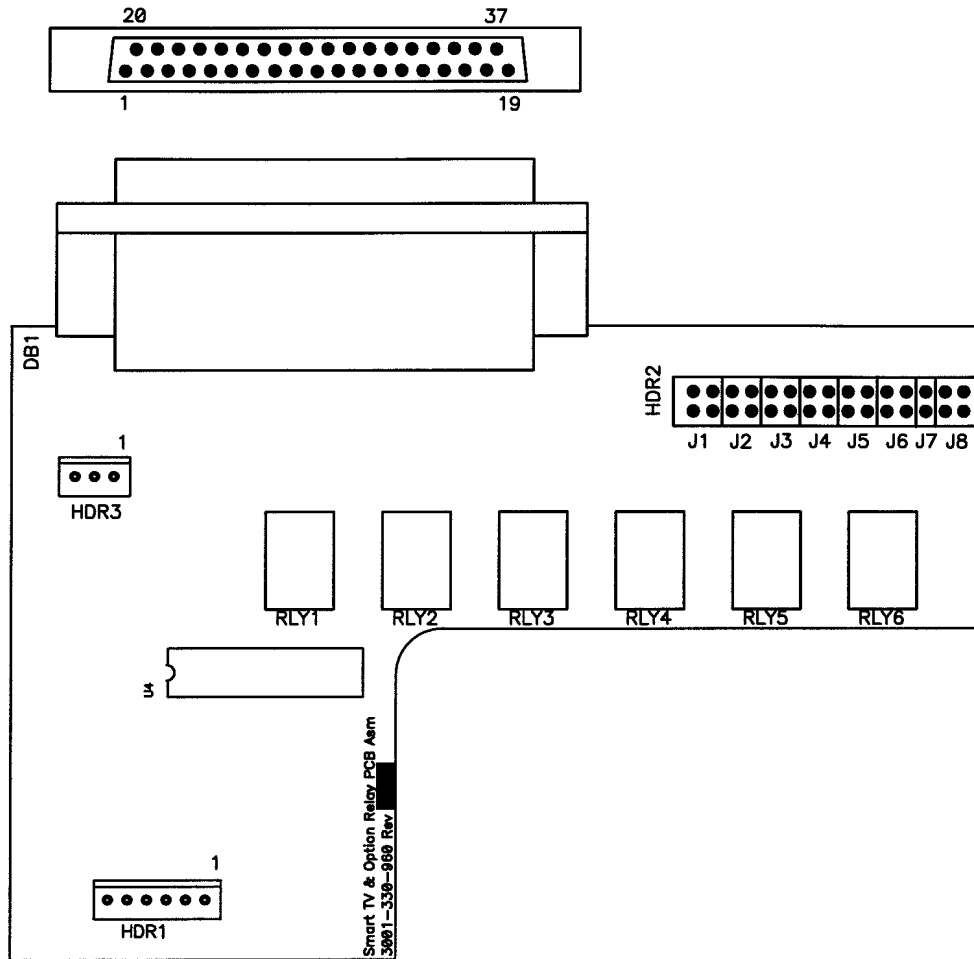

CONNECTOR LOCATION	VOLTAGE	POSITIVE LEAD	NEGATIVE LEAD	DESCRIPTION
HDR 1	5 VDC	Pin 2	Pin 1	Regulated 5 VDC Power to the board
HDR 1	Digital Control	Pin 3–5	Pin 1	Serial control lines
HDR 1	5 VDC	Pin 6	Pin 1	5 VDC for option relay
HDR 3	+5 or +12 VDC	2	Pin 1	Power/control line from the TV Note: This header provides TV control to a non–Stryker pendant
DB1	+5 or +12 VDC	Pin 34	Pin 33	Power/Control line from the TV Note: If this polarity is reversed, place the shunts of J8 in the alternate position

Optional Bed Communications Tester

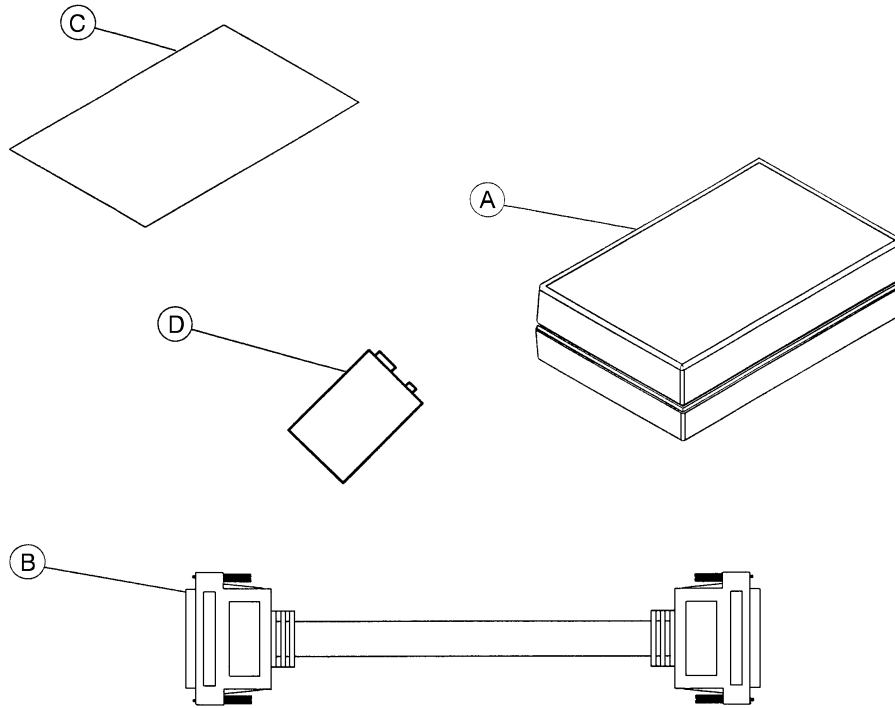

Item	Part No.	Part Name	Qty.
A	3001-303-160	BCT Unit	1
B	3001-303-825	37-Pin Cable	1
C	3001-303-162	Instructions	1
D	3000-303-871	9V Battery	1

Head Wall Output Configuration

37-PIN CONNECTOR

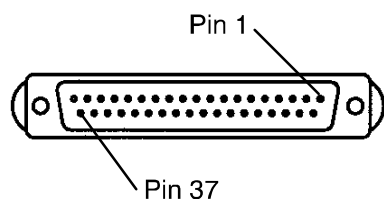

Pin 1	Option 2 Common
Pin 2	Read Light
Pin 3	Room Light
Pin 4	Speaker High
Pin 5	Pot Wiper
Pin 6	Radio Common
Pin 7	Nurse Call Interlock
Pin 8	Audio Transfer –
Pin 9	Audio Transfer +
Pin 10	Interlock +
Pin 11	Interlock –
Pin 12	Spare
Pin 13	Options 3 Common
Pin 14	Pot Low Common
Pin 15	Pot High Common
Pin 16	Nurse Answer Light +
Pin 17	Option 1 NO/NC
Pin 18	Option 1 Common
Pin 19	Nurse Call Light +
Pin 20	Option 2 NO/NC
Pin 21	Option 3 NO/NC
Pin 22	Option 3A NO/NC
Pin 23	Option 2A Common
Pin 24	Option 2A NO/NC
Pin 25	Nurse Call +
Pin 26	Nurse Call NO/NC
Pin 27	Room/Read Light Common
Pin 28	Nurse Call Light –
Pin 29	Nurse Answer Light –
Pin 30	Priority NO/NC
Pin 31	Priority Common
Pin 32	Option 3A Common
Pin 33	TV –
Pin 34	TV +
Pin 35	Speaker Low Common
Pin 36	Audio Shield
Pin 37	Radio NO/NC

STRYKER PENDANT PORT

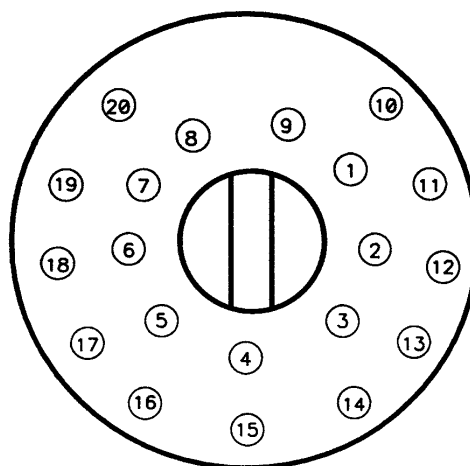

1	Scan Line
2	Audio (–)
3	Nurse Call (+)
4	+5 VDC
5	Scan Line
6	Scan Line
7	Nurse Call (–)
8	TV Channel Up
9	Backlight
10	Audio (+)
11	Gatch Up/Fowler In/Foot Up/DMS Firm
12	Gatch Down/Fowler Out/Foot Out/DMS Soft
13	Fowler Up/Trend In
14	Fowler Down/Trend Out
15	Audio Shield
16	Not Used – Socket Filled
17	Bed Up
18	Ground
19	Read Light/Bed Down
20	Room Light

Replacement Parts List

ELECTRICAL COMPONENTS

FOOT BOARD KEYBOARD (S/R LIGHTS, LOCKOUTS, ETC.)	3001-500-900
FOOT BOARD SCALE DISPLAY	3001-507-900
FOOT BOARD SCALE KEYBOARD	3001-507-910
FOOT BOARD BED EXIT KEYBOARD	3001-508-900
CPU KIT (NO OPTIONS)	3001-300-760
CPU KIT (COMMUNICATION ONLY)	3001-303-760
CPU KIT (SCALE AND COMMUNICATION ONLY)	3001-307-760
CPU KIT (BED EXIT AND COMMUNICATION ONLY)	3001-308-760
CPU KIT (SCALE, BED EXIT, & COMMUNICATION)	3001-307-762
POWER SUPPLY	59-157
SMART TV CIRCUIT BOARD	3001-330-930

SIDERAIL BOARDS

DMS BOARD	3001-402-900
INSIDE BOARD	3001-400-930
OUTSIDE BOARD	3001-400-910
SPEAKER W/CABLE	3000-403-831

OTHER COMPONENTS

CAPACITOR, FOWLER	59-780
CAPACITOR, FOWLER, 230V	3221-300-453
CAPACITOR, GATCH	59-779
CAPACITOR, GATCH, 230V	59-153
CAPACITOR, LIFT	59-778
CAPACITOR, LIFT, 230V	3221-200-243
CASTER, 6"	3001-200-60
CASTER, STEER, 6"	3001-200-50
CASTER, 8", OPTIONAL	3001-200-90
CASTER, STEER, 8", OPTIONAL	3001-200-80
COIL CORD, LIFT POWER	3001-200-824
COIL CORD, LIFT SENSOR	3001-200-815
COIL CORD, LITTER POWER	3001-300-844
COIL CORD, LITTER SIGNAL	3001-300-846
COMMUNICATIONS TESTER	3001-303-165
FOWLER BRAKE KIT	3001-300-775
ISOLATION PLATE KIT, LIFT MOTOR	3000-200-723
LOAD CELL	3001-307-57
MOTOR COUPLER KIT, LIFT	3000-200-725
MOTOR, FOWLER W/CLUTCH	3001-300-705
MOTOR, FOWLER W/CLUTCH, SHORT BED	3001-342-705
MOTOR, FOWLER W/CLUTCH, 230V	3221-300-705
MOTOR, GATCH	2025-232-70
MOTOR, GATCH, 230V	2026-232-70
MOTOR, LIFT (SAME FOR HEAD AND FOOT END)	3000-200-213

Replacement Parts List

OTHER COMPONENTS (CONTINUED)

MOTOR, LIFT, 230V (SAME FOR HEAD AND FOOT END)	3221-200-213
PADDED SIDERAIL COVER, HEAD, LEFT	3000-336-12
PADDED SIDERAIL COVER, HEAD, RIGHT	3000-336-11
PADDED SIDERAIL COVER, FOOT, LEFT	3000-336-14
PADDED SIDERAIL COVER, FOOT, RIGHT	3000-336-13
PADDED SIDERAIL COVERS, SET OF ALL FOUR	3000-336-701
PAINT, TOUCH-UP, OPAL, BOTTLE W/BRUSH	7000-1-321
PAINT, TOUCH-UP, OPAL, SPRAY CAN	7000-1-318
POTENTIOMETER, FOOT END	3001-200-230
POTENTIOMETER, HEAD END	3001-200-240
POWER CORD	39-254
SINGLE TUBE OF GREASE	3000-200-700

UPGRADE KITS

UPGRADE KIT – ADD SCALE AND BED EXIT OPTIONS TO A STANDARD BED	3001-700-11
UPGRADE KIT – ADD SCALE OPTION TO A STANDARD BED	3001-700-12
UPGRADE KIT – ADD BED EXIT OPTION TO A STANDARD BED	3001-700-13
UPGRADE KIT – ADD SCALE OPTION TO BED WITH BED EXIT OPTION	3001-700-14
UPGRADE KIT – ADD BED EXIT OPTION TO BED WITH SCALE OPTION	3001-700-15

Maintenance Procedures – Base

BRAKE PEDAL REPLACEMENT

Required Tools:

5/16" Hex Allen Wrench
Hammer

Torque Wrench
Punch

Loctite 242
#2 Phillips Screwdriver

Procedure:

1. Unplug the bed power cord from the wall socket.
2. Using a #2 Phillips screwdriver, remove the three screws holding both the head end and the foot end upper lift covers. If desired, hold the covers out of the way by using bungee cords (or the equivalent) to secure them to the litter top.
3. Using a 5/16" hex Allen wrench, remove the two bolts holding the brake pedal to the brake rod.
4. Using a hammer and punch, remove the roll pins holding the brake shaft crank to the brake rod on both the head and the foot end.
5. Push the brake rod through the frame until the brake pedal is clear. Remove the brake pedal.
6. Reverse the above steps to attach the new brake pedal.

NOTE

Use Loctite 242 when reinstalling the bolts and torque the bolts to 25 foot-pounds.

Maintenance Procedures – Base

LIFT MOTOR AND CAPACITOR REMOVAL AND REPLACEMENT

Required Tools:

3/8" Socket Wrench
Side Cutters

5/16" Socket Wrench
Bungee Cord (or equivalent)

#2 Phillips Screwdriver

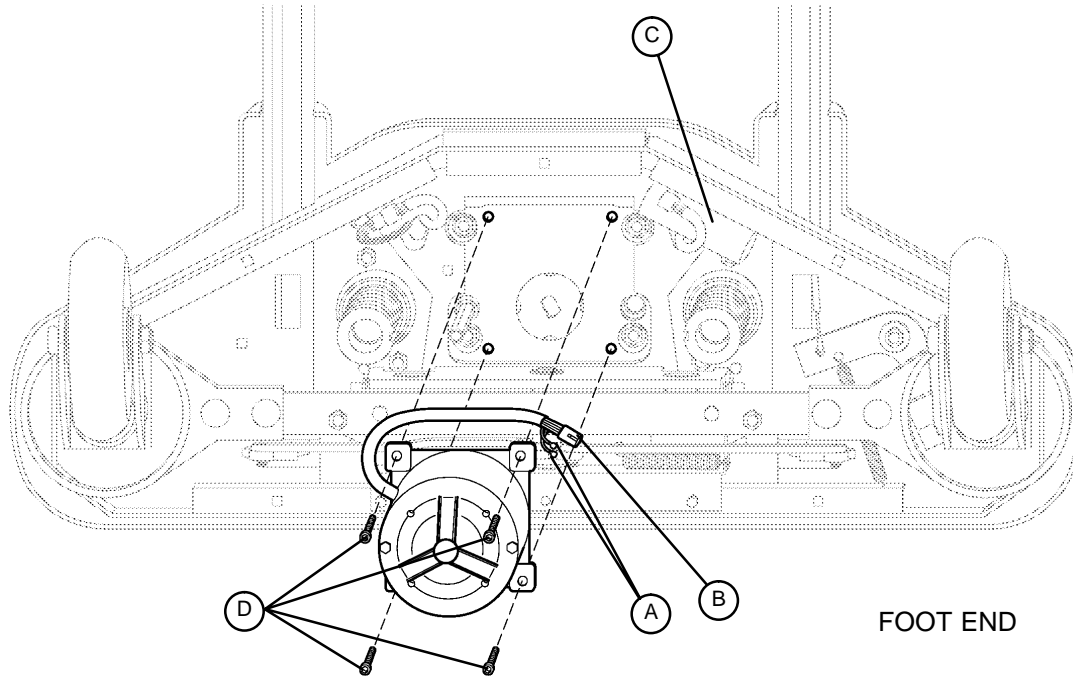

Procedure:

1. Unplug the bed power cord from the wall socket. Using a 5/16" socket wrench, remove the six bolts holding the lower lift cover to the base and remove the cover.
2. Using a #2 Phillips screwdriver, remove the three screws holding the upper lift cover to the base.
3. Disconnect the two connectors (A) at the motor capacitor.
4. Disconnect the white connector (B) from the power cord.
5. Using side cutters, cut the cable ties holding the capacitor (C) to the base and remove the capacitor.
6. Using a 3/8" socket wrench, remove the four screws (D) holding the motor assembly in the lift housing and remove the motor assembly.
7. Reverse the above steps to install the new motor.

NOTE

The drive shaft on the new motor probably will have to be turned to be aligned with the coupler. Use a 7/16" open end wrench to turn the drive shaft of the motor.

The procedure for lift motor and capacitor removal and replacement is the same for both ends of the bed.

Maintenance Procedures – Base

LIFT MOTOR ISOLATION PLATE REPLACEMENT

Required Tools:

7/16" Open End Wrench

5/16" Nut Driver or 5/16" Socket Wrench

3/8" Socket Wrench (w/6" ext.)

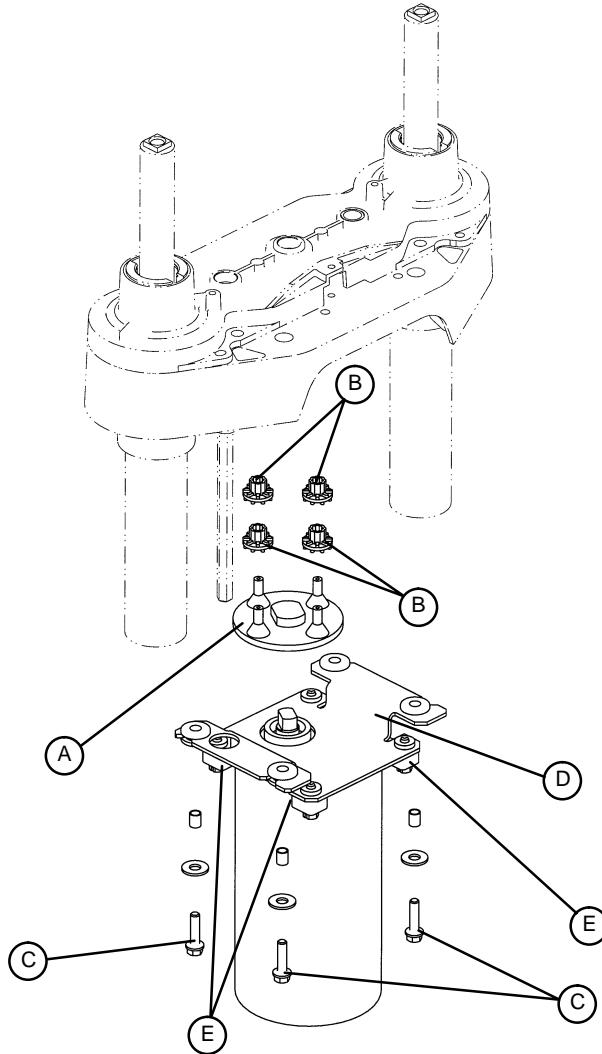

Procedure:

1. Unplug the bed power cord from the wall socket.
2. Using a 5/16" socket wrench, remove the six bolts securing the lower lift cover and remove the cover.
3. Using a 3/8" socket with a 6" extension, remove the four bolts (C) holding the lift motor isolation plate to the lift housing and carefully lower the isolation plate to the floor.
4. Remove the motor coupler (A) and bushings (B).
5. Using a 3/8" socket, remove the bolts and washers (E) from the motor and remove the isolation plate (D).
6. Reverse the above steps to install the new isolation plate and reattach all components to the bed.

NOTE

When reinstalling the lift motor, the drive shaft on the motor will have to be turned to be aligned with the coupler. Use a 7/16" open end wrench to turn the drive shaft of the motor.

Maintenance Procedures – Base

LIFT HOUSING REMOVAL AND REPLACEMENT

Required Tools:

#2 Phillips Screwdriver	Bungee Cord (or equivalent)	5/16" Socket Wrench
Side Cutters	9/16" Socket Wrench	5/16" Nut Driver
7/32" Hex Allen Socket Wrench	Sawhorses (or equivalent)	T27 Torx
3/8" Socket Wrench (w/ approx. 6" extension)		

Procedure:

1. Unplug the bed power cord from the wall socket.
2. Using a 5/16" socket wrench, remove the six bolts holding the lower lift cover to the base and remove the cover.
3. Using a #2 Phillips screwdriver, remove the three screws holding the upper lift cover to the base.
4. If you are working on the foot end of the bed, use a T27 Torx to remove the screw holding the litter access panel to the litter.
5. Remove the lift motor and capacitor (refer to procedure on page 39).
6. Remove lift potentiometer (refer to procedure on page 43).
7. Using a 5/16" socket wrench, remove the cable clamps holding the power and sensor coil cords on top of the lift housing assembly. Cut the cable ties and disconnect the coil cords from under the lift housing. The power and sensor coil cords are now free of the lift housing assembly. Drape them up out of the way.
8. Using a 7/32" hex Allen socket, remove the two screws (A) holding the lift screws to the header crossbar plate.

CAUTION

The bed litter retracts on rollers. Secure it to prevent it from rolling while the procedure is being done.

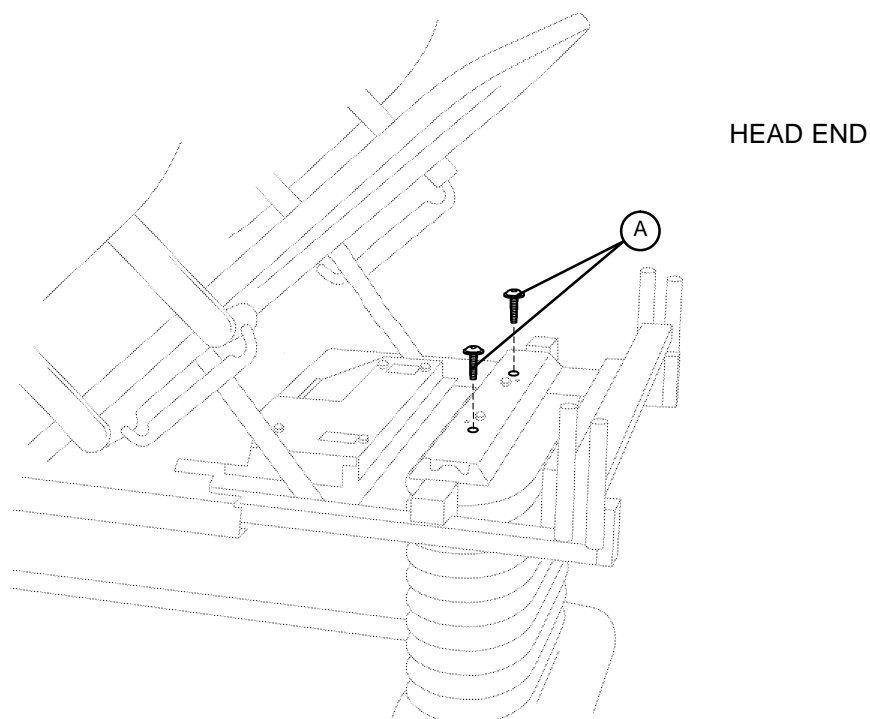

Maintenance Procedures – Base

LIFT HOUSING REMOVAL AND REPLACEMENT (CONTINUED)

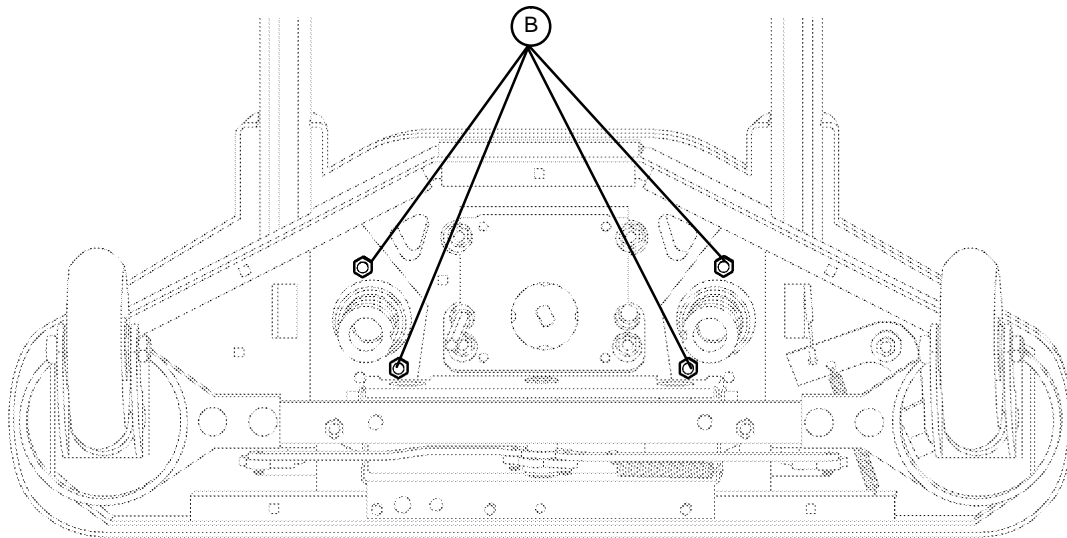

FOOT END – BOTTOM VIEW

9. Lift the litter top up and support it about 6" above the lift screws with sawhorses or the equivalent.
10. Under the base, using a 9/16" socket, remove the four nuts (B) holding the lift housing to the base.
11. Lift up and out on the lift housing assembly to remove it from the base.

CAUTION

See pages 46 and 47 for proper reattachment procedure for power and sensor coil cords and page 43 for reattachment of the lift potentiometer .

12. Reverse the above steps to reinstall the lift housing assembly after service is completed.

NOTE

The procedure for lift housing removal and replacement is the same for both ends of the bed.

Maintenance Procedures – Base

LIFT POTENTIOMETER REPLACEMENT AND ADJUSTMENT

Required Tools:

#2 Phillips Screwdriver
3/8" Open End Wrench

Bungee Cord (or equivalent)
Side Cutters

5/16" Socket Wrench

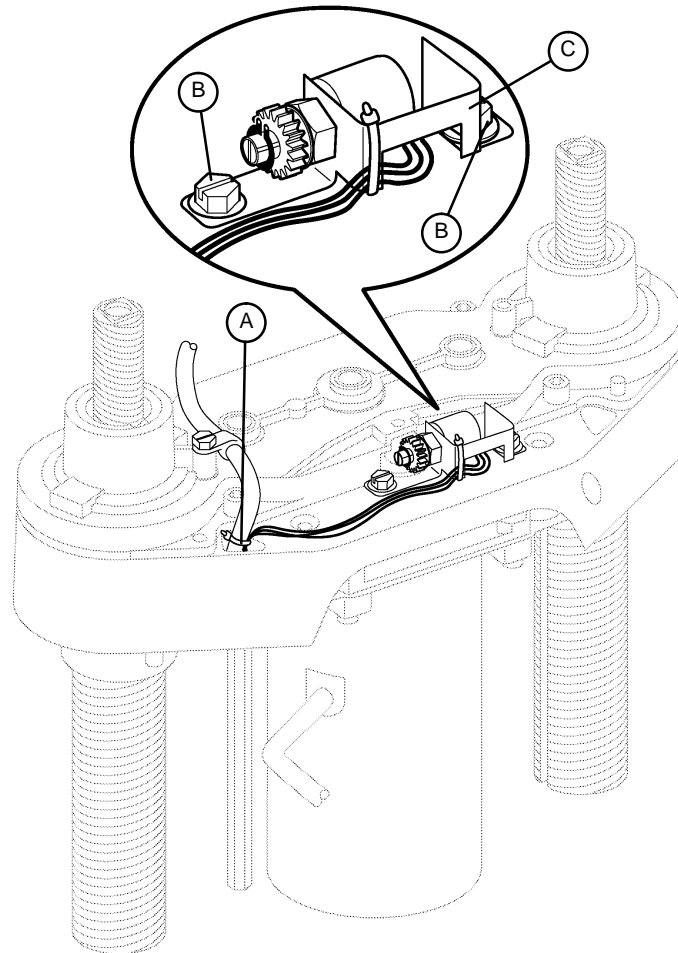

Procedure:

1. Unplug the bed power cord from the wall socket.
2. Using a 5/16" socket wrench, remove the six bolts holding the lower lift cover to the base and remove the cover.
3. Using a #2 Phillips screwdriver, remove the three screws holding the upper lift cover to the base.
4. Using side cutters, cut the cable tie (A) holding the pot cable to the coil cord.
5. Unplug the pot cable from the sensor coil cord. If replacing a pot at the head end of the bed, unplug the cables attached to the brake sensor switch.
6. Pull the pot cable up through the base.
7. Using a 3/8" open end wrench, remove the two bolts (B) holding the pot housing (C) to the lift housing.

Maintenance Procedures – Base

LIFT POTENTIOMETER REPLACEMENT AND ADJUSTMENT (CONTINUED)

8. Lift up and out on the pot housing assembly to remove it from the lift housing.
9. Before installing the new pot on the bed, turn it clockwise until it stops. Turn it back counterclockwise two full (360°) revolutions. This allows a "window" position for proper upper and lower limits.
10. Reverse steps 4–8 to install the new pot and pot housing assembly.
11. After installing the new pot, the "burn-in" procedure below must be followed.

NOTE

Be sure to maintain the pot position while installing.

LIFT POTENTIOMETER "BURN-IN" PROCEDURE

1. Unplug the bed power cord from the wall socket.
2. On the foot board control panel, hold down the Siderail Control Lights, Head Lock Out, and Up/Down Lock Out buttons simultaneously.
3. While holding down the above three buttons, plug the power cord into the wall socket. The Lights button on the foot board control panel should flash, indicating the bed is in the diagnostics mode.
4. Run both ends of the bed full down to a "hard stop".
5. Hold down the Bed Motion Lock button until the light flashes.
6. Release the button and unplug the power cord from the wall socket.
7. Plug the power cord back in to the wall socket. Run the bed to full up, then full down to verify the bed limits.
8. The distance between the floor and the top of the litter seat section (without a mattress) should be 16"–16 3/8" with the litter fully down and 29 1/4" – 29 7/8" with the litter fully up.

NOTE

These values are for beds equipped with 6 inch casters. Add two inches to both measurements for beds equipped with 8 inch casters.

Maintenance Procedures – Base

LIFT MOTOR COUPLER REPLACEMENT

Required Tools:

5/16" Socket Wrench

3/8" Socket Wrench (w/6" Extension)

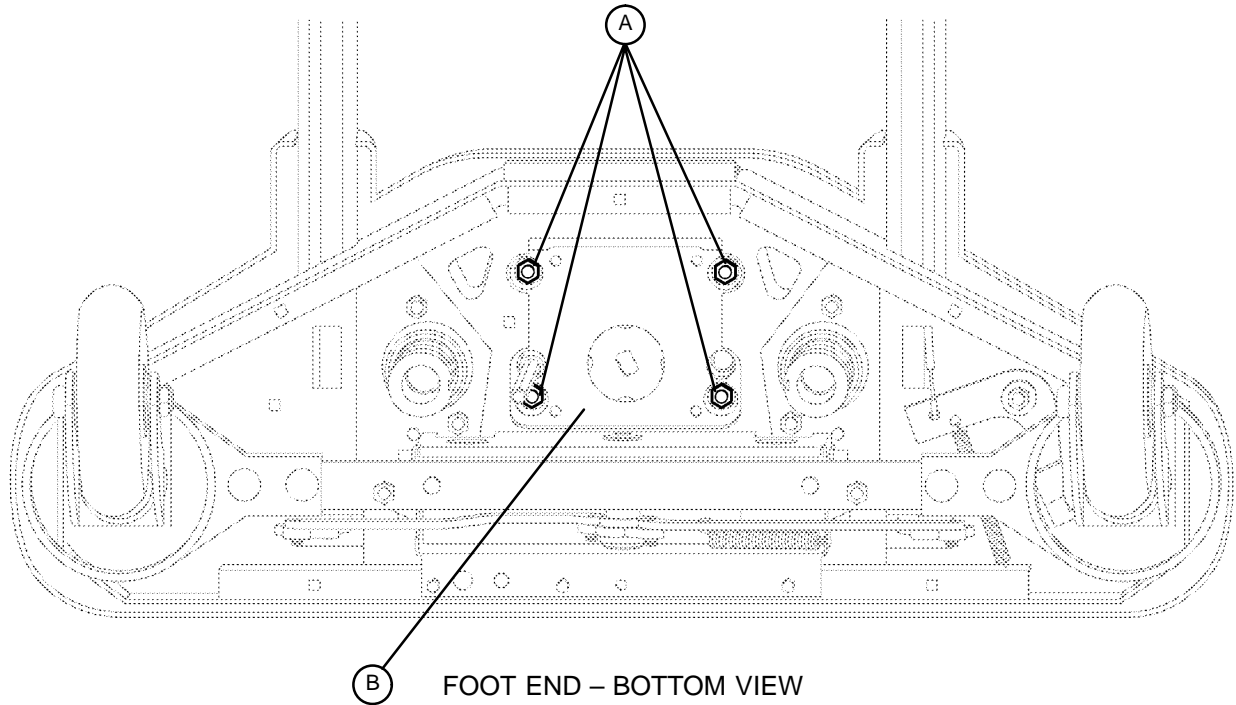

Procedure:

1. Unplug the bed power cord from the wall socket.
2. Using a 5/16" socket wrench, remove the six bolts holding the lower lift cover to the base and remove the cover.
3. Using a 3/8" socket with an extension, remove the four bolts (A) holding the isolation plate (B) to the lift housing and lower the lift motor and isolation plate assembly to allow access to the coupler.
4. The motor coupler can now be removed from the lift housing.
5. Reverse the above steps to install the new motor coupler and bushings.

Maintenance Procedures – Base

POWER AND SENSOR COIL CORD REPLACEMENT

Required Tools:

#2 Phillips Screwdriver	Side Cutters	5/16" Socket Wrench
Bungee Cord (or equivalent)	T27 Torx	5/16" Nut Driver

Procedure:

1. Unplug the bed power cord from the wall socket.
2. Using a 5/16" socket wrench, remove the six bolts holding the lower lift cover to the base and remove the cover.
3. Using a #2 Phillips screwdriver, remove the three screws holding the upper lift cover to the base.
4. If you are working on the foot end of the bed, use a T27 Torx to remove the screw holding the litter access panel to the litter.
5. Using side cutters, cut the cable ties holding the power and sensor coil cords to the base. Remove the ground wire coming from the sensor cord that is attached to the base (note the star washer arrangement).
6. Disconnect the cables going to the motor and the lift potentiometer (at the head end, the sensor cord is also attached to the brake switch sensor).
7. Pull both cords up through the frame of the bed and the lift housing.
8. Using a 5/16" nut driver, remove the two screws (A) holding the cable clamps* to the top of the lift housing.
9. Using a 5/16" nut driver, remove the two screws (B) securing the cable clamps* to the underside of the header crossbar assembly.
10. Pull both coil cords up through the header crossbar assembly.
11. Disconnect the power and sensor coil cords from the connectors.
12. The cords should now be completely removed from the bed. Reverse the above steps to install the new power and sensor cords*.

CAUTION

*When the power and sensor coil cords are being replaced, secure the cable clamps to the cords at the first coil on the top and on the bottom to assure there is not too much slack in the cords between the top of the lift housing assembly and the bottom of the header crossbar. Be sure the clamps are fastened at exactly the correct angle, as shown by the arrows in the illustration. Arrange the cords exactly as shown in the illustration (left in front of right). **If this is not done correctly, damage to the cords will result.**

Maintenance Procedures – Base

POWER AND SENSOR COIL CORD REPLACEMENT ILLUSTRATION

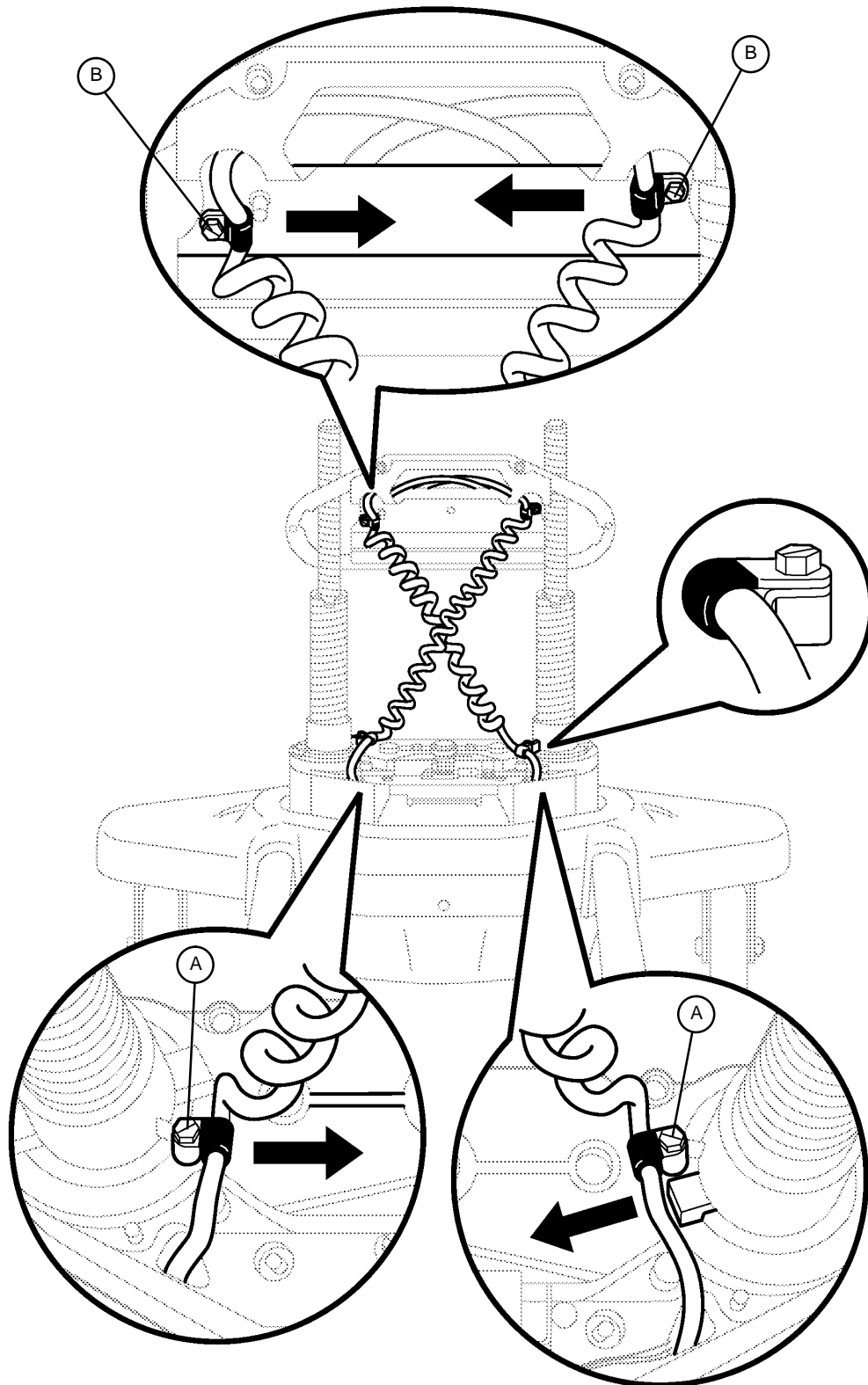

VIEW FROM CENTER OF BED

Maintenance Procedures – Litter

KNEE MOTOR REMOVAL AND REPLACEMENT

Required Tools:

T27 Torx

Needle Nose Pliers

3/8" Socket Wrench

Wire Cutters

Procedure:

1. Electrically run the litter fully up. Unplug the bed power cord from the wall receptacle.
2. Using a 3/8" socket wrench, remove the two bolts holding the motion interrupt pan to the litter frame and remove the pan.
3. Using needle nose pliers, remove the Rue pin (A) from the end of the drive tube.
4. Fold the Gatch section back toward the head end of the bed. Using a T27 Torx, remove the screw holding the mid-litter cover to the litter frame and remove the cover.
5. Remove the two wires from the auto contour micro switch (B) mounted next to the drive tube.
6. Using wire cutters, remove the cable ties. Disconnect the motor and capacitor wires.
7. Using needle nosed pliers, remove the Rue pin (C) from the motor bracket and lift the motor out.
8. Using a 3/8" socket wrench, remove the four bolts holding the motor bracket to the old motor. Remove the bracket and install it on the replacement motor using the same four bolts.
9. Install the replacement motor into the bed. **Do not** hook up the drive tube to the Gatch section yet.
10. Plug the bed power cord into a properly grounded wall receptacle. Using the button on the foot board or siderail, run the Gatch motor down until it stops.
11. Reinstall the mid-litter cover.
12. Fold the Gatch section back down. From underneath the bed, manually turn the drive tube in or out until it lines up with the hole in the Gatch section. Reinstall the pin, the wires for the auto contour switch, and the motion interrupt pan.
13. Test the bed for proper operation before returning it to service.

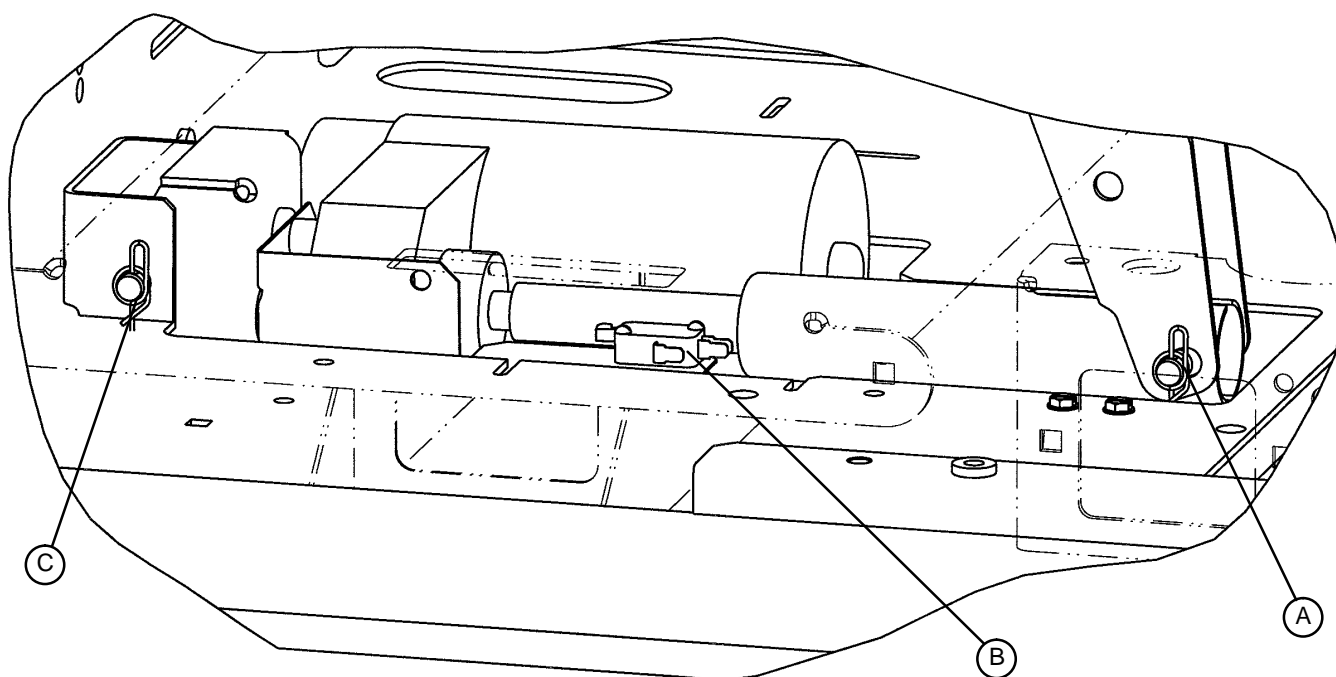

Maintenance Procedures – Litter

HEAD MOTOR CAM AND CAM GUIDE REPLACEMENT

Required Tools:

5/16" Nut Driver

3/8" Socket Wrench

T27 Torx

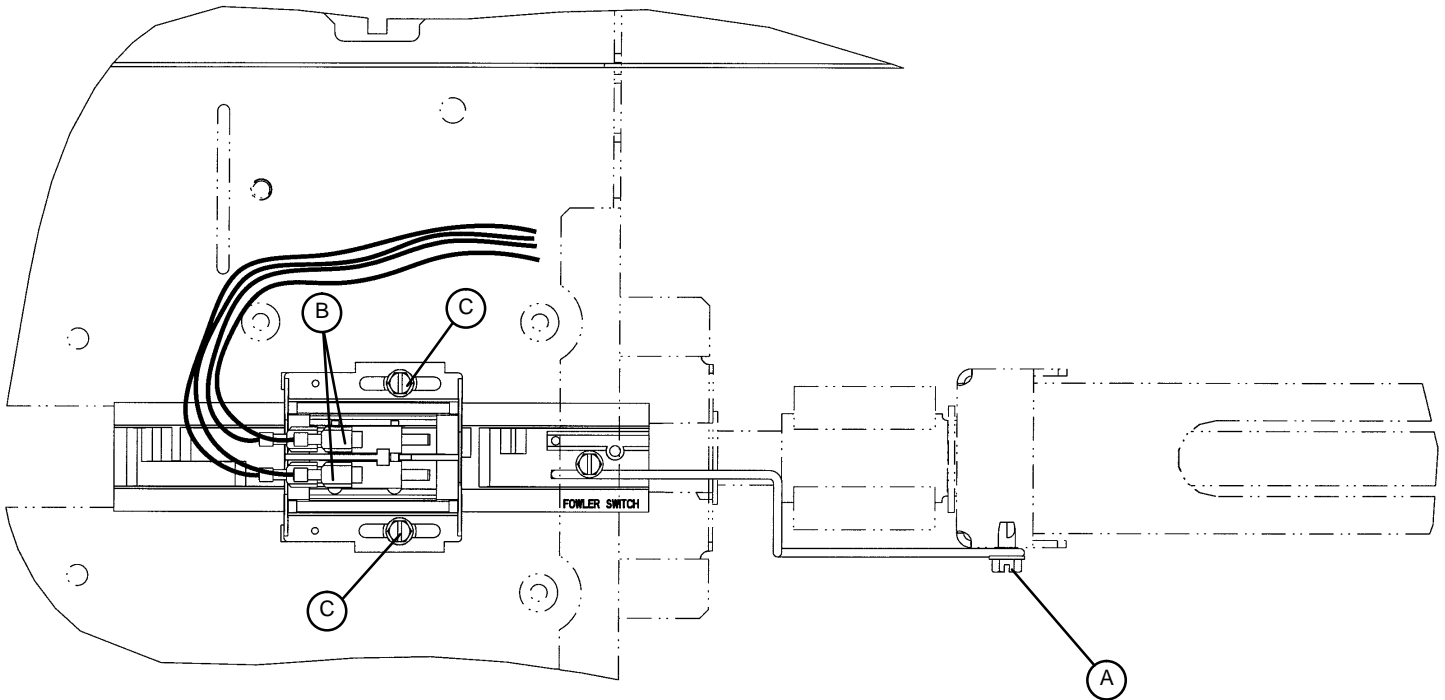

Procedure:

1. Run the Knee Gatch fully up. Unplug the bed power cord from the wall socket.
2. Using a T27 Torx, remove the screw holding the foot end litter cover to the frame and remove the cover.
3. Using a 3/8" socket wrench, remove the two bolts holding the motion interrupt pan to the litter and remove the pan.
4. Using a 5/16" nut driver, remove the screw (A) holding the cam retention wire to the ball nut assembly.
5. Disconnect the cables (B) from the micro switches. Take note of the locations of the cables so they will be connected properly to the replacement cam.
6. Using a 5/16" nut driver, remove the two screws (C) holding the cam and cam guide to the support bracket and remove the cam and cam guide with the attached micro switches from the bed.
7. Reverse the above steps to install the replacement cam and cam guide/micro switch assembly.
8. Refer to page 50 for "Limit Setting – Head Motor".

Maintenance Procedures – Litter

LIMIT SETTING – HEAD MOTOR

Required Tools:

5/16" Nut Driver

T27 Torx

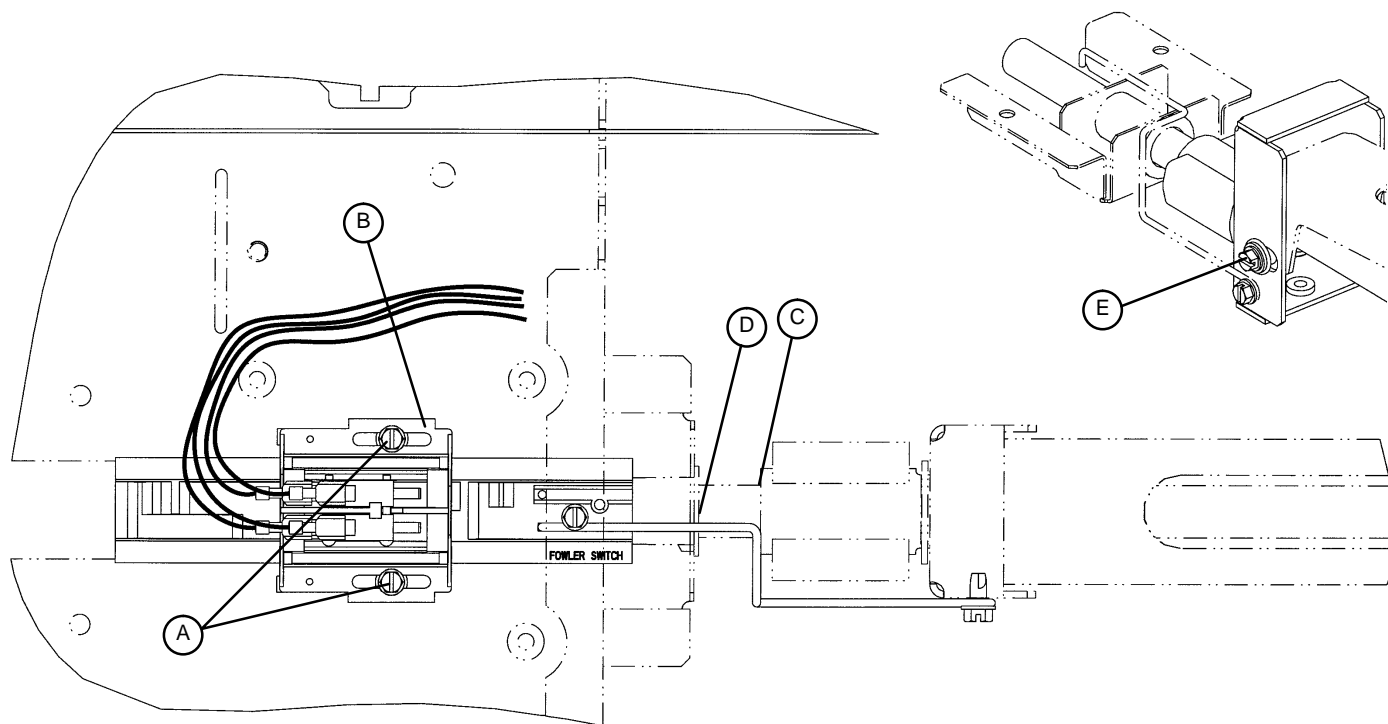

Procedure:

1. Run the Knee Gatch fully up.
2. Using a T27 Torx, remove the screw holding the midsection litter access covers to the litter and remove the covers.
3. Run the head section down electrically until flat (0°) or use the CPR release handle to fully lower the head.
4. Lightly tap the Fowler down button until the bolt and bushing (E) are centered in the slot.
5. Unplug the power cord from the wall socket.
6. Using a 5/16" nut driver, loosen the two screws (A) on the cam (B).
7. Slide the cam toward the head of the bed just until the microswitch is activated (the switch will make a clicking noise).

NOTE

Check that the cam "bump" is on the "head" side of the switch actuator.

8. Tighten the two screws (A).

CAUTION

Be sure the head section stops when it is fully up and the ball nut bracket (C) is approximately 3/4" from panel (D). If not, damage to the unit could result.

9. Ensure the head section will lower to flat (0°) before returning the bed to service. Verify the head section lowers onto the rubber rests and the motor stops running. Re-install the litter access panels removed in step 1.

Maintenance Procedures – Litter

HEAD MOTOR REMOVAL AND REPLACEMENT

Required Tools:

3/8" Socket Wrench

Procedure:

WARNING

The head motor is not grounded and may be an electrical hazard. Use caution when working around motors.

1. Using the CPR release, lower the Fowler to flat (0°).
2. Unplug the bed power cord from the wall socket.
3. Using a 3/8" socket wrench, remove the two bolts at the foot end of the motion interrupt pan and remove the pan.
4. Using a 3/8" socket wrench, remove the two bolts holding the motor bracket to the bed frame. Remove the motor.

NOTE

Use caution when removing the motor to avoid having the coupler come off the ball screw shaft.

5. Unplug the head motor cables from the bed and capacitor.

NOTE

The replacement motor will come with the attached CPR clutch. The mounting bracket will be re-used with the replacement motor.

6. Reverse the above steps to install the new motor assembly and reattach all litter panels.

Maintenance Procedures – Litter

HEAD MOTOR DRIVE ISOLATOR AND CPR DECOUPLER REMOVAL AND REPLACEMENT

Required Tools:

3/8" Socket Wrench

Needle Nose Pliers

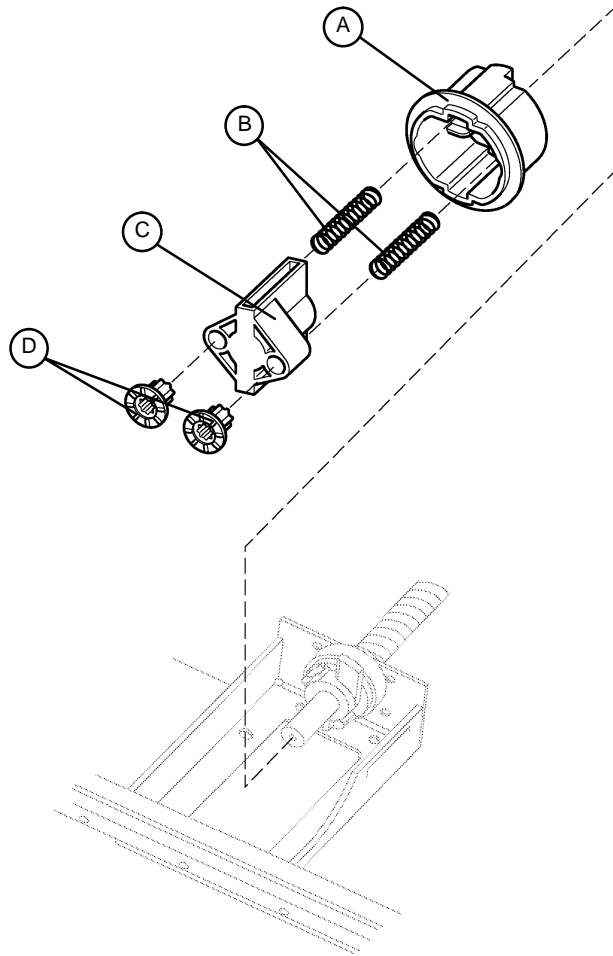

Procedure:

1. Refer to page 51 for the "Head Motor Removal and Replacement" procedure to access the isolator, springs and decoupler.
2. Pull the drive isolator (C) with the bushings (D), springs (B) and CPR decoupler (A) off the drive screw and remove it from the litter.

NOTE

These parts are spring-loaded. Use caution when removing them so they won't drop to the floor.

3. To reinstall, put the decoupler (A) on the shaft.
4. Using needle nose pliers, bend the end of the springs (B) out slightly to help hold the springs in the isolator. Put the springs in the isolator and install it on the shaft.
5. Reinstall the head motor (see page 51).
6. Run the Fowler up and down several times to test it before returning the bed to service.

Maintenance Procedures – Litter

DRIVE SCREW AND BALL NUT REPLACEMENT – HEAD MOTOR

Required Tools:

Large Snap–Ring Pliers

3/8" Socket Wrench

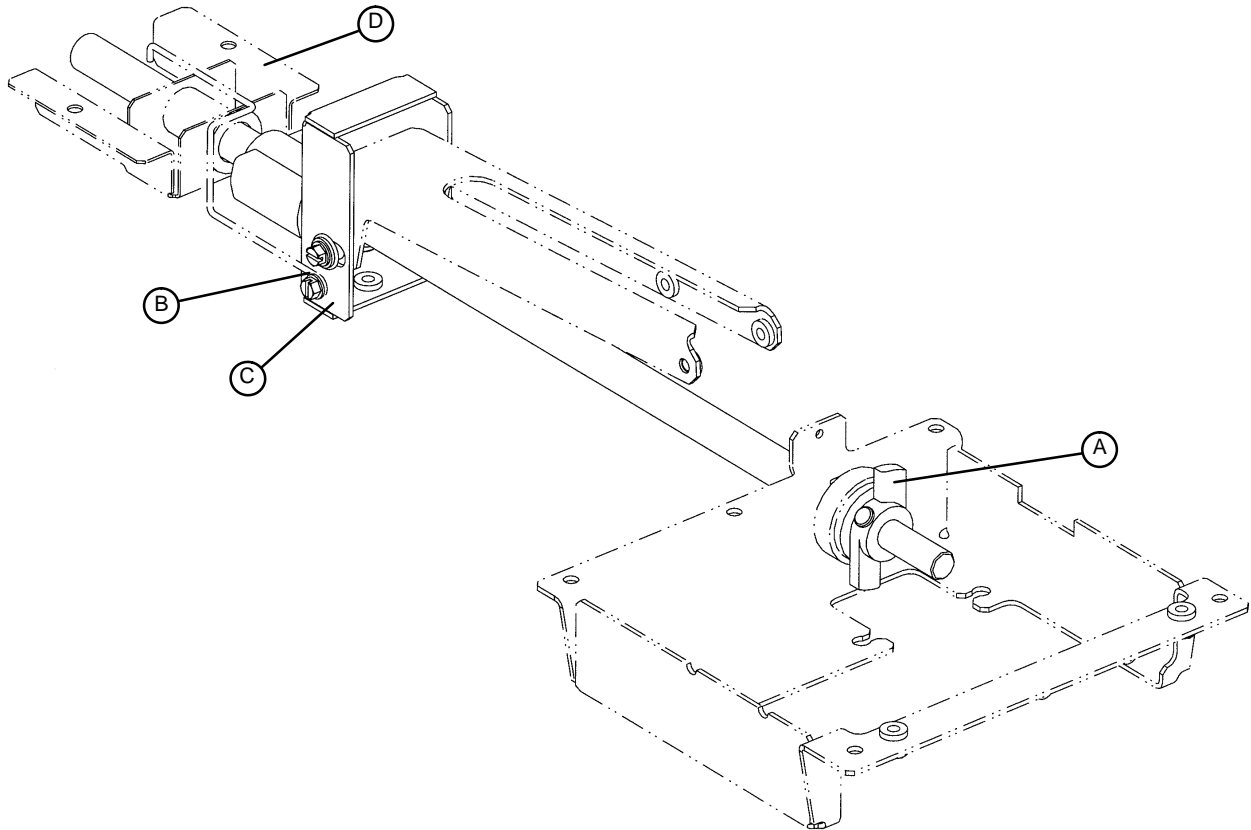

Procedure:

1. Run the bed fully up. Unplug the bed power cord from the wall socket.
2. Using a 3/8" socket wrench, remove the two bolts holding the motion interrupt pan to the litter and remove the pan.
3. Remove the head motor (see page 51) for access to the screw and ball nut.
4. Remove the head motor drive isolator and CPR decoupler (see page 52).
5. Using needle–nose pliers, remove the cotter pin holding the clevis pin to the drive screw "wing" (A).
6. Remove the clevis pin and slide the wing and tapered roller bearing off the drive screw.
7. Using a 3/8" socket wrench underneath the litter, remove the screw holding the cam retention wire (B) to the ball nut assembly.
8. Using a 3/8" socket wrench, remove the two bolts holding the ball screw support bracket (D) to the bottom of the litter and remove the bracket.
9. Using large snap ring pliers, remove the snap ring holding the ball nut to the bracket (C).

Maintenance Procedures – Litter

DRIVE SCREW AND BALL NUT REPLACEMENT – HEAD MOTOR (CONTINUED)

10. To prevent the ball nut from coming off the drive screw, cable tie both ends of the ball nut to the drive screw.
11. Pull the drive screw toward the foot of the bed and remove the head end of the drive screw and ball nut assembly from the support.

NOTE

Do not allow the ball nut assembly to come off the drive screw. The ball nut will be shipped attached to the drive screw and retained in position during shipment. Remove the restraining straps **after** installing the drive screw and nut.

12. Remove the thrust washers and bearing from the head end of the drive screw and set them aside.
13. Reverse the above steps to install the replacement drive screw and ball nut assembly.

NOTE

Apply grease to all bearing areas.

CAUTION

Verify the head motor stops properly at both upper and lower electric limits. If it does not, refer to page 50 for "Limit Setting – Head Motor".

HEAD MOTOR BRAKE/CLUTCH REPLACEMENT

Required Tools:

3/8" Socket Wrench

Snap Ring Pliers

9/16" Socket Wrench

9/16" Box End Wrench

Wire Cutters

Procedure:

1. Remove the head motor (see page 51).
2. Using snap ring pliers, remove the snap ring from the motor shaft.

CAUTION

The brake/clutch is spring-loaded. Use caution when removing the snap ring so the parts don't drop to the floor.

3. Remove the old brake/clutch from the motor and discard it.
4. Using a 9/16" socket wrench and a 9/16" box end wrench, remove the nut, bolt and washers from the new brake/clutch.
5. Install the new brake/clutch onto the motor. It may be necessary to turn the motor shaft to line up the key way with the brake/clutch.
6. Using the snap ring pliers, install the new snap ring.
7. Using the wire cutters, remove the two wire ties from the new brake/clutch.
8. Reinstall the head motor (see page 51).
9. Test the bed for proper operation before returning it to service.

Maintenance Procedures – Litter

SCALE SYSTEM DIAGNOSTICS

Diagnostic Mode Functions:

1. **Calibrate Scale:** This may be required in the field if the scale CPU is replaced.
2. **Display Corner:** This function displays the individual corner weights for each load cell assembly and can be used to isolate a defective load cell.
3. **Init. to Defaults:** This may be required in the field when replacing the scale CPU board.
4. **Display Factors:** This is factory preset.
5. **Exit Diagnostics:** Changes made in the diagnostic mode (with the exception of Calibrate Scale) **must** be saved in permanent memory using this function. Switching off power without saving will reset all variables to their previous values.

Diagnostic Mode:

NOTE

It requires **two people** to enable the diagnostic mode for the scale system.

1. To enter diagnostic mode, unplug the bed's power cord from the wall socket.
2. Press and **hold down** the LBS/KGS key.
3. While still holding the LBS/KGS key, plug the bed's power cord into the wall socket.
4. After two seconds, release the LBS/KGS key. The scale monitor should read CALIBRATE SCALE. The diagnostic mode is now active.

Displaying Individual Load Cell Outputs:

A defective load cell can be detected by entering diagnostics and displaying individual load cell outputs.

1. Enter the diagnostic mode. The scale monitor will display CALIBRATE when the diagnostic mode is active.
2. Repeatedly press and release LBS/KGS until the scale monitor displays DISPLAY CORNER.
3. Press and release SCALE ON. The scale monitor should display PICK CORNER NOW.

The four keys listed in the group below function as POSITION keys corresponding with the four corners of the bed's litter. Whenever the scale monitor displays PICK CORNER NOW, press one of these keys to select the load cell assembly at the desired corner.

- A. ZERO = head end, patient's right side
 - B. DELTA = head end, patient's left side
 - C. PLUS = foot end, patient's right side
 - D. MINUS = foot end, patient's left side
4. Press and release the position key that corresponds with the load cell to be checked. The scale monitor should display X/X=NNN.N. "X/X" represents the initials of the selected corner, i.e. H/R will be displayed for the patient's head end, right side. "NNN.N" represents the resistance of the load cell.
 5. Repeat step four for each corner. Head end weight readings will normally be lower than foot end weights. Weight readings should be constant. A drifting 000.0 or 999.9 weight, or a reading that does not change when weight is applied to that corner of the bed indicates a problem with the selected load cell assembly or load cell cable.
 6. When all the load cell outputs have been checked, repeatedly press and release SCALE ON until scale monitor displays EXIT DIAGNOSTICS. Press SCALE ON to exit diagnostics.

Maintenance Procedures – Litter

SCALE SYSTEM CALIBRATION

Verifying Scale Accuracy:

1. Zero the empty bed. Place a known weight on the center of the bed; the heavier the better and no less than 100 pounds. The displayed weight should be within 1% of the actual weight.
2. If the displayed weight is not accurate, remove the weight from the bed and place the scale CPU in calibration mode.

Scale Calibration:

NOTE

It requires **two people** to enable the calibration mode for the scale system.

Calibrate the scale system with a known weight of approximately 200 pounds.

1. To enter the calibration mode, unplug the bed's power cord from the wall socket.
2. Press and **hold down** the LBS/KGS key.
3. While still holding the LBS/KGS key, plug the bed's power cord into the wall socket.
4. After two seconds, release the LBS/KGS key. The scale monitor should read CALIBRATE SCALE. The calibration mode is now active.
5. Press and hold SCALE ON. Zero the bed, following the displayed instructions. When the bed is zeroed, the scale monitor should display REF X100=<2>000.0.
6. The displayed number must now be changed to match the known weight times 100. For example, if REF number to equal 19240. Change the REF number using the LBS/KGS key to position the brackets (<>) around the digit needing to be changed and the "+" key to scroll through the bracketed digit.
7. After the number is corrected, press and release SCALE ON. The scale should display ADD LBS, HIT ON.
8. Place calibration weight on the center of the bed and press and hold SCALE ON. The scale monitor should display RELEASE TO CAL.
9. Release SCALE ON. The scale monitor should display DO NOT TOUCH BED. Don't touch the bed. When calibration is complete, the scale monitor should display CALIBRATE SCALE.
10. Calibration is now complete, press LBS/KG until EXIT DIAGNOSTICS appears. Press SCALE ON and the display will read WEIGHING. Re-zero the empty bed. Check the scale accuracy with the weight used previously.

Maintenance Procedures – Litter

LOAD CELL REPLACEMENT

Required Tools:

1/4" Hex Allen Wrench

Wire Cutters

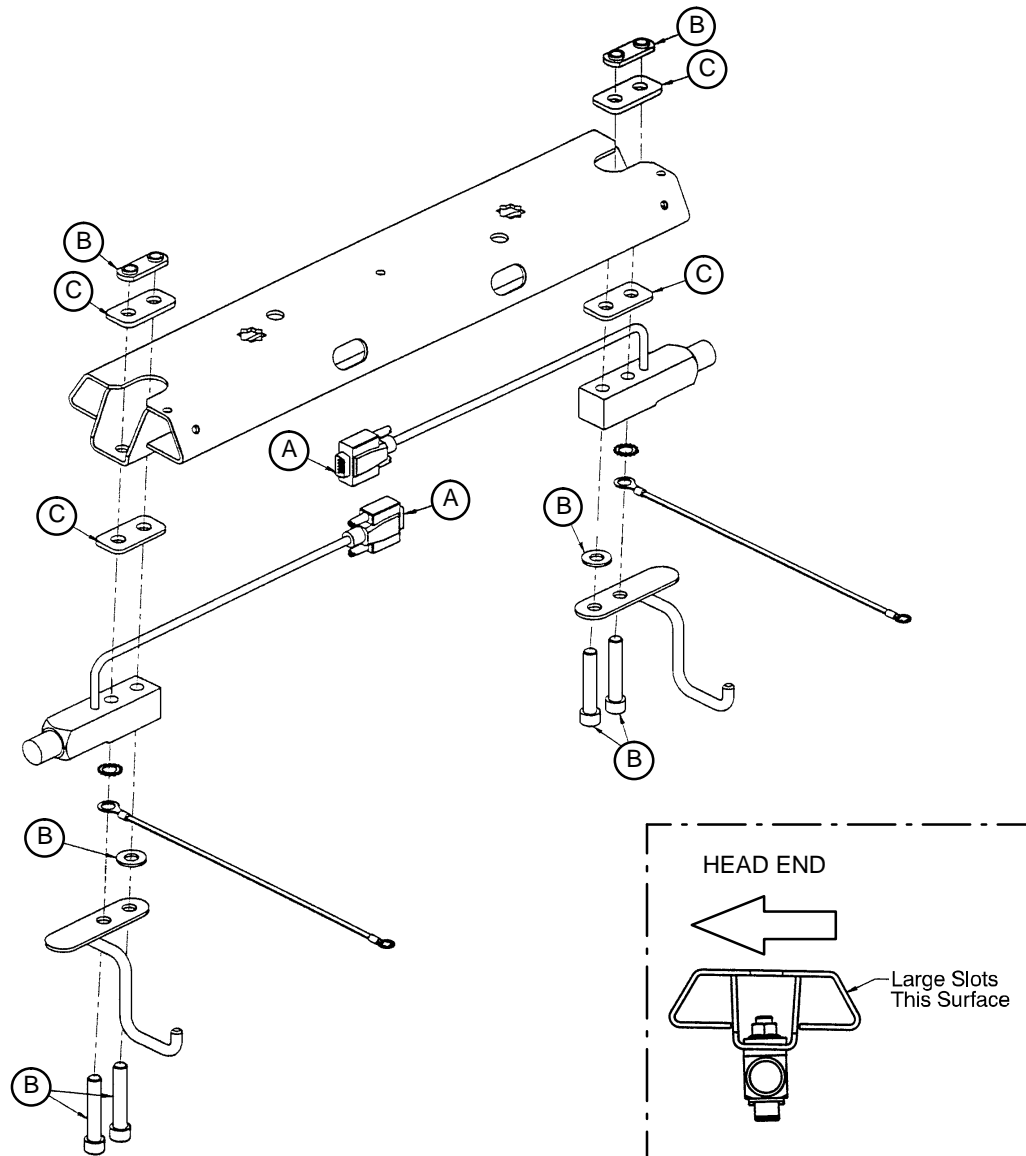

Procedure:

1. Unplug the bed power cord from the wall socket.
2. Support the corner of the litter where the load cell is being removed.
3. Unplug the load cell connector (A) from the load cell cable. Using side cutters, cut the cable ties.
4. Using a 1/4" hex Allen wrench, remove the two screws, washers, and nuts (B) holding the load cell to the bed.
5. To remove a load cell at the head end of the bed, slide the load cell toward the center of the bed to clear the bushing that supports the load cell. Remove the load cell by lifting it up and out. To remove a load cell at the foot end of the bed, slide the load cell with the roller bushing toward the center of the bed to clear the litter frame. Remove the load cell and the roller bushing by lifting them up and out.

Maintenance Procedures – Litter

LOAD CELL REPLACEMENT (CONTINUED)

NOTE

If your bed is equipped with a scale system, there are two tapered shims (C) for each load cell. Refer to page 57 as reference for proper installation of the shims. Proper installation of these shims is very important for scale accuracy.

6. Reverse the above procedure to install the new load cell.

CAUTION

Be sure the load cell's strain gauge is facing up when installing a new load cell or the weigh system will not work properly.

7. Recalibrate the weigh system (see page 55).

POWER SUPPLY REPLACEMENT

Required Tools:

#2 Phillips Screwdriver T27 Torx

Procedure:

1. Adjust the Fowler to approximately 25–30°. Unplug the bed power cord from the wall socket.
2. Properly ground yourself (see page 28 for static discharge precautions).
3. Using a T27 Torx, remove the two screws holding the head end litter access cover and remove the cover.
4. Disconnect all cables at the power supply. Note the locations of the cables so they will be reconnected properly to the replacement power board.
5. To remove the board from the litter standoffs, use a #2 Phillips screwdriver to remove the four screws holding the board to the litter. Remove the board.
6. Install the new board and reconnect all cables.
7. Reinstall the litter access panel and plug the bed power cord into a properly grounded wall receptacle.
8. Test the bed for accurate operation before returning it to service.

Maintenance Procedures – Litter

CPU BOARD REPLACEMENT

Required Tools:

T27 Torx

Procedure:

1. Adjust the Fowler to approximately 25–30°. Unplug the bed power cord from the wall socket.
2. Properly ground yourself (see page 28 for static discharge precautions).
3. Using a T27 Torx, remove the two screws holding the head end litter access cover and remove the cover.
4. Disconnect all cables at the litter CPU board. Note the locations of the cables so they will be connected properly to the replacement litter CPU.
5. To remove the board from the litter standoffs, pull out on the retention clips and lift upward on the board.
6. Install the new board and reconnect all cables.
7. Reinstall the litter access panel and plug the bed power cord into a properly grounded wall receptacle.
8. When a new CPU board is installed, a “burn-in” procedure must be done (see below). If your bed is equipped with a scale system, scale calibration must also be done (see page 55).
9. Test bed operations before returning the bed to service.

LIFT POTENTIOMETER “BURN-IN” PROCEDURE

1. Unplug the bed power cord from the wall socket.
2. On the foot board control panel, hold down the Siderail Control Lights, Head Lock Out, and Up/Down Lock Out buttons simultaneously.
3. While holding down the above three buttons, plug the power cord into the wall socket. The Lights button on the foot board control panel should flash, indicating the bed is in the diagnostics mode.
4. Run both ends of the bed full down to a “hard stop”.
5. Hold down the Bed Motion Lock button until the light flashes.
6. Release the button and unplug the power cord from the wall socket.
7. Plug the power cord back in to the wall socket. Run the bed to full up, then full down to verify the bed limits.
8. The distance between the floor and the top of the litter seat section (without a mattress) should be 16”–16 3/8” with the litter fully down and 29 1/4” – 29 7/8” with the litter fully up.

NOTE

These values are for beds equipped with 6 inch casters. Add two inches to both measurements for beds equipped with 8 inch casters.

Maintenance Procedures – Litter

OPTIONAL SMART TV INTERFACE BURN-IN PROCEDURE

This procedure is used for selecting the style of TV interface desired for your bed. If traditional TV is desired, select the “No Flash” setting. If optional Smart TV is available on the bed, select one of the TV manufacturers listed in the table below.

SET-UP

- Ensure the communication cable is connected between the bed and the Db37 wall port or the pillow speaker port of the nurse call system. If available, a bed communication tester can be used instead of the hospital wiring.

PROCEDURE

1. Place the bed in the lift potentiometer burn-in mode (see page 59).
2. Notice the Nurse Call LED (yellow) is not flashing. This represents the traditional TV mode. Notice the Nurse Answer LED (green) is flashing on/off slowly.
3. Press and release the TV ON/OFF switch on the bed’s siderail. Notice the Nurse Call LED flashes once. This is the first selection of TV manufacturers for the Smart TV mode. Notice the Nurse Answer LED (green) is flashing on/off slowly. The Nurse Answer LED will only light when the Nurse Call LED (yellow) is flashing.
4. Press and release the TV ON/OFF switch on the bed’s siderail to scroll to other TV manufacturers. Notice the number of times the Nurse Call LED flashes matches the number listed in the table below and represents the TV manufacturer selected.
5. When the desired TV manufacturer has been selected, unplug the bed power cord from the wall socket and plug it back in to complete the Smart TV burn-in procedure.

NOTE

If the bed is connected to a television during the burn-in procedure, the television will turn on when the correct setting is selected.

TV MANUFACTURER SELECTION FOR SMART TV BURN-IN PROCEDURE		
Press and release TV ON/OFF switch:	Nurse Call LED (Yellow)	TV Manufacturer
No press	No flash	Traditional TV
Once	One flash	RCA 1
Twice	Two flashes	RCA 2
Three times	Three flashes	Zenith 1
Four times	Four flashes	Zenith 2
Five times	Five flashes	Phillips/Magnavox
Six Times	Six flashes	Magnavox (models 9120, 9220, 9320)

Notes

Maintenance Procedures – Siderail

HEAD AND FOOT SIDERAIL COVER REMOVAL

Required Tools:

#2 Phillips Screwdriver

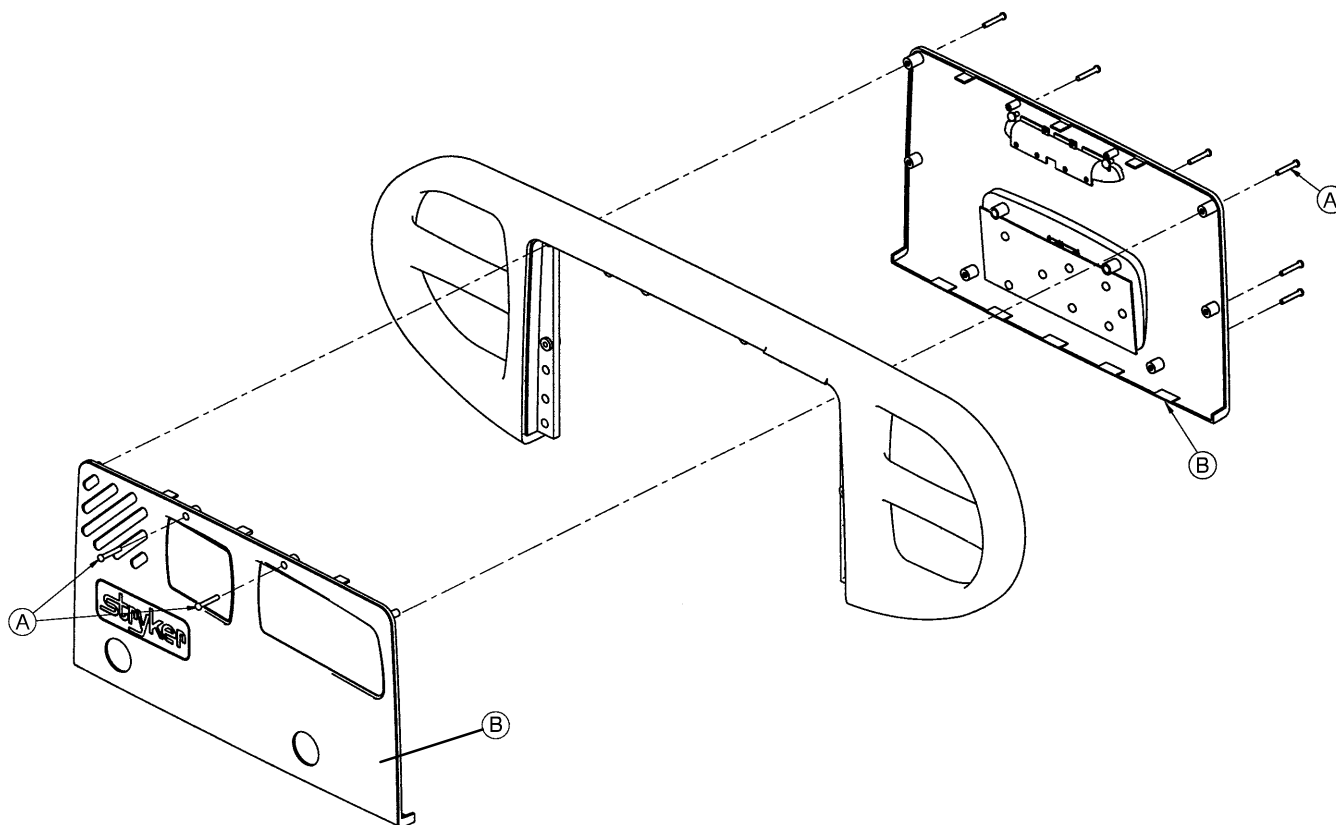

Removal Procedure:

1. Unplug the power cord from the wall receptacle.
2. Using a #2 Phillips screwdriver, remove the 8 phillips screws (A) holding the covers (B) to the siderail.

CAUTION

There are two cables connecting the outside cover to the head end siderail. Be careful not to pull on them when removing the cover.

3. Remove the cables from the siderail. Make note of the proper location for the cables.
4. Reverse the above steps to reattach the cover.

CAUTION

Do not snag the cables when installing the siderail cover.

NOTE

Follow the same procedure for siderail cover removal for the foot end rails.

Maintenance Procedures – Siderail

HEAD AND FOOT MOLDED SIDERAIL REPLACEMENT

Required Tools:

#2 Phillips Screwdriver

3/8" Nut Driver

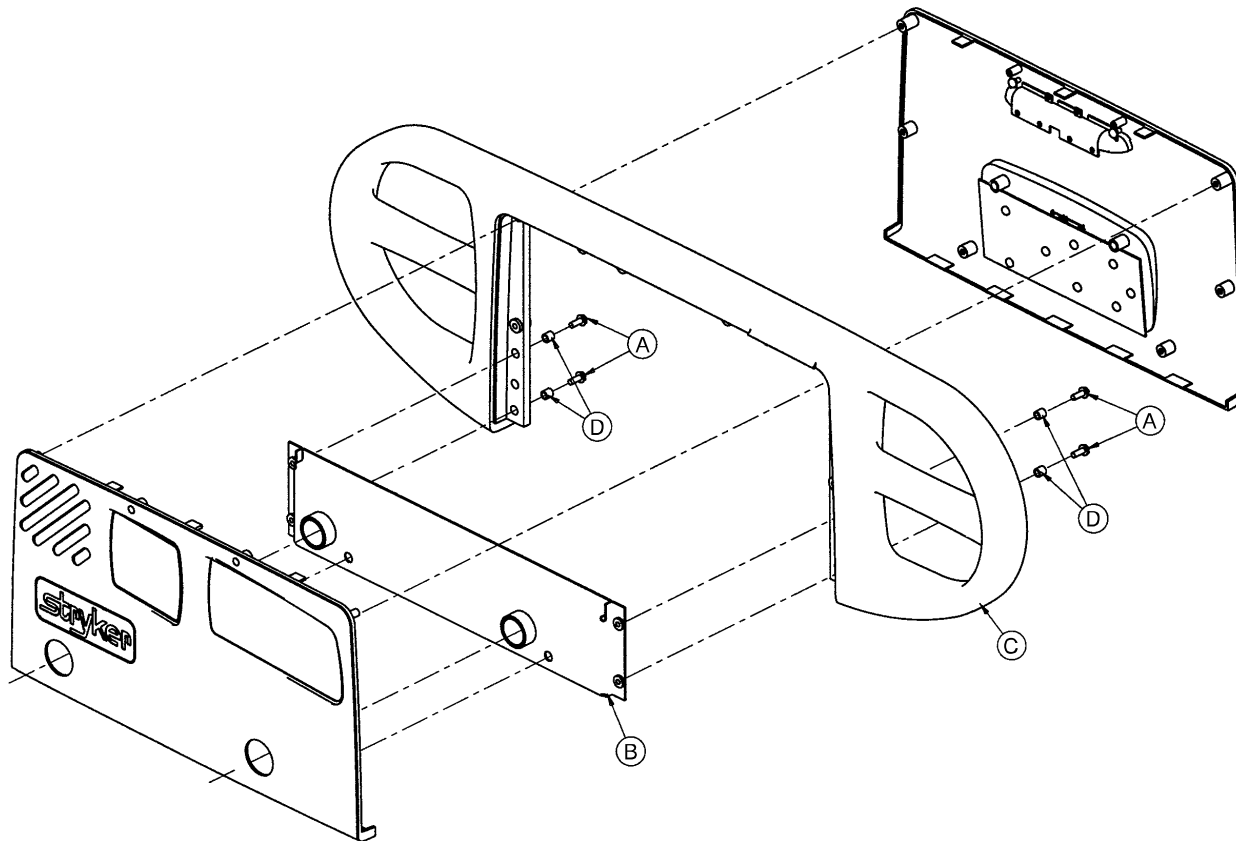

Procedure:

1. Unplug the bed power cord from the wall socket.
2. Remove the siderail cover (see page 60).
3. Using a 3/8" nut driver, remove the four screws (A) holding the molded rail (C) to the siderail support assembly (B).

NOTE

Note the location of the spacers (D) for re-assembly purposes.

4. Pull up on the molded rail (C) to remove it from the siderail assembly.
5. Reverse the above steps to install the new molded rail.

Maintenance Procedures – Siderail

HEAD END SIDERAIL CABLE REPLACEMENT

Required Tools:

#2 Phillips Screwdriver

Side Cutters

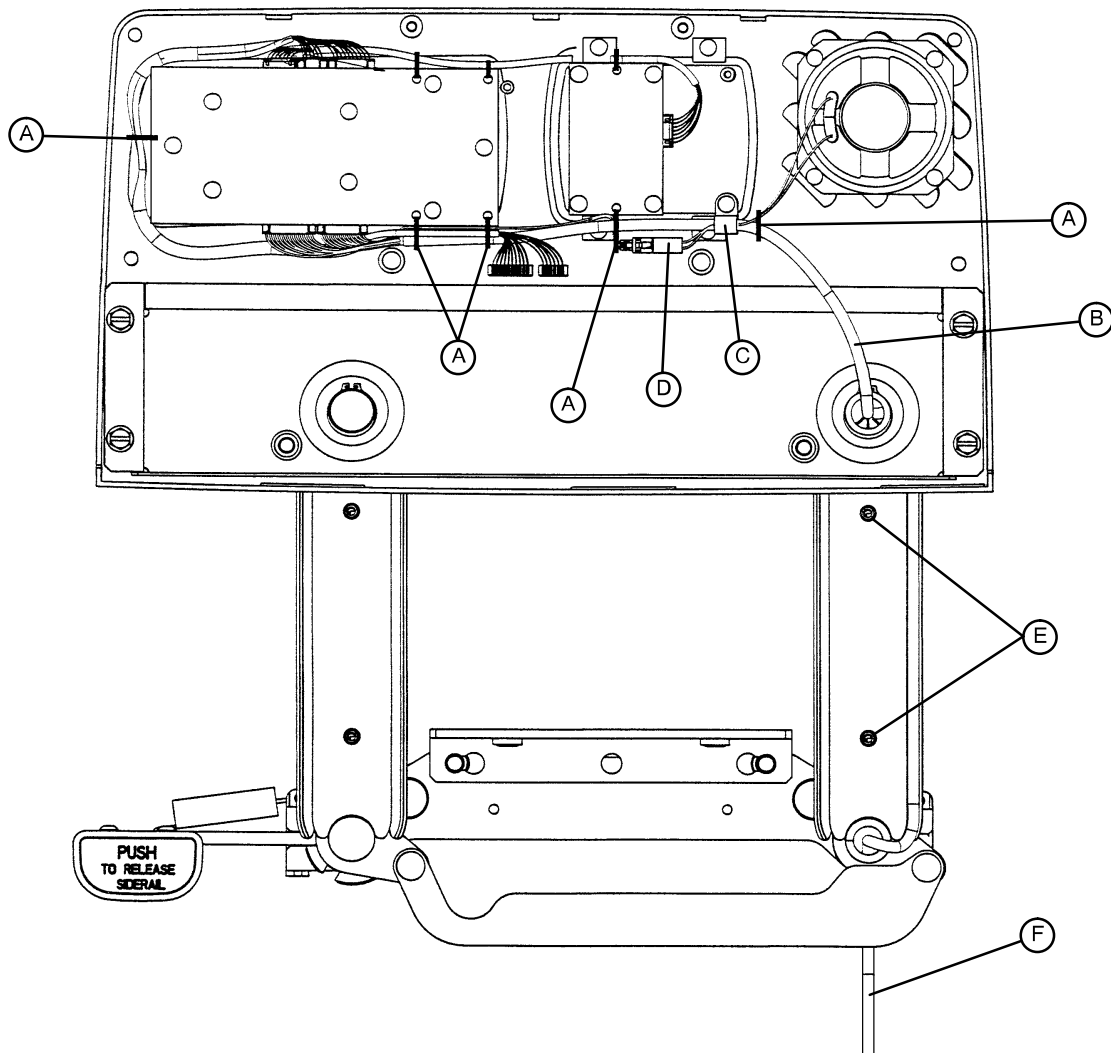

Procedure:

1. Run the head section fully up.
2. Unplug the bed power cord from the wall socket.
3. Using a #2 Phillips screwdriver, remove the eight screws holding the siderail cover and remove the cover.
4. Put the siderail in the down position.
5. Using a #2 Phillips screwdriver, remove the two screws (E) holding the rear siderail pivot arm cover to the pivot arm. Remove the cover to expose the siderail cables.

Maintenance Procedures – Siderail

HEAD END SIDERAIL CABLE REPLACEMENT (CONTINUED)

6. Using side cutters, clip the cable ties (A) holding the cables together.
7. Using a #2 Phillips screwdriver, remove the cable clamp (C) from the siderail.
8. Disconnect cable (B) from the circuit board and cable (D) from the speaker.

NOTE

The speaker and nurse call are optional equipment and may not be in the siderail as shown.

9. Pull the cables through the siderail (toward the center of the bed).
10. Unplug the cable assembly (F) underneath the head section.
11. Reverse the above steps to install the new cable.

CAUTION

Be sure to position the cables on both sides of the pivot arm, as shown in the illustration on page 62, before reattaching the pivot arm cover. If not done properly, the cover will not fit tightly and damage could occur to the cables.

Maintenance Procedures – Siderail

SIDERAIL ASSEMBLY REMOVAL

Required Tools:

T27 Torx

Removal Procedure:

1. Run the head section up electrically when removing a head end siderail.
2. Unplug the bed power cord from the wall socket.
3. Lower the siderail being removed.

NOTE

If removing a head end siderail, the cable must be unplugged.

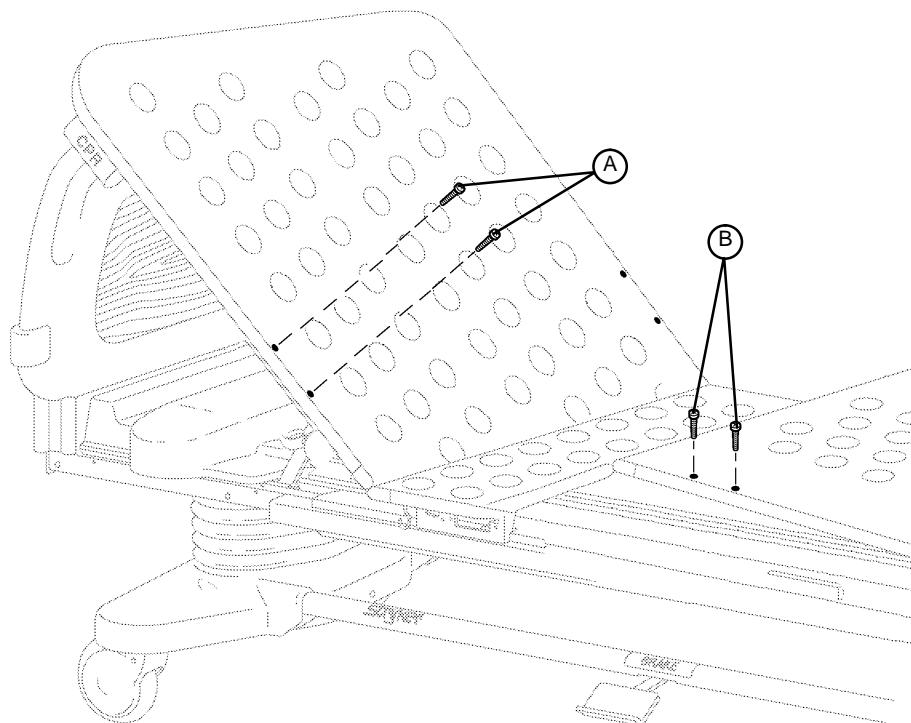

4. Using a T27 Torx, remove the screw from the ground strap and the two screws (A – head end) or (B – foot end) holding the complete siderail assembly on the head or foot section.
5. Push in on the siderail assembly to clear under the head or foot section and pull the siderail back to remove it from the bed.
6. Reverse the above steps to reinstall the siderail assembly.

NOTE

Grease the glide rods on the replacement siderail assembly with Syntech grease.

Maintenance Procedures – Foot Board

FOOT BOARD HINGE REMOVAL

Required Tools:

#2 Phillips Screwdriver

Procedure:

1. Using a #2 Phillips screwdriver, remove the screws (A & B) holding the door and hinge assembly to the foot board.
2. If replacing the hinge only, use a Phillips screwdriver to remove the screws holding the hinge to the door.
3. Reverse the above steps to attach the replacement door and/or hinge.

NOTE

Screw (B) is a machine screw and must be reinstalled in the proper hole.

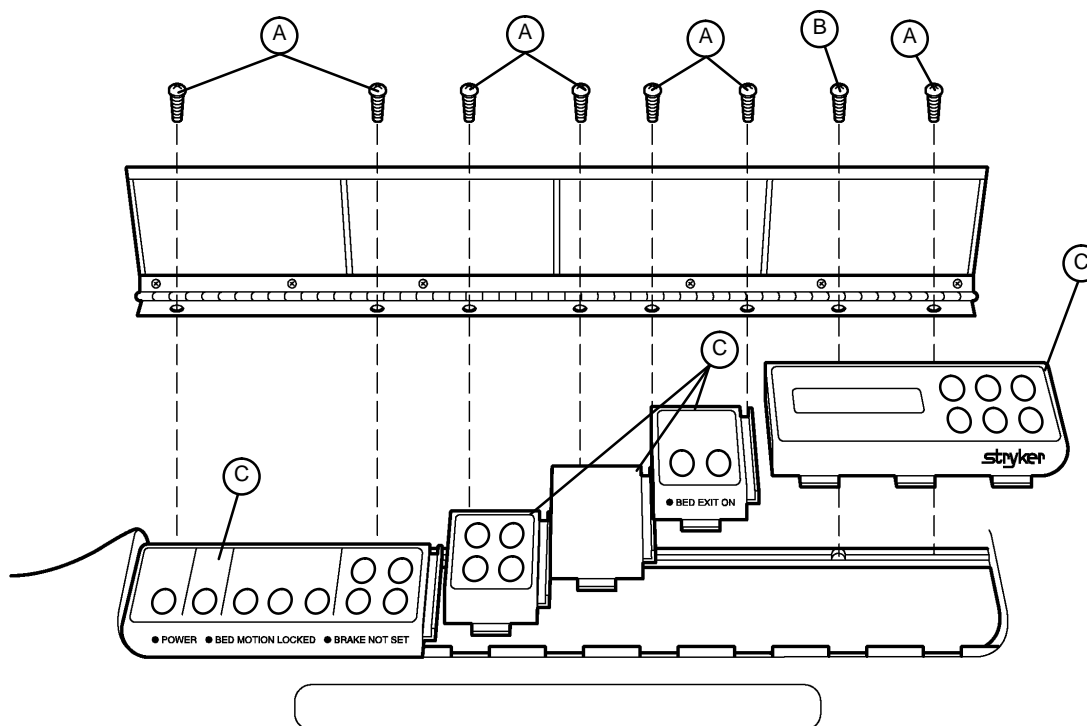

FOOT BOARD MODULE REPLACEMENT

Required Tools:

#2 Phillips Screwdriver

Procedure:

1. Unplug the bed power cord from the wall socket. Remove the foot board hinge (see above).

NOTE

Regardless of which module is being replaced, the farthest module to the right must be removed first.

2. Pull the module out of the foot board and disconnect the cable from the module (C).
3. Reverse the above steps to install the new module.

CAUTION

The modules must be overlapped as shown in the illustration to prevent fluids from entering the board cavity and causing damage.

Maintenance Procedures – Foot Board

FOOT BOARD INTERFACE PLUG REPLACEMENT

Required Tools:

#2 Phillips Screwdriver

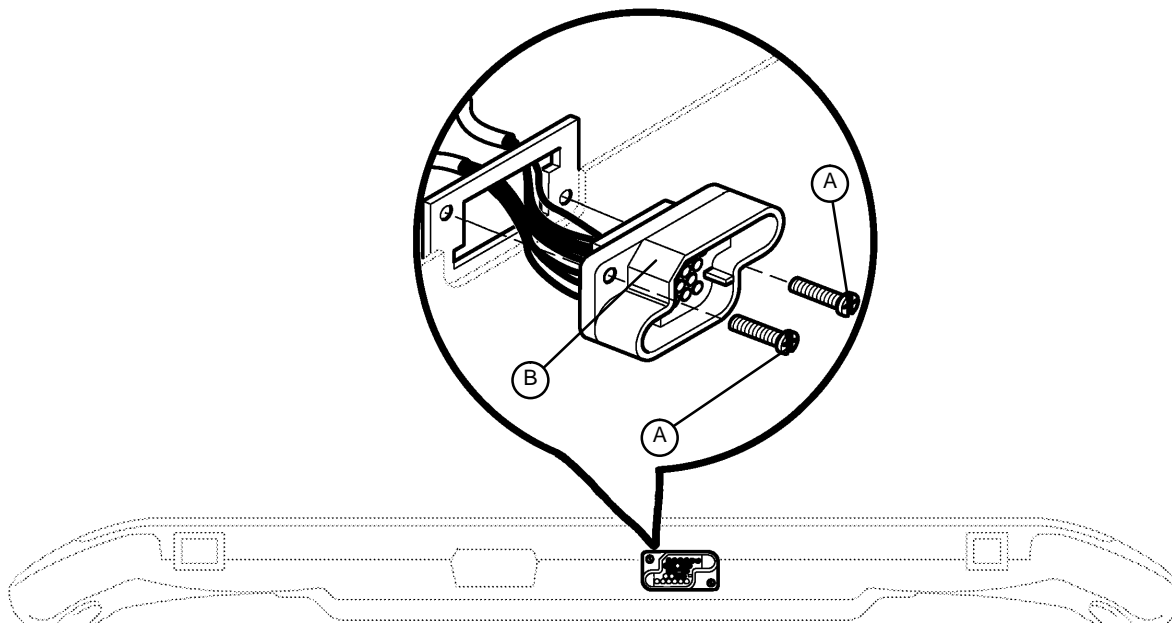

BOTTOM VIEW OF FOOT BOARD

Procedure:

1. Unplug the bed power cord from the wall socket.
2. Remove the foot board from the bed to access the bottom of the board.
3. Properly ground yourself (see page 28 for static discharge precautions).
4. Using a #2 Phillips screwdriver, remove the eight screws holding the foot board door to the foot board and remove the door.
5. Using a #2 Phillips screwdriver, remove the two screws (A) holding the plug to the foot board.
6. Disconnect the cable from the foot board module cable. Note proper placement of the cable so it will be reconnected properly.
7. Reverse the above steps to install the new interface plug.

CAUTION

Be sure to install the plug with the flat edge (B) at the top left, as shown in the illustration, or the foot board interface plug will not mate properly with the bed and damage to the plug or foot board could result.

Maintenance Procedures – Dynamic Mattress System

MATTRESS COVER REPLACEMENT

Required Tools:

Wire Cutters

Static Protection Equipment (see page 28)

Replacement Procedure:

1. Unplug the power supply from the wall socket.
2. Unzip and remove the upper mattress cover.
3. Remove and set aside the upper foam layer.
4. Properly ground yourself. (See page 28 for static discharge precautions).
5. Unplug the cables from the control unit.
6. Remove the remaining foam assembly from the bottom cover and set aside.
7. Cut the cable ties securing the cables through the bottom cover grommet.
8. Remove the cables from the bottom cover.
9. Spread out the new bottom cover on a flat surface.
10. Replace the cables through the grommet in the bottom cover.
11. Place the foam assembly containing the air bladder and control unit into the bottom cover being sure the control unit is at the foot end of the new bottom cover.
12. Route the cables along the patient left side of the foam assembly to the control unit.
13. Reconnect the cables to the control unit.
14. Push the cables down into the slit in the base foam assembly.
15. Lift the head end of the foam assembly and pull the cable slack out of the mattress.
16. Fold the grommet material around the cable and replace the cable ties where they were located prior to disassembly.
17. Place the foam assembly back into the bottom cover.
18. Reinstall the upper foam layer with the *pink side down*.
19. Place the upper cover on the mattress with the “Head End” stamp at the head end of the mattress.
20. Zip the upper mattress cover onto the lower cover.
21. Plug the power supply into the wall socket and test the mattress for proper operation.

To replace the upper cover only:

1. Unzip and remove the old upper cover.
2. Unpack the new upper cover and lay it flat on the mattress, aligning the zipper properly.
3. Zip the upper cover onto the lower cover.

Maintenance Procedures – Dynamic Mattress System

AIR BLADDER REPLACEMENT

Required Tools: None

Replacement Procedure:

1. Unplug the power supply from the wall socket.
2. Unzip and remove the upper mattress cover.
3. Remove and set aside the upper foam layer.
4. Unplug the hoses from the air bladder fittings.
5. Remove the air bladder from the mattress.
6. Install the new air bladder into the foam frame.
7. Install the hoses on the fittings of new air bladder.
8. Reinstall the upper foam layer, with the pink side down.
9. Reinstall the upper cover on the mattress with the “Head End” stamp at the head end of the mattress.
10. Zip the upper cover onto the lower cover.
11. Plug the power supply into the wall socket and test the mattress for proper operation.

FOAM BASE ASSEMBLY REPLACEMENT

Required Tools: Static Protection Equipment (see page 28)

Replacement Procedure:

1. Unplug the power supply from the wall socket.
2. Unzip and remove the upper mattress cover.
3. Remove and set aside the upper foam layer.
4. Disconnect the hoses from the air bladder. Remove the air bladder from the mattress and set it aside.
5. Properly ground yourself (see page 28 for static discharge precautions).
6. Disconnect the cables from the control unit. Remove the control unit and set it aside.
7. Remove entire foam base assembly.
8. Install the new foam base assembly with the cut-out for the control unit at the foot end of the cover.
9. Install the control unit into the new foam base.
10. Install the air bladder into the new base foam.
11. Reconnect the hoses to the fittings on the air bladder.
12. Route the cables along the patient left side of the foam assembly to the control unit.
13. Reconnect the cables to the control unit.
14. Push the cables down into the slit in the base foam assembly.
15. Reinstall the upper foam layer, pink side down.
16. Reinstall the upper cover on the mattress with the “Head End” stamp at the head end of the mattress.
17. Zip the upper cover onto the lower cover.
18. Plug the power supply into the wall socket and test the mattress for proper operation.

Maintenance Procedures – Dynamic Mattress System

PENDANT REPLACEMENT – (FOR PORTABLE AND HYBRID OPTIONS ONLY)

Required Tools:

Wire Cutters

Static Protection Equipment (see page 28)

Replacement Procedure:

1. Unplug the power supply from the wall socket.
2. Unzip and remove the upper mattress cover.
3. Remove the upper foam layer.
4. Properly ground yourself (see page 28 for static discharge precautions).
5. Disconnect the pendant cable from the control unit.
6. Cut the cable ties holding the cables together.
7. Lift the base foam assembly and cut the cable ties holding the cables through the bottom cover grommet.
8. Remove the pendant from the mattress.
9. Route the cable on the new pendant through the grommet in the bottom cover and along the left side of the foam assembly up to the control unit.
10. Connect the pendant cable to the control unit.
11. Replace the cable ties where they were located prior to disassembly.
12. Push the cables down into the slit in the base foam assembly.
13. Lift the head end of the foam assembly and pull the cable slack out of the mattress.
14. Fold the grommet material around the cable and replace the cable ties where they were located prior to disassembly.
15. Reinstall the upper foam layer, with the pink side down.
16. Reinstall the upper cover on the mattress with the “Head End” stamp at the head end of the mattress.
17. Zip the upper cover onto the lower cover.
18. Plug the power supply into the wall socket and test the mattress for proper operation.

Maintenance Procedures – Dynamic Mattress System

POWER SUPPLY REPLACEMENT – (FOR PORTABLE OPTION ONLY)

Required Tools:

Wire Cutters

Static Protection Equipment (see page 28)

Replacement Procedure:

1. Unplug the power supply from the wall socket.
2. Unzip and remove the upper mattress cover.
3. Remove and set aside the upper foam layer.
4. Properly ground yourself (see page 28 for static discharge precautions).
5. Disconnect the power supply cable from the control unit.
6. Cut the cable ties holding the cables together.
7. Lift the foam base assembly and cut the cable ties securing the cables through the bottom cover grommet.
8. Remove the power supply cable from the mattress.
9. Route the cable on the new power supply through the grommet in the bottom cover and along the left side of the foam assembly up to the control unit.
10. Reconnect the power supply cable to the control unit.
11. Install cable ties around the cables near the control unit where they were located prior to disassembly.
12. Push the cables down into the slit in the base foam assembly.
13. Lift the head end of the foam assembly and pull the cable slack out of the mattress.
14. Fold the grommet material around the cable and replace the cable ties where they were located prior to disassembly.
15. Reinstall the upper foam layer, *pink side down*.
16. Reinstall the upper cover on the mattress with the “Head End” stamp at the head end of the mattress.
17. Zip the upper cover onto the lower cover.
18. Plug the power supply into the wall socket and test the mattress for proper operation.

Maintenance Procedures – Dynamic Mattress System

CONTROL UNIT CIRCUIT BOARD REPLACEMENT

Required Tools:

Static Protection Equipment (see page 28) Standard Screwdriver Needle Nose Pliers
5/16" Socket Wrench or Nut Driver 3/16" Socket Wrench or Nut Driver

Replacement Procedure:

1. Unplug the power supply from the wall socket.
2. Unzip and remove the upper mattress cover.
3. Remove and set aside the upper foam layer.
4. Properly ground yourself (see page 28 for static discharge precautions).
5. Disconnect the cables from the control unit.
6. Disconnect the hoses from the air bladder.
7. Remove the control unit from the mattress.
8. Using a standard screwdriver, unsnap the cover of the control unit.
9. Unplug the power connector for the air compressor.
10. Remove the two 5/16" nuts holding the circuit board cover to the bottom cover of the control unit.
11. Remove the two 3/16" modified standoff screws holding the circuit board hand pendant port to the side of the bottom cover.
12. Remove the pressure switch hose from the circuit board.
13. Using needle nose pliers, squeeze the two standoffs holding the circuit board in place and lift up slightly on the circuit board from the circuit board end to remove the circuit board.
14. Reverse the above procedure to install the new circuit board.
15. Plug the power supply into the wall socket and test the mattress for proper operation.

CONTROL UNIT AIR COMPRESSOR REPLACEMENT

Required Tools:

Standard Screwdriver

Replacement Procedure:

1. Unplug the power supply from the wall socket.
2. Unzip and remove the upper mattress cover.
3. Remove and set aside the upper foam layer.
4. Disconnect the cables from the control unit.
5. Disconnect the hoses from the air bladder.
6. Remove the control unit from the mattress.
7. Using a standard screwdriver, unsnap the cover of the control unit.
8. Unplug the power connector for the air compressor.
9. Unplug the pressure switch hose from the air compressor.

Maintenance Procedures – Dynamic Mattress System

CONTROL UNIT AIR COMPRESSOR REPLACEMENT (CONTINUED)

10. Firmly grip the air compressor and lift it out of the control unit box (the air compressor is held down with double-faced tape).
11. Clean the double-faced tape off the bottom cover.
12. Remove the protective coating from the double-faced tape on the replacement air compressor.
13. Install the replacement air compressor into the control unit box. Press down firmly to secure the double-faced tape.
14. Reconnect the pressure switch hose to the air compressor.
15. Reconnect the power connector to the inside of the control unit box.
16. Snap the top cover onto the control unit.
17. Reinstall the control unit into the mattress.
18. Reconnect the hoses to the air bladder.
19. Reconnect the cables to the control unit.
20. Reinstall the upper foam layer.
21. Zip the upper cover onto the lower cover.
22. Plug the power supply into the wall socket and test the mattress for proper operation.

CONTROL UNIT REPLACEMENT

Required Tools:

Static Protection Equipment (see page 28)

Replacement Procedure:

1. Unplug the power supply from the wall socket.
2. Unzip and remove the upper mattress cover.
3. Remove and set aside the upper foam layer.
4. Properly ground yourself (see page 28 for static discharge precautions).
5. Disconnect the cables from the control unit.
6. Disconnect the hoses from the air bladder.
7. Remove the control unit from the mattress.
8. Install the new control unit into the mattress.
9. Connect the cables to the new control unit.
10. Reconnect the hoses to the air bladder.
11. Push the cables down into the slit in the base foam assembly.
12. Reinstall the upper foam layer, *pink side down*.
13. Reinstall the upper cover on the mattress with the “Head End” stamp at the head end of the mattress.
14. Zip the upper cover onto the lower cover.
15. Plug in the power supply and test the mattress for proper operation.

Bed Assembly

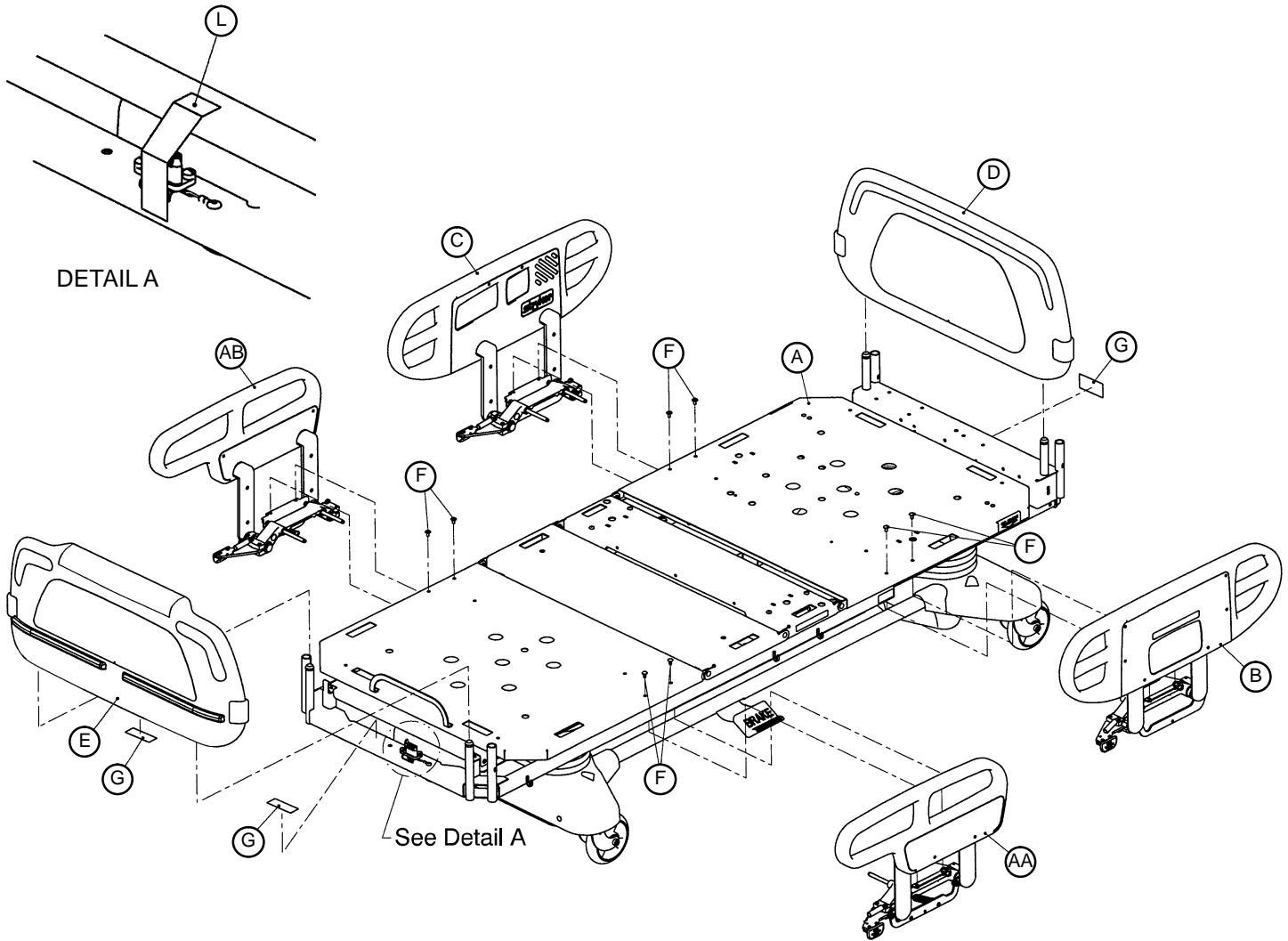

Bed Assembly – Common Components

Item	Part No.	Part Name	Qty.	Item	Part No.	Part Name	Qty.
A	(page 98–106)	Litter Assembly	1	G	3000–300–625	Date-of-Man. Label	1
B	(page 150–168)	Head, Left Siderail Ass'y	1	H	3–124	Hex Washer Hd. Screw	4
C	(page 150–168)	Head, Right Siderail Ass'y	1	J	16–41	Keq-Nut	4
D	3000–600–000	Head Board Assembly	1	K	3000–300–113	Cable Tie	6
E	(page 189–193)	Foot Board Assembly	1	L	3000–300–641	Foot Board Ground Label	1
F	7–65	Truss Hd. Screw w/Patch	8				

Bed Assembly – Standard Length Bed

Item	Part No.	Part Name	Qty.
A	(page 98–106)	Litter Assembly	1
B	(page 150–168)	Head, Left Siderail Ass'y	1
C	(page 150–168)	Head, Right Siderail Ass'y	1
E	(page 189–193)	Foot Board Assembly	1
AA	(page 182–184)	Foot, Left Siderail Ass'y	1
AB	(page 182–184)	Foot, Right Siderail Ass'y	1

Bed Assembly – 8" Shorter Bed

Item	Part No.	Part Name	Qty.
A	(page 98–106)	Litter Assembly	1
B	(page 150–168)	Head, Left Siderail Ass'y	1
C	(page 150–168)	Head, Right Siderail Ass'y	1
E	(page 189–193)	Foot Board Assembly	1
AA	(page 182–184)	Foot, Left Siderail Ass'y	1
AB	(page 182–184)	Foot, Right Siderail Ass'y	1

Bed Assembly

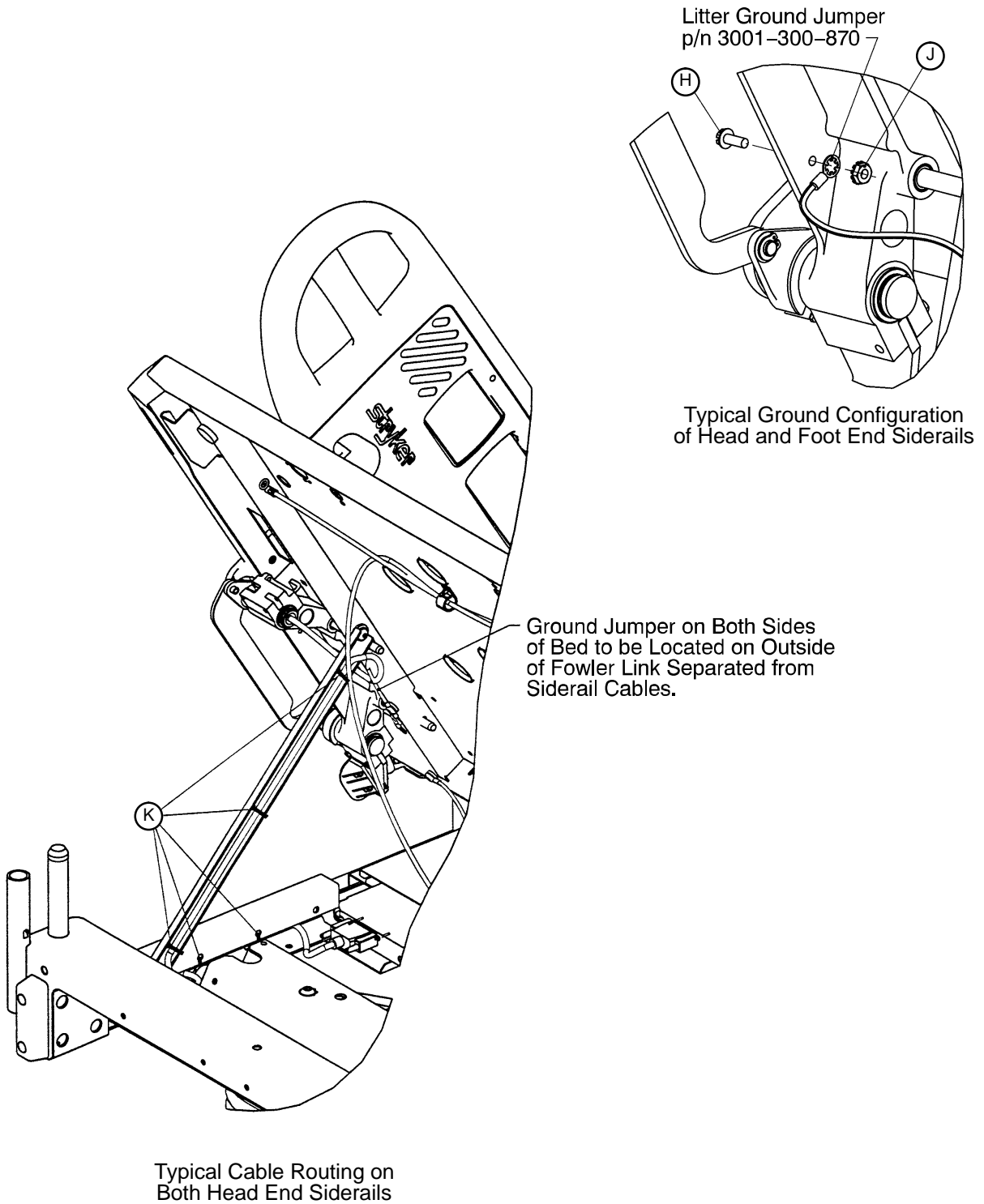

Assembly part number 3001-200-3 (reference only)

75

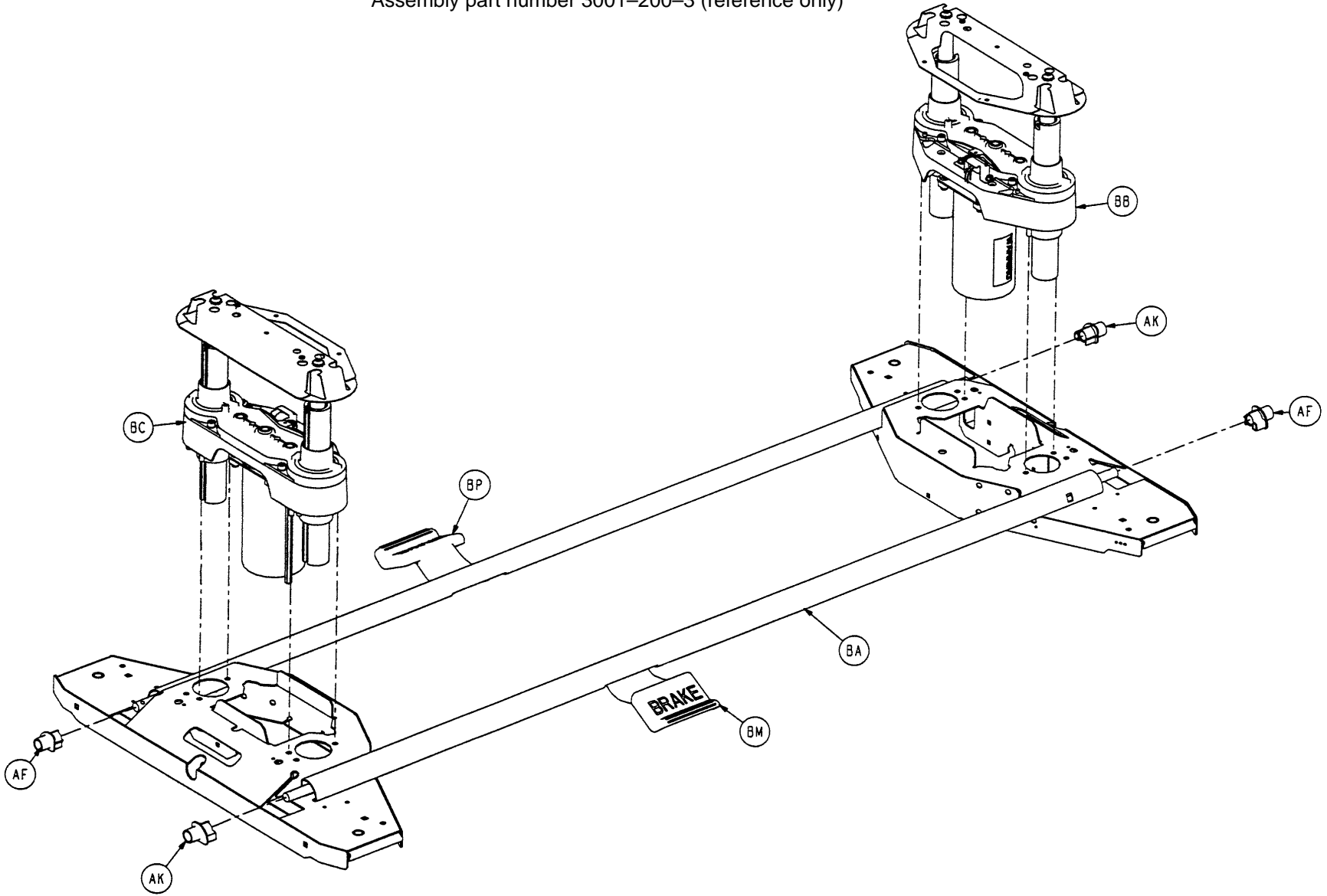

Base Assembly

Base Assembly

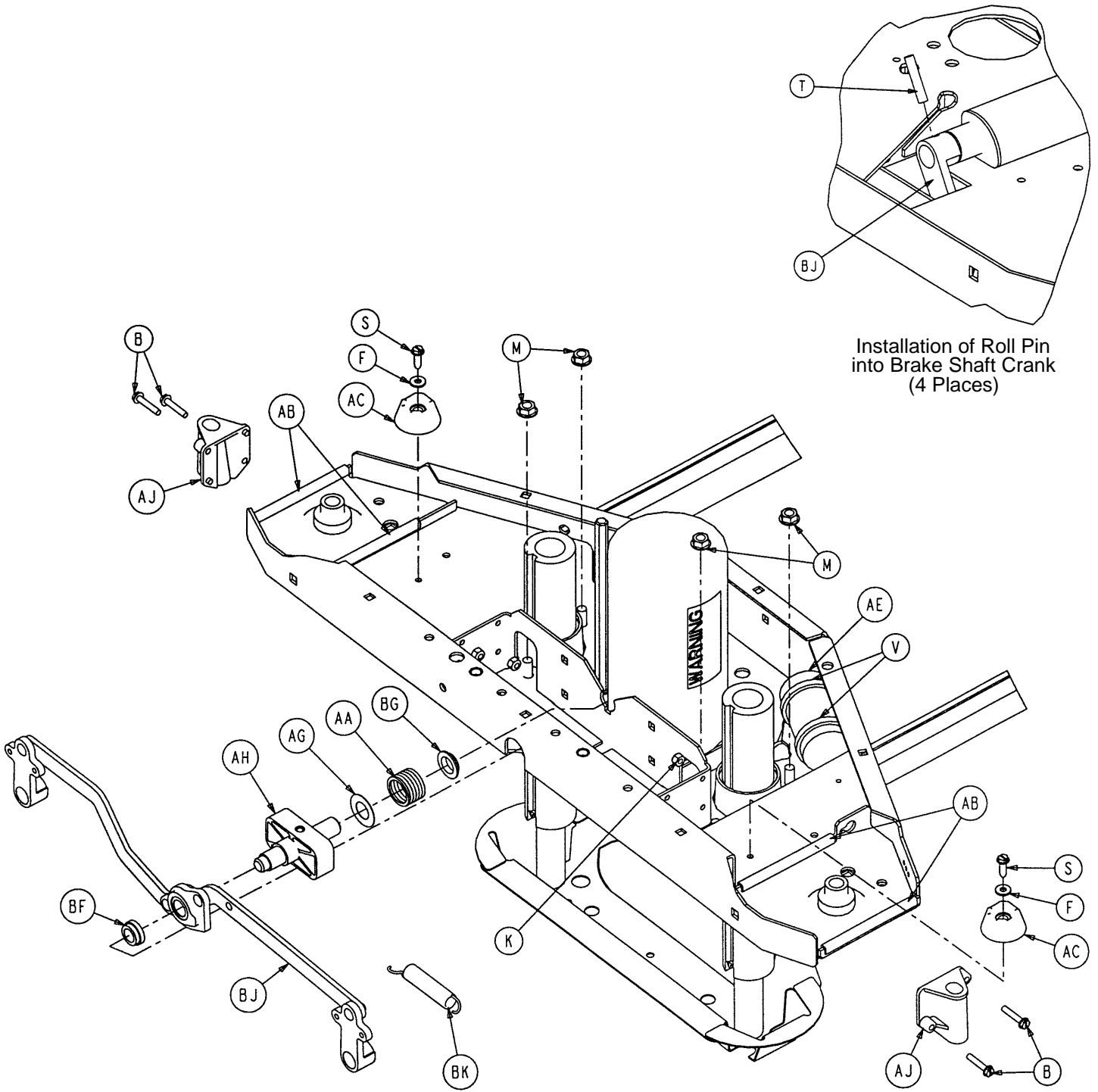

Base Assembly

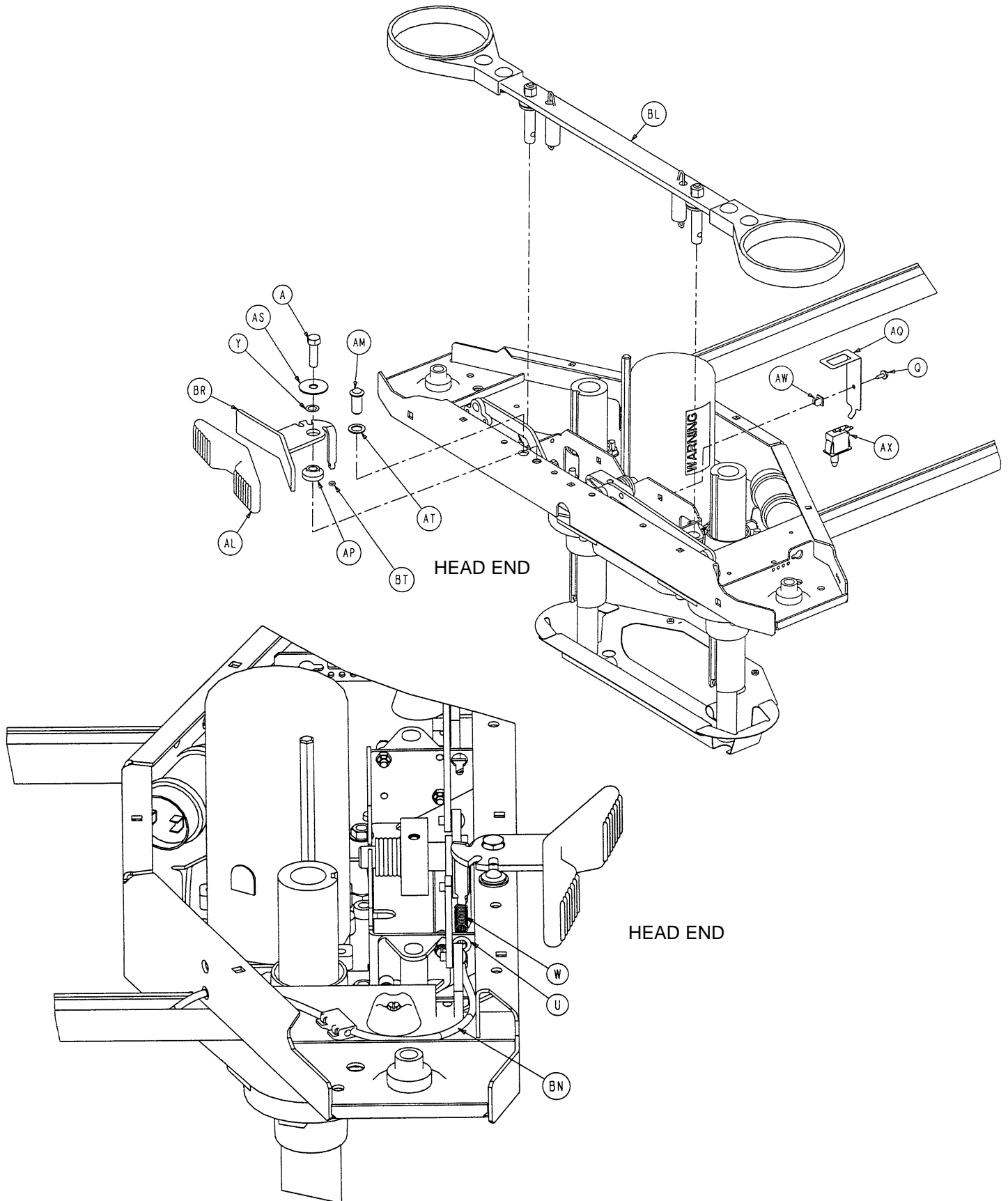

Base Assembly

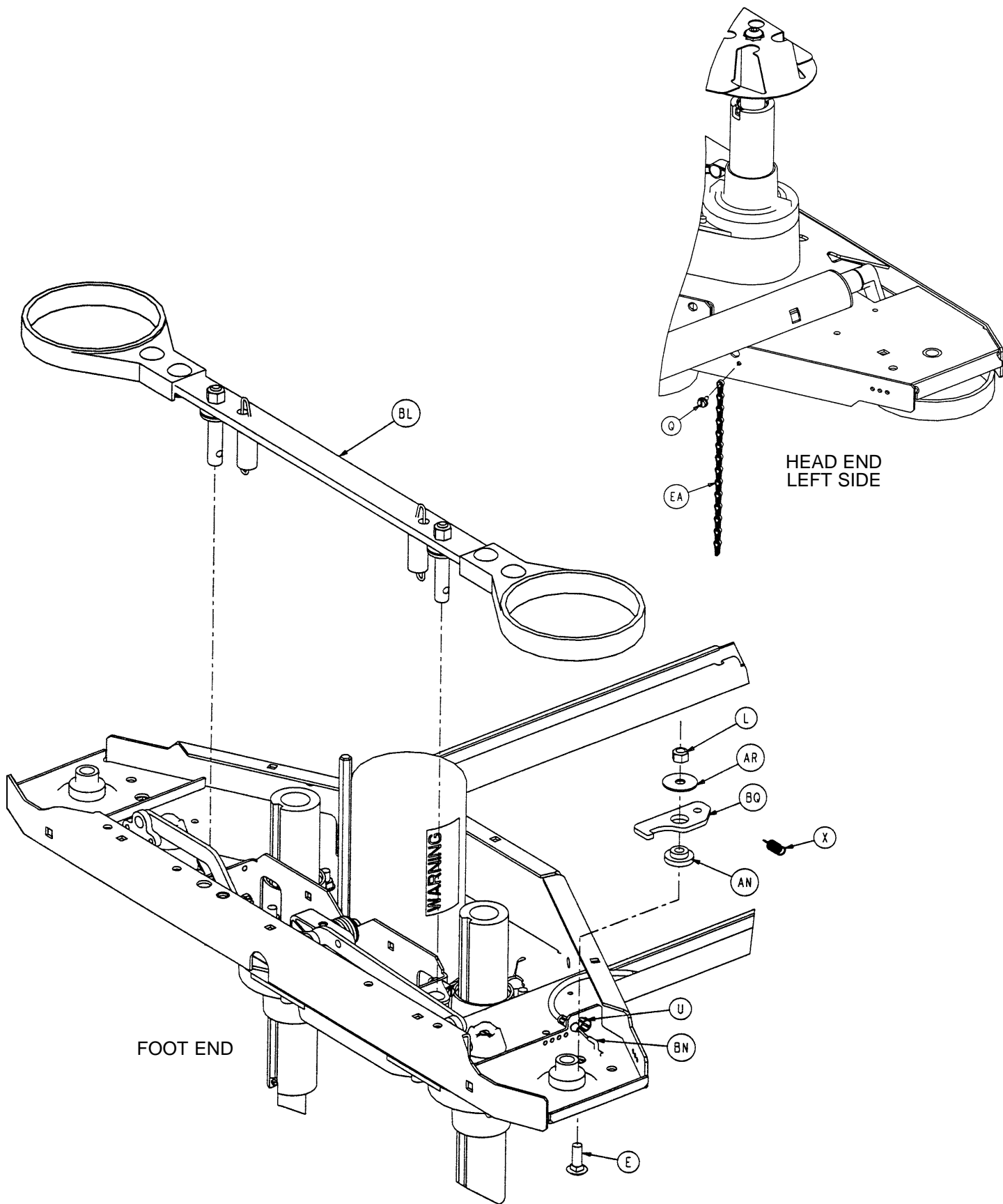

Base Assembly

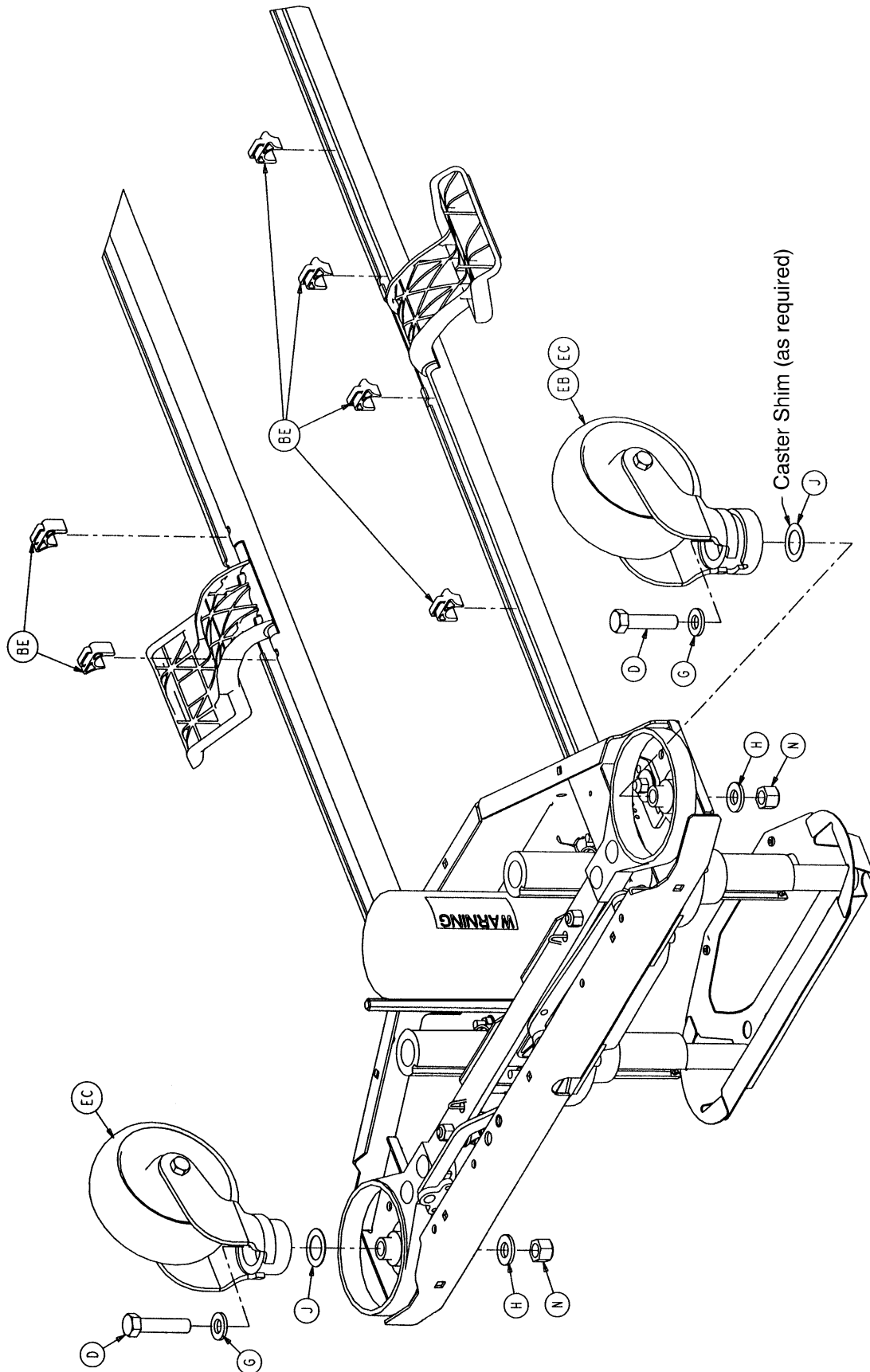

Base Assembly

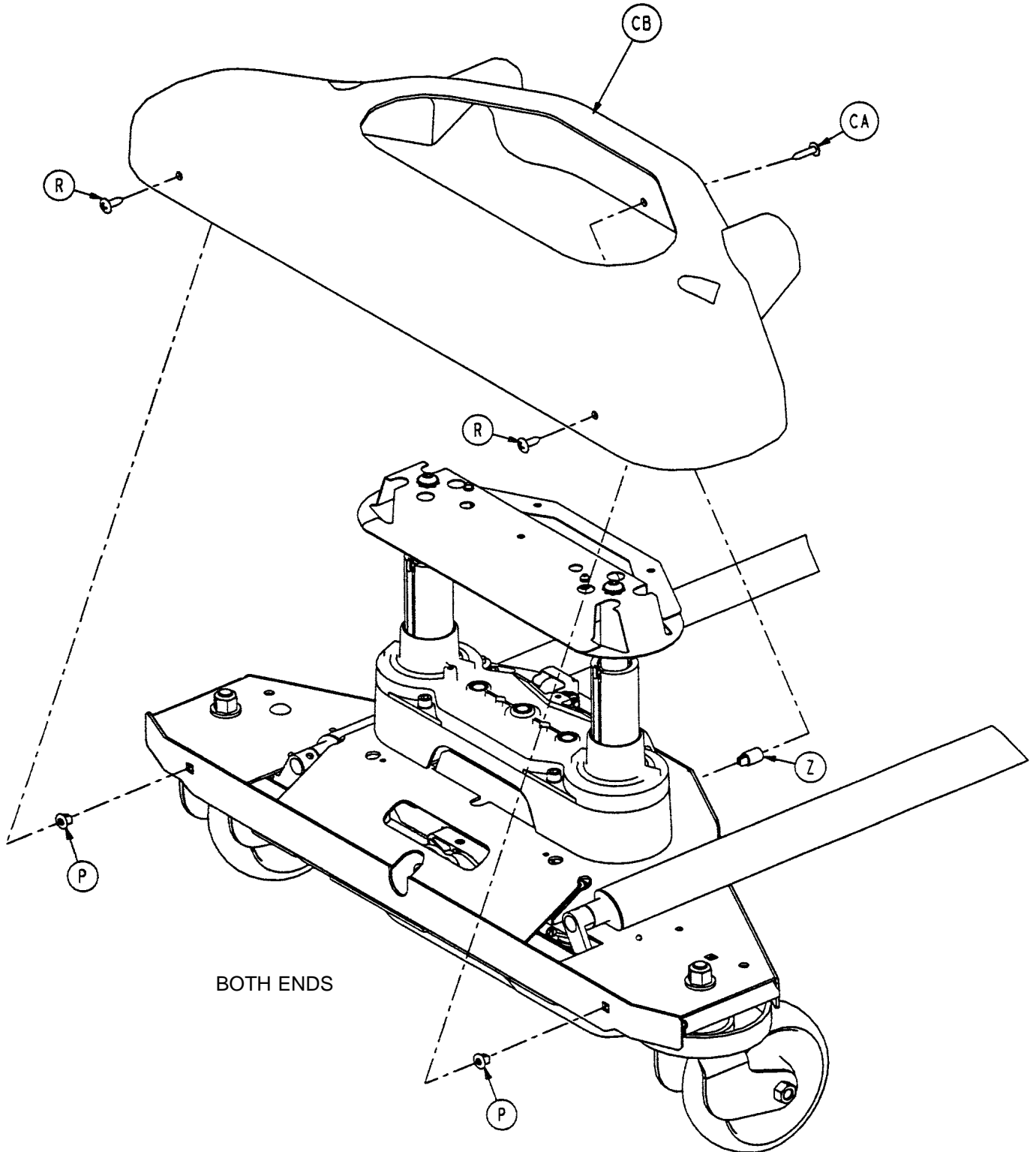

Base Assembly

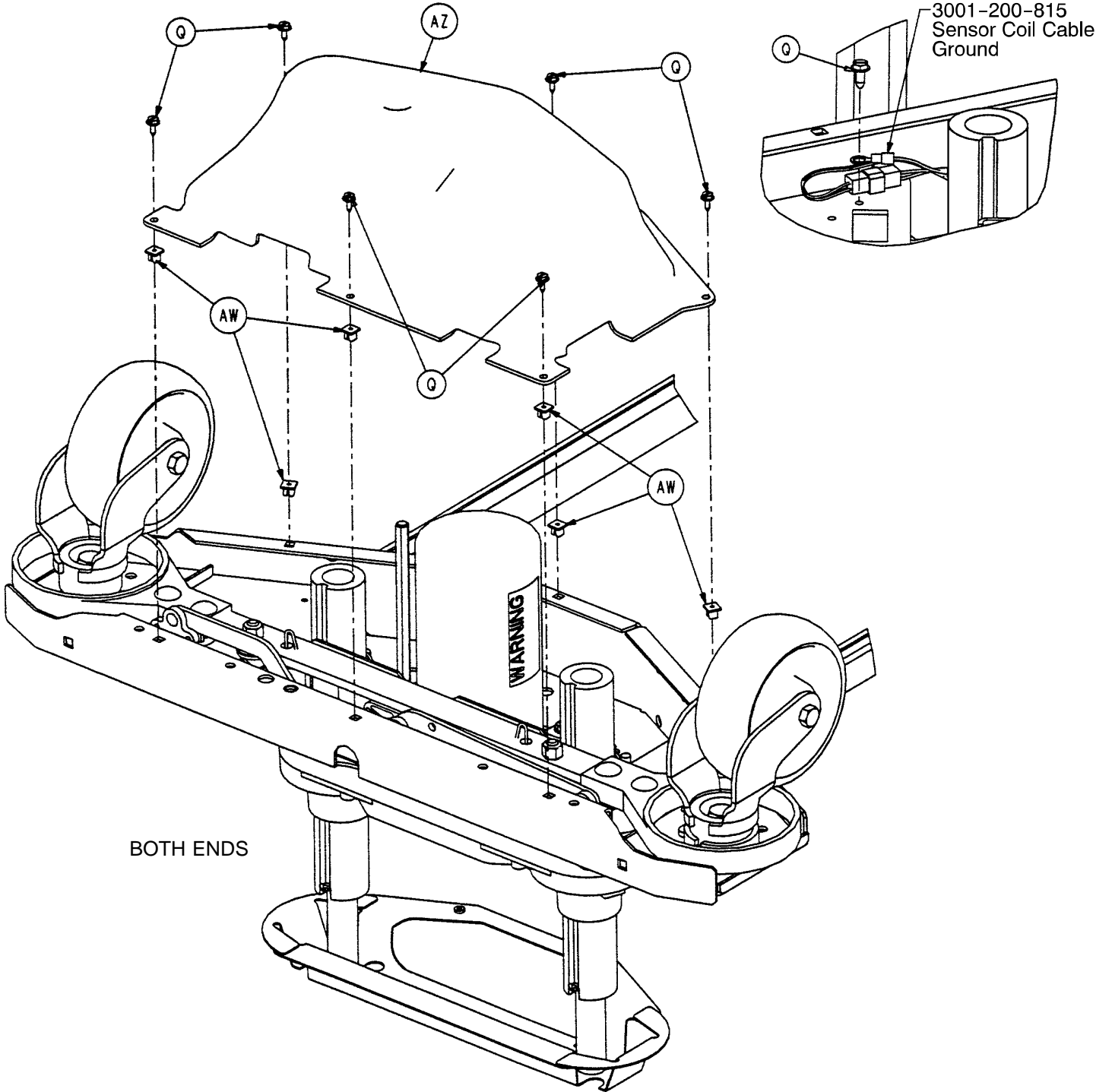

Base Assembly

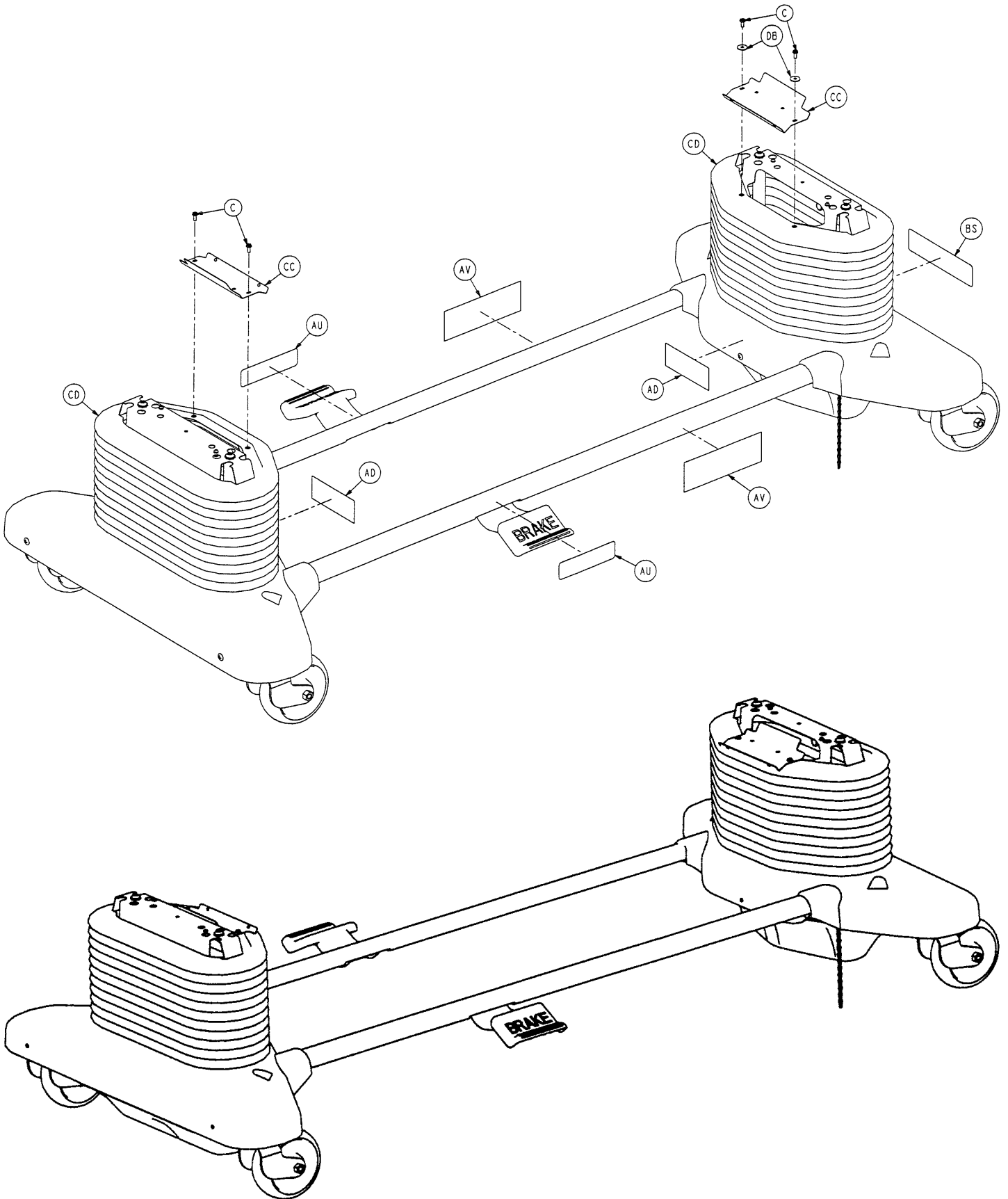

Base Assembly

Item	Part No.	Part Name	Qty.	Item	Part No.	Part Name	Qty.
A	3-349	Hex Hd. Cap Screw	1	AQ	3000-200-343	Brake Switch Bracket	1
B	3-122	Hex Washer Hd. Screw	8	AR	3000-200-347	Special Washer	1
C	3-224	Hex Washer Hd. Screw	4	AS	3000-200-348	Special Wide Washer	1
D	3-333	Hex Hd. Cap Screw	4	AT	3000-200-349	Special Narrow Washer	1
E	5-20	Carriage Bolt	1	AU	3000-200-601	Brake Pedal Label	2
F	11-302	Flat Washer	4	AV	3000-200-602	Stryker Logo Label	2
G	11-310	Washer	4	AW	3000-300-2	Plastic Clip Nut	13
H	11-333	Flat Washer	4	AX	3000-300-58	Plunger Switch	1
J	11-417	Washer	4	AY	3000-300-113	Cable Tie	6
K	16-2	Nylock Nut	8	AZ	3001-200-20	Bottom Cover	2
L	16-11	Nylock Nut	1	BA	3001-200-102	Base Weldment	1
M	16-98	Hex Flange Nut	8	BB	(page 87)	Head End Lift Ass'y	1
N	16-104	Nylock Nut	4	BC	(page 87)	Foot End Lift Ass'y	1
P	18-36	Plastic Clip Nut	4	BE	3001-200-306	Brake Pedal Shaft Brg.	6
Q	23-25	Hex Washer Hd. Screw	16	BF	3001-200-317	Brake Cam Shaft Bshg.	2
R	23-92	Phillips Truss Hd. Screw	4	BG	3001-200-321	Brake Cam Shaft Bshg.	2
S	23-101	Hex Washer Hd. Screw	4	BJ	(page 89)	Brake Crank Ass'y	2
T	26-14	Roll Pin	4	BK	3001-200-334	Brake Return Spring	2
U	30-52	Snap Bushing	2	BL	(page 90)	Brake Bar Assembly	2
V	38-151	Cable Tie	4	BM	(page 91)	Brake Shaft Ass'y, Left	1
W	38-414	Pedal Extension Spring	1	BN	3001-200-342	Steer Cable Assembly	1
X	38-416	Lever Extension Spring	1	BP	(page 91)	Brake Shaft Ass'y, Right	1
Y	52-305	Flat Washer	1	BQ	3001-200-370	Steer Lock Lever	1
Z	52-800	Mounting Standoff	2	BR	3001-200-371	Steer Pedal Arm	1
AA	52-812	Cam Shaft Spring	2	BS	5000-90-13	Steer Label	1
AB	3001-200-14	Edge Strip	8	BT	45-8	O-Ring	1
AC	59-746	Mounting Feet	4	CA	23-264	Truss Hd. Screw	2
AD	988-2-708	Caution Label	2	CB	3000-200-9	Uni-Pan Cover	2
AE	59-778	Lift Motor Capacitor	2	CC	3001-200-8	Bellows Bracket	2
AF	3000-200-305	Brake Shaft Bshg., Rt.	2	CD	3000-200-11	Bellows	2
AG	3000-200-311	Cam Shaft Thrust Washer	2	EA	715-1-156	6" Ground Chain	1
AH	(page 88)	Brake Cam Assembly	2		3001-200-53	8" Ground Chain (Option)	1
AJ	3000-200-328	Brake Guide Bushing	4	EB	(page 93)	6" Steer Caster	1
AK	3000-200-331	Brake Shaft Bshg., Lt.	2		(page 96)	8" Steer Caster (Option)	1
AL	3000-200-336	Rubber Steer Pedal	1	EC	(page 92)	6" Caster	3
AM	3000-200-337	Push Fit Ball Plunger	1		(page 95)	8" Caster (Option)	3
AN	3000-200-339	Steer Lock Lever Bshg.	1	FA	2025-1-47	Caster Cover, Right	4
AP	3000-200-341	Steer Pedal Bushing	1	FB	2025-1-48	Caster Cover, Left	4

Assembly part number 3000-200-275 (reference only)

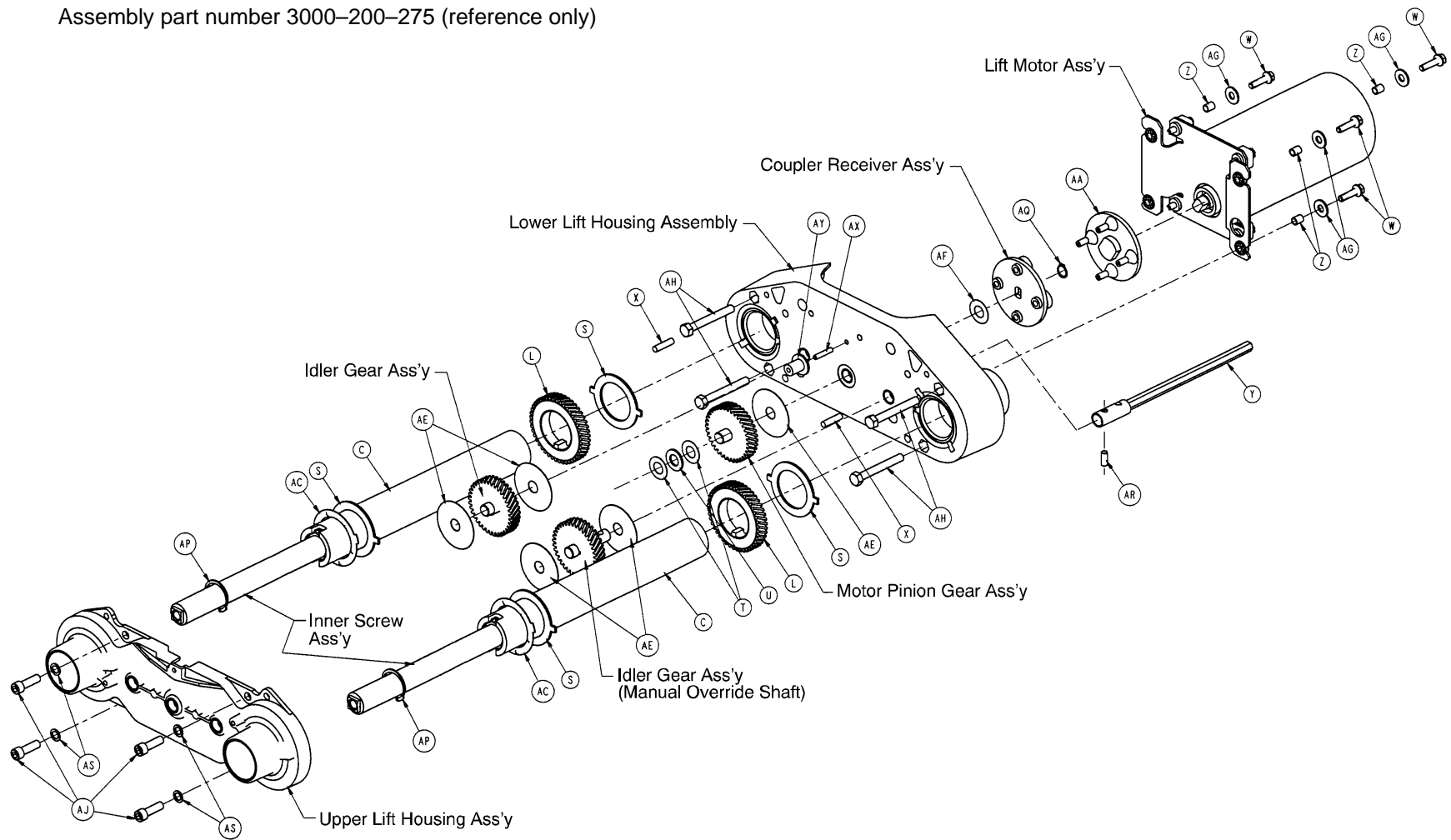

Lift Assembly (Common)

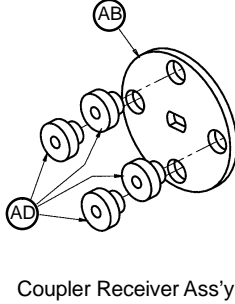
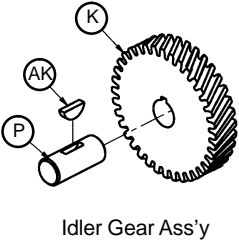
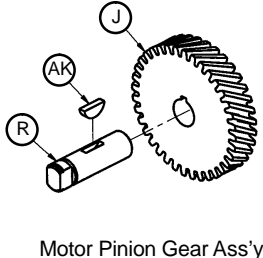
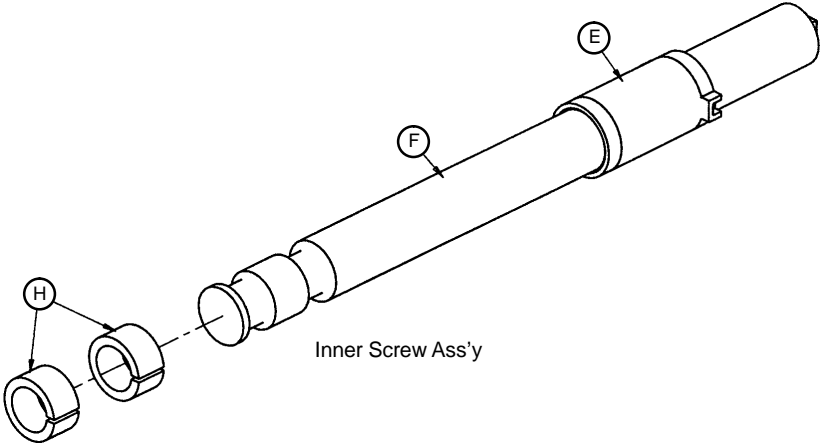
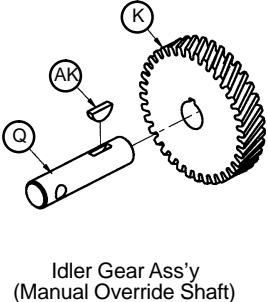
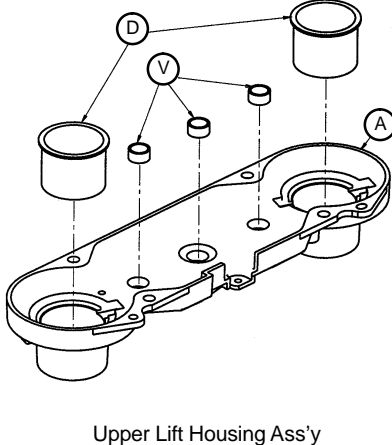
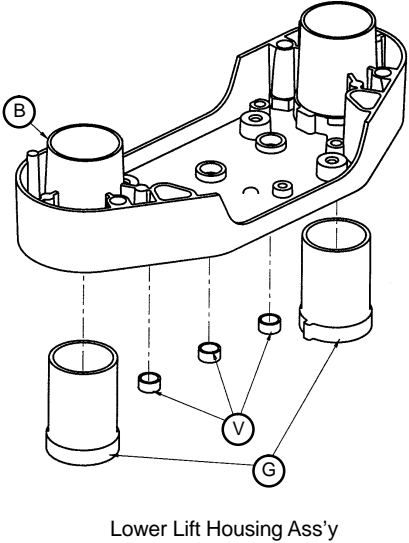
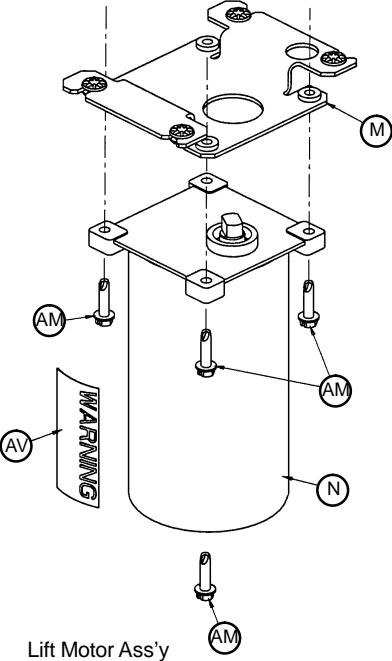

Lift Assembly (Common)

Item	Part No.	Part Name	Qty.
A	3000-200-201	Upper Lift Housing	1
B	3000-200-202	Lower Lift Housing	1
C	3000-200-251	Outer Screw	2
D	3000-200-204	Upper Housing Sleeve	2
E	3000-200-205	Upper Stage Nut	2
F	3000-200-249	Inner Screw	2
G	3000-200-207	Lower Stage Nut	2
H	3000-200-208	Glide Bushing	4
J	3000-200-209	Motor Pinion Gear	1
K	3000-200-210	Idler Gear	2
L	3000-200-252	Output Gear	2
M	(page 88)	Motor Isolation Plate Ass'y	1
N	3000-200-213	Lift Motor	1
	3221-200-213	230V Lift Motor	1
P	3000-200-218	Idler Shaft, Lift	1
Q	3000-200-219	Idler Man. Over. Shaft	1
R	3000-200-220	Input Pinion Shaft	1
S	3000-200-223	Output Gear Thr. Washer	4
T	3000-200-224	Input Gear Thr. Washer	2
U	3000-200-225	Input Pinion Thr. Bearing	1
V	3000-200-226	Pinion Shaft Bushing	6
W	3001-200-228	Mounting Standoff	4
X	26-231	Dowel Pin	2
Y	3001-200-235	Man. Override Shaft Ass'y	1
Z	3001-300-19	Isolation Sleeve	4
AA	3000-200-233	Lift Motor Coupler	1
AB	3000-200-234	Coupler Receiver	1
AC	3000-200-241	Crush Washer	2
AD	3000-300-455	Isolation Bushing	4
AE	3000-200-245	Gear Washer	5
AF	3000-200-246	Nylon Washer	1
AG	11-408	Flat Washer	4
AH	3-82	Hex Hd. Cap Screw	4
AJ	4-213	Soc. Hd. Cap Screw	4
AK	58-44	Woodruff Key	3
AM	3-331	Hex Washer Hd. Screw	4
AP	28-121	Retaining Ring	2
AQ	28-97	Retaining Ring	1
AR	26-178	Roll Pin	1
AS	11-308	Serrated Belleville Washer	4
AV	3000-300-604	Warning Label	1
AX	3000-200-239	Pot. Drive Gear Shaft	1
AY	3000-200-216	Potentiometer Drive Gear	1

Lift Assembly (Head & Foot End)

Cable Clamp on Bellows Bracket to be installed straight.

Cable Clamp on Lift Housing to be installed at angle

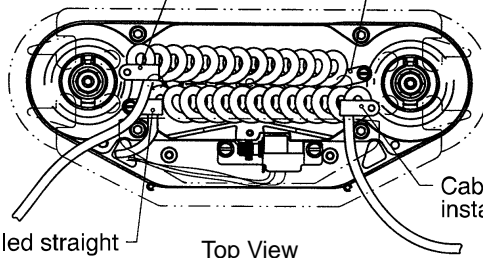

Cable Clamp on Bellows Bracket to be installed straight.

Cable Clamp on Lift Housing to be installed straight

Top View

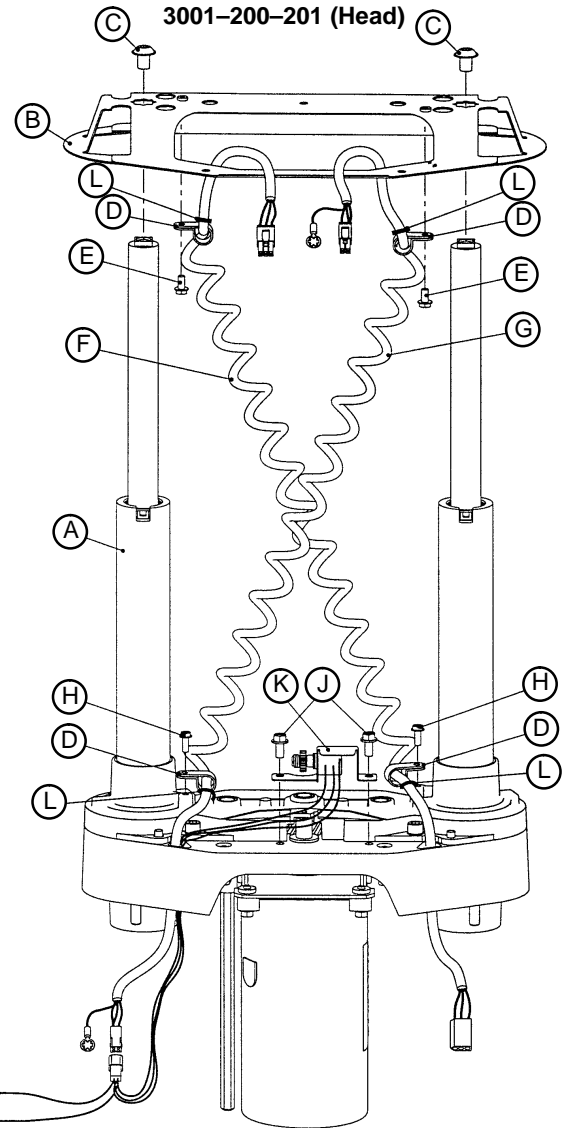
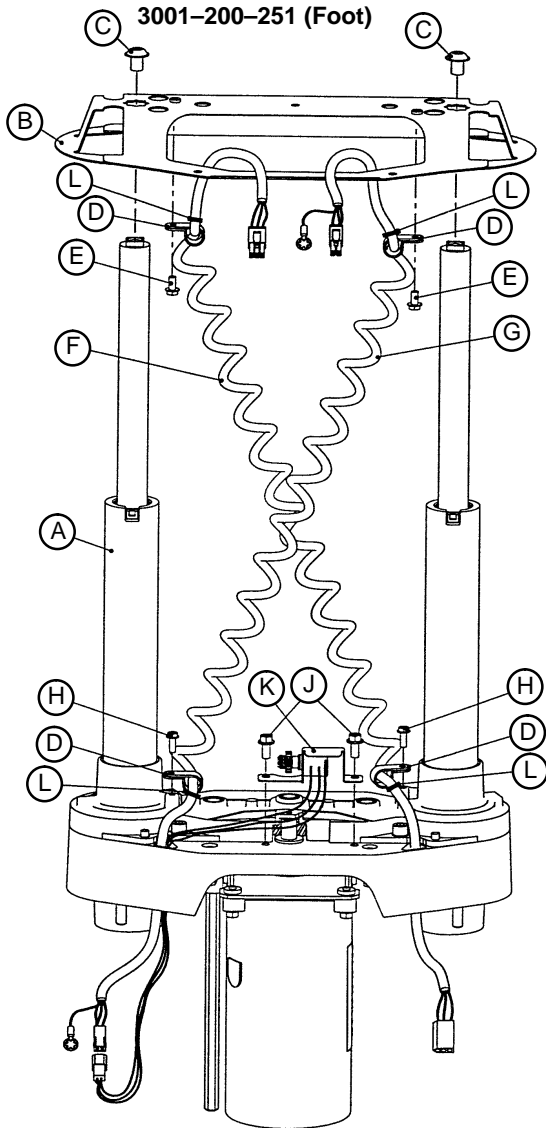

Item	Part No.	Part Name	Qty.	Item	Part No.	Part Name	Qty.
A	(page 84-86)	Common Lift Assembly	1	G	3001-200-815	Sensor Coil Cord	1
B	3000-200-52	Bellows Bracket	1	H	3-128	Hex Washer Hd. Screw	2
C	4-338	Flanged But. Hd. Screw	2	J	3-121	Hex Washer Hd. Screw	2
D	34-22	Cord Clamp	4	K	3001-200-240	Head End Pot. Ass'y	1
E	3-123	Hex Washer Hd. Screw	2	K	3001-200-230	Foot End Pot. Ass'y	1
F	3001-200-864	Power Coil Cord	1	L	3000-300-113	Cable Tie	4

3000-200-723 Isolation Plate Assembly

Assembly part number 3001-200-214 (reference only)

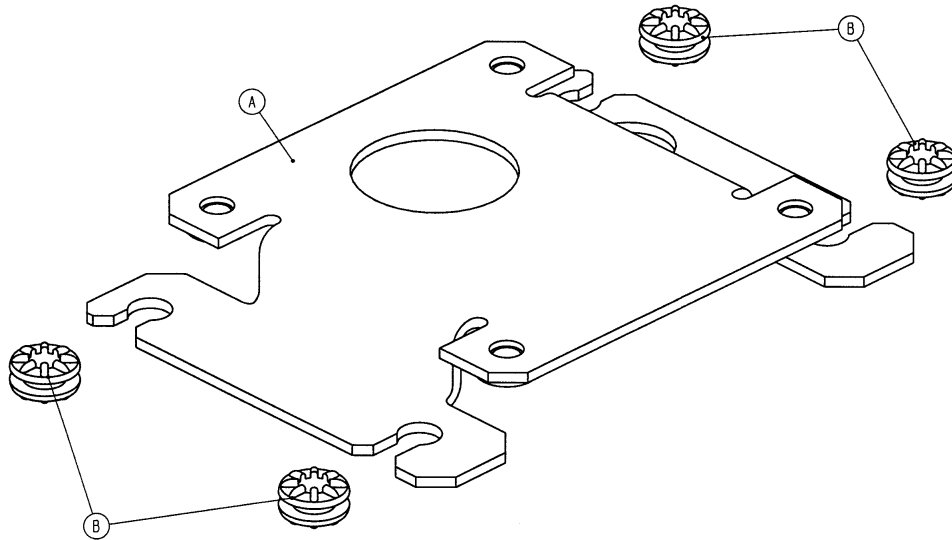

Item	Part No.	Part Name	Qty.
A	3001-200-213	Isolation Plate	1
B	3000-300-442	Grommet	4

3001-200-305 Brake Cam Assembly

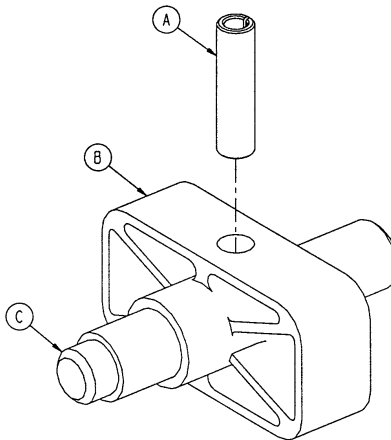

Item	Part No.	Part Name	Qty.
A	3000-200-313	Slotted Roll Pin	1
B	3001-200-304	Plastic Brake Cam	1
C	3001-200-323	Brake Cam Shaft	1

3001-200-330 Brake Crank Assembly

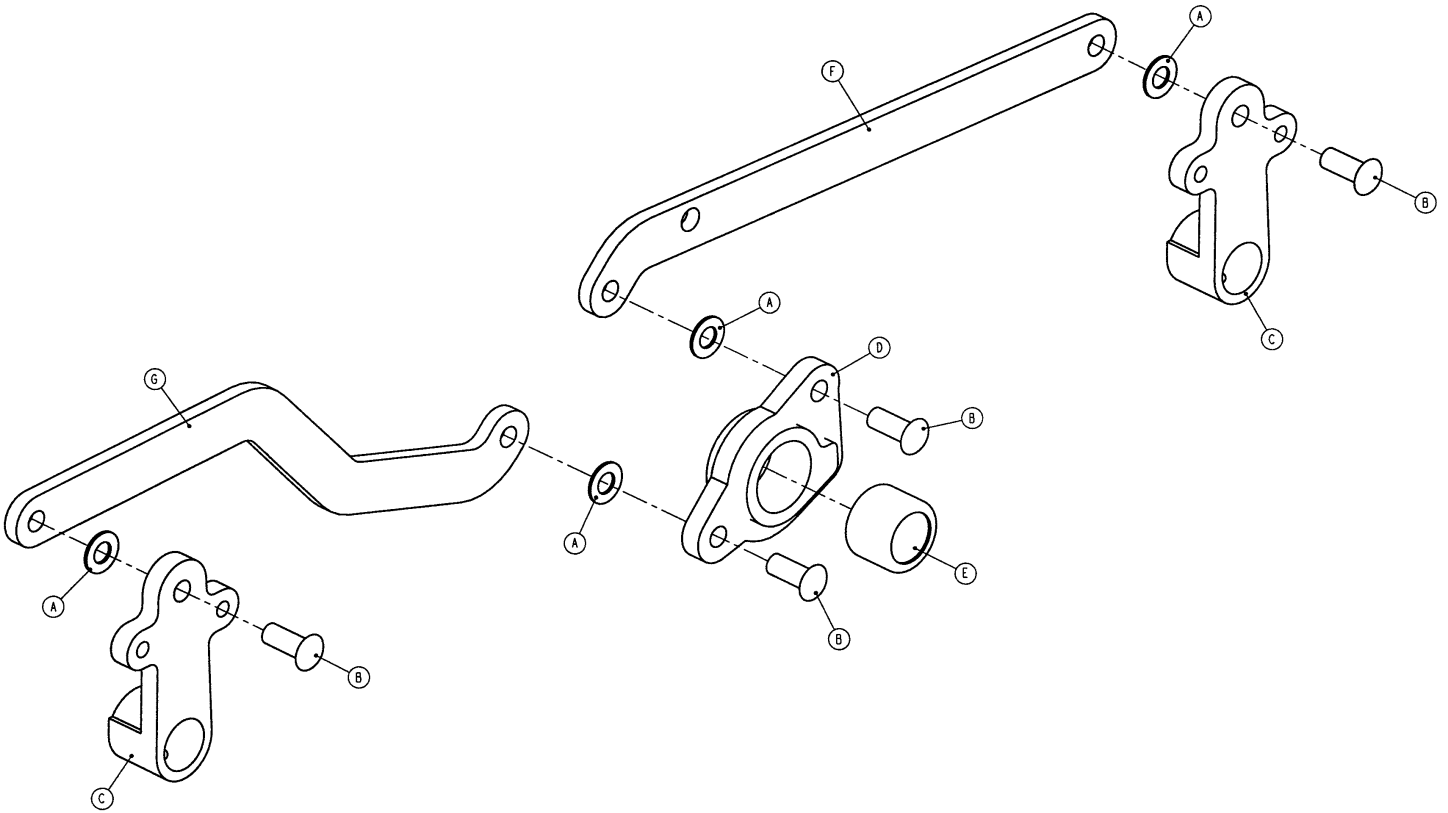

Item	Part No.	Part Name	Qty.
A	14-4	Nylon Washer	4
B	25-146	Rivet	4
C	3000-200-302	Brake Shaft Crank	2
D	3000-200-322	Brake Crank Wheel	1
E	3000-200-338	Drawn Cup Roller Clutch	1
F	3001-200-311	Brake Link	1
G	3001-200-312	Dog Leg Brake Link	1

Brake Bar Assembly

Assembly part number 3001-200-335
(reference only)

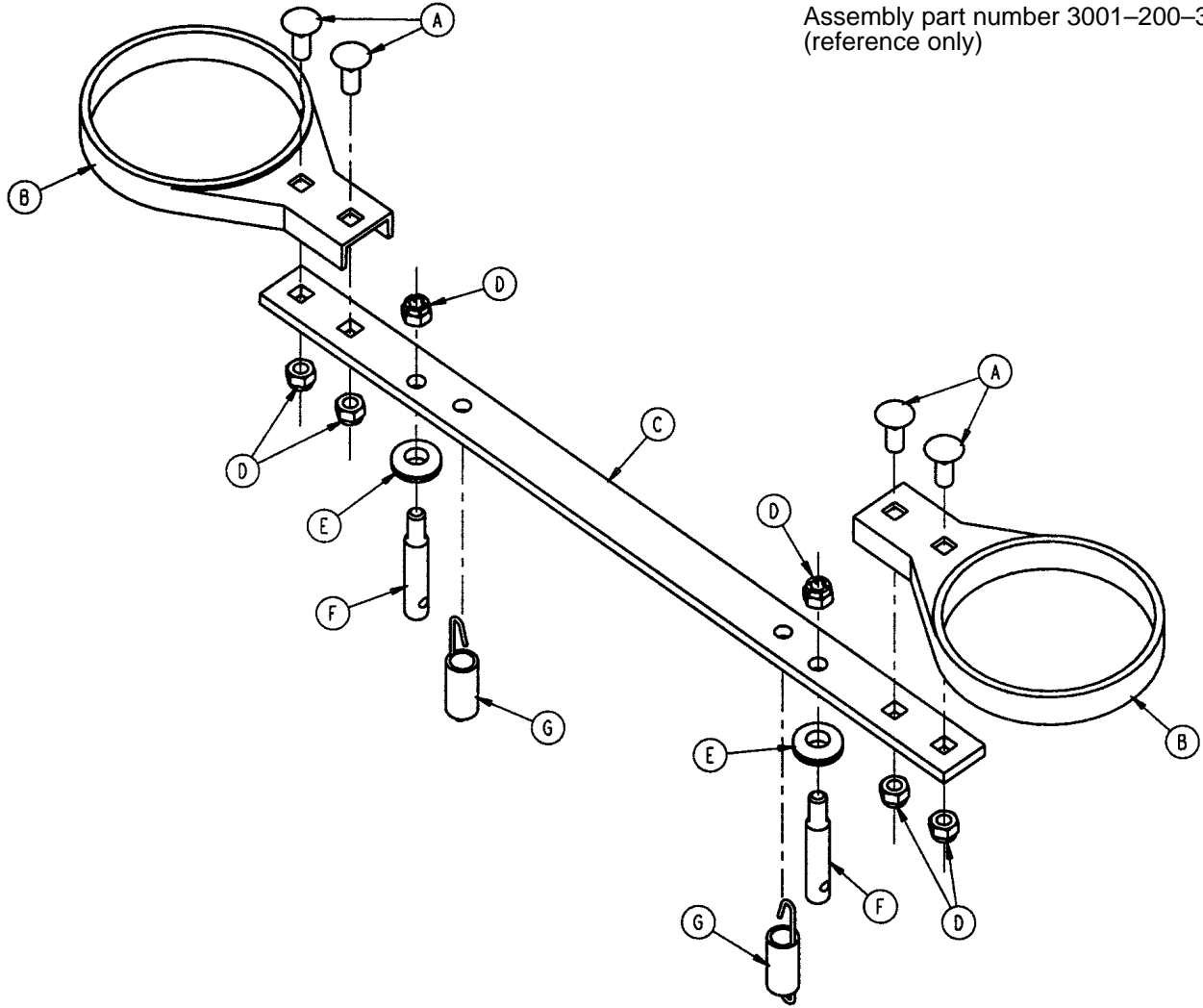

Item	Part No.	Part Name	Qty.
A	5-18	Carriage Bolt	4
B	3000-200-321	Brake Ring	2
C	3000-200-323	Brake Bar	1
D	16-35	Nylock Nut	6
E	3000-200-324	Brake Bar Bumper	2
F	3000-200-318	Guide Pin	2
G	3000-200-352	Brake Bar Return Spring	2

Brake Shaft Assembly, Left and Right

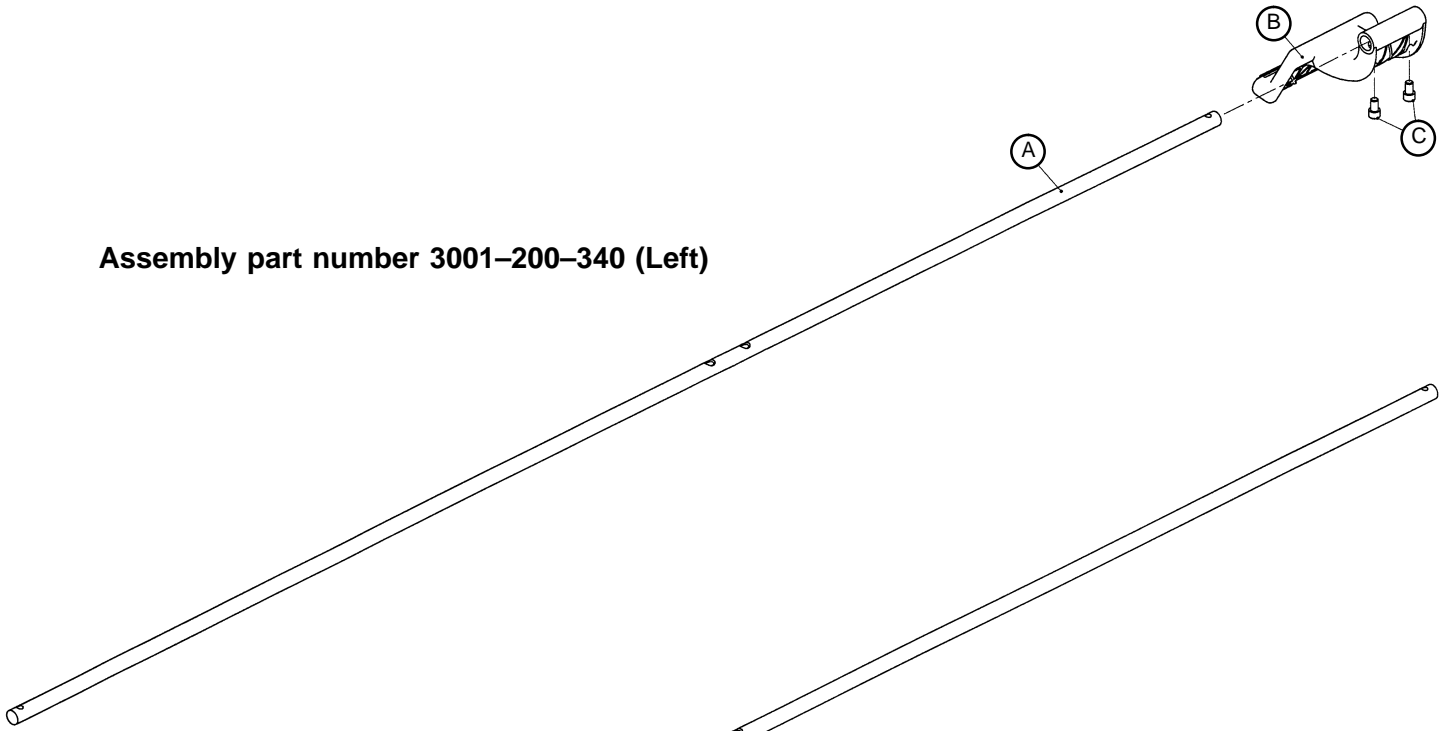

Assembly part number 3001-200-340 (Left)

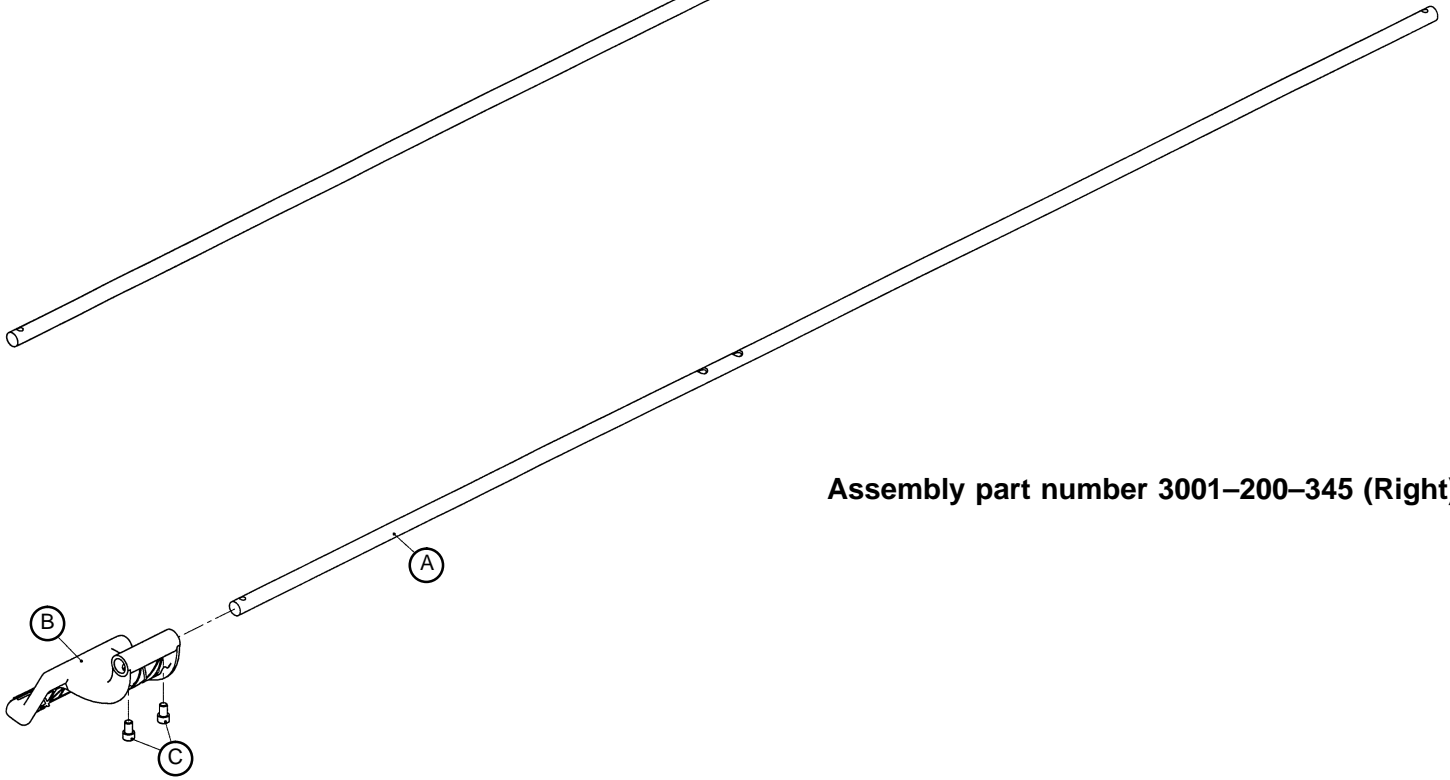

Assembly part number 3001-200-345 (Right)

Item	Part No.	Part Name	Qty.
A	3000-200-314	Brake Shaft	1
B	3001-200-325	Brake Pedal	1
C	4-270	Soc. Hd. Cap Screw	2

3001-200-60 6" Caster Assembly

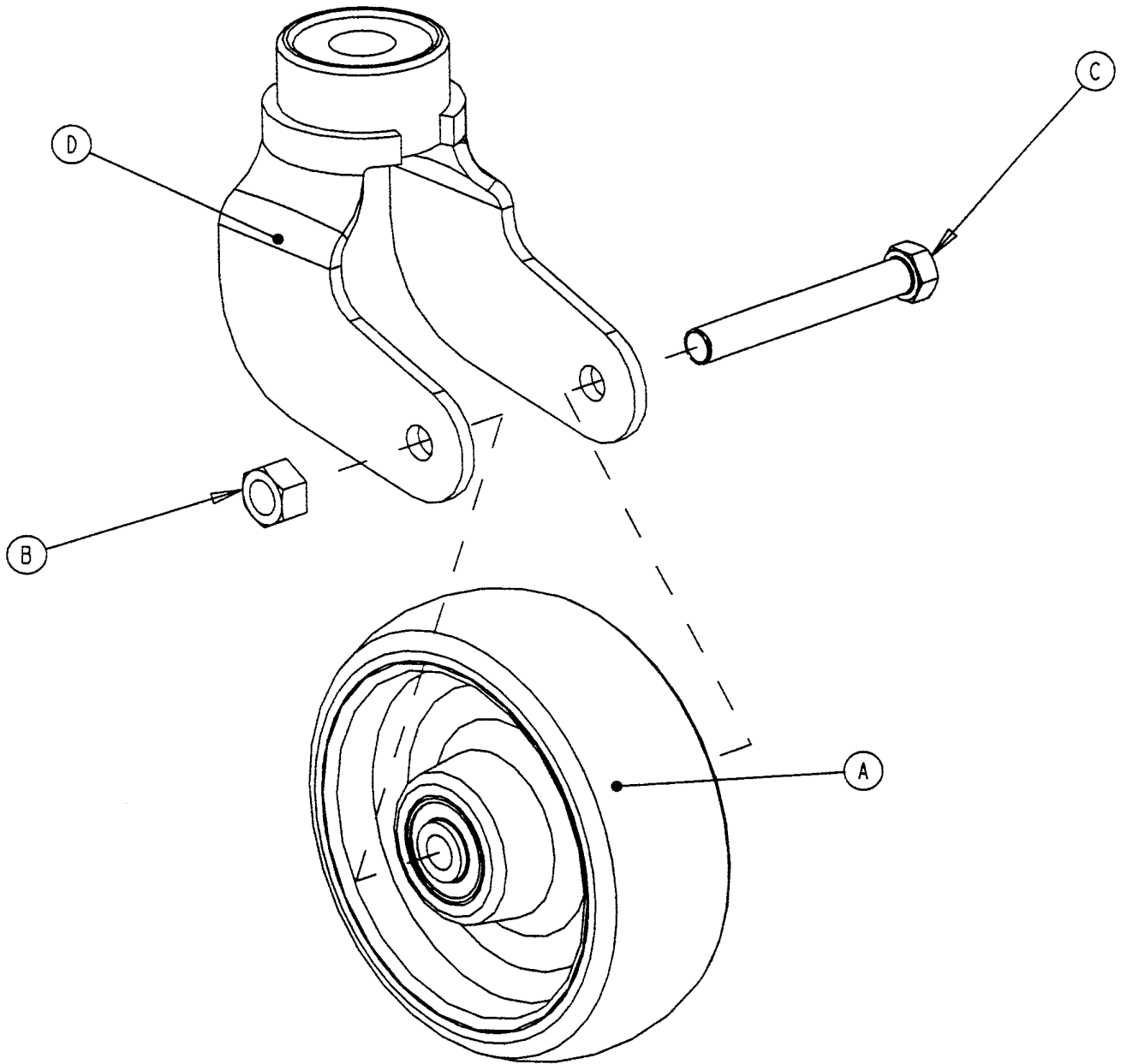

Item	Part No.	Part Name	Qty.
A	(page 94)	Wheel Assembly	1
B	16-60	Lock Nut	1
C	3-342	Hex Hd. Cap Screw	1
D	3001-200-61	Caster Horn w/Bearing	1

3001-200-50 6" Steer Caster Assembly

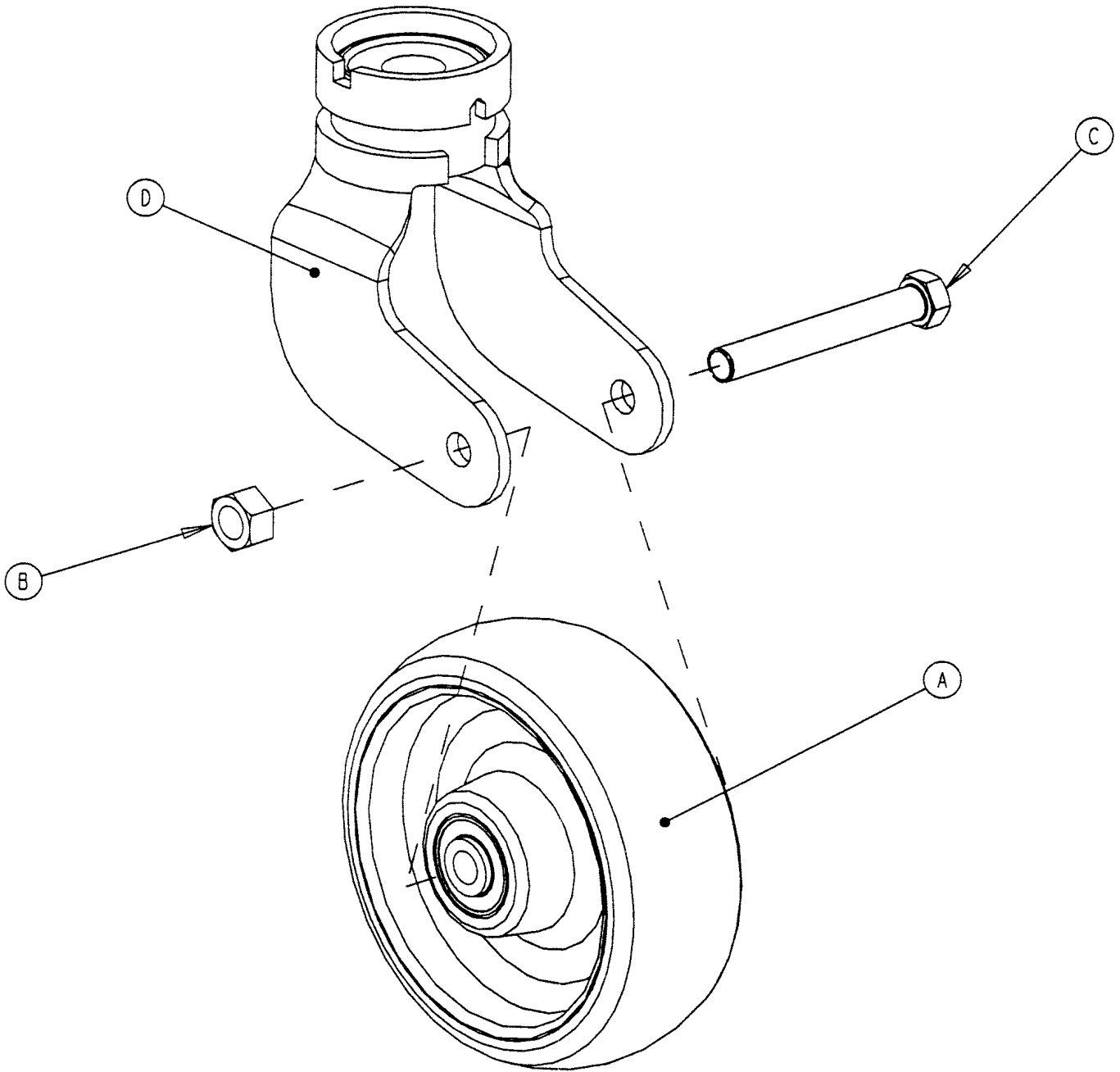

Item	Part No.	Part Name	Qty.
A	(page 94)	Wheel Assembly	1
B	16-60	Lock Nut	1
C	3-342	Hex Hd. Cap Screw	1
D	3001-200-51	Steer Caster Horn w/Bearing	1

5000-2-10 6" Molded Wheel Assembly

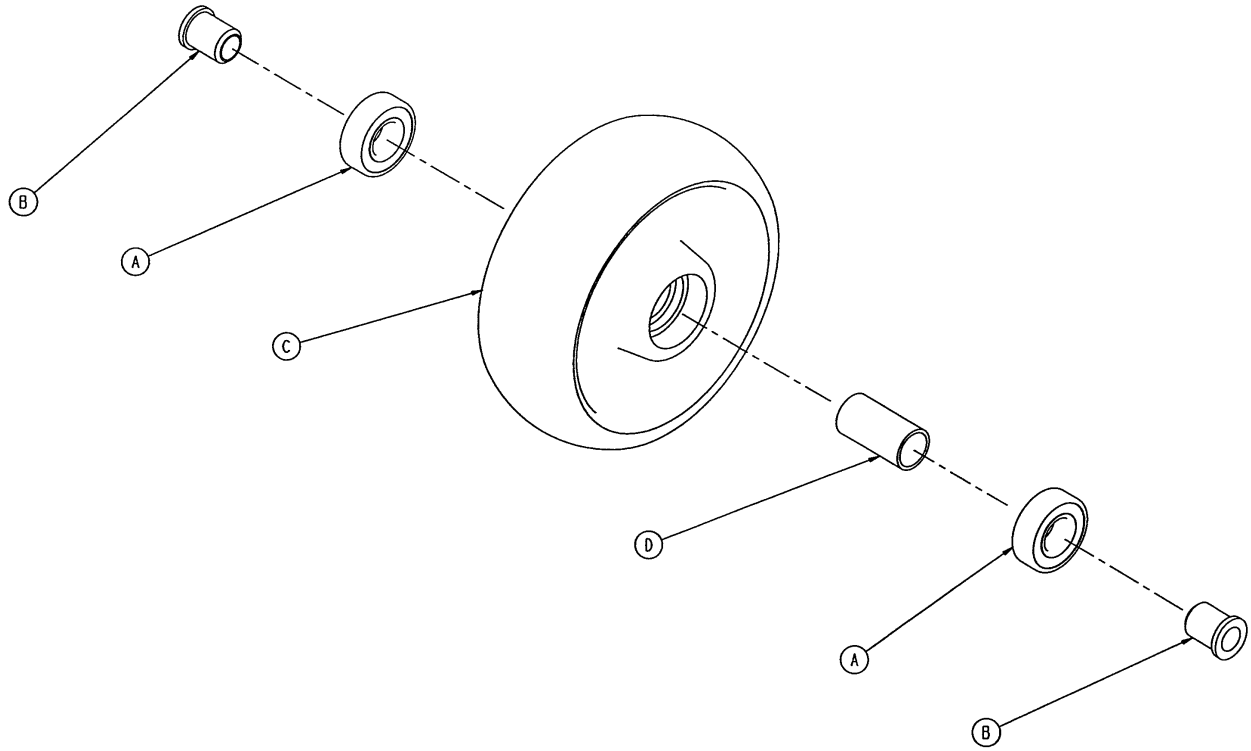

Item	Part No.	Part Name	Qty.
A	81-226	Bearing	2
B	715-1-255	Wheel Bushing	2
C	5000-2-20	Molded Wheel	1
D	6060-2-46	Bearing Spacer	1

3001-200-90 Optional 8" Caster Assembly

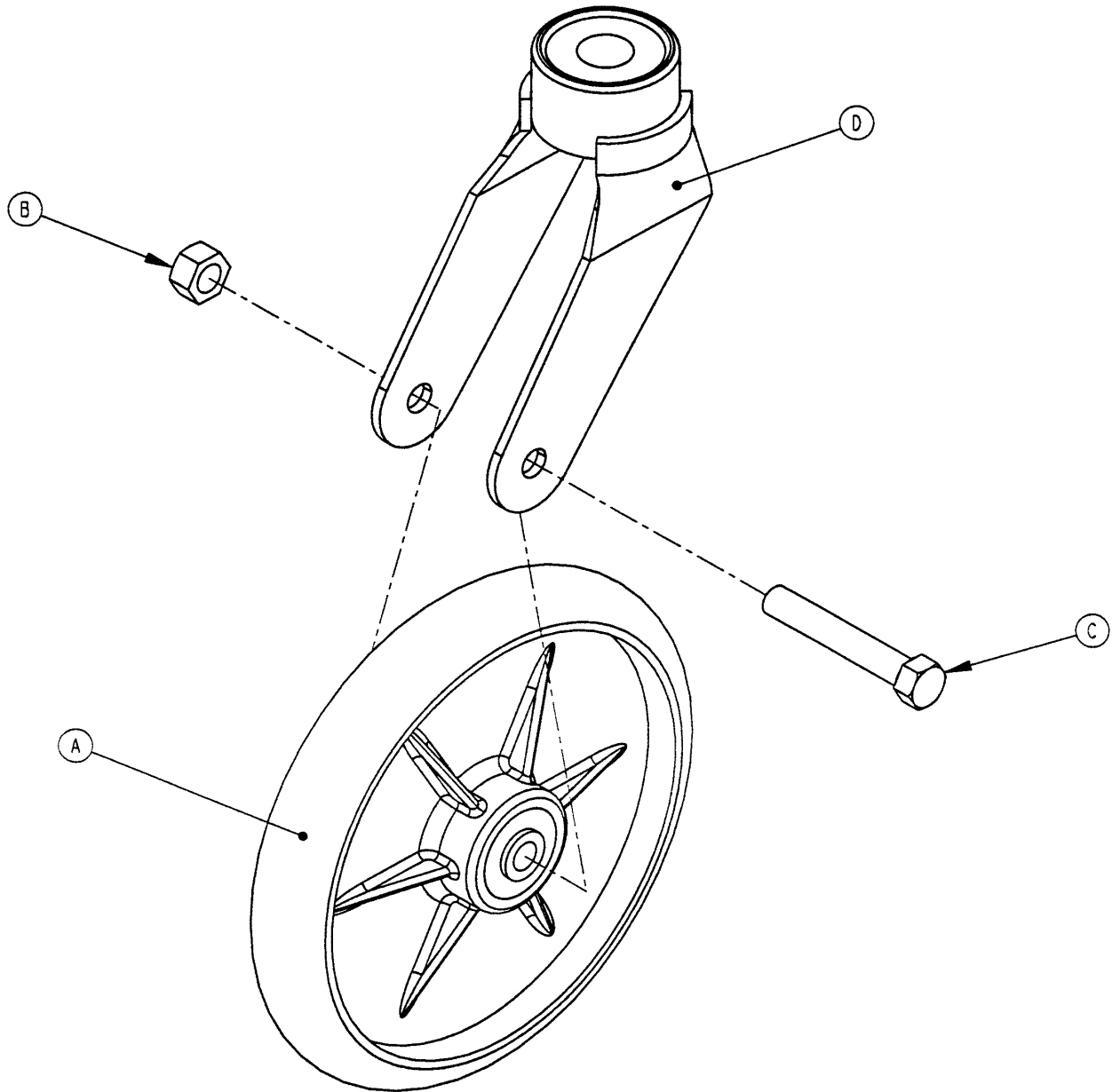

Item	Part No.	Part Name	Qty.
A	(page 97)	Wheel Assembly	1
B	16-60	Hex Nut	1
C	3-99	Hex Hd. Cap Screw	1
D	3001-200-76	Caster Horn	1

3001-200-80 Optional 8" Steer Caster Assembly

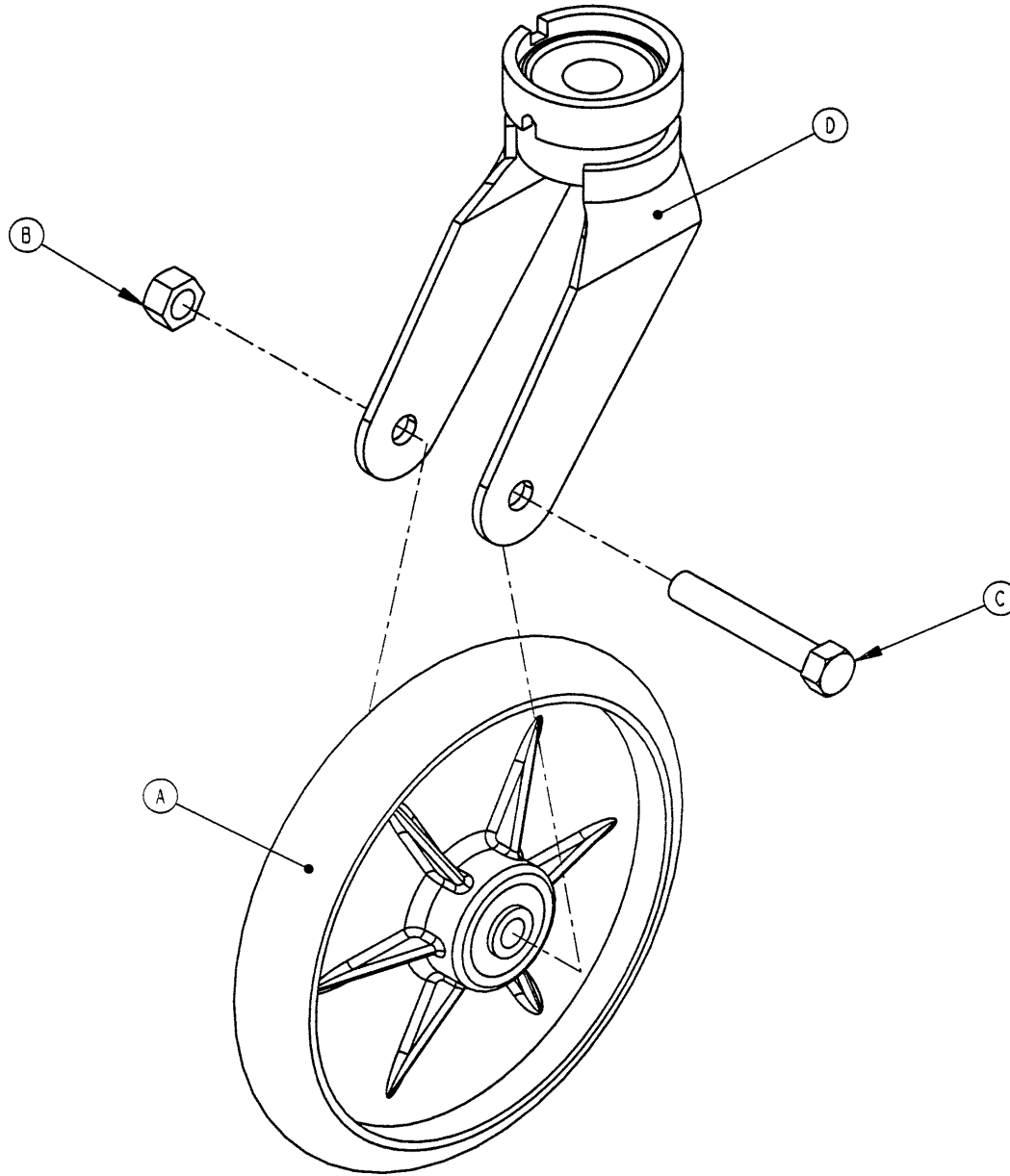

Item	Part No.	Part Name	Qty.
A	(page 97)	Wheel Assembly	1
B	16-60	Hex Nut	1
C	3-99	Hex Hd. Cap Screw	1
D	3001-200-81	Caster Horn	1

2025-1-49 Optional 8" Wheel Assembly

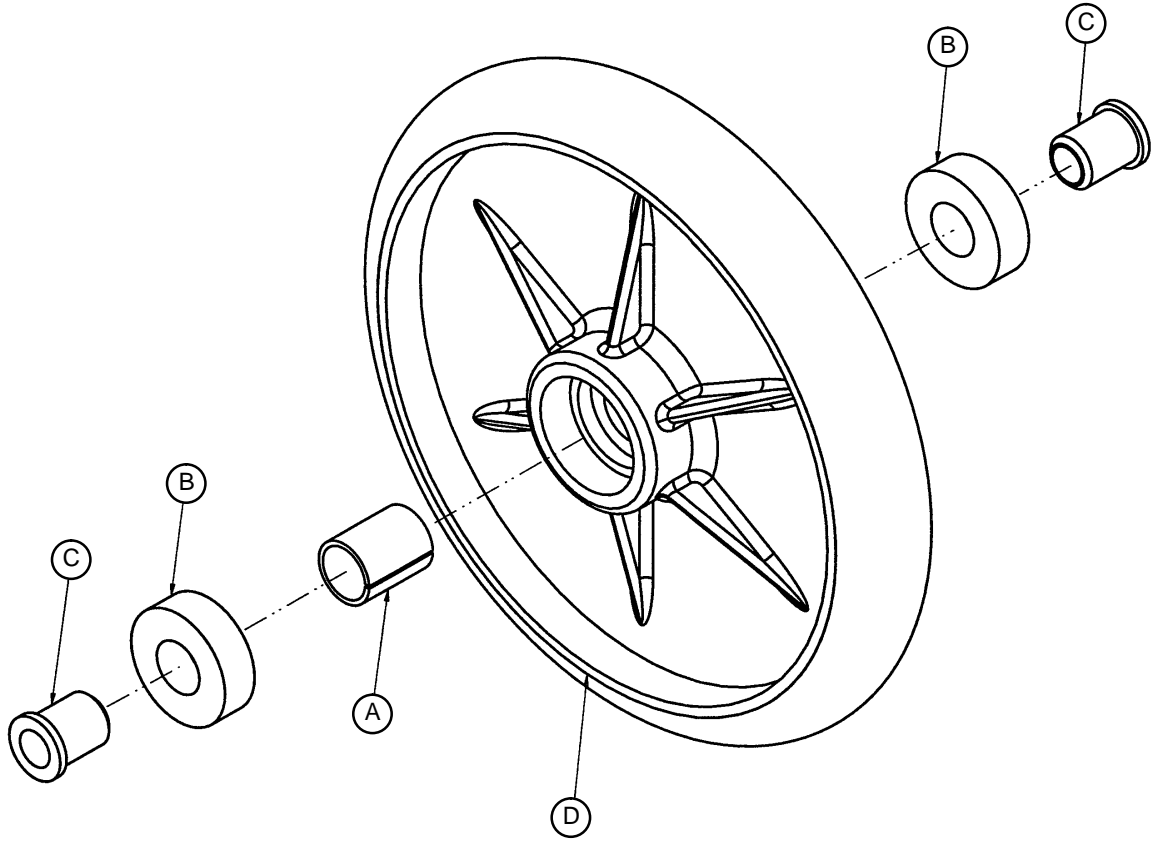

Item	Part No.	Part Name	Qty.
A	52-503	Bearing Spacer	1
B	81-226	Bearing	2
C	715-1-255	Wheel Bearing	2
D	2025-1-46	Wheel	1

Litter Assembly

Assembly part number 3001-300-002 (reference only)

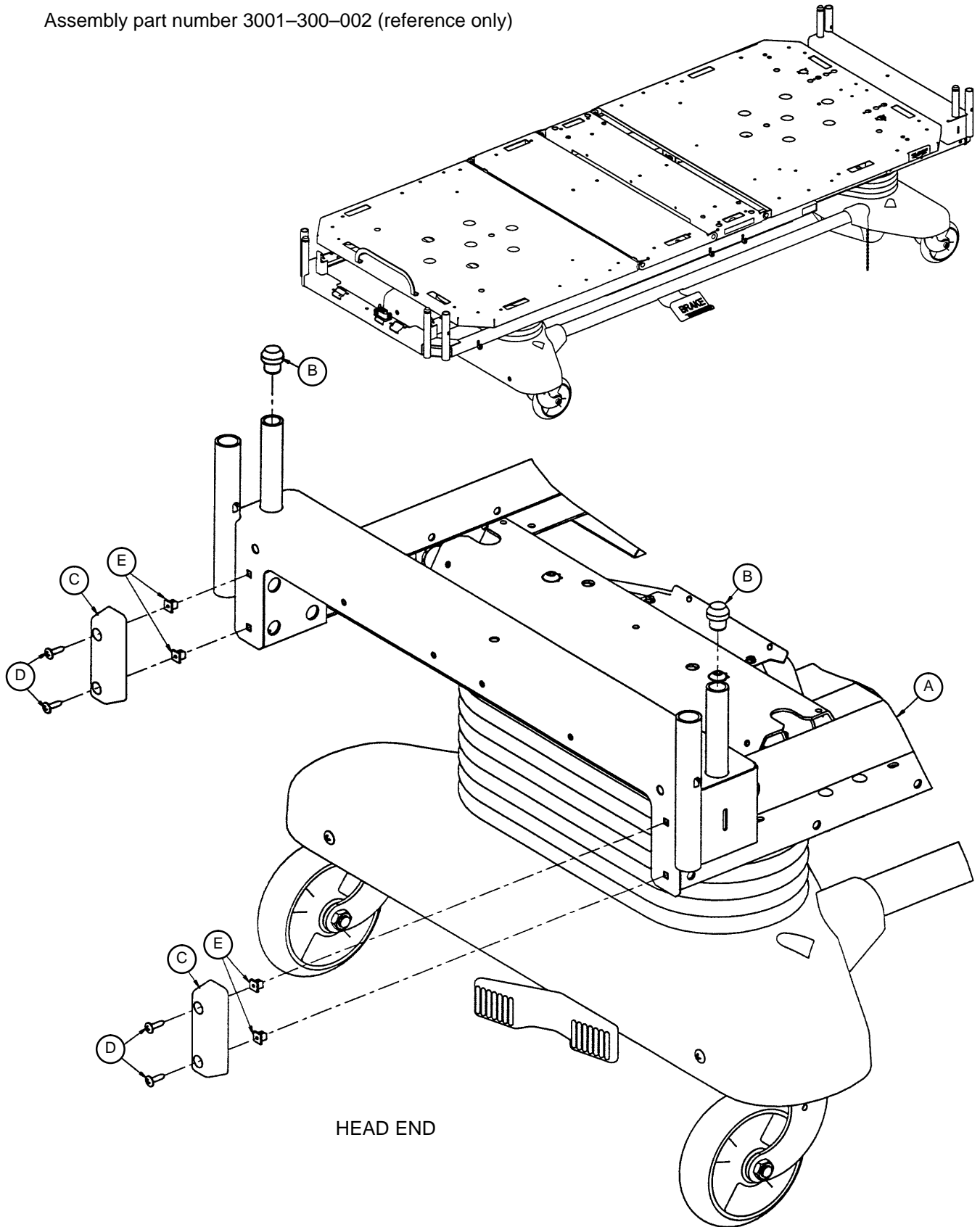

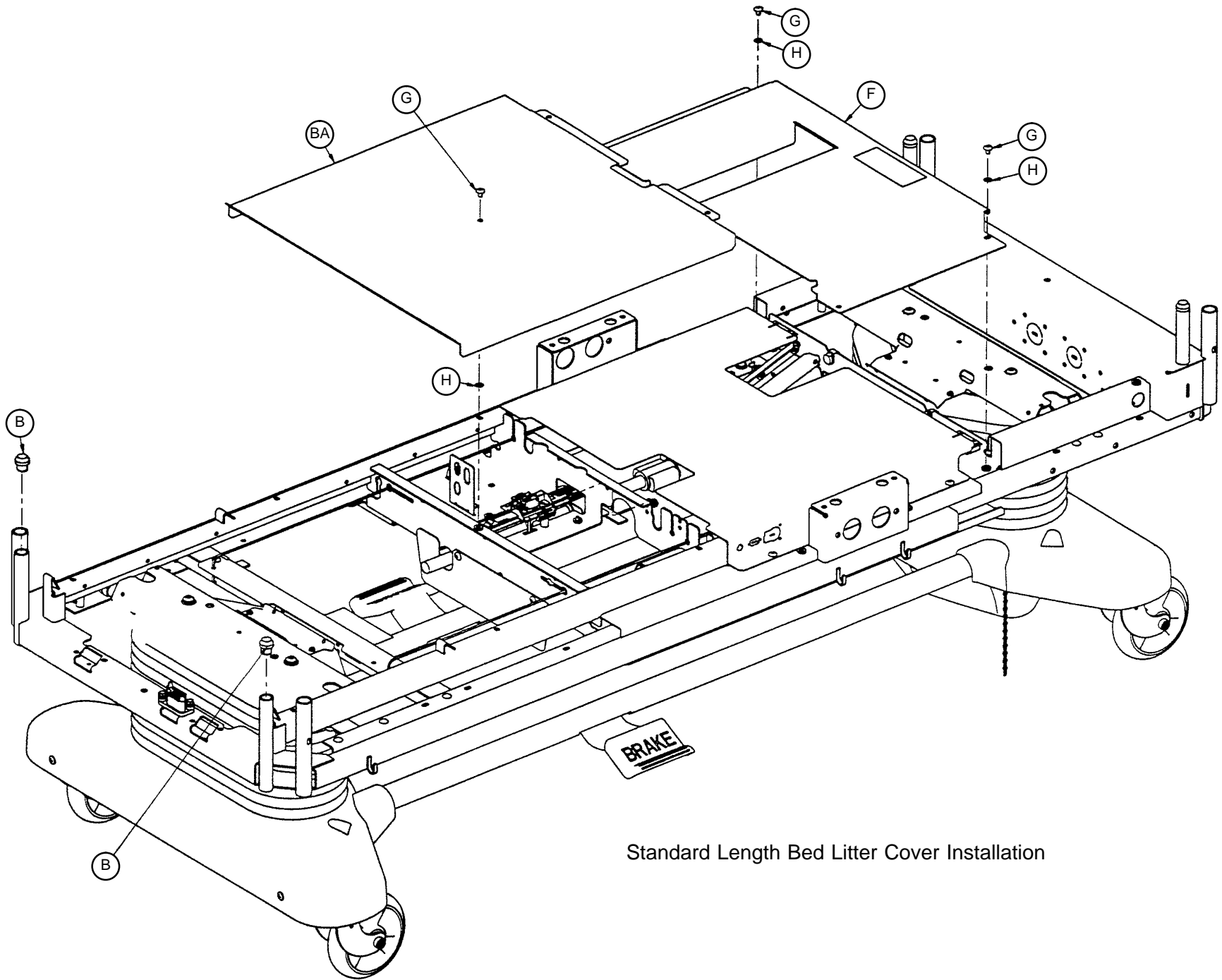

Standard Length Bed Litter Cover Installation

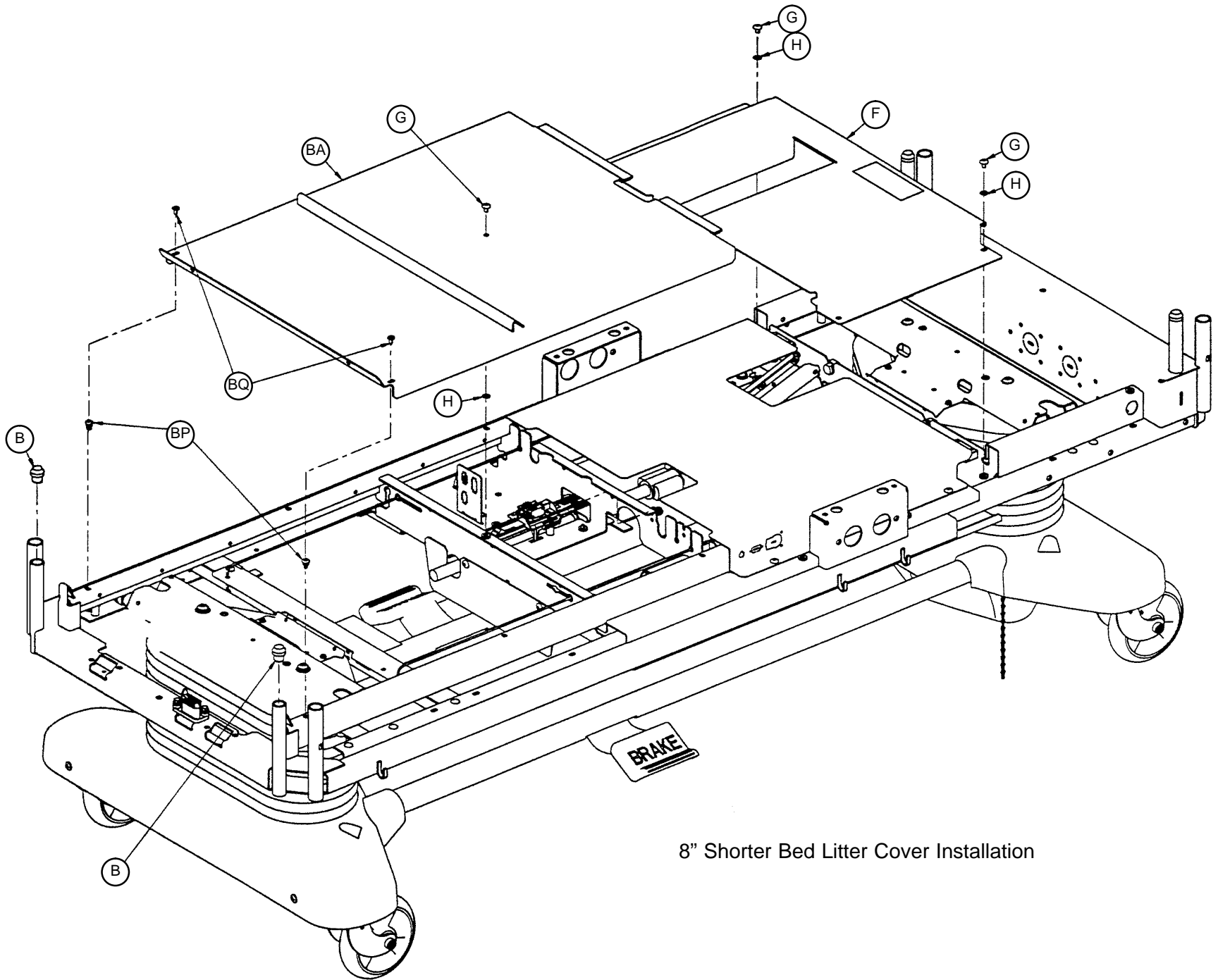

8" Shorter Bed Litter Cover Installation

Litter Assembly

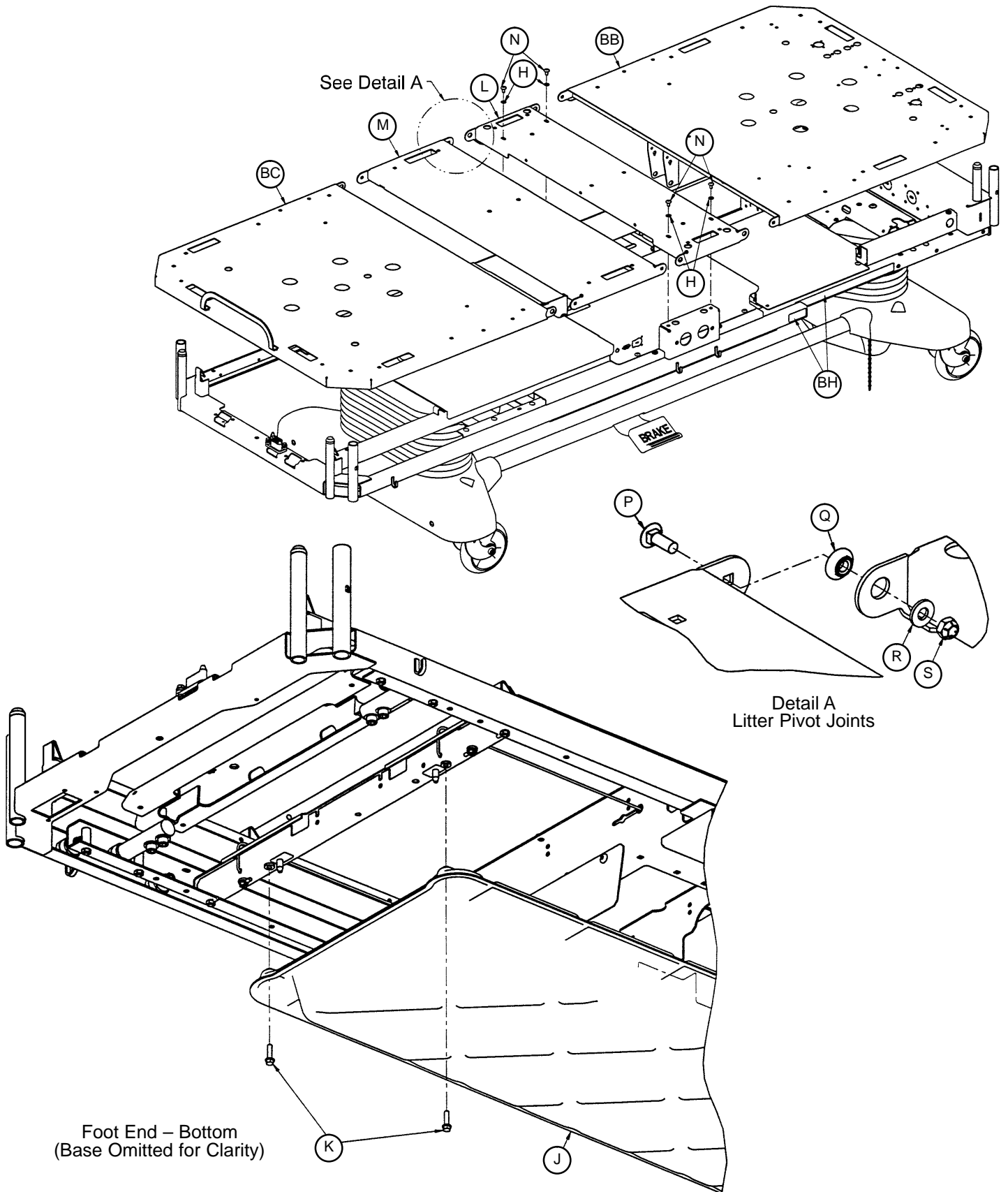

Litter Assembly

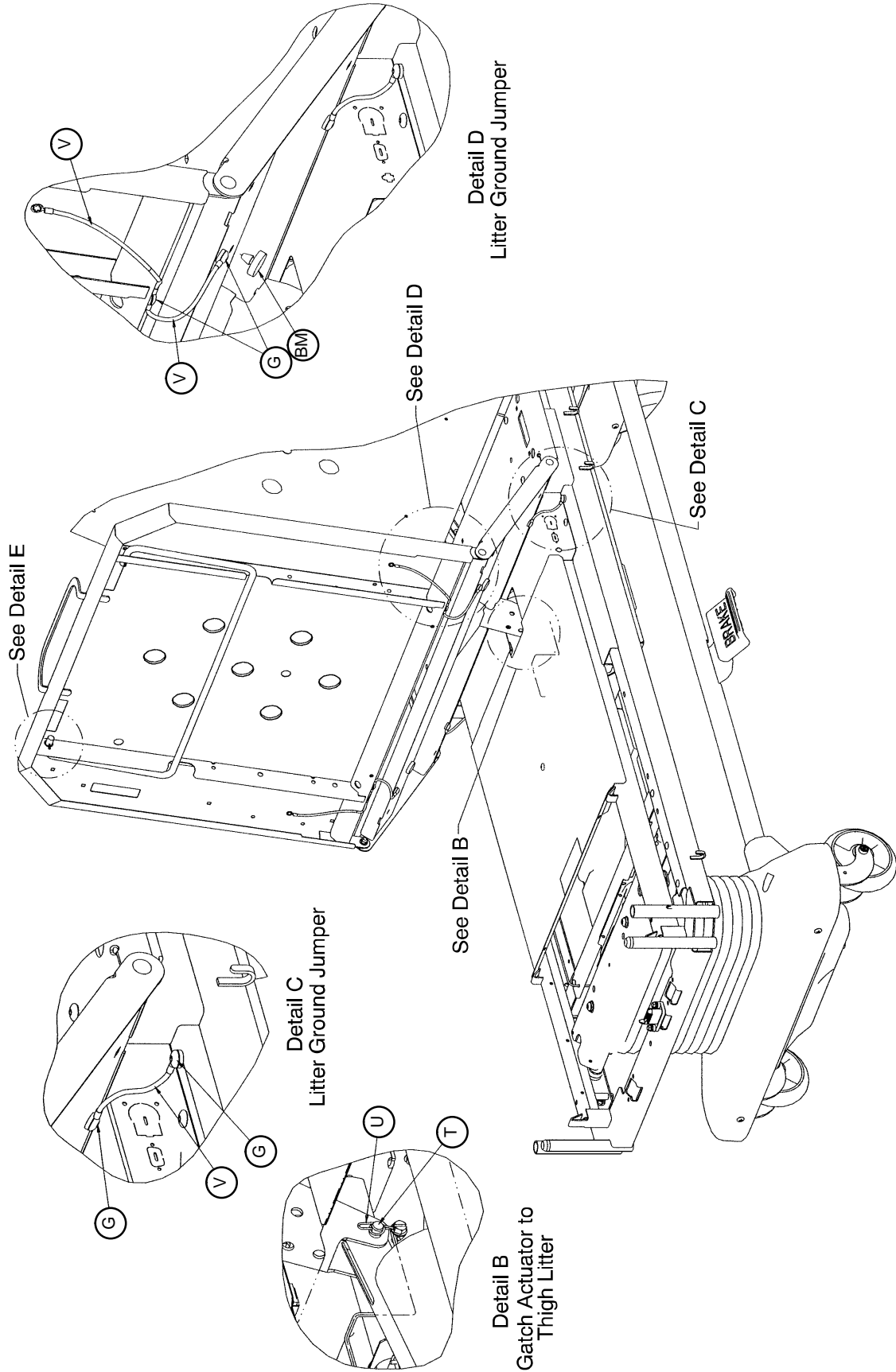

Litter Assembly

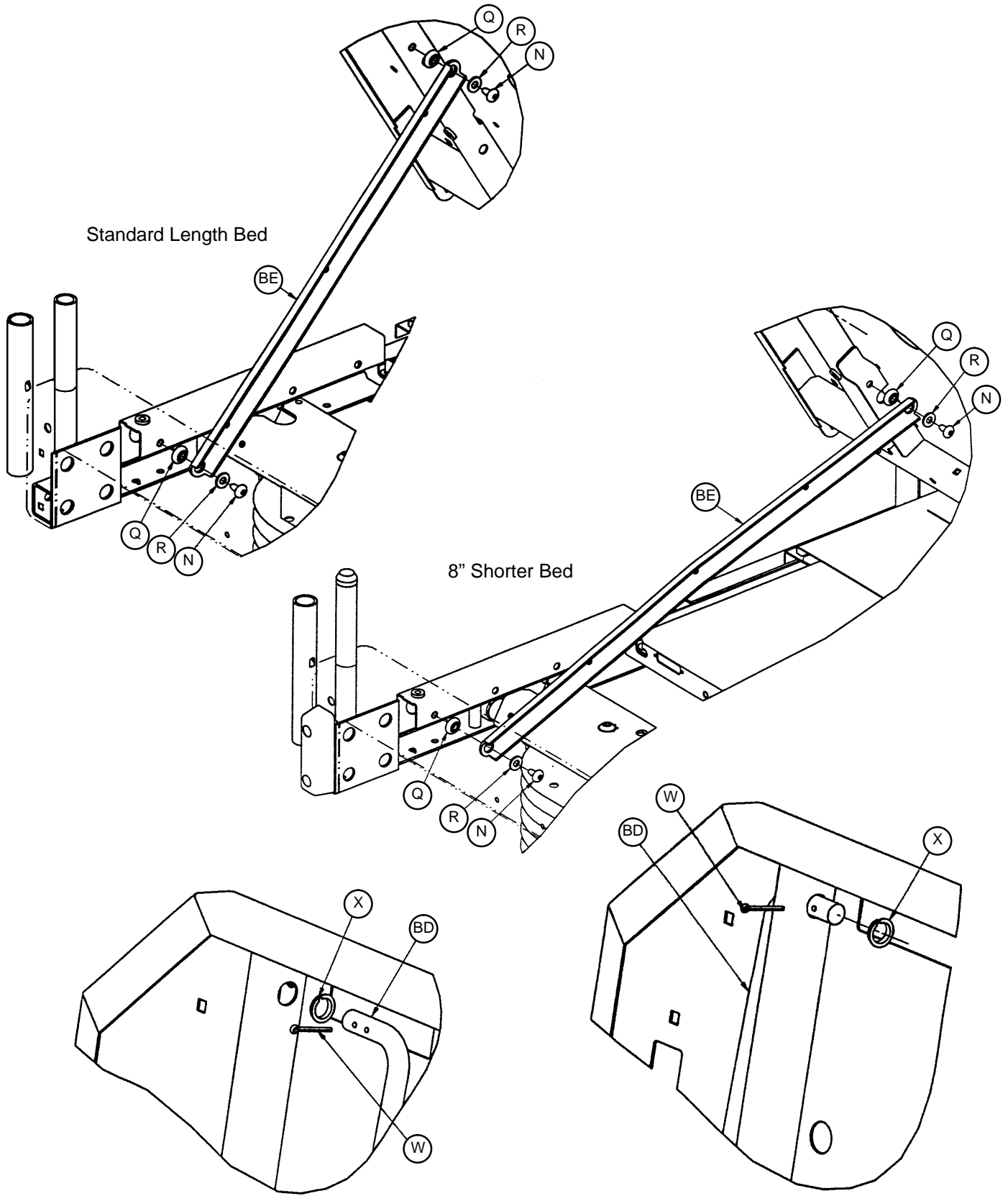

DETAIL E – 8" Shorter Bed Foot Prop Installation

DETAIL E – Standard Length Bed Foot Prop Installation

Litter Assembly

Fowler Crank Shown
in Phantom for Clarity

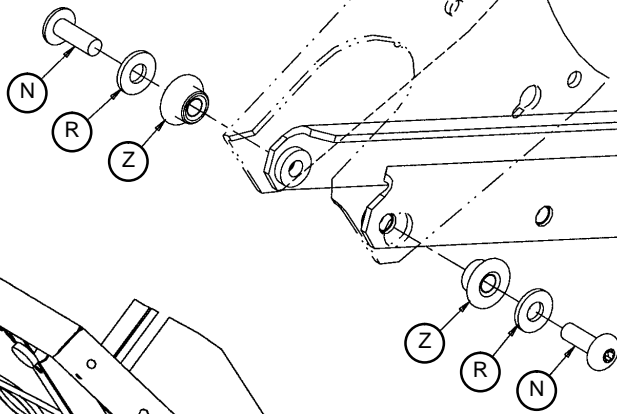

DETAIL F
Fowler Actuator Link
to Fowler Litter

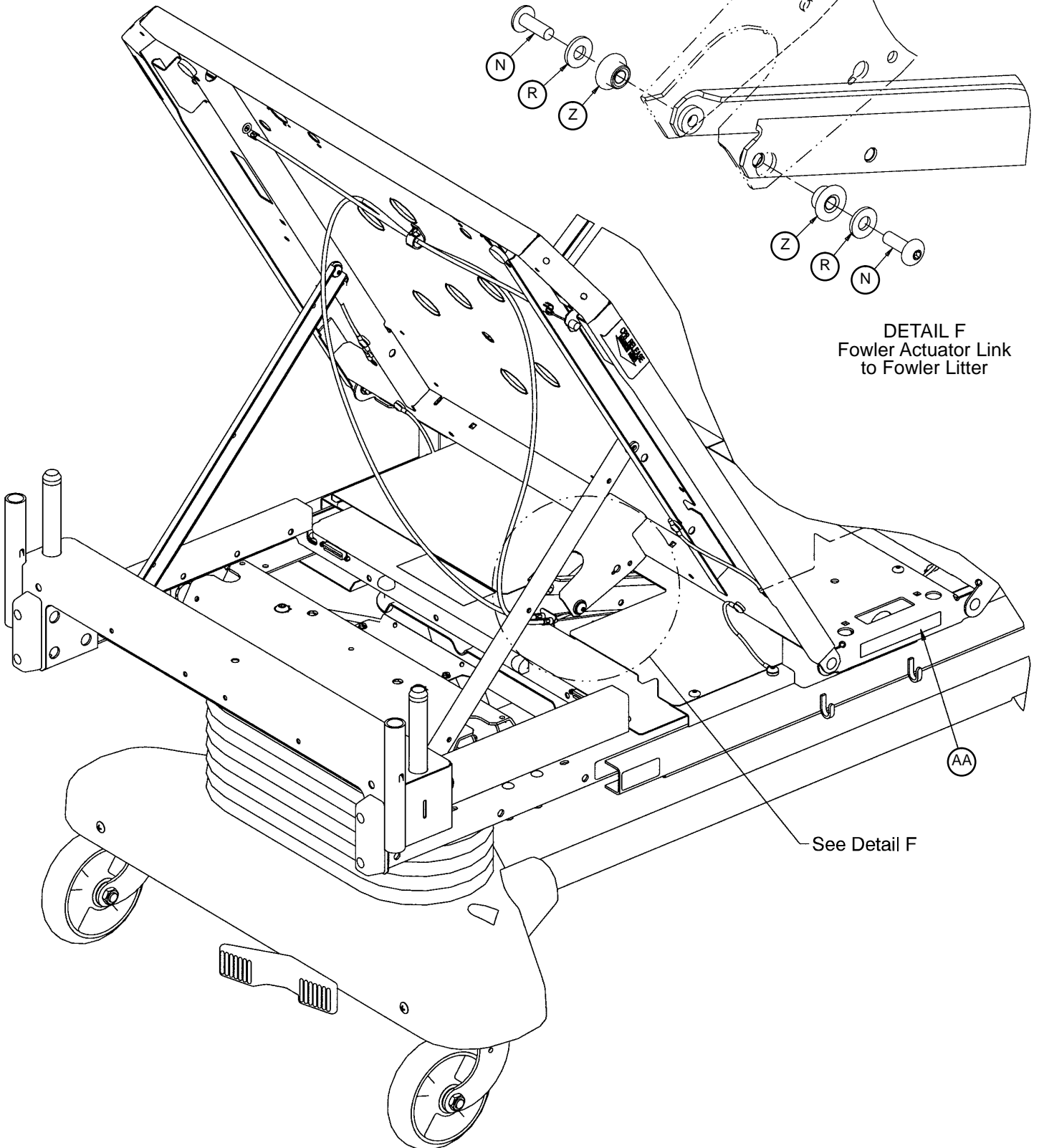

Litter Assembly

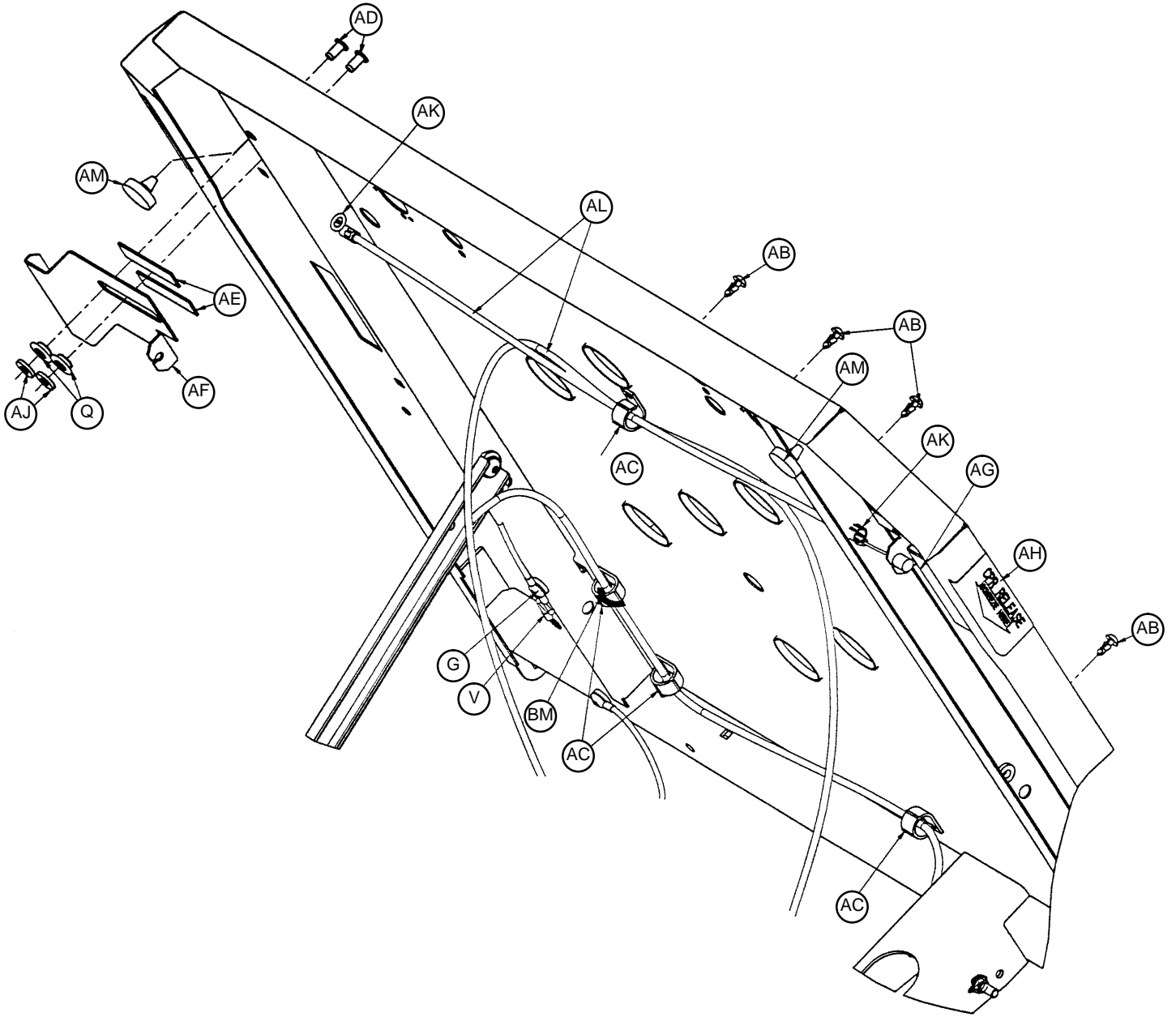

Litter Assembly

3001-300-2 Litter Assembly – Common Components

Item	Part No.	Part Name	Qty.	Item	Part No.	Part Name	Qty.
A	(page 109-115)	Electrical Litter Ass'y	1	U	27-22	Rue Ring	1
B	3000-300-349	Cap	4	V	3001-300-870	Litter Ground Jumper	6
C	3000-300-350	Head End Bumper	2	W	27-7	Cotter Pin	2
D	23-80	Cap	4	X	52-754	Bushing	2
E	3000-300-2	Plastic Clip Nut	4	Z	3000-300-99	Fowler Bushing	2
F	(page 107)	CPU Cover Ass'y	1	AA	2020-88-820	Caution Label	2
G	7-53	Truss Hd. Screw	17	AB	3000-300-477	CPR Conduit Stud	1
H	13-10	Ext. Tooth Lock Washer	7	AC	59-743	Wire Harness Clip	1
J	3001-300-83	Motion Interrupt Pan	1	AD	25-120	Pop Rivet	4
K	3001-200-228	Mounting Standoff	2	AE	3001-300-663	Velcro Strip	4
L	3001-300-135	Seat Litter	1	AF	3001-300-662	CPR Handle, Left	1
M	3001-300-170	Thigh Litter Ass'y	1	AG	3001-300-661	CPR Handle, Right	1
N	7-52	Truss Hd. Screw	10	AH	3001-300-603	CPR Release Label	2
P	5-17	Carriage Bolt	6	AJ	11-376	Washer	4
Q	3001-300-99	Fowler Bushing	14	AK	30-52	Snap Bushing	2
R	11-303	Flat Washer	12	AL	3001-300-670	CPR Cable Ass'y	2
S	16-16	Fiber Lock Nut	6	AM	3001-300-8	Thigh Bumper	2
T	26-277	Clevis Pin	1				

3001-343-2 Litter Assembly – Standard Bed

Item	Part No.	Part Name	Qty.
BA	(page 108)	Foot Cover Ass'y	1
BB	3001-300-145	Fowler Litter Ass'y	1
BC	3001-300-190	Foot Litter Ass'y	1
BD	3001-300-162	Foot Prop Rod	1
BE	3001-300-5	Fowler Link	2
BH	3001-300-602	Fowler Angle Label	1

3001-342-2 Litter Assembly – 8" Shorter Bed

Item	Part No.	Part Name	Qty.
BA	(page 108)	Foot Cover Ass'y	1
BB	3001-342-130	Fowler Litter Ass'y	1
BC	3001-342-180	Foot Litter Assembly	1
BD	3001-342-162	Foot Prop Rod	1
BE	3001-342-8	Fowler Link	2
BH	3001-342-604	Fowler Angle Label	1
BP	52-816	Screw Grommet	2
BQ	23-265	Truss Hd. Screw	2

3001-300-97 CPU Cover Assembly

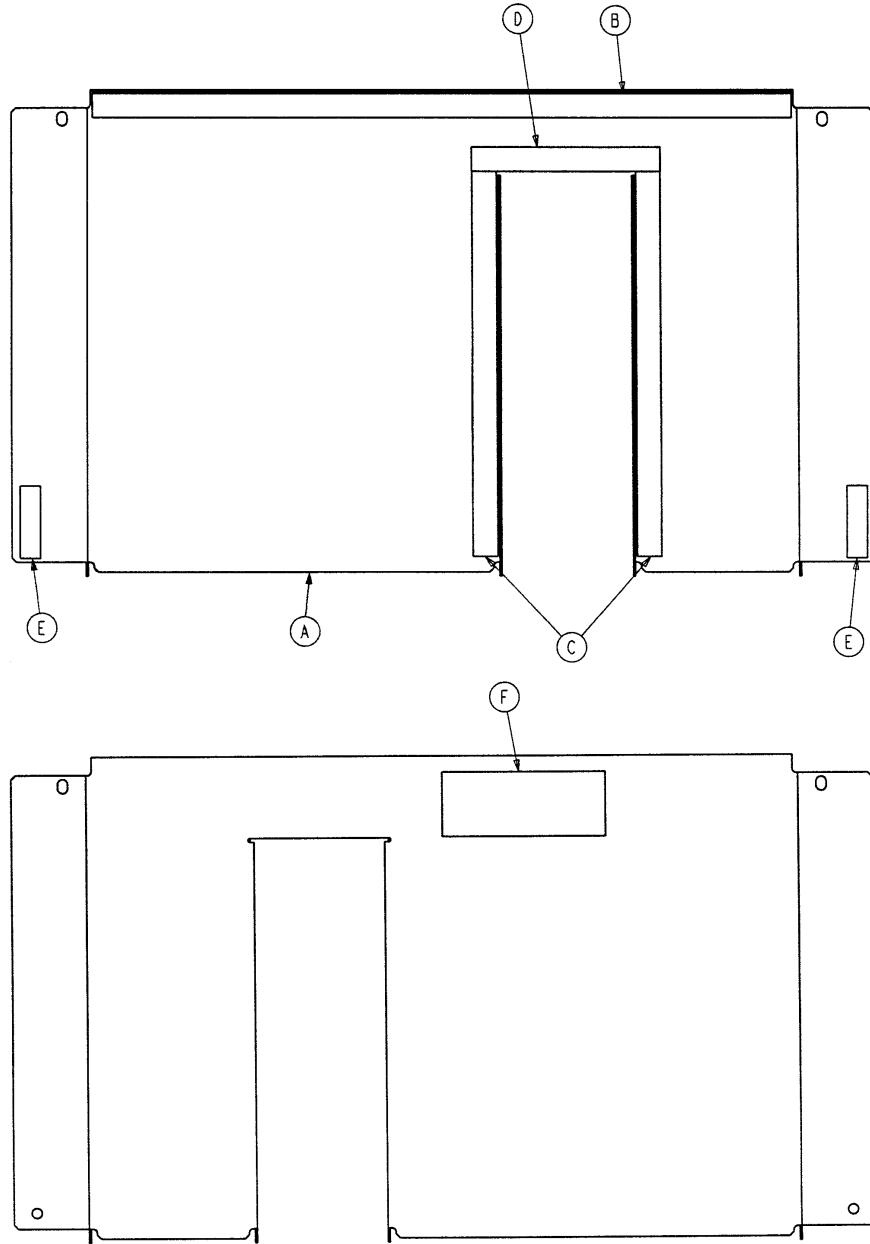

Item	Part No.	Part Name	Qty.
A	3001-300-98	CPU Cover	1
B	7900-1-291	Foam Tape (21.38")	1
C	7900-1-291	Foam Tape (12")	2
D	7900-1-291	Foam Tape (5.75")	1
E	3001-300-663	Velcro Strip	2
F	988-2-708	Service Caution Label	1

3001-300-42 Foot Cover Assembly, Standard Bed 3001-342-41 Foot Cover Assembly 8" Shorter Bed

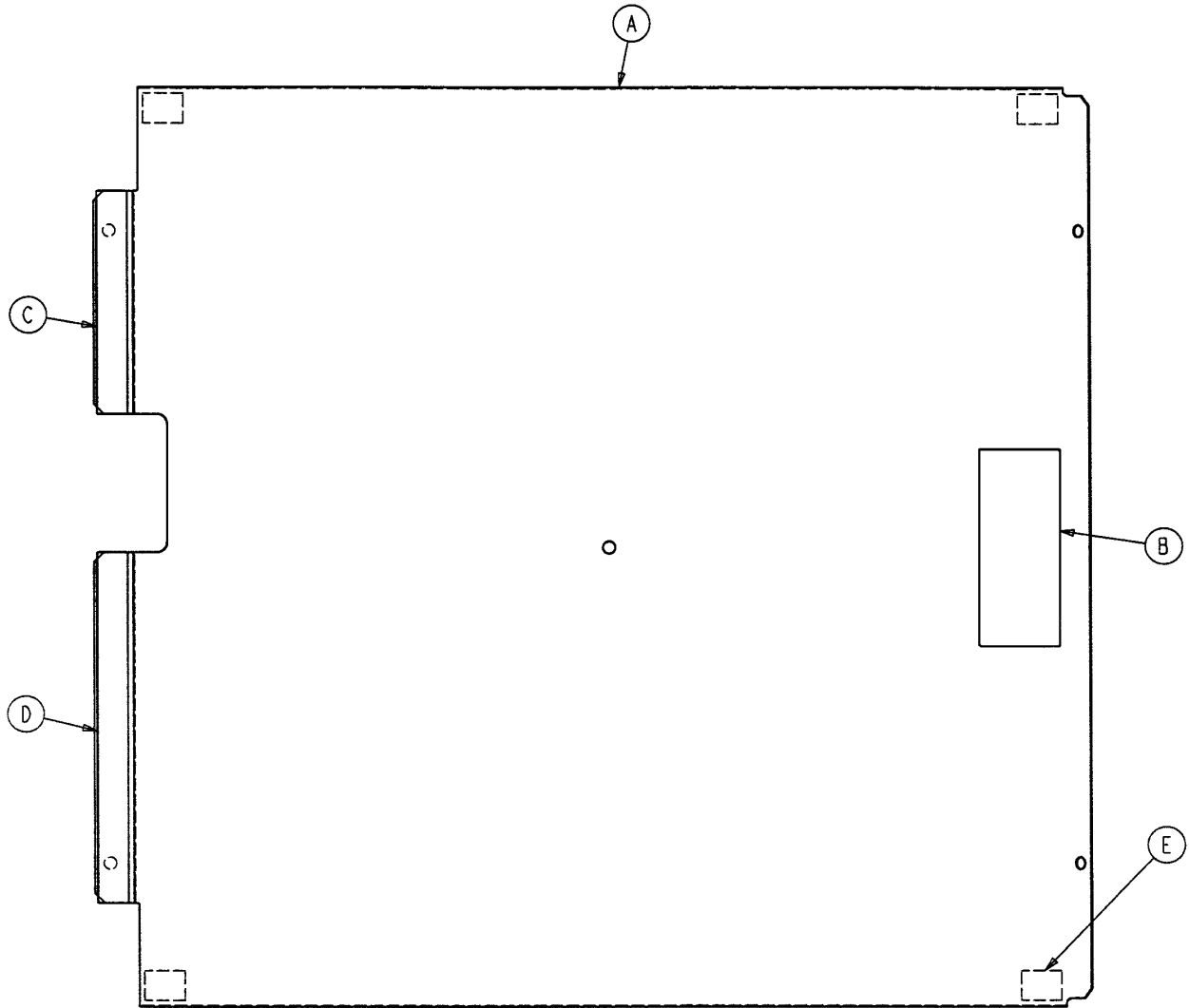

Item	Part No.	Part Name	Qty.
A	3001-300-43	Foot Cover (Standard)	1
	3001-342-41	Foot Cover (8" Shorter Bed)	1
B	988-2-708	Service Caution Label	1
C	7900-1-291	Foam Tape (5.63")	1
D	7900-1-291	Foam Tape (8.88")	1
E	7900-1-291	Foam Tape (1")	4

Electrical Litter Assembly

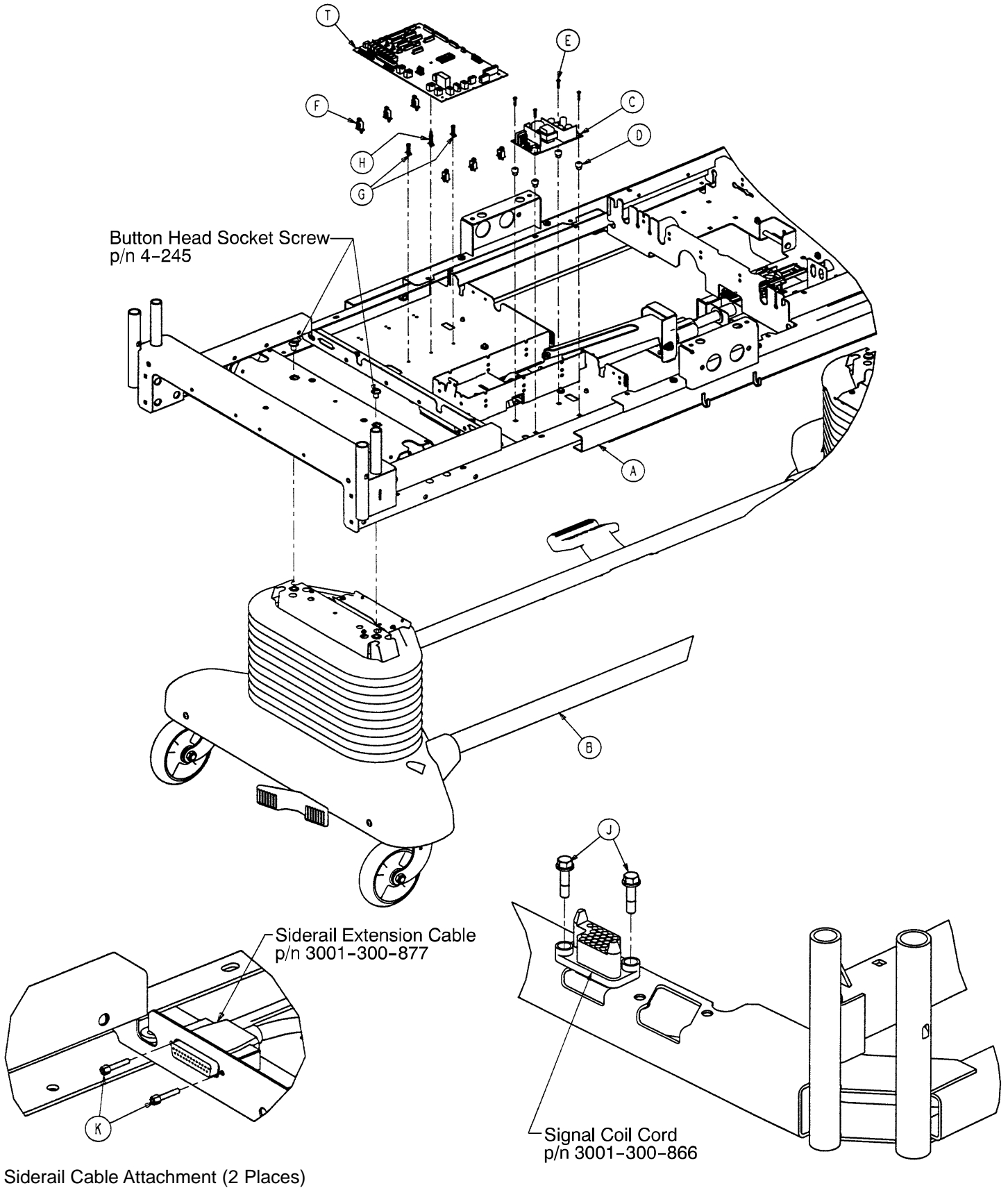

Electrical Litter Assembly

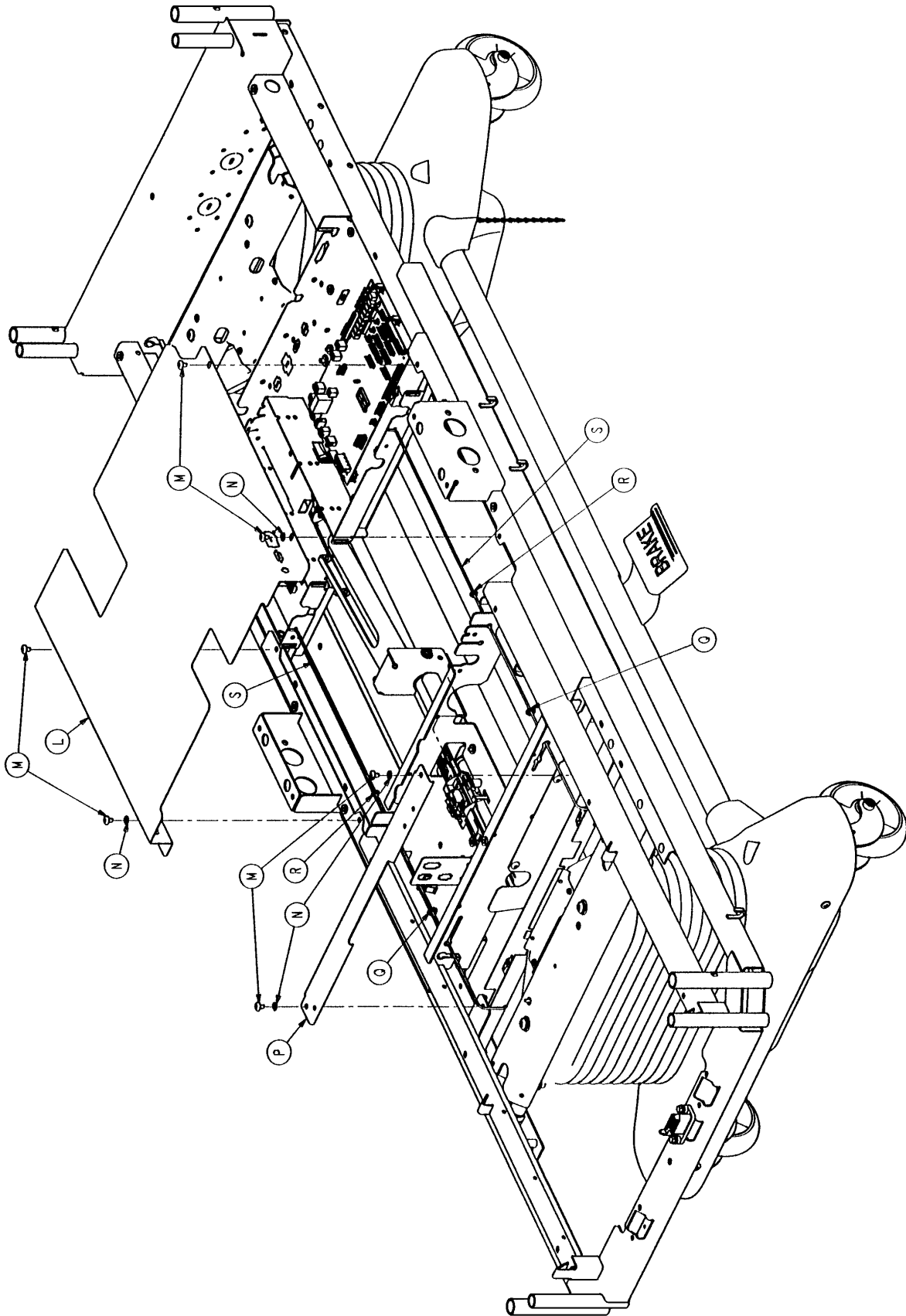

Electrical Litter Assembly

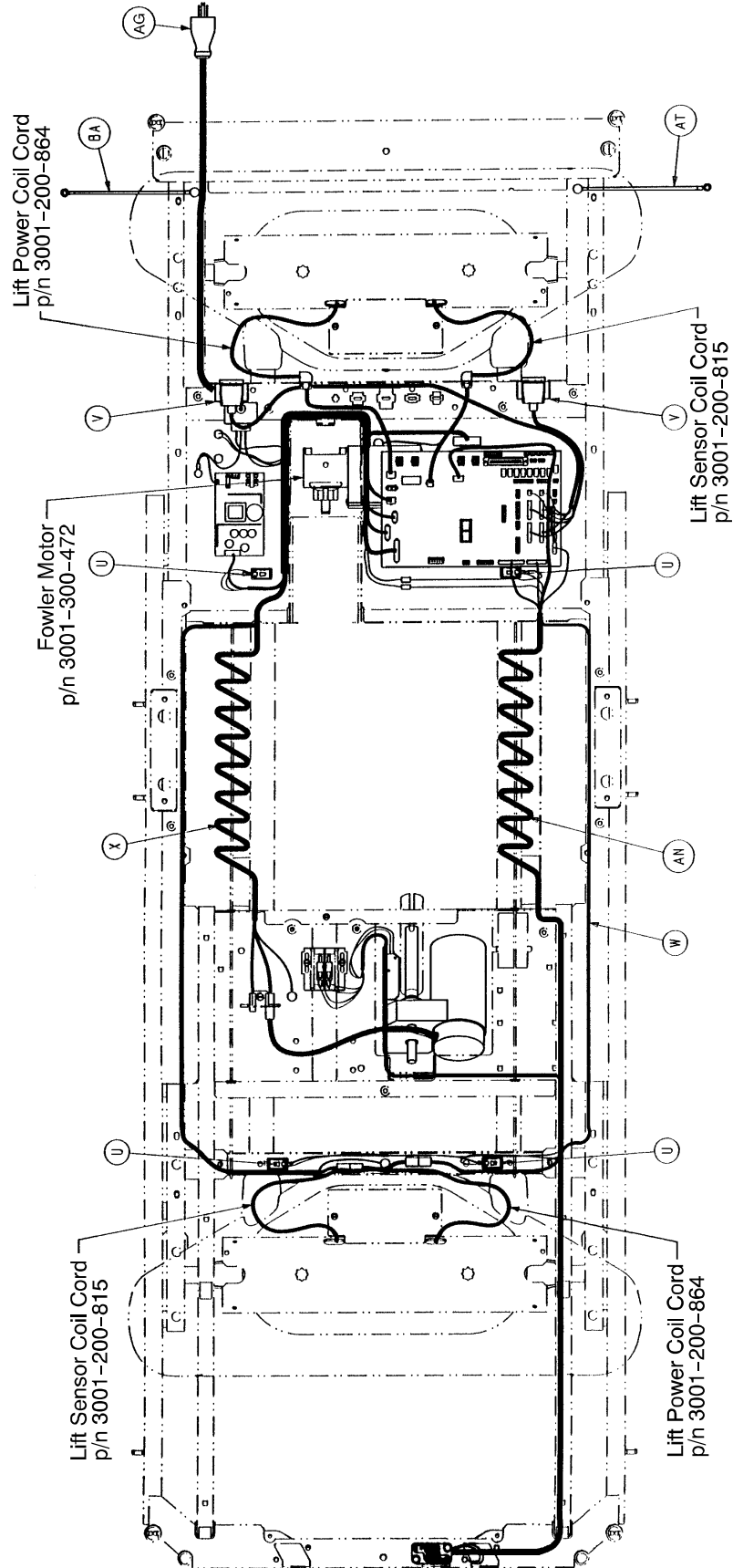

Electrical Litter Assembly

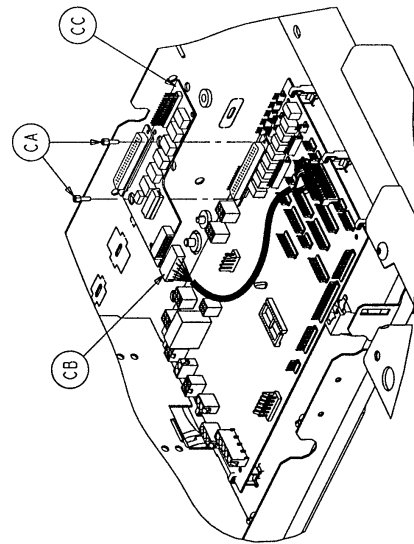
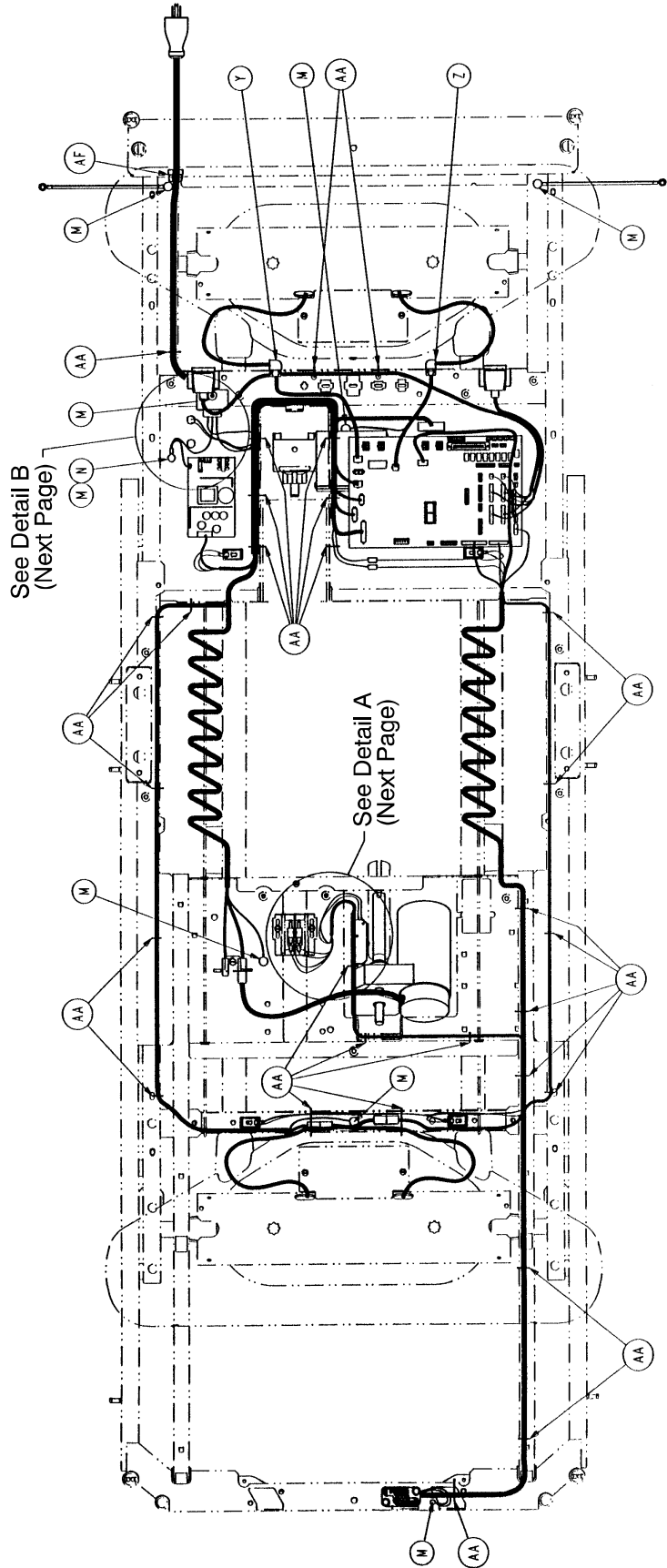

Smart TV Option

Electrical Litter Assembly

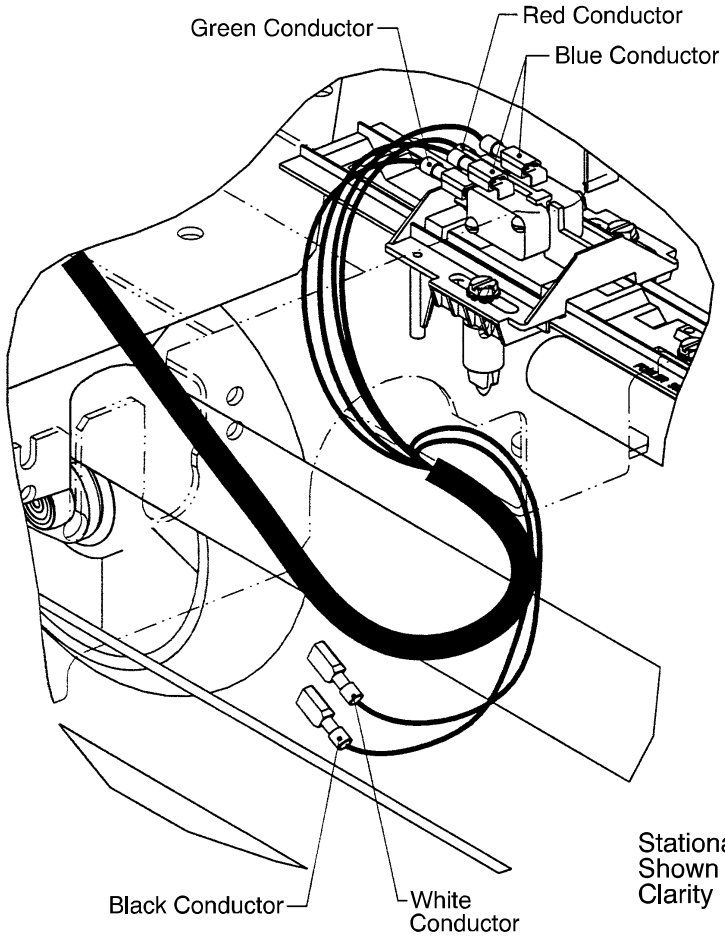

DETAIL A

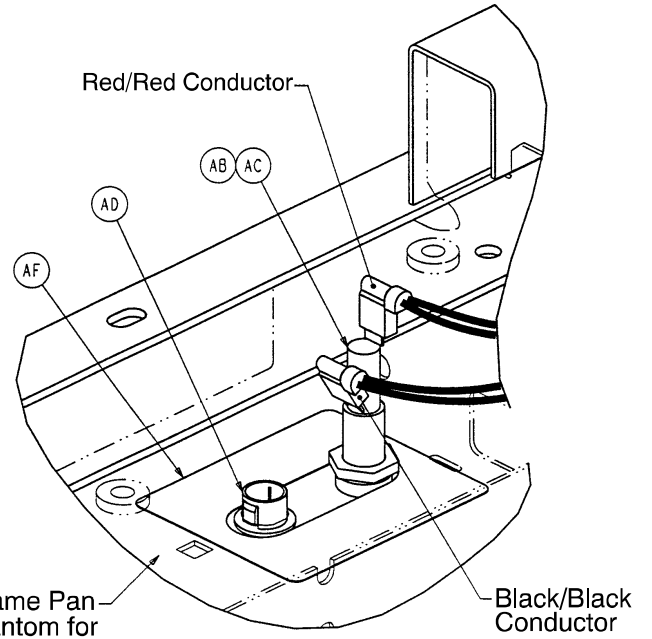

DETAIL B
115 V BED

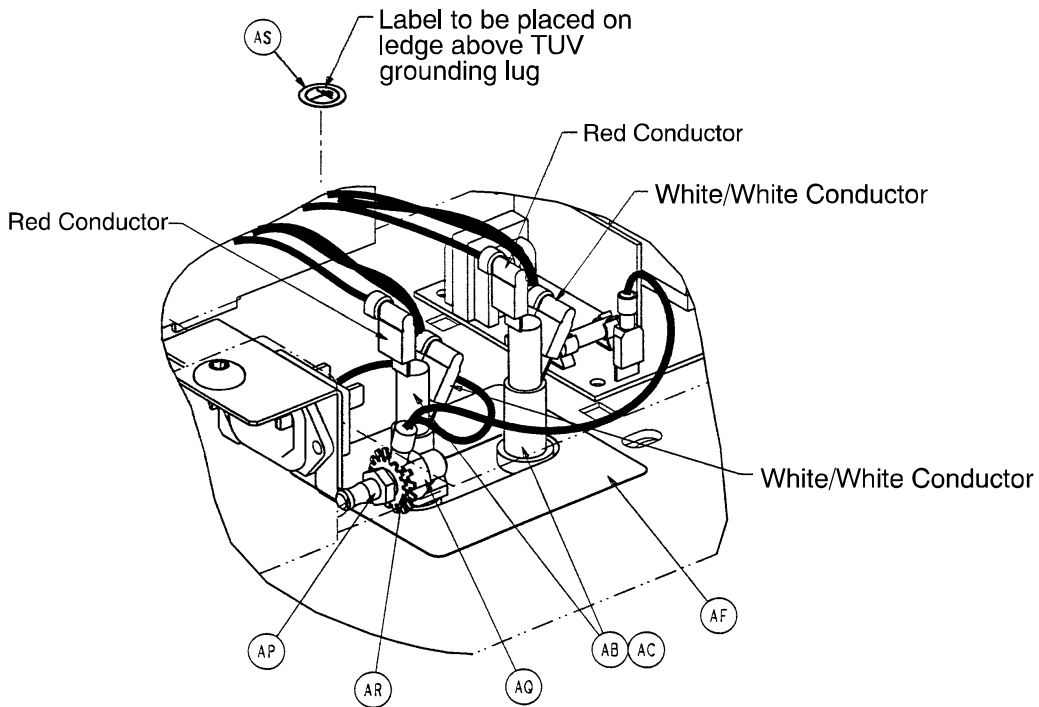

DETAIL B 230V BED

Electrical Litter Assembly

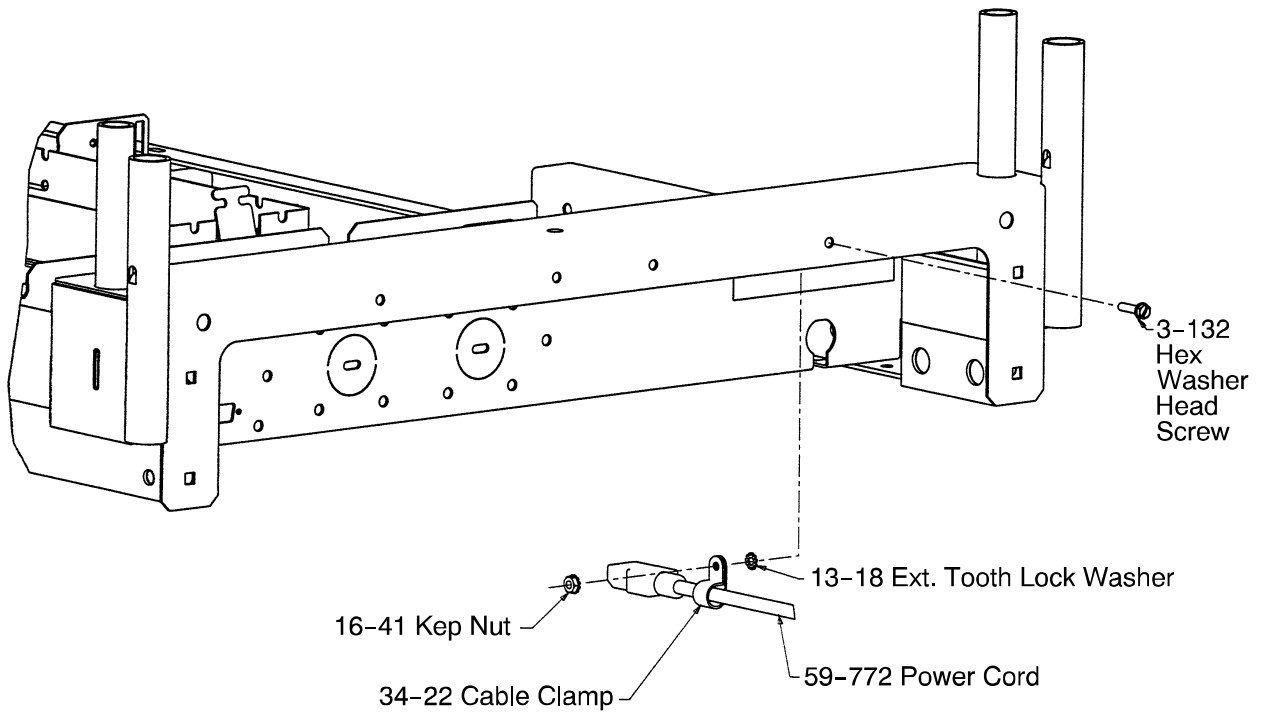
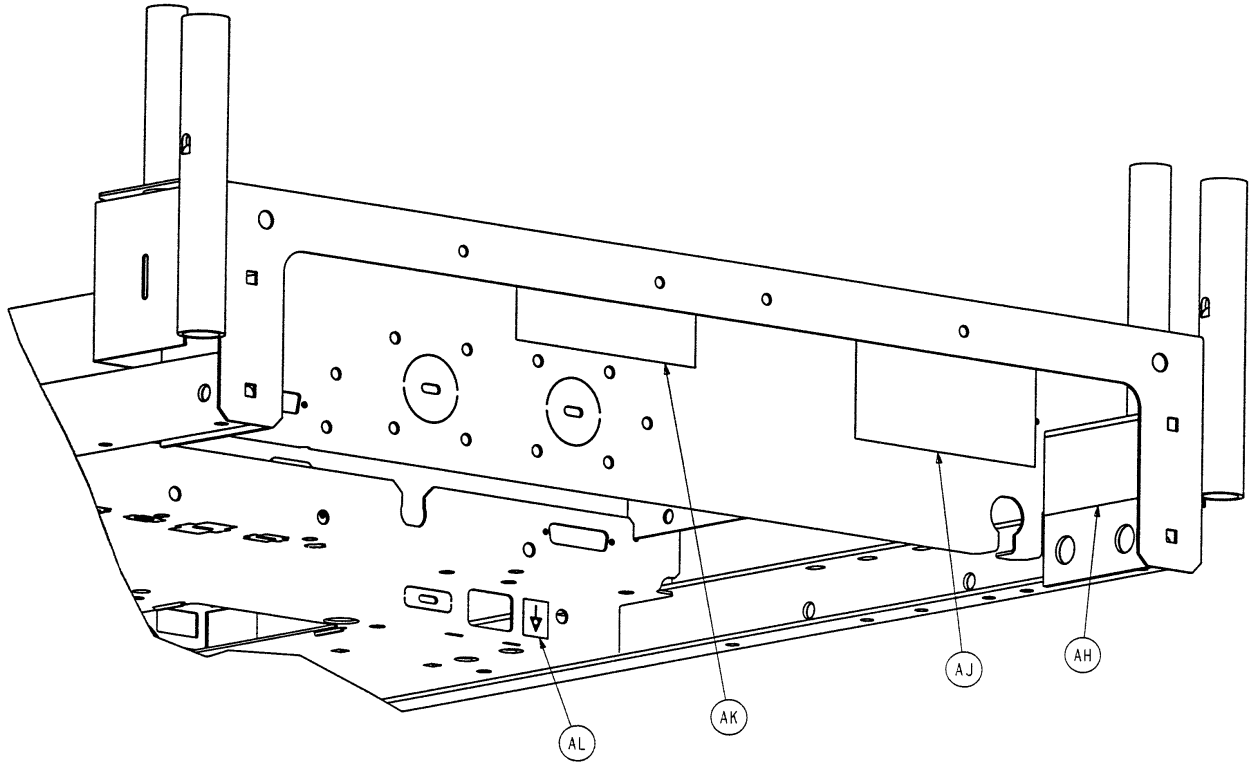

Cable Installation Shown for United Kingdom Power Cord

Electrical Litter Assembly

3001-300-895 Electrical Litter Assembly – Common Components

Item	Part No.	Part Name	Qty.	Item	Part No.	Part Name	Qty.
A	(page 116-119)	Litter Ass'y, Mechanical	1	Y	30-48	Strain Relief	1
B	(page 75-83)	Base Assembly	1	Z	30-47	Strain Relief	1
C	59-157	Power Supply	1	AA	3000-300-113	Cable Tie	29
D	52-287	Grommet	4	AB	2020-2-664	Fuse Holder	1
E	23-138	Ph. Hd. Screw	4	AC	59-150	7 Amp Fuse	1
F	59-745	Board Mount	6		59-777	Fuse	1
G	59-773	Push Spacer	2	AD	59-735	Plug	1
H	59-774	Locking Circuit Bd. Supt.	1	AE	3001-300-611	Fuse Label	1
J	3001-200-228	Mounting Standoff	2		3221-300-611	230V Fuse Label	1
K	3001-300-7	Screw	4	AF	30-45	Strain Relief	1
L	3001-300-88	Mid Litter Cover Ass'y	1	AG	39-254	Power Cord	1
M	7-53	Truss Hd. Torx Screw	14		3221-300-839	230 V Power Cord	1
N	13-10	Ext. Tooth Lock Washer	5	AH	2011-1-104	Warning Label	1
P	3001-300-23	Cross Support Cover	1	AJ	3000-300-624	Specification Label	1
R	52-822	Nyliner Bearing	2		3221-300-625	230V Spec. Label	1
S	3001-300-11	Guide Rod	2	AK	1550-90-1	Hosp. Grade Plug Label	1
T	*	CPU Board	1	AL	36-115	Ground Label	1
U	3000-300-58	Switch Plunger	4	AN	3001-300-866	Litter Signal Coil Cable	1
V	3001-300-877	Siderail Extension Cable	1	AP	2011-1-215	TUV Grounding Lug	1
W	3001-300-865	Mot. Int. Lift Sen. Cable	1	AQ	16-33	Kep Nut	1
X	3001-300-860	Power Ass'y Harness	1	AR	13-38	Ext. Tooth Lock Washer	1
	3221-300-860	230V Pwr. Ass'y Harness	1	AS	36-46	Ground Label	1
				AT	3001-300-874	Litter Ground Jumper	2

* 3001-300-760 – CPU Kit (No Options)
 3001-303-760 – CPU Kit (Communication Only)
 3001-307-760 – CPU Kit (Scale & Comm. Only)
 3001-308-760 – CPU Kit (Bed Exit & Comm. Only)
 3001-307-762 – CPU Kit (Scale, Bed Exit & Comm.)

3001-343-895 Litter Assembly – Standard Bed

Item	Part No.	Part Name	Qty.
A	(page 116-119)	Litter Ass'y, Mechanical	1
B	(page 75-83)	Base Assembly	1

3001-242-895 Litter Ass'y – 8" Shorter Bed

Item	Part No.	Part Name	Qty.
A	(page 116-119)	Litter Ass'y, Mechanical	1
B	(page 75-83)	Base Assembly	1

3001-999-227 Litter Assembly – Smart TV Option

Item	Part No.	Part Name	Qty.
CA	59-176	Jackscrew	2
CB	2035-32-806	Smart TV Control Cable	1
CC	3001-330-920	Smart TV CPU Ass'y	1

Litter Assembly, Mechanical

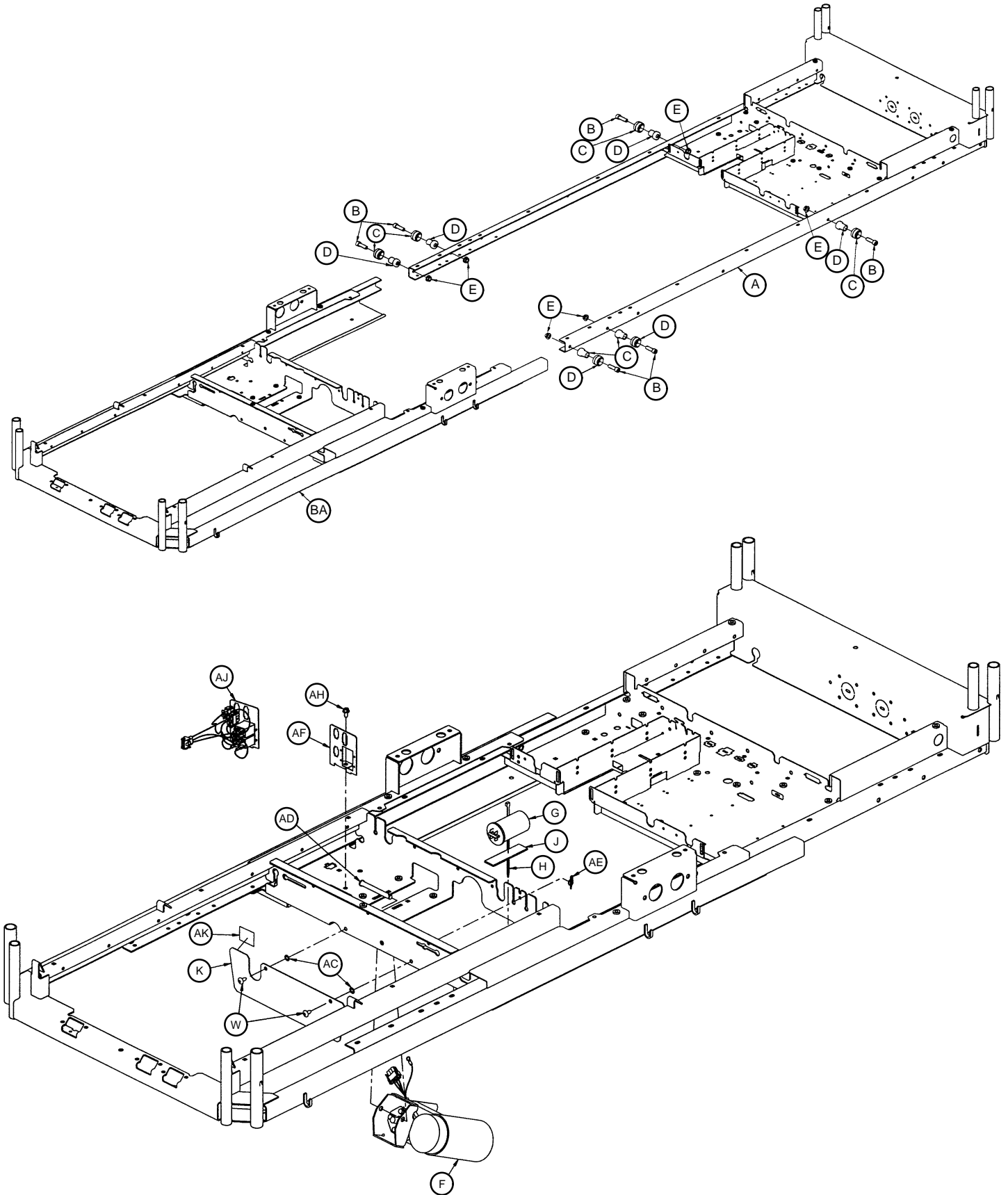

Litter Assembly, Mechanical

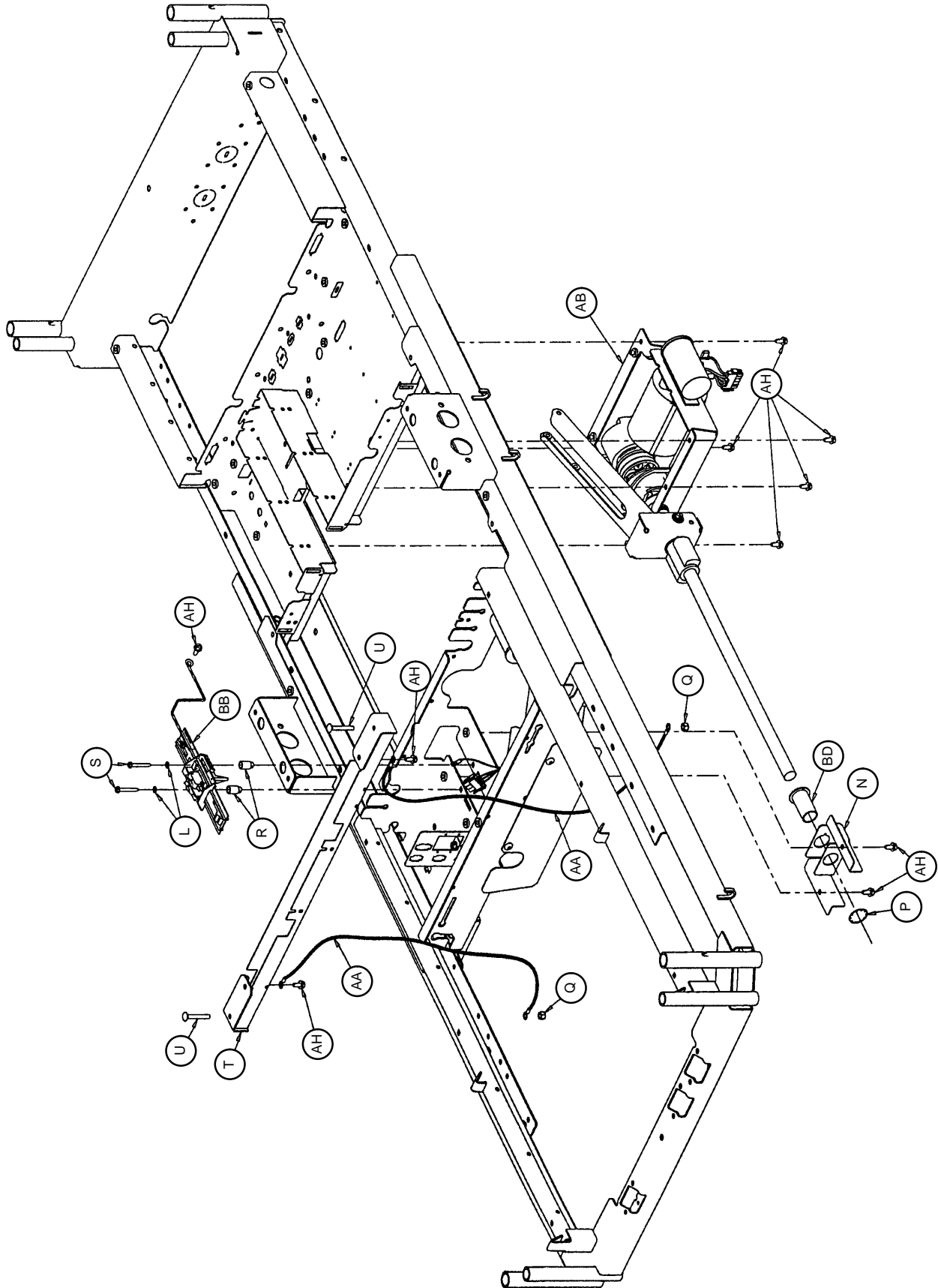

Litter Assembly, Mechanical

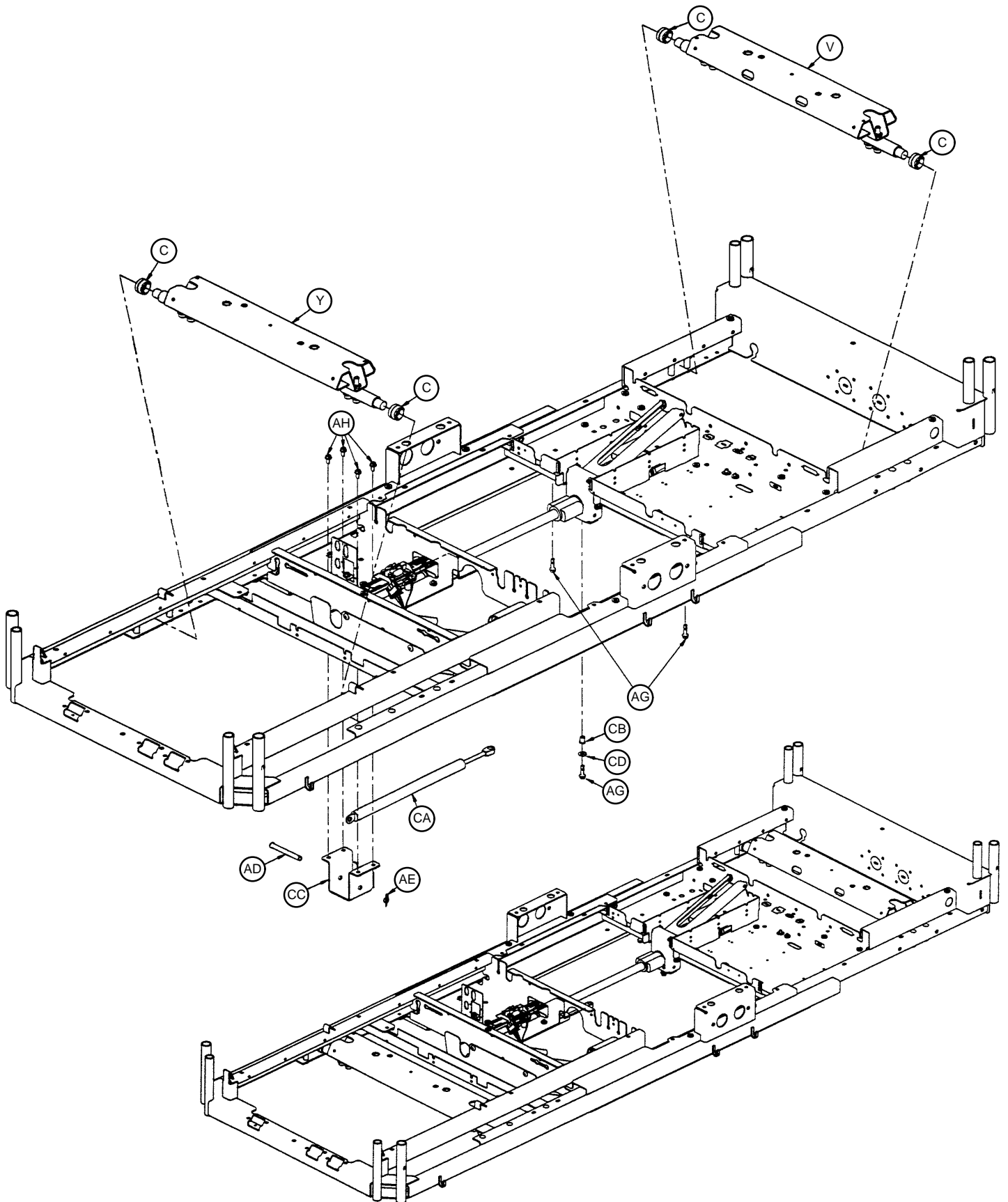

Litter Assembly, Mechanical

3001-300-197 Mechanical Litter Assembly – Common Components

Item	Part No.	Part Name	Qty.	Item	Part No.	Part Name	Qty.
A	3001-300-303	Stationary Frame Ass'y	1	T	3001-300-370	Cross Support Ass'y	1
B	4-211	Soc. Hd. Cap Screw	6	U	5-22	Carriage Bolt	10
C	3000-300-353	Roller	10	V	(page 120 & 121)	Std. Lift Header Ass'y	2
D	3000-300-352	Roller Shaft	6	W	3-221	Truss Hd. Screw	2
E	16-93	Flange Lock Nut	6	Z	3001-300-4	Stationary Frame Spacer	8
F	(page 123)	Gatch Motor Ass'y	1	AA	3001-300-870	Litter Ground Jumper	4
G	59-779	Capacitor	1	AB	(page 124 & 125)	Fowler Drive Ass'y	1
H	38-151	11" Cable Tie	1	AC	13-10	Ext. Tooth Lock Washer	2
J	44-29	Double-Sided Tape	1	AD	26-279	Clevis Pin	1
K	3001-300-417	Gatch Shield	1	AE	27-22	Rue Cotter Pin	1
L	13-18	Ext. Tooth Lock Washer	2	AF	3001-300-269	Connector Mtg. Bracket	1
N	3001-300-491	Screw Support Bracket	1	AG	3001-200-228	Mounting Standoff	2
P	28-122	Retaining Ring	1	AH	3-221	Hex Washer Hd. Screw	11
Q	16-6	Kep Nut	10	AJ	(page 122)	230V Surge Suppressor	1
R	52-800	Grommet	2	AK	7900-1-291	Vibration Tape	1"
S	23-251	Hex Washer Hd. Screw	2				

3001-343-197 Mech. Litter Ass'y – Std. Bed

Item	Part No.	Part Name	Qty.
AB	3001-343-550	Fowler Drive Ass'y	1
BA	3001-300-204	Moving Frame Assembly	1
BB	(page 126)	Fowler Limit Ass'y	1
BD	3000-300-9	Screw Support Bushing	1

3001-342-197 Mech. Litter Ass'y – 8" Shorter Bed

Item	Part No.	Part Name	Qty.
AB	3001-342-550	Fowler Drive Ass'y	1
AD	26-279	Clevis Pin	1
AE	27-22	Rue Cotter Pin	1
AG	3001-200-228	Mounting Standoff	1
AH	3-221	Hex Washer Hd. Screw	4
AL	3001-342-550	Fowler Drive Ass'y	1
BA	3001-342-204	Moving Frame Assembly	1
BB	(page 127)	Fowler Limit Assembly	1
BD	3001-342-9	Screw Support Bushing	1
CA	52-819	Dampener Cylinder	1
CB	52-818	Flange Bearing	1
CC	3001-345-489	Cylinder Mtg. Bracket	1
CD	11-303	Flat Washer	1

Lift Header Assemblies

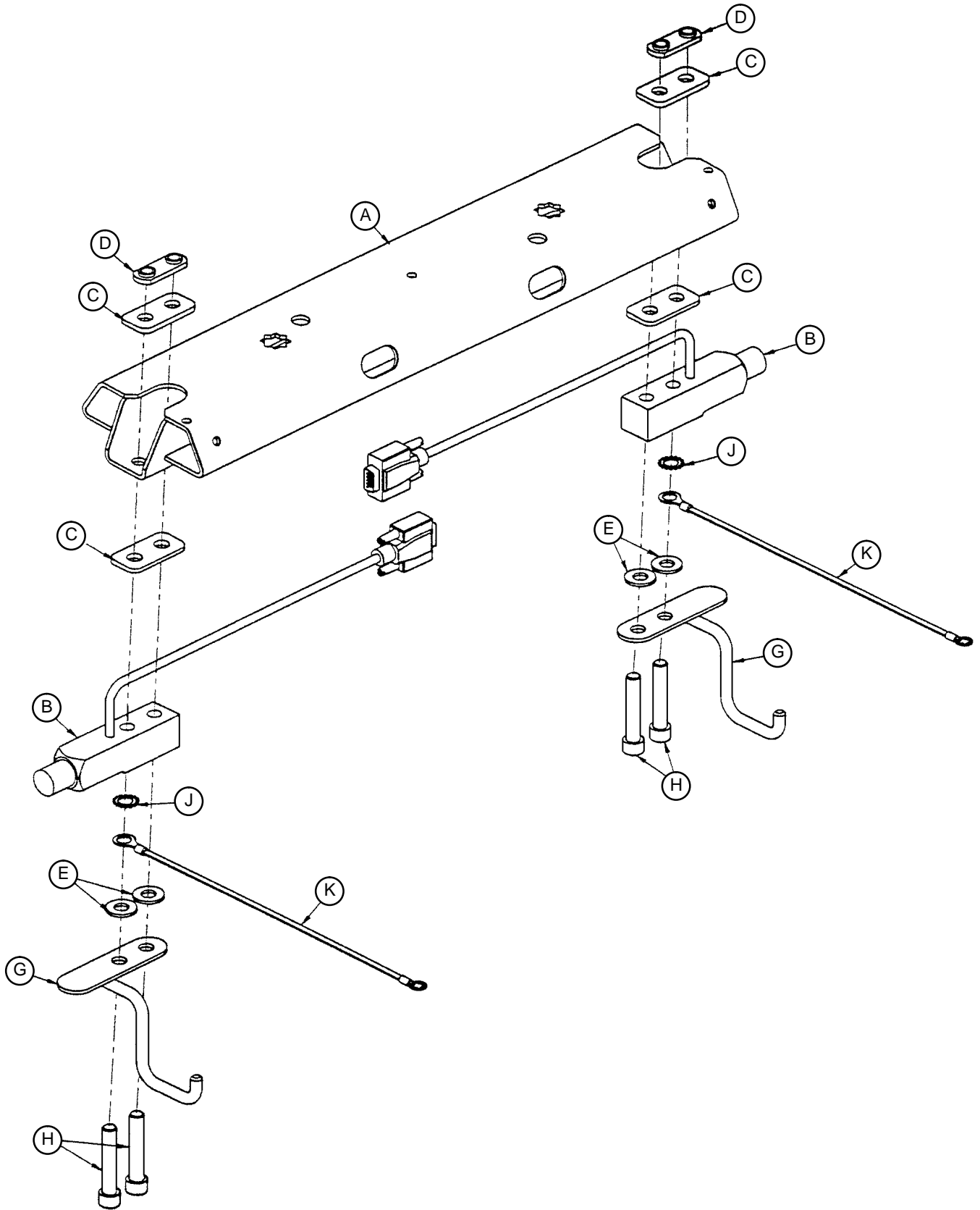

Lift Header Assemblies

3001-300-500 Lift Header Assembly – Standard Bed

Item	Part No.	Part Name	Qty.
A	3001-300-530	Lift Header Assembly	1
B	3001-300-511	“Imitation” Load Cell	2
D	3001-300-509	Lift Header Weld Nut	2
E	11-301	Flat Washer	4
H	4-288	Hex Soc. Hd. Cap Screw	4
J	13-32	External Tooth Lock Washer	2
K	3001-300-871	Ground Jumper	2

3001-307-500 Lift Header Assembly – Scale Bed

Item	Part No.	Part Name	Qty.
A	3001-300-530	Lift Header Assembly	1
B	3001-307-57	Load Cell	2
C	3001-307-21	Load Cell Shim	4
D	3001-300-509	Lift Header Weld Nut	2
E	11-301	Flat Washer	4
H	4-288	Hex Soc. Hd. Cap Screw	4

3001-326-500 Lift Header Assembly – Scale Bed/Isolated Foley Bag Hooks

Item	Part No.	Part Name	Qty.
A	3001-300-530	Lift Header Assembly	1
B	3001-307-57	Load Cell	2
D	3001-300-509	Lift Header Weld Nut	2
E	11-301	Flat Washer	2
F	3001-326-20	Isolated Foley Bag Ass'y, Rt.	1
G	3001-326-10	Isolated Foley Bag Ass'y, Lt.	1
H	4-288	Hex Soc. Hd. Cap Screw	4

3001-326-550 Lift Header Assembly – Standard Bed/Isolated Foley Bag Hooks

Item	Part No.	Part Name	Qty.
A	3001-300-530	Lift Header Assembly	1
B	3001-300-511	“Imitation” Load Cell	2
D	3001-300-509	Lift Header Weld Nut	2
E	11-301	Flat Washer	2
F	3001-326-20	Isolated Foley Bag Ass'y, Rt.	1
G	3001-326-10	Isolated Foley Bag Ass'y, Lt.	1
H	4-288	Hex Soc. Hd. Cap Screw	4

3221-300-270 230V Surge Suppressor Assembly

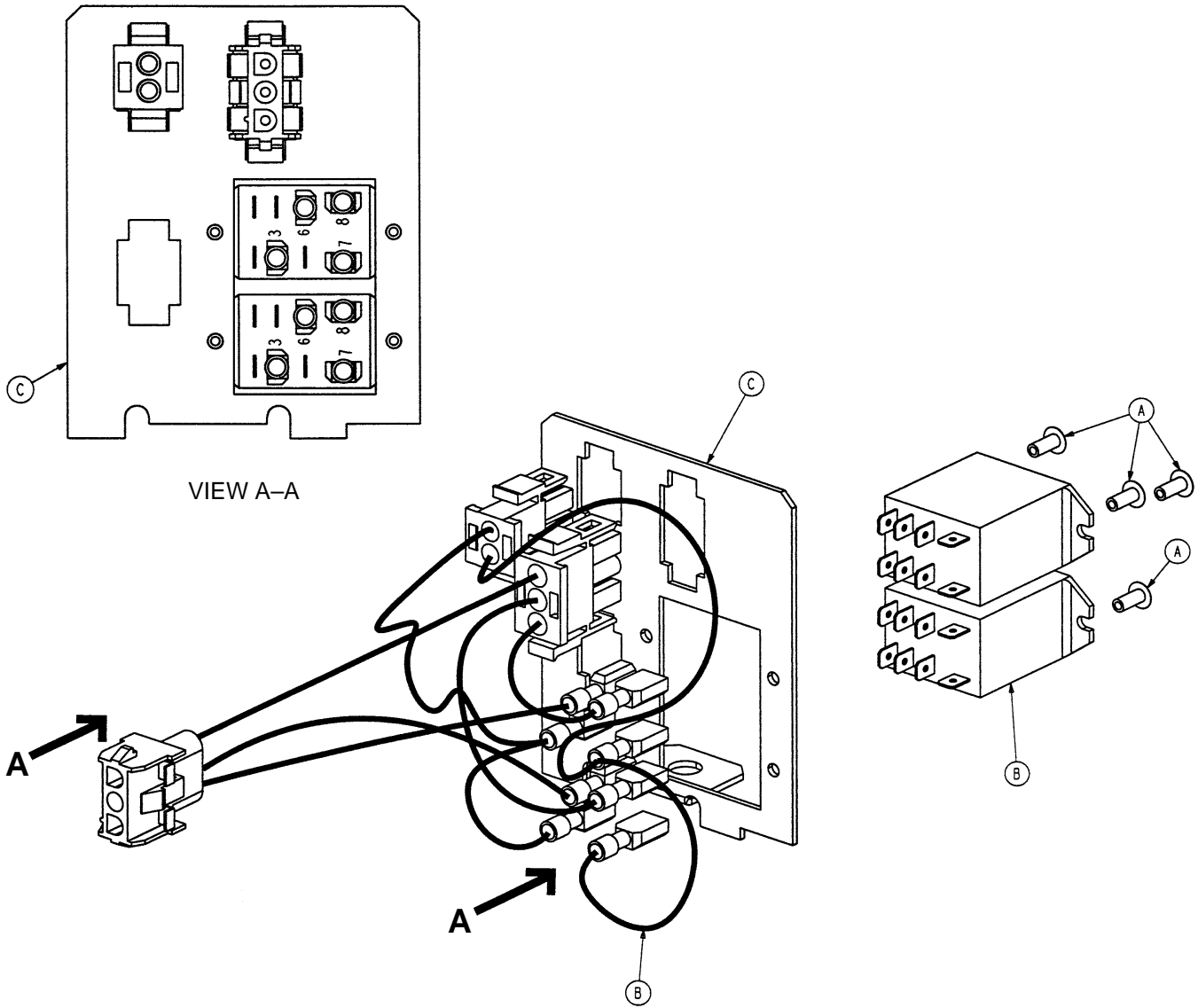

Item	Part No.	Part Name	Qty.
A	25-40	Pop Rivet	4
B	3221-300-268	Cable Assembly	1
C	3001-300-269	Connector Mtg. Bracket	1

Gatch Motor Assembly

Assembly part number 3001-300-420
(reference only)

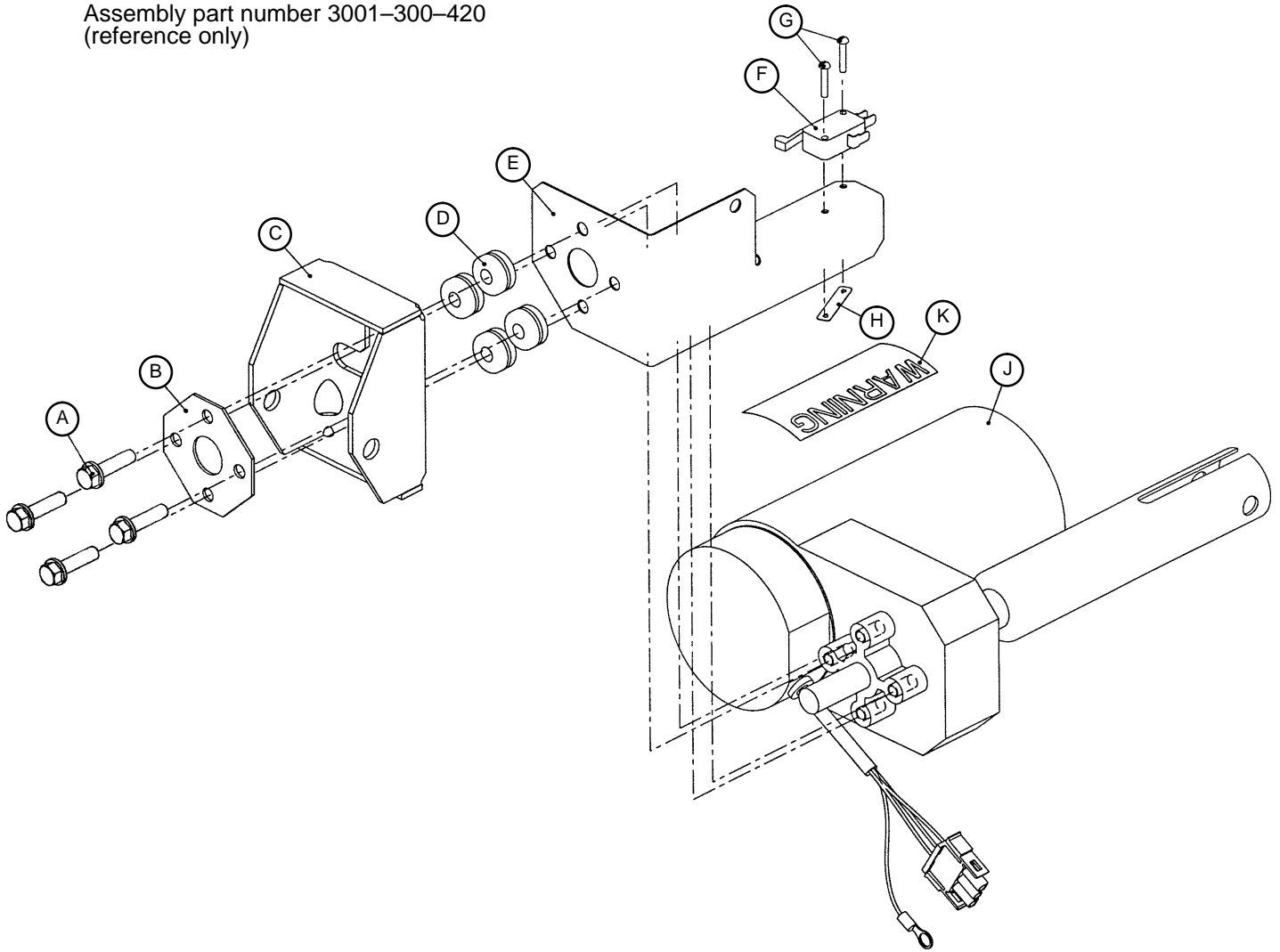

Item	Part No.	Part Name	Qty.
A	3001-200-228	Mounting Standoff	4
B	3001-300-499	Gatch Motor Mounting Plate	1
C	3001-300-225	Motor Mount Bracket	1
D	52-817	Grommet	4
E	3001-300-421	Gatch Limit Bracket	1
F	3000-300-41	Micro Switch	1
G	2-51	Round Hd. Mach. Screw	2
H	16-69	Twin-Type Fastener	1
J	2025-232-70	Gatch Motor	1
	2026-232-70	230V Gatch Motor	1
K	3000-300-604	Warning Label	1

Fowler Drive Assembly

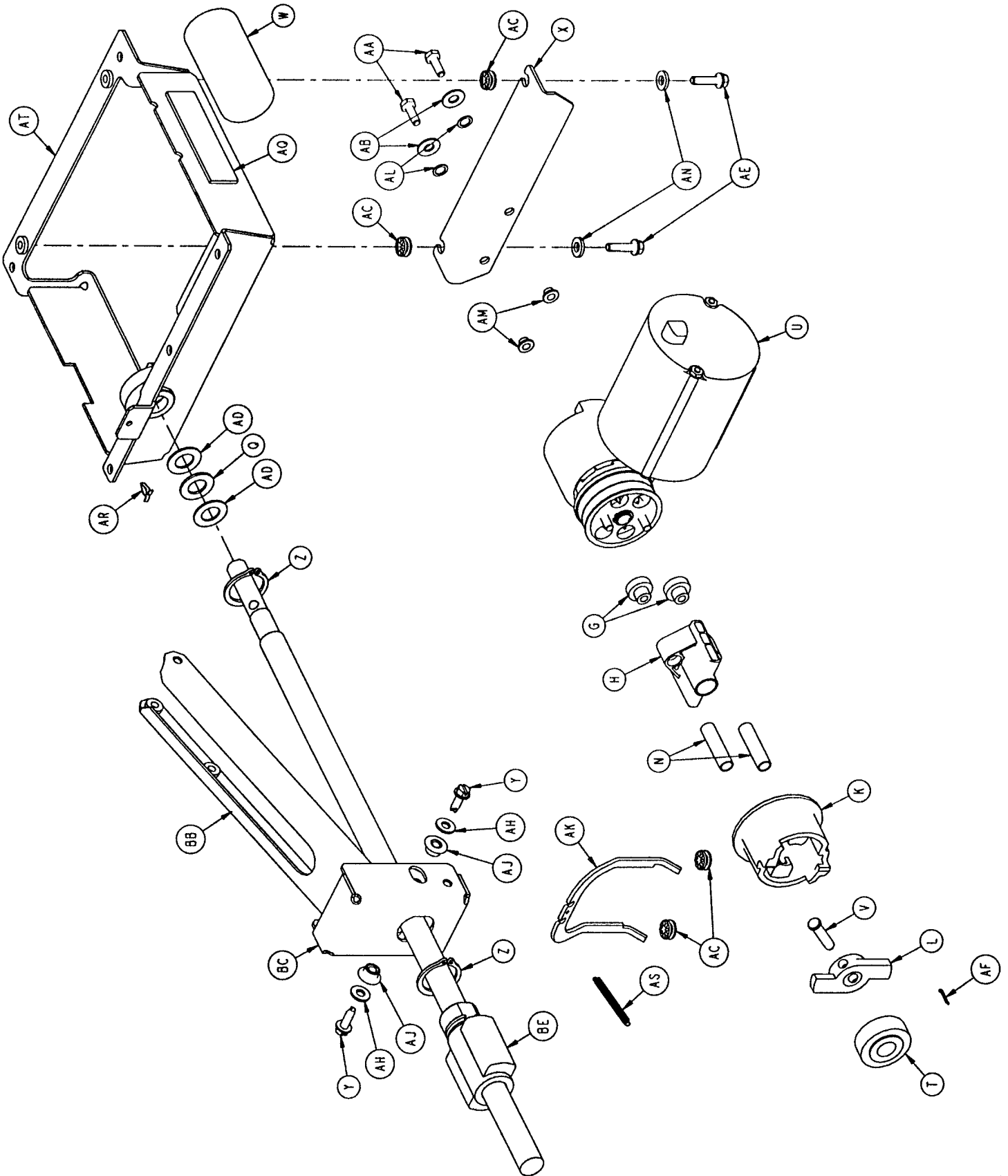

Fowler Drive Assembly

Item	Part No.	Part Name	Qty.	Item	Part No.	Part Name	Qty.
G	3000-300-455	CPR Isolation Bushing	2	AB	11-3	Flat Washer	2
H	3000-300-456	CPR Isolator	1	AC	3000-300-442	Fowler Drive Grommet	4
K	3000-300-461	CPR Decoupler	1	AE	3001-200-228	Mounting Standoff	2
L	3000-300-462	CPR Wing	1	AF	27-17	Cotter Pin	1
N	3000-300-464	CPR Engagement Spring	2	AG	38-151	Cable Tie	2
Q	3000-300-466	Thrust Bearing	1	AH	11-303	Flat Washer	1
T	3000-300-471	Roller Bearing	1	AJ	3000-300-99	Litter Pivot Bushing	2
U	3001-300-705	CPR Motor	1	AK	3000-300-658	CPR Release Arm	1
V	3000-300-473	Clevis Pin	1	AL	52-719	Nylon Flat Washer	2
W	59-780	Motor Capacitor	1	AM	52-718	Nylon Insulator	2
	3221-300-453	230V Motor Capacitor	1	AN	11-304	Shim Washer	2
X	3001-300-487	Actuator Mounting Brkt.	1	AQ	44-29	Double-Stick Tape	1
Y	3-226	Hex Washer Hd. Screw	2	AR	52-764	Dart Type Clip	1
Z	28-120	External Retaining Ring	2	AS	3001-300-664	CPR Spring	1
AA	3-214	Hex Hd. Cap Screw	2	AT	3001-300-485	Fowler Actuator Wldmt.	1

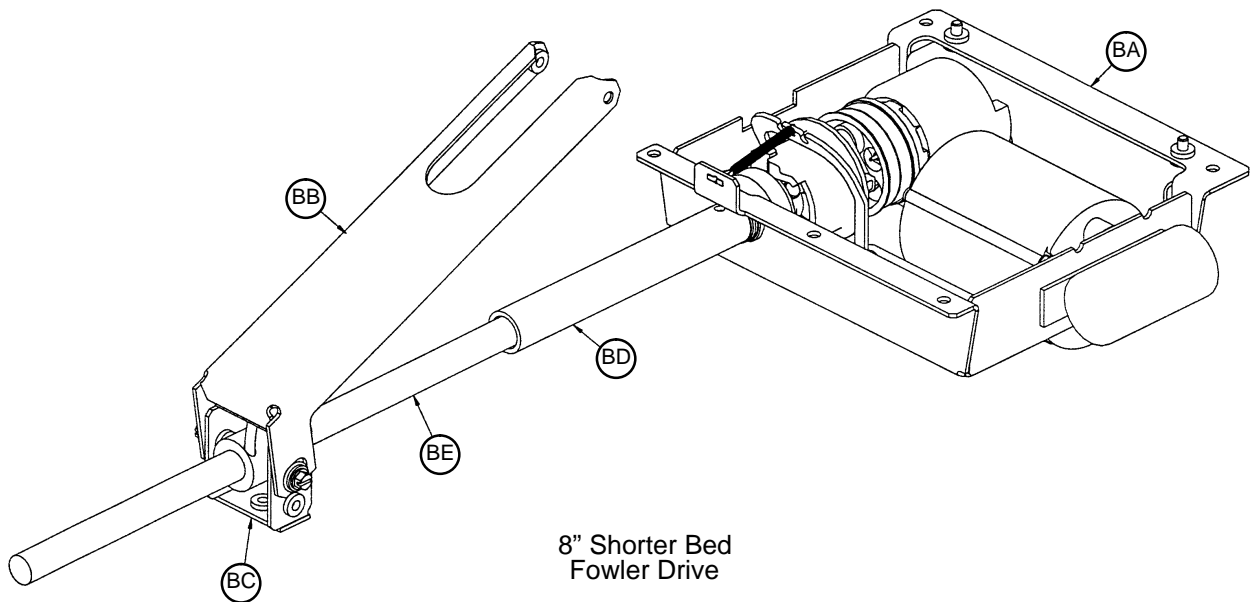

3001-343-550 Fowler Actuator – Standard Bed

Item	Part No.	Part Name	Qty.
AD	14-83	Thrust Washer	1
BB	3001-300-496	Fowler Link	1
BC	3001-300-493	Fowler Link	1
BE	3000-342-457	CPR Ball Screw	1

3001-342-550 Fowler Actuator – 8" Shorter Bed

Item	Part No.	Part Name	Qty.
AD	14-83	Thrust Washer	1
BB	3001-342-496	Fowler Link	1
BC	3001-342-499	Fowler Link Bracket	1
BD	3001-342-457	Fowler Nut Stop Tube	1
BE	3001-342-467	CPR Ball Screw	1

Standard Bed Fowler Limit Switch Assembly

Assembly part number 3001-343-35
(reference only)

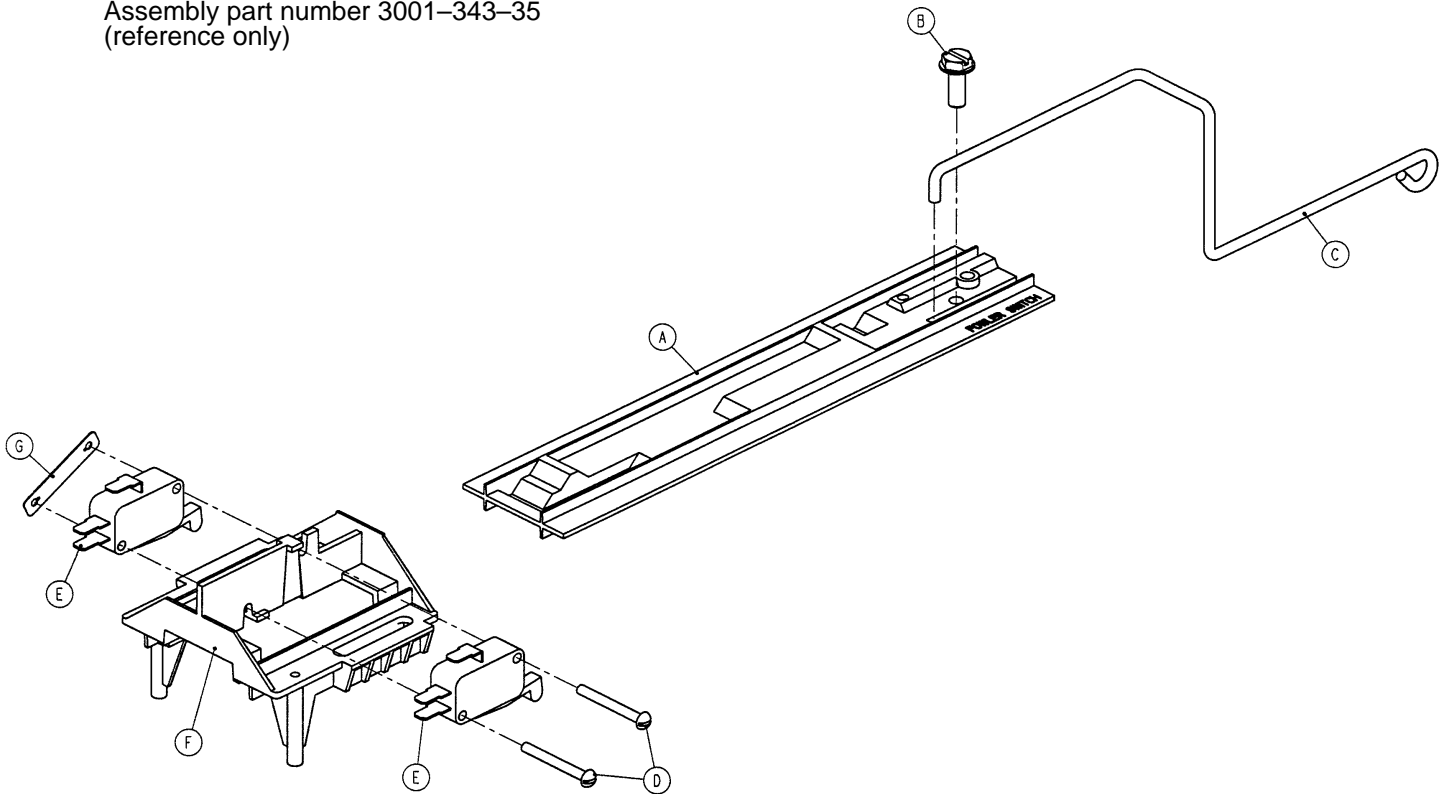

Item	Part No.	Part Name	Qty.
A	3000-300-36	Fowler Cam Card	1
B	23-82	Hex Washer Hd. Screw	1
C	3001-300-38	Link Wire	1
D	2-3	Round Hd. Screw	2
E	3000-300-41	Micro Switch	2
F	3000-300-44	Cam Guide	1
G	16-69	Twin Fastener	1

8" Shorter Bed Fowler Limit Switch Assembly

Assembly part number 3001-342-25
(reference only)

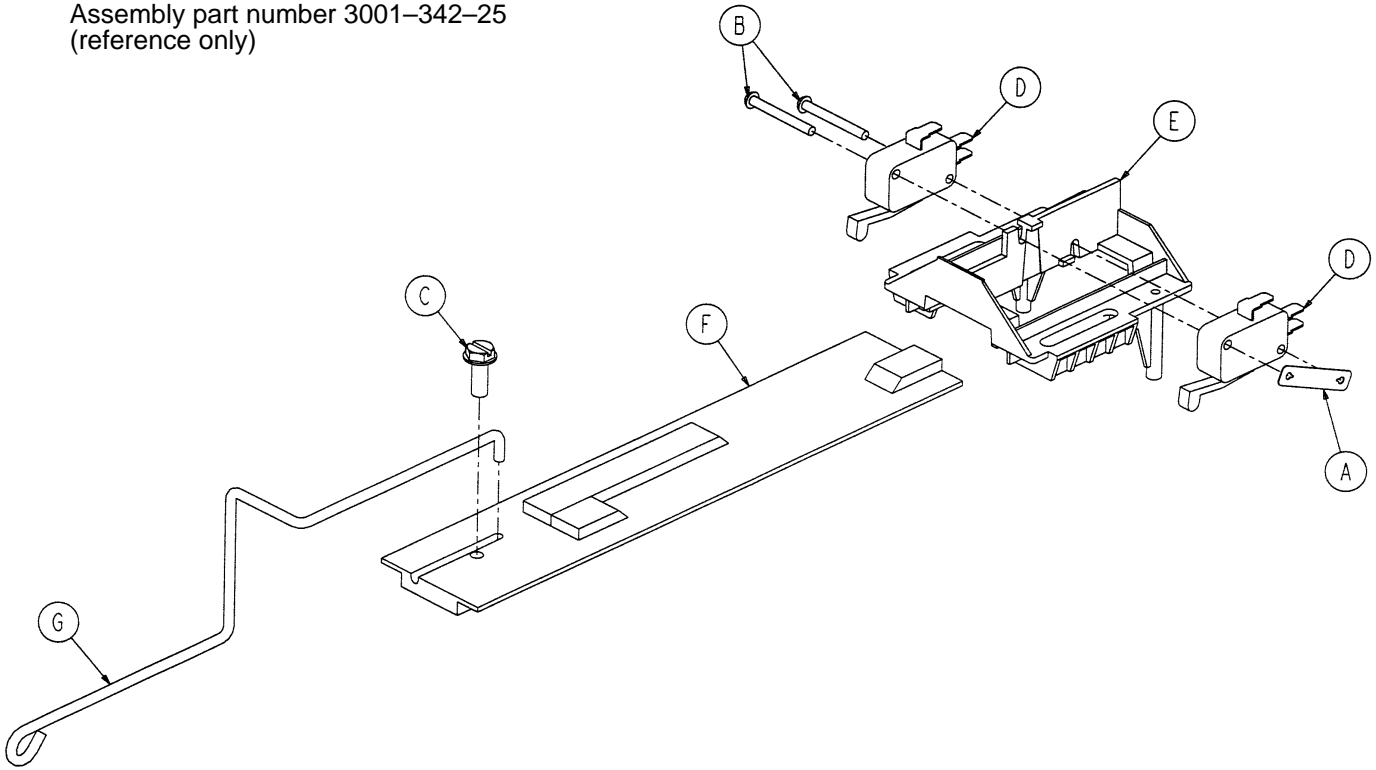

Item	Part No.	Part Name	Qty.
A	16-69	Twin Fastener	1
B	2-3	Round Hd. Screw	2
C	23-82	Hex Washer Hd. Screw	1
D	3000-300-41	Micro Switch	2
E	3000-300-44	Cam Guide	1
F	3001-342-32	Fowler Cam Card	1
G	3001-300-38	Link Wire	1

3001-300-775 Fowler Brake Kit Assembly

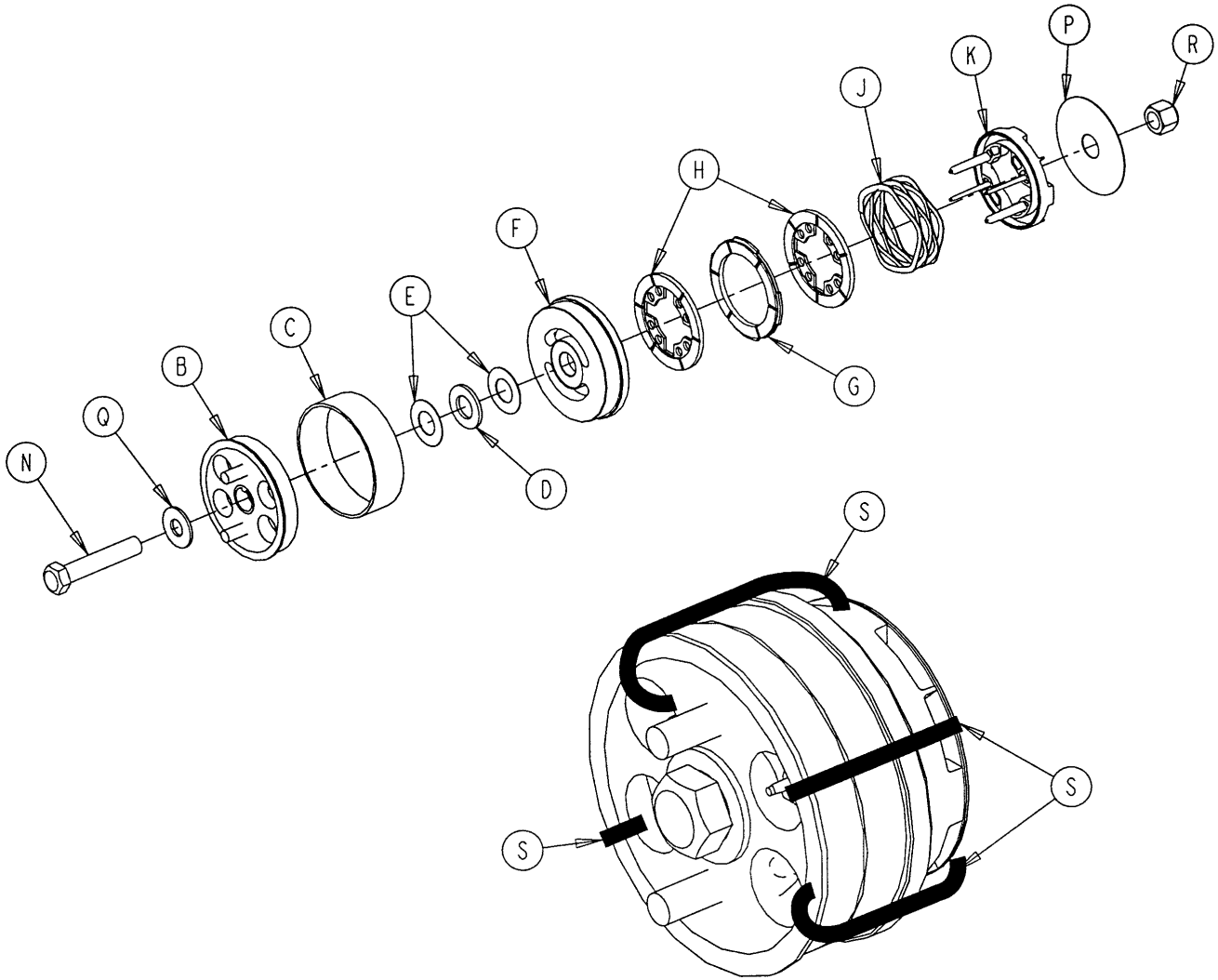

Item	Part No.	Part Name	Qty.
B	3001-300-455	CPR Coupler Assembly	1
C	3000-300-465	CPR Clutch Spring	1
D	3000-200-225	CPR Thrust Bearing	1
E	3000-200-224	Idler Gear Thrust Washer	2
F	3001-300-569	Brake Cup	1
G	3001-300-552	CPR Brake Disc	1
H	3001-300-551	CPR Spring Cup	2
J	3001-300-563	CPR Brake Spring	1
K	3001-300-570	CPR Spring Cup	1
N	3-64	Hex Hd. Cap Screw	1
P	3000-300-776	Flat Washer	1
Q	11-193	Heavy Flat Washer	1
R	16-35	Nylock Nut	1
S	3000-300-113	8" Wire Tie	4

Notes

3001-320-50 Optional 110V Outlet Assembly

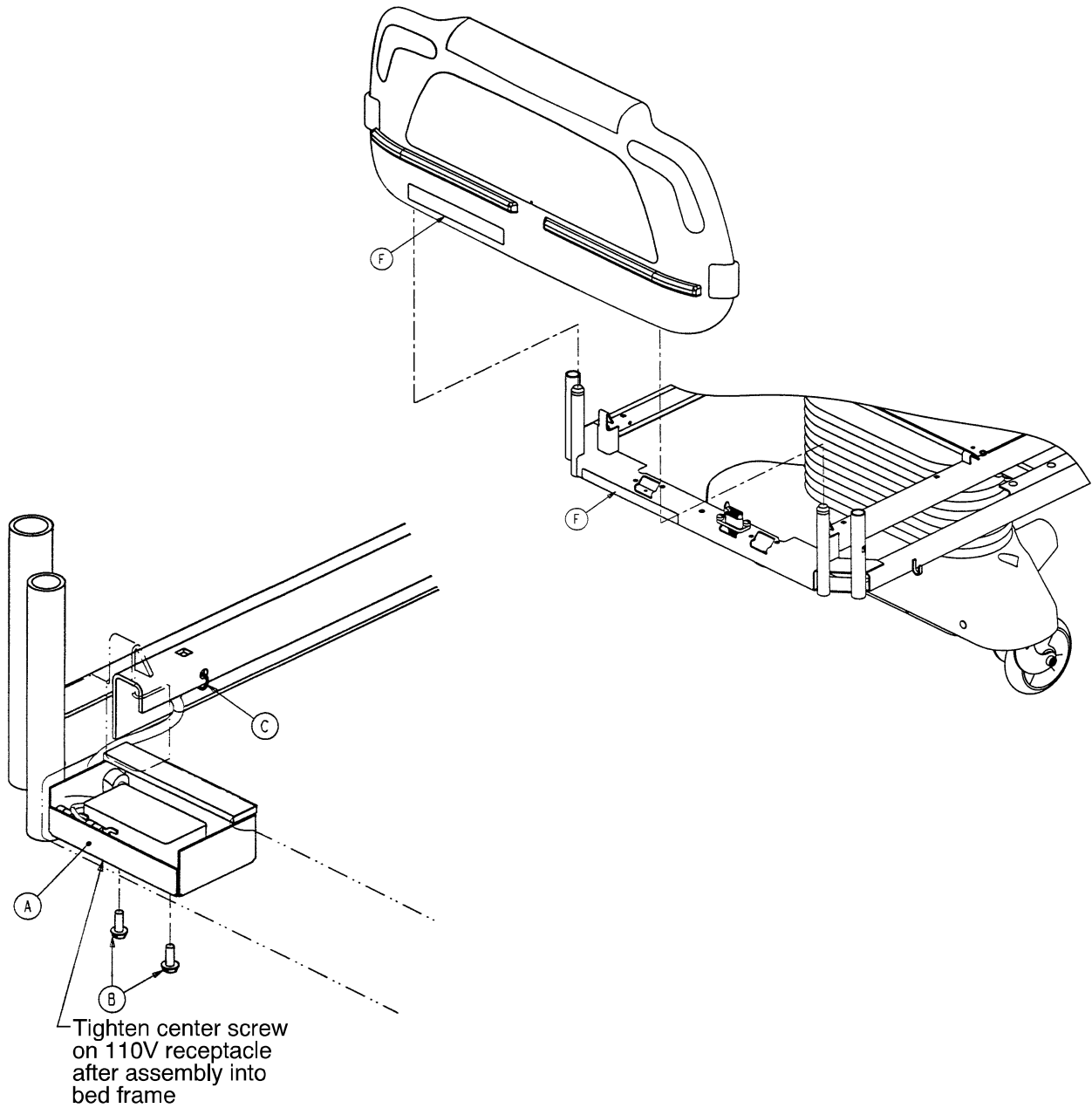

Item	Part No.	Part Name	Qty.
A	(page 130)	110V Outlet Box Assembly	1
B	3-224	Hex Washer Hd. Screw	2
C	3000-300-113	Cable Tie	3
D	2020-2-664	Fuse Holder	1
E	2020-2-666	5 Amp Fuse	1
F	3001-320-626	110V Outlet Label	2

3001-320-50 Optional 110V Outlet Assembly

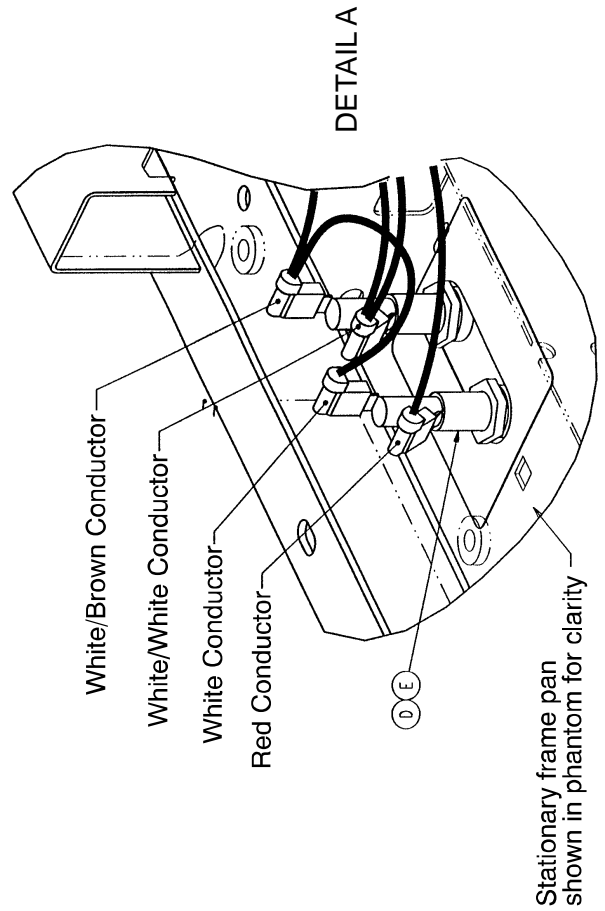
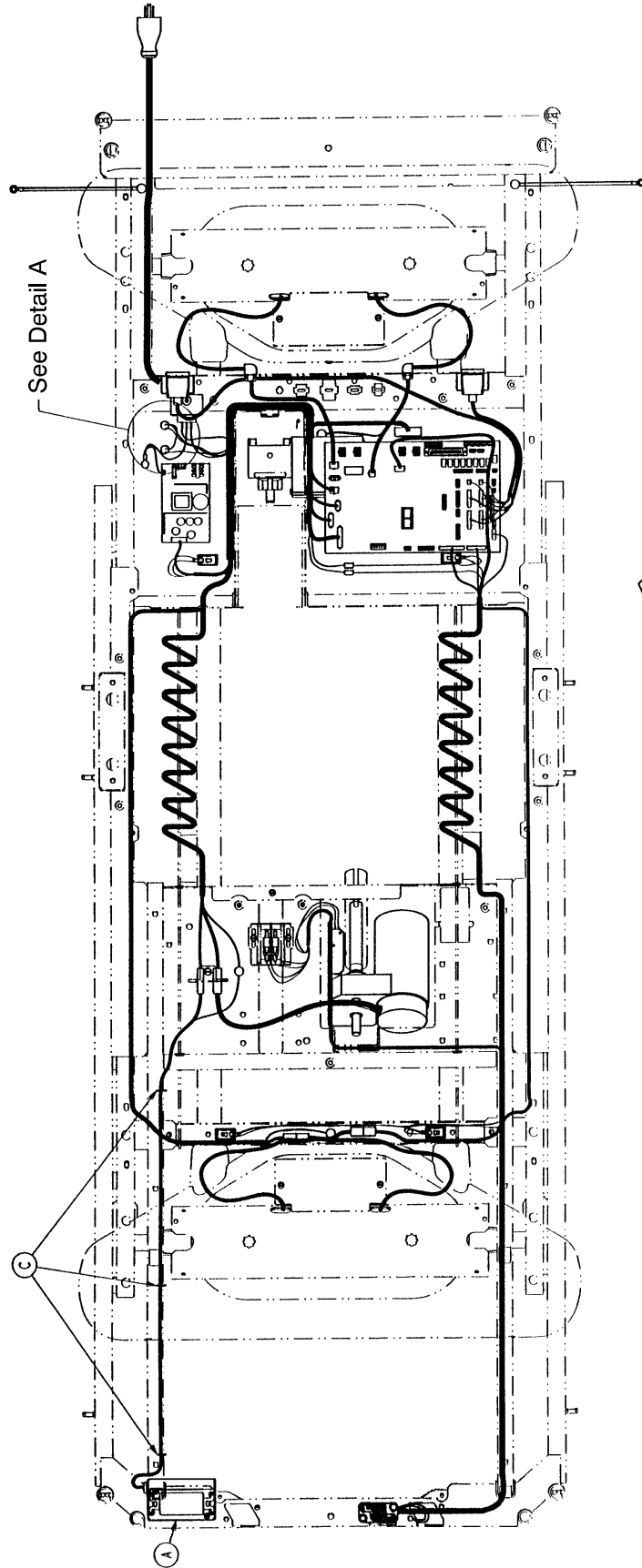

Optional 110V Outlet Box Assembly

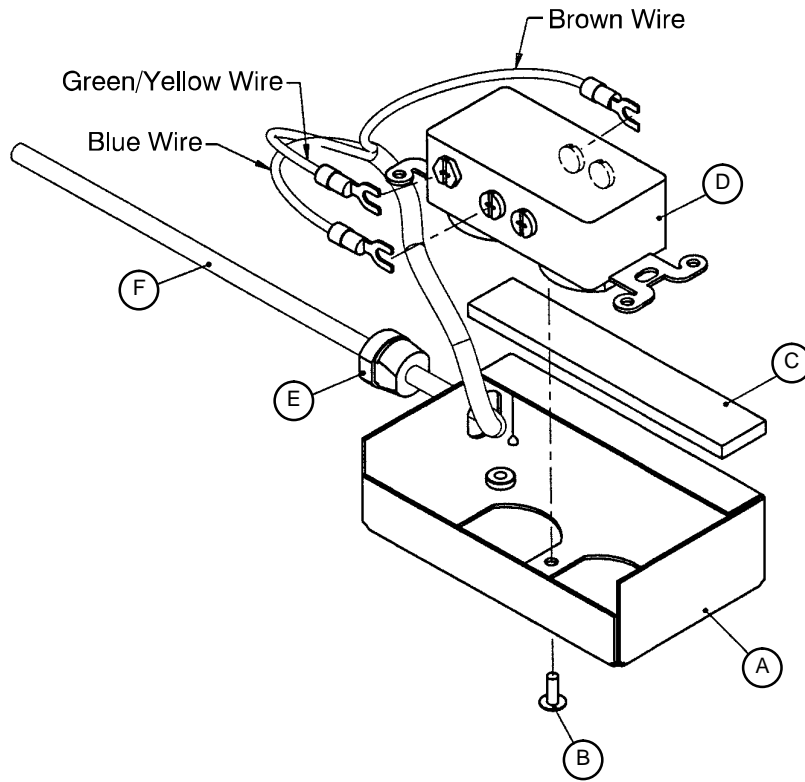

Item	Part No.	Part Name	Qty.
A	3001-320-20	110V Enclosure Bracket	1
B	7-28	Phillips Truss Hd. Screw	1
C	7900-1-291	Foam Tape	1
D	59-733	Hospital Grade Receptacle	1
E	34-133	Strain Relief	1
F	3001-320-801	110V Outlet Cable	1

Notes

Optional Scale/Bed Exit Assembly

Assembly part number 3001-307-2 (reference only)

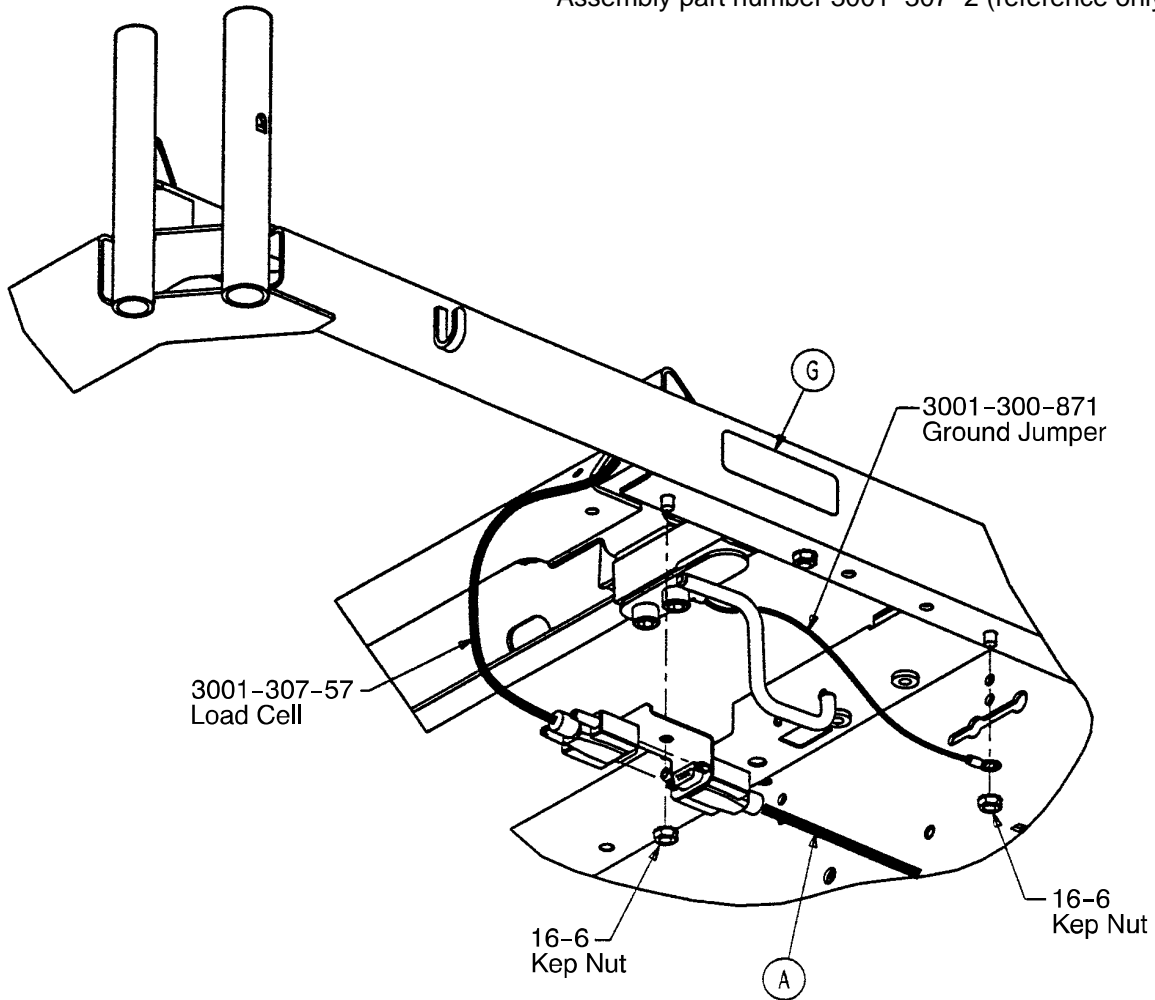

Item	Part No.	Part Name	Qty.
A	3001-307-834	Load Cell Cable, Head End	2
B	3001-307-835	Load Cell Cable, Foot End	2
C	7-53	Truss Hd. Screw	2
D	3000-300-113	Cable Tie	9
E	(page 120 & 121)	Scale Lift Header Ass'y	1
F	(page 120 & 121)	Scale Lift Hdr. w/Foley Bag Hooks	1
G	3000-300-601	Foley Bag Label	2

Optional Scale/Bed Exit Assembly

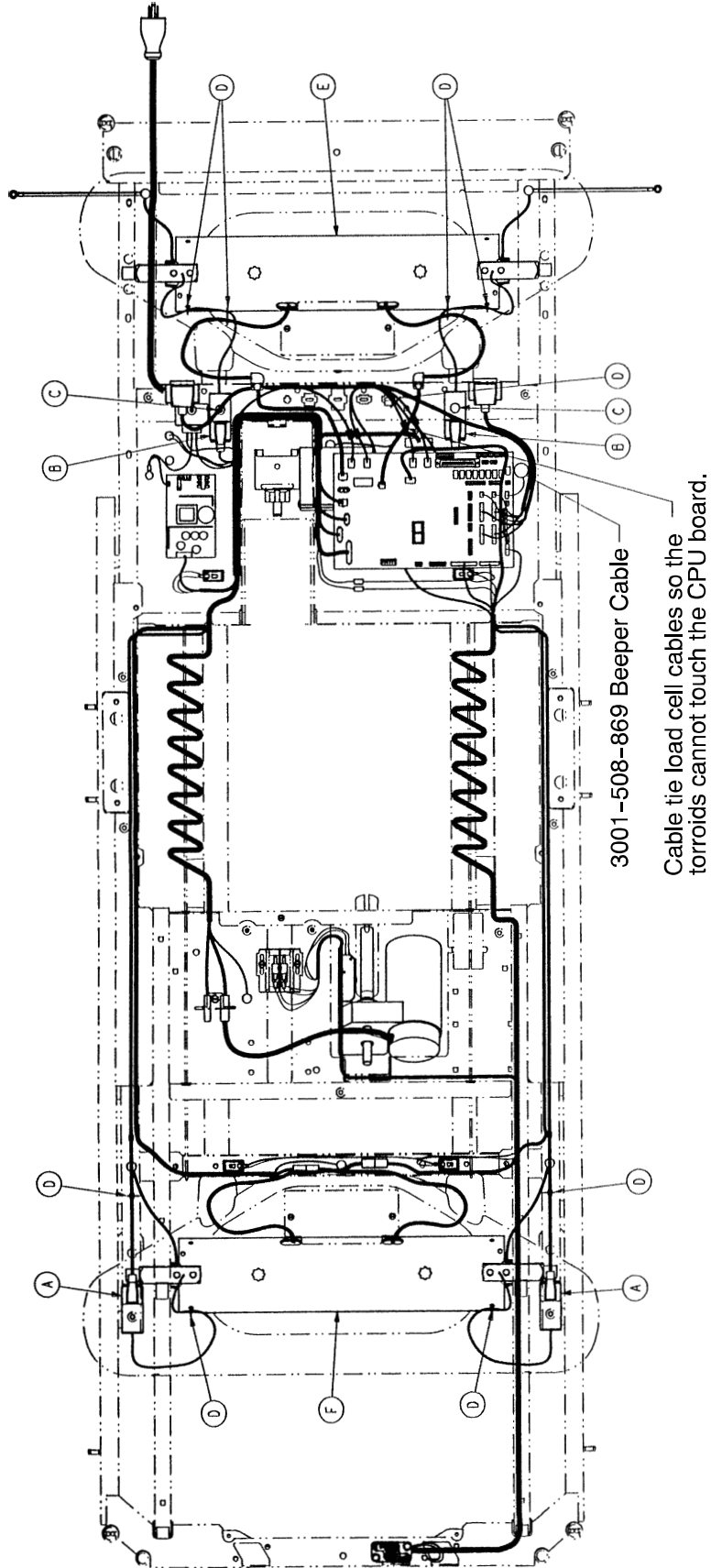

Optional 12V DMS Litter Assembly

Assembly part number 3001-302-31 (reference only)

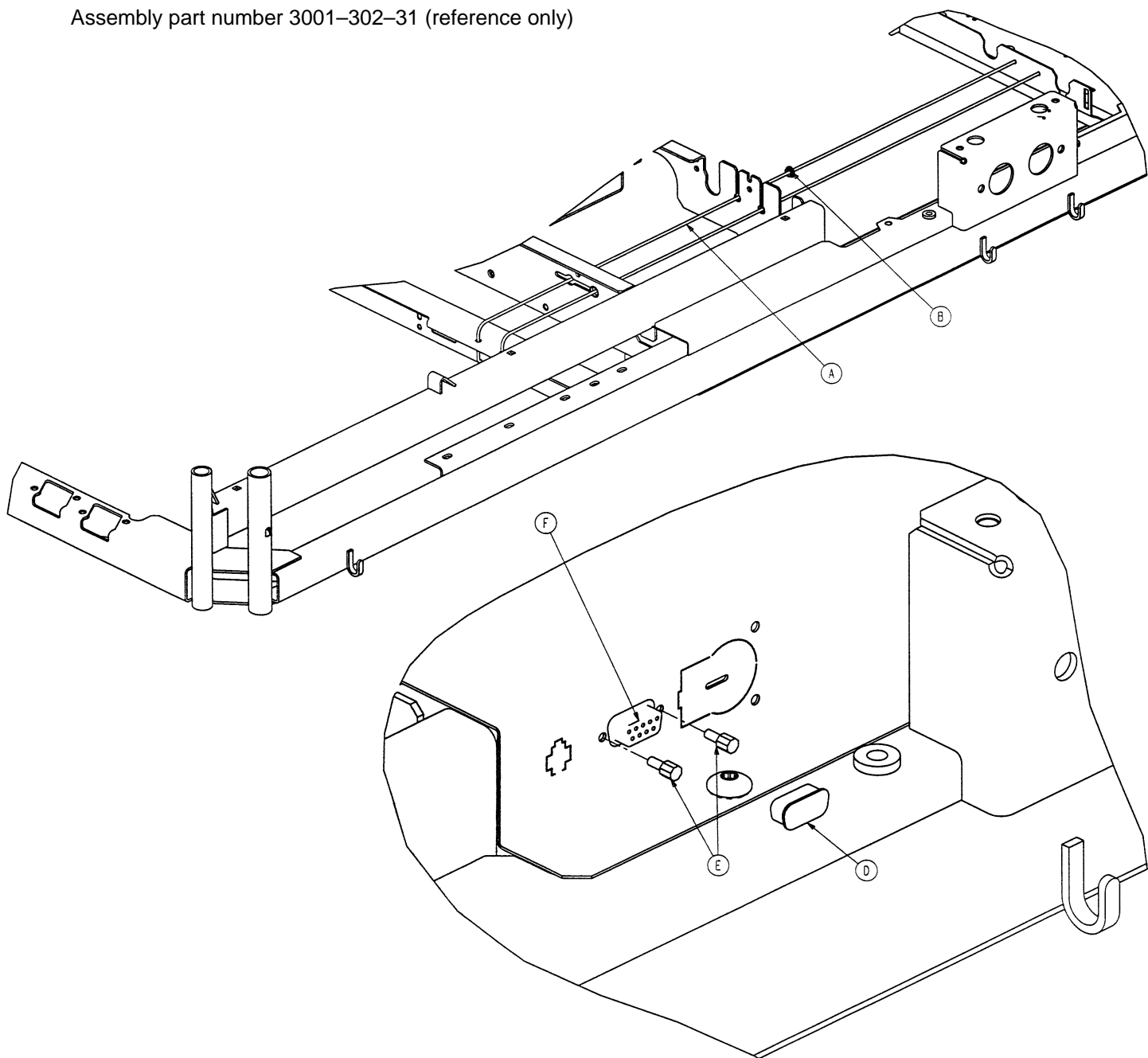

Item	Part No.	Part Name	Qty.
A	3001-300-11	Guide Rod	1
B	52-822	Snap-In Bearing	1
D	59-771	Static Cap	1
E	59-727	Female Screwlock	2
F	3001-302-862	DMS Coil Cable	1
G	3000-300-113	Cable Tie	1
H	7-53	Truss Hd. Torx	1

Optional 12V DMS Litter Assembly

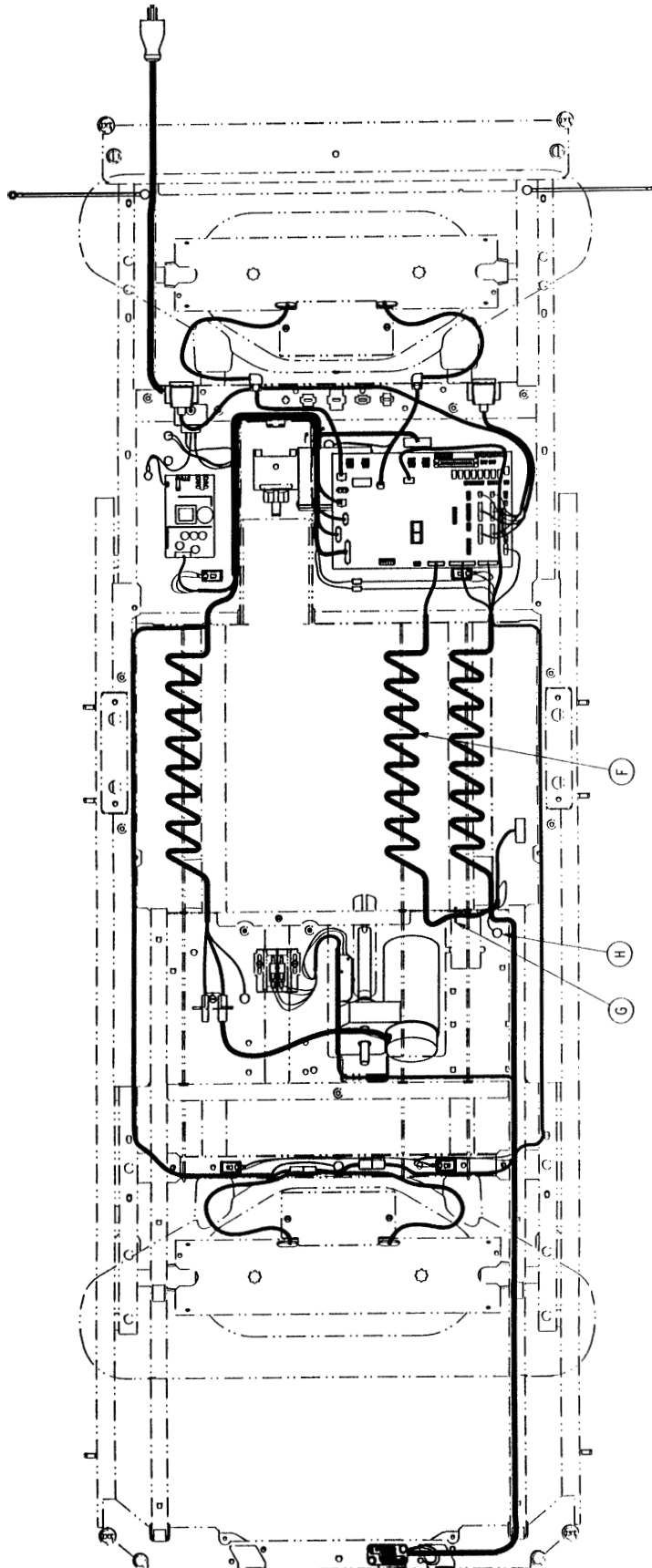

Optional 24V Hybrid DMS Litter Assembly

Assembly part number 3001-302-41

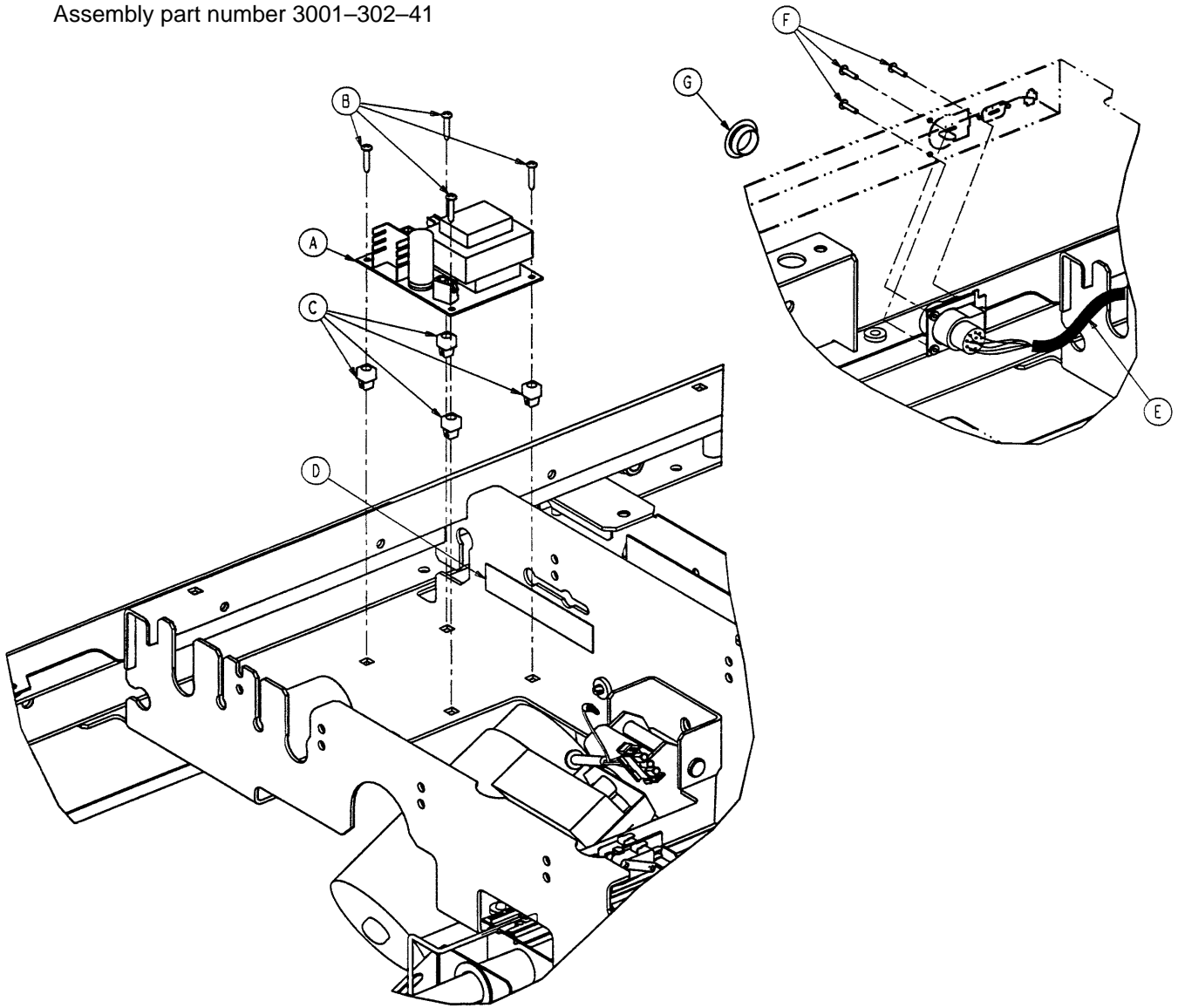

Item	Part No.	Part Name	Qty.
A	3000-302-939	DMS Power PCB Ass'y	1
B	23-138	Phillips Hd. Screw	4
C	52-287	Grommet	4
D	2020-250-527	Fuse Warning Label	1
E	3001-302-842	24V DMS Port Cable	1
F	7-46	Truss Hd. Screw	3
G	59-711	Static Plug	1
H	7-53	Truss Hd, Screw	1
J	3000-300-113	Cable Tie	2

Optional 24V Hybrid DMS Litter Assembly

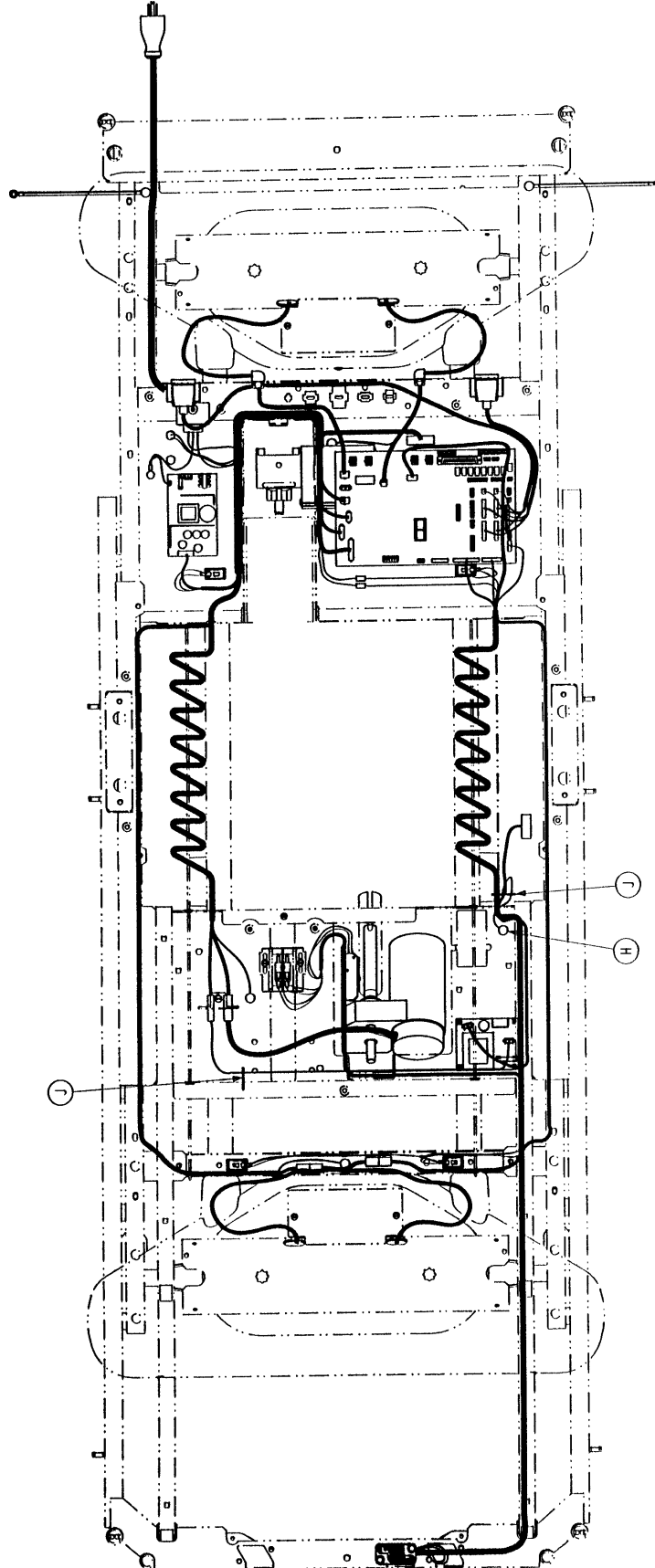

Optional DMS Mattress Assembly

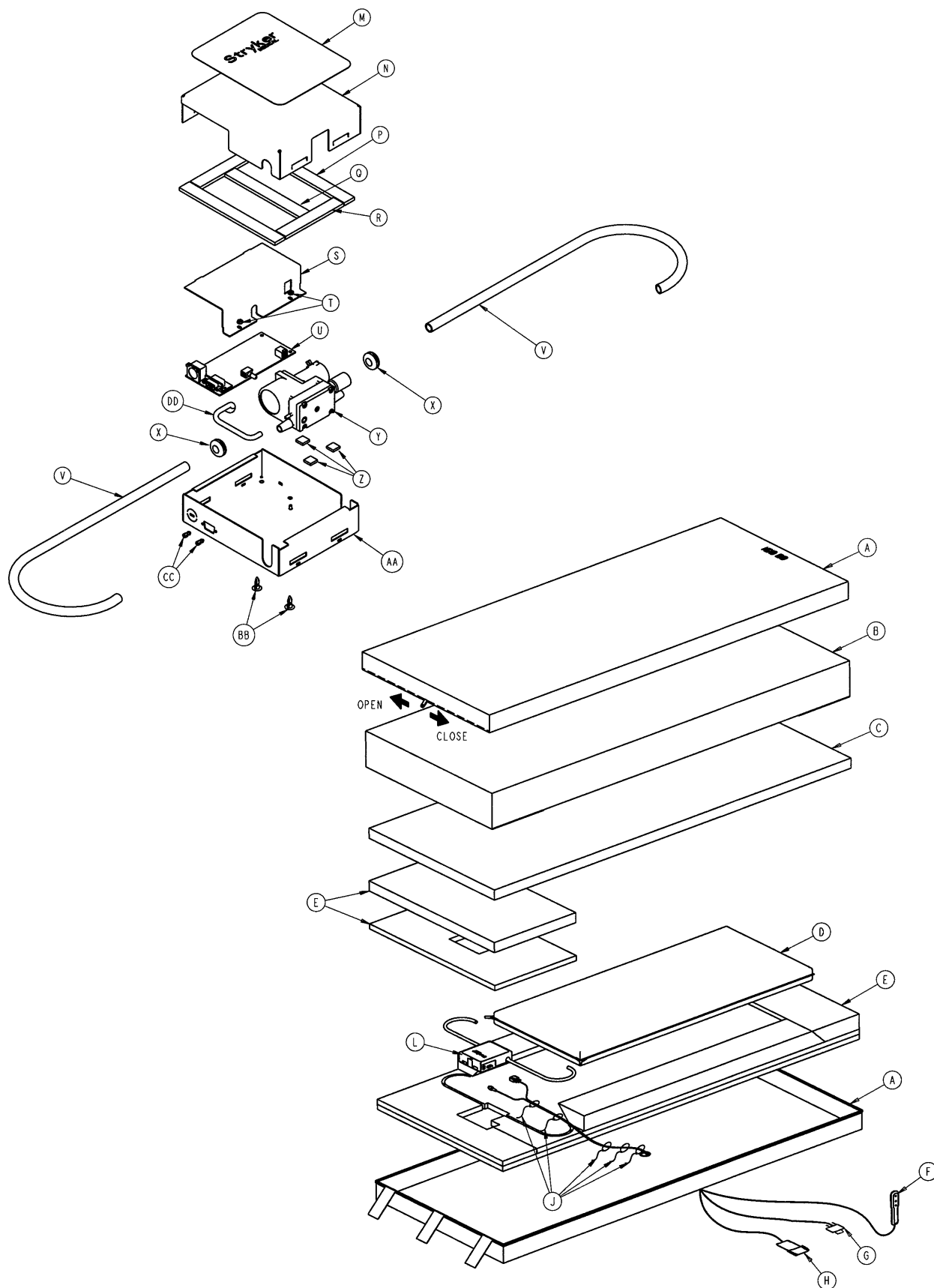

Optional DMS Mattress Assembly

Item	Part No.	Part Name	Qty.
A	(see below)	Mattress Cover Assembly	1
B	2400-200-000	Flame Barrier Cover	1
C	2500-202-4	Foam Topper, 35" x 84"	1
D	2500-900-24	Air Bladder Kit	1
E	2500-212-21	Foam Base Assembly, 35" x 84"	1
F	2500-311-000	DMS Pendant Assembly	1
G	2500-490-801	Integrated DMS Cable	1
H	(see below)	DMS Cable	1
L	(see below)	Control Unit	1
M	2500-411-124	12VDC Hyb. DMS Ctrl. Unit Label	1
N	2500-491-104	Upper Enclosure	1
P	7900-1-291	Foam Tape (7" Long)	2
Q	7900-1-291	Foam Tape (5.5" Long)	1
R	7900-1-291	Foam Tape (4.25" Long)	1
S	2500-901-58	PCB Shield	1
T	16-23	Locking Nut	2
U	2500-401-900	DMS Controller PCB	1
V	7900-1-261	3/8" I.D. Hose (20.5" Long)	2
X	52-811	Hose Mounting Grommet	2
Y	2500-901-007	12VDC DMS Pump	1
Z	2500-901-54	Rubber Pump Mount	3
AA	2500-491-103	Lower Enclosure	1
BB	59-765	PCB Mount	2
CC	59-725	Female Screwlock	2
DD	7900-1-260	1/8" I.D. Hose (6" Long)	1

ITEM	PART NUMBER	PART NAME	QTY.
A1	2500-354-000	Cover Kit, 35x84, Nylon	1
A2	2500-354-100	Cover Kit, 35x84, Rose	1
A3	2500-354-200	Cover Kit, 35x84, Lectrolite	1

ITEM	PART NUMBER	PART NAME	QTY.
H1	2500-491-301	12VDC Hybrid DMS Cable	
H2	2500-490-801	Integrated DMS Cable	1
H3	2500-492-301	24VDC Hybrid Cable	1

ITEM	PART NUMBER	PART NAME	QTY.
L1	2500-406-123	12VDC Hybrid Control Unit	1
L2	2500-402-123	Integrated DMS Control Unit	1
L3	2500-403-123	24VDC Hybrid Control Unit	1

Optional StryKair Litter Assembly

Assembly part number 2600-300-10

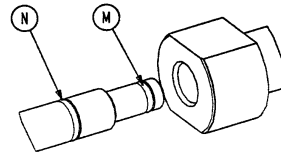

DETAIL A

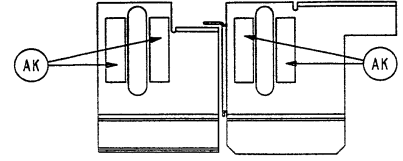

VIEW B-B

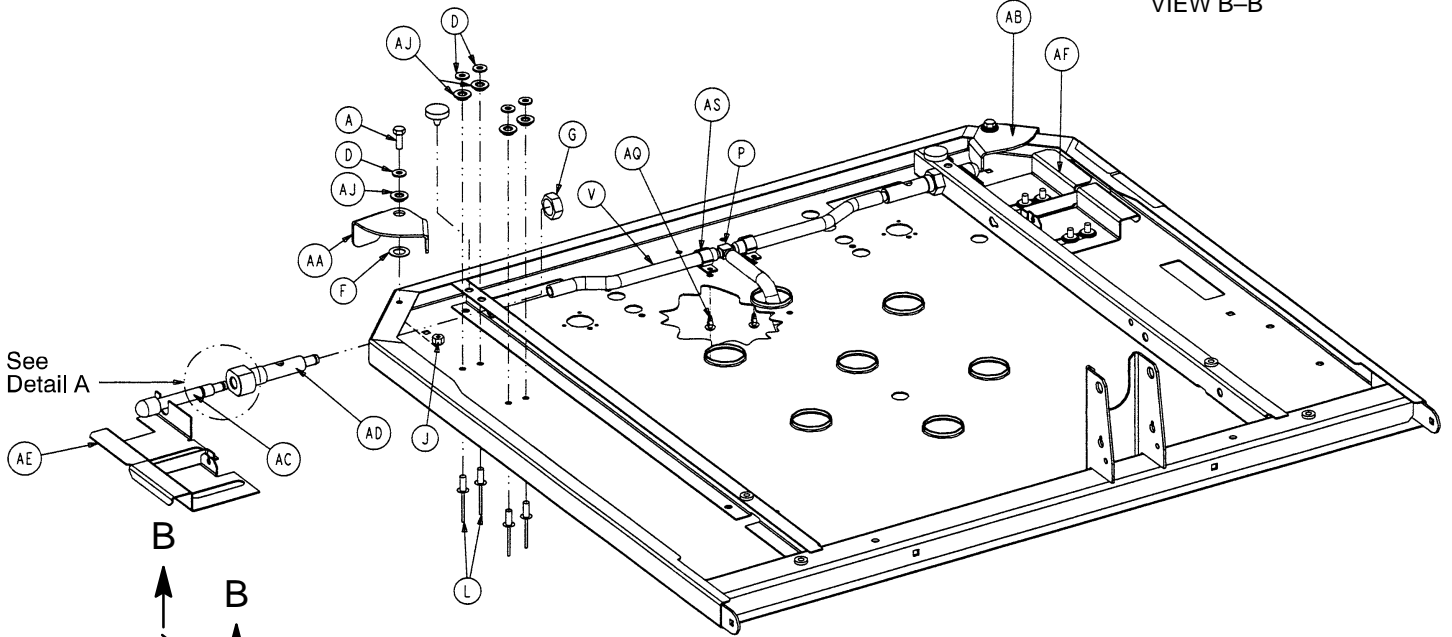

See Detail A

3001-300-88

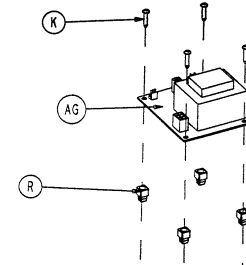

FOOT END

HEAD END

3001-300-864

For use with Night Light option

Optional StryKair Litter Assembly

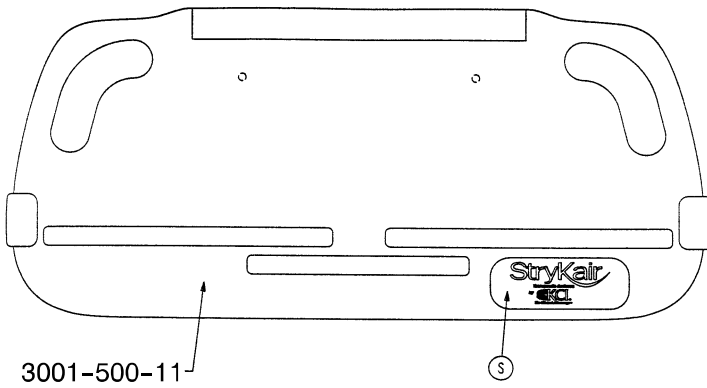

LABEL DETAILS

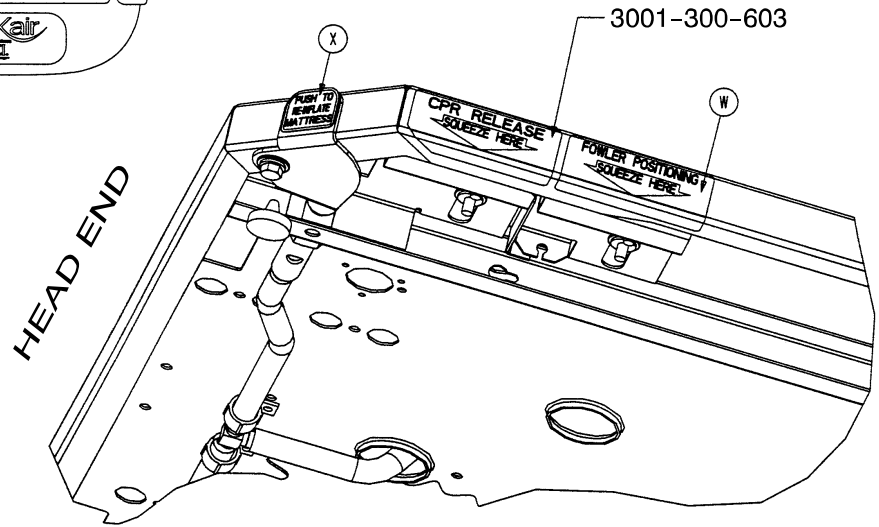

Item	Part No.	Part Name	Qty.	Item	Part No.	Part Name	Qty.
A	3-50	Hex Hd. Cap Screw	2	X	2600-90-99	Mattress Reset Label	2
C	7-53	Truss Hd. Screw	1	Y	2600-242-801	StryKair Port Cable	1
D	11-63	Washer	6	Z	2600-242-803	StryKair Signal Cable	1
F	14-7	Washer	2	AA	2600-300-96	Mattress Reset Lever, Lt.	1
G	15-61	Hex Jam Nut	2	AB	2600-300-97	Mattress Reset Lever, Rt.	1
H	16-7	Fiberlock Nut	2	AC	2600-300-98	Plunger	2
J	16-28	Hex Nut	2	AD	2600-300-99	Plunger Guide Tube	2
K	23-108	Phillips Hd. Screw	4	AE	2600-300-661	Matt. CPR Handle, Lt.	1
L	25-120	Pop Rivet	4	AF	2600-300-662	Matt. CPR Handle, Rt.	1
M	45-993	O-Ring	2	AG	2600-300-900	StryKair Power Supply	1
N	45-994	O-Ring	2	AH	3000-300-113	Cable Tie	8
P	48-171	Tee Fitting	1	AJ	3001-300-99	Bushing	6
Q	59-727	Jack Screw	2	AK	3001-300-663	Velcro Strip	4
R	52-287	Grommet	4	AL	2600-242-804	StryKair Pwr. Sup. Cable	1
S	2600-22-46	Foot Board Logo Label	1	AM	3001-302-862	DMS Coil Cord	1
T	2600-30-99	Port Cable Mtg. Plate	1	AN	2600-320-606	Fuse Warning Label	1
V	2600-40-1	CPVC Hose	2	AQ	3000-300-477	CPR Conduit Stud	2
W	2600-90-98	Bed Reposition Label	2	AS	59-743	Wire Harness Clip	2

NOTE

The StryKair mattress is not included with this assembly. The mattress is part number 2600-000-010.

Optional HWI Communication Litter Assembly

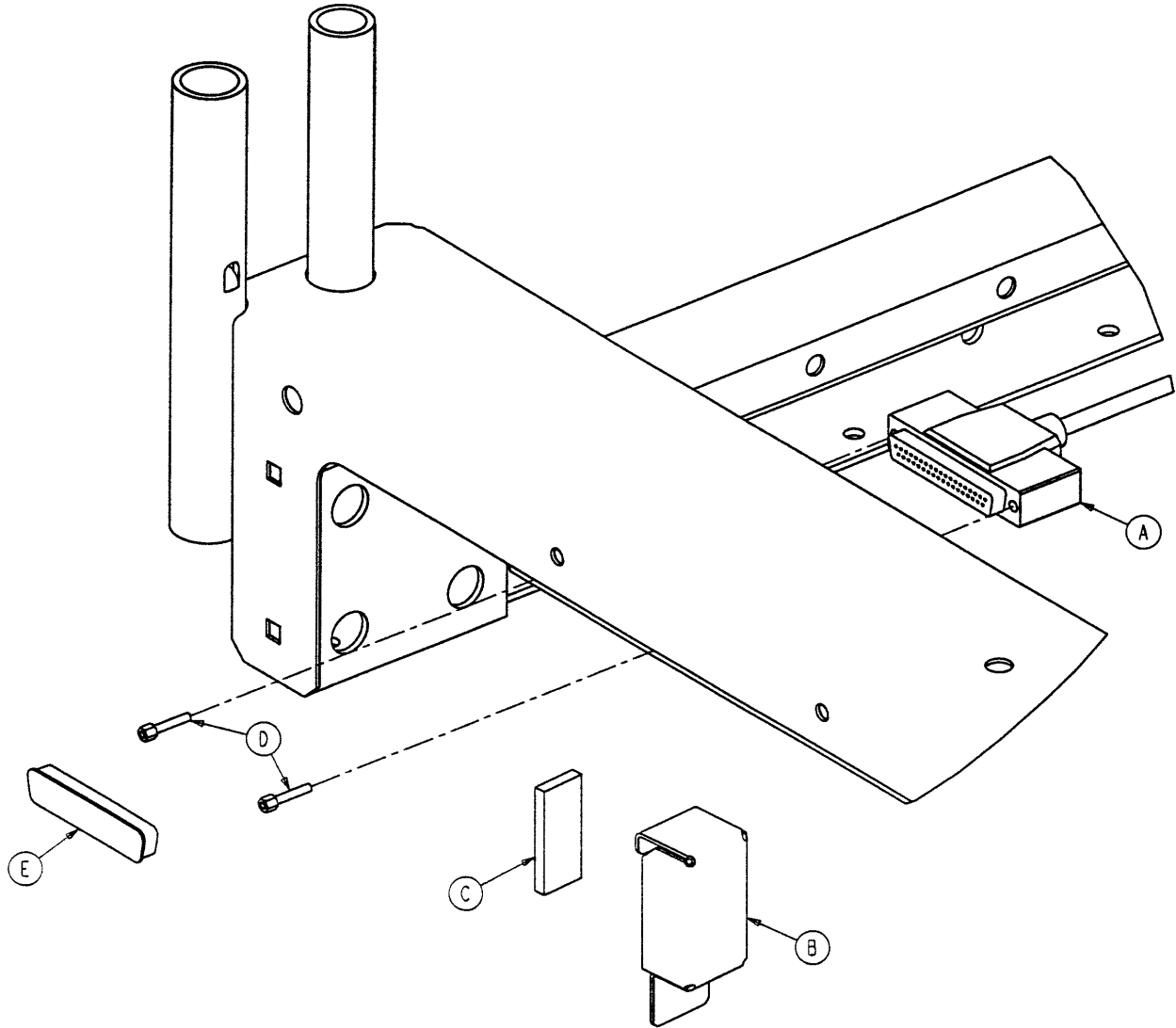

3001-303-52 Nurse Call & Comm. Assembly

Item	Part No.	Part Name	Qty.
A	3001-303-821	Headwall Interface Cable	1
B	(page 147)	Battery Enclosure Ass'y	1
C	7900-1-291	Foam Tape	1
D	3001-300-7	Female Screwjack	2
E	59-710	Static Plug	1
F	3000-300-113	Cable Tie	4

3001-303-122 Communication Assembly

Item	Part No.	Part Name	Qty.
A	3001-303-821	Headwall Interface Cable	1
D	3001-300-7	Female Screwjack	2
E	59-710	Static Plug	1
F	3000-300-113	Cable Tie	3

Optional HWI Communication Litter Assembly

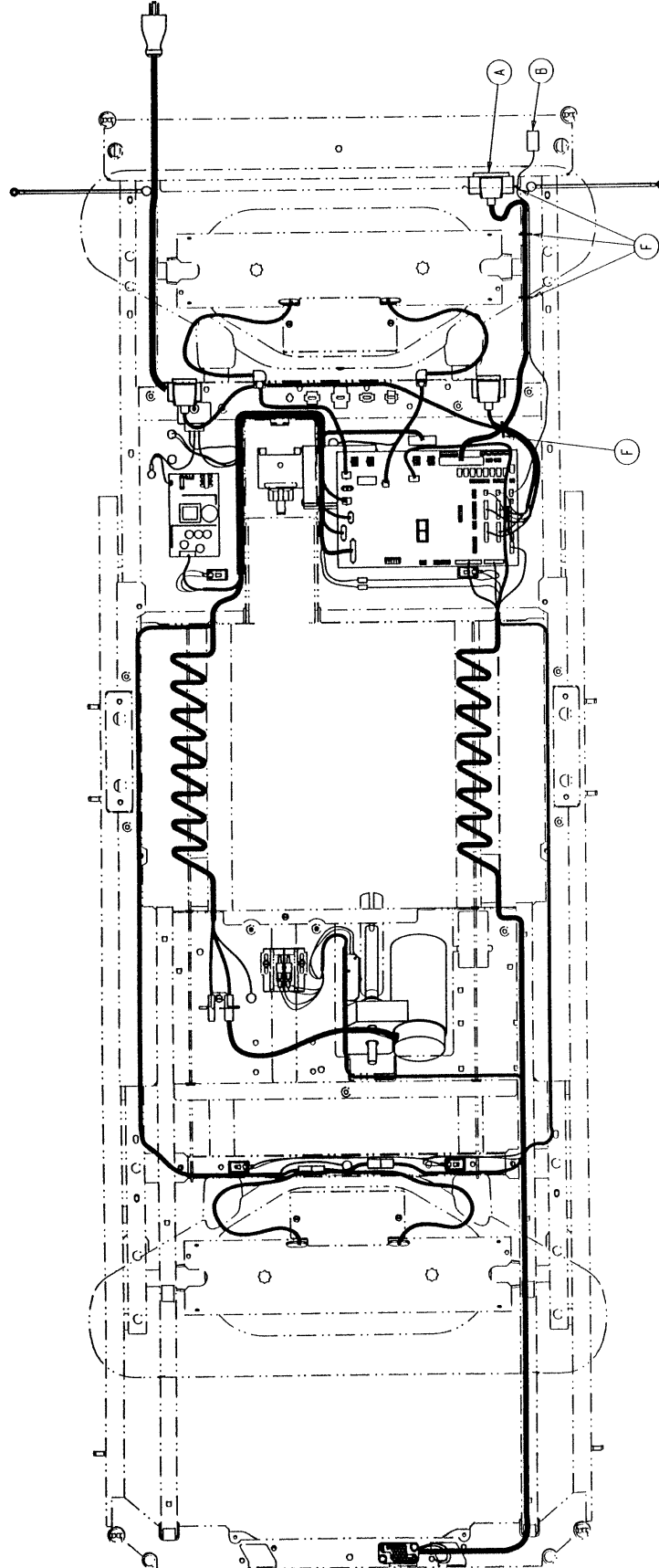

Optional HWI w/Communication & Ports Litter Assembly

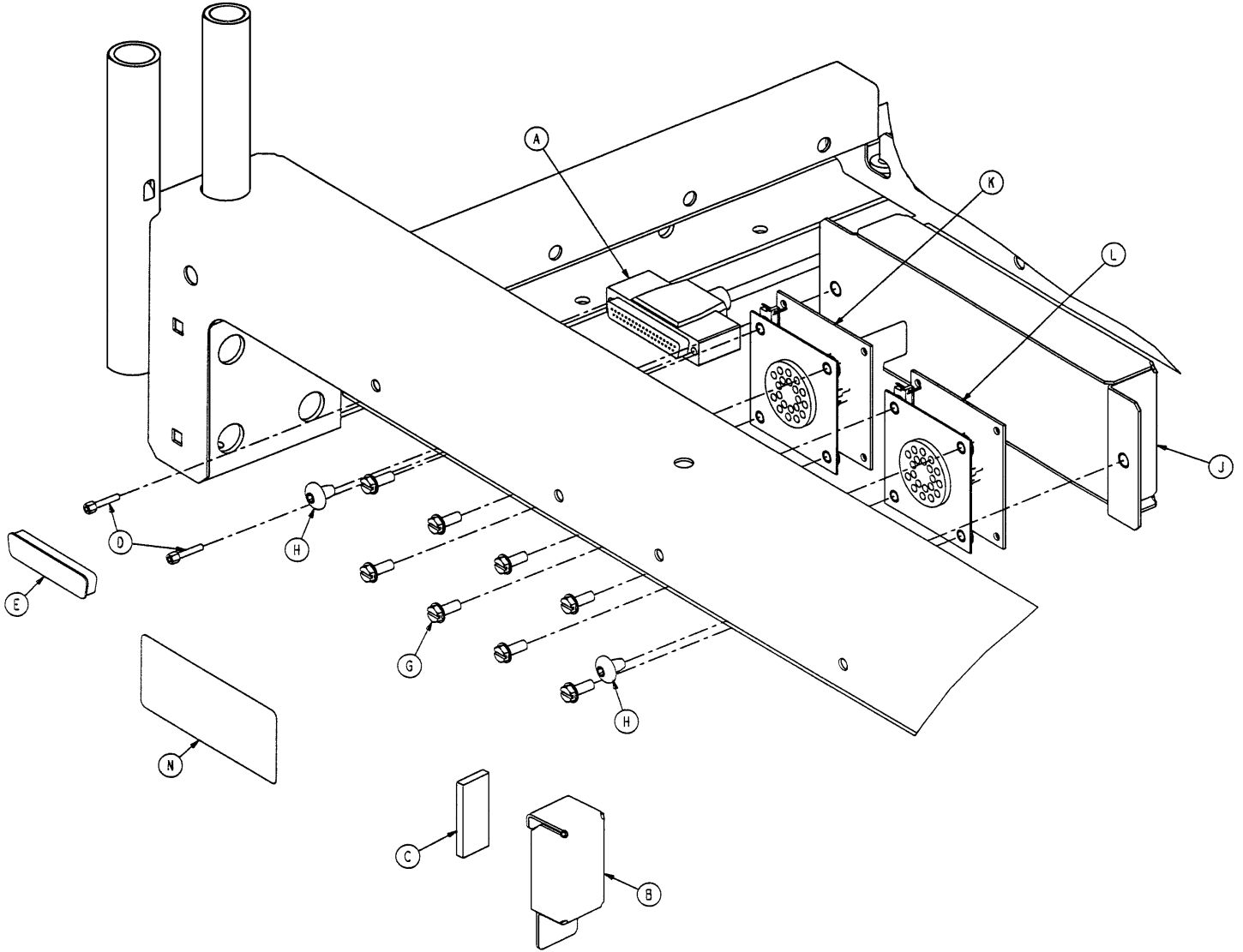

Optional HWI w/Communication & Ports Litter Assembly

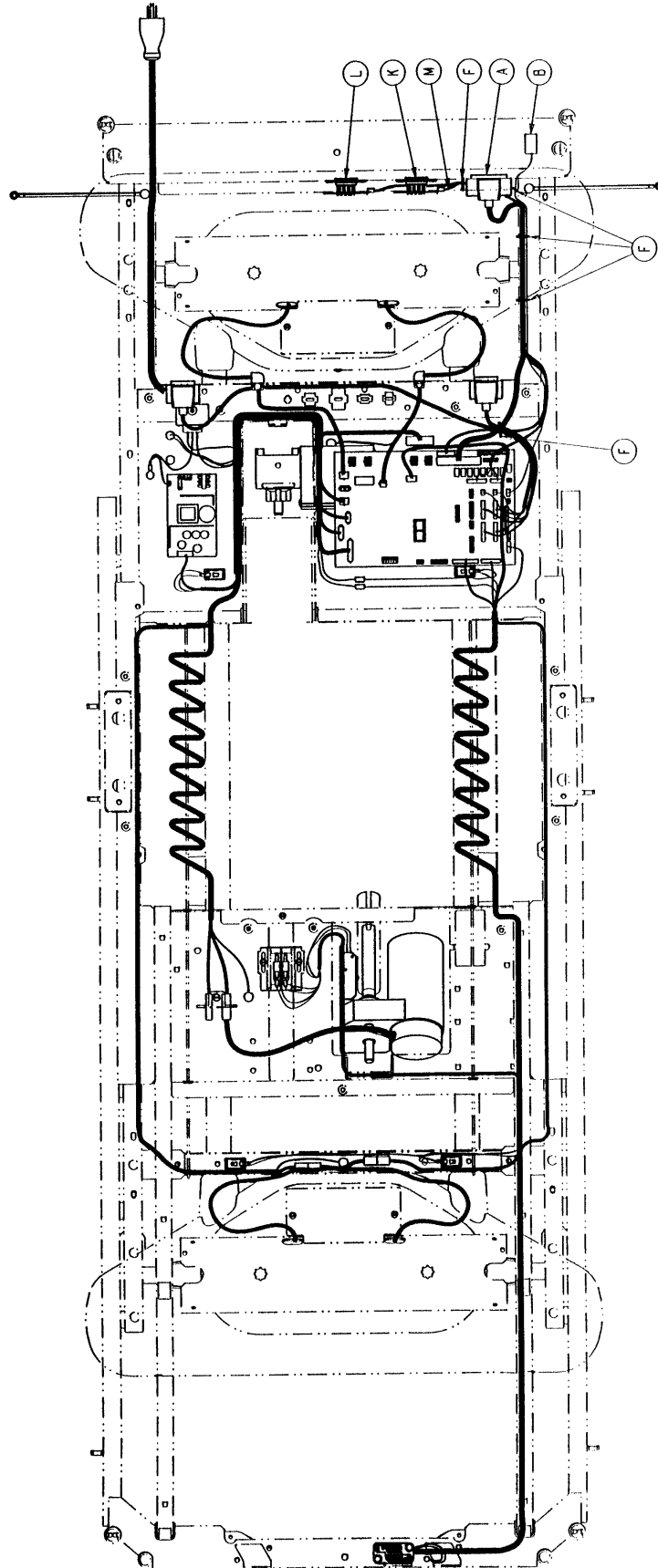

Optional HWI w/Communication & Ports Litter Assembly

3001-314-12 HWI w/1 Stryker Port

Item	Part No.	Part Name	Qty.
A	3001-303-821	Headwall Interface Cable	1
B	(page 147)	Battery Enclosure Ass'y	1
C	7900-1-291	Foam Tape	1
D	3001-300-7	Female Screwjack	2
E	59-710	Static Plug	1
F	3000-300-113	Cable Tie	5
G	3-224	Hex Washer Hd. Screw	4
H	7-53	Truss Hd. Screw	2
J	3001-314-006	Pendant Port Cover	1
K	3001-314-920	HWI Pendant Port PCB	1
M	3001-314-821	Pendant Port Cable	1
N	5000-90-28	Cord Out Label	1

3001-314-22 HWI w/2 Stryker Ports

Item	Part No.	Part Name	Qty.
A	3001-303-821	Headwall Interface Cable	1
B	(page 147)	Battery Enclosure Ass'y	1
C	7900-1-291	Foam Tape	1
D	3001-300-7	Female Screwjack	2
E	59-710	Static Plug	1
F	3000-300-113	Cable Tie	5
G	3-224	Hex Washer Hd. Screw	8
H	7-53	Truss Hd. Screw	2
J	3001-314-006	Pendant Port Cover	1
K	3001-314-920	HWI Pendant Port PCB	2
M	3001-314-821	Pendant Port Cable	1
N	5000-90-28	Cord Out Label	1

3001-314-112 HWI w/1 Custom Port

Item	Part No.	Part Name	Qty.
A	3001-303-821	Headwall Interface Cable	1
B	(page 147)	Battery Enclosure Ass'y	1
C	7900-1-291	Foam Tape	1
D	3001-300-7	Female Screwjack	2
E	59-710	Static Plug	1
F	3000-300-113	Cable Tie	5
G	3-224	Hex Washer Hd. Screw	4
H	7-53	Truss Hd. Screw	2
J	3001-314-006	Pendant Port Cover	1
K	3001-314-889	HWI Cust. Pend. Port PCB	1
M	3001-314-821	Pendant Port Cable	1
N	5000-90-28	Cord Out Label	1

3001-314-122 HWI w/1 Stryker & 1 Custom Port

Item	Part No.	Part Name	Qty.
A	3001-303-821	Headwall Interface Cable	1
B	(page 147)	Battery Enclosure Ass'y	1
C	7900-1-291	Foam Tape	1
D	3001-300-7	Female Screwjack	2
E	59-710	Static Plug	1
F	3000-300-113	Cable Tie	5
G	3-224	Hex Washer Hd. Screw	8
H	7-53	Truss Hd. Screw	2
J	3001-314-006	Pendant Port Cover	1
K	3001-314-920	HWI Pendant Port PCB	1
L	3001-314-889	HWI Cust. Pend. Port PCB	1
M	3001-314-821	Pendant Port Cable	1
N	5000-90-28	Cord Out Label	1

Battery Enclosure Assembly

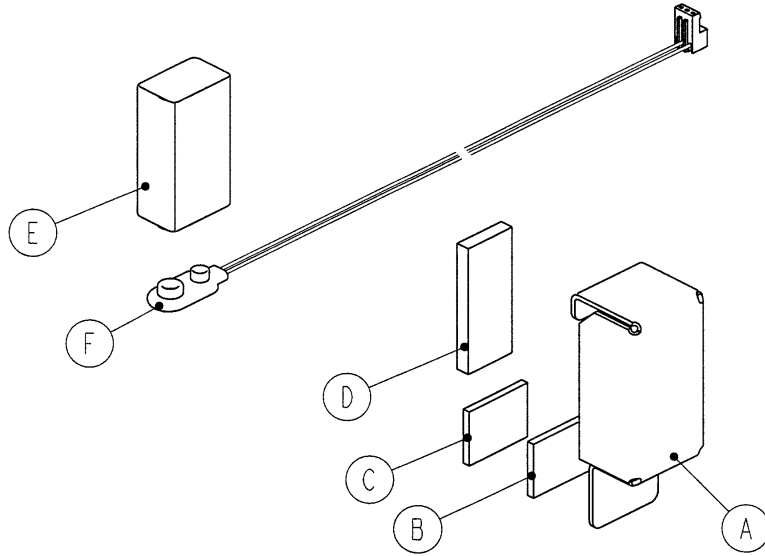

Item	Part No.	Part Name	Qty.
A	3001-303-12	Battery Enclosure	1
B	29-10	Fine Duo-Lock	1
C	29-8	Coarse Duo-Lock	1
D	7900-1-291	Foam Tape	1
E	3000-303-871	Battery	1
F	3001-303-811	Battery Cable	1

Optional Night Light Assembly

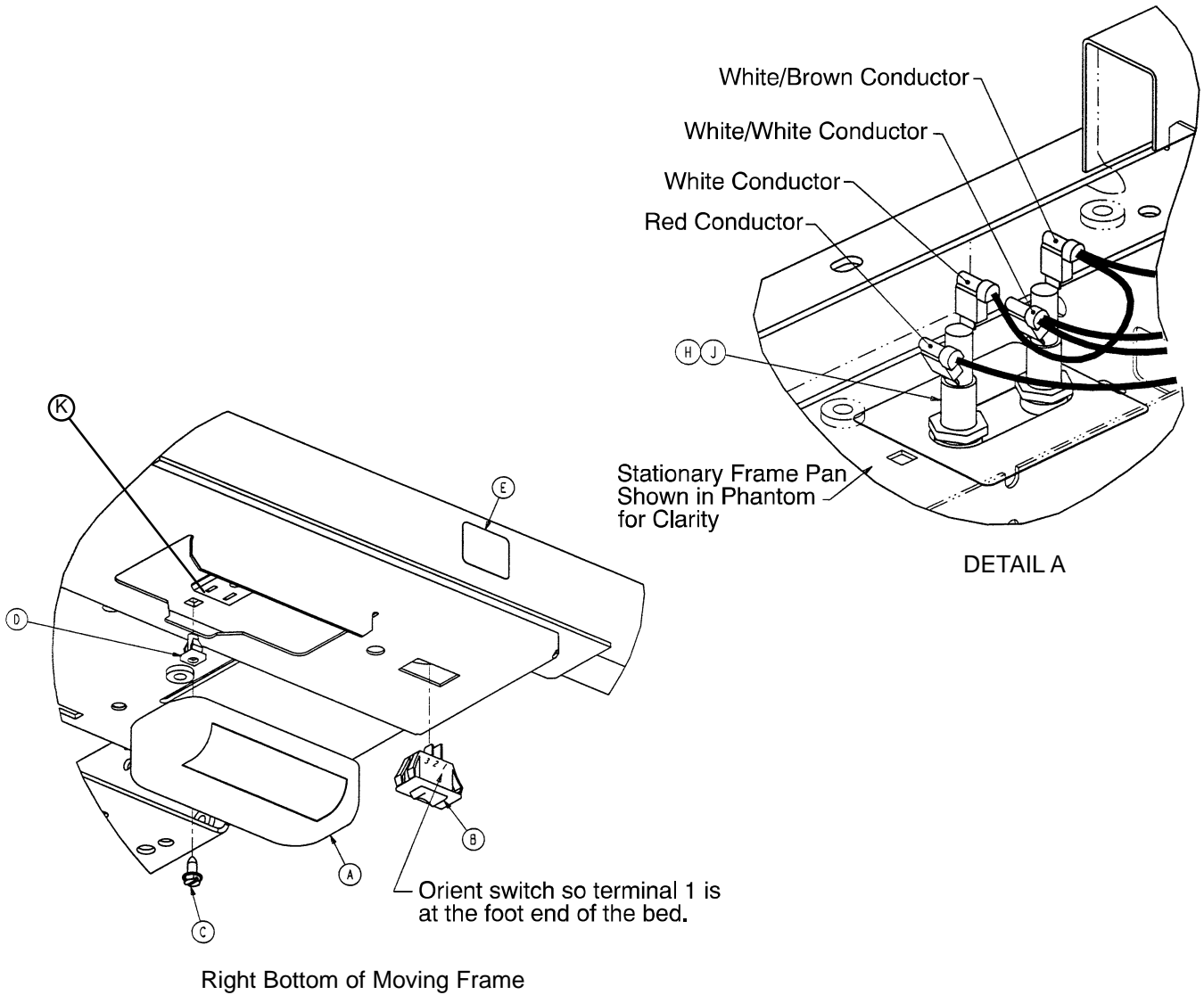

3001-310-20 Night Light Assembly

Item	Part No.	Part Name	Qty.
A	59-160	Plug-In Night Light	2
B	59-165	Toggle Switch	1
C	23-25	Hex Washer Hd. Screw	2
D	52-816	Plastic Clip Nut	2
E	3001-310-601	Night Light Label	1
F	3000-300-113	Cable Tie	1
G	3001-310-802	Night Light Cable	1
H	2020-2-664	Fuse Holder	1
J	2020-2-666	5 Amp Fuse	1
K	59-166	Night Light Plug	2

3221-310-20 230V Night Light Assembly

Item	Part No.	Part Name	Qty.
A	59-160	Plug-In Night Light	2
B	59-165	Toggle Switch	1
C	23-25	Hex Washer Hd. Screw	2
D	52-816	Plastic Clip Nut	2
E	3001-310-601	Night Light Label	1
F	3000-300-113	Cable Tie	1
G	3221-310-802	Night Light Cable	1
H	2020-2-664	Fuse Holder	1
J	2020-2-666	5 Amp Fuse	1
K	59-166	Night Light Plug	2

Optional Night Light Assembly

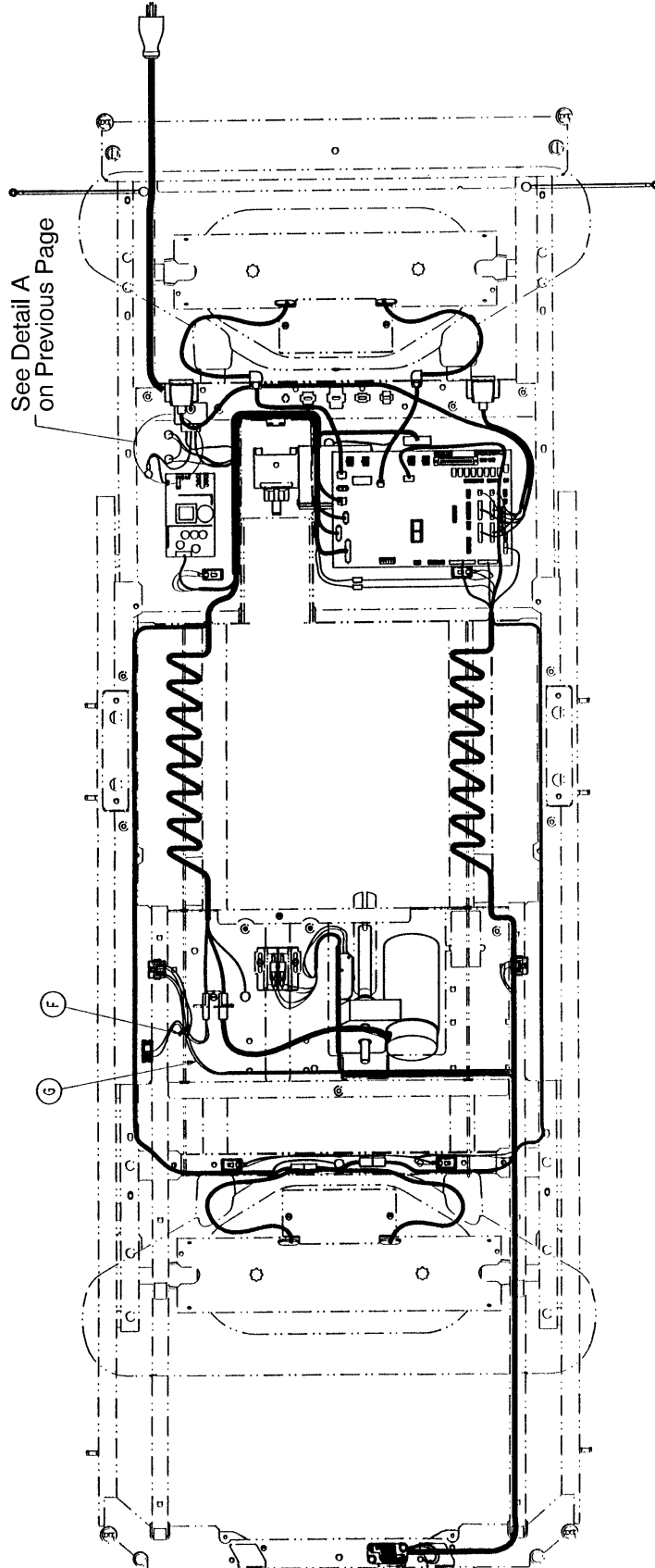

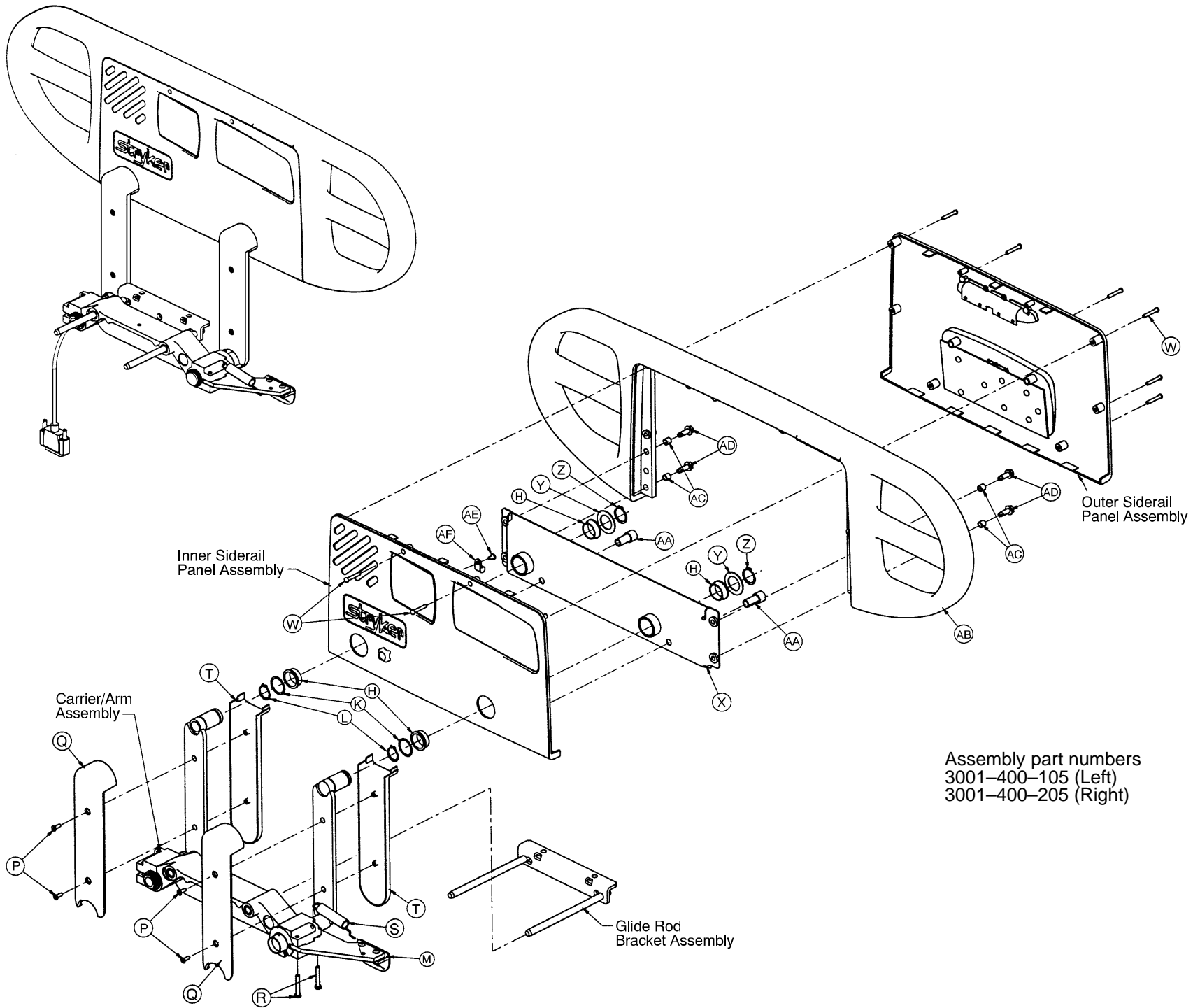

Assembly part numbers
3001-400-105 (Left)
3001-400-205 (Right)

Head End Siderail Assembly

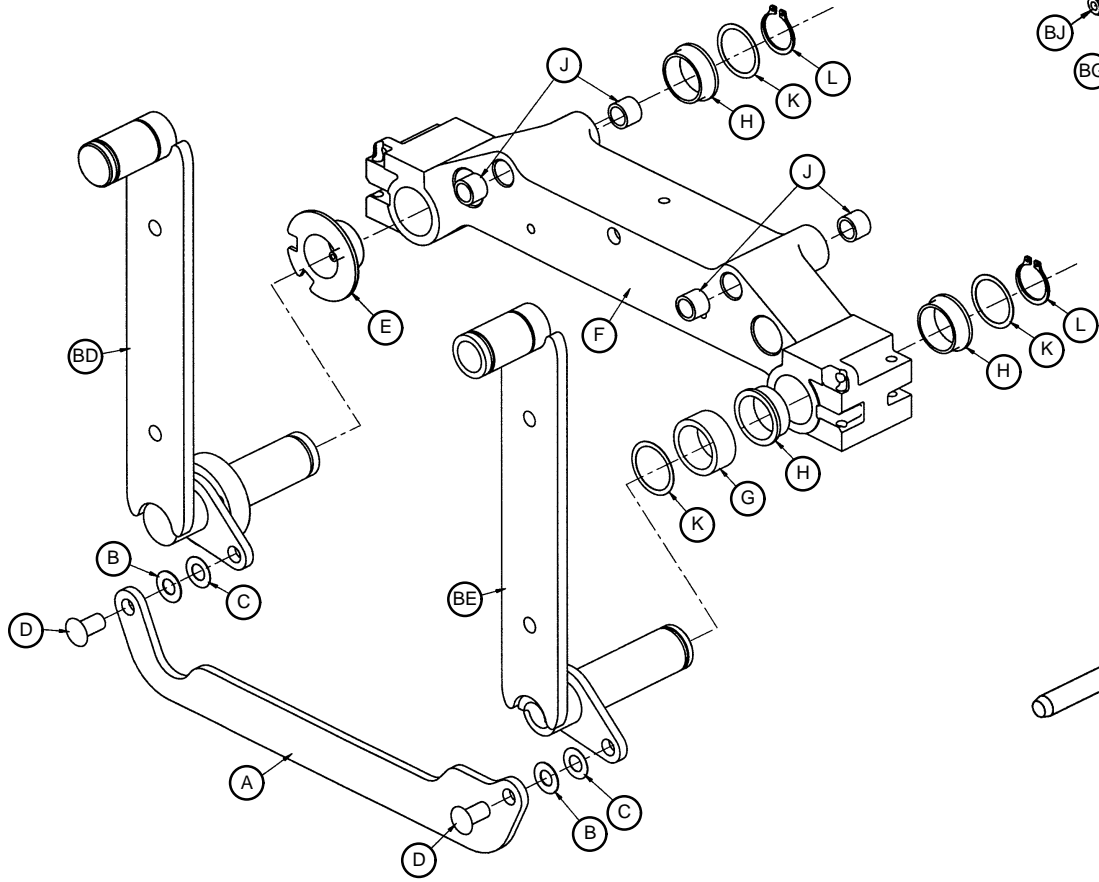

Carrier/Arm Assembly

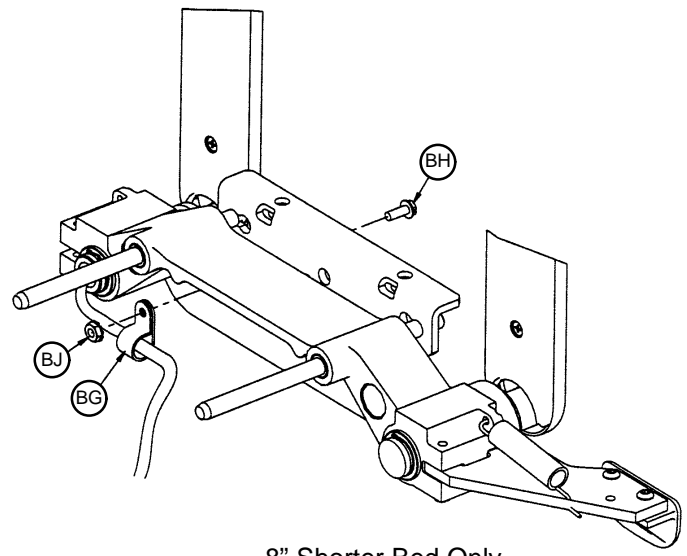

8" Shorter Bed Only

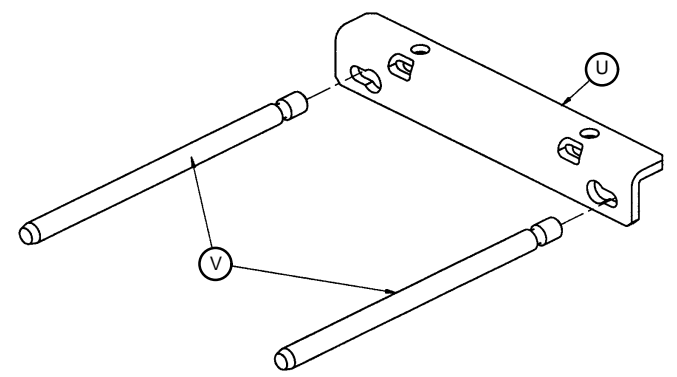

Glide Rod Bracket Assembly

Head End Siderail Assembly

Head End Siderail Assembly

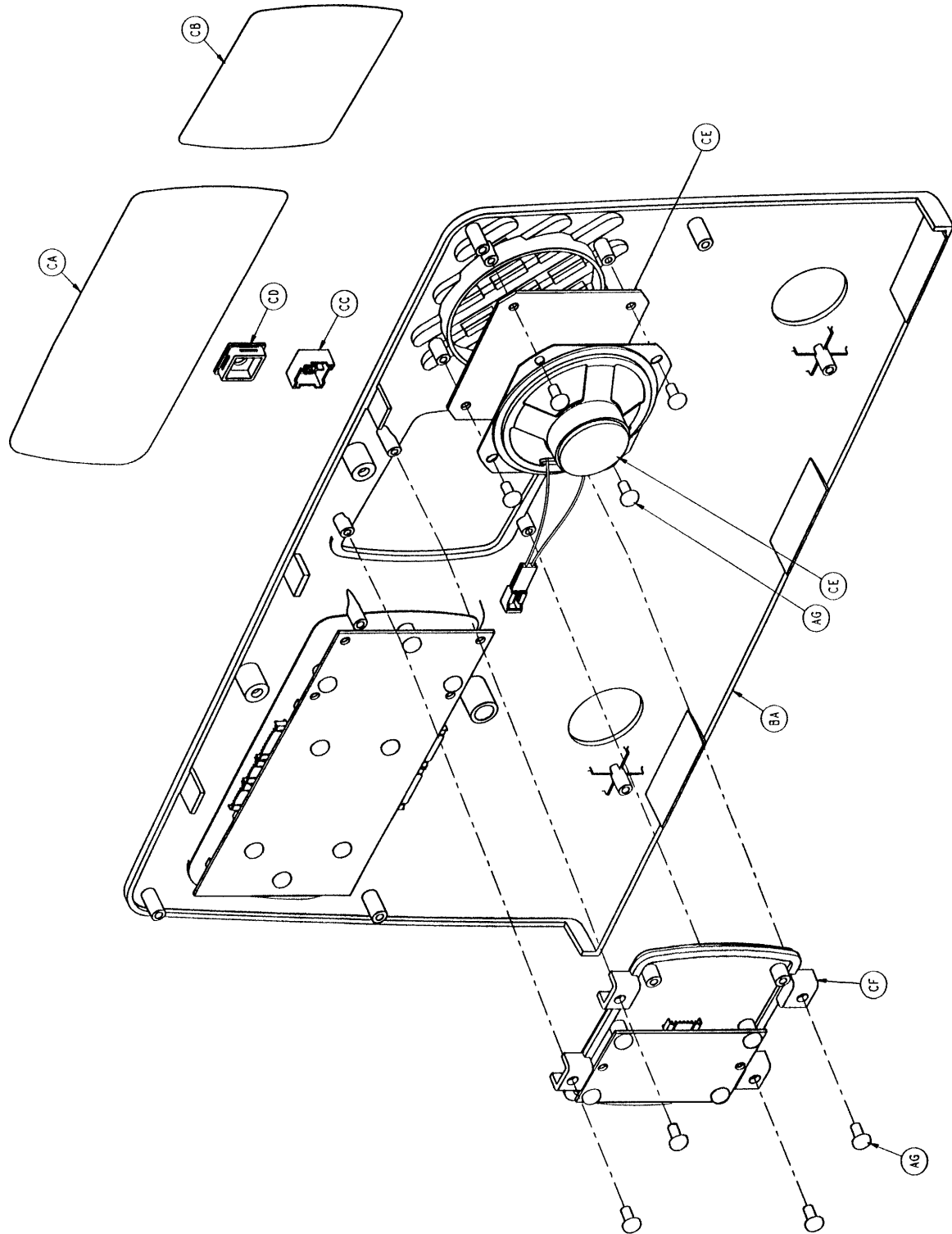

Inner Siderail Panel Assembly

Head End Siderail Assembly

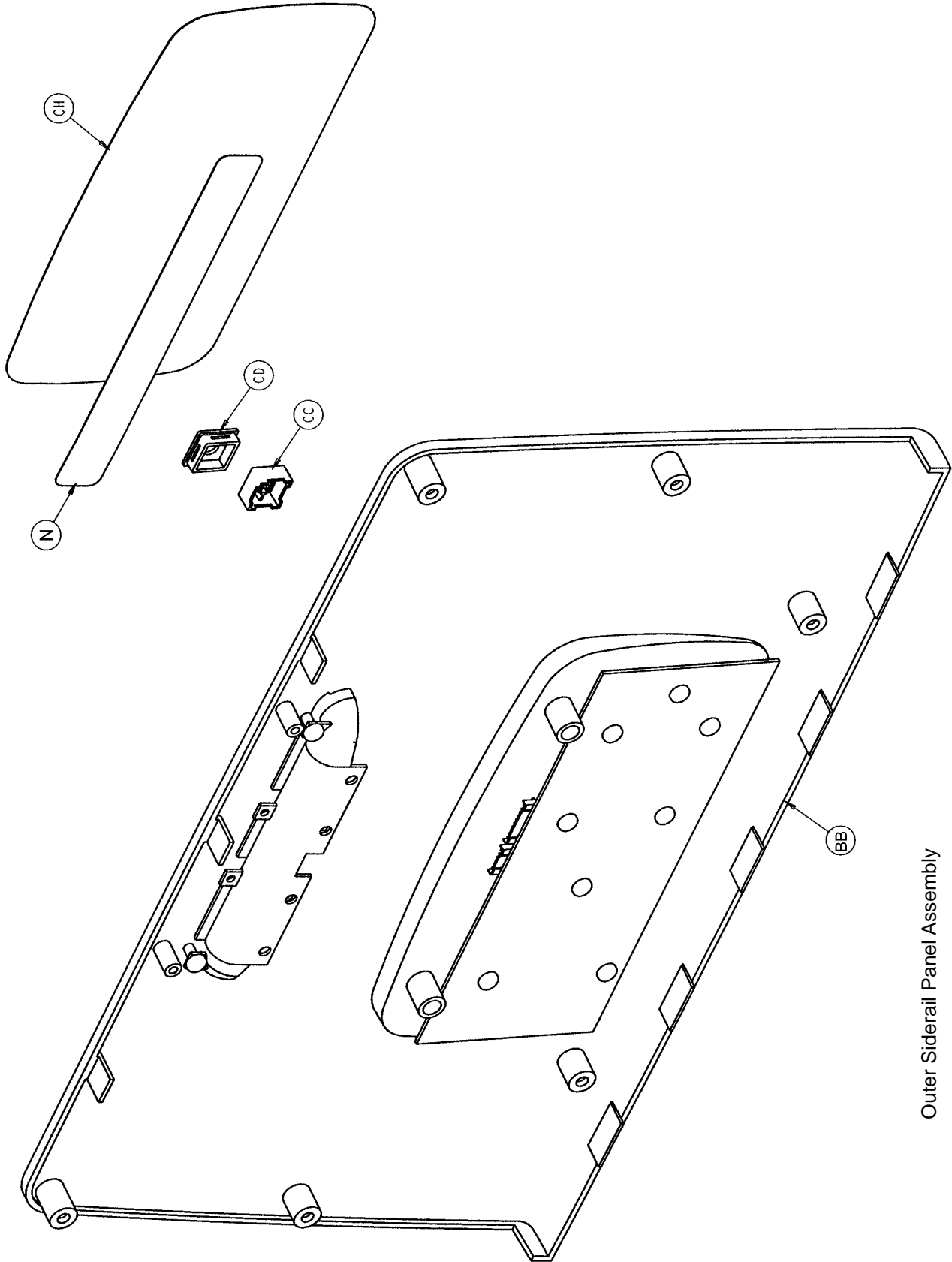

Outer Siderail Panel Assembly

Head End Siderail Assembly

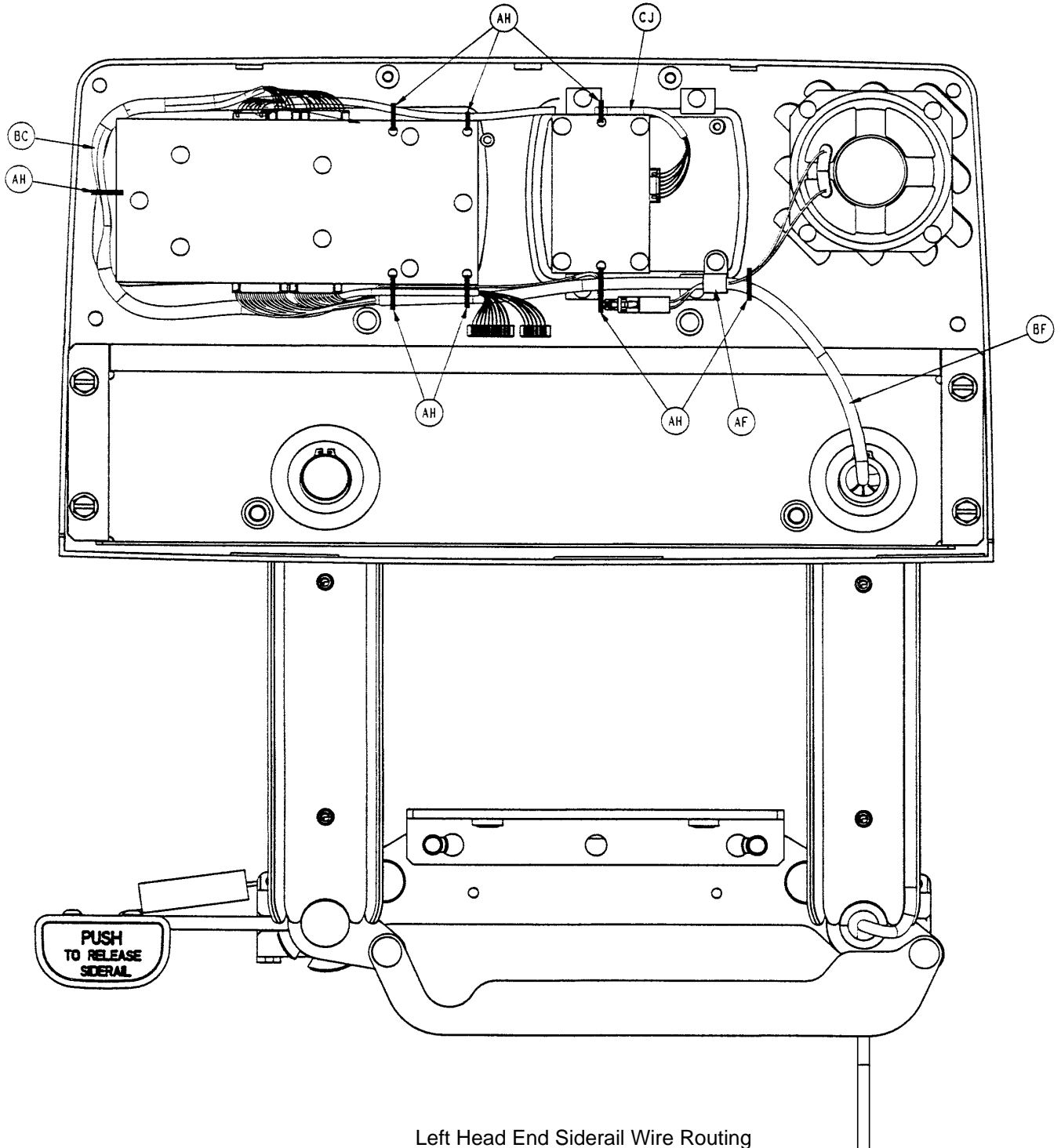

Left Head End Siderail Wire Routing

Head End Siderail Assembly

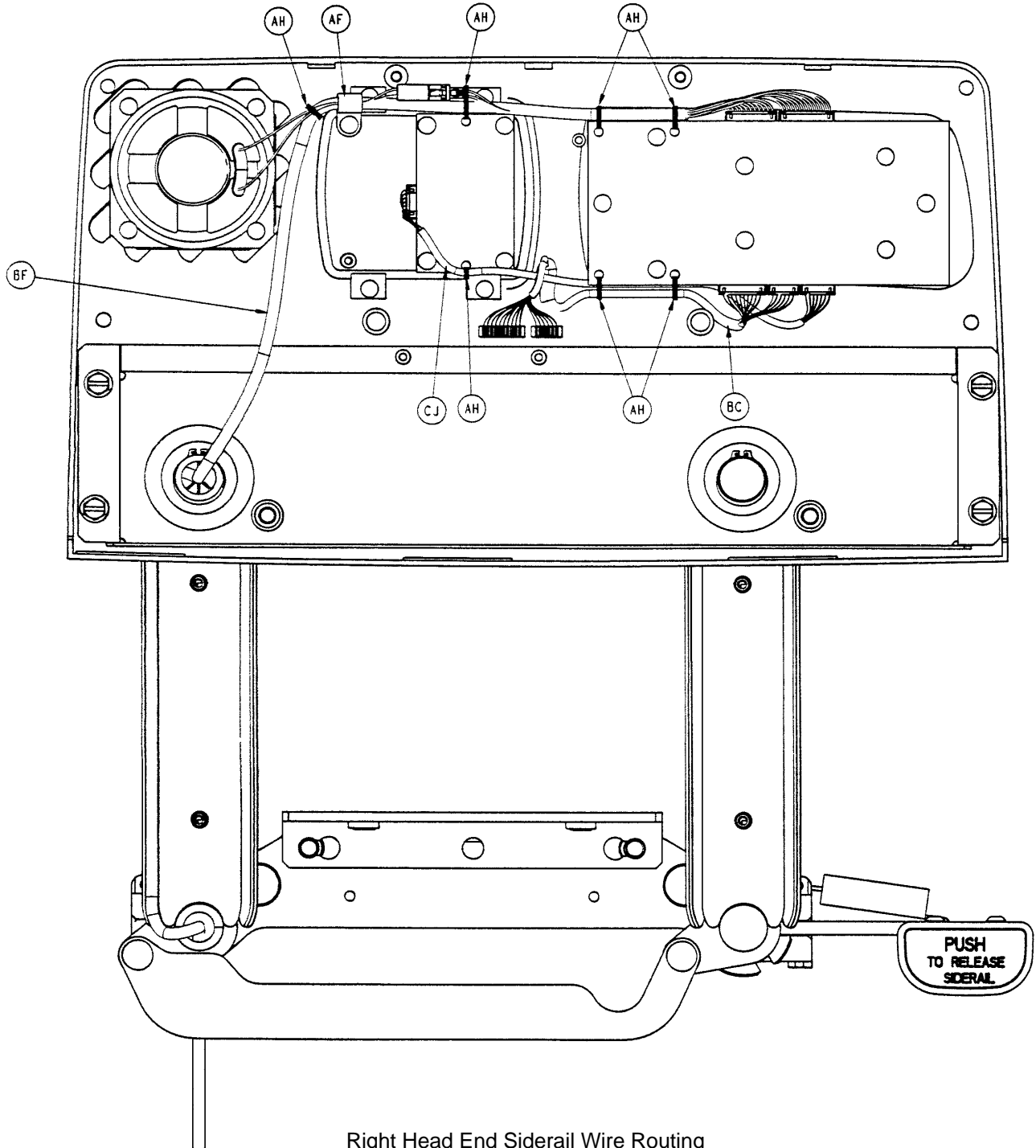

Right Head End Siderail Wire Routing

Head End Siderail Assembly

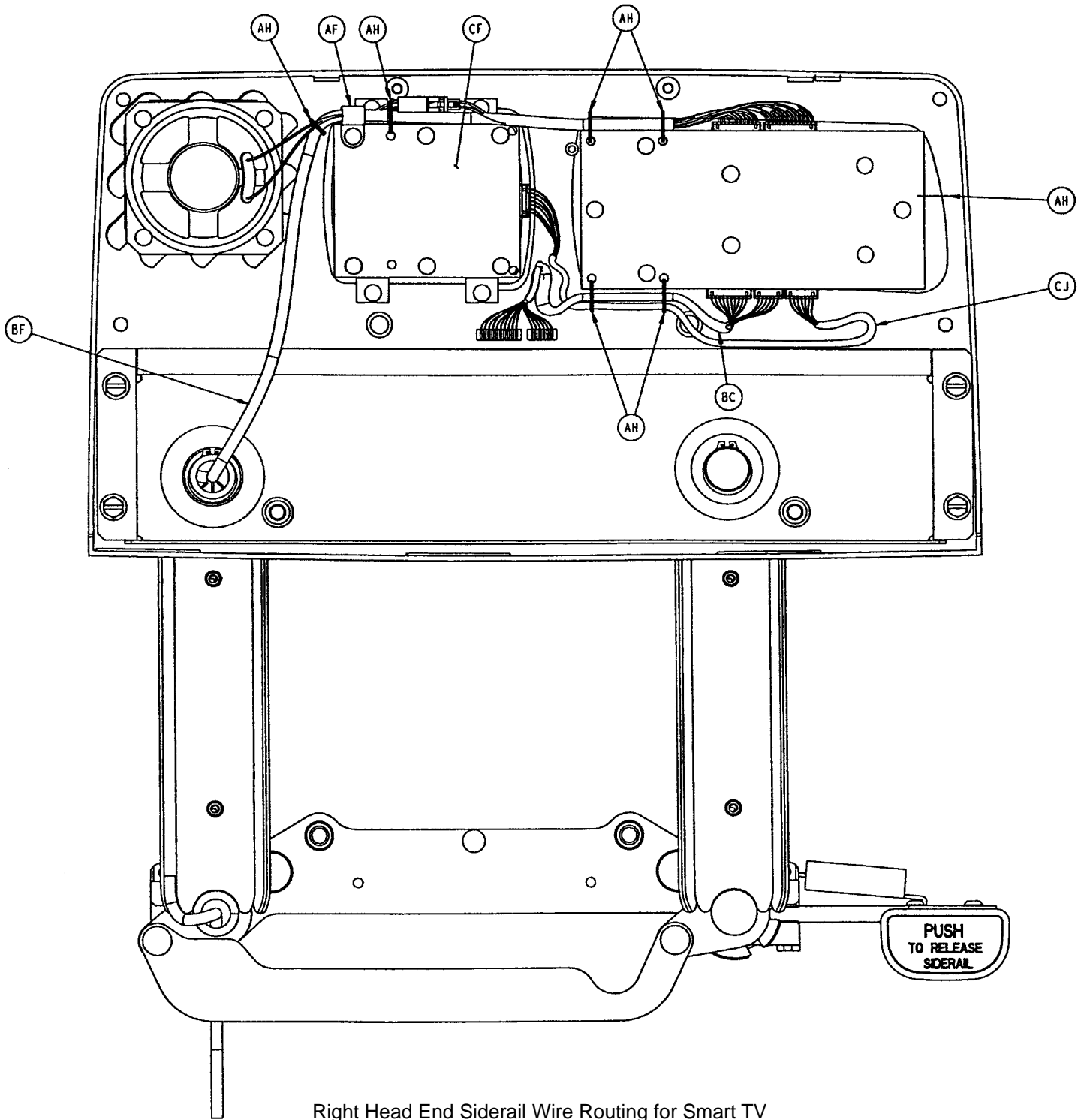

Right Head End Siderail Wire Routing for Smart TV

Head End Siderail Assembly

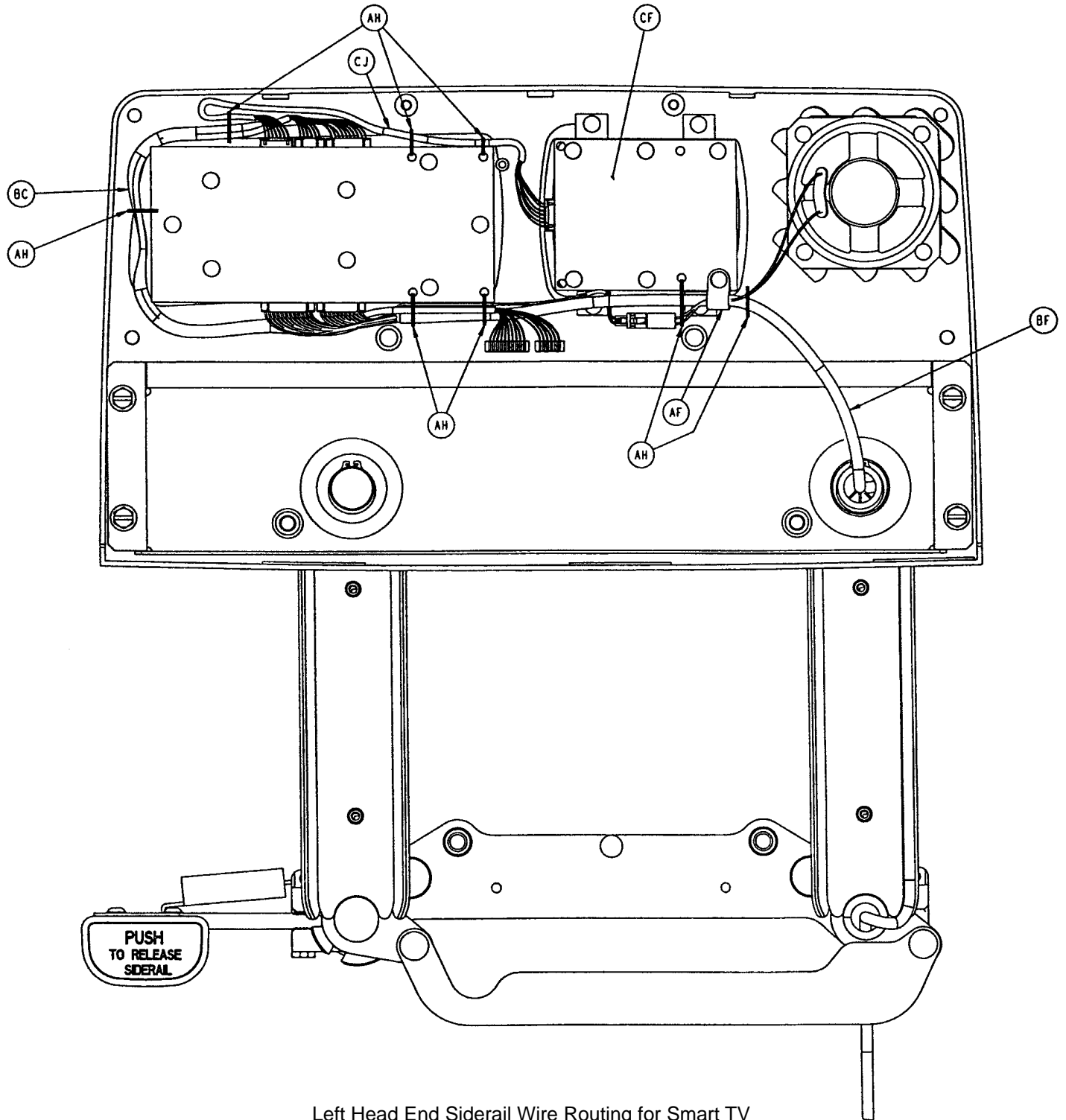

Left Head End Siderail Wire Routing for Smart TV

Head End Siderail Assembly

3001-400-105 Left Standard Components

Item	Part No.	Part Name	Qty.
A	3001-400-11	Timing Link Weldment, Hd.	1
B	11-403	Shim Washer	2
C	11-377	Nylon Washer	2
D	3001-400-501	Siderail Linkage Rivet	2
E	3001-400-513	Wear Bushing	1
F	3001-400-528	Siderail Carrier	1
G	3001-400-530	Siderail Arm Spacer	1
H	3000-400-513	Flange Bearing	7
J	3000-400-557	Sleeve Bearing	4
K	11-353	Shim Washer	5
L	28-128	Retaining Ring	4
M	(page 185)	Release Lever, Left	1
N	3000-400-556	Warning Label	1
P	23-280	Self-Tapping Screw	4
Q	5000-20-5	Inner Arm Cover	2
R	3-344	Hex Washer Hd. Screw	2
S	3000-200-334	Extension Spring	1
T	5000-20-6	Outer Arm Cover	2
U	3001-400-555	Mounting Bracket	1
V	3001-400-564	Glide Rod	2
W	23-90	High-Low Tapping Screw	8
X	3001-400-130	Supt. Weldment, Hd., Lt.	1
Y	11-343	Shim Washer	2
Z	28-132	Bowed Retaining Ring	2
AA	3000-400-523	Panel Spacer	2
AB	3001-400-515	Head Rail	1
AC	3001-400-558	Siderail Spacer	4
AD	3-226	Hex Washer Hd. Screw	4
AE	23-86	High-Low Tapping Screw	1
AF	3000-300-478	CPR Conduit Clamp	1
AG	23-112	High-Low Tapping Screw	8
AH	3000-300-114	4" Cable Tie	8

3001-400-205 Right Standard Components

Item	Part No.	Part Name	Qty.
A	3001-400-11	Timing Link Weldment, Hd.	1
B	11-403	Shim Washer	2
C	11-377	Nylon Washer	2
D	3001-400-501	Siderail Linkage Rivet	2
E	3001-400-513	Wear Bushing	1
F	3001-400-528	Siderail Carrier	1
G	3001-400-530	Siderail Arm Spacer	1
H	3000-400-513	Flange Bearing	7
J	3000-400-557	Sleeve Bearing	4
K	11-353	Shim Washer	5
L	28-128	Retaining Ring	4
M	(page 186)	Release Lever, Right	1
N	3000-400-556	Warning Label	1
P	23-280	Self-Tapping Screw	4
Q	5000-20-5	Inner Arm Cover	2
R	3-330	Hex Washer Hd. Screw	2
S	3000-200-334	Extension Spring	1
T	5000-20-6	Outer Arm Cover	2
U	3001-400-555	Mounting Bracket	1
V	3001-400-564	Glide Rod	2
W	23-90	High-Low Tapping Screw	8
X	3001-400-230	Supt. Weldment, Hd., Rt.	1
Y	11-343	Shim Washer	2
Z	28-132	Bowed Retaining Ring	2
AA	3000-400-523	Panel Spacer	2
AB	3001-400-515	Head Rail	1
AC	3001-400-558	Siderail Spacer	4
AD	3-226	Hex Washer Hd. Screw	4
AE	23-86	High-Low Tapping Screw	1
AF	3000-300-478	CPR Conduit Clamp	1
AG	23-112	High-Low Tapping Screw	8
AH	3000-300-114	4" Cable Tie	7

3001-443-105 Left Rail – Standard Bed

Item	Part No.	Part Name	Qty.
BA	(page 157)	Inner Panel Ass'y, Left	1
BB	(page 158)	Outer Panel Ass'y	1
BC	3001-400-802	Main Outside Cable, Lt.	1
BD	3001-400-127	Arm Weldment, Left, Ft.	1
BE	3001-400-128	Arm Weldment, Left, Hd.	1
BF	3001-400-862	Siderail Cable	1

3001-443-205 Right Rail – Standard Bed

Item	Part No.	Part Name	Qty.
BA	(page 157)	Inner Panel Ass'y, Right	1
BB	(page 158)	Outer Panel Ass'y	1
BC	3001-400-801	Main Outside Cable, Rt.	1
BD	3001-400-227	Arm Weldment, Right, Ft.	1
BE	3001-400-228	Arm Weldment, Right, Hd.	1
BF	3001-400-862	Siderail Cable	1

3001-442-105 Left Rail – 8" Shorter Bed

Item	Part No.	Part Name	Qty.
BA	(page 157)	Inner Panel Ass'y, Left	1
BB	(page 158)	Outer Panel Ass'y	1
BC	3001-400-802	Main Outside Cable, Lt.	1
BD	3001-400-127	Arm Weldment, Left, Ft.	1
BE	3001-400-128	Arm Weldment, Left, Hd.	1
BF	3001-442-862	Siderail Cable	1
BG	34-22	Cable Clamp	1
BH	3-124	Hex Washer Hd. Screw	1
BJ	16-41	Kep Nut	1

3001-442-205 Right Rail – 8" Shorter Bed

Item	Part No.	Part Name	Qty.
BA	(page 157)	Inner Panel Ass'y, Right	1
BB	(page 158)	Outer Panel Ass'y	1
BC	3001-400-801	Main Outside Cable, Rt.	1
BD	3001-400-227	Arm Weldment, Right, Ft.	1
BE	3001-400-228	Arm Weldment, Right, Hd.	1
BF	3001-442-862	Siderail Cable	1
BG	34-22	Cable Clamp	1
BH	3-124	Hex Washer Hd. Screw	1
BJ	16-41	Kep Nut	1

Siderail Inner Panel Assembly

Assembly part numbers
3001-400-40 (Left) &
3001-400-45 (Right)
(reference only)

(Left Side is Shown)

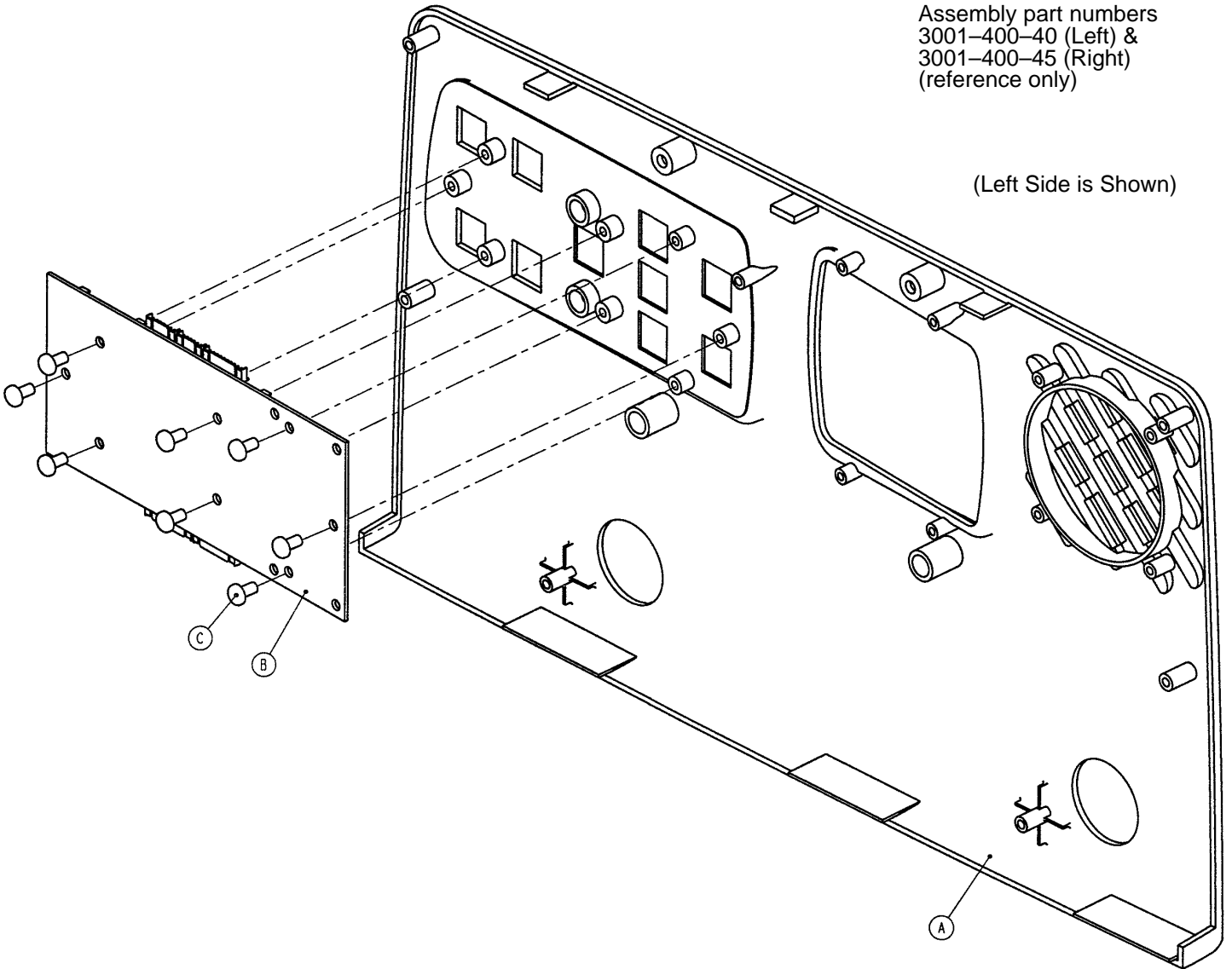

Item	Part No.	Part Name	Qty.
A	3001-400-101	Left Inner Panel	1
	3001-400-201	Right Inner Panel	1
B	3001-400-930	Inner Siderail PCB Assembly	1
C	23-112	Hi-Low Tapping Screw	8

Siderail Outer Panel Assembly

Assembly part number 3001-400-35
(reference only)

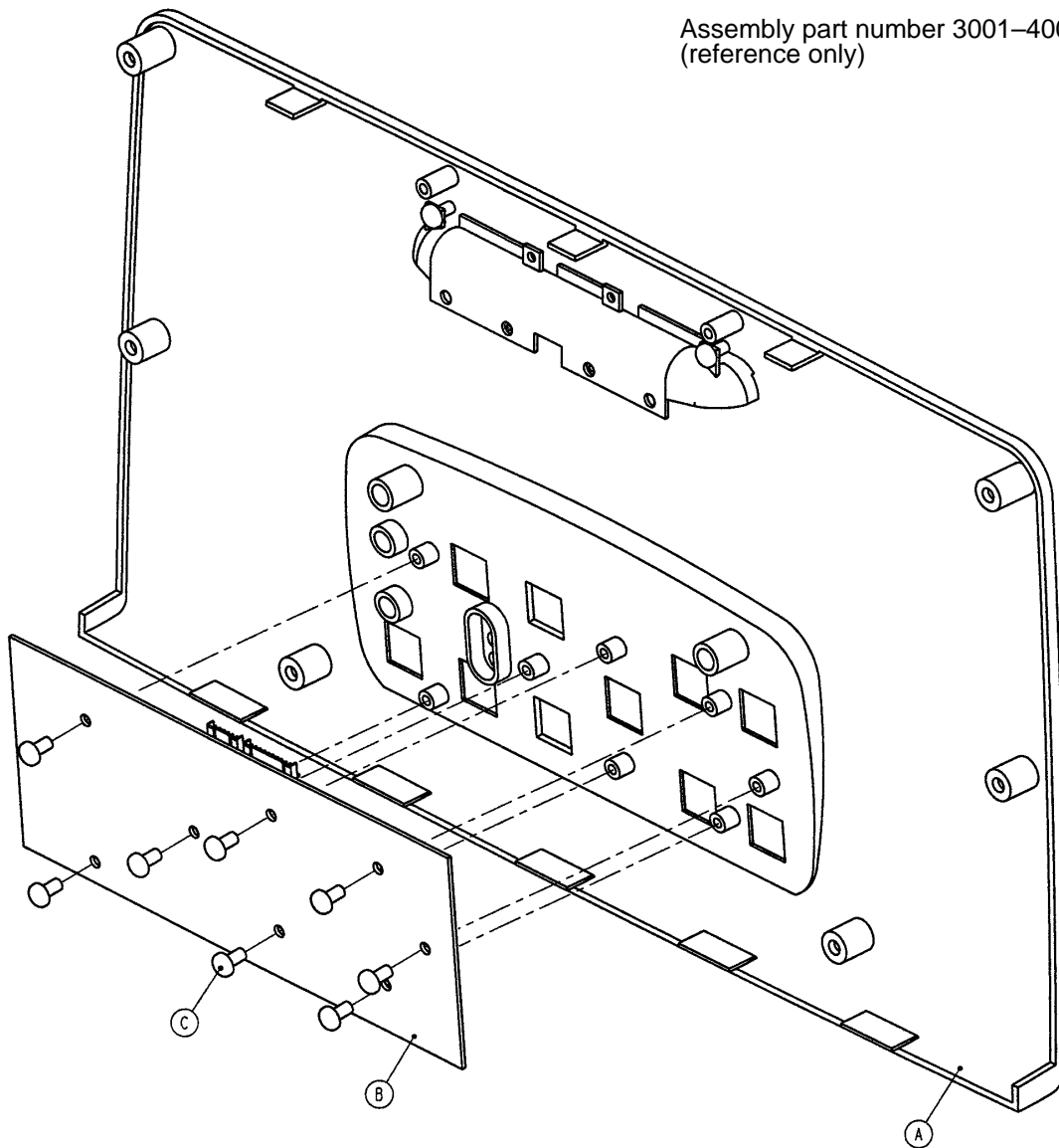

Item	Part No.	Part Name	Qty.
A	3001-400-50	Outer Panel Assembly	1
B	3001-400-910	Outer Siderail PCB Assembly	1
C	23-112	Hi-Low Tapping Screw	8

Head End Siderail Assembly

Standard Siderail

Item	Part No.	Part Name	Qty.
CA	3001-400-620	Standard Label, Inner, Left	1
CA	3001-400-610	Standard Label, Inner, Right	1
CC	3001-400-953	Switch Cap	12
CD	3001-400-522	Filler Cap	28
CE	3001-400-517	Speaker Seal	2
CF	3001-400-535	Blank Module	2
CH	3001-400-630	Standard Label, Outer, Left	1
CH	3001-400-640	Standard Label, Outer, Right	1

Inner Right Siderail Label

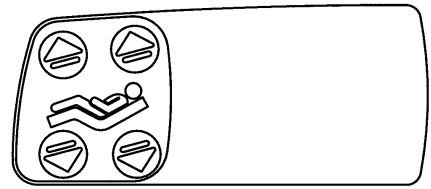

Outer Right Siderail Label

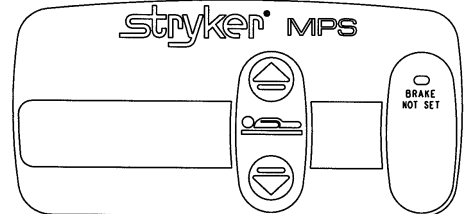

Standard Siderail with Nurse Call

Item	Part No.	Part Name	Qty.
CA	3001-400-621	Nurse Call Label, Inner, Left	1
CA	3001-400-611	Nurse Call Label, Inner, Right	1
CC	3001-400-953	Switch Cap	16
CD	3001-400-522	Filler Cap	24
CE	3001-403-831	Speaker With Cable	2
CF	3001-400-535	Blank Module	2
CH	3001-400-631	Nurse Call Label, Outer, Left	1
CH	3001-400-641	Nurse Call Label, Outer, Right	1

Inner Right Siderail Label

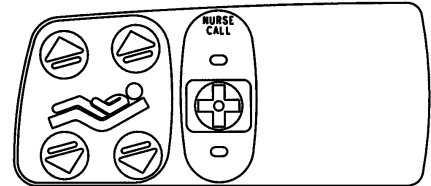

Outer Right Siderail Label

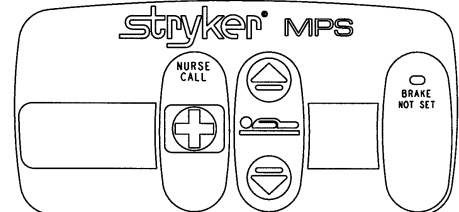

Standard Siderail with TV/Radio

Item	Part No.	Part Name	Qty.
CA	3001-400-626	TV Label, Inner, Left	1
CA	3001-400-616	TV Label, Inner, Right	1
CC	3001-400-953	Switch Cap	18
CD	3001-400-522	Filler Cap	22
CE	3001-403-831	Speaker With Cable	2
CF	3001-400-535	Blank Module	2
CH	3001-400-630	NC, G/F Label, Outer, Left	1
CH	3001-400-640	NC, G/F Label, Outer, Right	1

Inner Right Siderail Label

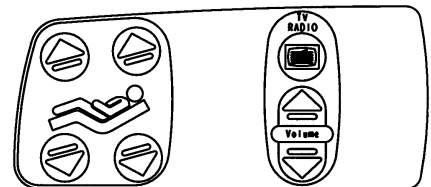

Outer Right Siderail Label

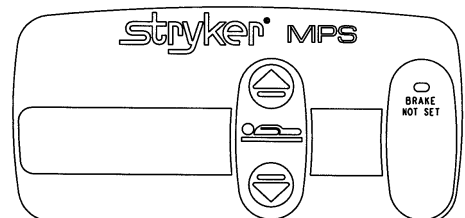

Head End Siderail Assembly

Standard Siderail with Lights

Item	Part No.	Part Name	Qty.
CA	3001-400-627	Lights Label, Inner, Left	1
CA	3001-400-617	Lights Label, Inner, Right	1
CC	3001-400-953	Switch Cap	16
CD	3001-400-522	Filler Cap	24
CE	3001-400-517	Speaker Seal	2
CF	3001-400-535	Blank Module	2
CH	3001-400-630	Standard Label, Outer, Left	1
CH	3001-400-640	Standard Label, Outer, Right	1

Inner Right Siderail Label

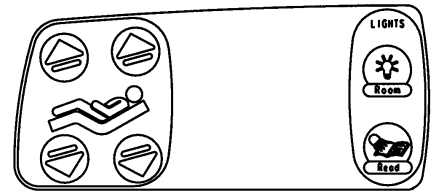

Outer Right Siderail Label

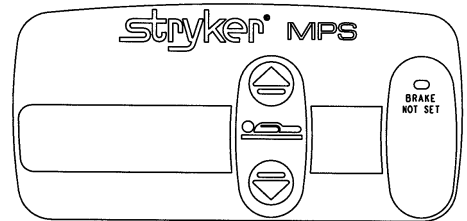

Standard Siderail with Gatch/Fowler

Item	Part No.	Part Name	Qty.
CA	3001-400-620	Standard Label Inner, Left	1
CA	3001-400-610	Standard Label, Inner, Right	1
CC	3001-400-953	Switch Cap	20
CD	3001-400-522	Filler Cap	20
CE	3001-400-517	Speaker Seal	2
CF	3001-400-535	Blank Module	2
CH	3001-400-636	G/F Label, Outer, Left	1
CH	3001-400-646	G/F Label, Outer, Right	1

Inner Right Siderail Label

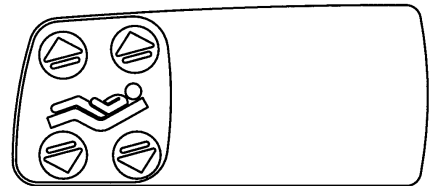

Outer Right Siderail Label

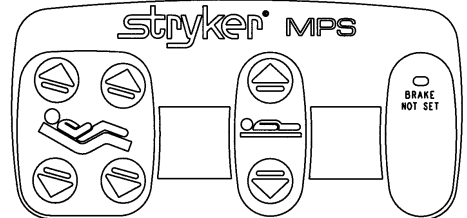

Head End Siderail Assembly

Standard Siderail with Nurse Call & TV/Radio

Item	Part No.	Part Name	Qty.
CA	3001-400-622	NC, TV Label, Inner, Left	1
CA	3001-400-612	NC, TV Label, Inner, Right	1
CC	3001-400-953	Switch Cap	22
CD	3001-400-522	Filler Cap	18
CE	3001-403-831	Speaker With Cable	2
CF	3001-400-535	Blank Module	2
CH	3001-400-631	Nurse Call Label, Outer, Left	1
CH	3001-400-641	Nurse Call Label, Outer, Right	1

Inner Right Siderail Label

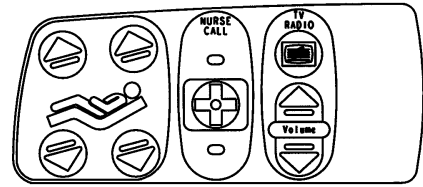

Outer Right Siderail Label

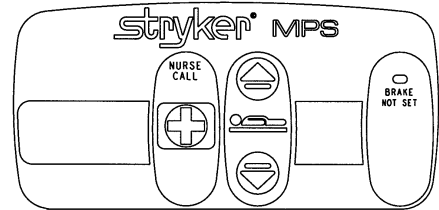

Standard Siderail with Nurse Call and Lights

Item	Part No.	Part Name	Qty.
CA	3001-400-625	NC, Lights Label, Inner, Left	1
CA	3001-400-615	NC, Lights Label, Inner, Right	1
CC	3001-400-953	Switch Cap	20
CD	3001-400-522	Filler Cap	20
CE	3001-403-831	Speaker With Cable	2
CF	3001-400-535	Blank Module	2
CH	3001-400-631	NC Label, Outer, Left	1
CH	3001-400-641	NC Label, Outer, Right	1

Inner Right Siderail Label

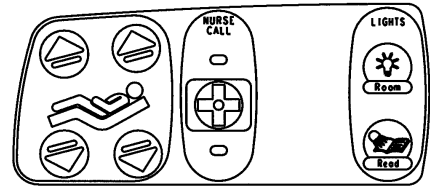

Outer Right Siderail Label

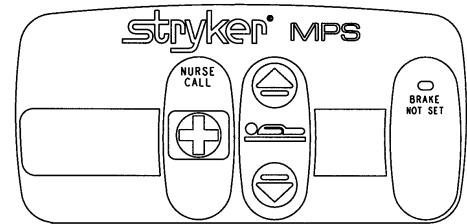

Standard Siderail with Nurse Call and G/F

Item	Part No.	Part Name	Qty.
CA	3001-400-621	Nurse Call Label, Inner, Left	1
CA	3001-400-611	Nurse Call Label, Inner, Right	1
CC	3001-400-953	Switch Cap	24
CD	3001-400-522	Filler Cap	16
CE	3001-403-831	Speaker With Cable	2
CF	3001-400-535	Blank Module	2
CH	3001-400-632	NC, G/F Label, Outer, Left	1
CH	3001-400-642	NC, G/F Label, Outer, Right	1

Inner Right Siderail Label

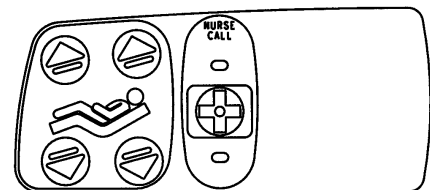

Outer Right Siderail Label

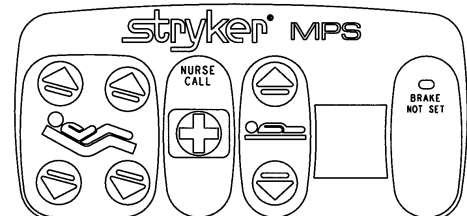

Head End Siderail Assembly

Standard Siderail with Nurse Call, TV/Radio & Lights

Item	Part No.	Part Name	Qty.
CA	3001-400-623	NC, TV, Lights Label, Inner, Left	1
CA	3001-400-613	NC, TV, Lights Label, Inner, Right	1
CC	3001-400-953	Switch Cap	26
CD	3001-400-522	Filler Cap	14
CE	3001-403-831	Speaker with Cable	2
CF	3001-400-535	Blank Module	2
CH	3001-400-631	Nurse Call Label, Outer, Left	1
CH	3001-400-641	Nurse Call Label, Outer, Right	1

Inner Right Siderail Label

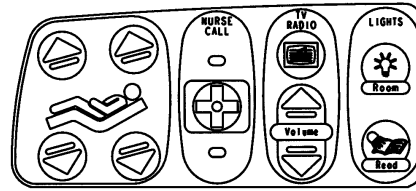

Outer Right Siderail Label

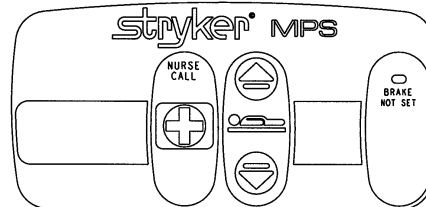

Standard Siderail with Nurse Call, Smart TV & Lights

Item	Part No.	Part Name	Qty.
AN	3000-300-114	Cable Tie	3
CA	3001-430-623	NC, STV, Lights Label, Inner, Left	1
CA	3001-430-613	NC, STV, Lights Label, Inner, Right	1
CB	3001-430-131	STV Label, Left	1
CB	3001-430-132	STV Label, Right	1
CC	3001-400-953	Switch Cap	34
CD	3001-400-522	Filler Cap	18
CE	3001-403-831	Speaker with Cable	2
CF	(page 177)	STV Module, Left	1
CF	(page 178)	STV Module, Right	1
CH	3001-400-631	Nurse Call Label, Outer, Left	1
CH	3001-400-641	Nurse Call Label, Outer, Right	1
CJ	3001-402-803	Main to Options PCB Cable	2

Inner Right Siderail Label

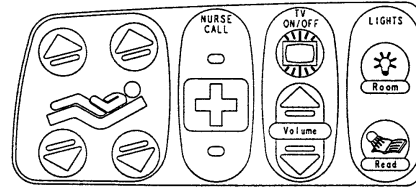

Outer Right Siderail Label

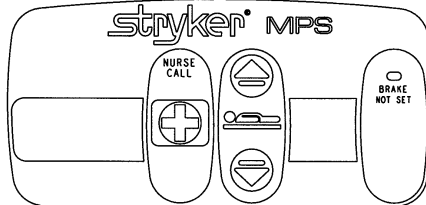

Inner STV Label

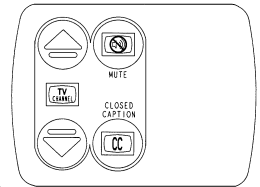

Standard Siderail w/Nurse Call, TV/Radio, & G/F

Item	Part No.	Part Name	Qty.
CA	3001-400-622	NC, TV Label, Inner, Left	1
CA	3001-400-612	NC, TV Label, Inner, Right	1
CC	3001-400-953	Switch Cap	30
CD	3001-400-522	Filler Cap	10
CE	3001-403-831	Speaker with Cable	2
CF	3001-400-535	Blank Module	2
CH	3001-400-632	NC, G/F Label, Outer, Left	1
CH	3001-400-642	NC, G/F Label, Outer, Right	1

Inner Right Siderail Label

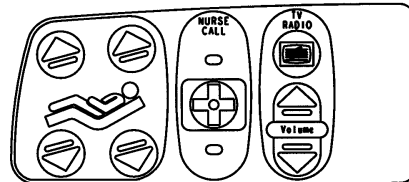

Outer Right Siderail Label

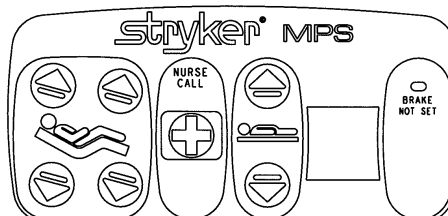

Head End Siderail Assembly

Standard Siderail with Nurse Call, Lights, and G/F

Item	Part No.	Part Name	Qty.
CA	3001-400-625	NC, Lights Label Inner, Left	1
CA	3001-400-615	NC, Lights Label, Inner, Right	1
CC	3001-400-953	Switch Cap	28
CD	3001-400-522	Filler Cap	12
CE	3001-403-831	Speaker With Cable	2
CF	3001-400-535	Blank Module	2
CH	3001-400-632	NC, G/F Label, Outer, Left	1
CH	3001-400-642	NC, G/F Label, Outer, Right	1

Inner Right Siderail Label

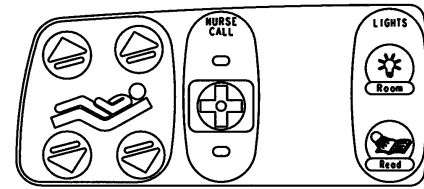

Outer Right Siderail Label

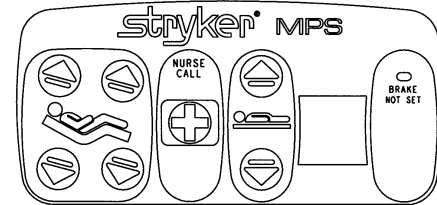

Standard Siderail w/Nurse Call, TV/Radio, Lights, & G/F

Item	Part No.	Part Name	Qty.
CA	3001-400-623	NC, TV, Lights Label, Inner, Left	1
CA	3001-400-613	NC, TV, Lights Label, Inner, Right	1
CC	3001-400-953	Switch Cap	34
CD	3001-400-522	Filler Cap	6
CE	3001-403-831	Speaker with Cable	2
CF	3001-400-535	Blank Module	2
CH	3001-400-632	NC, G/F Label, Outer, Left	1
CH	3001-400-642	NC, G/F Label, Outer, Right	1

Inner Right Siderail Label

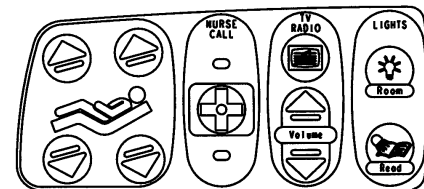

Outer Right Siderail Label

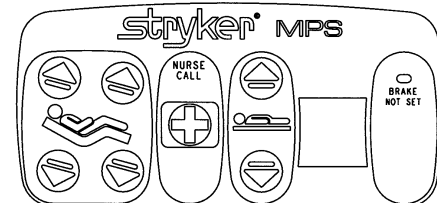

Standard Siderail with TV/Radio and Lights

Item	Part No.	Part Name	Qty.
CA	3001-400-624	TV, Lights Label, Inner, Left	1
CA	3001-400-614	TV, Lights Label, Inner, Right	1
CC	3001-400-953	Switch Cap	26
CD	3001-400-522	Filler Cap	14
CE	3001-403-831	Speaker with Cable	2
CF	3001-400-535	Blank Module	2
CH	3001-400-630	Standard Label, Outer, Left	1
CH	3001-400-640	Standard Label, Outer, Right	1

Inner Right Siderail Label

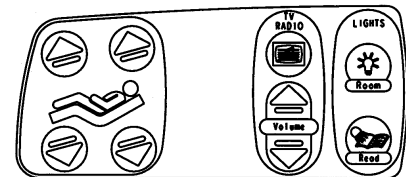

Outer Right Siderail Label

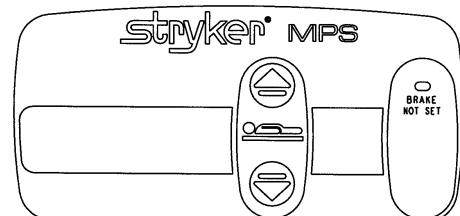

Head End Siderail Assembly

Standard Siderail with TV/Radio and G/F

Item	Part No.	Part Name	Qty.
CA	3001-400-626	TV Label, Inner, Left	1
CA	3001-400-616	TV Label, Inner, Right	1
CC	3001-400-953	Switch Cap	26
CD	3001-400-522	Filler Cap	14
CE	3001-403-831	Speaker with Cable	2
CF	3001-400-535	Blank Module	2
CH	3001-400-636	G/F Label, Outer, Left	1
CH	3001-400-646	G/F Label, Outer, Right	1

Inner Right Siderail Label

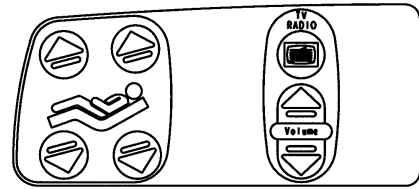

Outer Right Siderail Label

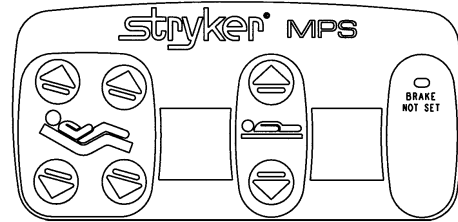

Standard Siderail with TV/Radio, Lights, and G/F

Item	Part No.	Part Name	Qty.
CA	3001-400-624	TV, Lights Label, Inner, Left	1
CA	3001-400-614	TV, Lights Label, Inner, Right	1
CC	3001-400-953	Switch Cap	30
CD	3001-400-522	Filler Cap	10
CE	3001-403-831	Speaker with Cable	2
CF	3001-400-535	Blank Module	2
CH	3001-400-636	G/F Label, Outer, Left	1
CH	3001-400-646	G/F Label, Outer, Right	1

Inner Right Siderail Label

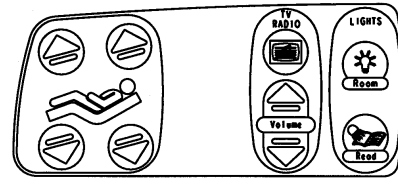

Outer Right Siderail Label

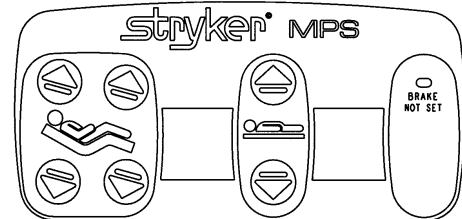

Standard Siderail with Lights and Gatch/Fowler

Item	Part No.	Part Name	Qty.
CA	3001-400-627	Lights Label, Inner, Left	1
CA	3001-400-617	Lights Label, Inner, Right	1
CC	3001-400-953	Switch Cap	24
CD	3001-400-522	Filler Cap	16
CE	3001-400-517	Speaker Seal	2
CF	3001-400-535	Blank Module	2
CH	3001-400-636	G/F Label, Outer, Left	1
CH	3001-400-646	G/F Label, Outer, Right	1

Inner Right Siderail Label

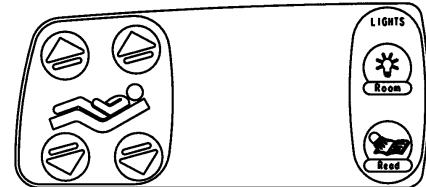

Outer Right Siderail Label

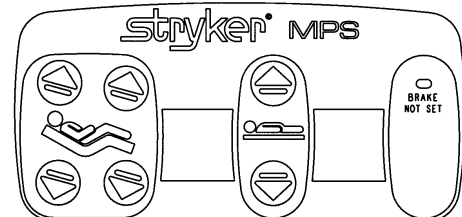

Head End Siderail Assembly

Standard Siderail with DMS

Item	Part No.	Part Name	Qty.
AN	3000-300-114	Cable Tie	3
CA	3001-400-620	Standard Label, Inner, Left	1
CA	3001-400-610	Standard Label, Inner, Right	1
CB	3001-402-1	Inner DMS Label, Left	1
CB	3001-402-2	Inner DMS Label, Right	1
CC	3001-400-953	Switch Cap	14
CD	3001-400-522	Filler Cap	26
CE	3001-400-517	Speaker Seal	2
CF	(page 181)	DMS Module	2
CH	3001-400-637	DMS Label, Outer, Left	1
CH	3001-400-647	DMS Label, Outer, Right	1
CJ	3001-402-804	Main to Options PCB Cable, Left	1
CJ	3001-402-803	Main to Options PCB Cable, Right	1

Inner Right Siderail Label

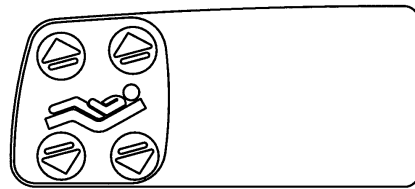

Inner DMS Label



Outer Right Siderail Label

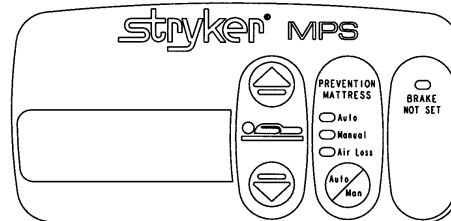

Standard Siderail with StryKair

Item	Part No.	Part Name	Qty.
AN	3000-300-114	Cable Tie	3
CA	3001-400-620	Standard Label, Inner, Left	1
CA	3001-400-610	Standard Label, Inner, Right	1
CB	3001-402-1	Inner DMS Label, Left	1
CB	3001-402-2	Inner DMS Label, Right	1
CC	3001-400-953	Switch Cap	14
CD	3001-400-522	Filler Cap	26
CE	3001-400-517	Speaker Seal	2
CF	(page 181)	DMS Module	2
CH	3001-400-937	StryKair Label, Outer, Left	1
CH	3001-400-947	StryKair Label, Outer, Right	1
CJ	3001-402-804	Main to Options PCB Cable, Left	1
CJ	3001-402-803	Main to Options PCB Cable, Right	1

Inner Right Siderail Label

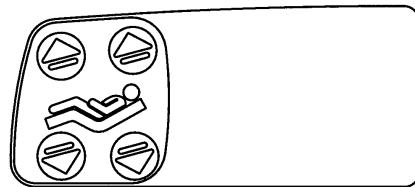

Inner DMS Label



Outer Right Siderail Label

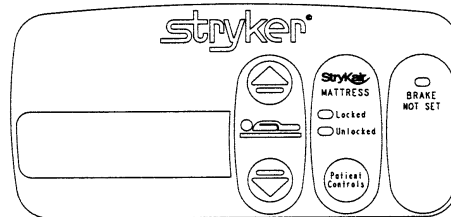

Standard Siderail with Nurse Call and DMS

Item	Part No.	Part Name	Qty.
AN	3000-300-114	Cable Tie	3
CA	3001-400-621	Nurse Call Label, Inner, Left	1
CA	3001-400-611	Nurse Call Label, Inner, Right	1
CB	3001-402-1	Inner DMS Label, Left	1
CB	3001-402-2	Inner DMS Label, Right	1
CC	3001-400-953	Switch Cap	18
CD	3001-400-522	Filler Cap	22
CE	3001-403-831	Speaker With Cable	2
CF	(page 181)	DMS Module	2
CH	3001-400-635	NC, DMS Label, Outer, Left	1
CH	3001-400-645	NC, DMS Label, Outer, Right	1
CJ	3001-402-804	Main to Options PCB Cable, Left	1
CJ	3001-402-803	Main to Options PCB Cable, Right	1

Inner Right Siderail Label

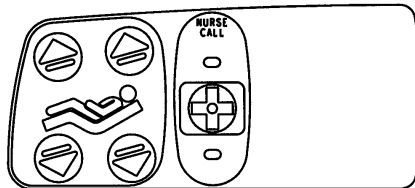

Inner DMS Label

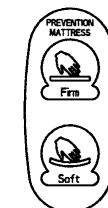

Outer Right Siderail Label

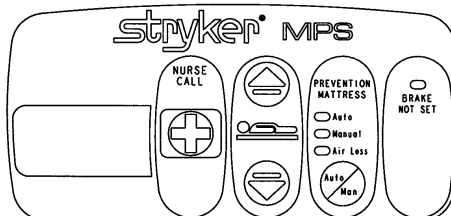

Head End Siderail Assembly

Standard Siderail with Nurse Call and StryKair

Item	Part No.	Part Name	Qty.
AN	3000-300-114	Cable Tie	3
CA	3001-400-621	Nurse Call Label, Inner, Left	1
CA	3001-400-611	Nurse Call Label, Inner, Right	1
CB	3001-402-1	Inner DMS Label, Left	1
CB	3001-402-2	Inner DMS Label, Right	1
CC	3001-400-953	Switch Cap	18
CD	3001-400-522	Filler Cap	22
CE	3001-403-831	Speaker With Cable	2
CF	(page 181)	DMS Module	2
CH	3001-400-935	NC, StryKair Label, Outer, Left	1
CH	3001-400-945	NC, StryKair Label, Outer, Right	1
CJ	3001-402-804	Main to Options PCB Cable, Left	1
CJ	3001-402-803	Main to Options PCB Cable, Right	1

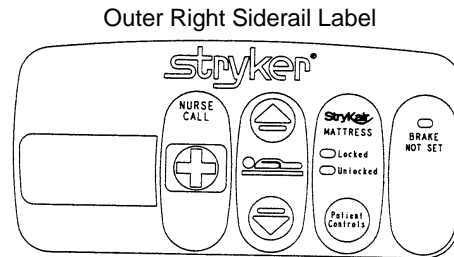
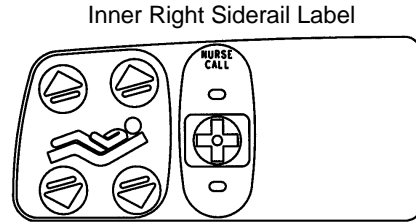

Standard Siderail with TV/Radio and DMS

Item	Part No.	Part Name	Qty.
AN	3000-300-114	Cable Tie	3
CA	3001-400-626	TV Label, Inner, Left	1
CA	3001-400-616	TV Label, Inner, Right	1
CB	3001-402-1	Inner DMS Label, Left	1
CB	3001-402-2	Inner DMS Label, Right	1
CC	3001-400-953	Switch Cap	20
CD	3001-400-522	Filler Cap	20
CE	3001-403-831	Speaker With Cable	2
CF	(page 181)	DMS Module	2
CH	3001-400-637	DMS Label, Outer, Left	1
CH	3001-400-647	DMS Label, Outer, Right	1
CJ	3001-402-804	Main to Options PCB Cable, Left	1
CJ	3001-402-803	Main to Options PCB Cable, Right	1

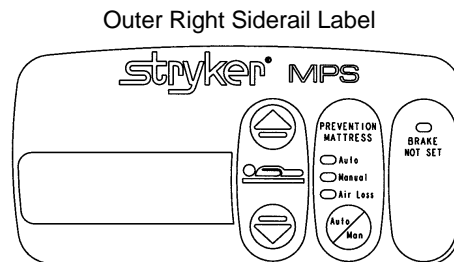
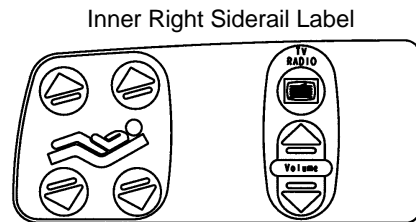

Standard Siderail with TV/Radio and StryKair

Item	Part No.	Part Name	Qty.
AN	3000-300-114	Cable Tie	3
CA	3001-400-626	TV Label, Inner, Left	1
CA	3001-400-616	TV Label, Inner, Right	1
CB	3001-402-1	Inner DMS Label, Left	1
CB	3001-402-2	Inner DMS Label, Right	1
CC	3001-400-953	Switch Cap	20
CD	3001-400-522	Filler Cap	20
CE	3001-403-831	Speaker With Cable	2
CF	(page 181)	DMS Module	2
CH	3001-400-937	StryKair Label, Outer, Left	1
CH	3001-400-947	StryKair Label, Outer, Right	1
CJ	3001-402-804	Main to Options PCB Cable, Left	1
CJ	3001-402-803	Main to Options PCB Cable, Right	1

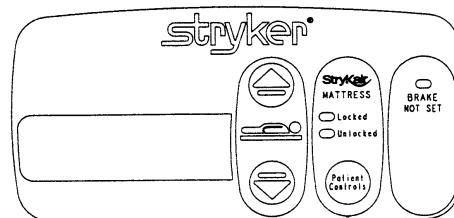
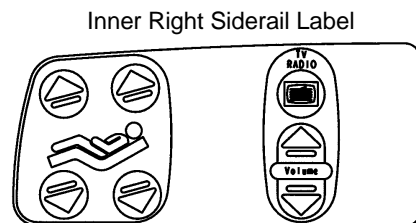

Head End Siderail Assembly

Standard Siderail with Lights and DMS

Item	Part No.	Part Name	Qty.
AN	3000-300-114	Cable Tie	3
CA	3001-400-627	Lights Label, Inner, Left	1
CA	3001-400-617	Lights Label, Inner, Right	1
CB	3001-402-1	Inner DMS Label, Left	1
CB	3001-402-2	Inner DMS Label, Right	1
CC	3001-400-953	Switch Cap	18
CD	3001-400-522	Filler Cap	22
CE	3001-400-517	Speaker Seal	2
CF	(page 181)	DMS Module	2
CH	3001-400-637	DMS Label, Outer, Left	1
CH	3001-400-647	DMS Label, Outer, Right	1
CJ	3001-402-804	Main to Options PCB Cable, Left	1
CJ	3001-402-803	Main to Options PCB Cable, Right	1

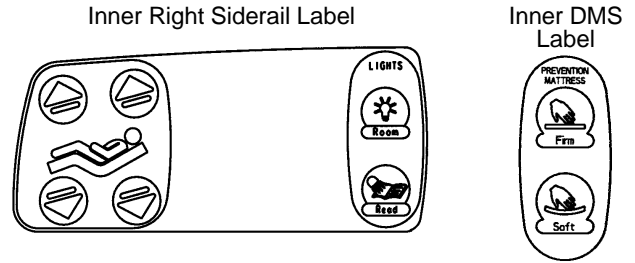

Standard Siderail with Lights and StryKair

Item	Part No.	Part Name	Qty.
AN	3000-300-114	Cable Tie	3
CA	3001-400-627	Lights Label, Inner, Left	1
CA	3001-400-617	Lights Label, Inner, Right	1
CB	3001-402-1	Inner DMS Label, Left	1
CB	3001-402-2	Inner DMS Label, Right	1
CC	3001-400-953	Switch Cap	18
CD	3001-400-522	Filler Cap	22
CE	3001-400-517	Speaker Seal	2
CF	(page 181)	DMS Module	2
CH	3001-400-937	StryKair Label, Outer, Left	1
CH	3001-400-947	StryKair Label, Outer, Right	1
CJ	3001-402-804	Main to Options PCB Cable, Left	1
CJ	3001-402-803	Main to Options PCB Cable, Right	1

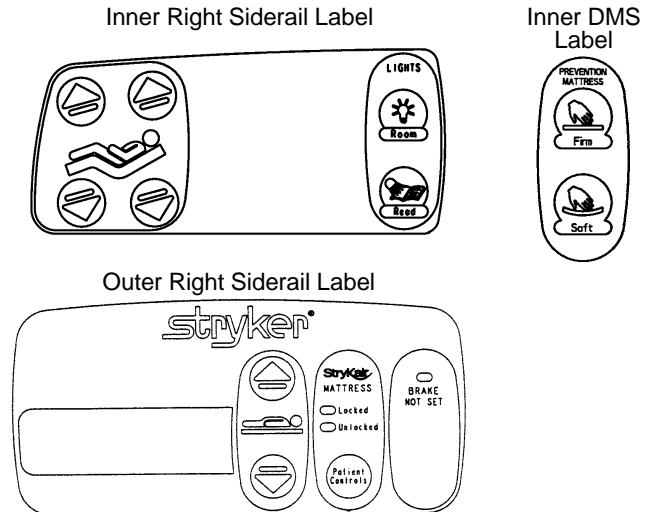

Standard Siderail with G/F & DMS

Item	Part No.	Part Name	Qty.
AN	3000-300-114	Cable Tie	3
CA	3001-400-620	Standard Label, Inner, Left	1
CA	3001-400-610	Standard Label, Inner, Right	1
CB	3001-402-1	Inner DMS Label, Left	1
CB	3001-402-2	Inner DMS Label, Right	1
CC	3001-400-953	Switch Cap	18
CD	3001-400-522	Filler Cap	22
CE	3001-400-517	Speaker Seal	2
CF	(page 181)	DMS Module	2
CH	3001-400-634	DMS, G/F Label, Outer, Left	1
CH	3001-400-644	DMS, G/F Label, Outer, Right	1
CJ	3001-402-804	Main to Options PCB Cable, Left	1
CJ	3001-402-803	Main to Options PCB Cable, Right	1

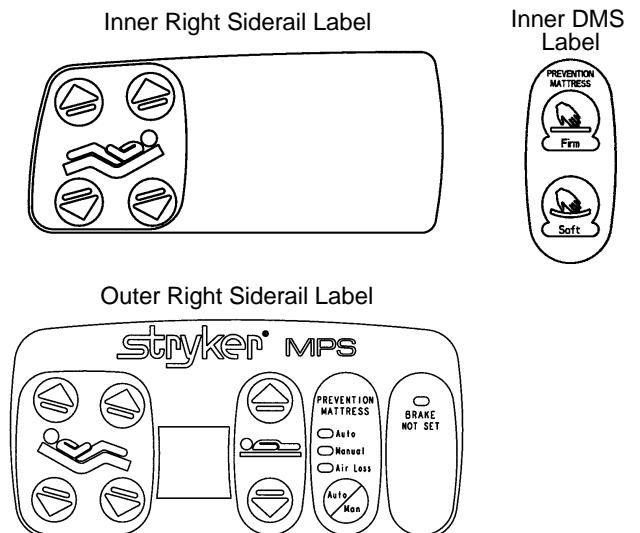

Head End Siderail Assembly

Standard Siderail with G/F & StryKair

Item	Part No.	Part Name	Qty.
AN	3000-300-114	Cable Tie	3
CA	3001-400-620	Standard Label, Inner, Left	1
CA	3001-400-610	Standard Label, Inner, Right	1
CB	3001-402-1	Inner DMS Label, Left	1
CB	3001-402-2	Inner DMS Label, Right	1
CC	3001-400-953	Switch Cap	22
CD	3001-400-522	Filler Cap	18
CE	3001-400-517	Speaker Seal	2
CF	(page 181)	DMS Module	2
CH	3001-400-934	StryKair, G/F Label, Outer, Left	1
CH	3001-400-944	StryKair, G/F Label, Outer, Right	1
CJ	3001-402-804	Main to Options PCB Cable, Left	1
CJ	3001-402-803	Main to Options PCB Cable, Right	1

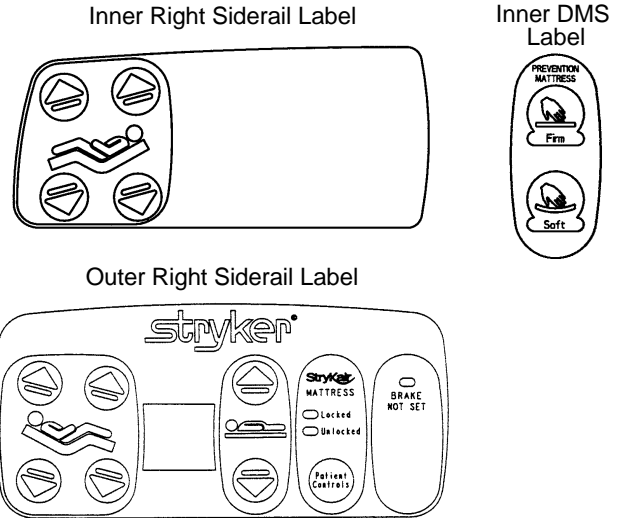

Standard Siderail w/Nurse Call, TV/Radio & DMS

Item	Part No.	Part Name	Qty.
AN	3000-300-114	Cable Tie	3
CA	3001-400-622	NC, TV Label, Inner, Left	1
CA	3001-400-612	NC, TV Label, Inner, Right	1
CB	3001-402-1	Inner DMS Label, Left	1
CB	3001-402-2	Inner DMS Label, Right	1
CC	3001-400-953	Switch Cap	24
CD	3001-400-522	Filler Cap	16
CE	3001-403-831	Speaker With Cable	2
CF	(page 181)	DMS Module	2
CH	3001-400-635	NC, DMS Label, Outer, Left	1
CH	3001-400-645	NC, DMS Label, Outer, Right	1
CJ	3001-402-804	Main to Options PCB Cable, Left	1
CJ	3001-402-803	Main to Options PCB Cable, Right	1

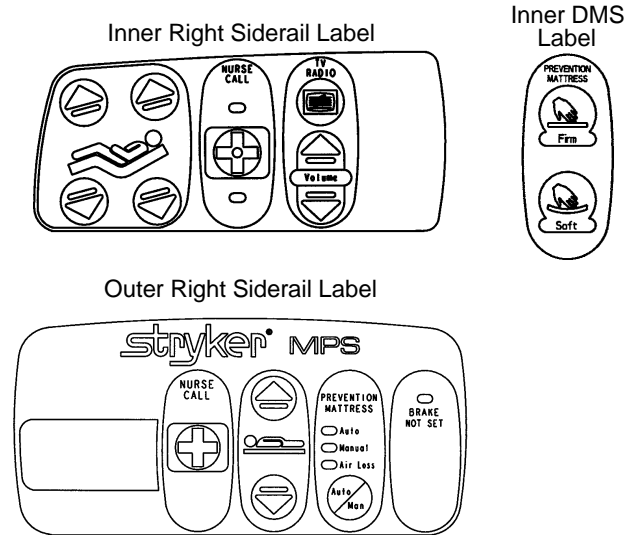

Standard Siderail w/Nurse Call, TV/Radio & StryKair

Item	Part No.	Part Name	Qty.
AN	3000-300-114	Cable Tie	3
CA	3001-400-622	NC, TV Label, Inner, Left	1
CA	3001-400-612	NC, TV Label, Inner, Right	1
CB	3001-402-1	Inner DMS Label, Left	1
CB	3001-402-2	Inner DMS Label, Right	1
CC	3001-400-953	Switch Cap	24
CD	3001-400-522	Filler Cap	16
CE	3001-403-831	Speaker With Cable	2
CF	(page 181)	DMS Module	2
CH	3001-400-935	NC, StryKair Label, Outer, Left	1
CH	3001-400-945	NC, StryKair Label, Outer, Right	1
CJ	3001-402-804	Main to Options PCB Cable, Left	1
CJ	3001-402-803	Main to Options PCB Cable, Right	1

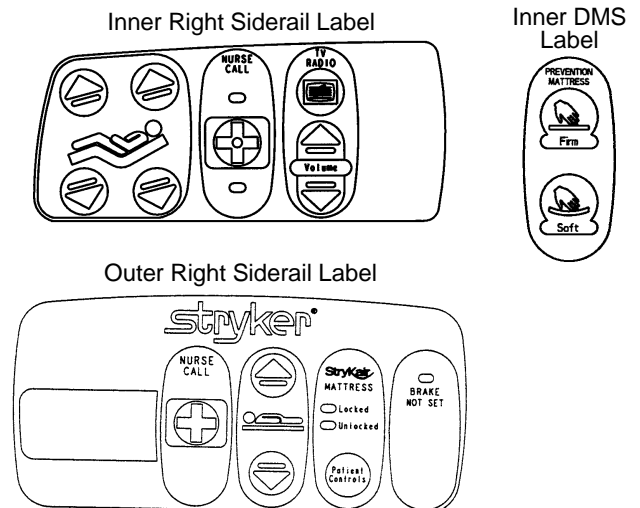

Head End Siderail Assembly

Standard Siderail w/Nurse Call, Lights and DMS

Item	Part No.	Part Name	Qty.
AN	3000-300-114	Cable Tie	3
CA	3001-400-625	NC, Lights Label, Inner, Left	1
CA	3001-400-615	NC, Lights Label, Inner, Right	1
CB	3001-402-1	Inner DMS Label, Left	1
CB	3001-402-2	Inner DMS Label, Right	1
CC	3001-400-953	Switch Cap	22
CD	3001-400-522	Filler Cap	18
CE	3001-403-831	Speaker With Cable	2
CF	(page 181)	DMS Module	2
CH	3001-400-635	NC, DMS Label, Outer, Left	1
CH	3001-400-645	NC, DMS Label, Outer, Right	1
CJ	3001-402-804	Main to Options PCB Cable, Left	1
CJ	3001-402-803	Main to Options PCB Cable, Right	1

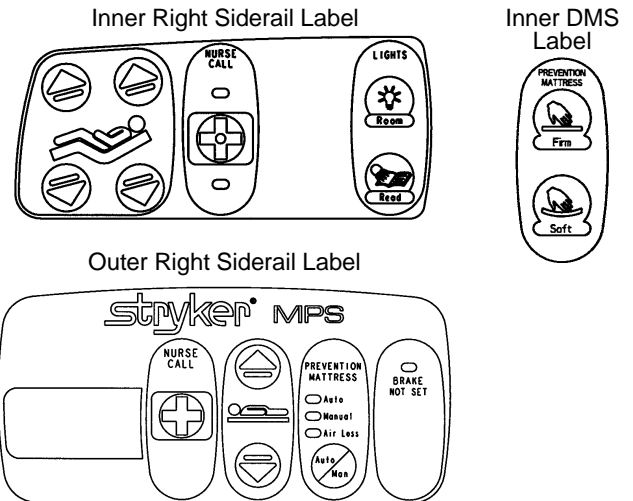

Standard Siderail w/Nurse Call, Lights and StryKair

Item	Part No.	Part Name	Qty.
AN	3000-300-114	Cable Tie	3
CA	3001-400-625	NC, Lights Label, Inner, Left	1
CA	3001-400-615	NC, Lights Label, Inner, Right	1
CB	3001-402-1	Inner DMS Label, Left	1
CB	3001-402-2	Inner DMS Label, Right	1
CC	3001-400-953	Switch Cap	22
CD	3001-400-522	Filler Cap	18
CE	3001-403-831	Speaker With Cable	2
CF	(page 181)	DMS Module	2
CH	3001-400-935	NC, StryKair Label, Outer, Left	1
CH	3001-400-945	NC, StryKair Label, Outer, Right	1
CJ	3001-402-804	Main to Options PCB Cable, Left	1
CJ	3001-402-803	Main to Options PCB Cable, Right	1

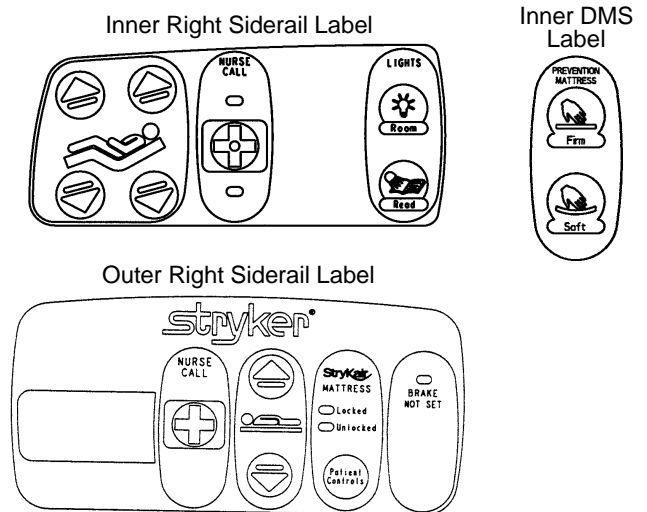

Standard Siderail with Nurse Call, G/F & DMS

Item	Part No.	Part Name	Qty.
AN	3000-300-114	Cable Tie	3
CA	3001-400-621	Nurse Call Label, Inner, Left	1
CA	3001-400-611	Nurse Call Label, Inner, Right	1
CB	3001-402-1	Inner DMS Label, Left	1
CB	3001-402-2	Inner DMS Label, Right	1
CC	3001-400-953	Switch Cap	26
CD	3001-400-522	Filler Cap	14
CE	3001-403-831	Speaker with Cable	2
CF	(page 181)	DMS Module	2
CH	3001-400-633	NC, G/F, DMS Label, Outer, Left	1
CH	3001-400-643	NC, G/F, DMS Label, Outer, Right	1
CJ	3001-402-804	Main to Options PCB Cable, Left	1
CJ	3001-402-803	Main to Options PCB Cable, Right	1

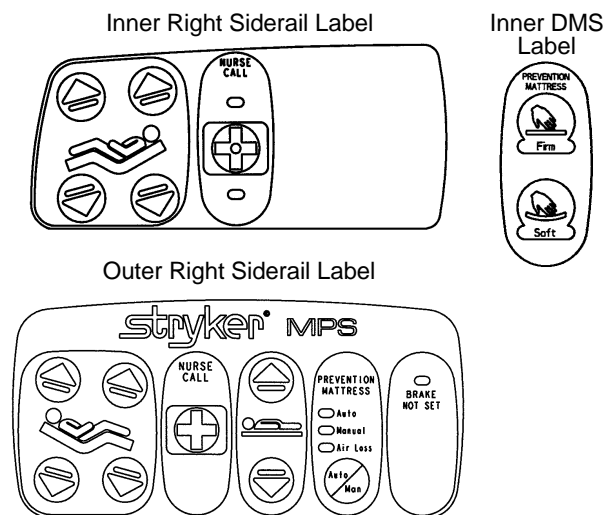

Head End Siderail Assembly

Standard Siderail with Nurse Call, G/F & StryKair

Item	Part No.	Part Name	Qty.
AN	3000-300-114	Cable Tie	3
CA	3001-400-621	Nurse Call Label, Inner, Left	1
CA	3001-400-611	Nurse Call Label, Inner, Right	1
CB	3001-402-1	Inner DMS Label, Left	1
CB	3001-402-2	Inner DMS Label, Right	1
CC	3001-400-953	Switch Cap	26
CD	3001-400-522	Filler Cap	14
CE	3001-403-831	Speaker with Cable	2
CF	(page 181)	DMS Module	2
CH	3001-400-673	NC, G/F, StryKair Label, Outer, Lt.	1
CH	3001-400-943	NC, G/F, StryKair Label, Outer, Rt.	1
CJ	3001-402-804	Main to Options PCB Cable, Left	1
CJ	3001-402-803	Main to Options PCB Cable, Right	1

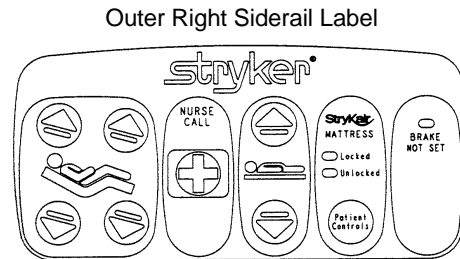
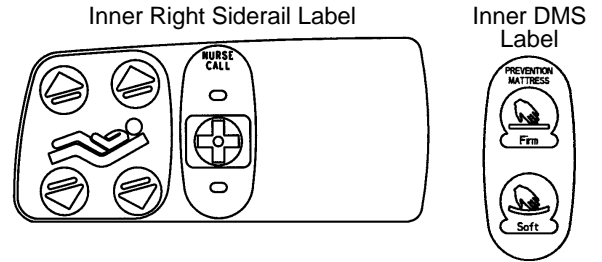

Std. Siderail w/Nurse Call, TV/Radio, Lights, & DMS

Item	Part No.	Part Name	Qty.
AN	3000-300-114	Cable Tie	3
CA	3001-400-623	NC, TV, Lights Label, In., Lt.	1
CA	3001-400-613	NC, TV, Lights Label, In., Rt.	1
CB	3001-402-1	Inner DMS Label, Left	1
CB	3001-402-2	Inner DMS Label, Right	1
CC	3001-400-953	Switch Cap	28
CD	3001-400-522	Filler Cap	12
CE	3001-403-831	Speaker With Cable	2
CF	(page 181)	DMS Module	2
CH	3001-400-635	NC, DMS Label, Outer, Left	1
CH	3001-400-645	NC, DMS Label, Outer, Right	1
CJ	3001-402-804	Main to Options PCB Cable, Left	1
CJ	3001-402-803	Main to Options PCB Cable, Right	1

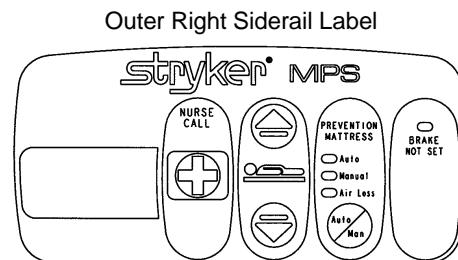
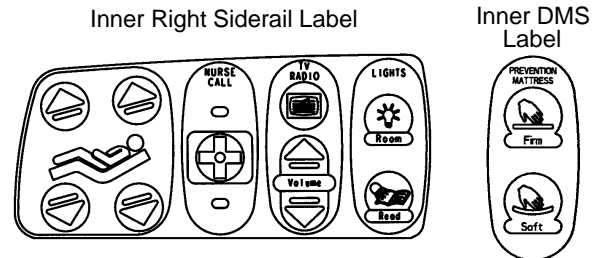

Std. Siderail w/Nurse Call, TV/Radio, Lights, & StryKair

Item	Part No.	Part Name	Qty.
AN	3000-300-114	Cable Tie	3
CA	3001-400-623	NC, TV, Lights Label, In., Lt.	1
CA	3001-400-613	NC, TV, Lights Label, In., Rt.	1
CB	3001-402-1	Inner DMS Label, Left	1
CB	3001-402-2	Inner DMS Label, Right	1
CC	3001-400-953	Switch Cap	28
CD	3001-400-522	Filler Cap	12
CE	3001-403-831	Speaker With Cable	2
CF	(page 181)	DMS Module	2
CH	3001-400-935	NC, StryKair Label, Outer, Left	1
CH	3001-400-945	NC, StryKair Label, Outer, Right	1
CJ	3001-402-804	Main to Options PCB Cable, Left	1
CJ	3001-402-803	Main to Options PCB Cable, Right	1

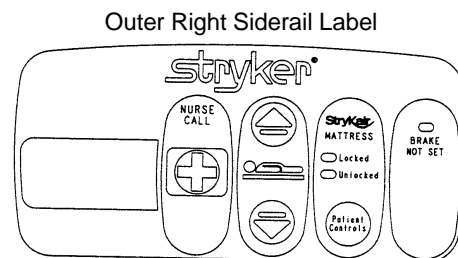
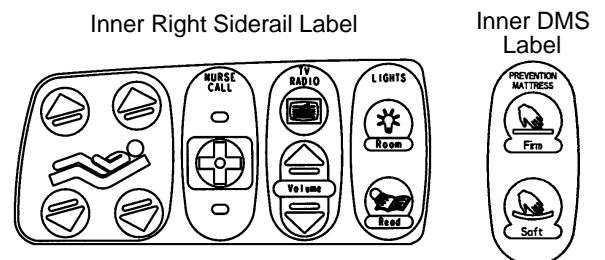

Head End Siderail Assembly

Std. Siderail w/Nurse Call, STV, Lights, & DMS

Item	Part No.	Part Name	Qty.
AN	3000-300-114	Cable Tie	3
CA	3001-400-623	NC, TV, Lights Label, In., Lt.	1
CA	3001-400-613	NC, TV, Lights Label, In., Rt.	1
CB	3001-402-1	Inner DMS Label, Left	1
CB	3001-402-2	Inner DMS Label, Right	1
CC	3001-400-953	Switch Cap	28
CD	3001-400-522	Filler Cap	12
CE	3001-403-831	Speaker With Cable	2
CF	(page 181)	DMS Module	2
CH	3001-400-635	NC, DMS Label, Outer, Left	1
CH	3001-400-645	NC, DMS Label, Outer, Right	1
CJ	3001-402-803	Main to Options PCB Cable	2

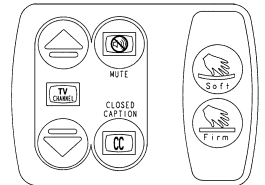
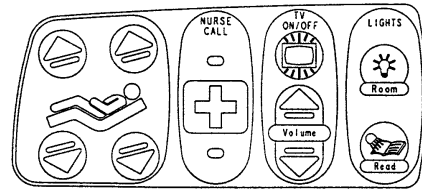

Outer Right Siderail Label

Inner STV Label

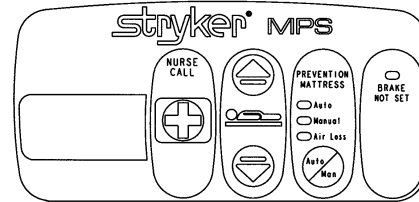

Inner Right Siderail Label

Inner DMS Label

Std. Siderail w/Nurse Call, TV/Radio, G/F, & DMS

Item	Part No.	Part Name	Qty.
AN	3000-300-114	Cable Tie	3
CA	3001-400-622	NC, TV Label, Inner, Left	1
CA	3001-400-612	NC, TV Label, Inner, Right	1
CB	3001-402-1	DMS Label, Left	1
CB	3001-402-2	DMS Label, Right	1
CC	3001-400-953	Switch Cap	32
CD	3001-400-522	Filler Cap	8
CE	3001-403-831	Speaker With Cable	2
CF	(page 181)	DMS Module	2
CH	3001-400-633	NC, G/F, DMS Label, Outer, Left	1
CH	3001-400-643	NC, G/F, DMS Label, Outer, Right	1
CJ	3001-402-804	Main to Options PCB Cable, Left	1
CJ	3001-402-803	Main to Options PCB Cable, Right	1

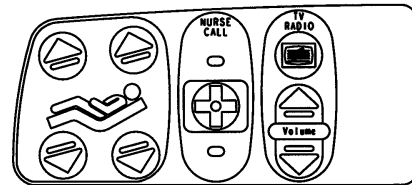

Outer Right Siderail Label



Inner Right Siderail Label

Inner DMS Label

Std. Siderail w/Nurse Call, TV/Radio, G/F, & StryKair

Item	Part No.	Part Name	Qty.
AN	3000-300-114	Cable Tie	3
CA	3001-400-622	NC, TV Label, Inner, Left	1
CA	3001-400-612	NC, TV Label, Inner, Right	1
CB	3001-402-1	Inner DMS Label, Left	1
CB	3001-402-2	Inner DMS Label, Right	1
CC	3001-400-953	Switch Cap	32
CD	3001-400-522	Filler Cap	8
CE	3001-403-831	Speaker With Cable	2
CF	(page 181)	DMS Module	2
CH	3001-400-673	NC, G/F, StryKair Label, Outer, Lt.	1
CH	3001-400-943	NC, G/F, StryKair Label, Outer, Rt.	1
CJ	3001-402-804	Main to Options PCB Cable, Left	1
CJ	3001-402-803	Main to Options PCB Cable, Right	1

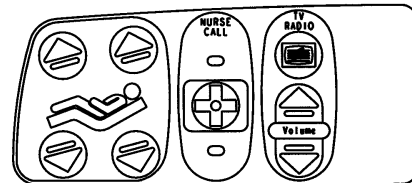

Outer Right Siderail Label

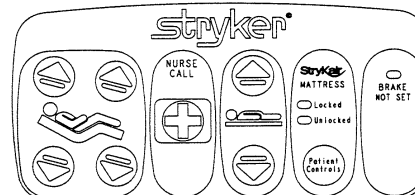
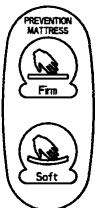

Head End Siderail Assembly

Standard Siderail w/Nurse Call, Lights, G/F & DMS

Item	Part No.	Part Name	Qty.
AN	3000-300-114	Cable Tie	3
CA	3001-400-625	NC, Lights, Label, Inner, Left	1
CA	3001-400-615	NC, Lights, Label, Inner, Right	1
CB	3001-402-1	Inner DMS Label, Left	1
CB	3001-402-2	Inner DMS Label, Right	1
CC	3001-400-953	Switch Cap	30
CD	3001-400-522	Filler Cap	10
CE	3001-403-831	Speaker with Cable	2
CF	(page 181)	DMS Module	2
CH	3001-400-633	NC, G/F, DMS Label, Outer, Left	1
CH	3001-400-643	NC, G/F, DMS Label, Outer, Right	1
CJ	3001-402-804	Main to Options PCB Cable, Left	1
CJ	3001-402-803	Main to Options PCB Cable, Right	1

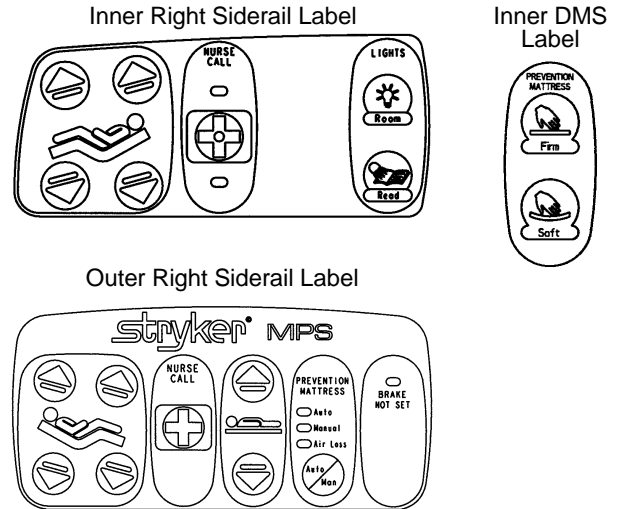

Standard Siderail w/Nurse Call, Lights, G/F & StryKair

Item	Part No.	Part Name	Qty.
AN	3000-300-114	Cable Tie	3
CA	3001-400-625	NC, Lights, Label, Inner, Left	1
CA	3001-400-615	NC, Lights, Label, Inner, Right	1
CB	3001-402-1	Inner DMS Label, Left	1
CB	3001-402-2	Inner DMS Label, Right	1
CC	3001-400-953	Switch Cap	30
CD	3001-400-522	Filler Cap	10
CE	3001-403-831	Speaker with Cable	2
CF	(page 181)	DMS Module	2
CH	3001-400-673	NC, G/F, StryKair Label, Outer, Lt.	1
CH	3001-400-943	NC, G/F, StryKair Label, Outer, Rt.	1
CJ	3001-402-804	Main to Options PCB Cable, Left	1
CJ	3001-402-803	Main to Options PCB Cable, Right	1

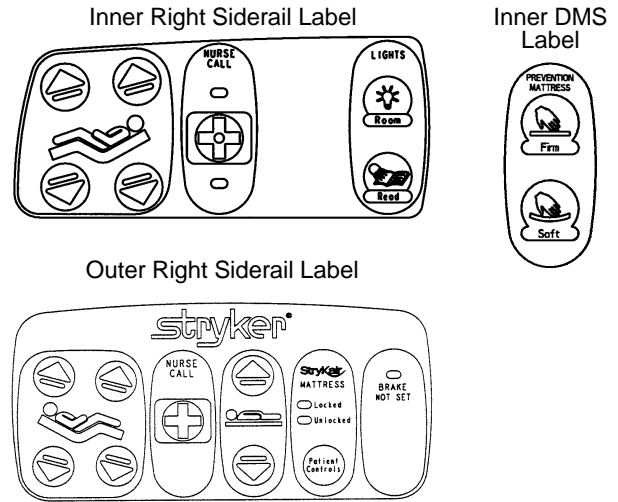

Std. Siderail w/Nurse Call, STV, Lights, & G/F

Item	Part No.	Part Name	Qty.
AN	3000-300-114	Cable Tie	3
CA	3001-430-623	NC, TV Label, Inner, Left	1
CA	3001-430-613	NC, TV Label, Inner, Right	1
CB	3001-430-131	STV Label, Left	1
CB	3001-430-132	STV Label, Right	1
CC	3001-400-953	Switch Cap	42
CD	3001-400-522	Filler Cap	10
CE	3001-403-831	Speaker With Cable	2
CF	(page 180)	TV Control Module, Left	1
CF	(page 179)	TV Control Module, Right	1
CH	3001-400-632	NC, G/F, Label, Outer, Left	1
CH	3001-400-642	NC, G/F, Label, Outer, Right	1
CJ	3001-402-803	Main to Options PCB Cable	2

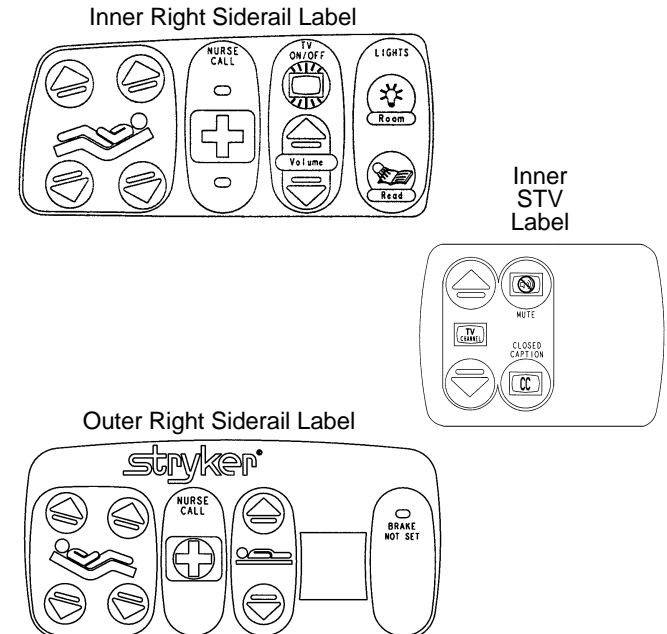

Head End Siderail Assembly

Std. Siderail w/NC, TV/Radio, Lights, G/F, & DMS

Item	Part No.	Part Name	Qty.
AN	3000-300-114	Cable Tie	3
CB	3001-402-1	Inner DMS Label, Left	1
CB	3001-402-2	Inner DMS Label, Right	1
CA	3001-400-623	NC, TV, Lights Label, In., Lt.	1
CA	3001-400-613	NC, TV, Lights Label, In., Rt.	1
CC	3001-400-953	Switch Cap	36
CD	3001-400-522	Filler Cap	4
CE	3001-403-831	Speaker With Cable	2
CF	(page 181)	DMS Module	2
CH	3001-400-633	NC, DMS, G/F Label, Outer, Left	1
CH	3001-400-643	NC, DMS, G/F Label, Outer, Right	1
CJ	3001-402-804	Main to Options PCB Cable, Left	1
CJ	3001-402-803	Main to Options PCB Cable, Right	1

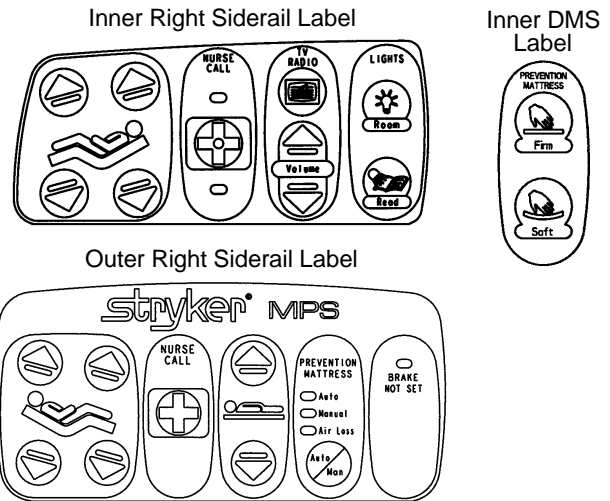

Std. Siderail w/NC, TV/Radio, Lights, G/F, & StryKair

Item	Part No.	Part Name	Qty.
AN	3000-300-114	Cable Tie	3
CA	3001-400-623	NC, TV, Lights Label, In., Lt.	1
CA	3001-400-613	NC, TV, Lights Label, In., Rt.	1
CB	3001-402-1	Inner DMS Label, Left	1
CB	3001-402-2	Inner DMS Label, Right	1
CC	3001-400-953	Switch Cap	36
CD	3001-400-522	Filler Cap	4
CE	3001-403-831	Speaker With Cable	2
CF	(page 181)	DMS Module	2
CH	3001-400-673	NC, StryKair, G/F Label, Outer, Lt.	1
CH	3001-400-943	NC, StryKair, G/F Label, Outer, Rt.	1
CJ	3001-402-804	Main to Options PCB Cable, Left	1
CJ	3001-402-803	Main to Options PCB Cable, Right	1

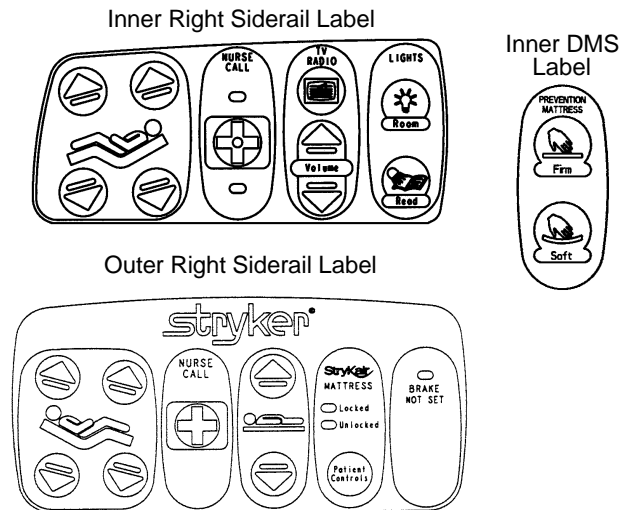

Std. Siderail w/NC, STV, Lights, G/F, & DMS

Item	Part No.	Part Name	Qty.
AN	3000-300-114	Cable Tie	3
CB	3001-402-1	Inner DMS Label, Left	1
CB	3001-402-2	Inner DMS Label, Right	1
CA	3001-400-623	NC, TV, Lights Label, In., Lt.	1
CA	3001-400-613	NC, TV, Lights Label, In., Rt.	1
CC	3001-400-953	Switch Cap	36
CD	3001-400-522	Filler Cap	4
CE	3001-403-831	Speaker With Cable	2
CF	(page 181)	DMS Module	2
CH	3001-400-633	NC, DMS, G/F Label, Outer, Left	1
CH	3001-400-643	NC, DMS, G/F Label, Outer, Right	1
CJ	3001-402-803	Main to Options PCB Cable	2

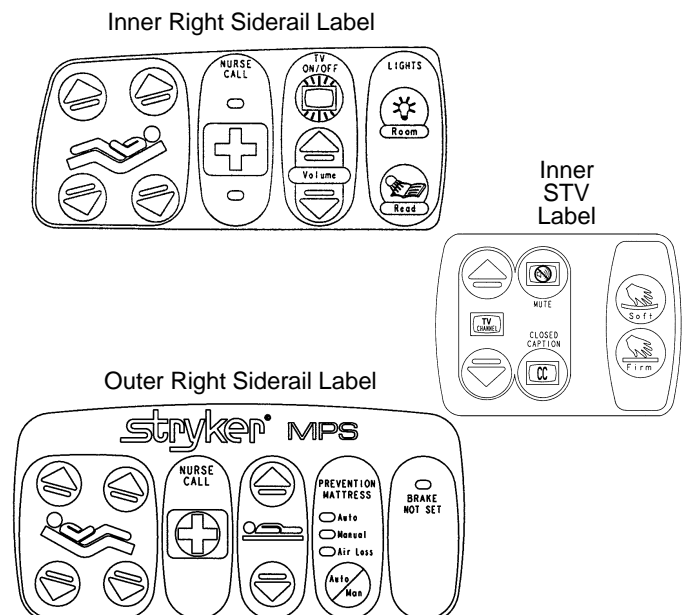

Head End Siderail Assembly

Standard Siderail with TV/Radio, Lights, & DMS

Item	Part No.	Part Name	Qty.
AN	3000-300-114	Cable Tie	3
CA	3001-400-624	TV, Lights Label, Inner, Left	1
CA	3001-400-614	TV, Lights Label, Inner, Right	1
CB	3001-402-1	Inner DMS Label, Left	1
CB	3001-402-2	Inner DMS Label, Right	1
CC	3001-400-953	Switch Cap	24
CD	3001-400-522	Filler Cap	16
CE	3001-403-831	Speaker With Cable	2
CH	3001-400-637	DMS Label, Outer, Left	1
CH	3001-400-647	DMS Label, Outer, Right	1
CJ	3001-402-804	Main to Options PCB Cable, Left	1
CJ	3001-402-803	Main to Options PCB Cable, Right	1

Inner Right Siderail Label

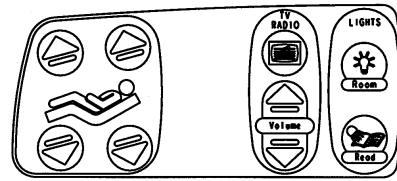

Inner DMS Label



Outer Right Siderail Label

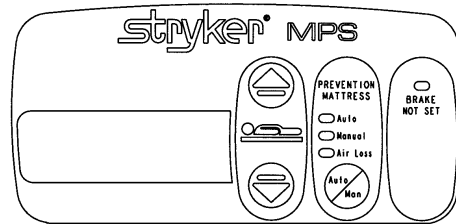

Standard Siderail with TV/Radio, Lights, & StryKair

Item	Part No.	Part Name	Qty.
AN	3000-300-114	Cable Tie	3
CA	3001-400-624	TV, Lights Label, Inner, Left	1
CA	3001-400-614	TV, Lights Label, Inner, Right	1
CB	3001-402-1	Inner DMS Label, Left	1
CB	3001-402-2	Inner DMS Label, Right	1
CC	3001-400-953	Switch Cap	24
CD	3001-400-522	Filler Cap	16
CE	3001-403-831	Speaker With Cable	2
CH	3001-400-937	StryKair Label, Outer, Left	1
CH	3001-400-947	StryKair Label, Outer, Right	1
CJ	3001-402-804	Main to Options PCB Cable, Left	1
CJ	3001-402-803	Main to Options PCB Cable, Right	1

Inner Right Siderail Label

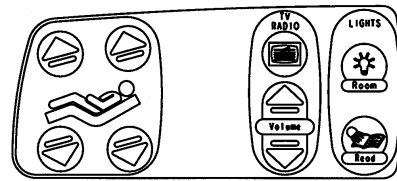

Inner DMS Label

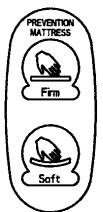

Outer Right Siderail Label

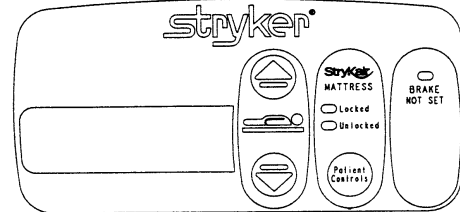

Standard Siderail with TV/Radio, G/F and DMS

Item	Part No.	Part Name	Qty.
AN	3000-300-114	Cable Tie	3
CA	3001-400-626	TV Label, Inner, Left	1
CA	3001-400-616	TV Label, Inner, Right	1
CB	3001-402-1	Inner DMS Label, Left	1
CB	3001-402-2	Inner DMS Label, Right	1
CC	3001-400-953	Switch Cap	28
CD	3001-400-522	Filler Cap	12
CE	3001-403-831	Speaker With Cable	2
CF	(page 181)	DMS Module	2
CH	3001-400-634	DMS, G/F Label, Outer, Left	1
CH	3001-400-644	DMS, G/F Label, Outer, Right	1
CJ	3001-402-804	Main to Options PCB Cable, Left	1
CJ	3001-402-803	Main to Options PCB Cable, Right	1

Inner Right Siderail Label

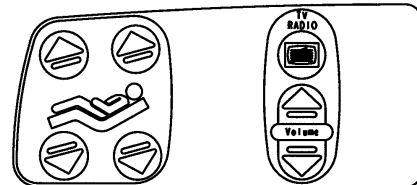

Inner DMS Label



Outer Right Siderail Label

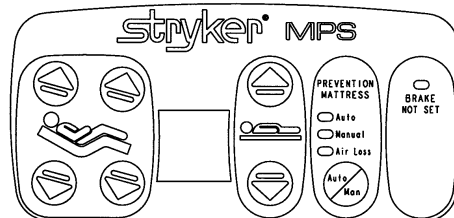

Head End Siderail Assembly

Standard Siderail with TV/Radio, G/F and StryKair

Item	Part No.	Part Name	Qty.
AN	3000-300-114	Cable Tie	3
CA	3001-400-626	TV Label, Inner, Left	1
CA	3001-400-616	TV Label, Inner, Right	1
CB	3001-402-1	Inner DMS Label, Left	1
CB	3001-402-2	Inner DMS Label, Right	1
CC	3001-400-953	Switch Cap	28
CD	3001-400-522	Filler Cap	12
CE	3001-403-831	Speaker With Cable	2
CF	(page 181)	DMS Module	2
CH	3001-400-934	StryKair, G/F Label, Outer, Left	1
CH	3001-400-944	StryKair, G/F Label, Outer, Right	1
CJ	3001-402-804	Main to Options PCB Cable, Left	1
CJ	3001-402-803	Main to Options PCB Cable, Right	1

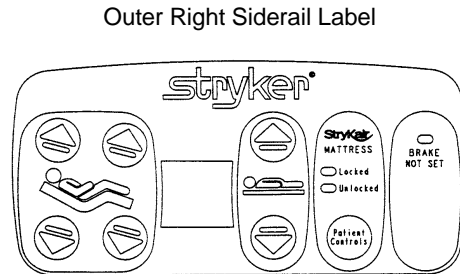
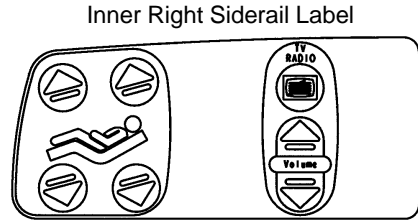

Std. Siderail with TV/Radio, Lights, G/F, & DMS

Item	Part No.	Part Name	Qty.
AN	3000-300-114	Cable Tie	3
CA	3001-400-624	TV, Lights Label, Inner, Left	1
CA	3001-400-614	TV, Lights Label, Inner, Right	1
CB	3001-402-1	Inner DMS Label, Left	1
CB	3001-402-2	Inner DMS Label, Right	1
CC	3001-400-953	Switch Cap	32
CD	3001-400-522	Filler Cap	8
CE	3001-403-831	Speaker With Cable	2
CF	(page 181)	DMS Module	2
CH	3001-400-634	DMS, G/F Label, Outer, Left	1
CH	3001-400-644	DMS, G/F Label, Outer, Right	1
CJ	3001-402-804	Main to Options PCB Cable, Left	1
CJ	3001-402-803	Main to Options PCB Cable, Right	1

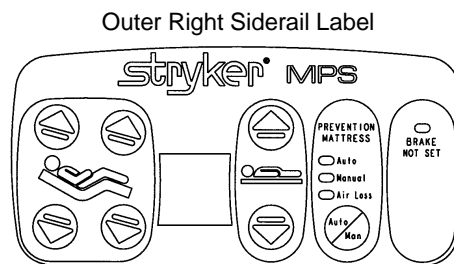
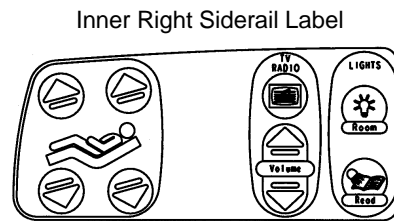

Std. Siderail with TV/Radio, Lights, G/F, & StryKair

Item	Part No.	Part Name	Qty.
AN	3000-300-114	Cable Tie	3
CA	3001-400-624	TV, Lights Label, Inner, Left	1
CA	3001-400-614	TV, Lights Label, Inner, Right	1
CB	3001-402-1	Inner DMS Label, Left	1
CB	3001-402-2	Inner DMS Label, Right	1
CC	3001-400-953	Switch Cap	32
CD	3001-400-522	Filler Cap	8
CE	3001-403-831	Speaker With Cable	2
CF	(page 181)	DMS Module	2
CH	3001-400-934	StryKair, G/F Label, Outer, Left	1
CH	3001-400-944	StryKair, G/F Label, Outer, Right	1
CJ	3001-402-804	Main to Options PCB Cable, Left	1
CJ	3001-402-803	Main to Options PCB Cable, Right	1

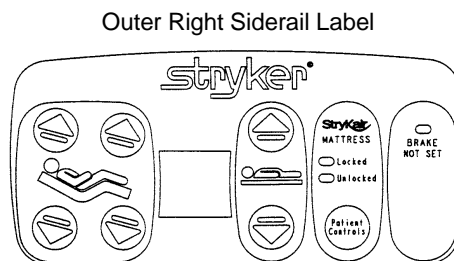
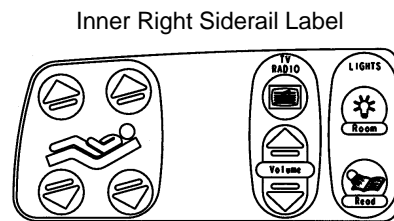

Head End Siderail Assembly

Standard Siderail with Lights, G/F and DMS

Item	Part No.	Part Name	Qty.
AN	3000-300-114	Cable Tie	3
CA	3001-400-627	Lights Label, Inner, Left	1
CA	3001-400-617	Lights Label, Inner, Right	1
CB	3001-402-1	Inner DMS Label, Left	1
CB	3001-402-2	Inner DMS Label, Right	1
CC	3001-400-953	Switch Cap	26
CD	3001-400-522	Filler Cap	14
CE	3001-400-517	Speaker Seal	2
CF	(page 181)	DMS Module	2
CH	3001-400-634	DMS, G/F Label, Outer, Left	1
CH	3001-400-644	DMS, G/F Label, Outer, Right	1
CJ	3001-402-804	Main to Options PCB Cable, Left	1
CJ	3001-402-803	Main to Options PCB Cable, Right	1

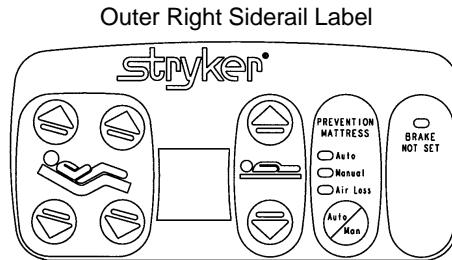
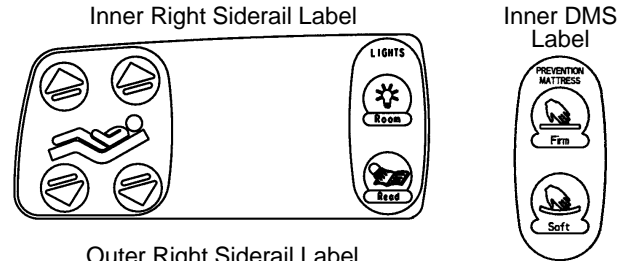

Standard Siderail with Lights, G/F and StryKair

Item	Part No.	Part Name	Qty.
AN	3000-300-114	Cable Tie	3
CA	3001-400-627	Lights Label, Inner, Left	1
CA	3001-400-617	Lights Label, Inner, Right	1
CB	3001-402-1	Inner DMS Label, Left	1
CB	3001-402-2	Inner DMS Label, Right	1
CC	3001-400-953	Switch Cap	26
CD	3001-400-522	Filler Cap	14
CE	3001-400-517	Speaker Seal	2
CF	(page 181)	DMS Module	2
CH	3001-400-934	StryKair, G/F Label, Outer, Left	1
CH	3001-400-944	StryKair, G/F Label, Outer, Right	1
CJ	3001-402-804	Main to Options PCB Cable, Left	1
CJ	3001-402-803	Main to Options PCB Cable, Right	1

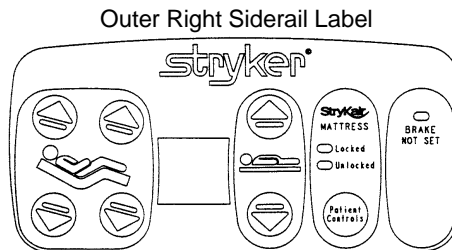
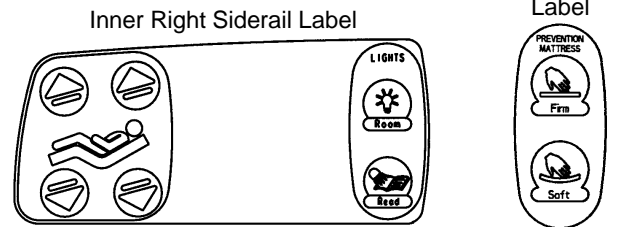

Std. Siderail w/NC, TV/Radio, Lights & StryKair Capable

Item	Part No.	Part Name	Qty.
AN	3000-300-114	Cable Tie	3
CA	3001-400-623	NC, TV, Lights Label, In., Lt.	1
CA	3001-400-613	NC, TV, Lights Label, In., Rt.	1
CB	2035-000-105	Blank Label	2
CC	3001-400-953	Switch Cap	36
CD	3001-400-522	Filler Cap	18
CE	3001-403-831	Speaker With Cable	2
CF	(page 181)	DMS Module	2
CH	3001-400-631	Nurse Call Label, Outer, Left	1
CH	3001-400-641	Nurse Call Label, Outer, Right	1
CJ	3001-402-804	Main to Options PCB Cable, Left	1
CJ	3001-402-803	Main to Options PCB Cable, Right	1

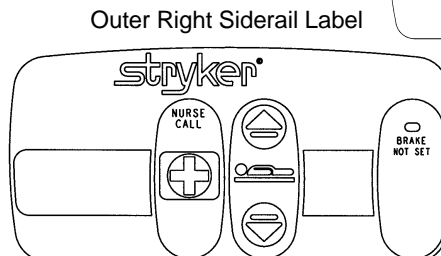
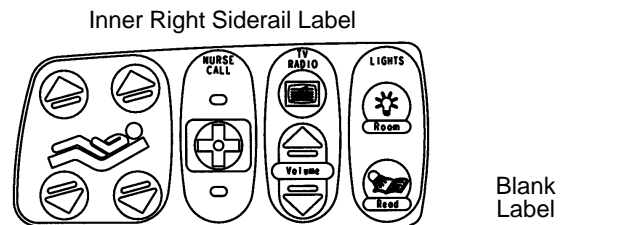

Head End Siderail Assembly

Std. Siderail w/NC, TV/Radio, Lights, G/F, & StryKair Capable

Item	Part No.	Part Name	Qty.
AN	3000-300-114	Cable Tie	3
CA	3001-400-623	NC, TV, Lights Label, In., Lt.	1
CA	3001-400-613	NC, TV, Lights Label, In., Rt.	1
CB	2035-000-105	Blank Label	2
CC	3001-400-953	Switch Cap	34
CD	3001-400-522	Filler Cap	10
CE	3001-403-831	Speaker With Cable	2
CF	(page 181)	DMS Module	2
CH	3001-400-632	NC, G/F Label, Outer, Left	1
CH	3001-400-642	NC, G/F Label, Outer, Right	1
CJ	3001-402-804	Main to Options PCB Cable, Left	1
CJ	3001-402-803	Main to Options PCB Cable, Right	1

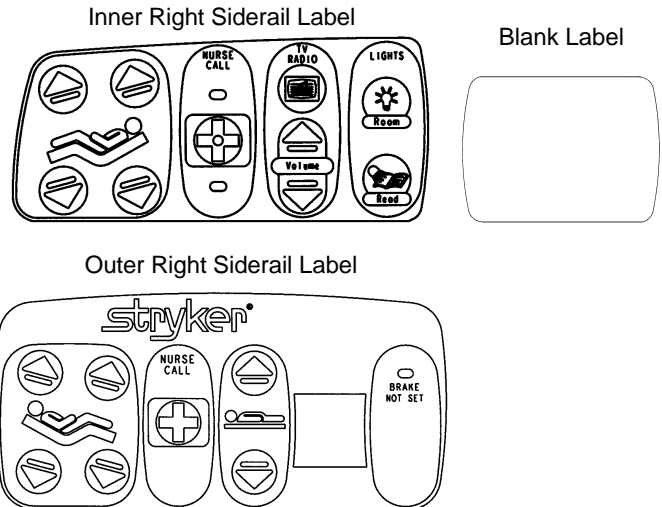

Std. Siderail w/Nurse Call, TV/Radio, G/F, & StryKair Capable

Item	Part No.	Part Name	Qty.
AN	3000-300-114	Cable Tie	3
CA	3001-400-622	NC, TV Label, Inner, Left	1
CA	3001-400-612	NC, TV Label, Inner, Right	1
CB	2035-000-105	Blank Label	2
CC	3001-400-953	Switch Cap	30
CD	3001-400-522	Filler Cap	14
CE	3001-403-831	Speaker With Cable	2
CF	(page 181)	DMS Module	2
CH	3001-400-632	NC, G/F, Label, Outer, Left	1
CH	3001-400-642	NC, G/F, Label, Outer, Right	1
CJ	3001-402-804	Main to Options PCB Cable, Left	1
CJ	3001-402-803	Main to Options PCB Cable, Right	1

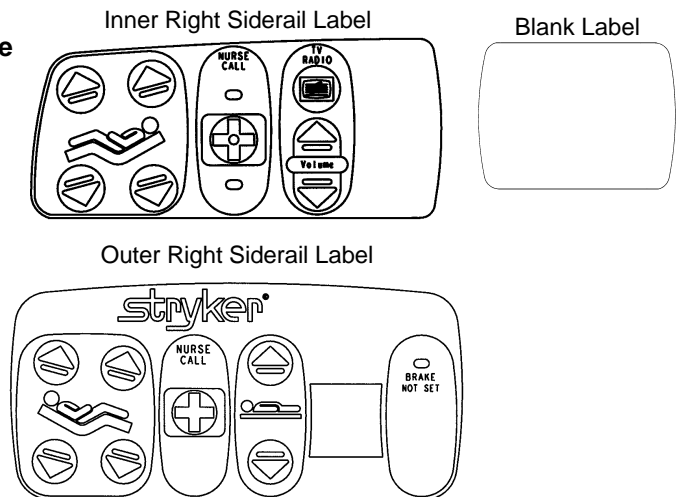

Standard Siderail w/Nurse Call, TV/Radio & StryKair Capable

Item	Part No.	Part Name	Qty.
AN	3000-300-114	Cable Tie	3
CA	3001-400-622	NC, TV Label, Inner, Left	1
CA	3001-400-612	NC, TV Label, Inner, Right	1
CB	2025-000-105	Blank Label	2
CC	3001-400-953	Switch Cap	22
CD	3001-400-522	Filler Cap	22
CE	3001-403-831	Speaker With Cable	2
CF	(page 181)	DMS Module	2
CH	3001-400-631	Nurse Call Label, Outer, Left	1
CH	3001-400-641	Nurse Call Label, Outer, Right	1
CJ	3001-402-804	Main to Options PCB Cable, Left	1
CJ	3001-402-803	Main to Options PCB Cable, Right	1

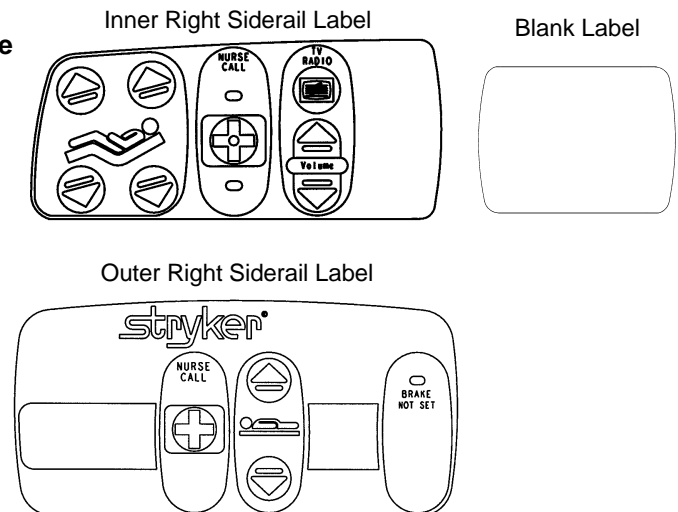

Head End Siderail Assembly

Standard Siderail w/Nurse Call, Lights and StryKair Capable

Item	Part No.	Part Name	Qty.
AN	3000-300-114	Cable Tie	3
CA	3001-400-625	NC, Lights Label, Inner, Left	1
CA	3001-400-615	NC, Lights Label, Inner, Right	1
CB	2035-000-105	Blank Label	2
CC	3001-400-953	Switch Cap	22
CD	3001-400-522	Filler Cap	22
CE	3001-403-831	Speaker With Cable	2
CF	(page 181)	DMS Module	2
CH	3001-400-631	Nurse Call Label, Outer, Left	1
CH	3001-400-641	Nurse Call Label, Outer, Right	1
CJ	3001-402-804	Main to Options PCB Cable, Left	1
CJ	3001-402-803	Main to Options PCB Cable, Right	1

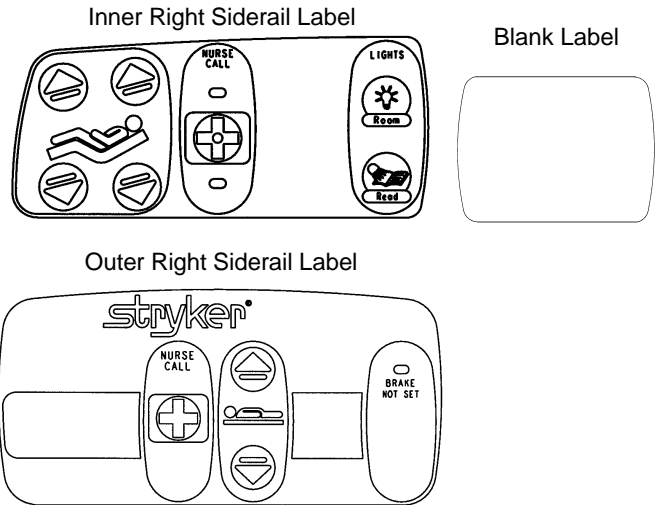

Standard Siderail w/NC, Lights, G/F and Strykair Capable

Item	Part No.	Part Name	Qty.
AN	3000-300-114	Cable Tie	3
CA	3001-400-625	NC, Lights, Label, Inner, Left	1
CA	3001-400-615	NC, Lights, Label, Inner, Right	1
CB	2035-000-105	Blank Label	2
CC	3001-400-953	Switch Cap	28
CD	3001-400-522	Filler Cap	16
CE	3001-403-831	Speaker with Cable	2
CF	(page 181)	DMS Module	2
CH	3001-400-632	NC, G/F Label, Outer, Left	1
CH	3001-400-642	NC, G/F Label, Outer, Right	1
CJ	3001-402-804	Main to Options PCB Cable, Left	1
CJ	3001-402-803	Main to Options PCB Cable, Right	1

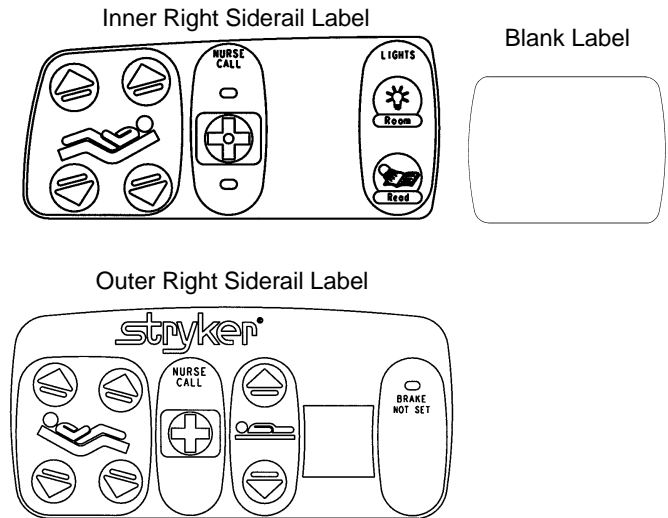

Standard Siderail with Nurse Call and StryKair Capable

Item	Part No.	Part Name	Qty.
AN	3000-300-114	Cable Tie	3
CA	3001-400-621	Nurse Call Label, Inner, Left	1
CA	3001-400-611	Nurse Call Label, Inner, Right	1
CB	2035-000-105	Blank Label	2
CC	3001-400-953	Switch Cap	16
CD	3001-400-522	Filler Cap	28
CE	3001-403-831	Speaker With Cable	2
CF	(page 181)	DMS Module	2
CH	3001-400-631	Nurse Call Label, Outer, Left	1
CH	3001-400-641	Nurse Call Label, Outer, Right	1
CJ	3001-402-804	Main to Options PCB Cable, Left	1
CJ	3001-402-803	Main to Options PCB Cable, Right	1

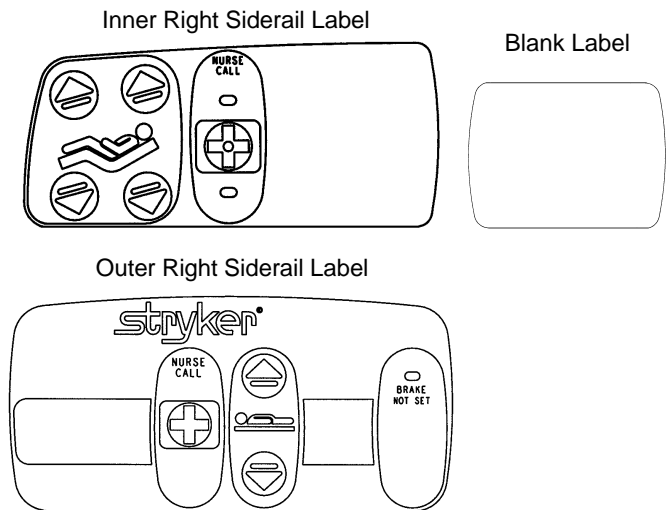

Head End Siderail Assembly

Standard Siderail with Nurse Call, G/F & StryKair Capable

Item	Part No.	Part Name	Qty.
AN	3000-300-114	Cable Tie	3
CA	3001-400-621	Nurse Call Label, Inner, Left	1
CA	3001-400-611	Nurse Call Label, Inner, Right	1
CB	2035-000-105	Blank Label	2
CC	3001-400-953	Switch Cap	14
CD	3001-400-522	Filler Cap	20
CE	3001-403-831	Speaker with Cable	2
CF	(page 181)	DMS Module	2
CH	3001-400-632	NC, G/F Label, Outer, Left	1
CH	3001-400-642	NC, G/F Label, Outer, Right	1
CJ	3001-402-804	Main to Options PCB Cable, Left	1
CJ	3001-402-803	Main to Options PCB Cable, Right	1

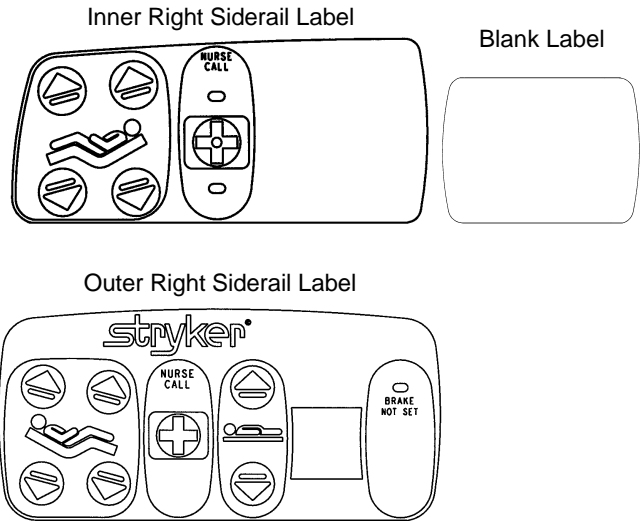

Standard Siderail with TV/Radio, Lights, & StryKair Capable

Item	Part No.	Part Name	Qty.
AN	3000-300-114	Cable Tie	3
CA	3001-400-624	TV, Lights Label, Inner, Left	1
CA	3001-400-614	TV, Lights Label, Inner, Right	1
CB	2035-000-105	Blank Label	2
CC	3001-400-953	Switch Cap	22
CD	3001-400-522	Filler Cap	20
CE	3001-403-831	Speaker With Cable	2
CH	3001-400-630	Standard Label, Outer, Left	1
CH	3001-400-640	Standard Label, Outer, Right	1
CJ	3001-402-804	Main to Options PCB Cable, Left	1
CJ	3001-402-803	Main to Options PCB Cable, Right	1

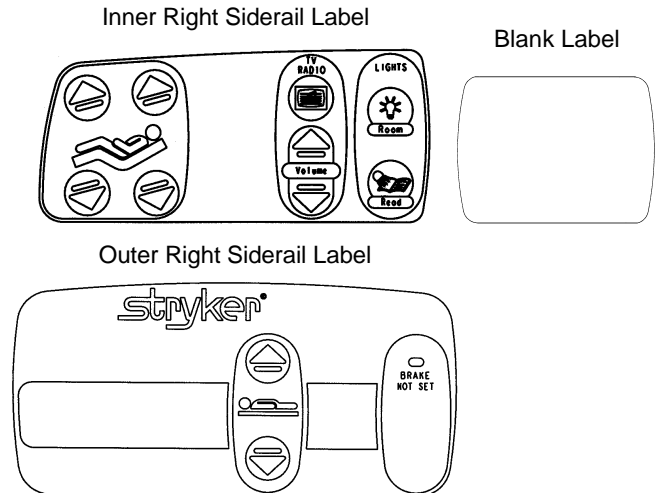

Std. Siderail with TV/Radio, Lights, G/F, & StryKair Capable

Item	Part No.	Part Name	Qty.
AN	3000-300-114	Cable Tie	3
CA	3001-400-624	TV, Lights Label, Inner, Left	1
CA	3001-400-614	TV, Lights Label, Inner, Right	1
CB	3001-402-1	Blank Label	2
CC	3001-400-953	Switch Cap	30
CD	3001-400-522	Filler Cap	14
CE	3001-403-831	Speaker With Cable	2
CF	(page 181)	DMS Module	2
CH	3001-400-636	G/F Label, Outer, Left	1
CH	3001-400-646	G/F Label, Outer, Right	1
CJ	3001-402-804	Main to Options PCB Cable, Left	1
CJ	3001-402-803	Main to Options PCB Cable, Right	1

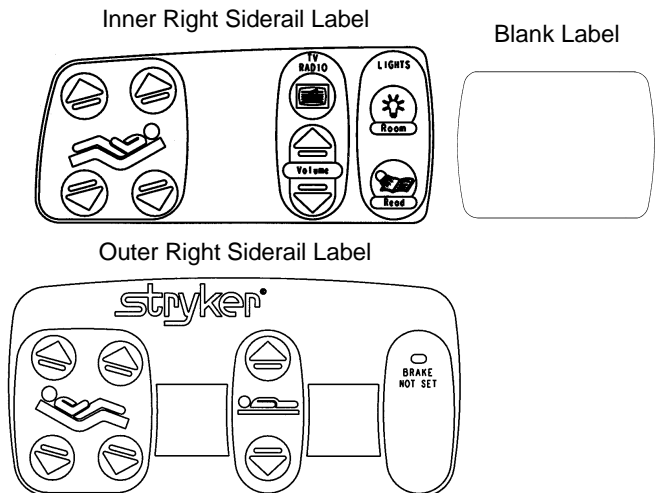

Head End Siderail Assembly

Standard Siderail with TV/Radio, G/F and StryKair Capable

Item	Part No.	Part Name	Qty.
AN	3000-300-114	Cable Tie	3
CA	3001-400-626	TV Label, Inner, Left	1
CA	3001-400-616	TV Label, Inner, Right	1
CB	2035-000-105	Blank Label	2
CC	3001-400-953	Switch Cap	26
CD	3001-400-522	Filler Cap	18
CE	3001-403-831	Speaker With Cable	2
CF	(page 181)	DMS Module	2
CH	3001-400-636	G/F Label, Outer, Left	1
CH	3001-400-646	G/F Label, Outer, Right	1
CJ	3001-402-804	Main to Options PCB Cable, Left	1
CJ	3001-402-803	Main to Options PCB Cable, Right	1

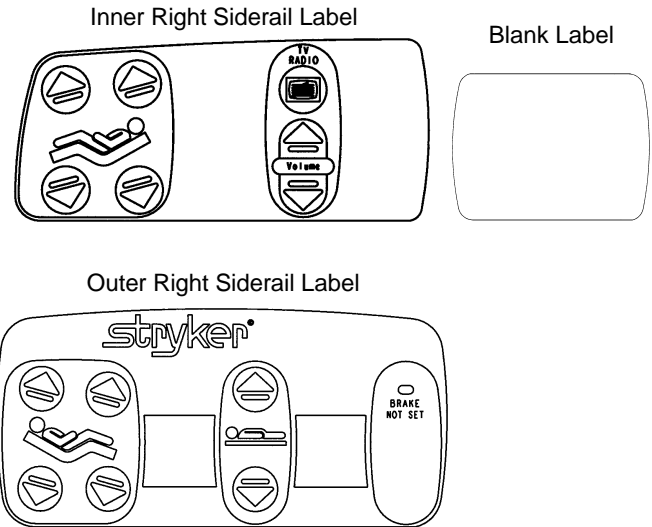

Standard Siderail with TV/Radio and StryKair Capable

Item	Part No.	Part Name	Qty.
AN	3000-300-114	Cable Tie	3
CA	3001-400-626	TV Label, Inner, Left	1
CA	3001-400-616	TV Label, Inner, Right	1
CB	3001-402-1	Inner DMS Label, Left	2
CC	3001-400-953	Switch Cap	18
CD	3001-400-522	Filler Cap	26
CE	3001-403-831	Speaker With Cable	2
CF	(page 181)	DMS Module	2
CH	3001-400-630	Standard Label, Outer, Left	1
CH	3001-400-640	Standard Label, Outer, Right	1
CJ	3001-402-804	Main to Options PCB Cable, Left	1
CJ	3001-402-803	Main to Options PCB Cable, Right	1

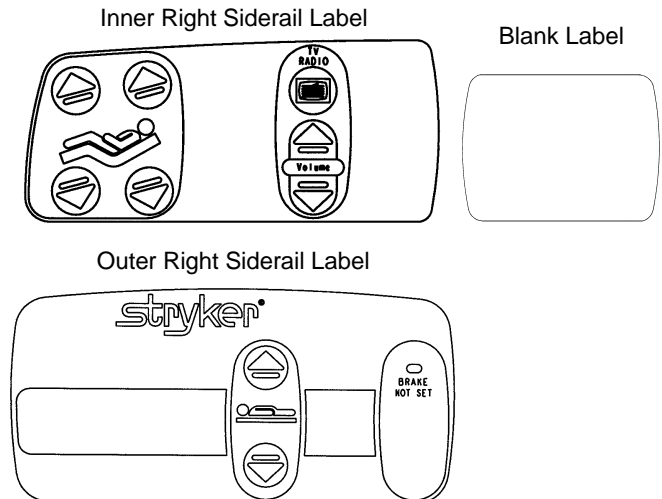

Standard Siderail with Lights and StryKair Capable

Item	Part No.	Part Name	Qty.
AN	3000-300-114	Cable Tie	3
CA	3001-400-627	Lights Label, Inner, Left	1
CA	3001-400-617	Lights Label, Inner, Right	1
CB	2035-000-105	Blank Label	2
CC	3001-400-953	Switch Cap	16
CD	3001-400-522	Filler Cap	28
CE	3001-400-517	Speaker Seal	2
CF	(page 181)	DMS Module	2
CH	3001-400-630	Standard Label, Outer, Left	1
CH	3001-400-640	Standard Label, Outer, Right	1
CJ	3001-402-804	Main to Options PCB Cable, Left	1
CJ	3001-402-803	Main to Options PCB Cable, Right	1

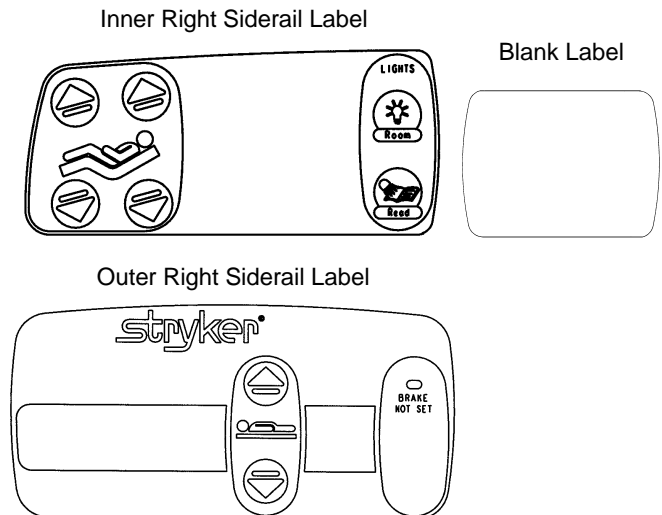

Head End Siderail Assembly

Standard Siderail with Lights, G/F and StryKair Capable

Item	Part No.	Part Name	Qty.
AN	3000-300-114	Cable Tie	3
CA	3001-400-627	Lights Label, Inner, Left	1
CA	3001-400-617	Lights Label, Inner, Right	1
CB	2035-000-105	Blank Label	2
CC	3001-400-953	Switch Cap	24
CD	3001-400-522	Filler Cap	20
CE	3001-400-517	Speaker Seal	2
CF	(page 181)	DMS Module	2
CH	3001-400-636	G/F Label, Outer, Left	1
CH	3001-400-646	G/F Label, Outer, Right	1
CJ	3001-402-804	Main to Options PCB Cable, Left	1
CJ	3001-402-803	Main to Options PCB Cable, Right	1

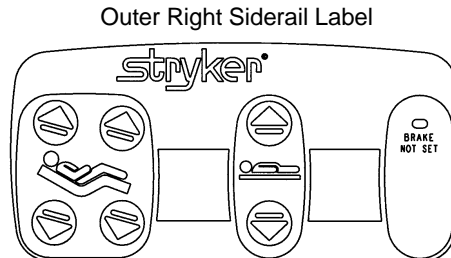
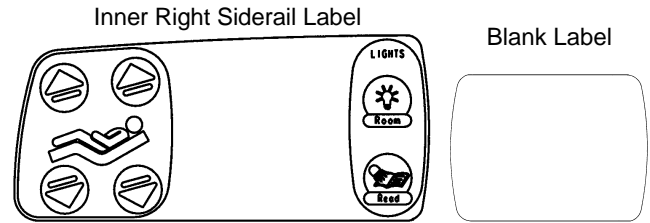

Standard Siderail with StryKair Capable

Item	Part No.	Part Name	Qty.
AN	3000-300-114	Cable Tie	3
CA	3001-400-620	Standard Label, Inner, Left	1
CA	3001-400-610	Standard Label, Inner, Right	1
CB	3001-402-1	Inner DMS Label, Left	2
CC	3001-400-953	Switch Cap	12
CD	3001-400-522	Filler Cap	32
CE	3001-400-517	Speaker Seal	2
CF	(page 181)	DMS Module	2
CH	3001-400-630	Standard Label, Outer, Left	1
CH	3001-400-640	Standard Label, Outer, Right	1
CJ	3001-402-804	Main to Options PCB Cable, Left	1
CJ	3001-402-803	Main to Options PCB Cable, Right	1

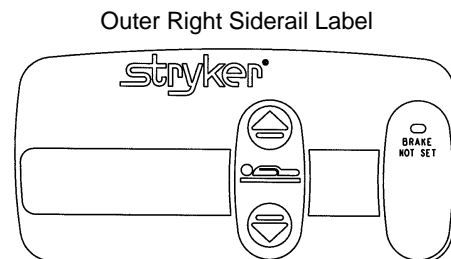
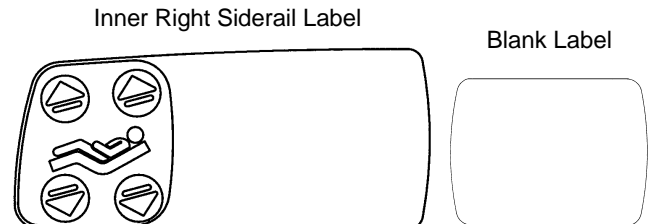

Standard Siderail with G/F & StryKair Capable

Item	Part No.	Part Name	Qty.
AN	3000-300-114	Cable Tie	3
CA	3001-400-620	Standard Label, Inner, Left	1
CA	3001-400-610	Standard Label, Inner, Right	1
CB	3001-402-1	Inner DMS Label, Left	2
CC	3001-400-953	Switch Cap	20
CD	3001-400-522	Filler Cap	24
CE	3001-400-517	Speaker Seal	2
CF	(page 181)	DMS Module	2
CH	3001-400-636	G/F Label, Outer, Left	1
CH	3001-400-646	G/F Label, Outer, Right	1
CJ	3001-402-804	Main to Options PCB Cable, Left	1
CJ	3001-402-803	Main to Options PCB Cable, Right	1

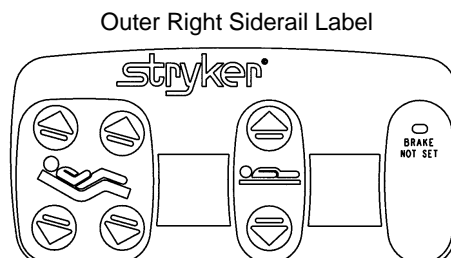
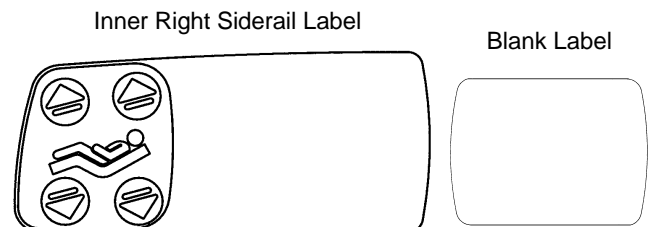

Notes

2035-400-53 Optional Smart TV Siderail Module, Right

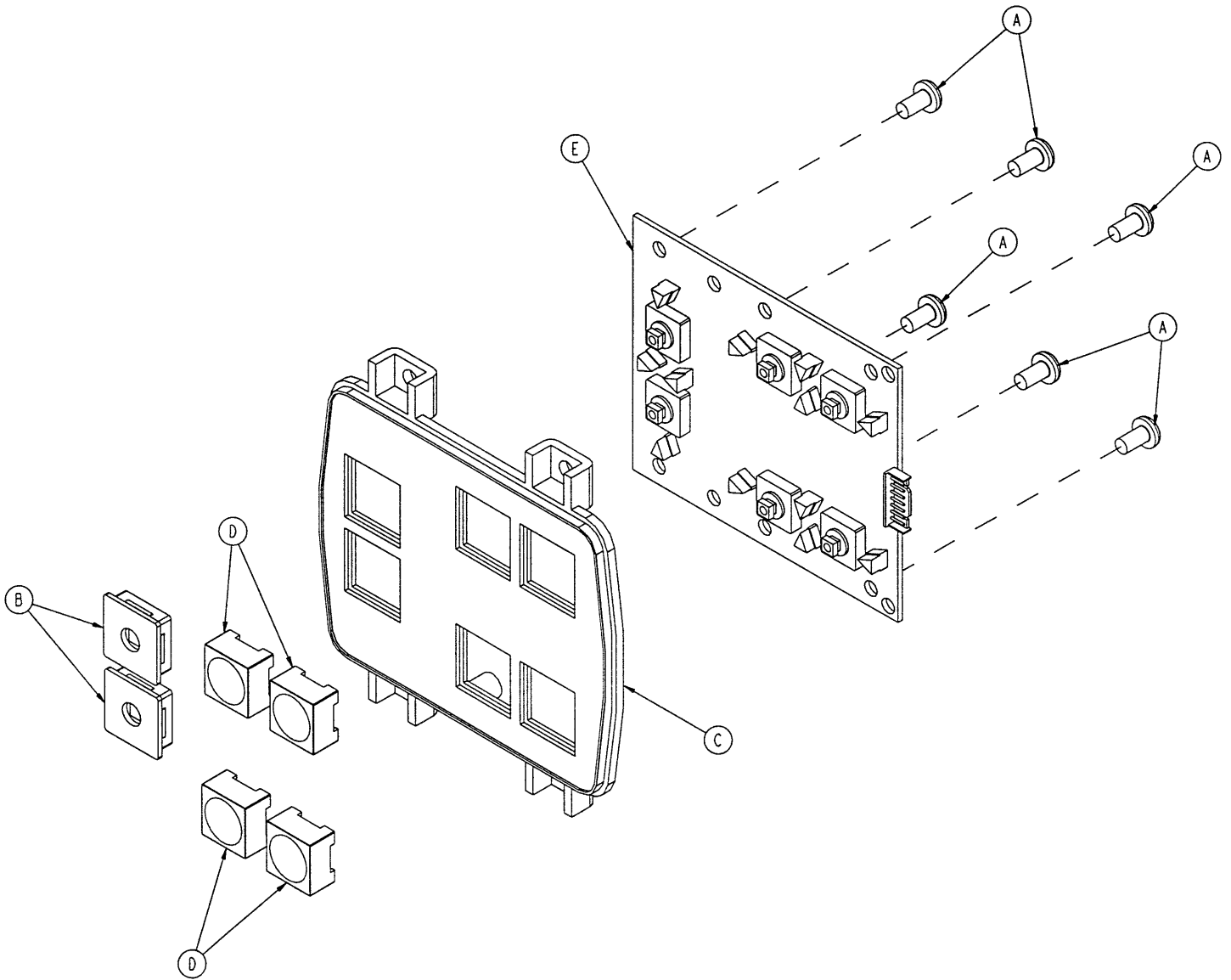

Item	Part No.	Part Name	Qty.
A	23-112	Ph. Hd. Hi-Lo Tapping Screw	6
B	3001-400-522	Filler Cap	2
C	3001-400-524	Module	1
D	3001-400-953	Switch Cap	4
E	5000-400-930	Keypad PCB, Left	1

2035-400-51 Optional Smart TV Siderail Module, Left

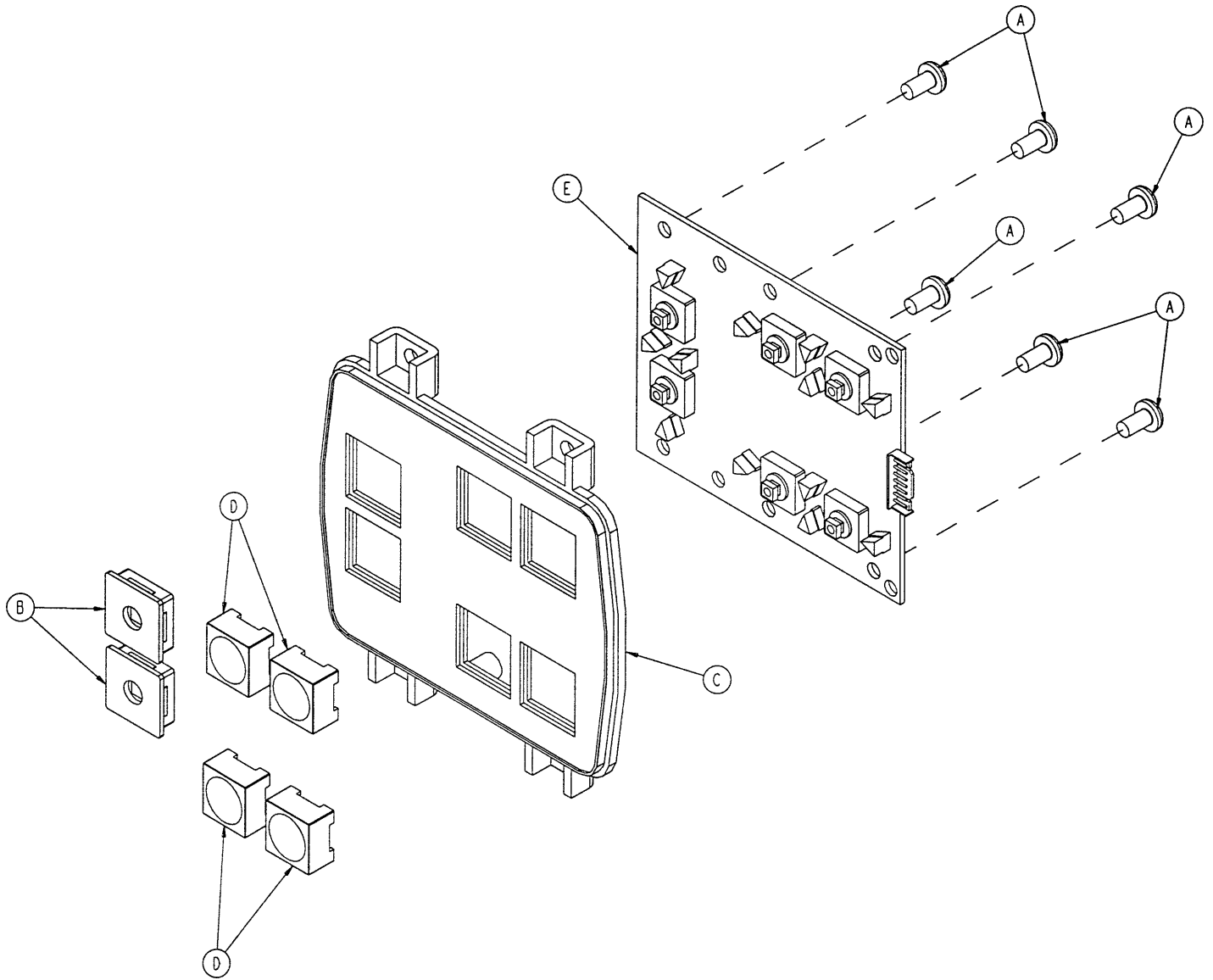

Item	Part No.	Part Name	Qty.
A	23-112	Ph. Hd. Hi-Lo Tapping Screw	6
B	3001-400-522	Filler Cap	2
C	3001-400-524	Module	1
D	3001-400-953	Switch Cap	4
E	5000-400-920	Keypad PCB, Right	1

5000-20-27 Optional TV Control Module, Right

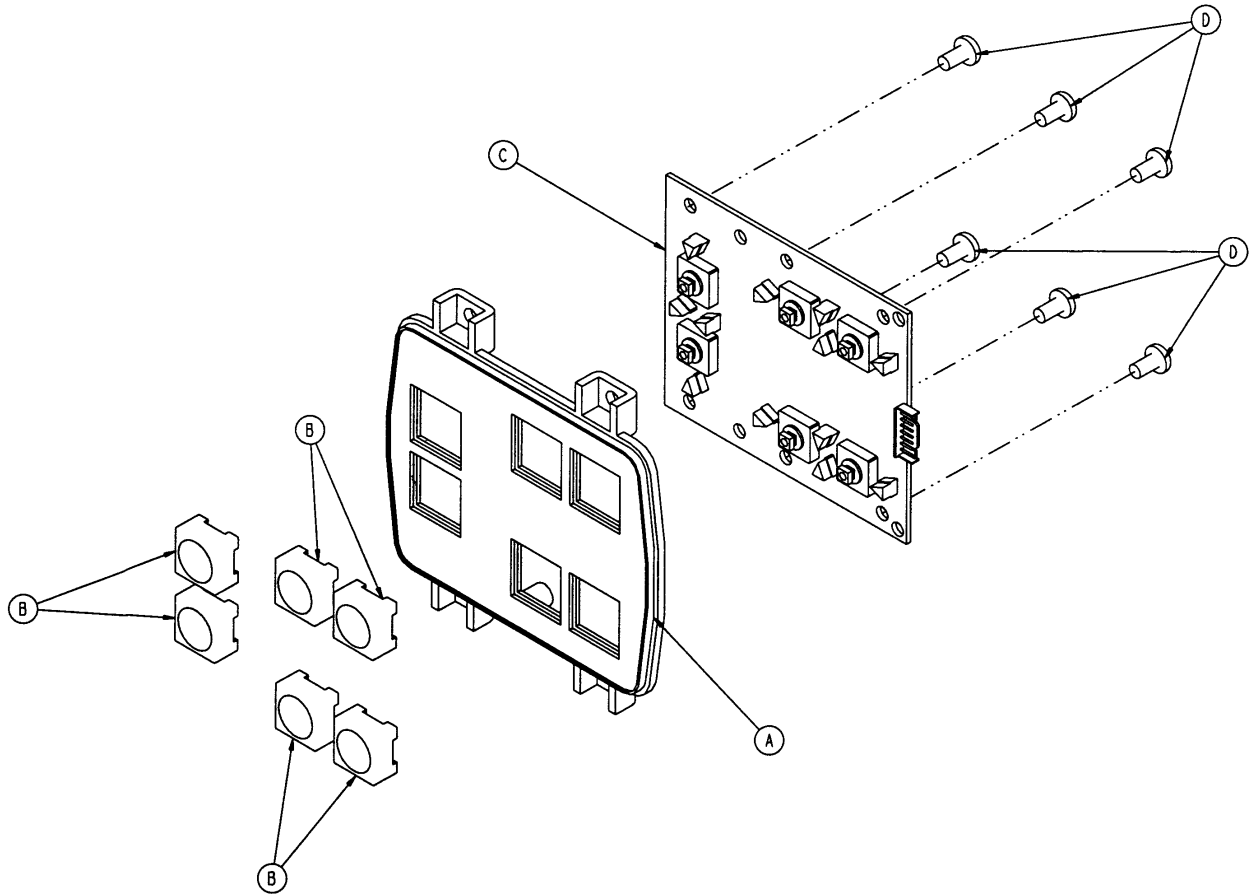

Item	Part No.	Part Name	Qty.
A	3001-400-524	Lumbar Module	1
B	3001-400-953	Switch Cap	6
C	5000-400-930	Lumbar Keypad PCB, Left	1
D	23-112	Tapping Screw	6

5000-20-26 Optional TV Control Module, Left

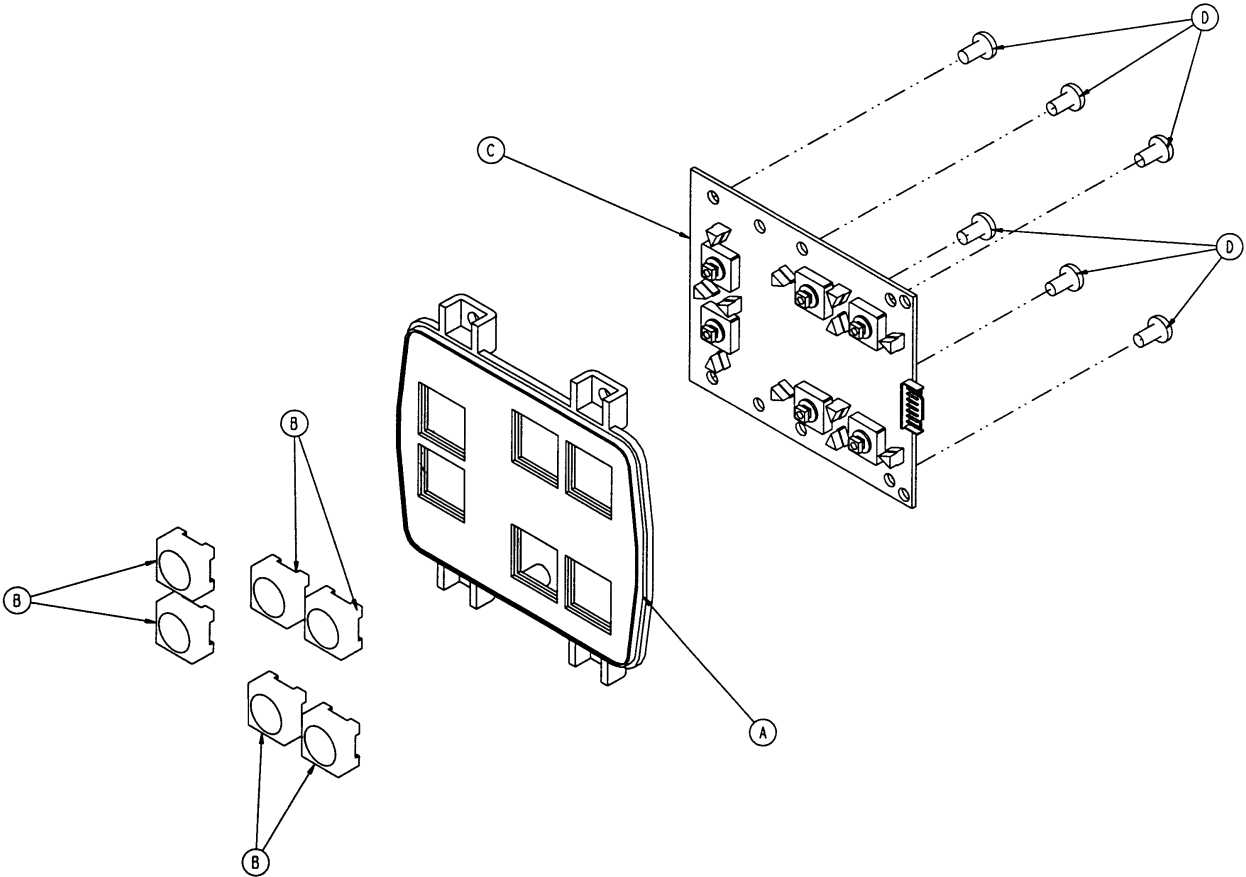

Item	Part No.	Part Name	Qty.
A	3001-400-524	Lumbar Module	1
B	3001-400-953	Switch Cap	6
C	5000-400-920	Lumbar Keypad PCB, Right	1
D	23-112	Tapping Screw	6

3001-402-30 Optional DMS Module Assembly

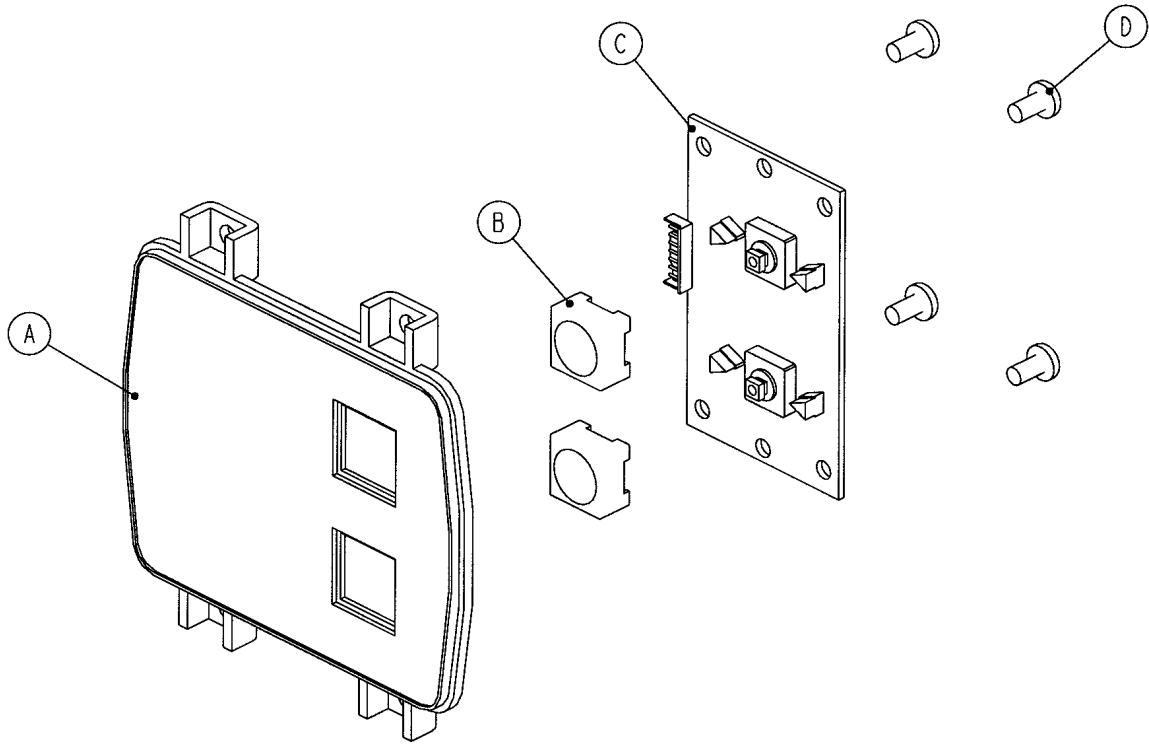

Item	Part No.	Part Name	Qty.
A	3001-400-521	DMS Module	1
B	3001-400-953	Switch Cap	2
C	3001-402-900	DMS Keypad PCB	1
D	23-112	Tapping Screw	4

Foot End Siderail Assembly

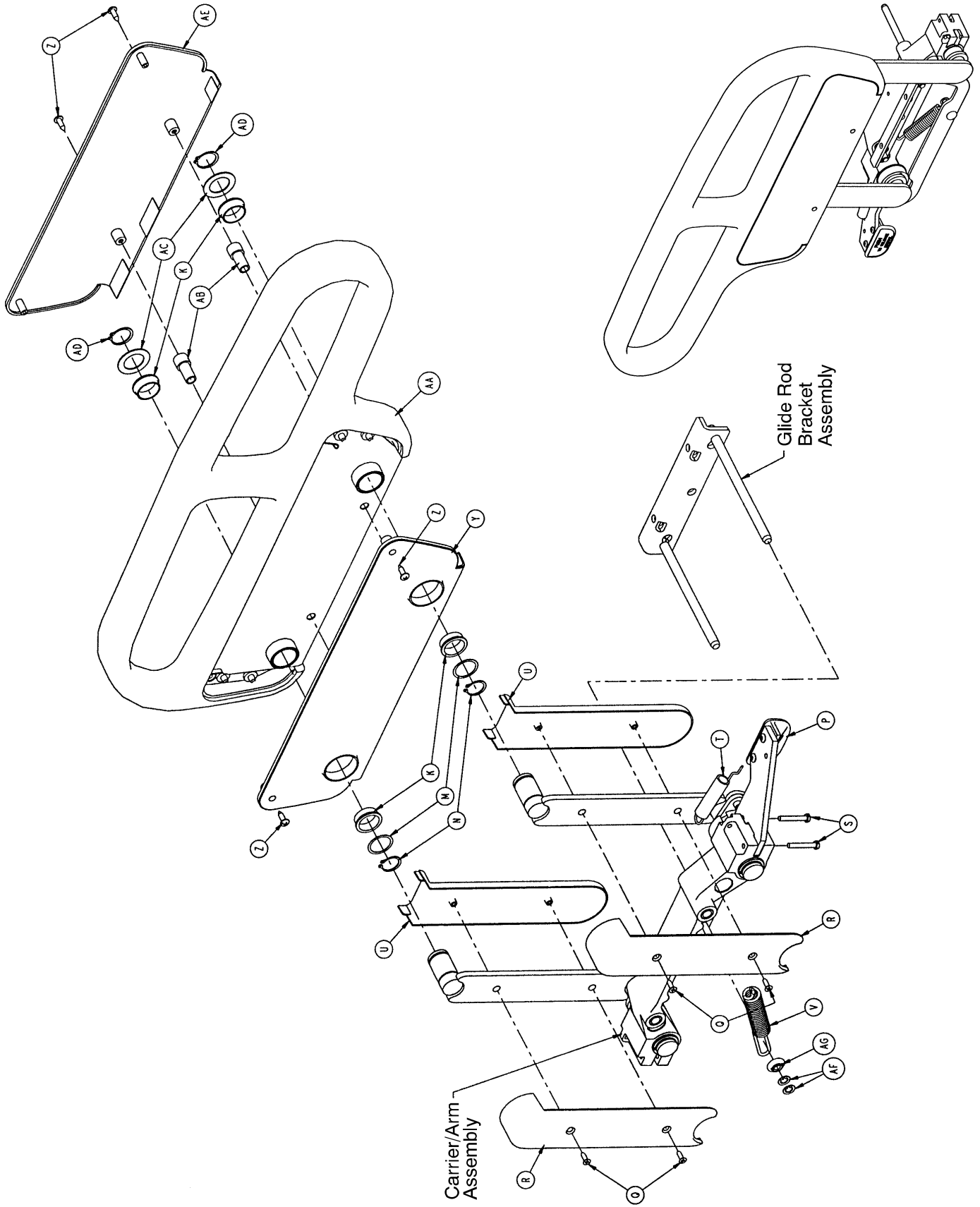

Foot End Siderail Assembly

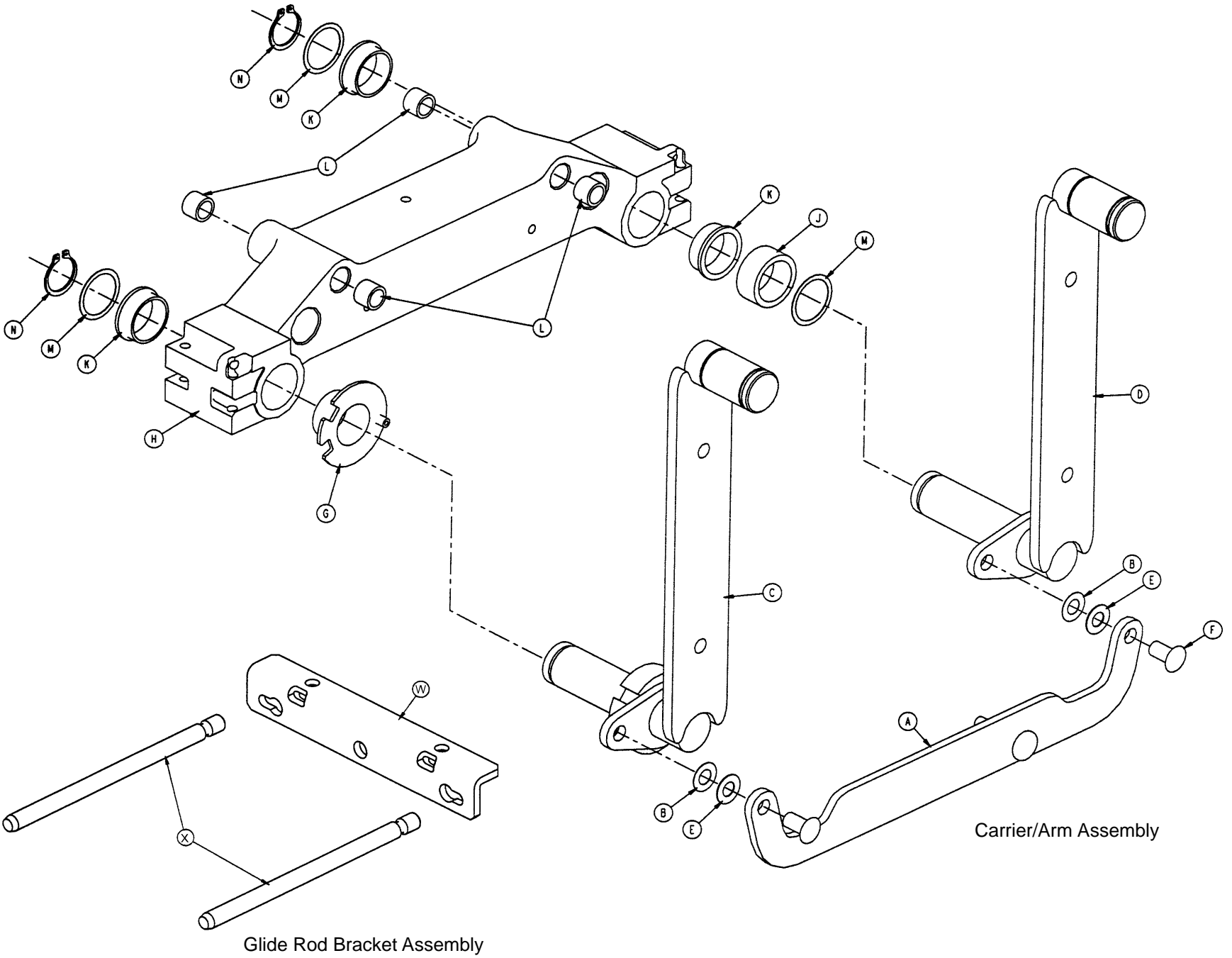

Foot End Siderail Assembly

3001-400-300 Left Common Components

Item	Part No.	Part Name	Qty.
A	3001-400-325	Timing Link Weldment, Lt.	1
B	11-403	Shim Washer	2
D	3001-400-327	Foot Arm Wldmt., Lt., Head	1
E	11-377	Nylon Washer	2
F	3001-400-501	Siderail Linkage Rivet	2
G	3001-400-513	Wear Bushing	1
H	3001-400-528	Siderail Carrier	1
J	3001-400-530	Siderail Arm Spacer	1
K	3000-400-513	Flange Bearing	7
L	3000-400-557	Sleeve Bearing	4
M	11-353	Shim Washer	5
N	28-128	Retaining Ring	4
P	(page 185)	Release Lever, Left	1
Q	23-280	Flat Hd. Tapping Screw	4
R	5000-20-5	Inner Arm Cover	2
S	3-344	Hex Hd. Cap Screw	2
T	3000-200-334	Extension Spring	1
U	5000-20-6	Outer Arm Cover	2
V	3000-400-545	Tension Spring	1
W	3001-400-555	Mounting Bracket	1
X	3001-400-564	Glide Rod	2
Y	3001-400-526	Inner Panel	1
Z	23-90	High-Low Tapping Screw	4
AA	3001-400-360	Support Plate, Left	1
AB	3000-400-523	Panel Spacer	2
AC	11-343	Shim Washer	2
AD	28-132	Bowed Retaining Ring	2
AE	3001-400-527	Outer Panel	1
AF	28-171	Push-On Retaining Ring	1
AG	3001-300-99	Fowler Pivot Bushing	1

3001-400-400 Right Common Components

Item	Part No.	Part Name	Qty.
A	3001-400-425	Timing Link Weldment, Rt.	1
B	11-403	Shim Washer	2
D	3001-400-427	Foot Arm Wldmt., Rt., Head	1
E	11-377	Nylon Washer	2
F	3001-400-501	Siderail Linkage Rivet	2
G	3001-400-513	Wear Bushing	1
H	3001-400-528	Siderail Carrier	1
J	3001-400-530	Siderail Arm Spacer	1
K	3000-400-513	Flange Bearing	7
L	3000-400-557	Sleeve Bearing	4
M	11-353	Shim Washer	5
N	28-128	Retaining Ring	4
P	(page 186)	Release Lever, Right	1
Q	23-280	Flat Hd. Tapping Screw	4
R	5000-20-5	Inner Arm Cover	2
S	3-344	Hex Hd. Cap Screw	2
T	3000-200-334	Extension Spring	1
U	5000-20-6	Outer Arm Cover	2
V	3000-400-545	Tension Spring	1
W	3001-400-555	Mounting Bracket	1
X	3001-400-564	Glide Rod	2
Y	3001-400-526	Inner Panel	1
Z	23-90	High-Low Tapping Screw	4
AA	3001-400-460	Support Plate, Right	1
AB	3000-400-523	Panel Spacer	2
AC	11-343	Shim Washer	2
AD	28-132	Bowed Retaining Ring	2
AE	3001-400-527	Outer Panel	1
AF	28-171	Push-On Retaining Ring	1
AG	3001-300-99	Fowler Pivot Bushing	1

3001-442-300 Left Rail – 8” Shorter Bed

Item	Part No.	Part Name	Qty.
BA	3001-442-318	Foot Arm Wldmt., Lt., Foot	1

3001-442-400 Right Rail – 8” Shorter Bed

Item	Part No.	Part Name	Qty.
BA	3001-442-418	Foot Arm Wldmt., Rt., Foot	1

3001-443-300 Left Rail – Standard Bed

Item	Part No.	Part Name	Qty.
BA	3001-400-328	Foot Arm Wldmt., Lt., Foot	1

3001-443-400 Right Rail – Standard Bed

Item	Part No.	Part Name	Qty.
BA	3001-400-428	Foot Arm Wldmt., Rt., Foot	1

Siderail Release Lever Assembly, Left

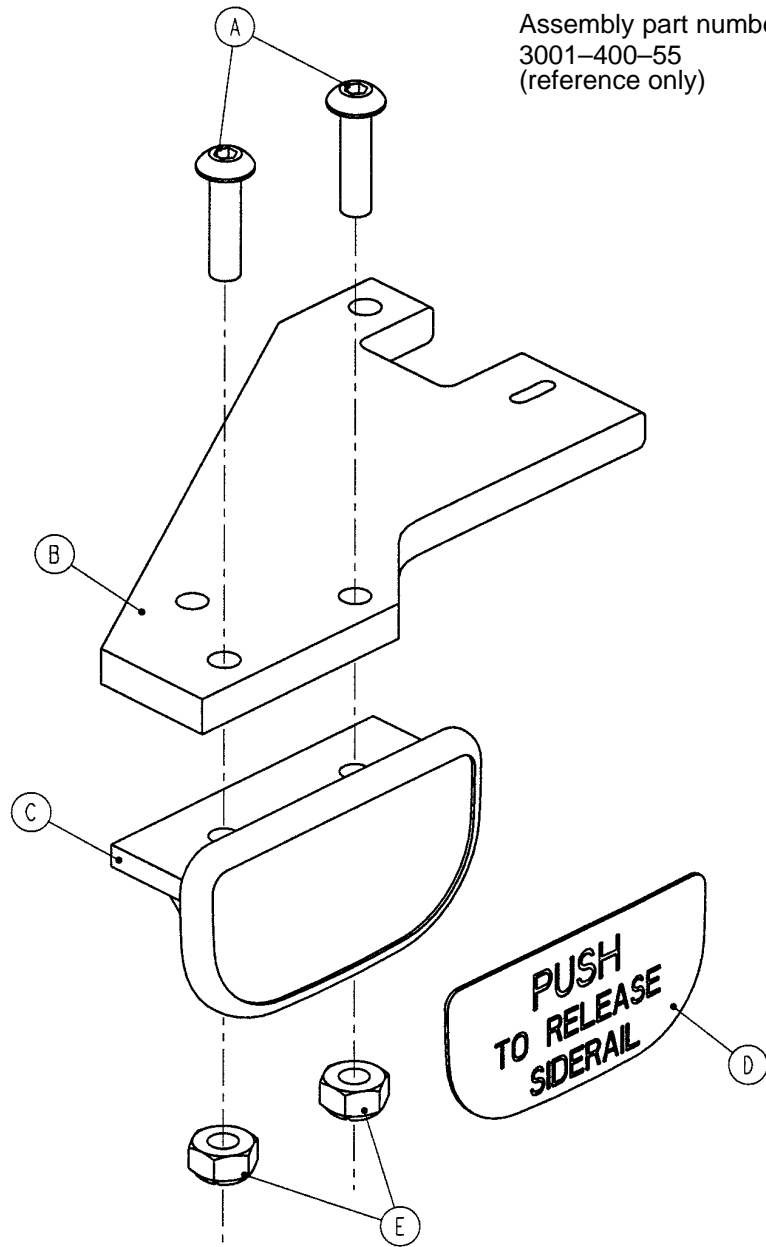

Item	Part No.	Part Name	Qty.
A	4-278	Button Hd. Screw	2
B	3001-400-552	Release Lever	1
C	3001-400-514	Release Lever Pad	1
D	3001-400-505	Pad Label	1
E	16-2	Nylock Nut	2

Siderail Release Lever Assembly, Right

Assembly part number 3001-400-65
(reference only)

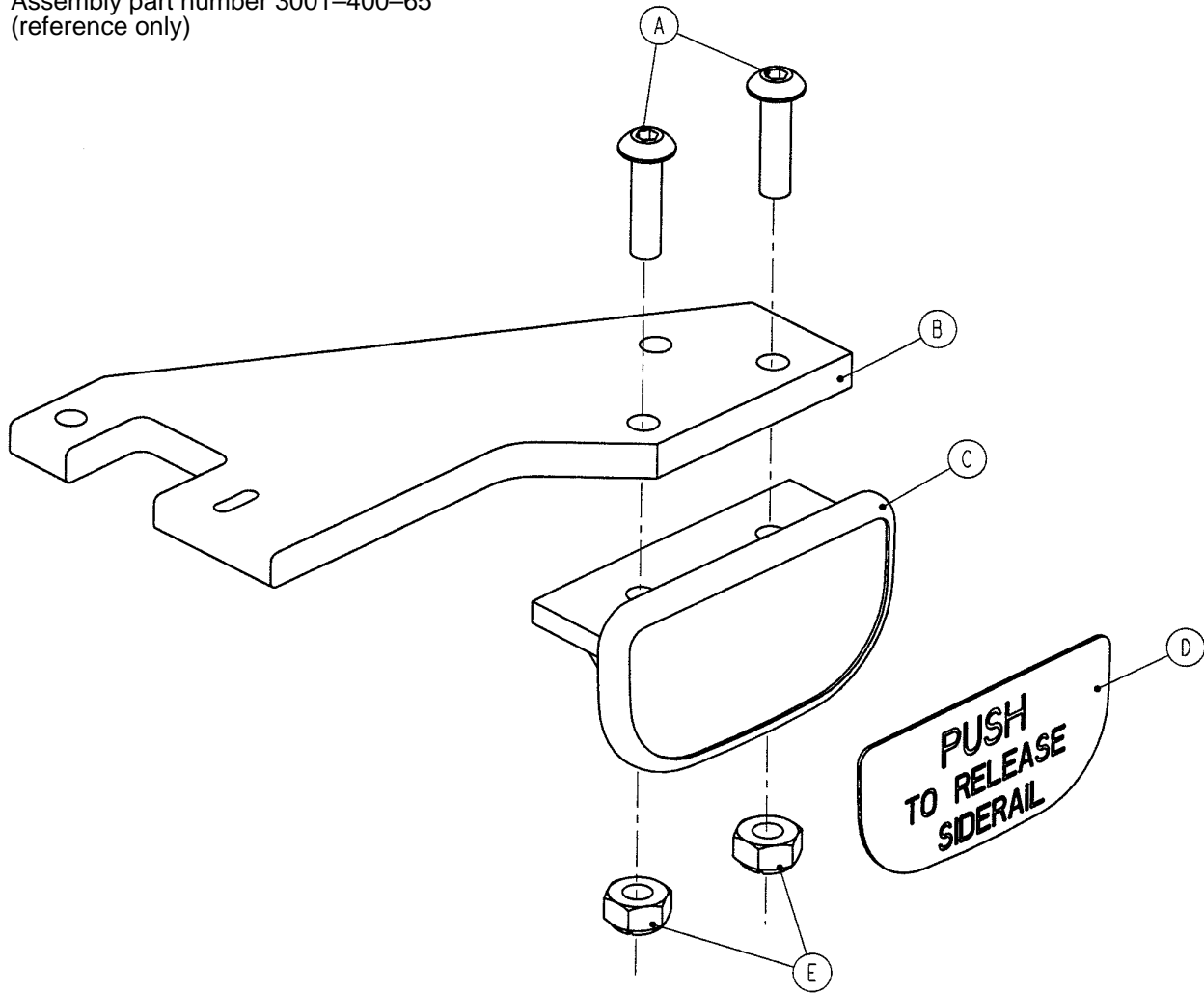

Item	Part No.	Part Name	Qty.
A	4-278	Button Hd. Screw	2
B	3001-400-552	Release Lever	1
C	3001-400-514	Release Lever Pad	1
D	3001-400-505	Pad Label	1
E	16-2	Nylock Nut	2

Left Siderail Support Assembly

Assembly part number 3001-400-360 (reference only)

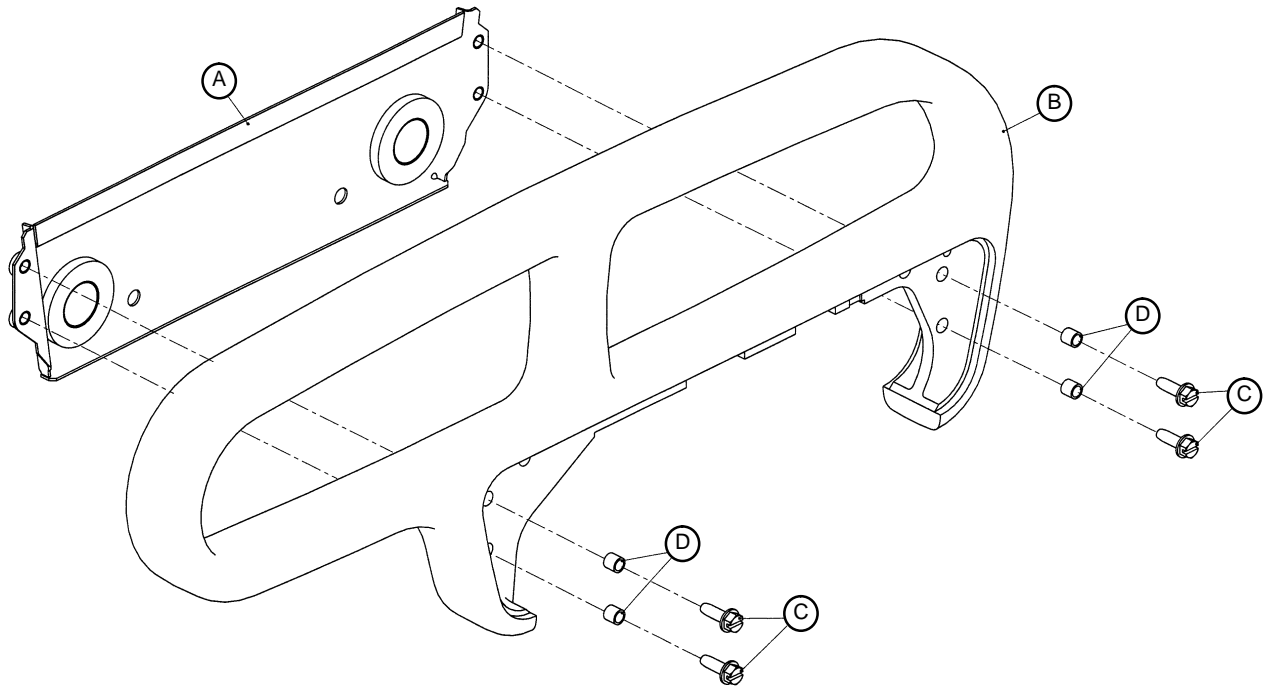

Item	Part No.	Part Name	Qty.
A	3001-400-31	Foot Support Weldment	1
B	3000-400-520	Foot Rail	1
C	3-224	Hex Washer Hd. Screw	6
D	3000-400-558	Siderail Spacer	6

Right Foot End Siderail Support Assembly

Assembly part number 3001-400-460 (reference only)

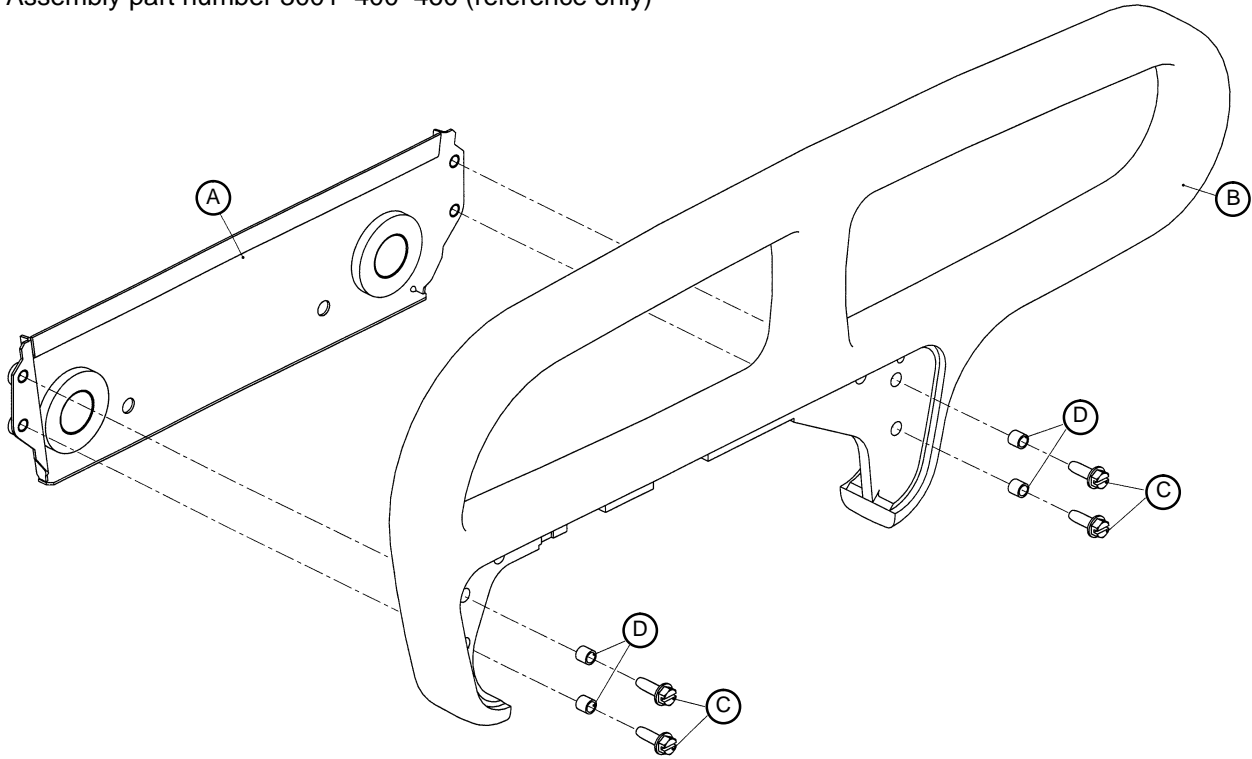

Item	Part No.	Part Name	Qty.
A	3001-400-580	Foot Support Weldment	1
B	3000-400-520	Foot Rail	1
C	3-226	Hex Washer Hd. Screw	4
D	3001-400-558	Siderail Spacer	4

Foot Board Assembly

part number 3001-500-24

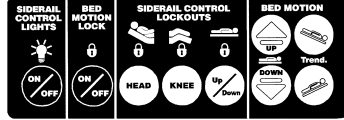

POWER BED MOTION LOCKED BRAKE NOT SET

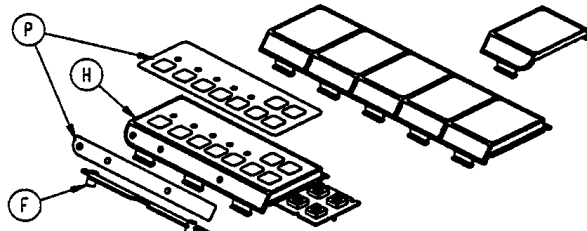
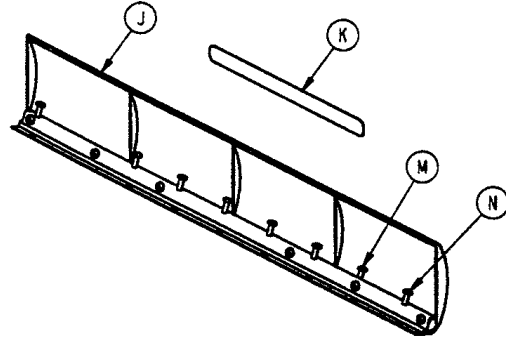

Optional Laminate
 Victorian Cherry 3000-500-50
 English Oak 3000-500-49
 Oak Suede Classic 3000-500-48
 Peche Contempe Blush 3000-500-45

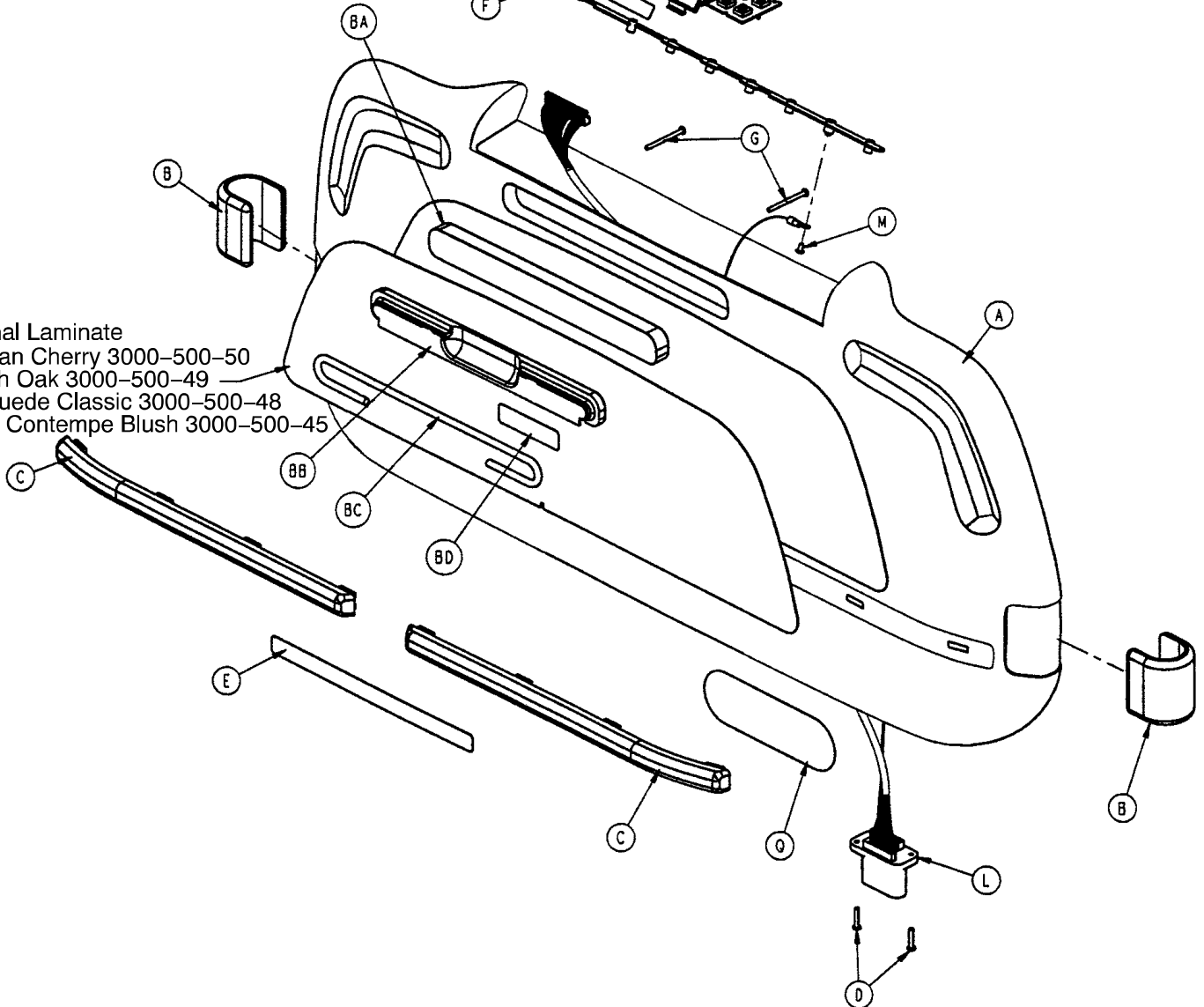

BED EXIT OPTION ONLY

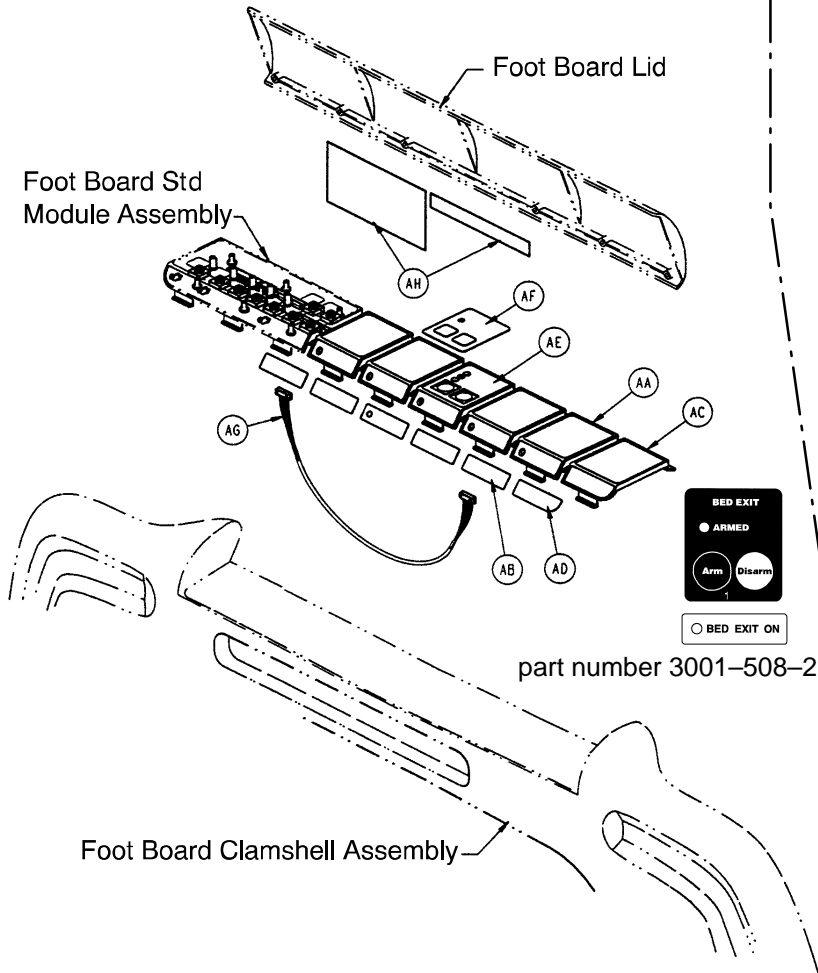

SCALE OPTION ONLY

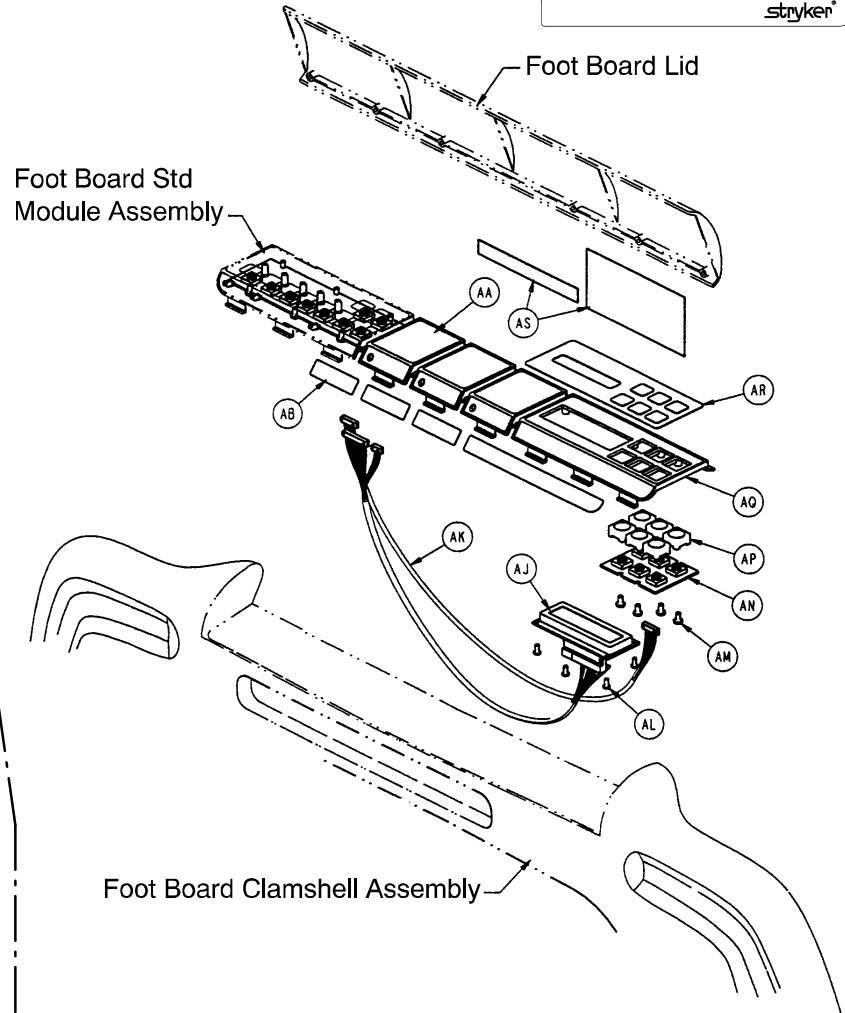
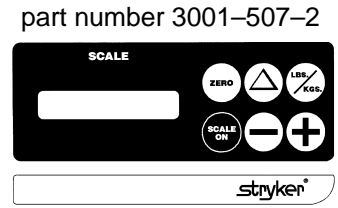

SCALE AND BED EXIT OPTIONS

part number 3001-508-2

part number 3001-507-2

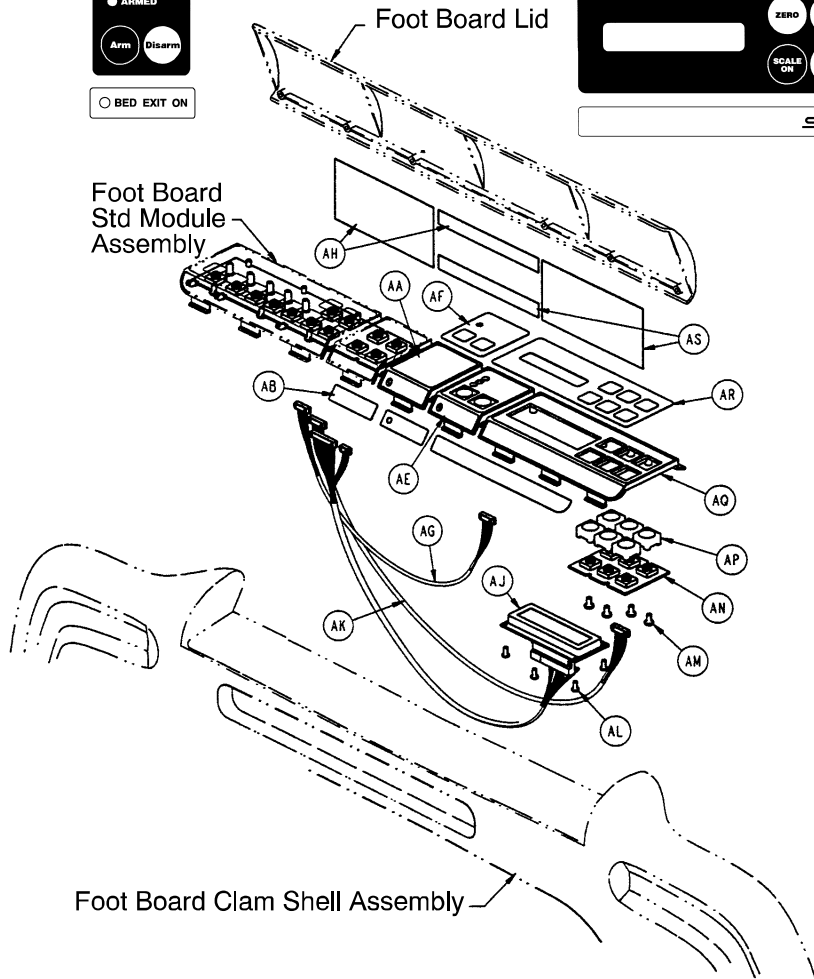
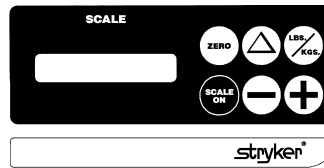
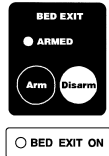

NO SCALE OR BED EXIT OPTIONS

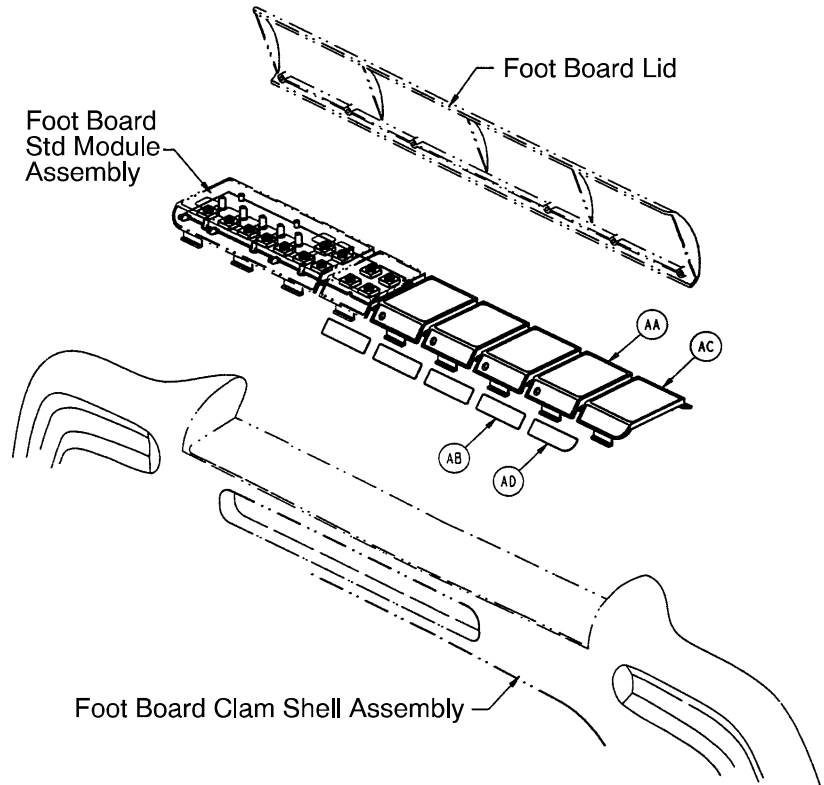

191

Foot Board Assembly

GATCH/FOWLER OPTION

part number 3001-501-2

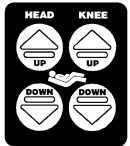

Foot Board Std
Module Assembly

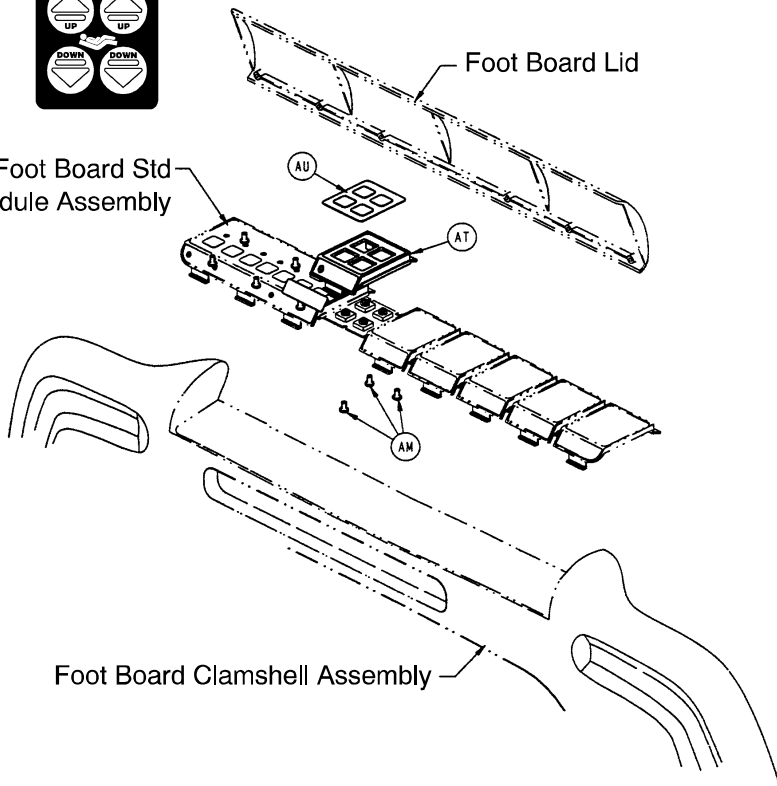

NO GATCH/FOWLER OPTION

Foot Board Standard
Module Assembly

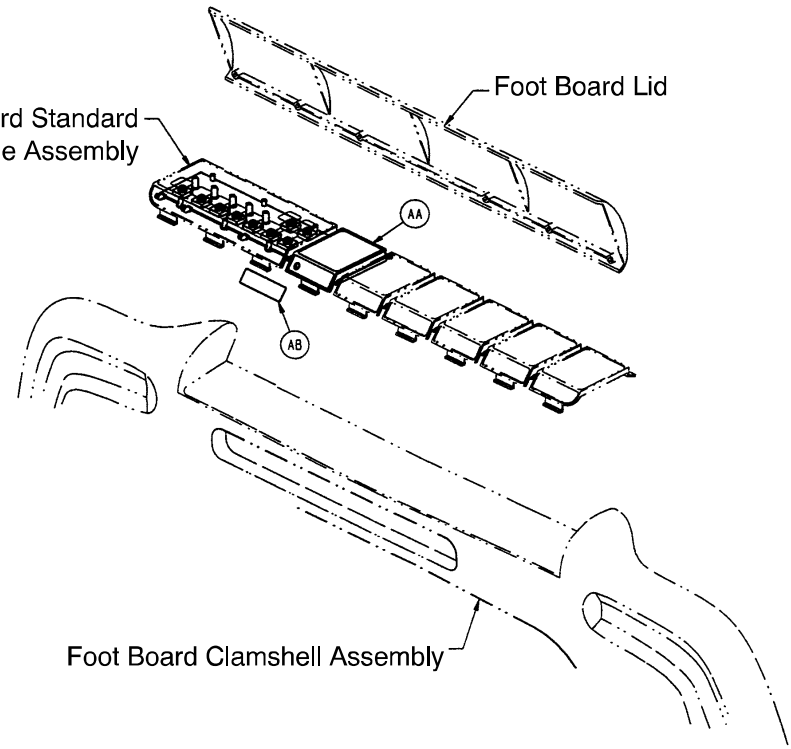

Foot Board Assembly

3001-500-11 Standard Components

Item	Part No.	Part Name	Qty.	Item	Part No.	Part Name	Qty.
A	3001-500-10	Clam Shell Assembly	1	J	3001-500-1	Lid Assembly	1
B	3000-500-7	"C" Bumper	2	K	3000-500-25	Lid Label	1
C	3000-500-6	Bumper Strip	2	L	3001-500-801	Foot Board Drawer Cable	1
D	50-39	Pan Hd. Mach. Screw	2	M	50-38	Pan Hd. Mach. Screw	2
E	3000-500-29	Hazard Label	1	N	23-103	Pan Hd. Hi-Lo Tap. Screw	7
F	3001-500-64	Hinge Plate	1	P	3001-500-24	Ft. Bd. Std. Module Label	1
G	23-99	Phillips Pan Hd. Screw	2	Q	3001-500-601	"Secure" Logo Label	1
H	(page 194)	Std. Control Module Ass'y	1	R	72-2-71	"C" Bumper Adhesive	1

3000-525-000 Chart/Constavac Hanger Option

Item	Part No.	Part Name	Qty.
BB	3000-525-1	Chart Rack	1
BC	3000-525-2	Chart Rod	1
BD	3000-525-4	Chart Rack Label	1

3000-525-10 No Chart/Constavac Hanger

Item	Part No.	Part Name	Qty.
BA	3000-500-8	Chart Rack Cover	1

3001-508-11 Bed Exit Option Only

Item	Part No.	Part Name	Qty.
AA	3001-500-3	Blank Module	4
AB	3000-500-26	Blank Module Label	4
AC	3000-500-4	End Module	1
AD	3000-500-27	End Module Label	1
AE	(page 195)	Bed Exit Module Assembly	1
AF	3001-508-2	Bed Exit Module Label	1
AG	3001-508-800	Bed Exit Keypad Cable	1
AH	3000-508-11	Bed Exit Label	1

3001-507-12 Scale Option Only

Item	Part No.	Part Name	Qty.
AA	3001-500-3	Blank Module	3
AB	3000-500-26	Blank Module Label	3
AJ	3001-507-900	Scale LCD Display Cable	1
AK	3001-507-800	Scale Keypad Cable	1
AL	23-91	Pan Hd. Hi-Lo Tap. Screw	4
AM	23-87	Pan Hd. Hi-Lo Tap. Screw	4
AN	3001-507-910	Scale Keypad Assembly	1
AP	3001-400-953	Switch Cap	6
AQ	3001-507-1	Scale Module	1
AR	3001-507-2	Scale Module Label	1
AS	3001-507-11	Scale Label	1

3001-507-21 Scale and Bed Exit Options

Item	Part No.	Part Name	Qty.
AA	3001-500-3	Blank Module	1
AB	3000-500-26	Blank Module Label	1
AE	(page 195)	Bed Exit Module Ass'y	1
AF	3001-508-2	Bed Exit Module Label	1
AG	3001-508-800	Bed Exit Keypad Cable	1
AH	3000-508-11	Bed Exit Label	1
AJ	3001-507-900	Scale LCD Display Cable	1
AK	3001-507-800	Scale Keypad Cable	1
AL	23-91	Pan-Hd. Hi-Lo Tap. Screw	4
AM	23-87	Pan-Hd. Hi-Lo Tap. Screw	4
AN	3001-507-910	Scale Keypad Assembly	1
AP	3001-400-953	Switch Cap	6
AQ	3001-507-1	Scale Module	1
AR	3001-507-2	Scale Module Label	1
AS	3001-507-11	Scale Label	1

3001-507-120 No Scale or Bed Exit Option

Item	Part No.	Part Name	Qty.
AA	3001-500-3	Blank Module	4
AB	3000-500-26	Blank Module Label	4
AC	3000-500-4	End Module	1
AD	3000-500-27	End Module Label	1

3001-501-11 Gatch/Fowler Option

Item	Part No.	Part Name	Qty.
AM	23-87	Pan Hd. Hi-Lo Tap. Screw	3
AT	3000-501-1	Gatch/Fowler Module	1
AU	3001-501-2	Gatch/Fowler Module Label	1

3001-501-110 No Gatch/Fowler Option

Item	Part No.	Part Name	Qty.
AA	3001-500-3	Blank Module	1
AB	3000-500-26	Blank Module Label	1

3001-500-28 Foot Board Standard Module Assembly

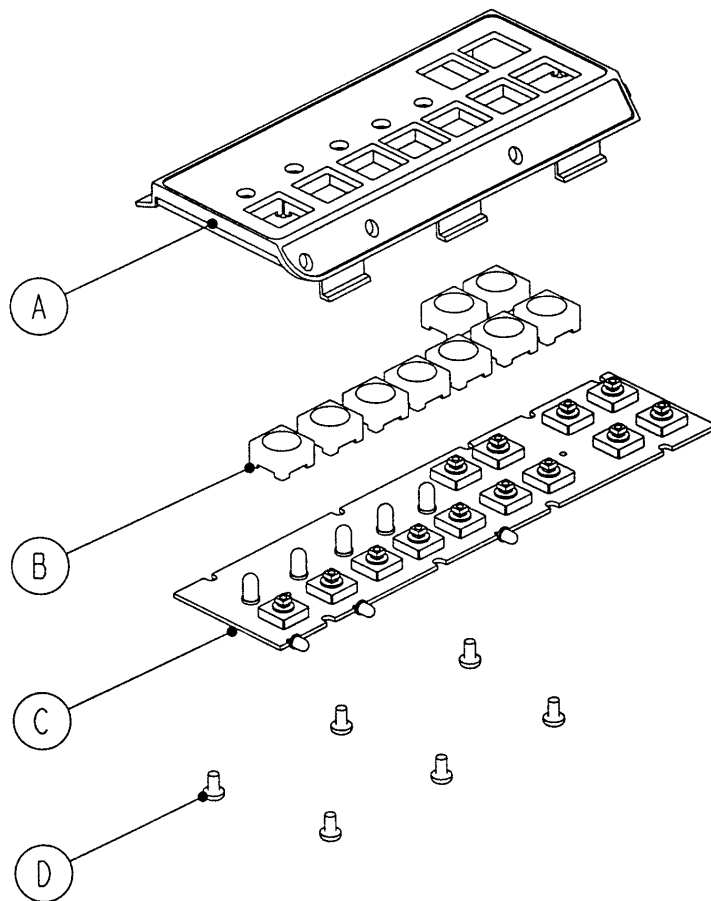

Item	Part No.	Part Name	Qty.
A	3000-500-2	Foot Board Standard Module	1
B	3001-400-953	Switch Cap	9
C	3001-500-930	Main Foot Board Keyboard	1
D	23-87	Pan Hd. Tapping Screw	6

3001-508-30 Optional Bed Exit Module Assembly

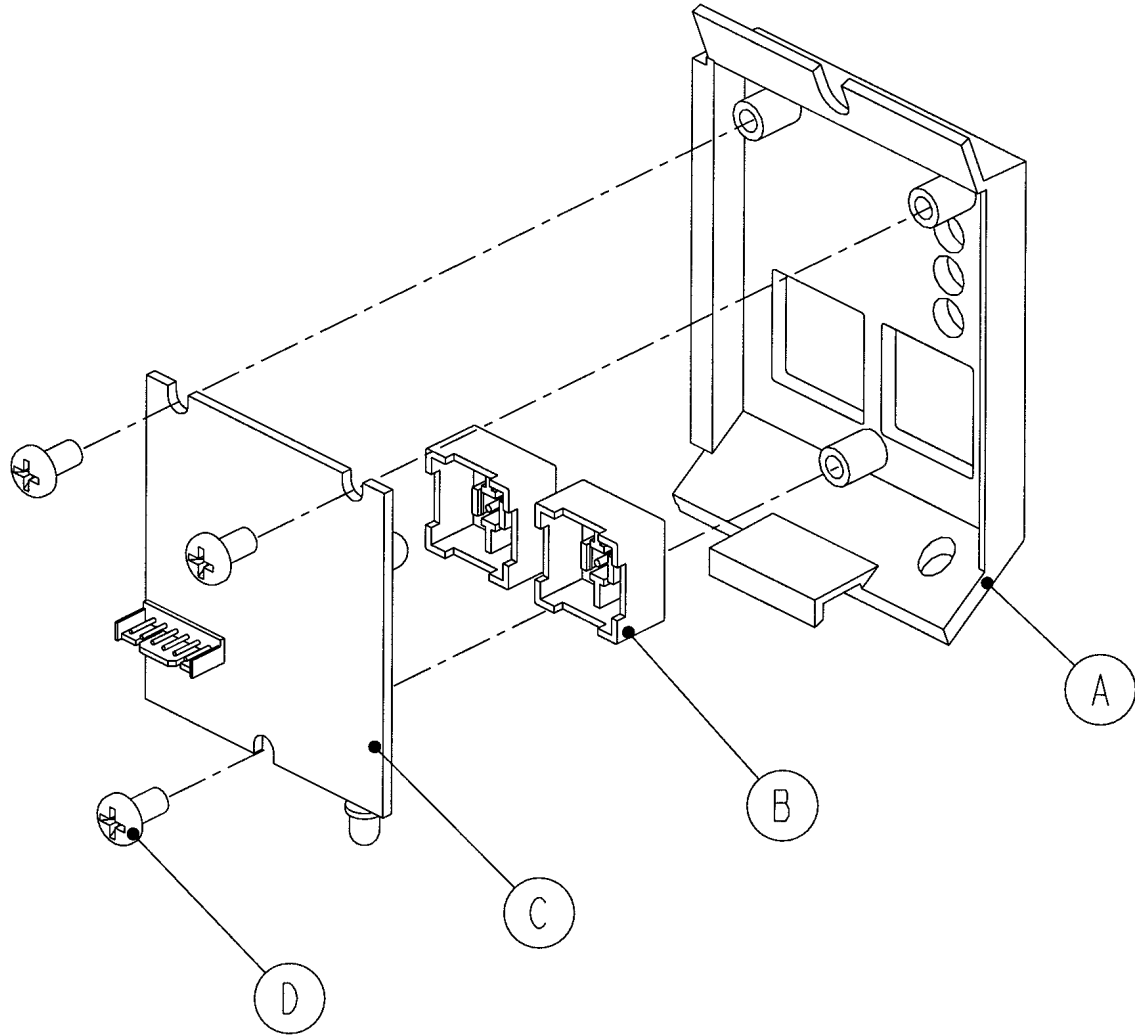

Item	Part No.	Part Name	Qty.
A	3000-508-1	Bed Exit Module Panel	1
B	3001-400-953	Switch Cap	2
C	3001-508-910	Bed Exit Keypad Ass'y	1
D	23-87	Tapping Screw	3

3001-507-35 Scale Display Assembly

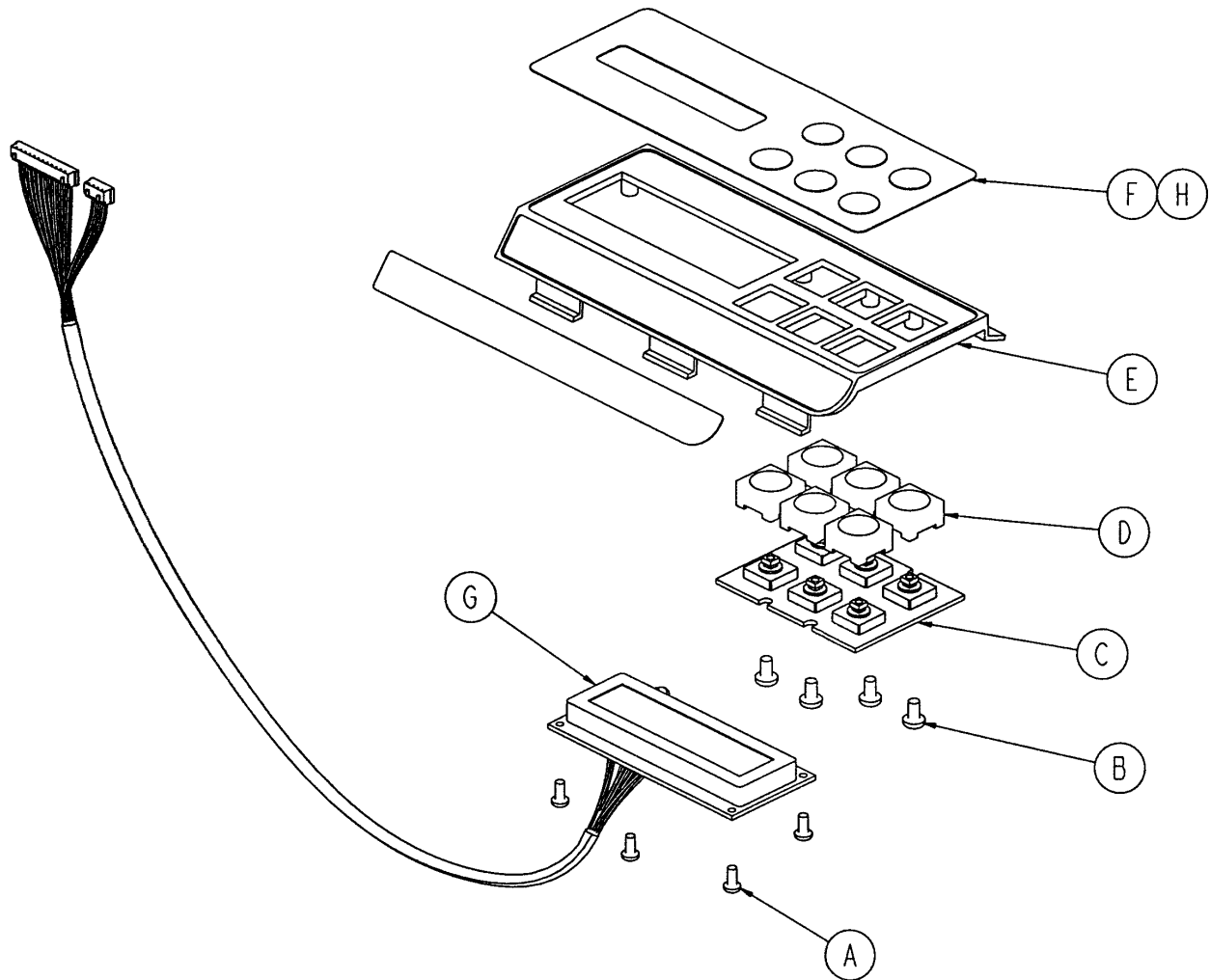

Item	Part No.	Part Name	Qty.
A	23-91	Pan Hd. Hi-Lo Tapping Screw	4
B	23-87	Pan Hd. Hi-Lo Tapping Screw	4
C	3001-507-910	Scale Keypad Assembly	1
D	3001-400-953	Switch Cap	6
E	3001-507-1	Scale Module	1
F	3001-507-2	Scale Module Label	1
G	3001-507-900	Scale LCD Display	1

Notes

3000-600-000 Head Board Assembly

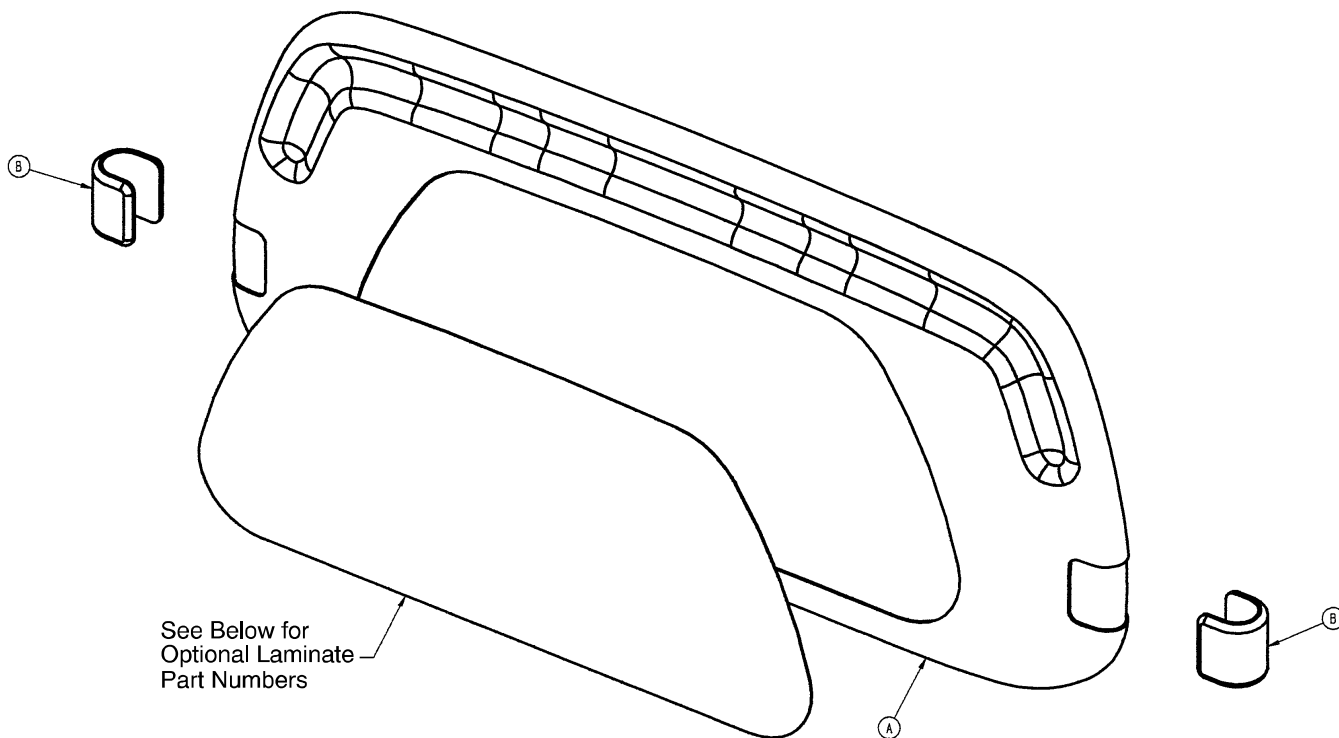

Item	Part No.	Part Name	Qty.
A	3000-600-10	Clamshell Assembly	1
B	3000-500-7	"C" Bumper	2
C	72-2-71	"C" Bumper Adhesive	1

Laminate Color	Part Number
Victorian Cherry	3000-600-50
English Oak	3000-600-49
Pech Contempe Blush	3000-600-45
Oak Suede Classic	3000-600-48

3000-526-10 Optional CPR Board Assembly

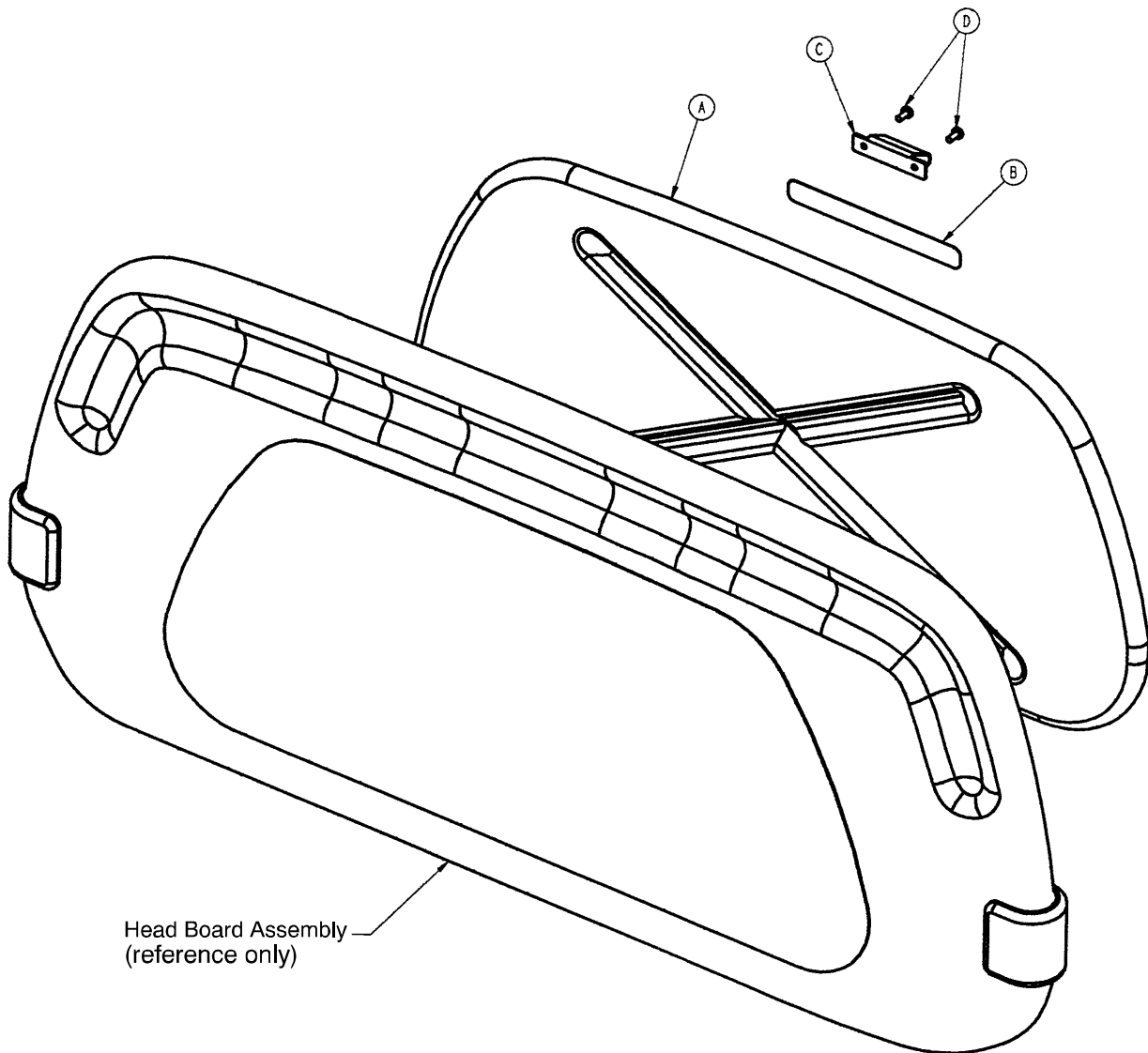

Item	Part No.	Part Name	Qty.
A	3000-526-1	CPR Board	1
B	3000-526-3	CPR Board Label	1
C	3000-526-2	CPR Head Board Clip	1
D	23-88	Pan Hd. Tapping Screw	2

Optional Pendant Assembly

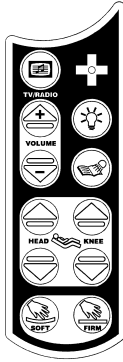

**3001-315-11 Combination Pendant
Motion/Comm./DMS**



**3001-315-16 Combination Pendant
Communication Only**

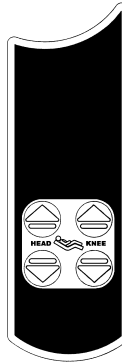

**3001-315-14 Combination Pendant
Motion Only**

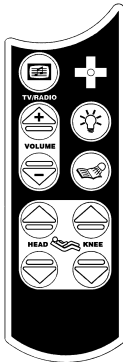

**3001-315-12 Combination Pendant
Motion/Communication**

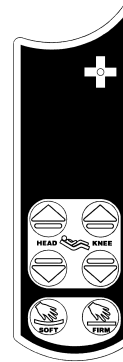

**3001-315-17 Combination Pendant
Motion/DMS/NC**

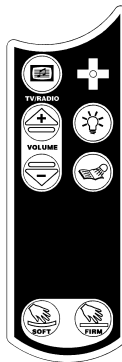

**3001-315-15 Combination Pendant
Communication/DMS**

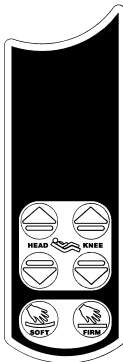

**3001-315-13 Combination Pendant
Motion/DMS**



**3001-315-18 Combination Pendant
Motion/NurseCall**

3001-338-10 Removable I.V. Pole Mounting Assembly

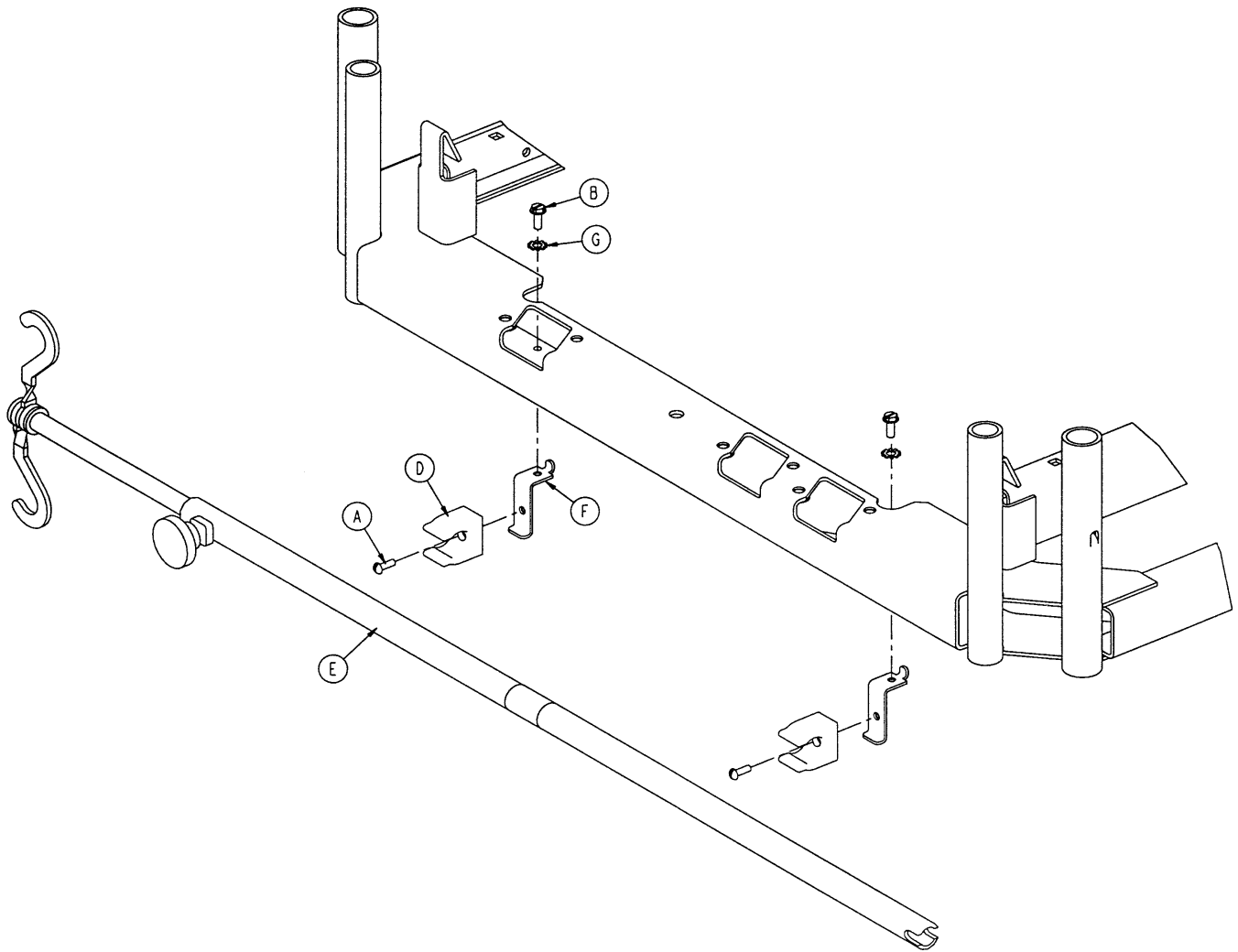

Item	Part No.	Part Name	Qty.
A	2-31	Round Hd. Screw	2
B	3-124	Hex Washer Hd. Screw	2
D	958-1-224 (page 200)	I.V. Clip	2
E	3001-300-87	I.V. Pole Assembly	1
F	3001-300-87	Mounting Bracket	2
G	13-18	External Tooth Lock Washer	2

3000-300-80 Removable I.V. Pole Assembly

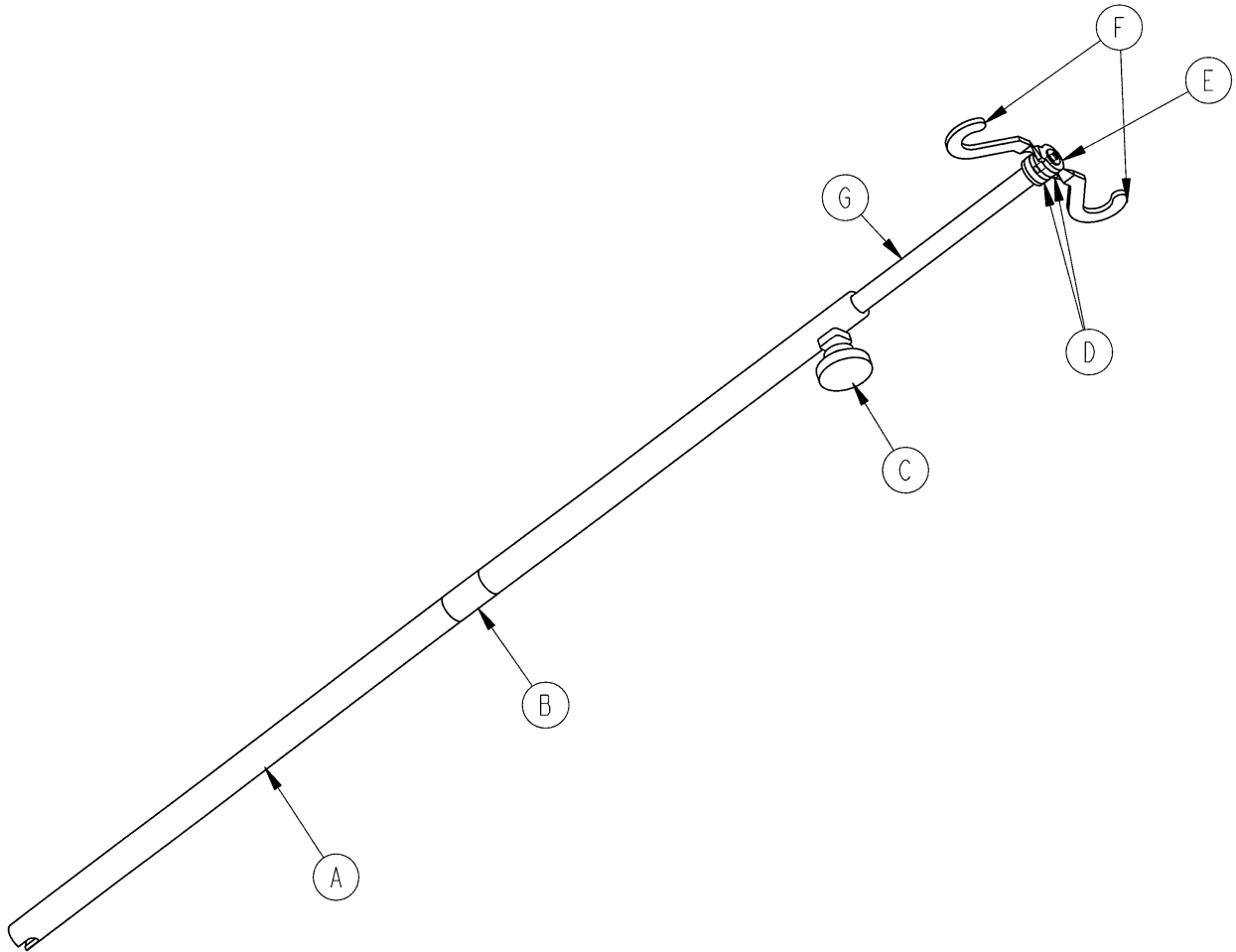

Item	Part No.	Part Name	Qty.
A	3000-300-81	Outer Tube	1
B	3000-300-89	Label	1
C	24-50	Fluted Knob	1
D	52-17	Spacer	2
E	7-40	Phillips Truss Hd. Screw	1
F	1010-59-16	I.V. Hook	2
G	3000-300-85	Inner Tube Assembly	1

3000-311-10 Permanent I.V. Pole Mtg. Ass'y, Hd. End

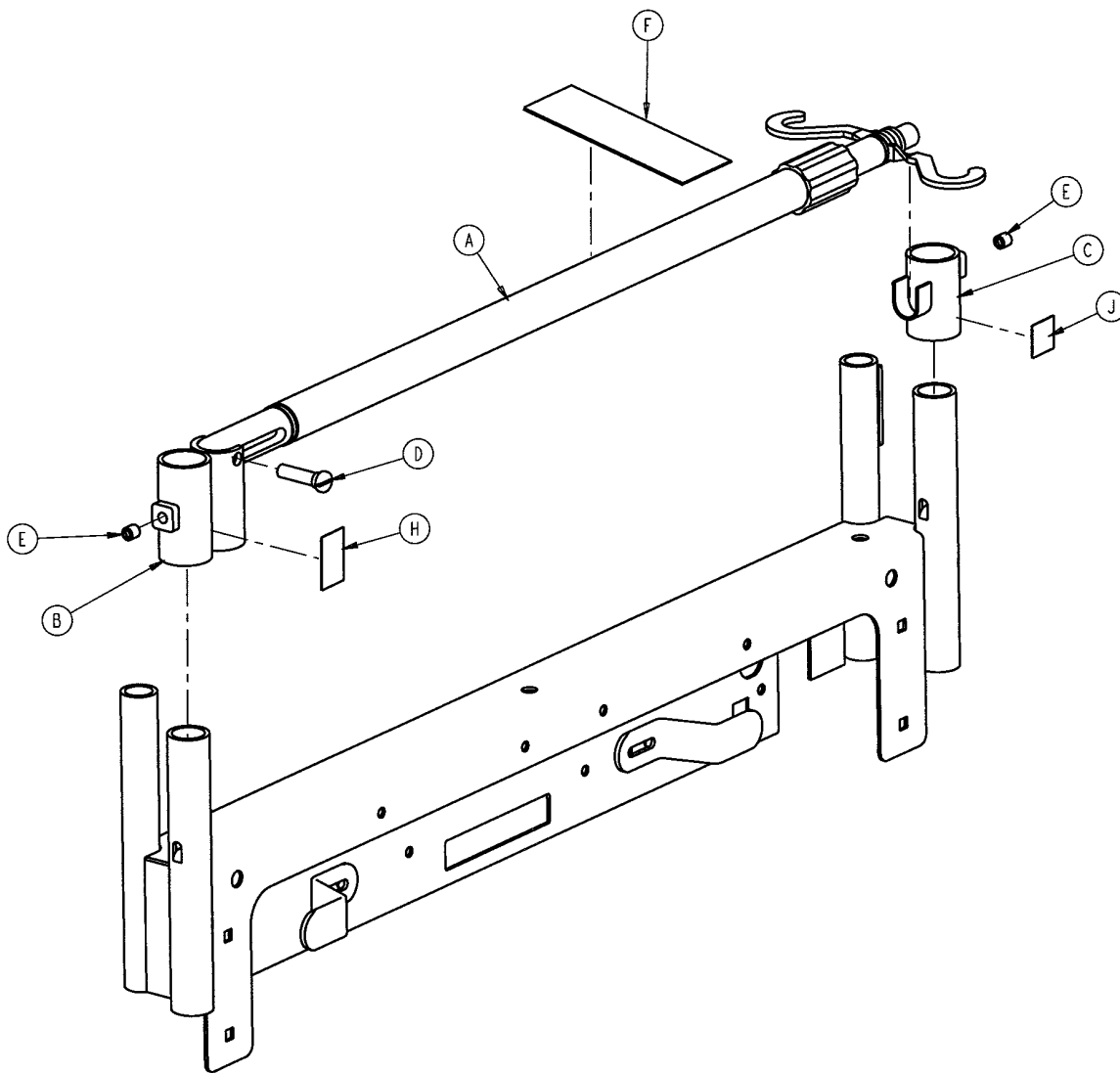

Item	Part No.	Part Name	Qty.
A	(page 203)	I.V. Pole Assembly	1
B	3000-311-11	I.V. Receptacle Assembly	1
C	3000-311-16	I.V. Rest Assembly	1
D	1015-24-35	Retaining Pin	1
E	21-140	Set Screw	2
F	3000-311-5	Spec. Label	1
H	3000-311-15	Receptacle Label	1
J	3000-311-6	Cradle Label	1

3000-312-10 Permanent I.V. Pole Mtg. Ass'y, Foot End

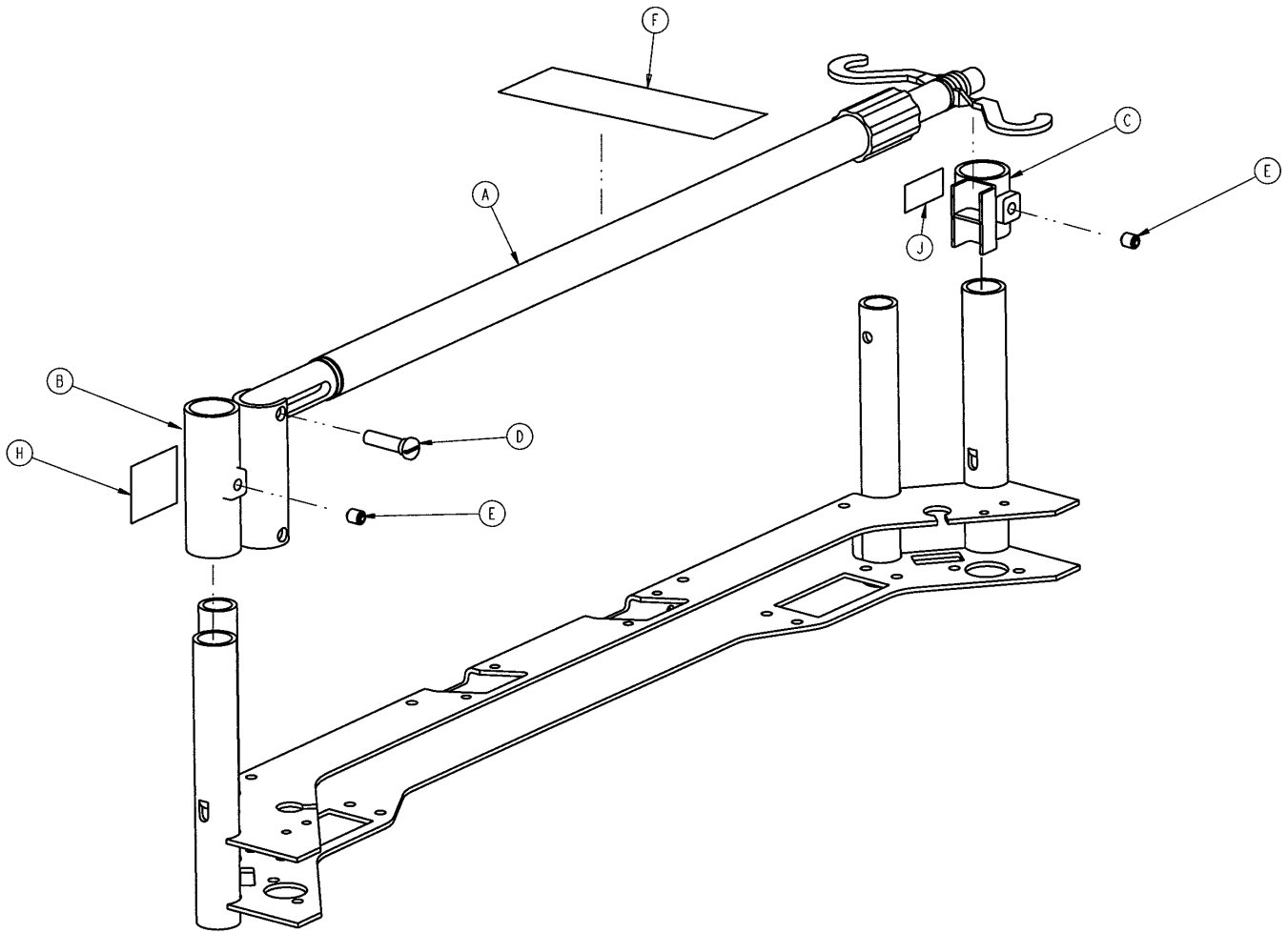

Item	Part No.	Part Name	Qty.
A	(page 203)	I.V. Pole Assembly	1
B	3000-312-11	I.V. Receptacle Assembly	1
C	3000-312-35	I.V. Cradle Assembly	1
D	1015-24-35	Retaining Pin	1
E	21-140	Set Screw	2
F	3000-311-5	Spec. Label	1
H	3000-312-7	Receptacle Label	1
J	3000-312-6	I.V. Cradle Label	1

3000-311-26 Optional Perm. Mounted I.V. Pole Ass'y

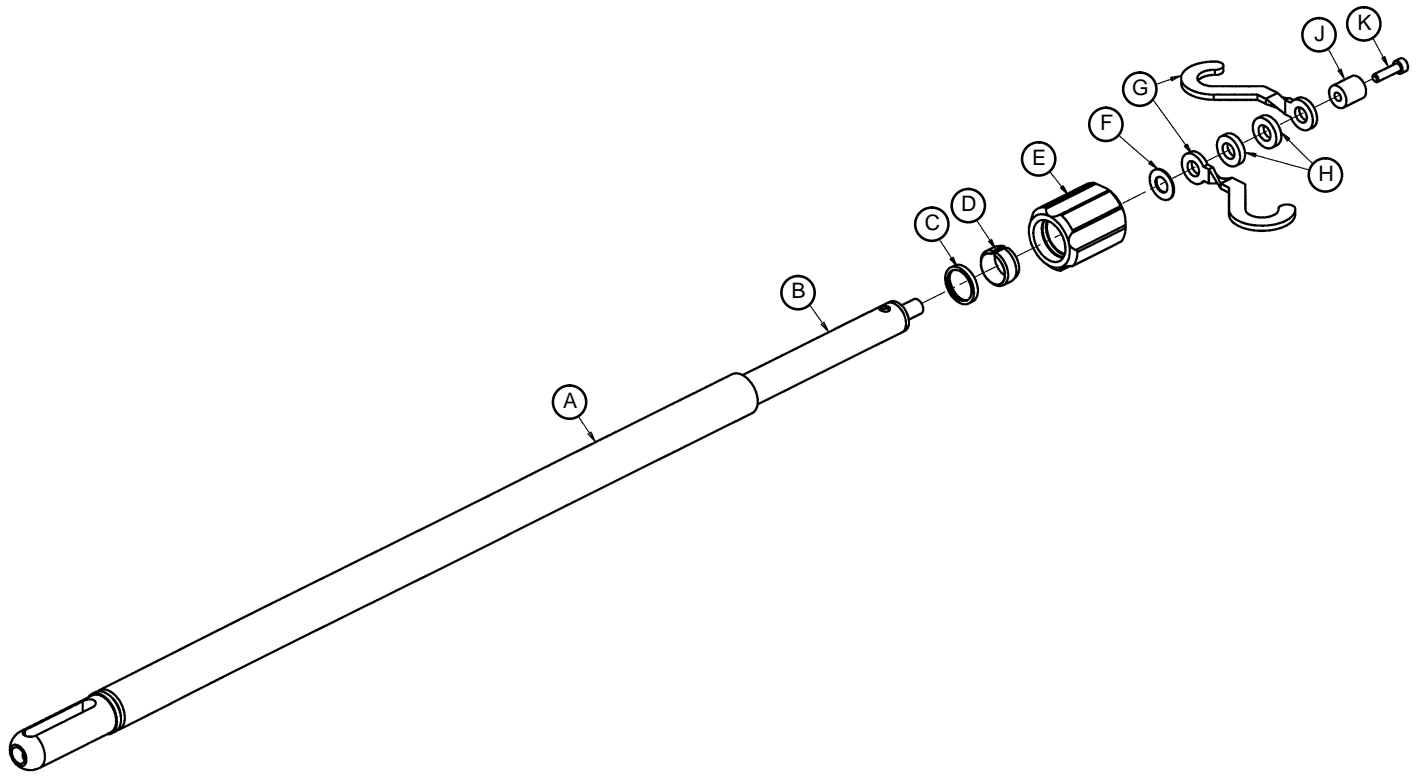

Item	Part No.	Part Name	Qty.
A	1010-59-24	Base Tube Assembly	1
B	1010-59-30	Extension Tube Assembly	1
C	1210-110-46	Back-Up Ring	1
D	1210-110-47	Lock Ring	1
E	1210-110-49	Actuator	1
F	14-20	Nylon Flat Washer	1
G	1010-59-16	I.V. Hook	2
H	52-17	Nylon Spacer	2
J	3000-311-19	End Spacer	1
K	4-8	Socket Hd. Cap Screw	1

3000-335 Optional Litter Roller Assembly

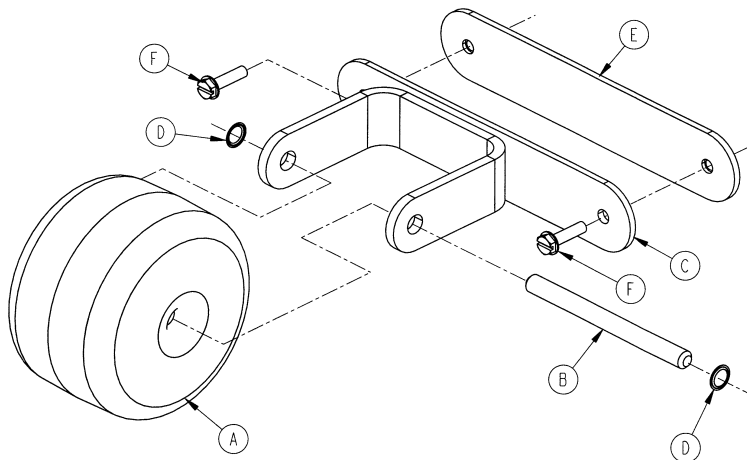
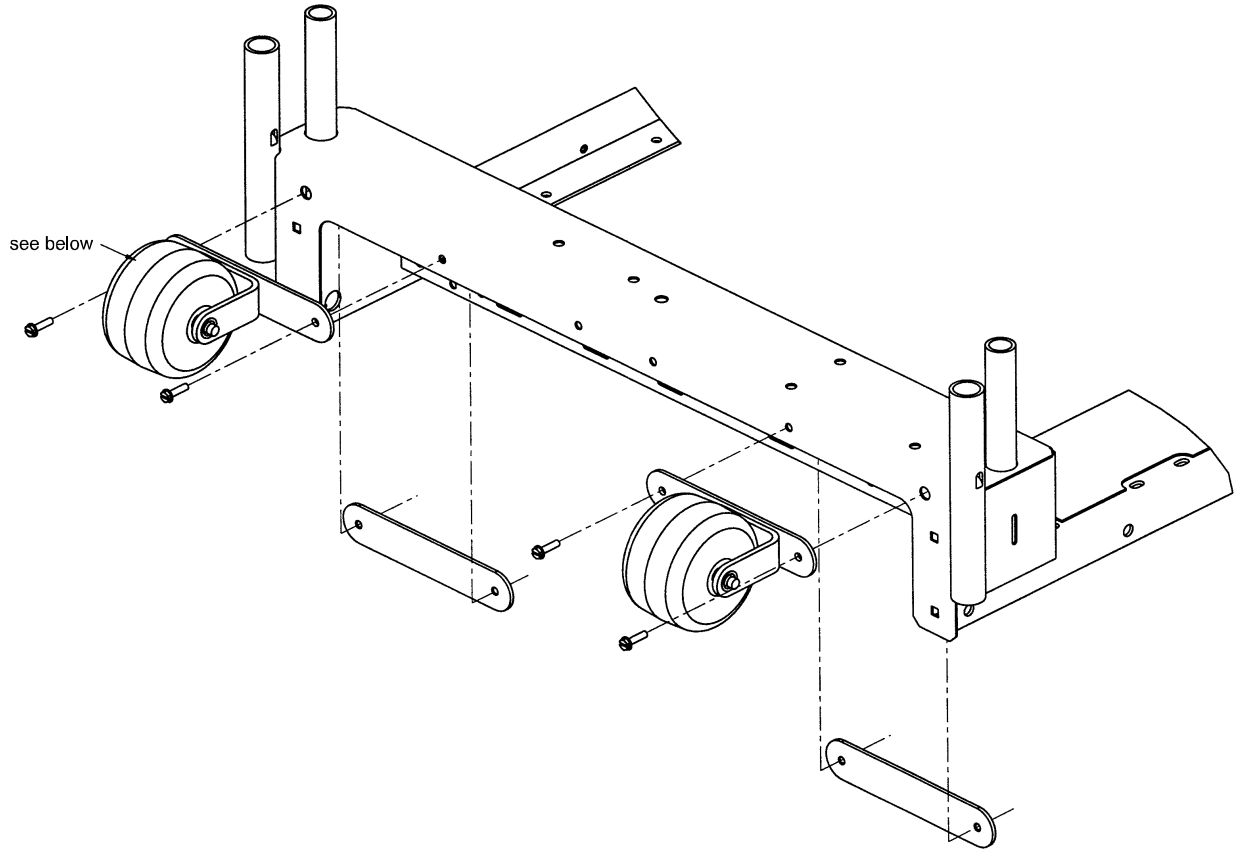

Assembly part number 3000-335-5
(reference only)

Item	Part No.	Part Name	Qty.
A	3000-335-11	Roller Bumper	1
B	3000-335-12	Roller Shaft	1
C	3000-335-20	Roller Bracket Assembly	1
D	52-727	Retainer Ring	2
E	3000-335-25	Roller Mounting Plate	1
F	3-225	Hex Washer Hd. Screw	2

Optional 90° Power Cord

Assembly part number 3001-334-10 (reference only)

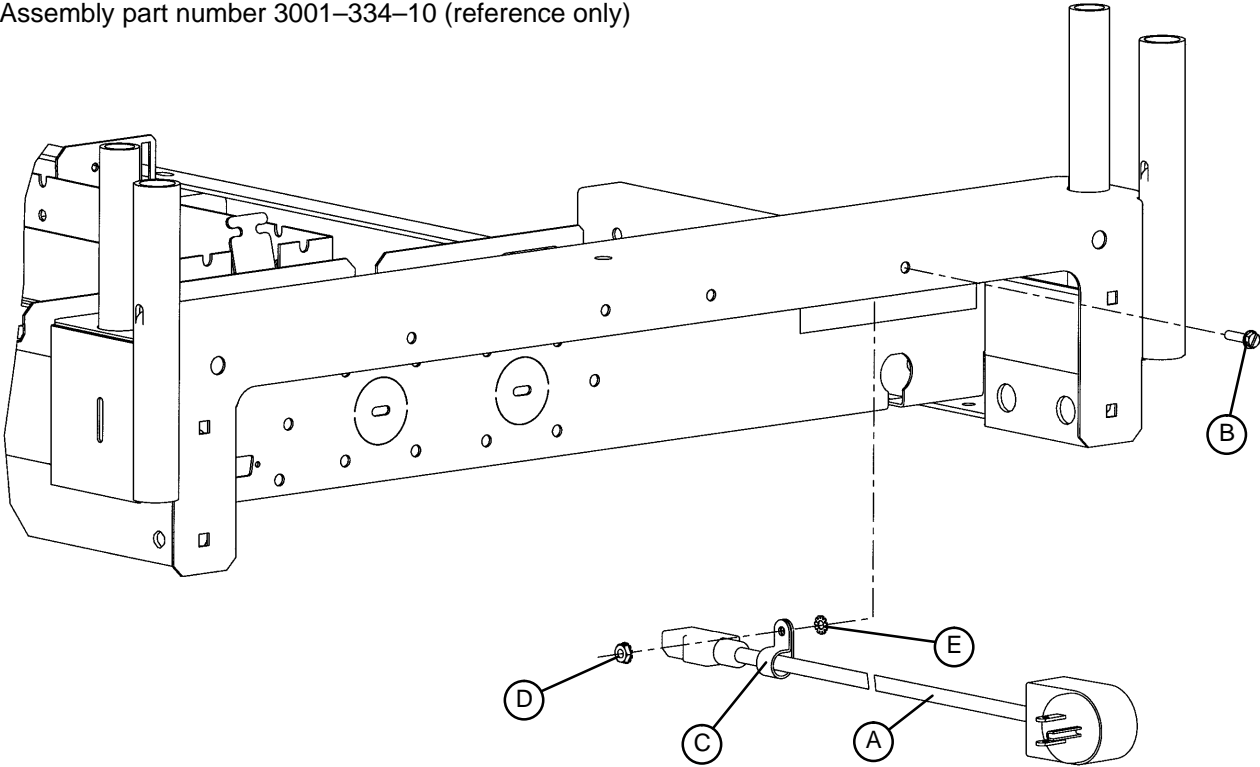

Item	Part No.	Part Name	Qty.
A	3001-334-850	90° Power Cord (12 O'Clock)	1
	3001-334-851	90° Power Cord (9 O'Clock)	1
	3001-334-852	90° Power Cord (6 O'Clock)	1
	3001-334-853	90° Power Cord (3 O'Clock)	1
B	3-132	Hex Washer Hd. Screw	1
C	34-22	Cable Clamp	1
D	16-41	Kep Nut	1
E	13-18	External Tooth Lock Washer	1

3001-333-000 Optional Accessory Adapter Frame

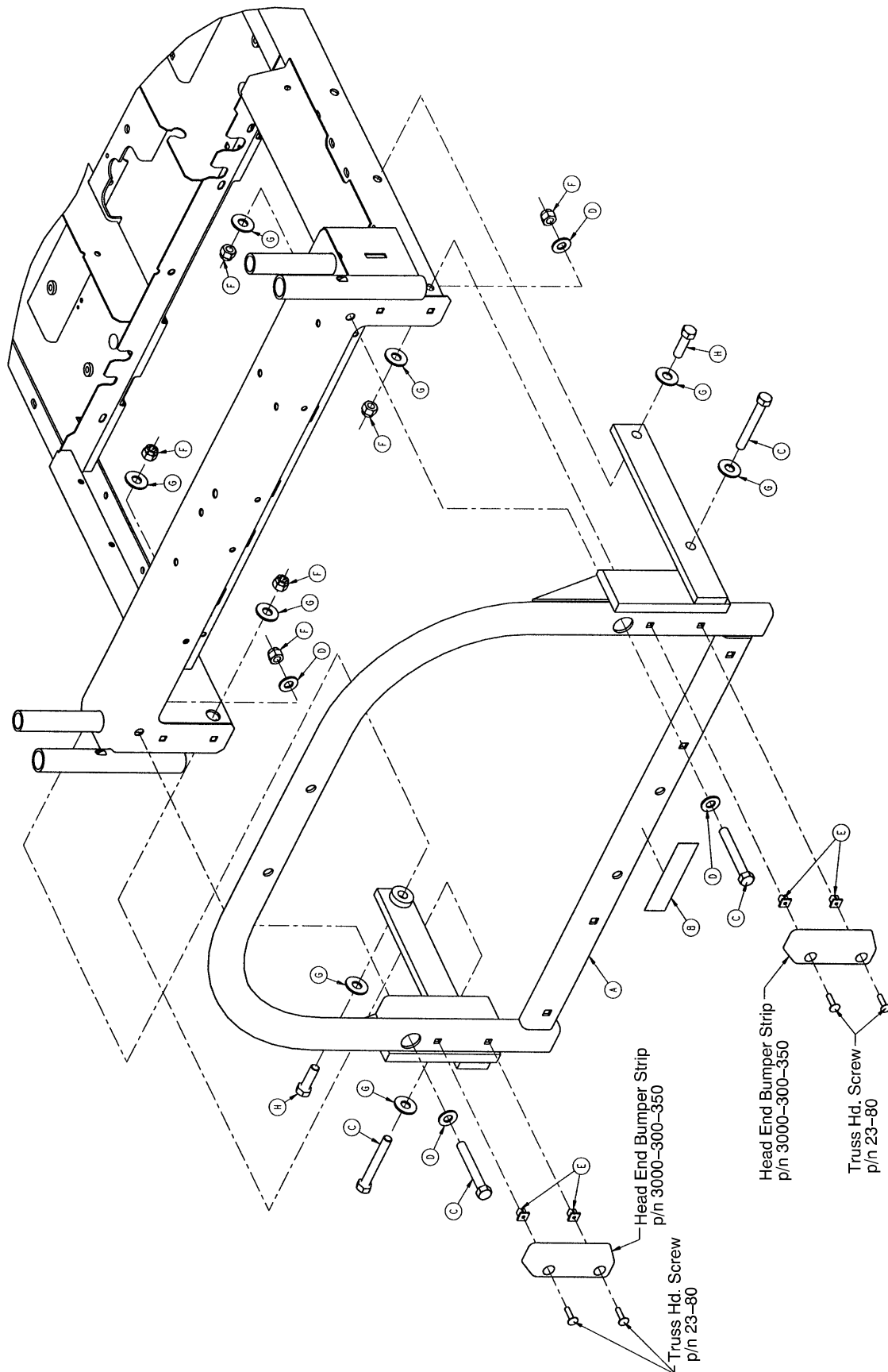

3001–333–000 Optional Accessory Adapter Frame

Item	Part No.	Part Name	Qty.
A	3001–333–10	Frame Assembly	1
B	3000–333–15	Accessory Adapter Label	1
C	3–208	Hex Hd. Cap Screw	4
D	11–301	Flat Washer	4
E	3000–300–2	Plastic Clip Nut	4
F	16–35	Nylock Nut	6
G	11–361	Flat Washer	8
H	3–120	Hex Hd. Cap Screw	2

3000-318-20 Optional Bed Extender Assembly (MPS & Secure Bed)

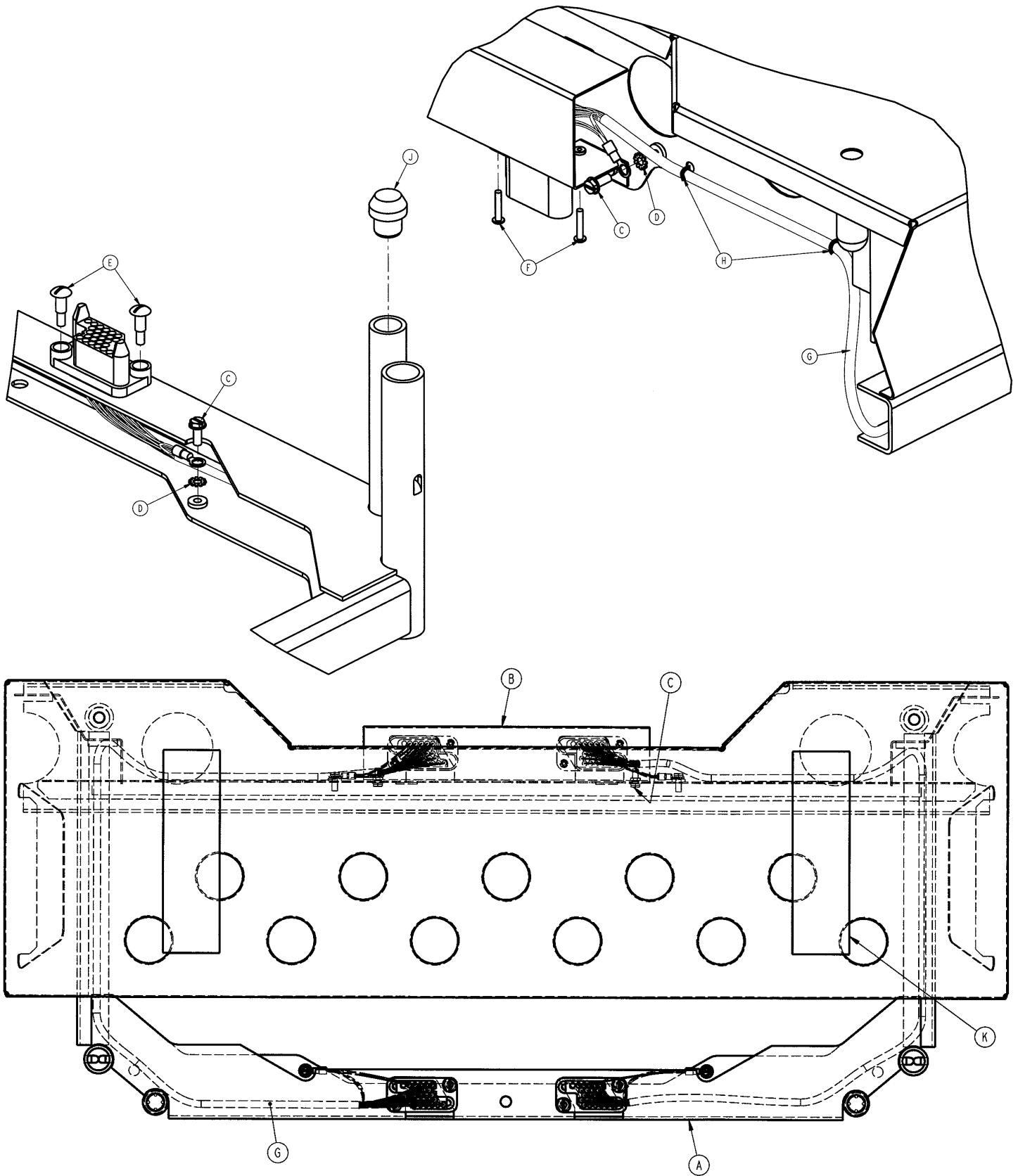

3000–318–20 Optional Bed Extender Assembly (MPS & Secure Bed)

Item	Part No.	Part Name	Qty.
A	3000–318–30	Bed Extender Weldment	1
B	3000–318–21	Connector Mounting Bracket	1
C	3–124	Hex Washer Hd. Screw	6
D	13–18	External Tooth Lock Washer	4
E	52–729	Truss Hd. Shoulder Screw	4
F	50–39	Pan Hd. Machine Screw	4
G	3000–318–801	Bed Extender Cable	4
H	3000–300–114	Cable Tie	4
J	3000–300–349	Cap	2
K	7900–1–102	Velcro Adhesive Pile	2

3001-318-20 Optional Bed Extender Ass'y (Secure Only)

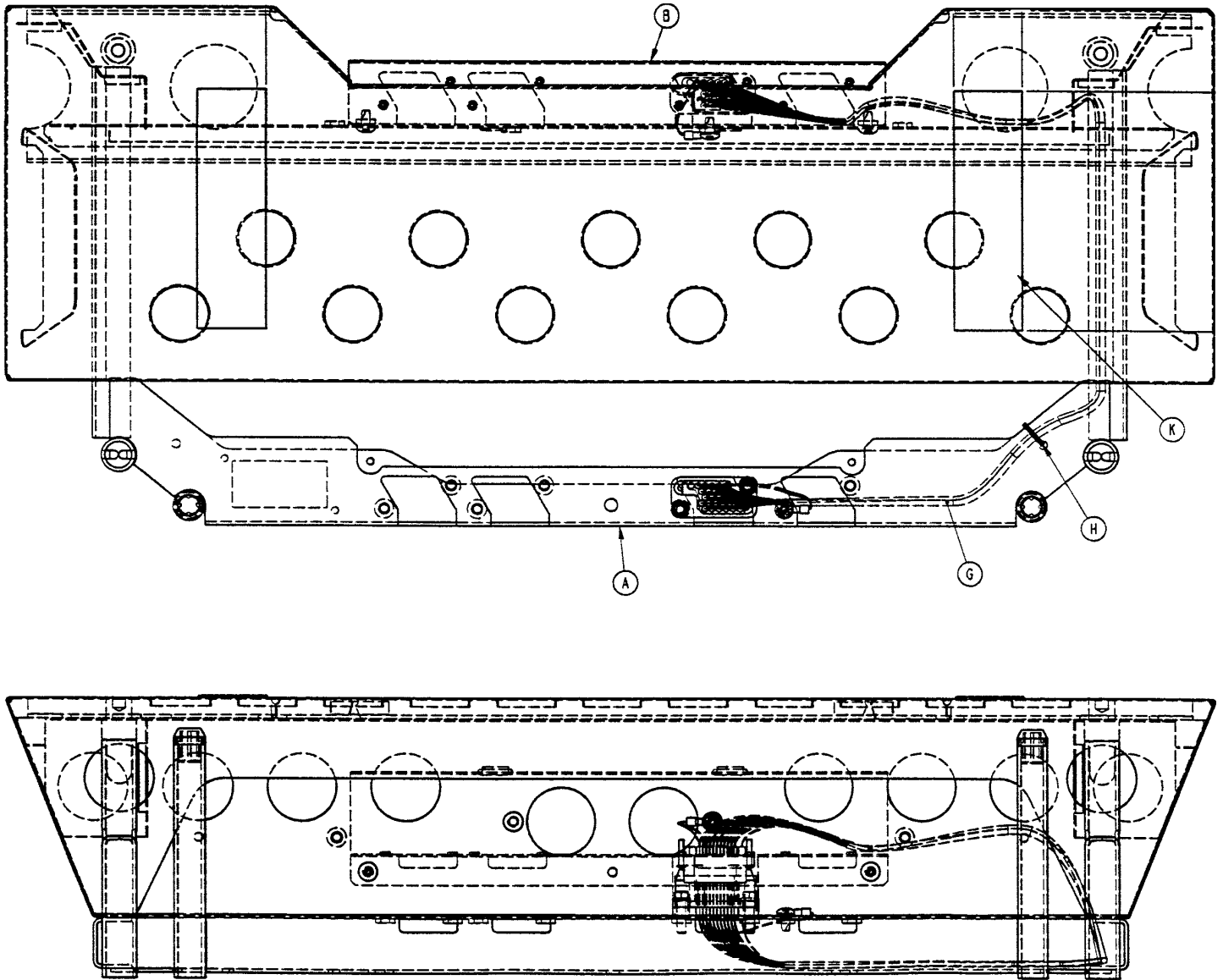

Item	Part No.	Part Name	Qty.
A	3001-318-50	Bed Extender Weldment	1
B	3001-318-31	Connector Mounting Bracket	1
C	7-52	Truss Hd. Screw	4
D	13-10	External Tooth Lock Washer	2
E	3001-200-228	Mounting Standoff	2
F	50-39	Pan Hd. Machine Screw	2
G	3000-318-801	Bed Extender Cable	1
H	3000-300-114	Cable Tie	2
J	3000-300-349	Cap	2
K	7900-1-102	Velcro Adhesive Pile	2

3001-318-20 Optional Bed Extender Ass'y (Secure Only)

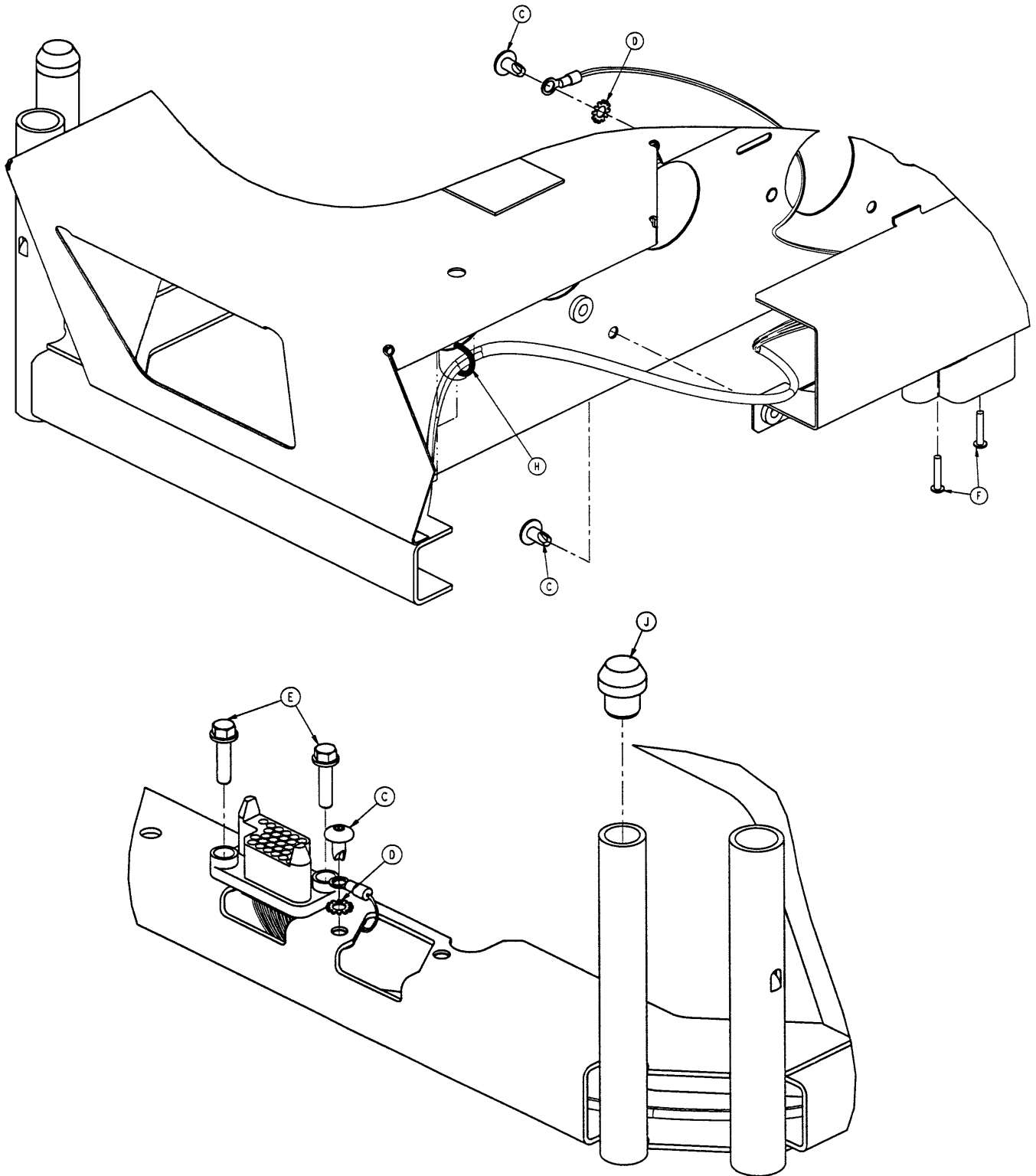

3000-318-50 Optional Bed Extender Mattress

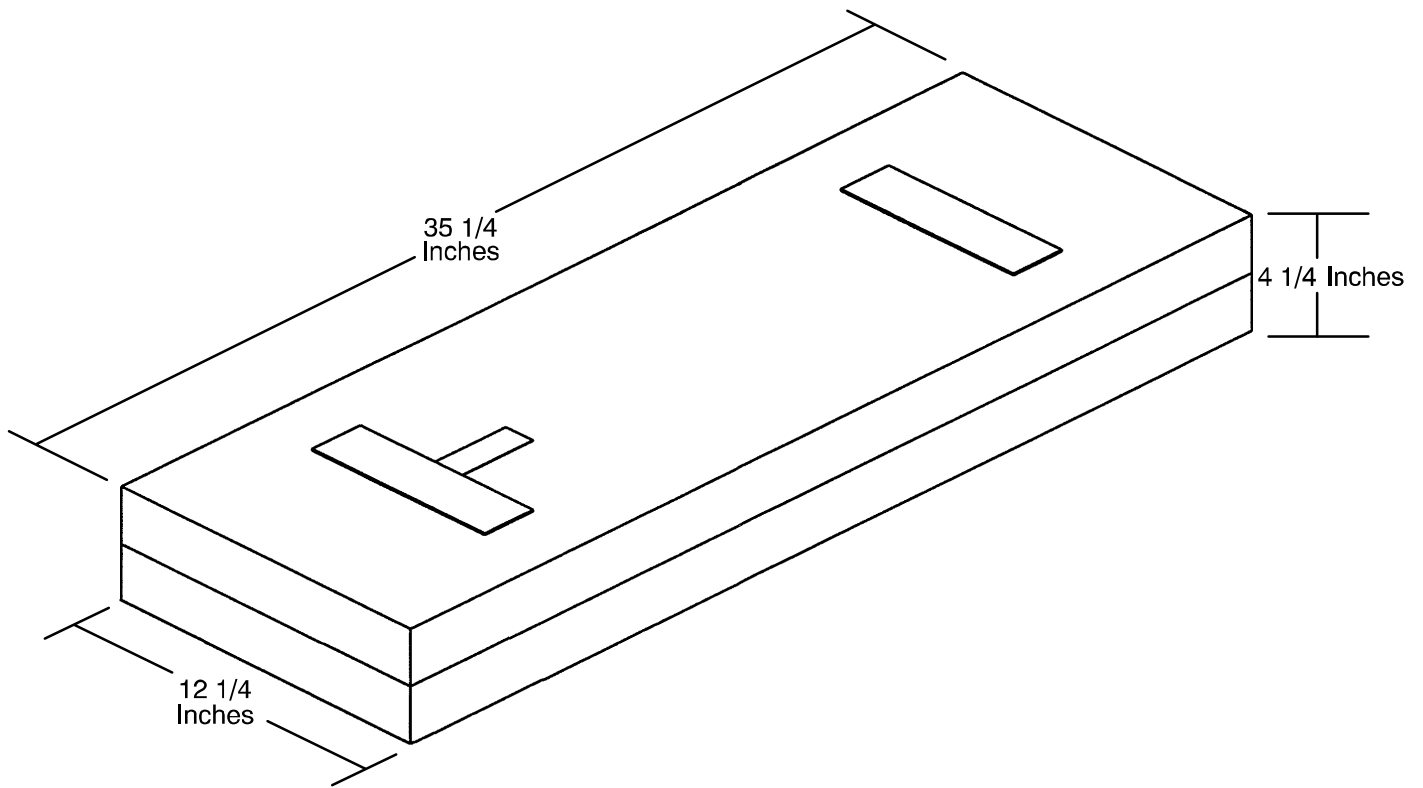

3001-305-702 Optional Telephone Mtg. Bracket Ass'y

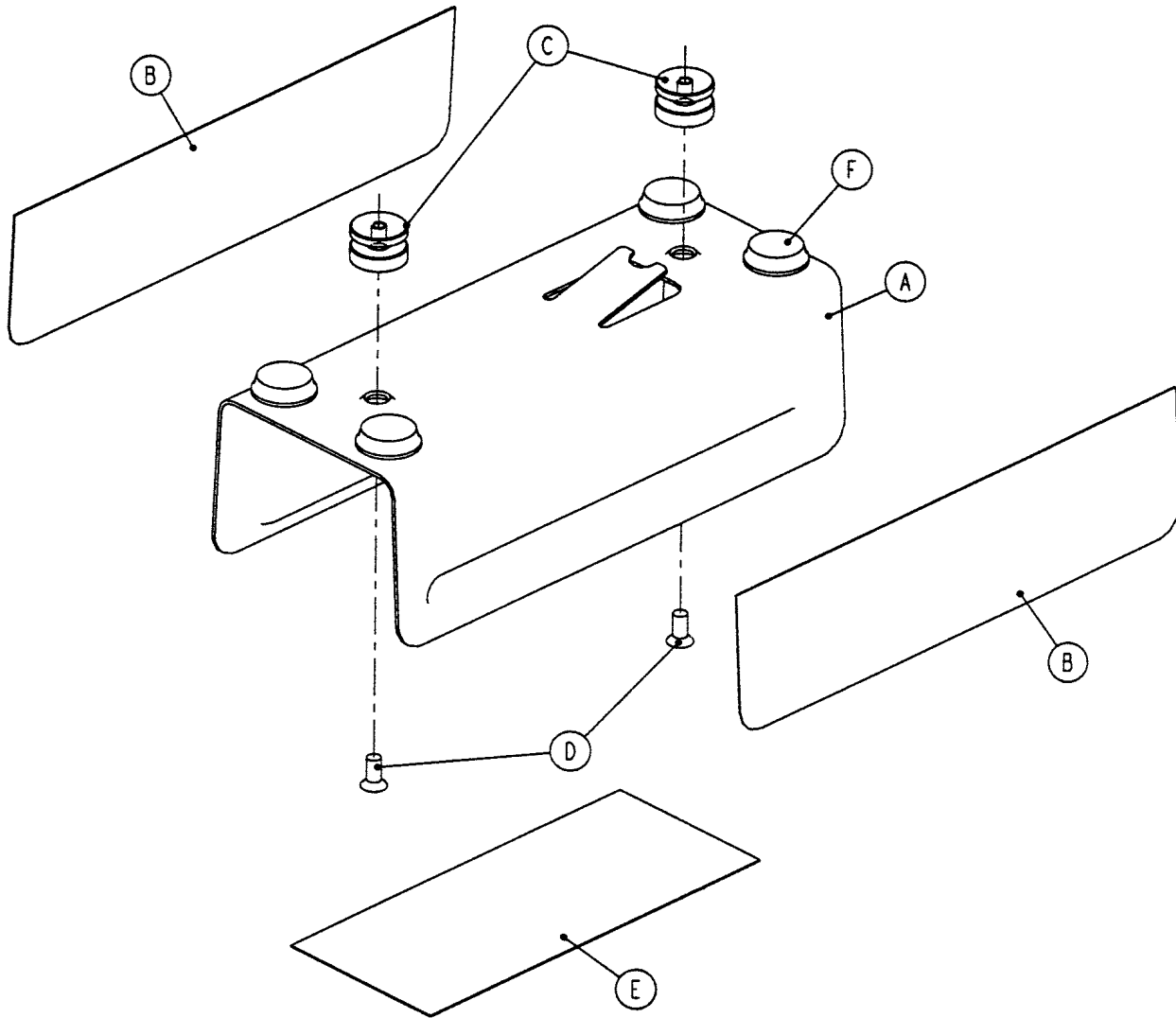

Item	Part No.	Part Name	Qty.
A	3001-305-1	Telephone Bracket	1
B	3000-305-11	Installation Label	2
C	3000-305-13	Mounting Post	2
D	1-22	Flat Soc. Hd. Cap Screw	2
E	3001-305-12	Identification Label	1
F	56-14	Bumper	4

Optional Traction Socket Extension

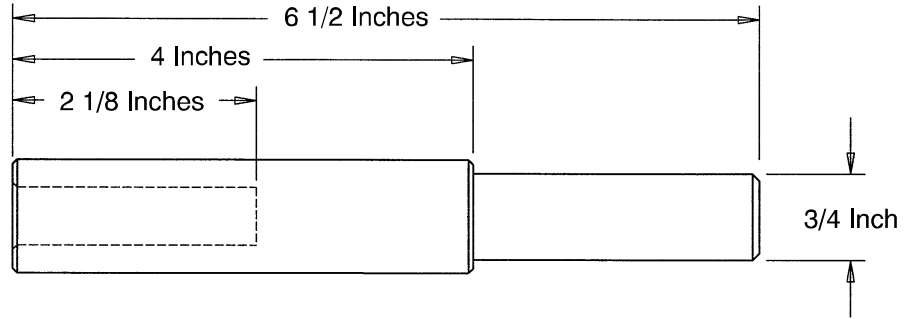
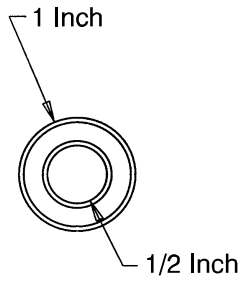

Part number 3000-337-450

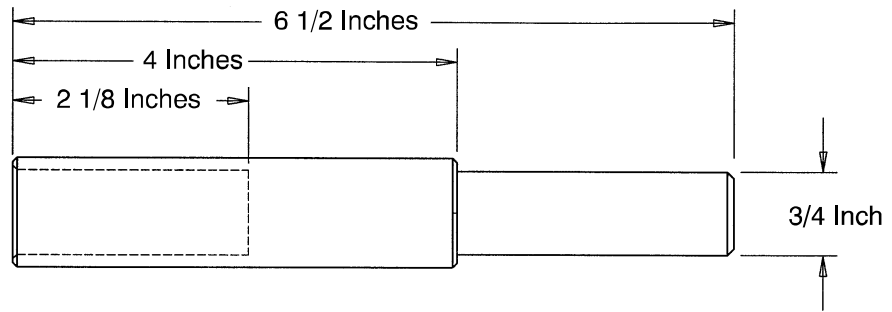
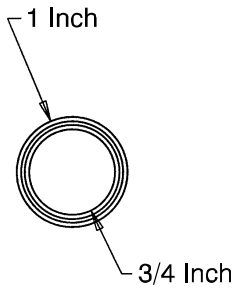

Part number 3000-337-475

3000-339-10 Optional Urine Bottle Hanger

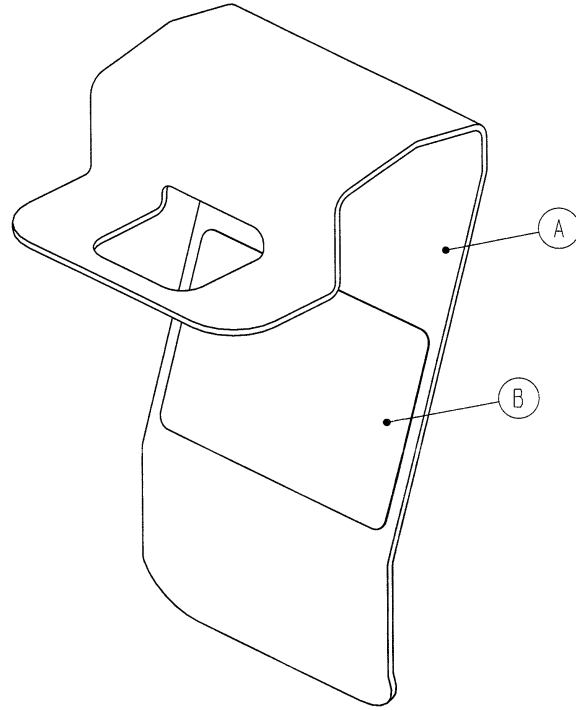

Item	Part No.	Part Name	Qty.
A	3000-339-11	Hanger	1
B	3000-339-12	Hanger Label	1

3000-336-701 Optional Padded Siderail Cover Kit

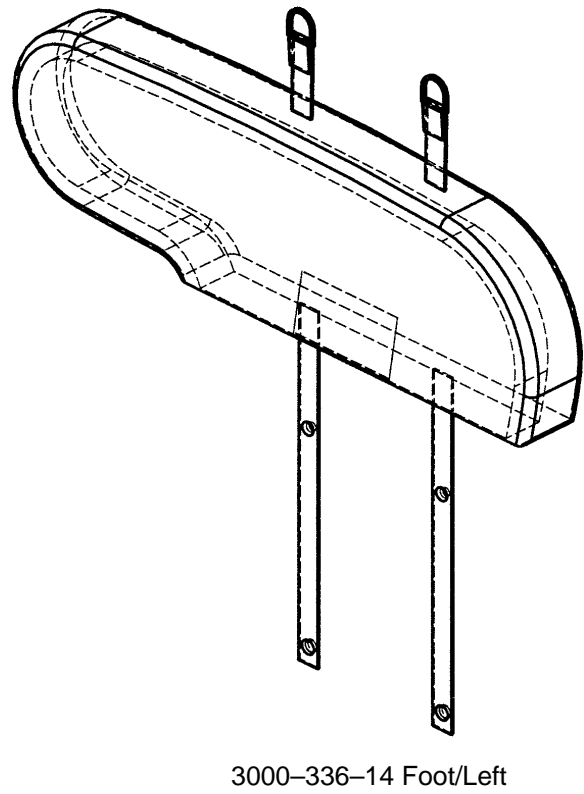
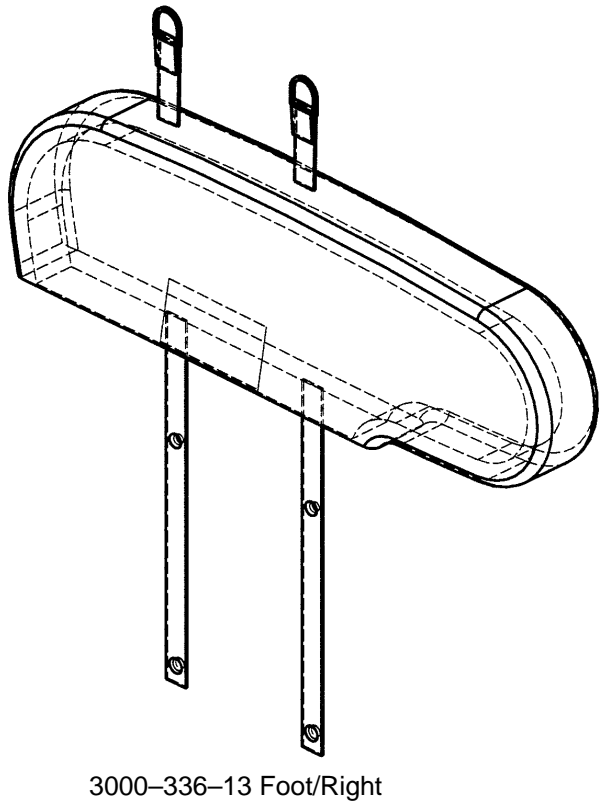
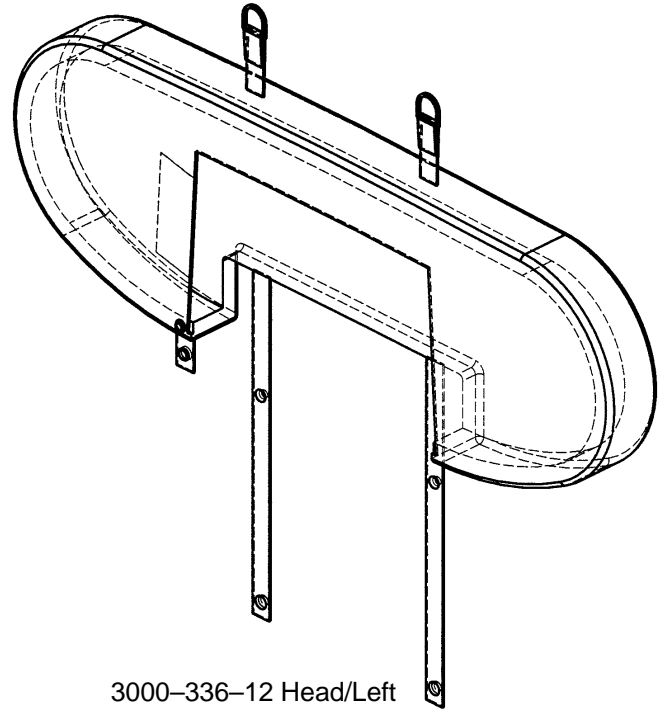
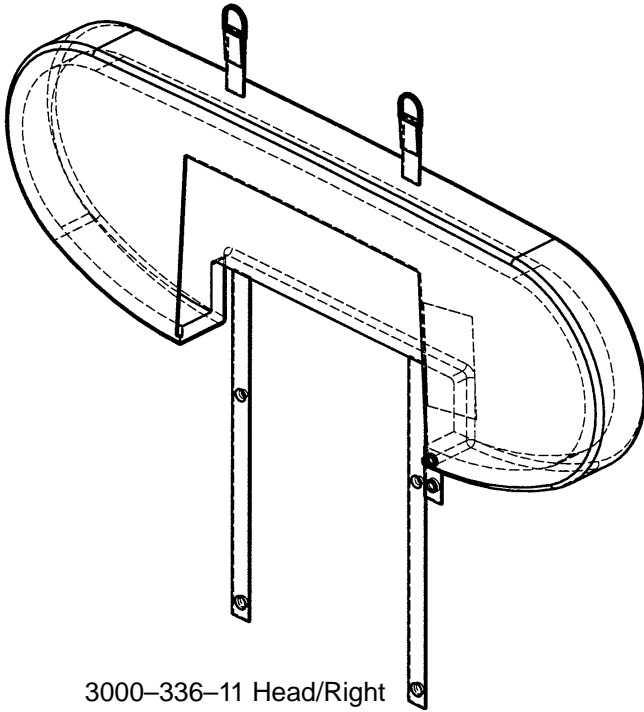



European Representative

Stryker France
BP 50040-95946 Roissy Ch. de Gaulle
Cedex-France

Phone: 33148632290
Fax: 33148632175

stryker[®]
Medical

6300 Sprinkle Road, Kalamazoo, MI 49001-9799

(800) 327-0770



DH 7/00 3001-5-98 REV D