



Secure II
MedSurg Bed
Model 3002

stryker[®]

Maintenance Manual



For technical assistance
USA: 1-800-327-0770 (option 2)
Canada: 1-888-233-6888

Table of Contents

Introduction	8
Intended Use	8
Specifications	8
Mattress Specifications	9
Warning/Caution/Note Definition	9
Bed Illustration	10
Symbols	11
Safety Tips and Guidelines	12
Zoom™ Option	14
iBED Awareness Option	15
Static Discharge Precautions	16
Setup Procedures	17
Zoom™ Option	18
Optional iBED Awareness Maintenance Menu Guide	19
Maintenance Menu Screen	19
Preventative Maintenance	26
Checklist	26
Cleaning	27
Troubleshooting Guide	28
iBED Awareness System Error Codes	34
Error Handling	34
Logged Errors	34
Error Messages	35
Quick Reference Replacement Parts List	38
Service Information	40
Brake Pedal Replacement	40
Lift Motor and Capacitor Removal and Replacement	41
Lift Housing Removal and Replacement	42
Lift Potentiometer Replacement and Adjustment	44
Lift Potentiometer “Burn-in” Procedure (Standard Bed)	45
Lift Potentiometer “Burn-in” Procedure (iBED Awareness option)	45
Lift Motor Isolation Plate Replacement	46
Lift Motor Coupler Replacement	47
Power and Sensor Coil Cord Replacement	48
Power and Sensor Coil Cord Replacement Illustration	49
Knee Motor Removal and Replacement	50
Head Motor CAM and CAM Guide Replacement	51
Limit Setting - Head Motor	52
Head Motor Removal and Replacement	53
Head Motor Drive Isolator and CPR Decoupler Removal and Replacement	54
Head Motor Drive Screw and Ball Nut Replacement	55
Head Motor Brake/Clutch Replacement	56
Optional Scale System Diagnostics and Calibration	57

Table of Contents

Service Information (Continued)	
Load Cell Replacement	60
Power Supply Replacement	61
CPU Board Replacement	61
Optional Smart TV Interface “Burn-In” Procedure	62
Optional Smart TV Interface “Burn-In” Procedure (<i>i</i> BED Awareness Option)	63
Fowler Potentiometer Replacement (<i>i</i> BED Awareness Option)	64
Fowler Potentiometer “Burn-In” Procedure (<i>i</i> BED Awareness Option).	64
Zoom® Option Battery Removal and Replacement	65
Zoom® Option DC Motor Board Removal and Replacement	66
Zoom Option Drive Motor Removal and Replacement	67
Zoom® Option Control Bar Potentiometer Replacement	68
Zoom® Option Control Bar Potentiometer “Burn-In” Procedure	69
Zoom® Option AC Crossover Board Replacement.	70
Zoom® Option Display/CPU Board Replacement.	71
Head and Foot Siderail Cover Removal.	72
Head and Foot Molded Siderail Replacement	73
Siderail Assembly Removal	76
Foot Board Hinge Removal.	77
Foot Board Module Replacement	78
Foot Board Interface Plug Replacement	79
CPU Board.	80
Standard CPU Board = 3002-407-950 / <i>i</i> BED Awareness CPU Board - 3003-407-900	80
Software Configuration	82
Power Supply	84
Zoom® Option Inverter/Charger Board	85
Zoom® Option Display/CPU	86
Zoom® Option AC Crossover Board	87
Bed Circuit Boards	88
Optional DC Motor Power Board - 2040-001-900	88
Night Light Board - 3002-310-900.	88
Head Wall Output Configuration	89
Zoom® Option Inverter Protection Features.	90
Assembly Drawings	91
Bed Assembly, Standard	91
Bed Assembly, <i>i</i> BED Awareness Option	94
Bed Assembly, <i>i</i> BED Awareness/Battery Backup Option	98
Bed Assembly, <i>i</i> BED Awareness/Zoom Option	102
Base Assembly and Options.	106
Brake Plate Assembly	114
Lift Assembly (Head and Foot End)	116
Lift Assembly.	117
Motor Isolation Plate Assembly.	120
Brake Shaft Assembly, Left	121

Table of Contents

Assembly Drawings (Continued)

Brake Shaft Assembly, Right	121
Brake Crank Assembly	122
Brake Bar Assembly	123
6" Caster Assembly	124
6" Steer Caster Assembly	125
6" Molded Wheel Assembly	126
Base Uni-Pan Cover Assembly	127
Base Assembly with Zoom® Option	128
Zoom® Option Drive Wheel Lift Lever Assembly	136
Bottom Cover	137
Zoom Option Head End Bottom Cover	137
Zoom Option Drive Train Assembly	138
Zoom Option Battery Tray Assembly	139
Zoom Option Base Power Assembly	140
Base Assembly with Battery Backup Option	141
Battery Backup Option Power Assembly	146
Litter Assembly, Standard Components	147
Litter Assembly, Standard Bed	152
Litter Assembly, iBED Awareness Option	159
Litter Assembly, iBED Awareness/Battery Backup Option	165
Litter Assembly, iBED Awareness/Zoom Option	171
Foot Prop Assembly, Standard Length Bed	177
Litter CPU Cover Assembly	178
Foot Cover Assembly	179
Electrical Litter Assembly, Standard Bed	180
Electrical Litter Assembly, iBED Awareness Option	186
Electrical Litter Assembly, Optional Battery Backup	194
Electrical Litter Assembly, iBED Awareness/Secure Zoom Option	195
Mechanical Litter Assembly	196
Lift Header Assembly - No Load Cells	201
Lift Header Assembly with Load Cells	202
Gatch Motor Assembly	203
Fowler Driver Assembly	204
Fowler Brake Kit Assembly	206
Standard Bed Fowler Limit Switch Assembly	207
8" Short Bed, Fowler Limit Switch Assembly Option	208
Night Light Assembly	209
Optional 110V Outlet Assembly	211
110V Outlet Box Assembly	213
Optional Scale/Bed Exit Assembly	214
Optional HWI Assembly with Communication	216
Optional HWI Assembly with Communication and Ports	218

Table of Contents

Assembly Drawings (Continued)

Battery Enclosure Assembly	221
Zoom® Option Litter Assembly	222
Battery Backup Option Head End Enclosure	229
Head End Siderail Assembly	234
Head End Siderail Outer Panel Assembly	257
Head End Siderail Inner Panel Assembly	258
Timing Link Assembly, Head End, Left	259
Timing Link Assembly, Head End, Right	260
Siderail Latch Assembly, Head End, Left	261
Siderail Latch Assembly, Head End, Right	262
Assembly Name	263
Siderail Assembly, iBED Awareness Option, Head End, Left	263
Siderail Assembly, iBED Awareness Option, Head End, Right	264
Switch Assembly, iBED Awareness Option, Head End	265
Foot End Siderail Assembly	266
Timing Link Assembly, Foot End, Left	269
Timing Link Assembly, Foot End, Right	270
Siderail Latch Assembly, Foot End, Left	271
Siderail Latch Assembly, Foot End, Right	272
Siderail Release Lever Assembly, Left	273
Siderail Release Lever Assembly, Right	274
Siderail Bypass Detent Clip Assembly	275
Siderail Assembly, iBED Awareness Option, Foot End Left	276
Siderail Assembly, iBED Awareness Option, Foot End, Right	277
Switch Assembly, iBED Awareness Option, Foot End	278
Optional Pendant Assembly	279
Foot Board Assembly - 3002-500-011	280
Foot Board Assembly, No Options	281
Foot Board Assembly, Scale Option	282
Foot Board Assembly, Bed Exit Option	283
Foot Board Assembly, Zone Control/Bed Exit Option	284
Foot Board Assembly, Bed Exit/Scale Option	285
Foot Board Assembly, Zone Control/Bed Exit/Scale Option	286
Foot Board Assembly, No Gatch/Fowler Option	287
Foot Board Assembly, Gatch/Fowler Option	288
Foot Board Standard Module Assembly	289
Optional Foot Board Bed Exit Module	290
Optional Foot Board Zone Cntrl/Bed Exit Module	291
Foot Board Scale Module Assembly	292
Foot Board Assembly, iBED Awareness Option, Std. Comp.	293
Foot Board Assembly, iBED Awareness Option w/Bed Exit	295
Foot Board Assembly, iBED Awareness Option w/Zone Control	296

Table of Contents

Assembly Drawings (Continued)	
Head Board Assembly	297
Optional CPR Board Assembly	298
Optional Removable I.V. Pole and Mounting Assembly	299
Removable I.V. Pole Assembly	300
Optional 2-Stage I.V. Pole Assembly	301
Optional Dual Head End I.V. Pole Assembly	302
2-Stage I.V. Pole	304
I.V. Pole Latch Assembly	305
Optional Defibrillator Tray Assembly	306
Optional Pleur-Evac Rack Assembly	307
Optional Pleur-Evac Rack with Defibrillator Tray	308
Optional Pump Rack Assembly	310
Optional 90° Power Cord	311
Optional Upright O2 Bottle Holder Assembly	312
Optional Accessory Adapter Frame	313
Optional Litter Roller Assembly	315
Roller Assembly	316
Optional Bed Extender Assembly	317
Optional Bed Extender Mattress	319
Optional Padded Siderail Covers	320
Optional Traction Socket Extensions	321
Warranty	322
Limited Warranty	322
To Obtain Parts and Service	322
Service Contract Coverage	322
Service Contract programs	323
Return Authorization	323
Damaged Merchandise	323
International Warranty Clause	323

Introduction

Intended Use

This manual is designed to assist you with the maintenance of the Stryker Model 3002 Secure II Bed. Read it thoroughly before using the equipment or beginning any maintenance on it.

Specifications

	Safe Working Load		500 lbs	227 kg	
	Note: Safe Working Load indicates the sum of the patient, mattress, and accessory weight.				
Scale System Capacity (optional equipment). Loads weighing up to			500 lbs	227 kg	
Scale System Accuracy (optional equipment)			± 2 pounds at $0^\circ - \pm 10^\circ$ Trendelenburg for patients weighing 100 pounds or less $\pm 2\%$ of the total patient weight at $0^\circ - \pm 10^\circ$ Trendelenburg for patients weighing greater than 100 pounds		
Overall Length/Width	Standard Bed (Inside US and Canada)	Siderails Up	93" x 42.5"	236 cm x 108 cm	
		Siderails Down	93" x 40"	236 cm x 101.6 cm	
	Standard Bed (Outside US and Canada)	Siderails Up	93" x 42.5"	236 cm x 108 cm	
		Siderails Down	93" x 36"	236 cm x 91.4 cm	
	Short Bed (Inside US and Canada)	Siderails Up	85" x 42.5"	216 cm x 108 cm	
		Siderails Down	85" x 36"	216 cm x 91.4 cm	
	Zoom® Bed (Inside US and Canada)	Siderails Up	95" x 42.5"	241 cm x 108 cm	
		Siderails Down	95" x 40"	241 cm x 101.6 cm	
	Zoom® Short Bed (Inside US and Canada)	Siderails Up	87" x 42.5"	221 cm x 108 cm	
		Siderails Down	87" x 36"	221 cm x 91.4 cm	
	Patient Sleep Surface - Standard Bed		84" x 35"	213 cm x 89 cm	
	Patient Sleep Surface - Short Beds		76" x 35"	193 cm x 89 cm	
Bed Height to Top of Seat Litter - 6" Casters	Standard		16" to 30" ± 0.5	41 cm to 76 cm	
	Beds with Zoom® Option		19.75" x 30"	50 cm x 76 cm	
	Short Beds w/Zoom® Option		20.5" x 30"	52 cm x 76 cm	
Litter Platform to Top of Siderail	Full Up	Head End Siderail	15.75"	40 cm	
		Foot End Siderail	15.25"	39 cm	
	Outside US/Canada	Head End Siderail	15"	38.1 cm	
		Foot End Siderail	14"	35.6 cm	
Space Between Siderails (Full Up)		9.75"	25 cm		
Outside the US and Canada		9.125" (8")	23.2 cm		
Knee Gatch Angle			0° to 40°		
Fowler Angle			0° to 60°		
Trendelenburg/Reverse Trendelenburg			-12° to $+12^\circ \pm 1^\circ$ -10° to $+10^\circ \pm 1^\circ$ - Beds with Zoom® Option -8° to $+8^\circ \pm 1^\circ$ - Short Beds		
Electrical Requirements - all electrical requirements meet UL 2601 specifications.			115 VAC, 60 Hz, 8.0 A Optional: 230 VAC, 50/60 Hz, 4.0 A		
Outlet Option			125 VAC, 60 Hz, 10.0 A (not available with Zoom® Option)		
¹ If the bed is equipped with the enhanced height option, the scale accuracy is as described above for litter angles from 0° to $\pm 5^\circ$ Trend.					

[Return To Table of Contents](#)

Introduction

Mattress Specifications

Thickness	6"	15.2 cm
Width	>= 35"	>= 88.9 cm
Length	>= 84"	>= 213.4 cm
ILD	80 lbs	36.3 kg

Stryker reserves the right to change specifications without notice.

Specifications listed are approximate and may vary slightly from unit to unit or by power supply fluctuations.

Warning/Caution/Note Definition

The words **Warning**, **Caution** and **Note** carry special meanings and should be carefully reviewed.

WARNING

Alerts the reader about a situation, which if not avoided, could result in death or serious injury. It may also describe potential serious adverse reactions and safety hazards.

CAUTION

Alerts the reader of a potentially hazardous situation, which if not avoided, may result in minor or moderate injury to the user or patient or damage to the equipment or other property. This includes special care necessary for the safe and effective use of the device and the care necessary to avoid damage to a device that may occur as a result of use or misuse.

Note

This provides special information to make maintenance easier or important instructions clearer.

Bed Illustration

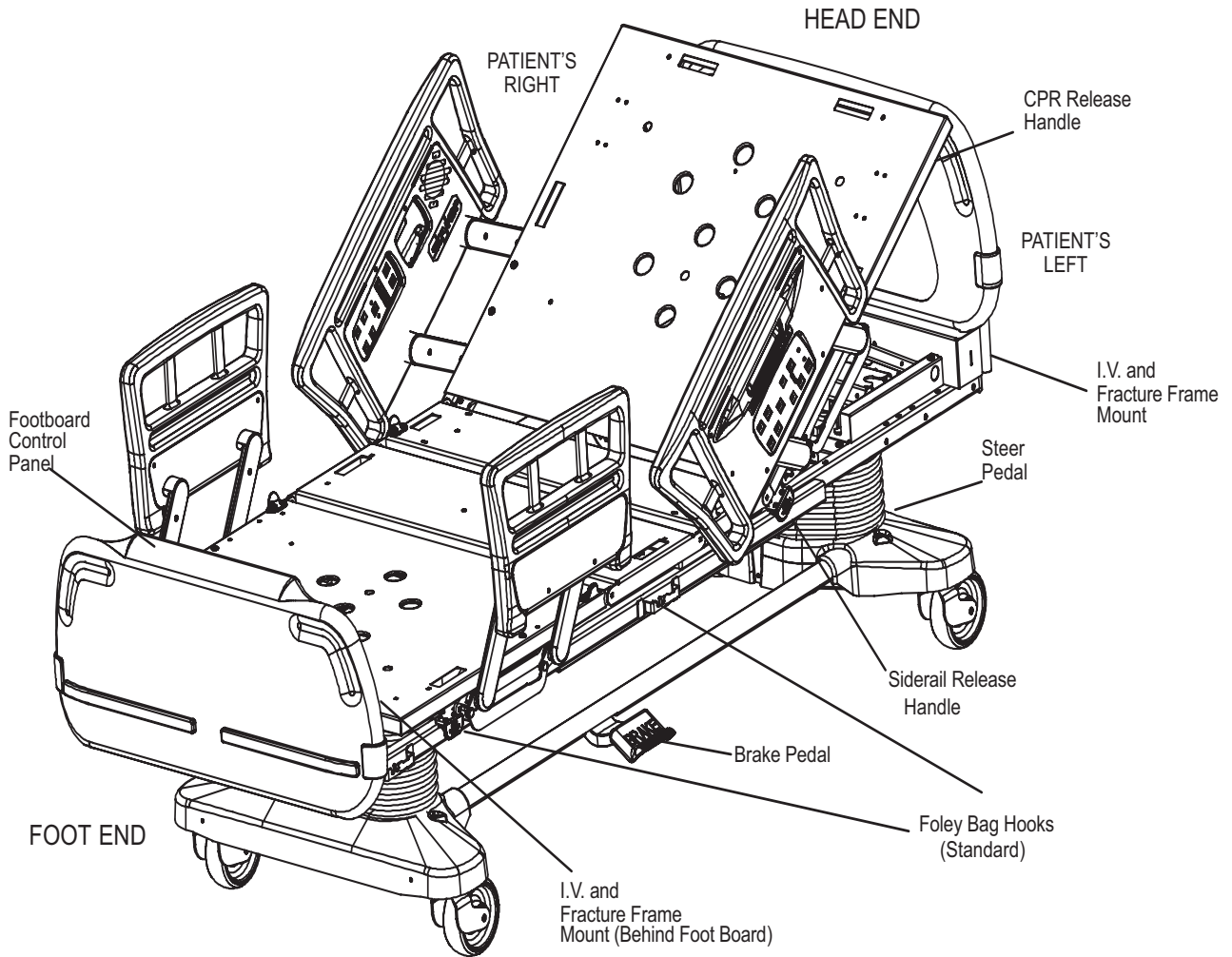

Symbols



Warning, consult accompanying documentation



Alternating Current



Type B Equipment: equipment providing a particular degree of protection against electric shock, particularly regarding allowable leakage current and reliability of the protective earth connection.

Class 1 Equipment: equipment in which protection against electric shock does not rely on BASIC INSULATION only, but which includes an additional safety precaution in that means are provided for the connection of the EQUIPMENT to the protective earth conductor in the fixed wiring of the installation in such a way that ACCESSIBLE METAL PARTS cannot become live in the event of a failure of the BASIC INSULATION.

Mode of Operation: Continuous

IPX4: Protection from liquid splash



Dangerous Voltage Symbol



Protective Earth Terminal



Potentiometerential Equalization Symbol



Medical Equipment Classified by Underwriters Laboratories Inc. with Respect to Electric Shock, Fire, Mechanical and Other Specified Hazards Only in Accordance with UL 60601-1, First Edition (2003) and CAN/CSA C22.2 No. 601.1-M90 with updates 1 and 2.



Safe Working Load Symbol



In accordance with European Directive 2002/96/EC on Waste Electrical and Electronic Equipment, this symbol indicates that the product must not be disposed of as unsorted municipal waste, but should be collected separately. Refer to your local distributor for return and/or collection systems available in your country.

Safety Tips and Guidelines

Before operating the Secure Bed II, it is important to read and understand all information in this manual. Carefully read and strictly follow the safety guidelines listed on this page.

It is important that all users have been trained and educated on the inherent hazards associated with the usage of electric beds.

WARNINGS

- Danger: Explosion hazard. Do not use in the presence of flammable anesthetics.
- Always apply the caster brakes when a patient is getting on or off the bed. Always keep the caster brakes applied when a patient is on the bed (except during transport). After the brake pedal is applied, push on the bed to ensure the brakes are locked. Serious injury could result if the bed moves while a patient is getting in or out of bed.
- Ensure the brakes are completely released prior to attempting to move the unit. Attempting to move the unit with the brakes actuated could result in injury to the user and/or patient.
- Do not attempt to move the foot end of the bed laterally when the steer pedal is activated. When the steer pedal is activated, the steer caster at the foot end of the bed cannot swivel. Attempting to move the bed laterally when the steer pedal is activated may cause injury to the user.
- The Secure II Bed is not intended for use with patients less than two years of age.
- Serious injury can result if caution is not used when operating the unit. Operate the unit only when all persons are clear of the electrical and mechanical systems.
- To help reduce the number and severity of falls by patients, always leave the bed in the lowest position when the patient is unattended.
- When attaching equipment to the frame, ensure it will not impede normal frame operation. For example: hooks on hanging equipment must not actuate control buttons, equipment must not hide the Nurse Call button, etc.
- Use only a Stryker supplied interface cable. Use of any other cable may cause the bed to function improperly which may result in patient or user injury.
- The Secure II Bed is equipped with a hospital grade plug for protection against shock hazard. It must be plugged directly into a properly grounded three-prong receptacle. Grounding reliability can be achieved only when a hospital grade receptacle is used.
- When using the manual override shaft to manually actuate bed functions, always unplug the bed power cord from the wall socket to avoid injury in the event of a sudden return of power to the bed.
- When raising the siderails, listen for the “click” that indicates the siderail has locked in the up position. Pull firmly on the siderail to ensure it is locked into position. Siderails are not intended to be a patient restraint device. It is the responsibility of attending medical personnel to determine the degree of restraint and the siderail positioning to ensure a patient will remain safely in bed.
- The Bed Exit System is intended only to aid in the detection of a patient exiting the unit. It is NOT intended to replace patient monitoring protocol. The Bed Exit System signals when a patient is about to exit. Adding or subtracting objects from the frame after zeroing the weigh system may cause a reduction in the sensitivity of the Bed Exit System.
- Always unplug the bed power cord from the wall socket and push the battery power On/Off switch to the “Off” position before servicing or cleaning the bed. When working under the bed with the bed in the high position, always place blocks under the litter frame and apply the brakes to prevent injury in case the Bed Down switch is accidentally pressed.
- The CPR emergency release on the Short Bed frame may require assistance to lower the back when the back is in the highest position. Attempting to lower the back in this position without assistance may result in injury to the operator.
- Only use equipment with the following electrical specs: 110VAC; 10A; 60Hz. Maximum total load drawn by equipment used in this receptacle outlet must not exceed 10A. The total system chassis risk current should not exceed 300uA. Grounding continuity should be checked periodically.
- To avoid risk of electrical shock, unplug all power cords before opening the service compartment, junction box or receptacle.
- Do not use the optional 110V outlet for life sustaining equipment.
- To avoid pinching your fingers, place the I.V. pole in the upright position before using the drive handle.

Safety Tips and Guidelines

WARNINGS (CONTINUED)

- When using any mattress and/or mattress overlay that increases the overall height greater than 6" extra caution and/or operator supervision is required to help reduce the likelihood of a patient fall occurring.

To avoid possible injury and to assure proper operation when using a powered mattress replacement system such as XPRT:

- Confirm proper Scale System operation following mattress installation. For best results, secure the therapy mattress power cord to prevent damage to the cord or interference with the bed frame and the Scale System.
- Do not zero bed scales or weigh patient with Percussion, Vibration, Rotation or Turn-Assist active. Patient motion and position resulting from the dynamic therapy mattress may adversely affect Scale System performance.
- Do not initialize (Arm) Bed Exit with Percussion, Vibration, Rotation or Turn-Assist active. The patient motion and position resulting from the dynamic therapy mattress may adversely affect Bed Exit System performance.
- When using an XPRT Therapy Mattress extra caution and/or operator supervision is required to help reduce the likelihood of a patient fall occurring.

CAUTIONS

- When large spills occur in the area of the circuit boards, 110V cables and motors, immediately unplug the bed power cord from the wall socket. Remove the patient from the bed and clean up the fluid. Have maintenance completely check the bed. Fluids can affect the operational capabilities of any electrical product. Do Not put the bed back into service until it is completely dry and has been thoroughly tested for safe operation.
- Preventative maintenance should be performed at a minimum of annually to ensure all bed features are functioning properly. Close attention should be given to safety features including, but not limited to:

Safety side latching mechanisms, frayed electrical cords and components, all electrical controls return to off or neutral position when released, caster braking systems, no controls or cabling entangled in bed mechanisms, leakage current 300uA maximum, Scale and Bed Exit Systems calibrated properly.

- Because individual beds may have different options, foot boards should not be moved from one bed to another. Mixing foot boards could result in unpredictable bed operation.
- The lockout buttons on the foot board lock the Fowler, Gatch and Bed Up/Down functions and prevent motion of the bed. It is the responsibility of attending medical personnel to determine whether these functions should be locked and to use the buttons accordingly.
- The weight of the I.V. bags should not exceed 40 pounds.
- Scale function may be affected by siderail/caster interference. With the litter fully lowered or lowered in Reverse Trendelenburg, the siderails tucked under the litter in the storage position and the casters turned, there is the potential for interference between the siderail and the caster. Raise the siderails when lowering the litter to the full down position to prevent the interference from causing the Scale System to weigh inaccurately.
- When attaching equipment to the frame, ensure it will not impede normal operation. For example: hooks on hanging equipment must not actuate control buttons, equipment must not hide the Nurse Call button, etc.
- The use of a mattress overlay may reduce the effectiveness of the siderail.
- The I.V. poles should not be used as a bed push/pull device.
- The cleanliness and integrity of both ground chains must be maintained to minimize static build-on and discharge.
- Do not add or remove weight when the Bed Exit System is armed.

[Return To Table of Contents](#)

Safety Tips and Guidelines

Zoom™ Option

In addition to the previous warnings and cautions, all of the following warnings and cautions apply to units equipped with the Zoom® option.

WARNINGS

- The 3002 Patient Transport Frame is intended for use by trained hospital personnel only. Failure to properly train personnel could result in injury.
- Use Caution while maneuvering the unit with the drive wheel activated. Always ensure there are no obstacles near the unit while the drive wheel is activated. Injury to the patient, user or bystanders or damage to the frame or surrounding equipment could occur if the unit collides with an obstacle.
- Use Caution when transporting the unit down halls, through doors, in and out of elevators, etc. Damage to the siderails or other parts of the unit could occur if the unit comes in contact with walls or door frames.
- Put the drive wheel in the neutral position and release the brakes before pushing the unit manually. Do not attempt to push the unit manually with the drive wheel engaged. The unit will be difficult to push and injury could result.
- If unanticipated motion occurs, unplug the power cord from the wall socket, push the battery power On/Off switch to the "Off" position (the LED will not be illuminated) and actuate the drive wheel pedal to the neutral position.
- The power save mode is activated after one hour on battery power with no motion release switch activation. Functions including Bed Exit, Scale and Motion will cease to operate when the unit enters the power save mode. Injury to the patient could occur if proper patient monitoring protocol is not observed.
- Always unplug the power cord and push the battery power On/Off switch to the "Off" position before service or cleaning. When working under the frame, always place blocks under the litter frame to prevent injury in case the Bed Down switch is accidentally activated.
- Due to the weight the battery adds to the bed (approximately 50 pounds), additional force is required to move the bed. Caution should be used when transporting this bed. Additional assistance should be used when necessary. Failure to use caution while transporting this bed may result in injury to the user. Battery posts, terminals and related accessories contain lead and lead compounds, chemicals known to the State of California to cause cancer and birth defects or other reproductive harm. Wash hands after handling.
- Do not modify the 3002 Patient Transport Frame. Modifying the unit can cause unpredictable operation resulting in injury to the patient or operator. Modifying the unit will also void its warranty.

CAUTIONS

- To avoid damage while transporting the bed, verify the I.V. pole is at a low enough height to allow it to safely pass through door openings and under light fixtures.
- The battery tray assembly weighs 50 pounds. Take care when removing the two hexagonal head screws securing it to the base frame or personal injury could result.

Safety Tips and Guidelines

iBED Awareness Option

In addition to the previous warnings and cautions, all of the following warnings and cautions apply to units equipped with the iBED Awareness option.

WARNING

- The optional iBED Awareness system only indicates the siderail position, it does NOT indicate if the siderail is locked. It is the caregiver's responsibility to ensure that the siderails are locked after every move and also before leaving a patient in the room.
- The optional iBED Awareness system indicator lights are only an aid to the caregiver but in no way replace the caregiver's responsibility of checking on patients. Caregivers should not rely on the lights to perform their duties.
- Before arming the optional iBED Awareness system, the nurse must physically verify that siderails are locked.
-
-

CAUTION

- If the optional iBED Awareness system is being used; ensure the bed is in the desirable state (Bed Status ON and with the light Green) before leaving the room.
- If the optional iBED Awareness system is being used and the Bed Status is alerting, do not turn off iBED Awareness as the display information to troubleshoot the bed will get lost.
- If the optional iBED Awareness system is being used; use of accessories that cover the alert light are not recommended.

Static Discharge Precautions

The electronic circuits in the Secure II Bed are completely protected from static electricity damage only while the bed is assembled. It is extremely important that all service personnel always use adequate static protection when servicing the electronic systems of the Secure II Bed. Whenever you are touching wires, you should be using static protection.

Static Protection Equipment

The necessary equipment for proper static protection is:

- 1 static wrist strap; 3M part number 2214 or equivalent,
- 1 grounding plug; 3M part number 61038 or equivalent,
- 1 test lead with a banana plug on one end and an alligator clip on the other; Smith part number N132B699 or equivalent.

CAUTION

All electronic service parts will be shipped in static shielding bags. Do not open the bags until you have completed steps 2 and 3 of the following procedure. Do not place unprotected circuit boards on the floor. All circuit boards to be returned to Stryker Medical should be shipped in the static shielding bags the new boards were shipped in.

Static Protection Procedure

1. Unplug the power cord from the wall receptacle.
2. Insert the grounding plug into a properly grounded hospital grade wall receptacle. Plug the banana plug of the test lead into the receptacle on the grounding plug. Connect the alligator clip on the other end of the test lead to a ground point on the bed.
3. Place the static control wrist strap on your wrist. Connect the alligator clip at the other end of the wrist strap cord to a ground point on the bed.

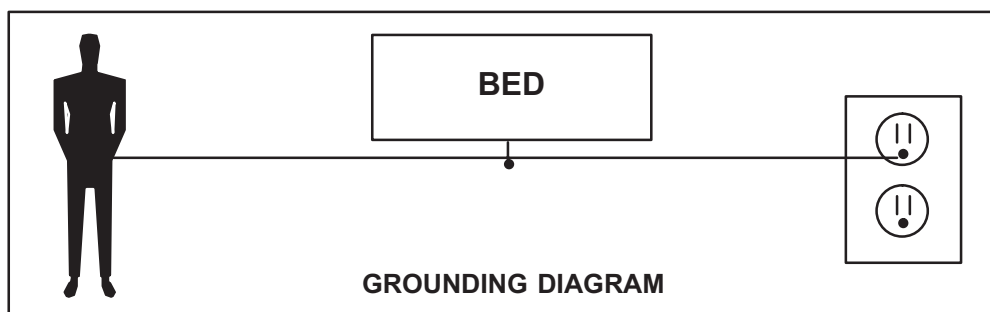

Setup Procedures

It is important that the Secure II Bed is working properly before it is put into service. The following list will help ensure that each part of the bed is tested.

- Plug the bed into a properly grounded, hospital grade wall receptacle and ensure the “Power” LED light at the foot end of the bed comes on.

WARNING

The Secure II Bed is equipped with a hospital grade plug for protection against shock hazard. It must be plugged directly into a properly grounded three-prong receptacle. Grounding reliability can be achieved only when a hospital grade receptacle is used.

- Plug the optional interface cable into the 37 pin connector under the litter frame at the head end of the bed, and into the “Patients Station”, “Head Wall”, “Dock Station”, or equivalent (whichever applies). Test the interface cable to verify it is functioning properly.

WARNING

Use only a Stryker supplied interface cable. Use of any other cable may cause the bed to function improperly which may result in patient or user injury.

- Ensure the siderails raise, lower and store smoothly and lock in the up position and in the intermediate position when lowered (see “Positioning Siderails” section).
- Ensure that all four casters lock when the brake pedal is engaged (see “Brake Pedal Operation” section).
- Raise the Back up to approximately 60°. Squeeze the CPR release handle and ensure the Back will drop with minimal effort.

Note

Ensure that the “Brake Not Set” LED’s located on the outside of the head end siderails and on the foot board control panel come on when the brakes are disengaged.

- Run through each function on the foot board control panel to ensure that each function is working properly (see “Foot Board Operation Guide” section).
- Run through each function on both head end siderails to ensure that each is working properly (see “Siderail Operation Guide” section).
- Activate the motion stop system to ensure it is functioning properly: press and hold down the **Bed Down** key. As the bed lowers, lift up on the motion interrupt pan (reference drawing in “Bed Illustration” section) and ensure the downward motion stops. Release the pan and allow the downward motion to continue.

Note

The bed’s upward motion or other functions are not disrupted by the motion stop system.

Setup Procedures

Zoom™ Option

If your bed is equipped with the Zoom™ drive wheel option, run through the setup procedures and continue with the procedures listed below.

- Plug the power cord into a properly grounded, hospital grade wall receptacle. The 12V batteries that provide power to the drive wheel and backup power to the unit functions will charge whenever the power cord is plugged into the wall socket. The batteries require approximately 10 hours of charging time before the bed is put into service.
- Unplug the power cord from the wall socket. Push the battery power switch located on the lower left corner of the head end to the On position. Again, verify each function on the foot board and siderails is operating properly.
- With the battery power switch in the On position and the brakes engaged, ensure the “Release Brakes” LED on the head end control panel is illuminated.
- With the battery power switch in the On position and the drive wheel in the neutral position (not touching the floor), ensure the “Engage Drive Wheel” LED on the head end control panel is illuminated.
- Run through the operation of the drive wheel (see “Zoom™ Option Operation Guide” to ensure it is operating properly).

If any problems are found during bed setup, contact Stryker Customer Service at 800-327-0770.

Optional iBED Awareness Maintenance Menu Guide

Maintenance Menu Screen

The Maintenance Menu contains all of the non-regularly accessible features of the product. This menu provides an interface to the user and/or service personnel in order to provide the ability to control and access maintenance features.

Maintenance Menu Items

The following are menu items listed in the maintenance menu screen:

1. Calib. Scale (Calibrate Scale)
2. TV Config. (TV Configuration)
3. Scale Info. (Scale Info/Stats)
4. Clear Statistics (Clear Scale Stats)
5. Error Log (View Error Log)
6. Clear Errors (Clear Error Log)
7. Scale Units (Lock Scale Units)
8. About (About Product)
9. Exit Menu (Exit Maintenance)

- Each of the menu items provide the operator with a different function.
- Using the up and down menu buttons you can scroll through the menu elements.
- To select a menu item, scroll to the desired menu item using the Up and Down menu button. When the desired feature is highlighted, press the Enter/Check button. Depending on the feature the display will move into the sequence for the feature selected.

Load Cell Check

- This feature automatically checks all four load cells to make sure they are working properly.
- The purpose of this feature is to provide a self diagnostic of the load cells.
- When maintenance is entered a self-diagnostic feature should run and display results.
- While procedure is running the following message is displayed "Load Cell Check".
- Any load cell errors will be displayed as a message "Load Cell Error" and then depending on the error an HL, HR, FL or FR will be displayed below the message. (Refer to the Error Handling Section).
- If no errors are present then maintenance menu will be displayed and menu items 1-9 above may be accessed.

Calibrate Scale

- This feature allows the operator to calibrate the scale system.
- This calibration is used to provide the system with a weight offset that occurs when the product is put into trend and reverse trend.
- This calibration does not calibrate the load cells, the load cells are pre-calibrated.

To calibrate the scale system:

1. In the Maintenance Menu select the Calibrate Scale item then press and hold the Enter/Check button.
2. The display should present the following message:
"Do Not Touch Bed". The message should be flashing.
3. Use the up and down arrow to select the proper weight (50lbs is the default).
4. Press the "Enter/Check" button when the display shows the proper weight.

Optional iBED Awareness Maintenance Menu Guide

Maintenance Menu (Continued)

Calibrate Scale (Continued)

5. The display should present the following message:
“Place Weight in Center”.
6. Place the weight in the center of the bed.
7. Press the “Enter/Check” button when completed.
8. The display should present the following message:
“Press Reverse Trend”.
9. Press the reverse trend button.
10. The display should present the following message when the bed in the proper position:
“Release Button”.
11. Release the button and do not touch the bed. When the button is released the following message is displayed:
“Do Not Touch Bed”. The message should be flashing.
12. The display should present the following message when the bed is ready to continue:
“Press Trend”.
13. Press the trend button.
14. The display should present the following message when the bed in the proper position:
“Release Button”.
15. Release the button and do not touch the bed. When the button is released the following message is displayed:
“Do Not Touch Bed”. The message should be flashing.
16. The display should present the following message when the bed is ready to continue:
“Save Calibration?” “Check – Save” “X – Cancel.”
17. Press the “Enter/Check” button to save the calibration.
18. The display should present the following message when the bed is ready to continue:
“Save Successful”.

Note:

If an error occurs during the procedure the display will show an error message “Calibration Error” for 4 seconds.

Optional iBED Awareness Maintenance Menu Guide

Maintenance Menu (Continued)

TV Configuration

- This feature allows the operator to set up the TV configuration.
- This configuration provides the product with the information to communicate with the proper entertainment system.

To Configure the System:

1. In the Maintenance Menu select the TV Configuration item then press and hold the Enter/Check button.
2. The TV Configuration Screen will be displayed. The current TV selection will be highlighted.
3. Use the up and down arrow buttons to highlight the desired item.
4. Press the "Enter/Check" button to select the new setting.
5. The following message will be shown on the display screen when the new setting is saved:
"Save Successful".
6. The TV Configuration screen should reappear after 2 seconds and the new setting should be highlighted.
7. Pressing the Exit/X button or if the screen remains dormant for more than 30 seconds, the display will return you to the maintenance menu, without saving any changes.

Note: The user will use the arrow buttons to select the option. The selected item on initialization will be the item that is currently set. If the user presses the 'Enter' button then the new setting will be saved. If the user presses the 'Exit' button or the menu times out (30 seconds after last button press) then the old setting will remain and the screen will return to the 'Maintenance menu'.

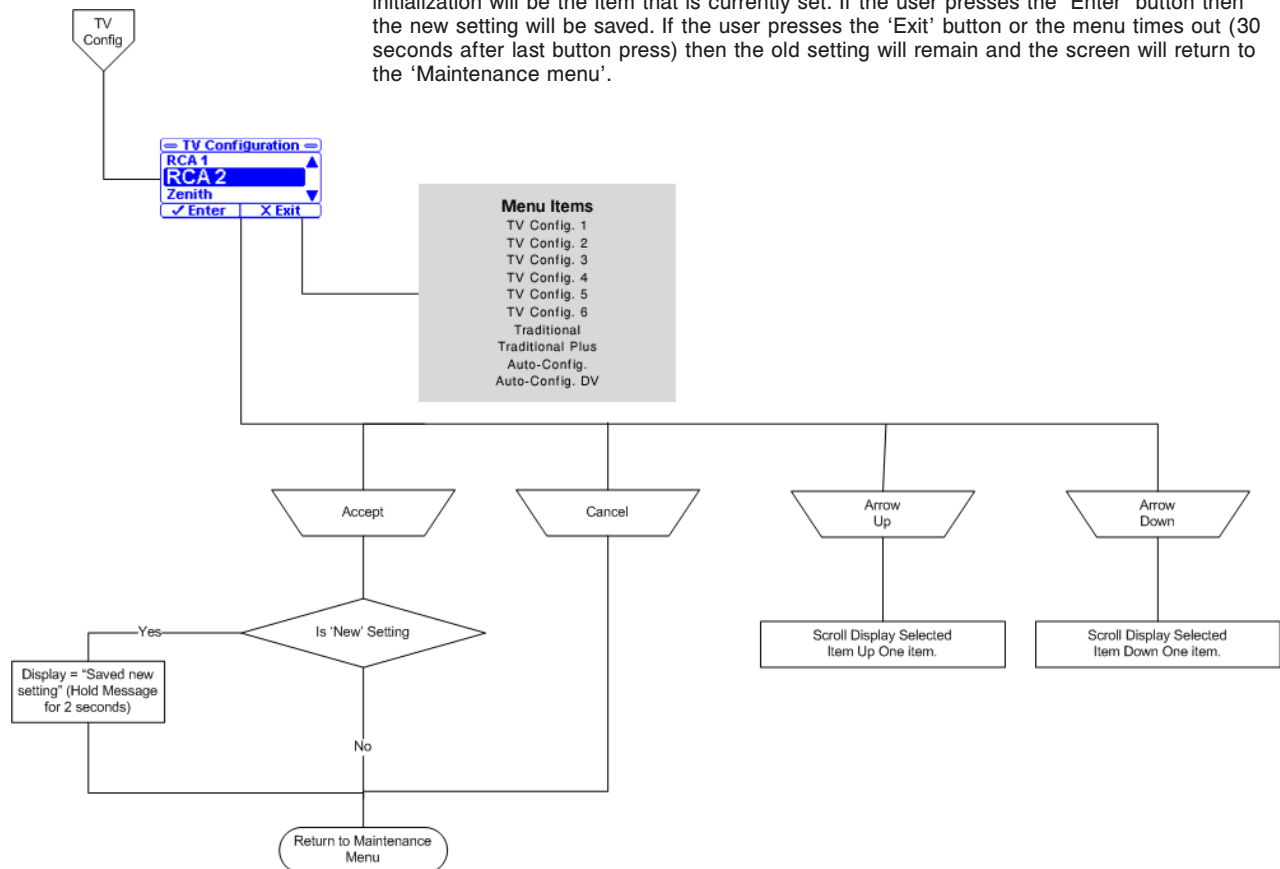

[Return To Table of Contents](#)

Optional *i*BED Awareness Maintenance Menu Guide

Maintenance Menu (Continued)

Scale Information

- This diagnostic feature shows data from the load cells. This includes the raw count data, the weight data (in lb), the maximums, and the minimums.
- When the menu item is selected, the raw count data from the 4 load cells will be displayed.
- When cancel/exit is pressed the menu should return.
- When the menu item is selected the weight data from the 4 load cells will be displayed.
- When cancel/exit is pressed the menu should return.
- When the menu item is selected the maximum values for each of the load cells will be displayed.
- Values should update every 0.25 seconds.

Note: The scale information and statistics are important when trying to diagnose the scale system.

To View the Scale Information:

1. In the Maintenance Menu select the Scale Info/Stats item then press and hold the Enter/Check button.
2. The Scale Info/Stats screen will be displayed.
3. Use the arrows to navigate through the four screens, lb, counts, maximums, and minimums. Each screen will have the four load cells and the information in the format of that screen.
4. Press the Exit/X button to return to the Maintenance Menu screen.

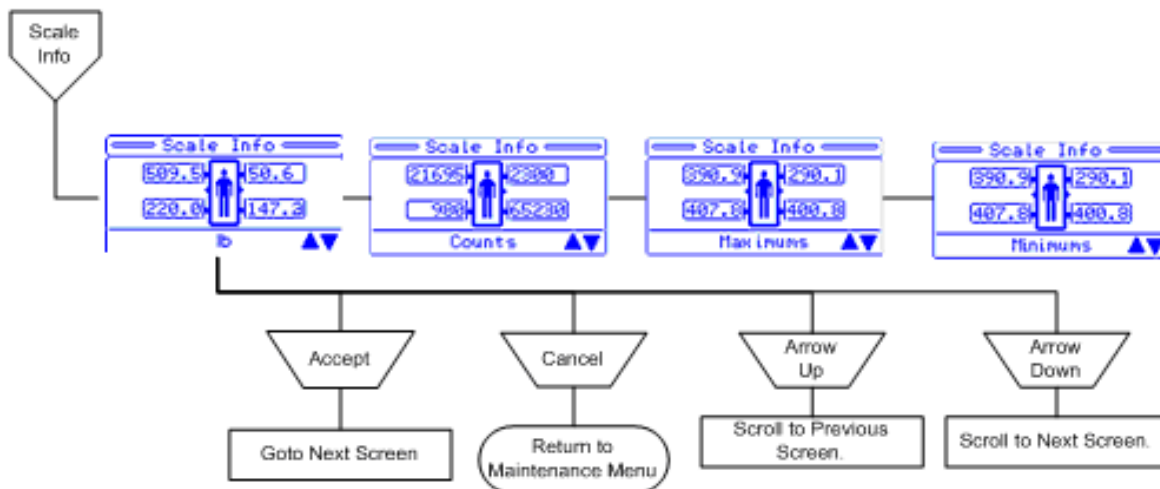

Clear Scale Statistics

- This diagnostic feature allows the statistics for the load cells to be cleared.
- To remove old data. This may be done because the load cell is being replaced, or the system has been re-calibrated.
- When the menu item is selected and held for 1 second the statistics should be erased and a message should be displayed. When cancel/exit is pressed the menu should return to the Maintenance Menu Screen.

Note: The scale statistics (Maximums and Minimums) can be cleared using this feature.

Optional iBED Awareness Maintenance Menu Guide

Maintenance Menu (Continued)

To Clear the Information:

1. In the Maintenance Menu select the Clear Scale Stats item then press and hold the Enter/Check button.
2. The following message will be shown on the display screen:
“Clear Scale Statistics?”.
3. Press and hold the Enter/Check button to clear the stats.
4. The following message will be shown on the display screen when the stats are cleared:
“Statistics Cleared”.
5. The Maintenance Menu screen should reappear after 2 seconds and the new setting should be highlighted.

Note: Items that are cleared during this operation are:

- Maximums (for each load cell)
- Minimums (for each load cell)

View Error Log

- This feature allows the operator to view the Error Log.
- This log provides information pertaining to the error system and any errors that are logged during product use.

To view the error log:

1. In the Maintenance Menu select the View Error Log item then press and hold the Enter/Check button.
2. The Error Log Screen will be displayed. The most recent error will be at the top.
3. Use the up and down arrow buttons to view any errors that are not shown on the screen.
4. Pressing the Exit/X button will return you to the Maintenance Menu screen without saving any changes.
5. If the screen remains dormant for more than 30 seconds, you will be returned to the Maintenance Menu screen without saving any changes.

Clear Error Log

This feature allows the user to clear the error log.

To clear the error log:

1. In the Maintenance Menu select the Clear Error Log item then press and hold the Enter/Check button.
2. The following confirmation screen will be displayed:
Clear Error Log? “Enter” to Accept, “Exit” to Cancel.
3. If “Exit” is chosen, then you will be returned to the Maintenance Menu screen.
4. If “Enter” is chosen, then the error log is cleared and a message is displayed: **“Error Log Cleared”** and you will be returned to the Maintenance Menu screen.

Optional *i*BED Awareness Maintenance Menu Guide

Maintenance Menu (Continued)

Lock lb/kg

- This feature allows the user to lock and/or unlock the unit of weight measurement as well as select the default scale units (lb or kg).
- When the Lock menu item is selected, the unit of measure will be locked and the current unit of measure will be displayed.
- When cancel/exit is pressed the menu will return to the Maintenance Menu Screen.
- The default setting is Unlocked.

To lock/unlock the Scale Units:

1. In the Maintenance Menu select the Scale Units item then press and hold the Enter/Check button.
2. The Scale Units Screen will display Figure 41 with the current state as the highlighted item.
3. Use the Up and Down Arrow buttons to highlight the desired units and identify whether you want them locked or unlocked.
4. Press and hold the Enter/Check button to select and save the new state.
5. The following screen message will be displayed:
“Save Successful”.
6. The Scale Units screen will reappear after 2 seconds and the new setting will be highlighted.
7. Pressing the Exit/X button will return you to the Maintenance Menu screen without saving the new state.



Figure 41

About Product

The display will indicate the current bed configuration settings and indicate the software versions for all software targets connected on the internal CAN network.

To view this information:

1. In the Maintenance Menu select the About item then press and hold the Enter/Check button.
2. The About Screen will be displayed.
3. Use the Up and Down Arrow buttons to scroll through the information if it does not fit on one screen.
4. Press the Exit/X button to return to the Maintenance Menu screen.
5. The Type information should indicate, depending on the options: **“Zoom”**, **“Scale”**, **“Bed Exit”**, and **“Bed Status”**.

Exit Maintenance

- This feature allows the operator to exit the menu back to the previous screen.
- When this menu item is selected the screen will exit to the “Status” screen.

Notes

Preventative Maintenance

Beds require an effective maintenance program, we recommend checking these items annually. Use this sheet for your records. Keep on file.

Checklist

- _____ All fasteners secure (reference all assembly prints).
- _____ Engage brake pedal and push on the bed to ensure all casters lock securely.
- _____ Inspect the brake assembly (Brake Cam, Brake Plate Body, Brake Ratchet Spring and Brake Bar) for degradation or signs of wear at the foot end and head end of the bed. Ensure brake assembly components are functioning properly.
- _____ “Brake Not Set” LED on the foot board (*iBED Awareness option only*) blinks when brakes are not engaged.
- _____ “Brake” LED on the foot board (*iBED Awareness option only*) blinks when brakes are not engaged.
- _____ Locking steer caster engages and disengages properly.
- _____ Siderails move, latch and stow properly.
- _____ CPR release working properly.
- _____ Optional foot prop intact and working properly.
- _____ I.V. pole working properly.
- _____ Foley bag hooks intact.
- _____ Optional CPR board not cracked or damaged and stores properly.
- _____ No cracks or splits in head and foot boards.
- _____ No rips or cracks in mattress cover.
- _____ All functions on head end siderails working properly (including LED's).
- _____ All functions on footboard working properly (including LED's).
- _____ Scale and Bed Exit system calibrated properly.
- _____ Motion Interrupt switches working properly.
- _____ Night light working properly.
- _____ Power cord not frayed.
- _____ No cables worn or pinched.
- _____ All electrical connections tight.
- _____ All grounds secure to the frame.
- _____ Ground impedance not more than 100 milliohms.
- _____ Current leakage not more than 300 microamps.
- _____ Apply grease to the bed grease points including the fowler clutch and brake cam.
- _____ Engage drive wheel and ensure it is operating properly (Zoom option).
- _____ Motion release switches working properly (Zoom option).
- _____ Confirm Head End Control Panel functionality (Zoom option).
- _____ Confirm battery powered functionality (Zoom option).
- _____ Ensure ground chains are clean, intact, and have at least two links touching the floor.
- _____ Check Fowler angle for accuracy 0° - 60° (*iBED Awareness option*).
- _____ Siderail switches working properly (*iBED Awareness option*).
- _____ *iBED Awareness Light Bar LEDs* working properly (*iBED Awareness option*).
- _____ *iBED Awareness Side Indicator LEDs* working properly (*iBED Awareness option*).
- _____ Inspect footboard control labeling for signs of degradation (*iBED Awareness option*).

Bed Serial Number:		

Completed by: _____ Date: _____

[Return To Table of Contents](#)

Cleaning

Hand wash all surfaces of the bed with warm water and mild detergent. Dry thoroughly. Do not steam clean or hose off the Secure II Bed. Do not immerse any part of the bed. Some of the internal parts of the bed are electric and may be damaged by exposure to water.

Suggested cleaners for bed surfaces:

Quaternary Cleaners (active ingredients - ammonium chloride)

Phenolic Cleaners (active ingredient - o-phenylphenol)

Chlorinated Bleach Solution (5.25% - less than 1 part bleach to 100 parts water)

Avoid over saturation and ensure the product does not stay wet longer than the chemical manufacturer's guidelines for proper disinfecting.

 **CAUTION**

Some cleaning products are corrosive in nature and may cause damage to the product if used improperly. If the products described above are used to clean Stryker patient care equipment, measures must be taken to insure the beds are wiped with a damp cloth soaked in clean water and thoroughly dried following cleaning. Failure to properly rinse and dry the beds will leave a corrosive residue on the surface of the bed, possibly causing premature corrosion of critical components. Failure to follow the above directions when using these types of cleaners may void this product's warranty.

For mattress cleaning instructions, please see the tag on the mattress, or contact the mattress manufacturer.

Clean Velcro® **after each use**. Saturate Velcro® with disinfectant and allow disinfectant to evaporate. (Appropriate disinfectant for nylon Velcro® should be determined by the hospital.)

Troubleshooting Guide

Note

See “Bed Circuit Boards” section for an outline of bed PCB’s and voltage test points.

Problem / Failure	Recommended Action
No power to bed.	<ul style="list-style-type: none"> A. Verify the power cord connections at the wall and the bed. B. Check circuit breakers, under the Litter/Fowler section on the patient left side. If the circuit breaker is tripped, reset it by pushing in. C. Check for 120VAC at J1 on the power supply, Pin 1 and 2. D. Check for DC voltages on J2 (Pins 1, 2, 3 & 6) on power supply. See “Power Supply” in Bed Circuit Boards section for power supply voltage test points. <ul style="list-style-type: none"> a. If voltage is present, check connector W on the CPU board and check for the same DC voltages. If OK, go to step E. b. If voltage is not present, unplug connector W on the CPU board and recheck for DC voltages at J2 on the power supply. <ul style="list-style-type: none"> 1. If voltages come back, re-connect cable W to the CPU board, and go to step c. 2. If DC voltage does not come back, replace the power supply. a. Unplug all connectors except for F, FF, O, and W from the CPU board and recheck voltages on connector W. <ul style="list-style-type: none"> 1. If DC voltages come back, plug the cable connections back in until problem comes back, isolate the problem to a component or assembly. 2. If DC voltages do not come back, replace the CPU board. E. Check for 120VAC at connector O on the CPU board. <ul style="list-style-type: none"> a. If voltage is present, replace the CPU board. F. Verify bed function and return to service.

Troubleshooting Guide

Problem / Failure	Recommended Action
No bed down motion.	<ul style="list-style-type: none"> A. Enter diagnostics, (see Scale System Diagnostics and Calibration section) and press bed down. <ul style="list-style-type: none"> a. If motion is not present, verify the two wire connection is present on connector Z. <ul style="list-style-type: none"> 1. Test bed down motion, if motion is present then go to step D. b. If motion is present, re-burn lift potentiometer limits, see Lift Potentiometer “Burn-In” Procedure. B. Check for 5VDC on TP 9 (HL) and TP 7 (FL), reference ground test point while pushing the bed down button. <ul style="list-style-type: none"> a. If 5VDC is present, go to step C. b. If 5VDC is not present, replace CPU board. C. Check for 120VAC power on connector N (HL) and G (FL), pin 1 white and pin 3 black, of the CPU board, while pressing bed motion up. <ul style="list-style-type: none"> a. If voltage is not present, replace CPU board. b. If voltage is present: <ul style="list-style-type: none"> 1. Verify the motors are running, if so, replace lift couplers. 2. If motors are not running, check voltage at motor connection. 3. If voltage is present at motor, check capacitors or motors. D. Verify bed function and return to service.
No bed up motion.	<ul style="list-style-type: none"> A. Enter diagnostics, (see Scale System Diagnostics and Calibration section) and press bed up. <ul style="list-style-type: none"> a. If motion is not present, got to step B. b. If motion is present, re-burn lift potentiometer limits, see Lift Potentiometer “Burn-In” Procedure. B. Check for 5VDC on TP 10 (HL) and TP 8 (FL) on the CPU board, reference ground test point while pushing the bed up button. <ul style="list-style-type: none"> d. If 5VDC is present, go to step C. e. If 5VDC is not present, replace CPU board. C. Check for 120VAC power on connector N (HL) and G (FL), pin 1 white and pin 6 red, of the CPU board while pressing bed motion up. <ul style="list-style-type: none"> a. If voltage is not present, replace CPU board. b. If voltage is present: <ul style="list-style-type: none"> 1. Verify the motors are running, if so, replace lift couplers. 2. If motors are not running, check voltage at motor connection. 3. If voltage is present at motor, check capacitors or motors. D. Verify bed function and return to service.

Troubleshooting Guide

Problem / Failure	Recommended Action
No Gatch down motion.	<p>A. Check for 5VDC on TP4 on the CPU board, reference ground test point while pushing the fowler down button.</p> <p style="margin-left: 20px;">a. If 5VDC is present, go to step B.</p> <p style="margin-left: 20px;">b. If 5VDC is not present, replace CPU board.</p> <p>B. Check for 120 VAC on connector GG, Pin 1 (white) and pin3 (red), of the CPU board while pressing Fowler down.</p> <p style="margin-left: 20px;">a. If voltage is not present, replace the CPU board</p> <p style="margin-left: 20px;">b. If 5VDC is present, check the capacitor and motor.</p> <p>C. Verify bed function and return to service.</p>
No Gatch up motion.	<p>A. Check for 5VDC on TP 3 on the CPU board, reference ground test point while pushing the fowler up button.</p> <p style="margin-left: 20px;">a. If 5VDC is present, go to step B.</p> <p style="margin-left: 20px;">b. If 5VDC is not present, replace CPU board.</p> <p>B. Check for 120VAC on connector GG, Pin 1 (white) and pin 2 (black), of the CPU board while pressing Fowler up.</p> <p style="margin-left: 20px;">a. If voltage is not present, replace the CPU board</p> <p style="margin-left: 20px;">b. If 5VDC is present, check the capacitor and motor.</p> <p>C. Verify bed function and return to service.</p>
No Fowler up motion.	<p>A. Check for 5VDC on TP 6 on the CPU board, reference ground test point while pushing the gatch up button.</p> <p style="margin-left: 20px;">a. If 5VDC is present, go to step B.</p> <p style="margin-left: 20px;">b. If 5VDC is not present, replace CPU board.</p> <p>B. Check for 120VAC on connector CC, pin 1 (black) and pin3 (white), of the CPU board while pressing gatch up.</p> <p style="margin-left: 20px;">a. If voltage is not present, replace the CPU board</p> <p style="margin-left: 20px;">b. If 5VDC is present, check the capacitor and motor.</p> <p>C. Verify bed function and return to service.</p>
No Fowler down motion.	<p>A. Check for 5VDC on TP 5 on the CPU board, reference ground test point while pushing the gatch down button.</p> <p style="margin-left: 20px;">a. If 5VDC is present, go to step B.</p> <p style="margin-left: 20px;">b. If 5VDC is not present, replace CPU board.</p> <p>B. Check for 120VAC power on connector CC, pin 2 (red) and pin 3 (white), of the CPU board while pressing gatch down.</p> <p style="margin-left: 20px;">a. If voltage is not present, replace the CPU board.</p> <p style="margin-left: 20px;">b. If 5VDC is present, check the capacitor and motor.</p> <p>C. Verify bed function and return to service.</p>

Optional ZOOM Troubleshooting Guide

This section of the troubleshooting guide includes the Zoom® self-propelled drive and the battery backup functions. When using this guide, assume the bed is functioning properly when powered by the AC line cord with the exception of the battery charging components.

Problem/Failure	Possible Cause	Recommended Action
On/Off switch is in the On position but the power LED is Off and the bed does not function.	No DC voltage from the batteries.	A. Check the circuit breakers at the head end of the bed. B. Verify the battery voltage is greater than 24VDC. C. Check the battery fuse - replace if necessary (2040-001-802). D. Check the cable connections from the batteries to the display board. E. Check the On/Off switch and cabling.
On/Off switch is in the on position, the power LED is on but the bed does not function.	Display board is not functioning or is locking out all functions.	A. Check the safety switches on the drive bar. B. Verify the battery voltage is greater than 24VDC. C. Verify the display board is functioning (see note below). D. Check all cable connections on the display and power boards.
On/Off switch is in the on position, the power LED is on, the Zoom® drive works but the battery backup does not work.	The thermostat on the inverter/charger board has tripped, indicating a temperature above 110° C (230° F).	A. Wait approximately 3-5 minutes to allow the inverter/charger board to cool down.
The Zoom® drive does not work - the bed does not drive - but all other functions are working.	Zoom® drive circuitry is not responding.	A. Verify the display board is functioning (see note below). B. Perform the "Zoom® Option Control Bar Potentiometer 'Burn-In' Procedure". C. Check the control bar potentiometer. When the bar is centered, there should be 2.25VDC - 2.75VDC between pin 1 and pin 2 on header 1 on the display/CPU board (see "Zoom® Option Display/CPU Board - 2040-031-900") D. Check all cable connections on the display and power boards. E. Verify the power board is functioning. F. Verify the drive wheel is functioning.
The Zoom® drive does work - the bed will drive - but all other bed functions are not working.	No AC power from the Zoom® base.	A. Check AC voltage coming out of the inverter. It should be 120VAC between pin 1 and pin 4 on head-er 5 on the AC crossover board (see page 52) B. Check all cable connections from the batteries to the converter. C. Check the AC crossover board.
The bed power cord is plugged in but the battery does not charge	The battery charger is not functioning.	A. Check the circuit breakers on the litter. B. Check the battery charger. C. Check all cable connections on the charger.

Note

The display board will display the state of battery charge when the bed is first powered using the On/Off switch:
 Three LED's flash = 66% - 100% charged One LED flashes = less than 33% charged
 Two LED's flash = 33% - 66% charged No LED's flash = No significant charge remaining.

[Return To Table of Contents](#)

Troubleshooting Guide

Inverter, Charger, Battery & Zoom®

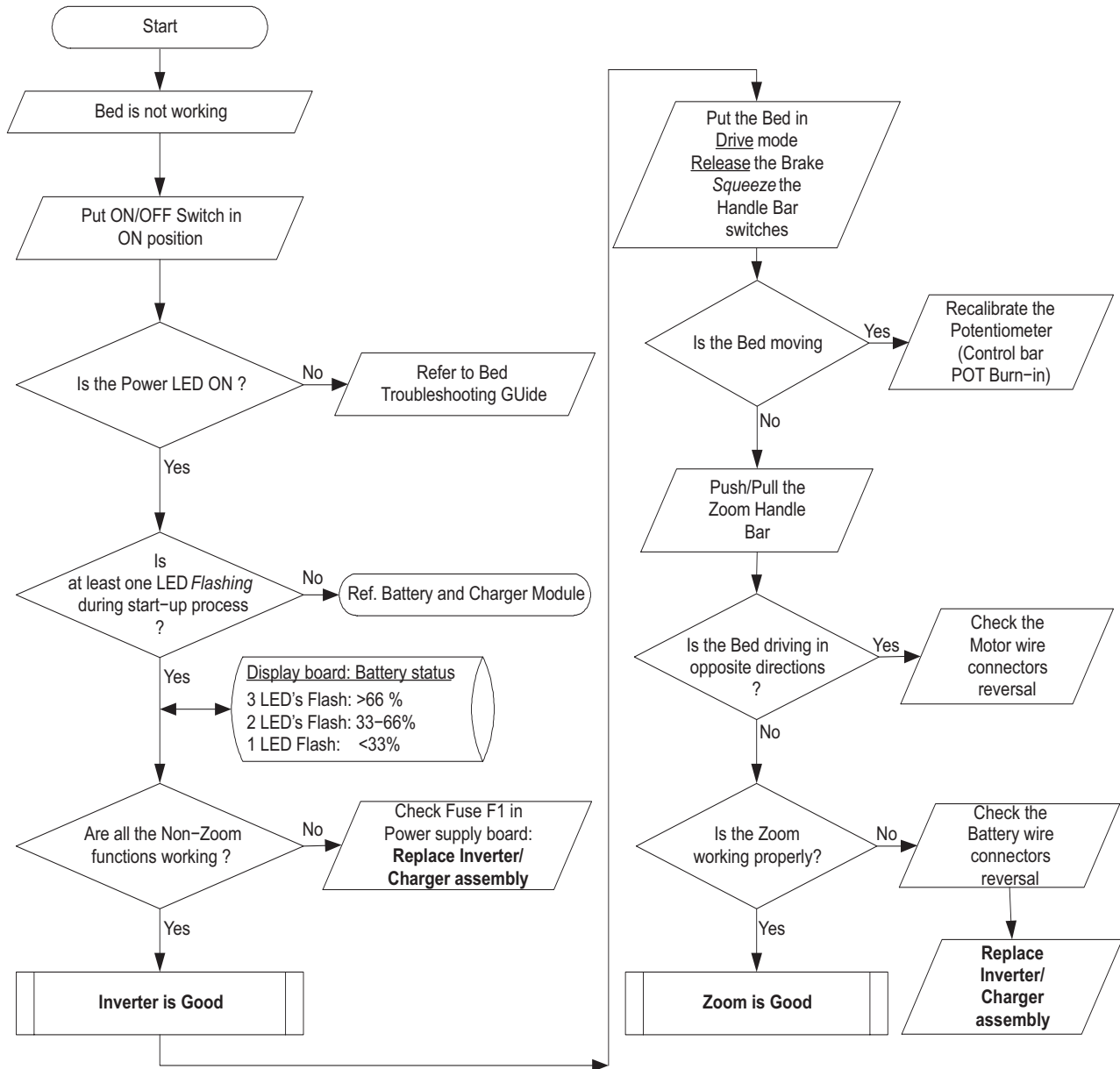

Troubleshooting Guide

Inverter, Charger, Battery & Zoom (Continued)

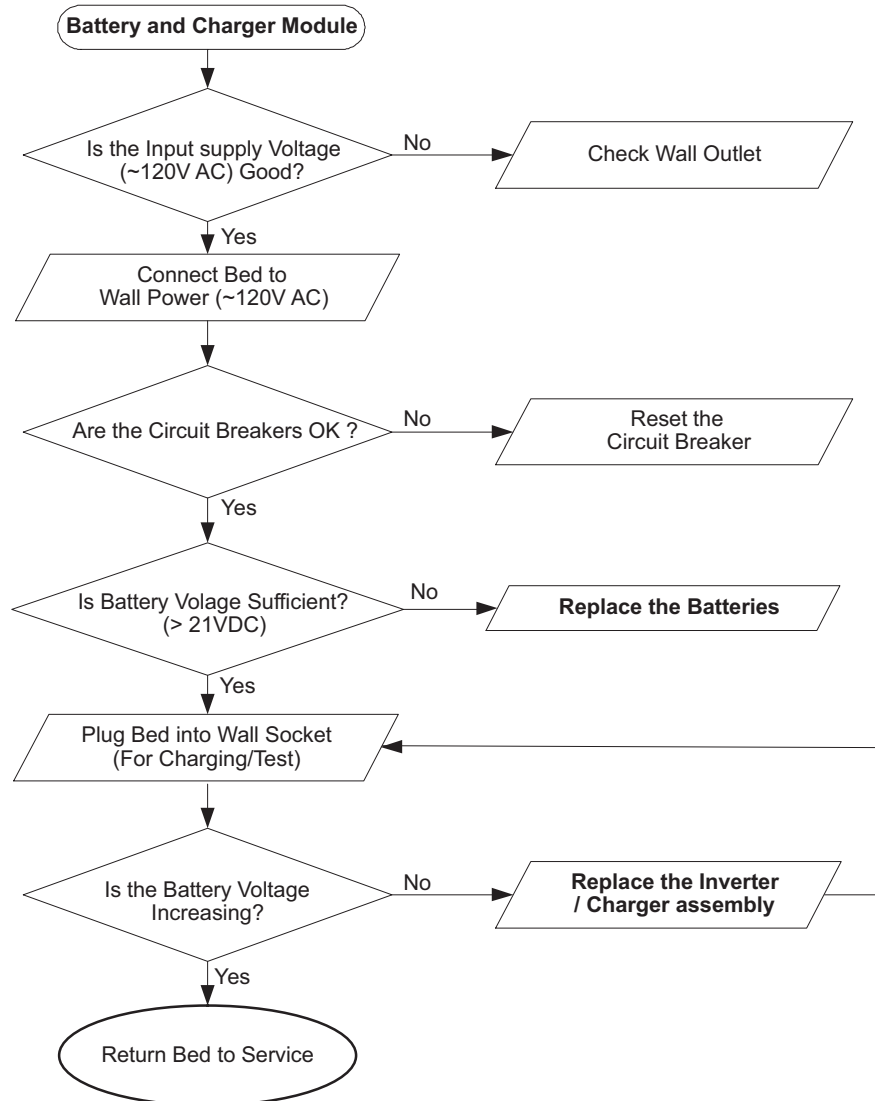

iBED Awareness System Error Codes

Error Handling

- The error handling system provides a mechanism for capturing errors known to the product and providing feedback to the operator through logged errors or message errors.
- All Logged errors generate a generic blinking error message which will be displayed on the status screen in the lower area: “Error XXX Call Service”, where XXX is the error code.
- Errors will only be logged if the error log does not already contain the error.
- In the event multiple errors are displayed on the status screen, the error code is used to identify the priority. The lowest code has the highest priority.
- All logged errors and message errors are persistent until the power is cycled, or the condition is fixed.
- The details for each logged error and error message are detailed in the table below.

Logged Errors

Error Code	Name	Description	Type	Affected Systems
100	Not Used	Highest Priority Errors		
102	StuckSafetyRelay	This error is checked while the product is “On”. If the safety relay signal is “On” and there is no button press on the product then set this error after 1 minute.” Note: This should not be checked when in Auto-Cycle Mode.	Logged	Motion
103	InputTimer	If any footboard motion or side rail/pendant input is sensed to be “On” continuously for a total of 5 minutes then provide an exception message. Note: This should not be checked when in Auto-Cycle Mode.	Logged	Motion
200	Not Used	Scale System		
201	HL-Load Cell	Patient Head Left Load Cell. Under/Over range.	Logged	Scale, Bed Exit, iBED Awareness
202	HR-Load Cell	Patient Head Right Load Cell. Under/Over range.	Logged	Scale, Bed Exit, iBED Awareness
203	FL-Load Cell	Patient Foot Left Load Cell. Under/Over range.	Logged	Scale, Bed Exit, iBED Awareness
204	FR-Load Cell	Patient Foot Right Load Cell. Under/Over range.	Logged	Scale, Bed Exit, iBED Awareness
206	CS5533Fatal	Non-Recoverable Communication Error. CS5533 Fatal occurs when the CPU fails to communicate to the External ADC for the Load cells and cannot recover.	Logged	Scale, Bed Exit, iBED Awareness
207	ZeroFail	Zero Fail error occurs when the system cannot provide a stable zero value for three consecutive attempts at zeroing the product.	Logged	Scale, Bed Exit, iBED Awareness

iBED Awareness System Error Codes

Logged Errors (Continued)

Error Code	Name	Description	Type	Affected Systems
300	Not Used	Side Rails		
301	HLSRSwitch	Head Left Side Rail Switch General.	Logged	iBED Awareness
302	HRSRSwitch	Head Right Side Rail Switch General.	Logged	iBED Awareness
303	FLSRSwitch	Foot Left Side Rail Switch General.	Logged	iBED Awareness
304	FRSRSwitch	Foot Right Side Rail Switch General.	Logged	iBED Awareness
400	Not Used	Memory System		
401	EEPROM	EEPROM Memory Corruption Any detected non recoverable memory failure will produce an error and localize the error to a section of memory.	Logged	
500	Not Used	Motion System		

Error Messages

Error Code	Name	Description	Type	Affected Systems
800	Not Used	Non-Logged Errors		
801	NurseCallBattery	When the nurse call battery falls below the 5v threshold a message will appear in the lower status window "N/C Battery Low".	Non-Logged	N/A
802	LiftCalibration	When the lift calibration has not been completed then when in normal mode the message "Lift Calib. Err" will be displayed in the lower status screen window.	Non-Logged	N/A
803	FowlerCalibration	When the fowler calibration has not been completed then when in normal mode the message "Fowler Calib. Err" will be displayed in the lower status screen window.	Non-Logged	N/A
804	ScaleCalibration	Scale Calibration error occurs when the product in a normal operation mode and the scale system is present on the product but the scale system has not been calibrated. The message "Scale Calib. Err" will be displayed in the lower status screen window.	Non-Logged	N/A

[Return To Table of Contents](#)

iBED Awareness System Error Codes

Error Messages (Continued)

NOTE: The 900 error codes are not logged.

Error Code	Name	Description	Type	Affected Systems
900	Not Used	<p>Message Errors</p> <p>- When the timeout for the message error has expired the display should return to the status screen unless otherwise noted or unless a higher priority screen is being handled.</p>		
901	ScaleSystem	<p>When turning on the Scale system, using the Scale Button, if a “Logged” error is present that affects the scale system (see affected systems column) the message “Function Disabled - Call Service” will blink.</p>	System	N/A
902	BedExitSystem	<p>When turning on the Bed Exit system if a “Logged” error is present that affects the scale or bed exit systems (see affected systems column) the message “Function Disabled - Call Service” will blink.</p> <p>Bed Exit will alarm if Bed Exit is armed and a 200 level exception occurs. The message will be displayed “Turn off Bed Exit - Call Service”. When the system is disarmed, the display will go back to the status screen. Since the bed exit alarm has the highest priority, if the Bed Exit alarm is tripped due to the error condition this message will not be seen.</p>	Message	N/A
903	LBSSystem	<p>When turning on the iBED Awareness system if a “Logged” error is present that affects the iBED Awareness system (see affected systems column) the message “Function Disabled - Call Service” will blink.</p> <p>iBED Awareness will alarm if iBED Awareness is “On” and a 200 or 300 level Logged error occurs. The message will be displayed “Turn off Bed Status - Call Service”, When the system is turned off, the display will go back to the status screen.</p>	Message	N/A
904	UnknownBedType	<p>Unknown bed type occurs when the configuration switch bank does not contain a value that is recognized by the software. This will cause the product to stop all function and product a message screen indicating the error number and the message “Unknown Bed Type - Call Service”</p>	Message	N/A

iBED Awareness System Error Codes

Logged Errors (Continued)

Error Code	Name	Description	Type	Affected Systems
905	CANConnectivity	If the footboard does not see the Main board Heart beat within 10 seconds then the message "Communication Failed - Call Service"	Message	N/A
906	ScaleFeatures	A message will be displayed when user tries to activate any scale function (Ex. Gain/Loss, Change Equipment...) that is disabled due to a logged scale exception (200 Series). Message "Function Disabled - Call Service" at 0.8 Hz (70% Duty Cycle) for 4 seconds.	Message	N/A
907	ZeroAttemptFailed	The "Unable to Zero - Try Again" message will flash be displayed when the user tries to zero the bed and the scale system cannot stabilize the weight in time. Note: This applies to any use of the zeroing feature, even if that is within another scale function. If a zero attempt has failed then the scale system will be suspended until a successful zero is saved or the power is cycled. If the scale button is pressed the "Function Not Available - Zero Bed" message will flash.	Message	N/A
910	LoadCellCheck	The load cells will be checked when the maintenance menu is entered and a message will be displayed if any load cell errors are detected. The message should be displayed "Load Cell Error – HL HR FL FR". Note: Only the load cells that are in error will be displayed. This message will be persistent until any of the menu type buttons are pressed.	Message	N/A
911	MenuException	If the footboard menu system is provided with data that is out of range the display will present "Menu Error – Call Service". The message will persist until a menu state is correct.	Message	N/A
912	CalibrationException	If the scale calibration routine fails then the message "Calibration Error" will be displayed for 4 seconds and then return to the maintenance menu.	Message	Motion

Quick Reference Replacement Parts List

Note

The parts and accessories listed on this page are all currently available for purchase. Some of the parts identified on the assembly drawing parts in this manual may not be individually available for purchase. Please call Stryker Customer Service USA: 1-800-327-0770 (Option 2), Canada: 1-888-233-6888 for availability and pricing.

Part Name	Part Number
Electrical Components	
Foot Board Keyboard (S/R Lights, Lockouts, etc.)	3001-500-028
Foot Board Scale Display	3002-507-900
Foot Board Scale Keyboard	3002-507-910
Foot Board Bed Exit Keyboard	3001-508-900
CPU Board	3002-407-950
Power Supply	0059-157-000
Siderail Board, Inside	3001-400-930
Siderail Board, Outside	3001-400-910
Siderail Speaker with Cable	3000-403-831
Night Light Circuit Board	3002-310-900
Other Components	
Beeper Kit, Bed Exit, Low Sounding	3002-700-029
Beeper Kit, Bed Exit, High Sounding	3002-700-030
Capacitor, Fowler	0059-785-000
Capacitor, Fowler, 230V	3221-300-453
Capacitor, Gatch	0059-783-000
Capacitor, Gatch, 230V	0059-153-000
Capacitor, Lift	0059-786-000
Capacitor, Lift, 230V	3221-200-243
Caster, 6"	3001-200-060
Caster, Steer, 6"	3001-200-050
Coil Cord, Lift Power	3001-200-824
Coil Cord, Lift Sensor	3001-200-815
Coil Cord, Litter Power	3001-300-844
Coil Cord, Litter Signal	3001-300-846
Fowler Brake Kit	3001-300-775
Load Cell	3002-307-057

Quick Reference Replacement Parts List

Part Name	Part Number
Other Components (Continued)	
Motor Coupler Kit, Lift	3000-200-725
Motor, Fowler with Clutch	3004-300-106
Motor, Fowler with Clutch, Short Bed	3004-700-108
Motor, Fowler with Clutch, 230V	3221-300-705
Motor, Gatch	3003-016-602
Motor Gatch, 230V	2026-232-070
Motor, Lift (Same for Head and Foot End)	3003-016-603
Motor, Lift, 230V (Same for Head and Foot End)	3221-200-213
Paint, Touch-Up, Opal, Bottle with Brush	7000-001-321
Paint, Touch-Up, Opal, Spray Can	7000-001-318
Potentiometer, Foot End	3001-200-230
Potentiometer, Head End	3001-200-240
Power Cord	3002-700-049
Single Tube of Grease	3000-200-700
Head/Foot Board "C" Bumper Adhesive	0072-002-071
Zoom® Option Components	
Drive Potentiometer with Cable	2040-031-804
Drive Wheel Motor	3002-001-072
On/Off Switch	0059-191-000
Transformer	3002-001-010
Zoom® Inverter/Charger Board	3002-001-030
Zoom® Display/CPU Board	2040-031-910
Zoom® AC Crossover Board	2040-031-900
/BED Awareness Option Components	
Foot End Siderail Switch, Right	3004-401-415
Foot End Siderail Switch, Left	3004-401-315
Head End Siderail Switch, Right	3004-402-215
Head End Siderail Switch, Left	3004-402-115
Fowler Potentiometer	3001-345-807
LBS Light Indicator, Right	3004-300-225
LBS Light Indicator, Right	3004-300-230
CPU Board	3003-407-900

[Return To Table of Contents](#)

Service Information

Brake Pedal Replacement

TOOLS REQUIRED:

- 5/16" Hex Allen Wrench
- Torque Wrench
- Loctite 242
- Hammer
- Punch
- #2 Phillips Screwdriver

PROCEDURE:

1. Unplug the bed power cord from the wall socket.
2. Using a #2 Phillips screwdriver, remove the three screws holding both the head end and the foot end upper lift covers. If desired, hold the covers out of the way by using bungee cords (or the equivalent) to secure them to the litter top.
3. Using a 5/16" hex Allen wrench, remove the two bolts holding the brake pedal to the brake rod.
4. Using a hammer and punch, remove the roll pins holding the brake shaft crank to the brake rod on both the head and the foot end.
5. Push the brake rod through the frame until the brake pedal is clear. Remove the brake pedal.
6. Reverse the above steps to attach the new brake pedal.

Note

Use Loctite 242 when reinstalling the bolts and torque the bolts to 25 foot-pounds.

Service Information

Lift Motor and Capacitor Removal and Replacement

TOOLS REQUIRED:

- 3/8" Socket Wrench w/Extension
- 5/16" Socket Wrench
- Floor Jack
- Side Cutters
- 7/16" Open End Wrench
- 2x4 (or Equivalent)

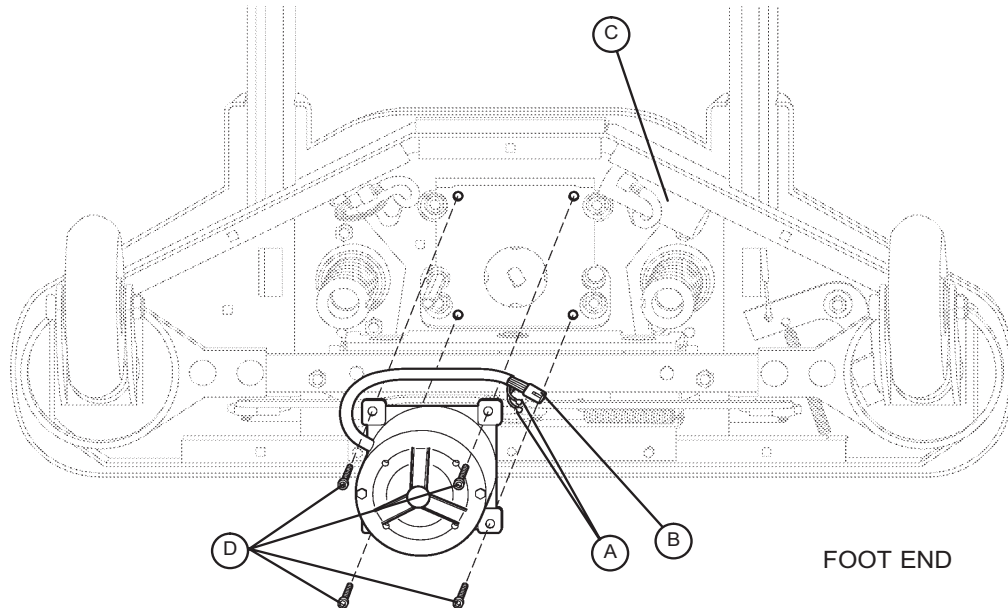

PROCEDURE:

Note

If you need more space to work under the base frame, place a 2x4 across the base frame rails and use a floor jack to raise the base frame off the floor.

1. Unplug the bed power cord from the wall socket. Using a 5/16" socket wrench, remove the five bolts holding the lower lift cover to the base and remove the cover.
2. Disconnect the two connectors (A) at the motor capacitor.
3. Disconnect the white connector (B) from the power cord.
4. Using side cutters, cut the cable ties holding the capacitor (C) to the base and remove the capacitor.
5. Using a 3/8" socket wrench, remove the four screws (D) holding the motor assembly in the lift housing and remove the motor assembly.
6. Reverse the above steps to install the new motor.

Note

The drive shaft on the new motor probably will have to be turned to be aligned with the coupler. Use a 7/16" open end wrench to turn the drive shaft of the motor.

The procedure for lift motor and capacitor removal and replacement is the same for both ends of the bed.

[Return To Table of Contents](#)

Service Information

Lift Housing Removal and Replacement

TOOLS REQUIRED:

- #2 Phillips Screwdriver
- Bungee Cord (or equivalent)
- 5/16" Socket Wrench
- Side Cutters
- 9/16" Socket Wrench
- 5/16" Nut Driver
- 7/32" Hex Allen Socket Wrench
- Sawhorses (or equivalent)
- T27 Torx
- 3/8" Socket Wrench (with approximately 6" extension)

PROCEDURE:

1. Unplug the bed power cord from the wall socket.
2. Using a 5/16" socket wrench, remove the five bolts holding the lower lift cover to the base and remove the cover.
3. Using a #2 Phillips screwdriver, remove the three screws holding the upper lift cover to the base.
4. If you are working on the foot end of the bed, use a T27 Torx to remove the screw holding the litter access panel to the litter.
5. Remove the lift motor and capacitor (refer to procedure "Lift Motor and Capacitor Removal and Replacement").
6. Remove lift potentiometer (refer to procedure "Lift Potentiometer Replacement and Adjustment").
7. Using a 5/16" socket wrench, remove the cable clamps holding the power and sensor coil cords on top of the lift housing assembly. Cut the cable ties and disconnect the coil cords from under the lift housing. The power and sensor coil cords are now free of the lift housing assembly. Drape them up out of the way.
8. Using a 7/32" hex Allen socket, remove the two screws (A) holding the lift screws to the header crossbar plate.

CAUTION

The bed litter retracts on rollers. Secure it to prevent it from rolling while the procedure is being done.

Service Information

Lift Housing Removal and replacement (Continued)

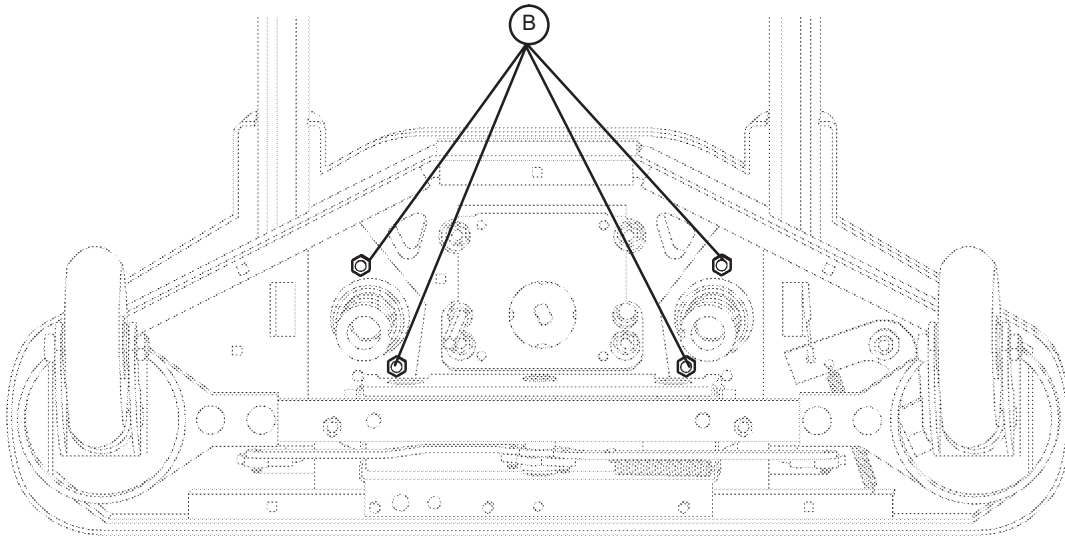

FOOT END – BOTTOM VIEW

9. Lift the litter top up and support it about 6” above the lift screws with sawhorses or the equivalent.
10. Under the base, using a 9/16” socket, remove the four nuts (B) holding the lift housing to the base.
11. Lift up and out on the lift housing assembly to remove it from the base.

 **CAUTION**

See “Power and Sensor Coil Cord Replacement” section for proper reattachment procedure for power and sensor coil cords and “Lift Potentiometer Replacement and Adjustment” for reattachment of the lift potentiometer.

12. Reverse the above steps to reinstall the lift housing assembly after service is completed.

Note

The procedure for lift housing removal and replacement is the same for both ends of the bed.

Service Information

Lift Potentiometer Replacement and Adjustment

TOOLS REQUIRED:

- #2 Phillips Screwdriver
- Bungee Cord (or equivalent)
- 5/16" Socket Wrench
- 3/8" Open End Wrench
- Side Cutters

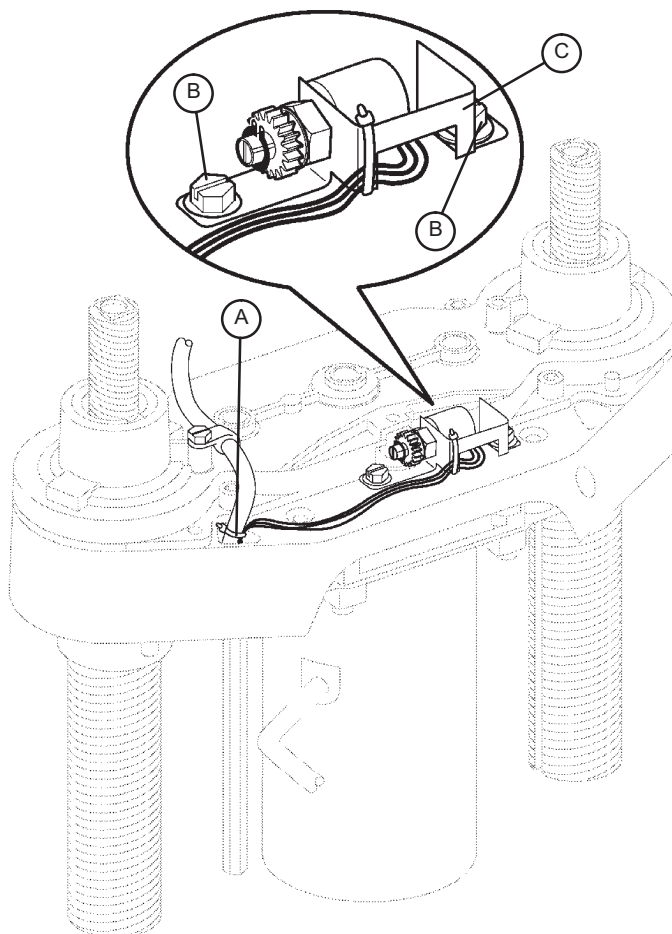

PROCEDURE:

1. Unplug the bed power cord from the wall socket.
2. Using a 5/16" socket wrench, remove the five bolts holding the lower lift cover to the base and remove the cover.
3. Using a #2 Phillips screwdriver, remove the three screws holding the upper lift cover to the base.
4. Using side cutters, cut the cable tie (A) holding the potentiometer cable to the coil cord.
5. Unplug the potentiometer cable from the sensor coil cord. If replacing a potentiometer at the head end of the bed, unplug the cables attached to the brake sensor switch.
6. Pull the potentiometer cable up through the base.
7. Using a 3/8" open end wrench, remove the two bolts (B) holding the potentiometer housing (C) to the lift housing.
8. Lift up and out on the potentiometer housing assembly to remove it from the lift housing.
9. Before installing the new potentiometer on the bed, turn it clockwise until it stops. Turn it back counterclockwise two full (360) revolutions. This allows a "window" position for proper upper and lower limits.
10. Reverse steps 4-8 to install the new potentiometer and potentiometer housing assembly.
11. After installing the new potentiometer, the "burn-in" procedure below must be followed.

Note

Be sure to maintain the potentiometer position while installing.

Service Information

Lift Potentiometer “Burn-in” Procedure (Standard Bed)

1. Unplug the bed power cord from the wall socket.
2. On the foot board control panel, hold down the Siderail Control Lights, Head Lockout, and Up/Down Lockout buttons simultaneously.
3. While holding down the above three buttons, plug the power cord into the wall socket. The Lights button on the foot board control panel should flash, indicating the bed is in the diagnostics mode.
4. On a bed without the Zoom® power drive option, run both ends of the bed full down to a “hard stop”. On a bed with the Zoom® option, run both ends of the bed full up to a “hard stop”.
5. Hold down the Bed Motion Lock button until the light flashes.
6. Release the button and unplug the power cord from the wall socket.
7. Plug the power cord back in to the wall socket. Run the bed to full up, then full down to verify the bed limits.
8. The distance between the floor and the top of the litter seat section on a standard Secure bed (without a mattress) should be 16” - 16 3/8” with the litter fully down and 29 1/4” - 29 7/8” with the litter fully up.
The distance between the floor and the top of the litter seat section on a Secure Zoom® bed (without a mattress) should be 19.5” with the litter fully down and 30” - 30 1/4” with the litter fully up. The distance between the floor and the top of the litter seat section on a Secure short bed with Zoom® (without a mattress) should be 20.5” with the litter fully down and 30” - 30 1/4” with the litter fully up.

Lift Potentiometer “Burn-in” Procedure (iBED Awareness option)

1. Unplug the bed power cord from the wall socket.
2. On the foot board control panel, hold down the Bed Motion Lock, Gatch Lock, and Reverse Trend buttons simultaneously. While still holding down the buttons, plug the power cord into the wall socket. Release the footboard button.
3. On a bed without the Zoom® power drive option, run both ends of the bed full down to a “hard stop”. On a bed with the Zoom® option, run both ends of the bed full up to a “hard stop”.
4. Hold down the Bed Motion Lock button until the light flashes.
5. Release the button and unplug the power cord from the wall socket.
6. Plug the power cord back in to the wall socket. Run the bed to full up, then full down to verify the bed limits.
7. The distance between the floor and the top of the litter seat section on a standard Secure bed (without a mattress) should be 16” - 16 3/8” with the litter fully down and 29 1/4” - 29 7/8” with the litter fully up.
The distance between the floor and the top of the litter seat section on a Secure Zoom® bed (without a mattress) should be 19.5” with the litter fully down and 30” - 30 1/4” with the litter fully up. The distance between the floor and the top of the litter seat section on a Secure short bed with Zoom® (without a mattress) should be 20.5” with the litter fully down and 30” - 30 1/4” with the litter fully up.

Note

These values are for beds equipped with 6” casters. Add 2” to both measurements for beds equipped with 8” casters.

Service Information

Lift Motor Isolation Plate Replacement

TOOLS REQUIRED:

- 7/16" Open End Wrench
- 5/16" Nut Driver or 5/16" Socket Wrench
- 3/8" Socket Wrench (with 6" ext.)

PROCEDURE:

1. Unplug the bed power cord from the wall socket.
2. Using a 5/16" socket wrench, remove the five bolts securing the lower lift cover and remove the cover.
3. Using a 3/8" socket with a 6" extension, remove the four bolts (C) holding the lift motor isolation plate to the lift housing and carefully lower the isolation plate to the floor.
4. Remove the motor coupler (A) and bushings (B).
5. Using a 3/8" socket, remove the bolts and washers (E) from the motor and remove the isolation plate (D).
6. Reverse the above steps to install the new isolation plate and reattach all components to the bed.

Note

When reinstalling the lift motor, the drive shaft on the motor will have to be turned to be aligned with the coupler. Use a 7/16" open end wrench to turn the drive shaft of the motor.

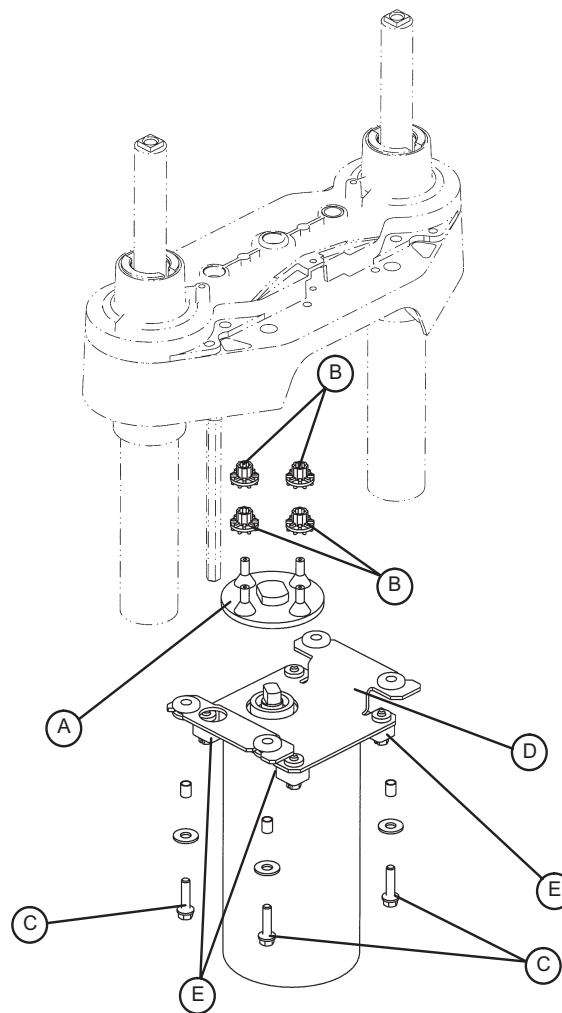

Service Information

Lift Motor Coupler Replacement

TOOLS REQUIRED:

- 5/16" Socket Wrench
- 3/8" Socket Wrench (with 6" Extension)
- Floor Jack
- 2x4 (or equivalent)

PROCEDURE:

Note

If you need more space to work under the base frame, place a 2x4 across the base frame rails and use a floor jack to raise the base frame off the floor.

1. Unplug the bed power cord from the wall socket.
2. Using a 5/16" socket wrench, remove the five bolts holding the lower lift cover to the base and remove the cover.
3. Using a 3/8" socket with an extension, remove the four bolts (A) holding the isolation plate (B) to the lift housing and lower the lift motor and isolation plate assembly to allow access to the coupler (C).
4. The motor coupler can now be removed from the lift housing.
5. Reverse the above steps to install the new motor coupler and bushings.

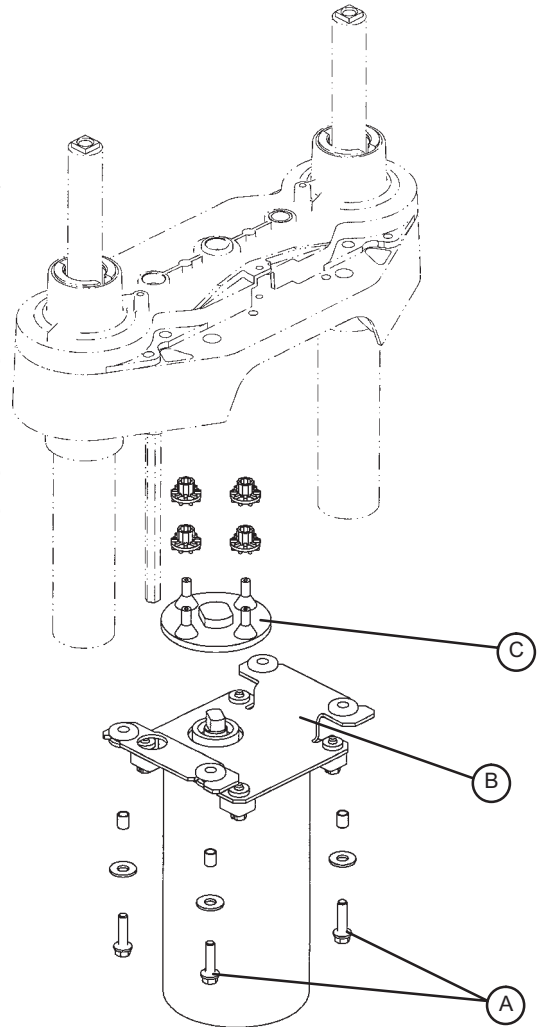

Service Information

Power and Sensor Coil Cord Replacement

TOOLS REQUIRED:

- #2 Phillips Screwdriver
- Side Cutters
- 5/16" Socket Wrench
- Bungee Cord (or equivalent)
- 5/16" Nut Driver
- Floor Jack
- 2x4 (or equivalent)

PROCEDURE:

Note

If you need more space to work under the base frame, place a 2x4 across the base frame rails and use a floor jack to raise the base frame off the floor.

1. Unplug the bed power cord from the wall socket.
2. Using a 5/16" socket wrench, remove the five bolts holding the lower lift cover to the base and remove the cover.
3. Using a #2 Phillips screwdriver, remove the three screws holding the upper lift cover to the base. If you want, hold the covers out of the way by using bungee cords (or the equivalent) to secure them to the litter top.
4. Using side cutters, cut the cable ties holding the power and sensor coil cords to the base. Remove the ground wire coming from the sensor cord that is attached to the base (note the star washer arrangement).
5. Disconnect the cables going to the motor and the lift potentiometer (at the head end, the sensor cord is also attached to the brake switch sensor).
6. Pull both cords up through the frame of the bed and the lift housing.
7. Using a 5/16" socket wrench, remove the two screws (A) holding the cable clamps* to the top of the lift housing.
8. Using a 5/16" socket wrench, remove the two screws (B) securing the cable clamps* to the underside of the header crossbar assembly.
9. Pull both coil cords up through the header crossbar assembly.
10. Disconnect the power and sensor coil cords from the connectors.
11. The cords should now be completely removed from the bed. Reverse the above steps to install the new power and sensor cords.*

CAUTION

* When replacing the power and sensor coil cords, secure the cable clamps to the cords at the first coil both on the top and on the bottom to ensure there is not too much slack in the cords between the top of the lift housing assembly and the bottom of the header crossbar. Be sure the clamps are fastened at exactly the correct angle, as shown by the arrows in the illustration. Arrange the cords exactly as shown in the illustration (left in front of right). **If this is not done correctly, damage to the cords will result.**

Service Information

Power and Sensor Coil Cord Replacement Illustration

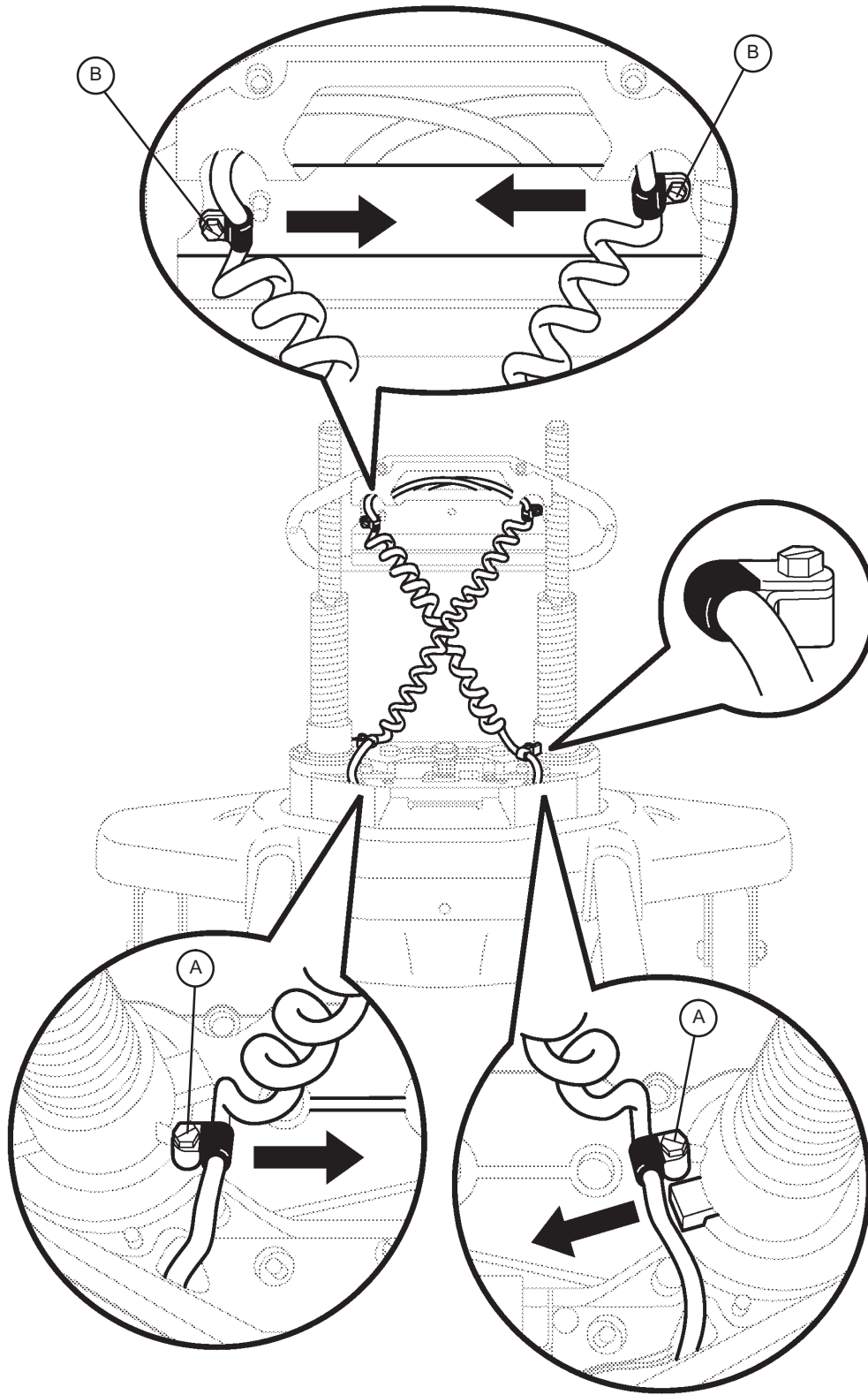

View from Center of Bed

[Return To Table of Contents](#)

Service Information

Knee Motor Removal and Replacement

TOOLS REQUIRED:

- T27 Torx
- Needle Nose Pliers
- 3/8" Socket Wrench
- Wire Cutters

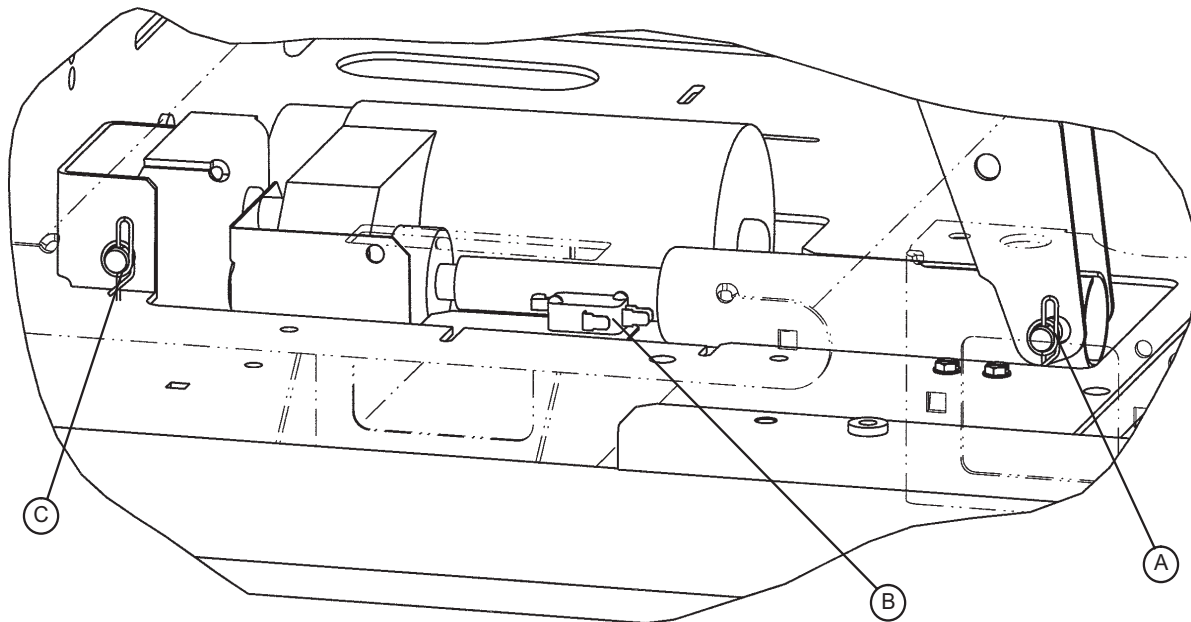

PROCEDURE:

1. Electrically run the litter fully up. Unplug the bed power cord from the wall receptacle.
2. Using a 3/8" socket wrench, remove the two bolts holding the motion interrupt pan to the litter frame and remove the pan.
3. Using needle nose pliers, remove the Rue pin (A) from the end of the drive tube.
4. Fold the Gatch section back toward the head end of the bed. Using a T27 Torx, remove the screw holding the mid-litter cover to the litter frame and remove the cover.
5. Remove the two wires from the auto contour micro switch (B) mounted next to the drive tube.
6. Using wire cutters, remove the cable ties. Disconnect the motor and capacitor wires.
7. Using needle nosed pliers, remove the Rue pin (C) from the motor bracket and lift the motor out.
8. Using a 3/8" socket wrench, remove the four bolts holding the motor bracket to the old motor. Remove the bracket and install it on the replacement motor using the same four bolts.
9. Install the replacement motor into the bed. Do not hook up the drive tube to the Gatch section yet.
10. Plug the bed power cord into a properly grounded wall receptacle. Using the button on the foot board or siderail, run the Gatch motor down until it stops.
11. Reinstall the mid-litter cover.
12. Fold the Gatch section back down. From underneath the bed, manually turn the drive tube in or out until it lines up with the hole in the Gatch section. Reinstall the pin, the wires for the auto contour switch, and the motion interrupt pan.
13. Test the bed for proper operation before returning it to service.

Service Information

Head Motor CAM and CAM Guide Replacement

TOOLS REQUIRED:

- 5/16" Nut Driver
- 3/8" Socket Wrench
- T27 Torx

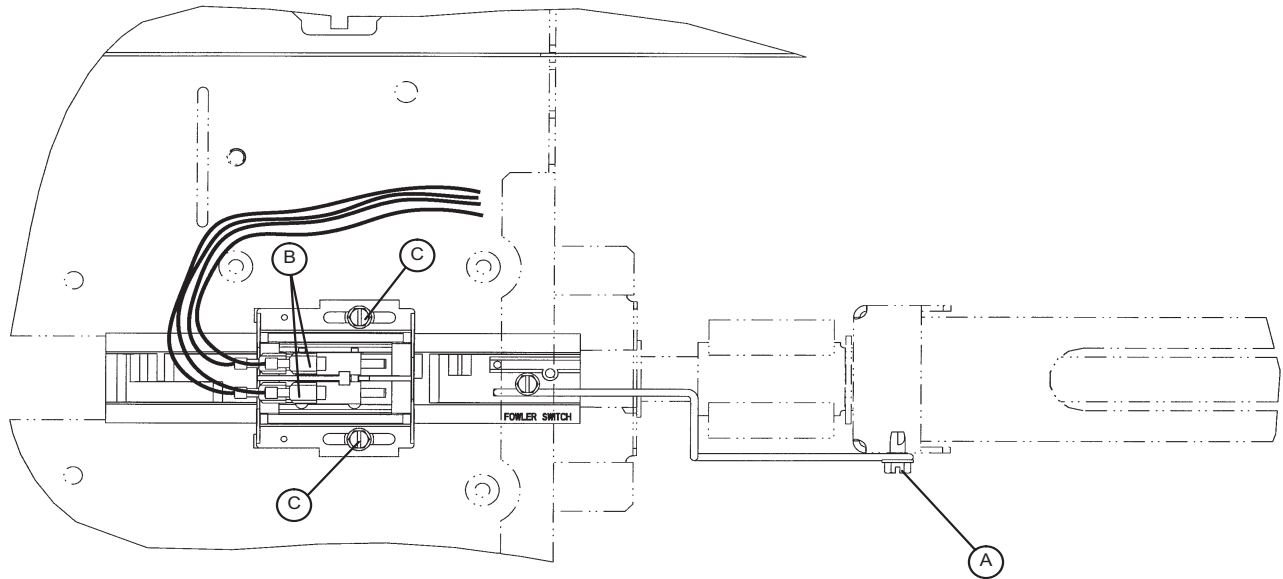

PROCEDURE:

1. Run the Knee Gatch fully up. Unplug the bed power cord from the wall socket.
2. Using a T27 Torx, remove the screw holding the foot end litter cover to the frame and remove the cover.
3. Using a 3/8" socket wrench, remove the two bolts holding the motion interrupt pan to the litter and remove the pan.
4. Using a 5/16" nut driver, remove the screw (A) holding the cam retention wire to the ball nut assembly.
5. Disconnect the cables (B) from the micro-switches. Take note of the locations of the cables so they will be connected properly to the replacement cam.
6. Using a 5/16" nut driver, remove the two screws (C) holding the cam and cam guide to the support bracket and remove the cam and cam guide with the attached micro-switches from the bed.
7. Reverse the above steps to install the replacement cam and cam guide/micro switch assembly.
8. Refer to "Limit Setting - Head Motor" section.

Service Information

Limit Setting - Head Motor

TOOLS REQUIRED:

- 5/16" Nut Driver
- T27 Torx

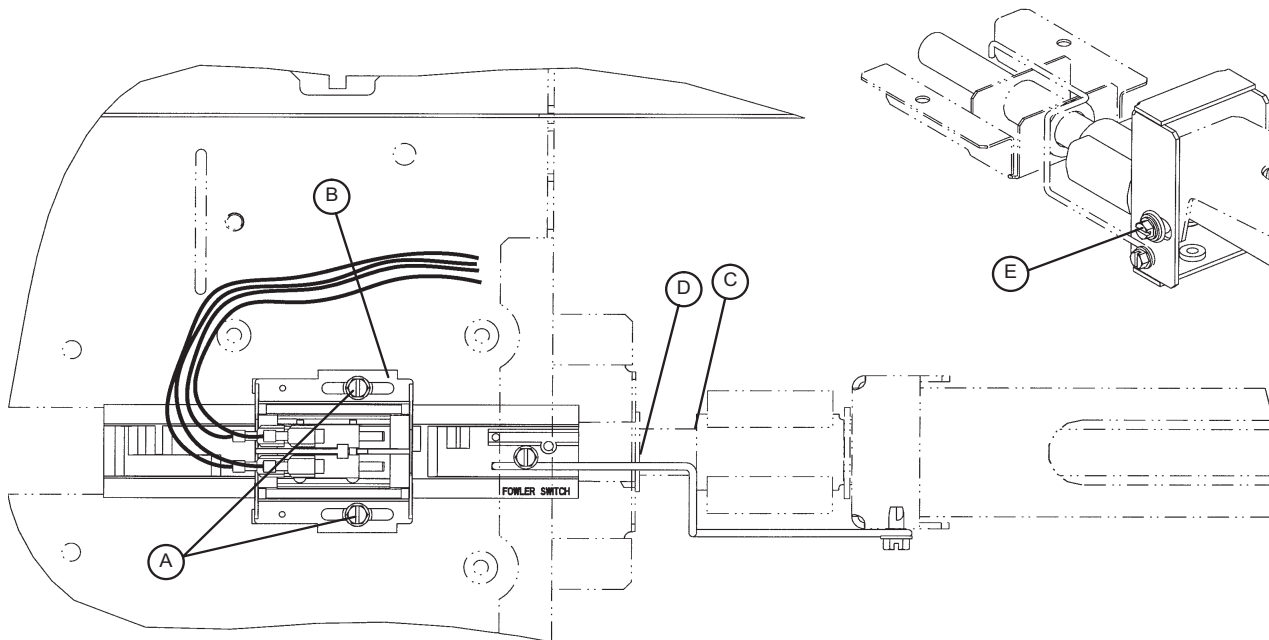

PROCEDURE:

1. Run the Knee Gatch fully up.
2. Using a T27 Torx, remove the screw holding the midsection litter access covers to the litter and remove the covers.
3. Run the head section down electrically until flat (0) or use the CPR release handle to fully lower the head.
4. Lightly tap the Fowler down button until the bolt and bushing (E) are centered in the slot.
5. Unplug the power cord from the wall socket.
6. Using a 5/16" nut driver, loosen the two screws (A) on the cam (B).
7. Slide the cam toward the head of the bed just until the micro-switch is activated (the switch will make a clicking noise).

Note

Check that the cam "bump" is on the "head" side of the switch actuator.

8. Tighten the two screws (A).

CAUTION

Be sure the head section stops when it is fully up and the ball nut bracket (C) is approximately 3/4" from panel (D). If not, damage to the unit could result.

9. Ensure the head section will lower to flat (0) before returning the bed to service. Verify the head section lowers onto the rubber rests and the motor stops running. Reinstall the litter access panels removed in step 1.

Service Information

Head Motor Removal and Replacement

TOOLS REQUIRED:

- 3/8" Socket Wrench

PROCEDURE:

WARNING

The head motor is not grounded and may be an electrical hazard. Use caution when working around motors.

1. Using the CPR release, lower the Fowler to flat (0).
2. Unplug the bed power cord from the wall socket.
3. Using a 3/8" socket wrench, remove the two bolts at the foot end of the motion interrupt pan and remove the pan.
4. Using a 3/8" socket wrench, remove the two bolts holding the motor bracket to the bed frame. Remove the motor.

Note

Use caution when removing the motor to avoid having the coupler come off the ball screw shaft.

5. Unplug the head motor cables from the bed and capacitor.

Note

The replacement motor will come with the attached CPR clutch. The mounting bracket will be re-used with the replacement motor.

6. Reverse the above steps to install the new motor assembly and reattach all litter panels.

Service Information

Head Motor Drive Isolator and CPR Decoupler Removal and Replacement

TOOLS REQUIRED:

- 3/8" Socket Wrench
- Needle Nose Pliers

PROCEDURE:

1. Refer to the "Head Motor Removal and Replacement" procedure to access the isolator, springs and decoupler.
2. Pull the drive isolator (C) with the bushings (D), springs (B) and CPR decoupler (A) off the drive screw and remove it from the litter.

Note

These parts are spring-loaded. Use caution when removing them so they will not drop to the floor.

3. To reinstall, put the decoupler (A) on the shaft.
4. Using needle nose pliers, bend the end of the springs (B) out slightly to help hold the springs in the isolator. Put the springs in the isolator and install it on the shaft.
5. Reinstall the head motor (see "Head Motor Removal and Replacement" section).
6. Run the Fowler up and down several times to test it before returning the bed to service.

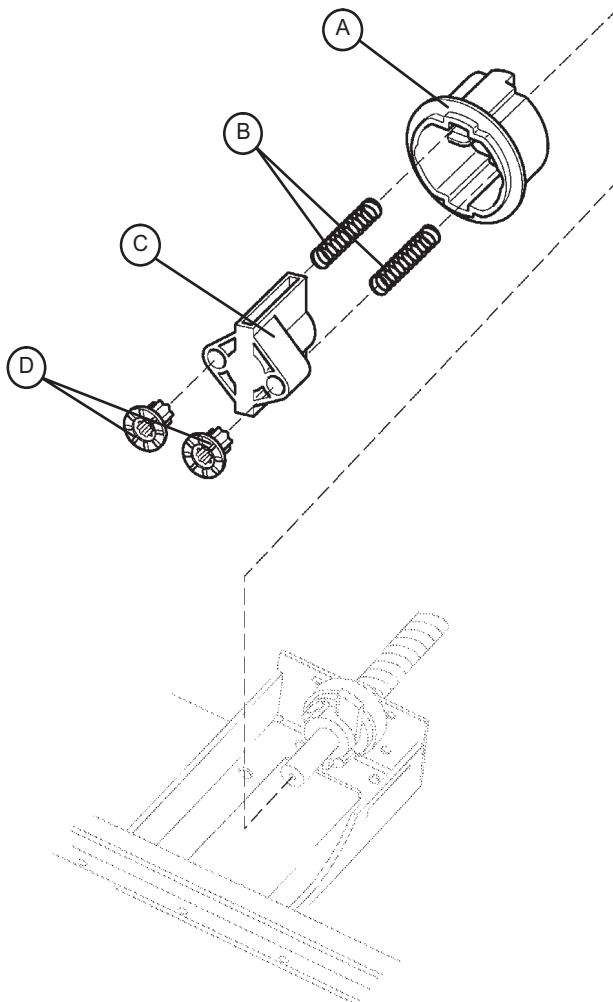

Service Information

Head Motor Drive Screw and Ball Nut Replacement

TOOLS REQUIRED:

- Large Snap-Ring Pliers
- 3/8" Socket Wrench

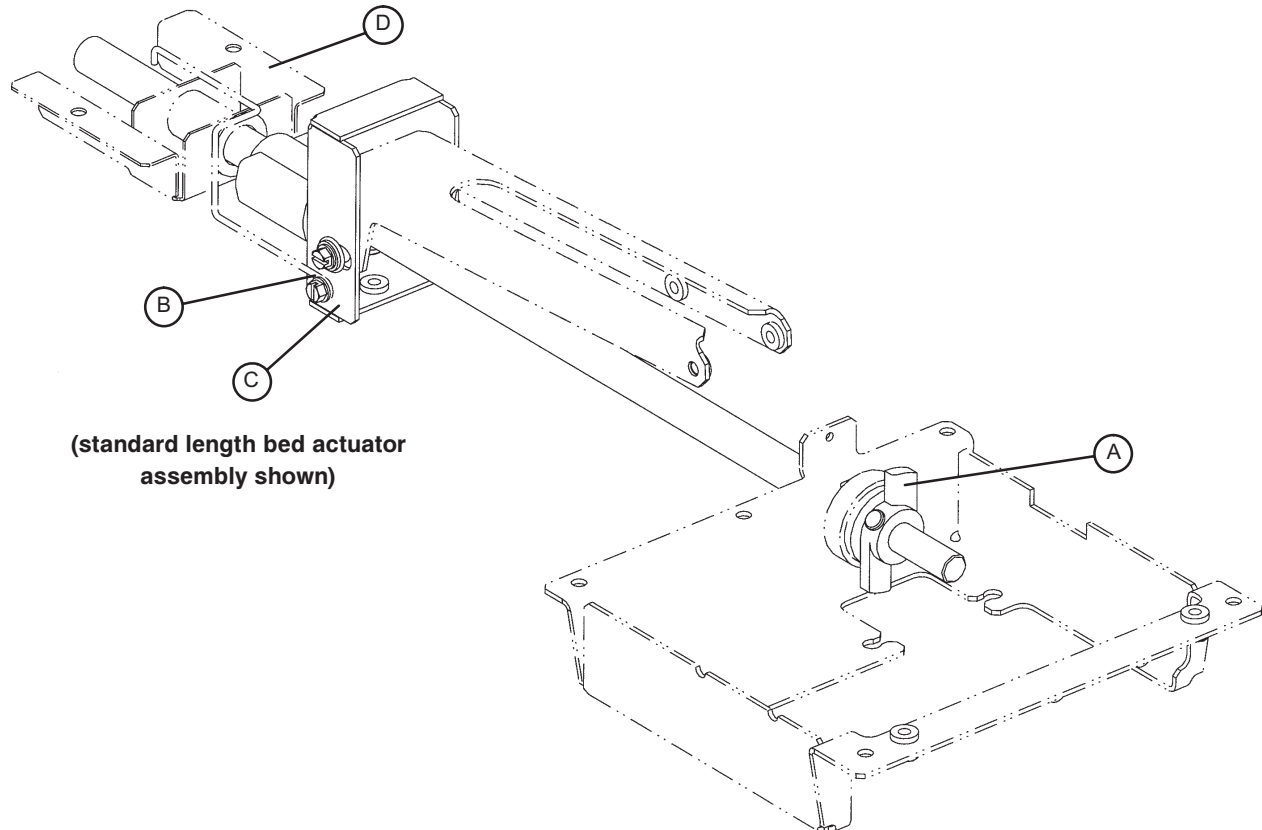

PROCEDURE:

1. Run the bed fully up. Unplug the bed power cord from the wall socket.
2. Using a 3/8" socket wrench, remove the two bolts holding the motion interrupt pan to the litter and remove the pan.
3. Remove the head motor (see "Head Motor Removal and Replacement" section) for access to the screw and ball nut.
4. Remove the head motor drive isolator and CPR decoupler (see "Head Motor Drive Isolator and CPR Decoupler Removal and Replacement" section).
5. Using needle nose pliers, remove the cotter pin holding the clevis pin to the drive screw "wing" (A).
6. Remove the clevis pin and slide the wing and tapered roller bearing off the drive screw.
7. Using a 3/8" socket wrench underneath the litter, remove the screw holding the cam retention wire (B) to the ball nut assembly.
8. Using a 3/8" socket wrench, remove the two bolts holding the ball screw support bracket (D) to the bottom of the litter and remove the bracket.
9. Using large snap ring pliers, remove the snap ring holding the ball nut to the bracket (C).
10. To prevent the ball nut from coming off the drive screw, cable tie both ends of the ball nut to the drive screw.
11. Pull the drive screw toward the foot of the bed and remove the head end of the drive screw and ball nut assembly from the support.

[Return To Table of Contents](#)

Service Information

Head Motor Drive Screw and Ball Nut Replacement (Continued)

Note

Do not allow the ball nut assembly to come off the drive screw. The ball nut will be shipped attached to the drive screw and retained in position during shipment. Remove the restraining straps after installing the drive screw and nut.

12. Remove the thrust washers and bearing from the head end of the drive screw and set them aside.
13. Reverse the above steps to install the replacement drive screw and ball nut assembly.

Note

Apply grease to all bearing areas.

CAUTION

Verify the head motor stops properly at both upper and lower electric limits. If it does not, refer to “Limit Setting - Head Motor”.

Head Motor Brake/Clutch Replacement

TOOLS REQUIRED:

- 3/8” Socket Wrench
- Snap Ring Pliers
- 9/16” Socket Wrench
- 9/16” Box End Wrench
- Wire Cutters

PROCEDURE:

1. Remove the head motor (see “Head Motor Removal and Replacement” section).
2. Using snap ring pliers, remove the snap ring from the motor shaft.

CAUTION

The brake/clutch is spring-loaded. Use caution when removing the snap ring so the parts do not drop to the floor.

3. Remove the old brake/clutch from the motor and discard it.
4. Using a 9/16” socket wrench and a 9/16” box end wrench, remove the nut, bolt and washers from the new brake/clutch.
5. Install the new brake/clutch onto the motor. It may be necessary to turn the motor shaft to line up the key way with the brake/clutch.
6. Using the snap ring pliers, install the new snap ring.
7. Using the wire cutters, remove the two wire ties from the new brake/clutch.
8. Reinstall the head motor (see “Head Motor Removal and Replacement” section)
9. Test the bed for proper operation before returning it to service.

Service Information

Optional Scale System Diagnostics and Calibration

Diagnostic Mode Functions:

ANGLE CALIBRATE	This may be required in the field to recalibrate the scale. Calibrate using 50 pounds.
DISP. CORNER LBS	This function displays the individual corner weights in pounds for each load cell and can be used to isolate a defective load cell.
DISP. CORNER CTS	This function displays the individual corner weights in counts for each load cell and can be used to isolate a defective load cell.
DISPLAY FACTORS	This function is used to see the scale calibration factors. This can be used to diagnose a bad scale calibration.
DISPLAY AVERAGES	This function is used to see the average weight in pounds each load cell has experienced.
DISPLAY MAXIMUMS	This function is used to see the maximum weight each load cell has experienced.
CLEAR STATISTICS	This function is used to clear the averages and maximums.
INIT TO DEFAULTS	This function is used to reset the scale factors back to defaults.
VIEW ERROR LOG	This function can be used to see a log of scale errors and the time they occurred.
LOCK/UNLOCK LBS/KG	This function can be used to lock out the ability to change weight units.
PICK EXIT ALARM	This function can be used to select a different bed exit alarm tone.
BRAKE ALARM OFF/ON	This function can be used to enable or disable an audible alarm when the brakes are not set. Not available for beds with ZOOM® or Battery Backup.
DEFAULT ANGLE	This function can be used to select the default angle displayed to either fowler or trend.
SOFTWARE CONFIG	This function can be used to see what the bed configuration is.
SOFTWARE VERSION	This function can be used to see what software version it is.
CALIBRATE SCALE	This is the old scale calibration routine with 200 pounds. Only there for backup purposes.
EXIT DIAGNOSTIC	This function will give you the ability to exit the diagnostic mode and go into scale mode.

Diagnostic Mode:

Note

It requires two people to enable the diagnostic mode for the Scale System.

1. To enter diagnostic mode, unplug the bed's power cord from the wall socket.
2. Press and hold down the LBS/KGS button.
3. While still holding the LBS/KGS button, plug the bed's power cord into the wall socket.
4. After two seconds, release the LBS/KGS button. The LCD should read "**Angle Calibrate**". The diagnostic mode is now active.

Service Information

Optional Scale System Diagnostics and Calibration (Continued)

Displaying Individual Load Cell Outputs:

A defective load cell can be detected by entering diagnostics and displaying individual load cell outputs.

1. Enter the diagnostic mode. The LCD will display "**Angle Calibrate**" when the diagnostic mode is activated.
2. Repeatedly press and release the up or down arrow button (**Zero** or **Scale On/off**) until the LCD displays "**Display Corner CTS**".
3. Press and release the **Enter** button (LBS/KGS). The LCD should display "<?> **Select Corner**". The two buttons listed below function as **Position** buttons to select the four corners of the bed's litter. Whenever the LCD displays "<?> **Select Corner**", press one of these buttons to cycle through the corners and to select the load cell assembly at the desired corner
 - A. **Zero** - cycle up through the four corners
 - B. **Scale On/off** - cycle down through the four corners
4. Press and release the position button that corresponds with the load cell to be checked. The LCD should display "X/X=NNN.N". "X/X" represents the initials of the selected corner, i.e. H/R will be displayed for the patient's head end, right side. "NNN.N" represents the resistance of the load cell.
5. Repeat step four for each corner. Head end weight readings will normally be lower than foot end weights. Weight readings should be constant. A drifting 000.0 or 999.9 weight, or a reading that does not change when weight is applied to that corner of the bed indicates a problem with the selected load cell assembly or load cell cable.

Verifying Scale Accuracy:

1. Zero the empty bed. Place a known weight on the center of the bed; the heavier the better and no less than 100 pounds. The displayed weight should be within $\pm 2\%$ of the actual weight.
2. If the displayed weight is not accurate, remove the weight from the bed and place the scale CPU in calibration mode.

Scale Calibration:

Note

It requires **two people** to enable the calibration mode for the Scale System.

Calibrate the Scale System with a known weight of approximately 50 pounds.

1. To enter the calibration mode, unplug the bed's power cord from the wall socket.
2. Press and hold down the LBS/KGS button.
3. While still holding the LBS/KGS button, plug the bed's power cord into the wall socket.
4. After two seconds, release the LBS/KGS button. The LCD should read "**Angle Calibrate**". The calibration mode is now active.
5. Press and hold the **Enter** button (LBS/KGS). Zero the bed, following the displayed instructions. When the bed is zeroed, the LCD should display "REF X100=<0>5000". This is the factory default for 50 pounds. If 50 pounds will be used to calibrate the scale, proceed to step 7.

Service Information

Optional Scale System Diagnostics and Calibration (Continued)

Scale Calibration (Continued):

6. If exactly 50 pounds is not available, change the display to match the weight you are using. Pressing the **Change Equip** button will move the cursor position to the right. Pressing the up arrow (**Zero**) button will increase the numbers. Pressing the down arrow (**Scale On/Off**) button will decrease the numbers. Scroll through the numbers until they match the weight you will use for calibration.
7. Place the 50 pound calibrated weight in the center of the bed. Press and release the **Enter** button and the LCD will display "**Press Rev. Trend**". Press and hold the button with the Reverse Trendelenburg symbol (feet down/head up) until the bed stops. Release the button and the LCD will display "**Do Not touch Bed**". Press and hold the Reverse Trendelenburg button again until the bed stops. Release the button and the LCD will display "**Do Not Touch Bed**".
8. The LCD will display "**Press Trend.**" Press and hold the button with the Trendelenburg symbol (feet up/head down) until the bed stops. Release the button and the LCD will display "**Do Not Touch Bed**". Press and hold the Trend button again until the bed stops. Release the button and the LCD will display "**Do Not Touch Bed**".
9. The LCD will display the weight. This indicates the calibration procedure is complete.
10. Level the bed at a full up or full down position. Remove the weight and zero the bed.
11. Verify scale accuracy and functionality before returning the bed to service.

Service Information

Load Cell Replacement

TOOLS REQUIRED:

- 1/4" Hex Allen Wrench
- Wire Cutters

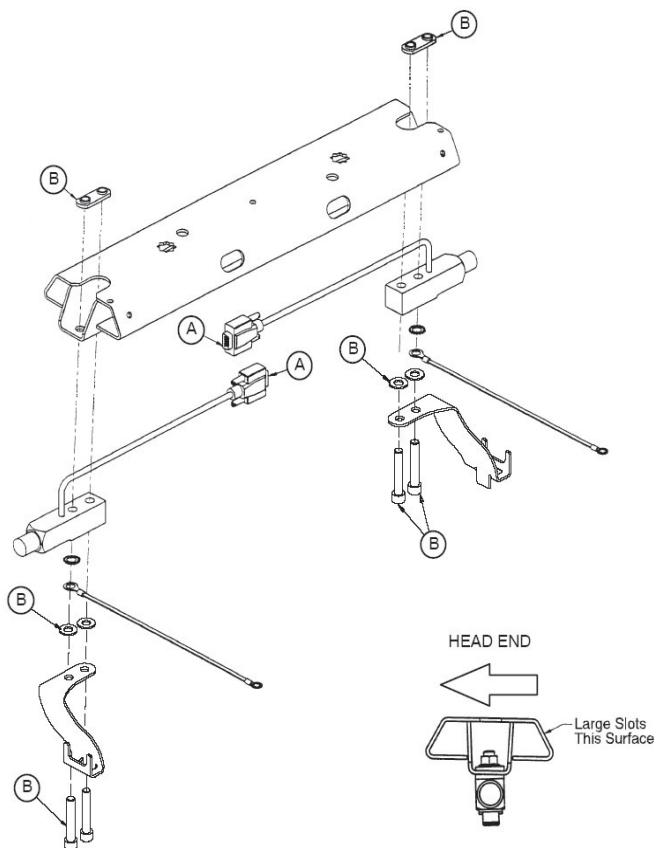

PROCEDURE:

1. Unplug the bed power cord from the wall socket.
2. Support the corner of the litter where the load cell is being removed.
3. Unplug the load cell connector (A) from the load cell cable. Using the side cutters, cut the cable ties.
4. Using a 1/4" hex Allen wrench, remove the screws, washers, and nuts (B) holding the load cell to the bed.
5. To remove a load cell at the head end of the bed, slide the load cell toward the center of the bed to clear the bushing that supports the load cell. Remove the load cell by lifting it up and out. To remove a load cell at the foot end of the bed, slide the load cell with the roller bushing toward the center of the bed to clear the litter frame. Remove the load cell and the roller bushing by lifting them up and out.
6. Reverse the above procedure to install the new load cell.

CAUTION

Be sure the load cell's strain gauge is facing up when installing a new load cell or the weigh system will not work properly.

7. Recalibrate the weigh system (see "Scale Calibration" in "Scale System Diagnostics and Calibration" section).

Service Information

Power Supply Replacement

TOOLS REQUIRED:

- #2 Phillips Screwdriver
- T27 Torx

PROCEDURE:

1. Adjust the Fowler to approximately 25-30. Unplug the bed power cord from the wall socket.
2. Properly ground yourself (see “Static Discharge Precautions” section).
3. Using a T27 Torx, remove the two screws holding the head end litter access cover and remove the cover.
4. Disconnect all cables at the power supply. Note the locations of the cables so they will be reconnected properly to the replacement power board.
5. To remove the board from the litter standoffs, use a #2 Phillips screwdriver to remove the four screws holding the board to the litter. Remove the board.
6. Install the new board and reconnect all cables.
7. Reinstall the litter access panel and plug the bed power cord into a properly grounded wall receptacle.
8. Test the bed for accurate operation before returning it to service.

CPU Board Replacement

TOOLS REQUIRED:

- T27 Torx

PROCEDURE:

1. Adjust the Fowler to approximately 25-30. Unplug the bed power cord from the wall socket.
2. Properly ground yourself (see “Static Discharge Precautions” section).
3. Using a T27 Torx, remove the two screws holding the head end litter access cover and remove the cover.
4. Disconnect all cables at the litter CPU board. Note the locations of the cables so they will be connected properly to the replacement litter CPU.
5. To remove the board from the litter standoffs, pull out on the retention clips and lift upward on the board.
6. Install the new board and reconnect all cables.
7. Reinstall the litter access panel and plug the bed power cord into a properly grounded wall receptacle.
8. Before installing new CPU, SB1, SB2, SB3 and SB4, the dip switches must be set (see “CPU Board - 3002-407-950” section).
9. When a new CPU board is installed, a “burn-in” procedure must be done (see “Lift Potentiometer ‘Burn-In’ Procedure”). If your bed is equipped with a Scale System, scale calibration must also be done (see “Scale Calibration” in “Scale System Diagnostics and Calibration” section). Refer to Zoom® manual for proper switch settings.
10. Test bed operations before returning the bed to service.

Service Information

Optional Smart TV Interface “Burn-In” Procedure

This procedure is used for selecting the style of TV interface needed for your bed. If traditional TV is desired, no calibration is required. If optional Smart TV is available on the bed, select one of the TV manufacturers listed in the table below.

SETUP

Ensure the communication cable is connected between the bed and the Db37 wall port or the pillow speaker port of the Nurse Call System. If available, a bed communication tester can be used instead of the hospital wiring.

PROCEDURE

1. Place the bed in the lift potentiometer burn-in mode (see “Lift Potentiometer ‘Burn-In’ Procedure”).
2. Notice the Nurse Call LED (yellow) is flashing. Notice the Nurse Answer LED (green) is flashing On/Off slowly.
3. Press and release the TV On/Off switch on the bed’s siderail once. Notice the Nurse Call LED flashes once. This is the first selection of TV manufacturers for the Smart TV mode. Notice the Nurse Answer LED (green) is flashing On/Off slowly. The Nurse Answer LED will only light when the Nurse Call LED (yellow) is flashing.
4. Press and release the TV On/Off switch on the bed’s siderail to scroll to other TV manufacturers. Notice the number of times the Nurse Call LED flashes matches the number listed in the table below and represents the TV manufacturer selected.
5. When the desired TV manufacturer has been selected, unplug the bed power cord from the wall socket and plug it back in to complete the Smart TV burn-in procedure.

Note

If the bed is connected to a television during the burn-in procedure, the television will turn on when the correct setting is selected.

TV Manufacturer Selection For Smart TV Burn-in Procedure

Press And Release TV On/Off Switch:	Nurse Call LED (Yellow)	TV Manufacturer
One time	One flash	RCA 1
Two times	Two flashes	RCA 2
Three times	Three flashes	Zenith 1
Four times	Four flashes	Zenith 2
Five times	Five flashes	Philips/Magnavox
Six times	Six flashes	Magnavox (models 9120, 9220, 9320)
Seven times	Seven flashes	Traditional TV
Eight times	Eight flashes	Traditional Plus
Nine times	Nine flashes	Auto Detect: Smart TV
Ten times	Ten flashes	Auto Detect w/Digital Volume Smart TV

Service Information

Optional Smart TV Interface “Burn-In” Procedure (iBED Awareness Option)

This procedure is used for selecting the style of TV interface needed for your bed. If traditional TV is desired, no calibration is required. If optional Smart TV is available on the bed, select one of the TV Mode/Brands listed in the table below.

PROCEDURE

1. Press and Hold the “Enter” button. While Holding, cycle bed power. Continue to hold until display flashes “Load Cell Check”. Release.
2. The display should present the Maintenance Menu. Ensure the “TV config” element is highlighted and press “Enter”.
3. The display should present the “TV config” Screen. The current TV selection will be highlighted. (Default selection is Traditional)
4. Use the up and down arrow buttons to highlight the desired “TV config”. See Table below for Model/Selection list.
5. Press the “Enter” button to select the new setting.
6. The display should present the following message when the new setting is saved “Save Successful”.
7. The “TV config” screen should reappear after 2 seconds and the new setting should be highlighted.

TV Configuration Menu Settings

TV Mode / Brand	Display TV Menu Select
RCA 1	TV Config. 1
RCA 2	TV Config. 2
Zenith 1	TV Config. 3
Zenith 2	TV Config. 4
Philips	TV Config. 5
Magnavox	TV Config. 6
Traditional	Traditional
Traditional Plus	Traditional Plus
Auto-Configure	Auto-Configure
Auto-Configure DV	Auto-Configure DV

Service Information

Fowler Potentiometer Replacement (iBED Awareness Option)

TOOLS REQUIRED:

- T27 Torx.
- Wire Cutters.
- 1/2" Open End Wrench.
- 7/64" Allen Wrench.

PROCEDURE

1. Unplug the bed power cord from the wall socket.
2. Manually raise the fowler to 60 degrees.
3. Using a 7/64" Allen wrench, loosen the screw holding the linkage to the potentiometer shaft and remove the linkage from the shaft.
4. Using a 1/2" open end wrench, remove the nut holding the potentiometer to the frame and disconnect from the 3 pin quick disconnect.
5. Install the fowler potentiometer to the Fowler platform arm using a 1/2" combination wrench, making sure to align the potentiometer alignment tab up with the notch in the fowler frame.
6. Using a multi-meter and small flat blade screwdriver, set the fowler potentiometer to 550 +/-25 ohms, using the black and white wires from the fowler potentiometer.
7. Using a 7/64" Allen wrench tighten set screw on the fowler potentiometer linkage attaching to the potentiometer, make sure to double check the ohms reading after tightening the set screw, readjustment maybe necessary.
8. Refer to Fowler Potentiometer "burn-in" procedure to set Fowler angle.

Fowler Potentiometer "Burn-In" Procedure (iBED Awareness Option)

Note: It requires **two people** to enable the diagnostics mode for the bed.

PROCEDURE

1. Unplug the bed power cord from the wall.
2. On the footboard control panel, hold down the bed motion lock button, the knee lock out button and the Reverse Trend button. While still holding the buttons, plug the power cord into the wall socket. Release the foot board buttons, a message will appear on the scale display "Set Fowler to Lower Limit"
3. Using the foot board controls, run the Fowler to 0 degrees. Press the Enter button, a message will appear on the scale display "Set Fowler to 30 degrees.
4. Using the footboard controls, run the fowler to 30 degrees. Press the Enter button, a message will appear on the scale display "Set Fowler to Upper Limit (60 degrees).
5. Using the footboard controls, run the fowler to Upper Limit (60 degrees). Press the Enter button, a message will appear on the scale display "Fowler calibration complete"
6. Unplug the bed and plug back in to return to normal operating mode.

Service Information

Zoom® Option Battery Removal and Replacement

TOOLS REQUIRED:

- Torx T27
- 7/16" Wrench
- 1/2" Socket Wrench
- Bungee Cords
- Phillips Screwdriver
- 5/32" Allen

PROCEDURE:

1. Raise the litter to full up. Unplug the power cord from the wall socket and push the battery power On/Off switch to the "Off" position.
2. Using a Phillips screwdriver, remove the four screws holding the base hood to the base frame.
3. Lift the base hood and support it from the litter frame using bungee cords or the equivalent.
4. Properly ground yourself (see "Static Discharge Precautions" section).
5. Open the cable clamp at the head end, left side of the base frame and remove the cables from the clamp.
6. Using a Torx T27, remove the four screws (A) holding the electronics box cover and remove the cover.
7. Disconnect the two battery cables (B).

WARNING

The battery tray assembly weighs 50 pounds. Use caution when removing the two hex head screws securing it to the base frame or personal injury could result. Battery posts, terminals and related accessories contain lead and lead compounds, chemicals known to the State of California to cause cancer and birth defects or other reproductive harm. Wash hands after handling.

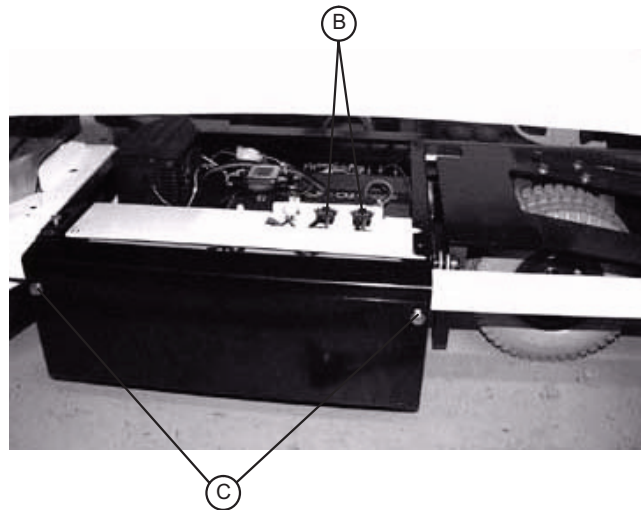
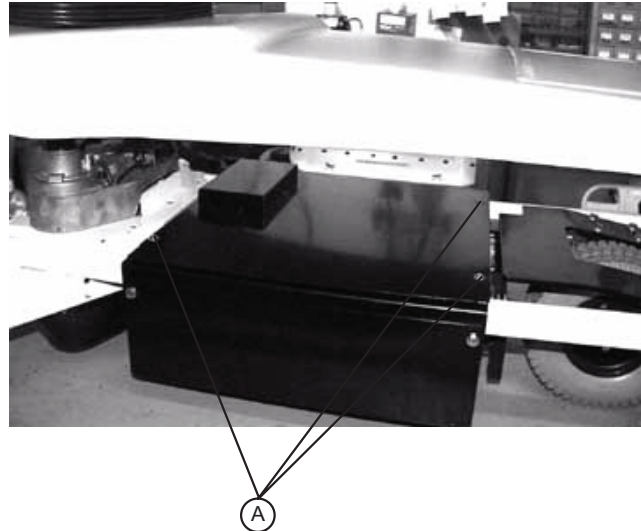

8. Support the battery tray assembly from the bottom. Using a 7/16" hex socket or wrench, remove the two screws (C) supporting the battery tray.
9. The back of the battery tray assembly has a lip which catches on the electronics box. Lift up and out to remove the battery tray assembly.
10. Using a Phillips screwdriver, remove the two screws holding the battery terminal to the battery tray assembly.
11. Using a 5/32" Allen wrench and a 7/16" wrench, remove the four screws and nuts holding the battery harness to the battery terminals.
12. Reverse steps 1 - 11 to install the new batteries. Complete the last four items of the setup procedures in the "Setup Procedures (Zoom™ Option)" section.

[Return To Table of Contents](#)

Service Information

Zoom® Option DC Motor Board Removal and Replacement

TOOLS REQUIRED:

- Phillips Screwdriver
- 1/8" Allen Wrench
- Bungee Cords
- T27 Torx

PROCEDURE:

1. Raise the litter to the full up position.
2. Unplug the power cord from the wall socket and push the battery power On/Off switch to the "Off" position.
3. Using a Phillips screwdriver, remove the four screws holding the base hood to the base frame.
4. Open the cable clamp at the head end, left side of the base frame and remove the cables from the clamp.
5. Lift the base hood and support it from the litter frame using bungee cords or the equivalent.
6. Using a T27 Torx, remove the four screws holding the cover to the side of the electronics box.
7. Properly ground yourself (see "Static Discharge Precautions" section).
8. Using a 1/8" Allen wrench, remove the four bolts and standoffs holding the motor board to the electronics box.
9. Remove all cables from the motor board and remove the board.

Note

Note the locations of the cables so you can connect them properly to the new motor board.

10. Reverse steps 1 - 8 to install the new power board.

Service Information

Zoom Option Drive Motor Removal and Replacement

TOOLS REQUIRED:

- Phillips Screwdriver
- 1/2" Socket Wrench
- Bungee Cords
- Floor Jack
- T27 Torx

PROCEDURE:

1. Raise the litter to the full up position.
2. Unplug the power cord from the wall socket and push the battery power On/Off switch to the "Off" position.
3. Using a Phillips screwdriver, remove the four screws holding the base hood to the base frame.
4. Open the cable clamp at the head end, left side of the base frame and remove the cables from the clamp.
5. Lift the base hood and support it from the litter frame using bungee cords or the equivalent.
6. Using a T27 Torx, remove the four screws holding the power board cover to the side of the electronics box. Remove the two motor wires from the power board and remove the T27 Torx ground screw.
7. Apply the brakes and disengage the drive wheel. Place a floor jack under the leaf spring at the foot end of the bed and raise the wheels approximately 3" off the floor.
8. Using a 1/2" socket wrench, remove the four bolts holding the drive motor to the leaf spring.

CAUTION

Support the drive motor before removing the four bolts to prevent it from falling to the floor and becoming damaged.

9. Reverse steps 1 - 8 to install the new drive motor.
10. Run through the operation of the power drive wheel to ensure it is operating properly before returning the unit to service.

Service Information

Zoom® Option Control Bar Potentiometer Replacement

Tools Required:

- T27 Torx
- 1/2" Box End Wrench
- #2 Phillips Screwdriver
- Wire Cutters
- Small Flat Blade Screwdriver
- 5/16" Nut Driver
- Multimeter

PROCEDURE

1. Raise the litter and the head end to the full up position.
2. Remove the head board from the bed.
3. Unplug the power cord from the wall socket and push the battery power On/Off switch to the "Off" position.
4. Using a 5/16" nut driver, remove the screw holding the power cord clamp to the bumper weldment and remove the clamp from the bumper.
5. Using a T27 Torx, remove the four bolts (A) at the head end of the bed holding the control bar mounting bracket to the head end (see Figure 1).
6. Using a #2 Phillips screwdriver, remove the three screws (B) holding the control bar cover to the head end of the bed (see Figure 2).
7. Standing at the head end, pull the control bar toward you and fold down the control bar mounting bracket.
8. Using a 1/2" wrench, remove the nut holding the potentiometer to the mount. Using wire cutters, cut the wire ties. Unplug the potentiometer cable from the CPU display board and remove the potentiometer.
9. Install the new potentiometer. Using a small flat blade screwdriver, turn the potentiometer shaft clockwise until it stops. Turn it back counterclockwise 1/2 turn until multimeter reads 2.35 to 2.55 using the black and red wires.
10. After the new potentiometer has been installed, the potentiometer "burn-in" procedure must be performed (see "Zoom® Option Control Bar Potentiometer 'Burn-In' Procedure").
11. After performing the "burn-in" procedure, reverse steps 1 - 7 to reassemble the bed.
12. Test all functions before returning the unit to service.

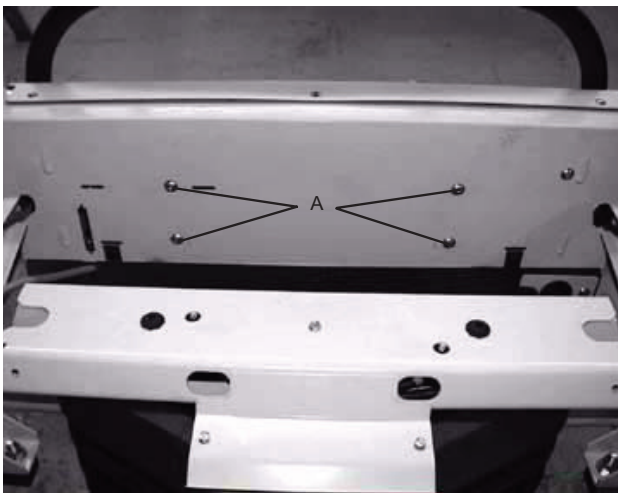

Figure 1

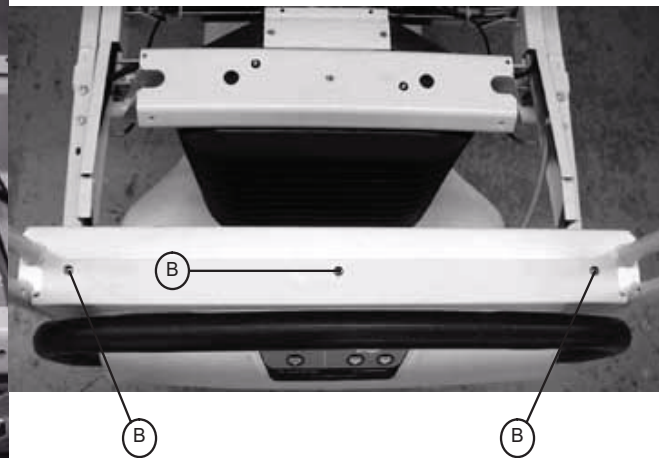

Figure 2

Service Information

Zoom® Option Control Bar Potentiometer “Burn-In” Procedure

Tools Required:

- T27 Torx
- 1/2” Box End Wrench
- # 2 Phillips Screwdriver
- Wire Cutters
- Small Flat Blade Screwdriver
- 5/16” Nut Driver

PROCEDURE

1. If it has not already been done, follow steps 1 - 7 of the “Zoom® Option Control Bar Potentiometer Replacement Procedure on [previous page](#).
2. Ensure the battery on/off switch is in the “Off” position (LED is Off).
3. Hold down the yellow button on the back of the display CPU board.
4. With the switch depressed, move the battery power on/off switch to the “ON” position (LED will light) and continue holding for three seconds.
5. Press and hold the yellow button on the back of the display CPU board.
6. Move the battery power on/off switch to the “on” position (LED will light) and continue holding switch for three seconds.
7. Verify the “Engage Drive Wheel” led at the head end display housing is flashing.
8. Move the battery power on/off switch back to the “Off” position (all LED’s will go out).
9. Close the drive box.
10. Ensure the control bar is in the center of travel by pushing and pulling the bar, then returning the bar to the neutral position.
11. With no objects touching the control bar, turn the battery power on/off switch to the “On” position.
12. The three LED’s on the front of the bed will flash initially to show the battery voltage of the bed by lighting zero, one, two, or three LED’s.
13. After the battery charge has been displayed by the three LED’s, all three LED’s will flash twice.
14. After all three LED’s have flashed twice, push the drive handle to the full forward position. Hold the drive handle in the full forward position until all three LED’s flash twice again (3 seconds).
15. The “ENGAGE DRIVE WHEEL” LED will flash once.
16. The control bar potentiometer is calibrated.
17. Return the control bar to the neutral position.
18. Grasp the control bar and squeeze either motion switch without moving the control bar forward or backward.
19. Verify the bed does not move.
20. Standing at the head end of the bed, grasp the control bar and squeeze either motion switch, then push the control bar forward.
21. Verify the bed moves forward.
22. Standing at the head end of the bed, grasp the control bar and squeeze either motion switch, then pull the control bar backwards.
23. Verify the bed moves backward.
24. Move the battery power on/off switch “Off”, wait a few seconds, then back “On” again.
25. Repeat steps 18-23 to verify that the burn in procedure was performed correctly.

Service Information

Zoom® Option AC Crossover Board Replacement

TOOLS REQUIRED:

- T27 Torx
- 1/2" Box End Wrench
- #2 Phillips Screwdriver
- Wire Cutters
- Small Flat Blade Screwdriver
- Needle Nose Pliers
- 5/16" Nut Driver

PROCEDURE

1. Follow steps 1-7 of the "Zoom® Option Control Bar Potentiometer Replacement Procedure".
2. Using a T-27 Torx, remove the two bolts holding the AC crossover board cover to the head end frame and remove the cover.
3. Disconnect all wires from the AC crossover board
4. Using needle nose pliers, release the four mounting standoffs from the board and remove the board.
5. Reverse steps 1 - 4 to install the new board.
6. Reverse steps 1 - 7 of the "Zoom® Option Control Bar Potentiometer Replacement Procedure" to reassemble the bed.

Service Information

Zoom® Option Display/CPU Board Replacement

TOOLS REQUIRED:

- T27 Torx
- 1/2" Box End Wrench
- #2 Phillips Screwdriver
- Wire Cutters
- Small Flat Blade Screwdriver
- Needle Nose Pliers
- 5/16" Nut Driver

PROCEDURE

1. Follow steps 1 - 7 of the "Zoom® Option Control Bar Potentiometer Replacement Procedure".
2. Disconnect all wires from the display/CPU board.
3. Using a #2 Phillips screwdriver, remove the six screws holding the display/CPU board to the control bar cover and remove the board.
4. Reverse steps 2 and 3 to install the new board. After the new board has been installed, the potentiometer "burn-in" procedure must be performed (see "Zoom® Option Control Bar Potentiometer 'Burn-In' Procedure" section).
5. Reverse steps 1 - 7 of the "Zoom® Option Control Bar Potentiometer Replacement Procedure" to reassemble the bed.

Maintenance Procedures - Siderail

Head and Foot Siderail Cover Removal

TOOLS REQUIRED:

- #2 Phillips Screwdriver

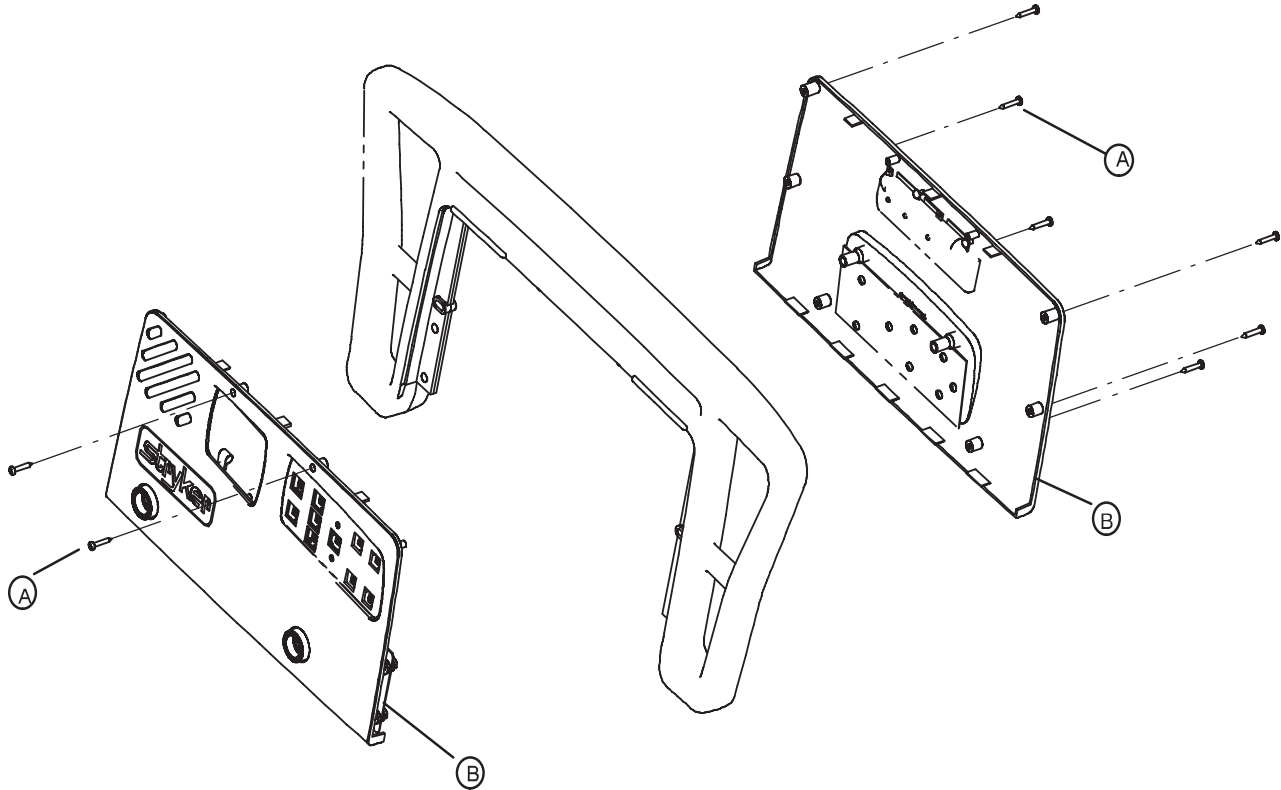

PROCEDURE

1. Unplug the power cord from the wall receptacle.
2. Using a #2 Phillips screwdriver, remove the 8 phillips screws (A) holding the covers (B) to the siderail.

CAUTION

There are two cables connecting the outside cover to the head end siderail. Be careful not to pull on them when removing the cover.

3. Remove the cables from the siderail. Make note of the proper location for the cables.
4. Reverse the above steps to reattach the cover.

CAUTION

Do not snag the cables when installing the siderail cover.

Note

Follow the same procedure for siderail cover removal for the foot end rails.

Maintenance Procedures - Siderail

Head and Foot Molded Siderail Replacement

TOOLS REQUIRED:

#2 Phillips Screwdriver
3/8" Nut Driver

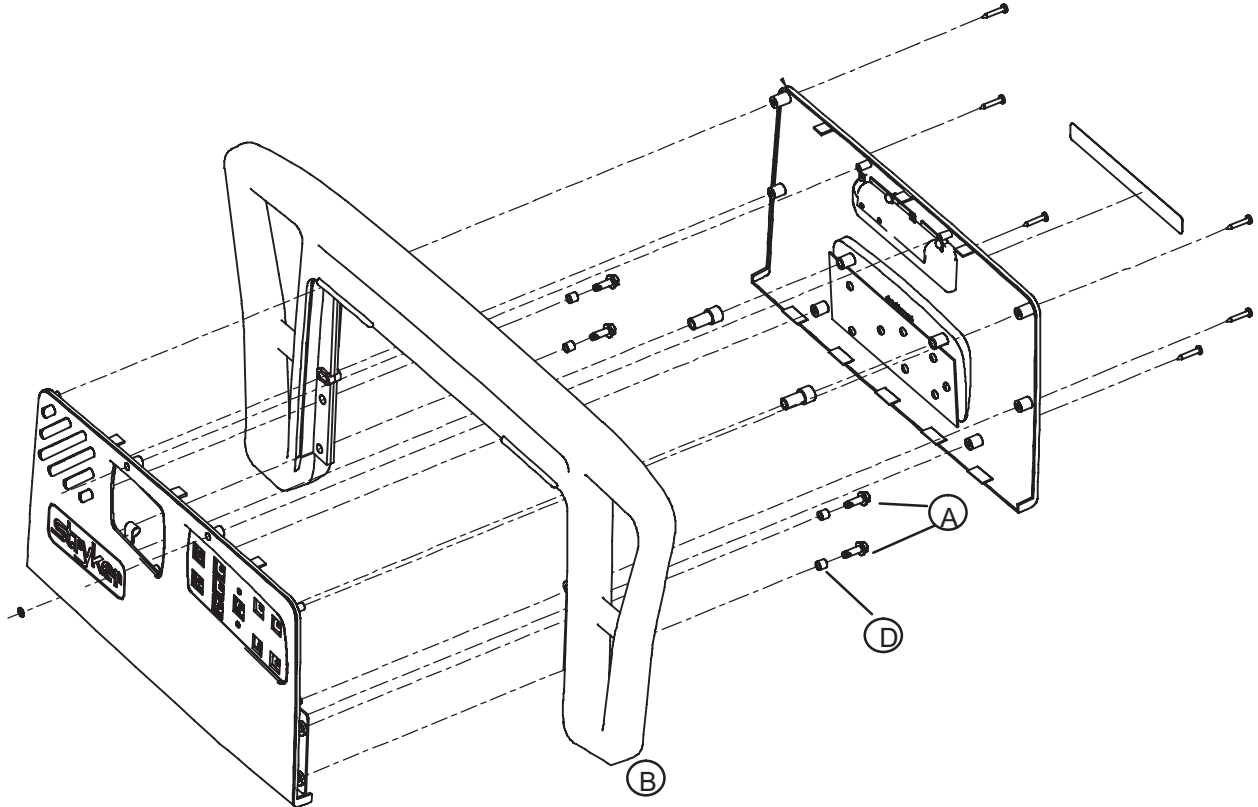

PROCEDURE

1. Unplug the bed power cord from the wall socket.
2. Remove the siderail cover (see "Head and Foot Siderail Cover Removal" section)..
3. Using a 3/8" nut driver, remove the screws (A) holding the molded rail (B) to the siderail support assembly.

Note

Note the location of the spacers (D) for reassembly purposes.

4. Pull up on the molded rail (B) to remove it from the siderail assembly.
5. Reverse the above steps to install the new molded rail.

Notes

Notes

Maintenance Procedures - Siderail

Siderail Assembly Removal

TOOLS REQUIRED:

- T27 Torx

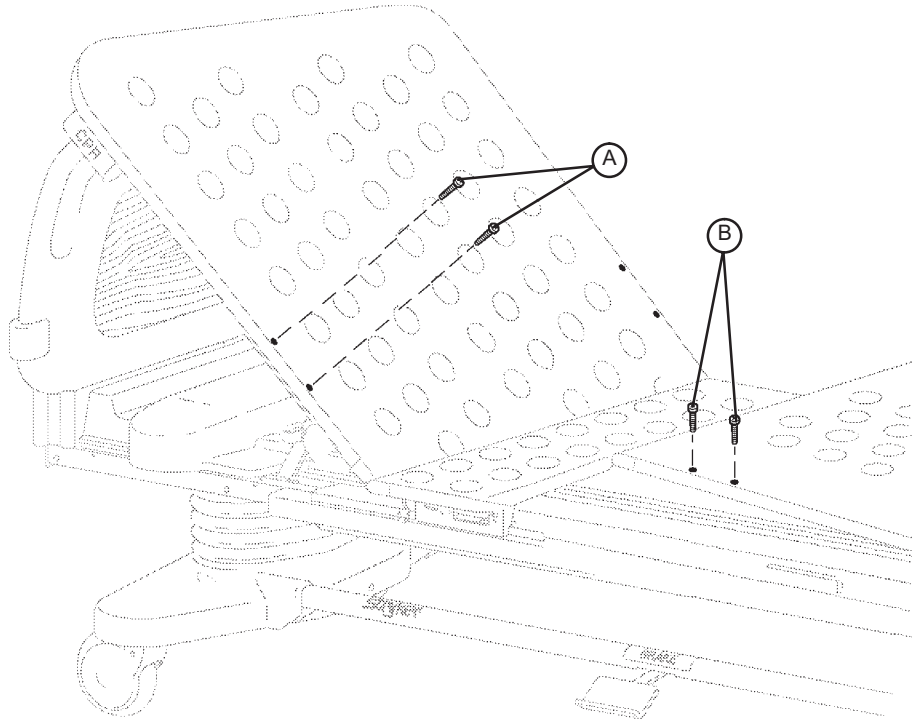

PROCEDURE

1. Run the head section up electrically when removing a head end siderail.
2. Unplug the bed power cord from the wall socket.
3. Lower the siderail being removed.

Note

If removing a head end siderail, the cable must be unplugged.

4. Using a T27 Torx, remove the screw from the ground strap and the two screws (A - head end) or (B - foot end) holding the complete siderail assembly on the head or foot section.
5. Push in on the siderail assembly to clear under the head or foot section and pull the siderail back to remove it from the bed.
6. Reverse the above steps to reinstall the siderail assembly. Be sure to reinstall the foot end siderails to the same location (holes) they were removed from.

Note

Grease the glide rods on the replacement siderail assembly with Syntech grease.

Maintenance Procedures - Foot Board

Foot Board Hinge Removal

TOOLS REQUIRED:

#2 Phillips Screwdriver

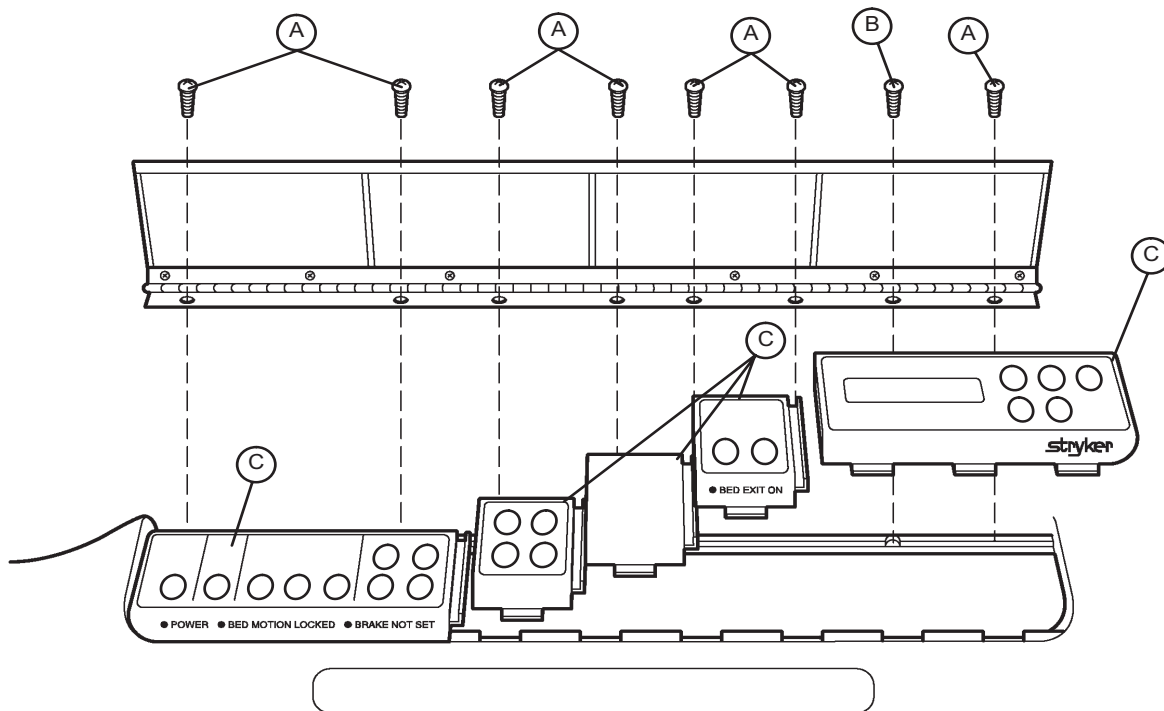

PROCEDURE

1. Using a #2 Phillips screwdriver, remove the screws (A & B) holding the door and hinge assembly to the foot board.
2. If replacing the hinge only, use a Phillips screwdriver to remove the screws holding the hinge to the door.
3. Reverse the above steps to attach the replacement door and/or hinge.

Note

Screw (B) is a machine screw and must be reinstalled in the proper hole.

Service Information

Foot Board Module Replacement

TOOLS REQUIRED:

- #2 Phillips Screwdriver

PROCEDURE

1. Unplug the bed power cord from the wall socket. Remove the foot board hinge (see “Foot Board Hinge Removal” section).

Note

No matter which module is being replaced, the farthest module to the right must be removed first.

2. Pull the module out of the foot board and disconnect the cable from the module (C).
3. Reverse the above steps to install the new module.



CAUTION

The modules must be overlapped as shown in the illustration to prevent fluids from entering the board cavity and causing damage.

Maintenance Procedures - Foot Board

Foot Board Interface Plug Replacement

TOOLS REQUIRED:

- #2 Phillips Screwdriver

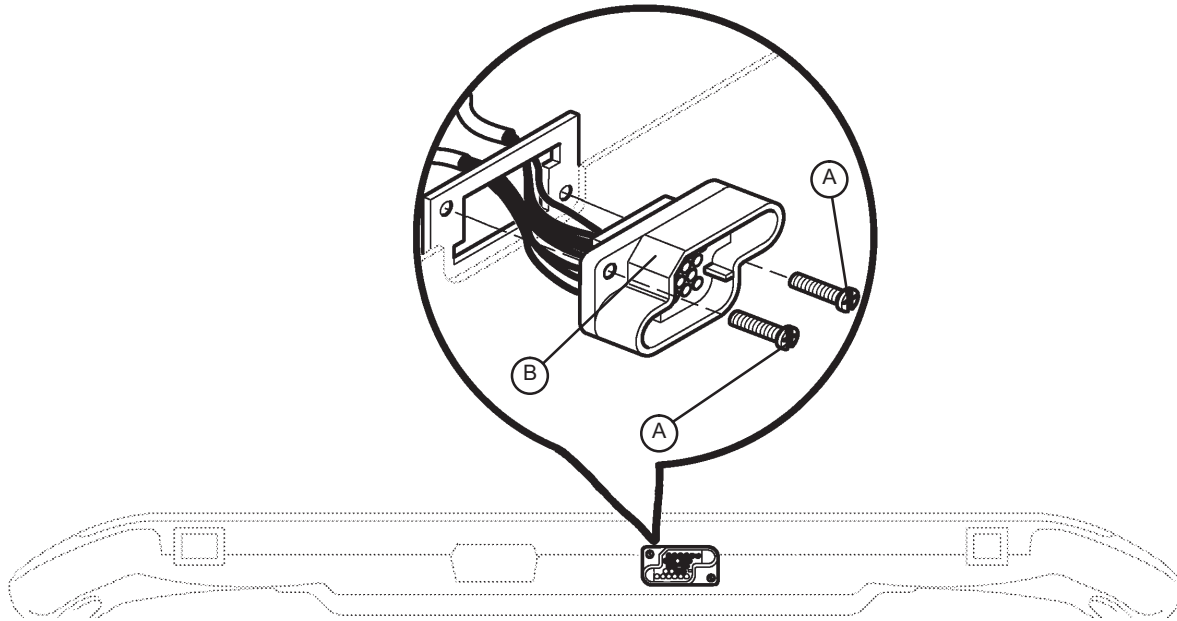

BOTTOM VIEW OF FOOT BOARD

PROCEDURE

1. Unplug the bed power cord from the wall socket.
2. Remove the foot board from the bed to access the bottom of the board.
3. Properly ground yourself (see “Static Discharge Precautions” section).
4. Using a #2 Phillips screwdriver, remove the eight screws holding the foot board door to the foot board and remove the door.
5. Using a #2 Phillips screwdriver, remove the two screws (A) holding the plug to the foot board.
6. Disconnect the cable from the foot board module cable. Note proper placement of the cable so it will be reconnected properly.
7. Reverse the above steps to install the new interface plug.

CAUTION

Be sure to install the plug with the flat edge (B) at the top left, as shown in the illustration, or the foot board interface plug will not mate properly with the bed. Damage to the plug or the foot board could result.

CPU Board

Standard CPU Board = 3002-407-950 / iBED Awareness CPU Board - 3003-407-900

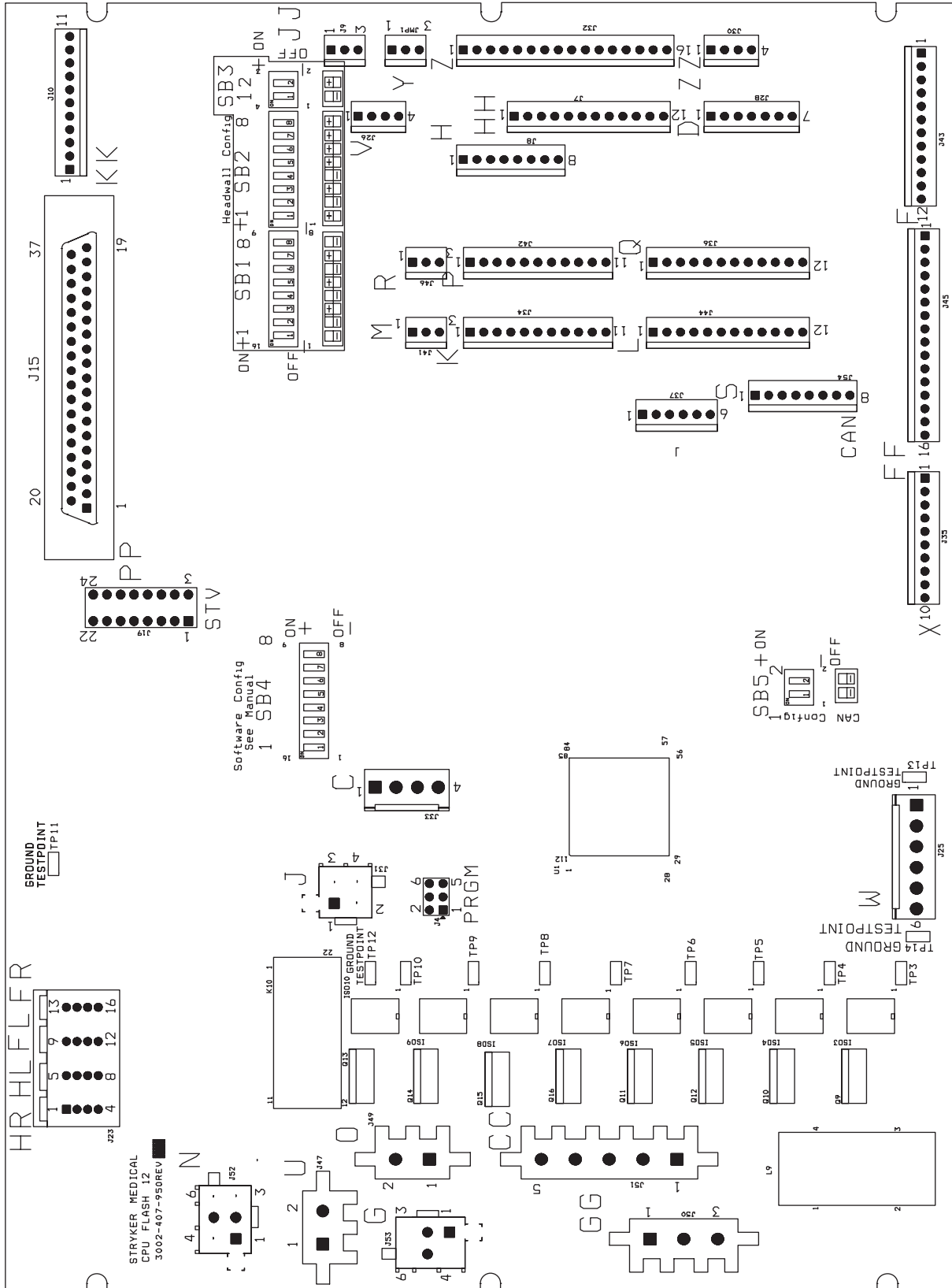

CPU Board

Standard CPU Board = 3002-407-950 / iBED Awareness CPU Board - 3003-407-900 (Continued)

Cable Location	Voltage	Positive Lead	Negative Lead	Description
W	+12VDC	Pin 1	Pin 4 or 5	Relays & Siderails Light Voltage
W	+5VDC	Pin 2 & 3	Pin 4 or 5	+5VDC from Power Supply
W	-12VDC	Pin 6	Pin 4 or 5	Relays & Siderails Light Voltage
J	+5VDC	Pin 4	Pin 2	+5VDC for Head Lift Potentiometer
J	0 - 5VDC	Pin 3	Pin 2	Head Lift Potentiometer Wiper
C	+5VDC	Pin 1	Pin 2	+5VDC for Foot Lift Potentiometer
C	0 - 5VDC	Pin 3	Pin 2	Foot Lift Potentiometer Wiper
GG	0VAC w/o Switch 120VAC w/Switch	Pin 2 Purple	Pin 1 Blue	Gatch Up
GG	0VAC w/o Switch 120VAC w/Switch	Pin 3 Red	Pin 1 Blue	Gatch Down
CC	0VAC w/o Switch 120VAC w/Switch	Pin 1 Black	Pin 3 Red	Fowler Up
CC	0VAC w/o Switch 120VAC w/Switch	Pin 2 White	Pin 3 Red	Fowler Down
O	110VAC	Pin 1	Pin 2	Line Voltage to Bed
N	0VAC w/o Switch 120VAC w/Switch	Pin 3 Black	Pin 1 White	Head Lift Down
N	0VAC w/o Switch 120VAC w/Switch	Pin 6 Red	Pin 1 White	Head Lift Up
G	0VAC w/o Switch 120VAC w/Switch	Pin 3 Black	Pin 1 Red	Foot Lift Down
G	0VAC w/o Switch 120VAC w/Switch	Pin 6 White	Pin 1 Red	Foot Lift Up





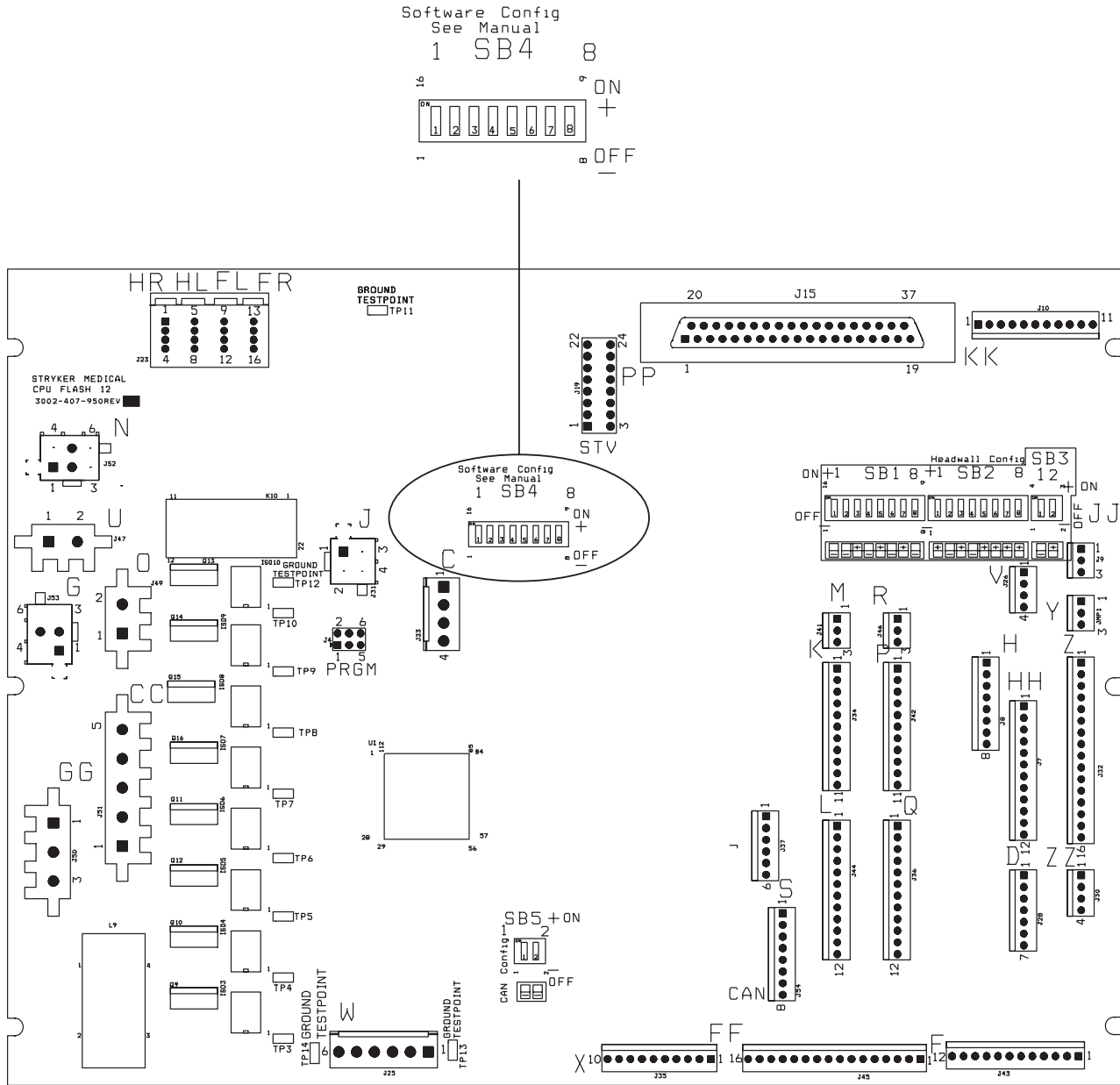







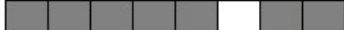



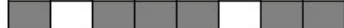

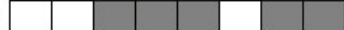
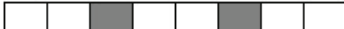

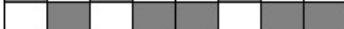
[Return To Table of Contents](#)

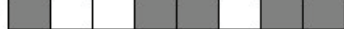
Software Configuration

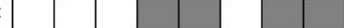

1. Locate switch bank 4, labeled SB4 on the CPU board (see above).
2. Move the switches to the appropriate positions for the specific bed (see "Software Configuration" section).
3. To verify the switch settings, check what the foot board LCD displays in the burn-in mode. For beds with a Scale System, select software configuration in the diagnostic mode.

Software Configuration

<p>ON </p> <p>OFF </p> <p>1 2 3 4 5 6 7 8</p>	Functional Test
<p>ON </p> <p>OFF </p> <p>1 2 3 4 5 6 7 8</p>	Med-Surg-Standard Bed
<p>ON </p> <p>OFF </p> <p>1 2 3 4 5 6 7 8</p>	Med-Surg-Zoom®/Standard Bed
<p>ON </p> <p>OFF </p> <p>1 2 3 4 5 6 7 8</p>	Med-Surg-Zoom®/Scale/Bed Exit
<p>ON </p> <p>OFF </p> <p>1 2 3 4 5 6 7 8</p>	Med-Surg-Zoom®/Scale/Zone Control Bed Exit
<p>ON </p> <p>OFF </p> <p>1 2 3 4 5 6 7 8</p>	Med-Surg-Scale/Bed Exit
<p>ON </p> <p>OFF </p> <p>1 2 3 4 5 6 7 8</p>	Med-Surg-Scale/Zone Control Bed Exit
<p>ON </p> <p>OFF </p> <p>1 2 3 4 5 6 7 8</p>	Med-Surg-Short/Zoom®/Standard Bed
<p>ON </p> <p>OFF </p> <p>1 2 3 4 5 6 7 8</p>	Med-Surg-Short/Zoom®/Scale/Bed Exit
<p>ON </p> <p>OFF </p> <p>1 2 3 4 5 6 7 8</p>	Med-Surg-Short/Zoom®/Scale/Zone Control Bed Exit
<p>ON </p> <p>OFF </p> <p>1 2 3 4 5 6 7 8</p>	Med-Surg-Scale/Bed Exit/Bed Status (iBED Awareness Option)
<p>ON </p> <p>OFF </p> <p>1 2 3 4 5 6 7 8</p>	Med-Surg-Zoom/Scale/Bed Exit/Bed Status (iBED Awareness Option)

Power Supply

0059-157-000

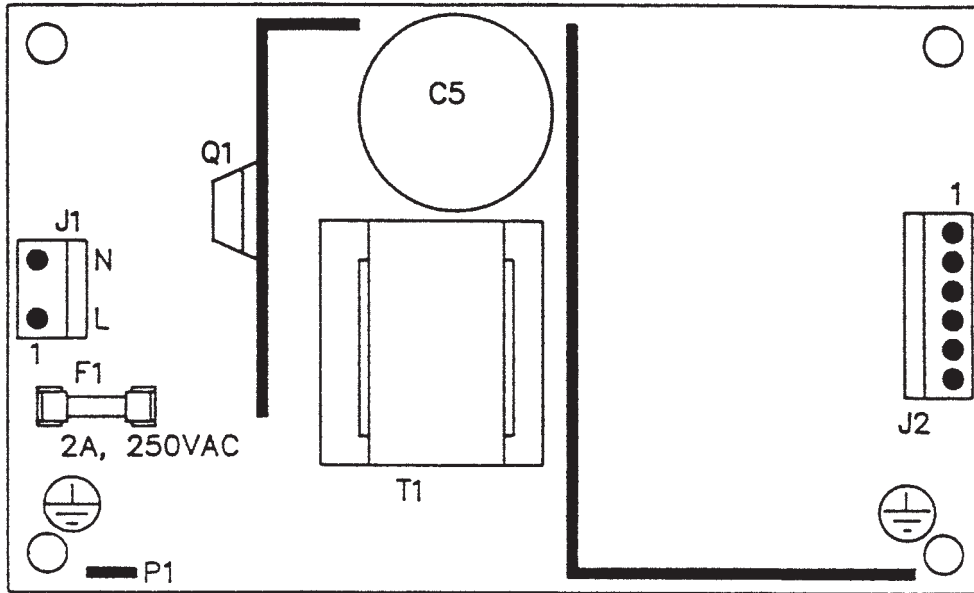

Connector Location	Voltage	Positive Lead	Negative Lead
J1	110V	Pin 1	Pin 2
J2	12V	Pin 1	Pin 4 or 5
J2	5V	Pin 2	Pin 4 or 5
J2	5V	Pin 3	Pin 4 or 5
J2	GND	Pin 4	Pin 4 or 5
J2	GND	Pin 5	Pin 4 or 5
J2	-12V	Pin 6	Pin 4 or 5

Zoom® Option Inverter/Charger Board

3002-001-030

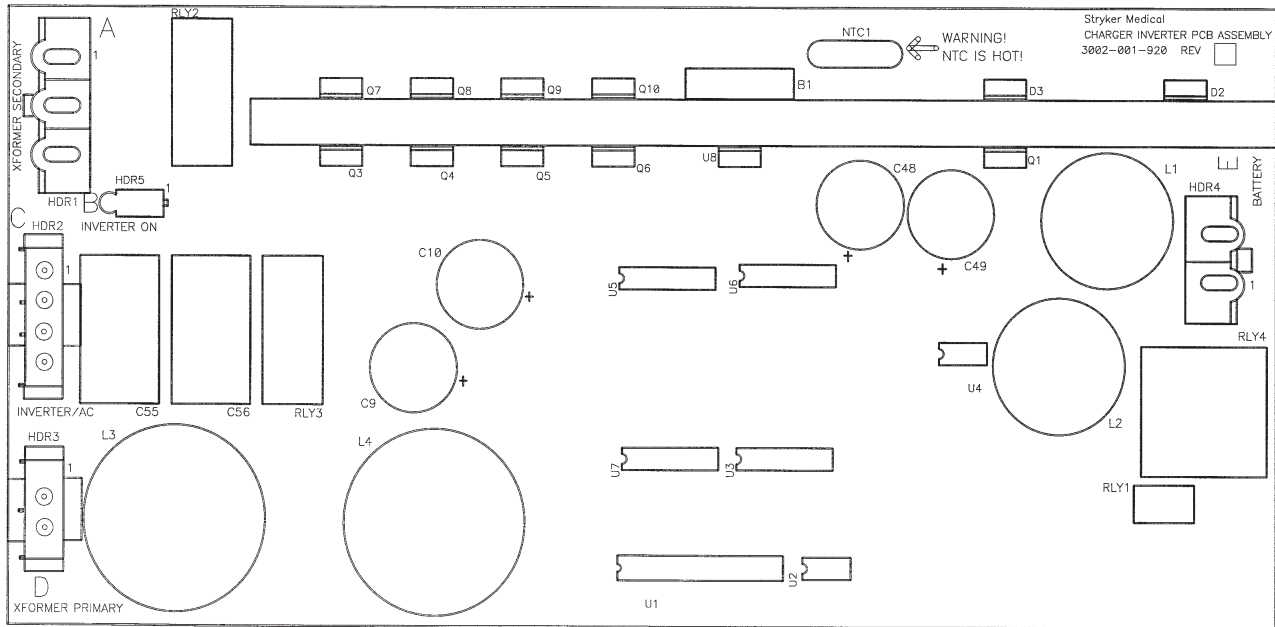

Connector Location	Voltage	Positive Lead	Negative Lead	Description
HDR 4	26VDC	Pin 2 Red	Pin 1 Black	From Battery - unplugged
HDR 1	22VAC	Pin 3 Red	Pin 2	Secondaries from transformer - plugged in
HDR 1	34VAC	Pin 1 Green	Pin 2 Brown	Secondaries from transformer - plugged in
HDR 2	110-140VAC	Pin 4 Brown	Inverter Module Pin 3 Blue	Unplugged
HDR 2	110V	Pin 2 Brown	Pin 1 Blue	From Wall - plugged in
HDR 3	120V	Pin 2	Plug-in Pin 1	Wall Voltage - plugged in

[Return To Table of Contents](#)

Zoom® Option Display/CPU

2040-031-910

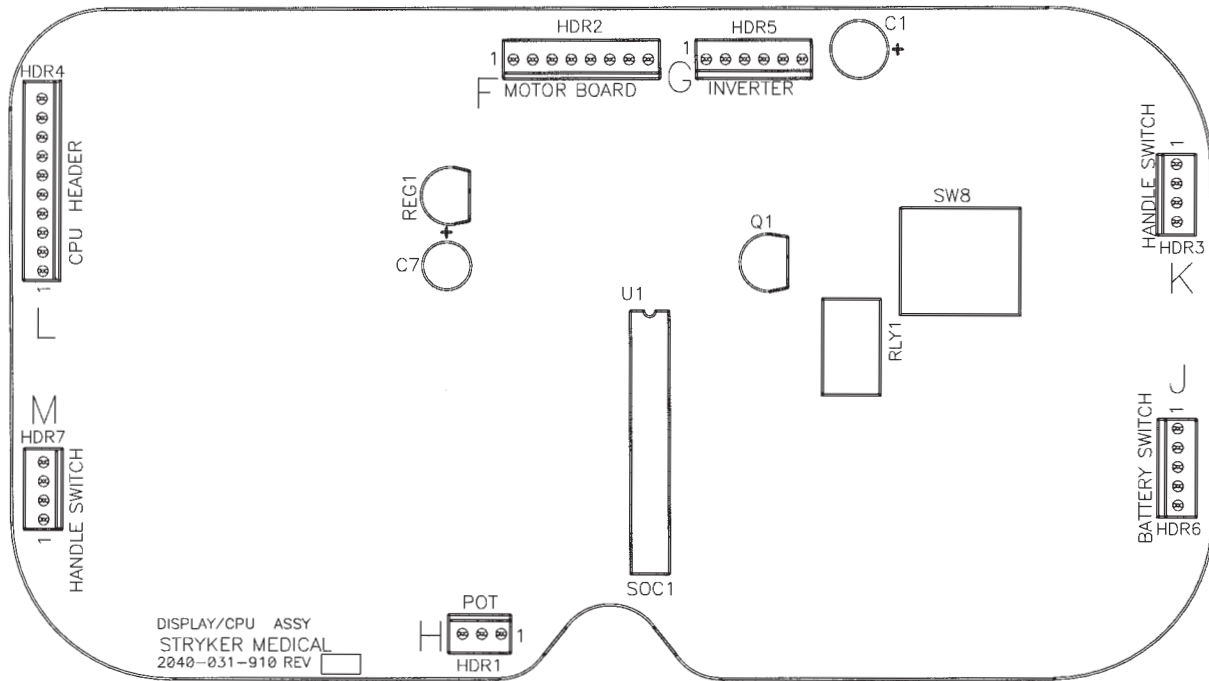

Connector Location	Voltage	Positive Lead	Negative Lead	Description
HDR 1 (H)	0-5VDC	Pin 1	Pin 2	Control Potentiometer Wiper Voltage (with Switch On)
HDR 6 (j)	Battery voltage around 26VDC	Pin 1	Pin 5	Battery Voltage Return from On/Off Switch (with Switch On)
HDR 4 (L)	5VDC	Pin 9	Pin 1	Voltage from CPU
HDR 1	5VDC	Pin 1	Pin 3	DC Voltage to Potentiometer
HDR 7	Continuity	Pin 1	Pin 4	Right Hand Switch
HDR 3	Continuity	Pin 1	Pin 4	Left Hand Switch
HDR 2	26VDC	Pin 3	Pin 1	Battery Voltage

Zoom® Option AC Crossover Board

2040-031-900

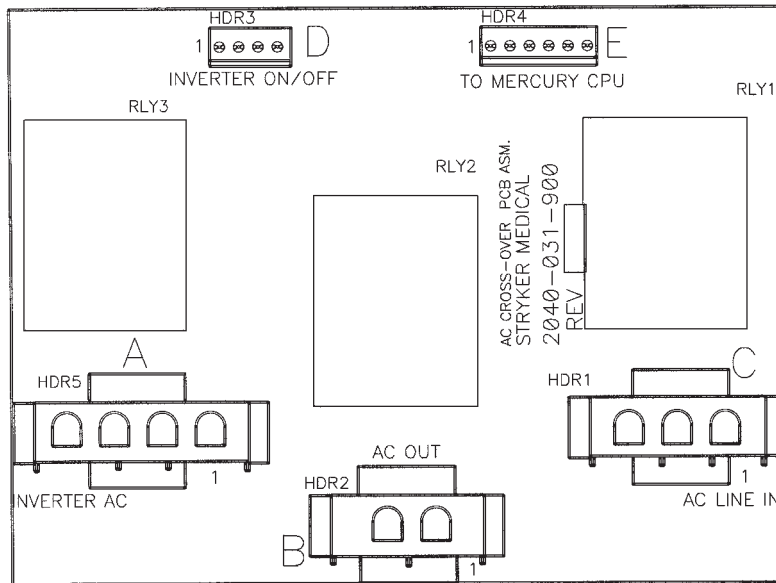

Connector Location	Voltage	Positive Lead	Negative Lead	Description
HDR 5 (A)	120VAC	Pin 4	Pin 1	AC Input to Board from the Inverter with the Power Cord Unplugged
HDR 1 (C)	120VAC	Pin 3	Pin 1	AC Input to Board from the Wall Receptacle
HDR 2 (B)	120VAC	Pin 2	Pin 1	AC Output of Board to Main Power
HDR 4 (E)	+5VDC	Pin 4	Pin 1	+5VDC when AC is Unplugged from the Wall Receptacle

[Return To Table of Contents](#)

Bed Circuit Boards

Optional DC Motor Power Board - 2040-001-900

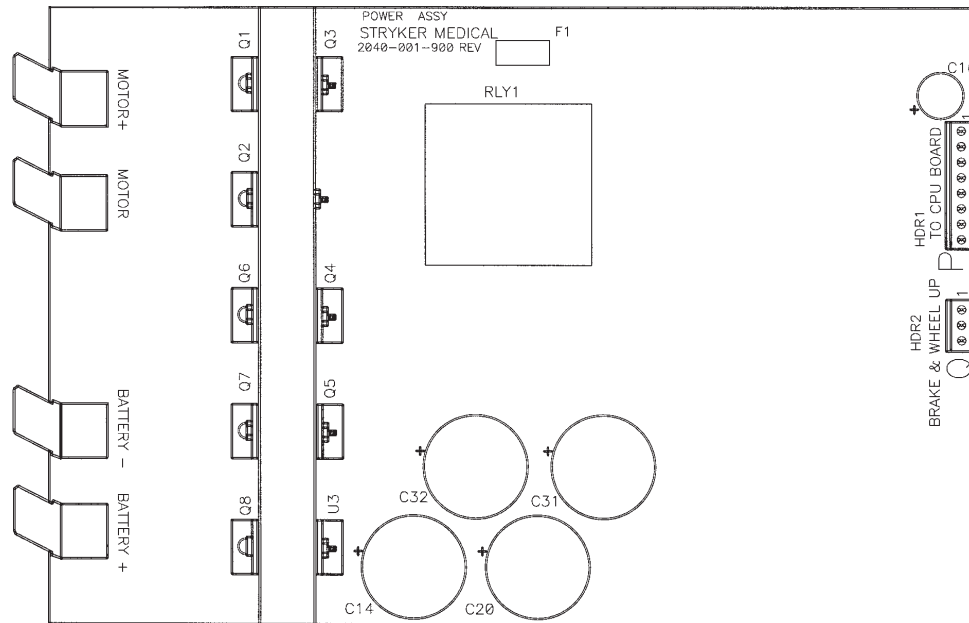

Connector Location	Voltage	Positive Lead	Negative Lead	Description
HDR 1 (P)	Battery voltage around 26VDC	Pin 3 Red	Pin 1 Black	Battery Voltage out to the Display/ CPU Board
HDR 2 (Q)	5VDC Disengaged 0VDC Engaged	Pin 1 Red	Pin 3 Black	Drive Wheel
HDR 2 (Q)	5VDC Disengaged 0VDC Engaged	Pin 2 Red	Pin 3 Black	Brakes

Night Light Board - 3002-310-900

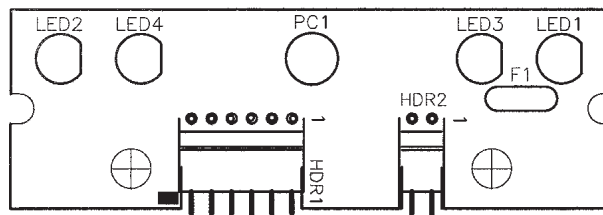

Connector Location	Negative Lead	Positive Lead	Voltage	Description
HDR 2	Pin 1	Pin 2	5VDC	Supply IN
HDR 1	Pin 1 HDR 2	Pin 2 Pin 4	5VDC	Output Voltage for Optional LED's

Head Wall Output Configuration

37-Pin Connector

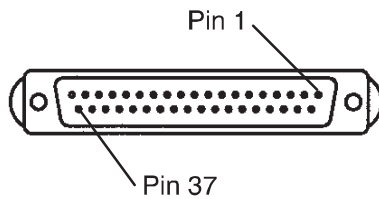

Stryker Pendant Port

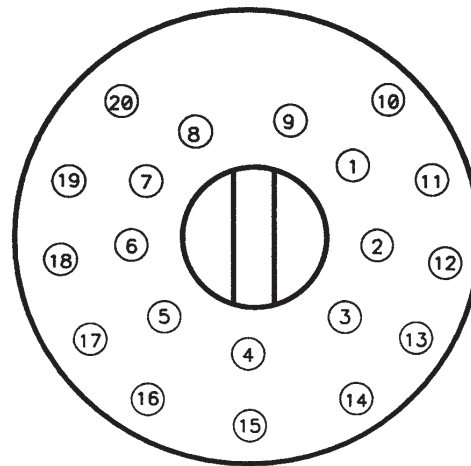

Pin 1	Option 2 Common
Pin 2	Read Light
Pin 3	Room Light
Pin 4	Speaker High
Pin 5	Potentiometer Wiper
Pin 6	Radio Common
Pin 7	Nurse Call Interlock
Pin 8	Audio Transfer -
Pin 9	Audio Transfer +
Pin 10	Interlock +
Pin 11	Interlock -
Pin 12	Spare
Pin 13	Options 3 Common
Pin 14	Potentiometer Low Common
Pin 15	Potentiometer High
Pin 16	Nurse Answer Light +
Pin 17	Option 1 NO/NC
Pin 18	Option 1 Common
Pin 19	Nurse Call Light +
Pin 20	Option 2 NO/NC
Pin 21	Option 3 NO/NC
Pin 22	Option 3A NO/NC
Pin 23	Option 2A Common
Pin 24	Option 2A NO/NC
Pin 25	Nurse Call +
Pin 26	Nurse Call NO/NC
Pin 27	Room/Read Light Common
Pin 28	Nurse Call Light -
Pin 29	Nurse Answer Light -
Pin 30	Priority NO/NC
Pin 31	Priority Common
Pin 32	Option 3A Common
Pin 33	TV - (Std.)/Data (STV)
Pin 34	TV + (Std.)/Common (STV)
Pin 35	Speaker Low Common
Pin 36	Audio Shield
Pin 37	Radio NO/NC

1	Scan Line
2	Audio (-)
3	Nurse Call (+)
4	+5 VDC
5	Scan Line
6	Scan Line
7	Nurse Call (-)
8	TV Channel Up
9	Backlight
10	Audio (+)
11	Gatch Up/Fowler In/Foot Up/DMS Firm
12	Gatch Down/Fowler Out/Foot Out/DMS Soft
13	Fowler Up/Trend In
14	Fowler Down/Trend Out
15	Audio Shield
16	Not Used - Socket Filled
17	Bed Up
18	Ground
19	Read Light/Bed Down
20	Room Light

Zoom® Option Inverter Protection Features

The inverter has several features to prevent internal damage:

1. Low Battery Voltage - If the battery voltage at the inverter drops below the low voltage cutoff, the inverter will shut off.
2. Over-Temperature - If the inverter gets too hot, it will shut off. The overheating may be caused by high ambient temperature, blocked air flow or an overload condition. When the inverter reaches an acceptable temperature, it will restart.
3. Over-Power - The inverter will source up to its maximum power rating. If the load requires more, the output voltage will shut down. Turning the power switch off and on will reset the inverter. Plugging the bed power cord into the wall socket to charge the battery will reset the inverter.

 **WARNING**

The inverter generates 115VAC, the same as a wall receptacle. To prevent injury, do not put anything into the electrical outlets other than an appliance power cord. Keep the outlets covered when not in use. Do not submerge the unit or subject it to moisture.

Bed Assembly, Standard

For Reference Only: 3003-043-102

STANDARD BED SHOWN

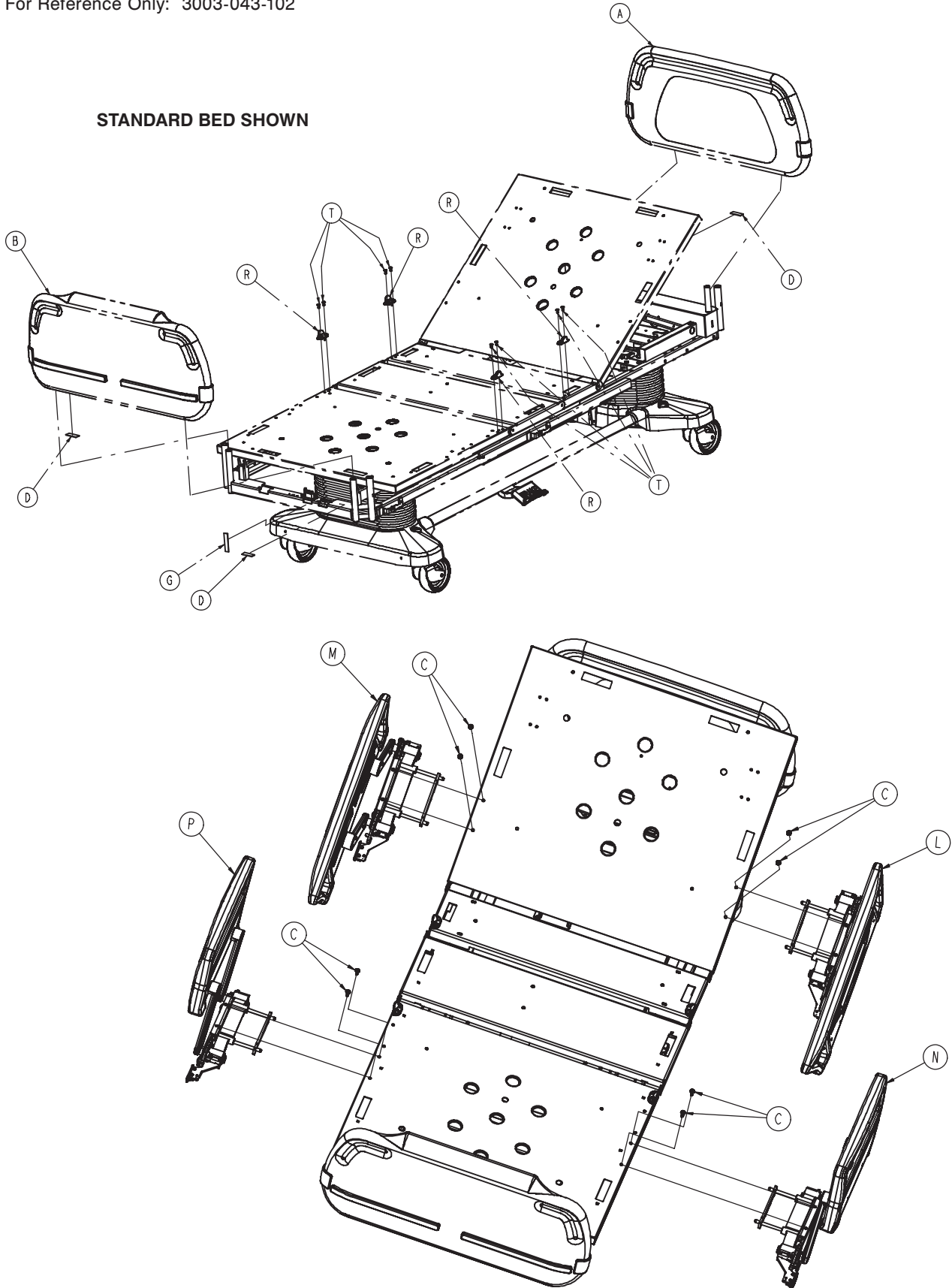

[Return To Table of Contents](#)

Bed Assembly, Standard

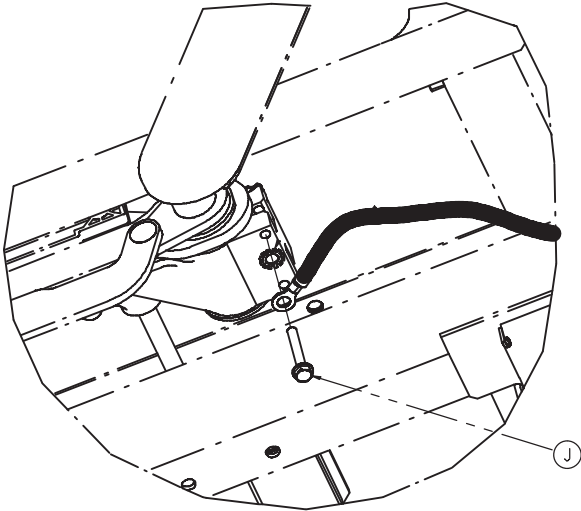

Foot End Siderail Ground Configuration

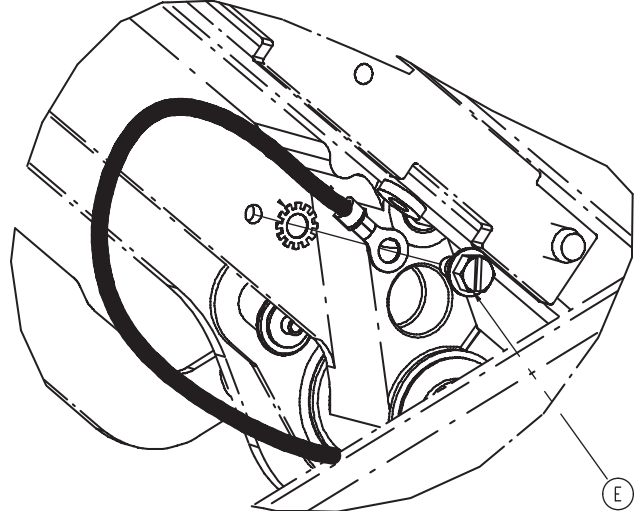

Head End Siderail Ground Configuration

Standard Length Bed Components - 3003-043-102 (Reference Only)

Item	Part No.	Part Name	Qty.
A	3002-600-000	Head Board Assembly	1
B	3002-500-011	Foot Board Assembly	1
C	0007-065-000	Truss Head Screw	8
D	3000-300-625	Date of Manufacture Label	1
E	0003-221-000	Hex Washer Head Screw	2
F	3000-300-113	8" Cable Tie	10
G	3000-300-641	Foot Board Ground Label	1
H	3002-410-020	Night Light Assembly (Option)	1
J	0003-369-000	Hex Washer Head Screw	2
K	3003-343-002	Litter Assembly	1
L	3003-402-105	HE Siderail Assembly, Left (pg.243)	1
M	3003-402-205	HE Siderail Assembly, Right (pg.243)	1
N	3003-401-300	FE Siderail Assembly, Left (pg.268)	1
P	3003-401-400	FE Siderail Assembly, Right (pg.268)	1
R	3003-300-033	Mattress Retainer	4
T	0025-120-000	Rivet	8

8" Shorter Bed Components - 3003-042-102 - (Reference Only)

Item	Part No.	Part Name	Qty.
F	3000-300-113	8" Cable Tie	10
K	3003-300-002	Litter Assembly	1
R	3003-402-105	HE Siderail Assembly, Left (pg.243)	1
T	3003-402-205	HE Siderail Assembly, Right (pg.243)	1
U	3003-401-300	FE Siderail Assembly, Left (pg.268)	1
V	3003-401-400	FE Siderail Assembly, Right (pg.268)	1

Bed Assembly, Standard

Zoom Option Bed Components - 3003-044-102 - (Reference Only)

item	Part No.	Part Name	Qty.
F	3000-300-113	8" Cable Tie	10
K	3003-300-002	Litter Assembly	1
L	3003-402-105	HE Siderail Assembly, Left (pg.243)	1
M	3003-402-205	HE Siderail Assembly, Right (pg.243)	1
N	3003-401-300	FE Siderail Assembly, Left (pg.268)	1
P	3003-401-400	FE Siderail Assembly, Right (pg.268)	1
R	3003-300-033	Mattress Retainer	4
T	0025-120-000	Pop Rivet	8
U	3002-031-113	Umbilical Cable Isolation Bracket	1

Zoom Option 8" Shorter Bed Components - 3003-046-102 - (Reference Only)

item	Part No.	Part Name	Qty.
F	3000-300-113	8" Cable Tie	10
K	3003-300-002	Litter Assembly	1
R	3003-402-105	HE Siderail Assembly, Left (pg.243)	1
T	3003-402-205	HE Siderail Assembly, Right (pg.243)	1
U	3003-401-300	FE Siderail Assembly, Left (pg.268)	1
V	3003-401-400	FE Siderail Assembly, Right (pg.268)	1
W	3002-031-113	Umbilical Cable Isolation Bracket	1

Battery Backup Option Components - 3003-350-000 - (Reference Only)

item	Part No.	Part Name	Qty.
F	3000-300-113	8" Cable Tie	10
K	3003-300-002	Litter Assembly	1
L	3003-402-105	HE Siderail Assembly, Left (pg.243)	1
M	3003-402-205	HE Siderail Assembly, Right (pg.243)	1
N	3003-401-300	FE Siderail Assembly, Left (pg.268)	1
P	3003-401-400	FE Siderail Assembly, Right (pg.268)	1
R	3003-300-033	Mattress Retainer	4
T	0025-120-000	Pop Rivet	8

Bed Assembly, iBED Awareness Option

For Reference Only: 3004-053-102

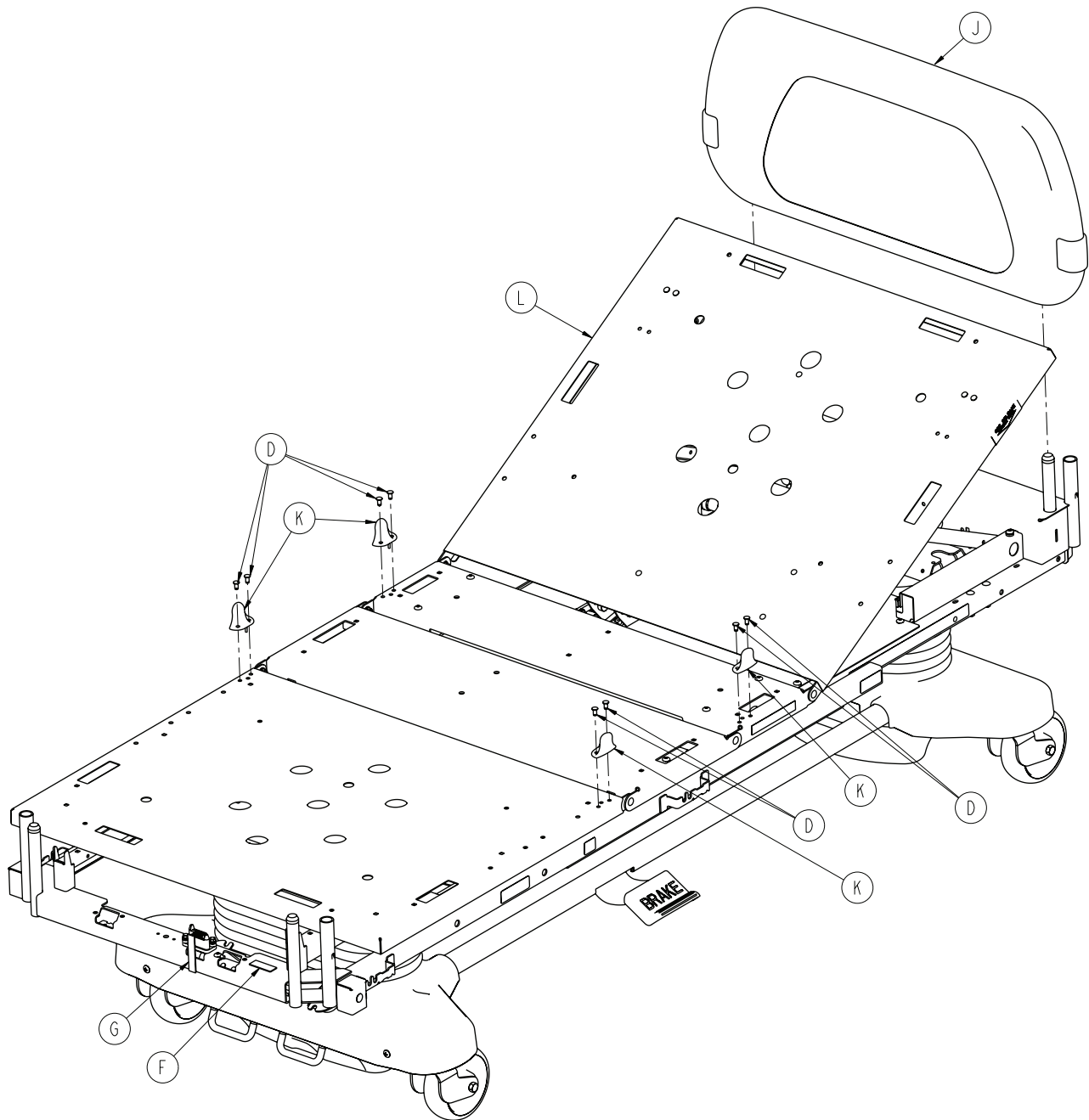

Bed Assembly, iBED Awareness Option

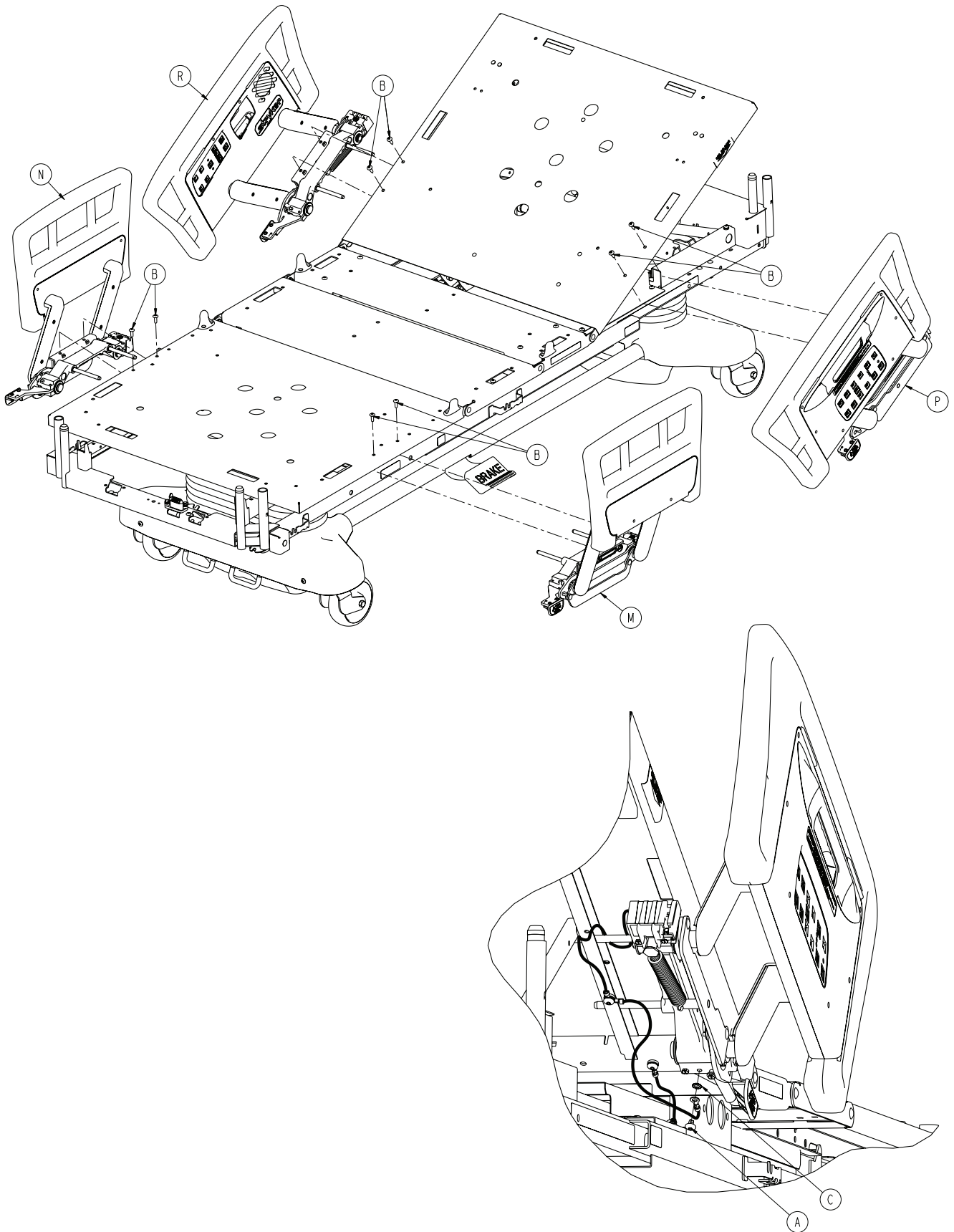

[Return To Table of Contents](#)

Bed Assembly, iBED Awareness Option

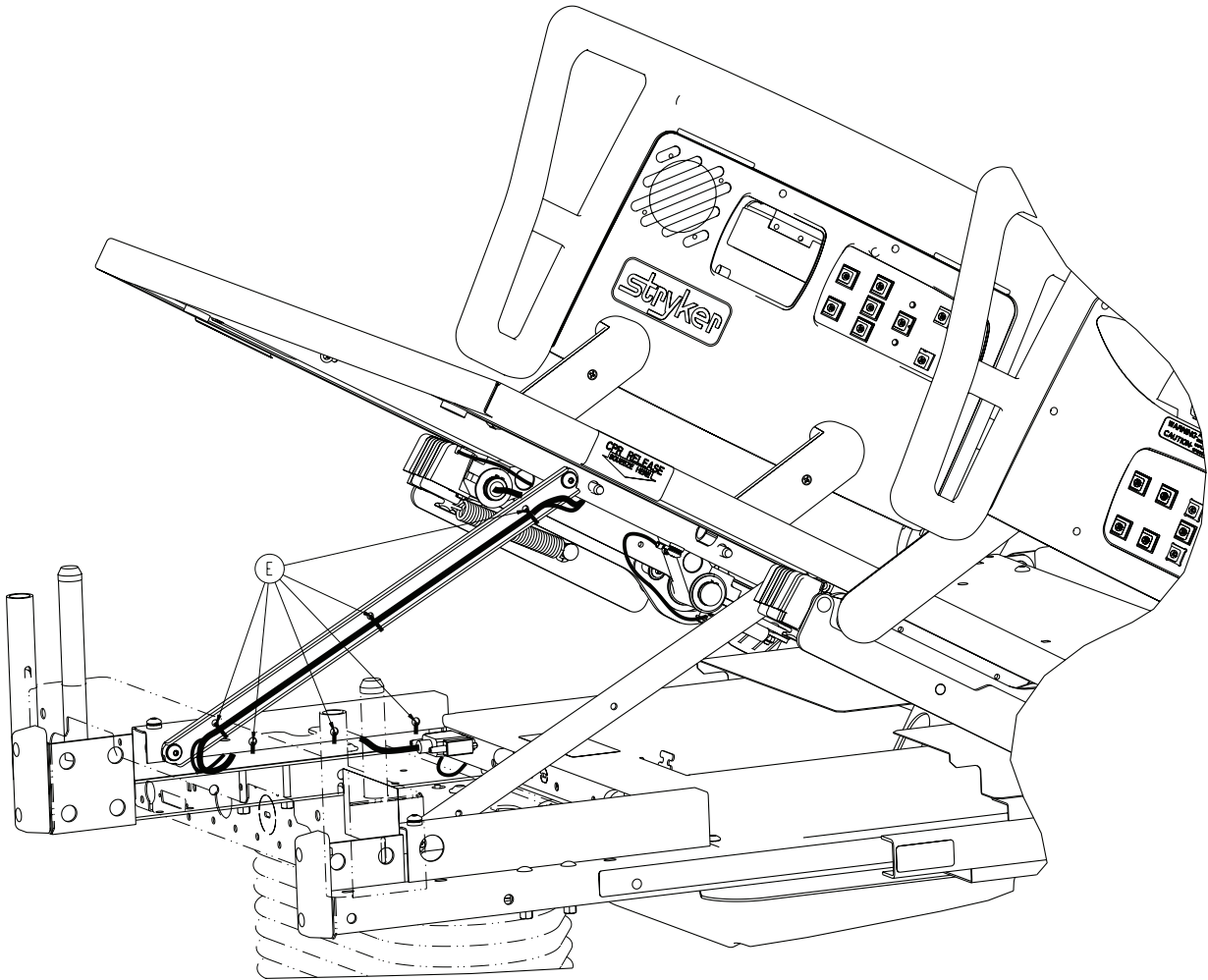

**Headend Siderail Cable Routing
Typical Both Sides**

Bed Assembly, iBED Awareness Option

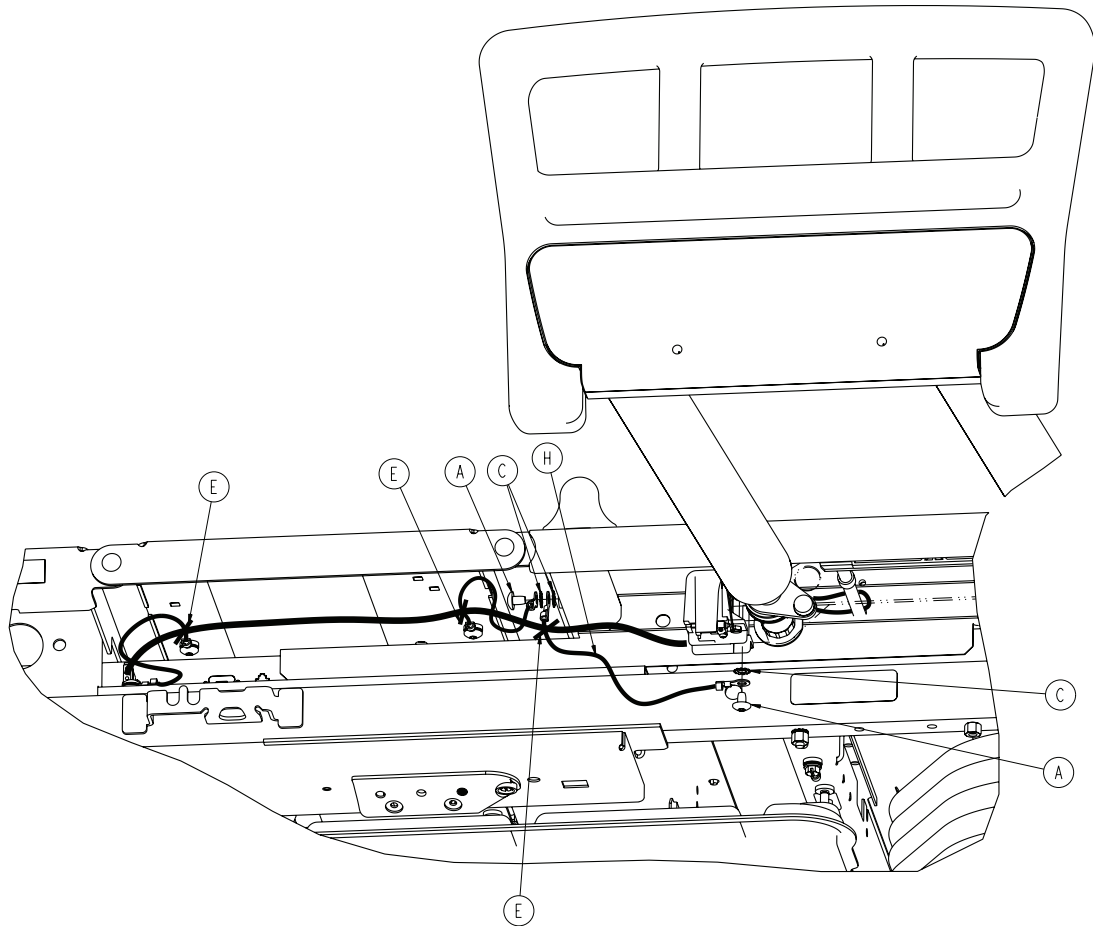

Item	Part No.	Part Name	Qty.
A	0007-053-000	Truss Head Screw	6
B	0007-065-000	Truss Head Screw	8
C	0013-010-000	External Tooth Lock Washer	8
D	0025-120-000	Dome Head Rivet	8
E	3000-300-113	8" Cable Tie	18
F	3000-300-625	Date of Manufacture Label	1
G	3000-300-641	Footboard Ground Label	1
H	3002-300-870	8" Litter Ground Jumper	2
J	3002-600-000	Head Board Assembly	1
K	3003-300-033	Mattress Retainer	4
L	3004-353-002	LBS Litter Assembly, Standrad Bed (pg.159)	1
M	3004-401-300	LBS, Siderail Assembly, FE, Left (pg.276)	1
N	3004-401-400	LBS, Siderail Assembly, FE, Right (pg.277)	1
P	3004-402-105	LBS, Siderail Assembly, HE, Left (pg.263)	1
R	3004-402-205	LBS, Siderail Assembly, HE, Right (pg.264)	1

[Return To Table of Contents](#)

Bed Assembly, iBED Awareness/Battery Backup Option

For Reference Only: 3004-350-010

Head End Siderail Grounding Typical Both Sides

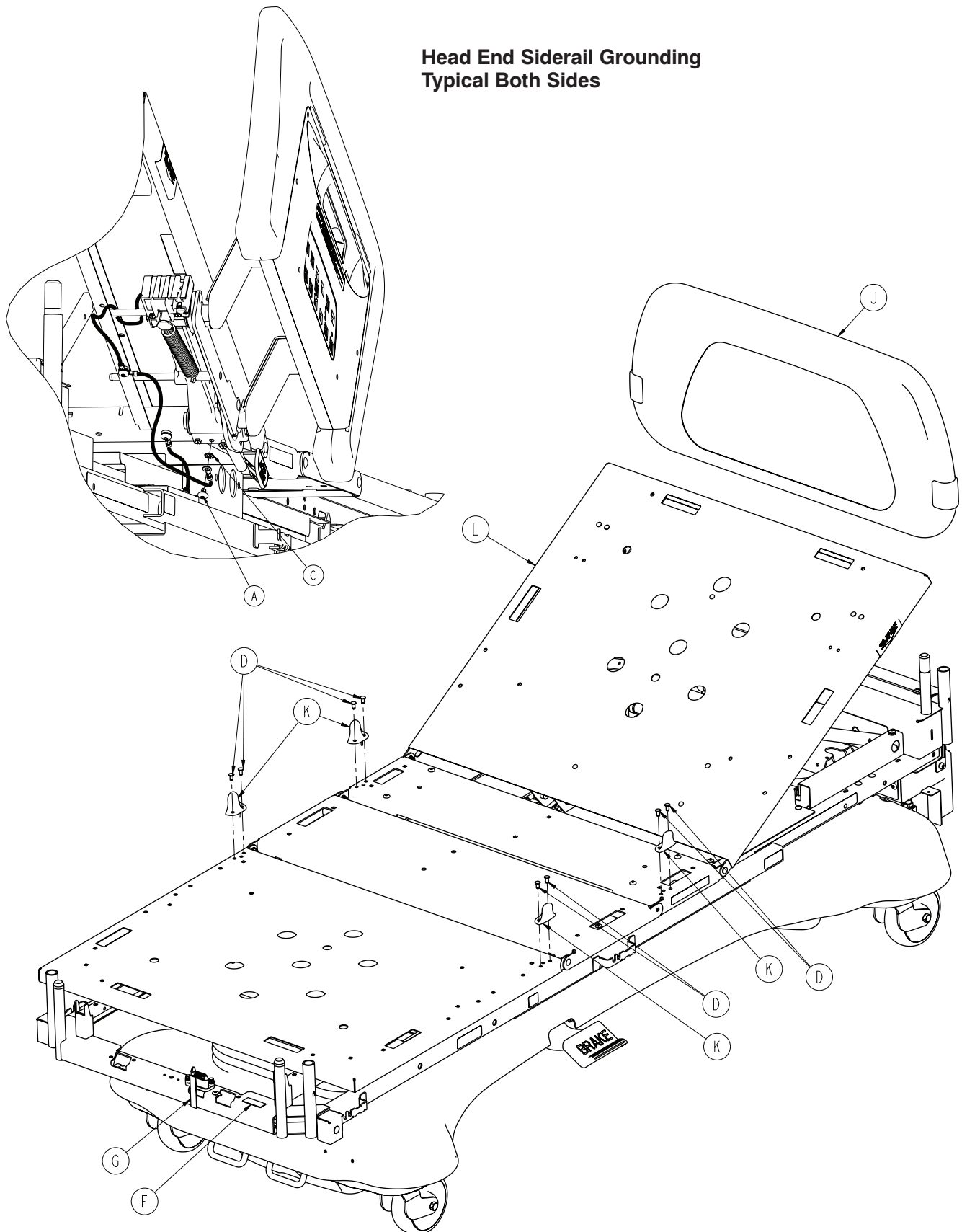

[Return To Table of Contents](#)

Bed Assembly, iBED Awareness/Battery Backup Option

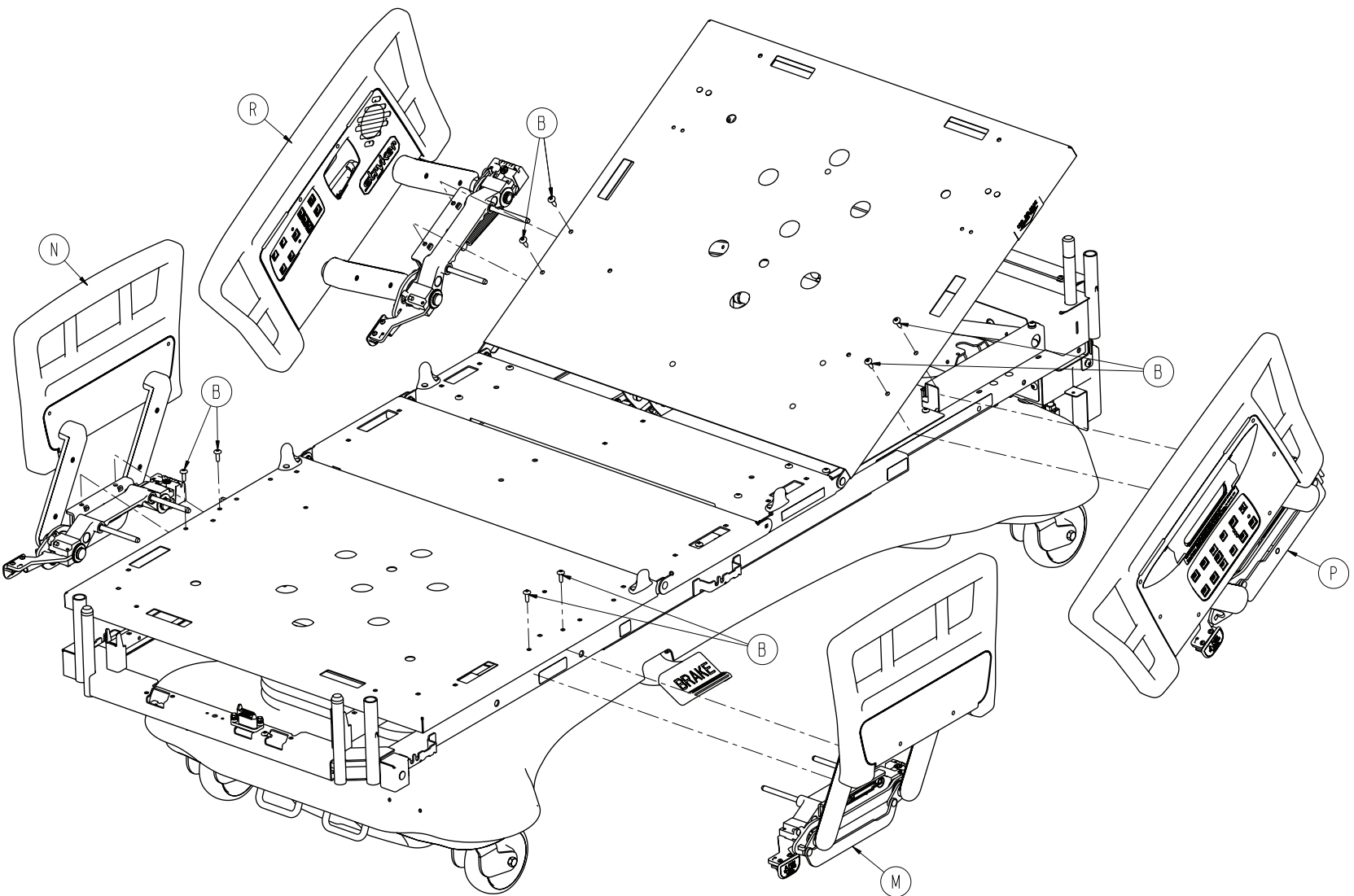

Bed Assembly, iBED Awareness/Battery Backup Option

**Foot End Siderail Cable Routing
Typical Both Sides**

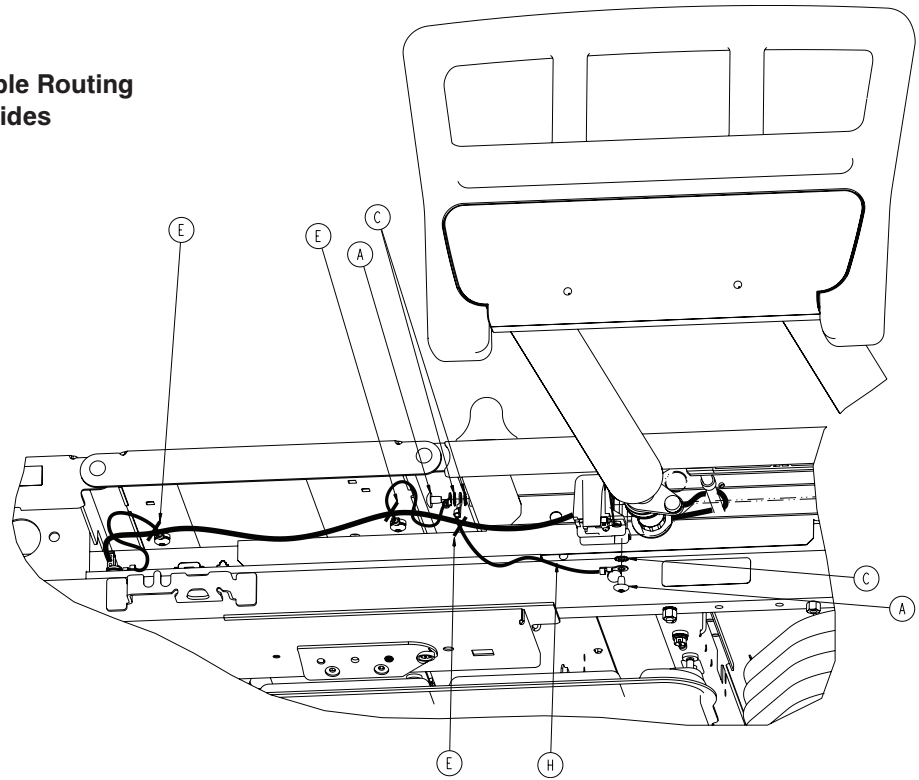

**Head End Siderail Cable Routing
Typical Both Sides**

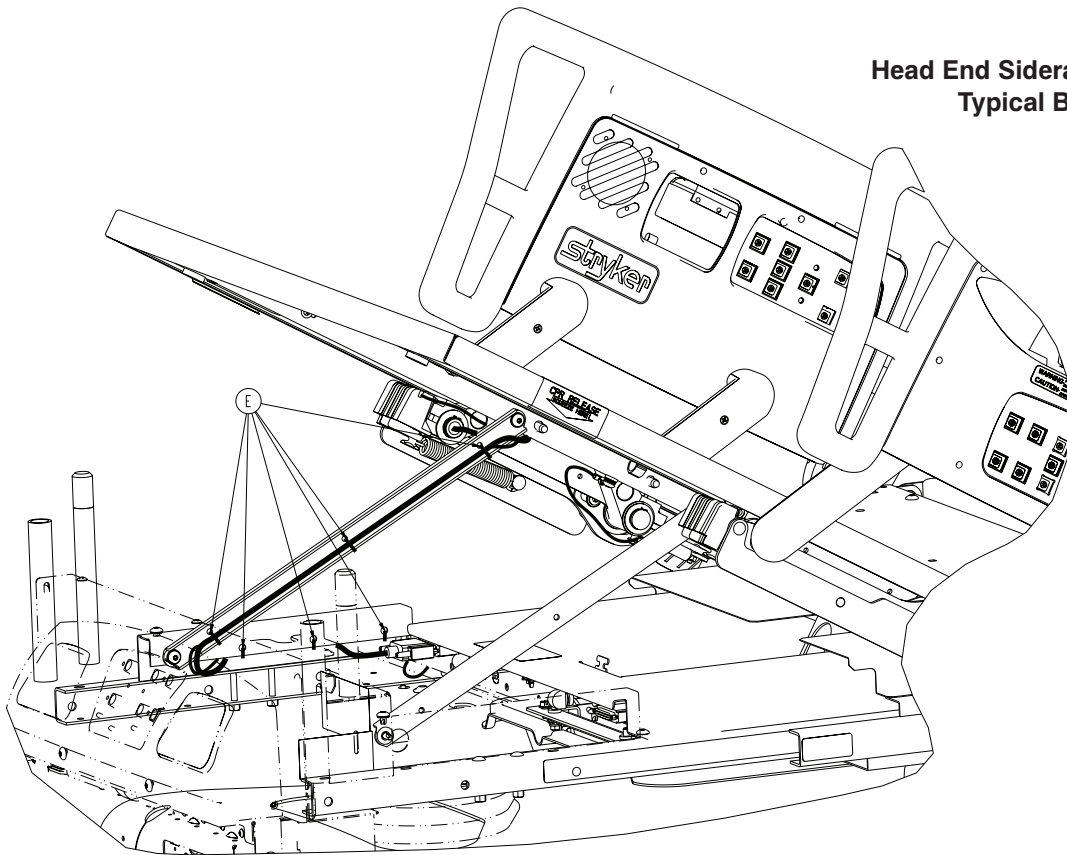

Bed Assembly, iBED Awareness/Battery Backup Option

Item	Part No.	Part Name	Qty.
A	0007-053-000	Truss Head Screw	6
B	0007-065-000	Truss Head Screw	8
C	0013-010-000	External Tooth Lock Washer	8
D	0025-120-000	Dome Head Rivet	8
E	3000-300-113	8" Cable Tie	18
F	3000-300-625	Date of Manufacture Label	1
G	3000-300-641	Foot Board Ground Label	1
H	3002-300-870	8" Litter Ground Jumper	2
J	3002-600-000	Head Board Assembly	1
K	3003-300-033	Retainer Mattress	4
L	3004-350-100	LBS, Litter Ass'y, Battery Backup Option (pg.165)	1
M	3004-401-300	LBS, FE Siderail Assembly, Left (pg.276)	1
N	3004-401-400	LBS, FE Siderail Assembly, Right (pg.277)	1
P	3004-402-105	LBS, HE Siderail Assembly, Left (pg.263)	1
R	3004-402-205	LBS, HE Siderail Assembly, Right (pg.264)	1

Bed Assembly, iBED Awareness/Zoom Option

For Reference Only: 3004-057-102

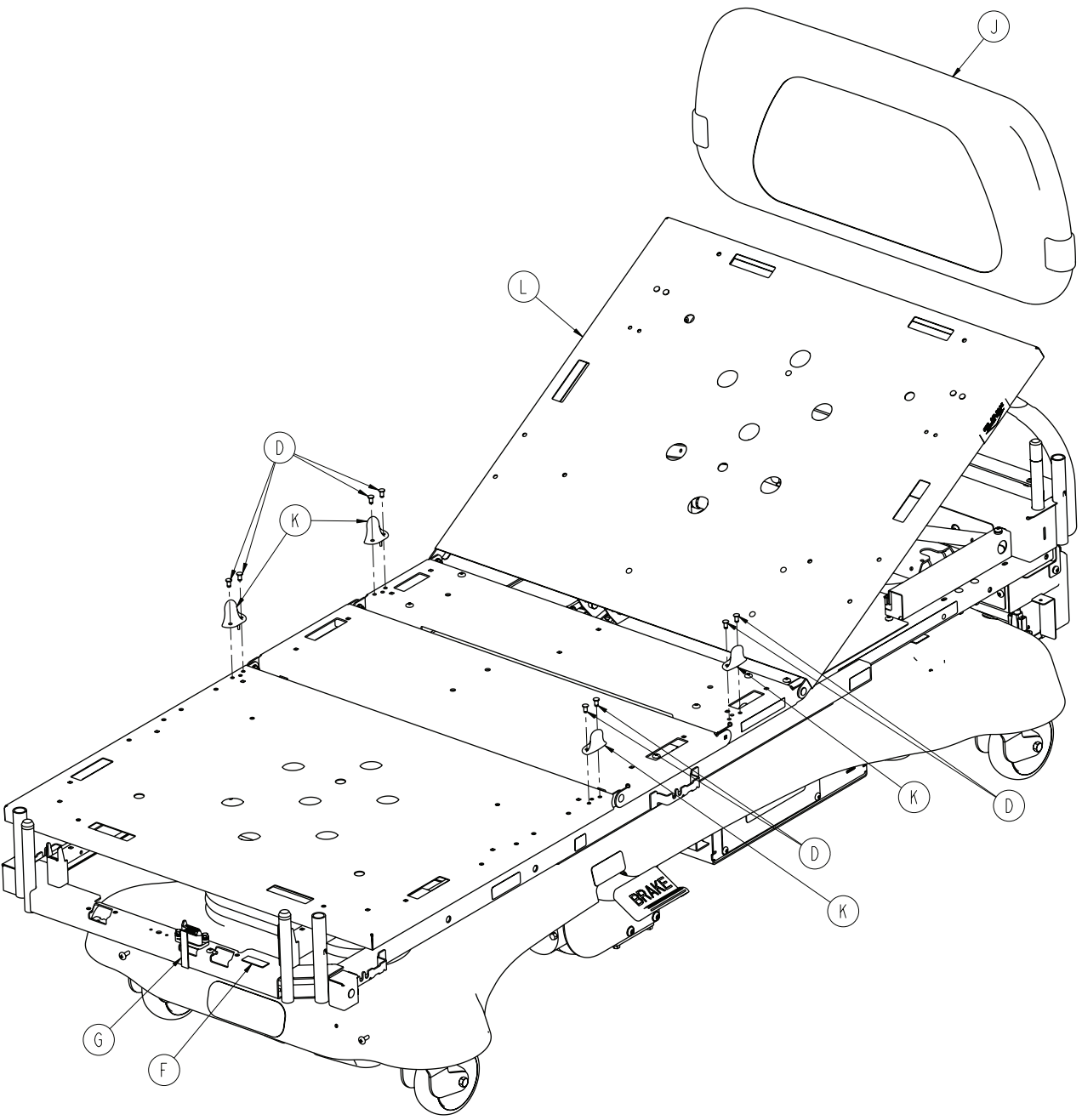

Bed Assembly, iBED Awareness/Zoom Option

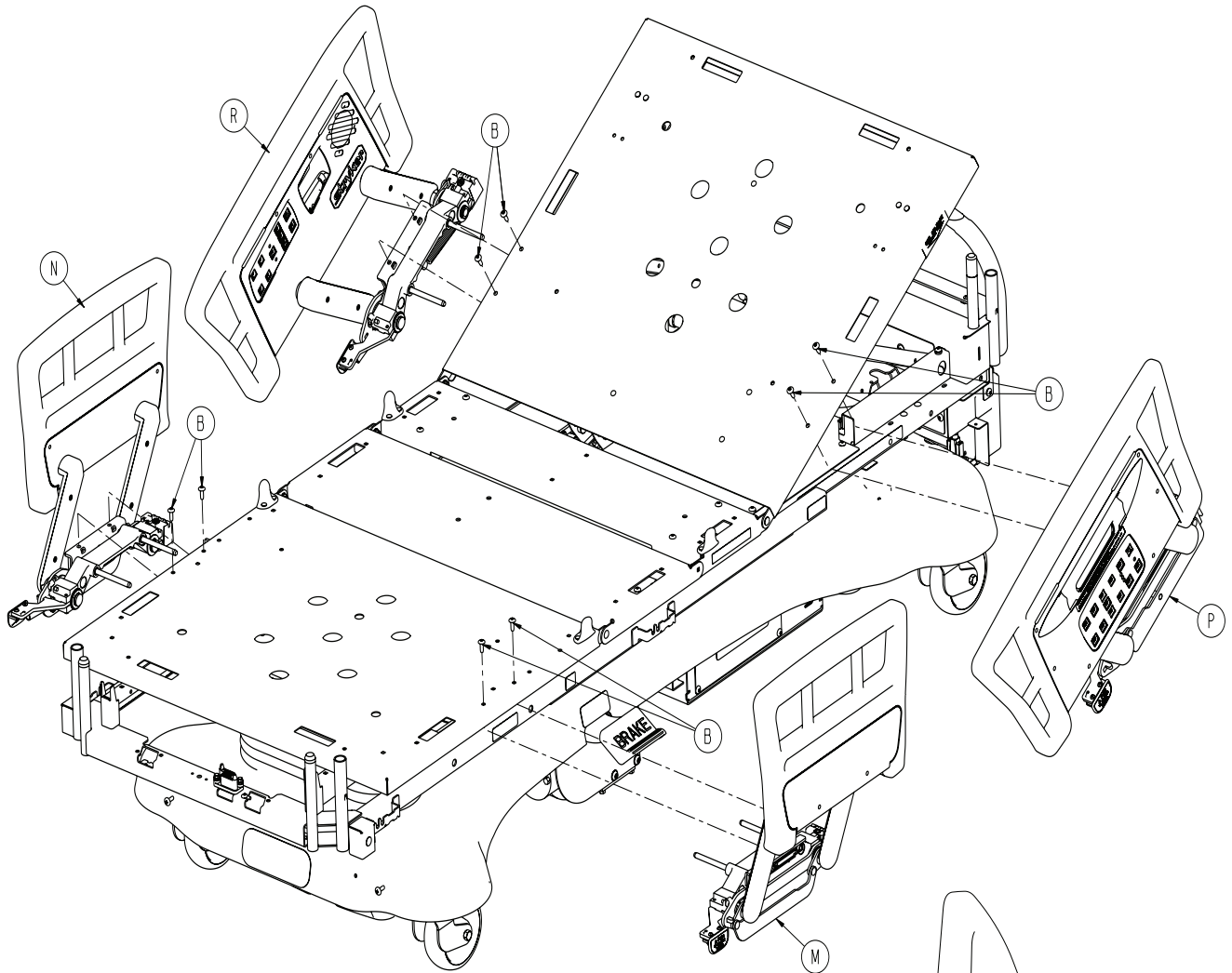

**Head End Siderail Grounding
Typical Both Sides**

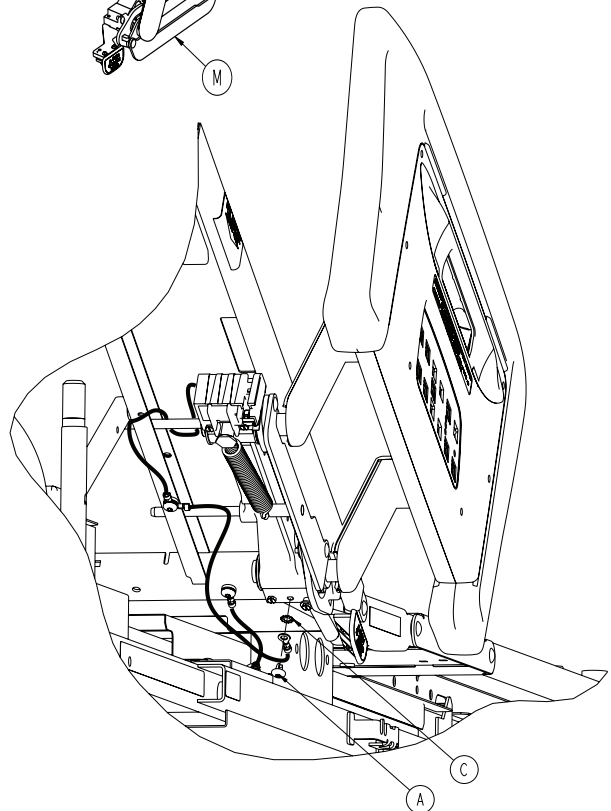

[Return To Table of Contents](#)

Bed Assembly, iBED Awareness/Zoom Option

Head End Siderail Cable Routing
Typical Both Sides

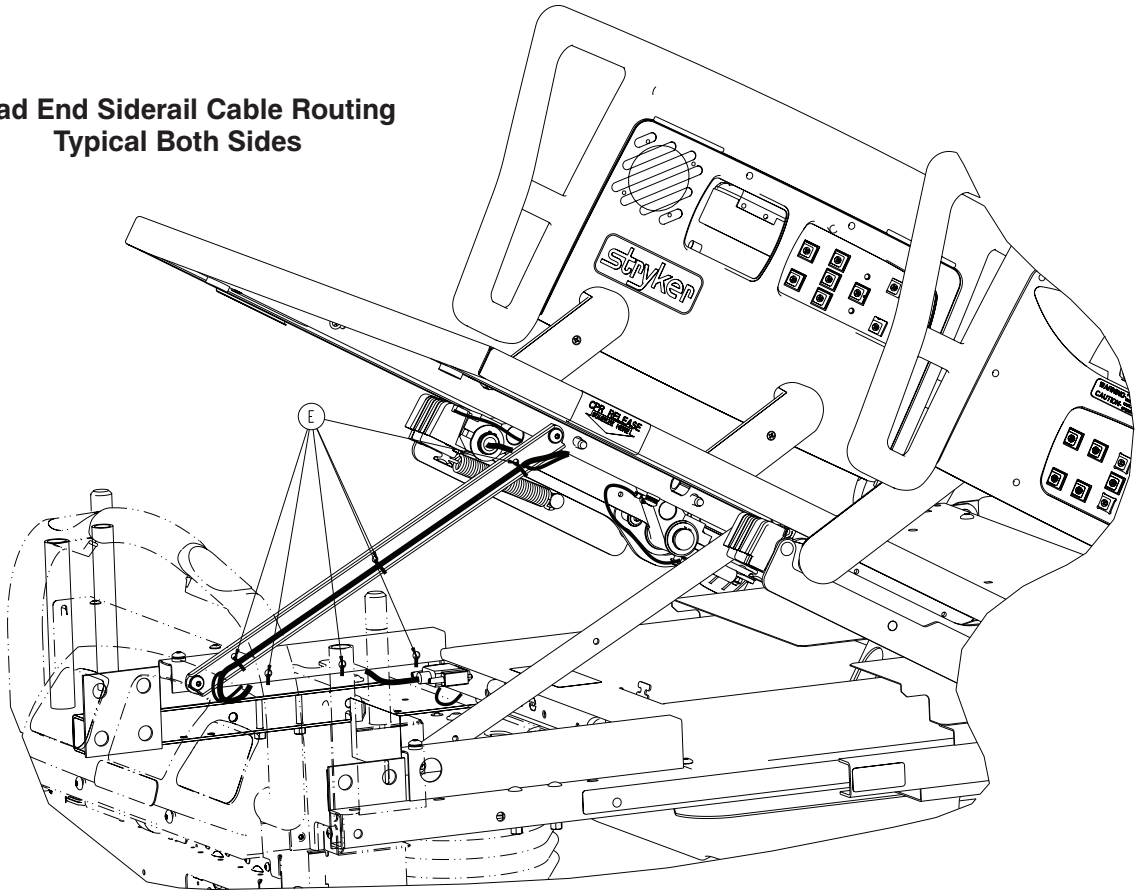

Foot End Siderail Cable Routing
Typical Both Sides

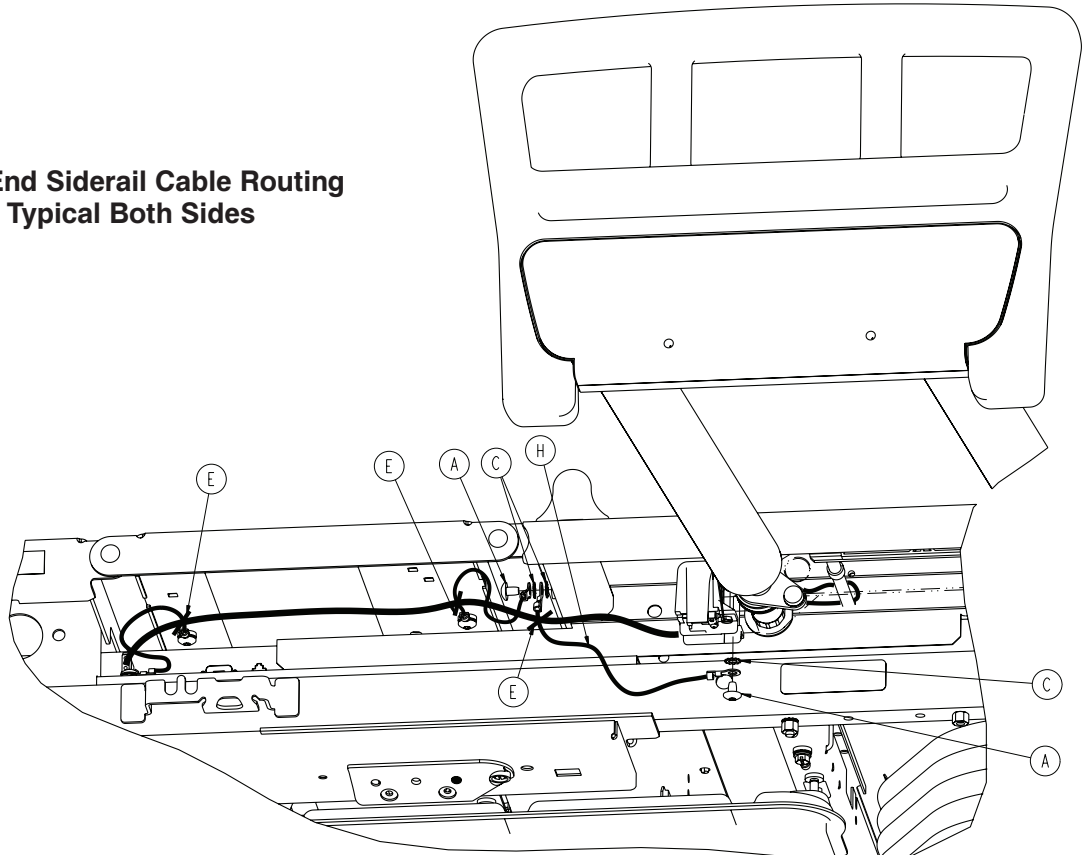

Bed Assembly, iBED Awareness/Zoom Option

Item	Part No.	Part Name	Qty.
A	0007-053-000	Truss Head Screw	6
B	0007-065-000	Truss Head Screw	8
C	0013-010-000	External Tooth Lock Washer	8
D	0025-120-000	Dome Head Rivet	8
E	3000-300-113	8" Cable Tie	18
F	3000-300-625	Date of Manufacture Label	1
G	3000-300-641	Foot Board Ground Label	1
H	3002-300-870	8" Litter Ground Jumper	2
J	3002-600-000	Head Board Assembly	1
K	3003-300-033	Mattress Retainer	4
L	3004-357-002	LBS, Litter Ass'y, Zoom Option (pg.171)	1
M	3004-401-300	LBS, FE Siderail Assembly, Left (pg.276)	1
N	3004-401-400	LBS, FE Siderail Assembly, Right (pg.277)	1
P	3004-402-105	LBS, HE Siderail Assembly, Left (pg.263)	1
R	3004-402-205	LBS, HE Siderail Assembly, Right (pg.264)	1

Base Assembly and Options

For Reference Only: 3002-200-003

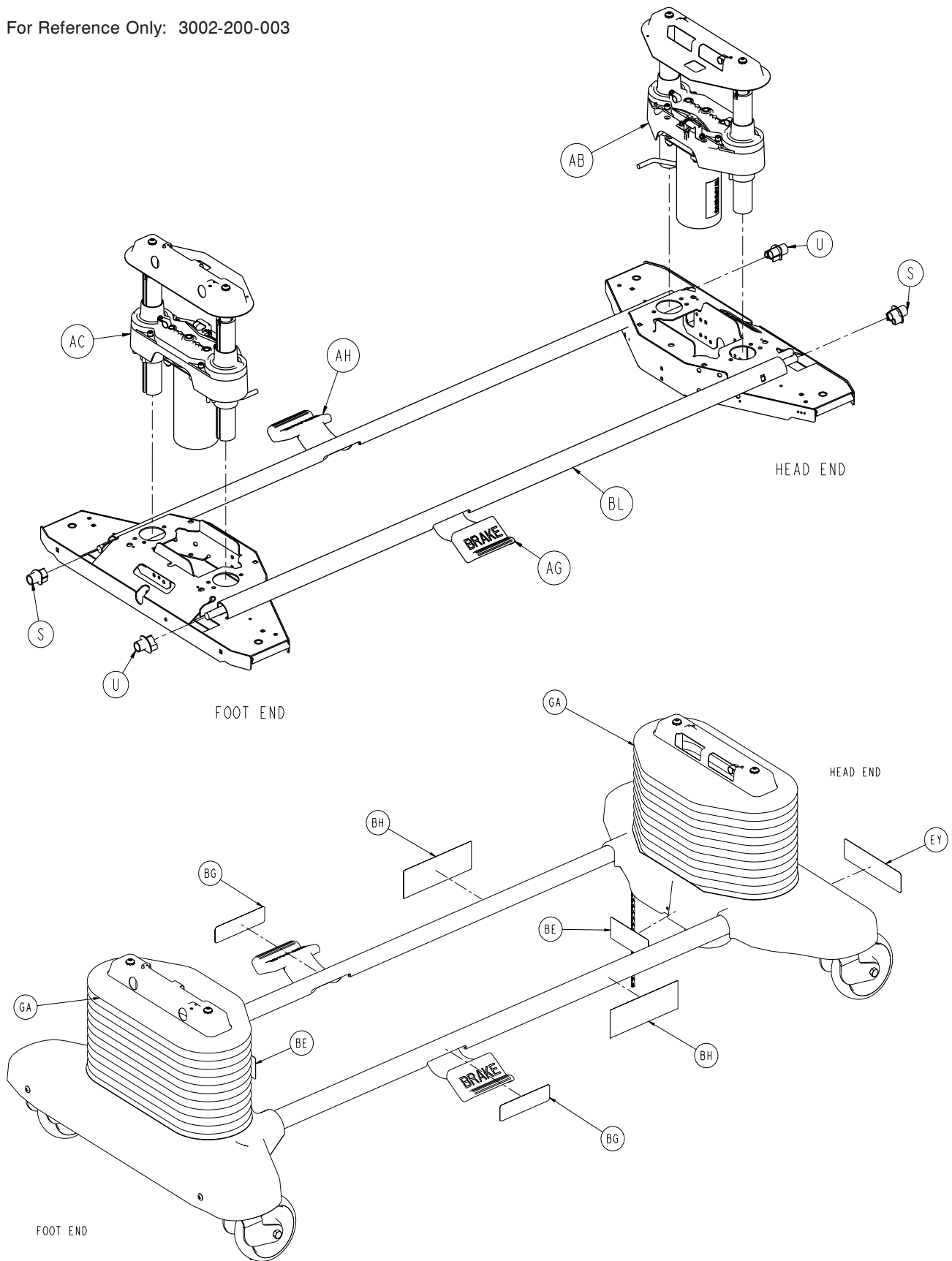

[Return To Table of Contents](#)

Base Assembly and Options

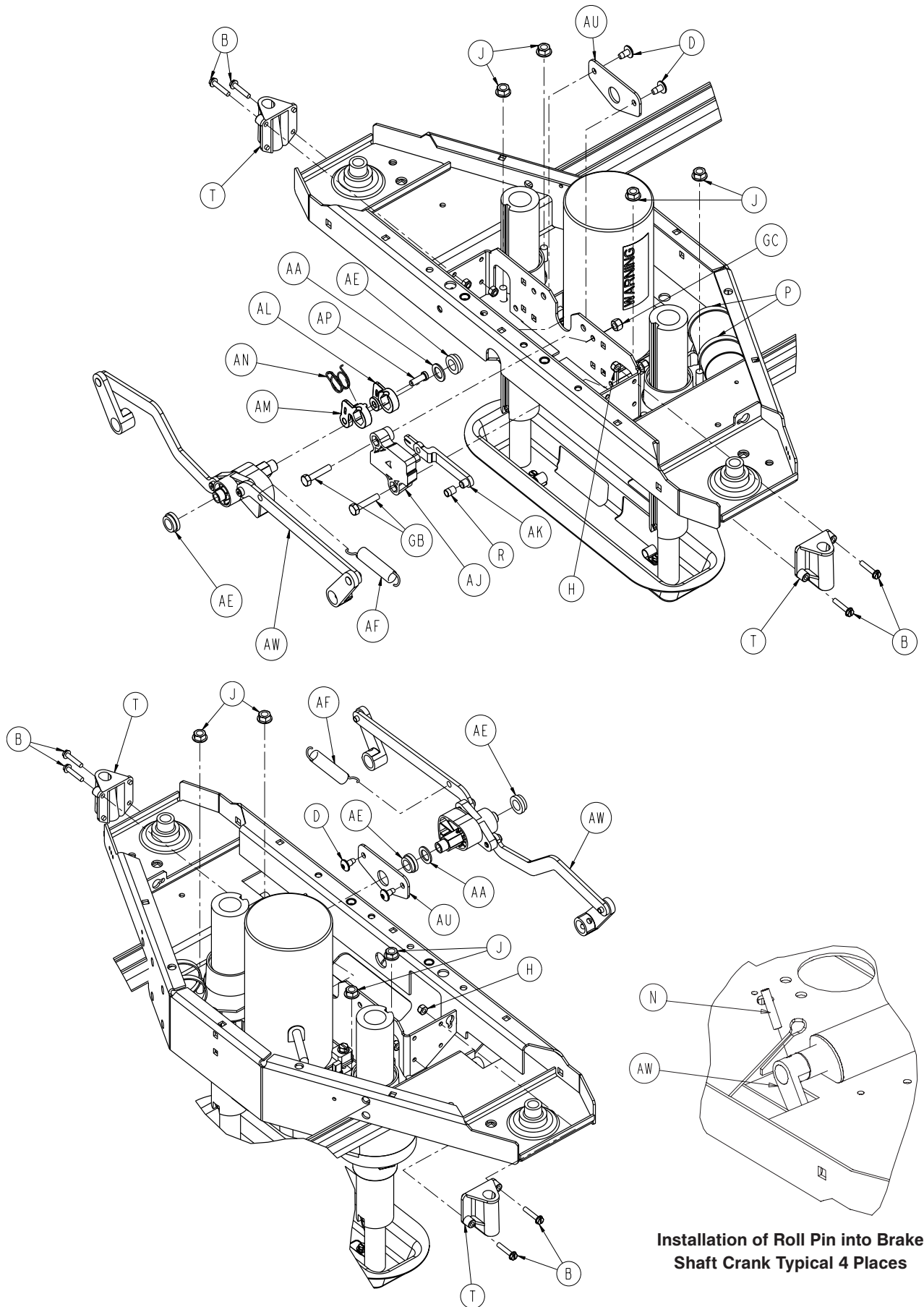

Installation of Roll Pin into Brake Shaft Crank Typical 4 Places

[Return To Table of Contents](#)

Base Assembly and Options

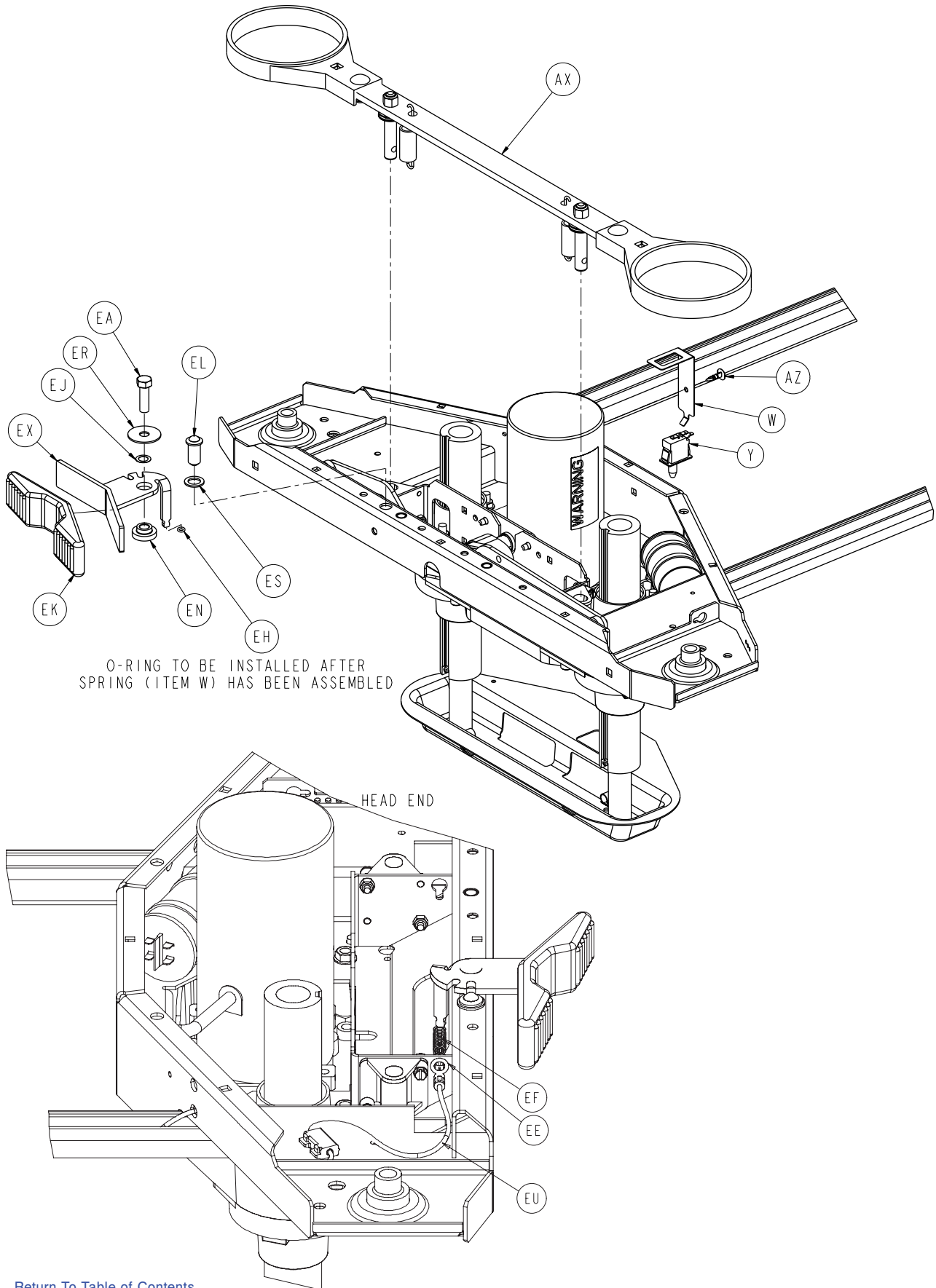

[Return To Table of Contents](#)

Base Assembly and Options

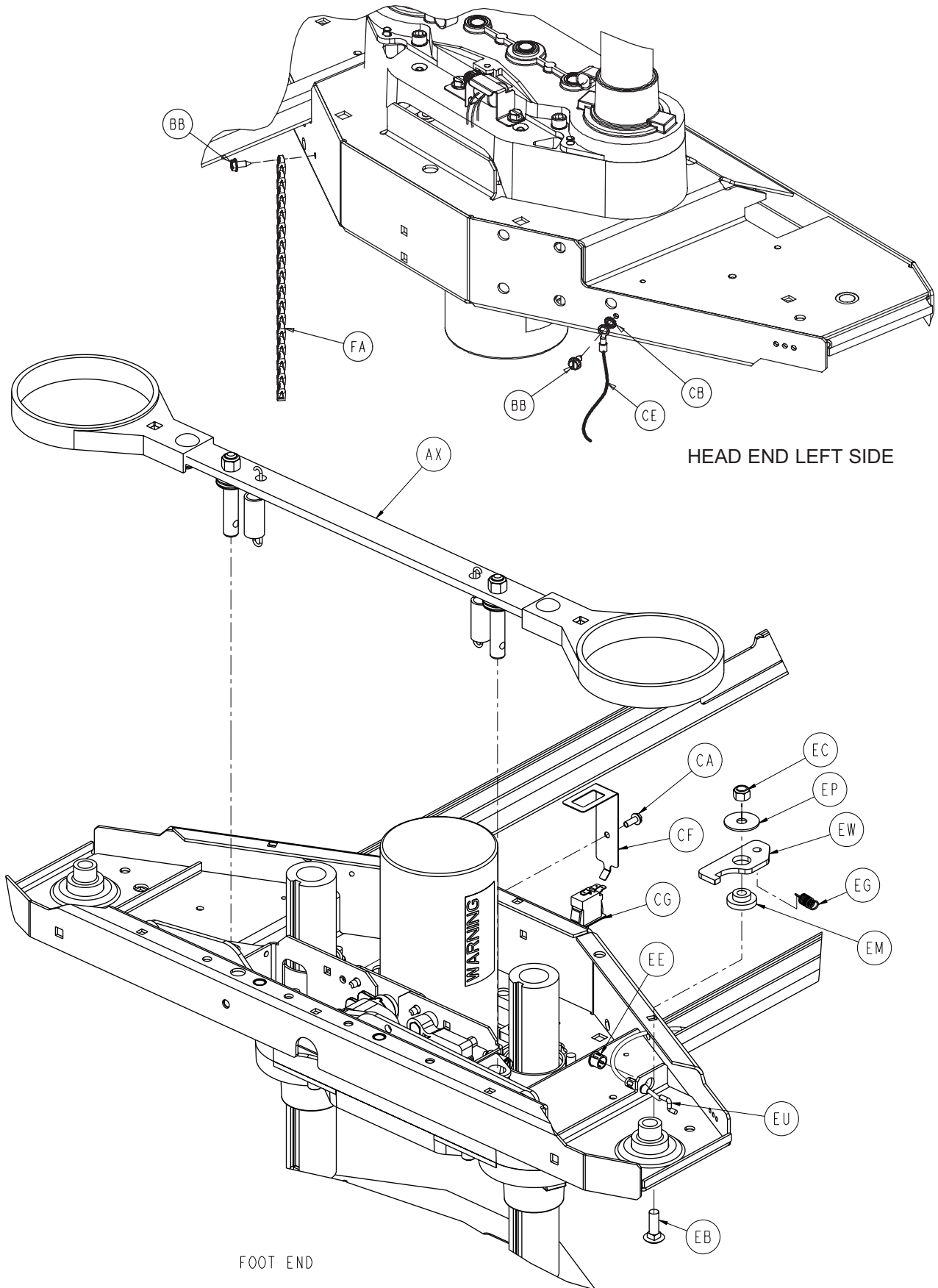

[Return To Table of Contents](#)

Base Assembly and Options

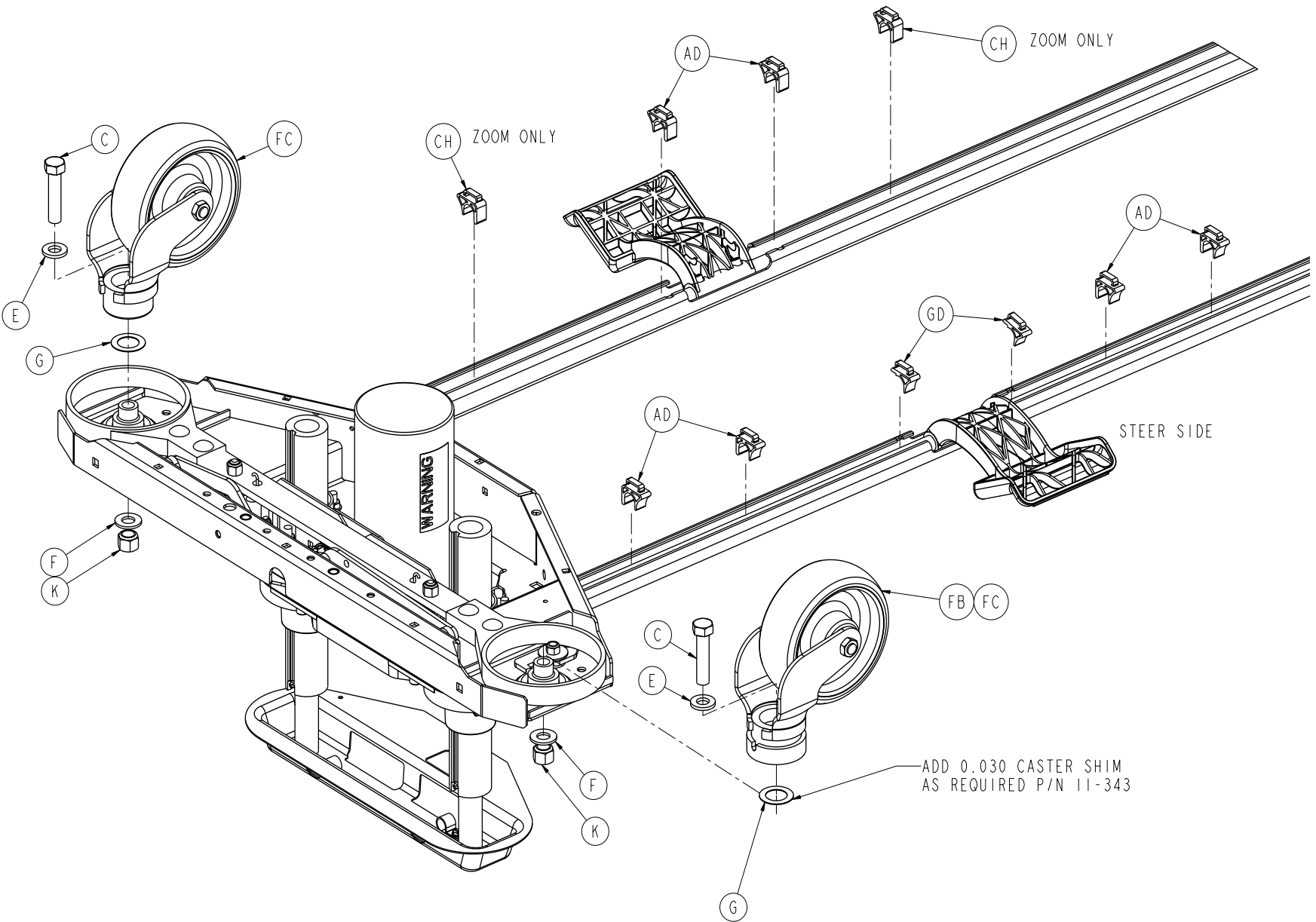

Base Assembly and Options

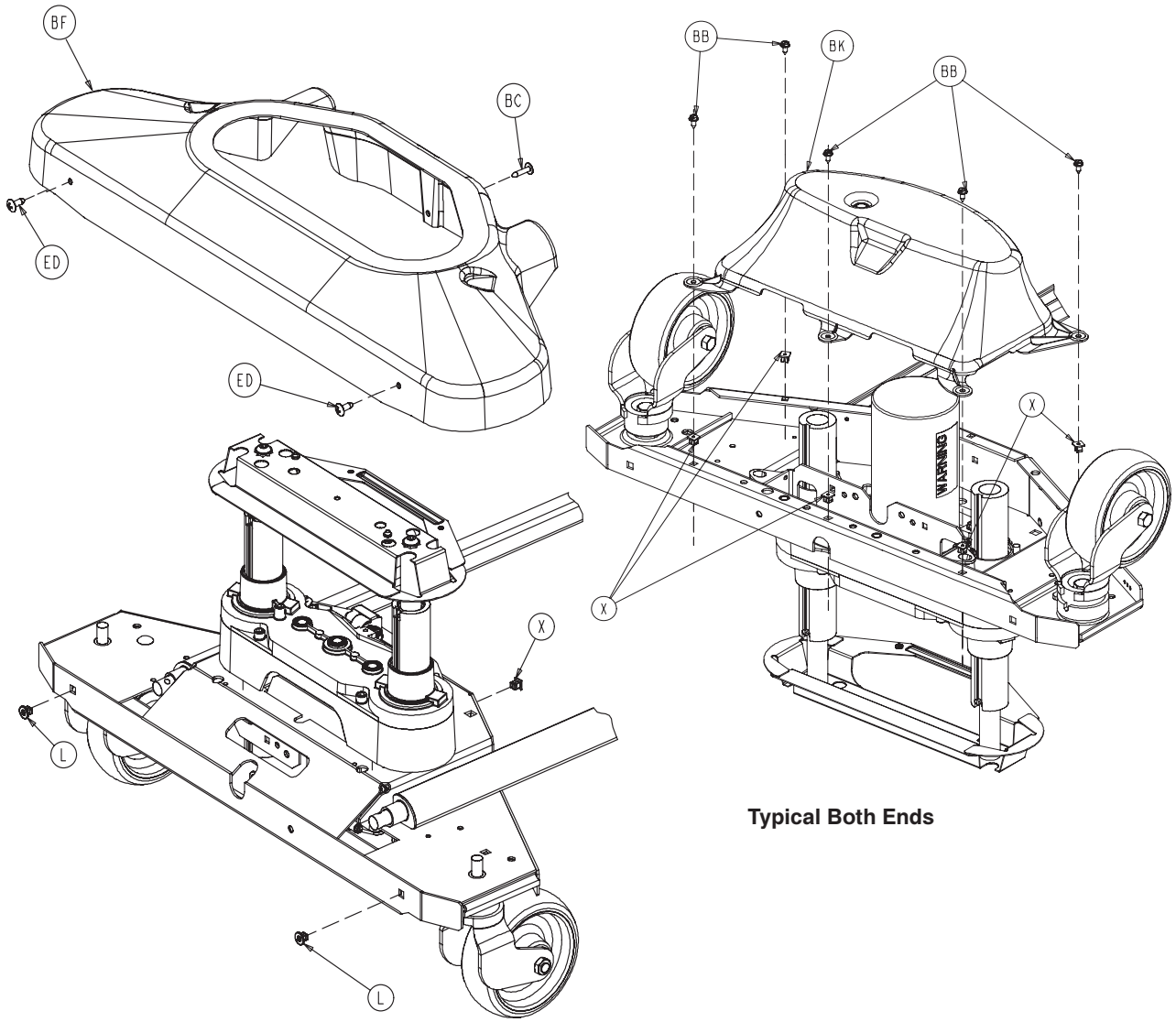

Typical Both Ends

Sensor Coil Cable p/n 3001-200-815 Ground

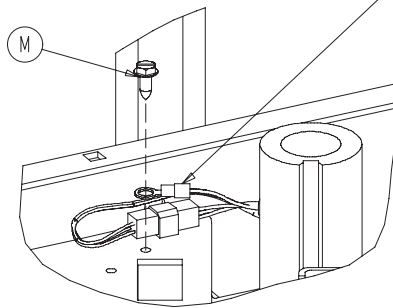

Typical Both Ends

Base Assembly and Options

Base Assembly Common Components - 3002-200-003 (Reference Only)

Item	Part No.	Part Name	Qty.	Item	Part No.	Part Name	Qty.
B	0003-122-000	Hex Washer Head Screw	8	AB	3001-200-201	HE Lift Assembly (pg.116)	1
D	0007-052-000	Truss Head Torx	4	AC	3001-200-251	FE Lift Assembly (pg.116)	1
E	0011-310-000	Washer	4	AD	3001-200-306	Brake Pedal Shaft Bearing	4
G	0011-343-000	Washer	1	AE	3001-200-317	Brake Cam Shaft Bushing	4
H	0016-002-000	Nylock Nut	8	AF	3001-200-334	Brake Return Ext. Spring	2
J	0016-098-000	Hex Flange Nut	8	AG	3001-200-340	Brake Shaft Ass'y, Lt.(pg.121)	1
K	0016-049-000	Nylock Jam Nut	4	AH	3001-200-345	Brake Shaft Ass'y, Rt.(pg.121)	1
L	0018-036-000	Plastic Clip Nut	4	AJ	3002-201-301	Brake Ratchet Track	1
M	0003-224-000	Hex Washer Hd. Screw	2	AK	3002-200-302	Brake Ratchet Link Ass'y	1
N	0026-014-000	Roll Pin	4	AL	3002-200-305	Brake Ratchet Crank, Left	1
P	0038-151-000	Cable Tie	4	AM	3002-200-306	Brake Ratchet Crank, Right	1
R	3002-200-316	Brake Track Roller	1	AN	3002-200-307	Brake Latch Spring	1
S	3000-200-305	Brake Shaft Bushing, Right	2	AP	3002-200-308	Brake Ratchet Crank Pin	1
T	3000-200-328	Brake Guide Bushing	4	AU	3002-200-314	Brake Mounting Bracket	2
U	3000-200-331	Brake Shaft Bushing, Left	2	AW	3002-200-330	Brake Crank Ass'y (pg.122)	2
W	3000-200-343	Brake Switch Bracket	1	AX	3002-200-335	Brake Bar Ass'y (pg.123)	2
X	3000-300-002	Plastic Clip Nut	10	AZ	3000-300-115	Stand-Off	1
Y	3000-300-058	Plunger Switch	1	GB	0003-074-000	Hex Hd. Bolt	2
Z	3000-300-113	8" Cable Tie	6	GC	0016-028-000	Nylock Nut	2
AA	3000-200-349	Washer	2	GD	3002-316-000	Steer Cable Retaining Clip	2

Base Assembly, Standard Secure Bed - 3002-243-003 (Reference Only)

Item	Part No.	Part Name	Qty.
C	0003-333-000	Hex Hd. Cap Screw	4
F	0011-333-000	Flat Washer	4
X	3000-300-002	Clip Nut	2
AB	3001-200-201	HE Lift Assembly (pg.116)	1
AC	3001-200-251	FE Lift Assembly (pg.116)	1
BB	0023-025-000	Hex Washer Head Screw	13
BC	0023-080-000	Truss Head Screw	2
BE	0988-002-708	Caution Label	2
BF	3002-300-010	Uni-Pan Cover Assembly (pg.127)	2
BG	3000-200-601	Brake Pedal Label	2
BH	3000-200-602	Stryker Logo Label	2
BJ	3001-200-008	Bellows Bracket	2
BK	3001-200-022	Bottom Cover	2
BL	3002-200-102	Base Weldment	1
GA	2030-001-101	Bellows Trim, Blue Stone	2

Base Assembly, Zoom Secure Bed - 3002-244-003 (Reference Only)

Item	Part No.	Part Name	Qty.
C	0003-333-000	Hex Head Cap Screw	4
AB	3001-200-201	HE Lift Assembly (pg.116)	1
AC	3001-200-251	FE Lift Assembly (pg.116)	1
BL	3002-200-102	Base Weldment	1
CA	3000-300-115	Standoff	1
CB	0013-018-000	External Tooth Lock Washer	1
CE	2025-031-805	Ground Strap	1
CF	3000-200-343	Brake Switch Bracket	1
CG	3000-300-058	Switch Plunger	1
CH	3001-200-306	Brake Pedal Shaft Bearing	2
GA	2030-001-101	Bellows Trim, Blue Stone	2

Base Assembly and Options

Base Assembly, Steer Option - 3001-999-137 (Reference Only)

Item	Part No.	Part Name	Qty.
EA	0003-349-000	Hex Head Cap Screw	1
EB	0005-020-000	Carriage Bolt	1
EC	0016-036-000	Nylock Nut	1
ED	0023-092-000	Truss Phillips Head Screw	4
EE	0030-052-000	Snap Bushing	2
EF	0038-414-000	Pedal Extension Spring	1
EG	0038-416-000	Lever Extension Spring	1
EH	0045-008-000	O-Ring	1
EJ	0052-305-000	Brass Flat Washer	1
EK	3000-200-336	Steer Pedal	1
EL	3000-200-337	Push Fit Ball Plunger	1
EM	3000-200-339	Steer Lock Lever Bushing	1
EN	3000-200-341	Steer Pedal Bushing	1
EP	3000-200-347	Special Washer	1
ER	3000-200-348	Special Wide Washer	1
ES	3000-200-349	Special Narrow Washer	1
ET	3001-200-306	Brake Pedal Shaft Bearing	2
EU	3001-200-342	Steer Cable Assembly	1
EW	3001-200-370	Steer Lock Lever	1
EX	3001-200-371	Steer Pedal Arm	1
EY	5000-090-013	Steer Label	1

Base Assembly, 6" Caster Option - 3001-999-138 (Reference Only)

Item	Part No.	Part Name	Qty.
FA	3001-200-052	6" Ground Chain	2
FB	3001-200-050	6" Steer Caster Assembly	1
FC	3001-200-060	6" Caster Assembly	3

Zoom Base Assembly, 6" Caster Option - 3002-999-138 (Reference Only)

Item	Part No.	Part Name	Qty.
FA	3001-200-052	6" Ground Chain	2
FC	3001-200-060	6" Caster Assembly	4

Brake Plate Assembly

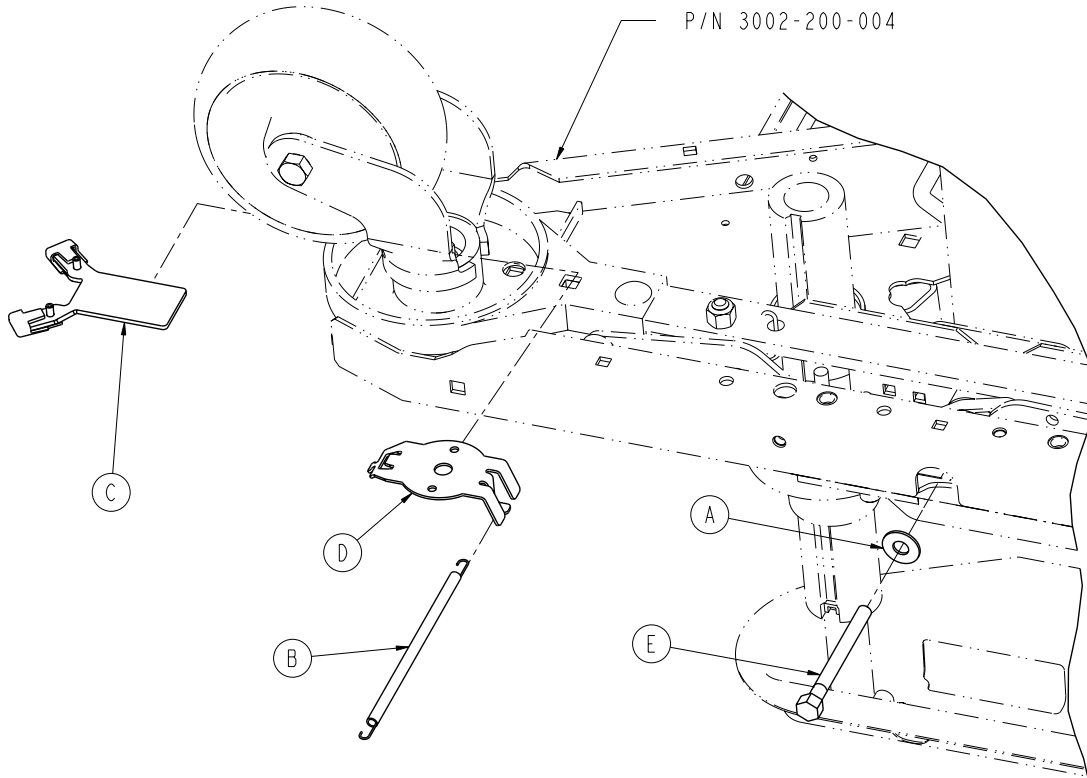

ITEM B MUST BE ASSEMBLED ABOVE
THE CASTER WELD LINE AS SHOWN

Item	Part No.	Part Name	Qty.
A	0011-193-000	Heavy Flat Washer	2
B	3006-200-352	Brake Plate Spring	4
C	3006-200-354	Brake Plate, Fork Assembly	4
D	3006-200-356	Gill Brake Plate, Body	4
E	3006-200-362	Hex Head Cap Screw, LH	2

Notes

Lift Assembly (Head and Foot End)

Cable Clamp on Bellows Bracket to be installed straight.

Cable Clamp on Lift Housing to be installed at angle

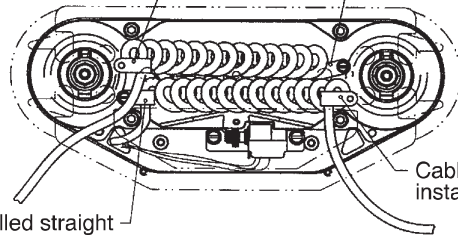

Cable Clamp on Bellows Bracket to be installed straight.

Cable Clamp on Lift Housing to be installed straight

FOOT END: 3001-200-251

HEAD END: 3001-200-201

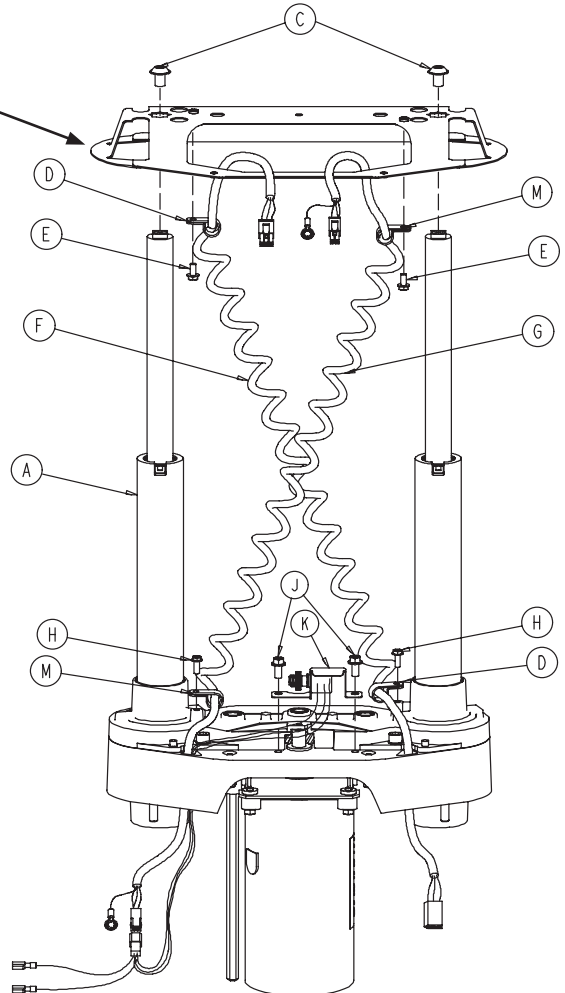
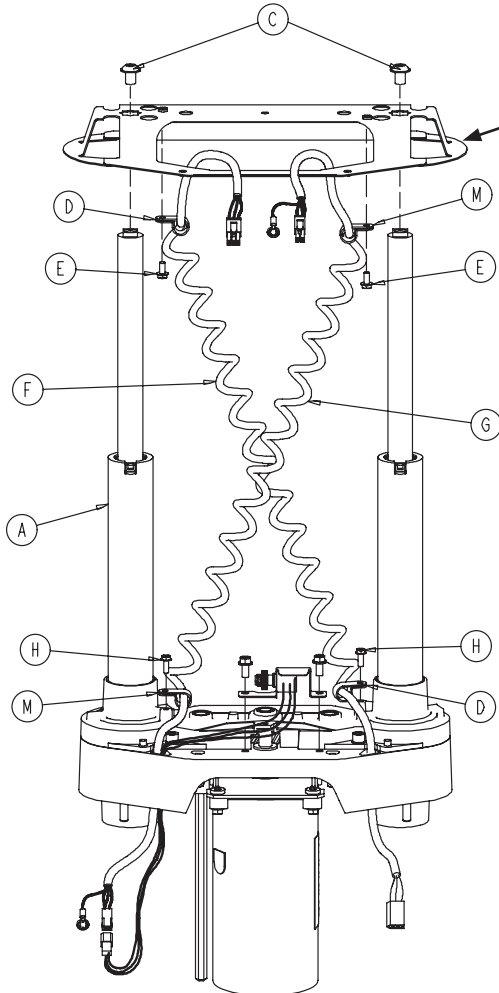

Item	Part No.	Part Name	Qty.
A	3000-200-275	Common Lift Assembly	1
D	0034-022-000	Cord Clamp	2
E	0003-106-000	Hex Washer Head Screw	2
F	3001-200-864	Power Coil Cord	1
G	3001-200-815	Sensor Coil Cord	1
H	0003-128-000	Hex Washer Head Screw	2
J	0003-121-000	Hex Washer Head Screw	2
K	3001-200-240	HE Potentiometer Assembly	1
	3001-200-230	FE Potentiometer Assembly	1
M	0034-381-000	Cord Clamp	2

Lift Assembly

For Reference Only: 3000-200-276

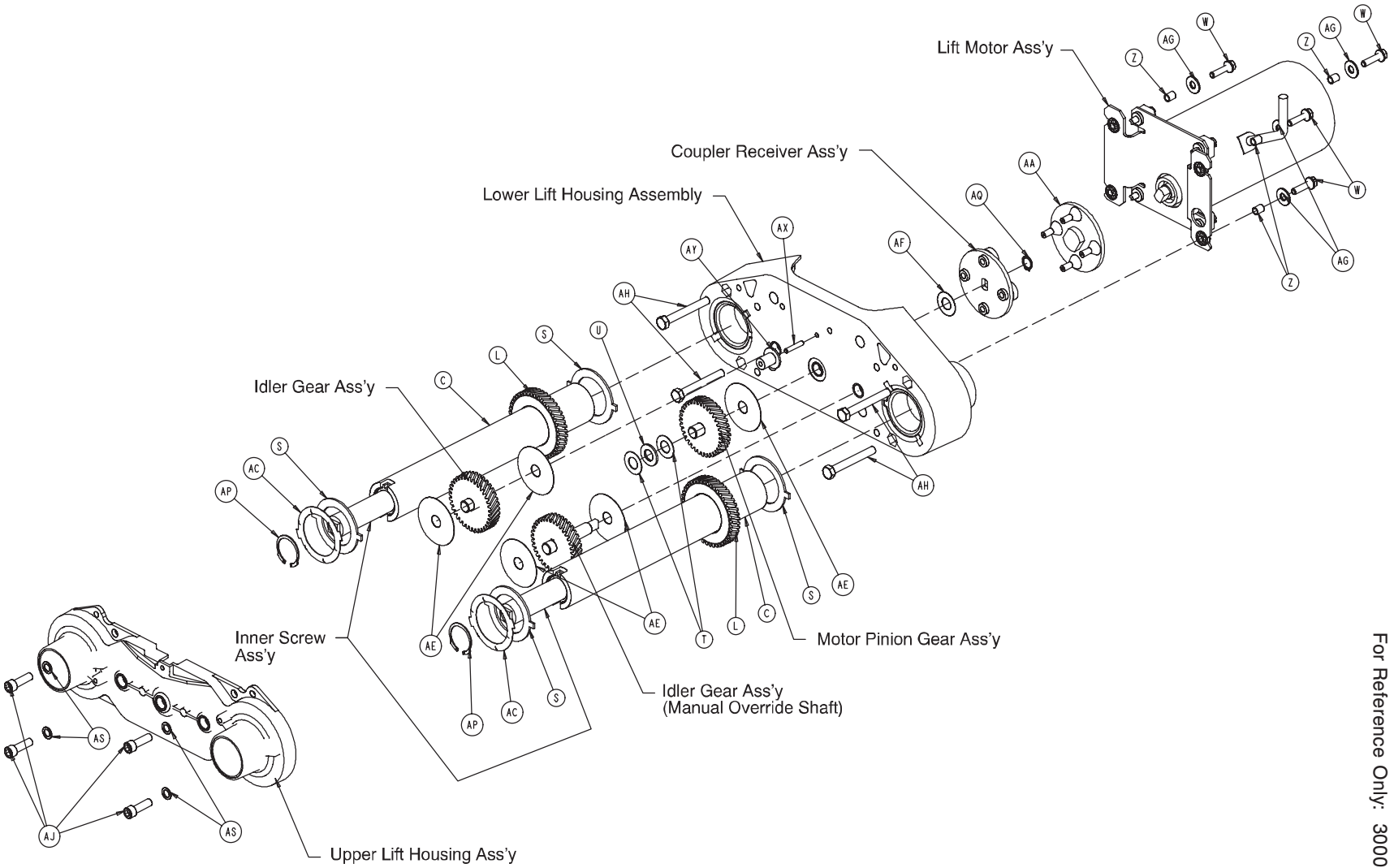

Lift Assembly

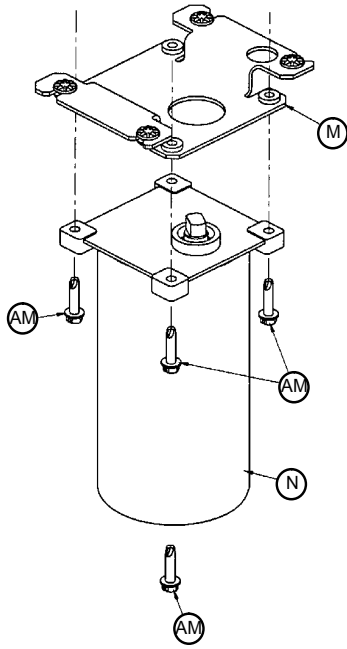

Lift Motor Ass'y

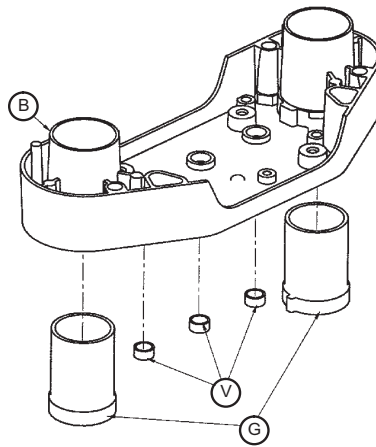

Lower Lift Housing Ass'y

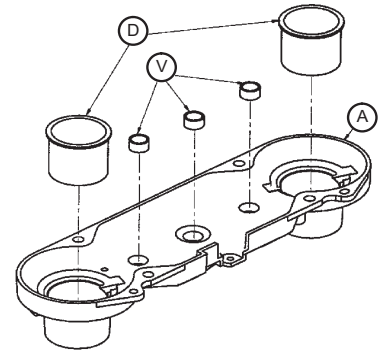

Upper Lift Housing Ass'y

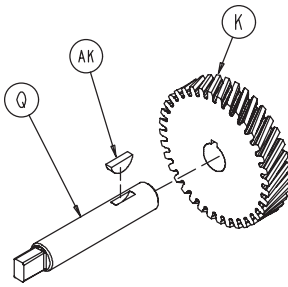

**Idler Gear Ass'y
(Manual Override Shaft)**

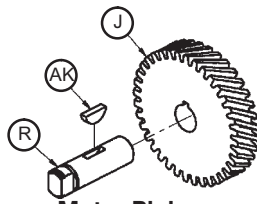

**Motor Pinion
Gear Ass'y**

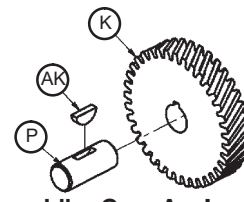

Idler Gear Ass'y

P/N 3000-200-249 (shown)

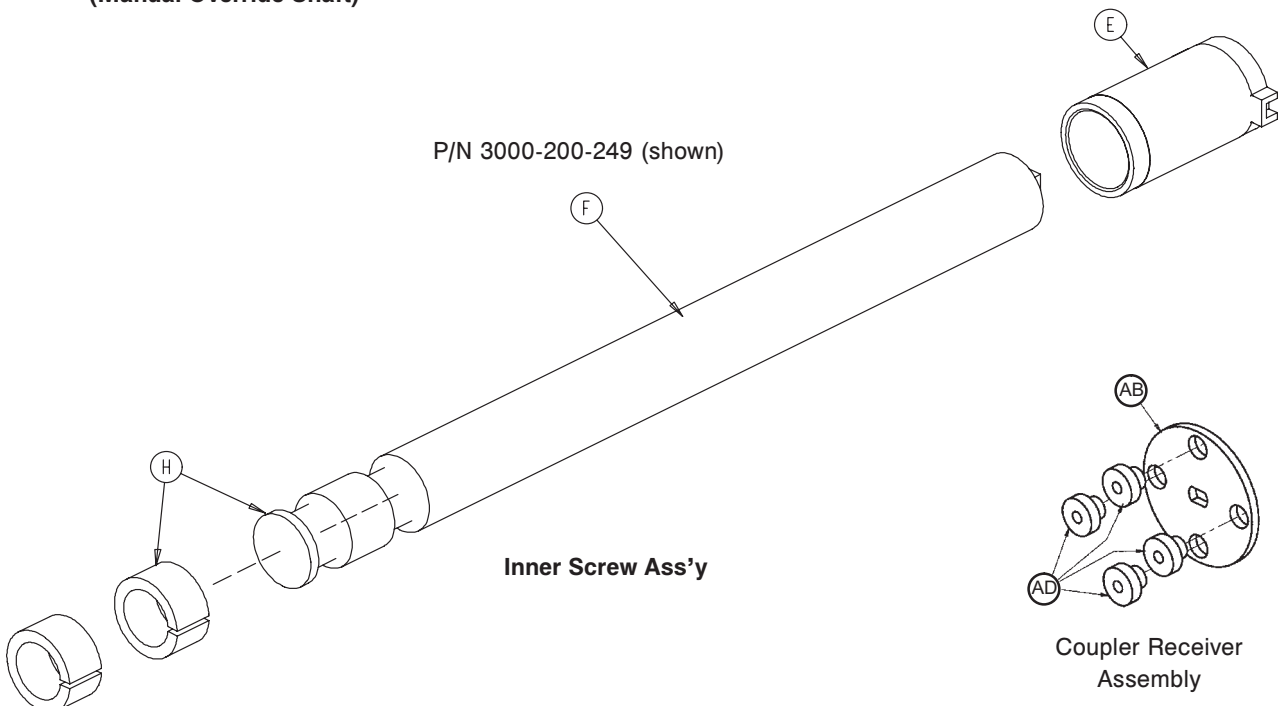

Inner Screw Ass'y

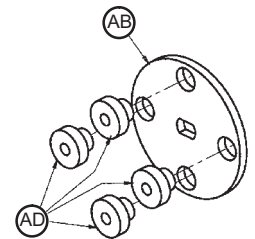

**Coupler Receiver
Assembly**

[Return To Table of Contents](#)

Lift Assembly

Lift Assembly Common Components - 3000-200-275 (Reference Only)

Item	Part No.	Part Name	Qty.
A	3000-200-201	Upper Lift Housing	1
B	3000-200-202	Lower Lift Housing	1
C	3000-200-251	Outer Screw	2
D	3000-200-204	Upper Housing Sleeve	2
E	3000-200-205	Upper Stage Nut	2
G	3000-200-207	Lower Stage Nut	2
H	3000-200-208	Glide Bushing	4
J	3000-200-209	Motor Pinion Gear	1
K	3000-200-210	Idler Gear	2
L	3000-200-252	Output Gear	2
M	3001-200-214	Motor Isolation Plate Assembly (pg.120)	1
N	3003-016-603	Lift Motor	1
	3221-200-213	230V Lift Motor	1
P	3000-200-218	Idler Shaft, Lift	1
Q	3002-200-235	Manual Override Drive Shaft	1
R	3000-200-220	Input Pinion Shaft	1
S	3000-200-223	Output Gear Thrust Washer	4
T	3000-200-224	Input Gear Thrust Washer	2
U	0081-212-000	Thrust Needle Roller Bearing	1
V	3000-200-226	Pinion Shaft Bushing	6
W	3001-200-228	Mounting Standoff	4
Z	3001-300-019	Isolation Sleeve	4
AA	3000-200-233	Lift Motor Coupler	1
AB	3000-200-234	Coupler Receiver	1
AC	3000-200-241	Crush Washer	2
AD	3000-300-455	Isolation Bushing	4
AE	3000-200-245	Gear Washer	5
AF	3000-200-246	Nylon Washer	1
AG	0011-408-000	Flat Washer	4
AH	0003-082-000	Hex Head Cap Screw	4
AJ	0004-213-000	Socket Head Cap Screw	4
AK	0058-044-000	Woodruff Key	3
AM	0003-331-000	Hex Washer Head Screw	4
AP	0028-121-000	Retaining Ring	2
AQ	0028-097-000	Retaining Ring	1
AS	0011-308-000	Serrated Belleville Washer	4
AX	3000-200-239	Potentiometer Drive Gear Shaft	1
AY	3000-200-216	Potentiometer Drive Gear	1

Motor Isolation Plate Assembly

3000-200-723

For Reference Only: 3001-200-214

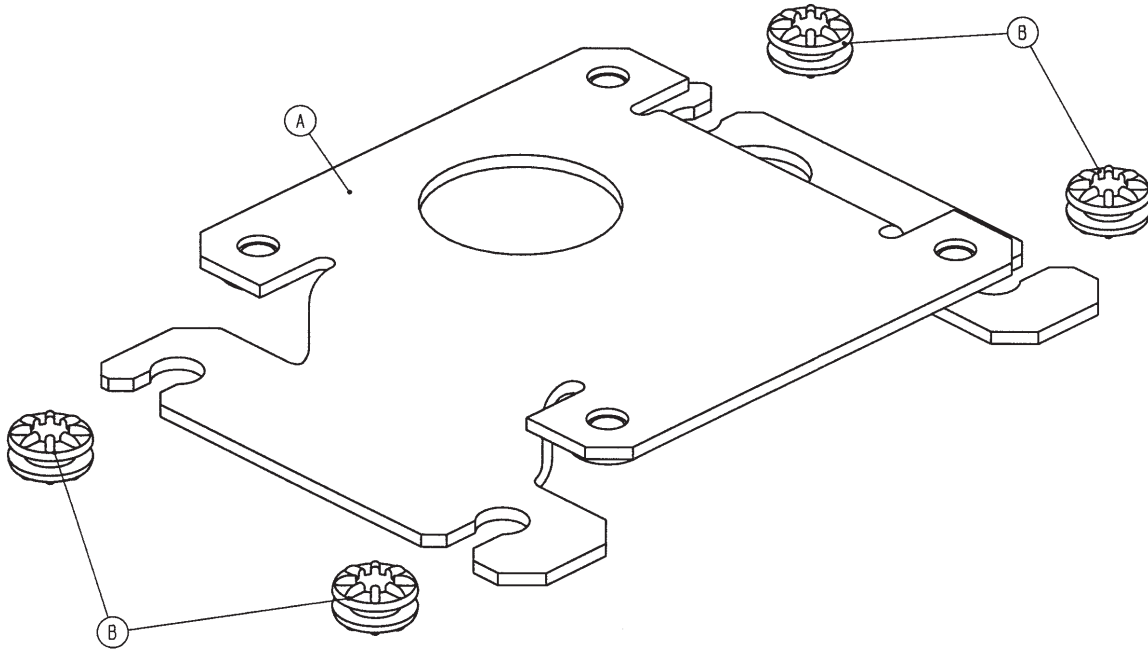

Item	Part No.	Part Name	Qty.
A	3001-200-213	Isolation Plate	1
B	3000-300-442	Grommet	4

Brake Shaft Assembly, Left

3001-200-340

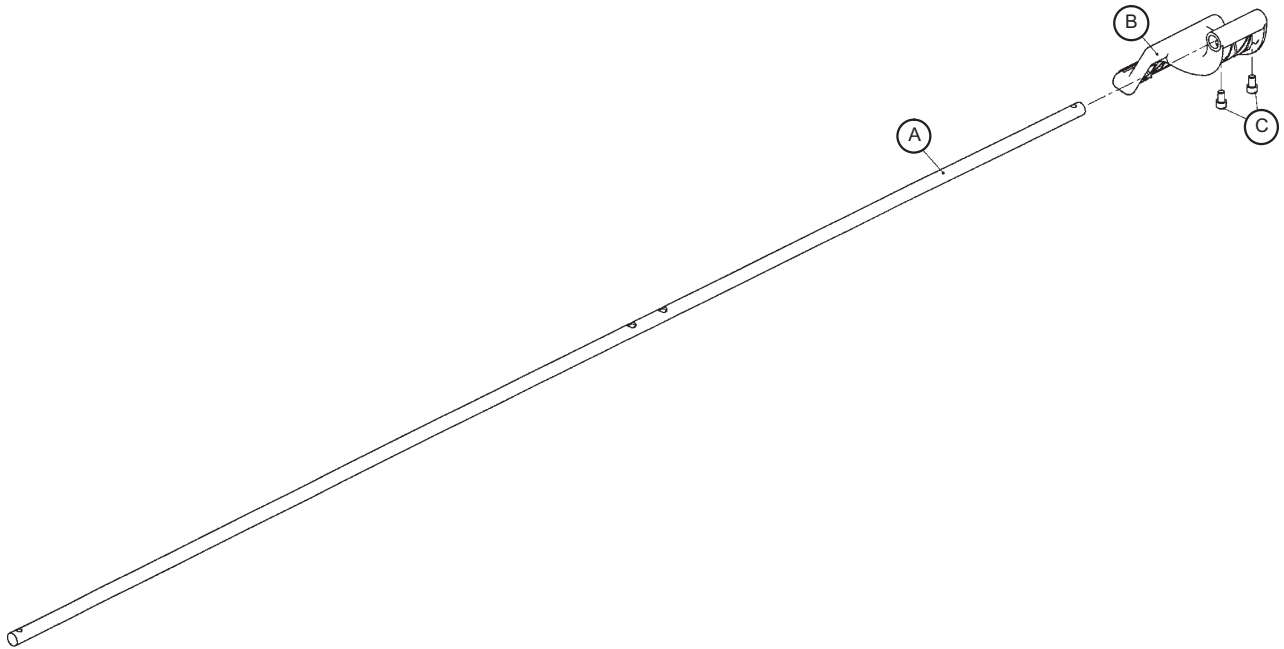

Brake Shaft Assembly, Right

3001-200-345

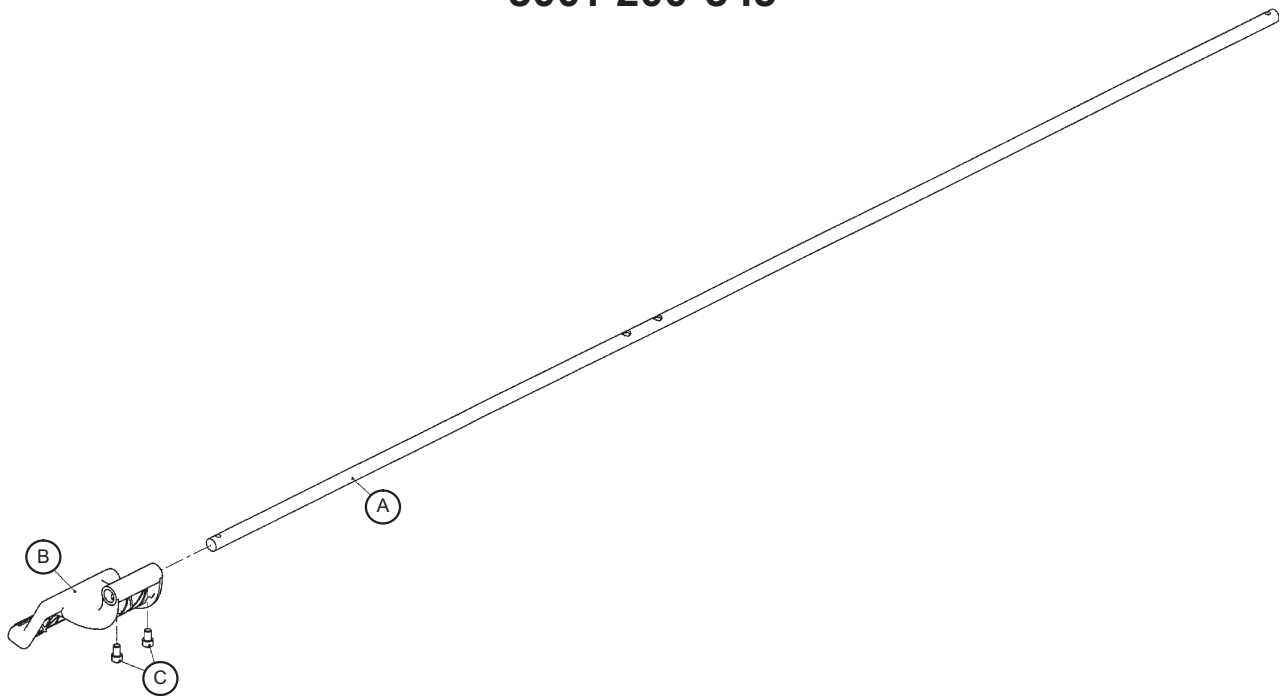

Item	Part No.	Part Name	Qty.
A	3000-200-314	Brake Shaft	1
B	3001-200-325	Brake Pedal	1
C	0004-270-000	Socket Head Cap Screw	2

[Return To Table of Contents](#)

Brake Crank Assembly

3002-200-330

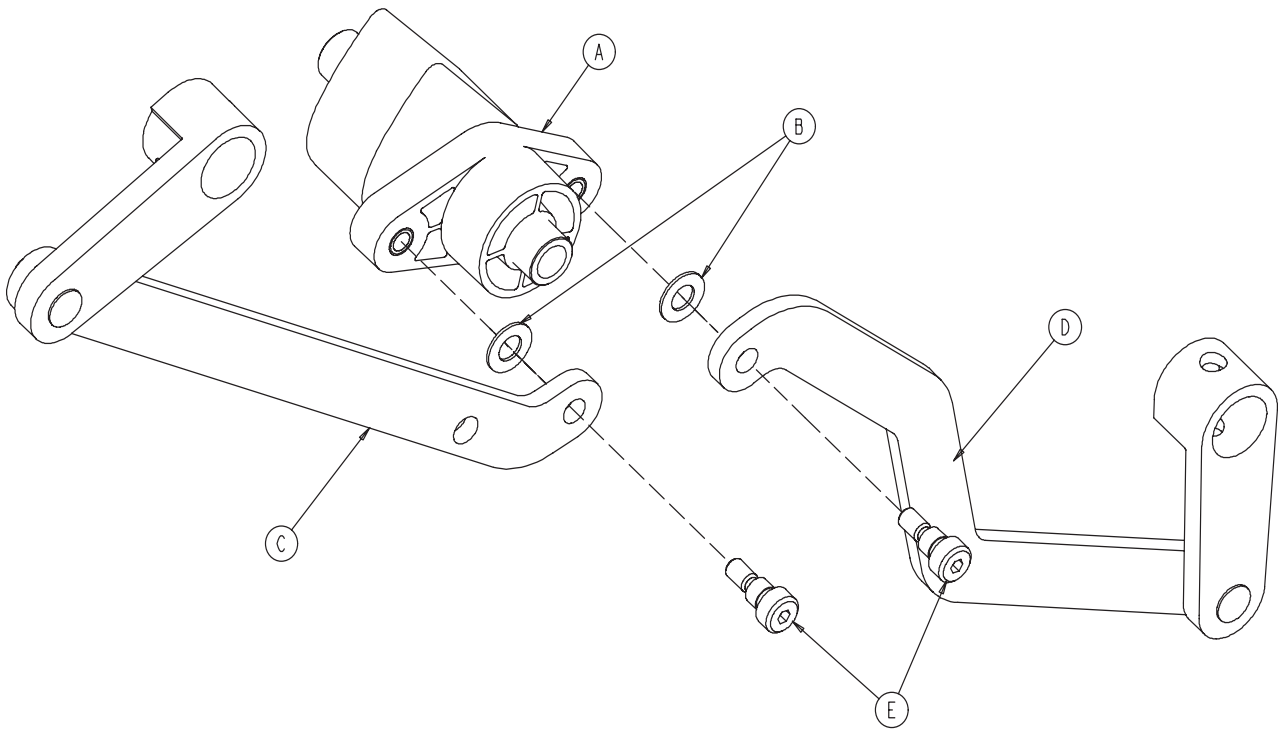

Item	Part No.	Part Name	Qty.
A	3002-201-309	Brake Cam Shaft Crank	1
B	0014-004-000	Washer	2
C	3002-200-331	Brake Link	1
D	3002-200-332	Dog Leg Brake Link	1
E	0002-108-000	Socket Head Shoulder Screw	2

Brake Bar Assembly

3002-200-335

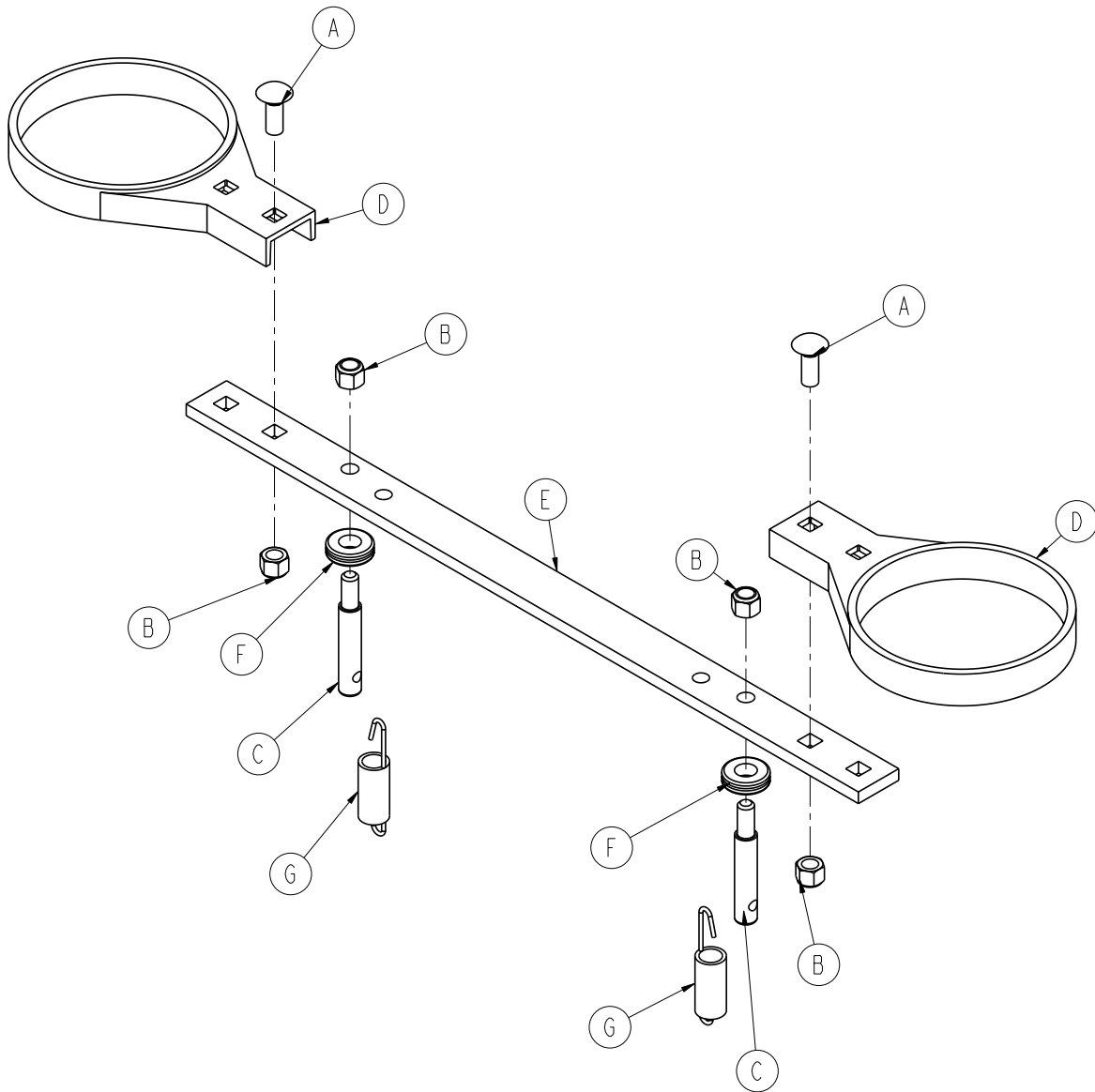

Item	Part No.	Part Name	Qty.
A	0005-018-000	Carriage Bolt	2
B	0016-035-000	Nylock Hex Nut	2
C	3000-200-318	Guide Pin	2
D	3000-200-321	Brake Ring	2
E	3003-200-323	Brake Bar	1
F	3000-200-324	Brake Bar Bumper	2
G	3002-200-310	Brake Bar Return Spring	2

[Return To Table of Contents](#)

6" Caster Assembly

3001-200-060

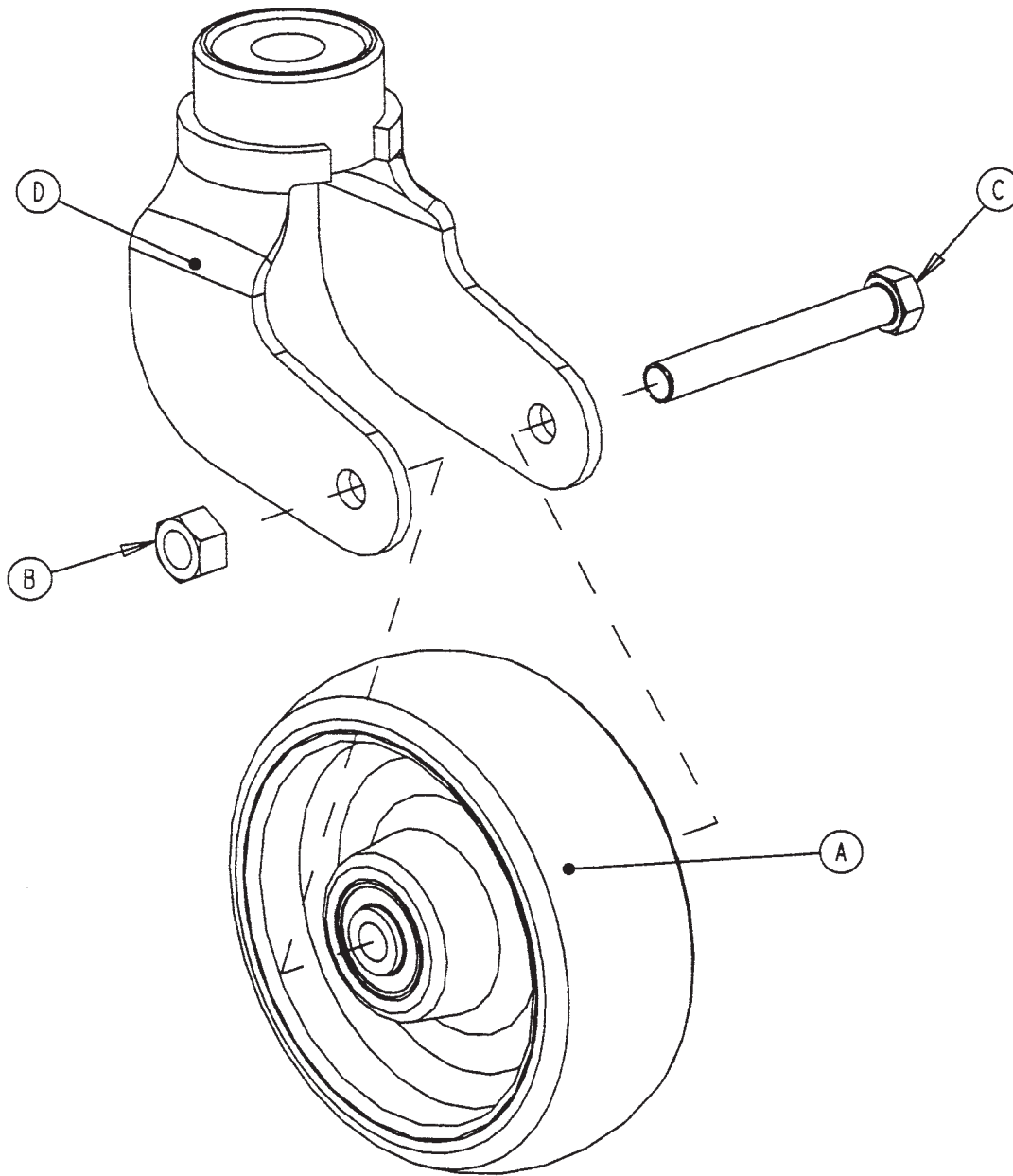

Item	Part No.	Part Name	Qty.
A	5000-002-010	Wheel Assembly (pg.126)	1
B	0016-060-000	Lock Nut	1
C	0003-342-000	Hex Head Cap Screw	1
D	3001-200-061	Caster Horn with Bearing	1

6" Steer Caster Assembly

3001-200-050

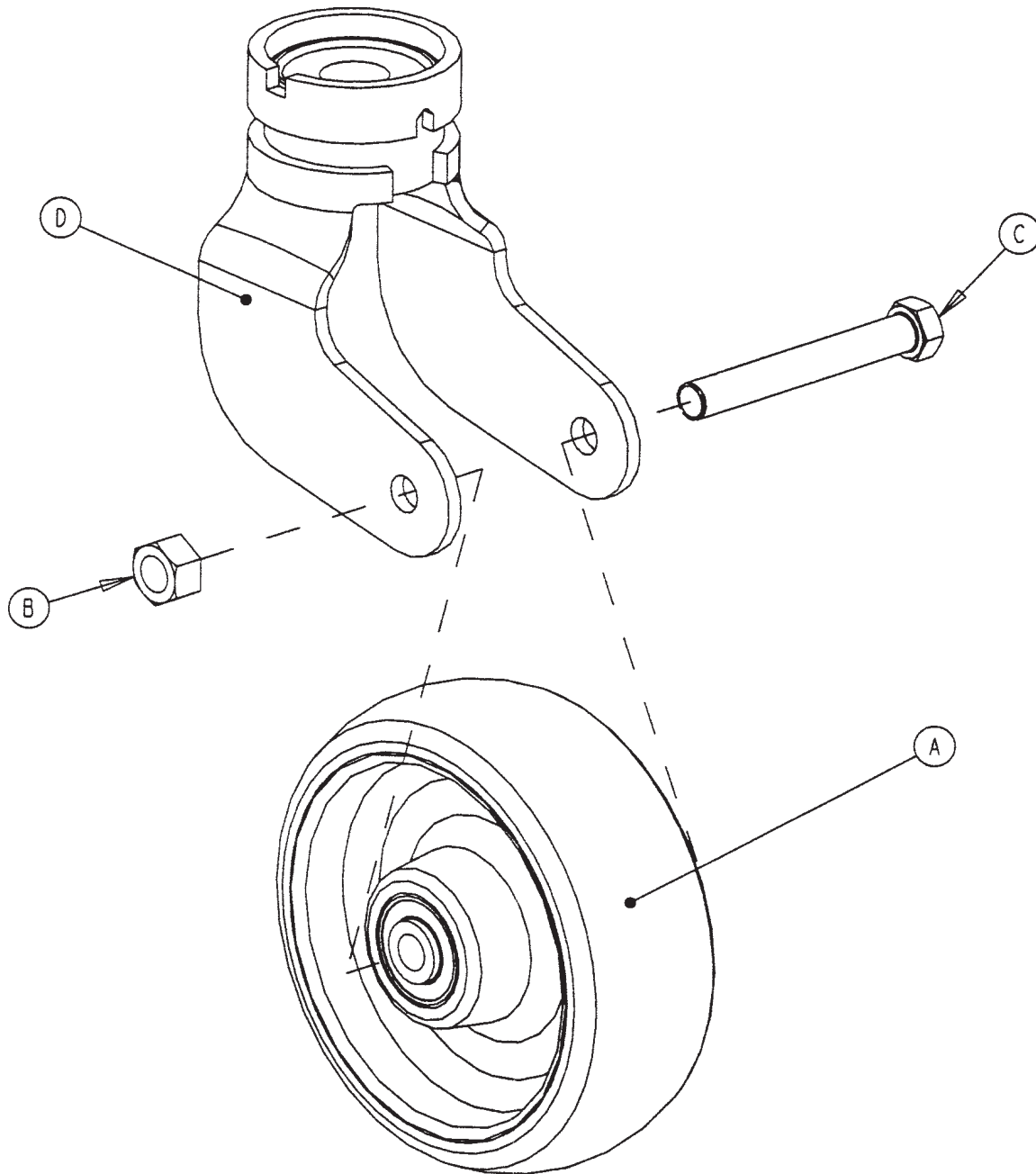

Item	Part No.	Part Name	Qty.
A	5000-002-010	Wheel Assembly (pg.126)	1
B	0016-060-000	Lock Nut	1
C	0003-342-000	Hex Head Cap Screw	1
D	3001-200-051	Steer Caster Horn with Bearing	1

[Return To Table of Contents](#)

6" Molded Wheel Assembly

5000-002-010

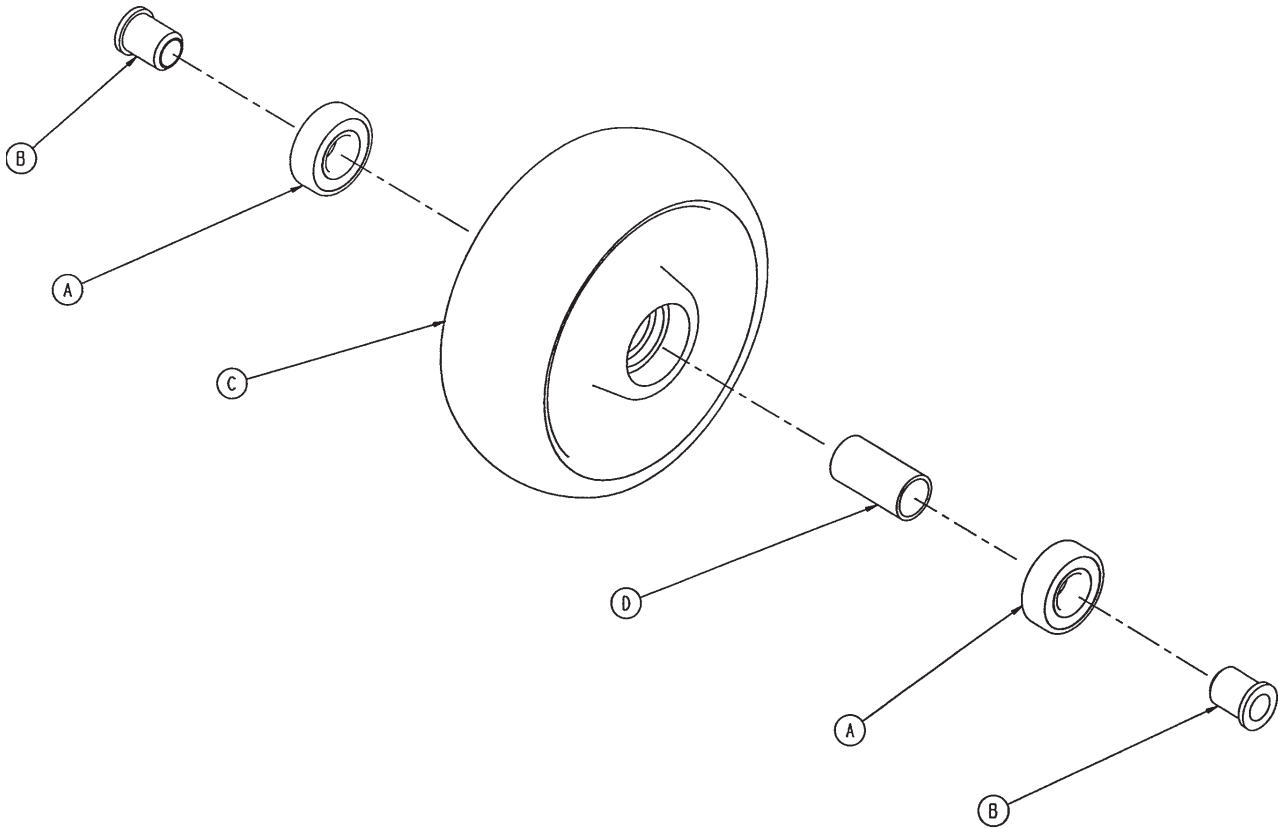

Item	Part No.	Part Name	Qty.
A	0081-226-000	Bearing	2
B	0715-001-255	Wheel Bushing	2
C	5000-002-020	Molded Wheel	1
D	6060-002-046	Bearing Spacer	1

Base Uni-Pan Cover Assembly

3002-300-010

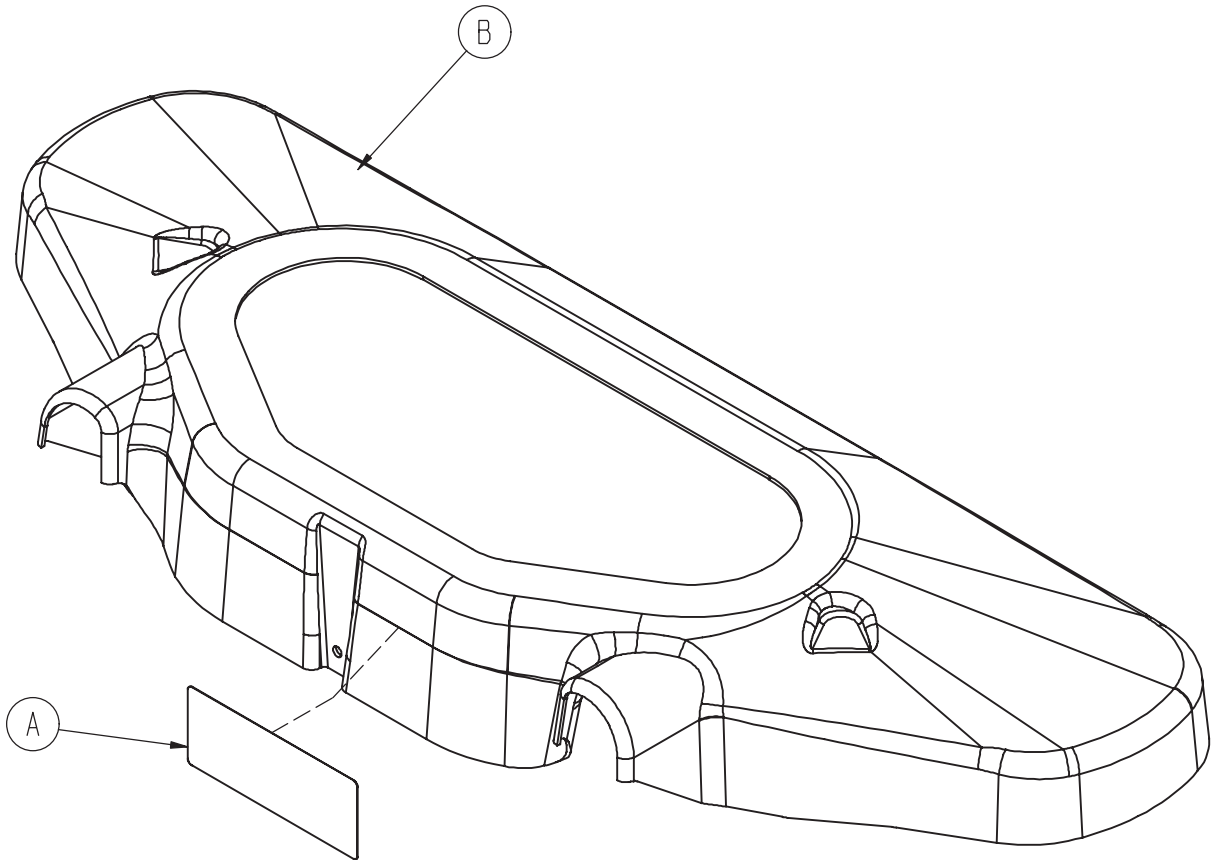

Item	Part No.	Part Name	Qty.
A	0988-002-708	Service Caution Label	1
B	3002-300-009	Uni-Pan Cover	1

[Return To Table of Contents](#)

Base Assembly with Zoom® Option

For Reference Only: 3002-001-001

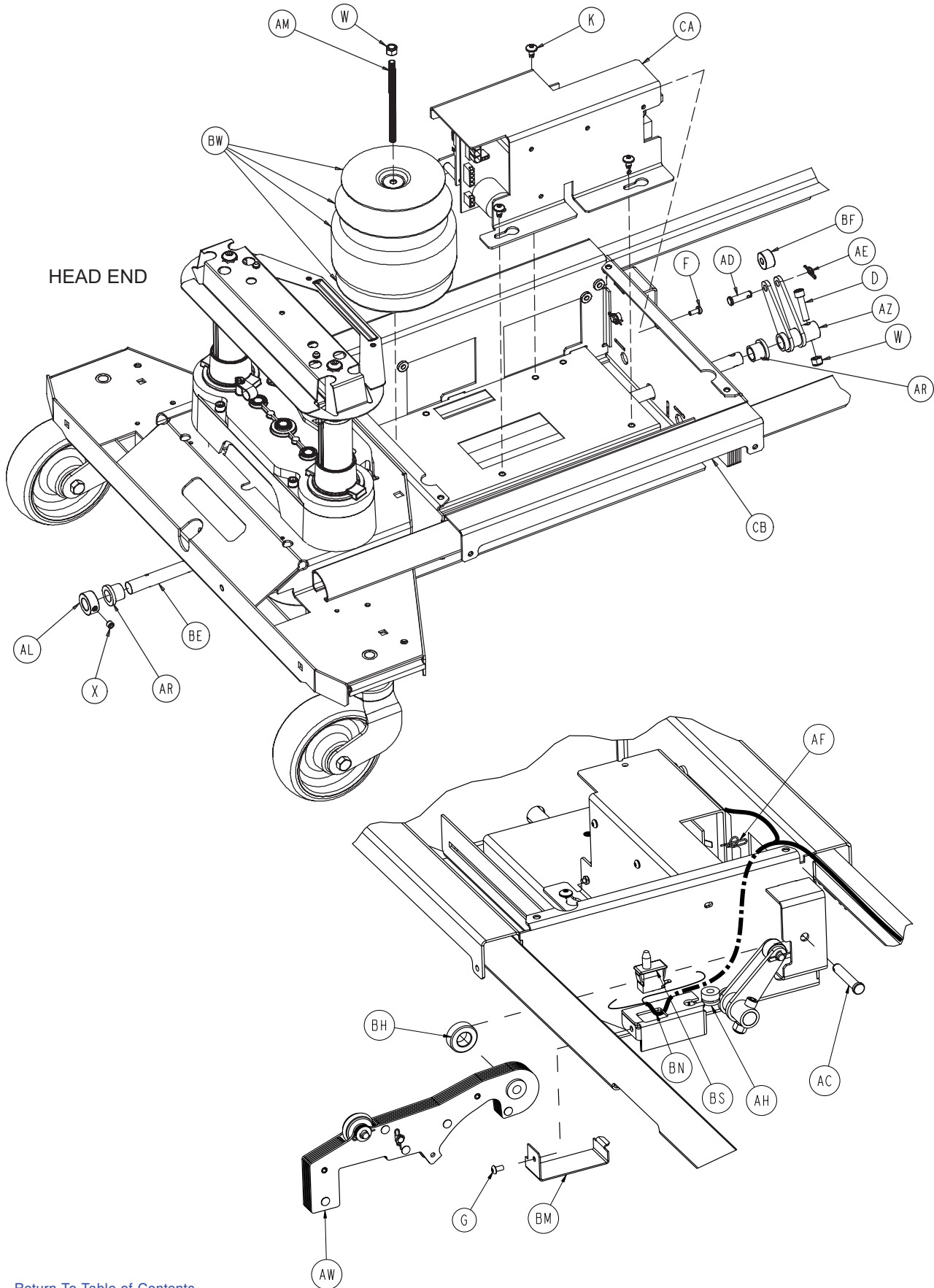

[Return To Table of Contents](#)

Base Assembly with Zoom® Option

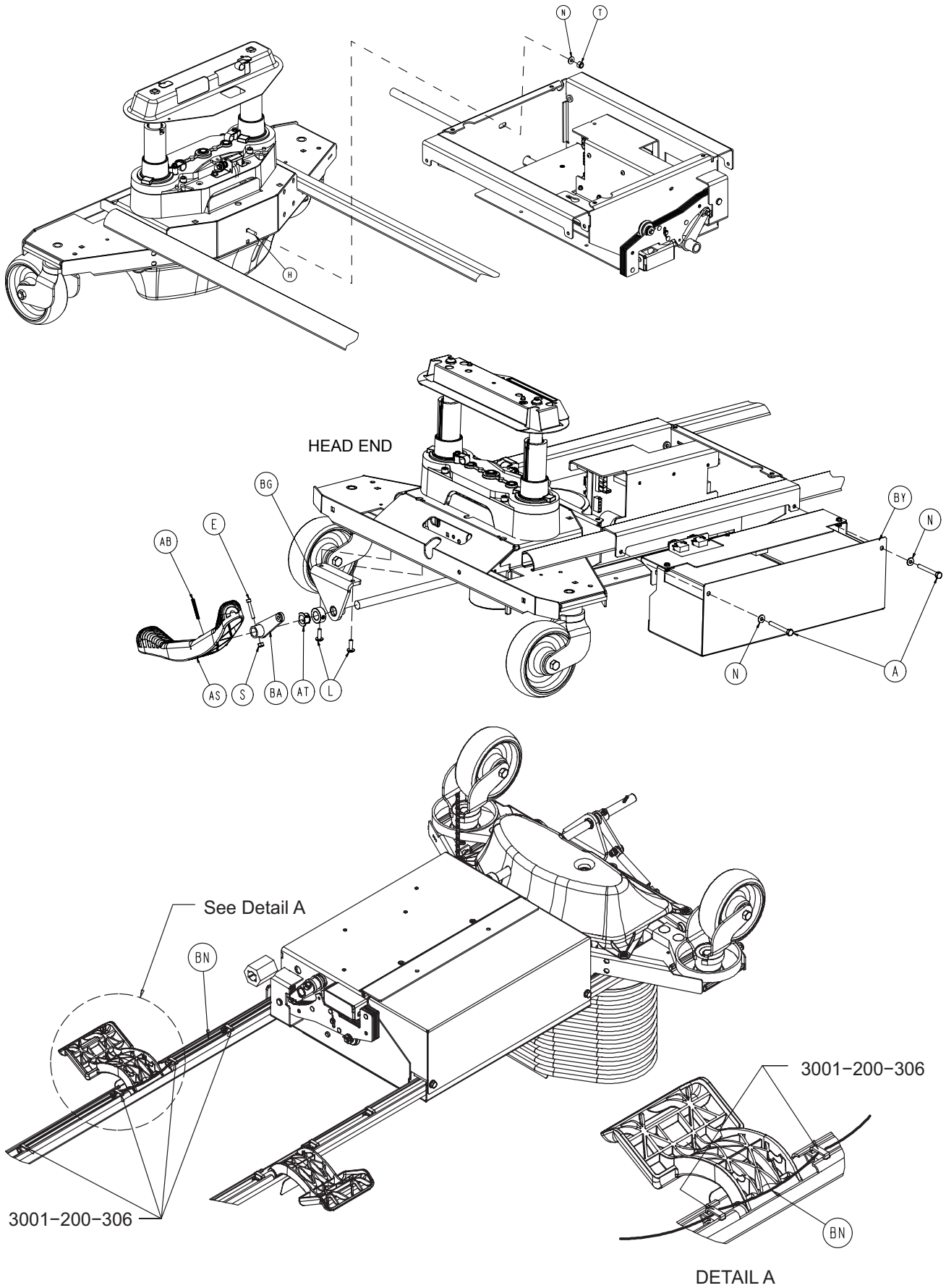

[Return To Table of Contents](#)

Base Assembly with Zoom® Option

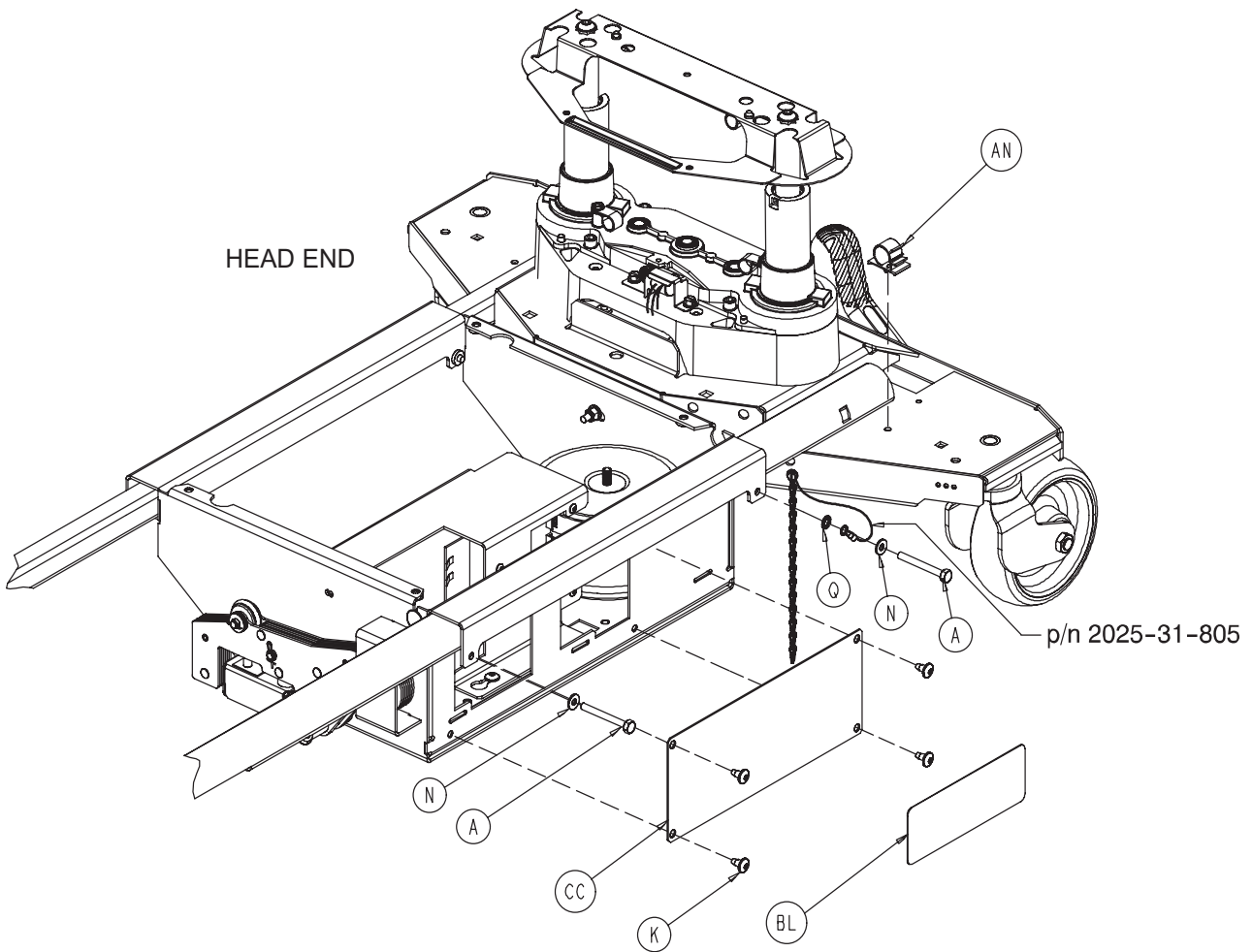
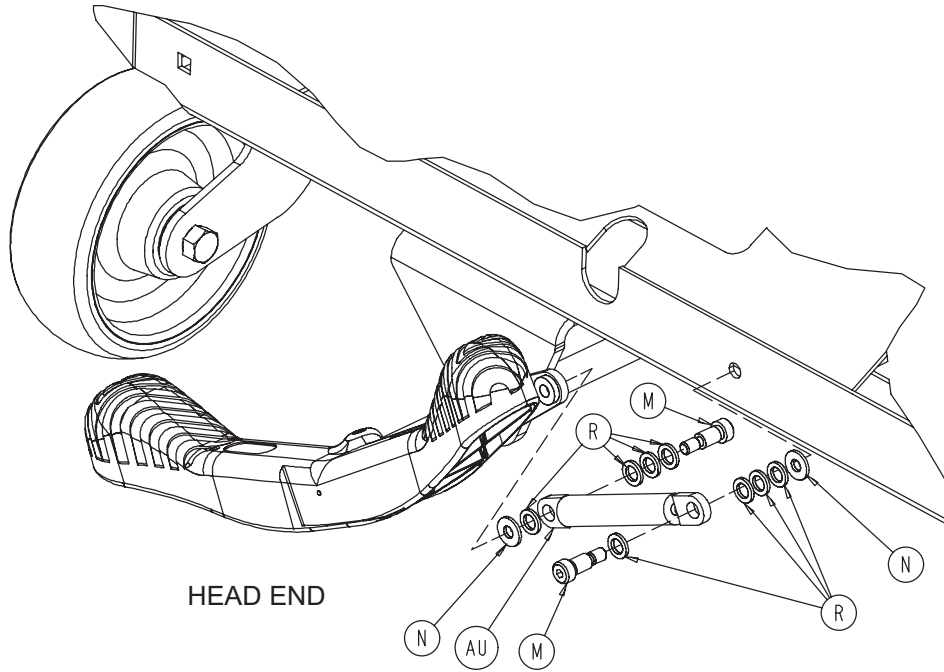

Base Assembly with Zoom® Option

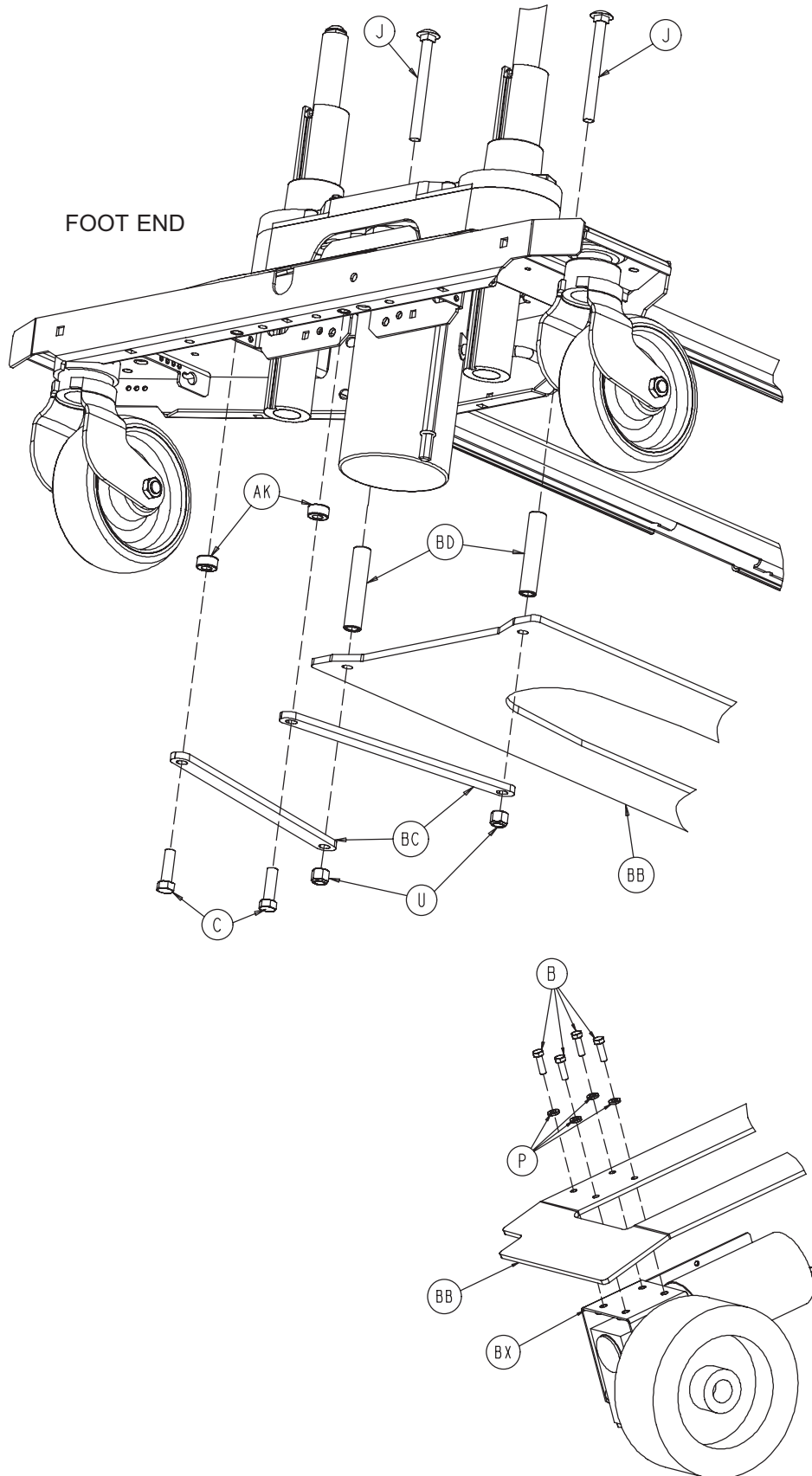

[Return To Table of Contents](#)

Base Assembly with Zoom® Option

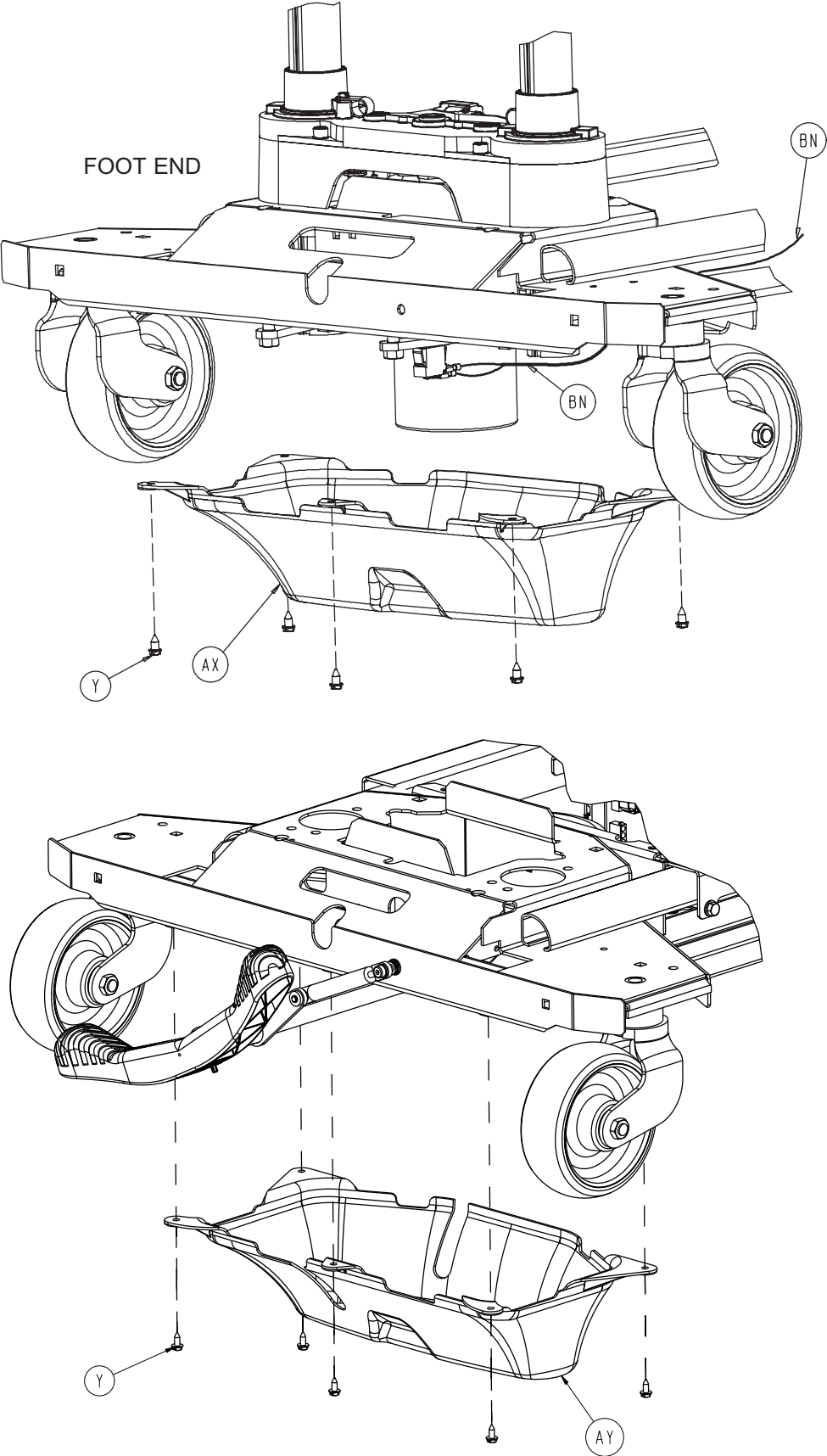

Base Assembly with Zoom® Option

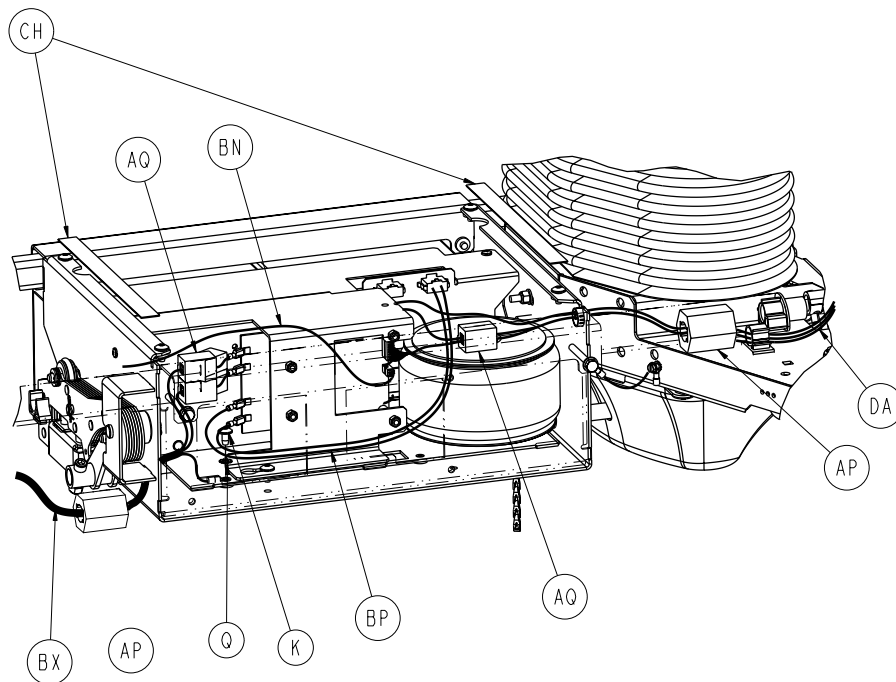
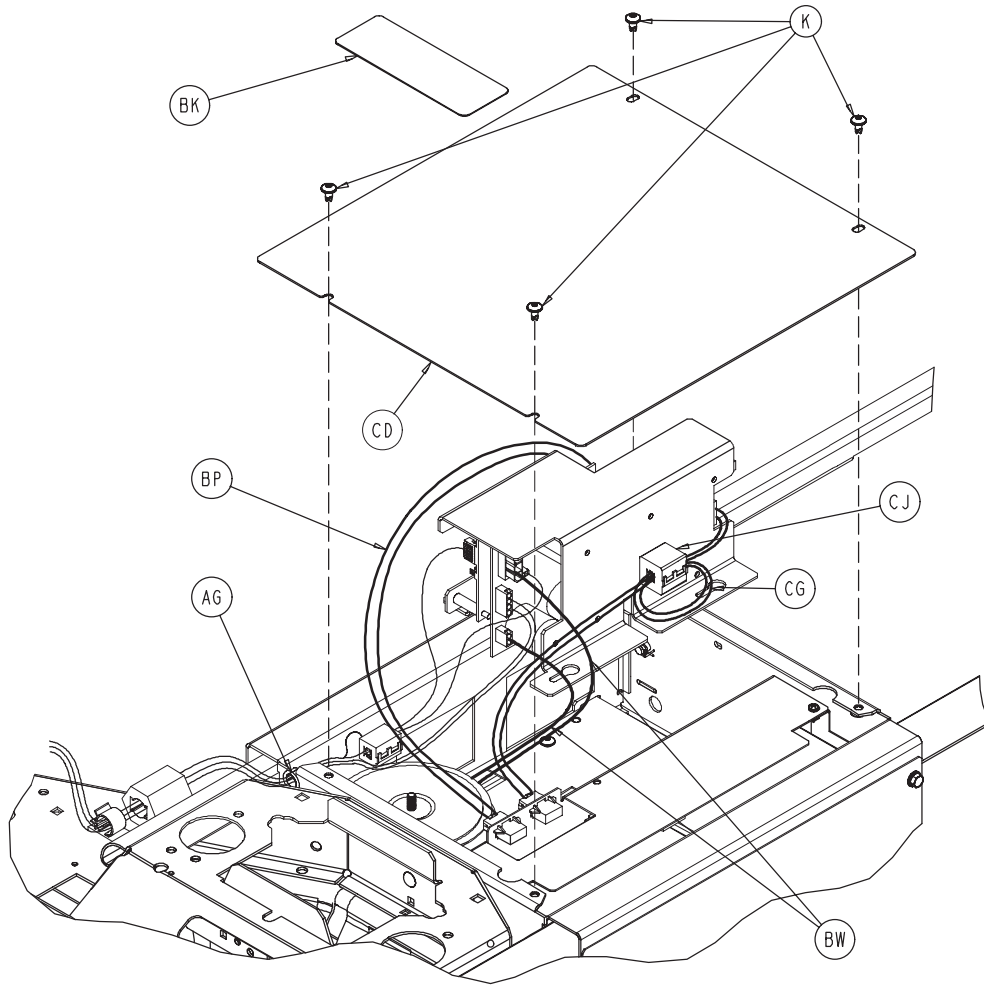

[Return To Table of Contents](#)

Base Assembly with Zoom® Option

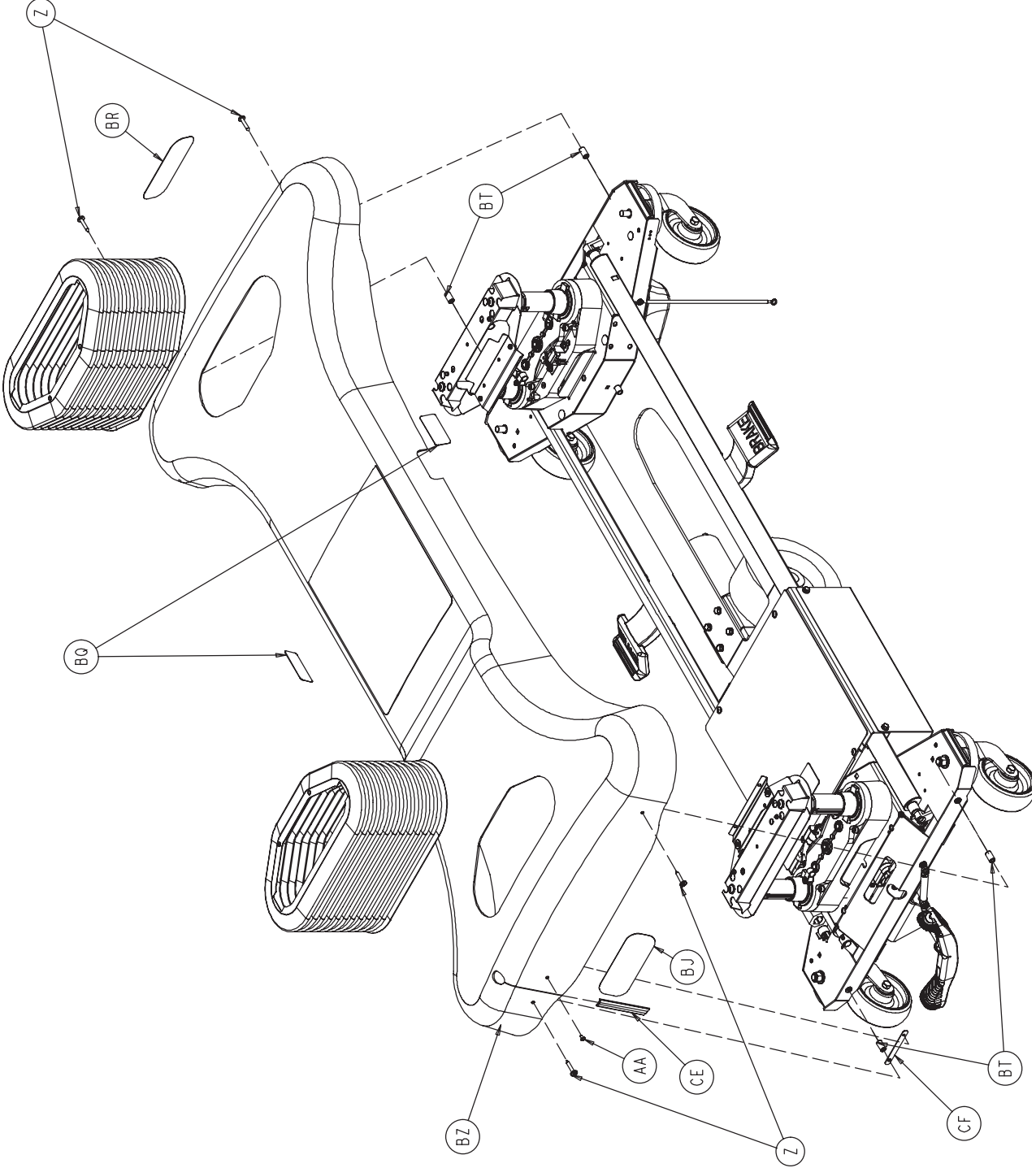

Base Assembly with Zoom® Option

Zoom Option Common Components - 3002-001-001 (Reference Only)

Item	Part No.	Part Name	Qty.	Item	Part No.	Part Name	Qty.
A	0003-032-000	Hex Head Cap Screw	4	AT	1210-201-251	Insert Bushing	1
C	0003-120-000	Hex Head Cap Screw	2	AU	1210-201-671	Damper	1
D	0004-039-000	Soc. Head Cap Screw	1	AW	2040-001-012	Drive Wheel Lift Lever Assembly (pg.136)	1
E	0004-160-000	Soc. Head Cap Screw	1	AX	3001-200-022	FE Bottom Cover (pg.137)	1
F	0004-301-000	Pan Head Machine Screw	1	AY	2040-001-017	HE Bottom Cover (pg.137)	1
G	0004-307-000	Soc. Button Head Cap Screw	1	AZ	2040-001-051	Pedal Crank Weldment	1
H	0005-017-000	Carriage Bolt	1	BA	2040-001-053	Damper Crank Weldment	1
J	0005-031-000	Carriage Bolt	2	BB	2040-001-060	Leaf Spring	1
K	0007-052-000	Truss Head Torx	12	BC	2040-001-061	Tie Down Strap	2
L	0007-063-000	Truss Head Torx	2	BD	2040-001-062	Reinforcement Tube	2
M	0008-049-000	Socket Head Shoulder Bolt	2	BE	2040-001-082	Pedal Rod	1
N	0011-063-000	Washer	7	BF	2040-001-083	Pedal Crank Roller	1
P	0012-020-000	Lock Washer	4	BG	2040-001-084	Pedal Rod Pivot Bracket	1
Q	0013-010-000	Ext. Tooth Star Washer	5	BH	2040-001-098	Lift Lever Spacer	1
R	0014-003-000	Plastic Washer	8	BJ	2040-001-100	Drive Wheel Position Label	1
S	0016-003-000	Nylock Nut	1	BK	2040-001-101	Charger Box Cover Label	1
T	0016-028-000	Nylock Nut	1	BL	2040-001-102	Power Board Cover Label	1
U	0016-035-000	Nylock Nut	2	BM	2040-001-103	Switch Bracket Cover	1
W	0016-036-000	Nylock Nut	2	BN	2040-001-801	Base Switch Cable	1
X	0021-022-000	Set Screw	1	BP	2040-001-804	Power Board DC Pwr. Cable	1
Y	0023-025-000	Hex Washer Head Screw	10	BQ	3000-200-601	Brake Label	2
Z	0023-281-000	Self-Tapping Screw	4	BR	3000-200-602	Stryker Logo Label	1
AA	0025-079-000	Pop Rivet	1	BS	3000-300-058	Limit Switch	1
AB	0026-261-000	Groove Pin	1	BT	3000-300-428	Gatch Link Sleeve	4
AC	0026-277-000	Clevis Pin	1	BU	3000-300-113	Wire Ties	2
AD	0026-297-000	Clevis Pin	1	BW	3002-001-010	Transformer	1
AE	0027-021-000	Rue Ring Cotter	1	BX	3002-001-014	Drive Train Ass'y (pg.138)	1
AF	0027-022-000	Rue Ring Cotter	1	BY	3002-001-015	Battery Tray Ass'y (pg.139)	1
AG	0030-038-000	Split Bushing	1	BZ	3002-001-018	Hood Assembly	1
AH	0030-040-000	E-A-R Grommet	1	CA	3002-001-030	Base Power Ass'y (pg.140)	1
AK	0042-006-000	Collar	2	CB	3002-001-050	Charger Box Weldment	1
AL	0042-020-000	Lock Collar	1	CC	3002-001-068	Power PCB Cover	1
AM	0058-090-000	Threaded Stud	1	CD	3002-001-071	Charger/Inverter Cover	1
AN	0059-133-000	Push-Mount Wire Clip	1	CE	3002-001-078	Hood Slot Trim	1
AP	0059-192-000	Split Ferrite	1	CF	3002-001-079	Hood Slot Trim Bracket	1
AQ	0059-194-000	Split Ferrite	3	CG	3002-001-802	Inverter/Battery Cable	1
AR	0081-245-000	Bronze Bushing	2	CH	7000-001-326	Foam Tape (10")	2
AS	1210-201-153	Butterfly "V" Pedal	1	CJ	0059-144-000	Split Ferrite	1

Zoom Base, 6" Casters - 3002-44-010 (Reference Only)

Item	Part No.	Part Name	Qty
B	0003-085-000	Hex Hd. Cap Screw	4
DA	3002-001-801	Umbilical Cable Ass'y	1

[Return To Table of Contents](#)

Zoom® Option Drive Wheel Lift Lever Assembly

2040-001-012

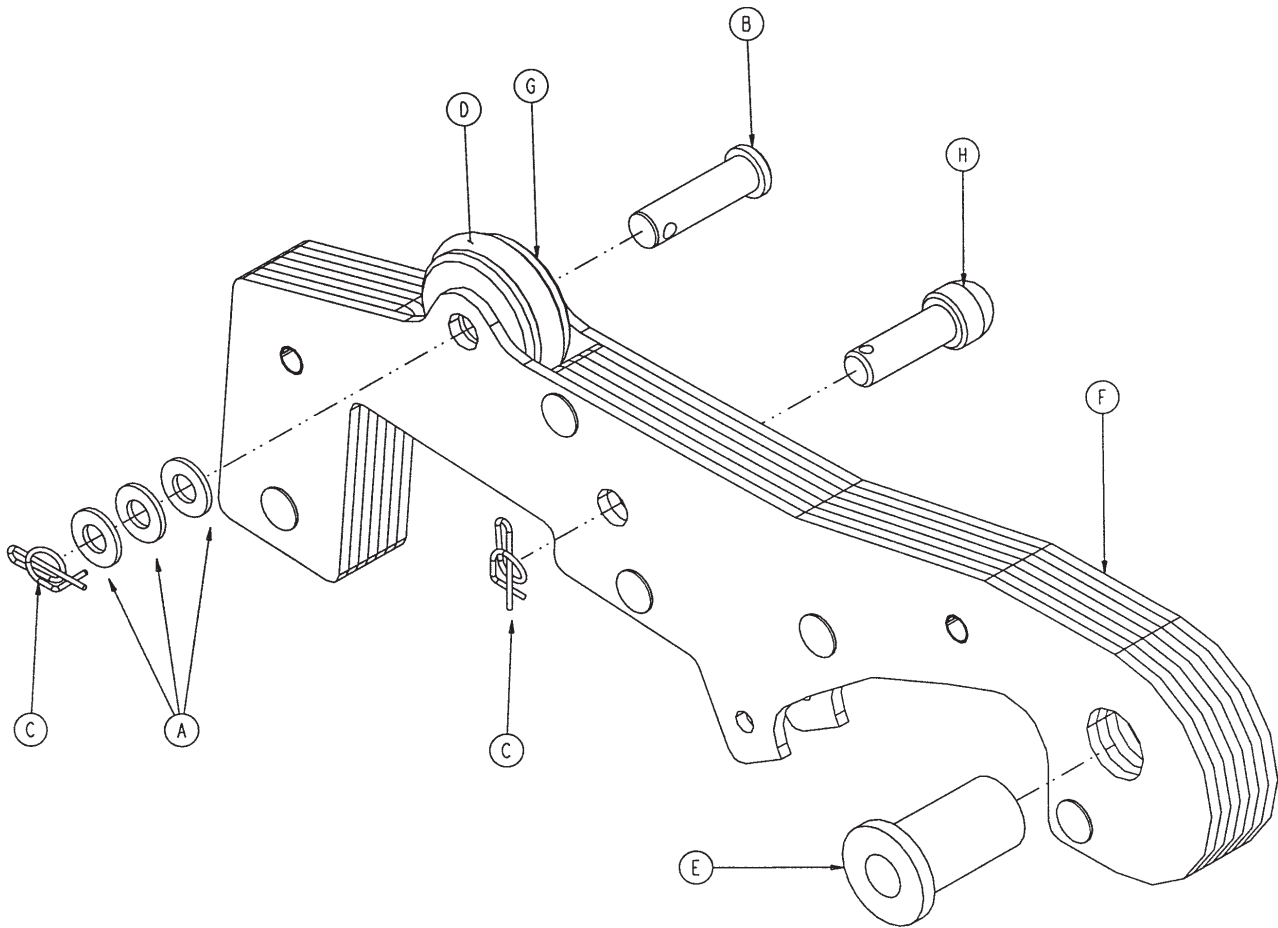

Item	Part No.	Part Name	Qty.
A	0011-003-000	Washer	3
B	0026-297-000	Clevis Pin	1
C	0027-021-000	Rue Ring	2
D	0045-232-000	O-Ring	1
E	0081-070-000	Flange Bearing	1
F	2040-201-013	Drive Wheel Lift Plate Ass'y	1
G	2040-001-087	Lift Lever Roller	1
H	2040-001-099	Lift Lever Guide	1

Bottom Cover

3001-200-022

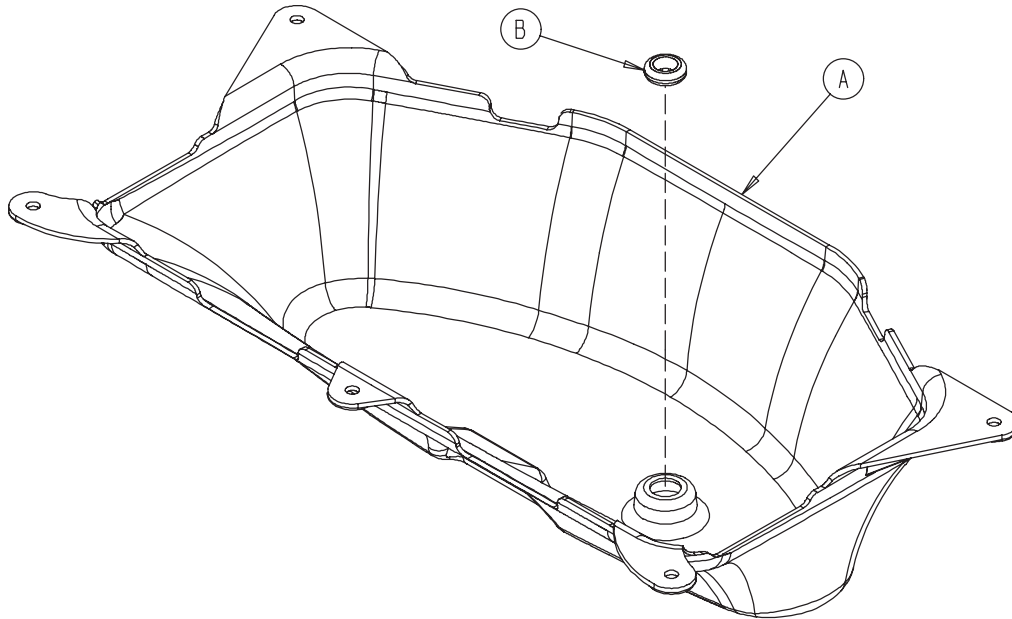

Item	Part No.	Part Name	Qty.
A	3002-001-100	Bottom Cover	1
B	3000-000-039	Grommet	1

Zoom Option Head End Bottom Cover

2040-001-017

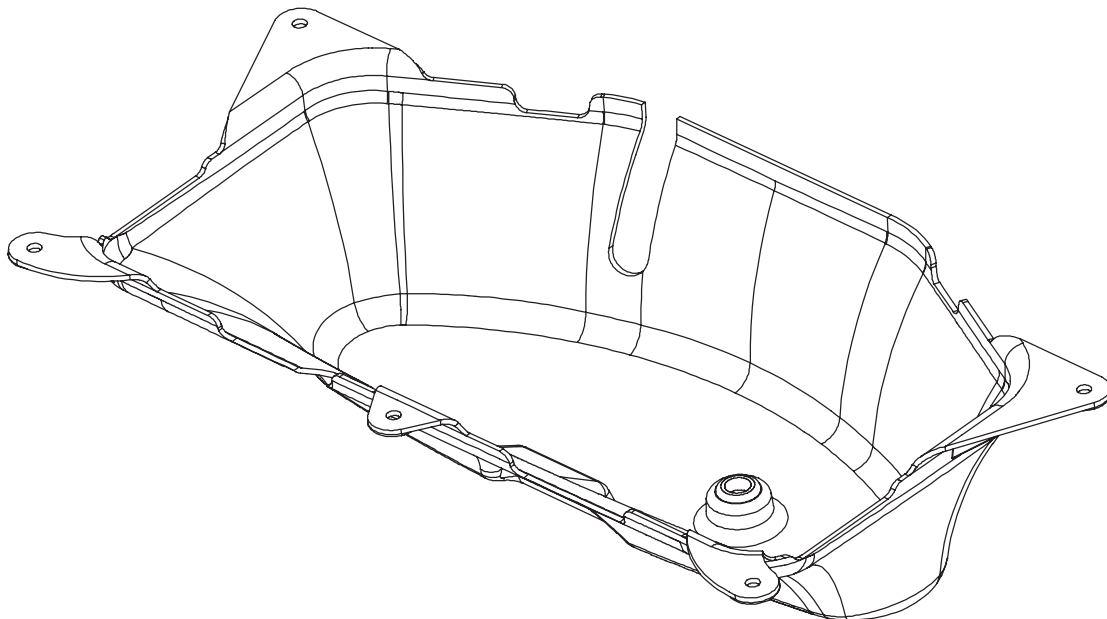

[Return To Table of Contents](#)

Zoom Option Drive Train Assembly

3002-001-014

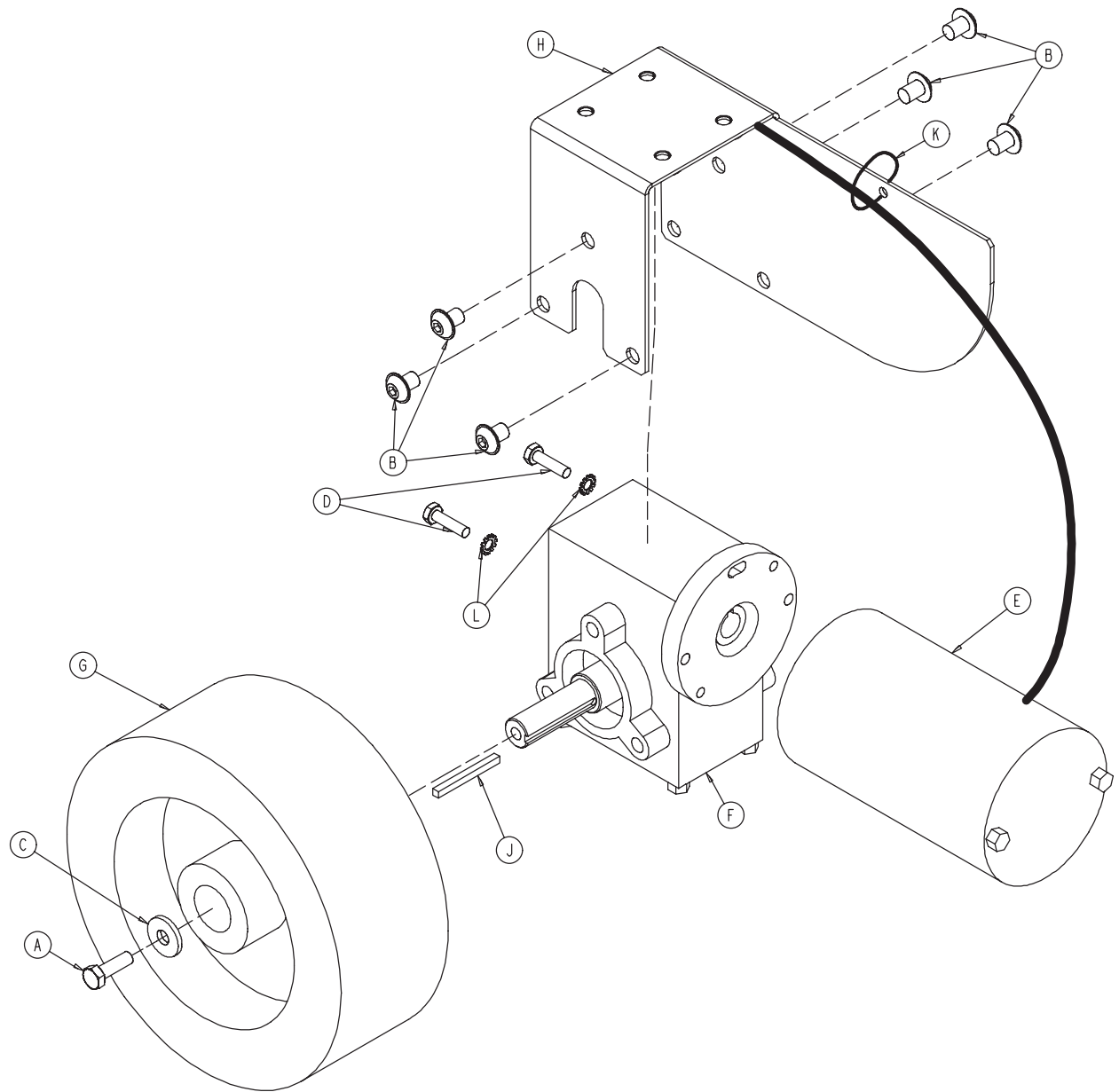

Item	Part No.	Part Name	Qty.
A	8839-793-700	Hex Head Cap Screw	1
B	0004-338-000	Flanged Button Head Cap Screw	6
C	0011-262-000	Washer	1
D	0003-054-000	Hex Head Cap Screw	2
E	3002-001-072	Drive Train Motor	1
F	2040-001-073	Gear Box	1
G	2040-001-074	Drive Train Wheel	1
H	2040-001-075	Motor Mounting Bracket	1
J	2040-001-097	Square Key	1
K	3000-300-113	Wire Tie	1
L	0013-010-000	Star Washer	2

Zoom Option Battery Tray Assembly

Battery Kit Part Number 2040-700-013 (Includes Two Batteries)

For Reference Only: 3002-001-015

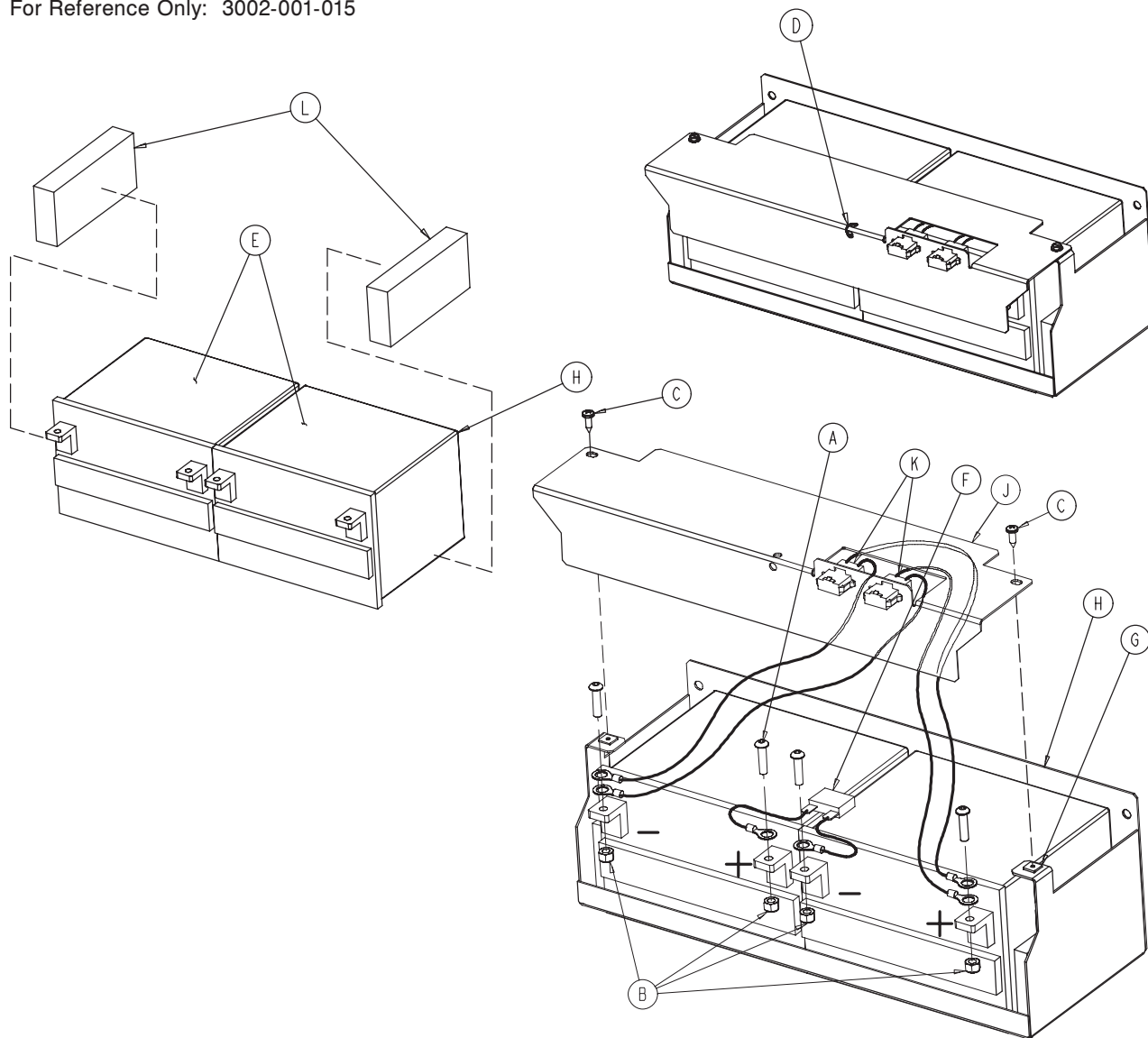

Item	Part No.	Part Name	Qty.
A	0004-046-000	But. Head Cap Screw	4
B	0016-028-000	Nylock Nut	4
C	0023-256-000	Pan Head Screw	2
D	0038-151-000	Cable Tie	1
E	2040-001-070	Battery	2
F	2040-001-802	Battery Jumper Cable	1
G	3000-300-002	Push Nut	2
H	3002-001-069	Battery Tray	1
J	3002-001-091	Terminal Guard	1
K	3002-001-803	Battery Harness Cable	2
L	3002-101-043	Foam Spacer	2

[Return To Table of Contents](#)

Zoom Option Base Power Assembly

3002-001-030

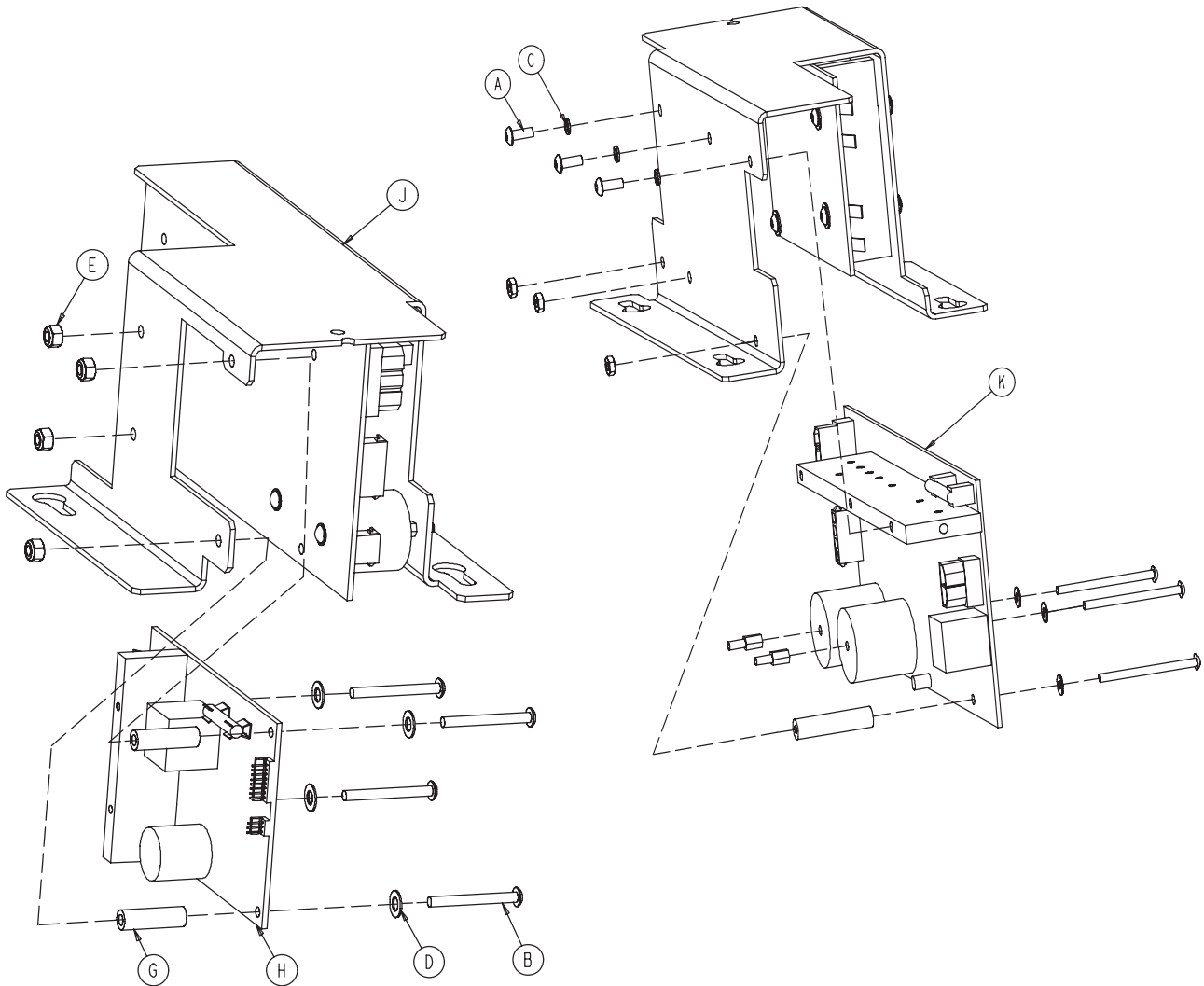

Item	Part No.	Part Name	Qty.
A	0004-263-000	But. Head Cap Screw	3
B	0004-315-000	But. Head Cap Screw	4
C	0012-006-000	Helical Lock Washer	3
D	0014-004-000	Nylon Washer	4
E	0016-002-000	Fiberlock Nut	4
G	0059-187-000	Spacer	2
H	2040-001-900	Power Board	1
J	3002-001-017	Charger/Inverter Heat Bracket	1
K	3002-001-930	Charger/Inverter Board Assembly	1

Base Assembly with Battery Backup Option

For Reference Only: 3002-350-170

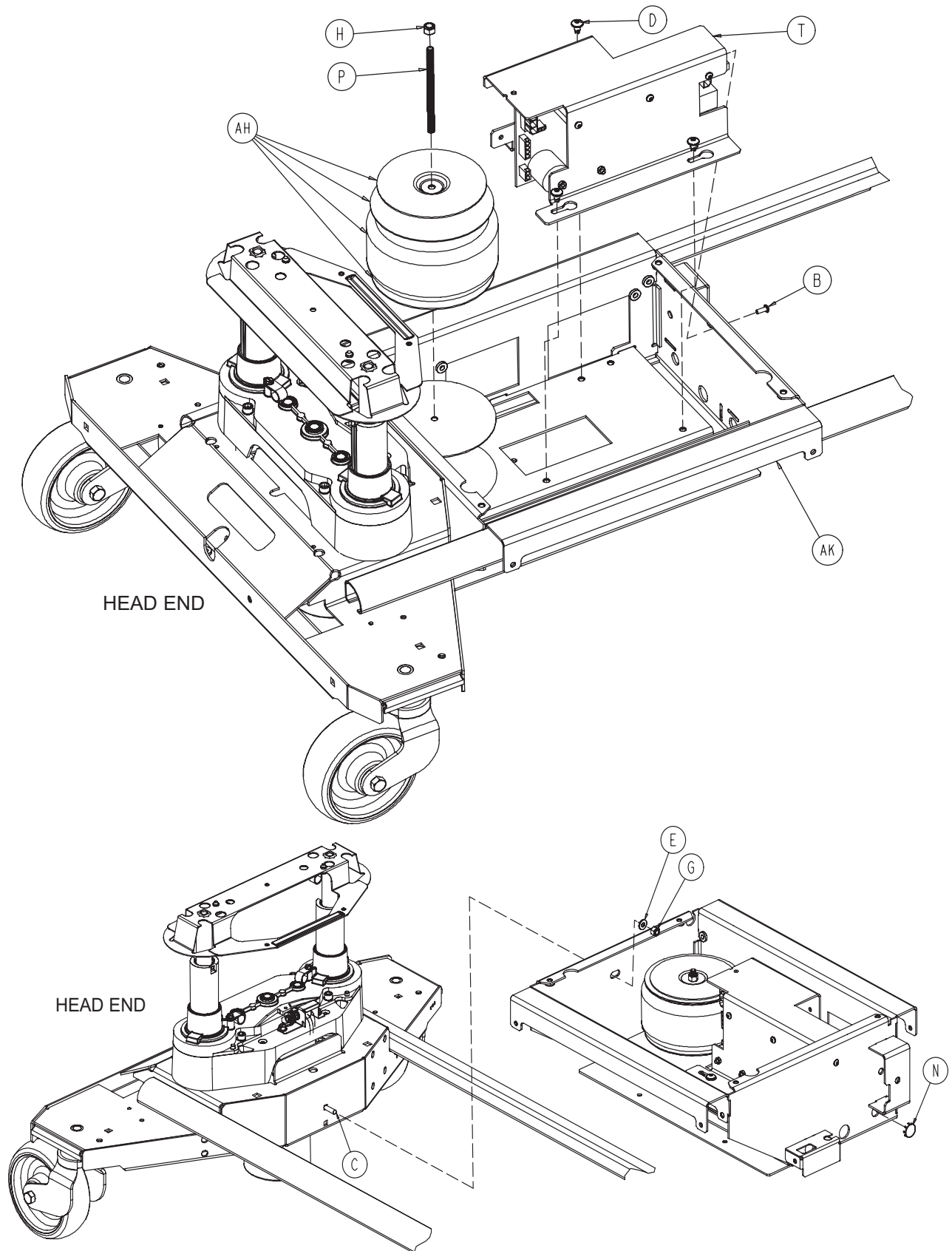

[Return To Table of Contents](#)

Base Assembly with Battery Backup Option

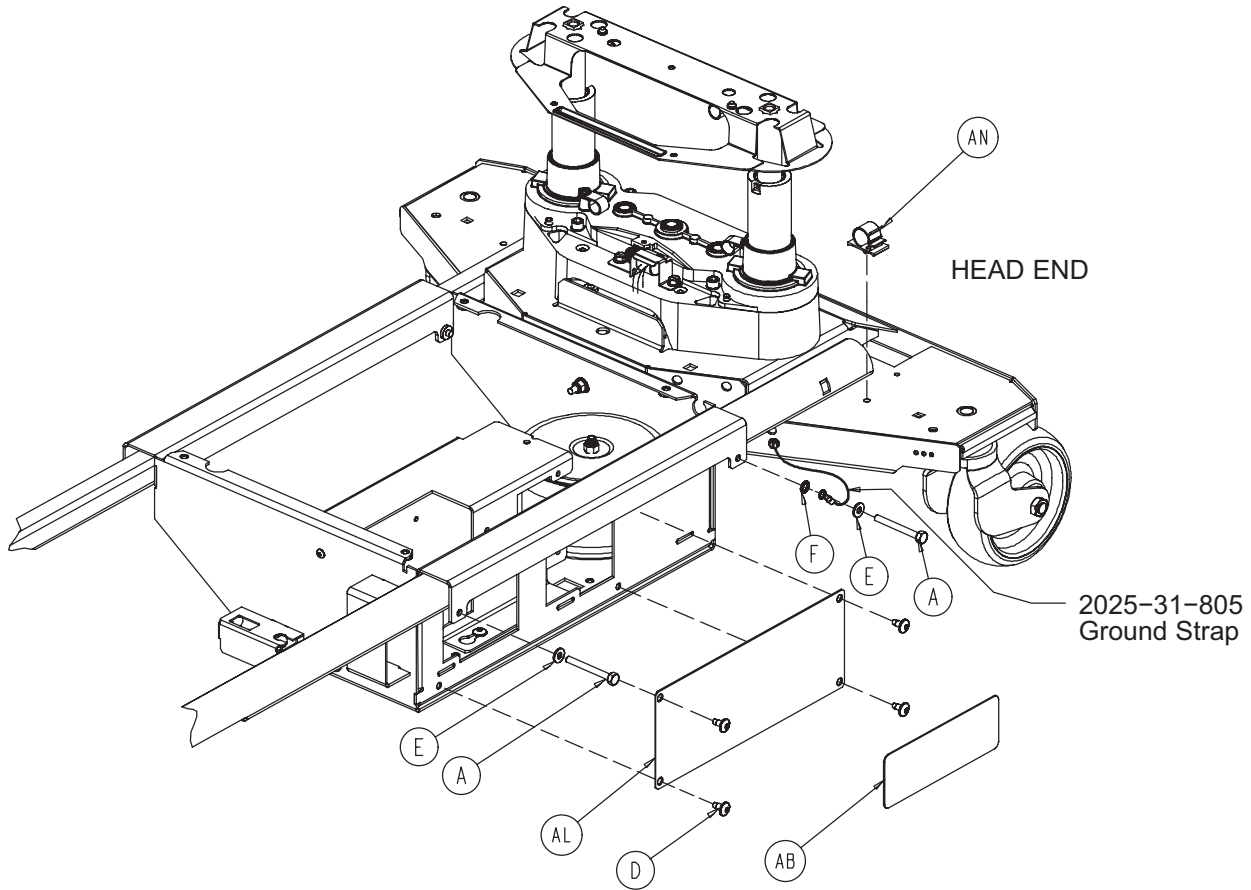
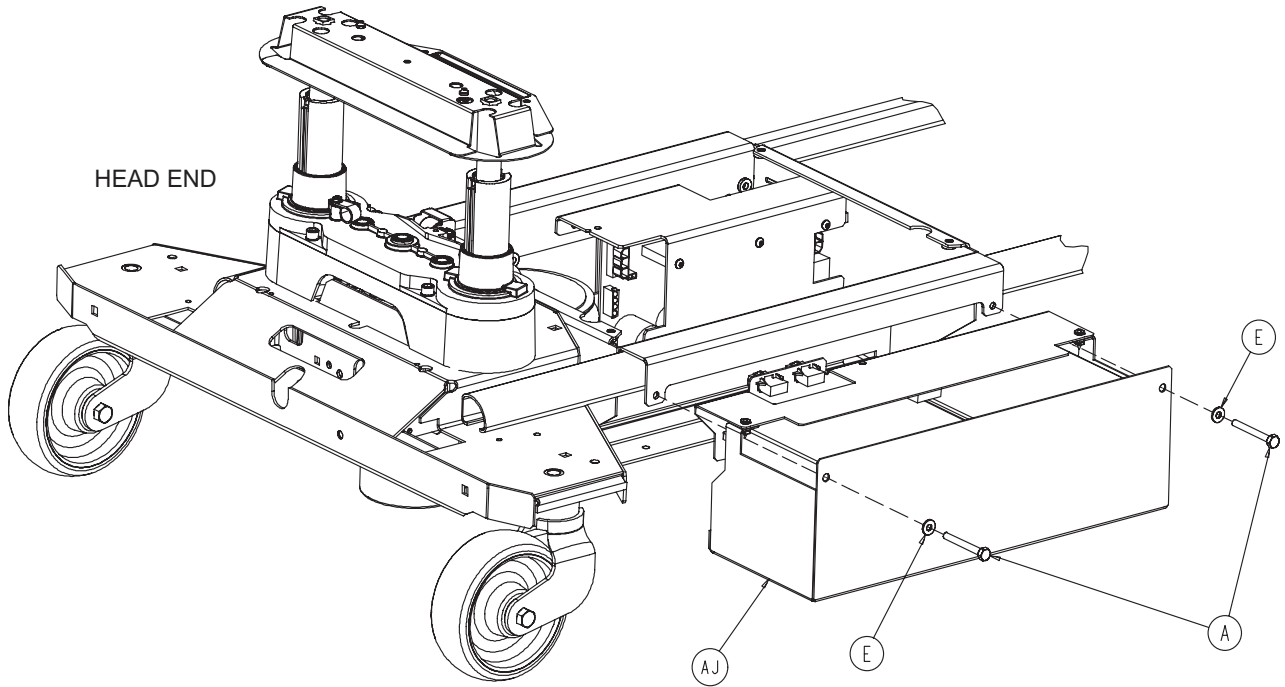

Base Assembly with Battery Backup Option

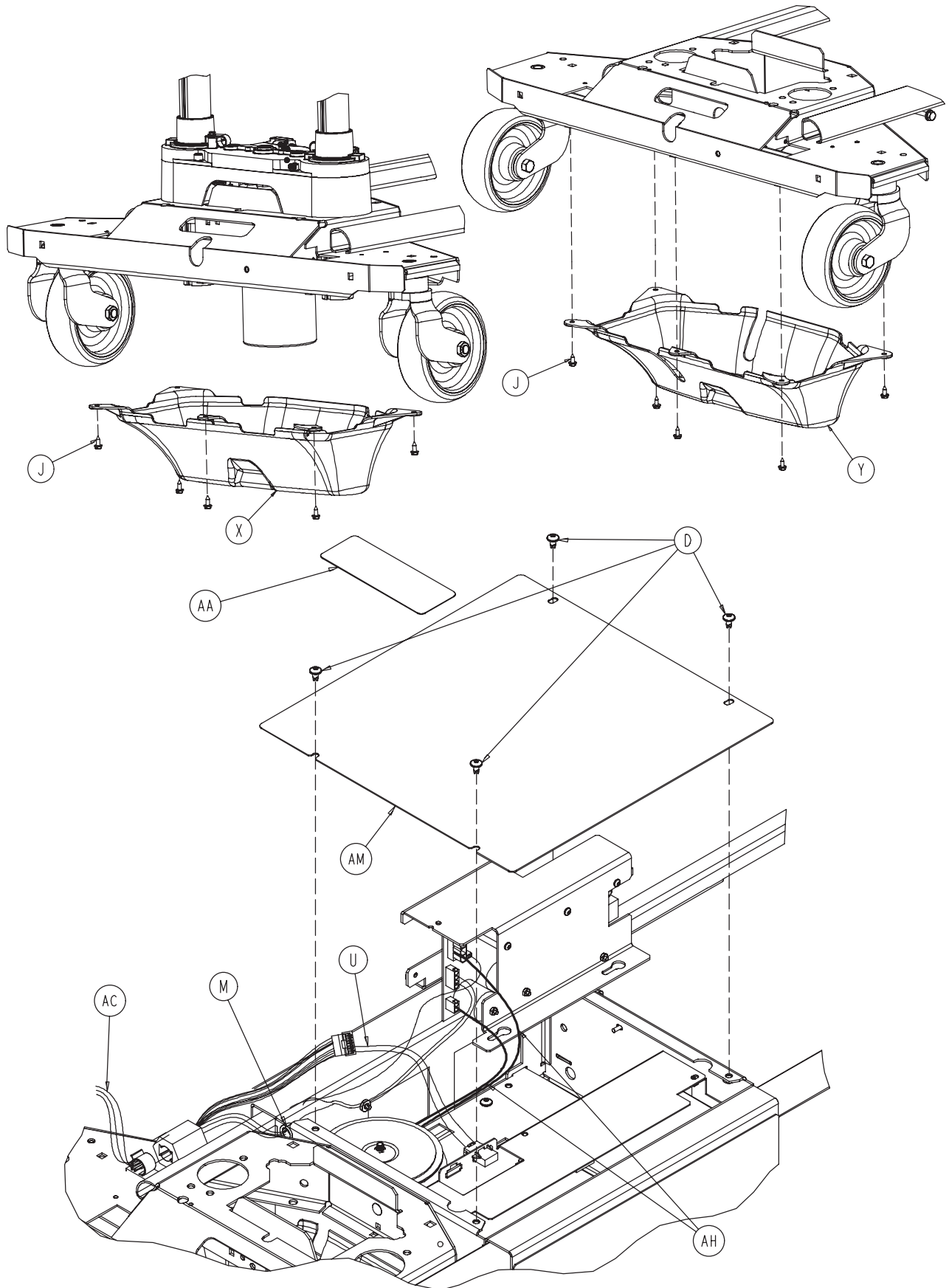

[Return To Table of Contents](#)

Base Assembly with Battery Backup Option

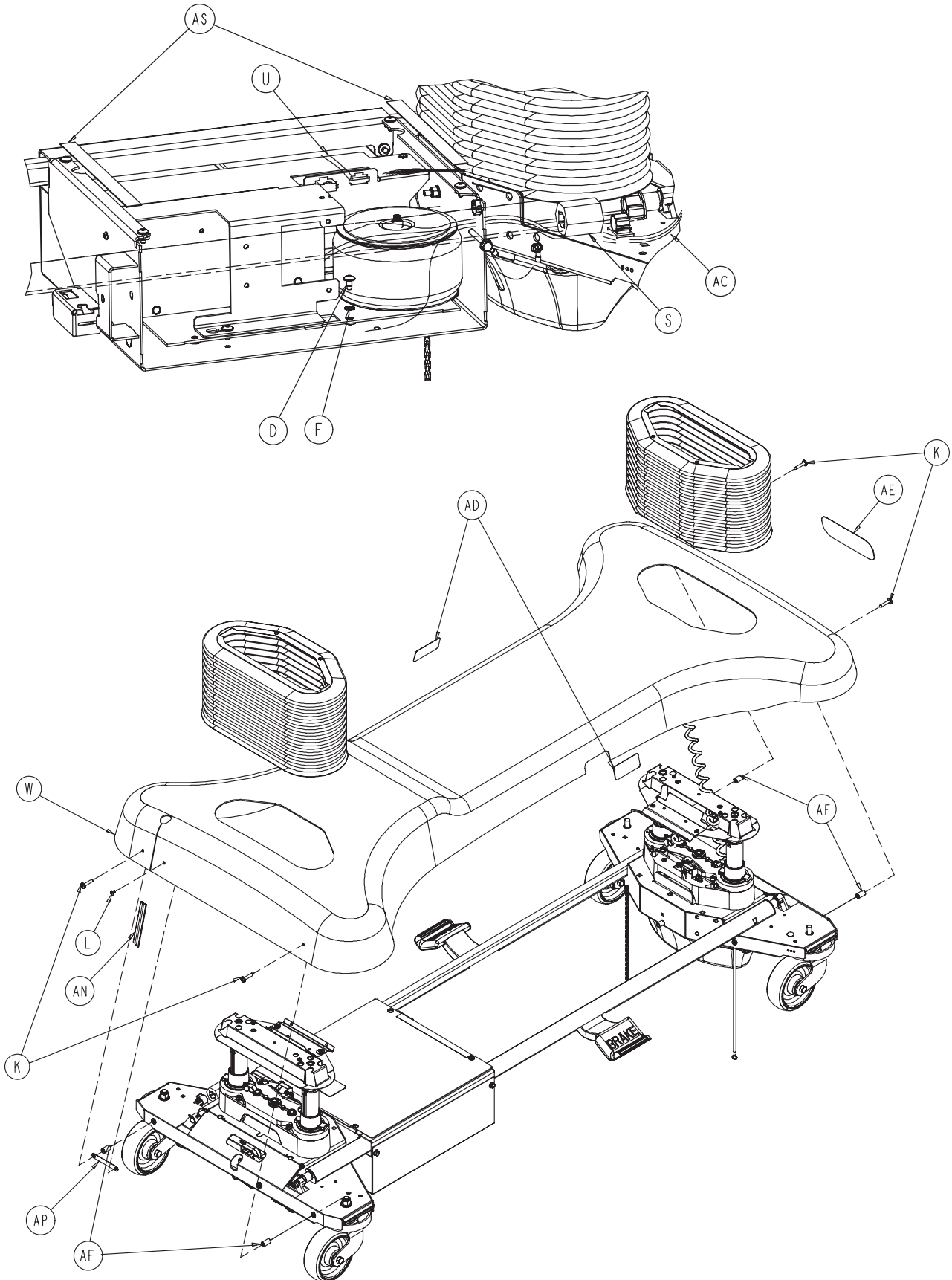

[Return To Table of Contents](#)

Base Assembly with Battery Backup Option

Base Assembly with Battery Backup Option - 3002-350-170 (Reference Only)

Item	Part No.	Part Name	Qty.
A	0003-032-000	Hex Head Cap Screw	4
B	0004-301-000	Pan Head Machine Screw	1
C	0005-017-000	Carriage Bolt	1
D	0007-052-000	Truss Head Torx Screw	13
E	0011-063-000	Washer	5
F	0013-010-000	External Tooth Star Washer	5
G	0016-028-000	Nylock Nut	1
H	0016-036-000	Nylock Nut	1
J	0023-025-000	Hex Washer Head Screw	10
K	0023-281-000	Self-Tapping Screw	4
L	0025-079-000	Pop Rivet	1
M	0030-038-000	Split Bushing	1
N	0037-221-000	Hole Plug	1
P	0058-090-000	Threaded Stud	1
R	0059-133-000	Push-Mount Wire Clip	1
S	0059-192-000	Split Ferrite	1
T	2030-001-030	Base Power Assembly (pg.146)	1
U	2030-080-802	Epic+ DC Jumper Assembly	1
W	2030-201-005	Base Hood	1
X	3001-200-022	FE Bottom Cover Assembly (pg.137)	1
Y	2040-001-017	HE Bottom Cover Assembly (pg.137)	1
Z	2040-001-100	Drive Wheel Position Label	1
AA	2040-001-101	Charger Box Cover Label	1
AB	2040-001-102	Power Board Cover Label	1
AC	3002-031-113	Umbilical Cable Isolation Bracket	1
AD	3000-200-601	Brake Label	2
AE	3000-200-602	Stryker Logo Label	1
AF	3000-300-428	Gatch Link Sleeve	4
AG	3000-300-113	Wire Tie	2
AH	3002-001-010	Transformer	1
AJ	3002-001-015	Battery Tray Assembly (pg.139)	1
AK	3002-001-050	Charger Box	1
AL	3002-001-068	Power PCB Cover	1
AM	3002-001-071	Charger/Inverter Cover	1
AN	3002-001-078	Hood Slot Trim	1
AP	3002-001-079	Hood Slot Trim Bracket	1
AR	3002-001-802	Inverter/Battery Cable	1
AS	7000-001-326	Foam Tape (10")	2

Battery Backup Option Power Assembly

2030-001-030

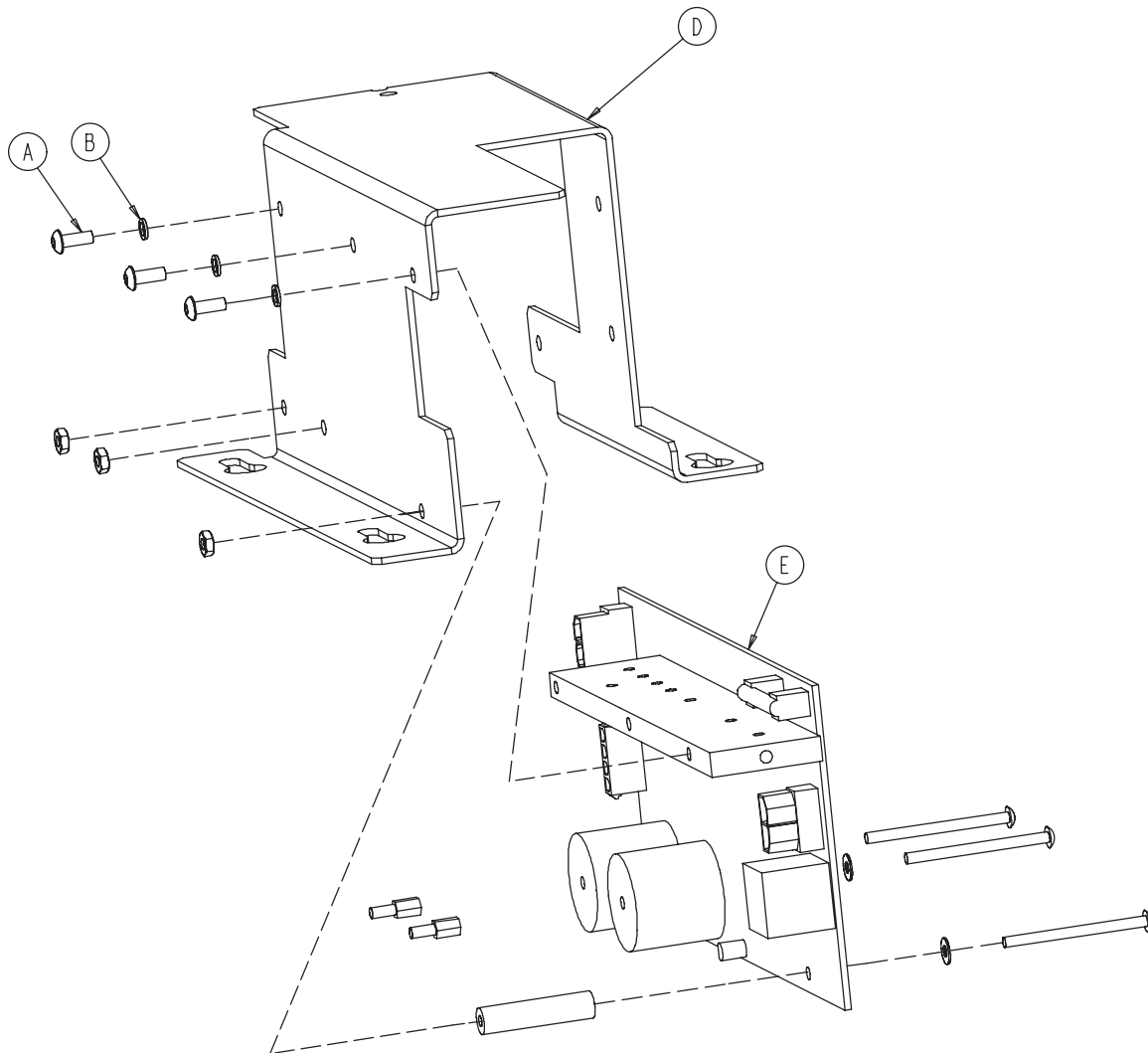

Item	Part No.	Part Name	Qty.
A	0004-263-000	Button Head Cap Screw	3
B	0012-006-000	Helical Lock Washer	3
D	3002-001-017	Charger/Inverter Heat Bracket	1
E	3002-001-930	Charger/Inverter Board	1

Litter Assembly, Standard Components

For Reference Only: 3003-300-002

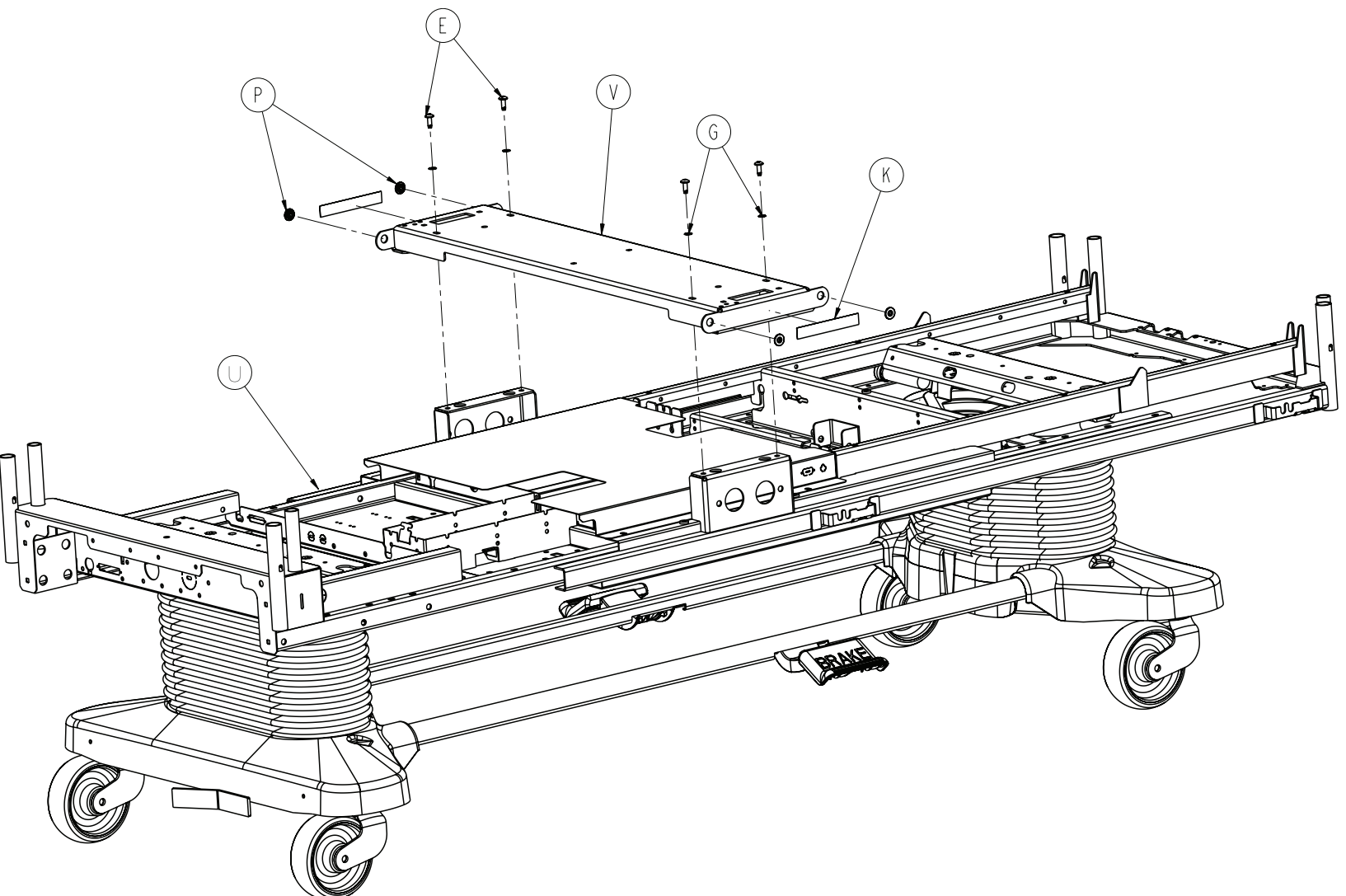

[Return To Table of Contents](#)

Litter Assembly, Standard Components

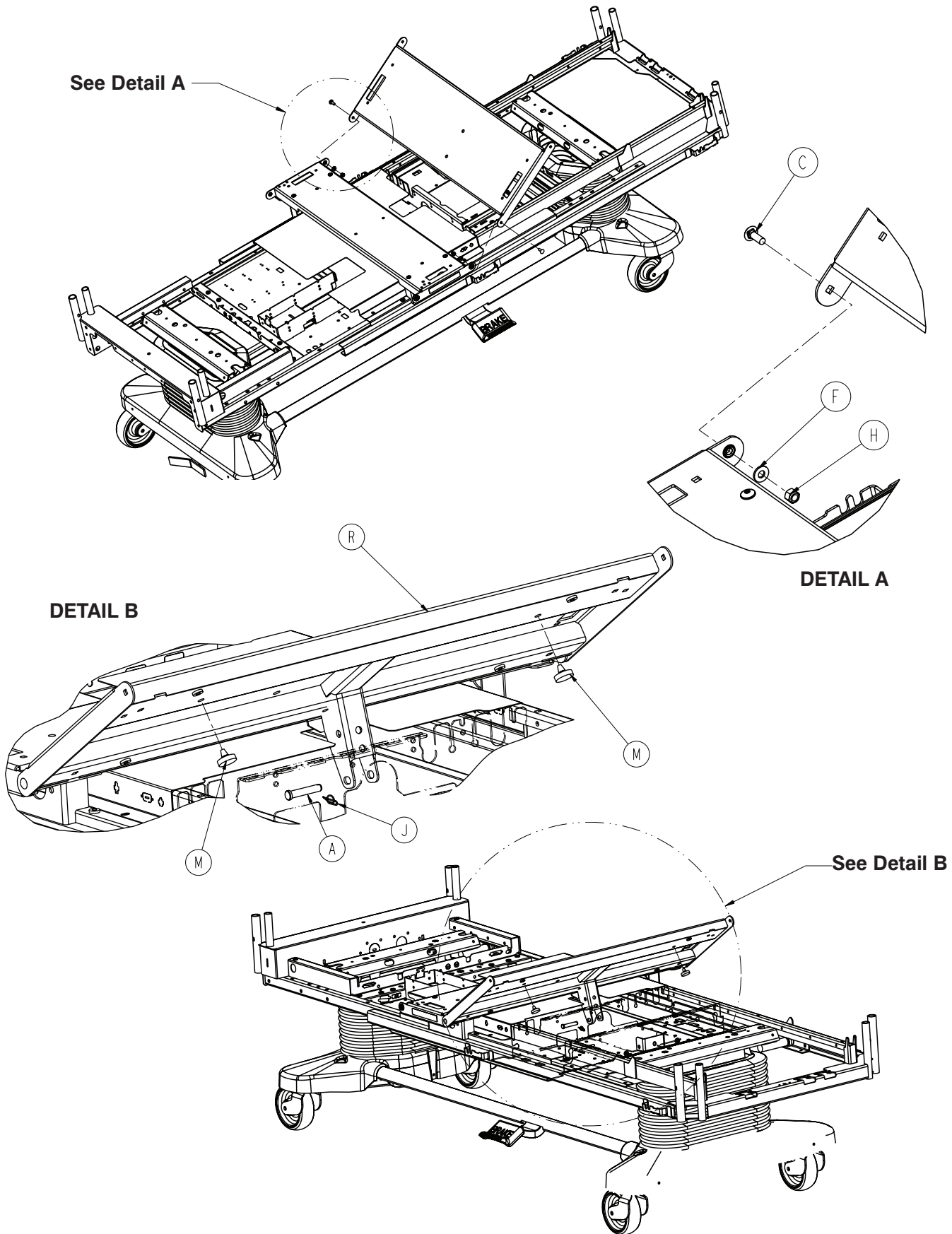

Litter Assembly, Standard Components

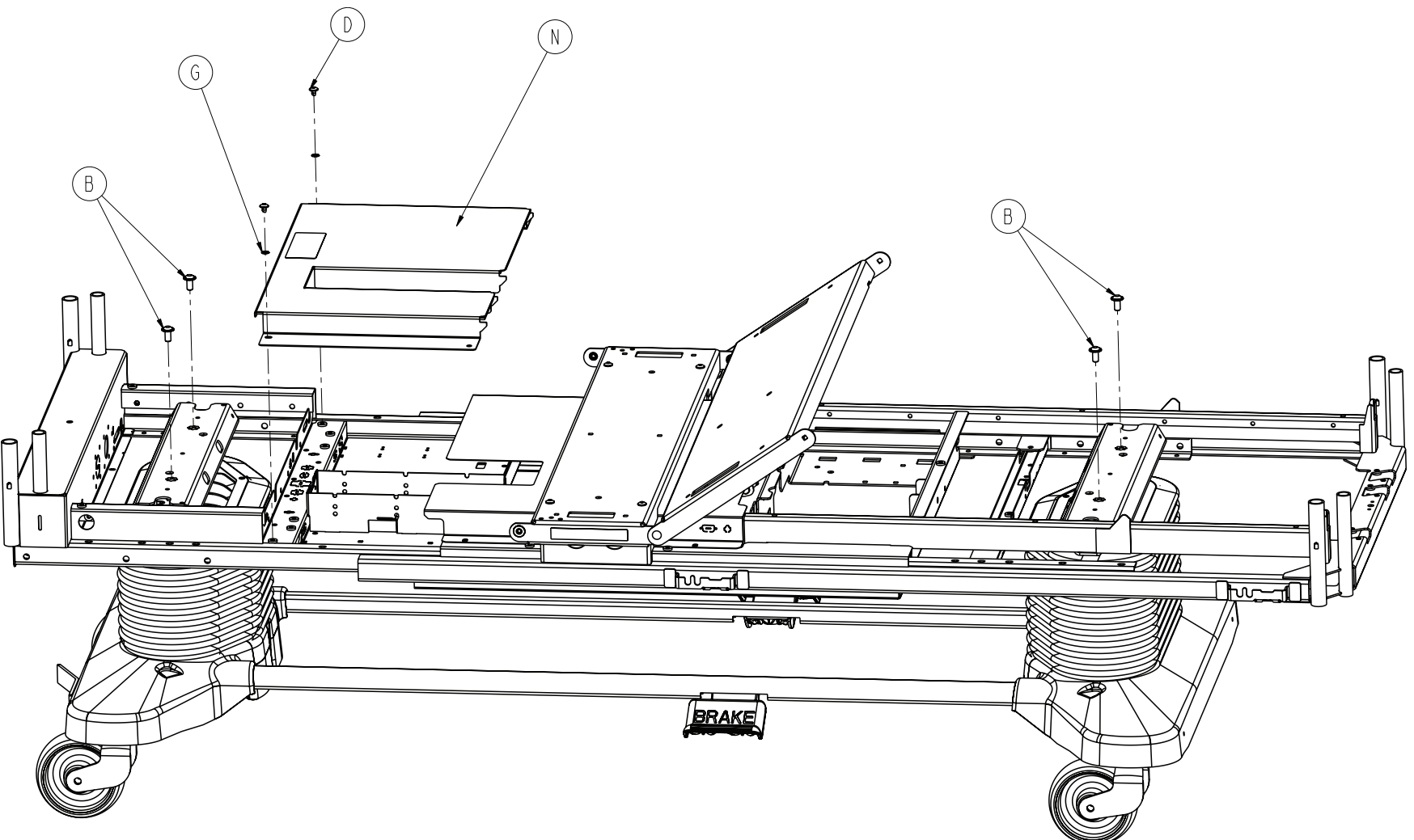

Litter Assembly, Standard Components

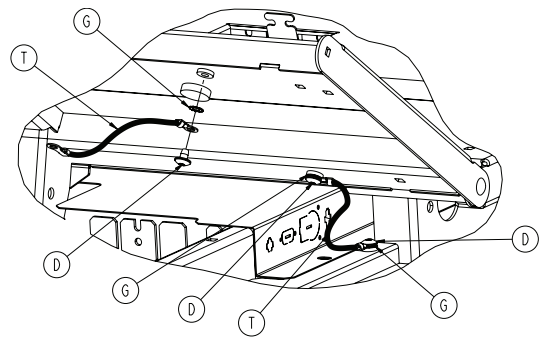
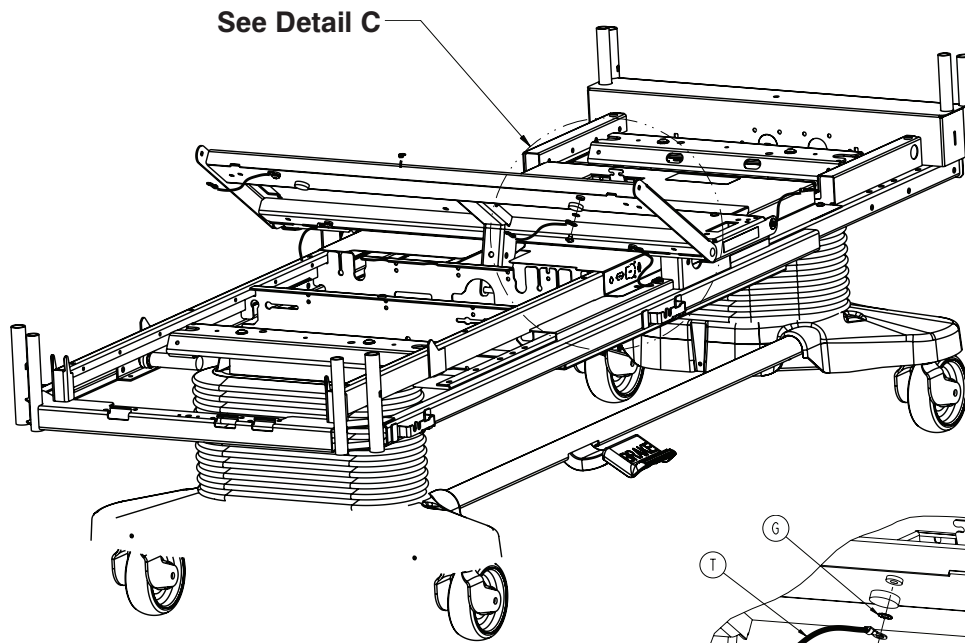

DETAIL C

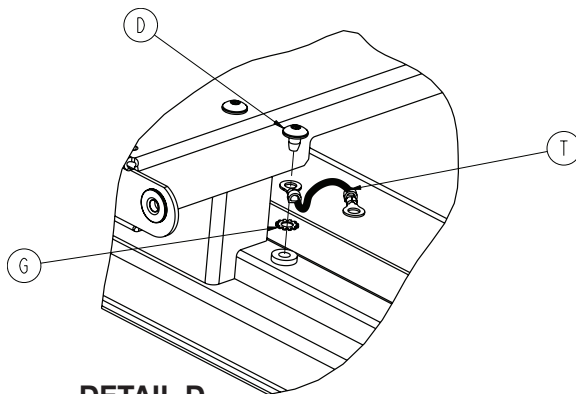
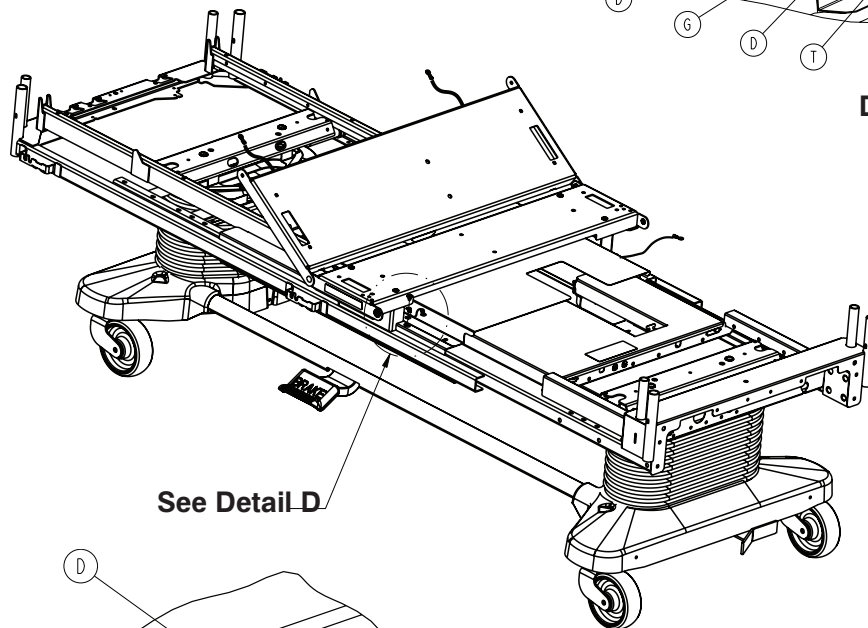

DETAIL D

Litter Assembly, Standard Components

Litter Assembly, Standard Components - 3003-300-002 (Reference Only)

Item	Part No.	Part Name	Qty.
A	0026-277-000	Clevis Pin	1
B	0004-338-000	Truss Head Screw	4
C	0005-017-000	Carriage Bolt	2
D	0007-053-000	Truss Head Screw	10
E	0007-063-000	Truss Head Screw	4
F	0011-077-000	Washer	2
G	0013-010-000	External Tooth Lock Washer	14
H	0016-028-000	Fiberlock Hex Nut	2
J	0027-022-000	Rue Ring Cotter	1
K	2020-088-820	Caution Label	2
M	3001-300-008	Bumper	2
N	3001-300-097	CPU Cover Assembly	1
P	3001-300-099	Fowler Bushing	4
R	3001-300-170	Litter, Thigh Assembly	1
T	3002-300-870	8" Litter Ground Jumper	6
U	3003-300-895	Electrical Litter Standard Components	1
V	3003-300-135	Skin Seat Weldment	1

Litter Assembly, Standard Bed

For Reference Only: 3003-343-002

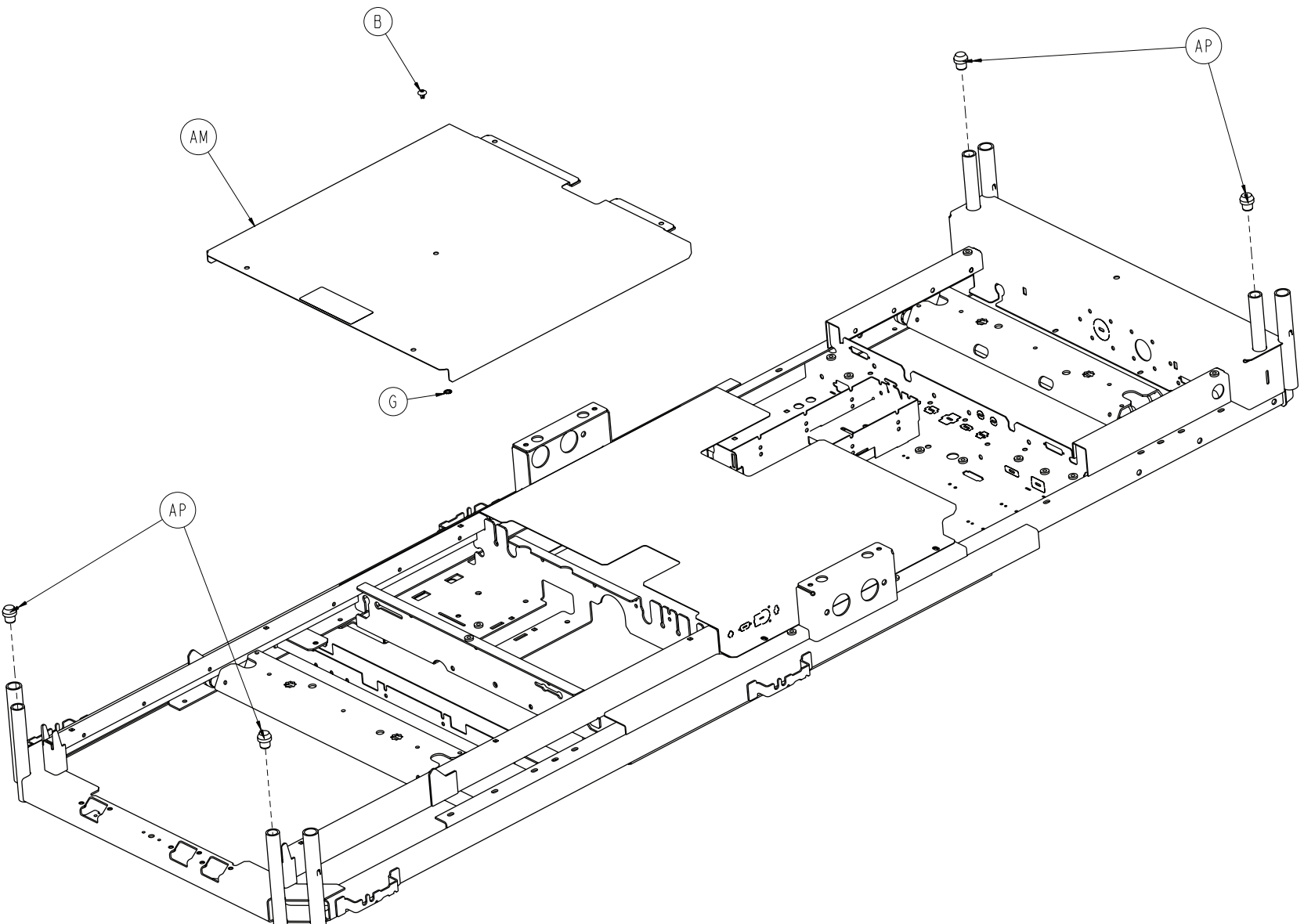

[Return To Table of Contents](#)

Litter Assembly, Standard Bed

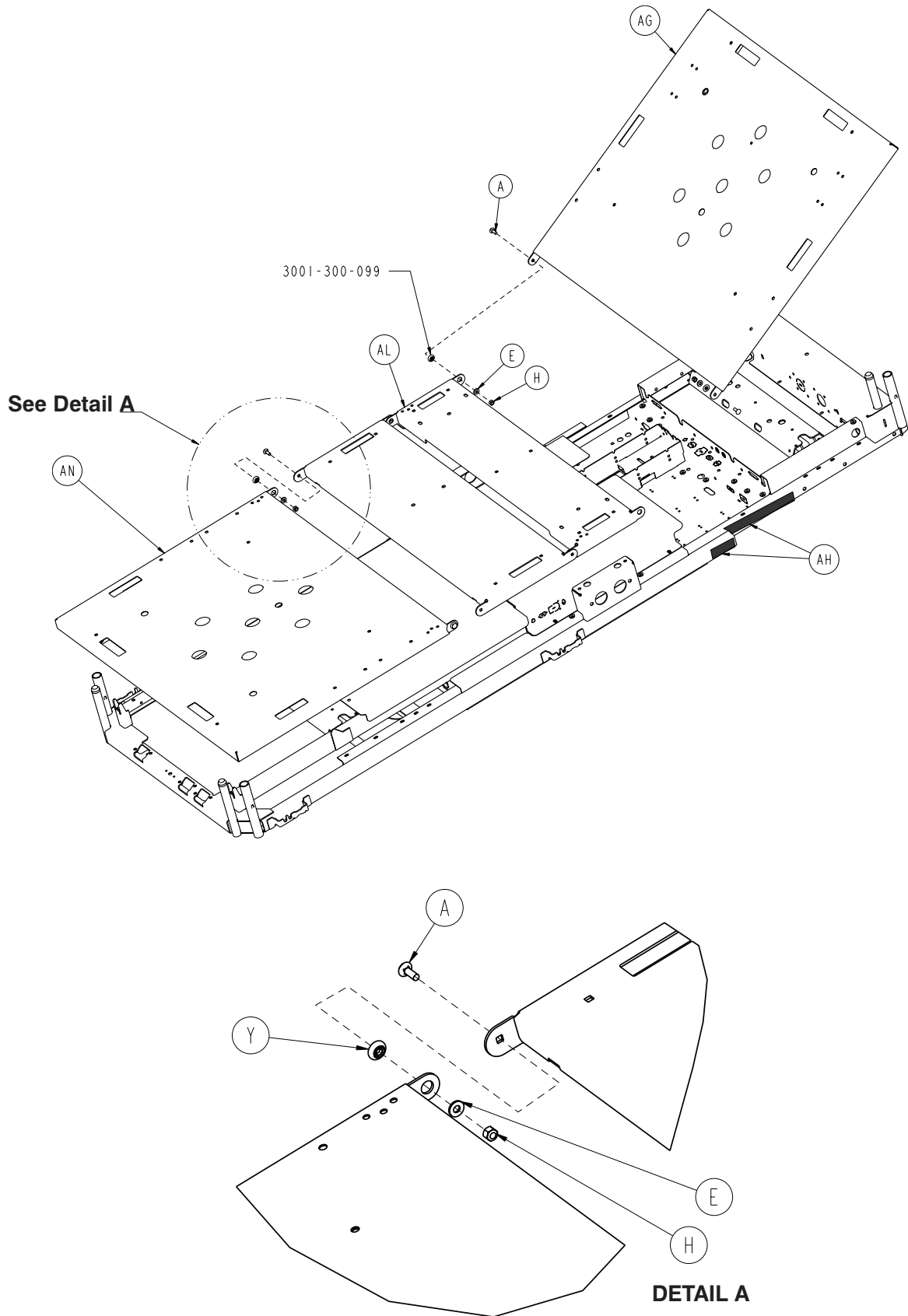

Litter Assembly, Standard Bed

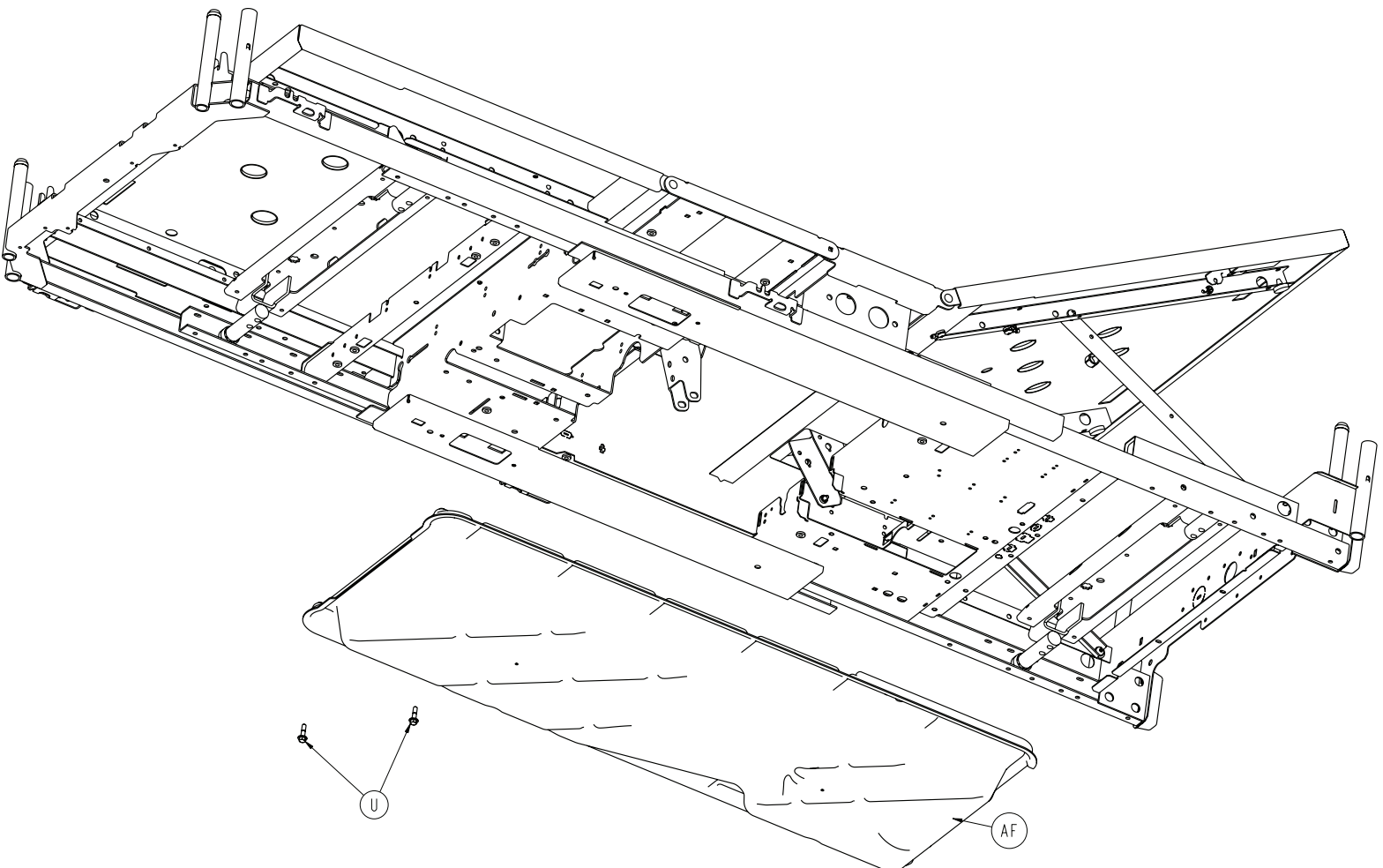

Litter Assembly, Standard Bed

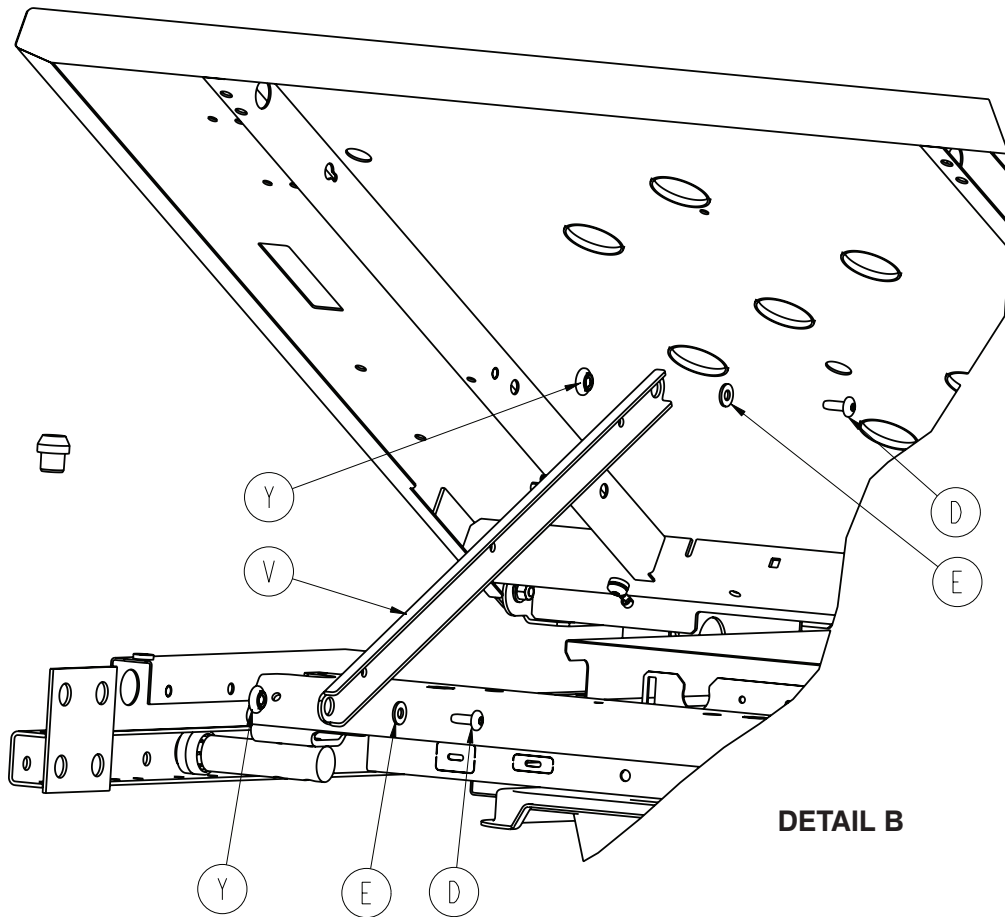
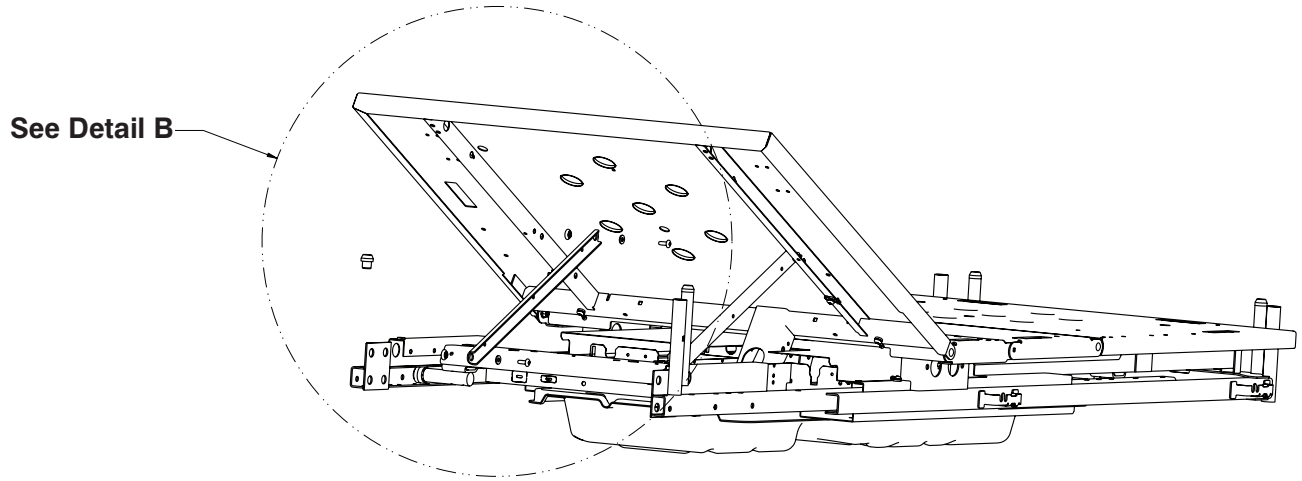

Litter Assembly, Standard Bed

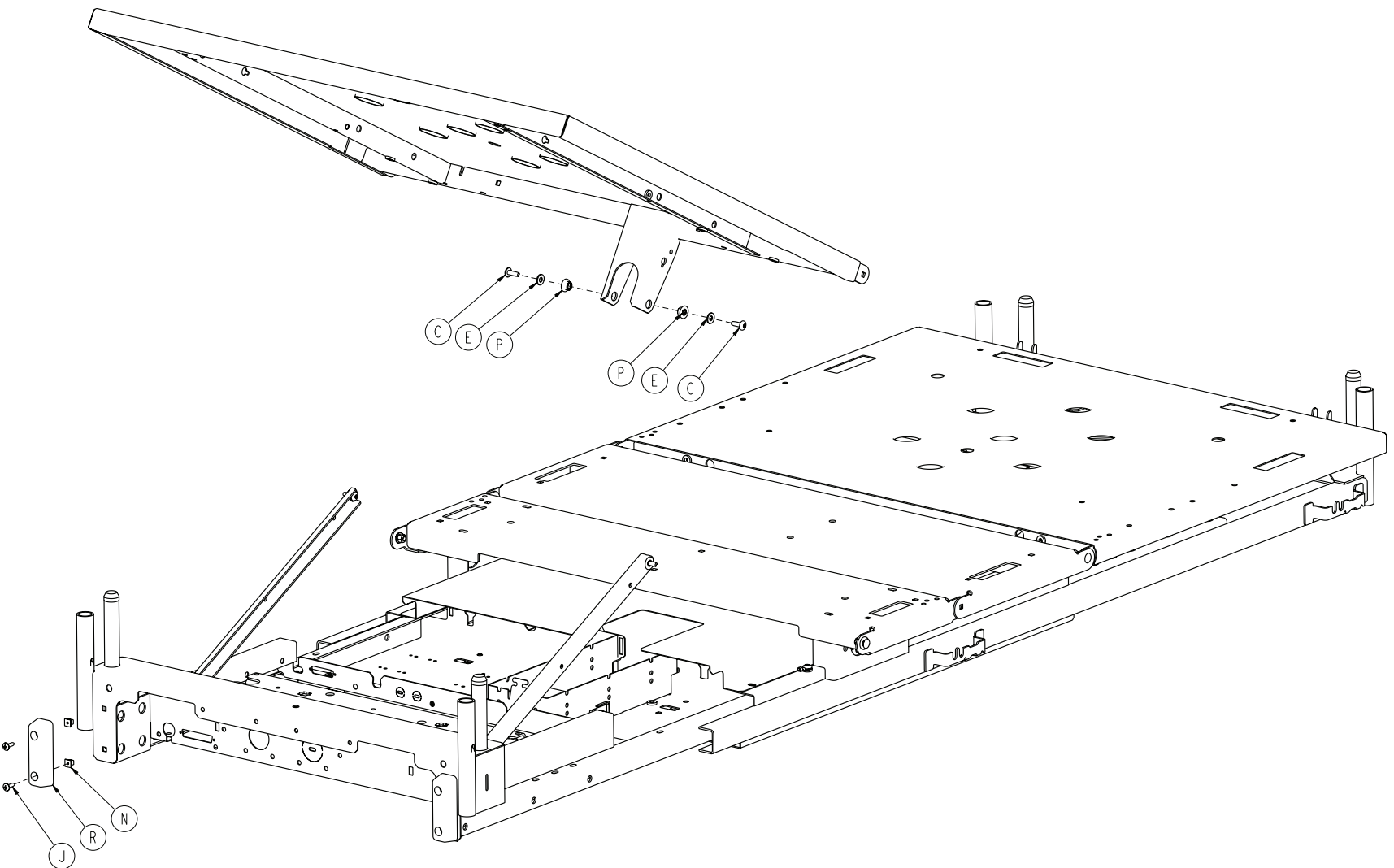

Litter Assembly, Standard Bed

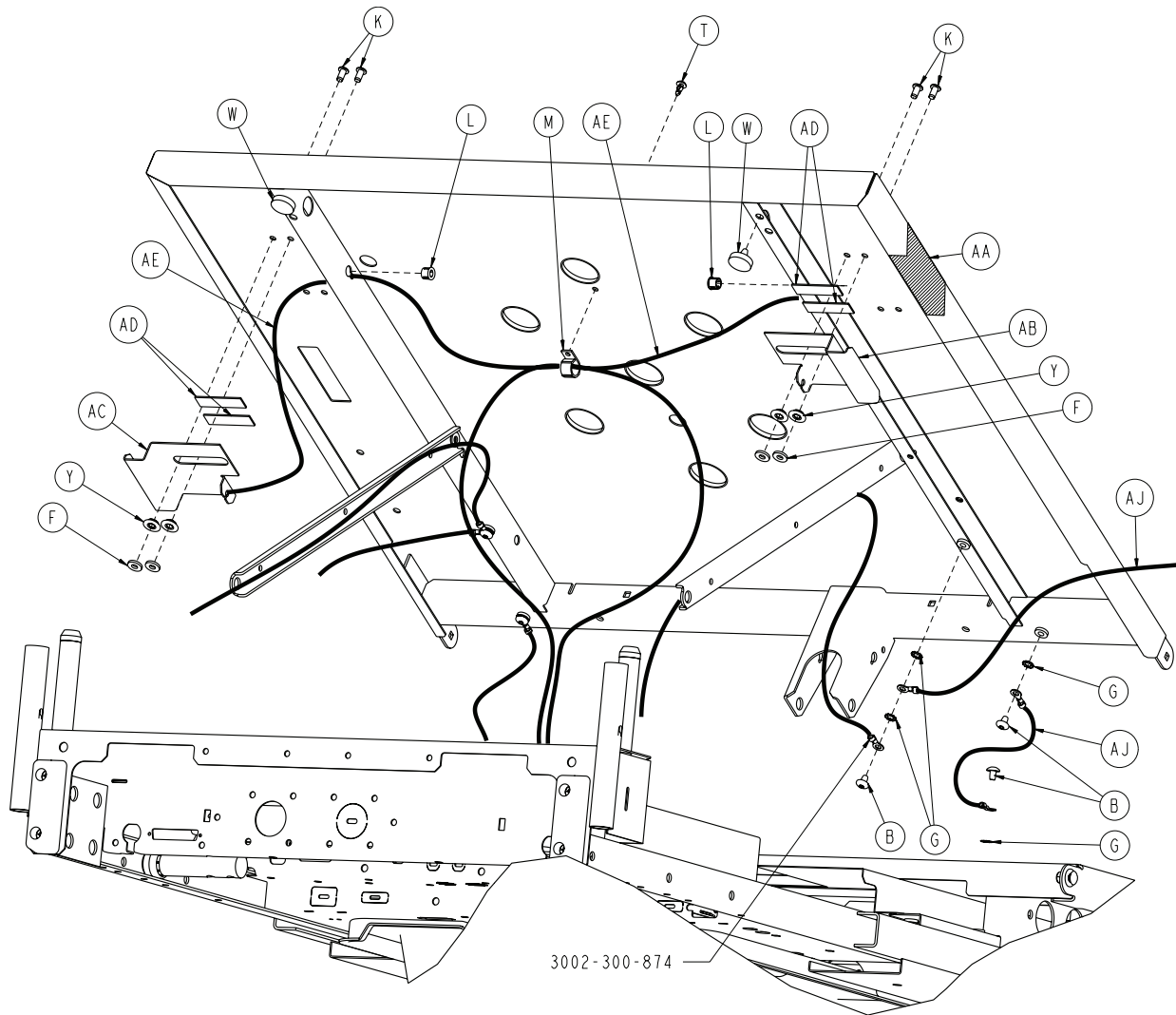

Litter Assembly, Standard Bed

Litter Assembly, Standard Length Bed 3003-343-002 (reference only)

Item	Part No.	Part Name	Qty.
A	0005-017-000	Carriage Bolt	4
B	0007-053-000	Truss Head Screw	7
C	0007-063-000	Truss Head Screw	2
D	0007-065-000	Truss Head Screw	4
E	0011-077-000	Washer	10
F	0011-376-000	Washer	4
G	0013-010-000	External Tooth Lock Washer	11
H	0016-028-000	Fiberlock Hex Nut	4
J	0023-080-000	Truss Head Screw	4
K	0025-120-000	Pop Rivet	4
L	0030-052-000	Heyco Snap Bushing	2
M	0059-743-000	Wire Harness Clip	1
N	3000-300-002	Plastic Clip Nut	4
P	3000-300-099	Fowler Bushing	2
R	3000-300-350	Head End Bumper	2
T	3000-300-477	CPR Conduit Stud	1
U	3001-200-229	Mounting Standoff	2
V	3001-300-005	Fowler Link	2
W	3001-300-008	Bumper	2
Y	3001-300-099	Fowler Bushing	10
AA	3001-300-603	CPR Release Label	2
AB	3001-300-661	CPR Release Handle, Right	1
AC	3001-300-662	CPR Release Handle, Left	1
AD	3001-300-663	Velcro Strip	4
AE	3001-300-670	CPR Cable Assembly	2
AF	3002-300-083	Motion Interrupt	1
AG	3002-300-145	Fowler Litter Weldment	1
AH	3002-300-602	Fowler Elevation Angle, Label	1
AJ	3002-300-870	8" Ground Litter Jumper	4
AK	3002-343-895	Electrical Assembly, Standard Length Bed (pg.185)	1
AL	3003-300-002	Litter Assembly, Standard Components (pg.147)	1
AM	3003-300-042	Foot Cover Assembly	1
AN	3003-300-190	Foot Litter Weldment	1
AP	3000-300-349	Cap	4

Battery Backup Litter Option 3002-350-200 (Reference Only)

Item	Part No.	Part Name	Qty.
A	3002-350-110	Battery Backup Ass'y (pg.185)	1
J	3002-300-083	Motion Interrupt Pan	1
Z	3000-300-099	Fowler Bushing	2
AM	3001-300-008	Bumper	2
BE	3001-300-005	Fowler Link	2

8" Shorter Litter Option - 3003-342-002 (Reference Only)

Item	Part No.	Part Name	Qty.
A	3002-300-895	Electrical Litter Ass'y (pg.180)	1
C	3000-300-350	Head End Bumper	2
D	0023-080-000	Truss Hd. Screw	6
E	3000-300-002	Plastic Clip Nut	4
J	3001-300-083	Motion Interrupt Pan	1
Z	3001-300-099	Fowler Bushing	2
AM	3001-300-008	Bumper	2
BA	3001-342-041	Foot Cover Ass'y (pg.179)	1
BB	3002-342-130	Fowler Litter Ass'y	1
BC	3002-342-180	Foot Litter Assembly	1
BD	3001-342-162	Foot Prop Rod (Option)	1
BE	3001-342-008	Fowler Link	2
BP	0052-816-000	Screw Grommet	2
BR	3002-300-602	Fowler Angle Label	1

Zoom Litter Option 3003-344-002 (Reference Only)

Item	Part No.	Part Name	Qty.
A	3002-350-110	Battery Backup Ass'y (pg.162)	1
J	3002-300-083	Motion Interrupt Pan	1
Z	3000-300-099	Fowler Bushing	2
AM	3001-300-008	Bumper	2
BE	3001-300-005	Fowler Link	2
BA	3003-300-042	Foot Cover Ass'y (pg.179)	1
BB	3002-300-145	Fowler Litter Ass'y	1
BC	3003-300-190	Foot Litter Ass'y	1
BD	3003-300-162	Foot Prop Rod (option)	1
BR	3002-300-602	Fowler Angle Label	1

8" Shorter Zoom Litter Option 3003-346-002 (Ref. Only)

Item	Part No.	Part Name	Qty.
A	3002-300-895	Electrical Litter Ass'y (pg.180)	1
D	0023-080-000	Truss Hd. Screw	2
J	3002-300-083	Motion Interrupt Pan	1
Z	3001-300-099	Fowler Bushing	2
AM	3001-300-008	Bumper	2
BA	3003-300-042	Foot Cover Ass'y (pg.179)	1
BB	3002-342-130	Fowler Litter Ass'y	1
BC	3002-342-180	Foot Litter Ass'y	1
BD	3001-342-162	Foot Prop Rod (option)	1
BE	3001-342-008	Fowler Link	2
BP	0052-816-000	Screw Grommet	2
BR	3002-300-602	Fowler Angle Label	1

Litter Assembly, iBED Awareness Option

For Reference Only: 3004-353-002

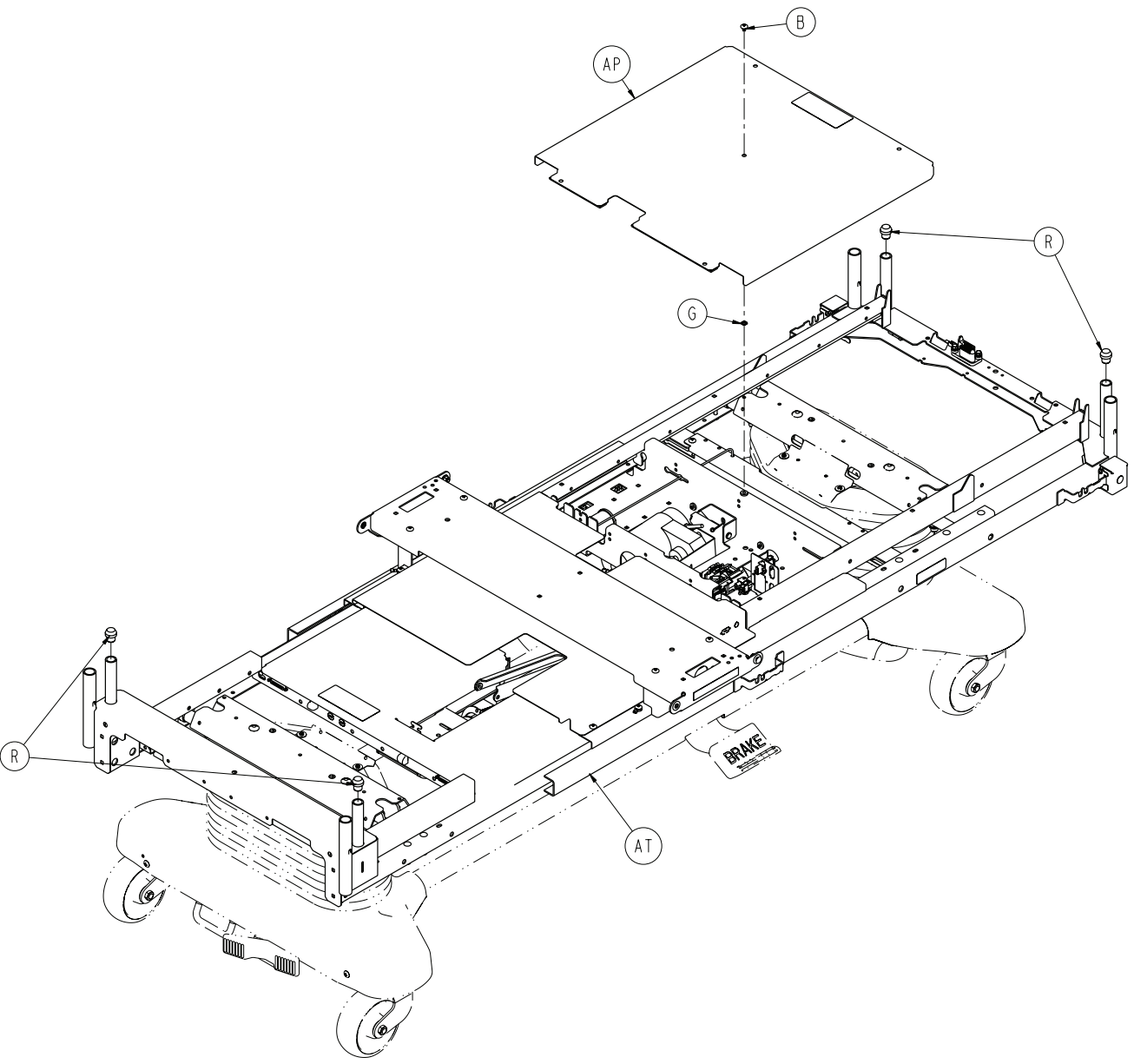

Litter Assembly, iBED Awareness Option

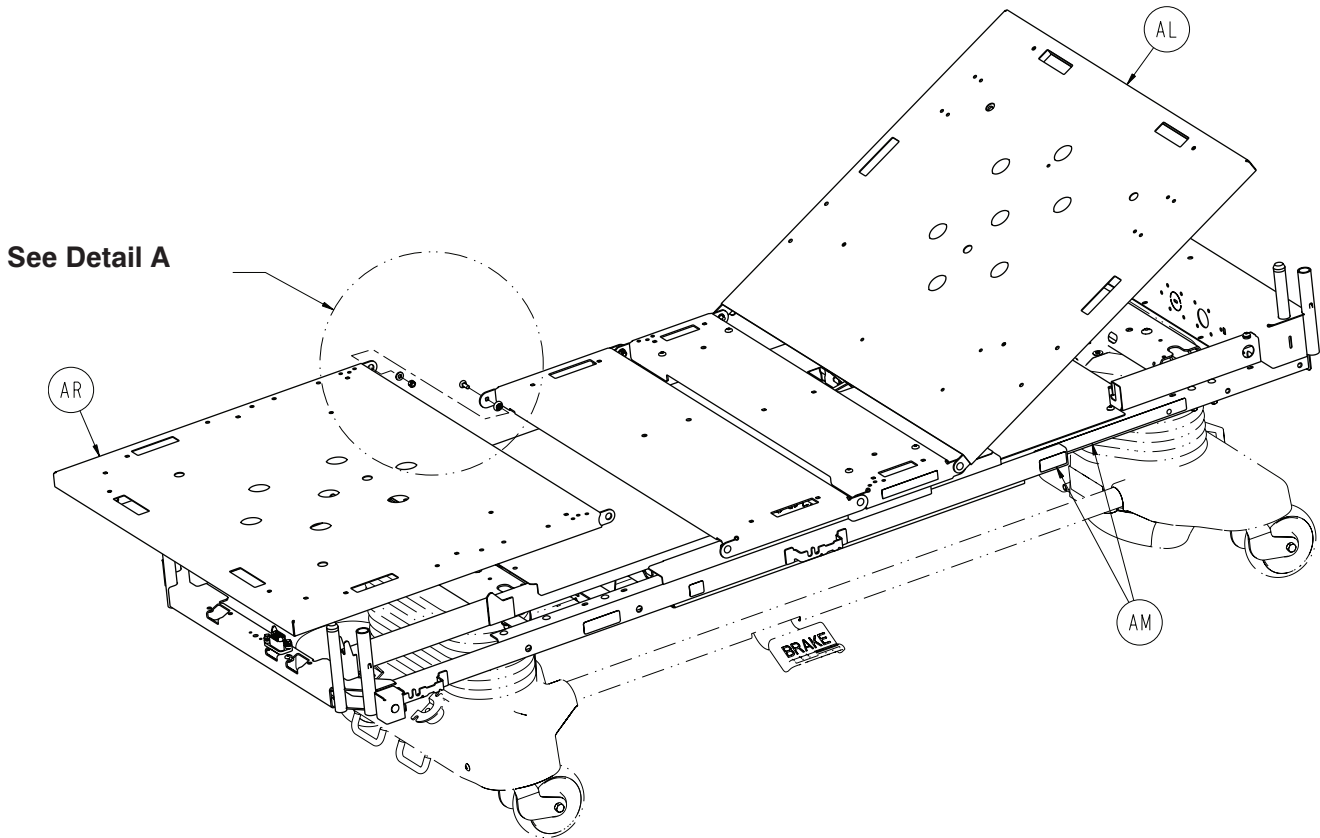

DETAIL A

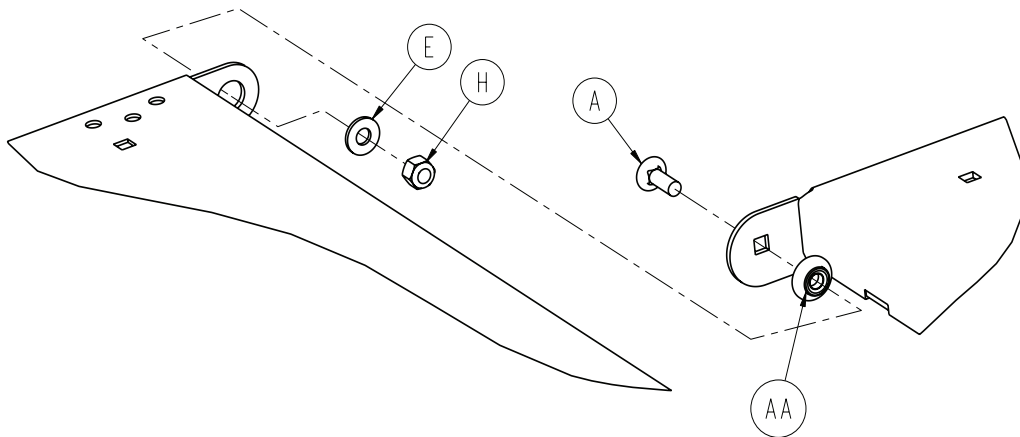

Litter Assembly, iBED Awareness Option

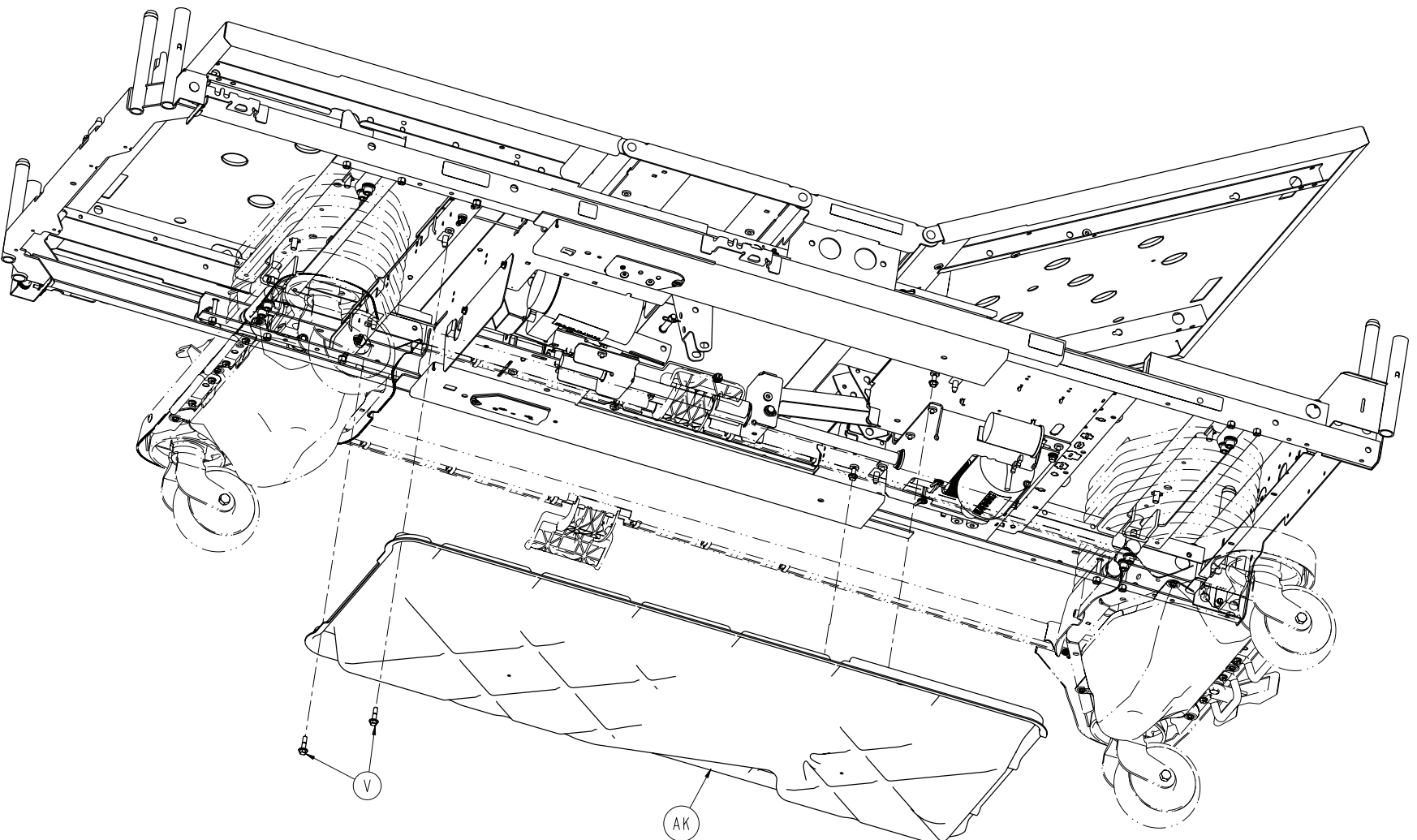

Litter Assembly, iBED Awareness Option

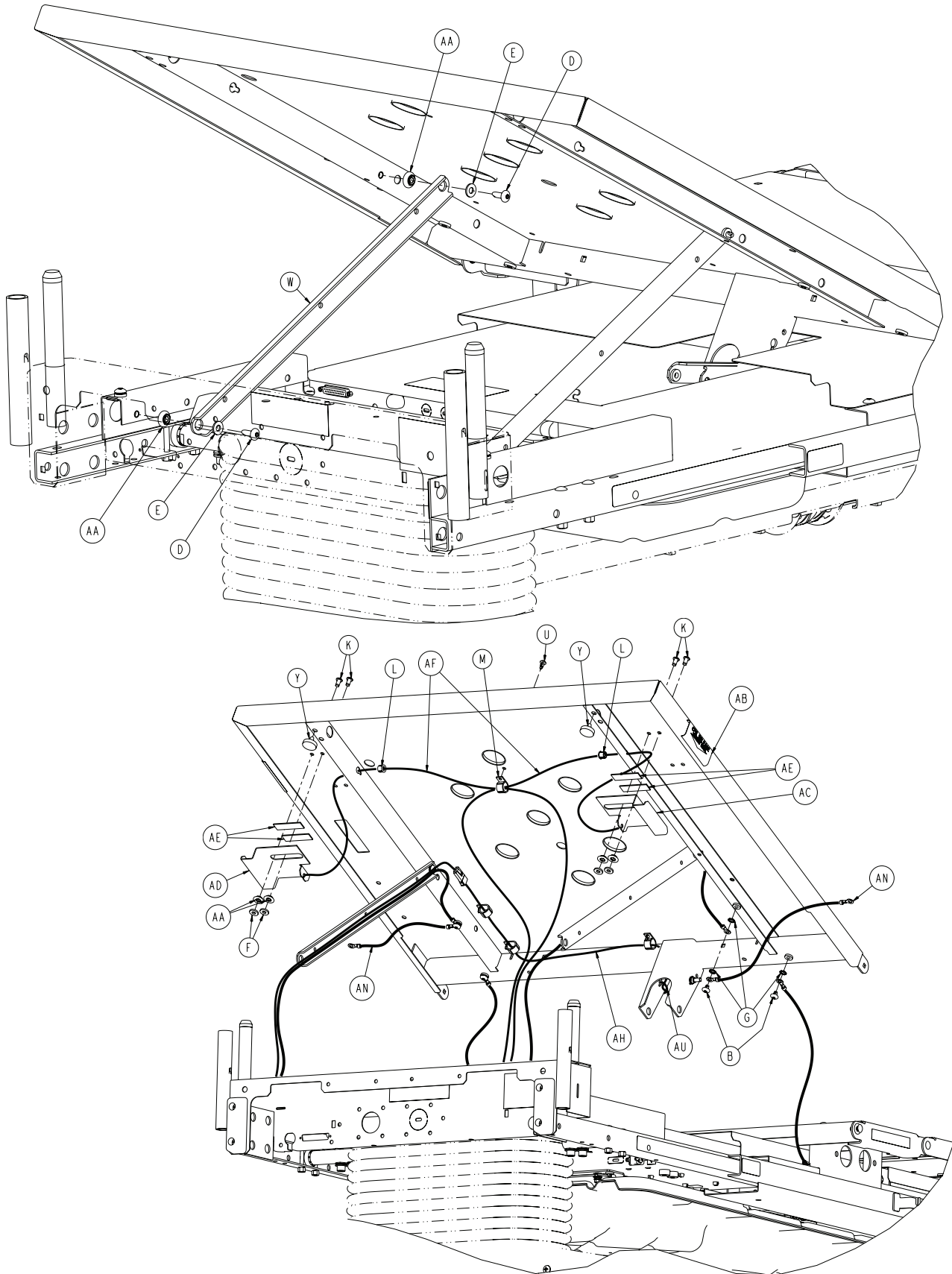

Litter Assembly, iBED Awareness Option

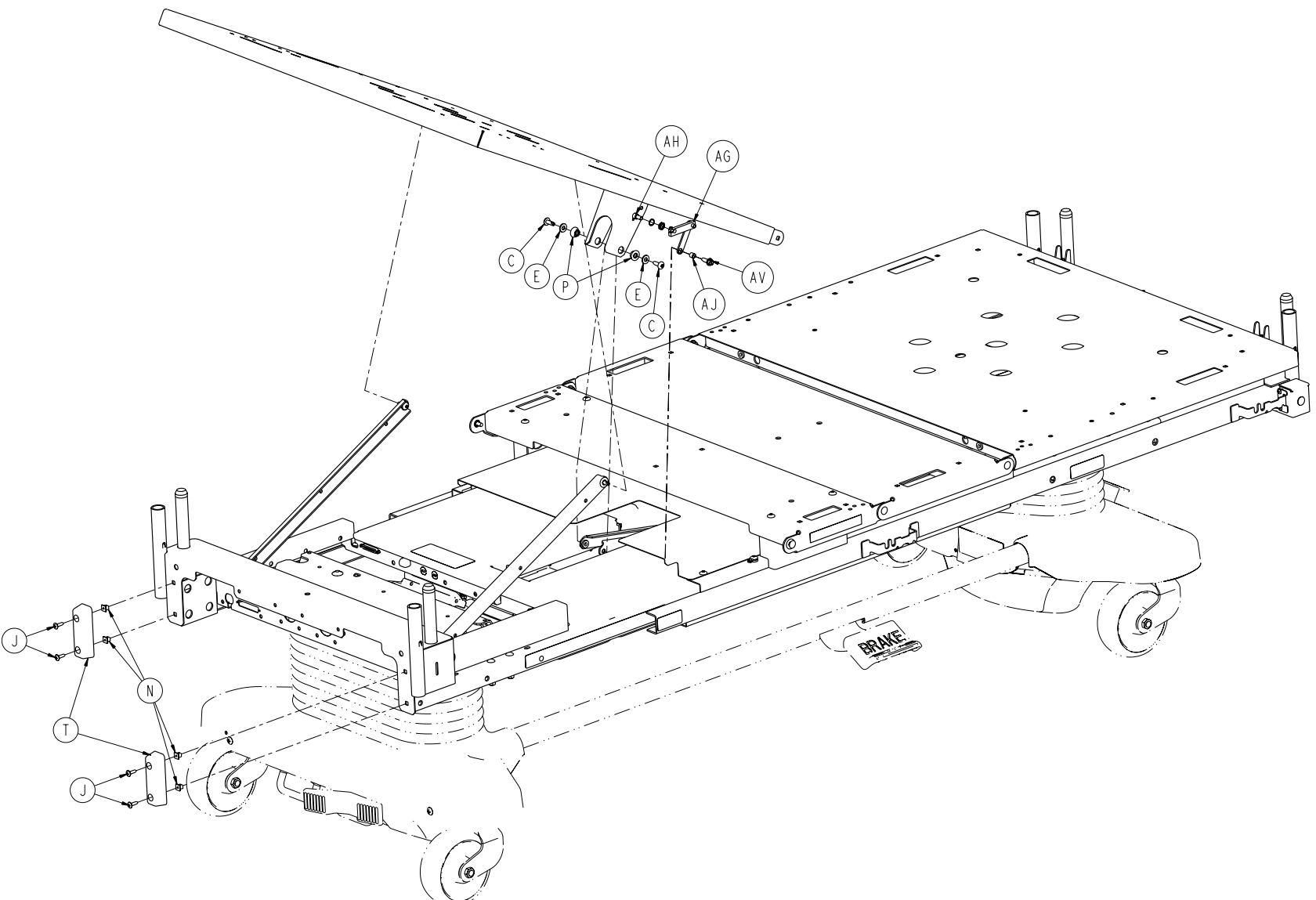

Litter Assembly, iBED Awareness Option

Litter Assembly, LBS Option - 3004-353-002 (Reference Only)

Item	Part No.	Part Name	Qty.
A	0005-017-000	Carriage Bolt	4
B	0007-053-000	Truss Head Screw	5
C	0007-063-000	Truss Head Screw	2
D	0007-065-000	Truss Head Screw	4
E	0011-077-000	Washer	10
F	0011-376-000	Washer	4
G	0013-010-000	External Tooth Lock Washer	8
H	0016-028-000	Fiberlock Hex Nut	4
J	0023-080-000	Truss Head Screw	4
K	0025-120-000	Dome Head Rivet	4
L	0030-052-000	Heyco Snap Bushing	2
M	0059-743-000	Wire Harness Clip	4
N	3000-300-002	Plastic Clip Nut	4
P	3000-300-099	Fowler Bushing	2
R	3000-300-349	Cap	4
T	3000-300-350	Head End Bumper	2
U	3000-300-477	CPR Conduit Stud	4
V	3001-200-229	Mounting Standoff	2
W	3001-300-005	Fowler Link	2
Y	3001-300-008	Bumper	2
AA	3001-300-099	Fowler Bushing	10
AB	3001-300-603	CPR Release Label	2
AC	3001-300-661	CPR Handle, Right	1
AD	3001-300-662	CPR Handle, Left	1
AE	3001-300-663	Velcro Strip	4
AF	3001-300-670	CPR Cable Assembly	2
AG	3001-345-450	POT Linkage Assembly	1
AH	3001-345-807	Fowler Pot Cable	1
AJ	3001-400-558	Spacer	1
AK	3002-300-083	Motion Interrupt Pan	1
AL	3002-300-145	Fowler Litter Assembly	1
AM	3002-300-602	Fowler Elevation Label	1
AN	3002-300-870	8" Litter Ground Jumper	2
AP	3003-300-042	Foot Cover Assembly	1
AR	3003-300-190	Foot Litter Assembly	1
AT	3004-353-895	LBS, Electrical Litter Assembly, Standard Bed (pg. 186)	1
AU	3000-300-113	8" Cable Tie	1
AV	0003-226-000	Hex Washer Head Screw	1

Litter Assembly, iBED Awareness/Battery Backup Option

For Reference Only: 3004-350-100

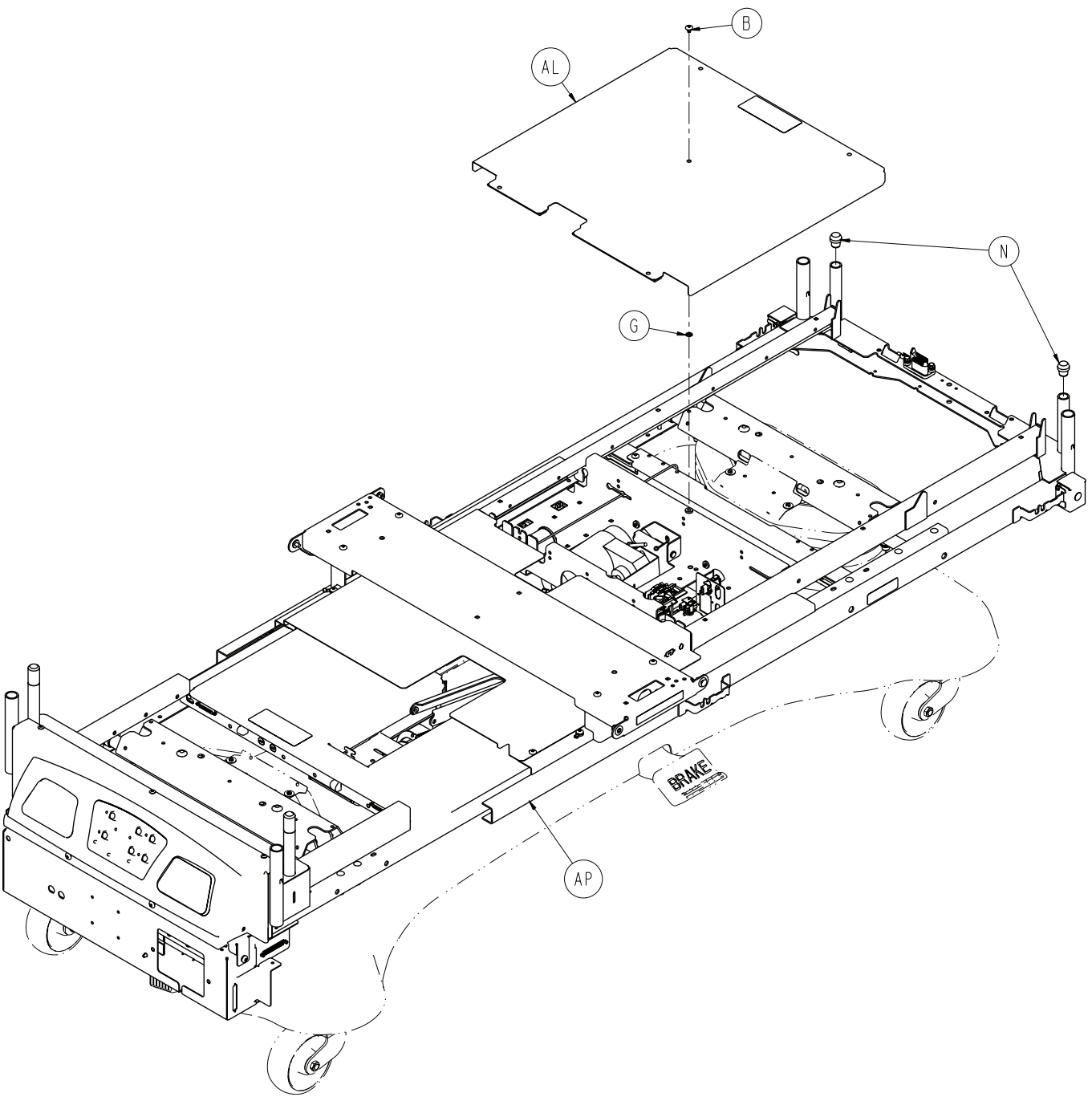

Litter Assembly, iBED Awareness/Battery Backup Option

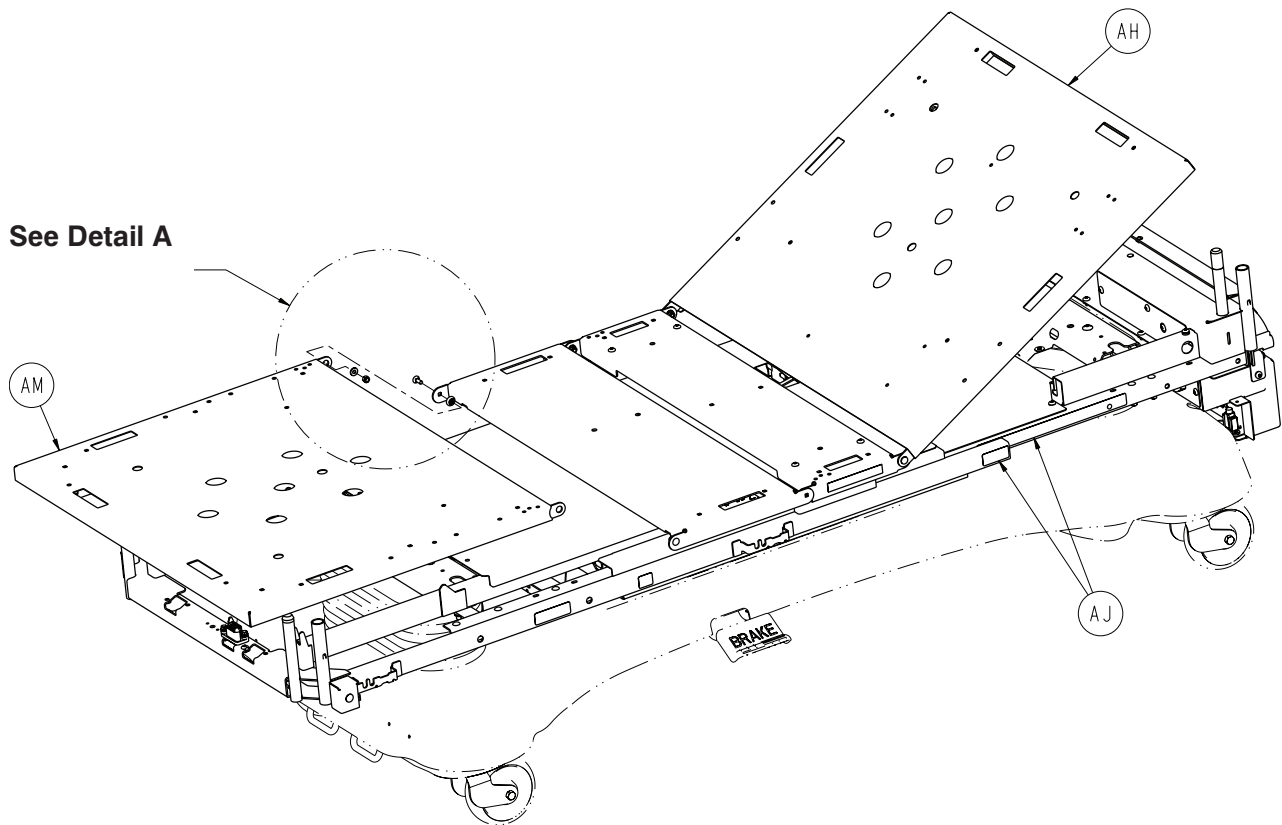

DETAIL A

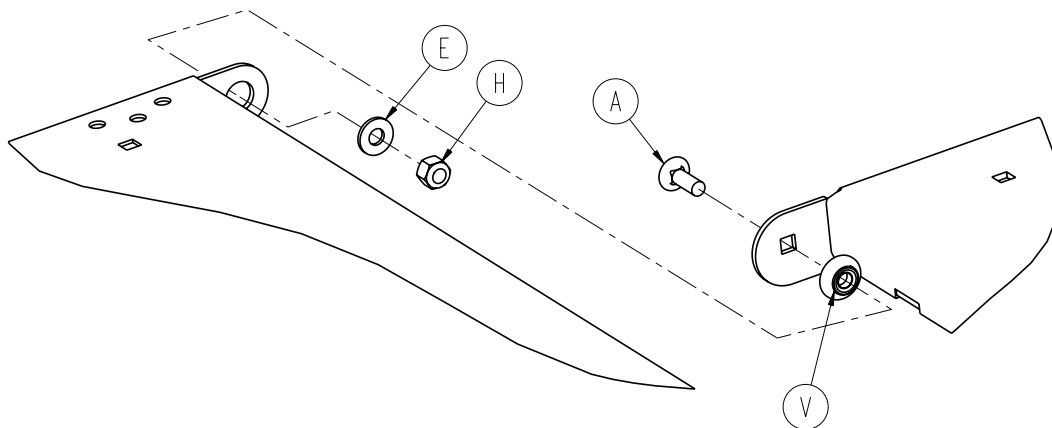

Litter Assembly, iBED Awareness/Battery Backup Option

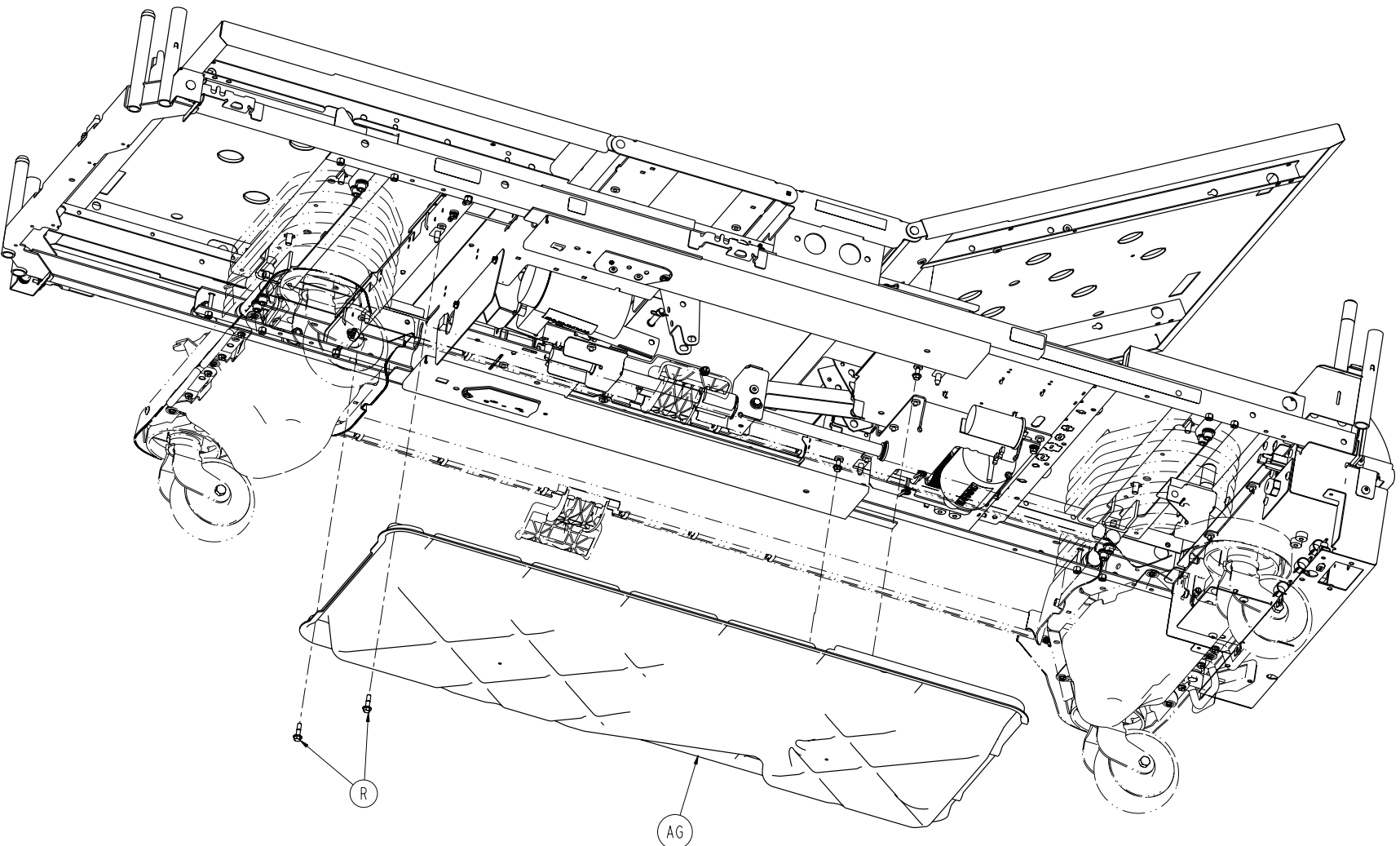

Litter Assembly, iBED Awareness/Battery Backup Option

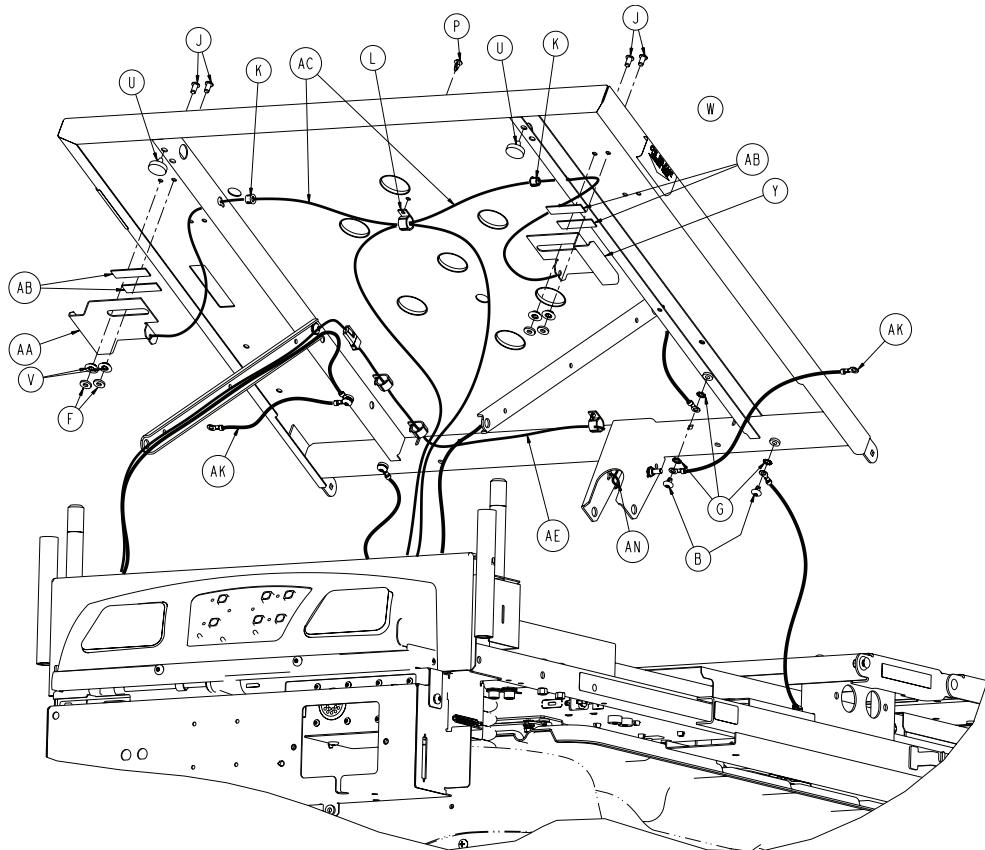
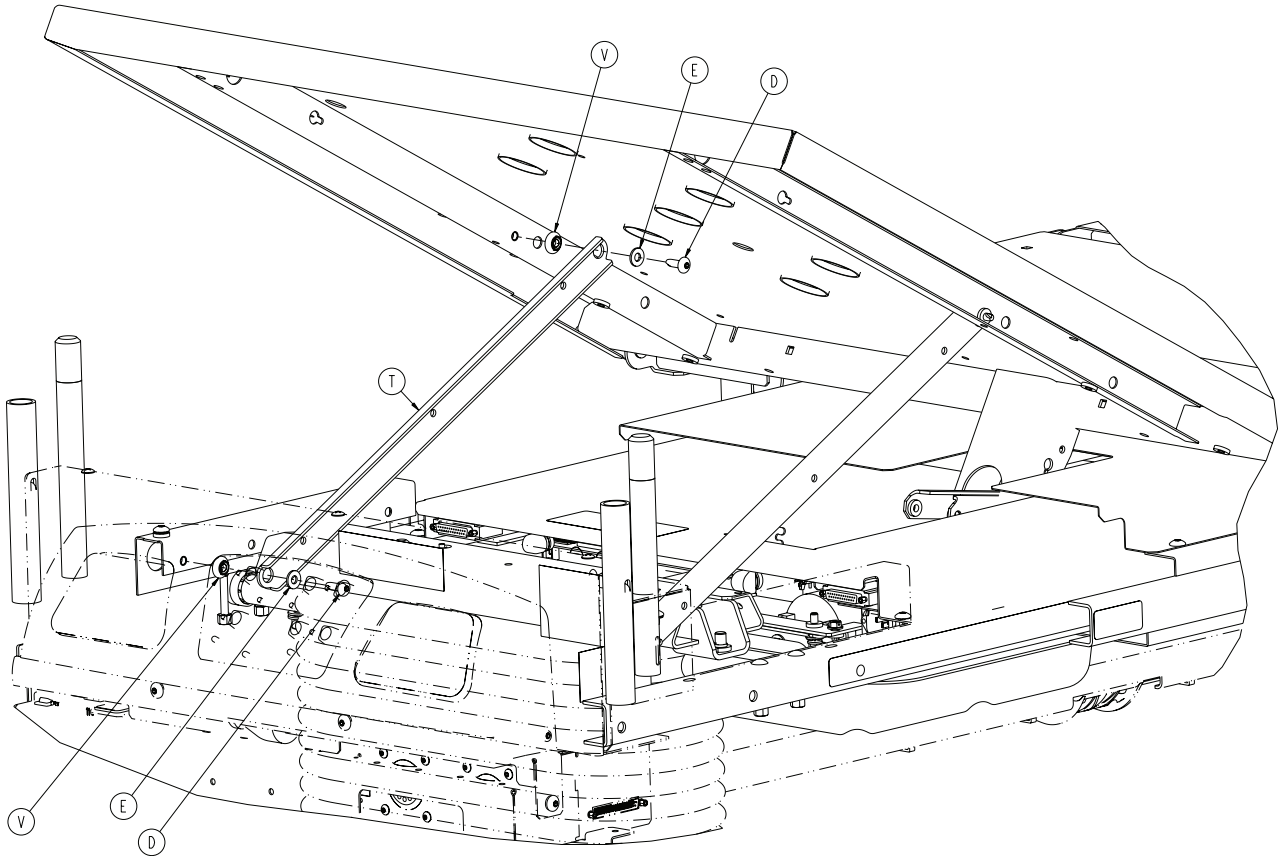

Litter Assembly, iBED Awareness/Battery Backup Option

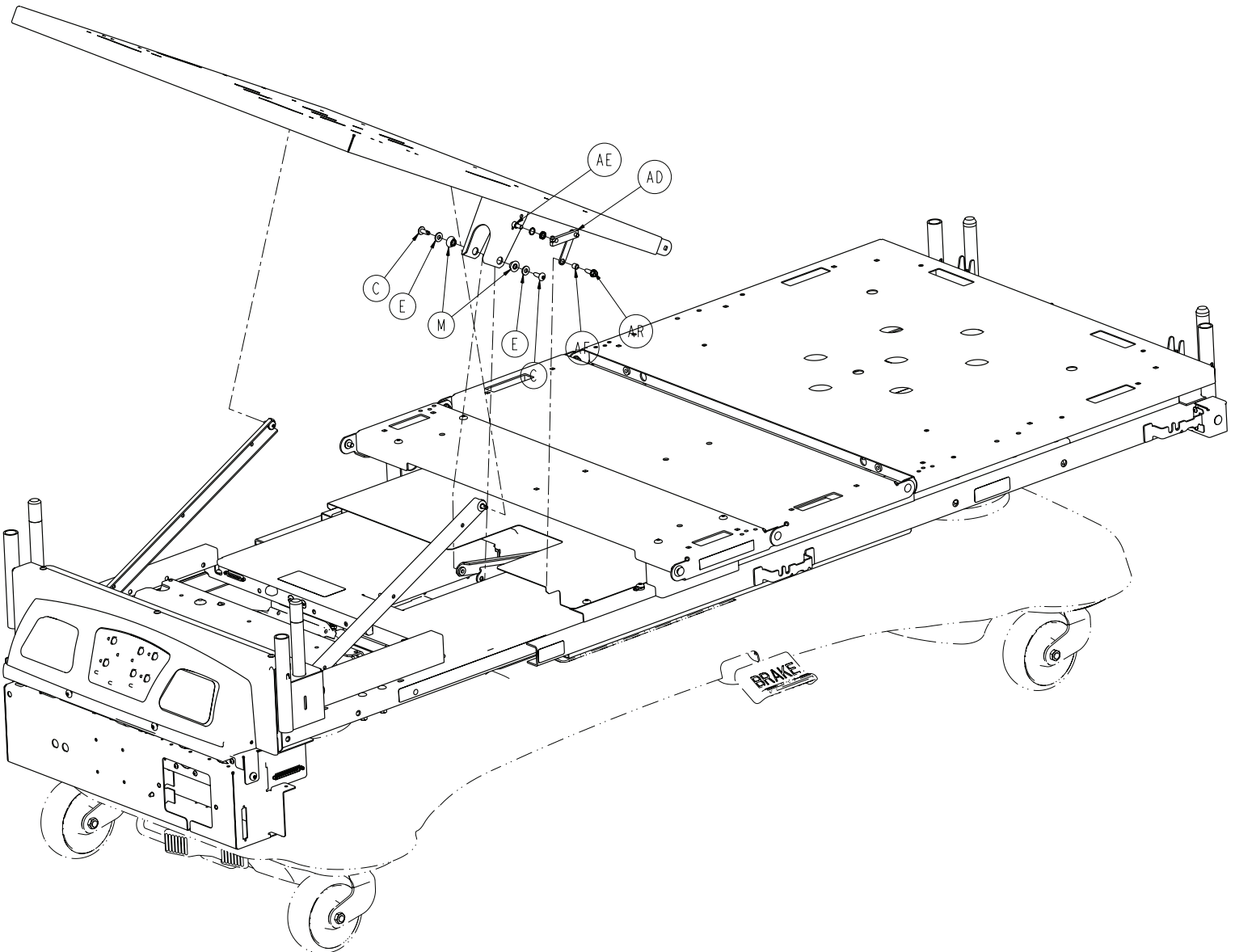

Litter Assembly, iBED Awareness/Battery Backup Option

Litter Assembly, LBS Battery Backup Option - 3004-350-100 (Reference Only)

Item	Part No.	Part Name	Qty.
A	0005-017-000	Carriage Bolt	4
B	0007-053-000	Truss Head Screw	5
C	0007-063-000	Truss Head Screw	2
D	0007-065-000	Truss Head Screw	4
E	0011-077-000	Washer	10
F	0011-376-000	Washer	4
G	0013-010-000	External Tooth Lock Washer	8
H	0016-028-000	Fiberlock Hex Nut	4
J	0025-120-000	Dome Head Rivet	4
K	0030-052-000	Heyco Snap Bushing	2
L	0059-743-000	Wire Harness Clip	4
M	3000-300-099	Fowler Bushing	2
N	3000-300-349	Cap	2
P	3000-300-477	CPR Conduit Stud	4
R	3001-200-229	Mounting Standoff	2
T	3001-300-005	Fowler Link	2
U	3001-300-008	Bumper	2
V	3001-300-099	Fowler Bushing	10
W	3001-300-603	CPR Release Label	2
Y	3001-300-661	CPR Handle, Right	1
AA	3001-300-662	CPR Handle, Left	1
AB	3001-300-663	Velcro Strip	4
AC	3001-300-670	CPR Cable Assembly	2
AD	3001-345-450	Pot. Linkage Assembly	1
AE	3001-345-807	Fowler Pot. Cable	1
AF	3001-400-558	Spacer	1
AG	3002-300-083	Motion Interrupt Pan	1
AH	3002-300-145	Fowler Litter Assembly	1
AJ	3002-300-602	Fowler Elevation Label	1
AK	3002-300-870	8" Litter Ground Jumper	2
AL	3003-300-042	Foot Cover Assembly	1
AM	3003-300-190	Foot Litter Assembly	1
AN	3000-300-113	8" Cable Tie	1
AP	3004-350-110	Optional Battery Backup	1
AR	0003-226-000	Hex Washer Head Screw	1

Litter Assembly, iBED Awareness/Zoom Option

For Reference Only: 3004-357-002

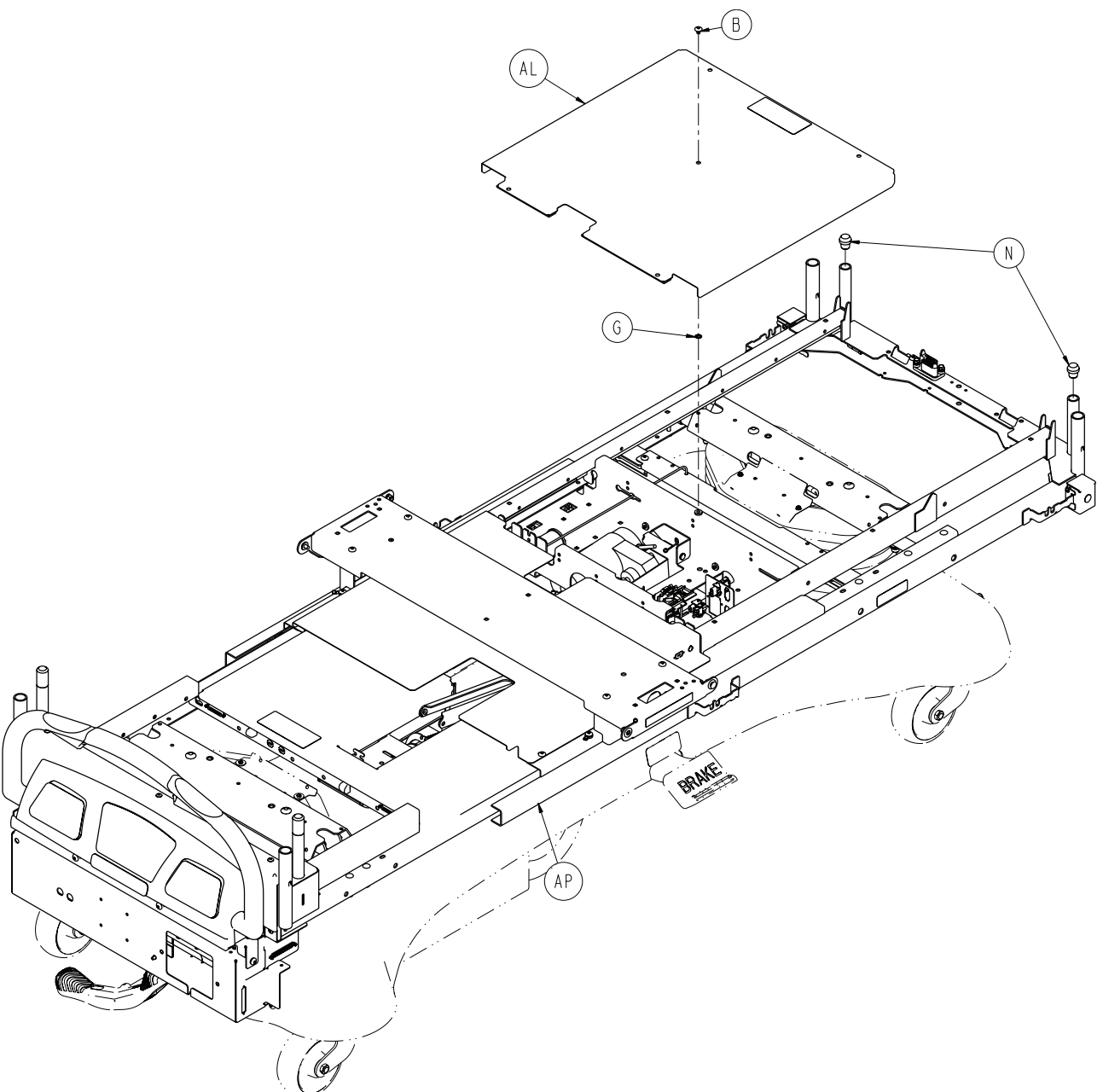

Litter Assembly, iBED Awareness/Zoom Option

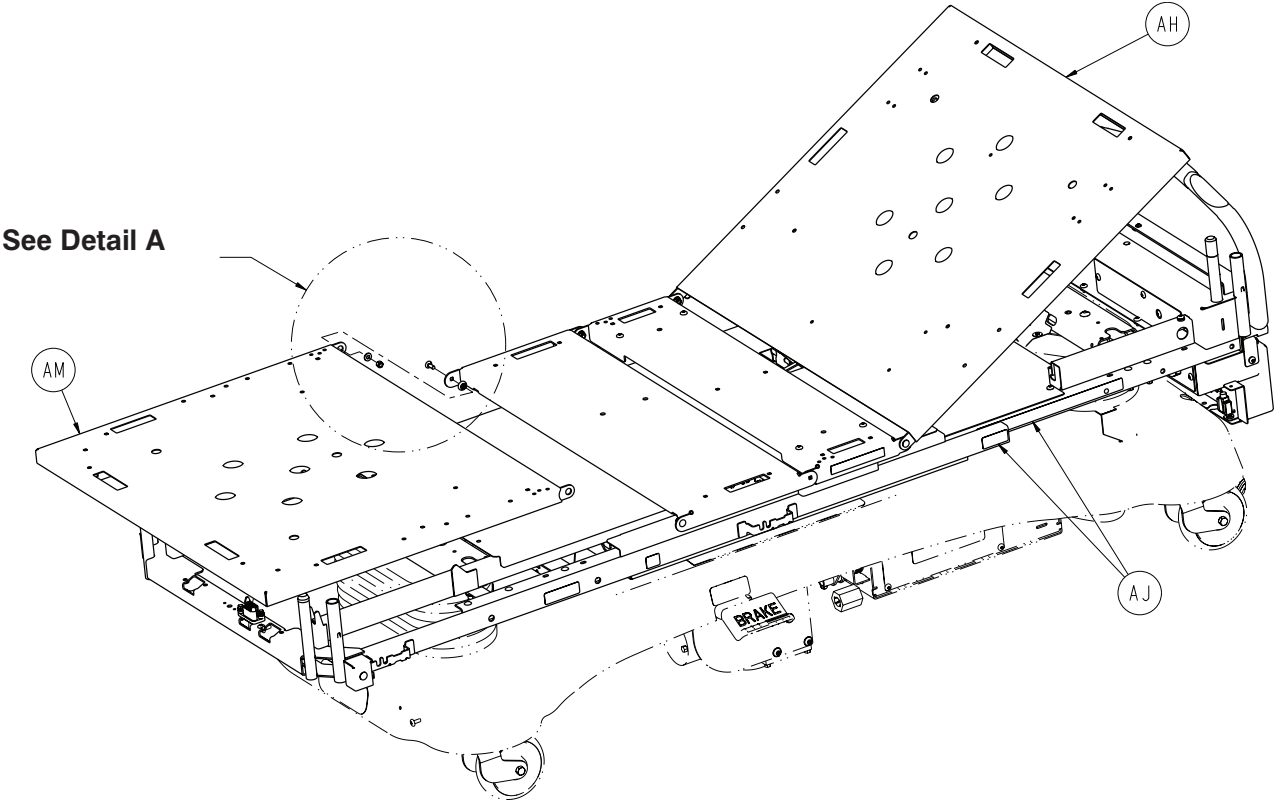

DETAIL A

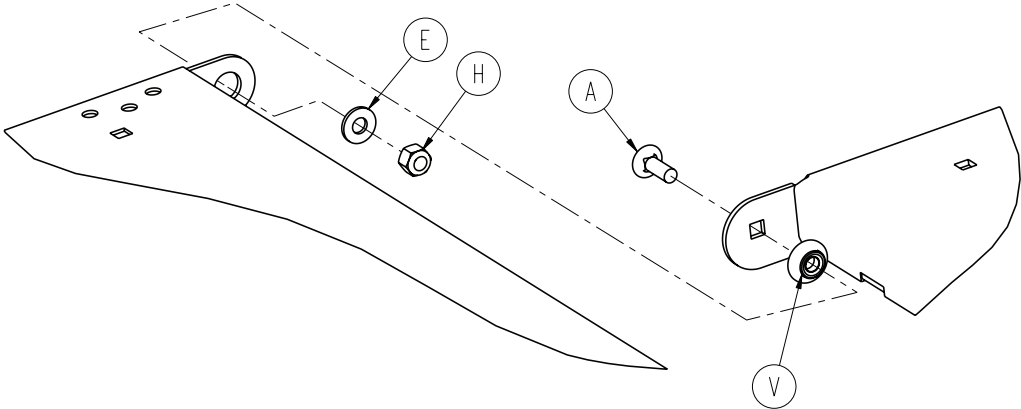

Litter Assembly, iBED Awareness/Zoom Option

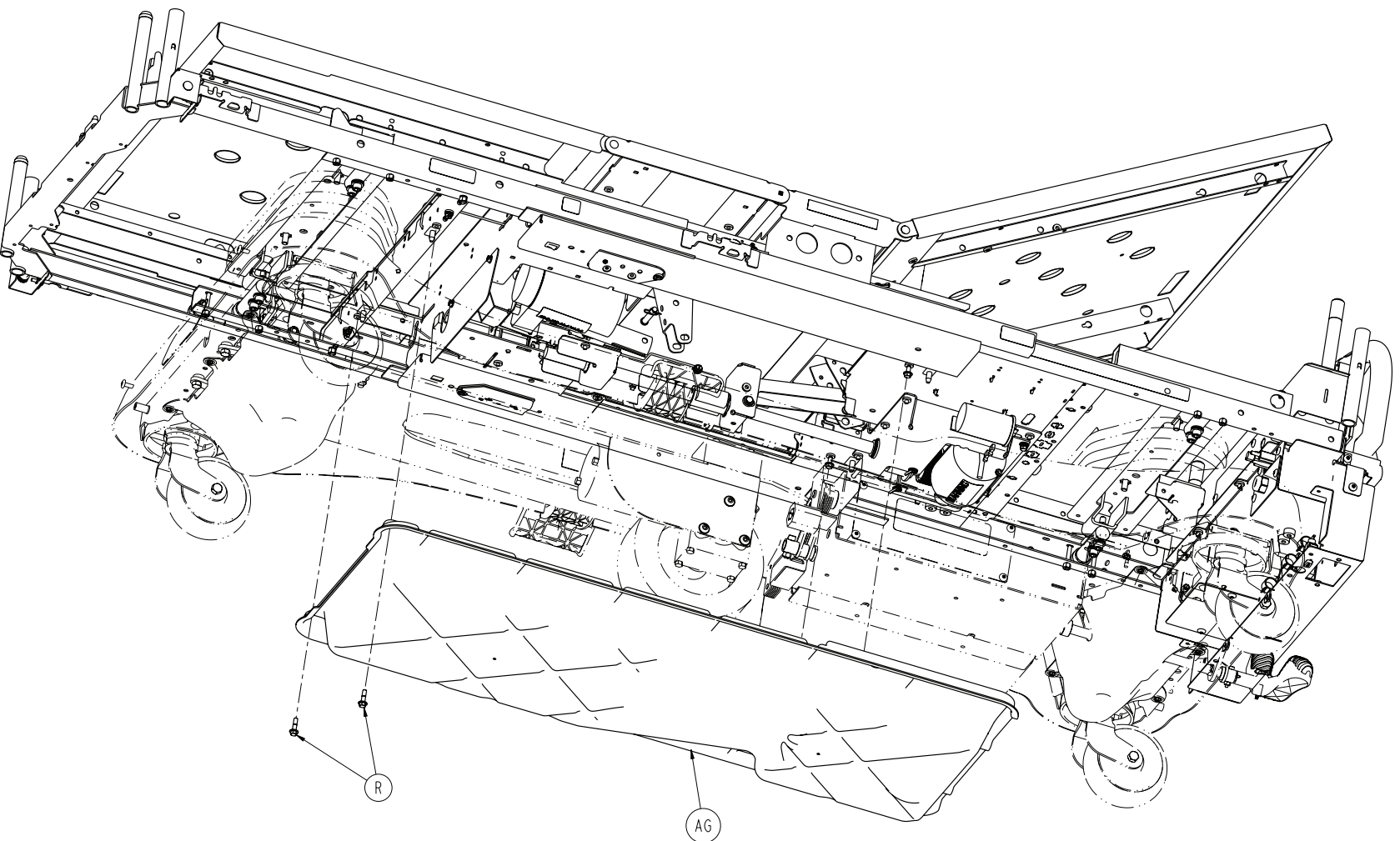

Litter Assembly, iBED Awareness/Zoom Option

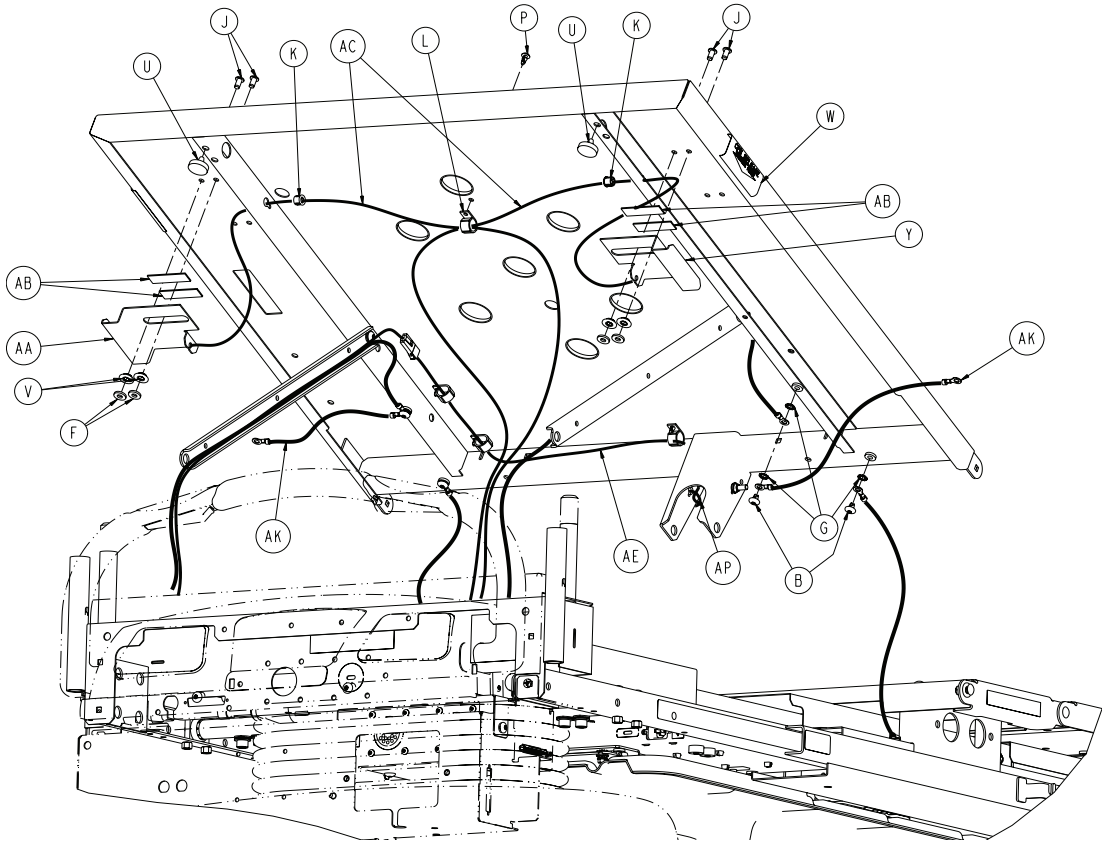
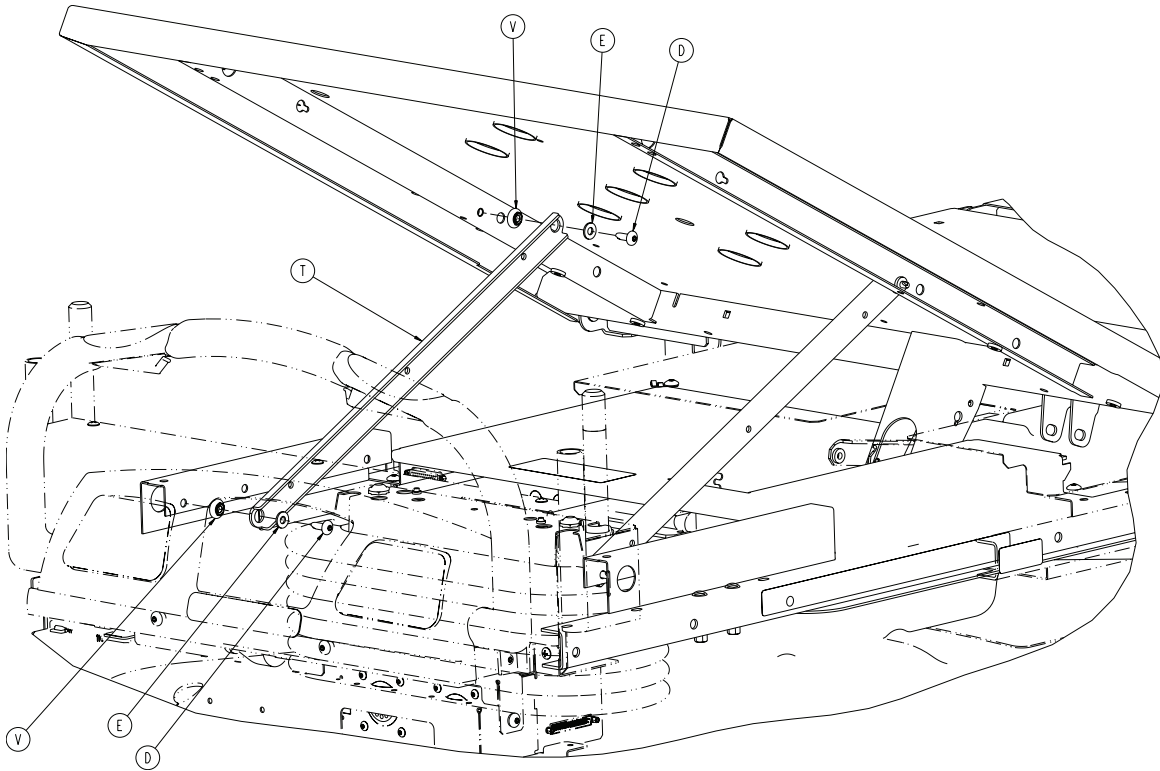

Litter Assembly, iBED Awareness/Zoom Option

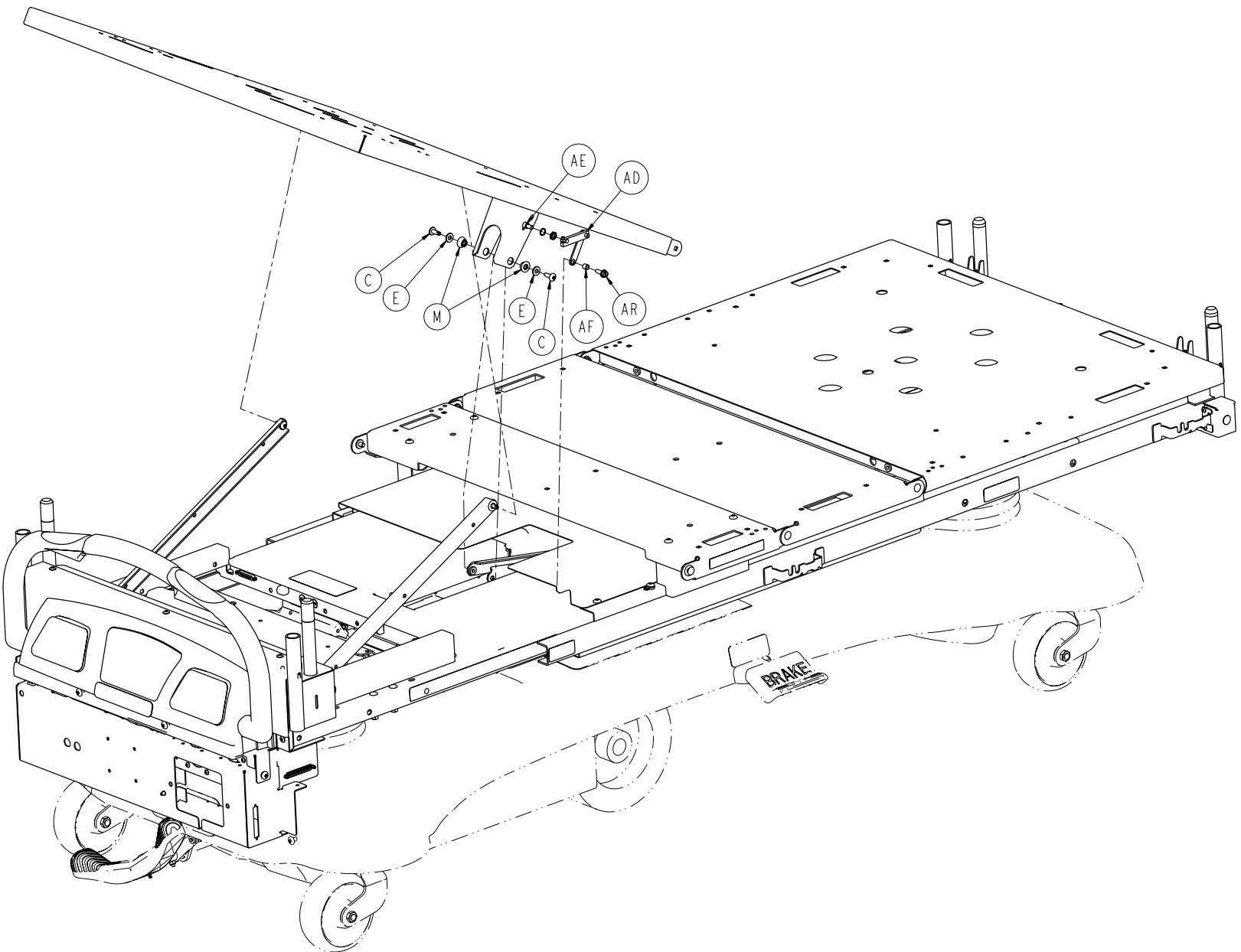

Litter Assembly, iBED Awareness/Zoom Option

Litter Assembly, iAwareness Zoom Option - 3004-357-002 (Reference Only)

Item	Part No.	Part Name	Qty.
A	0005-017-000	Carriage Bolt	4
B	0007-053-000	Truss Head Screw	5
C	0007-063-000	Truss Head Screw	2
D	0007-065-000	Truss Head Screw	4
E	0011-077-000	Washer	10
F	0011-376-000	Washer	4
G	0013-010-000	External Tooth Lock Washer	8
H	0016-028-000	Fiberlock Hex Nut	4
J	0025-120-000	Dome Head Rivet	4
K	0030-052-000	Heyco Snap Bushing	2
L	0059-743-000	Wire Harness Clip	4
M	3000-300-099	Fowler Bushing	2
N	3000-300-349	Cap	2
P	3000-300-477	CPR Conduit Stud	4
R	3001-200-229	Mounting Standoff	2
T	3001-300-005	Fowler Link	2
U	3001-300-008	Bumper	2
V	3001-300-099	Fowler Bushing	10
W	3001-300-603	CPR Release Label	2
Y	3001-300-661	CPR Handle, Right	1
AA	3001-300-662	CPR Handle, Left	1
AB	3001-300-663	Velcro Strip	4
AC	3001-300-670	CPR Cable Assembly	2
AD	3001-345-450	Pot. Linkage Assembly	1
AE	3001-345-807	Fowler Pot. Cable	1
AF	3001-400-558	Spacer	1
AG	3002-300-083	Motion Interrupt Pan	1
AH	3002-300-145	Fowler Litter Assembly	1
AJ	3002-300-602	Fowler Elevation Label	1
AK	3002-300-870	8" Litter Ground Jumper	2
AL	3003-300-042	Foot Cover Assembly	1
AM	3003-300-190	Foot Litter Ass'y	1
AN	3004-357-895	iAwareness, Electrical Litter Ass'y, Secure Zoom (pg. 195)	1
AP	3000-300-113	8" Cable Tie	1
AR	0003-226-000	Hex Washer Head Screw	1

Foot Prop Assembly, Standard Length Bed

3003-034-010

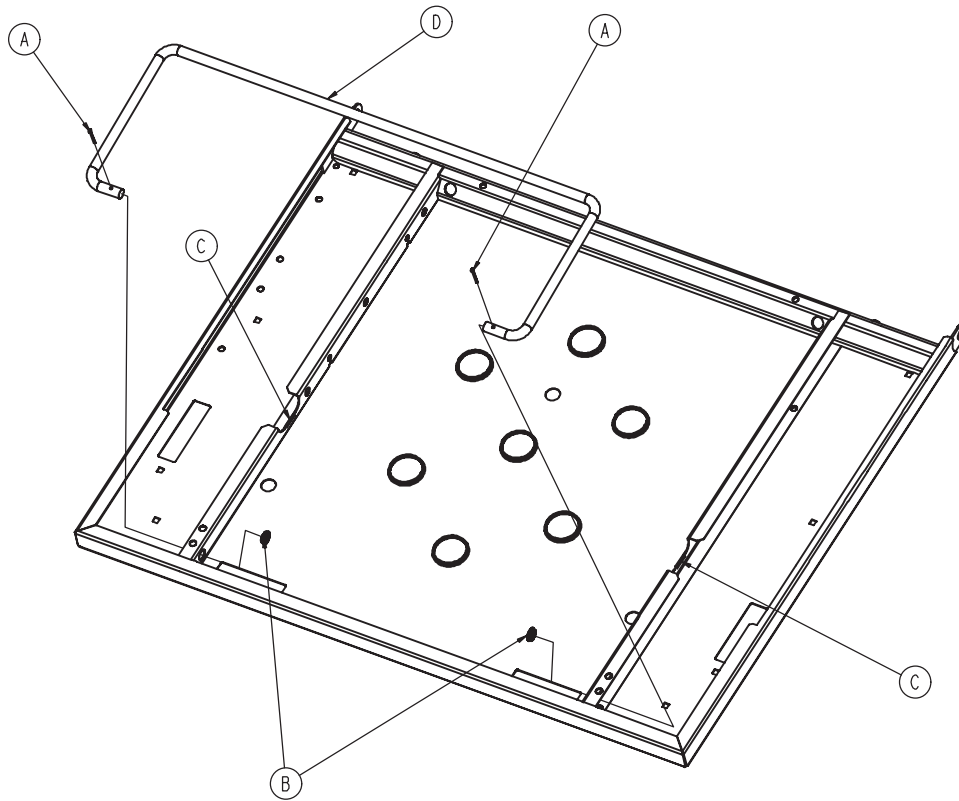

Item	Part No.	Part Name	Qty.
A	0027-007-000	Cotter Pin	2
B	0052-754-000	Bushing	2
C	0058-056-000	Black Edge Trim	3"
D	3003-300-162	Rod, Foot Prop	1

[Return To Table of Contents](#)

Litter CPU Cover Assembly

3001-300-097

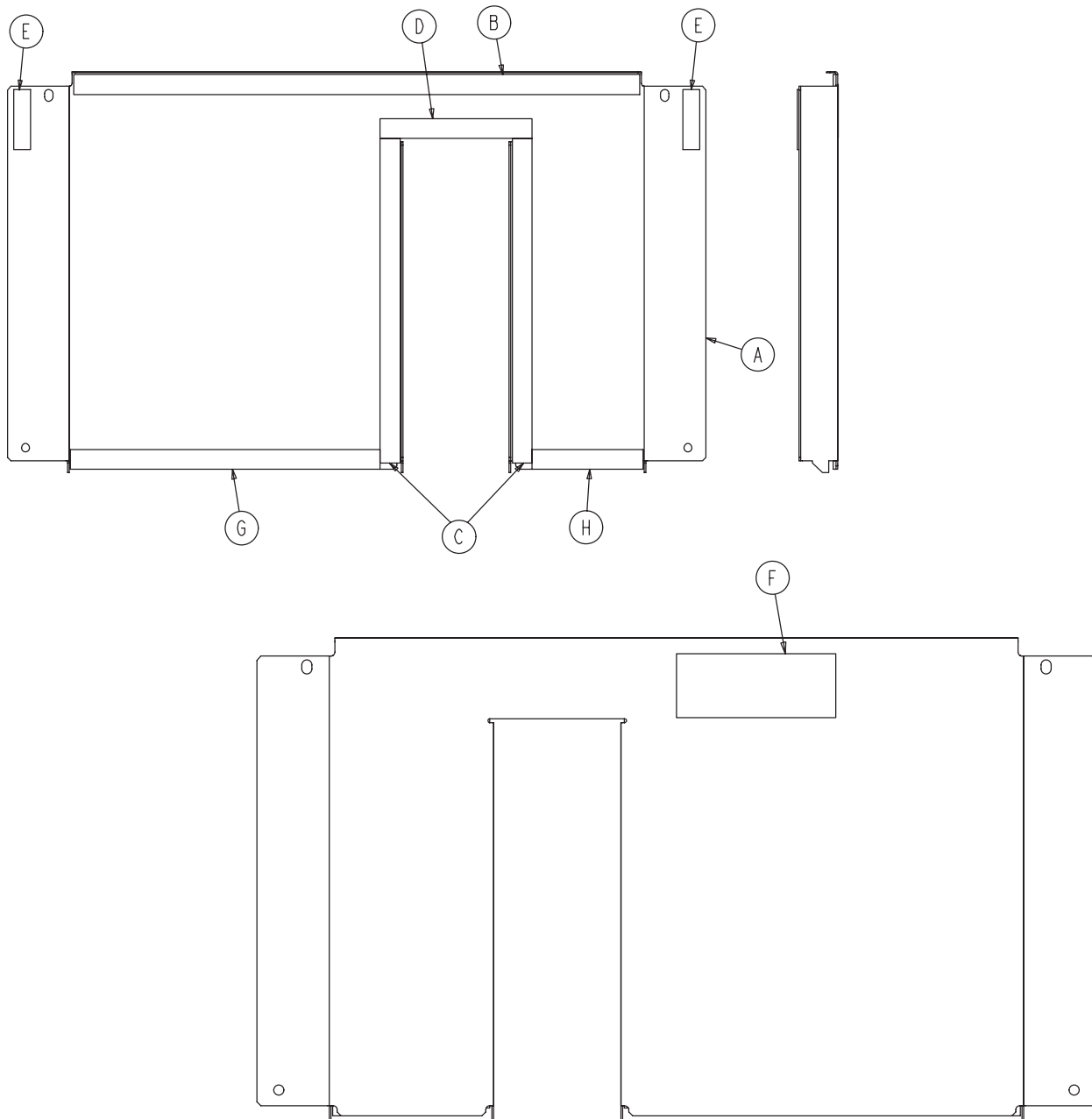

Item	Part No.	Part Name	Qty.
A	3001-300-098	CPU Cover	1
B	7900-001-291	Foam Tape (21.38")	1
C	7900-001-291	Foam Tape (12.25")	2
D	7900-001-291	Foam Tape (5.75")	1
E	3001-300-663	Velcro Strip	2
F	0988-002-708	Service Caution Label	1
G	7900-001-291	Foam Tape (11.75")	1
H	7900-001-291	Foam Tape (4.25")	1

Foot Cover Assembly

8" Shorter Bed - 3001-342-041 / Standard Bed - 3003-300-042

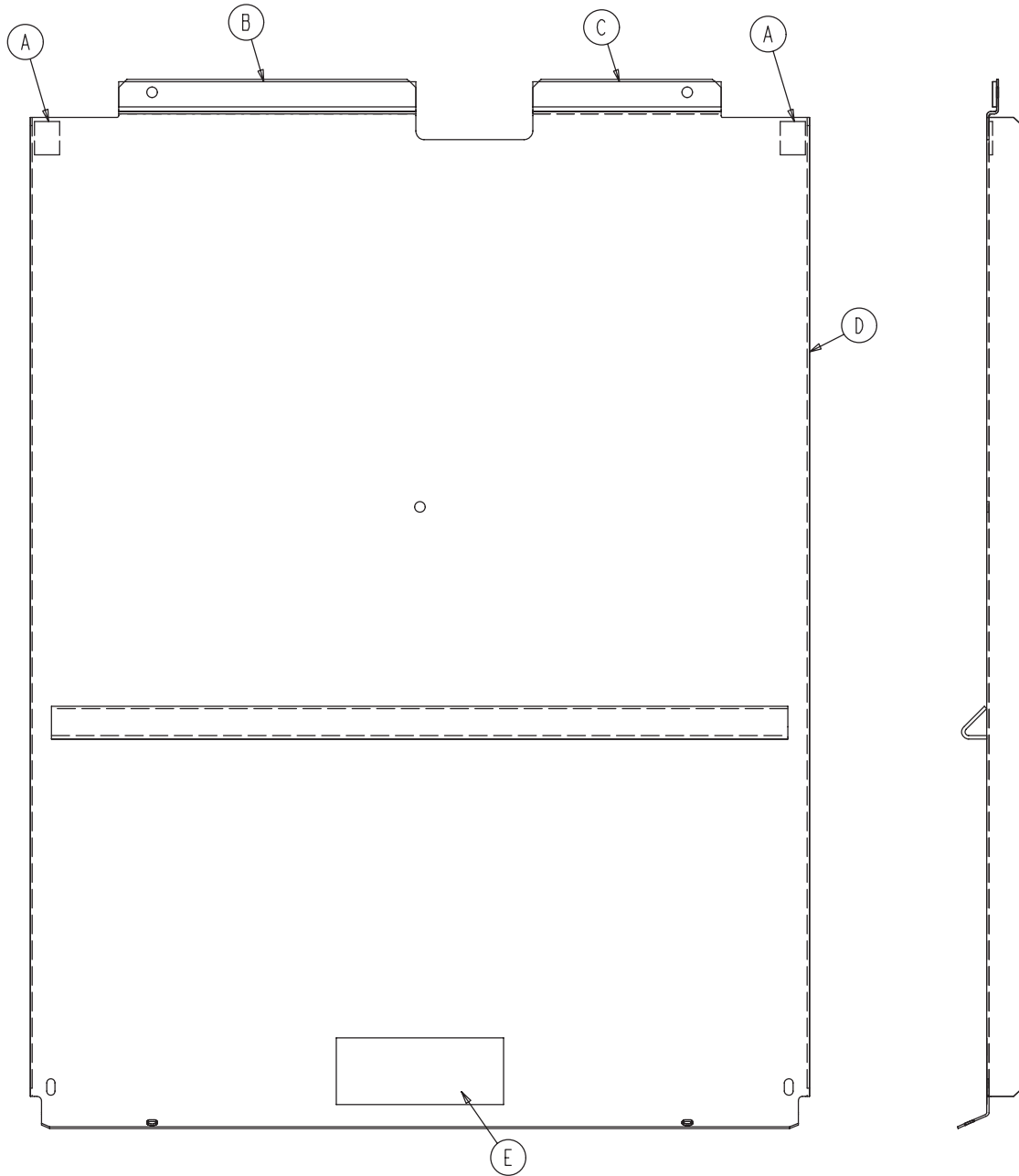

Item	Part No.	Part Name	Qty.
A	7900-001-291	Foam Tape (5.63")	1
B	7900-001-291	Foam Tape (8.88")	1
C	7900-001-291	Foam Tape (1")	4
D	3003-300-043	Foot Cover (Standard)	1
	3001-342-042	Foot Cover (8" Shorter Bed)	1
E	0988-002-708	Service Caution Label	1

[Return To Table of Contents](#)

Electrical Litter Assembly, Standard Bed

For Reference Only: 3002-300-895

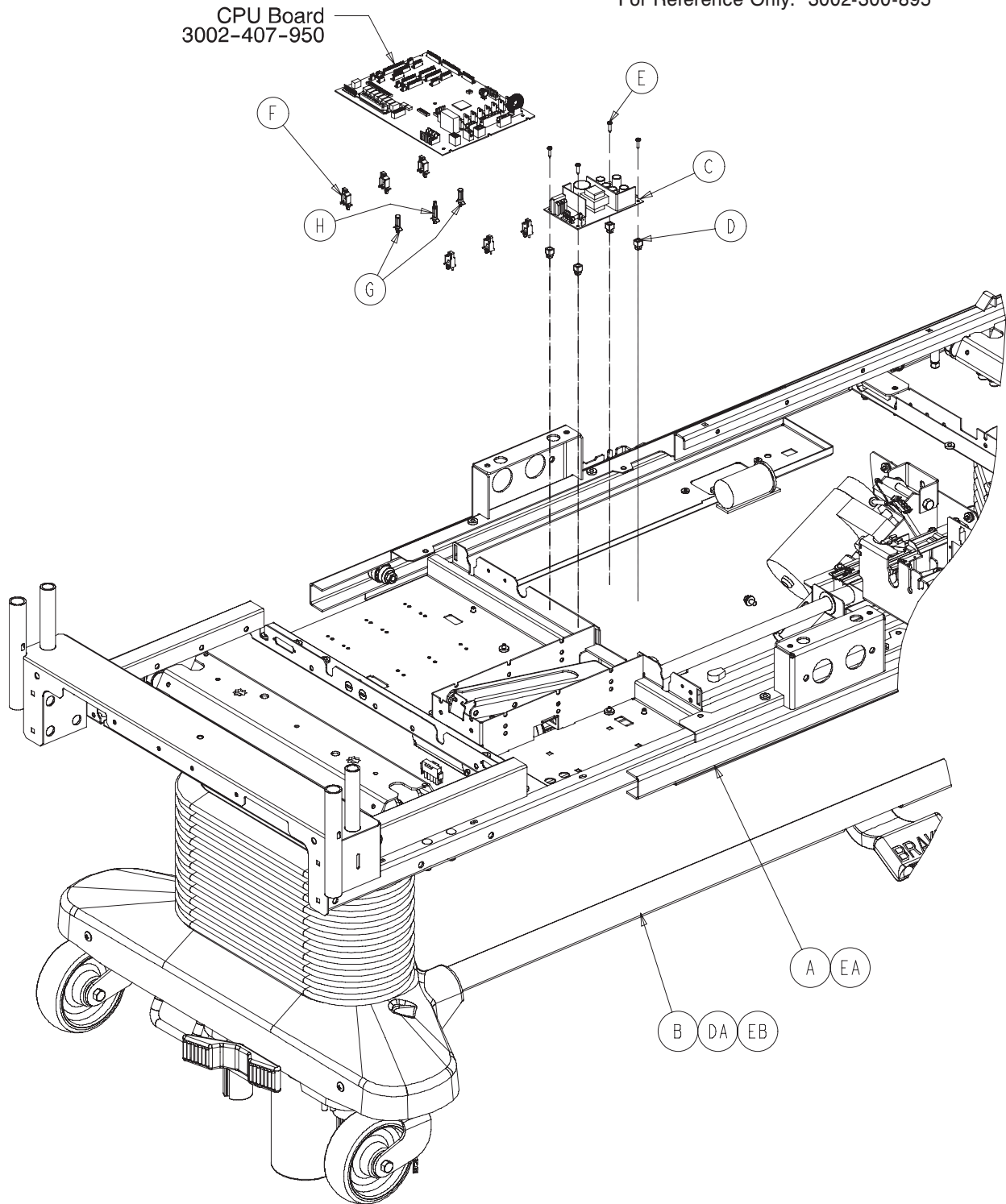

Electrical Litter Assembly, Standard Bed

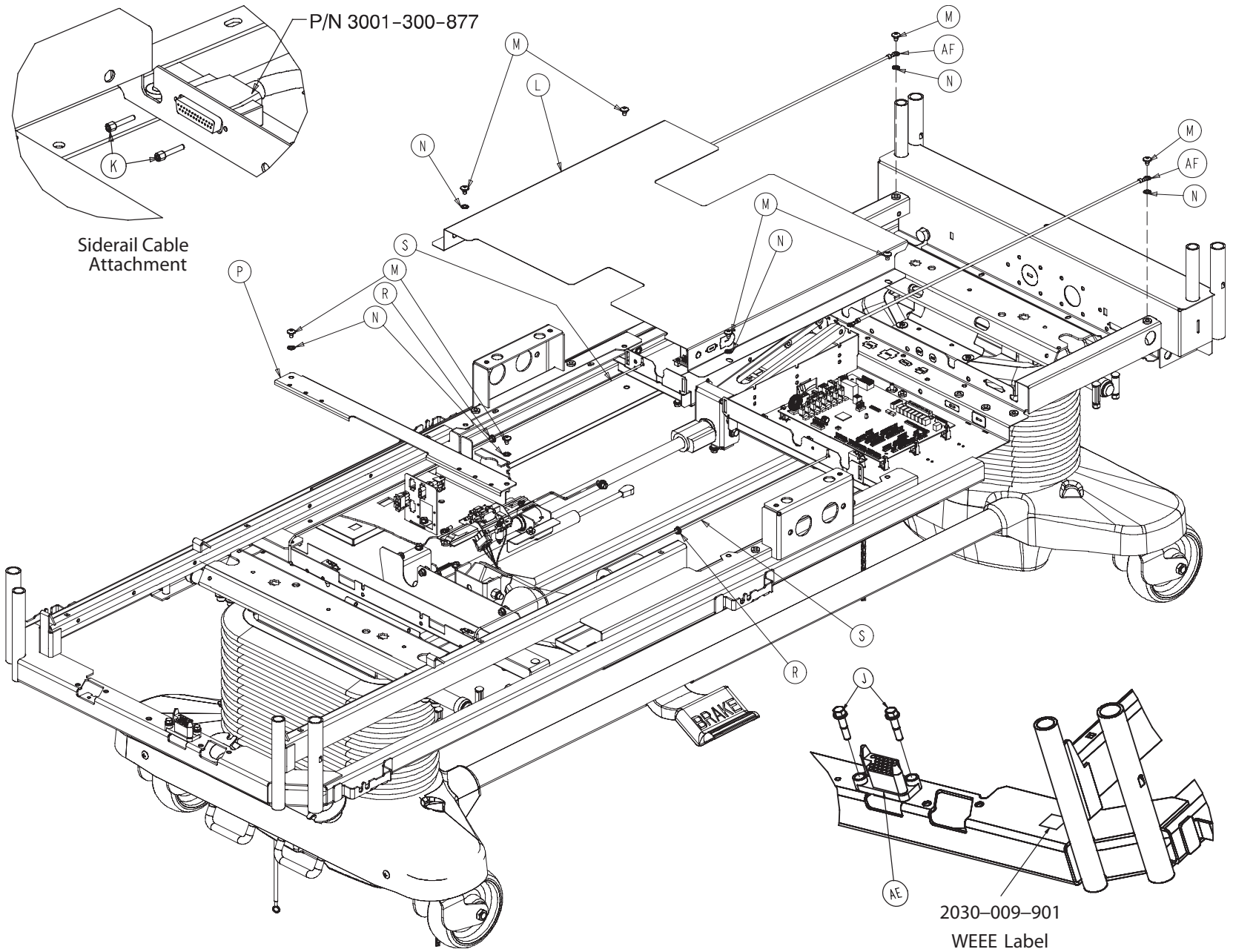

Electrical Litter Assembly, Standard Bed

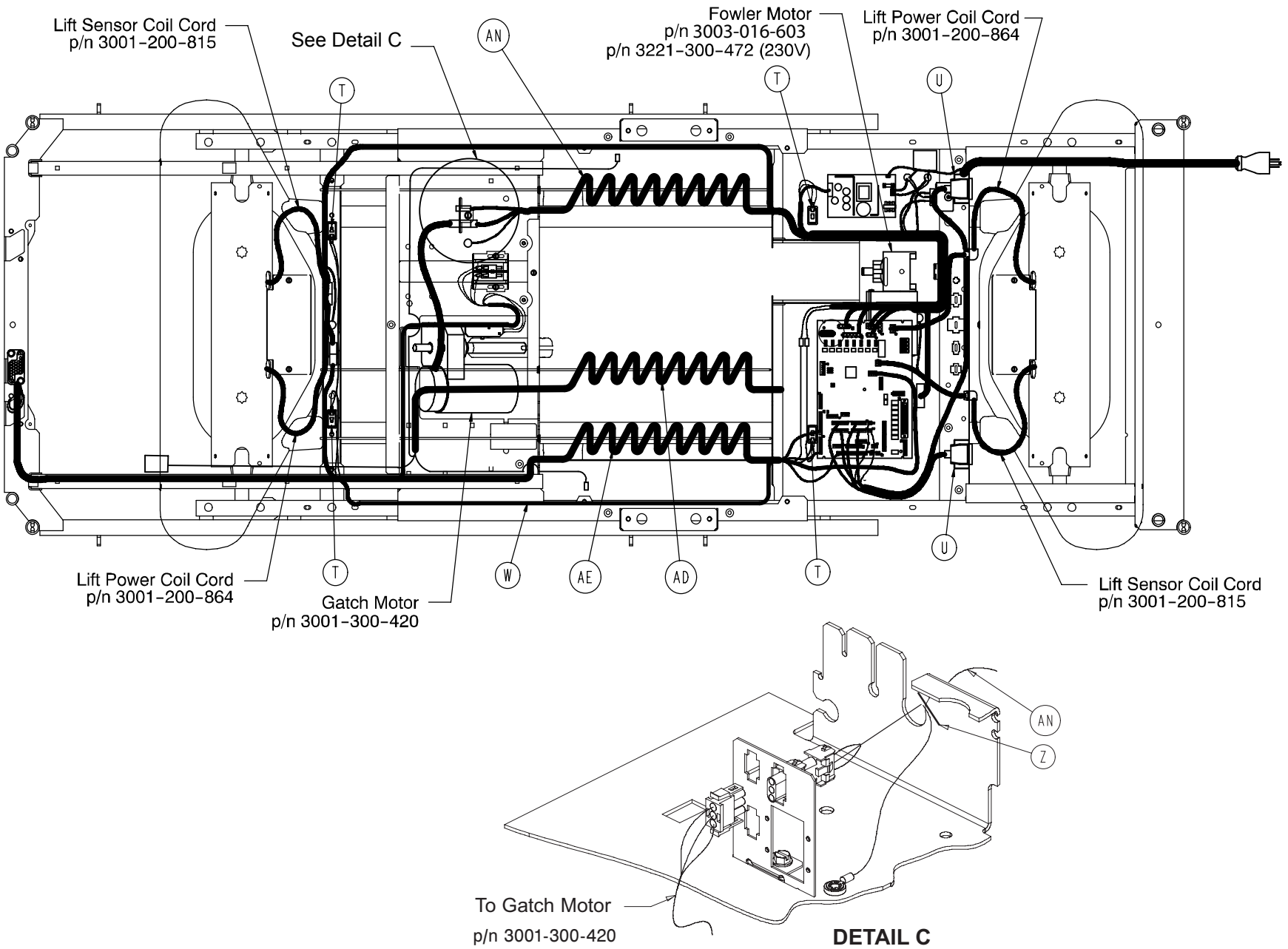

Electrical Litter Assembly, Standard Bed

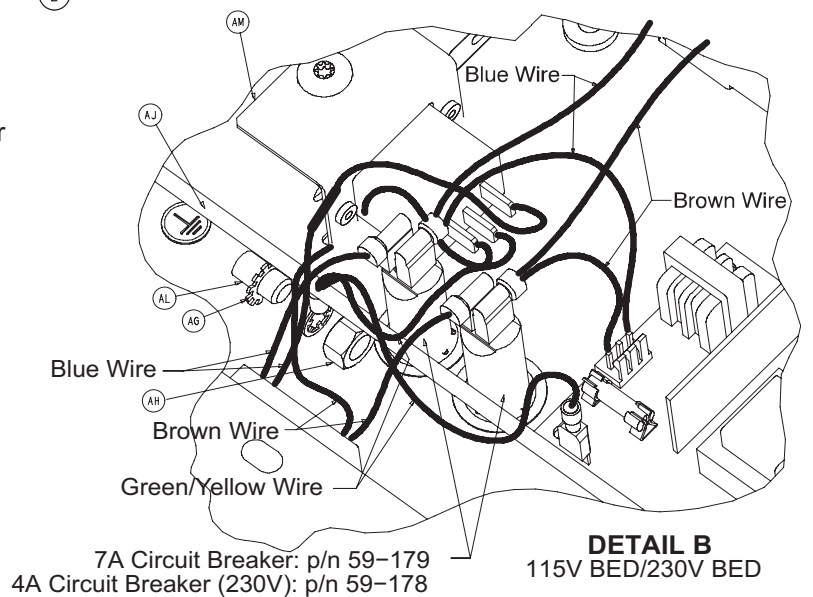
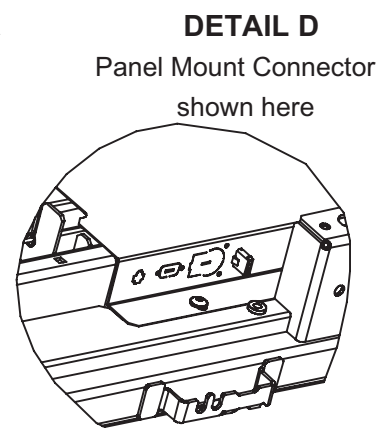
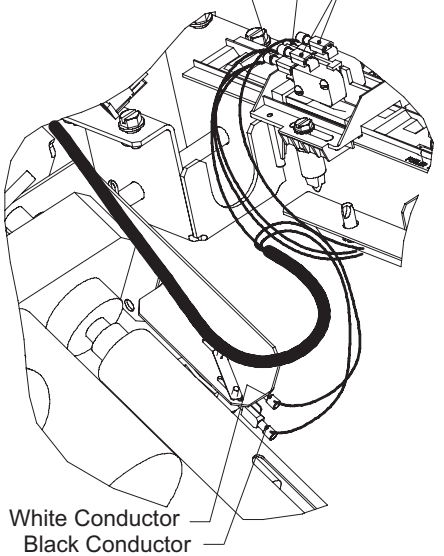
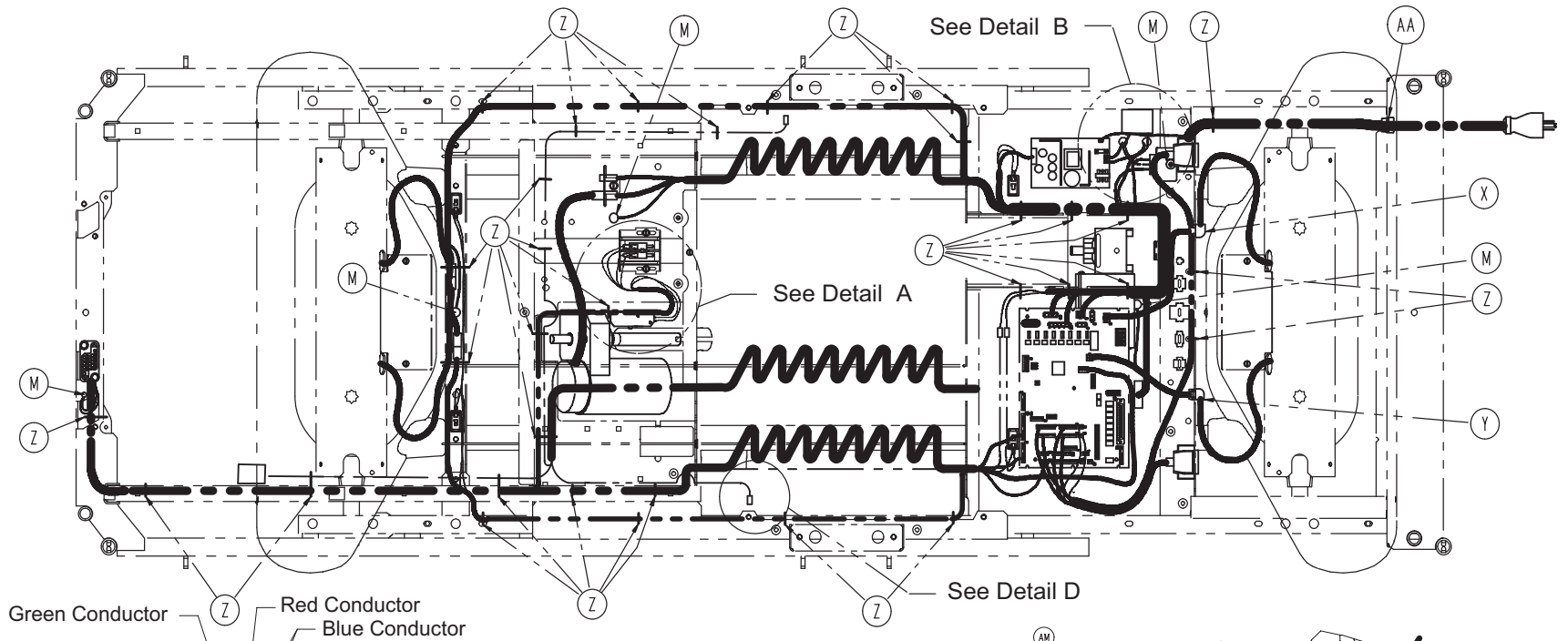

Electrical Litter Assembly, Standard Bed

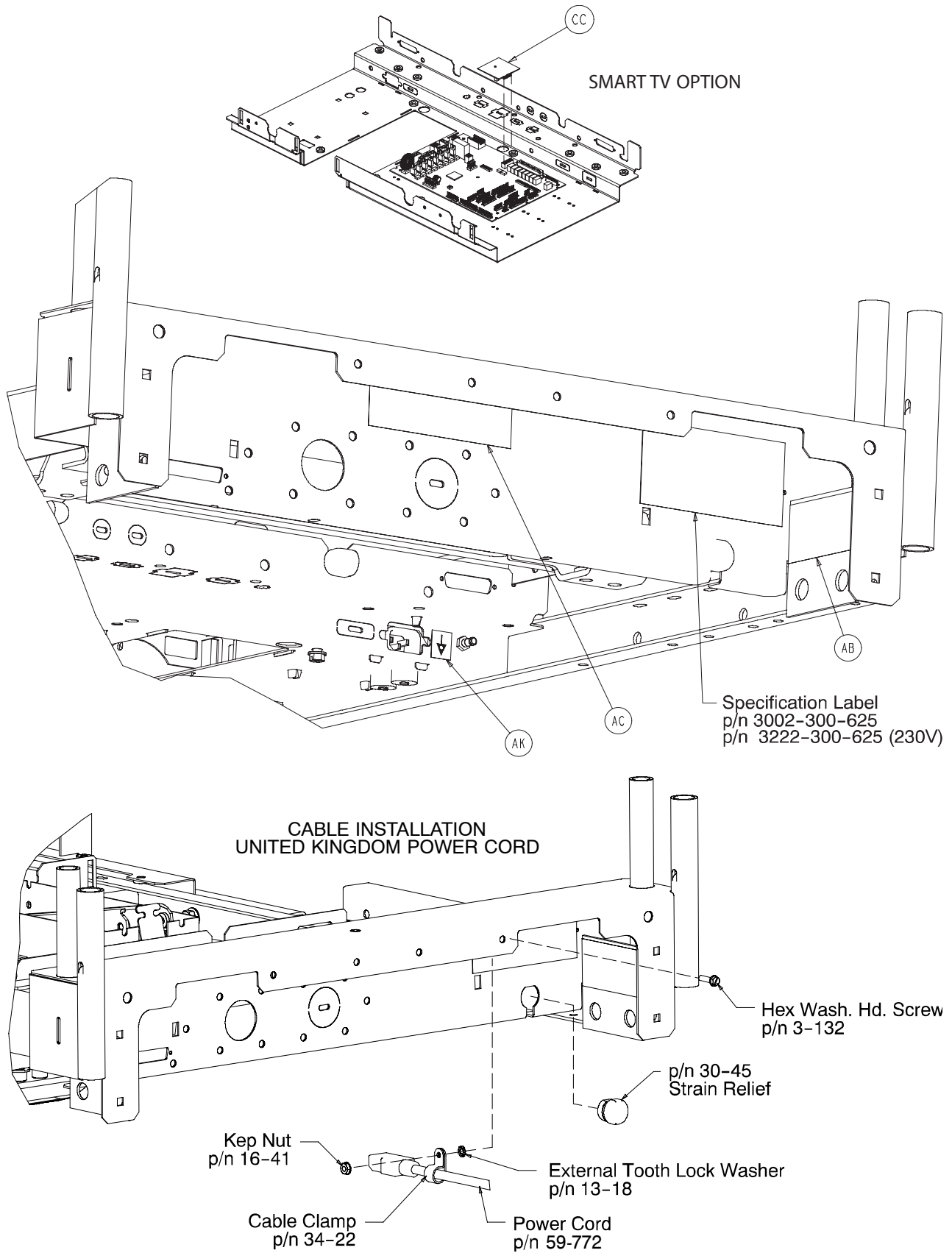

Electrical Litter Assembly, Standard Bed

Electrical Litter Assembly - Common Components 3002-300-895 (Reference Only)

Item	Part No.	Part Name	Qty.
A	3002-300-197	Litter Ass'y, Mech. (pg.196)	1
B	3002-200-003	Base Assembly (pg.106)	1
C	0059-157-000	Power Supply	1
D	0052-287-000	Grommet	4
E	0023-138-000	Pan Head Screw	4
F	0059-745-000	Board Mount	6
G	0059-773-000	Push Spacer	2
H	0059-774-000	Locking Circuit Board Supt.	1
J	3001-200-228	Mounting StandOff	2
K	3001-300-007	Screw	4
L	3001-300-088	Mid Litter Cover Assembly	1
M	0007-053-000	Truss Head Torx Screw	13
N	0013-010-000	Ext. Tooth Lock Washer	6
P	3001-300-023	Cross Support Cover	1
R	0052-822-000	Nyliner Bearing	3
S	3001-300-011	Guide Rod	3
T	3000-300-058	Switch Plunger	4
U	3001-300-877	Siderail Extension Cable	1
W	3001-300-865	Motion Int. Lift Sensor Cable	1
X	0030-048-000	Strain Relief	1
Y	0030-047-000	Strain Relief	1
Z	3000-300-113	Cable Tie	34
AA	0030-027-000	Strain Relief	1
AB	2011-001-104	Warning Label	1
AC	1550-090-001	Hosp. Grade Plug Label	1
AF	3002-300-874	Litter Ground Jumper	2
AG	0013-038-000	Lock Washer	1
AH	0016-033-000	Keyp Nut	1
AJ	0036-046-000	Ground Label	1
AK	0036-115-000	Ground Label	1
AL	2011-001-215	Grounding Lug	1
AN	3002-300-861	Power Harness	1
AP	3002-300-601	Foley Bag Hook Label	2

Standard Bed - 3002-343-895 (Reference Only)

Item	Part No.	Part Name	Qty.
A	3002-300-197	Litter Ass'y, Mech. (pg.196)	1
B	3002-200-003	Base Assembly (pg.106)	1
AE	3002-300-866	Litter Signal Coil Cable	1
AM	3002-300-881	Power Inlet Cable	1

8" Shorter Bed - 3002-342-895 (Reference Only)

Item	Part No.	Part Name	Qty.
A	3002-300-197	Litter Ass'y, Mech. (pg.196)	1
B	3002-200-003	Base Assembly (pg.106)	1
AE	3002-300-866	Litter Signal Coil Cable	1
AM	3002-300-881	Power Inlet Cable	1

Zoom Option

3002-344-895 (Reference Only)

Item	Part No.	Part Name	Qty.
A	3002-300-197	Litter Ass'y, Mech. (pg.196)	1
B	3002-200-003	Base Assembly (pg.106)	1
AE	3002-300-866	Litter Signal Coil Cable	1
AM	3006-300-881	Power Inlet Cable	1
DA	3002-001-101	Zoom Base Assembly	1
DC	3002-131-010	Litter Assembly, Zoom	1

Zoom 8" Shorter Bed Option 3002-346-895 (Reference Only)

Item	Part No.	Part Name	Qty.
A	3002-300-197	Litter Ass'y, Mech. (pg.196)	1
B	3002-200-003	Base Assembly (pg.106)	1
AE	3002-300-866	Litter Signal Coil Cable	1
AM	3002-300-881	Power Inlet Cable	1

Smart TV Option 3002-999-229 (Reference Only)

Item	Part No.	Part Name	Qty.
CC	3002-039-800	Smart TV Board	1

Smart TV Interface w/Relays Option 3002-346-895 (Reference Only)

Item	Part No.	Part Name	Qty.
CA	0059-727-000	Jackscrew	2
CB	2035-232-806	Smart TV Control Cable	1
CC	3001-330-980	Smart TV Plug/PCB Ass'y	1

Battery Backup Option 3002-350-110 (Reference Only)

Item	Part No.	Part Name	Qty.
A	3002-300-197	Litter Ass'y, Mech. (pg.196)	1
B	3002-200-003	Base Assembly (pg.106)	1
AE	3002-300-866	Litter Signal Coil Cable	1
EA	3002-450-150	Enclosure Assembly (pg.229)	1
EB	3002-350-170	Base Assembly (pg.141)	1
AM	3002-300-881	Power Inlet Cable	1

Battery Backup Option 3002-350-100 (Reference Only)

Item	Part No.	Part Name	Qty.
A	3002-300-197	Litter Ass'y, Mech. (pg.196)	1
B	3002-200-003	Base Assembly (pg.106)	1
AE	3002-300-866	Litter Signal Coil Cable	1
EA	3002-300-150	Secure II+, Litter	1
EB	3002-350-170	Secure II+, Base	1

[Return To Table of Contents](#)

Electrical Litter Assembly, iBED Awareness Option

For Reference Only: 3004-353-895

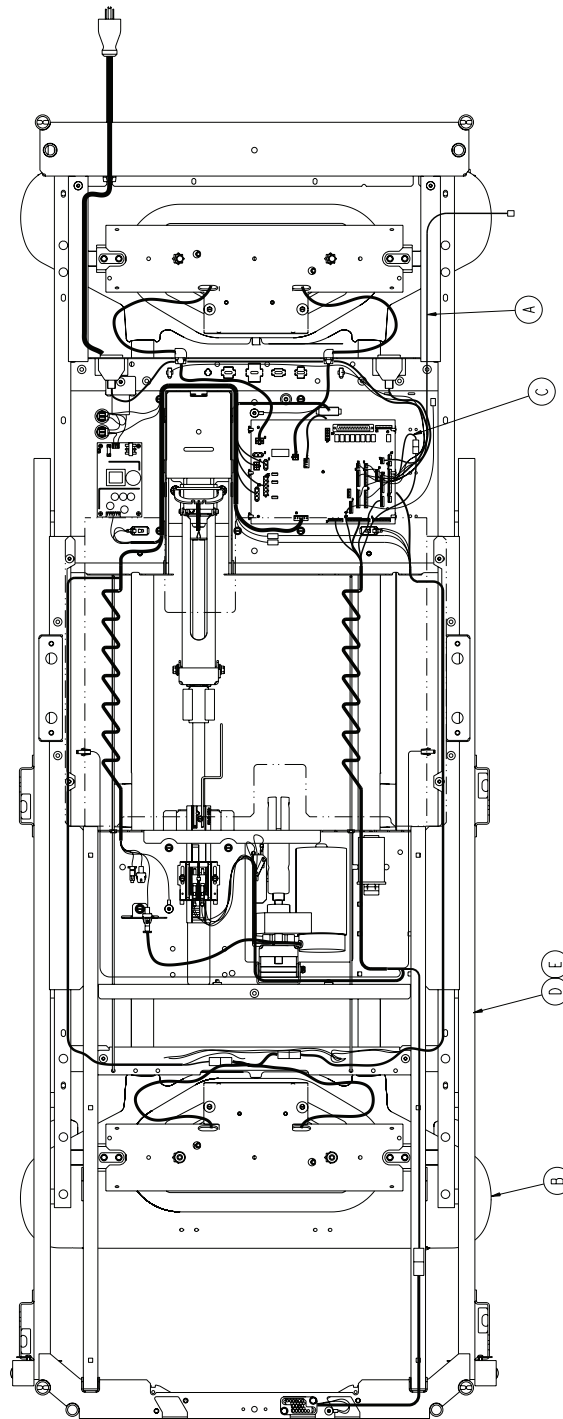

Item	Part No.	Part Name	Qty.
A	3001-345-809	Fowler Pot. Extension Cable	1
B	3002-243-003	Base Assembly, Standard Length Bed (pg.112)	1
C	3003-300-803	CPU to Siderail Sensor Cable	1
D	3002-343-197	Mechanical Litter Assembly (pg.200)	1
E	3004-300-002	LBS Litter Ass'y, Std. Comp.	1

Electrical Litter Assembly, iBED Awareness Option

For Reference Only: 3004-300-895

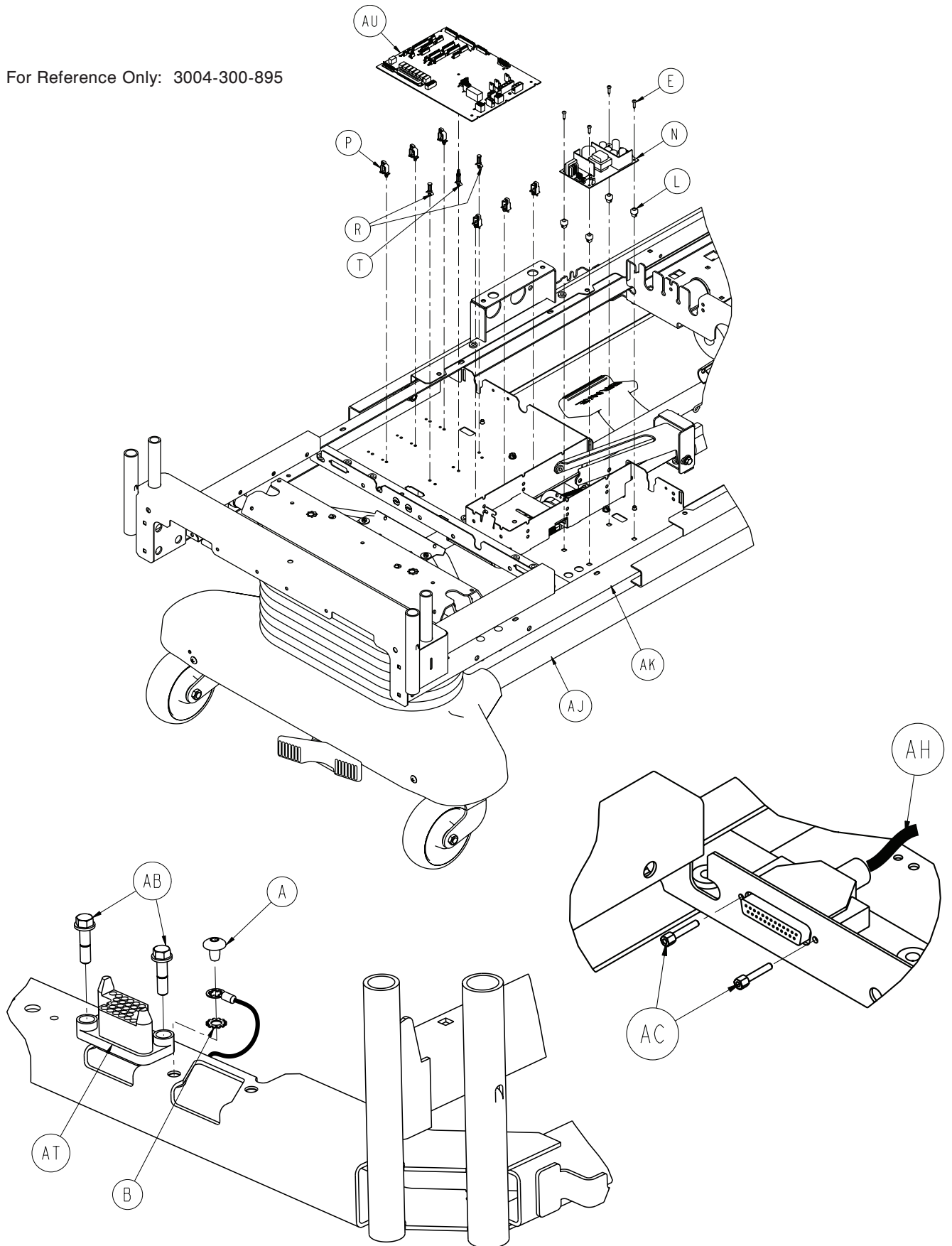

[Return To Table of Contents](#)

Electrical Litter Assembly, iBED Awareness Option

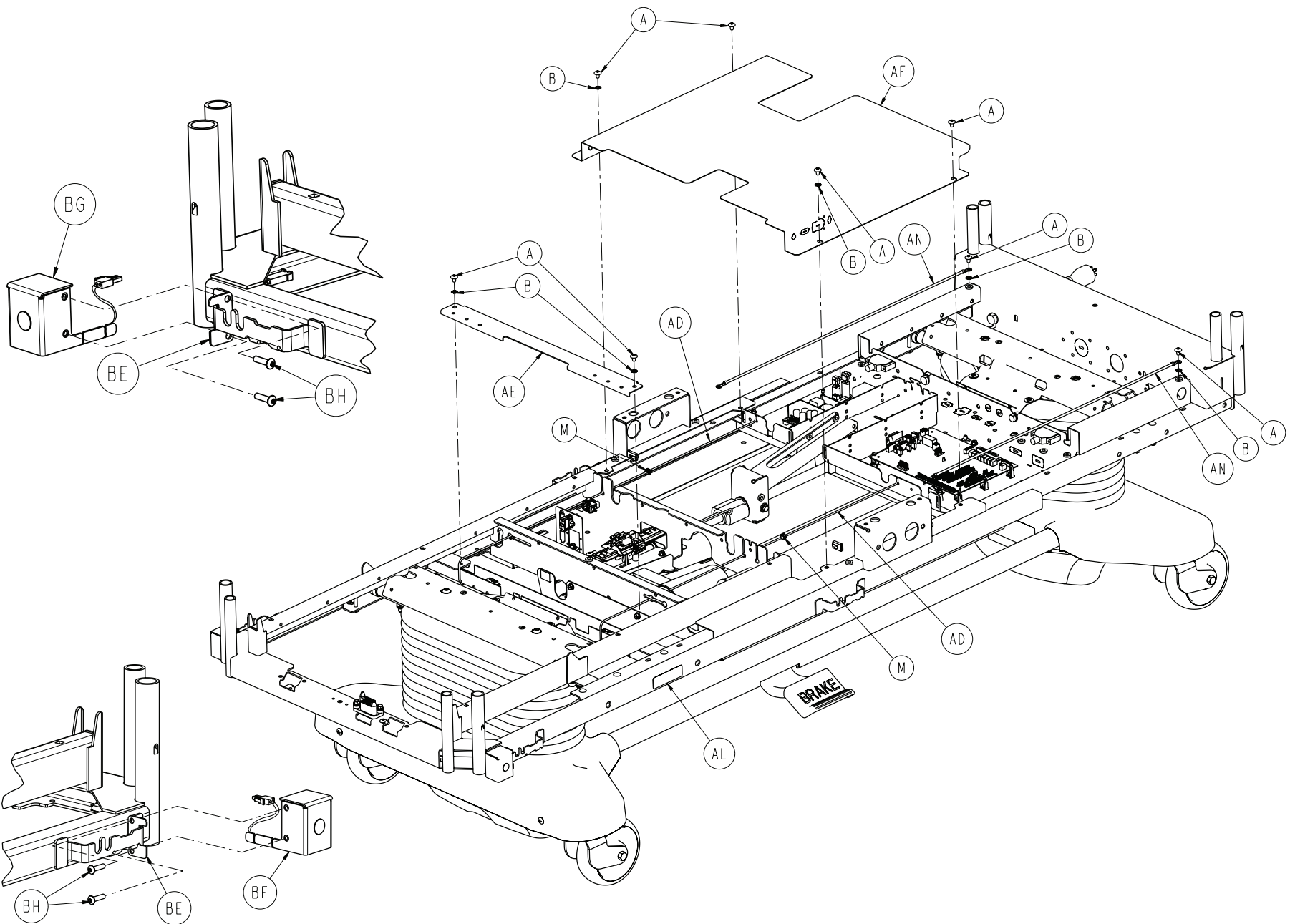

Electrical Litter Assembly, iBED Awareness Option

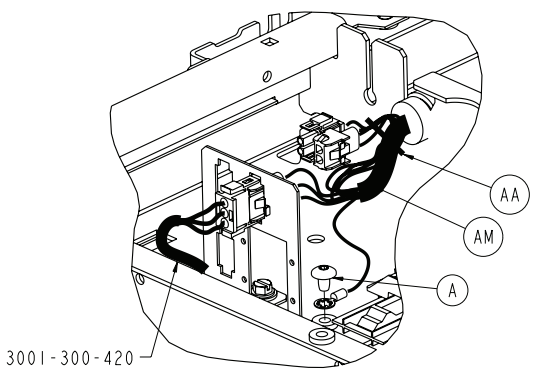
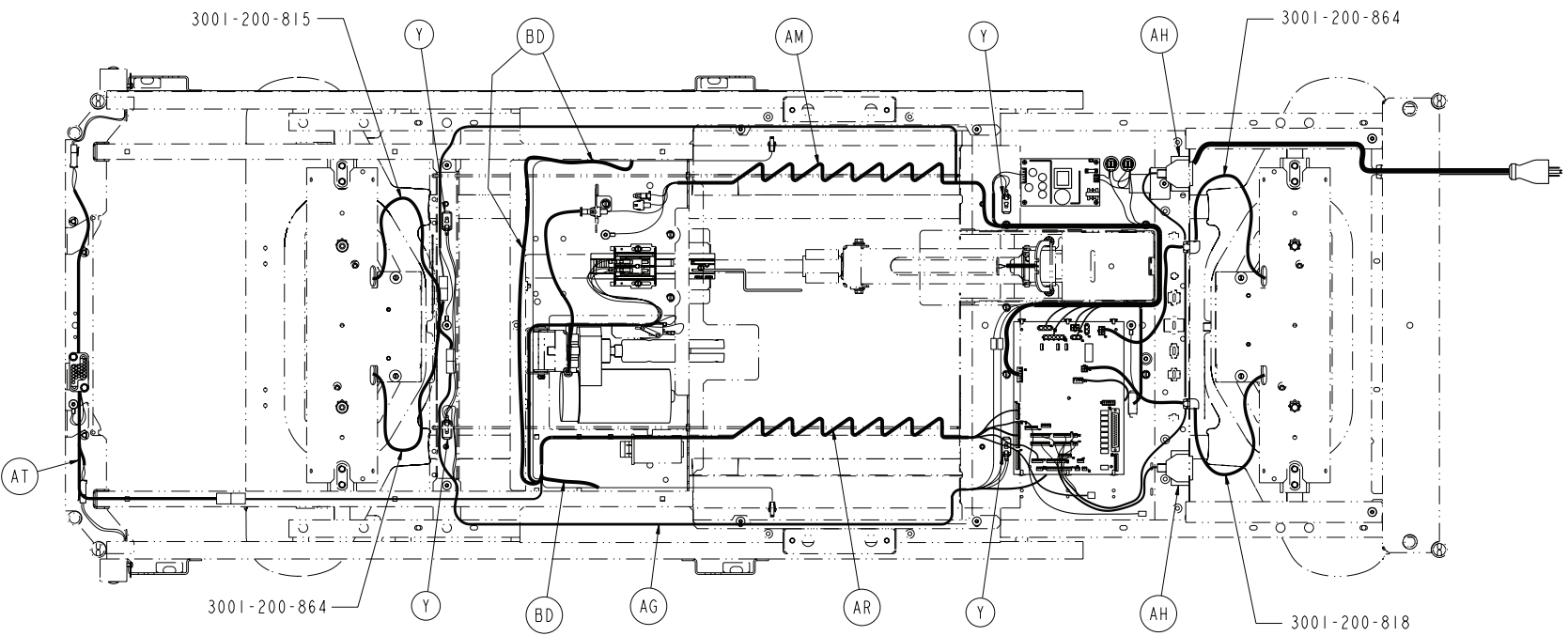

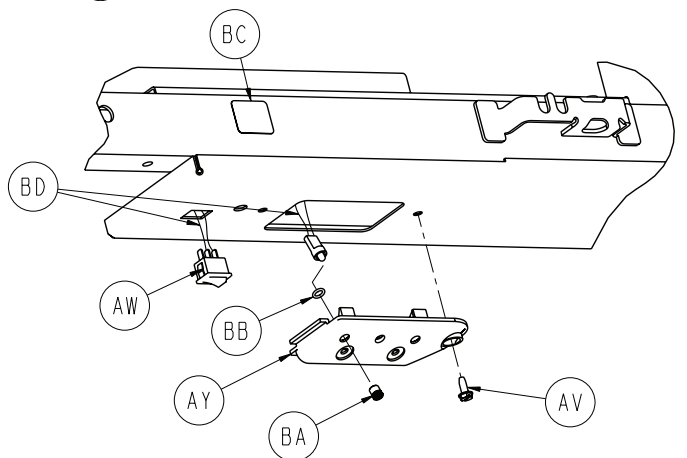
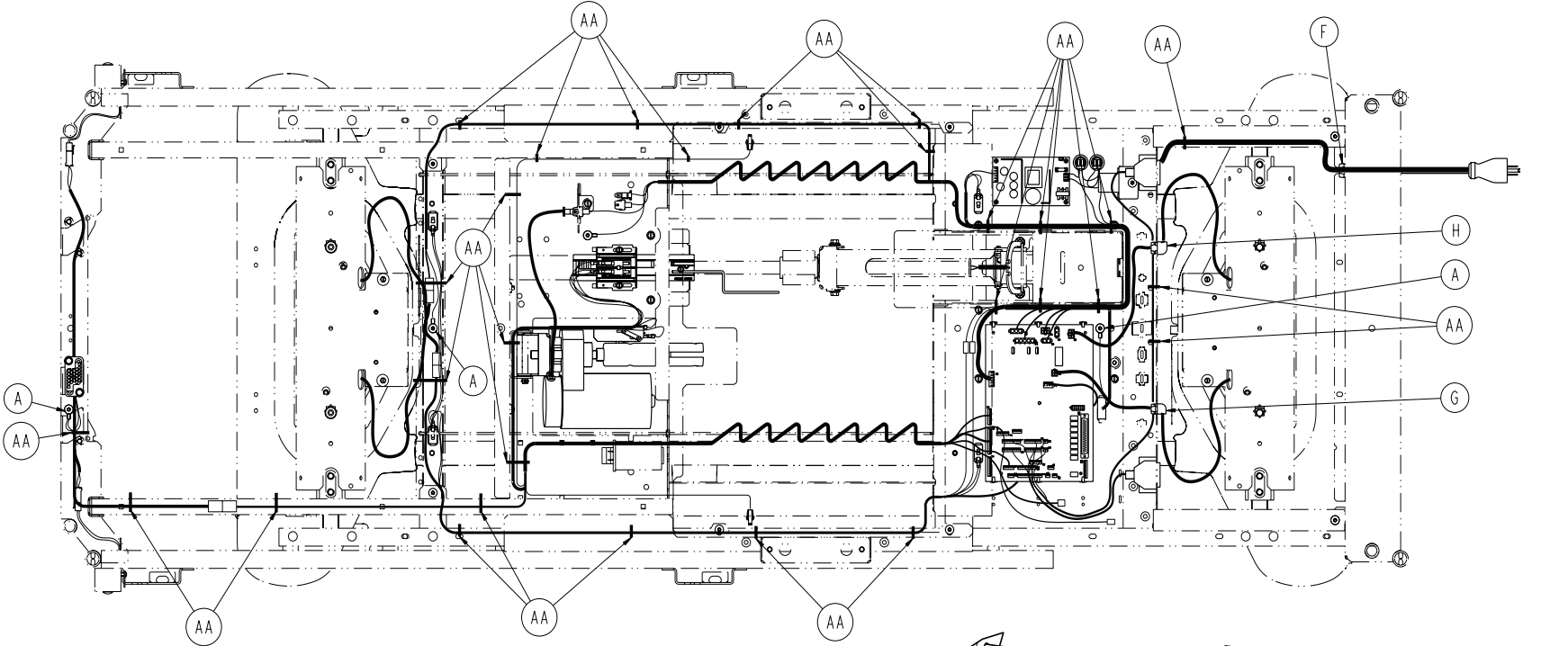

LH Bottom Side of Moving Frame
Reference Only: 3002-300-204

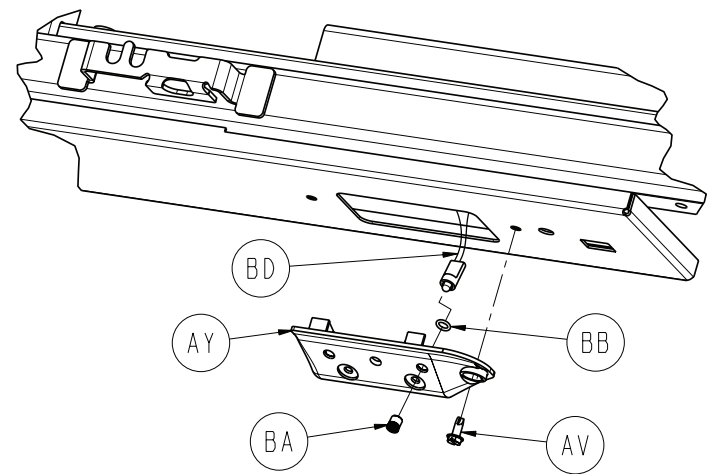

RH Bottom Side of Moving Frame
Reference Only: 3002-300-204

Electrical Litter Assembly, iBED Awareness Option

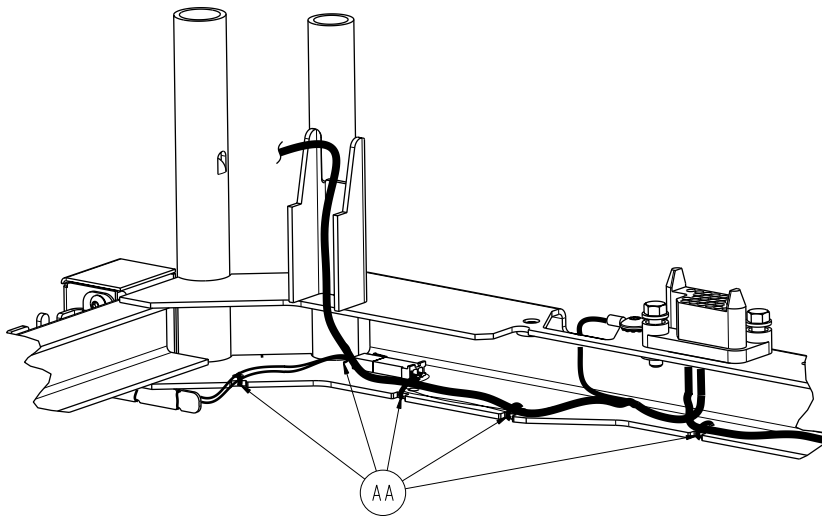

Foot End Left - LED Indicator Wire Routing

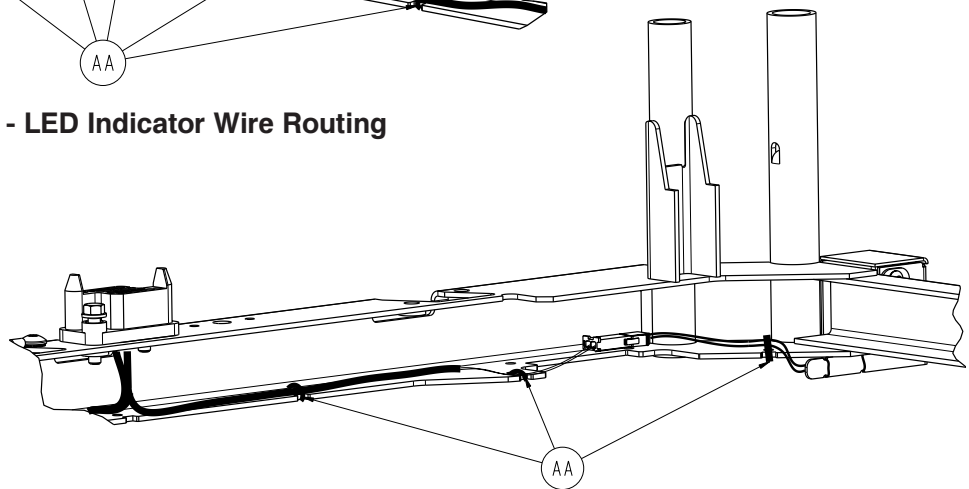

Foot End Right - LED Indicator Wire Routing

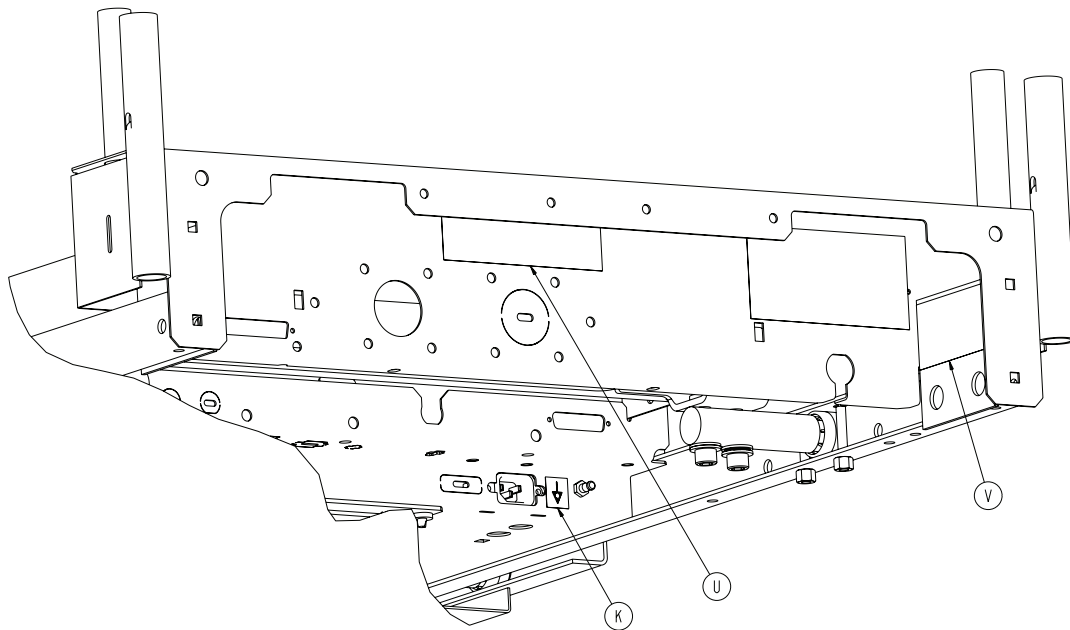

Electrical Litter Assembly, iBED Awareness Option

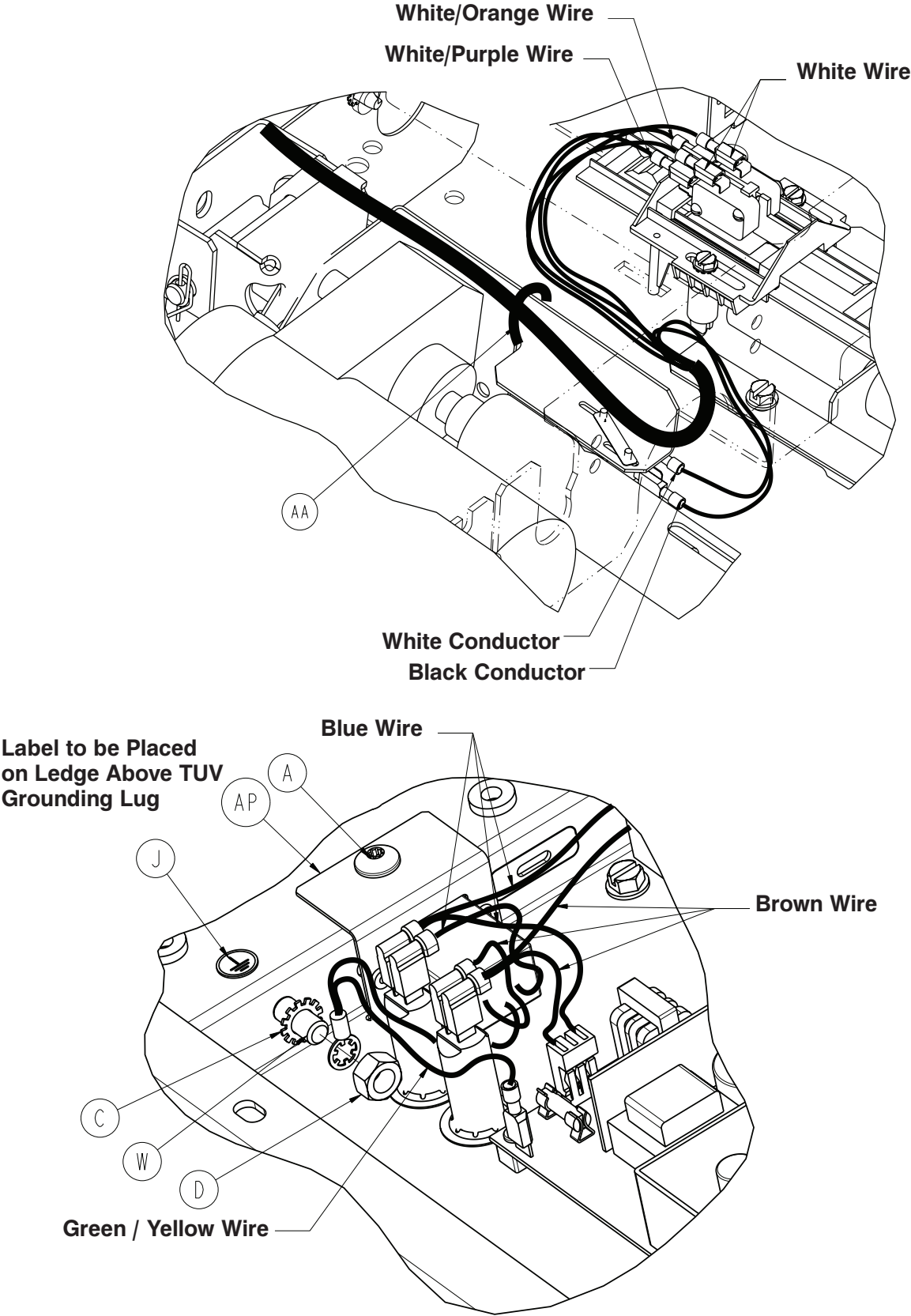

Electrical Litter Assembly, iBED Awareness Option

Electrical Litter Assembly, LBS Option - 3004-300-895 (Reference Only)

Item	Part No.	Part Name	Qty.
A	0007-053-000	Truss Head Screw	13
B	0013-010-000	External Tooth Lock Washer	6
C	0013-038-000	External Tooth Lock Washer	1
D	0016-033-000	Hex Kep Nut	1
E	0023-138-000	Pan Head Truss Screw	4
F	0030-027-000	Strain Relief Bushing	1
G	0030-047-000	Heyco Strain Relief	1
H	0030-048-000	Heyco Strain Relief	1
J	0036-046-000	Ground Label	1
K	0036-115-000	Ground Label	1
L	0052-287-000	Fastex Plastic Grommet	4
M	0052-822-000	Snap In Nyliner	2
N	0059-157-000	Power Supply	1
P	0059-745-000	Universal Board Mount	6
R	0059-773-000	Push Spacer	2
T	0059-774-000	Locking Circuit Board Sup.	1
U	1550-090-001	Hospital Grade Plug	1
V	2011-001-104	Danger Label	1
W	2011-001-215	Grounding Lug TUV	1
Y	3000-300-058	Plunger Switch	4
AA	3000-300-113	8" Cable Tie	46
AB	3001-200-228	Mounting Standoff	2
AC	3001-300-007	Screw Jack	4
AD	3001-300-011	Guide Rod	2
AE	3001-300-023	Cross Support Cover	1
AF	3001-300-088	Mid Litter Cover	1
AG	3001-300-865	Motion Interrupt Lift Sensor	1
AH	3001-300-877	Siderail Extension Cable	1
AJ	3002-200-003	Base Assembly	1
AK	3002-300-197	Mechanical Litter Assembly (pg.196)	1
AL	3002-300-601	Foley Bag Hook	2
AM	3002-300-861	Power Harness	1
AN	3002-300-874	Ground Cable	2
AP	3002-300-881	Power Inlet Cable	1
AR	3002-345-808	Siderail Coil Cord	1
AT	3003-300-802	Coil Cord Extension Cable	1
AU	3003-407-900	LBS CPU Assembly	1
AV	0003-224-000	Hex Washer Head Screw	2
AW	0059-191-000	Toggle Switch	1
AY	3002-310-018	Night Light Cover	2
BA	3002-310-010	LED Lens	2
BB	3002-310-025	Retaining Spacer	2
BC	3002-310-601	Night Light Label	1
BD	3002-036-801	Night Light Wiring Harness	1
BE	3003-300-216	LBS Bracket Mounting Plate	2
BF	3004-300-225	LBS Indicator Assembly, Right	1
BG	3004-300-230	LBS Indicator Assembly, Left	1
BH	0004-443-000	Button Head Torx Screw	4

Electrical Litter Assembly, Optional Battery Backup

For Reference Only: 3004-350-110

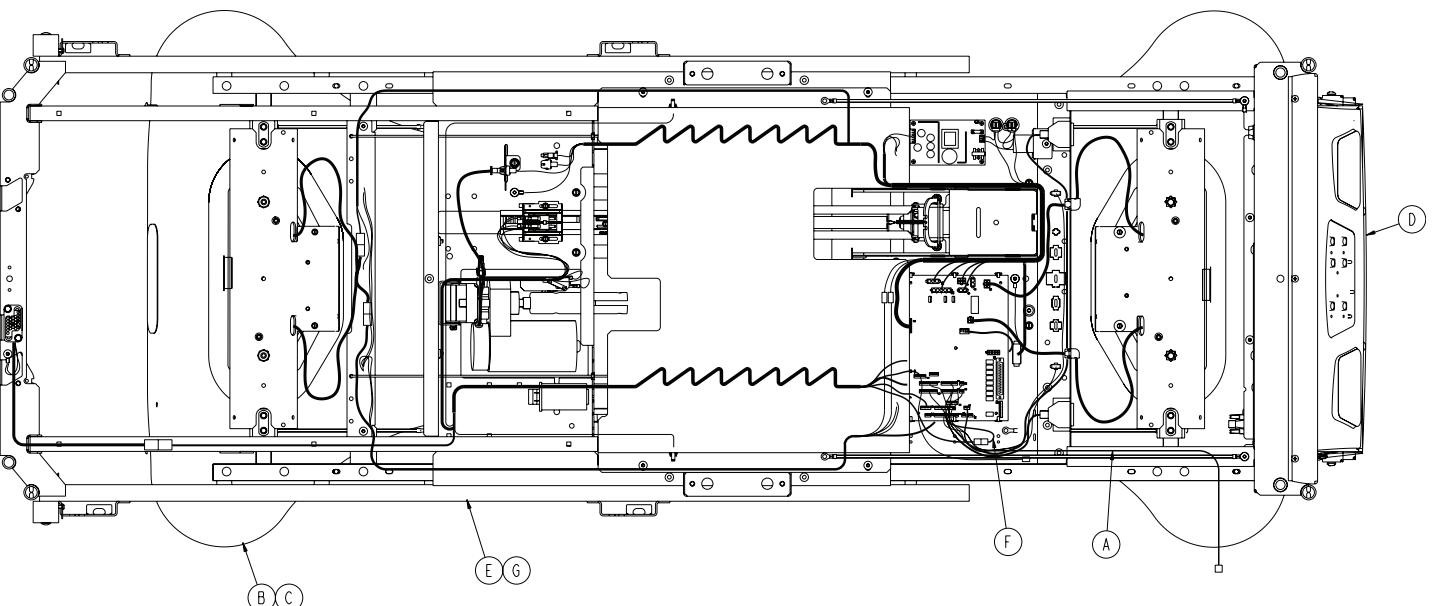

Item	Part No.	Part Name	Qty.
A	3001-345-809	Fowler Pot. Extension Cable	1
B	3002-243-003	Base Assembly, Standard Length Bed (pg. 112)	1
C	3002-350-170	Secure II + Base	1
D	3002-450-150	Secure II + Litter	1
E	3002-343-197	Mechanical Litter Assembly, Standard Bed (pg.200)	1
F	3003-300-803	CPU to Siderail Sensor Cable	1
G	3004-300-002	LBS Litter Ass'y, Std. Components	1

[Return To Table of Contents](#)

Electrical Litter Assembly, iBED Awareness/Secure Zoom Option

For Reference Only: 3004-357-895

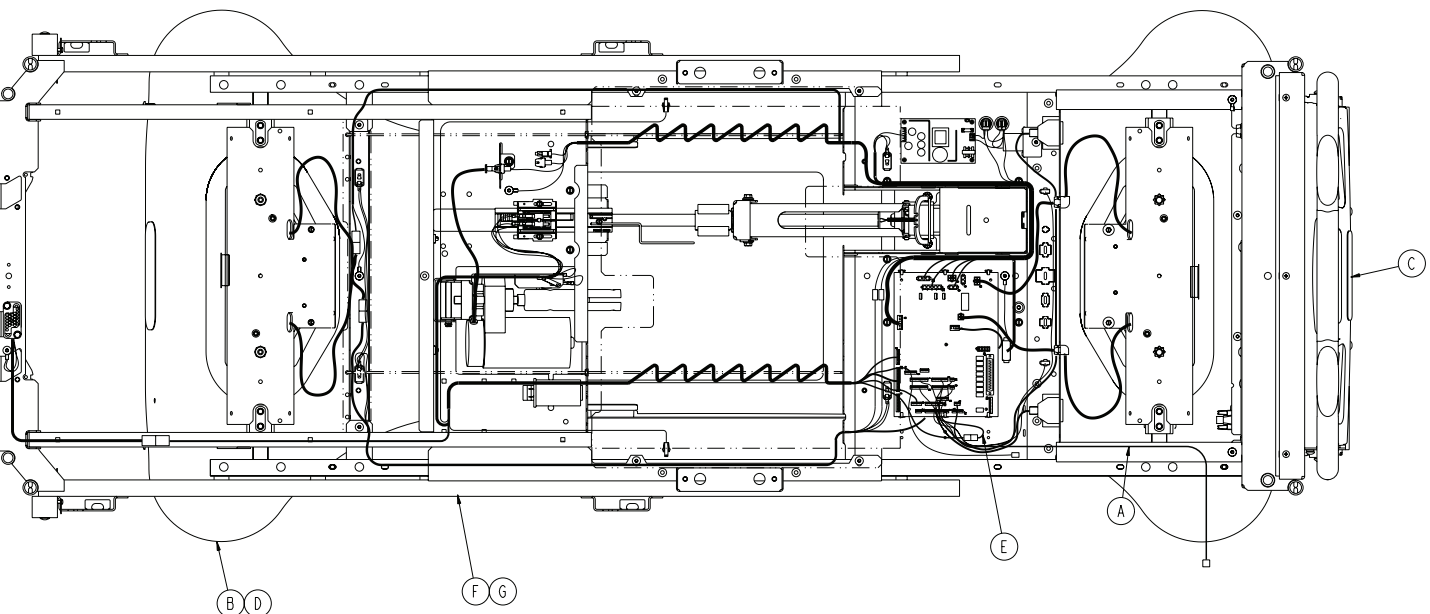

Item	Part No.	Part Name	Qty.
A	3001-345-809	Fowler Pot. Extension Cable	1
B	3002-001-001	Zoom Base Ass'y, Std. Comp.	1
C	3002-131-010	Litter Assembly, Zoom Option (pg.222)	1
D	3002-244-003	Base Assembly, Zoom Secure Bed (pg.112)	1
E	3003-300-803	CPU to Siderail Sensor Cable	1
F	3002-343-197	Mechanical Litter Assembly (pg.200)	1
G	3004-300-002	LBS Litter Ass'y, Std. Comp.	1

[Return To Table of Contents](#)

Mechanical Litter Assembly

For Reference Only: 3002-300-197

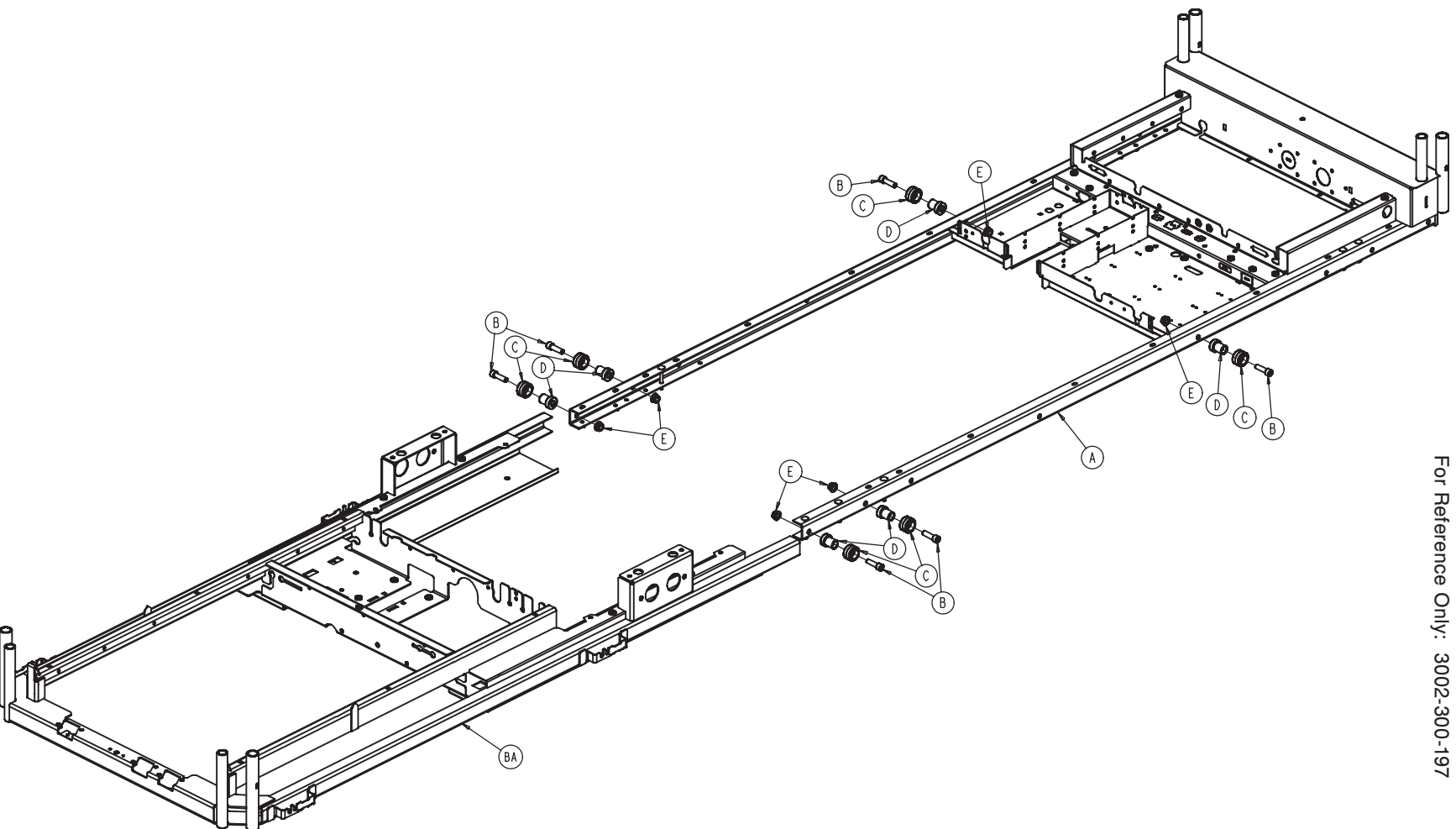

Mechanical Litter Assembly

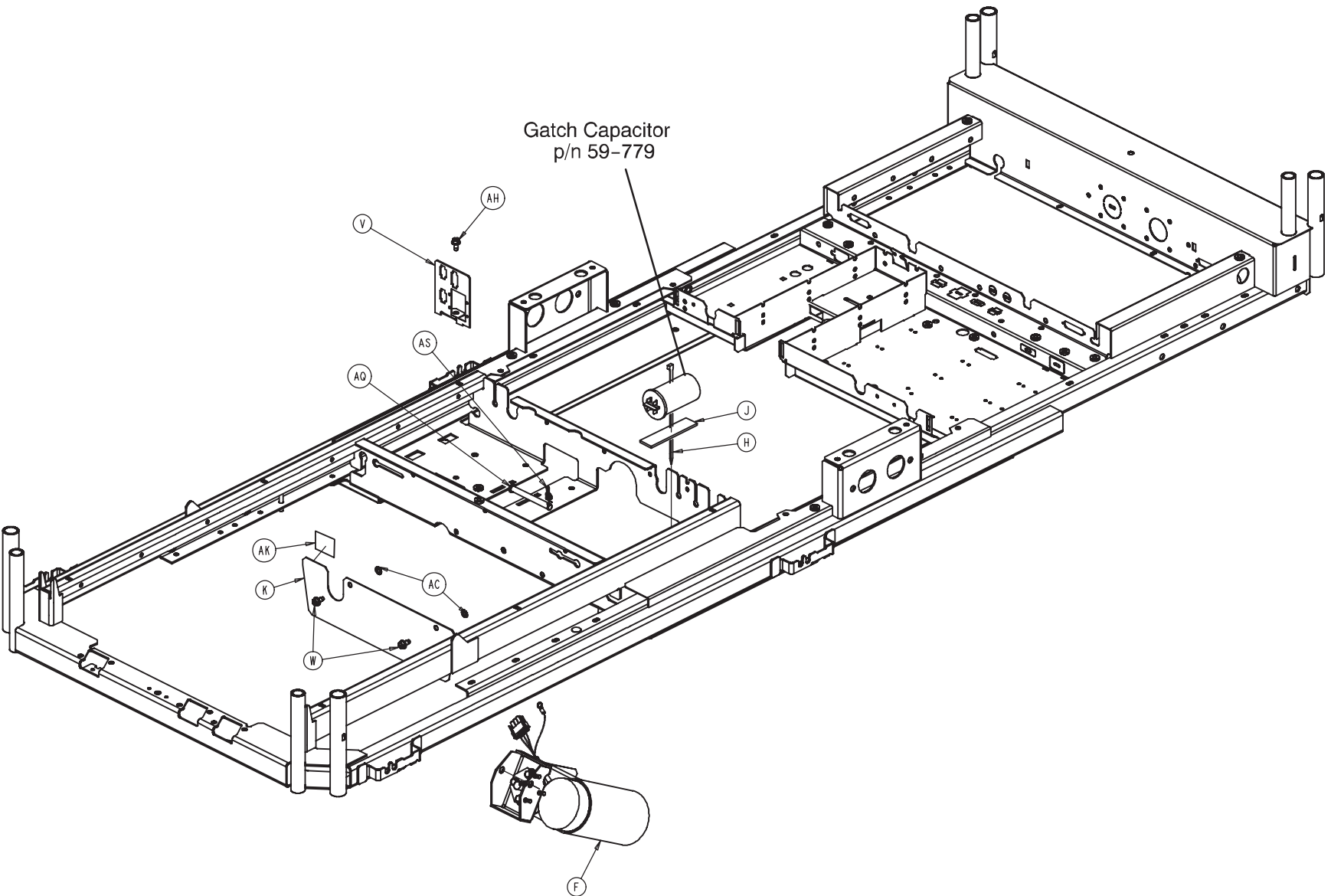

Mechanical Litter Assembly

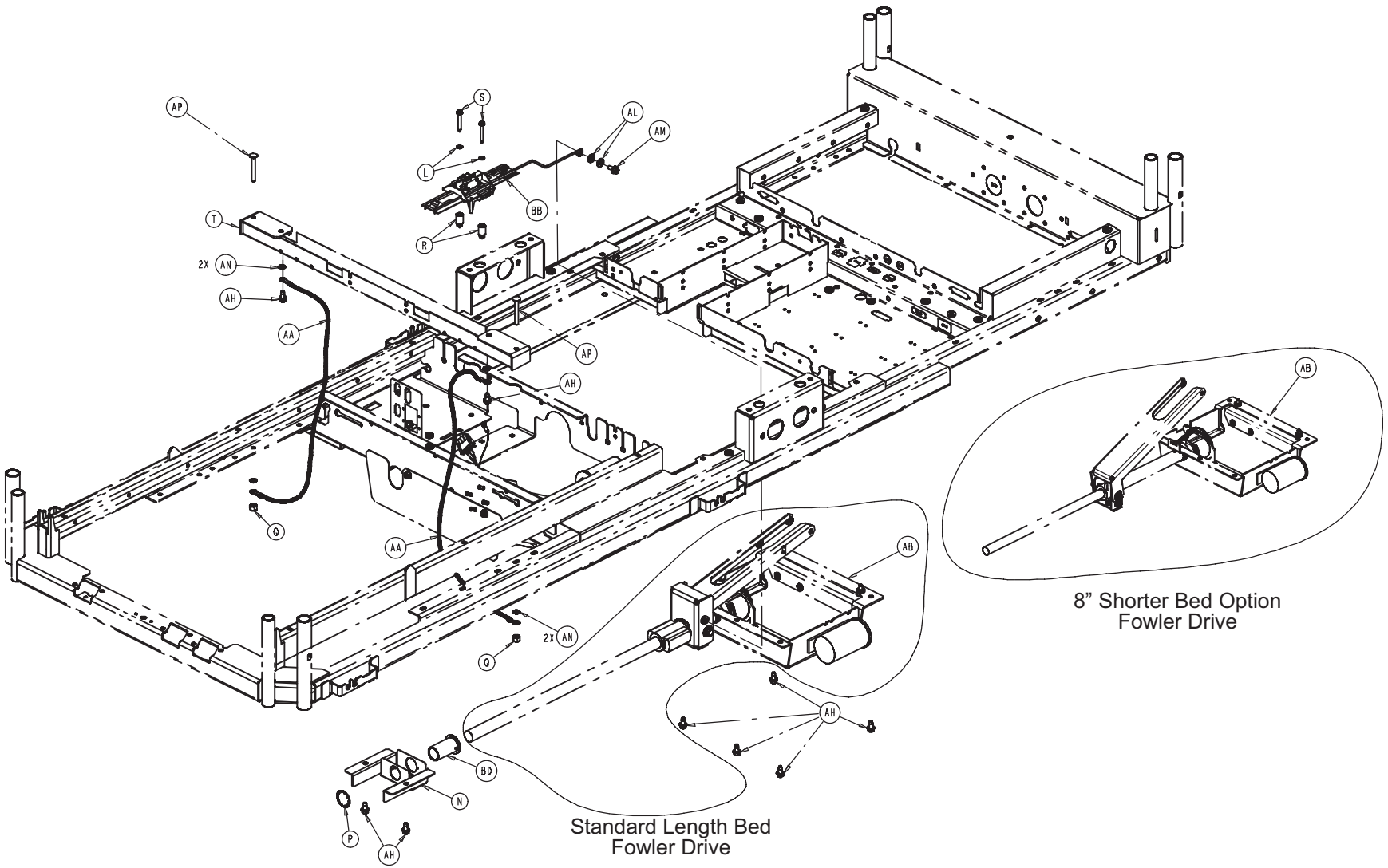

Mechanical Litter Assembly

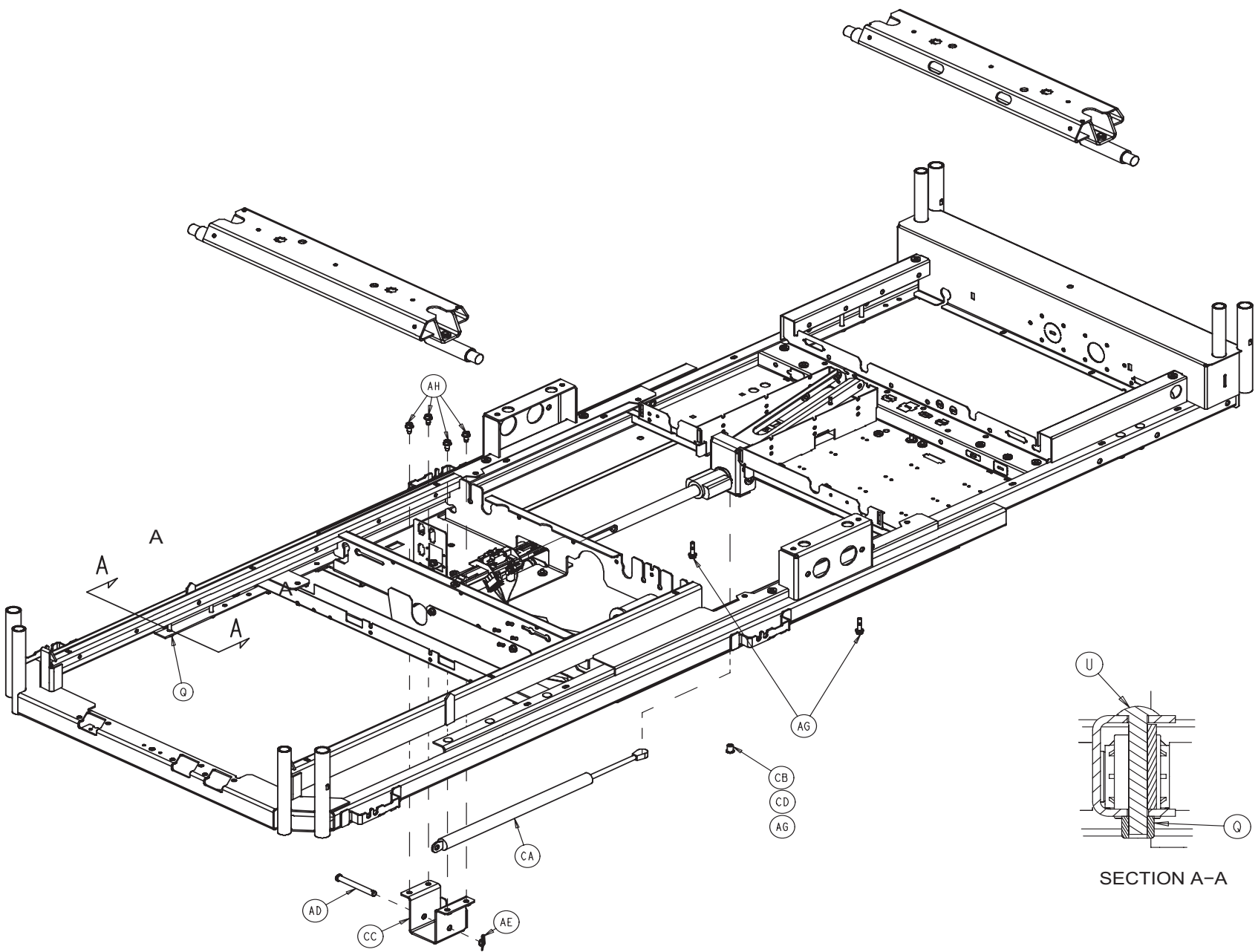

Mechanical Litter Assembly

Mechanical Litter Assembly Common Components - 3002-300-197 (Reference only)

Item	Part No.	Part Name	Qty.
A	3002-300-303	Stationary Frame Assembly	1
B	0004-211-000	Socket Head Cap Screw	6
C	3000-300-353	Roller	6
D	3000-300-352	Roller Shaft	6
E	0016-093-000	Flange Lock Nut	6
F	3001-300-420	Gatch Motor Ass'y (pg.170)	1
H	0038-151-000	11" Cable Tie	1
J	0044-029-000	Double-Sided Tape	1
K	3001-300-417	Gatch Shield	1
L	0013-018-000	Ext. Tooth Lock Washer	2
N	3002-300-491	Screw Support Bracket	1
P	0028-122-000	Retaining Ring	1
Q	0016-006-000	Kep Nut	10
R	0052-800-000	Grommet	2
S	0023-251-000	Hex Washer Hd. Screw	2
T	3001-300-370	Cross Support Assembly	1
U	0005-046-000	Carriage Bolt	8
V	3001-300-269	Mounting Bracket	1
W	0003-221-000	Truss Head Screw	2
AA	3002-300-870	Litter Ground Jumper	2
AB	3002-400-550	Fowler Drive Ass'y (pg.172)	1
AC	0013-010-000	Ext. Tooth Lock Washer	2
AG	3001-200-229	Mounting Standoff	2
AH	0003-221-000	Hex Washer Head Screw	10
AK	7900-001-291	Vibration Tape	1"
AL	0011-063-000	Washer	2
AM	0003-121-000	Hex Washer Hd. Screw	1
AN	0013-010-000	Int. Tooth Lock Washer	4
AP	0005-024-000	Carriage Bolt	2
AQ	0026-279-000	Clevis Pin	1
AR	0011-529-000	Adhesive Rubber Washer	1
AS	0027-022-000	3/8" Rue Ring Cotter	1

Standard Bed 3002-343-197 (Reference Only)

Item	Part No.	Part Name	Qty.
AB	3002-400-550	Fowler Drive Ass'y (pg.172)	1
BA	3003-300-204	Moving Frame Assembly	1
BB	3002-343-035	Fowler Limit Ass'y (pg.174)	1
BD	3000-300-009	Screw Support Bushing	1

8" Shorter Bed 3002-342-197 (Reference Only)

Item	Part No.	Part Name	Qty.
AB	3002-400-550	Fowler Drive Ass'y (pg.172)	1
AD	0026-279-000	Clevis Pin	1
AE	0027-022-000	Rue Cotter Pin	1
AG	3001-200-228	Mounting StandOff	1
AH	0003-221-000	Hex Washer Head Screw	4
BA	3002-342-204	Moving Frame Assembly	1
BB	3002-342-025	Fowler Limit Ass'y (pg.175)	1
BD	3001-342-009	Screw Support Bushing	1
CA	0052-819-000	Dampener Cylinder	1
CB	0052-818-000	Flange Bearing	1
CC	3001-345-489	Cylinder Mtg. Bracket	1
CD	0011-002-000	Flat Washer	1

Lift Header Assembly - No Load Cells

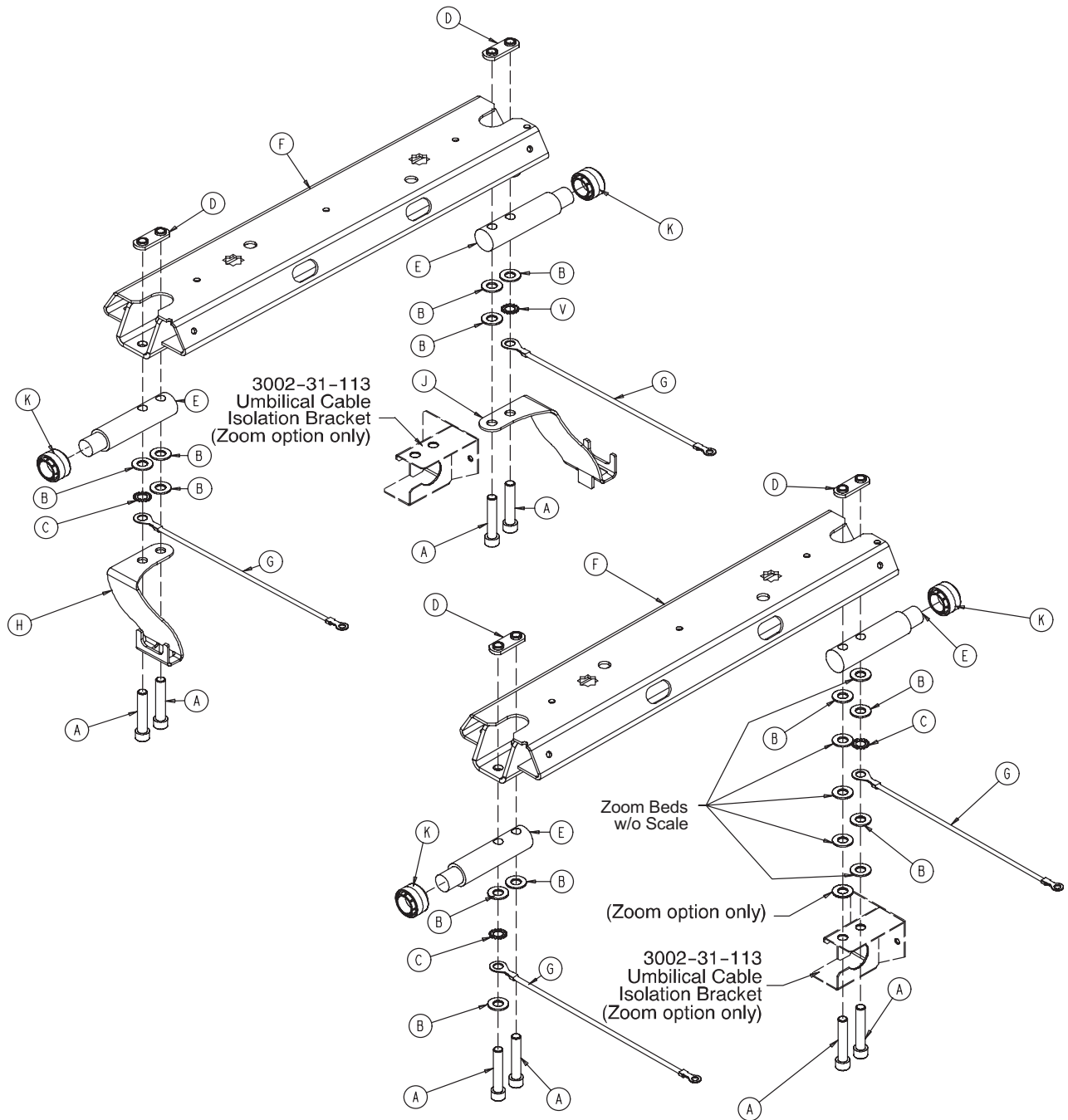

Lift Header - Standard Bed - 3002-300-500

Item	Part No.	Part Name	Qty.
A	0004-288-000	Hex Soc. Hd. Cap Screw	4
B	0011-004-000	Flat Washer	6
C	0013-032-000	Ext. Tooth Lock Washer	2
D	3002-300-509	Weldnut	2
E	3001-300-511	"Imitation" Load Cell	2
F	3001-300-530	Lift Header	1
G	3002-300-871	Ground Jumper	2

Lift Header - Std. Bed/Iso. Foley Bags - 3002-326-550

Item	Part No.	Part Name	Qty.
A	0004-288-000	Hex Soc. Hd. Cap Screw	4
B	0011-004-000	Flat Washer	2
C	0013-032-000	Ext. Tooth Lock Washer	2
D	3002-300-509	Weldnut	2
E	3002-300-511	"Imitation" Load Cell	2
F	3001-300-530	Lift Header	1
G	3002-300-871	Ground Jumper	2
H	3002-326-010	Iso. Foley Bag Ass'y, Lt.	1
J	3002-326-020	Iso. Foley Bag Ass'y, Rt.	1
H	3000-300-353	Roller Cap	2

[Return To Table of Contents](#)

Lift Header Assembly with Load Cells

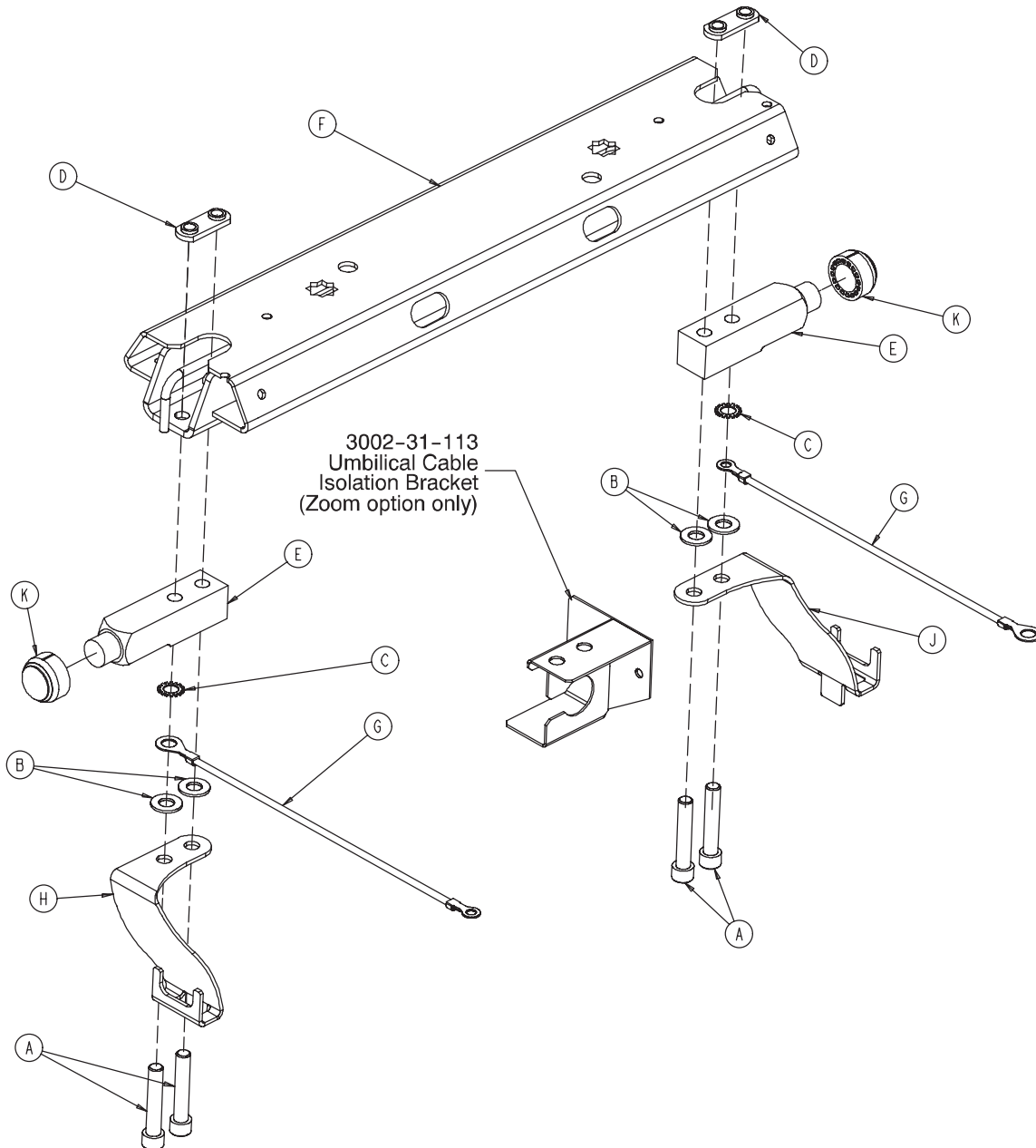

Lift Header - Load Cells - 3002-307-501

Item	Part No.	Part Name	Qty.
A	0000-004-288	Hex Soc. Hd. Cap Screw	4
B	0000-011-004	Flat Washer	4
C	0000-013-032	Ext. Tooth Lock Washer	2
D	3001-300-509	Weldnut	2
E	3002-307-057	Load Cell	2
F	3001-300-530	Lift Header	1
G	3002-300-871	Ground Jumper	2
K	3000-300-353	Roller Cap	2

Lift Hdr - Load Cells/Iso. Foley Hooks - 3002-326-501

Item	Part No.	Part Name	Qty.
A	0000-004-288	Hex. Soc. Hd. Cap Screw	4
B	0000-011-004	Flat Washer	4
C	0000-013-032	Ext. Tooth Lock Washer	2
D	3002-300-509	Weldnut	2
E	3002-307-057	Load Cell	2
F	3001-300-530	Lift Header	1
G	3002-300-871	Ground Jumper	2
J	3002-326-010	Iso. Foley Bag Ass'y, Lt	1
K	3002-326-020	Iso. Foley Bag Ass'y, Rt.	1
H	3000-300-353	Roller Cap	2

Gatch Motor Assembly

3001-300-420

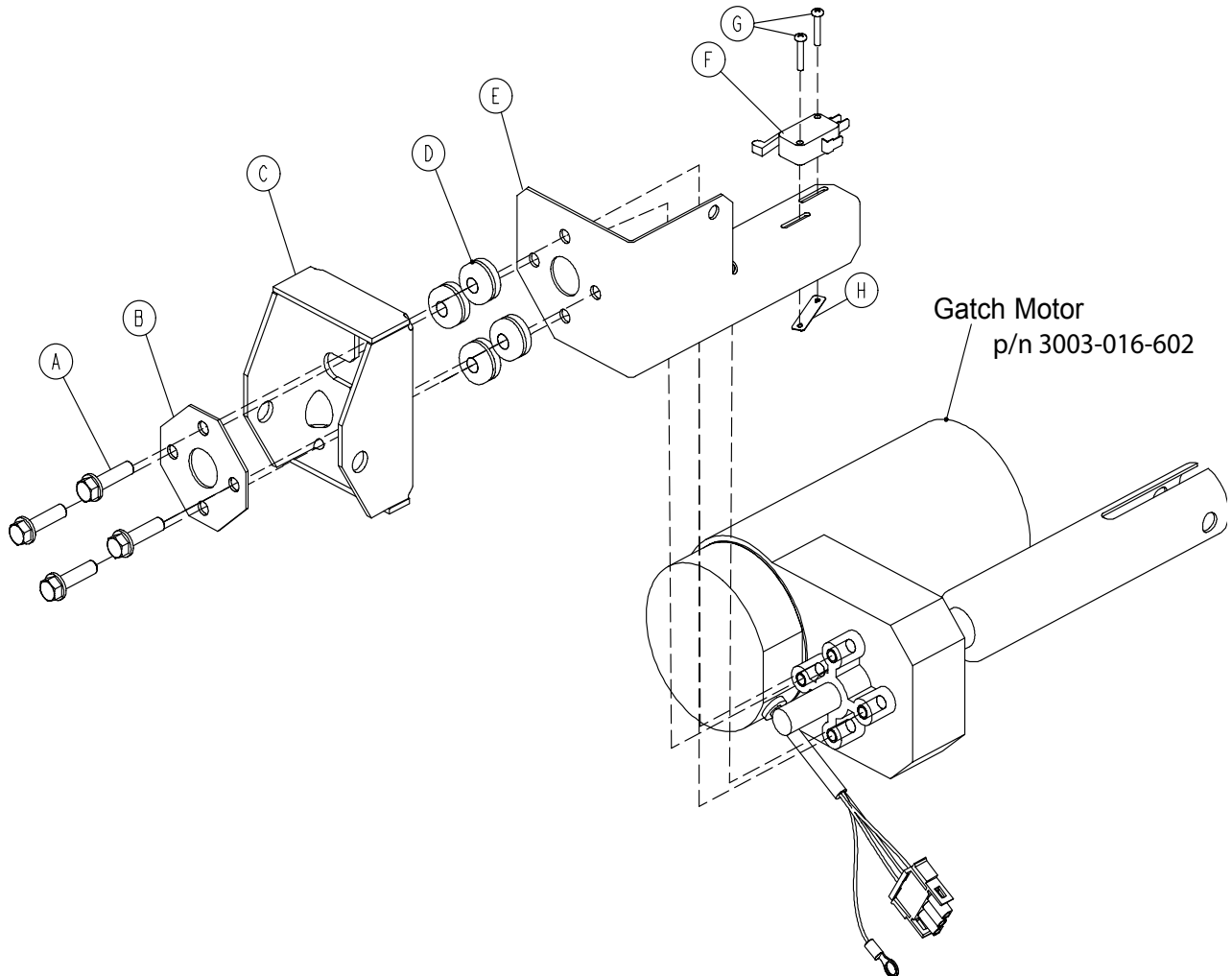

Item	Part No.	Part Name	Qty.
A	3001-200-228	Mounting Standoff	4
B	3001-300-499	Gatch Motor Mounting Plate	1
C	3001-300-225	Motor Mount Bracket	1
D	0052-817-000	Grommet	4
E	3002-300-421	Gatch Limit Bracket	1
F	3000-300-041	Micro Switch	1
G	0002-107-000	Phillips Round Hd. Screw	2
H	0016-069-000	Twin-Type Fastener	1
L	3000-300-114	Wire Tie (not shown)	1

[Return To Table of Contents](#)

Fowler Driver Assembly

3002-400-550

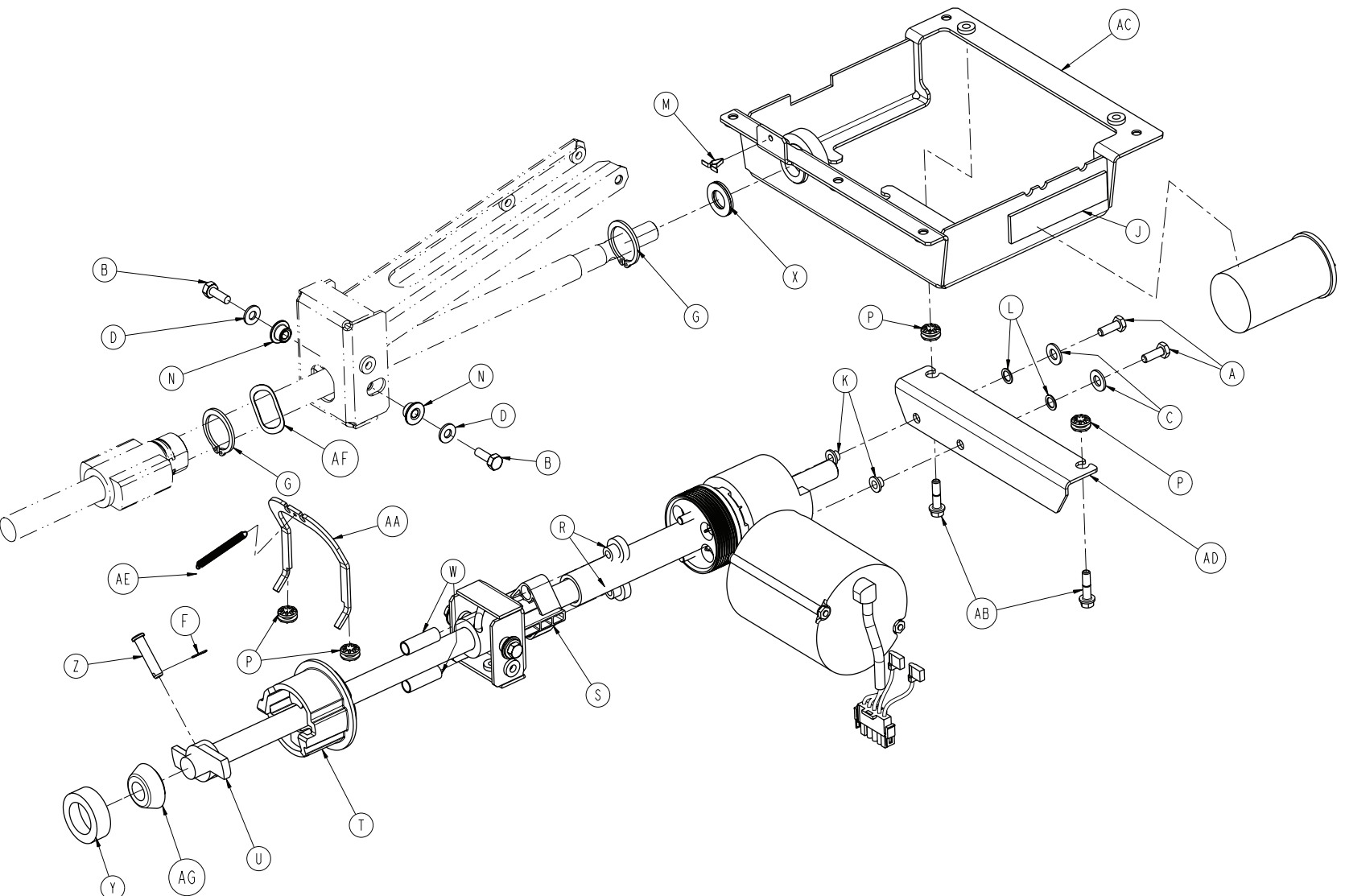

Fowler Drive Assembly

3002-400-550

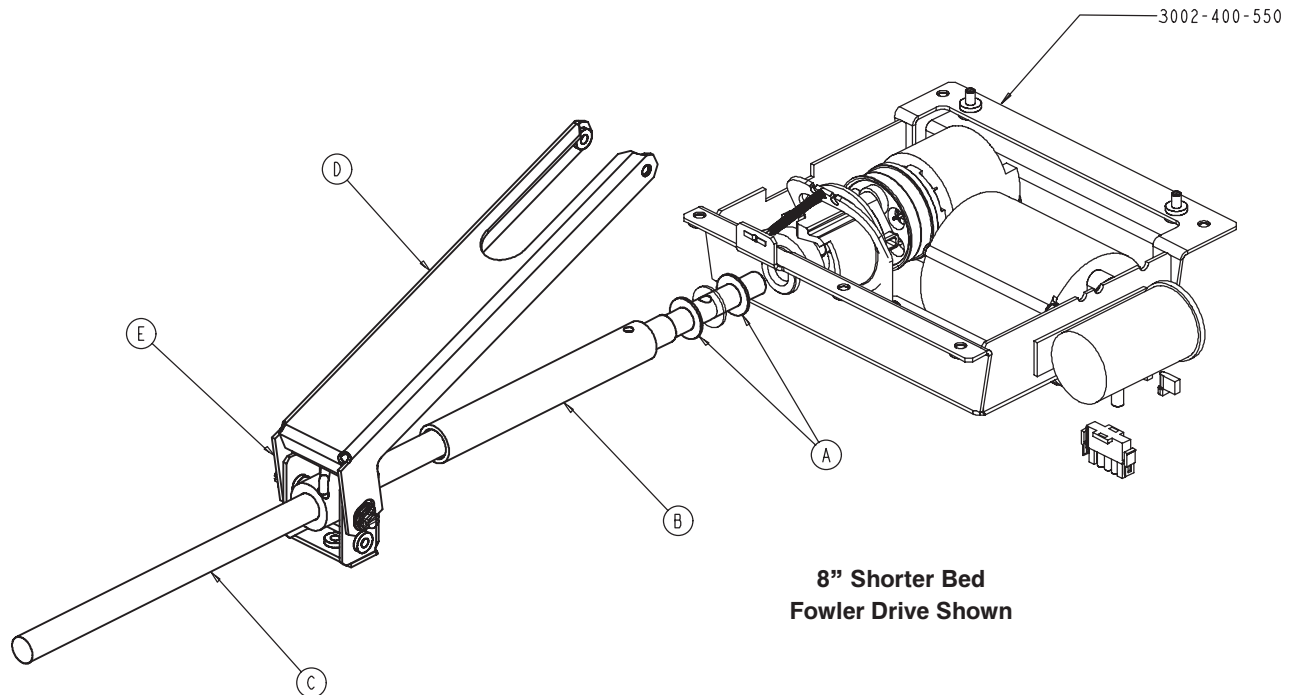

Fowler Actuator Common Components - 3002-400-550

Item	Part No.	Part Name	Qty.	Item	Part No.	Part Name	Qty.
A	0003-214-000	Hex Head Cap Screw	2	S	3000-300-456	CPR Isolator	1
B	0003-050-000	Hex Washer Head Screw	2	T	3000-300-461	CPR Decoupler	1
C	0011-003-000	Flat Washer	2	U	3000-300-462	CPR Wing	1
D	0011-002-000	Flat Washer	2	W	3000-300-464	CPR Engagement Spring	2
F	0027-017-000	Cotter Pin	1	X	3000-300-466	Thrust Bearing	1
G	0028-120-000	External Retaining Ring	2	Y	3000-300-471	CPR Bearing Housing	1
H	0038-151-000	Cable Tie	2	Z	3000-300-473	Clevis Pin	1
J	0044-029-000	Double-Stick Tape	1	AA	3000-300-658	CPR Release Arm	1
K	0052-718-000	Nylon Insulator	2	AB	3001-200-228	Mounting Standoff	2
L	0052-719-000	Nylon Flat Washer	2	AC	3001-300-485	Fowler Actuator Wldmt.	1
M	0029-021-000	Dart Clip	1	AD	3001-300-487	Actuator Mounting Brkt.	1
N	3000-300-099	Litter Pivot Bushing	2	AE	3001-300-664	CPR Spring	1
P	3000-300-442	Fowler Drive Grommet	4	AF	0038-478-000	Wave Spring	1
				AG	3000-300-444	CPR Bearing	1

Fowler Actuator - Standard Bed - 3002-443-550

Item	Part No.	Part Name	Qty.
BA	0014-083-000	Thrust Washer	1
BC	3000-300-457	CPR Ball Screw	1
BD	3001-300-496	Fowler Link	1
BE	3002-300-493	Fowler Link Bracket	1

Fowler Actuator - 8" Shorter Bed - 3002-442-550

Item	Part No.	Part Name	Qty.
BA	0014-083-000	Thrust Washer	2
BB	3001-342-457	Fowler Nut Stop Tube	1
BC	3001-342-467	CPR Ball Screw	1
BD	3001-342-496	Fowler Link	1
BE	3001-342-499	Fowler Link Bracket	1

[Return To Table of Contents](#)

Fowler Brake Kit Assembly

3001-300-775

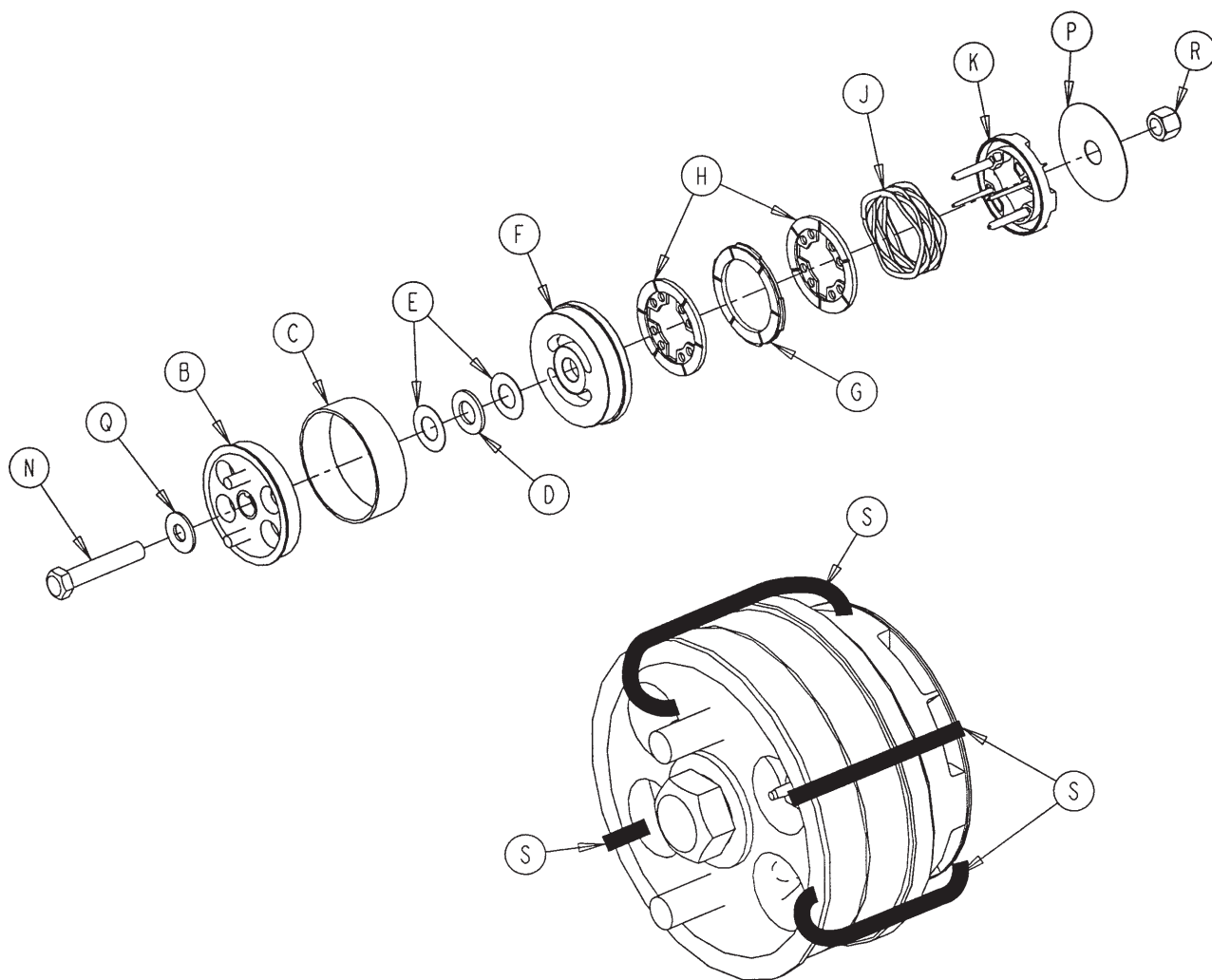

Item	Part No.	Part Name	Qty.
B	3001-300-455	CPR Coupler Assembly	1
C	3000-300-465	CPR Clutch Spring	1
D	0081-212-000	Thrust Needle Roller Brg.	1
E	3000-200-224	Idler Gear Thrust Washer	2
F	3001-300-569	Brake Cup	1
G	3001-300-552	CPR Brake Disc	1
H	3001-300-551	CPR Spring Cup	2
J	3001-300-563	CPR Brake Spring	1
K	3001-300-570	CPR Spring Cup	1
N	0003-064-000	Hex Head Cap Screw	1
P	3000-300-776	Flat Washer	1
Q	0011-193-000	Heavy Flat Washer	1
R	0016-035-000	Nylock Nut	1
S	3000-300-113	8" Wire Tie	4

Standard Bed Fowler Limit Switch Assembly

3002-343-035

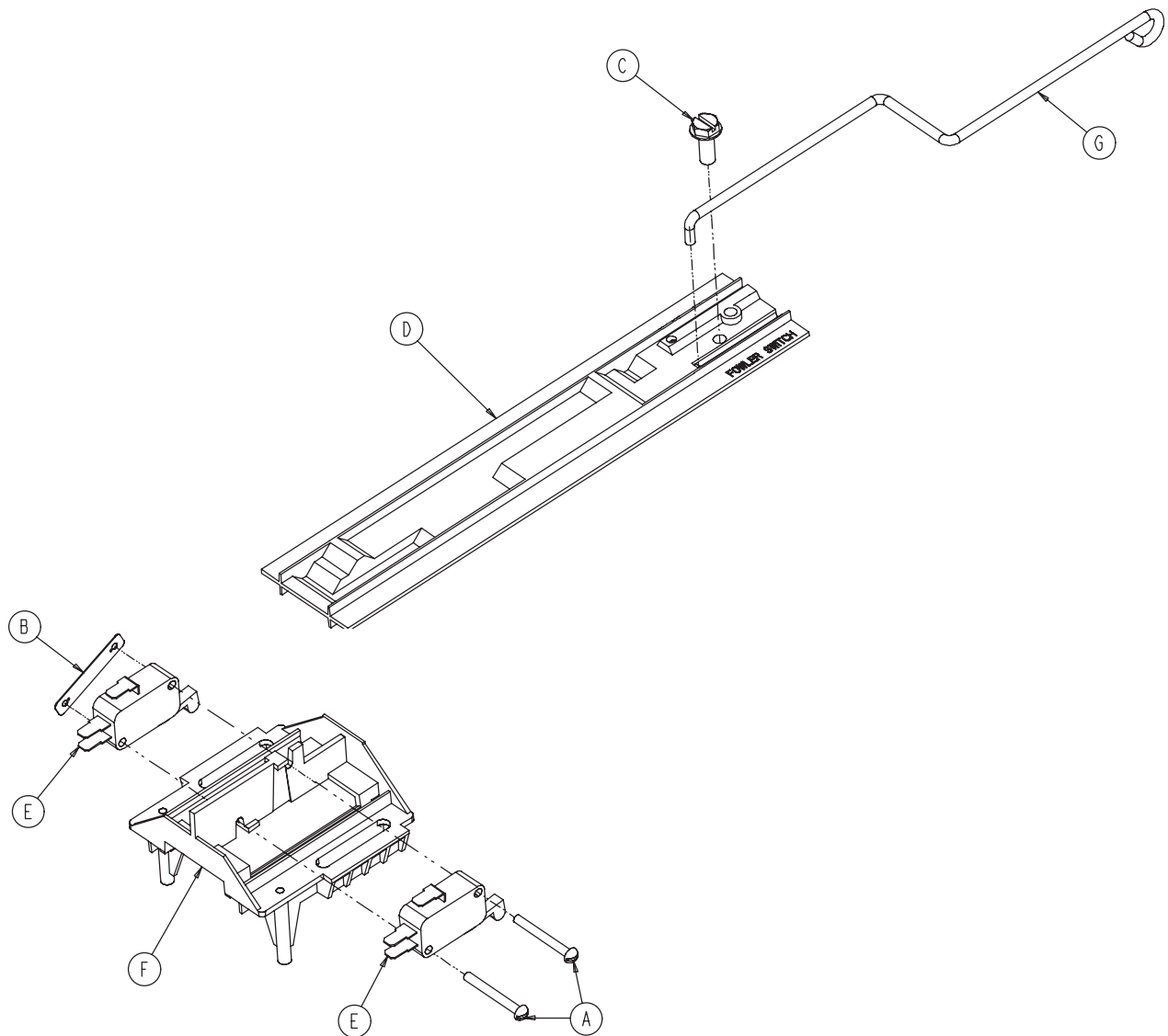

Item	Part No.	Part Name	Qty.
A	0002-003-000	Round Head Screw	2
B	0016-069-000	Twin Type Fastener	1
C	0016-129-000	Hex Washer Head Screw	1
D	3000-300-036	Fowler Cam Card	1
E	3000-300-041	Micro Switch	2
F	3000-300-044	Cam Guide	1
G	3002-300-038	Link Wire	1

[Return To Table of Contents](#)

8" Short Bed, Fowler Limit Switch Assembly Option

3002-342-025

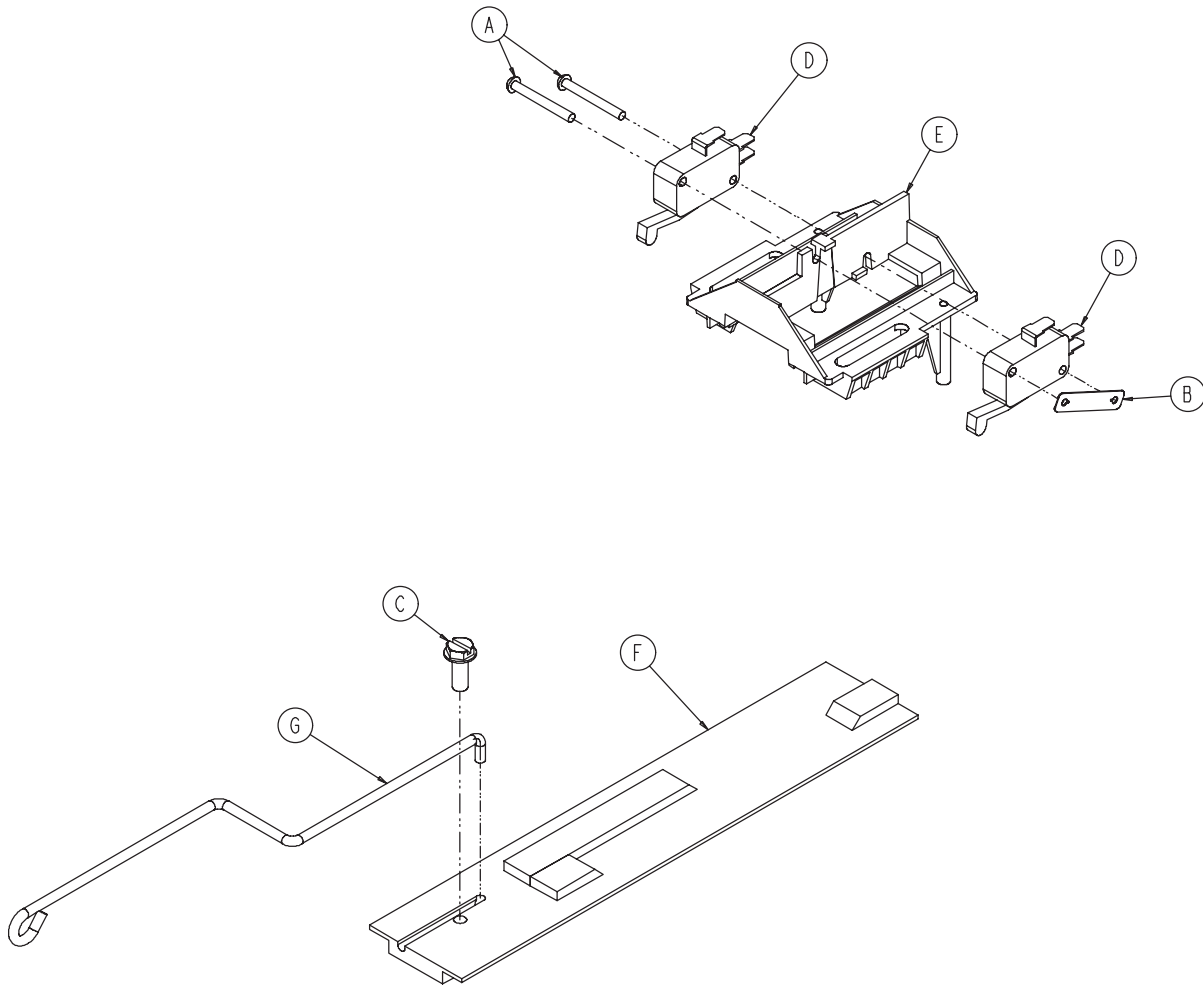

Item	Part No.	Part Name	Qty.
A	0002-003-000	Round Head Screw	2
B	0016-069-000	Twin Type Fastener	1
C	0023-082-000	Hex Washer Head Screw	1
D	3000-300-041	Micro Switch	2
E	3000-300-044	Cam Guide	1
F	3001-342-032	Fowler Cam Card	1
G	3002-300-038	Link Wire	1

Night Light Assembly

3002-410-020

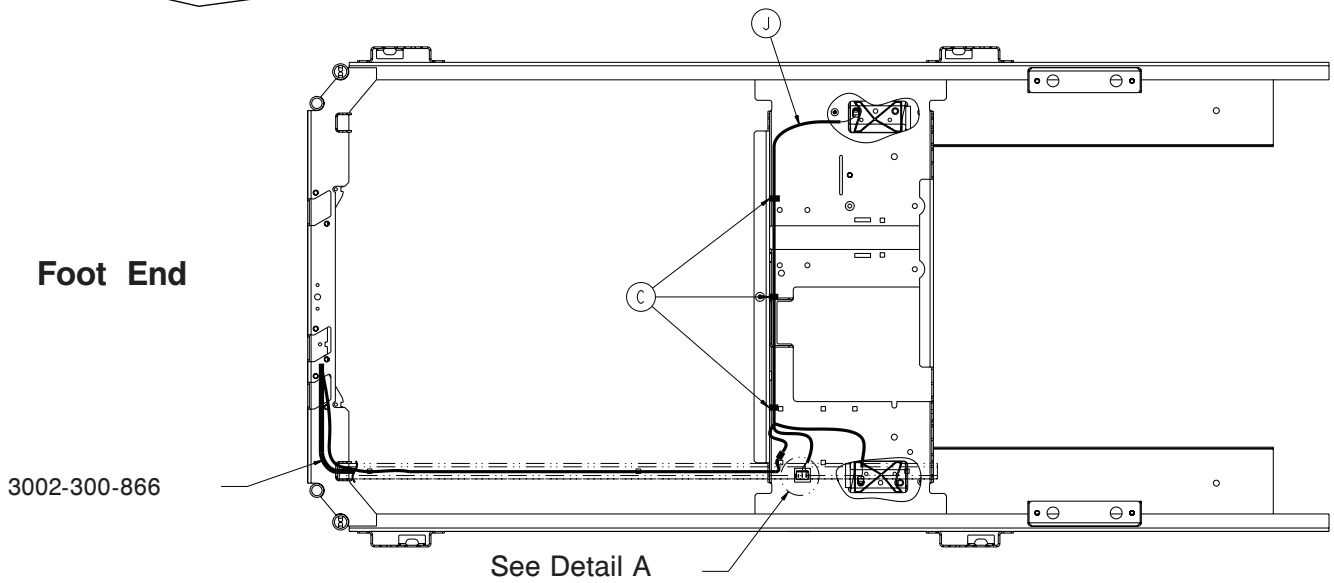
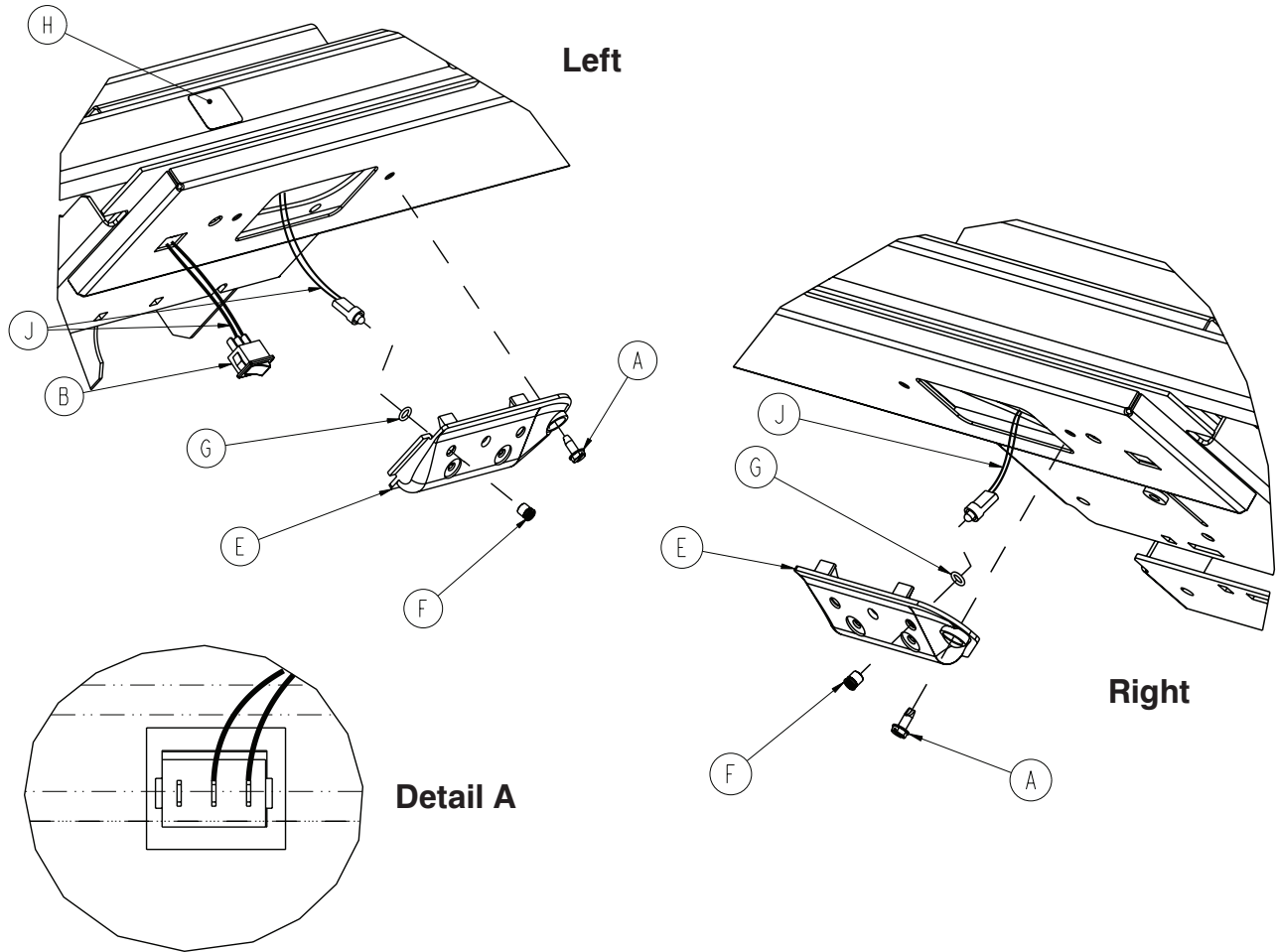

Top View - Some components are removed or shown in phantom for clarity

[Return To Table of Contents](#)

Night Light Assembly

3002-410-020

Item	Part No.	Part Name	Qty.
A	0003-224-000	Hex Washer Head Screw	2
B	0059-191-000	Toggle Switch	1
C	3000-300-113	8" Cable Tie	3
E	3002-310-018	Night Light Cover	2
F	3002-310-010	LED Lens	4
G	3002-310-025	Retaining Spacer	2
H	3002-310-601	Night Light Label	1
J	3002-036-801	Night Light Wiring Harness	1

Optional 110V Outlet Assembly

3002-320-050

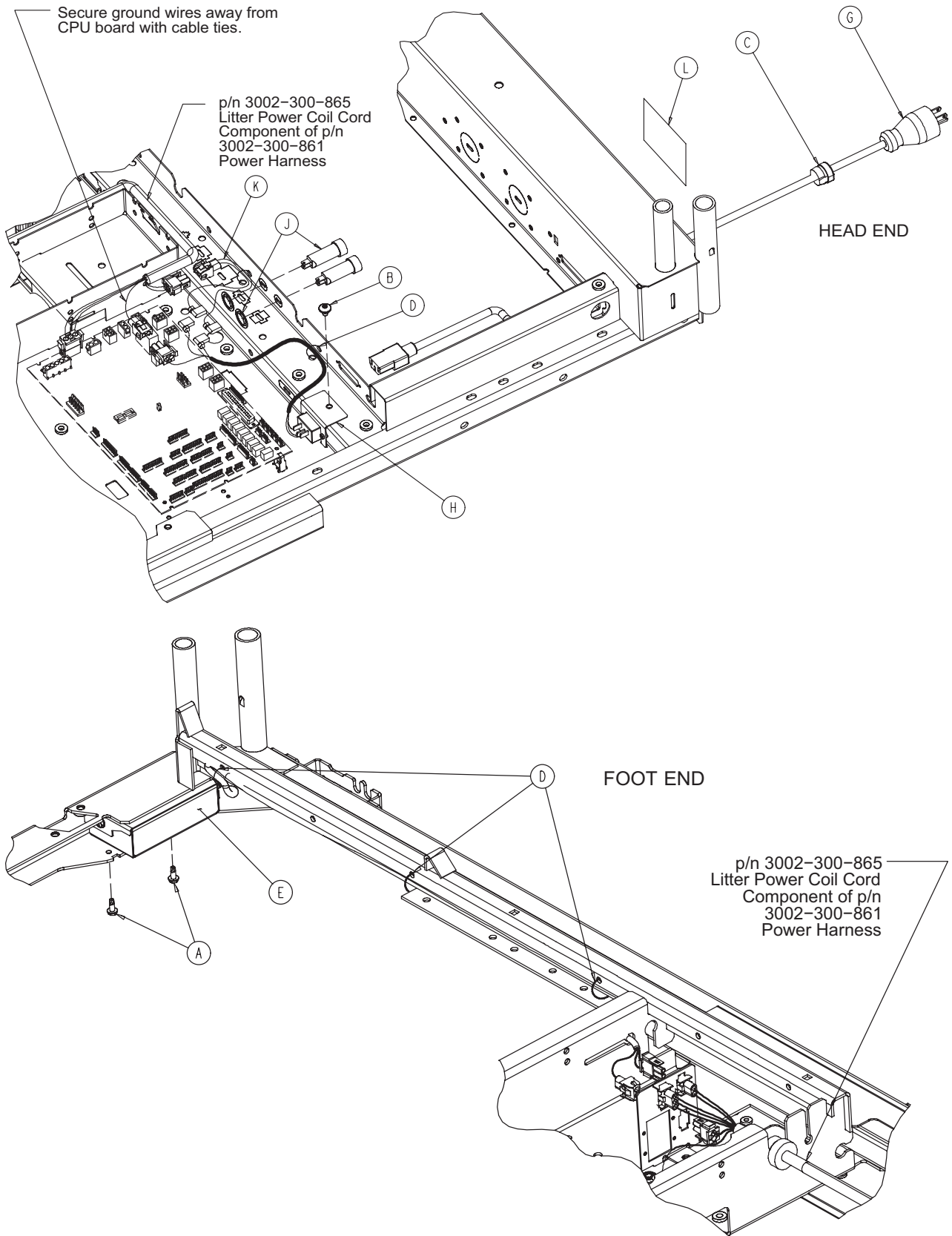

[Return To Table of Contents](#)

Optional 110V Outlet Assembly

3002-320-050

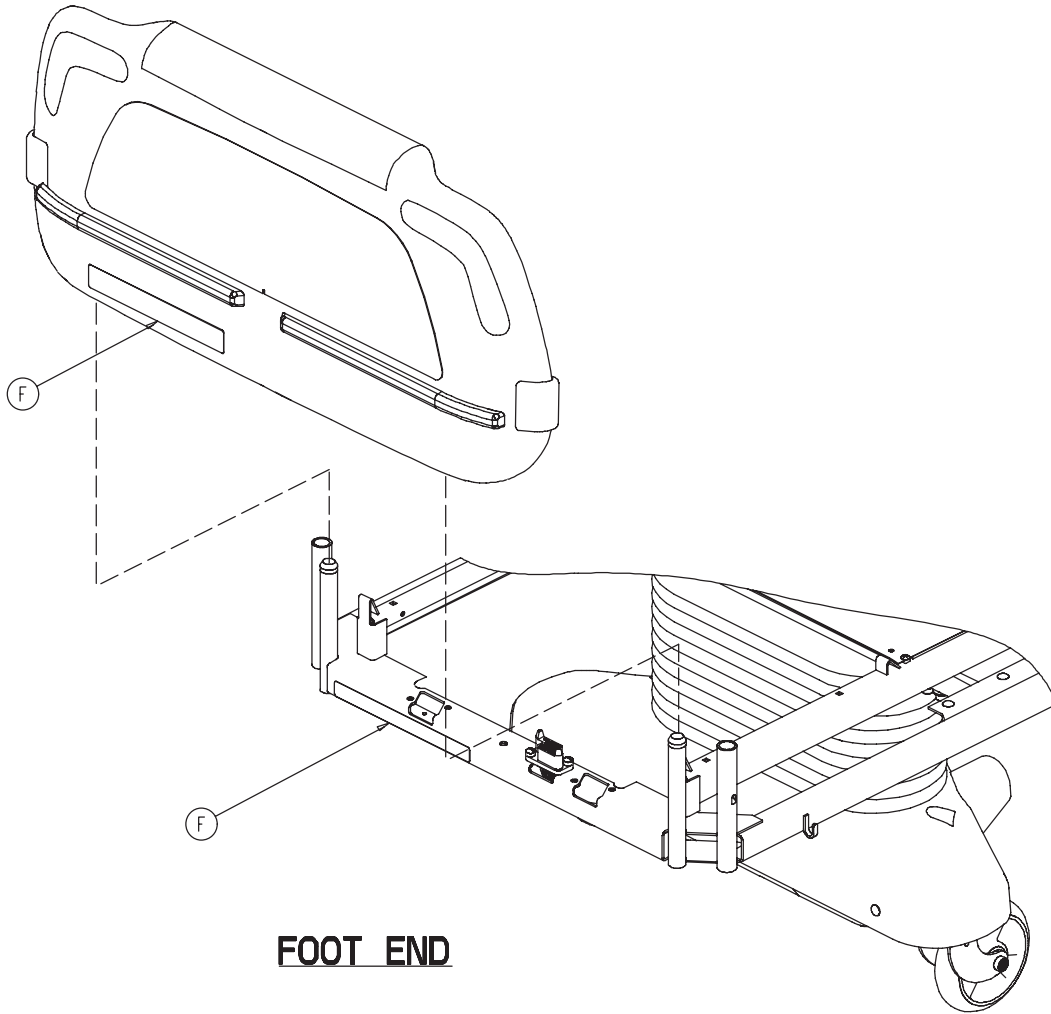

FOOT END

Item	Part No.	Part Name	Qty.
A	0003-224-000	Hex Washer Head Screw	2
B	0007-053-000	Truss Head Torx	1
C	0030-027-000	Strain Relief	1
D	3000-300-113	Cable Tie	5
E	3002-320-060	Outlet Box Assembly (pg.213)	1
F	3002-320-626	110V Outlet Label	1
G	3002-320-801	Power Cord	1
H	3002-320-878	110V Power Inlet Cable	1
J	0059-196-000	10A Circuit Breaker	2
K	3002-320-803	110V Power Jumper	1
L	3002-320-625	Shock Hazard Caution Label	1
M	3002-320-624	110V Outlet Label	1

110V Outlet Box Assembly

3002-320-060

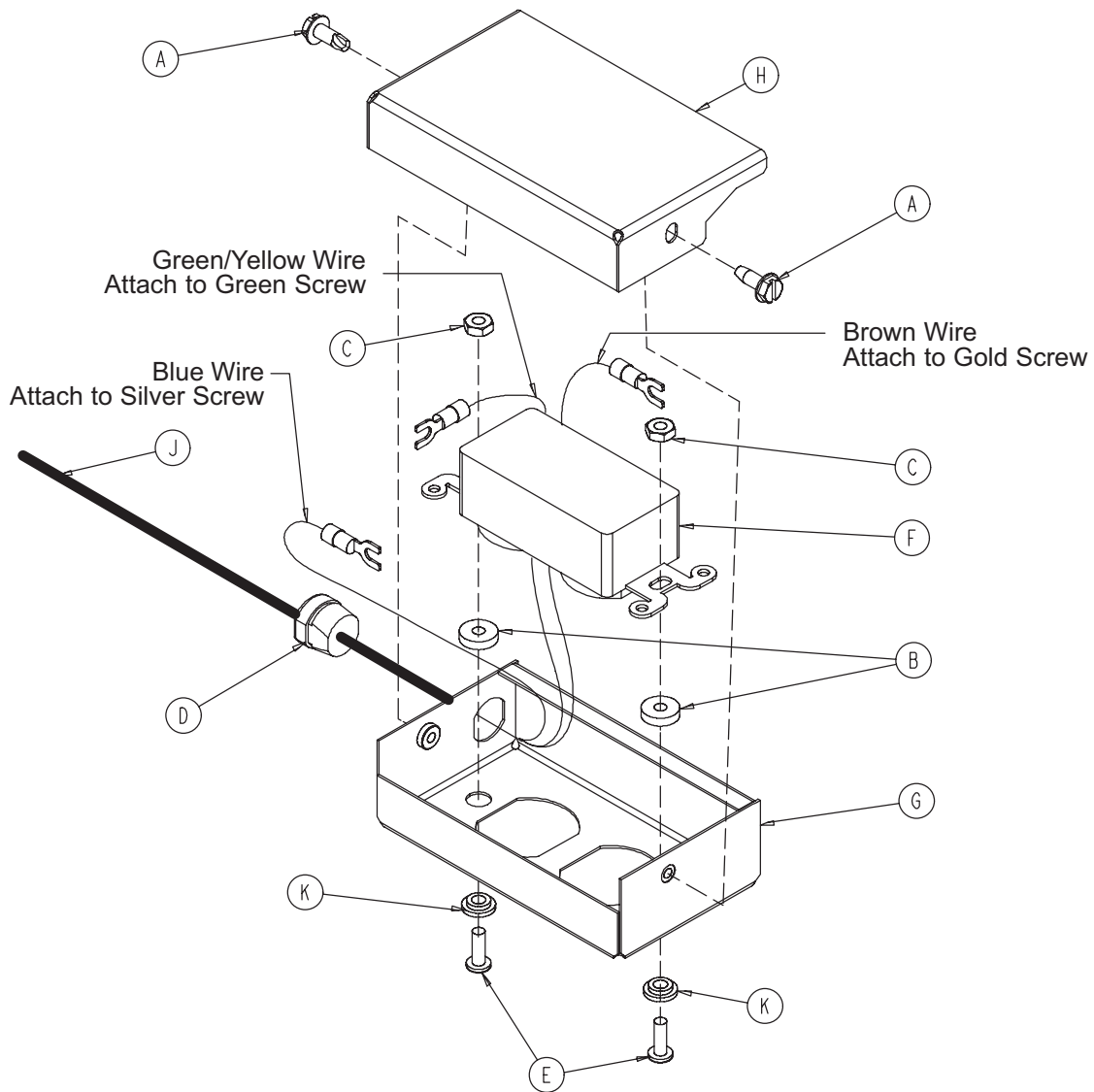

Item	Part No.	Part Name	Qty.
A	0003-224-000	Hex Washer Head Screw	2
B	0052-318-000	Round Spacer	2
C	0016-014-000	Hex Nut	2
D	0034-133-000	Strain Relief	1
E	0004-265-000	Button Head Machine Screw	2
F	0059-733-000	Hospital Grade Receptacle	1
G	3002-320-020	110V Outlet Box	1
H	3002-320-021	110V Outlet Box Cover	1
J	3002-320-802	110V Outlet Cable	1
K	0052-317-000	Shoulder Washer	2

[Return To Table of Contents](#)

Optional Scale/Bed Exit Assembly

For Reference Only: 3002-317-003

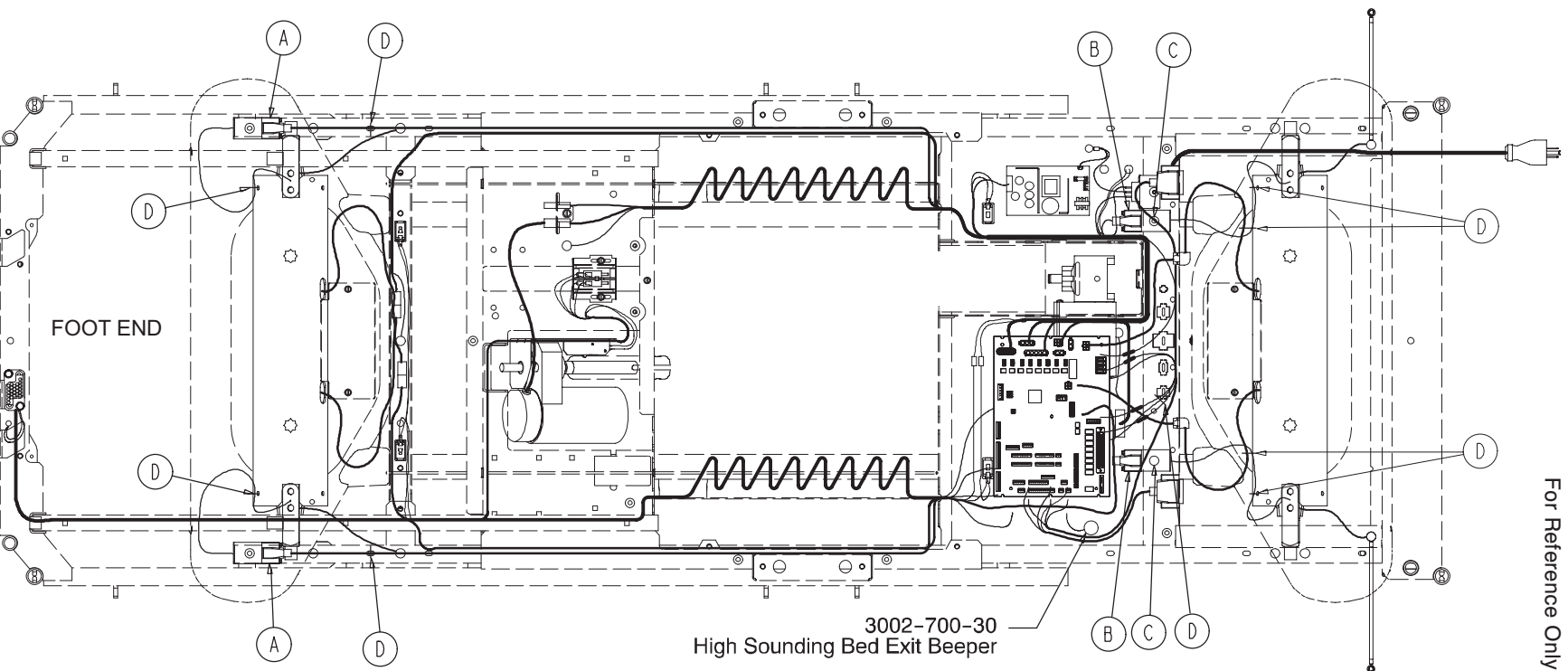

3002-700-30
High Sounding Bed Exit Beeper

Optional Scale/Bed Exit Assembly

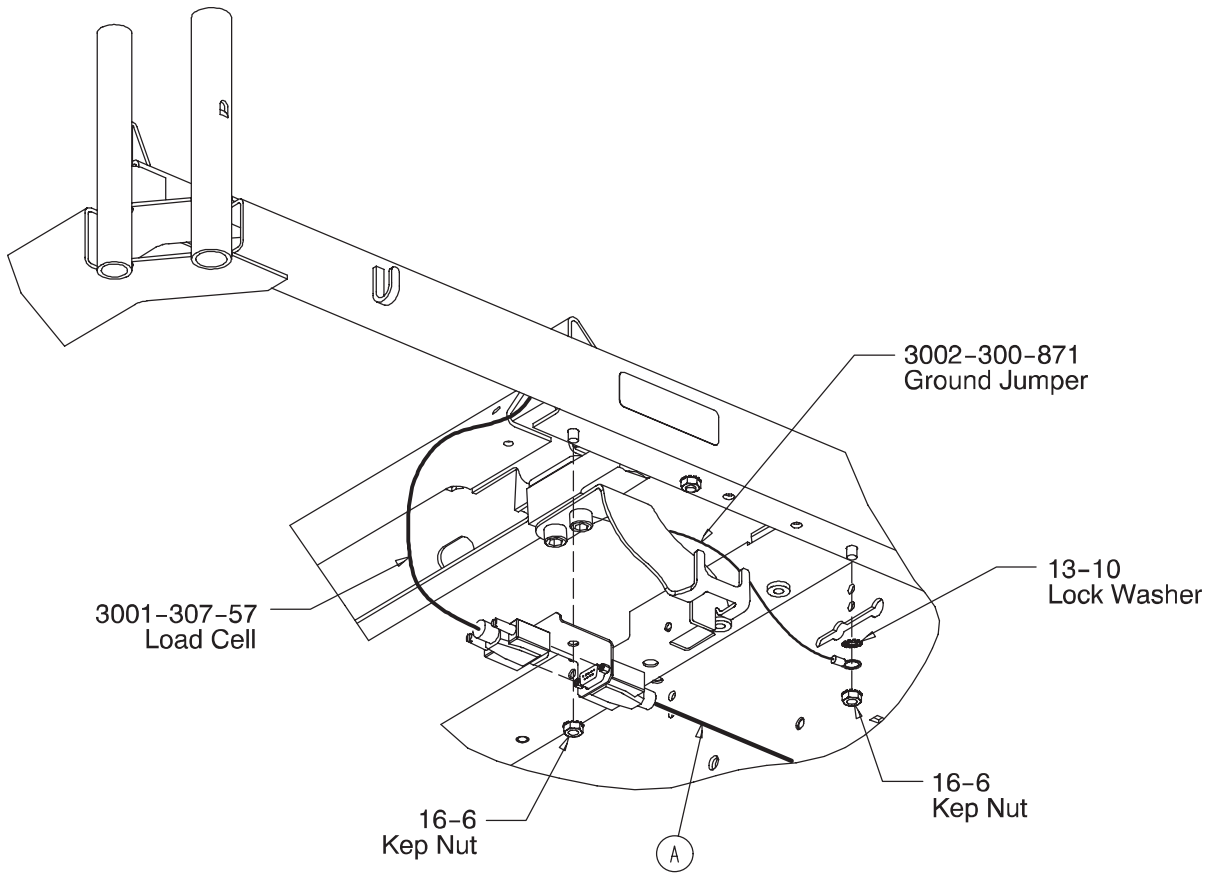

**Foot End Load Cell Cable Installation
(Typical Both Sides of the Bed)**

Item	Part No.	Part Name	Qty.
A	3002-317-835	FE Load Cell Cable	2
B	3002-317-834	HE Load Cell Cable	2
C	0007-053-000	Truss Head Torx	2
D	3000-300-113	Cable Tie	9

[Return To Table of Contents](#)

Optional HWI Assembly with Communication

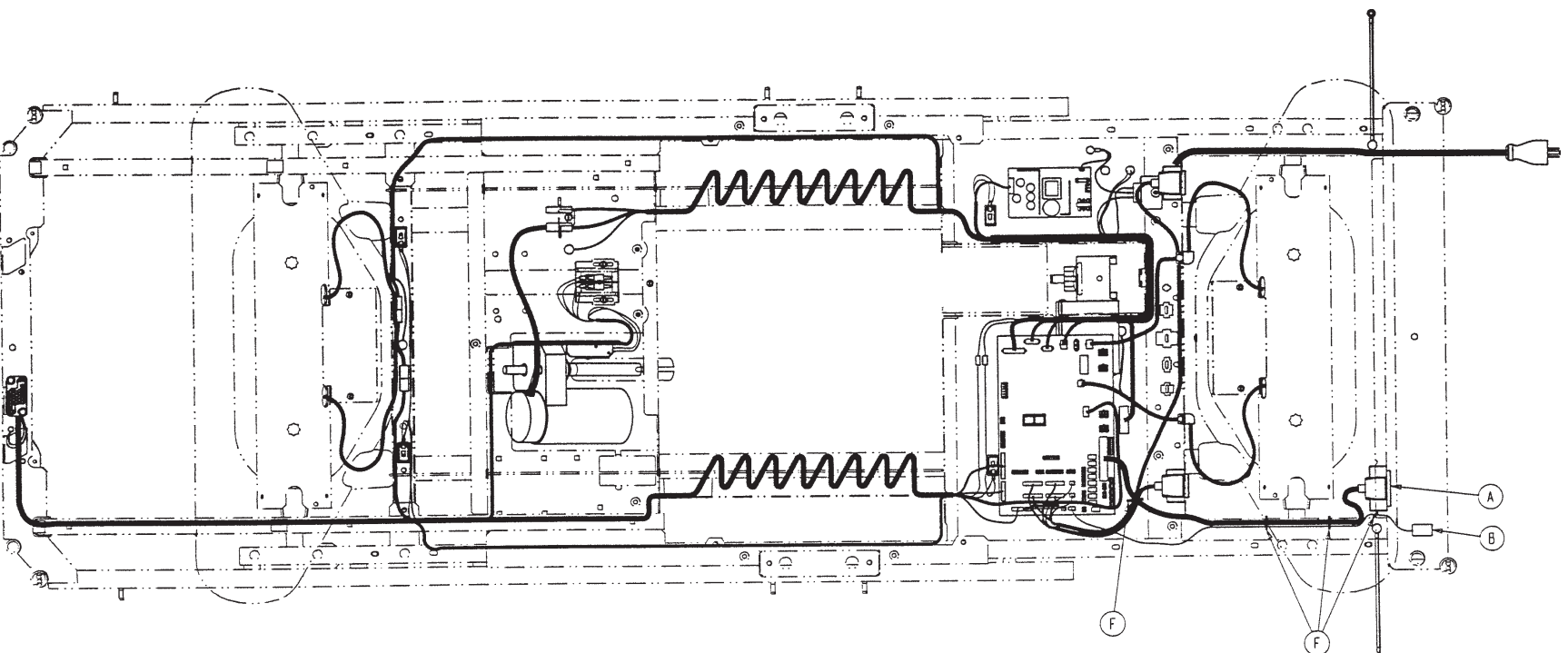

Optional HWI Assembly with Communication

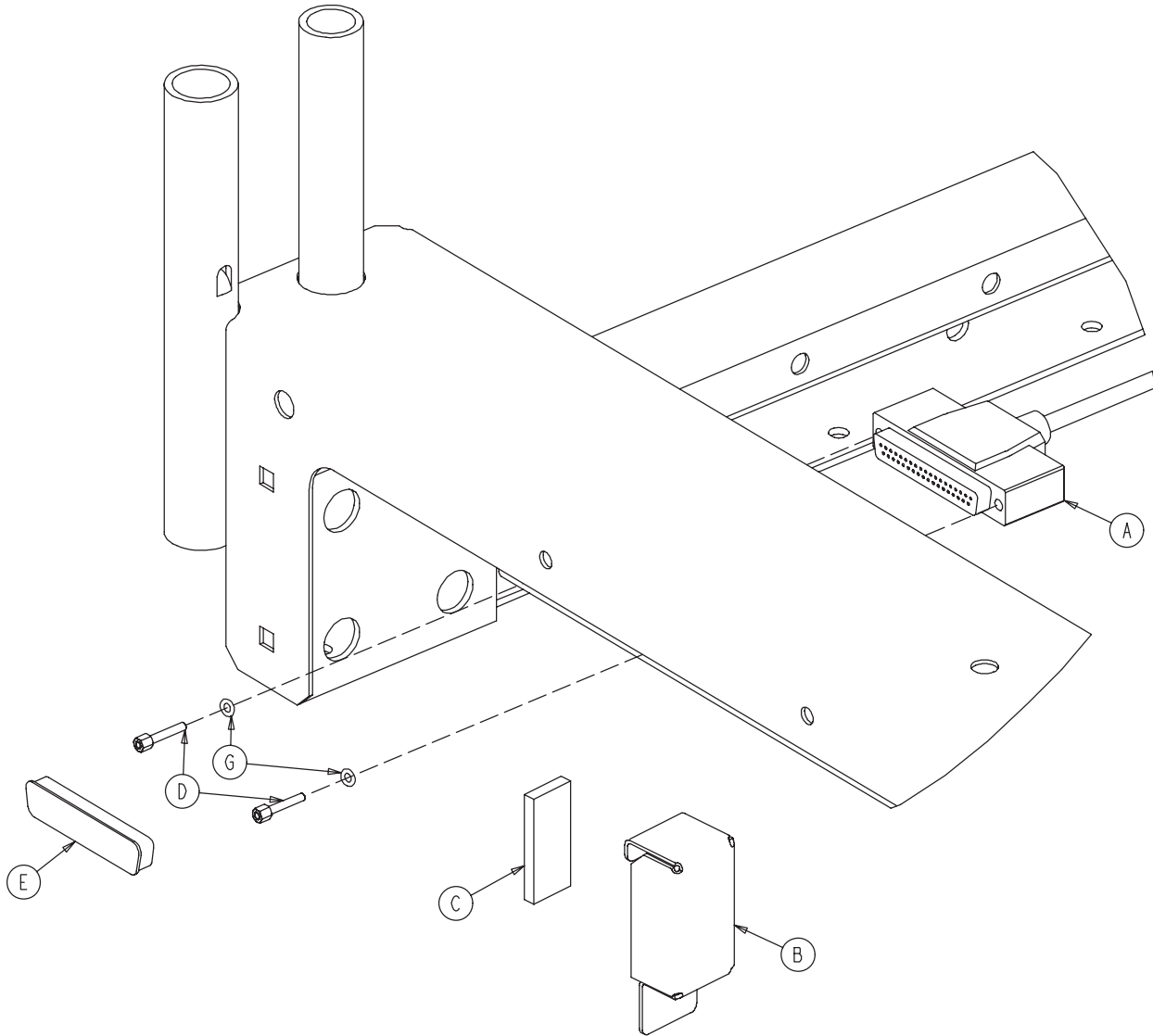

Nurse Call & Communication - 3001-303-52

Item	Part No.	Part Name	Qty.
A	3001-303-821	Headwall Interface Cable	1
B	3001-303-045	Battery Enclosure Assembly (pg.221)	1
C	7900-001-291	Foam Tape	1
D	3001-300-007	Female Screwjack	2
E	0059-710-000	Static Plug	1
F	3000-300-113	Cable Tie	4
G	0012-046-000	Split Lock Washer	2

Communication - 001-303-122

Item	Part No.	Part Name	Qty.
A	3001-303-821	Headwall Interface Cable	1
D	3001-300-007	Female Screwjack	2
E	0059-710-000	Static Plug	1
F	3000-300-113	Cable Tie	3
G	0012-046-000	Split Lock Washer	2

[Return To Table of Contents](#)

Optional HWI Assembly with Communication and Ports

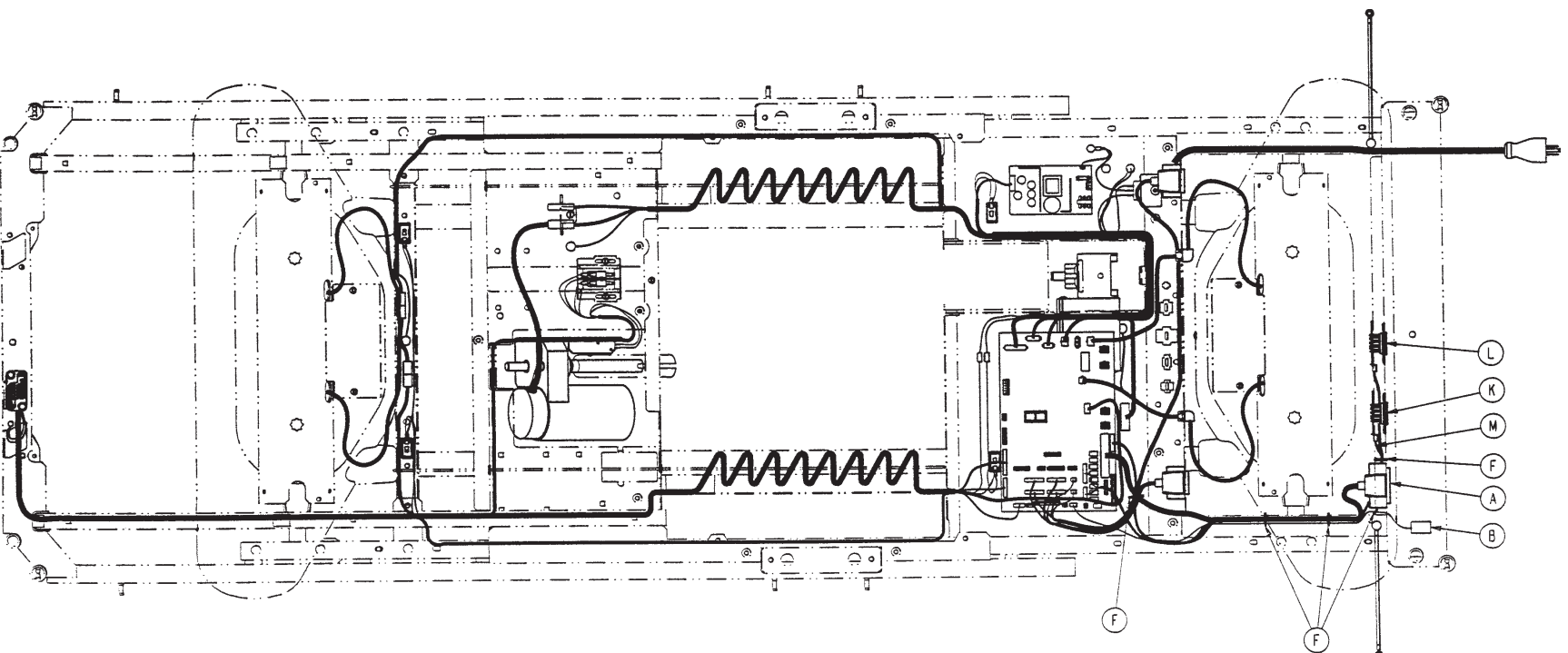

Optional HWI Assembly with Communication and Ports

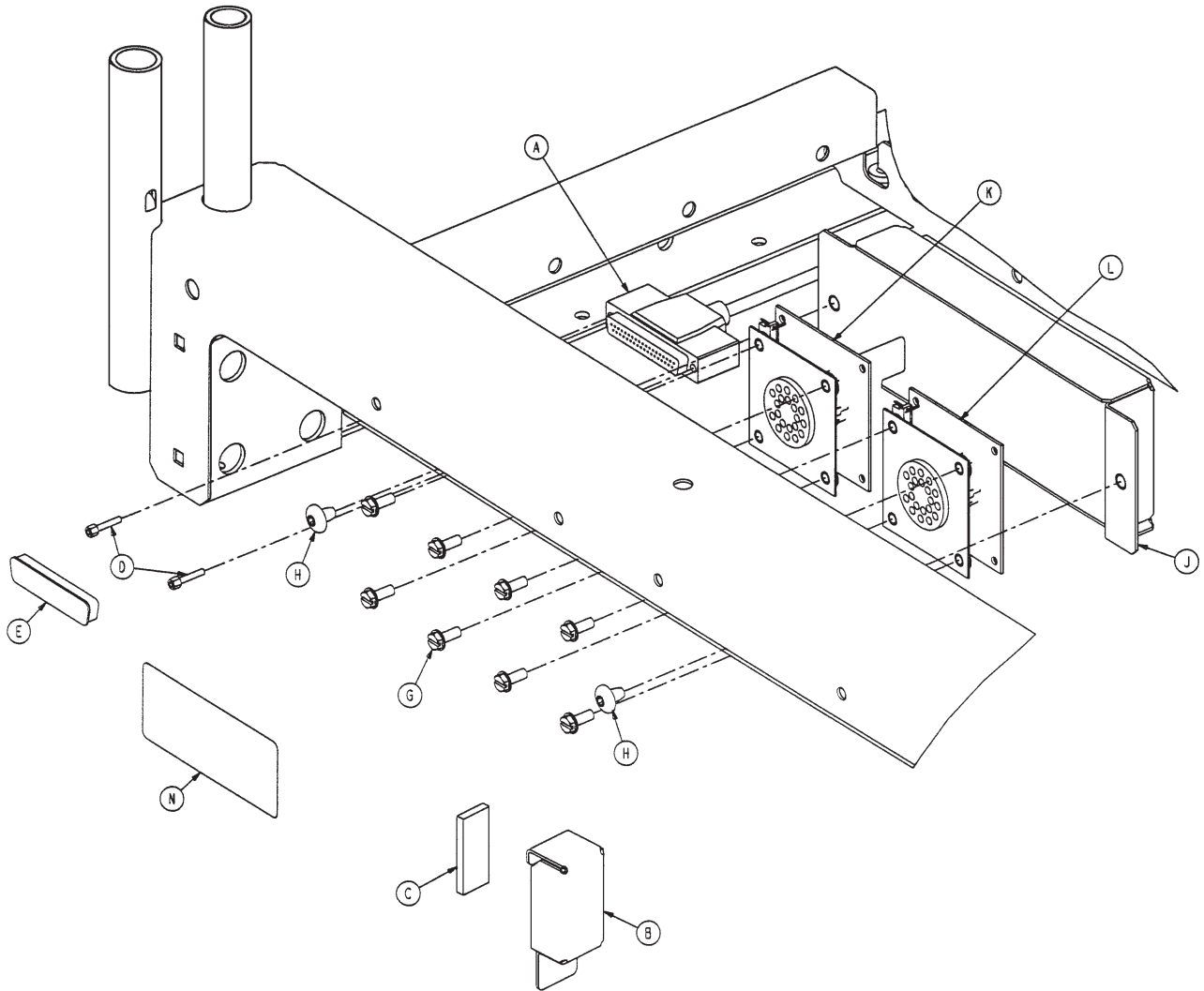

[Return To Table of Contents](#)

Optional HWI Assembly with Communication and Ports

HWI with 1 Stryker Port - 3001-314-012

Item	Part No.	Part Name	Qty.
A	3001-303-821	Headwall Interface Cable	1
B	3001-303-045	Battery Enclosure Assembly (pg.221)	1
C	7900-001-291	Foam Tape	1
D	3001-300-007	Female Screwjack	2
E	0059-710-000	Static Plug	1
F	3000-300-113	Cable Tie	5
G	0003-224-000	Hex Washer Head Screw	4
H	0007-053-000	Truss Head Screw	2
J	3001-314-006	Pendant Port Cover	1
K	3001-314-920	HWI Pendant Port PCB	1
M	3001-314-821	Pendant Port Cable	1
N	5000-090-028	Cord Out Label	1

HWI with 1 Stryker & 1 Custom Port - 3001-314-122

Item	Part No.	Part Name	Qty.
A	3001-303-821	Headwall Interface Cable	1
B	3001-303-045	Battery Enclosure Assembly (pg.221)	1
C	7900-001-291	Foam Tape	1
D	3001-300-007	Female Screwjack	2
E	0059-710-000	Static Plug	1
F	3000-300-113	Cable Tie	5
G	0003-224-000	Hex Washer Head Screw	8
H	0007-053-000	Truss Head Screw	2
J	3001-314-0006	Pendant Port Cover	1
K	3001-314-920	HWI Pendant Port PCB	1
L	3001-314-889	HWI Cust. Pend. Port PCB	1
M	3001-314-821	Pendant Port Cable	1
N	5000-090-028	Cord Out Label	1

HWI with 1 Custom Port - 3001-314-112

Item	Part No.	Part Name	Qty.
A	3001-303-821	Headwall Interface Cable	1
B	3001-303-045	Battery Enclosure Assembly (pg.221)	1
C	7900-001-291	Foam Tape	1
D	3001-300-007	Female Screwjack	2
E	0059-710-000	Static Plug	1
F	3000-300-113	Cable Tie	5
G	0003-224-000	Hex Washer Head Screw	4
H	0007-053-000	Truss Head Screw	2
J	3001-314-006	Pendant Port Cover	1
K	3001-0314-889	HWI Cust. Pend. Port PCB	1
M	3001-314-821	Pendant Port Cable	1
N	5000-090-028	Cord Out Label	1

No Pendant Port Option - 3002-999-066

Item	Part No.	Part Name	Qty.
A	0037-220-000	Hole Plug	1

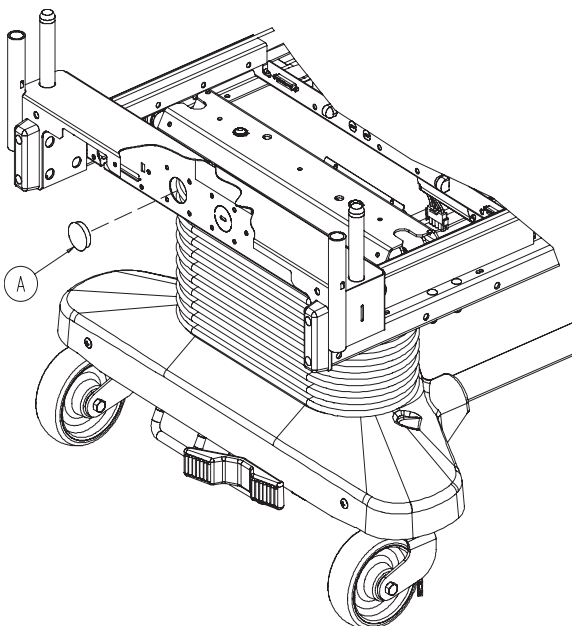

[Return To Table of Contents](#)

Battery Enclosure Assembly

3001-303-045

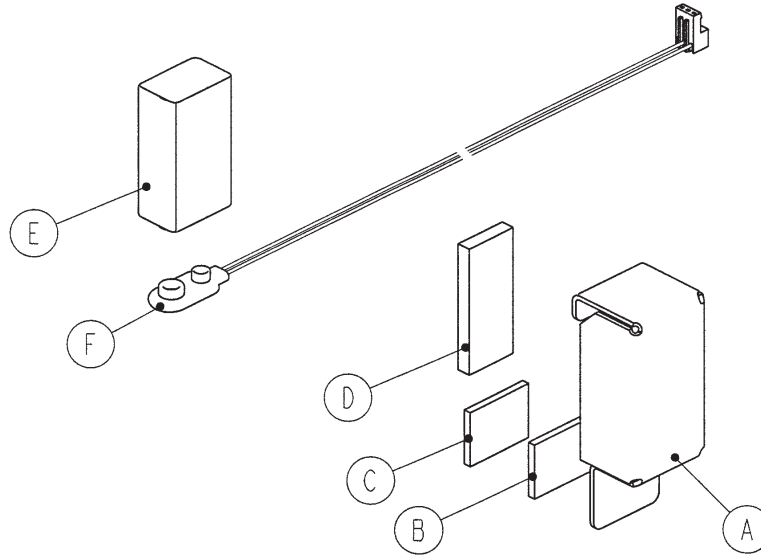

Item	Part No.	Part Name	Qty.
A	3001-303-012	Battery Enclosure	1
B	0029-010-000	Fine Duo-Lock	1
C	0029-008-000	Coarse Duo-Lock	1
D	7900-001-291	Foam Tape	1
E	3000-303-871	Battery	1
F	3001-303-811	Battery Cable	1

Zoom® Option Litter Assembly

For Reference Only: 3002-131-010

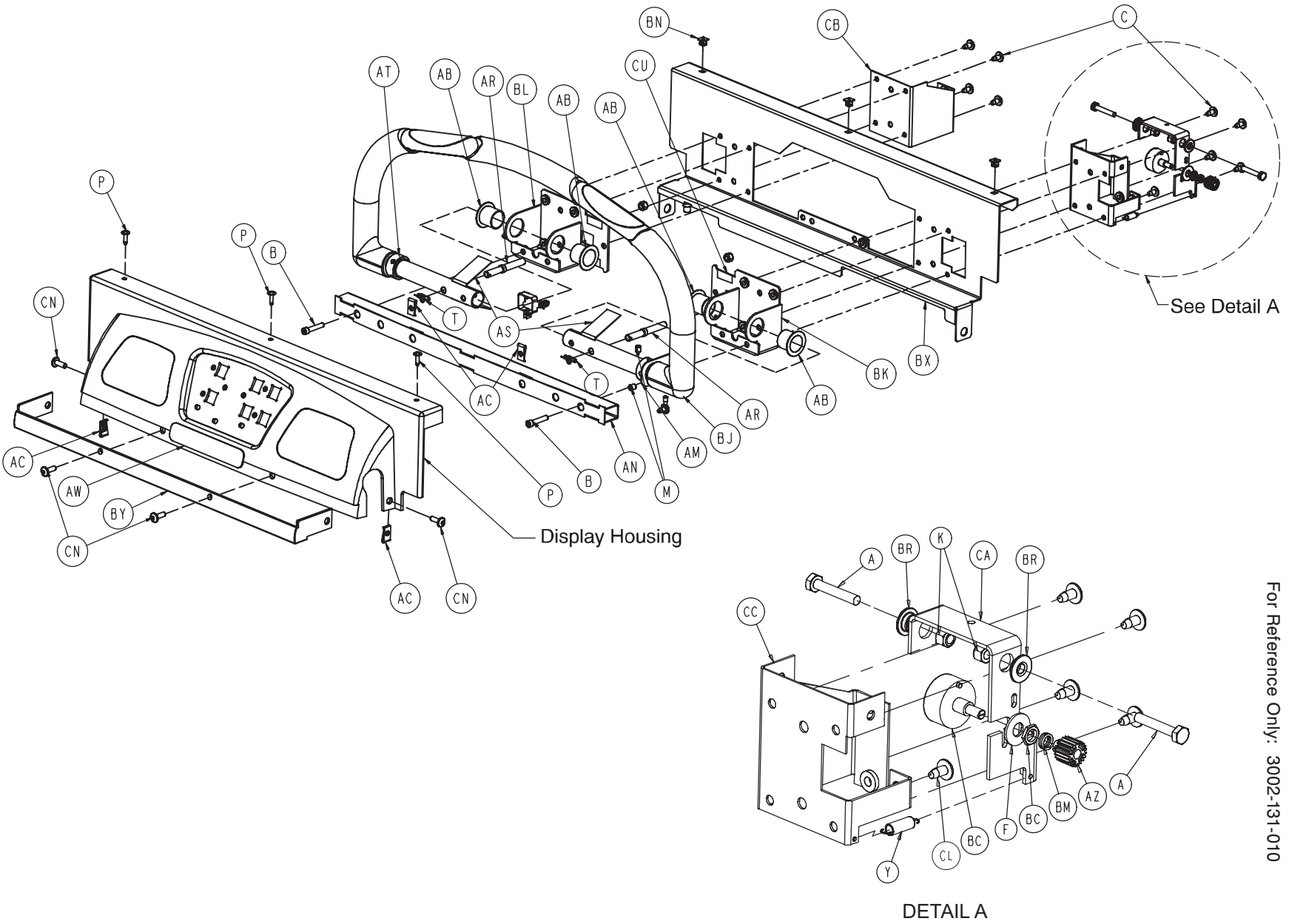

Display Housing

DETAIL A

Zoom® Option Litter Assembly

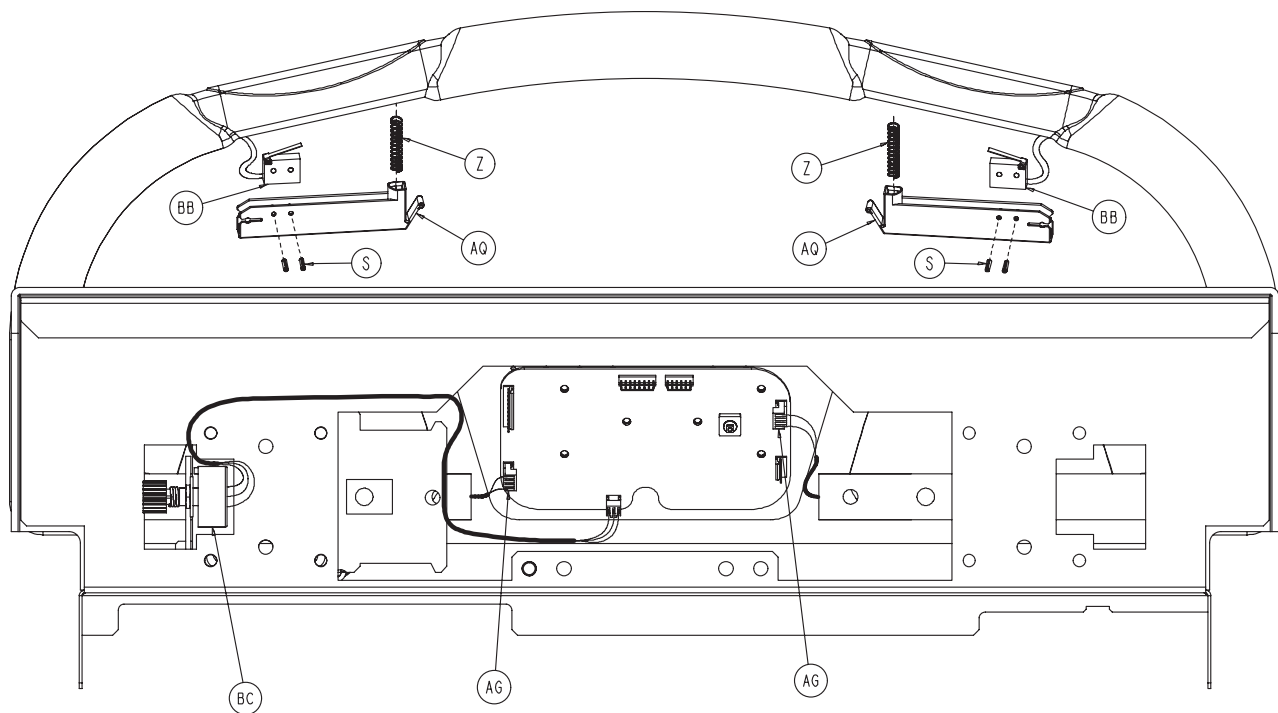
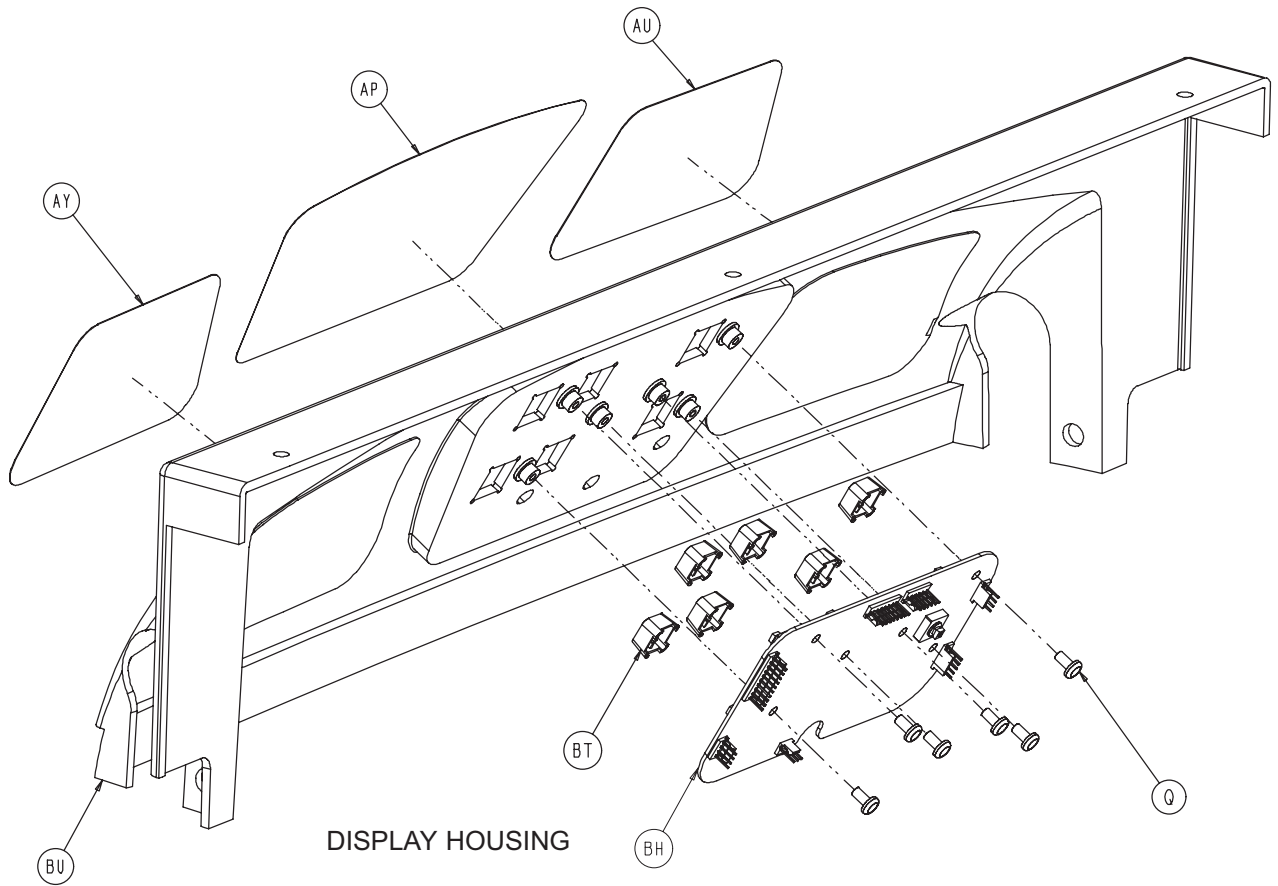

[Return To Table of Contents](#)

Zoom® Option Litter Assembly

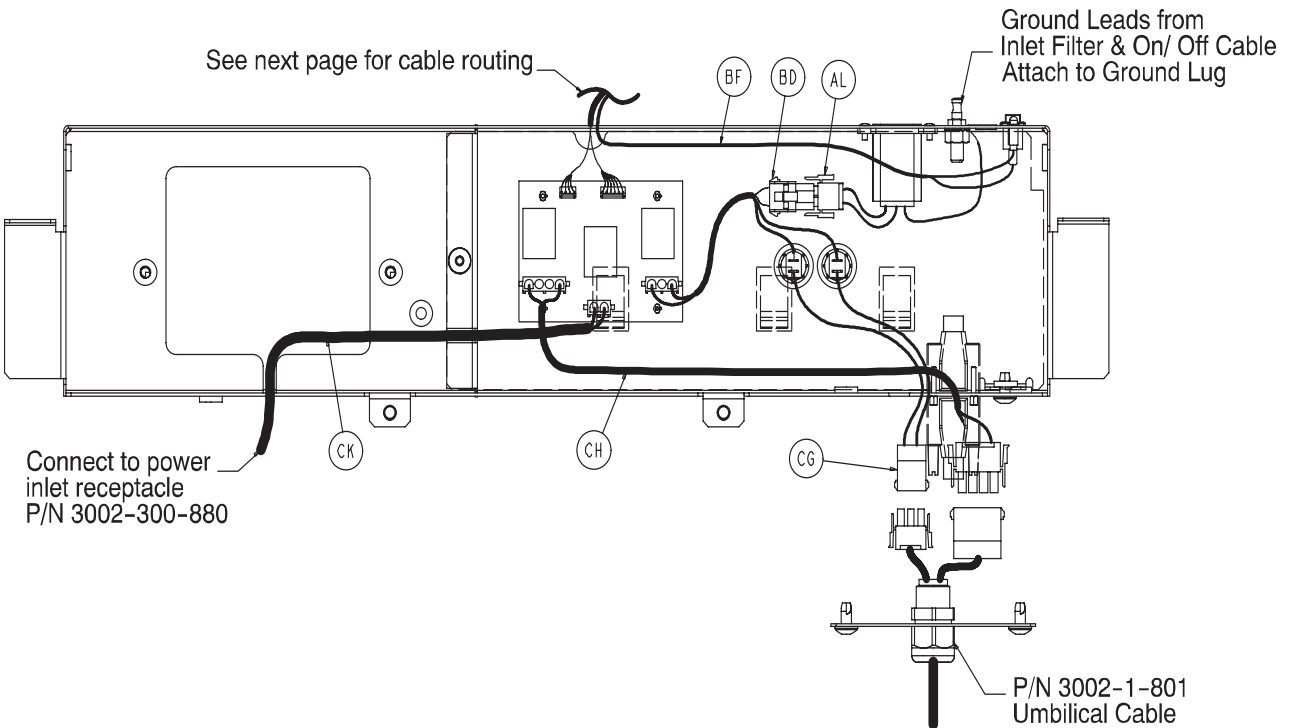
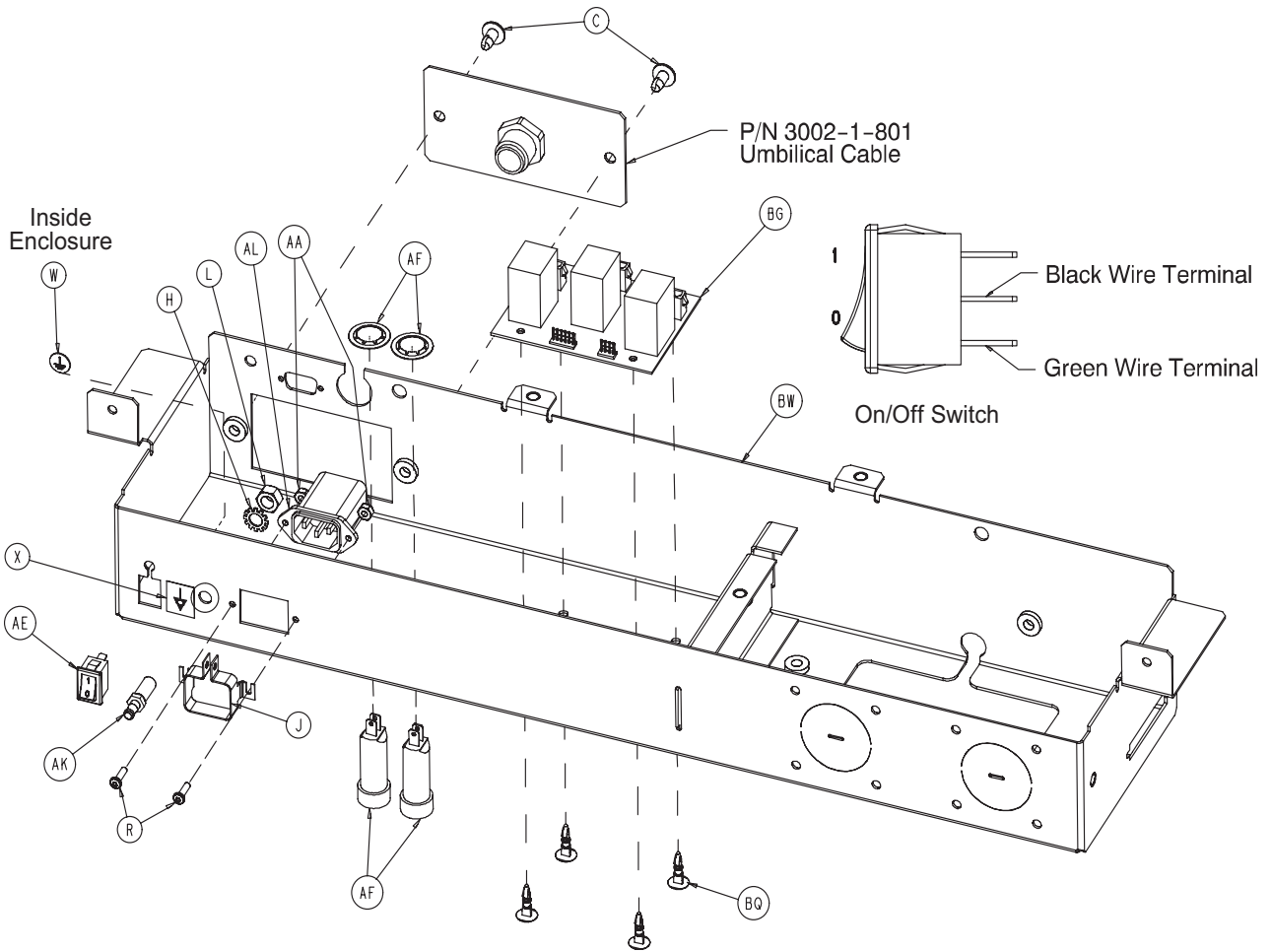

Zoom® Option Litter Assembly

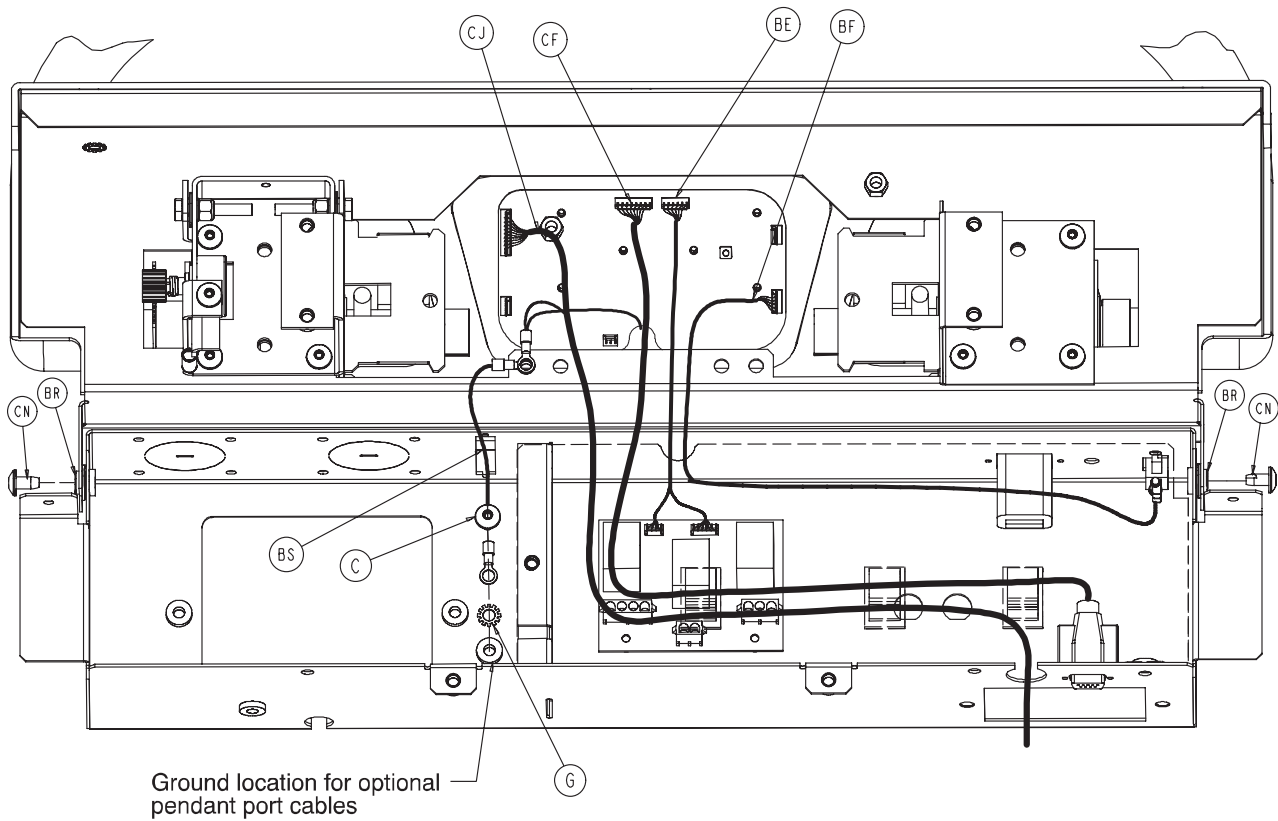
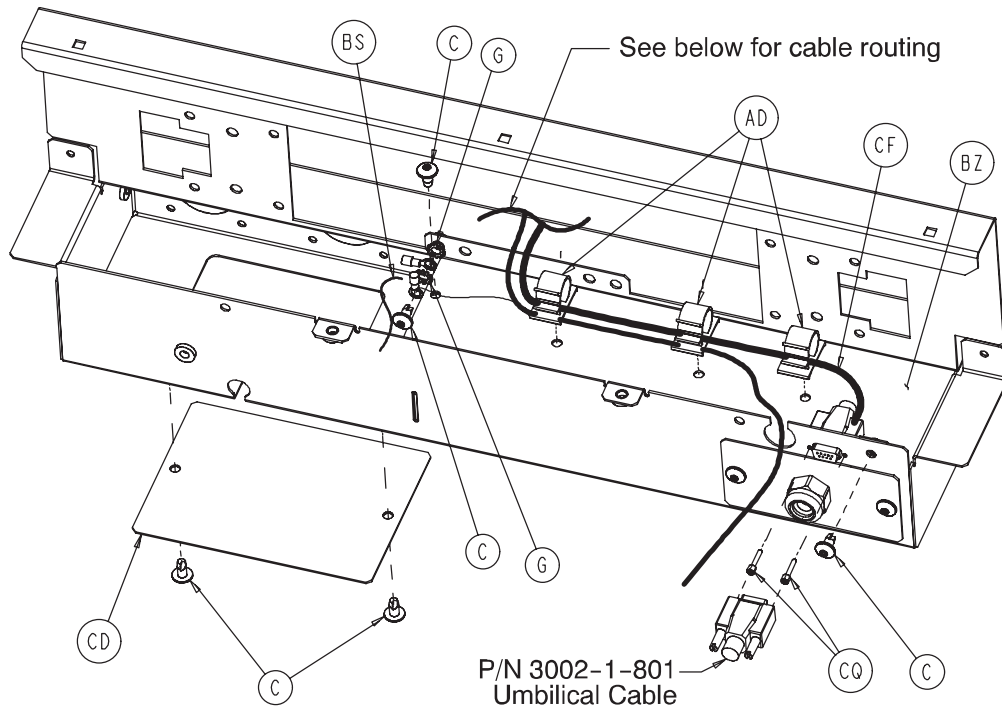

Zoom® Option Litter Assembly

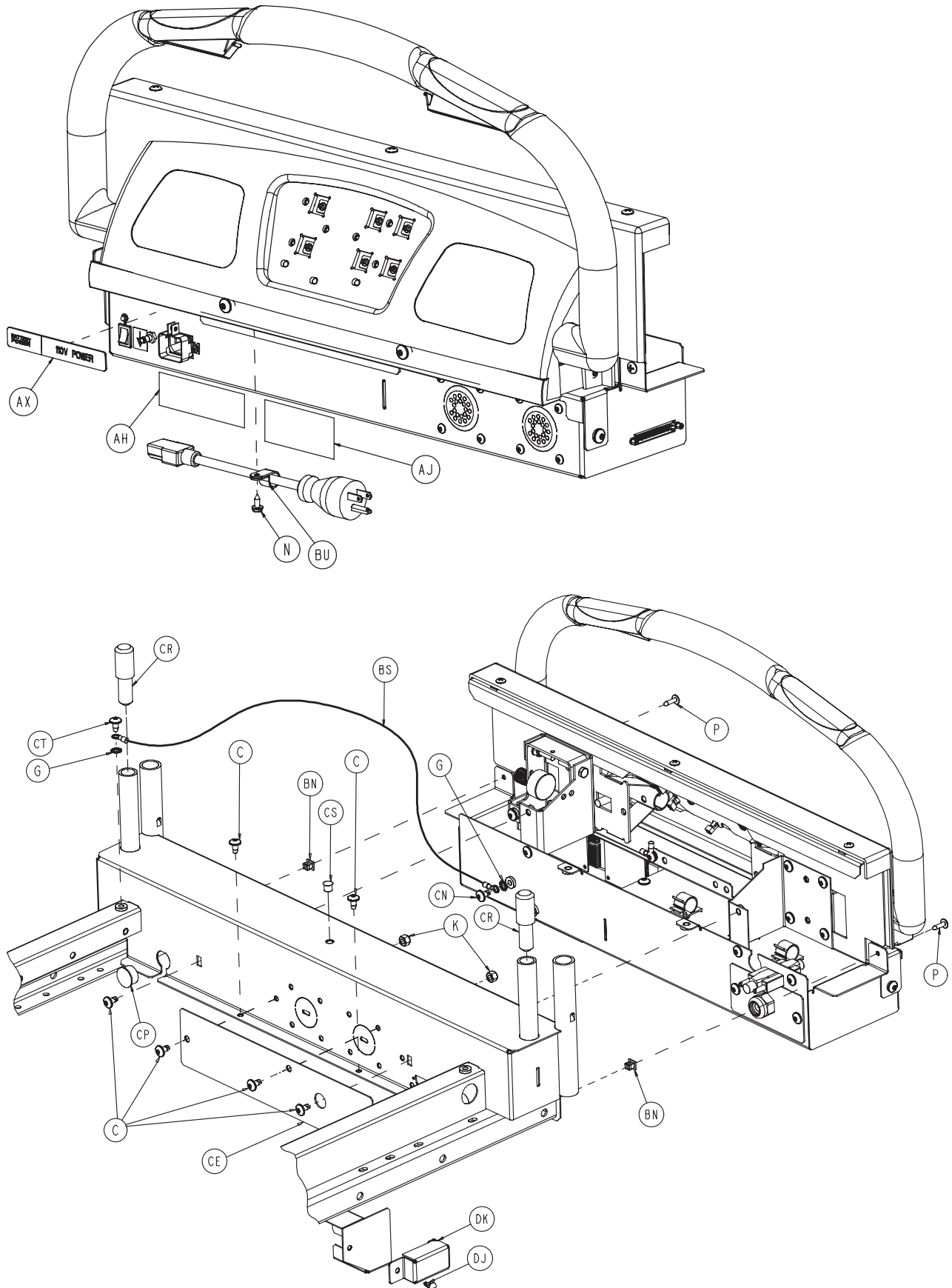

[Return To Table of Contents](#)

Zoom® Option Litter Assembly

Zoom® Option Litter Assembly - 3002-131-010

Item	Part No.	Part Name	Qty.	Item	Part No.	Part Name	Qty.
A	0003-050-000	Hex Head Cap Screw	2	AY	2040-031-105	Logo Label	1
B	0004-142-000	Socket Head Cap Screw	2	AZ	2040-031-106	Potentiometer Gear	1
C	0007-052-000	Truss Head Torx	25	BB	2040-031-803	Mom. Contact Switch Cable	2
F	0011-193-000	Flat Washer	1	BC	2040-031-804	Potentiometer Cable	1
G	0013-010-000	Ext. Tooth Lock Washer	5	BD	2040-031-808	Charger AC Jumper Cable	1
H	0013-038-000	External Lock Washer	1	BE	2040-031-809	CPU/Crossover Cable	1
J	0059-205-000	Connector Lock	1	BF	2040-031-810	On/Off Cable	1
K	0016-028-000	Nylock Nut	4	BG	2040-031-900	AC/Switchover PCB Ass'y	1
L	0016-033-000	Kep Nut	1	BH	2040-031-910	Display/CPU Assembly	1
M	0021-140-000	Set Screw	4	BJ	2040-231-064	Control Bar	1
N	0023-025-000	Hex Washer Head Screw	1	BK	2040-031-110	Pivot Bracket, Right	1
P	0023-080-000	Truss Head Screw	5	BL	2040-031-111	Pivot Bracket, Left	1
Q	0023-112-000	Hi-Low Tapping Screw	6	BM	3000-200-253	Pot. Worm Gear Retainer	1
R	0050-032-000	Pan Head Machine Screw	2	BN	3000-300-002	Plastic Clip Nut	5
S	0026-303-000	Roll Pin	4	BP	3000-300-114	4" Wire Tie	5
T	0027-022-000	Rue Pin	2	BQ	3000-300-115	Standoff	4
U	0034-022-000	Cord Clamp	1	BR	3001-300-099	Pivot Bearing	4
W	0036-046-000	Ground Label	1	BS	3002-300-870	8" Ground Strap	2
X	0036-115-000	Ground Label	1	BT	3001-400-953	Switch Cap	6
Y	0038-482-000	Extension Spring	1	BU	3002-031-011	Top Display Housing	1
Z	0038-448-000	Switch Handle Return Spring	2	BW	3002-031-053	Head End Bottom Enclosure	1
AA	0016-023-000	Nylock Nut	2	BX	3002-031-063	Head End Top Enclosure	1
AB	0052-762-000	Flange Bearing	4	BY	2040-231-069	Display Bumper	1
AC	0055-027-000	"U"-Type Nut	4	BZ	3002-031-092	Head End Electronics Cover	1
AD	0059-133-000	Push-Mount Wire Clip	3	CA	3002-031-108	Potentiometer Mount	1
AE	0059-191-000	On/Off Switch	1	CB	3002-031-109	Reinforcement Bracket, Left	1
AF	0059-195-000	Circuit Breaker	2	CC	3002-031-110	Reinforcement Bracket, Right	1
AG	0059-781-000	4-Position Connector	2	CD	3002-031-112	Pendant Port Cover	1
AH	1550-090-001	Hosp. Grade Plug Label	1	CE	3002-031-115	Cover Plate	1
AJ	2011-001-104	Danger Label	1	CF	3002-031-801	Zoom CPU Signal Jumper	1
AK	2011-001-215	Grounding Lug	1	CG	3002-031-802	Zoom Breaker Jumper	1
AL	2035-031-880	Power Inlet Cable	1	CH	3002-031-803	Zoom Crossover PCB Jumper	1
AM	2040-031-051	Potentiometer Collar	1	CJ	3002-007-805	Zoom/Bed CPU Jumper	1
AN	2040-031-054	Bumper Attachment Wldmt.	1	CK	3002-031-805	Bed AC Power Jumper	1
AP	2040-031-062	Display Label	1	CL	0004-325-000	Socket Head Cap Screw	1
AQ	2040-031-068	Contact Switch Handle	2	CN	0007-063-000	Truss Head Torx	7
AR	2040-031-073	Stop Pin	2	CP	0037-240-000	Hole Plug	1
AS	2040-031-074	Control Bar Return Spring	2	CQ	3001-300-007	M/F Screw	2
AT	2040-031-082	Potentiometer Collar	1	CR	3002-031-114	Head Board Extender	2
AU	2040-031-101	Drive Instruction Label	1	CS	0059-738-000	Hole Plug	1
AW	2040-031-102	Drive Warning Label	1	CT	0007-065-000	Truss Head Screw	1
AX	2040-031-103	Power Label	1	CU	0044-032-000	Pressure Sensitive Tape	4

[Return To Table of Contents](#)

Zoom Option Litter Assembly

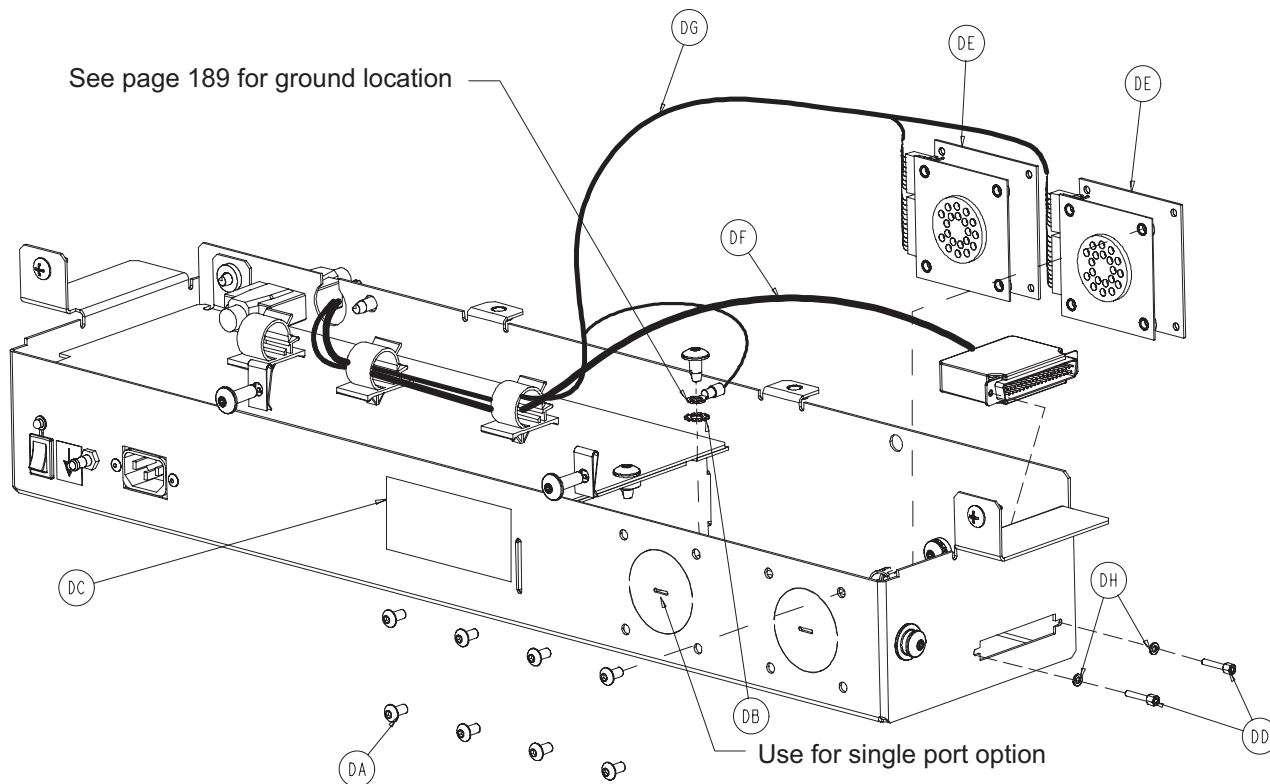

Head Wall Communication Option - 3002-031-200

Item	Part No.	Part Name	Qty.
DD	3001-300-007	M/F Screw	2
DF	3002-080-008	Head Wall IF Cable	1

HW Comm. w/NC & 1 Stryker Port - 3002-031-202

Item	Part No.	Part Name	Qty.
DA	0004-307-000	Button Head Cap Screw	4
DB	0013-010-000	External Tooth Lock Washer	1
DC	2040-031-104	Cord Out Label	1
DD	3001-300-007	M/F Screw	2
DE	3001-314-920	Head Wall Pend. Port PCB	1
DF	3002-080-008	Head Wall Interface Cable	1
DG	3002-031-807	Zoom Pendant Port Cable	1
DH	0012-046-000	Split Lock Washer	2
DK	3001-303-045	Battery Enclosure Assembly (pg.221)	1

Head Wall Comm. w/Nurse Call - 3002-031-201

Item	Part No.	Part Name	Qty.
DD	3001-300-007	M/F Screw	2
DF	5010-080-008	Head Wall Interface Cable	1
DH	0012-046-000	Split Lock Washer	2
DK	3001-303-045	Battery Enclosure Assembly (pg.221)	1

Battery Backup Option Head End Enclosure

For Reference Only: 3002-450-150

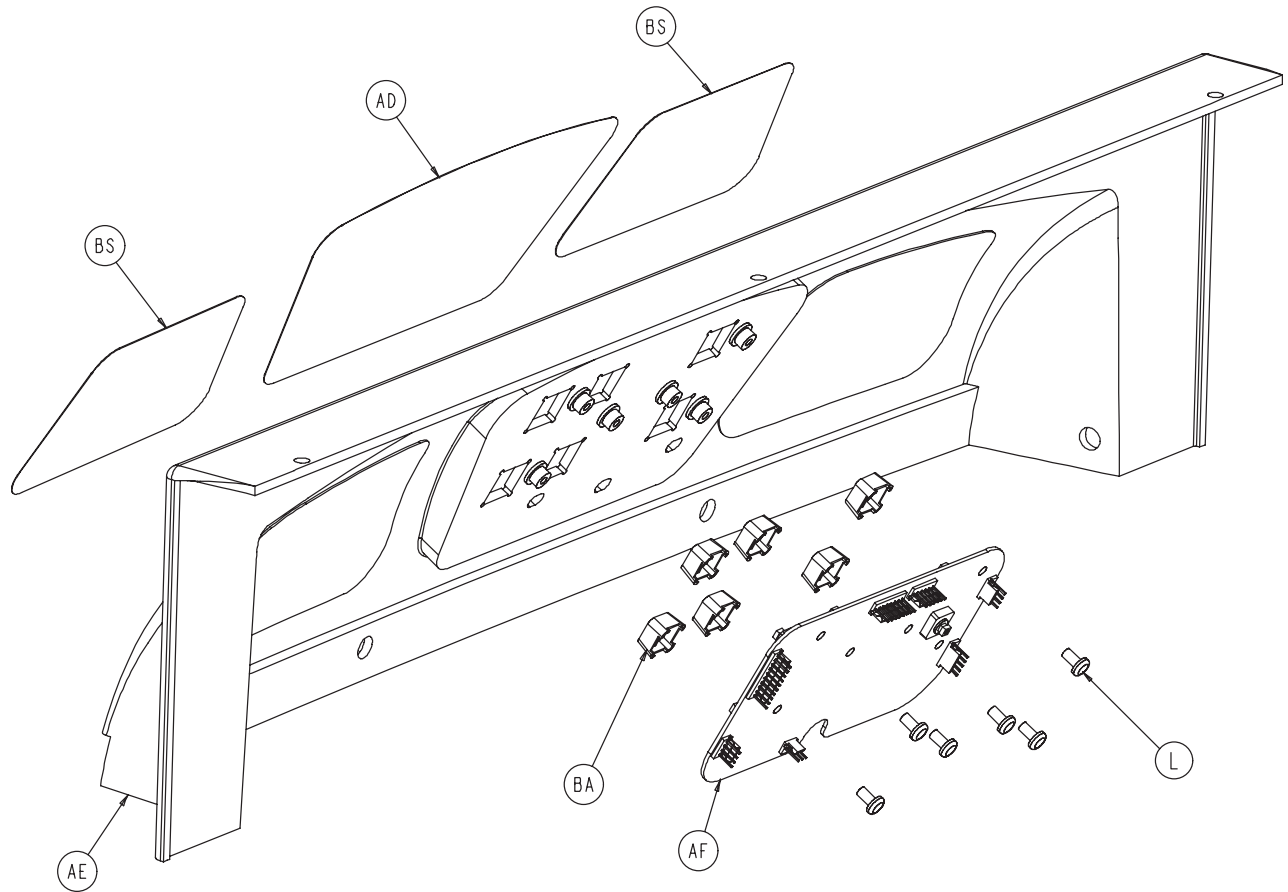
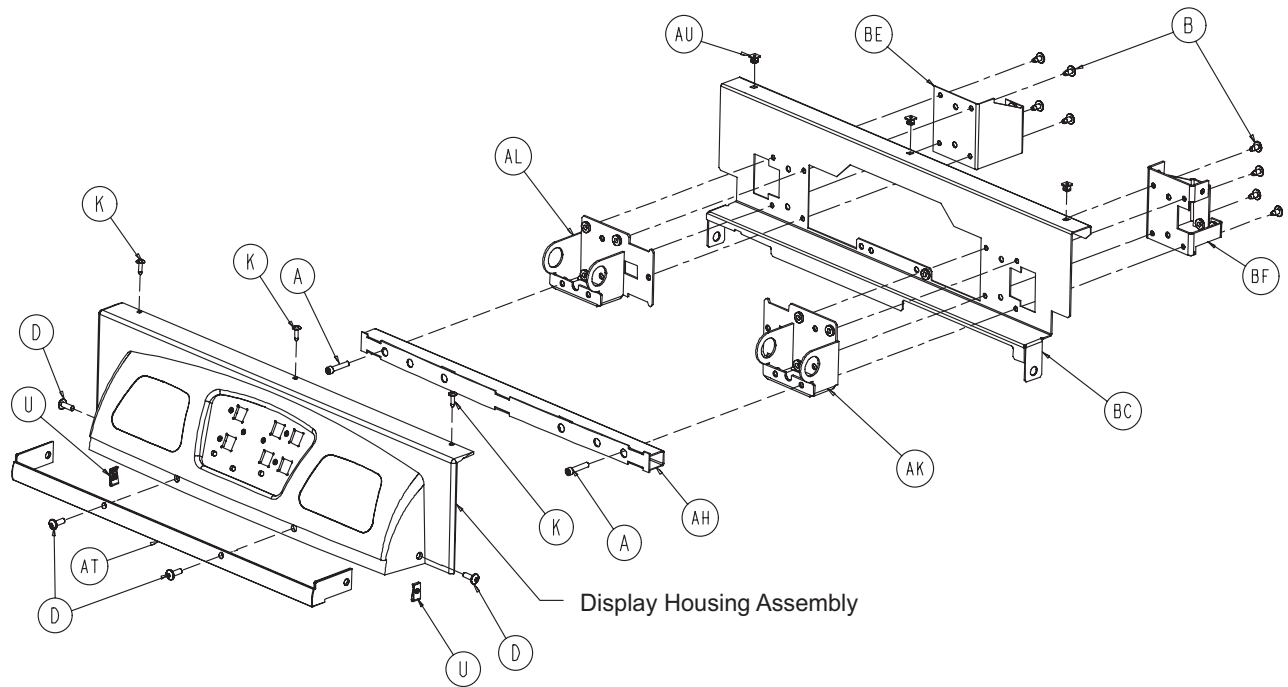

[Return To Table of Contents](#)

Battery Backup Option Head End Enclosure

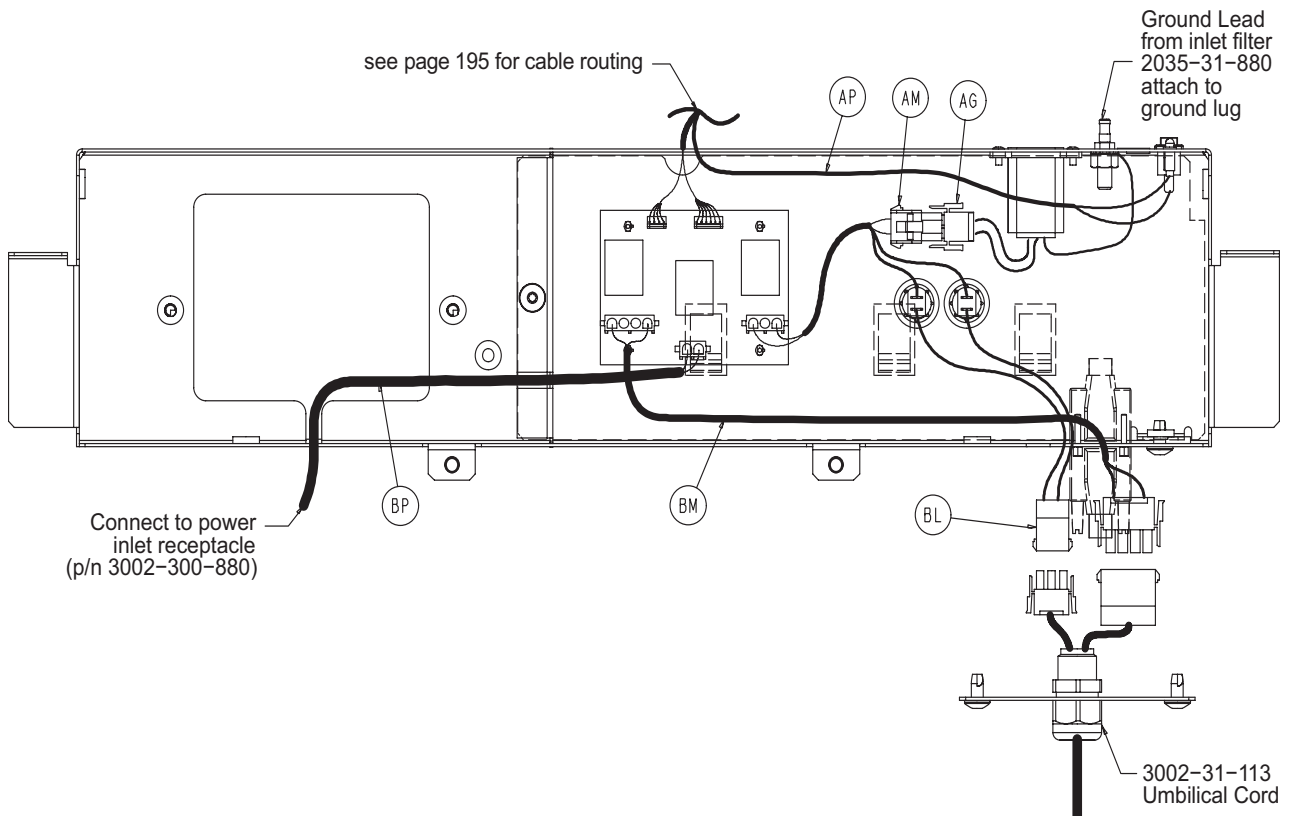
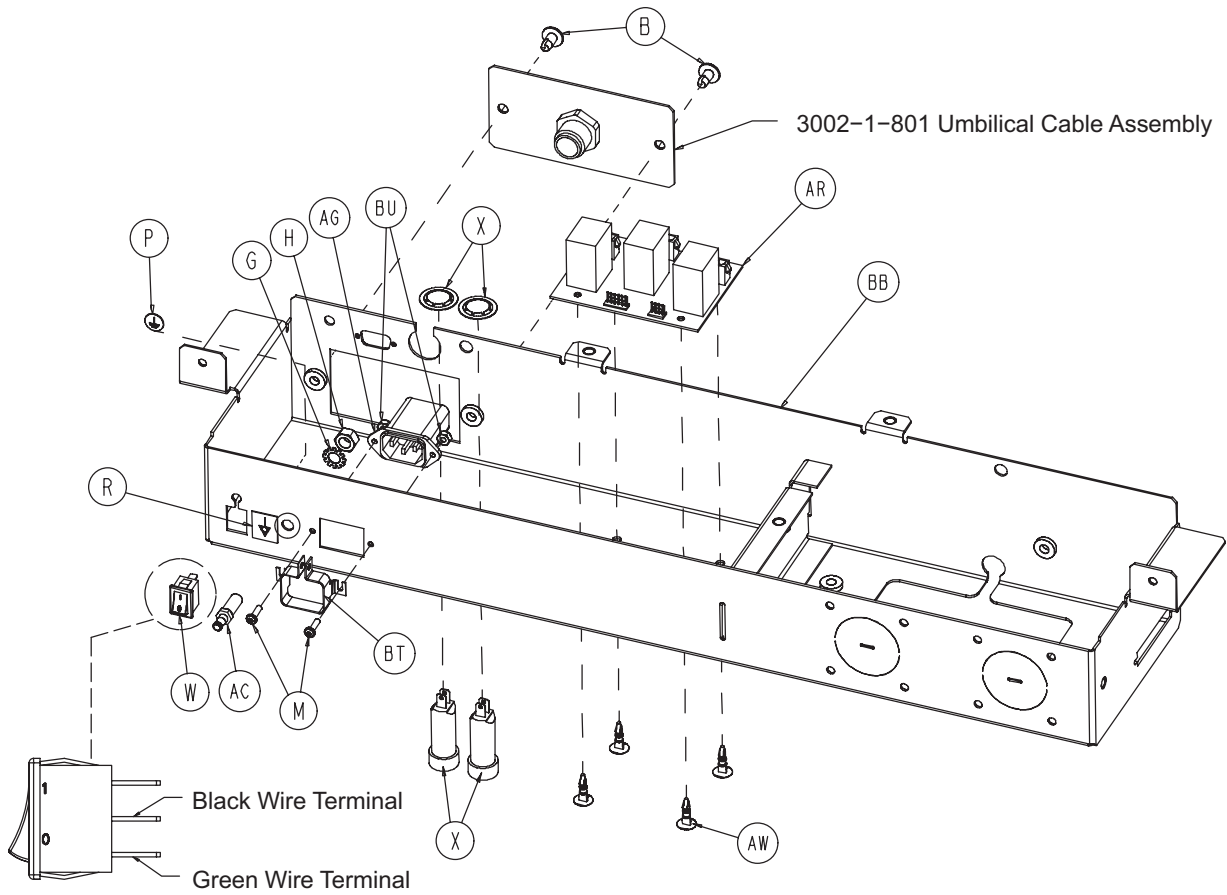

Battery Backup Option Head End Enclosure

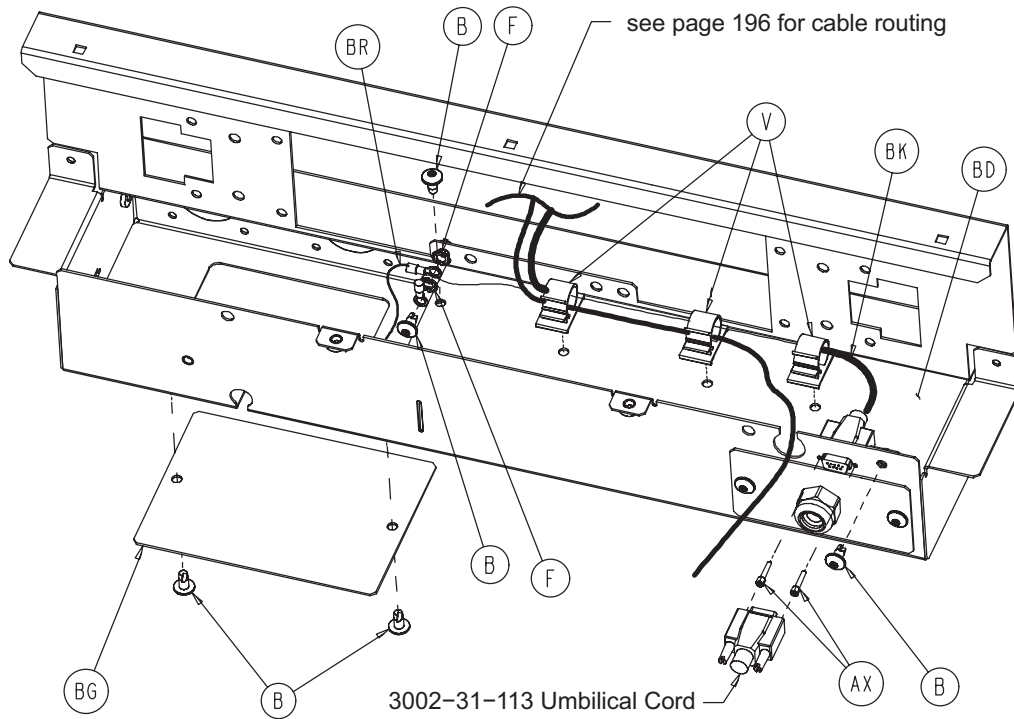
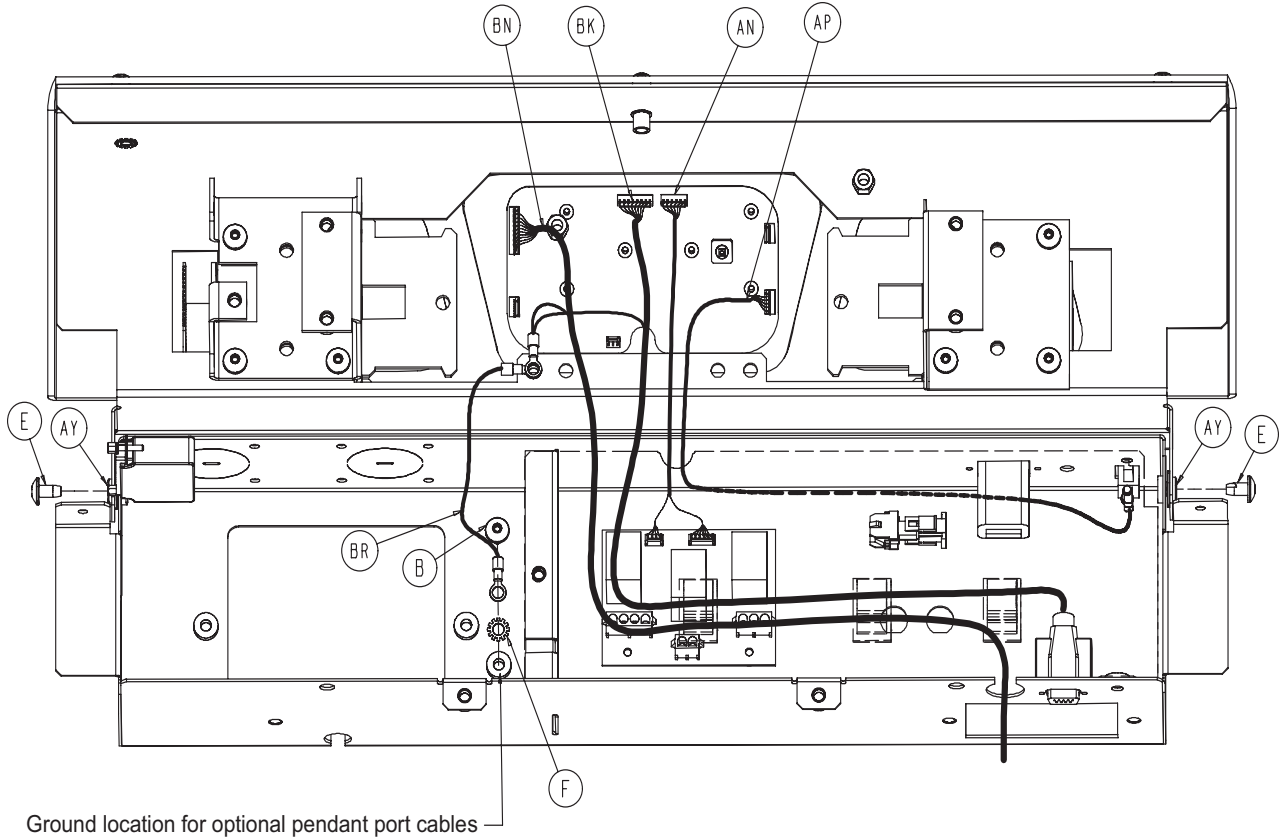

Battery Backup Option Head End Enclosure

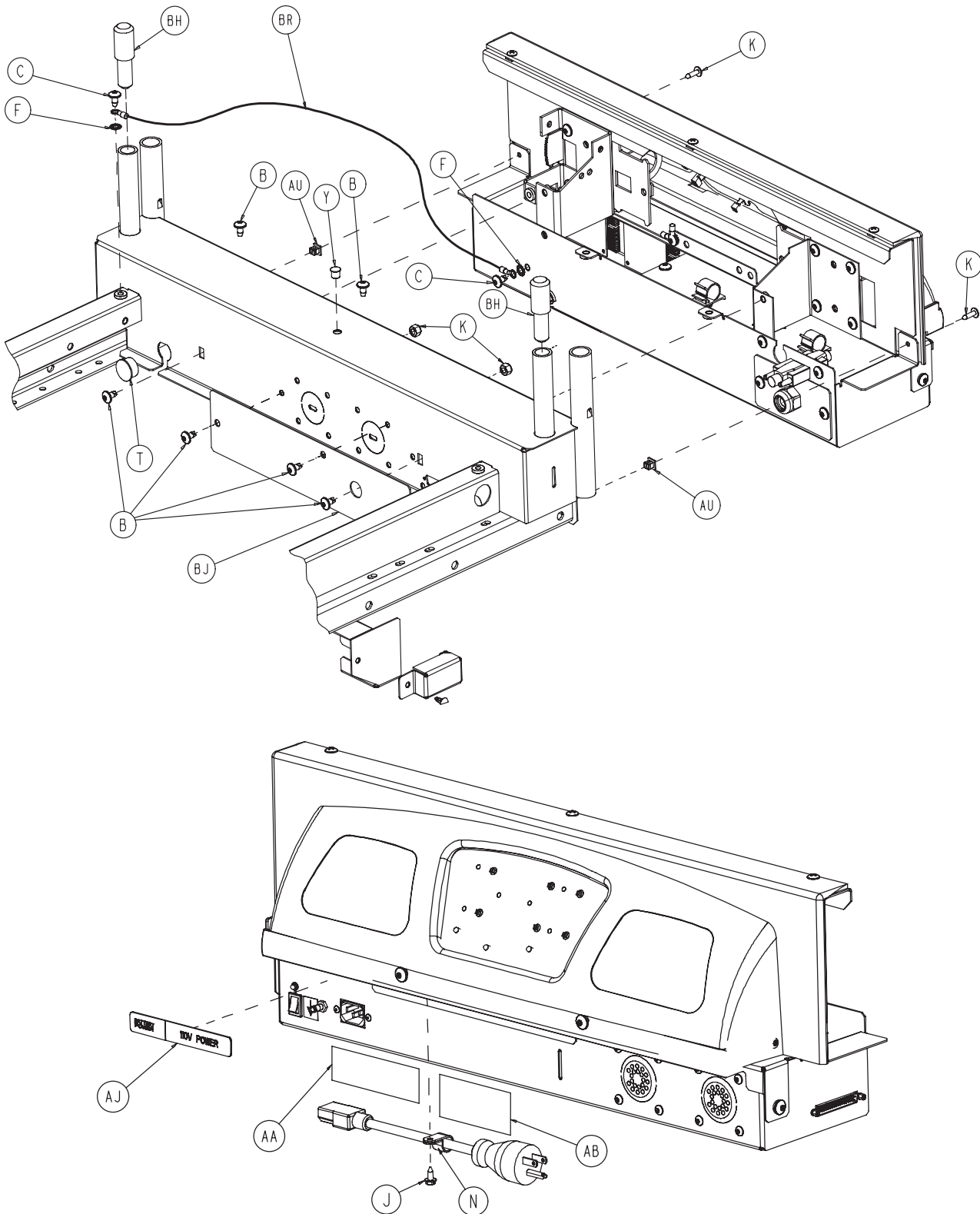

Battery Backup Option Head End Enclosure

Battery Backup Option Head End Enclosure - 3002-450-150

Item	Part No.	Part Name	Qty.	Item	Part No.	Part Name	Qty.
A	0004-142-000	Socket Head Cap Screw	2	AM	2040-031-808	Charger AC Jumper Cable	1
B	0007-052-000	Truss Head Torx Screw	22	AN	2040-031-809	CPU/Crossover PCB Jumper	1
C	0007-053-000	Truss Head Torx Screw	2	AP	2040-031-810	On/Off Cable	1
D	0007-063-000	Truss Head Torx Screw	4	AR	2040-031-900	AC Switchover PCB	1
E	0007-063-000	Truss Head Torx Screw	2	AT	2040-231-069	Display Bumper	1
F	0013-010-000	External Tooth Lock Washer	5	AU	3000-300-002	Plastic Clip Nut	5
G	0013-038-000	External Tooth Lock Washer	1	AV	3000-300-114	Wire Tie	5
H	0016-033-000	KEP Nut	1	AW	3000-300-115	Standoff	4
J	0023-025-000	Hex Washer Head Screw	1	AX	3001-300-007	Jack Screw	2
K	0023-080-000	Truss Head Screw	5	AY	3001-300-099	Pivot Bearing	2
L	0023-112-000	Hi-Low Tapping Screw	6	BA	3001-400-953	Switch Cap	6
M	0025-040-000	Rivet	2	BB	3002-031-053	Bottom HE Enclosure	1
N	0034-022-000	Cord Clamp	1	BC	3002-031-063	Top HE Enclosure	1
P	0036-046-000	Ground Label	1	BD	3002-031-092	HE Electronics Cover	1
R	0036-115-000	Ground Label	1	BE	3002-031-109	Reinforcement Bracket, Head, Left	1
T	0037-240-000	Hole Plug	1	BF	3002-031-110	Reinforcement Bracket, Head, Right	1
U	0055-027-000	"U" Type Nut	2	BG	3002-031-112	Pendant Port Cover	1
V	0059-113-000	Push-Mount Wire Clip	3	BH	3001-031-114	Head Board Extender	2
W	0059-191-000	On/Off Switch	1	BJ	3002-031-115	Cover Plate	1
X	0059-195-000	3A Circuit Breaker	2	BK	3002-031-801	CPU Signal Jumper	1
Y	0059-738-000	Hole Plug	1	BL	3002-031-802	Breaker Jumper	1
AA	1550-090-001	Hospital Grade Plug Label	1	BM	3002-031-803	Crossover PCB Jumper	1
AB	2011-001-104	Danger Label	1	BN	3002-007-805	Zoom to Bed CPU Jumper	1
AC	2011-001-215	Grounding Lug	1	BP	3002-031-805	Bed AC Power Jumper	1
AD	2030-031-010	Display Label	1	BR	3002-300-870	Ground Strap	2
AE	2030-031-208	Display Housing	1	BS	3002-350-151	Secure II Logo Label	2
AF	2030-031-910	Display / CPU	1	BT	0059-205-000	Connector Lock	1
AG	3006-031-880	Inlet Filter Cable	1	BU	0016-023-000	Nylock Hex Nut	2
AH	2040-031-054	Bumper Attachment Wldmt.	1				
AJ	2040-031-103	Power Label	1				
AK	2040-031-110	Pivot Bracket, Right	1				
AL	2040-031-111	Pivot Bracket, Left	1				

Head End Siderail Assembly

Inside the US and Canada

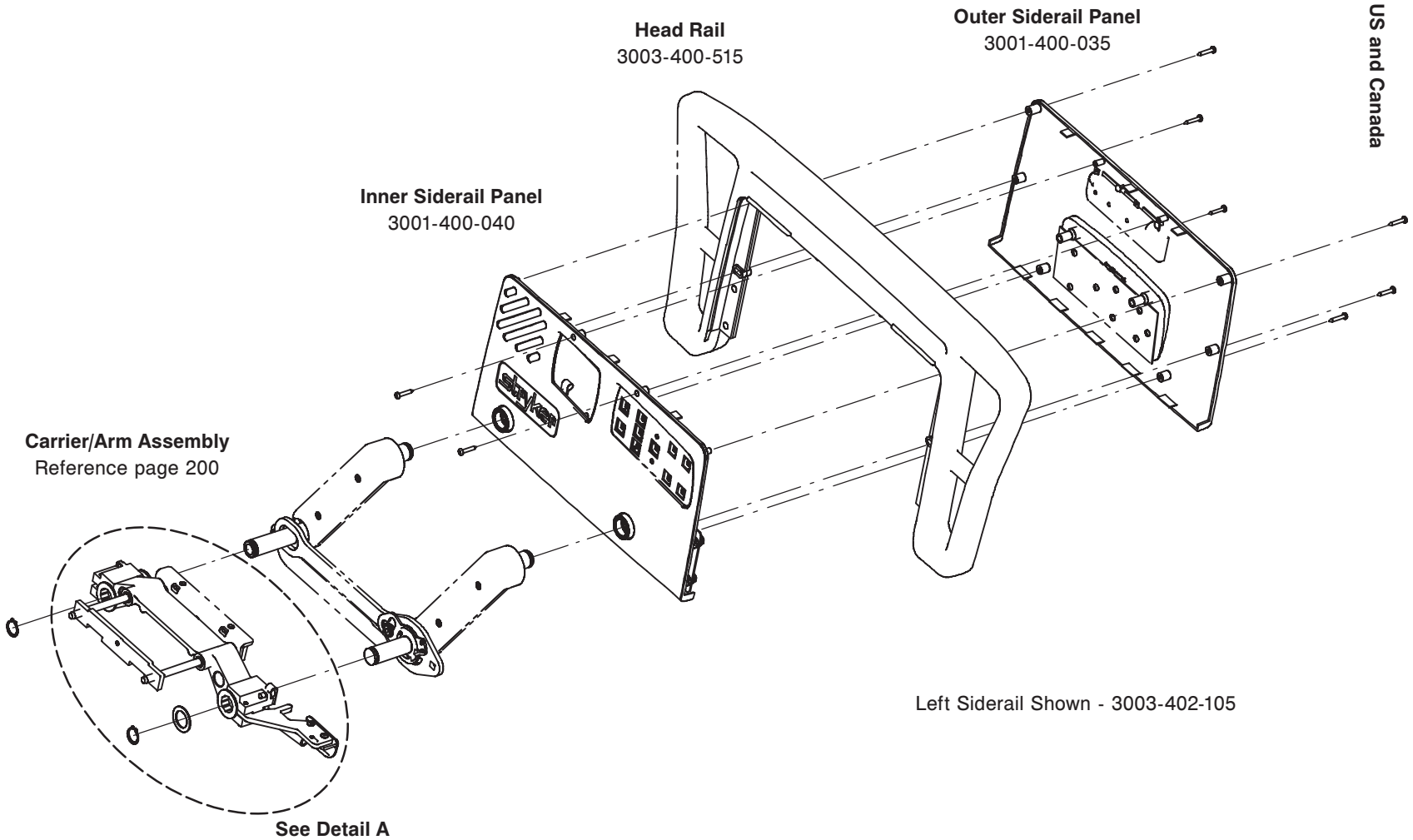

Head End Siderail Assembly

Inside the US and Canada

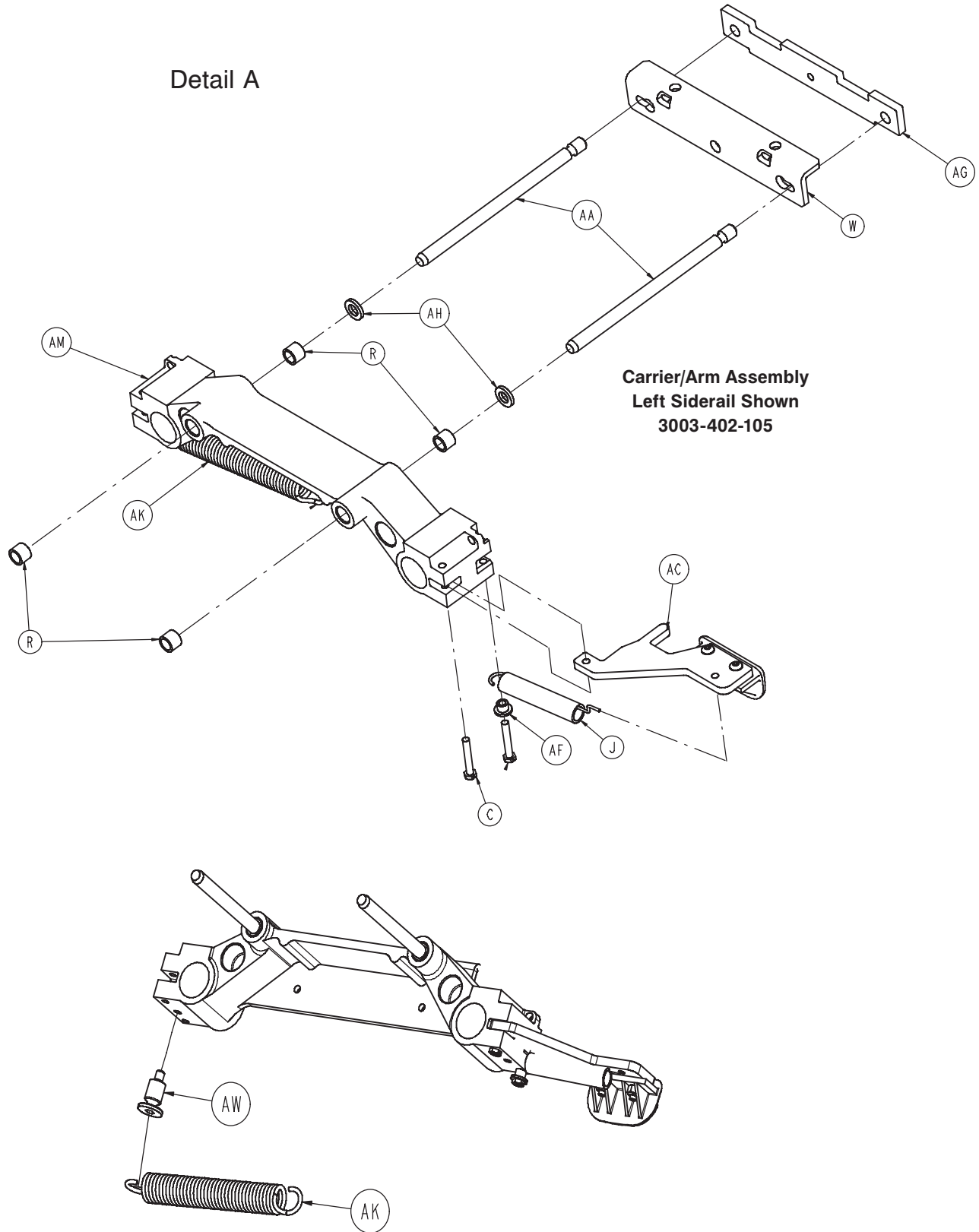

Head End Siderail Assembly

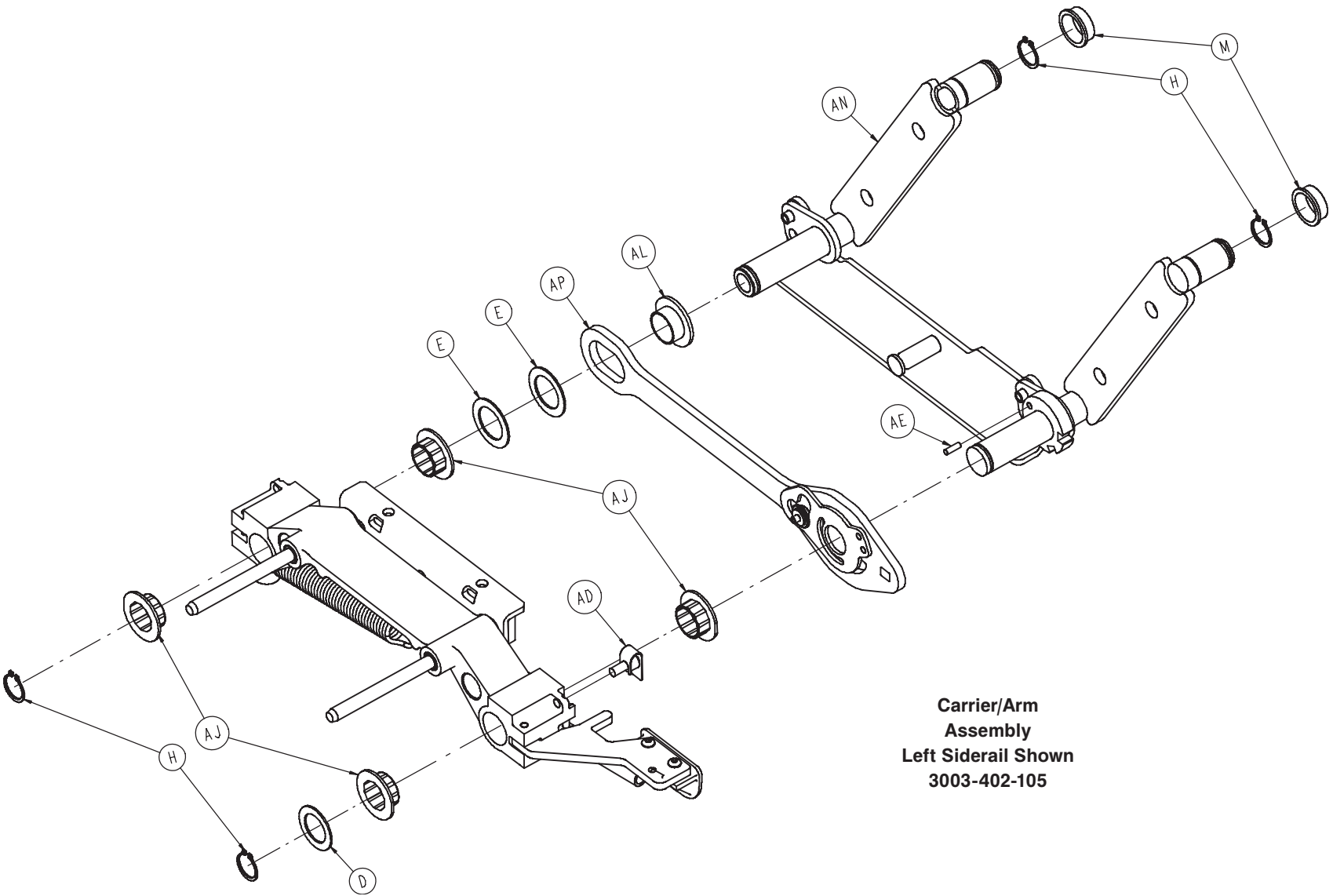

**Carrier/Arm
Assembly
Left Siderail Shown
3003-402-105**

Head End Siderail Assembly

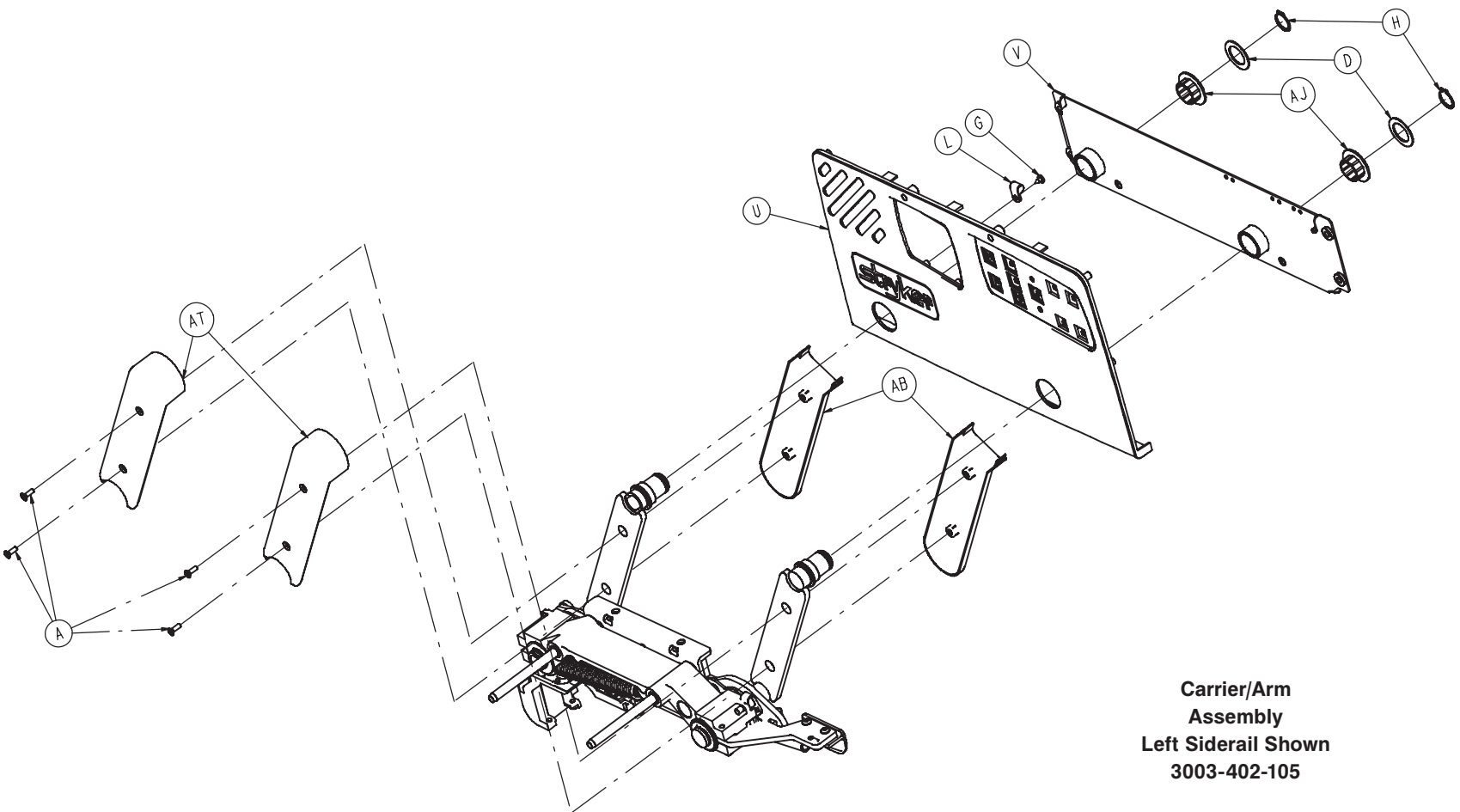

Carrier/Arm
Assembly
Left Siderail Shown
3003-402-105

Head End Siderail Assembly

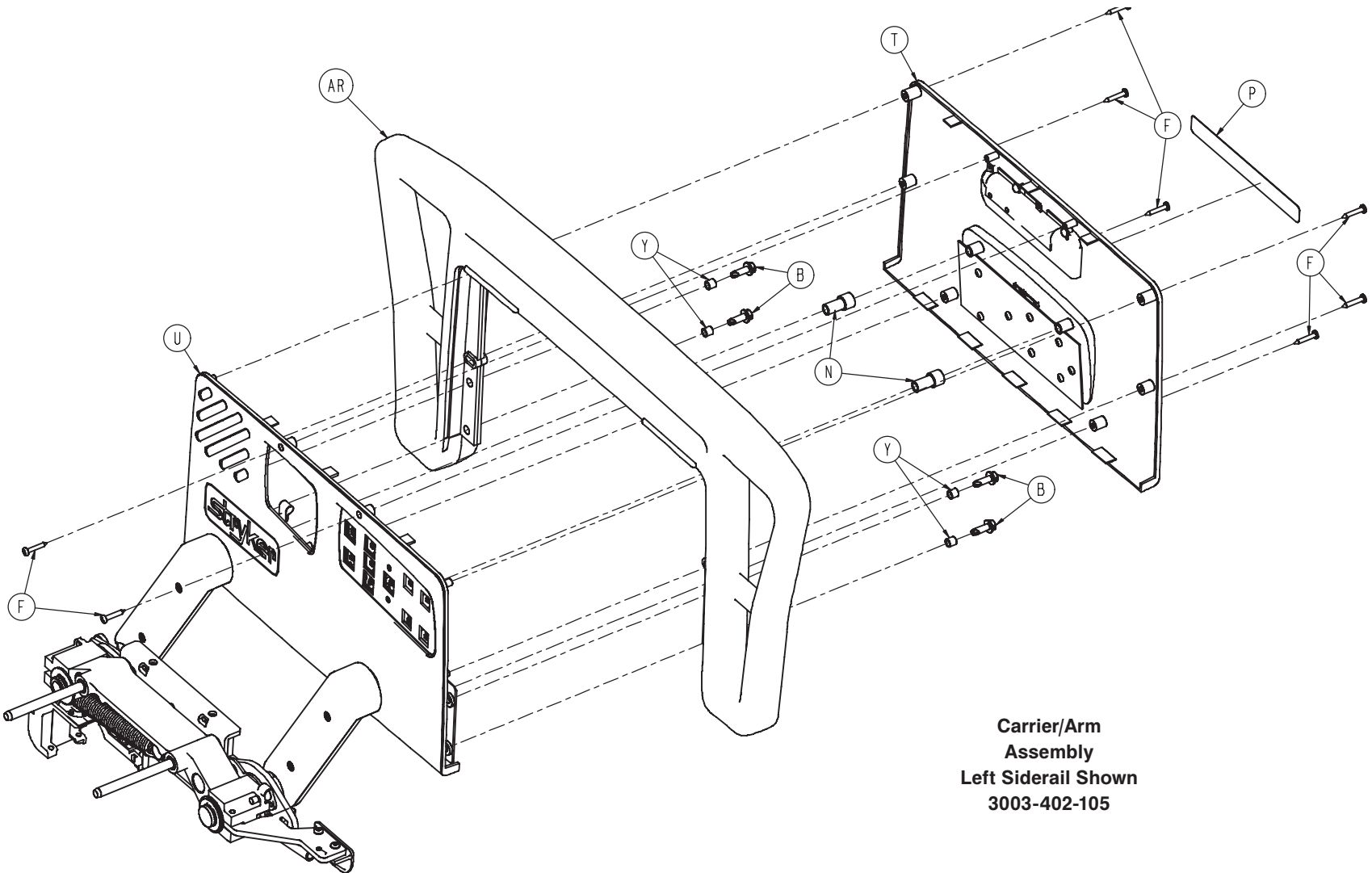

Carrier/Arm
Assembly
Left Siderail Shown
3003-402-105

Head End Siderail Assembly

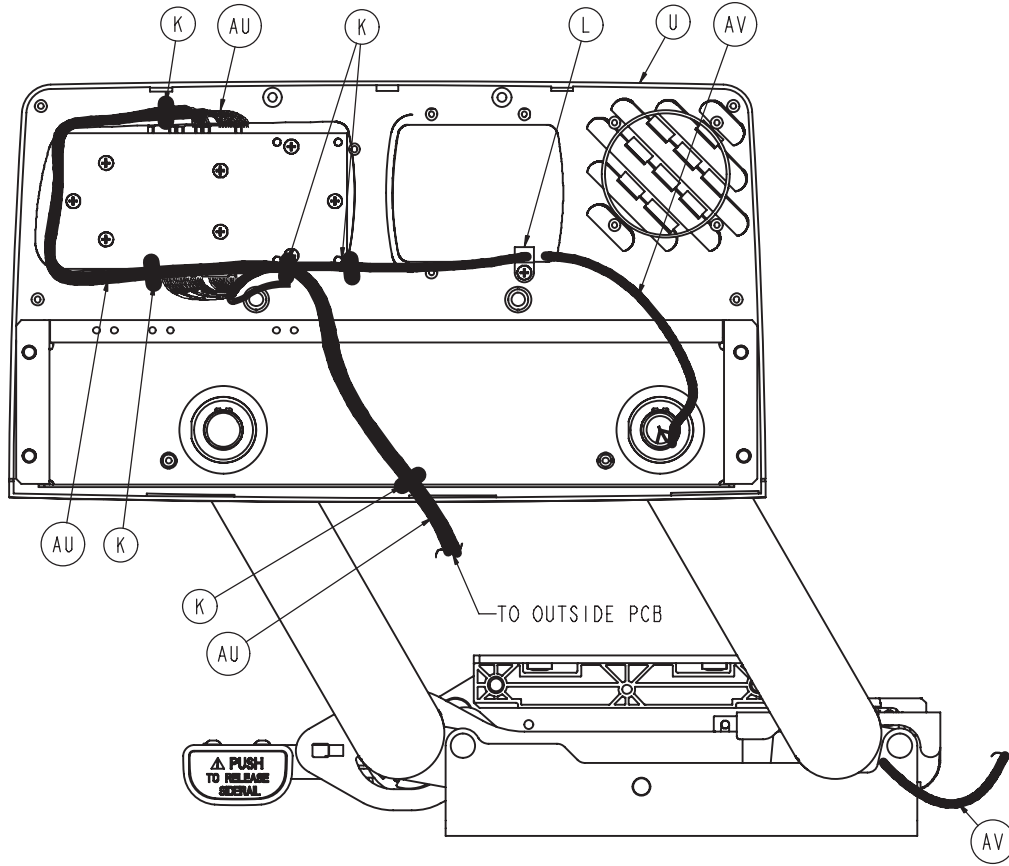

Left Siderail Wire Routing (Connection to Main PCB)

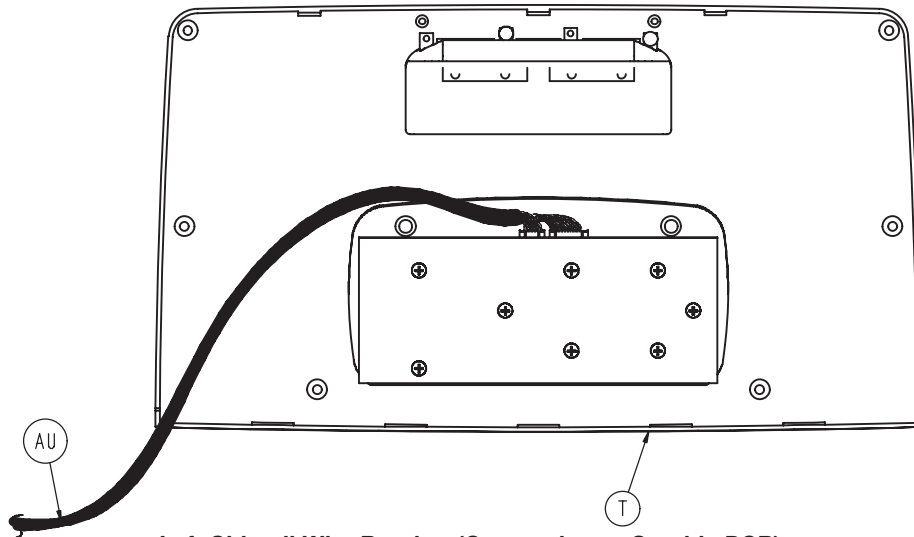

Left Siderail Wire Routing (Connection to Outside PCB)

Head End Siderail Assembly

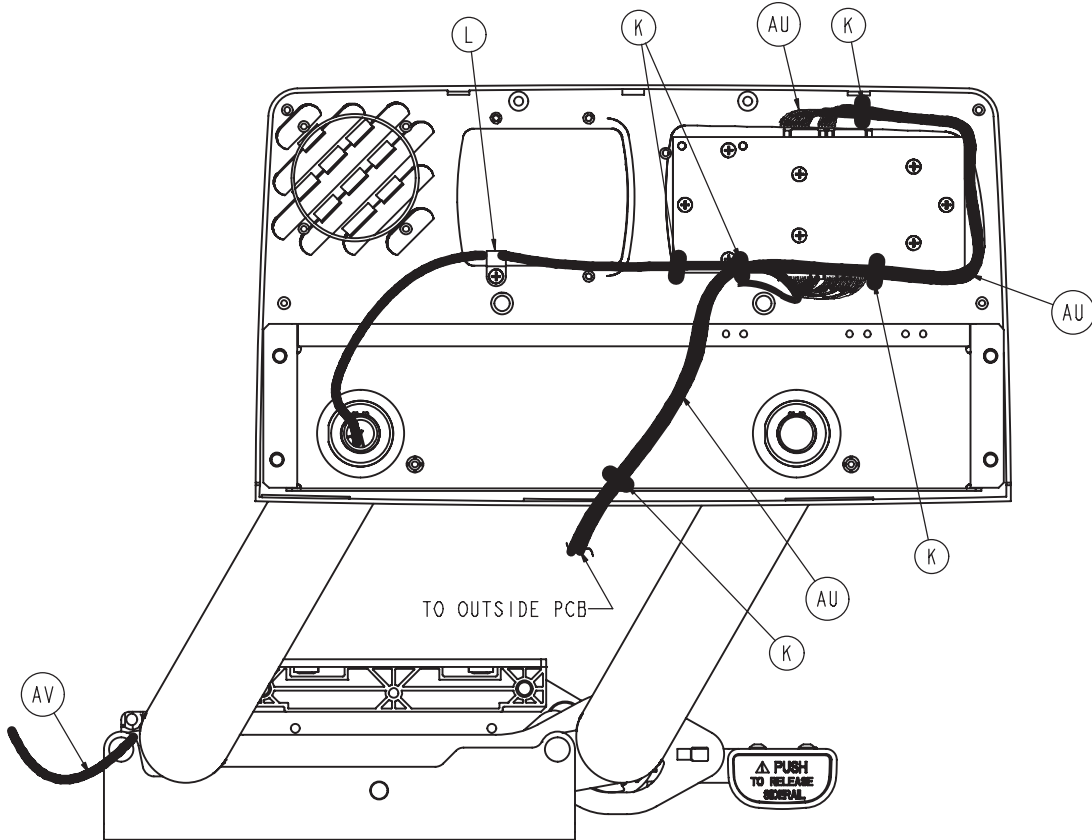

Right Siderail Wire Routing (Connection to Main PCB)

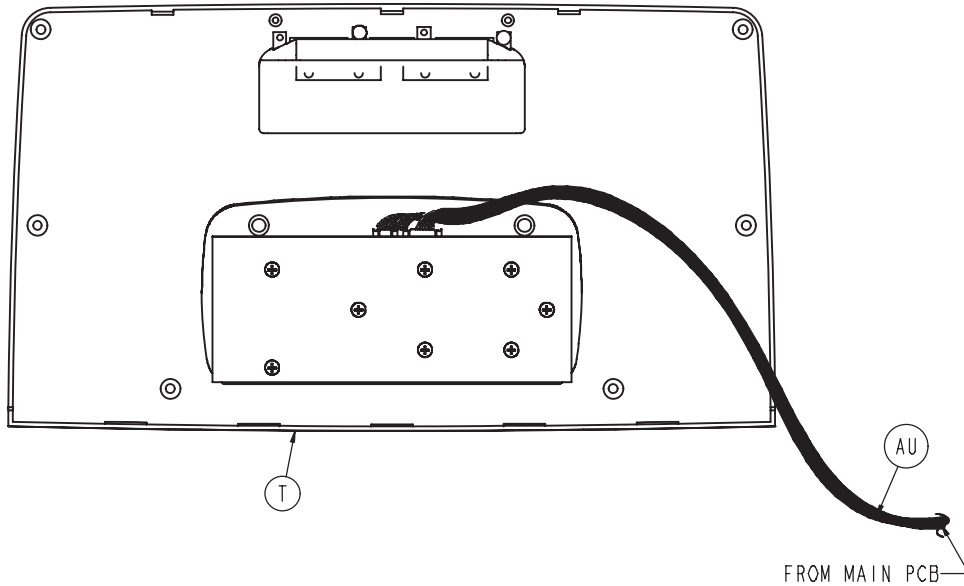

Right Siderail Wire Routing (Connection to Outside PCB)

Head End Siderail Assembly

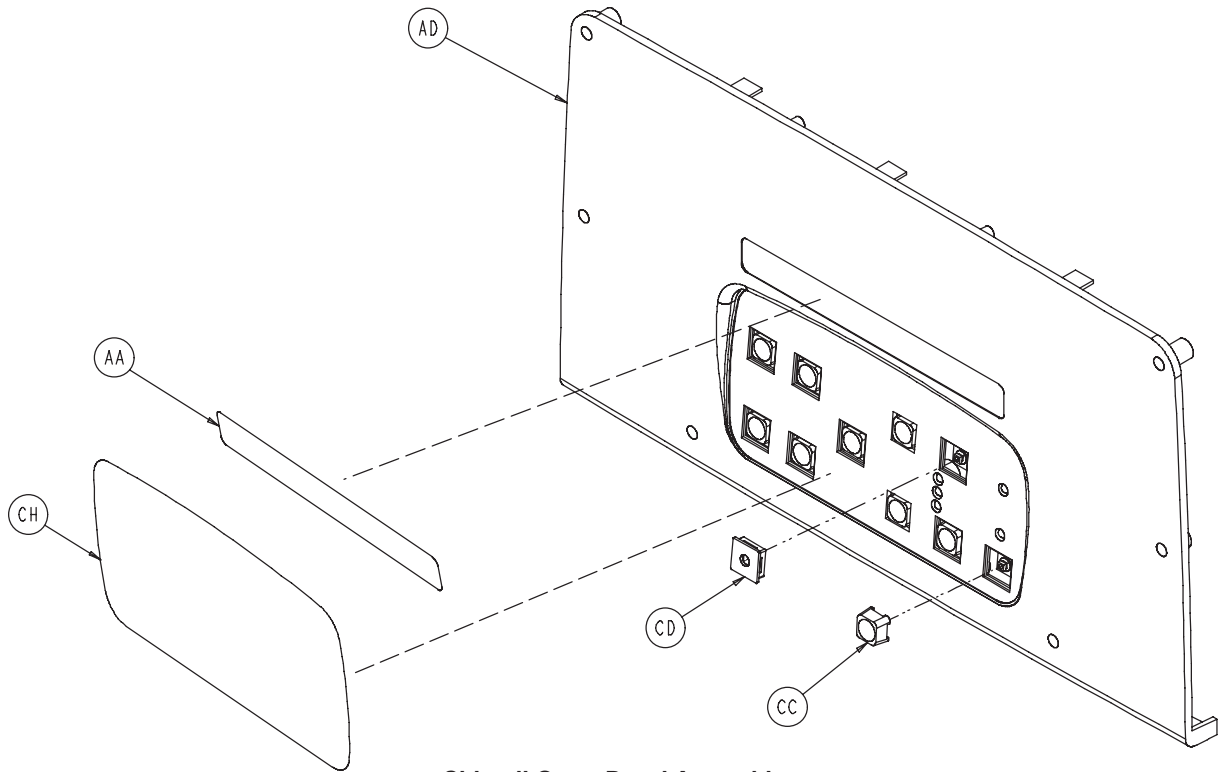

Siderail Outer Panel Assembly

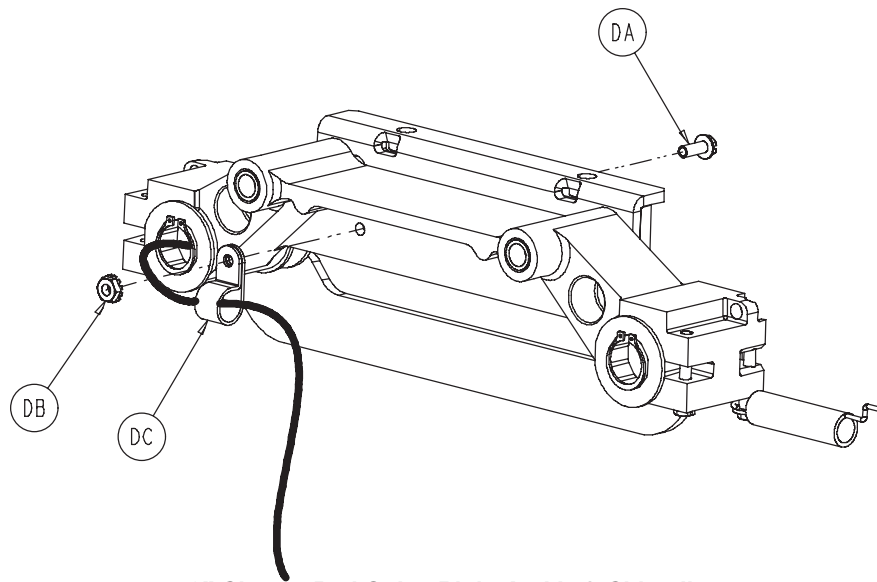

8" Shorter Bed Only - Right And Left Siderails

Head End Siderail Assembly

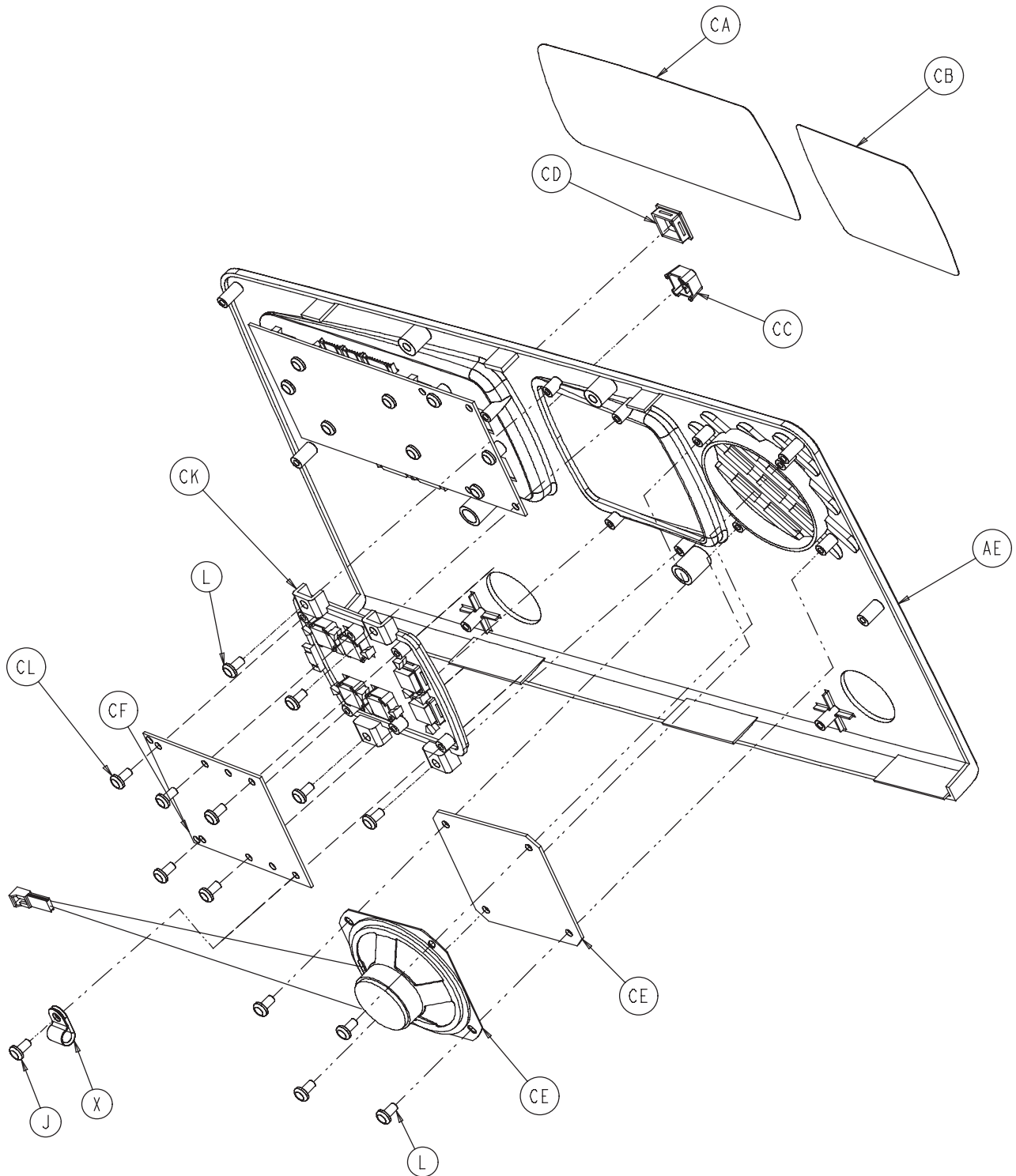

Siderail Inner Panel Assembly

Head End Siderail Assembly

Inside the US and Canada Only

Left Standard Components - 3003-402-105				Right Standard Components - 3003-402-205			
Item	Part No.	Part Name	Qty.	Item	Part No.	Part Name	Qty.
A	0001-072-000	Flat Head Machine Screw	4	A	0001-072-000	Flat Head Machine Screw	4
B	0003-226-000	Hex Washer Head Screw	4	B	0003-226-000	Hex Washer Hd. Screw	4
C	0003-344-000	Hex Head Screw	2	C	0003-344-000	Hex Hd. Screw	2
D	0011-343-000	Shim Washer	3	D	0011-343-000	Shim Washer	3
E	0014-093-000	Washer	2	E	0014-093-000	Washer	2
F	0023-090-000	High-Low Tapping Screw	8	F	0023-090-000	High-Low Tapping Screw	8
G	0023-112-000	High-Low Tapping Screw	1	G	0023-112-000	High-Low Tapping Screw	1
H	0028-128-000	Retaining Ring	6	H	0028-128-000	Retaining Ring	6
J	3000-200-334	Release Lever Spring	1	J	3000-200-334	Release Lever Spring	1
K	3000-300-114	4" Cable Tie	5	K	3000-300-114	4" Cable Tie	5
L	3000-300-478	CPR Conduit Clamp	1	L	3000-300-478	CPR Conduit Clamp	1
M	3000-400-513	Wear Bushing	2	M	3000-400-513	Wear Bushing	2
N	3000-400-523	Panel Spacer	2	N	3000-400-523	Panel Spacer	2
P	3000-400-556	Warning Label	1	P	3000-400-556	Warning Label	1
R	3000-400-557	Sleeve Bearing	4	R	3000-400-557	Sleeve Bearing	4
T	3001-400-035	Outer Siderail Panel Ass'y (pg.257)	1	T	3001-400-035	Outer Siderail Panel Ass'y (pg.257)	1
U	3001-400-040	Inner Siderail Panel Ass'y (pg.258)	1	U	3001-400-045	Inner Siderail Panel Ass'y (pg.258)	1
V	3003-400-130	Support Wldmt., Hd., LT	1	V	3003-400-230	Support Weldment, Hd., RH	1
W	3001-400-555	Mounting Bracket	1	W	3001-400-555	Mounting Bracket	1
Y	3001-400-558	Siderail Spacer	4	Y	3001-400-558	Siderail Spacer	4
AA	3001-400-564	Glide Rod	2	AA	3001-400-564	Glide Rod	2
AB	3001-400-619	Outer Arm Cover	2	AB	3001-400-619	Outer Arm Cover	2
AC	3002-400-055	Release Lever Ass'y, LT (pg.273)	1	AC	3002-400-065	Release Lever Ass'y, RT (pg.274)	1
AD	3002-400-090	Ball Detent Clip Ass'y (pg.275)	1	AD	3002-400-090	Ball Detent Clip Ass'y (pg.275)	1
AE	3002-400-505	Bypass Pin	1	AE	3002-400-505	Bypass Pin	1
AF	3002-400-509	Bypass Spacer Bushing	1	AF	3002-400-509	Bypass Spacer Bushing	1
AG	3002-400-511	Glide Rod Bumper Pad	2	AG	3002-400-511	Glide Rod Bumper Pad	2
AH	3002-400-512	Bumper Washer	2	AH	3002-400-512	Bumper Washer	2
AJ	3002-400-513	Pivot Bushing	6	AJ	3002-400-513	Pivot Bushing	6
AK	3003-402-517	Foot Rail Tuck Spring	1	AK	3003-402-517	Foot Rail Tuck Spring	1
AL	3002-400-519	Latch Bushing	1	AL	3002-400-519	Latch Bushing	1
AM	3002-400-528	Siderail Carrier	1	AM	3002-400-528	Siderail Carrier	1
AN	3003-402-005	Timing Link Ass'y, HE, LT (pg.259)	1	AN	3003-402-010	Timing Link Ass'y, HE, RT Pg.260)	1
AP	3003-400-070	Latch Ass'y, HE, LT (pg.261)	1	AP	3003-400-075	Latch Ass'y, HE, RT (pg.262)	1
AR	3003-400-515	Head Rail	2	AR	5003-400-515	Head Rail	2
AT	5000-020-005	Inner Arm Cover	1	AT	5000-020-005	Inner Arm Cover	1
AU	3001-400-802	Main Outside Cable, LT	1	AU	3001-400-801	Main Outside Cable, RH	1
AV	3001-400-862	Siderail Cable	1	AV	3001-400-862	Siderail Cable	1
AW	3003-402-114	Spring Attachment Pin	1	AW	3003-402-114	Spring Attachment Pin	1
Left Rail - 8" Shorter Bed - 3002-442-106				Right Rail - 8" Shorter Bed - 3002-442-206			
Item	Part No.	Part Name	Qty.	Item	Part No.	Part Name	Qty.
DA	0003-124-000	Hex Washer Hd. Screw	1	DA	0003-124-000	Hex Washer Hd. Screw	1
DB	0016-041-000	Keyp Nut	1	DB	0016-041-000	Keyp Nut	1
DC	0034-022-000	Cable Clamp	1	DC	0034-022-000	Cable Clamp	1
AV	3001-442-862	Siderail Cable	1	AV	3001-442-862	Siderail Cable	1

[Return To Table of Contents](#)

Head End Siderail Assembly

Standard Siderail - 3002-999-001

Item	Part No.	Part Name	Qty.
CA	3002-400-620	Standard Label, Inner, Left	1
CA	3002-400-610	Standard Label, Inner, Right	1
CC	3001-400-953	Switch Cap	12
CD	3001-400-522	Filler Cap	28
CE	3001-400-517	Speaker Seal	2
CF	3001-400-535	Blank Module	2
CH	3002-400-630	Blue Standard Label, Outer, Left	1
CH	3002-400-640	Blue Standard Label, Outer, Right	1

Inner Right Siderail Label

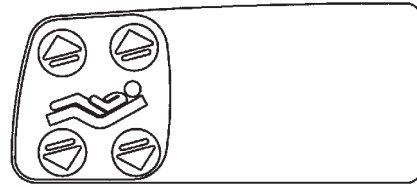

Outer Right Siderail Label

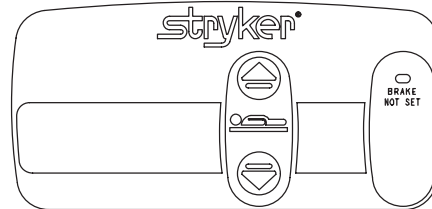

Standard Siderail with Nurse Call - 3002-999-002

Item	Part No.	Part Name	Qty.
CA	3002-400-621	Nurse Call Label, Inner, Left	1
CA	3002-400-611	Nurse Call Label, Inner, Right	1
CC	3001-400-953	Switch Cap	16
CD	3001-400-522	Filler Cap	24
CE	3001-403-831	Speaker With Cable	2
CF	3001-400-535	Blank Module	2
CH	3002-400-631	Blue Nurse Call Label, Outer, Left	1
CH	3002-400-641	Blue Nurse Call Label, Outer, Right	1

Inner Right Siderail Label

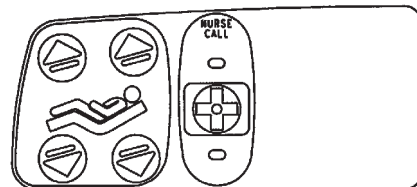

Outer Right Siderail Label

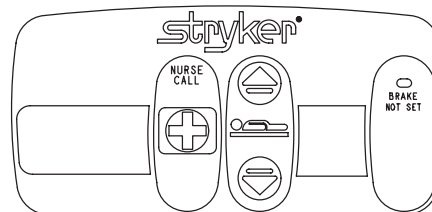

Standard Siderail with TV/Radio - 3002-999-018

Item	Part No.	Part Name	Qty.
CA	3002-400-626	TV Label, Inner, Left	1
CA	3002-400-616	TV Label, Inner, Right	1
CC	3001-400-953	Switch Cap	18
CD	3001-400-522	Filler Cap	22
CE	3001-403-831	Speaker With Cable	2
CF	3001-400-535	Blank Module	2
CH	3002-400-630	Blue Standard Label, Outer, Left	1
CH	3002-400-640	Blue Standard Label, Outer, Right	1

Inner Right Siderail Label

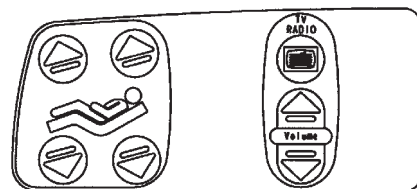

Outer Right Siderail Label

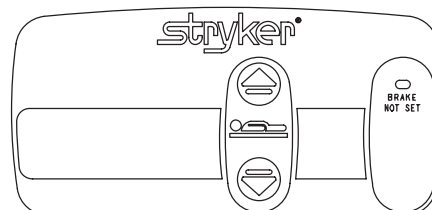

Head End Siderail Assembly

Standard Siderail with Lights - 3002-999-029

Item	Part No.	Part Name	Qty.
CA	3002-400-627	Lights Label, Inner, Left	1
CA	3002-400-617	Lights Label, Inner, Right	1
CC	3001-400-953	Switch Cap	16
CD	3001-400-522	Filler Cap	24
CE	3001-400-517	Speaker Seal	2
CF	3001-400-535	Blank Module	2
CH	3002-400-630	Blue Standard Label, Outer, Left	1
CH	3002-400-640	Blue Standard Label, Outer, Right	1

Inner Right Siderail Label

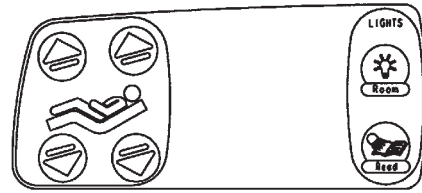

Outer Right Siderail Label

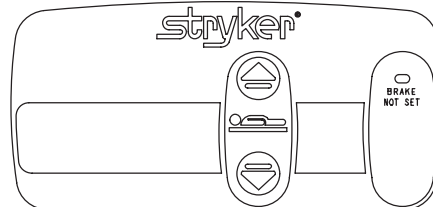

Inner Right Siderail Label

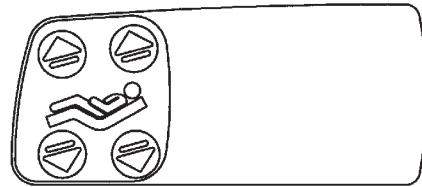

Outer Right Siderail Label

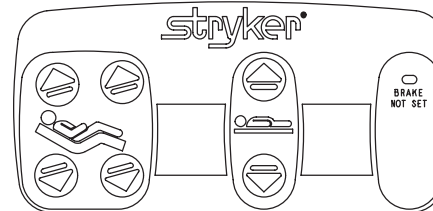

Standard Siderail with Gatch/Fowler - 3002-999-032

Item	Part No.	Part Name	Qty.
CA	3002-400-620	Standard Label Inner, Left	1
CA	3002-400-610	Standard Label, Inner, Right	1
CC	3001-400-953	Switch Cap	20
CD	3001-400-522	Filler Cap	20
CE	3001-400-517	Speaker Seal	2
CF	3001-400-535	Blank Module	2
CH	3002-400-636	Blue G/F Label, Outer, Left	1
CH	3002-400-646	Blue G/F Label, Outer, Right	1

Inner Right Siderail Label

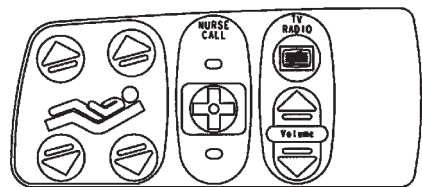

Outer Right Siderail Label

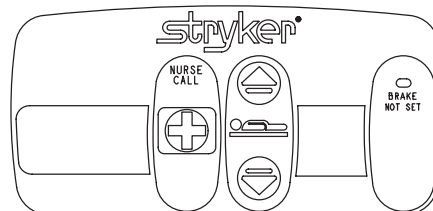

Standard Siderail w/Nurse Call & TV/Radio - 3002-999-003

Item	Part No.	Part Name	Qty.
CA	3002-400-622	NC, TV Label, Inner, Left	1
CA	3002-400-612	NC, TV Label, Inner, Right	1
CC	3001-400-953	Switch Cap	22
CD	3001-400-522	Filler Cap	18
CE	3001-403-831	Speaker With Cable	2
CF	3001-400-535	Blank Module	2
CH	3002-400-631	Blue Nurse Call Label, Outer, Left	1
CH	3002-400-641	Blue Nurse Call Label, Outer, Right	1

Head End Siderail Assembly

Standard Siderail w/Nurse Call & Lights - 3002-999-011

Item	Part No.	Part Name	Qty.
CA	3002-400-625	NC, Lights Label, Inner, Left	1
CA	3002-400-615	NC, Lights Label, Inner, Right	1
CC	3001-400-953	Switch Cap	20
CD	3001-400-522	Filler Cap	20
CE	3001-403-831	Speaker With Cable	2
CF	3001-400-535	Blank Module	2
CH	3002-400-631	Blue NC Label, Outer, Left	1
CH	3002-400-641	Blue NC Label, Outer, Right	1

Inner Right Siderail Label

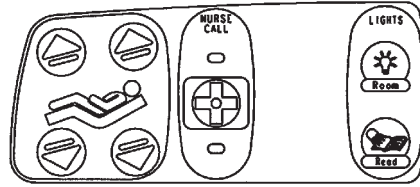

Outer Right Siderail Label



Standard Siderail with Nurse Call & Gatch/Fowler - 3002-999-017

Item	Part No.	Part Name	Qty.
CA	3002-400-621	Nurse Call Label, Inner, Left	1
CA	3002-400-611	Nurse Call Label, Inner, Right	1
CC	3001-400-953	Switch Cap	24
CD	3001-400-522	Filler Cap	16
CE	3001-403-831	Speaker With Cable	2
CF	3001-400-535	Blank Module	2
CH	3002-400-632	Blue NC, G/F Label, Outer, Left	1
CH	3002-400-642	Blue NC, G/F Label, Outer, Right	1

Inner Right Siderail Label

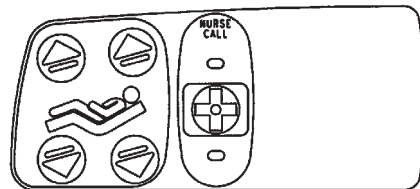

Outer Right Siderail Label

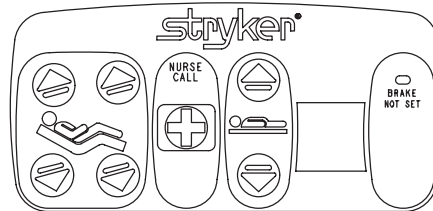

Standard Siderail with Nurse Call, TV/ Radio & Lights - 3002-999-004

Item	Part No.	Part Name	Qty.
CA	3002-400-623	NC, TV, Lights Label, Inner, Left	1
CA	3002-400-613	NC, TV, Lights Label, Inner, Right	1
CC	3001-400-953	Switch Cap	26
CD	3001-400-522	Filler Cap	14
CE	3001-403-831	Speaker with Cable	2
CF	3001-400-535	Blank Module	2
CH	3002-400-631	Blue Nurse Call Label, Outer, Left	1
CH	3002-400-641	Blue Nurse Call Label, Outer, Right	1

Inner Right Siderail Label

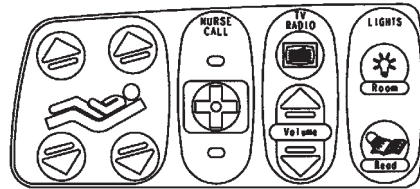

Outer Right Siderail Label

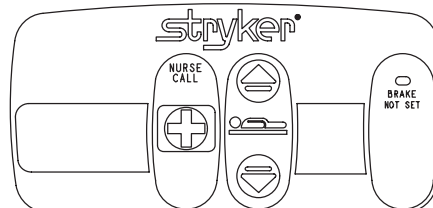

Head End Siderail Assembly

Standard Siderail w/Nurse Call, TV/ Radio, & G/F - 3002-999-010

Item	Part No.	Part Name	Qty.
CA	3002-400-622	NC, TV Label, Inner, Left	1
CA	3002-400-612	NC, TV Label, Inner, Right	1
CC	3001-400-953	Switch Cap	30
CD	3001-400-522	Filler Cap	10
CE	3001-403-831	Speaker with Cable	2
CF	3001-400-535	Blank Module	2
CH	3002-400-632	Blue NC, G/F Label, Outer, Left	1
CH	3002-400-642	Blue NC, G/F Label, Outer, Right	1

Inner Right Siderail Label

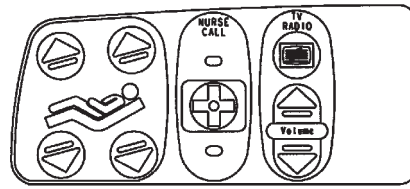

Outer Right Siderail Label

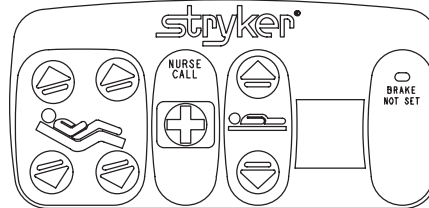

Standard Siderail with Nurse Call, Lights, and G/F - 3002-999-014

Item	Part No.	Part Name	Qty.
CA	3002-400-625	NC, Lights Label Inner, Left	1
CA	3002-400-615	NC, Lights Label, Inner, Right	1
CC	3001-400-953	Switch Cap	28
CD	3001-400-522	Filler Cap	12
CE	3001-403-831	Speaker With Cable	2
CF	3001-400-535	Blank Module	2
CH	3002-400-632	Blue NC, G/F Label, Outer, Left	1
CH	3002-400-642	Blue NC, G/F Label, Outer, Right	1

Inner Right Siderail Label

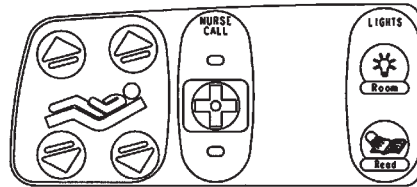

Outer Right Siderail Label

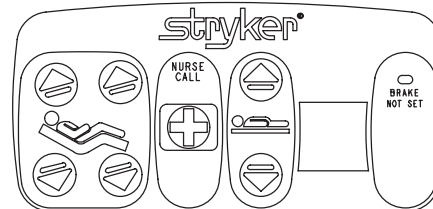

Standard Siderail w/Nurse Call, TV/ Radio, Lights, & G/F - 3002-999-007

Item	Part No.	Part Name	Qty.
CA	3002-400-623	NC, TV, Lights Label, Inner, Left	1
CA	3002-400-613	NC, TV, Lights Label, Inner, Right	1
CC	3001-400-953	Switch Cap	34
CD	3001-400-522	Filler Cap	6
CE	3001-403-831	Speaker with Cable	2
CF	3001-400-535	Blank Module	2
CH	3002-400-632	Blue NC, G/F Label, Outer, Left	1
CH	3002-400-642	Blue NC, G/F Label, Outer, Right	1

Inner Right Siderail Label

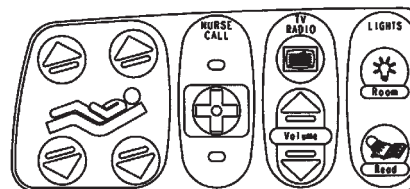

Outer Right Siderail Label

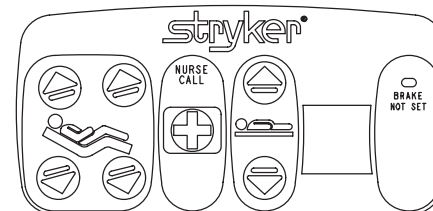

Head End Siderail Assembly

Standard Siderail w/Nurse Call, TV/ Radio, Lights, & G/F - 3002-999-007

Item	Part No.	Part Name	Qty.
CA	3002-400-623	NC, TV, Lights Label, Inner, Left	1
CA	3002-400-613	NC, TV, Lights Label, Inner, Right	1
CC	3001-400-953	Switch Cap	34
CD	3001-400-522	Filler Cap	6
CE	3001-403-831	Speaker with Cable	2
CF	3001-400-535	Blank Module	2
CH	3002-400-632	Blue NC, G/F Label, Outer, Left	1
CH	3002-400-642	Blue NC, G/F Label, Outer, Right	1

Inner Right Siderail Label

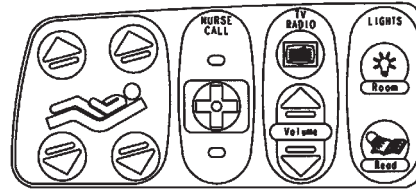

Outer Right Siderail Label

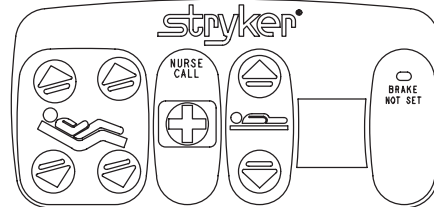

Inner Right Siderail Label

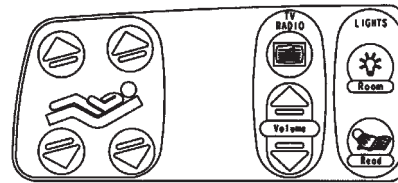

Outer Right Siderail Label

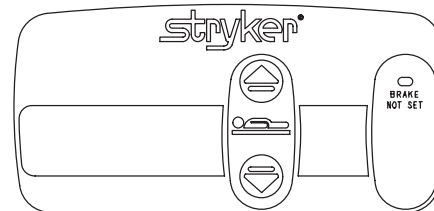

Inner Right Siderail Label

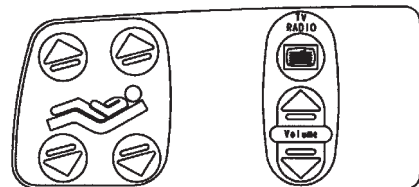

Outer Right Siderail Label

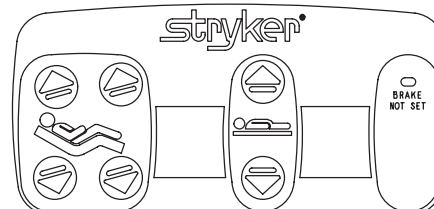

Standard Siderail with TV/Radio & Lights - 3002-999-019

Item	Part No.	Part Name	Qty.
CA	3002-400-624	TV, Lights Label, Inner, Left	1
CA	3002-400-614	TV, Lights Label, Inner, Right	1
CC	3001-400-953	Switch Cap	26
CD	3001-400-522	Filler Cap	14
CE	3001-403-831	Speaker with Cable	2
CF	3001-400-535	Blank Module	2
CH	3002-400-630	Blue Standard Label, Outer, Left	1
CH	3002-400-640	Blue Standard Label, Outer, Right	1

Standard Siderail with TV/Radio and G/F - 3002-999-025

Item	Part No.	Part Name	Qty.
CA	3002-400-626	TV Label, Inner, Left	1
CA	3002-400-616	TV Label, Inner, Right	1
CC	3001-400-953	Switch Cap	26
CD	3001-400-522	Filler Cap	14
CE	3001-403-831	Speaker with Cable	2
CF	3001-400-535	Blank Module	2
CH	3002-400-636	Blue G/F Label, Outer, Left	1
CH	3002-400-646	Blue G/F Label, Outer, Right	1

Head End Siderail Assembly

Standard Siderail with TV/Radio, Lights, and G/F - 3002-999-022

Item	Part No.	Part Name	Qty.
CA	3002-400-624	TV, Lights Label, Inner, Left	1
CA	3002-400-614	TV, Lights Label, Inner, Right	1
CC	3001-400-953	Switch Cap	30
CD	3001-400-522	Filler Cap	10
CE	3001-403-831	Speaker with Cable	2
CF	3001-400-535	Blank Module	2
CH	3002-400-636	Blue G/F Label, Outer, Left	1
CH	3002-400-646	Blue G/F Label, Outer, Right	1

Inner Right Siderail Label

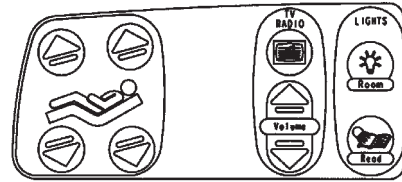

Outer Right Siderail Label

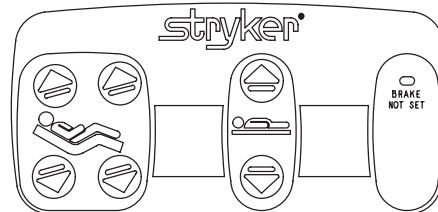

Inner Right Siderail Label

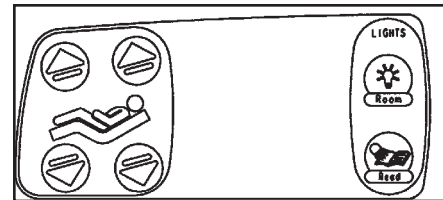

Outer Right Siderail Label

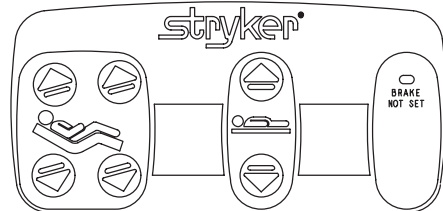

Inner Right Siderail Label

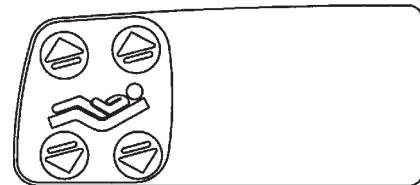

Outer Right Siderail Label

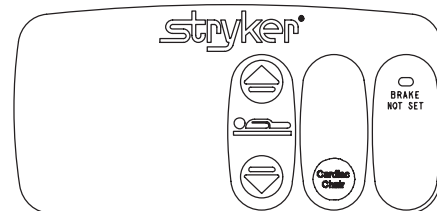

Standard Siderail with Lights and Gatch/Fowler - 3002-999-028

Item	Part No.	Part Name	Qty.
CA	3002-400-627	Lights Label, Inner, Left	1
CA	3002-400-617	Lights Label, Inner, Right	1
CC	3001-400-953	Switch Cap	24
CD	3001-400-522	Filler Cap	16
CE	3001-400-517	Speaker Seal	2
CF	3001-400-535	Blank Module	2
CH	3002-400-636	Blue G/F Label, Outer, Left	1
CH	3002-400-646	Blue G/F Label, Outer, Right	1

Standard Siderail with Cardiac Chair - 3002-999-030

Item	Part No.	Part Name	Qty.
CA	3002-400-620	Standard Label, Inner, Left	1
CA	3002-400-610	Standard Label, Inner, Right	1
CC	3001-400-953	Switch Cap	14
CD	3001-400-522	Filler Cap	26
CE	3001-400-517	Speaker Seal	2
CF	3001-400-535	Blank Module	2
CH	3002-400-637	Blue CC Label, Outer, Left	1
CH	3002-400-647	Blue CC Label, Outer, Right	1

Head End Sderail Assembly

Standard Siderail with Cardiac Chair and Nurse Call - 3002-999-015

Item	Part No.	Part Name	Qty.
CA	3002-400-621	Nurse Call Label, Inner, Left	1
CA	3002-400-611	Nurse Call Label, Inner, Right	1
CC	3001-400-953	Switch Cap	18
CD	3001-400-522	Filler Cap	22
CE	3001-403-831	Speaker With Cable	2
CF	3001-400-535	Blank Module	2
CH	3002-400-635	Blue CC & N/C Label, Outer, Left	1
CH	3002-400-645	Blue CC & N/C Label, Outer, Right	1

Inner Right Siderail Label

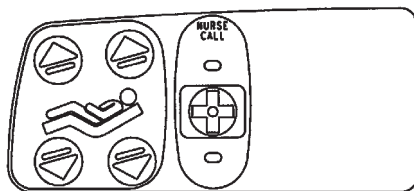

Outer Right Siderail Label



Standard Siderail with Cardiac Chair and TV/Radio - 3002-999-024

Item	Part No.	Part Name	Qty.
CA	3002-400-626	TV Label, Inner, Left	1
CA	3002-400-616	TV Label, Inner, Right	1
CC	3001-400-953	Switch Cap	18
CD	3001-400-522	Filler Cap	22
CE	3001-403-831	Speaker With Cable	2
CF	3001-400-535	Blank Module	2
CH	3002-400-637	Blue CC, TV Label, Outer, Left	1
CH	3002-400-647	Blue CC Label, Outer, Right	1

Inner Right Siderail Label

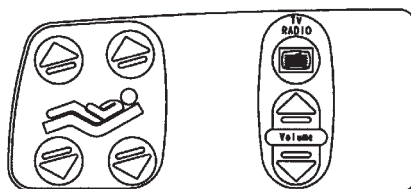

Outer Right Siderail Label

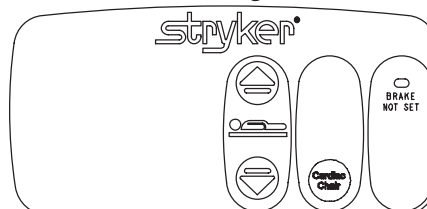

Inner Right Siderail Label

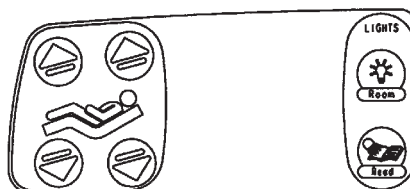

Outer Right Siderail Label

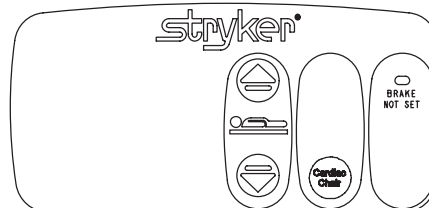

Standard Siderail with Cardiac Chair and Lights - 3002-999-026

Item	Part No.	Part Name	Qty.
CA	3002-400-627	Lights Label, Inner, Left	1
CA	3002-400-617	Lights Label, Inner, Right	1
CC	3001-400-953	Switch Cap	18
CD	3001-400-522	Filler Cap	22
CE	3001-400-517	Speaker Seal	2
CF	3001-400-535	Blank Module	2
CH	3002-400-637	Blue CC Label, Outer, Left	1
CH	3002-400-647	Blue CC Label, Outer, Right	1

Head End Siderail Assembly

Standard Siderail with Cardiac Chair and Gatch/Fowler - 3002-999-031

Item	Part No.	Part Name	Qty.
CA	3002-400-620	Standard Label Inner, Left	1
CA	3002-400-610	Standard Label, Inner, Right	1
CC	3001-400-953	Switch Cap	22
CD	3001-400-522	Filler Cap	18
CE	3001-400-517	Speaker Seal	2
CF	3001-400-535	Blank Module	2
CH	3002-400-634	Blue CC, G/F Label, Outer, Left	1
CH	3002-400-644	Blue CC, G/F Label, Outer, Right	1

Inner Right Siderail Label

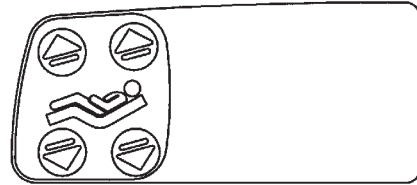

Outer Right Siderail Label



Inner Right Siderail Label

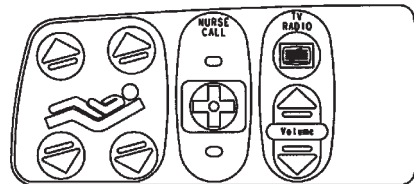

Outer Right Siderail Label

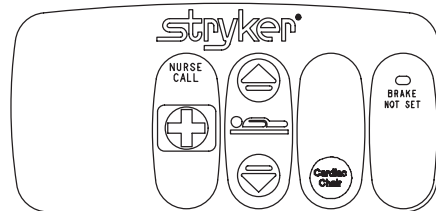

Inner Right Siderail Label

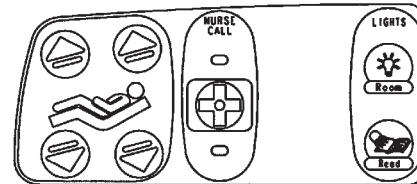

Outer Right Siderail Label

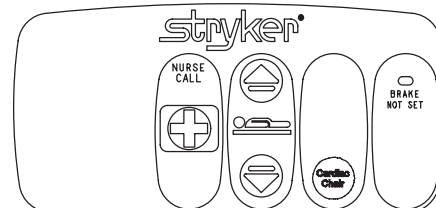

Standard Siderail with Cardiac Chair, N/C and TV/Radio - 3002-999-009

Item	Part No.	Part Name	Qty.
CA	3002-400-622	NC, TV Label, Inner, Left	1
CA	3002-400-612	NC, TV Label, Inner, Right	1
CC	3001-400-953	Switch Cap	24
CD	3001-400-522	Filler Cap	16
CE	3001-403-831	Speaker With Cable	2
CF	3001-400-535	Blank Module	2
CH	3002-400-635	Blue CC & N/C Label, Outer, Left	1
CH	3002-400-645	Blue CC & N/C Label, Outer, Right	1

Standard Siderail with Cardiac Chair, Nurse Call & Lights - 3002-999-012

Item	Part No.	Part Name	Qty.
CA	3002-400-625	NC, Lights Label, Inner, Left	1
CA	3002-400-615	NC, Lights Label, Inner, Right	1
CC	3001-400-953	Switch Cap	22
CD	3001-400-522	Filler Cap	18
CE	3001-403-831	Speaker With Cable	2
CF	3001-400-535	Blank Module	2
CH	3002-400-635	Blue CC & N/C Label, Outer, Left	1
CH	3002-400-645	Blue CC & N/C Label, Outer, Right	1

Head End Siderail Assembly

Standard Siderail with Cardiac Chair, N/C & Gatch/Fowler - 3002-999-016

Item	Part No.	Part Name	Qty.
CA	3002-400-621	Nurse Call Label, Inner, Left	1
CA	3002-400-611	Nurse Call Label, Inner, Right	1
CC	3001-400-953	Switch Cap	26
CD	3001-400-522	Filler Cap	14
CE	3001-403-831	Speaker With Cable	2
CF	3001-400-535	Blank Module	2
CH	3002-400-633	Blue NC, G/F Label, Outer, Left	1
CH	3002-400-643	Blue NC, G/F Label, Outer, Right	1

Inner Right Siderail Label

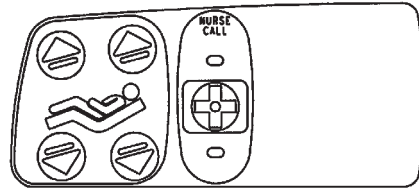

Outer Right Siderail Label

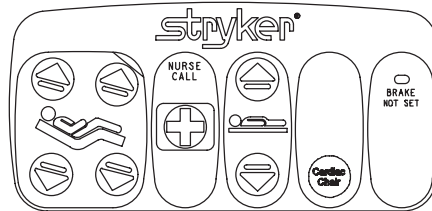

Inner Right Siderail Label

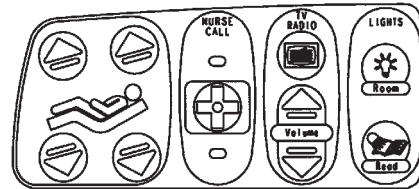

Outer Right Siderail Label

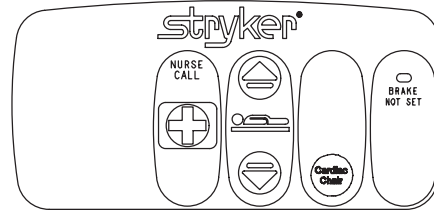

Inner Right Siderail Label

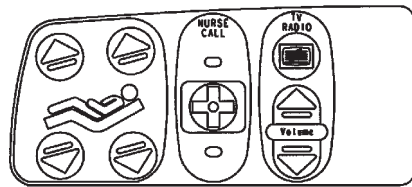

Outer Right Siderail Label

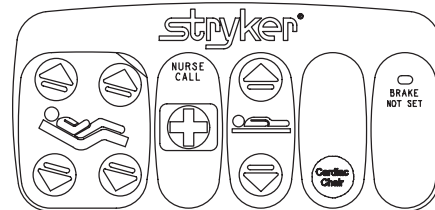

Standard Siderail with Cardiac Chair, N/C, TV/Radio & Lights - 3002-999-005

Item	Part No.	Part Name	Qty.
CA	3002-400-623	NC, TV, Lights Label, Inner, Left	1
CA	3002-400-613	NC, TV, Lights Label, Inner, Right	1
CC	3001-400-953	Switch Cap	28
CD	3001-400-522	Filler Cap	12
CE	3001-403-831	Speaker with Cable	2
CF	3001-400-535	Blank Module	2
CH	3002-400-635	Blue CC & N/C Label, Outer, Left	1
CH	3002-400-645	Blue CC & N/C Label, Outer, Right	1

Standard Siderail w/Cardiac Chair, N/C, TV/Radio & G/F - 3002-999-008

Item	Part No.	Part Name	Qty.
CA	3002-400-622	NC, TV Label, Inner, Left	1
CA	3002-400-612	NC, TV Label, Inner, Right	1
CC	3001-400-953	Switch Cap	32
CD	3001-400-522	Filler Cap	8
CE	3001-403-831	Speaker with Cable	2
CF	3001-400-535	Blank Module	2
CH	3002-400-633	Blue CC, N/C, G/F Label, Outer, Lt.	1
CH	3002-400-643	Blue CC, N/C, G/F Label, Outer, Rt.	1

Head End Siderail Assembly

Standard Siderail with Cardiac Chair, TV/Radio & G/F - 3002-999-023

Item	Part No.	Part Name	Qty.
CA	3002-400-626	TV Label, Inner, Left	1
CA	3002-400-616	TV Label, Inner, Right	1
CC	3001-400-953	Switch Cap	28
CD	3001-400-522	Filler Cap	12
CE	3001-403-831	Speaker with Cable	2
CF	3001-400-535	Blank Module	2
CH	3002-400-634	Blue CC, G/F Label, Outer, Left	1
CH	3002-400-644	Blue CC, G/F Label, Outer, Right	1

Inner Right Siderail Label

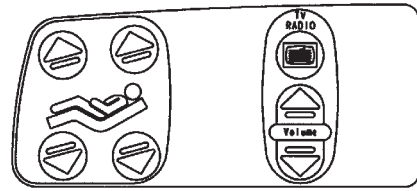

Outer Right Siderail Label

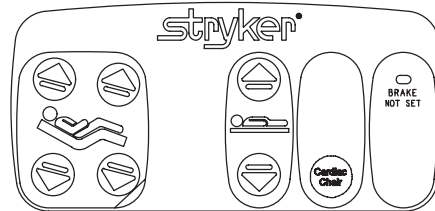

Standard Siderail with Cardiac Chair, Lights & G/F - 3002-999-027

Item	Part No.	Part Name	Qty.
CA	3002-400-627	Lights Label, Inner, Left	1
CA	3002-400-617	Lights Label, Inner, Right	1
CC	3001-400-953	Switch Cap	26
CD	3001-400-522	Filler Cap	14
CE	3001-400-517	Speaker Seal	2
CF	3001-400-535	Blank Module	2
CH	3002-400-634	Blue CC, G/F Label, Outer, Left	1
CH	3002-400-644	Blue CC, G/F Label, Outer, Right	1

Inner Right Siderail Label

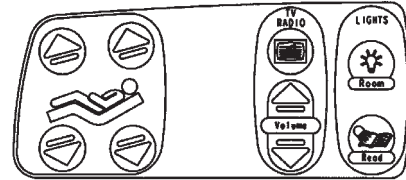

Outer Right Siderail Label

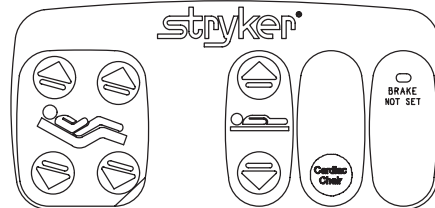

Standard Siderail w/C. Chair, TV/Radio, Lights & G/F - 3002-999-021

Item	Part No.	Part Name	Qty.
CA	3002-400-624	TV, Lights Label, Inner, Left	1
CA	3002-400-614	TV, Lights Label, Inner, Right	1
CC	3001-400-953	Switch Cap	32
CD	3001-400-522	Filler Cap	8
CE	3001-403-831	Speaker with Cable	2
CF	3001-400-535	Blank Module	2
CH	3002-400-634	Blue CC, G/F Label, Outer, Left	1
CH	3002-400-644	Blue CC, G/F Label, Outer, Right	1

Inner Right Siderail Label

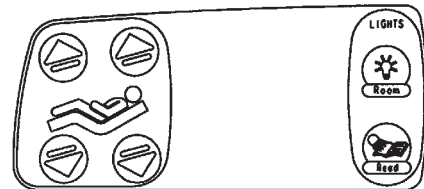

Outer Right Siderail Label

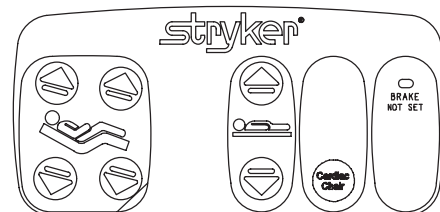

[Return To Table of Contents](#)

Head End Siderail Assembly

Standard Siderail with Cardiac Chair, N/C, G/F & Lights - 3002-999-013

Item	Part No.	Part Name	Qty.
CA	3002-400-625	NC, Lights Label, Inner, Left	1
CA	3002-400-615	NC, Lights Label, Inner, Right	1
CC	3001-400-953	Switch Cap	30
CD	3001-400-522	Filler Cap	10
CE	3001-403-831	Speaker With Cable	2
CF	3001-400-535	Blank Module	2
CH	3002-400-633	Blue CC, N/C, G/F Label, Outer, Lt.	1
CH	3002-400-643	Blue CC, N/C, G/F Label, Outer, Rt.	1

Inner Right Siderail Label

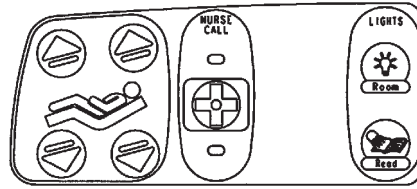

Outer Right Siderail Label

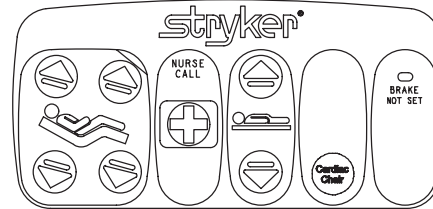

Standard Siderail w/C. Chair, N/C, TV/ Radio, Lights and G/F - 3002-999-006

Item	Part No.	Part Name	Qty.
CA	3002-400-623	NC, TV, Lights Label, Inner, Left	1
CA	3002-400-613	NC, TV, Lights Label, Inner, Right	1
CC	3001-400-953	Switch Cap	36
CD	3001-400-522	Filler Cap	4
CE	3001-403-831	Speaker With Cable	2
CF	3001-400-535	Blank Module	2
CH	3002-400-633	Blue CC, N/C, G/F Label, Outer, Lt.	1
CH	3002-400-643	Blue CC, N/C, G/F Label, Outer, Rt.	1

Inner Right Siderail Label

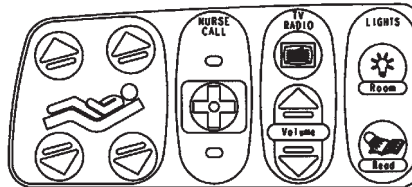

Outer Right Siderail Label

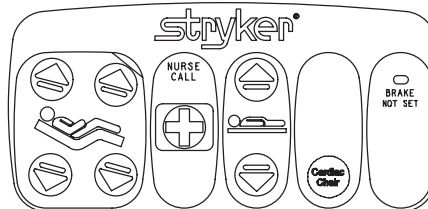

Inner Right Siderail Label

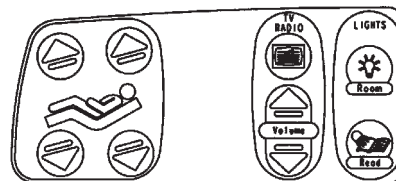

Outer Right Siderail Label

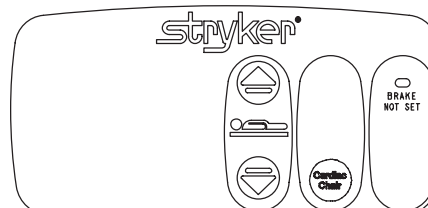

Standard Siderail with Cardiac Chair, TV/ Radio and Lights - 3002-999-020

Item	Part No.	Part Name	Qty.
CA	3002-400-624	TV, Lights Label, Inner, Left	1
CA	3002-400-614	TV, Lights Label, Inner, Right	1
CC	3001-400-953	Switch Cap	24
CD	3001-400-522	Filler Cap	16
CE	3001-403-831	Speaker With Cable	2
CF	3001-400-535	Blank Module	2
CH	3002-400-633	Blue CC, N/C, G/F Label, Outer, Lt.	1
CH	3002-400-643	Blue CC, N/C, G/F Label, Outer, Rt.	1

Head End Siderail Assembly

Standard Siderail with N/C, Lights and Smart TV - 3002-999-401

Item	Part No.	Part Name	Qty.
CA	3002-430-623	NC, Lights, Smart TV Label, Inner, Left	1
CA	3002-430-613	NC, Lights Smart TV Label, Inner, Right	1
CB	3002-430-131	Smart TV Only Label, Right	1
CB	3002-430-132	Smart TV Only Label, Left	1
CC	3001-400-953	Switch Cap	34
CD	3001-400-522	Filler Cap	18
CE	3001-403-831	Speaker With Cable	2
CF	5000-400-930	Board, Siderail, Lumbar, Left	1
CF	5000-400-920	Board, Siderail, Lumbar, Right	1
CH	3002-400-631	N/C Label, Outer, Left	1
CH	3002-400-641	N/C Label, Outer, Right	1
CJ	3001-402-804	Main to Options PCB Cable, Right	2
CK	3001-400-524	Lumbar Module	1
CL	0023-112-000	Pan Head Tapping Screw	5
CN	3000-300-114	4" Cable tie	3

Inner Right Siderail Label

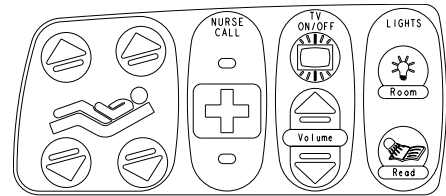

Outer Right Siderail Label

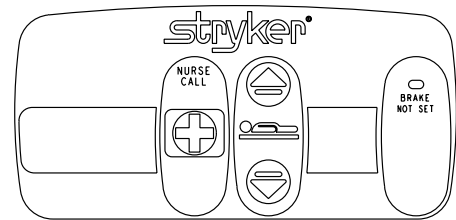

Smart TV Label

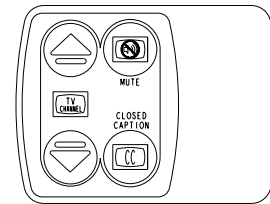

Standard Siderail with N/C, Lights, Cardiac Chair and Smart TV - 3002-999-402

Item	Part No.	Part Name	Qty.
CA	3002-430-623	NC, Lights, Smart TV Label, Inner, Left	1
CA	3002-430-613	NC, Lights Smart TV Label, Inner, Right	1
CB	3002-430-131	Smart TV, CC Label, Right	1
CB	3002-430-132	Smart TV, CC Label, Left	1
CC	3001-400-953	Switch Cap	36
CD	3001-400-522	Filler Cap	18
CE	3001-403-831	Speaker With Cable	2
CF	5000-400-930	Board, Siderail, Lumbar, Left	1
CF	5000-400-920	Board, Siderail, Lumbar, Right	1
CH	3002-400-635	N/C, CC Label, Outer, Left	1
CH	3002-400-645	N/C, CC Label, Outer, Right	1
CJ	3001-402-804	Main to Options PCB Cable, Right	2
CK	3001-400-524	Lumbar Module	1
CL	0023-112-000	Pan Head Tapping Screw	5
CN	3000-300-114	4" Cable tie	3

Inner Right Siderail Label

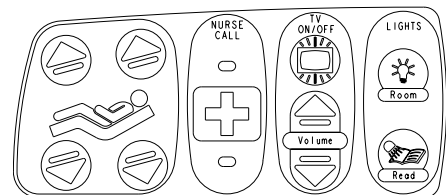

Outer Right Siderail Label

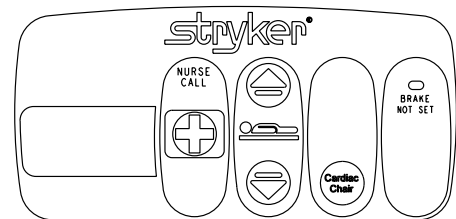

Smart TV Label

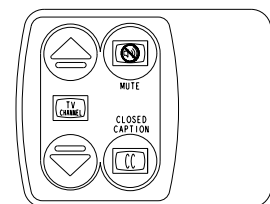

[Return To Table of Contents](#)

Head End Siderail Assembly

Standard Siderail with N/C, Lights, G/F and Smart TV - 3002-999-403

Item	Part No.	Part Name	Qty.
CA	3002-430-623	NC, Lights, Smart TV Label, Inner, Left	1
CA	3002-430-613	NC, Lights Smart TV Label, Inner, Right	1
CB	3002-430-131	Smart TV Only Label, Right	1
CB	3002-430-132	Smart TV Only Label, Left	1
CC	3001-400-953	Switch Cap	42
CD	3001-400-522	Filler Cap	10
CE	3001-403-831	Speaker With Cable	2
CF	5000-400-930	Board, Siderail, Lumbar, Left	1
CF	5000-400-920	Board, Siderail, Lumbar, Right	1
CH	3002-400-632	N/C, G/F Label, Outer, Left	1
CH	3002-400-642	N/C, G/F Label, Outer, Right	1
CJ	3001-402-804	Main to Options PCB Cable, Right	2
CK	3001-400-524	Lumbar Module	1
CL	0023-112-000	Pan Head Tapping Screw	5
CN	3000-300-114	4" Cable tie	3

Inner Right Siderail Label

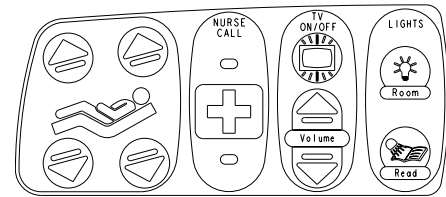

Outer Right Siderail Label

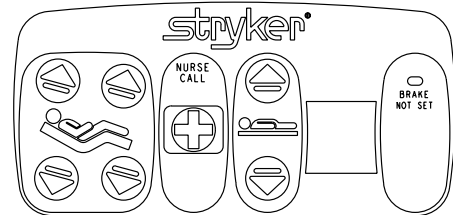

Smart TV Label

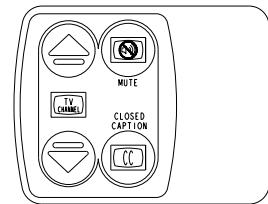

Standard Siderail with N/C, Lights, G/F, Cardiac Chair and Smart TV - 3002-999-404

Item	Part No.	Part Name	Qty.
CA	3002-430-623	NC, Lights, Smart TV Label, Inner, Left	1
CA	3002-430-613	NC, Lights Smart TV Label, Inner, Right	1
CB	3002-430-131	Smart TV, DMS Label, Right	1
CB	3002-430-132	Smart TV, DMS Label, Left	1
CC	3001-400-953	Switch Cap	44
CD	3001-400-522	Filler Cap	8
CE	3001-403-831	Speaker With Cable	2
CF	5000-400-930	Board, Siderail, Lumbar, Left	1
CF	5000-400-920	Board, Siderail, Lumbar, Right	1
CH	3002-400-633	N/C, G/F, DMS Label, Outer, Left	1
CH	3002-400-643	N/C, G/F, DMS Label, Outer, Right	1
CJ	3001-402-804	Main to Options PCB Cable, Right	2
CK	3001-400-524	Lumbar Module	1
CL	0023-112-000	Pan Head Tapping Screw	5
CN	3000-300-114	4" Cable tie	3

Inner Right Siderail Label

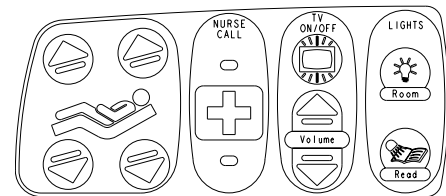

Outer Right Siderail Label

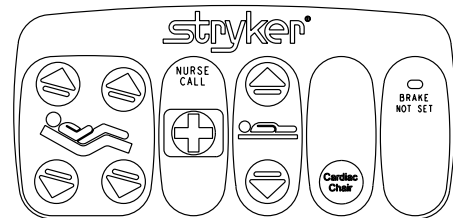

Smart TV Label

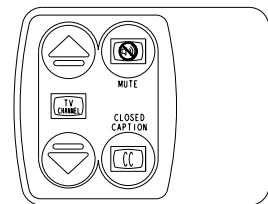

Head End Siderail Outer Panel Assembly

3001-400-035

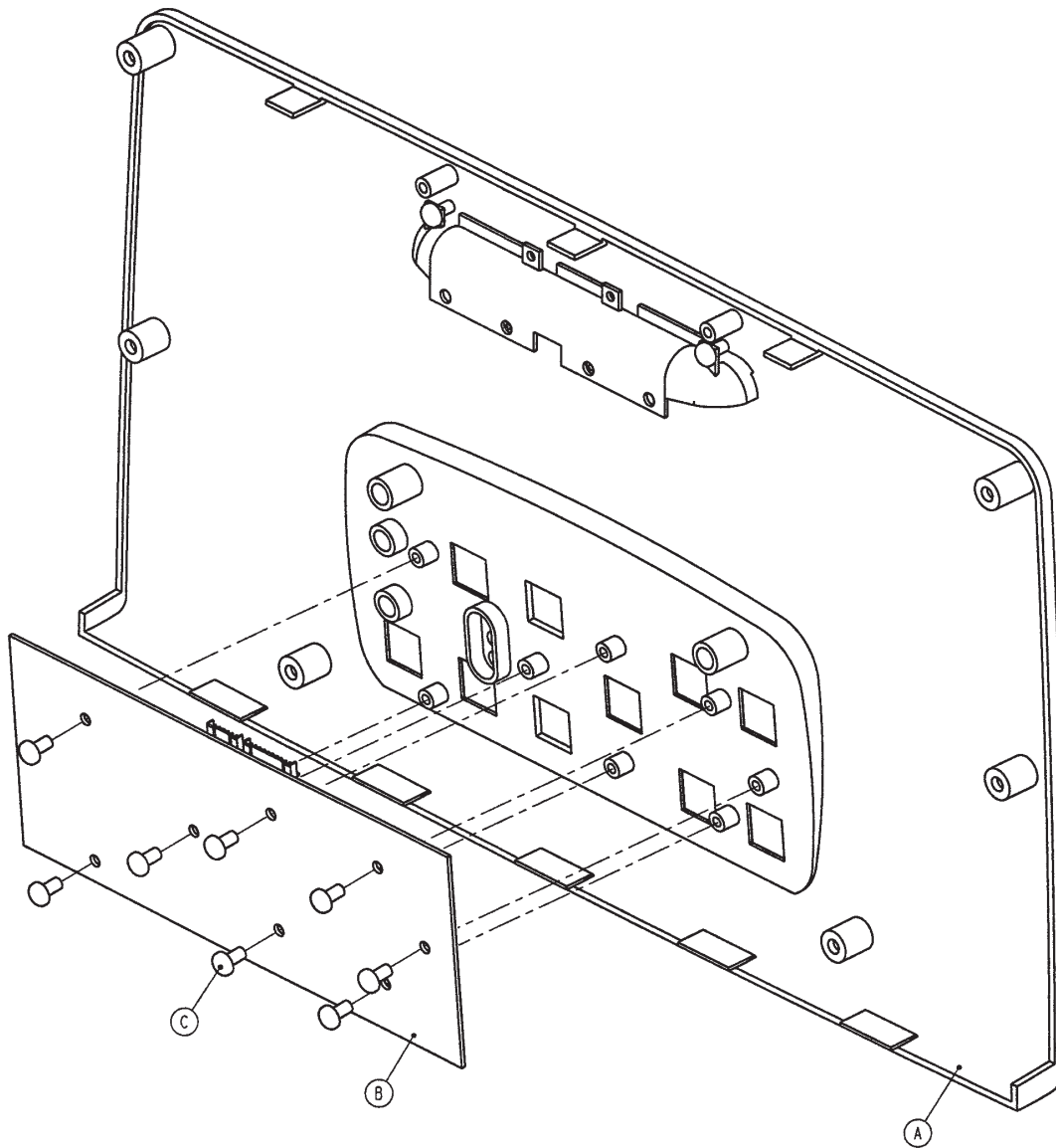

Item	Part No.	Part Name	Qty.
A	3001-400-050	Outer Panel Assembly	1
B	3001-400-910	Outer Siderail PCB Assembly	1
C	0023-112-000	Hi-Low Tapping Screw	8

[Return To Table of Contents](#)

Head End Siderail Inner Panel Assembly

For Reference Only
 3001-400-040 (LEFT)
 3001-400-045 (RIGHT)

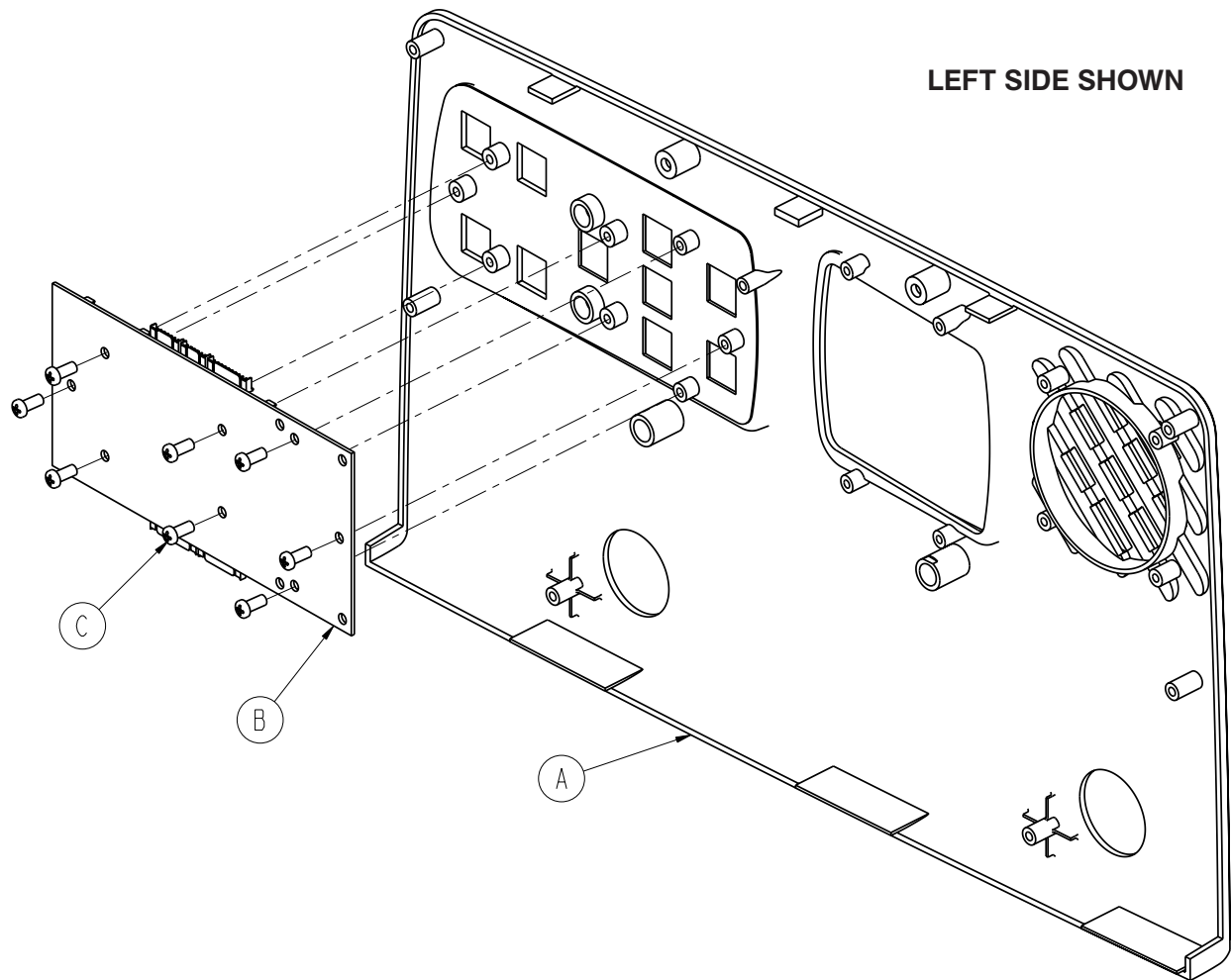

Item	Part No.	Part Name	Qty.
A	3001-400-101	Left Inner Panel	1
	3001-400-201	Right Inner Panel	1
B	3001-400-930	Inner Siderail PCB Assembly	1
C	0023-088-000	Hi-Low Pan Head Screw	8

Timing Link Assembly, Head End, Left

3003-402-005

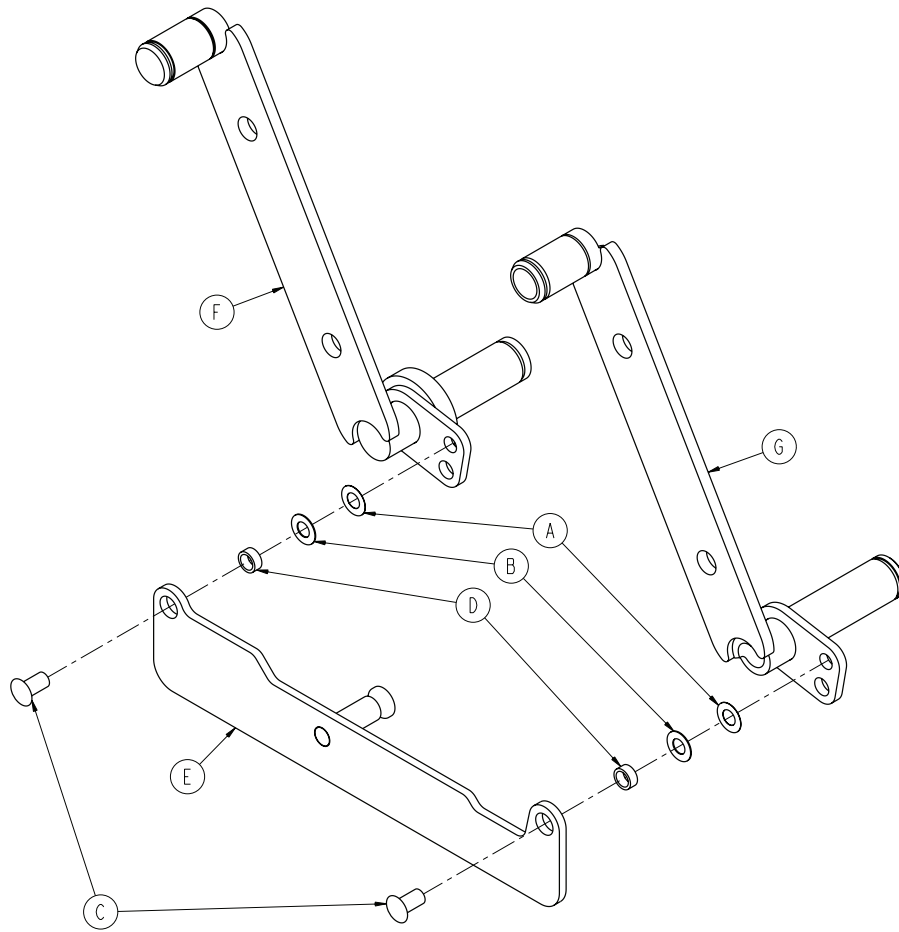

Item	Part No.	Part Name	Qty.
A	0011-377-000	Washer	2
B	0011-491-000	Washer	2
C	3001-400-501	Siderail Linkage Rivot	2
D	3003-401-001	Bushing	2
E	3003-402-112	Timing Link	1
F	3003-402-127	Arm Weldment - LHF	1
G	3003-402-128	Arm Weldment - LHH	1

[Return To Table of Contents](#)

Timing Link Assembly, Head End, Right

3003-402-010

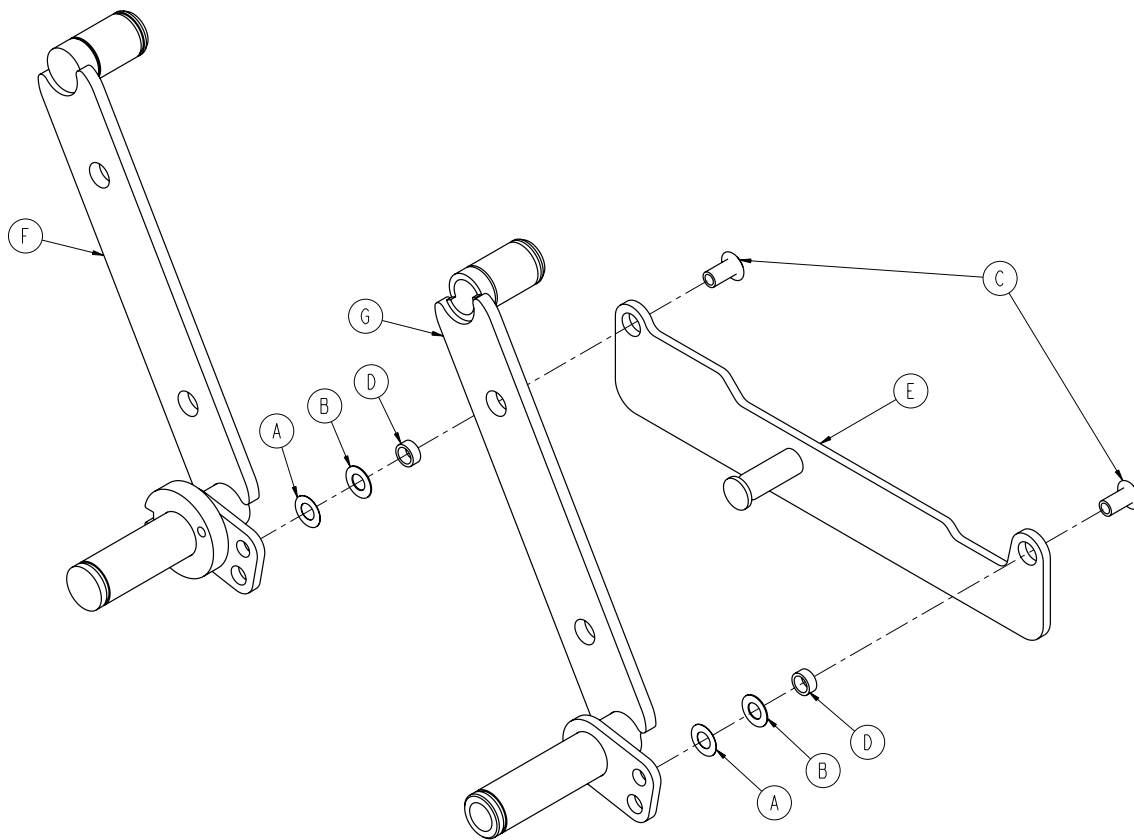

Item	Part No.	Part Name	Qty.
A	0011-377-000	Washer	2
B	0011-491-000	Washer	2
C	3001-400-501	Siderail Linkage Rivot	2
D	3003-401-001	Bushing	2
E	3003-402-117	Timing Link	1
F	3003-402-227	Arm Weldment - RHF	1
G	3003-402-228	Arm Weldment - RHH	1

Siderail Latch Assembly, Head End, Left

3003-400-070

Inside the US and Canada

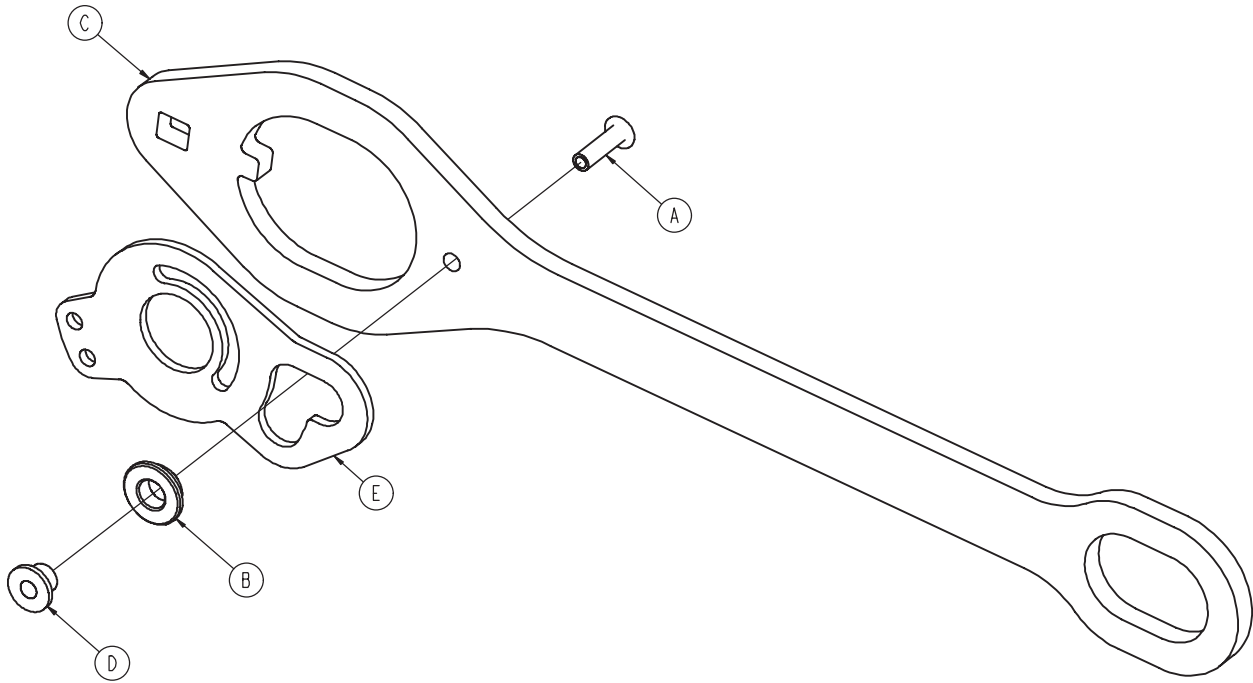

Item	Part No.	Part Name	Qty.
A	0025-086-000	Blind Rivet	1
B	0081-317-000	Bronze Bushing	1
C	3002-400-501	Latch	1
D	3002-400-509	Bypass Bushing Spacer	1
E	3003-400-503	Head End Bypass Plate	1

[Return To Table of Contents](#)

Siderail Latch Assembly, Head End, Right

3003-400-075

Inside the US and Canada

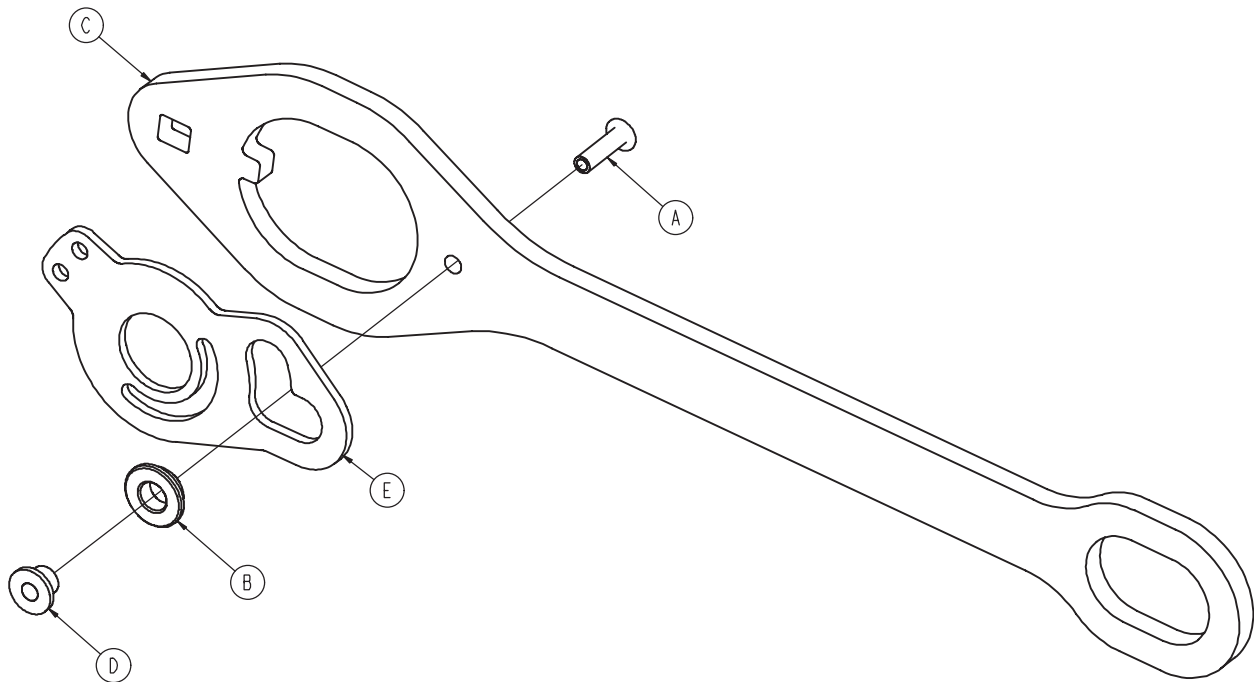

Item	Part No.	Part Name	Qty.
A	0025-086-000	Blind Rivet	1
B	0081-317-000	Bronze Bushing	1
C	3002-400-501	Latch	1
D	3002-400-509	Bypass Bushing Spacer	1
E	3003-400-503	Head End Bypass Plate	1

Siderail Assembly, iBED Awareness Option, Head End. Left

3004-402-105

For Reference Only: Part Number

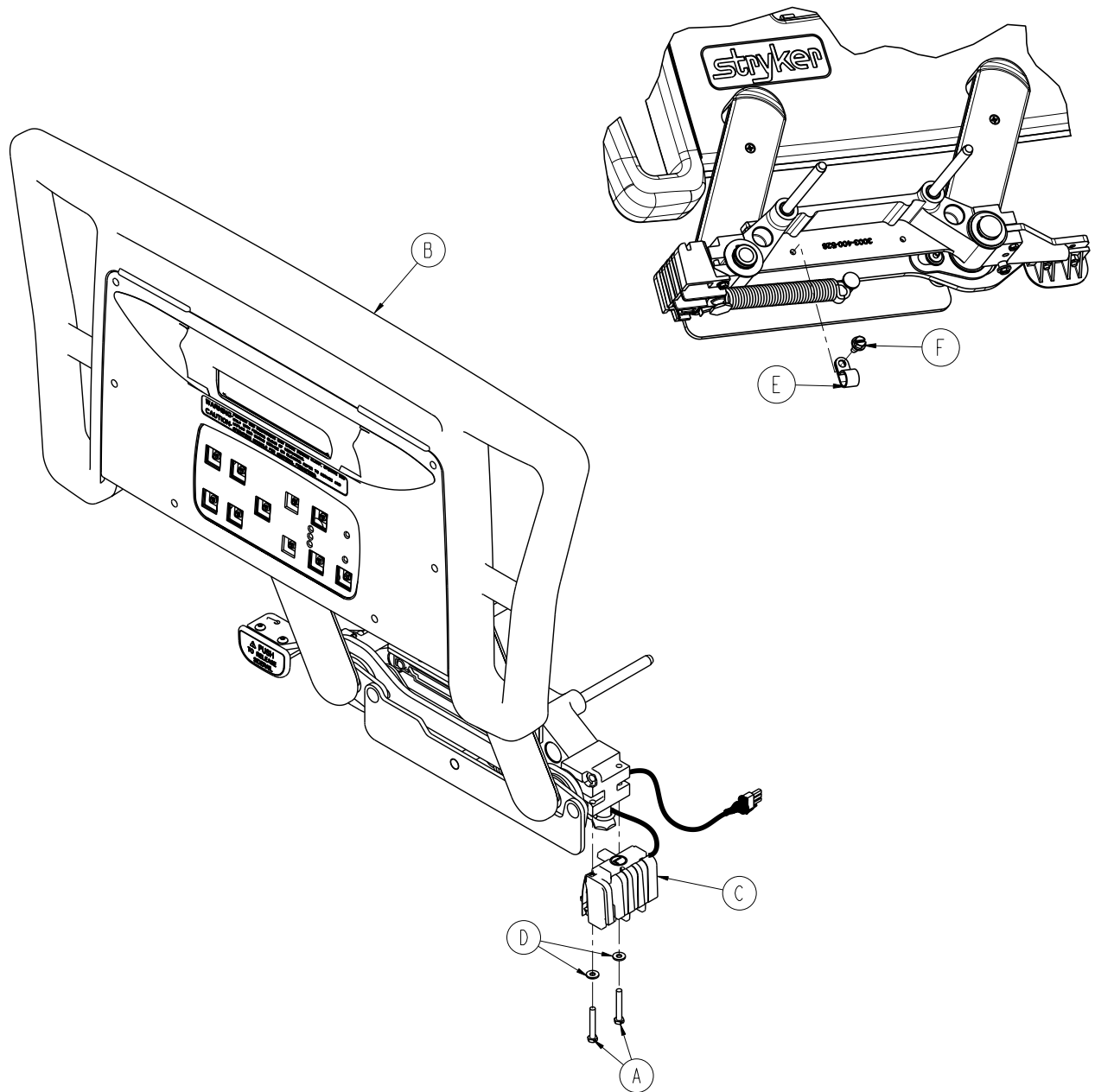

Item	Part No.	Part Name	Qty.
A	0003-344-000	Hex Head Machine Screw	2
B	3003-402-105	Siderail Assembly, HE, Left (pg.243)	1
C	3004-402-115	Siderail Switch Assembly, HE, Left (pg.265)	1
D	0011-062-000	Washer	2
E	0034-443-000	Cord Clamp	1
F	0003-221-000	Hex Washer Head Screw	1

[Return To Table of Contents](#)

Siderail Assembly, iBED Awareness Option, Head End, Right

3004-402-205

For Reference Only: Part Number

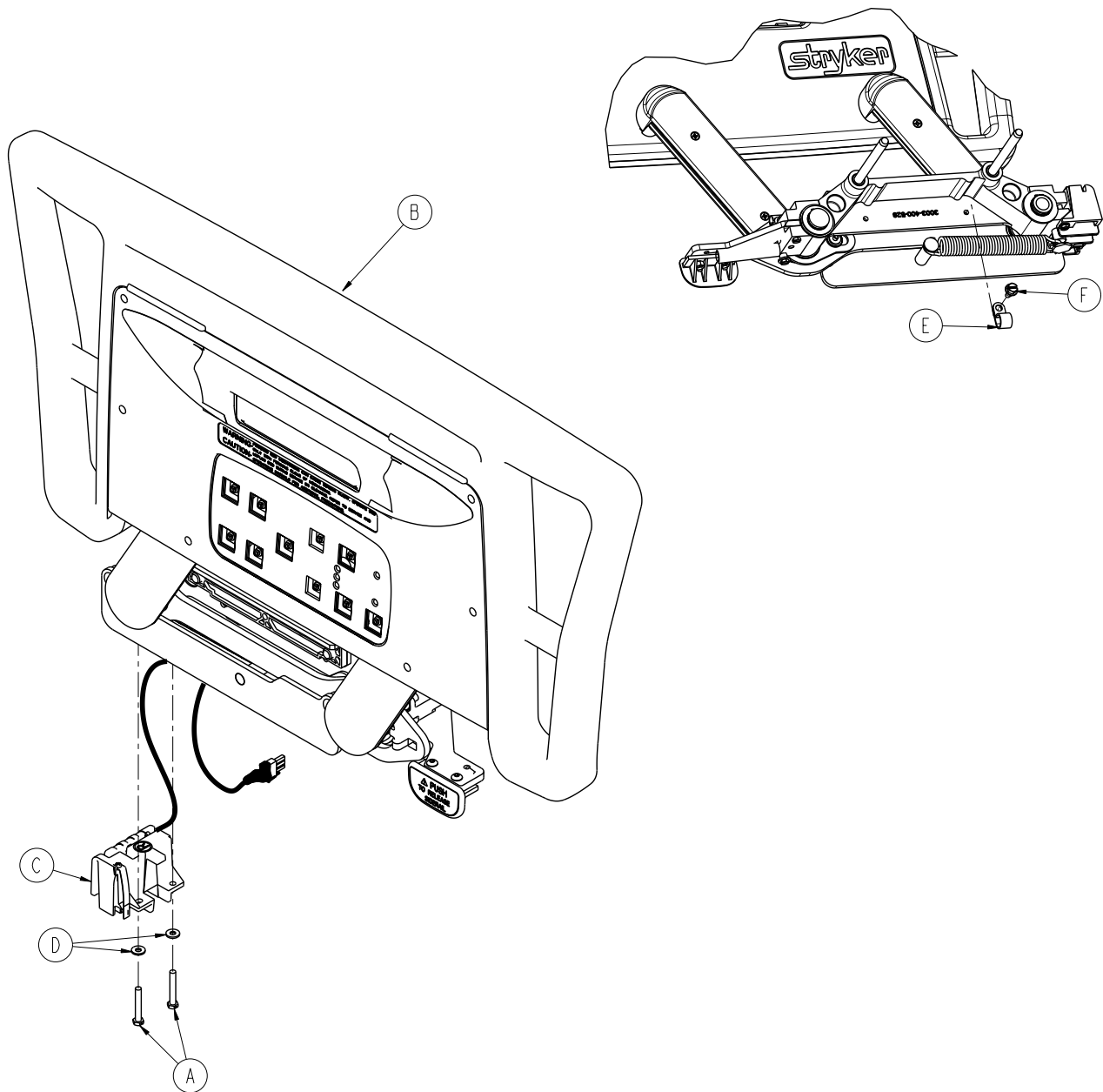

Item	Part No.	Part Name	Qty.
A	0003-344-000	Hex Head Machine Screw	2
B	3003-402-205	Siderail Assembly, HE, Right (pg.243)	1
C	3004-402-215	Siderail Switch Assembly, HE, Right (pg.265)	1
D	0011-062-000	Washer	2
E	0034-443-000	Cord Clamp	1
F	0003-221-000	Hex Washer Head Screw	1

Switch Assembly, iBED Awareness Option, Head End

For Reference Only: Part Number

LEFT SHOWN

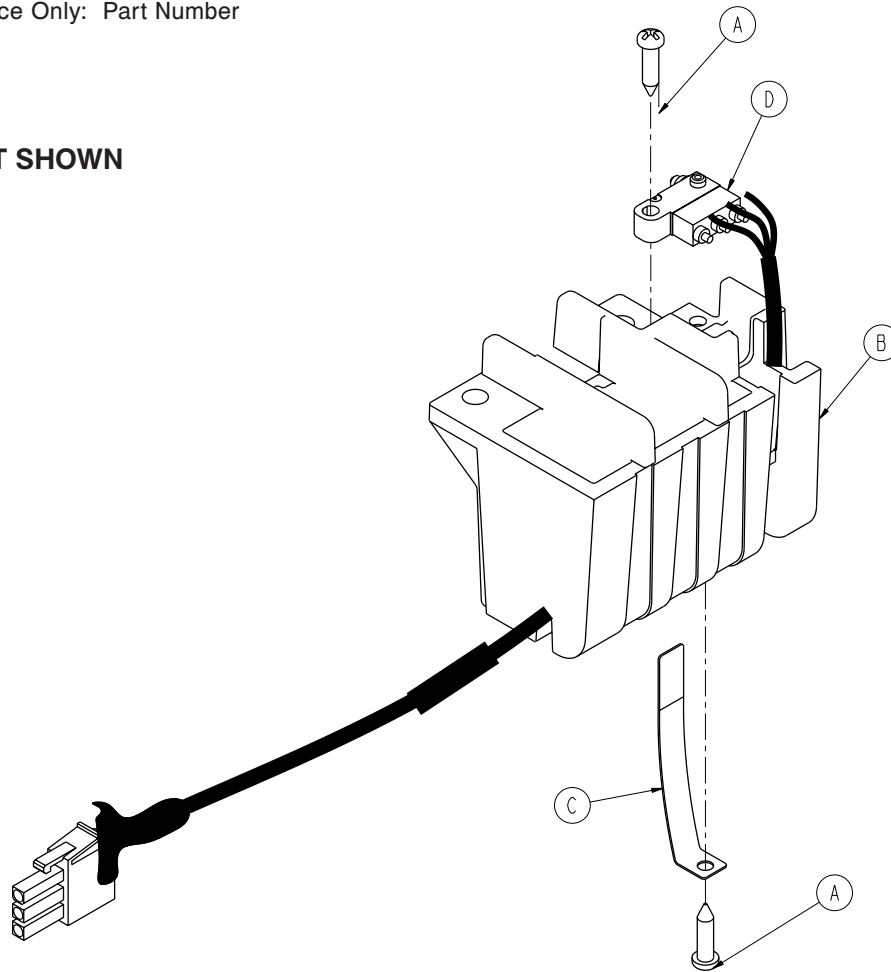

HEAD END LEFT - 3004-402-115 / HEAD END RIGHT - 3004-402-215

Item	Part No.	Part Name	Qty.
A	0023-294-000	High-Low Tapping Screw	1
B	3003-400-300	Switch Holder, Left	1
	3003-400-400	Switch Holder, Right	1
C	3003-400-500	Switch Holder, Spring Blade	1
D	3003-400-802	Secure Head Siderail Switch Cable	1

[Return To Table of Contents](#)

Foot End Siderail Assembly

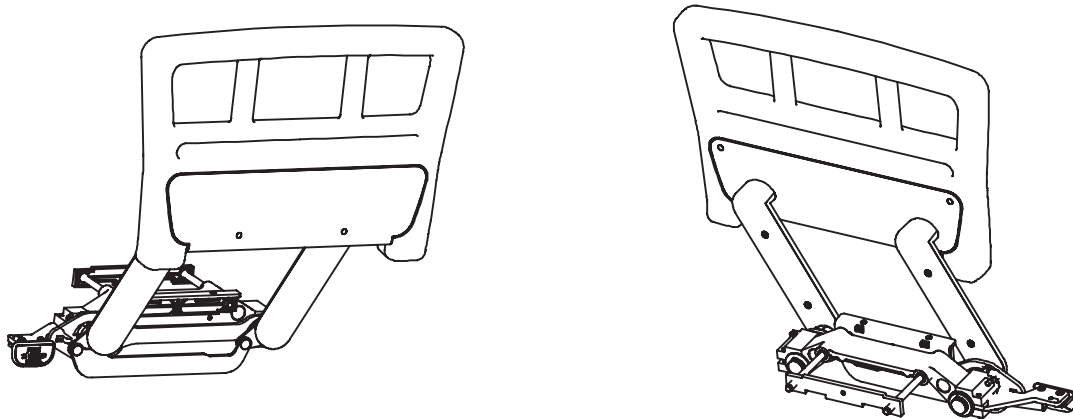
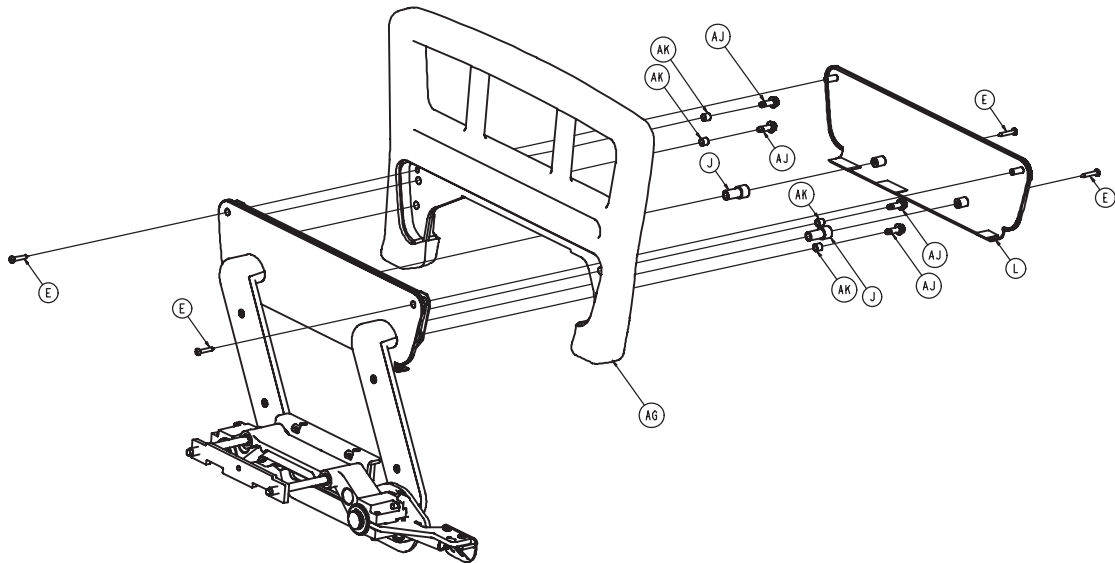
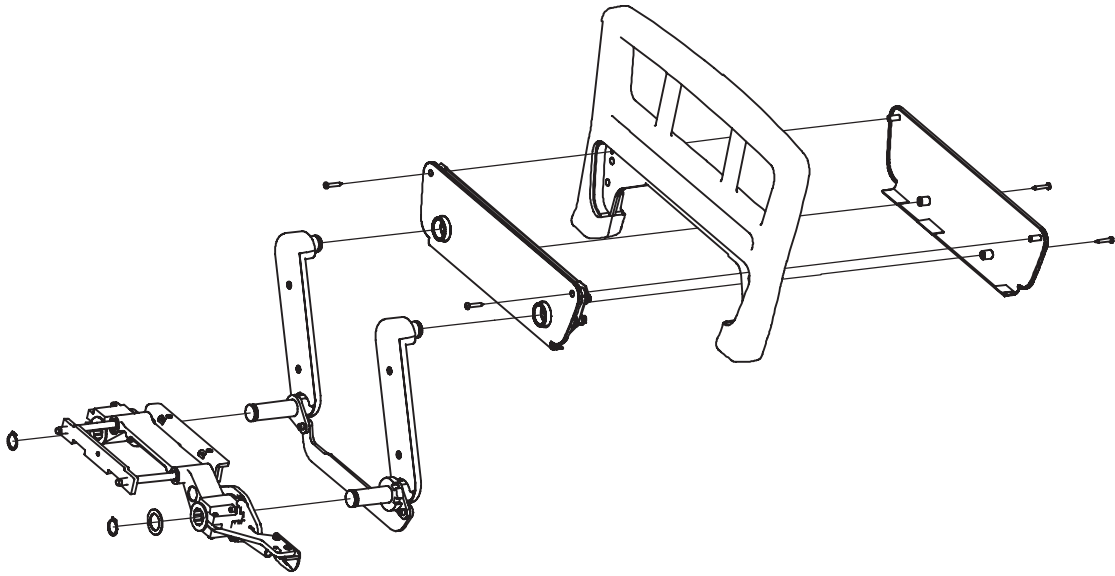

(Left Siderail Shown)

Foot End Siderail Assembly

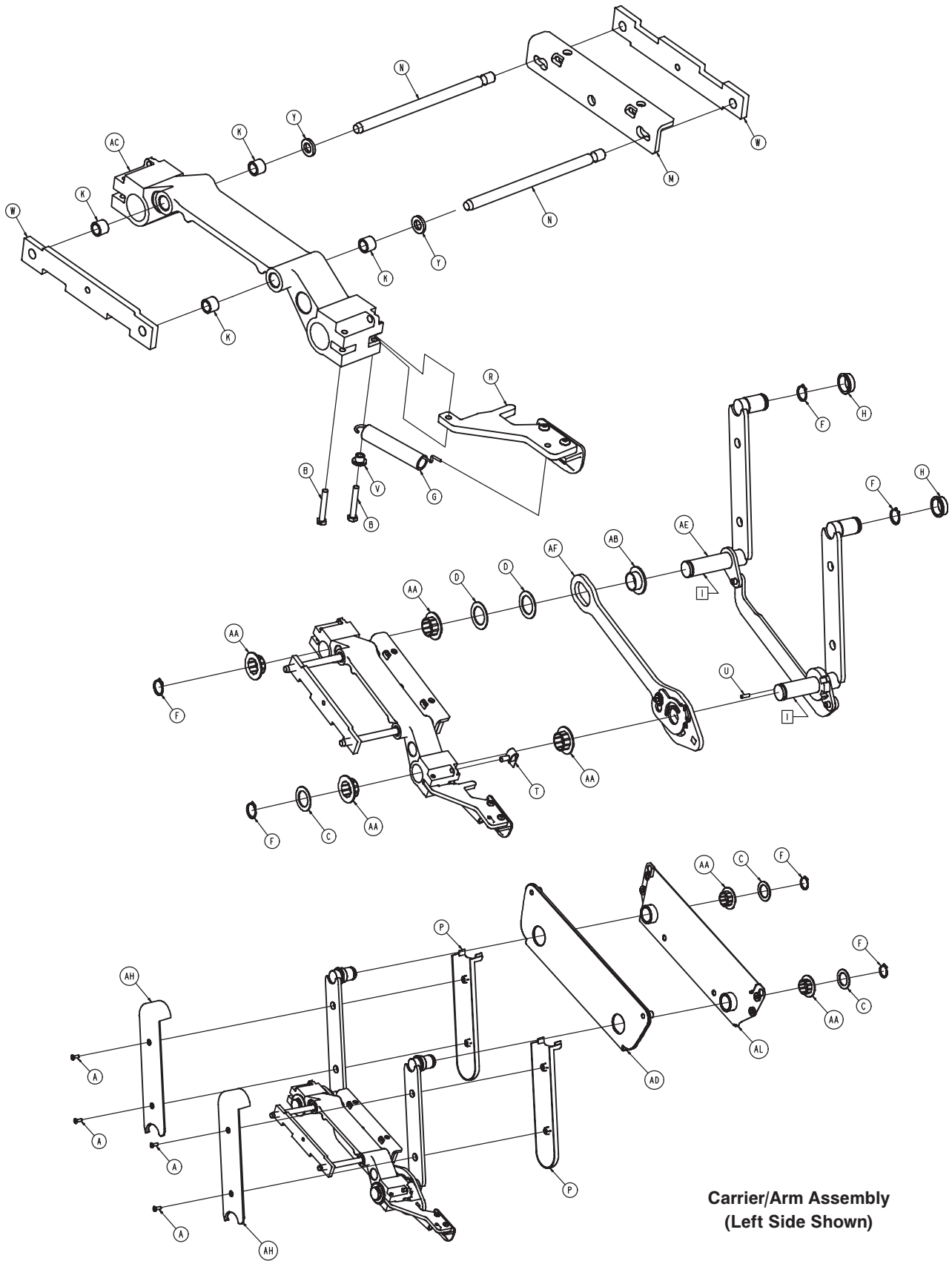

**Carrier/Arm Assembly
(Left Side Shown)**

Foot End Siderail Assembly

Left Common Components - 3003-401-300

Item	Part No.	Part Name	Qty.
A	0001-072-000	Hex Head Machine Screw	4
B	0003-344-000	Hex Hd. Cap Screw	2
C	0011-343-000	Shim Washer	3
D	0014-093-000	Washer	2
E	0023-090-000	Pan Hd. Tapping Screw	4
F	0028-128-000	Retaining Ring	6
G	3000-200-334	Extension Spring	1
H	3000-400-513	Flange Bearing	2
J	3000-400-523	Panel Spacer	2
K	3000-400-557	Sleeve Bearing	4
L	3001-400-527	Outer Panel	1
M	3001-400-555	Mounting Bracket	1
N	3001-400-564	Glide Rod	2
P	3001-400-619	Outer Arm Cover	2
R	3002-400-055	Release Lever Ass'y, LT (pg.273)	1
T	3002-400-090	Ball Dent Clip Ass'y (pg.275)	1
U	3002-400-505	Bypass Pin	1
V	3002-400-509	Bypass Bushing Spacer	1
W	3002-400-511	Glide Rod Bumper Pad	2
Y	3002-400-512	Washer	2
AA	3002-400-513	Pivot Bushing	6
AB	3002-400-519	Delrin Latch Bushing	1
AC	3002-400-528	Carrier, Siderail	1
AD	3003-400-526	Inner Panel	1
AE	3003-401-020	Timing Link Ass'y, FE, LT (pg.269)	1
AF	3003-400-085	Latch Ass'y, FE, LT (pg.271)	1
AG	3003-400-520	Foot Rail	1
AH	5000-020-005	Inner Arm Cover	2
AJ	0003-226-000	Hex Washer Head Screw	4
AK	3001-400-558	Spacer	4
AL	3003-400-580	Support Plate Weldment	1

Right Common Components - 3003-401-400

Item	Part No.	Part Name	Qty.
A	0001-072-000	Hex Head Machine Screw	4
B	0003-344-000	Hex Hd. Cap Screw	2
C	0011-343-000	Shim Washer	3
D	0014-093-000	Washer	2
E	0023-090-000	Pan Hd. Tapping Screw	4
F	0028-128-000	Retaining Ring	6
G	3000-200-334	Extension Spring	1
H	3000-400-513	Flange Bearing	2
J	3000-400-523	Panel Spacer	2
K	3000-400-557	Sleeve Bearing	4
L	3001-400-527	Outer Panel	1
M	3001-400-555	Mounting Bracket	1
N	3001-400-564	Glide Rod	2
P	3001-400-619	Outer Arm Cover	2
R	3002-400-065	Release Lever Ass'y, RT (pg.274)	1
T	3002-400-090	Ball Dent Clip Ass'y (pg.275)	1
U	3002-400-505	Bypass Pin	1
V	3002-400-509	Bypass Bushing Spacer	1
W	3002-400-511	Glide Rod Bumper Pad	2
Y	3002-400-512	Washer	2
AA	3002-400-513	Pivot Bushing	6
AB	3002-400-519	Delrin Latch Bushing	1
AC	3002-400-528	Carrier, Siderail	1
AD	3003-400-526	Inner Panel	1
AE	3003-401-015	Timing Link Ass'y, FE, RT (pg.270)	1
AF	3003-400-080	Latch Ass'y, FE, RT (pg.272)	1
AG	3003-400-520	Foot Rail	1
AH	5000-020-005	Inner Arm Cover	2
AJ	0003-226-000	Hex Washer Head Screw	4
AK	3001-400-558	Spacer	4
AL	3003-400-580	Support Plate Weldment	1

Timing Link Assembly, Foot End, Left

3003-401-020

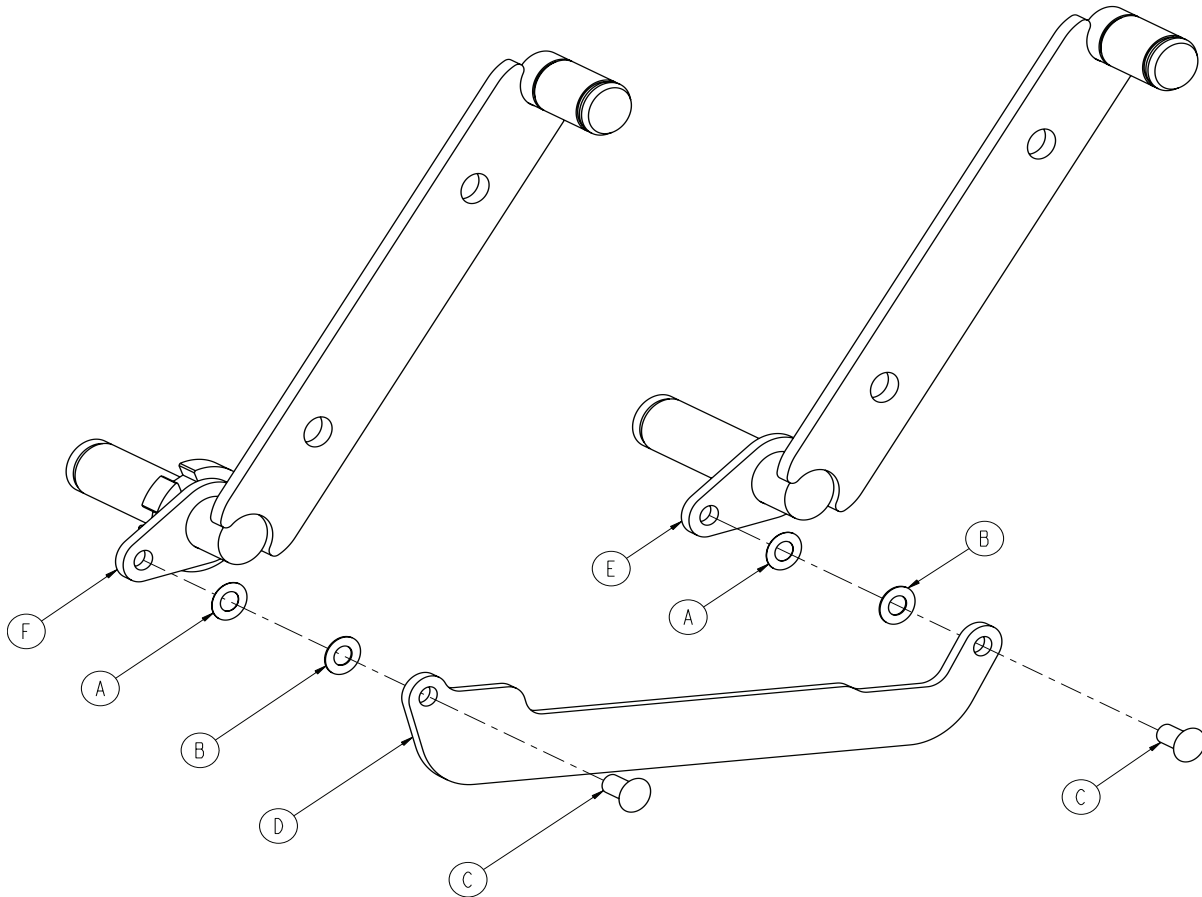

Item	Part No.	Part Name	Qty.
A	0011-377-000	Washer	2
B	0011-491-000	Washer	2
C	3001-400-501	Siderail Linkage Rivot	2
D	3003-401-001	Bushing	2
E	3003-402-112	Timing Link	1
F	3003-402-127	Arm Weldment - LHF	1
G	3003-402-128	Arm Weldment - LHH	1

Timing Link Assembly, Foot End, Right

3003-401-015

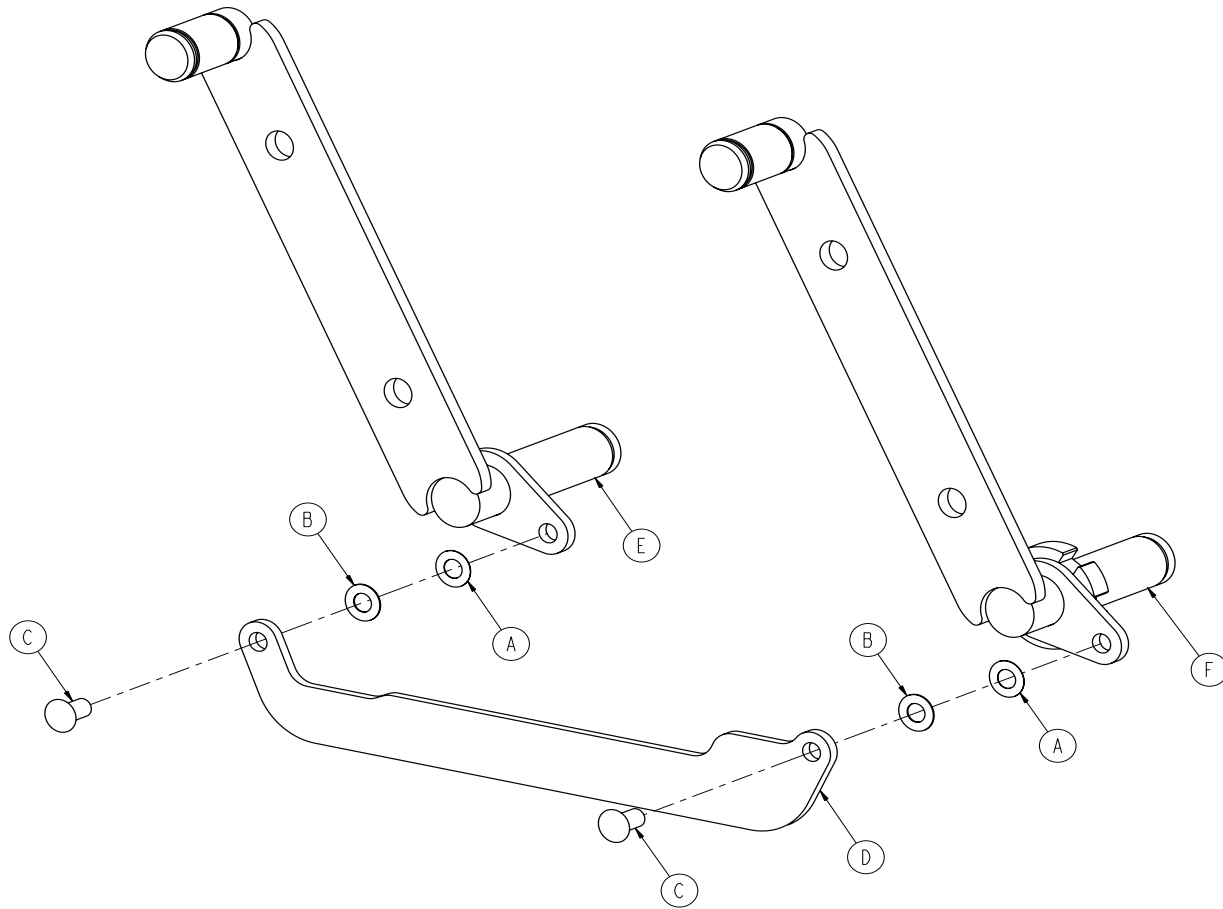

Item	Part No.	Part Name	Qty.
A	0011-377-000	Washer	2
B	0011-491-000	Washer	2
C	3001-400-501	Siderail Linkage Rivot	2
D	3003-401-001	Bushing	2
E	3003-402-117	Timing Link	1
F	3003-402-227	Arm Weldment - LHF	1
G	3003-402-228	Arm Weldment - LHH	1

Siderail Latch Assembly, Foot End, Left

3003-400-085

Inside the US and Canada

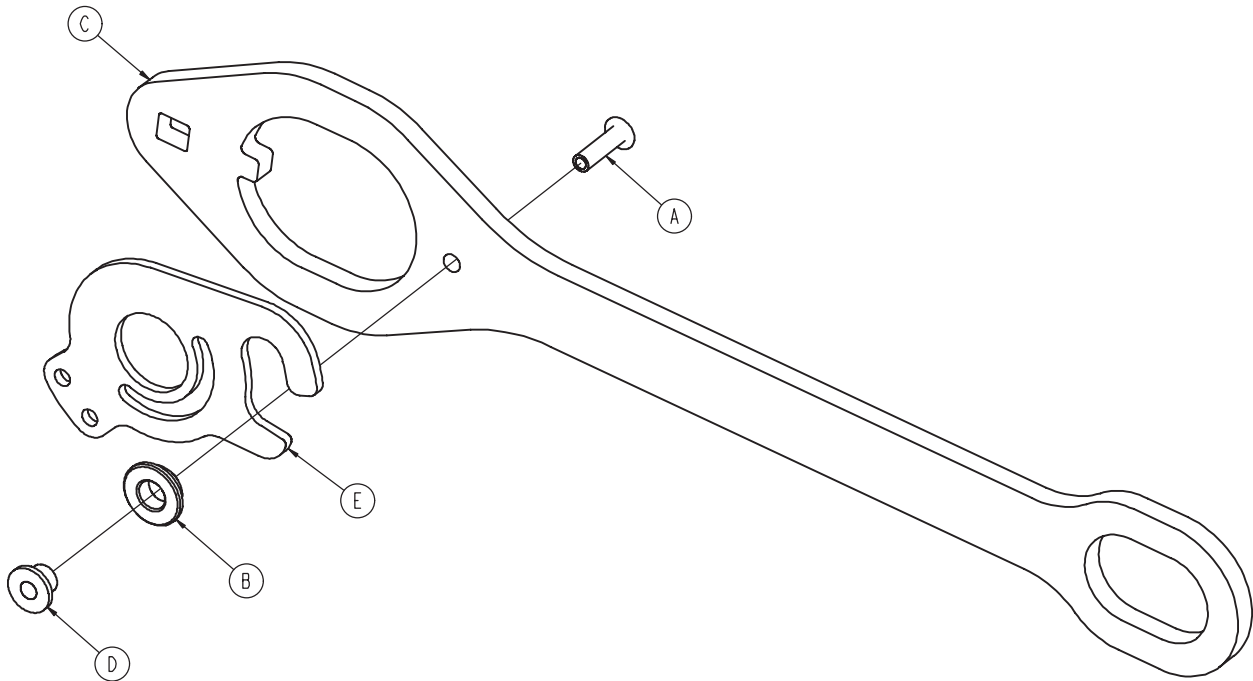

Item	Part No.	Part Name	Qty.
A	0025-086-000	Blind Rivet	1
B	0081-317-000	Bronze Bushing	1
C	3002-400-501	Latch	1
D	3002-400-509	Bypass Bushing Spacer	1
E	3003-400-504	Bypass Plate, Foot	1

[Return To Table of Contents](#)

Siderail Latch Assembly, Foot End, Right

3003-400-080

Inside the US and Canada

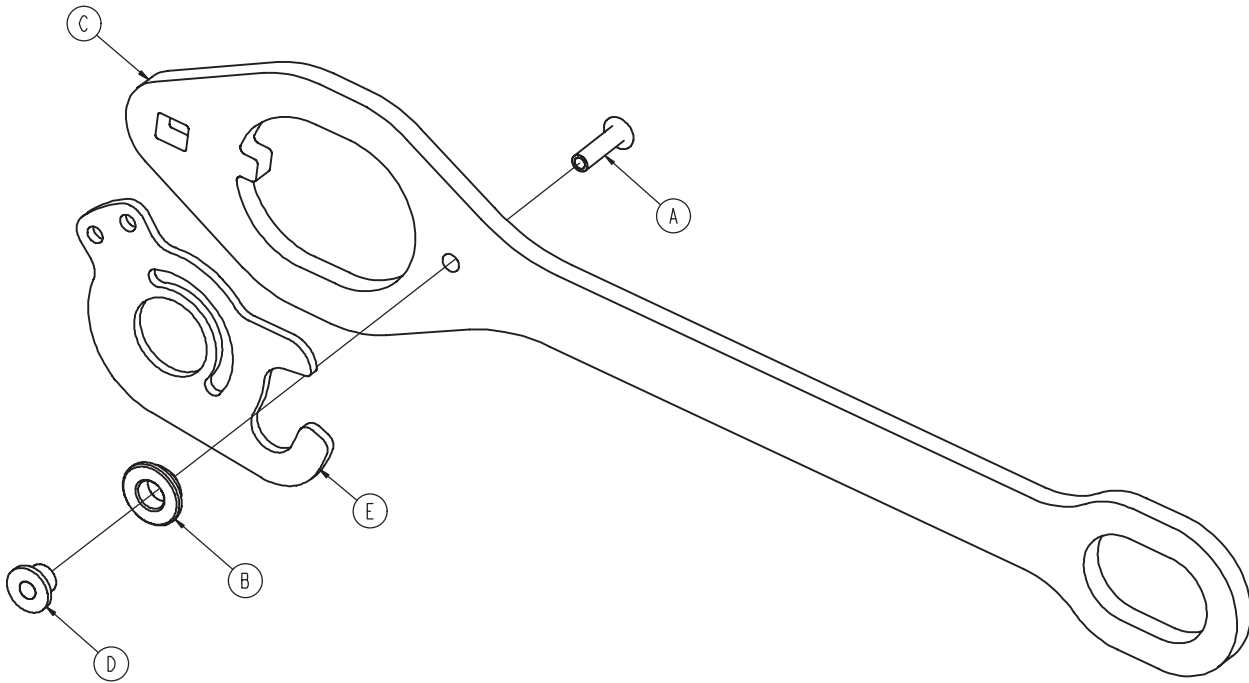

Item	Part No.	Part Name	Qty.
A	0025-086-000	Blind Rivet	1
B	0081-317-000	Bronze Bushing	1
C	3002-400-501	Latch	1
D	3002-400-509	Bypass Bushing Spacer	1
E	3003-400-504	Bypass Plate, Foot	1

Siderail Release Lever Assembly, Left

3002-400-055

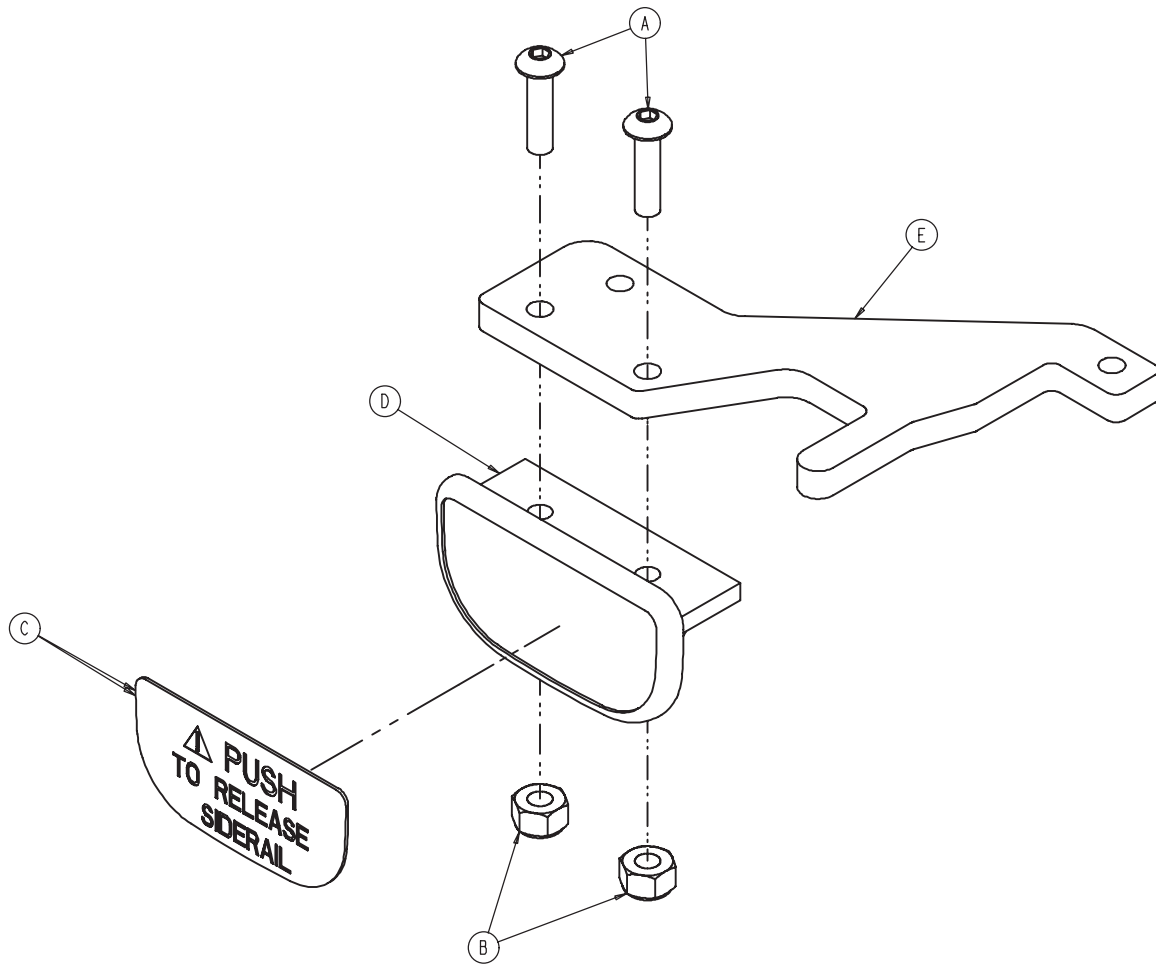

Item	Part No.	Part Name	Qty.
A	0004-278-000	Socket Button Head Cap Screw	2
B	0016-002-000	Hex Nut	2
C	3002-503-901	Release Label	1
D	3001-400-514	Release Lever Pad	1
E	3002-400-510	Release Lever	1

Siderail Release Lever Assembly, Right

3002-400-065

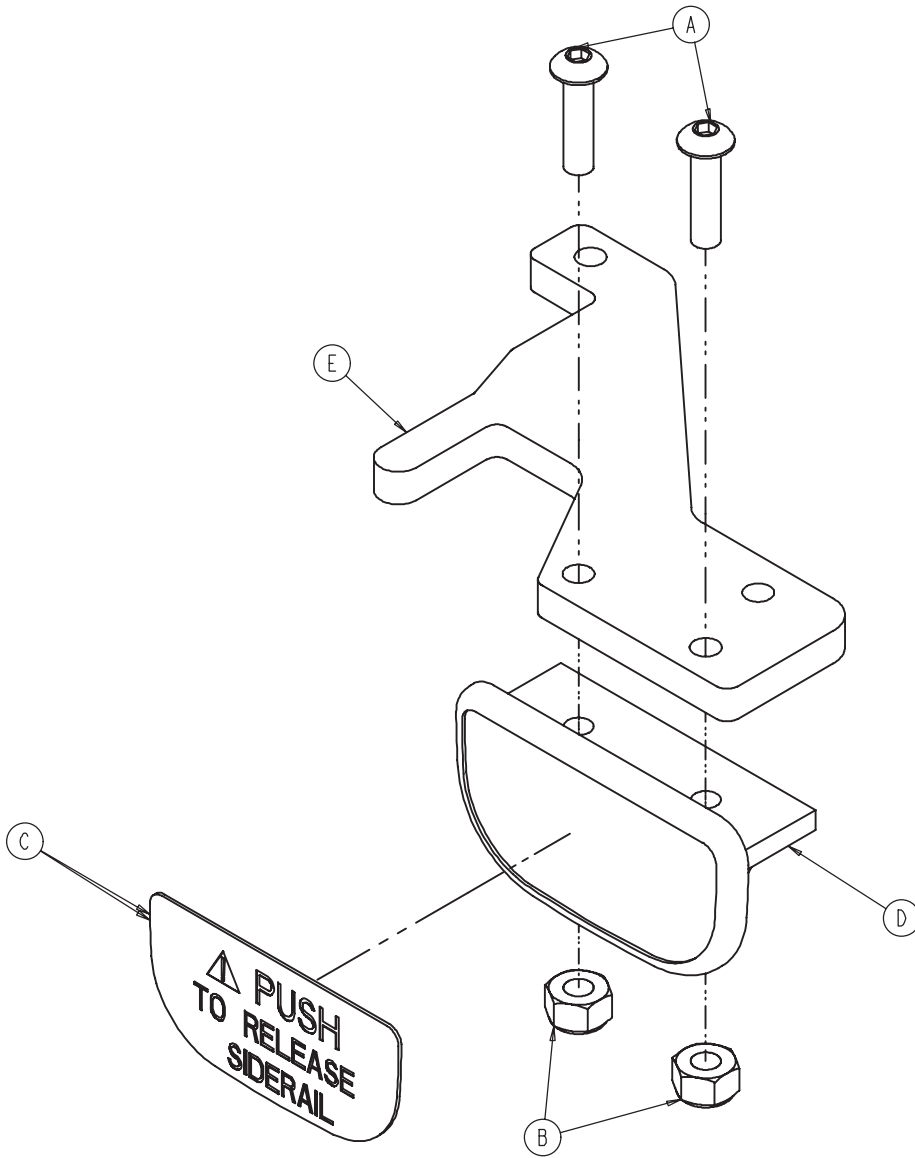

Item	Part No.	Part Name	Qty.
A	0004-278-000	Socket Button Head Cap Screw	2
B	0016-200-000	Hex Nut	2
C	3002-503-901	Release Label	1
D	3001-400-514	Release Lever Pad	1
E	3002-400-510	Release Lever	1

Siderail Bypass Detent Clip Assembly

3002-400-090

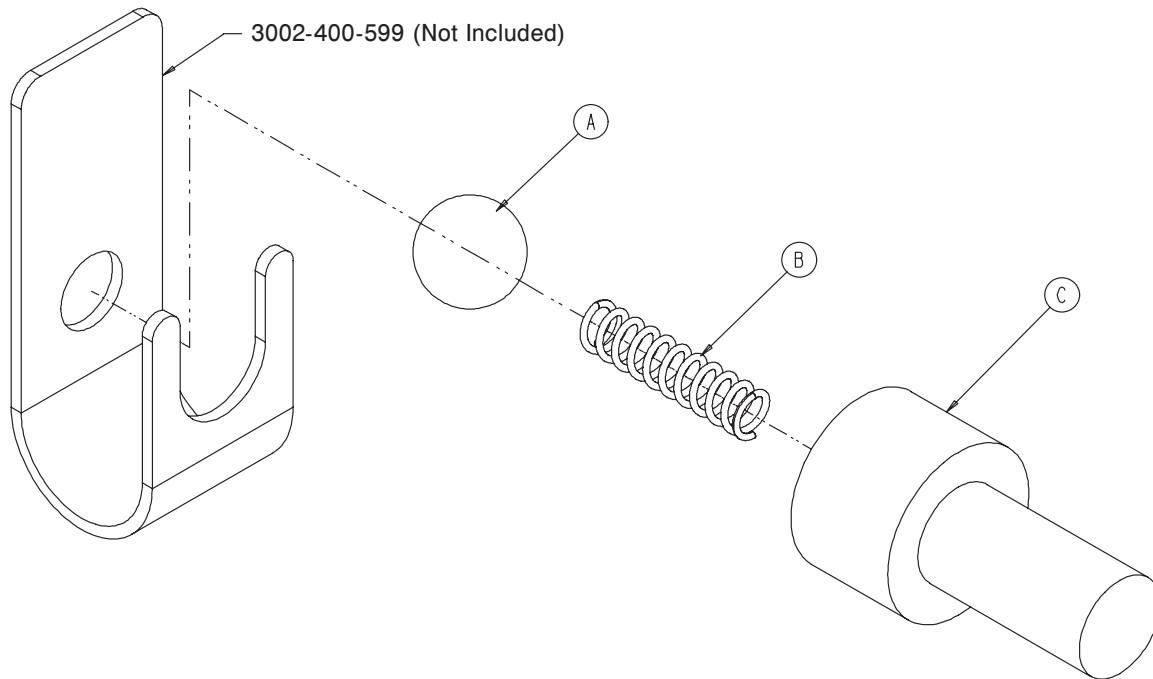

Item	Part No.	Part Name	Qty.
A	0031-137-000	Steel Ball	1
B	0038-464-000	Compression Spring	1
C	3002-400-524	Bypass Detent Housing	1

Siderail Assembly, iBED Awareness Option, Foot End Left

3004-401-300

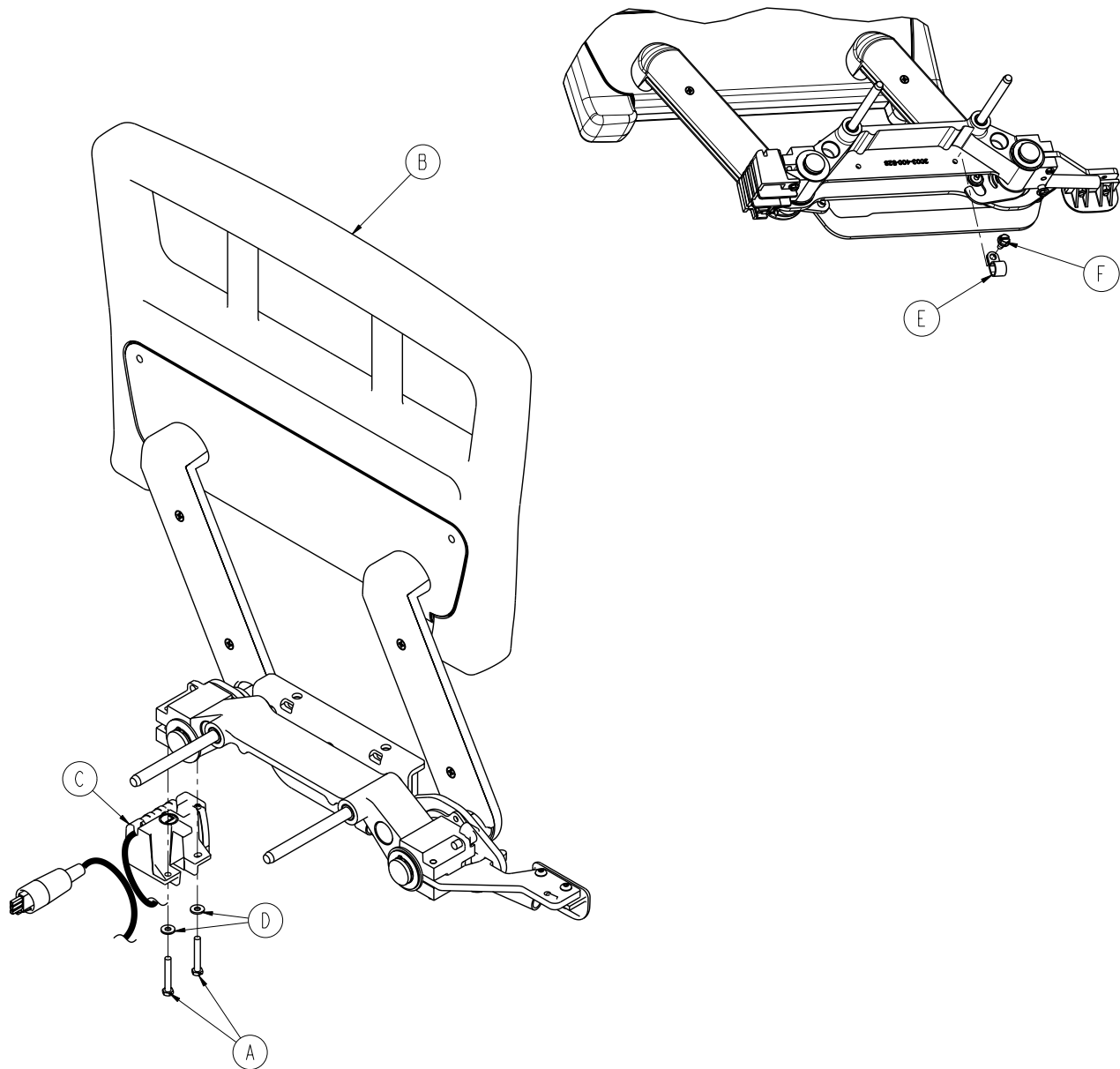

Item	Part No.	Part Name	Qty.
A	0003-344-000	Hex Head Machine Screw	2
B	3003-401-300	Siderail Assembly, FE, Left (pg.268)	1
C	3004-401-315	Siderail Switch Assembly, FE, Left (pg.278)	1
D	0011-062-000	Washer	2
E	0034-443-000	Cord Clamp	1
F	0003-221-000	Hex Washer Head Screw	1

Siderail Assembly, iBED Awareness Option, Foot End, Right

3004-401-400

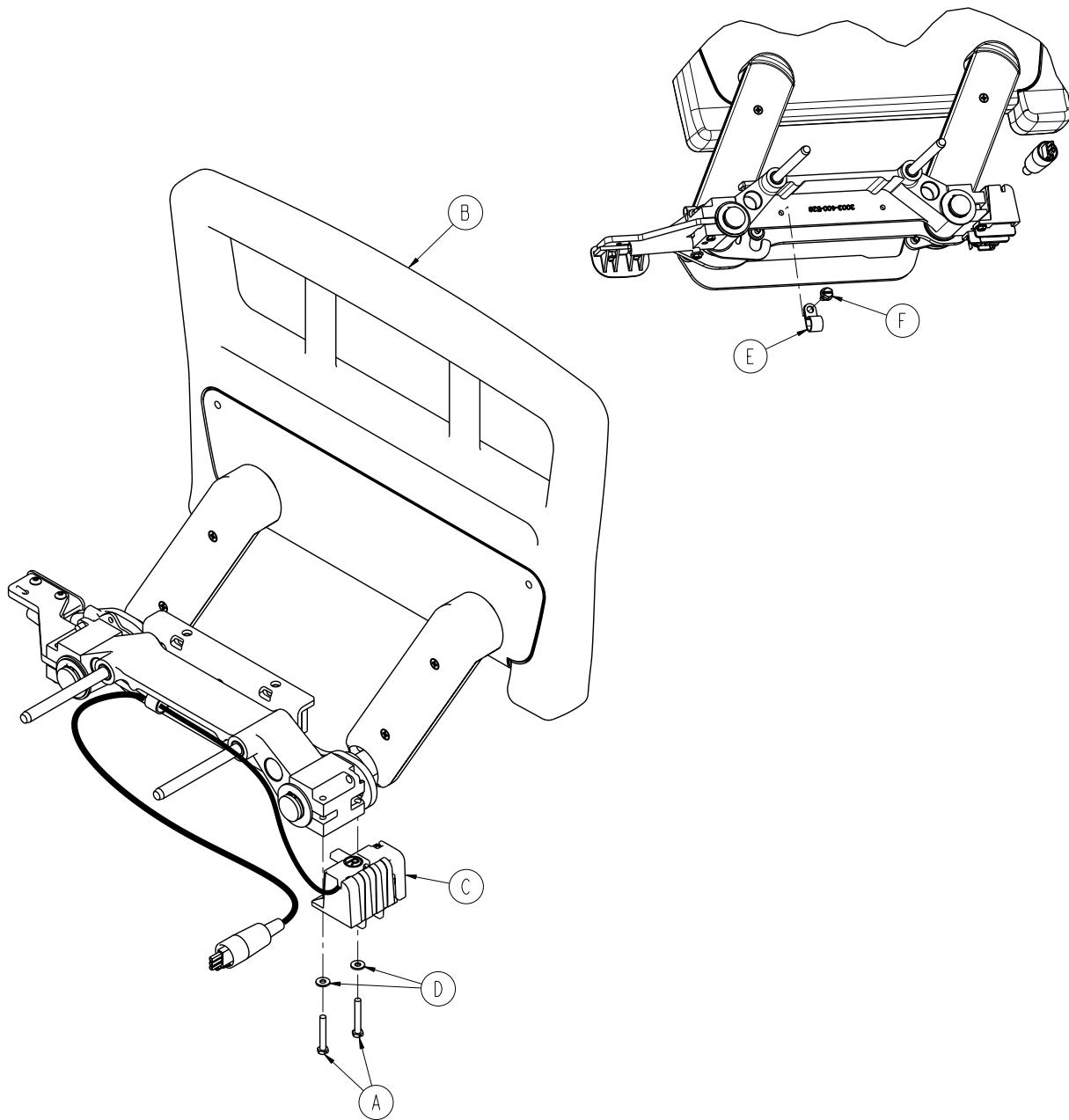

Item	Part No.	Part Name	Qty.
A	0003-344-000	Hex Head Machine Screw	2
B	3003-401-400	Siderail Assembly, FE, Right (pg.268)	1
C	3004-401-415	Siderail Switch Assembly, FE, Right (pg.278)	1
D	0011-062-000	Washer	2
E	0034-443-000	Cord Clamp	1
F	0003-221-000	Hex Washer Head Screw	1

[Return To Table of Contents](#)

Switch Assembly, iBED Awareness Option, Foot End

LEFT SHOWN

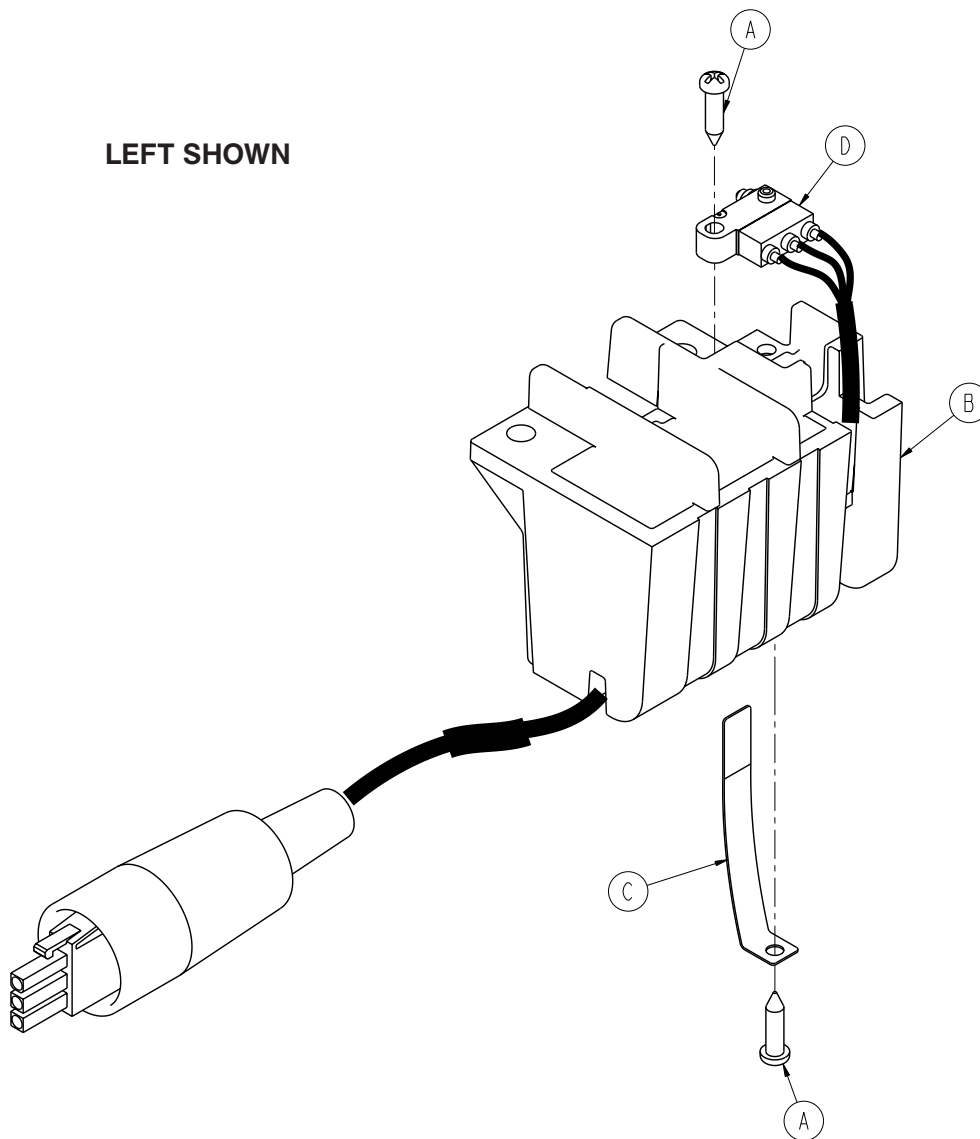

FOOT END LEFT - 3004-401-315 / FOOT END RIGHT - 3004-401-415

Item	Part No.	Part Name	Qty.
A	0023-294-000	High-Low Tapping Screw	2
B	3003-400-300	Switch Holder, Left	1
	3003-400-400	Switch Holder, Right	1
C	3003-400-500	Switch Holder, Spring Blade	1
D	3003-400-801	Secure Foot Siderail Switch Cable	1

Optional Pendant Assembly

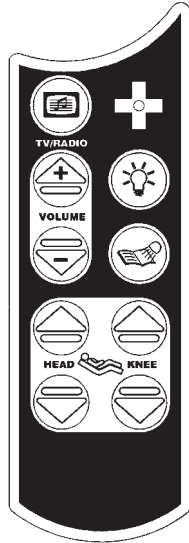

**Combination Pendant Motion/
Communication - 3001-315-012**

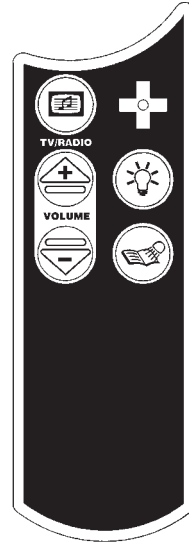

**Combination Pendant Communication
Only - 3001-315-016**

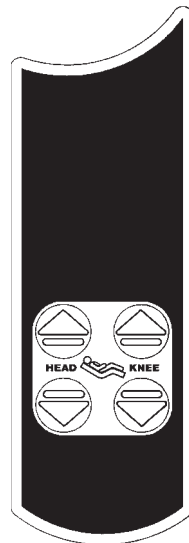

Combination Pendant Motion Only - 3001-315-014

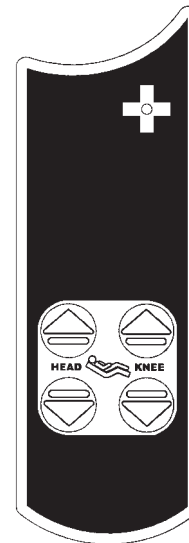

Combination Pendant Motion/Nurse Call - 3001-315-018

Foot Board Assembly - 3002-500-011

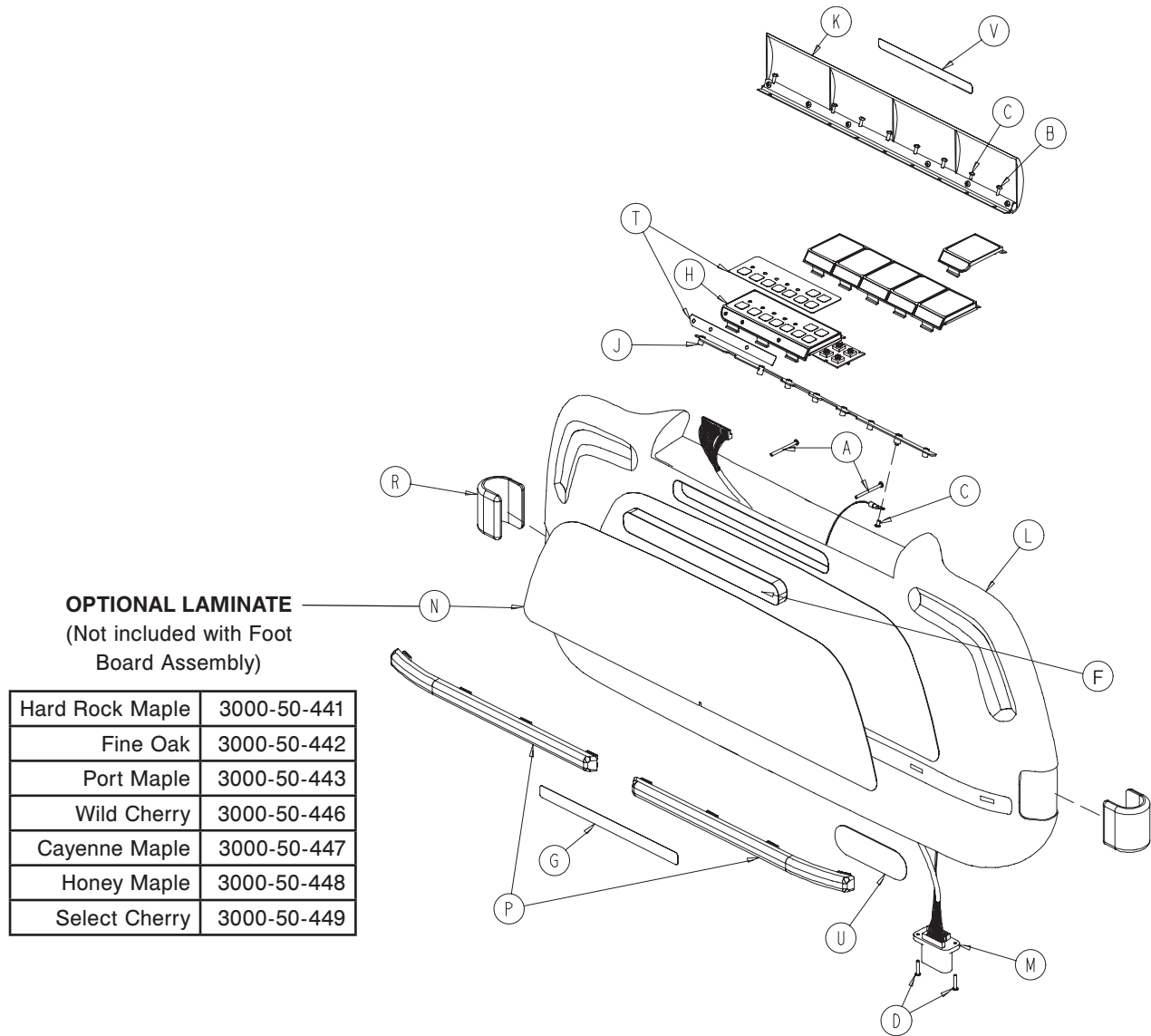

Item	Part No.	Part Name	Qty.	Item	Part No.	Part Name	Qty.
A	0023-099-000	Phillips Pan Head Screw	2	K	3001-500-001	Lid Assembly	1
B	0023-103-000	Pan Head Hi-Lo Tap. Screw	7	L	3001-500-010	Clam Shell Assembly	1
C	0050-038-000	Pan Head Machine Screw	2	M	3001-500-801	Foot Board Drawer Cable	1
D	0050-039-000	Pan Head Machine Screw	2	N	see table	Foot board Laminate	1
F	3000-500-008	Chart Rack Cover	1	P	2025-000-105	Bumper Strip	2
G	3000-500-029	Hazard Label	1	R	3002-500-007	C-Bumper	2
H	3001-500-028	Std. Control Module Ass'y (pg.289)	1	T	3002-500-024	Standard Module Label	1
J	3001-500-064	Hinge Plate	1	U	3002-500-601	Secure II Label	1
				V	3002-500-025	Lid Label	1

Foot Board Assembly, No Options

3002-507-120

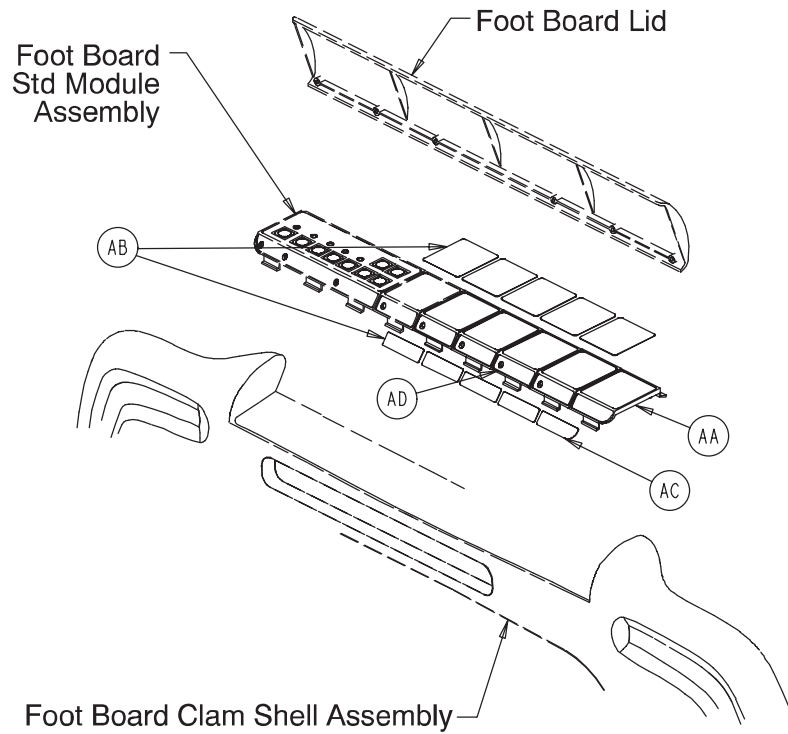

Item	Part No.	Part Name	Qty.
AA	3000-500-004	End Module	1
AB	3002-508-004	Blank Module Label	5
AC	3002-500-027	End Module Label	1
AD	3001-500-003	Blank Module	4

Foot Board Assembly, Scale Option

3002-507-013

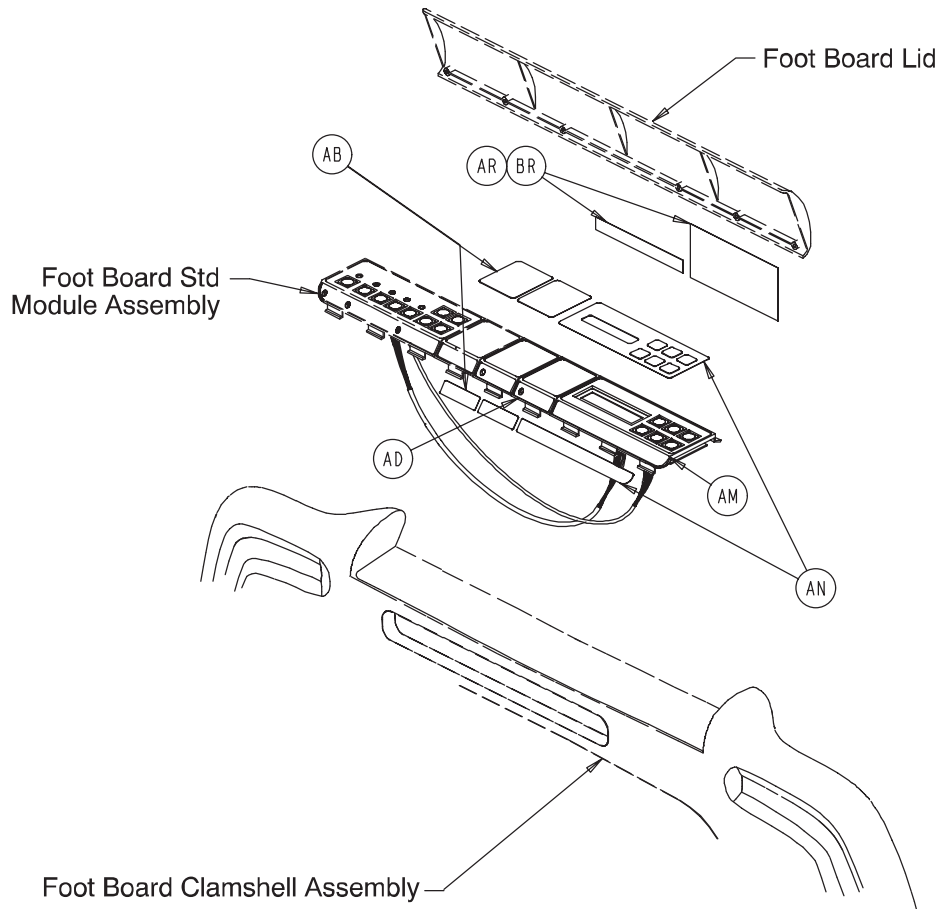

Item	Part No.	Part Name	Qty.
AB	3002-508-004	Blank Module Label	2
AD	3001-500-003	Blank Module	2
AM	3002-507-030	Scale Module (pg.292)	1
AN	3002-000-152	Scale Module Label	1
AR	3002-507-011	Scale Label (Lid)	1

Foot Board Assembly, Bed Exit Option

3002-508-011

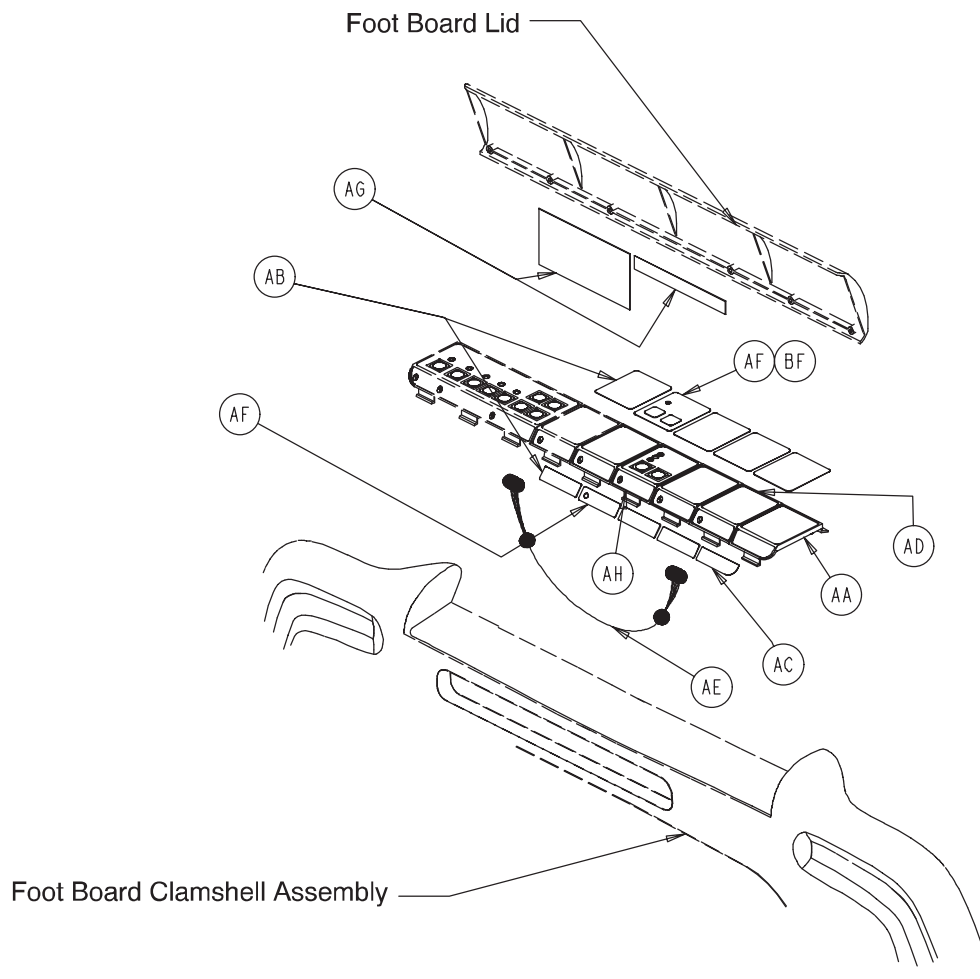

Item	Part No.	Part Name	Qty.
AA	3000-500-004	End Module	1
AB	3002-508-004	Blank Module Label	4
AC	3002-500-027	End Module Label	1
AD	3001-500-003	Blank Module	3
AE	3001-508-800	Bed Exit Keypad Cable	1
AF	3002-508-002	Bed Exit Module Label	1
AG	3002-508-010	Bed Exit Label (Lid)	1
AH	3001-508-030	Bed Exit Module (pg.290)	1

Foot Board Assembly, Zone Control/Bed Exit Option

3002-508-021

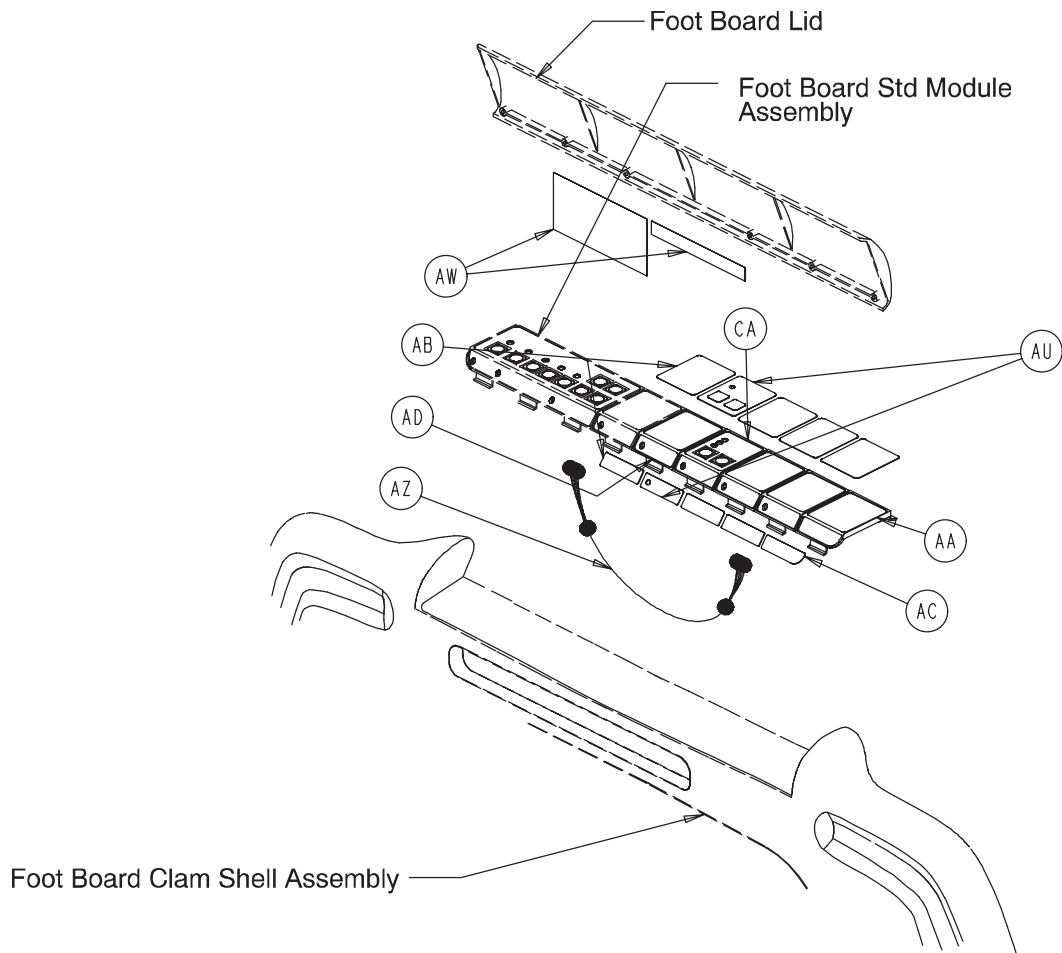

Item	Part No.	Part Name	Qty.
AA	3000-50-004	End Module	1
AB	3002-508-004	Blank Module Label	4
AC	3002-500-027	End Module Label	1
AD	3001-500-003	Blank Module	3
AU	3002-508-003	Zone Control II Module Label	1
AW	3002-508-012	Zone Control II Label (Lid)	1
AZ	3002-508-800	Zone Control Keypad Cable	1
CA	3002-508-030	Bed Exit Module (pg.291)	1

Foot Board Assembly, Bed Exit/Scale Option

3002-507-121

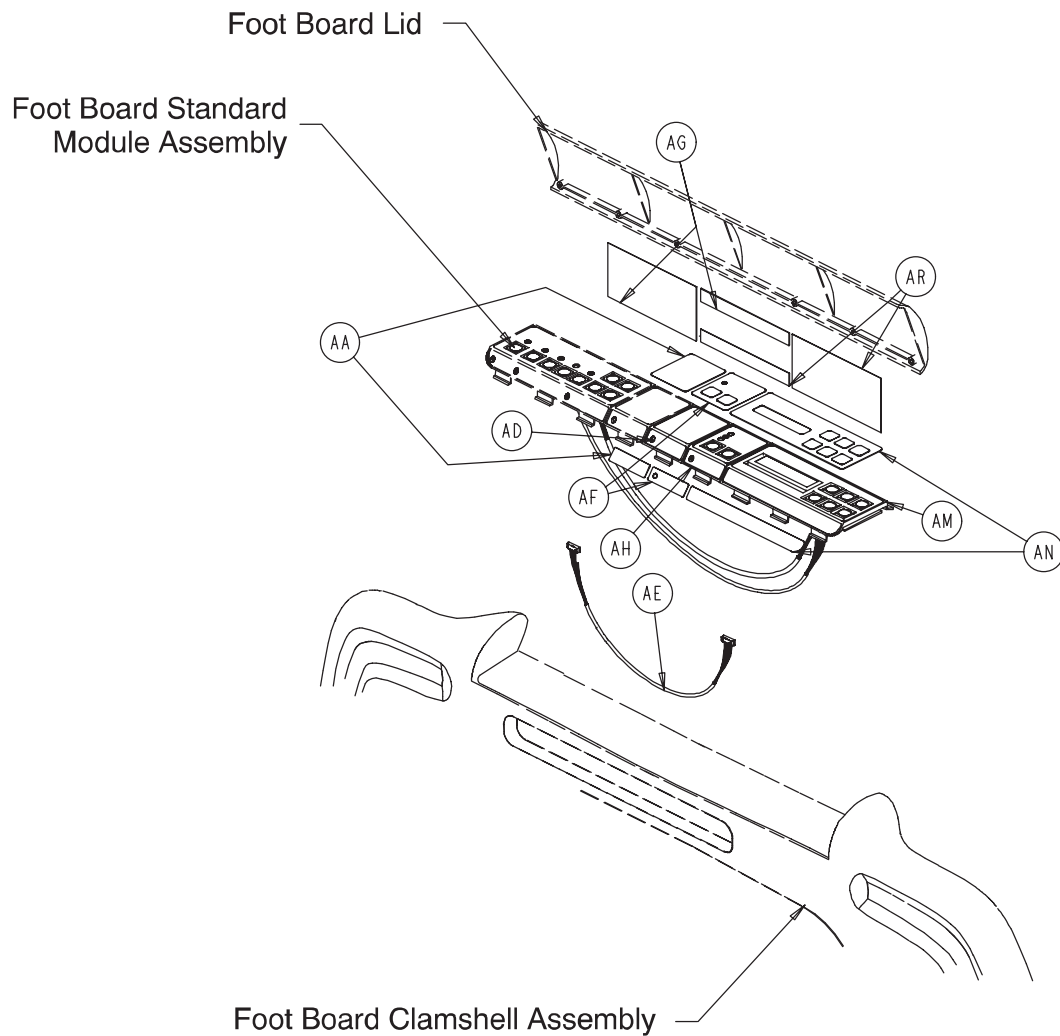

Item	Part No.	Part Name	Qty.
AB	3002-508-004	Blank Module Label	1
AD	3001-500-003	Blank Module	1
AE	3001-508-800	Bed Exit Keypad Cable	1
AF	3002-508-002	Bed Exit Module Label	1
AG	3002-508-010	Bed Exit Label (Lid)	1
AH	3001-508-030	Bed Exit Module (pg.290)	1
AM	3002-507-030	Scale Module (pg.292)	1
AN	3002-000-152	Scale Module Label	1
AR	3002-507-011	Scale Label (Lid)	1

Foot Board Assembly, Zone Control/Bed Exit/Scale Option

3002-507-122

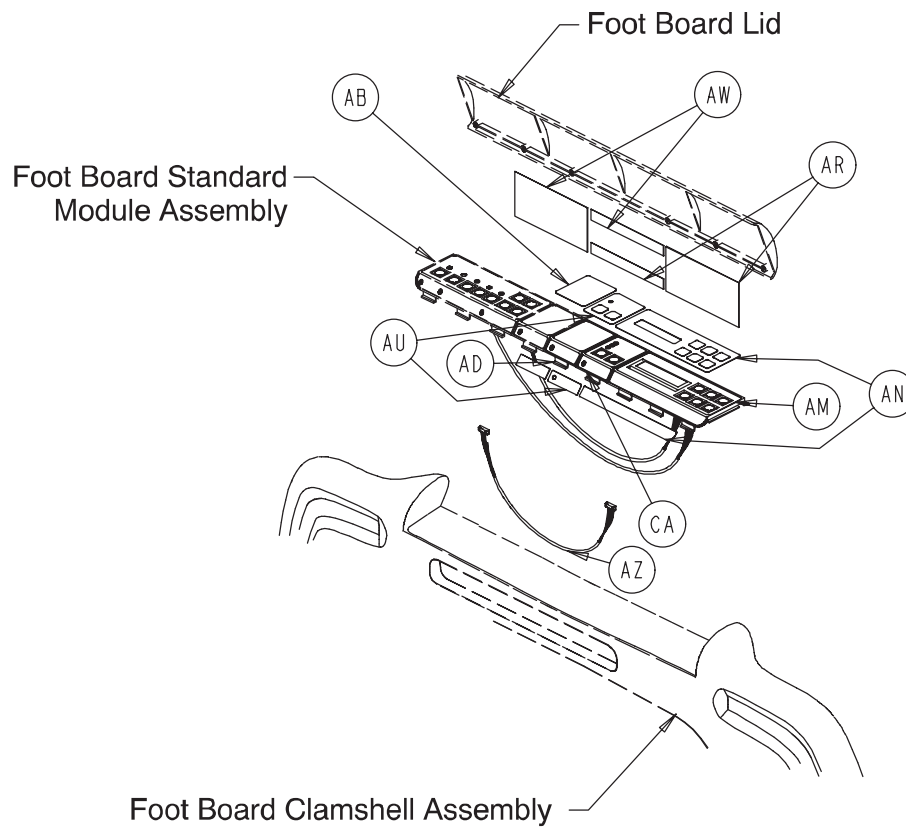

Item	Part No.	Part Name	Qty.
AB	3002-508-004	Blank Module Label	4
AD	3001-500-003	Blank Module	3
AM	3002-507-030	Scale Module (pg.292)	1
AN	3002-000-152	Scale Module Label	1
AR	3002-507-011	Scale Label (Lid)	1
AU	3002-508-003	Zone Control II Module Label	1
AW	3002-508-012	Zone Control II Label (Lid)	1
AZ	3002-508-800	Zone Control Keypad Cable	1
CA	3002-508-030	Zone Control Bed Exit Module (pg.291)	1

Foot Board Assembly, No Gatch/Fowler Option

3002-501-110

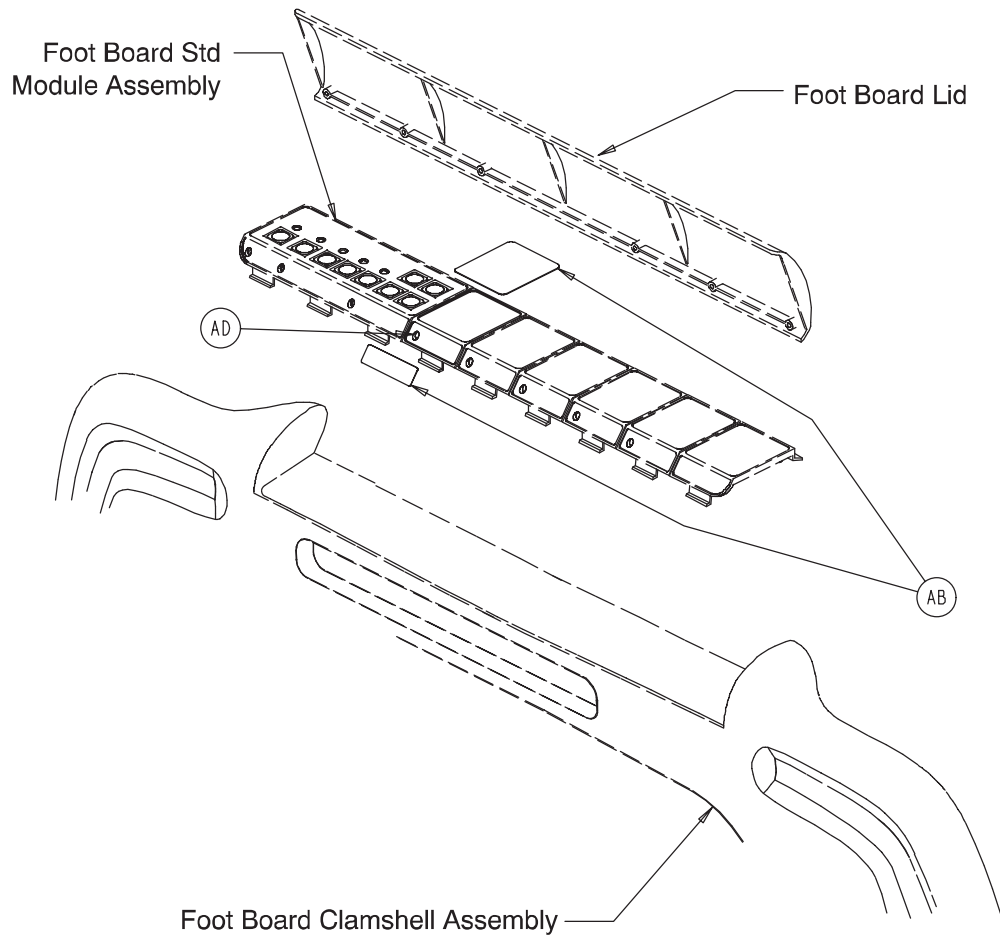

Item	Part No.	Part Name	Qty.
AB	3002-508-004	Blank Module Label	1
AD	3001-500-003	Blank Module	1

[Return To Table of Contents](#)

Foot Board Assembly, Gatch/Fowler Option

3002-501-011

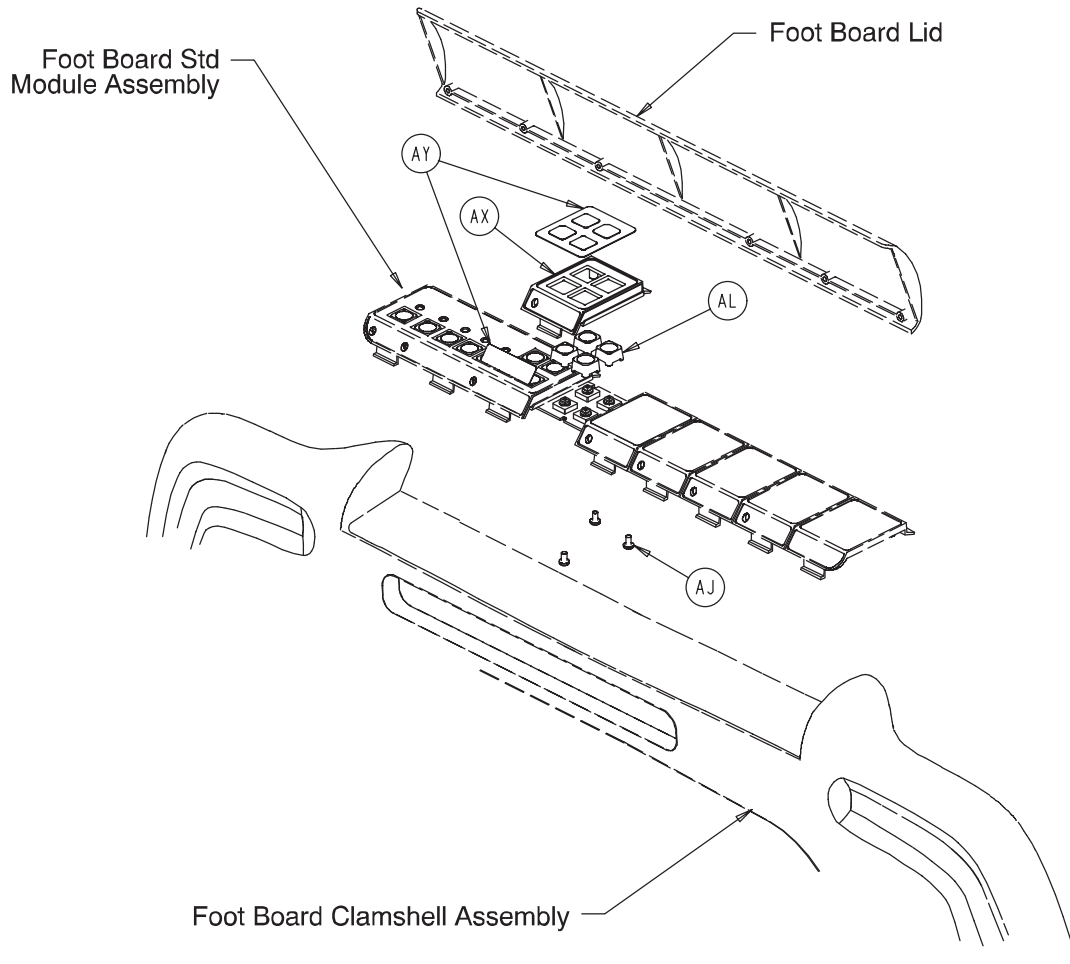

Item	Part No.	Part Name	Qty.
AJ	0023-087-000	Pan Head Hi-Lo Tap. Screw	3
AL	3001-400-953	Switch Cap	4
AX	3000-501-001	Gatch/Fowler Module	1
AY	3002-501-002	Gatch/Fowler Module Label	1

Foot Board Standard Module Assembly

3001-500-028

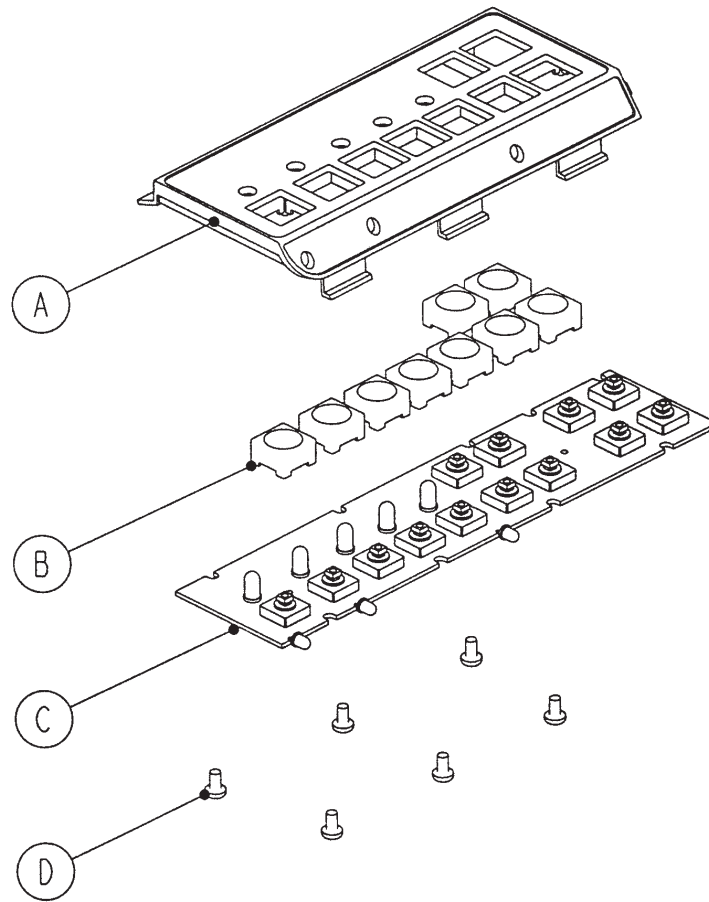

Item	Part No.	Part Name	Qty.
A	3000-500-002	Foot Board Standard Module	1
B	3001-400-953	Switch Cap	9
C	3001-500-930	Main Foot Board Keyboard	1
D	0023-087-000	Pan Head Tapping Screw	6

Optional Foot Board Bed Exit Module

3001-508-030

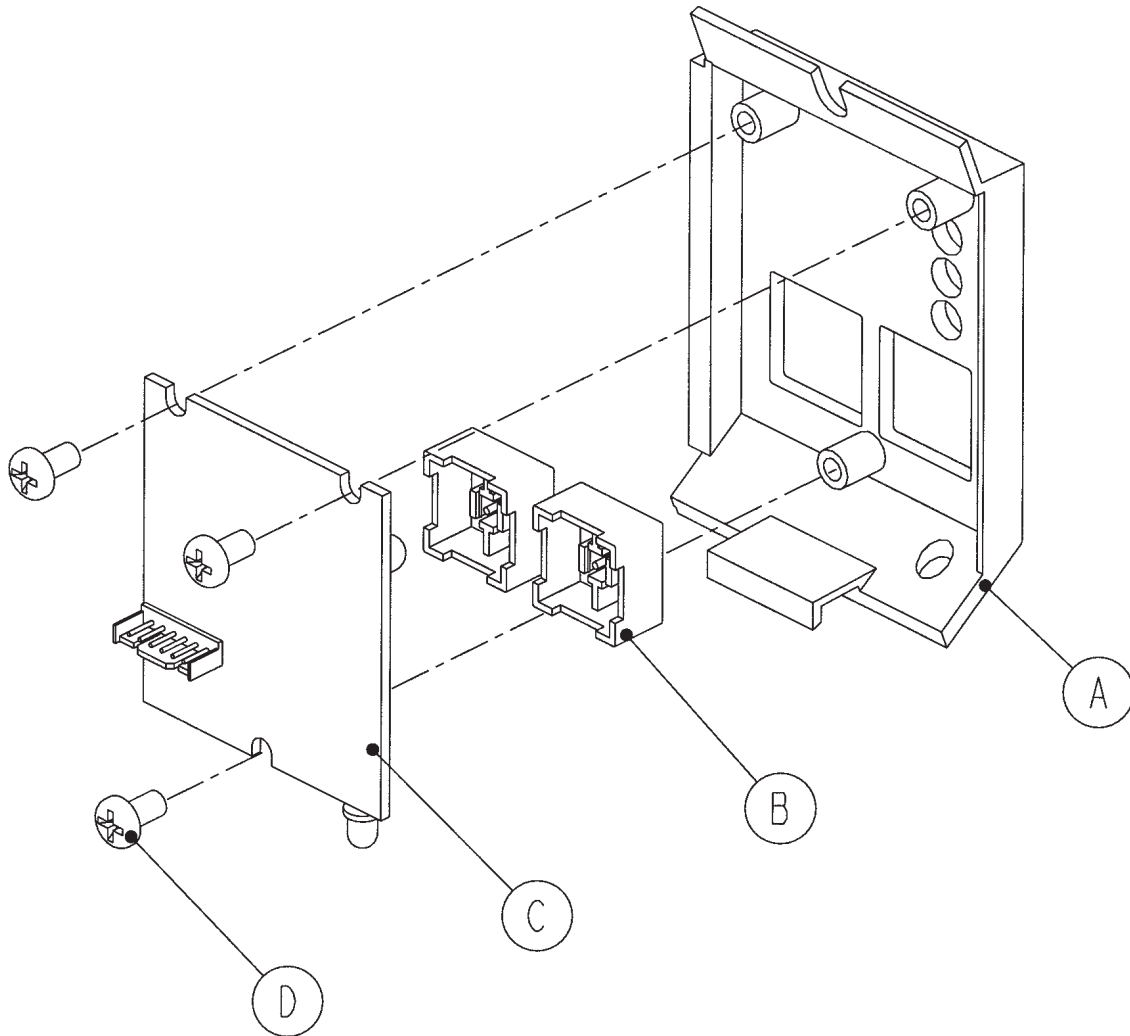

Item	Part No.	Part Name	Qty.
A	3000-508-001	Bed Exit Module Panel	1
B	3001-400-953	Switch Cap	2
C	3001-508-910	Bed Exit Keypad Assembly	1
D	0023-087-000	Tapping Screw	3

Optional Foot Board Zone Cntrl/Bed Exit Module

3002-508-030

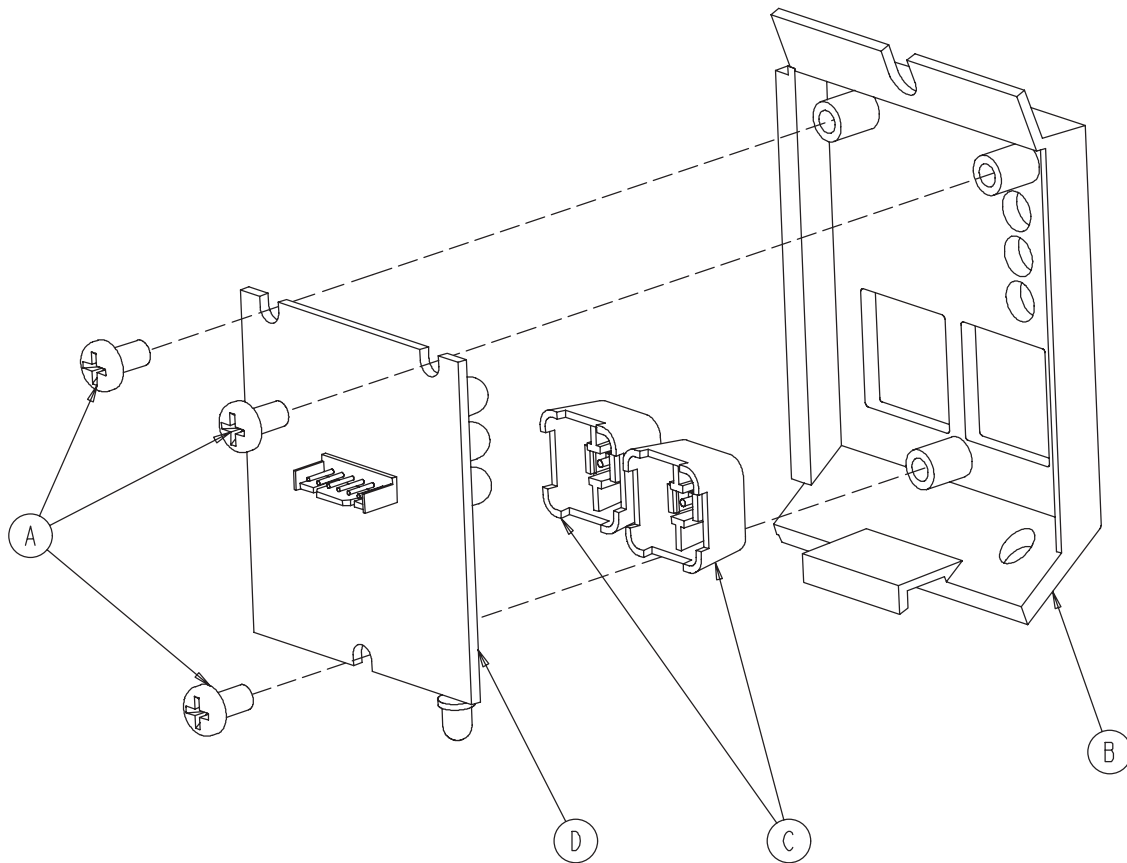

Item	Part No.	Part Name	Qty.
A	0023-087-000	Hi-Low Tapping Screw	3
B	3000-508-001	End Exit Module Panel	1
C	3001-400-953	Switch Cap	2
D	3002-508-900	Bed Exit Board	1

[Return To Table of Contents](#)

Foot Board Scale Module Assembly

3002-507-030

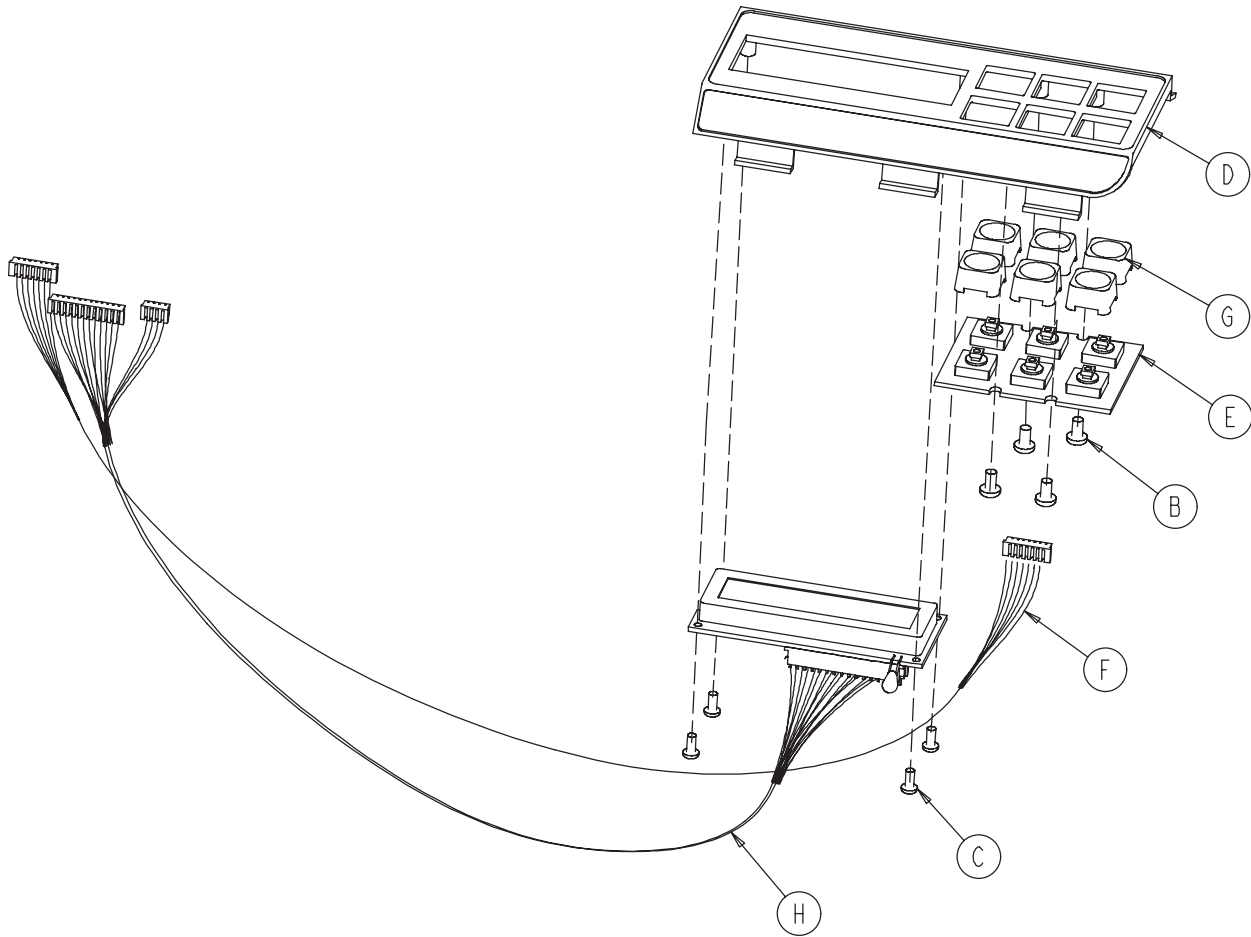

Item	Part No.	Part Name	Qty.
B	0023-087-000	Pan Head Hi-Lo Tapping Screw	4
C	0023-091-000	Pan Head Hi-Lo Tapping Screw	4
D	3001-507-001	Scale Module	1
E	3001-507-910	Scale Keypad	1
F	3001-507-800	Scale Keypad Cable	1
G	3001-400-953	Switch Cap	6
H	3002-507-900	Scale Display Cable	1

Foot Board Assembly, iBED Awareness Option, Std. Comp.

For Reference Only: 3004-500-010

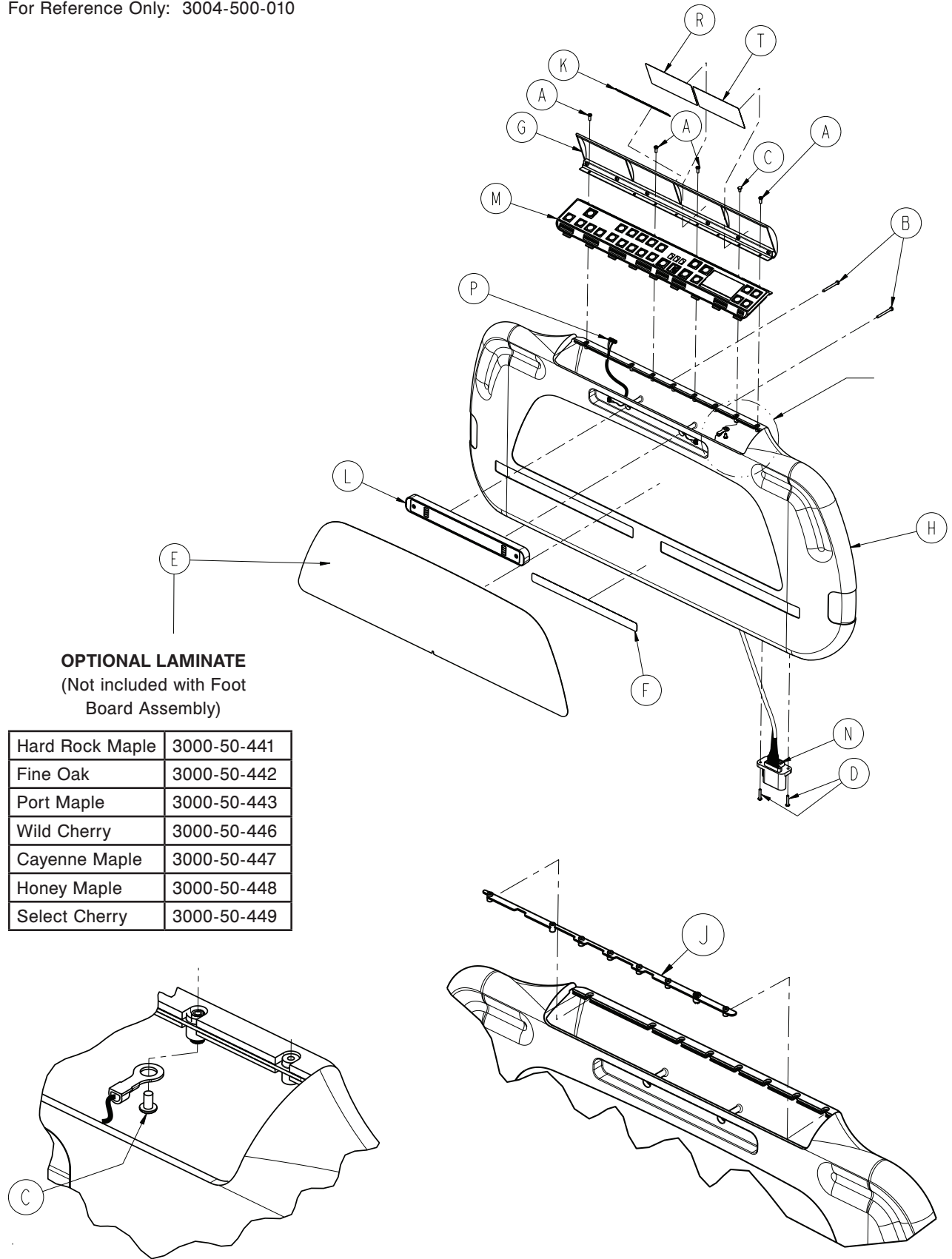

OPTIONAL LAMINATE
(Not included with Foot Board Assembly)

Hard Rock Maple	3000-50-441
Fine Oak	3000-50-442
Port Maple	3000-50-443
Wild Cherry	3000-50-446
Cayenne Maple	3000-50-447
Honey Maple	3000-50-448
Select Cherry	3000-50-449

[Return To Table of Contents](#)

Foot Board Assembly, iBED Awareness Option, Std. Comp.

3004-500-010 Foot Board Assembly, Standard Components, (iBed Awareness Option)

Item	Part No.	Part Name	Qty.
A	0023-103-000	Pan Head Hi - Low Tapping Screw	4
B	0023-118-000	Pan Head Screw	2
C	0050-039-000	Pan Head Screw	2
D	0050-039-000	Pan Head Screw	2
E	see table	Foot Board Laminate	1
F	3000-500-029	Hazard Label	1
G	3001-500-001	Lid Assembly	1
H	3001-500-010	Foot Board Assembly	1
J	3001-500-064	Hinge Plate	1
K	3002-500-025	Lid Label	1
L	3004-500-008	LBS Foot Board Indicator Light, Ass'y.	1
M	3004-553-011	LBS Foot Board PCB Assembly	1
N	3003-500-801	Foot Board CAN Cable	1
P	3003-500-804	Lens Foot Board Cable	1
R	3003-508-007	Scale Label	1
T	3003-508-008	Bed Status Label	1

Foot Board Assembly, iBED Awareness Option w/Bed Exit

3004-500-012

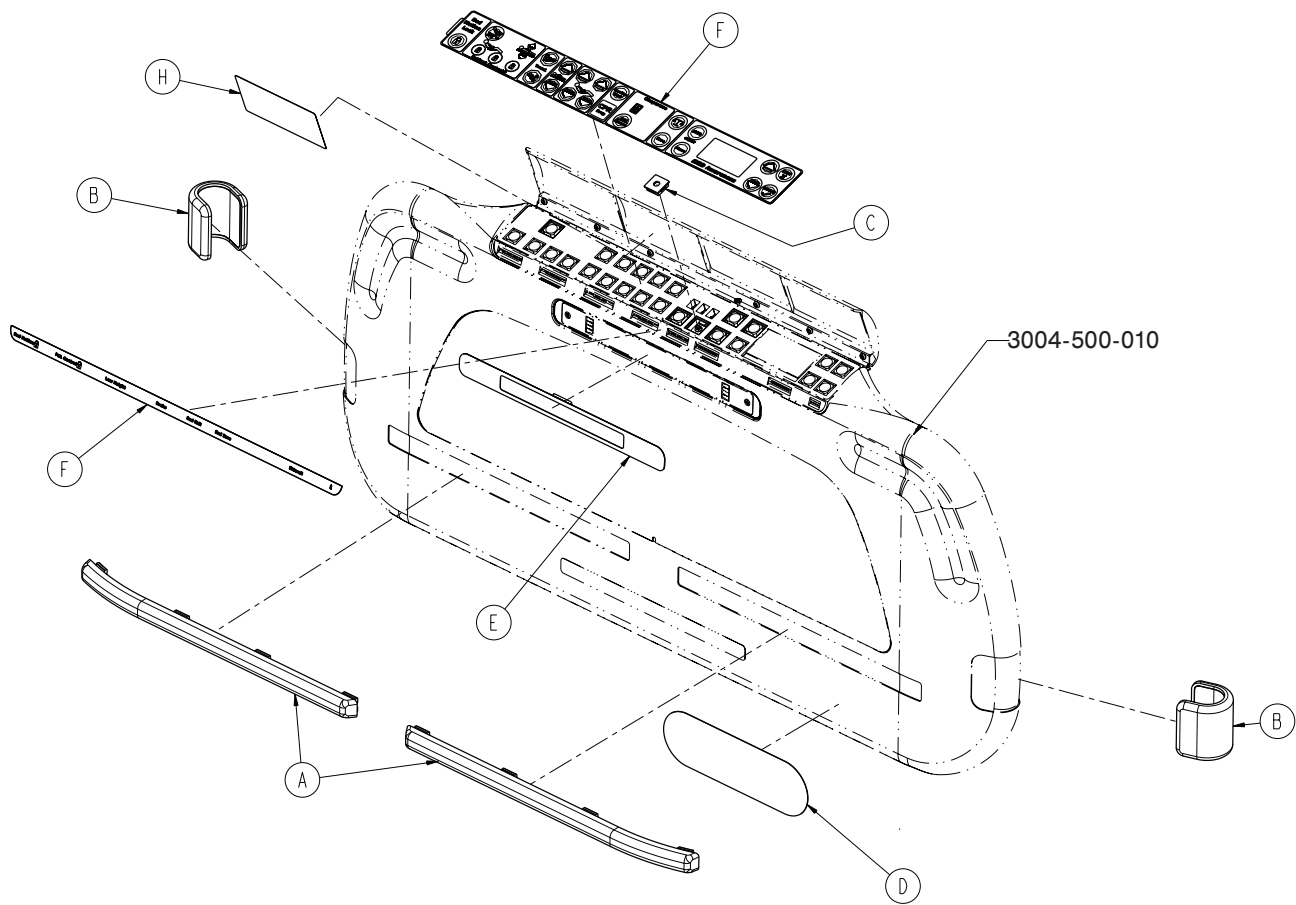

Item	Part No.	Part Name	Qty.
A	2025-000-105	Bumper Strip	2
B	3002-500-007	"C" Bumper	2
C	3001-400-522	Filler Cap	1
D	3002-500-601	Secure II Label	1
E	3003-508-004	iBed Awareness, Foot Board Lens Label	1
F	3003-508-003	Footboard Module Bed Exit Label	1
H	3003-508-006	Bed Exit Label	1

[Return To Table of Contents](#)

Foot Board Assembly, iBED Awareness Option w/Zone Control

3004-500-011

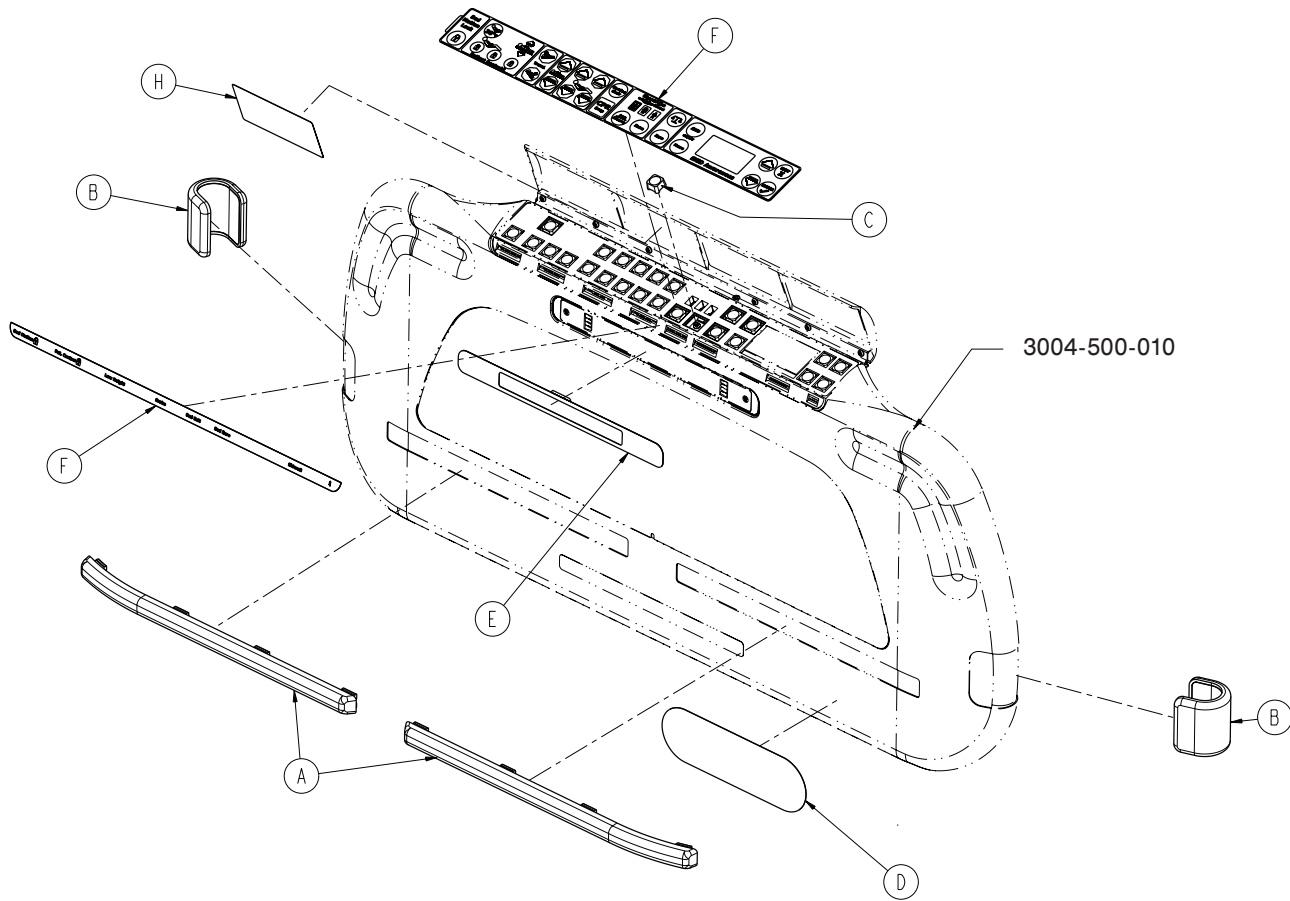

Item	Part No.	Part Name	Qty.
A	2025-000-105	Bumper Strip	2
B	3002-500-007	"C" Bumper	2
C	3001-400-953	Switch Cap	1
D	3002-500-601	Secure II Label	1
E	3003-508-004	iBed Awareness, Foot Board Lens Label	1
F	3003-508-002	Footboard Module Zone Control Label	1
H	3003-508-009	Bed Exit With Zone Control Label	1

Head Board Assembly

3002-600-000

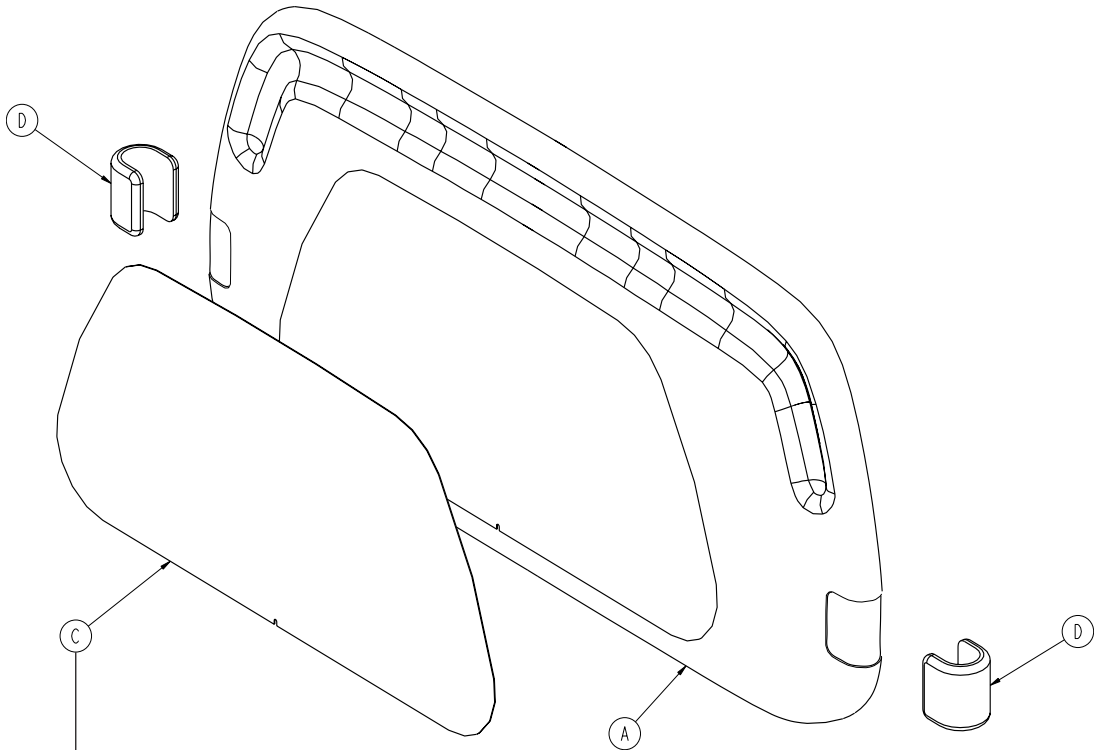

OPTIONAL LAMINATE
(Not included with Head Board Assembly)

Hard Rock Maple	3000-60-441
Fine Oak	3000-60-442
Port Maple	3000-60-443
Wild Cherry	3000-60-446
Cayenne Maple	3000-60-447
Honey Maple	3000-60-448
Select Cherry	3000-60-449

Item	Part No.	Part Name	Qty.
A	3000-600-010	Clamshell Assembly	1
C	see table	Headboard Laminate	1
D	3002-500-007	C-Bumper	2

[Return To Table of Contents](#)

Optional CPR Board Assembly

3000-526-010

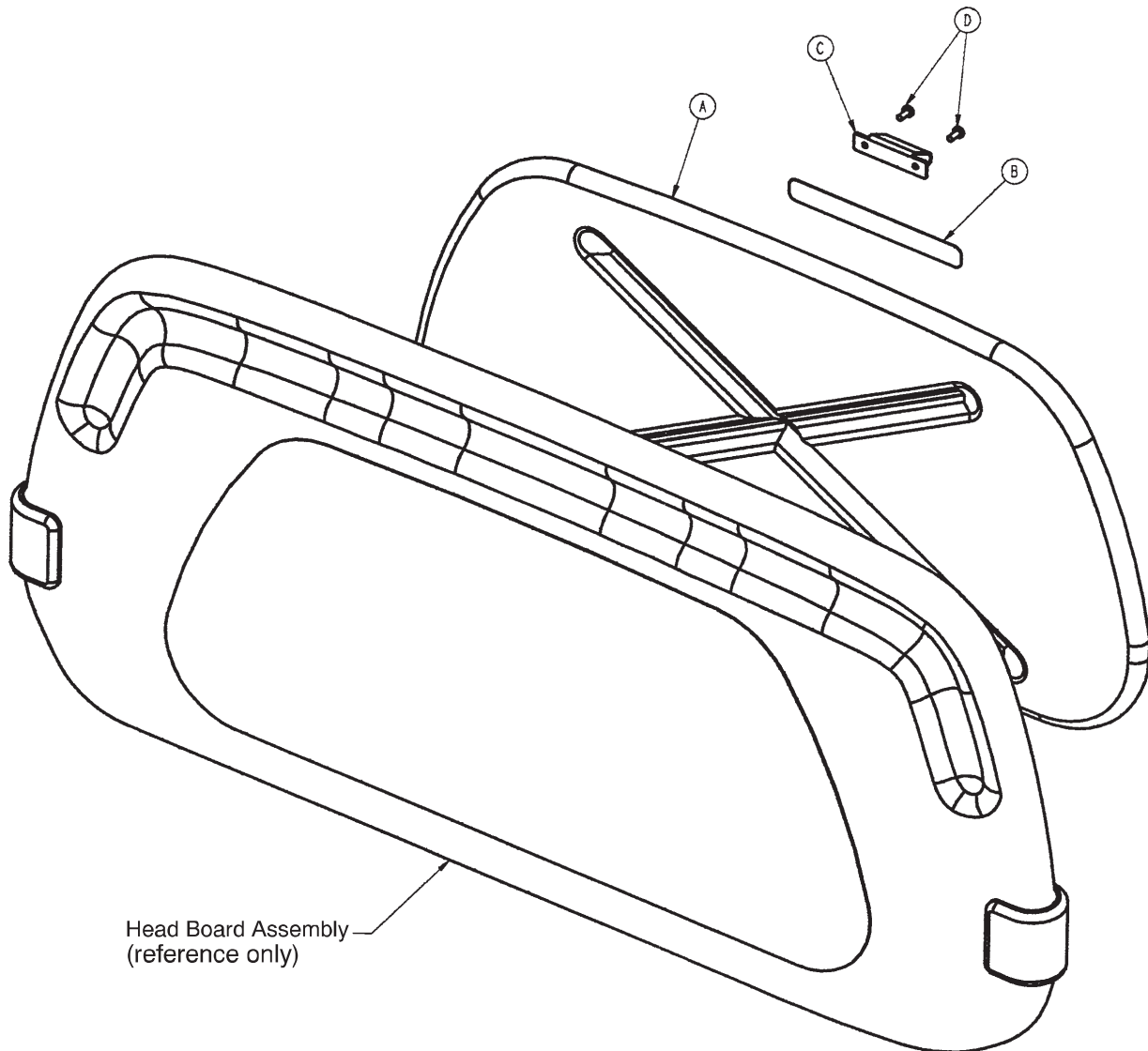

Head Board Assembly
(reference only)

Item	Part No.	Part Name	Qty.
A	3000-526-001	CPR Board	1
B	3000-526-003	CPR Board Label	1
C	3000-526-002	CPR Head Board Clip	1
D	0023-088-000	Pan Head Tapping Screw	2

Optional Removable I.V. Pole and Mounting Assembly

3001-338-010

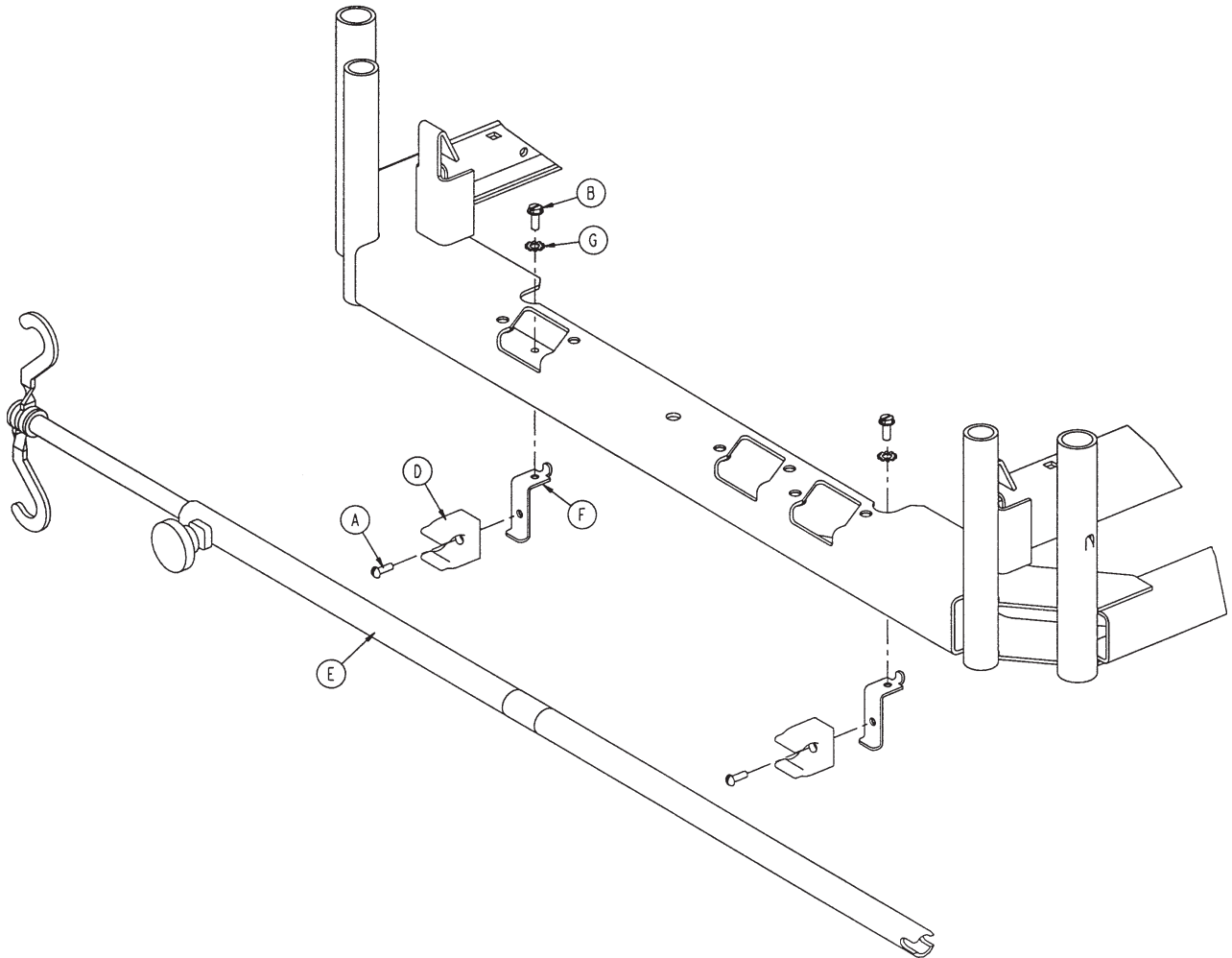

Item	Part No.	Part Name	Qty.
A	0002-031-000	Round Head Screw	2
B	0003-124-000	Hex Washer Head Screw	2
D	0958-001-224	I.V. Clip	2
E	3000-300-080	I.V. Pole Assembly	1
F	3001-300-087	Mounting Bracket	2
G	0013-018-000	External Tooth Lock Washer	2

[Return To Table of Contents](#)

Removable I.V. Pole Assembly

3000-300-080

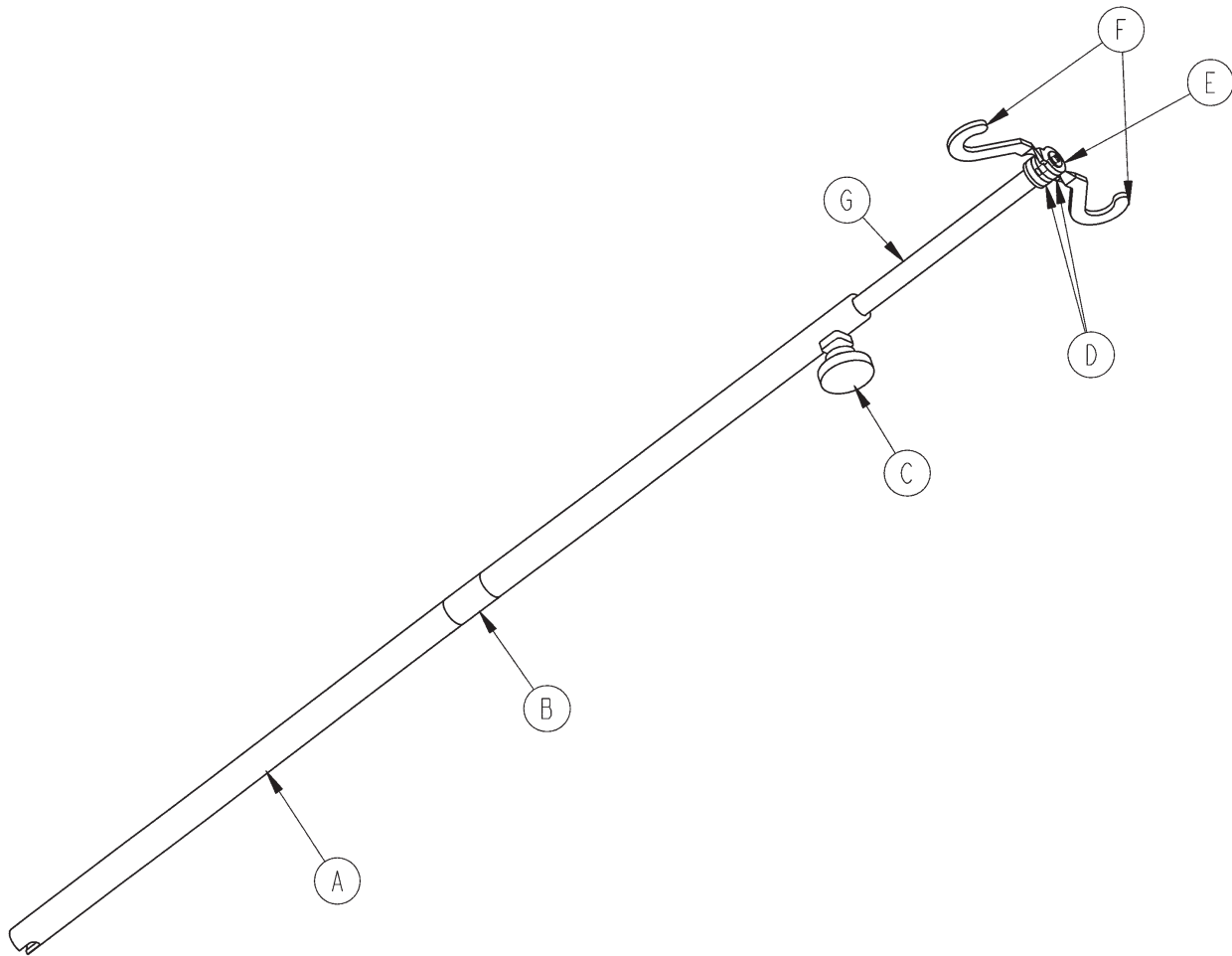

Item	Part No.	Part Name	Qty.
A	3000-300-081	Outer Tube	1
B	3000-300-089	Label	1
C	0024-050-000	Fluted Knob	1
D	0052-017-000	Spacer	2
E	0007-040-000	Phillips Truss Head Screw	1
F	1010-059-016	I.V. Hook	2
G	3000-300-085	Inner Tube Assembly	1

Optional 2-Stage I.V. Pole Assembly

2035-112-000

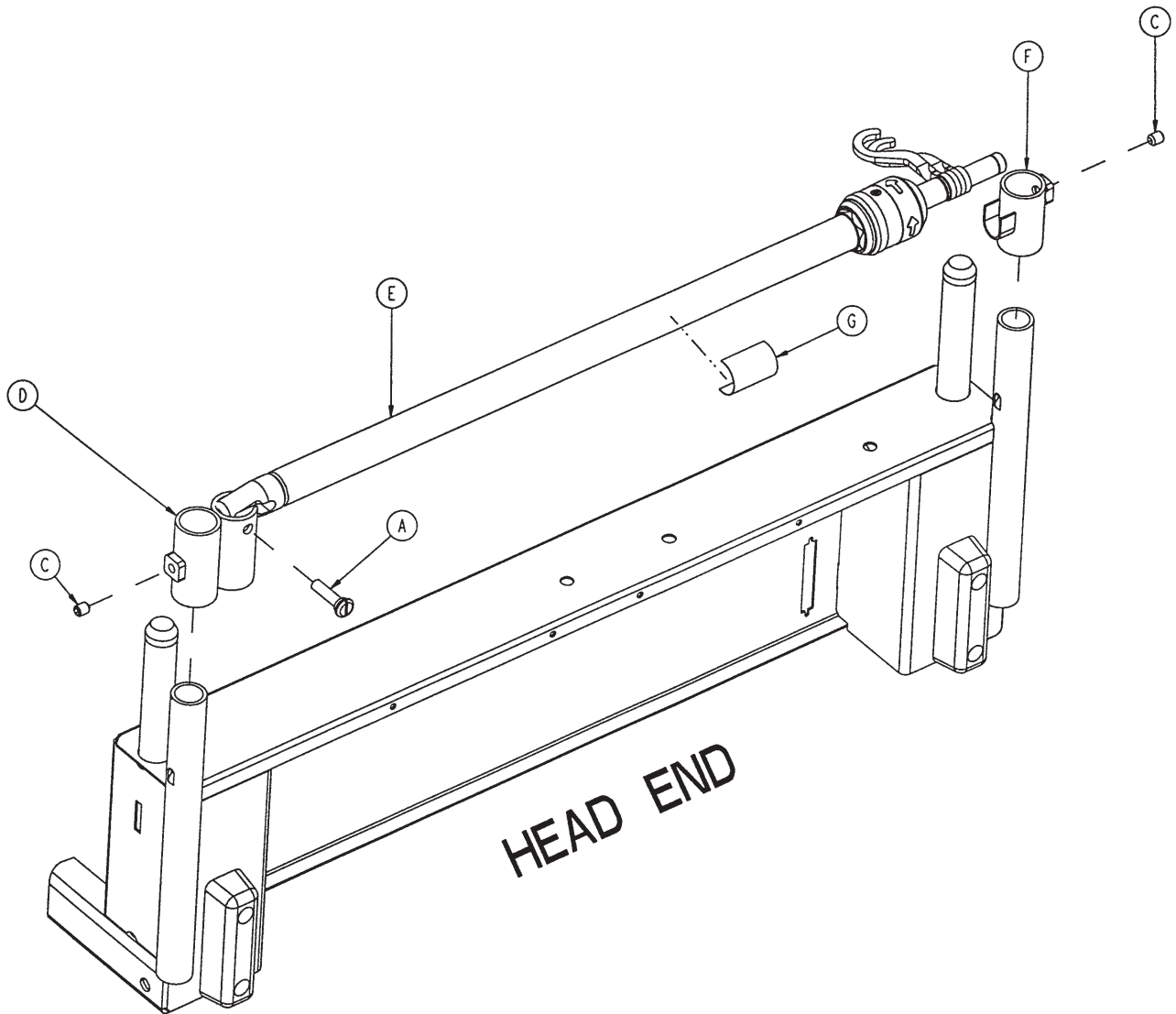

Item	Part No.	Part Name	Qty.
A	1015-024-035	Retaining Pin	1
C	0021-140-000	Set Screw	2
D	2035-112-001	I.V. Receptacle, HE, Left	1
E	2035-112-010	I.V. Pole Assembly, HE, Left (pg.304)	1
F	3000-311-016	I.V. Rest	1
G	2035-112-110	Specification Label	1

[Return To Table of Contents](#)

Optional Dual Head End I.V. Pole Assembly

2035-113-000

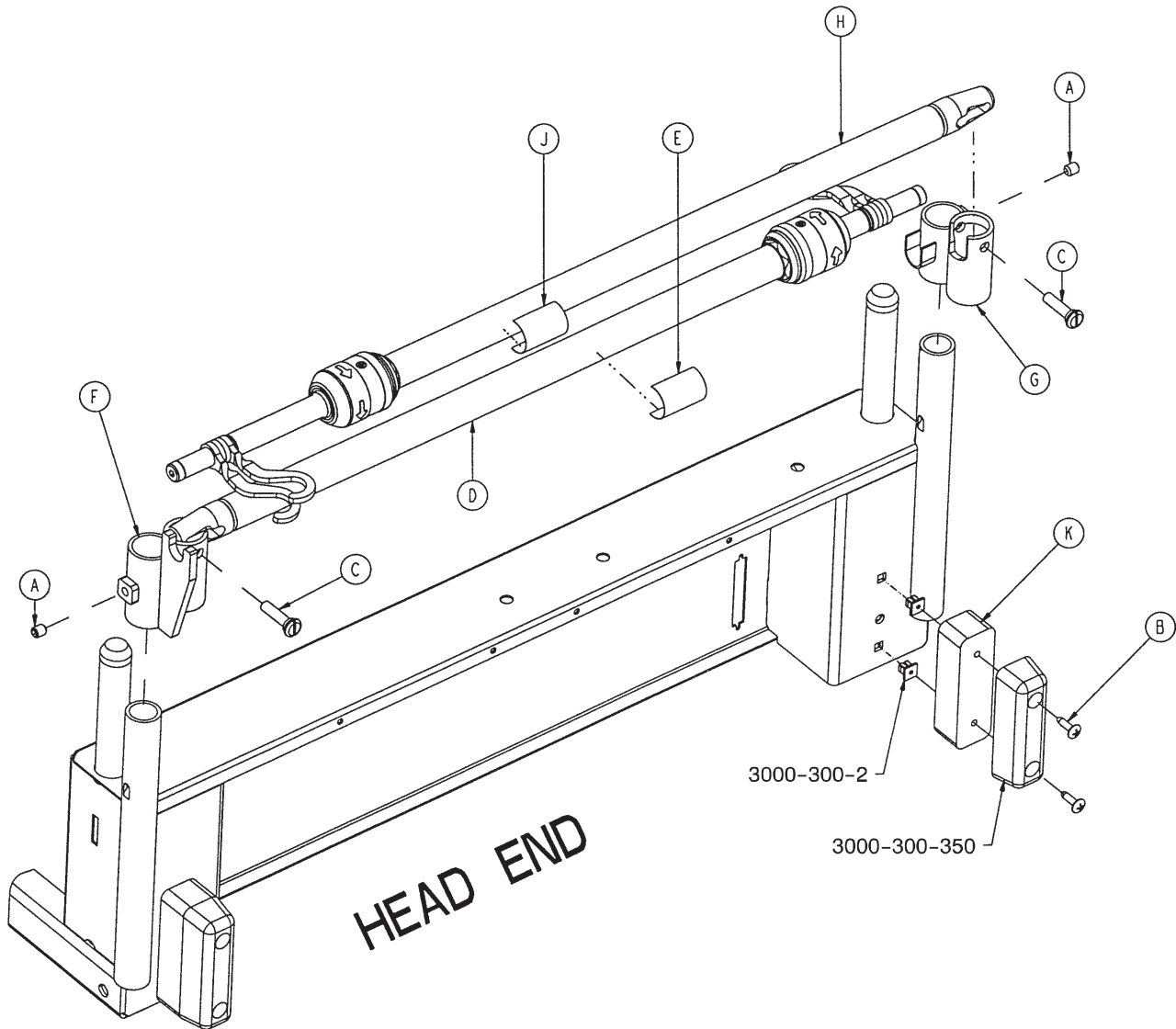

Item	Part No.	Part Name	Qty.
A	0021-140-000	Set Screw	2
B	0023-277-000	Truss Head Screw	4
C	1015-024-035	Retaining Pin	2
D	2035-112-010	I.V. Pole Assembly, HE, Left (pg.304)	1
E	2035-112-110	Specification Label	1
F	2035-113-002	I.V. Receptacle, Dual HE, Left	1
G	2035-113-001	I.V. Receptacle, Dual HE, Right	1
H	2035-113-011	I.V. Pole Assembly, HE, Right	1
J	2035-113-111	Specification Label	1
K	2035-113-006	Head End Bumper Spacer	2

Optional Dual Head End I.V. Pole Assembly

2040-110-003

FOR ZOOM® OPTION ONLY

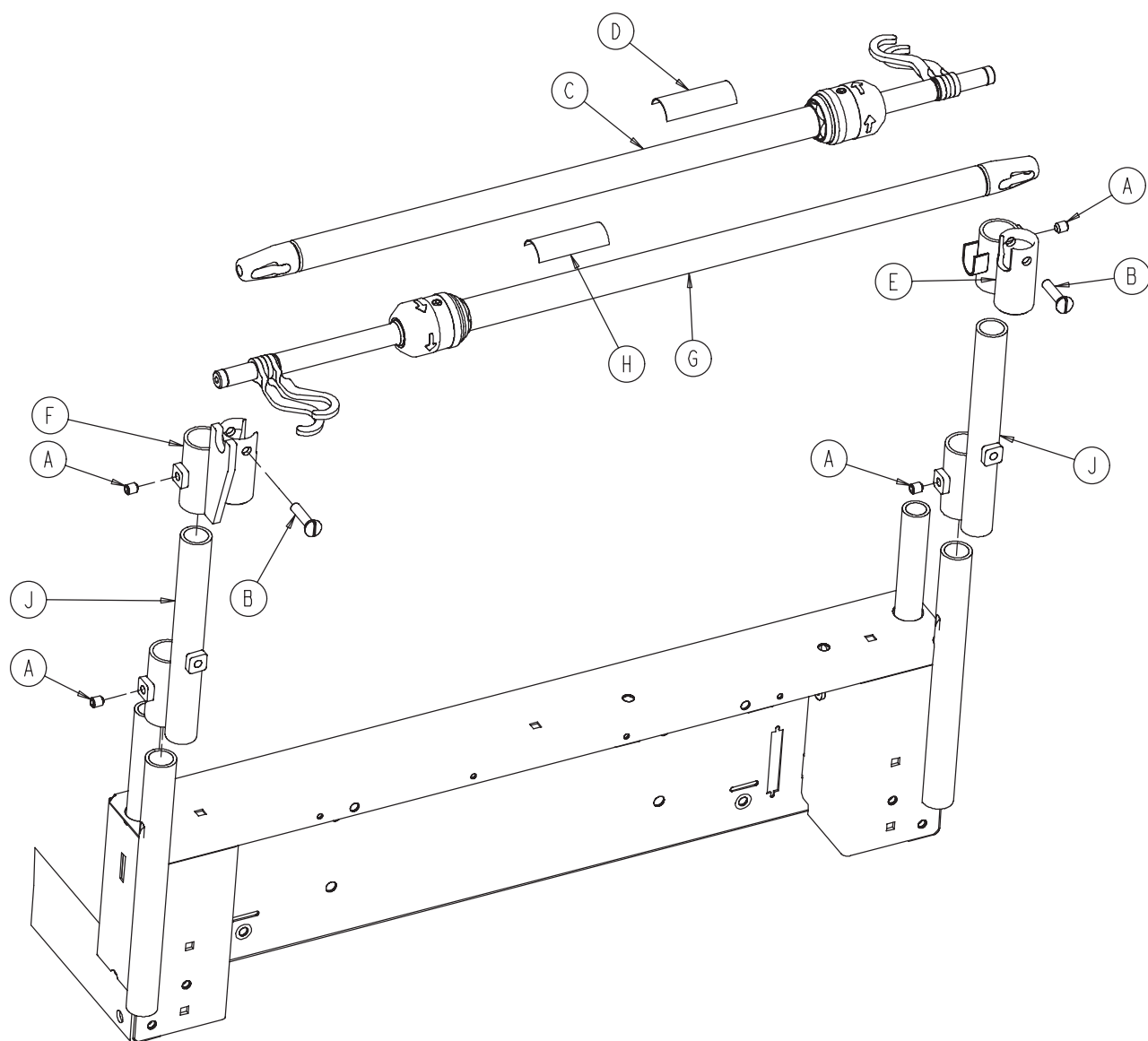

Item	Part No.	Part Name	Qty.
A	0021-140-000	Set Screw	4
B	1015-024-035	Retaining Pin	2
C	2035-112-010	I.V. Pole Assembly, Left (pg.304)	1
D	2035-11-110	Specification Label	1
E	2035-113-002	I.V. Receptacle, Dual HE, Right	1
F	2035-113-001	I.V. Receptacle, Dual HE, Left	1
G	2035-113-011	I.V. Pole Assembly, Right (pg.304)	1
H	2035-113-111	Specification Label	1
J	2040-110-002	I.V. Pole Extension	2

[Return To Table of Contents](#)

2-Stage I.V. Pole

2035-112-010 & 2035-113-011

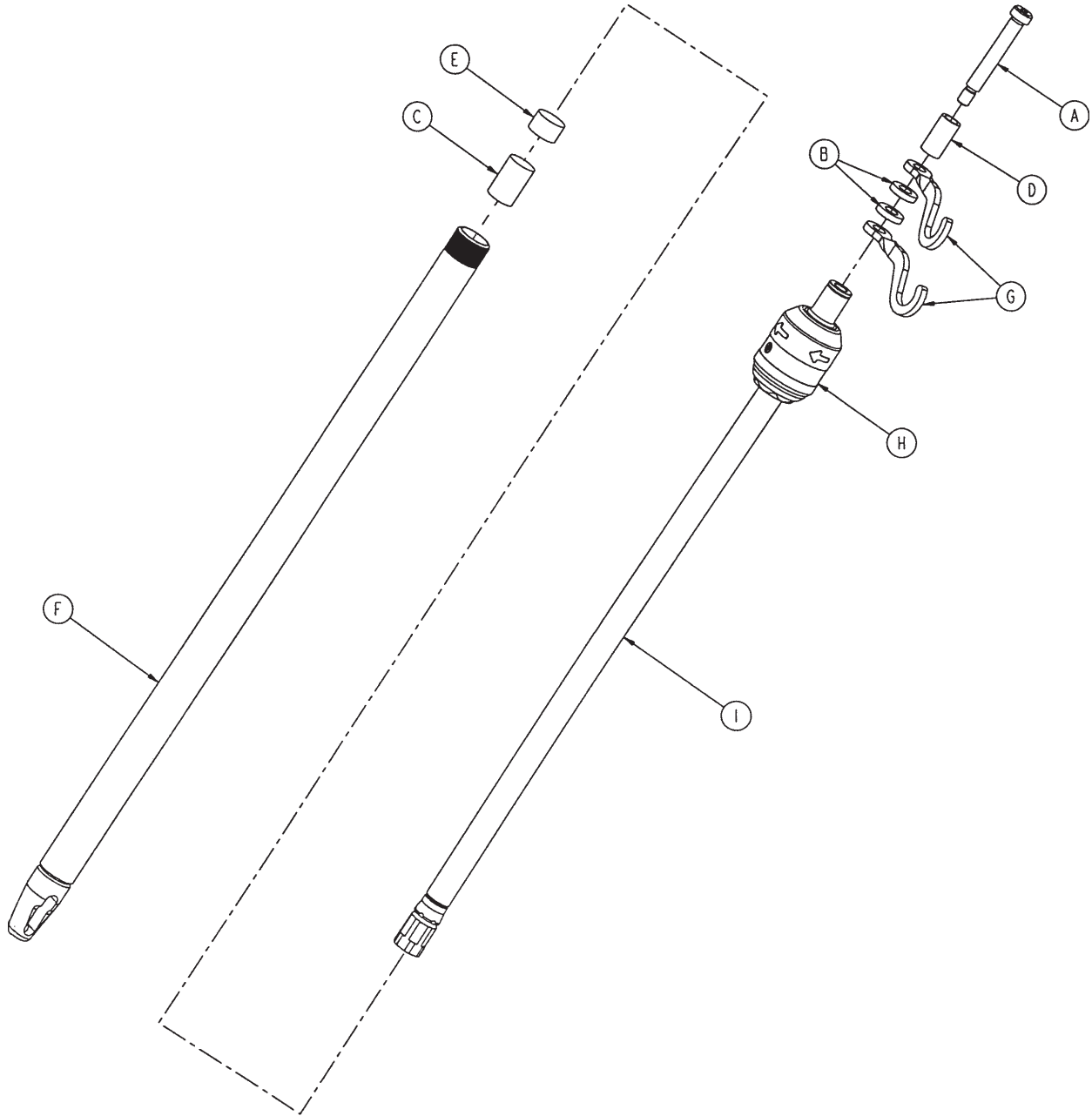

Left Side - 2035-112-010

Right Side - 2035-113-011

Item	Part No.	Part Name	Qty	Item	Part No.	Part Name	Qty.
A	0008-031-000	Socket Head Shoulder Screw	1	A	0008-031-000	Socket Head Shoulder Screw	1
B	0052-017-000	Washer	2	B	0052-017-000	Washer	2
C	0052-310-000	Spacer	1	C	0052-311-000	Spacer	1
D	0926-400-162	Spacer	1	D	0926-400-162	Spacer	1
E	1001-259-013	Dampener	1	E	1001-259-013	Dampener	1
F	1001-259-032	Base Tube Weldment	1	F	1001-259-032	Base Tube Weldment	1
G	1010-259-016	I.V. Hook	2	G	1010-259-016	I.V. Hook	2
H	0785-035-103	I.V. Pole Latch (pg.305)	1	H	0785-035-103	I.V. Pole Latch (pg.305)	1
I	1211-110-029	2nd Stage Assembly	1	I	1211-110-029	2nd Stage Assembly	1

[Return To Table of Contents](#)

I.V. Pole Latch Assembly

0785-035-103

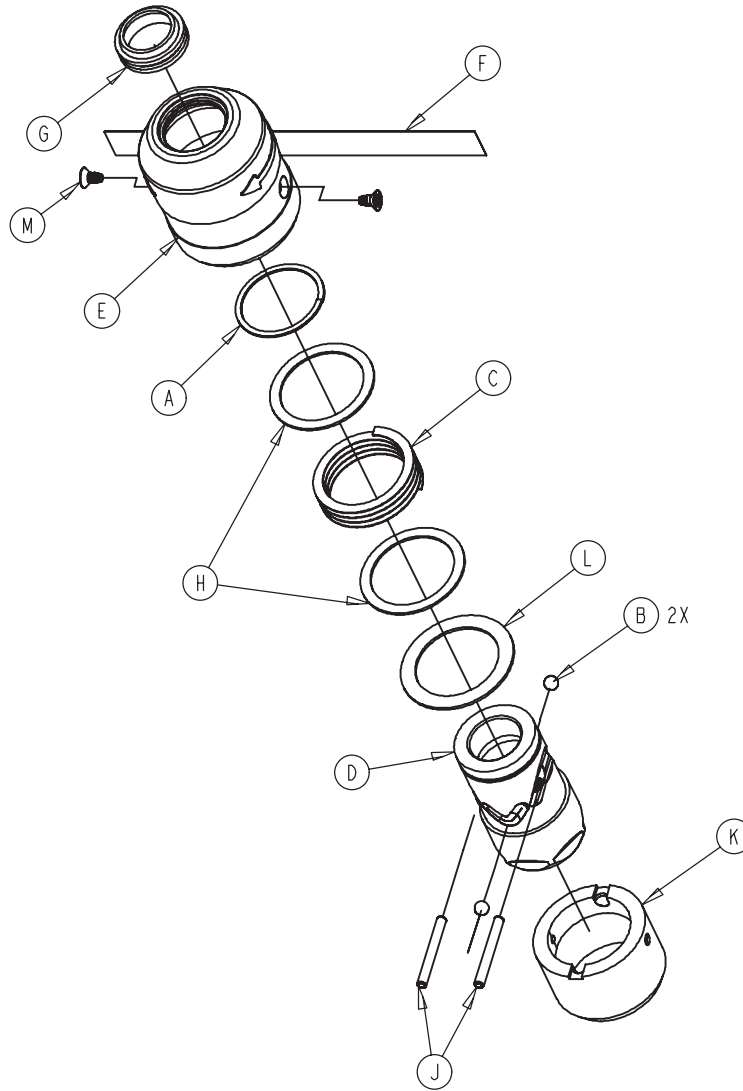

Item	Part No.	Part Name	Qty.
A	0028-167-000	Retaining Ring	1
B	0031-004-000	Steel Ball	2
C	0038-392-000	Wave Spring	1
D	0785-035-023	I.V. Latch ID Housing	1
E	0785-035-024	I.V. Latch OD Housing	1
F	0785-035-029	I.V. Release Label	2
G	1211-011-018	I.V. Latch Seal	2
H	1211-110-020	Washer	2
J	1211-110-021	I.V. Latch Locking Pin	2
K	1211-110-022	I.V. Latch Guide	1
L	1211-110-035	Washer	1
M	1211-110-036	Self-Tapping Screw	2

[Return To Table of Contents](#)

Optional Defibrillator Tray Assembly

2025-120-000

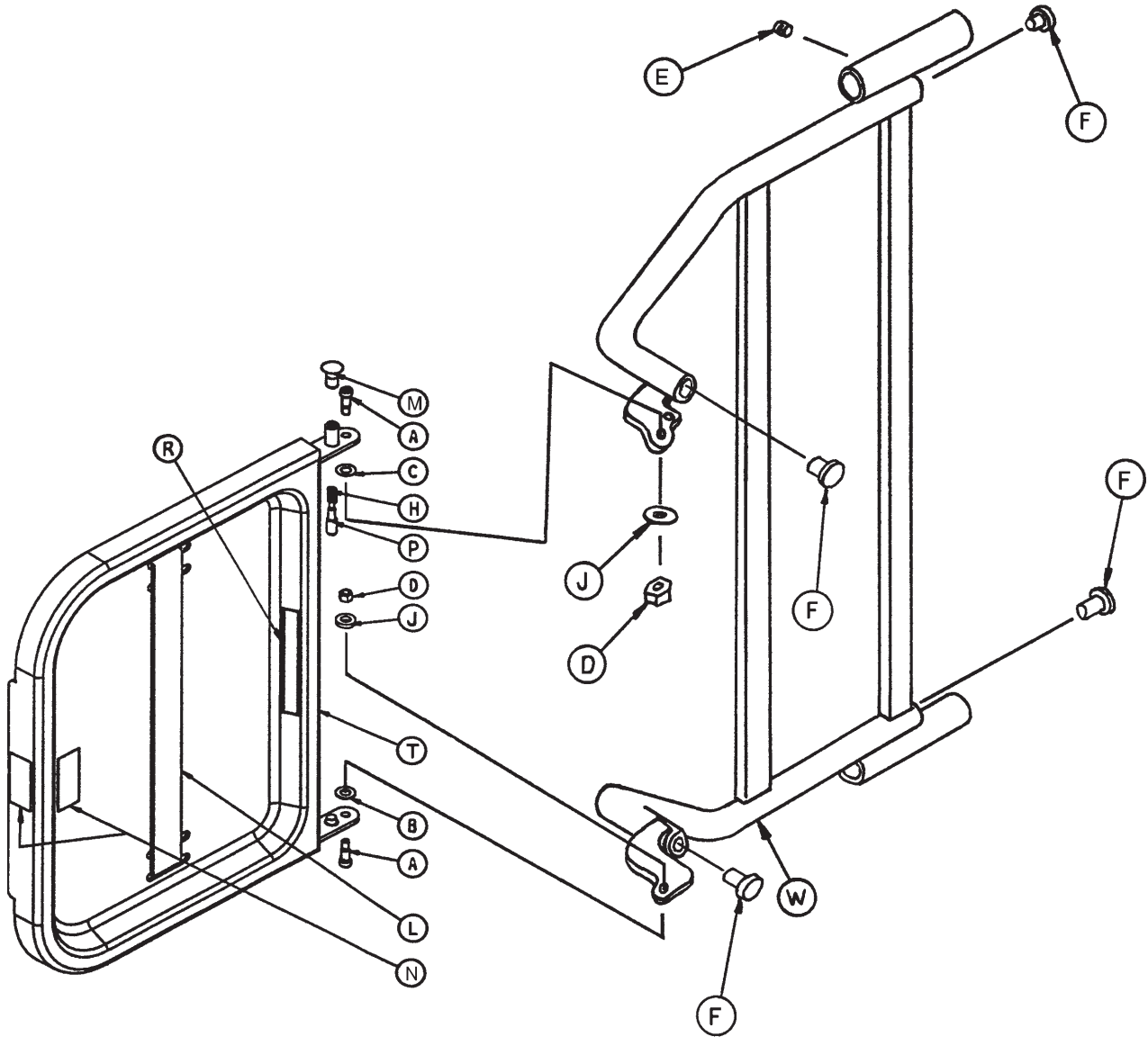

Item	Part No.	Part Name	Qty.	Item	Part No.	Part Name	Qty.
A	0008-049-000	Socket Head Shoulder Bolt	2	L	1010-050-021	Long Strap	1
B	0014-020-000	Thrust Washer	1	M	1010-050-050	Knob	1
C	0014-021-000	Thrust Washer	1	N	1010-050-057	Maximum Weight Label	4
D	0016-028-000	Fiberlock Nut	2	P	1010-050-242	Lock Pin	1
E	0021-017-000	Set Screw	4	R	2025-120-005	Equipment Label	1
F	0037-214-000	Hole Plug	4	S	2025-120-006	Specification Label	1
H	0038-133-000	Spring	1	T	2025-120-018	Tray Assembly	1
J	0052-017-000	Spacer	2	W	2025-120-025	Pivot Weldment Frame	1
K	1010-050-019	"Push/Pull" Label	1				

Optional Pleur-Evac Rack Assembly

2040-120-020

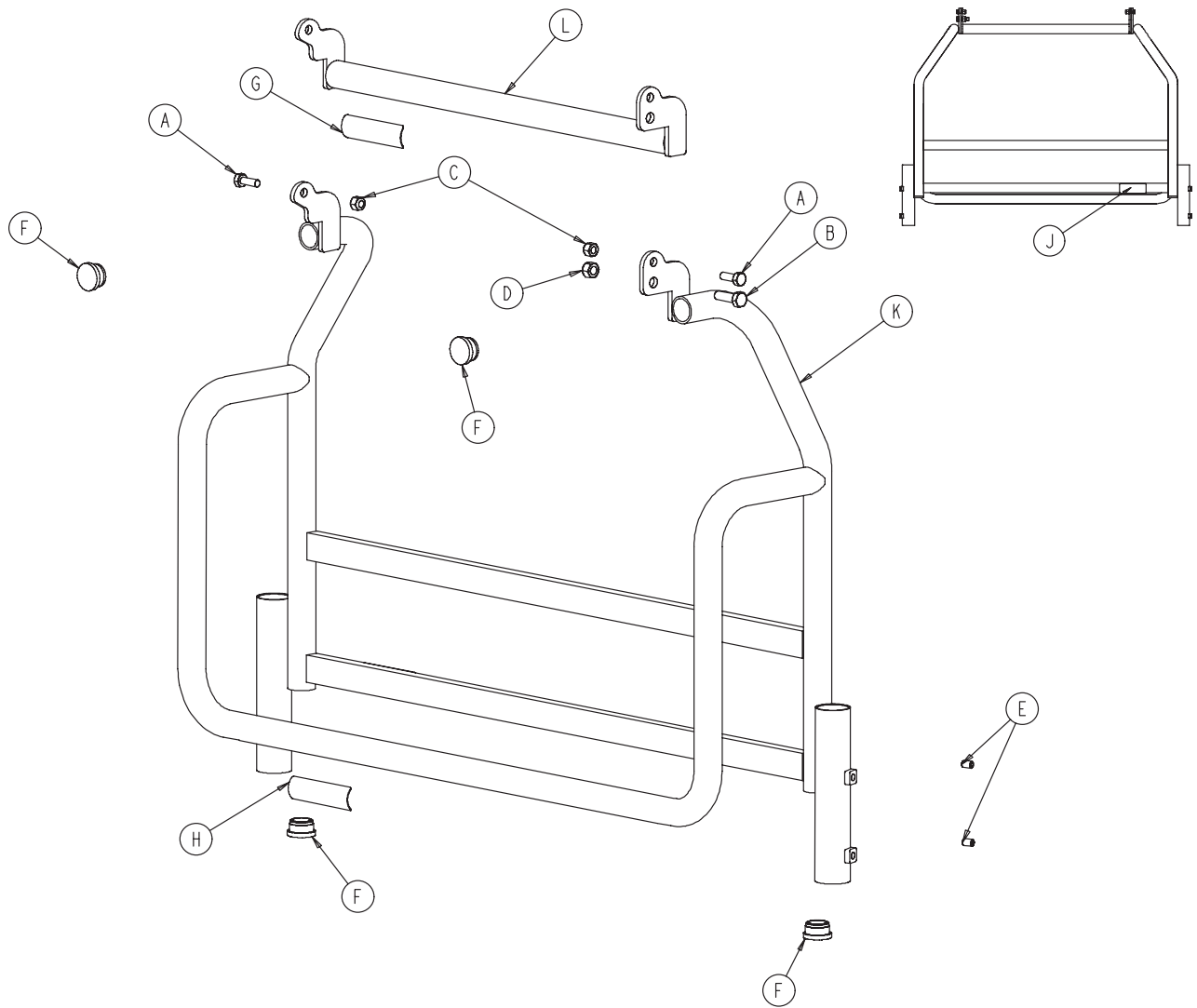

Item	Part No.	Part Name	Qty.
A	0003-050-000	Hex Head Cap Screw	2
B	0003-085-000	Hex Head Cap Screw	1
C	0015-028-000	Nylock Nut	2
D	0016-036-000	Nylock Nut	1
E	0021-017-000	Set Screw	4
F	0037-214-000	Hole Plug	4
G	1010-050-057	Maximum Weight Label	1
H	2040-090-001	Accessory Rail Warning Label	1
J	2040-090-004	Specification Label	1
K	2040-120-003	Rack Weldment	1
L	2040-120-010	Rack Top Weldment	1

[Return To Table of Contents](#)

Optional Pleur-Evac Rack with Defibrillator Tray

2040-120-004

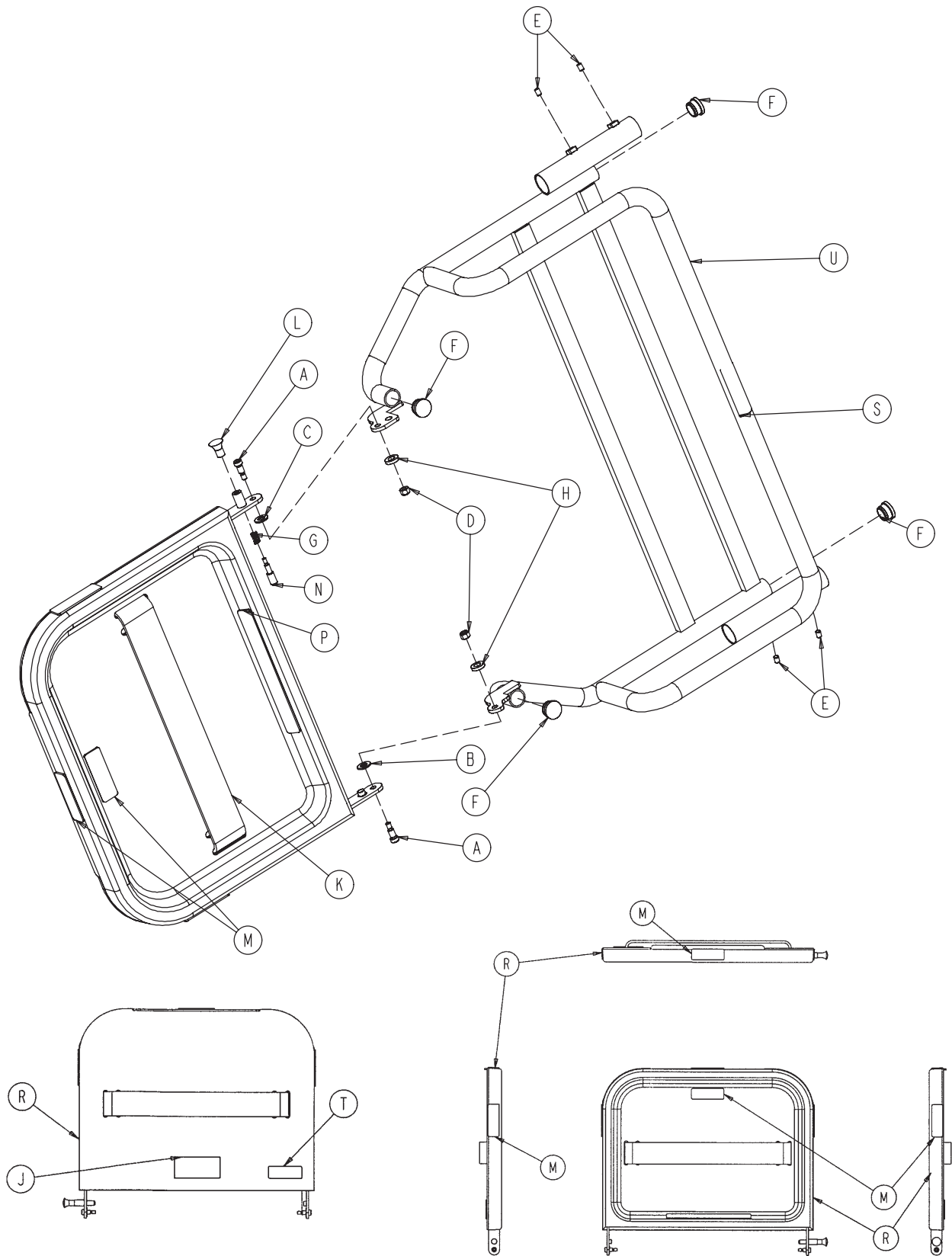

Optional Pleur-Evac Rack with Defibrillator Tray

2040-120-004

Item	Part No.	Part Name	Qty.
A	0008-049-000	Socket Head Shoulder Bolt	2
B	0014-020-000	Thrust Washer	1
C	0014-021-000	Thrust Washer	1
D	0016-028-000	Fiberlock Nut	2
E	0021-017-000	Set Screw	4
F	0037-214-000	Hole Plug	4
G	0038-133-000	Spring	1
H	0052-017-000	Spacer	2
J	1010-050-019	"Push/Pull" Label	1
K	1010-050-021	Long Strap	1
L	1010-050-050	Knob	1
M	1010-050-057	"Max. Weight" Label	4
N	1010-050-242	Lock Pin	1
P	2025-120-005	Equipment Label	1
R	2025-120-018	Tray Assembly	1
S	2040-090-001	Warning Label	1
T	2040-090-005	Specification Label	1
U	2040-120-003	Rack Weldment	1

Optional Pump Rack Assembly

2040-111-000

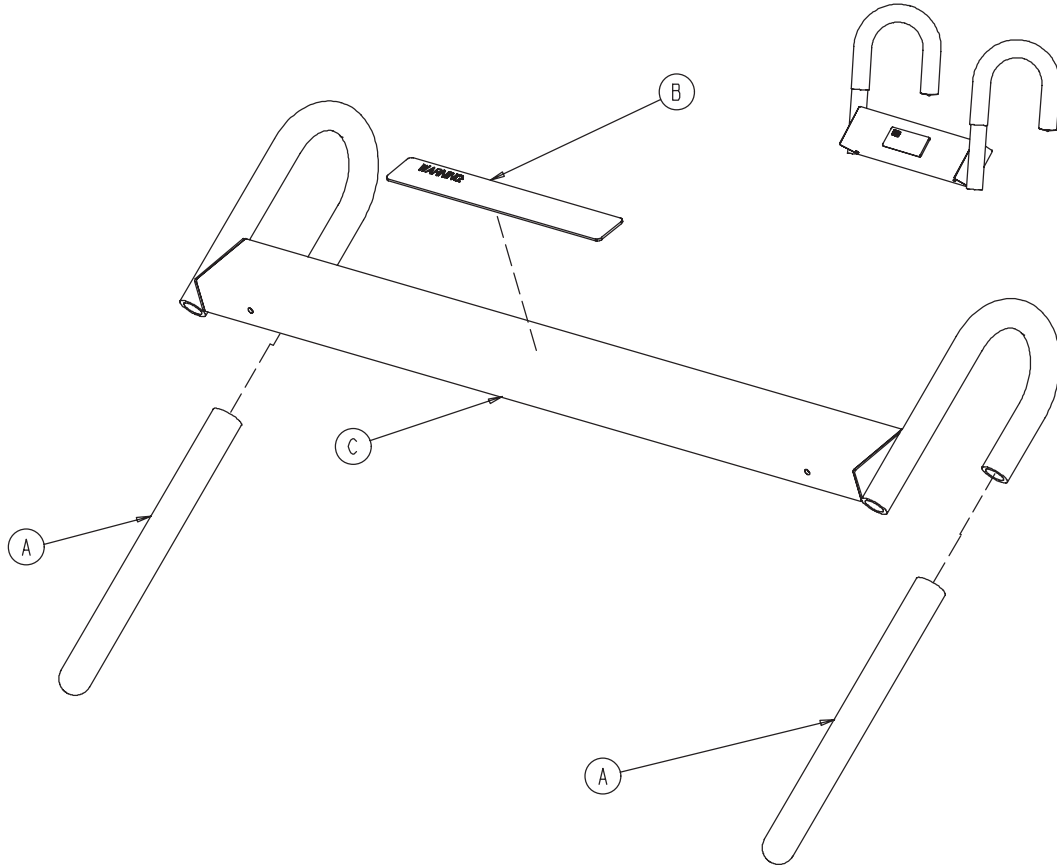

Item	Part No.	Part Name	Qty.
A	0058-087-000	End Cap	2
B	2030-140-002	Pump Rack Label	1
C	2040-111-005	Pump Rack Tube	1

Optional 90° Power Cord

3001-334-010

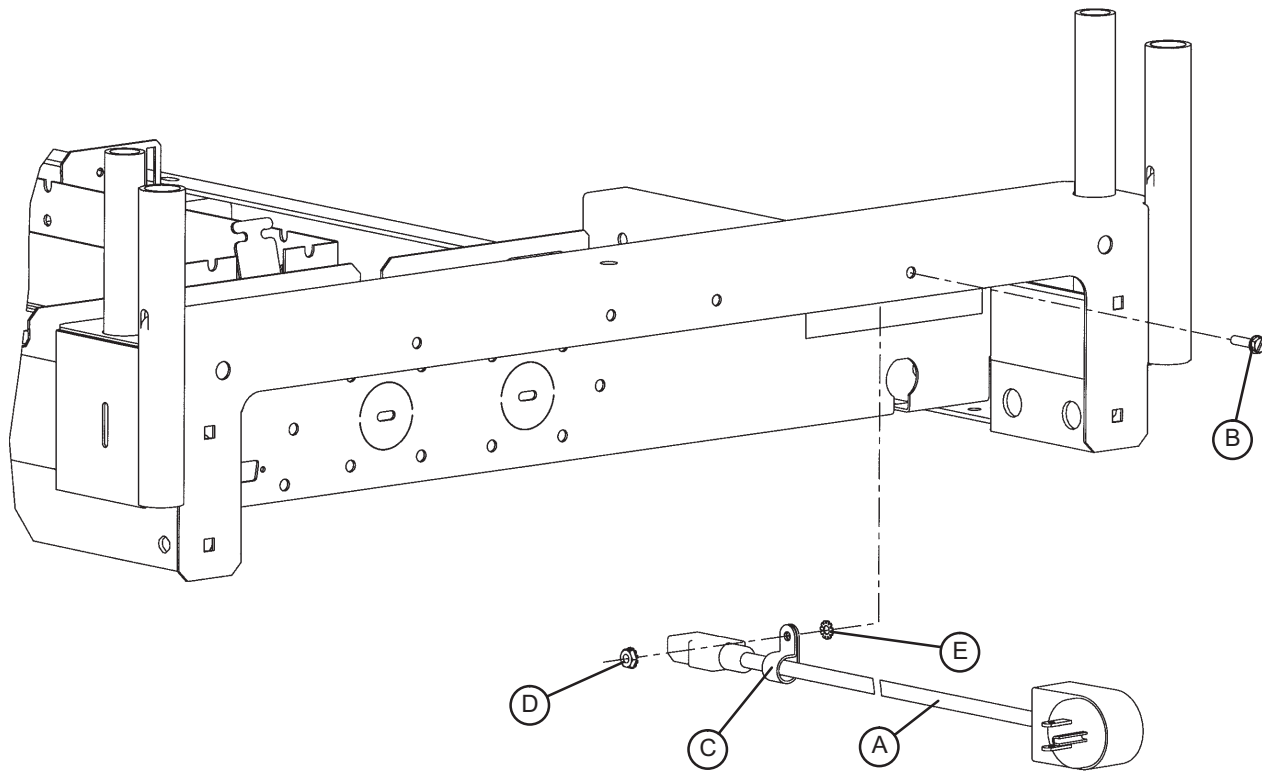

Item	Part No.	Part Name	Qty.
A	3001-334-860	90 Power Cord (12 O'Clock)	1
	3001-334-861	90 Power Cord (9 O'Clock)	1
	3001-334-862	90 Power Cord (6 O'Clock)	1
	3001-334-863	90 Power Cord (3 O'Clock)	1
B	0003-132-000	Hex Washer Head Screw	1
C	0034-022-000	Cable Clamp	1
D	0016-041-000	KePIN Nut	1
E	0013-018-000	External Tooth Lock Washer	1

[Return To Table of Contents](#)

Optional Upright O2 Bottle Holder Assembly

2025-150-010

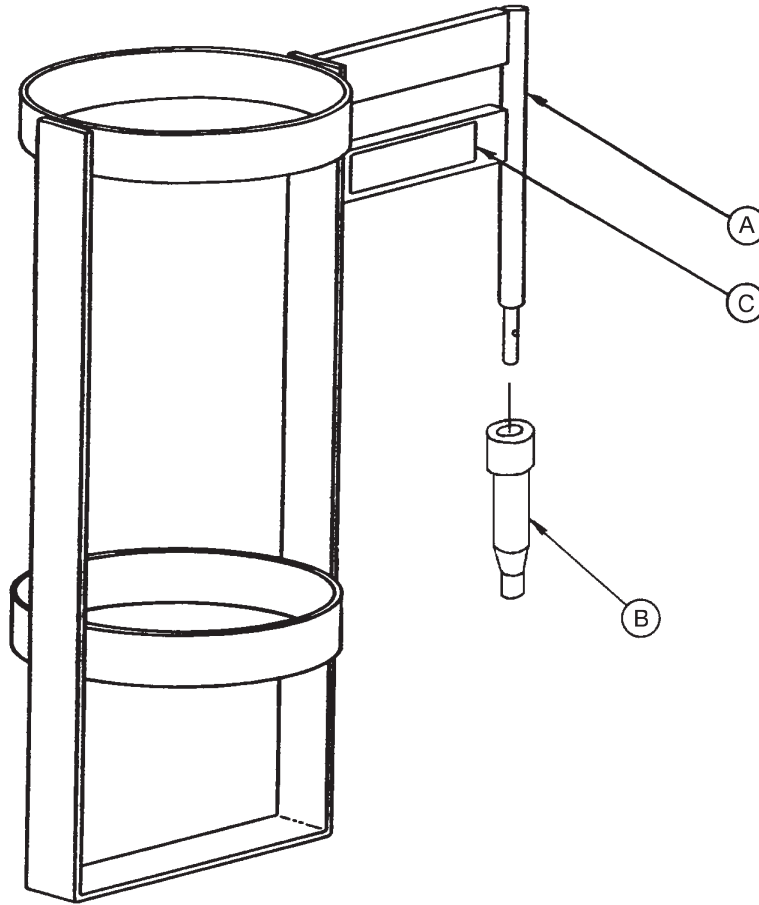

Item	Part No.	Part Name	Qty.
A	1010-030-011	Upright Bottle Holder	1
B	2025-150-001	Bottle Holder Adapter	1
C	2025-150-002	Specification Label	1

Optional Accessory Adapter Frame

3001-333-000

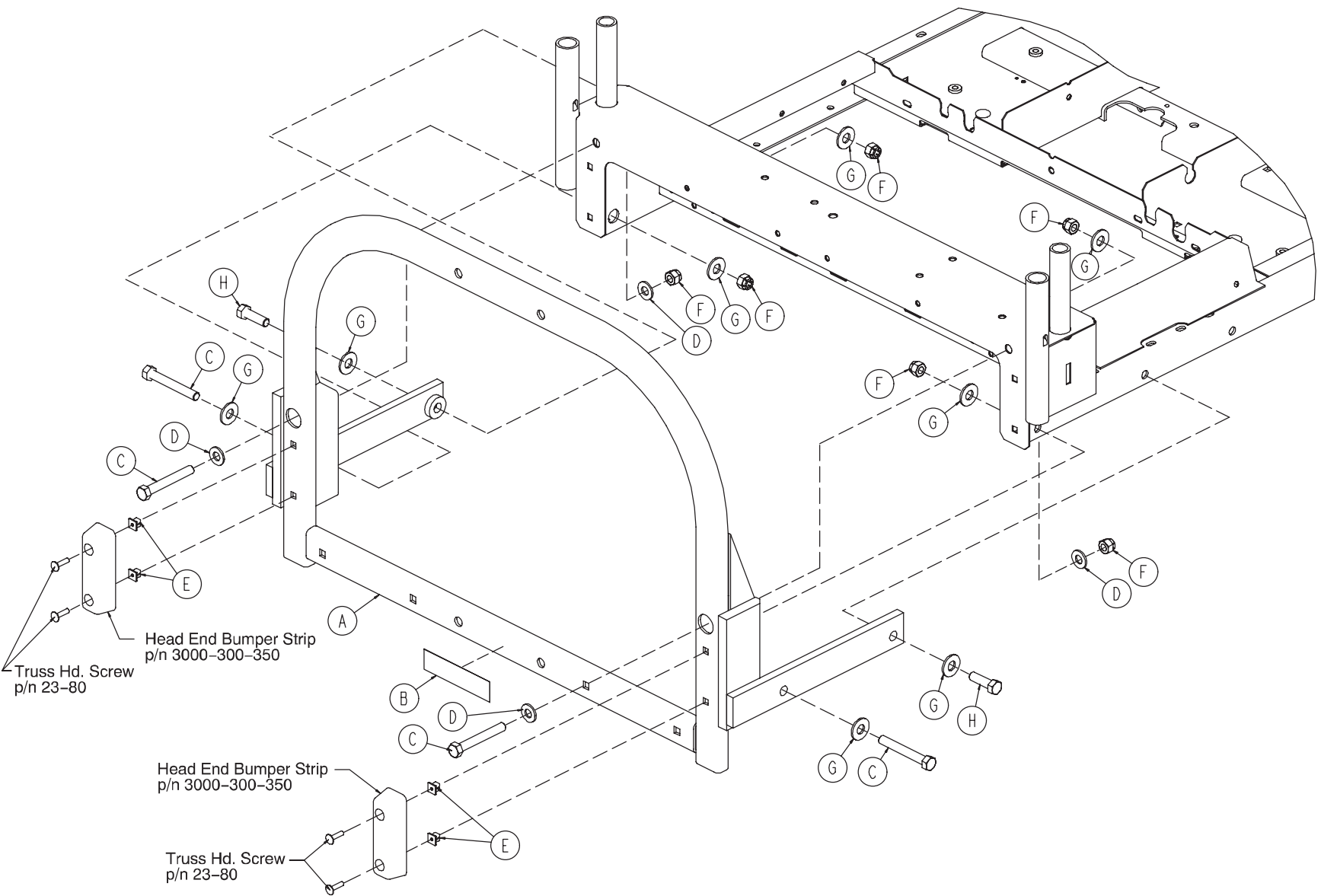

Optional Accessory Adapter Frame

3001-333-000

Item	Part No.	Part Name	Qty.
A	3001-333-010	Frame Assembly	1
B	3000-333-015	Accessory Adapter Label	1
C	0003-208-000	Hex Head Cap Screw	4
D	0011-004-000	Flat Washer	4
E	3000-300-002	Plastic Clip Nut	4
F	0016-035-000	Nylock Nut	6
G	0011-361-000	Flat Washer	8
H	0003-025-000	Hex Head Cap Screw	2

Optional Litter Roller Assembly

3002-335-000

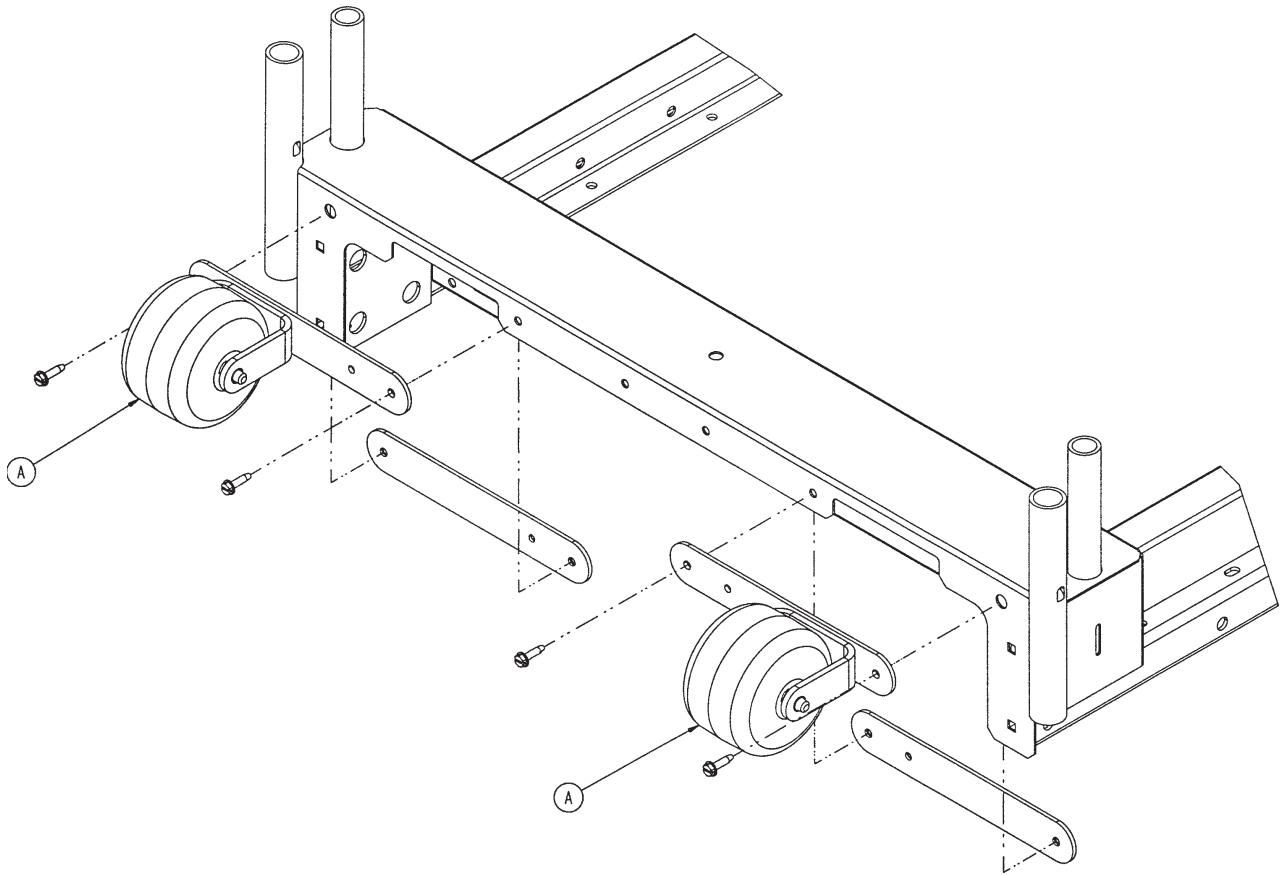

Item	Part No.	Part Name	Qty.
A	3002-335-005	Roller Assembly (pg. 316)	2

Roller Assembly

3002-335-005

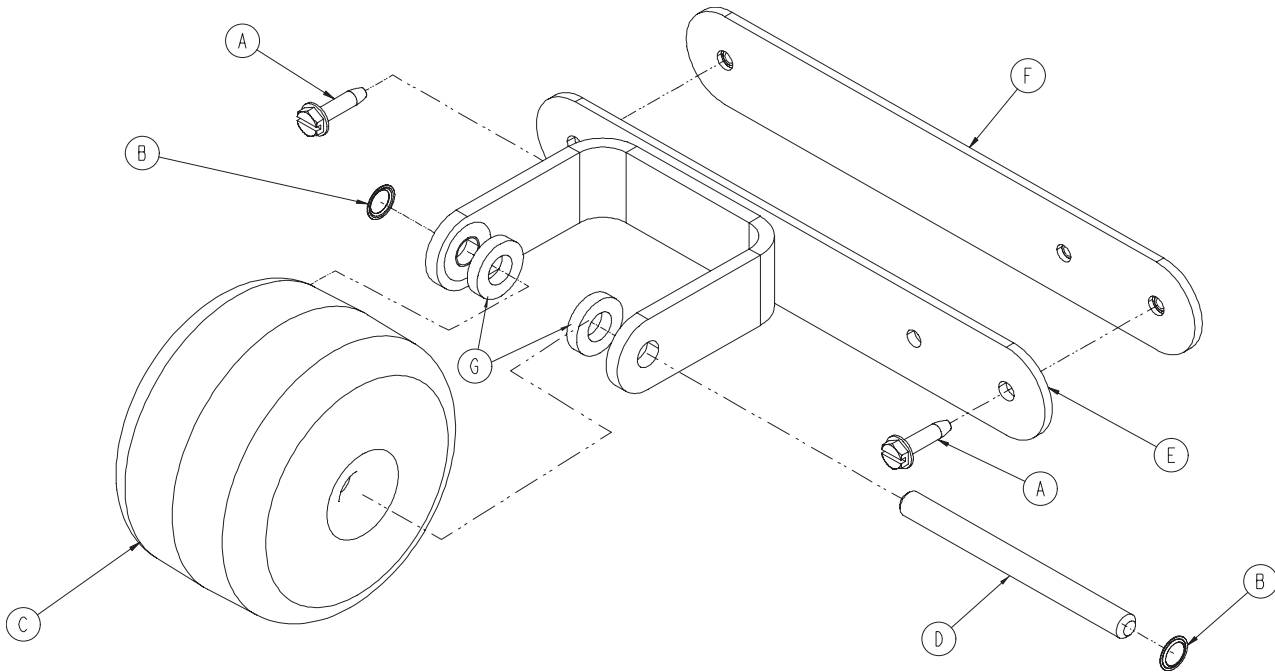

Item	Part No.	Part Name	Qty.
A	0003-225-000	Hex Washer Head Screw	2
B	0052-727-000	Grooveless Retainer Ring	2
C	3000-335-011	Roller Bumper	1
D	3000-335-012	Roller Shaft	1
E	3002-335-020	Roller Bracket	1
F	3002-335-025	Roller Mounting Plate	1
G	0052-017-000	Plastic Washer	2

Optional Bed Extender Assembly

3001-318-020

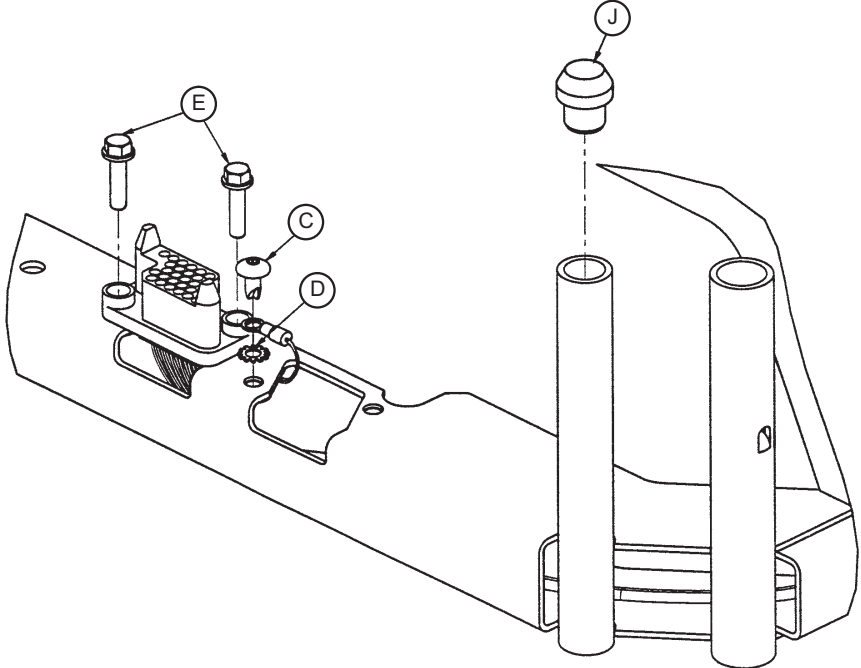
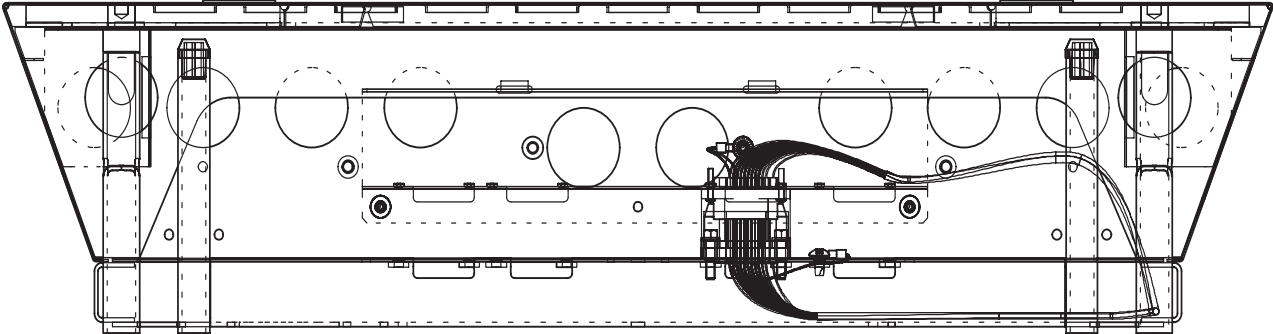
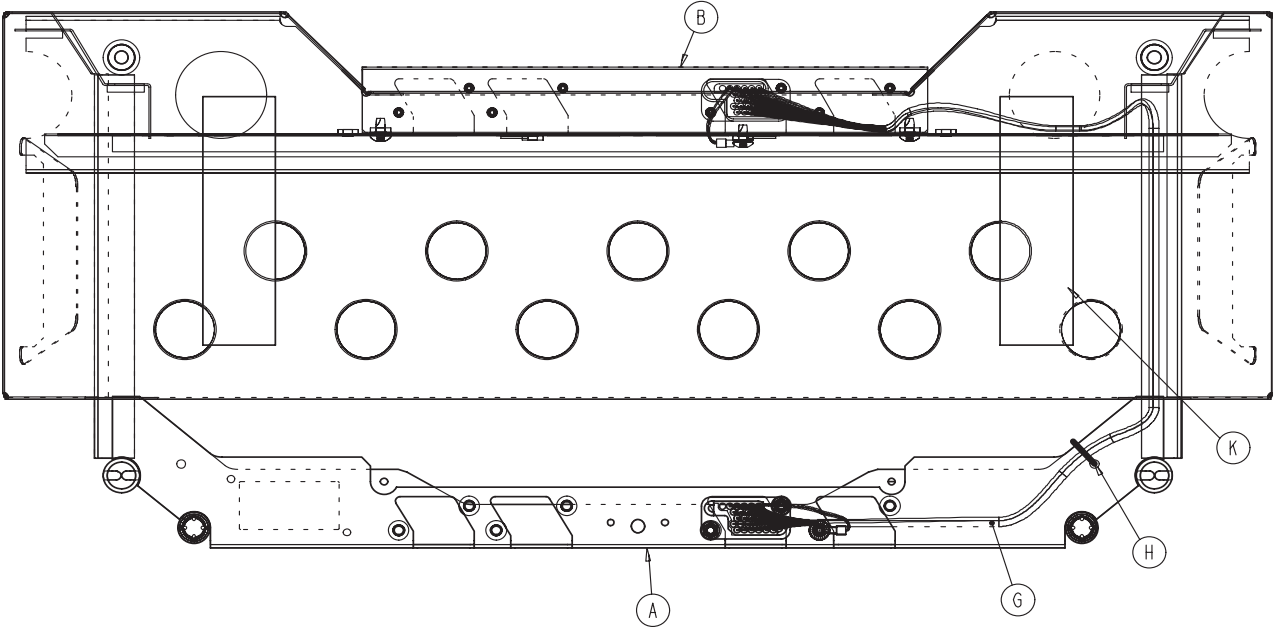

[Return To Table of Contents](#)

Optional Bed Extender Assembly

3001-318-020

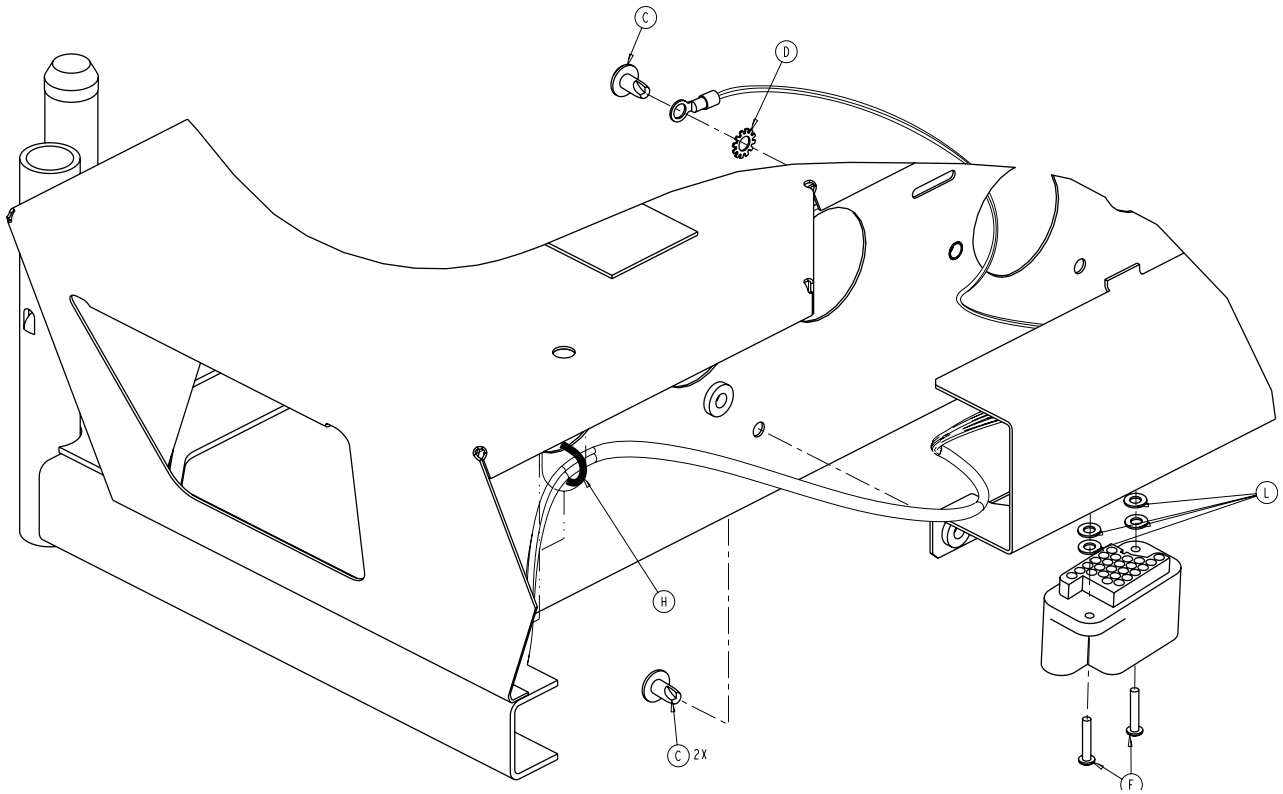

Item	Part No.	Part Name	Qty.
A	3001-318-050	Bed Extender Weldment	1
B	3001-318-031	Connector Mounting Bracket	1
C	0007-052-000	Truss Head Screw	4
D	0013-010-000	External Tooth Lock Washer	2
E	3001-200-228	Mounting StandOff	2
F	0050-039-000	Pan Head Machine Screw	2
G	3000-318-801	Bed Extender Cable	1
H	3000-300-114	Cable Tie	2
J	3000-300-349	Cap	2
K	7900-001-102	Velcro Adhesive Pile	2
L	0011-146-000	Washer	4

Optional Bed Extender Mattress

3000-318-050

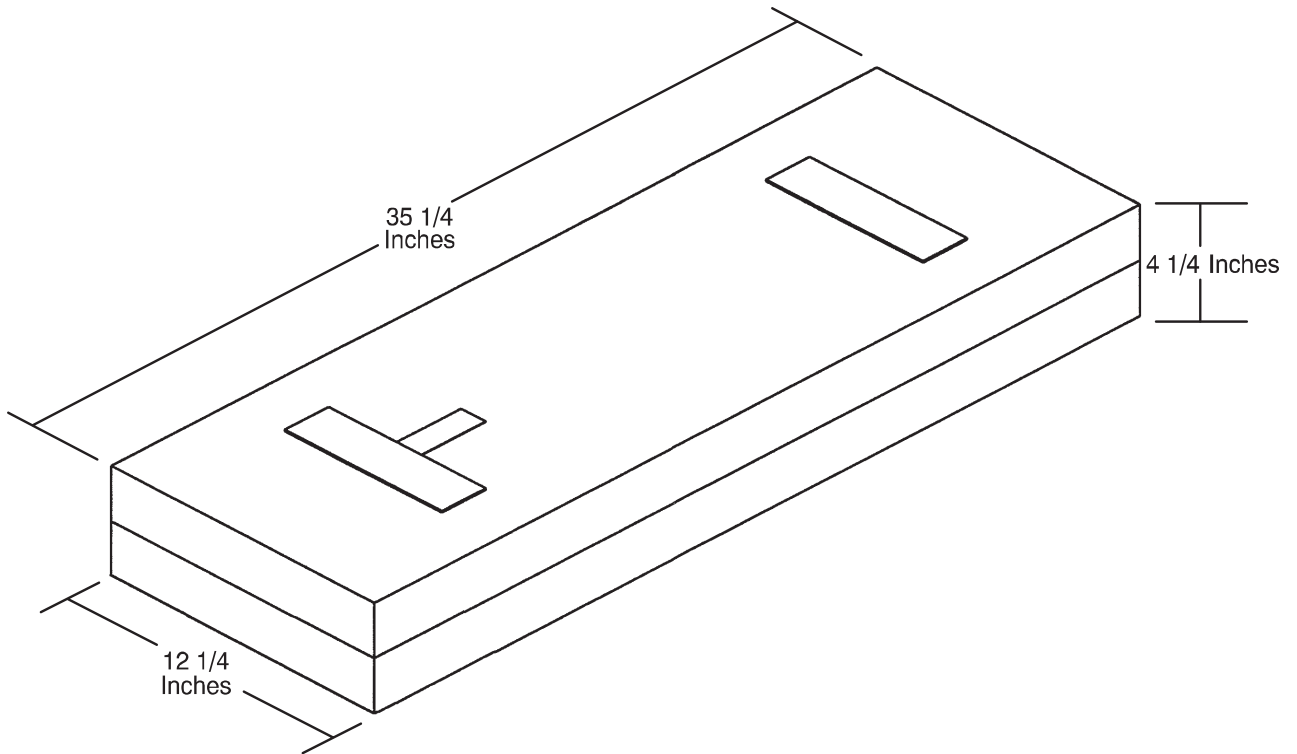

Optional Padded Siderail Covers

3003-336-020

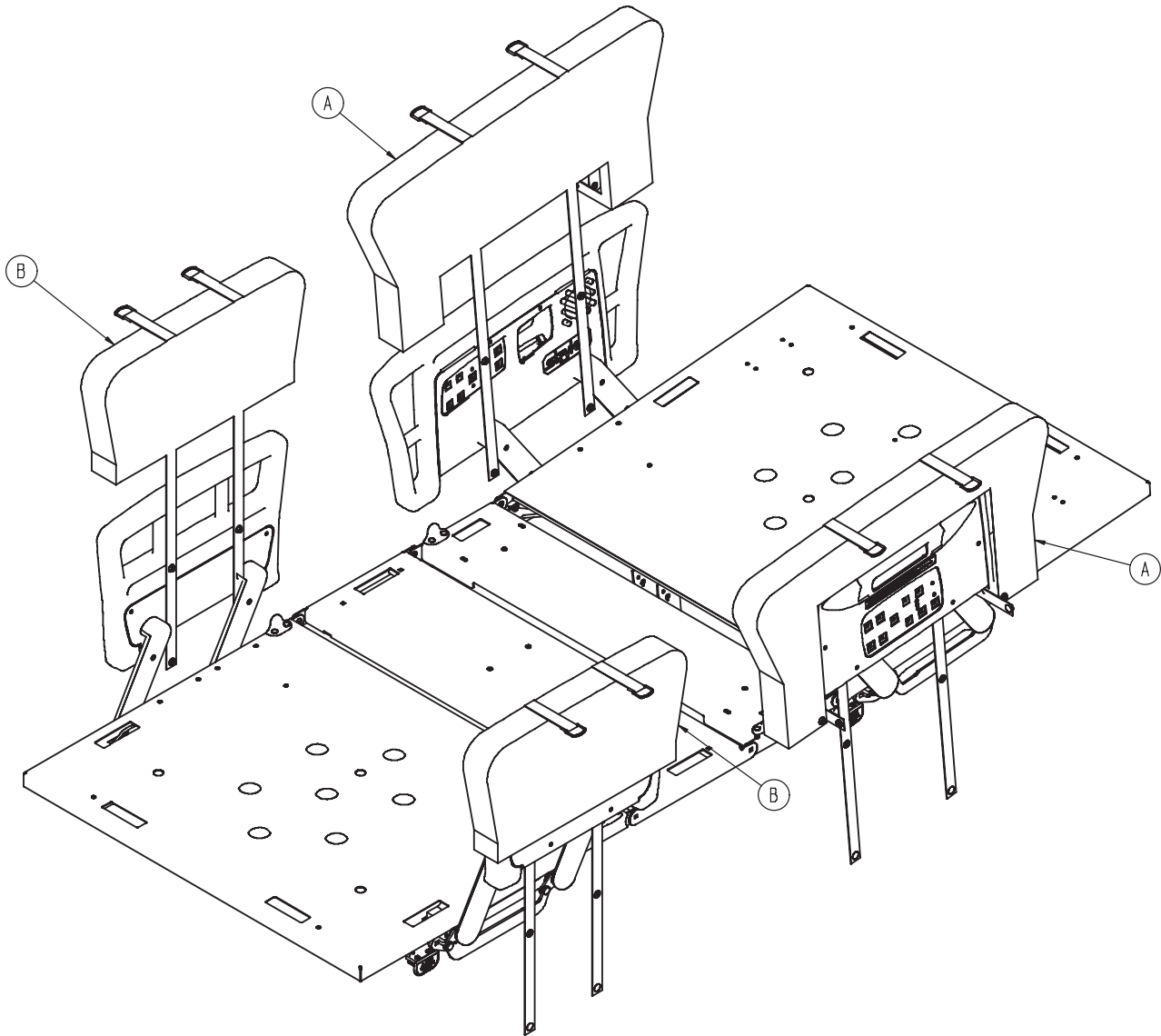

Item	Part No.	Part Name	Qty.
A	3003-336-011	Padded Cover, HE	2
B	3003-336-013	Padded Covers, FE	2

Optional Traction Socket Extensions

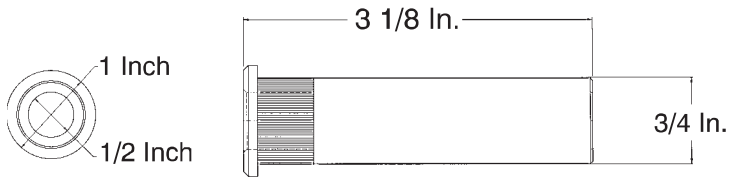

For Reference Only: 3000-337-050

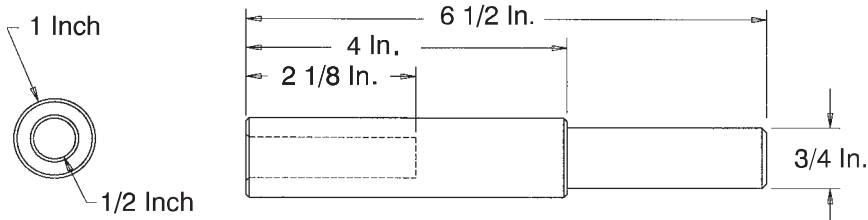

For Reference Only: 3000-337-450

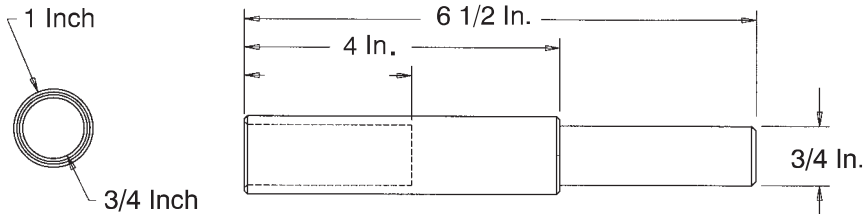

For Reference Only: 3000-337-475

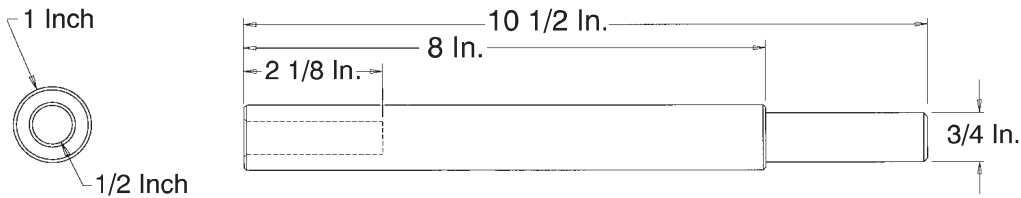

For Reference Only: 3000-337-850

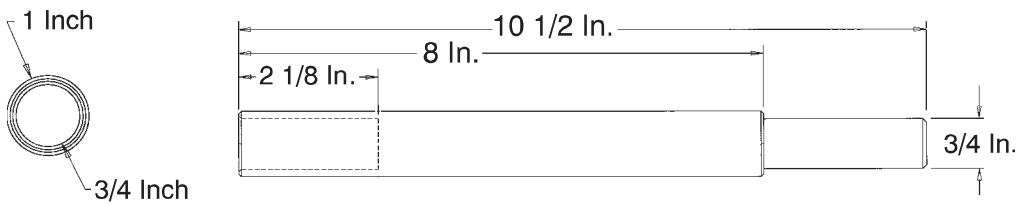

For Reference Only: 3000-337-875

[Return To Table of Contents](#)

Warranty

Limited Warranty

Stryker Medical Division, a division of Stryker Corporation, warrants to the original purchaser the Secure II Med-Surg bed to be free from defects in material and workmanship for a period of one (1) years after date of delivery. Stryker's obligation under this warranty is expressly limited to supplying replacement parts and labor for, or replacing, at its option, any product which is, in the sole discretion of Stryker, found to be defective. If requested by Stryker, products or parts for which a warranty claim is made shall be returned prepaid to the factory. Any improper use or any alteration or repair by others in such manner as in Stryker's judgment affects the product materially and adversely shall void this warranty. Any repair of Stryker products using parts not provided or authorized by Stryker shall void this warranty. No employee or representative of Stryker is authorized to change this warranty in any way.

Stryker Medical beds are designed for a 15 year expected service life under normal use, conditions, and with appropriate periodic maintenance as described in the maintenance manual for each device. Stryker warrants to the original purchaser that the welds on its beds will be free from structural defects for the expected 15 year life of the bed as long as the original purchaser owns the product.

This statement constitutes Stryker's entire warranty with respect to the aforesaid equipment. **Stryker Makes No Other Warranty Or Representation, Either Expressed Or Implied, Except As Set Forth Herein. There Is No Warranty Of Merchantability And There Are No Warranties Of Fitness For Any Particular Purpose. In No Event Shall Stryker Be Liable Here Under For Incidental Or Consequential Damages Arising From Or In Any Manner Related To Sales Or Use Of Any Such Equipment.**

To Obtain Parts and Service

Stryker products are supported by a nationwide network of dedicated Stryker Field Service Representatives. These representatives are factory trained, available locally, and carry a substantial spare parts inventory to minimize repair time. Simply call your local representative, or call Stryker Customer Service USA at 1-800-327-0770, Canada 1-888-233-6888.

Service Contract Coverage

Stryker has developed a comprehensive program of service contract options designed to keep your equipment operating at peak performance at the same time it eliminates unexpected costs. We recommend that these programs be activated before the expiration of the new product warranty to eliminate the potential of additional equipment upgrade charges.

A SERVICE CONTRACT HELPS TO:

- Ensure equipment reliability
- Stabilize maintenance budgets
- Diminish downtime
- Establish documentation for JCAHO
- Increase product life
- Enhance trade-in value
- Address risk management and safety

Warranty

Service Contract programs

Stryker Offers the following service contract programs:

Service Agreement Options *	Gold	Silver	Parts	Labor	PM
Annually scheduled preventative maintenance	X				X
All parts	X	X	X		
All labor and travel	X	X		X	
Unlimited emergency service calls	X	X		X	
Priority one contact: two hour phone response	X	X	X	X	
Most repairs completed within 3 days	X	X		X	
JCAHO documentation	X	X		X	X
On-site record of PM & emergency service	X				X
Factory-trained Stryker service technician	X	X		X	X
Stryker authorized parts used	X	X	X	X	X
Service during regular business hours (8-5)	X	X	X	X	X

* Does not include maintenance due to abuse or for any disposable items. Stryker reserves the right to change options without notice.

Stryker Medical also Offers personalized service contracts.
Pricing is determined by age, location, model and condition of product.

**For more information on our service contracts,
please call your local representative.**

Return Authorization

Merchandise cannot be returned without approval from the Stryker Customer Service Department. An authorization number will be provided which must be printed on the returned merchandise. Stryker reserves the right to charge shipping and restocking fees on returned items. **Special, Modified, Or Discontinued Items Not Subject To Return.**

Damaged Merchandise

ICC Regulations require that claims for damaged merchandise must be made with the carrier within fifteen (15) days of receipt of merchandise. **Do Not Accept Damaged Shipments Unless Such Damage Is Noted On The Delivery Receipt At The Time Of Receipt.** Upon prompt notification, Stryker will file a freight claim with the appropriate carrier for damages incurred. Claim will be limited in amount to the actual replacement cost. In the event that this information is not received by Stryker within the fifteen (15) day period following the delivery of the merchandise, or the damage was not noted on the delivery receipt at the time of receipt, the customer will be responsible for payment of the original invoice in full. Claims for any short shipment must be made within thirty (30) days of invoice.

International Warranty Clause

This warranty reflects U.S. domestic policy. Warranty outside the U.S. may vary by country. Please contact your local Stryker Medical representative for additional information.

[Return To Table of Contents](#)

UNITED STATES
Stryker Medical
3800 E. Centre Ave.,
Portage, Michigan USA
49002

CANADA
Stryker Canada
45 Innovation Drive
Hamilton, Ontario Canada
L9H 7L8

EC	REP
----	-----

European Representative
Stryker France
ZAC Satolas Green Pusignan
Av. De Satolas Green
69881 MEYZIEU Cedex
France

stryker[®]