

### ELECTRIC MEDICAL CARE BED Model FL23E



#### TECHNICAL ASSISTANCE AND PARTS

Canada: 1 888 233-6888

United States: 1 800 327 0770

Outside Canada and the United States: Contact your local representative



# TABLE OF CONTENTS

1. INTRODUCTION.....	4
1.1 Bed Specifications .....	4
1.2 Technical Support.....	5
1.3 Warning / Caution / Note Definitions .....	5
1.4 Safety Tips and Guidelines .....	5
1.5 Warranty.....	7
Limited Warranty .....	7
To Obtain Service and/or Parts.....	7
Return Authorization.....	7
Damaged Merchandise.....	7
1.6 Symbols.....	8
1.7 Set-Up Procedure .....	9
1.8 Cleaning and Preventative Maintenance.....	10
Bed Cleaning and Mattress Care .....	10
Preventative Maintenance .....	11
1.9 Bed Position Pictograms.....	12
1.10 Bed Illustration .....	12
2. OPERATION GUIDE .....	13
2.1 Powering the Bed .....	13
2.2 Brake/Steer Pedal.....	13
2.3 Applying the Brakes.....	13
2.4 Moving the bed .....	14
2.5 Foley Bag Hook Usage.....	14
2.6 Patient Restraint Strap Locations.....	14
2.7 Night Light (Optional) Usage.....	14
2.8 CPR Emergency Release (Optional).....	15
Lowering the Fowler During a Power Failure .....	15
2.9 Auxiliary Power Outlet Usage (Optional).....	15
2.10 Positioning Siderails .....	16
2.11 Head and Foot Board Operation .....	16
2.12 Foot End Control Panel Guide .....	17
Pendant Control Lockouts.....	17
Head Section Controls.....	17
Thigh Section Controls .....	17
Bed Hi-Lo Controls .....	18
Trendelenburg Controls .....	18
Auto Contour Positioning (Optional).....	18
3. ACCESSORIES .....	19

## 1. INTRODUCTION

This manual is designed to assist in the operation of Stryker's FL23E Medical Care bed. Read it thoroughly before operating the bed. Hospital staff should be able to refer to this manual at all time when using the bed.

This Operations Manual is an integral part of the bed and should be included if the bed is sold or transferred.

### 1.1 BED SPECIFICATIONS \*

Safe Working Load	227 kg (500 lb)
Overall Length/Width -Siderails Raised	2296 x 1049 mm (90.4 x 41.3" )
Weight w/Boards	177 kg (390 lb)
Patient Sleep Surface	89 x 198 cm (35 x 78")
Recommended Mattress Size - Length/Width - <b>Maximum</b> thickness - BNQ Standard - Bed w/Ø12.7 cm (5") casters - Bed w/Ø15.2 cm (6") casters - Non BNQ Standard	89 x 198 cm or 203 cm (35 x 78" or 80")  15.2 cm (6") 12.7 cm (5") 15.2 cm (6")
Minimum/Maximum Bed Height - W/Ø12.7 cm (5") casters - W/Ø15.2 cm (6") casters	29.8 to 73.7 cm (11.75 to 29") 32.4 x 76.2 cm (12.75 to 30")
Fowler Angle	0 to 62°
Knee Gatch Angle - W/Auto Contour - W/o Auto Contour	0 to 25° 0 to 32°
Trendelenburg/Reverse Trendelenburg	+17° to -17°
Environmental Conditions - Transport and storage - Ambient Temperature - Relative humidity - Atmospheric Pressure - Operating - Ambient Temperature - Relative humidity - Atmospheric Pressure	-40 to 70°C (-40 to 158°F) 10 to 100% 500 to 1060 hPa  10 to 40°C (50 to 104°F) 5 to 95% without <b>condensation</b> 700 to 1060 hPa
** Electrical Requirements - Comply with the following standards: CSA 22.2 No. 601.1, UL 60601-1, IEC 60601-1, 60601-2-38 and BNQ 6641-120:2003.	100V~, 50-60Hz, 7.5A - Two 250V, 10A Fast Acting Fuses 120V~, 50-60Hz, 4.0A (9.8A w/120V Optional Auxiliary Outlet) - Two 250V, 10A Fast Acting Fuses 200V~, 50-60Hz, 3.2A -Two 250V, 6.3A Slow Blow Fuses 220V~, 50-60Hz, 2.9A -Two 250V, 6.3A Slow Blow Fuses 240V~, 50-60Hz, 2.7A -Two 250V, 6.3A Slow Blow Fuses

\* Stryker pays special attention to product improvement and reserves the right to change specifications without notice.

\*\* The device has a 10% duty cycle.

## 1.2 TECHNICAL SUPPORT

For questions regarding this product, contact the following Technical Service department or your local representative:

### In Canada:

Stryker Canada  
1 888 233-6888  
45, Innovation Drive  
Hamilton, Ontario, L9H 7L8  
Canada

### In the United States:

Stryker Medical  
1 800 327-0770  
6300, South Sprinkle Road  
Kalamazoo, MI 49001-9799  
USA

## 1.3 WARNING / CAUTION / NOTE DEFINITIONS

The words **WARNING**, **CAUTION** and **NOTE** carry special meanings and should be carefully reviewed.



### WARNING

The personal safety of the patient or user may be involved. Disregarding this information could result in injury to the patient or user.



### CAUTION

These instructions point out special procedures or precautions that must be followed to avoid damaging the equipment.

### NOTE

Notes provide special information to make maintenance easier or important instructions clearer.

## 1.4 SAFETY TIPS AND GUIDELINES

Before operating the bed, it is important to read and understand all information in this manual. Carefully read and strictly follow the safety guidelines listed below.

It is important that all users have been trained and educated on the inherent hazards associated with the usage of electric beds.



### WARNING

- This bed is not intended for pediatric use.
- The mattress thickness should never exceed 15.24 cm (6").
- Do not use an accessory that slides under the bed frame when the bed is in low position or remove it before lowering the bed. Failure to conform to this safety precaution could result in serious patient injury and equipment damage.
- This bed is equipped with a hospital grade plug for protection against shock hazard. It must be plugged directly into a properly grounded receptacle. Grounding reliability can be achieved only when a hospital grade receptacle is used.
- Shock Hazard - Improper handling of the power cord may result in damage to the power cord and potential shock hazards. If damage has occurred to the power cord, immediately remove the bed from service, and contact the appropriate maintenance personnel. Failure to conform to this safety precaution could result in death or serious injury.
- Serious injury can result if caution is not used when operating the bed. Operate the bed only when all people and equipment are clear of the electrical and mechanical systems.
- Always apply the brakes when a patient is on the bed or entering/exiting the bed. Serious injury could result if the bed moves while a patient is getting on or off the bed. After the brake pedal is engaged, push on the bed to ensure the brakes are securely applied.

- When the patient is unattended and unless the patient's medical condition dictates otherwise, keep the sleep surface horizontal in its lowest position and the siderails fully raised, except for beds equipped with half-length siderails, in which case the foot siderails should be left down to allow the patient to exit the bed should he want to. When raising the siderails, be sure that you hear the "click" that signals the locked condition. Pull firmly on the siderail to ensure it is locked into position.
- When the sleep surface sections are articulated, ensure that all patient's extremities are within the raised siderails to avoid patient injury.
- When a patient's condition requires greater safety measures for his/her security, remove any optional pendant control and install protective pads on the siderails.
- Siderails, with or without their padded covers, are not intended to serve as restraint devices to keep patient from exiting the bed. Siderails are designed to keep a patient from inadvertently rolling off the bed. It is the responsibility of the attending medical personnel to determine the degree of restraint necessary to ensure a patient will remain safely in bed. Failure to utilize the siderails properly could result in serious patient injury.
- To reduce risk of injury, ensure the sleep surface is horizontal and in the lowest position with the siderails fully raised and locked when moving the bed with a patient in it.
- To avoid injury to the patient and/or user, do not attempt to move the bed laterally with the steer mode engaged.
- The CPR emergency release (optional) is for emergency use only. To avoid serious injury personal injury or equipment damage, ensure all people and equipment are removed from the area below and around the head, thigh and foot sections of the bed, before activating the CPR release handle.
- Possible fire hazard exists when this bed is used with oxygen administering equipment other than nasal, mask type or half bed-length tent type. It is recommended to unplug the bed power cord from the wall when oxygen-administering equipment is used. When using a half bed-length tent type, ensure the siderails are outside the oxygen tent and oxygen tent should not extend below the mattress support level.
- When a large fluid spill occurs, immediately unplug the bed power cord from the wall outlet. Remove the patient from the bed and clean up the fluid. Have maintenance completely check the bed. Fluids can have an adverse effect on operational capabilities of any electrical product. DO NOT put the bed back into service until it is completely dried and has been thoroughly tested for safe operation.
- Do not steam clean, hose off or ultrasonically clean the bed. Do not immerse any part of the bed. The internal electrical parts may be damaged by exposure to water. Hand wash regularly all surfaces of the bed with warm water and a mild detergent. Wipe cleaned surfaces dry to avoid build up of cleaning substance. Inspect the mattress after each use. Discontinue use if any cracks or rips, which may allow fluid to enter the mattress, are found in the mattress cover. Failure to properly clean the mattress, or dispose of it if defective, may increase the risk of exposure to pathogenic substances and may bring about diseases to the patient and user.
- Preventive maintenance should be performed at least once a year to ensure all bed features are operating properly. Ensure that any bed malfunction is promptly reported to your service personnel for immediate attention.
- Always unplug the bed power cord from the wall outlet when servicing or cleaning the bed. When working under the bed with the bed in the high position, always place blocks under the mattress support frame and apply the brakes to prevent injury in case the bed down control is accidentally pressed.
- To avoid damage to the siderail mechanisms, do not move the bed using the raised siderails. Use the head or foot board to move the bed.
- Before using the optional emergency crank during a power failure, always unplug the power cord. An unexpected return of power could rotate the handle and cause injury.

- When servicing, use only identical replacement parts provided by Stryker.

**NOTE**

Throughout this operations manual, the words “right” and “left” refer to the right and left sides of a patient lying face up on the bed.

**1.5 WARRANTY****LIMITED WARRANTY**

All Stryker products are guaranteed against material or manufacturing defects, improper operation of mechanisms, and premature wear of bed components under normal use conditions.

For questions regarding warranty, please contact the Technical Service department (see section 1.2) or your local representative.

**TO OBTAIN SERVICE AND/OR PARTS**

For an on-site diagnosis of a malfunction by a Field Service Representatives or to order replacement parts, simply contact the Technical Service department (see section 1.2) or your local representative. For the part ordering procedure, refer to section 1.5 of the bed Maintenance Manual, “To Obtain Service and/or Parts”.

**RETURN AUTHORIZATION**

Merchandise cannot be returned without approval from the Technical Service department. An authorization number will be provided, which must be clearly printed on the returned merchandise packaging. Stryker reserves the right to charge shipping and restocking fees on returned items.

**DAMAGED MERCHANDISE**

Claims for damaged merchandise must be made with the carrier within fifteen (15) days of receipt of merchandise. **DO NOT ACCEPT DAMAGED SHIPMENTS UNLESS SUCH DAMAGE IS NOTED ON THE DELIVERY RECEIPT AT THE TIME OF RECEIPT.** Upon prompt notification, Stryker will file a freight claim with the appropriate carrier for damages incurred. Claims will be limited in amount to the actual replacement cost. In the event that this information is not received by Stryker within the fifteen (15) day period following the delivery of the merchandise, or the damage was not noted on the delivery notice at the time of receipt, the customer will be responsible for payment of the original invoice in full.

Claims for any short shipment must be made within five (5) days of invoice.

## 1.6 SYMBOLS



Warning, consult accompanying documents.



Fuse rating for bed with the 100V~ and 120V~ electric systems.



Fuse rating for beds with 200V~, 220V~ and 240V~ electric systems.



Protective earth (ground).



Alternating Current.



Type B Equipment.

**IPX4** Protection from liquid splash.



**1.7 SET-UP PROCEDURE****CHECKLIST**

It is important to ensure that the bed is working properly before it is put into service. The following list will help ensure that each part of the bed is checked.

- Install the foot and head boards on the bed. If the bed is equipped with the foot board control panel (optional), insert the foot board carefully so that the board and the casing connectors fit in smoothly.
- Plug the power cord to the bed connector at the head end of the bed and into a properly grounded hospital grade wall outlet. Turn on the power switch located on the power connector.

**WARNING**

The bed is equipped with a hospital grade plug for protection against shock hazard. It must be plugged directly into a properly grounded receptacle. Grounding reliability can be achieved only when a hospital grade receptacle is used.

- On both sides of the bed, depress fully down the side of the pedal identified with a red sticker and ensure that the brakes are applied and the bed immobilized. Toggle the pedal to neutral and ensure the brakes are released.
- On both sides of the bed, depress fully down the side of the pedal identified with a green sticker and ensure that the steer mode (bed steer caster or optional 5th wheel) is engaged. Toggle the pedal to neutral and ensure that the steer mode disengages.
- Ensure that the siderails raise, lock in the up position and lower smoothly. See section 2.10.
- Run through each control of the foot end and optional foot board panels. See section 2.12.
- Raise the bed to full up position and activate the Trendelenburg function. Ensure the head end lowers to the full down position. See **E**, section 2.12. Level the bed using the Hi-Lo controls.
- Raise the bed to full up position and activate the reverse Trendelenburg function. Ensure the foot end lowers to the full down position. See **E**, section 2.12. Level the bed using the Hi-Lo controls.
- Verify the CPR emergency release (optional). Raise the Fowler fully up. Using the CPR release handle, lower the Fowler gradually to flat position by pulling, holding and releasing the handle several times. Ensure the Knee Gatch (if raised) also starts flattening when the Fowler is completely down. Following the complete lowering of the Fowler, wait approximately 30 seconds - the time for the Fowler motor to reset itself - and verify that the motor has indeed reset itself completely by raising the Fowler fully up using the Fowler up control.
- Verify the optional equipment for proper operation (see the documentation accompanying each accessory).

If any problems are found during the bed set up procedure, contact our Technical Service department (see section 1.2).

## 1.8 CLEANING AND PREVENTATIVE MAINTENANCE

### BED CLEANING AND MATTRESS CARE

---



#### WARNING

Always unplug the bed power cord from the wall outlet when cleaning or servicing the bed.

---



#### CAUTION

Do not use harsh cleaners, solvents or detergents. Do not steam clean, hose off or ultrasonically clean the bed. Do not immerse any part of the bed. The bed electrical parts may be damaged by exposure to water.

Germicidal disinfectant, used as directed, and/or Chlorine Bleach products are not considered mild detergents. These products are corrosive in nature and may cause damage to your bed if used improperly. If these types of products are used, ensure the beds are rinsed with clean water and thoroughly dried following cleaning. Failure to properly rinse and dry the beds will leave a corrosive residue on the surface of the bed, possibly causing premature corrosion of critical components. Failure to follow the above directions when using these types of cleaners may void this product warranty.

#### Bed Cleaning

Hand wash all surfaces of the bed with a soft cloth moistened with a solution of lukewarm water and a mild detergent.

Wipe the bed clean and dry thoroughly to avoid build up of cleaning solution.

#### Mattress Care

---



#### WARNING

Inspect the mattress after each use. Discontinue use if any cracks or rips, which may allow fluid to enter the mattress, are found in the mattress cover. Failure to properly clean the mattress, or dispose of it if defective, may increase the risk of exposure to pathogenic substances and may bring about diseases to the patient and user.

---

- **Inspection**

Implement local policies to address regular care, maintenance, and cleaning of mattresses and covers. The cover cleaning procedure can be found below and on the mattress label.

Inspect mattress cover surface (also zip fasteners and cover inner surface if mattresses have zip fasteners) regularly for signs of damage. If the mattress cover is heavily stained, soiled or torn, remove the mattress from service.

- **Cleaning**

Stains: Wash with lukewarm water using a mild detergent. Rinse with water and let dry. For tough stains use bleach diluted with ten parts of water.

## PREVENTATIVE MAINTENANCE

### Annual Checklist

- All fasteners secure.
- Inspect for excessive wear the oil-impregnated bronze shoulder spacers found at the bed hinge points. **Do not** lubricate these spacers, replace as needed.
- On both sides of the bed, depress fully down the side of the pedal identified with a red sticker and ensure that the brakes are applied and the bed immobilized. Toggle the pedal to neutral and ensure the brakes are released.
- On both sides of the bed, depress fully down the side of the pedal identified with a green sticker and ensure that the steer mode - bed steer caster or optional 5th wheel - is engaged. Toggle the pedal to neutral and ensure that the steer mode disengages.
- Siderails move upward and downward, and latch properly. See section 2.10.
- All controls on the foot end and optional foot board panels working properly, including Trendelenburg and lockout LEDs. See section 2.12.
- Fowler and Knee Gatch (if raised) flatten and the Fowler control motor resets itself automatically (as soon as the fowler is completely lowered) when both CPR handles (optional) are pulled until the Fowler is horizontal.
  - Wait about 30 seconds - the time for the Fowler motor to reset itself - then raise the Fowler to ensure that the resetting of the motor has indeed occurred.
- Verify the Fowler, Knee Gatch and Hi-Lo motions to ensure that the motion interrupt switch integrated to the four electric actuators is operating properly.
- Auxiliary outlet (optional) working properly.
- Night light (optional) working properly.
- Head end bumpers tightly secured to frame and working properly.
- No rips or cracks in mattress cover. Replace if so.
- Power cord not frayed. Replace in presence of the slightest cut or rip of the protective sheath.
- No cables worn or pinched.
- All electrical connections tight.
- All grounds secure to the frame.
- All casters roll properly. Check caster for cuts, wear, etc.
- Measure current leakage and grounding continuity of the bed and the optional auxiliary outlet. Check with the Technical Service department (see section 1.2) for the acceptable values.

### 1.9 BED POSITION PICTOGRAMS

The following pictograms appear on the membrane of the foot end control panel.

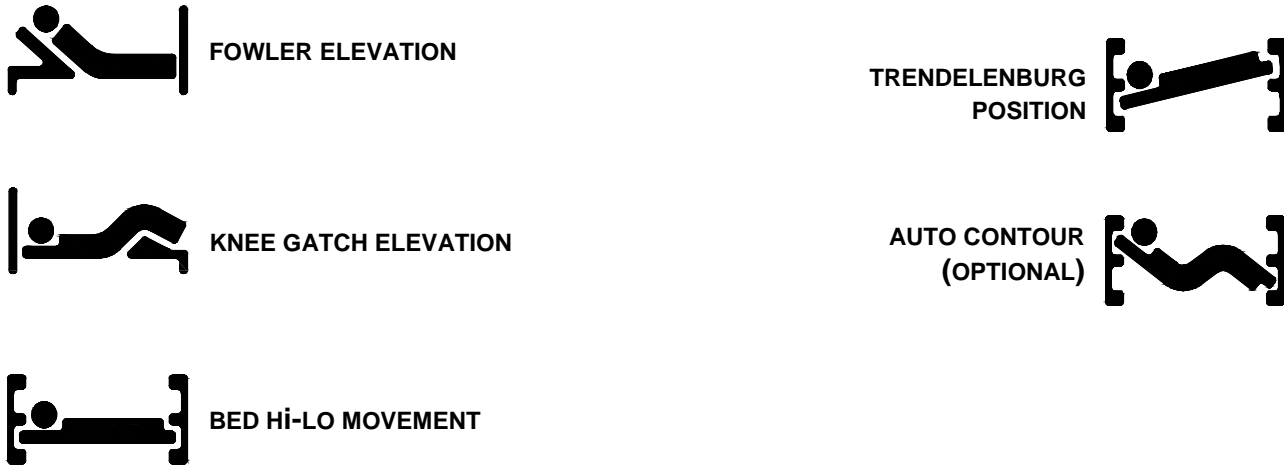

Figure 1.9

### 1.10 BED ILLUSTRATION

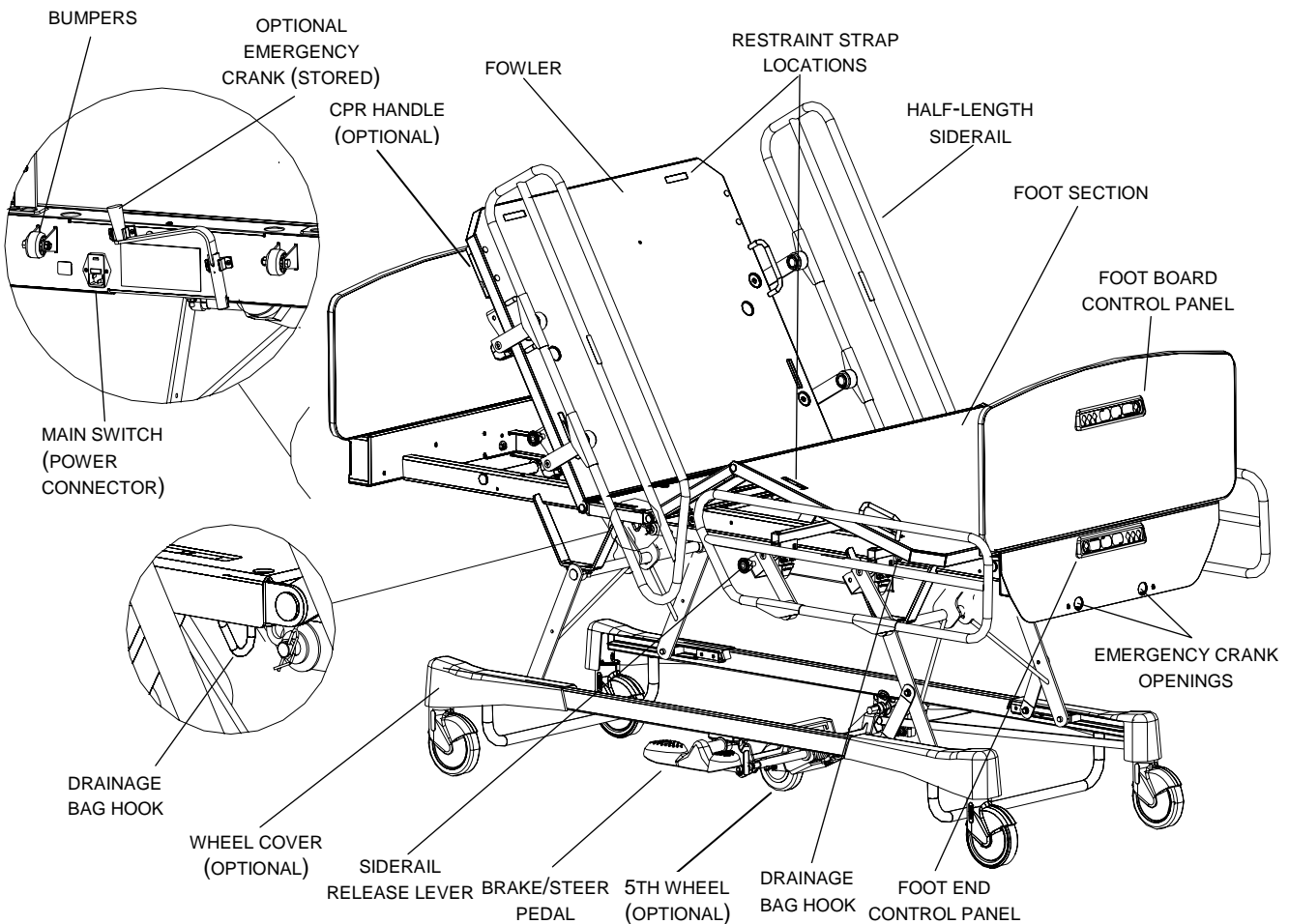

Figure 1.10

## 2. OPERATION GUIDE

### 2.1 POWERING THE BED

The bed is equipped with a main power switch located at the head end of the bed where the power cord connects to the power connector (see illustration 10, page 12). Turn it on to activate the bed functions. When the bed power switch is turned off or in the event of a power failure, the setting of the pendant control lockouts (optional, see page 17) are saved.



#### WARNING

Shock Hazard - Improper handling of the power cord may result in damage to the power cord and potential shock hazards. If damage has occurred to the power cord, immediately remove the bed from service, and contact the appropriate maintenance personnel. Failure to do so could result in death or serious injury.

### 2.2 BRAKE/STEER PEDAL

The bed is equipped with two lateral pedals. They control the brakes and the 5th steer wheel. The following illustrations, appearing on the label affixed on the optional 5th wheel hood or the frame, schematizes the operation of the pedals.

#### Left Side



#### Right Side



Figure 2.2

### 2.3 APPLYING THE BRAKES

The bed is equipped with a central locking system activated by either lateral brake/steer pedals (see figure 1.10, page 12).



#### WARNING

Always apply the brakes when a patient is on the bed or entering/exiting the bed. Serious injury could result if the bed moves while a patient is getting on or off the bed. After the brake pedal is engaged, push on the bed to ensure the brakes are securely applied.

#### Brake Pedal Operation

To **engage** the brakes, fully depress the side of the pedal identified with a red label and represented by the BRAKE red arrow (figure 2.2 above).

To **disengage** the brakes, toggle the pedal to neutral position.

## 2.4 MOVING THE BED

The bed is equipped with a steer mode using a bed steer caster or an optional 5th wheel. The steer mode is activated by either lateral pedals (see figure 1.10, page 12). The steer mode helps in guiding the bed along a straight line and helps the bed pivot around corners.



### WARNING

To reduce risk of injury, ensure the sleep surface is horizontal and in the lowest position with the siderails fully raised and locked when moving the bed with a patient in it.

To avoid injury to the patient and/or user, do not attempt to move the bed laterally with the steer mode engaged.



### CAUTION

To avoid damage to the siderail mechanisms, do not move the bed using the raised siderails. Use the head or foot board to move the bed.

### Steer Mode Operation

To **engage** the steer mode, fully depress the side of the pedal identified with a green label and represented by the STEER green arrow (figure 2.2 above).

To **disengage** the steer mode, toggle the pedal to neutral position.

## 2.5 FOLEY BAG HOOK USAGE

The four Foley bag hooks (see figure 1.10, page 12) are located on both sides of the bed under the edges of the mattress support seat and foot sections.

## 2.6 PATIENT RESTRAINT STRAP LOCATIONS

The bed has 12 locations on the mattress support for installing patient restraint straps. Ten of them are located on the mattress support edges directly across from each other and the remaining two are located on the top edge of the head section (see figure 1.10, page 12).



### WARNING

Improperly adjusted restraint straps can cause serious injury to a patient. It is the responsibility of the attending medical personnel to determine proper use of restraint straps and restraint strap locations.

## 2.7 NIGHT LIGHT (OPTIONAL) USAGE

The bed may be equipped with an optional photoelectric night light to illuminate the floor area around the bed. The night light turns on as the room lights dim.

---

**2.8 CPR EMERGENCY RELEASE (OPTIONAL)**

---

**WARNING**

The CPR emergency release (optional) is for emergency use only. To avoid serious injury personal injury or equipment damage, ensure all people and equipment are removed from the area below and around the head, thigh and foot sections of the bed before activating the CPR release handle.

---

When quick access to the patient is needed and the Fowler is raised, pull outward one of the two CPR release handles until the Fowler is completely lowered. The Knee Gatch, if raised, will also flatten. The CPR handles are located under the upper right and left sides of the head section (see figure 1.10, page 12).

The CPR handle can be released at any time to stop the lowering movement of the Fowler. But doing so will subsequently required that the Fowler be completely lowered, using the CPR handle or the Fowler down control, to enable the Fowler motor to reset itself. **Failing to do so will prevent the Fowler from being fully raised.**

**NOTE**

The use of the CPR release handle to partially lower the Fowler creates a situation where the Fowler motor is out of sync with the actual position of the Fowler. The situation is corrected, and only then, when the Fowler is completely lowered. The Fowler motor then begins an automatic resetting process to harmonize its course with the Fowler flat position. During the time the resetting process is going on - approximately 30 seconds- the Fowler controls are not available.

- **Lowering the Fowler During a Power Failure**

The CPR emergency release can also be used during a power failure to partially or completely lower the Fowler. Simply pull one of the CPR handles until the desired angle is reached and release it then. When current resume, fully lower the Fowler to enable the Fowler motor to reset itself (see above note).

If the bed is not equipped with the CPR emergency release, unplug the bed power cord from the wall outlet and use the emergency handle (optional) to lower the Fowler. A pictogram affixed on the head end casing cover illustrate clearly in which direction the handle should be turned to obtain the desired angle.

---

**WARNING**

Before using the optional emergency crank during a power failure, always unplug the power cord. An unexpected return of power could rotate the handle and cause injury.

---

**2.9 AUXILIARY POWER OUTLET USAGE (OPTIONAL)**

---

Located on the left side at the foot end of the bed, this feature provides nursing staff with a convenient power source for peripheral equipment. A 5A breaker is integrated to the power outlet.

---

**WARNING**

Use only hospital grade electric equipment consuming five (5) amperes or less with the auxiliary power outlet (optional). The use of standard electric equipment may bring the current leakage to a level unacceptable for hospital equipment.

---

## 2.10 POSITIONING SIDERAILS

The bed may be equipped with two types of siderail: half-length and full-length.



### WARNING

Siderails, with or without their padded covers, are not intended to serve as restraint devices to keep patient from exiting the bed. Siderails are designed to keep a patient from inadvertently rolling off the bed. It is the responsibility of the attending medical personnel to determine the degree of restraint necessary to ensure a patient will remain safely in bed. Failure to utilize the siderails properly could result in serious patient injury.

When the patient is unattended and unless the patient's medical condition dictates otherwise, keep the sleep surface horizontal in its lowest position and the siderails fully raised, except for beds equipped with half-length siderails, in which case the foot siderails should be left down to allow the patient to egress the bed should he want to. When raising the siderails, be sure that you hear the "click" that signals the up and locked condition. Pull firmly on the siderail to ensure it is locked into position.

### Half-Length Siderail

To **lower** the **head** siderail, grasp the rail in its centre, pull the yellow release lever and rotate the siderail downward toward the head end of the bed until it is completely lowered.

To **lower** the **foot** siderail, the same procedure is required as for the head siderail, however, the siderail rotates toward the foot end of the bed.

To **engage** the **head** siderail, grasp the rail in its centre, pull the yellow release lever and rotate the rail upward toward the head end of the bed until it locks in the full up position.

To **engage** the **foot** siderail, the same procedure is required as for the head siderail, however, the siderail rotates to the foot end of the bed.

### Full-Length Siderail

To **lower** a full-length siderail, grasp the rail in its centre, pull the yellow release lever and rotate the siderail downward toward the foot end of the bed until it is completely lowered.

To **engage** a full-length siderail, grasp the rail in its centre and rotate the rail upward toward the foot end of the bed until it locks in the full up position.

## 2.11 HEAD AND FOOT BOARD OPERATION

The head and foot boards may be removed and replaced easily. The removal of the head board enables quick access to the patient's head.

### Board Removal/Installation

- Removal: Seize both ends of the board and lift up.
- Installation: Insert the board posts inside the mounting sockets.

If the bed is equip with the optional foot board control panel, slide the foot board slowly in the mounting sockets while ensuring that the board connector properly fits into the foot casing connector.



## 2.12 FOOT END CONTROL PANEL GUIDE

The bed is equipped standard with a control panel located on the frame at the foot end of the bed. An additional control panel (optional), identical to the standard one, may also be present on the foot board. When both panels are present, the bed functions may be activated from the controls of either panel.

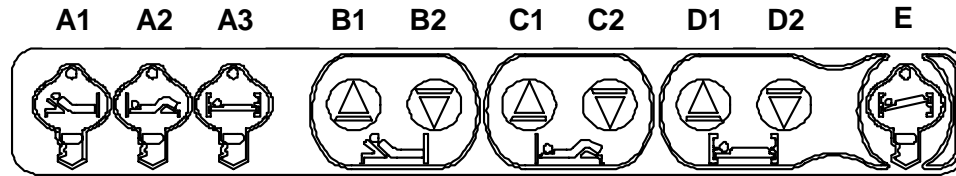

**Figure 2.12**

### Pendant Control Lockouts (A1 to A3)

These three controls allow the selective lock out of controls available to the patient through the pendant control (optional). The state of the green LED associated to each control informs on the availability of the control to the patient: a lit LED indicates that the control is available to the patient; an off LED, that the control is locked.

#### NOTE

This bed model does not allow the adjustment of the bed height through the pendant control (optional), thus the Hi-Lo control lockout (**A3**) is not functional. The LED associated with this lockout will light up if the control is pressed, but with no consequence on the bed operation.

**A1:** Press to lock out the pendant Fowler controls. The green LED will go off.

**A2:** Press to lock out the pendant Knee Gatch controls. The green LED will go off.

The Knee Gatch lockout is also used to enable the Auto Contour positioning (see below).

**A3:** Not available

#### NOTE

The foot end controls, described below, are not affected by the lockouts.

The lockout setting will be saved should a power failure happen and will return unchanged with the power.

### Fowler Controls (B1 and B2)

These two controls enable the adjustment of the Fowler position.

**B1:** Press to raise the Fowler.

**B2:** Press to lower the Fowler.

### Knee Gatch Controls (C1 and C2)

These two controls enable the adjustment of the Knee Gatch position.

**C1:** Press to raise the Knee Gatch.

**C2:** Press to lower the Knee Gatch.

## Bed Hi-Lo Controls (D1 and D2)



### WARNING

Do not use an accessory that slides under the bed frame when the bed is in low position or remove it before lowering the bed. Failure to conform to this safety precaution could result in serious patient injury and equipment damage.

---

These two controls enable the adjustment of the bed height.

**D1:** Press to raise the bed.

**D2:** Press to lower the bed.

## Trendelenburg Controls (E)

Once this control is activated, the Trendelenburg positions become available through the bed Hi-Lo controls (**D1** and **D2**). The Trendelenburg pictogram LED will go on.

**E:** Press to activate the Trendelenburg positioning.

**Trendelenburg:** Press the Hi-Lo up control (**D1**) to lower the bed head end and raise the foot end.

**Reverse Trendelenburg:** Press the Hi-Lo down control (**D2**) to lower the bed foot end and raise the head end.

### NOTE

To replace the sleep surface to horizontal position after a Trendelenburg positioning, press the Trendelenburg control to deactivate it (LED will go off) and use the bed Hi-Lo controls to either raise or lower the sleep surface to its limit. Then set the bed to the desired height.

## Auto Contour Positioning (Optional)

The bed may be equipped with the optional Auto Contour positioning. The Auto Contour positioning partially raises the thigh section as the head section is raised. It prevents the patient from slipping toward the foot end of the bed.

To enable the Auto Contour positioning, deactivate the Knee Gatch lockout (**A2**). The lockout green LED will go on.

### NOTE

Deactivating the Knee Gatch lockout to enable the Auto Contour positioning will also give the patient control of the Knee Gatch position through the pendant control (optional).

### 3. ACCESSORIES

Listed below are the accessories certified for the FL23E bed according to the IEC 60601-2-38 standard, as well as their maximum load capacity where applicable.

- Bed extension
- Bed extension cushions
- Two-function pendant control
- Monitor tray - Maximum load: 40 lb (18 kg)
- Ø 1" removable anodized aluminum I. V. pole - Maximum load: 11 lb (5 kg)
- Ø 1" fixed anodized aluminum I. V. pole - Maximum load: 11 lb (5 kg)
- Ø 1/2" removable anodized aluminum I. V. pole - Maximum load: 11 lb (5 kg)
- Emergency crank
- Overhead trapeze, model ST6020-24 from Texas Medical Industries - Maximum load: 150 lb (68 kg)
- Padded siderail covers for full-length siderails (set of two)
- Padded siderail covers for half-length siderails (set of four)