

### ELECTRIC MEDICAL CARE BED Model FL23E



#### TECHNICAL ASSISTANCE AND PARTS

Canada: 1 888 233-6888

United States: 1 800 327-0770

Outside Canada and the United States: Contact your local representative



# TABLE OF CONTENTS

1. INTRODUCTION .....	5
1.1 Specifications .....	5
1.2 Technical Support .....	6
1.3 Warning, Caution, Note Definition .....	6
1.4 Static Discharge Precautions .....	6
1.5 Warranty .....	7
Limited Warranty .....	7
To Obtain Service and/or Parts .....	7
Return Authorization .....	8
Damaged Merchandise .....	8
1.6 Symbols .....	8
2. PREVENTATIVE MAINTENANCE .....	9
2.1 Bed Cleaning and Mattress Care .....	9
Cleaning Beds .....	9
Mattress Care .....	9
2.2 Actuator Lubrication .....	10
2.3 Preventative Maintenance Program .....	12
Annual Checklist .....	12
Recommended Spare Parts .....	13
3. TROUBLESHOOTING .....	15
3.1 Troubleshooting Guide .....	15
4. MAINTENANCE PROCEDURES .....	16
4.1 Maintenance Procedure- Siderail .....	16
Rail Replacement .....	16
Half-Length Siderail Assembly Replacement .....	17
Full-Length Siderail Assembly Replacement .....	19
Transfer Plate Replacement .....	20
4.2 Maintenance Procedure - Control Panel .....	21
Foot End Control Panel Replacement .....	21
Foot End Casing Connector Replacement (Optional) .....	22
Foot Board Control Panel Replacement (Optional) .....	23
Foot Board Connector Replacement (Optional) .....	24
Siderail Control Panel Component Replacement .....	25
4.3 Maintenance Procedure - Mattress Support .....	26
Foot Section Replacement .....	27
Thigh Section Replacement .....	27
Seat Section Replacement .....	28
Head Section Replacement .....	28
Fowler Actuator Replacement .....	31
Knee Gatch Actuator Replacement .....	33
Hi-Lo Actuator Replacement .....	34
Toroidal Transformer Replacement (International Series Models) .....	36
Motor Control Board Replacement .....	36

Power Connector and Fuse Replacement .....	37
Auto Contour Micro Switch Replacement (Optional) .....	38
Head Section Micro Switch .....	39
Thigh Section Micro Switch .....	39
CPR Micro Switch Replacement (Optional) .....	40
Micro Switch Attached to the Head Section Lever .....	40
Micro Switch Attached to the Frame.....	41
CPR Activation Cable Replacement (Optional) .....	41
CPR Pneumatic Cylinder Replacement (Optional) .....	42
4.4 Maintenance Procedures - Base .....	43
Brake/Steer Pedal Replacement.....	43
5th Wheel Caster Replacement (Optional) .....	44
5th Wheel Assembly Replacement (Optional) .....	44
5th Wheel Swing Arm Assembly Replacement (Optional) .....	45
Bed Caster Replacement .....	46
Brake Rod Replacement .....	47
Appendix A: Connection Diagram .....	48

## 1. INTRODUCTION

This manual is designed to assist in the servicing of Stryker's FL23E Medical Care beds. Read it thoroughly before beginning any service on the bed. Qualified maintenance personnel should be able to refer to this manual at all time when servicing the bed.

This Maintenance Manual is an integral part of the bed and should be included if the bed is sold or transferred.

### 1.1 SPECIFICATIONS \*

Safe Working Load	227 kg (500 lb)
Overall Length/Width	2296 x 1049 mm (90.4 x 41.3") – siderails up 2296 x 991 mm (90.4 x 39") – siderails down
Weight w/Boards	177 kg (390 lb)
Patient Sleep Surface	89 x 198 cm (35 x 78")
Recommended Mattress Size	
- Length/Width	89 x 198 cm or 203 cm (35 x 78" or 80")
- <b>Maximum</b> thickness	
- BNQ Standard	
- Bed w/Ø12.7 cm (5") casters	15.2 cm (6")
- Bed w/Ø15.2 cm (6") casters	12.7 cm (5")
- non BNQ Standard	15.2 cm (6")
Minimum/Maximum Bed Height	
- W/Ø12.7 cm (5") casters	29.8 to 73.7 cm (11.75 to 29")
- W/Ø15.2 cm (6") casters	32.4 x 76.2 cm (12.75 to 30")
Fowler Angle	0 to 62°
Knee Gatch Angle	
- W/Auto Contour	0 to 25°
- W/o Auto Contour	0 to 32°
Trendelenburg/Reverse Trendelenburg	+17° to -17°
Environmental Conditions	
- Transport and storage	
- Ambient Temperature	-40 to 70°C (-40 to 158°F)
- Relative humidity	10 to 100%
- Atmospheric Pressure	500 to 1060 hPa
- Operating	
- Ambient Temperature	10 to 40°C (50 to 104°F)
- Relative humidity	5 to 95% without <b>condensation</b>
- Atmospheric Pressure	700 to 1060 hPa
** Electrical Requirement - complies with the following standards: CSA C22.2 No. 601.1, UL 60601-1, IEC 60601-1, 60601-2-38 and BNQ 6641-120 : 2003.	100V~, 50-60Hz, 7.5A - Two 250V, 10A Fast Acting Fuses 120V~, 50-60Hz, 4A (9.8A w/120V Optional Auxiliary Outlet) - Two 250V, 10A Fast Acting Fuses 200V~, 50-60Hz, 3.2A -Two 250V, 6.3A Slow Blow Fuses 220V~, 50-60Hz, 2.9A -Two 250V, 6.3A Slow Blow Fuses 240V~, 50-60Hz, 2.7A -Two 250V, 6.3A Slow Blow Fuses

\* Stryker pays special attention to product improvement and reserves the right to change specifications without notice.

\*\* The device has a 10% duty cycle.

## 1.2 TECHNICAL SUPPORT

For questions regarding this product, contact the following Technical Service department or your local representative:

Stryker Canada  
1 888 233-6888  
45, Innovation Drive  
Hamilton, Ontario, L9H 7L8  
Canada

Stryker Medical  
1 800 327-0770  
6300, South Sprinkle Road  
Kalamazoo, MI 49001-9799  
USA

## 1.3 WARNING, CAUTION, NOTE DEFINITION

The words WARNING, CAUTION and NOTE carry special meanings and should be carefully reviewed.



### WARNING

The personal safety of the patient or user may be involved. Disregarding this information could result in injury to the patient or user.



### CAUTION

These instructions point out special procedures or precautions that must be followed to avoid damaging the equipment.

### NOTE

Notes provide special information to make maintenance easier or important instruction clearer.

## 1.4 STATIC DISCHARGE PRECAUTIONS

The electronic circuits of the bed are protected from static electricity damage only while the bed is assembled. It is extremely important that all service personnel always use adequate static protection when servicing the electronic components of the bed.

### Static Protection Equipment

The necessary equipment for a proper static protection is:

- 1 static wrist strap
- 1 grounding plug
- 1 test lead with a banana plug on one end and an alligator clip on the other.

### Static Protection Procedure

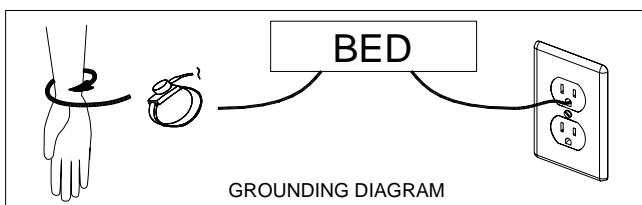

1. Unplug the bed power cord from the wall outlet.
2. Insert the grounding plug into a properly grounded hospital grade wall receptacle. Plug the banana plug of the test lead into the receptacle on the grounding plug. Connect the alligator clip on the other end of the test lead to a ground point on the bed.
3. Place the static control wrist strap on your wrist. Connect the clip at the other end of the wrist strap cord to a ground point on the bed.

## 1.5 WARRANTY

### LIMITED WARRANTY

All Stryker products are guaranteed against material or manufacturing defects, improper operation of mechanisms, and premature wear of bed components under normal use conditions.

For questions regarding warranty, please contact the Technical Service department (see section 1.2) or your local representative.

### TO OBTAIN SERVICE AND/OR PARTS

- **To Require Service**

For an on-site diagnosis of a malfunction by one of our Filed Service Representative, contact the Technical Service department (see section 1.2) or your local representative.

- **To Order Parts**

In order to correctly identify and order parts to be replaced, proceed as follows:

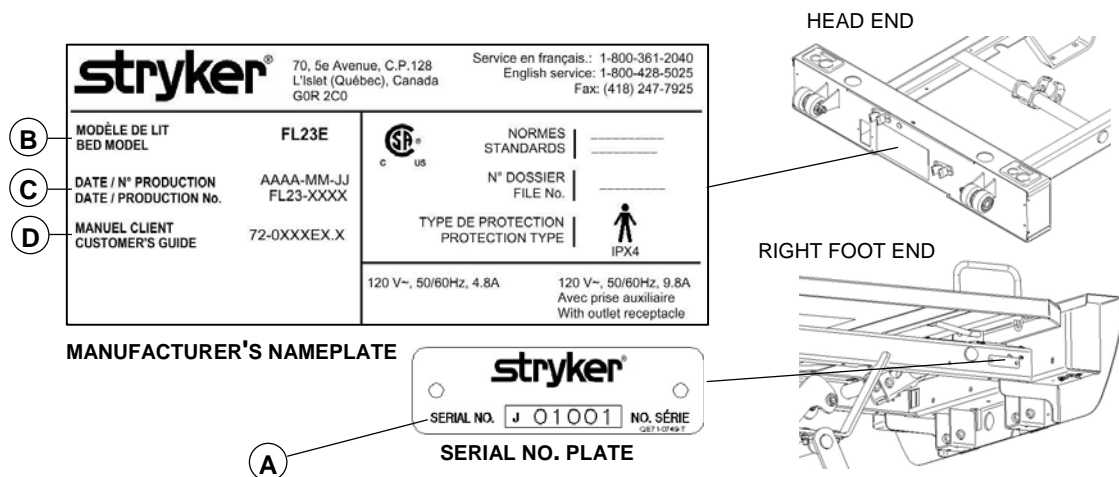

**Figure 1.5**

- Locate the serial number plate and the manufacturer's nameplate affixed respectively to the right side of the frame at the foot end of the bed, and on the right side of the head end casing.
- From the serial plate, write down the serial number (A).
- From the manufacturer's nameplate, write down the bed model (B), the production number (C), ex. FL23-XXXX, and the Customer's Guide number (D).
- Consult the parts lists and the drawings contained in the Parts List Manual included in the Customer's Guide to identify the defective part. Write down the name of the part and its part number, and the problem encountered while using the equipment.

#### NOTE

It is very important that you refer to the parts lists and drawings of the Parts List manual specific to the bed needing to be repaired.

The Technical Service representative will help you identify the parts to be replaced. However, if an error occurs when ordering, the user remains responsible for identifying the parts to change. Stryker will take back wrong parts ordered but will not assume shipping charges, and restocking fees will be charged to the user unless a Technical Service Representative has been requested for an on-site diagnosis of the malfunction.

### RETURN AUTHORIZATION

Merchandise cannot be returned without approval from the Technical Service department. An authorization number will be provided, which must be clearly printed on the returned merchandise. Stryker reserves the right to charge shipping and restocking fees on returned items.

### DAMAGED MERCHANDISE

Claims for damaged merchandise must be made with the carrier within fifteen (15) days of receipt of merchandise. **DO NOT ACCEPT DAMAGED SHIPMENTS UNLESS SUCH DAMAGE IS NOTED ON THE DELIVERY RECEIPT AT THE TIME OF RECEIPT.** Upon prompt notification, Stryker will file a freight claim with the appropriate carrier for damages incurred. Claims will be limited in amount to the actual replacement cost. In the event that this information is not received by Stryker within the fifteen (15) day period following the delivery of the merchandise, or the damage was not noted on the delivery notice at the time of receipt, the customer will be responsible for payment of the original invoice in full.

Claims for any short shipment must be made within 5 days of invoice.

## 1.6 SYMBOLS



Warning, refer to Maintenance Manual



Fuse rating for bed with the 100V~ and 120V~ electric systems



Fuse rating for beds with 200V~, 220V~ and 240V~ electric systems



Protective earth (ground)



Alternating Current



Type B Equipment

**IPX4** Protection from liquid splash



## 2. PREVENTATIVE MAINTENANCE

### 2.1 BED CLEANING AND MATTRESS CARE

**WARNING**

Always unplug the bed power cord from the wall outlet when cleaning or servicing the bed.

**CAUTION**

Do not use harsh cleaners, solvents or detergents. Equipment damage could occur. Do not steam clean, hose off or ultrasonically clean the bed. Do not immerse any part of the bed. The bed electrical parts may be damaged by exposure to water.

Germicidal disinfectant, used as directed, and/or Chlorine Bleach products are not considered mild detergents. These products are corrosive in nature and may cause damage to your bed if used improperly. If these types of products are used, ensure the beds are wiped with clean water and thoroughly dried following cleaning. Failure to properly rinse and dry the beds will leave a corrosive residue on the surface of the bed, possibly causing premature corrosion of critical components. Failure to follow the above directions when using these types of cleaners may void this product warranty.

**CLEANING BEDS**

Hand wash all surfaces of the bed with a soft cloth moistened with a solution of lukewarm water and a mild detergent.

Wipe the bed clean and dry thoroughly to avoid build up of cleaning solution.

**MATTRESS CARE****WARNING**

Inspect the mattress after each use. Discontinue use if any cracks or rips, which may allow fluid to enter the mattress, are found in the mattress cover. Failure to properly clean the mattress, or dispose of it if defective, may increase the risk of exposure to pathogenic substances and may bring about diseases to the patient and user.

**• Inspection**

Implement local policies to address regular care, maintenance, and cleaning of mattresses and covers. The cover cleaning procedure can be found below and on the bed label.

Inspect mattress cover surface (also zip fasteners and cover inner surface if mattresses have zip fasteners) regularly for signs of damage. If the mattress cover is heavily stained or soiled, or is torn, remove the mattress from service.

**• Cleaning**

Stains: Wash with lukewarm water using a mild detergent. Rinse with water and let dry. For tough stains use bleach diluted with ten parts of water.

## 2.2 ACTUATOR LUBRICATION

### NOTE

In compliance with the service life requirement of the BNQ 6641-120/2003 standard, this unit was designed maintenance free with regard to lubrication. However, if the bed is used improperly or cleaned without following the recommendations set forth in the Maintenance Manual (presence of cleaning detergent on the actuator screws), a lubrication of the actuator could be necessary.

### Required Tools:

Phillips Screwdriver

1/4" Ratchet (w/6" extension) and 5/16" Socket

Bungee Cords

OG2 Grease (P/N M0027)

Brush

### Procedure:

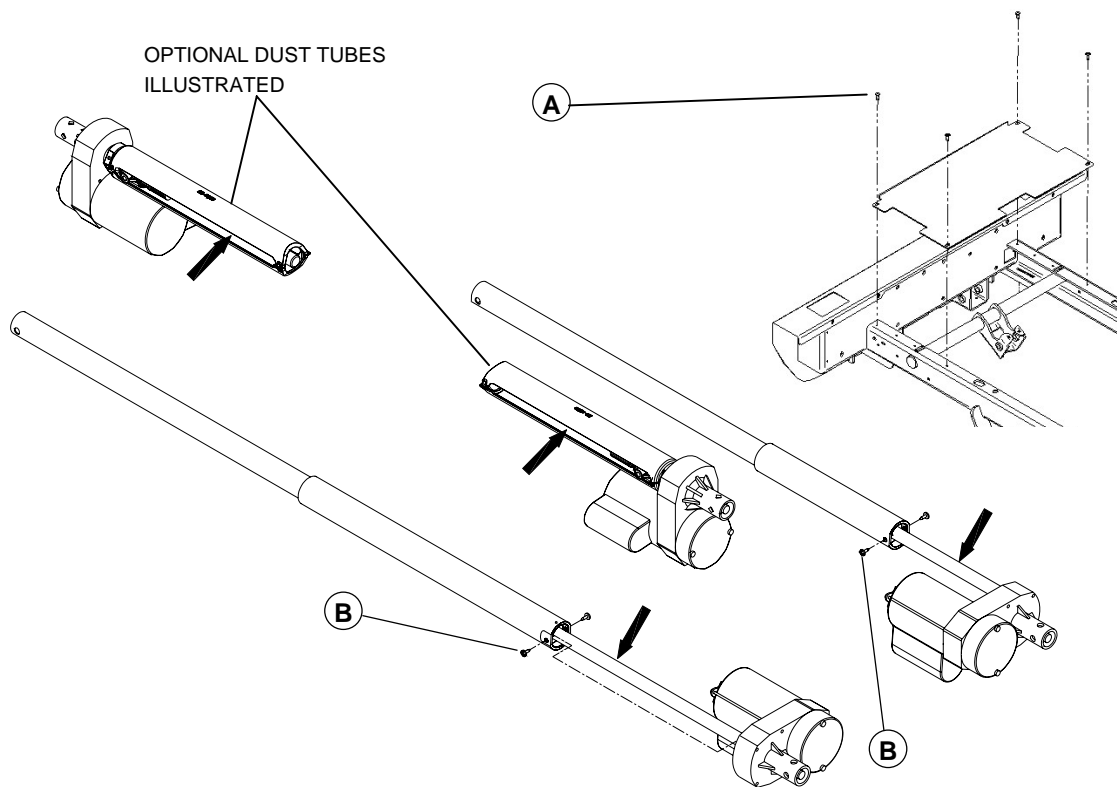

Figure 2.2

### Head and Thigh Actuators

1. Raise the bed fully up and apply the brakes.
2. Fully raise the head section and flatten the thigh section to expose maximum screw threads on both actuators.
3. Unplug the power cord from the wall outlet.
4. Lift and fold back the foot section toward the head end of the bed. Attach the section to the bed using bungee cords.
5. Using a Phillips screwdriver, remove the four screws (A) holding the cover plate to the frame and remove the plate. Remove the optional night light if present.
6. Using a 1/4" ratchet (w/6" extension) and a 5/16" socket, remove the two screws (B) holding the dust tube of each actuator.
7. Using a brush, apply grease on the screw threads. Make sure the grease reaches the bottom of the threads.

8. Replace the dust tubes.
9. Using the electric controls, raise and lower several times the Fowler and Knee Gatch to spread the grease evenly.
10. Replace the cover plate.

**Hi-Lo Actuators**

1. Lower the bed completely and apply the brakes.
2. Raise the head and foot sections fully up, then lift and fold back the foot section toward the head end of the bed.
3. Unplug the power cord from the wall outlet.
4. Using a brush, apply grease on the threads of the Hi-Lo actuators screws. Optional dust tubes may be present, then simply apply grease through the dust tube side openings. Make sure the grease reaches the bottom of the threads.
5. Using the electric controls, raise and lower the bed several times to spread the grease evenly.

**2.3 PREVENTATIVE MAINTENANCE PROGRAM**

---



**WARNING**

When servicing use only identical replacement parts provided by Stryker.

---

**ANNUAL CHECKLIST**

- All fasteners secure.
- Inspect for excessive wear the oil-impregnated bronze shoulder spacers found at the bed hinge points. Replace as needed. **Do not** lubricate these spacers.
- On both sides of the bed, depress fully down the side of the pedal identified with a red sticker and ensure that the brakes are applied and the bed immobilized. Toggle the pedal to neutral and ensure the brakes are released.
- On both sides of the bed, depress fully down the side of the pedal identified with a green sticker and ensure that the steer mode (5th wheel (optional) or bed wheel) is engaged. Toggle the pedal to neutral and ensure that the steer mode disengages.
- Siderails move smoothly and latch properly in high position.
- Ensure that each control on the inner and outer sides of the head siderails (optional) is working properly.
- All controls of the foot end panel and those, optional, of the foot board panel working properly, including Trendelenburg and lockout LED's.
- Fowler and Knee Gatch (if raised) flatten and the Fowler control motor resets itself automatically when the two CPR handles (optional) are pulled until Fowler is flattened.
  - Wait about 30 seconds, the time for the Fowler motor to reset itself, and then raise the Fowler to ensure that the resetting of the motor has indeed occurred.
- Verify the Fowler, Knee Gatch and Hi-lo movements to ensure that the motion interrupt switch integrated to the four electric actuators is operating properly.
- Auxiliary outlet (option available only with 120V beds) working properly.
- Night light (option) working properly.
- Head end bumpers tightly secured to frame and working properly.
- No rips or cracks in mattress cover.
- Power cord not frayed.
- No cables worn or pinched.
- All electrical connections tight.
- All grounds secure to the frame.
- All casters roll properly. Check caster for cuts, wear, etc.
- Measure current leakage and grounding continuity of the bed and the optional auxiliary outlet. Check with our Technical Service department for the acceptable values.

**Serial No.:** \_\_\_\_\_  
                  \_\_\_\_\_  
                  \_\_\_\_\_

**Inspected by:** \_\_\_\_\_ **Date:** \_\_\_\_\_

**RECOMMENDED SPARE PARTS**

The following is a list of recommended on hand spare parts for the FL23E bed.

<b>Description</b>	<b>Part Number</b>	<b>Parts List</b>
<b>• Electric/Electronic Components</b>		
Motor control board	QDF23-0315	OL230015
Micro switch	1325P003	OL230005/ OL230037
Fuse - Fast acting 10A, 250V for 100/120V electric systems	QDF8078	OL230015
Fuse - Slow blow 6.3A, 250V for 200/220/240V electric systems	QDF8068	OL230116
Power cord with straight N A molded plug	QDF8066	OL250053
Night light (optional)	QDF9539	OL230017
5A circuit breaker (for optional auxiliary outlet)	QDF9025	OL230010
Hi-Lo actuator	23-0431	OL230015
Head section actuator	23-0335	OL230015
Thigh section actuator	23-0336	OL230015
Toroidal Transformer - international series beds	14-1160	OL230116
Stand-off pins	QP23-0258	OL230015
Strain-relief bushing	QDF9541	OL230015
Support for the foot end control panel membrane	17-0127	OL230026/ OL230033
Foot end control panel membrane	17-0180	OL230026/ OL230033
<b>• Siderail Components</b>		
Protective cap	QP18748-07	OL230003
Transfer plate - full-length siderail	23-0161G	OL230001
Transfer plate - half-length siderail	23-0093G	OL230003
Two-function control panel membrane, head-foot, w/o nurse call	QDF23-0392	OL230199
Two-function control panel membrane, foot-head, w/o nurse call	QDF23-0393	
Two-function control panel membrane, head-foot, with nurse call	QDF23-0396	OL230198
Two-function control panel membrane, foot-head, with nurse call	QDF23-0397	
<b>• Mattress Support Components</b>		
Lateral mattress retainer	QP14034-07	L23-002
I. V. pole holder	QP17-0121	L23-003
<b>• Caster</b>		
6" with lock mechanism	R25-0388	OL230048
6" without lock mechanism	R25-0493	OL230048
6" with steer mechanism	R25-0496	OL230048
5" with lock mechanism	R25-0494	OL230044
5" without lock mechanism	R25-0391	OL230044
5" with steer mechanism	R25-0495	OL230044

5th wheel caster (optional)	RL5	OL230113
-----------------------------	-----	----------

• **Base Components**

Rue ring cotter Ø3/8"	QDF7878	OL230042/ OL230043
Green sticker - 5th wheel	QE71-0496	OL230042/ OL230043
Red sticker - brake	QE71-0511	OL230042/ OL230043
Wheel cover - right (optional)	QP25-0022-07	OL230101
Wheel cover - left (optional)	QP25-0039-07	OL230101
Brake/steer pedal	QP21-3761	OL230042/ OL230043
Velcro fastener	25-0302	OL230101

• **Miscellaneous**

Grey spray paint	DDCAP-GSP	
Shoulder spacer	QDF17-0020	
Nylon cable tie	QDF9521	

### 3. TROUBLESHOOTING

Please consult the following troubleshooting guide before calling the Technical Service department (see section 1.2).

#### 3.1 TROUBLESHOOTING GUIDE

PROBLEM/FAILURE	WHAT TO CHECK
No power to bed	<ul style="list-style-type: none"> <li>• Is the bed power switch at the head end of the bed turned on?</li> <li>• Is the power cord connected to the power connector and plugged into the wall outlet?</li> <li>• Is the power cord severed? Replace if so.</li> <li>• Are the two fuses inside the power connector still operational (see page 35)</li> <li>• Verify power at wall outlet.</li> </ul>
No bed up or down motion	<ul style="list-style-type: none"> <li>• Check points of the “No power to bed” problem described above.</li> </ul>
No Fowler up or down motion when: <ul style="list-style-type: none"> <li>• the pendant control (optional) is used</li> <li>• the foot board command is used</li> </ul>	<ul style="list-style-type: none"> <li>• Is the Fowler lockout activated (LED off)? Deactivate it (LED on).</li> <li>• Is the cable of the pendant control (optional) properly connected to the bed connector under the mattress support?</li> <li>• Check points of the “No power to bed” problem described above.</li> </ul>
The Fowler does not <b>fully</b> raise	<p>This situation arises when the CPR emergency release (optional) is used to partially lower the Fowler. The use of the CPR for this purpose creates a situation where the Fowler motor is out of sync with the actual position of the Fowler. To correct the situation:</p> <ul style="list-style-type: none"> <li>• Lower the Fowler <b>completely</b> using a CPR handle or the Fowler electric control to enable the Fowler motor to reset itself and thus synchronize its course with the actual position (flatten) of the Fowler.</li> </ul>
No Knee Gatch up or down motion when: <ul style="list-style-type: none"> <li>• the pendant control (optional) is used</li> <li>• the foot board command is used</li> </ul>	<ul style="list-style-type: none"> <li>• Is the Knee Gatch lockout activated (LED off)? If so, deactivate it (LED on).</li> <li>• Is the cable of the pendant control (optional) properly connected to the bed connector under the mattress support?</li> <li>• Check points of the “No power to bed” problem described above.</li> </ul>
The positioning mechanisms of the Fowler, and/or the Knee Gatch, and /or the bed height operate with difficulty.	Check the four actuator screws to verify their lubrication condition and apply grease if needed (see section 2.2 above).
No Auto Contour (optional) motion	<ul style="list-style-type: none"> <li>• Is the Knee Gatch lockout activated (LED off)? If so, deactivate it (LED on).</li> <li>• Check and replace if needed (see page 36) the two Auto Contour limit switches.</li> </ul>
Improper operation of the CPR emergency release (optional): Knee Gatch does not lower and/or the Fowler actuator does not reset.	<ul style="list-style-type: none"> <li>• Check and replace if needed (see page 38) the two CPR mechanism limit switches.</li> </ul>

## 4. MAINTENANCE PROCEDURES



### WARNING

To prevent injury when working under the bed with the bed in the high position, always place blocks under the Hi-Lo levers and apply the brakes. Always unplug the bed power cord from the wall outlet when servicing or cleaning the bed.

### NOTE

Throughout this operations manual, the words “right” and “left” refer to the right and left sides of a patient lying face up on the bed.

### 4.1 MAINTENANCE PROCEDURE - SIDERAIL

#### RAIL REPLACEMENT

##### Required Tools:

Small Slotted Head Screwdriver  
Rubber Mallet

Long Nose Pliers

Retaining Ring Pliers

##### Procedure:

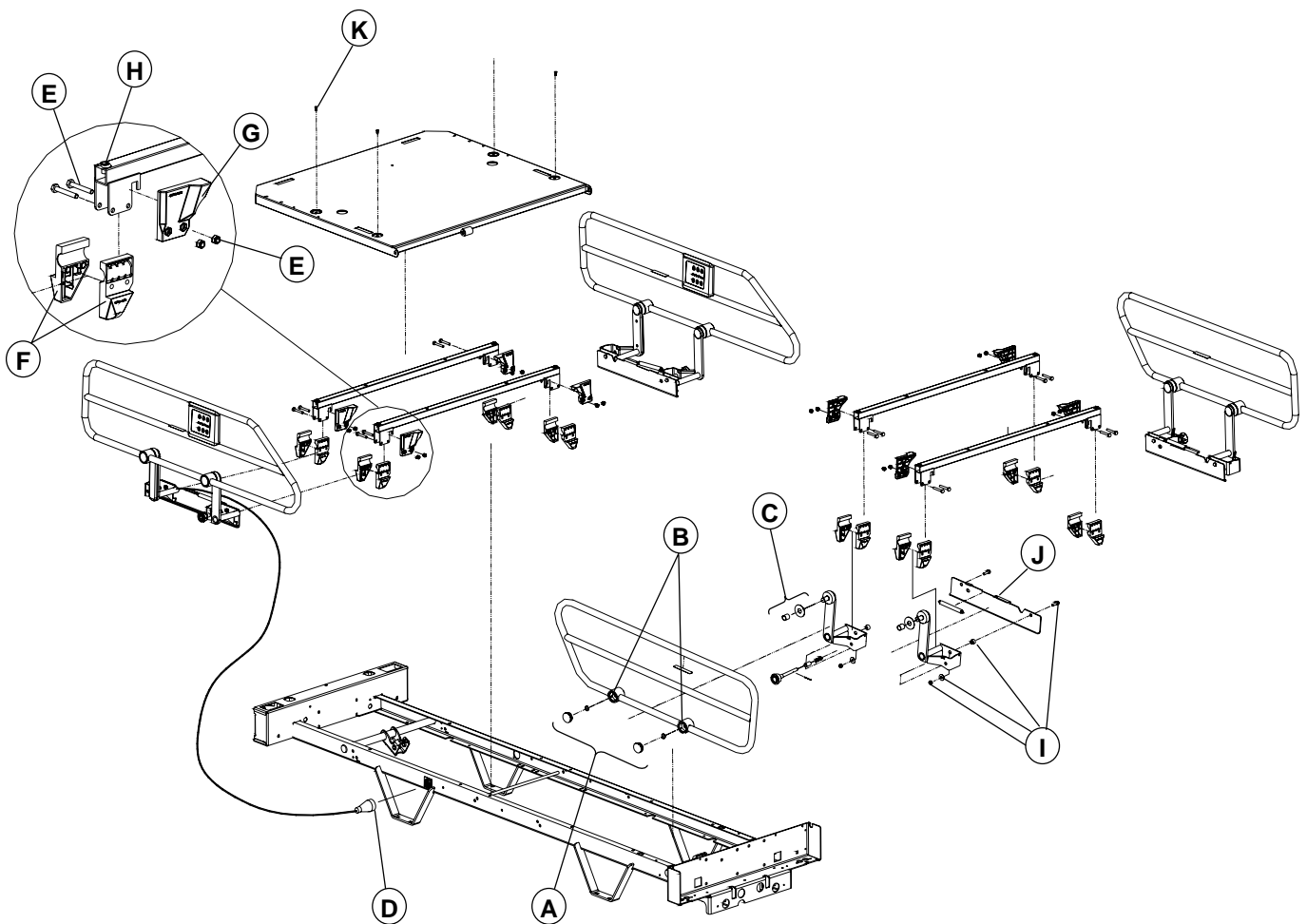

Figure 4.1A



**NOTE**

This procedure applies to both types of siderails: half-length and full-length.

Replacing the rail of a head siderail equipped with a fixed control panel is a complex task requiring technical knowledge of the product. We strongly recommend that you contact our Technical Service department (see section 1.2) in order for them to suggest an appropriate solution to the problem.

1. Raise the bed fully up and apply the brakes.
2. Position all the mattress support sections to flat.
3. Unplug the bed power cord from the wall outlet.
4. Raise the siderail needing repair.
5. Using a small slotted head screwdriver and long nose pliers, remove the two protective caps (A). Be careful while using the tools not to damage the siderail paint.

**NOTE**

Replace the caps using a rubber mallet. The removal of the caps may damage them; make sure you have some on hand.

6. Using retaining ring pliers, remove the two retaining rings (B) holding the rail in place. Remove the rail and recuperate the self-lubricating bearings/washers (C).

**NOTE**

Inspect the self-lubricating bearings for wear and replace them if need be.

7. Reverse the above steps to install the replacement rail.
8. Verify the siderail movement for proper operation before returning the bed to service.

**HALF-LENGTH SIDERAIL ASSEMBLY REPLACEMENT****Required Tools:**

7/16" Socket Wrench

7/16" Wrench

Cutting Pliers

**Procedure:****NOTE**

Unless otherwise indicated, refer to figure 4.1A page 16 for the illustration of the references contained in the following replacement procedure.

1. Raise the bed fully up and apply the brakes.
2. Depending on the position of the siderail needing repair, place the mattress support sections as follows:
  - **Head siderail:** Raise the head section fully up.
  - **Foot siderail:** Lower completely the head section. Raise the thigh section fully up, then lift and fold back the foot section toward the head end of the bed.
3. Unplug the bed power cord from the wall outlet.
4. Raise the siderail needing repair.
5. Using cutting pliers, cut the cable ties holding the siderails cables. Loosen the lock ring (D) and unplug the siderail control cable.

**NOTE**

Note the position and the gathering of the cable before cutting the cable ties to make sure the new cable will be connected correctly.

6. Using a 7/16" socket wrench and 7/16" wrench, remove the two locknuts/bolts (E) holding the two half bushings (F), the stopper (G) and the siderail mechanism to each of the two siderail support (H). Remove the half-bushings and the mechanism from their location - hold the bushings to prevent them from falling to the ground.

**NOTE**

Remove first the two locknuts/bolts at one end of the assembly and, while holding the assembly, finish with the ones at the opposite end.

7. Reverse the above steps to install the replacement siderail assembly.
8. Verify the siderail for proper operation before returning the bed to service.

**FULL-LENGTH SIDERAIL ASSEMBLY REPLACEMENT****Required Tools:**

7/16" Socket Wrench

7/16" Wrench

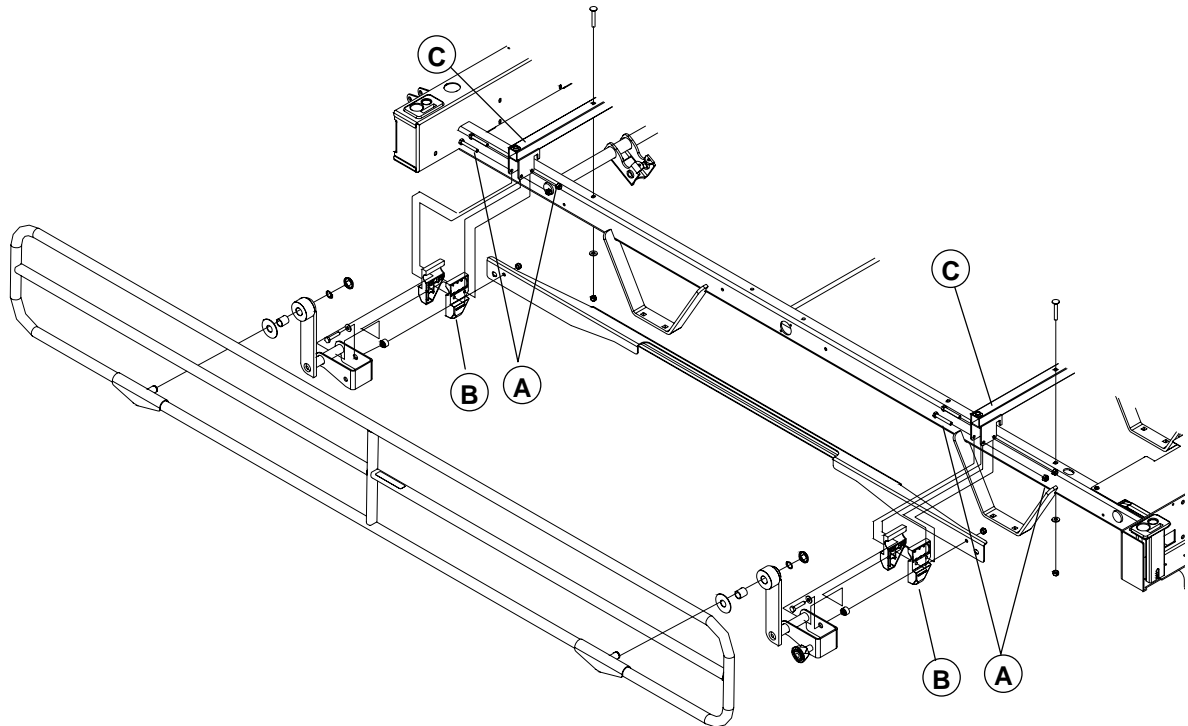
**Procedure:****Figure 4.1B**

1. Lower the bed fully down and raise the siderail needing repair.
2. Raise the head and thigh sections fully up, and lift and fold back the foot section toward the head end of the bed.
3. Unplug the bed power cord from the wall outlet.
4. Using a 7/16" socket wrench and 7/16" wrench, remove the two locknuts/bolts (A) holding the two half bushings (B) and the siderail mechanism to each of the two siderail supports (C). Remove the half-bushings and the mechanism from their location - hold the bushings to prevent them from falling to the ground.

**NOTE**

Remove first the two locknuts/bolts at one end of the assembly and, while holding the assembly, finish with the ones at the opposite end.

5. Reverse the above steps to install the replacement siderail assembly.
6. Verify the siderail for proper operation before returning the bed to service.

## TRANSFER PLATE REPLACEMENT

### Required Tools:

7/16" Socket Wrench

7/16" Wrench

Torque Wrench

### Procedure:

#### NOTE

Unless otherwise indicated, refer to figure 4.1A page 16 for the illustration of the references contained in the following replacement procedure.

1. Raise the bed fully up and apply the brakes.
2. Depending on the type and the position of the siderail, place the mattress support sections as follows:
  - **Half-Length Siderail**
    - Head siderail: Raise the head section fully up.
    - Foot siderail: Lower completely the head section. Raise fully up the thigh section, then lift and fold back the foot section toward the head end of the bed.
  - **Full-Length Siderail**

Raise fully up the head and thigh sections, then lift and fold back the foot section toward the head end of the bed.
3. Unplug the bed power cord from the wall outlet.
4. Lower the siderail needing repair.
5. Using a 7/16" socket wrench and 7/16" wrench, remove the two locknuts /bushings/washers/bolts (I) holding the transfer plate (J) to the siderail mechanism.

#### NOTE

At assembly, tighten the two locknuts to a 75 lbf/in torque.

6. Reverse the above steps to install the replacement transfer plate.
7. Verify the siderail for proper operation before returning the bed to service.

## 4.2 MAINTENANCE PROCEDURE - CONTROL PANEL

### FOOT END CONTROL PANEL REPLACEMENT

#### NOTE

The control panel is made of a membrane and its support. Both parts should be ordered for this replacement procedure. Refer to the "Recommended Spare Parts" section on page 13.

#### Required Tools:

Phillips Screwdriver

#### Procedure:

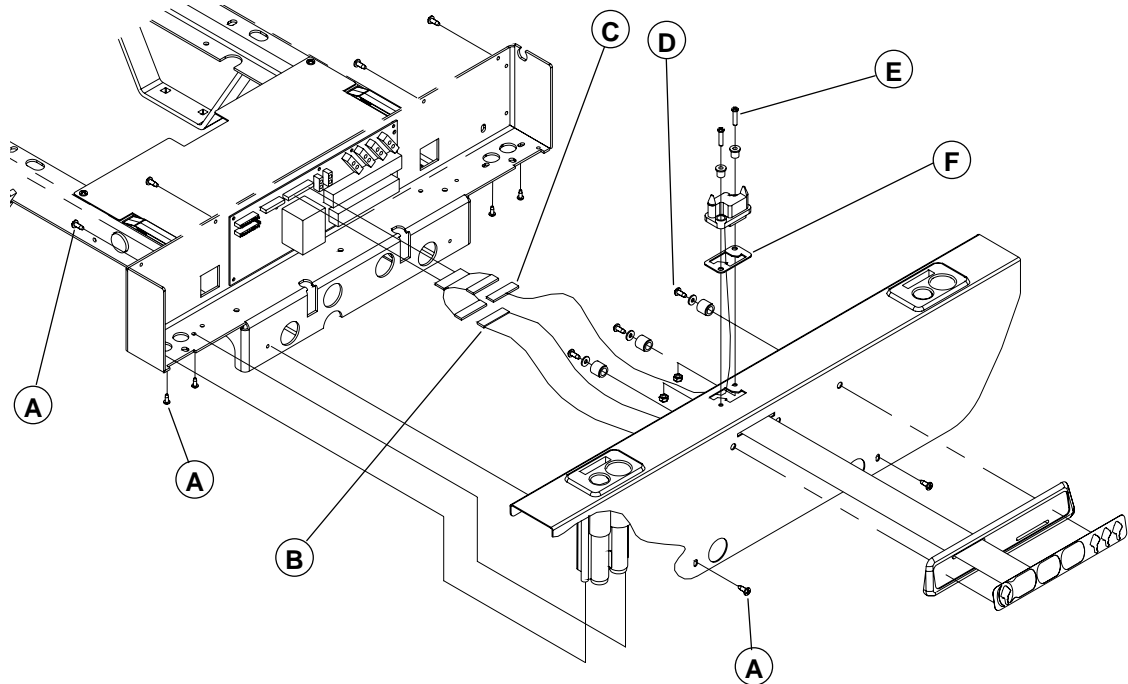

Figure 4.2A

1. Raise the bed fully up and apply the brakes.
2. Unplug the bed power cord from the wall outlet.
3. Remove the foot board.
4. Using a Phillips screwdriver, remove the 10 screws (A) holding the cover and the I.V. pole holders to the foot casing.
5. Lift and remove the cover while taking care to disconnect the control panel cable (B) from the control board and the foot casing connector cable (C, optional), if present. Lay the cover on a workbench.
6. Using a Phillips screwdriver, remove the three screws/washers/spacers(D) holding the panel to the cover.
7. Reverse the above steps to install the replacement foot end control panel.
8. Verify all the controls of the foot end control panel before returning the bed to service.

## **FOOT END CASING CONNECTOR REPLACEMENT (OPTIONAL)**

### **Required Tools:**

Phillips Screwdriver    3/8" wrench

### **Procedure:**

#### **NOTE**

Unless otherwise indicated, refer to figure 4.2A page 21 for the illustration of the references contained in the following replacement procedure.

1. Raise the bed fully up and apply the brakes.
2. Unplug the bed power cord from the wall outlet.
3. Remove the foot board.
4. Using a Phillips screwdriver, remove the 10 screws (A) holding the cover and the I.V. pole holders to the foot casing.
5. Lift and remove the cover while taking care to disconnect the control panel cable (B) from the control board and the foot casing connector cable (C). Lay the cover on a workbench.
6. Using a 3/8" wrench, remove the two locknuts/shoulder spacers/screws (E) holding the connector to the cover. Remove the defective connector. Keep the seal (F) for the replacement connector.
7. Reverse the above steps to install the replacement connector.
8. Verify all the controls of the foot end control panel for proper operation before returning the bed to service.

**FOOT BOARD CONTROL PANEL REPLACEMENT (OPTIONAL)****NOTE**

The control panel is made of a membrane and its support. Both parts should be ordered for this replacement procedure. Refer to the "Recommended Spare Parts" section on page 13.

**Required Tools:**

Phillips Screwdriver

Transfer Tape

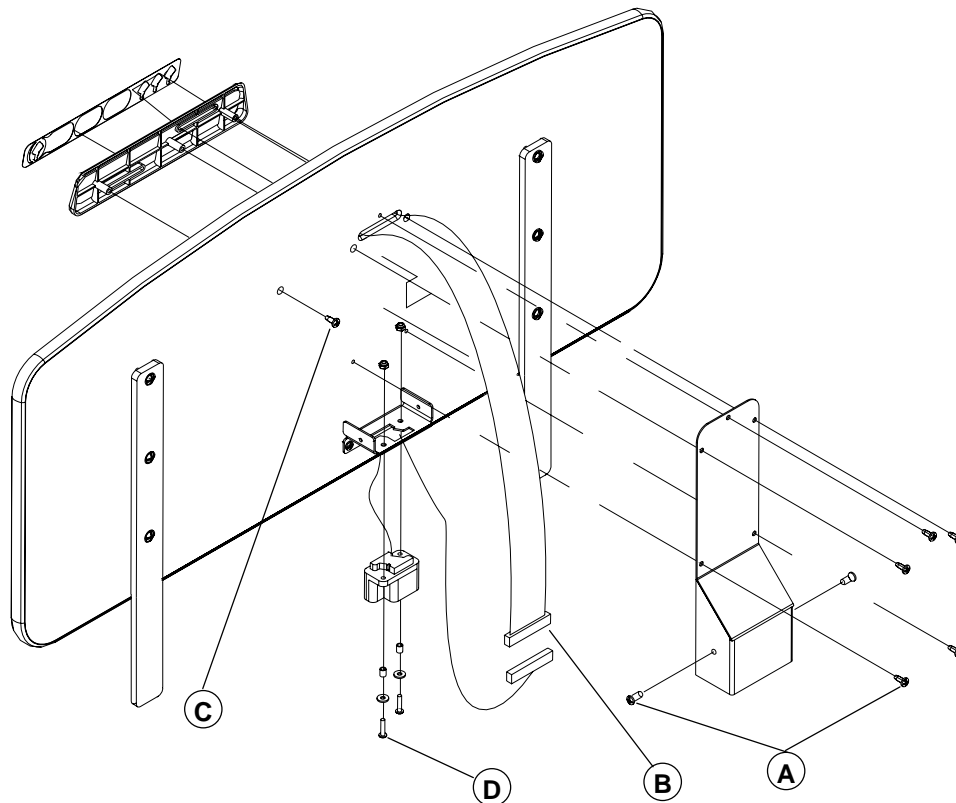
**Procedure:****Figure 4.2B**

1. Raise the bed fully up and apply the brakes.
2. Unplug the bed power cord from the wall outlet.
3. Remove the foot board and lay it on a workbench.
4. Using a Phillips screwdriver, remove the 7 screws (A) holding the support cover to the inner face of the foot board and remove the cover.
5. Disconnect the foot board panel cable (B).
6. Using a Phillips screwdriver, remove the last screw (C) holding the control panel to the foot board. Remove the panel. A small part of the panel cable will be stuck to the inner face of the board using a small transfer tape. Do the same at reassembly.
7. Reverse the above steps to install the replacement foot board panel.
8. Verify all the controls of the foot board panel for proper operation before returning the bed to service.

## **FOOT BOARD CONNECTOR REPLACEMENT (OPTIONAL)**

### **Required Tools:**

Phillips Screwdriver

9 mm Wrench

### **Procedure:**

#### **NOTE**

Unless otherwise indicated, refer to figure 4.2B page 23 for the illustration of the references contained in the following replacement procedure.

1. Raise the bed fully up and apply the brakes.
2. Unplug the bed power cord from the wall outlet.
3. Remove the foot board and lay it on a workbench.
4. Using a Phillips screwdriver, remove the 7 screws (A) holding the support cover to the inner face of the foot board and remove the cover.
5. Disconnect the foot board connector cable (B).
6. Using a 9 mm wrench and a Phillips screwdriver, remove the two locknuts/washers/sleeves/screws (D) holding the connector to its support. Remove the defective connector.
7. Reverse the above steps to install the replacement connector.
8. Verify the foot board controls for proper operation before returning the bed to service.



## SIDERAIL CONTROL PANEL COMPONENT REPLACEMENT

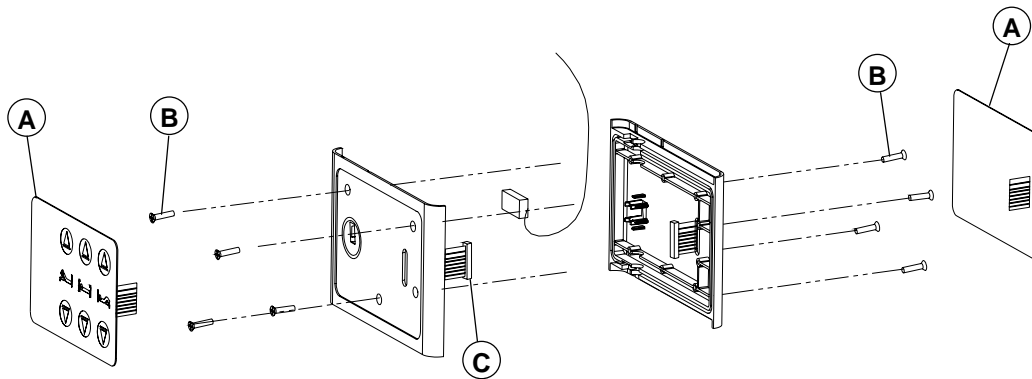

Figure 4.2C

### NOTE

The replacement of a membrane implies that the one facing it on the inner or outer control panel also has to be replaced. Service kits that include both membranes are available (see page 13).

### Required Tools:

Phillips Screwdriver

### Replacement Procedure:

1. Raise the bed fully up and apply the brakes. Bring the head section to horizontal position.
2. Unplug the bed power cord.
3. Raise the head siderail needing repair.
4. Properly ground yourself (see section 1.4)
5. Detach the two membranes (A) from their mounting plates and let them hang down.
6. Using a Phillips screwdriver, remove the eight screws (B) holding together the two sections of the control panel housing.
7. Open the housing. Disconnect the defective membrane cable (B) and remove the membrane.
8. Reverse the above steps to install the replacement control panel membranes.

### NOTE

Make sure to connect the membrane cables before fastening together the two sections of the control panel housing. Affix the membrane to the support at the end of the replacement procedure.

9. Verify all the siderail functions (inner and outer panels) for proper operation before returning the bed to service.

4.3 MAINTENANCE PROCEDURE - MATTRESS SUPPORT

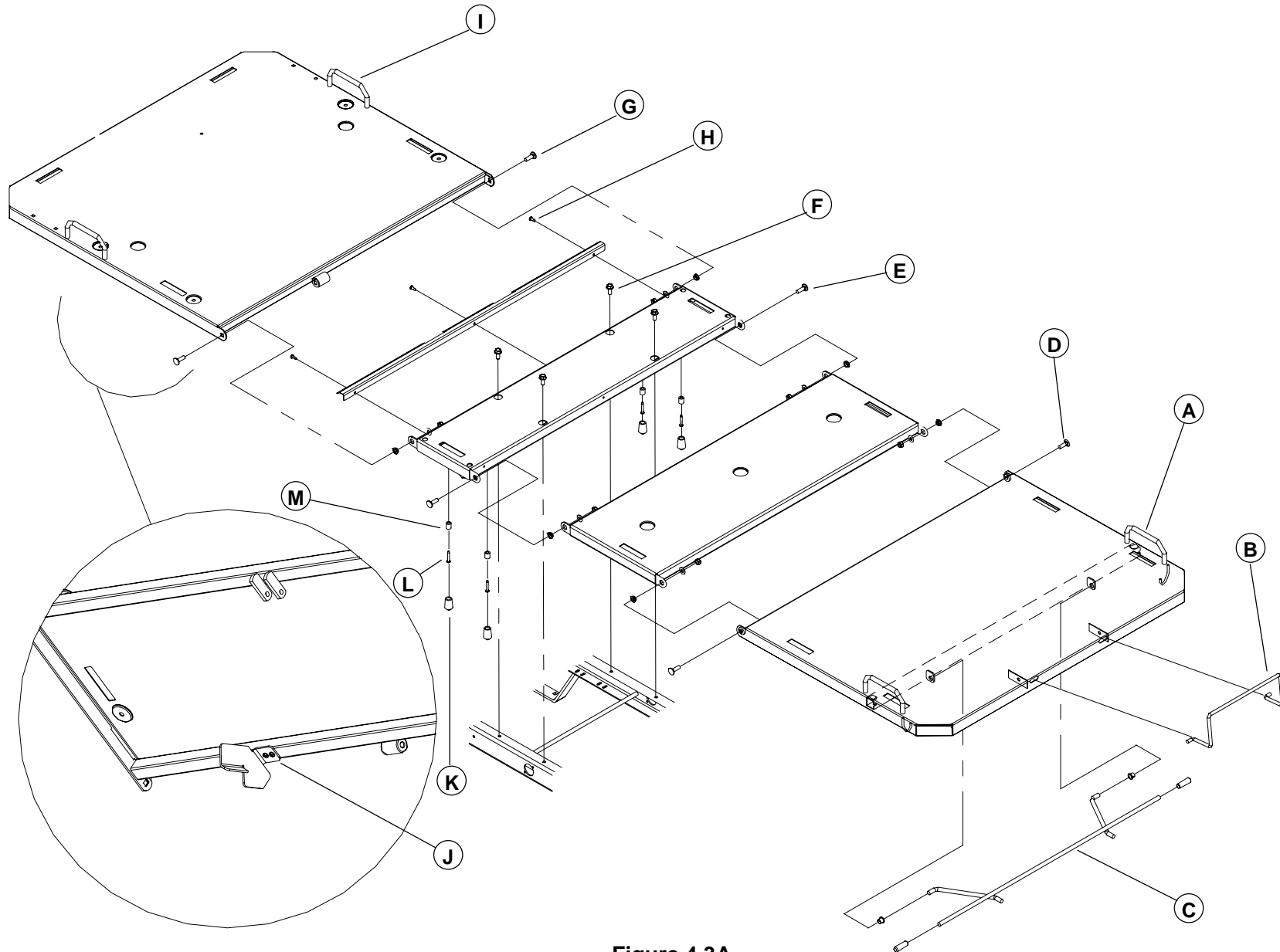

Figure 4.3A

**FOOT SECTION REPLACEMENT****Required Tools:**

Phillips Screwdriver                      Bungee Cords                      1/2" Wrench

**Procedure:**

1. Run the bed fully up and apply the brakes. Flatten all sections of the mattress support.
2. Unplug the bed power cord from the wall outlet.
3. Lower the siderails.
4. Lift and fold back the foot section toward the head end of the bed. Secure the section to the bed using bungee cords.
5. Using a Phillips screwdriver, remove the lateral mattress retainers (A).
6. Remove the foot end mattress retainer (B).
7. Remove the foot prop rod (C).
8. Remove the bungee cords and replace the foot section to horizontal position.
9. Using a 1/2" wrench, remove the two locknuts/washers/shoulder spacers/bolts (D) linking the foot section to the thigh section and remove the defective section.
10. Reverse the above steps to install the replacement foot section.

**THIGH SECTION REPLACEMENT****Required Tools:**

Long Nose Pliers                      Bungee Cords                      1/2" wrench

**Procedure:****NOTE**

Unless otherwise indicated, refer to figure 4.3A page 26 for the illustration of the references contained in the following replacement procedure.

1. Run the bed fully up and apply the brakes. Flatten all sections of the mattress support.
2. Unplug the bed power cord from the wall outlet.
3. Lower the siderails.
4. Lift and fold back the foot section toward the head end of the bed. Secure the section to the bed using bungee cords.
5. Using long nose pliers, remove the rue ring cotter/washers/clevis pin (E, fig. 4.3C, page 31) linking the thigh section lever arms to the thigh actuator tube.

**NOTE**

Before linking back the thigh actuator tube to the thigh section lever arms, verify that the actuator course was preserved. To do so, refer to the caution that follows step 16 of the Knee Gatch actuator replacement procedure and proceed with step 17 of the procedure.

6. Remove the bungee cords and bring the foot section back to flat position.
7. Using a 1/2" wrench, remove the four locknuts/washers/shoulder spacers/bolts (D, E) linking the thigh section to the foot and seat sections and remove the thigh section.
8. Reverse the above steps to install the replacement thigh section.

## SEAT SECTION REPLACEMENT

### Required Tools:

1/2" Long Socket Wrench                      1/2" Wrench                      Torque Wrench  
Phillips Screwdriver

### Procedure:

#### NOTE

Unless otherwise indicated, refer to figure 4.3A page 26 for the illustration of the references contained in the following replacement procedure.

1. Raise the bed fully up and apply the brakes. Flatten the mattress support.
2. Unplug the power plug from the wall outlet.
3. Lower the siderails.
4. Using a 1/2" long socket wrench, remove the four screws (F) holding the seat section to the frame.

#### NOTE

Tighten the four bolts to a 135 lbf/in torque at assembly.

5. Using a 1/2" wrench, remove the four locknuts/washers/shoulder spacers/bolts (E, G) linking the seat section to the thigh and head sections and remove the seat section.
5. Turn the seat section up side down and remove the three screws (H) holding the protective plate to the seat section. Keep the plate for the replacement seat section.
6. Remove the four rubber caps (K) covering the screws (L) holding the stops (M) to the defective section and replace the parts on the replacement section.
7. Reverse the above steps to install the replacement seat section.

## HEAD SECTION REPLACEMENT

### Required Tools:

Phillips Screwdriver                      1/2" Wrench (2)                      Strap  
7/16" Wrench (2)

### Procedure:

#### NOTE

Unless otherwise indicated, refer to figure 4.3A page 26 for the illustration of the references contained in steps 1 to 14 below.

1. Raise the bed fully up and apply the brakes.
2. If the bed is equipped with full-length siderails, lower them.  
If equipped with half-length siderails, raise the head siderails and lower the foot ones.
3. Remove the head board.
4. Raise the head section fully up and attach it securely to the bed using a strap.
5. Unplug the bed power cord from the wall outlet.
6. Using a Phillips screwdriver, remove the two lateral mattress retainers (I) and keep them for the replacement head section.

If the bed is **not** equipped with the CPR emergency release (optional), proceed with steps 7 to 14.

Otherwise, proceed with step 15 to 24.

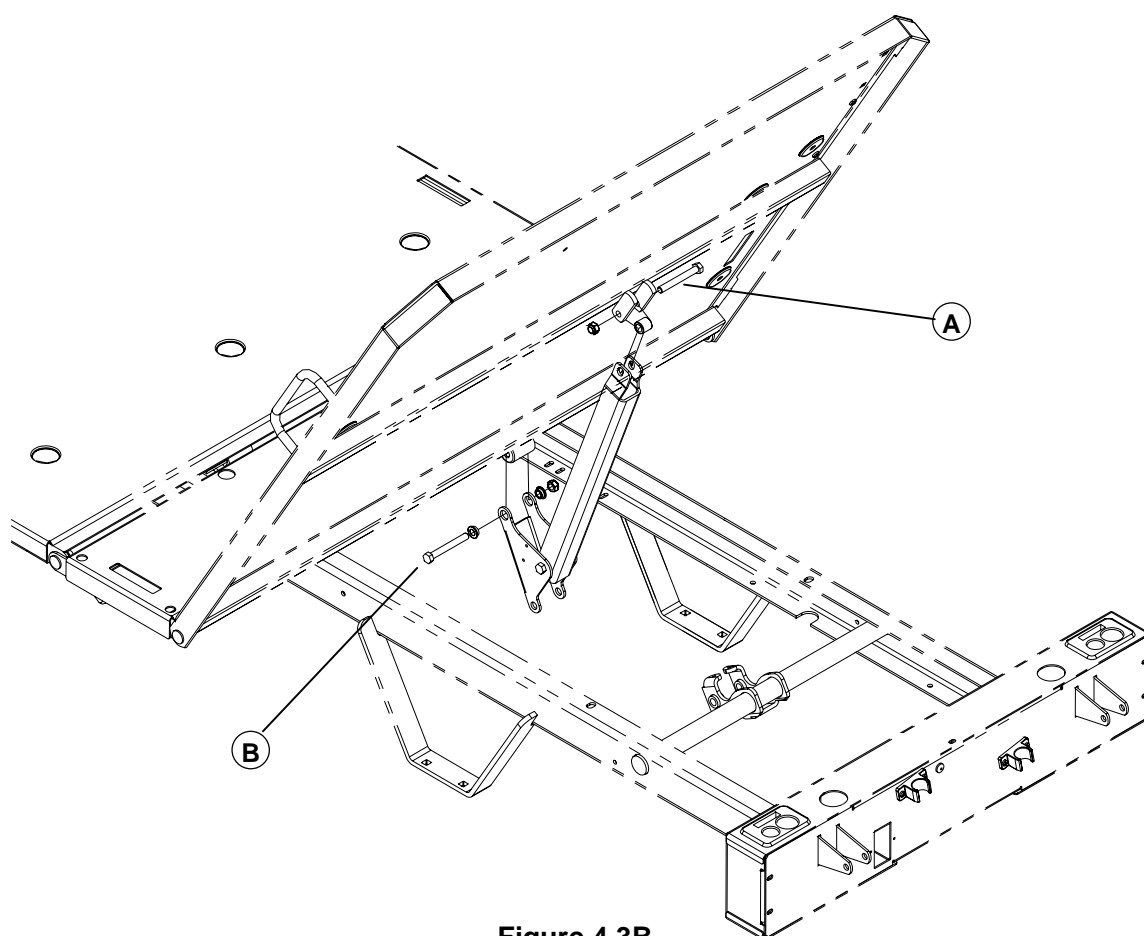
**Figure 4.3B**

7. Using two 1/2" wrenches, remove the locknut/spacer/bolt (A) holding the upper part of the compression bar to the head section and lay it down.
8. Using two 1/2" wrenches, remove the locknut/shoulder spacers/bolt (B) linking the mattress support lever to the head section and remove the lever/compression bar assembly.
9. Remove the strap and manually lower the head section completely.
10. If the bed is equipped with half-length siderails, lower the head siderails, and use a Phillips screwdriver to remove the four screws (K, fig. 4.1A, page 16) holding the two siderail supports to the head section. Let the supports/siderails assembly rest on the frame.
11. Using a 1/2" wrench, remove the two locknuts/flat washers/shoulder spacers/bolts (G) linking the head section to the seat section. Remove the defective head section.
12. Using a Phillips screwdriver, remove the two screws (J) holding the micro switch activator (optional) to the head section.

**NOTE**

The activator is present only if the bed is equipped with the optional Auto Contour positioning. Note the position of the micro switch activator before removing the screws. Properly positioned, the blade of the Auto Contour micro switch is pushed in by the activator when the Fowler is in flat position.

13. Reverse the above steps to install the replacement head section.
  14. Verify the Auto Contour positioning (optional) for proper operation before returning the bed to service.
- End of procedure.

**NOTE**

Unless otherwise indicated, refer to figure 4.3A page 26 for the illustration of the references contained in the following steps.

15. Disconnect the two wires (A, fig. 4.3F, page 40) from the micro switch located on the head section lever. Note their position before doing so.
16. Using two 7/16" wrenches, remove the locknut/bolt (B, fig. 4.3F, page 40) holding the cylinder end fitting to the head section.
17. Using two 1/2" wrenches, remove the nut/shoulder spacers/bolt (C, fig. 4.3F, page 40) holding the upper part of the head section lever to the head section.
18. Using a 7/16" wrench, remove the two locknuts/bolts (D, fig. 4.3F, page 40) holding each CPR release handle to the head section.
19. Remove the strap and manually lower the head section completely.
20. If the bed is equipped with half-length siderails, lower the head siderails, and use a Phillips screwdriver to remove the four screws (K, fig. 4.1A, page 16) holding the two siderail supports to the head section. Let the supports/siderails assembly rests on the frame.
21. Using a 1/2" wrench, remove the two locknuts/shoulder spacers/washers/bolts (G) holding the head section to the seat section. Remove the defective head section.
22. Using a Phillips screwdriver, remove the two screws holding the micro switch activator (J) to the head section.

**NOTE**

Note the position of the micro switch activator before removing the screws. Properly positioned, the blade of the CPR and Auto Contour (optional) micro switches are pushed in by the activator when the Fowler is in flat position.

23. Reverse the above steps to install the replacement head section.
24. Verify the CPR emergency release and the Auto Contour positioning for proper operation before returning the bed to service.

**FOWLER ACTUATOR REPLACEMENT**

**Required Tools:**

Long Nose Pliers  
Side Cutters

Phillips Screwdriver

Small Slotted Head Screwdriver

Pliers

5/16" Socket Wrench

**Procedure:**

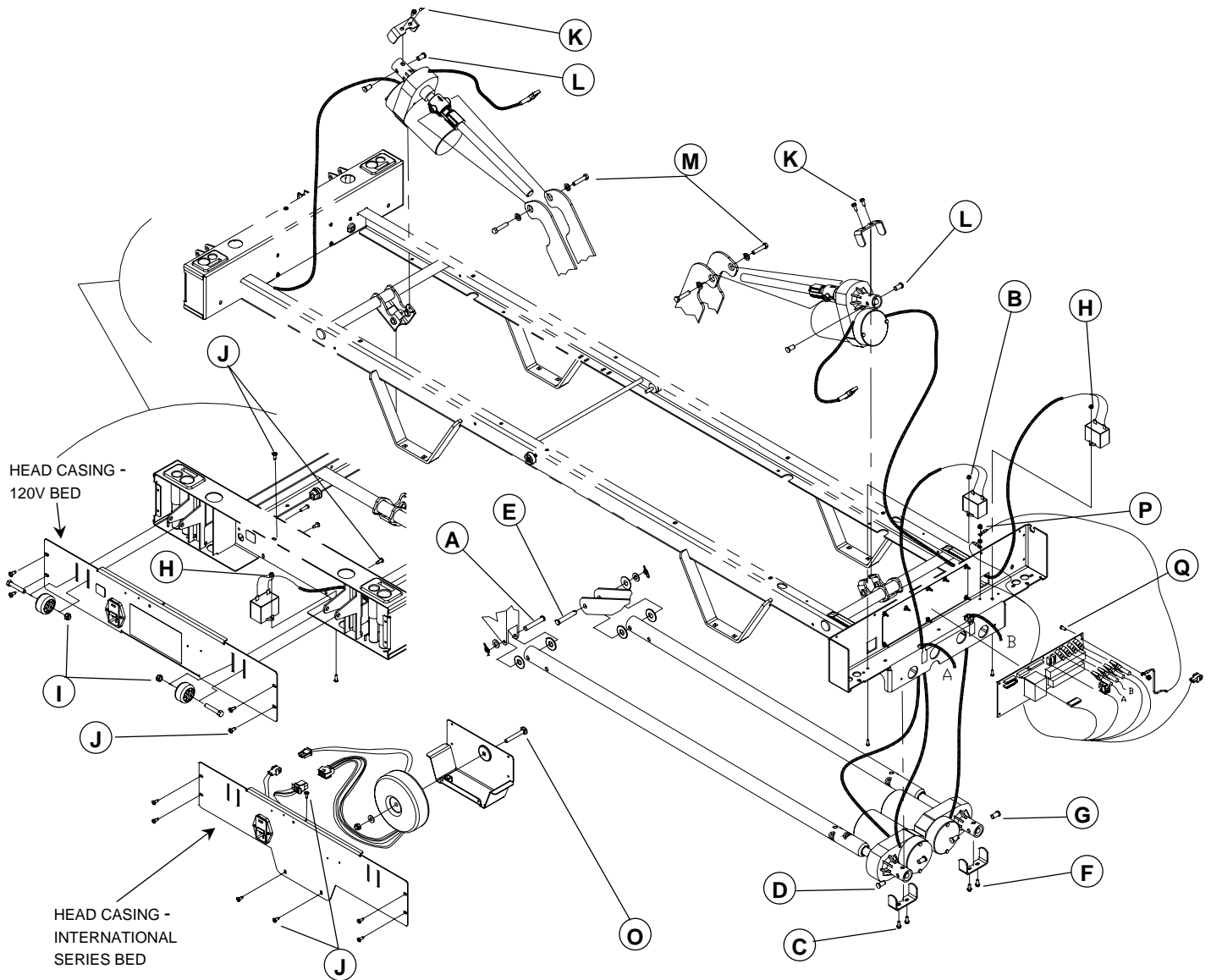

**Figure 4.3C**

1. Raise the bed fully up and apply the brakes. Flatten the Fowler and raise fully up the Knee Gatch.
2. Unplug the bed power cord from the wall outlet.
3. Raise the siderails.
4. Manually lift and fold the foot section back toward the head end of the bed.
5. Using long nose pliers, remove the rue ring cotter/washers/clevis pin (A) linking the actuator tube to the head section lever arms.
6. Remove the foot board.

7. Using a Phillips screwdriver, remove the 10 screws (A, fig. 4.2A, page 21) holding the cover and the two I. V. pole holders to the foot casing.
8. Lift up and remove the cover, taking care first to disconnect, from the control board, the control panel cable (B, fig. 4.2A, page 21) and, if present, the foot casing connector cable (optional, C, fig. 4.2A, page 21).
9. Properly ground yourself (see section 1.4).
10. Using side cutters, clip the cable tie holding the head actuator cable to the other cables.
11. Disconnect the actuator cable (connector J8) from the control board and remove the cable from the foot end casing.
12. Remove from the capacitor the two wires connected to it and remove, using a Phillips screwdriver and a 9 mm wrench, the nut/bolt (B) holding the capacitor to the foot casing. Dispose of the capacitor.
13. Using a 5/16" socket wrench, remove the two screws (C) holding the retaining plate to the actuator support.
14. Remove the two pivot pins (D) holding the actuator to the support. To facilitate the removal of the pins, insert a small slotted head screwdriver into the opening at the end of the actuator and push out the pins.
15. Move the actuator toward the centre of the bed to remove it from its location.
16. Reverse the above steps to install the replacement actuator. Take note of the following caution before hooking up the actuator tube to the head section lever arms.



**CAUTION**

**It is of utmost importance** that the course of the replacement head actuator be adjusted before hooking up its tube to the head section lever arms. An improper adjustment can damage the head section structure.

19. To adjust the course of the replacement head actuator, proceed as follows:
  - A. Make sure that the actuator cable is connected to the control board, and then connect the bed power cord.
  - B. Grab the replacement actuator tube and position its holes horizontally. While firmly holding the tube with one hand to prevent it from rotating, press the Fowler up control for a few seconds using the other hand, then press the down control until the actuator stops. This will be the lower limit of the Fowler actuator course.
  - C. Gently turn the tube in either direction to align the tube holes with those of the head section lever arms. Then, still holding firmly the tube, raise again the Fowler a few inches, and lower it completely.
  - D. Check the alignment of the holes. If the tube holes are not aligned any more with those of the lever arms, repeat steps **B** and **C** until they are. Once the holes are aligned, install the washers and the clevis pin. Slightly raise the head section manually to ease the insertion of the clevis pin.
  - E. Before installing the rue ring cotter to finalize the head actuator replacement, raise and lower completely the Fowler. Check that the actuator stops working as soon as the head section reaches the frame.



**KNEE GATCH ACTUATOR REPLACEMENT****Required Tools:**

Strap	Long Nose Pliers	Phillips Screwdriver
Pliers	Side Cutters	Small Slotted Head Screwdriver
5/16" Socket Wrench		

**Procedure:****NOTE**

Unless otherwise indicated, refer to figure 4.3C page 31 for the illustration of the references contained in the following replacement procedure.

1. Raise the bed fully up and apply the brakes. Flatten the mattress support.
2. Unplug the bed power cord from the wall outlet.
3. Raise the siderails.
4. Manually lift and fold the foot section back toward the head end of the bed. Attach it securely to the bed using a strap.
5. Using long nose pliers, remove the rue ring cotter/washers/clevis pin (E) linking the actuator tube to the thigh section lever arms.
6. Using a Phillips screwdriver, remove the 10 screws (A, fig. 4.2A, page 21) holding the cover and the two I. V. pole holders to the foot casing.
7. Lift up and remove the cover, taking care first to disconnect, from the control board, the control panel cable (B, fig. 4.2A, page 21) and, if present, the foot casing connector cable (optional, C, fig. 4.2A, page 21).
8. Properly ground yourself (see section 1.4).
9. Using side cutters, clip the cable tie holding the thigh actuator cable to the other cables.
10. Disconnect the actuator cable (connector J9) from the control board.
11. Using pliers, squeeze the upper part of the black strain-relief bushing holding the actuator cable to the foot casing and raise the bushing to disengage it from its location.
12. Disengage the cable from the strain-relief bushing and remove the cable from the foot casing.
13. Using a 5/16" socket wrench, remove the two screws (F) holding the retaining plate to the actuator support.
14. Remove the two pivot pins (G) holding the actuator to the support. To facilitate the removal of the pins, insert a small slotted head screwdriver into the opening at the end of the actuator and push out the pins.
15. Move the actuator toward the centre of the bed to remove it from its location.
16. Reverse the above steps to install the replacement actuator. Take note of the following caution before hooking up the actuator tube to the thigh section lever arms.

**CAUTION**

**It is of utmost importance** that the course of the replacement thigh actuator be adjusted before hooking up its tube to the thigh section lever arms. An improper adjustment can damage the thigh section structure.

17. To adjust the course of the replacement thigh actuator, proceed as follows:
  - A. Make sure that the actuator cable is connected to the control board, then connect the bed power cord.

- B. Grab the replacement actuator tube and position its holes horizontally. While firmly holding the tube with one hand to prevent it from rotating, press the Knee Gatch up control for a few seconds using the other hand, then press the down control until the actuator stops. This will be the lower limit of the Knee Gatch actuator course.
- C. Gently turn the tube in either direction to align the tube holes with those of the thigh section lever arms. Then, still holding firmly the tube, raise again the Knee Gatch a few inches, and lower it completely.
- D. Check the alignment of the holes. If the tube holes are not aligned any more with those of the lever arms, repeat steps **B** and **C** until they are. Once the holes are aligned, install the washers and the clevis pin. Slightly raise the head section manually to ease the insertion of the clevis pin.
- E. Before installing the rue ring cotter to finalize the head actuator replacement, raise and lower completely the Knee Gatch. Check that the actuator stops working as soon as the thigh section reaches the frame.

### HI-LO ACTUATOR REPLACEMENT

#### NOTE

In order to preserve the adjustment of the bed lowest position when replacing a Hi-lo actuator, a special tool kit designed for that purpose must be used. The kit includes alignment jigs. To obtain this kit, contact our Technical Service department (see section 1.2) and order part number KR0121.

#### Required Tools:

KR0121 Tool Kit	Side Cutters	5/16" Socket Wrench
Phillips Screwdriver	1/2" Wrench (2)	Small Slotted Head Screwdriver

#### Procedure:

#### NOTE

Unless otherwise indicated, refer to figure 4.3C page 31 for the illustration of the references contained in the following replacement procedure.

1. Position the mattress support sections depending on the location of the Hi-Lo actuator to replace:
  - At the foot of the bed:** Fully raise the thigh section, then lift and fold back the foot section toward the head end of the bed. Finally raise the Fowler fully up.
  - At the head of the bed:** Fully raise the Fowler.

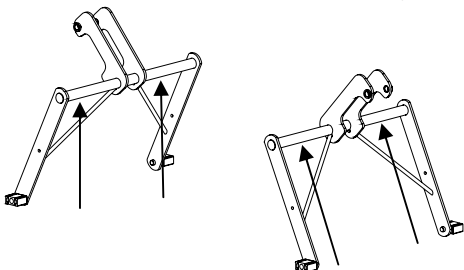

2. Position the alignment jigs on the floor, on a plane surface, right under the two transversal tubes supporting the link arms of both Hi-Lo levers. Lower the bed until the tubes come to rest on the jigs (see opposite figure). Use a socket wrench with the 1/2" socket provided in the kit to lower a defective Hi-Lo actuator until the tube rests on the jig.

3. Unplug the bed power cord from the wall outlet.
4. Raise the siderails.
5. Disconnect the actuator cable and clip, using side cutters, the cable ties holding it to the frame.
6. Remove from the capacitor the two wires connected to it and remove, using a Phillips screwdriver and a 9 mm wrench, the nut/bolt (H) holding in place the capacitor. Dispose of the capacitor.

- The capacitor of the head Hi-Lo actuator is located in the head casing. To access it, proceed as follows:
    - o Using two 1/2" wrenches, remove the two locknuts/bolts (I) holding the bumpers to their supports.
    - o Using a Phillips screwdriver, remove the 7 screws (J) holding the cover to the head casing.
    - o Remove the cables connected to the power connector after having carefully noted their position and remove the cover.
  - The capacitor of the foot Hi-Lo actuator is located in the foot casing. To access it, proceed as follows:
    - o Using a Phillips screwdriver, remove the 10 screws (A, fig. 4.2A, page 21) holding the cover and the two I. V. pole holders to the foot casing.
    - o Lift up and remove the cover, taking care first to disconnect, from the control board, the control panel cable (B, fig. 4.2A, page 21) and, if present, the foot casing connector cable (optional, C, fig. 4.2A, page 21).
7. Using a 5/16" socket wrench, remove the two screws (K) holding the retaining plate to the actuator support.
  8. Remove the two pivot pins (L) holding the actuator to the support. To facilitate the removal of the pins, insert a small slotted head screwdriver into the opening at the end of the actuator and push out the pins.
  9. Using a 1/2" wrench, remove the two bolts/washers (M) holding the molded nut support to the Hi-Lo lever. Remove the molded nut support and keep it for the replacement actuator.

**NOTE**

Make sure that the support and the molded nut holes are aligned before screwing in the bolts. If resistance is felt, it means that the holes are not aligned.

10. Remove the defective actuator.
11. Using a Phillips screwdriver, remove the two screws holding together the two parts of the screw cover (optional) and keep it for the replacement actuator.
12. Reverse the above steps to install the replacement actuator. Take note of the following caution before hooking up the actuator to the Hi-Lo lever.

**CAUTION**

The course of the replacement actuator must be adjusted prior to hooking it to the Hi-Lo lever. An improper adjustment can damage the Hi-Lo mechanism.

12. To adjust the replacement actuator, proceed as follows:
  - A. Once the replacement actuator cable is connected, plug the bed power cord and press the bed down control until the actuator stops. This will be the lower limit of the actuator course.
  - B. Link the actuator to the Hi-Lo lever.
  - C. The alignment jigs still in position, raise and lower completely the bed to ensure that the lower limit has been preserved following the actuator replacement.

## **TOROIDAL TRANSFORMER REPLACEMENT (INTERNATIONAL SERIES MODELS)**

### **Required Tools:**

Tournevis Phillips                      9 mm Wrench                      1/2" Wrench (2)

### **Procedure:**

#### **NOTE**

Unless otherwise indicated, refer to figure 4.3C page 31 for the illustration of the references contained in the following replacement procedure.

1. Raise the bed fully up and apply the brakes.
2. Unplug the bed power cord from the wall socket.
3. Remove the head board.
4. Using two 1/2" wrenches, remove the two locknuts/bolts (I) holding the bumpers to their supports.
5. Using a Phillips screwdriver, remove the 7 screws (J) holding the cover to the head casing.
6. Remove the cables connected to the power connector after having carefully noted their position and remove the cover.
7. Disconnect the transformer cable.
8. Using a 1/2" wrench, remove the nut/washer/bolt (O) holding the transformer to the head casing.

#### **NOTE**

Do not over tighten the nut.

9. Reverse the above steps to install the replacement transformer.
10. Test all the bed electric controls for proper operation before returning the bed to service.

## **MOTOR CONTROL BOARD REPLACEMENT**

### **Required Tools:**

Phillips Screwdriver                      Long-Nose Pliers                      Side Cutters  
3/8" Wrench

### **Procedure:**

#### **NOTE**

Unless otherwise indicated, refer to figure 4.3C page 31 for the illustration of the references contained in the following replacement procedure

1. Raise the bed fully up and apply the brakes.
2. Unplug the bed power cord from the wall outlet.
3. Remove the foot board.
4. Using a Phillips screwdriver, remove the 10 screws (A, fig. 4.2A, page 21) holding the cover and the I. V. pole holders to the foot casing.
5. Lift up and remove the cover, taking care first to disconnect, from the control board, the control panel cable (B, fig. 4.2A, page 21) and, if present, the foot casing connector cable (optional, C, fig. 4.2A, page 21).
6. Properly ground yourself (see section 1.4).
7. Using side cutters, clip the cable ties holding together the cables.

#### **NOTE**

Carefully note the position and the grouping together of the cables before clipping the cable ties.

8. Remove all cables connected to the control board. Note their location so they will be connected properly to the replacement board. Refer to the connection diagram in appendix A for the connecting position of the cables on the motor control board

9. Using a 3/8" wrench, remove the nut (P) holding the ground cable to the frame and remove the cable.
10. Using long-nose pliers, pinch the upper part of the stand-off pins and gradually lift the board up and out.

**NOTE**

Verify that the DIP switches of the replacement control board are set as the ones of the defective board. They should be as follows: Dip switch no.1: off; no. 2: off; no. 3: on; no. 4: on.

11. Using a 3/8" wrench and a Phillips screwdriver, remove the nut/screw (Q) holding the ground cable to the board.
12. Reverse the above steps to install the replacement control board.
13. Test all the bed electric functions before returning the bed to service.

**POWER CONNECTOR AND FUSE REPLACEMENT****Required Tools**

1/2" Wrench (2)

Phillips Screwdriver

No.1 Phillips Screwdriver

Small Slotted Head Screwdriver

**Procedure:****NOTE**

For the replacement of a fuse, proceed with steps 10 to 12.

Fuses used in this bed, powered by the 120V electrical system, are of the fast acting type and their rating is 250V, 10A. For beds powered by other electrical system, see section 1.1 "Specifications" for the fuse ratings.

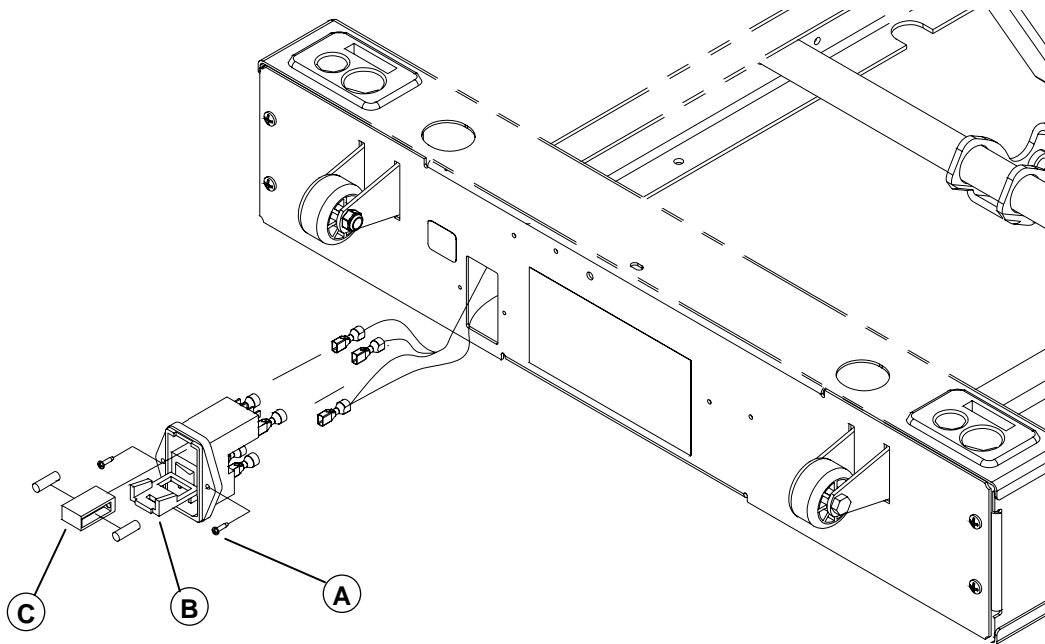
**Figure 4.3D**

1. Raise the bed fully up and apply the brakes.
2. Unplug the bed power cord from the wall outlet.
3. Remove the foot board.
4. Using two 1/2" wrenches, remove the two nuts/bolts (I, fig. 4.3C, page 31) holding the bumpers to their supports.

5. Using a Phillips screwdriver, remove the 7 screws (J, fig. 4.3C, page 31 holding the cover to the head casing.
6. Remove all the cables connected to the power connector. Note their location so they will be connected correctly to the replacement power connector.
7. Remove the cover and lay it on a work bench.
8. Using a No. 1 Phillips screwdriver, remove the two screws (A) holding the power connector to the cover.
9. Press the connector clips to remove it from its location.
10. Using a small slotted screwdriver, open and slide down the fuse compartment door (B).
11. Still using the small screwdriver, remove the fuse holder (C).
12. Remove the fuses from the fuse holder and keep them for the replacement power connector, taking care to check that are still in good condition, or replace them if you are only proceeding with the replacement of the fuses.

**NOTE**

There is only one way to install the fuse holder. The characters "250V" must be apparent through the small window of the door. If replaced the wrong way, the bed will not be powered.

13. Reverse the above steps to install the replacement power connector.
14. Turn the power switch on and check that the bed is powered before returning it to service.

**AUTO CONTOUR MICRO SWITCH REPLACEMENT (OPTIONAL)**

**Required Tools:**

Phillips Screwdriver

No. 1 Phillips screwdriver

**Procedure:**

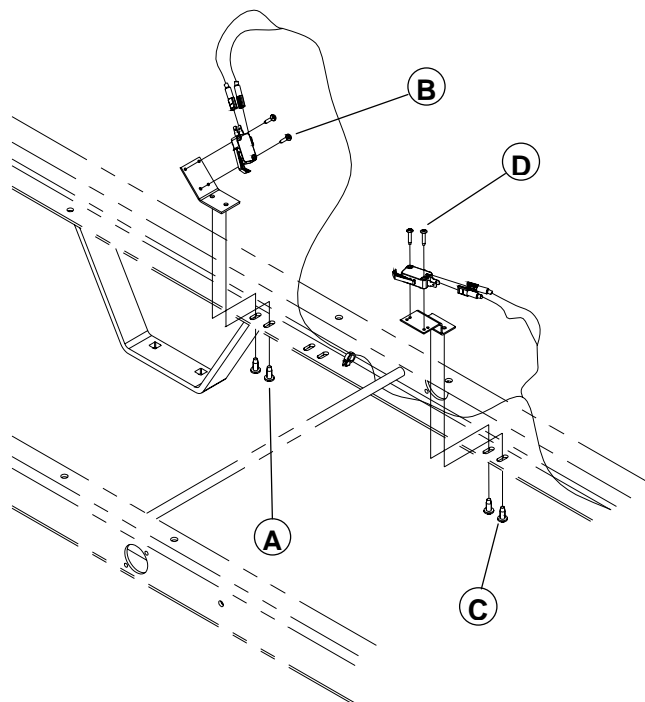

**Figure 4.3E**

1. Raise the bed fully up and apply the brakes.
2. Deactivate the Auto Contour function by pressing the Knee Gatch lockout switch at the foot end of the bed. The lockout switch LED will go off.

3. Raise the Fowler fully up.
4. Unplug the bed power cord from the wall socket.

- **Head Section Micro Switch**

This switch signals to the motor control board that the Knee Gatch must be lowered. The signal is sent during the lowering of the Fowler when the bed is in the Auto Contour position.

5. Remove the cable wires from the switch. Note their location so they will be connected correctly to the replacement switch.
6. Using a Phillips screwdriver, remove the two screws (A) holding the support to the frame and remove the support.

**NOTE**

The mounting position of the support may be adjusted thanks to the oblong holes present on the frame. The proper adjustment of the support is obtained when the switch blade is pushed in by the activator, located at the base of the head section, when the Fowler is in flat position.

7. Using a no. 1 Phillips screwdriver, remove the two screws (B) holding the switch to the support and remove the defective switch.
8. Reverse the above steps to install the replacement micro switch.
9. Test the Auto Contour positioning for proper operation before returning the bed to service.

- **Thigh Section Micro Switch**

This switch signals to the motor control board that the Knee Gatch has reached the maximum elevation angle in the Auto Contour positioning context. As a consequence, the Knee Gatch stops raising.

1. Raise the head section fully up.
2. Unplug the bed power cord from the wall outlet.
3. Remove the cable wires from the switch. Note their location so they will be connected correctly to the new switch.
4. Using a Phillips screwdriver, remove the two screws (C) holding the support to the frame and remove the support.

**NOTE**

The mounting position of the support may be adjusted thanks to the oblong holes present on the frame. The proper adjustment of the support is obtained when the switch blade is pushed in by the thigh section outer lever arm, located underneath the thigh section, when the thigh section is in flat position.

5. Using a no. 1 Phillips screwdriver, remove the two screws (D) holding the switch to the support.
6. Reverse the above steps to install the replacement micro switch.
7. Test the Auto Contour positioning for proper operation before returning the bed to service.

## CPR MICRO SWITCH REPLACEMENT (OPTIONAL)

### Required Tools:

Angle Indicator

No. 1 Phillips Screwdriver

Phillips Screwdriver

### Procedure:

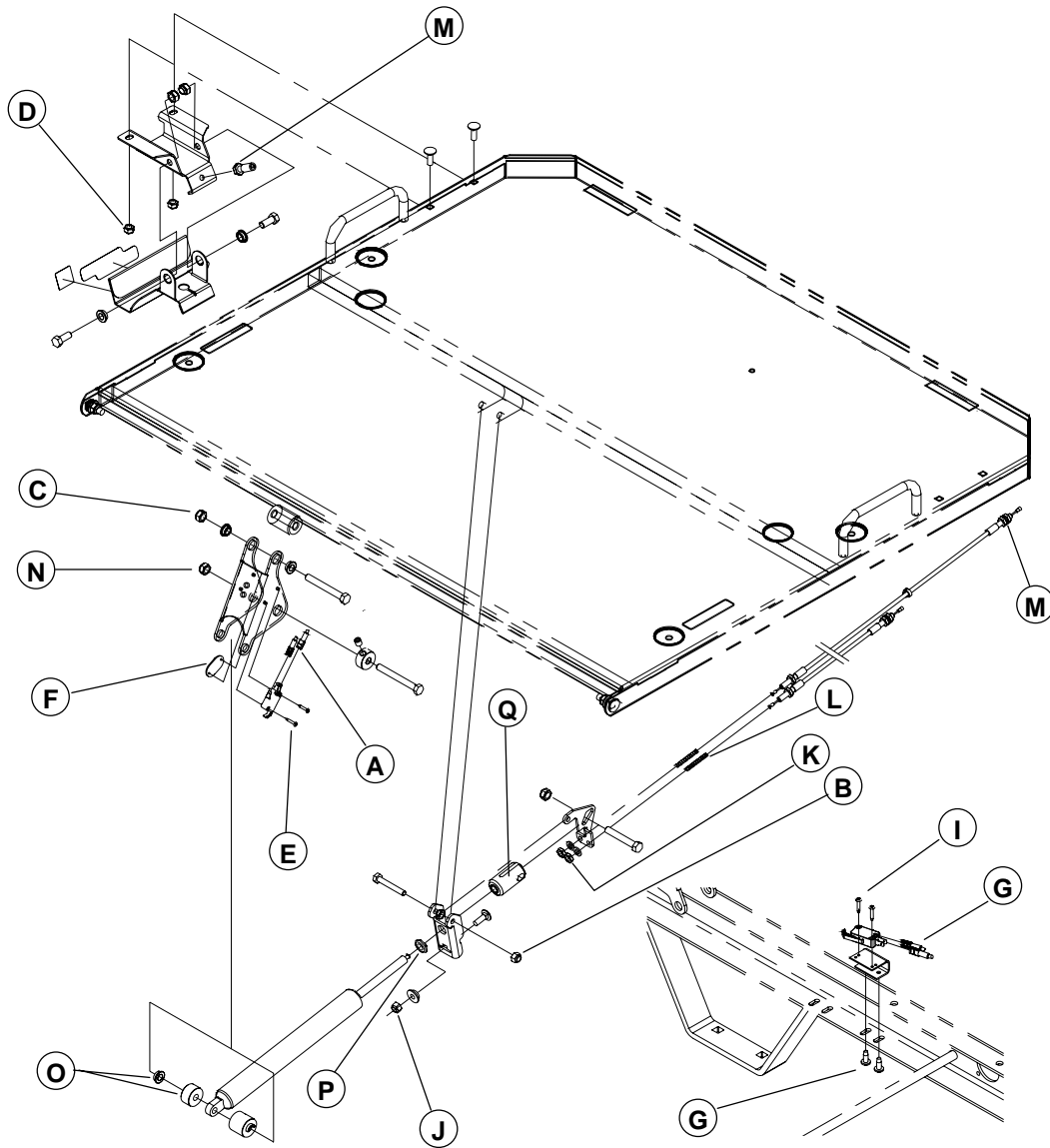

Figure 4.3F

1. Raise the bed fully up and apply the brakes.
2. Raise the head siderails.

- **Micro Switch Attached to the Head Section Lever**

This switch informs on the state of the Fowler actuator (engaged or disengaged) when the CPR emergency release is activated.

3. Raise the head section approximately 45°.
4. Unplug the bed power cord from the wall outlet.



5. Remove the cable wires (A) from the micro switch. Note the location of the wires so they will be connected correctly to the replacement micro switch.
6. Using a no. 1 Phillips screwdriver, remove the two screws (E) holding the micro switch to the head section lever. Keep the mounting plate (F). Remove the defective micro switch.
7. Reverse the above steps to install the replacement micro switch.
8. Test the CPR emergency release before returning the bed to service.

- **Micro Switch Attached to the Frame.**

This switch signals to the motor control board on the one hand that the resetting of the Fowler actuator may begin because the Fowler is completely lowered, and on the other hand that the lowering to flat of the Knee Gatch may also begin.

1. Raise the Fowler fully up.
2. Unplug the bed power cord from the wall outlet.
3. Remove the cable wires (G) from the micro switch. Note the location of the wires so they will be connected correctly to the replacement micro switch.
4. Using a Phillips screwdriver, remove the screw (H) holding the support to the frame and remove the support.

**NOTE**

The mounting position of the support may be adjusted thanks to the oblong holes present on the frame. The proper adjustment of the support is obtained when the switch blade is pushed in by the activator, located at the base of the head section, when the Fowler is in flat position.

5. Using a no. 1 Phillips screwdriver, remove the two screws (I) holding the switch to the support.
6. Reverse the above steps to install the replacement micro switch.
7. Test the CPR emergency release before returning the bed to service.

### **CPR ACTIVATION CABLE REPLACEMENT (OPTIONAL)**

**Required Tools:**

7/16"

**Procedure:**

**NOTE**

Unless otherwise indicated, refer to figure 4.3F page 40 for the illustration of the references contained in the following replacement procedure.

1. Raise the bed fully up and apply the brakes.
2. Raise the Fowler fully up and remove the head board.
3. Unplug the bed power cord from the wall outlet.
4. Using a 7/16" wrench, remove the nut/sleeve/bolt (J) holding both ends of the activation cable to the fixed lever.
5. Using 7/16" wrench, remove the nut/washer (K) holding the defective cable jacket to the mobile lever. Remove the cable from the lever and keep the spring (L). Try as much as possible not to move the other cable from its position.
6. Unscrew completely the two lock nuts (M) holding the defective cable at the CPR handle end. Remove the cable.
7. Reverse the above steps to install the replacement cable.

**NOTE**

Make sure there is no free play at the CPR handle once the replacement cable is installed.

8. Test the CPR emergency release before returning the bed to service.

### **CPR PNEUMATIC CYLINDER REPLACEMENT (OPTIONAL)**

#### **Required Tools:**

Two 1/2" Wrenches                      11/16" Wrench

#### **Procedure:**

##### **NOTE**

Unless otherwise indicated, refer to figure 4.3F page 40 for the illustration of the references contained in the following replacement procedure.

1. Raise the bed fully up and apply the brakes.
2. Raise the head section fully up.
3. Unplug the bed power cord from the wall outlet.
4. Using two 1/2" wrenches, remove the nut (N) from the bolt holding the lower end of the pneumatic cylinder.
5. Partially remove the bolt until the lower end of the cylinder is free. Keep the shoulder spacer/sleeve (O). Disengage the lower end of the cylinder from the sleeve still in place.
6. Using an 11/16" wrench, loosen the locknut (P) and unscrew the cylinder completely from the end fitting (Q). Note the location of the lock nut before loosening it so the replacement cylinder will be properly screwed into the end fitting.
7. Reverse the above steps to install the replacement cylinder.
8. Test the CPR emergency release for proper operation before returning the bed to service.

#### 4.4 MAINTENANCE PROCEDURES - BASE

##### BRAKE/STEER PEDAL REPLACEMENT

###### Required Tools

1/2" Socket Wrench

Soft Hammer

###### Procedure:

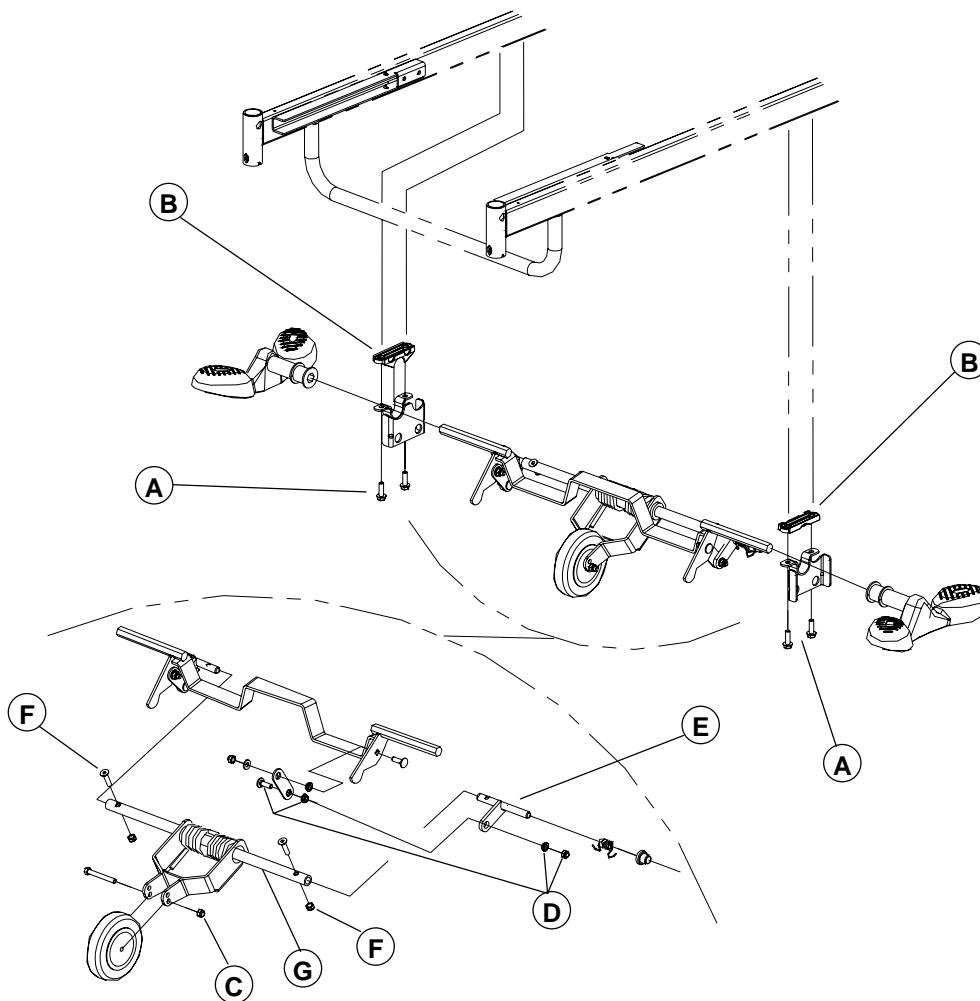

Figure 4.4A

1. Raise the bed fully up.
2. Unplug the bed power cord from the wall outlet.
3. Position the brake/steer pedal to neutral.
4. Using a 1/2" socket wrench, remove the two bolts (A) holding the 5th wheel support or the lever support (A, fig. 4.4B, page 46) on the side of the defective pedal and lay the support down. Keep the molded spacer (B).
5. Remove the pedal from the activation lever shaft. Use a soft hammer if necessary.
6. Reverse the above steps to install the replacement pedal.

### **5th WHEEL CASTER REPLACEMENT (OPTIONAL)**

#### **Required Tools:**

1/2" Wrench (2)

#### **Procedure:**

##### **NOTE**

Unless otherwise indicated, refer to figure 4.4A page 43 for the illustration of the references contained in the following replacement procedure.

1. Raise the bed fully up.
2. Unplug the bed power cord from the wall outlet.
3. Position the brake/steer pedal to neutral.
4. Using two 1/2" wrenches, remove the nut/bolt (C) holding the caster to the swing arm.
5. Reverse the above steps to install the replacement caster.

### **5th WHEEL ASSEMBLY REPLACEMENT (OPTIONAL)**

#### **Required Tools:**

1/2" Socket Wrench

Soft Hammer

#### **Procedure:**

##### **NOTE**

Unless otherwise indicated, refer to figure 4.4A page 43 for the illustration of the references contained in the following replacement procedure.

1. Raise the bed fully up.
2. Unplug the bed power cord from the wall outlet.
3. Position the brake/steer pedal to neutral.
4. Using a 1/2" socket wrench, remove the two nuts/washers/shoulder spacers/bolts (F1, fig. 4.4B, page 46) linking the end of the brake rod to the locking levers, on the side of the pedals. If the optional four-wheel brake system is present on the bed, also remove the fasteners linking the end of the two other brake rods to the same locking levers.
5. Using a 1/2" socket wrench, remove the four bolts (A) holding both 5th wheel supports to the base. Keep the molded spacers (B). Remove the assembly.
6. Remove the two brake/steer pedals from the activation lever shafts. Use a soft hammer if necessary.
7. Remove and keep the two locking levers (C, fig. 4.4B, page 46).
8. Reverse the above steps to install the replacement 5th wheel assembly.
9. Test the 5th wheel for proper operation before returning the bed to service.

**5th WHEEL SWING ARM ASSEMBLY REPLACEMENT (OPTIONAL)****Required Tools :**

1/2" Socket Wrench

1/2" Wrench (2)

3/16" Allen Key

**Procedure:****NOTE**

Unless otherwise indicated, refer to figure 4.4A page 43 for the illustration of the references contained in the following replacement procedure.

1. Raise the bed fully up.
2. Unplug the bed power cord from the wall outlet.
3. Position the brake/steer pedal to neutral.
4. Using a 1/2" socket wrench, remove the two bolts (A) holding the left or right 5th wheel support to the base. Lay the support down and keep the molded spacer (B).
5. Using two 1/2" wrenches, remove the nut/shoulder spacers/bolt (D) holding the torsion lever (E) to the lower part of the counter lever.
6. Using a 1/2" wrench and a 3/16" Allen key, remove the two nuts/Allen screws (F) holding the torsion levers (E) to both ends of the torque shaft (G).

**NOTE**

At reassembly, screw down the Allen screws before installing the nuts.

7. Disengage the swing arm assembly from the torsion levers and remove it.
8. Using two 1/2" wrenches, remove the nut/bolt (C) holding the caster to the swing arm and keep it for the replacement swing arm assembly.
9. Reverse the above steps to install the replacement swing arm assembly.
10. Test the 5th wheel for proper operation before returning the bed to service.

### BED CASTER REPLACEMENT

#### Required Tools:

Jack Stand

Long Nose Pliers

1/2" Wrench

#### Procedure:

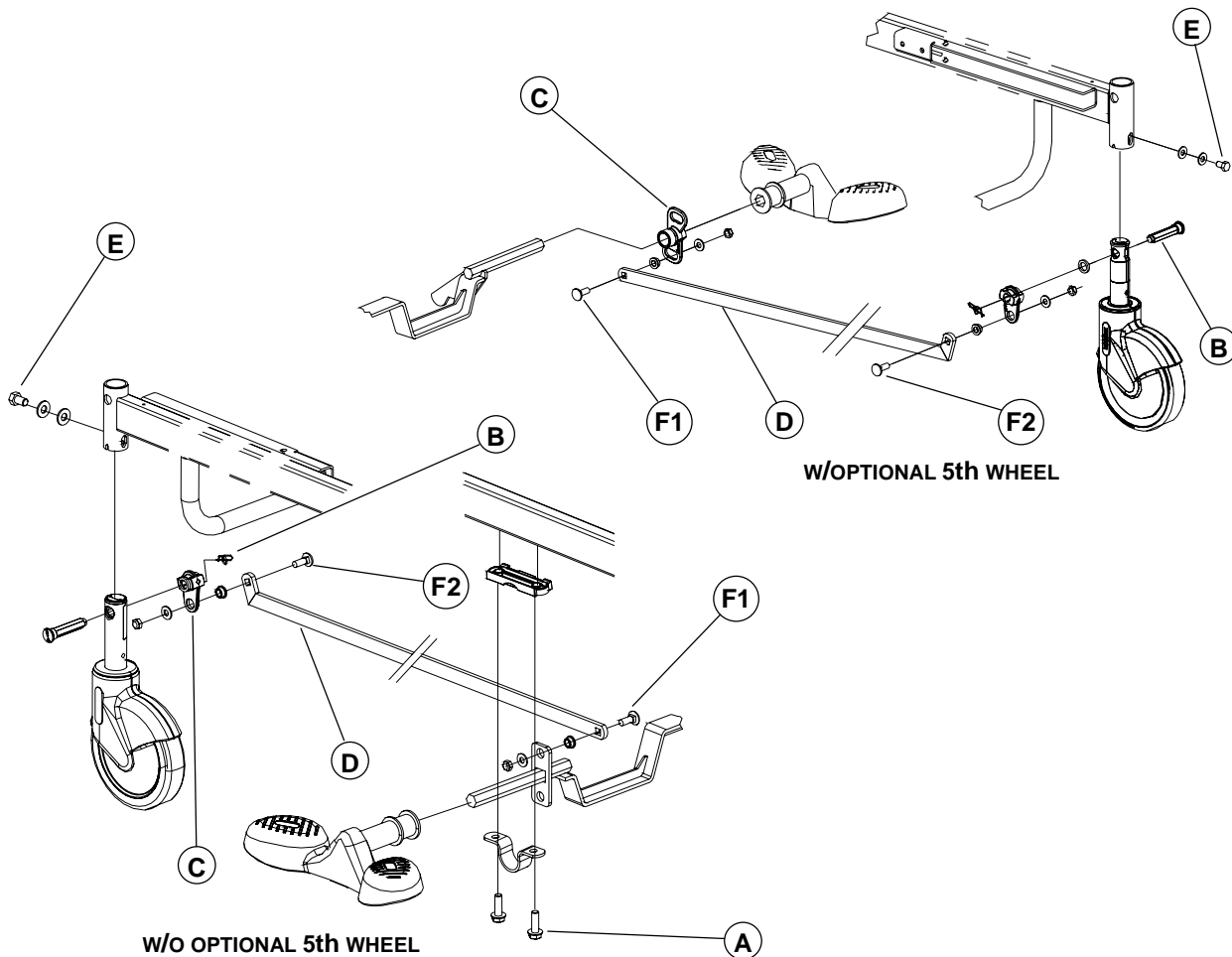
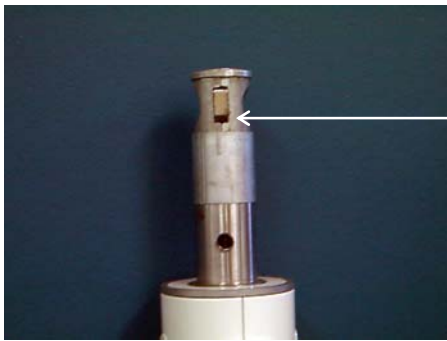

Figure 4.4B

1. Raise the bed fully up.
2. Position the brake/steer to neutral
3. Install a jack stand under the frame near the defective caster.
4. If present, remove the wheel cover (optional).
5. Lower the bed until the caster is six inches off the ground.
6. Unplug the bed power cord from the wall outlet.
7. If the caster is part of the braking mechanism, remove, using long-nose pliers, the rue ring/washer/locking axle (B) linking the caster shaft to the locking lever (C) and the brake rod (D).

**NOTE**

The shaft of a caster that is part of the braking mechanism must be properly oriented before mounting it to the base. The opposite illustration shows the side of the shaft that should be facing the inside of the bed: it is the side showing the largest opening below the cam in neutral position.

8. Using a 1/2" wrench, remove the bolt/washers (E) holding the caster to the base.

**NOTE**

Before tightening the bolt (E), make sure that the caster shaft is completely inserted into the mounting socket.

9. Reverse the above steps to install the replacement caster.
10. If the replacement caster is part of the brake mechanism, apply the brakes and check that the caster is locked before returning the bed to service

**BRAKE ROD REPLACEMENT****Required Tools:**

1/2" Wrench

**Procedure:****NOTE**

Unless otherwise indicated, refer to figure 4.4B page 46 for the illustration of the references contained in the following replacement procedure.

1. Raise the bed fully up.
2. Using a 1/2" wrench, remove the nut/shoulder spacer/washer/bolt (F1, F2) holding each end of the brake rod.
3. Remove the defective rod.
4. Reverse the above steps to install the replacement brake rod.
5. Test the brakes before returning the bed to service.

APPENDIX A: CONNECTION DIAGRAM

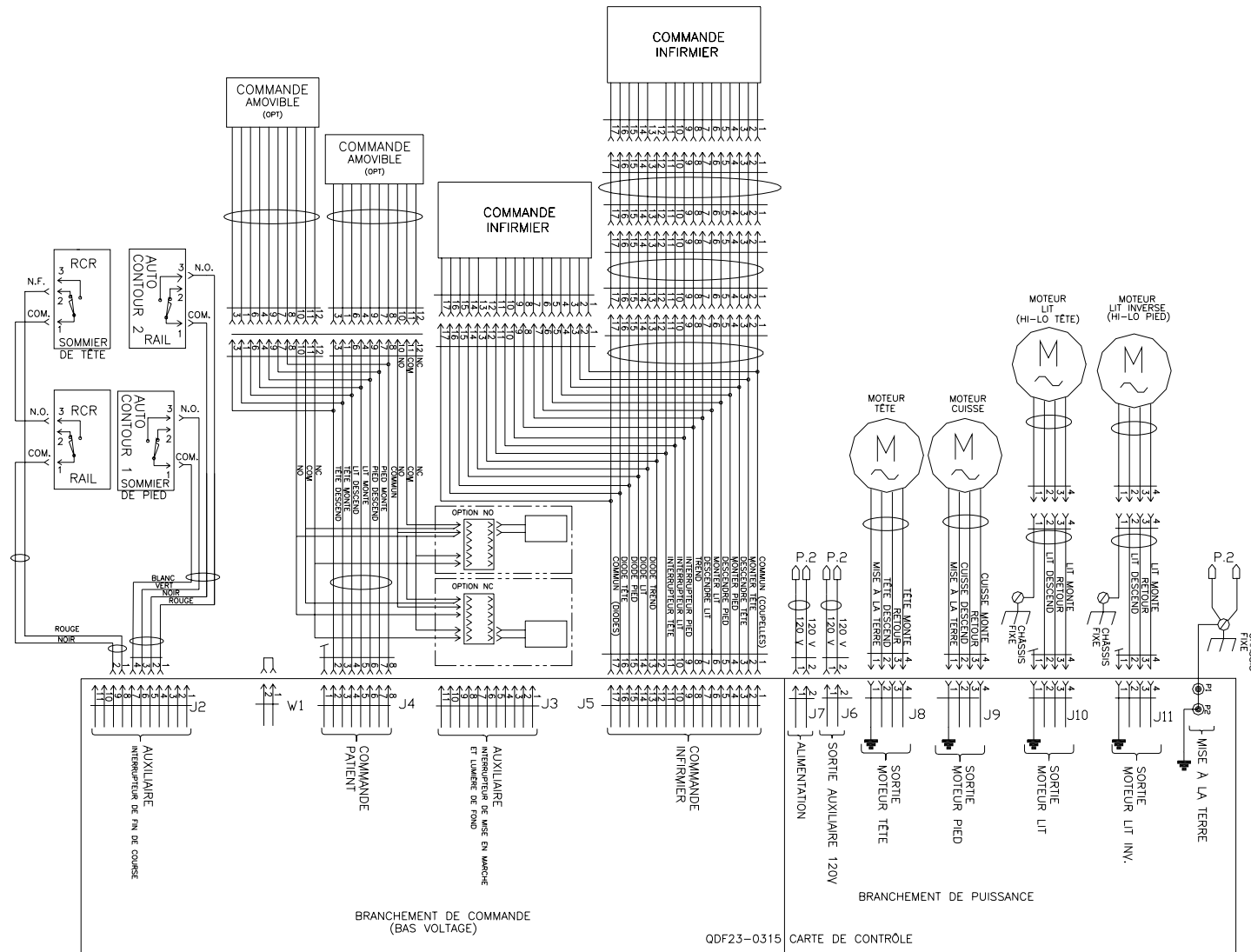

POSITION DES INTERRUPTEURS DE SW1

MODÈLE DE LIT ET TEST DE MAINTENANCE	SW1			
	1	2	3	4
LIT BNQ : FL23	OFF	OFF	ON	ON
TEST DE MAINTENANCE	ON	ON	ON	ON



**APPENDIX A: CONNECTION DIAGRAM**

Alimentation 120V

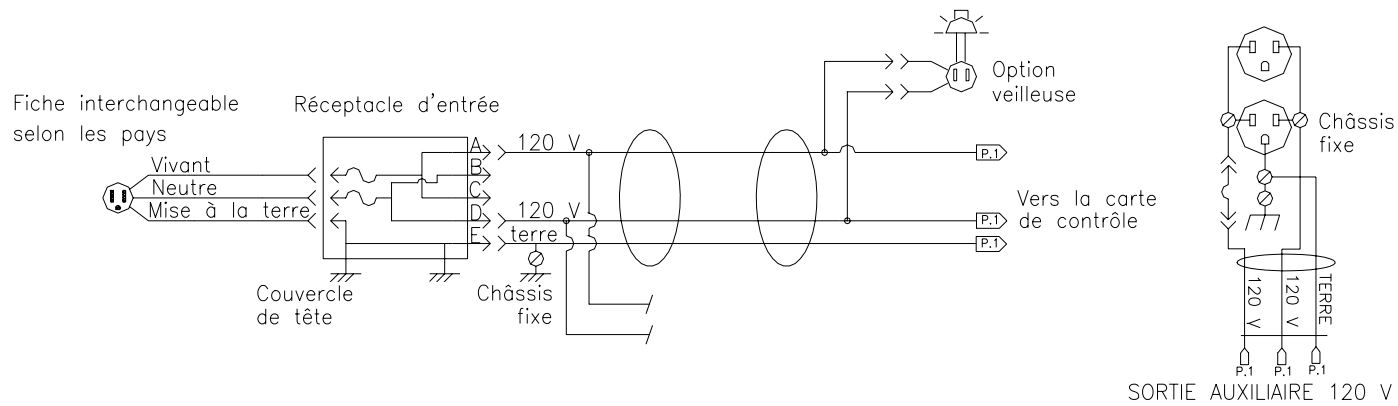

Alimentation  
100 V, 200 V, 220 V et 240 V

