

---

# stryker®

**IMPORTANT**  
File in your  
maintenance  
records



---

## Transport Stretcher

---

### Model 721

### MAINTENANCE MANUAL

For Parts or Technical Assistance  
1-800-327-0770 (Option 2)

---

# Table of Contents

---

Introduction	
Specifications .....	4
Warning / Caution / Note Definition .....	4
Preventative Maintenance	
Checklist .....	5
Cleaning .....	6
Service Information	
Caster Cover Installation and Removal .....	7
Caster Removal .....	7
Release Pedal Adjustment .....	8
Brake Rod Removal .....	8
Side Control Brake Rod Removal .....	9
Brake Ring Removal .....	10
Fifth Wheel Assembly Removal .....	10
Litter Top Removal .....	11
Big Wheel Hubcap Removal .....	11
Big Wheel Removal .....	12
Big Wheel Carriage Removal .....	12
Big Wheel Cam Gas Spring Dampener Removal .....	13
Side Control Big Wheel Linkage Assembly Removal .....	13
Jack Descent Rate Adjustment .....	14
Removal of Excess Air from the Hydraulic System .....	14
Head End Hydraulic Jack Removal .....	15
Foot End Hydraulic Jack Removal .....	16, 17
Pneumatic Fowler Adjustment .....	17
Transfer Board Counterbalance Adjustment .....	18
Siderail Latch Adjustment .....	18
Replacement Parts and Kits .....	19, 20
Assembly Drawings and Parts Lists	
Fifth Wheel Base Assembly .....	21
Fifth Wheel Assembly .....	22, 23
Base Assembly with Standard Brakes (Fifth Wheel Base) .....	24, 25
Brake Rod Assembly .....	26
Drive Link Assembly .....	27, 28
Caster Assembly .....	29
Base Assembly with Four-Sided Brakes .....	30, 31
Side Control Brake Rod Assembly .....	32
Brake Rod Assembly .....	33

# Table of Contents

---

## Assembly Drawings and Parts Lists (Continued)

Base Assembly with Dual Side Hydraulics (Fifth Wheel Base) .....	34–36
Release Pedal Assembly .....	37
Pump Pedal Assembly .....	38
Base Assembly with Three Side Hydraulics (Fifth Wheel Base) .....	39–41
Release Pedal Assembly .....	42
Pump Pedal Assembly .....	43
Base Labeling Assembly .....	44–46
Big Wheel Base Assembly .....	47–49
Base Assembly with Standard Brakes (Big Wheel Base) .....	50, 51
Drive Link Assembly .....	52
Brake Rod Assembly .....	53
Base Assembly with Dual Side Hydraulics (Big Wheel Base) .....	54–56
Release Pedal Assembly .....	57
Cam Bracket Assembly .....	58, 59
Big Wheel Carriage Assembly .....	60
Side Control Big Wheel Base Assembly .....	61–63
Side Control Big Wheel Carriage Assembly .....	64, 65
Side Control Big Wheel Linkage Assembly .....	66
Base Labeling Assembly .....	67, 68
Variable Descent Hydraulic Jack Option .....	69
Constant Descent Hydraulic Jack Option .....	70
Litter Assembly .....	71–73
Siderail Assembly .....	74
Manual Fowler Assembly .....	75
Pneumatic Fowler Assembly .....	76–78
Transfer System Assembly .....	79–84
Removable I.V. Pole Assembly .....	85
Tethered I.V. Pole Assembly .....	86, 87
2–Stage I.V. Assembly .....	88–90
3–Stage I.V. Assembly .....	91–93
C–Spine Cassette Holder Assembly .....	94–96
Defibrillator Tray Assembly .....	97
Foot Extension/Defibrillator Tray Assembly .....	98
Foot Board .....	99
O2 Bottle Holder .....	99, 100
Mattresses and Siderail Pads .....	101, 102

# Table of Contents

---

Warranty

Obtaining Parts and Service ..... 103

Service Contract Coverage ..... 103

Return Authorization ..... 104

Freight Damage Claims ..... 104

# Introduction

---

## INTRODUCTION

This manual is designed to assist you with the maintenance of the Model 721 Advanced Transport Stretcher. Read it thoroughly before using the equipment or beginning any maintenance on it.

## SPECIFICATIONS

Maximum Weight Capacity	500 pounds
Overall Stretcher Length \ Width	83" / 30"
Minimum \ Maximum Bed Height	21.5" / 36"
Fowler Angle	0° to 90°
Trendelenburg \ Reverse Trendelenburg	+18° to -18°

Stryker reserves the right to change specifications without notice.

## WARNING / CAUTION / NOTE DEFINITION

The words WARNING, CAUTION and NOTE carry special meanings and should be carefully reviewed.

---

### WARNING

The personal safety of the patient or user may be involved. Disregarding this information could result in injury to the patient or user.

---

---

### CAUTION

These instructions point out special procedures or precautions that must be followed to avoid damaging the equipment.

---

### NOTE

This provides special information to make maintenance easier or important instructions clearer.

# Preventative Maintenance

---

## CHECKLIST

- \_\_\_\_\_ All fasteners secure
- \_\_\_\_\_ Siderails move and latch properly
- \_\_\_\_\_ Engage the brake pedal and push on the stretcher to ensure all casters lock securely
- \_\_\_\_\_ All casters secure and swiveling properly
- \_\_\_\_\_ Body restraints working properly
- \_\_\_\_\_ I.V. pole intact and operating properly
- \_\_\_\_\_ Oxygen bottle holder intact and operating properly
- \_\_\_\_\_ Fowler operates and latches properly
- \_\_\_\_\_ Trendelenburg/Reverse Trendelenburg operating properly
- \_\_\_\_\_ No rips or cracks in mattress cover
- \_\_\_\_\_ Transfer boards intact and operating properly
- \_\_\_\_\_ Ground chain intact
- \_\_\_\_\_ No leaks at hydraulic connections
- \_\_\_\_\_ Hydraulic jacks holding properly
- \_\_\_\_\_ Hydraulic drop rate set properly
- \_\_\_\_\_ Hydraulic oil level sufficient
- \_\_\_\_\_ Lubricate where required
- \_\_\_\_\_ Accessories and mounting hardware in good condition and working properly

Serial No. \_\_\_\_\_  
\_\_\_\_\_  
\_\_\_\_\_  
\_\_\_\_\_  
\_\_\_\_\_

Completed By: \_\_\_\_\_ Date: \_\_\_\_\_

## NOTE

Preventative maintenance should be performed at a minimum of annually. A preventative maintenance program should be established for all Stryker Medical equipment. Preventative maintenance may need to be performed more frequently based on the usage level of the product.

# Cleaning

Hand wash all surfaces of the stretcher with warm water and mild detergent. Dry thoroughly. **DO NOT STEAM CLEAN, PRESSURE WASH, HOSE OFF OR ULTRASONICALLY CLEAN.** Using these methods of cleaning is **not** recommended and may void this product's warranty.

Clean Velcro **AFTER EACH USE**. Saturate Velcro with disinfectant and allow disinfectant to evaporate. (Appropriate disinfectant for nylon Velcro should be determined by the hospital.)

In general, when used in those concentrations recommended by the manufacturer, either phenolic type or quaternary type disinfectants can be used. Iodophor type disinfectants are not recommended for use because staining may result. The following products have been tested and have been found not to have a harmful effect **WHEN USED IN ACCORDANCE WITH MANUFACTURERS RECOMMENDED DILUTION.\***

TRADE NAME	DISINFECTANT TYPE	MANUFACTURER	*MANUFACTURER'S RECOMMENDED DILUTION
A33	Quaternary	Airwick (Professional Products Division)	2 ounces/gallon
A33 (dry)	Quaternary	Airwick (Professional Products Division)	1/2 ounce/gallon
Beaucoup	Phenolic	Huntington Laboratories	1 ounce/gallon
Blue Chip	Quaternary	S.C. Johnson	2 ounces/gallon
Elimstaph	Quaternary	Walter G. Legge	1 ounce/gallon
Franklin Phenomysan F2500	Phenolic	Purex Corporation	1 1/4 ounce/gallon
Franklin Sentinel	Quaternary	Purex Corporation	2 ounces/gallon
Galahad	Phenolic	Puritan Churchill Chemical Company	1 ounce/gallon
Hi-Tor	Quaternary	Huntington Laboratories	1/2 ounce/gallon
LPH	Phenolic	Vestal Laboratories	1/2 ounce/gallon
Matar	Phenolic	Huntington Laboratories	1/2 ounce/gallon
Omega	Quaternary	Airwick (Professional Products Division)	1/2 ounce/gallon
Quanto	Quaternary	Huntington Laboratories	1 ounce/gallon
Sanikleen	Quaternary	West Chemical Products	2 ounces/ gallon
Sanimaster II	Quaternary	Service Master	1 ounce/gallon
Vesphene	Phenolic	Vestal Laboratories	1 1/4 ounce/ gallon

Quaternary Germicidal Disinfectants, used as directed, and/or Chlorine Bleach products, typically 5.25% Sodium Hypochlorite in **dilutions ranging between 1 part bleach to 100 parts water, and 2 parts bleach to 100 parts water are not considered mild detergents. These products are corrosive in nature and may cause damage to your stretcher if used improperly.** If these types of products are used to clean Stryker patient handling equipment, measures must be taken to insure the stretchers are rinsed with clean water and thoroughly dried following cleaning. Failure to properly rinse and dry the stretchers will leave a corrosive residue on the surface of the stretcher, possibly causing premature corrosion of critical components.

## NOTE

Failure to follow the above directions when using these types of cleaners may void this product's warranty.

## REMOVAL OF IODINE COMPOUNDS

This solution may be used to remove iodine stains from mattress cover surfaces.

1. Use a solution of 1–2 tablespoons Sodium Thiosulfate in a pint of warm water to clean the stained area. Clean as soon as possible after staining occurs. If stains are not immediately removed, allow solution to soak or stand on the surface.
2. Rinse surfaces which have been exposed to the solution in clear water before returning bed to service.

# Service Information

## CASTER COVER INSTALLATION AND REMOVAL

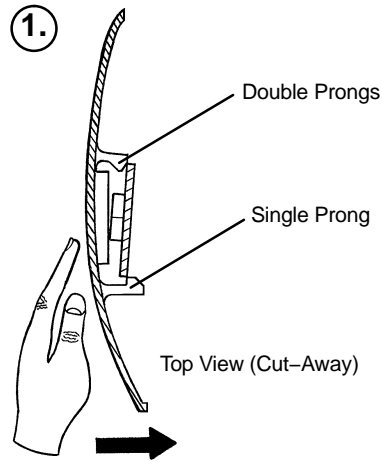

Looking through the larger of the two side cut-outs, align the cover with the axle nut or bolt head, as shown. Push down on the opposite side of the cover until the single prong engages the caster horn.

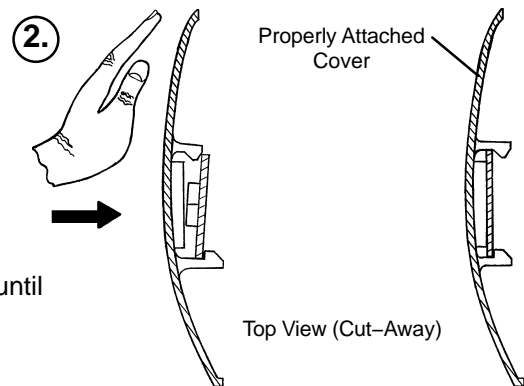

Push on the cover with your palm until the double prongs engage.

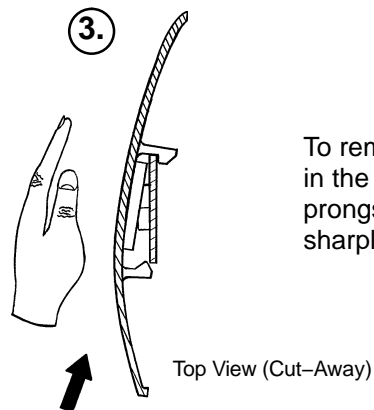

To remove the wheel cover, insert a large screwdriver into the cut-out in the side of the wheel cover and into the space between the double prongs. Pry up the cover to disengage the double prongs and push sharply upward to disengage the single prong.

## CASTER REMOVAL

### Required Tools:

9/16" Open End Wrench

1. Remove the caster cover.
2. While keeping pressure on the caster bolt with your index finger, use a 9/16" open end wrench to remove the nylock hex nut on top of the caster assembly.
3. Using the brake ring, lift up on the base assembly and pull the caster assembly down to remove it.
4. Reverse steps 1-3 to install the new caster.



# Service Information

---

## RELEASE PEDAL ADJUSTMENT

1. Manually disengage the release pedal swivel (item K on [page 35](#)) from the release pedal assembly.
2. To increase the release rod engagement with the release valve, turn the release pedal swivel clockwise on the threaded release rod.
3. To decrease the release rod engagement with the release valve, turn the release pedal swivel counter-clockwise on the threaded release rod.

### NOTE

If the pedal swivel assembly is threaded too far onto the release rod, the release valve will be partially activated and the jack will drift.

## BRAKE ROD REMOVAL

### Required Tools:

Hammer

7/32" Punch

String or Bungee Cords

### Fifth Wheel Base

1. Pump the litter up to full height.
2. Lift the base hood and support it from the litter using string or bungee cords.
3. Remove the hex head cap screws connecting the brake rod supports to the base frame.
4. Remove the bolt connecting the drive link assembly to the fifth wheel cam.
5. Remove the rue ring cotter and clevis pin connecting the rod end link to the side control link.
6. Remove the rue ring cotter connecting the drive link assembly to the bearing pivot support on the base frame (under the brake ring weldment).
7. Remove the three hex washer head screws holding the brake rod assembly to the base frame.
8. Remove the slotted spring pins connecting the butterfly "V" pedals, drive link assemblies and side control link to the brake rod.
9. Reverse steps 1–8 to reinstall the brake rod. When reinstalling the brake rod supports, torque the hex head cap screws to 12–15 ft.-lbs.

---

### CAUTION

When reattaching the brake rod assembly to the base frame, set the torque specs **no higher** than 15 ft.-lbs. or damage could occur to the bolts.

### Big Wheel Base

1. Pump the litter up to full height.
2. Lift the base hood and support it from the litter using string or bungee cords.
3. With the brake/steer pedal in the steer position, remove the clevis pin and rue ring cotter connecting the brake rod to the brake rod drive link at each end of the stretcher.
4. Remove the two clevis pins and rue ring cotters connecting the brake rods to the drive arm at the center of the base near the cam bracket assembly.
5. Pull on the butterfly "V" pedals to remove the brake rods from the base.
6. Reverse steps 1–5 to reinstall the brake rod.

# Service Information

---

## SIDE CONTROL BRAKE ROD REMOVAL

### Required Tools:

Hammer                      7/32" Punch                      Needle Nose Pliers                      String or Bungee Cords

### Fifth Wheel Base

1. Pump the litter up to full height.
2. Lift the base hood and support it from the litter using string or bungee cords.
3. Remove the rue ring cotter and clevis pin connecting the rod end link to the side control link.
4. Remove the four bolts holding the brake rod assembly to the base frame and remove the entire assembly.
5. Using a hammer and 7/32" punch, drive the slotted spring pin out of the butterfly "V" pedal on the patient's left side and remove the pedal,
6. Using a hammer and 7/32" punch, drive the slotted spring pin out of the hard stop in the center of the support weldment.
7. Using a hammer and 7/32" punch, drive out the slotted spring pin connecting the side control link to the side control brake rod on the patient's right side.
8. Pull on the butterfly "V" pedal on the patient's right side to remove the side control brake rod from the base.
9. Reverse steps 1–8 to reinstall the brake rod. When reinstalling the assembly, torque the hex head cap screws to 12–15 ft.–lbs.

---

### CAUTION

When reattaching the brake rod assembly to the base frame, set the torque specs **no higher** than 15 ft.–lbs. or damage could occur to the bolts.

### Big Wheel Base

1. Pump the litter up to full height.
2. Lift the base hood and support it from the litter using string or bungee cords.
3. Using a hammer and 7/32" punch, drive the groove pin out of the butterfly "V" pedal on the patient's left side and remove the pedal.
4. Using a hammer and 7/32" punch, drive out the groove pin connecting the side control link to the side control brake rod.
5. Pull on the butterfly "V" pedal on the patient's right side to remove the side control brake rod from the base.
6. Reverse steps 1–5 to reinstall the brake rod.

# Service Information

---

## BRAKE RING REMOVAL

### Required Tools:

9/16" Socket w/Extension    3/8" Drive Ratchet    Needle–Nose Pliers    String or Bungee Cord

1. Pump the litter up to full height.
2. Lift the base hood and support it from the litter using string or bungee cords.
3. Using needle–nose pliers, unhook the extension springs from the top of the base caster tubes.
4. Remove the plastic caster covers.
5. While putting pressure on the caster carriage bolt, use a 9/16" socket and a 3/8" drive ratchet to remove the caster nut on both sides of the stretcher.
6. Remove the casters.
7. Remove the brake rod (see procedure).
8. Remove the cotter pin from the clevis pin in the center of the brake ring weldment.
9. Remove the cotter pin from the bearing pivot support.
10. Remove the 3/4" nylock hex nut from the bearing pivot support.
11. Remove the drive link assembly.
12. Pull the brake ring down and out away from the stretcher base frame.
13. Reverse steps 1–12 to reinstall the brake ring.

## FIFTH WHEEL ASSEMBLY REMOVAL

### Required Tools:

1/2" Socket    3/8" Drive Ratchet

1. Using a 1/2" socket and 3/8" drive ratchet, remove the 1/2" bolt holding the fifth wheel cam drive link and fifth wheel drive link to the fifth wheel cam.
2. Remove the two 1/2" bolts holding the fifth wheel mounting bracket to the base frame weldment.
3. Remove the fifth wheel assembly.
4. Reverse steps 1 and 2 to reinstall the fifth wheel. When reinstalling the assembly, torque the hex head cap screws to 12–15 ft.–lbs.

---

### CAUTION

When reattaching the fifth wheel assembly to the base frame, set the torque specs **no higher** than 15 ft.–lbs. or damage could occur to the bolts.

# Service Information

---

## LITTER TOP REMOVAL

### Required Tools:

1/2" Socket w/Extension

3/8" Drive Ratchet

Standard Screwdriver

1. Using the foot pedal, pump up the litter top to full height.
2. Remove the stretcher mattress
3. Remove the round, black hole plugs from the jack supports at each end of the litter to expose the jack support tube truss head screws.
4. Using a 1/2" socket, and a 3/8" drive ratchet, remove the truss head screws holding the jack support tubes to the jack shafts.
5. Thread a 7/16–20 fine thread bolt far enough into the top of the jack supports to separate the litter top from the jack shaft.
6. With the assistance of another person, lift the litter straight up to remove it from the jack shafts and set it aside.

## BIG WHEEL HUBCAP REMOVAL

### Required Tools:

Large Standard Screwdriver

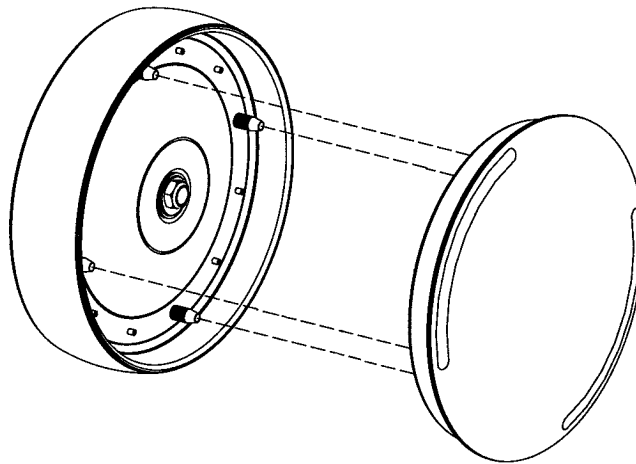

1. Using a large standard screwdriver, pry evenly around the entire edge of the Big Wheel hubcap until it pops off the mounting studs on the wheel.

---

## CAUTION

---

Do not attempt to pull off the hubcap after prying up only one side. Damage to the slots on the hubcap or the mounting studs on the wheel could result.

2. To reinstall the hubcap, place it on the wheel, aligning the slots in the hubcap with the mounting studs on the wheel. Press down evenly on the edges of the hubcap until it snaps into place.

# Service Information

---

## BIG WHEEL REMOVAL

### Required Tools:

Large Standard Screwdriver      Small Standard Screwdriver      String or Bungee Cords

1. Lift the base hood and separate the Velcro holding it to the base frame. Support the hood from the litter using bungee cords so it is out of the way.
2. Using a large, standard screwdriver, pop off the big wheel cover.
3. Using a small, standard screwdriver, remove the spiral retaining ring from the groove on the Big Wheel axle.
4. Remove the Big Wheel.
5. Reverse steps 1–4 to reinstall the Big Wheel.

## BIG WHEEL CARRIAGE ASSEMBLY REMOVAL

### Required Tools:

1/2" Socket      3/8" Drive Ratchet      Needle–Nose Pliers

1. Remove the litter top from the stretcher (see [page 11](#)).
2. Lift the base hood off the base frame.
3. With the brake/steer pedal in the steer position, remove the clevis pin and rue ring cotter connecting the brake rod to the brake rod drive link at each end of the stretcher.
4. Remove the two clevis pins and rue ring cotters connecting the brake rods to the drive arm at the center of the base near the cam bracket assembly.
5. Pull the brake shafts straight out away from the base.
6. Remove the four hex washer head screws holding the cam bracket assembly to the base frame and remove the cam bracket assembly.

### NOTE

On a base with 4–sided brakes, remove the rue ring cotter and clevis pin connecting the side control big wheel linkage assembly to the yoke weldment on the end control brake pad at the foot end of the stretcher.

7. Remove the two hex washer head screws holding the carriage weldment to the base frame and remove the carriage assembly.
8. Reverse steps 1–7 to reinstall the carriage assembly.

# Service Information

---

## BIG WHEEL CAM GAS SPRING DAMPENER REMOVAL

### Required Tools:

1/2" Socket

3/8" Drive Ratchet

Needle–Nose Pliers

1. Remove the litter top from the stretcher (see [page 11](#)).
2. Lift the base hood off the base frame.
3. Remove the two clevis pins and rue ring cotters connecting the brake rods to the drive arm at the center of the base near the cam bracket assembly.
4. Pull the brake shafts straight out away from the base.
5. Remove the four hex washer head screws holding the cam bracket assembly to the base frame and remove the cam bracket assembly.
6. Remove the rue ring cotter from the dampener mounting pin and remove the pin.
7. Lift up on the (patient) left side of the cam bracket and remove the rue ring cotter holding the dampener to the dampener arm and remove the dampener.
8. Reverse steps 1–7 to install the new dampener.

## SIDE CONTROL BIG WHEEL LINKAGE ASSEMBLY REMOVAL

### Required Tools:

1/4" Punch

Hammer

Needle–Nose Pliers

String or Bungee Cords

1. Pump the litter up to full height.
2. Lift the base hood and support it from the litter using string or bungee cords.
3. Using a hammer and 1/4" punch, drive out the slotted spring pin connecting the butterfly "V" pedal on the patient's right side to the side control wheel axle.
4. Remove the butterfly "V" pedal and set it aside.
5. Using the hammer and 1/4" punch, drive out the slotted spring pin holding the side control Big Wheel linkage yoke weldment to the side control wheel axle.
6. Pull straight out on the patient's left side butterfly "V" pedal and remove the side control wheel axle.
7. Using needle–nose pliers, remove the hair pin cotter and washer holding the toggle pivot plate to the side control Big Wheel carriage assembly.
8. Remove the rue ring cotter and clevis pin connecting the side control Big Wheel linkage rod end link to the end control brake rod.
9. Remove the side control Big Wheel linkage assembly and set it aside.
10. Reverse steps 1–9 to reinstall the linkage assembly.

# Service Information

---

## JACK DESCENT RATE ADJUSTMENT

### Required Tools:

Screwdriver

Bungee Cords (or equivalent)

### Adjustment Procedure:

1. Pump the litter up to full height.
2. Lift the base hood, separating the hood from the base frame. Support the hood from the litter using bungee cords so it is out of the way.
3. The descent rate needle valve is located on the base of the jack. Turning the needle valve clockwise, with a screwdriver, will decrease the rate of descent. Turning it counterclockwise will increase the rate of descent.

### NOTE

The larger percentage of a patient's weight is located in the torso area. Adjust descent rate accordingly.

4. Remove the bungee cords supporting the base hood and secure the hood to the base frame.

### NOTE

The jack descent rate is preset at the factory and adjustment is not recommended.

## REMOVAL OF EXCESS AIR (VACUUM) FROM THE HYDRAULIC SYSTEM

1. Verify all hydraulic linkages are secure and operating properly.
2. Using the pump pedal, actuate the system several times to force the air through the system. The jack should now raise properly.

# Service Information

---

## HEAD END HYDRAULIC JACK REMOVAL

**Required Tools:**                      1/2" Socket w/Extension                      3/8" Drive Ratchet

1. Remove the litter top from the stretcher (see [page 11](#)).
2. Using a 1/2" socket with extension and a 3/8" drive ratchet, remove the two hex head screws holding the jack base to the stretcher base frame.
3. Remove the two hex head screws holding the jack reservoir clamp to the base frame and remove the clamps.
4. Lift straight up on the pump connecting rod and disconnect the pump piston from the connecting rod.
5. Disconnect the pump pedal swivel from the release pedal mounting plate.
6. Remove the head end release rod from the release valve assembly.
7. Using a 1/2" socket with extension and a 3/8" drive ratchet, remove the two hex head screws holding the jack base to the stretcher base frame.
8. Lift out the jack assembly.
9. To reinstall the jack, install the bolts on the jack and reservoir clamp but do not tighten them fully.
10. Reinstall the pump connecting rod and release rod.
11. Depress the pump pedal fully (to the floor). This will properly locate the jack onto the base frame.
12. Tighten the bolts on the jack and reservoir clamp.
13. Pump up the litter and apply weight to verify the jacks hold and do not drift.

### **NOTE**

The jack descent rate is preset at the factory and adjustment is not recommended.



# Service Information

---

## FOOT END HYDRAULIC JACK REMOVAL (BASE WITH DUAL CONTROLS)

### Required Tools:

1/2" Socket                                  3/8" Drive Ratchet                                  Pliers

1. Remove the litter top from the stretcher (see [page 11](#)).
2. Lift the base hood off the base frame.
3. Remove the two hex washer head screws and washers connecting the pump pedal link to the foot end pump pedal assembly and pump connecting rod.
4. Remove the foot end release rod from the release valve on the jack assembly by dislodging the release pedal swivel from the pins on the release pedal weldment.
5. Dislodge the jack pump piston from the pump connecting rod.
6. Remove the two hex washer head screws holding the reservoir clamp.
7. Remove the jack assembly.
8. Reverse steps 1–7 to install the new jack.

### NOTE

The jack descent rate is preset at the factory and adjustment is not recommended.

## FOOT END HYDRAULIC JACK REMOVAL (BASE WITH 3–SIDED CONTROLS)

### Required Tools:

1/2" Socket                                  3/8" Drive Ratchet                                  Pliers

1. Remove the litter top from the stretcher (see [page 11](#)).
2. Lift the base hood off the base frame.
3. Remove the two hex washer head screws and washers connecting the pump pedal link to the foot end pump pedal assembly and pump connecting rod.
4. Remove the foot end pump pedal return spring.
5. Remove the cotter pin from the center of the foot end pump pedal assembly and slide out the pivot pin.
6. Slide the foot end pump pedal assembly up and over the foot end mounting bracket.
7. Remove the four hex washer head screws fastening the foot end mounting bracket to the base frame and set the bracket aside.
8. Remove the foot end release rod from the release valve on the jack assembly by dislodging the release pedal swivel from the pins on the release pedal weldment.
9. Dislodge the jack pump piston from the pump connecting rod.
10. Remove the two hex washer head screws holding the reservoir clamp.
11. Remove the jack assembly.
12. Reverse steps 1–11 to install the new jack.

### NOTE

The jack descent rate is preset at the factory and adjustment is not recommended.

# Service Information

---

## FOOT END HYDRAULIC JACK REMOVAL (BIG WHEEL BASE WITH 3–SIDED CONTROLS)

### Required Tools:

1/2" Socket

3/8" Drive Ratchet

Pliers

1. Remove the litter top from the stretcher (see [page 11](#)).
2. Lift the base hood off the base frame.
3. Remove the hair pin cotter and washer connecting the side control Big Wheel linkage toggle pivot plates to the side control Big Wheel carriage weldment.
4. Remove the rue ring cotter and clevis pin connecting the side control Big Wheel rod end link to the yolk weldment on the end control brake rod.
5. Remove the Big Wheel carriage assembly (see [page 12](#)).
6. Remove the two hex washer head screws and washers connecting the pump pedal link to the foot end pump pedal assembly and pump connecting rod.
7. Remove the foot end pump pedal return spring.
8. Remove the cotter pin from the center of the foot end pump pedal assembly and slide out the pivot pin.
9. Slide the foot end pump pedal assembly up and over the foot end mounting bracket.
10. Remove the four hex washer head screws fastening the foot end mounting bracket to the base frame and set the bracket aside.
11. Remove the foot end release rod from the release valve on the jack assembly by dislodging the release pedal swivel from the pins on the release pedal weldment.
12. Dislodge the jack pump piston from the pump connecting rod.
13. Remove the two hex washer head screws holding the reservoir clamp.
14. Remove the jack assembly.
15. Reverse steps 1–11 to install the new jack.

### NOTE

The jack descent rate is preset at the factory and adjustment is not recommended.

## PNEUMATIC FOWLER ADJUSTMENT

### Required Tools:

5/32" Hex Allen Wrench

1/2" Open End Wrench

1. Refer to the pneumatic Fowler assembly drawing on [page 77](#) for parts reference.
2. For easier access, raise the Fowler to 75° or higher.
3. Using a 1/2" open end wrench, loosen the hex nuts (item E) in the actuator arms on the end of the trip bar (item M).
4. To adjust the Fowler, use a 5/32" hex Allen wrench to turn the Allen screws (item J) 1 to 2 turns counter-clockwise if the Fowler will not move or 1 to 2 turns clockwise if the Fowler will not hold its position.
5. Retighten the hex nuts. Be sure the Fowler travels from flat up to 90° and down again and holds its position when weight is applied before returning the stretcher to service.

# Service Information

---

## TRANSFER BOARD COUNTERBALANCE ADJUSTMENT

### Required Tools:

7/16 Open End Wrench

1. Raise the transfer board to the full up position.
2. Unhook the extension spring at the eye bolt.
3. Using a 7/16 open end wrench, loosen the jam nut at the eye bolt.
4. Adjust the eye bolt to the desired position.
5. Tighten the jam nut.
6. Hook the extension spring to the eye bolt.
7. Allow the transfer board to lower on its own.
8. Repeat steps 1–7 until the desired counterbalance is achieved.

## FOLDDOWN SIDERAIL LATCH ADJUSTMENT

### Required Tools:

1/8" Hex Allen Wrench

---

### WARNING

The siderail latches are preset at the factory, and do not normally need adjustment. If adjustment must be done, it is important to follow the procedure below. If adjustment is not done properly, injury to the patient or user could result.

---

1. Using a 1/8" hex Allen wrench, adjust the hex Allen screw located on the latch assembly opposite the latch. Turning the screw clockwise will **DECREASE** the amount of "play" in the latching mechanism. Turning counterclockwise will **INCREASE** the amount.

### NOTE

The amount of "play" in the siderail, when in full up engaged position, should be approximately 1/8 to 3/16 inches.

---

### CAUTION

Too much "play" when the siderail is in the full up engaged position will give the siderail the appearance of being unstable and could also cause premature wearing of the latch system.

Too little "play" will obstruct the latch and keep it from engaging completely in the full up position, which may result in damage to the latch and/or injury to the patient or user.

# Replacement Parts and Kits

---

<b><u>PART NAME</u></b>	<b><u>PART NUMBER</u></b>
Caster Assembly (1 complete) .....	0753-010-020
Chartholder .....	0946-028-100
C-Spine Cassette Holder .....	1001-070-000
Defibrillator/Equipment Tray .....	0926-039-000
Defibrillator Tray/Foot Extension .....	1010-050-100
Foot Board/Chartholder Combination .....	0926-040-100
Foot Board (1 per package) .....	0946-029-001
Foot Board (2 per package) .....	0946-029-100
Hydraulic Jack Assembly, Constant Descent .....	0753-002-001
Hydraulic Jack Assembly, Variable Descent .....	0753-002-070
Instrument/Serving Tray .....	1052-026-000
I.V. Pole, Standard Removable .....	0390-025-000
I.V. Pole Kit, Permanent 2-Stage, Head and Foot End .....	0721-400-001
I.V. Pole, Permanent 3-Stage, Head End .....	0721-061-000
I.V. Pole, Permanent 3-Stage, Foot End .....	0721-062-000
I.V. Pole, Tethered .....	0721-117-000
Mattress, 3" x 24", Standard .....	1059-324-140
Mattress, 4" x 24", Standard .....	1059-424-140
Mattress, 3" x 26", Standard .....	1059-326-140
Mattress, 4" x 26", Standard .....	1059-426-140
Mattress, 3" x 24", Enhanced Comfort .....	0721-248-106
Mattress, 4" x 24", Enhanced Comfort .....	0721-247-106
Mattress, 3" x 26", Enhanced Comfort .....	1001-048-106
Mattress, 4" x 26", Enhanced Comfort .....	1001-047-106
Oxygen Bottle Holder, Upright .....	1020-030-000

# Replacement Parts and Kits

---

<b><u>PART NAME</u></b>	<b><u>PART NUMBER</u></b>
Paint, Touch-Up, Gloss Black, Bottle w/Brush .....	7000-001-322
Paint, Touch-Up, Gloss Black, Spray Can .....	7000-001-319
Paint, Touch-Up, Gray, Bottle w/Brush .....	7000-001-320
Paint, Touch-Up, Gray, Spray Can .....	7000-001-317
Pneumatic Cylinder .....	1010-031-078
Restraint Strap, Ankle .....	0946-043-100
Restraint Straps, Body .....	0390-019-000
Restraint Strap, Wrist .....	0946-044-100
Siderail Pad Set .....	1010-052-000

# 0753-006-110 Retractable Fifth Wheel Base Assembly

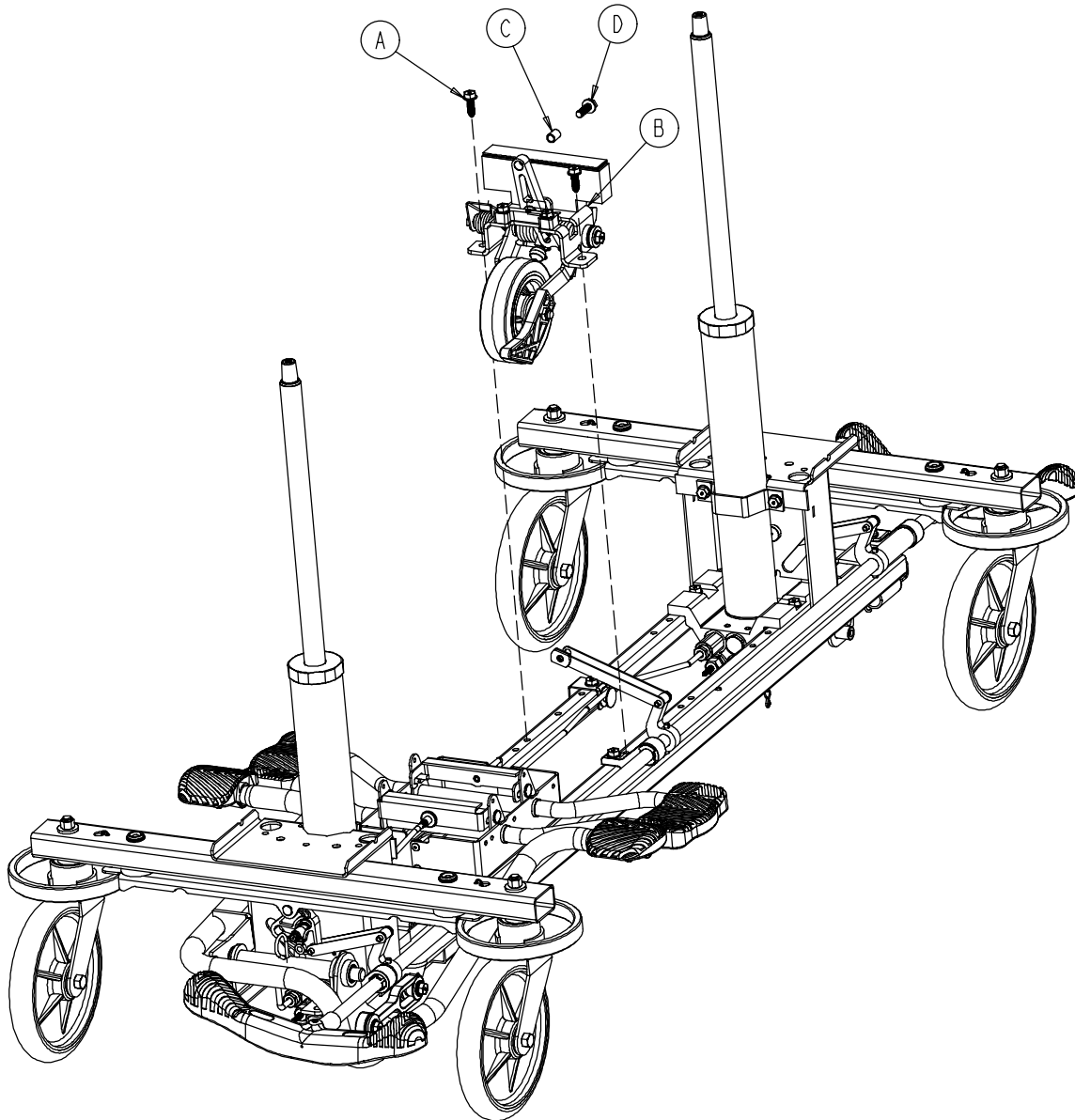

Item	Part No.	Part Name	Qty.
A	0023-288-000	Hex Washer Hd. Screw	2
B	<a href="#">(page 22)</a>	Fifth Wheel Assembly	1
C	0753-006-148	Cam Bearing	1
D	0023-305-000	Hex Hd. Cap Screw	1

# 0753-006-130 Fifth Wheel Assembly

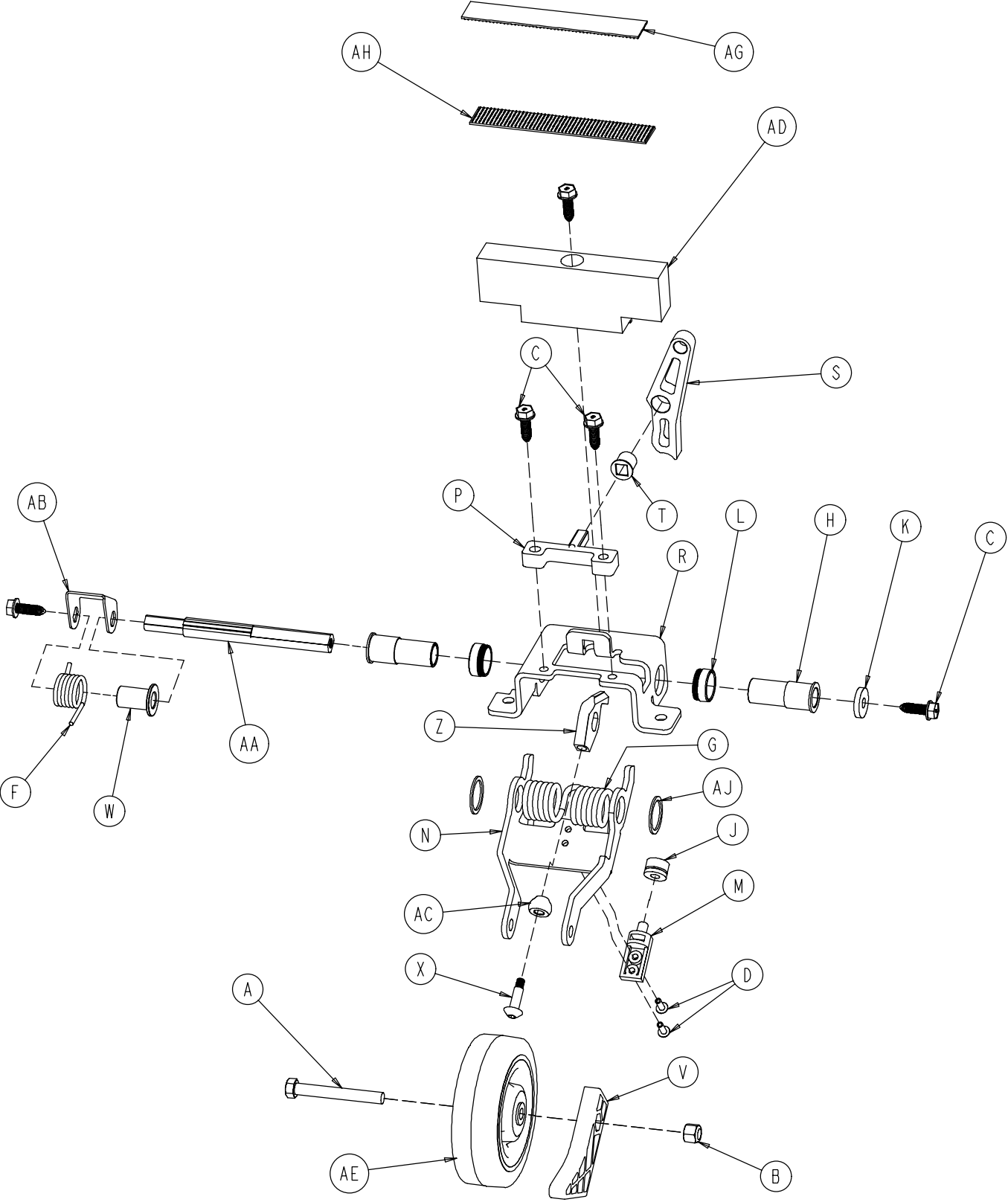

# 0753-006-130 Fifth Wheel Assembly

---

<b>Item</b>	<b>Part No.</b>	<b>Part Name</b>	<b>Qty.</b>
A	0003-083-000	Hex Hd. Cap Screw	1
B	0016-035-000	Nylock Hex Nut	1
C	0023-288-000	Hex Washer Hd. Screw	5
D	0025-050-000	Rivet	2
F	0753-006-074	Torsion Spring	1
G	0753-006-075	Torsion Spring	1
H	0753-006-097	Drive Shaft Bearing	2
J	0753-006-106	Dampener	1
K	0753-006-108	Thrust Washer	1
L	0753-006-115	Bearing	2
M	0753-006-120	Bumper Mounting Pin	1
N	0753-006-126	Wheel Bracket	1
P	0753-006-133	Cam Pivot Block	1
R	0753-006-134	Fifth Wheel Mounting Bracket	1
S	0753-006-142	Fifth Wheel Cam	1
T	0753-006-143	Cam Bearing	1
V	0753-006-149	5th Wheel Ramp	1
W	0753-006-152	Spring Spacer	1
X	0753-006-153	Roller Stem	1
Z	0753-006-198	Drive Pin	1
AA	0753-006-223	Drive Shaft	1
AB	0753-006-227	Return Spring Hook	1
AC	0753-006-277	Roller	1
AD	0753-010-045	Hood Standoff	1
AE	1210-001-147	Wheel	1
AG	0753-006-280	Dual Lock	1
AH	0753-006-281	Dual Lock	1
AJ	0011-360-000	Washer	2



# Base Assembly w/Standard Brakes (Fifth Wheel Base)

Assembly part number  
0753-003-005  
(reference only)

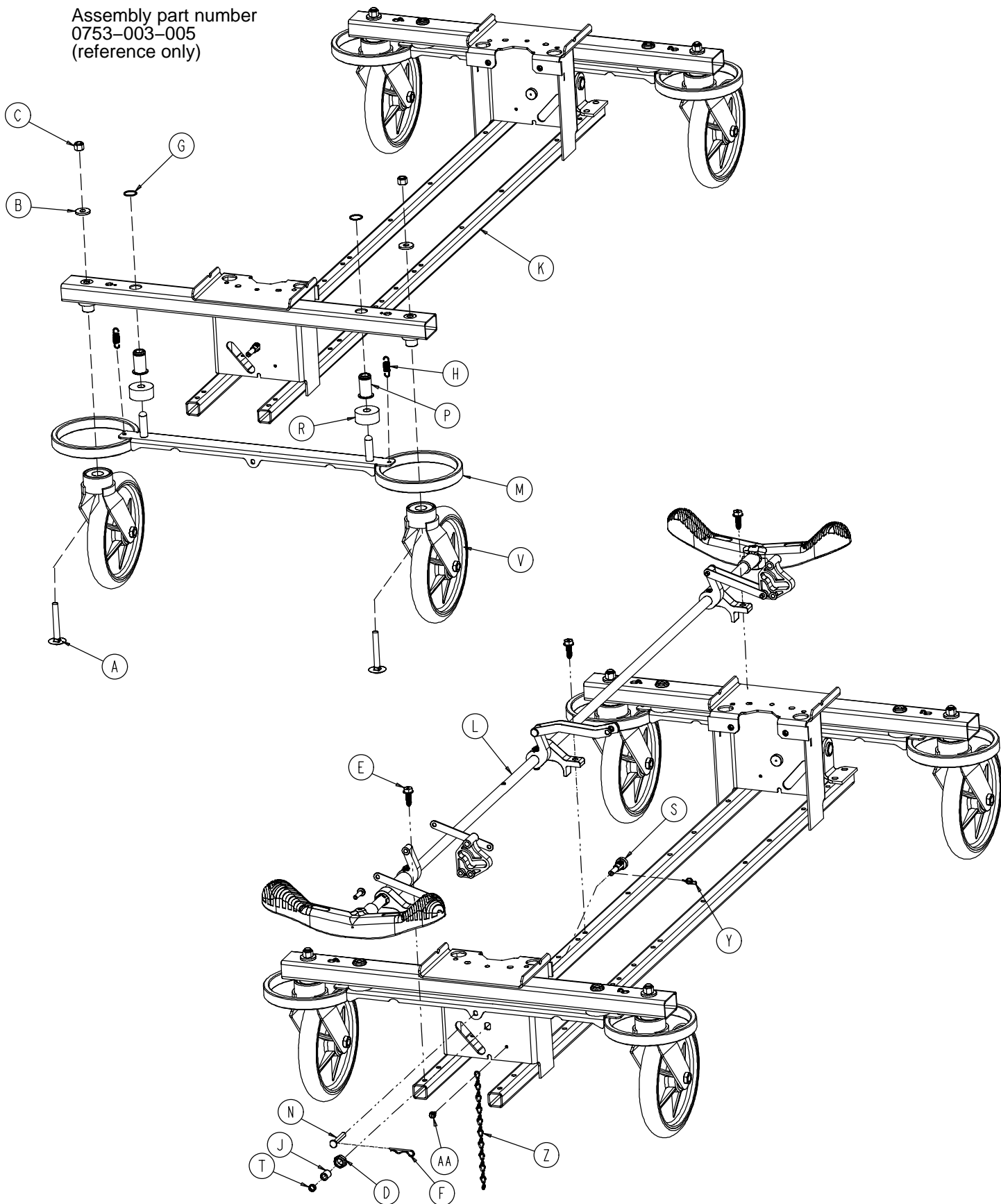

# Base Assembly w/Standard Brakes (Fifth Wheel Base)

---

Item	Part No.	Part Name	Qty.
A	0005-039-000	Step Bolt	4
B	0011-262-000	Washer	4
C	0016-035-000	Nylock Hex Nut	4
D	0016-049-000	Nylock Hex Nut	2
E	0023-288-000	Hex Washer Hd. Screw	3
F	0027-012-000	Hitch Pin	2
G	0028-037-000	External Retaining Ring	4
H	0038-439-000	Extension Spring	4
J	0081-272-000	Roller Bearing	2
K	0753-001-001	Base Frame	1
L	<a href="#">(page 26)</a>	Brake Rod Assembly	1
M	0753-003-006	Brake Ring	2
N	0753-003-066	Clevis Pin	2
P	0753-003-079	Caster Tube Brake Pin Guide	4
R	0753-003-121	Brake Cushion	4
S	0753-003-130	Bearing Pivot Support	2
T	0753-003-131	Spacer	2
V	<a href="#">(page 29)</a>	Caster Assembly	4
Y	0027-019-000	Rue Ring Cotter Pin	2
Z	0753-010-012	Ground Chain	1
AA	0023-025-000	H. Washer Hd. Tapping Screw	1

# Brake Rod Assembly

Assembly part number 0753-003-001 (reference only)

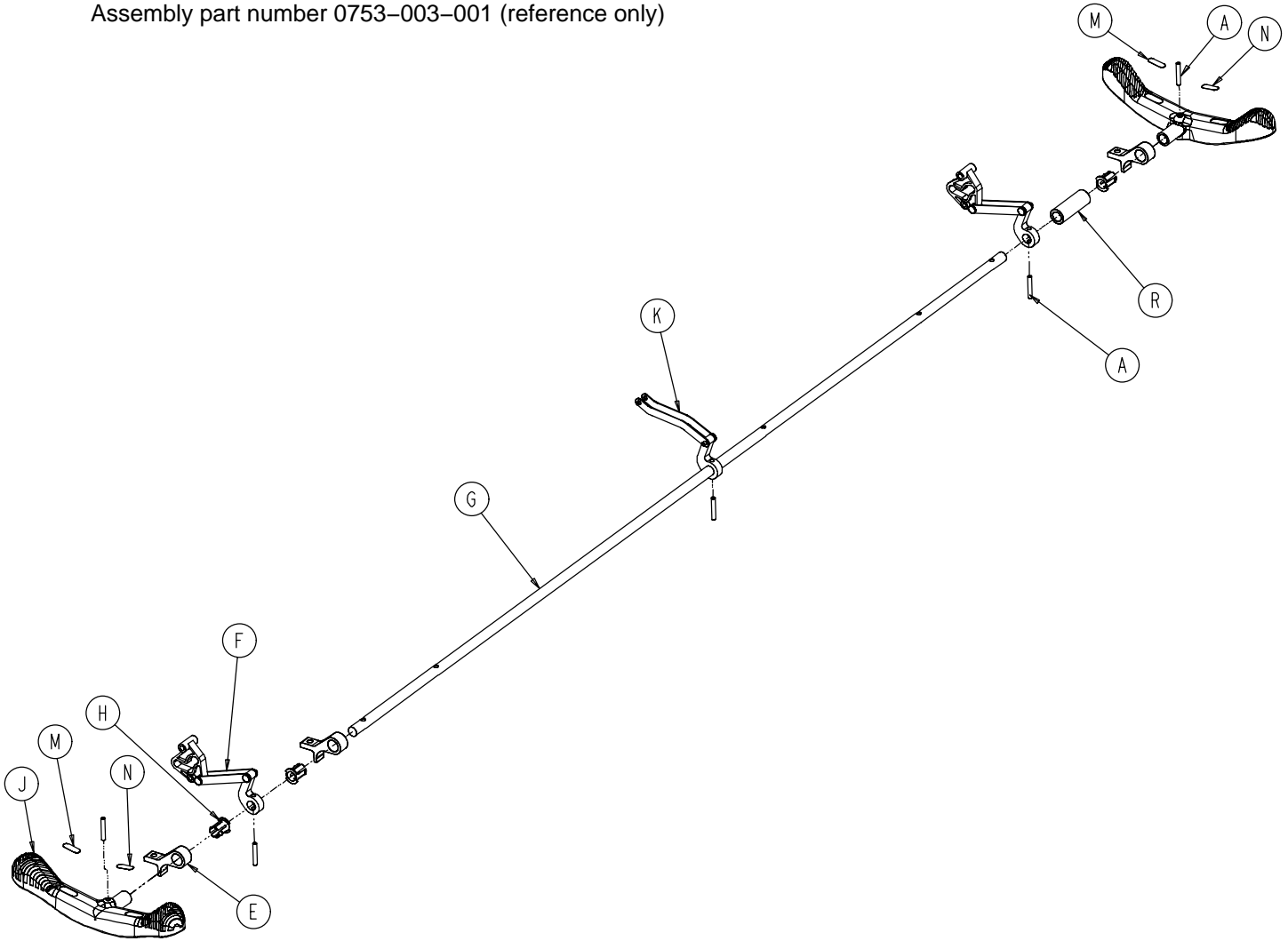

Item	Part No.	Part Name	Qty.
A	0026-067-000	Slotted Spring Pin	2
E	0753-003-004	Brake Rod Support	3
F	(page 27)	Drive Link Assembly	2
G	0753-003-014	Brake Rod	1
H	0753-003-015	Nyliner	3
J	0753-003-099	Butterfly "V" Pedal	2
K	(page 28)	Drive Link Assembly	1
M	1210-201-335	Red Brake Label	2
N	1210-201-336	Green Steer Label	2
R	0753-003-133	Retainment Spacer	1

# 0753-003-010 Drive Link Assembly

---

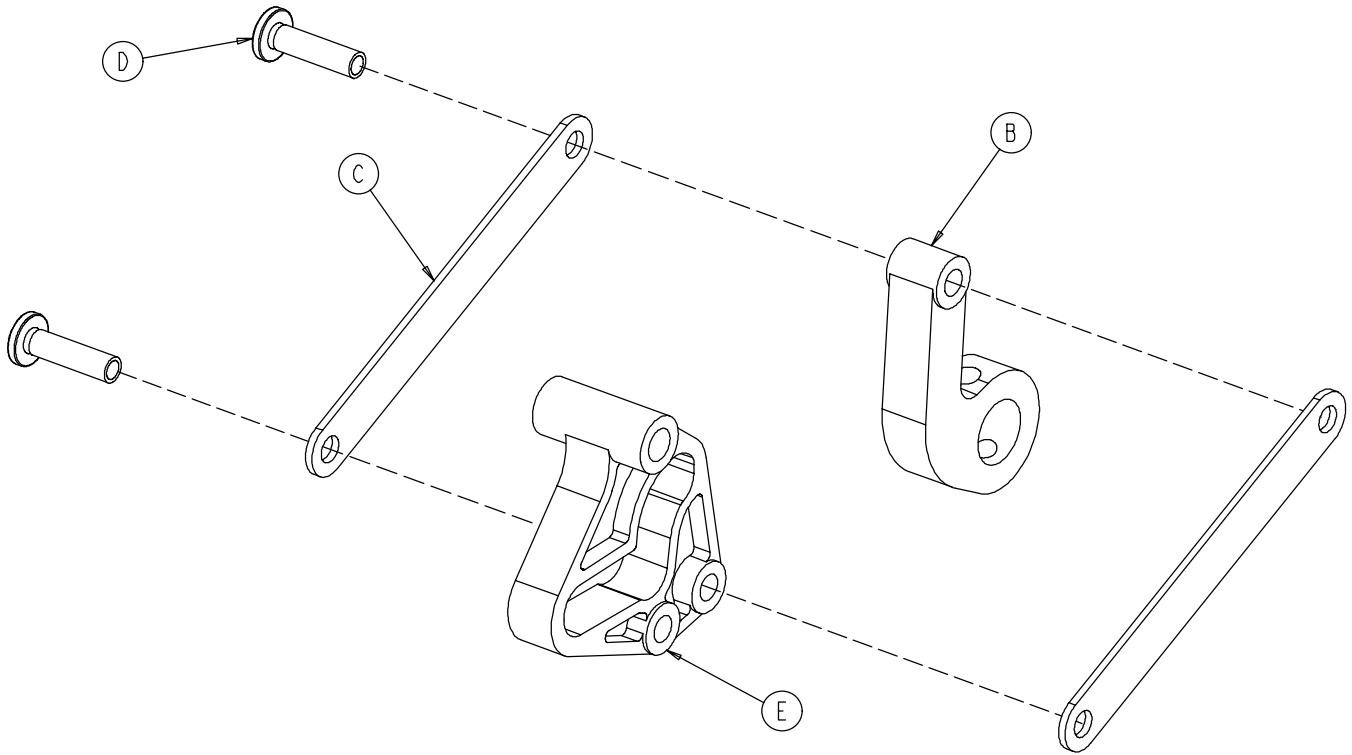

Item	Part No.	Part Name	Qty.
B	0753-003-011	Brake Rod Drive Link	1
C	0753-003-061	Brake Cam Drive Link	2
D	0753-003-098	Flat Hd. Semi-Tubular Rivet	2
E	0753-003-102	Brake Cam	1

# 0753-006-135 Drive Link Assembly

---

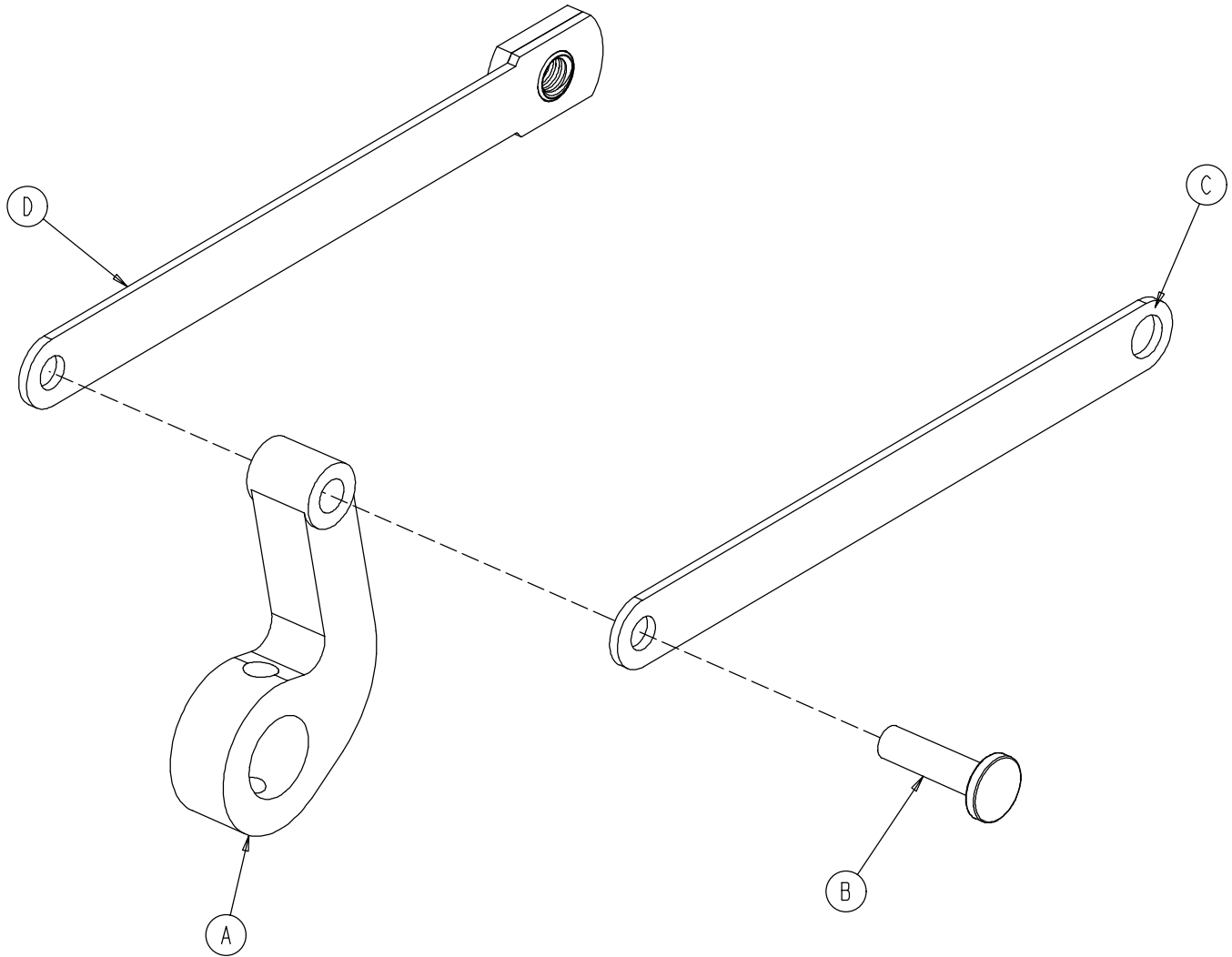

Item	Part No.	Part Name	Qty.
A	0753-003-011	Brake Rod Drive Link	1
B	0753-003-098	Semi-Tubular Rivet	1
C	0753-006-122	5th Wheel Cam Drive Link	1
D	0753-006-147	Fifth Wheel Drive Link	1

# 0753-010-020 8" Caster Assembly

---

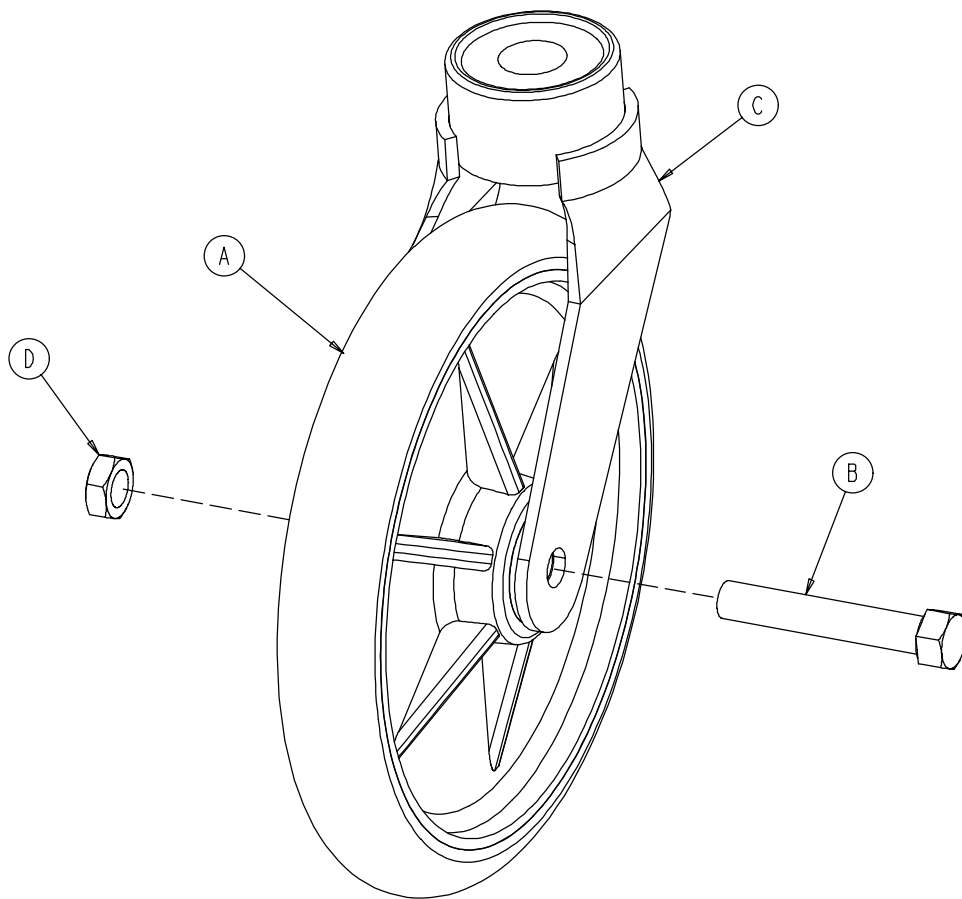

Item	Part No.	Part Name	Qty.
A	0715-002-025	Wheel	1
B	0003-099-000	Hex Hd. Cap Screw	1
C	0753-010-021	Caster Horn w/Bearing	1
D	0016-060-000	Centerlock Nut	1

# Base Assembly with 4-Sided Brakes

Assembly part number 0753-003-120 (reference only)

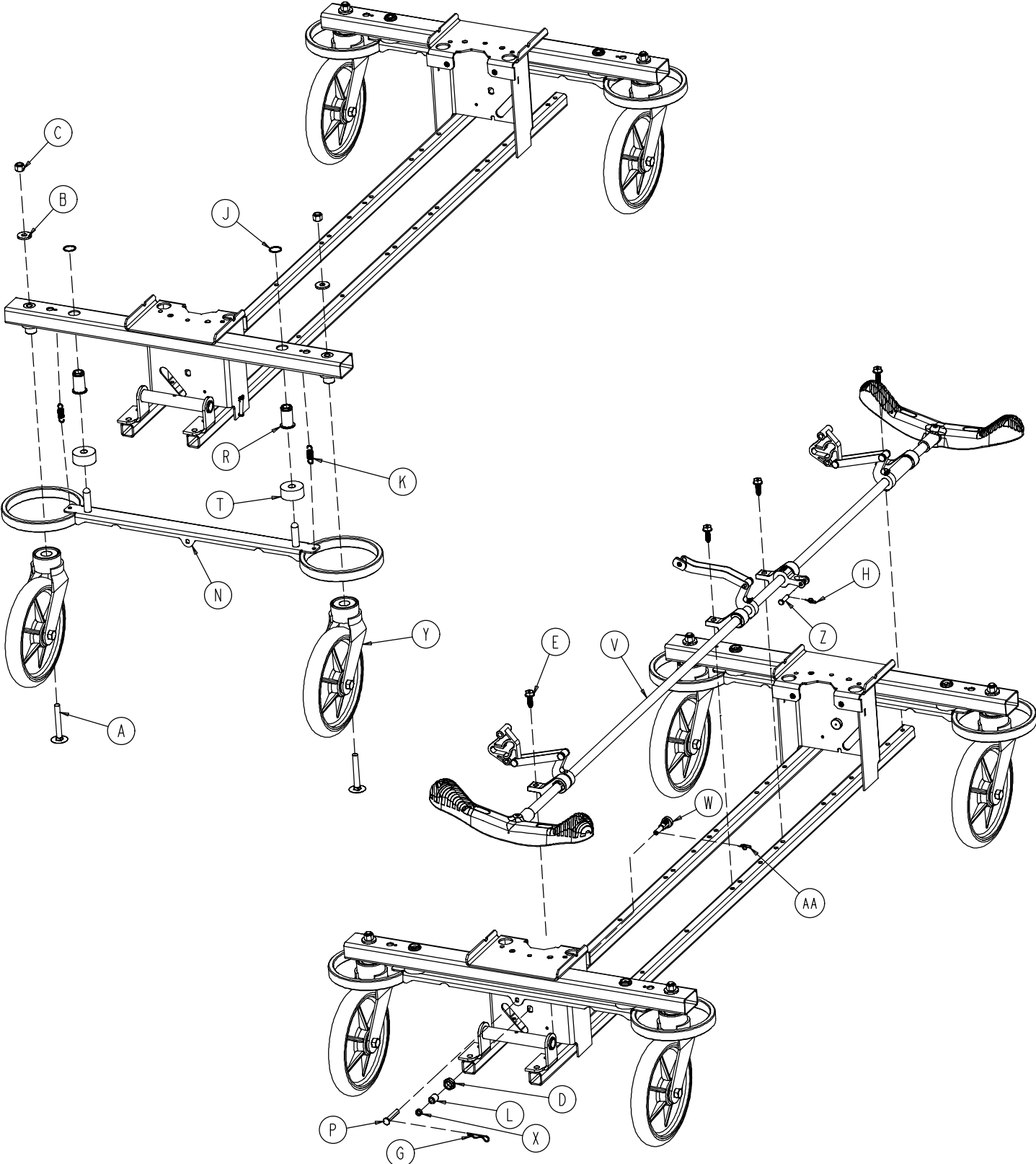

# Base Assembly with 4-Sided Brakes

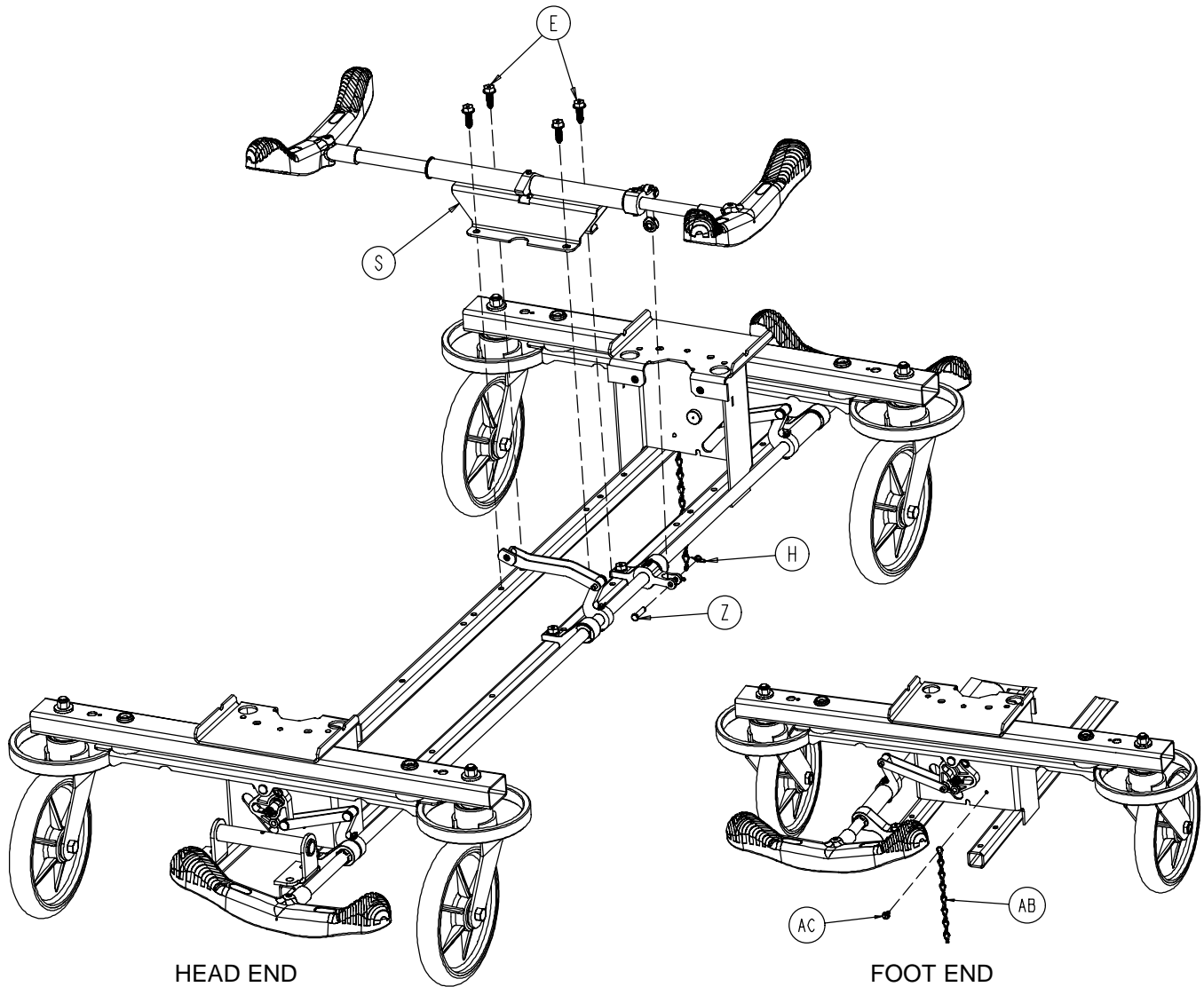

Item	Part No.	Part Name	Qty.	Item	Part No.	Part Name	Qty.
A	0005-039-000	Step Bolt	4	P	0753-003-066	Clevis Pin	2
B	0011-262-000	Washer	4	R	0753-003-079	Brake Pin Guide	4
C	0016-035-000	Nylock Hex Nut	4	S	(page 32)	Side Brake Rod Ass'y	1
D	0016-049-000	Nylock Hex Nut	2	T	0753-003-121	Brake Cushion	4
E	0023-288-000	Hex Washer Hd. Screw	8	V	(page 33)	Brake Rod Assembly	1
G	0027-012-000	Hitch Pin	2	W	0753-003-130	Bearing Pivot Support	2
H	0027-020-000	Rue Ring Cotter	1	X	0753-003-131	Spacer	2
J	0028-037-000	External Retaining Ring	4	Y	(page 29)	Caster Assembly	4
K	0038-439-000	Extension Spring	4	Z	0026-340-000	Clevis Pin	1
L	0081-272-000	Roller Bearing	2	AA	0027-019-000	Rue Ring Cotter Pin	2
M	0753-001-001	Base Weldment	1	AB	0753-010-012	Ground Chain	1
N	0753-003-006	Brake Ring Weldment	2	AC	0023-025-000	H. Washer Hd. Tap. Scr.	1



# 0753-003-110 Side Control Brake Rod Assembly

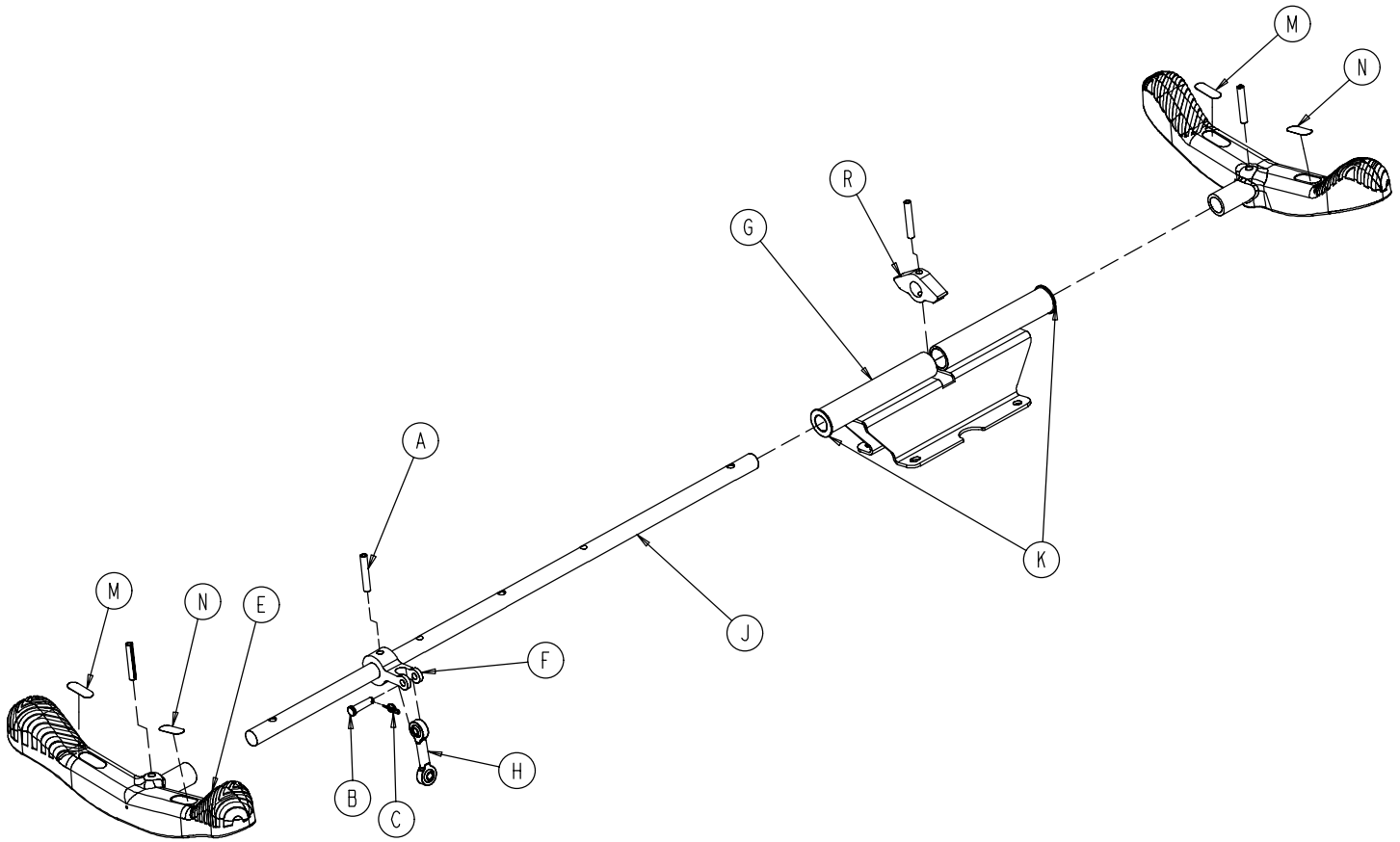

Item	Part No.	Part Name	Qty.
A	0026-067-000	Slotted Spring Pin	4
B	0026-340-000	Clevis Pin	1
C	0027-020-000	Rue Ring Cotter	1
E	0753-003-099	Butterfly "V" Pedal	2
F	0753-003-112	Side Control Link	1
G	0753-003-114	Support Weldment	1
H	0753-003-117	Rod End Link	1
J	0753-003-119	Side Control Brake Rod	1
K	0753-005-044	Pedal Bushing	2
M	1210-201-335	Red Brake Label	2
N	1210-201-336	Green Steer Label	2
R	0753-003-132	Hard Stop	1

# Brake Rod Assembly

Assembly part number 0753-003-125 (reference only)

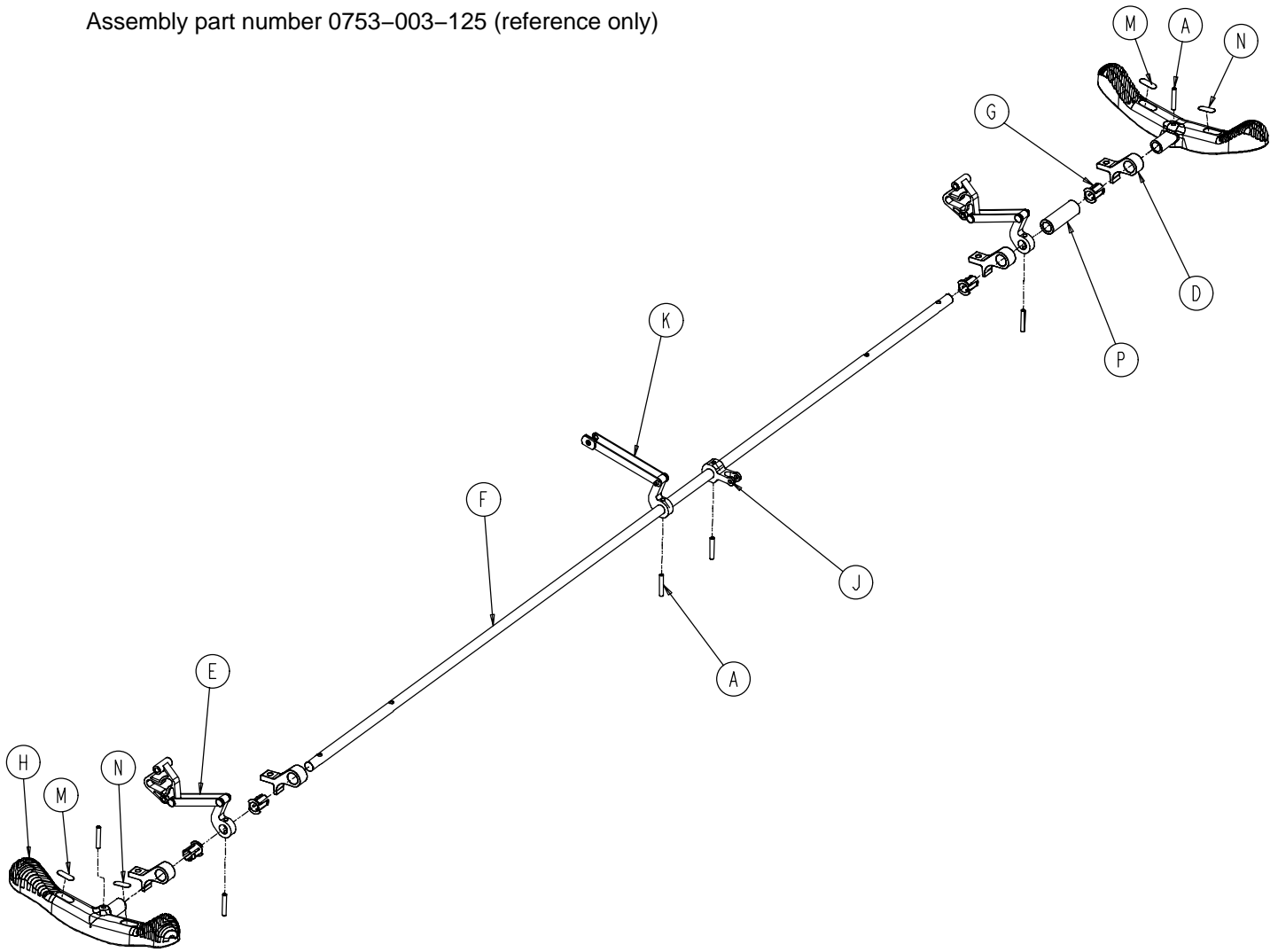

Item	Part No.	Part Name	Qty.
A	0026-067-000	Slotted Spring Pin	6
D	0753-003-004	Brake Rod Support	4
E	<a href="#">(page 27)</a>	Drive Link Assembly	2
F	0753-003-014	Brake Rod	1
G	0753-003-015	Brake Rod Nyliner	4
H	0753-003-099	Butterfly "V" Pedal	2
J	0753-003-112	Side Control Link	1
K	<a href="#">(page 28)</a>	Drive Link Assembly	1
M	1210-201-335	Red Brake Label	2
N	1210-201-336	Green Steer Label	2
P	0753-003-133	Retainment Spacer	1

# Base with Dual Side Hydraulics (Fifth Wheel Base)

Assembly part number 0753-005-100 (reference only)

Insert pump ram into keyhole slot on both ends. Lower pump connecting rod weldment onto pump ram as shown

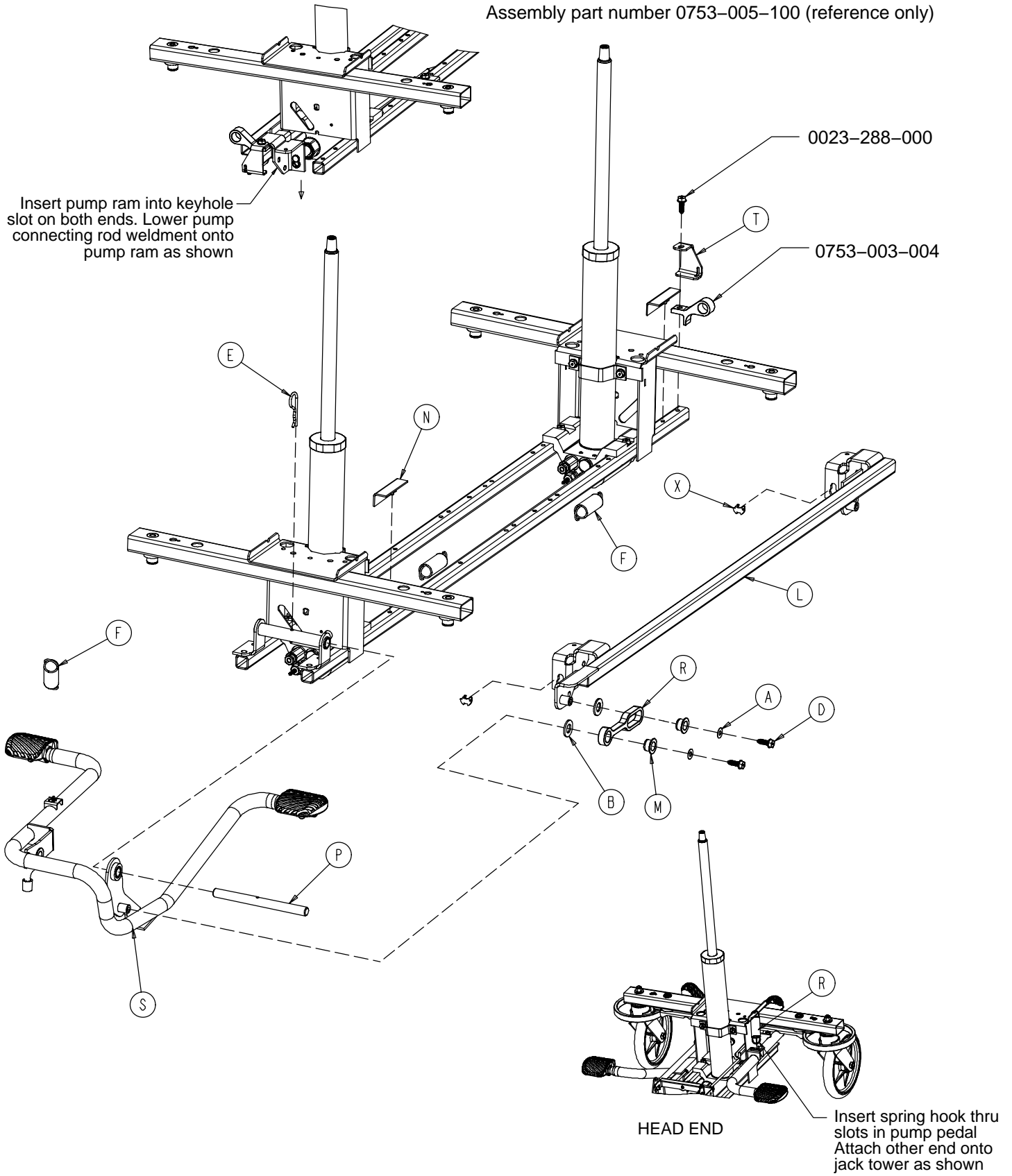

# Base with Dual Side Hydraulics (Fifth Wheel Base)

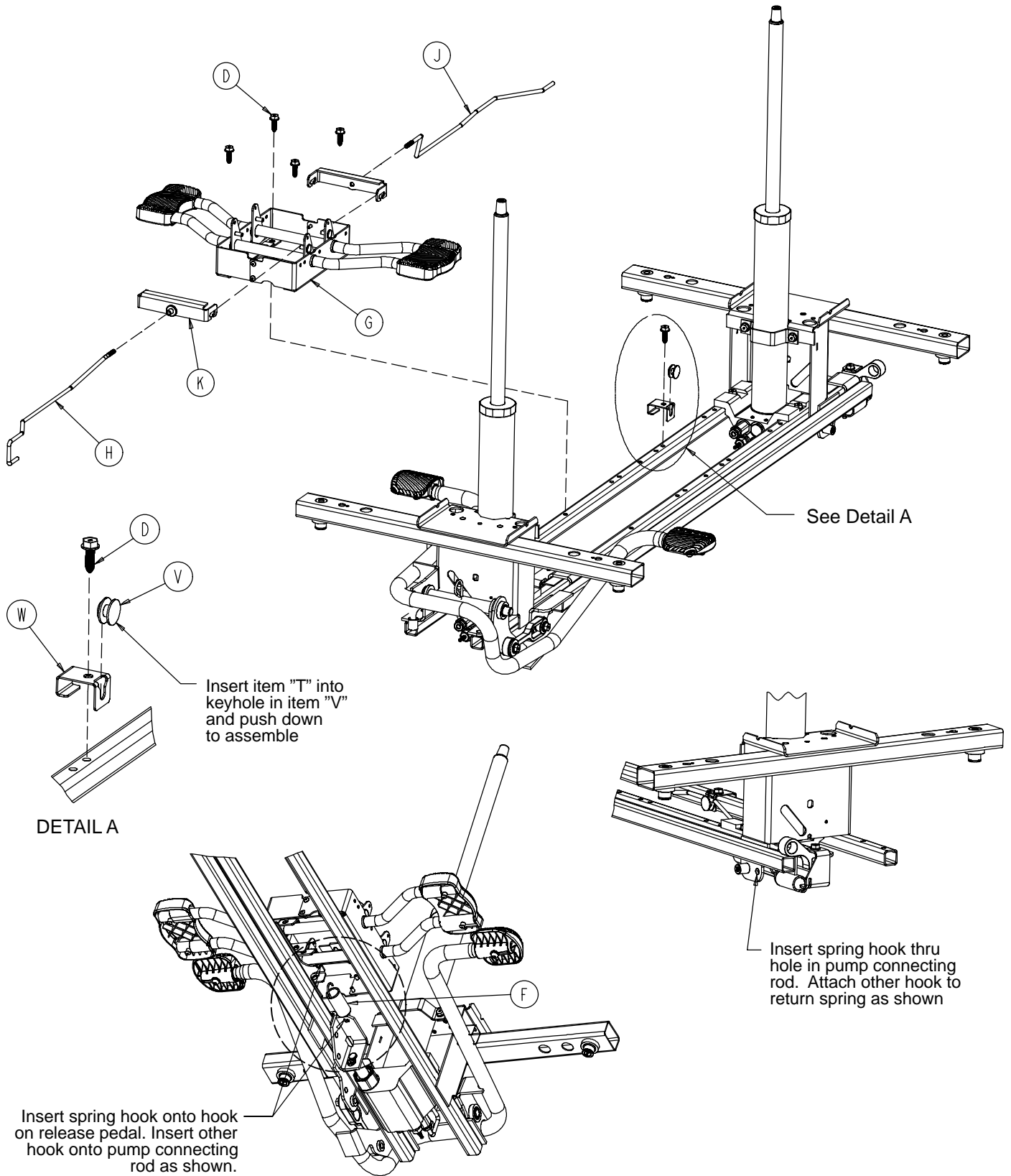

# Base with Dual Side Hydraulics (Fifth Wheel Base)

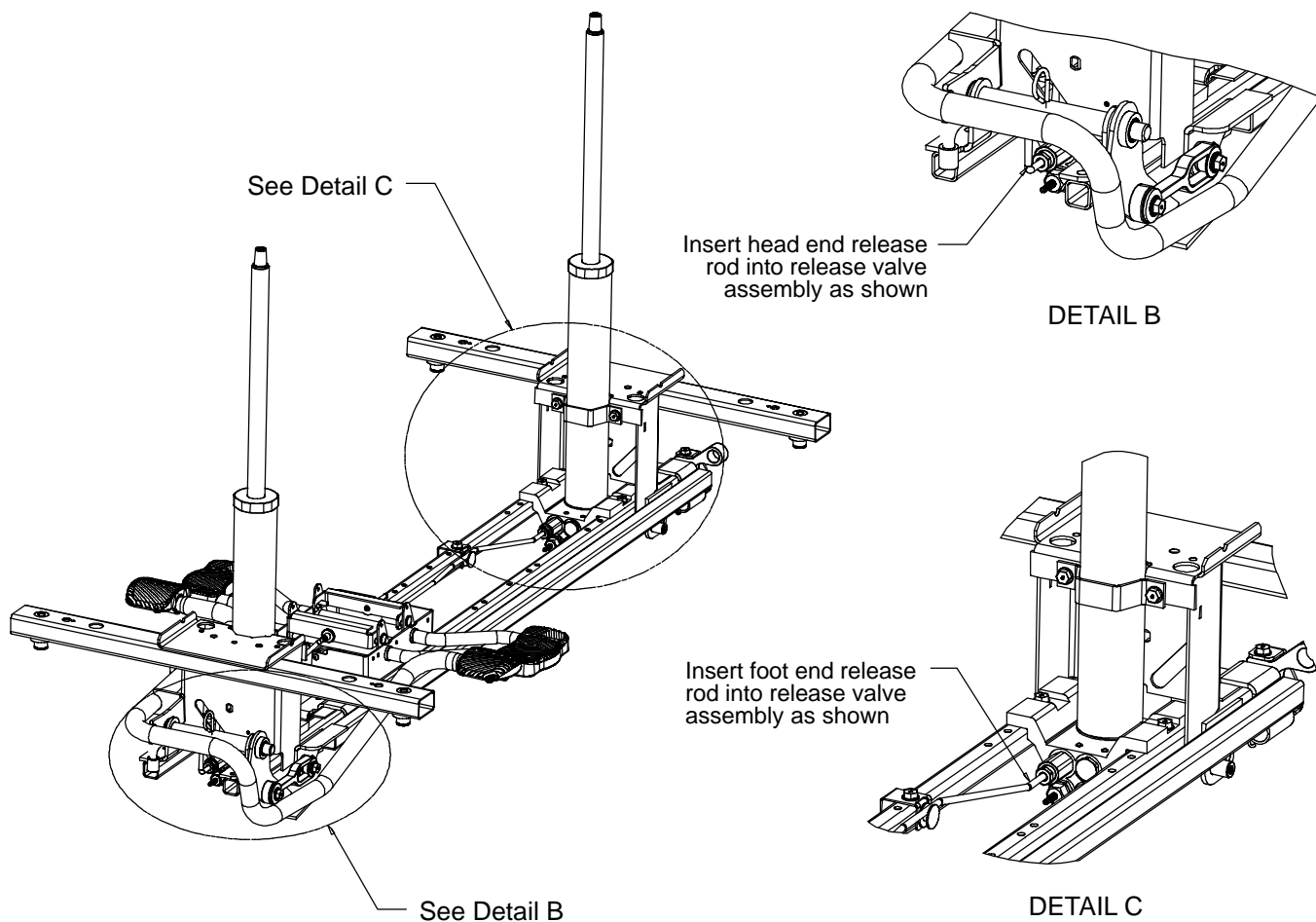

Item	Part No.	Part Name	Qty.
A	0011-023-000	Washer	2
B	0014-071-000	Washer	2
D	0023-288-000	Hex Washer Hd. Screw	7
E	0027-031-000	Hair Pin Cotter	1
F	0038-497-000	Extension Spring	3
G	(page 37)	Release Pedal Assembly	1
H	0753-004-014	Head End Release Rod	1
J	0753-004-015	Foot End Release Rod	1
K	0753-004-032	Release Pedal Swivel	2
L	0753-005-037	Pump Connecting Rod	1
M	0753-005-044	Pump Pedal Bushing	2
N	0753-005-088	Wear Strip	2
P	0753-005-074	Pivot Pin	1
R	0753-005-075	Pump Pedal Link	1
S	(page 38)	Head End Pump Pedal Ass'y	1
T	0753-005-087	Return Spring Hook	1
V	0753-010-015	Release Rod Guide	1
W	0753-010-115	Release Rod Bracket	1
X	0753-005-089	Pump Ram Plug	2

# 0753-004-001 Release Pedal Assembly

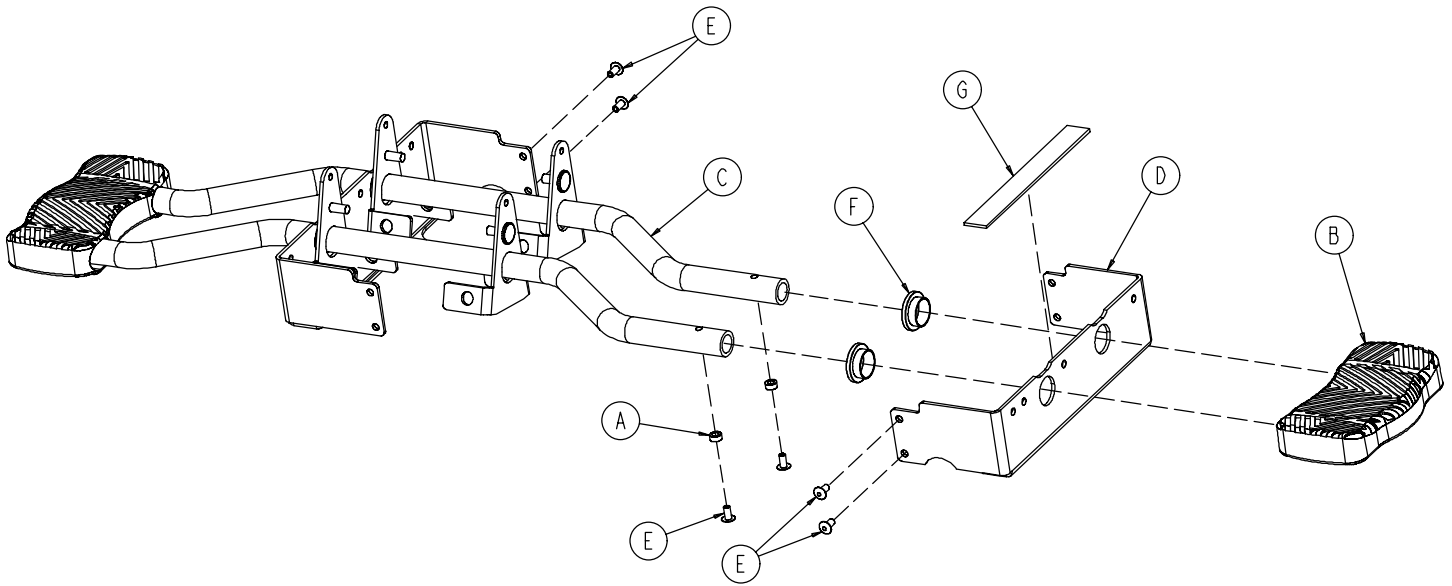

Item	Part No.	Part Name	Qty.
A	0753-004-029	Release Pedal Standoff	4
B	1061-201-127	Short Uni-Pedal	2
C	0753-004-004	Release Pedal Weldment	2
D	0753-004-121	Release Pedal Mtg. Plate	2
E	0025-079-000	Dome Head Rivet	8
F	0753-004-036	Bushing	4
G	0753-004-035	Release Pedal Bumper Strip	2

# 0753-005-185 Head End Pump Pedal Assembly

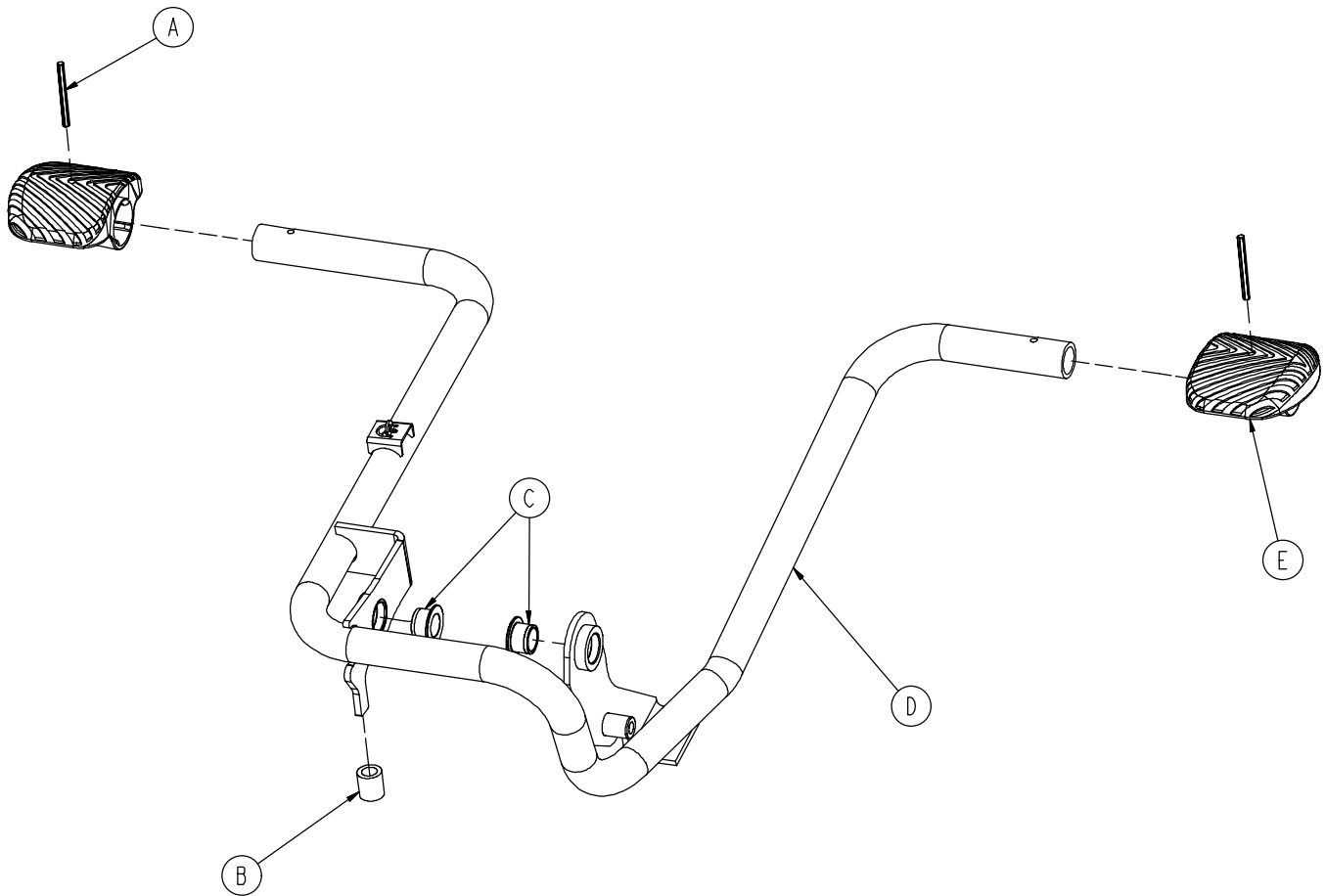

Item	Part No.	Part Name	Qty.
A	0026-343-000	Groove Pin	2
B	0715-001-140	Vinyl Tube	1
C	0753-005-044	Pump Pedal Bushing	2
D	0753-005-180	Head End Pump Pedal Weldment	1
E	0753-201-126	Pump Pedal	2

# Base with 3-Side Hydraulics (Fifth Wheel Base)

Assembly part number 0753-005-110 (reference only)

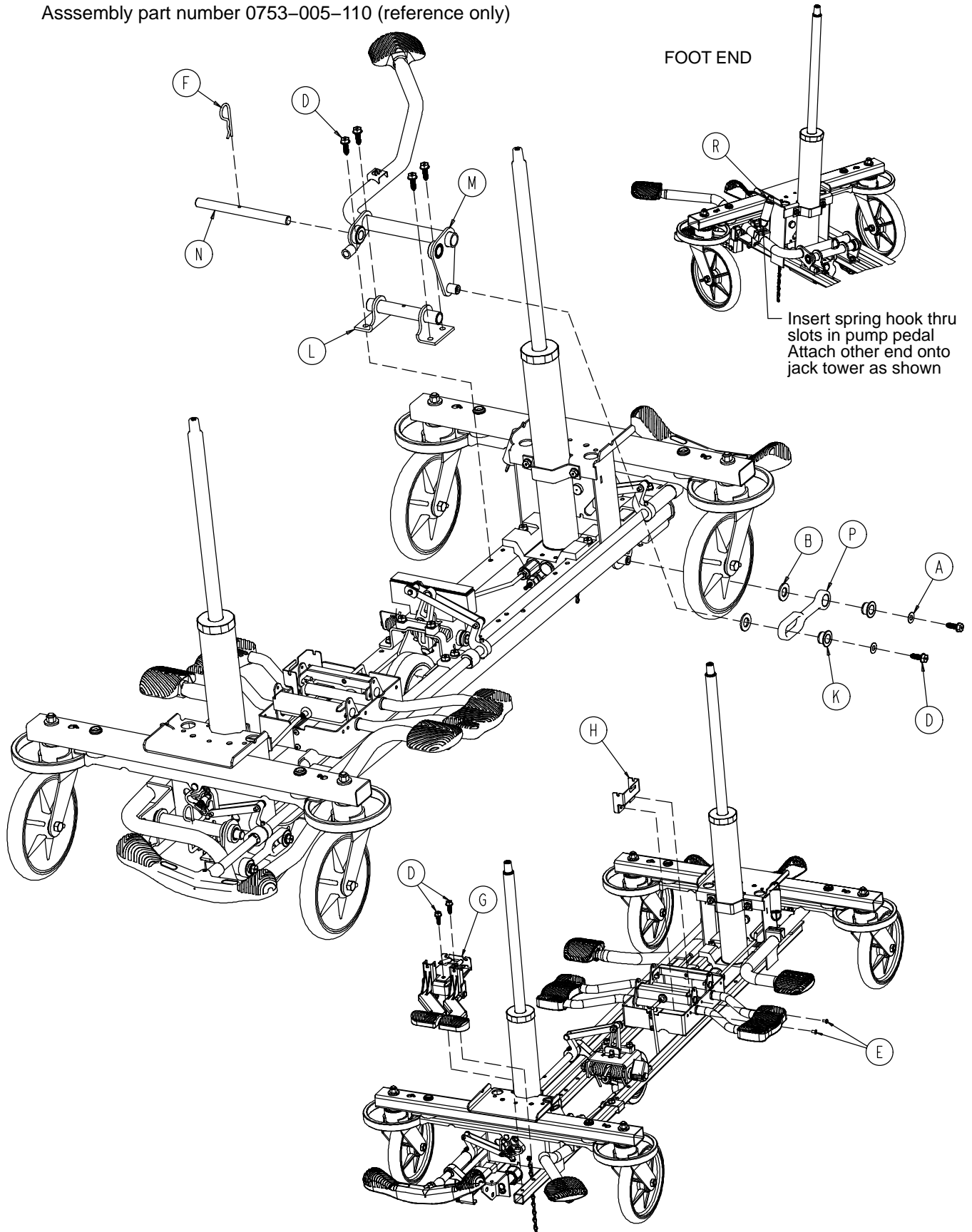



# Base with 3-Side Hydraulics (Fifth Wheel Base)

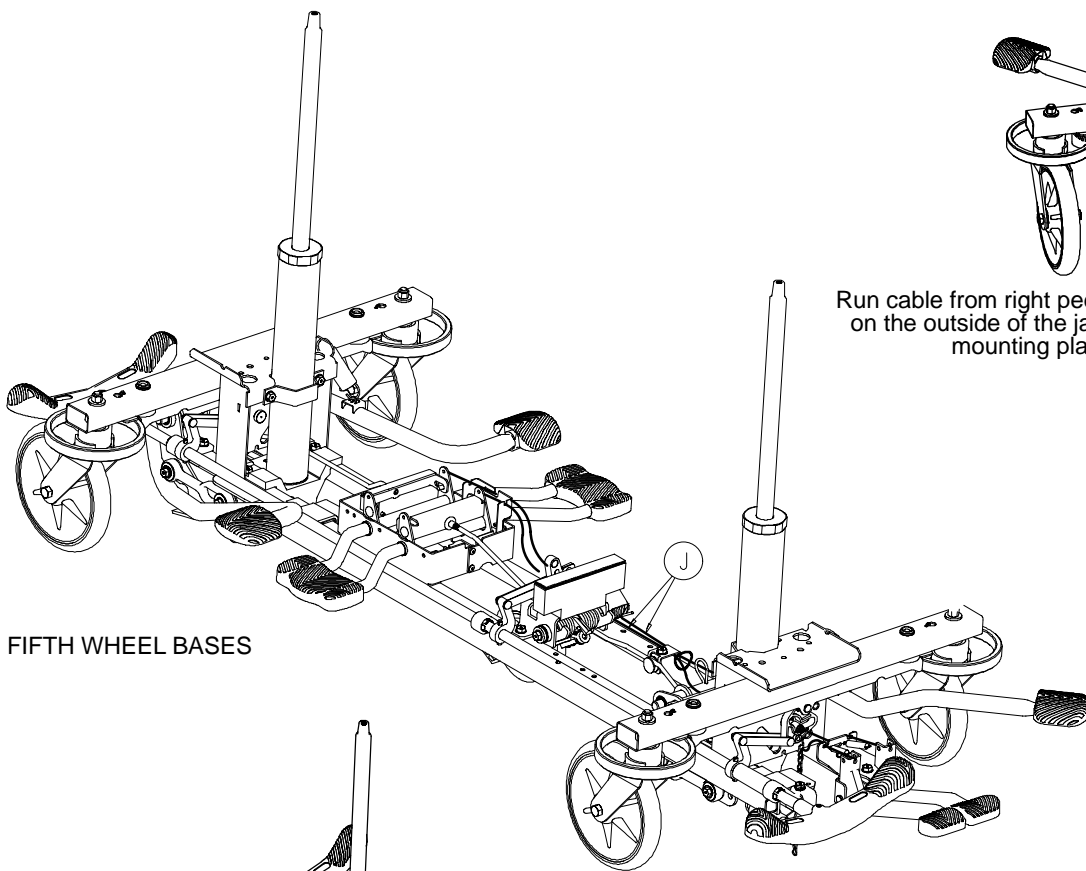

FIFTH WHEEL BASES

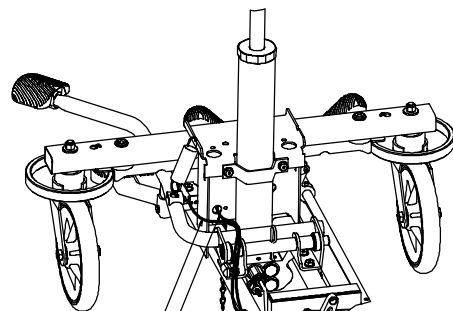

Run cable from right pedal on the outside of the jack mounting plate.

Run cable from left pedal through the hole in the jack mounting plate.

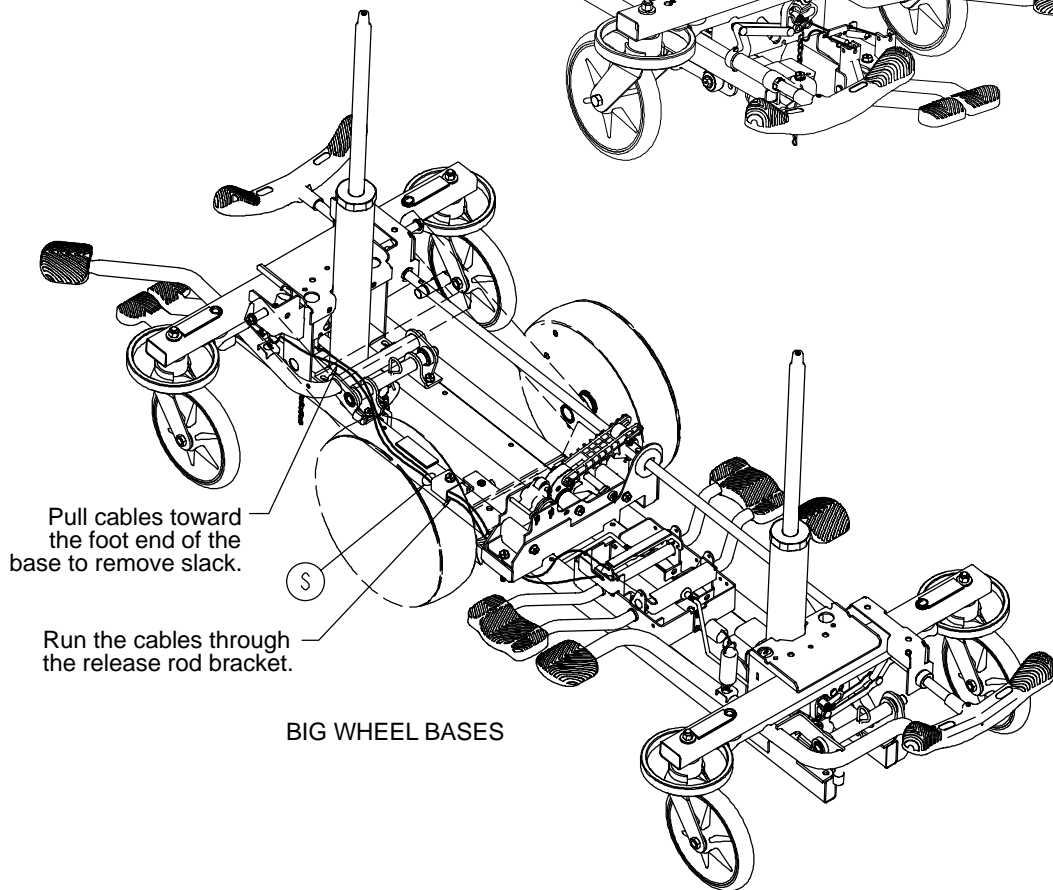

Pull cables toward the foot end of the base to remove slack.

Run the cables through the release rod bracket.

BIG WHEEL BASES

## Base with 3-Side Hydraulics (Fifth Wheel Base)

---

Item	Part No.	Part Name	Qty.
A	0011-023-000	Washer	2
B	0014-071-000	Washer	2
D	0023-288-000	Hex Washer Hd. Screw	8
E	0025-079-000	Rivet	2
F	0027-031-000	Cotter Pin	1
G	<a href="#">(page 42)</a>	Foot End Release Pedal Ass'y	1
H	0753-004-127	Cable Mounting Plate	1
J	0753-004-030	Foot End Release Cable	2
K	0753-005-044	Pump Pedal Bushing	2
L	0753-005-063	Foot End Mtg. Bracket	1
M	<a href="#">(page 43)</a>	Foot End Pedal/Brg. Ass'y	1
N	0753-005-074	Pivot Pin	1
P	0753-005-075	Pump Pedal Link	1
R	0038-497-000	Extension Spring	1
S	8815-029-200	Cable Tie	1

# Foot End Release Pedal Assembly

Assembly part number 0753-004-123 (reference only)

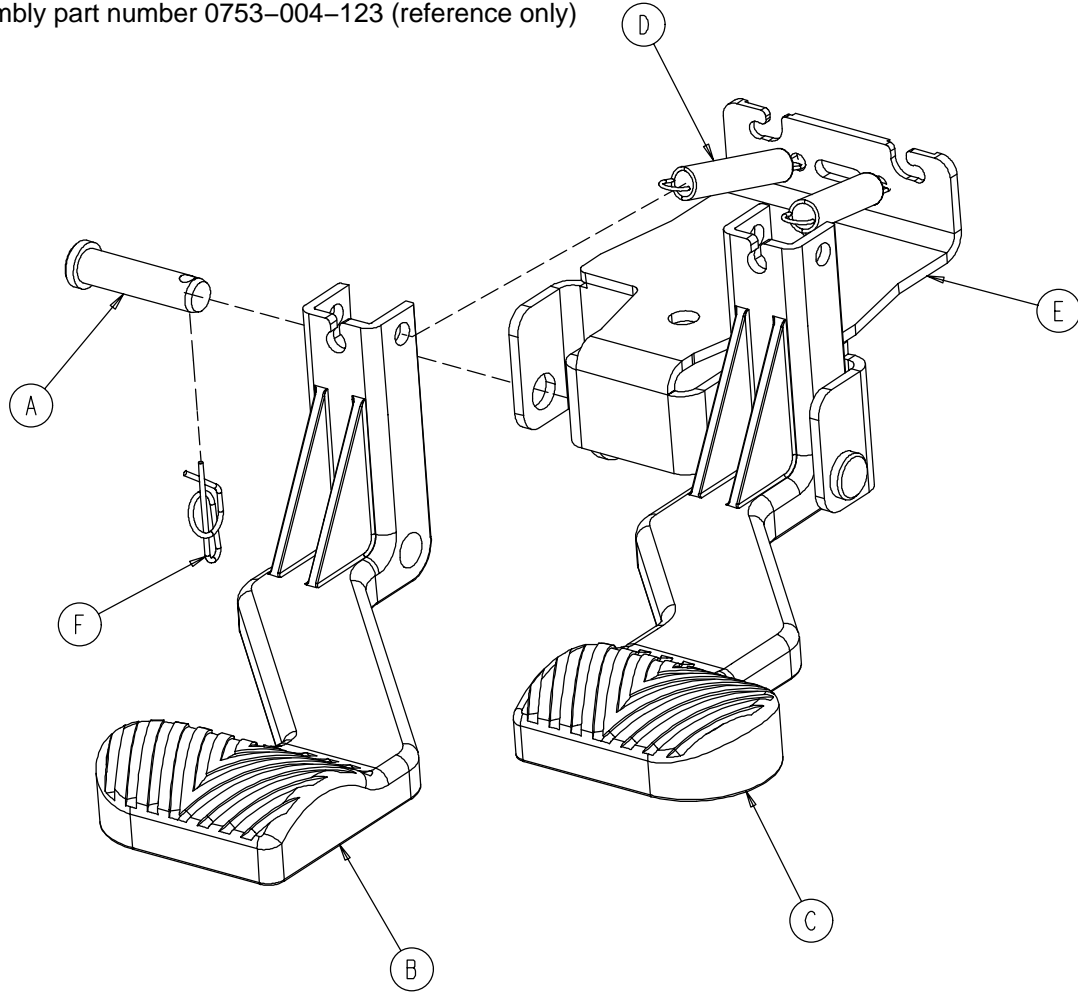

Item	Part No.	Part Name	Qty.
A	0026-132-000	Clevis Pin	2
B	0753-004-024	Release Pedal, Foot End, Left	1
C	0753-004-025	Release Pedal, Foot End, Right	1
D	0753-004-028	Release Pedal Return Spring	2
E	0753-004-322	Release Pedal Mtg. Plate	1
F	0027-022-000	Rue Ring Cotter	2

# 0753-005-173 Foot End Pump Pedal Assembly

---

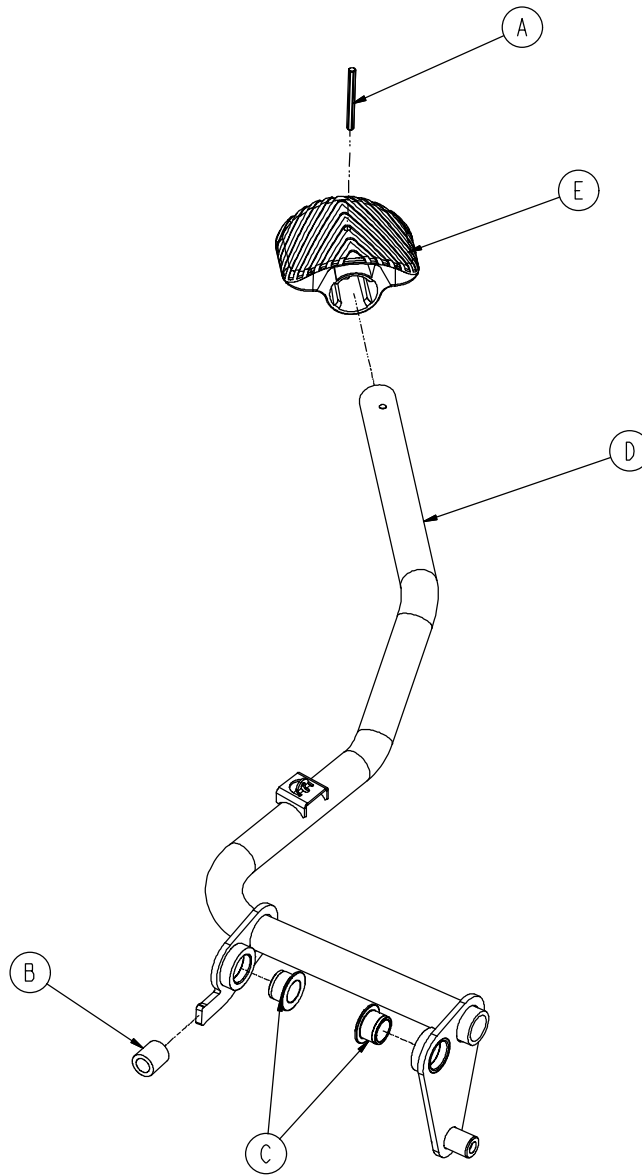

Item	Part No.	Part Name	Qty.
A	0026-343-000	Groove Pin	1
B	0715-001-140	Clear Vinyl Tubing	1
C	0753-005-044	Pump Pedal Bushing	2
D	0753-005-171	Foot End Pedal Weldment	1
E	0715-201-126	Plastic Pump Pedal	1

# Base Labeling Assembly

Assembly part number 0753-010-062 (reference only)

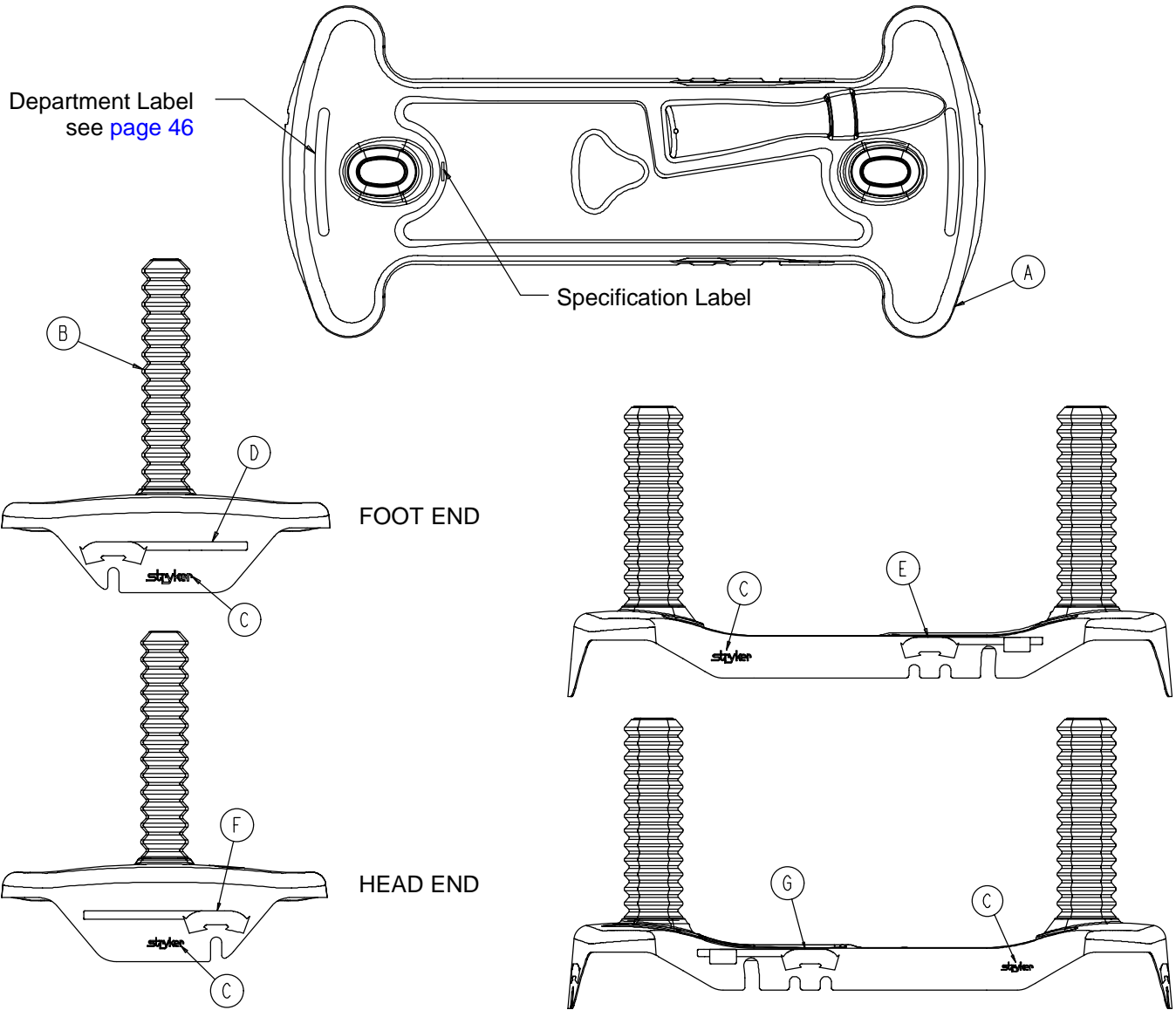

Item	Part No.	Part Name	Qty.
A	0753-010-040	Base Hood	1
B	1040-010-134	Bellows	2
C	0946-201-060	Stryker Logo Label	4

# Base Labeling Assembly, 4-Sided Brakes

Assembly part number 0753-010-063 (reference only)

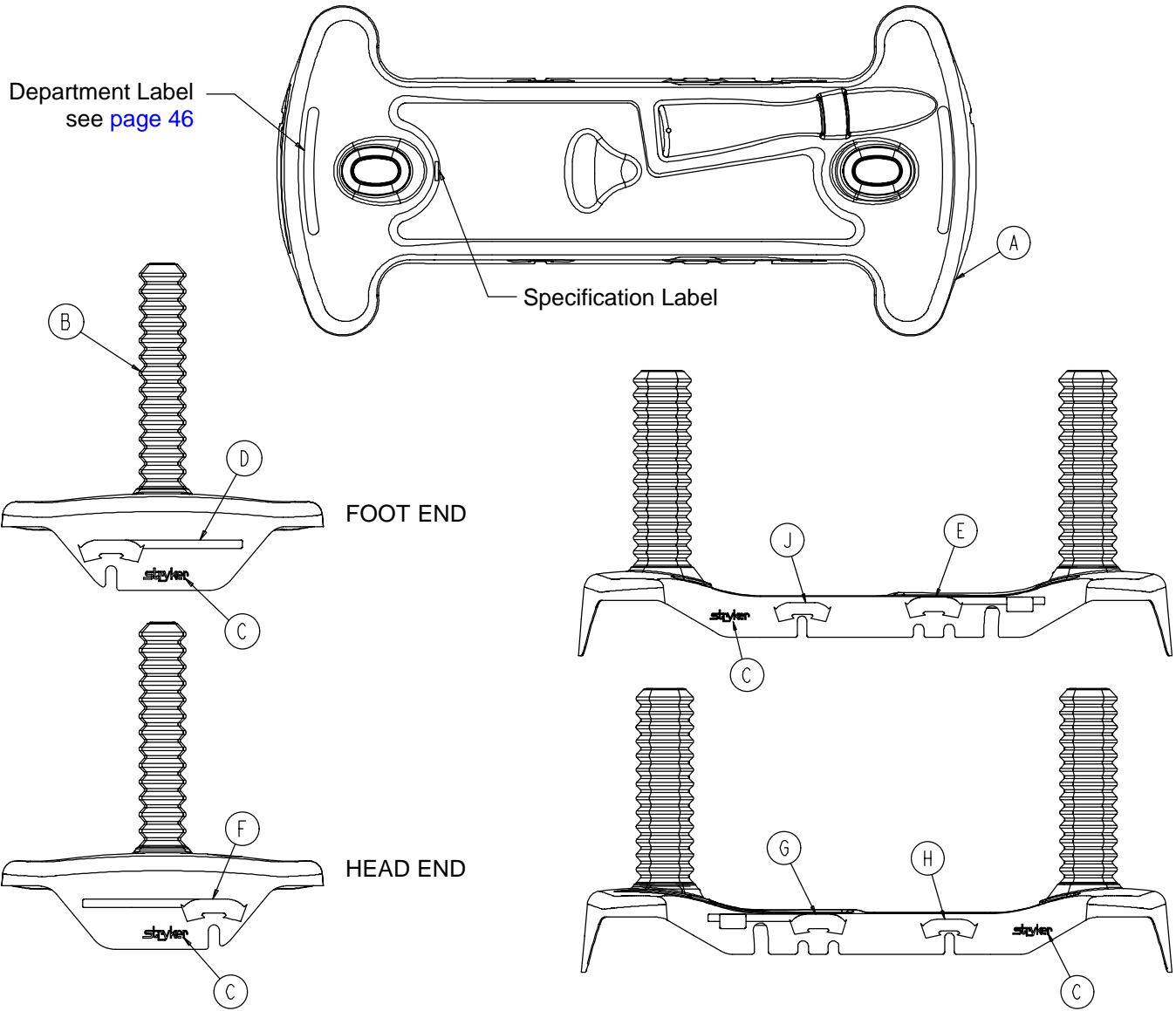

Item	Part No.	Part Name	Qty.
A	0753-010-040	Base Hood	1
B	1040-010-134	Bellows	2
C	0946-201-060	Stryker Logo Label	4
H	0753-010-018	Brake/Steer Label, Right	1
J	0753-010-019	Brake/Steer Label, Left	1

# Base Labeling Assembly

---

<b>Color Set P/N</b>	<b>Item D Brake/Steer, Foot End</b>	<b>Item E Lift/Lower, Left</b>	<b>Item F Brake/Steer, Head End</b>	<b>Item G Lift/Lower, Right</b>	<b>Litter Bumper Strip</b>
RED 0753-010-120	0753-010-051	0753-010-055	0753-010-017	0753-010-054	1010-700-015
PURPLE 0753-010-121	0753-010-151	0753-010-155	0753-010-170	0753-010-154	1010-700-025
GREEN 0753-010-122	0753-010-251	0753-010-255	0753-010-270	0753-010-254	1010-700-035
GRAY 0753-010-123	0753-010-351	0753-010-355	0753-010-370	0753-010-354	1010-700-045
TEAL 0753-010-124	0753-010-451	0753-010-455	0753-010-470	0753-010-454	1010-700-055
PINK 0753-010-125	0753-010-551	0753-010-555	0753-010-570	0753-010-554	1010-700-065
BLUE 0753-010-126	0753-010-651	0753-010-655	0753-010-670	0753-010-654	1010-700-075

## BASE HOOD DEPARTMENT LABELS

<b>Department</b>	<b>Label Part Number</b>
Emergency	1010-900-215
PACU	1010-900-220
Transport	1010-900-225
Surgery	1010-900-230
Extended Stay	1010-900-235
Maternity	1010-900-240
Endoscopy	1010-900-245
Radiology	1010-900-250
Nuclear Medicine	1010-900-255
Ambulatory Surgery	1010-900-260
G.I. Lab	1010-900-265
Cath. Lab	1010-900-270
Same Day Surgery	1010-900-275
Cardio.	1010-900-280
Ultrasound	1010-900-285

### NOTE

All base hood department labels are quantity of two.

# Big Wheel End Control Base Assembly

Assembly part number 1040-015-105 (reference only)

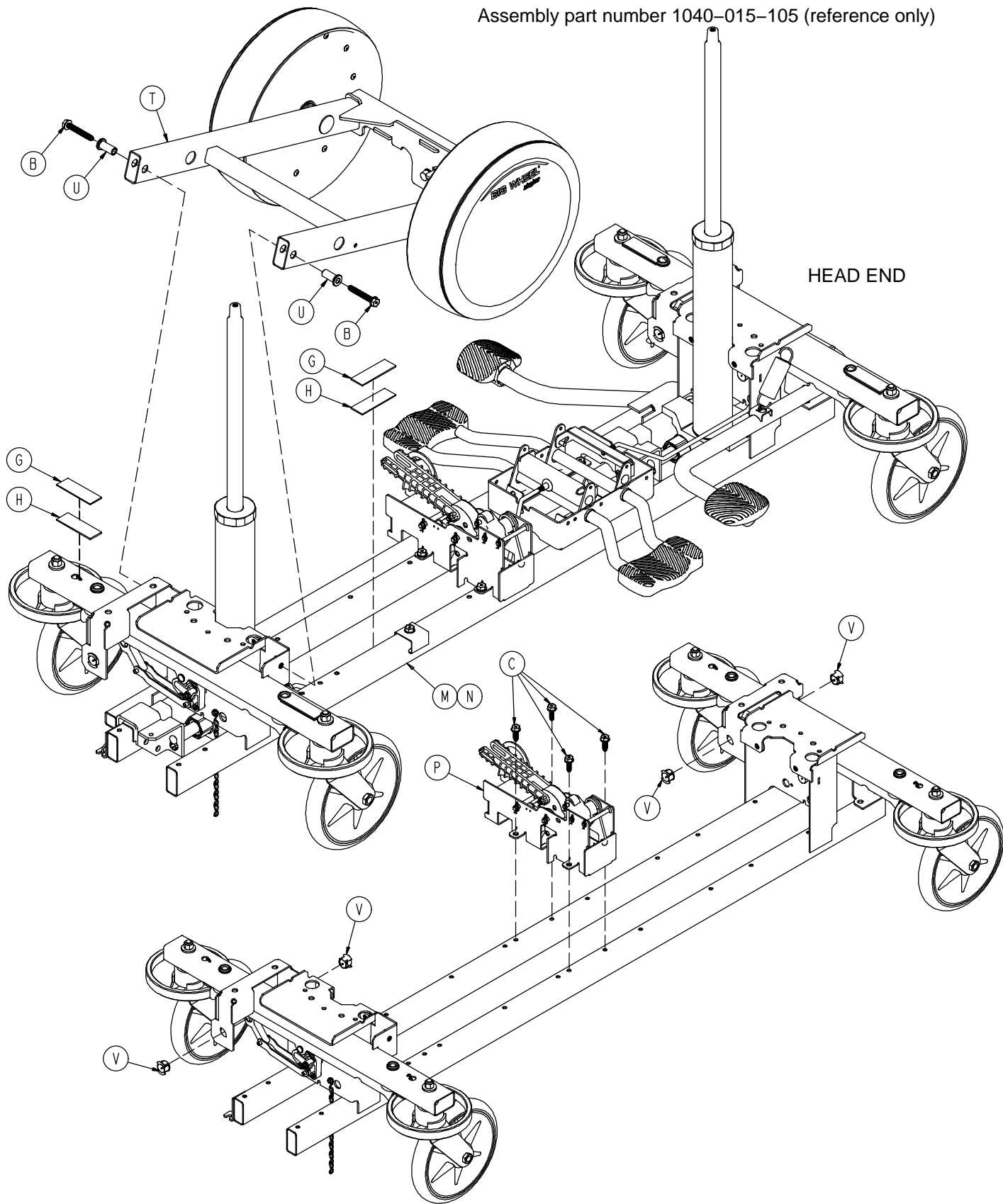



# Big Wheel End Control Base Assembly

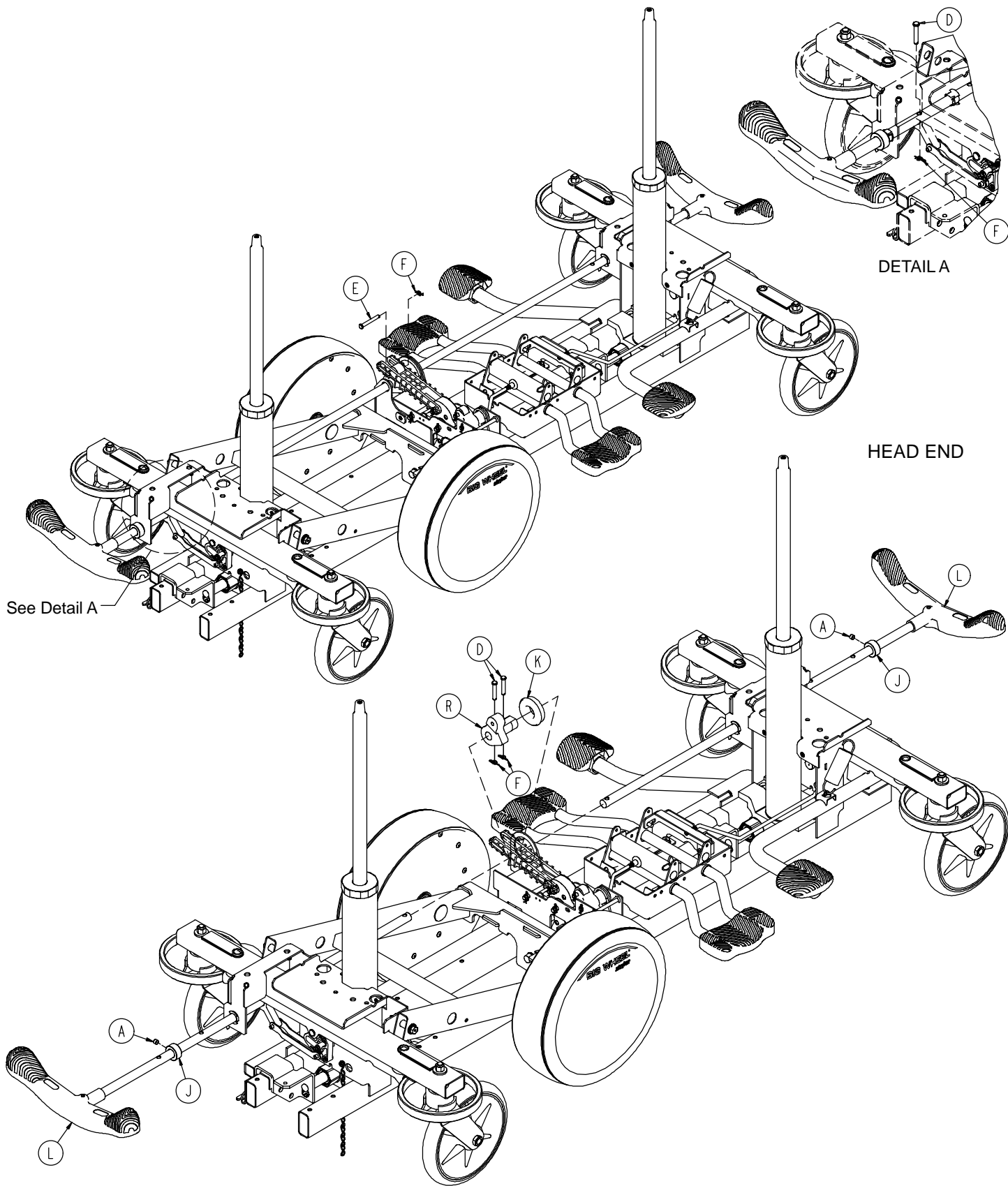

# Big Wheel End Control Base Assembly

---

Item	Part No.	Part Name	Qty.
A	0021-166-000	Set Screw	2
B	0023-150-000	Hex Washer Hd. Screw	2
C	0023-288-000	Hex Washer Hd. Screw	4
D	0026-273-000	Clevis Pin	4
E	0025-330-000	Clevis Pin	1
F	0027-020-000	Rue Ring Cotter	5
G	0029-007-000	Dual Lock	5
H	0029-009-000	Dual Lock	5
J	0042-020-000	Collar	2
K	0081-330-000	Radial Bearing	1
L	<a href="#">(page 53)</a>	Brake Rod Assembly	2
M	<a href="#">(page 50)</a>	Base Assembly w/ Standard Brakes	1
N	<a href="#">(page 54)</a>	Dual Sided Hydraulics	1
P	<a href="#">(page 58)</a>	Cam Bracket Assembly	1
R	1040-006-231	Drive Arm	1
T	<a href="#">(page 60)</a>	Big Wheel Carriage Assembly	1
U	1040-015-007	Carriage Pivot Bushing	2
V	1210-201-251	Insert	4

# Base Assembly w/Standard Brakes (Big Wheel Base)

Assembly part number  
1040-003-205  
(reference only)

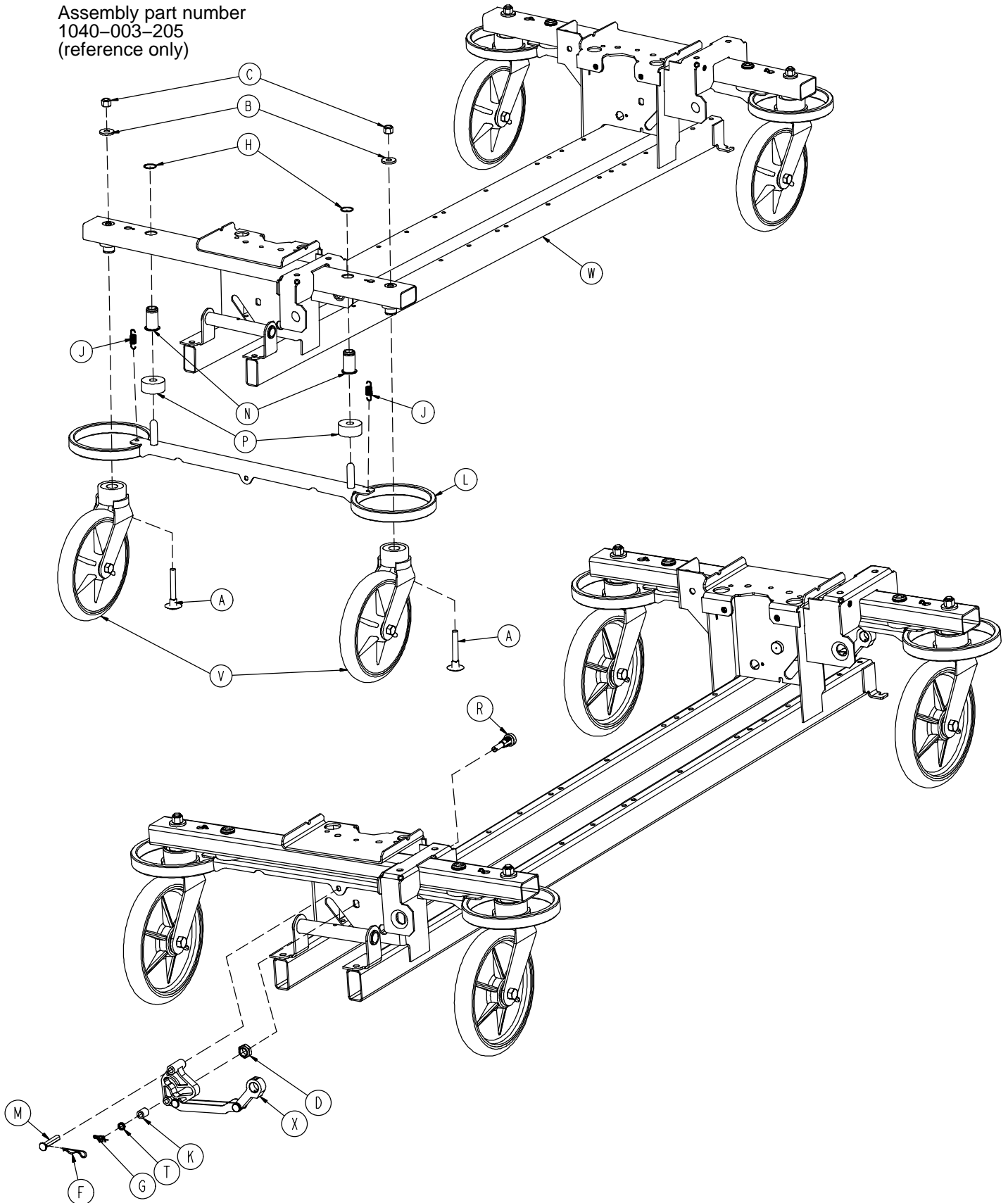

# Base Assembly w/Standard Brakes (Big Wheel Base)

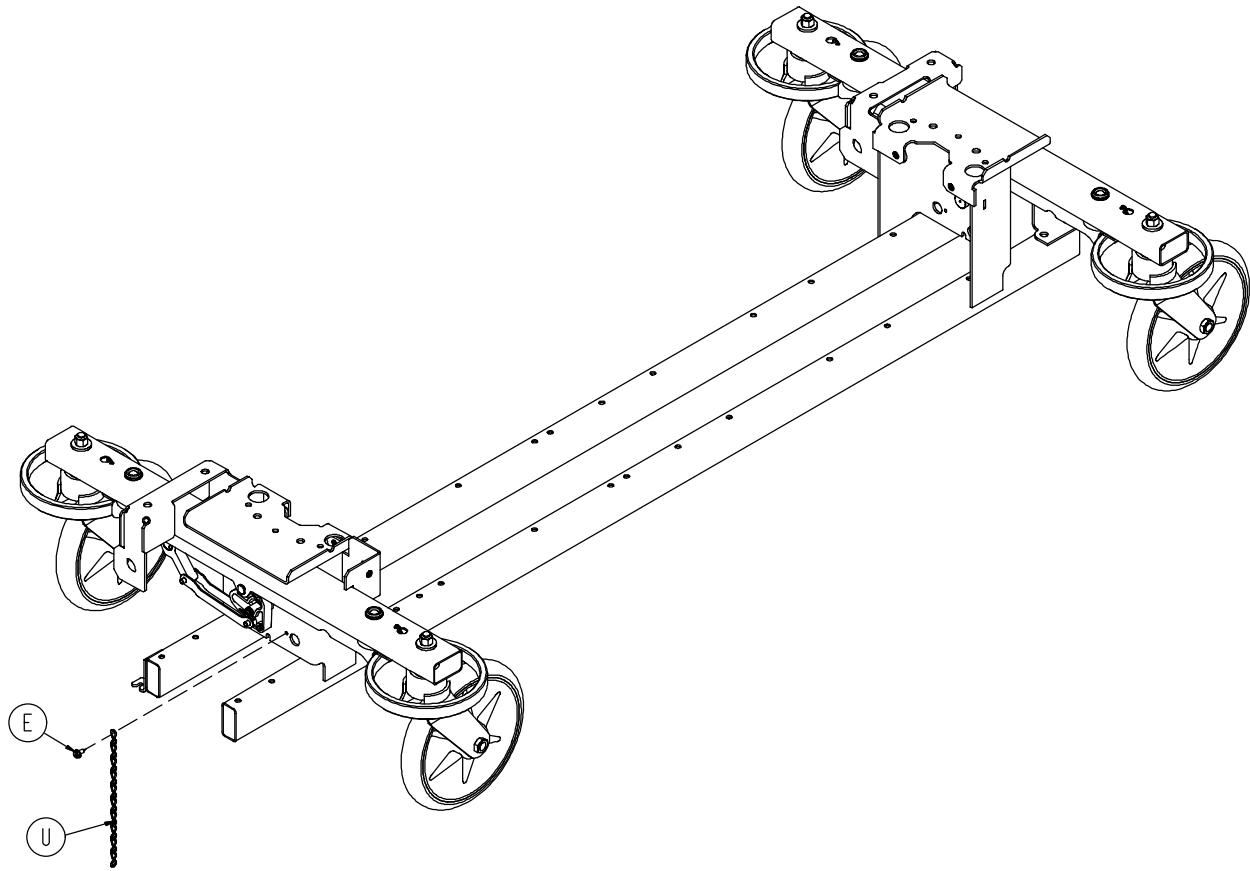

Item	Part No.	Part Name	Qty.
A	0005-039-000	Step Bolt	4
B	0011-262-000	Washer	4
C	0016-035-000	Nylock Hex Nut	4
D	0016-049-000	Nylock Hex Nut	2
E	0023-025-000	Hex Washer Hd. Screw	3
F	0027-012-000	Hitch Pin	2
G	0027-019-000	Rue Ring Cotter Pin	2
H	0028-037-000	External Retaining Ring	4
J	0038-439-000	Extension Spring	4
K	0081-272-000	Roller Bearing	2
L	0753-003-006	Brake Ring	2
M	0753-003-066	Clevis Pin	2
N	0753-003-079	Caster Tube Brake Pin Guide	4
P	0753-003-121	Brake Cushion	4
R	0753-003-130	Bearing Pivot Support	2
T	0753-003-131	Spacer	2
U	0753-010-012	Ground Chain	1
V	<a href="#">(page 29)</a>	Caster Assembly	4
W	1040-001-301	Base Frame	1
X	<a href="#">(page 52)</a>	Drive Link Assembly	2

# 1040-003-185 Drive Link Assembly

---

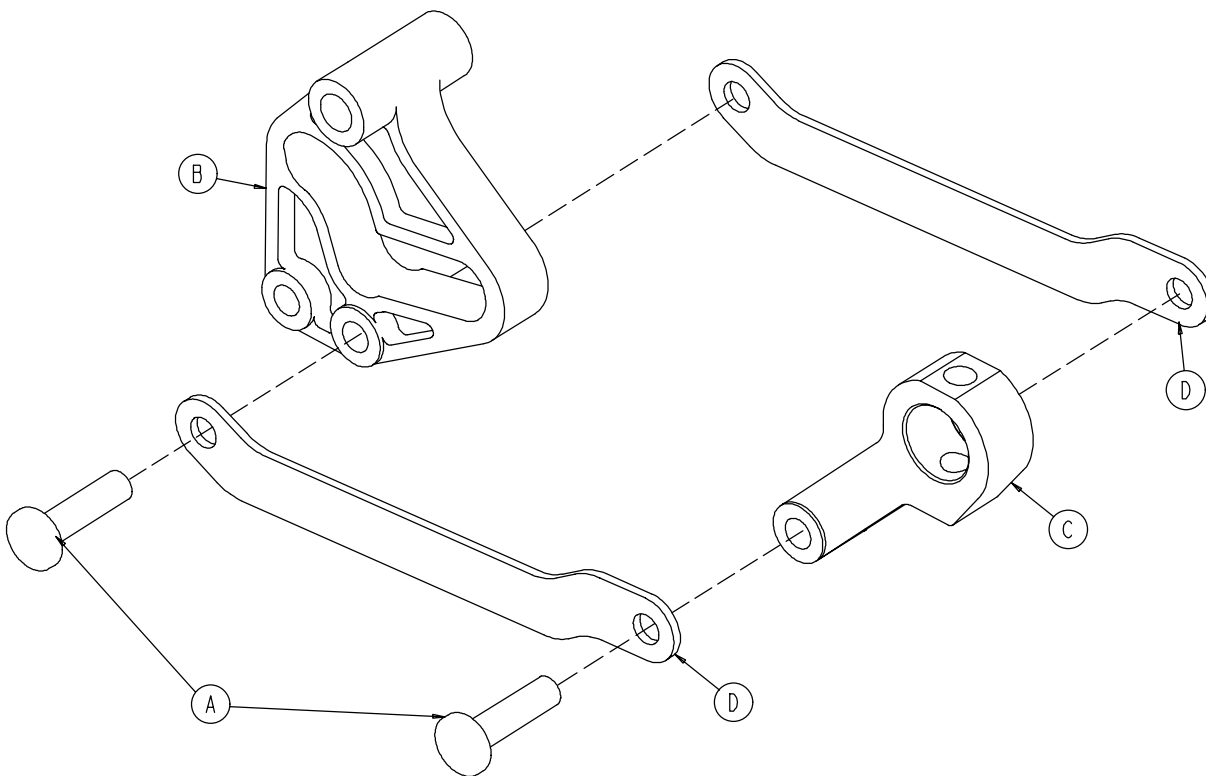

Item	Part No.	Part Name	Qty.
A	0753-003-098	Semi-Tubular Rivet	2
B	0753-003-102	Brake Cam	1
C	1040-003-174	Brake Rod Drive Link	1
D	1040-003-076	Cam Drive Link	2

# 1040-003-191 Brake Rod Assembly (Big Wheel Base)

---

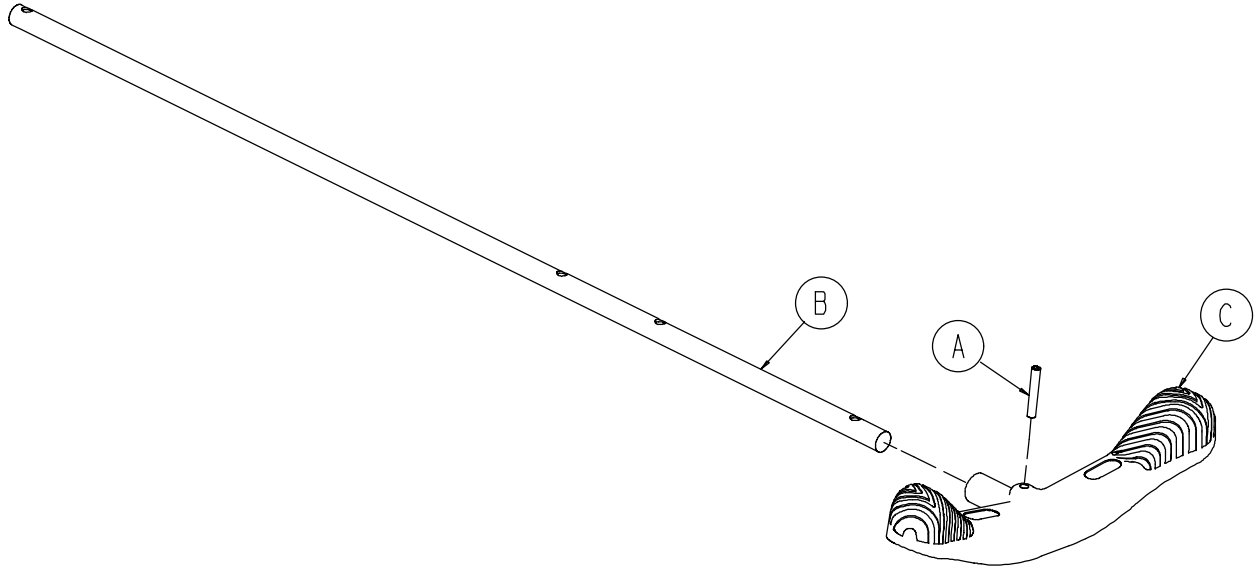

Item	Part No.	Part Name	Qty.
A	0026-067-000	Slotted Spring Pin	1
B	1040-003-113	Brake Rod	1
C	0753-003-099	Butterfly "V" Pedal	1

# Base with Dual Side Hydraulics (Big Wheel Base)

Assembly part number 1040-005-200 (reference only)

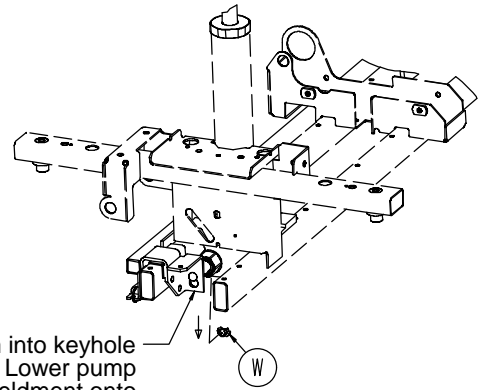

Insert pump ram into keyhole slot on both ends. Lower pump connecting rod weldment onto pump ram as shown. Insert item W to retain pump connecting rod.

0753-002-025 Constant Descent Jacks  
0753-002-080 Variable Descent Jacks

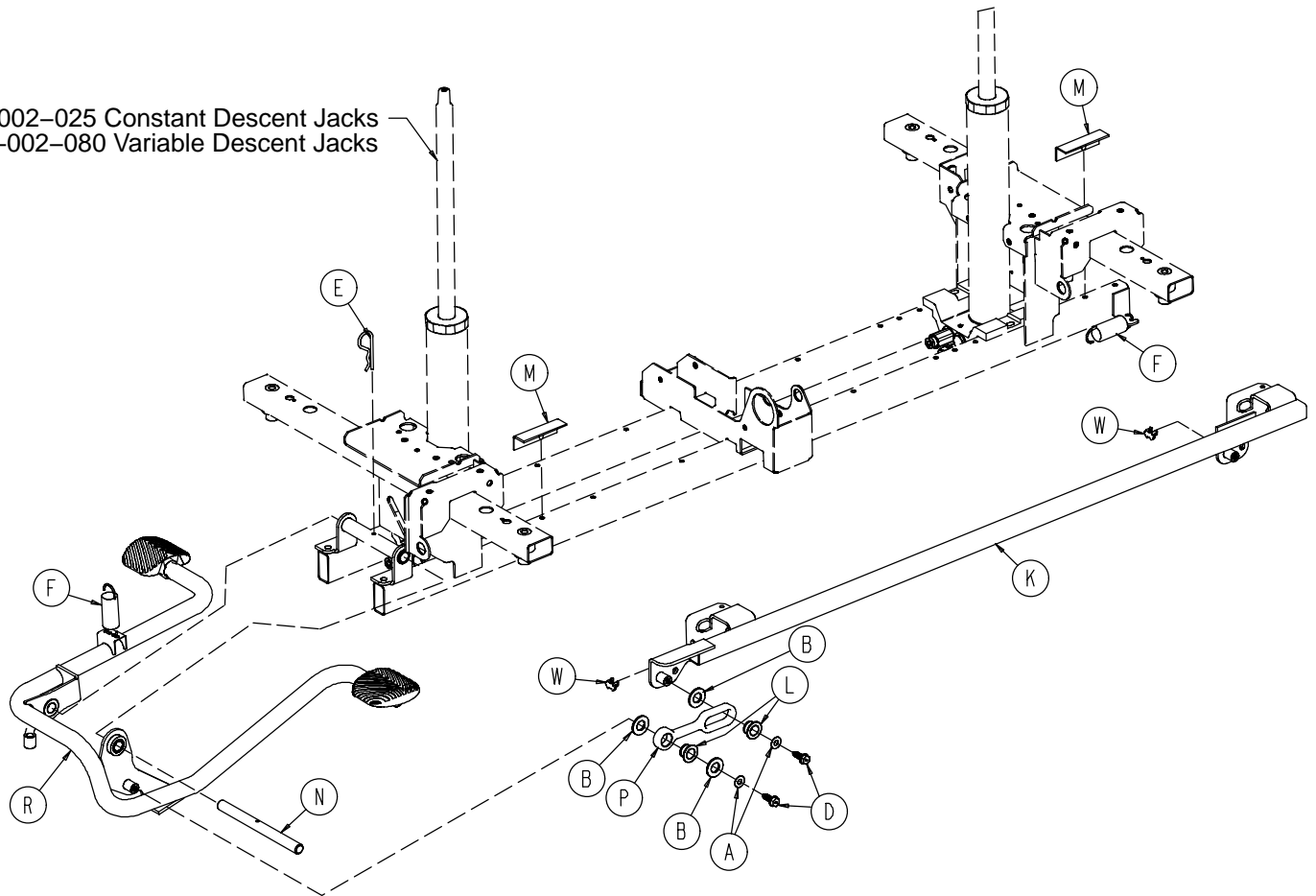

# Base with Dual Side Hydraulics (Big Wheel Base)

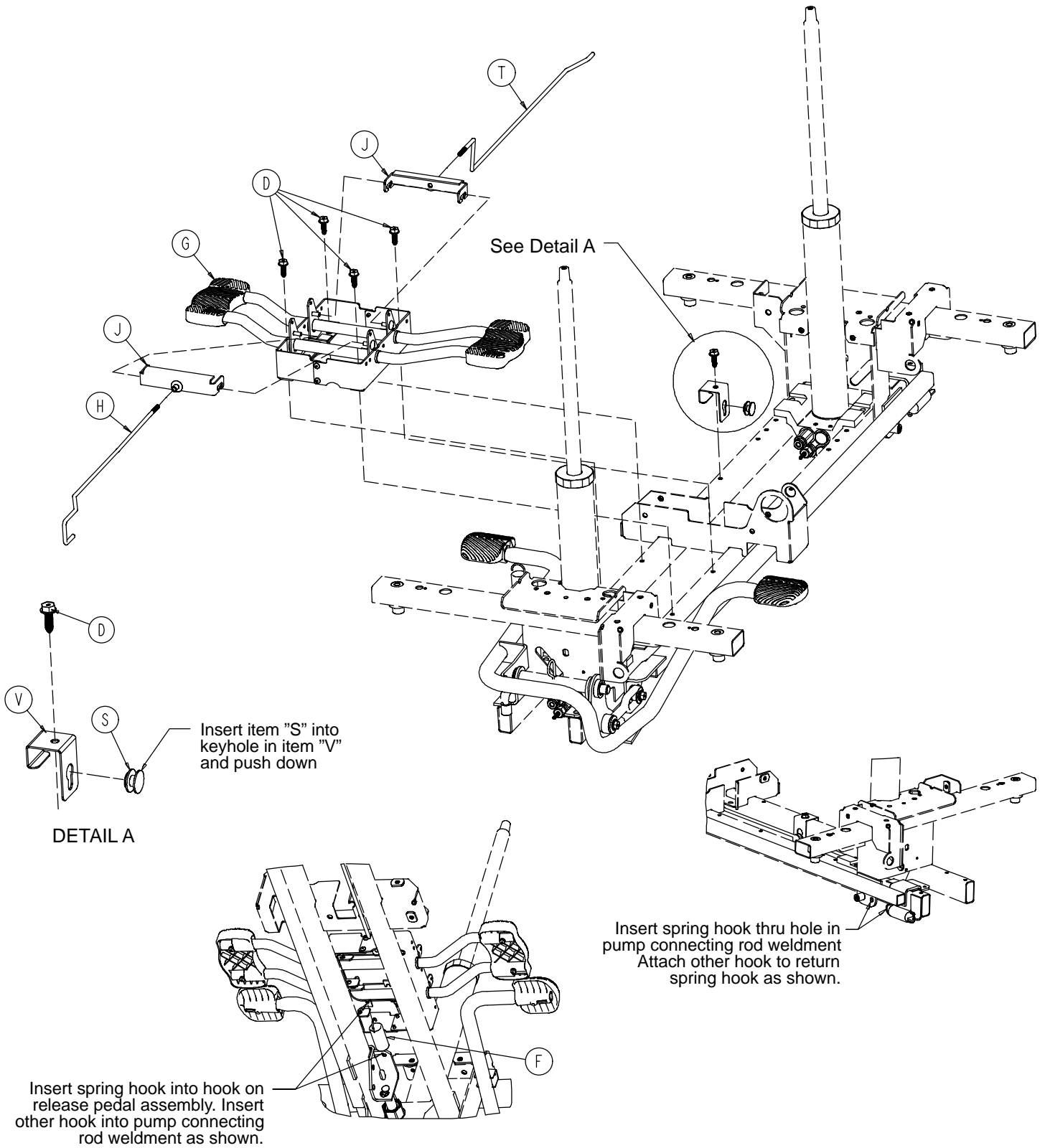



# Base with Dual Side Hydraulics (Big Wheel Base)

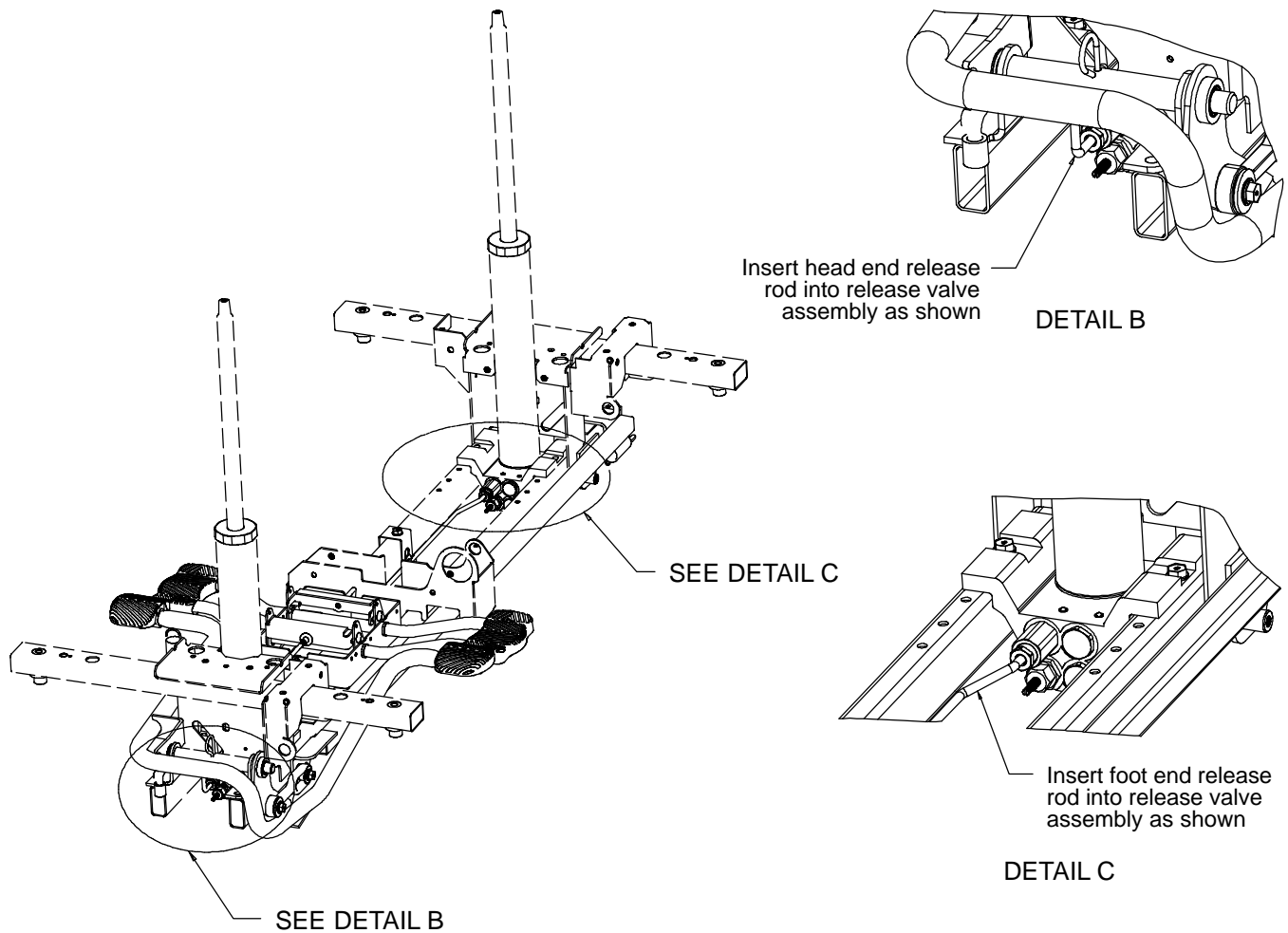

Item	Part No.	Part Name	Qty.
A	0011-023-000	Washer	2
B	0014-071-000	Washer	2
D	0023-288-000	Hex Washer Hd. Screw	7
E	0027-031-000	Hair Pin Cotter	1
F	0038-497-000	Extension Spring	2
G	(page 57)	Release Pedal Assembly	1
H	0753-004-014	Head End Release Rod	1
J	0753-004-032	Release Pedal Swivel	2
K	0753-005-037	Pump Connecting Rod	1
L	0753-005-044	Pump Pedal Bushing	2
M	0753-005-088	Wear Strip	3
N	0753-005-074	Pivot Pin	1
P	0753-005-075	Pump Pedal Link	1
R	(page 38)	Head End Pump Pedal Ass'y	1
S	0753-010-015	Release Rod Guide	1
T	1040-004-015	Foot End Release Rod	1
V	1040-010-115	Release Rod Bracket	1
W	0753-005-089	Pump Ram Plug	2

# 0753-004-001 Release Pedal Assembly

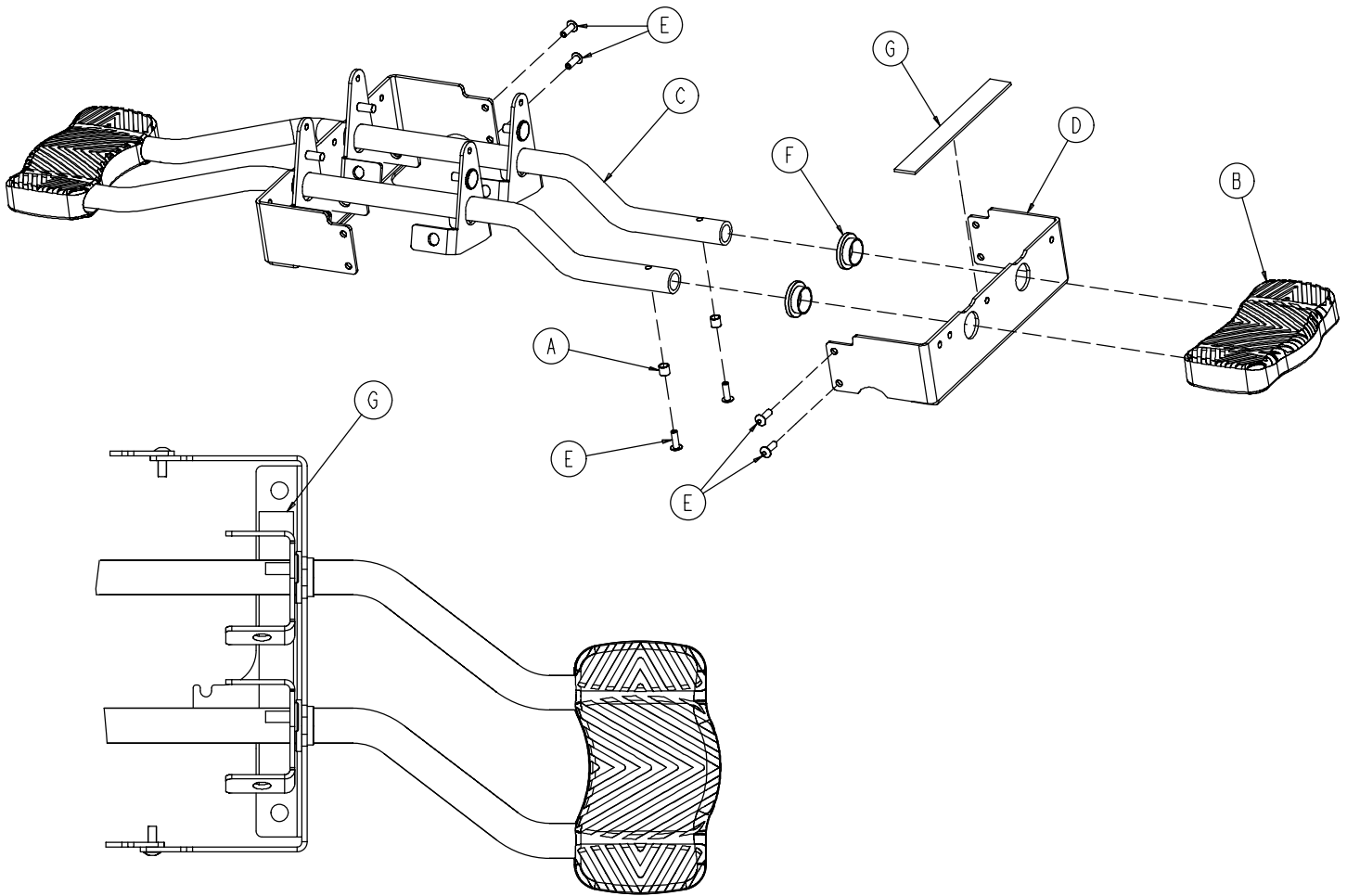

Item	Part No.	Part Name	Qty.
A	0715-001-333	Release Rod Stop Sleeve	4
B	1061-201-127	Short Uni Pedal	2
C	0753-004-004	Release Pedal Weldment	2
D	0753-004-121	Release Pedal Mtg. Plate	2
E	0025-171-000	Blind Rivet	8
F	0753-004-036	Bushing	4
G	0753-004-035	Rel. Pedal Bumper Strip	2

# Cam Bracket Assembly

Assembly part number 1040-006-201 (reference only)

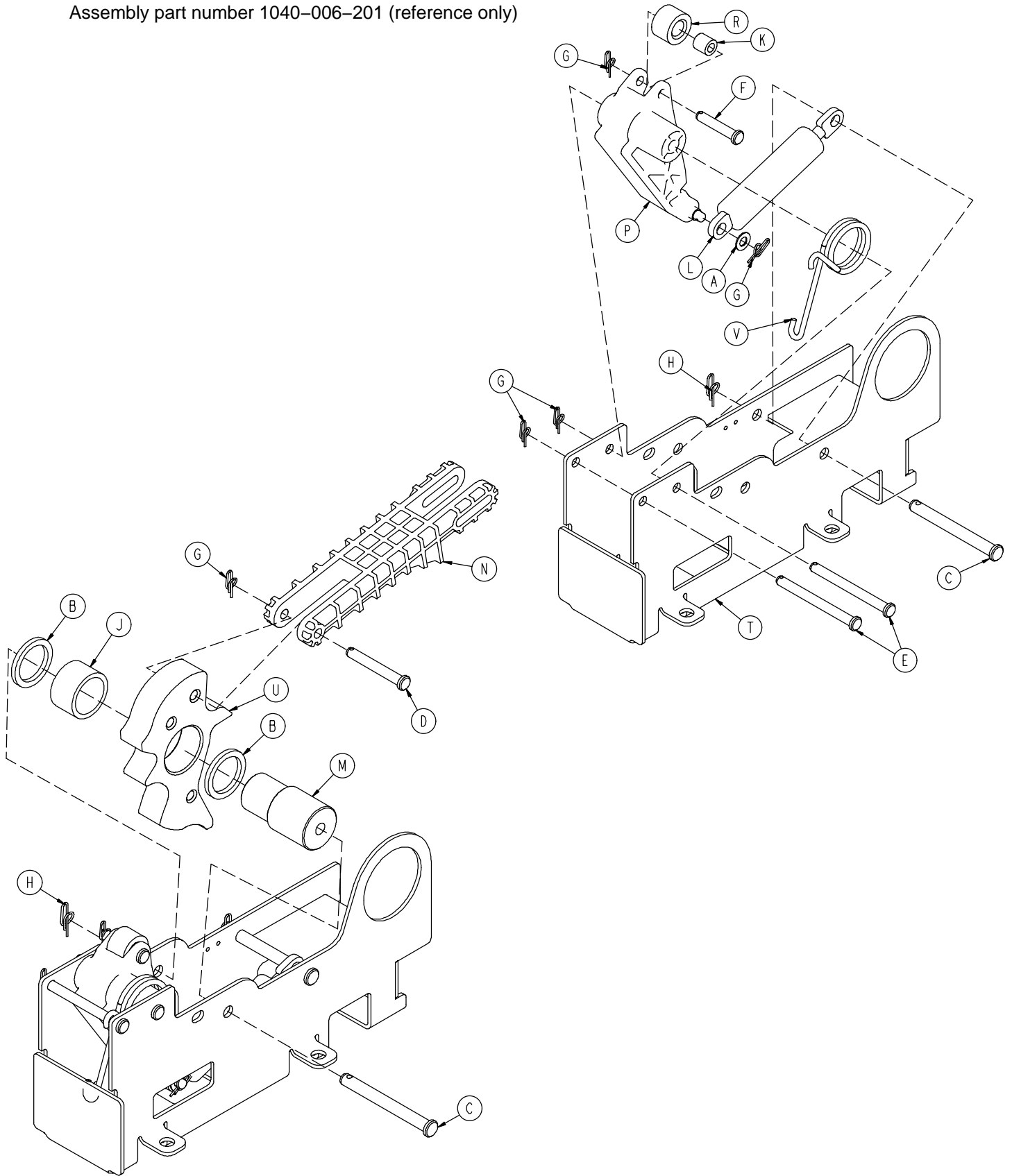

# Cam Bracket Assembly

---

<b>Item</b>	<b>Part No.</b>	<b>Part Name</b>	<b>Qty.</b>
A	0014-004-000	Washer	1
B	0014-063-000	Washer	2
C	0023-262-000	Clevis Pin	2
D	0026-330-000	Clevis Pin	1
E	0026-341-000	Clevis Pin	2
F	0026-349-000	Clevis Pin	1
G	0027-020-000	Rue Ring Cotter	5
H	0027-025-000	Rue Ring Cotter	2
J	0081-400-000	Needle Bearing	1
K	0081-634-000	Needle Bearing	1
L	1040-006-109	Dampener	1
M	1040-006-141	Cam Pivot	1
N	1040-006-144	Drive Link	1
P	1040-006-163	Dampener Arm	1
R	1040-006-171	Dampener Roller	1
T	1040-006-221	Cam Bracket	1
U	1040-006-313	Lift Cam	1
V	1210-001-146	Torsion Spring	1

# Big Wheel Carriage Assembly

Assembly part number 1040-015-101 (reference only)

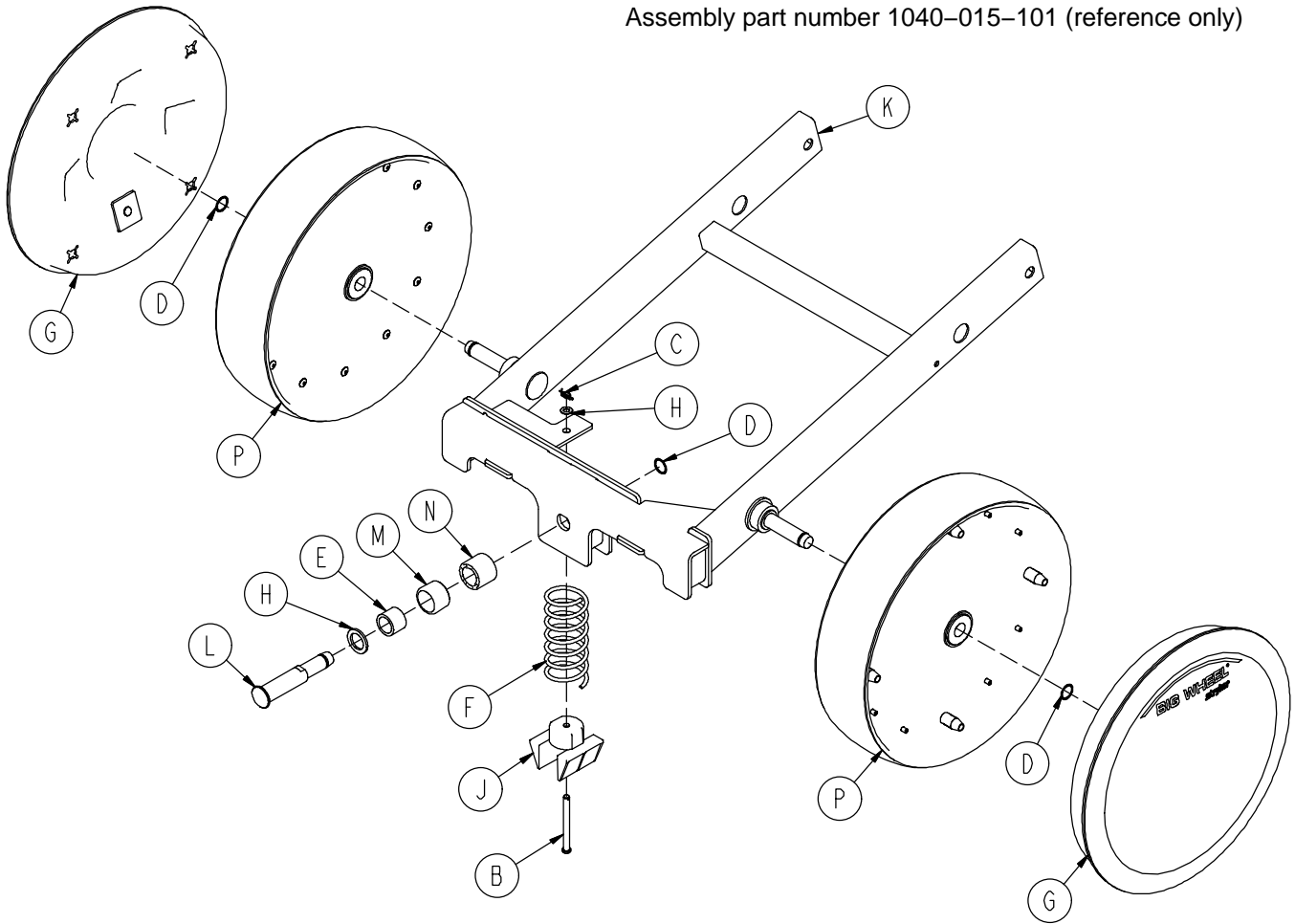

Item	Part No.	Part Name	Qty.
A	0014-004-000	Washer	1
B	0026-341-000	Clevis Pin	1
C	0027-020-000	Rue Ring Cotter	1
D	0028-330-000	Spiral Retaining Ring	3
E	0081-011-000	Needle Bearing	1
F	1040-015-006	Carriage Return Spring	1
G	1040-015-030	Cover w/Counterweight	2
H	1040-015-038	Washer	1
J	1040-015-053	Carriage Spring Retainer	1
K	1040-015-110	Carriage Weldment	1
L	1040-020-122	Cam Follower Pivot Pin	1
M	1040-020-128	Lift Cam Roller	1
N	1040-020-129	Carriage Roller Guide	1
P	1210-301-619	Wheel Assembly	2

# Big Wheel 4-Sided Control Base

Assembly part number 1040-025-105 (reference only)

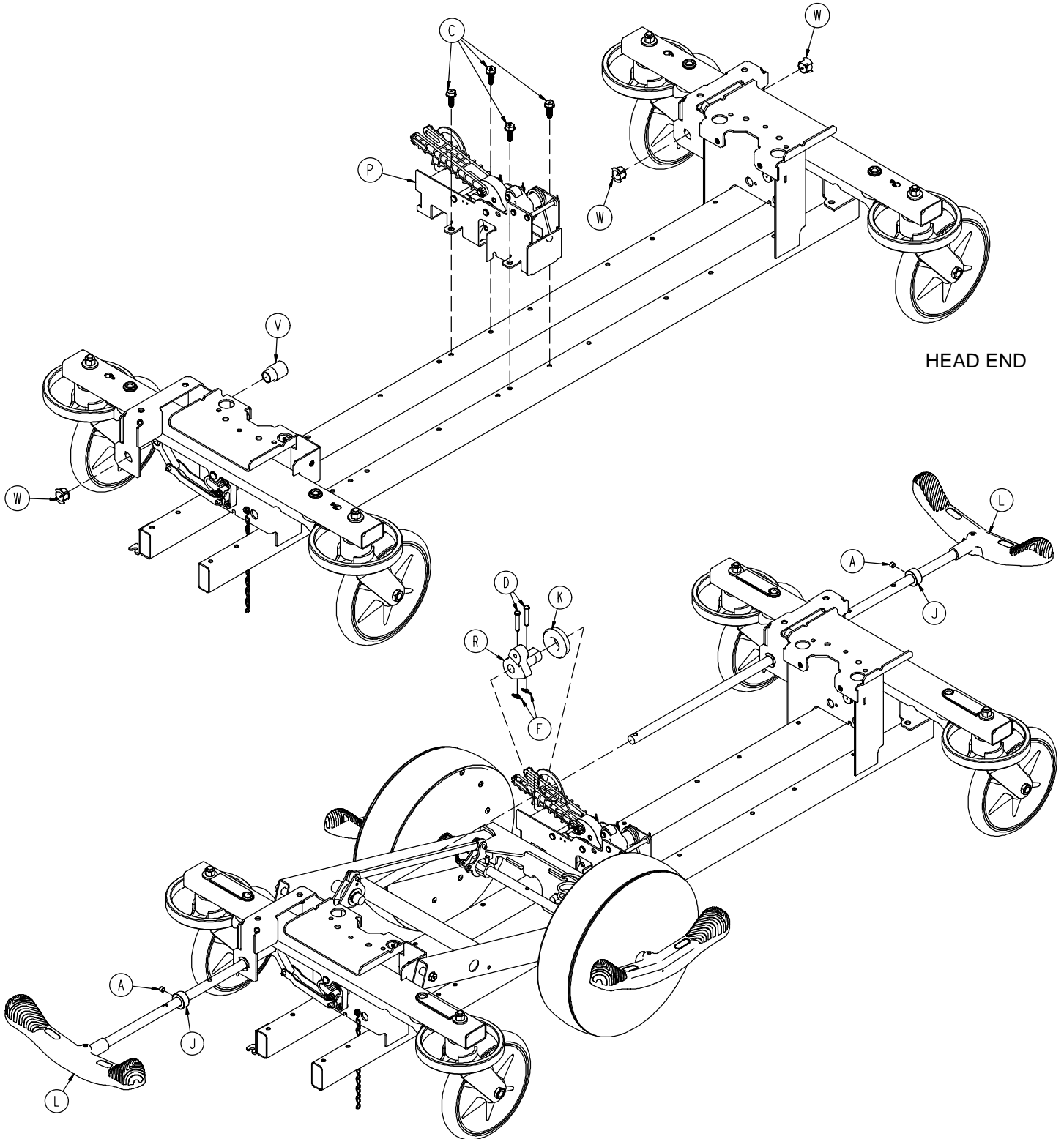

# Big Wheel 4-Sided Control Base

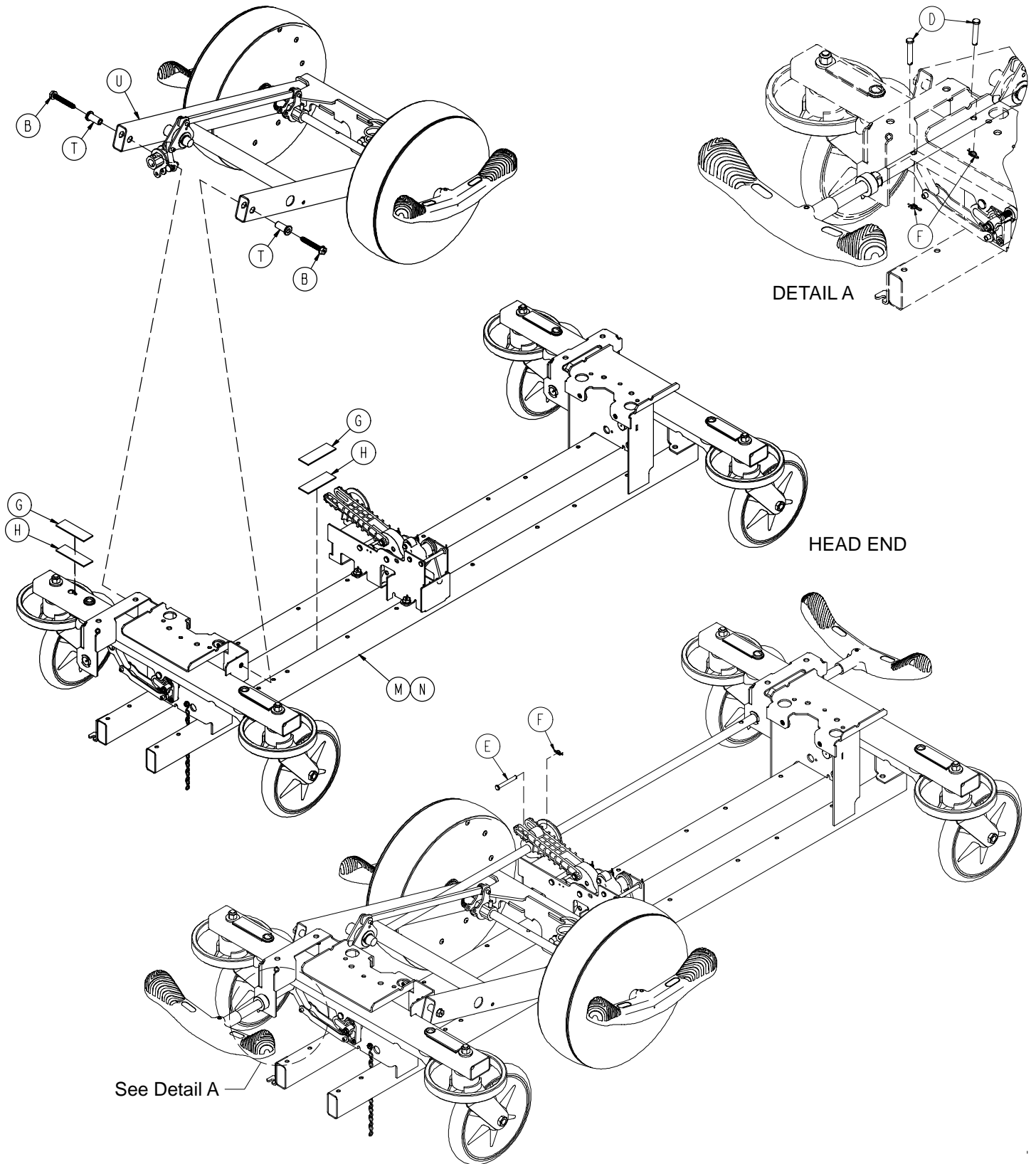

# Big Wheel 4-Sided Control Base

---

Item	Part No.	Part Name	Qty.
A	0021-166-000	Set Screw	2
B	0023-150-000	Hex Washer Hd. Screw	2
C	0023-288-000	Hex Washer Hd. Screw	4
D	0026-273-000	Clevis Pin	5
E	0026-330-000	Clevis Pin	1
F	0027-020-000	Rue Ring Cotter	6
G	0029-007-000	Dual Lock	5
H	0029-009-000	Dual Lock	5
J	0042-020-000	Collar	2
K	0081-330-000	Radial Bearing	1
L	<a href="#">(page 53)</a>	Brake Rod Assembly	2
M	<a href="#">(page 50)</a>	Base Assembly w/ Standard Brakes	1
N	<a href="#">(page 54)</a>	Dual Sided Hydraulics	1
P	<a href="#">(page 58)</a>	Cam Bracket Assembly	1
R	1040-006-231	Drive Arm	1
T	1040-015-007	Carriage Pivot Bushing	2
U	<a href="#">(page 64)</a>	Side Control Big Wheel Carriage Ass'y	1
V	1040-025-026	Brake Rod Bushing	1
W	1210-201-251	Insert	3



# Side Control Big Wheel Carriage Assembly

Assembly part number 1040-025-101 (reference only)

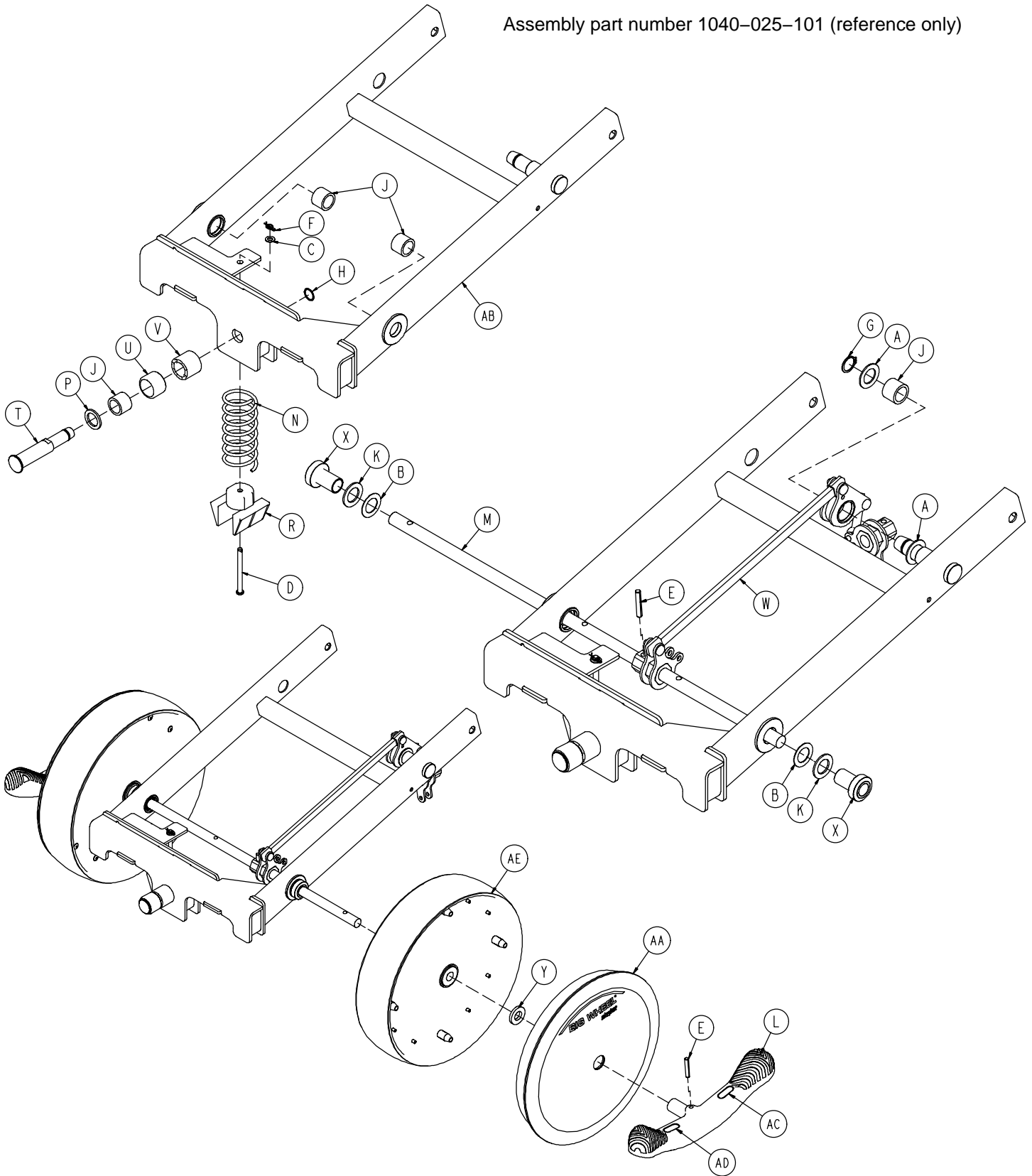

# Side Control Big Wheel Carriage Assembly

---

Item	Part No.	Part Name	Qty.
A	0011-148-000	Washer	2
B	0011-525-000	Washer	2
C	0014-004-000	Washer	1
D	0026-341-000	Clevis Pin	1
E	0026-342-000	Groove Pin	3
F	0027-020-000	Rue Ring Cotter	1
G	0028-166-000	External Retaining Ring	1
H	0028-330-000	External Retaining Ring	1
J	0081-011-000	Needle Bearing	4
K	0081-175-000	Thrust Bearing	2
L	0753-003-099	Butterfly "V" Pedal	2
M	0753-003-119	Side Control Brake Rod	1
N	1040-015-006	Carriage Return Spring	1
P	1040-015-038	Washer	1
R	1040-015-053	Carriage Spring Retainer	1
T	1040-020-122	Cam Follower Pivot Pin	1
U	1040-020-128	Lift Cam Roller	1
V	1040-020-129	Carriage Roller Guide	1
W	<a href="#">(page 66)</a>	Side Control Linkage Ass'y	1
X	1040-025-014	Side Control Wheel Spacer	2
Y	1040-025-017	Side Control Pedal Spacer	2
AA	1040-025-030	Cover w/Counterweight	2
AB	1040-025-110	4-Sided Carriage	1
AC	1210-201-335	Red Brake Label	2
AD	1210-201-336	Green Steer Label	2
AE	1210-301-619	Wheel Assembly	2

# 1040-025-010 Side Control Big Wheel Linkage Ass'y

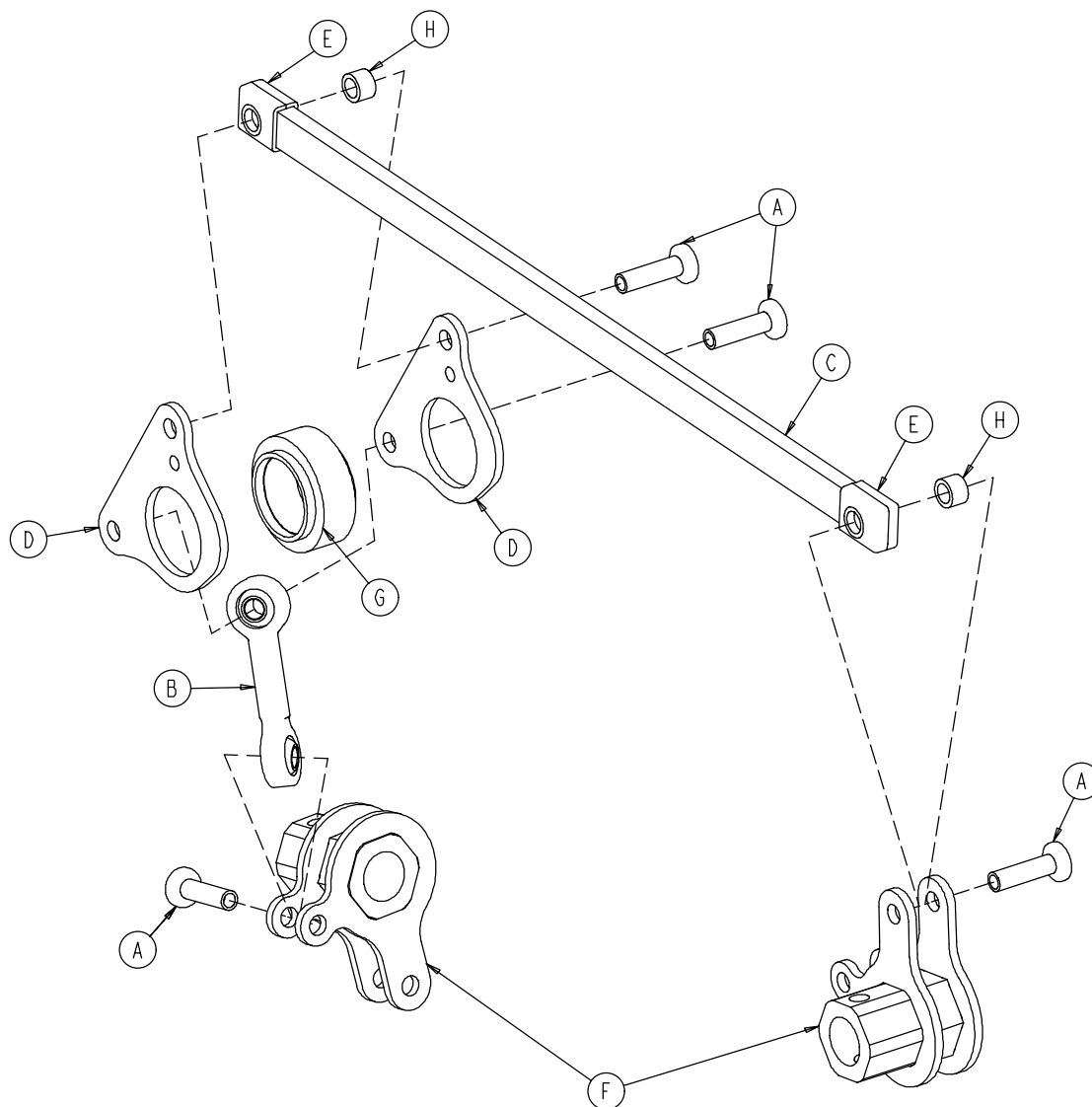

Item	Part No.	Part Name	Qty.
A	0753-003-098	Flat Hd. Semi-Tubular Rivet	4
B	0753-003-117	Rod End Link	1
C	1040-025-011	Main Link	1
D	1040-025-013	Toggle Pivot Plate	2
E	1040-025-016	Main Link Cover	2
F	1040-025-020	Yoke Weldment	2
G	1040-025-018	Toggle Pivot Spacer	1
H	1040-025-027	Link Spacer	2

# Base Labeling Assembly – Big Wheel Base

Assembly part number 1040-015-400 (reference only)

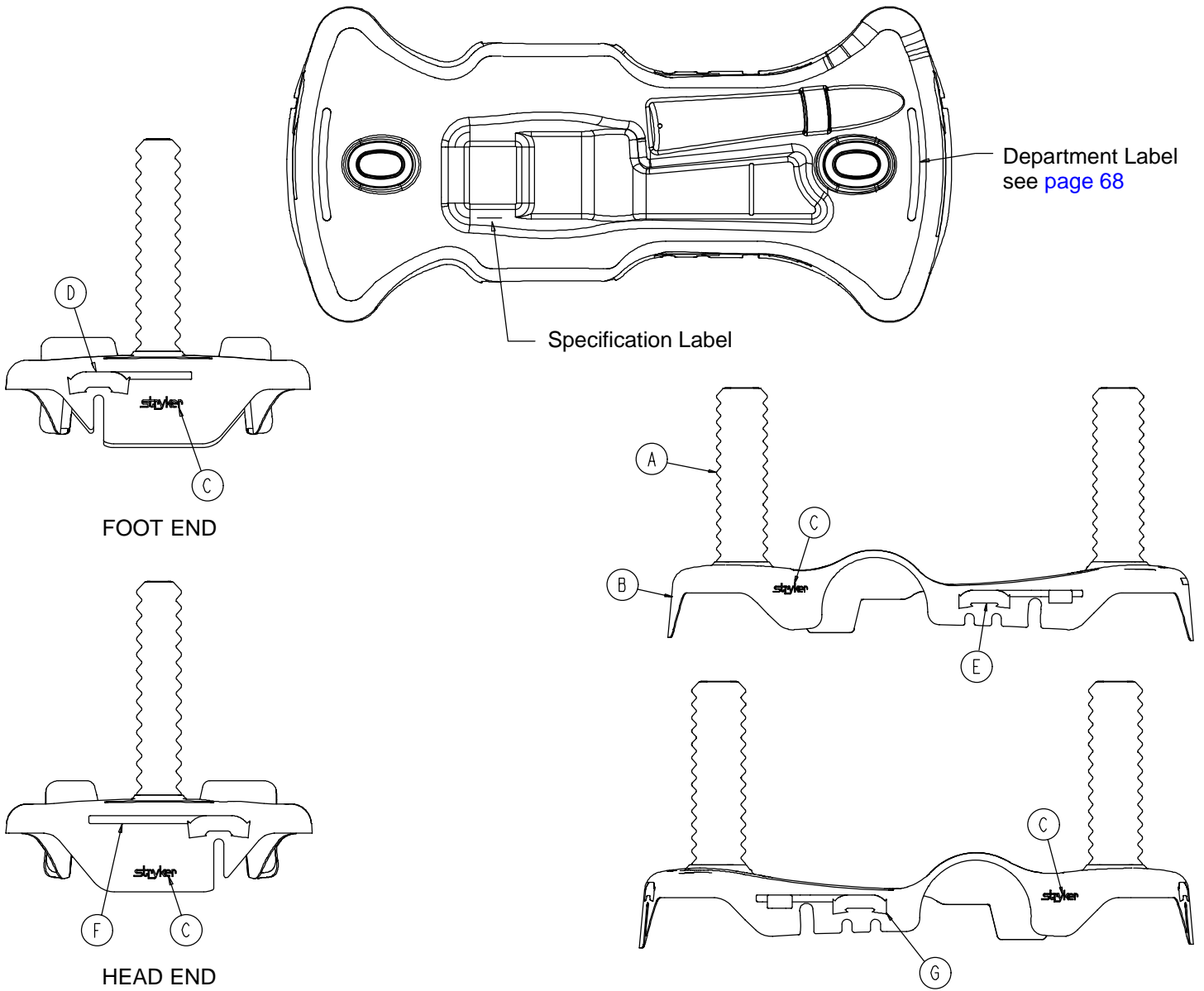

Item	Part No.	Part Name	Qty.
A	1040-010-134	Bellows	2
B	1040-015-404	Base Hood	1
C	0946-201-060	Stryker Logo Label	4

# Base Labeling Assembly

---

<b>Color Set P/N</b>	<b>Item D Brake/Steer, Foot End</b>	<b>Item E Lift/Lower, Left</b>	<b>Item F Brake/Steer, Head End</b>	<b>Item G Lift/Lower, Right</b>	<b>Litter Bumper Strip</b>
RED 0753-010-120	0753-010-051	0753-010-055	0753-010-017	0753-010-054	1010-700-015
PURPLE 0753-010-121	0753-010-151	0753-010-155	0753-010-170	0753-010-154	1010-700-025
GREEN 0753-010-122	0753-010-251	0753-010-255	0753-010-270	0753-010-254	1010-700-035
GRAY 0753-010-123	0753-010-351	0753-010-355	0753-010-370	0753-010-354	1010-700-045
TEAL 0753-010-124	0753-010-451	0753-010-455	0753-010-470	0753-010-454	1010-700-055
PINK 0753-010-125	0753-010-551	0753-010-555	0753-010-570	0753-010-554	1010-700-065
BLUE 0753-010-126	0753-010-651	0753-010-655	0753-010-670	0753-010-654	1010-700-075

## BASE HOOD DEPARTMENT LABELS

<b>Department</b>	<b>Label Part Number</b>
Emergency	1010-900-215
PACU	1010-900-220
Transport	1010-900-225
Surgery	1010-900-230
Extended Stay	1010-900-235
Maternity	1010-900-240
Endoscopy	1010-900-245
Radiology	1010-900-250
Nuclear Medicine	1010-900-255
Ambulatory Surgery	1010-900-260
G.I. Lab	1010-900-265
Cath. Lab	1010-900-270
Same Day Surgery	1010-900-275
Cardio.	1010-900-280
Ultrasound	1010-900-285

### NOTE

All base hood department labels are quantity of two.

# 0753-002-080 Variable Descent Hydraulic Jack Option

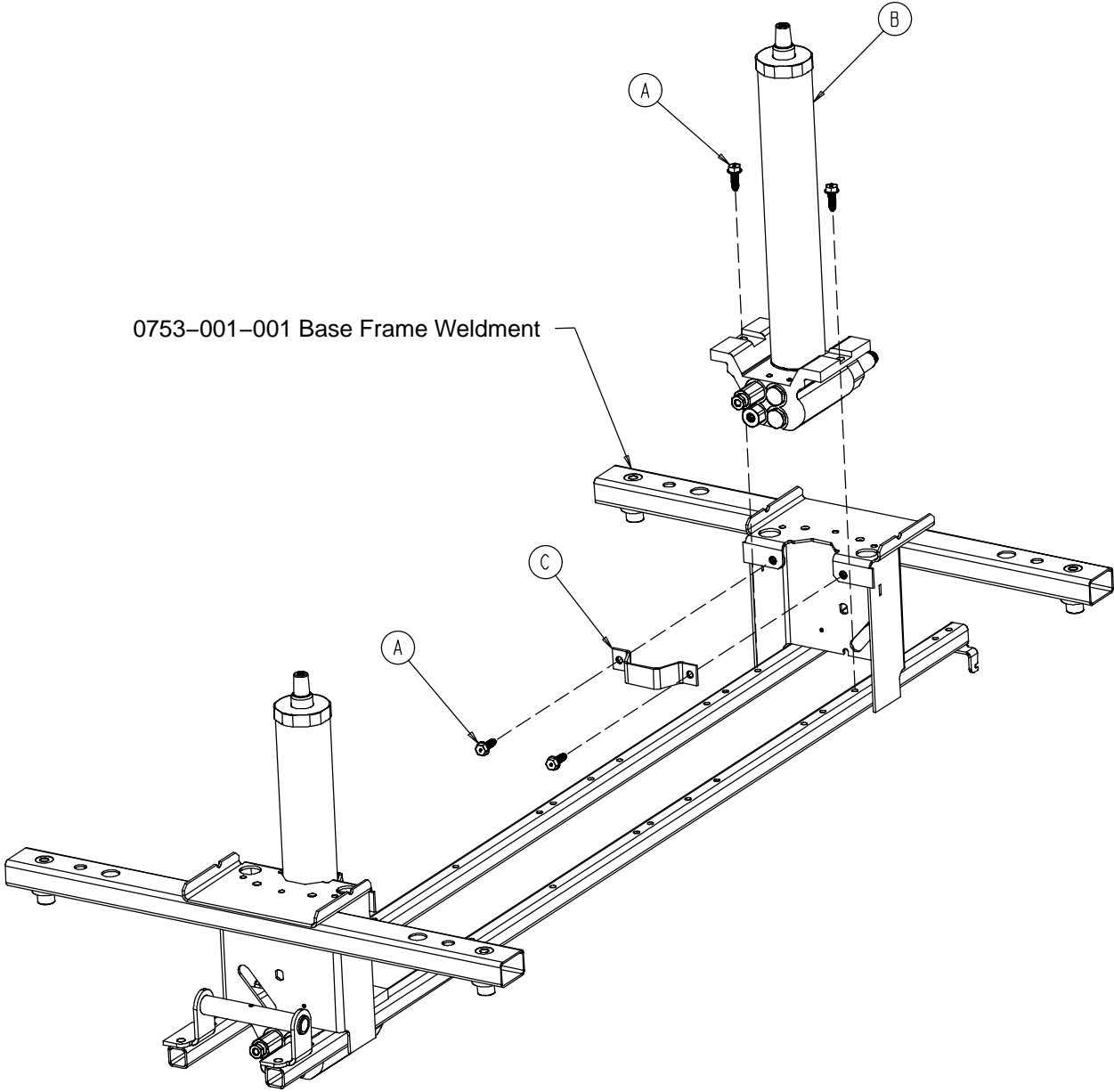

Item	Part No.	Part Name	Qty.
A	0023-288-000	Hex Washer Hd. Screw	8
B	0753-002-070	Variable Descent Jack Assembly	2
C	0753-010-007	Reservoir Clamp	2

# 0753-002-025 Constant Descent Hydraulic Jack Option

---

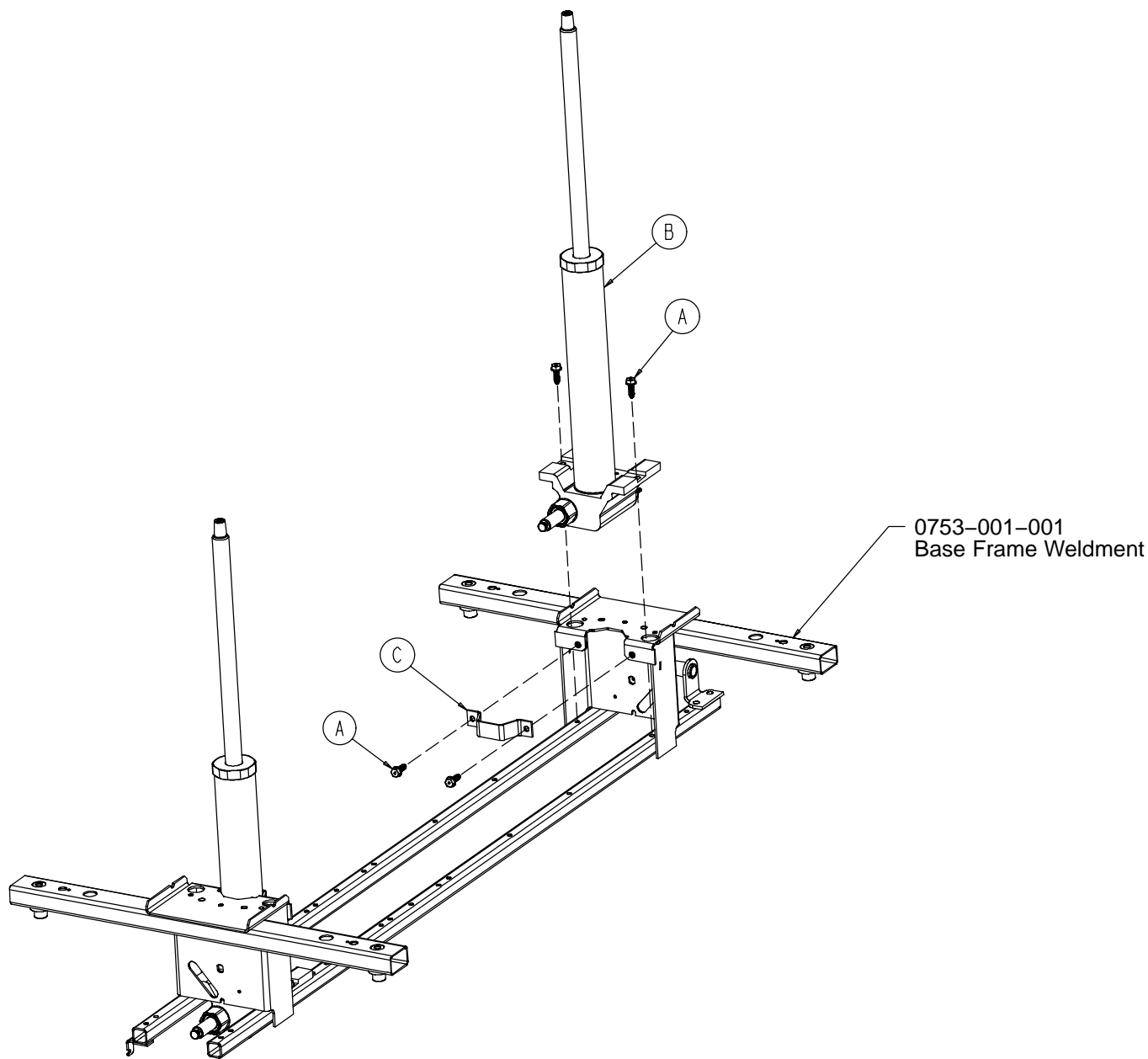

Item	Part No.	Part Name	Qty.
A	0023-288-000	Hex Washer Hd. Screw	8
B	0753-002-001	Constant Descent Jack Ass'y	2
C	0753-010-007	Reservoir Clamp	2

# Litter Assembly

Assembly part number 0721-301-010 (reference only)

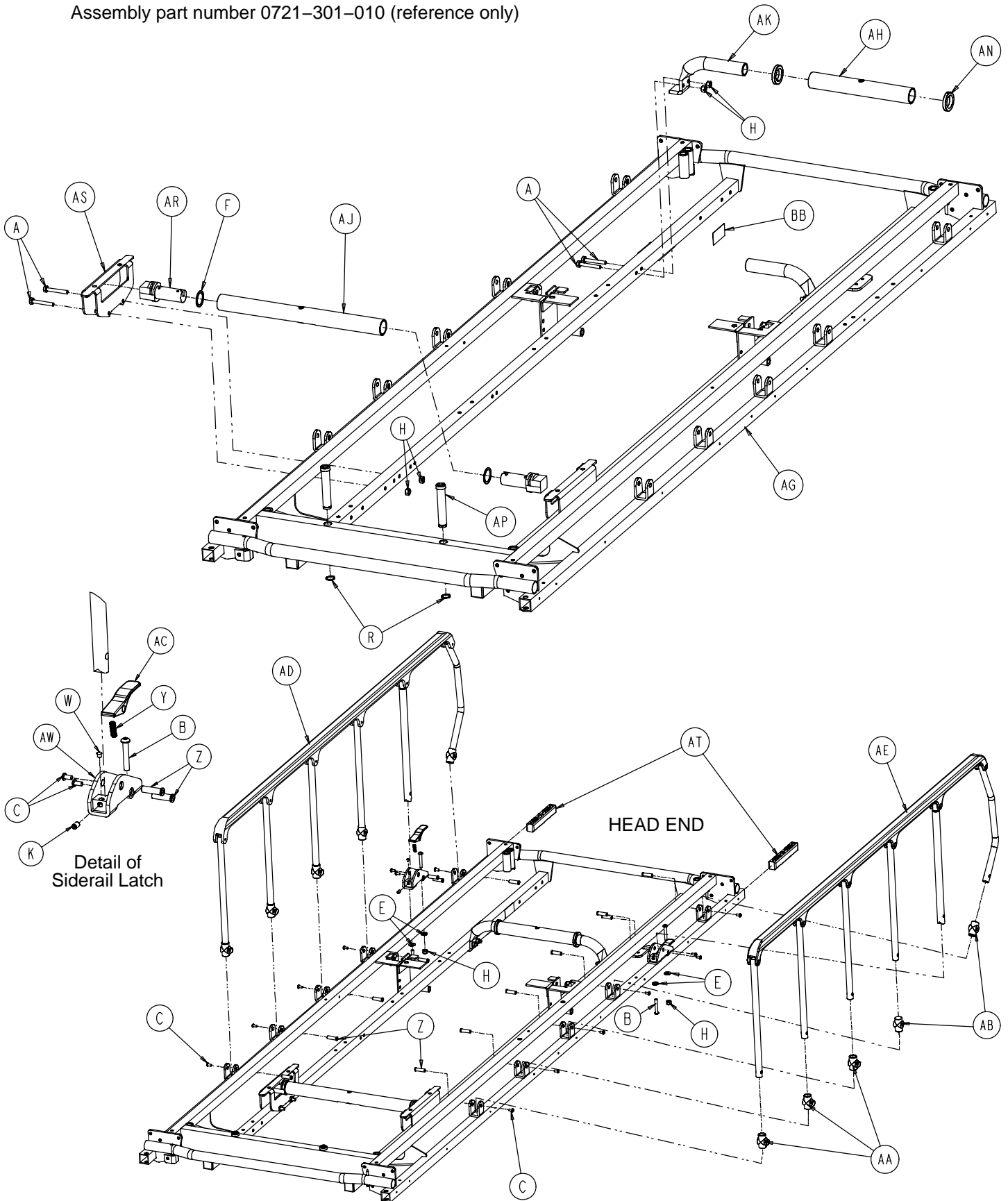



# Litter Assembly

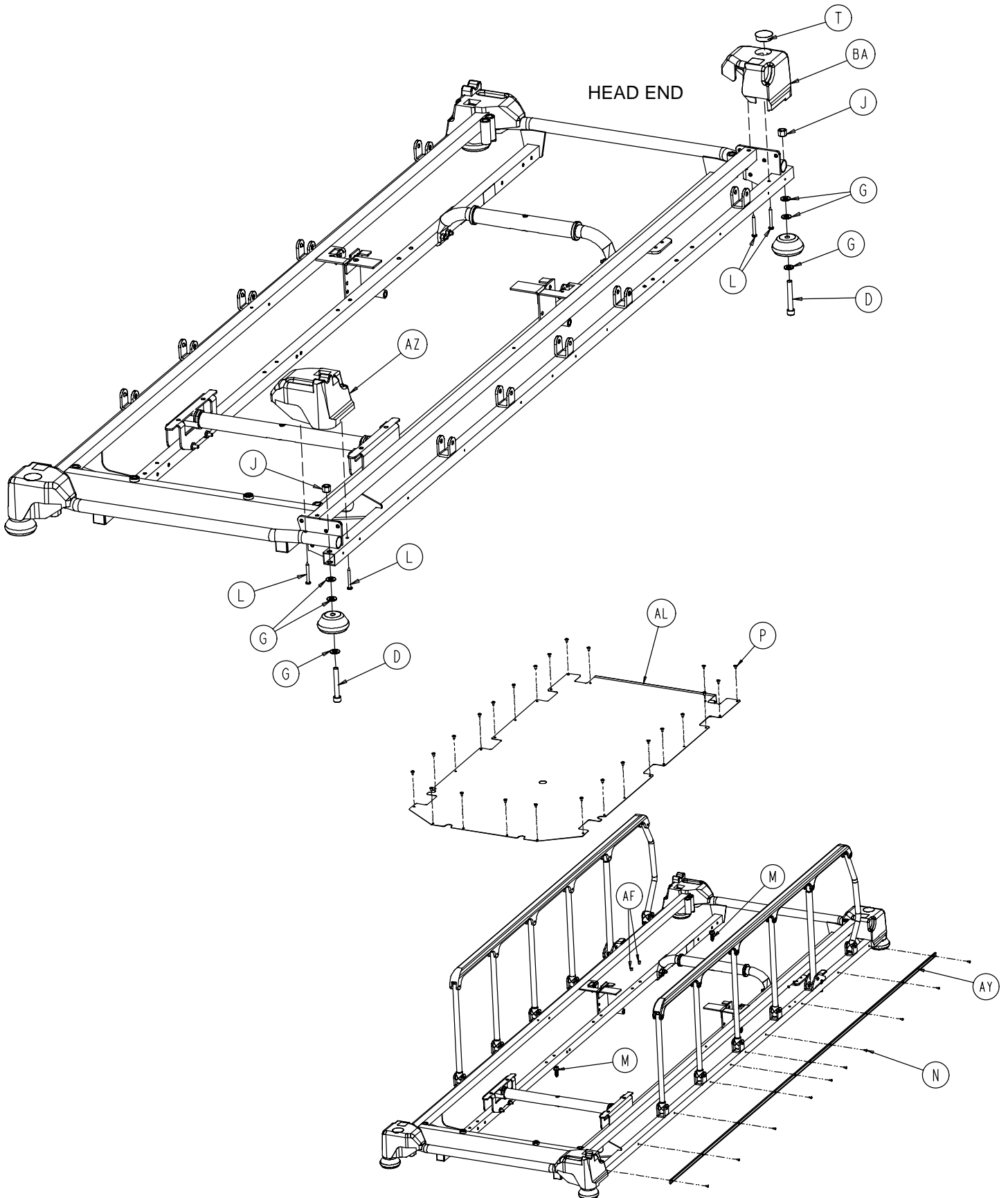

# Litter Assembly

---

Item	Part No.	Part Name	Qty.
A	0003-359-000	Hex Hd. Cap Screw	8
B	0004-135-000	But. Hd. Cap Screw	4
C	0004-136-000	But. Hd. Cap Screw	14
D	0004-330-000	Soc. Hd. Cap Screw	4
E	0011-077-000	Washer	4
F	0011-360-000	Washer	2
G	0014-021-000	Washer	12
H	0016-118-000	Hex Nut	10
J	0016-117-000	Stover Hex Lock Nut	4
K	0021-105-000	Set Screw	2
L	0023-104-000	Pan Hd. Hi-Lo Tapping Screw	8
M	0023-288-000	Hex Washer Hd. Screw	2
N	0025-038-000	Dome Hd. Rivet	20
P	0025-122-000	Dome Hd. Rivet	24
R	0028-023-000	External Retaining Ring	2
S	0037-010-000	Hole Plug	2
T	0037-059-000	Hole Plug	2
W	0037-074-000	Hole Plug	6
Y	0038-220-000	Compression Spring	2
Z	0721-026-066	Pivot Screw	14
AA	0721-026-068	Upright Cradle	6
AB	0721-026-069	Upright Sleeve	4
AC	0721-026-074	Lock Handle	2
AD	<a href="#">(page 74)</a>	Siderail Assembly, Right	1
AE	<a href="#">(page 74)</a>	Siderail Assembly, Left	1
AF	0721-031-065	Hole Plug	4
AG	0721-201-020	Litter Frame Weldment	1
AH	0753-010-036	Support Tube, Head End	1
AJ	0753-010-042	Support Tube, Foot End	1
AK	0753-010-043	Jack Supt. Tube, Hd. End	2
AL	0753-010-044	Stationary Foot Section Skin	1
AM	0926-400-142	Bumper	4
AN	0938-001-401	Collar	2
AP	1001-040-012	Foot Board Receptacle	2
AR	1001-201-029	Nylon Insert	2
AS	1001-401-030	Trend Support	2
AT	1010-026-069	Lock Support	2
AW	1010-026-080	Lock Housing, Left	1
AX	1010-026-081	Lock Housing, Right	1
AY	1010-201-027	Bumper Channel	2
AZ	1010-201-238	Corner Cover, Slot	2
BA	1010-201-239	Corner Cover, Hole	2
BB	1210-800-008	Patent Label	1

# Siderail Assembly, Right & Left

Assembly part numbers  
 0721-026-096 (Right)  
 0721-026-097 (Left)

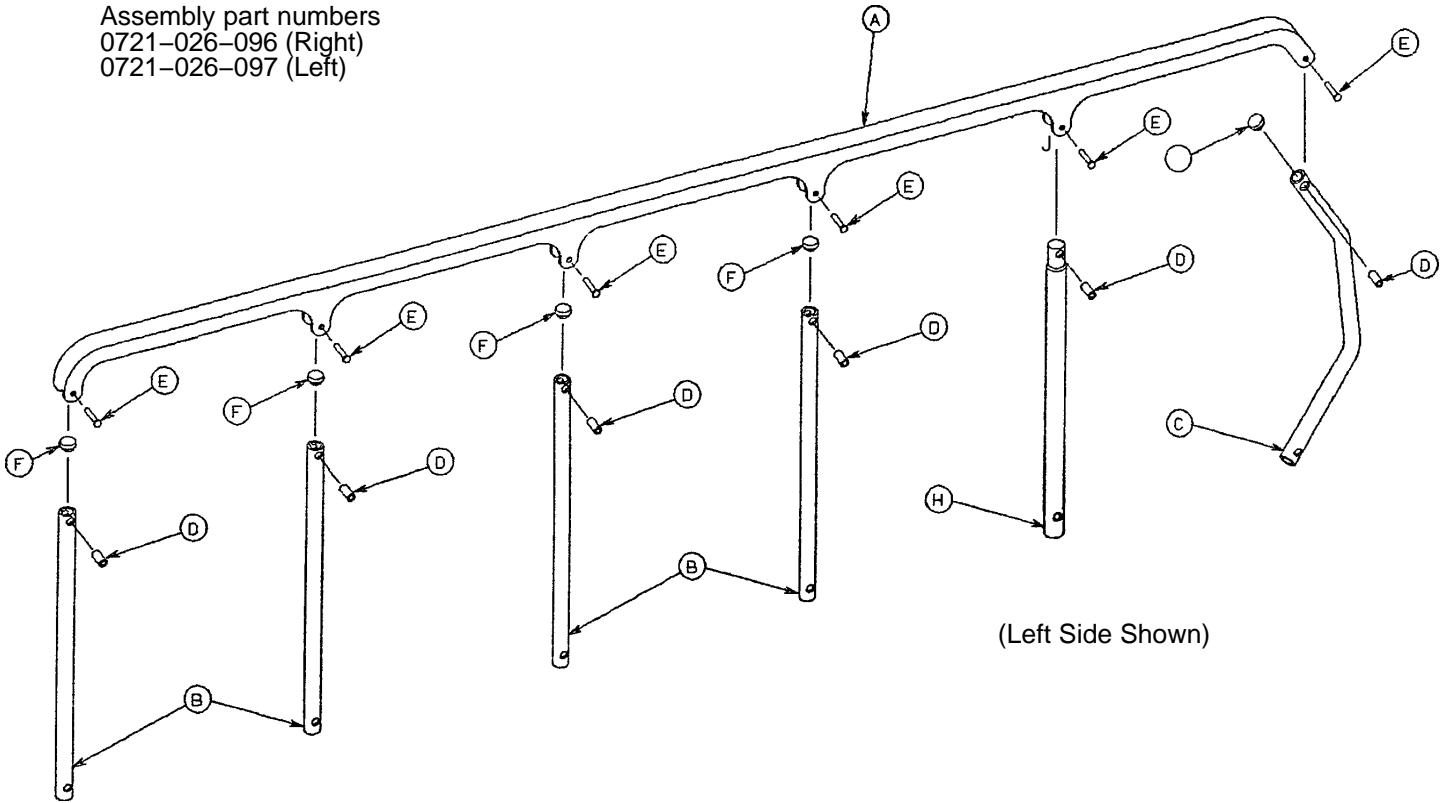

Item	Part No.	Part Name	Qty.
A	1010-026-015	Top Rail	1
B	1010-026-083	Upright	4
C	1010-026-084	Upright, Bent	1
D	1010-026-082	Spacer	6
E	0025-106-000	Semi-Tubular Rivet	6
F	1010-026-010	Round Hole Plug	4
H	1010-026-085	Upright, Latch	1
J	1010-026-012	Bent Spindle Stop	1

# Manual Fowler Assembly

Assembly part number 0721-232-010  
(reference only)

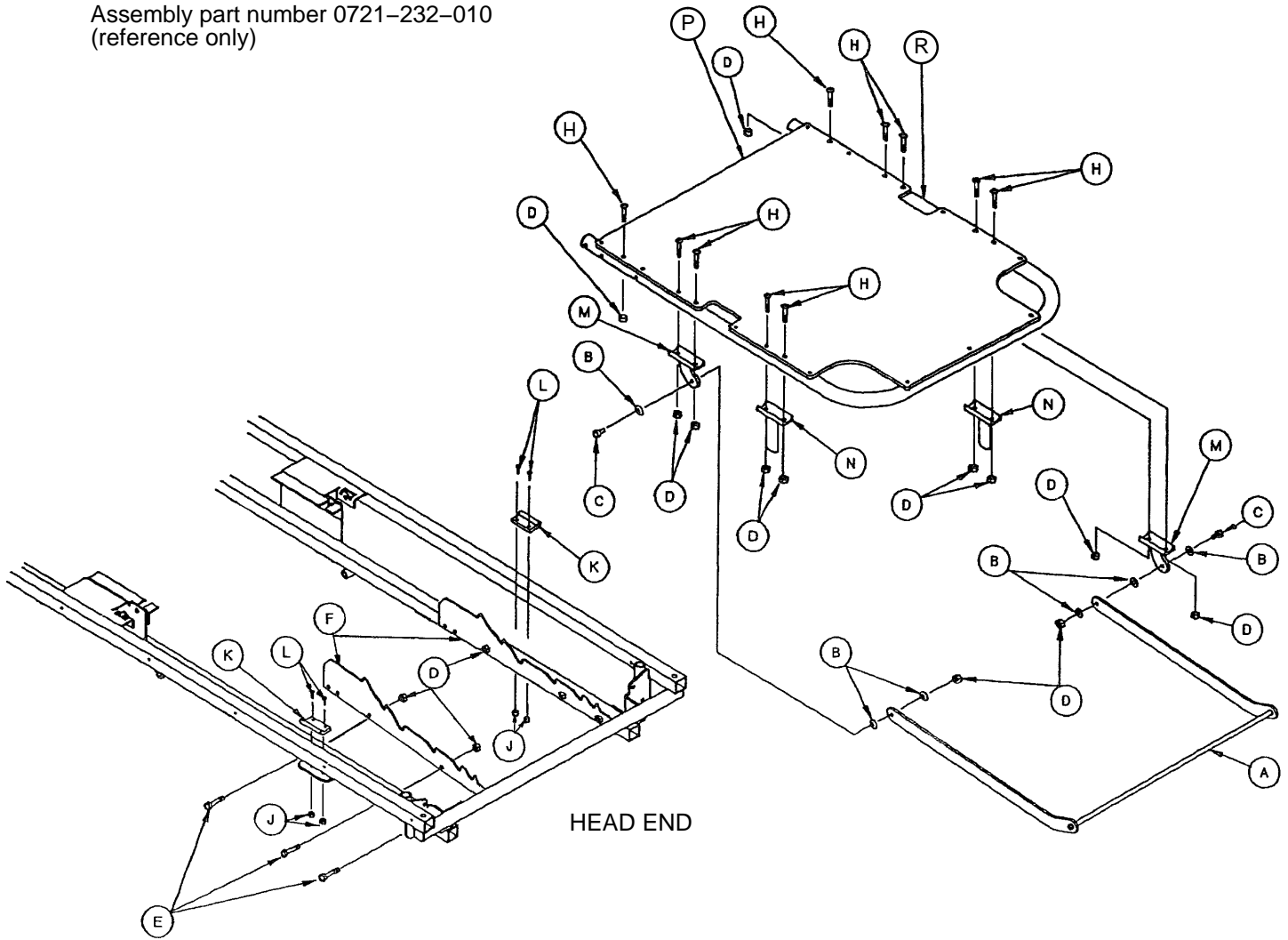

Item	Part No.	Part Name	Qty.
A	0721-232-019	Brace Assembly	1
B	0014-002-000	Nylon Flat Washer	6
C	0003-357-000	Hex Hd. Cap Screw	2
D	0016-118-000	Nylock Hex Nut	18
E	0003-355-000	Hex Hd. Cap Screw	6
F	1001-032-022	Position Bar Rest	2
H	0004-135-000	But. Hd. Cap Screw	10
J	0016-003-000	Lock Nut	4
K	1001-032-026	Manual Fowler Rest	2
L	0004-169-000	But. Hd. Cap Screw	4
M	1001-032-023	Tab Assembly	2
N	1001-032-028	Riser Assembly	2
P	0721-231-012	Fowler Skin	1
R	0721-231-013	Fowler Tube	1

# Pneumatic Fowler Assembly

Assembly part number 0721-231-110 (reference only)

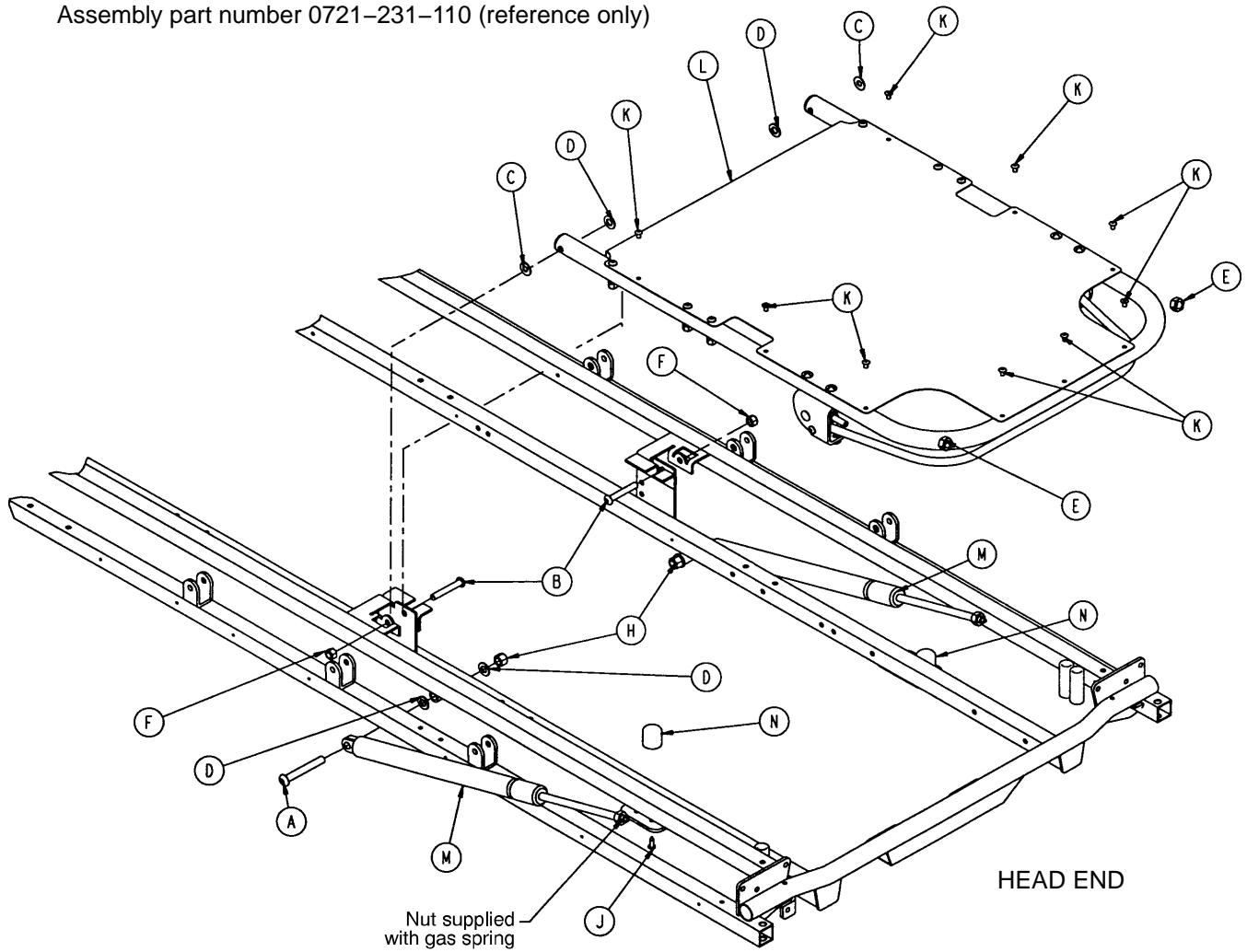

Item	Part No.	Part Name	Qty.
A	0004-182-000	Hex Soc. But. Hd. Cap Screw	2
B	0004-183-000	Hex Soc. But. Hd. Cap Screw	2
C	0011-179-000	Washer	2
D	0014-021-000	Washer	8
E	0015-060-000	Hex Jam Nut	2
F	0016-116-000	Hex Nut	2
H	0016-117-000	Hex Nut	2
J	0023-256-000	Self-Tapping Screw	2
K	0025-122-000	Blind Rivet	9
L	<a href="#">(page 77)</a>	Pneumatic Fowler Assembly	1
M	1010-031-078	Gas Cylinder	2
N	1211-031-031	Pneumatic Fowler Rest	2

# Pneumatic Fowler Assembly

Assembly part number  
0721-231-120 (reference only)

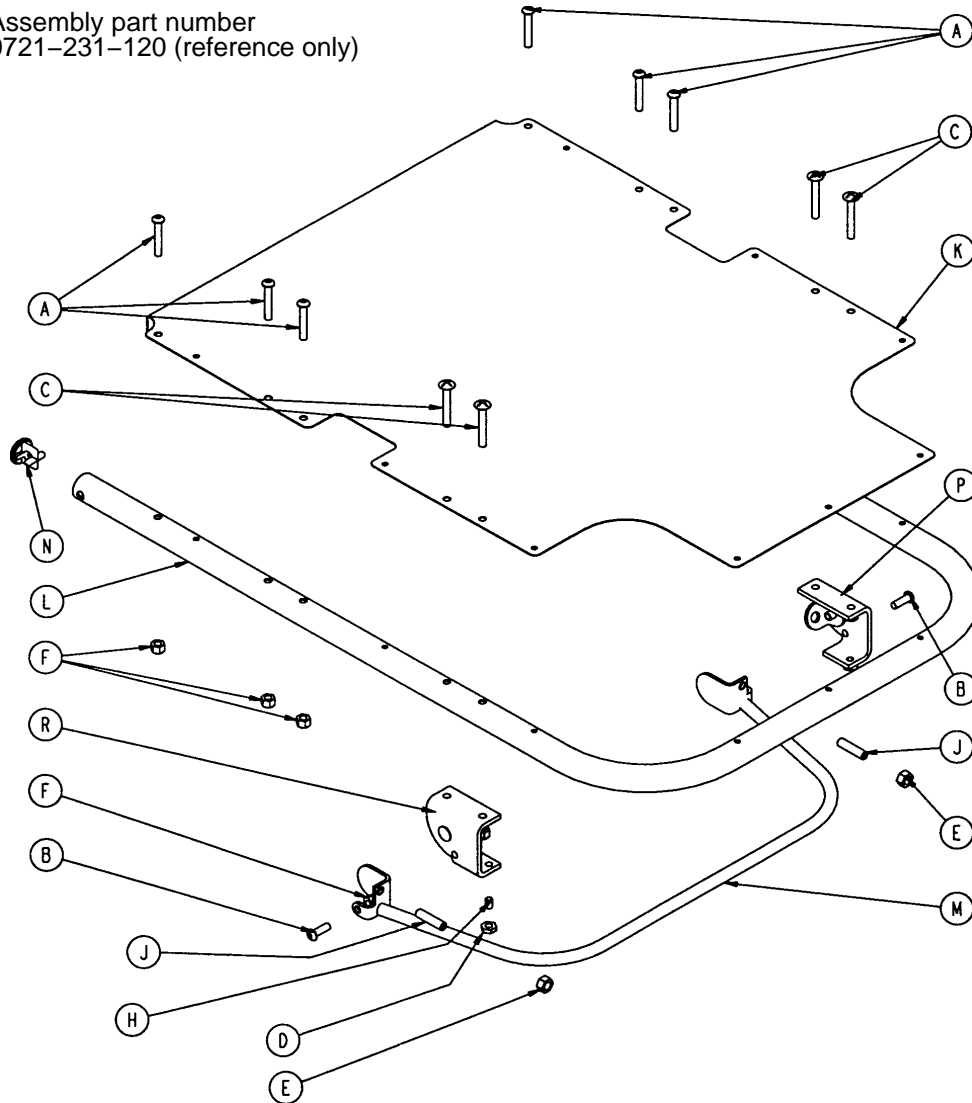

Item	Part No.	Part Name	Qty.
A	0004-135-000	But Hd. Cap Screw	6
B	0004-161-000	Hex Soc. But. Hd. Cap Screw	2
C	0007-071-000	Truss Hd. Mach. Screw	4
D	0015-037-000	Jam Nut	2
E	0015-050-000	Hex Nut	2
F	0016-118-000	Stover Lock Nut	12
H	0021-125-000	Set Screw	2
J	0021-126-000	Set Screw	2
K	0721-231-012	Fowler Skin	1
L	0721-231-013	Fowler Tube	1
M	0721-231-118	Trip Bar Assembly	1
N	1001-001-036	Hole Plug	2
P	<a href="#">(page 78)</a>	Outer Housing Ass'y, Right	1
R	<a href="#">(page 78)</a>	Outer Housing Ass'y, Left	1

# Pneumatic Fowler Outer Housing Assembly

Assembly part number 1210-031-106 (Right)

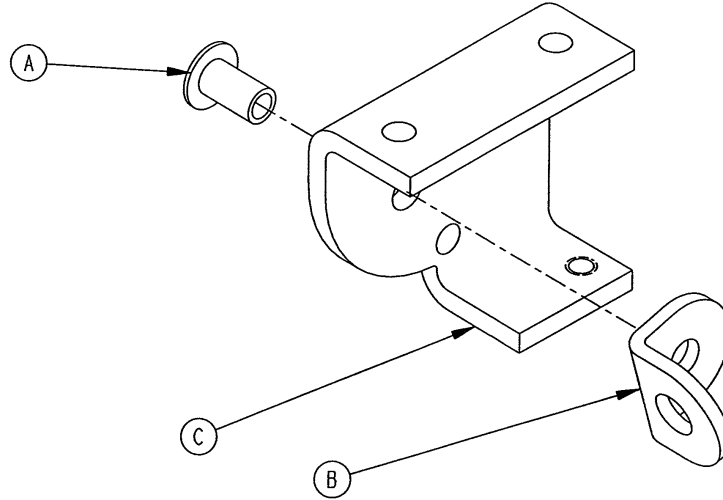

Item	Part No.	Part Name	Qty.
A	0025-144-000	Semi-Tubular Rivet	1
B	1210-031-103	Pivot Tab	1
C	1210-031-104	Outer Housing, Right	1

Assembly part number 1210-031-107 (Left)

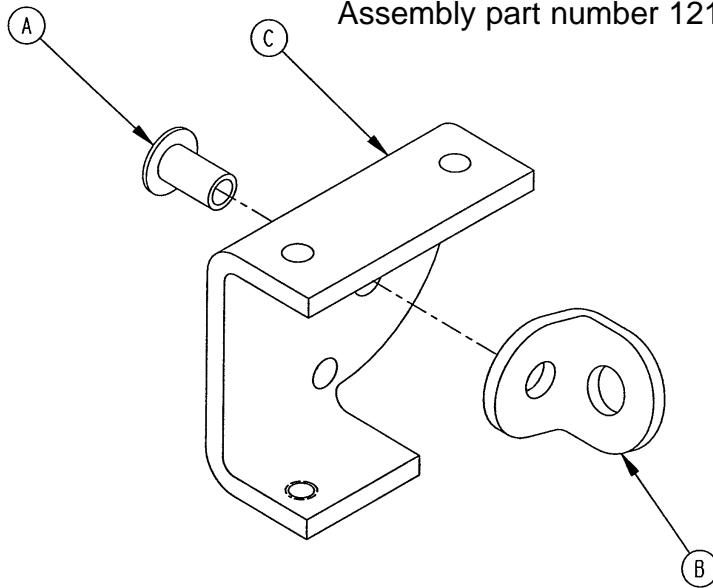

Item	Part No.	Part Name	Qty.
A	0025-144-000	Semi-Tubular Rivet	1
B	1210-031-103	Pivot Tab	1
C	1210-031-105	Outer Housing, Left	1

# 0721-239-010 Optional Short Transfer System Assembly

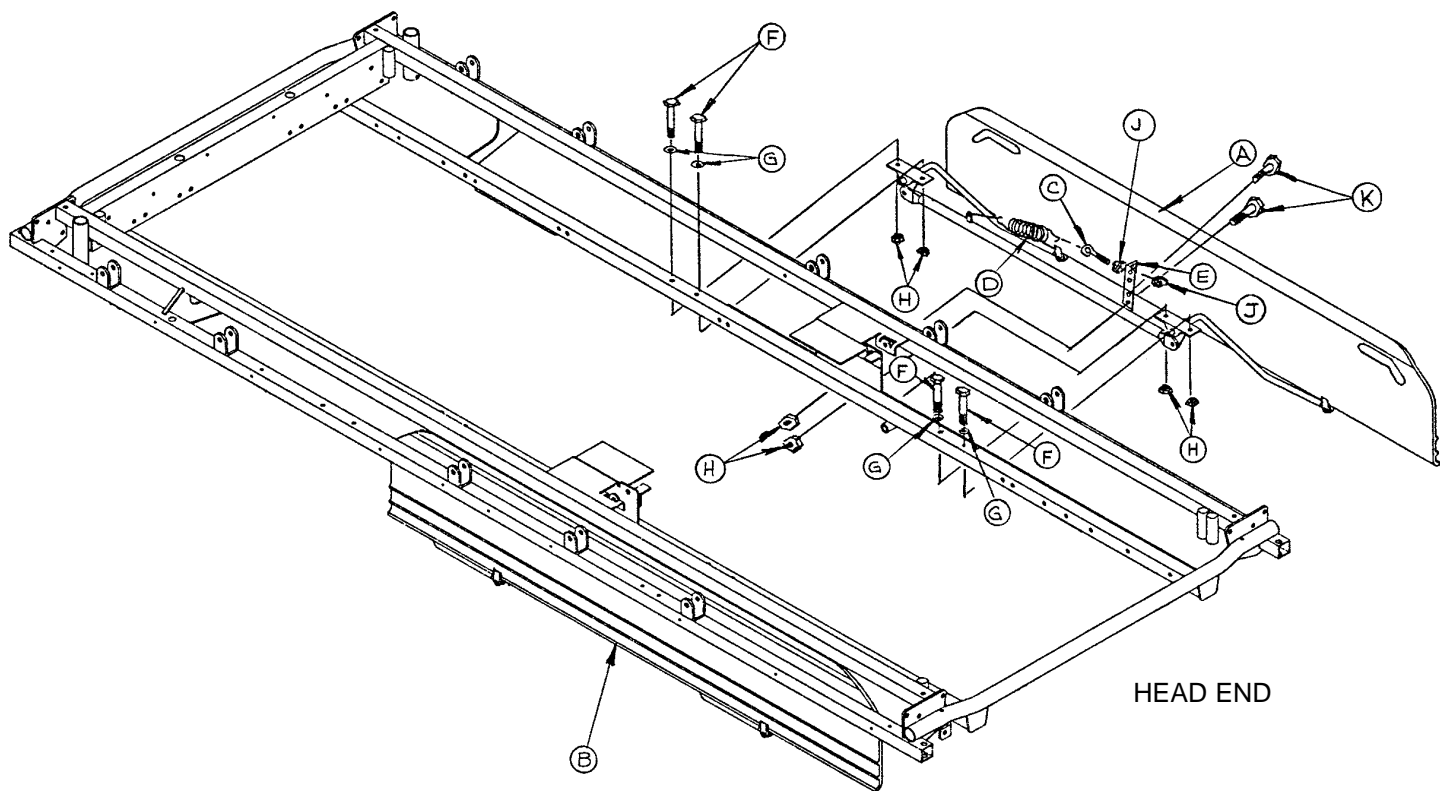

Item	Part No.	Part Name	Qty.
A	(page 80)	Transfer System Ass'y, Rt.	1
B	(page 81)	Transfer System Ass'y, Lt.	1
C	0010-011-000	Eye Bolt	2
D	0038-218-000	Tension Spring	2
E	1010-224-025	Spring Retainer	2
F	0003-359-000	Hex Hd. Cap Screw	8
G	0011-180-000	Flat Washer	8
H	0016-118-000	Nylock Hex Nut	12
J	0015-021-000	Jam Nut	4
K	0003-356-000	Hex Hd. Cap Screw	4



# 1010-232-010 Short Transfer Board Assembly, Right

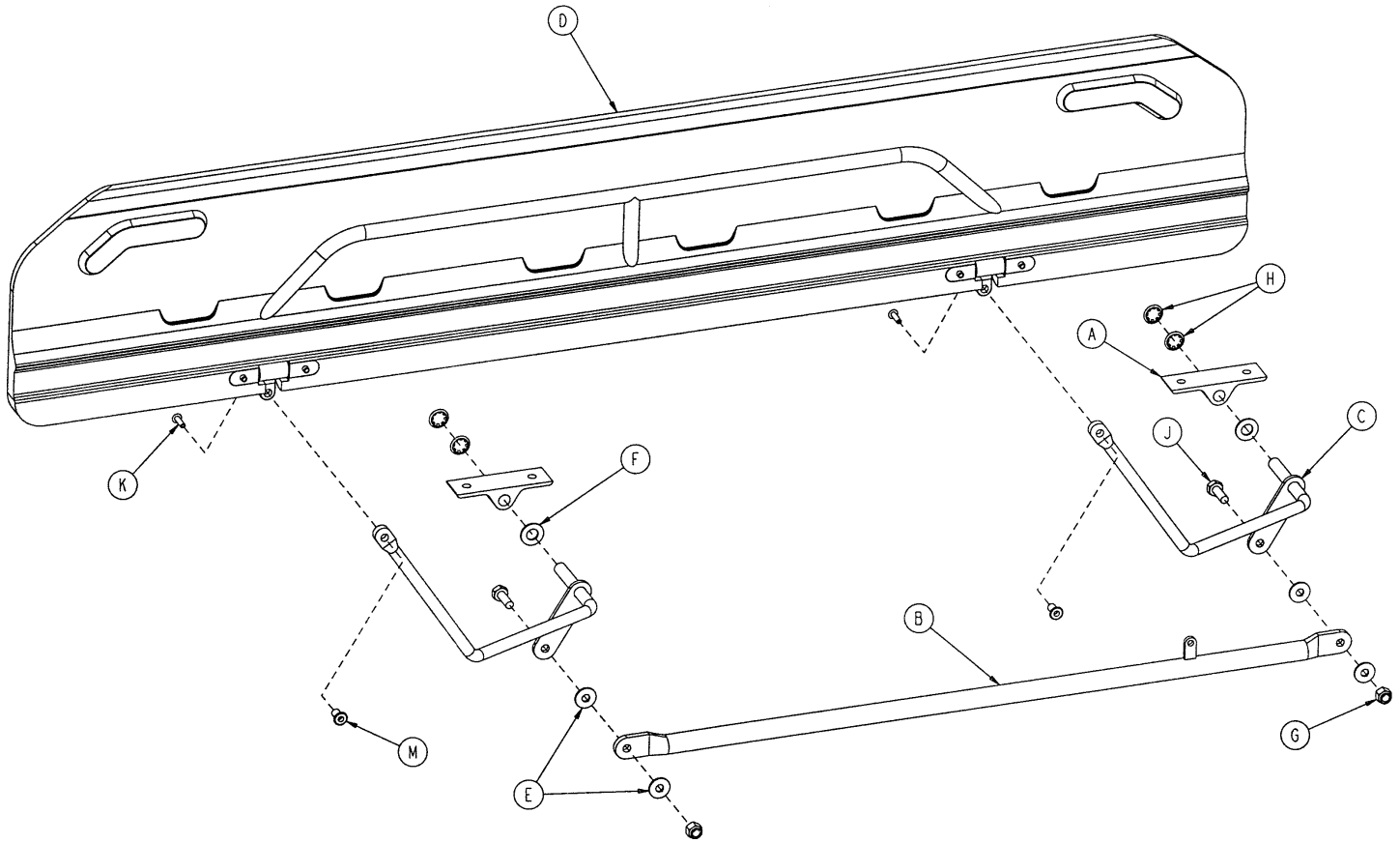

Item	Part No.	Part Name	Qty.
A	1010-032-098	Pivot	2
B	1010-224-033	Connecting Link Ass'y, Rt.	1
C	1010-232-016	Pivot Arm Ass'y, Right	2
D	1020-032-100	Transfer Board Ass'y	1
E	0011-224-000	Nylon Flat Washer	4
F	0014-021-000	Nylon Flat Washer	2
G	0016-118-000	Nylock Hex Nut	2
H	0028-093-000	Retaining Ring	4
J	0003-356-000	Hex Hd. Cap Screw	2
K	0025-157-000	Blind Rivet	2
L	0721-024-046	Label	1
M	1211-132-025	Pivot Sleeve	2

# 1010-232-011 Short Transfer Board Assembly, Left

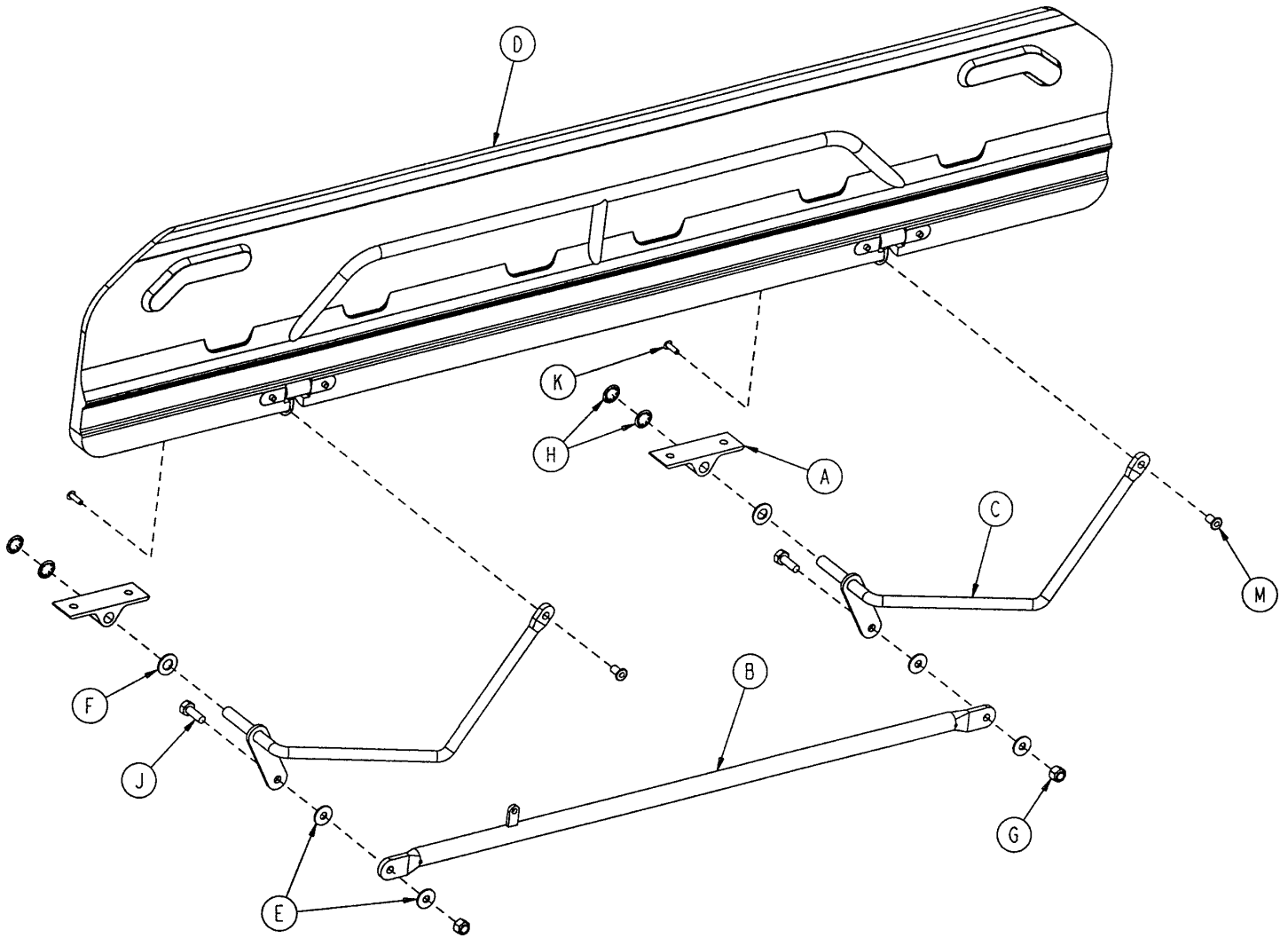

Item	Part No.	Part Name	Qty.
A	1010-032-098	Pivot	2
B	1010-224-033	Connecting Link Ass'y	1
C	1010-232-017	Pivot Arm Ass'y, Lt.	2
D	1020-032-100	Transfer Board Ass'y	1
E	0011-224-000	Nylon Flat Washer	4
F	0014-021-000	Nylon Flat Washer	2
G	0016-118-000	Nylock Hex Nut	2
H	0028-093-000	Retaining Ring	4
J	0003-356-000	Hex Hd. Cap Screw	2
K	0025-157-000	Blind Rivet	2
L	0721-024-046	Label	1
M	1211-132-025	Pivot Sleeve	2

# 0721-234-010 Optional Long Transfer System Assembly

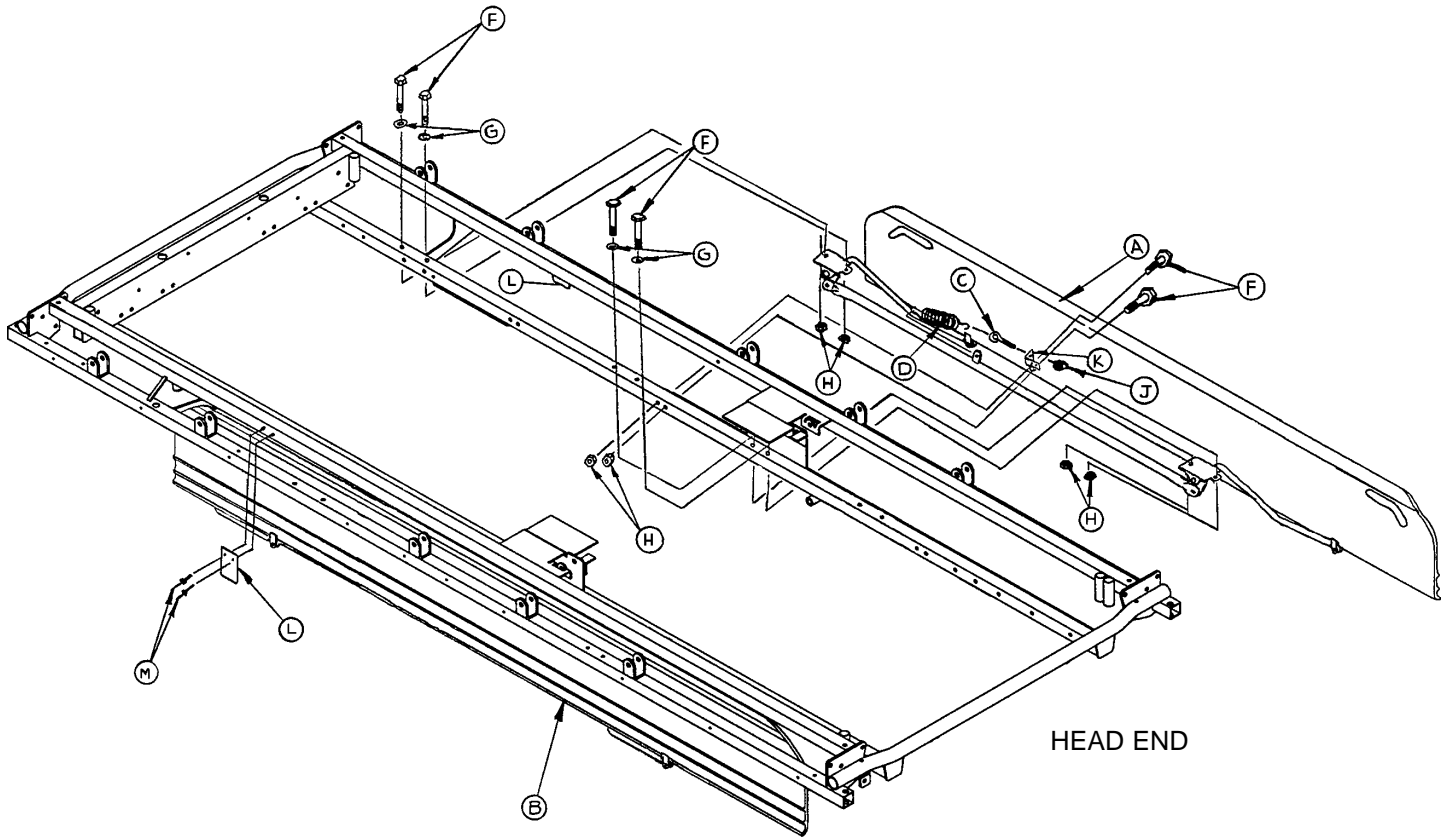

Item	Part No.	Part Name	Qty.
A	(page 84)	Transfer System Ass'y, Rt.	1
B	(page 83)	Transfer System Ass'y, Lt.	1
C	0010-011-000	Eye Bolt	2
D	0038-218-000	Tension Spring	2
E	0721-224-025	Spring Retainer, Rt.	1
F	0003-359-000	Hex Hd. Cap Screw	12
G	0011-180-000	Flat Washer	8
H	0016-118-000	Nylock Hex Nut	12
J	0015-021-000	Jam Nut	2
K	0721-224-024	Spring Retainer, Lt.	1
L	0721-024-061	Pivot Arm Rest	2
M	0025-179-000	Pop Rivet	4
N	0721-201-017	Riser Tube (not shown)	2

# 0721-234-012 Long Transfer Board Assembly, Left

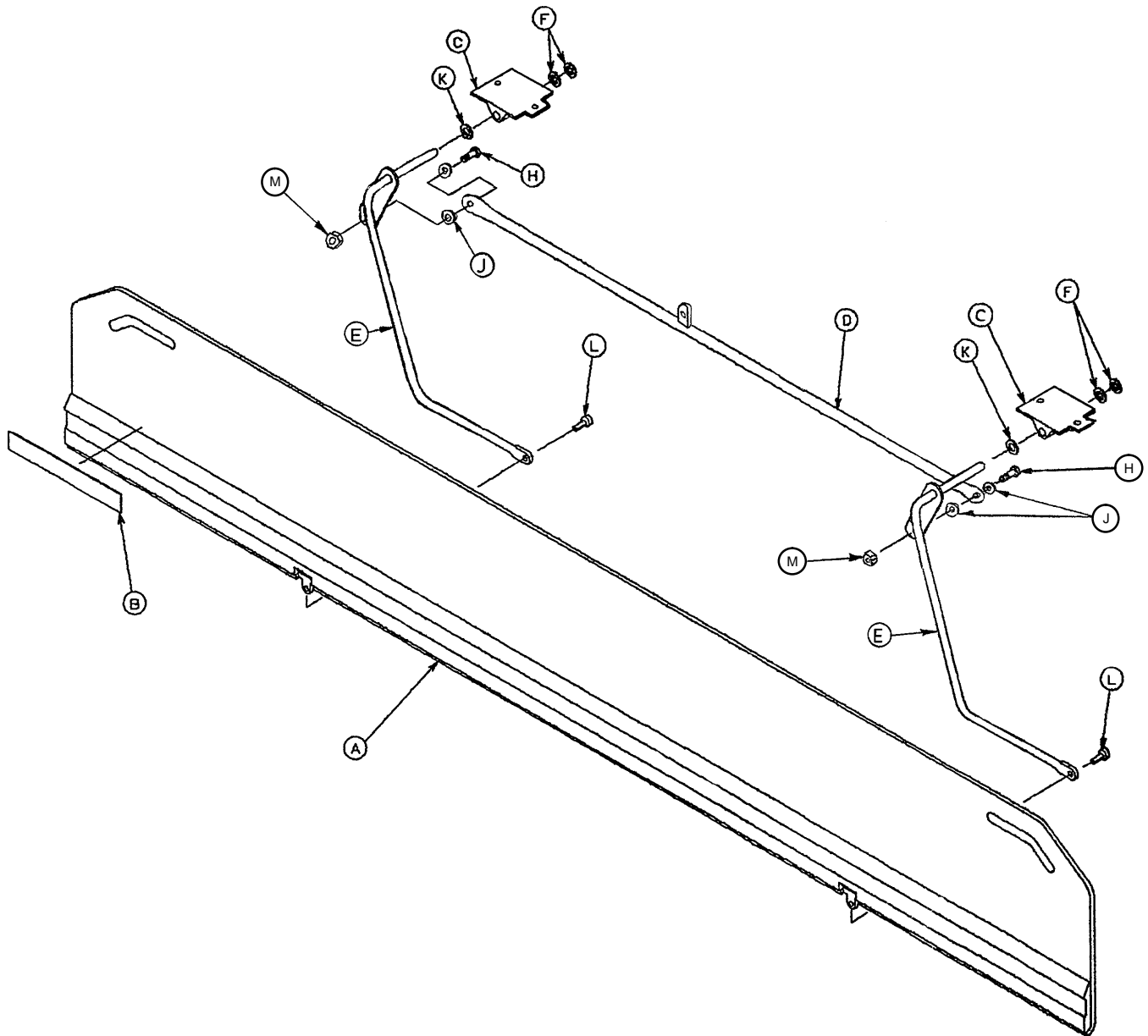

Item	Part No.	Part Name	Qty.
A	0721-024-055	Transfer Board Ass'y	1
B	0721-024-046	Label	1
C	0721-224-016	Long Pivot, Machined	2
D	0721-224-033	Connecting Link Ass'y	1
E	0721-232-017	Pivot Arm Ass'y, Lt.	2
F	0028-093-000	Retaining Ring	4
H	0003-050-000	Hex Hd. Cap Screw	2
J	0011-224-000	Nylon Flat Washer	4
K	0014-021-000	Nylon Flat Washer	2
L	0004-156-000	Soc. Hd. Cap Screw	2
M	0016-028-000	Nylock Hex Nut	2

# 0721-234-013 Long Transfer Board Assembly, Right

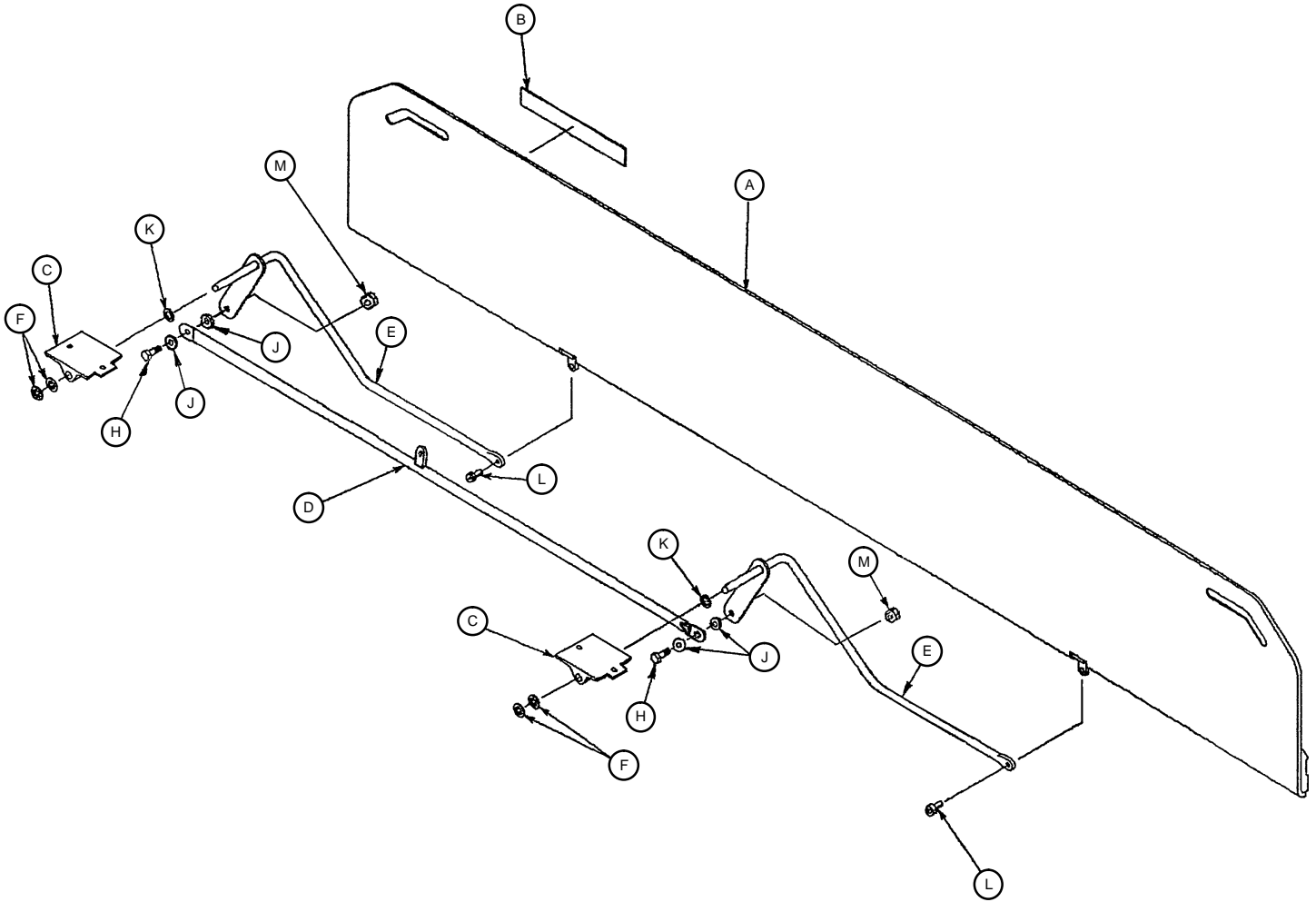

Item	Part No.	Part Name	Qty.
A	0721-024-055	Transfer Board Ass'y	1
B	0721-024-046	Label	1
C	0721-224-016	Long Pivot, Machined	2
D	0721-224-033	Connecting Link Ass'y, Rt.	1
E	0721-232-016	Pivot Arm Ass'y, Right	2
F	0028-093-000	Retaining Ring	4
H	0003-050-000	Hex Hd. Cap Screw	2
J	0011-224-000	Nylon Flat Washer	4
K	0014-021-000	Nylon Flat Washer	2
L	0004-156-000	Soc. Hd. Cap Screw	2
M	0016-028-000	Nylock Hex Nut	2

# 0390-025-000 Standard, Removable I.V. Pole Assembly

Item	Part No.	Part Name	Qty.
A	0024-023-000	Plastic Knob	1
B	0390-003-053	Double I.V. Ass'y	1
C	0393-003-043	Tube Assembly	1
D	0004-496-000	Soc. Hd. Cap Screw	1

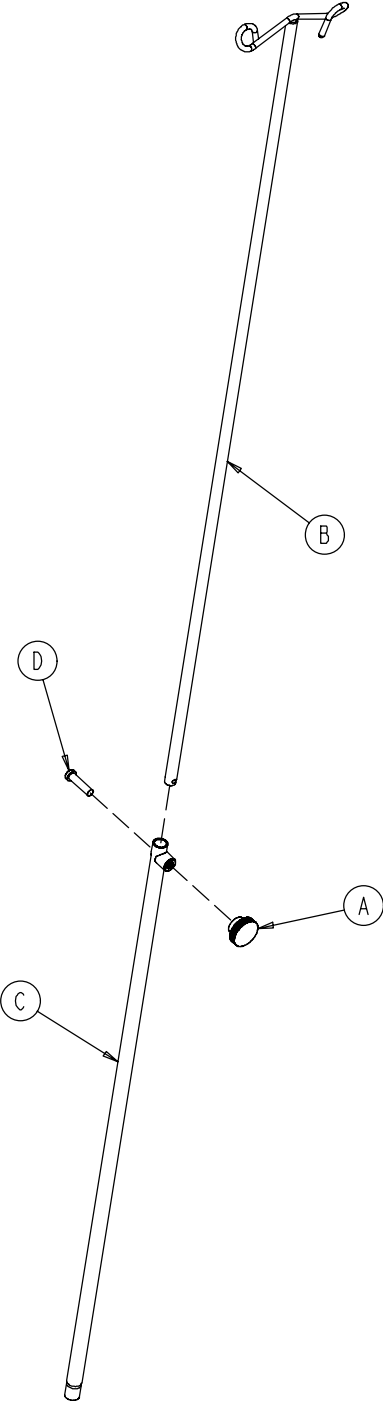

# 0721-117-000 Optional Tethered I.V. Assembly

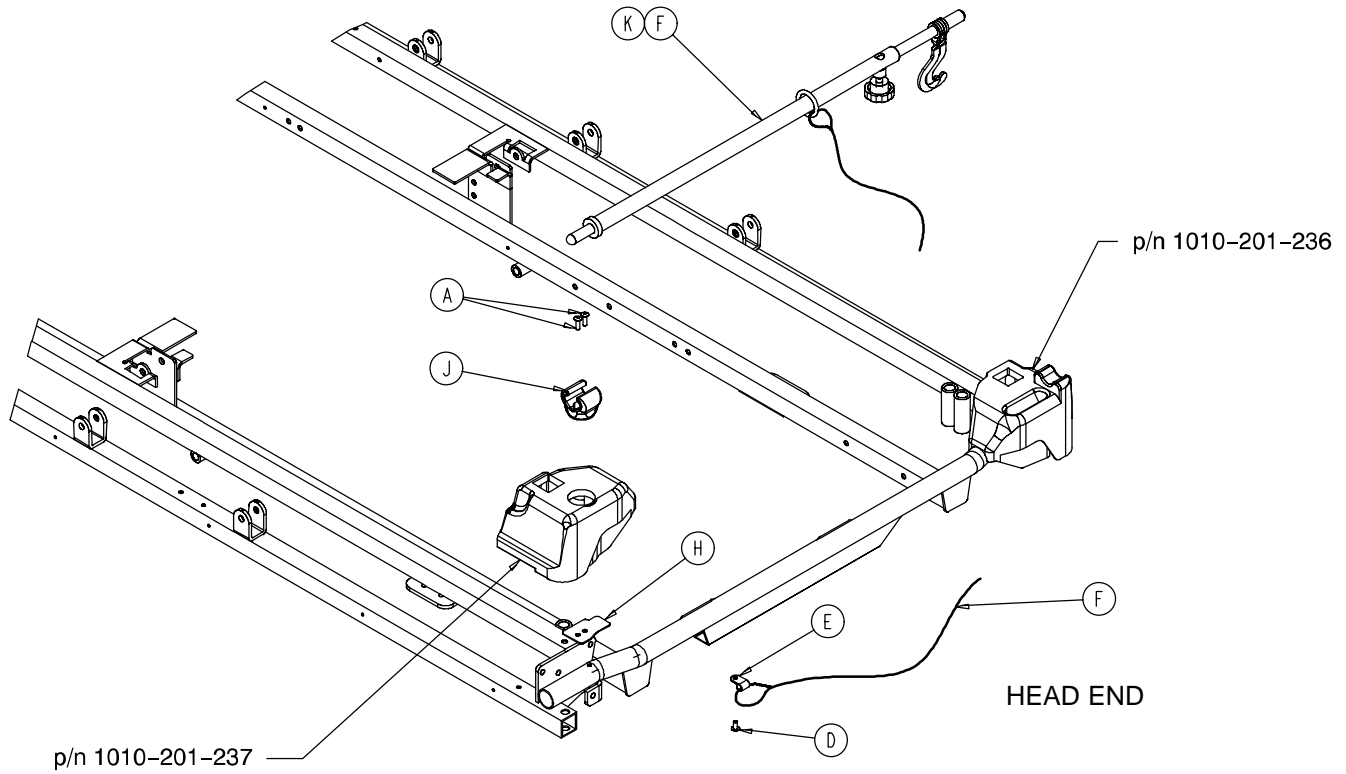

Item	Part No.	Part Name	Qty.
A	0025-133-000	Pop Rivet	2
D	0025-179-000	Rivet	1
E	0034-022-000	Cable Clamp	1
F	1001-159-042	I.V. Plug	1
H	(page 87)	Tethered I.V. Pole Assembly	1
J	1211-117-021	Backing Plate	1
K	1211-117-022	I.V. Clip	1

# 1211-117-010 Tethered I.V. Pole Assembly

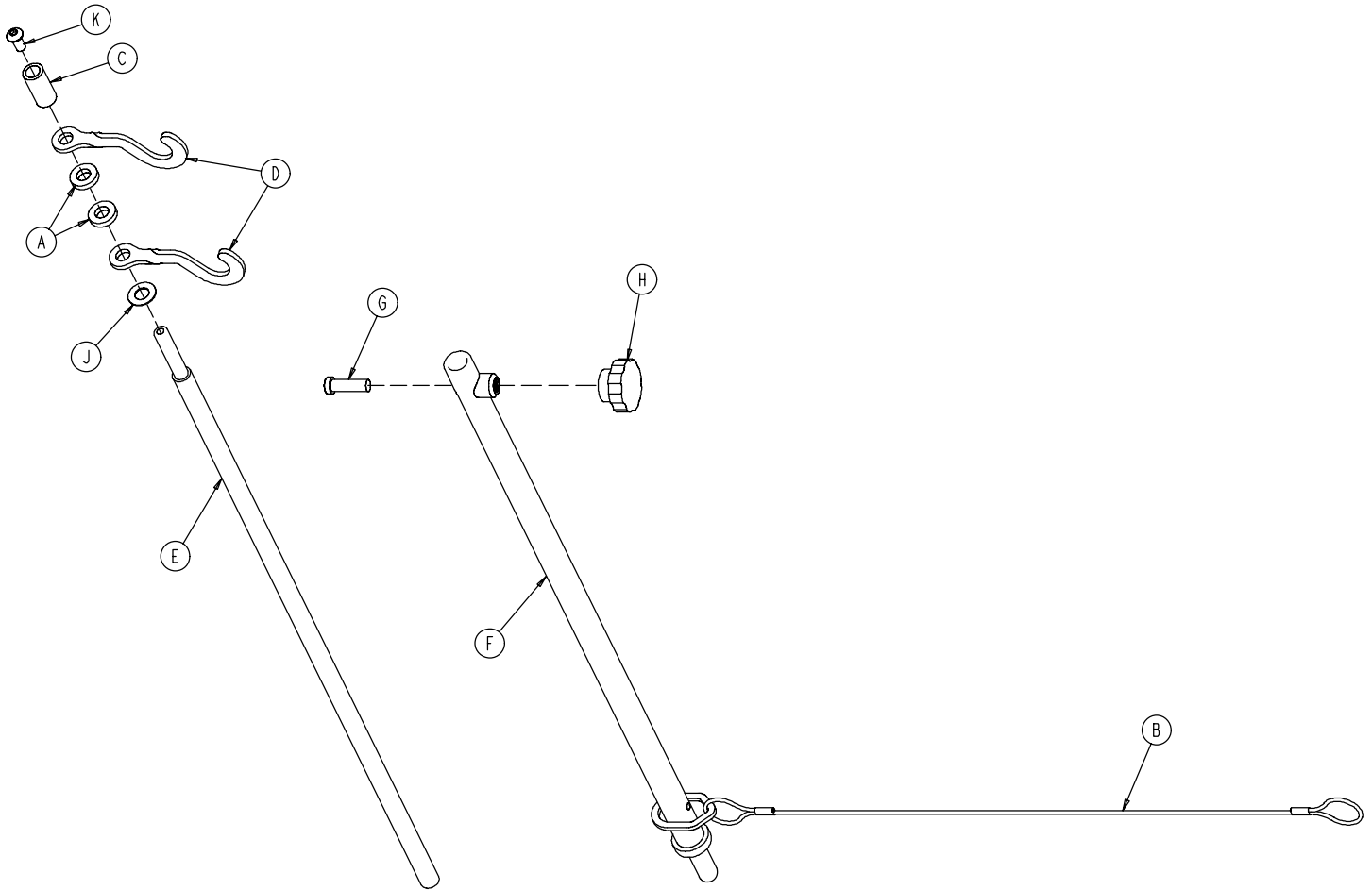

Item	Part No.	Part Name	Qty.
A	0052-017-000	Spacer	2
B	1211-117-020	Cable Assembly	1
C	0926-400-062	Stop Sleeve	1
D	1010-059-016	I.V. Hook	2
E	1211-117-011	Extension Rod	1
F	1211-117-012	Base Tube Weldment	1
G	0004-495-000	Low Hd. Soc. Hd. Cap Screw	1
H	1211-117-016	Knob	1
J	0014-020-000	Nylon Washer	1
K	0004-232-000	Button Hd. Cap Screw	1



# 721-400-001 Optional 2-Stage I.V. Assembly

Assembly part number 0721-280-000 & 0721-281-000  
(reference only)

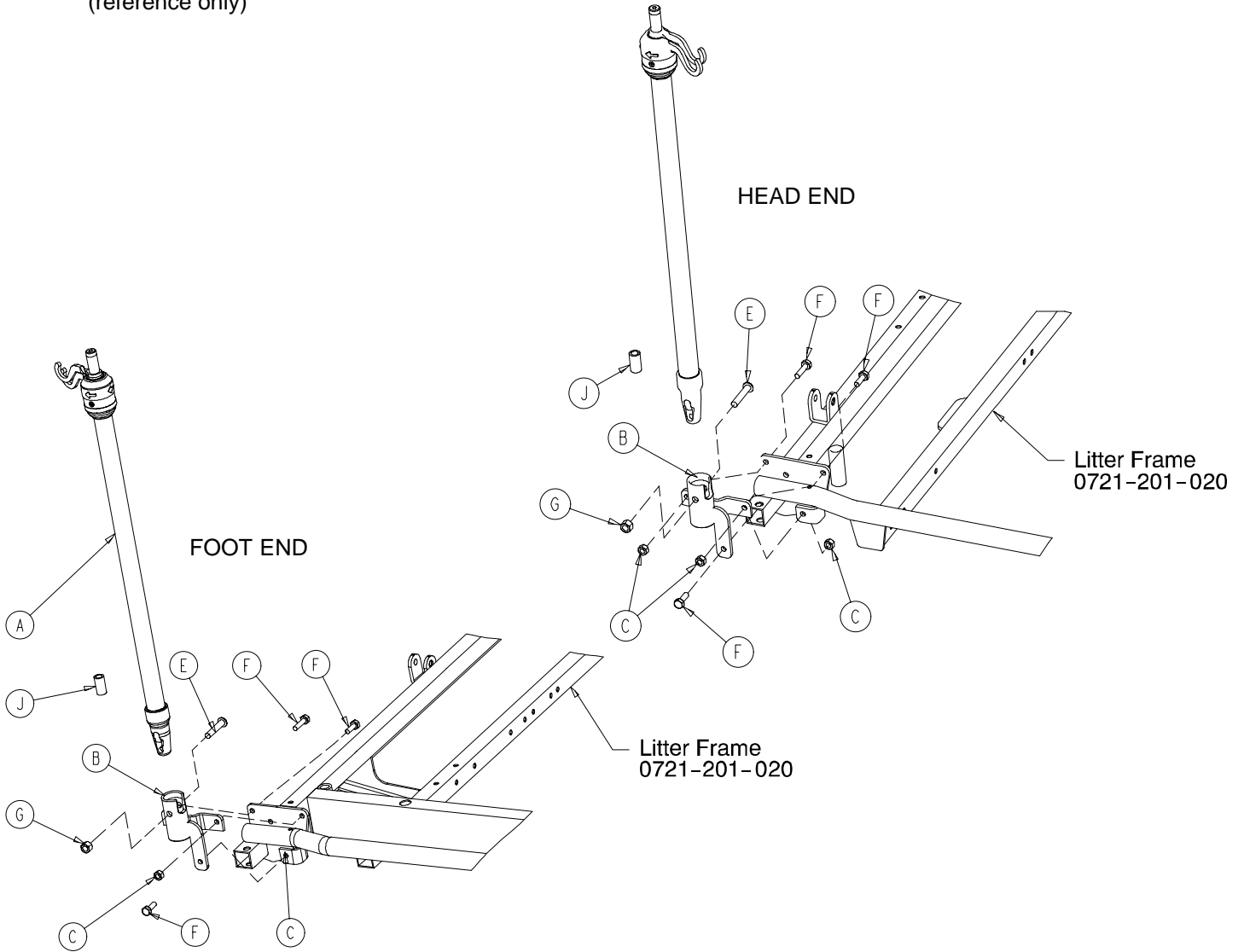

Item	Part No.	Part Name	Qty
A	(page 89)	I.V. Pole Assembly	1
B	1001-259-103	I.V. Pivot	1
C	0016-118-000	Fiberlock Nut	3
E	0004-452-000	But. Hd. Cap Screw	1
F	0003-356-000	Hex Hd. Cap Screw	3
G	0016-116-000	Flexlock Nut	1
J	1001-259-042	I.V. Plug	1

# 1211-210-010 Optional 2-Stage I.V. Pole Assembly

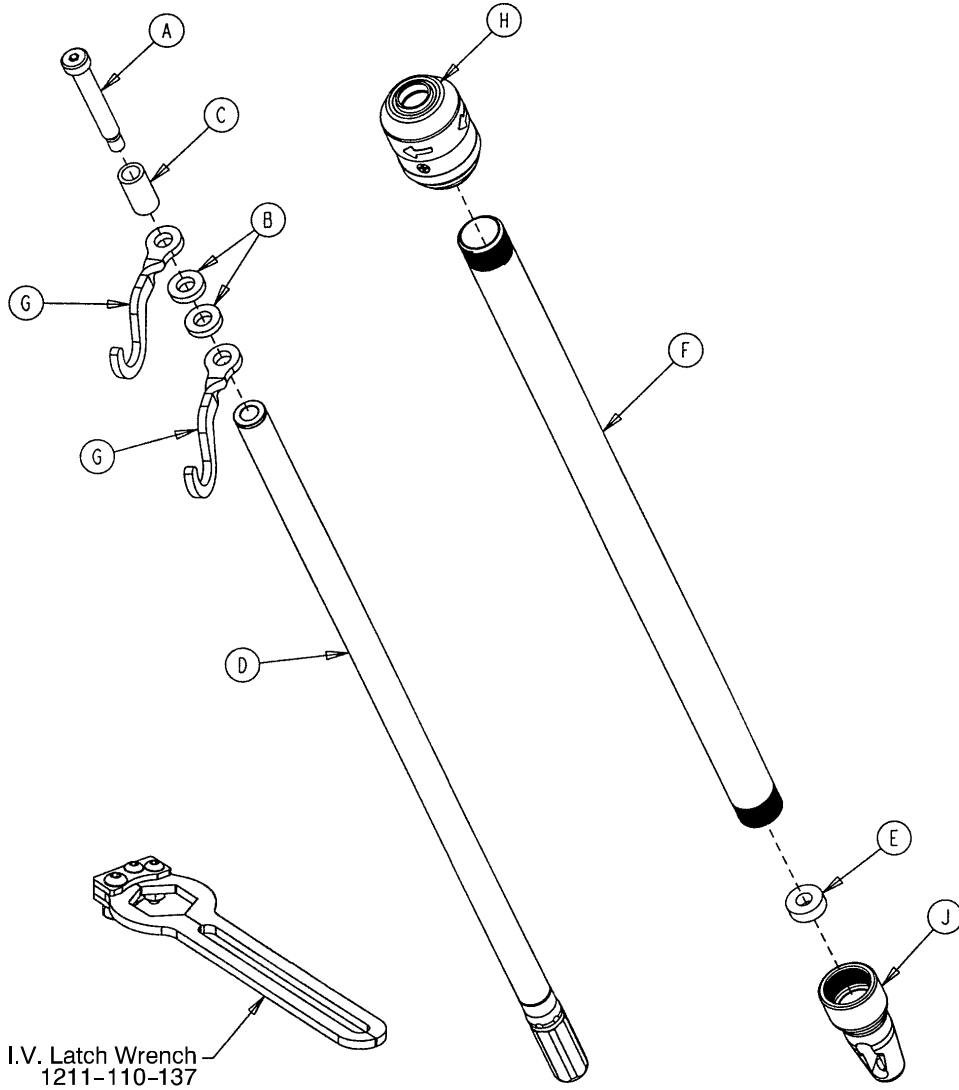

Item	Part No.	Part Name	Qty.
A	0008-031-000	Soc. Hd. Cap Screw	1
B	0052-017-000	Washer	2
C	0926-400-162	Spacer	1
D	1211-210-029	2nd Stage Assembly	1
E	1001-359-013	Dampener	1
F	1001-159-028	Base Tube	1
G	1010-059-016	I.V. Hook	2
H	(page 90)	I.V. Pole Latch	1
J	1001-359-112	Pivot	1

# 1211-210-026 I.V. Pole Latch Assembly

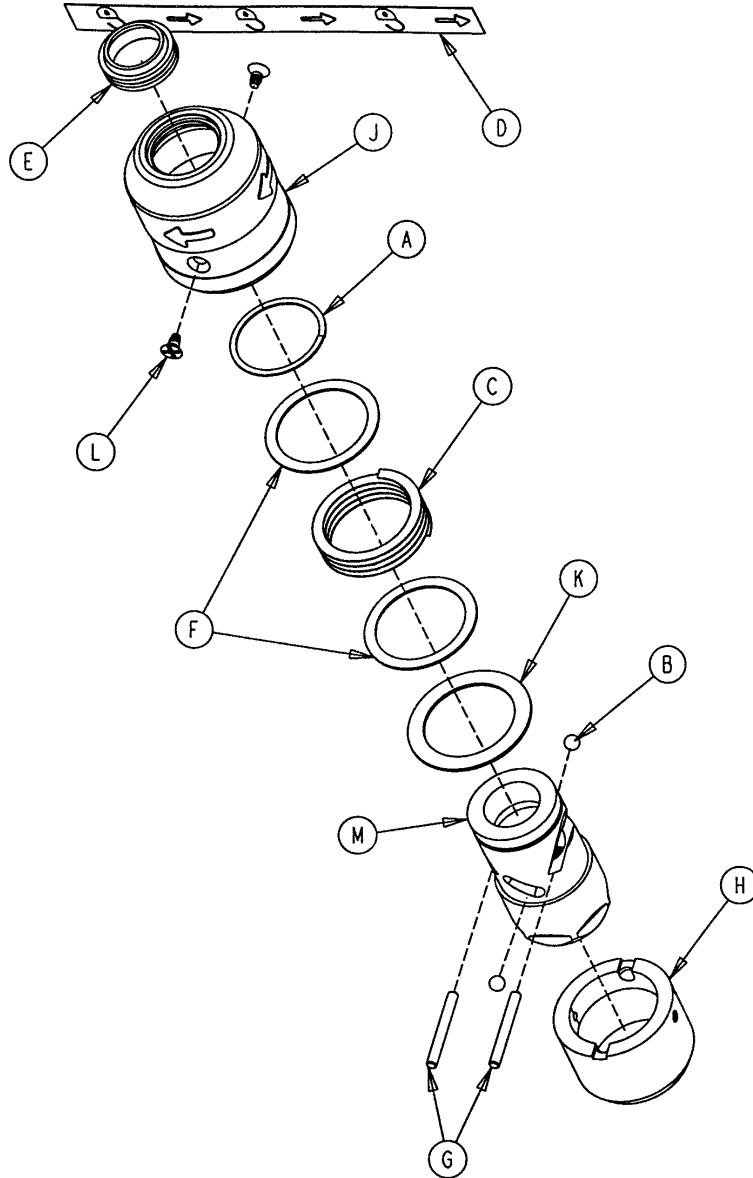

Item	Part No.	Part Name	Qty.
A	0028-167-000	Retaining Ring	1
B	0031-004-000	Steel Ball	2
C	0038-392-000	Crest-to-Crest Spring	1
D	1211-091-034	Release Label	1
E	1211-110-018	I.V. Latch Seal	1
F	1211-110-020	Washer	2
G	1211-110-021	I.V. Latch Locking Pin	2
H	1211-110-022	I.V. Latch Guide	1
J	1211-110-024	I.V. Latch O.D. Housing	1
K	1211-110-035	Washer	1
L	1211-110-036	Self-Tapping Screw	2
M	1211-210-023	I.V. Latch I.D. Housing	1

# 0721-061-000 Optional 3-Stage I.V. Assembly, Head

# 0721-062-000 Optional 3-Stage I.V. Assembly, Foot

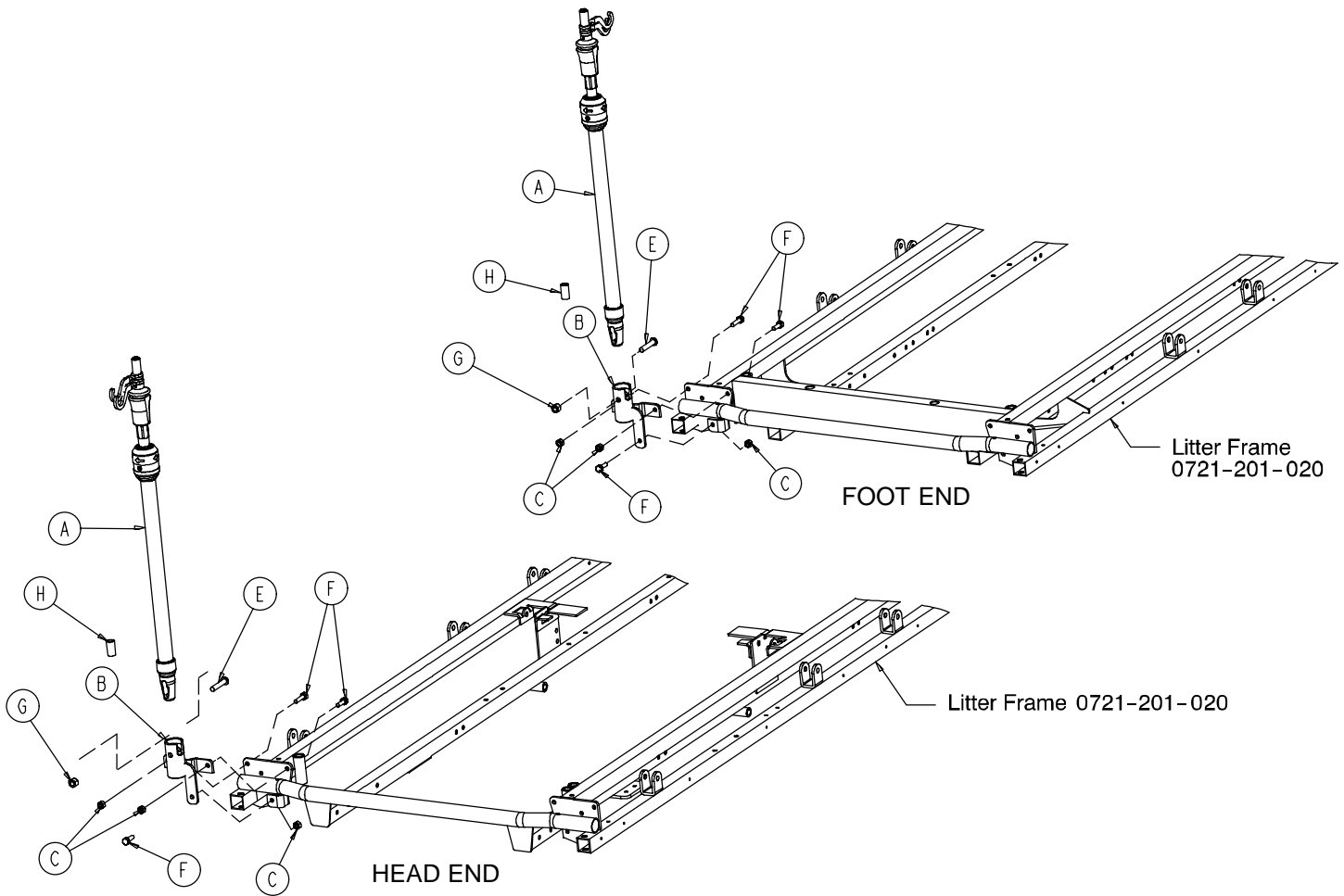

Item	Part No.	Part Name	Qty.
A	(page 92)	I.V. Pole Assembly	1
B	1001-259-103	I.V. Pivot	1
C	0016-118-000	Fiberlock Nut	3
E	0004-452-000	But. Hd. Cap Screw	1
F	0003-356-000	Hex Hd. Cap Screw	3
G	0016-116-000	Flexlock Nut	1
H	1001-259-042	Plug	1

# 1211-211-010 Optional 3-Stage I.V. Pole Assembly

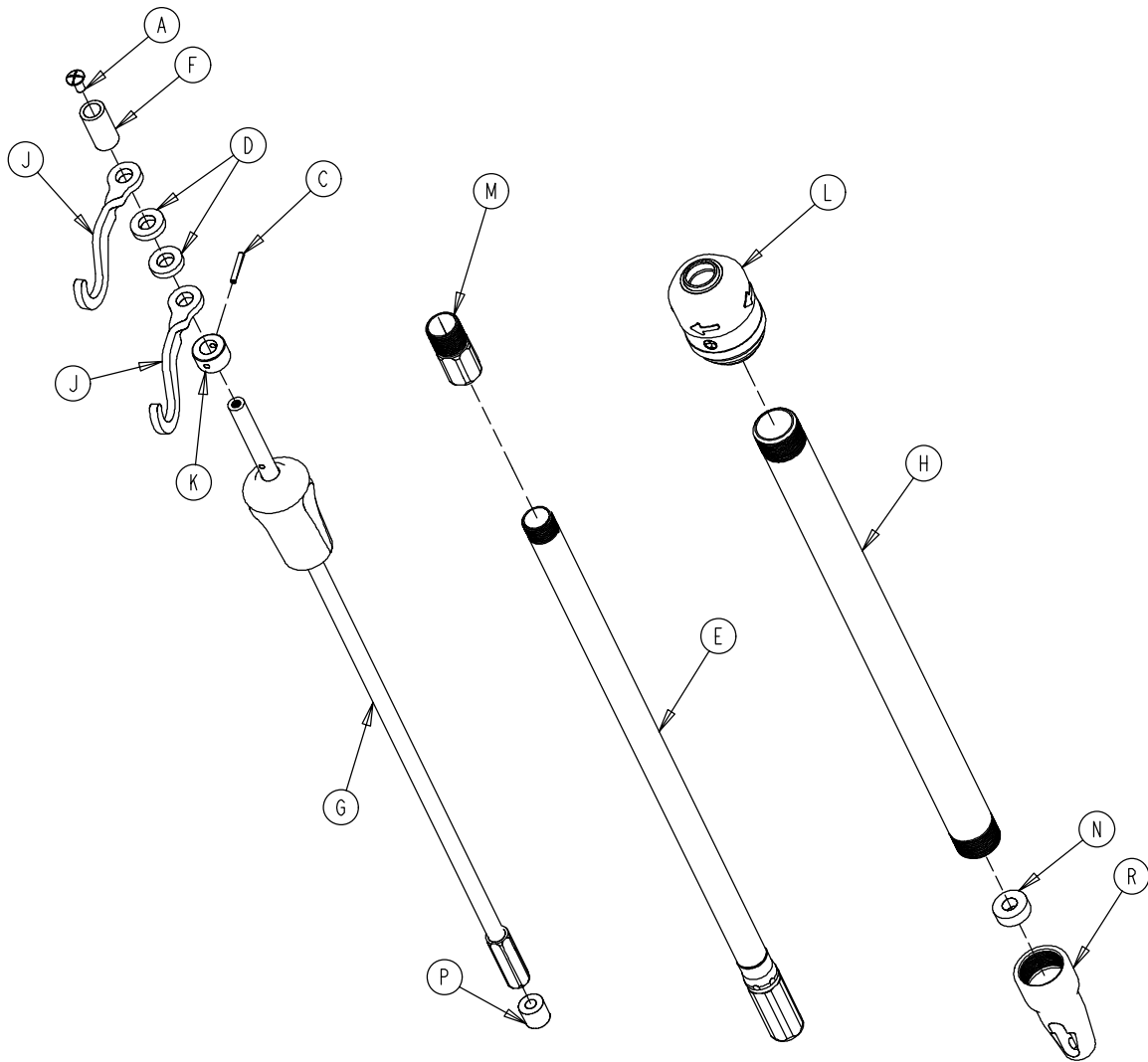

Item	Part No.	Part Name	Qty.
A	0007-004-000	Truss Hd. Machine Screw	1
C	0026-076-000	Roll Pin	1
D	0052-017-000	Spacer	2
E	1211-210-031	2nd Stage Assembly	1
F	0926-400-162	Spacer	1
G	<a href="#">(page 93)</a>	3rd Stage Assembly	1
H	1001-161-023	Base Tube	1
J	1010-059-016	I.V. Hook	2
K	1010-061-014	Collar	1
L	<a href="#">(page 90)</a>	I.V. Pole Latch	1
M	1211-110-016	Threaded Adaptor	1
N	1001-359-013	Dampener	1
P	1001-359-014	Dampener	1
R	1001-359-112	Pivot	1

# 3-Stage I.V. Pole 3rd Stage Assembly

Assembly part number 1211-110-032  
(reference only)

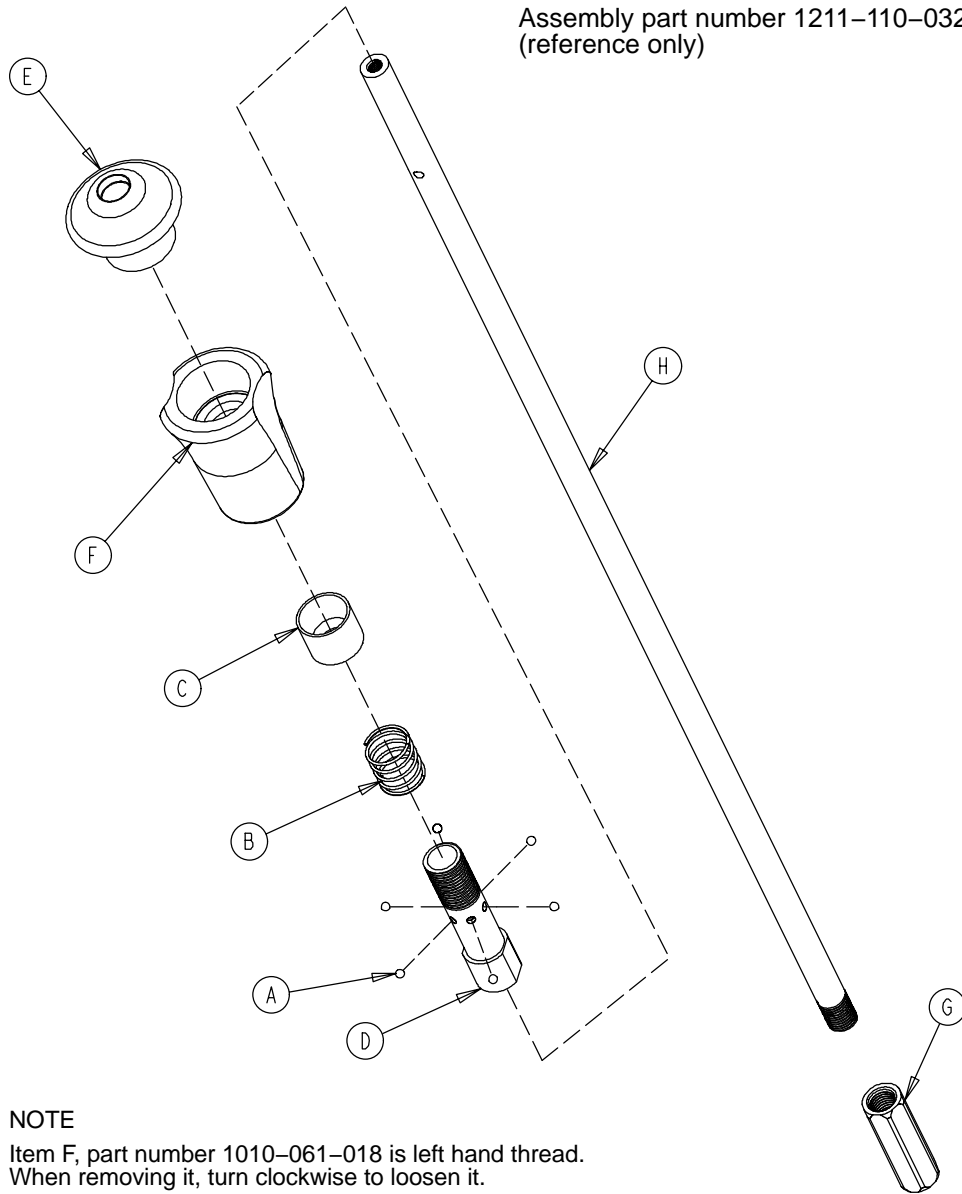

**NOTE**

Item F, part number 1010-061-018 is left hand thread.  
When removing it, turn clockwise to loosen it.

Item	Part No.	Part Name	Qty.
A	0031-021-000	Ball	6
B	0038-303-000	Compression Spring	1
C	1010-061-013	Ball Retainer	1
D	1010-061-016	Retaining Shaft	1
E	1010-061-017	Thumb Knob	1
F	1010-061-018	Hand Guard	1
G	1211-110-117	Nut	1
H	1211-110-033	3rd Extension Rod	1

# 1001-070-000 C-Spine Cassette Holder Assembly

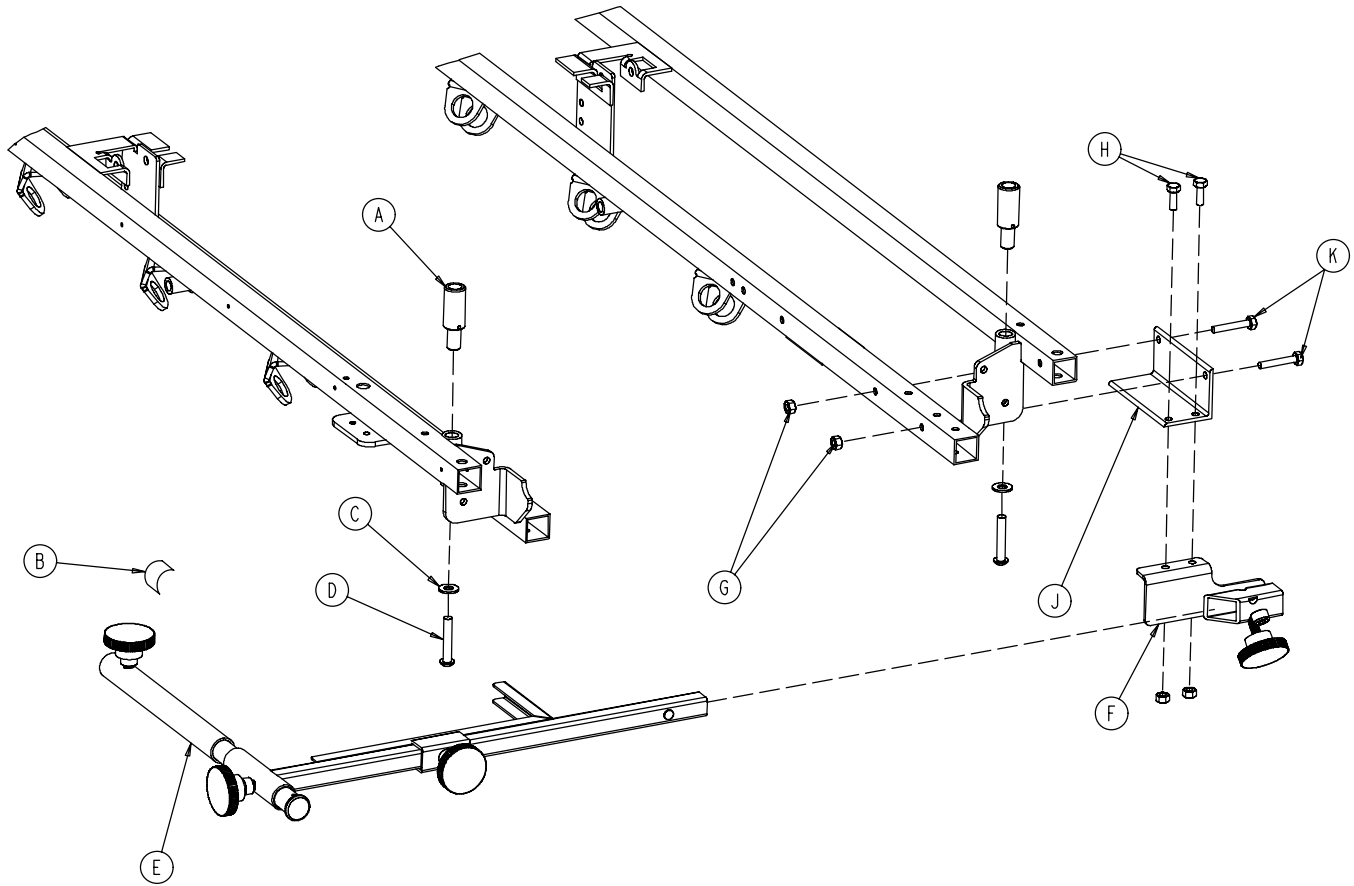

Item	Part No.	Part Name	Qty.
A	1010-070-025	I.V. Adaptor	2
B	1010-070-018	Specification Label	1
C	0011-447-000	Flat Washer	2
D	0004-054-000	But. Hd. Cap Screw	2
E	(page 95)	Support Pole Assembly	1
F	(page 96)	Storage Bracket Ass'y	1
G	0016-118-000	Nylock Nut	4
H	0003-356-000	Hex Hd. Cap Screw	2
J	1001-070-011	Attachment Bracket	1
K	0003-355-000	Hex Hd. Cap Screw	2

# 1010-070-010 C-Spine Support Pole Assembly

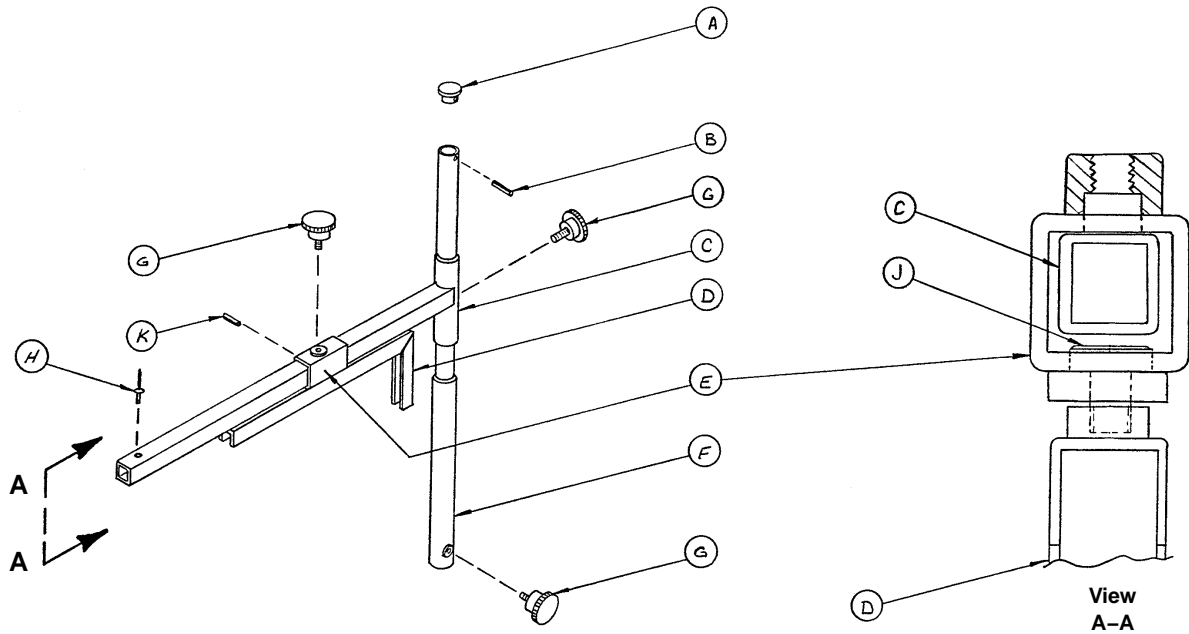

Item	Part No.	Part Name	Qty.
A	1010-070-033	Support Tube Cap	1
B	0026-006-000	Roll Pin	1
C	1010-070-034	Support Arm Weldment	1
D	1010-070-042	Cassette Holder Weldment	1
E	1010-070-050	Adjustment Tube Weldment	1
F	1010-070-030	Base Tube Weldment	1
G	1010-070-045	Knob	3
H	0025-055-000	Pop Rivet	1
J	1010-070-044	Pivot Pin	1
K	0026-005-000	Roll Pin	1



# 1010-070-019 C-Spine Storage Bracket Assembly

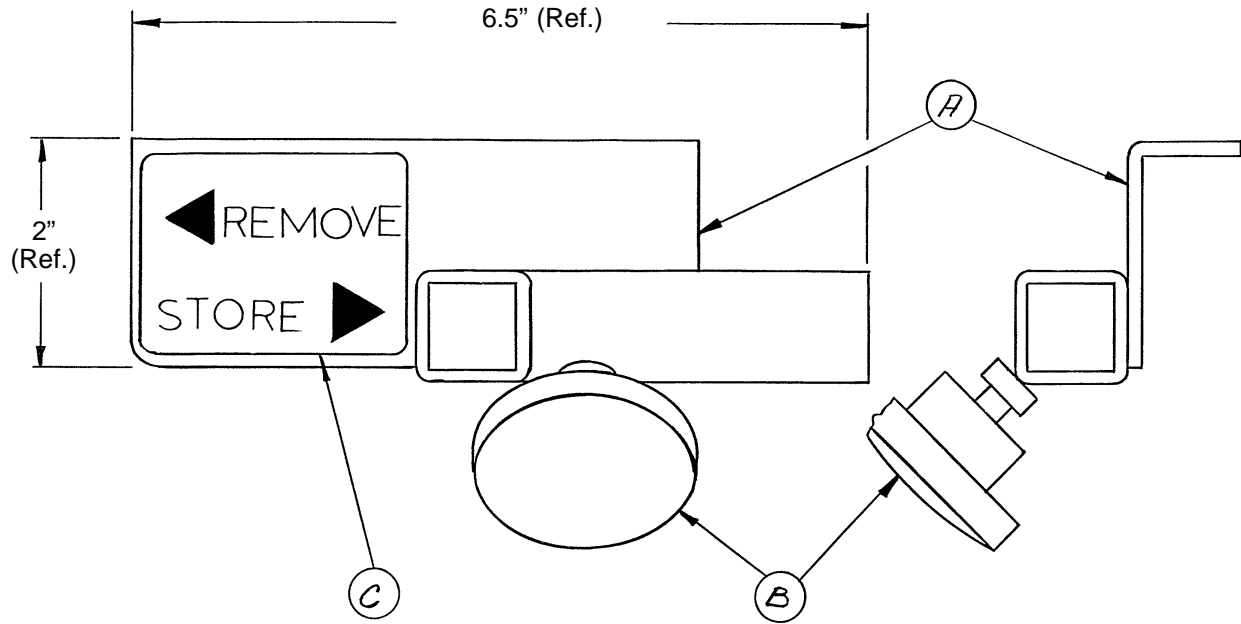

Item	Part No.	Part Name	Qty.
A	1010-070-020	Storage Bracket Weldment	1
B	1010-070-045	Knob	1
C	1010-070-023	Storage Label	1

# 0926-039-000 Optional Defibrillator Tray Assembly

Assembly part number 0926-039-010  
(reference only)

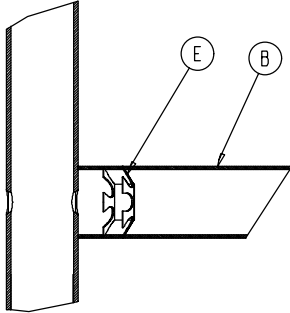

Umbrella Nut/Crosstube Detail

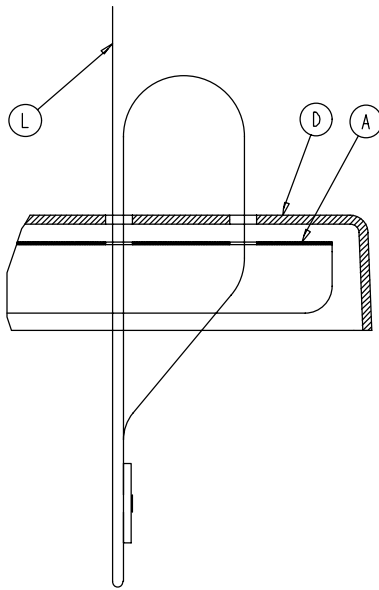

Strap Securing Detail

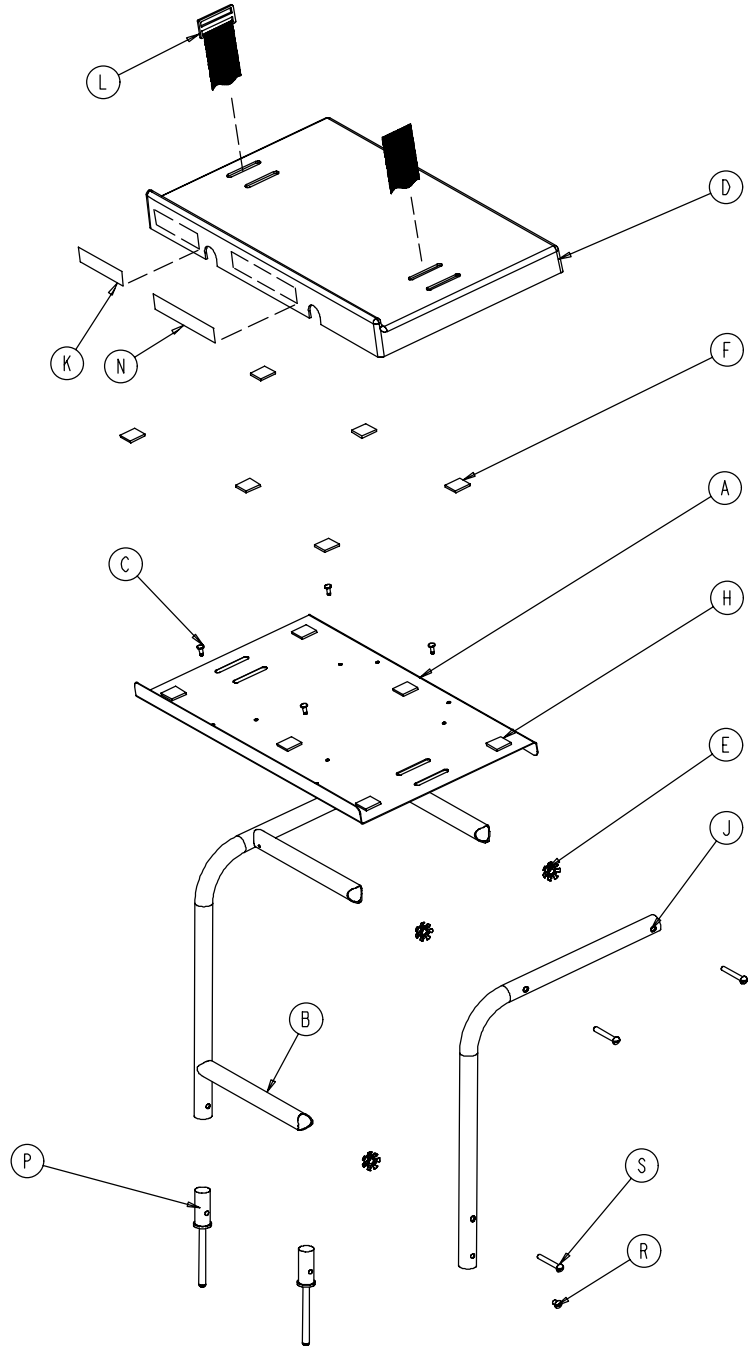

Item	Part No.	Part Name	Qty.	Item	Part No.	Part Name	Qty.
A	0946-039-004	Tray	1	J	0946-039-003	Support Tube	2
B	0926-039-016	Crosstube	3	K	0926-001-082	Label	1
C	0025-055-000	Rivet	4	L	1010-050-021	Long Strap	1
D	0926-039-009	Cover	1	N	0946-001-283	Label	1
E	0018-006-000	Umbrella Nut	6	P	0926-039-015	Holder	2
F	0029-008-000	Dual Lock	6	R	0002-044-000	Screw	2
H	0029-010-000	Dual Lock	6	S	0002-105-000	Rd. Hd. Mach. Screw	6

# 1010-050-100 Foot Extension/Defibrillator Tray Ass'y

Assembly part number 1010-050-210 (reference only)

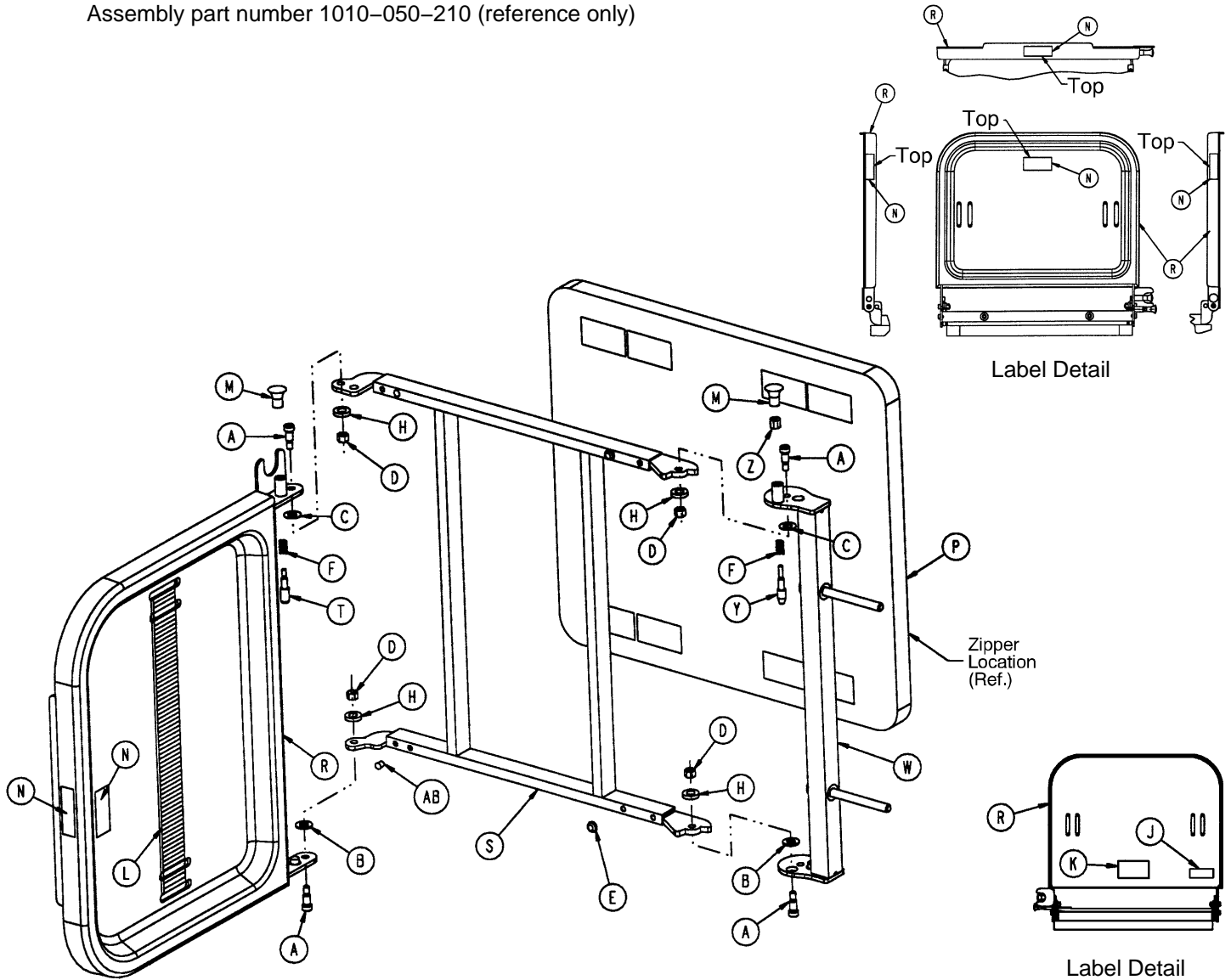

Item	Part No.	Part Name	Qty.	Item	Part No.	Part Name	Qty.
A	0008-049-000	Soc. Hd. Shoulder Bolt	4	M	1010-050-050	Knob	2
B	0014-020-000	Nylon Washer	2	N	1010-050-057	"Max. Weight" Label	4
C	0014-021-000	Nylon Washer	2	P	1010-050-205	Cushion Assembly	1
D	0016-028-000	Fiberlock Nut	4	R	1010-050-218	Foot & Tray Board	1
E	0037-052-000	Rubber Bumper	2	S	1010-050-225	Pivot Frame Weldment	1
F	0038-133-000	Spring	2	T	1010-050-242	Pin Lock	1
H	0052-017-000	Spacer	4	W	1010-050-246	Base Mounting Ass'y	1
J	1010-050-017	Specification Label	1	Y	1010-050-248	Lower Pin Lock	1
K	1010-050-019	"Push/Pull" Label	1	Z	1010-050-250	Pin Adjuster	1
L	1010-050-021	Long Strap	1	AB	0721-031-065	Hole Plug	2

# 0926-040-100 Foot Board/Chartholder Assembly

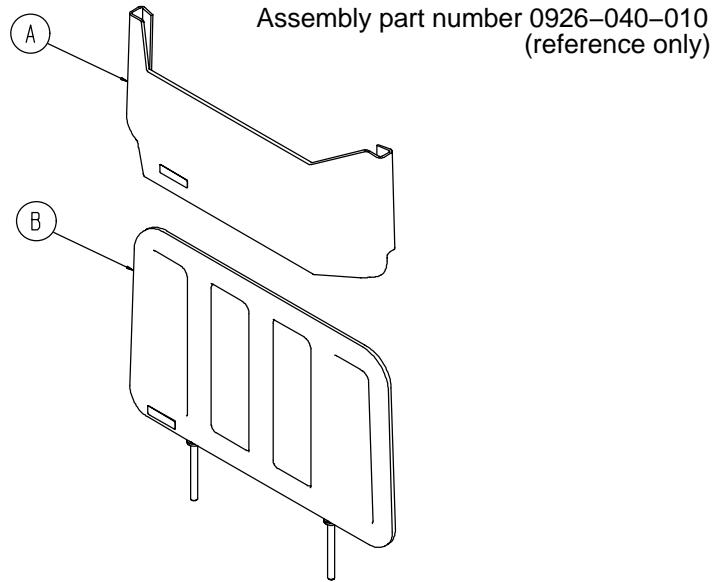

Item	Part No.	Part Name	Qty.
A	0946-028-011	Chart Holder	1
B	0946-029-006	Foot Board	1

# 1020-030-000 Upright Oxygen Bottle Holder Ass'y

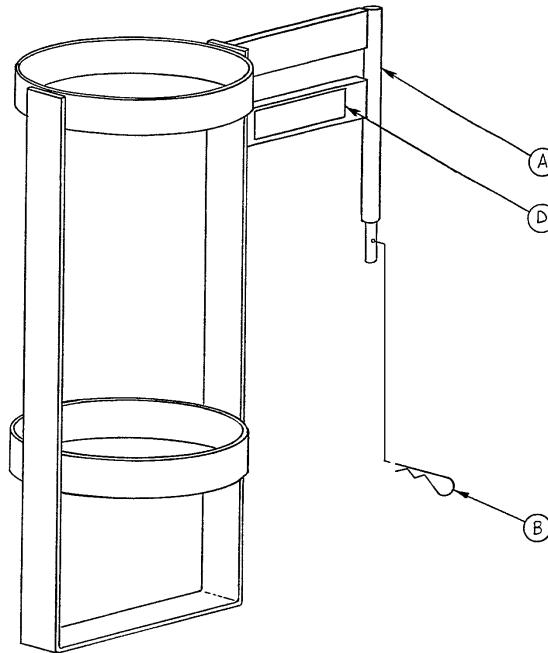

Item	Part No.	Part Name	Qty.
A	1020-030-011	Upright Bottle Holder	1
B	0027-012-000	Cotter Pin	1
D	1020-030-017	Specification Label	1

# 1040-010-090 Optional O<sub>2</sub> Bottle Retainer Assembly

---

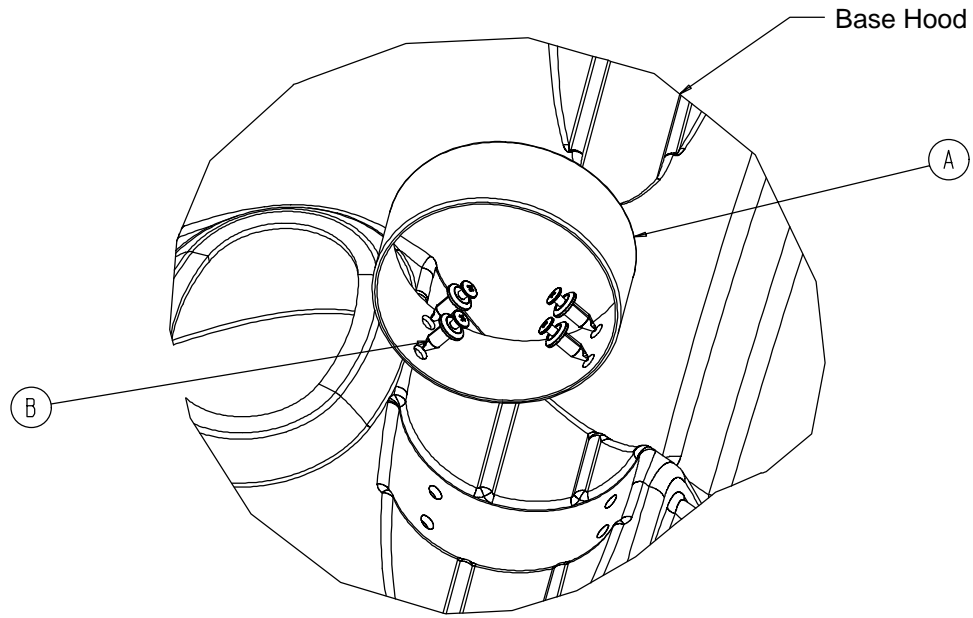

<b>Item</b>	<b>Part No.</b>	<b>Part Name</b>	<b>Qty.</b>
A	1040-010-091	Bottle Retainer	1
B	1040-010-092	Scrulok Fastener	4

# Mattresses and Siderail Pads

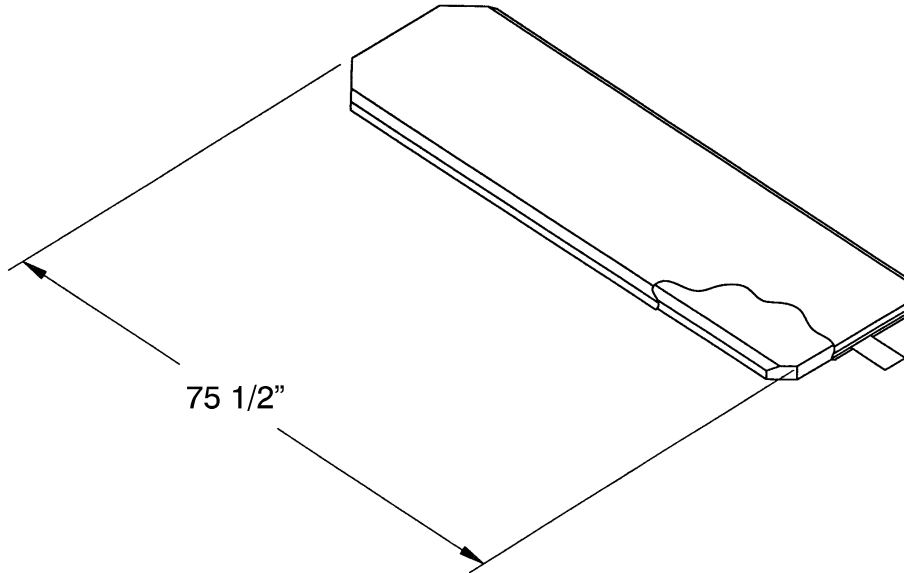

- Mattress, 3" Thick x 24" Wide, Standard ..... part # 1059-324-140
- Mattress, 4" Thick x 24" Wide, Standard ..... part # 1059-424-140
- Mattress, 3" Thick x 26" Wide, Standard ..... part # 1059-326-140
- Mattress, 4" Thick x 26" Wide, Standard ..... part # 1059-426-140
- Mattress, 3" Thick x 24" Wide, Enhanced Comfort ..... part # 0721-248-106
- Mattress, 4" Thick x 24" Wide, Enhanced Comfort ..... part # 0721-247-106
- Mattress, 3" Thick x 26" Wide, Enhanced Comfort ..... part # 1001-048-106
- Mattress, 4" Thick x 26" Wide, Enhanced Comfort ..... part # 1001-047-106

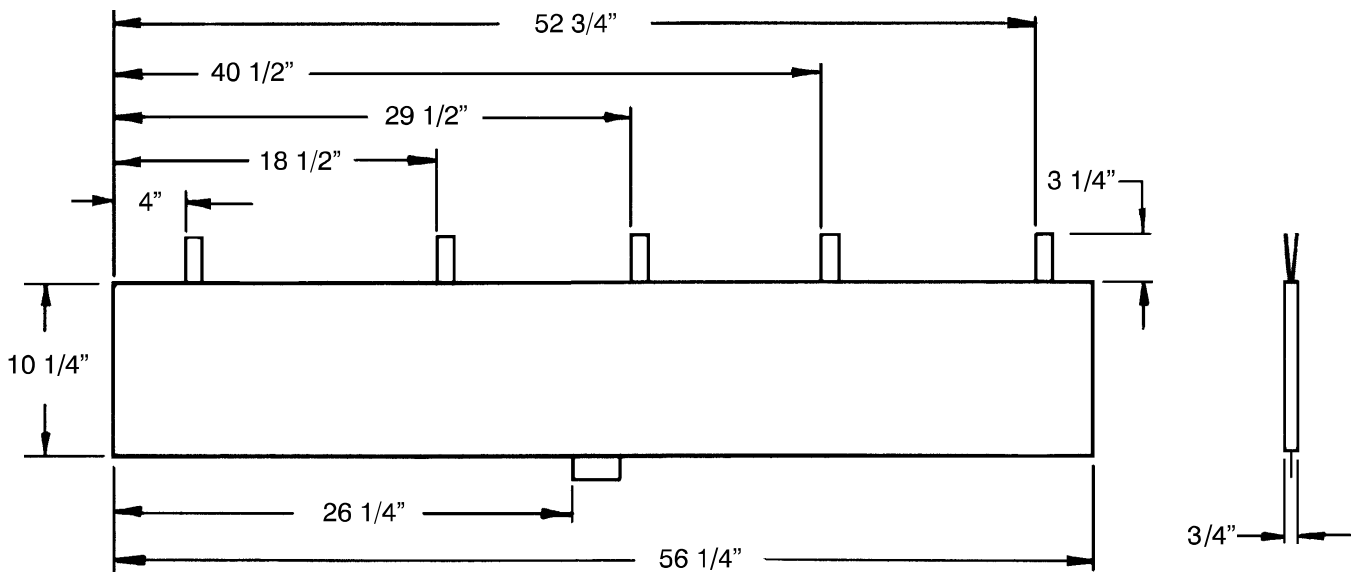

- Siderail Pad Set ..... part # 1010-052-000

# Mattresses and Siderail Pads

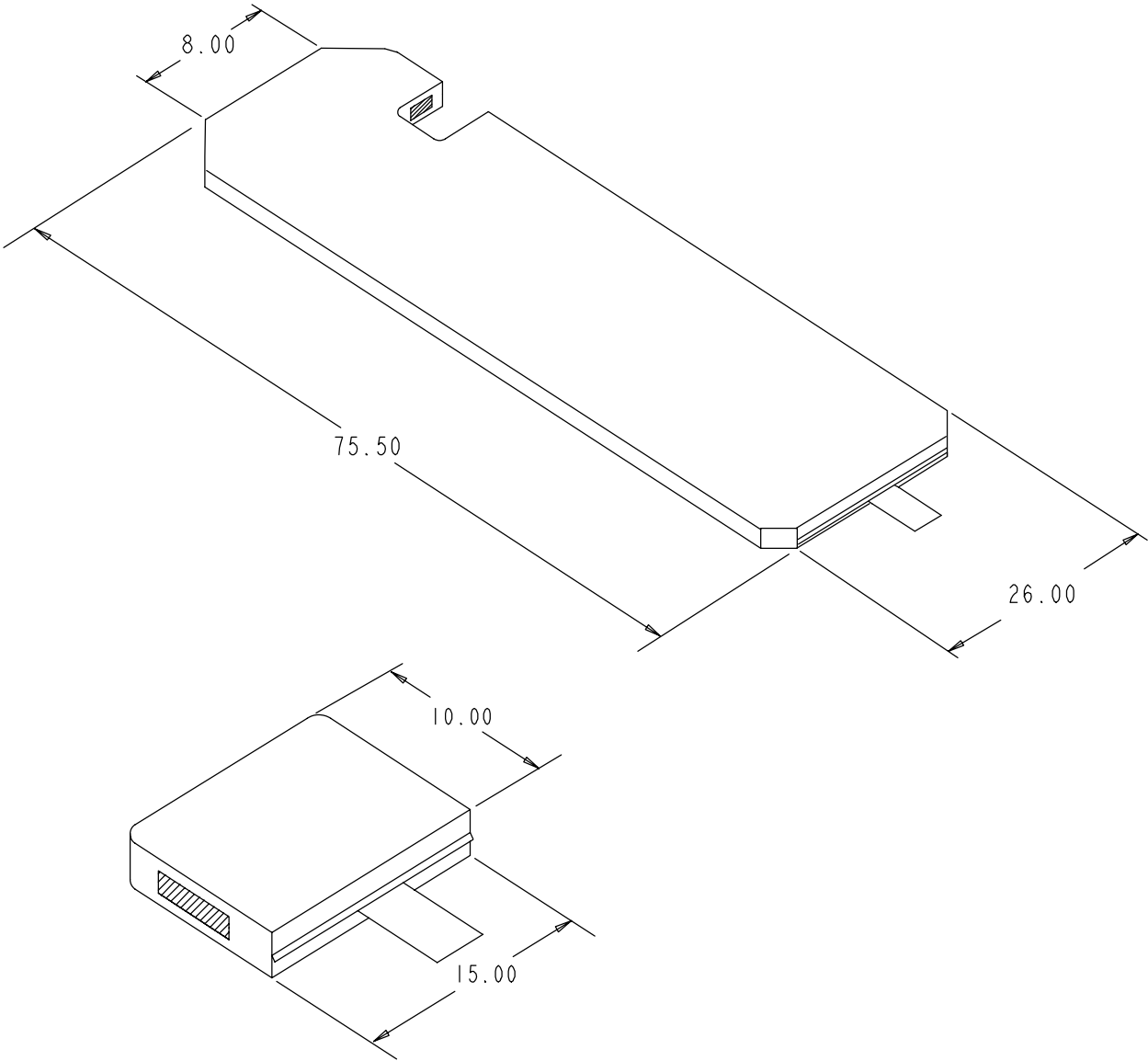

Mattress, 26" Wide ..... part # 1059-426-010

# Warranty

---

## Limited Warranty:

Stryker Medical Division, a division of Stryker Corporation, warrants to the original purchaser that its products should be free from defects in material and workmanship for a period of one (1) year after date of delivery. Stryker's obligation under this warranty is expressly limited to supplying replacement parts and labor for, or replacing, at its option, any product which is, in the sole discretion of Stryker, found to be defective. Stryker warrants to the original purchaser that the frame and welds on its beds will be free from structural defects for as long as the original purchaser owns the bed. If requested by Stryker, products or parts for which a warranty claim is made shall be returned prepaid to Stryker's factory. Any improper use or any alteration or repair by others in such manner as in Stryker's judgement affects the product materially and adversely shall void this warranty. Any repair of Stryker products using parts not provided or authorized by Stryker shall void this warranty. No employee or representative of Stryker is authorized to change this warranty in any way.

Stryker Medical stretchers are designed for a 10 year expected life under normal use conditions and appropriate periodic maintenance as described in the maintenance manual for each device.

This statement constitutes Stryker's entire warranty with respect to the aforesaid equipment. STRYKER MAKES NO OTHER WARRANTY OR REPRESENTATION, EITHER EXPRESSED OR IMPLIED, EXCEPT AS SET FORTH HEREIN. THERE IS NO WARRANTY OF MERCHANTABILITY AND THERE ARE NO WARRANTIES OF FITNESS FOR ANY PARTICULAR PURPOSE. IN NO EVENT SHALL STRYKER BE LIABLE HEREUNDER FOR INCIDENTAL OR CONSEQUENTIAL DAMAGES ARISING FROM OR IN ANY MANNER RELATED TO SALES OR USE OF ANY SUCH EQUIPMENT.

## To Obtain Parts and Service:

Stryker products are supported by a nationwide network of dedicated Stryker Field Service Representatives. These representatives are factory trained, available locally, and carry a substantial spare parts inventory to minimize repair time. Simply call your local representative, or call Stryker Customer Service at (800) 327-0770.

## Service Contract Coverage:

Stryker has developed a comprehensive program of service contract options designed to keep your equipment operating at peak performance at the same time it eliminates unexpected costs. We recommend that these programs be activated *before* the expiration of the new product warranty to eliminate the potential of additional equipment upgrade charges.

## **A SERVICE CONTRACT HELPS TO:**

- Ensure equipment reliability
- Stabilize maintenance budgets
- Diminish downtime
- Establish documentation for JCAHO
- Increase product life
- Enhance trade-in value
- Address risk management and safety



# Warranty

**Stryker offers the following service contract programs:**

<b>SPECIFICATIONS</b>	<b>GOLD</b>	<b>SILVER</b>	<b>PM* ONLY</b>
Annually scheduled preventative maintenance	X		X
All parts,** labor, and travel	X	X	
Unlimited emergency service calls	X	X	
Priority one contact; two hour phone response	X	X	X
Most repairs will be completed within 3 business days	X	X	
JCAHO documentation	X	X	X
On-site log book w/ preventative maintenance & emergency service records	X		
Factory-trained Stryker Service Technicians	X	X	X
Stryker authorized parts	X	X	X
End of year summary	X		
Stryker will perform all service during regular business hours (9-5)	X	X	X

\* Replacement parts and labor for products under PM contract will be discounted.

\*\* Does not include any disposable items, I.V. poles (except for Stryker HD permanent poles), mattresses, or damage resulting from abuse.

**Stryker Medical also offers *personalized* service contracts.**

**Pricing is determined by age, location, model and condition of product.**

***For more information on our service contracts, please call your local representative or call (800) 327-0770 (option #2).***

## **Return Authorization:**

Merchandise cannot be returned without approval from the Stryker Customer Service Department. An authorization number will be provided which must be printed on the returned merchandise. Stryker reserves the right to charge shipping and restocking fees on returned items.

**SPECIAL, MODIFIED, OR DISCONTINUED ITEMS NOT SUBJECT TO RETURN.**

## **Damaged Merchandise:**

ICC Regulations require that claims for damaged merchandise must be made with the carrier within fifteen (15) days of receipt of merchandise. **DO NOT ACCEPT DAMAGED SHIPMENTS UNLESS SUCH DAMAGE IS NOTED ON THE DELIVERY RECEIPT AT THE TIME OF RECEIPT.** Upon prompt notification, Stryker will file a freight claim with the appropriate carrier for damages incurred. Claim will be limited in amount to the actual replacement cost. In the event that this information is not received by Stryker within the fifteen (15) day period following the delivery of the merchandise, or the damage was not noted on the delivery receipt at the time of receipt, the customer will be responsible for payment of the original invoice in full.

Claims for any short shipment must be made within thirty (30) days of invoice.

## **International Warranty Clause:**

This warranty reflects U.S. domestic policy. Warranty outside the U.S. may vary by country. Please contact your local Stryker Medical representative for additional information.



## **European Representative**

Stryker EMEA RA/QA Director  
Stryker France  
ZAC Satolas Green Pusignan  
Av. De Satolas Green  
69881 MEYZIEU Cedex  
France

**stryker<sup>®</sup>**  
**Medical**

6300 S. Sprinkle Road, Kalamazoo, MI 49001-9799

(800) 327-0770  
[www.strykermedical.com](http://www.strykermedical.com)



DH 1/04 0721-109-002 REV A