

Transport Stretcher

Operations Manual

REF 747



















REF 748



Global symbol glossary

See the Global Symbol Glossary at ifu.stryker.com for symbol definitions.

Symbols

	Consult instructions for use
	General warning
	Caution
	No pushing
	Do not store the oxygen bottle
	Catalogue number
	Serial number
	For US Patents see www.stryker.com/patents
	CE mark
	Authorized representative in the European Community
	European medical device
	Quantity
	Unique device identifier
	Manufacturer
	Date of manufacture
	Importer
	Safe working load
	Turn the crank handle clockwise to raise the Gatch. Turn the crank handle counterclockwise to lower the Gatch.





	Lubricate
	Type B applied part
	Do not stack
	This way up
	Fragile, handle with care

Table of Contents

Warning/Caution/Note Definition	2
Summary of safety precautions	3
Pinch points.....	4
Introduction	5
Product description	5
Indications for use.....	5
Clinical benefits	5
Contraindications	5
Expected service life	5
Disposal/recycle	5
Specifications	6
Product illustration	8
Contact information.....	8
Serial number location.....	9
Date of manufacture.....	9
Setup.....	10
Operation	11
Applying and releasing the brakes.....	11
Raising or lowering the litter	11
Positioning the product in Trendelenburg.....	12
Positioning the product in Reverse Trendelenburg.....	12
Transporting a patient with the retractable fifth wheel.....	13
Positioning or stowing the push handles (optional).....	13
Raising or lowering the siderails	13
Raising or lowering the pneumatic Fowler backrest.....	14
Raising or lowering the gatch	14
Storing objects in the base hood.....	15
Accessories and parts	16
Date of manufacture for medical device accessories.....	17
Attaching the defibrillator tray.....	17
Converting the defibrillator tray/foot extender to a defibrillator tray	17
Converting the defibrillator tray/foot extender to a foot extender.....	18
Attaching the footboard/chart holder	18
Attaching the IV caddy.....	19
Positioning the two-stage permanently attached IV pole.....	19
Positioning the three-stage permanently attached IV pole	20
Attaching and positioning the removable IV pole.....	21
Attaching the upright oxygen bottle holder.....	22
Extending or stowing the serving tray holder/footboard	22
Attaching the siderail pads.....	23
Locating the patient restraint strap tie-ins	23
Cleaning.....	24
Cleaning the product	24
Cleaning the mattress	24
Remove iodine.....	25
Special instructions	25
Disinfecting	26
Disinfecting the product	26
Disinfecting the mattress	26
Preventive maintenance	28
Lubrication points.....	28

Warning/Caution/Note Definition

The words **WARNING**, **CAUTION**, and **NOTE** carry special meanings and should be carefully reviewed.

WARNING

Alerts the reader about a situation which, if not avoided, could result in death or serious injury. It may also describe potential serious adverse reactions and safety hazards.

CAUTION

Alerts the reader of a potentially hazardous situation which, if not avoided, may result in minor or moderate injury to the user or patient or damage to the product or other property. This includes special care necessary for the safe and effective use of the device and the care necessary to avoid damage to a device that may occur as a result of use or misuse.

Note - Provides special information to make maintenance easier or important instructions clearer.

Summary of safety precautions

Always follow the warnings and cautions listed on this page. Service only by qualified personnel.

WARNING

- Always allow the product to reach room temperature before you setup the product or test functional operations. Permanent product damage may occur.
 - Always operate the product when all operators are clear of the mechanisms.
 - Always apply the brakes when a patient is getting on the product or off the product or when the product is not moving. Injury could result if the product moves while a patient is getting on the product or off the product.
 - Always put the product in the lowest position with the siderails up and latched when you leave a patient unattended on the product. Do not leave the product at a higher height.
 - Always remove any devices that may be in the way before you raise or lower the litter.
 - Do not sit on the end of the product. The product may tip.
 - Always keep patient and operator extremities away from collapsed siderails to avoid injury.
 - Always position the patient in the center of the product.
 - Always lock the siderails in the full up position with the sleep surface flat in the lowest position when you transport a patient.
 - Always keep patient and operator extremities away from siderail spindles when you raise or lower the siderails.
 - Do not allow the siderails to lower on their own.
 - Always keep hands and fingers clear of the Fowler backrest release handles and the Fowler backrest frame when you lower the Fowler backrest.
 - Always use caution when you raise a pneumatic Fowler backrest while a patient is on the product. Use proper lifting techniques and get assistance, if necessary.
 - Do not place items that weigh more than 30 lb (14 kg) on the defibrillator tray. Always strap down all devices that you place on the defibrillator tray.
 - Always use caution if the defibrillator tray/foot extender, footboard/chart holder, or upright oxygen bottle holder is attached to avoid pinching your fingers when you position the foot end push handle option.
 - Do not place items that weigh more than 30 lb (14 kg) on the defibrillator tray/foot extender. Always strap down all devices that you place on the defibrillator tray.
 - Always secure the IV pole to the IV caddy when you transport the product.
 - Always store the IV caddy when not in use to avoid product damage.
 - Do not use the IV pole as a push/pull device. Product damage may occur.
 - Do not place objects that exceed 40 lb (18 kg) in the upright oxygen bottle holder.
 - Do not place objects that exceed 30 lb (14 kg) on the serving tray.
 - Always use caution when you attach restraint straps. Patient or operator injury may occur. Physical restraints, even if secured, may result in serious harm to patients and operators, including entanglement, entrapment, physical injury, or death.
 - Always attach restraint straps or devices only at the identified attachment points of the product. Failure to do so may result in patient or operator injury. Do not attach restraint straps to the siderail.
 - Always refer to the applicable state and federal restrictions and regulations and the appropriate facility protocols before you use any restraint strap or device.
 - Do not clean, service, or perform maintenance while the product is in use.
 - Do not immerse the mattress in cleaning or disinfectant solutions. Excess moisture could cause product malfunction that results in product damage or patient injury.
 - Do not allow fluid to pool on the mattress. Fluids can cause corrosion of components and may cause the safety and performance of this product to become unpredictable.
 - Always inspect mattress covers for tears, punctures, excessive wear, and misaligned zippers every time you clean the covers. Remove and replace a damaged mattress to prevent cross-contamination.
 - Do not steam clean, pressure wash, hose off, or ultrasonically clean mattresses. These methods of cleaning may void the product's warranty.
 - Do not steam clean, hose off, or ultrasonically clean the product. Use of these methods of cleaning is not recommended and may void the product's warranty.
 - Always disinfect the mattress between patients. Failure to do so could result in cross-contamination and infection.
-

CAUTION

- Improper usage of the product can cause injury to the patient or operator. Operate the product only as described in this manual.
 - Do not modify the product or any components of the product. Modifying the product can cause unpredictable operation resulting in injury to patient or operator. Modifying the product also voids its warranty.
 - Do not use the hydraulics on the base to raise the product with a patient lift under the product.
 - Do not place objects that exceed 60 lb (27 kg) in the base hood.
 - Do not sit, step, or stand on the base hood.
 - Always raise the IV pole before you attach the defibrillator tray/foot extender to the product. If you do not raise the IV pole, the foot extender will not operate.
 - Do not use the IV pole as a push/pull device. Product damage may occur.
 - Do not hang IV bags that exceed 40 lb (18 kg) on the IV pole.
 - Always make sure that the IV pole is at a low height to pass through door openings when you transport a patient.
-

Pinch points



Figure 1 – Pinch points

Introduction

This manual assists you with the operation or maintenance of your Stryker product. Read this manual before operating or maintaining this product. Set methods and procedures to educate and train your staff on the safe operation or maintenance of this product.

CAUTION

- Improper usage of the product can cause injury to the patient or operator. Operate the product only as described in this manual.
 - Do not modify the product or any components of the product. Modifying the product can cause unpredictable operation resulting in injury to patient or operator. Modifying the product also voids its warranty.
-

Note

- This manual is a permanent part of the product and should remain with the product even if the product is sold.
- Stryker continually seeks advancements in product design and quality. This manual contains the most current product information available at the time of printing. There may be minor discrepancies between your product and this manual. If you have any questions, contact Stryker Customer Service or Technical Support at 1-800-327-0770.

Product description

The Stryker Model 747/748 Transport Stretcher is a general purpose patient transport and treatment stretcher.

Indications for use

The Stryker Model 747/748 Transport Stretcher is a non-powered, wheeled device which consists of a platform mounted on a wheeled frame that is designed to support patients in a horizontal position. The device has siderails and has the option available to support the temporary or permanent placement of IV poles. A stretcher provides the operator a method of transporting patients within a health care facility. Some stretchers may also be used for minor procedures and short-term stay (treatment and recovery).

Clinical benefits

Patient transport and facilitate treatment

Contraindications

None known.

Expected service life

The Transport Stretcher has a 10 year expected service life under normal use conditions and with appropriate periodic maintenance.

Disposal/recycle

Always follow the current local recommendations and/or regulations governing environmental protection and the risks associated with recycling or disposing of the equipment at the end of its useful life.

Specifications

		Model 747 Transport Stretcher		Model 748 Transport Stretcher (wide) HT Packs	
 Safe working load Note - Safe working load indicates the sum of the patient, mattress, and accessory weight		500 lb	225 kg	500 lb	225 kg
		Overall length	83 in.	210.8 cm	83 in.
Overall width		30 in.	76.2 cm	34 in.	86.4 cm
Height	High	36 in.	91.4 cm	36 in.	91.4 cm
	Low	21.5 in.	54.6 cm	21.5 in.	54.6 cm
Patient surface		26 in. x 75.5 in.	66 cm x 192 cm	30 in. x 75.5 in.	76 cm x 192 cm
Siderails		13 in. x 55 in.	33 cm x 139.5 cm	13 in. x 55 in.	33 cm x 139.5 cm
Litter positioning	Backrest	0° to 90°		0° to 90°	
	Knee gatch	Not applicable		0° to 30°	
	Trendeleburg/Reverse Trendelenburg	+18° / -18°		+18° / -18°	
Caster diameter		8 in.	20 cm	8 in.	20 cm
Minimum under product clearance		6 in. nominal	15 cm	6 in. nominal	15 cm
		1.75 in. under the hydraulic cylinders and fifth wheel	4.5 cm	1.75 in. under the hydraulic cylinders and fifth wheel	4.5 cm

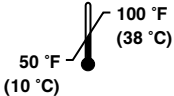
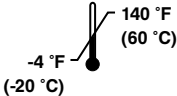
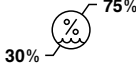
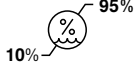
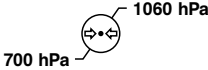
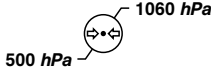
Environmental conditions	Operation	Storage and transportation
Temperature		
Relative humidity		
Atmospheric pressure		

In accordance with the European REACH regulation and other environmental regulatory requirements, the components that contain declarable substances are listed.

Description	Number	Substance of very high concern (SVHC) chemical name
Corner cover with two-stage IV pole assembly option, head end	0744-035-020	Lead
Corner cover with two-stage IV pole assembly option, head end	0744-035-025	Lead
Corner cover with three-stage IV pole assembly option, foot end	0744-035-070	Lead
Corner cover with three-stage IV pole assembly option, foot end	0744-035-075	Lead
Two-stage IV pole assembly	1211-210-010	Lead

Stryker reserves the right to change specifications without notice.

Product illustration

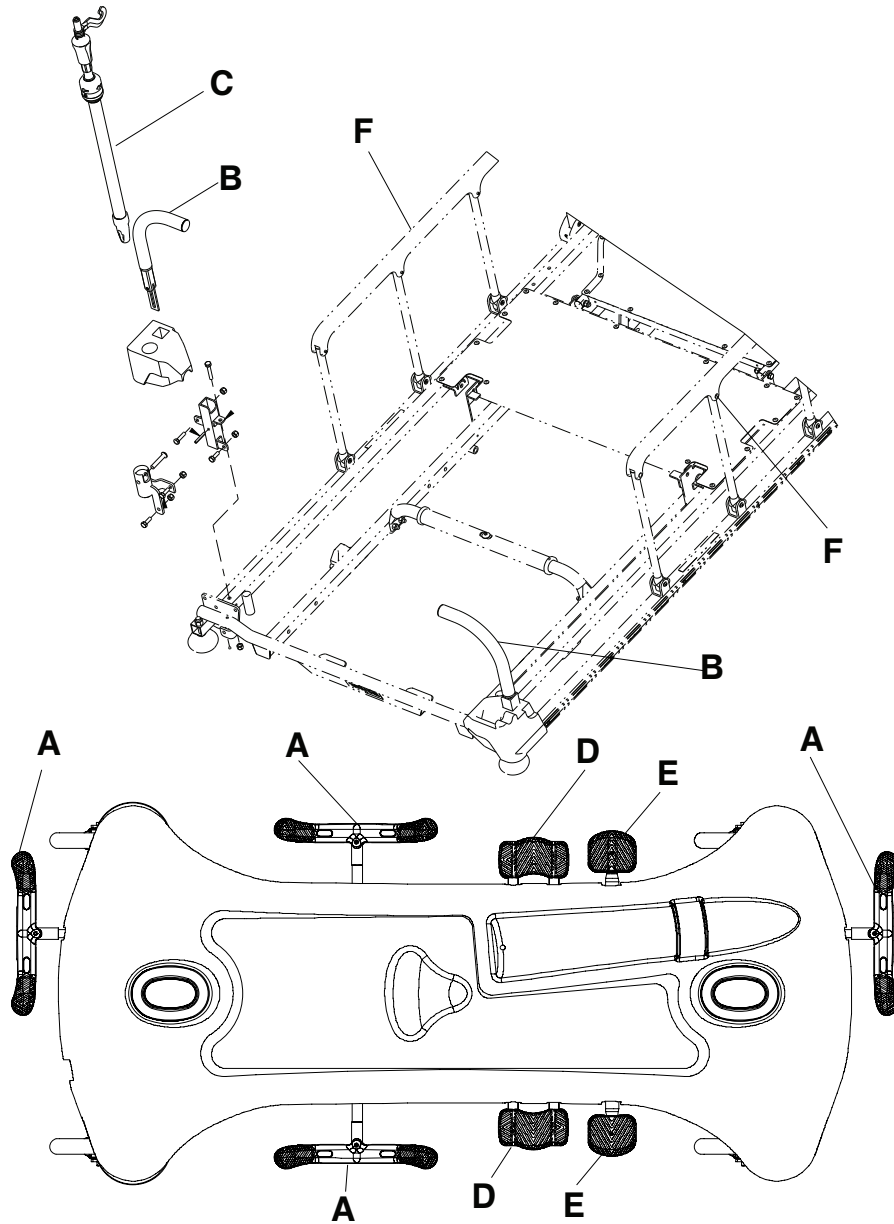

A	Brake/steer pedal
B	Head end push handle
C	IV pole

D	Lowering pedal
E	Pump pedal
F	Siderail

Contact information

Contact Stryker Customer Service or Technical Support at: 1-800-327-0770.

Stryker Medical
 3800 E. Centre Avenue
 Portage, MI 49002
 USA

Note - The user and/or the patient should report any serious product-related incident to both the manufacturer and the Competent authority of the European Member State where the user and/or patient is established.

To view your operations or maintenance manual online, see <https://techweb.stryker.com/>.

Have the serial number (A) of your Stryker product available when calling Stryker Customer Service or Technical Support. Include the serial number in all written communication.

Serial number location

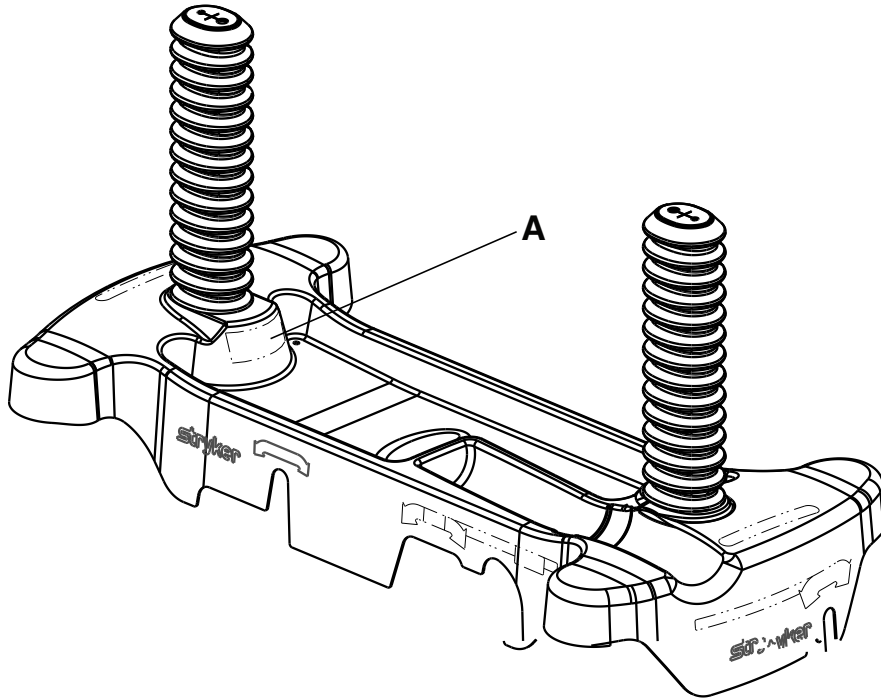

Date of manufacture

The year of manufacture is the first four digits of the serial number.

Setup

To unpack your product, see the unpacking instructions that are attached to the product inside of the shipping crate.

WARNING

- Always allow the product to reach room temperature before you setup the product or test functional operations. Permanent product damage may occur.
 - Always operate the product when all operators are clear of the mechanisms.
-

Make sure that the product is working before the product is put into service.

1. Apply the brakes. Push on the product to make sure that all four casters are locked.
2. Raise and lower the hydraulic lift system.
3. Raise the product to the highest height and put the product in the Trendelenburg position. Make sure that the head end lowers to the lowest position.
4. Raise the product to the highest height and put the product in the Reverse Trendelenburg position. Make sure that the foot end lowers to the lowest position.
5. Apply the fifth wheel to make sure that it guides and pivots the product.
6. Make sure that the siderails raise, lower, and lock in place.
7. Raise and lower the Fowler backrest.

Operation

Applying and releasing the brakes

WARNING - Always apply the brakes when a patient is getting on the product or off the product or when the product is not moving. Injury could result if the product moves while a patient is getting on the product or off the product.

To apply the brakes, push down on the brake (red) side of the brake/steer pedal. Push on the product to make sure that the brakes work.

To release the brakes, push down on the steer (green) side of the brake/steer pedal.

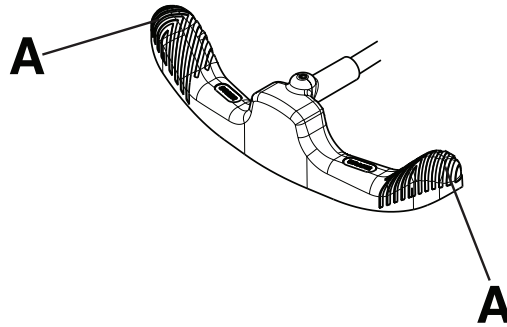

Figure 2 – Operating the brake/steer pedal

Note - Do not push down on the center of the brake/steer pedal. Always push down on the outer side (A) of the brake/steer pedal (Figure 2).

Raising or lowering the litter

WARNING

- Always put the product in the lowest position with the siderails up and latched when you leave a patient unattended on the product. Do not leave the product at a higher height.
 - Always remove any devices that may be in the way before you raise or lower the litter.
 - Do not sit on the end of the product. The product may tip.
 - Always keep patient and operator extremities away from collapsed siderails to avoid injury.
-

To raise the litter, pump the pump pedal (D) until you achieve the desired height (Figure 3).

To lower the entire litter, press on the center of the uni-lower pedal (C).

To lower the head end of the litter, press on the side of the uni-lower pedal (C) closest to the head end of the product.

To lower the foot end of the litter, press on the side of the uni-lower pedal (C) closest to the foot end of the product.

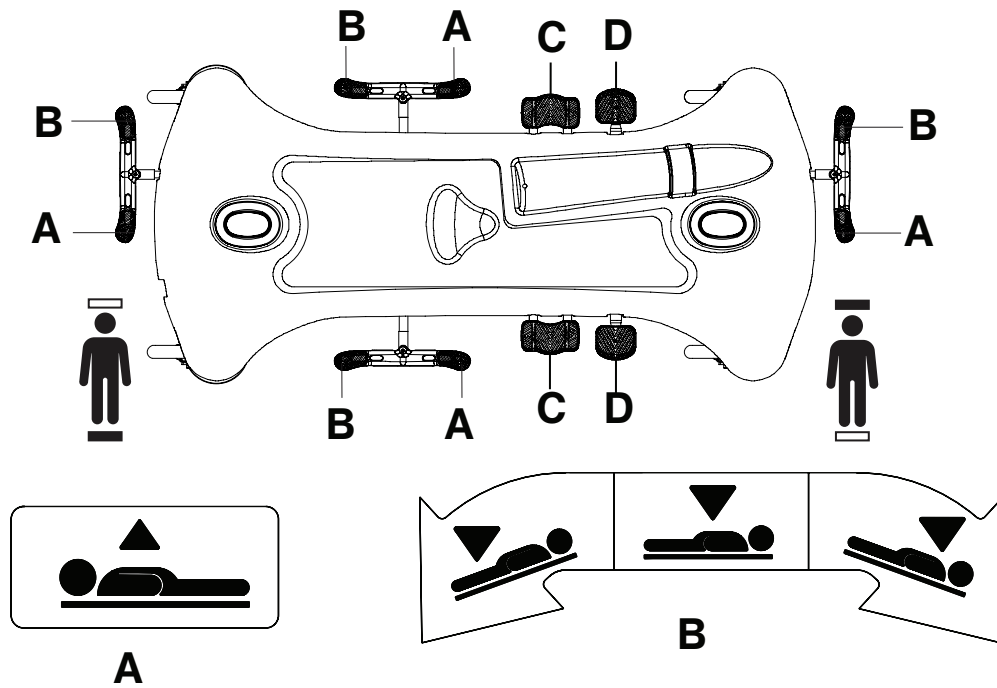

Figure 3 – Raising or lowering the litter

Positioning the product in Trendelenburg

WARNING - Always remove any devices that may be in the way before you raise or lower the litter.

CAUTION - Do not use the hydraulics on the base to raise the product with a patient lift under the product.

To position the product in the Trendelenburg position (head down), raise the litter to the highest height (Figure 3).

Note - Raise the litter to the highest height for a greater Trendelenburg angle.

Push down on the side of the uni-lower pedal closest to the head end (C).

To lower the product from Trendelenburg position, push down on the center of the uni-lower pedal (C) until the litter is flat.

Positioning the product in Reverse Trendelenburg

WARNING - Always remove any devices that may be in the way before you raise or lower the litter.

CAUTION - Do not use the hydraulics on the base to raise the product with a patient lift under the product.

To position the product in the Reverse Trendelenburg position (foot down), raise the litter to the highest height (Figure 3)

Note - Raise the litter to the highest height for a greater Trendelenburg angle.

Push down on the side of the uni-lower pedal closest to the foot end (C).

To lower the product from Reverse Trendelenburg position, push down on the center of the uni-lower pedal (C) until the litter is flat.

Transporting a patient with the retractable fifth wheel

WARNING

- Always position the patient in the center of the product.
 - Always remove any devices that may be in the way before you raise or lower the litter.
 - Always lock the siderails in the full up position with the sleep surface flat in the lowest position when you transport a patient.
-

CAUTION - Do not use the hydraulics on the base to raise the product with a patient lift under the product.

To transport a patient with the retractable fifth wheel:

1. Push down on the steer side of the brake/steer pedal to apply the fifth wheel.
2. Put the pedal in the neutral position to move the product laterally. Move the product to the desired location.

Note - Do not attempt to move the product laterally with the retractable fifth wheel applied.

3. Apply the brakes to lock the product in place.

Note - Always make sure that the brake is released before you move the product to avoid operator or patient injury.

Positioning or stowing the push handles (optional)

To position or stow the push handles:

1. Pivot the handles up from the end of the product (Figure 4).
2. Push down on the handles to lock them into position.
3. Reverse steps to stow the handles.

Note - Only use the push handles as push/pull devices unless otherwise specified to avoid product damage.

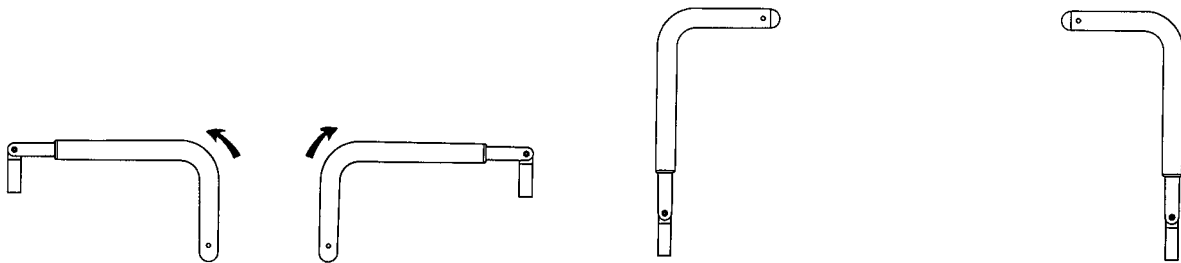

Figure 4 – Positioning the head end push handles

Raising or lowering the siderails

WARNING

- Always put the product in the lowest position with the siderails up and latched when you leave a patient unattended on the product. Do not leave the product at a higher height.
 - Always lock the siderails in the full up position with the sleep surface flat in the lowest position when you transport a patient.
 - Always keep patient and operator extremities away from siderail spindles when you raise or lower the siderails.
 - Do not allow the siderails to lower on their own.
-

To raise the siderails, use two hands to grasp the siderail. Raise the siderail until the release latch clicks into place. Pull on the siderail to make sure that the siderail is locked.

To lower the siderails, pull on the release latch. Guide the siderail to the lowest position.

Note - Do not use siderails as restraint devices to keep the patient from exiting the product. The siderails keep the patient from rolling off the product. The operator must determine the degree of restraint necessary to make sure that the patient is safe.

Raising or lowering the pneumatic Fowler backrest

WARNING

- Always keep hands and fingers clear of the Fowler backrest release handles and the Fowler backrest frame when you lower the Fowler backrest.
 - Always use caution when you raise a pneumatic Fowler backrest while a patient is on the product. Use proper lifting techniques and get assistance, if necessary.
-

To raise the Fowler backrest, squeeze the red Fowler backrest release handle (A) and pull the Fowler backrest up to the desired position (Figure 5).

To lower the Fowler backrest:

1. Squeeze the Fowler backrest release handle (A).
2. Push the Fowler backrest down to the desired position.

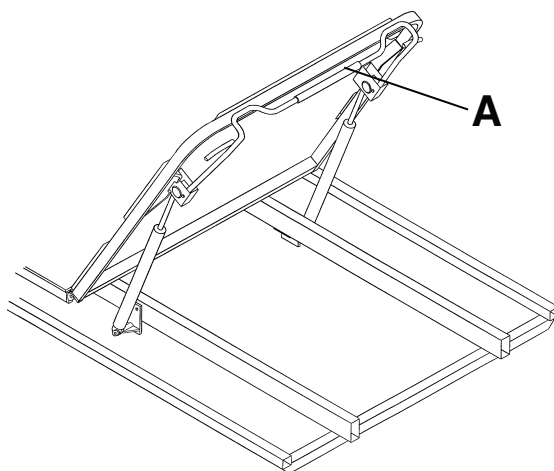

Figure 5 – Pneumatic Fowler

Raising or lowering the gatch

To raise the gatch (B), turn the crank handle (A) clockwise (Figure 6).

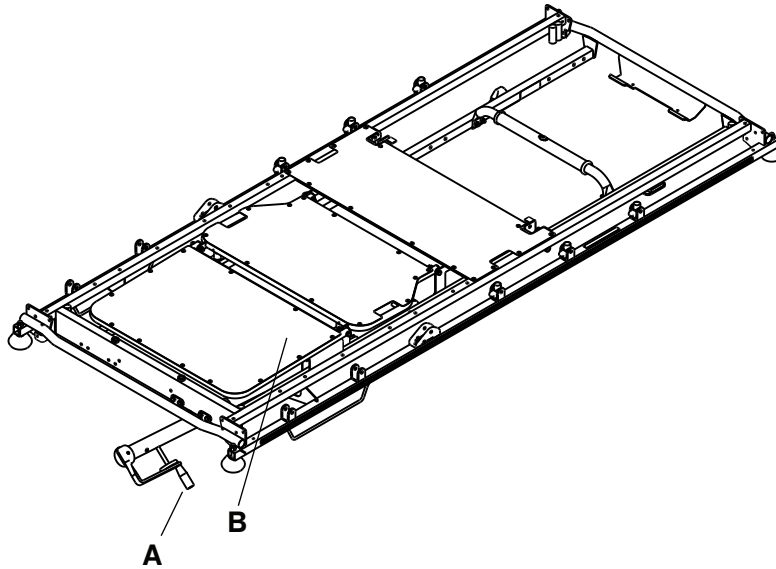

Figure 6 – Gatch and crank handle

To lower the gatch (B), turn the crank handle (A) counterclockwise.

Storing objects in the base hood

CAUTION

- Do not place objects that exceed 60 lb (27 kg) in the base hood.
 - Do not sit, step, or stand on the base hood.
-

You can store patient belongings in the base hood. Do not use the oxygen bottle holder cutout to store oxygen bottles or patient belongings.

Accessories and parts

These accessories may be available for use with your product. Confirm availability for your configuration or region. Call Stryker Customer Service: 1-800-327-0770.

Name	Part number
Brake cam and link	0853-003-035
Caster with full cover assembly	0853-503-020
Defibrillator tray	1105-045-200
Defibrillator tray/foot extender/footboard	1105-045-400
Fifth wheel assembly	1105-006-130
Footboard/chart holder	1105-045-500
IV caddy	0785-155-000
Havasu IV pole, removable	0390-025-000
Mattress, Ultra Comfort, 4" x 26"	0785-034-603
Mattress, Enhanced Comfort, 4" x 26"	0785-034-623
Mattress, Ultra Comfort, 5" x 26"	0785-034-633
Mattress, Ultra Comfort SE, domestic, 4" x 26"	1704-034-600
Mattress, Ultra Comfort SE, fire barrier, international, 4" x 26"	1704-034-601
Mattress, standard, 3" x 26"	1059-326-001
Mattress, ComfortGel SE, without fire barrier, 26"	1805-034-600
Mattress, ComfortGel SE, fire barrier, 26"	1805-034-601
Oxygen bottle retainer	1037-010-090
Oxygen bottle holder, upright	1115-130-000
Pneumatic cylinder	1010-031-078
Restraint strap, ankle	0946-043-001
Restraint strap, body	0390-019-000
Restraint strap, chest	1010-058-000
Restraint strap, full package	1010-077-000
Restraint strap, wrist	0946-044-001
Serving tray	1105-045-700
Serving tray holder/footboard	1105-045-800
Siderail pad set	1010-052-000

Date of manufacture for medical device accessories

The year of manufacture is the first four digits of the serial number.

Attaching the defibrillator tray

WARNING

- Do not place items that weigh more than 30 lb (14 kg) on the defibrillator tray. Always strap down all devices that you place on the defibrillator tray.
 - Always use caution if the defibrillator tray/foot extender, footboard/chart holder, or upright oxygen bottle holder is attached to avoid pinching your fingers when you position the foot end push handle option.
-

To attach the defibrillator tray:

1. Insert the defibrillator tray pins into the sockets at the foot end of the product.
2. Use the strap to secure devices to the defibrillator tray.

Note

- Do not use the defibrillator tray as a push/pull device. Product damage may occur.
- Always raise the foot end push handles when you use accessories (such as the defibrillator tray/foot extender, footboard/chart holder, upright oxygen bottle holder) or the accessories will not function.

Converting the defibrillator tray/foot extender to a defibrillator tray

WARNING

- Do not place items that weigh more than 30 lb (14 kg) on the defibrillator tray/foot extender. Always strap down all devices that you place on the defibrillator tray.
 - Always use caution if the defibrillator tray/foot extender, footboard/chart holder, or upright oxygen bottle holder is attached to avoid pinching your fingers when you position the foot end push handle option.
-

CAUTION - Always raise the IV pole before you attach the defibrillator tray/foot extender to the product. If you do not raise the IV pole, the foot extender will not operate.

To convert the defibrillator tray/foot extender to a defibrillator tray:

1. Pull out the top knob (A) (Figure 7).
2. Pivot the defibrillator tray (B) until the tray is flat over the foot end of the product. Release the top knob (A). Make sure that the defibrillator tray is locked in place.
3. Use the strap to secure devices to the defibrillator tray.

Note

- Do not use the defibrillator tray/foot extender as a push/pull device. Product damage may occur.
- Do not attach items to the foot extender.

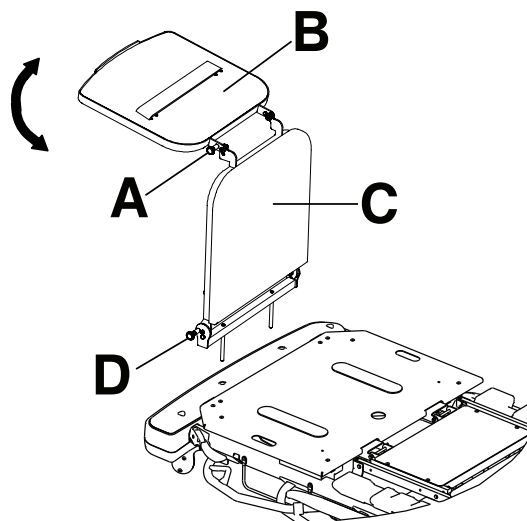

Figure 7 – Defibrillator tray/foot extender

Converting the defibrillator tray/foot extender to a foot extender

WARNING

- Do not place items that weigh more than 30 lb (14 kg) on the defibrillator tray/foot extender. Always strap down all devices that you place on the defibrillator tray.
- Always use caution if the defibrillator tray/foot extender, footboard/chart holder, or upright oxygen bottle holder is attached to avoid pinching your fingers when you position the foot end push handle option.

CAUTION - Always raise the IV pole before you attach the defibrillator tray/foot extender to the product. If you do not raise the IV pole, the foot extender will not operate.

To convert the defibrillator tray/foot extender to a foot extender (Figure 7):

1. Pull out the top knob (A).
2. Pivot the defibrillator tray (B) until the tray locks against the foot extender.
3. Pull out the bottom knob (D) while you hold the defibrillator tray/foot extender assembly.
4. Lower the foot extender (C) until the foot extender is flat.
5. Release the bottom knob (D). Push on the foot extender to make sure that the foot extender is locked in place.

Note

- Do not use the defibrillator tray/foot extender as a push/pull device. Product damage may occur.
- Do not attach items to the foot extender.

Attaching the footboard/chart holder

WARNING - Always use caution if the defibrillator tray/foot extender, footboard/chart holder, or upright oxygen bottle holder is attached to avoid pinching your fingers when you position the foot end push handle option.

To attach the footboard/chart holder, insert the footboard/chart holder pins into the sockets at the foot end of the product.

Note - Do not use the footboard/chart holder as a push/pull device. Product damage may occur.

Attaching the IV caddy

WARNING

- Always secure the IV pole to the IV caddy when you transport the product.
 - Always store the IV caddy when not in use to avoid product damage.
-

To attach the IV caddy (Figure 8):

1. Lift the IV caddy out of the storage tray or from the storage clip.
2. Pivot the IV caddy to the desired position.
3. Turn the knob (A) counterclockwise to loosen the pole clamp (C).
4. Pivot the knob (A) away from the arm connection assembly (B).
5. Open the clamp (C).
6. Place the IV pole into the clamp (C).
7. Close the clamp (C) around the IV pole and pivot the knob (A) into position.
8. Turn the knob (A) clockwise to tighten the knob.
9. Reverse steps to disconnect the IV caddy from the product.

To store the IV caddy, place the IV caddy in the storage tray or secure the caddy in the storage clip.

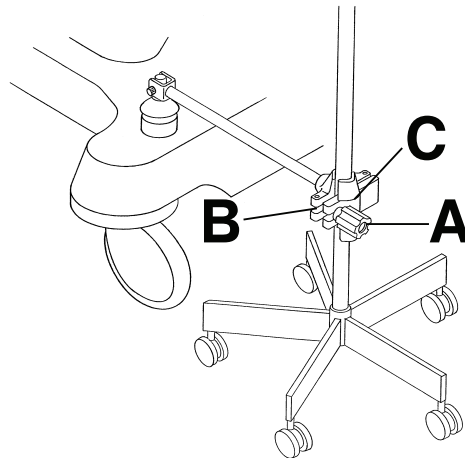

Figure 8 – IV caddy

Positioning the two-stage permanently attached IV pole

WARNING - Do not use the IV pole as a push/pull device. Product damage may occur.

You can purchase the product with the two-stage IV pole option permanently attached at the head end, foot end, or both ends of the product. The IV pole is equipped with a telescopic pole that extends to provide a second height position. You can fold and store the IV pole when not in use.

To position the two-stage IV pole (Figure 9):

1. Lift and pivot the pole from the storage position.
2. Push the IV pole down until the IV pole locks in place.
3. To raise the height of the IV pole, pull up on the telescoping portion (A) until the pole locks in place at the fully raised position.
4. Rotate the IV hangers (B) to the desired position and hang the IV bags.
5. To lower the IV pole, hold the telescoping portion of the IV pole, turn the latch (C), and lower the telescoping portion.

Note

- Do not hang IV bags that exceed 40 lb (18 kg) on the IV pole.
- Always make sure that the IV pole is at a low height to pass safely through door openings when you transport a patient.

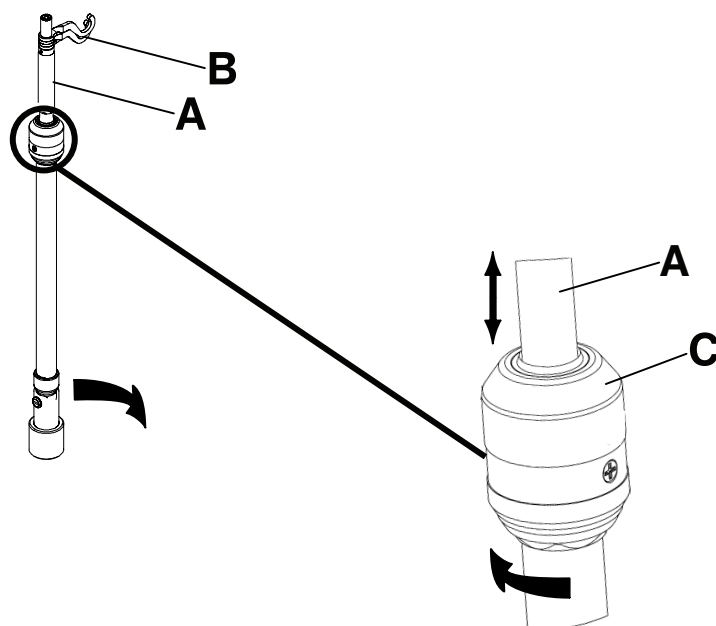

Figure 9 – Positioning the 2 stage permanently attached IV pole

Positioning the three-stage permanently attached IV pole

WARNING - Do not use the IV pole as a push/pull device. Product damage may occur.

You can purchase the product with the three-stage IV pole option permanently attached at the head end, foot end, or both ends of the product. The IV pole is equipped with a telescopic pole that extends to provide a second and third height position. You can also fold and store the IV pole when not in use.

To position the three-stage IV pole (Figure 10):

1. Lift and pivot the pole from the storage position.
2. Push the IV pole down until the pole locks in place.
3. To raise the height of the IV pole, pull up on the telescoping portion (A) until the pole locks into place at the fully raised position.
4. For a higher IV pole, pull up on section (B). Release section (B) at any desired height to lock the pole in place.
5. Rotate the IV hangers (C) to the desired position and hang the IV bags.
6. To lower the IV pole, push up on the yellow portion of the grip (D) while holding on to section (B) until the pole lowers.
7. Turn the latch (E) and lower the IV pole telescoping portion.

Note

- Do not hang IV bags that exceed 12 lb (5 kg) total for all bags on the IV pole.
- Do not hang IV bags that exceed 9.3 lb (4.2 kg) on a single IV hanger.
- Always make sure that the IV pole is at a low height to allow the pole to pass safely through door openings when you transport a patient.

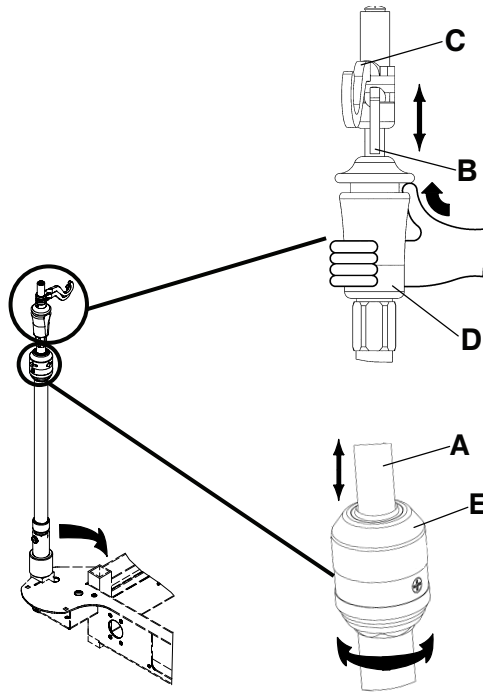

Figure 10 – Positioning the three-stage permanently attached IV pole

Attaching and positioning the removable IV pole

CAUTION

- Do not use the IV pole as a push/pull device. Product damage may occur.
 - Do not hang IV bags that exceed 40 lb (18 kg) on the IV pole.
 - Always make sure that the IV pole is at a low height to pass through door openings when you transport a patient.
-

To attach and position the removable IV pole (Figure 11):

1. Insert the IV pole into a socket at the head end or foot end of the product.
2. Turn the knob (A) counterclockwise and pull up on the telescoping portion (B) until you reach the desired height.
3. Turn the knob (A) clockwise to lock the telescoping portion in place.

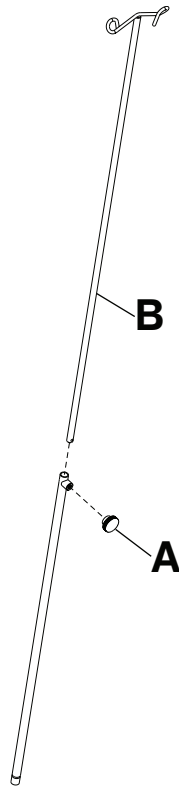

Figure 11 – Removable IV pole

Attaching the upright oxygen bottle holder

WARNING

- Do not place objects that exceed 40 lb (18 kg) in the upright oxygen bottle holder.
 - Always use caution if the defibrillator tray/foot extender, footboard/chart holder, or upright oxygen bottle holder is attached to avoid pinching your fingers when you position the foot end push handle option.
-

The upright oxygen bottle holder supports an oxygen bottle in a vertical position.

To attach the upright oxygen bottle holder:

1. Insert the support bar into any of the IV sockets.
2. Insert the cotter pin through the hole in the support bar to secure the bottle holder to the product.

Note - Do not use the upright oxygen bottle holder as a push/pull device. Product damage may occur.

Extending or stowing the serving tray holder/footboard

WARNING - Do not place objects that exceed 30 lb (14 kg) on the serving tray.

To fit the serving tray on the siderail, pull out on both sides of the serving tray and position the tray over the siderails.

To stow the serving tray:

1. Remove the serving tray from the siderails.
2. Push in the sides of the serving tray.
3. Store the serving tray in the footboard.

Note - Do not use the serving tray/footboard as a push/pull device. Product damage may occur.

Attaching the siderail pads

To attach the siderail pads:

1. Tuck the siderail pad between the mattress and the siderail.
2. Attach the hook and loop fastener straps around the top of the siderail to secure the siderail pad.

Locating the patient restraint strap tie-ins

WARNING

- Always use caution when you attach restraint straps. Patient or operator injury may occur. Physical restraints, even if secured, may result in serious harm to patients and operators, including entanglement, entrapment, physical injury, or death.
 - Always attach restraint straps or devices only at the identified attachment points of the product. Failure to do so may result in patient or operator injury. Do not attach restraint straps to the siderail.
 - Always refer to the applicable state and federal restrictions and regulations and the appropriate facility protocols before you use any restraint strap or device.
-

There are eight patient restraint strap tie-in locations on the litter assembly for attaching patient restraint straps (Figure 12 or Figure 13).

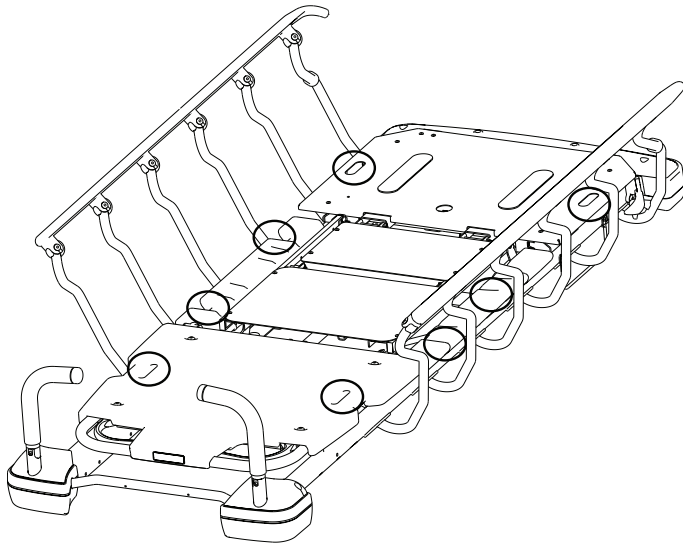

Figure 12 – Prime restraint strap locations

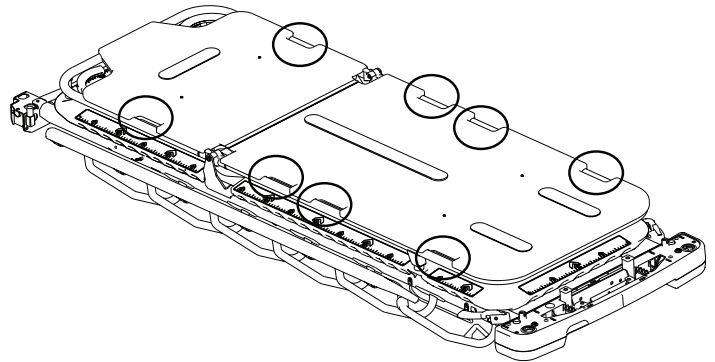

Figure 13 – Prime X option restraint strap locations

Note - Restraint straps are Type B applied parts.

Cleaning

Cleaning the product

WARNING - Do not clean, service, or perform maintenance while the product is in use.

Recommended cleaning method:

1. Follow the cleaning solution manufacturer's dilution recommendations.
2. Hand wash all surfaces of the product with warm water and mild detergent.
3. Avoid over-saturation and make sure that the product does not stay wet longer than the detergent manufacturer's guidelines for proper cleaning.
4. Dry thoroughly. Do not replace the mattress on the product until the product is dry.
5. Check functionality before you return the product to service.
 - Raise and lower the product
 - Lock and unlock the brake/steer pedal in both positions
 - Latch and unlatch the siderails
 - Raise and lower the Fowler backrest
 - Raise and lower the Gatch
 - Make sure all components have proper lubrication
 - Make sure all labels are intact

Note

- Direct skin contact with visibly soiled, permeable material may increase the risk of infection.
- Some cleaning agents are corrosive in nature and may cause damage to the product if you use them improperly. If you do not properly rinse and dry the product, a corrosive residue may be left on the surface of the product that could cause premature corrosion of critical components. Failure to follow these cleaning instructions may void your warranty.
- Do not steam clean, power wash, hose off, or ultrasonically clean the product. Use of these methods of cleaning is not recommended and may void the product's warranty.
- Clean the base hood.
- Clean the bottom of the brake pads to prevent wax or floor remnant buildup.

Cleaning the mattress

WARNING

- Do not clean, service, or perform maintenance while the product is in use.
 - Do not immerse the mattress in cleaning or disinfectant solutions. Excess moisture could cause product malfunction that results in product damage or patient injury.
 - Do not allow fluid to pool on the mattress. Fluids can cause corrosion of components and may cause the safety and performance of this product to become unpredictable.
 - Always inspect mattress covers for tears, punctures, excessive wear, and misaligned zippers every time you clean the covers. Remove and replace a damaged mattress to prevent cross-contamination.
 - Do not steam clean, pressure wash, hose off, or ultrasonically clean mattresses. These methods of cleaning may void the product's warranty.
-

The life of the mattress can be affected by an increase in frequency of usage, which might include more frequent cleaning and disinfection.

Recommended cleaning method:

1. Use a clean, soft cloth to wipe down the entire mattress with a mild soap and water solution to remove foreign material.
2. Wipe down the mattress with a clean, dry cloth to remove any excess liquid or cleaning agents.
3. Rinse and dry covers after cleaning.
4. Disinfect as needed with a hospital grade disinfectant after cleaning has been completed.

Note

- Do not iron, dry-clean, or tumble dry the mattress, as this will cause malfunction and damage the product.
- The mattress cover must be completely dry before you store, add linens, or place a patient on the mattress to prevent impairment of the product performance.
- Avoid over-exposure to alcohol or hydrogen peroxide. The cover material will swell.
- Do not allow liquid to seep into the zipper area and watershed cover barrier. Fluids allowed to come in contact with the zipper may leak into the mattress which could impair the product performance.
- Some cleaning agents are corrosive in nature and may cause damage to the product. If you do not rinse and dry the product well, a corrosive residue may be left on the surface of the product that could cause premature corrosion of critical components. Failure to follow these cleaning instructions may void your warranty.

Remove iodine

1. Make a solution of 1 to 2 tablespoons of sodium thiosulfate in a pint of warm water. Use the solution to wipe down the stained area.
2. Clean the stain as soon as possible after the stain occurs.
3. If stains are not immediately removed, allow solution to soak or stand on the mattress before you wipe the mattress.
4. Rinse the mattresses which have been exposed to the solution with clear water before you return the mattresses to service.

Note - Failure to follow these directions when you use these types of cleaners may void this product's warranty.

Special instructions

Hook and loop fasteners	Saturate with disinfectant, rinse with water, and allow the solution to evaporate.
Solids or stains	Use neutral soaps and warm water. Do not use harsh cleansers, solvents, or abrasive cleaners.
Hard-to-clean spots	Use standard household cleansers or vinyl cleansers and a soft bristle brush on troublesome spots or stains. Pre-soak dried-on soil.
Laundering	Laundering is not recommended. Laundering may decrease the useful life of the mattress.

Disinfecting

Disinfecting the product

WARNING

- Do not clean, service, or perform maintenance while the product is in use.
 - Do not steam clean, hose off, or ultrasonically clean the product. Use of these methods of cleaning is not recommended and may void the product's warranty.
-

Recommended disinfectants:

- Quaternaries (active ingredient - ammonium chloride) that contain less than 3% glycol ether
- Phenolic disinfectant (active ingredient - o-phenylphenol)
- Chlorinated bleach solution (5.25% bleach diluted 1 part bleach to 100 parts water which equals 520 ppm available chlorine (40 mL of a 5.25% bleach solution per 4000 mL water))
- 70% isopropyl alcohol

Recommended disinfection method:

1. Follow the disinfectant solution manufacturer's dilution recommendations.
2. Hand wash all surfaces of the product with a disinfectant solution.
3. Avoid oversaturation and make sure that the product does not stay wet longer than the chemical manufacturer's guidelines for proper disinfecting.
4. Dry the product. Do not place the mattress on the product until the product is dry.
5. Disinfect the hook and loop fasteners after every use. Saturate the hook and loop fasteners with disinfectant, rinse with water, and allow the disinfectant to evaporate (appropriate disinfectant is determined by the facility).
6. Check functionality before you return the product to service.
 - Raise and lower the product.
 - Lock and unlock the brake/steer pedal in both positions.
 - Latch and unlatch the siderails.
 - Raise and lower the Fowler backrest.
 - Raise and lower the Gatch.
 - Make sure all components have proper lubrication.
 - Make sure all labels are intact.

Note

- Direct skin contact with visibly soiled, permeable material may increase the risk of infection.
- Some cleaning agents are corrosive in nature and may cause damage to the product. If you do not rinse and dry the product well, a corrosive residue may be left on the surface of the product that could cause premature corrosion of critical components. Failure to follow these cleaning instructions may void your warranty.

Disinfecting the mattress

WARNING - Always disinfect the mattress between patients. Failure to do so could result in cross-contamination and infection.

Recommended disinfectants:

- Quaternaries (active ingredient - ammonium chloride) that contain less than 3% glycol ether
- Phenolic disinfectant (active ingredient - o-phenylphenol)

- Chlorinated bleach solution (5.25% bleach diluted 1 part bleach to 100 parts water which equals 520 ppm available chlorine (40 mL of a 5.25% bleach solution per 4000 mL water))
- 70% isopropyl alcohol

Recommended disinfection method:

1. Make sure that the mattress is clean and dry before you apply disinfectants.
2. Wipe down the mattress with a clean, dry cloth to remove any excess liquid or disinfectant.
3. Rinse and dry covers after disinfection.

Note

- The mattress cover must be dry before you store or add linens. Failure to remove excess disinfectant could cause degradation of the cover material.
- Some cleaning agents are corrosive in nature and may cause damage to the product if you use them improperly. If you do not rinse and dry the product well, a corrosive residue may be left on the surface of the product that could cause premature corrosion of critical components. Failure to follow these cleaning instructions may void your warranty.
- Frequent or prolonged exposure to higher concentrations of disinfectant solutions may prematurely age the cover fabric.
- The use of accelerated hydrogen peroxides or quaternaries that contain glycol ethers may damage the cover.

Preventive maintenance

Remove product from service before you perform the preventive maintenance inspection. Check all items listed during annual preventive maintenance for all Stryker Medical products. You may need to perform preventive maintenance checks more often based on your level of product usage. Service only by qualified personnel.

Note - Clean and disinfect the exterior of the mattress before inspection, if applicable.

Inspect the following items:

- _____ All welds
- _____ All fasteners are secure
- _____ Brake mechanism works
- _____ Steer function works
- _____ Siderails raise, lower, and latch
- _____ Casters lock when you apply the brakes
- _____ Casters lock and swivel
- _____ Casters are free of wax and debris
- _____ Fowler backrest raises, lowers, and latches
- _____ Gatch raises, lowers, and latches
- _____ Skins are not cracked
- _____ Trendelenburg/Reverse Trendelenburg raises and lowers from all locations
- _____ IV pole option is intact and latches in all positions
- _____ Oxygen bottle holder option is intact and opens and closes
- _____ No damage to the head and foot trays
- _____ Ground chain intact
- _____ Body restraints option latch and are secure
- _____ No rips or cracks in the mattress cover
- _____ Accessories and mounting hardware in good condition and work
- _____ No leaks at hydraulic connections
- _____ Hydraulic jacks hold
- _____ Hydraulic drop rate set
- _____ Hydraulic oil level sufficient
- _____ Lubricate where required (*Lubrication points* (page 28))

Product serial number:
Completed by:
Date:

Lubrication points

With the Fowler backrest at 0 degrees, apply Syntech grease (3000-200-719) through the slot and hole in the crank screw assembly (Figure 14). Wipe off excess grease.

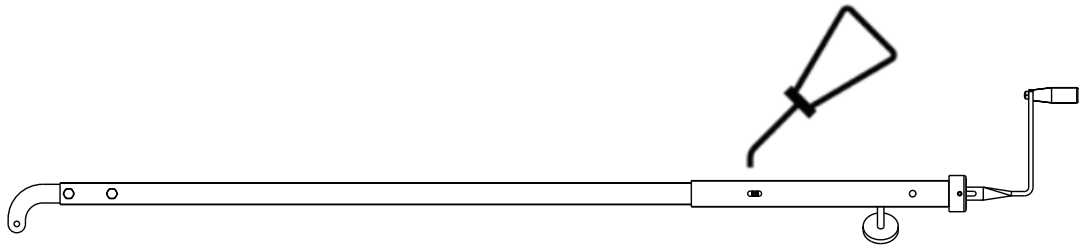

Figure 14 – Crank screw lubrication



Stryker Corporation or its divisions or other corporate affiliated entities own, use or have applied for the following trademarks or service marks: **ComfortGel, Havasu, Stryker**. All other trademarks are trademarks of their respective owners or holders.



Stryker Medical
3800 E. Centre Avenue
Portage, MI 49002
USA