

stryker[®]
Medical

Advantage Series

1001 Emergency Care Stretcher
1501 PACU Stretcher
Maintenance Manual

For Parts or Technical Assistance
800-327-0770

Table of Contents

Introduction	
Specifications	4
Warning / Caution / Note Definition	4
Preventative Maintenance	
Checklist	5
Cleaning	6
Service Information	
Caster Assembly Replacement	7
Fifth Wheel Replacement	7
Caster Cover Installation And Removal	8
Brake Cam Replacement	9
Brake Ring Replacement	9
Brake Adjustment	10
Base Side Control Pedal Linkage Adjustment	10
Base Side Control Brake/Steer Gear Replacement	11
Uni-Pedal Replacement	11
Jack Replacement	12
Jack Torque Specifications	13
Hydraulic Troubleshooting	13
Removal Of Excess Air (Vacuum) From The Hydraulic System	13
Checking Hydraulic Fluid Level	14
Jack Descent Rate Adjustment	14, 15
Adjustable P.C. Valve Replacement	15, 16
Hydraulic Valve Replacement	17, 18
Base Lubrication	19
Big Wheel/Bearing Replacement	20
Big Wheel Adjustment	21
Big Wheel Return Spring Adjustment	21
Pneumatic Fowler Adjustment	22
Replacement Parts	23
Assembly Drawings and Parts Lists	
Side Control Base Assembly	24-27
End Control Base Assembly	28-31
Brake Adjuster Assembly	32
Brake Cam Assembly	33
Side Control Pump Pedal Assembly	34
End Control Pump Pedal Assembly, Foot End	35
End Control Pump Pedal Assembly, Head End	36
Base Assembly with Steerlock Caster Option	37
Caster Assembly with Steerlock	38

Table of Contents

Assembly Drawings and Parts Lists (Continued)

Standard Caster Assembly	39
Base Assembly with Fifth Wheel Option	40
Pivot Rod Assembly	41
Wheel Arm Assembly	42
Side Control Big Wheel Base Assembly	43-47
End Control Big Wheel Base Assembly	48-52
Big Wheel Interface Assembly	53
Big Wheel Roller Assembly	54
Big Wheel Assembly	55
Big Wheel Cam Assembly	56
Jack Assembly	57
Jack Base Assembly	58
Constant Flow Jack Assembly	59
Constant Flow Jack Base Assembly	60
Jack Pump Piston Assembly	61
Base Assembly with Side Control Brakes	62, 63
Base Assembly with Uni-Lower Pedal	64
Base Assembly with Dual Lowering Pedals	65
Side Control Stretcher Base Labeling Assembly	66
End Control Stretcher Base Labeling Assembly	67
Big Wheel Side Control Stretcher Base Labeling Assembly	68
Big Wheel End Control Stretcher Base Labeling Assembly	69
Department Labels	70
Litter Assembly, Fold to Head Siderails	71, 72
Siderail to Litter Assembly, Fold to Head	73-75
Litter Assembly, Fold to Foot Siderails	76, 77
Siderail to Litter Assembly, Fold to Foot	78-80
Dual Siderail Latch Assembly	79
Pneumatic Fowler Assembly	82-90
Crank Fowler Assembly	91, 92
Fowler Crankscrew Assembly	93
Stationary Foot End Assembly	94-99
Crank Knee Gatch Assembly	100-103
Knee Gatch Crankscrew Assembly	104
Head End Push Handle Assembly	105
Foot End Push Handle Assembly	106
Push Handle Assembly	107
Push Bar Assembly	108, 109
Head Board/Pushbar Assembly	110, 111

Table of Contents

Assembly Drawings and Parts Lists (Continued)

Removable I.V. Pole Assembly	112
2-Stage I.V. Pole Assembly	113-120
3-Stage I.V. Pole Assembly	121-126
Fowler X-Ray Cassette Assembly	127-130
Foot Board/Chartholder Assembly	131
Upright Oxygen Bottle Holder Assembly	131
Foot Extension/ Defibrillator Tray Assembly	132
Defibrillator Tray Assembly	133
Heel Stirrup and Support Assembly	134
Right Stirrup Support Assembly	135
Left Stirrup Support Assembly	136
Heel Stirrup Assembly	137
C-Spine Cassette Holder Assembly	138
C-Spine Support Pole Assembly	139
C-Spine Storage Bracket Assembly	140
O ₂ Bottle Retainer Assembly	141
Mattresses and Siderail Pads	142, 143

Warranty

Obtaining Parts and Service	144
Supplemental Warranty Coverage	144
Return Authorization	145
Freight Damage Claims	145

Introduction

INTRODUCTION

This manual is designed to assist you with the maintenance of the 1001 Emergency Care Stretcher and the 1501 PACU Stretcher. Read it thoroughly before using the equipment or beginning any maintenance on it.

SPECIFICATIONS

	1001	1501
Maximum Weight Capacity	500 pounds	500 pounds
Overall Bed Length \ Width	83 1/2" \ 31 1/2"	83 1/2" \ 34
Minimum \ Maximum Bed Height	22" \ 35"	22" \ 35"
Fowler Angle	0 to 90°	0 to 90°
Knee Gatch Angle	0 to 35°	0 to 35°
Trendelenburg \ Reverse Trendelenburg	+12 to -18°	+12 to -18°

Stryker reserves the right to change specifications without notice.

WARNING / CAUTION / NOTE DEFINITION

The words WARNING, CAUTION and NOTE carry special meanings and should be carefully reviewed.

WARNING

The personal safety of the patient or user may be involved. Disregarding this information could result in injury to the patient or user.

CAUTION

These instructions point out special procedures or precautions that must be followed to avoid damaging the equipment.

NOTE

This provides special information to make maintenance easier or important instructions clearer.

WARNING

Patients should be discouraged from sitting directly on the ends of the stretcher. Excessive weight will cause the litter surface to tip up, possibly causing patient injury.

Always apply the caster brakes when a patient is getting on or off the stretcher. Push on the stretcher to ensure the brakes are securely locked. Always engage the brakes unless the stretcher is being moved. Injury could result if the stretcher moves while a patient is getting on or off the stretcher.

Preventative Maintenance

CHECKLIST

- _____ All fasteners secure (reference all assembly prints)
- _____ Siderails move and latch properly
- _____ Engage brake pedal and push on the stretcher to ensure all casters lock securely (page 10)
- _____ Steer function working properly
- _____ All casters secure and swivel properly
- _____ Body restraints working properly
- _____ I.V. pole intact and operating properly (page 113-126)
- _____ Oxygen bottle holder intact and operating properly (page 131)
- _____ Fowler operates and latches properly (pneumatic: page 22)
- _____ Knee Gatch operates properly
- _____ Trendelenburg/Reverse Trendelenburg operating properly
- _____ No rips or cracks in mattress cover
- _____ Ground chain intact
- _____ No leaks at hydraulic connections
- _____ Hydraulic jacks holding properly (page 13)
- _____ Hydraulic drop rate set properly (page 14)
- _____ Hydraulic oil level sufficient (page 14)
- _____ Lubricate where required, including the brake adjuster assembly and brake cam (page 19)
- _____ Accessories and mounting hardware in good condition and working properly
- _____ Optional Big Wheel adjusted properly (page 20)
- _____ Lubricate Big Wheel roller and linkage

Serial No. _____

_____	_____	_____
_____	_____	_____
_____	_____	_____

Completed By: _____ Date: _____

NOTE

Preventative maintenance should be performed at a minimum of annually. A preventative maintenance program should be established for all Stryker Medical equipment. Preventative maintenance may need to be performed more frequently based on the usage level of the product.

NOTE

References to the right or left side of the stretcher refer to the right and left sides of a patient lying face up on the stretcher.

Cleaning

Hand wash all surfaces of the stretcher with warm water and mild detergent. Dry thoroughly. DO NOT STEAM CLEAN, PRESSURE WASH, HOSE OFF OR ULTRASONICALLY CLEAN. Using these methods of cleaning is **not** recommended and may void this product's warranty.

Clean Velcro **AFTER EACH USE**. Saturate Velcro with disinfectant and allow disinfectant to evaporate. (Appropriate disinfectant for nylon Velcro should be determined by the hospital.)

In general, when used in those concentrations recommended by the manufacturer, either phenolic type or quaternary type disinfectants can be used. Iodophor type disinfectants are not recommended for use because staining may result. The following products have been tested and have been found not to have a harmful effect WHEN USED IN ACCORDANCE WITH MANUFACTURERS RECOMMENDED DILUTION.*

TRADE NAME	DISINFECTANT TYPE	MANUFACTURER	*MANUFACTURER'S RECOMMENDED DILUTION
A33	Quaternary	Airwick (Professional Products Division)	2 ounces/gallon
A33 (dry)	Quaternary	Airwick (Professional Products Division)	1/2 ounce/gallon
Beaucoup	Phenolic	Huntington Laboratories	1 ounce/gallon
Blue Chip	Quaternary	S.C. Johnson	2 ounces/gallon
Elimstaph	Quaternary	Walter G. Legge	1 ounce/gallon
Franklin Phenomysan F2500	Phenolic	Purex Corporation	1 1/4 ounce/gallon
Franklin Sentinel	Quaternary	Purex Corporation	2 ounces/gallon
Galahad	Phenolic	Puritan Churchill Chemical Company	1 ounce/gallon
Hi-Tor	Quaternary	Huntington Laboratories	1/2 ounce/gallon
LPH	Phenolic	Vestal Laboratories	1/2 ounce/gallon
Matar	Phenolic	Huntington Laboratories	1/2 ounce/gallon
Omega	Quaternary	Airwick (Professional Products Division)	1/2 ounce/gallon
Quanto	Quaternary	Huntington Laboratories	1 ounce/gallon
Sanikleen	Quaternary	West Chemical Products	2 ounces/ gallon
Sanimaster II	Quaternary	Service Master	1 ounce/gallon
Vesphene	Phenolic	Vestal Laboratories	1 1/4 ounce/ gallon

Quaternary Germicidal Disinfectants, used as directed, and/or Chlorine Bleach products, typically 5.25% Sodium Hypochlorite in **dilutions ranging between 1 part bleach to 100 parts water, and 2 parts bleach to 100 parts water are not considered mild detergents. These products are corrosive in nature and may cause damage to your stretcher if used improperly.** If these types of products are used to clean Stryker patient handling equipment, measures must be taken to insure the stretchers are rinsed with clean water and thoroughly dried following cleaning. Failure to properly rinse and dry the stretchers will leave a corrosive residue on the surface of the stretcher, possibly causing premature corrosion of critical components.

NOTE

Failure to follow the above directions when using these types of cleaners may void this product's warranty.

REMOVAL OF IODINE COMPOUNDS

This solution may be used to remove iodine stains from mattress cover and foam footrest pad surfaces.

1. Use a solution of 1-2 tablespoons Sodium Thiosulfate in a pint of warm water to clean the stained area. Clean as soon as possible after staining occurs. If stains are not immediately removed, allow solution to soak or stand on the surface.
2. Rinse surfaces which have been exposed to the solution in clear water before returning bed to service.

Service Information

CASTER ASSEMBLY REPLACEMENT

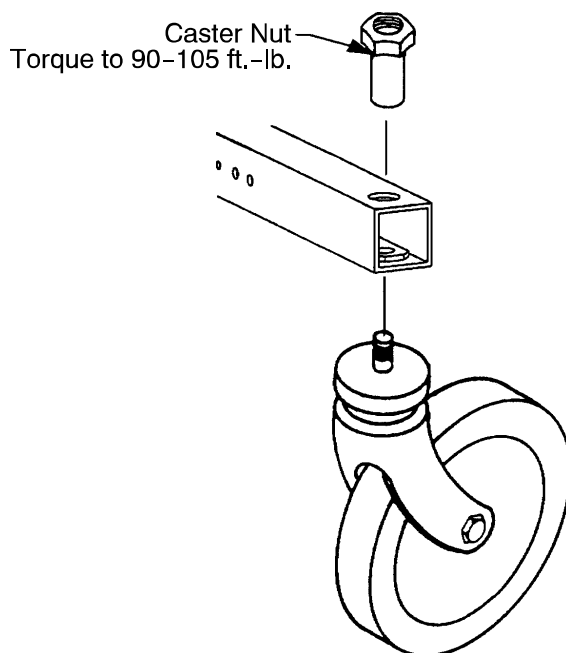

1. Remove the old caster assembly.
2. Install the replacement caster and caster nut. Tighten the caster nut to 90-105 ft.-lb. with a torque wrench.

NOTE

A new caster assembly with a 3M patch does not require the application of Loctite at assembly. However, the patch is appropriate for only one installation. If the caster is removed and reassembled for any reason, apply Loctite 242 to two or three threads of both the bolt and caster nut and tighten to 90-105 ft.-lb. with a torque wrench.

FIFTH WHEEL REPLACEMENT

Required Tools:

Pliers

String or Bungee Cord

3/16" Allen Wrench

(2) 9/16" Box End Wrenches

Procedure:

1. Apply the stretcher brakes.
2. Pump the litter up to full height.
3. Lift and support the base hood using string or bungee cord.
4. Using pliers, remove the cotter pin from the end of the fifth wheel pivot rod and remove the two washers.
5. Pull up on the fifth wheel arm and pull down on the tension spring to release the pressure on the arm.
6. Using a 3/16" Allen wrench, remove the hex Allen bolt from the center of the pivot rod and pull the pivot rod out of the wheel arm.
7. Reverse the above steps to install a new fifth wheel assembly.

NOTE

To replace the wheel only, use two 9/16" box end wrenches to remove the bolt and nut holding it to the wheel arm.

Service Information

CASTER COVER INSTALLATION AND REMOVAL

1.

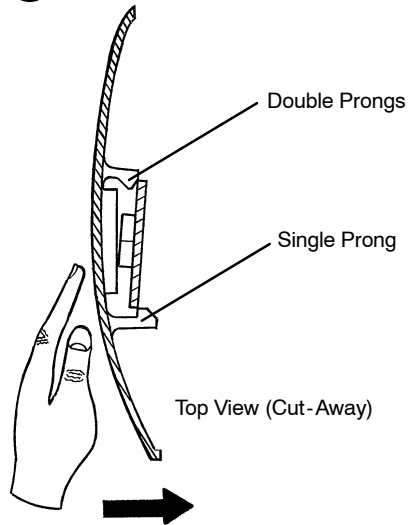

Looking through the larger of the two side cut-outs, align cover with axle nut or bolt head, as shown. Push down on the opposite side of the cover until single prong engages with caster horn.

Push with palm on cover until double prongs engage.

2.

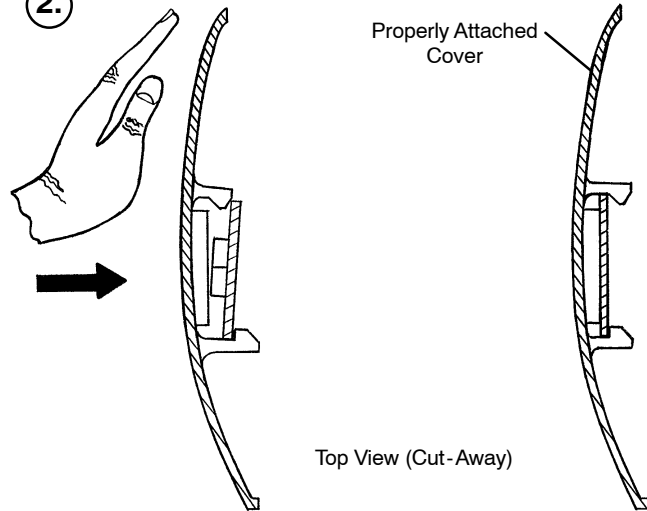

3.

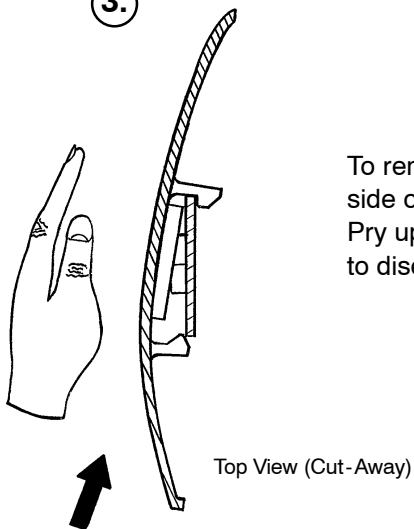

To remove wheel cover, insert large screwdriver into cut-out in side of wheel cover and into the space between the double prongs. Pry up cover to disengage double prongs and push sharply upward to disengage single prong.

Service Information

BRAKE CAM REPLACEMENT

Brake Cam Part Number 715-201-213

Required Tools:

Phillips Screwdriver	String or Bungee Cord	3/32" Allen Wrench
1/8" Allen Wrench		

Procedure:

1. Remove the four Phillips screws holding the base hood to the frame. Lift and support the base hood using string or bungee cord.
2. Using a 3/32" Allen wrench, loosen the set screw holding the brake adjuster to the brake ring and turn the adjuster clockwise to remove it.
3. Using a 1/8" Allen wrench, remove the shoulder bolt and nut holding the brake link on the cam and remove the cam.
4. Reverse steps 3 and 4 to install the new cam. Verify the brakes are operating properly. If adjustment is required, see page 10. Reinstall the base hood.

BRAKE RING REPLACEMENT

Brake Ring Part Number 715-1-61

Required Tools:

Phillips Screwdriver	String or Bungee Cord	Floor Jack, Small Crate (or equiv.)
Large Standard Screwdriver	3/32" Allen Wrench	11/16" Socket & Ratchet
5/8" Wrench	Needle-Nose Pliers	(2) 7/16" Wrenches

Procedure:

1. Remove the four Phillips screws holding the base hood to the frame. Lift and support the base hood using string or bungee cord. Put the brake/steer pedal in the neutral position. Lift the end of the base needing service until the casters are approximately 12" off the floor and support it with a jack or the equivalent.
2. Using a 3/32" Allen wrench, loosen the set screw holding the brake adjuster to the brake ring and turn the adjuster clockwise to remove it.
3. Remove the caster covers on both casters (see page 8).
4. Remove one of the casters (see page 7). On the other caster, use an 11/16" socket and ratchet and a 5/8" wrench to remove the nut and bolt holding the wheel on the caster horn and remove only the wheel.
5. Using needle-nose pliers, carefully squeeze and remove the spring between the brake cam and the brake ring.

WARNING

The spring is tightly compressed. Use caution when removing it or personal injury could result.

6. If you are working on an end control base, remove the spring from the pump pedal.
7. Lower the brake ring and remove it from the base. Remove the brake pads and bushings and install them on the new brake ring.
8. Reverse the above steps to install the new brake ring and reinstall the caster and wheel. Apply and release the brakes to verify they operate properly. If adjustment is required, see page 10. Reinstall the base hood.

Service Information

BRAKE ADJUSTMENT

Required Tools:

3/32" Hex Allen Wrench
Pry Bar
Thread "Locktite"

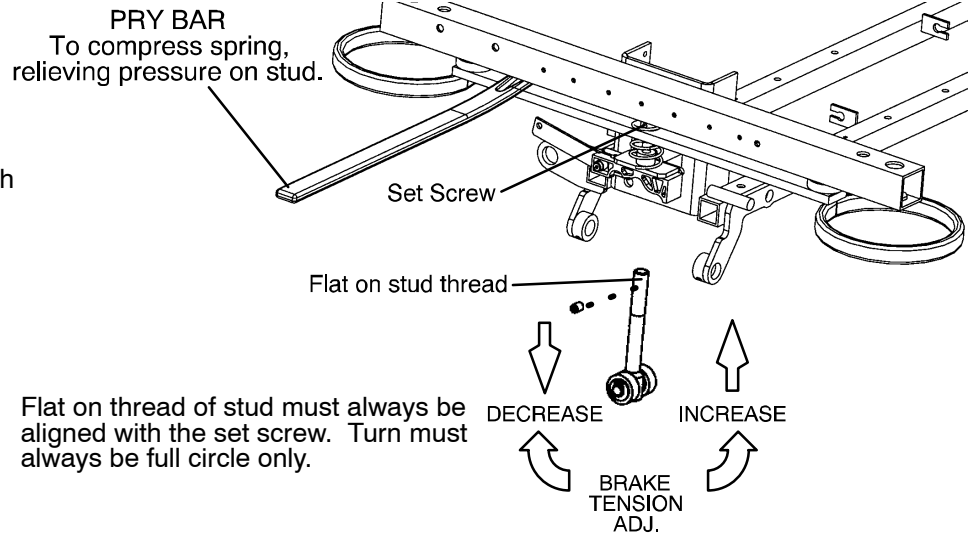

BASE SIDE CONTROL PEDAL LINKAGE ADJUSTMENT

Required Tools:

3/8" Wrench 5/32" Hex Allen Wrench 7/16" Wrench
Bungee Cords

Adjustment Procedure:

1. Place 150-200 pounds on the litter and pump the litter up to full height.
2. Lift the base hood, separating the hood from the base frame. Using the bungee cords, support the base hood.
3. Using a 3/8" wrench and a 5/32" hex Allen wrench, loosen the appropriate pedal linkage adjustment nut until the jack stops "drifting". Raise the litter to full up.
4. Tighten the pedal linkage adjustment nut until the jack begins to slowly descend.
5. Using a 7/16" wrench, back the pedal linkage adjustment nut out four full turns. Raise the litter to full up.
6. Loosen the pedal linkage adjustment nut and ensure no drift occurs. If the jack drifts, repeat procedure.

Service Information

BASE SIDE CONTROL BRAKE/STEER GEAR REPLACEMENT

Required Tools:

Pliers	String or Bungee Cord	Floor Jack or Equivalent
1/8" Allen Wrench	5/32" Allen Wrench	3/8" Box End Wrench
(2) 9/16" Box End Wrenches	3/16" Punch	1/4" Punch
Hammer		

Procedure:

1. Apply the stretcher brakes.
2. Pump the litter up to full height.
3. Lift and support the base hood using string or bungee cord.
4. Using pliers, remove the cotter pins from both jack pump pistons and the pump linkage.
5. Using the 9/16" box end wrenches, remove the two bearing plate bolts.
6. Remove the cotter pin on the side brake bar.
7. Remove the bearing plate and pull out the idler gear rod while holding onto the gear. Lift the gear out.
8. Slide the miter gear away from the rod spacer and remove the dowel pin.
9. Using the floor jack, raise the side of the base you are working on approximately four inches.
10. Rotate the brake bar so the pedals are upside down.
11. Using a 1/4" punch and a hammer, remove the groove pin from the side brake rod.
12. Using a 3/16" punch and hammer, remove the 3/16" groove pin from the pedal.
13. Using a 5/32" Allen wrench, remove the set screw from the collar inside the gear box.
14. Remove the brake rod while holding the gear on the rod.
15. Using a 1/8" Allen wrench and a 3/8" box end wrench, remove the nuts and bolts holding the brake link to the rod.
16. Using a 5/32" Allen wrench, remove the set screw from the collar outside of the gear box.
17. Using a 1/4" punch, remove the roll pin from the cam and brake link collar.
18. Reverse the above steps to install the replacement gear.
19. Inspect each gear for wear. Lube with MPG-2 grease or the equivalent if necessary.

UNI-PEDAL REPLACEMENT

Required Tools:

Drill w/3/16" Drill Bit	Floor Jack	Pop Rivet Tool
-------------------------	------------	----------------

Replacement Procedure:

1. Set the stretcher brake and pump the litter up fully.
2. Use the floor jack to raise the side of the base frame off the floor approximately four inches.
3. Using a drill with a 3/16" drill bit, drill out the rivets on the bottom of the pedal to be replaced.
4. Using a pop rivet tool and rivets, install the replacement pedal.
5. Lower the stretcher to the floor. Test the operation of the pedal before returning the stretcher to service.

Service Information

JACK REPLACEMENT (WITHOUT COMPRESSION SPRING)

Required Tools:

3/8" Wrench

1/2" Socket

1/2" Wrench

Needle-Nosed Pliers

Replacement Procedure:

1. Apply stretcher brakes. Raise litter to full up. Raise Fowler to full up and raise siderails.
2. Use a 3/8" wrench to remove the bolt in the litter support tube above black bellows on both ends.
3. With the assistance of another person, lift off the stretcher litter and set it aside, taking care not to damage the siderails, etc.
4. Push down on the jack actuator to put the jack in the full down position.
5. Lift off the plastic base hood, separating the Velcro holding it to the base frame.
6. Using a 1/2" socket and 1/2" wrench, remove the four bolts, washers and nuts holding the jack support straps to the base frame.
7. Using needle-nosed pliers, remove the two cotter keys on the pump link and remove the pump link.
8. Using a 1/2" socket and a 1/2" wrench, remove the four bolts holding the jack base to the base frame (using a 3" extension may be required). Remove the jack from the base frame.
9. Reverse steps 6-8 to install the replacement jack. Reinstall the base hood and the stretcher litter.

JACK REPLACEMENT (WITH COMPRESSION SPRING)

Required Tools:

3/8" Wrench

Needle-Nosed Pliers

Straight Screwdriver

Spring Compression Tool

Replacement Procedure:

1. Apply stretcher brakes. Raise litter to full up. Raise Fowler to full up and raise siderails.
2. Use a 3/8" wrench to remove the bolt in the litter support tube above black bellows on both ends.
3. With the assistance of another person, lift off the stretcher litter and set it aside, taking care not to damage the siderails, etc.
4. Push down on the jack actuator to put the jack in the full down position.
5. Lift off the plastic base hood, separating the Velcro holding it to the base frame.
6. Using needle-nosed pliers, pull cotter pin from pump cylinder.
7. Using a straight screwdriver and pump spring compression tool (available upon request), compress the pump spring and pry the pump link out of the pump cylinder.

CAUTION

Be sure not to let the pump piston come out of the jack or damage may occur.

8. Remove and replace jack as described in the procedure above.
9. Replace pump spring and pump link using the straight screwdriver and the pump compression tool.
10. Reinstall the base hood and the stretcher litter.

Service Information

JACK ASSEMBLY TORQUE SPECIFICATION

Jack Assembly with Threads Oiled

- | | |
|---|----------------------|
| 1. Jack Cap Assembly to Jack Actuator Cylinder | 75 to 85 Foot Pounds |
| 2. Jack Actuator Cylinder to Jack Base Assembly | 55 to 65 Foot Pounds |

Jack Base Assembly with Threads Oiled

- | | |
|---|----------------------|
| 1. Jack Pump Cylinder to Jack Base Machined | 45 to 55 Foot Pounds |
| 2. Jack Pin Housing to Jack Base Machined | 35 to 45 Foot Pounds |
| 3. Jack Base Plugs to Jack Base Machined | 8 to 12 Foot Pounds |
| 4. Jack Valve Plug to Jack Base Machined | 8 to 12 Foot Pounds |
| 5. Flow Control Valve to Jack Base Machined | 16 to 20 Foot Pounds |

HYDRAULIC TROUBLESHOOTING

Be sure the pedal linkage has been adjusted properly before beginning service on the jacks (see page 10).

PROBLEM/SYMPTOM	SOLUTION
Jack will not raise to full height.	Add hydraulic fluid (see p.14). Check for leaks.
Jack will not hold in raised position.	Close the needle valve completely. If the jack holds, replace the release valve (see p.18).
Jack will not pump up and the jack actuator rod does not move.	Close the needle valve. If the jack will now pump up, replace the release valve (see p.18). If the jack still will not pump up after closing the needle valve, replace the poppet valve (see p. 18).
Jack will not pump up but the jack actuator rod does move when the pump pedal is activated.	Replace the check valve (see p. 17).
Jack will not pump up and the jack actuator rod may or may not move.	Remove excess air (vacuum) in system (see below).

Contact Stryker technical service at 1-800-327-0770 for further assistance.

REMOVAL OF EXCESS AIR (VACUUM) FROM THE HYDRAULIC SYSTEM

Procedure:

1. Verify all hydraulic linkages are secure and operating properly (see pedal linkage adjustment procedure page 10).
2. Using pump pedal, actuate system several times. This will force the air through the system and the jack should now pump up.

Service Information

CHECKING HYDRAULIC FLUID LEVEL

Required Tools:

3/8 Open End Wrench 3/4 Open End Wrench

Procedure:

WARNING

To avoid personal injury or damage to the stretcher, remove the litter and the base hood before beginning service on the jacks.

1. Using a 3/8 open end wrench, remove square head set screws from both head and foot end jack support tubes. Remove litter top and set aside.
2. Lift base hood off base frame and set aside.
3. Be sure there are no hydraulic leaks. If there are, jack replacement will be necessary.
4. Lower the jack to the full down position.
5. Using a 3/4 open end wrench, slowly turn the fill plug located on the side of the reservoir counterclockwise to allow excess system pressure to vent. Remove the fill plug.
6. The hydraulic fluid should be visible at the bottom of the fill hole. If it is not, add Mobil Aero HFA hydraulic fluid (Stryker part number 2020-70-475) until the fluid is visible at the bottom of the fill hole. Replace the fill plug.

CAUTION

Use of other types of oil may damage hydraulic units.

7. Replace the hood and the litter.

JACK DESCENT RATE ADJUSTMENT

Required Tools:

Screwdriver Bungee Cords (or equivalent)

Adjustment Procedure:

1. Pump the litter up to full height.
2. Lift the base hood, separating the hood from the base frame. Using the bungee cords, support the base hood.
3. The descent rate needle valve is located on the base of the jack. Turning the needle valve clockwise, with a screwdriver, will decrease the rate of descent. Turning it counterclockwise will increase the rate of descent.
4. Adjust the needle valve so that the foot end of the stretcher descends slightly faster than the head end.

NOTE

The larger percentage of a patient's weight is located in the torso area. Adjust descent rate accordingly.

5. Remove the bungee cords supporting the base hood and secure the hood to the base frame.

NOTE

The jack descent rate was preset at the factory to drop the foot end faster than the head. It is recommended that the foot drop faster to avoid patient disorientation.

Service Information

CONSTANT FLOW JACK DESCENT RATE ADJUSTMENT

Required Tools:

Bungee Cords

Adjustment Procedure:

1. Pump the litter up to full height
2. Lift the base hood, separating the Velcro holding it to the base frame.
3. The adjustable descent valve is located on the base of the jack and has a blue knob on the end. To adjust, loosen the silver locking ring by turning it counterclockwise. Turning the blue knob clockwise will increase the rate of litter descent. Turning it counterclockwise will decrease the rate of descent.
4. Adjust the valve so that the jack at the foot end of the stretcher will descend slightly faster than the jack at the head end.
5. Remove the bungee cords supporting the base hood and secure the hood to the base frame.

NOTE

The jack descent rate was preset at the factory to lower the foot end 3-7 seconds faster than the head. It is recommended to have the foot end lower faster to avoid patient disorientation.

ADJUSTABLE PRESSURE COMPENSATED (P.C.) VALVE REPLACEMENT

P.C. Valve Part Number 5050-70-50

WARNING

To avoid personal injury or damage to the stretcher, always remove the litter and the base hood before beginning service on the jacks. Lower the jack rod completely to relieve the pressure on the pump piston side of the jack.

Required Tools:

3/8" Wrench

13/16" Wrench

Replacement Procedure:

NOTE

It requires two people to safely perform this procedure.

1. Apply the stretcher brakes. Raise the litter to full up. Raise the Fowler and the siderails.
2. Using a 3/8" wrench, remove the bolts in the litter support tubes above the black bellows on both ends of the litter.
3. With the assistance of another person, lift the litter off the base and set it aside, taking care not to damage the leg section linkages and other litter components.
4. Push down on the jack actuator to put the jack in the full down position.
5. Lift off the plastic base hood, separating the Velcro holding it to the base frame.

Service Information

ADJUSTABLE PRESSURE COMPENSATED (P.C.) VALVE REPLACEMENT (CONTINUED)

6. Using a 13/16" wrench, remove the adjustable P.C. valve.
7. Check for any contaminants in the valve as well as in the jack base.
8. Install the replacement P.C. valve. Moisten the O-ring seal with hydraulic fluid to ensure a tight seal.
9. Tighten the valve manually and then an additional 1/8- 1/4 turn with a 13/16" wrench. **Do not over -tight-en** or damage may occur to the O-ring seal.
10. Pump up the jack to the maximum height and press the release pedal to lower it to check the jack's operation.
11. Check for any hydraulic fluid leaks before replacing the base hood and litter.

Service Information

HYDRAULIC VALVE REPLACEMENT

Required Tools:

3/8 Open End Wrench
3/4 Open End Wrench

Stiff Wire (with bent, pointed end)
Torque Wrench (with Ft. Lbs. adjust.)

Small Needle Nose Pliers
7/32 Hex Allen Wrench

Replacement of Check Valve

WARNING

To avoid personal injury or damage to the stretcher, remove the litter and the base hood before beginning service on the jacks. Lower the jack rod completely to relieve the pressure on the pump piston side of the jack. This will prevent large hydraulic fluid loss and possible damage when the base plugs are removed.

1. Remove the base plug (3) and the seal (4).
2. Remove the valve plug (5).
3. Using a stiff wire with a bent, pointed end, remove the valve (1).
4. Install the new valve (1) with the beveled end up (as shown in the illustration).
5. Reinstall the valve plug (5) with the beveled end down toward valve (1) and tighten to 10 foot-pounds torque.
6. Reinstall the seal (4) and the base plug (3) and tighten to 10 foot-pounds torque.
7. Pump up the jack to the maximum height.
8. Be sure there are no hydraulic leaks before replacing the base hood and the litter.

ITEM	PART NO.	PART NAME
1	926-20-153	Check Valve
2	715-1-341	Poppet
3	715-1-301	Base Plug
4	926-20-156	Seal
5	715-1-309	Valve Plug
6	926-20-154	Seal
7	715-1-301	Base Plug
8	926-20-156	Seal
9	390-2-134	Compression Spring
10	715-270-100	Valve Assembly*
10	2025-700-26	Valve Assembly**
11	715-100-325	Pump Piston

* Used on jack part number 1231-70-10.

** Used on jack part number 1231-70-210.

(See label on side of jack reservoir for jack part number).

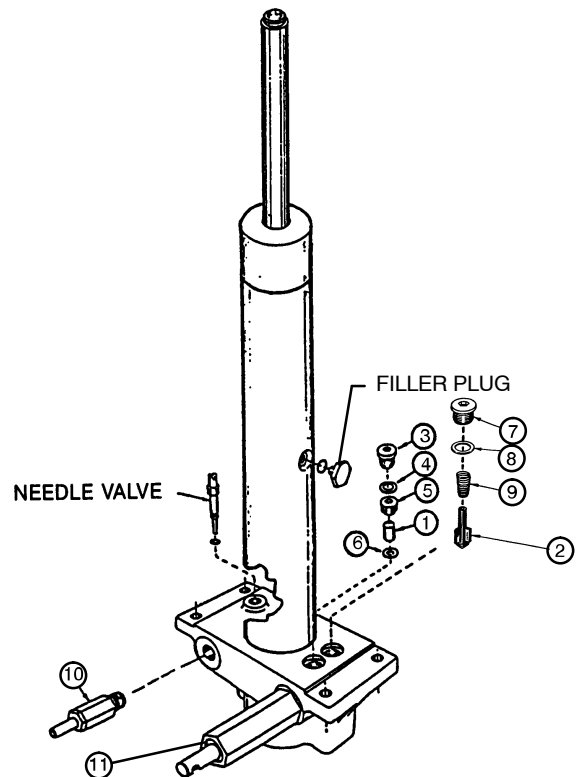

Service Information

HYDRAULIC VALVE REPLACEMENT (CONTINUED)

Replacement of Release Valve

WARNING

To avoid personal injury or damage to the stretcher, remove the litter and the base hood before beginning service on the jacks. Lower the jack rod completely to relieve the pressure on the pump piston side of the jack. This will prevent large hydraulic fluid loss and possible damage when the base plugs are removed.

1. Remove the release valve (10).
2. Install the new release valve (10).
3. Pump up the jack to the maximum height.
4. Be sure there are no hydraulic leaks before replacing the base hood and the litter.

Replacement of Poppet Valve

WARNING

To avoid personal injury or damage to the stretcher, remove the litter and the base hood before beginning service on the jacks. Lower the jack rod completely to relieve the pressure on the pump piston side of the jack. This will prevent large hydraulic fluid loss and possible damage when the base plugs are removed.

1. Remove the base plug (7) and the seal (8).
2. Remove the compression spring (9).
3. Using small needle nose pliers, remove the poppet valve (2).
4. Install the new poppet valve (2).
5. Reinstall the compression spring (9).
6. Reinstall the seal (18) and the base plug (7) and tighten to 10 foot-pounds torque.
7. Pump up the jack to the maximum height to check its operation.
8. Check for hydraulic leaks before replacing the base hood and the litter.

Service Information

BASE LUBRICATION

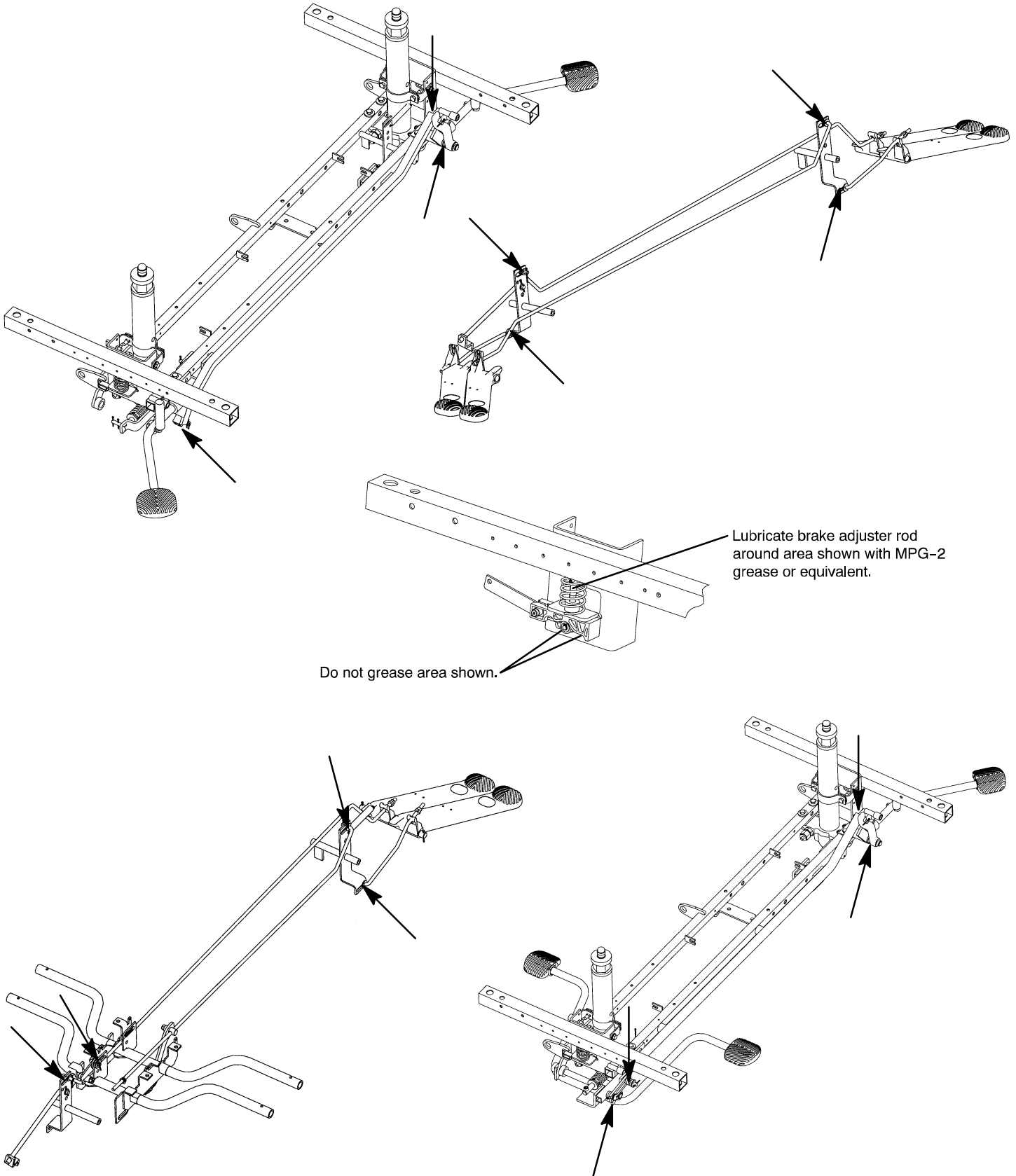

Service Information

BIG WHEEL/BEARING REPLACEMENT

Required Tools:

15/16" Wrench or Socket & Ratchet (2) Bungee Cords Torque Wrench
Small Standard Screwdriver

Procedure:

1. Apply the stretcher brakes.
2. Pump the litter up to full height.
3. Lift the base hood and support it from the litter frame using bungee cords.
4. Using a small standard screwdriver, remove the big wheel hub cap, being careful not to damage the outer surface of the hub cap (see page 46 for part reference).
5. Using a 15/16" wrench or socket and ratchet, remove the nut holding the big wheel to the frame. Remove the bearing and sleeve (see page 55 for part reference).
6. Install the replacement bearing and the sleeve onto the wheel bolt. Install the big wheel and outer bearing.
7. Install the nut and tighten it to 30 foot-pounds using a torque wrench.
8. Remove the bungee cords and reinstall the base hood.
9. Verify the brake and steer functions are working properly before returning the bed to service.

BIG WHEEL ADJUSTMENT

Required Tools:

9/16" Wrench (2) Bungee Cords Small Ruler or Tape Measure

Procedure:

1. Apply the stretcher brakes.
2. Pump the litter up to full height.
3. Lift the base hood and support it from the litter frame using bungee cords.
4. Using a 9/16" wrench, remove the two side bolts on the cam adjuster block (see page 46 for part reference).
5. Release the brakes and engage the big wheel.
6. Adjust the two top bolts on the adjuster block equal amounts so the foot end casters are raised off the floor 1/4". Reinstall the two side bolts on the cam adjuster block after applying Loctite to both bolts.
7. Apply the stretcher brakes.
8. Remove the bungee cords and reinstall the base hood.
9. Verify the brake and steer functions are working properly before returning the bed to service.

Service Information

BIG WHEEL RETURN SPRING ADJUSTMENT

Required Tools:

1/2" Deep Well Socket & Ratchet (2) Bungee Cords

Procedure:

1. Apply the stretcher brakes.
2. Pump the litter up to full height.
3. Lift the base hood and support it from the litter frame using bungee cords.
4. Using a 1/2" deep well socket and ratchet, loosen the nut on the eyebolt to the end of the threads. Remove the spring from the frame and eyebolt (see page 46 for part reference).
5. Install the new spring and tighten the nut on the eyebolt.
6. Check for proper operation.
7. Apply the stretcher brakes.
8. Remove the bungee cords and reinstall the base hood.
9. Verify the brake and steer functions are working properly before returning the bed to service.

BIG WHEEL HUBCAP REMOVAL

Required Tools:

Large Standard Screwdriver

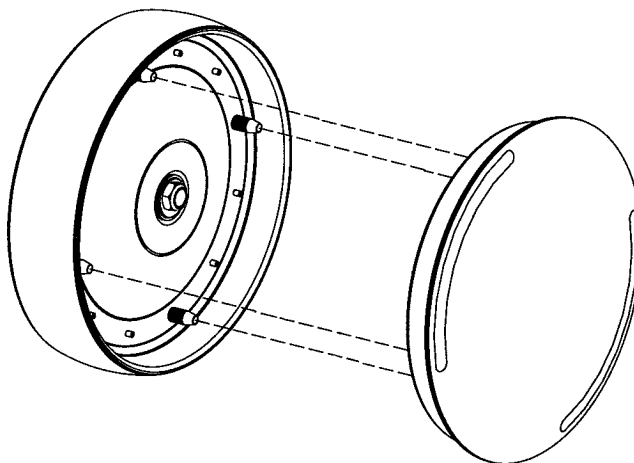

Removal Procedure:

1. Using a large standard screwdriver, pry evenly around the entire edge of the Big Wheel hubcap until it pops off the mounting studs on the wheel.

CAUTION

Do not attempt to pull off the hubcap after prying up only one side. Damage to the slots on the hubcap or the mounting studs on the wheel could result.

2. To reinstall the hubcap, place it on the wheel, aligning the slots in the hubcap with the mounting studs on the wheel. Press down evenly on the edges of the hubcap until it snaps into place.

Service Information

PNEUMATIC FOWLER ADJUSTMENT (OUTSIDE MOUNTED CYLINDERS)

Required Tools:

5/32" Hex Allen Wrench 1/2" Open End Wrench

Adjustment Procedure:

1. Refer to drawings 1210-31-120 or 1710-31-120 (Pneumatic Fowler Assembly, page 83 or page 85) for parts reference.
2. For easier access, move Fowler to 75 degrees or higher.
3. Using a 1/2" open end wrench, loosen the nuts (item K) in the actuator arms on the end of the trip bar (F).
4. To adjust the Fowler, use a 5/32" hex Allen wrench to turn the Allen screws (item N) 1 to 2 turns counter-clockwise if the Fowler will not move or 1 to 2 turns clockwise if the Fowler will not hold its position.
5. Retighten the nuts. Be sure the Fowler will travel from flat to 90° and down again and will hold its position when weight is applied before returning the stretcher to service.

PNEUMATIC FOWLER ADJUSTMENT (CENTER MOUNTED CYLINDERS)

Required Tools:

3/32 Hex Allen Wrench 1/2 Socket w/Ratchet 1/8 Hex Allen Wrench
Channel Lock Pliers 5/32 Hex Allen Wrench Towel or Cloth
7/16 Open End Wrench Thread "Loctite"

Adjustment Procedure:

1. Refer to drawings 1211-31-10 & 1211-131-20 or 1711-31-10 & 1711-131-20 (Pneumatic Fowler Assembly, page 87 & 88 or page 89 & 90) for parts reference.
2. For easier access, move Fowler to 75 degrees or higher.
3. Using a 3/32" hex Allen wrench, remove set screws (K on p. 88 or 90), located in center of yokes (Y on p. 88 or 90).
4. Using a 9/16" box end wrench and 5/16" hex Allen wrench, remove the cap screws (A on p. 87 or 89), flat washers (C on p. 87 or 89) and hex nuts (D on p. 87 or 89) holding the gas cylinders (K on p. 87 or 89) to the litter frame.
5. To adjust the Fowler, turn the gas cylinder 1 to 2 turns counterclockwise if the Fowler will not move and 1 to 2 turns clockwise if the Fowler will not hold its position.
6. Replace the cap screws (A) and check the Fowler adjustment. Lower the Fowler approximately 10° to 20°, release the handle and apply weight to the Fowler to assure it will hold its position. If the Fowler will not lower or will not hold its position when weight is applied, repeat step 5.
7. When the Fowler is properly adjusted, replace the washers (C) and hex nuts (D) to secure the pivot bolts.
8. Using thread locktite, reinstall set screws (K).

Replacement Parts

<u>PART NAME</u>	<u>PART NUMBER</u>
Brake Adjuster Service Tool	715-700-150
C-Spine Cassette Holder	1001-70
Defibrillator/Equipment Tray	926-39
Foot Board/Chartholder	926-40
Foot Extension/Defibrillator Tray Assembly	1010-50-100
Fowler X-Ray Cassette Tray	1211-143-12
Head/Foot Board Assembly (2)	946-29-100
Head Board/Push Bar	1211-139-10
Hydraulic Jack, Constant Descent	1231-70-210
Hydraulic Jack, Variable Descent	1231-70-10
Hydraulic Oil, Mobil Aero HFA - 1 Quart	2020-70-475
Instrument/Serving Tray	1052-129
I.V. Caddy	1050-1-100
I.V. Pole, Standard, Removable	390-25
I.V. Pole, Tethered	1001/1501-117
I.V. Pole, 2-Stage Permanently Attached, Head End	1001/1501-110
I.V. Pole, 2-Stage Permanently Attached, Foot End	1001/1501-112
I.V. Pole, 3-Stage Permanently Attached, Head End	1001/1501-111
I.V. Pole, 3-Stage Permanently Attached, Foot End	1001/1501-113
Mattress, 2" x 26", Standard	1059-226-140
Mattress, 3" x 26" Standard	1059-326-140
Mattress, 3" x 29", Standard	1059-329-140
Mattress, 4" x 26", Standard	1059-426-140
Mattress, 4" x 29", Standard	1059-429-140
Mattress, 3" x 26", Enhanced Comfort	1001-48-106
Mattress, 3" x 29", Enhanced Comfort	1501-48-106
Mattress, 4" x 26", Enhanced Comfort	1001-47-106
Mattress, 4" x 29", Enhanced Comfort	1501-47-106
Mattress, 4" x 26", Ultra Comfort	1210-40-4
Mattress, 5" x 26", Ultra Comfort	1210-40-5
Mattress, 4" x 29", Ultra Comfort	1710-40-4
Mattress, 5" x 29", Ultra Comfort	1710-40-5
Oxygen Bottle Holder Assembly	1020-30
Paint, Touch-Up, Gloss Black, Bottle w/Brush	7000-1-322
Paint, Touch-Up, Gloss Black, Spray Can	7000-1-319
Paint, Touch-Up, Gray, Bottle w/Brush	7000-1-320
Paint, Touch-Up, Gray, Spray Can	7000-1-317
Restraint Strap, Ankle	946-43-100
Restraint Strap, Chest	1010-58
Restraint Strap, Wrist	946-44-100
Restraint Strap, 2 Piece	390-19
Siderail Pads, Glideaway™ Rails	1001-52
Steer Handles, Foot End/Head End	1001-152/151
Wheel Cover Replacement Kit	1010-56-200

Side Control Base Assembly

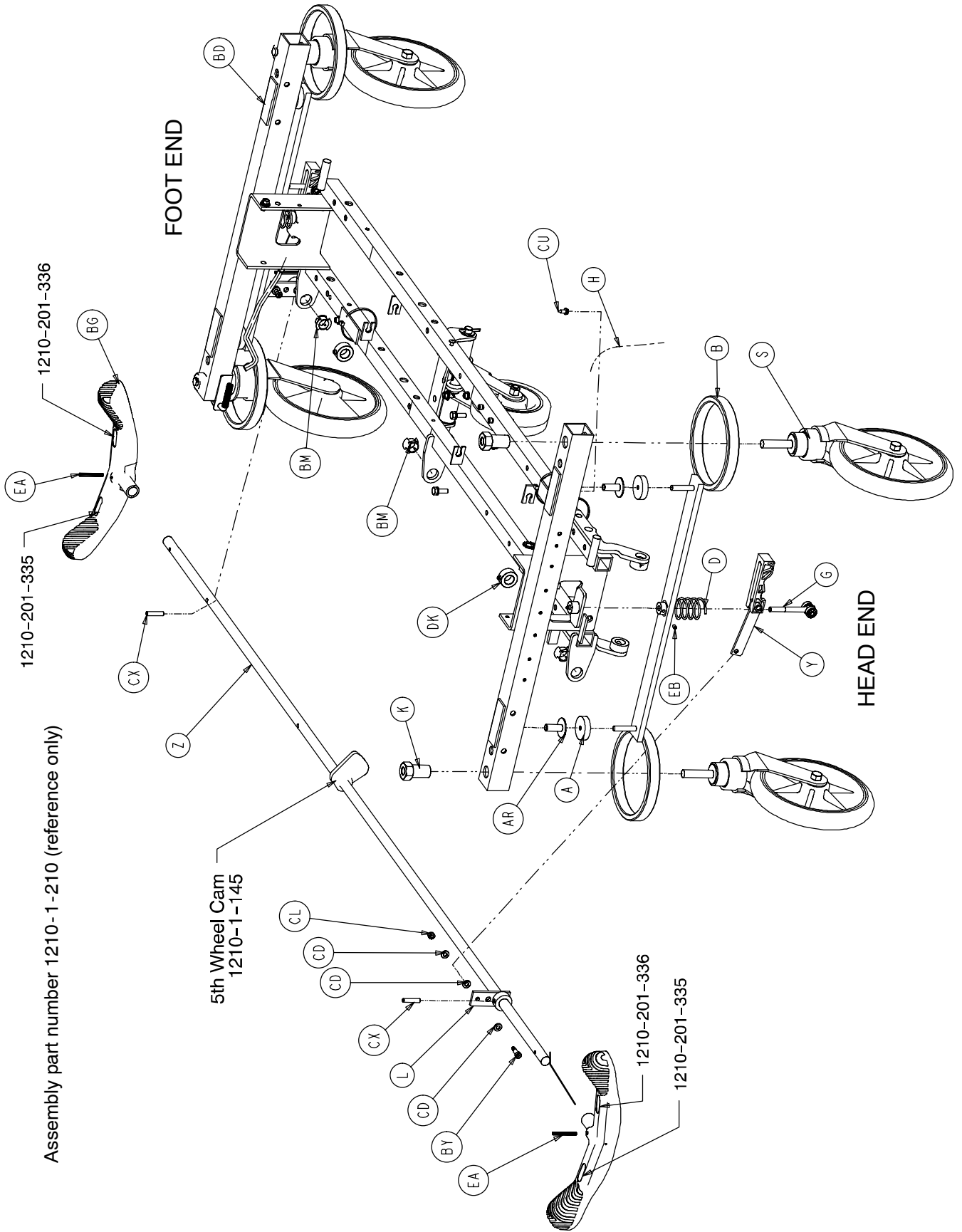

Assembly part number 1210-1-210 (reference only)

Side Control Base Assembly

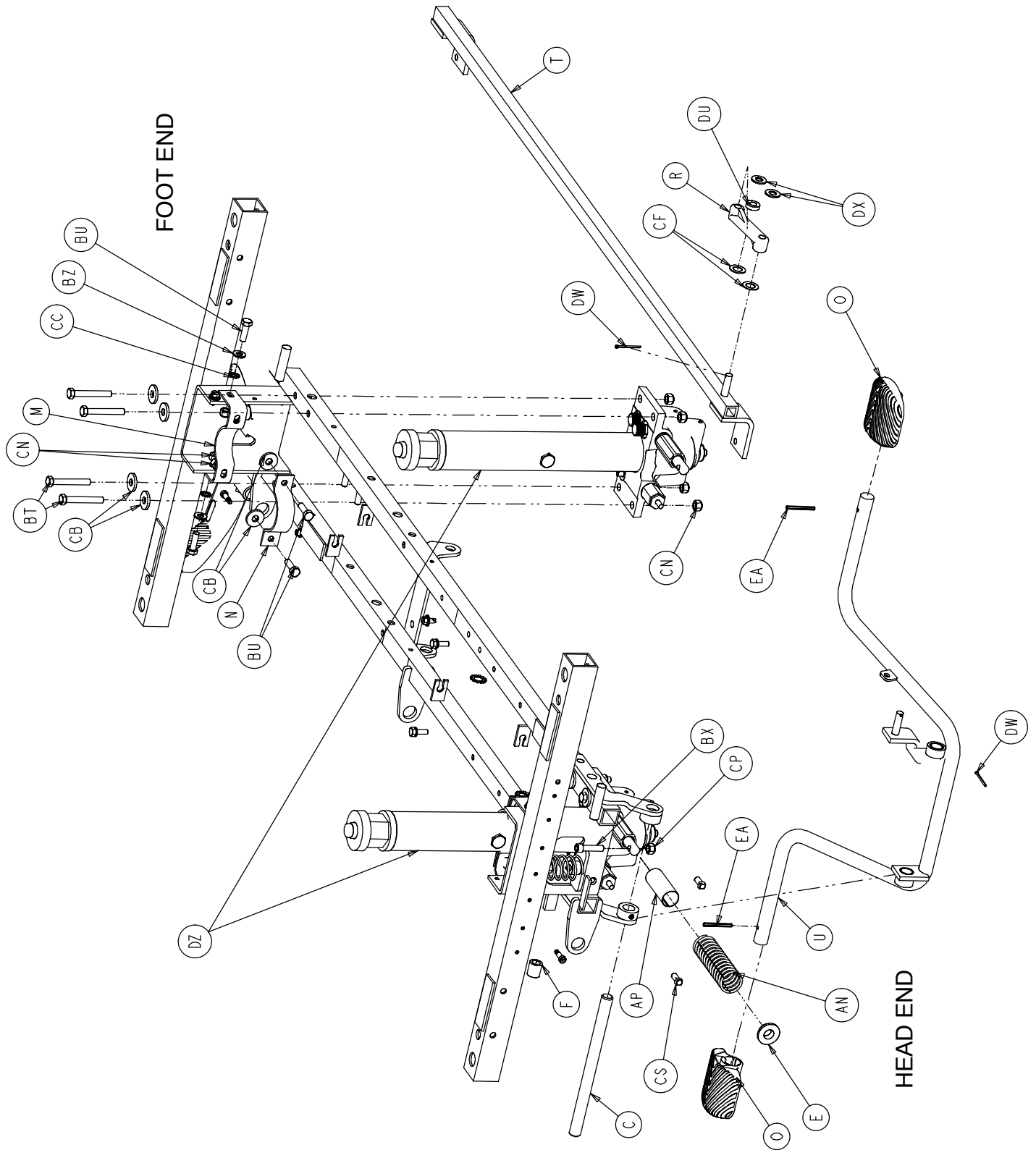

Side Control Base Assembly

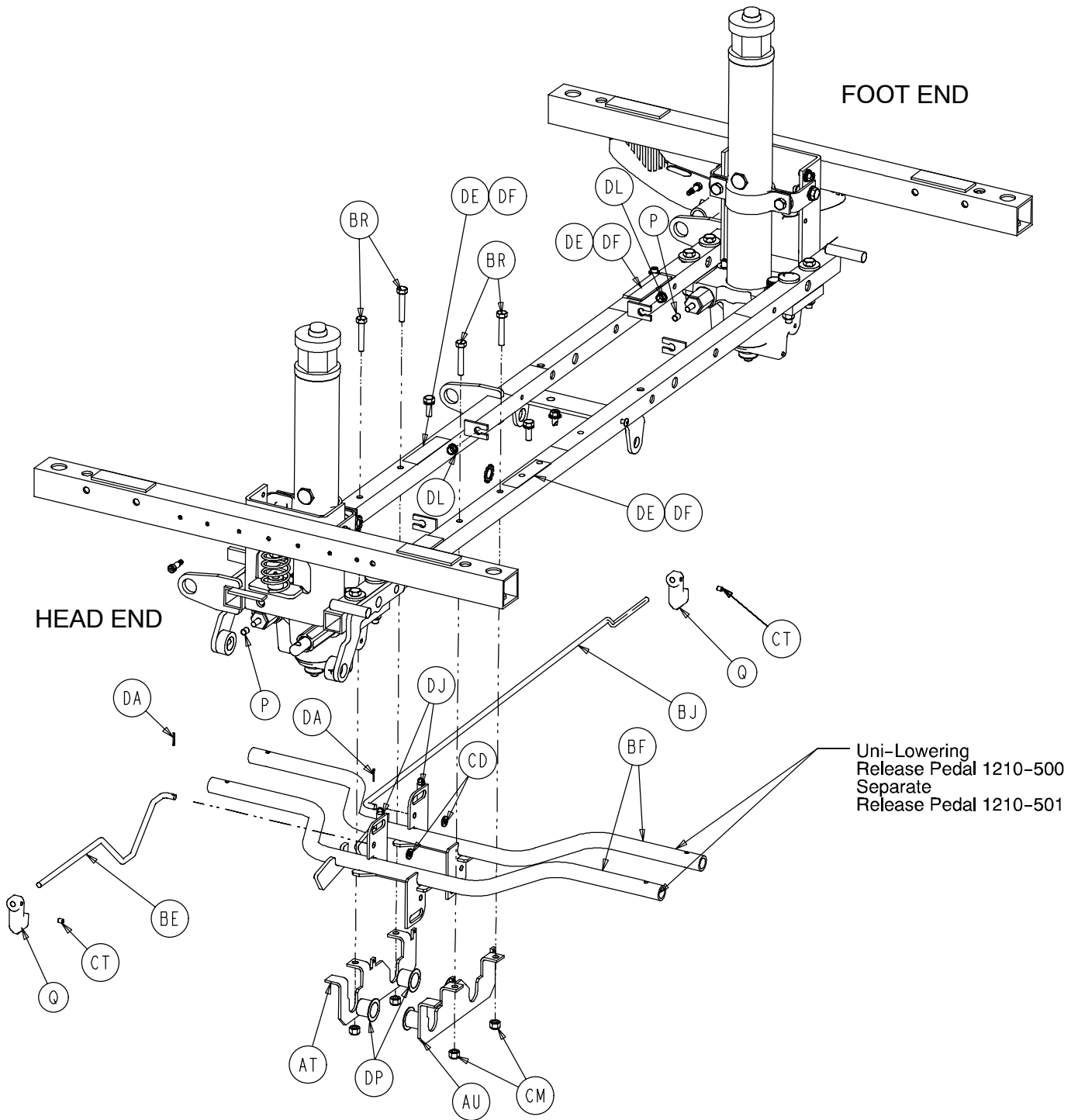

Side Control Base Assembly

Item	Part No.	Part Name	Qty.	Item	Part No.	Part Name	Qty.
A	715-1-11	Brake Cushion	4	BR	3-47	Hex Hd. Cap Screw	4
B	715-1-61	Caster Brake Weldment	2	BT	3-62	Hex Hd. Cap Screw	8
C	715-1-92	Pump Pedal Shaft	1	BU	3-85	Hex Hd. Cap Screw	8
D	715-201-94	Compression Spring	2	BX	4-146	Soc. Hd. Cap Screw	2
E	715-1-133	Collar	1	BY	8-17	Shoulder Bolt	2
F	715-1-140	Vinyl Tube	1	BZ	11-3	Washer	12
G	(page 32)	Brake Adjuster	2	CB	11-262	Washer	12
H	715-1-156	Ground Chain	1	CC	13-38	Ext. Tooth Lock Washer	4
K	715-1-158	Caster Nut	4	CD	14-2	Washer	8
L	715-1-165	Actuator Plate Weldment	2	CF	14-9	Washer	2
M	715-1-192	Jack Support	2	CL	16-59	Hex Nut	2
N	715-1-193	Jack Support Clamp	2	CM	16-28	Hex Nut	4
O	715-201-126	Slip-On Pump Pedal	2	CN	16-36	Hex Nut	16
P	715-1-333	Release Rod Stop Sleeve	2	CP	16-48	Hex Nut	2
Q	715-1-346	Release Paddle	2	CS	46-2	Square Hd. Set Screw	2
R	715-1-214	Connecting Link	1	CT	21-50	Set Screw	2
S	(page 39)	Caster Assembly	*	CU	23-25	Self-Tapping Screw	1
T	715-201-27	Pump Rod Assembly	1	CX	26-13	Spring Pin	2
U	(page 34)	Pump Pedal Assembly	1	DA	27-4	Cotter Pin	2
Y	(page 33)	Brake Cam Assembly	2	DE	29-12	Velcro Loop	3
Z	715-201-230	Brake Bar	1	DF	29-14	Velcro Hook	3
AN	38-246	Jack Spring	1	DJ	38-355	Extension Spring	2
AP	763-1-16	Spring Holder	1	DK	42-20	Collar	2
AR	946-1-116	Brake Bar Bushing	4	DL	52-245	Nyliner	2
AT	1210-1-115	Pedal Pivot, Left	1	DP	52-747	Flange Bearing	4
AU	1210-1-114	Pedal Pivot, Right	1	DU	52-284	Spacer Washer	1
BD	1210-201-120	Base Frame Weldment	1	DW	27-3	Cotter Pin	2
BE	1210-201-139	Pull Release Rod, Head	1	DX	11-4	Washer	2
BF	1210-201-152	Release Pedal Weldment	2	DZ	(p. 57 or 59)	Jack Assembly	2
BG	1210-201-153	Butterfly "V" Pedal	2	EA	26-143	Groove Pin	4
BJ	1210-201-222	Push Release Rod	1	EB	21-151	Set Screw	2
BM	1210-201-251	Insert	3				

* Caster assembly is quantity of 4 if the fifth wheel option is present on the stretcher and quantity of 3 if the steering caster option is present.

End Control Base Assembly

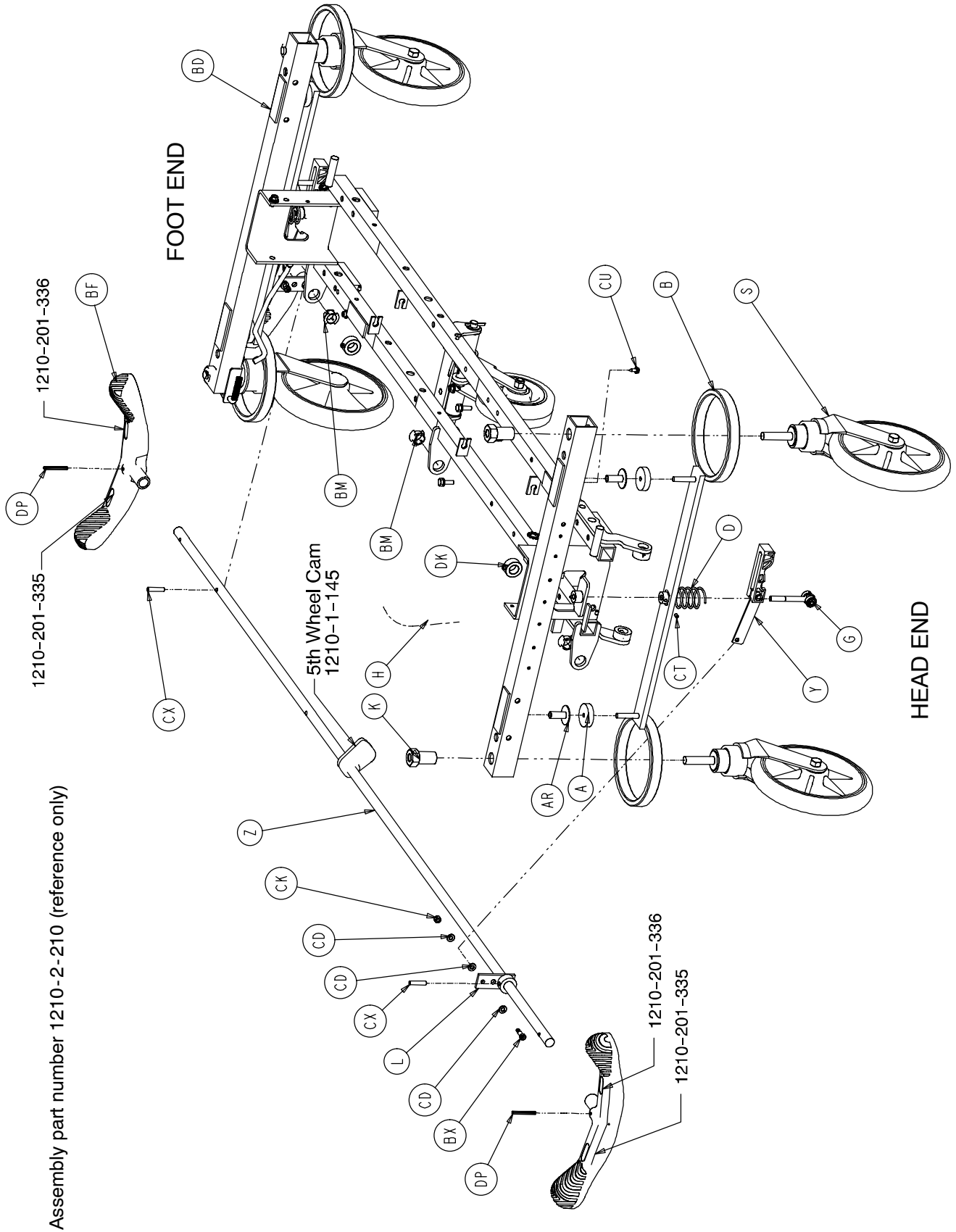

Assembly part number 1210-2-210 (reference only)

End Control Base Assembly

Assembly part number 1210-2-210 (reference only)

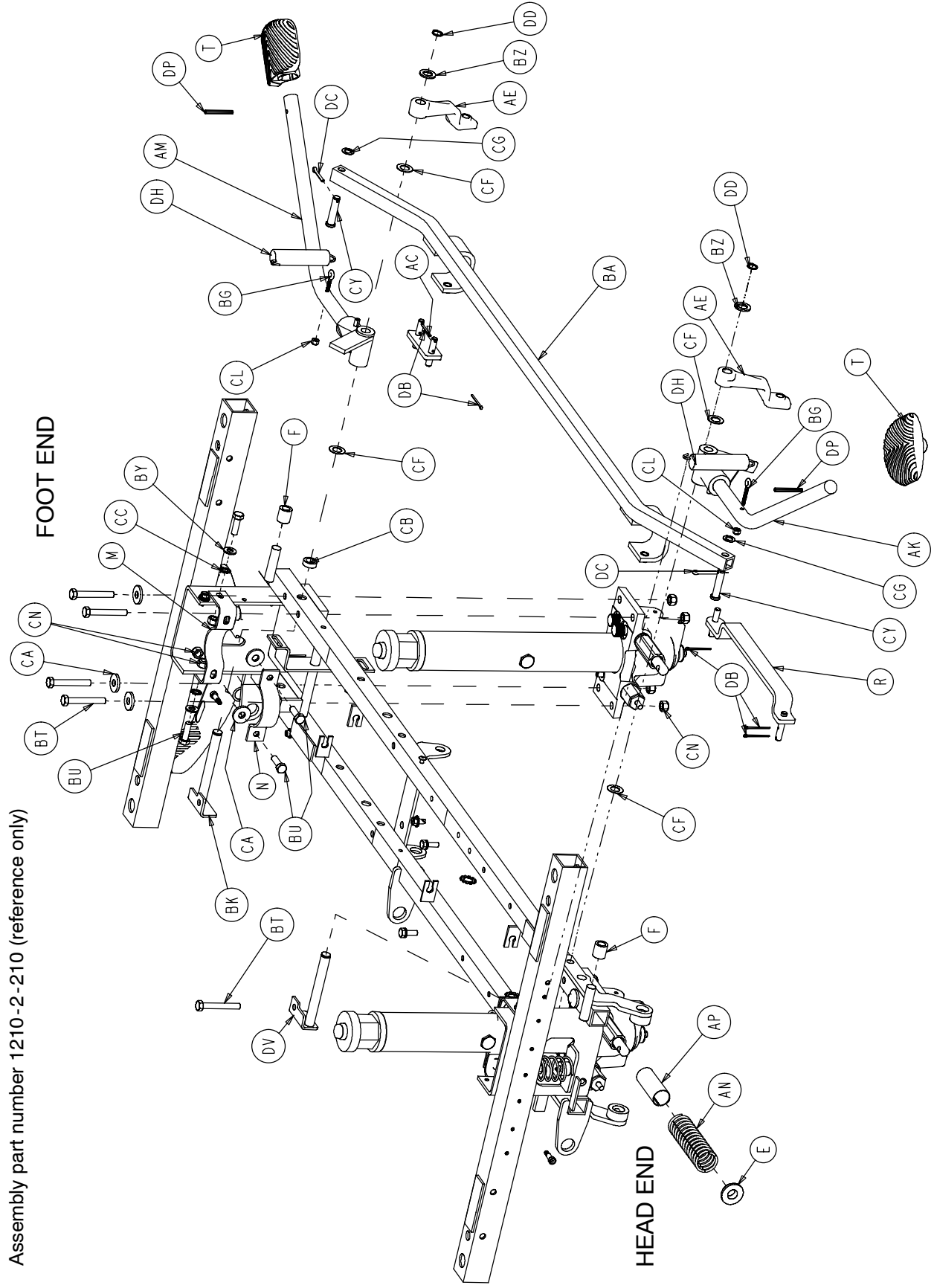

End Control Base Assembly

Assembly part number 1210-2-210 (reference only)

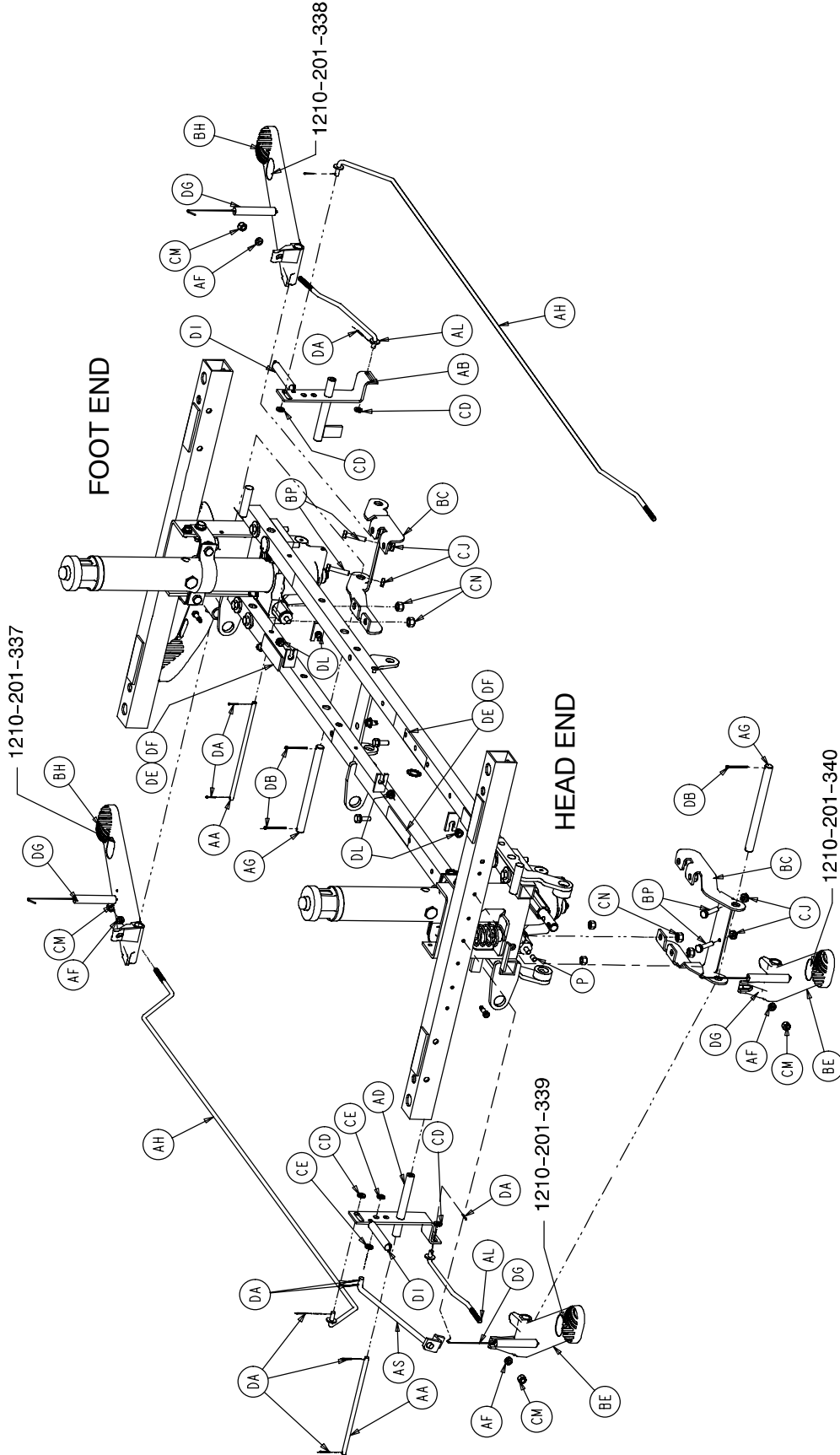

End Control Base Assembly

Item	Part No.	Part Name	Qty.	Item	Part No.	Part Name	Qty.
A	715-1-11	Brake Cushion	4	BH	1210-201-155	Foot Rel. Pedal, Offset, Lt	2
B	715-1-61	Caster Brake Weldment	2	BK	1210-201-201	Pivot Pin Bracket, Foot End	1
D	715-201-94	Compression Spring	2	BM	1210-201-251	Insert	3
E	715-1-133	Collar	2	BP	3-3	Hex Cap Screw	4
F	715-1-140	Vinyl Tube	2	BT	3-62	Hex Hd. Cap Screw	8
G	(page 32)	Brake Adjuster	2	BU	3-85	Hex Hd. Cap Screw	8
H	715-1-156	Ground Chain	1	BX	8-17	Shoulder Bolt	2
K	715-1-158	Caster Nut	4	BY	11-3	Washer	4
L	715-1-165	Actuator Plate Weldment	2	BZ	11-13	Washer	2
M	715-1-192	Jack Support	2	CA	11-262	Washer	10
N	715-1-193	Jack Support Clamp	2	CB	11-350	Spacer Washer	1
P	715-1-333	Release Rod Stop Sleeve	2	CC	13-38	Ext. Tooth Lock Washer	4
R	716-1-109	Head End Pump Link	1	CD	14-2	Washer	10
S	(page 39)	Caster Assembly	*	CE	14-3	Washer	2
T	715-201-26	Slip-On Pump Pedal	2	CF	14-7	Washer	4
Y	(page 33)	Brake Cam Assembly	2	CG	14-9	Washer	2
Z	715-201-230	Brake Bar	1	CJ	15-11	Hex Nut	4
AA	716-1-15	Release Pivot Bar	2	CK	16-2	Hex Nut	2
AB	716-1-52	Pivot Assembly, Foot End	1	CL	16-14	Nylock Nut	2
AC	716-1-102	Pump Link Weldment, Ft.	1	CM	16-102	Hex Nut	4
AD	716-1-119	Pivot Assembly, Head End	1	CN	16-36	Hex Nut	16
AE	716-201-281	Pump Idler Link	2	CT	21-151	Set Screw	2
AF	716-1-286	Release Ball Spacer	4	CU	23-25	Self-Tapping Screw	1
AG	716-201-61	Release Pedal Pivot Rod	2	CX	26-13	Spring Pin	2
AH	716-201-70	Long Release Rod	2	CY	26-195	Clevis Pin	2
AK	(page 36)	Head End Pump Pedal	1	DA	27-4	Cotter Pin	9
AL	716-201-74	Release Rod	2	DB	27-7	Cotter Pin	9
AM	(page 35)	Foot End Pump Pedal	1	DC	27-16	Cotter Pin	2
AN	763-1-15	Jack Spring	1	DD	28-97	Ext. Tooth Retaining Ring	2
AP	763-1-16	Spring Holder	1	DE	29-12	Velcro Loop	3
AR	946-1-116	Brake Bar Bushing	4	DF	29-14	Velcro Hook	3
AS	1210-1-112	Rel. Rod, Head End, Lt.	1	DG	38-235	Desc. Pedal Return Spring	4
BA	1210-201-27	Pump Connecting Rod	1	DH	38-251	Pump Return Spring	2
BC	1210-201-111	End Release Pedal Brkt.	2	DI	38-326	Extension Spring	2
BD	1210-201-120	Base Frame Weldment	1	DK	42-20	Collar	2
BE	1210-201-154	Head Rel. Pedal, Offset, Rt.	2	DL	52-245	Nyliner	4
BF	1210-201-153	Butterfly "V" Pedal	2	DM	(p. 57 or 59)	Jack Assembly	2
BG	1210-201-551	Eye Bolt	2	DP	26-143	Groove Pin	4

* Caster assembly is quantity of 4 if the fifth wheel option is present on the stretcher and quantity of 3 if the steering caster option is present.

715-201-150 Brake Adjuster Assembly

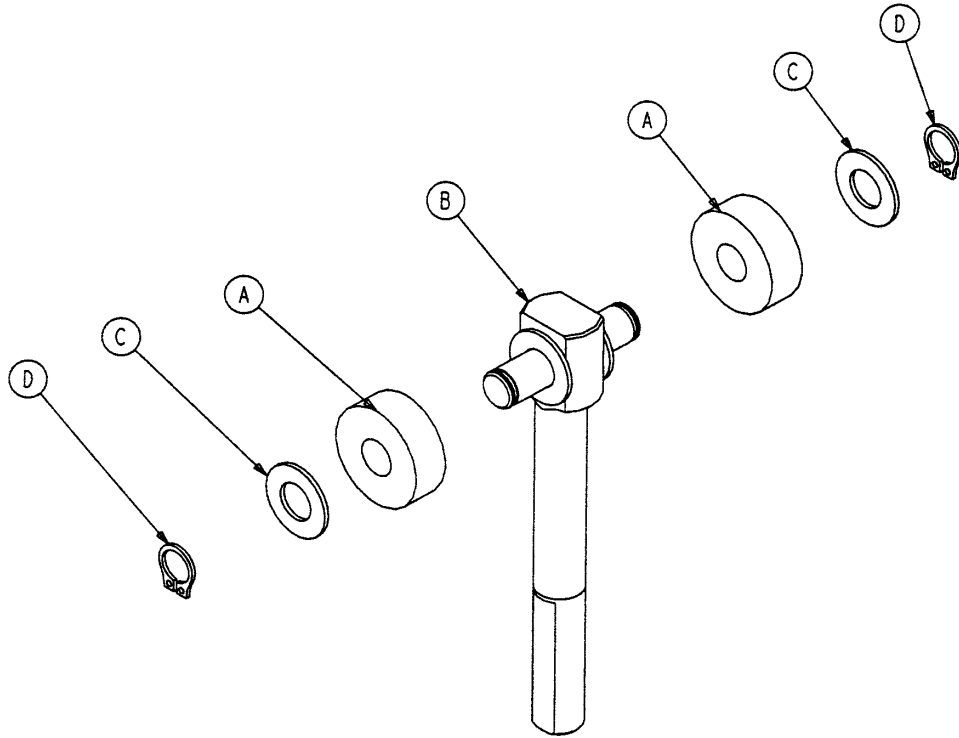

Item	Part No.	Part Name	Qty.
A	715-1-180	Cam Bearing	2
B	715-201-62	Threaded Stud Assembly	1
C	14-4	Nylon Washer	4
D	28-8	External Retaining Ring	2

715-201-213 Brake Cam Assembly

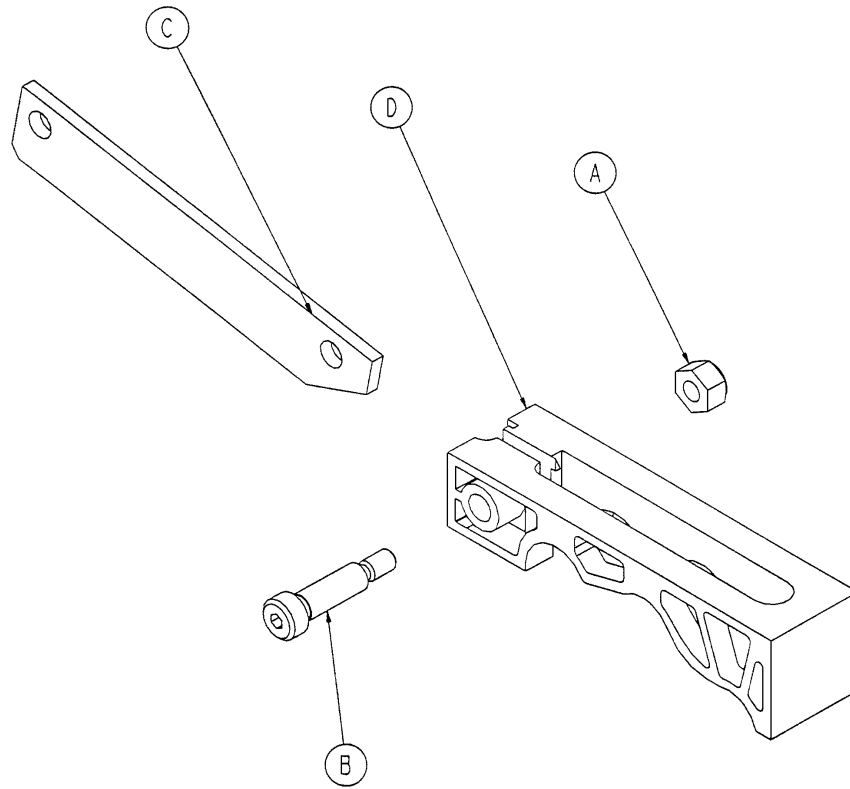

Item	Part No.	Part Name	Qty.
A	16-59	Hex Nut	1
B	8-21	Soc. Hd. Shoulder Screw	1
C	715-201-173	Brake Connecting Link	1
D	715-301-221	Brake Cam	1

Side Control Pump Pedal Assembly

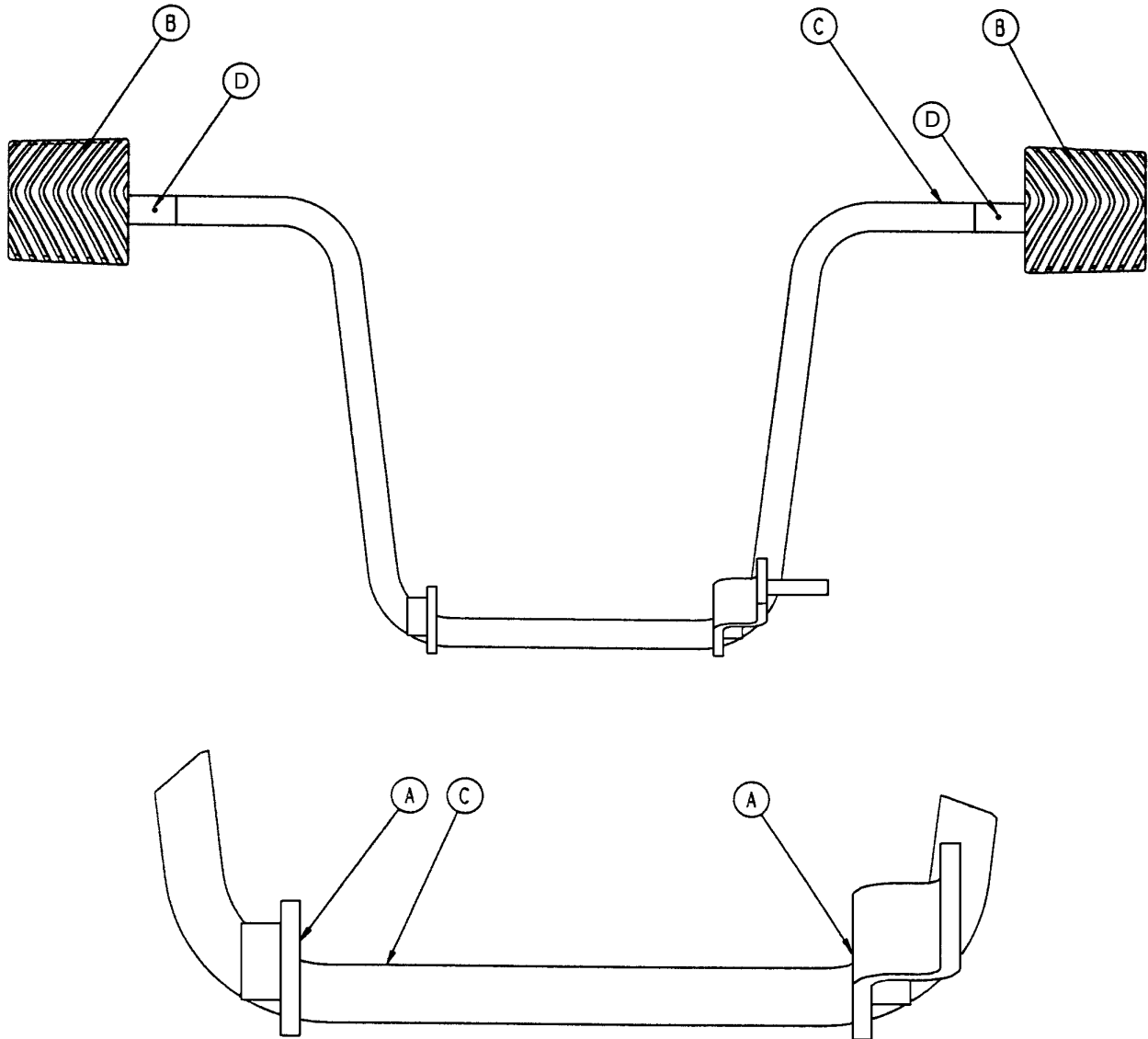

Item	Part No.	Part Name	Qty.
A	81-44	Bronze Bearing	2
B	715-201-126	Slip-On Pedal Pad	2
C	715-201-83	Pump Pedal Weldment	1
D	26-143	Groove Pin	2

716-201-288 Foot End Pump Pedal Assembly

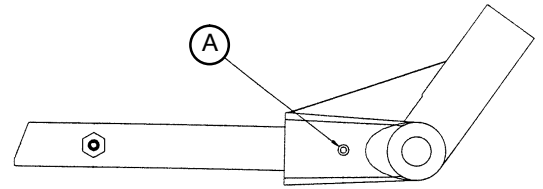
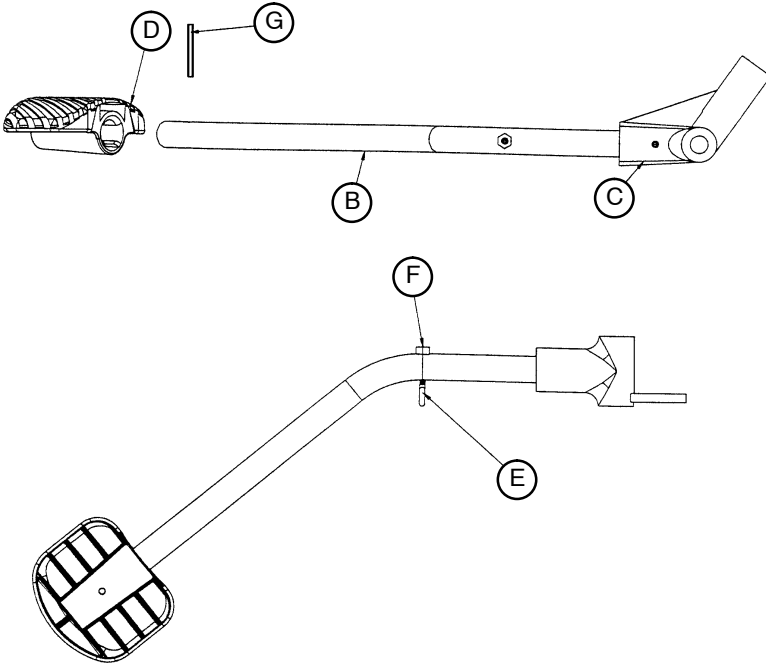

Item	Part No.	Part Name	Qty.
A	26-145	Spring Pin	1
B	716-201-14	Foot End Pump Rod	1
C	716-1-283	Pump Pivot Housing	1
D	715-201-126	Pedal	1
E	1210-201-551	Eye Bolt	1
F	16-14	Nylock Nut	1
G	26-261	Groove Pin	1

716-201-292 Head End Pump Pedal Assembly

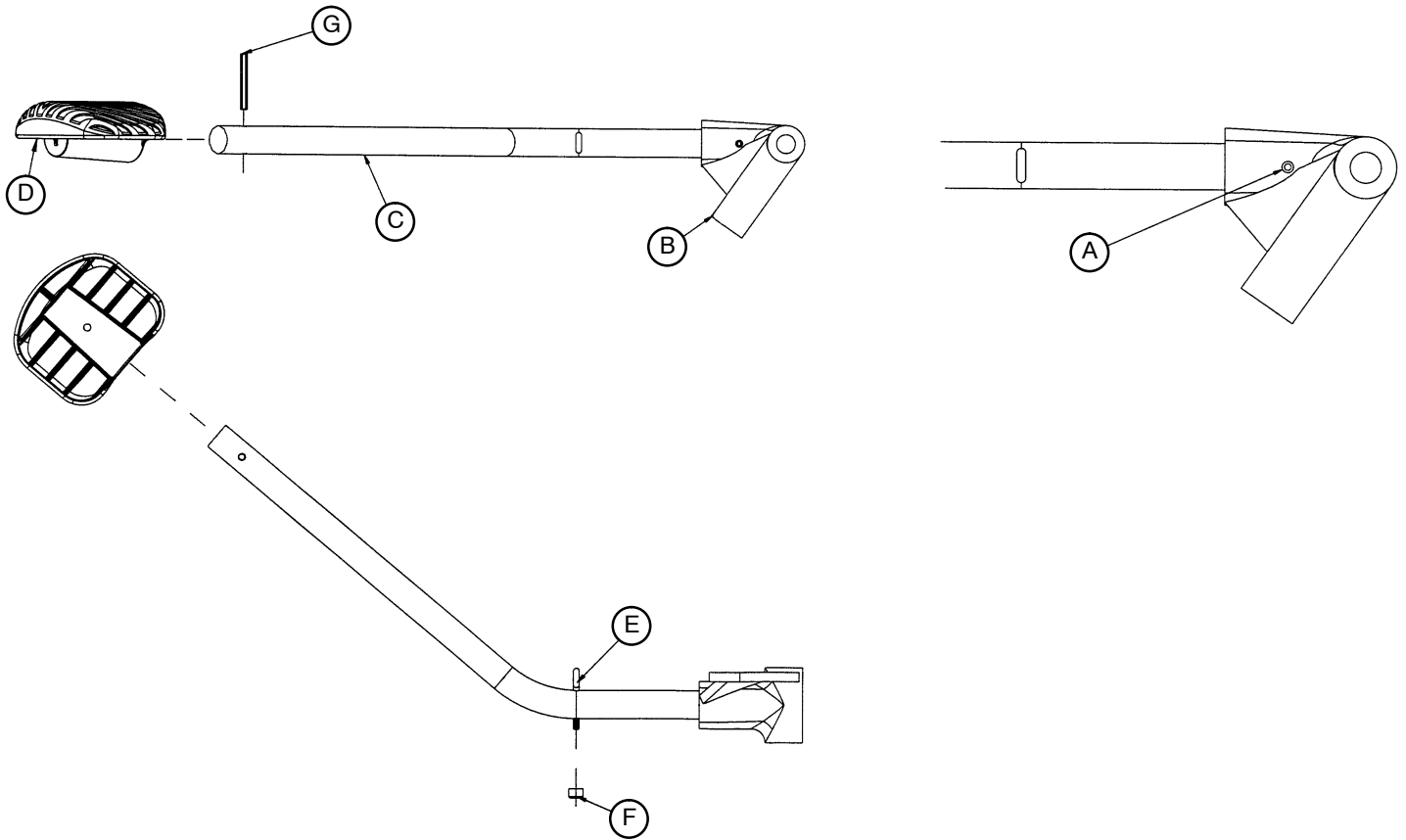

Item	Part No.	Part Name	Qty.
A	26-145	Spring Pin	1
B	716-1-285	Pump Pivot Housing, Hd. End	1
C	716-201-14	Head End Pump Rod	1
D	715-201-126	Pedal	1
E	1210-201-551	Eye Bolt	1
F	16-14	Nylock Nut	1
G	26-261	Groove Pin	1

Base Assembly w/Steerlock Caster Option

Assembly part number 1000-159
(reference only)

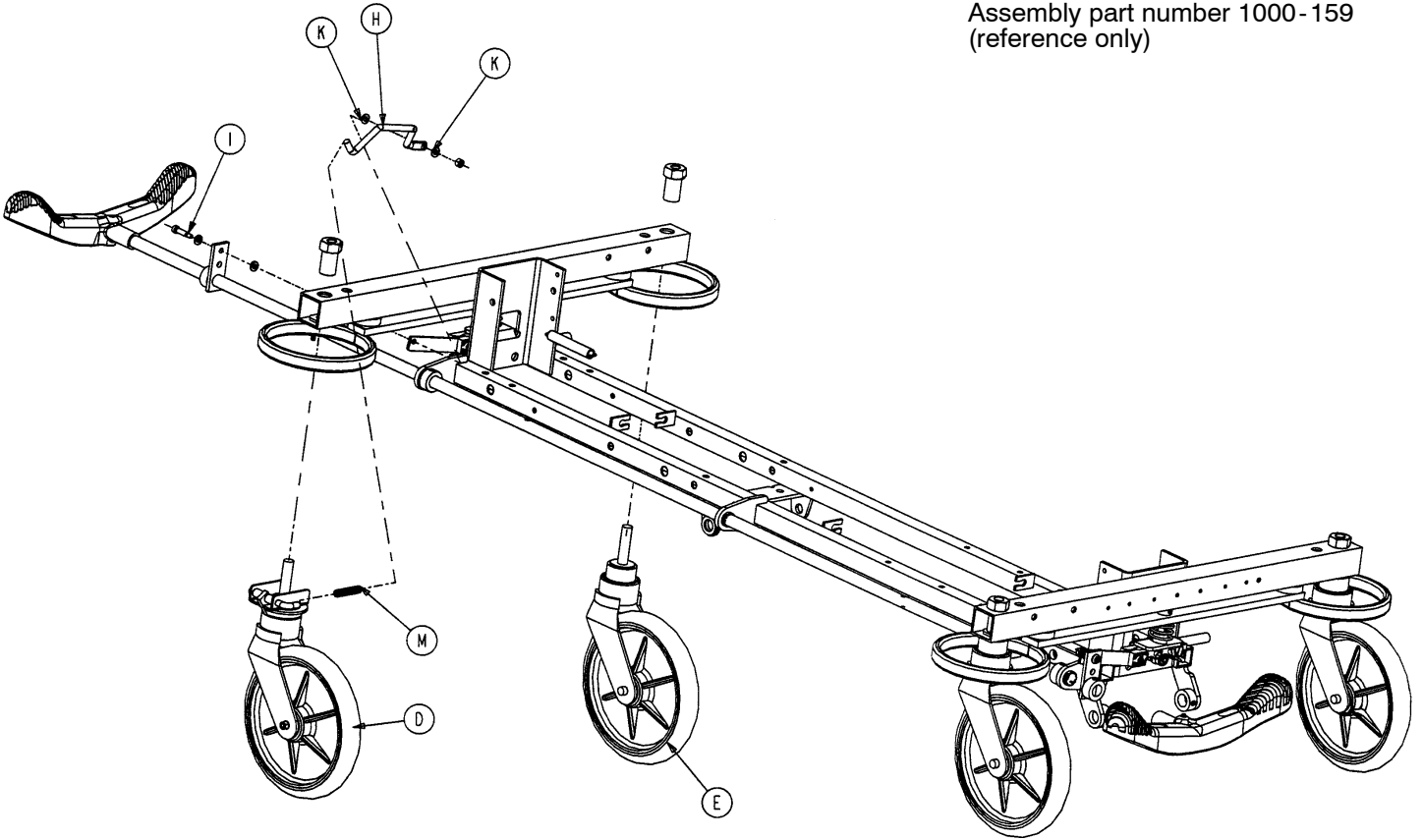

Item	Part No.	Part Name	Qty.
D	(page 38)	Steer Caster Assembly	1
E	(page 39)	Caster Assembly	3
H	1000-210-62	Steer Lock Linkage Bar	1
I	8-21	Shoulder Bolt	1
K	14-2	Washer	2
M	38-211	Spring	1

715-269-100 Caster Assembly w/Steerlock

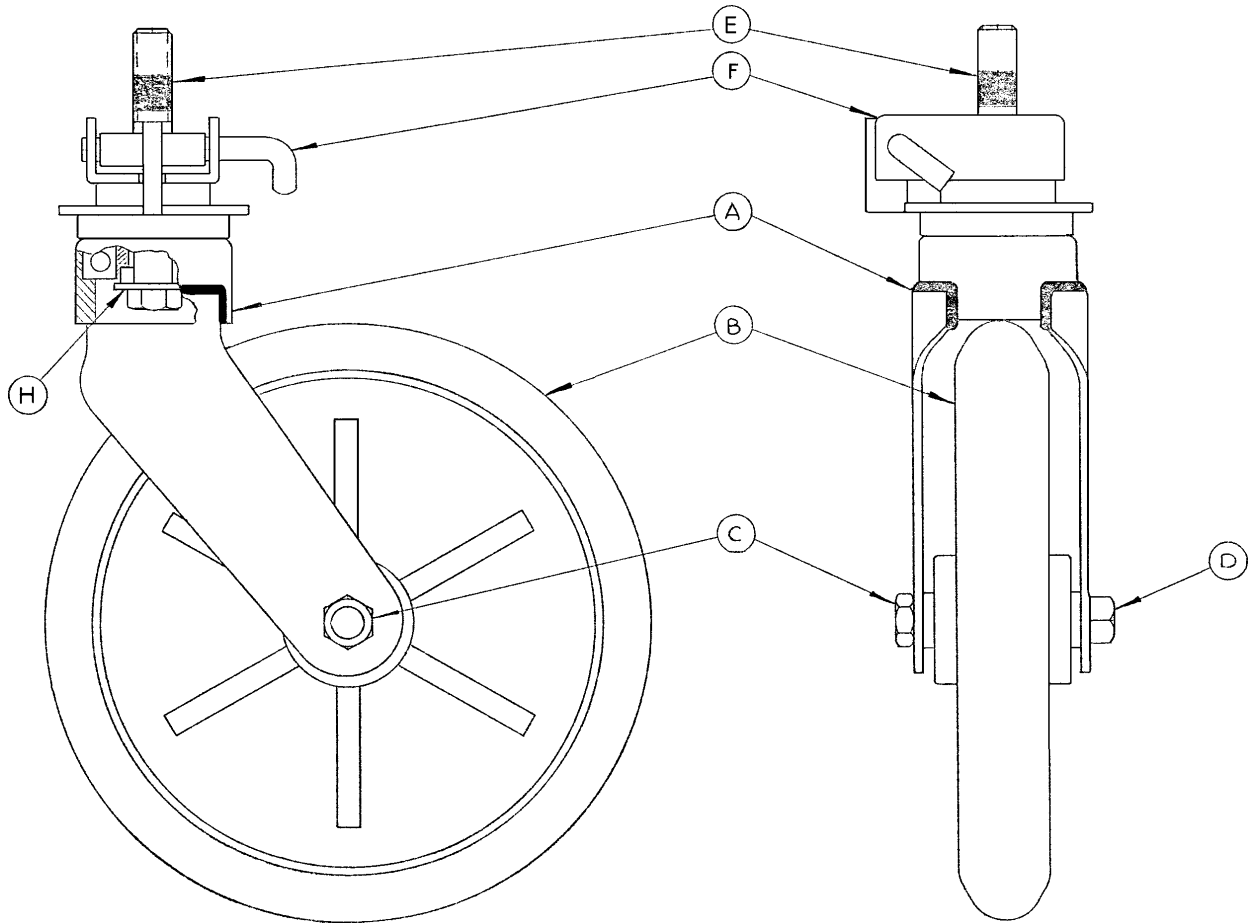

Assembly part number 715-2-21 (reference only)

Item	Part No.	Part Name	Qty.
A	700-10-50	Steer Lock Caster Weldment	1
B	715-2-25	Caster Wheel	1
C	16-60	Hex Nut	1
D	3-99	Hex Bolt	1
E	715-3-96	Hex Bolt	1
F	1000-59-10	Latch Assembly	1
H	11-310	Flat Washer	1

Standard Caster Assembly

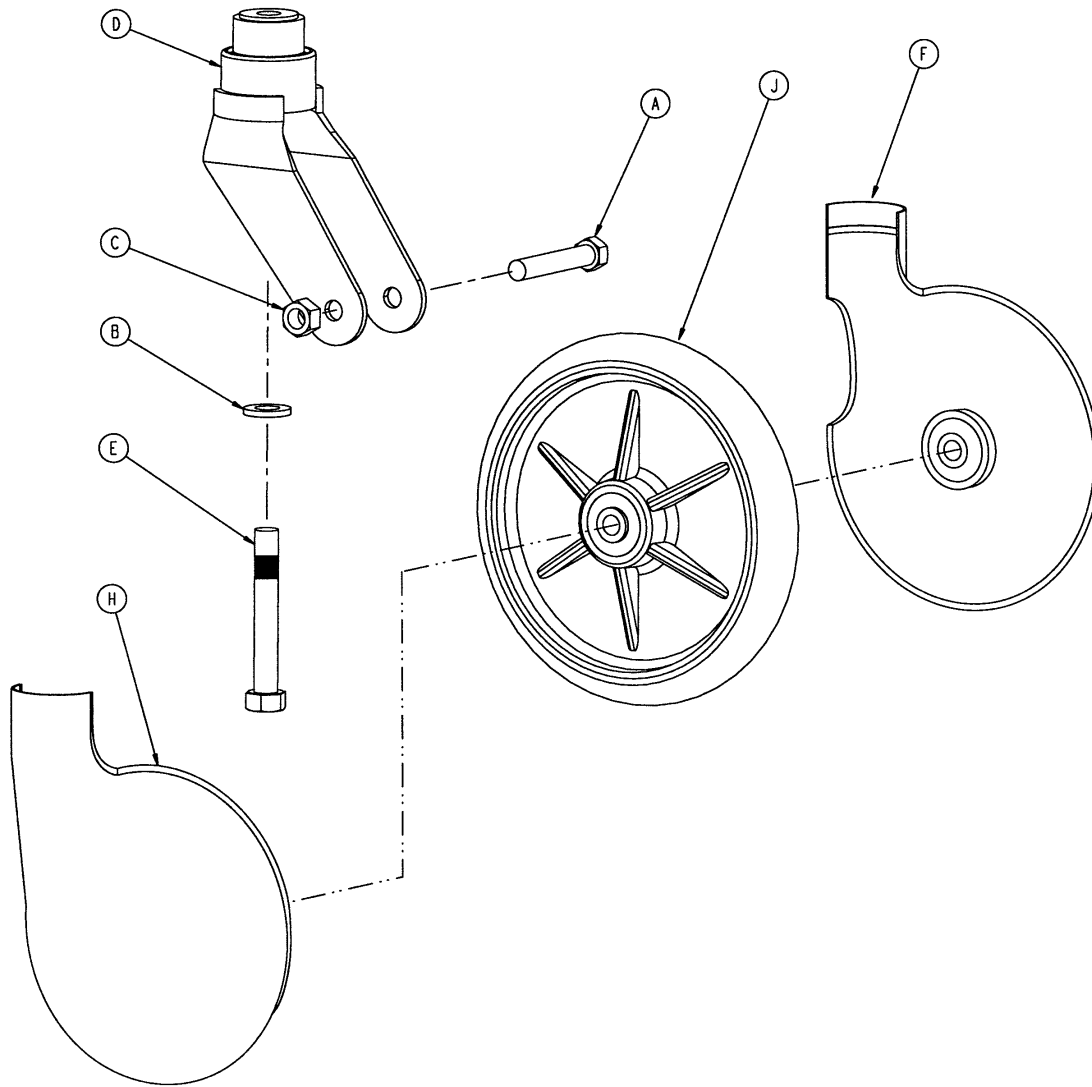

Item	Part No.	Part Name	Qty.
A	3-99	Hex Hd. Cap Screw	1
B	11-310	Washer	1
C	16-60	Hex Nut	1
D	715-2-16	Horn Assembly	1
E	715-3-96	Hex Hd. Cap Screw	1
F	715-1-265	Wheel Cover, Right	1
H	715-1-266	Wheel Cover, Left	1
J	715-2-25	Wheel	1
	715-1-158	Caster Nut (not shown)	1

p/n 715-259-400 - Kit to replace 4 standard caster assemblies with hardware - no caster covers.

p/n 715-269-400 - Kit to replace 3 standard caster assemblies and 1 steerlock caster with hardware - no caster covers.

p/n 715-259-100 - Kit to replace 1 standard caster assembly with hardware - no caster covers.

p/n 1010-56-200 - Kit to replace both caster covers on all four wheels.

Base Assembly w/Fifth Wheel Option

Assembly part number 1010-260 (reference only)

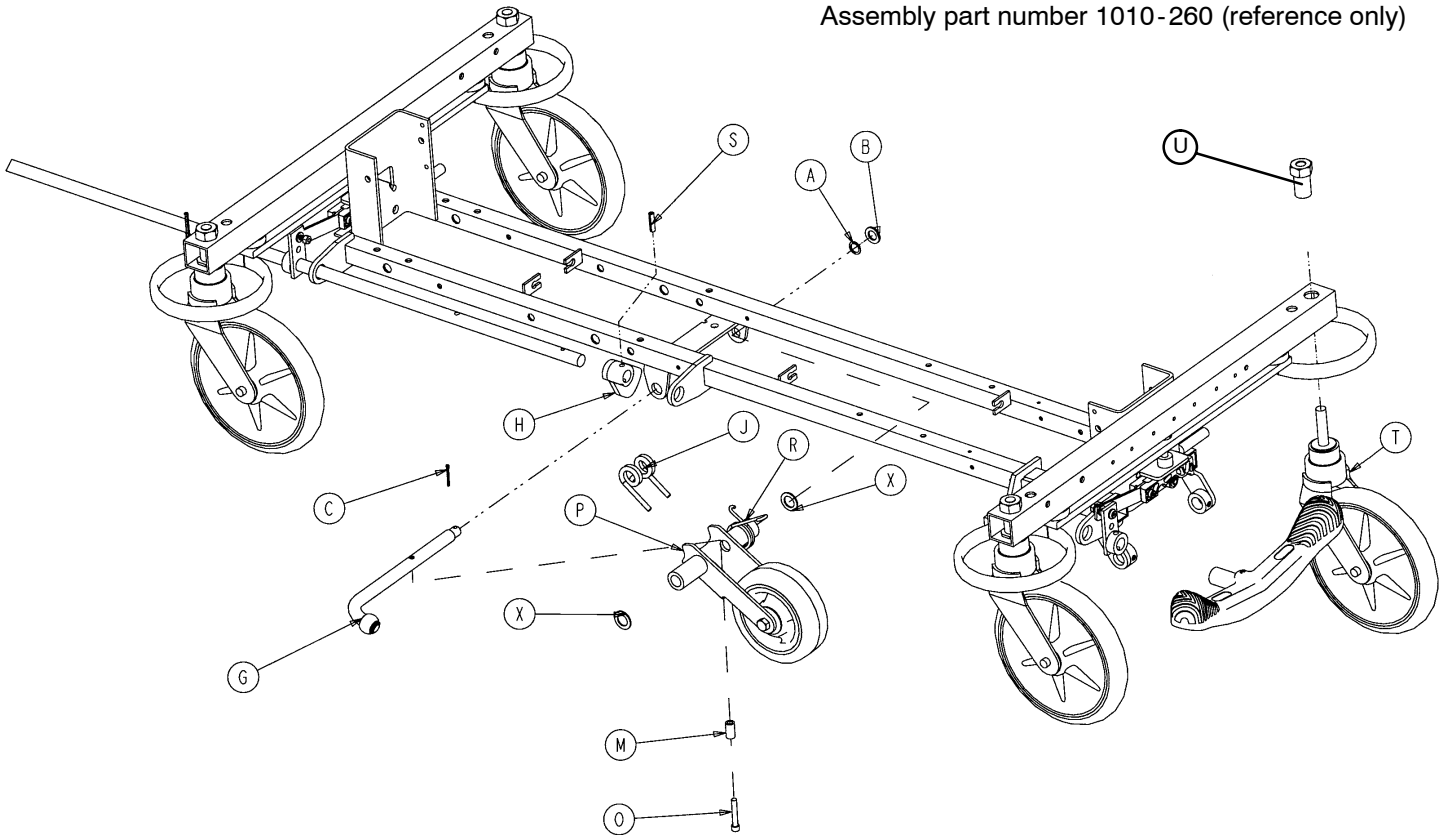

Item	Part No.	Part Name	Qty.
A	14-79	Nylon Washer	1
B	11-13	Washer	1
C	27-16	Cotter Pin	1
G	(page 41)	Pivot Rod Assembly	1
H	1210-1-145	Cam	1
J	1210-1-148	Torsion Spring	1
M	1210-201-149	Spring Spacer	1
O	4-10	Bolt	1
P	(page 42)	Wheel Arm Assembly	1
R	1210-1-146	Torsion Spring	1
S	26-35	Roll Pin	1
T	(page 39)	Caster Assembly	4
U	715-1-158	Caster Nut	4
X	14-80	Nylon Washer	2

Pivot Rod Assembly

Assembly part number 1210-201-2
(reference only)

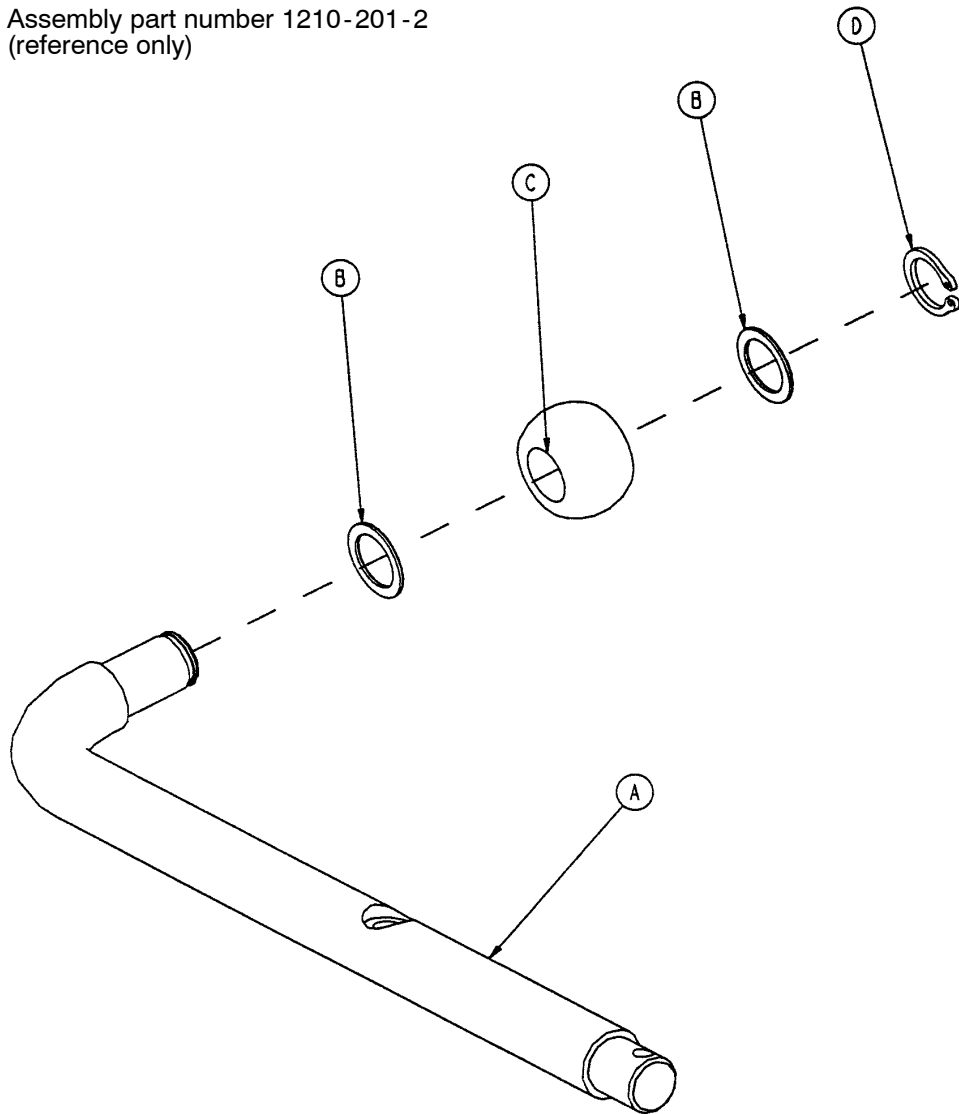

Item	Part No.	Part Name	Qty.
A	1210-1-143	Pivot Rod	1
B	14-79	Nylon Washer	2
C	1210-1-144	Roller	1
D	28-131	Snap Ring	1
E	27-16	Cotter Pin	1

715-201 -125 Wheel Arm Assembly

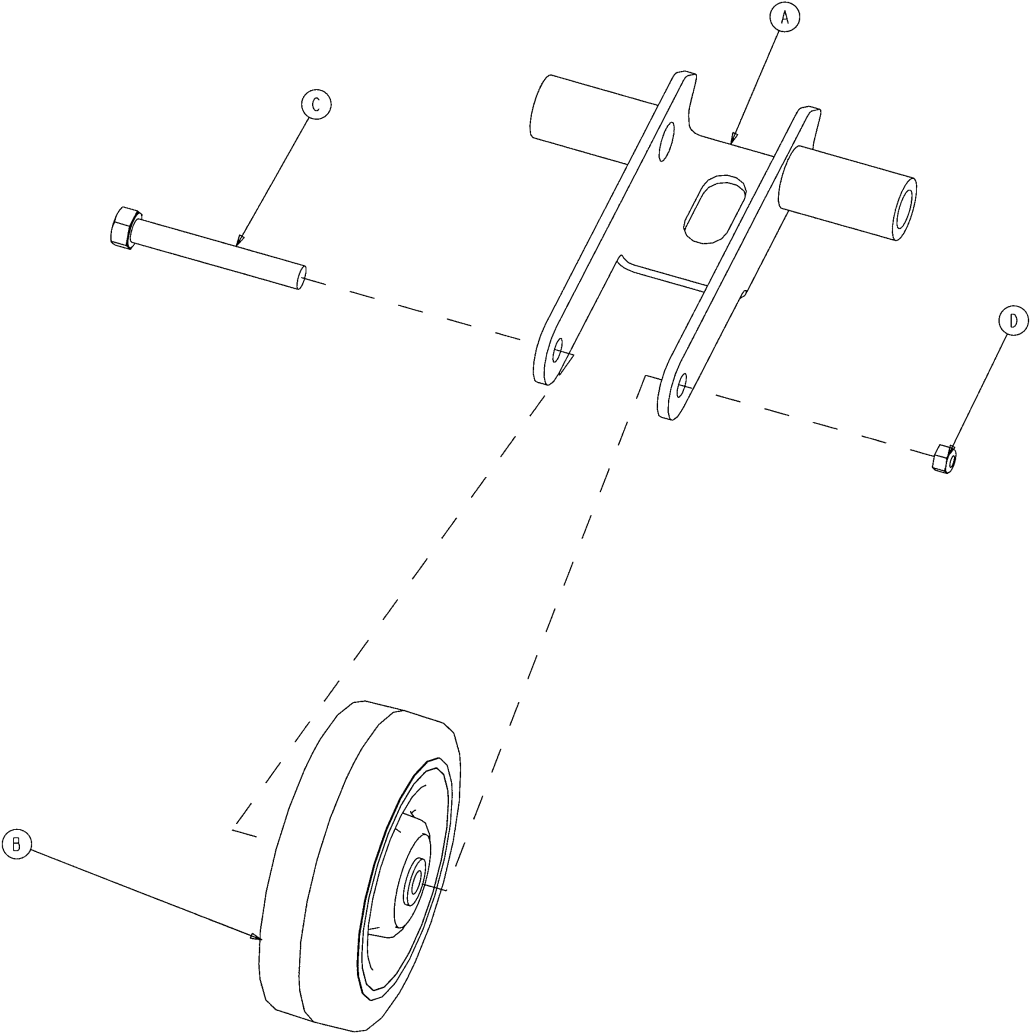

Item	Part No.	Part Name	Qty.
A	1210-201-553	Wheel Arm	1
B	1210-1-147	Fifth Wheel	1
C	3-31	Hex Hd. Cap Screw	1
D	16-35	Nylock Nut	1

Optional Side Control Big Wheel Base Assembly

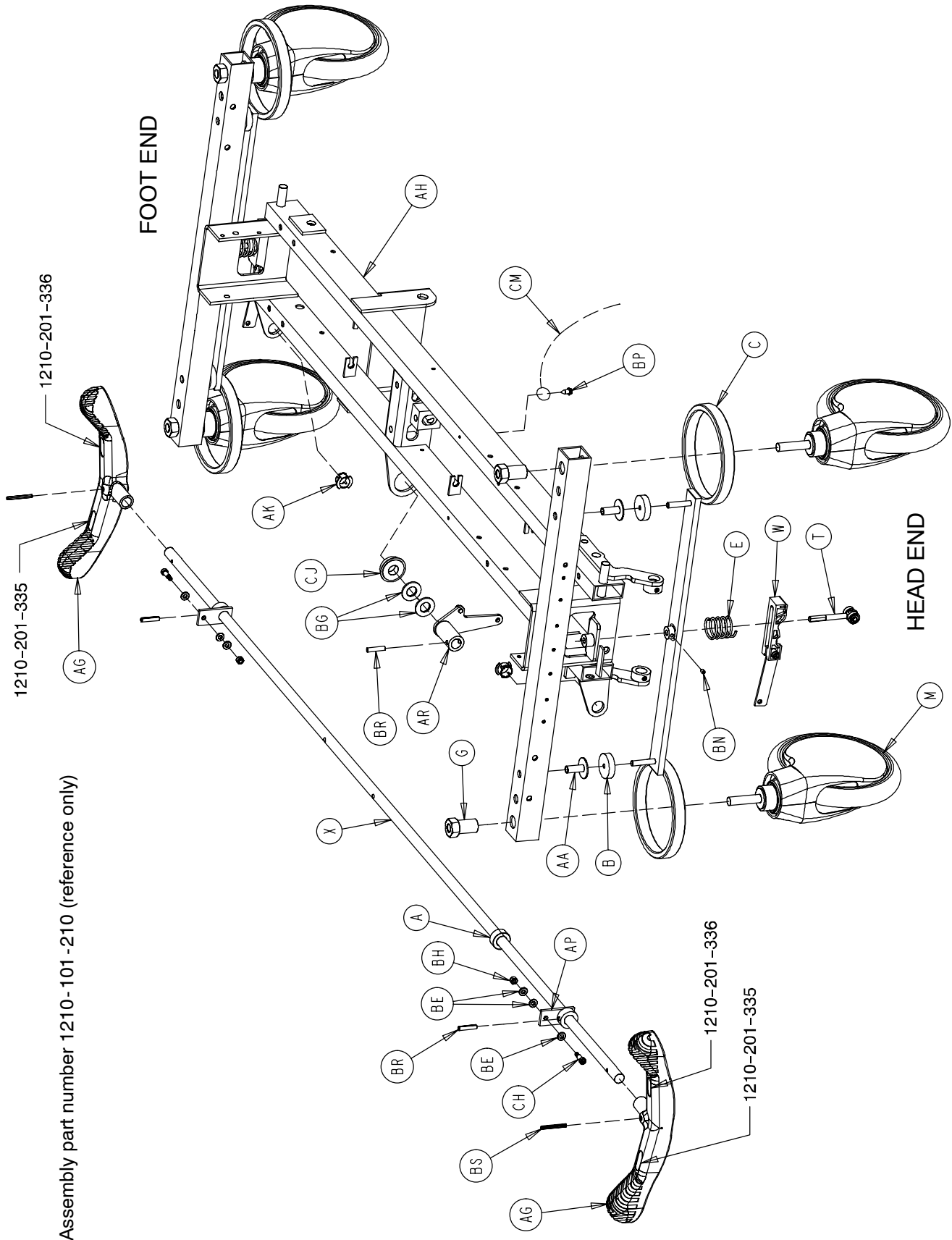

Assembly part number 1210-101-210 (reference only)

Optional Side Control Big Wheel Base Assembly

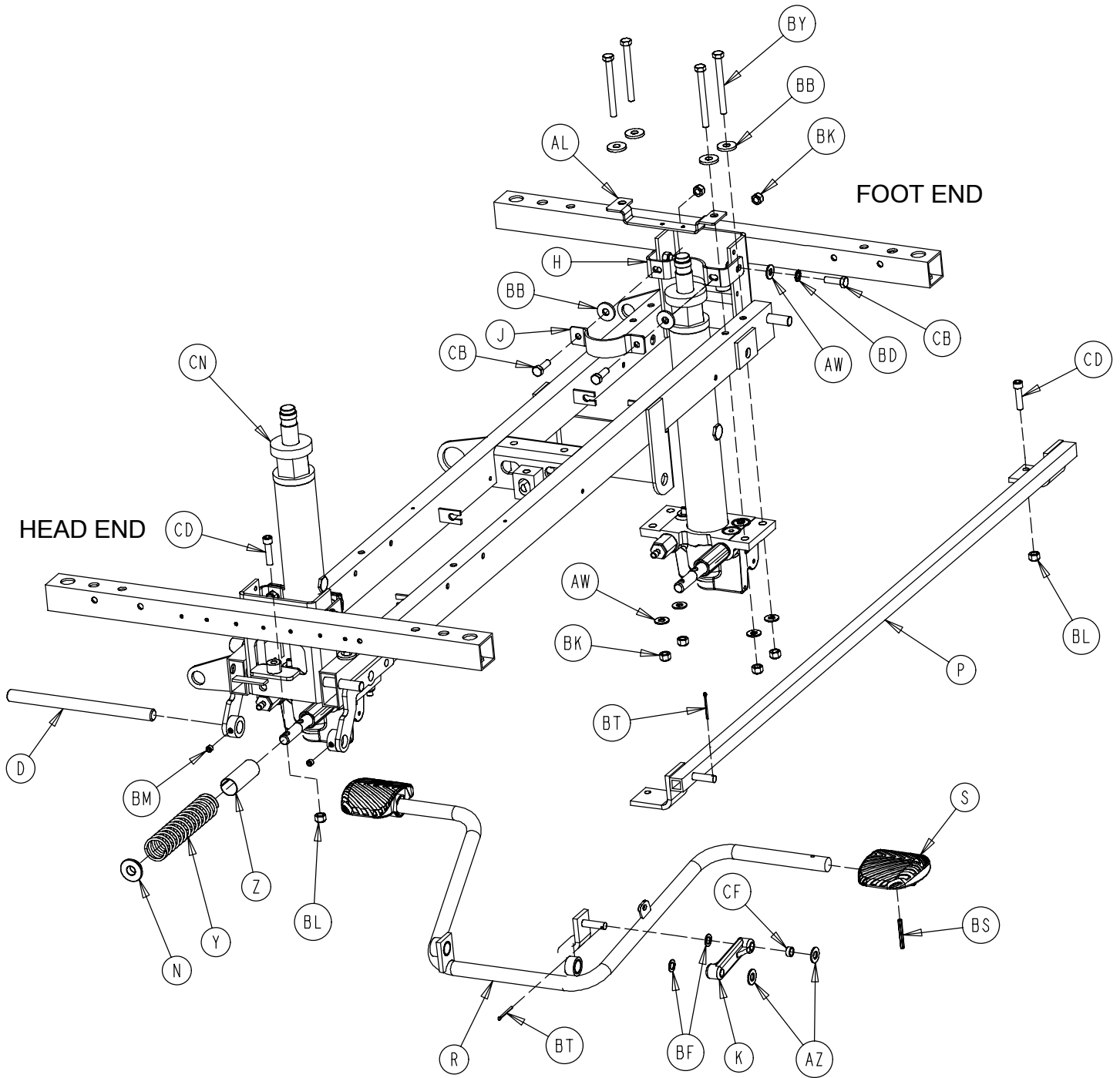

Optional Side Control Big Wheel Base Assembly

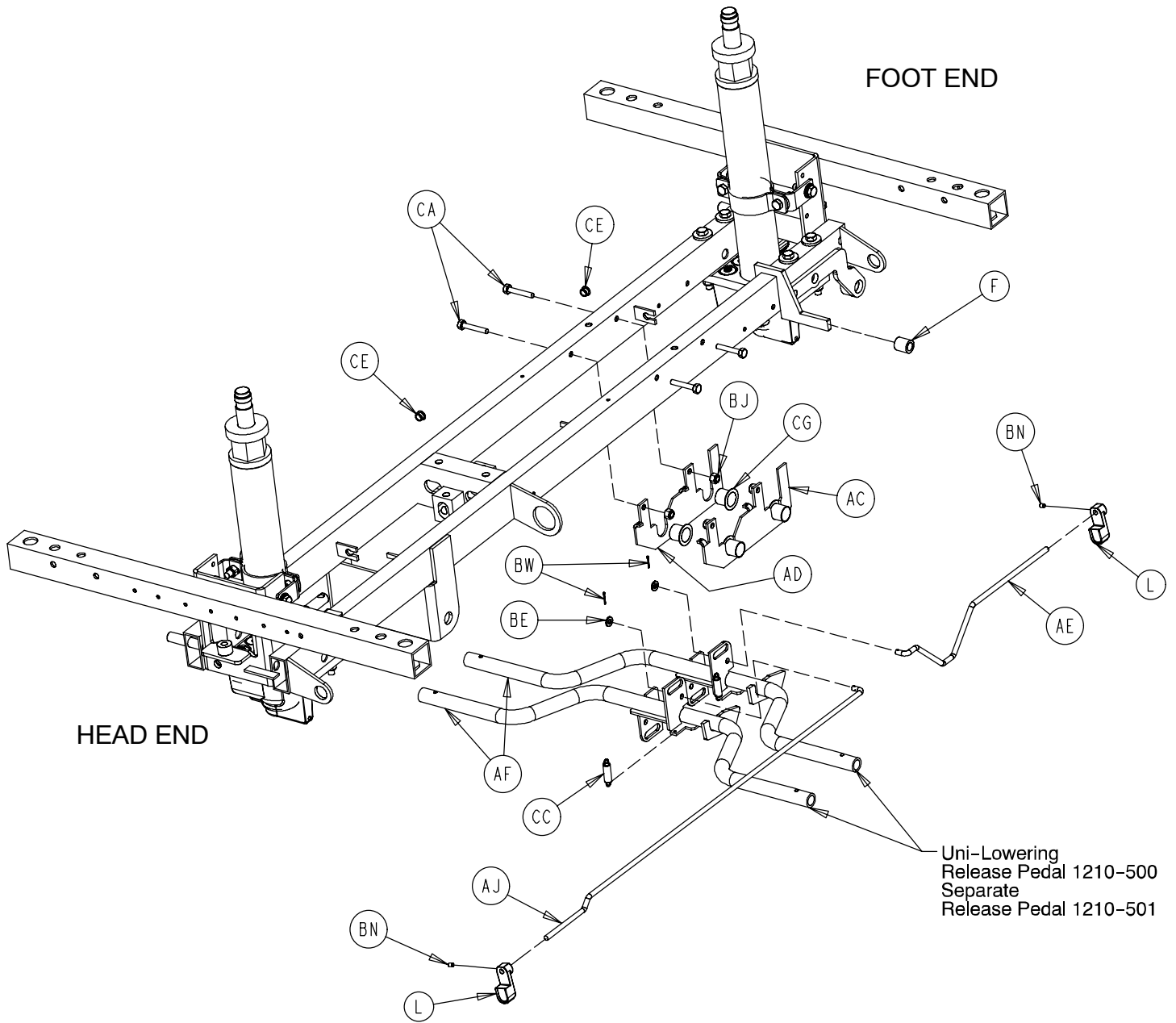

Optional Side Control Big Wheel Base Assembly

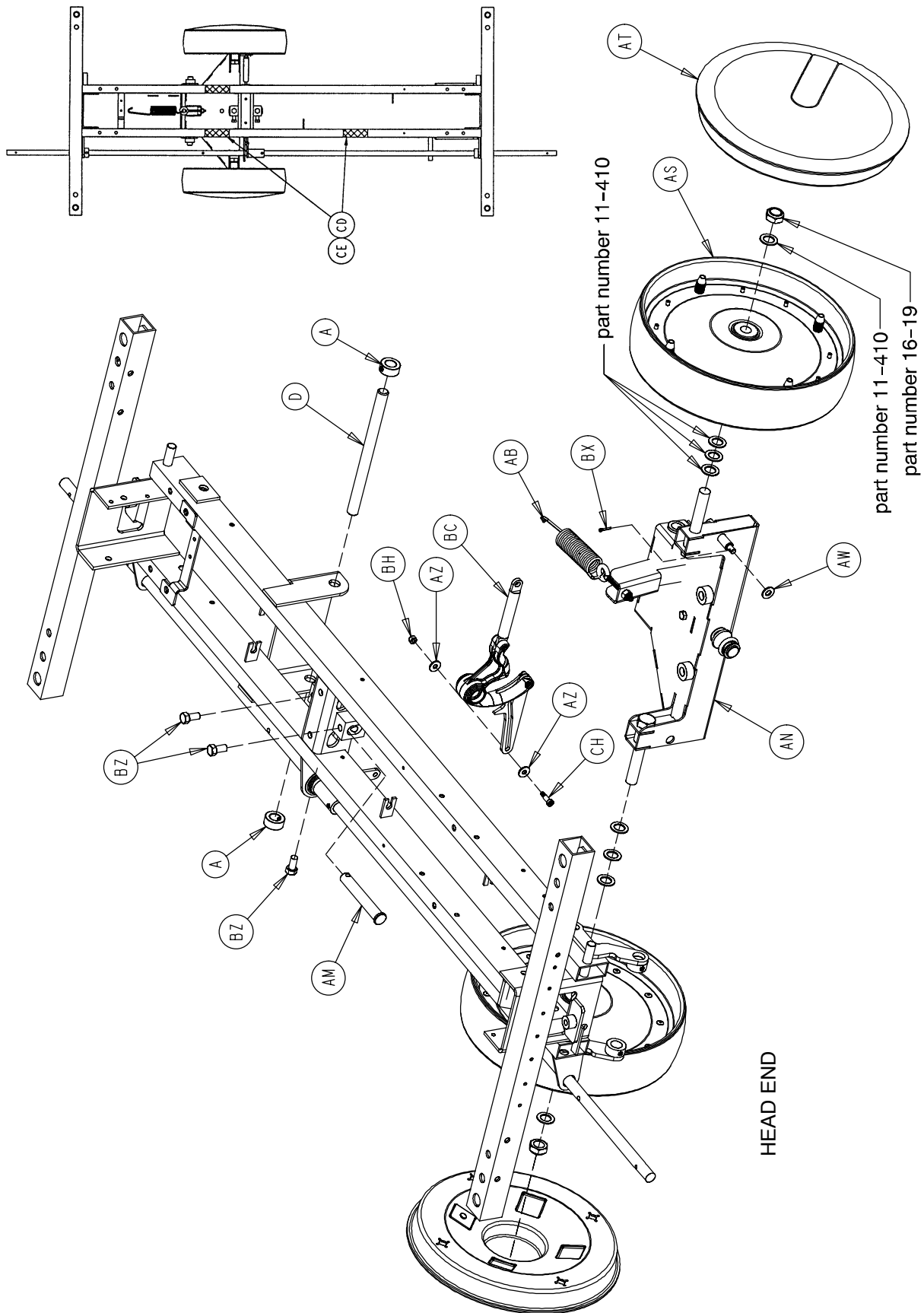

Optional Side Control Big Wheel Base Assembly

Item	Part No.	Part Name	Qty.	Item	Part No.	Part Name	Qty.
A	42-20	Collar	3	AT	1210-301-653	Wheel Cover Assembly	2
B	715-1-11	Brake Cushion	4	AW	11-3	Washer	11
C	715-1-61	Caster Brake Weldment	2	AZ	11-4	Washer	2
D	715-1-92	Pump Pedal Shaft	2	BA	11-224	Washer	2
E	715-1-94	Compression Spring	2	BB	11-262	Washer	12
F	715-1-140	Vinyl Tube	1	BC	(page 56)	Cam Assembly	1
G	715-1-158	Caster Nut	4	BD	13-38	Lock Washer	4
H	715-1-192	Jack Support	2	BE	14-2	Washer	8
J	715-1-193	Jack Support Clamp	2	BF	14-9	Washer	2
K	715-1-214	Connecting Link	1	BG	14-71	Washer	2
L	715-1-346	Release Paddle	2	BH	16-2	Hex Nut	3
M	(page 39)	Caster Assembly	4	BJ	16-28	Hex Nut	4
N	715-1-133	Collar	1	BK	16-36	Hex Nut	16
P	715-201-27	Pump Rod Weldment	1	BL	16-48	Hex Nut	2
R	715-201-108	Pump Pedal	1	BM	21-22	Set Screw	2
S	715-201-126	Slip On Pump Pedal	2	BN	21-50	Set Screw	4
T	(page 32)	Brake Adjuster Assembly	2	BP	23-25	Hex Washer Hd. Tap. Screw	1
W	(page 33)	Brake Cam Assembly	2	BR	26-13	Spring Pin	3
X	715-201-230	Brake Rod	1	BS	26-143	Groove Pin	4
Y	763-1-15	Jack Spring	1	BT	27-3	Cotter Pin	2
Z	763-1-16	Spring Guide	1	BW	27-4	Cotter Pin	2
AA	946-1-116	Brake Bar Bushing	4	BX	27-13	Cotter Pin	1
AB	1210-1-151	Interface Spring	1	BY	3-11	Hex Cap Screw	8
AC	1210-201-114	Pedal Pivot, Left	1	BZ	3-21	Hex Cap Screw	4
AD	1210-201-115	Pedal Pivot, Right	1	CA	3-47	Hex Cap Screw	4
AE	1210-201-139	Pull Release Rod, Hd. End	1	CB	3-85	Hex Cap Screw	8
AF	1210-201-152	Side Release Pedal Wldmt.	2	CC	38-355	Extension Spring	2
AG	1210-201-153	Butterfly "V" Pedal	2	CD	4-146	Soc. Hd. Cap Screw	2
AH	1210-201-220	Base Frame Weldment	1	CE	52-245	Nyliner	2
AJ	1210-201-222	Push Release Rod, Hd. End	1	CF	52-284	Washer	1
AK	1210-201-251	Insert	2	CG	52-747	Flange Bearing	4
AL	1210-201-330	Spring Support	1	CH	8-10	Shoulder Bolt	3
AM	1210-201-412	Roller Pin	1	CJ	81-301	Bearing	1
AN	(page 53)	Interface Assembly	1	CK	29-12	Velcro Loop	3
AP	1210-201-620	Actuator Weldment	2	CL	29-14	Velcro Hook	3
AR	1210-201-630	Horn Weldment	1	CM	715-1-156	Ground Chain	1
AS	(page 55)	Wheel Assembly	2	CN	(p. 57 or 59)	Jack Assembly	2

Optional End Control Big Wheel Base Assembly

Assembly part number 1210-102-210 (reference only)

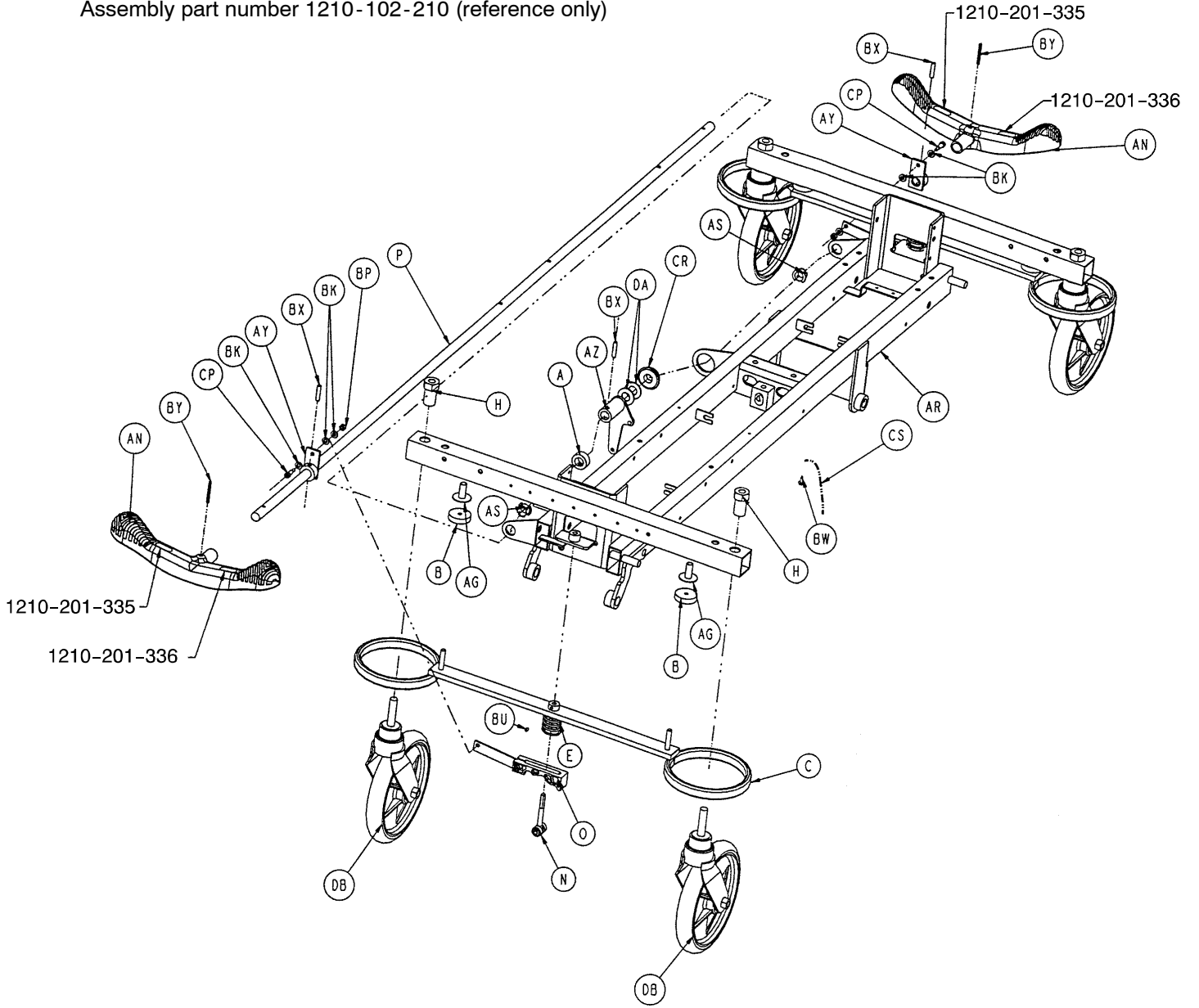

Optional End Control Big Wheel Base Assembly

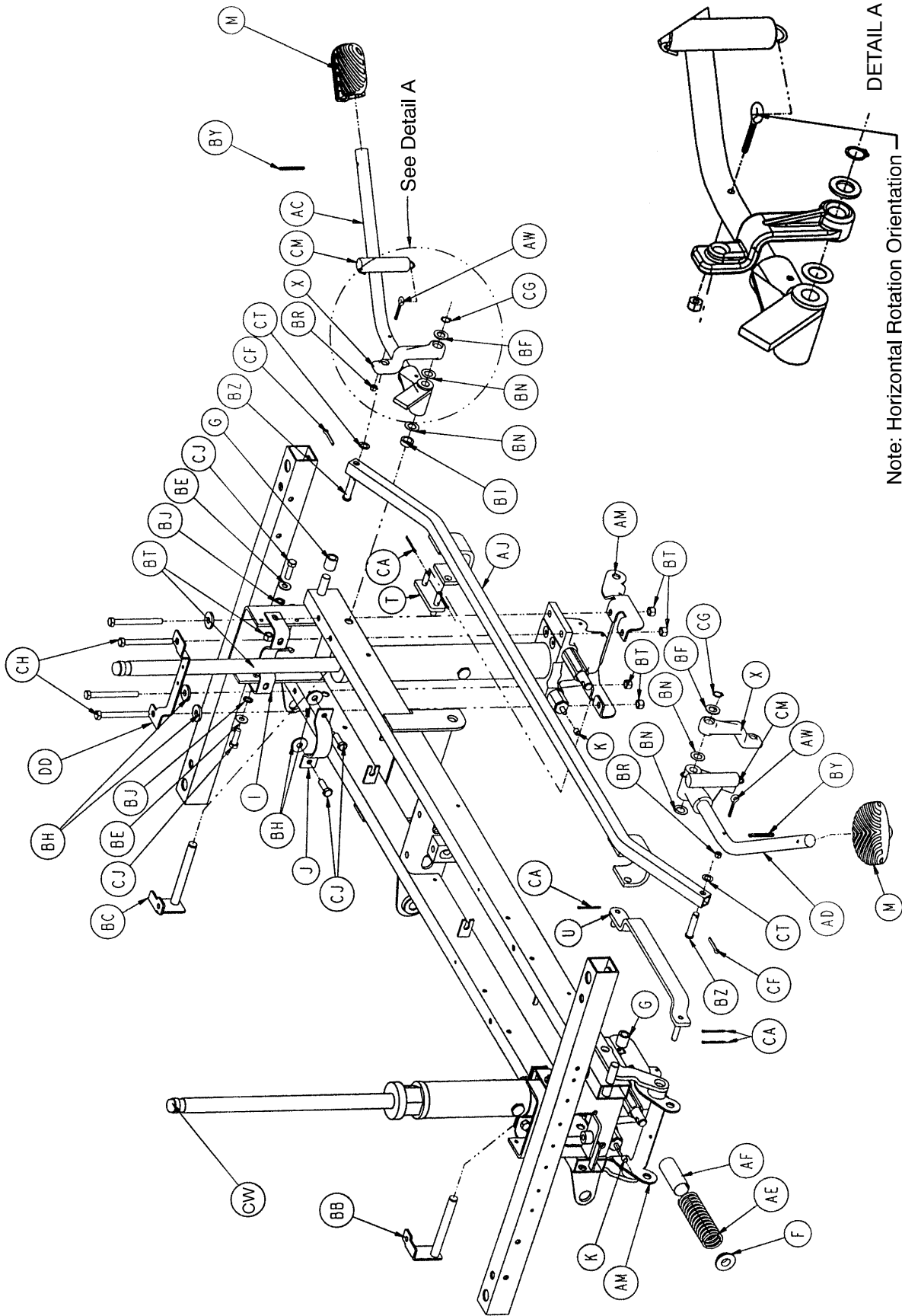

Optional End Control Big Wheel Base Assembly

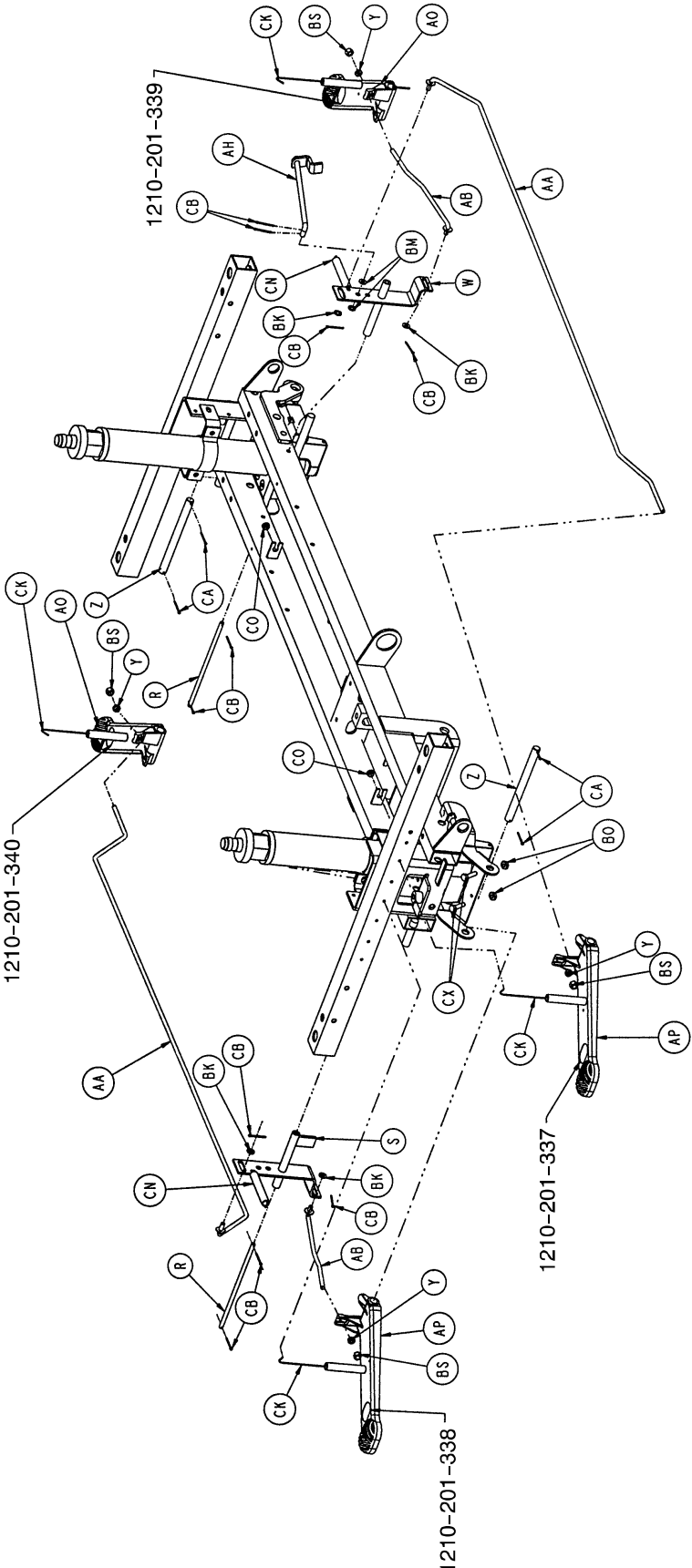

Optional End Control Big Wheel Base Assembly

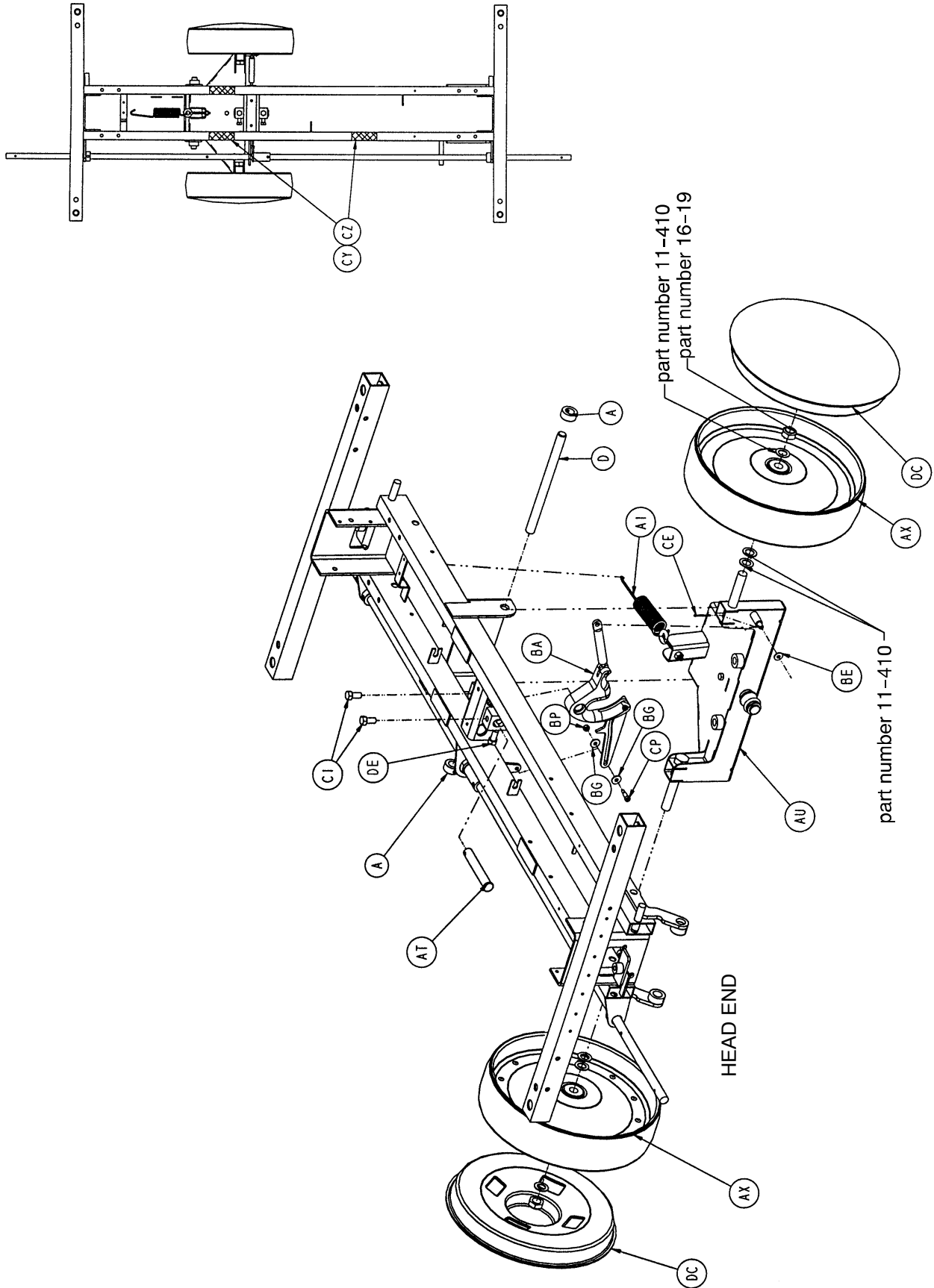

Optional End Control Big Wheel Base Assembly

Item	Part No.	Part Name	Qty.	Item	Part No.	Part Name	Qty.
A	42-20	Collar	4	BB	1210-301-200	Hd. End Pin Brkt. Pivot	1
B	715-1-11	Brake Cushion	4	BC	1210-301-201	Ft. End Pin Brkt. Pivot	1
C	715-1-61	Caster Brake Weldment	2	BE	11-3	Washer	5
D	715-1-92	Pump Pedal Shaft	2	BF	11-13	Washer	2
E	715-1-94	Compression Spring	2	BG	11-224	Washer	2
F	715-1-133	Jack Spring Collar	1	BH	11-262	Washer	10
G	715-1-140	Vinyl Tube	2	BI	11-350	Washer	1
H	715-1-158	Caster Nut	4	BJ	13-38	Lock Washer	4
I	715-1-192	Jack Support	2	BK	14-2	Washer	6
J	715-1-193	Jack Support Clamp	2	BM	14-3	Washer	2
K	715-1-333	Release Rod Stop Sleeve	2	BN	14-7	Washer	4
M	715-201-126	Slip On Pump Pedal	2	BO	15-11	Hex Nut	4
N	(page 32)	Brake Adjuster Assembly	2	BP	16-2	Hex Nut	3
O	(page 33)	Brake Cam Assembly	2	BR	16-14	Hex Nut	2
P	715-201-230	Brake Rod	1	BS	16-102	Hex Nut	4
R	716-1-15	Release Pivot Bar	2	BT	16-36	Hex Nut	16
S	716-1-52	Pivot Assembly, Ft. End	1	BU	21-151	Set Screw	2
T	716-1-102	Pump Link Wldmt., Ft. End	1	BW	23-25	Hex Washer Hd. Tap. Screw	1
U	716-1-109	Pump Link Wldmt., Hd. End	1	BX	26-13	Spring Pin	3
W	716-1-119	Pivot Assembly, Hd. End	1	BY	26-143	Groove Pin	4
X	716-1-281	Pump Idler Link	2	BZ	26-195	Clevis Pin	2
Y	716-1-286	Ball Release Spacer	4	CA	27-3	Cotter Pin	8
Z	716-201-61	Release Pedal Pivot Rod	2	CB	27-4	Cotter Pin	8
AA	716-201-70	Long Release Rod	2	CE	27-13	Cotter Pin	1
AB	716-301-74	Release Rod	2	CF	27-16	Cotter Pin	2
AC	(page 35)	Pump Pedal Ass'y, Ft. End	1	CG	28-97	External Retaining Ring	2
AD	(page 36)	Pump Pedal Ass'y, Hd. End	1	CH	3-11	Hex Cap Screw	8
AE	763-1-15	Jack Spring	1	CI	3-21	Hex Cap Screw	2
AF	763-1-16	Spring Guide	1	CJ	3-85	Hex Cap Screw	8
AG	946-1-116	Brake Bar Bushing	4	CK	38-235	Desc. Pedal Return Spring	4
AH	1210-101-112	Release Rod, Hd. End, Lt.	1	CM	38-451	Pump Return Spring	2
AI	1210-1-151	Interface Spring	1	CN	38-326	Extension Spring	2
AJ	1210-201-27	Pump Rod Ass'y Angle	1	CO	52-245	Nyliner	4
AM	1210-201-111	End Release Pedal Bracket	2	CP	8-17	Shoulder Bolt	3
AN	1210-201-153	Butterfly "V" Pedal	2	CR	81-301	Bearing	1
AO	1210-201-154	Rel. Pedal, Hd., Offset, Rt.	2	CS	715-1-156	Ground Chain	1
AP	1210-201-155	Rel. Pedal, Ft., Offset, Lt.	2	CT	14-9	Washer	2
AR	1210-201-220	Base Frame Weldment	1	CW	(p. 57 or 59)	Jack Assembly	2
AS	1210-201-251	Insert	2	CX	3-3	Hex Bolt	4
AT	1210-201-412	Roller Pin	1	CY	29-12	Velcro Loop	3
AU	(page 53)	Interface Assembly	1	CZ	29-14	Velcro Hook	3
AW	1210-201-551	Eye Bolt	2	DA	14-71	Washer	2
AX	(page 55)	Wheel Assembly	2	DB	(page 39)	Caster Assembly	4
AY	1210-201-620	Actuator Weldment	2	DC	1210-201-650	Wheel Cover Assembly	2
AZ	1210-201-630	Horn Weldment	1	DD	1210-201-330	Spring Support	1
BA	(page 56)	Cam Assembly	1	DE	3-351	Hex Hd. Cap Screw	2

Optional Big Wheel Interface Assembly

Assembly part number 1210-201-450 (reference only)

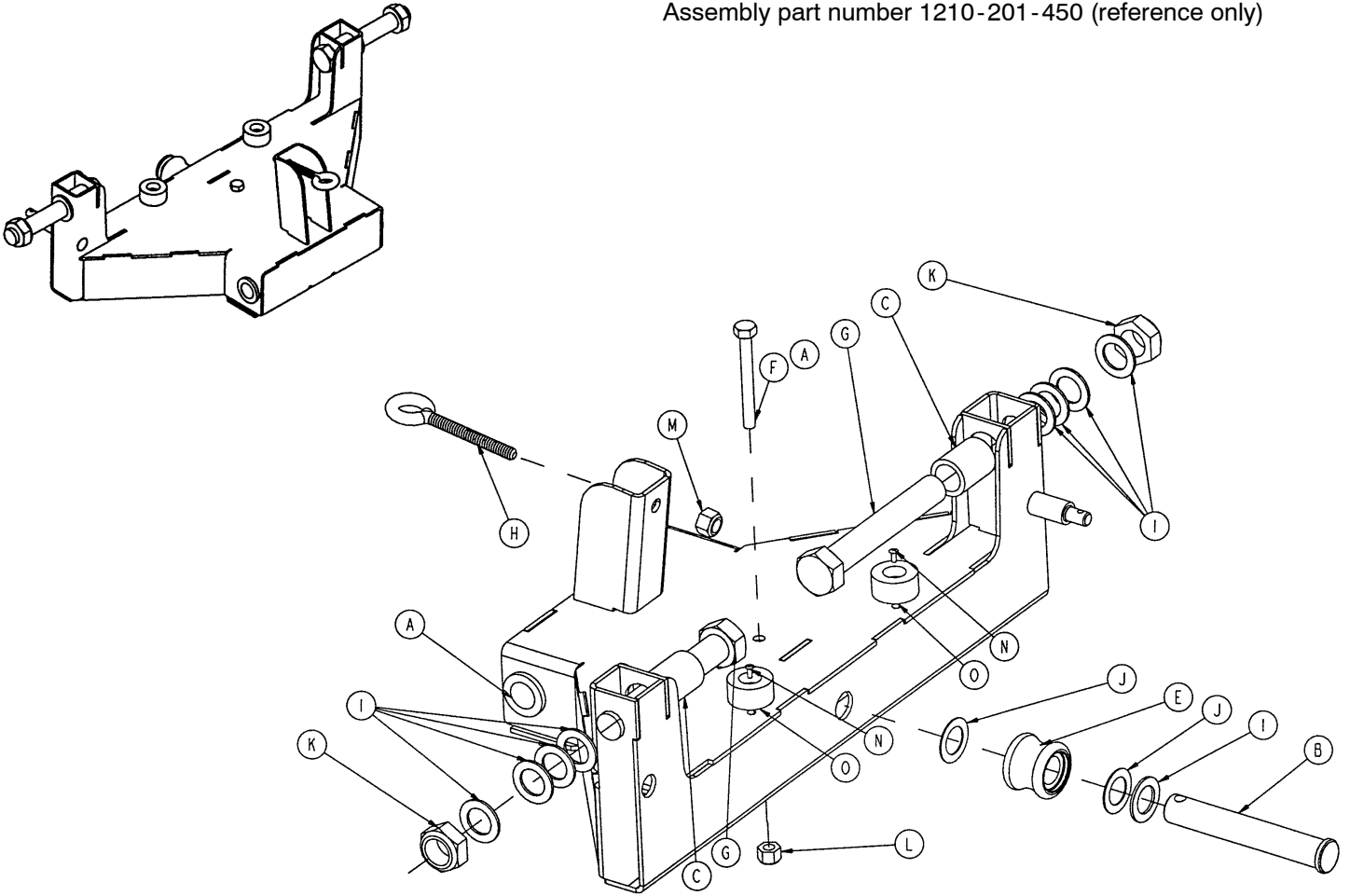

Item	Part No.	Part Name	Qty.
A	81-303	Flange Bushing	2
B	1210-201-412	Roller Pin	1
C	1210-201-625	Interface Sleeve	2
D	1210-201-445	Interface Weldment	1
E	(page 54)	Roller Assembly	1
F	3-32	Hex Hd. Cap Screw	1
G	3-345	Hex Hd. Cap Screw	2
H	10-4	Eye Bolt	1
I	11-410	Washer	9
J	14-80	Washer	2
K	16-19	Hex Nut	2
L	16-28	Hex Nut	1
M	16-36	Hex Nut	1
N	25-133	Rivet	2
O	56-16	Bumper Pad	2

1210-301-641 Optional Big Wheel Roller Assembly

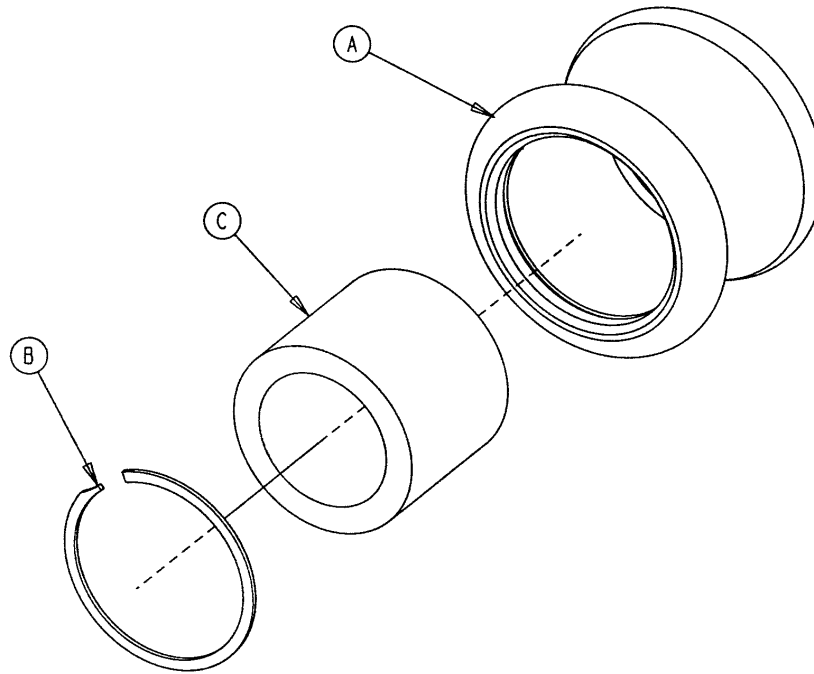

Item	Part No.	Part Name	Qty.
A	1210-301-640	Roller	1
B	28-184	Snap Ring	1
C	81-299	Bearing	1

1210-301-619 Optional Big Wheel Assembly

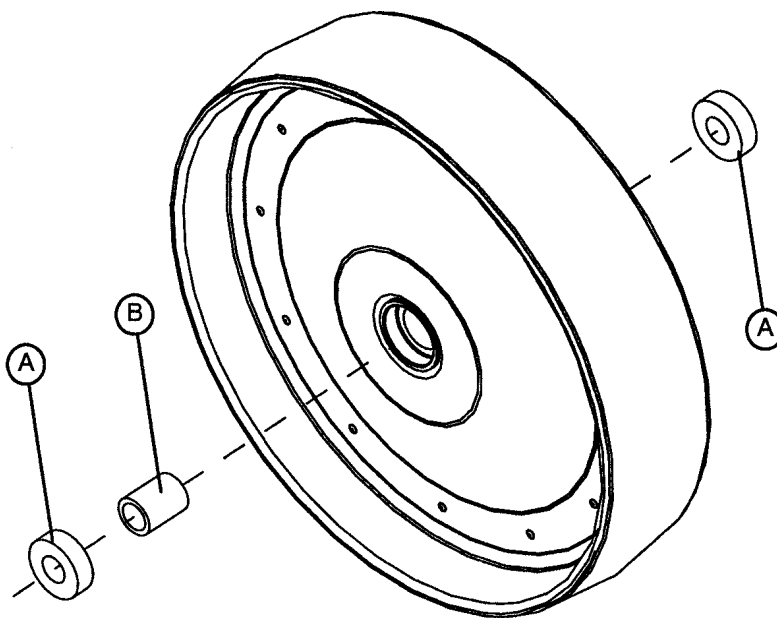

Item	Part No.	Part Name	Qty.
A	81-226	Bearing	2
B	1210-201-625	Wheel Inner Sleeve	1

1210-301-900 Optional Big Wheel Cam Assembly

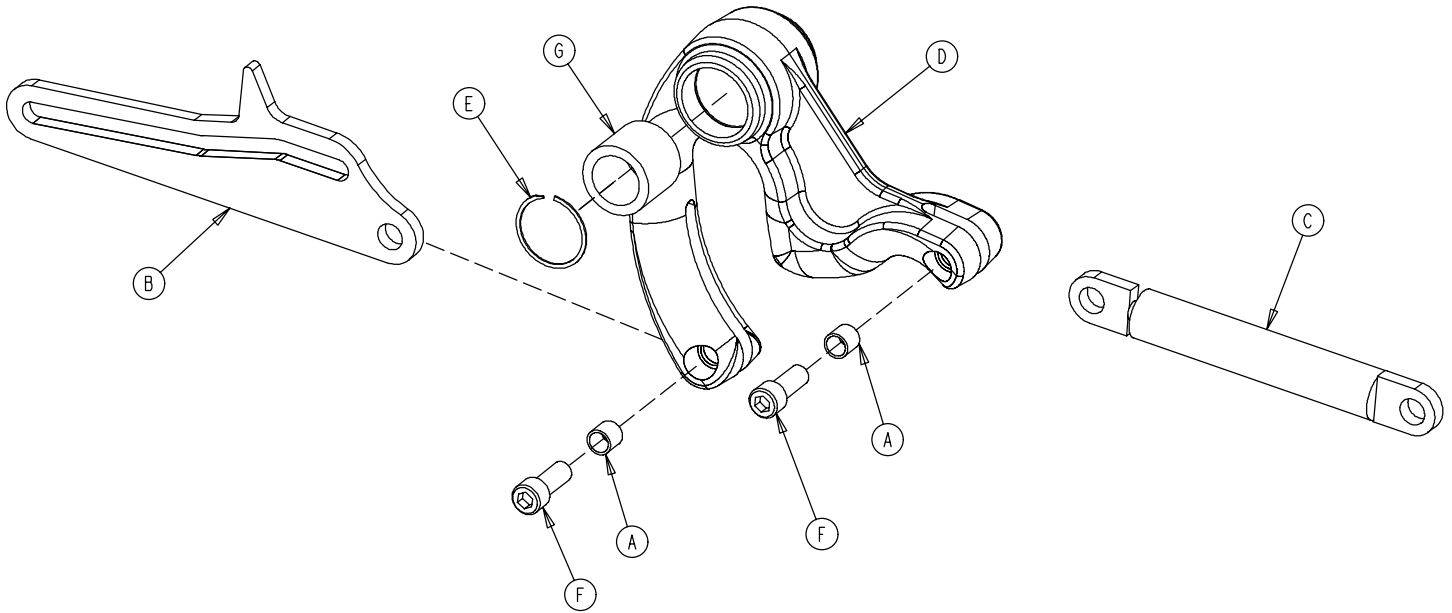

Item	Part No.	Part Name	Qty.
A	715-1-333	Release Valve Stop Sleeve	2
B	1210-201-610	Connecting Link	1
C	1210-201-671	Dampener	1
D	1210-301-901	Cam	1
E	28-184	Snap Ring	1
F	4-328	Soc. Hd. Cap Screw	2
G	81-299	Needle Bearing	1

1231-70-10 Variable Descent Jack Assembly

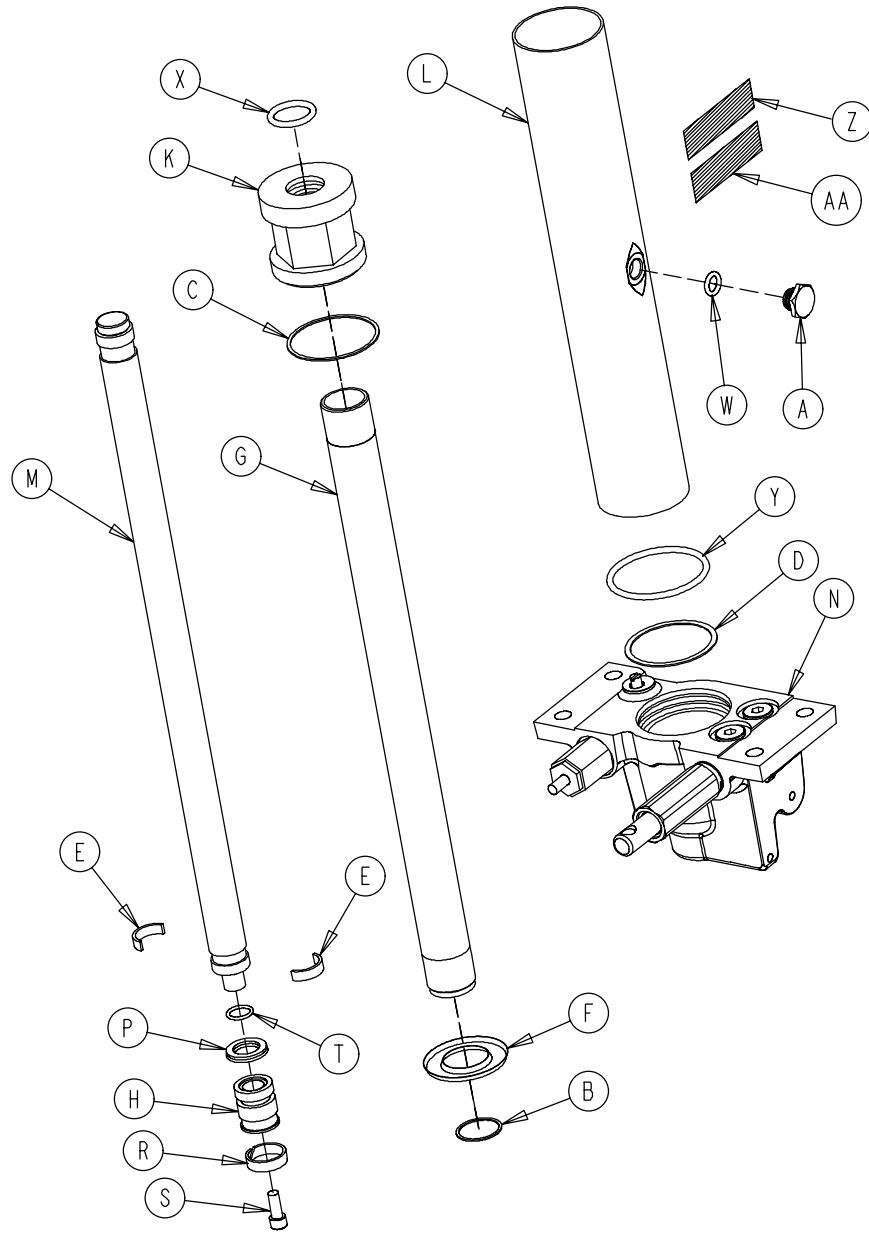

Item	Part No.	Part Name	Qty.	Item	Part No.	Part Name	Qty.
A	388-100-38	Plug	1	N	(page 58)	Jack Base Ass'y	1
B	390-1-238	Actuator Gasket	1	P	926-20-161	Parker Packing	1
C	390-1-243	Gasket	1	R	926-20-162	Wear Ring	1
D	390-1-244	Base Gasket	1	S	4-14	Soc. Hd. Cap Screw	1
E	390-2-139	Retaining Ring	2	T	45-14	O-Ring	1
F	715-1-320	Jack Screen	1	W	45-110	O-Ring	1
G	715-1-323	Actuator Cylinder	1	X	45-904	O-Ring	1
H	715-1-331	Piston End	1	Y	45-978	O-Ring	1
K	715-1-340	Jack Cap Assembly	1	Z	1231-70-110	Label	1
L	715-1-422	Reservoir	1	AA	921-1-252	Serial Number Label	1
M	715-1-325	Actuator Rod	1				

Jack Base Assembly

Assembly part number 1231-70-5 (reference only)

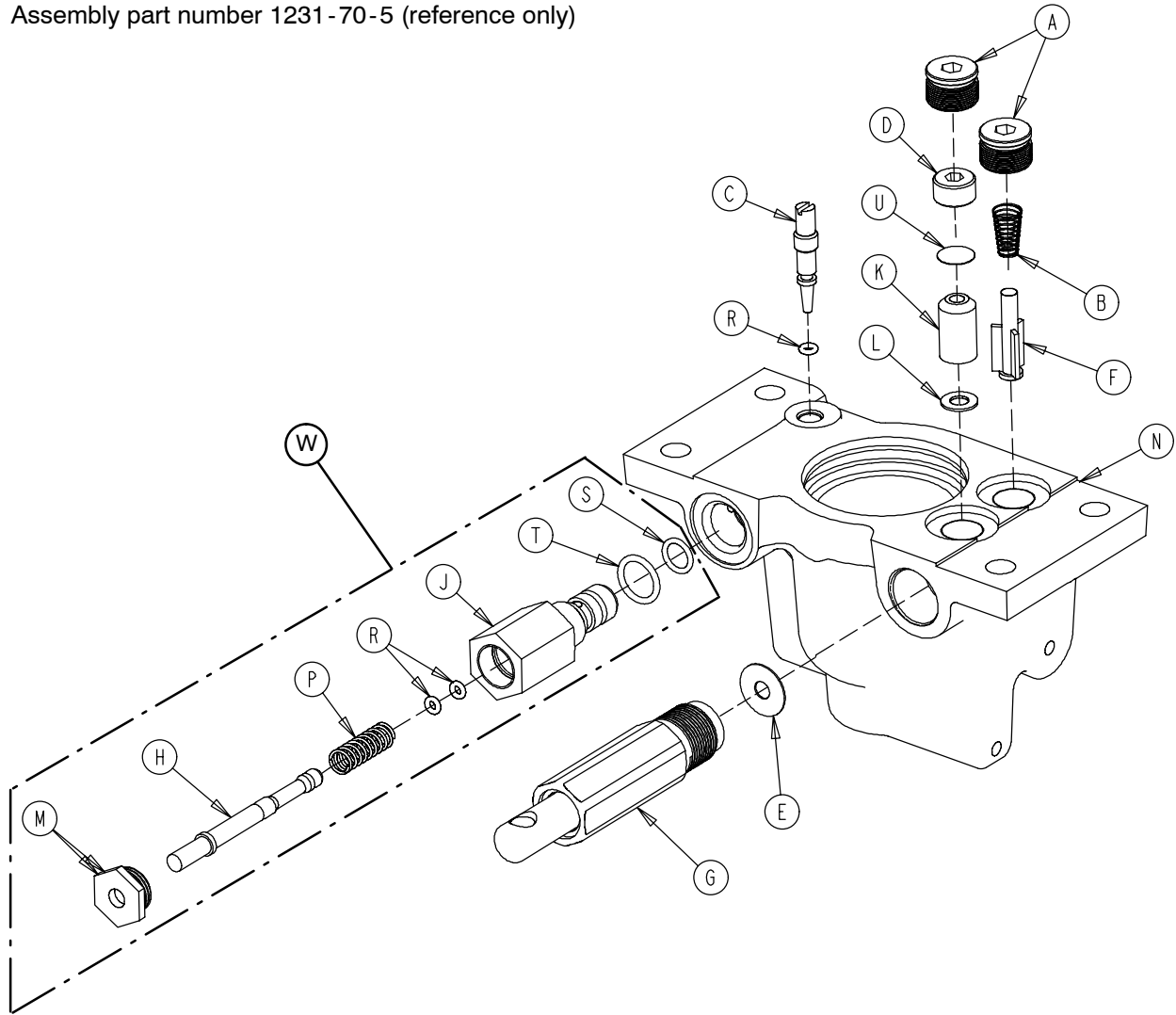

Item	Part No.	Part Name	Qty.	Item	Part No.	Part Name	Qty.
A	48-147	Base Plug	2	L	926-20-154	Seal	1
B	390-2-134	Conical Comp. Spring	1	M	1210-170-13	Base Plug	1
C	715-1-307	Needle Valve	1	N	1210-270-12	Jack Base	1
D	715-1-309	Valve Plug	1	P	38-311	Compression Spring	1
E	715-1-329	Pump Seal	1	R	45-6	O-Ring	3
F	715-1-341	Poppet	1	S	45-966	O-Ring	1
G	(page 61)	Pump Piston Assembly	1	T	45-967	O-Ring	1
H	715-270-1	Pin	1	U	715-1-321	Check Valve Screen	1
J	715-270-2	Pin Housing	1	W	715-270-100	Relief Valve Assembly	1
K	926-20-153	Check Valve	1				

1231-70-210 Constant Flow Jack Assembly

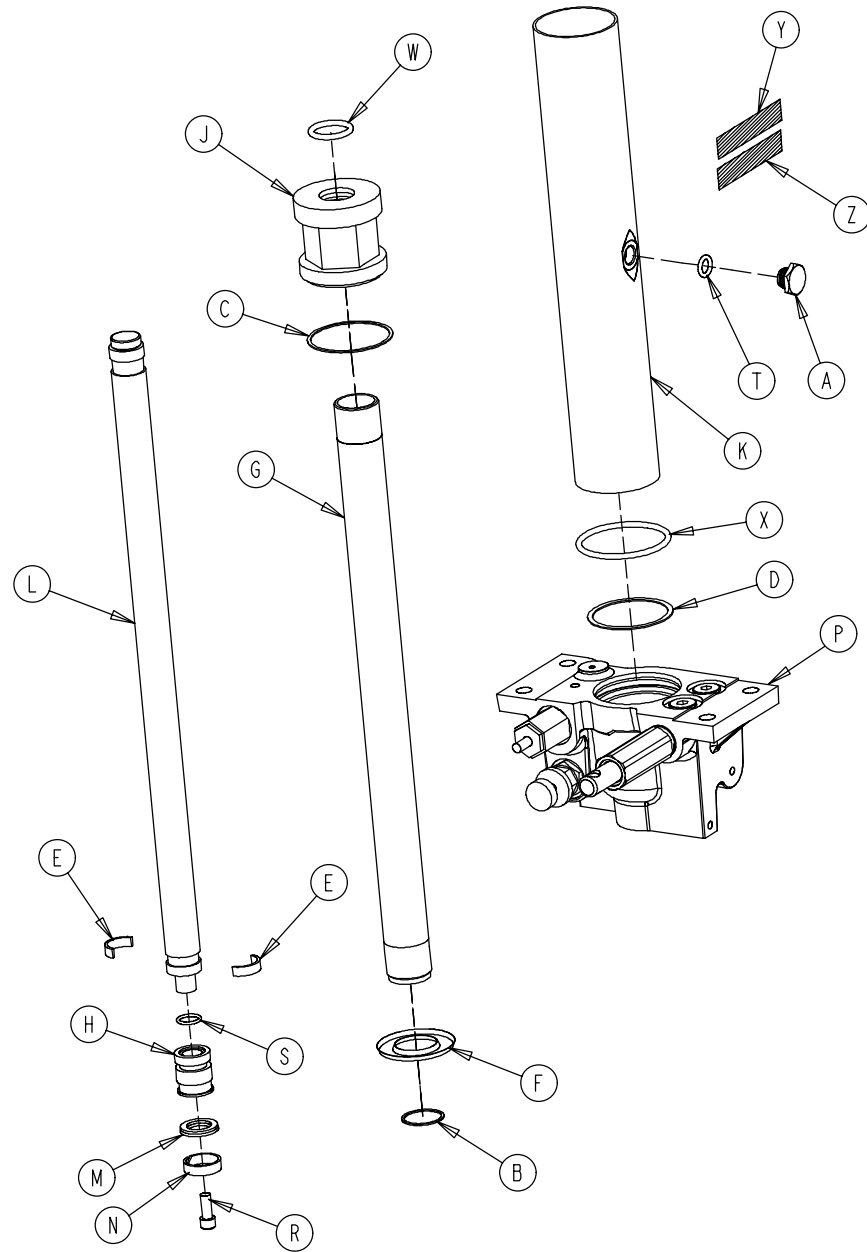

Item	Part No.	Part Name	Qty.	Item	Part No.	Part Name	Qty.
A	388-100-38	Plug	1	M	926-20-161	Parker Packing	1
B	390-1-238	Actuator Gasket	1	N	926-20-162	Wear Ring	1
C	390-1-243	Gasket	1	P	(page 60)	Jack Base Ass'y	1
D	390-1-244	Base Gasket	1	R	4-14	Soc. Hd. Cap Screw	1
E	390-2-139	Retaining Ring	2	S	45-14	O-Ring	1
F	715-1-320	Jack Screen	1	T	45-110	O-Ring	1
G	715-1-323	Actuator Cylinder	1	W	45-904	O-Ring	1
H	715-1-331	Piston End	1	X	45-978	O-Ring	1
J	715-1-340	Jack Cap Assembly	1	Y	1231-70-211	Label	1
K	715-1-422	Reservoir	1	Z	921-1-252	Serial Number Label	1
L	715-1-325	Actuator Rod	1				

Constant Flow Jack Base Assembly

Assembly part number 5050-370-100 (reference only)

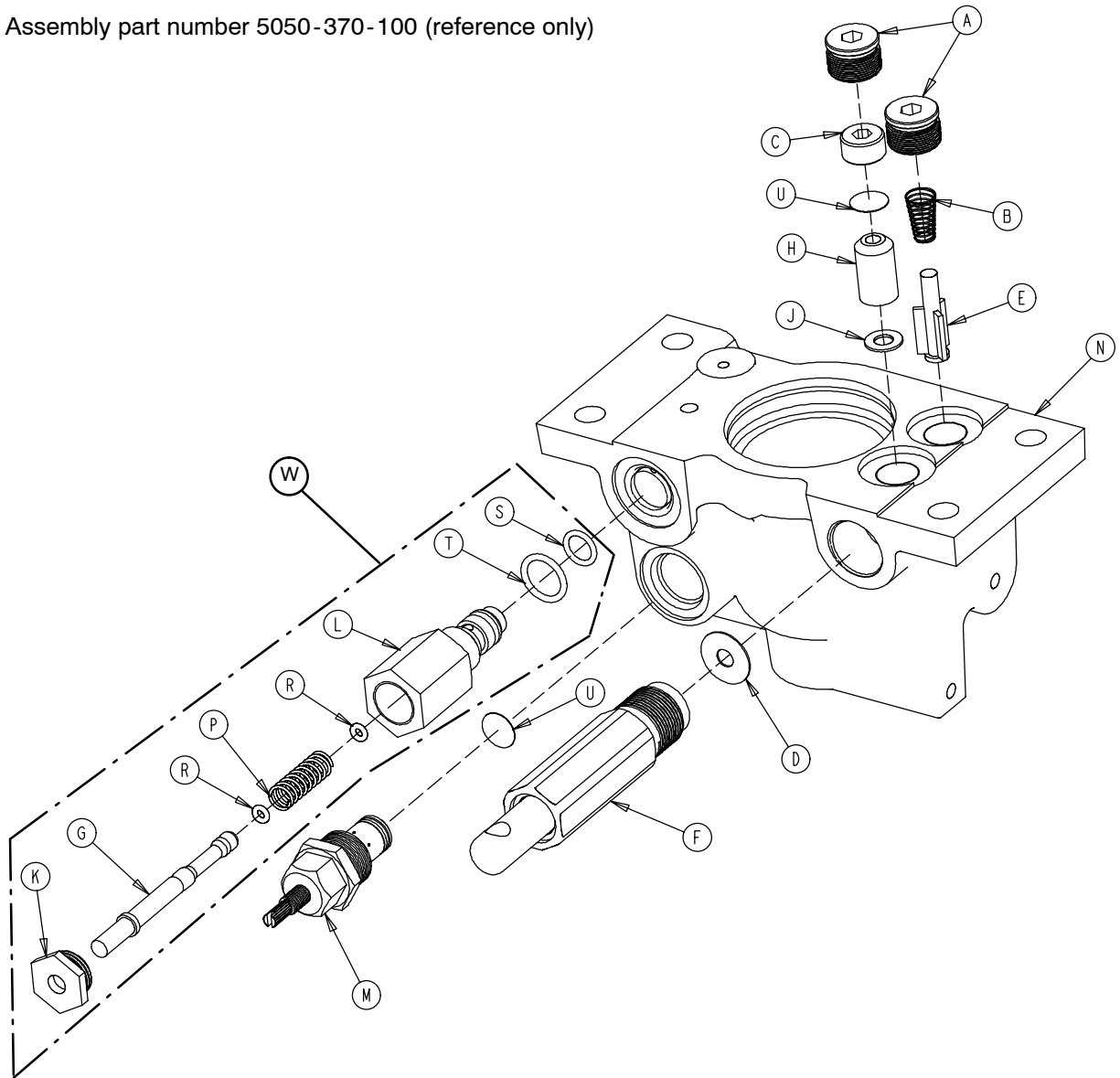

Item	Part No.	Part Name	Qty.	Item	Part No.	Part Name	Qty.
A	48-147	Base Plug	2	L	2025-75-87	Pin Housing	1
B	390-2-134	Conical Comp. Spring	1	M	5050-170-50	Adj. P.C. Valve Cartridge	1
C	715-1-309	Valve Plug	1	N	5050-370-110	Jack Base	1
D	715-1-329	Pump Seal	1	P	38-311	Compression Spring	1
E	715-1-341	Poppet	1	R	45-6	O-Ring	2
F	(page 61)	Pump Piston Assembly	1	S	45-966	O-Ring	1
G	715-270-1	Pin	1	T	45-967	O-Ring	1
H	926-20-153	Check Valve	1	U	715-1-321	Check Valve Screen	2
J	926-20-154	Seal	1	W	2025-700-26	Relief Valve Assembly	1
K	1210-170-13	Base Plug	1				

715-100-425 Jack Pump Piston Assembly

Assembly part number 715-201-325 (reference only)

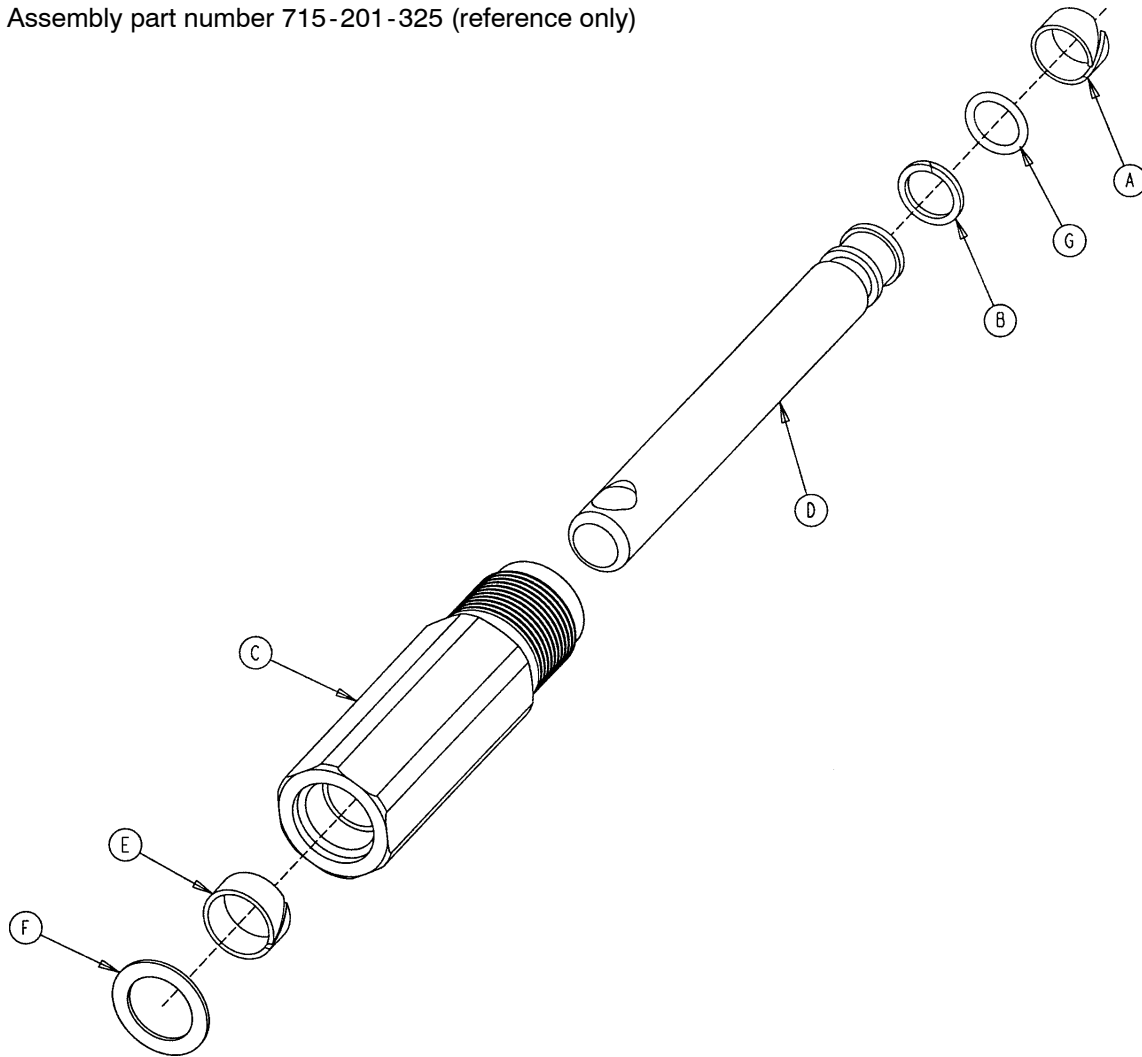

Item	Part No.	Part Name	Qty.
A	715-1-328	Piston Wear Ring	1
B	715-1-400	O-Ring Back Up	1
C	715-200-316	Pump Cylinder	1
D	715-201-318	Pump Piston	1
E	715-201-327	Cylinder Wear Ring	1
F	14-50	Bearing Retainer	1
G	45-110	O-Ring	1
	715-1-329	Pump Seal (not shown)	1

Optional Side Control Brake Assembly

Assembly part number 1001 -400 (reference only)

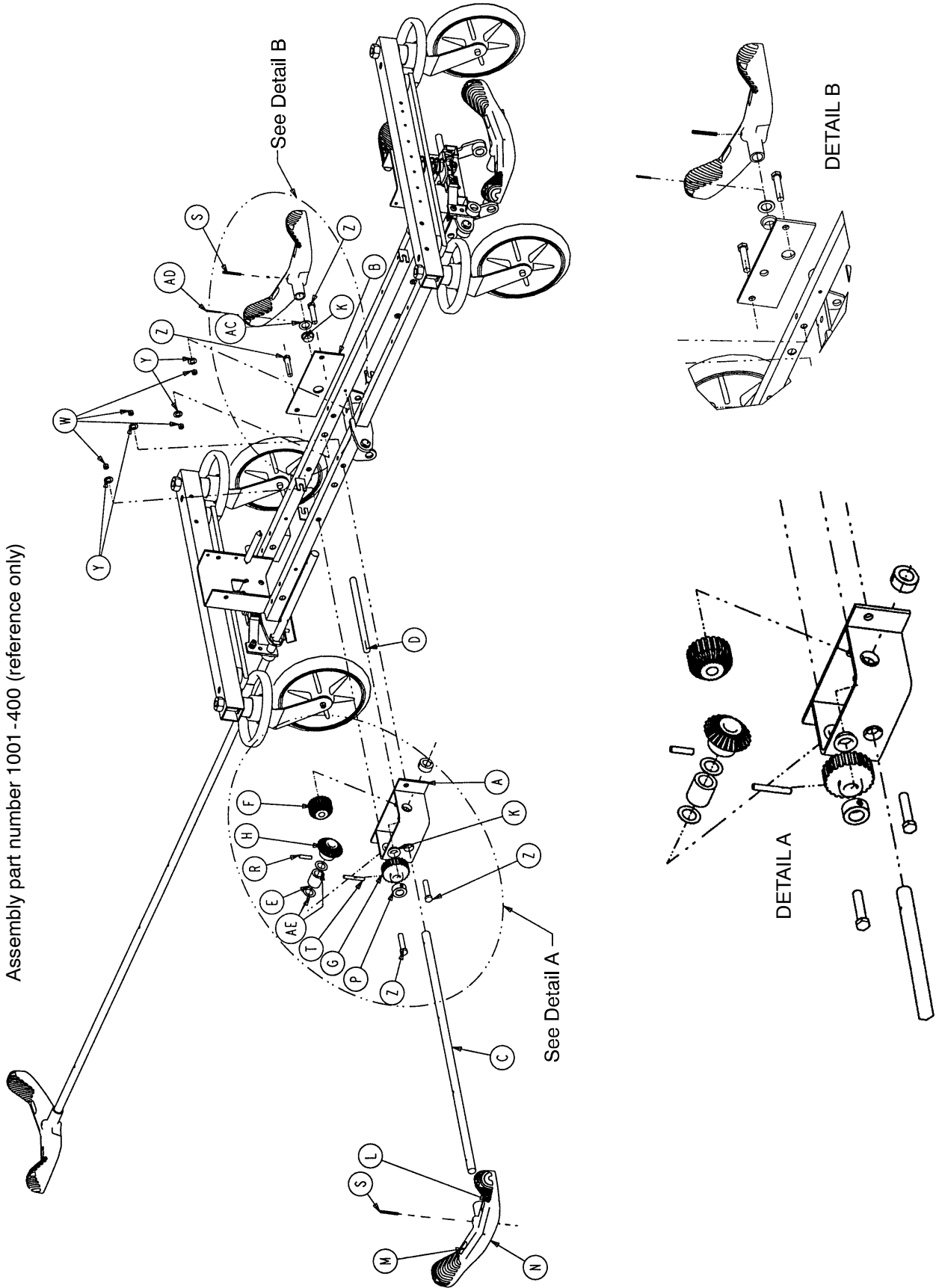

Optional Side Control Brake Assembly

Item	Part No.	Part Name	Qty.
A	1210-301-400	Gear Box Weldment	1
B	1210-301-412	Support	1
C	1210-201-409	Side Control Brake/Steer Rod	1
D	1210-201-407	Pin	1
E	1210-301-406	Spacer	1
F	1210-301-405	Miter/Spur Gear	1
G	1210-301-404	Spur Gear	1
H	1210-301-403	Miter Gear	1
K	1210-201-401	Flange Bearing	5
L	1210-201-336	Steer Label	2
M	1210-201-335	Brake Label	2
N	1210-201-153	Butterfly "V" Pedal	2
P	42-20	Collar	1
R	26-265	Gear Dowel Pin	1
S	26-143	Pedal Dowel Pin	2
T	26-166	Groove Pin	1
W	16-35	Lock Nut	4
Y	11-4	Flat Washer	4
Z	3-45	Hex Hd. Cap Screw	4
AA	1210-201-341	Brake/Steer Label, Right	1
AB	1210-201-342	Brake/Steer Label, Left	1
AC	14-71	Washer	1
AD	27-16	Cotter Pin	1
AE	14-80	Washer	2

Optional Uni-Lower Pedal Assembly

Assembly part number 1210-500 (reference only)

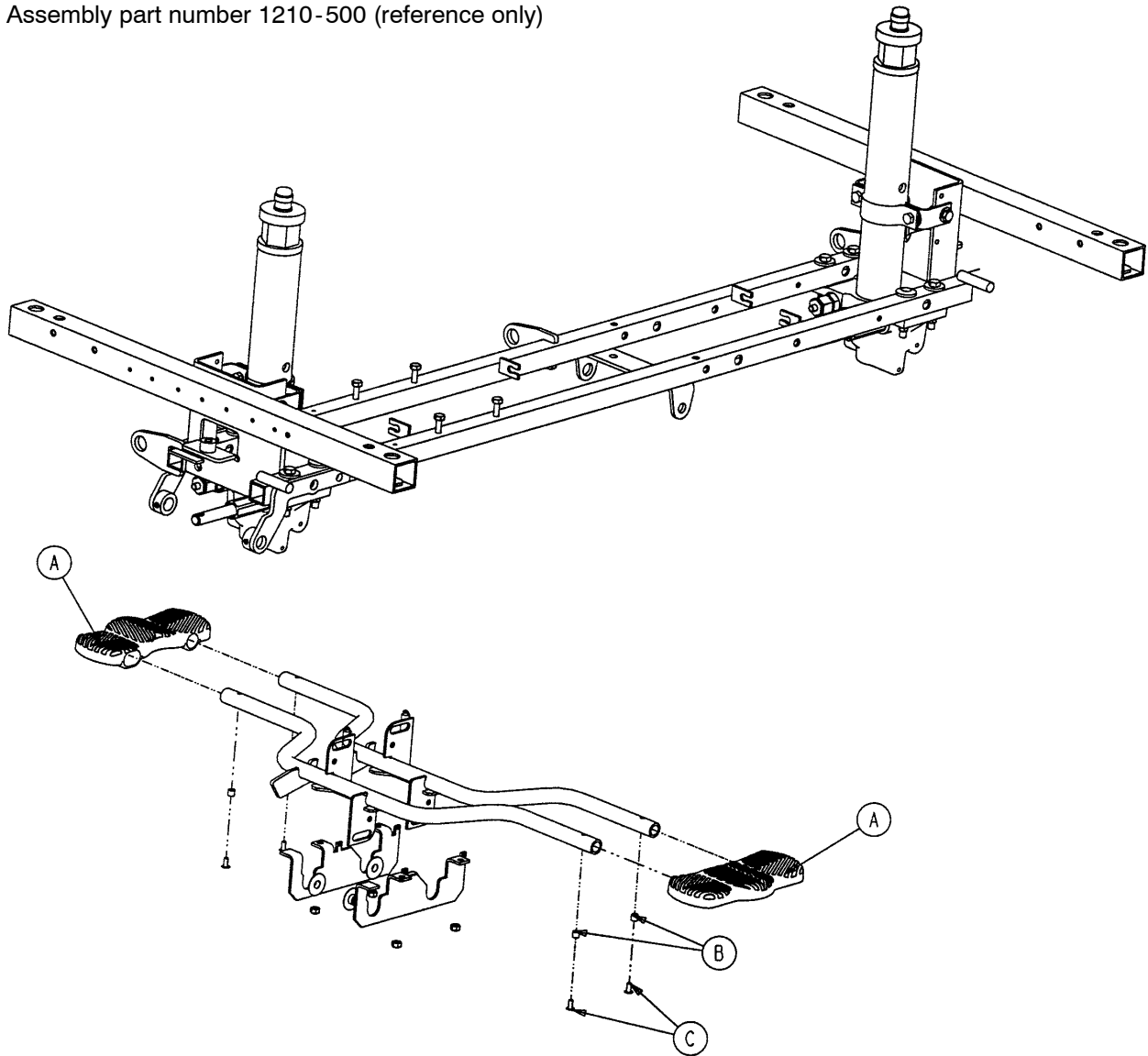

Item	Part No.	Part Name	Qty.
A	715-201-127	Uni-Lowering Pedal	2
B	715-1-333	Release Rod Stop Sleeve	4
C	25-50	Pop Rivet	4

Optional Dual Lowering Pedal Assembly

Assembly part number 1210-501 (reference only)

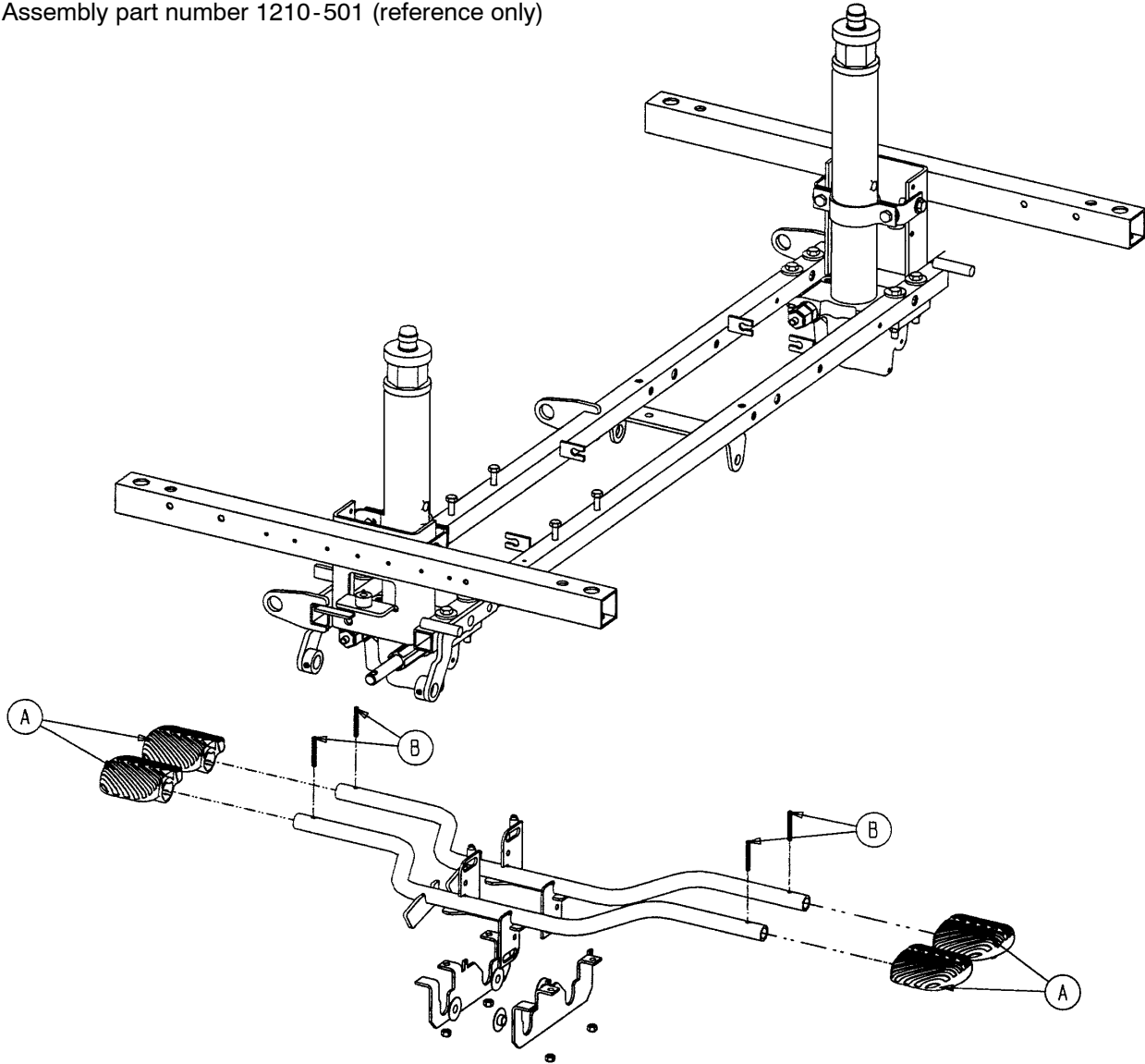

Item	Part No.	Part Name	Qty.
A	715-201-126	Pump Pedal	4
B	26-143	Groove Pin	4

Side Control Base Labeling Assembly

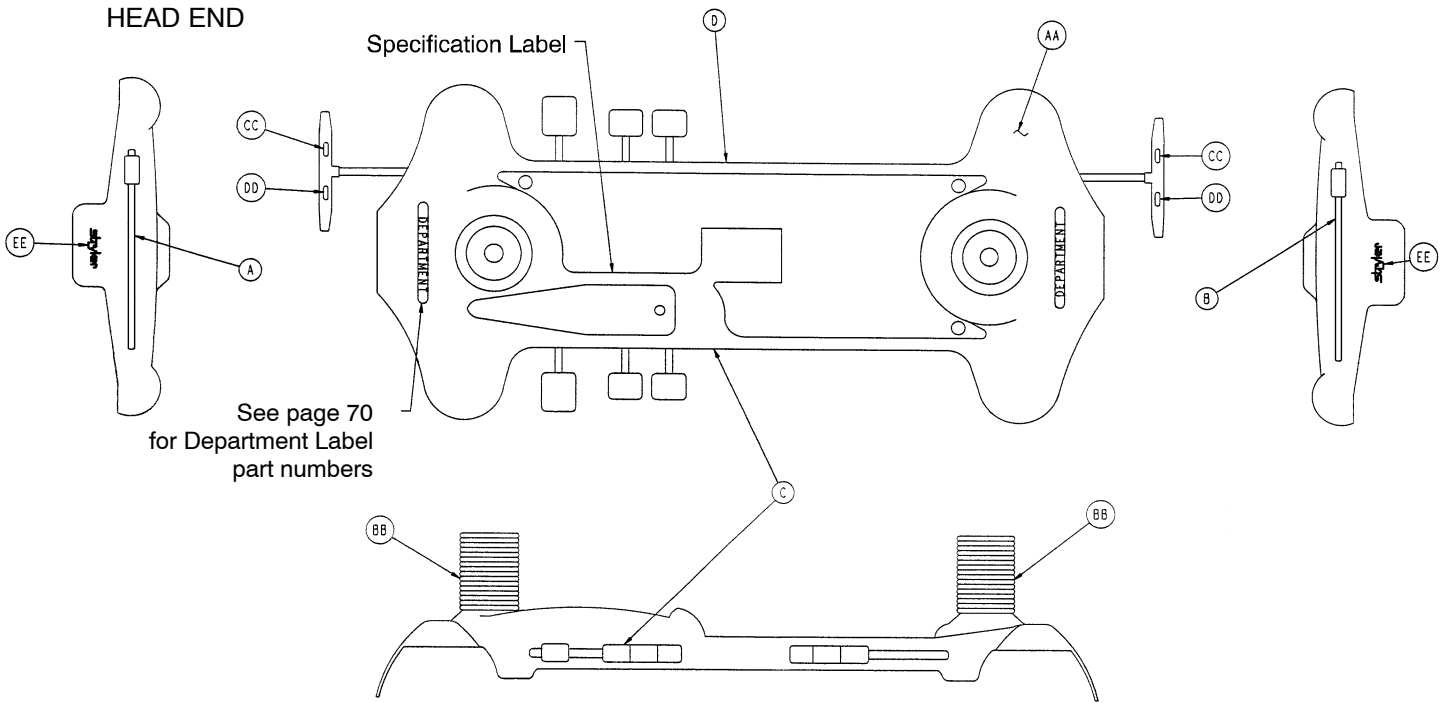

Item	Part No.	Part Name	Qty.
AA	1001-200-1	Base Hood	1
BB	715-1-134	Bellows	2
CC	1210-201-335	Red Brake Label	2
DD	1210-201-336	Green Steer Label	2
EE	946-201-60	Stryker Logo Label	4

Color Set P/N	Item A Control Label, Head End	Item B Control Label, Foot End	Item C Control Label, Right	Item D Control Label, Left	Litter Bumper Strip
RED 1001-700-110	1001-700-113	1001-700-114	1001-700-211	1001-700-212	1010-700-15
PURPLE 1001-700-120	1001-700-123	1001-700-124	1001-700-221	1001-700-222	1010-700-25
GREEN 1001-700-130	1001-700-133	1001-700-134	1001-700-231	1001-700-232	1010-700-35
GRAY 1001-700-140	1001-700-143	1001-700-144	1001-700-241	1001-700-242	1010-700-45
TEAL 1001-700-150	1001-700-153	1001-700-154	1001-700-251	1001-700-252	1010-700-55
PINK 1001-700-160	1001-700-163	1001-700-164	1001-700-261	1001-700-262	1010-700-65
BLUE 1001-700-170	1001-700-173	1001-700-174	1001-700-271	1001-700-272	1010-700-75

End Control Base Labeling Assembly

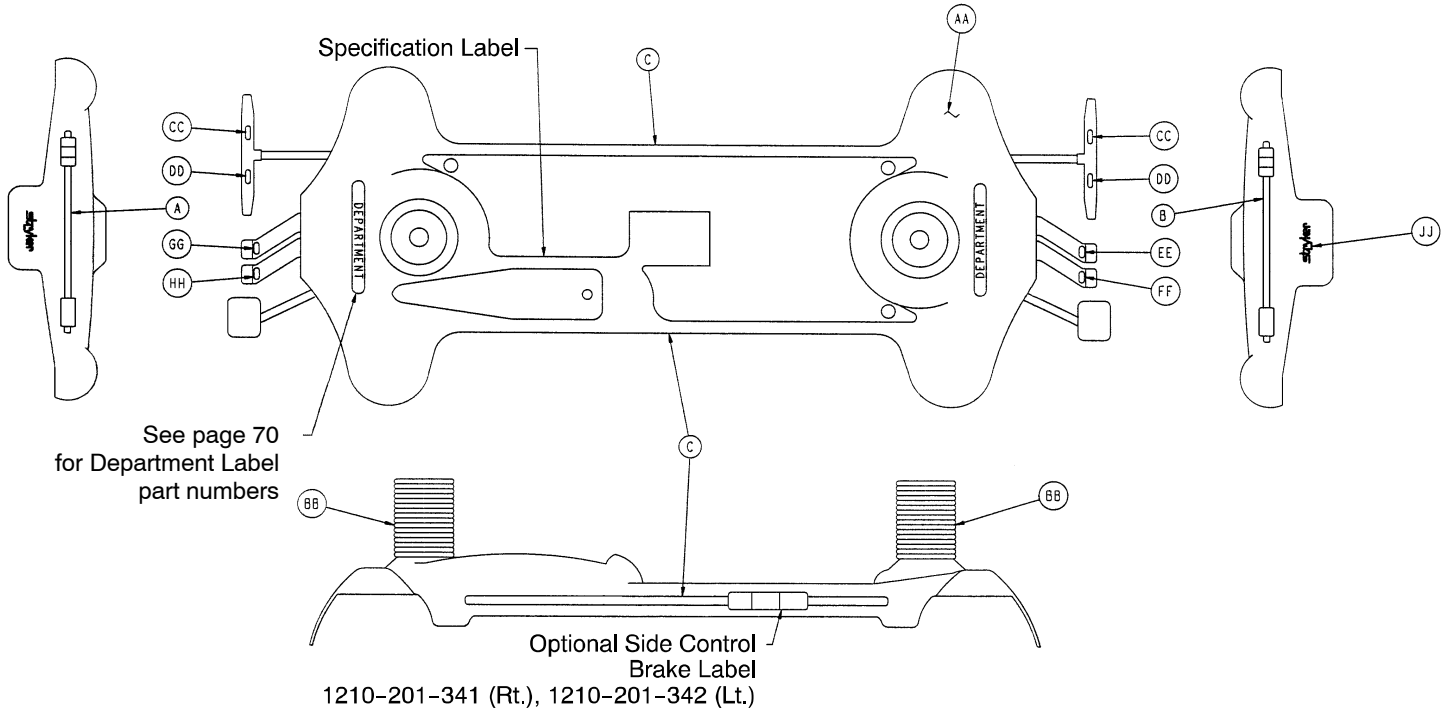

Item	Part No.	Part Name	Qty.
AA	1001-200-1	Hood	1
BB	715-1-134	Bellows	2
CC	1210-201-335	Brake Label	2
DD	1210-201-336	Steer Label	2
EE	1210-201-337	Head Down Label, Foot End	1
FF	1210-201-338	Foot Down Label, Foot End	1
GG	1210-201-339	Head Down Label, Head End	1
HH	1210-201-340	Foot Down Label, Head End	1
JJ	946-201-6	Stryker Logo Label	2

Color Set P/N	Item A Control Label, Head End	Item B Control Label, Foot End	Item C Side Control Label	Litter Bumper Strip
RED 1001-800-110	1001-800-111	1001-800-112	1001-800-13	1010-700-15
PURPLE 1001-800-120	1001-800-121	1001-800-122	1001-800-23	1010-700-25
GREEN 1001-800-130	1001-800-131	1001-800-132	1001-800-33	1010-700-35
GRAY 1001-800-140	1001-800-141	1001-800-142	1001-800-43	1010-700-45
TEAL 1001-800-150	1001-800-151	1001-800-152	1001-800-53	1010-700-55
PINK 1001-800-160	1001-800-161	1001-800-162	1001-800-63	1010-700-65
BLUE 1001-800-170	1001-800-171	1001-800-172	1001-800-73	1010-700-75

Optional Big Wheel Side Control Base Labeling Ass'y

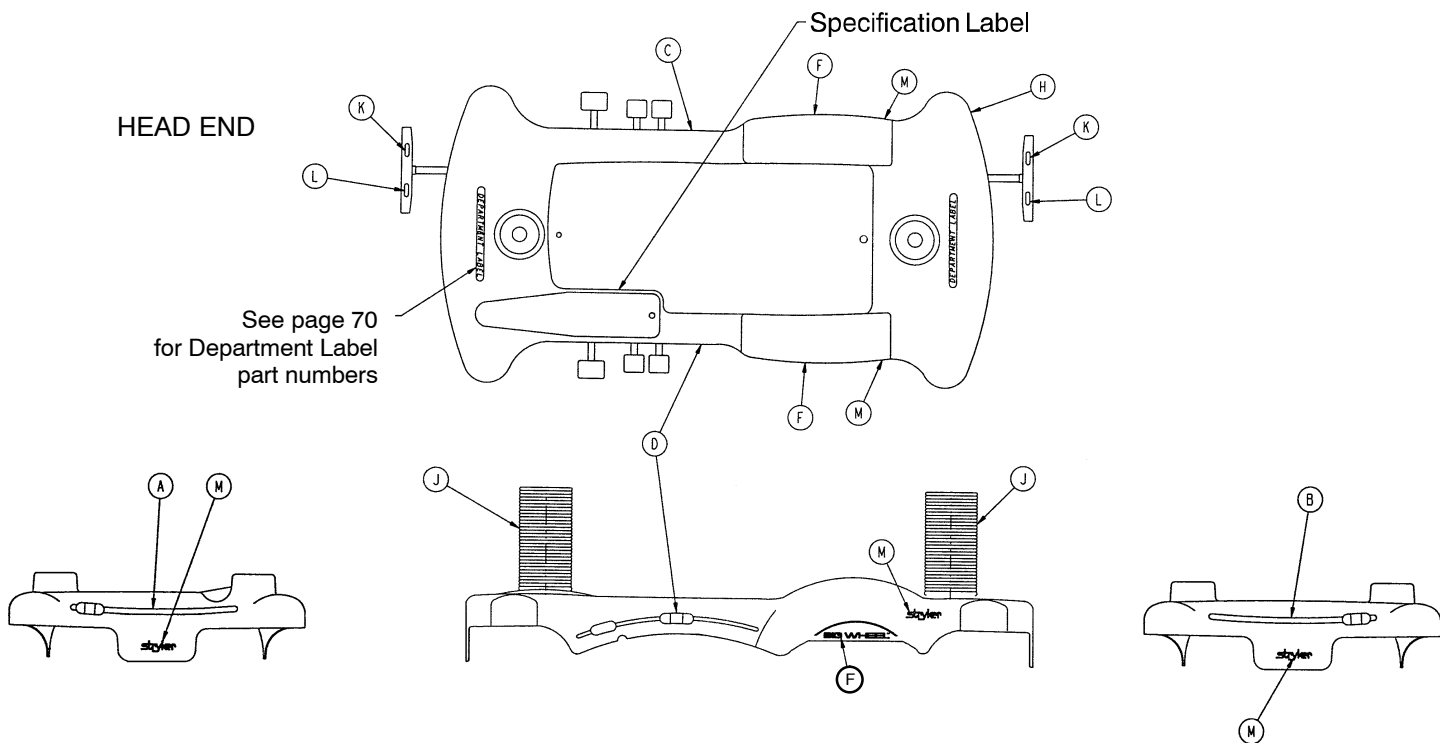

Color Set P/N	Item A Control Label, Head End	Item B Control Label, Foot End	Item C Control Label, Right	Item D Control Label, Left	Litter Bumper Strip
RED 1001-700-315	1210-800-113	1210-850-116	1210-800-114	1210-800-115	1010-700-15
PURPLE 1001-700-325	1210-800-123	1210-850-126	1210-800-124	1210-800-125	1010-700-25
GREEN 1001-700-335	1210-800-133	1210-850-136	1210-800-134	1210-800-135	1010-700-35
GRAY 1001-700-345	1210-800-143	1210-850-146	1210-800-144	1210-800-145	1010-700-45
TEAL 1001-700-355	1210-800-153	1210-850-156	1210-800-154	1210-800-155	1010-700-55
PINK 1001-700-365	1210-800-163	1210-850-166	1210-800-164	1210-800-165	1010-700-65
BLUE 1001-700-375	1210-800-173	1210-850-176	1210-800-174	1210-800-175	1010-700-75

Item	Part No.	Part Name	Qty.
F	1210-201-651	Big Wheel Label	2
H	1210-245-25	Base Hood	1
J	715-1-134	Bellows	2
K	1210-201-335	Red Brake Label	2
L	1210-201-336	Green Steer Label	2
M	946-201-60	Stryker Logo Label	2

Optional Big Wheel End Control Base Labeling Ass'y

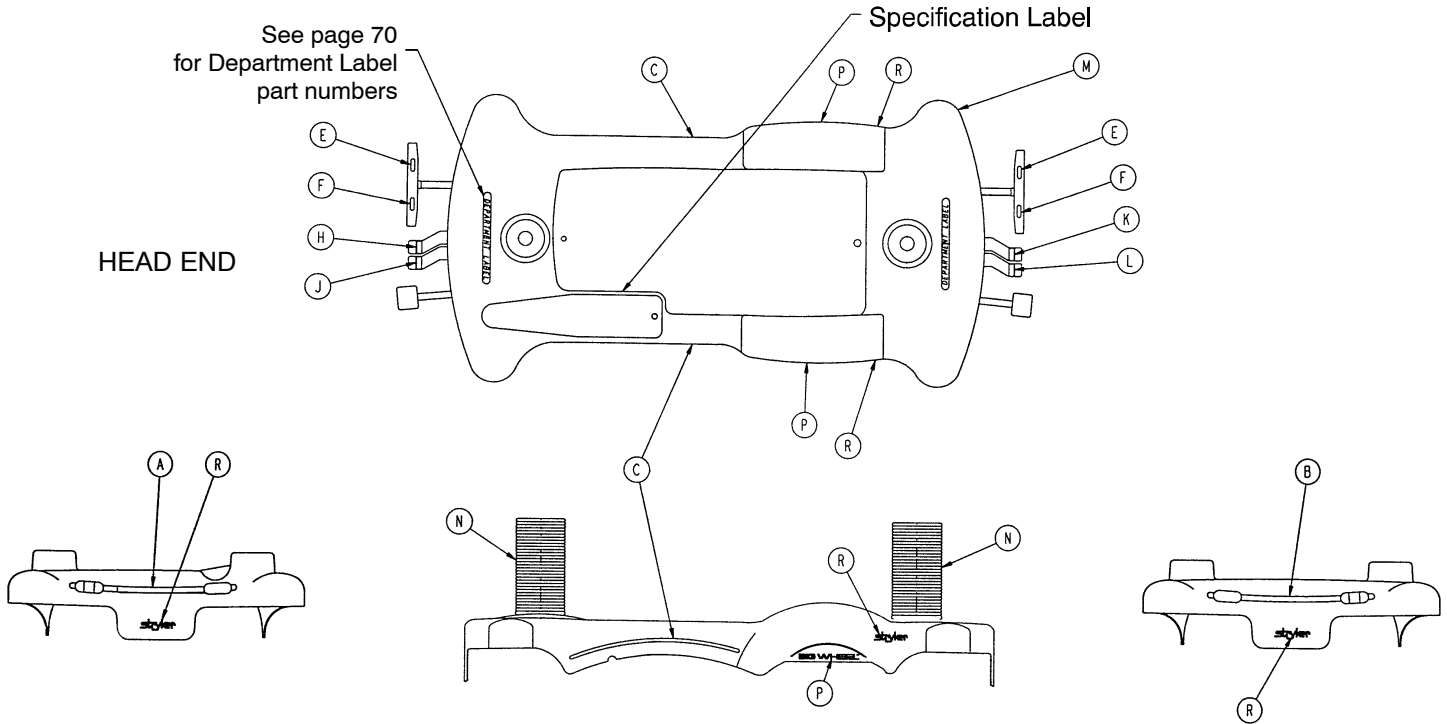

Color Set P/N	Item A Control Label, Head End	Item B Control Label, Foot End	Item C Side Control Label	Litter Bumper Strip
RED 1001-800-315	1210-800-117	1210-850-115	1210-850-113	1010-700-15
PURPLE 1001-800-325	1210-800-127	1210-850-125	1210-850-123	1010-700-25
GREEN 1001-800-335	1210-800-137	1210-850-135	1210-850-133	1010-700-35
GRAY 1001-800-345	1210-800-147	1210-850-145	1210-850-143	1010-700-45
TEAL 1001-800-355	1210-800-157	1210-850-155	1210-850-153	1010-700-55
PINK 1001-800-365	1210-800-167	1210-850-165	1210-850-163	1010-700-65
BLUE 1001-800-375	1210-800-177	1210-850-175	1210-850-173	1010-700-75

Item	Part No.	Part Name	Qty.
E	1210-201-335	Brake Label	2
F	1210-201-336	Steer Label	2
H	1210-201-339	Head Down Label, Head End	1
J	1210-201-340	Foot Down Label, Head End	1
K	1210-201-337	Head Down Label, Foot End	1
L	1210-201-338	Foot Down Label, Foot End	1
M	1210-245-25	Hood	1
N	715-1-134	Bellows	2
P	1210-201-651	Big Wheel Label	2
R	946-201-60	Stryker Logo Label	4

Department Labels

BASE HOOD DEPARTMENT LABELS

Department	Label Part Number
Emergency	1010-900-215
PACU	1010-900-220
Transport	1010-900-225
Surgery	1010-900-230
Extended Stay	1010-900-235
Maternity	1010-900-240
Endoscopy	1010-900-245
Radiology	1010-900-250
Nuclear Medicine	1010-900-255
Ambulatory Surgery	1010-900-260
G.I. Lab	1010-900-265
Cath. Lab	1010-900-270
Same Day Surgery	1010-900-275
Cardio.	1010-900-280
Ultrasound	1010-900-285

NOTE

All base hood department labels are quantity of two.

FOOT BOARD DEPARTMENT LABELS

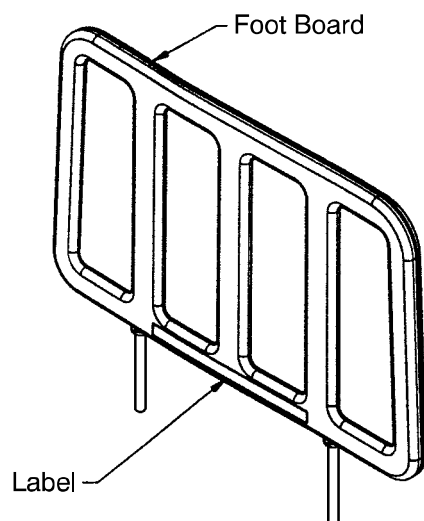

Department	Label Part No.
Demo Stryker	1010-900-186
Ophthalmology	1010-900-187
Outpatient Surgery	1010-900-188
Recovery	1010-900-189
Trauma	1010-900-190
Urgence	1010-900-191
Special (Blank)	1010-900-192

1001 Litter Assembly, Fold to Head Siderails

Assembly part number 1001-30-10
(reference only)

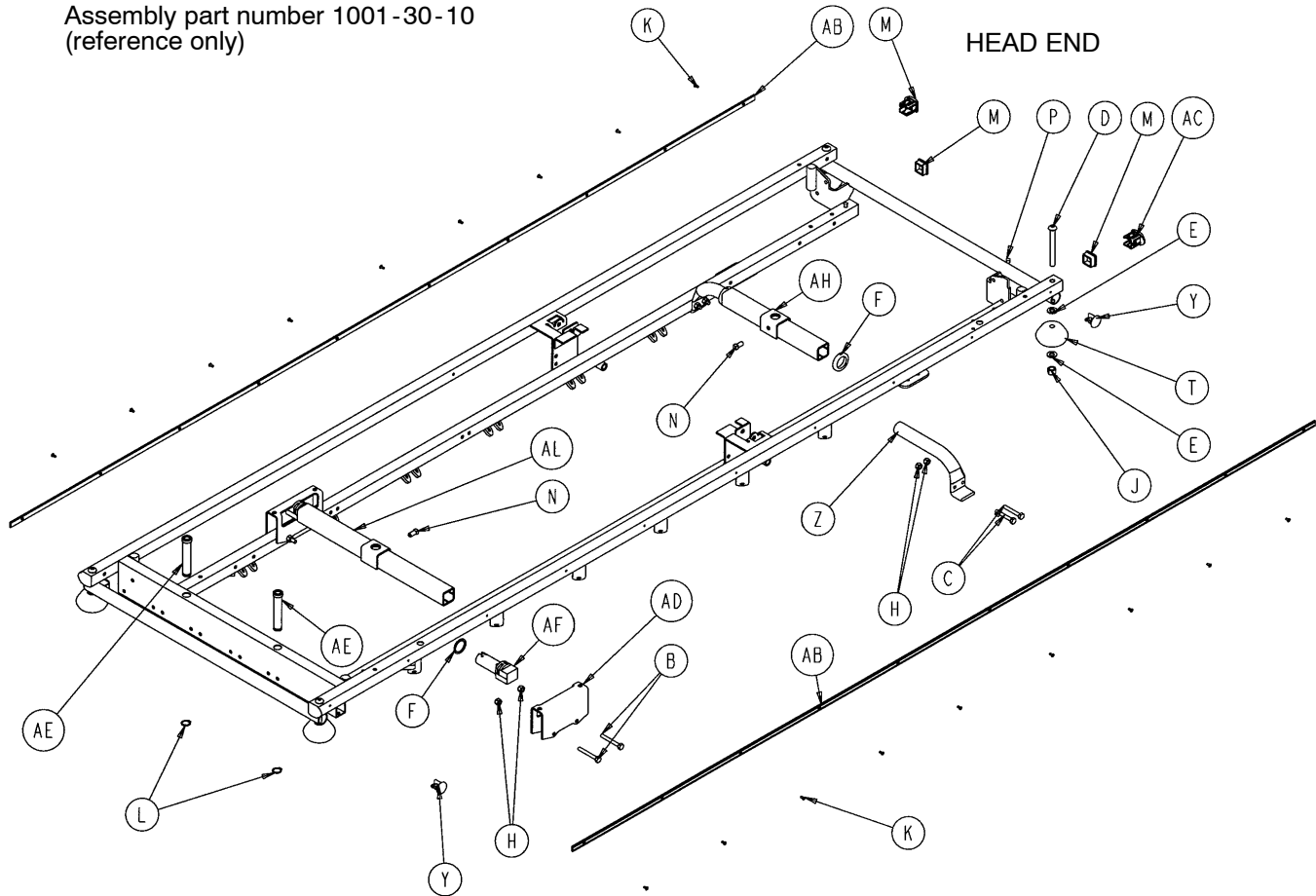

Item	Part No.	Part Name	Qty.	Item	Part No.	Part Name	Qty.
B	3-358	Hex Hd. Cap Screw	4	T	926-400-142	Bumper Wheel	4
C	3-359	Hex Hd. Cap Screw	4	W	938-1-401	Collar	2
D	4-181	But. Hd. Cap Screw	4	Y	1001-1-36	Hole Plug	4
E	14-21	Washer	8	Z	1001-1-37	Jack Supt. Tube, Hd.	2
F	11-360	Plastic Spacer	2	AB	1001-26-34	Bumper Channel	2
H	16-118	Fiberlock Nut	8	AC	1001-30-29	End Plug	4
J	16-117	Nylock Nut	4	AD	1001-201-30	Support Stamping	2
K	25-38	Pop Rivet	20	AE	1001-40-12	Foot Board Receptacle	2
L	28-72	Retaining Ring	2	AF	1001-201-29	Plastic Insert	2
M	37-10	Hole Plug	4	AH	1010-32-85	Support Tube Ass'y	1
N	46-1	Set Screw	2	AK	1210-800-8	Patent Label	1
P	721-31-65	Hole Plug	2	AL	1001-201-31	Support Tube Ass'y	1

1501 Litter Assembly, Fold to Head Siderails

Assembly part number 1501-30-10 (reference only)

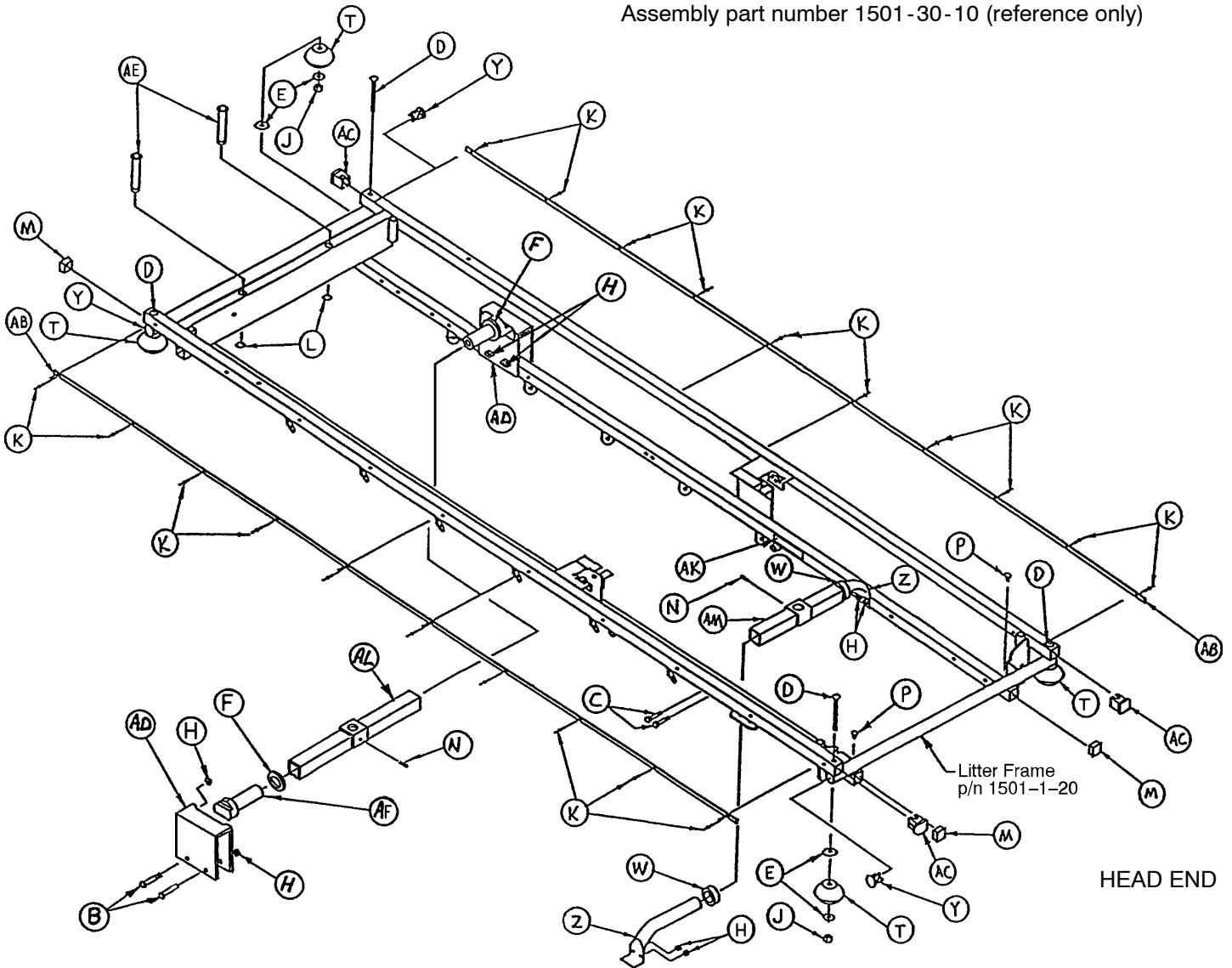

Item	Part No.	Part Name	Qty.	Item	Part No.	Part Name	Qty.
B	3-358	Hex Hd. Cap Screw	4	T	926-400-142	Bumper Wheel	4
C	3-359	Hex Hd. Cap Screw	4	W	938-1-401	Collar	2
D	4-181	But. Hd. Cap Screw	4	Y	1001-1-36	Hole Plug	4
E	14-21	Washer	12	Z	1001-1-37	Jack Supt. Tube, Hd.	2
F	11-360	Plastic Spacer	2	AB	1001-26-34	Bumper Channel	2
H	16-118	Fiberlock Nut	8	AC	1001-30-29	End Plug	4
J	16-117	Nylock Nut	4	AD	1001-201-30	Support Stamping	2
K	25-40	Pop Rivet	20	AE	1001-40-12	Foot Board Receptacle	2
L	28-72	Retaining Ring	2	AF	1001-201-29	Plastic Insert	2
M	37-10	Hole Plug	4	AK	1210-800-8	Patent Label	1
N	46-3	Set Screw	2	AL	1501-201-31	Support Tube Ass'y	1
P	721-31-65	Hole Plug	2	AM	1510-32-20	Support Tube Ass'y	1

Siderail to Litter Assembly, Fold-to-Head

Assembly part number 1211 -120-10 (reference only)

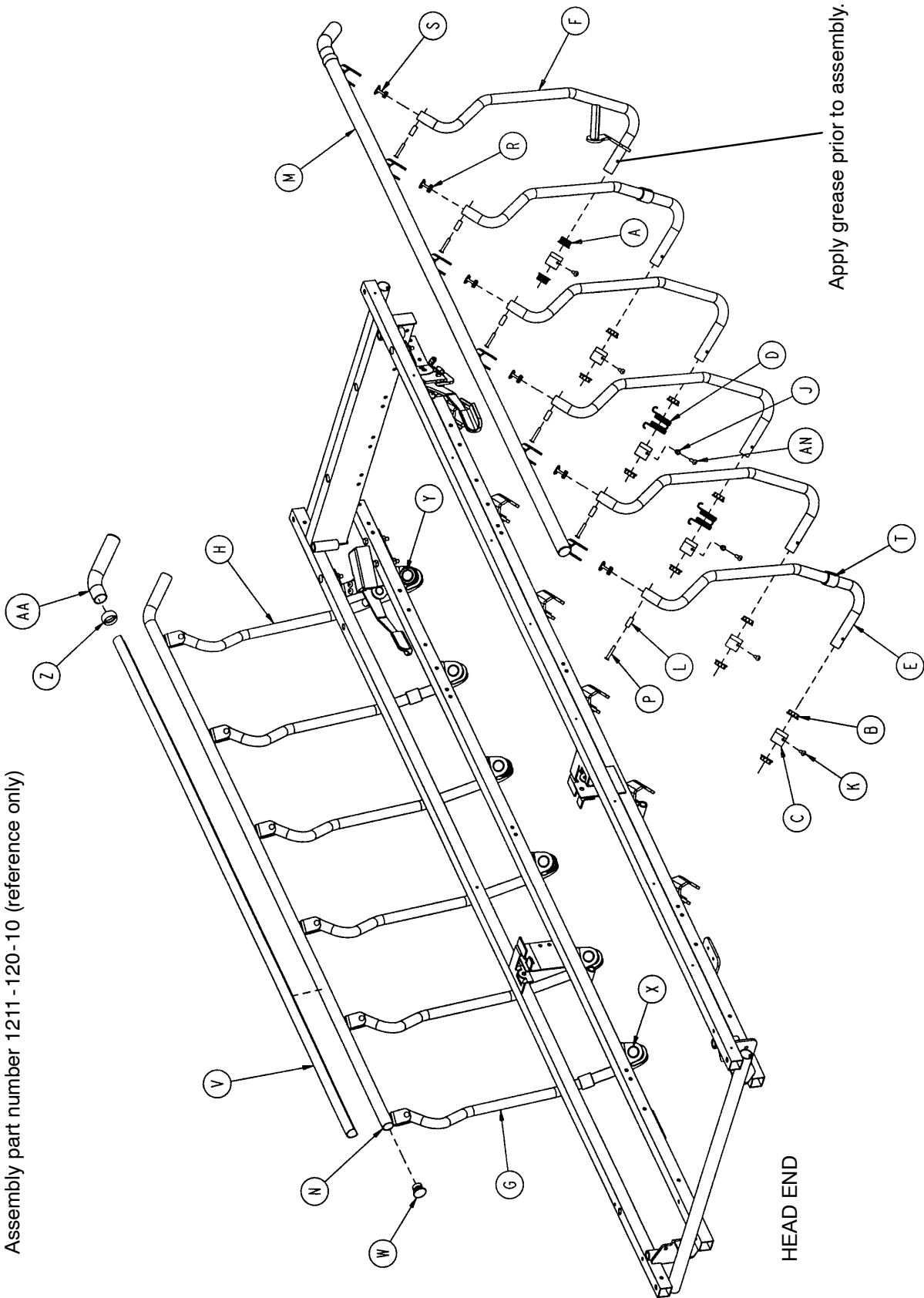

Siderail to Litter Assembly, Fold-to-Head

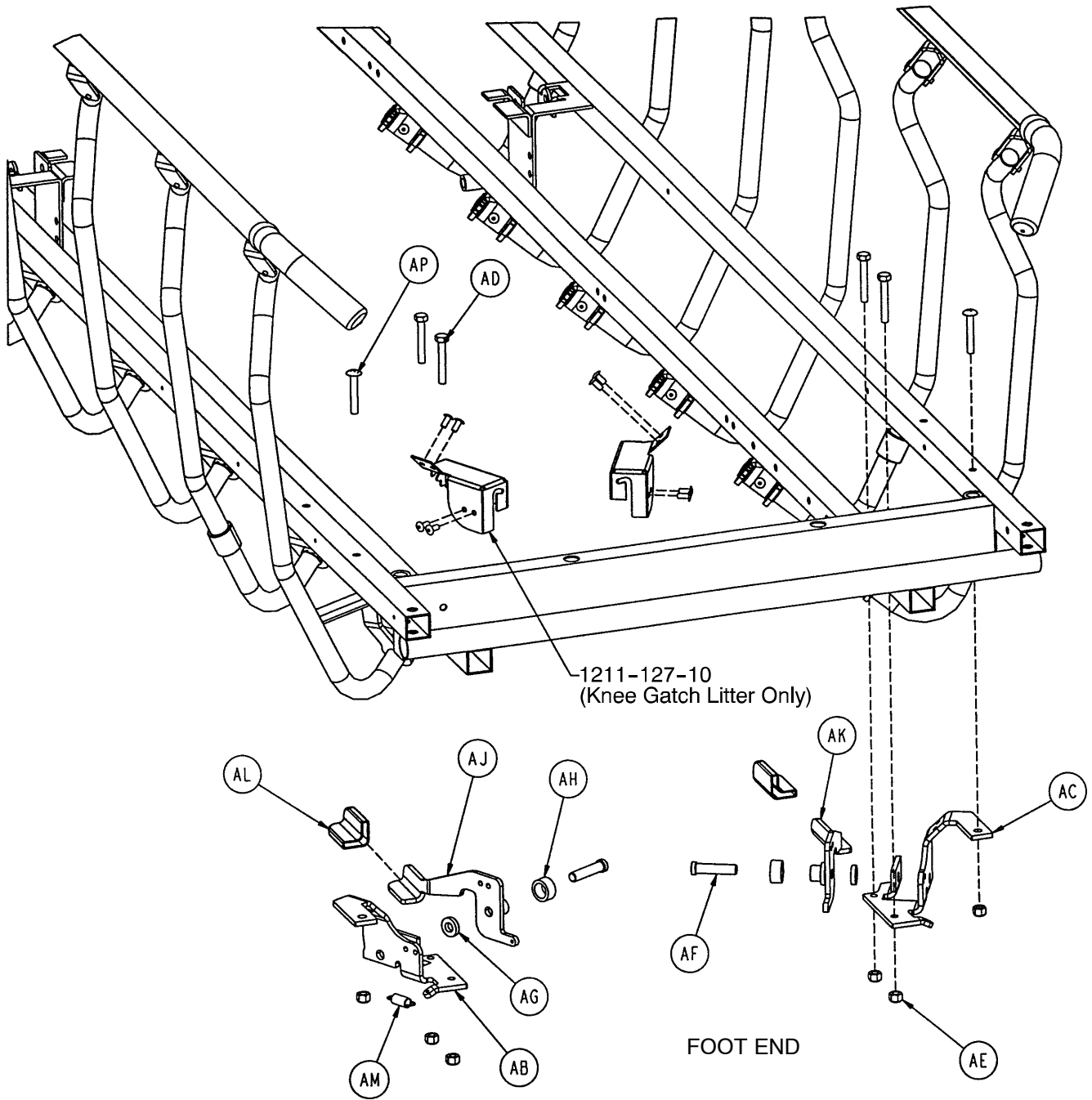

Siderail to Litter Assembly, Fold-to-Head

Item	Part No.	Part Name	Qty.
A	1001-226-116	Pivot Bearing	4
B	1001-226-16	Pivot Bearing	20
C	1001-226-15	Pivot Sleeve	12
D	1001-226-17	Siderail Spring	2
E	1001-326-27	Right Spindle	5
F	1001-326-31	Lock Spindle Weldment, Rt.	1
G	1001-326-28	Left Spindle	5
H	1001-326-33	Lock Spindle Weldment, Lt.	1
J	1001-226-20	Siderail Spring Spacer	2
K	25-172	Rivet	8
L	1010-226-82	Top Rail Bearing	12
M	1001-226-40	Top Rail Weldment, Right	1
N	1001-226-30	Top Rail Weldment, Left	1
P	25-61	Semi-Tubular Rivet	12
R	1001-226-101	Plug Assembly	10
S	1001-226-102	Plug Assembly	2
T	1001-226-19	Rubber Stop	4
V	1001-226-63	Top Rail Cap	2
W	1001-226-100	End Cap Assembly	2
X	37-215	Dome Plug	10
Y	59-100	Dome Plug	2
Z	1001-226-163	Top Rail Retainer	2
AA	1001-226-162	Top Rail Handle	2
AB	1001-226-46	Latch Pivot, Right	1
AC	1001-226-47	Latch Pivot, Left	1
AD	3-359	But. Hd. Cap Screw	4
AE	16-118	Nylock Nut	6
AF	1001-226-142	Latch Pin	2
AG	52-17	Washer	2
AH	1001-226-45	Latch Spacer	2
AJ	1001-226-152	Latch Plate Weldment, Rt.	1
AK	1001-226-153	Latch Plate Weldment, Lt.	1
AL	1001-226-158	Latch Cover	2
AM	38-422	Extension Spring	2
AN	25-181	Blind Rivet	2
AP	7-70	Machine Screw	2

1001 Litter Assembly, Fold to Foot Siderails

Assembly part number 1001-130-10 (reference only)

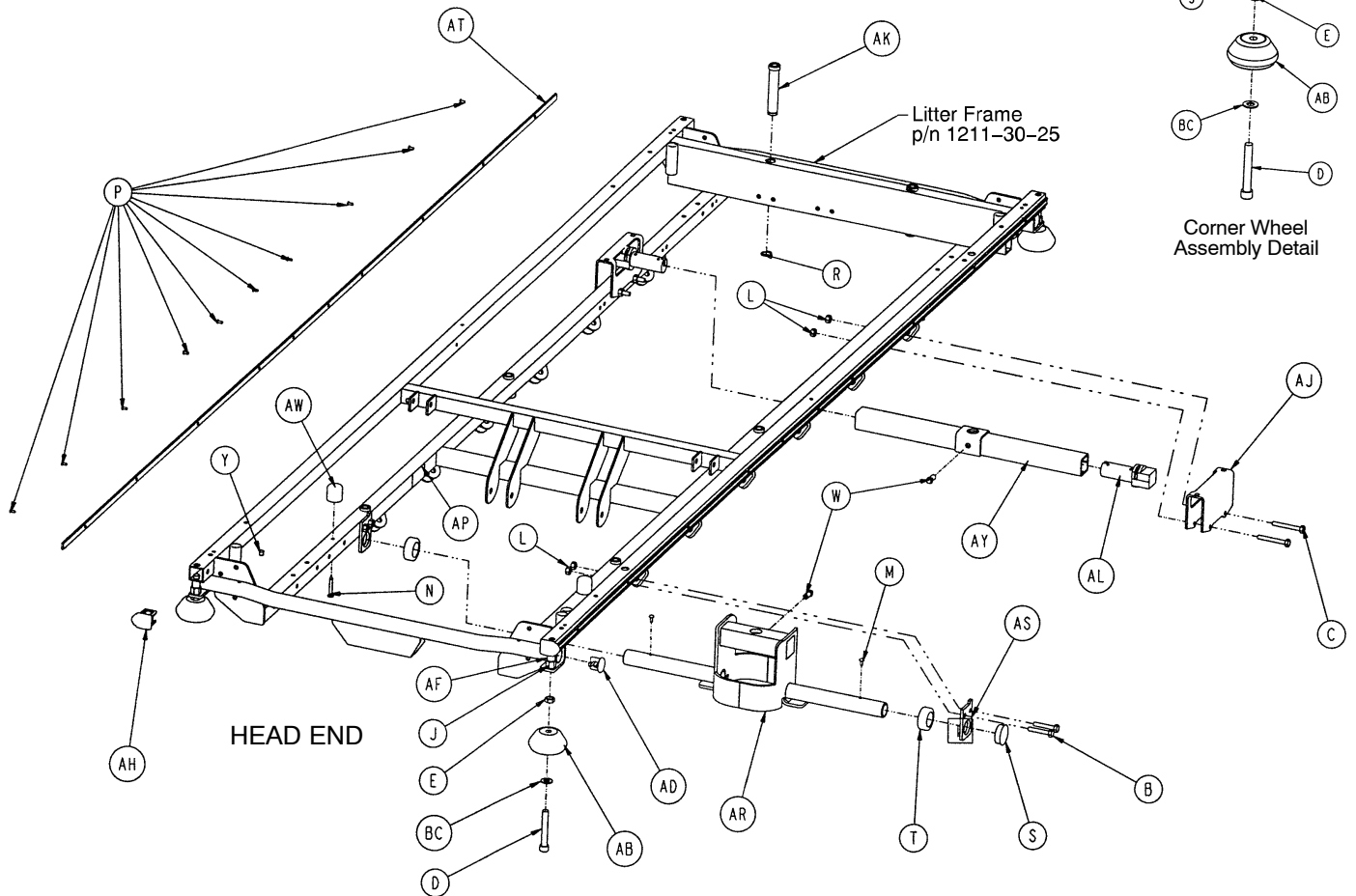

Item	Part No.	Part Name	Qty.	Item	Part No.	Part Name	Qty.
A	11-360	Plastic Spacer	2	Y	721-31-65	Hole Plug	6
B	3-355	Hex Hd. Cap Screw	4	AB	926-400-142	Bumper Wheel	4
C	3-358	Hex Hd. Cap Screw	4	AD	1001-1-36	End Plug	4
D	4-330	Soc. Hd. Cap Screw	4	AF	1001-30-28	Thread Sleeve	4
E	15-27	Jam Nut	4	AH	1001-30-29	End Plug	4
F	16-116	Nylock Nut	2	AJ	1001-201-30	Trend Support	2
J	16-117	Nylock Nut	4	AK	1001-40-12	Footboard Receptacle	2
L	16-118	Nylock Nut	8	AL	1001-201-29	Insert	2
M	22-10	Drive Screw	2	AP	1210-800-8	Patent Label	1
N	23-283	Self-Tapping Screw	2	AR	1211-30-7	Jack Support Wldmt.	1
P	25-40	Pop Rivet	24	AS	1211-30-18	Jack Support Bracket	2
R	28-72	Retaining Ring	2	AT	1001-30-44	Bumper Channel	2
S	37-30	Hole Plug	2	AW	1211-31-31	Pneumatic Fowler Rest	2
T	42-7	Collar	2	AY	1001-201-31	Support Tube Ass'y	1
W	46-3	Square Hd. Screw	2	BC	14-21	Nylon Washer	4

1501 Litter Assembly, Fold to Foot Siderails

Assembly part number 1501-130-10 (reference only)

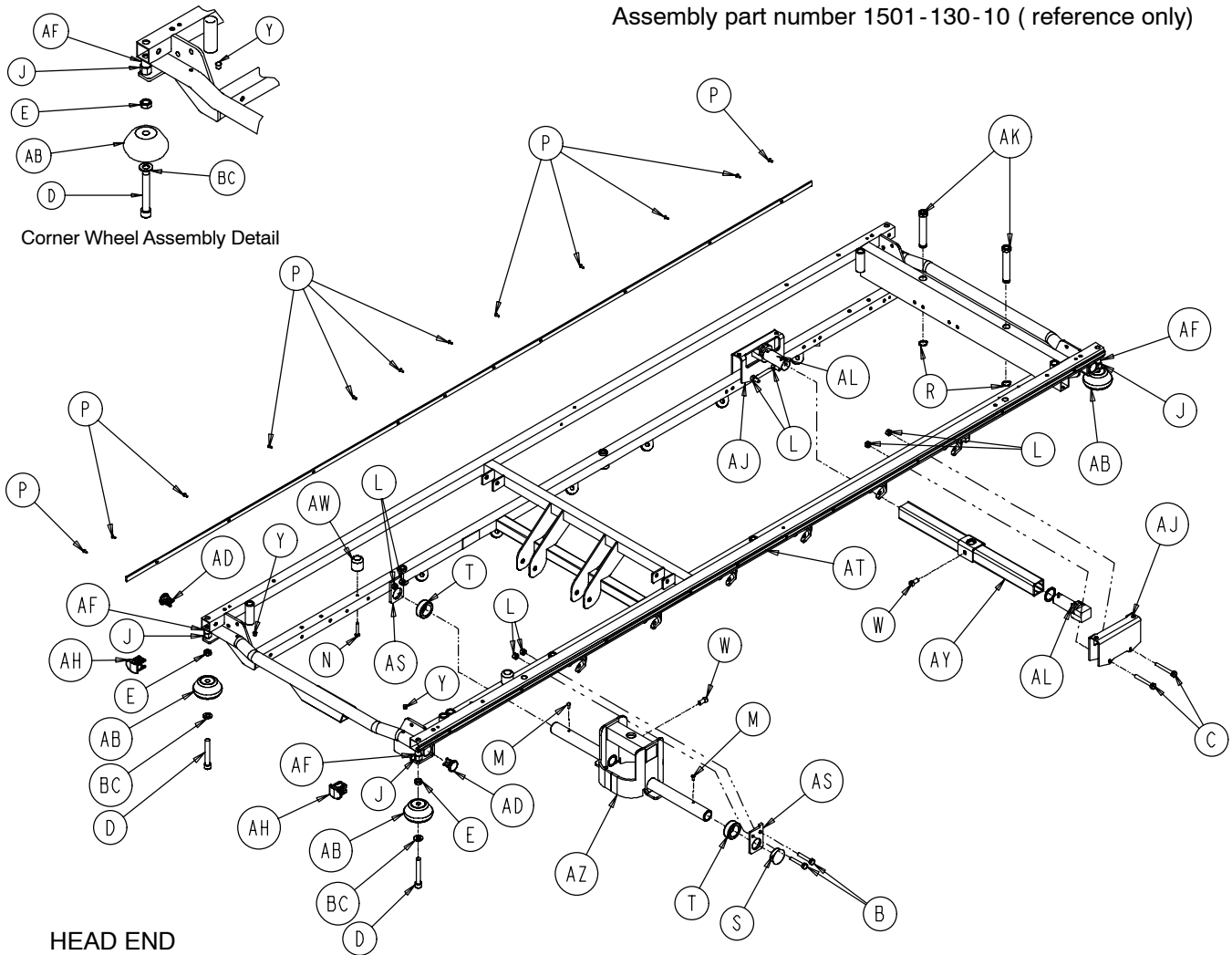

HEAD END

Item	Part No.	Part Name	Qty.	Item	Part No.	Part Name	Qty.
A	11-360	Plastic Spacer	2	AB	926-400-142	Bumper Wheel	4
B	3-355	Hex Hd. Cap Screw	4	AD	37-208	End Plug	4
C	3-359	Hex Hd. Cap Screw	4	AF	1001-30-28	Thread Sleeve	4
D	4-330	Soc. Hd. Cap Screw	4	AH	1001-30-29	End Plug	4
E	15-27	Jam Nut	4	AJ	1001-201-30	Trend Support	2
J	16-117	Nylock Nut	4	AK	1001-40-12	Footboard Receptacle	2
L	16-118	Nylock Nut	8	AL	1010-201-29	Insert	2
M	22-10	Drive Screw	2	AP	1210-800-8	Patent Label	1
N	23-283	Self-Tapping Screw	2	AS	1211-30-18	Jack Support Bracket	2
P	25-40	Pop Rivet	24	AT	1001-30-44	Bumper Channel	2
R	28-72	Retaining Ring	2	AW	1211-31-31	Pneumatic Fowler Rest	2
S	37-30	Hole Plug	2	AY	1501-201-31	Support Tube Ass'y	1
T	42-7	Collar	2	AZ	1711-30-7	Jack Support Wldmt.	1
W	46-3	Square Hd. Screw	2	BA	37-35	Hole Plug	4
Y	721-31-65	Hole Plug	6	BC	14-21	Washer	4

Siderail to Litter Assembly, Fold-to-Foot

Assembly part number 1211-121-10 (reference only)

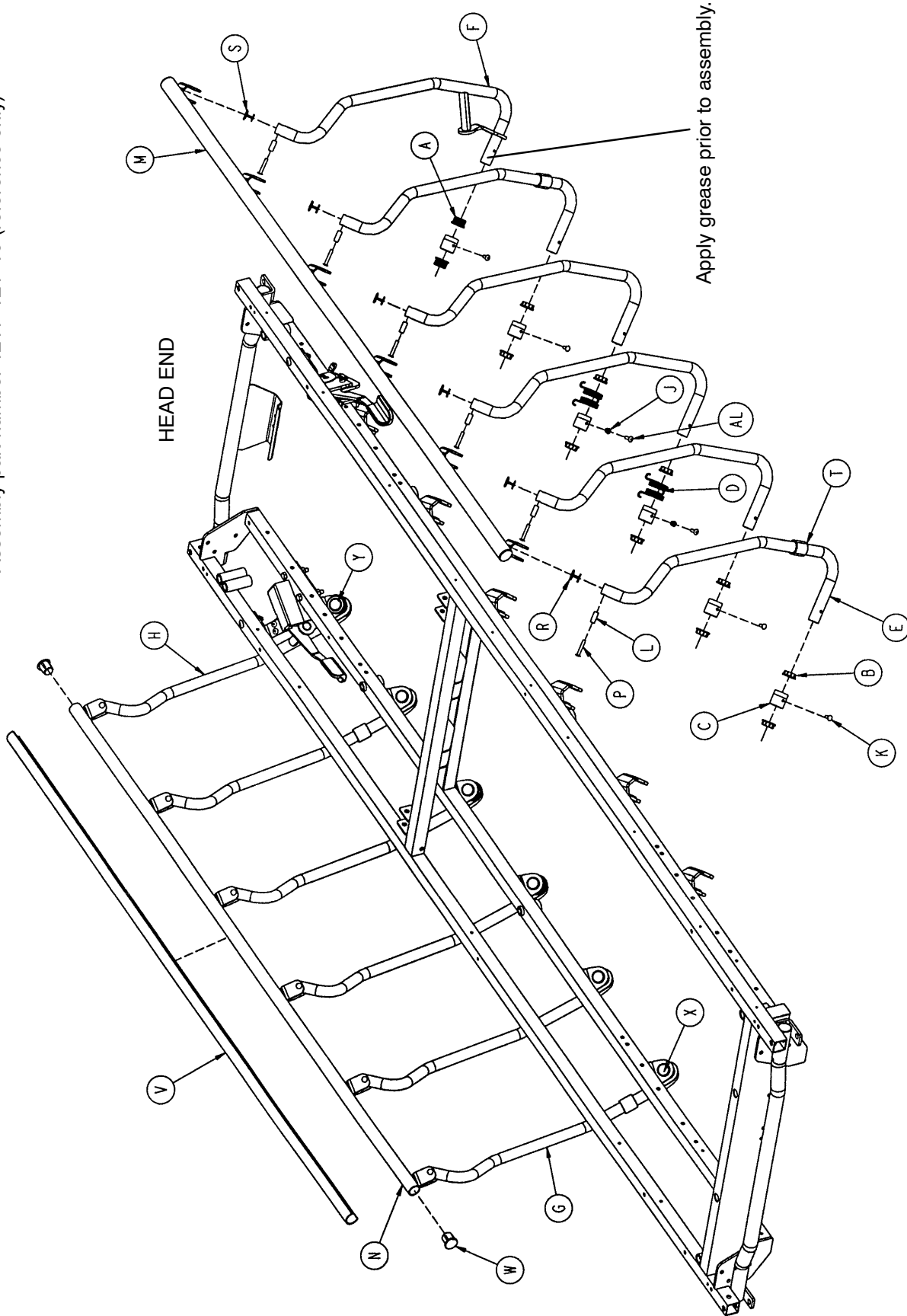

Siderail to Litter Assembly, Fold-to-Foot

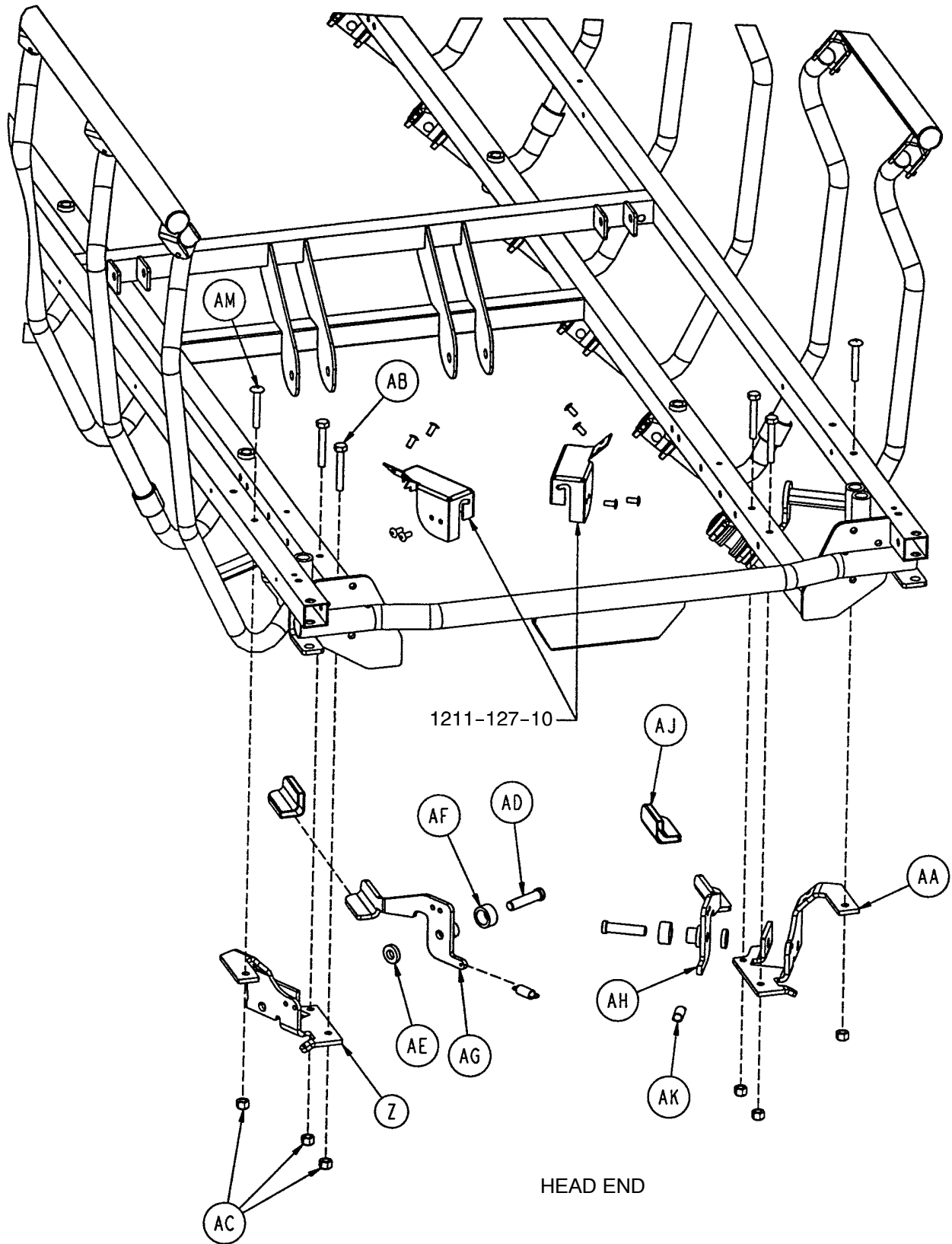

Siderail to Litter Assembly, Fold-to-Foot

Item	Part No.	Part Name	Qty.
A	1001-226-116	Pivot Bearing	4
B	1001-226-16	Pivot Bearing	20
C	1001-226-15	Pivot Sleeve	12
D	1001-226-17	Siderail Spring	4
E	1001-326-27	Right Spindle	5
F	1001-326-31	Lock Spindle Weldment, Rt.	1
G	1001-326-28	Left Spindle	5
H	1001-326-33	Lock Spindle Weldment, Lt.	1
J	1001-226-20	Siderail Spring Spacer	4
K	25-172	Semi-Tubular Rivet	8
L	1010-226-82	Top Rail Bearing	12
M	1001-226-140	Top Rail Weldment, Rt., FTF	1
N	1001-226-130	Top Rail Weldment, Lt., FTF	1
P	25-61	Semi-Tubular Rivet	12
R	1001-226-101	Plug Assembly	10
S	1001-226-102	Plug Assembly	2
T	1001-226-19	Rubber Stop	4
V	1001-226-63	Top Rail Cap	2
W	1001-226-100	End Cap Assembly	4
X	37-215	Dome Plug	10
Y	59-100	Dome Plug	2
Z	1001-226-46	Right Latch Pivot	1
AA	1001-226-47	Left Latch Pivot	1
AB	3-359	But. Hd. Cap Screw	4
AC	16-118	Nylock Nut	6
AD	1001-226-142	Latch Pin	2
AE	52-17	Washer	2
AF	1001-226-45	Latch Spacer	2
AG	1001-226-152	Latch Plate Weldment, Rt.	1
AH	1001-226-153	Latch Plate Weldment, Lt.	1
AJ	1001-226-158	Latch Cover	2
AK	38-422	Extension Spring	2
AL	25-181	Rivet	4
AM	7-70	Machine Screw	2

1211-127 Optional Dual Siderail Latch Assembly

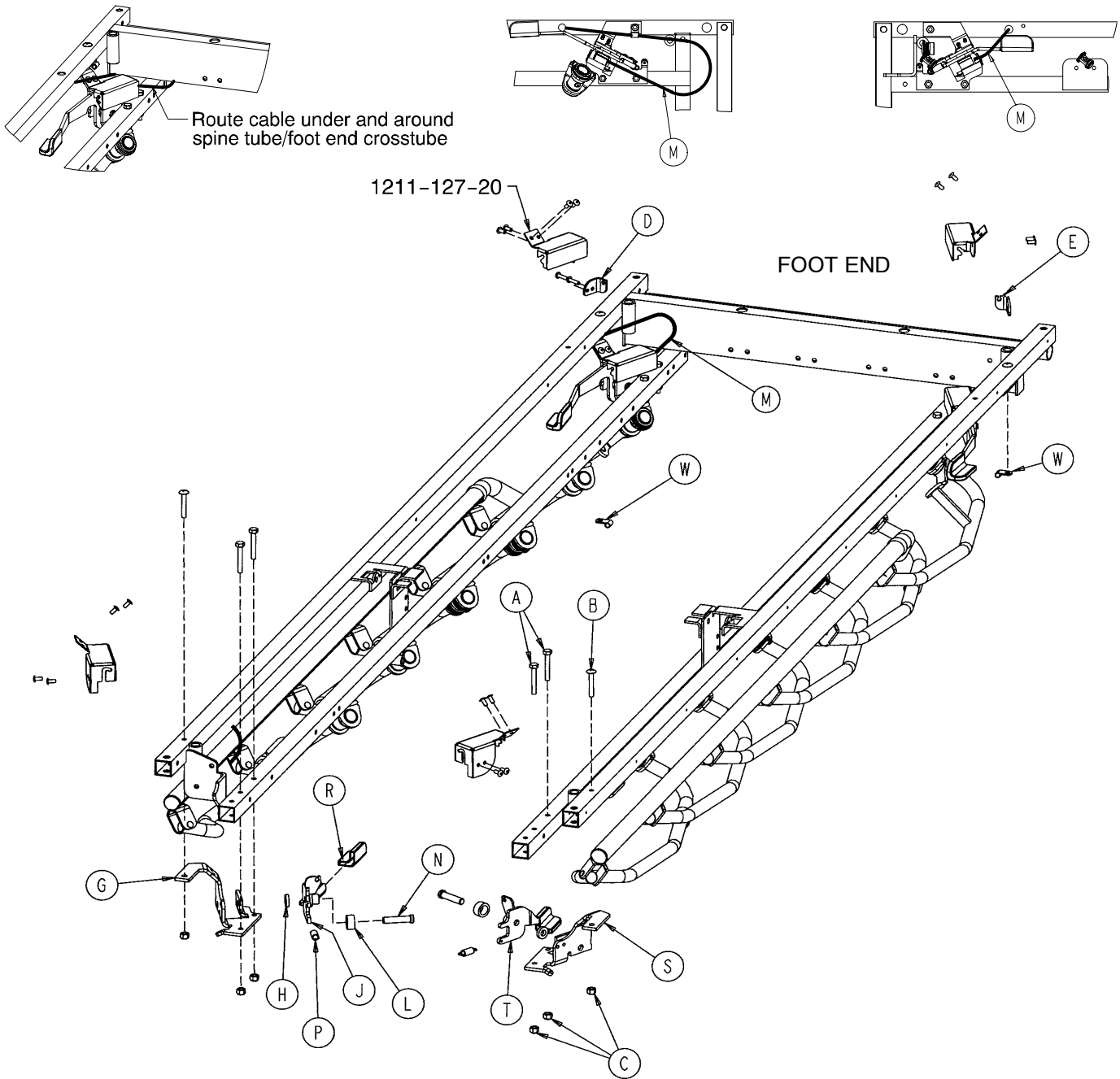

Item	Part No.	Part Name	Qty.	Item	Part No.	Part Name	Qty.
A	3-359	Hex Hd. Cap Screw	4	L	1001-226-45	Latch Spacer	2
B	7-70	Truss Hd. Mach. Screw	2	M	1001-226-161	Dual Latch Cable Ass'y	2
C	16-118	Nylock Nut	6	N	1001-226-142	Latch Pin	2
D	1001-226-147	Dual Latch Pivot	1	P	38-222	Extension Spring	2
E	1001-226-170	Dual Latch Pivot	1	R	1001-226-158	Latch Cover	2
G	1001-226-46	Latch Pivot, Right	1	S	1001-226-47	Latch Pivot, Left	1
H	52-17	Nylon Washer	2	T	1001-226-157	Dual Latch Wldmt., Left	1
J	1001-226-156	Dual Latch Wldmt., Right	1	W	59-767	Cable Clamp	2

1001 Pneumatic Fowler Assembly, Fold-to-Head

Assembly part number 1210-31-10
(reference only)

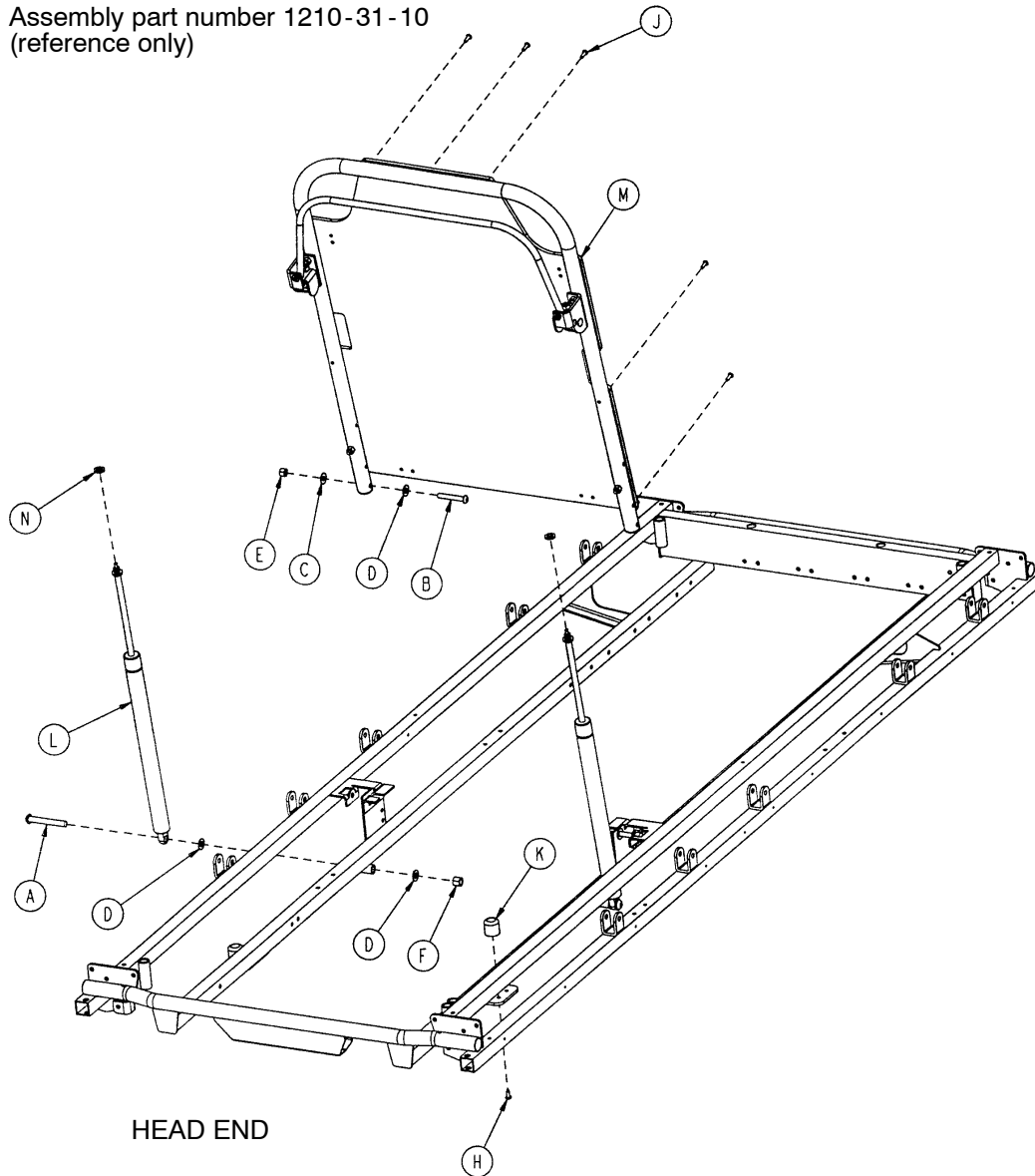

Item	Part No.	Part Name	Qty.
A	4-182	But. Hd. Cap Screw	2
B	4-104	But. Hd. Cap Screw	2
C	11-179	Nylon Washer	2
D	14-21	Nylon Washer	6
E	16-116	Nylock Hex Nut	2
F	16-117	Nylock Hex Nut	2
H	23-256	Self-Tapping Screw	2
J	25-133	Pop Rivet	7
K	1211-31-31	Pneumatic Fowler Rest	2
L	1010-31-78	Gas Cylinder	2
M	(page 83)	Pneumatic Fowler Ass'y	1
N	15-60	Hex Jam Nut	2

1001 Pneumatic Fowler Assembly, Fiberresin, Fold-to-Head

Assembly part number
1210-31-120
(reference only)

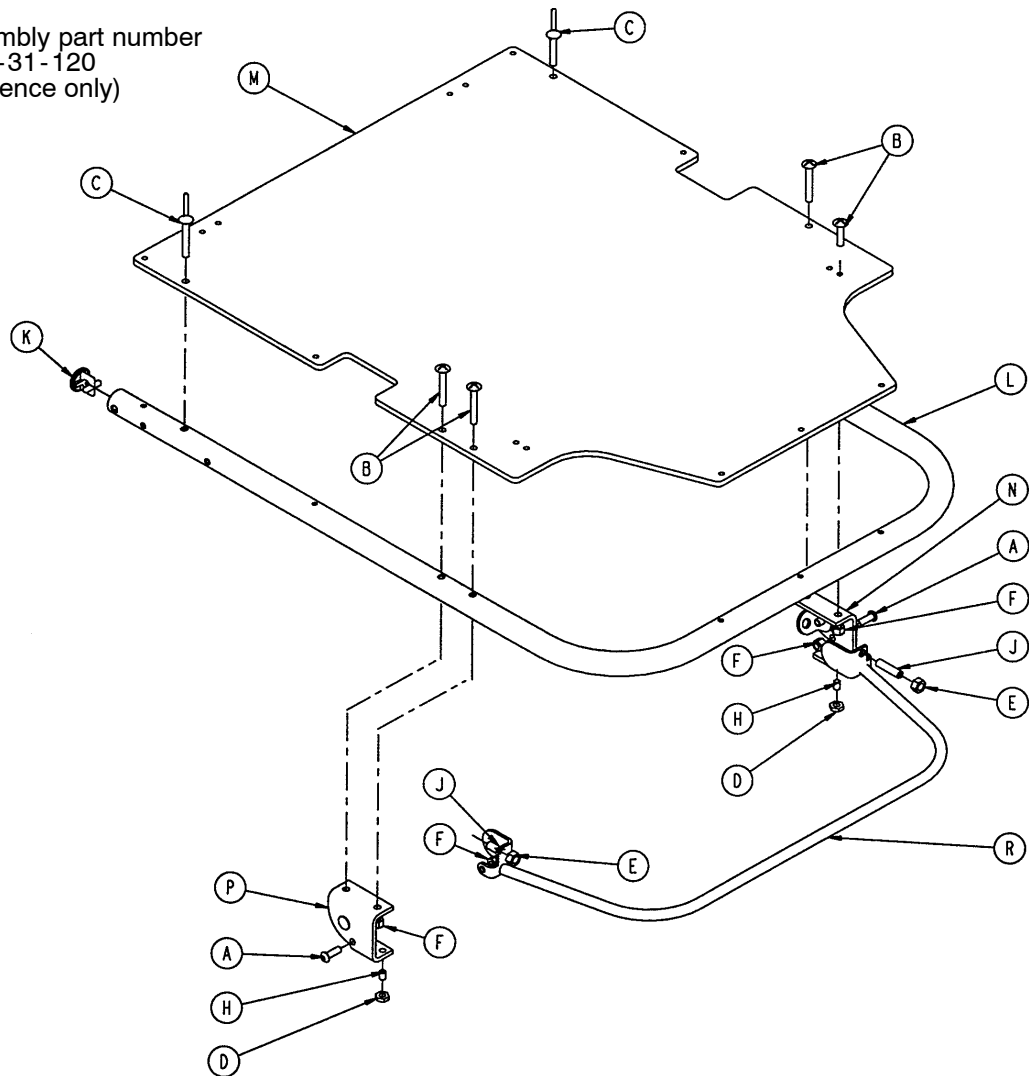

Item	Part No.	Part Name	Qty.
A	4-161	Hex Soc. But. Hd. Cap Screw	2
B	7-20	Truss Hd. Mach. Screw	4
C	25-124	Pop Rivet	2
D	15-37	Jam Nut	2
E	15-50	Hex Nut	2
F	16-28	Nylock Nut	6
H	21-125	Set Screw	2
J	21-126	Set Screw	2
K	1001-1-36	Hole Plug	2
L	1001-31-13	Fowler Tube	1
M	1010-231-12	Fowler Skin (Fiberresin)	1
N	(page 86)	Outer Housing Ass'y, Right	1
P	(page 86)	Outer Housing Ass'y, Left	1
R	1210-31-118	Trip Bar Assembly	1

1501 Pneumatic Fowler Assembly, Fold-to-Head

Assembly part number 1710-31-10
(reference only)

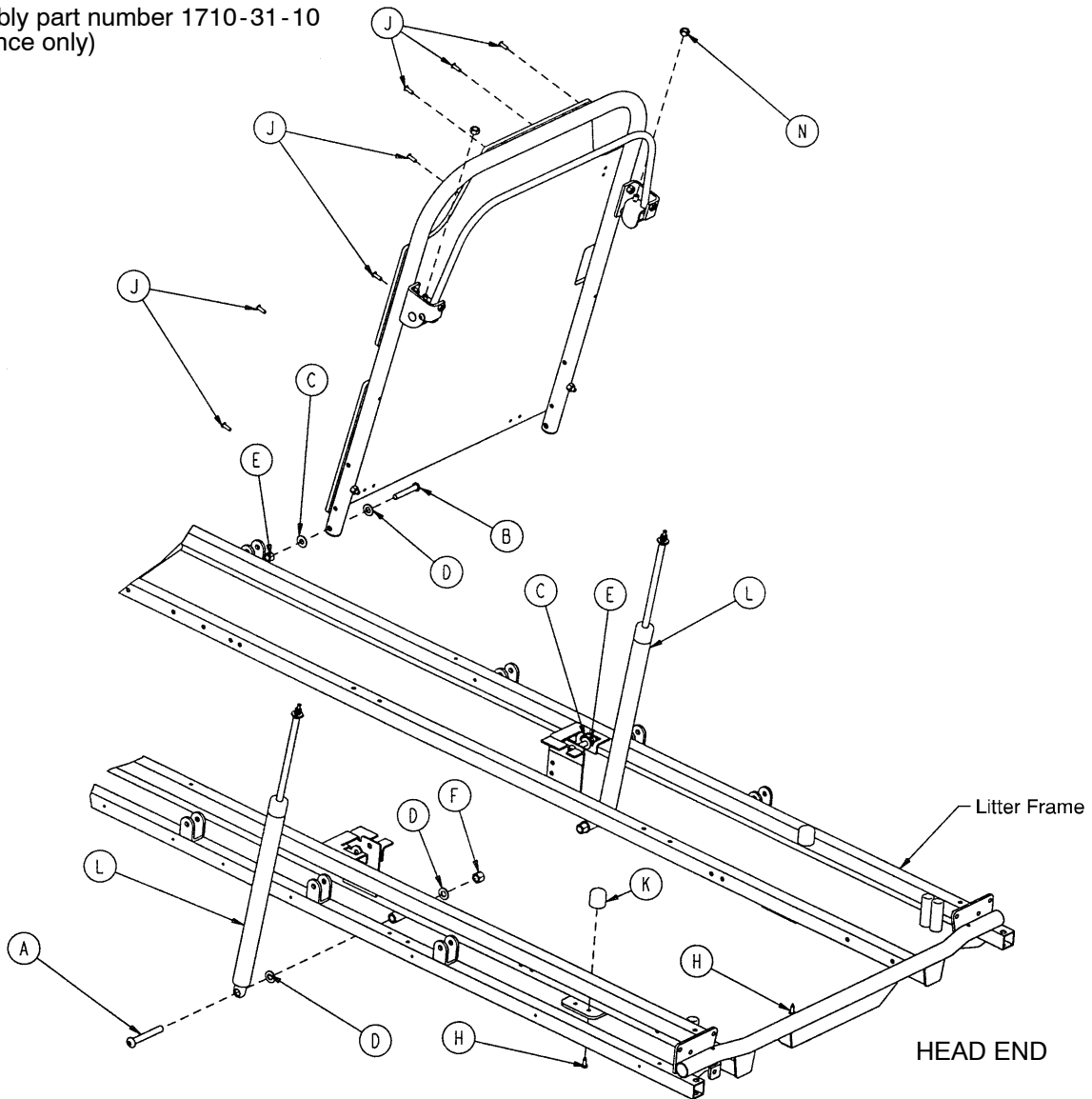

Item	Part No.	Part Name	Qty.
A	4-182	But. Hd. Cap Screw	2
B	4-104	But. Hd. Cap Screw	2
C	11-179	Nylon Washer	4
D	14-21	Nylon Washer	6
E	16-116	Nylock Hex Nut	2
F	16-117	Nylock Hex Nut	2
H	23-256	Self-Tapping Screw	2
J	25-133	Pop Rivet	7
K	1211-31-31	Pneumatic Fowler Rest	2
L	1010-31-78	Gas Cylinder	2
M	(page 85)	Pneumatic Fowler Ass'y	1
N	15-60	Hex Nut	2

1501 Pneumatic Fowler Assembly, Fiberresin, Fold-to-Head

Assembly part number
1710-31-120
(reference only)

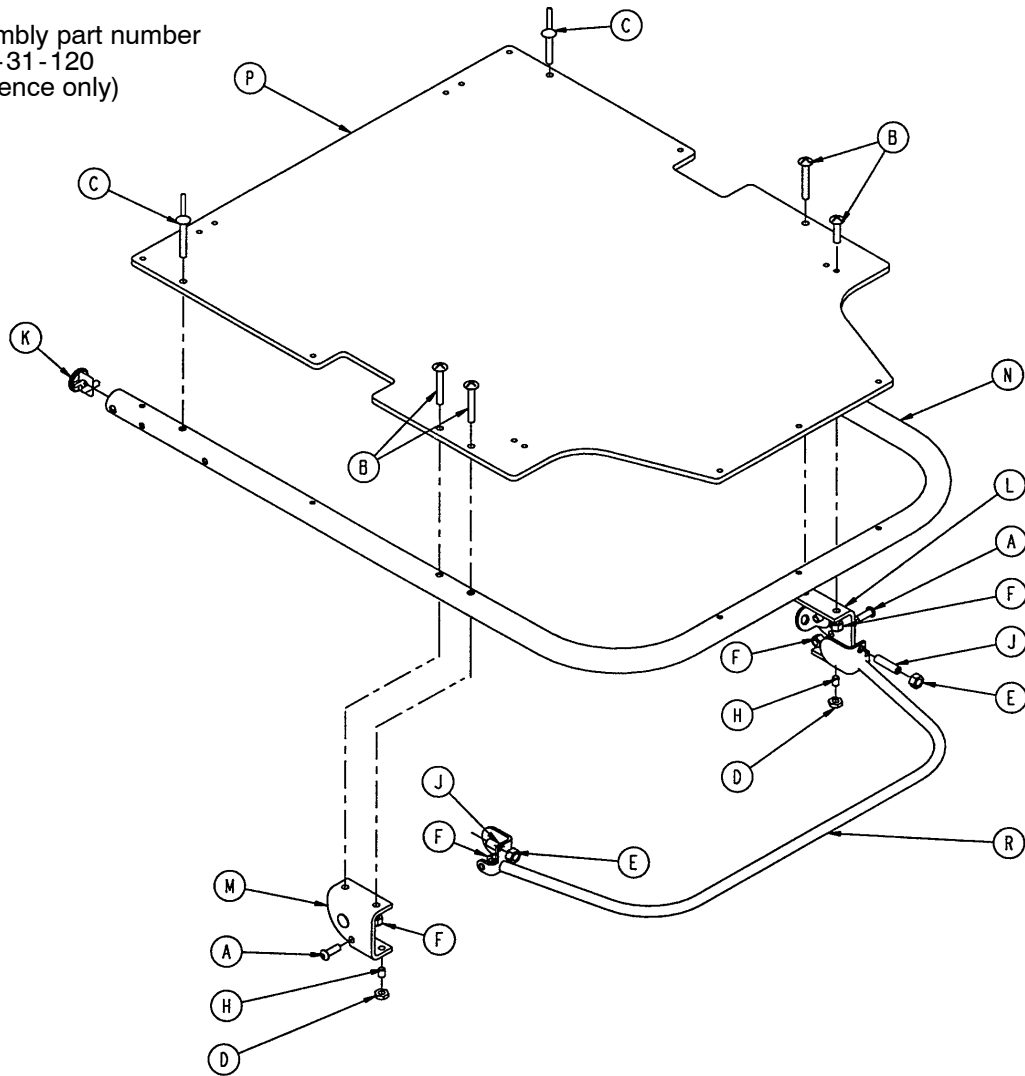

Item	Part No.	Part Name	Qty.
A	4-161	But. Hd. Cap Screw	2
B	7-20	Truss Hd. Mach. Screw	4
C	25-124	Pop Rivet	2
D	15-37	Jam Nut	2
E	15-50	Hex Nut	2
F	16-28	Fiberlock Nut	6
H	21-125	Set Screw	2
J	21-126	Set Screw	2
K	1001-1-36	Hole Plug	2
L	(page 86)	Outer Housing Ass'y, Rt.	1
M	(page 86)	Outer Housing Ass'y, Lt.	1
N	1501-31-13	Fowler Tube	1
P	1510-231-12	Fowler Skin (Fiberresin)	1
R	1710-31-118	Trip Bar Assembly	1

Outer Housing Assembly, Right and Left

Assembly part number 1210-31-106 (Right)

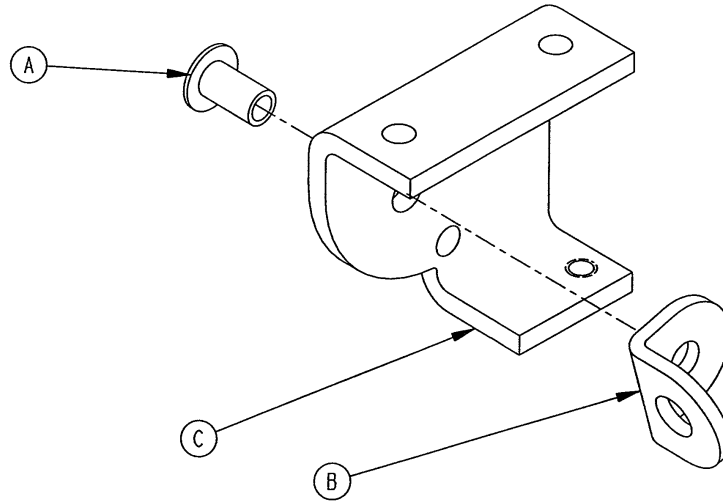

Item	Part No.	Part Name	Qty.
A	25-144	Semi-Tubular Rivet	1
B	1210-31-103	Pivot Tab	1
C	1210-31-104	Outer Housing, Right	1

Assembly part number 1210-31-107 (Left)

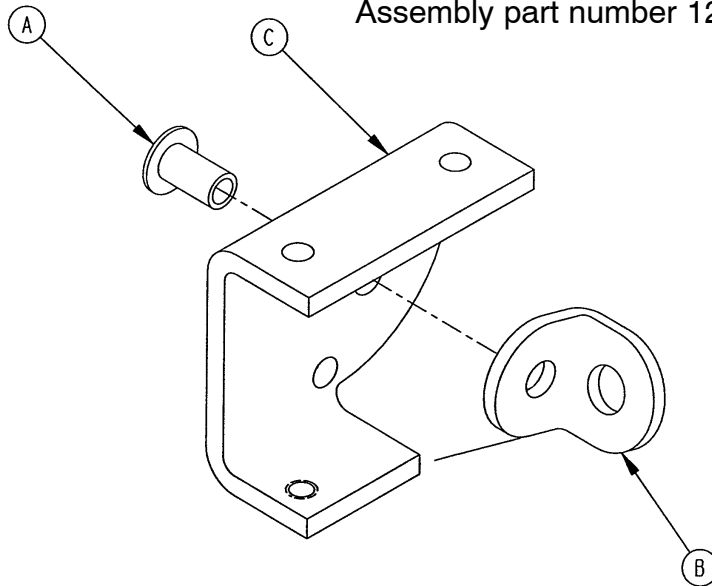

Item	Part No.	Part Name	Qty.
A	25-144	Semi-Tubular Rivet	1
B	1210-31-103	Pivot Tab	1
C	1210-31-105	Outer Housing, Left	1

1001 Pneumatic Fowler to Frame Assembly

Assembly part number 1211-31-10 (reference only)

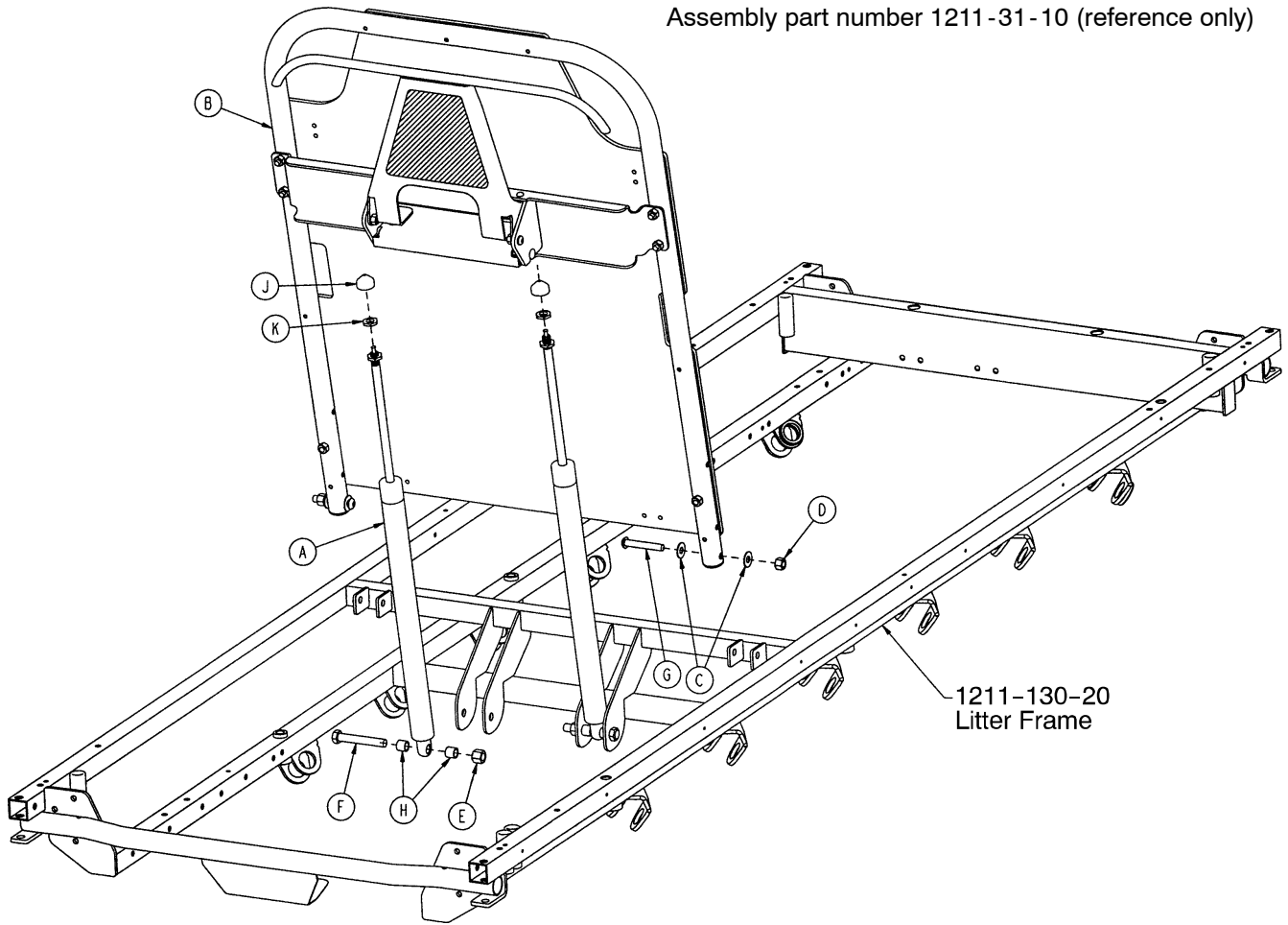

HEAD END

Item	Part No.	Part Name	Qty.
A	1010-31-78	Gas Cylinder	2
B	(page 88)	Pneumatic Fowler Ass'y	1
C	11-179	Washer	4
D	16-116	Stover Locknut	2
E	16-119	Stover Locknut	2
F	3-360	Hex Hd. Cap Screw	2
G	4-103	Torx But. Hd. Cap Screw	2
H	52-306	Nylon Spacer	4
J	1211-131-26	Gas Spring Cap	2
K	15-60	Metric Jam Nut	2

Pneumatic Fowler Assembly, Fiberresin, Fold-to-Foot

Assembly part number 1211-131-20 (reference only)

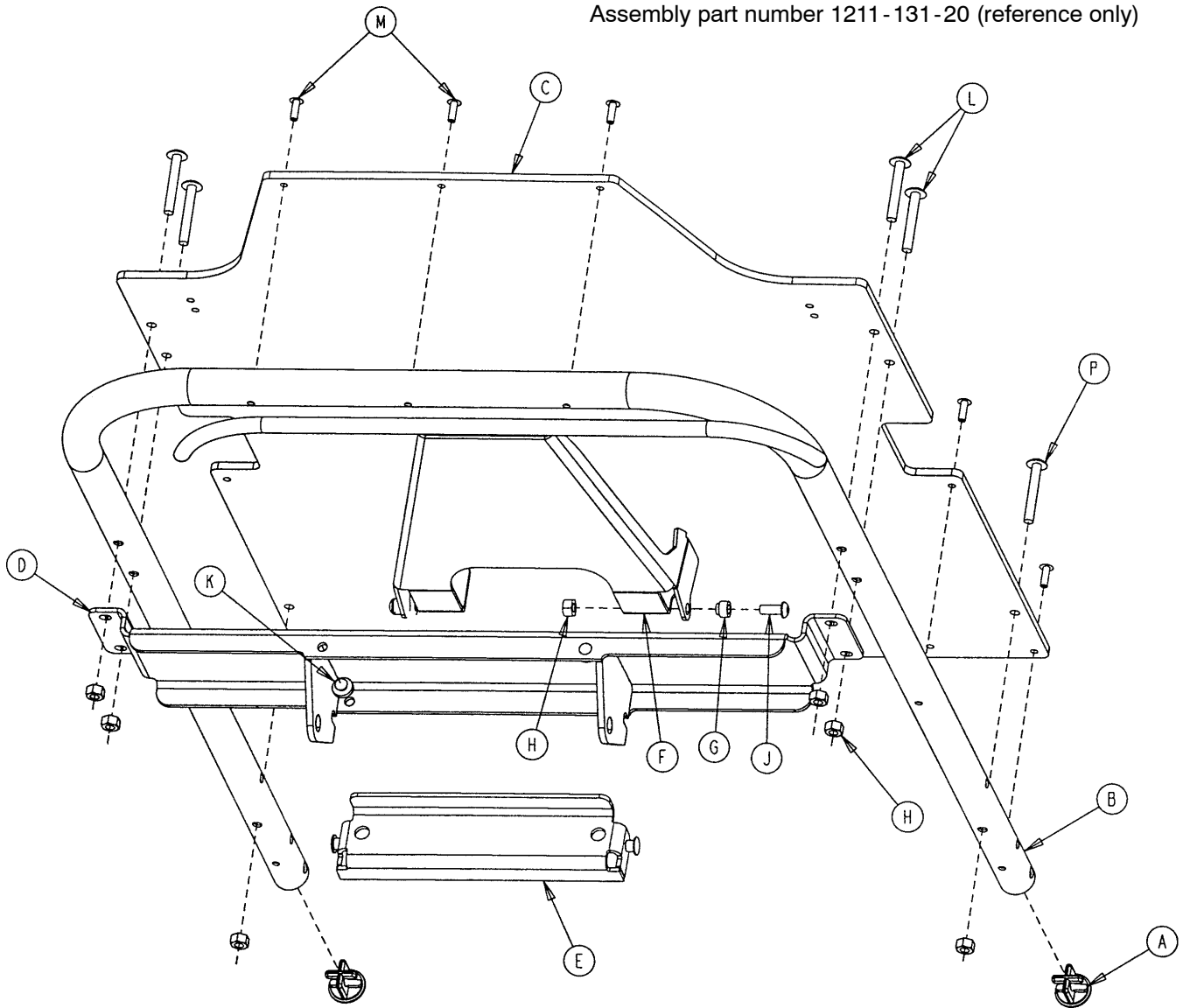

Item	Part No.	Part Name	Qty.	Item	Part No.	Part Name	Qty.
A	1001-1-36	Hole Plug	2	H	16-118	Hex Nut	8
B	1001-31-13	Fowler Tube	1	J	4-455	But. Hd. Cap Screw	2
C	1010-231-12	Fowler Skin	1	K	37-64	Grommet Bumper	2
D	1211-131-14	Pneu. Pivot Bar Wldmt.	1	L	7-70	Truss Hd. Mach. Screw	4
E	1211-231-29	Gas Spring Mount, Wldmt.	1	M	25-172	Blind Rivet	7
F	1211-231-18	Trip Bar Weldment	1	N	1211-131-30	Handle Grip	2
G	1211-231-25	Trip Bar Pivot	2	P	4-135	But. Hd. Cap Screw	2

1501 Pneumatic Fowler to Frame Assembly

Assembly part number 1711-31-10 (reference only)

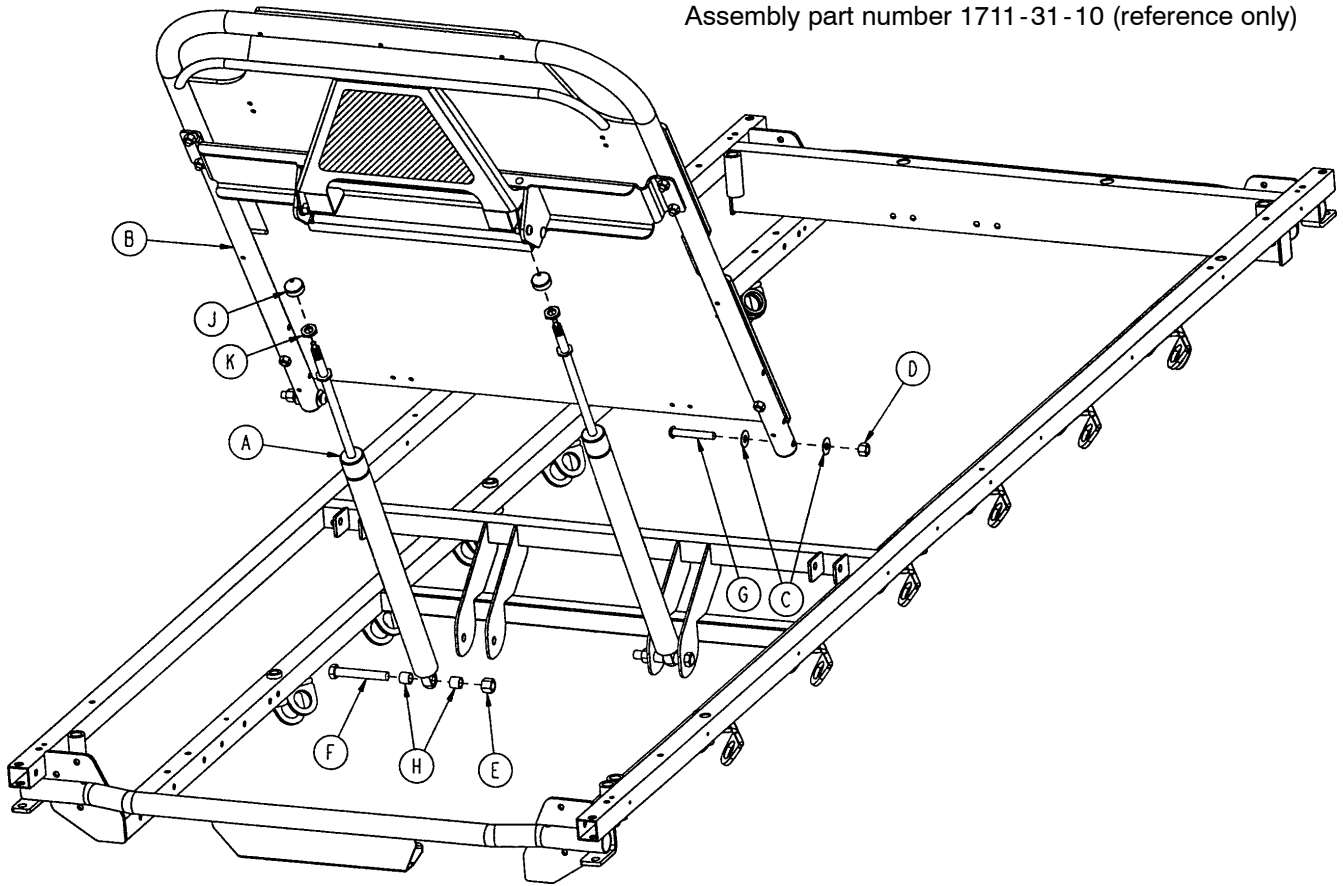

HEAD END

Item	Part No.	Part Name	Qty.
A	1010-31-78	Gas Cylinder	2
B	(page 90)	Pneumatic Fowler Ass'y	1
C	11-179	Washer	4
D	16-116	Stover Locknut	2
E	16-119	Stover Locknut	2
F	3-360	Hex Hd. Cap Screw	2
G	4-103	Torx But. Hd. Cap Screw	2
H	52-306	Nylon Spacer	4
J	1211-131-26	Gas Spring Cap	2
K	15-60	Metric Jam Nut	2

Pneumatic Fowler Assembly, Fiberresin, Fold-to-Foot

Assembly part number 1711-131-20 (reference only)

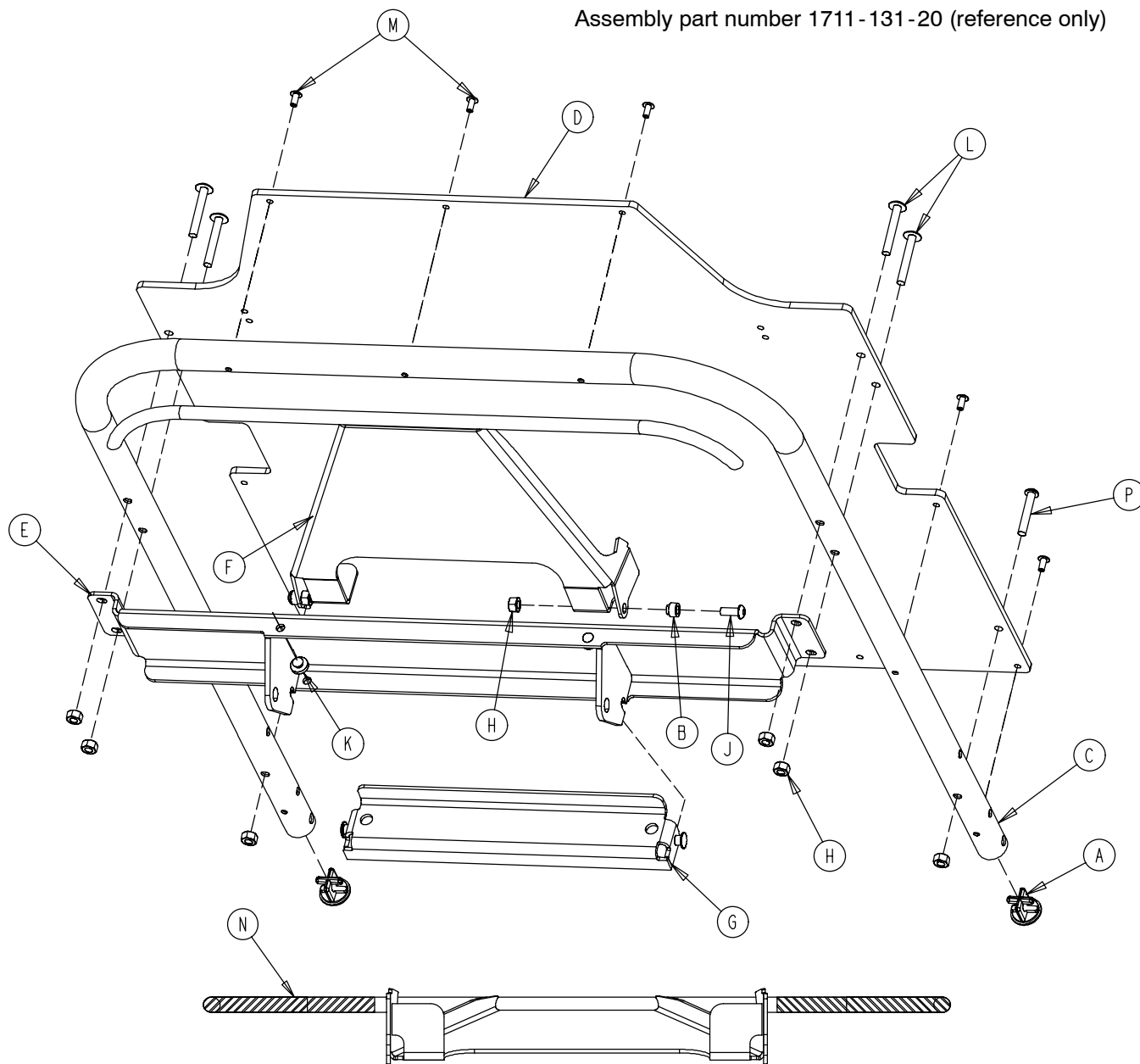

Item	Part No.	Part Name	Qty.	Item	Part No.	Part Name	Qty.
A	1001-1-36	Hole Plug	2	H	16-118	Hex Nut	8
B	1211-231-25	Trip Bar Pivot	2	J	4-455	But. Hd. Cap Screw	2
C	1501-31-13	Fowler Tube	1	K	37-64	Grommet Bumper	2
D	1510-231-12	Fowler Skin (Fiberresin)	1	L	7-70	Truss Hd. Mach. Screw	4
E	1711-131-14	Pneu. Pivot Bar Wldmt.	1	M	25-172	Blind Rivet	7
F	1711-231-18	Trip Bar Weldment	1	N	1211-131-30	Handle Grip	2
G	1711-231-29	Gas Spring Mount Wldmt.	1	P	4-135	But. Hd. Cap Screw	2

1001 Crank Fowler Assembly (Fiberresin, Fold-to-Head)

Assembly part number 1210-33-10
(reference only)

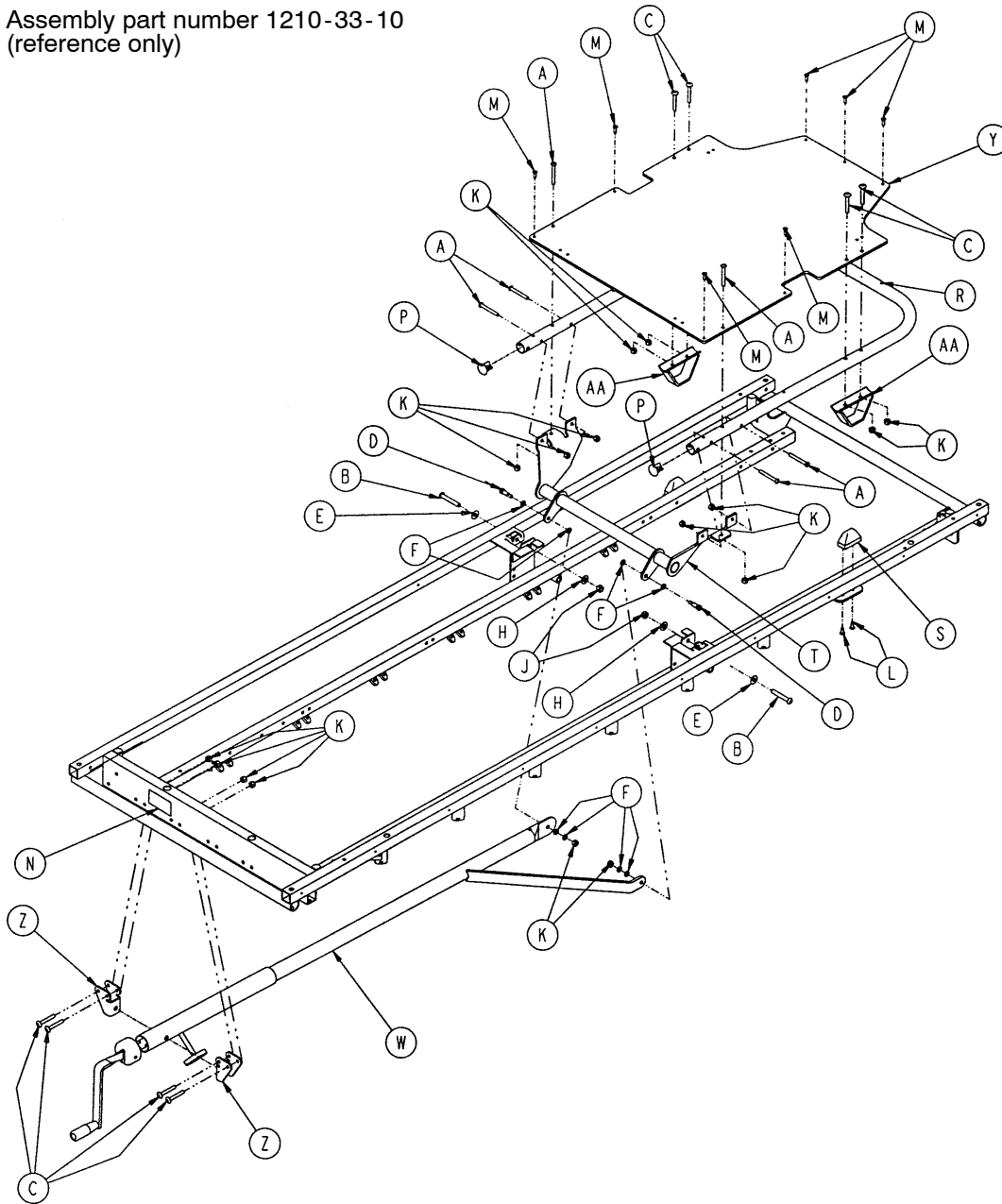

Item	Part No.	Part Name	Qty.	Item	Part No.	Part Name	Qty.
A	4-97	Hex But. Hd. Cap Screw	6	M	25-133	Pop Rivet	7
B	4-104	But. Hd. Cap Screw	2	N	946-1-64	Fowler Operation Label	1
C	7-70	Truss Hd. Mach. Screw	8	P	1001-1-36	Hole Plug	2
D	8-15	Shoulder Bolt	2	R	1001-31-13	Fowler Tube	1
E	11-179	Nylon Washer	4	S	1001-31-31	Pneumatic Fowler Rest	2
F	14-3	Thrust Washer	8	T	1001-33-24	Fowler Lever Assembly	1
H	14-21	Washer	2	W	(page 93)	Crankscrew Assembly	1
J	16-36	Hex Nut	2	Y	1010-231-12	Fowler Skin (Fiberresin)	1
K	16-118	Fiberlock Hex Nut	16	Z	1010-234-15	Mounting Bracket Ass'y	2
L	23-256	Ph. Hd. Self-Tap. Screw	4	AA	1550-33-31	Fowler Support Ass'y	2

1501 Crank Fowler Assembly (Fiberresin, Fold-to-Head)

Assembly part number 1710-33-10
(reference only)

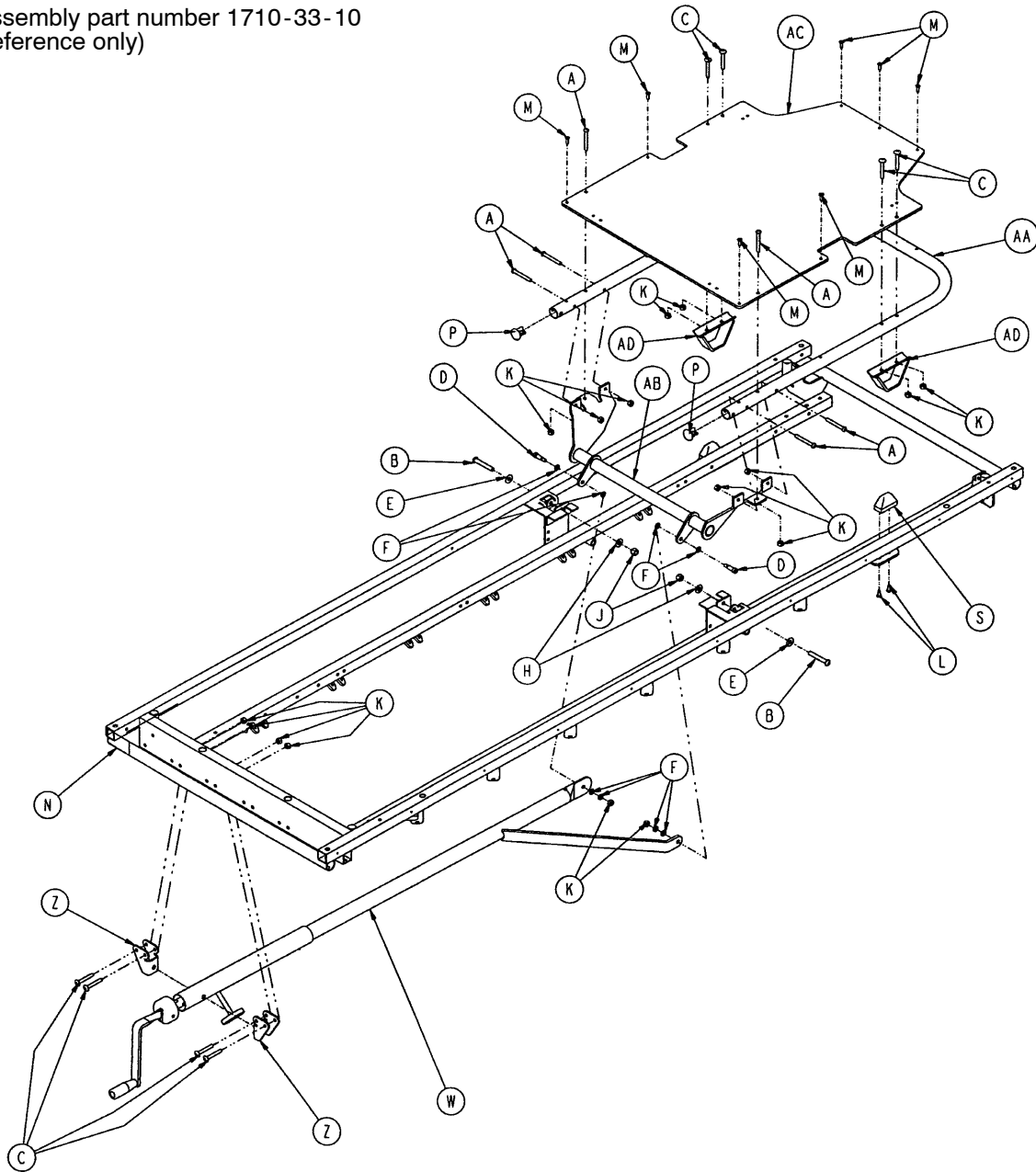

Item	Part No.	Part Name	Qty.	Item	Part No.	Part Name	Qty.
A	4-97	Hex But. Hd. Cap Screw	6	M	25-133	Pop Rivet	7
B	4-104	But. Hd. Cap Screw	2	N	946-1-64	Fowler Operation Label	1
C	7-70	Truss Hd. Mach. Screw	8	P	1001-1-36	Hole Plug	2
D	8-15	Shoulder Bolt	2	S	1001-31-31	Pneumatic Fowler Rest	2
E	11-179	Washer	2	W	(page 93)	Crankscrew Assembly	1
F	14-3	Thrust Washer	8	Z	1010-234-15	Mounting Bracket Ass'y	2
H	14-21	Washer	2	AA	1501-31-13	Fowler Tube	1
J	16-116	Nylock Hex Nut	2	AB	1501-33-24	Fowler Lever Ass'y	1
K	16-118	Fiberlock Nut	16	AC	1510-231-12	Fowler Skin (Fiberresin)	1
L	23-256	Ph. Hd. Self-Tap. Screw	4	AD	1550-33-31	Fowler Support Ass'y	2

1001-33-25 (1001) Fowler Crankscrew Ass'y

1501-33-25 (1501) Fowler Crankscrew Ass'y

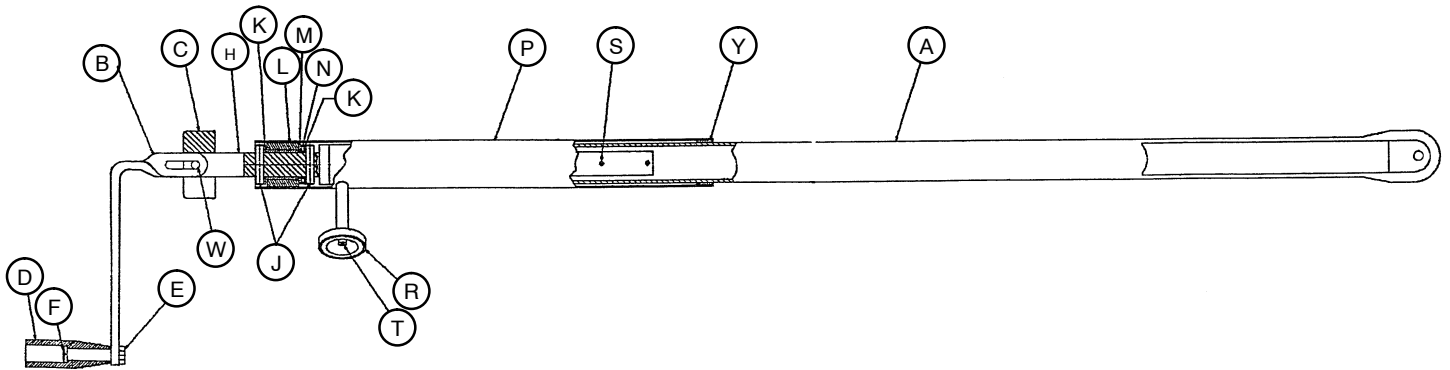
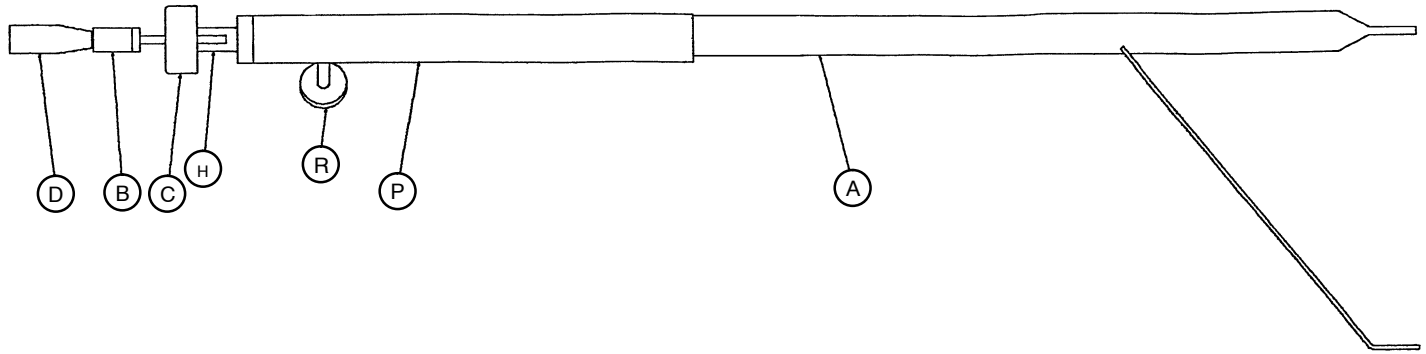

Item	Part No.	Part Name	Qty.
A	1001-33-26	Drive Bar Assembly	1
	1501-33-26	Drive Bar Assembly	1
B	1550-1-16	Crank Assembly	1
C	946-33-18	Crank Disc	1
D	938-1-177	Knob	1
E	16-102	Kep Nut	1
F	378-124-29	Shoulder Bolt	1
H	946-33-35	Fowler Screw	1
J	26-14	Roll Pin	2
K	81-174	Thrust Washer	2
L	938-1-175	Bearing Assembly	1
M	81-176	Thrust Washer	1
N	81-175	Thrust Bearing	1
P	1510-34-84	Screw Cover Assembly	1
R	1550-1-14	Magnet	1
S	26-118	Roll Pin	1
T	4-107	Soc. Hd. Cap Screw	1
W	26-145	Roll Pin	1
Y	7900-1-102	Velcro Pile	1

1001 Stationary Foot End Assembly, Steel, Fold-to-Head

Assembly part number 1010-232-20 (reference only)

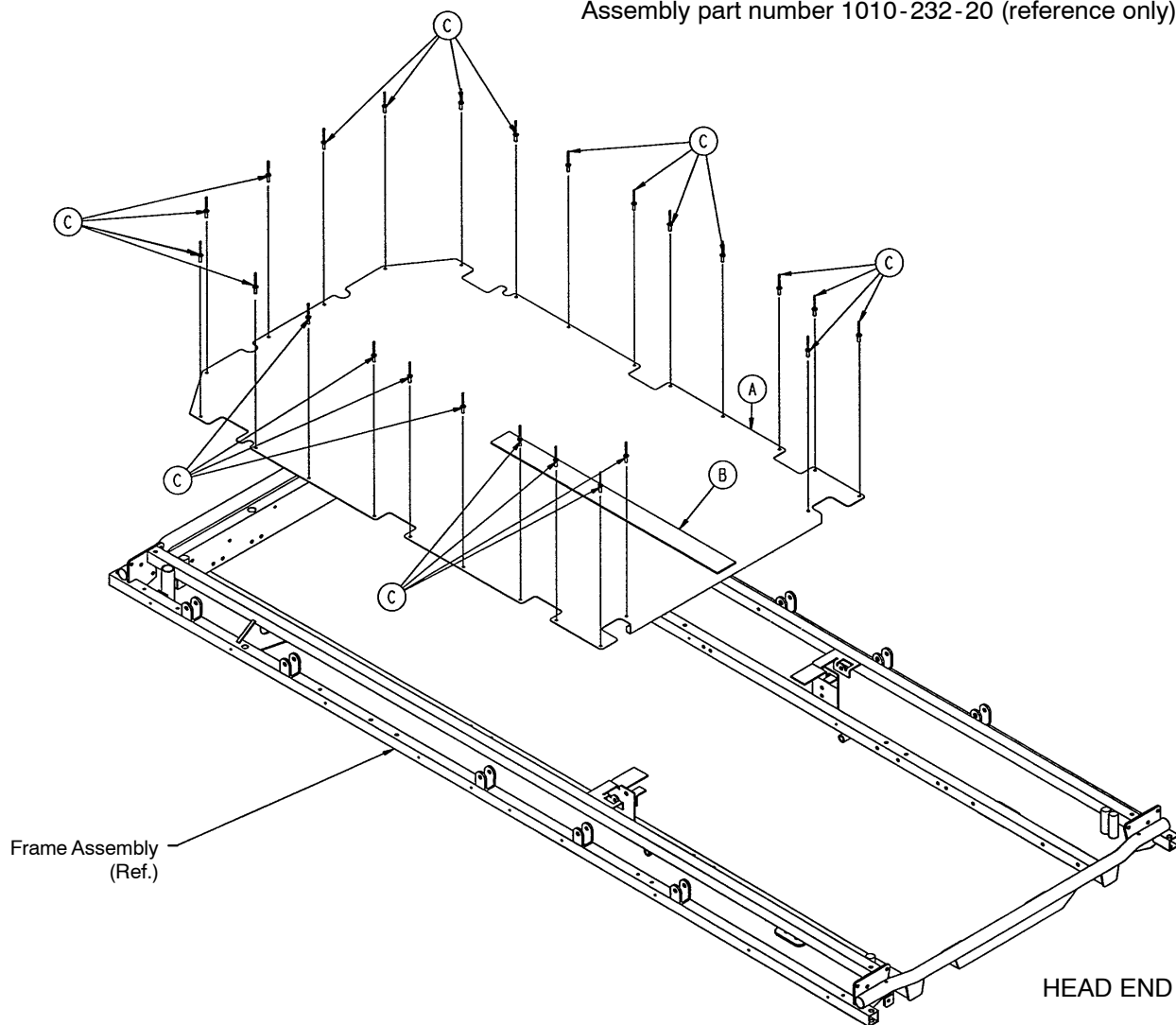

Item	Part No.	Part Name	Qty.
A	1010-232-21	Footsection Skin (Steel)	1
B	381-24-7	Velcro Pile	1
C	25-79	Pop Rivet	24

1001 Stationary Foot End Ass'y, Fiberresin, Fold-to-Head

Assembly part number 1010-332-20 (reference only)

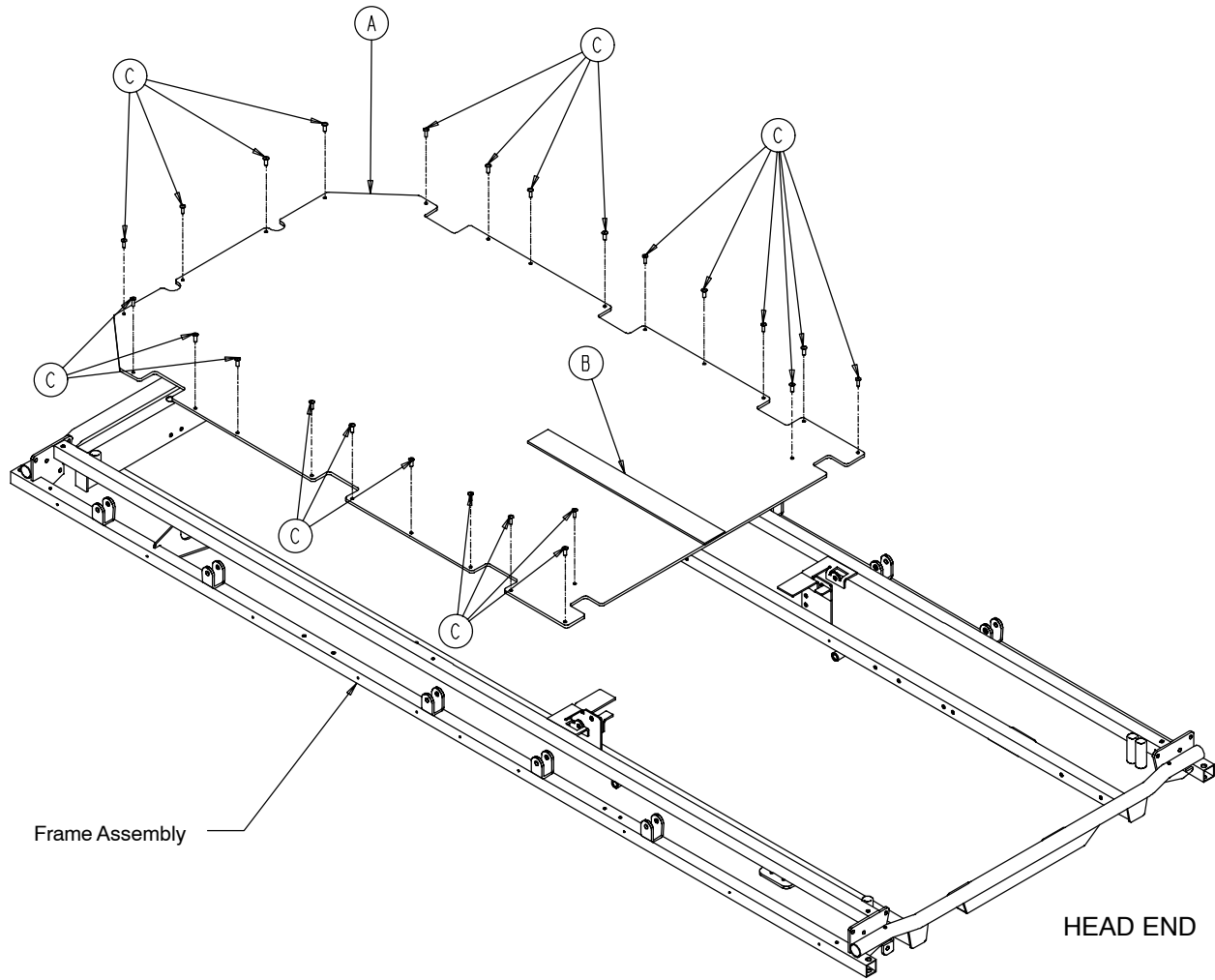

Item	Part No.	Part Name	Qty.
A	1010-332-21	Ftsec. Skin, Fiberresin	1
B	381-24-7	Velcro Pile	1
C	25-171	Pop Rivet	24

1501 Stationary Foot End Assembly, Steel, Fold-to-Head

Assembly part number 1510-232-20
(reference only)

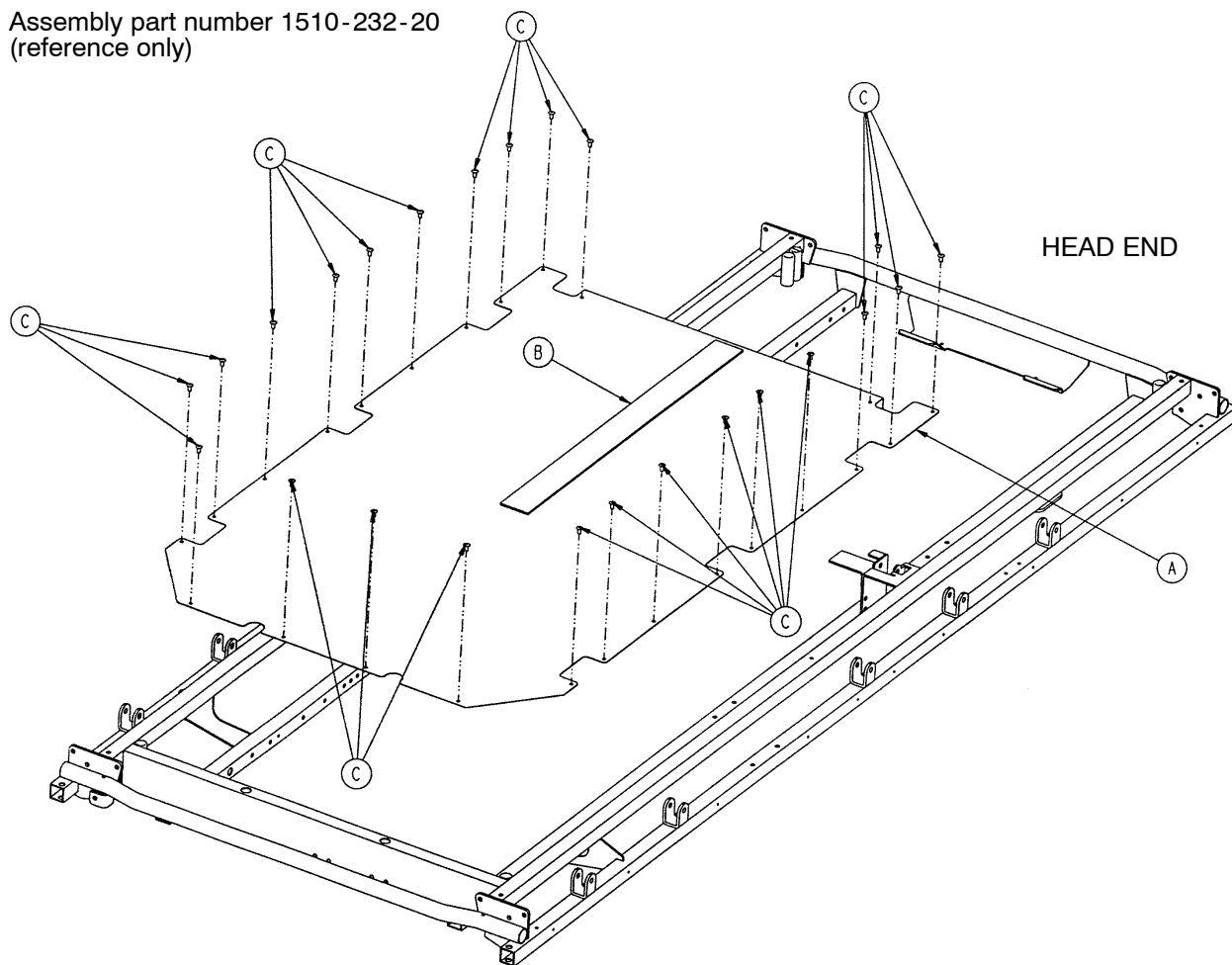

Item	Part No.	Part Name	Qty.
A	1510-232-21	Footsection Skin	1
B	381-24-7	Velcro Pile	24 1/2"
C	25-79	Pop Rivet	24

1501 Stationary Foot End Ass'y, Fiberresin, Fold-to-Head

Assembly part number 1510-332-20 (reference only)

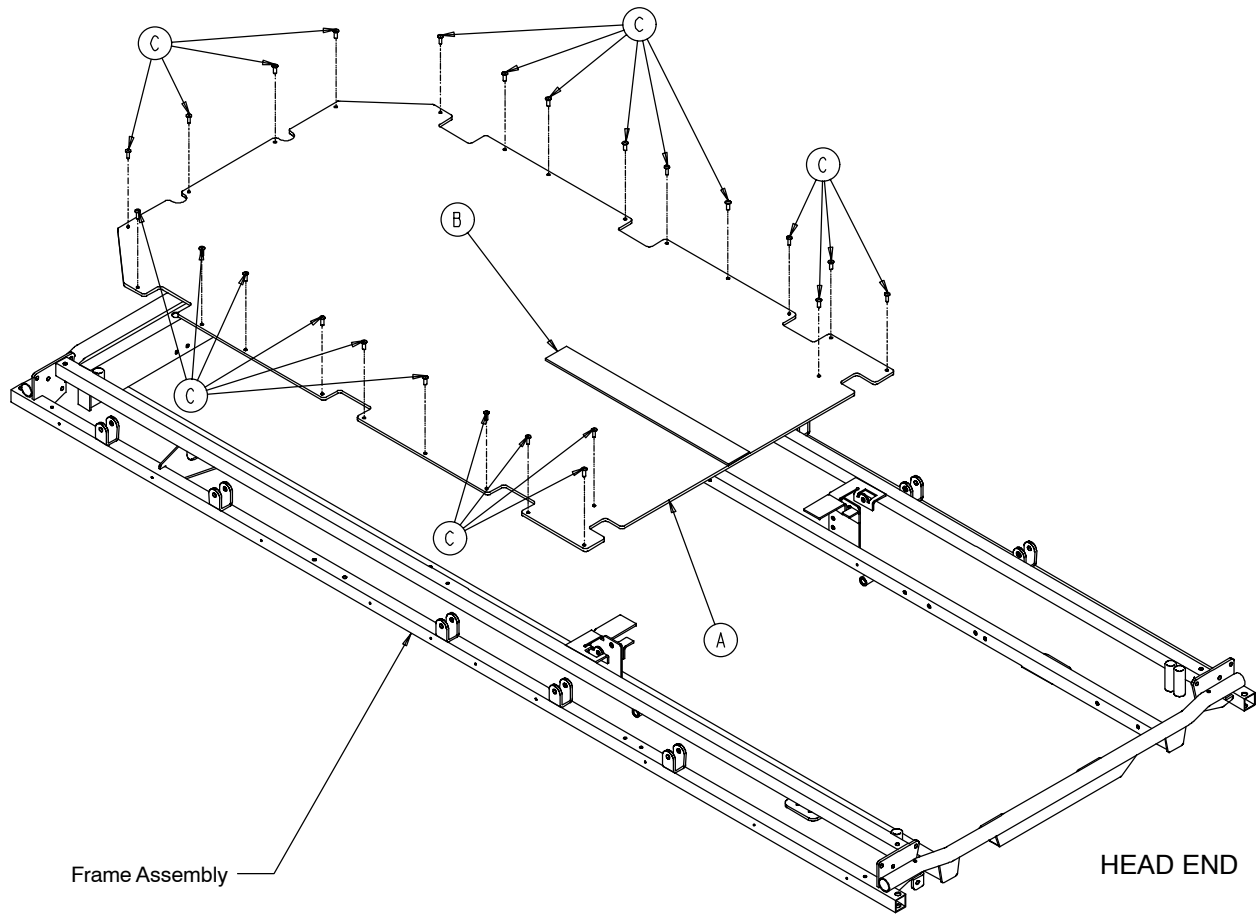

Item	Part No.	Part Name	Qty.
A	1510-332-21	Footsection Skin, Fiberresin	1
B	381-24-7	Velcro Pile	1
C	25-171	Pop Rivet	24

1001 Stationary Foot End Assembly, Steel, Fold-to-Foot

Assembly part number 1001-132-20 (reference only)

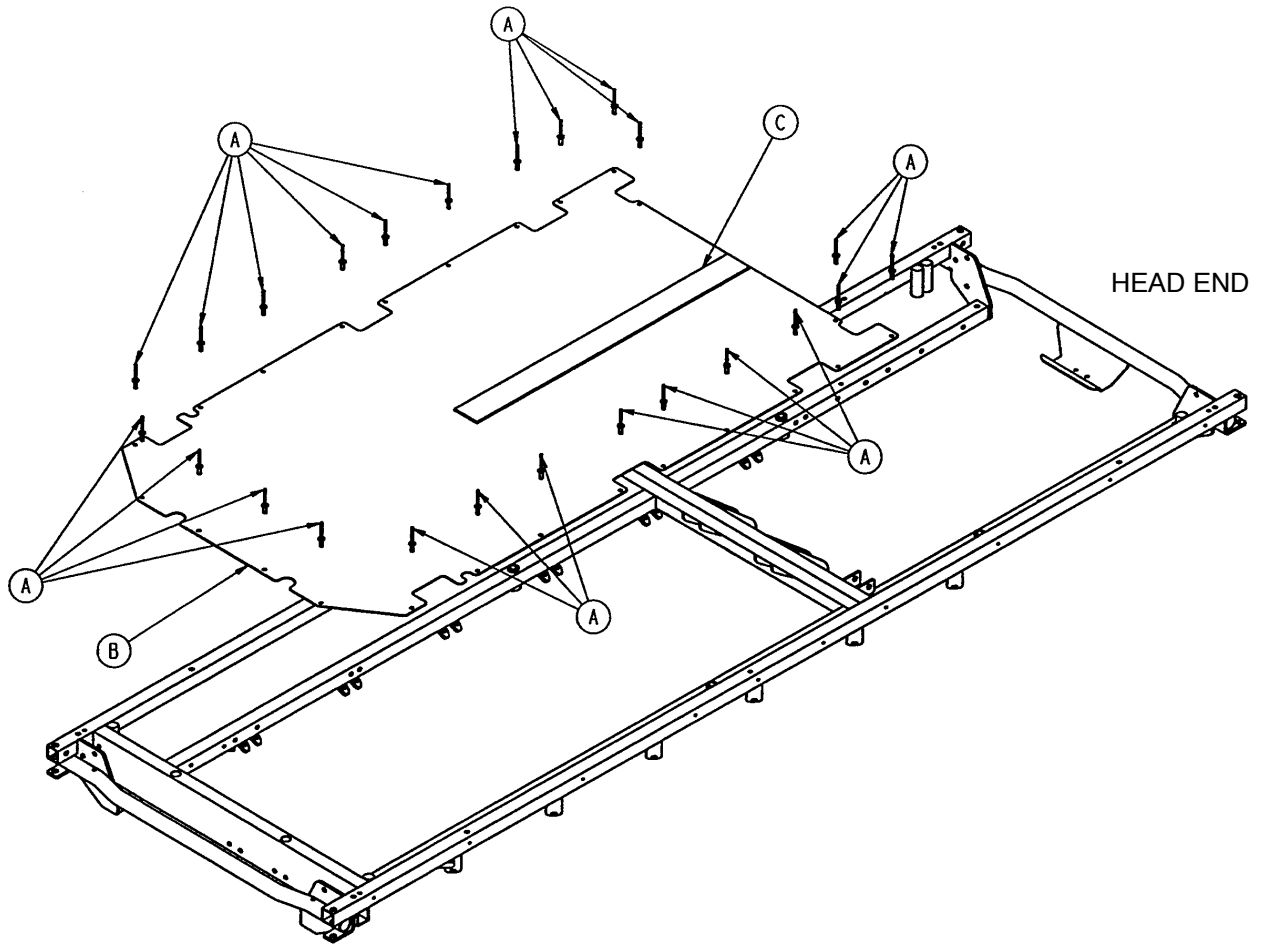

Item	Part No.	Part Name	Qty.
A	25-172	Pop Rivet	24
B	1001-132-21	Footsection Skin (Steel)	1
C	381-24-7	Velcro Pile	1

1501 Stationary Foot End Assembly, Steel, Fold-to-Foot

Assembly part number 1501-132-20 (reference only)

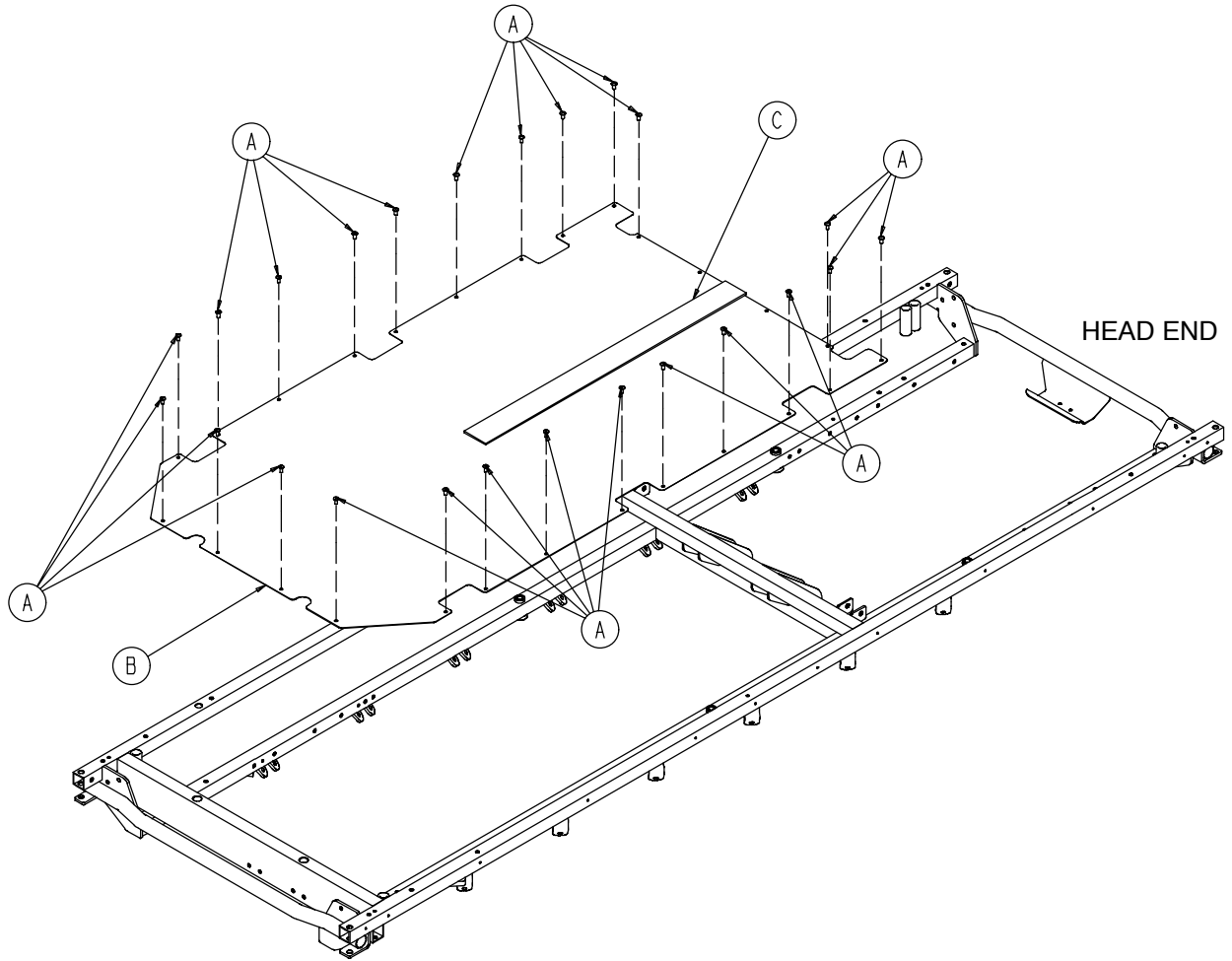

Item	Part No.	Part Name	Qty.
A	25-172	Pop Rivet	26
B	1501-132-21	Footsection Skin (Steel)	1
C	381-24-7	Velcro Pile	1

1001 Knee Gatch Ass'y, Steel, Fold-to-Head Siderails

Assembly part number 1010-634-10
(reference only)

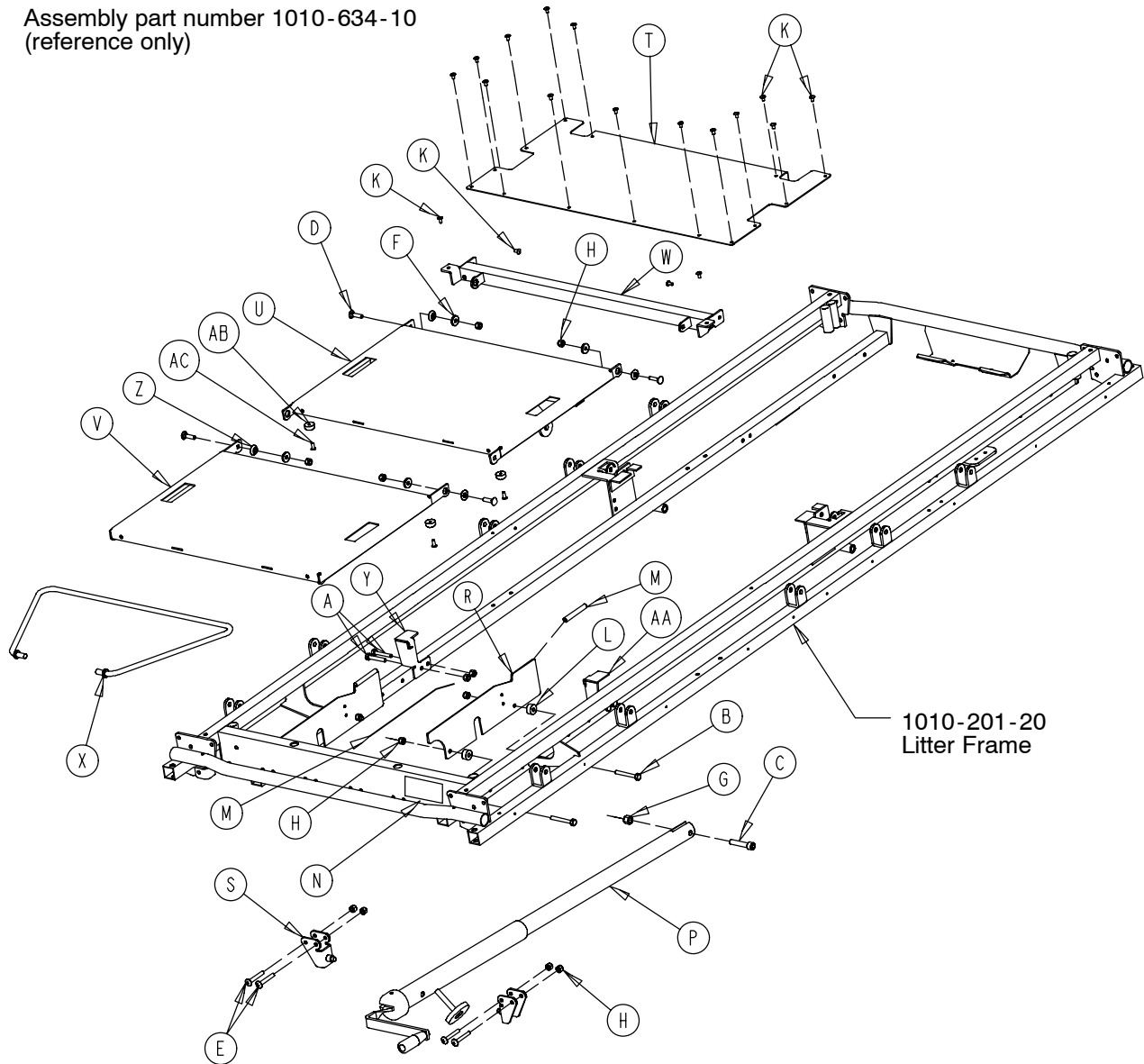

Item	Part No.	Part Name	Qty.	Item	Part No.	Part Name	Qty.
A	3-355	Hex Hd. Cap Screw	4	R	1001-34-131	Slider Support	2
B	3-358	Hex Hd. Cap Screw	4	S	1010-234-15	Mounting Bracket	2
C	4-327	Soc. Hd. Cap Screw	1	T	1010-234-27	Midsection Skin	1
D	5-34	Rd. Hd. Sq. Neck Bolt	4	U	1210-34-11	Thigh Section Weldment	1
E	7-70	Truss Hd. Mach. Screw	4	V	1210-34-12	Calf Section Weldment	1
F	11-159	Washer	4	W	1210-34-23	Midsection Supt. Widmt.	1
G	16-117	Flexlock Nut	1	X	1210-34-27	Calf Stand Bar	1
H	16-118	Nylock Nut	16	Y	1211-234-24	Thigh Support, Left	1
K	25-79	Blind Rivet	18	Z	3001-300-99	Modified Fowler Bushing	4
L	52-291	Nylon Spacer	4	AA	1211-234-25	Thigh Support, Right	1
M	58-56	Edge Cover	4	AB	56-19	Bumper	4
N	946-1-65	Knee Gatch Label	1	AC	25-179	Blind Rivet	4
P	(page 104)	Gatch Crankscrew Ass'y	1				

1501 Knee Gatch Ass'y, Steel, Fold-to-Head Siderails

Assembly part number 1510-634-10
(reference only)

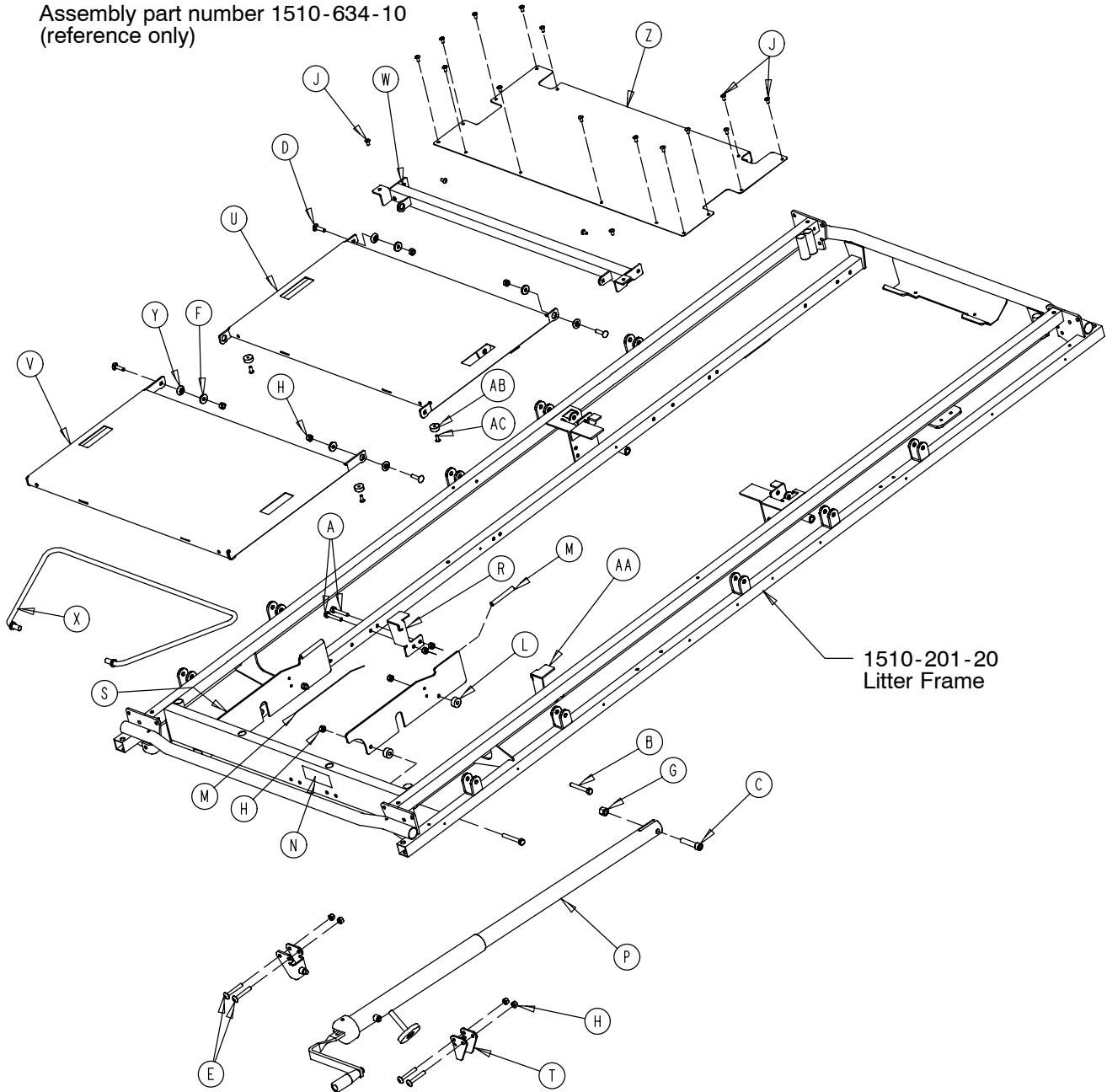

Item	Part No.	Part Name	Qty.	Item	Part No.	Part Name	Qty.
A	3-47	Hex Hd. Cap Screw	4	P	(page 104)	Gatch Crankscrew Ass'y	1
B	3-76	Hex Hd. Cap Screw	4	R	1211-234-24	Thigh Support, Left	1
C	4-105	Soc. Hd. Cap Screw	1	S	1001-34-131	Slider Support	2
D	5-19	Rd. Hd. Sq. Neck Bolt	4	T	1010-234-15	Mounting Bracket	2
E	7-20	Truss Hd. Mach. Screw	4	U	1710-34-11	Thigh Section Weldment	1
F	11-158	Washer	4	V	1710-34-12	Calf Section Weldment	1
G	16-12	Flexlock Nut	1	W	1710-34-23	Midsection Supt. Wldmt.	1
H	16-28	Nylock Nut	16	X	1710-34-27	Calf Stand Bar	1
J	25-79	Blind Rivet	4	Y	3001-300-99	Modified Fowler Bushing	4
K	25-122	Blind Rivet	14	Z	1510-234-27	Midsection Skin	1
L	52-291	Nylon Spacer	4	AA	1211-234-25	Thigh Support, Right	1
M	58-56	Edge Cover	2'	AB	56-19	Bumper	4
N	946-1-65	Knee Gatch Label	1	AC	25-179	Blind Rivet	4

1001 Knee Gatch Ass'y, Steel, Fold-to-Foot Siderails

Assembly part number 1211-334-10 (reference only)

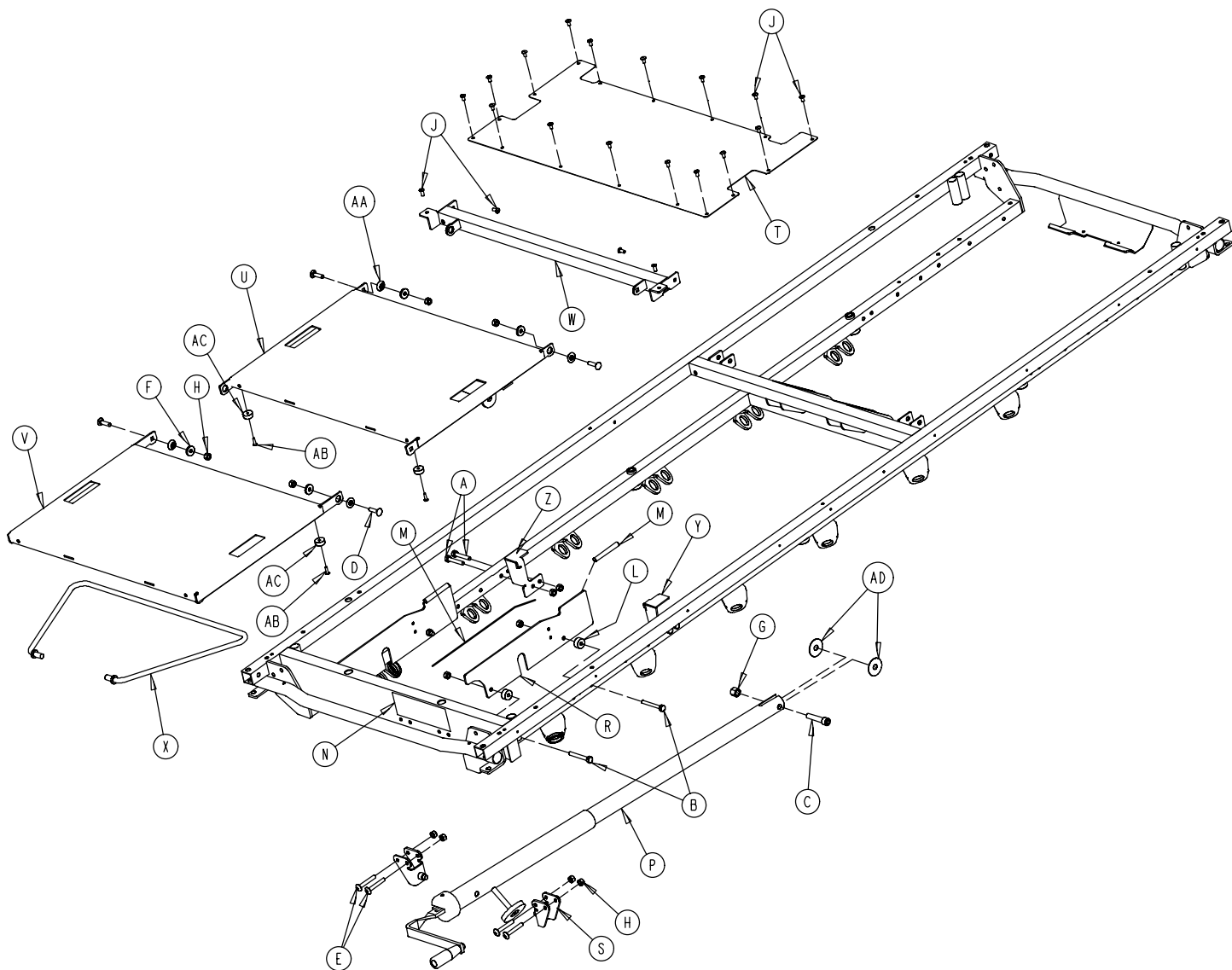

Item	Part No.	Part Name	Qty.	Item	Part No.	Part Name	Qty.
A	3-355	Hex Hd. Cap Screw	4	R	1001-34-131	Slider Support	2
B	3-358	Hex Hd. Cap Screw	4	S	1010-234-15	Mounting Bracket	2
C	4-327	Soc. Hd. Cap Screw	1	T	1001-134-27	Midsection Skin	1
D	5-34	Rd. Hd. Sq. Neck Bolt	4	U	1210-34-11	Thigh Section Weldment	1
E	7-70	Truss Hd. Mach. Screw	4	V	1210-34-12	Calf Section Weldment	1
F	11-159	Washer	4	W	1210-34-23	Midsection Supt. Wldmt.	1
G	16-117	Flexlock Nut	1	X	1210-34-27	Calf Stand Bar	1
H	16-118	Nylock Nut	16	Y	1211-234-25	Thigh Support, Right	1
J	25-172	Blind Rivet	20	Z	1211-234-24	Thigh Support, Left	1
L	52-291	Nylon Spacer	4	AA	3001-300-99	Modified Fowler Bushing	4
M	58-56	Edge Cover	2'	AB	25-157	Blind Rivet	4
N	946-1-65	Knee Gatch Label	1	AC	56-19	Bumper	4
P	(page 104)	Gatch Crankscrew Ass'y	1	AD	11-351	Washer	2

1501 Knee Gatch Ass'y, Steel, Fold-to-Foot Siderails

Assembly part number 1711-334-10 (reference only)

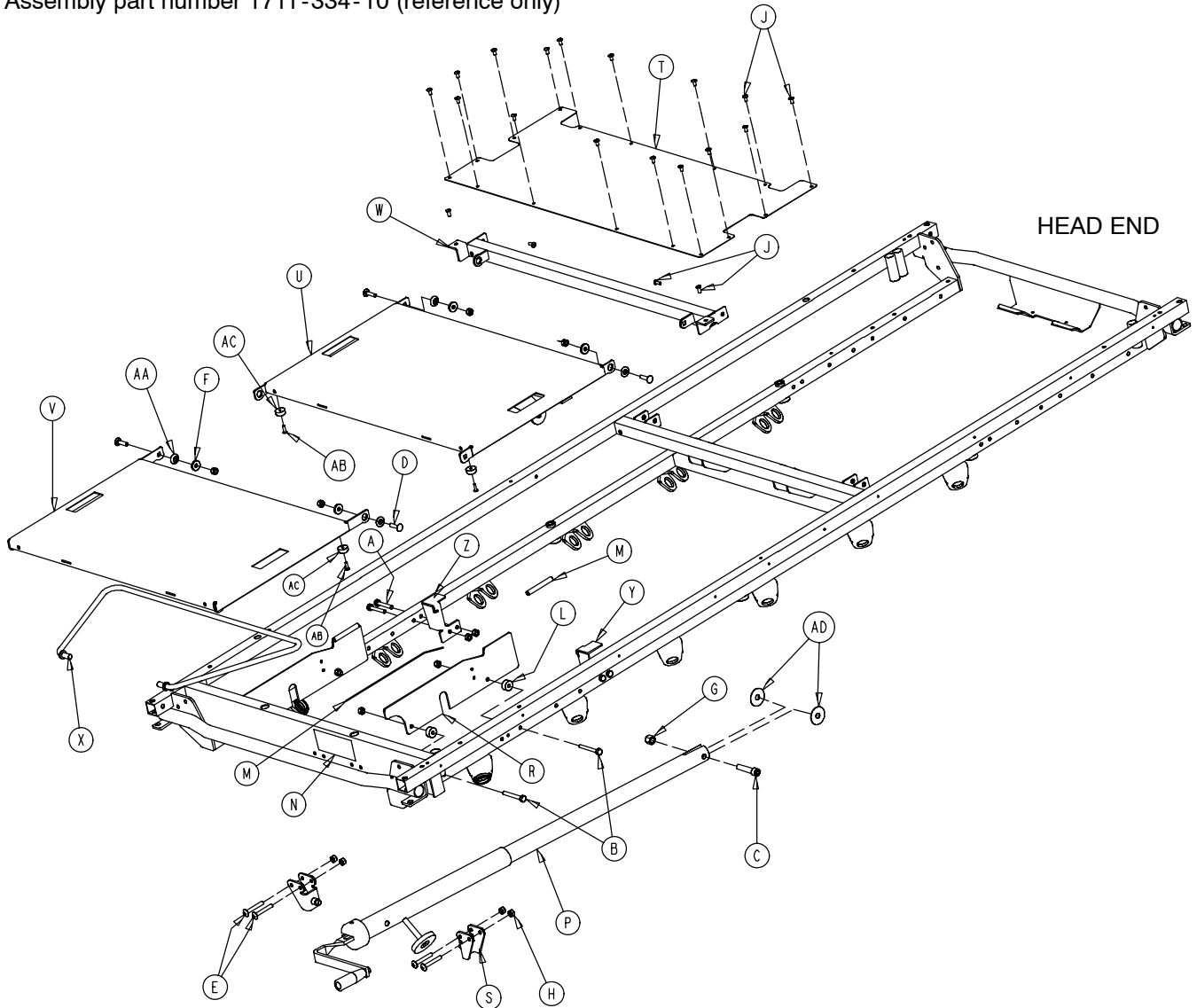

Item	Part No.	Part Name	Qty.	Item	Part No.	Part Name	Qty.
A	3-355	Hex Hd. Cap Screw	4	R	1001-34-131	Slider Support	2
B	3-358	Hex Hd. Cap Screw	4	S	1010-234-15	Mounting Bracket	2
C	4-327	Soc. Hd. Cap Screw	1	T	1501-134-27	Midsection Skin	1
D	5-34	Rd. Hd. Sq. Neck Bolt	4	U	1710-34-11	Thigh Section Weldment	1
E	7-70	Truss Hd. Mach. Screw	4	V	1710-34-12	Calf Section Weldment	1
F	11-159	Washer	4	W	1710-34-23	Midsection Supt. Wldmt.	1
G	16-117	Flexlock Nut	1	X	1710-34-27	Calf Stand Bar	1
H	16-118	Nylock Nut	16	Y	1211-234-25	Thigh Support, Right	1
J	25-172	Blind Rivet	20	Z	1211-234-24	Thigh Support, Left	1
L	52-291	Nylon Spacer	4	AA	3001-300-99	Modified Fowler Bushing	4
M	58-56	Edge Cover	2'	AB	26-157	Blind Rivet	4
N	946-1-65	Knee Gatch Label	1	AC	56-19	Bumper	4
P	(page 104)	Gatch Crankscrew Ass'y	1	AD	11-351	Washer	2

1001-134-19 Knee Gatch Crankscrew Assembly

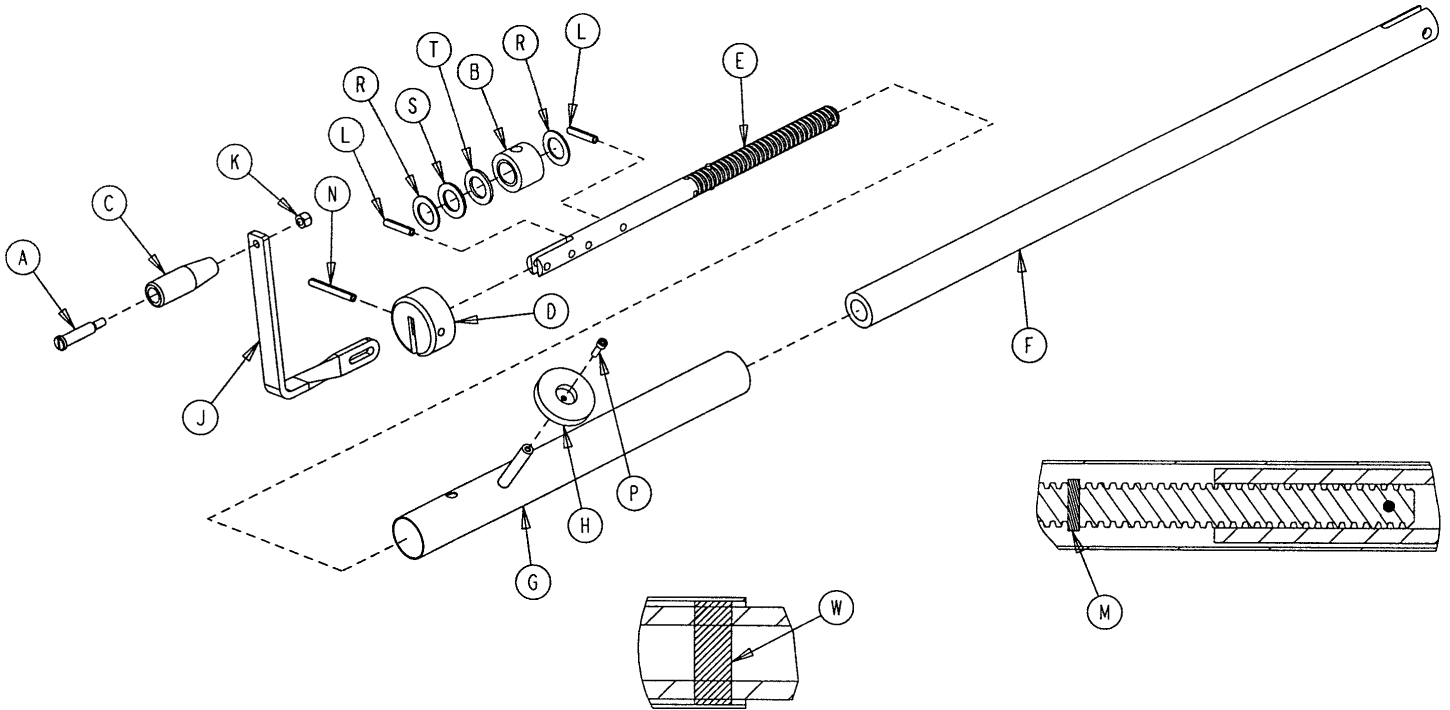

Item	Part No.	Part Name	Qty.
A	378-124-29	Shoulder Bolt	1
B	938-1-175	Bearing Assembly	1
C	938-1-177	Knob	1
D	946-33-18	Crank Disk	1
E	1001-134-47	Knee Gatch Screw	1
F	1510-34-55	Gatch Drive Tube Assembly	1
G	1510-34-84	Screw Cover Assembly	1
H	1550-1-14	Magnet	1
J	1550-1-16	Crank Assembly	1
K	16-118	Nylock Nut	1
L	26-14	Spring Pin	2
M	26-43	Spring Pin	2
N	26-145	Spring Pin	1
P	4-107	Soc. Head Cap Screw	1
R	81-174	Thrust Washer	2
S	81-175	Thrust Bearing	1
T	81-176	Thrust Washer	1
W	7900-1-102	Velcro Pile Tape	2

1001-151 Hd. End Push Handles, Fold-to-Head Siderails

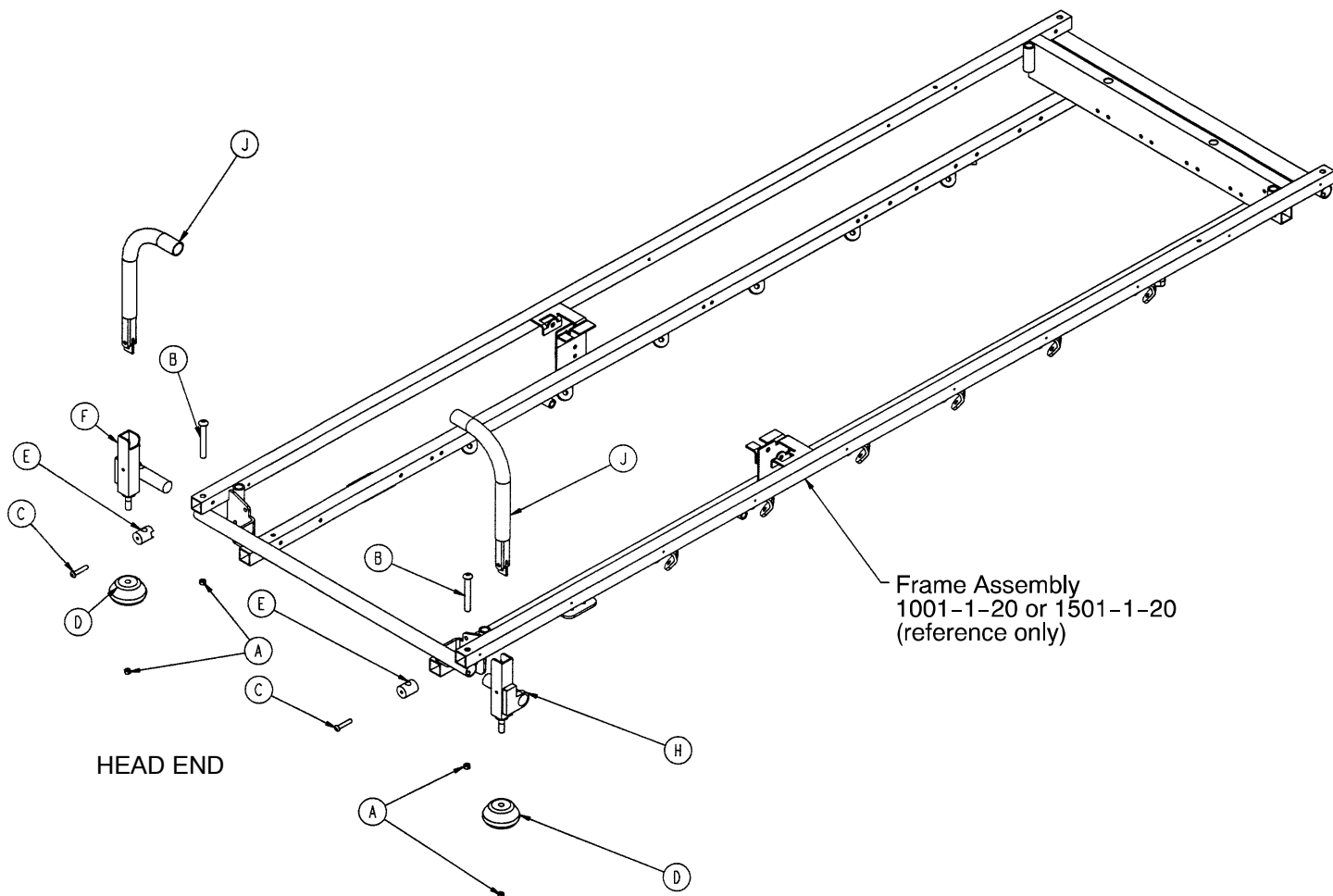

Item	Part No.	Part Name	Qty.
A	16-35	Hex Nut	4
B	4-182	Soc. But. Hd. Cap Screw	2
C	4-198	Soc. But. Hd. Cap Screw	2
D	926-400-142	Bumper	2
E	1001-151-13	Spacer Post	2
F	1001-151-23	Bolt-On Push Handle Socket, Lt.	1
H	1001-151-24	Bolt-On Push Handle Socket, Rt.	1
J	(page 107)	Push Handle Assembly	2

1001 -152 Hd. End Push Handles, Fold-to-Foot Siderails

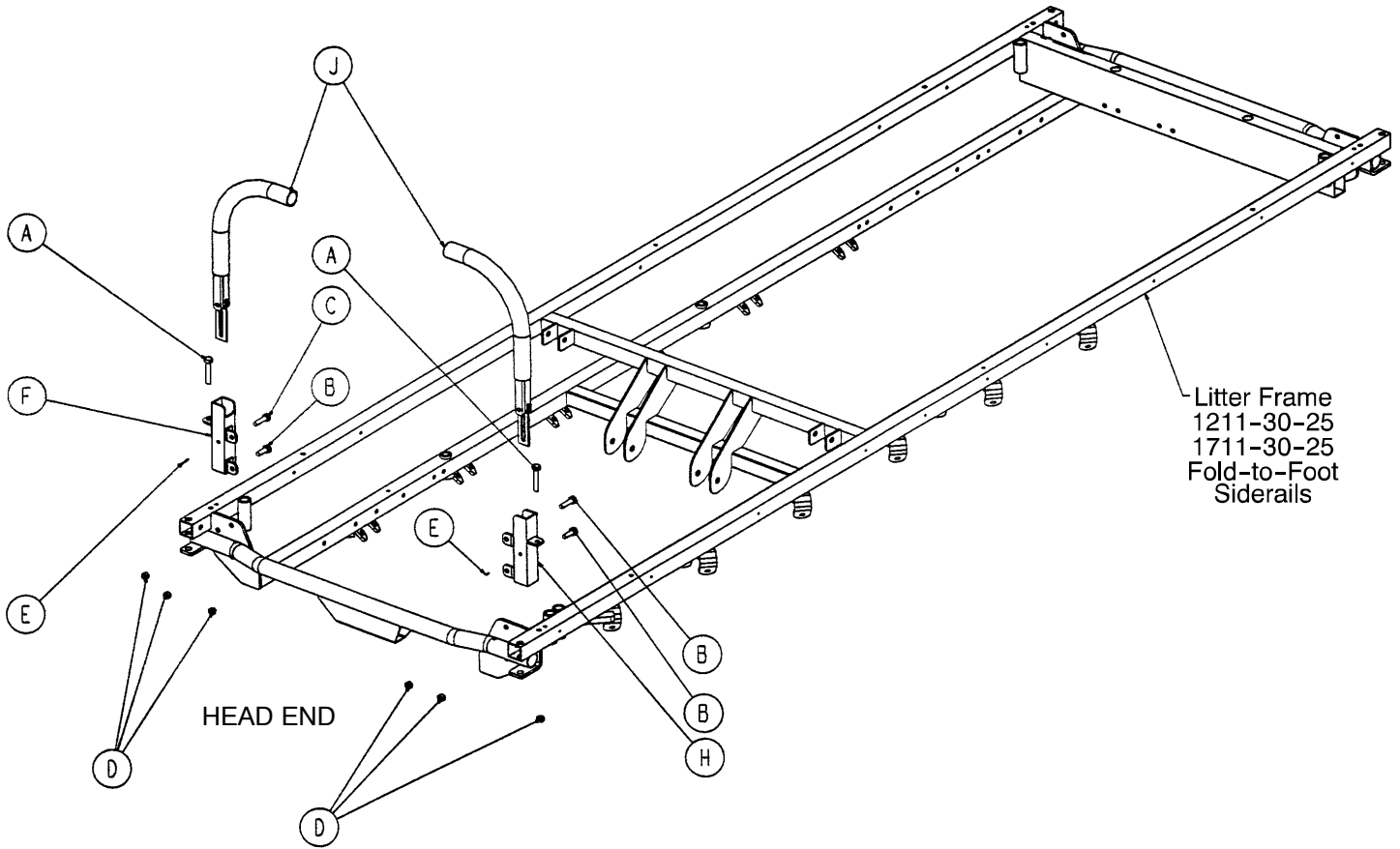

Item	Part No.	Part Name	Qty.
A	3-355	Hex Hd. Cap Screw	2
B	3-356	Hex Hd. Cap Screw	2
C	3-357	Hex Hd. Cap Screw	2
D	16-118	Hex Nut	6
E	26-11	Spring Pin	2
F	1211-151-4	Receptacle, Left	1
H	1211-151-6	Receptacle, Right	1
J	(page 107)	Push Handle Assembly	2

1211-351-10 Push Handle Assembly

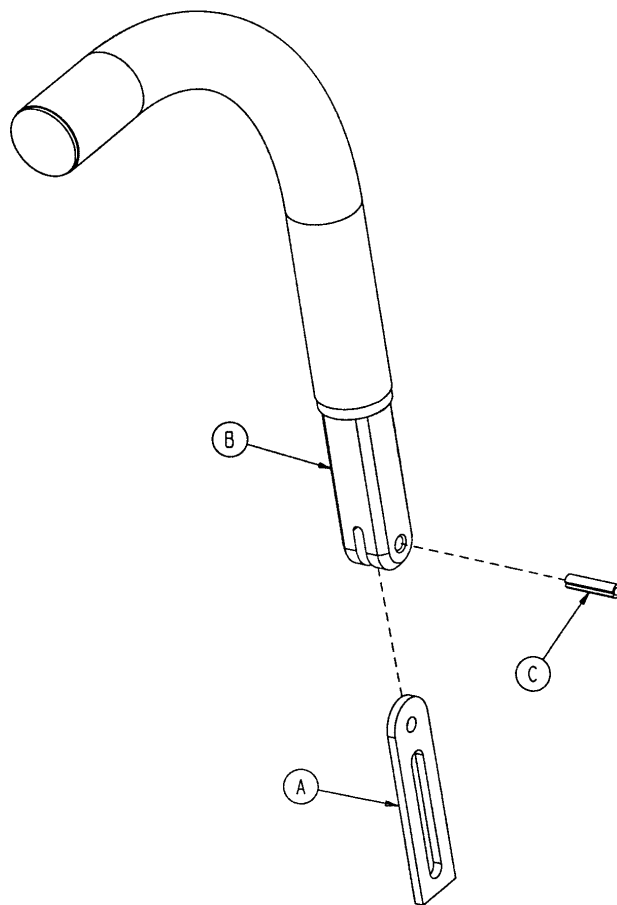

Item	Part No.	Part Name	Qty.
A	1010-354-24	Stop Link	1
B	1211-151-18	Sleeve Assembly	1
C	26-118	Roll Pin	1

1001 - 155 (1001) Fold-to-Head Push Bar Assembly

1501 - 155 (1501) Fold-to-Head Push Bar Assembly

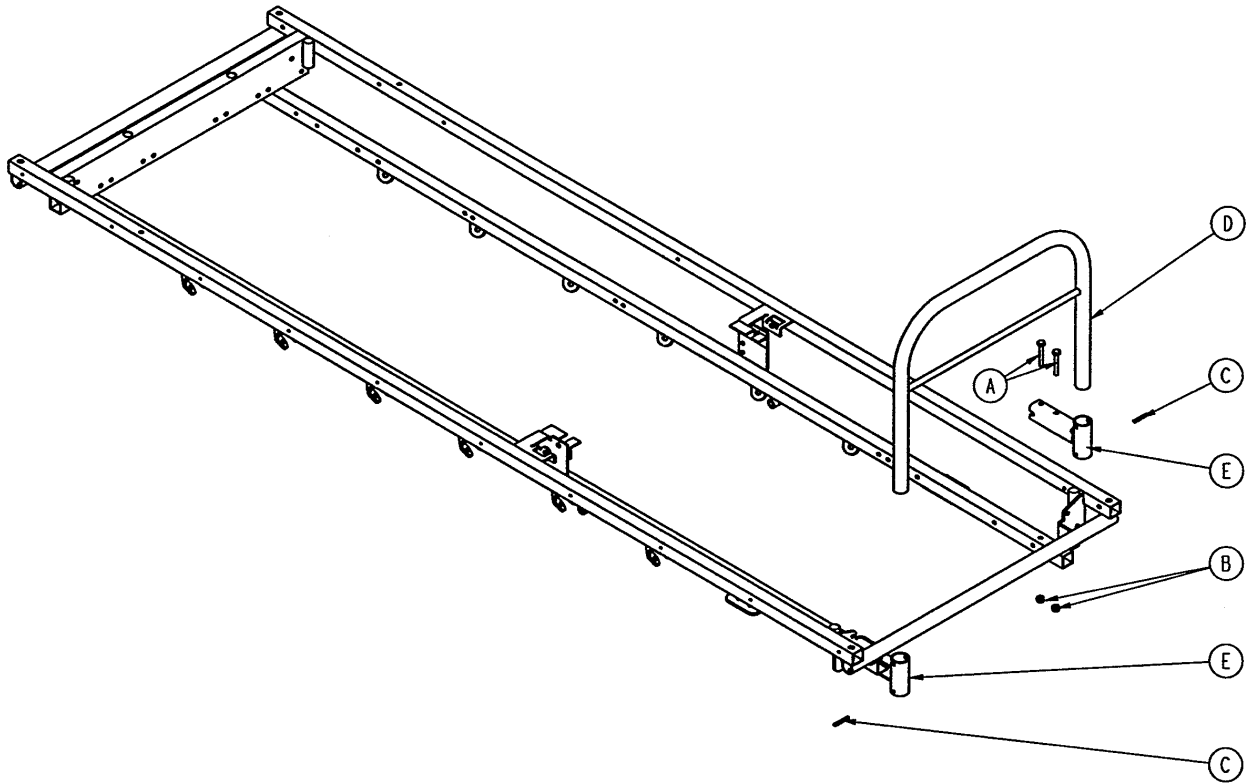

Item	Part No.	Part Name	Qty.
A	3-359	Hex Hd. Cap Screw	4
B	16-118	Fiberlock Nut	4
C	26-12	Roll Pin	2
D	1001-155-10	Push Bar Weldment	1
E	1501-155-10	Push Bar Weldment	1
E	1001-155-14	Push Bar Socket Weldment	2

1001 -156 (1001) Fold-to-Foot Push Bar Assembly

1501 -156 (1501) Fold-to-Foot Push Bar Assembly

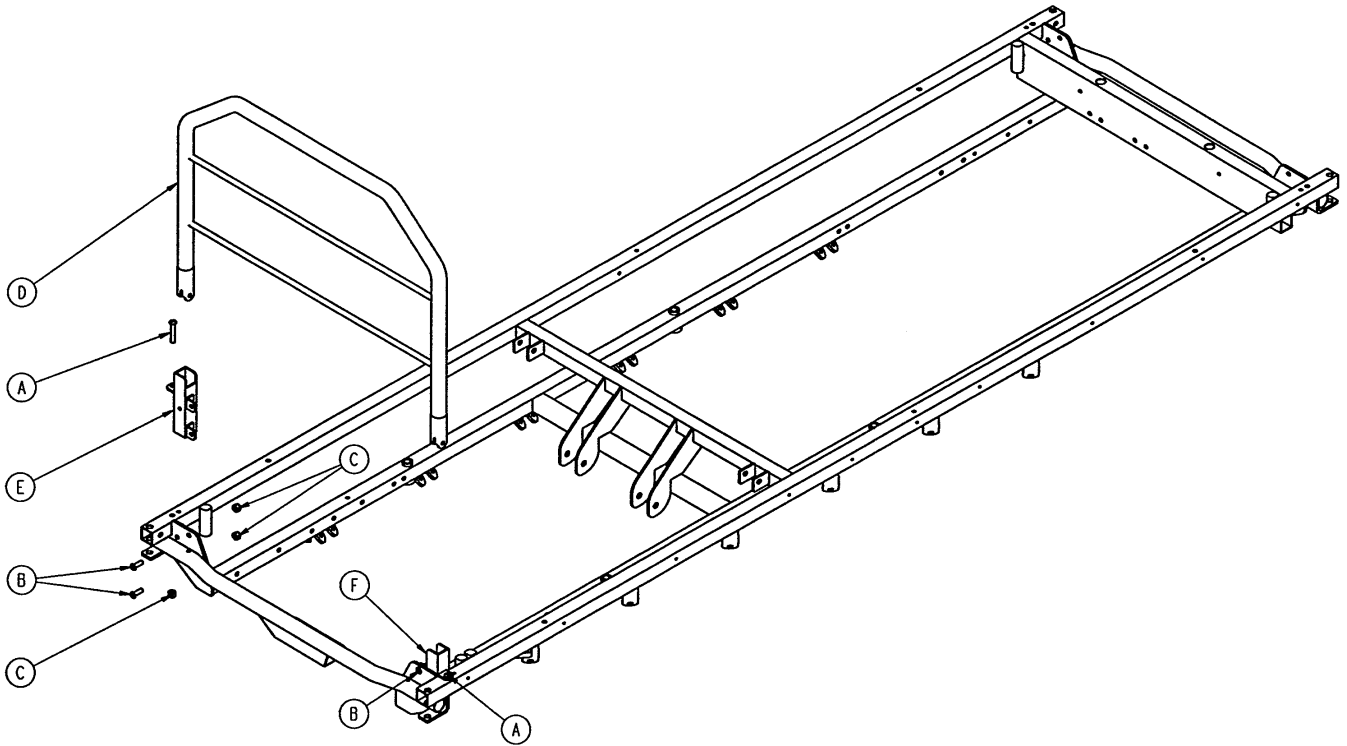

Item	Part No.	Part Name	Qty.
A	3-355	Hex Hd. Cap Screw	2
B	3-356	Hex Hd. Cap Screw	4
C	16-118	Nylock Nut	6
D	1211-139-11	Push Bar Weldment (1001)	1
	1711-139-11	Push Bar Weldment (1501)	1
E	1211-351-4	P.U.P. Receptacle Wldmt., Lt.	1
F	1211-351-6	P.U.P. Receptacle Wldmt., Rt.	1

1001-42-10 Head Board/Pushbar Ass'y, Fold-to-Head

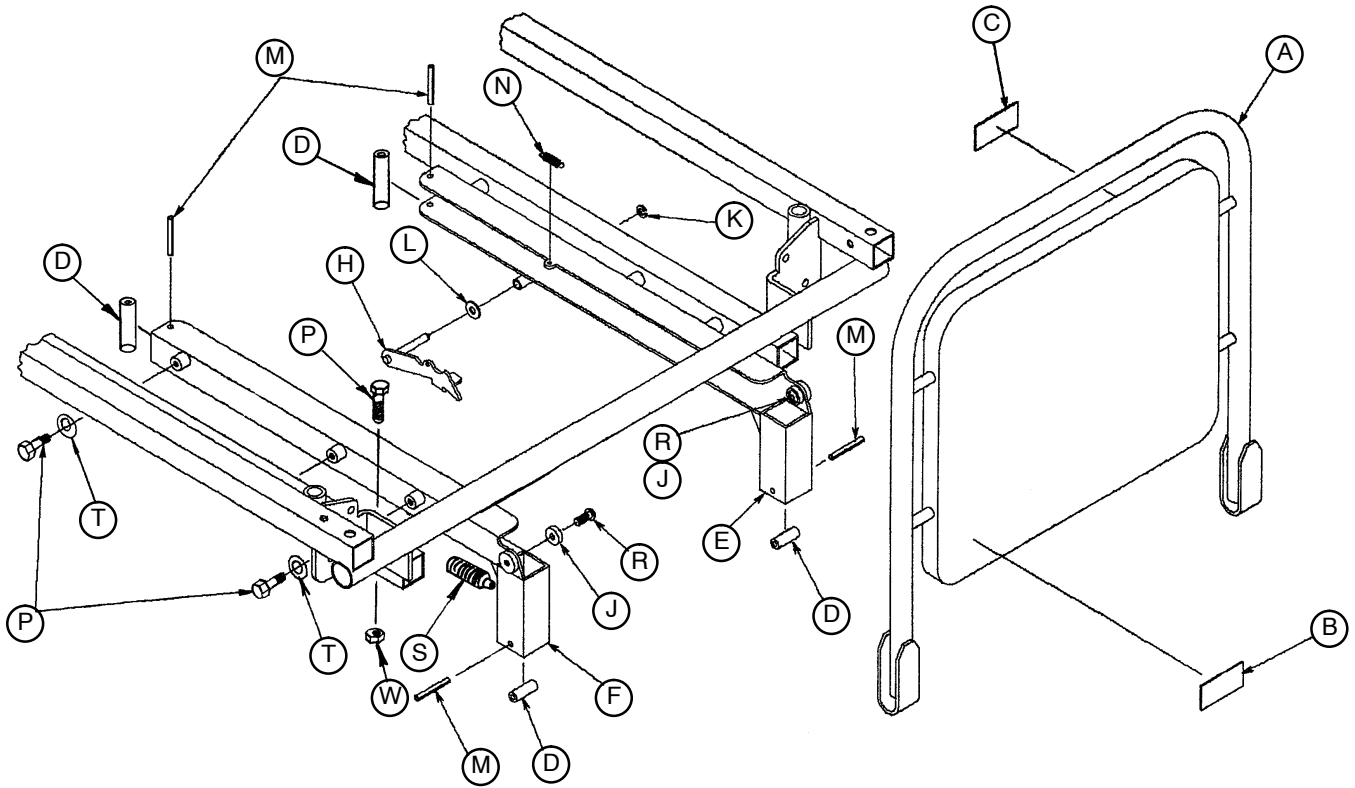

Item	Part No.	Part Name	Qty.
A	1001-42-15	Headboard Assembly	1
B	1001-42-14	Specification Label	1
C	1010-50-57	Weight Limit Label	1
D	1066-1-80	Sound Bumper	4
E	1001-42-25	Channel Weldment, Rt.	1
F	1001-42-26	Channel Weldment, Lt.	1
H	1001-42-30	Lock Assembly	1
J	1001-42-34	Spacer Guide	2
K	28-8	Snap Ring	1
L	14-46	Nylon Washer	1
M	26-12	Roll Pin	4
N	38-274	Extension Spring	1
P	3-355	Hex Hd. Cap Screw	6
R	4-78	Hex Soc. Flat Hd. Screw	2
S	21-132	Spring Plunger	1
T	14-2	Washer	4
W	16-118	Nylock Nut	2

1501-42-10 Head Board/Pushbar Ass'y, Fold-to-Head

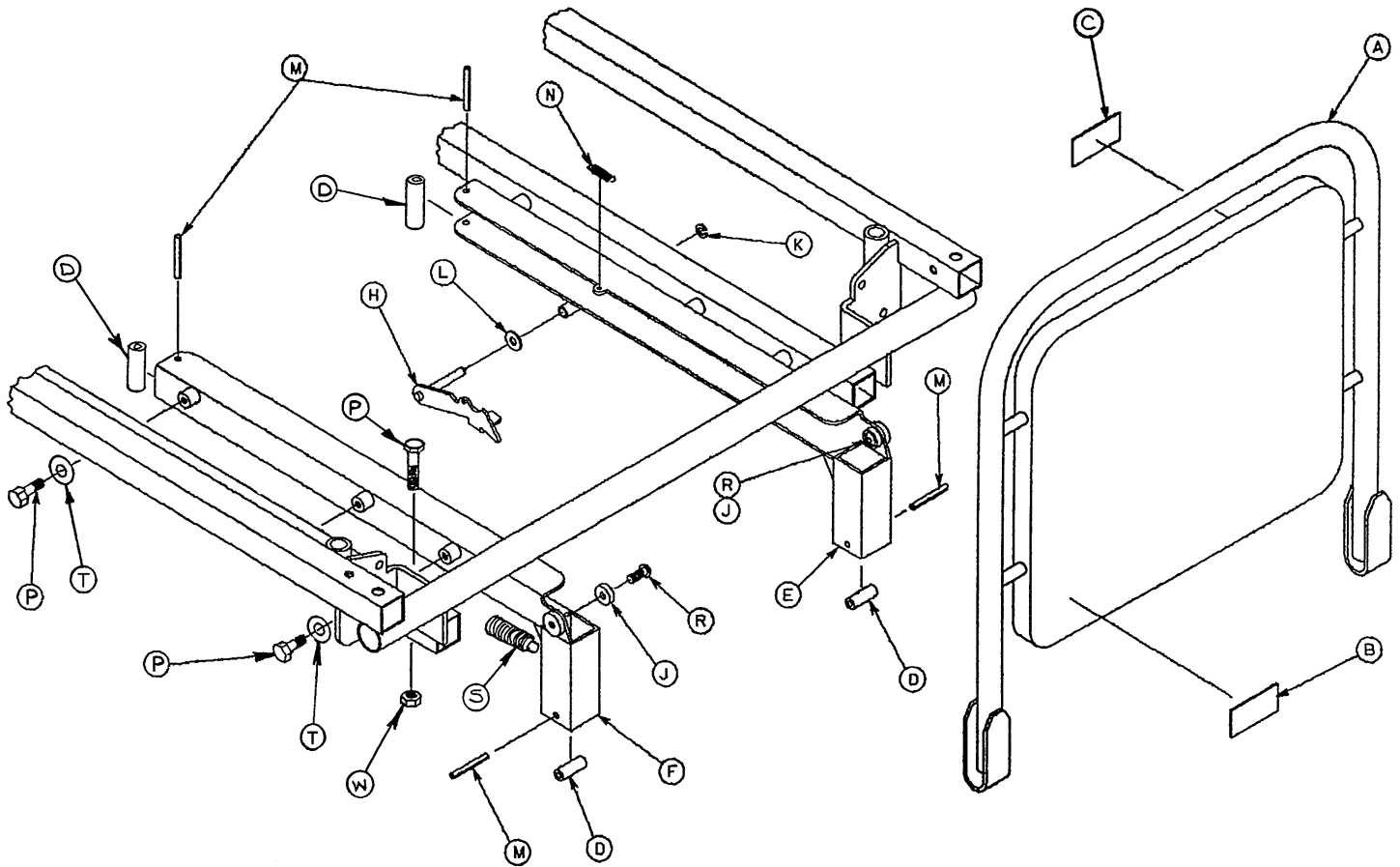

Item	Part No.	Part Name	Qty.
A	1501-42-15	Headboard Assembly	1
B	1501-42-14	Specification Label	1
C	1010-50-57	Weight Limit Label	1
D	1066-1-80	Sound Bumper	4
E	1001-42-25	Channel Weldment, Rt.	1
F	1001-42-26	Channel Weldment, Lt.	1
H	1001-42-30	Lock Assembly	1
J	1001-42-34	Spacer Guide	2
K	28-8	Snap Ring	1
L	14-46	Nylon Washer	1
M	26-12	Roll Pin	4
N	38-274	Extension Spring	1
P	3-355	Hex Hd. Cap Screw	6
R	4-78	Hex Soc. Flat Hd. Screw	2
S	21-132	Spring Plunger	1
T	14-2	Washer	4
W	16-118	Nylock Nut	2

390-25 Standard, Removable I.V. Pole Assembly

Item	Part No.	Part Name	Qty.
A	24-23	Plastic Knob	1
B	390-3-53	Double I.V. Ass'y	1
C	393-3-43	Tube Assembly	1
D	4-496	Soc. Hd. Cap Screw	1

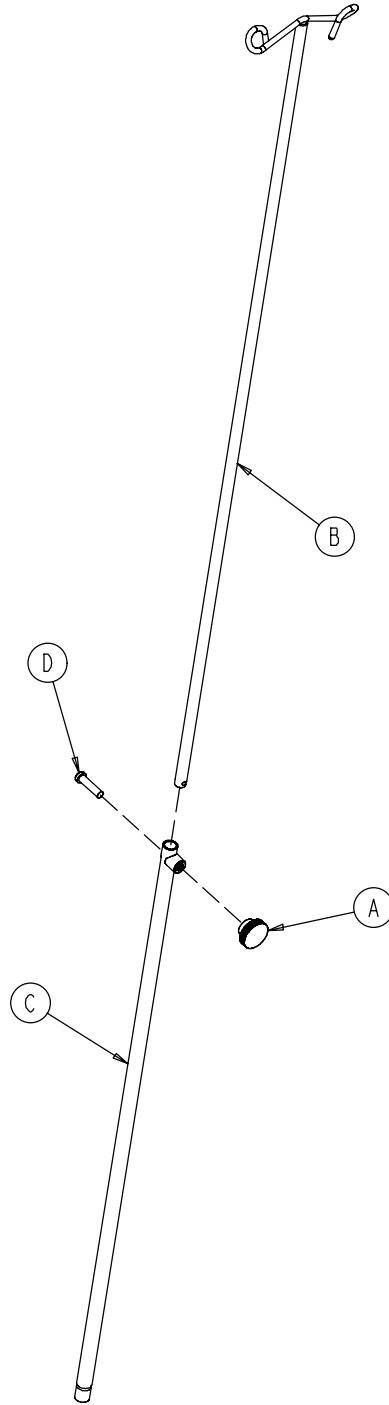

1001-117 & 1501-117 Optional Tethered I.V. Assembly

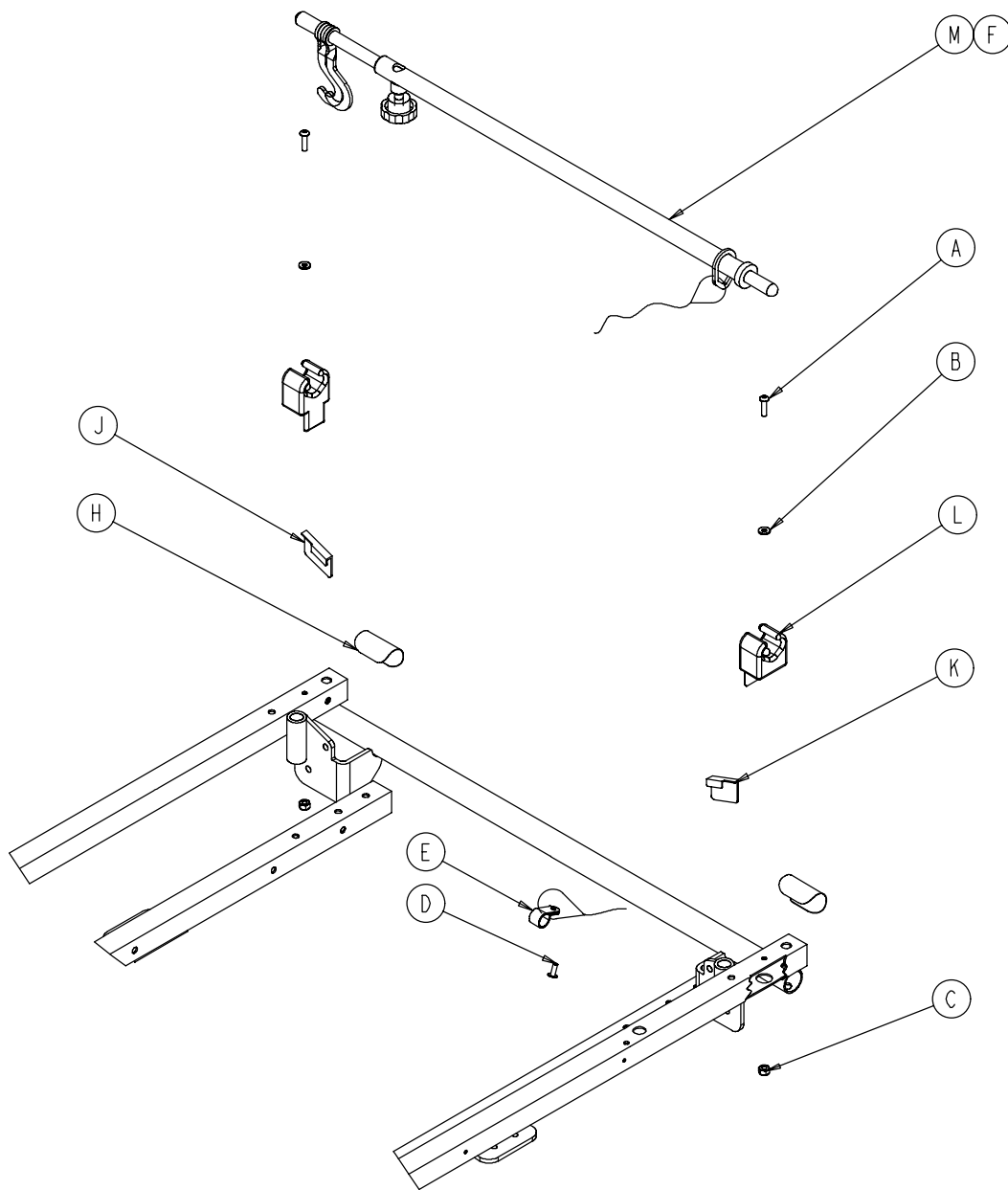

Item	Part No.	Part Name	Qty.
A	4-107	Soc. Hd. Cap Screw	2
B	11-62	Washer	2
C	16-3	Fiberlock Nut	2
D	25-179	Closed End Rivet	1
E	34-22	Cord Clamp	1
F	52-15	Spacer	1
H	1001-1-56	Round Hook Protector	2
J	1001-1-57	Hook Protector, Left	1
K	1001-1-58	Hook Protector, Right	1
L	1001-59-12	I.V. Clip	2
M	(page 112.2)	Tethered I.V. Pole Assembly	1

1211-117-10 Tethered I.V. Pole Assembly

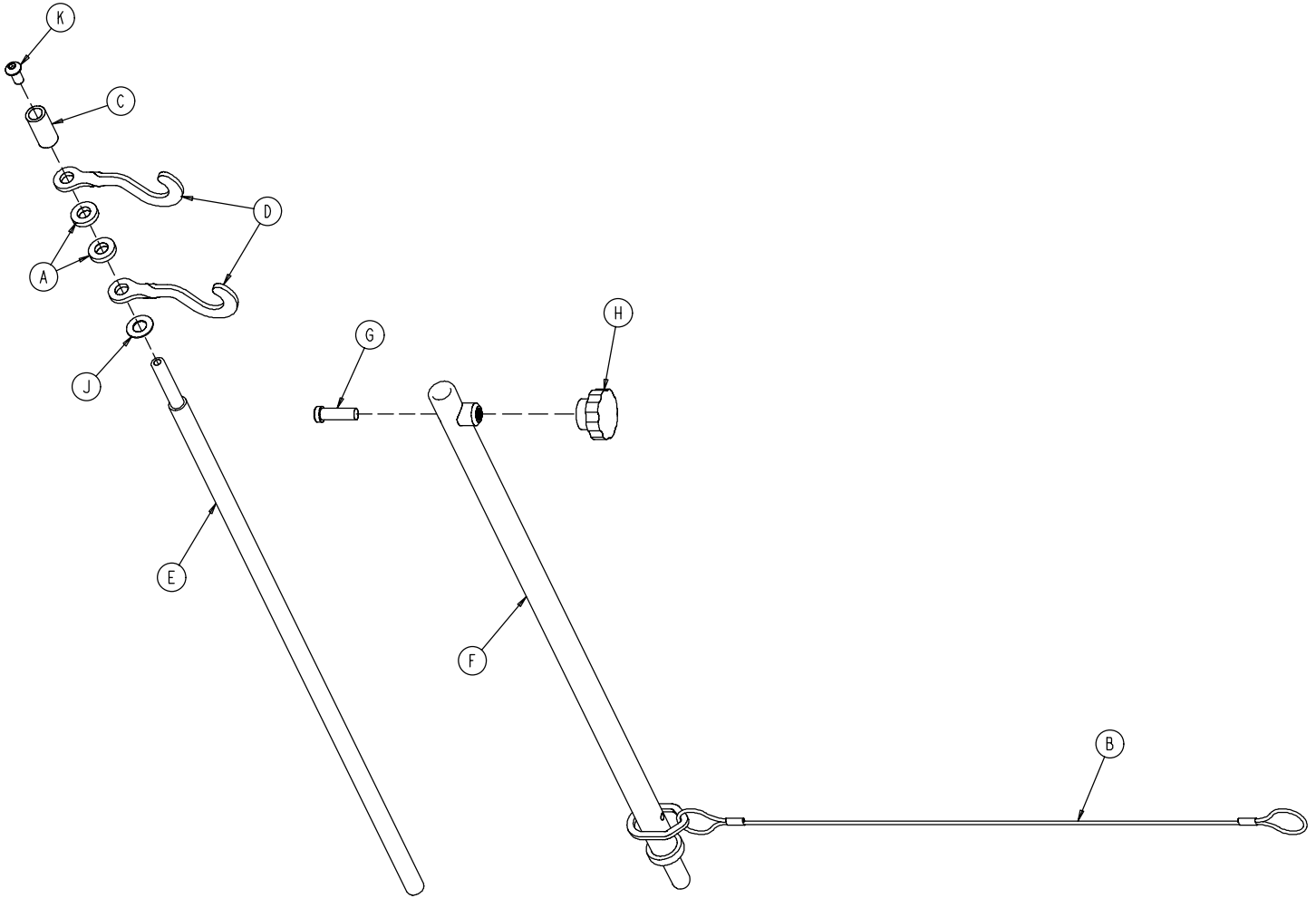

Item	Part No.	Part Name	Qty.
A	52-17	Spacer	2
B	1211-117-20	Cable Assembly	1
C	926-400-62	Stop Sleeve	1
D	1010-59-16	I.V. Hook	2
E	1211-117-11	Extension Rod	1
F	1211-117-12	Base Tube Weldment	1
G	4-495	Low Hd. Soc. Hd. Cap Screw	1
H	1211-117-16	Knob	1
J	14-20	Nylon Washer	1
K	4-232	Button Hd. Cap Screw	1

1001 Optional 2-Stage I.V. Pole Mounting Assembly (Used on litters with fold-to-foot siderails)

Assembly part numbers
 1001-110 (Head End, Left)
 1001-112 (Foot End, Right)

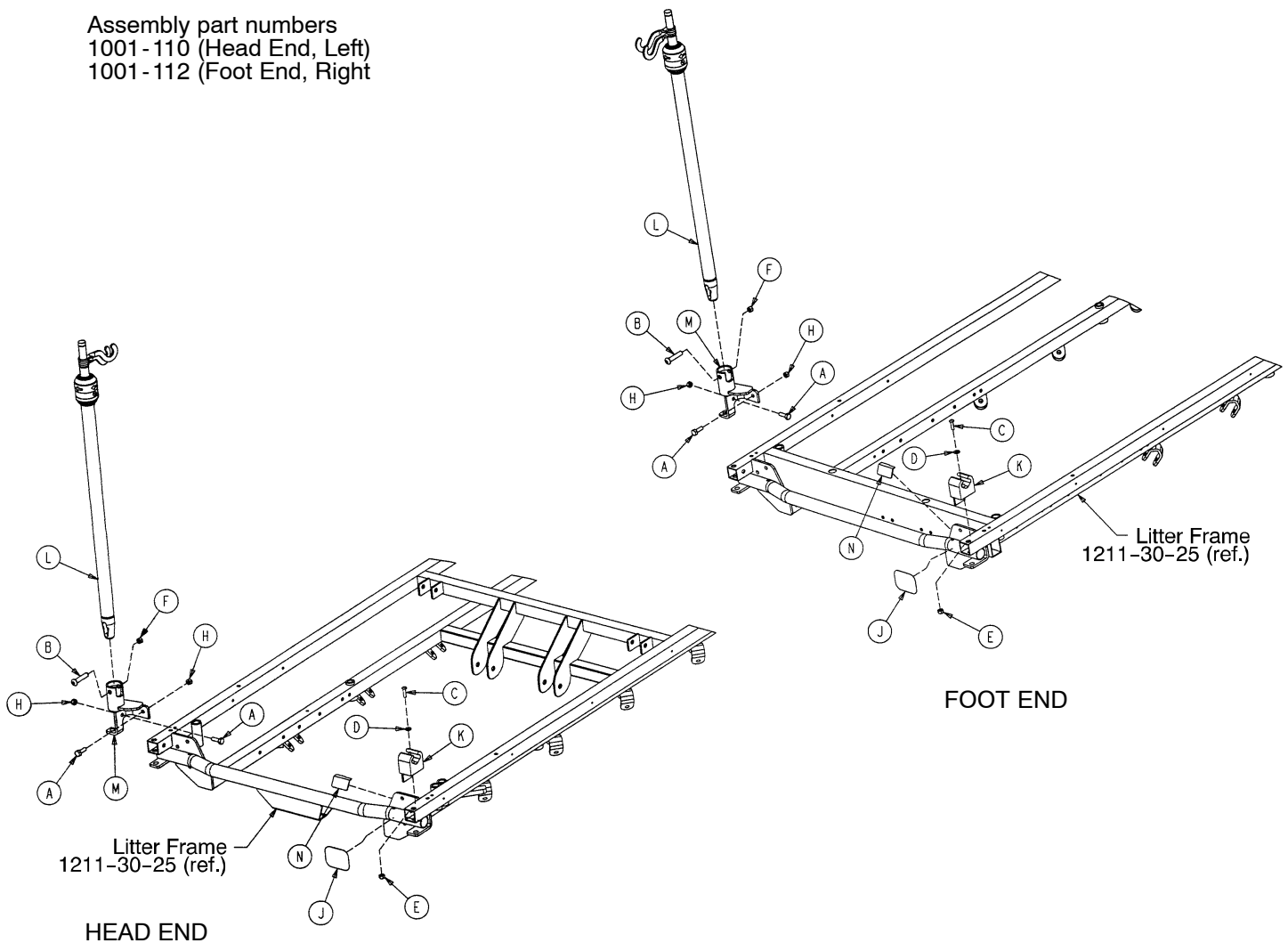

Item	Part No.	Part Name	Qty.
A	3-356	Hex Hd. Cap Screw	2
B	4-452	But. Hd. Cap Screw	1
C	4-169	But. Hd. Cap Screw	1
D	11-62	Washer	1
E	16-121	Fiberlock Nut	1
F	16-116	Center Lock Nut	1
H	16-118	Fiberlock Nut	2
J	1001-1-56	Round Hook Protector	1
K	1001-59-12	I.V. Clip	1
L	(page 119)	I.V. Pole Assembly	1
M	1211-310-112	I.V. Pivot Weldment	1
N	1001-1-58	Hook Protector	1

1501 Optional 2-Stage I.V. Pole Mounting Assembly (Used on litters with fold-to-foot siderails)

Assembly part numbers
 1501-110 (Head End, Left)
 1501-112 (Foot End, Right)

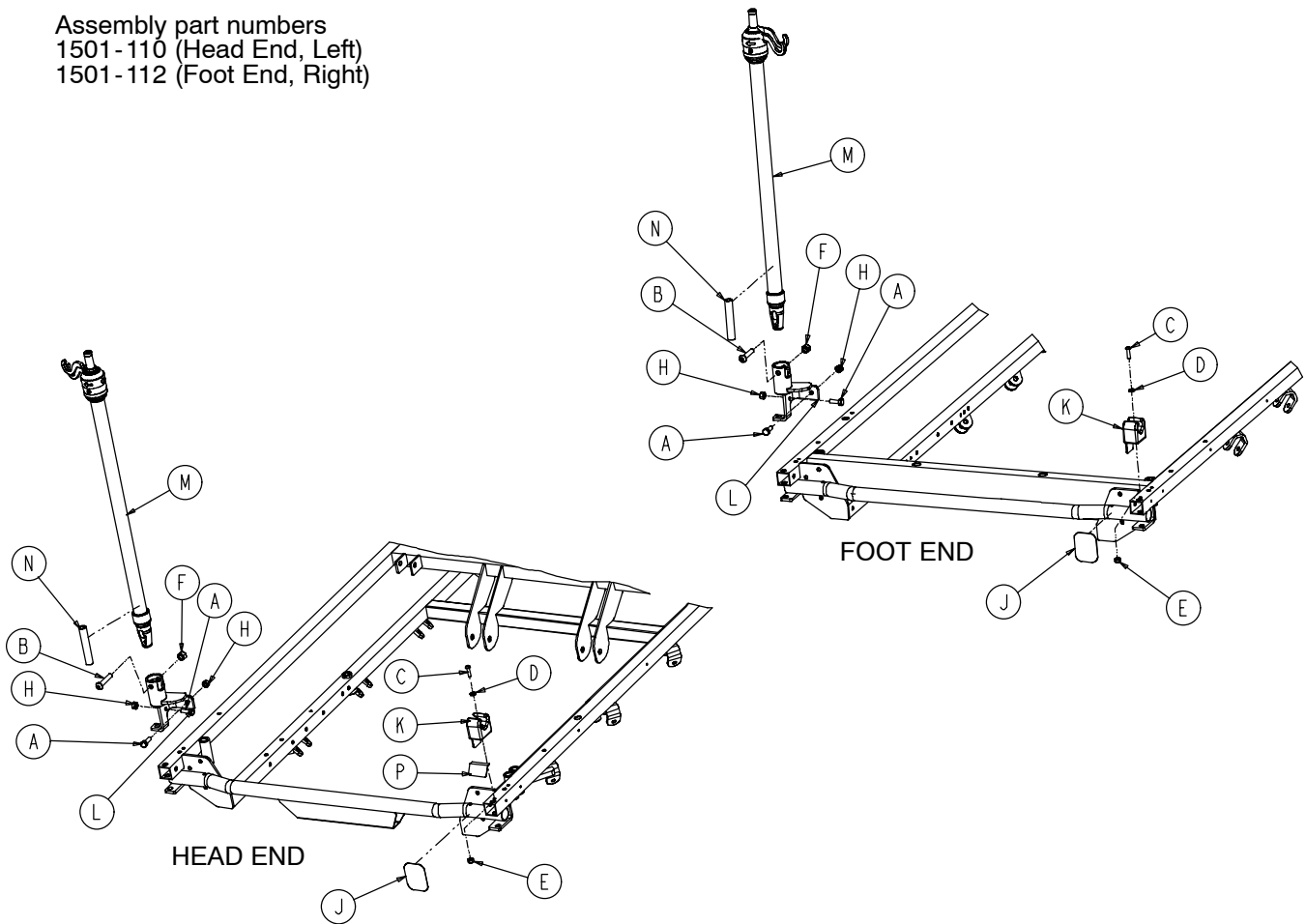

Item	Part No.	Part Name	Qty.
A	3-356	Hex Hd. Cap Screw	2
B	4-452	But. Hd. Cap Screw	1
C	4-169	But. Hd. Cap Screw	1
D	11-16	Washer	1
E	16-3	Fiberlock Nut	1
F	16-116	Center Lock Nut	1
H	16-118	Fiberlock Nut	2
J	1001-1-56	Round Hook Protector	1
K	1001-59-12	I.V. Clip	1
L	1211-310-112	I.V. Pivot Weldment	1
M	(page 119)	I.V. Pole Assembly	1
N	1501-127-19	I.V. Plug	1
P	1001-1-58	Hook Protector, Right	1

1001 Optional 2-Stage I.V. Pole Mounting Assembly (Used on litters with fold-to-head siderails)

Assembly part numbers
1001-80 (Foot End, Left)
1001-83 (Head End, Right)

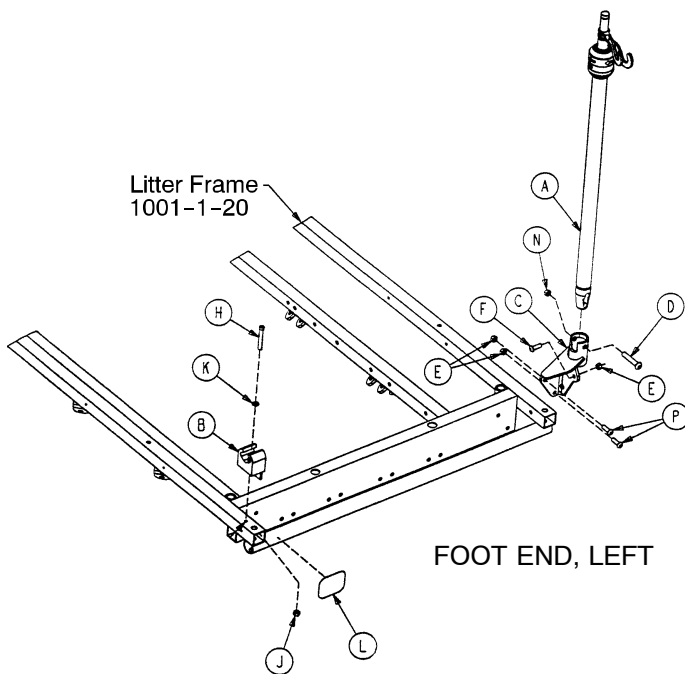

FOOT END, LEFT

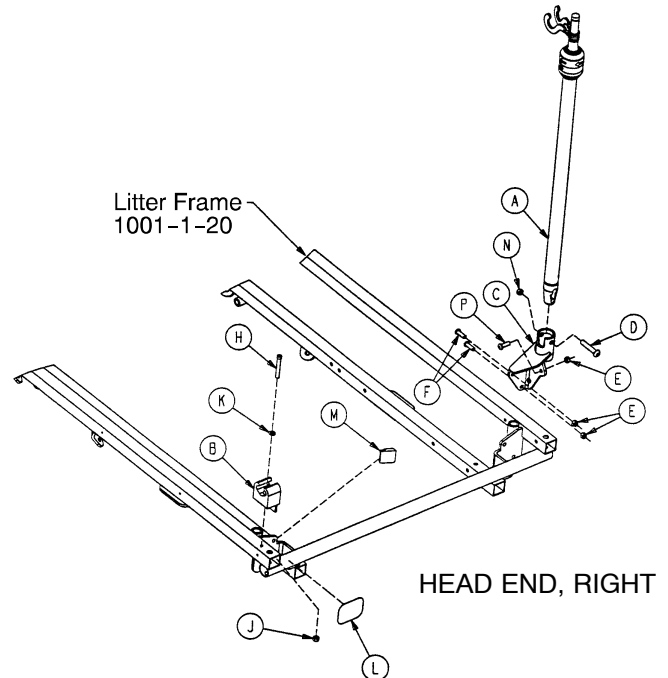

HEAD END, RIGHT

Item	Part No.	Part Name	Qty.	Item	Part No.	Part Name	Qty.
A	(page 119)	I.V. Pole Assembly	1	A	(page 119)	I.V. Pole Assembly	1
B	1001-59-12	I.V. Clip	1	B	1001-59-12	I.V. Clip	1
C	1001-259-121	Pivot Weldment	1	C	1001-259-121	Pivot Weldment	1
D	4-452	But. Hd. Cap Screw	1	D	4-452	But. Hd. Cap Screw	1
E	16-118	Nylock Hex Nut	3	E	16-118	Nylock Hex Nut	3
F	4-156	But. Hd. Cap Screw	1	F	4-161	Button Hd. Cap Screw	2
H	4-456	Soc. Hd. Cap Screw	1	H	4-456	Soc. Hd. Cap Screw	1
J	16-121	Fiberlock Hex Nut	1	J	16-121	Fiberlock Hex Nut	1
K	11-62	Washer	1	K	11-62	Washer	1
L	1001-1-56	Round Hook Protector	1	L	1001-1-56	Round Hook Protector	1
N	16-116	Fiberlock Nut	1	M	1001-1-57	Hook Protector, Left	1
P	3-355	Hex Hd. Cap Screw	2	N	16-116	Fiberlock Nut	1
				P	4-156	But. Hd. Cap Screw	1

1001 Optional 2-Stage I.V. Pole Mounting Assembly (Used on litters with fold-to-head siderails)

Assembly part numbers
1001-81 (Head End, Left)
1001-82 (Foot End, Right)

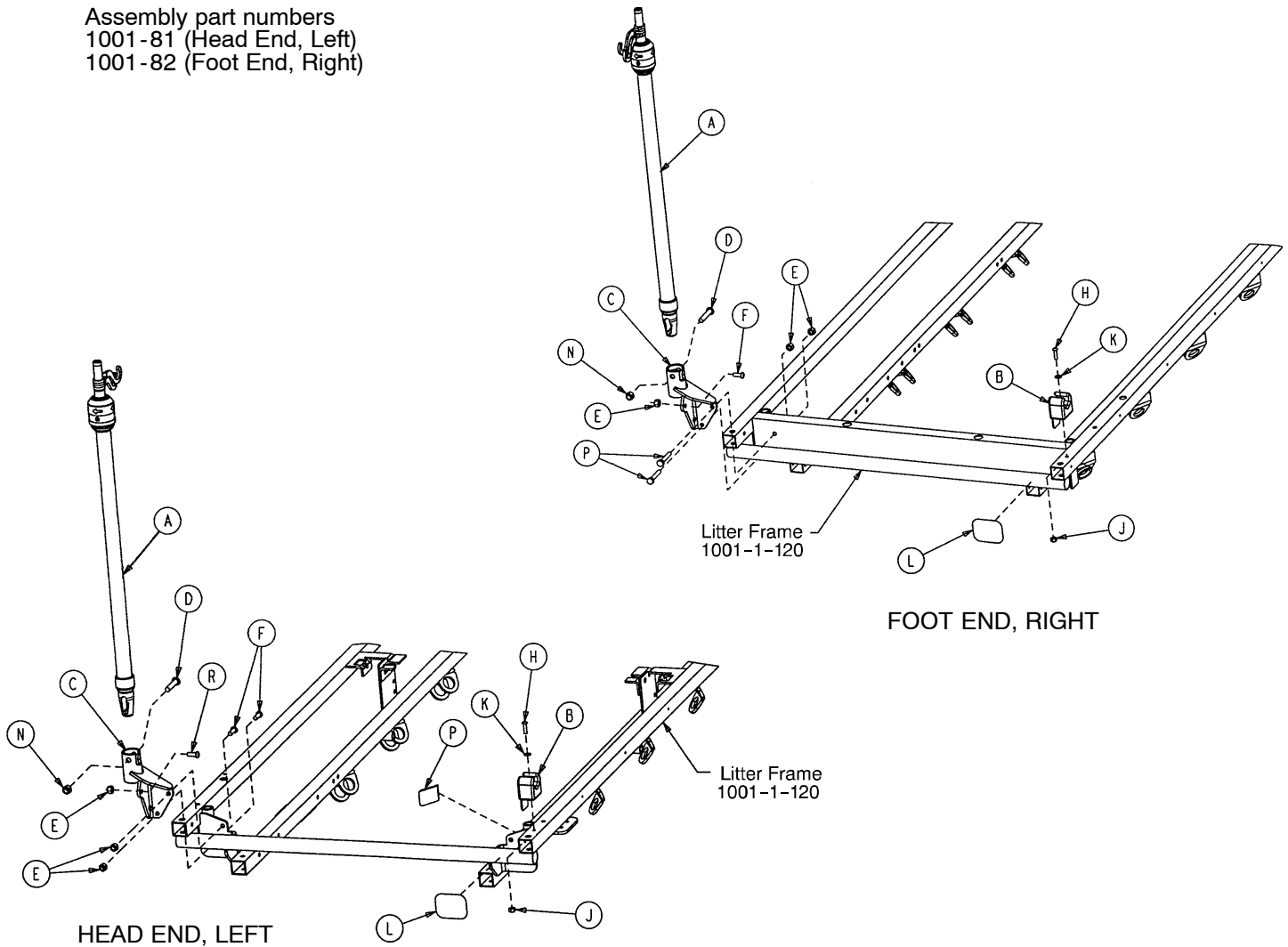

Item	Part No.	Part Name	Qty.	Item	Part No.	Part Name	Qty.
A	(page 119)	I.V. Pole Assembly	1	A	(page 119)	I.V. Pole Assembly	1
B	1001-59-12	I.V. Clip	1	B	1001-59-12	I.V. Clip	1
C	1001-259-122	Pivot Weldment	1	C	1001-259-122	Pivot Weldment	1
D	4-452	But. Hd. Cap Screw	1	D	4-452	But. Hd. Cap Screw	1
E	16-118	Nylock Hex Nut	3	E	16-118	Nylock Hex Nut	3
F	4-161	Button Hd. Cap Screw	2	F	4-156	Button Hd. Cap Screw	1
H	4-456	Soc. Hd. Cap Screw	1	H	4-456	Soc. Hd. Cap Screw	1
J	16-121	Fiberlock Hex Nut	1	J	16-121	Fiberlock Hex Nut	1
K	11-62	Washer	1	K	11-62	Washer	1
L	1001-1-56	Round Hook Protector	1	L	1001-1-56	Round Hook Protector	1
N	16-116	Fiberlock Nut	1	N	16-116	Fiberlock Nut	1
P	1001-1-58	Hook Protector	1	P	3-355	Hex Hd. Cap Screw	2
R	4-156	But. Hd. Cap Screw	1				

1501 Optional 2-Stage I.V. Pole Mounting Assembly (Used on litters with fold-to-head siderails)

Assembly part numbers
1501-80 (Foot End, Left)
1501-83 (Head End, Right)

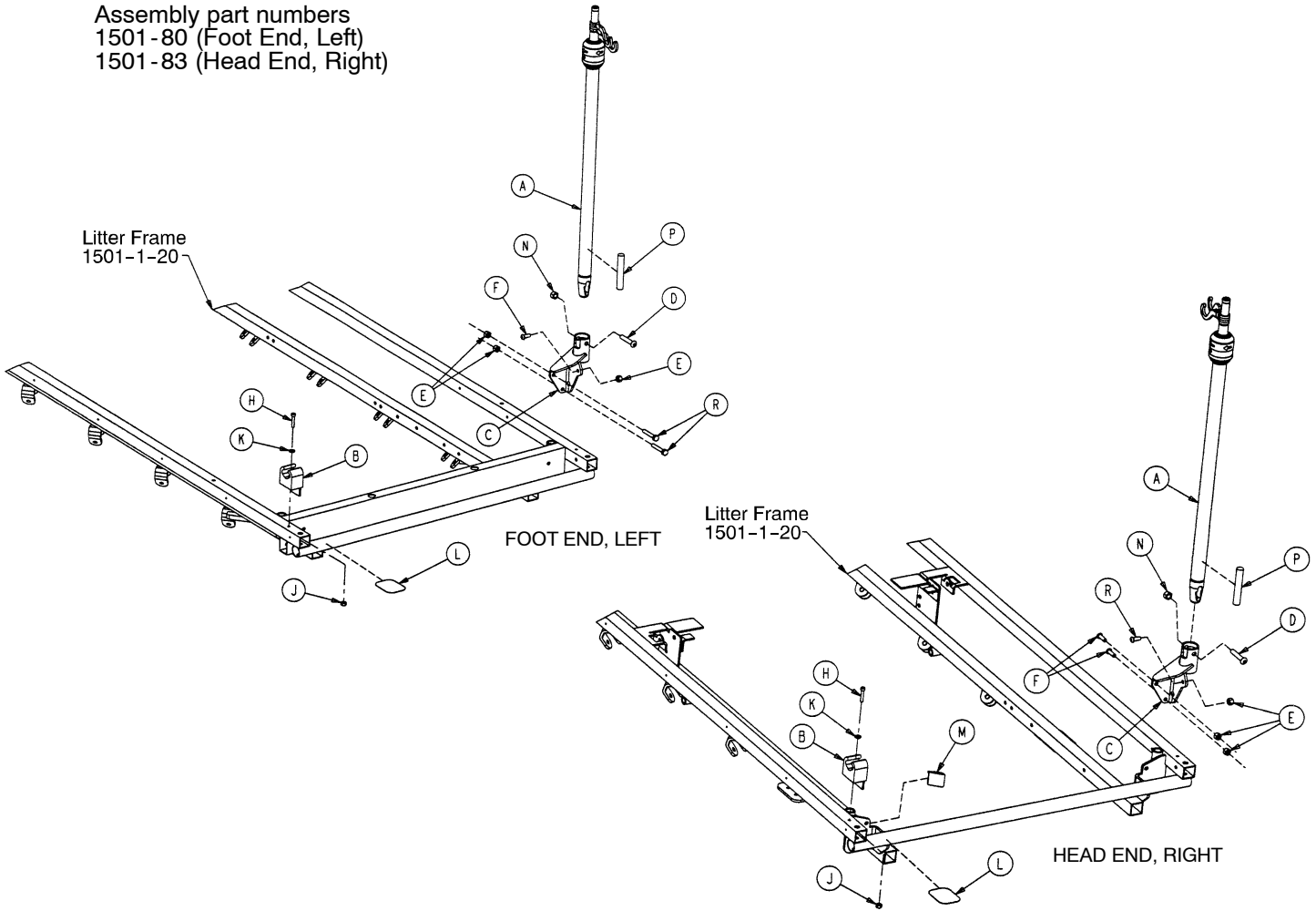

Item	Part No.	Part Name	Qty.	Item	Part No.	Part Name	Qty.
A	(page 119)	I.V. Pole Assembly	1	A	(page 119)	I.V. Pole Assembly	1
B	1001-59-12	I.V. Clip	1	B	1001-59-12	I.V. Clip	1
C	1001-259-121	I.V. Pivot	1	C	1001-259-121	I.V. Pivot	1
D	4-199	But. Hd. Cap Screw	1	D	4-199	But. Hd. Cap Screw	1
E	16-28	Nylock Hex Nut	3	E	16-28	Nylock Hex Nut	3
F	4-156	Button Hd. Cap Screw	3	F	4-161	But. Hd. Cap Screw	2
H	4-456	Soc. Hd. Cap Screw	1	H	4-456	Soc. Hd. Cap Screw	1
J	16-3	Fiberlock Hex Nut	1	J	16-3	Fiberlock Hex Nut	1
K	11-16	Washer	1	K	11-16	Washer	1
L	1001-1-56	Round Hook Protector	1	L	1001-1-56	Round Hook Protector	1
N	16-11	Flexlock Nut	1	M	1001-1-57	Hook Protector, Lt.	1
P	1501-27-19	I.V. Plug	1	N	16-11	Flexlock Nut	1
R	3-47	Hex Hd. Cap Screw	2	P	1501-27-19	I.V. Plug	1
				R	4-156	But. Hd. Cap Screw	2

1501 2-Stage I.V. Pole Mounting Assembly (Used on litters with fold-to-head siderails)

Assembly part numbers
1501-81 (Head End, Left)
1501-82 (Foot End, Right)

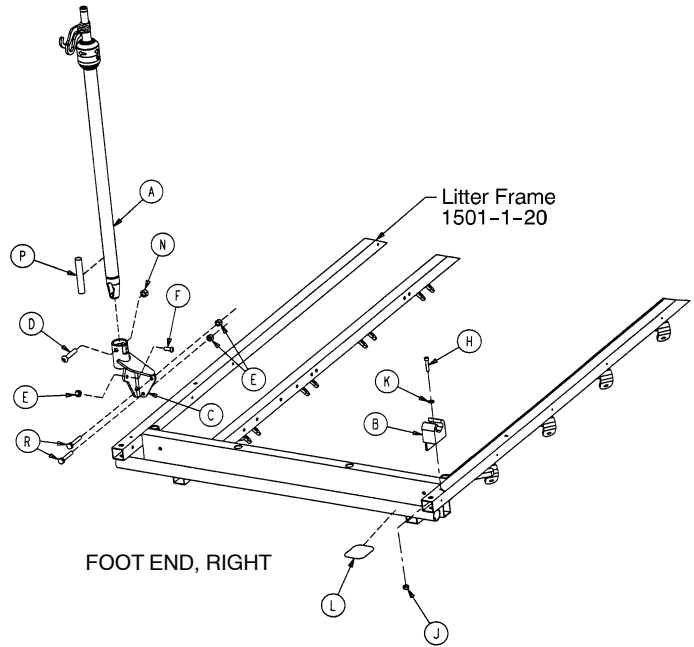
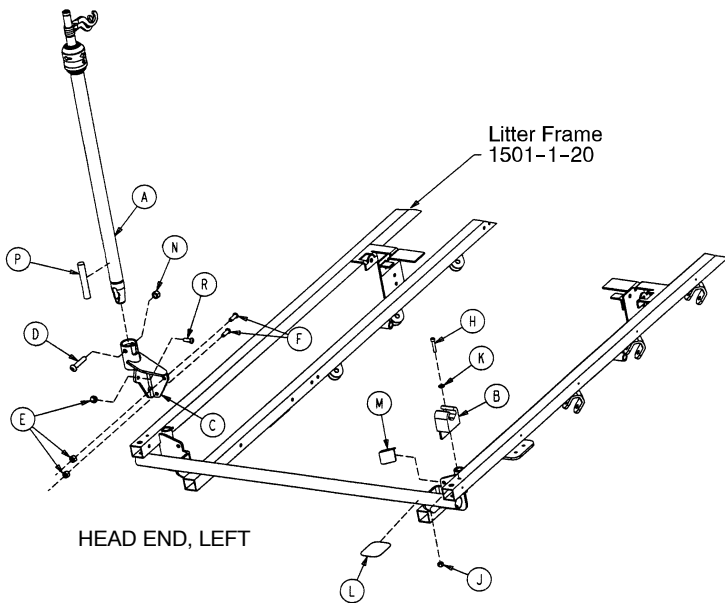

Item	Part No.	Part Name	Qty.
A	(page 119)	I.V. Pole Assembly	1
B	1001-59-12	I.V. Clip	1
C	1001-259-122	I.V. Pivot	1
D	4-452	But. Hd. Cap Screw	1
E	16-118	Nylock Hex Nut	3
F	4-161	Button Hd. Cap Screw	2
H	4-456	Soc. Hd. Cap Screw	1
J	16-3	Fiberlock Hex Nut	1
K	11-62	Washer	1
L	1001-1-56	Round Hook Protector	1
M	1001-1-58	Hook Protector, Rt.	1
N	16-116	Flexlock Nut	1
P	1501-127-19	I.V. Plug	1
R	4-156	But. Hd. Cap Screw	1

Item	Part No.	Part Name	Qty.
A	(page 119)	I.V. Pole Assembly	1
B	1001-59-12	I.V. Clip	1
C	1001-259-122	I.V. Pivot	1
D	4-452	But. Hd. Cap Screw	1
E	16-118	Nylock Hex Nut	3
F	4-156	Button Hd. Cap Screw	1
H	4-456	Soc. Hd. Cap Screw	1
J	16-3	Fiberlock Hex Nut	1
K	11-62	Washer	1
L	1001-1-56	Round Hook Protector	1
N	16-116	Flexlock Nut	1
P	1501-127-19	I.V. Plug	1
R	3-355	Hex Hd. Cap Screw	2

1211-210-10 Optional 2-Stage I.V. Pole Assembly

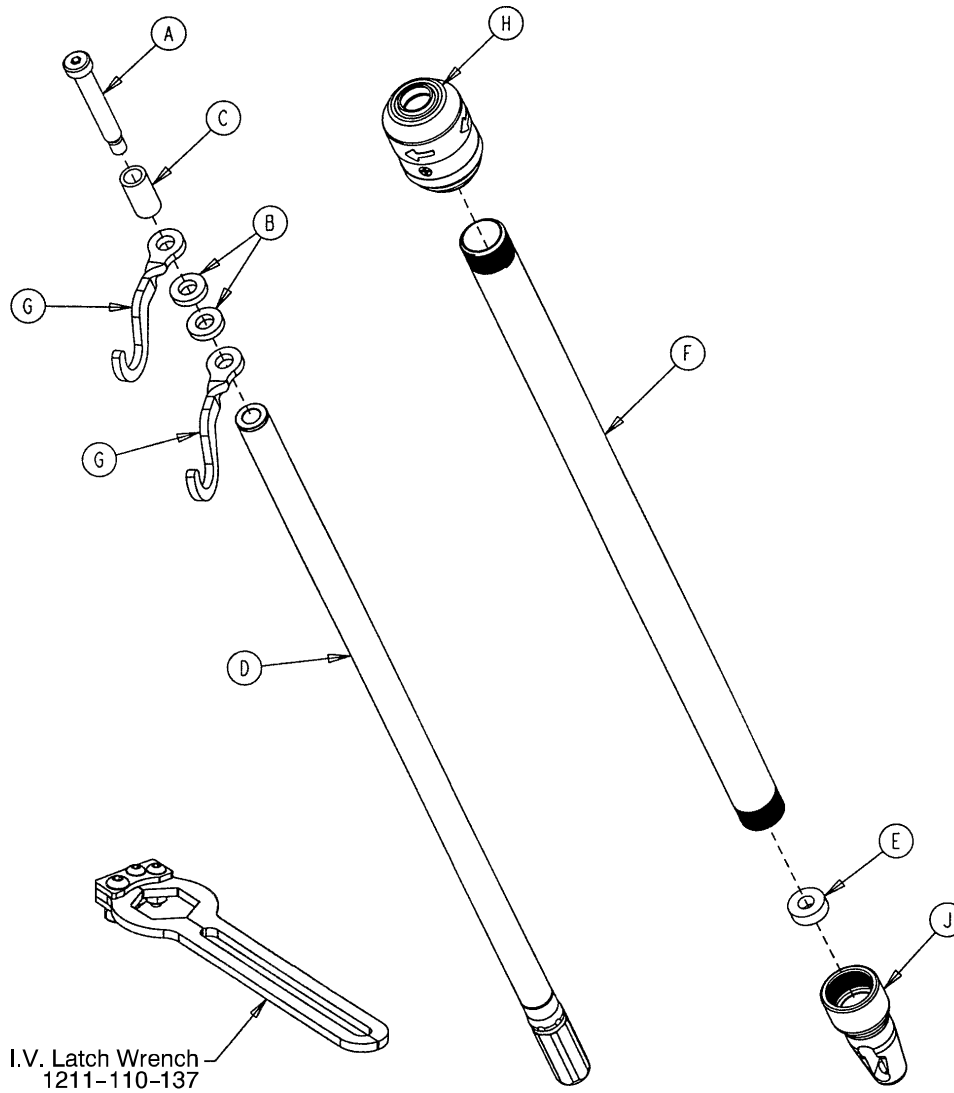

Item	Part No.	Part Name	Qty.
A	8-31	Soc. Hd. Cap Screw	1
B	52-17	Washer	2
C	926-400-162	Spacer	1
D	1211-210-29	2nd Stage Assembly	1
E	1001-359-13	Dampener	1
F	1001-159-28	Base Tube	1
G	1010-259-16	I.V. Hook	2
H	(page 120)	I.V. Pole Latch	1
J	1001-359-112	Pivot	1

1211-210-26 Optional I.V. Pole Latch Assembly

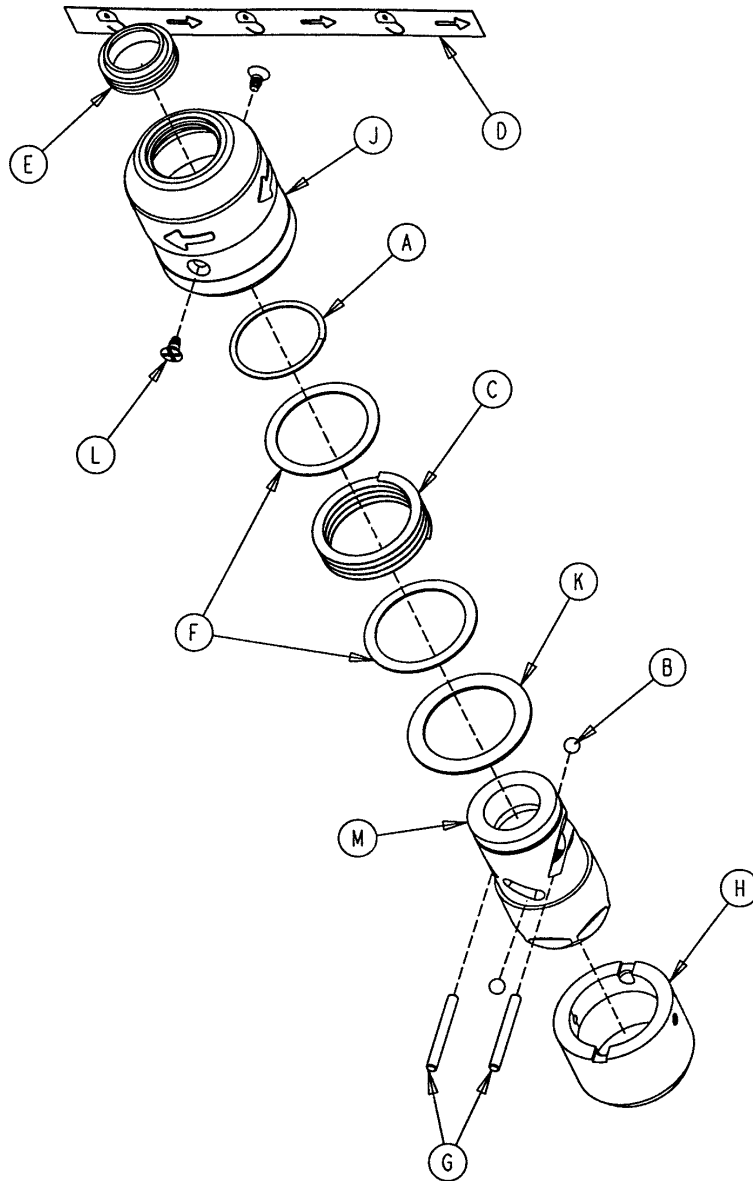

Item	Part No.	Part Name	Qty.
A	28-167	Retaining Ring	1
B	31-4	Steel Ball	2
C	38-392	Crest-to-Crest Spring	1
D	1211-91-34	Release Label	1
E	1211-110-18	I.V. Latch Seal	1
F	1211-110-20	Washer	2
G	1211-110-21	I.V. Latch Locking Pin	2
H	1211-110-22	I.V. Latch Guide	1
J	1211-110-24	I.V. Latch O.D. Housing	1
K	1211-110-35	Washer	1
L	1211-110-36	Self-Tapping Screw	2
M	1211-210-23	I.V. Latch I.D. Housing	1

1001 Optional 3-Stage I.V. Pole Mounting Assembly (Used on litters with fold-to-foot siderails)

Assembly part numbers
 1001-111 (Head End, Left)
 1001-113 (Foot End, Right)

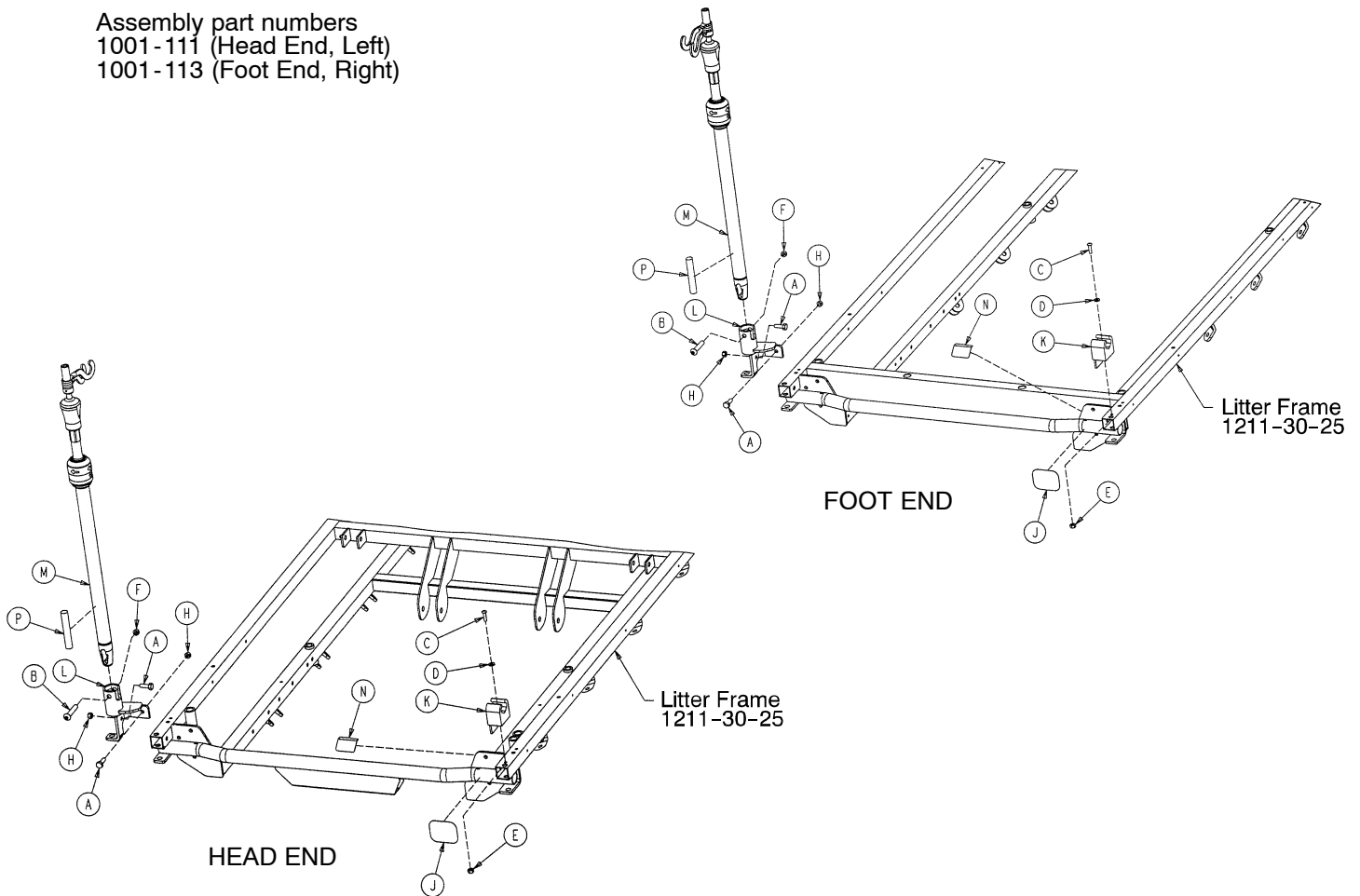

Item	Part No.	Part Name	Qty.
A	3-356	Hex Hd. Cap Screw	2
B	4-452	But. Hd. Cap Screw	1
C	4-169	But. Hd. Cap Screw	1
D	11-62	Washer	1
E	16-121	Fiberlock Nut	1
F	16-116	Flexlock Nut	1
H	16-118	Fiberlock Nut	2
J	1001-1-56	Round Hook Protector	1
K	1001-59-12	I.V. Clip	1
L	1211-310-112	I.V. Pivot	1
M	(page 125)	I.V. Pole Assembly	1
N	1001-1-58	Hook Protector	1

1501 Optional 3-Stage I.V. Pole Mounting Assembly (Used on litters with fold-to-foot siderails)

Assembly part numbers
 1501-111 (Head End, Left)
 1501-113 (Foot End, Right)

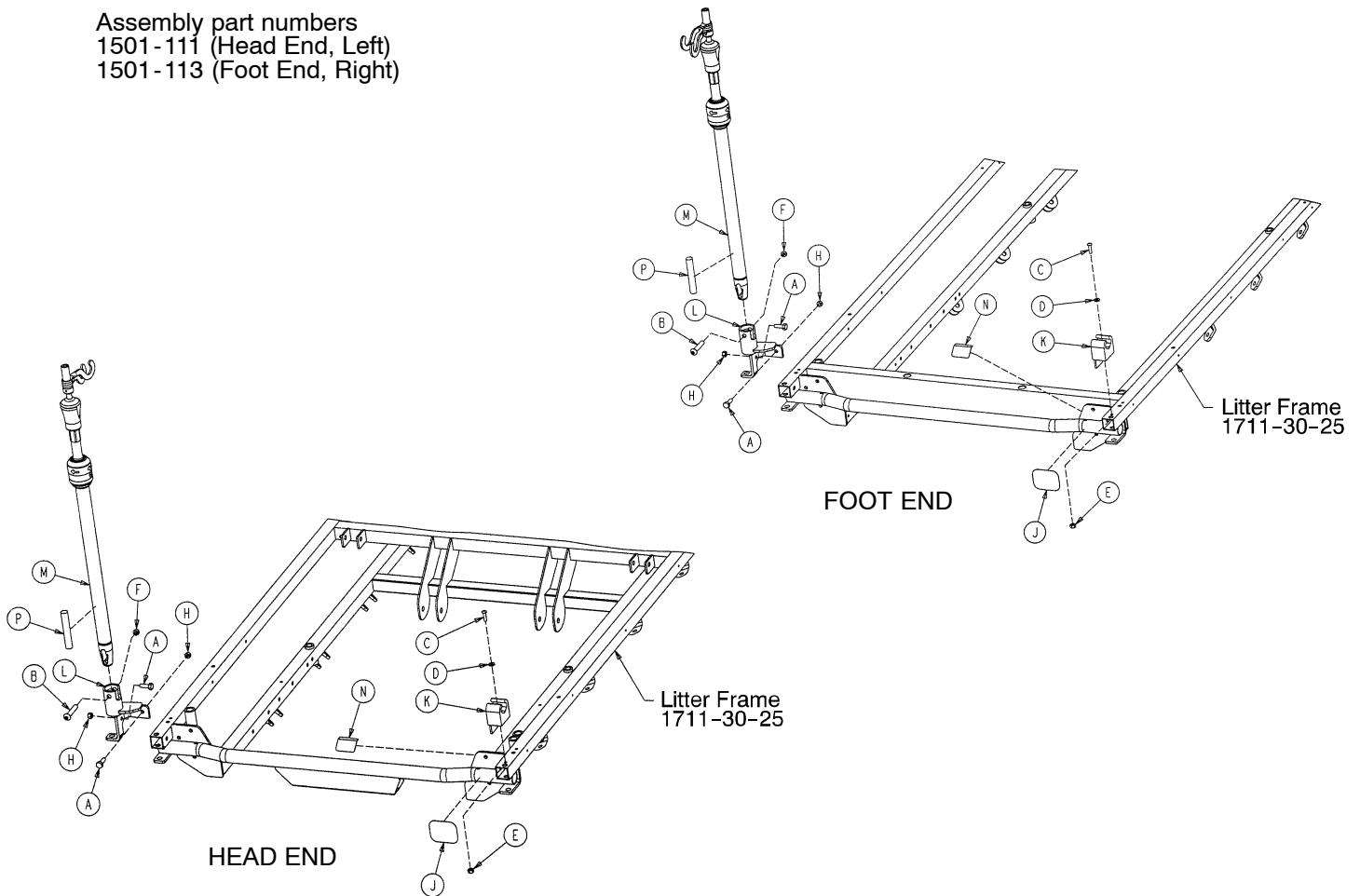

Item	Part No.	Part Name	Qty.
A	3-356	Hex Hd. Cap Screw	2
B	4-452	But. Hd. Cap Screw	1
C	4-169	But. Hd. Cap Screw	1
D	11-16	Washer	1
E	16-3	Fiberlock Nut	1
F	16-116	Center Lock Nut	1
H	16-118	Fiberlock Nut	2
J	1001-1-56	Round Hook Protector	1
K	1001-59-12	I.V. Clip	1
L	1211-110-112	I.V. Pivot	1
M	(page 125)	I.V. Pole Assembly	1
N	1001-1-58	Hook Protector	1
P	1501-127-19	Plug	1

Optional 3-Stage I.V. Pole Mounting Assembly (Used on litters with fold-to-head siderails)

Assembly part numbers
1001-61 (Head End, Left)
1001-62 (Foot End, Right)

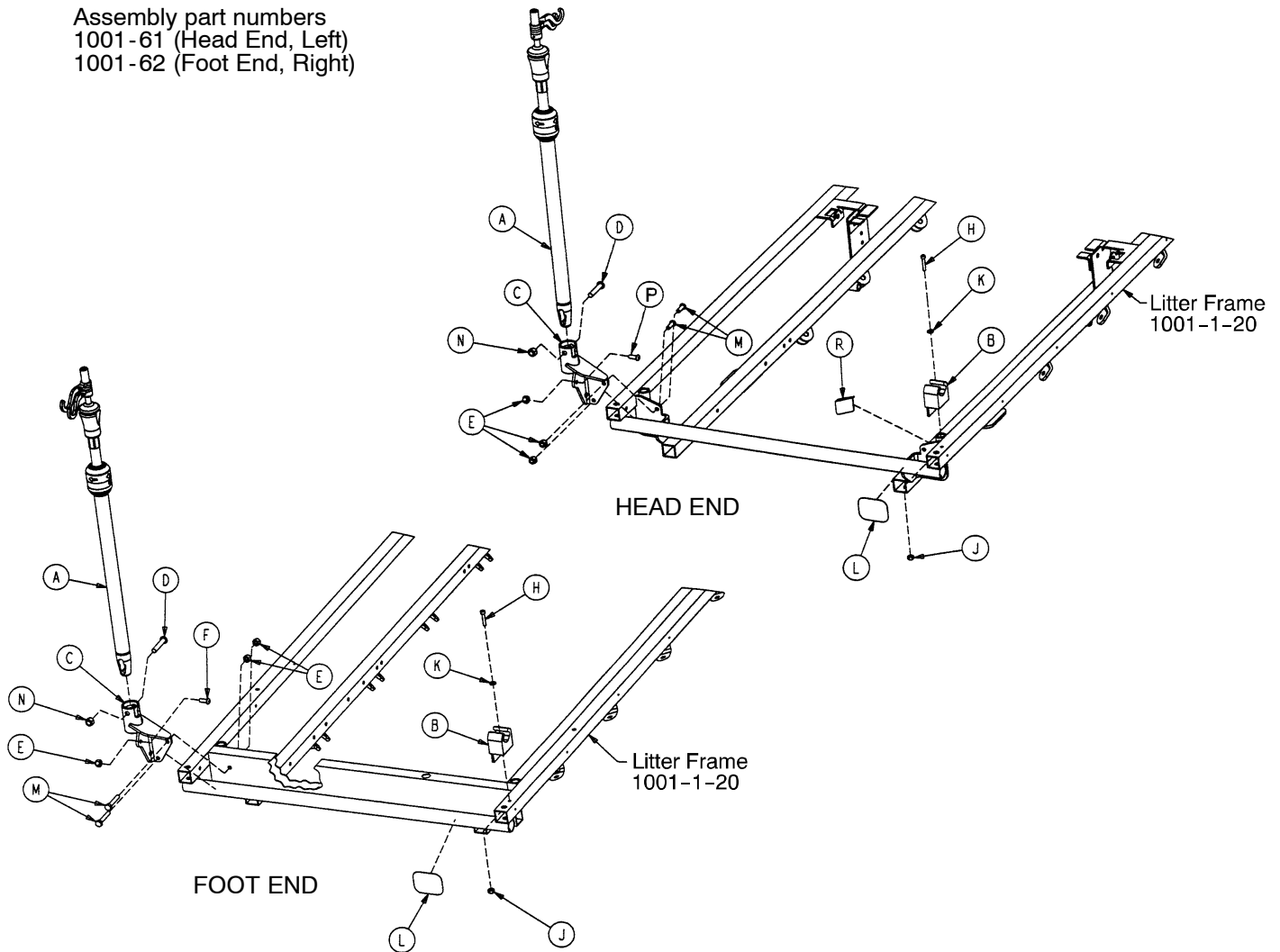

Item	Part No.	Part Name	Qty.	Item	Part No.	Part Name	Qty.
A	(page 125)	I.V. Pole Assembly	1	A	(page 125)	I.V. Pole Assembly	1
B	1001-59-12	I.V. Clip	1	B	1001-59-12	I.V. Clip	1
C	1001-259-122	I.V. Pivot	1	C	1001-259-122	I.V. Pivot	1
D	4-452	But. Hd. Cap Screw	1	D	4-452	But. Hd. Cap Screw	1
E	16-118	Stover Lock Nut	3	E	16-118	Stover Lock Nut	3
F	4-156	But. Hd. Cap Screw	1	F	4-156	Button Hd. Cap Screw	1
H	4-456	Soc. Hd. Cap Screw	1	H	4-456	Soc. Hd. Cap Screw	1
J	16-121	Fiberlock Hex Nut	1	J	16-121	Fiberlock Hex Nut	1
K	11-62	Washer	1	K	11-62	Washer	1
L	1001-1-56	Round Hook Protector	1	L	1001-1-56	Round Hook Protector	1
M	4-161	Button Hd. Cap Screw	2	M	3-355	Hex Hd. Cap Screw	2
N	16-116	Flexlock Nut	1	N	16-116	Flexlock Nut	1
R	1001-1-58	Hook Protector, Right	1				

1501 Optional 3-Stage I.V. Pole Mounting Assembly (Used on litters with fold-to-head siderails)

Assembly part numbers
1501-61 (Head End, Left)
1501-62 (Foot End, Right)

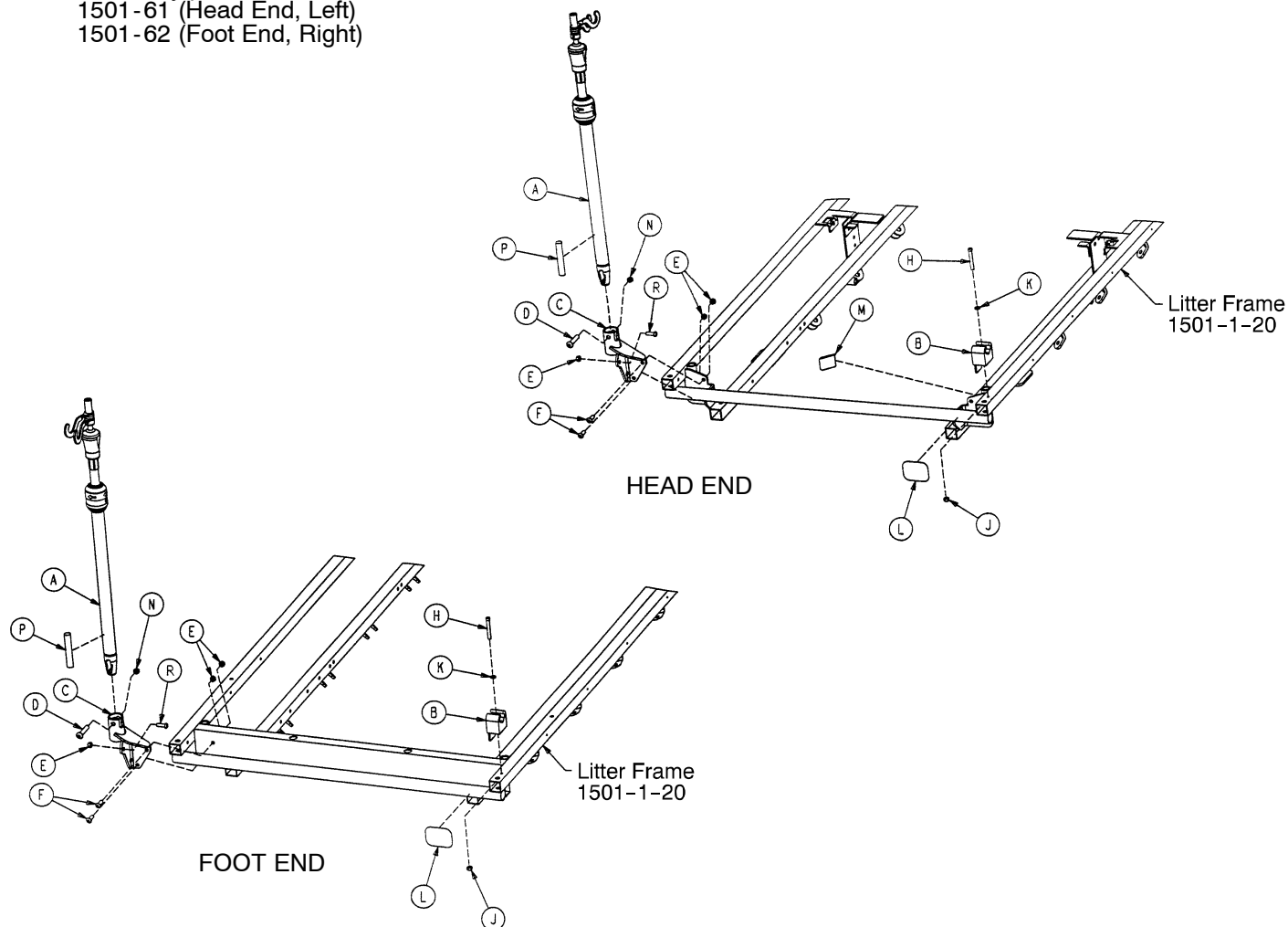

Item	Part No.	Part Name	Qty.
A	(page 125)	I.V. Pole Assembly	1
B	1001-59-12	I.V. Clip	1
C	1001-259-122	I.V. Pivot	1
D	4-452	But. Hd. Cap Screw	1
E	16-118	Nylock Hex Nut	3
F	4-161	Button Hd. Cap Screw	2
H	4-456	Soc. Hd. Cap Screw	1
J	16-3	Fiberlock Hex Nut	1
K	11-62	Washer	1
L	1001-1-56	Round Hook Protector	1
M	1001-1-58	Hook Protector, Right	1
N	16-116	Flexlock Nut	1
P	1501-127-19	Plug	1
R	4-156	Soc. Hd. Cap Screw	1

1211-211-10 Optional 3-Stage I.V. Pole Assembly

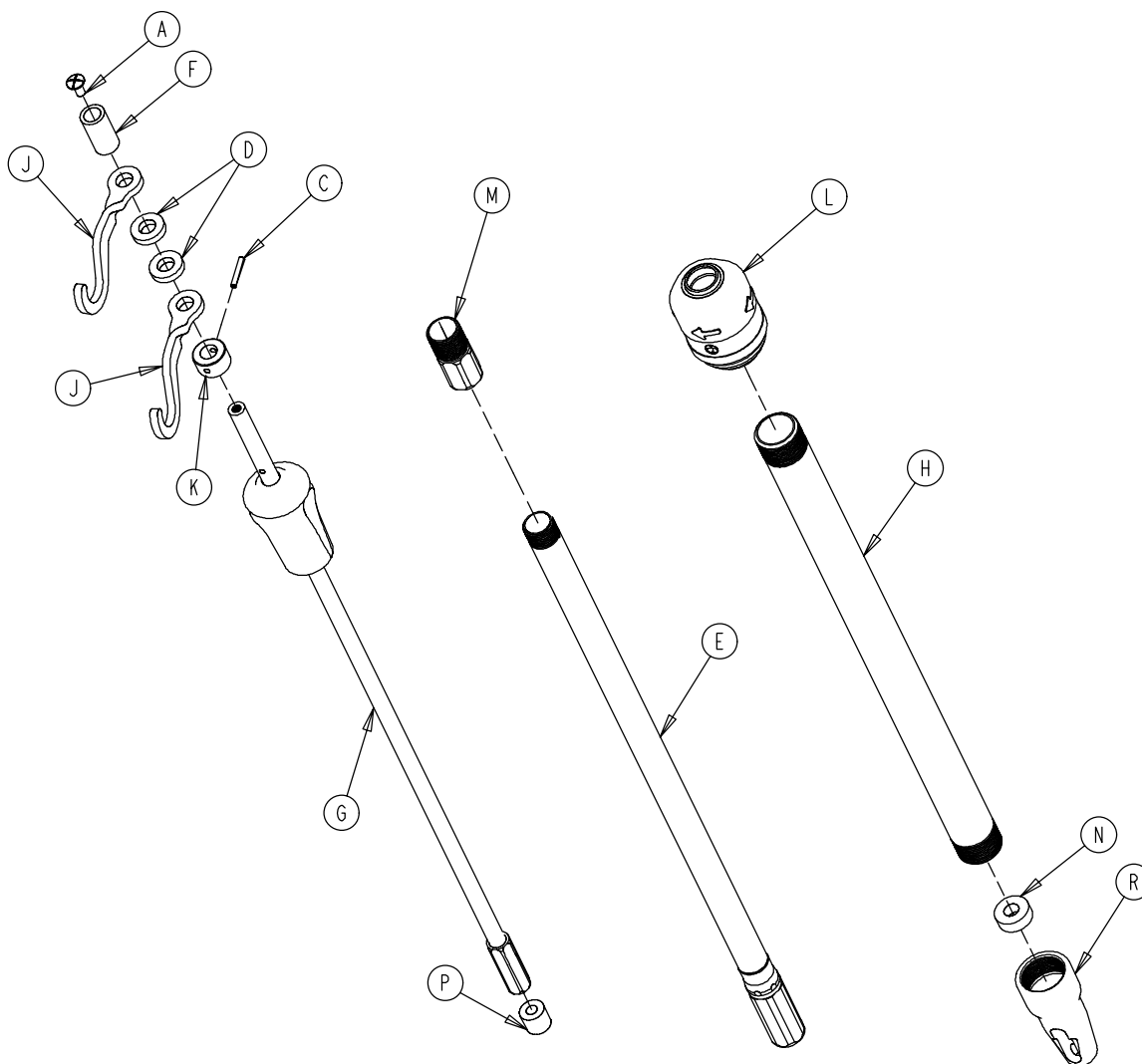

Item	Part No.	Part Name	Qty.
A	7-4	Truss Hd. Machine Screw	1
C	26-76	Roll Pin	1
D	52-17	Spacer	2
E	1211-210-31	2nd Stage Assembly	1
F	926-400-162	Spacer	1
G	(page 126)	3rd Stage Assembly	1
H	1001-161-23	Base Tube	1
J	1010-259-16	I.V. Hook	2
K	1010-61-14	Collar	1
L	(page 120)	I.V. Pole Latch	1
M	1211-110-16	Threaded Adaptor	1
N	1001-359-13	Dampener	1
P	1001-359-14	Dampener	1
R	1001-359-112	Pivot	1

1211-110-32 Optional 3rd Stage Assembly

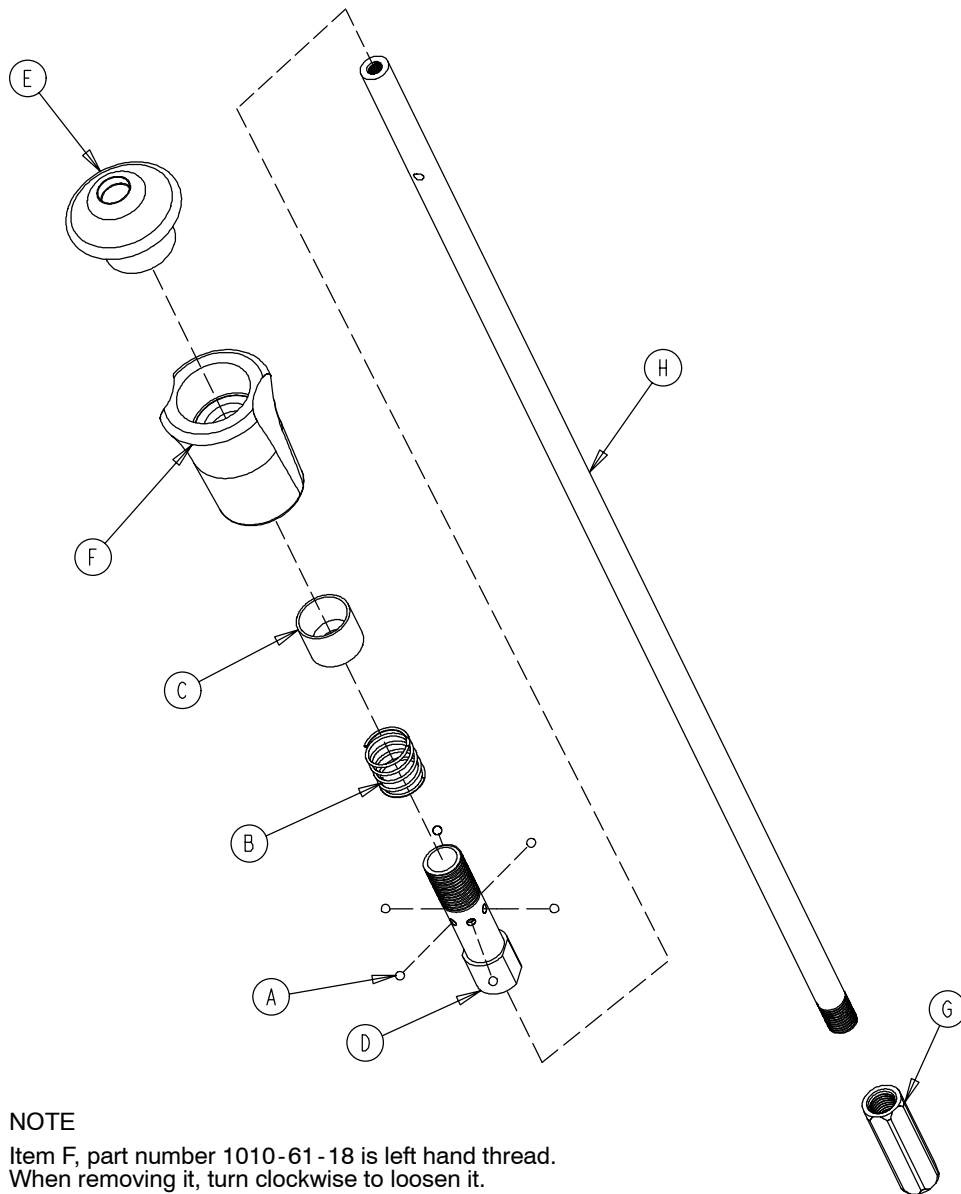

NOTE

Item F, part number 1010-61-18 is left hand thread.
When removing it, turn clockwise to loosen it.

Item	Part No.	Part Name	Qty.
A	31-21	Ball	6
B	38-303	Compression Spring	1
C	1010-61-13	Ball Retainer	1
D	1010-61-16	Retaining Shaft	1
E	1010-61-17	Thumb Knob	1
F	1010-61-18	Hand Guard	1
G	1211-110-117	Nut	1
H	1211-110-33	3rd Extension Rod	1

1001-23 Fowler X-Ray Cassette Mounting Assembly (Litters with Fold-to-Head Siderails)

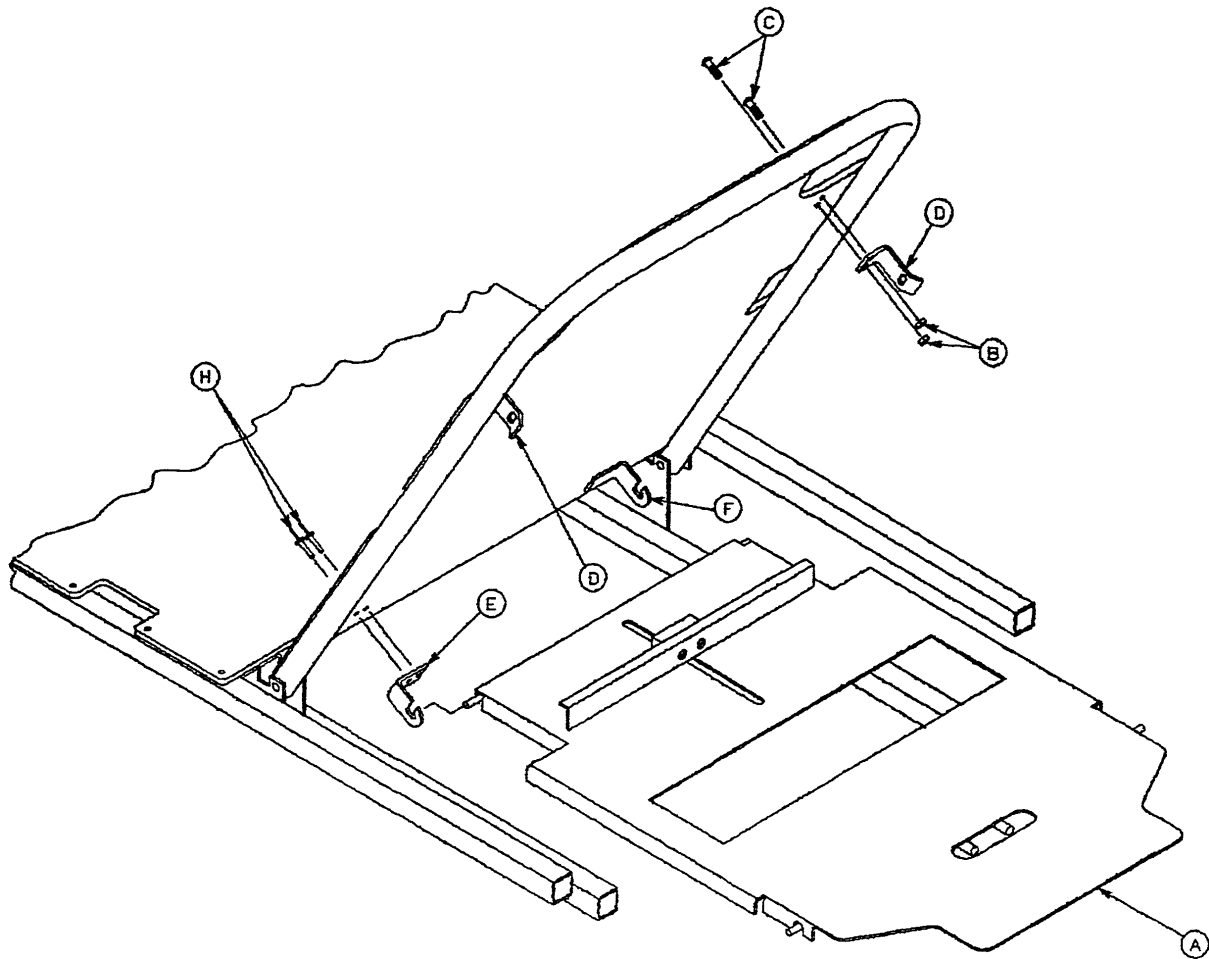

Item	Part No.	Part Name	Qty.
A	(page 128)	X-Ray Cassette Ass'y	1
B	16-121	Self-Locking Nut	4
C	4-456	Button Hd. Cap Screw	4
D	1001-23-13	Tray Latch	2
E	1020-23-13	Tray Hinge, Right	1
F	1020-23-12	Tray Hinge, Left	1
H	25-86	Pop Rivet	4

1001-23-10 Fowler X-Ray Cassette Assembly, (Litters with Fold-to-Head Siderails)

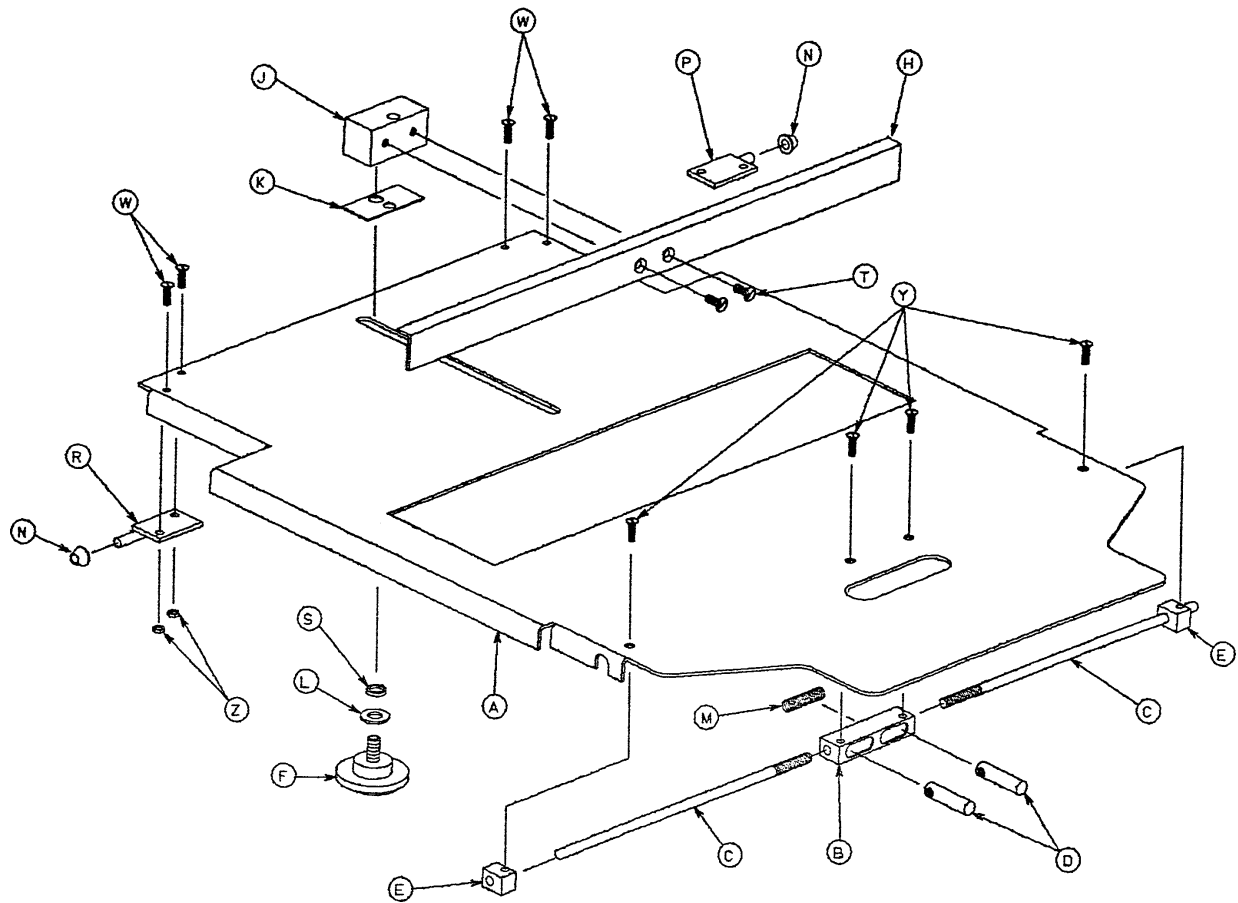

Item	Part No.	Part Name	Qty.
A	1001-23-12	Tray	1
B	1020-23-16	Post Housing	1
C	1001-23-14	Actuating Rod	2
D	926-23-64	Post	2
E	1010-23-37	Rod Guide	2
F	1020-23-21	Knob	1
H	1010-23-28	Tray Angle	1
J	926-23-70	Block Assembly	1
K	926-23-69	Washer	1
L	14-3	Washer	1
M	38-122	Compression Spring	1
N	1020-23-26	Spacer	2
P	1020-23-19	Tray Hinge, Right	1
R	1020-23-20	Tray Hinge, Left	1
S	926-23-71	Bushing	1
T	1-20	Flat Hd. Mach. Screw	2
W	4-149	Button Hd. Cap Screw	4
Y	1-22	Flat Hd. Mach. Screw	4
Z	16-3	Nylock Hex Nut	4
AA	1010-23-19	Instruction Label	1
AB	1001-23-25	Specification Label	1

Fowler X-Ray Cassette Mounting Assembly, (Litters with Fold-to-Foot Siderails)

Assembly part numbers 1211-243-10 (1001) & 1711-243-10 (1501)

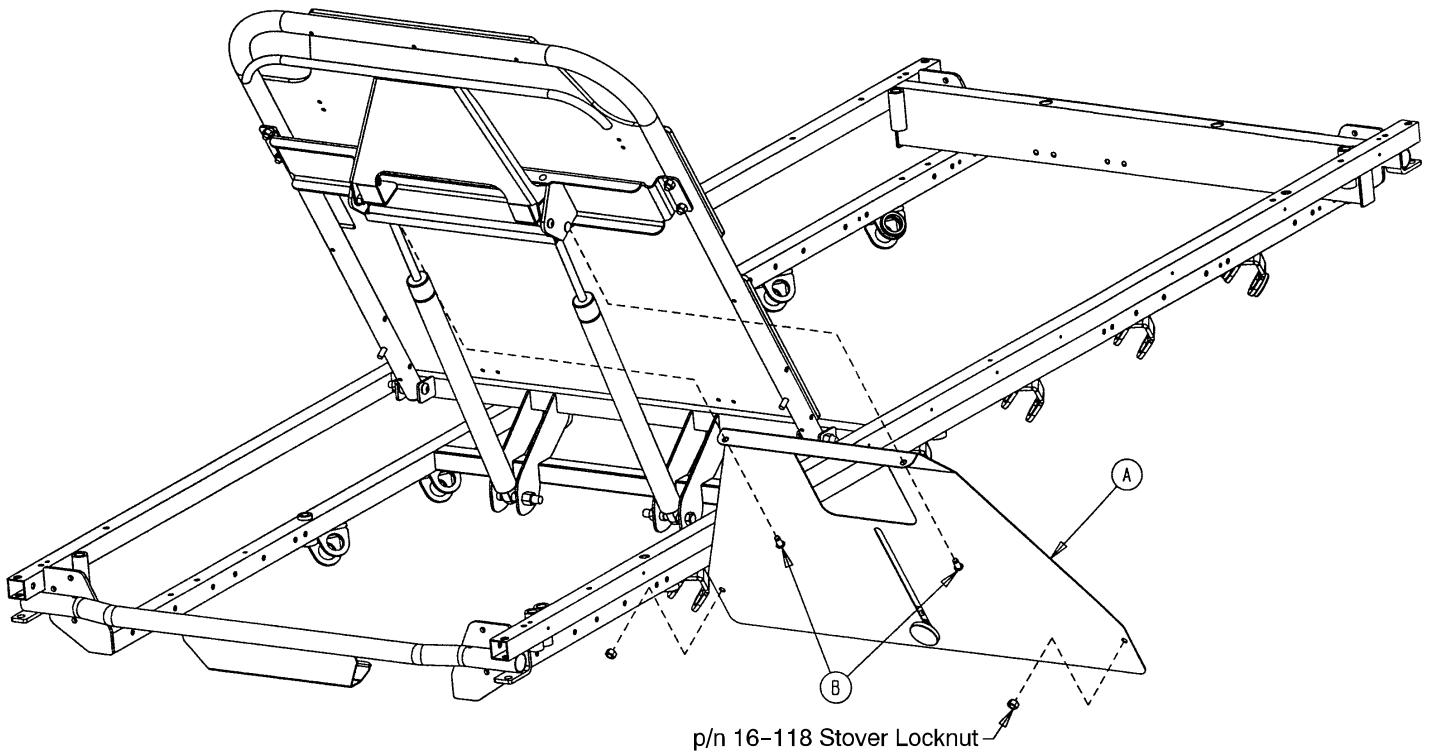

Item	Part No.	Part Name	Qty.
A	(page 130)	X-Ray Cassette Ass'y	1
B	25-121	Rivet	2

Fowler X-Ray Cassette Assembly, (Litters with Fold-to-Foot Siderails)

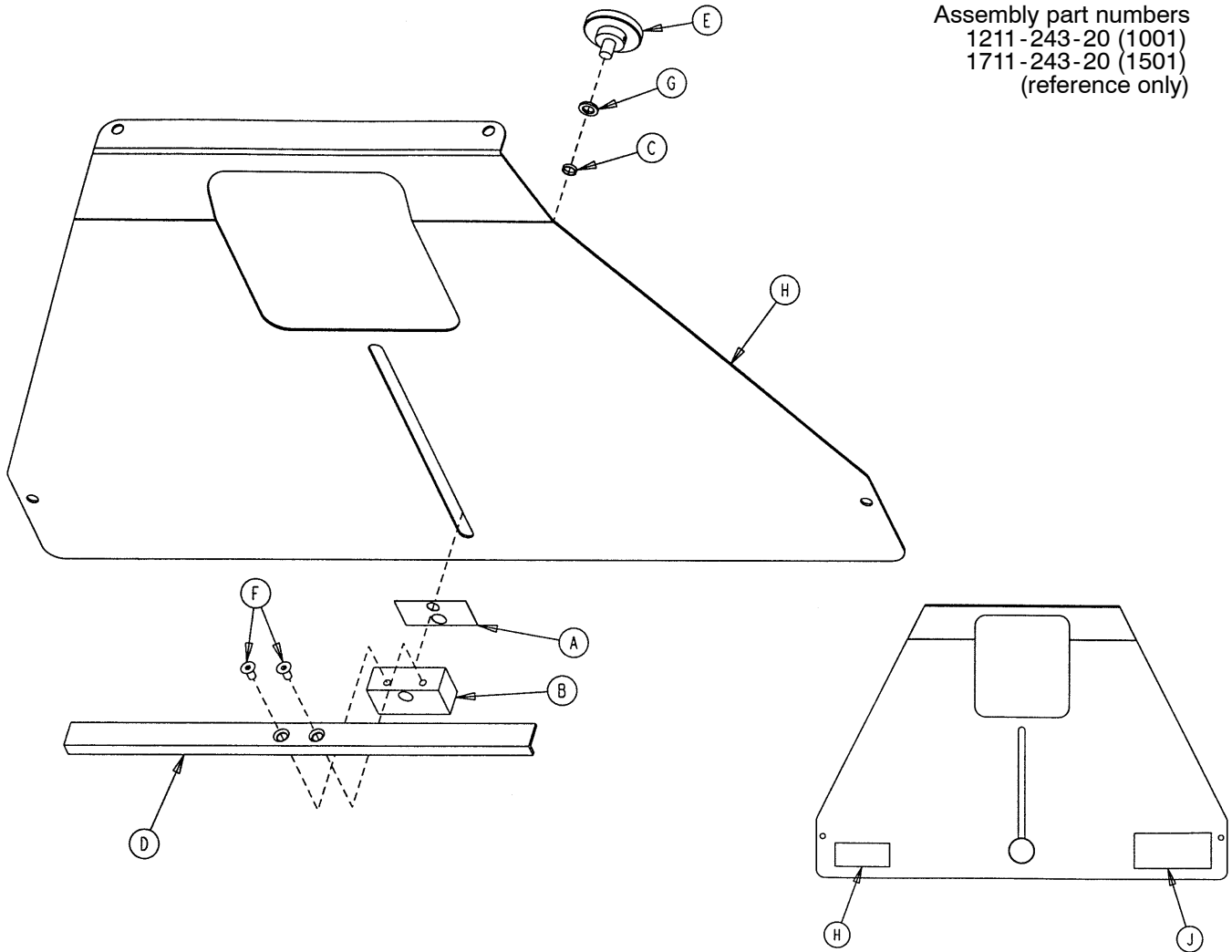

Assembly part numbers
 1211-243-20 (1001)
 1711-243-20 (1501)
 (reference only)

Item	Part No.	Part Name	Qty.
A	926-23-69	Washer	1
B	926-23-70	Block Assembly	1
C	926-23-71	Bushing	1
D	1010-23-28	Tray Angle	1
E	1020-23-21	Knob Assembly	1
F	1-30	Flat Hd. Mach. Screw	2
G	14-3	Thrust Washer	1
H	1211-243-12	X-Ray Cassette Tray	1
	1711-243-12	X-Ray Cassette Tray	1
J	1010-23-18	Warning Label	1
K	1211-243-25	Specification Label	1
	1711-243-25	Specification Label	1

926-40-100 Foot Board/Chartholder Assembly

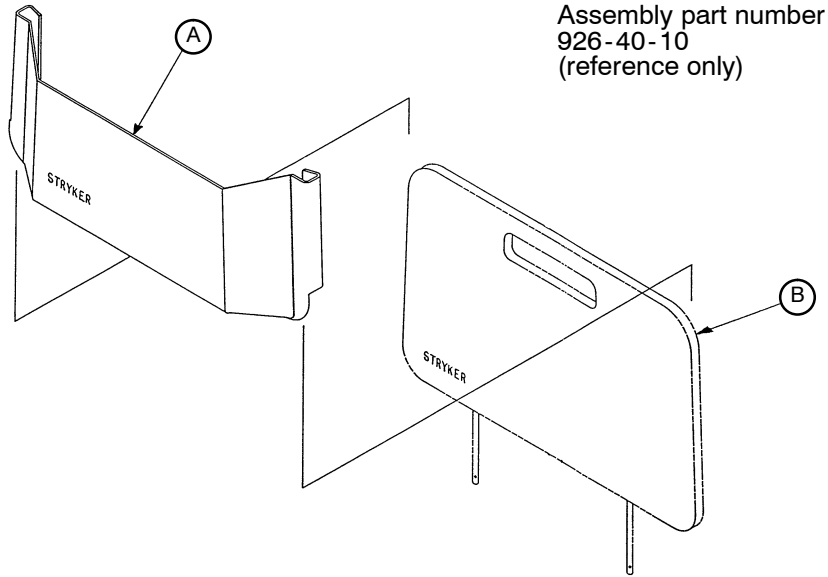

Item	Part No.	Part Name	Qty.
A	946-28-11	Chart Holder	1
B	946-29-6	Foot Board	1

1020-30 Upright Oxygen Bottle Holder Assembly

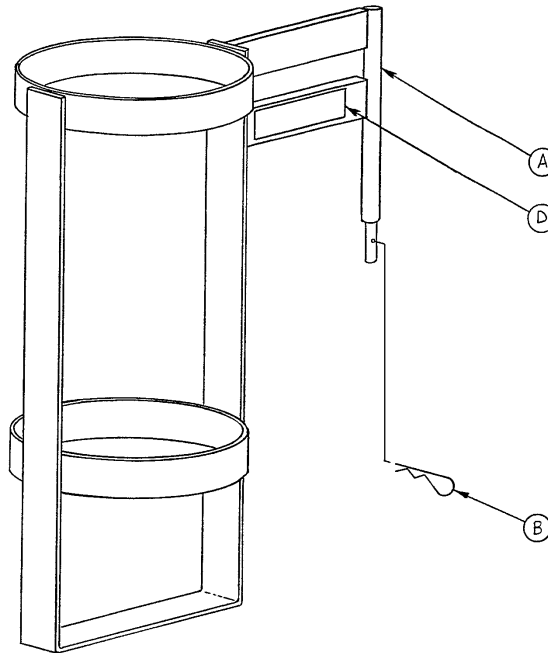

Item	Part No.	Part Name	Qty.
A	1020-30-11	Upright Bottle Holder	1
B	27-12	Cotter Pin	1
D	1020-30-17	Specification Label	1

1010-50-100 Foot Extension/Defibrillator Tray Ass'y

Assembly part number 1010-50-210 (reference only)

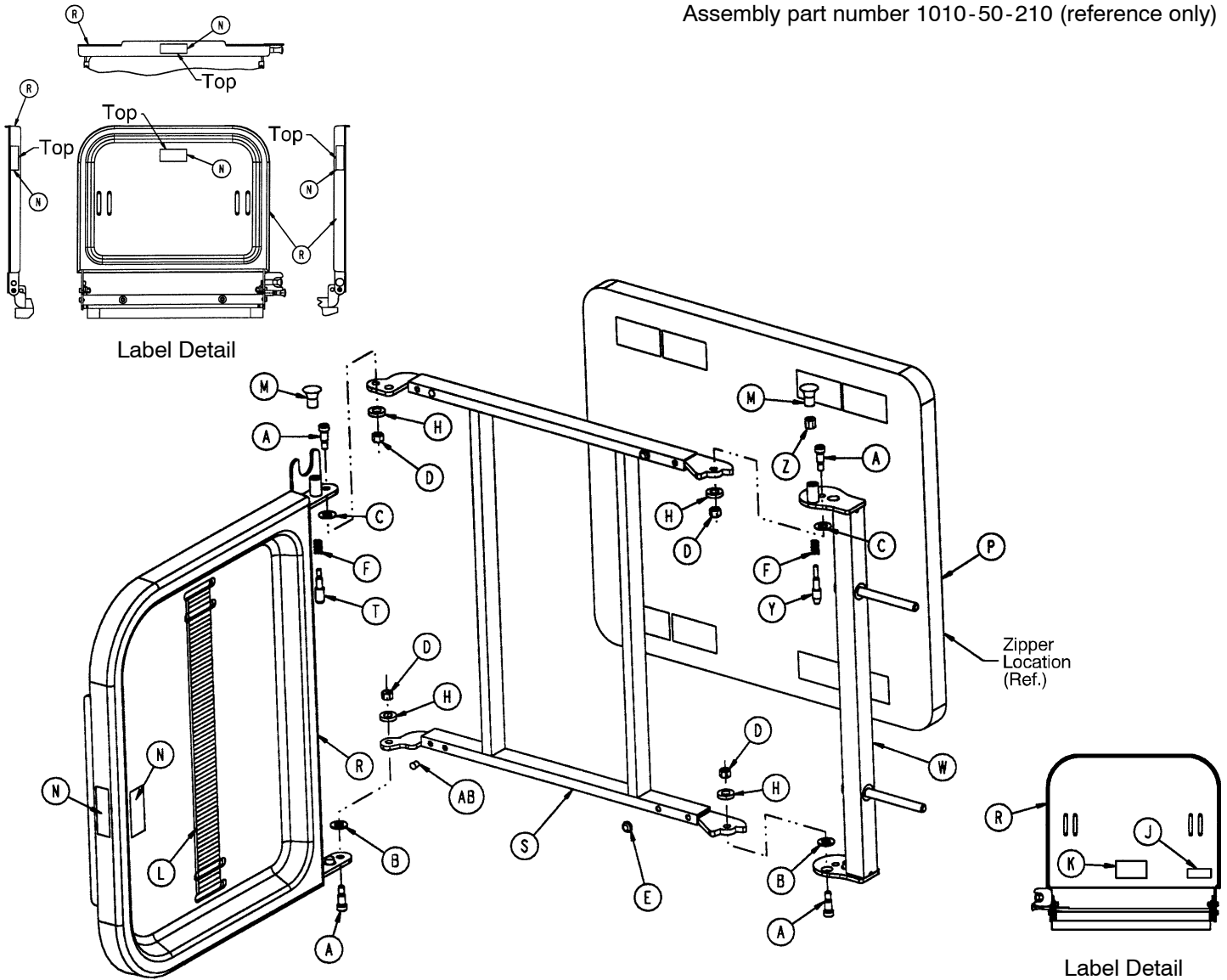

Item	Part No.	Part Name	Qty.	Item	Part No.	Part Name	Qty.
A	8-49	Socket Hd. Shoulder Bolt	4	M	1010-50-50	Knob	2
B	14-20	Nylon Washer	2	N	1010-50-57	"Max. Weight" Label	4
C	14-21	Nylon Washer	2	P	1010-50-205	Cushion Assembly	1
D	16-28	Fiberlock Nut	4	R	1010-50-218	Foot & Tray Board	1
E	37-52	Rubber Bumper	2	S	1010-50-225	Pivot Frame Weldment	1
F	38-133	Spring	2	T	1010-50-242	Pin Lock	1
H	52-17	Spacer	4	W	1010-50-246	Base Mounting Ass'y	1
J	1010-50-17	Specification Label	1	Y	1010-50-248	Lower Pin Lock	1
K	1010-50-19	"Push/Pull" Label	1	Z	1010-50-250	Pin Adjuster	1
L	1010-50-21	Long Strap	1	AB	721-31-65	Hole Plug	2

926-39 Optional Defibrillator Tray Assembly

Assembly part number 926-39-10 (reference only)

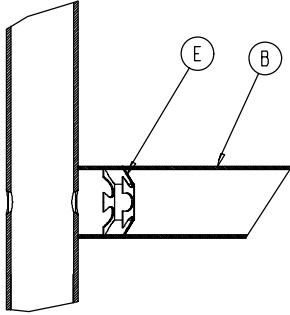

Umbrella Nut/Crosstube Detail

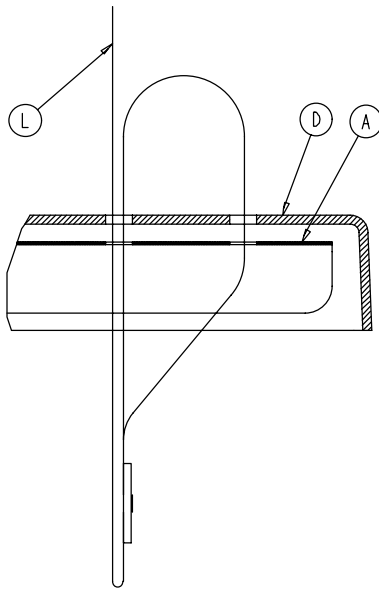

Strap Securing Detail

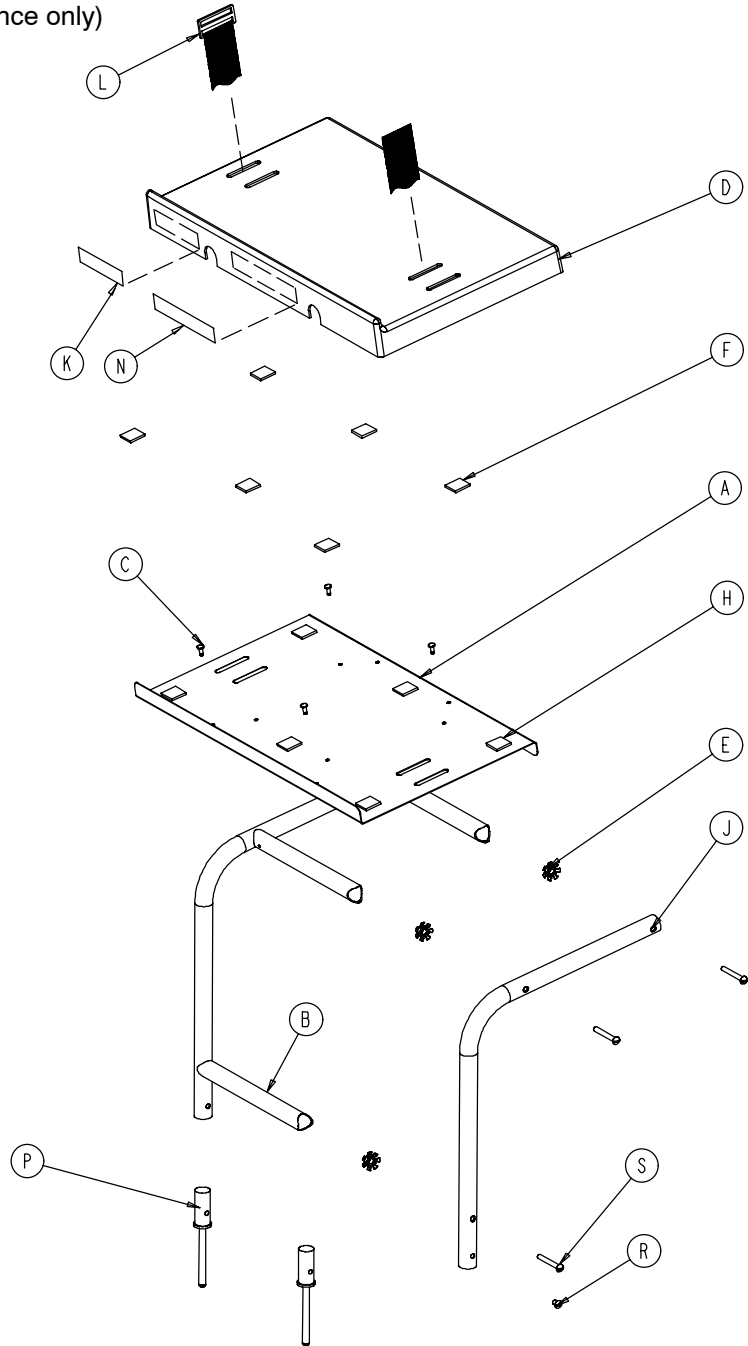

Item	Part No.	Part Name	Qty.	Item	Part No.	Part Name	Qty.
A	946-39-4	Tray	1	J	946-39-3	Support Tube	2
B	926-39-16	Crosstube	3	K	926-1-82	Label	1
C	25-55	Rivet	4	L	1010-50-21	Long Strap	1
D	926-39-9	Cover	1	N	946-1-283	Label	1
E	18-6	Umbrella Nut	6	P	926-39-15	Holder	2
F	29-8	Dual Lock	6	R	2-44	Screw	2
H	29-10	Dual Lock	6	S	2-105	Rd. Hd. Mach. Screw	6

1001 -55 Heel Stirrup and Support Assembly

Assembly part number 1001 -55- 10 (reference only)

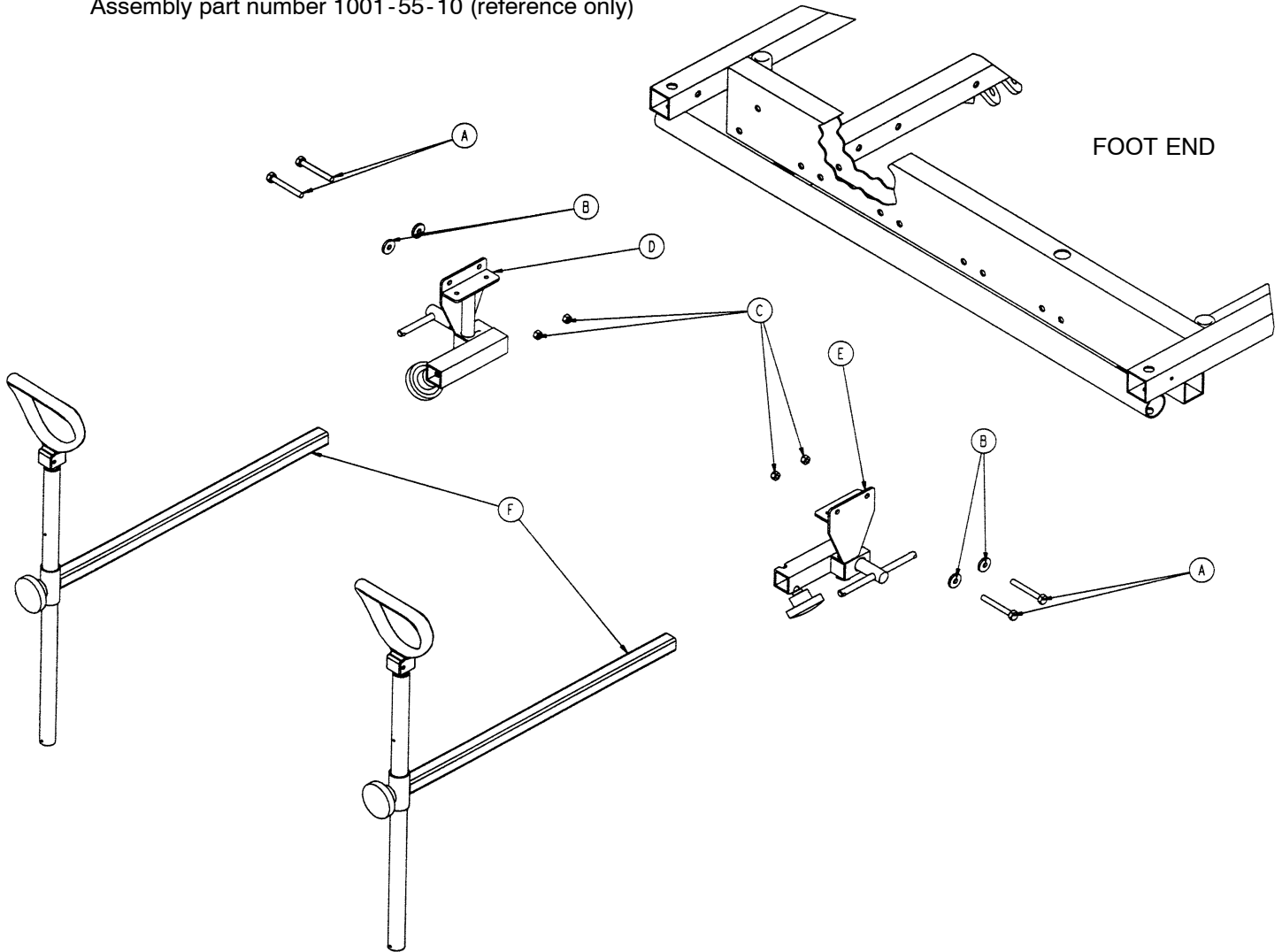

Item	Part No.	Part Name	Qty.
A	3-359*	Hex Hd. Cap Screw	4
B	11-159	Flat Washer	4
C	16-118	Nylock Hex Nut	4
D	(page 135)	Stirrup Support Ass'y, Rt.	1
E	(page 136)	Stirrup Support Ass'y, Lt.	1
F	(page 137)	Stirrup Assembly	2

* If the stretcher has the crank Fowler and/or crank Knee Gatch option, (2) 3-355 and (2) 3-358 replace (4) 3-359.

1001 -55-15 Right Stirrup Support Assembly

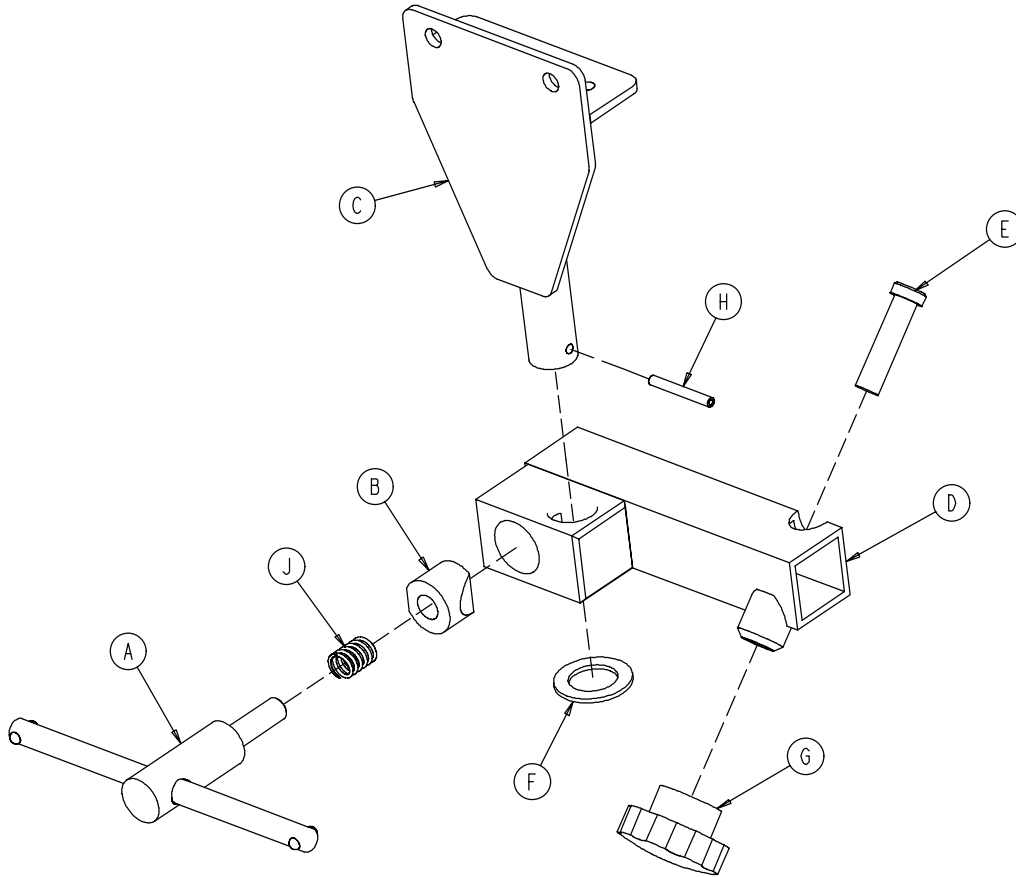

Item	Part No.	Part Name	Qty.
A	650-2-32	Lock Screw Assembly	1
B	966-51-19	Wedge Lock, Modified	1
C	1001-55-11	Mounting Bracket	1
D	1010-55-16	Right Support Tube Wldmt.	1
E	4-494	Soc. Hd. Cap Screw	1
F	11-410	Washer	1
G	1211-117-16	Knob	1
H	26-7	Roll Pin	1
J	38-171	Compression Spring	1

1001-55-16 Left Stirrup Support Assembly

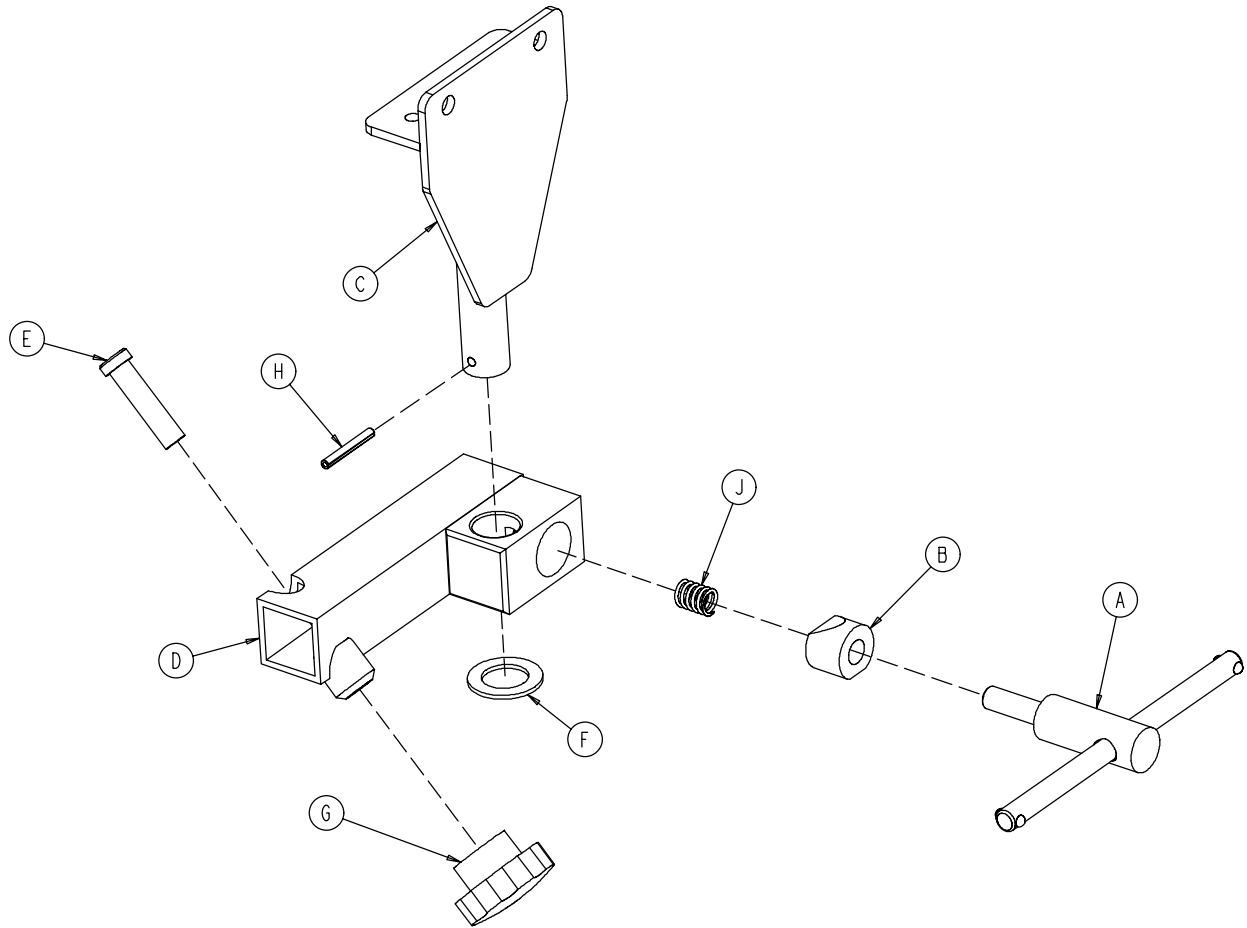

Item	Part No.	Part Name	Qty.
A	650-2-32	Lock Screw Assembly	1
B	966-51-19	Wedge Lock, Modified	1
C	1001-55-11	Mounting Bracket	1
D	1010-55-26	Left Support Tube Ass'y	1
E	4-494	Soc. Hd. Cap Screw	1
F	11-410	Washer	1
G	1211-117-16	Knob	1
H	26-7	Roll Pin	1
J	38-171	Compression Spring	1

Heel Stirrup Assembly

Assembly part number
1010-55-29 (reference only)

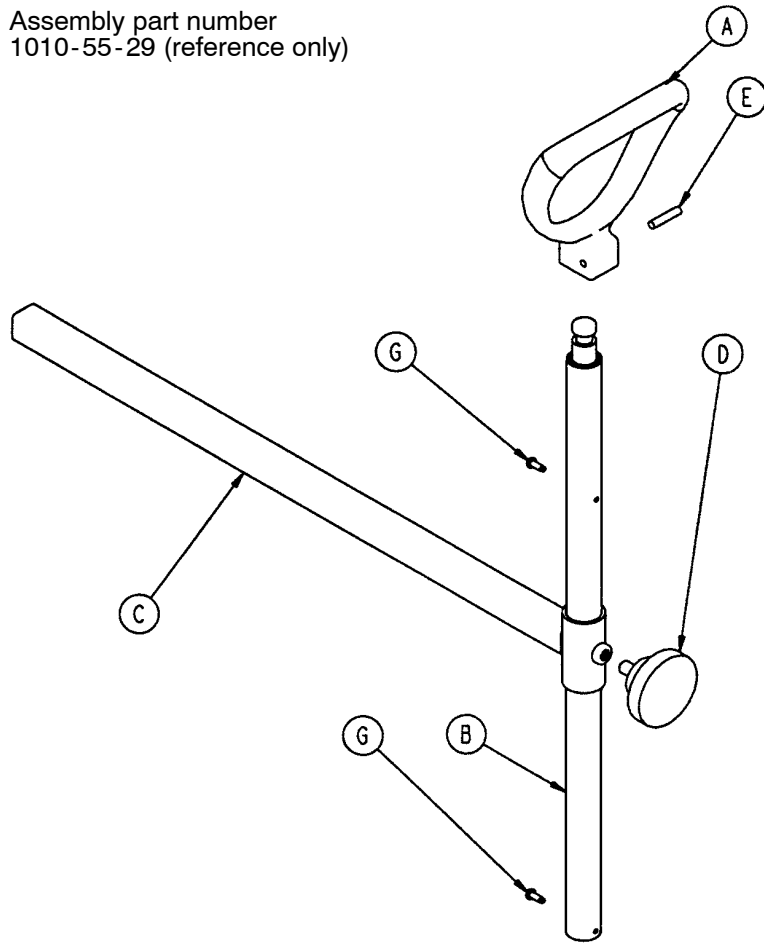

Item	Part No.	Part Name	Qty.
A	390-20-13	Stirrup	1
B	390-20-9	Stirrup Holder Assembly	1
C	1010-55-30	Extension Tube Assembly	1
D	24-11	Knob	1
E	26-43	Roll Pin	1
G	22-8	Drive Screw	2

1001-70 C-Spine Cassette Holder Assembly

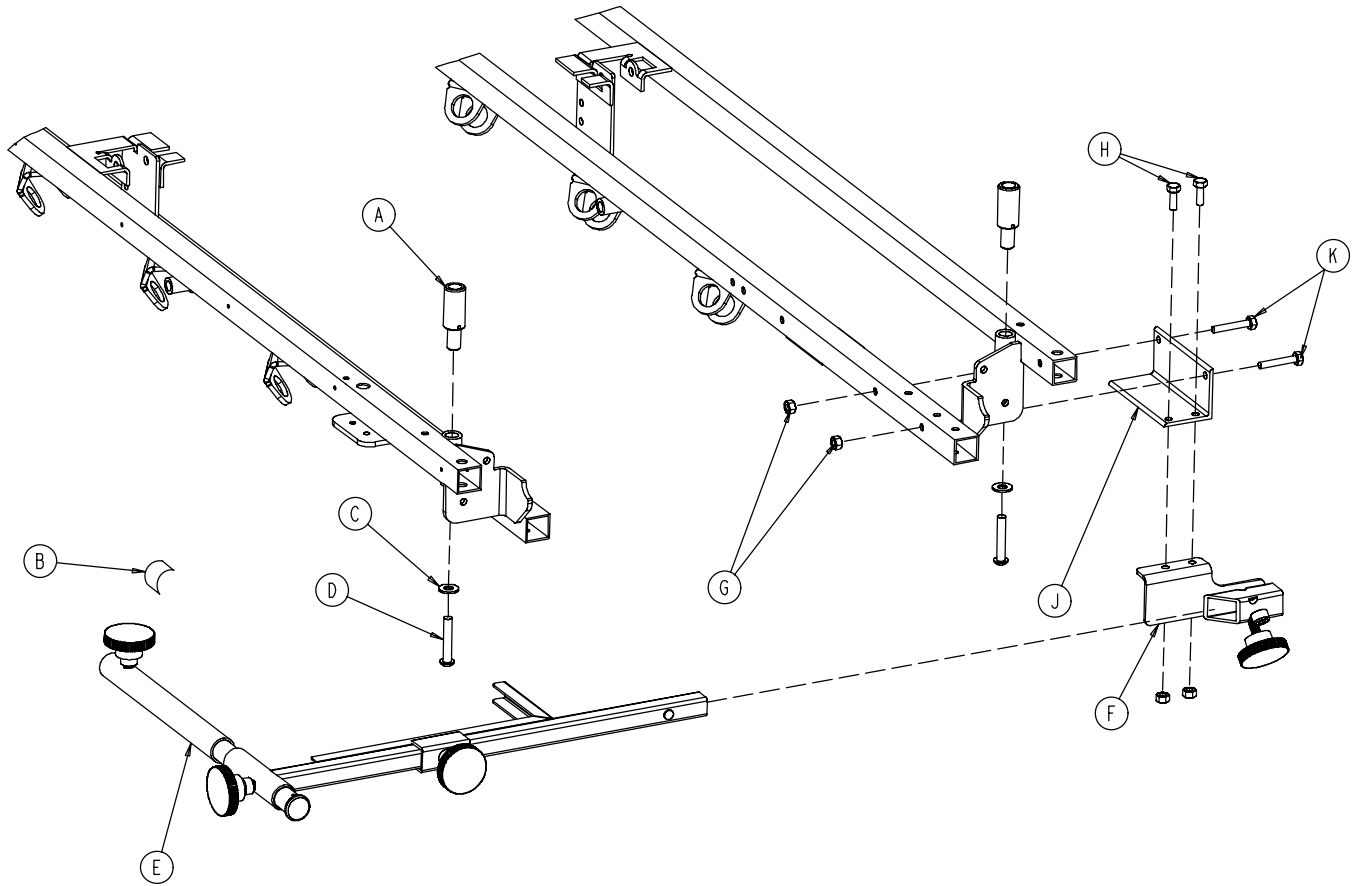

Item	Part No.	Part Name	Qty.
A	1010-70-25	I.V. Adaptor	2
B	1010-70-18	Specification Label	1
C	11-447	Flat Washer	2
D	4-54	But. Hd. Cap Screw	2
E	(page 139)	Support Pole Assembly	1
F	(page 140)	Storage Bracket Ass'y	1
G	16-118	Nylock Nut	4
H	3-356	Hex Hd. Cap Screw	2
J	1001-70-11	Attachment Bracket	1
K	3-355	Hex Hd. Cap Screw	2

C-Spine Support Pole Assembly

Assembly part number
1010-70-10
(reference only)

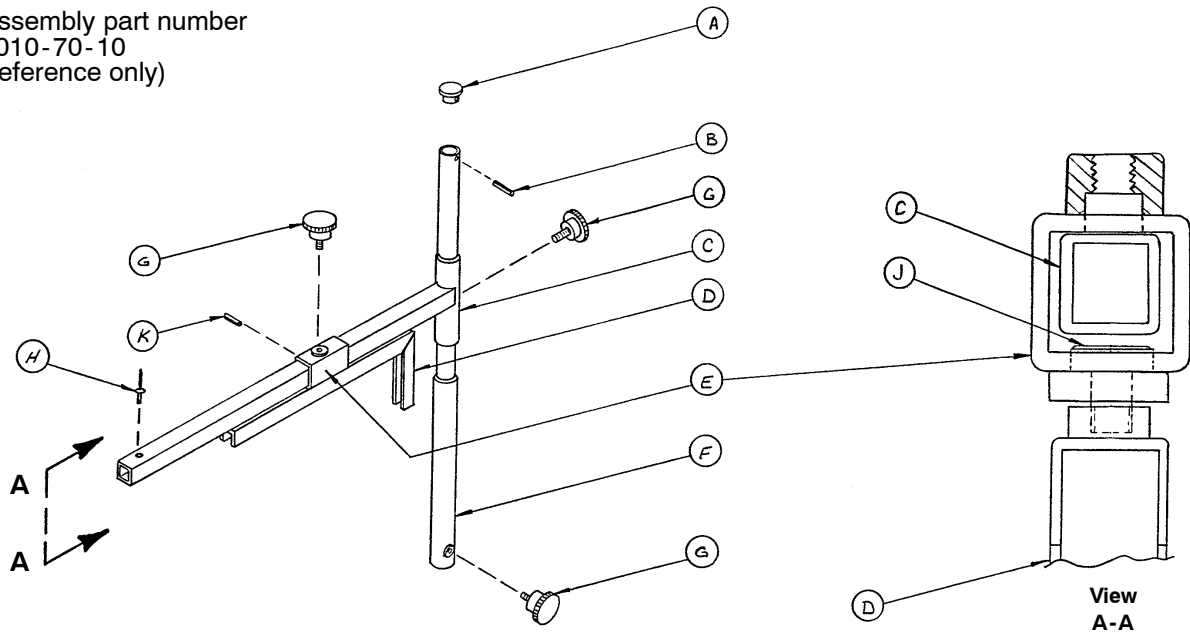

Item	Part No.	Part Name	Qty.
A	1010-70-33	Support Tube Cap	1
B	26-6	Roll Pin	1
C	1010-70-34	Support Arm Weldment	1
D	1010-70-42	Cassette Holder Weldment	1
E	1010-70-50	Adjustment Tube Weldment	1
F	1010-70-30	Base Tube Weldment	1
G	1010-70-45	Knob	3
H	25-55	Pop Rivet	1
J	1010-70-44	Pivot Pin	1
K	26-5	Roll Pin	1

C-Spine Storage Bracket Assembly

Assembly part number 1010-70-19 (reference only)

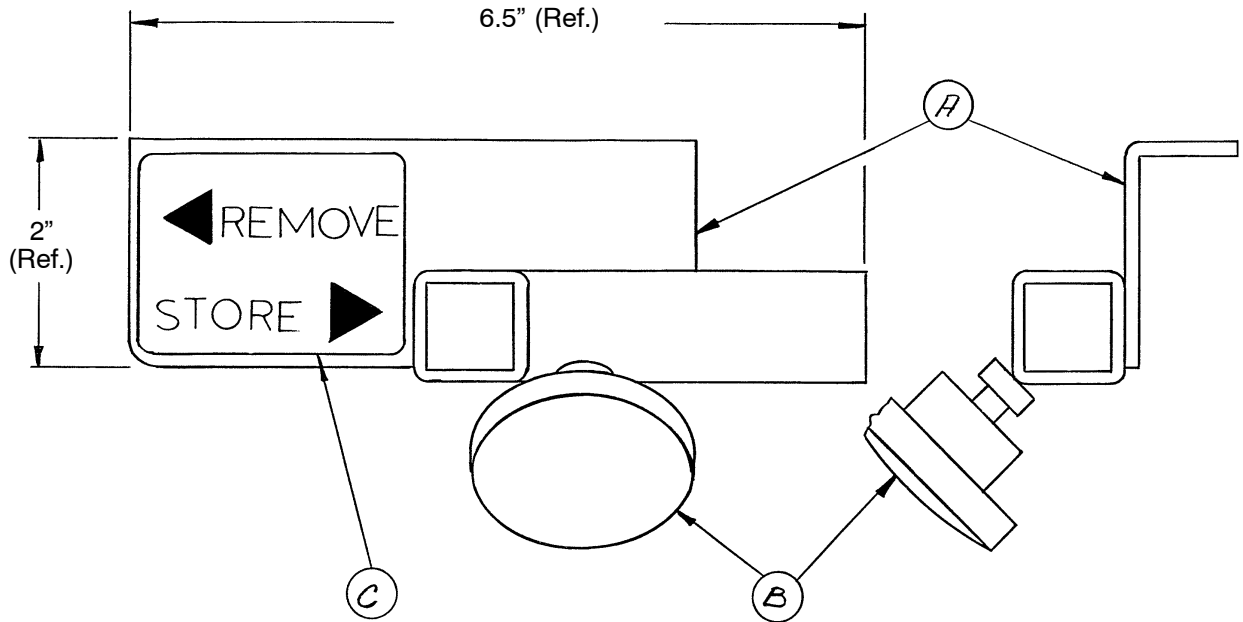

Item	Part No.	Part Name	Qty.
A	1010-70-20	Storage Bracket Weldment	1
B	1010-70-45	Knob	1
C	1010-70-23	Storage Label	1

1040-10-90 Optional O₂ Bottle Retainer Assembly

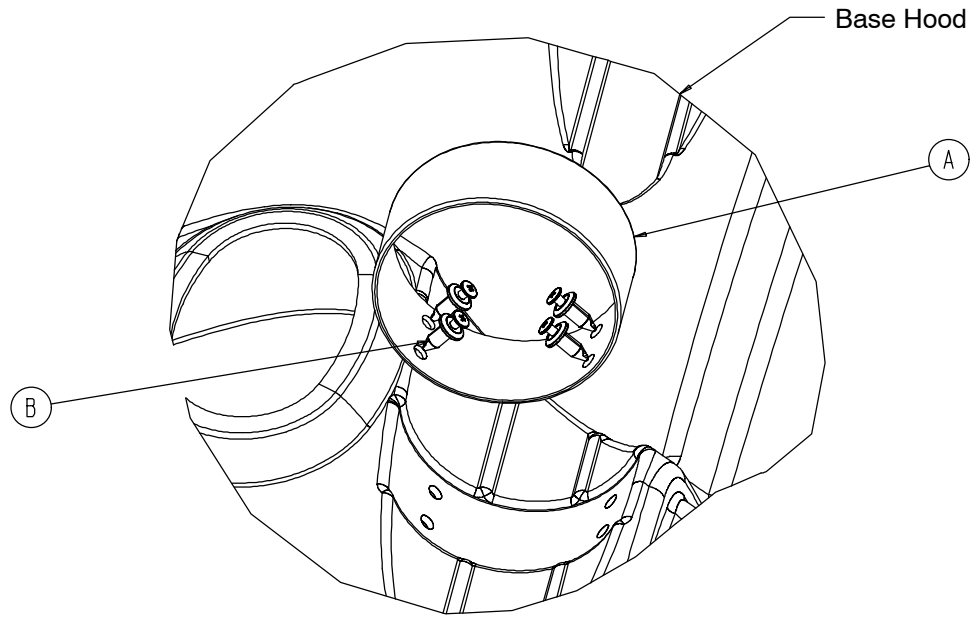

Item	Part No.	Part Name	Qty.
A	1040-10-91	Bottle Retainer	1
B	1040-10-92	Scrulok Fastener	4

Mattresses and Siderail Pads

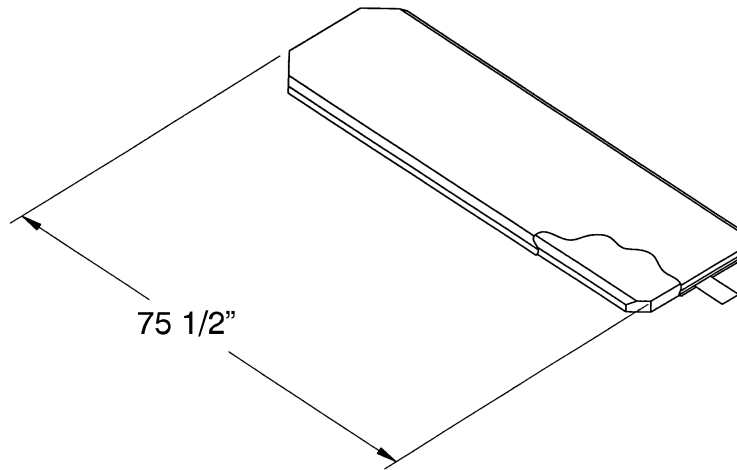

Mattress, 2" Thick x 26" Wide, Standard	part # 1059-226-140
Mattress, 3" Thick x 26" Wide, Standard	part # 1059-326-140
Mattress, 4" Thick x 26" Wide, Standard	part # 1059-426-140
Mattress, 3" Thick x 29" Wide, Standard	part # 1059-329-140
Mattress, 4" Thick x 29" Wide, Standard	part # 1059-429-140
Mattress, 3" Thick x 26" Wide, Enhanced Comfort	part # 1001-48-106
Mattress, 4" Thick x 26" Wide, Enhanced Comfort	part # 1001-47-106
Mattress, 3" Thick x 29" Wide, Enhanced Comfort	part # 1501-48-106
Mattress, 4" Thick x 29" Wide, Enhanced Comfort	part # 1501-47-106
Mattress, 4" Thick x 26" Wide, Ultra Comfort	part # 1210-40-4
Mattress, 5" Thick x 26" Wide, Ultra Comfort	part # 1210-40-5
Mattress, 4" Thick x 29" Wide, Ultra Comfort	part # 1710-40-4
Mattress, 5" Thick x 29" Wide, Ultra Comfort	part # 1710-40-5

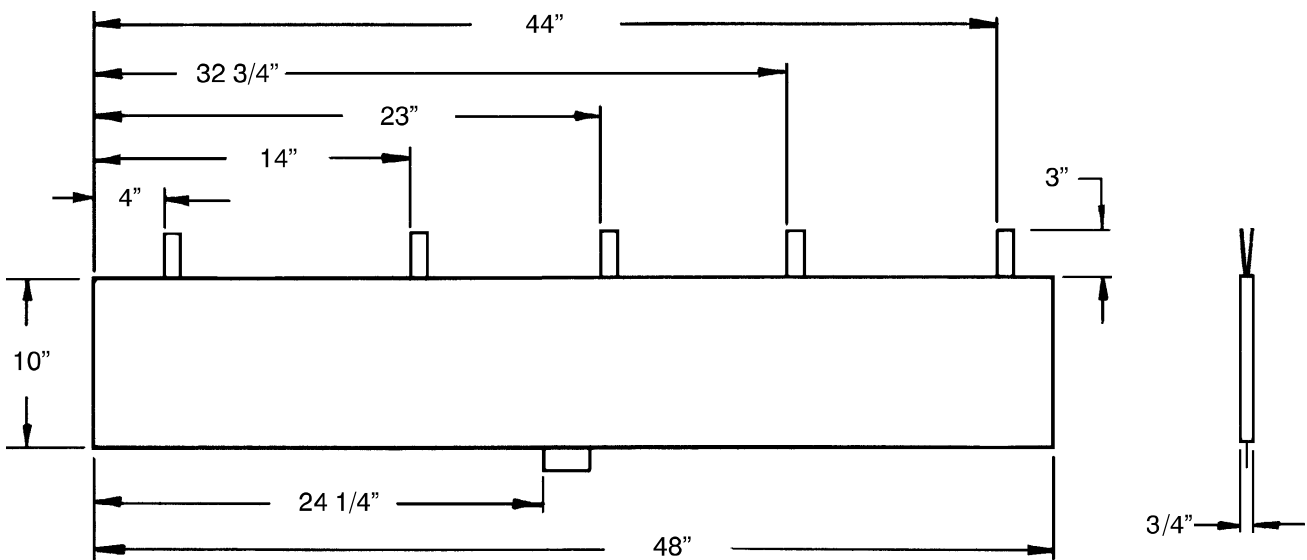

Siderail Pad Set	part # 1001-52
------------------------	----------------

Echo Mattresses

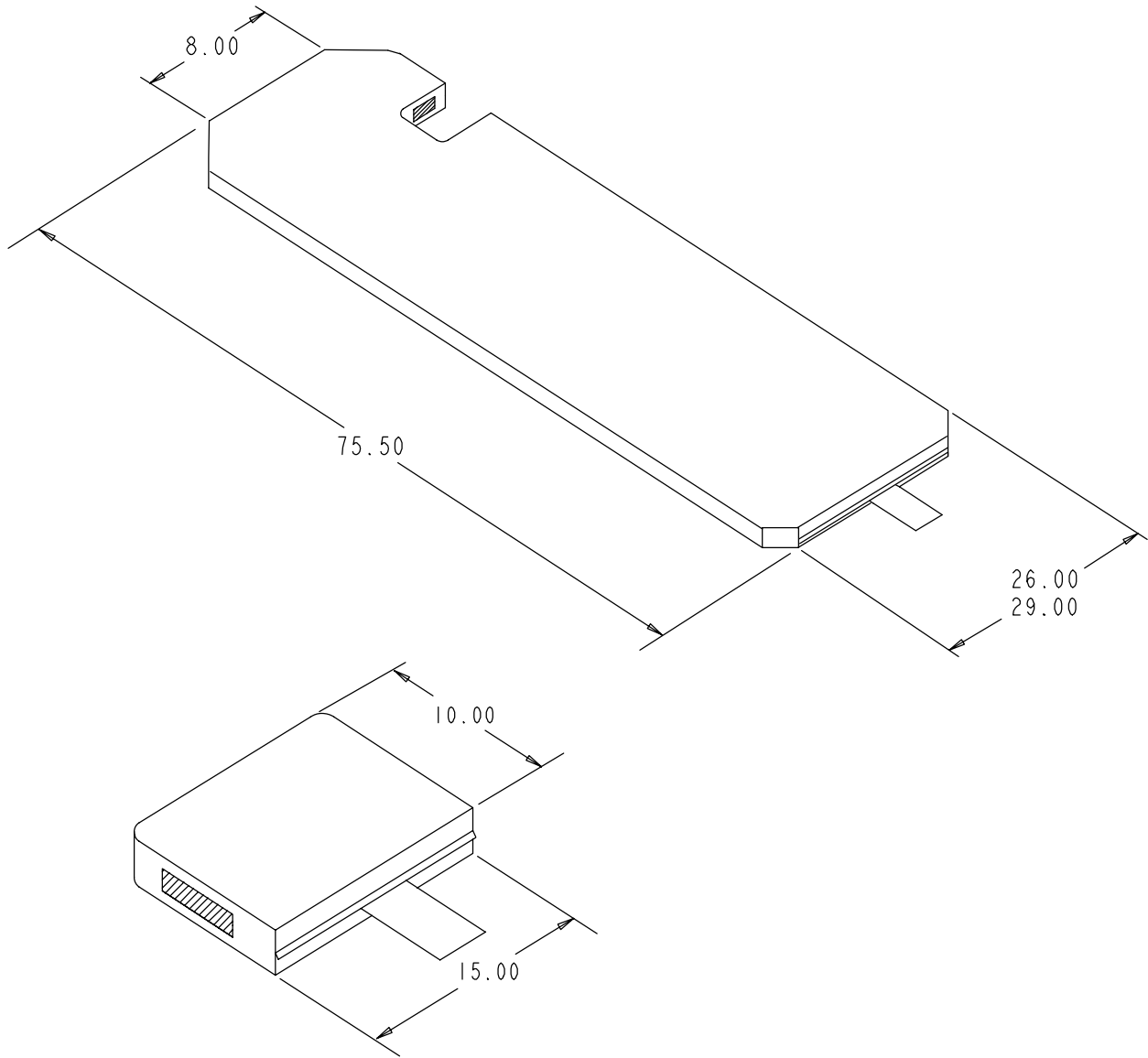

Mattress, 26" Wide	part # 1059-459-10
Mattress, 29" Wide	part # 1059-429-10
Cut-Out Mattress	part # 1059-426-28

Warranty

Limited Warranty:

Stryker Medical Division, a division of Stryker Corporation, warrants to the original purchaser that its products should be free from defects in material and workmanship for a period of one (1) year after date of delivery. Stryker's obligation under this warranty is expressly limited to supplying replacement parts and labor for, or replacing, at its option, any product which is, in the sole discretion of Stryker, found to be defective. Stryker warrants to the original purchaser that the frame and welds on its beds will be free from structural defects for as long as the original purchaser owns the bed. If requested by Stryker, products or parts for which a warranty claim is made shall be returned prepaid to Stryker's factory. Any improper use or any alteration or repair by others in such manner as in Stryker's judgement affects the product materially and adversely shall void this warranty. Any repair of Stryker products using parts not provided or authorized by Stryker shall void this warranty. No employee or representative of Stryker is authorized to change this warranty in any way.

Stryker Medical stretchers are designed for a 10 year expected life under normal use conditions and appropriate periodic maintenance as described in the maintenance manual for each device.

This statement constitutes Stryker's entire warranty with respect to the aforesaid equipment. STRYKER MAKES NO OTHER WARRANTY OR REPRESENTATION, EITHER EXPRESSED OR IMPLIED, EXCEPT AS SET FORTH HEREIN. THERE IS NO WARRANTY OF MERCHANTABILITY AND THERE ARE NO WARRANTIES OF FITNESS FOR ANY PARTICULAR PURPOSE. IN NO EVENT SHALL STRYKER BE LIABLE HEREUNDER FOR INCIDENTAL OR CONSEQUENTIAL DAMAGES ARISING FROM OR IN ANY MANNER RELATED TO SALES OR USE OF ANY SUCH EQUIPMENT.

To Obtain Parts and Service:

Stryker products are supported by a nationwide network of dedicated Stryker Field Service Representatives. These representatives are factory trained, available locally, and carry a substantial spare parts inventory to minimize repair time. Simply call your local representative, or call Stryker Customer Service at (800) 327-0770.

Service Contract Coverage:

Stryker has developed a comprehensive program of service contract options designed to keep your equipment operating at peak performance at the same time it eliminates unexpected costs. We recommend that these programs be activated *before* the expiration of the new product warranty to eliminate the potential of additional equipment upgrade charges.

A SERVICE CONTRACT HELPS TO:

- Ensure equipment reliability
- Stabilize maintenance budgets
- Diminish downtime
- Establish documentation for JCAHO
- Increase product life
- Enhance trade-in value
- Address risk management and safety

Warranty

Stryker offers the following service contract programs:

SPECIFICATIONS	GOLD	SILVER	PM* ONLY
Annually scheduled preventative maintenance	X		X
All parts,** labor, and travel	X	X	
Unlimited emergency service calls	X	X	
Priority one contact; two hour phone response	X	X	X
Most repairs will be completed within 3 business days	X	X	
JCAHO documentation	X	X	X
On-site log book w/ preventative maintenance & emergency service records	X		
Factory-trained Stryker Service Technicians	X	X	X
Stryker authorized parts	X	X	X
End of year summary	X		
Stryker will perform all service during regular business hours (9-5)	X	X	X

* Replacement parts and labor for products under PM contract will be discounted.

** Does not include any disposable items, I.V. poles (except for Stryker HD permanent poles), mattresses, or damage resulting from abuse.

Stryker Medical also offers *personalized* service contracts.

Pricing is determined by age, location, model and condition of product.

**For more information on our service contracts,
please call your local representative or call (800) 327-0770 (option #2).**

Return Authorization:

Merchandise cannot be returned without approval from the Stryker Customer Service Department. An authorization number will be provided which must be printed on the returned merchandise. Stryker reserves the right to charge shipping and restocking fees on returned items.

SPECIAL, MODIFIED, OR DISCONTINUED ITEMS NOT SUBJECT TO RETURN.

Damaged Merchandise:

ICC Regulations require that claims for damaged merchandise must be made with the carrier within fifteen (15) days of receipt of merchandise. **DO NOT ACCEPT DAMAGED SHIPMENTS UNLESS SUCH DAMAGE IS NOTED ON THE DELIVERY RECEIPT AT THE TIME OF RECEIPT.** Upon prompt notification, Stryker will file a freight claim with the appropriate carrier for damages incurred. Claim will be limited in amount to the actual replacement cost. In the event that this information is not received by Stryker within the fifteen (15) day period following the delivery of the merchandise, or the damage was not noted on the delivery receipt at the time of receipt, the customer will be responsible for payment of the original invoice in full.

Claims for any short shipment must be made within thirty (30) days of invoice.

International Warranty Clause:

This warranty reflects U.S. domestic policy. Warranty outside the U.S. may vary by country. Please contact your local Stryker Medical representative for additional information.



European Representative

Stryker EMEA RA/QA Director
Stryker France
ZAC Satolas Green Pusignan
Av. De Satolas Green
69881 MEYZIEU Cedex
France

stryker[®]
Medical

6300 Sprinkle Road, Kalamazoo, MI 49001 - 9799

(800) 327-0770
www.strykermedical.com