

stryker®

Maintenance Manual

Medical

Important
Information

File in your
maintenance
records

Model 1004
ASC Stretcher

For parts or technical
assistance call
800 327 0770 (option 2)



Table of Contents

Introduction

Specifications	4
Warning / Caution / Note Definition	4

Preventative Maintenance

Checklist	5
Cleaning	6, 7

Service Information

Caster Cover Installation and Removal	8
Caster Removal	8
Brake Rod Removal	9
Side Control Brake Rod Removal	9
Release Pedal Adjustment	10
Foot End Release Pedal Replacement	10
Foot End Release Pedal Rod Removal	10
Brake Ring Removal	11
Fifth Wheel Assembly Removal	11
Litter Top Removal	12
Jack Descent Rate Adjustment	12
Removal of Excess Air from the Hydraulic System	12
Head End Hydraulic Jack Removal	13
Foot End Hydraulic Jack Removal	13
Siderail Assembly Removal and Replacement	14, 15
Litter Corner Cover Replacement	15
Pneumatic Cylinder Replacement	16
IV Pole Replacement	16
Quick Reference Replacement Parts List	17

Table of Contents

Assembly Drawings and Parts Lists

Fifth Wheel Base Assembly	18
Fifth Wheel Assembly	19, 20
Base Assembly with Standard Brakes	21, 22
Brake Rod Assembly	23
Drive Link Assembly	24, 25
Caster Assembly	26
Base Assembly with Four-Sided Brakes	27, 28
Brake Rod Assembly	29
Side Control Brake Rod Assembly	30
Base Assembly with Dual Side Hydraulics	31–33
Release Pedal Assembly	34
Pump Pedal Assembly	35
Non-Constant Descent Jacks	36
Jack Base Assembly, Non-Constant Descent Jacks	37
Base Labeling Assembly	39–41
Litter Assembly	42
Siderail Assembly	43, 44
Siderail Latch Assembly	45, 46
Siderail Spindle Assembly	47, 48
Siderail Latch Spindle Assembly	49, 50
Dual Siderail Latch Assembly	51, 52
Latch Assembly	53–56
Standard Fowler/Stationary Foot Assembly	57
Standard Fowler Assembly	58, 59
Corner Cover Assembly	60, 61
Push Handle Assembly	62
No Push Handle Option	63
IV Poles	64–70

Table of Contents

Assembly Drawings and Parts Lists (Continued)

Oxygen Bottle Holder	71
Defibrillator Tray Assembly	72
Defibrillator Tray/Foot Extender/Foot Board Assembly	73
Serving Tray Assembly	74
Foot Board/Serving Tray Holder	75
Foot Board/Chartholder Assembly	76
Mattresses and Siderail Pads	77

Warranty

Obtaining Parts and Service	78
Service Contract Coverage	78
Return Authorization	79
Freight Damage Claims	79

Introduction

INTRODUCTION

This manual is designed to assist you with the maintenance of the Model 1004 Stretcher. Read it thoroughly before using the equipment or beginning any maintenance on it.

SPECIFICATIONS

Maximum Weight Capacity	500 pounds	
Overall Stretcher Length	84" (± .5")	
Overall Stretcher Width (Siderails Up)	33.5" & 37" (± .5")	
Overall Stretcher Width (Siderails Down)	30.25" & 30.75" (± .5")	
Minimum / Maximum Bed Height	21.5" / 36" (± .5")	
Fowler Angle	0 to 90° (± 3°)	
Trendelenburg / Reverse Trendelenburg	+16 / -16 ° (± 1°)	

WARNING / CAUTION / NOTE DEFINITION

The words WARNING, CAUTION and NOTE carry special meanings and should be carefully reviewed.

WARNING

Alerts the reader about a situation, which if not avoided, could result in death or serious injury. It may also describe potential serious adverse reactions and safety hazards.

CAUTION

Alerts the reader of a potentially hazardous situation, which if not avoided, may result in minor or moderate injury to the user or patient or damage to the equipment or other property. This includes special care necessary for the safe and effective use of the device and the care necessary to avoid damage to a device that may occur as a result of use or misuse.

NOTE

This provides special information to make maintenance easier or important instructions clearer.



Safe Working Load

Preventative Maintenance

CHECKLIST

- _____ All fasteners secure
- _____ Siderails move and latch properly
- _____ Engage brake pedal and push on the stretcher to ensure all casters lock securely
- _____ Steer function working properly
- _____ All casters secure and swivel properly
- _____ Body restraints working properly
- _____ IV pole intact and operating properly
- _____ Fowler operating and latching properly
- _____ Trendelenburg/Reverse Trendelenburg operating properly
- _____ No rips or cracks in mattress cover
- _____ Ground chain intact
- _____ No leaks at hydraulic connections
- _____ Hydraulic jacks holding properly
- _____ Hydraulic drop rate set properly
- _____ Hydraulic oil level sufficient
- _____ Lubricate where required
- _____ Accessories and mounting hardware in good condition and working properly

Serial No. _____

Completed By: _____ Date: _____

NOTE

Preventative maintenance should be performed at a minimum of annually. A preventative maintenance program should be established for all Stryker Medical equipment. Preventative maintenance may need to be performed more frequently based on the usage level of the product.

Cleaning

CLEANING

Model 1004 stretchers are designed to be power-washable. The unit may show some signs of oxidation or discoloration from continuous washing. However, no degradation of the stretcher's performance characteristics or functionality will occur due to power washing as long as the proper procedures are followed.

- Follow the cleaning solution manufacturer's dilution recommendations exactly.
- Remove the mattress prior to washing the unit; do not wash the mattress with the stretcher.
- Position the Fowler at 45°, place the unit in full reverse Trendelenburg (foot end down), raise the siderails, and place the I.V. poles and push handles in the up position.
- Stryker Medical recommends the standard hospital surgical cart washer for power washing Model 1004 stretchers.
- Do not replace the mattress on the stretcher until the unit is completely dry.
- Before returning the unit to service, verify all labels are intact, verify the brake/steer pedal locks properly in both positions and check all components for proper lubrication.

DO NOT STEAM CLEAN THE UNIT. Use a maximum water temperature of 180°F/82°C. Maximum air dry temperature (cart washers) is 240°F/115°C. Water pressure – 1500 psi/103.5 bar. If a hand held wand is being used to wash the unit, the pressure nozzle must be kept a minimum of 24 inches/.61m from the unit.

Stretchers must have maintenance performed after a minimum of every fifth washing. Refer to the maintenance manual for specific lubrication instructions.

Failure to comply with these instructions may invalidate any/all warranties.

Do not use abrasive cleaners to clean the display enclosure for the optional scale system. Do not allow cleaning solutions or other fluids to pool on the display unit. Wipe dry all surfaces after spills or cleaning.

Cleaning

CLEANING (CONTINUED)

Hand wash all surfaces of the stretcher with warm water and mild detergent. DRY THOROUGHLY. Do not steam clean, pressure wash, hose off or ultrasonically clean. Using these methods of cleaning is **not** recommended and may void this product's warranty.

Suggested cleaners for stretcher surfaces:

Quaternary Cleaners (active ingredient – ammonium chloride)

Phenolic Cleaners (active ingredient – o-phenylphenol)

Chlorinated Bleach Solution (5.25% – less than 1 part bleach to 100 parts water)

Avoid oversaturation and ensure the product does not stay wet longer than the chemical manufacturer's guidelines for proper disinfecting.



CAUTION

SOME CLEANING PRODUCTS ARE CORROSIVE IN NATURE AND MAY CAUSE DAMAGE TO THE PRODUCT IF USED IMPROPERLY. If the products described above are used to clean Stryker patient care equipment, measures must be taken to insure the beds are wiped with clean water and thoroughly dried following cleaning. Failure to properly rinse and dry the beds will leave a corrosive residue on the surface of the bed, possibly causing premature corrosion of critical components. Failure to follow the above directions when using these types of cleaners may void this product's warranty.

For mattress cleaning instructions, please see the tag on the mattress, or contact the mattress manufacturer.

Clean Velcro® AFTER EACH USE. Saturate Velcro® with disinfectant and allow disinfectant to evaporate. (Appropriate disinfectant for nylon Velcro® should be determined by the hospital.)

Service Information

CASTER COVER INSTALLATION AND REMOVAL

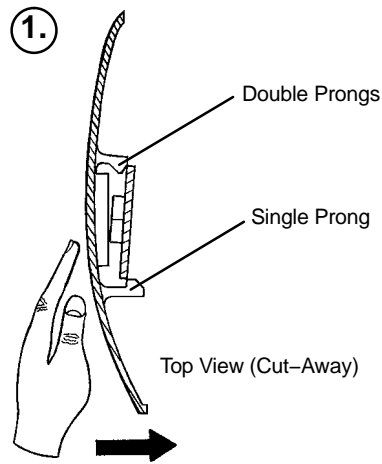

Looking through the larger of the two side cut-outs, align the cover with the axle nut or bolt head, as shown. Push down on the opposite side of the cover until the single prong engages the caster horn.

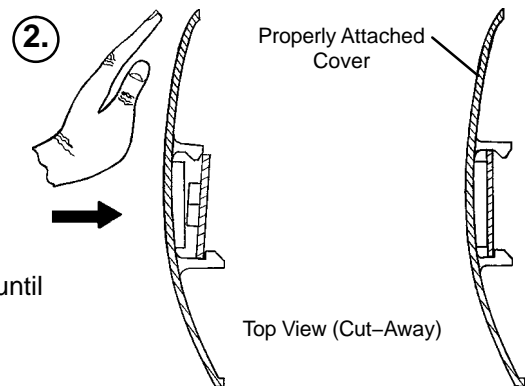

Push on the cover with your palm until the double prongs engage.

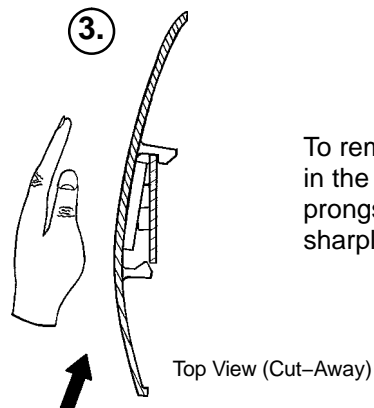

To remove the wheel cover, insert a large screwdriver into the cut-out in the side of the wheel cover and into the space between the double prongs. Pry up the cover to disengage the double prongs and push sharply upward to disengage the single prong.

CASTER REMOVAL

Required Tools:

9/16" Open End Wrench

1. Remove the caster cover.
2. While keeping pressure on the caster bolt with your index finger, use a 9/16" open end wrench to remove the nylock hex nut on top of the caster assembly.
3. Using the brake ring, lift up on the base assembly and pull the caster assembly down to remove it.
4. Reverse steps 1–3 to install the new caster.

Service Information

BRAKE ROD REMOVAL

Required Tools:

Hammer

7/32" Punch

String or Bungee Cords

1. Pump the litter up to full height.
2. Lift the base hood and support it from the litter using string or bungee cords.
3. Remove the hex head cap screws connecting the brake rod supports to the base frame.
4. Remove the bolt connecting the drive link assembly to the fifth wheel cam.
5. Remove the rue ring cotter and clevis pin connecting the rod end link to the side control link.
6. Remove the rue ring cotter connecting the drive link assembly to the bearing pivot support on the base frame (under the brake ring weldment).
7. Remove the three hex washer head screws holding the brake rod assembly to the base frame.
8. Remove the slotted spring pins connecting the butterfly "V" pedals, drive link assemblies and side control link to the brake rod.
9. Reverse steps 1–8 to reinstall the brake rod. When reinstalling the brake rod supports, torque the hex head cap screws to 12–15 ft.–lbs.

CAUTION

When reattaching the brake rod assembly to the base frame, set the torque specs **no higher** than 15 ft.–lbs. or damage could occur to the bolts.

SIDE CONTROL BRAKE ROD REMOVAL

Required Tools: Hammer 7/32" Punch Needle Nose Pliers String or Bungee Cords

1. Pump the litter up to full height.
2. Lift the base hood and support it from the litter using string or bungee cords.
3. Remove the rue ring cotter and clevis pin connecting the rod end link to the side control link.
4. Remove the four bolts holding the brake rod assembly to the base frame and remove the entire assembly.
5. Using a hammer and 7/32" punch, drive the slotted spring pin out of the butterfly "V" pedal on the patient's left side and remove the pedal,
6. Using a hammer and 7/32" punch, drive the slotted spring pin out of the hard stop in the center of the support weldment.
7. Using a hammer and 7/32" punch, drive out the slotted spring pin connecting the side control link to the side control brake rod on the patient's right side.
8. Pull on the butterfly "V" pedal on the patient's right side to remove the side control brake rod from the base.
9. Reverse steps 1–8 to reinstall the brake rod. When reinstalling the assembly, torque the hex head cap screws to 12–15 ft.–lbs.

CAUTION

When reattaching the brake rod assembly to the base frame, set the torque specs **no higher** than 15 ft.–lbs. or damage could occur to the bolts.

Service Information

RELEASE PEDAL ADJUSTMENT

1. Manually disengage the release pedal swivel (item J on [page 32](#)) from the release pedal assembly.
2. To increase the release rod engagement with the release valve, turn the release pedal swivel clockwise on the threaded release rod.
3. To decrease the release rod engagement with the release valve, turn the release pedal swivel counter-clockwise on the threaded release rod.

NOTE

If the pedal swivel assembly is threaded too far onto the release rod, the release valve will be partially activated and the jack will drift.

FOOT END RELEASE PEDAL REPLACEMENT

Required Tools: Needle Nose Pliers

1. Apply the stretcher brakes.
2. Disconnect the release pedal return springs from the foot end release pedals.
3. Remove the rue ring cotters and the clevis pins connecting the foot end release pedals to the mounting bracket.
4. Rotate the pedals upward.
5. Remove the rue ring cotters connecting the head end and foot end release rods to the foot end release pedals and remove the pedals.
6. Reverse steps 2–5 to install the new pedals.

FOOT END RELEASE PEDAL ROD REMOVAL

Required Tools: Needle Nose Pliers

1. Remove the foot end release pedal (see procedure above).
2. Remove the snap in nyliners holding the foot end pedal release rods in the pedal mounting bracket.
3. Unsnap the foot end pedal release rods from the white plastic release rod brackets.
4. Dislodge the side control release pedal swivels from the studs on the side control release pedal weldments.
5. Remove the foot end pedal release rods.
6. Reverse steps 1–5 to reinstall the pedal rods.

Service Information

BRAKE RING REMOVAL

Required Tools:

9/16" Socket w/Extension 3/8" Drive Ratchet Needle–Nose Pliers String or Bungee Cord

1. Pump the litter up to full height.
2. Lift the base hood and support it from the litter using string or bungee cords.
3. Using needle–nose pliers, unhook the extension springs from the top of the base caster tubes.
4. Remove the plastic caster covers.
5. While putting pressure on the caster carriage bolt, use a 9/16" socket and a 3/8" drive ratchet to remove the caster nut on both sides of the stretcher.
6. Remove the casters.
7. Remove the brake rod (see procedure).
8. Remove the cotter pin from the clevis pin in the center of the brake ring weldment.
9. Remove the cotter pin from the bearing pivot support.
10. Remove the 3/4" nylock hex nut from the bearing pivot support.
11. Remove the drive link assembly.
12. Pull the brake ring down and out away from the stretcher base frame.
13. Reverse steps 1–12 to reinstall the brake ring.

FIFTH WHEEL ASSEMBLY REMOVAL

Required Tools:

1/2" Socket 3/8" Drive Ratchet

1. Using a 1/2" socket and 3/8" drive ratchet, remove the 1/2" bolt holding the fifth wheel cam drive link and fifth wheel drive link to the fifth wheel cam.
2. Remove the two 1/2" bolts holding the fifth wheel mounting bracket to the base frame weldment.
3. Remove the fifth wheel assembly.
4. Reverse steps 1 and 2 to reinstall the fifth wheel. When reinstalling the assembly, torque the hex head cap screws to 12–15 ft.–lbs.

CAUTION

When reattaching the fifth wheel assembly to the base frame, set the torque specs **no higher** than 15 ft.–lbs. or damage could occur to the bolts.

Service Information

LITTER TOP REMOVAL

Required Tools: 1/2" Socket w/Extension 3/8" Drive Ratchet Standard Screwdriver

1. Using the foot pedal, pump up the litter top to full height.
2. Remove the stretcher mattress
3. Using a 1/2" socket, and a 3/8" drive ratchet, remove the truss head screws holding the jack support tubes to the jack shafts.
4. Thread a 7/16–20 fine thread bolt far enough into the top of the jack supports to separate the litter top from the jack shaft.
5. With the assistance of another person, lift the litter straight up to remove it from the jack shafts and set it aside.

JACK DESCENT RATE ADJUSTMENT

Required Tools:

Screwdriver Bungee Cords (or equivalent)

Adjustment Procedure:

1. Pump the litter up to full height.
2. Lift the base hood, separating the hood from the base frame. Support the hood from the litter using bungee cords so it is out of the way.
3. The descent rate needle valve is located on the base of the jack. Turning the needle valve clockwise, with a screwdriver, will decrease the rate of descent. Turning it counterclockwise will increase the rate of descent.

NOTE

The larger percentage of a patient's weight is located in the torso area. Adjust descent rate accordingly.

4. Remove the bungee cords supporting the base hood and secure the hood to the base frame.

NOTE

The jack descent rate is preset at the factory and adjustment is not recommended.

REMOVAL OF EXCESS AIR (VACUUM) FROM THE HYDRAULIC SYSTEM

1. Verify all hydraulic linkages are secure and operating properly.
2. Using the pump pedal, actuate the system several times to force the air through the system. The jack should now raise properly.

Service Information

HEAD END HYDRAULIC JACK REMOVAL

Required Tools: 1/2" Socket w/Extension 3/8" Drive Ratchet

1. Remove the litter top from the stretcher (see [page 12](#)).
2. Using a 1/2" socket with extension and a 3/8" drive ratchet, remove the two hex head screws holding the jack base to the stretcher base frame.
3. Remove the two hex head screws holding the jack reservoir clamp to the base frame and remove the clamps.
4. Lift straight up on the pump connecting rod and disconnect the pump piston from the connecting rod.
5. Disconnect the pump pedal swivel from the release pedal mounting plate.
6. Remove the head end release rod from the release valve assembly.
7. Using a 1/2" socket with extension and a 3/8" drive ratchet, remove the two hex head screws holding the jack base to the stretcher base frame.
8. Lift out the jack assembly.
9. To reinstall the jack, install the bolts on the jack and reservoir clamp but do not tighten them fully.
10. Reinstall the pump connecting rod and release rod.
11. Depress the pump pedal fully (to the floor). This will properly locate the jack onto the base frame.
12. Tighten the bolts on the jack and reservoir clamp.
13. Pump up the litter and apply weight to verify the jacks hold and do not drift.

NOTE

The jack descent rate is preset at the factory and adjustment is not recommended.

FOOT END HYDRAULIC JACK REMOVAL (BASE WITH DUAL CONTROLS)

Required Tools:

1/2" Socket 3/8" Drive Ratchet Pliers

1. Remove the litter top from the stretcher (see [page 12](#)).
2. Lift the base hood off the base frame.
3. Remove the two hex washer head screws and washers connecting the pump pedal link to the foot end pump pedal assembly and pump connecting rod.
4. Remove the foot end release rod from the release valve on the jack assembly by dislodging the release pedal swivel from the pins on the release pedal weldment.
5. Dislodge the jack pump piston from the pump connecting rod.
6. Remove the two hex washer head screws holding the reservoir clamp.
7. Remove the jack assembly.
8. Reverse steps 1–7 to install the new jack.

NOTE

The jack descent rate is preset at the factory and adjustment is not recommended.

Service Information

SIDERAIL ASSEMBLY REMOVAL AND REPLACEMENT

Required Tools:

1/2" Socket

3/8" Drive Ratchet

Torque Wrench

1. Raise the Fowler. Remove the slider board from the storage tray.
2. Pull up on the monitor/utility tray to remove it from the litter frame.
3. If you're replacing the left siderail assembly, use a 1/2" socket and 3/8" drive ratchet, remove the four hex head cap screws holding the O2 holder bracket to the litter frame and remove the O2 holder.
4. Remove the four hex head cap screws holding the slider board tray to the litter frame.
5. Remove the rue ring cotter holding the Fowler pivot bolt and remove the pivot bolt.
6. Remove the two bolts holding the frame tie weldment.
7. Remove the plastic litter corner covers (see [page 15](#)).
8. Remove the two bolts holding the Fowler drop seat bracket.
9. Remove the six bolts holding the siderail to the head end and foot end litter weldments.
10. Carefully remove the siderail assembly.
11. Slide the side of the stretcher with the remaining siderail next to a wall to brace it or support it with bungee cords before starting to install the new siderail.
12. Lift the new siderail into position.
13. Insert the foot end jack support into the hole in the support tube bracket on the siderail. Insert the head end jack support tube into the slot in the Trend slide block.
14. Install the three bolts at the foot end litter weldment. Tighten to 13 foot-pounds torque.
15. Install the two bolts at the frame tie weldment.
16. Install the three bolts at the head end litter weldment.
17. Install the two bolts at the Fowler drop seat bracket. Tighten to 13 foot-pounds torque.
18. Install the litter corner covers, the slider board tray, the O2 holder and the monitor tray.

Service Information

SIDERAIL LATCH REPLACEMENT

Required Tools:

3/8" Drive Ratchet

T40 Torx Bit

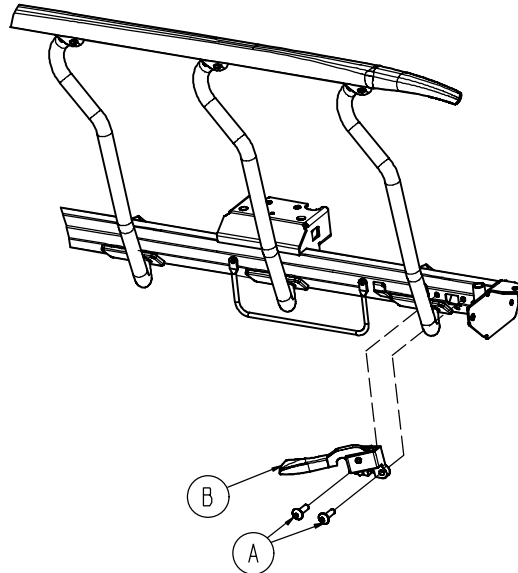

1. Using the foot pedal, raise the litter to maximum height.
2. Remove the two bolts (A) holding the siderail latch (B) to the litter frame and discard the bolts and latch.
3. Using the new bolts provided in the kit, install the new siderail latch.
4. Verify proper latching and unlatching of the siderail before returning the stretcher to service.

LITTER CORNER COVER REPLACEMENT

Required Tools:

Drill w/ 1/4" Bit

T25 Torx

Utility Knife

1. Drill out the rivet holding the IV pole and/or push handle in the socket and remove the IV pole/handle from the socket.
2. Using a utility knife, pry off the three hole plugs in the top of the cover.
3. Using a T25 Torx, remove the 3 screws holding the top and bottom covers together and pull apart the cover.
4. Reverse to install the new cover.

Service Information

PNEUMATIC CYLINDER REPLACEMENT

Required Tools:

3/8" Drive Ratchet

3/8" Socket

Needle Nose Pliers

1. Using a 3/8 drive ratchet and 3/8" socket, remove the bolt connecting the pneumatic cylinder to the Fowler weldment. Save the bushing and spacers to use with the new cylinder.
2. Turn the cylinder counterclockwise to thread it out of the gas spring trip on the litter frame tie weldment.
3. Pull the Fowler cable off the gas spring trip.
4. Using needle nose pliers, pull off the rue ring cotter and remove the clevis pin holding the gas spring trip to the litter frame tie weldment.
5. Depress the new cylinder fully.
6. Thread the cylinder into the gas spring trip until it stops.

CAUTION

Do not use a wrench, pliers, etc. to grip the cylinder. Gripping the cylinder too tightly may mar the surface of the cylinder and cause damage.

NOTE

When reinstalling the bolt and the clevis pin, use the holes in each bracket nearest the foot end of the stretcher for a drop seat Fowler and the holes in each bracket nearest the head end of the stretcher for a standard Fowler.

7. Replace the bolt, bushing and spacers holding the cylinder to the Fowler weldment. The bolt will only thread through the bracket from the patient right side.
8. Lift the Fowler slightly until the parts are aligned and replace the clevis pin and the rue ring cotter to connect the gas spring trip to the litter frame tie weldment.
9. Reconnect the Fowler cable.

IV POLE REPLACEMENT

Required Tools:

T25 Torx

Utility Knife

1/2" Socket

3/8" Drive Ratchet

1. Using a utility knife, pry off the three hole plugs in the top of the litter corner cover.
2. Using a T25 Torx, remove the 3 screws holding the top and bottom covers together and pull apart the cover.
3. Remove the bolt holding the IV pole socket to the litter frame and remove the IV pole.
4. Reverse to install the new IV pole and reinstall the litter corner cover.

Quick Reference Replacement Parts List

NOTE

The parts and accessories listed on this page are all currently available for purchase. Some of the parts identified on the assembly drawings pages in this manual may not be individually available for purchase. Please call Stryker Customer Service at 1-800-327-0770 for availability and pricing.

<u>PART NAME</u>	<u>PART NUMBER</u>
Caster Assembly (1 complete)	0753-010-020
Hydraulic Jack Assembly, Non Constant Descent	0753-002-080
IV Pole, Standard Removable	0390-025-000
Mattress, 4" x 30", Echo	0785-034-343
Mattress, 3" x 30", Enhanced	0785-034-313
Mattress, 4" x 30", Enhanced	0785-034-323
Mattress, 4" x 30", Ultra Comfort	0785-034-303
Mattress, 5" x 30", Ultra Comfort	0785-034-333
Paint, Touch-Up, Gloss Black, Bottle w/Brush	7000-001-322
Paint, Touch-Up, Gloss Black, Spray Can	7000-001-319
Paint, Touch-Up, Gray, Bottle w/Brush	7000-001-320
Paint, Touch-Up, Gray, Spray Can	7000-001-317
Pneumatic Fowler Cylinder	0360-031-077
Restraint Strap Package	0785-045-010
Restraint Strap, Ankle	0785-045-020
Restraint Straps, Body	0785-045-015
Restraint Strap, Wrist	0946-044-100
Siderail Latch Kit	0785-700-005

0753-006-110 Retractable Fifth Wheel Base Assembly

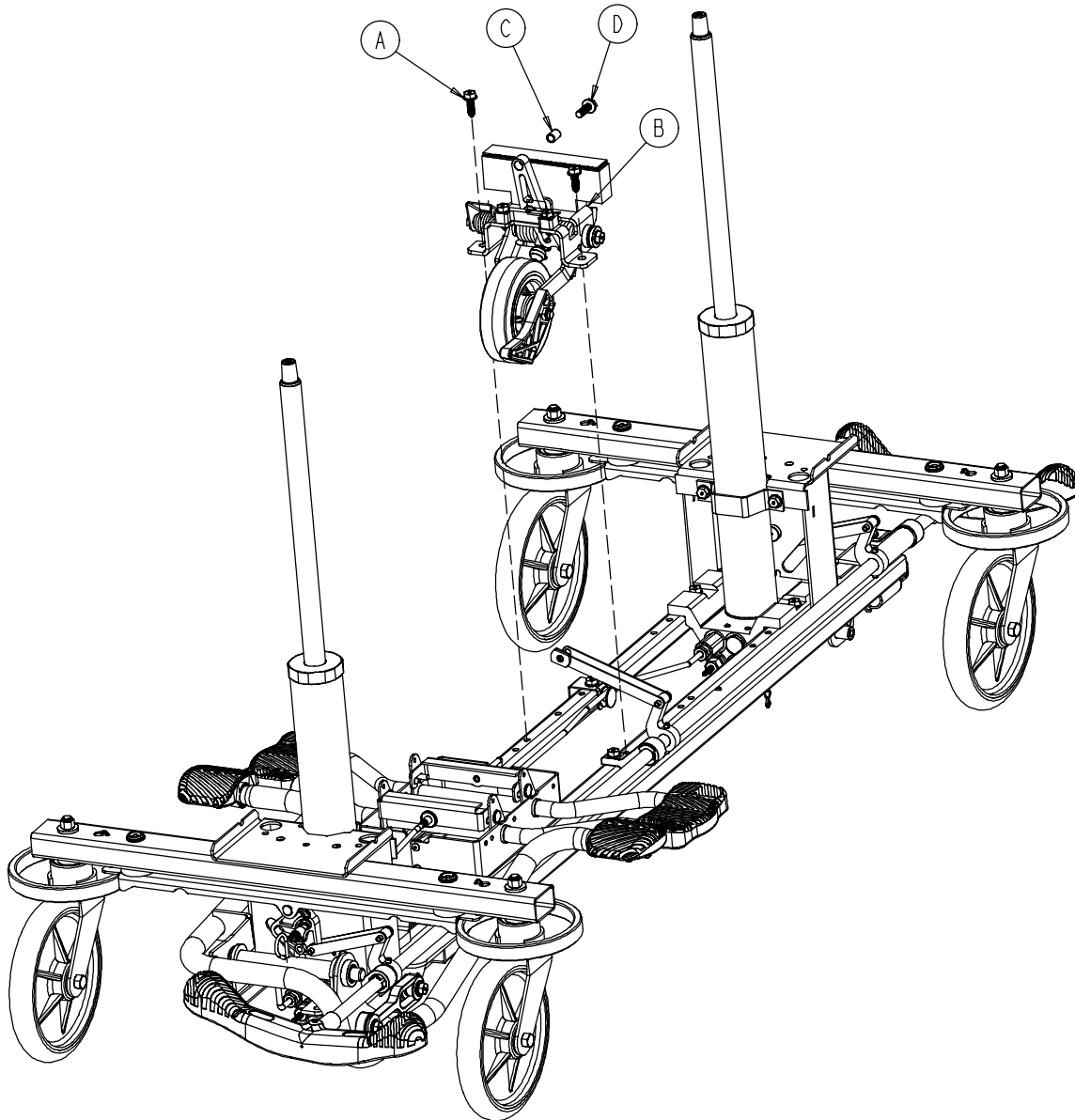

Item	Part No.	Part Name	Qty.
A	0023-288-000	Hex Washer Hd. Screw	2
B	(page 19)	Fifth Wheel Assembly	1
C	0753-006-148	Cam Bearing	1
D	0023-305-000	Hex Hd. Cap Screw	1

0753-006-130 Fifth Wheel Assembly

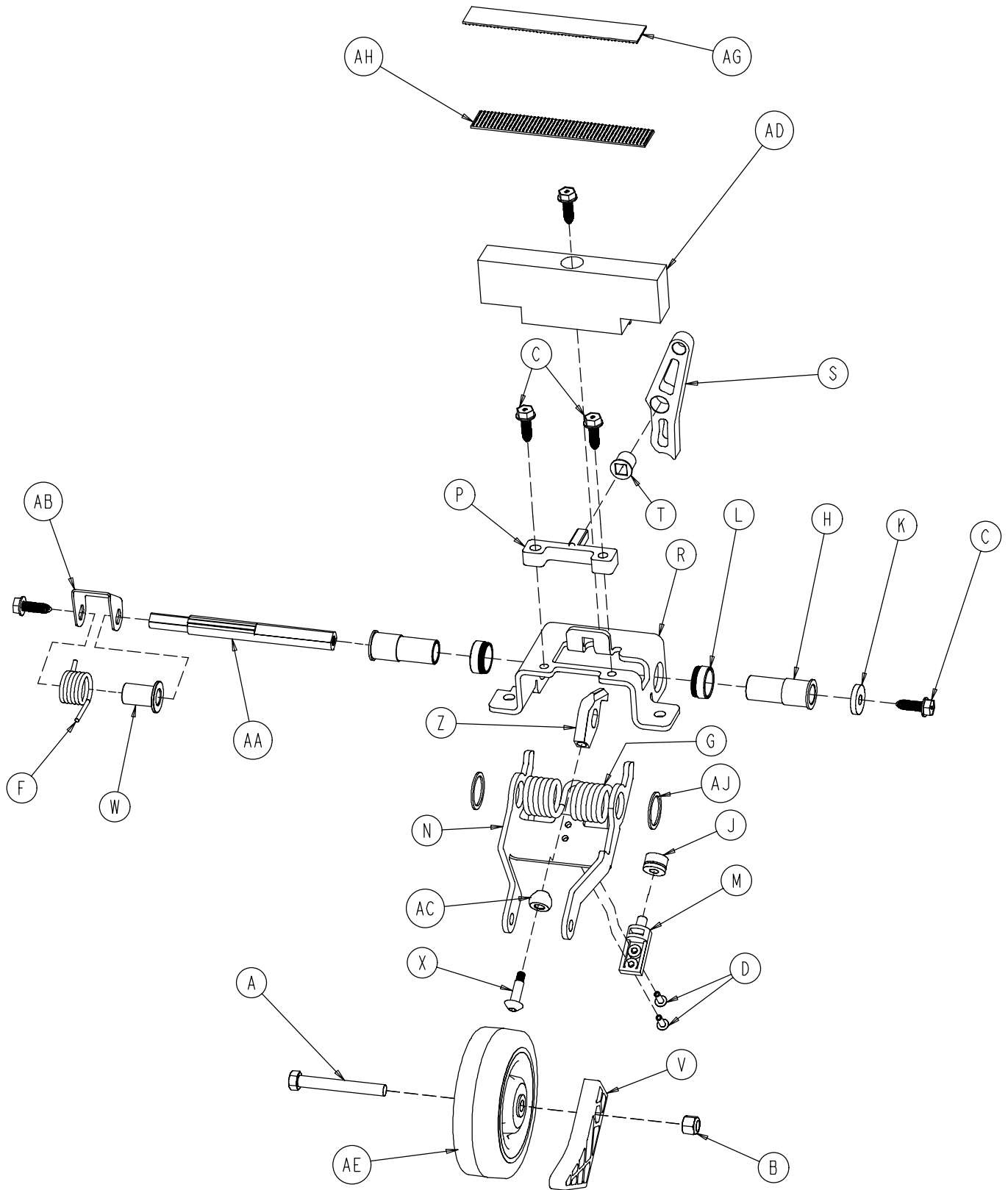

0753-006-130 Fifth Wheel Assembly

Item	Part No.	Part Name	Qty.
A	0003-083-000	Hex Hd. Cap Screw	1
B	0016-035-000	Nylock Hex Nut	1
C	0023-288-000	Hex Washer Hd. Screw	5
D	0025-050-000	Rivet	2
F	0753-006-074	Torsion Spring	1
G	0753-006-075	Torsion Spring	1
H	0753-006-097	Drive Shaft Bearing	2
J	0753-006-106	Dampener	1
K	0753-006-108	Thrust Washer	1
L	0753-006-115	Bearing	2
M	0753-006-120	Bumper Mounting Pin	1
N	0753-006-126	Wheel Bracket	1
P	0753-006-133	Cam Pivot Block	1
R	0753-006-134	Fifth Wheel Mounting Bracket	1
S	0753-006-142	Fifth Wheel Cam	1
T	0753-006-143	Cam Bearing	1
V	0753-006-149	5th Wheel Ramp	1
W	0753-006-152	Spring Spacer	1
X	0753-006-153	Roller Stem	1
Z	0753-006-198	Drive Pin	1
AA	0753-006-223	Drive Shaft	1
AB	0753-006-227	Return Spring Hook	1
AC	0753-006-277	Roller	1
AD	0753-010-045	Hood Standoff	1
AE	1210-001-147	Wheel	1
AG	0753-006-280	Dual Lock	1
AH	0753-006-281	Dual Lock	1
AJ	0011-360-000	Washer	2

Base Assembly w/Standard Brakes (Fifth Wheel Base)

Assembly part number
0753-003-105
(reference only)

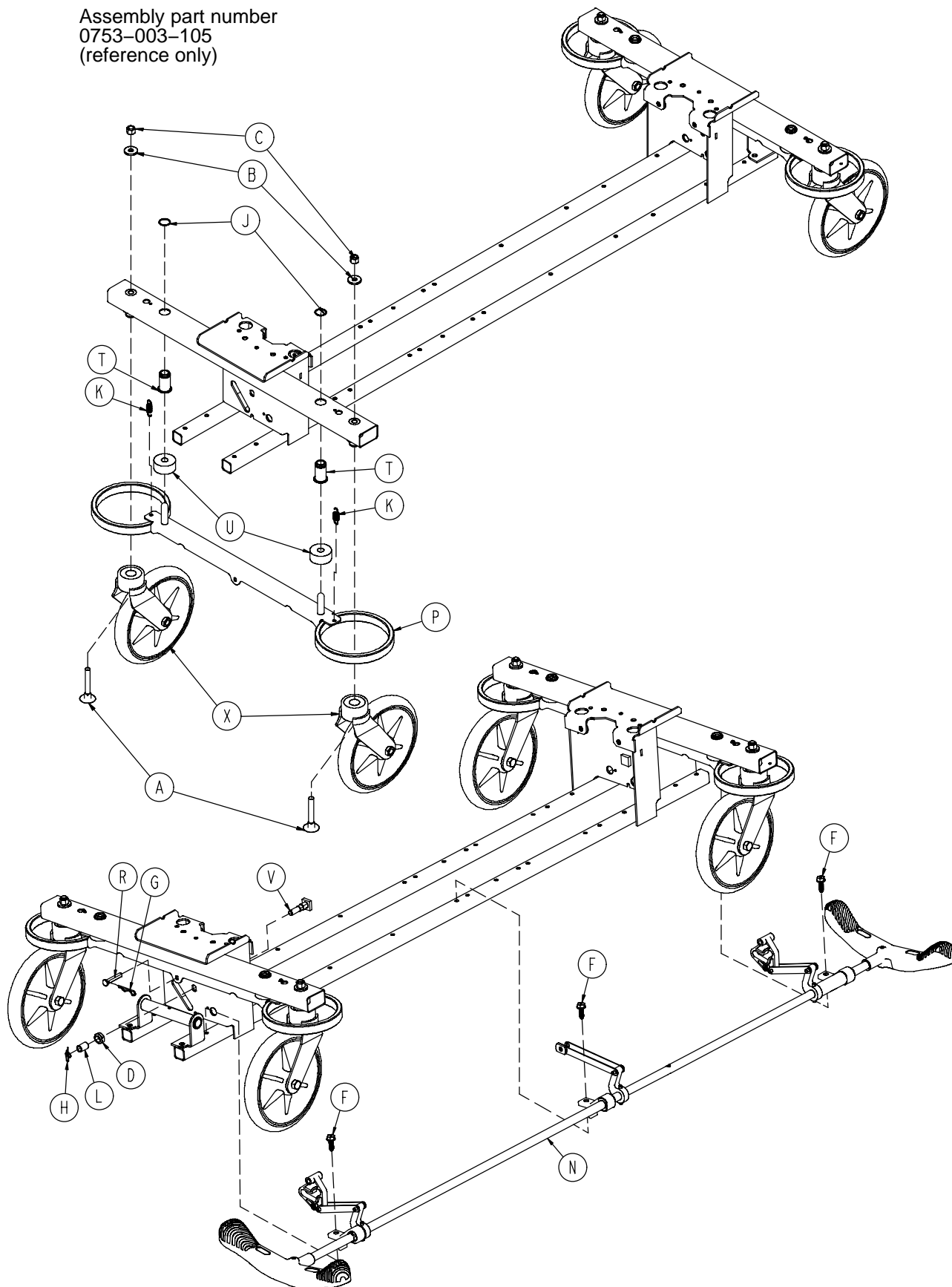

Base Assembly w/Standard Brakes (Fifth Wheel Base)

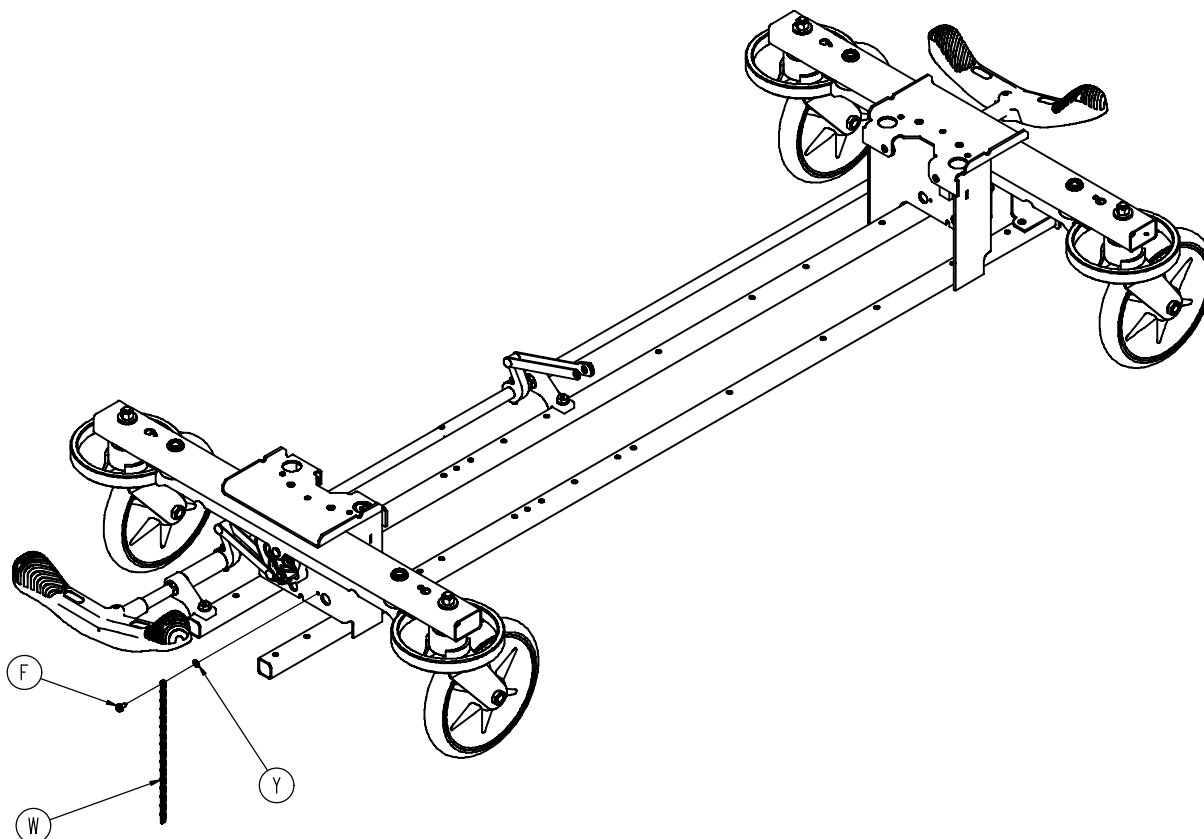

Item	Part No.	Part Name	Qty.
A	0005-044-000	Step Bolt	4
B	0011-262-000	Washer	4
C	0016-035-000	Nylock Hex Nut	4
D	0016-049-000	Nylock Hex Nut	2
E	0023-288-000	Hex Washer Hd. Screw	1
F	0003-364-000	Hex Washer Hd. Screw	1
G	0027-012-000	Hitch Pin	2
H	0027-022-000	Rue Ring Cotter	2
J	0028-037-000	External Retaining Ring	4
K	0038-439-000	Extension Spring	4
L	0081-037-000	Plane Bearing	2
M	0753-001-001	Base Frame	1
N	(page 23)	Brake Rod Assembly	1
P	0753-003-006	Brake Ring	2
R	0753-003-066	Clevis Pin	2
T	0753-003-079	Caster Tube Brake Pin Guide	4
U	0753-003-121	Brake Cushion	4
V	0753-003-230	Bearing Pivot Support	2
W	3001-200-052	Ground Chain	1
X	(page 26)	Caster Assembly	4
Y	0013-018-000	External Tooth Lock Washer	1

Brake Rod Assembly

Assembly part number 0753-003-001 (reference only)

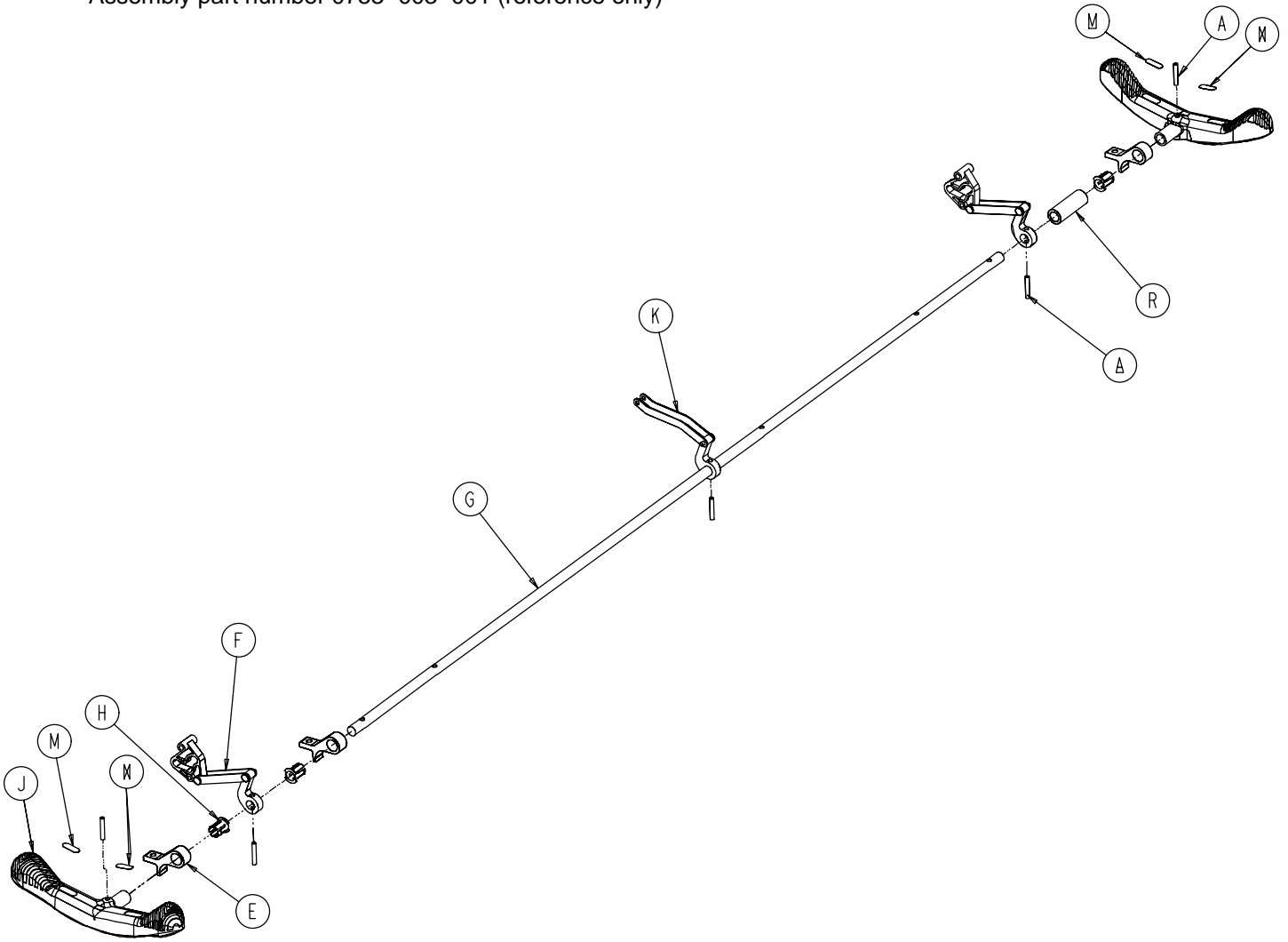

Item	Part No.	Part Name	Qty.
A	0026-067-000	Slotted Spring Pin	2
E	0753-003-004	Brake Rod Support	3
F	(page 24)	Drive Link Assembly	2
G	0753-003-014	Brake Rod	1
H	0753-003-015	Brake Rod Nyliner	3
J	0785-003-099	Butterfly "V" Pedal	2
K	(page 25)	Drive Link Assembly	1
M	1210-201-335	Red Brake Label	2
N	1210-201-336	Green Steer Label	2
R	0753-003-133	Retainment Spacer	1

0753-006-135 Drive Link Assembly

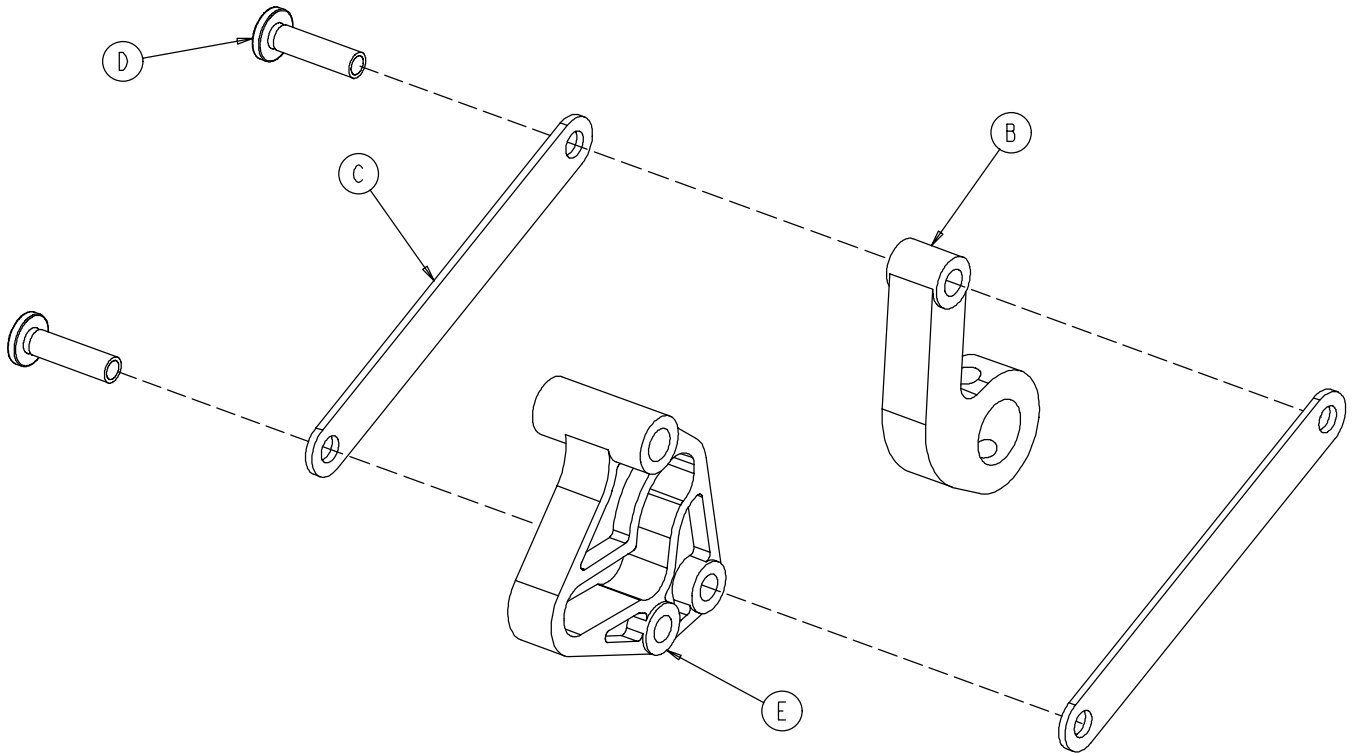

Item	Part No.	Part Name	Qty.
B	0753-003-011	Brake Rod Drive Link	1
C	0753-003-061	Brake Cam Drive Link	2
D	0753-003-098	Flat Hd. Semi-Tubular Rivet	2
E	0753-003-102	Brake Cam	1

0753-006-135 Drive Link Assembly

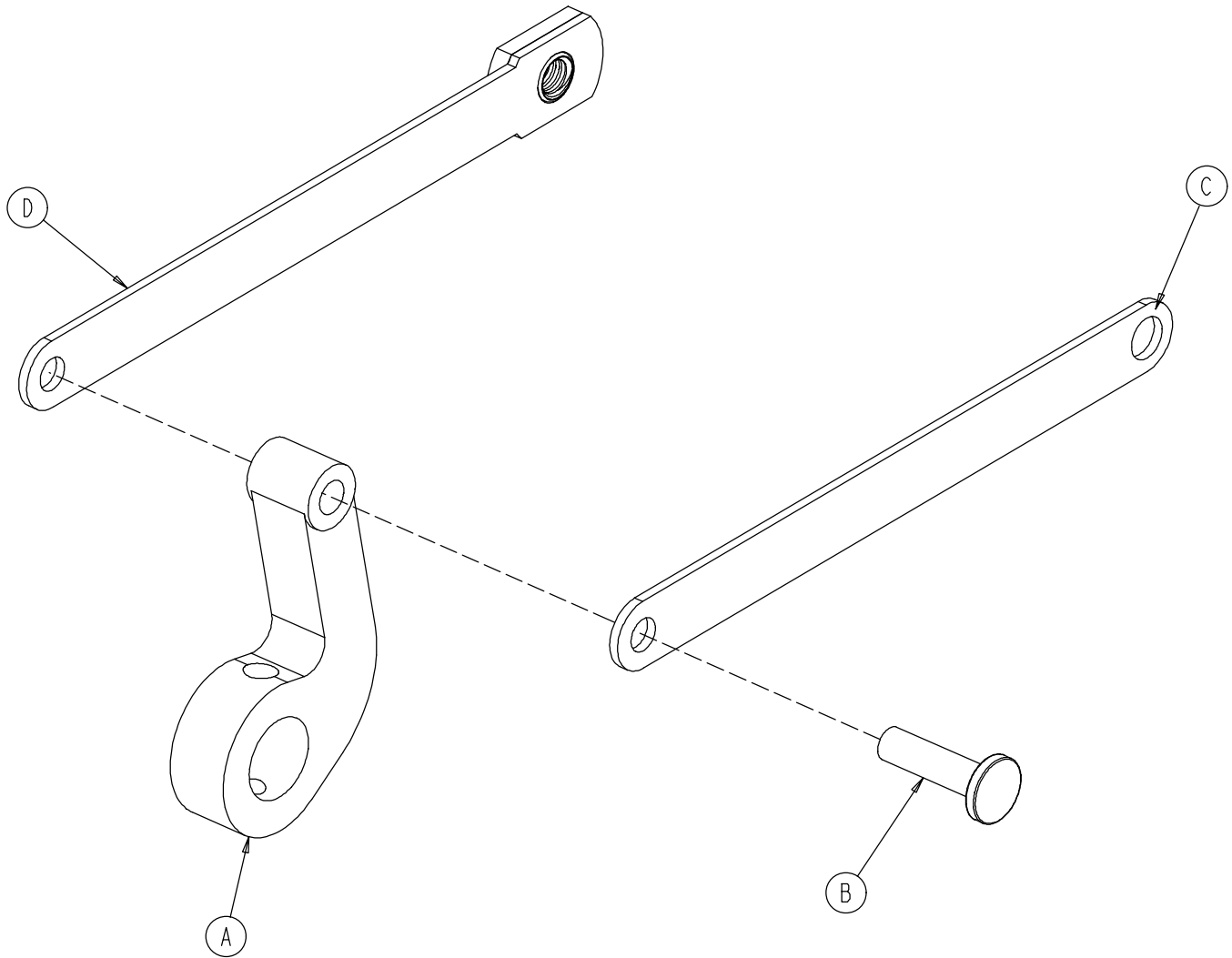

Item	Part No.	Part Name	Qty.
A	0753-003-011	Brake Rod Drive Link	1
B	0753-003-098	Semi-Tubular Rivet	1
C	0753-006-122	5th Wheel Cam Drive Link	1
D	0753-006-147	Fifth Wheel Drive Link	1

0753-010-220 8" Caster Assembly

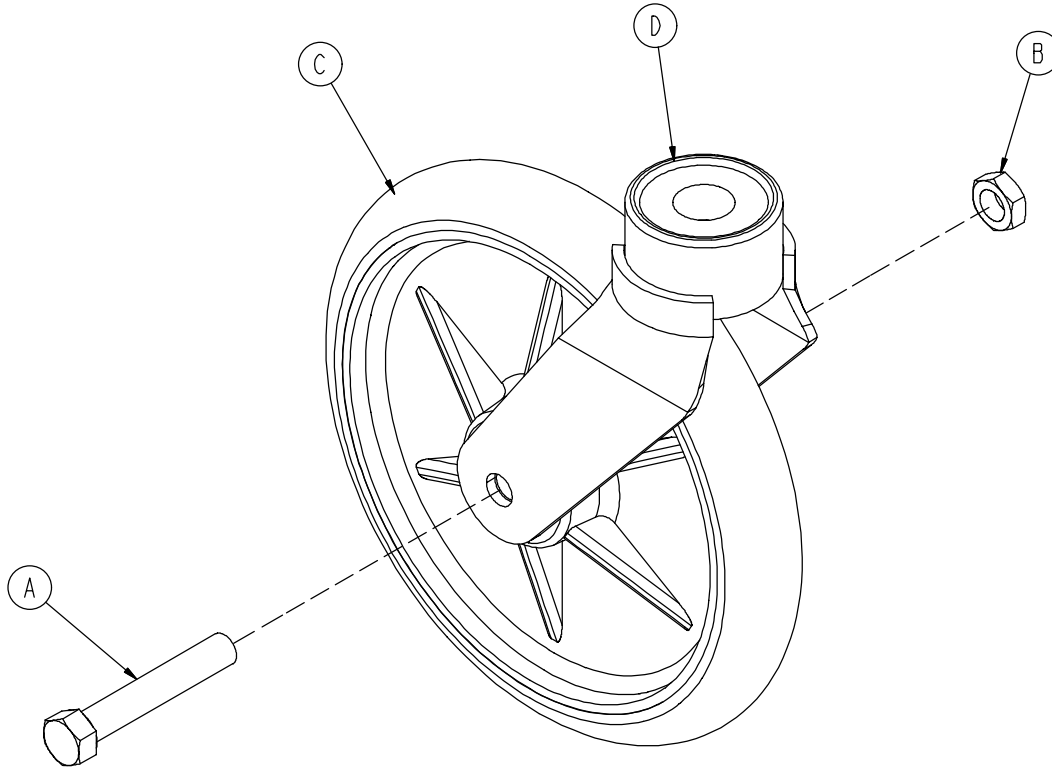

Item	Part No.	Part Name	Qty.
A	0003-099-000	Hex Hd. Cap Screw	1
B	0016-060-000	Centerlock Nut	1
C	0753-003-215	Wheel	1
D	0753-010-021	Caster Horn w/Bearing	1

Base Assembly with 4-Sided Brakes

Assembly part number 0753-003-120
(reference only)

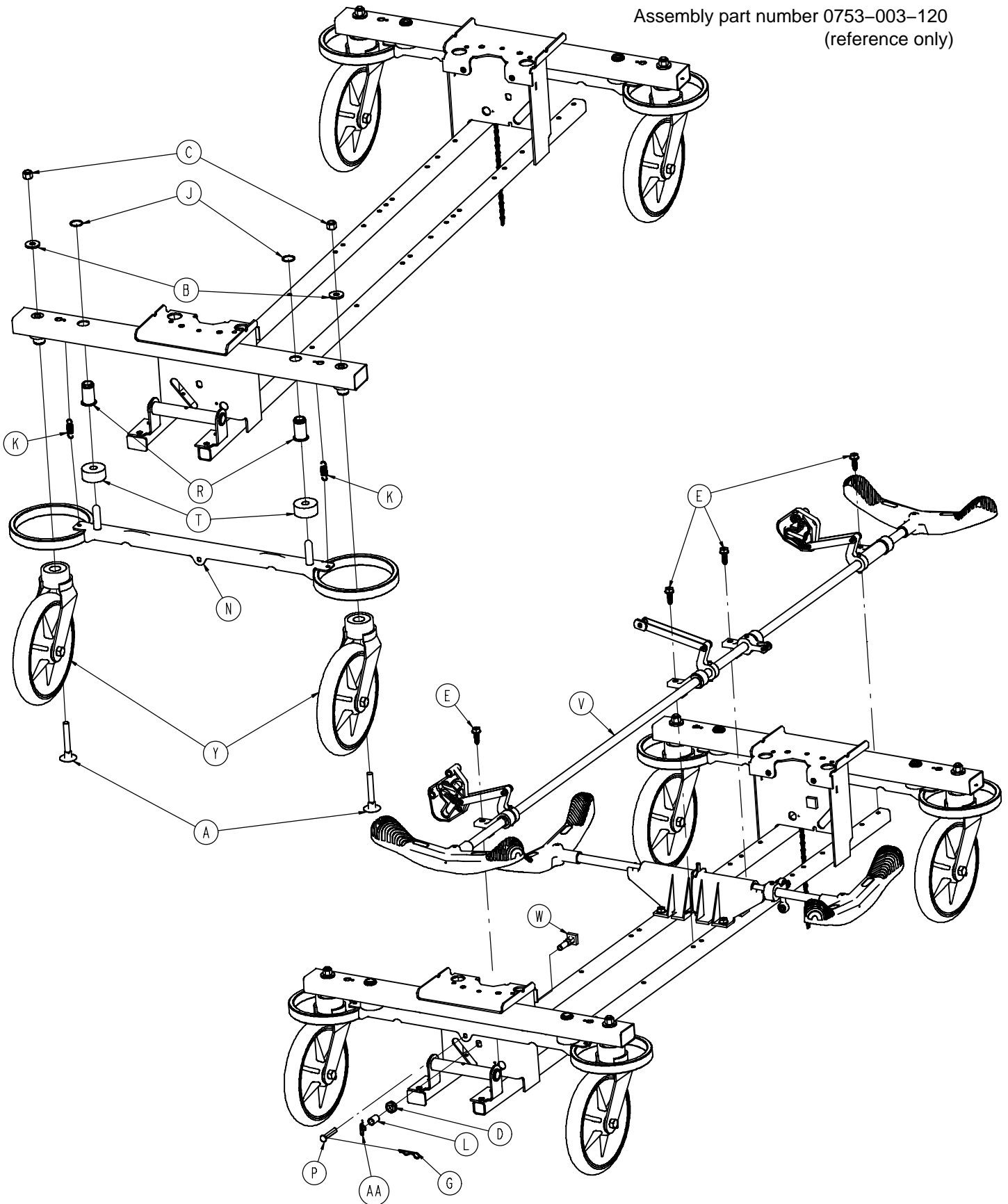

Base Assembly with 4-Sided Brakes

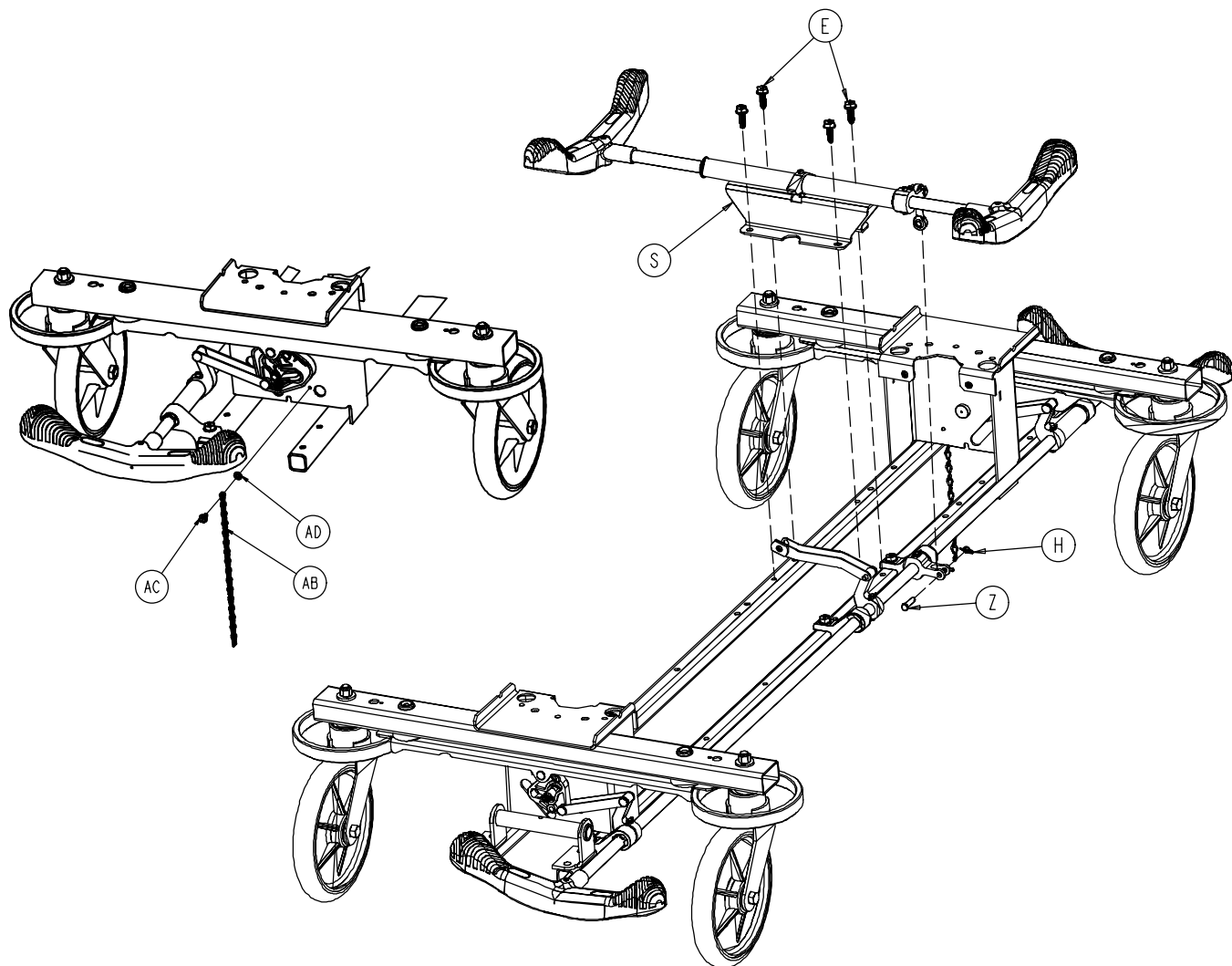

Item	Part No.	Part Name	Qty.	Item	Part No.	Part Name	Qty.
A	0005-044-000	Step Bolt	4	P	0753-003-066	Clevis Pin	2
B	0011-262-000	Washer	4	R	0753-003-079	Brake Pin Guide	4
C	0016-035-000	Nylock Hex Nut	4	S	(page 30)	Side Brake Rod Ass'y	1
D	0016-049-000	Nylock Hex Nut	2	T	0753-003-121	Brake Cushion	4
E	0023-288-000	Hex Washer Hd. Screw	8	V	(page 29)	Brake Rod Assembly	1
G	0027-012-000	Hitch Pin	2	W	0753-003-230	Bearing Pivot Support	2
H	0027-020-000	Rue Ring Cotter	1	Y	(page 26)	Caster Assembly	4
J	0028-037-000	External Retaining Ring	4	Z	0026-340-000	Clevis Pin	1
K	0038-439-000	Extension Spring	4	AA	0027-022-000	Rue Ring Cotter Pin	2
L	0081-037-000	Roller Bearing	2	AB	3001-200-052	Ground Chain	1
M	0753-001-001	Base Weldment	1	AC	0003-364-000	Hex Washer Hd. Screw	1
N	0753-003-006	Brake Ring Weldment	2	AD	0013-018-000	Ext. Tooth Lock Washer	1

Brake Rod Assembly, Base with 4-Sided Brakes

Assembly part number 0753-003-125 (reference only)

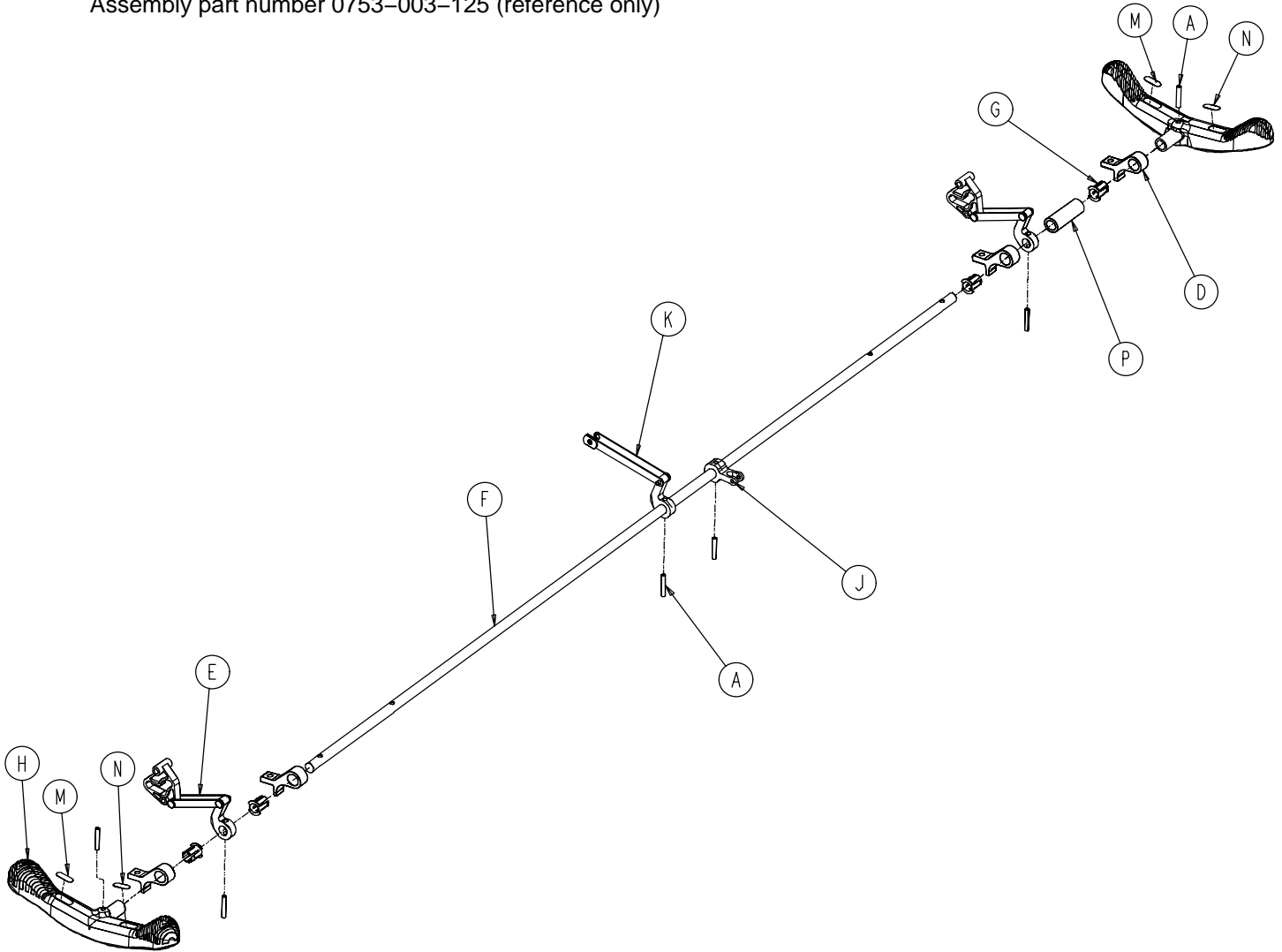

Item	Part No.	Part Name	Qty.
A	0026-067-000	Slotted Spring Pin	6
D	0753-003-004	Brake Rod Support	4
E	(page 24)	Drive Link Assembly	2
F	0753-003-014	Brake Rod	1
G	0753-003-015	Brake Rod Nyliner	4
H	0785-003-099	Butterfly "V" Pedal	2
J	0753-003-112	Side Control Link	1
K	(page 25)	Drive Link Assembly	1
M	1210-201-335	Red Brake Label	2
N	1210-201-336	Green Steer Label	2
P	0753-003-133	Retainment Spacer	1

Side Control Brake Rod Assembly

Assembly part number 0753-003-210 (reference only)

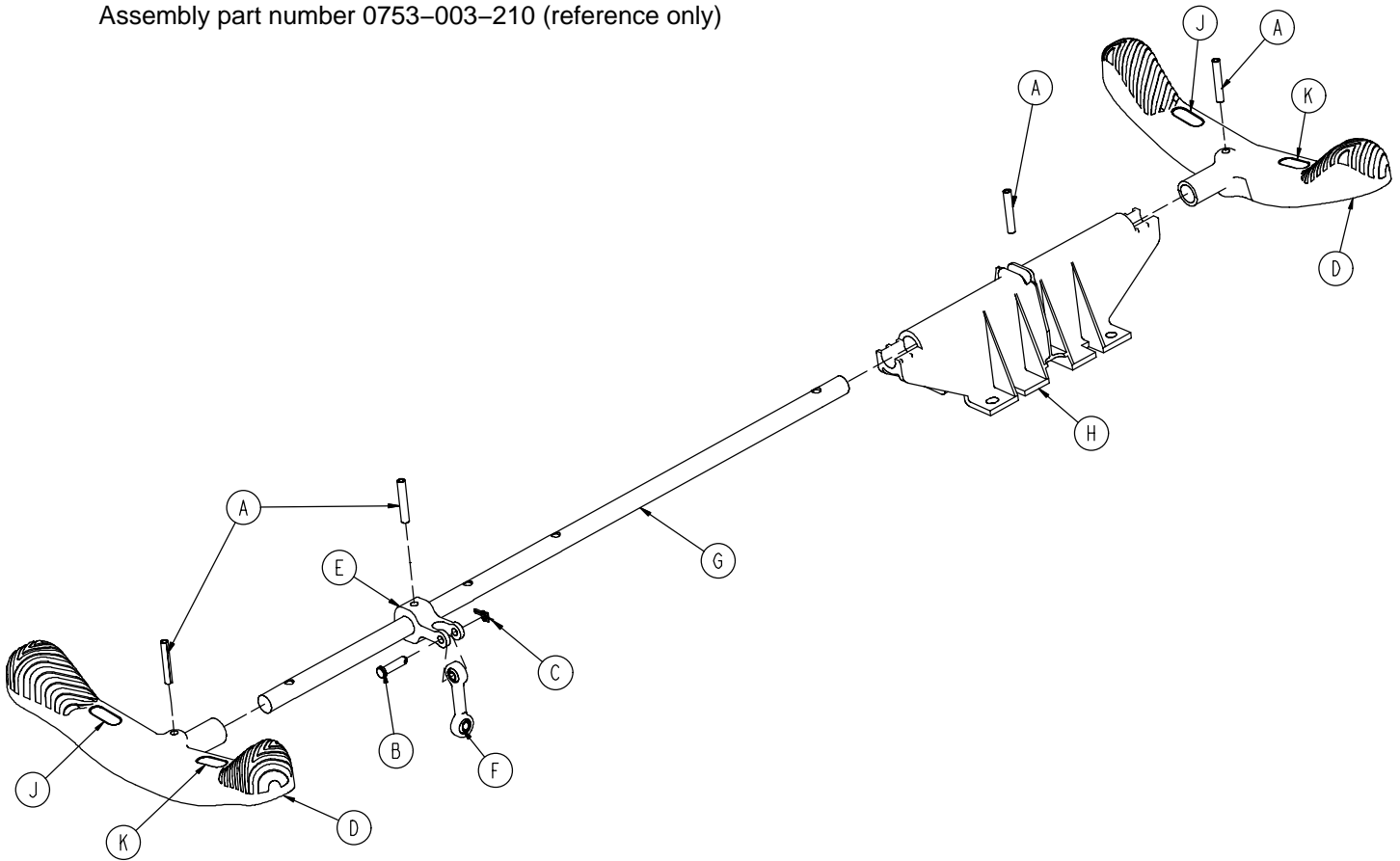

Item	Part No.	Part Name	Qty.
A	0026-067-000	Slotted Spring Pin	4
B	0026-340-000	Clevis Pin	1
C	0027-020-000	Rue Ring Cotter	1
D	0753-003-099	Butterfly "V" Pedal	2
E	0753-003-112	Side Control Link	1
F	0753-003-117	Rod End Link	1
G	0753-003-119	Side Control Brake Rod	1
H	0753-003-214	Shaft Support	1
J	1210-201-335	Red Brake Label	2
K	1210-201-336	Green Steer Label	2

Base with Dual Side Hydraulics (Fifth Wheel Base)

Assembly part number 0753-005-200 (reference only)

HEAD END

Insert pump ram into keyhole slot on both ends. Lower pump connecting rod weldment onto pump ram as shown

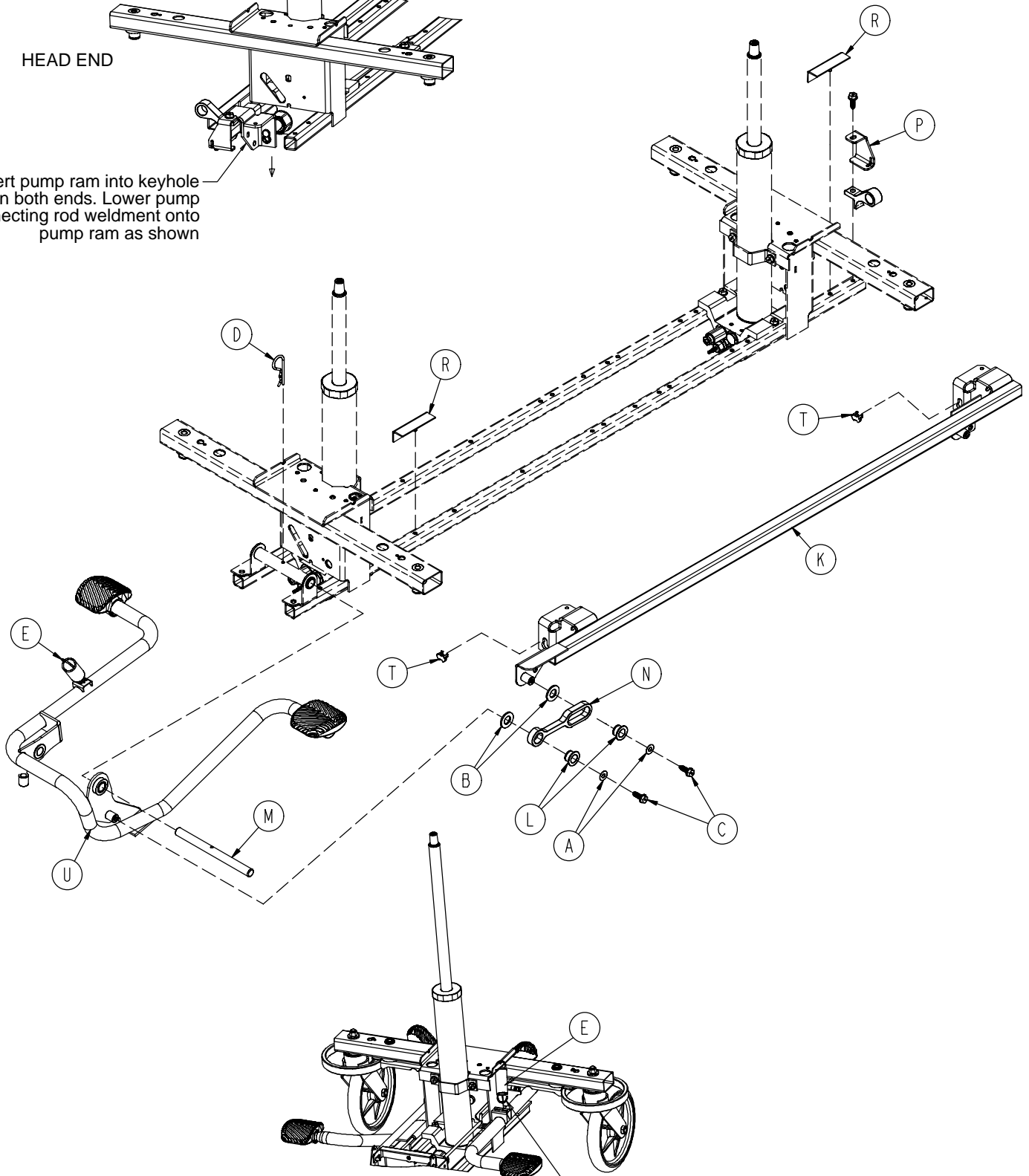

Insert spring hook thru slots in pump pedal. Attach other end onto jack tower as shown

Base with Dual Side Hydraulics (Fifth Wheel Base)

Insert spring hook thru hole in pump connecting rod. Attach other hook to return spring as shown

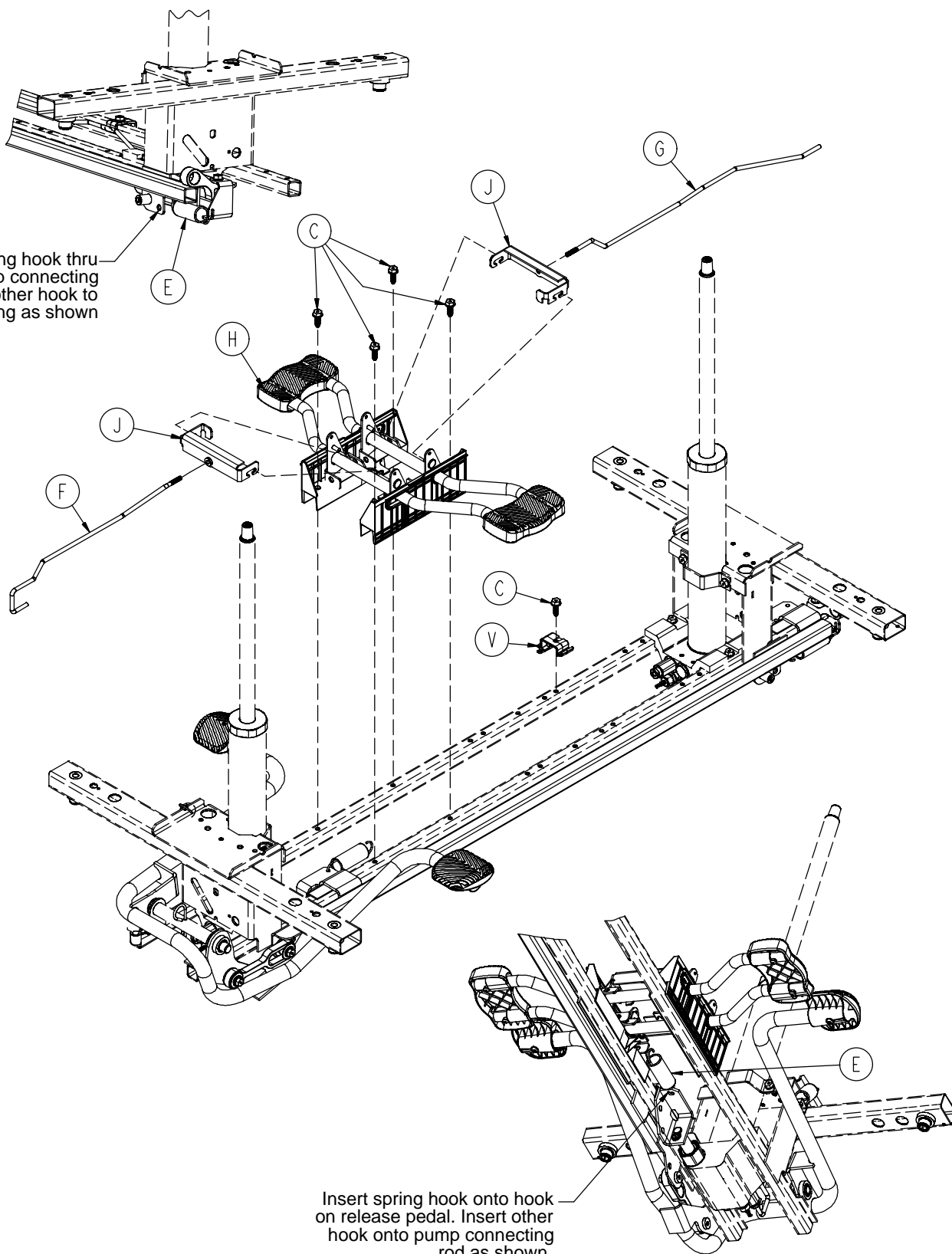

Insert spring hook onto hook on release pedal. Insert other hook onto pump connecting rod as shown.

Base with Dual Side Hydraulics (Fifth Wheel Base)

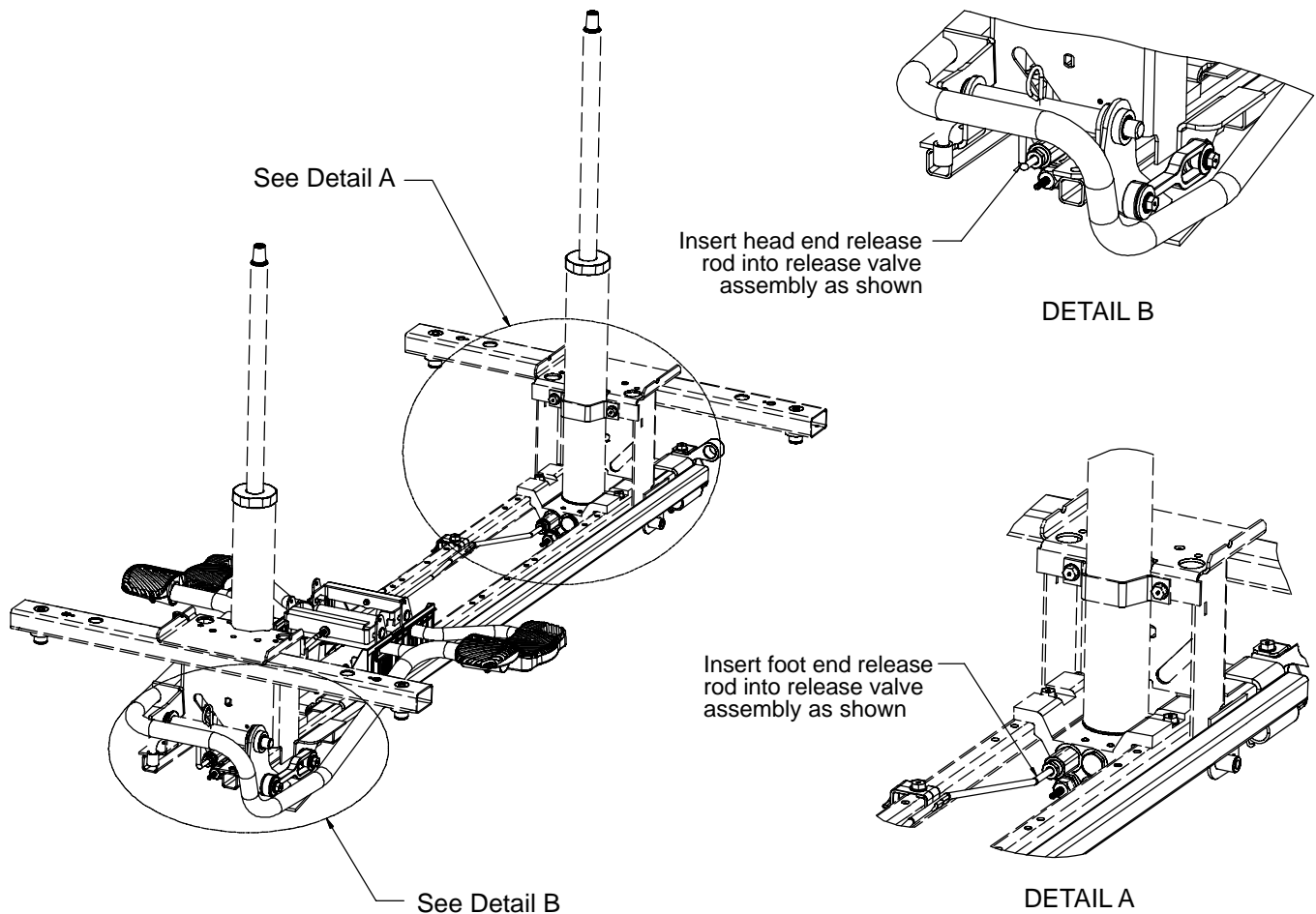

Item	Part No.	Part Name	Qty.
A	0011-023-000	Washer	2
B	0014-071-000	Washer	2
C	0023-288-000	Hex Washer Hd. Screw	7
D	0027-031-000	Hair Pin Cotter	1
E	0038-497-000	Extension Spring	3
F	0753-004-014	Head End Release Rod	1
G	0753-004-015	Foot End Release Rod	1
H	(page 34)	Release Pedal Assembly	1
J	0753-004-132	Release Pedal Swivel	2
K	0753-005-037	Pump Connecting Rod	1
L	0753-005-044	Pump Pedal Bushing	2
M	0753-005-074	Pivot Pin	1
N	0753-005-075	Pump Pedal Link	1
P	0753-005-087	Return Spring Hook	1
R	0753-005-088	Wear Strip	2
T	0753-005-089	Pump Ram Plug	2
U	(page 35)	Head End Pump Pedal Ass'y	1
V	0753-010-215	Release Rod Bracket	1

0753-004-101 Release Pedal Assembly

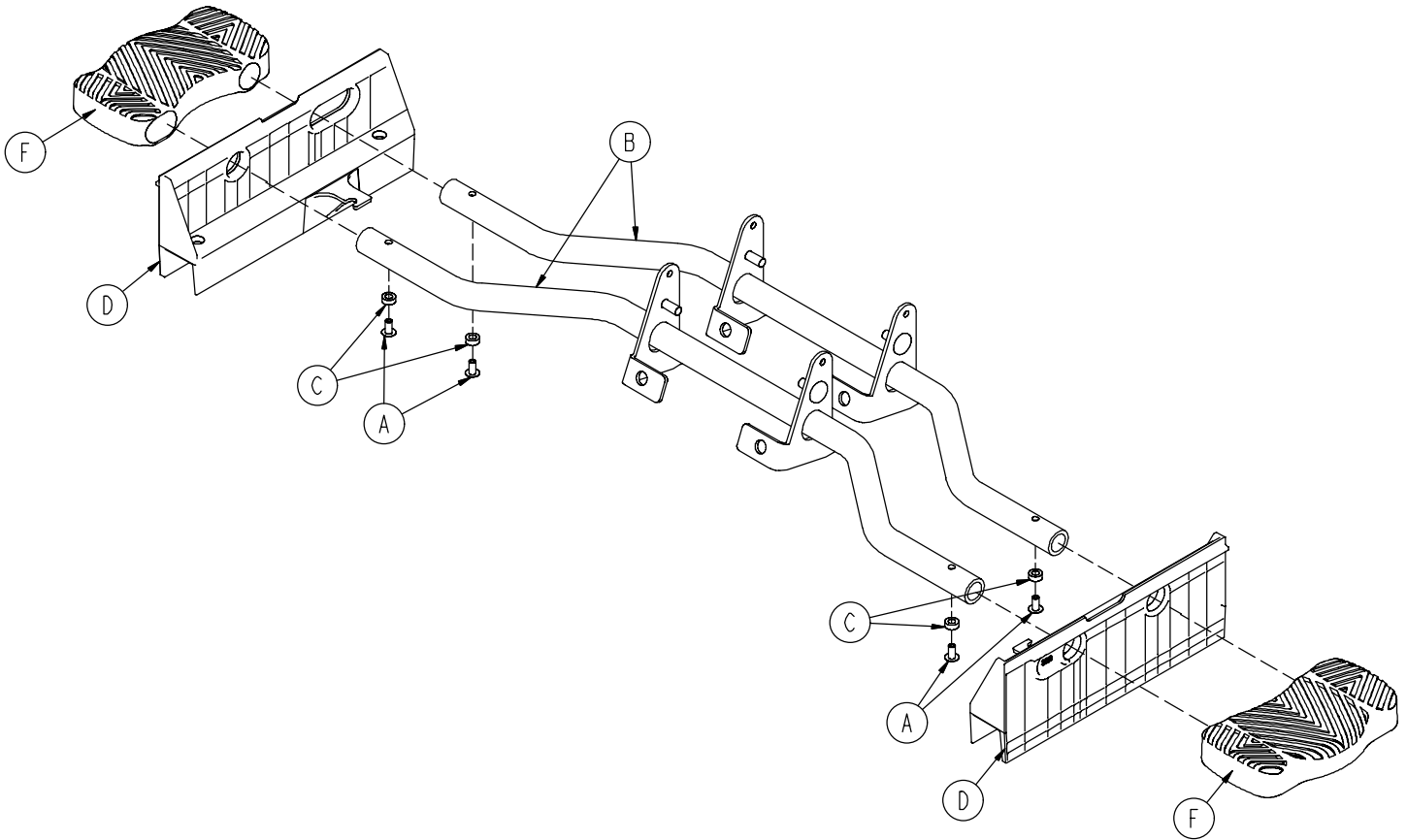

Item	Part No.	Part Name	Qty.
A	0025-079-000	Rivet	4
B	0753-004-004	Release Pedal Weldment	2
C	0753-004-029	Release Pedal Standoff	4
D	0753-004-320	Release Pedal Support	2
F	1061-201-127	Short Uni Pedal	2

0753-005-085 Head End Pump Pedal Assembly

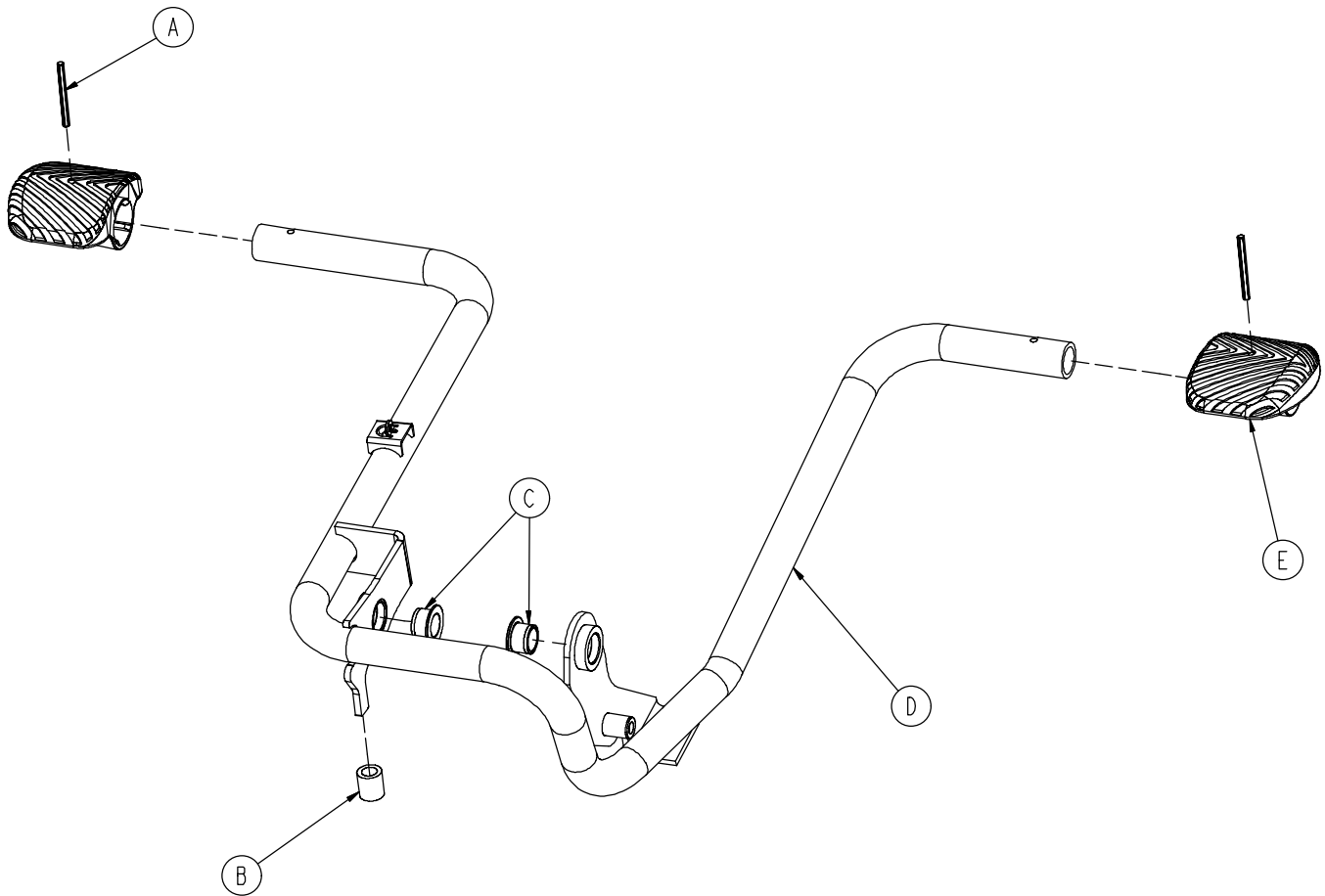

Item	Part No.	Part Name	Qty.
A	0026-343-000	Groove Pin	2
B	0715-001-140	Vinyl Tube	1
C	0753-005-044	Pump Pedal Bushing	2
D	0753-005-180	Head End Pump Pedal Weldment	1
E	0753-201-126	Pump Pedal	2

Non-Constant Descent Jacks

Assembly part number 0753-002-080
(reference only)

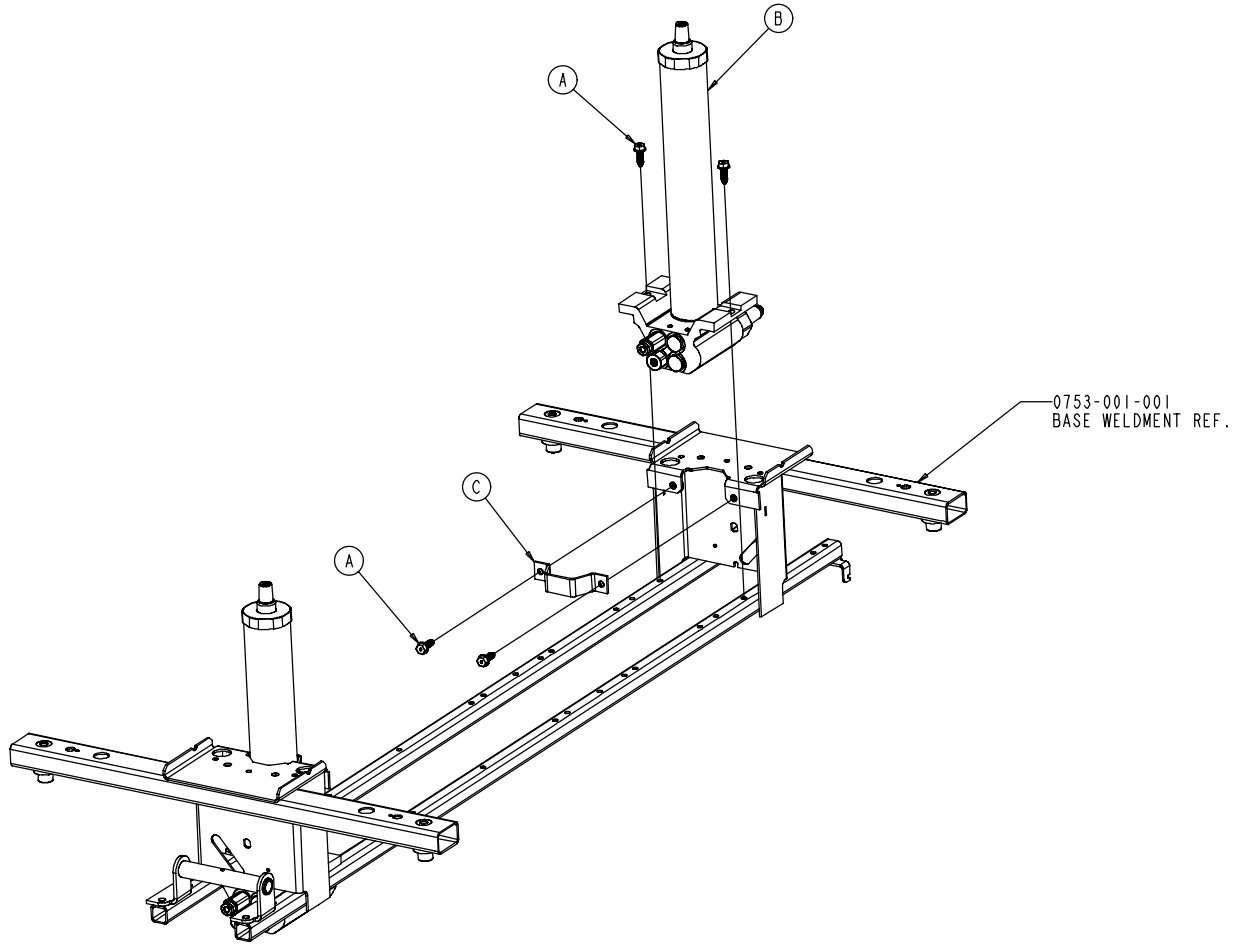

Item	Part No.	Part Name	Qty.
A	0023-288-000	Hex Washer Hd. Screw	8
B	0753-002-170	Variable Descent Jack Assembly	2
C	0753-010-007	Reservoir Clamp	2

Jack Base Assembly, Non-Constant Descent Jacks

Assembly part number 0753-002-075 (reference only)

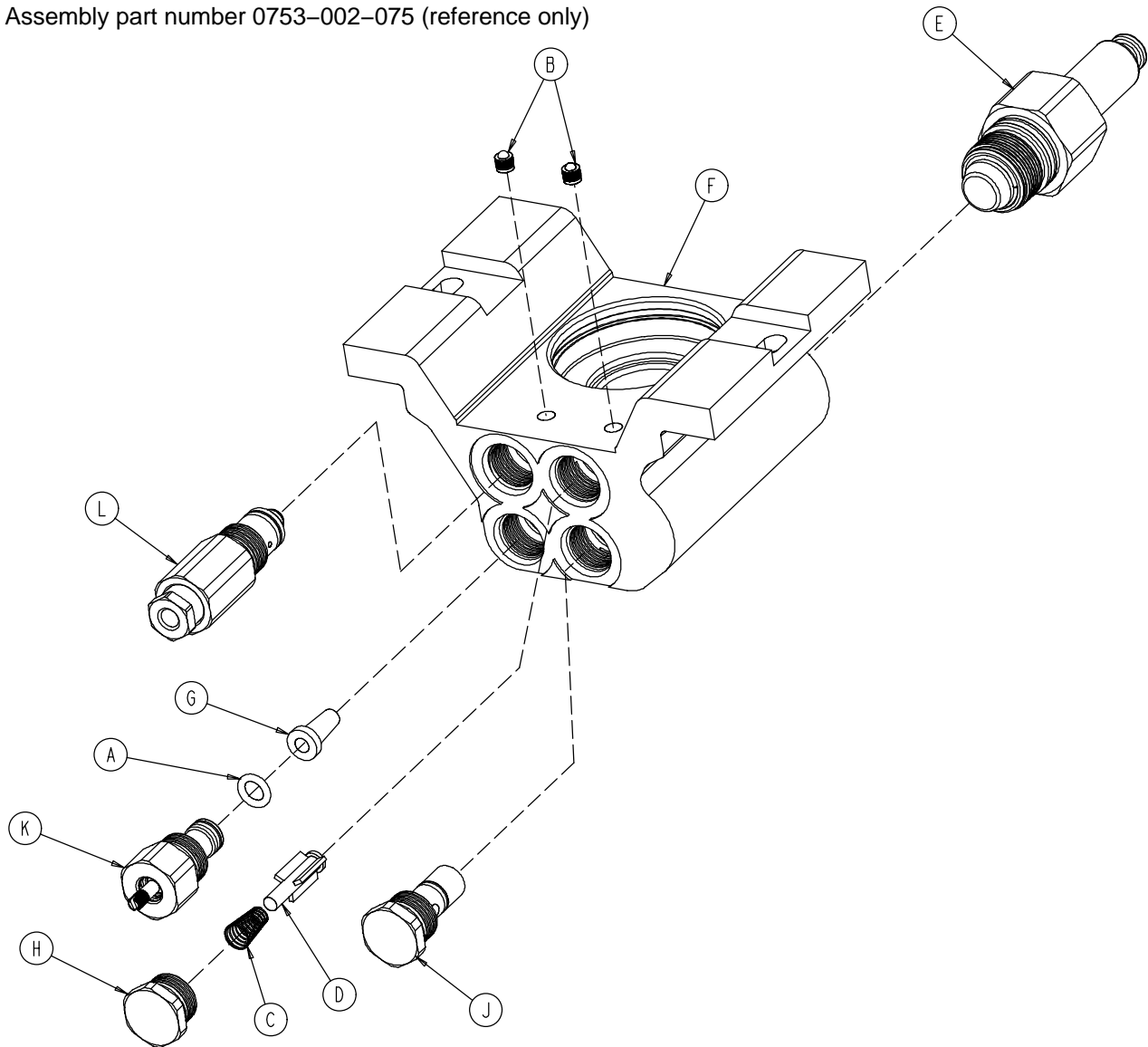

Item	Part No.	Part Name	Qty.
A	0046-004-000	O-Ring	1
B	0048-021-000	CV Plug	2
C	0390-002-134	Conical Compression Spring	1
D	0715-001-341	Poppet	1
E	0753-002-003	Pump Ram Assembly	1
F	0753-002-010	Jack Base	1
G	0753-002-019	Valve Filter	1
H	0753-002-051	Plug Assembly	1
J	0753-002-052	Check Valve Assembly	1
K	0753-002-063	Standard Descent Valve Assembly	1
L	0753-002-065	Release Valve Assembly	1

Notes

Base Labeling Assembly

Assembly part number 0753-010-062 (reference only)

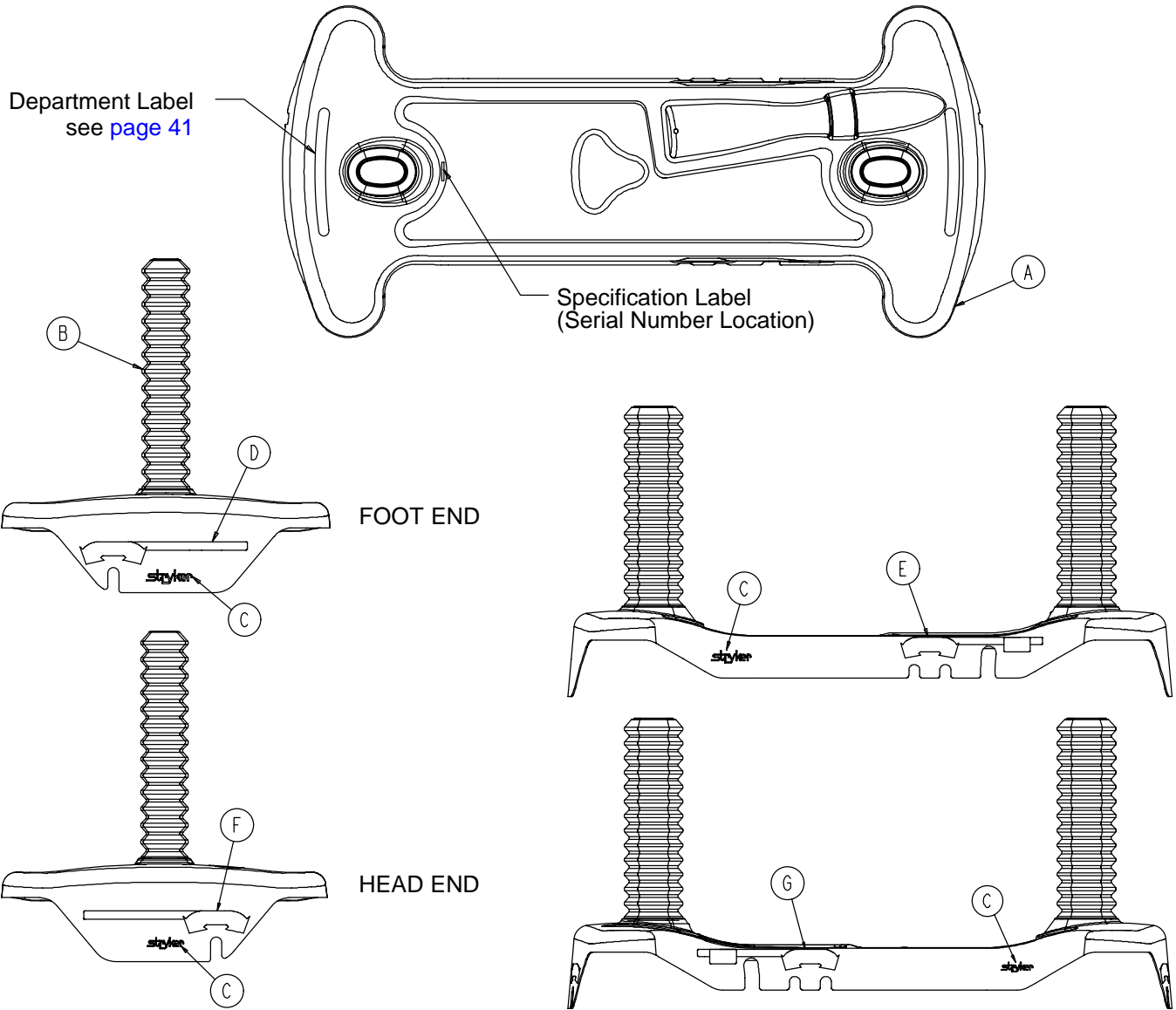

Item	Part No.	Part Name	Qty.
A	0753-010-040	Base Hood	1
B	1040-010-134	Bellows	2
C	0946-201-060	Stryker Logo Label	4

Base Labeling Assembly, 4-Sided Brakes

Assembly part number 0753-010-063 (reference only)

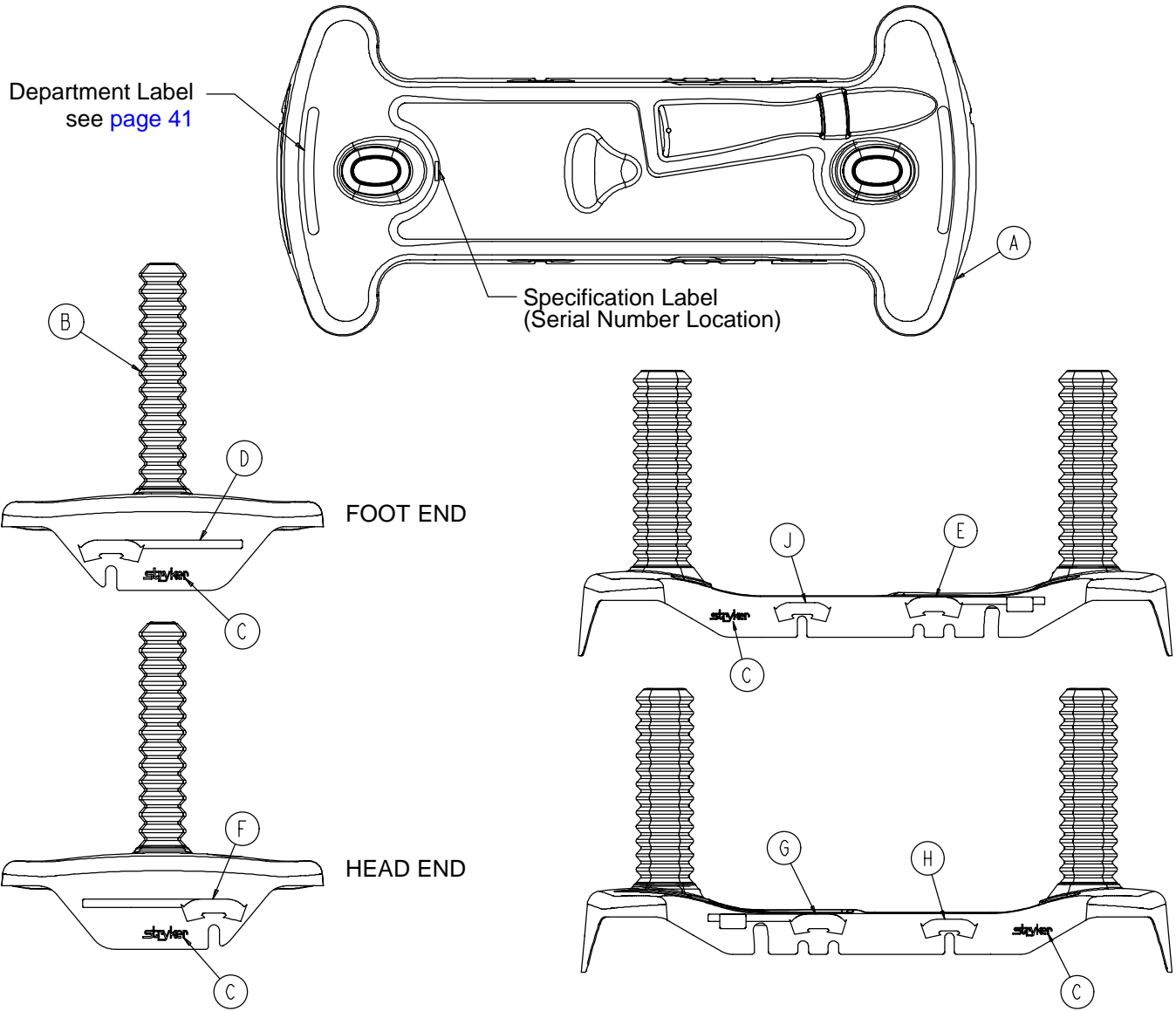

Item	Part No.	Part Name	Qty.
A	0753-010-040	Base Hood	1
B	1040-010-134	Bellows	2
C	0946-201-060	Stryker Logo Label	4
H	0753-010-018	Brake/Steer Label, Right	1
J	0753-010-019	Brake/Steer Label, Left	1

Base Labeling Assembly

Color Set P/N	Item D Brake/Steer, Foot End	Item E Lift/Lower, Left	Item F Brake/Steer, Head End	Item G Lift/Lower, Right	Litter Bumper Strip
RED 0753-010-120	0753-010-051	0753-010-055	0753-010-017	0753-010-054	1010-700-015
PURPLE 0753-010-121	0753-010-151	0753-010-155	0753-010-170	0753-010-154	1010-700-025
GREEN 0753-010-122	0753-010-251	0753-010-255	0753-010-270	0753-010-254	1010-700-035
GRAY 0753-010-123	0753-010-351	0753-010-355	0753-010-370	0753-010-354	1010-700-045
TEAL 0753-010-124	0753-010-451	0753-010-455	0753-010-470	0753-010-454	1010-700-055
PINK 0753-010-125	0753-010-551	0753-010-555	0753-010-570	0753-010-554	1010-700-065
BLUE 0753-010-126	0753-010-651	0753-010-655	0753-010-670	0753-010-654	1010-700-075

BASE HOOD DEPARTMENT LABELS

Department	Label Part Number
Emergency	1010-900-215
PACU	1010-900-220
Transport	1010-900-225
Surgery	1010-900-230
Extended Stay	1010-900-235
Maternity	1010-900-240
Endoscopy	1010-900-245
Radiology	1010-900-250
Nuclear Medicine	1010-900-255
Ambulatory Surgery	1010-900-260
G.I. Lab	1010-900-265
Cath. Lab	1010-900-270
Same Day Surgery	1010-900-275
Cardio.	1010-900-280
Ultrasound	1010-900-285

NOTE

All base hood department labels are quantity of two.

30" Litter Frame Assembly

Assembly part number 0785-010-301 (reference only)

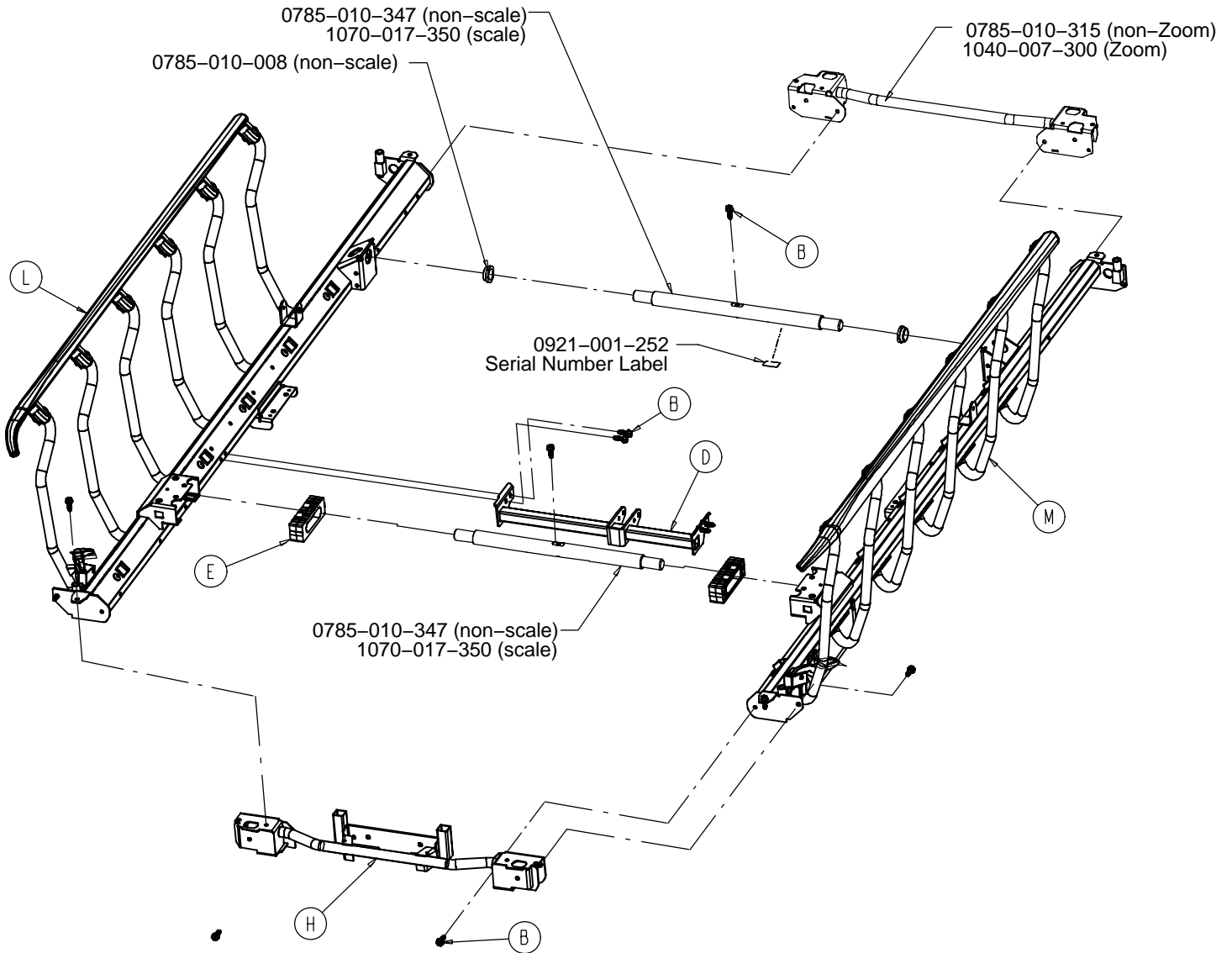

Item	Part No.	Part Name	Qty.
B	0023-288-000	Hex Washer Hd. Screw	12
D	0785-008-310	Frame Tie Weldment	1
E	0785-010-006	Trend Block Slide	2
H	0785-010-320	Foot End Weldment	1
L	(page 43)	Right Siderail Assembly	1
M	(page 44)	Left Siderail Assembly	1

Siderail Assembly, Right

Assembly part number 0785-011-040 (reference only)

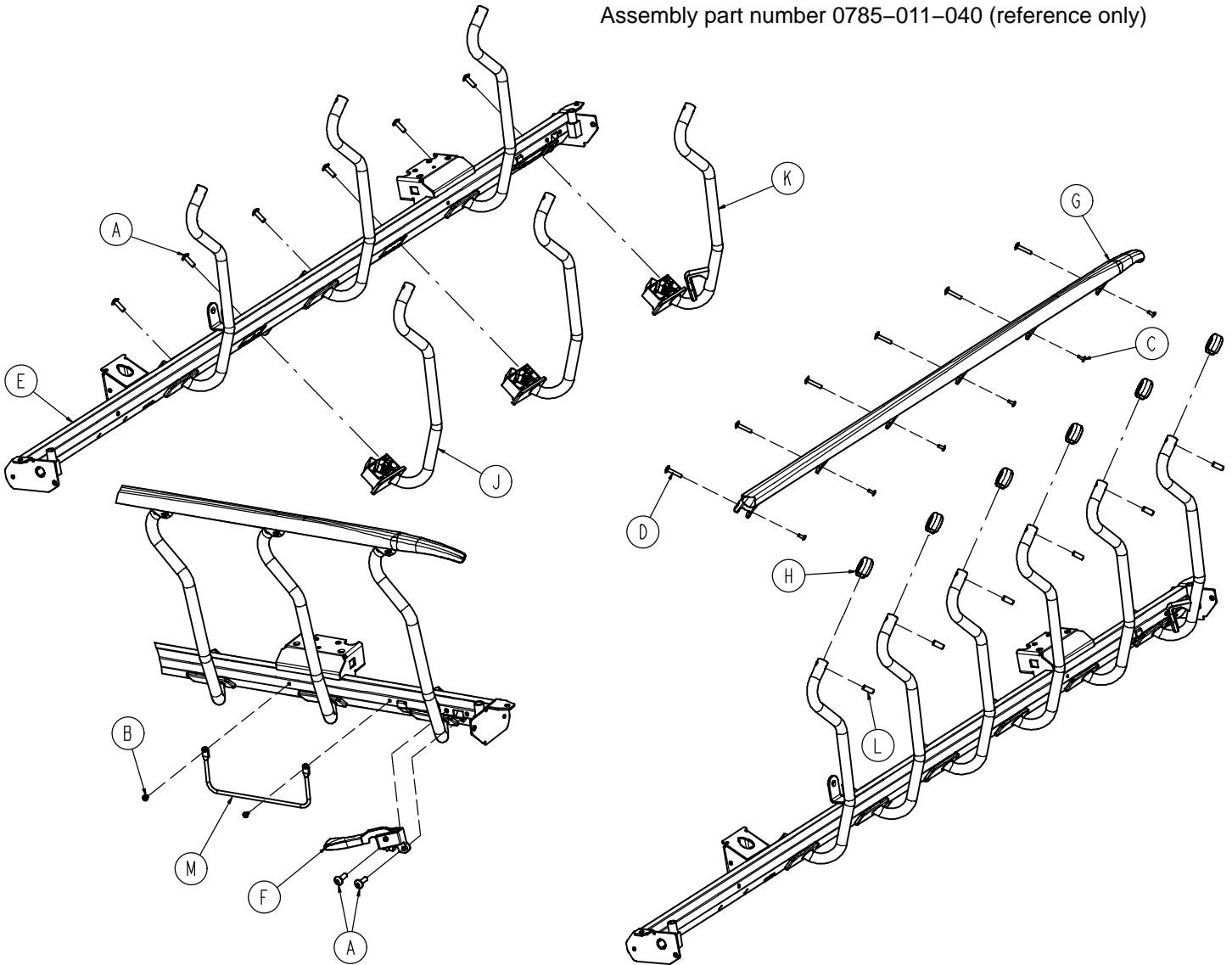

Item	Part No.	Part Name	Qty.
A	0007-074-000	Truss Hd. Machine Screw	8
B	0025-079-000	Rivet	2
C	0025-182-000	Rivet	6
D	0025-183-000	Tubular Component	6
E	0785-011-012	Right Tube Weldment	1
F	(page 45)	Right Latch Assembly	1
G	0785-011-037	Right Top Rail	1
H	0785-011-038	Spindle Plug	6
J	(page 47)	Right Spindle	5
K	(page 49)	Right Latch Spindle	1
L	0785-011-046	Spindle Bearing	6
M	1211-030-046	Foley Bag Rack	1

Siderail Assembly, Left

Assembly part number 0785-011-050 (reference only)

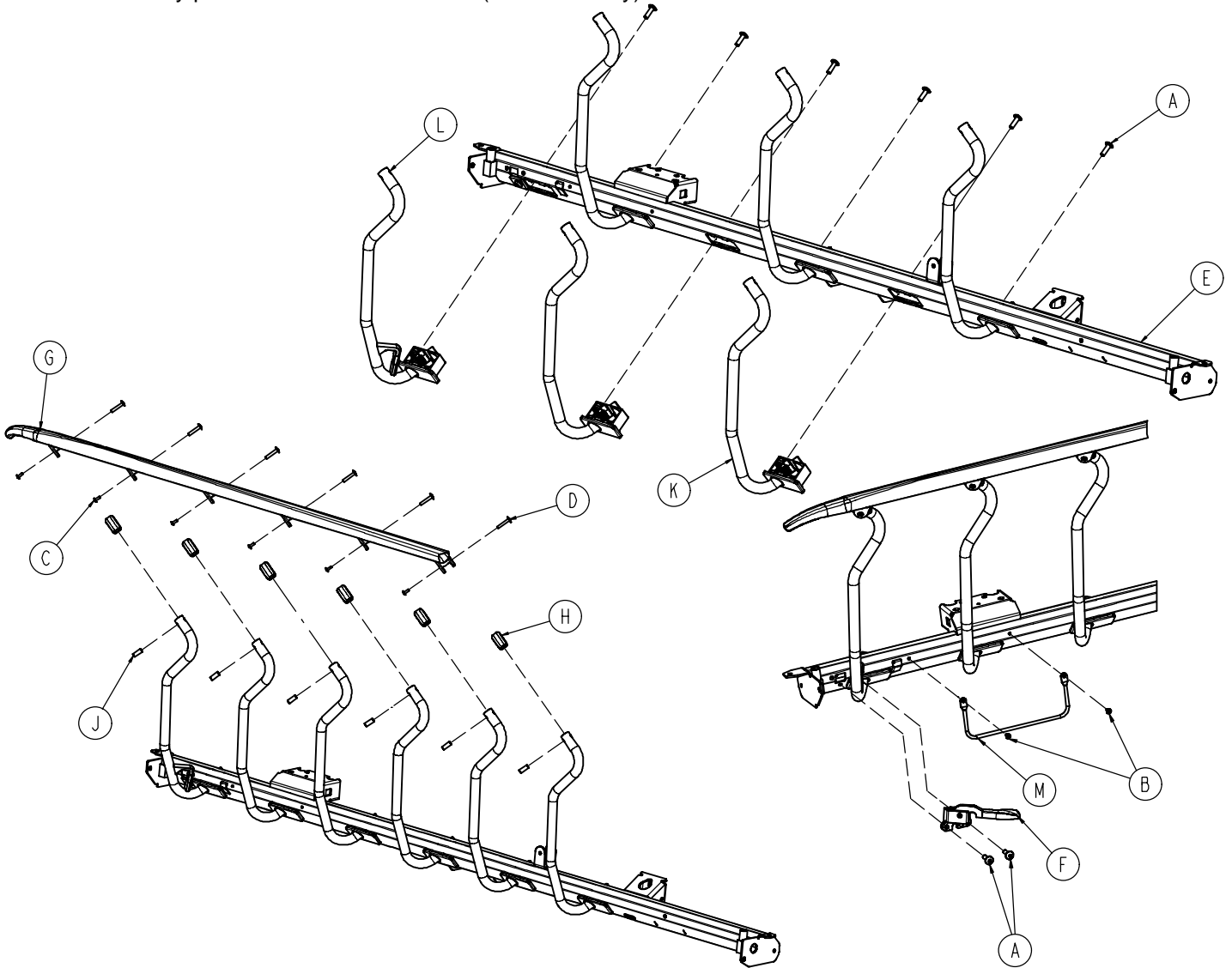

Item	Part No.	Part Name	Qty.
A	0007-074-000	Truss Hd. Machine Screw	8
B	0025-079-000	Rivet	2
C	0025-182-000	Rivet	6
D	0025-183-000	Tubular Component	6
E	0785-011-011	Left Tube Weldment	1
F	(page 46)	Left Latch Assembly	1
G	0785-011-036	Left Top Rail	1
H	0785-011-038	Spindle Plug	6
J	0785-011-046	Spindle Bearing	6
K	(page 48)	Left Spindle	5
L	(page 50)	Left Latch Spindle	1
M	1211-030-046	Foley Bag Rack	1

0785-011-020 Siderail Latch Assembly, Right

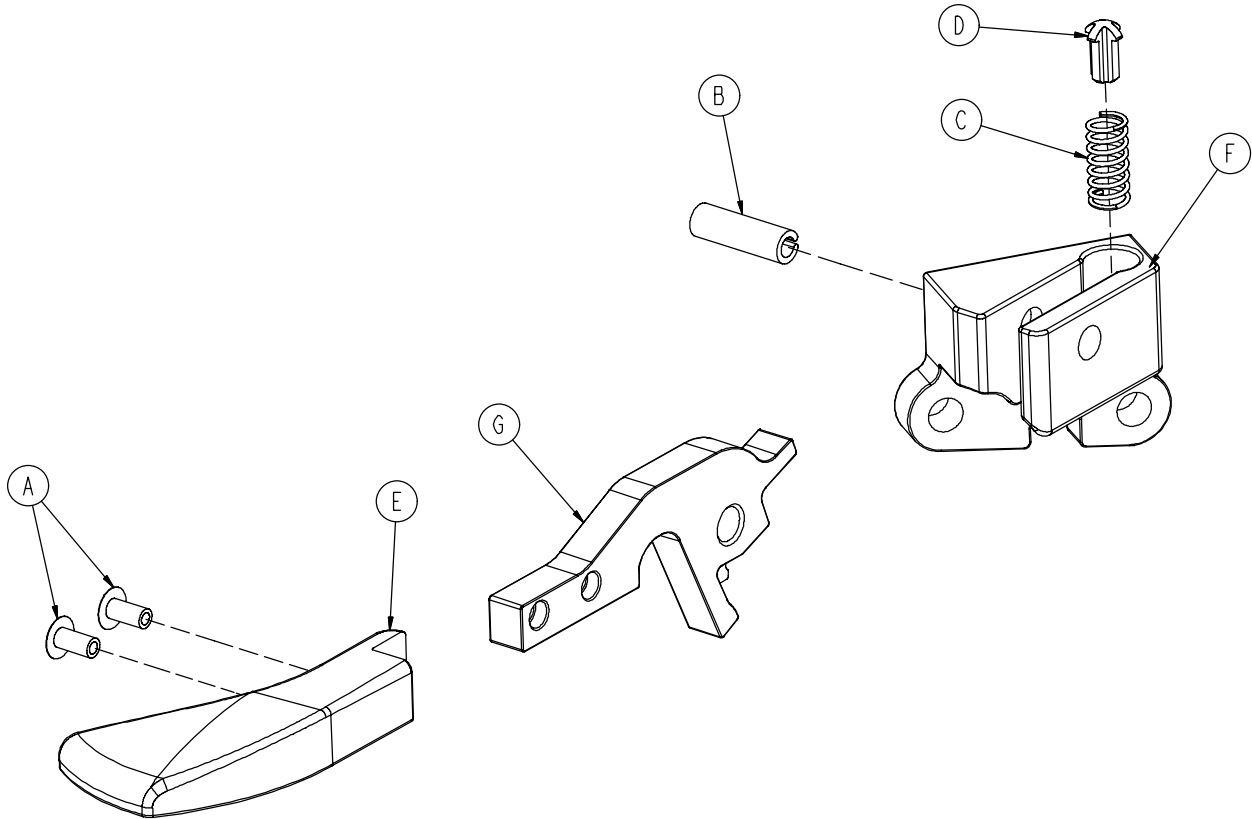

Item	Part No.	Part Name	Qty.
A	0025-079-000	Rivet	2
B	0026-365-000	Slotted Spring Pin	1
C	0038-526-000	Compression Spring	1
D	0785-011-054	Plunger	1
E	0785-011-056	Right Latch Handle	1
F	0785-011-128	Right Latch Mounting Block	1
G	0785-011-131	Latch Plate	1

0785-011-021 Siderail Latch Assembly, Left

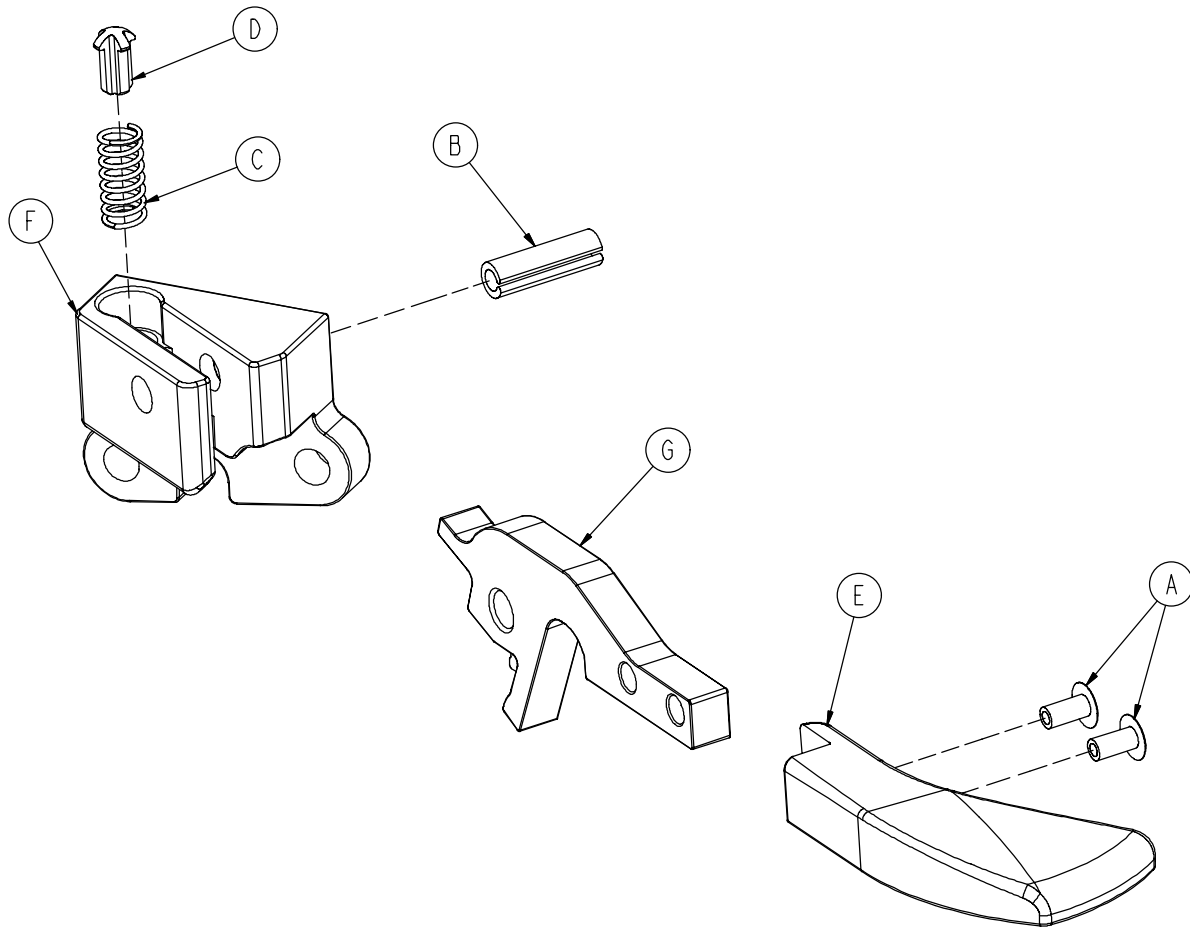

Item	Part No.	Part Name	Qty.
A	0025-079-000	Rivet	2
B	0026-365-000	Slotted Spring Pin	1
C	0038-526-000	Compression Spring	1
D	0785-011-054	Plunger	1
E	0785-011-057	Left Latch Handle	1
F	0785-011-123	Left Latch Mounting Block	1
G	0785-011-131	Latch Plate	1

0785-011-041 Siderail Spindle Assembly, Right

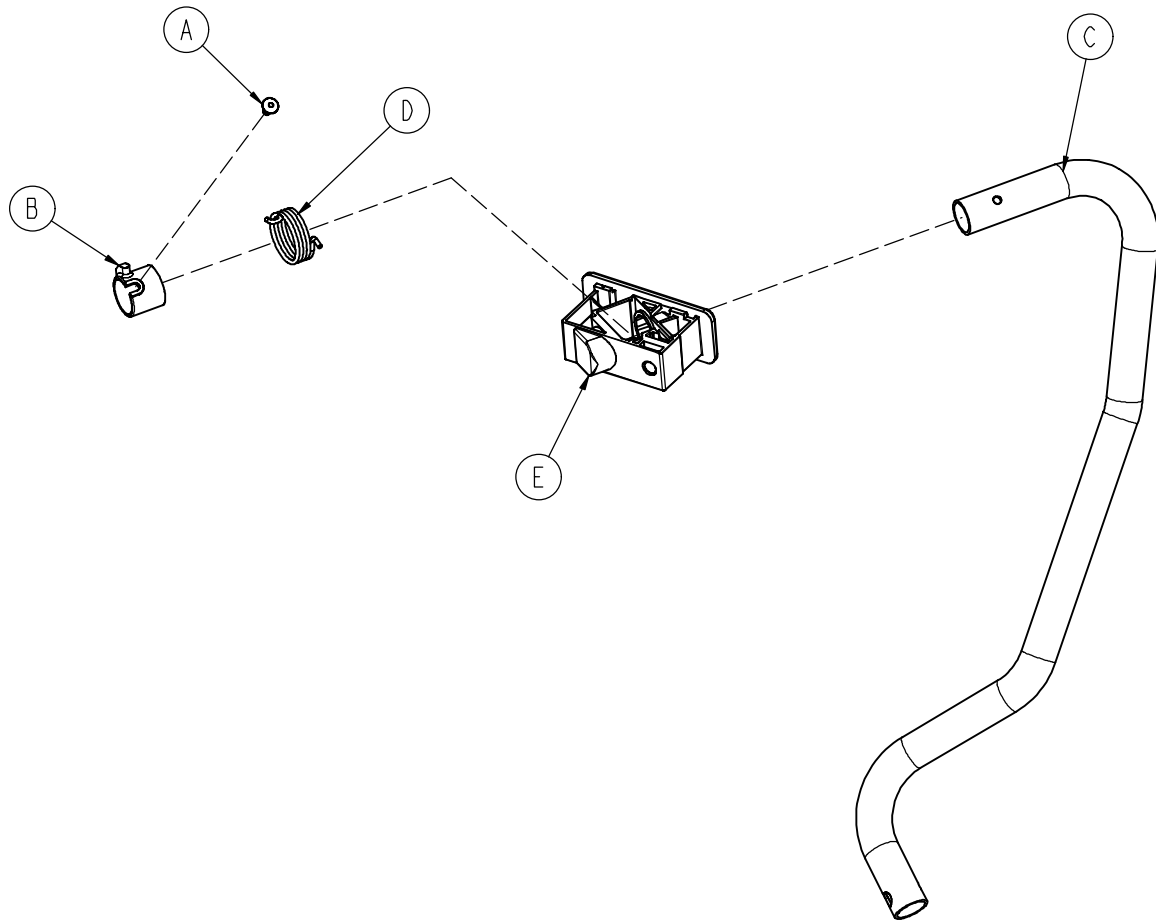

Item	Part No.	Part Name	Qty.
A	0025-079-000	Rivet	1
B	0785-011-013	Right Spindle Spacer	1
C	0785-011-032	Right Spindle	1
D	0785-011-047	Right Siderail Spring	1
E	0785-011-197	Siderail Pivot Block	1

0785-011-051 Siderail Spindle Assembly, Left

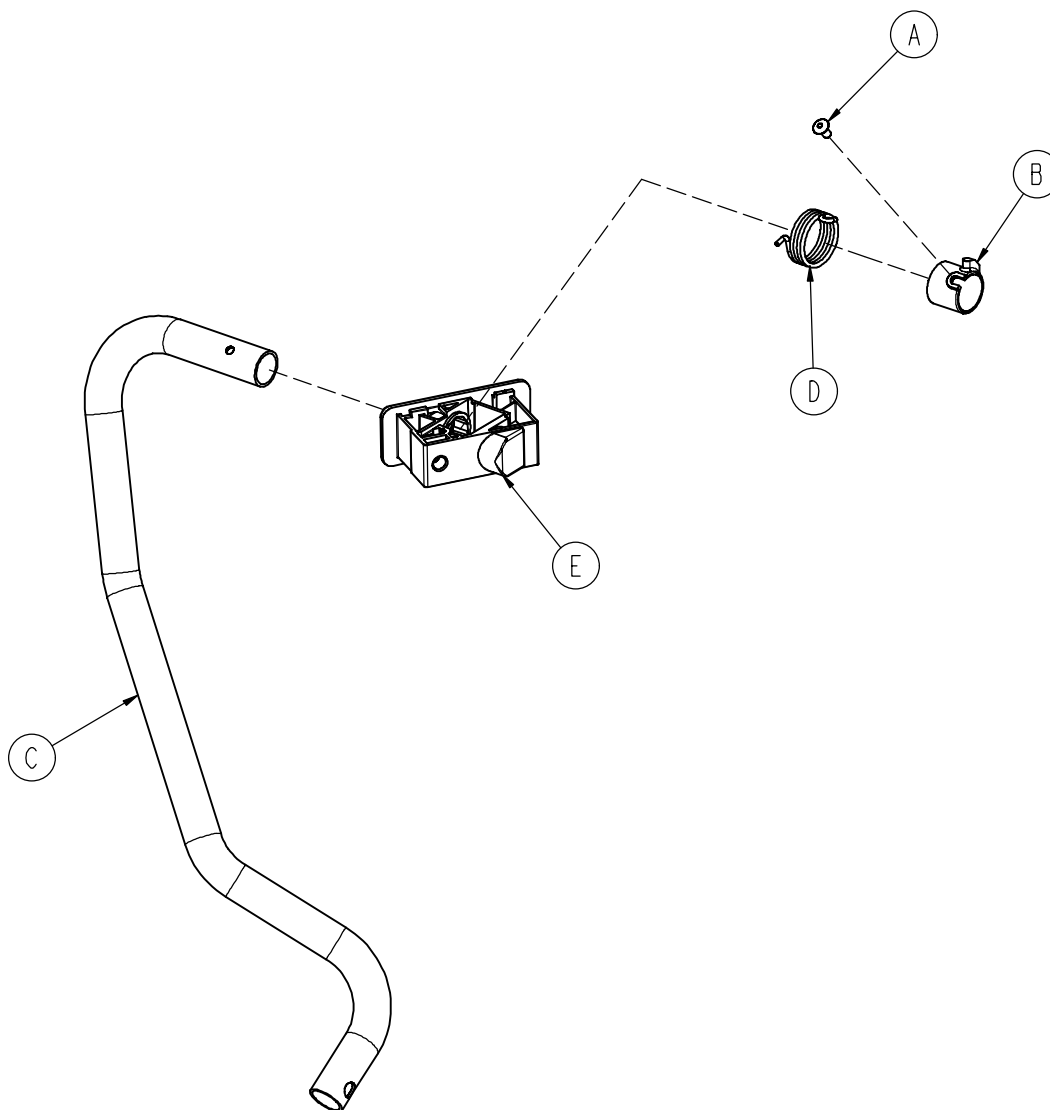

Item	Part No.	Part Name	Qty.
A	0025-079-000	Rivet	1
B	0785-011-010	Left Spindle Spacer	1
C	0785-011-033	Left Spindle	1
D	0785-011-048	Left Siderail Spring	1
E	0785-011-197	Siderail Pivot Block	1

0785-011-042 Siderail Latch Spindle Assembly, Right

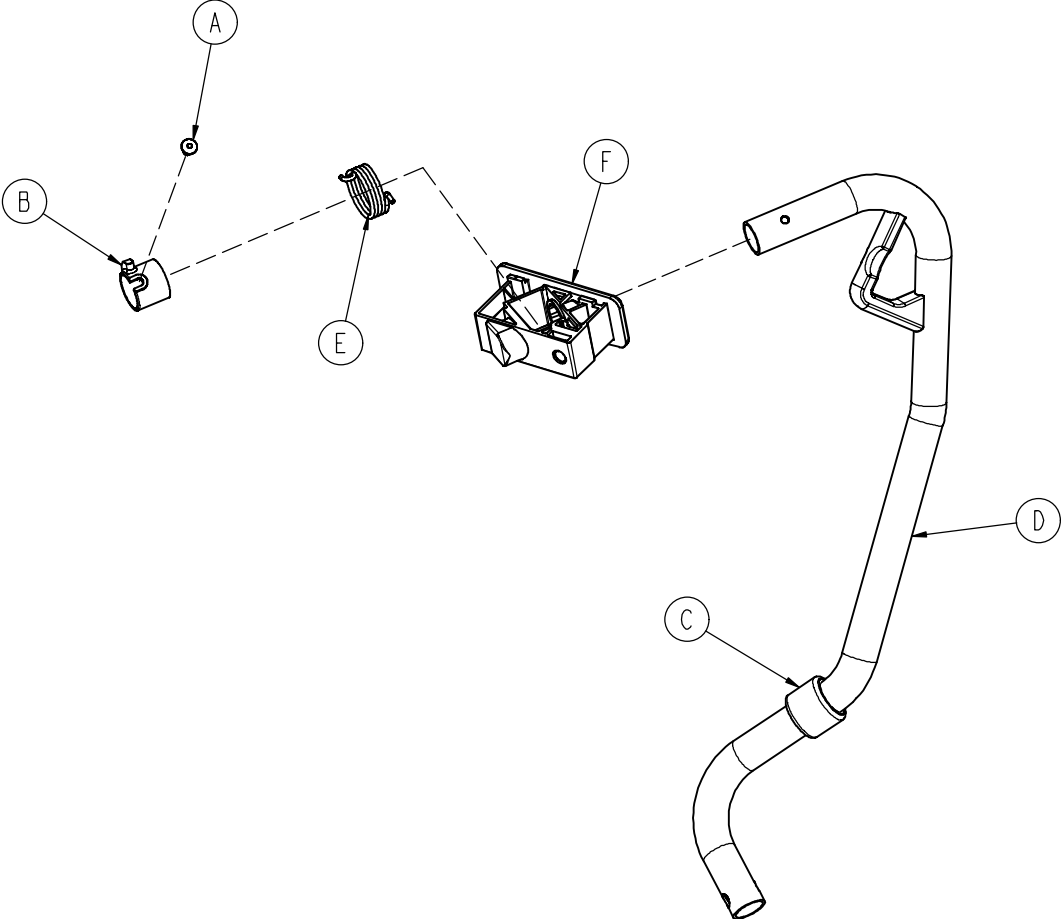

Item	Part No.	Part Name	Qty.
A	0025-079-000	Rivet	1
B	0785-011-013	Right Spindle Spacer	1
C	0785-011-016	Rubber Stop	1
D	0785-011-043	Right Latch Spindle	1
E	0785-011-047	Right Siderail Spring	1
F	0785-011-197	Spindle Pivot Block	1

0785-011-052 Siderail Latch Spindle Assembly, Left

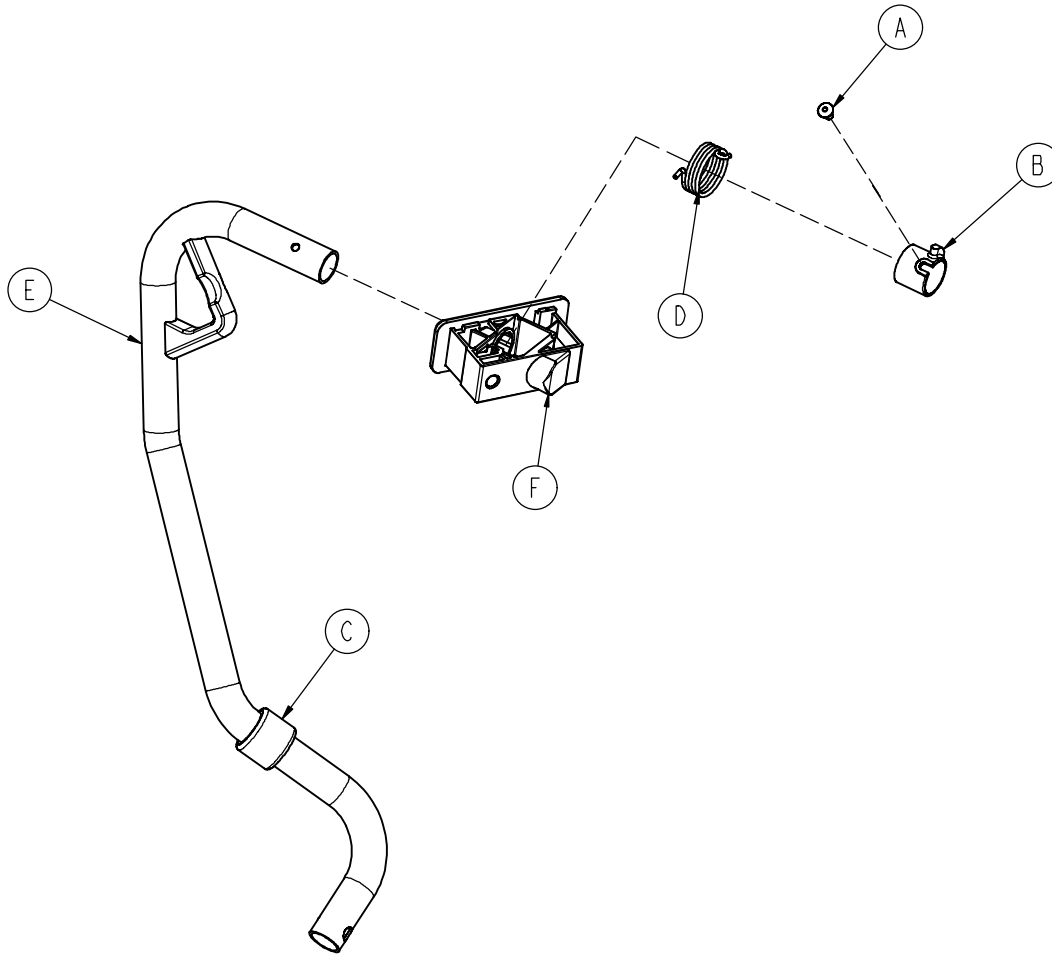

Item	Part No.	Part Name	Qty.
A	0025-079-000	Rivet	1
B	0785-011-010	Left Spindle Spacer	1
C	0785-011-016	Rubber Stop	1
D	0785-011-048	Left Siderail Spring	1
E	0785-011-053	Left Latch Spindle	1
F	0785-011-197	Spindle Pivot Block	1

Dual Siderail Latch Assembly, Right

Assembly part number 0785-011-140 (reference only)

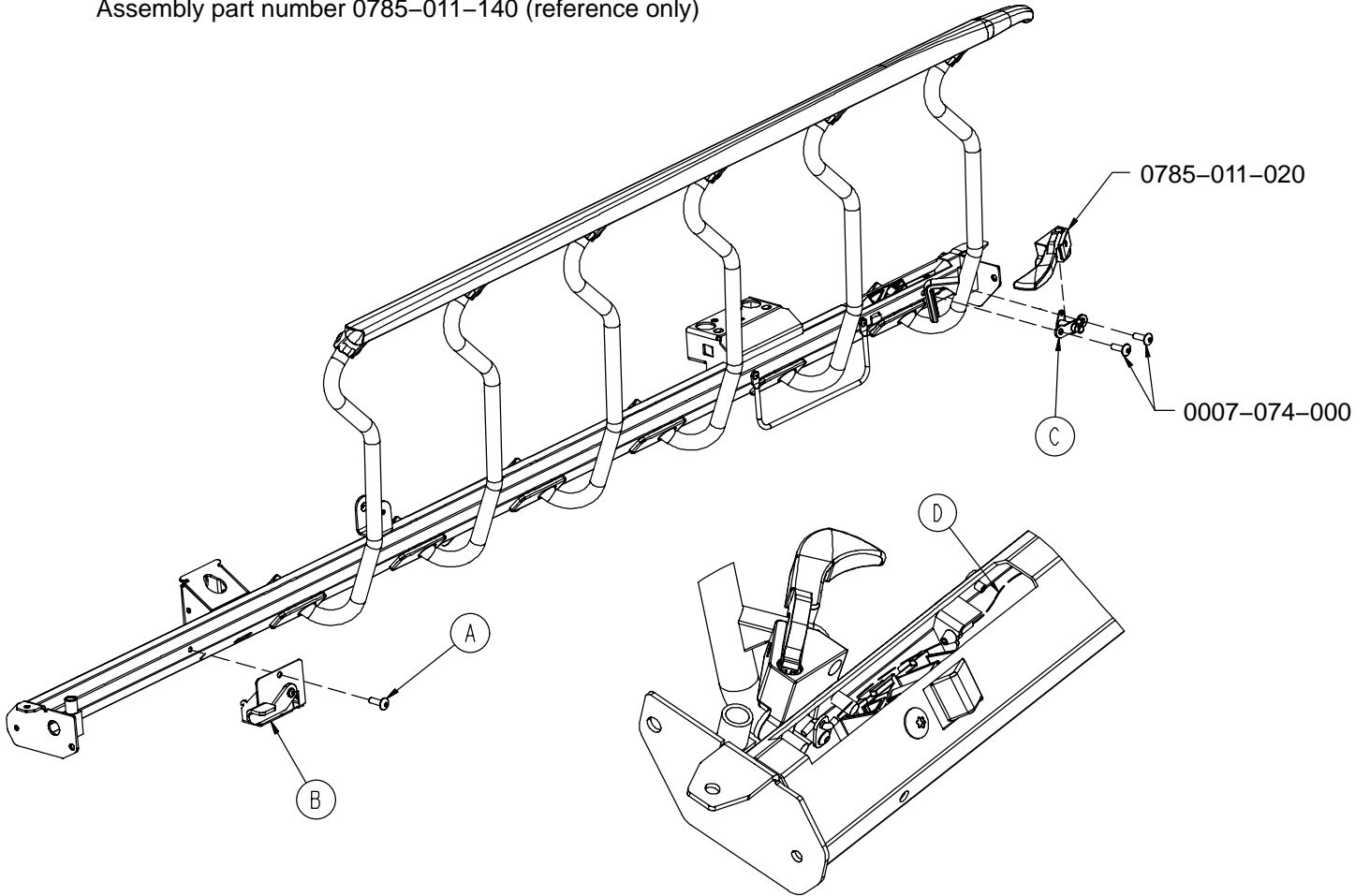

Item	Part No.	Part Name	Qty.
A	0007-074-000	Truss Hd. Machine Screw	1
B	(page 53)	Dual Latch, Head End, Right	1
C	(page 54)	Dual Latch, Foot End, Right	1
D	0785-011-110	Dual Latch Cable	1

Dual Siderail Latch Assembly, Left

Assembly part number 0785-011-150 (reference only)

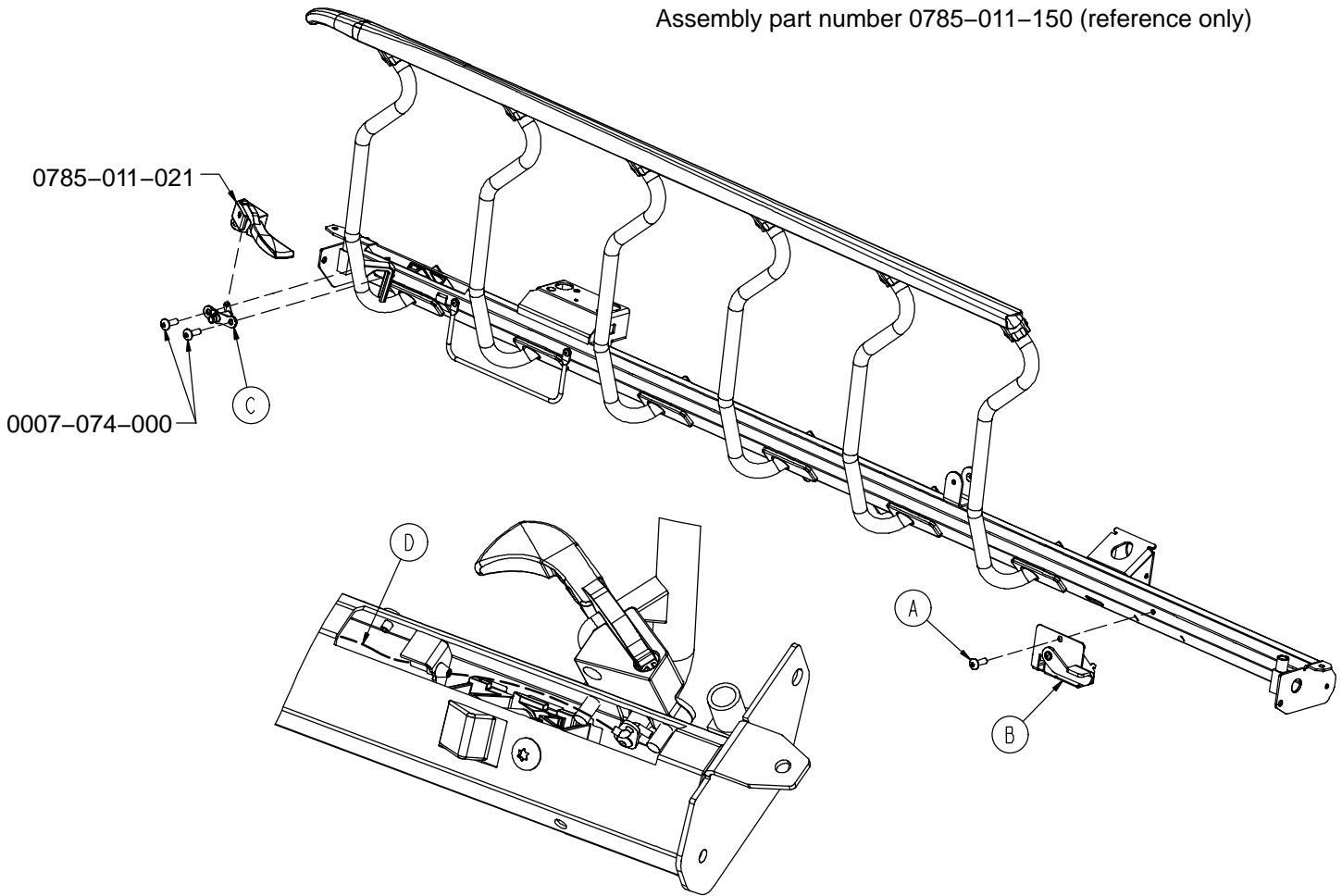

Item	Part No.	Part Name	Qty.
A	0007-074-000	Truss Hd. Machine Screw	1
B	(page 55)	Dual Latch, Head End, Left	1
C	(page 56)	Dual Latch, Foot End, Left	1
D	0785-011-110	Dual Latch Cable	1

0785-011-070 Latch Assembly, Head End, Right

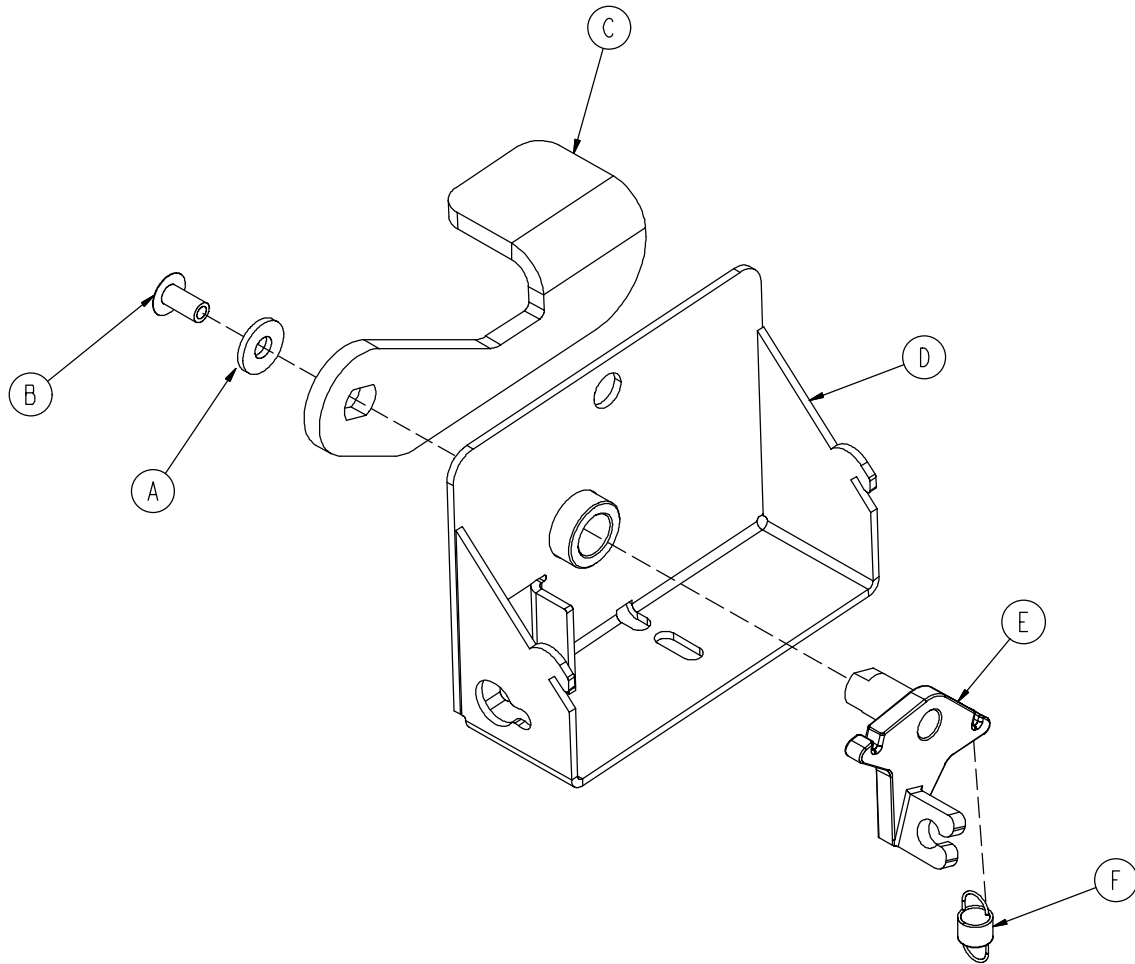

Item	Part No.	Part Name	Qty.
A	0011-063-000	Washer	1
B	0025-079-000	Rivet	1
C	0785-011-074	Dual Latch Handle, Right	1
D	0785-011-075	Mounting Bracket, Right	1
E	0785-011-077	Dual Latch Cable Arm	1
F	0785-011-093	Extension Spring	1

0785-011-100 Latch Assembly, Foot End, Right

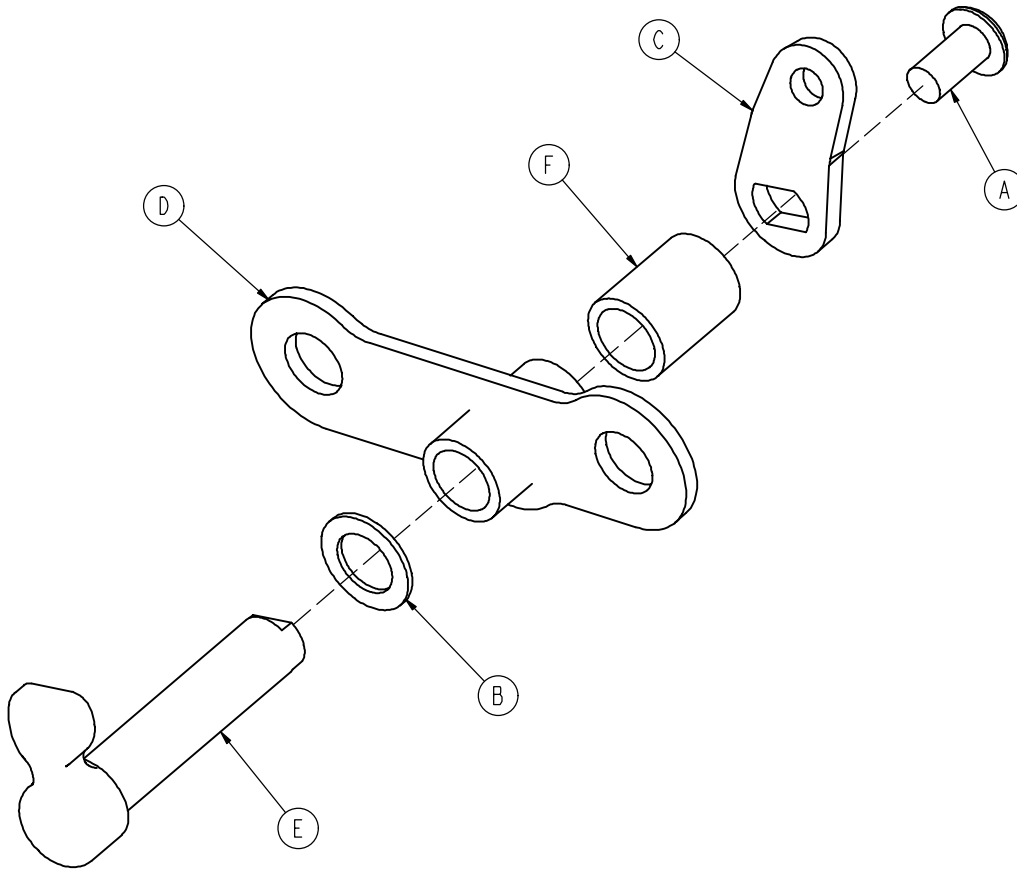

Item	Part No.	Part Name	Qty.
A	0004-136-000	Button Hd. Cap Screw	1
B	0014-122-000	Washer	1
C	0785-011-086	Cable Plate, Right	1
D	0785-011-090	Cam Pivot	1
E	0785-011-095	Dual Latch Cam	1
F	0785-011-096	Dual Latch Spacer	1

0785-011-130 Latch Assembly, Head End, Left

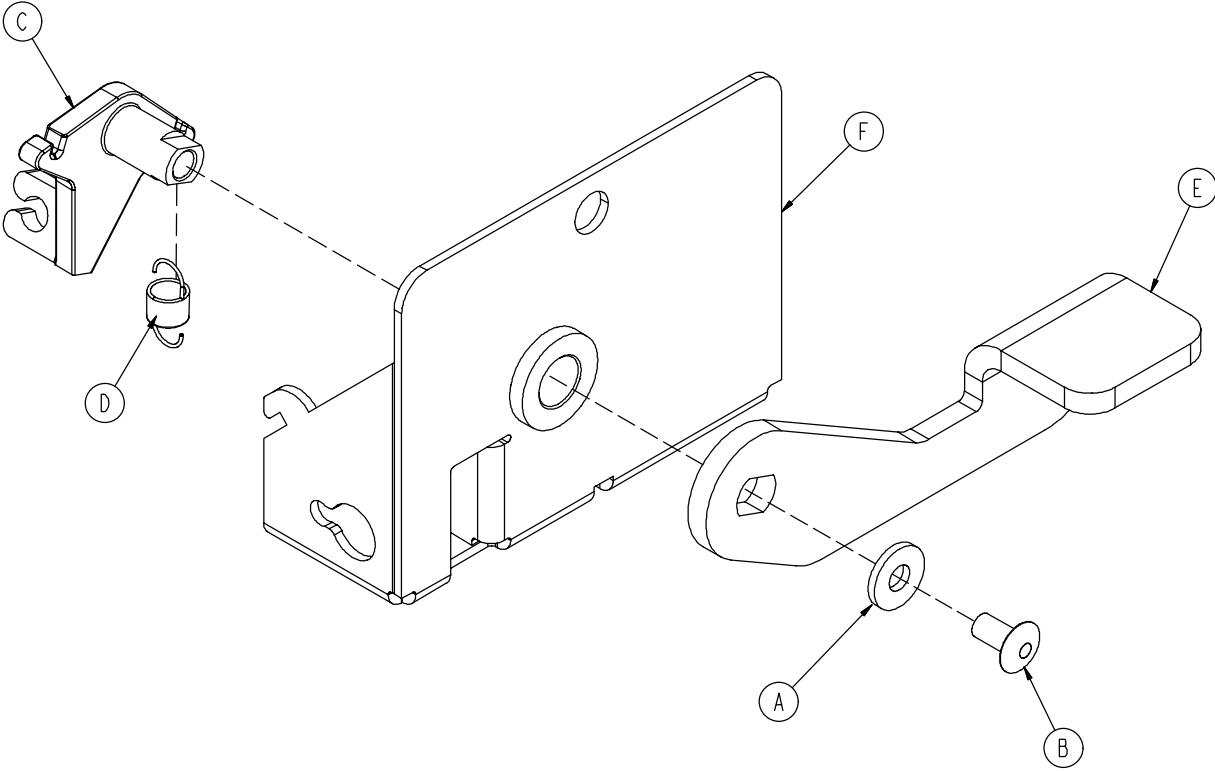

Item	Part No.	Part Name	Qty.
A	0011-063-000	Washer	1
B	0025-079-000	Rivet	1
C	0785-011-077	Dual Latch Cable Arm	1
D	0785-011-093	Extension Spring	1
E	0785-011-106	Dual Latch Handle, Left	1
F	0785-011-120	Mounting Bracket, Left	1

0785-011-135 Latch Assembly, Foot End, Left

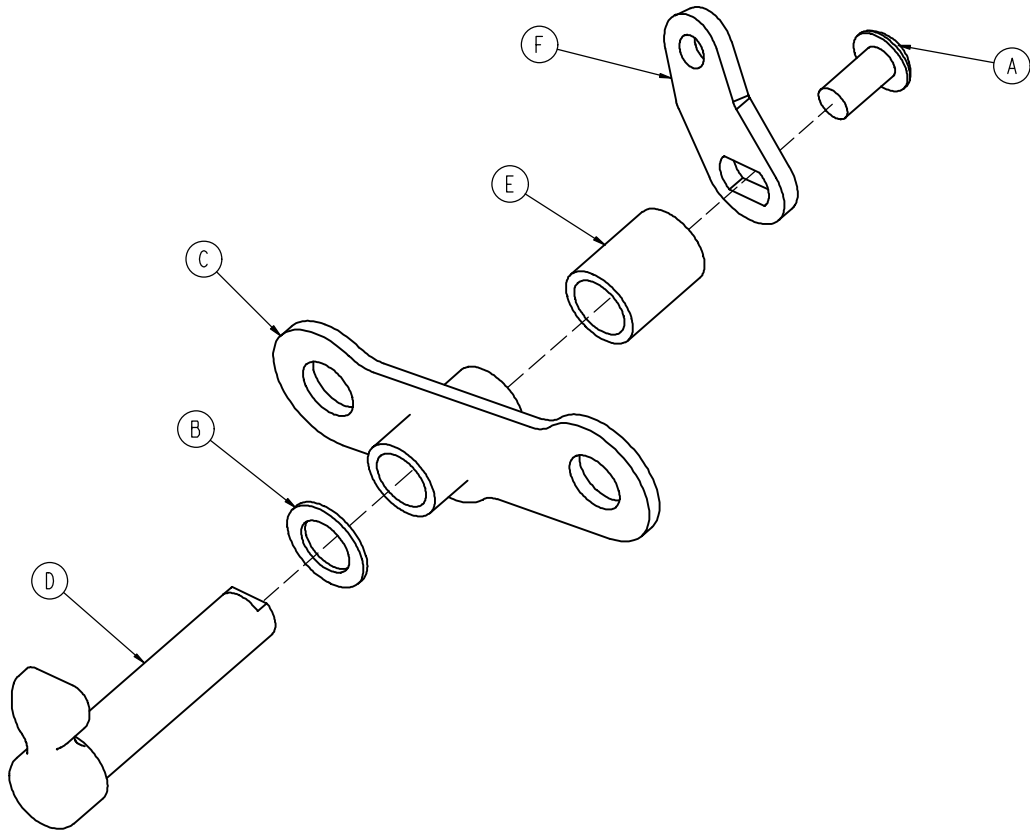

Item	Part No.	Part Name	Qty.
A	0004-136-000	Button Hd. Cap Screw	1
B	0014-122-000	Washer	1
C	0785-011-090	Cam Pivot	1
D	0785-011-095	Dual Latch Cam	1
E	0785-011-096	Dual Latch Spacer	1
F	0785-011-186	Cable Plate, Right	1

30" Standard Fowler/Stationary Foot Assembly

Assembly part number 1004-10-306 (reference only)

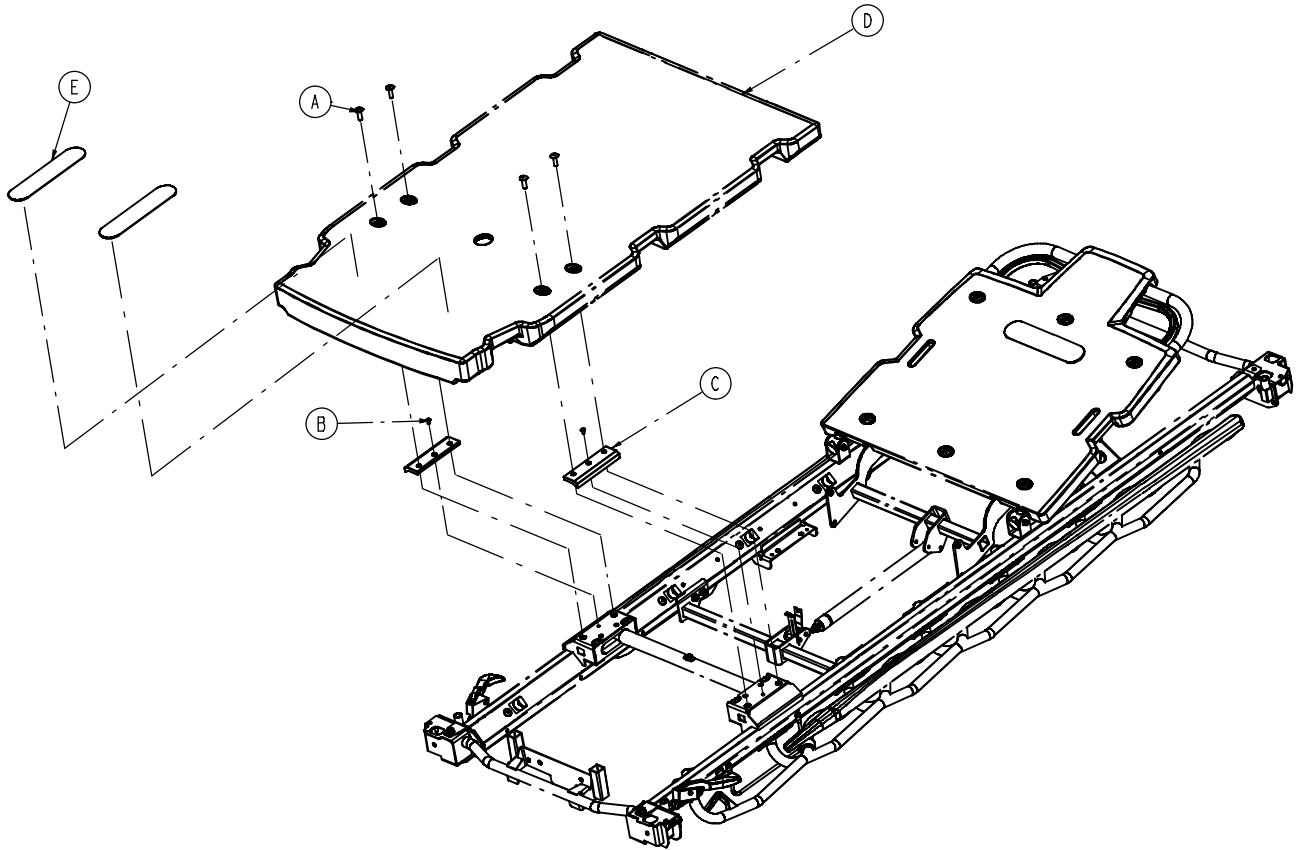

Item	Part No.	Part Name	Qty.
A	0007-074-000	Truss Hd. Machine Screw	4
B	0025-079-000	Rivet	2
C	0785-012-107	Footsection Skin Spacer	2
D	0785-015-350	Stationary Foot Section Skin	1
E	0785-034-005	Velcro Pile	2

30" Standard Fowler Assembly

Assembly part number 0785-012-302 (reference only)

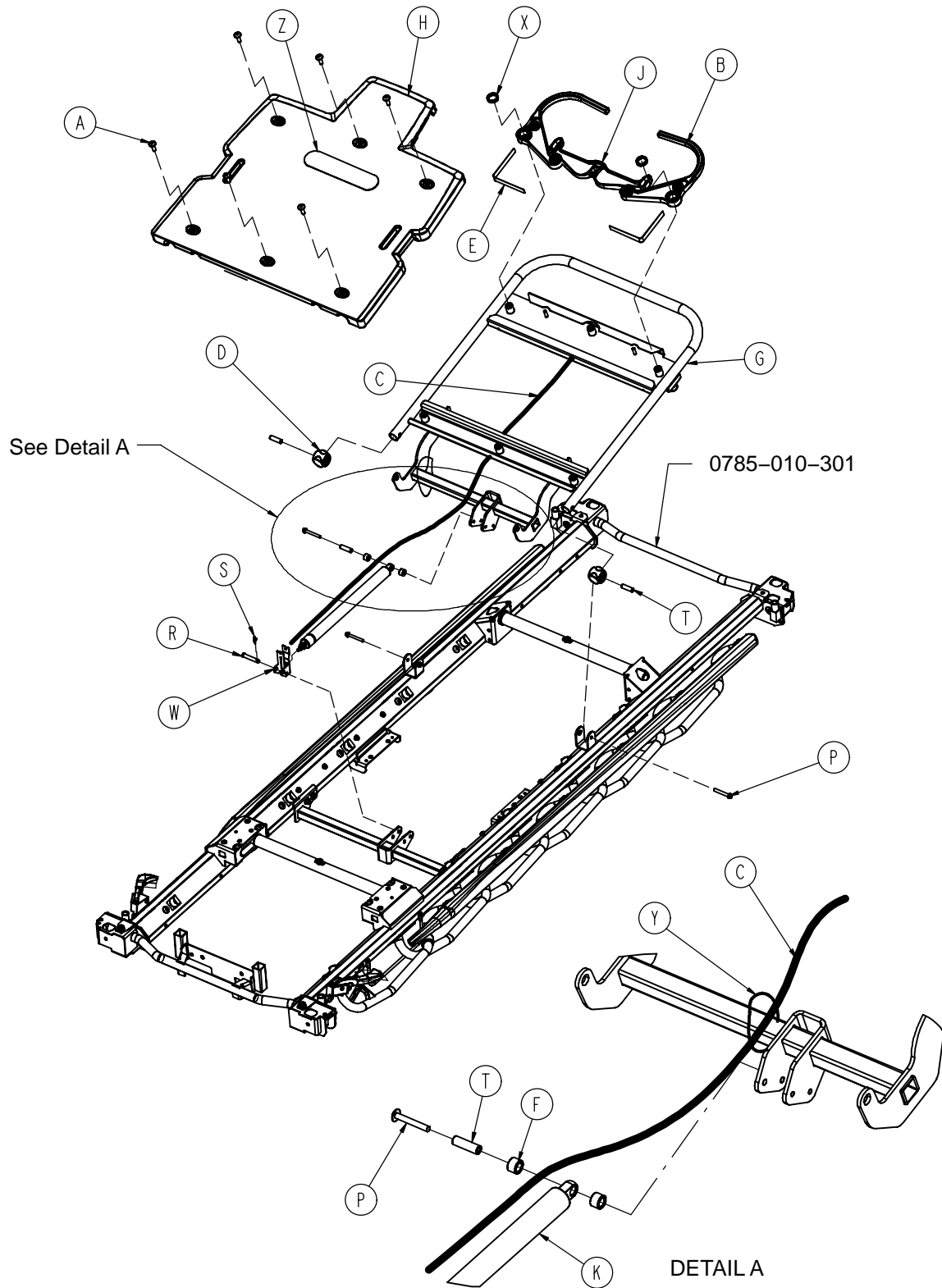

30" Standard Fowler Assembly

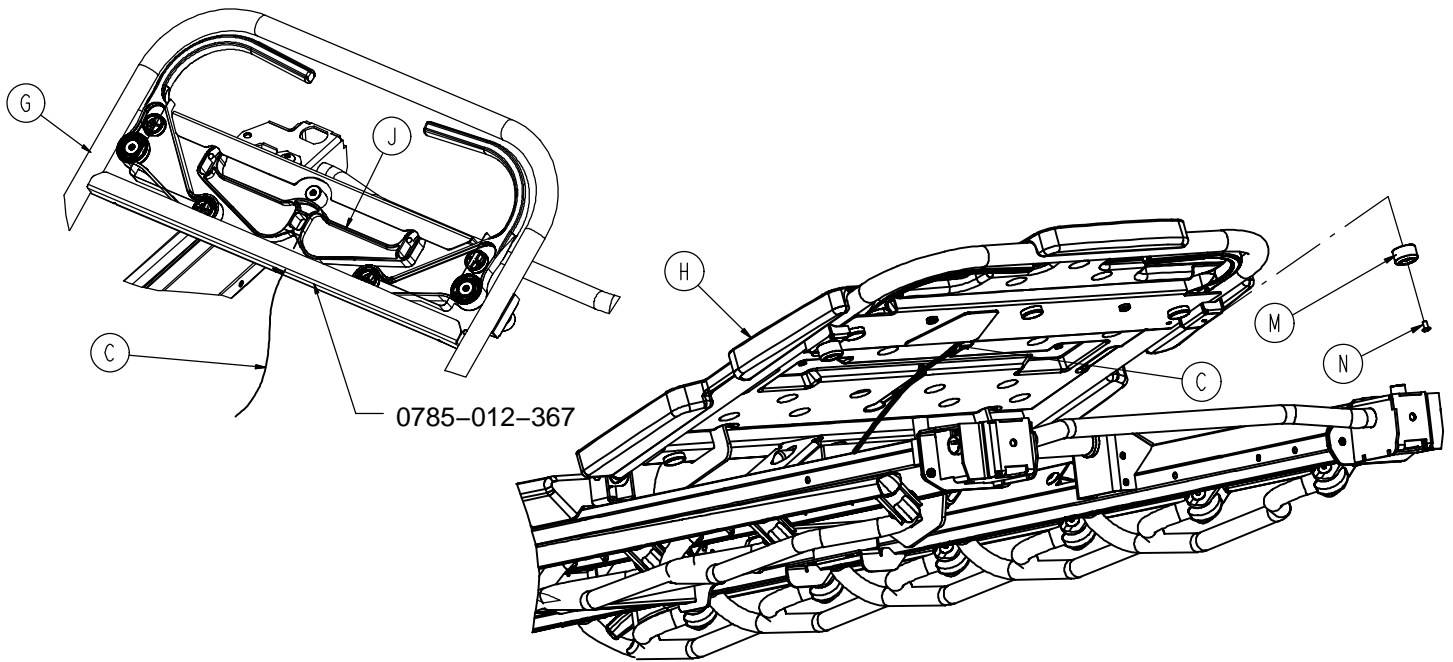

Item	Part No.	Part Name	Qty.
A	0007-074-000	Truss Hd. Machine Screw	6
B	0785-012-066	Fowler Release Handle	2
C	0785-012-080	Fowler Cable Assembly	1
D	0785-012-076	Fowler Tube Plug	2
E	0785-012-086	Fowler Spring	2
F	0785-012-094	Spacer	2
G	0785-012-305	Fowler Weldment	1
H	0785-012-350	Plastic Fowler	1
J	0785-012-366	Cable Release Pivot	1
K	0360-031-077	Gas Cylinder	1
M	0056-023-000	Bumper	2
N	0025-079-000	Rivet	2
P	0003-385-000	Hex Washer Hd. Screw	3
R	0026-296-000	Clevis Pin	1
S	0027-019-000	Rue Clip	1
T	0785-012-103	Sleeve	3
W	0785-012-116	Gas Spring Trip	1
X	0038-557-000	Crest to Crest Spring	2
Y	8815-029-200	Cable Tie	1
Z	0785-034-005	Velcro Pile	1

Corner Cover Assembly – 30” Litter

Assembly part number 0785-010-150 (reference only)

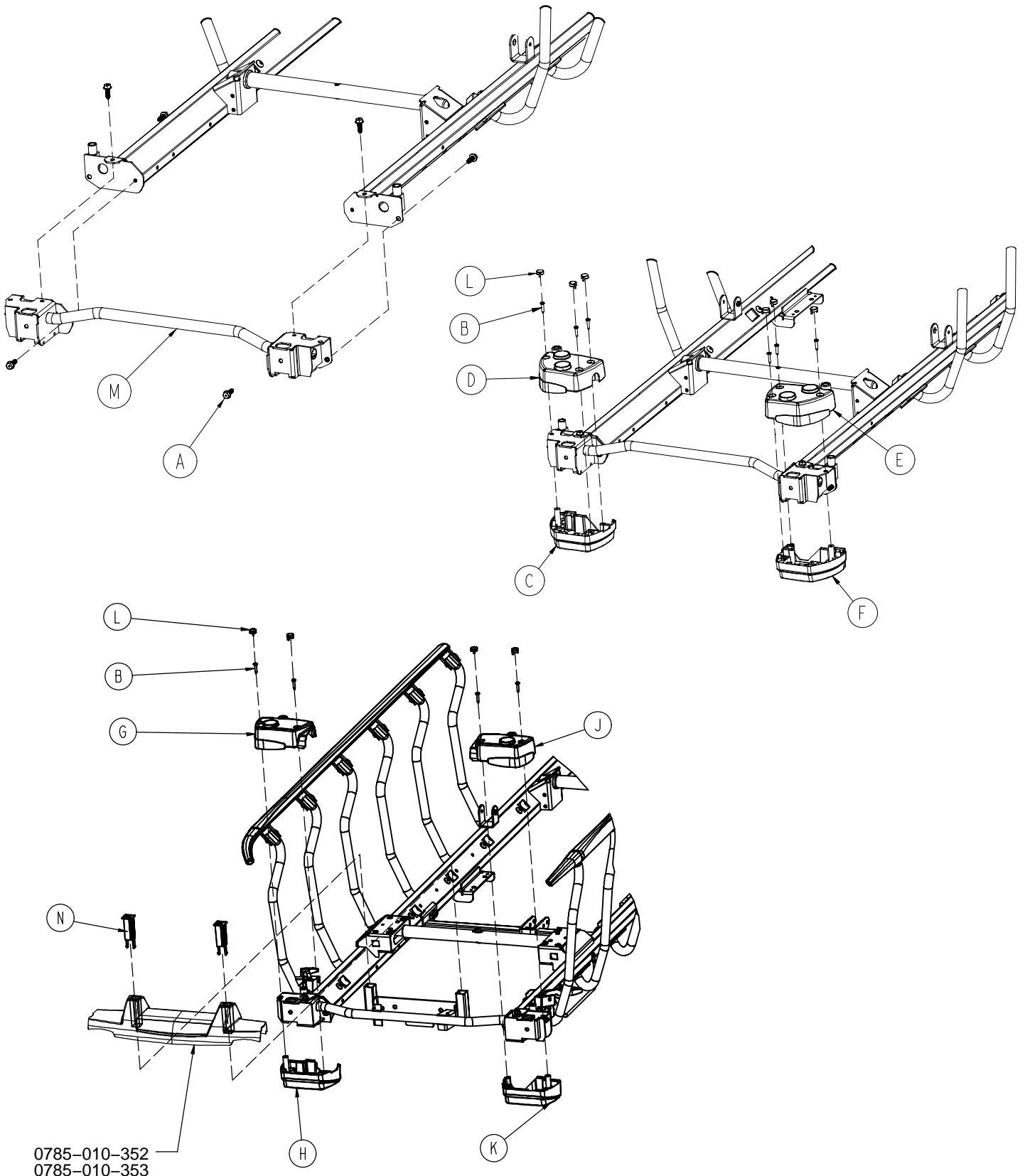

0785-010-352
0785-010-353

Corner Cover Assembly – 30” Litter

Item	Part No.	Part Name	Qty.
A	0023-288-000	Hex Washer Hd. Screw	6
B	0023-310-000	Pan Hd. Screw	10
C	0785-010-050	Cover, Hd. End, Bottom Left	1
D	0785-010-051	Cover, Hd. End, Top Left	1
E	0785-010-052	Cover, Hd. End, Top Right	1
F	0785-010-053	Cover, Hd. End, Bottom, Right	1
G	0785-010-058	Cover, Ft. End, Top Right	1
H	0785-010-059	Cover, Ft. End, Bottom Right	1
J	0785-010-062	Cover, Ft. End, Top Left	1
K	0785-010-063	Cover, Ft. End, Bottom, Left	1
L	0785-010-140	Hole Plug	10
M	0785-010-315	End Weldment, Head	1
N	0785-010-122	Foot Board Receptacle	2

0785-048-020 Push Handle Assembly

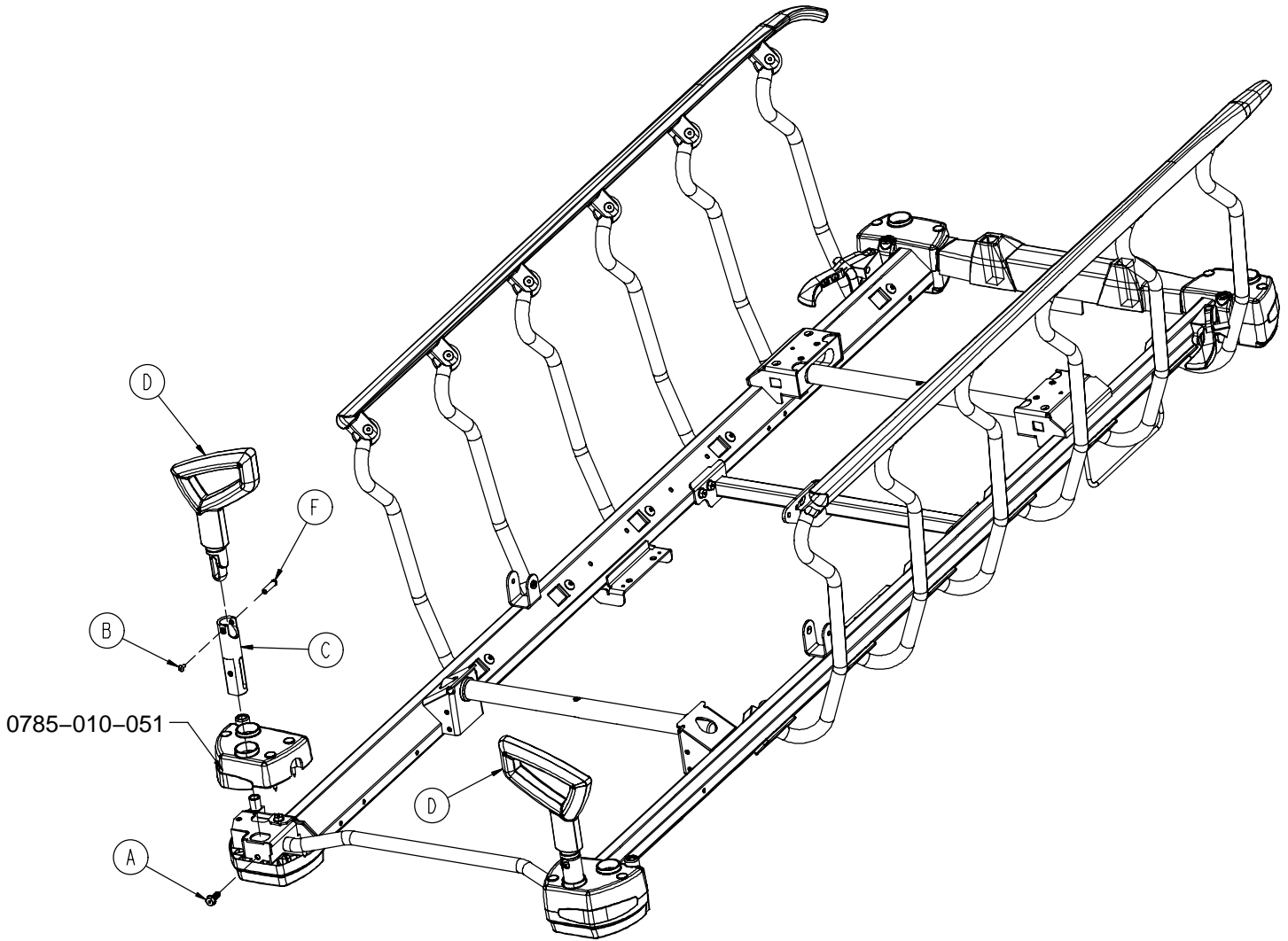

Item	Part No.	Part Name	Qty.
A	0023-288-000	Hex Washer Hd. Screw	2
B	0025-079-000	Rivet	2
C	0785-010-020	IV Pole Socket	2
D	0785-048-018	Push Handle	2
F	0785-048-025	Handle Pivot Pin	2

No Push Handle Option

Assembly part number 0785-048-030 (reference only)

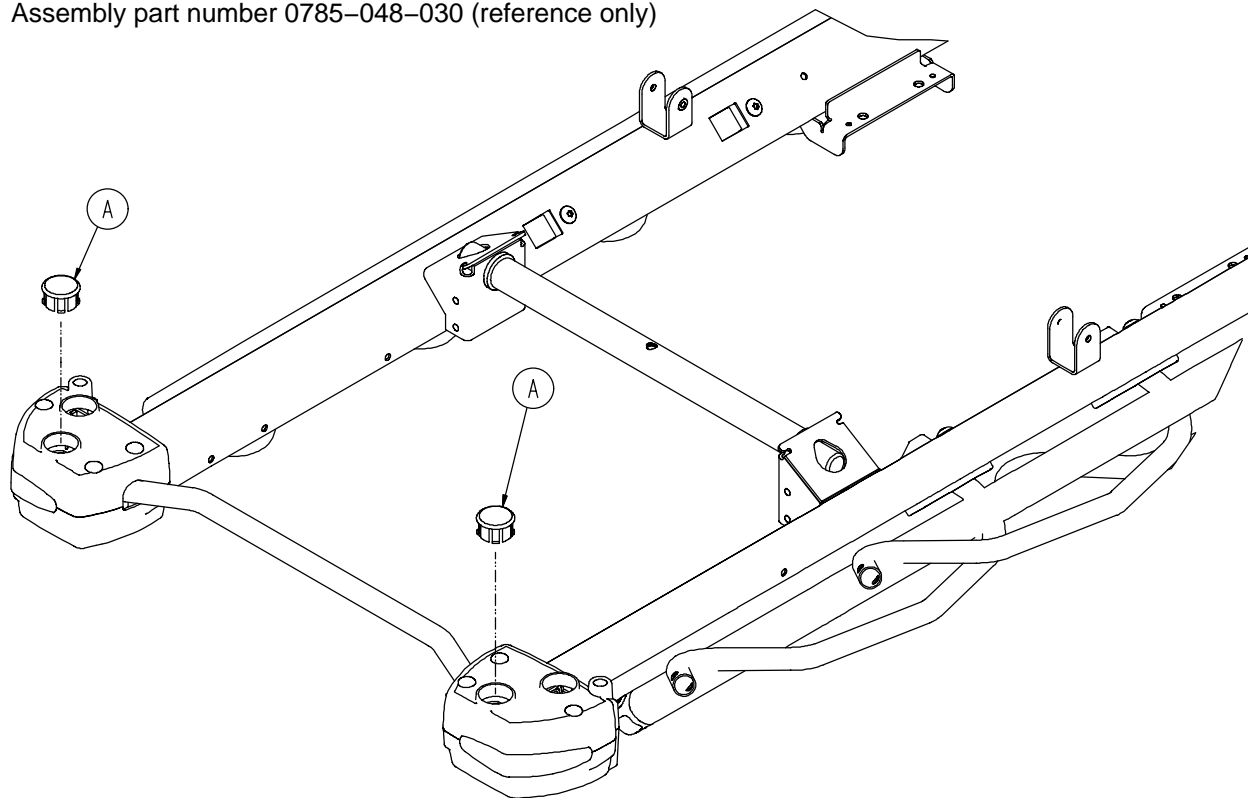

Item	Part No.	Part Name	Qty.
A	0785-010-131	Hole Plug	2

0390-025-022 Standard, Removable IV Pole Assembly

Item	Part No.	Part Name	Qty.
A	0024-023-000	Plastic Knob	1
B	0390-003-053	Double IV Ass'y	1
C	0393-003-043	Tube Assembly	1
D	0004-496-000	Soc. Hd. Cap Screw	1

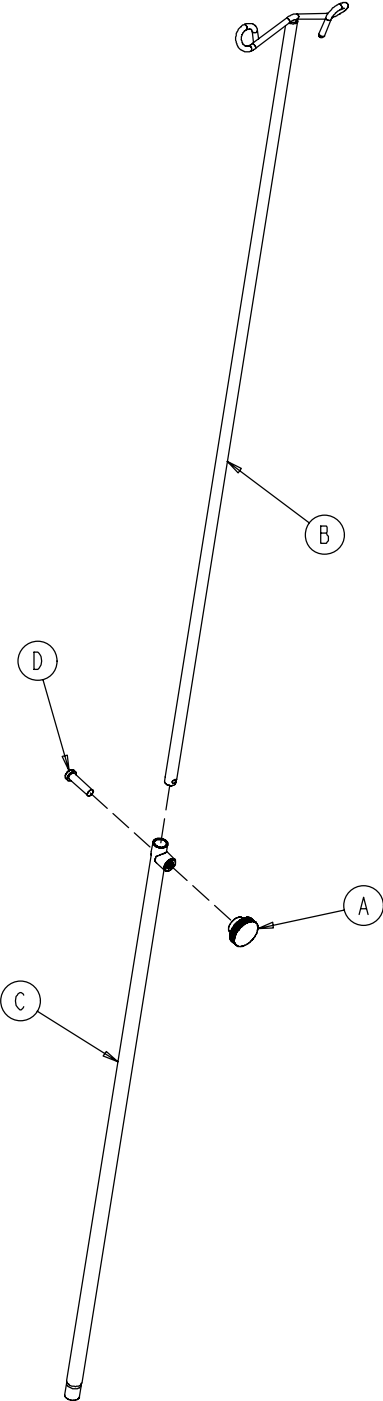

No IV Pole Option

Assembly part number 0785-035-250 (Head End)
Assembly part number 0785-035-251 (Foot End)
(reference only)

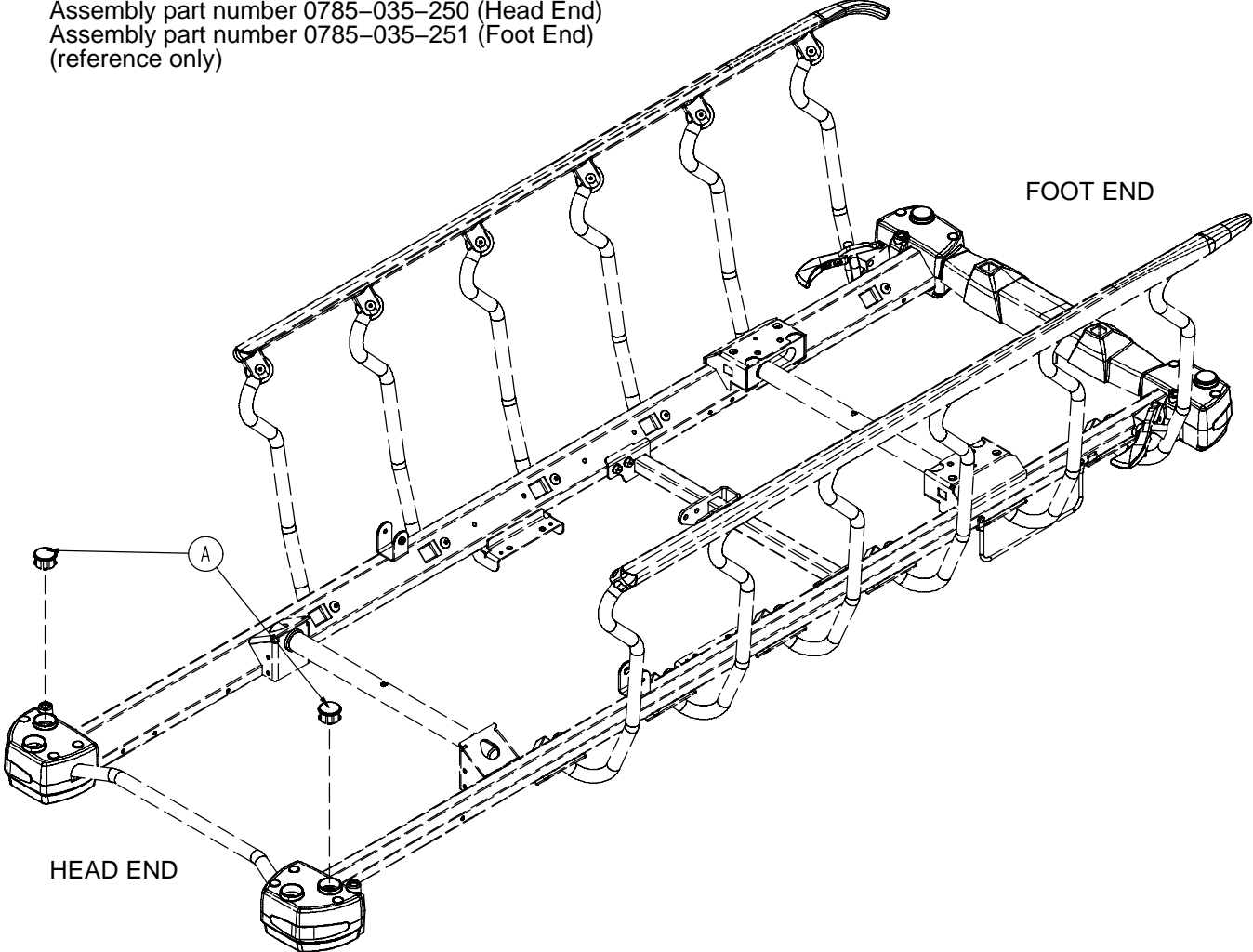

Item	Part No.	Part Name	Qty.
A	0785-010-131	Hole Plug	2

2-Stage IV Assembly

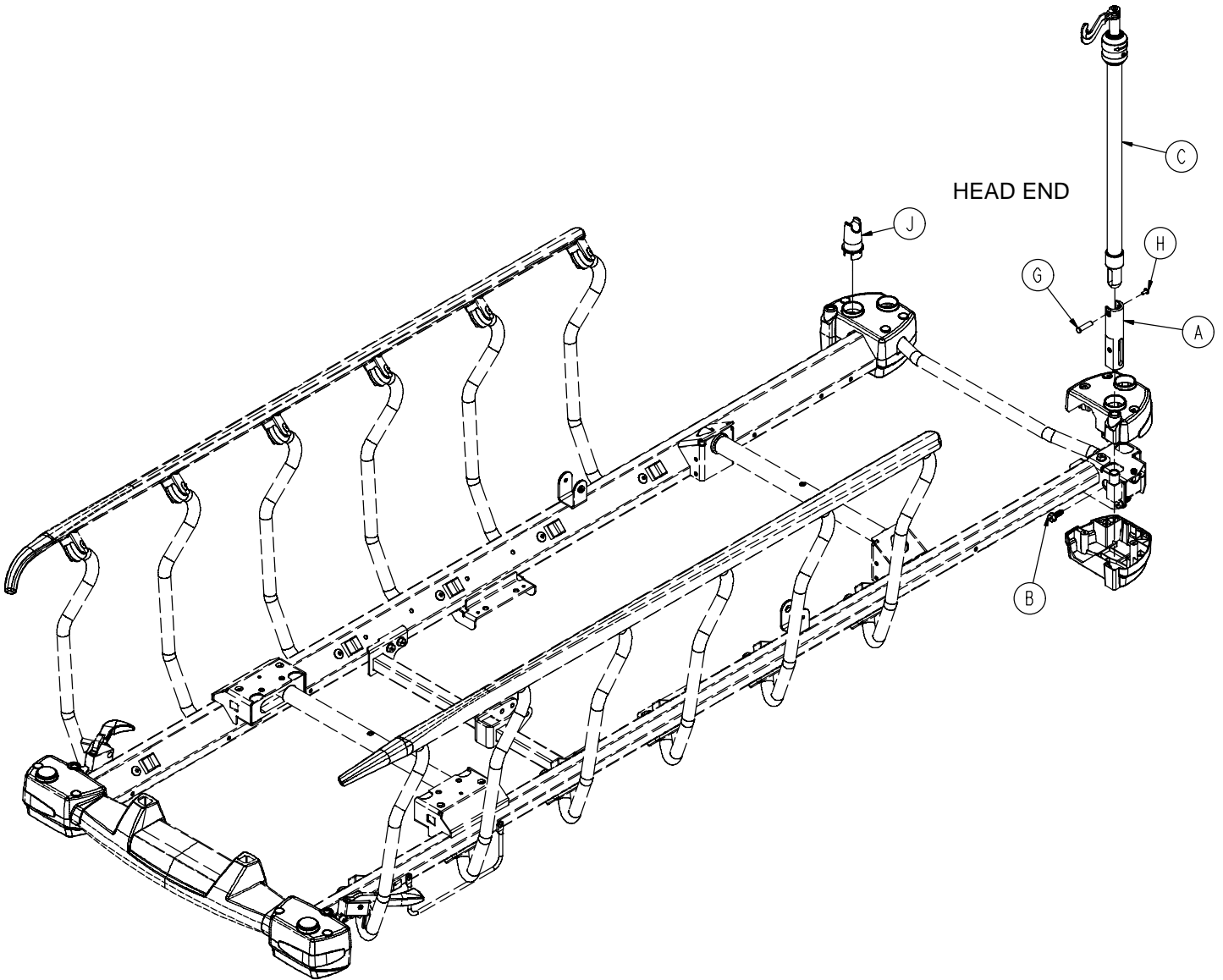

0785-035-338 2-Stage 30" IV, Head/Left
0785-035-341 2-Stage 30" IV, Head/Right
0785-035-340 2-Stage 30" IV, Foot/Left
0785-035-343 2-Stage 30" IV, Foot/Right

Item	Part No.	Part Name	Qty.
A	0785-010-020	IV Pole Socket	1
B	0023-288-000	Hex Washer Hd. Screw	1
C	(page 67)	30" 2-Stage IV Pole Ass'y	1
G	0785-048-025	Handle Pivot Pin	1
H	0025-079-000	Rivet	1
J	0785-035-004	IV Pole Support	1

0785-035-401 30" 2-Stage IV Pole Assembly

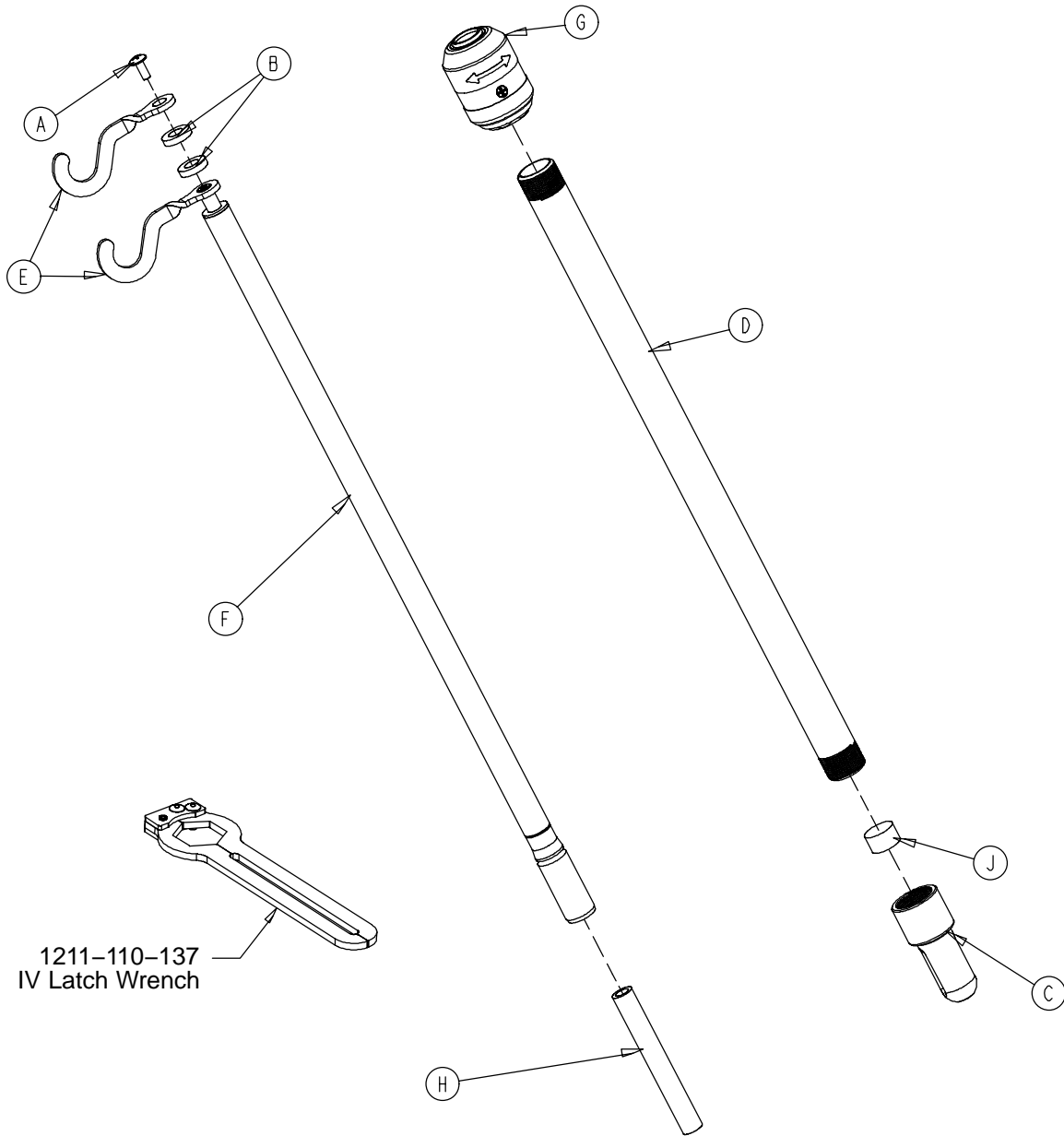

Item	Part No.	Part Name	Qty.
A	0007-040-000	Truss Hd. Machine Screw	1
B	0052-017-000	Spacer	2
C	0785-035-003	IV Pole Pivot	1
D	0785-035-027	Base Tube	1
E	1010-059-016	IV Hook	2
F	0785-035-102	2nd Stage Assembly	1
G	0785-035-103	IV Pole Latch	1
H	0785-035-301	Spacer	1
J	1001-259-013	Dampener	1

3-Stage IV Assembly

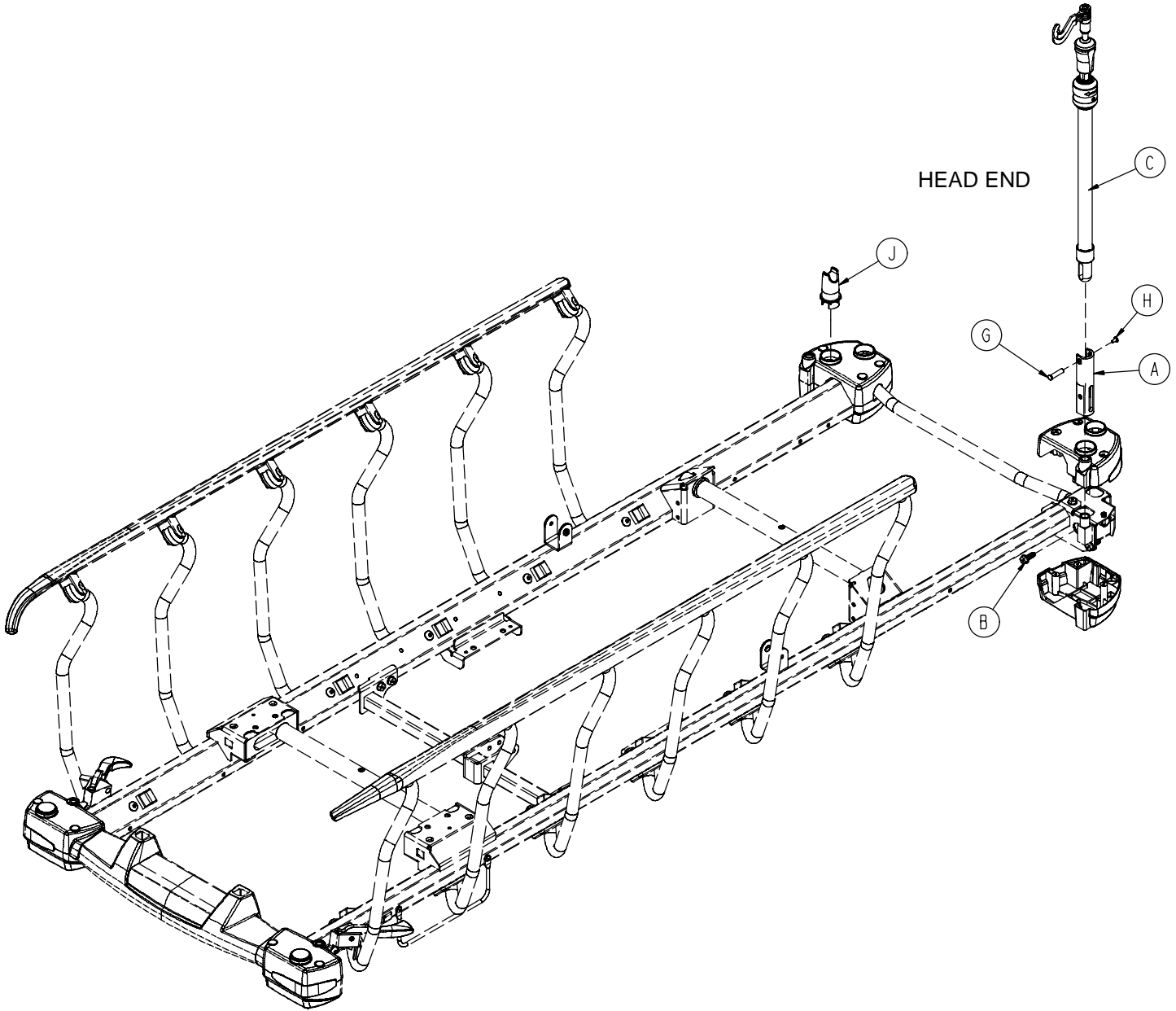

- 0785-035-342 3-Stage 30" IV, Head/Left
- 0785-035-337 3-Stage 30" IV, Head/Right
- 0785-035-344 3-Stage 30" IV, Foot/Left
- 0785-035-339 3-Stage 30" IV, Foot/Right

Item	Part No.	Part Name	Qty.
A	0785-010-020	IV Pole Socket	1
B	0023-288-000	Hex Washer Hd. Screw	1
C	(page 69)	30" 3-Stage IV Pole Ass'y	1
G	0785-048-025	Handle Pivot Pin	1
H	0025-079-000	Rivet	1
J	0785-035-004	IV Pole Support	1

0785-035-300 30" 3-Stage IV Pole Assembly

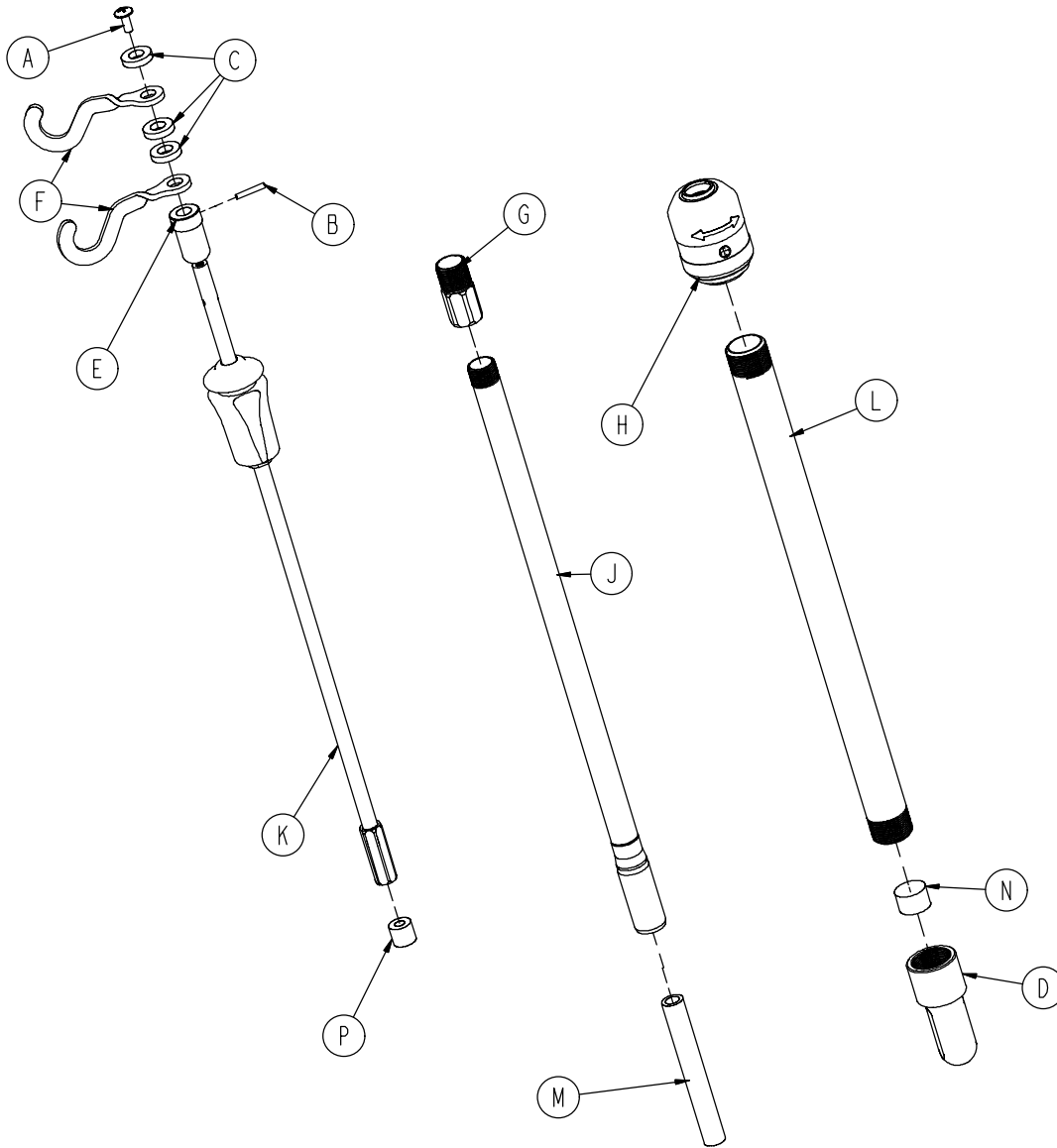

Item	Part No.	Part Name	Qty.
A	0007-004-000	Truss Hd. Machine Screw	1
B	0026-076-000	Slotted Spring Pin	1
C	0052-017-000	Spacer	3
D	0785-035-003	IV Pole Pivot	1
E	0785-035-026	Collar	1
F	1010-059-016	IV Hook	2
G	1211-110-016	Threaded Adaptor	1
H	0785-035-103	IV Pole Latch	1
J	0785-035-201	2nd Stage Assembly	1
K	(page 70)	3rd Stage Assembly	1
L	0785-035-204	Base Tube	1
M	0785-035-301	Spacer	1
N	1001-259-013	Dampener	1
P	1001-359-014	Dampener	1

0785-035-202 3-Stage IV Pole 3rd Stage Assembly

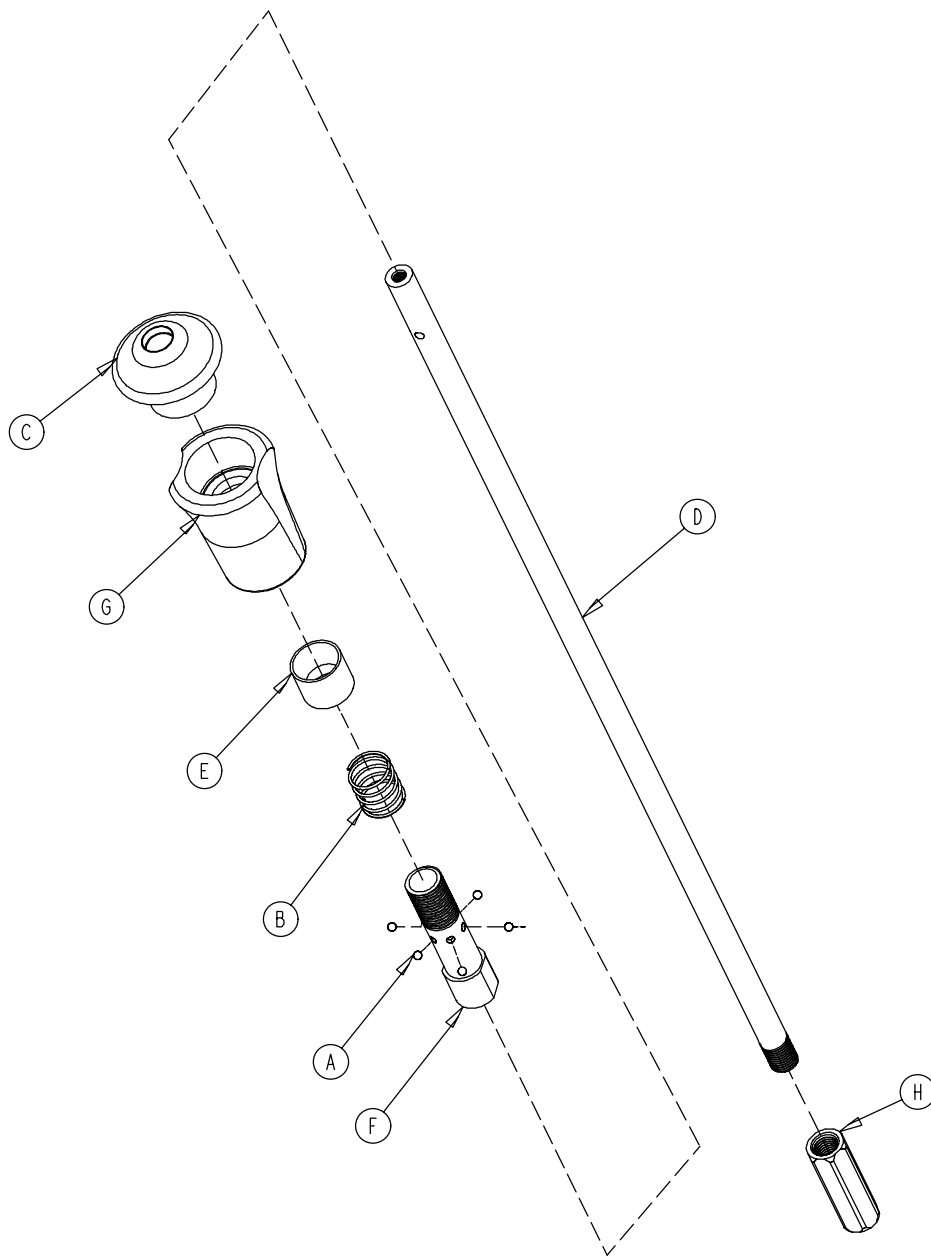

Item	Part No.	Part Name	Qty.
A	0031-021-000	Ball Bearing	6
B	0038-303-000	Compression Spring	1
C	0785-035-037	Thumb Knob	1
D	0785-035-206	Extension Rod	1
E	1010-061-013	Ball Retainer	1
F	1010-061-016	Retaining Shaft	1
G	1010-061-018	Hand Guard	1
H	1211-110-017	Nut	1

1020-130-000 Upright Oxygen Bottle Holder Assembly

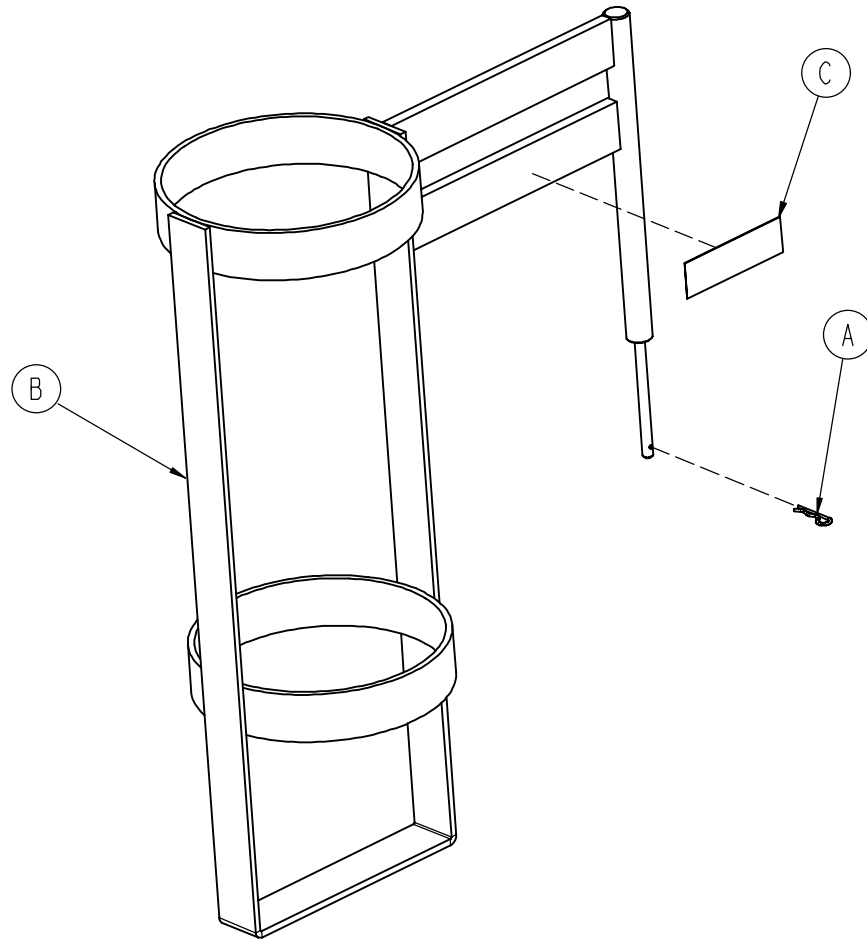

Item	Part No.	Part Name	Qty.
A	0027-030-000	Hair Pin Cotter	1
B	1020-030-111	Upright Bottle Holder	1
C	1020-030-117	Specification Label	1

0785-045-200 Defibrillator Tray Assembly

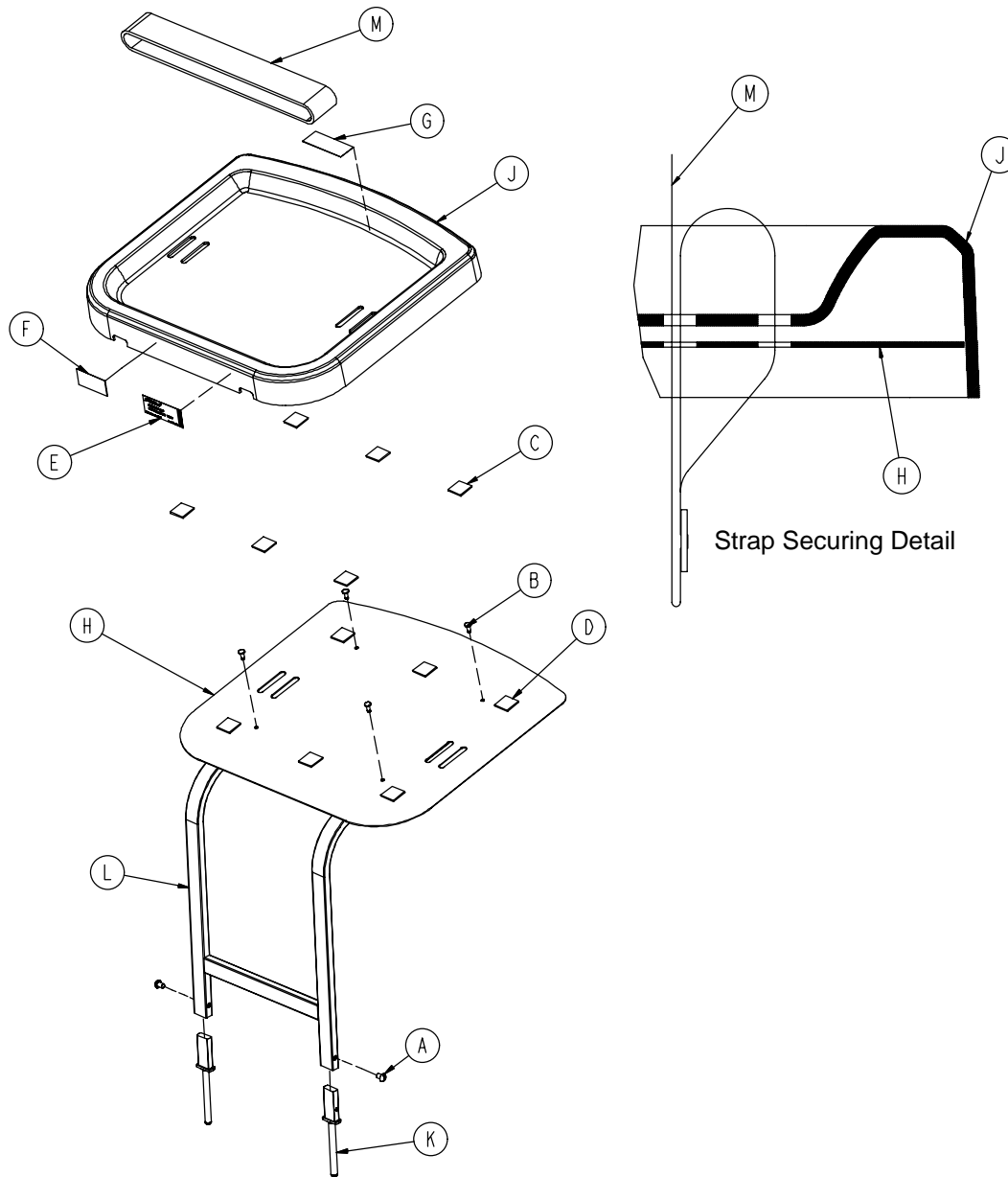

Item	Part No.	Part Name	Qty.
A	0002-044-000	Round Hd. Machine Screw	2
B	0025-055-000	Rivet	4
C	0029-008-000	Dual Lock	6
D	0029-010-000	Dual Lock	6
E	0785-045-201	Defib Tray Label	1
F	0785-045-402	Push/Pull Label	1
G	0785-045-403	Weight Capacity Label	1
H	0785-045-204	Tray Support	1
J	0785-045-207	Tray	1
K	0785-045-208	Bayonet	1
L	0785-045-210	Frame Weldment	1
M	1010-050-021	Long Strap	1

0785-045-400 Defib Tray/Foot Extender/Foot Board

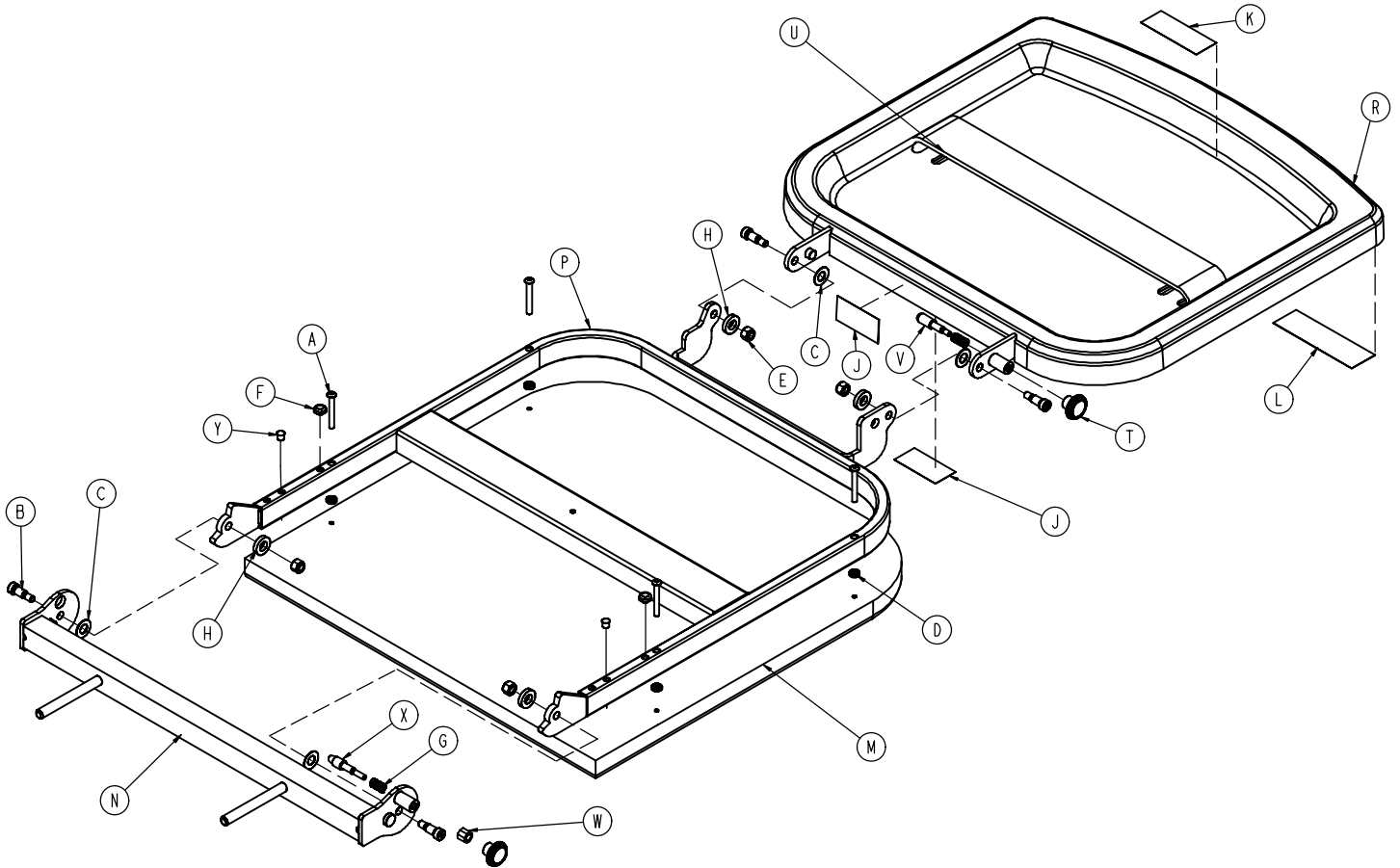

Item	Part No.	Part Name	Qty.
A	0004-215-000	But Hd. Cap Screw	4
B	0008-049-000	Soc. Hd. Cap Screw	4
C	0014-020-000	Washer	4
D	0014-120-000	Washer	4
E	0016-028-000	Hex Nut	4
F	0037-052-000	Rubber Bumper	2
G	0038-133-000	Compression Spring	2
H	0052-017-000	Spacer	4
J	0785-045-402	Push/Pull Label	2
K	0785-045-403	Weight Capacity Label	1
L	0785-045-401	Foot Extender/Defib Tray Label	1
M	0785-045-405	Cushion	1
N	0785-045-410	Base Mounting Weldment	1
P	0785-045-420	Frame Pivot Weldment	1
R	0785-045-430	Tray	1
T	0785-045-450	Knob	2
U	1010-050-021	Long Strap	1
V	1010-050-242	Lock Pin	1
W	1010-050-250	Lock Adjuster	1
X	1010-050-248	Lower Pin Lock	1
Y	0721-031-065	Hole Plug	2

0785-045-700 Optional Serving Tray Assembly

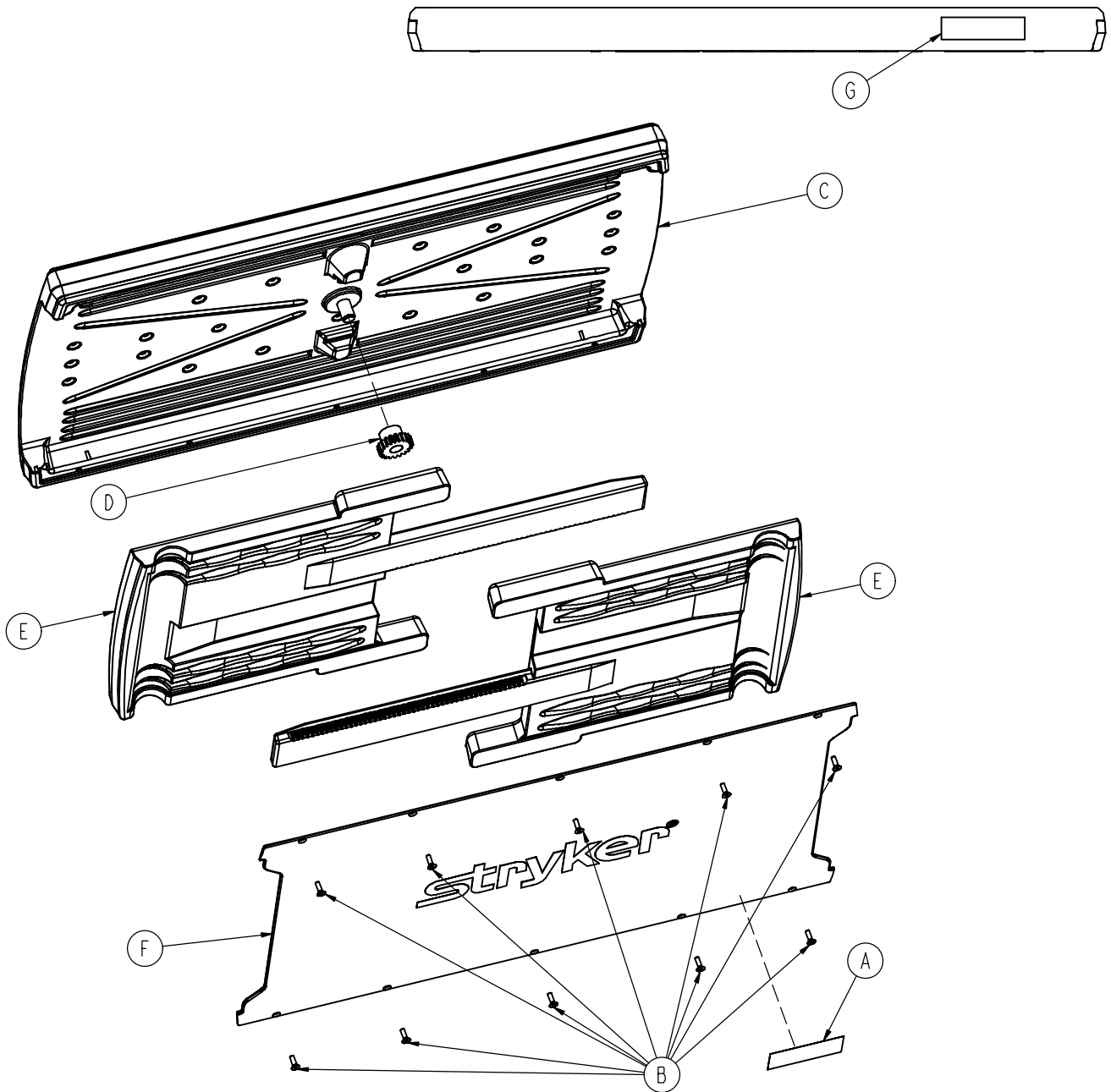

Item	Part No.	Part Name	Qty.
A	0785-045-701	Serving Tray Label	1
B	0785-045-704	Flat Hd. Torx Screw	10
C	0785-045-705	Serving Tray Top	1
D	0785-045-706	Serving Tray Pinion	1
E	0785-045-710	Serving Tray Slider	2
F	0785-045-715	Serving Tray Cover	1
G	0785-045-403	Weight Capacity Label	1

0785-045-800 Optional Foot Board/Serving Tray Holder

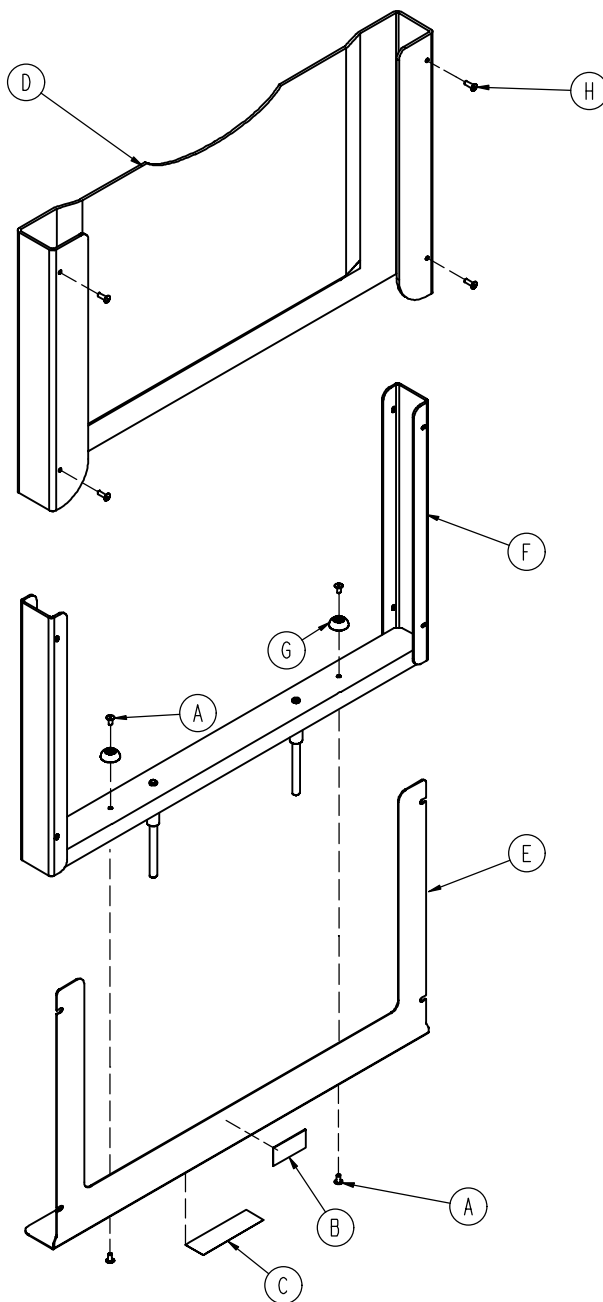

Item	Part No.	Part Name	Qty.
A	0025-079-000	Rivet	4
B	0785-045-402	Push/Pull Label	1
C	0785-045-801	Serving Tray Holder Label	1
D	0785-045-805	Foot Board	1
E	0785-045-806	Front Plate	1
F	0785-045-810	Foot Board Support Weldment	1
G	0946-001-155	Bumper	2
H	0025-133-000	Dome Head Pop Rivet	4

0785-045-500 Foot Board/Chartholder Assembly

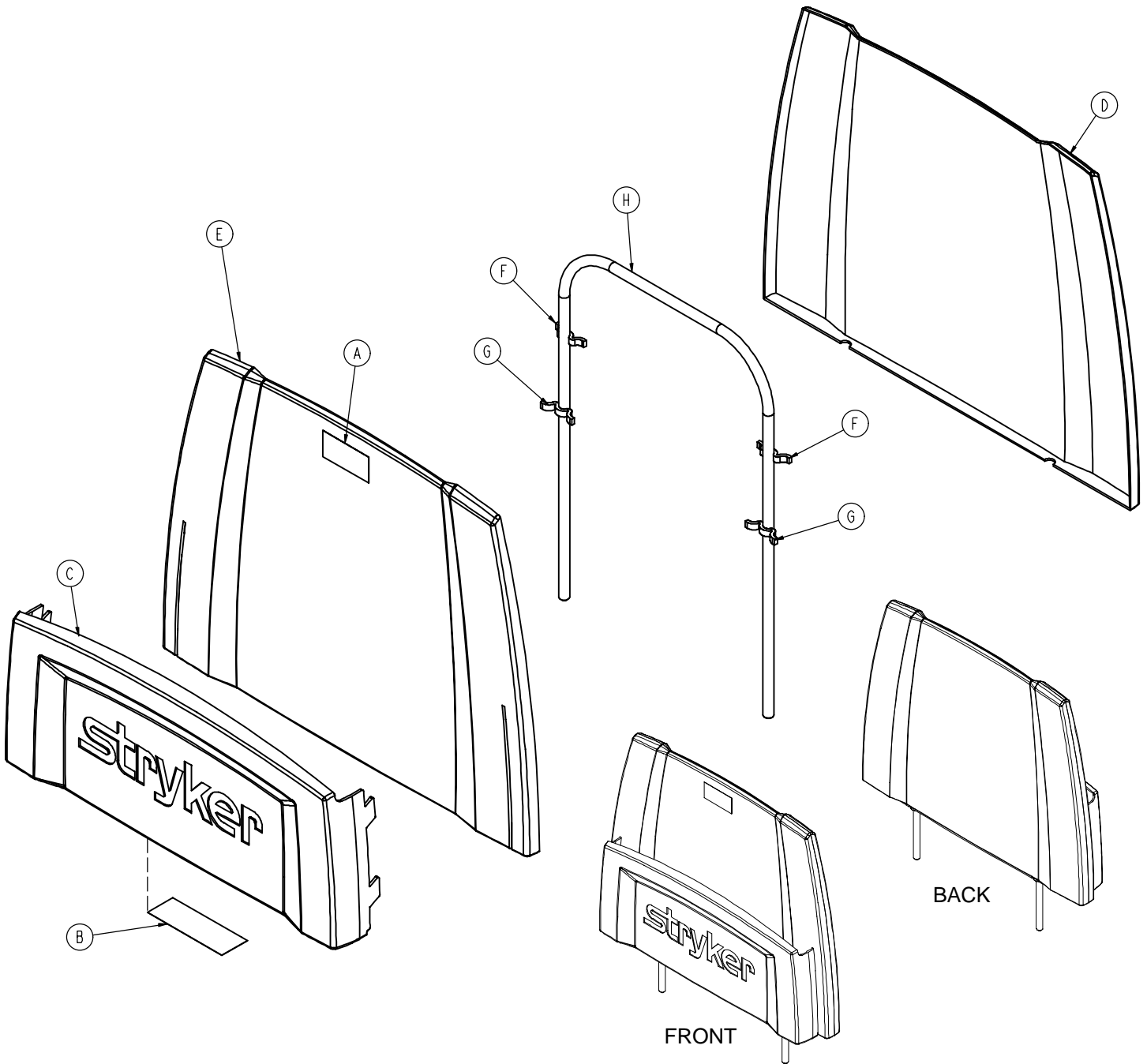

Item	Part No.	Part Name	Qty.
A	0785-045-402	Push/Pull Label	1
B	0785-045-501	Foot Board Label	1
C	0785-045-511	Chartholder	1
D	0785-045-512	Foot Board Back	1
E	0785-045-513	Foot Board Front	1
F	0785-045-514	Small Standoff	2
G	0785-045-515	Large Standoff	2
H	0946-029-010	Support Weldment	1

Mattresses and Siderail Pads

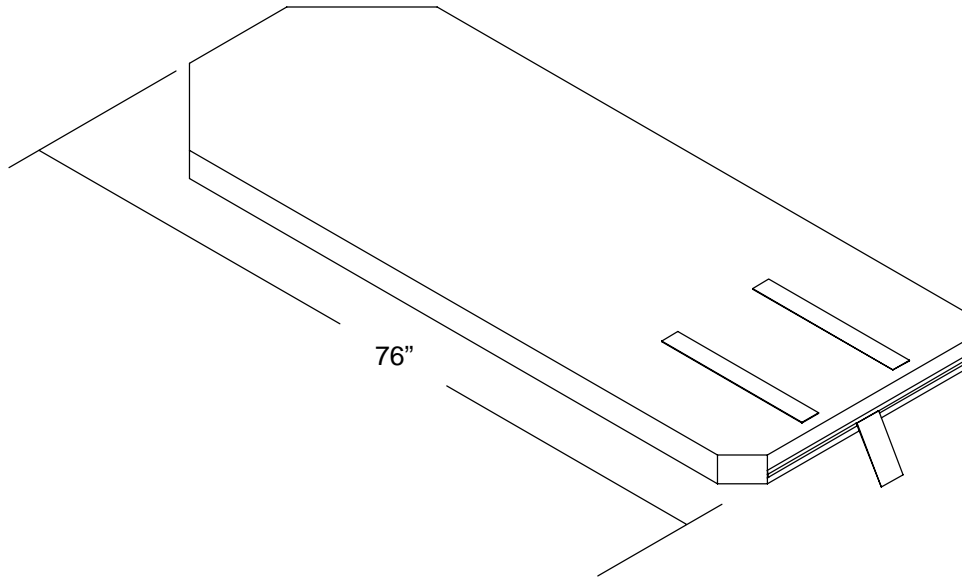

Mattress, 3" x 30", Enhanced	0785-034-313
Mattress, 4" x 30", Enhanced	0785-034-323
Mattress, 4" x 30", Ultra Comfort	0785-034-303
Mattress, 5" x 30", Ultra Comfort	0785-034-333

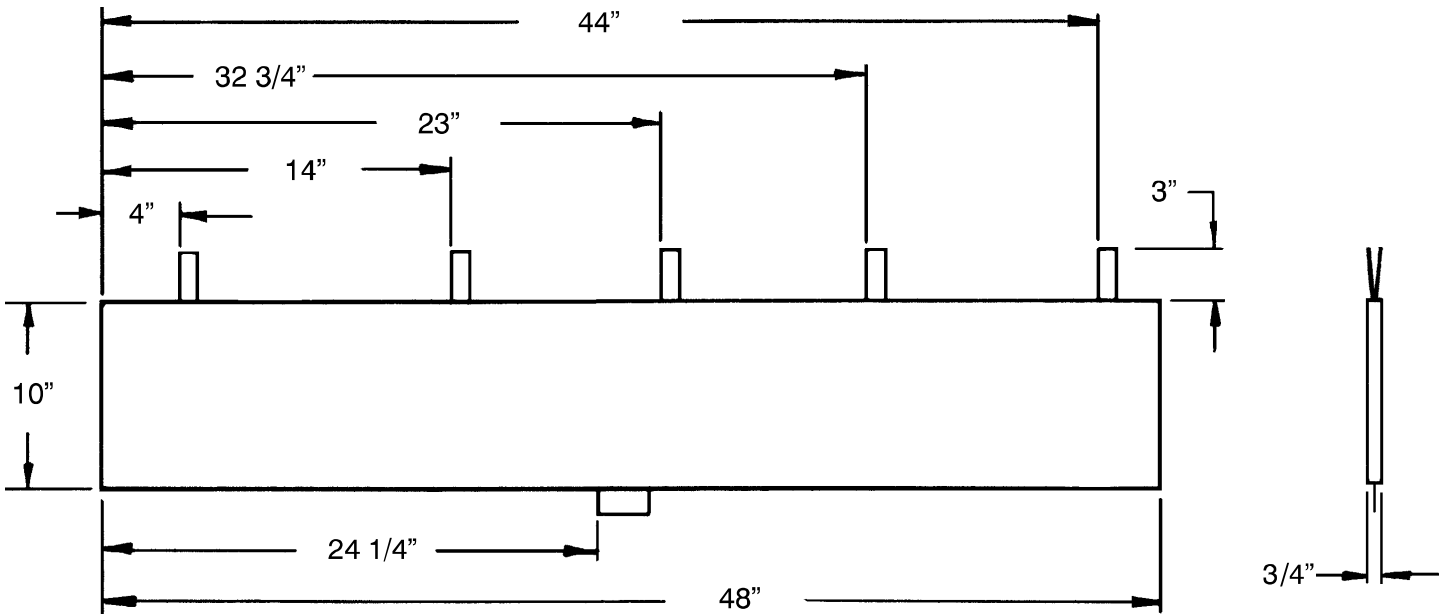

Siderail Pad Set	part # 1001-052-000
------------------------	---------------------

Warranty

Limited Warranty:

Stryker Medical Division, a division of Stryker Corporation, warrants to the original purchaser that its products should be free from defects in material and workmanship for a period of one (1) year after date of delivery. Stryker's obligation under this warranty is expressly limited to supplying replacement parts and labor for, or replacing, at its option, any product which is, in the sole discretion of Stryker, found to be defective. If requested by Stryker, products or parts for which a warranty claim is made shall be returned prepaid to Stryker's factory. Any improper use or any alteration or repair by others in such manner as in Stryker's judgement affects the product materially and adversely shall void this warranty. Any repair of Stryker products using parts not provided or authorized by Stryker shall void this warranty. No employee or representative of Stryker is authorized to change this warranty in any way.

Stryker Medical stretcher products are designed for a 10 year expected service life under normal use, conditions, and with appropriate periodic maintenance as described in the maintenance manual for each device. Stryker warrants to the original purchaser that the welds on its stretcher products will be free from structural defects for the expected 10 year life of the stretcher product as long as the original purchaser owns the product.

This statement constitutes Stryker's entire warranty with respect to the aforesaid equipment. STRYKER MAKES NO OTHER WARRANTY OR REPRESENTATION, EITHER EXPRESSED OR IMPLIED, EXCEPT AS SET FORTH HEREIN. THERE IS NO WARRANTY OF MERCHANTABILITY AND THERE ARE NO WARRANTIES OF FITNESS FOR ANY PARTICULAR PURPOSE. IN NO EVENT SHALL STRYKER BE LIABLE HEREUNDER FOR INCIDENTAL OR CONSEQUENTIAL DAMAGES ARISING FROM OR IN ANY MANNER RELATED TO SALES OR USE OF ANY SUCH EQUIPMENT.

To Obtain Parts and Service:

Stryker products are supported by a nationwide network of dedicated Stryker Field Service Representatives. These representatives are factory trained, available locally, and carry a substantial spare parts inventory to minimize repair time. Simply call your local representative, or call Stryker Customer Service at (800) 327-0770.

Service Contract Coverage:

Stryker has developed a comprehensive program of service contract options designed to keep your equipment operating at peak performance at the same time it eliminates unexpected costs. We recommend that these programs be activated *before* the expiration of the new product warranty to eliminate the potential of additional equipment upgrade charges.

A SERVICE CONTRACT HELPS TO:

- Ensure equipment reliability
- Stabilize maintenance budgets
- Diminish downtime
- Establish documentation for JCAHO
- Increase product life
- Enhance trade-in value
- Address risk management and safety

Warranty

Stryker offers the following service contract programs:

SPECIFICATIONS	GOLD	SILVER	PM* ONLY
Annually scheduled preventative maintenance	X		X
All parts,** labor, and travel	X	X	
Unlimited emergency service calls	X	X	
Priority one contact; two hour phone response	X	X	X
Most repairs will be completed within 3 business days	X	X	
JCAHO documentation	X	X	X
On-site log book w/ preventative maintenance & emergency service records	X		
Factory-trained Stryker Service Technicians	X	X	X
Stryker authorized parts	X	X	X
End of year summary	X		
Stryker will perform all service during regular business hours (9-5)	X	X	X

* Replacement parts and labor for products under PM contract will be discounted.

** Does not include any disposable items, I.V. poles (except for Stryker HD permanent poles), mattresses, or damage resulting from abuse.

Stryker Medical also offers *personalized* service contracts.

Pricing is determined by age, location, model and condition of product.

***For more information on our service contracts,
please call your local representative or call (800) 327-0770 (option #2).***

Return Authorization:

Merchandise cannot be returned without approval from the Stryker Customer Service Department. An authorization number will be provided which must be printed on the returned merchandise. Stryker reserves the right to charge shipping and restocking fees on returned items.

SPECIAL, MODIFIED, OR DISCONTINUED ITEMS NOT SUBJECT TO RETURN.

Damaged Merchandise:

ICC Regulations require that claims for damaged merchandise must be made with the carrier within fifteen (15) days of receipt of merchandise. **DO NOT ACCEPT DAMAGED SHIPMENTS UNLESS SUCH DAMAGE IS NOTED ON THE DELIVERY RECEIPT AT THE TIME OF RECEIPT.** Upon prompt notification, Stryker will file a freight claim with the appropriate carrier for damages incurred. Claim will be limited in amount to the actual replacement cost. In the event that this information is not received by Stryker within the fifteen (15) day period following the delivery of the merchandise, or the damage was not noted on the delivery receipt at the time of receipt, the customer will be responsible for payment of the original invoice in full.

Claims for any short shipment must be made within thirty (30) days of invoice.

International Warranty Clause:

This warranty reflects U.S. domestic policy. Warranty outside the U.S. may vary by country. Please contact your local Stryker Medical representative for additional information.

European Representative

Stryker EMEA RA/QA Director
Stryker France
ZAC Satolas Green Pusignan
Av. De Satolas Green
69881 MEYZIEU Cedex
France

stryker[®]

3800 E. Centre Ave., Portage, MI 49002
(800) 327-0770
www.stryker.com



JH 10/06 1004-009-002 REV C