



















Fluoroscopy Stretcher

Operations Manual

REF 1080



Symbols

| | |
|---|---|
|  | Consult instructions for use |
|  | General warning |
|  | Caution |
|  | No pushing |
|  | Do not store the oxygen bottle |
|  | Catalogue number |
|  | Serial number |
|  | For US Patents see www.stryker.com/patents |
|  | CE mark |
|  | Authorized representative in the European Community |
|  | European medical device |
|  | Manufacturer |
|  | Date of manufacture |
|  | Importer |
|  | Safe working load |
|  | Lubricate |
|  | Type B applied part |
|  | Do not stack |



| | |
|---|---------------------------|
|  | This way up |
|  | Fragile, handle with care |

Table of Contents

| | |
|--|----|
| Warning/Caution/Note Definition | 2 |
| Summary of safety precautions | 2 |
| Introduction | 4 |
| Product description | 4 |
| Indications for use | 4 |
| Clinical benefits | 4 |
| Contraindications | 5 |
| Expected service life | 5 |
| Disposal/recycle | 5 |
| Specifications | 5 |
| Product illustration | 6 |
| Contact information | 6 |
| Serial number location | 7 |
| Operation | 8 |
| Applying and releasing the brakes | 8 |
| Raising or lowering the litter | 8 |
| Positioning the product in Trendelenburg/Reverse Trendelenburg | 9 |
| Raising or lowering the siderails | 9 |
| Raising or lowering the pneumatic Fowler backrest | 10 |
| Accessories and parts | 11 |
| Attaching the footboard/chart holder | 11 |
| Positioning the two-stage permanently attached IV pole | 11 |
| Positioning the three-stage permanently attached IV pole | 12 |
| Attaching and positioning the removable IV pole | 13 |
| Attaching the upright oxygen bottle holder | 14 |
| Locating the patient restraint strap tie-ins | 14 |
| Cleaning | 16 |
| Cleaning the product | 16 |
| Cleaning the mattress | 16 |
| Remove iodine | 17 |
| Special instructions | 17 |
| Disinfecting | 18 |
| Disinfecting the product | 18 |
| Disinfecting the mattress | 18 |
| Preventive maintenance | 20 |

Warning/Caution/Note Definition

The words **WARNING**, **CAUTION**, and **NOTE** carry special meanings and should be carefully reviewed.

WARNING

Alerts the reader about a situation which, if not avoided, could result in death or serious injury. It may also describe potential serious adverse reactions and safety hazards.

CAUTION

Alerts the reader of a potentially hazardous situation which, if not avoided, may result in minor or moderate injury to the user or patient or damage to the product or other property. This includes special care necessary for the safe and effective use of the device and the care necessary to avoid damage to a device that may occur as a result of use or misuse.

Note - Provides special information to make maintenance easier or important instructions clearer.

Summary of safety precautions

Always read and strictly follow the warnings and cautions listed on this page. Service only by qualified personnel.

WARNING

- Always apply the brakes when a patient is getting on the product or off the product or when the product is not moving. Push on the product to make sure that the brakes are locked. Injury could result if the product moves while a patient is getting on the product or off the product.
- Always remove any devices that may be in the way before you raise or lower the litter.
- Always put the product in the lowest position with the siderails up and latched when you leave a patient unattended on the product. Do not leave the product at a higher height.
- Always lock the siderails in the full up position with the sleep surface flat in the lowest position when you transport a patient.
- Always keep patient and operator extremities away from siderail spindles when you raise or lower the siderails.
- Do not allow the siderails to lower on their own.
- Always keep hands and fingers clear of the Fowler backrest release handles and the Fowler backrest frame when you lower the Fowler backrest.
- Always use caution when you raise a pneumatic Fowler backrest while a patient is on the product. Use proper lifting techniques and get help, if necessary.
- Always use caution if the defibrillator tray/foot extender, footboard/chart holder, or upright oxygen bottle holder is attached to avoid pinching your fingers when you position the foot end push handle option.
- Do not use the IV pole as a push/pull device. Product damage may occur.
- Do not place objects that exceed 40 lb (18 kg) in the upright oxygen bottle holder.
- Always use caution when you attach restraint straps. Patient or operator injury may occur. Physical restraints, even if secured, may result in serious harm to patients and operators, including entanglement, entrapment, physical injury, or death.
- Always attach restraint straps or devices only at the identified attachment points of the product. Failure to do so may result in patient or operator injury. Do not attach restraints straps to the siderail.
- Always refer to the applicable state and federal restrictions and regulations and the appropriate facility protocols before you use any restraint strap or device.
- Do not clean, service, or perform maintenance while the product is in use.
- Do not immerse the mattress in cleaning or disinfectant solutions. Excess moisture could cause product malfunction that results in product damage or patient injury.
- Do not allow fluid to pool on the mattress. Fluids can cause corrosion of components and may cause the safety and performance of this product to become unpredictable.
- Always inspect mattress covers for tears, punctures, excessive wear, and misaligned zippers every time you clean the covers. Remove and replace a damaged mattress to prevent cross-contamination.

- Do not steam clean, pressure wash, hose off, or ultrasonically clean mattresses. These methods of cleaning may void the product's warranty.
 - Do not steam clean, hose off, or ultrasonically clean the product. Use of these methods of cleaning is not recommended and may void the product's warranty.
 - Always disinfect the mattress between patients. Failure to do so could result in cross-contamination and infection.
-

CAUTION

- Improper usage of the product can cause injury to the patient or operator. Operate the product only as described in this manual.
 - Do not modify the product or any components of the product. Modifying the product can cause unpredictable operation resulting in injury to patient or operator. Modifying the product also voids its warranty.
 - Do not use the IV pole as a push/pull device. Product damage may occur.
 - Do not hang IV bags that exceed 40 lb (18 kg) on the IV pole.
 - Always make sure that the IV pole is at a low height to pass through door openings when you transport a patient.
-

Introduction

This manual assists you with the operation or maintenance of your Stryker product. Read this manual before operating or maintaining this product. Set methods and procedures to educate and train your staff on the safe operation or maintenance of this product.

CAUTION

- Improper usage of the product can cause injury to the patient or operator. Operate the product only as described in this manual.
 - Do not modify the product or any components of the product. Modifying the product can cause unpredictable operation resulting in injury to patient or operator. Modifying the product also voids its warranty.
-

Note

- This manual is a permanent part of the product and should remain with the product even if the product is sold.
- Stryker continually seeks advancements in product design and quality. This manual contains the most current product information available at the time of printing. There may be minor discrepancies between your product and this manual. If you have any questions, contact Stryker Customer Service or Technical Support at 1-800-327-0770.

Product description

The Stryker Model 1080 Fluoroscopy Stretcher is a wheeled stretcher that consists of a platform mounted on a wheeled frame to transport patients in a horizontal position within a healthcare facility by health professionals or trained representatives of the user facility. The device has a U-shaped base and full-length C-arm access to enhance imaging capabilities. The device has siderails, supports for fluid infusion equipment, and various options and accessories that assist with the support and position of the patient during imaging or procedures requiring fluoroscopic X-ray system and transport of the patient.

Indications for use

The Stryker Model 1080 Fluoroscopy Stretcher is a wheeled device that provides support and positioning of a patient during transport, imaging, or interventional procedures, especially those requiring the use of a general-purpose fluoroscopic X-ray system, within healthcare facilities. The device has full-length C-arm access that offers flexibility during imaging and a dual pneumatic backrest that helps to provide access for imaging without the need to reposition the patient. The stretcher may be used for minor procedures and short-term stay, typical of existing stretcher applications, including outpatient clinical evaluation, treatment, minor procedures, and outpatient recovery.

The Fluoroscopy Stretcher is for use in all acute care hospitals and medical outpatient services.

The Fluoroscopy Stretcher has a safe working load up to 500 lb (225 kg).

The Fluoroscopy Stretcher is not for long-term inpatient treatment and recovery.

Clinical benefits

Patient transport, facilitate treatment, and diagnostic

Contraindications

None known.

Expected service life



The Fluoroscopy Stretcher has a 10 year expected service life under normal use conditions and with appropriate periodic maintenance.

Disposal/recycle

Always follow the current local recommendations and/or regulations governing environmental protection and the risks associated with recycling or disposing of the equipment at the end of its useful life.

Specifications

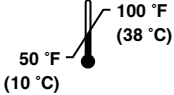
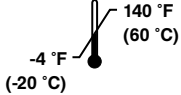
| | | | | |
|--|-------------------------------------|-------------------|--------------------|----------|
|  <p>Note - Safe working load indicates the sum of the patient, mattress, and accessory weight.</p> | | 500 lb | 225 kg | |
| | Overall length | | 87 in. | 220.9 cm |
| Height | High | | 32.75 in. | 83.2 cm |
| | Low | | 23.5 in. | 59.7 cm |
| Overall width | | 30.5 in. | 77.4 cm | |
| Litter positioning | Dual backrest operation | 0° to 90° | | |
| | Trendelenburg/Reverse Trendelenburg | ±8° | | |
| Patient surface | | 26 in. x 84 in. | 66 cm x 213.4 cm | |
| Siderails | | 26 in. x 84 in. | 33 cm x 139.5 cm | |
| Fluoroscopy window | | 27.5 in. x 66 in. | 69.9 cm x 167.6 cm | |
| Caster diameter | | 6 in. | 15 cm | |
| C-arm access width | | 54 in. | 137.2 cm | |

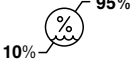
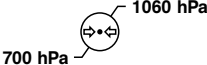
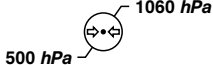
| Environmental conditions | Operation | Storage and transportation |
|--------------------------|---|---|
| Temperature |  |  |
| Relative humidity |  |  |
| Atmospheric pressure |  |  |

In accordance with the European REACH regulation and other environmental regulatory requirements, the components that contain declarable substances are listed.

| Description | Number | Substance of very high concern (SVHC) chemical name |
|----------------------------|--------------|---|
| IV pole assembly, head end | 1080-110-000 | Lead |
| IV pole assembly, foot end | 1080-112-000 | Lead |
| Two-stage IV pole assembly | 1211-210-010 | Lead |

Stryker reserves the right to change specifications without notice.

Product illustration

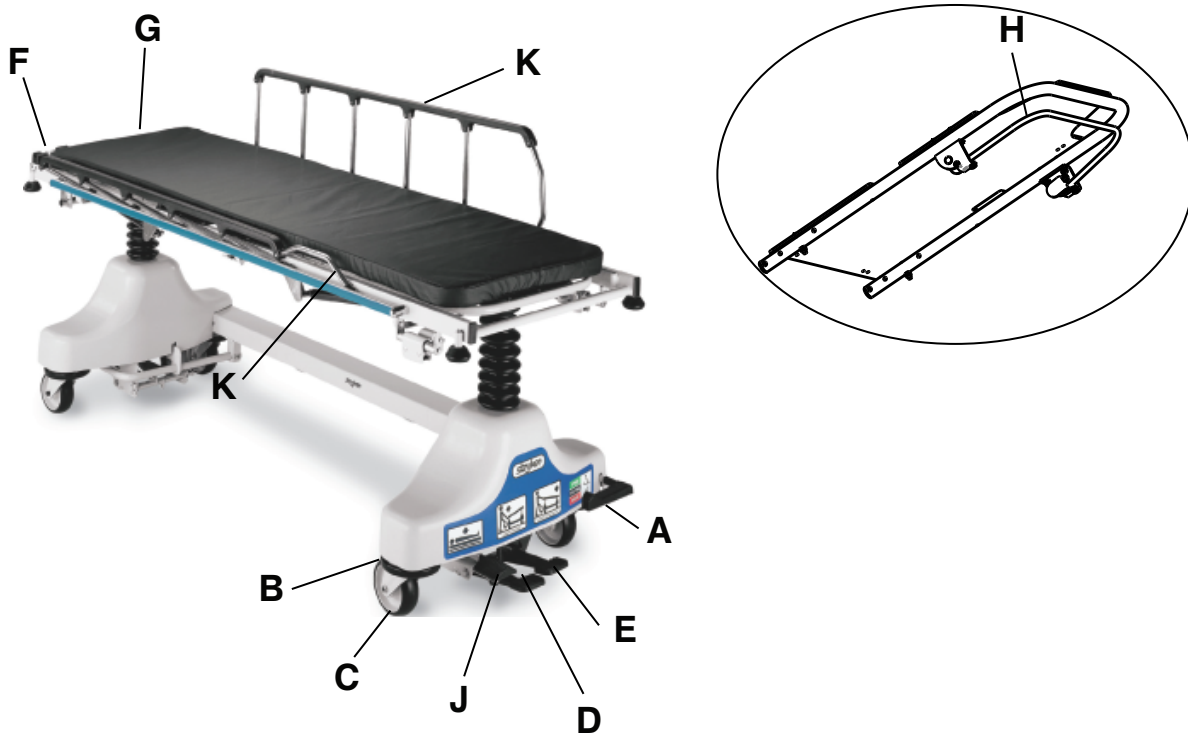

| | |
|---|----------------------------------|
| A | Brake/steer pedal |
| B | Bumper |
| C | Caster |
| D | Foot end hydraulic release pedal |
| E | Head end hydraulic release pedal |

| | |
|---|-----------------------------------|
| F | IV pole |
| G | Pneumatic backrest |
| H | Pneumatic backrest release handle |
| J | Pump pedal |
| K | Siderail |

Contact information

Contact Stryker Customer Service or Technical Support at: 1-800-327-0770.

Stryker Medical
3800 E. Centre Avenue

Portage, MI 49002
USA

Note - The user and/or the patient should report any serious product-related incident to both the manufacturer and the Competent authority of the European Member State where the user and/or patient is established.

To view your operations or maintenance manual online, see <https://techweb.stryker.com/>.

Have the serial number (A) of your Stryker product available when calling Stryker Customer Service or Technical Support. Include the serial number in all written communication.

Serial number location

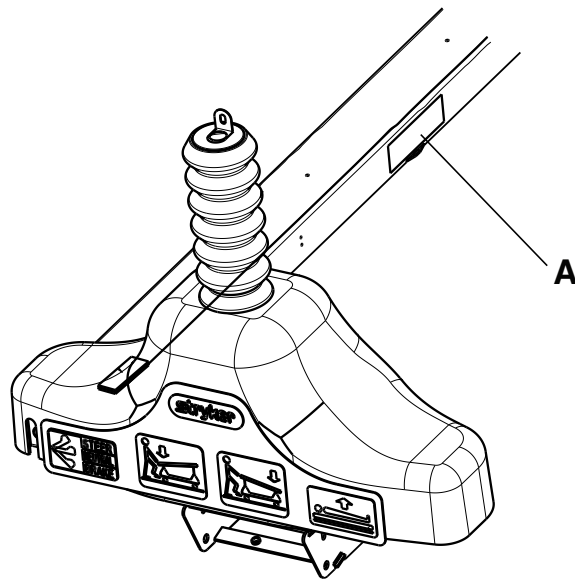

Operation

Applying and releasing the brakes

WARNING - Always apply the brakes when a patient is getting on the product or off the product or when the product is not moving. Push on the product to make sure that the brakes are locked. Injury could result if the product moves while a patient is getting on the product or off the product.

To apply the brakes, push down on the brake/steer pedal (A) (Figure 1). Push on the product to make sure that the brakes work.

To release the brakes, push up on the brake/steer pedal (B).

To put the brake/steer pedal in the neutral position, put the brake/steer pedal (C) straight.

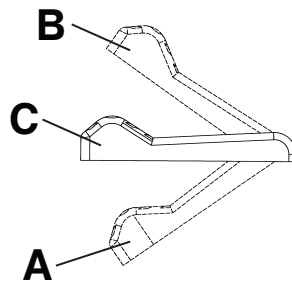

Figure 1 – Brake pedal

Raising or lowering the litter

WARNING - Always remove any devices that may be in the way before you raise or lower the litter.

To raise the litter, press down on the pump pedal (C) (Figure 2).

To lower the head end, push down on the hydraulic release pedal (B) at either end of the product.

To lower the foot end, push down on the hydraulic release pedal (A) at either end of the product.

To lower the entire litter, push down on both hydraulic release pedals (A and B) together.

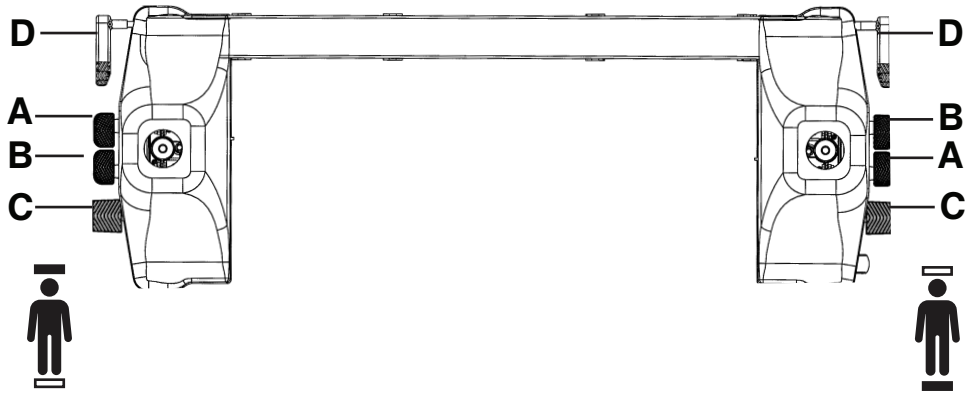

Figure 2 – Raising or lowering the litter

Positioning the product in Trendelenburg/Reverse Trendelenburg

WARNING - Always remove any devices that may be in the way before you raise or lower the litter.

To lower the head end of the litter (Trendelenburg), press down on the hydraulic release pedal (B) at either end of the product (Figure 2).

To lower the foot end of the litter (Reverse Trendelenburg), press down on the hydraulic pedal (A) at either end of the product.

Raising or lowering the siderails

WARNING

- Always put the product in the lowest position with the siderails up and latched when you leave a patient unattended on the product. Do not leave the product at a higher height.
 - Always lock the siderails in the full up position with the sleep surface flat in the lowest position when you transport a patient.
 - Always keep patient and operator extremities away from siderail spindles when you raise or lower the siderails.
 - Do not allow the siderails to lower on their own.
-

To raise the siderails, use two hands to grasp the siderail. Raise the siderail until the release latch clicks into place. Pull on the siderail to make sure that the siderail is locked.

To lower the siderails, pull up on the release latch. Guide the siderail to the lowest position.

Note - Do not use siderails as restraint devices to keep the patient from exiting the product. The siderails keep the patient from rolling off the product. The operator must determine the degree of restraint necessary to make sure that the patient is safe.

Raising or lowering the pneumatic Fowler backrest

WARNING

- Always keep hands and fingers clear of the Fowler backrest release handles and the Fowler backrest frame when you lower the Fowler backrest.
 - Always use caution when you raise a pneumatic Fowler backrest while a patient is on the product. Use proper lifting techniques and get help, if necessary.
-

To raise the Fowler backrest, squeeze the red Fowler backrest release handle. Pull the Fowler backrest up to the desired position.

To lower the Fowler backrest, squeeze the red Fowler backrest release handle. Push the Fowler backrest down to the desired position.

Note - You can operate the Fowler backrest from both ends of the product litter. This allows the patient to be reversed on the product when taking X-rays.

Accessories and parts

These accessories may be available for use with your product. Confirm availability for your configuration or region. Call Stryker Customer Service: 1-800-327-0770.

| Name | Part number |
|-----------------------------------|--------------|
| Brake adjuster assembly | 0715-201-150 |
| Caster wheel assembly | 1080-005-010 |
| Footboard/chart holder | 1080-134-000 |
| Fowler pneumatic cylinder | 1010-031-078 |
| Hydraulic jack assembly | 1080-070-010 |
| IV pole, two-stage, foot end | 1080-112-000 |
| IV pole, two-stage, head end | 1080-110-000 |
| HAVASU™ IV pole, removable | 0390-025-010 |
| Jack release valve assembly | 0962-001-152 |
| Mattress, 2" | 1080-226-001 |
| Mattress, cover assembly | 1080-226-210 |
| Oxygen bottle holder, upright | 1020-130-000 |
| Restraint strap, ankle | 0946-043-001 |
| Restraint strap, body | 0390-019-000 |
| Restraint strap, chest | 1010-058-000 |
| Restraint strap, full package | 1010-077-000 |
| Restraint strap, wrist | 0946-044-000 |

Attaching the footboard/chart holder

WARNING - Always use caution if the defibrillator tray/foot extender, footboard/chart holder, or upright oxygen bottle holder is attached to avoid pinching your fingers when you position the foot end push handle option.

To attach the footboard/chart holder, insert the footboard/chart holder pins into the sockets at the foot end of the product.

Note - Do not use the footboard/chart holder as a push/pull device. Product damage may occur.

Positioning the two-stage permanently attached IV pole

WARNING - Do not use the IV pole as a push/pull device. Product damage may occur.

You can purchase the product with the two-stage IV pole option permanently attached at the head end, foot end, or both ends of the product. The IV pole is equipped with a telescopic pole that extends to provide a second height position. You can fold and store the IV pole when not in use.

To position the two-stage IV pole (Figure 3):

1. Lift and pivot the pole from the storage position.

2. Push the IV pole down until the IV pole locks in place.
3. To raise the height of the IV pole, pull up on the telescoping portion (A) until the pole locks in place at the fully raised position.
4. Rotate the IV hangers (B) to the desired position and hang the IV bags.
5. To lower the IV pole, hold the telescoping portion of the IV pole, turn the latch (C), and lower the telescoping portion.

Note

- Do not hang IV bags that exceed 40 lb (18 kg) on the IV pole.
- Always make sure that the IV pole is at a low height to pass safely through door openings when you transport a patient.

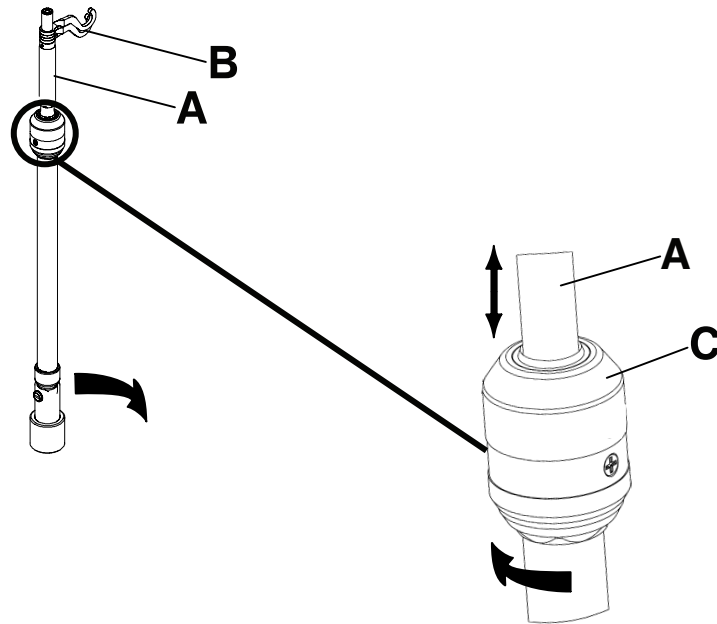

Figure 3 – Positioning the 2 stage permanently attached IV pole

Positioning the three-stage permanently attached IV pole

WARNING - Do not use the IV pole as a push/pull device. Product damage may occur.

You can purchase the product with the three-stage IV pole option permanently attached at the head end, foot end, or both ends of the product. The IV pole is equipped with a telescopic pole that extends to provide a second and third height position. You can also fold and store the IV pole when not in use.

To position the three-stage IV pole (Figure 4):

1. Lift and pivot the pole from the storage position.
2. Push the IV pole down until the pole locks in place.
3. To raise the height of the IV pole, pull up on the telescoping portion (A) until the pole locks into place at the fully raised position.
4. For a higher IV pole, pull up on section (B). Release section (B) at any desired height to lock the pole in place.
5. Rotate the IV hangers (C) to the desired position and hang the IV bags.
6. To lower the IV pole, push up on the yellow portion of the grip (D) while holding on to section (B) until the pole lowers.
7. Turn the latch (E) and lower the IV pole telescoping portion.

Note

- Do not hang IV bags that exceed 12 lb (5 kg) total for all bags on the IV pole.

- Do not hang IV bags that exceed 9.3 lb (4.2 kg) on a single IV hanger.
- Always make sure that the IV pole is at a low height to allow the pole to pass safely through door openings when you transport a patient.

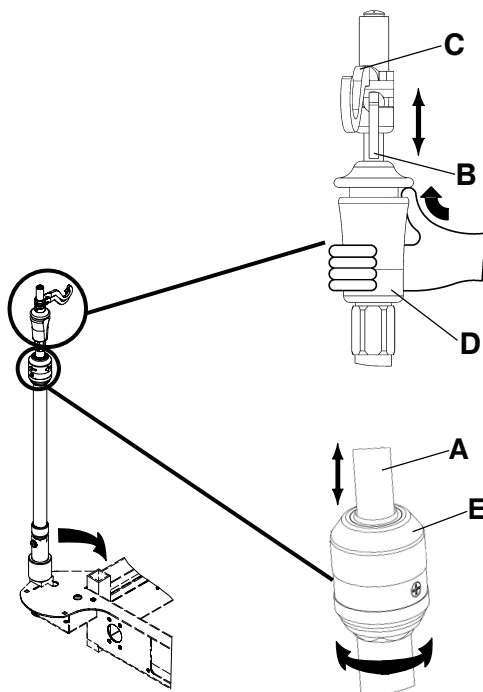

Figure 4 – Positioning the three-stage permanently attached IV pole

Attaching and positioning the removable IV pole

CAUTION

- Do not use the IV pole as a push/pull device. Product damage may occur.
- Do not hang IV bags that exceed 40 lb (18 kg) on the IV pole.
- Always make sure that the IV pole is at a low height to pass through door openings when you transport a patient.

To attach and position the removable IV pole (Figure 5):

1. Insert the IV pole into a socket at the head end or foot end of the product.
2. Turn the knob (A) counterclockwise and pull up on the telescoping portion (B) until you reach the desired height.
3. Turn the knob (A) clockwise to lock the telescoping portion in place.

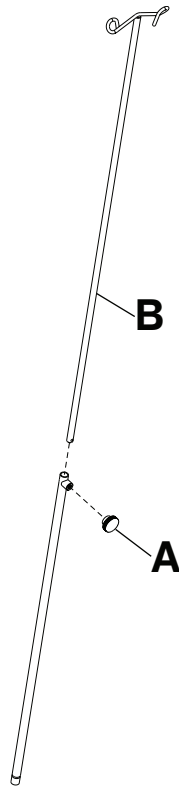

Figure 5 – Removable IV pole

Attaching the upright oxygen bottle holder

WARNING

- Do not place objects that exceed 40 lb (18 kg) in the upright oxygen bottle holder.
 - Always use caution if the defibrillator tray/foot extender, footboard/chart holder, or upright oxygen bottle holder is attached to avoid pinching your fingers when you position the foot end push handle option.
-

The upright oxygen bottle holder supports an oxygen bottle in a vertical position.

To attach the upright oxygen bottle holder:

1. Insert the support bar into any of the IV sockets.
2. Insert the cotter pin through the hole in the support bar to secure the bottle holder to the product.

Note - Do not use the upright oxygen bottle holder as a push/pull device. Product damage may occur.

Locating the patient restraint strap tie-ins

WARNING

- Always use caution when you attach restraint straps. Patient or operator injury may occur. Physical restraints, even if secured, may result in serious harm to patients and operators, including entanglement, entrapment, physical injury, or death.
 - Always attach restraint straps or devices only at the identified attachment points of the product. Failure to do so may result in patient or operator injury. Do not attach restraints straps to the siderail.
 - Always refer to the applicable state and federal restrictions and regulations and the appropriate facility protocols before you use any restraint strap or device.
-

There are eight patient restraint strap tie-in locations on the litter assembly for attaching patient restraint straps (Figure 6).

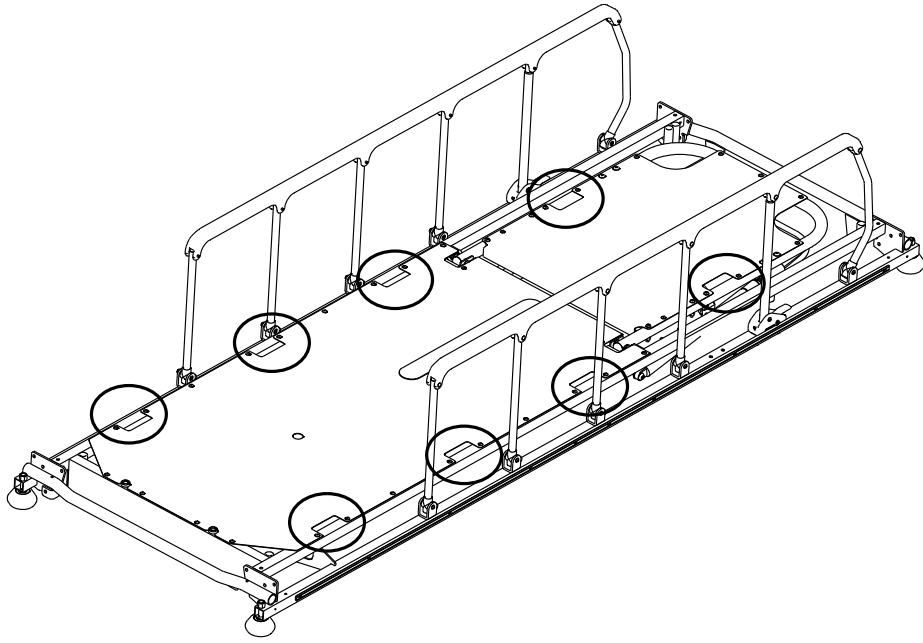

Figure 6 – Restraint strap tie-in locations

Cleaning

Cleaning the product

WARNING - Do not clean, service, or perform maintenance while the product is in use.

Recommended cleaning method:

1. Follow the cleaning solution manufacturer's dilution recommendations.
2. Hand wash all surfaces of the product with warm water and mild detergent.
3. Avoid over-saturation and make sure that the product does not stay wet longer than the detergent manufacturer's guidelines for proper cleaning.
4. Dry thoroughly. Do not replace the mattress on the product until the product is dry.
5. Check functionality before you return the product to service.
 - Raise and lower the product
 - Lock and unlock the brake/steer pedal in both positions
 - Latch and unlatch the siderails
 - Raise and lower the Fowler backrest
 - Raise and lower the Gatch
 - Make sure all components have proper lubrication
 - Make sure all labels are intact

Note

- Direct skin contact with visibly soiled, permeable material may increase the risk of infection.
- Some cleaning agents are corrosive in nature and may cause damage to the product if you use them improperly. If you do not properly rinse and dry the product, a corrosive residue may be left on the surface of the product that could cause premature corrosion of critical components. Failure to follow these cleaning instructions may void your warranty.
- Do not steam clean, power wash, hose off, or ultrasonically clean the product. Use of these methods of cleaning is not recommended and may void the product's warranty.
- Clean the base hood.
- Clean the bottom of the brake pads to prevent wax or floor remnant buildup.

Cleaning the mattress

WARNING

- Do not clean, service, or perform maintenance while the product is in use.
 - Do not immerse the mattress in cleaning or disinfectant solutions. Excess moisture could cause product malfunction that results in product damage or patient injury.
 - Do not allow fluid to pool on the mattress. Fluids can cause corrosion of components and may cause the safety and performance of this product to become unpredictable.
 - Always inspect mattress covers for tears, punctures, excessive wear, and misaligned zippers every time you clean the covers. Remove and replace a damaged mattress to prevent cross-contamination.
 - Do not steam clean, pressure wash, hose off, or ultrasonically clean mattresses. These methods of cleaning may void the product's warranty.
-

The life of the mattress can be affected by an increase in frequency of usage, which might include more frequent cleaning and disinfection.

Recommended cleaning method:

1. Use a clean, soft cloth to wipe down the entire mattress with a mild soap and water solution to remove foreign material.
2. Wipe down the mattress with a clean, dry cloth to remove any excess liquid or cleaning agents.
3. Rinse and dry covers after cleaning.
4. Disinfect as needed with a hospital grade disinfectant after cleaning has been completed (see *Disinfecting the mattress*).

Note

- Do not iron, dry-clean, or tumble dry the mattress, as this will cause malfunction and damage the product.
- The mattress cover must be completely dry before you store, add linens, or place a patient on the mattress to prevent impairment of the product performance.
- Avoid over-exposure to alcohol or hydrogen peroxide. The cover material will swell.
- Do not allow liquid to seep into the zipper area and watershed cover barrier. Fluids allowed to come in contact with the zipper may leak into the mattress which could impair the product performance.
- Some cleaning agents are corrosive in nature and may cause damage to the product if you use them improperly. If you do not rinse and dry the product well, a corrosive residue may be left on the surface of the product that could cause premature corrosion of critical components. Failure to follow these cleaning instructions may void your warranty.

Remove iodine

1. Make a solution of 1 to 2 tablespoons of sodium thiosulfate in a pint of warm water. Use the solution to wipe down the stained area.
2. Clean the stain as soon as possible after the stain occurs.
3. If stains are not immediately removed, allow solution to soak or stand on the mattress before you wipe the mattress.
4. Rinse the mattresses which have been exposed to the solution with clear water before you return the mattresses to service.

Note - Failure to follow these directions when you use these types of cleaners may void this product's warranty.

Special instructions

| | |
|---------------------|--|
| Velcro® | Saturate with disinfectant, rinse with water, and allow the solution to evaporate. |
| Solids or stains | Use neutral soaps and warm water. Do not use harsh cleansers, solvents, or abrasive cleaners. |
| Hard-to-clean spots | Use standard household cleansers or vinyl cleansers and a soft bristle brush on troublesome spots or stains. Pre-soak dried-on soil. |
| Laundering | Laundering is not recommended. Laundering may substantially decrease the useful life of the mattress. |

Disinfecting

Disinfecting the product

WARNING

- Do not clean, service, or perform maintenance while the product is in use.
 - Do not steam clean, hose off, or ultrasonically clean the product. Use of these methods of cleaning is not recommended and may void the product's warranty.
-

Recommended disinfectants:

- Quaternaries (active ingredient - ammonium chloride)
- Phenolic disinfectant (active ingredient - o-phenylphenol)
- Chlorinated bleach solution (5.25% bleach diluted 1 part bleach to 100 parts water which equals 520 ppm available chlorine (40 mL of a 5.25% bleach solution per 4000 mL water))
- 70% isopropyl alcohol

Recommended disinfection method:

1. Follow the disinfectant solution manufacturer's dilution recommendations.
2. Hand wash all surfaces of the product with a disinfectant solution.
3. Avoid over-saturation and make sure that the product does not stay wet longer than the chemical manufacturer's guidelines for proper disinfecting.
4. Dry the product. Do not place the mattress on the product until the product is dry.
5. Disinfect the **Velcro®** after every use. Saturate the **Velcro®** with disinfectant, rinse with water, and allow the disinfectant to evaporate (appropriate disinfectant is determined by the facility).
6. Check functionality before you return the product to service.
 - Raise and lower the product
 - Lock and unlock the brake/steer pedal in both positions
 - Latch and unlatch the siderails
 - Raise and lower the Fowler backrest
 - Raise and lower the Gatch
 - Make sure all components have proper lubrication
 - Make sure all labels are intact

Note

- Direct skin contact with visibly soiled, permeable material may increase the risk of infection.
- Some cleaning agents are corrosive in nature and may cause damage to the product if you use them improperly. If you do not rinse and dry the product well, a corrosive residue may be left on the surface of the product that could cause premature corrosion of critical components. Failure to follow these cleaning instructions may void your warranty.

Disinfecting the mattress

WARNING - Always disinfect the mattress between patients. Failure to do so could result in cross-contamination and infection.

Recommended disinfectants:

- Quaternaries (active ingredient - ammonium chloride)

- Phenolic disinfectant (active ingredient - o-phenylphenol)
- Chlorinated bleach solution (5.25% bleach diluted 1 part bleach to 100 parts water which equals 520 ppm available chlorine (40 mL of a 5.25% bleach solution per 4000 mL water))
- 70% isopropyl alcohol

Recommended disinfection method:

1. Make sure that the mattress is clean and dry before you apply disinfectants.
2. Wipe down the mattress with a clean, dry cloth to remove any excess liquid or disinfectant.
3. Rinse and dry covers after disinfection.

Note

- The mattress cover must be dry before you store or add linens. Failure to remove excess disinfectant could cause degradation of the cover material.
- Some cleaning agents are corrosive in nature and may cause damage to the product if you use them improperly. If you do not rinse and dry the product well, a corrosive residue may be left on the surface of the product that could cause premature corrosion of critical components. Failure to follow these cleaning instructions may void your warranty.
- Frequent or prolonged exposure to higher concentrations of disinfectant solutions may prematurely age the cover fabric.
- The use of accelerated hydrogen peroxides or quaternaries that contain glycol ethers may damage the cover.

Preventive maintenance

Remove product from service before you perform the preventive maintenance inspection. Check all items listed during annual preventive maintenance for all Stryker Medical products. You may need to perform preventive maintenance checks more often based on your level of product usage. Service only by qualified personnel.

Clean and disinfect the exterior of the mattress before inspection, if applicable.

Inspect the following items:

- _____ All welds
- _____ All fasteners are secure
- _____ Brake mechanism works
- _____ Steer function works
- _____ Siderails raise, lower, and latch
- _____ Casters lock when you apply the brakes
- _____ Casters secure and swivel
- _____ Casters are free of wax or debris
- _____ Fowler backrest raises, lowers, and latches
- _____ Skins are not cracked
- _____ Trendelenburg/Reverse Trendelenburg raises and lowers from all locations
- _____ IV pole option is intact
- _____ Oxygen bottle holder option is intact and is in good working condition
- _____ Body restraints are not torn and can be adjusted and latched
- _____ Accessories and mounting hardware are in good working condition
- _____ No rips, tears, or cracks in the mattress cover
- _____ **Velcro®** on the mattress is in good condition
- _____ **Velcro®** on litter is in good condition; replace if necessary (0381-024-007)
- _____ Ground chain is intact
- _____ No leaks at hydraulic connections
- _____ Hydraulic jacks holding
- _____ Hydraulic drop rate is set
- _____ Hydraulic oil level is sufficient
- _____ Lubricate where required, including the brake adjuster assembly, brake cam, and pump bar pivot brackets

| |
|------------------------|
| Product serial number: |
| Completed by: |
| Date: |

stryker



Stryker Medical
3800 E. Centre Avenue
Portage, MI 49002
USA