

Prime Series Stretcher

Maintenance Manual

Fifth Wheel

- REF** 1105
- REF** 1105MHT1
- REF** 1105-000-026
- REF** 1105-000-030
- REF** 1105-000-000X
- REF** 1105-000-000E
- REF** 1105-000-000XE
- REF** 1105-000-000C



Table of Contents

Warning/Caution/Note Definition	8
Summary of safety precautions	8
Pinch points	9
Introduction for service	10
Expected service life	10
Contact information	10
Serial number location	11
Product features	12
Preventive maintenance	13
Retractable fifth wheel lubrication	14
Troubleshooting	16
Scale system error codes, Prime and Prime X	20
Error codes, Prime Connect	21
Circuit boards	25
Litter control board - 1008-116-800	25
Non-lift base board - 1008-002-800	27
Lift base board - 1008-002-810	27
Scale exit board - 1008-237-840 and scale only board - 1008-237-850	28
Maintenance menu guide	29
Diagnostic mode for scale, Prime and Prime X	29
Service menu, Prime Connect	29
Diagnostics and calibration menu, Prime Connect	30
Display individual load cell readings, Prime and Prime X	30
Display individual load cell readings, Prime Connect	30
Checking the battery capacity, Prime and Prime X	30
Checking the battery capacity, Prime Connect	31
Calibrating the scale, Prime and Prime X	31
Calibrating the scale, Prime Connect	31
Service	32
Protecting against electrostatic discharge (ESD)	32
Raising the hood	32
Replacing the hood	33
Caster replacement components	34
Caster assembly replacement	34
Caster Steer-Lock gear replacement	35
Brake link assembly replacement, head end or foot end	36
Brake cam and link assembly replacement	36
Brake rod replacement	37
Side control brake rod replacement	39
Fifth wheel assembly replacement	40
Jack replacement, head end, non-electric lift	41
Jack replacement, foot end, non-electric lift	43
Jack replacement, head end, electric lift	44
Jack replacement, foot end, electric lift	45
Remove excess air from the hydraulic system	46
Side pump pedal replacement	46
Release pedal adjustment	47
Release pedal replacement, foot end, three-sided hydraulics	48
Release pedal rod replacement, foot end, three-sided hydraulics	49
Power board replacement, electric lift/litter	51
Pump motor replacement, electric lift	52
Litter top removal, non-electric litter	53
Litter top removal, electric litter	54
Siderail assembly removal and replacement	56
Siderail latch replacement	57

Gatch release handle replacement, non-electric litter	57
Gatch valve body replacement, non-electric litter	58
Fowler backrest gas cylinder replacement, non-electric litter	58
Oxygen bottle holder replacement	60
Fowler actuator replacement, electric litter	60
Gatch actuator replacement, electric litter	62
Control board replacement, electric litter	63
Transformer replacement, electric litter	64
Siderail control pad replacement, electric litter	65
Siderail cable replacement, electric litter	66
Operator control board replacement, electric litter	68
Operator control lockout board replacement, electric litter	69
Scale keypad and display replacement, non-electric litter	69
Keypad replacement, Prime Connect	70
IR/nurse call assembly replacement, Prime Connect	72
1/4" jack cable assembly replacement, Prime Connect	74
Display to nurse call cable assembly replacement, Prime Connect	75
Wireless module replacement, Prime Connect	78
Load cell replacement, scale system, non-electric litter	81
Scale battery replacement, non-electric litter	82
Scale battery replacement, electric litter	82
X-ray cassette panel replacement, head end, Prime X	83
X-ray cassette panel replacement, foot end, Prime X	84
Fowler skin replacement, Prime X	85
Foot skin replacement, Prime X	86
Fowler backrest gas cylinder replacement, Prime X	87
Oxygen storage hood replacement, international - Model 1105 only	89
Siderail removal and replacement, Prime X	92
Standard brake assembly	94
8" caster with full cover assembly - 0853-003-615	97
Brake rod assembly	99
Standard hydraulics assembly	101
End control hydraulics assembly	102
Side control brake assembly	103
Brake rod/side control assembly	107
Side control brake assembly	108
Bumper color options	109
Retractable fifth wheel assembly	110
Fifth wheel assembly - 1105-006-130	111
Dual-sided hydraulics assembly, non-electric	113
Three-sided hydraulics option	116
Pump pedal assembly, foot end - 1105-005-273	119
Three-sided hydraulics option, head end	120
Four-sided hydraulics option	121
Release pedal assembly, foot end	124
Release pedal assembly, head end	125
Constant descent jacks, non-electric	126
Constant descent jack assembly	127
Jack base assembly, non-electric	128
Common non-lift base components	129
Dual-sided hydraulics, non-powered	130
Lowering pedal assembly - 1105-004-201	136

Pump pedal assembly, head end - 1105-005-285	137
Common lift base components, 120V.....	138
Common lift base components, 230V.....	139
Dual-sided hydraulics, powered	140
Dual-sided hydraulics, electric lift/electric litter.....	148
Standard cord assembly	157
Standard power cord assembly, type E.....	158
Standard power cord assembly, type F	159
Standard power cord assembly, type G	160
Standard power cord assembly, type I	161
Cord reel assembly option	162
Fifth wheel hood/bellow assembly, non-electric.....	163
Fifth wheel hood/bellow assembly.....	164
Fifth wheel hood with three-sided hydraulics/bellow assembly, non-electric.....	165
Fifth wheel hood/bellow assembly, three-sided hydraulics	166
Fifth wheel hood with four-sided brakes/bellow assembly, non-electric	167
Fifth wheel hood/bellow assembly, four-sided brakes.....	168
Fifth wheel hood with four-sided brakes and three-sided hydraulics/bellow assembly, non-electric.....	169
Fifth wheel hood/bellow assembly, four-sided brakes, three-sided hydraulics.....	170
Fifth wheel hood/bellow assembly, electric	171
Fifth wheel hood/bellow assembly.....	172
Fifth wheel hood with three-sided hydraulics/bellow assembly, electric.....	173
Fifth wheel hood/bellow assembly, three-sided hydraulics	174
Fifth wheel hood with four-sided brakes/bellow assembly, electric.....	175
Fifth wheel hood/bellow assembly, four-sided brakes.....	176
Fifth wheel hood/bellow assembly, four-sided brakes, three-sided hydraulics	177
Fifth wheel hood with four-sided brakes and three-sided hydraulics/bellow assembly, electric.....	178
Fifth wheel hood/bellow assembly, four-sided brakes, three-sided hydraulics	179
26" common litter components	180
Common components, fifth wheel, 26"	181
26" common litter components	182
26" litter frame assembly	183
26" corner cover assembly	184
26" oxygen bottle assembly - 1105-030-610	185
26" oxygen receptacle assembly - 1105-030-601	186
26" monitor tray assembly - 1105-009-610	187
26" standard Fowler, stationary foot - non-electric litter (scale system option).....	188
26" standard Fowler, Gatch - non-electric litter (scale system option).....	191
26" drop seat Fowler, stationary foot - non-electric litter (scale system option).....	194
26" scale lifthead - 1070-117-600.....	197
30" common litter components, fifth wheel.....	198
Common components, fifth wheel, 30"	199
30" common litter components	200
30" litter frame assembly	201
30" corner cover assembly	202
30" oxygen bottle assembly - 1105-030-310	203

30" oxygen receptacle assembly - 1105-030-301	204
30" monitor tray assembly	205
30" standard Fowler, stationary foot - non-electric litter (scale system option).....	206
30" standard Fowler, Gatch - non-electric litter (scale system option)	209
30" drop seat Fowler, stationary foot - non-electric litter (scale system option).....	212
30" scale lifthead - 1070-117-300.....	215
Scale box assembly, non-electric litter -1070-237-020	216
Siderail assembly, right - non-electric litter.....	217
Siderail assembly, left - non-electric litter	219
Spindle assembly, right - 1105-011-041.....	221
Spindle assembly, left - 1105-011-051	222
Siderail latch assembly, right.....	223
Siderail latch assembly, left	224
Latch spindle assembly, right	225
Latch spindle assembly, left.....	226
Dual latch assembly option, right.....	227
Dual latch assembly option, left.....	228
Dual latch assembly option, right, head end.....	229
Dual latch assembly option, right, foot end.....	230
Dual latch assembly option, left, head end - 1105-011-130.....	231
Dual latch assembly option, left, foot end.....	232
26" standard Fowler assembly	233
26" standard Fowler, stationary foot assembly.....	235
26" standard Fowler with Gatch assembly	236
30" standard Fowler assembly	239
30" standard Fowler, stationary foot assembly.....	242
30" standard Fowler with Gatch assembly	244
26" drop seat Fowler assembly.....	247
26" drop seat Fowler assembly, stationary foot.....	248
26" drop seat Fowler with Gatch assembly	251
26" seat section assembly - 1105-013-610	254
26" thigh section assembly	255
26" foot assembly.....	256
26" Gatch assembly.....	257
26" Gatch release handle assembly	259
30" drop seat Fowler assembly.....	260
30" drop seat Fowler assembly, stationary foot.....	261
30" drop seat Fowler with Gatch assembly	263
30" seat section assembly	266
30" thigh section assembly	267
30" foot assembly.....	268
30" Gatch assembly.....	269
30" Gatch release handle assembly	271
Gatch valve body assembly - 0785-014-043.....	272
Gatch pump assembly	273
Common litter components, 120V	274

Common litter components, 230V	275
Common litter components, fifth wheel, electric.....	276
Common litter components, international fifth wheel, electric.....	277
Non-scale litter assembly option, electric litter	278
Drop seat Fowler assembly, electric litter.....	280
Siderail assembly, right, electric litter	287
Siderail assembly, left, electric litter	291
Spindle sub assembly, right, electric litter	295
Spindle sub assembly, left, electric litter.....	296
Siderail control assembly, right - 1008-011-320.....	297
Siderail control assembly, left - 1008-011-330.....	298
Control box assembly, electric litter.....	299
Fowler assembly, electric litter	301
Seat/Gatch assembly, electric litter	304
26" foot assembly, electric litter	305
30" foot assembly, electric litter	306
Operator control option, electric litter.....	307
Scale litter assembly option, electric litter.....	308
Scale control box assembly.....	314
Scale/Chaperone litter assembly option, electric litter	316
Connected litter assembly, Prime Connect	322
Scales keypad assembly, Prime Connect - 110507000214	328
Non-scales keypad assembly, Prime Connect - 110507000215	329
IR/nurse call assembly, NO, Prime Connect - 110507000212.....	330
IR/nurse call assembly, NC, Prime Connect - 110507000213.....	331
Wi-Fi option, Prime Connect - 110507000219 (US/CAN), 110507000220 (UAE/SA), 110507000221 (AUS/ NZ)	332
30" scale lifthead	333
Scale/Chaperone control box assembly.....	334
Scale/Chaperone control bottom box assembly.....	336
Covers assembly, no options, head end	337
Covers assembly with pop-up push handles, head end - 1105-210-061.....	338
Covers assembly with IV pole, head end - 1105-210-062.....	339
Covers assembly with IV pole and pop-up push handles, head end - 1105-210-063.....	340
26" top cover assembly, no options, foot end - 1105-210-660.....	341
30" top cover assembly, no options, foot end - 1105-210-360.....	342
26" top cover assembly with IV pole, without scales, foot end - 1105-210-670	343
30" top cover assembly with IV pole, without scales, foot end - 1105-210-370	344
26" top cover assembly without IV pole, with scale, foot end - 1105-210-662.....	345
30" top cover assembly without IV pole, with scale, foot end - 1105-210-362.....	346
26" top cover assembly, with scale and IV pole, foot end - 1105-210-672	347
30" top cover assembly, with scale and IV pole, foot end - 1105-210-372	348
30" top cover assembly, with lockout controls, without scale or IV pole, foot end - 1105-210-361	349
30" top cover assembly, with scale and lockout controls, foot end - 1105-210-363	350
30" top cover assembly, with nurse control and lockout controls, without scale, foot end - 1105-210- 364	351

30" top cover assembly, with scale, nurse control, lockout controls, and IV pole, foot end - 1105-210-365	352
30" top cover assembly, with lockout controls and IV pole, foot end - 1105-210-371.....	353
30" top cover assembly, with scale, lockout controls, and IV pole, foot end - 1105-210-373	354
30" top cover assembly, with nurse control, lockout controls, and IV pole, foot end - 1105-210-374.....	355
30" top cover assembly, with scale, nurse control, lockout controls, and IV pole, foot end - 1105-210-375	356
Heel pad assembly - 1105-045-022	357
Common components, fifth wheel, Prime X option	358
International common components, fifth wheel, Prime X option	359
Common components, fifth wheel, power lift, with Prime X option	360
Common components, fifth wheel, powered lift, Prime X.....	361
Litter assembly, Prime X.....	362
30" litter frame assembly, Prime X option.....	365
Head end assembly, Prime X option	367
Scale litter assembly option, Prime X option	368
Siderail assembly, right, Prime X option.....	371
Siderail assembly, left, Prime X option	372
Fowler assembly, Prime X option	373
Foot end assembly, Prime X option.....	374
Push handles assembly, head end, Prime X option.....	375
Scale option	376
Scale spacer	377
IV caddy - 0785-155-000	378
Defibrillator tray assembly - 1105-045-200	379
Defibrillator tray/foot extender/footboard - 1105-045-400.....	380
Footboard/chart holder - 1105-045-500	381
Havasu IV pole, removable - 0390-025-000.....	382
26" two-stage IV pole assembly.....	383
30" two-stage IV pole assembly.....	384
26" three-stage IV pole assembly.....	385
30" three-stage IV pole assembly.....	386
30" two-stage IV pole, Prime X option	387
30" three-stage IV pole, Prime X option	388
26" standard Fowler with Gatch, stretcher extender option	389
26" drop seat with Gatch, stretcher extender option	392
26" stretcher extender option.....	395
26" Gatch stretcher extender assembly	396
26" Gatch release handle, stretcher extender option	398
Gatch pump assembly, stretcher extender option.....	399
Gatch handle assembly, stretcher assembly.....	400
30" standard Fowler with Gatch, stretcher extender option	401
30" drop seat with Gatch, stretcher extender option	404
30" stretcher extender option.....	407
30" Gatch assembly, stretcher extender option.....	408
30" Gatch release handle, stretcher extender option	410
Upright bottle holder - 1115-130-000.....	411

26" pump bar weldment - 1105-045-065	412
30" pump bar weldment - 1105-045-035	413
26" push handle assembly - 1105-048-026	414
30" push handle assembly - 1105-048-030	415
Foot end push handles assembly - 1105-048-040	416
Foot end push handles assembly	417
Ankle restraint strap - 0785-045-020	418
Chest restraint strap - 1010-058-000	419
Wrist restraint strap - 0946-044-000	420
Body restraint strap - 0785-045-015	421
Full restraint strap package - 0785-045-010	422
Serving tray - 1105-045-700	423
Footboard/serving tray holder - 1105-045-800	424
26" slider board assembly - 1105-045-610	425
30" slider board assembly - 1105-045-310	426
Slider board - 0785-018-001	427
Upright assist assembly - 1105-045-300 (Prime X option only)	428
Lateral cassette assembly - 1105-045-100 (Prime X option only)	430
Mattresses and siderail pads	432
EMC information	434
Recycling passport	438
1070-110-260/1070-110-265/1070-110-360/1070-110-365/1070-110-270/1070-110-370	438
1070-117-600 / 1070-117-300	439
1070-237-020	440
1008-010-302	441
1008-011-320/1008-011-330	442
1008-015-020	443
1070-010-100	444
1070-010-100	445
1070-010-200	446
1070-010-200	447
1008-005-500	448
1008-005-510	449
100800370800	450
100800370810	451
100800380850	452
100800380860	453
100800680910	454

Warning/Caution/Note Definition

The words **WARNING**, **CAUTION**, and **NOTE** carry special meanings and should be carefully reviewed.

WARNING

Alerts the reader about a situation which, if not avoided, could result in death or serious injury. It may also describe potential serious adverse reactions and safety hazards.

CAUTION

Alerts the reader of a potentially hazardous situation which, if not avoided, may result in minor or moderate injury to the user or patient or damage to the product or other property. This includes special care necessary for the safe and effective use of the device and the care necessary to avoid damage to a device that may occur as a result of use or misuse.

Note - Provides special information to make maintenance easier or important instructions clearer.

Summary of safety precautions

Always read and strictly follow the warnings and cautions listed on this page. Service only by qualified personnel.

WARNING

- Portable RF communications equipment, including peripherals such as antenna cables and external antennas, should be no closer than 12 inches (30 cm) to any part of the **Prime Series** stretcher, including cables specified by the manufacturer.
- Avoid stacking or placing equipment adjacent with other equipment to prevent improper operation of the product. If such use is necessary, carefully observe stacked or adjacent equipment to make sure that they operate properly.
- The use of accessories, transducers, and cables, other than those specified or provided by the manufacturer, could result in increased electromagnetic emissions or decreased electromagnetic immunity and result in improper operation.

CAUTION

- Always use electrostatic discharge (ESD) protective equipment before you open antistatic bags and service electronic parts.
 - Do not place unprotected circuit boards on the floor.
-

Pinch points

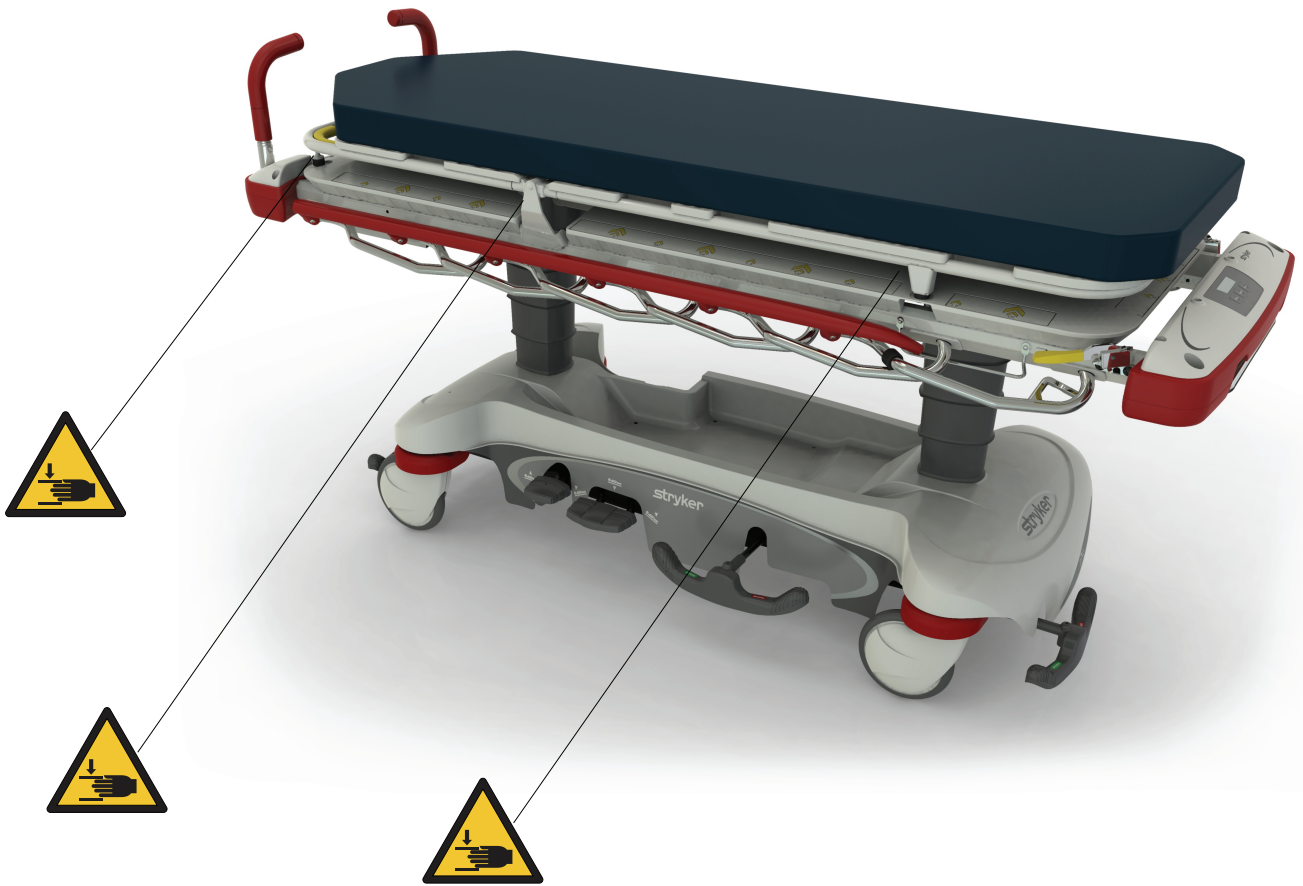

Figure 1 – Prime X

Introduction for service

This manual assists you with the service of your Stryker product. Read this manual to service this product. This manual does not address the operation of this product. See the Operations Manual for operating and use instructions. To view your Operations Manual online, see <https://techweb.stryker.com/>.

Expected service life

The **Prime Series** stretchers have a 10 year expected life under normal use conditions and with appropriate periodic maintenance.

Contact information

Contact Stryker Customer Service or Technical Support at: 1-800-327-0770.

Stryker Medical
3800 E. Centre Avenue
Portage, MI 49002
USA

Note - The user and/or the patient should report any serious product-related incident to both the manufacturer and the Competent authority of the European Member State where the user and/or patient is established.

To view your operations or maintenance manual online, see <https://techweb.stryker.com/>.

Have the serial number (A) of your Stryker product available when calling Stryker Customer Service or Technical Support. Include the serial number in all written communication.

Serial number location

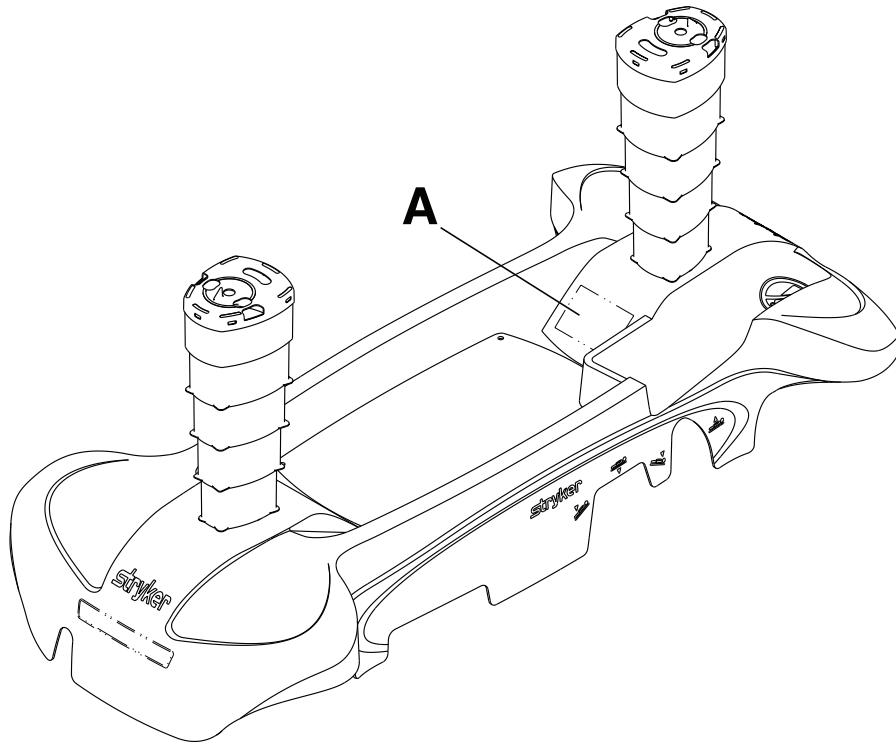

Figure 2 – Serial number location

Product features

Product feature availability depends on your **Prime Series** stretcher model, configuration, and region. To confirm availability, call Stryker Customer Service: 1-800-327-0770.

Feature	Prime manual	Prime electric	Prime Connect	Prime X
Electric lift	Not available	Option ¹	Option ¹	Option ¹
Electric litter	Not available	Standard	Standard	Not available
Bed exit	Not available	Option	Standard	Not available
Wireless communication	Not available	Not available	Standard ²	Not available
Scale system	Option ²	Option ²	Standard ²	Option ²
Bed exit over wired nurse call	Not available	Not available	Standard	Not available
Power cord with retractable cord reel	Not available	Option ²	Standard ²	Option ²
Head end push handles	Option	Option	Standard	Option
Side brake/steer pedal	Option ¹	Option ¹	Standard ¹	Option ¹
Lift Assist /recovery chair position	Option	Standard	Standard	Not available
Adjustable Gatch	Standard	Standard	Standard	Not available

¹ Product feature not available for Stryker Model 1125 **Prime Series** stretcher with **Zoom** Motorized Drive.

² Product feature not available in all regions.

Preventive maintenance

Remove the product from service before you perform the preventive maintenance inspection. Check all items listed during annual preventive maintenance for all Stryker Medical products. You may need to perform preventive maintenance checks more often based on your level of product usage. Service only by qualified personnel.

For product feature availability for your model, see *Product features* (page 12).

Note - Clean and disinfect the exterior of the mattress before inspection, if applicable.

Inspect the following items:

- _____ All fasteners are secure
- _____ Siderails move and latch
- _____ Casters lock with brake pedal applied
- _____ Casters are secure and swivel
- _____ Casters are free of wax and debris
- _____ Brake mechanism works
- _____ Steer function works
- _____ Check skins for cracks
- _____ Fowler raises, lowers, and latches in place
- _____ Gatch option raises, lowers, and secures in place
- _____ Trendelenburg/reverse Trendelenburg operates from all locations
- _____ Ground chain intact
- _____ No leaks at hydraulic connections
- _____ Hydraulic jacks hold
- _____ Lubricate where required
- _____ Body restraints option latch and are secure
- _____ IV pole option is intact, adjusts, and latches in all positions
- _____ Oxygen bottle holder option is intact and opens and closes
- _____ No rips or cracks in the mattress cover
- _____ Accessories and mounting hardware are in good condition
- _____ Battery backup works and powers features
- _____ Cables are not worn or pinched
- _____ Power cord option and plug are free of damage
- _____ All electrical connection options are tight
- _____ All grounds options secure to the frame
- _____ Ground impedance not more than 200 mΩ (milliohms), option
- _____ Current leakage not more than 300 μA (microamps) (per UL 60606-1-1), option
- _____ Batteries backup option charges
- _____ Display housing option is intact and not damaged
- _____ Load cell option is intact and not damaged
- _____ For foot support option, knee knob mechanism functions and you can secure in place
- _____ For foot support option, leg knob mechanism functions and you can secure in place
- _____ For foot support option, extends to the full extended position and stops in the correct position

- _____ For foot support option, self-tapping screws (6) are secured and not stripped
- _____ Scale option calibrated, recalibrate if necessary
- _____ Bed exit functions
- _____ Bed exit over wired nurse call functions (**Prime Connect**)
- _____ Wireless module is intact and wireless icon displays on screen if the wireless option is enabled (**Prime Connect**)
- _____ Location icon illuminates and product connects to the **iBed** Locator if the wireless option is enabled (**Prime Connect**)
- _____ All icons and buttons on operator keypad, operator control panel, patient control panel lockout, and siderail patient control panel work
- _____ Upright X-ray cassette holder is in good working condition and can be adjusted to fit all X-ray cassettes (**Prime X**)
- _____ No damage to the Fowler skin and foot skin (**Prime X**)
- _____ No damage to the head and foot trays (**Prime X**)
- _____ Bolt and nut through each Fowler pivot is not loose (**Prime X**)

Product serial number:
Completed by:
Date:

Retractable fifth wheel lubrication

Tools required:

- MPG-3 grease
- Bungee cords

Procedure:

1. Raise the product to the highest position.

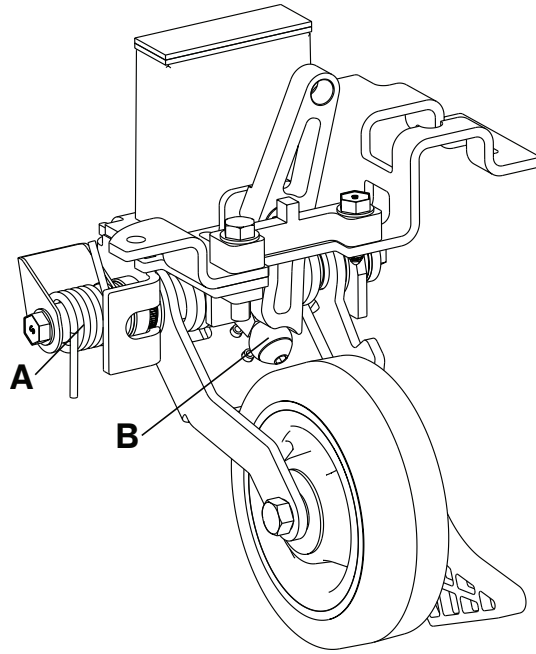

Figure 3 – Retractable fifth wheel lubrication

2. Raise the base hood and support the hood with bungee cords.
3. Apply MPG-3 grease to the spring (A) and roller (B) (Figure 3).
4. Remove the bungee cords and lower the hood.
5. Verify proper operation before you return the product to service.

Troubleshooting

Complete the recommended actions until you resolve the problem.

Problem	Recommended action
Product does not have power (with or without lift option)	<p>Check the following:</p> <ol style="list-style-type: none"> 1. Power cord connection 2. 120 VAC from the wall outlet 3. Lift control board <ol style="list-style-type: none"> 3.1. J1 (A) for 120 VAC (voltage from the wall outlet) 3.2. F2 and F3 without lift option (0034-287-000) or with lift option (0034-083-000) <ol style="list-style-type: none"> 3.2.1. Unplug the power cord from the wall outlet 3.2.2. Pull each fuse out of the circuit and check for continuity 3.3. J2 (B) for 120 VAC (voltage out to the DC control board) 4. DC control board (1008-002-810) <ol style="list-style-type: none"> 4.1. J8 (C) for 120 VAC 4.2. FH1 and FH2 (0034-290-000) <ol style="list-style-type: none"> 4.2.1. Unplug the power cord from the wall outlet 4.2.2. Pull each fuse out of the circuit and check for continuity 4.3. J10 (B) for 28 VAC on the black and red wires and 18 VAC on the brown and blue wires 4.4. FH3 (0034-087-000) and FH4 (0034-288-000) <ol style="list-style-type: none"> 4.4.1. Unplug the power cord from the wall outlet 4.4.2. Pull each fuse out of the circuit and check for continuity 4.5. TP3 (red lead) ref DGND (black lead) for 36 VDC 4.6. TP14 (red lead) ref DGND (black lead) for 18 VDC

Problem	Recommended action
Lift does not work	<p>Check the following:</p> <ol style="list-style-type: none"> 1. Power cord connection 2. 120 VAC from the wall outlet 3. Lift control board <ol style="list-style-type: none"> 3.1. J1 (A) for 120 VAC (voltage from wall outlet) 3.2. F2 and F3 (0034-082-000) and F1 (0034-085-000) <ol style="list-style-type: none"> 3.2.1. Unplug the power cord from the wall outlet 3.2.2. Pull each fuse out of the circuit and check for continuity 3.3. J4 (D) for 12 VDC (voltage to lift switch) 3.4. Disconnect J4 and go across the black and red wires for continuity on the lift switch 3.5. F4 and F5 (0034-083-000) (line voltage to the pump motor) <ol style="list-style-type: none"> 3.5.1. Unplug the power cord from the wall outlet 3.5.2. Pull each fuse out of the circuit and check for continuity 3.6. J3 (C) for 120 VAC when you press the pump pedal (voltage to the pump motor)
Lift raises very slowly	<p>Check the following:</p> <ol style="list-style-type: none"> 1. Lift control board (capacitor circuit) <ol style="list-style-type: none"> 1.1. J3 (C) for 160 VAC between pin 2 (black wire) and pin 3 (red wire) when you press the pump pedal 1.2. J3 (C) for 160 VAC between pin 2 (black wire) and pin 5 (white wire) when you press the pump pedal
Fowler does not raise	<p>Check the following:</p> <ol style="list-style-type: none"> 1. The lock icon on the patient control panel lockout is green 2. DC control board <ol style="list-style-type: none"> 2.1. J5 (D) for 35 VDC on pin 2 (blue wire/positive lead) and pin 1 (red wire/negative lead)
Fowler does not lower	<ol style="list-style-type: none"> 2.2. If the Fowler backrest does not raise, check J3 for 12 VDC on pin 2 (blue wire/positive lead) and pin 6 (black wire/negative lead) while you press the Fowler up button 2.3. If the Fowler backrest does not lower, check J3 for 12 VDC on pin 2 (blue wire/positive lead) and pin 6 (black wire/negative lead) while you press the Fowler down button

Problem	Recommended action
Gatch does not raise	Check the following: <ol style="list-style-type: none"> 1. The lock icon on the patient control panel lockout is green 2. DC control board <ol style="list-style-type: none"> 2.1. J4 (E) for 35 VDC on pin 2 (blue wire/positive lead) and pin 1 (red wire/negative lead)
Gatch does not lower	<ol style="list-style-type: none"> 2.2. If the Gatch does not raise, check J3 (F) for 12 VDC on pin 5 (brown wire/positive lead) and pin 6 (black wire/negative lead) while you press the Gatch up button 2.3. If the Gatch does not lower, check J3 (F) for 12 VDC on pin 4 (green wire/positive lead) and pin 6 (black wire/negative lead) while you press the Gatch down button
Patient control panel lockout does not lock (electric litter)	Check the following: <ol style="list-style-type: none"> 1. DC control board <ol style="list-style-type: none"> 1.1. J9 (K) for 12 VDC (voltage for lockout circuit) on pin 2 (red wire/positive lead) and pin 1 (black wire/negative lead) 1.2. J9 (K) for 12 VDC (voltage for lockout circuit when turned on) on pin 3 (white wire/positive lead) and pin 1 (black wire/negative lead)
Litter does not have power (electric litter)	Check the following: <ol style="list-style-type: none"> 1. DC control board <ol style="list-style-type: none"> 1.1. J8 (C) for 120 VAC (voltage from the base) 1.2. FH3 (0034-087-000) and FH4 (0034-288-000) <ol style="list-style-type: none"> 1.2.1. Unplug the power cord from the wall outlet 1.2.2. Pull each fuse out of the circuit and check for continuity 2. Check TP3 (red lead) ref DGND (black lead) for 36 VDC 3. Check TP14 (red lead) ref DGND (black lead) for 18 VDC

Problem	Recommended action
Scale or bed exit does not have power (electric litter)	<p>Check the following:</p> <ol style="list-style-type: none"> 1. Scale control board <ol style="list-style-type: none"> 1.1. J9 (M) for 12 VDC on pin 1 (red wire/positive lead) and pin 5 (black wire/negative lead) 1.2. J5 (L) for 20 VDC (power from DC control board) 1.3. FH1 (0034-089-000) <ol style="list-style-type: none"> 1.3.1. Unplug the power cord from the wall outlet 1.3.2. Pull each fuse out of the circuit and check for continuity 1.4. J7 (R) for 5 VDC on pin 3 (orange wire/positive lead) and pin 4 (blue wire/positive lead) and pin 10 (black wire/positive lead) all referencing pin 1 (green wire/negative lead)
Wireless icon does not display on the screen (Prime Connect)	<p>Check the following:</p> <ol style="list-style-type: none"> 1. Wireless option is installed 2. Wireless option is enabled <ol style="list-style-type: none"> 2.1. Enter the service menu 2.2. Scroll down and select Miscellaneous 2.3. Scroll down and select Enable Gateway 2.4. Make sure that the wireless option is Enabled
Location icon does not illuminate (Prime Connect)	<ol style="list-style-type: none"> 3. Cable connection at wireless module 4. Cable connections from the display 5. Cable connections to the control box and IR/nurse call assembly 6. Cables for damage

Problem	Recommended action
Wireless does not connect to a network (Prime Connect)	<p>Check the following:</p> <ol style="list-style-type: none"> 1. Wireless option is installed 2. Wireless option is enabled <ol style="list-style-type: none"> 2.1. Enter the service menu 2.2. Scroll down and select Miscellaneous 2.3. Scroll down and select Enable Gateway 2.4. Make sure that the wireless option is Enabled <p>If the wireless option is installed and enabled, complete the following:</p> <ol style="list-style-type: none"> 1. Enter the service menu and reset the wireless option to defaults 2. Setup a router broadcasting the Stryker default SSID <ol style="list-style-type: none"> 2.1. Verify that the wireless module connects 2.2. If the wireless module connects, reconfigure the wireless module with a good SSID and security settings for the site 2.3. If the wireless module does not connect, replace the wireless module
Bed exit does not work with the 1/4" cable (Prime Connect)	<p>Check the following:</p> <ol style="list-style-type: none"> 1. 1/4" jack cable assembly for a continuity state change: <ol style="list-style-type: none"> 1.1. Test the tip and the base of the 1/4" jack cable assembly and record if there is continuity 1.2. Trigger the bed exit alarm to verify there is a continuity state change 1.3. If there is a continuity state change, the 1/4" cable works. Check the nurse call cable or nurse call system 1.4. If there is not a continuity state change, complete steps 2 and 3 2. Cable connections from the display 3. Cable connections to the control box and IR/nurse call assembly

Scale system error codes, Prime and Prime X

The error handling system captures errors known to the scale system option and provides feedback to the operator through error messages.

The details for each message error are detailed in the table below.

Error message	Name	Description	Affected systems
Err-LC	Load cell error	Load cell error detected	Scale
EEP-Err	Memory corruption error	Scale memory corruption	Scale

Error codes, Prime Connect

Complete the troubleshooting steps until you resolve the error.

Error code ID	Fault area	Fault description	Troubleshooting
11x5-1-1-100	Chaperone board	EEPROM error	<ol style="list-style-type: none"> Using the power button, power cycle the product. Replace the Chaperone board.
11x5-1-1-101	Chaperone board	ADC configuration error	<ol style="list-style-type: none"> Using the power button, power cycle the product. Replace the Chaperone board.
11x5-1-1-102	Chaperone board	Low battery state 2	<ol style="list-style-type: none"> Using the power button, power cycle the product. Charge the battery for at least one hour. Replace the battery. Replace the Chaperone board.
11x5-1-1-103	Chaperone board	No battery	<ol style="list-style-type: none"> Using the power button, power cycle the product. Check the battery connection. Replace the battery.
11x5-1-1-104	Chaperone board	Load cell error	<ol style="list-style-type: none"> Using the power button, power cycle the product. Check the following: <ol style="list-style-type: none"> Load cell connections Load cell for damage Load cell cables to the Chaperone board Replace the load cell. Replace the Chaperone board.
11x5-1-1-105	Chaperone board	Scale failed calibration	<ol style="list-style-type: none"> Make sure that the stretcher is on stable ground. Recalibrate the scale. Complete the troubleshooting steps for load cell error. Complete the troubleshooting steps for ADC configuration error.
11x5-1-1-107	Chaperone board	Generic error	<ol style="list-style-type: none"> Using the power button, power cycle the product. Replace the Chaperone board.

Error code ID	Fault area	Fault description	Troubleshooting
11x5-1-1-108	Chaperone board/display board	Bed exit I2C frame missed error	<ol style="list-style-type: none"> Using the power button, power cycle the product. Check the display cable connections. Replace the display board. Replace the Chaperone board.
11x5-1-5-1300	Chaperone board/wireless module	CAN heartbeat lost	<ol style="list-style-type: none"> Using the power button, power cycle the product. Check the wireless module cable connection. Replace the wireless module. Replace the display board.
11x5-4-1-1301	Wireless module	CAN interface error	<ol style="list-style-type: none"> Check the wireless module cable connection. Replace the wireless module.
11x5-4-2-2005	Wireless module	CAN open invalid PDO received	<ol style="list-style-type: none"> Check the wireless module cable connections. Replace the wireless module.
11x5-4-2-2006	Wireless module	CAN open invalid SDO received	<ol style="list-style-type: none"> Check the wireless module cable connection. Replace the wireless module.
11x5-4-3-106	Wireless module	File system access error - Wi-Fi configuration file	<ol style="list-style-type: none"> Check the wireless module cable connection. Replace the wireless module.
11x5-4-4-106	Wireless module	File system access error - Wi-Fi configuration file directory	<ol style="list-style-type: none"> Check the wireless module cable connection. Replace the wireless module.
11x5-4-5-106	Wireless module	File system access error - watchdog	<ol style="list-style-type: none"> Check the wireless module cable connection. Replace the wireless module.
1x5-4-6-2204	Wireless module	Invalid update file - no software update package found	Download the software package.
11x5-4-6-2200	Wireless module	Update target communication error - invalid update command received from host	Host resends command.
11x5-4-7-2000	Wireless module	System initialization error - system controller	<ol style="list-style-type: none"> Check the wireless module cable connection. Replace the wireless module.

Error code ID	Fault area	Fault description	Troubleshooting
11x5-4-8-2001	Wireless module	Application termination error - CAN	<ol style="list-style-type: none"> 1. Check the wireless module cable connection. 2. Replace the wireless module.
11x5-4-8-2002	Wireless module	Application termination error - IOT	<ol style="list-style-type: none"> 1. Check the wireless module cable connection. 2. Replace the wireless module.
11x5-4-8-2003	Wireless module	Application termination error - Wi-Fi	<ol style="list-style-type: none"> 1. Check the wireless module cable connection. 2. Replace the wireless module.
11x5-4-8-2004	Wireless module	Application termination error - reboot	<ol style="list-style-type: none"> 1. Check the wireless module cable connection. 2. Replace the wireless module.
11x5-4-9-2007	Wireless module	Message queue - Wi-Fi thread manager	<ol style="list-style-type: none"> 1. Check the wireless module cable connection. 2. Replace the wireless module.
11x5-4-9-2008	Wireless module	Message queue - Wi-Fi error manager	<ol style="list-style-type: none"> 1. Check the wireless module cable connections. 2. Replace the wireless module.
11x5-4-9-2009	Wireless module	Message queue - Wi-Fi data manager	<ol style="list-style-type: none"> 1. Check the wireless module cable connection. 2. Replace the wireless module.
11x5-4-9-2010	Wireless module	Message queue - CAN	<ol style="list-style-type: none"> 1. Check the wireless module cable connection. 2. Replace the wireless module.
11x5-4-10-2011	Wireless module	Thread error - system controller heartbeat	<ol style="list-style-type: none"> 1. Check the wireless module cable connection. 2. Replace the wireless module.
11x5-4-10-2012	Wireless module	Thread error - IOT file download	<ol style="list-style-type: none"> 1. Check the wireless module cable connection. 2. Replace the wireless module.
11x5-4-7-2013	Wireless module	System initialization error - IOT	<ol style="list-style-type: none"> 1. Check the wireless module cable connection. 2. Replace the wireless module.

Error code ID	Fault area	Fault description	Troubleshooting
11x5-4-8-2014	Wireless module	System controller watchdog kick error	<ol style="list-style-type: none"> 1. Check the wireless module cable connection. 2. Replace the wireless module.
11x5-4-11-1951	Wireless module	Wi-Fi interface error	<ol style="list-style-type: none"> 1. Check the wireless module cable connections. 2. Replace the wireless module.
11x5-4-12-1952	Wireless module	Wireless interface configuration error	<ol style="list-style-type: none"> 1. Check the wireless module cable connection. 2. Replace the wireless module.
11x5-4-13-1953	Wireless module	Wi-Fi WPA command timeout error	<ol style="list-style-type: none"> 1. Check the wireless module cable connection. 2. Replace the wireless module.
11x5-4-14-1954	Wireless module	Wi-Fi WPA command execution error	<ol style="list-style-type: none"> 1. Check the wireless module cable connection. 2. Replace the wireless module.
11x5-4-15-1955	Wireless module	Wi-Fi network authentication error	<ol style="list-style-type: none"> 1. Check the wireless module cable connection. 2. Replace the wireless module.
11x5-4-16-1956	Wireless module	IOT schema generation error	<ol style="list-style-type: none"> 1. Check the wireless module cable connection. 2. Replace the wireless module.
11x5-4-17-1957	Wireless module	IOT schema ready act to CAN error	<ol style="list-style-type: none"> 1. Check the wireless module cable connection. 2. Replace the wireless module.
11x5-4-18-1958	Wireless module	Property JSON service registration error	<ol style="list-style-type: none"> 1. Check the wireless module cable connection. 2. Replace the wireless module.
11x5-4-18-1959	Wireless module	Wi-Fi configuration JSON service registration error	<ol style="list-style-type: none"> 1. Check the wireless module cable connection. 2. Replace the wireless module.

Error code ID	Fault area	Fault description	Troubleshooting
11x5-4-19-1960	Wireless module	Allegro client/server Initialization error	<ol style="list-style-type: none"> 1. Check the wireless module cable connection. 2. Replace the wireless module.
11x5-4-19-1961	Wireless module	Allegro ACE crypto engine initialization error	<ol style="list-style-type: none"> 1. Check the wireless module cable connection. 2. Replace the wireless module.

Circuit boards

Litter control board - 1008-116-800

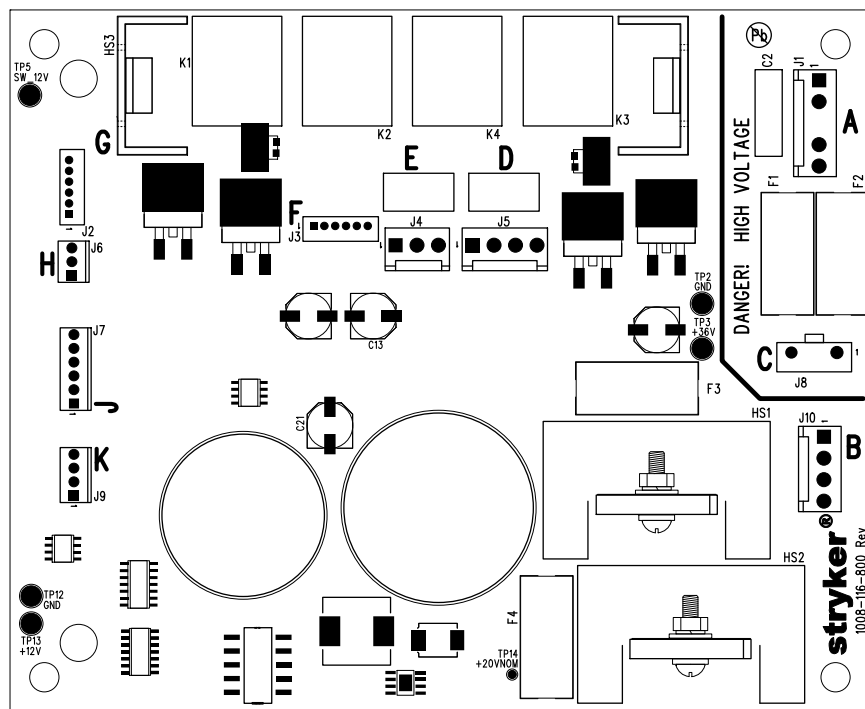

Fuse location	Voltage	Current	Operating speed	Breaking capacity
F1, F2	250 V	2 A	0.02-0.3 s	35 A
F3	125 V	6 A	3-30 s	3 A
F4	250 V	5 A	0.02-0.3 s	50 A

Connection	Location	Voltage	Positive lead	Negative lead	Description
J8	C	120 VAC	Pin 1	Pin 2	Line voltage
J4	E	36 VDC	3	1	Gatch up
J4	E	36 VDC	1	3	Gatch down
J5	D	36 VDC	3	1	Fowler up
J5	D	36 VDC	1	3	Fowler down

Connection	Location	Voltage	Positive lead	Negative lead	Description
J6	H	20 VDC	2	1	Power
J7	J	12 VDC	6	1	Staff control
J7	J	12 VDC with switch	2	6	Staff control, Fowler up
J7	J	12 VDC with switch	3	6	Staff control, Fowler down
J7	J	12 VDC with switch	4	6	Staff control, Gatch down
J7	J	12 VDC with switch	5	6	Staff control, Gatch up
J9	K	12 VDC	2	1	Lockout control
J9	K	12 VDC	2	4	Lock
J9	K	12 VDC	3	4	Unlock
J3	F	12 VDC	6	1	Left patient control
J3	F	12 VDC with switch	2	6	Left patient control, Fowler up
J3	F	12 VDC with switch	3	6	Left patient control, Fowler down
J3	F	12 VDC with switch	4	6	Left patient control, Gatch down
J3	F	12 VDC with switch	5	6	Left patient control, Gatch up
J2	G	12 VDC	6	16	Right patient control
J2	G	12 VDC with switch	2	6	Right patient control, Fowler up
J2	G	12 VDC with switch	3	6	Right patient control, Fowler down
J2	G	12 VDC with switch	4	6	Right patient control, Gatch down
J2	G	12 VDC with switch	5	6	Right patient control, Gatch up
J1	A	120 VAC	4	1	Voltage to transformer
J1	A	120 VAC	4	2	Voltage to transformer
J1	A	120 VAC	3	1	Voltage to transformer
J1	A	120 VAC	3	2	Voltage to transformer

Connection	Location	Voltage	Positive lead	Negative lead	Description
J10	B	24 VDC	2	1	Voltage from transformer
J10	B	15 VDC	4	3	Voltage from transformer

Non-lift base board - 1008-002-800

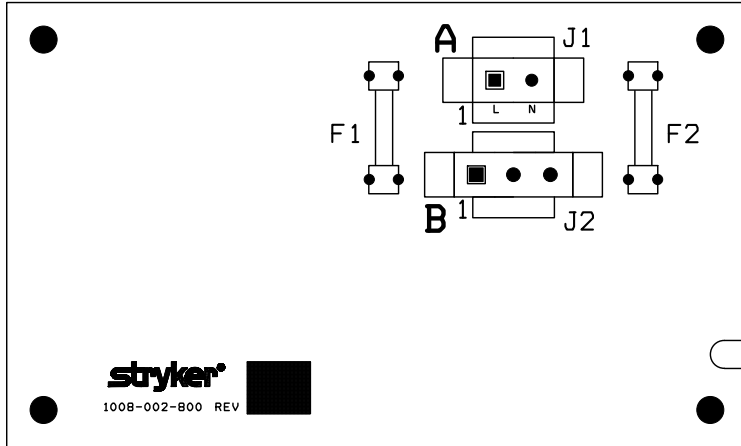

Fuse location	Voltage	Current	Operating speed	Breaking capacity
F1, F2	250 V	4 A	0.02-0.3 s	150 A
F2	250 V	4 A	0.02-0.3 s	150 A

Connection	Location	Voltage	Positive lead	Negative lead	Description
J1	A	120 VAC	Pin 1	Pin 2	VAC in
J1	B	120 VAC	1	3	VAC out to litter

Lift base board - 1008-002-810

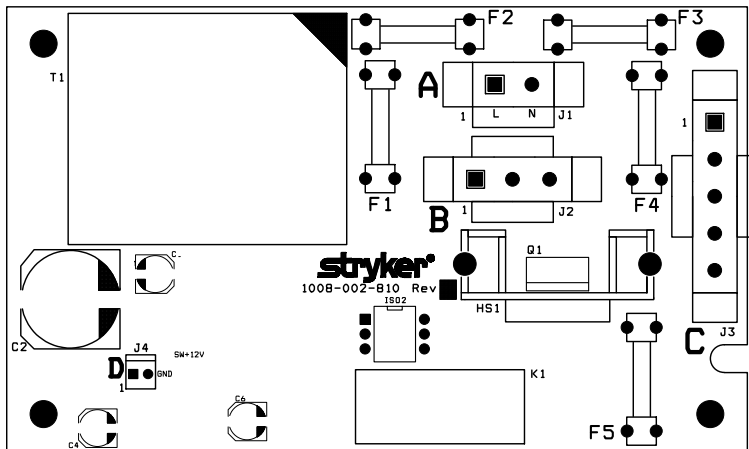

Fuse location	Voltage	Current	Operating speed	Breaking capacity
F1	250 V	0.63 A	0.06-1 s	35 A
F2	250 V	10 A	0.01-0.150 s	1500 A
F3	250 V	10 A	0.01-0.150 s	1500 A
F4, F5	250 V	8 A	0.4-4 s	200 A

Connection	Location	Voltage	Positive lead	Negative lead	Description
J1	A	120 VAC	Pin 1	Pin 2	VAC in
J2	B	120 VAC	1	3	VAC out to litter
J3	C	120 VAC with switch	1	2	VAC to pump
J4	D	12 VDC	1	2	VDC to lift switch

Scale exit board - 1008-237-840 and scale only board - 1008-237-850

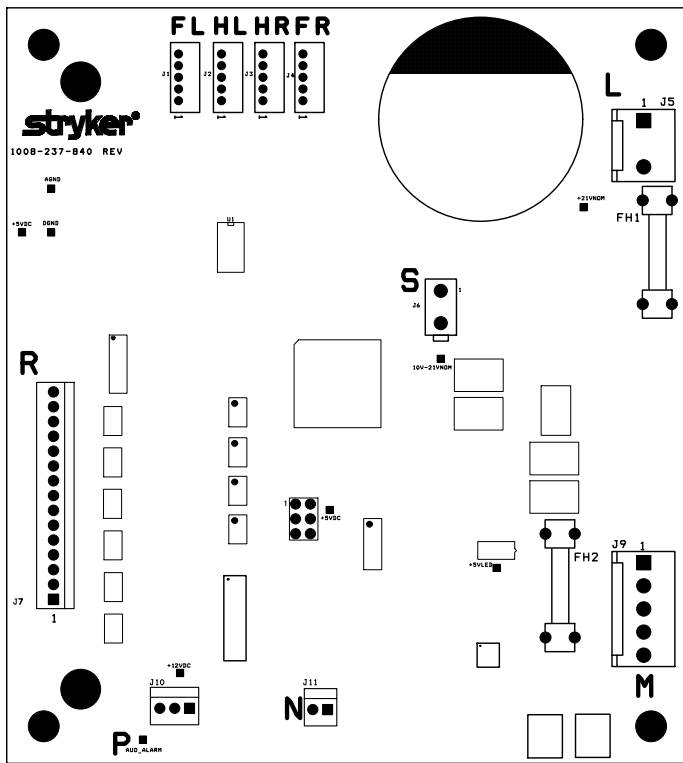

Scale exit board - 1008-237-840

Fuse location	Voltage	Current	Operating speed	Breaking capacity
F1	250 V	3 V	5-120 s	100 A
F2	250 V	3 A	2-5 s	100 A

Scale only board - 1008-237-850

Fuse location	Voltage	Current	Operating speed	Breaking capacity
F1	250 V	3 V	5-120 s	100 A
F2	250 V	3 A	2-5 s	100 A

Connection	Location	Voltage	Positive lead	Negative lead	Description
J5	L	20 VDC	Pin 2	Pin 1	VDC for control board
J9	M	12 VDC	1	5	VDC for scale system
J7	R	5 VDC	2	1	VDC for keypad

Maintenance menu guide

Diagnostic mode for scale, Prime and Prime X

Press and hold **Weigh**, **lb/kg**, and **Zero** for at least six seconds until **diag** displays on the screen.

- Press **lb/kg** to scroll up.
- Press **Zero** to scroll down.
- If no buttons are pressed, the system will remain in diagnostic mode for five minutes then turn off.

Diagnostics functions:

Display	Indication/units
diag	N/A
hr (head/right)	Head/right load cell reading in lb
hl (head/left)	Head/left load cell reading in lb
fr (foot/right)	Foot/right load cell reading in lb
fl (foot/left)	Foot/left load cell reading in lb
batt	Battery voltage percentage
soft	Software version number
hard	Hardware version number
calib	Slope factor
unit	Weight unit in lb, kg, or both

Service menu, Prime Connect

Press and hold **lb/kg**, **Zero**, and the **Weigh** button for at least six seconds until the service menu displays on the screen.

- Press the **Weigh** button to scroll up.
- Press **Zero** to scroll down.
- Press the **Arm/Disarm** button to select.
- Press **lb/kg** to go back.

Diagnostics and calibration menu, Prime Connect

To access the diagnostics and calibration menu:

1. Access the service menu. See *Service menu, Prime Connect* (page 29).
2. Press **Zero** to scroll down to **Miscellaneous**.
3. Press the **Arm/Disarm** button to select **Miscellaneous**.
4. Press **Zero** to scroll down to **Diagnostics & Calibration**.
5. Press the **Arm/Disarm** button to select **Diagnostics & Calibration**.

Display individual load cell readings, Prime and Prime X

To view the individual load cell readings:

1. Enter diagnostic mode. See *Diagnostic mode for scale, Prime and Prime X* (page 29).
2. Press the **lb/kg** button to scroll up through the load cell readings.

Note - A typical load cell reading for an empty stretcher is 15 lb - 45 lb. If the load cell reading is outside of that range, there is a problem with that load cell.

3. If you suspect a problem with a load cell, make sure that the cable to that load cell is connected before you replace the load cell.

Note - If the load cell reading is **497.5**, the cable is disconnected from the load cell or the load cell has been damaged.

4. If the system detects a defective load cell, the display will show **test**, and then **err**. Make sure that the load cell cable is connected. If the load cell cable is connected, then replace the load cell.

Note - When the load cell functions properly, the display will show **test** and then **good**. The scale operates normally.

Display individual load cell readings, Prime Connect

To view the individual load cell readings:

1. Access the diagnostics and calibration menu. See *Diagnostics and calibration menu, Prime Connect* (page 30).
2. Press **Zero** to scroll down through the load cell readings.

Note - A typical load cell reading for an empty stretcher is 15.0 - 45.0. If the load cell reading is outside of that range, there is a problem with that load cell.

3. If you suspect a problem with a load cell, make sure that the cable is connected to the load cell before you replace the load cell.

Note - If the load cell reading is **497.5**, the cable is disconnected from the load cell or the load cell has been damaged.

Checking the battery capacity, Prime and Prime X

For **Prime** and **Prime X** models without an electric litter.

To check the battery capacity:

1. Enter the diagnostic mode. See *Diagnostic mode for scale, Prime and Prime X* (page 29).
2. Press **lb/kg** to scroll up to **batt**. The battery voltage displays.
3. Change the batteries if the battery voltage is below 5.1.

Note - The screen displays **lo batt** and the battery icon flashes at this voltage.

Checking the battery capacity, Prime Connect

To check the battery capacity:

1. Access the diagnostics and calibration menu. See *Diagnostics and calibration menu, Prime Connect* (page 30).
2. Press **Zero** to scroll down to **Battery**. The battery percentage displays.

Calibrating the scale, Prime and Prime X

Note - Use 200 lb certified weight (for non-electric litter) or 50 lb certified weight (for electric litter) to calibrate the scale.

To calibrate the scale:

1. Remove all items from the product except the mattress and parts or accessories that are used during the patient's stay.
2. Enter diagnostic mode and select the calibration menu. See *Diagnostic mode for scale, Prime and Prime X* (page 29).
3. Press and hold **Zero** and **lb/kg** for two seconds to zero the scale while **hold** displays on the screen.
4. Release the buttons when **rel** displays on the screen. The screen displays **000.0**, and then **200.0 lb** (for non-electric litter) or **50.0 lb** (for electric litter).
5. Place 200 lb certified weight (for non-electric litter) or 50 lb certified weight (for electric litter) on the middle of the product litter.
6. Press and hold **Zero** and **lb/kg** for two seconds until **rel** displays on the screen. Calibration is complete.
7. Place several known certified weights on the litter to verify that the scale displays the correct weight reading.

Calibrating the scale, Prime Connect

Note - Use 50 lb certified weight to calibrate the scale.

To calibrate the scale:

1. Remove all items from the product except the mattress and parts or accessories that are used during the patient's stay.
2. Access the diagnostics and calibration menu. See *Diagnostics and calibration menu, Prime Connect* (page 30).
3. Press **lb/kg** and **Zero** to start calibration. **Ready to zero and calibrate** displays on the screen.
4. Press the **Arm/Disarm** button to zero the scale. **Zeroing** displays on the screen.
5. After the scale has been zeroed, place a certified 50 lb weight on the middle of the product litter.
6. Adjust the value on the screen to display the certified weight.
 - Press the **Weigh** button to increase the value on the screen by 0.1.
 - Press **Zero** to decrease the value on the screen by 0.1.
7. Press the **Arm/Disarm** button to start calibration. **Calibration complete** displays on the screen when finished.

Service

Protecting against electrostatic discharge (ESD)

CAUTION

- Always use electrostatic discharge (ESD) protective equipment before you open antistatic bags and service electronic parts.
 - Do not place unprotected circuit boards on the floor.
-

Note - Always ship the circuit boards back to Stryker. Use the antistatic bag that the new board was originally shipped in.

The electronic circuits in the product are completely protected from static electricity damage when factory assembled. Always use adequate static protection when you service the electronic systems of the product. All service personnel must use static protection whenever they touch wires.

Sample antistatic protection equipment includes:

- Antistatic wrist strap
- Grounding plug
- Test lead with a banana plug on one end and an alligator clip on the other end

Make sure that you follow the ESD manufacturer's instructions for appropriate protection against static discharge.

Raising the hood

Tools required:

- #2 Phillips screwdriver
- Bungee cords

Procedure:

1. Apply the brake. Push on the product to make sure that the brakes work.
2. Raise the product to the highest height position.
3. Raise the siderails to the highest height position.
4. Using a #2 Phillips screwdriver, remove the scrulok assemblies (C) that secure the hood to the hood retainer on the outside of the head end and foot end jacks, if applicable (Figure 4).

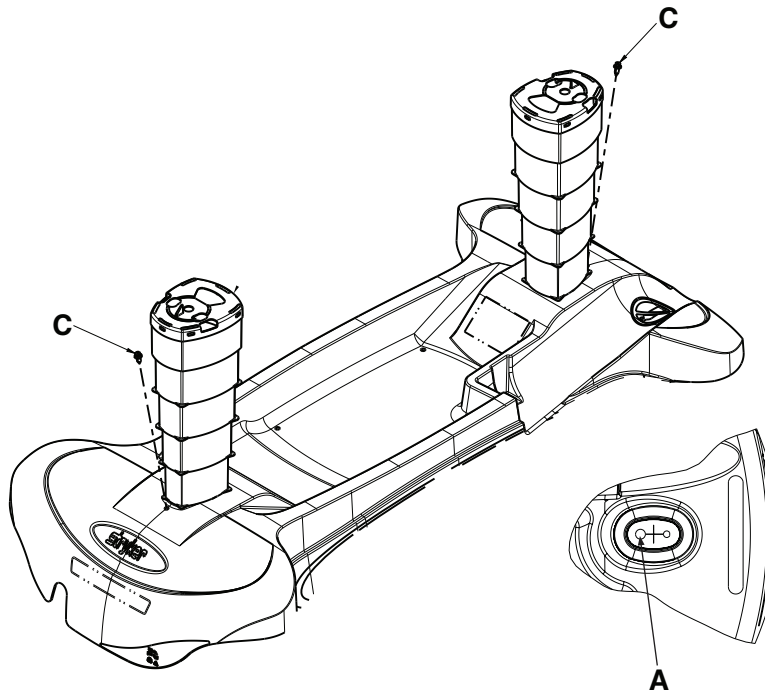

Figure 4 – Raising and lowering the hood

5. Using bungee cords, support the hood in a raised position.

Replacing the hood

Tools required:

- #2 Phillips screwdriver

Procedure:

1. Remove the litter. See *Litter top removal, non-electric litter* (page 53).
2. Apply the brake. Push on the product to make sure that the brake works.
3. Raise the product to the highest height position.
4. Raise the siderails to the highest height position.
5. Using a #2 Phillips screwdriver, remove the scrulok assembly (A) that secures the hood to the hood retainer on both ends of the product on the outside edge of the head end and foot end jacks, if applicable (Figure 4). Remove and discard the hood.
6. Remove and save the bellows.
7. Secure the supplied hood to the base.
8. Replace the bellows (removed in step 6) over the jack shaft on both ends of the product. Fit the bellows through the hole in the hood to secure the bellows to the hood. Make sure that the large hole (A) faces toward the center of the hood on both ends.
9. Replace the litter (removed in step 1).
10. Verify proper operation before you return the product to service.

Caster replacement components

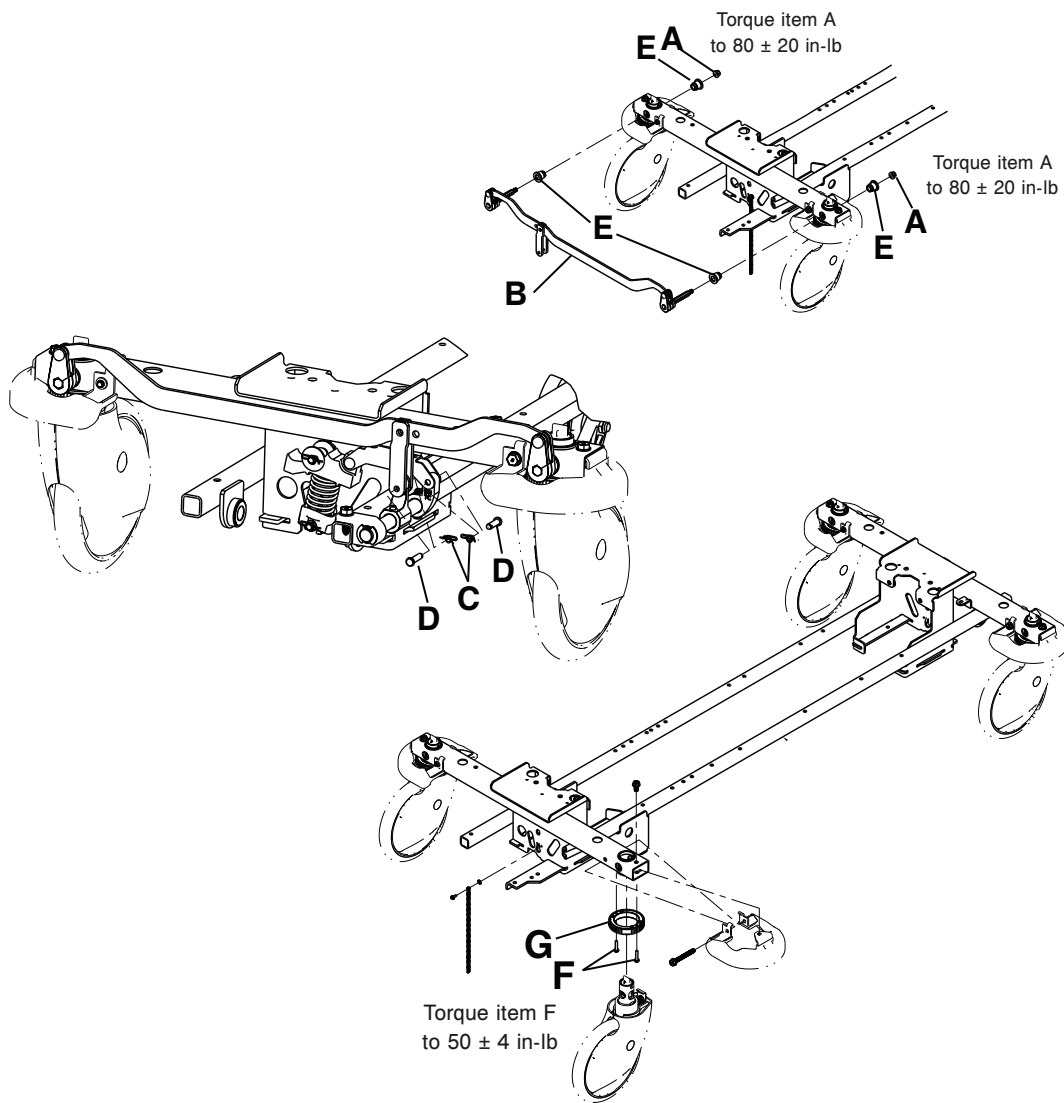

Caster assembly replacement

Tools required:

- 1/2" socket
- 3/8" drive ratchet
- 3/8" drive extension
- 3/8" drive torque wrench (in-lb)
- Small jack
- Needle nose pliers

Procedure:

1. Raise the hood. See *Raising the hood* (page 32).
2. Put the brake/steer pedal in the neutral position.
3. Using a 1/2" socket with a 3/8" drive extension and a 3/8" drive ratchet, remove the two flange nuts (A) (one on each side), that secure the brake link assembly (B) to the casters. See *Caster replacement components* (page 34).

Note - Using a 3/8" drive torque wrench, torque the two flange nuts to 80 ± 20 in-lb when you reinstall.

- Using needle nose pliers, remove the rue ring cotter (C) and clevis pin (D) from the brake rod activator.
- Apply the brake. Push on the product to make sure that the brakes work.
- Pull the brake link assembly (B) out to remove. Discard the brake link assembly.

Note - If the bearing (E) falls off when you remove the brake link assembly, replace the bearing when you reinstall the brake link assembly.

- Using a small jack, raise the product until the caster falls out of the frame socket. Discard the caster.
- Insert the supplied caster into the frame socket and lower the jack until the caster is secure. Remove the small jack.

Note - Make sure that the arrow located at the top of the caster assembly fork stem points toward the foot end of the product to avoid product damage.

- Reverse steps 1-6 to reinstall.
- Verify proper operation before you return the product to service.

Caster Steer-Lock gear replacement

Tools required:

- 1/2" socket
- 5/16" socket
- 3/8" drive ratchet
- 3/8" drive extension
- 3/8" drive torque wrench (in-lb)
- Small jack
- Needle nose pliers

Procedure:

- Raise the hood. See *Raising the hood* (page 32).
- Put the brake/steer pedal in the neutral position.
- Using a 1/2" socket with a 3/8" drive extension and a 3/8" drive ratchet, remove the two flange nuts (A) (one on each side) that secure the brake link assembly (B) to the casters. See *Caster replacement components* (page 34).

Note - Using a 3/8" drive torque wrench, torque the two flange nuts to 80 ± 20 in-lb when you reinstall.

- Using needle nose pliers, remove the rue ring cotter (C) and clevis pin (D) from the brake rod activator.
- Apply the brake. Push on the product to make sure that the brakes work.
- Pull the brake link assembly (B) out to remove. Discard the brake link assembly.

Note - If the bearing (E) falls off when you remove the brake link assembly, replace the bearing when you reinstall the brake link assembly.

- Using a small jack, raise the product until the caster falls out of the frame socket. Discard the caster.
- Using a 5/16" socket with a 3/8" drive extension and a 3/8" drive ratchet, remove the two hex washer head screws (F) that secure the caster **Steer-Lock** gear (G) to the base frame. Discard the caster **Steer-Lock** gear.
- Using a 5/16" socket with a 3/8" drive extension and a 3/8" drive ratchet, install the two hex washer head screws (F) to secure the supplied caster **Steer-Lock** gear (G) to the base frame. Using a 3/8" drive torque wrench, torque the hex washer head screws to 50 ± 4 in-lb.
- Connect the two caster **Steer-Lock** gear dowels to the base frame.
- Insert the supplied caster into the frame socket and lower the jack until the caster is secure. Remove the small jack.

Note - Make sure that the arrow located at the top of the caster assembly fork stem points toward the foot end of the product to avoid product damage.

- Reverse steps 1-7 to reinstall.
- Verify proper operation before you return the product to service.

Brake link assembly replacement, head end or foot end

Tools required:

- 1/2" socket
- 3/8" drive ratchet
- 3/8" drive extension
- 3/8" drive torque wrench (in-lb)
- Needle nose pliers

Procedure:

1. Raise the hood. See *Raising the hood* (page 32).
2. Put the brake/steer pedal in the neutral position.
3. Using a 1/2" socket with a 3/8" drive extension and a 3/8" drive ratchet, remove the two flange nuts (A) (one on each side) that secure the brake link assembly (B) to the casters (*Caster replacement components* (page 34)).

Note - Using a 3/8" drive torque wrench, torque the two flange nuts to 80 ± 20 in-lb when you reinstall.

4. Using needle nose pliers, remove the rue ring cotter (C) and clevis pin (D) from the brake rod activator.
5. Apply the brake. Push on the product to make sure that the brakes work.
6. Pull the brake link assembly (B) out to remove. Discard the brake link assembly.

Note - If the bearing (E) falls off when you remove the brake link assembly, replace the bearing when you reinstall the brake link assembly.

7. Reverse steps to install the supplied brake link assembly.
8. Verify proper operation before you return the product to service.

Brake cam and link assembly replacement

Tools required:

- Needle nose pliers

Procedure:

1. Raise the hood. See *Raising the hood* (page 32).
2. Put the brake/steer pedal in the neutral position.
3. Using needle nose pliers, remove the rue ring cotter (A) and clevis pin (B) that secure the brake cam and link assembly to the brake rod (Figure 5).

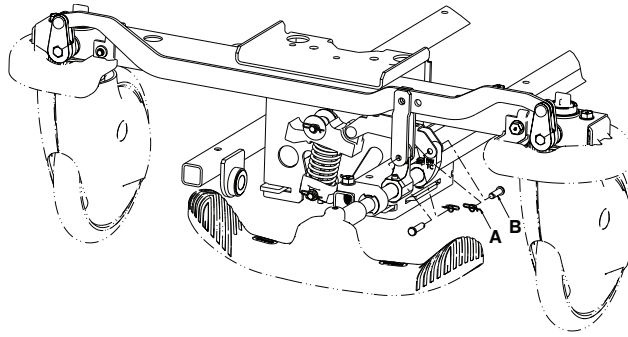

Figure 5 – Brake cam and link assembly

- Using needle nose pliers, remove the rue ring cotter (C) and washer (D) from the bearing pivot support (E) (Figure 6).

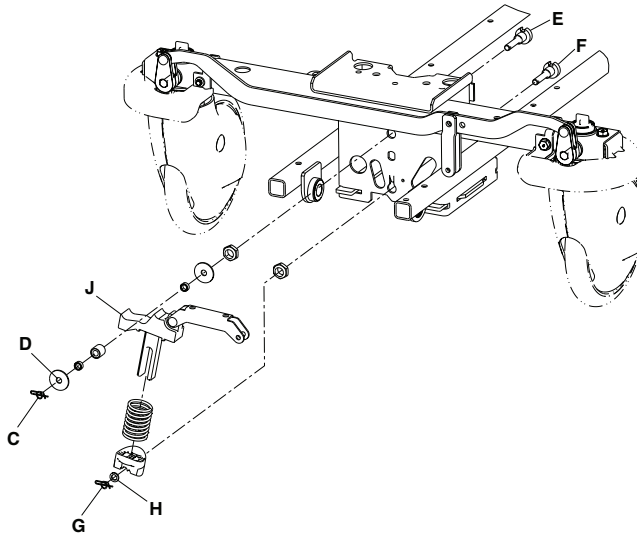

Figure 6 – Brake cam and link replacement

- Using needle nose pliers, remove the rue ring cotter (G) and plastic washer (H) from the bottom support (F).
- Raise the brake cam and link assembly (J) off of the brake rod actuator and pull out on the brake cam and link assembly to remove. Discard the brake cam and link assembly.

Note - When you install the supplied brake cam and link assembly, install the bottom first, and then push down and inward to install the brake cam and link assembly under the top bearing.

- Reverse steps to install the supplied brake cam and link assembly.
- Verify proper operation before you return the product to service.

Brake rod replacement

Tools required:

- 1/2" socket
- 3/8" drive torque wrench (ft-lb)
- 3/8" drive ratchet
- Needle nose pliers

Procedure:

- Raise the product to the highest height position.

2. Raise the siderails to the highest height position.
3. Raise the hood. See *Raising the hood* (page 32).
4. Apply the brake. Push on the product to make sure that the brakes work.
5. Using needle nose pliers, remove the rue ring cotter (A) and clevis pin (B) that secure the head end brake link assembly to the brake activation crank (Figure 7). Remove the brake rod crank cap. Save all parts.

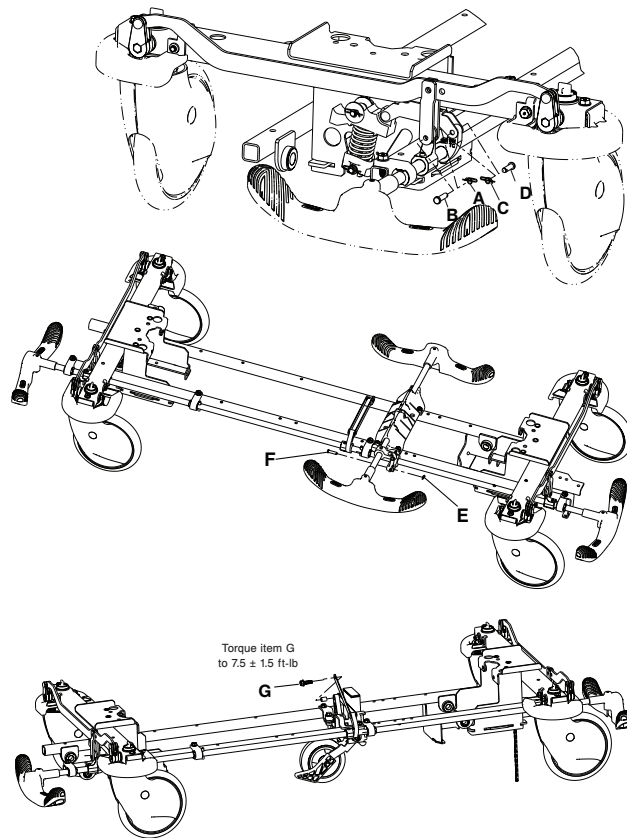

Figure 7 – Replace the brake rod

6. Using needle nose pliers, remove the rue ring cotter (C) and clevis pin (D) that secure the brake cam and link assembly to the brake rod assembly. Save all parts.
7. Using needle nose pliers, remove the rue ring cotter (C) and clevis pin (D) that secure the foot end brake link assembly to the brake activation crank. Remove the brake rod crank cap. Save all parts.
8. If the product has four-sided brakes, proceed to step 9. If the product has standard brakes, skip to step 10.
9. Using needle nose pliers, remove the rue ring cotter (E) and clevis pin (F) that secure the side control brake assembly to the side control brake rod link. Save all parts.
10. Using a 1/2" socket and a 3/8" drive ratchet, remove the hex washer head screw (G) and sleeve bearing that secure the fifth wheel drive link assembly to the brake rod assembly. Save all parts.

Note - Using a 3/8" drive torque wrench, torque the hex washer head screw to 7.5 ± 1.5 ft-lb when you reinstall.

11. Using needle nose pliers, disconnect the return spring (H) from the foot end (Figure 8).

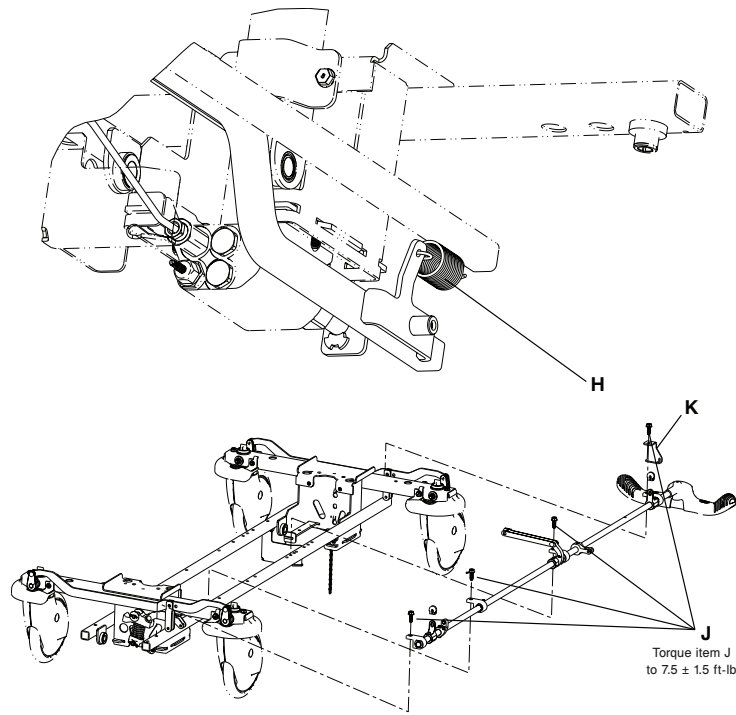

Figure 8 – Brake rod replacement - foot end

12. Using a 1/2" socket and a 3/8" drive ratchet, remove the four hex washer head screws (J) that secure the brake rod supports to the brake rod assembly. Remove the return spring hook (K). Save all parts.

Note - Using a 3/8" drive torque wrench, torque the hex washer head screws to 7.5 ± 1.5 ft-lb when you reinstall.

13. Reverse steps to install the supplied brake rod.

14. Verify proper operation before you return the product to service.

Side control brake rod replacement

Tools required:

- 1/2" socket
- 3/8" drive torque wrench (ft-lb)
- 3/8" drive ratchet
- Needle nose pliers

Procedure:

1. Raise the base hood. See *Raising the hood* (page 32).
2. Apply the brake. Push on the product to make sure that the brakes work.
3. Using needle nose pliers, remove the rue ring cotter (A) and clevis pin (B) that secure the side control brake assembly to the side control brake rod link (Figure 9). Save all parts.

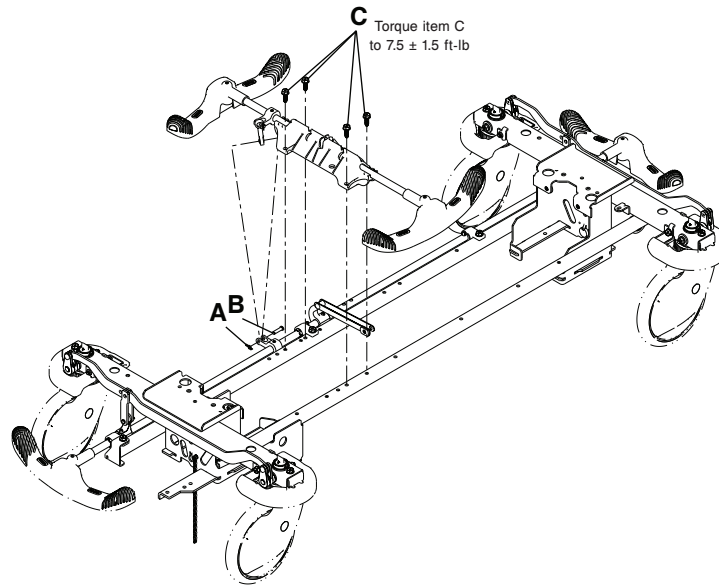

Figure 9 – Replace the brake rod

4. Using a 1/2" socket and 3/8" drive ratchet, remove the four hex washer head screws (C) that secure the side control brake rod assembly to the base assembly. Discard the side control brake rod assembly. Save the screws.

Note - Using a 3/8" drive torque wrench, torque the hex washer head screws to 7.5 ± 1.5 ft-lb when you reinstall.

5. Reverse steps to install the supplied side control brake rod assembly.
6. Verify proper operation before you return the product to service.

Fifth wheel assembly replacement

Tools required:

- 1/2" socket
- 3/8" drive ratchet
- 3/8" drive torque wrench (ft-lb)
- Needle nose pliers

Procedure:

1. Raise the hood. See *Raising the hood* (page 32).
2. Using a 1/2" socket with a 3/8" drive ratchet, remove the hex washer head screw (B) that secures the fifth wheel cam drive link to the cam (Figure 10).

Note - Using a 3/8" drive torque wrench, torque the hex washer head screw to 13 ± 2 ft-lb when you reinstall.

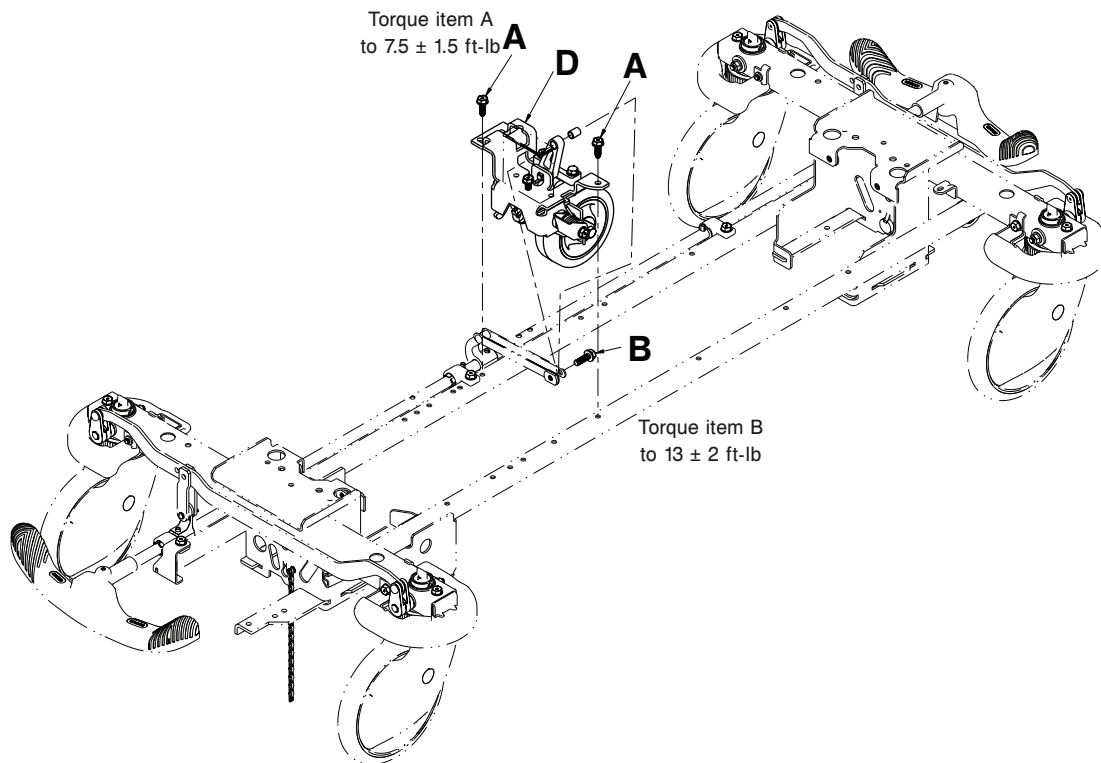

Figure 10 – Replace the fifth wheel assembly

- Using a 1/2" socket with a 3/8" drive ratchet, remove the two hex washer head screws (A) that secure the fifth wheel assembly (D) to the base frame.

Note - Using a 3/8" drive torque wrench, torque the hex washer head screws to 7.5 ± 1.5 ft-lb when you reinstall.

- Using needle nose pliers, remove the pump pedal return spring from the fifth wheel bracket.
- Using needle nose pliers, remove the rue ring cotter that secures the foot end jack release rod to the release pedal weldment.
- Remove the foot end jack release rod.
- Working from the patient left side, rotate the fifth wheel assembly counterclockwise. Lift the fifth wheel assembly up and out.
- Reverse steps to install the supplied fifth wheel assembly.
- Verify proper operation before you return the product to service.

Jack replacement, head end, non-electric lift

Tools required:

- #2 Phillips screwdriver
- 1/2" socket
- 3/8" drive ratchet
- 3/8" drive extension
- 3/8" drive torque wrench (ft-lb)

Procedure:

- Apply the brake. Push on the product to make sure that the brakes work.
- Remove the litter. See *Litter top removal, non-electric litter* (page 53).

3. Using a #2 Phillips screwdriver, remove the scrulok assemblies that secure the hood to the hood retainer (Figure 4).
4. Lift the hood off of the base frame and set aside.
5. Using a 1/2" socket with a 3/8" drive extension and a 3/8" drive ratchet, remove the two hex washer head screws (B) that secure the head end jack and reservoir clamp (F) to the base frame (Figure 11). Remove the reservoir clamp. Save the hex washer head screws.

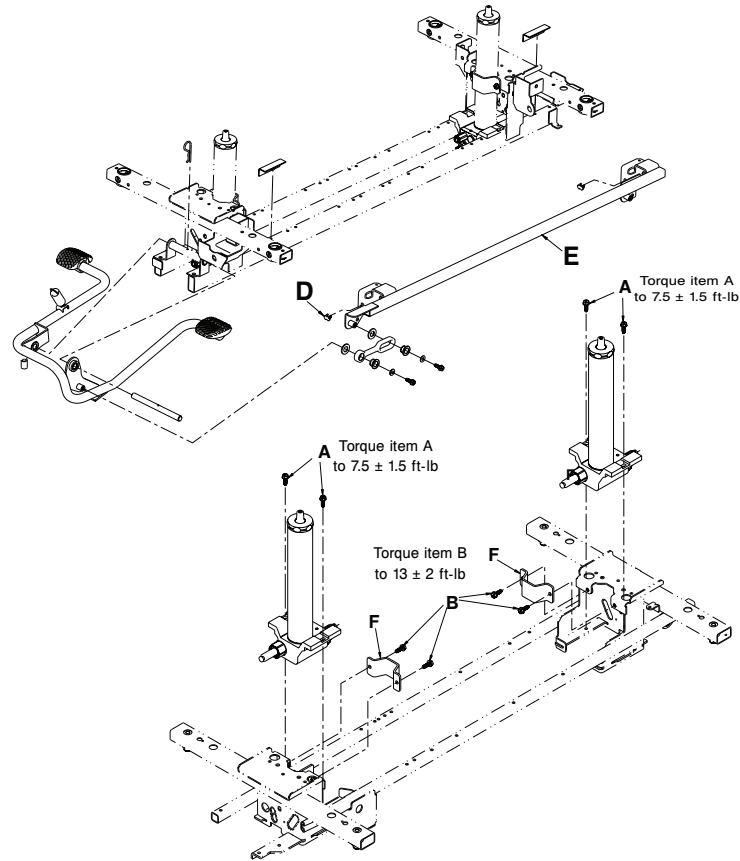

Figure 11 – Replace the jack

6. Lift up on the pump connecting rod and disconnect the pump piston from the pump connecting rod. Save the pump connecting rod.
7. Disconnect the release pedal swivel from the pins on the release pedal weldment.
8. Remove the head end release rod from the release valve on the jack assembly. Save the release rod.
9. Using a 1/2" socket with a 3/8" drive extension and a 3/8" drive ratchet, remove the two hex washer head screws (A) that secure the jack base assembly to the base frame.
10. Remove the jack assembly.
11. Using a 1/2" socket with a 3/8" drive extension and a 3/8" drive ratchet, install the hex washer head screws (B) (removed in step 5) on the jack and reservoir clamp, but do not tighten them.
12. Replace the pump connecting rod and release rod (removed in steps 6 and 8).
13. Press the pump pedal to the floor to position the jack on the base frame.
14. Using a 3/8" drive torque wrench, torque the hex washer head screws (B) to 13 ± 2 ft-lb.
15. Using a 1/2" socket with a 3/8" drive extension and a 3/8" drive ratchet, install the hex washer head screws (A) (removed in step 9) to secure the jack base assembly to the base frame. Using a 3/8" drive torque wrench, torque the hex washer head screws (A) to 7.5 ± 1.5 ft-lb.

Note - The jack descent rate is set at the factory. Do not adjust the rate.

16. Replace the hood (removed in step 4).

17. Replace the litter (removed in step 2).
18. Raise the product to the highest height position. Apply weight to the litter to make sure that the jacks hold and do not drift.
19. Verify proper operation before you return the product to service.

Jack replacement, foot end, non-electric lift

Tools required:

- 1/2" socket
- 3/8" drive ratchet
- 3/8" drive extension
- 3/8" drive torque wrench (ft-lb)

Procedure:

1. Apply the brake. Push on the product to make sure that the brakes work.
2. Remove the litter. See *Litter top removal, non-electric litter* (page 53).
3. Remove the hood. See *Raising the hood* (page 32).
4. Using a 1/2" socket with a 3/8" drive extension and a 3/8" drive ratchet, remove the two hex washer head screws (B) that secure the jack and reservoir clamp (F) to the base weldment (Figure 12). Remove the jack and reservoir clamp. Save all parts.

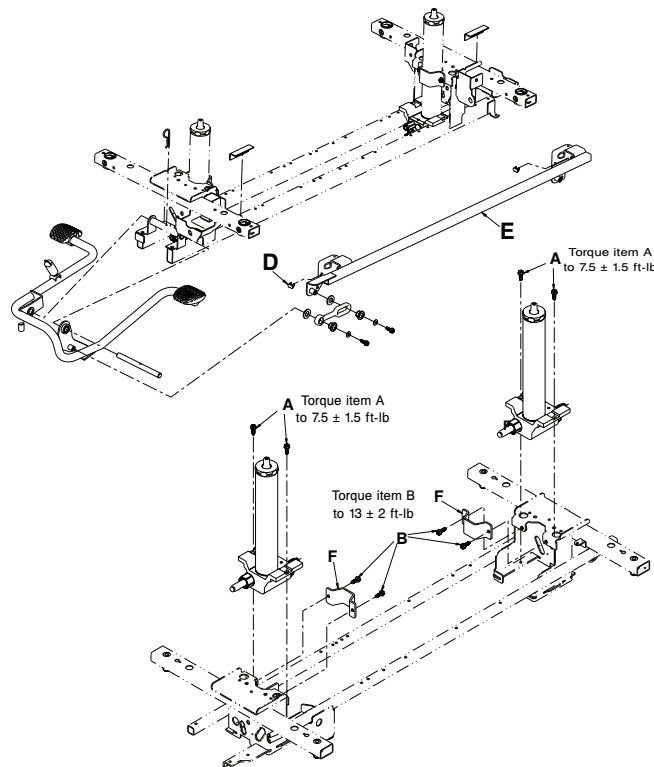

Figure 12 – Replace the jack

5. Disconnect the release pedal swivel from the pins on the release pedal weldment.
6. Remove the foot end release rod from the release valve on the jack assembly. Save the release rod.
7. Using your hand, remove the pump ram plug.
8. Disconnect the jack pump piston from the pump connecting rod. Remove and save the pump connecting rod.

9. Using a 1/2" socket with a 3/8" drive extension and a 3/8" drive ratchet, remove the hex washer head screws (A) that secure the jack assembly to the base frame. Save the screws.
10. Remove and discard the jack assembly.
11. Replace the hex washer head screws (B) (removed in step 4) that secure the jack and reservoir clamp (F) to the base weldment. Do not tighten the hex washer head screws.
12. Reverse steps 6-8 to reinstall.
13. Press the pump pedal to the floor to position the jack on the base frame.
14. Using a 1/2" socket with a 3/8" drive extension and a 3/8" drive ratchet, tighten the hex washer head screws (B) to secure the jack and reservoir clamp (F) to the base weldment. Using a 3/8" drive torque wrench, torque the hex washer head screws to 13 ± 2 ft-lb.
15. Using a 1/2" socket with a 3/8" drive extension and a 3/8" drive ratchet, reinstall the hex washer head screws (A) to secure the supplied jack assembly to the base frame. Using a 3/8" drive torque wrench, torque the hex washer head screws to 7.5 ± 1.5 ft-lb.

Note - The jack descent rate is set at the factory. Do not adjust the rate.

16. Replace the hood (removed in step 3).
17. Replace the litter (removed in step 2).
18. Raise the litter to the highest height position. Apply weight to the litter to make sure that the jacks hold and do not drift.
19. Verify proper operation before you return the product to service.

Jack replacement, head end, electric lift

Tools required:

- 1/2" socket
- 3/8" drive 6" extension
- Diagonal pliers
- 7/16" socket
- 3/8" drive ratchet
- Needle nose pliers
- Torque wrench (in-lb)

Procedure:

1. Apply the brake. Push on the product to make sure that the brake is working.
2. Remove the litter. See *Litter top removal, electric litter* (page 54).
3. Remove the hood. See *Raising the hood* (page 32).
4. Using a 1/2" socket with a 3/8" drive 6" extension and a 3/8" drive ratchet, remove the hex washer head screw that secures the pump ground wire to the base frame.
5. Using diagonal pliers, cut the cable tie that secures the ground wire to the jack pump hose.

Note - Pay attention to the location of the cable tie for when you reinstall.

6. Using a 7/16" socket with a 3/8" drive 6" extension and a 3/8" drive ratchet, remove the two hex washer head screws (A) that secure the foot end pump to the pump motor (Figure 13). Lower the pump to the floor.

Note - Using a torque wrench, torque the hex washer head screws to 80 ± 10 in-lb when you reinstall.

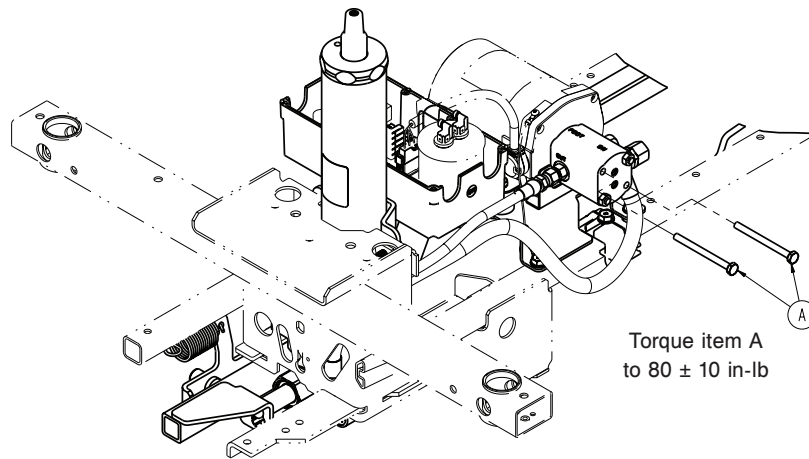

Figure 13 – Screws securing foot end pump to pump motor

7. Using a 1/2" socket with a 3/8" drive 6" extension and a 3/8" drive ratchet, remove the two hex washer head screws that secure the power cord mounting bracket to the base frame.
8. Using a 1/2" socket with a 3/8" drive 6" extension and a 3/8" drive ratchet, remove the two hex washer head screws that secure the reservoir support bracket to the base frame.
9. Using a 1/2" socket with a 3/8" drive 6" extension and a 3/8" drive ratchet, remove the two hex washer head screws that secure the jack base to the base frame.
10. Using needle nose pliers, remove the rue ring cotter on the head end jack release linkage and slide the linkage off of the release pedal.
11. Remove and save the pump ram plug.
12. Lift up on the pump pedal connecting link and push the jack pump piston in toward the jack.
13. Lift the jack pump assembly up, tip the assembly toward the foot end, and lift the assembly out of the base frame assembly.
14. Reverse steps to install the supplied jack.
15. Verify proper operation before you return the product to service.

Jack replacement, foot end, electric lift

Tools required:

- 1/2" socket
- 7/16" socket
- 3/8" drive ratchet
- 3/8" drive 6" extension
- Needle nose pliers
- Torque wrench (in-lb)

Procedure:

1. Raise the hood. See *Raising the hood* (page 32).
2. Remove the litter. See *Litter top removal, electric litter* (page 54).
3. Using a 7/16" socket with a 3/8" drive 6" extension and a 3/8" drive ratchet, remove the two hex washer head screws (A) that secure the foot end pump to the pump motor (Figure 14). Lower the pump to the floor.

Note - Using a torque wrench, torque the hex washer head screws to 80 ± 10 in-lb when you reinstall.

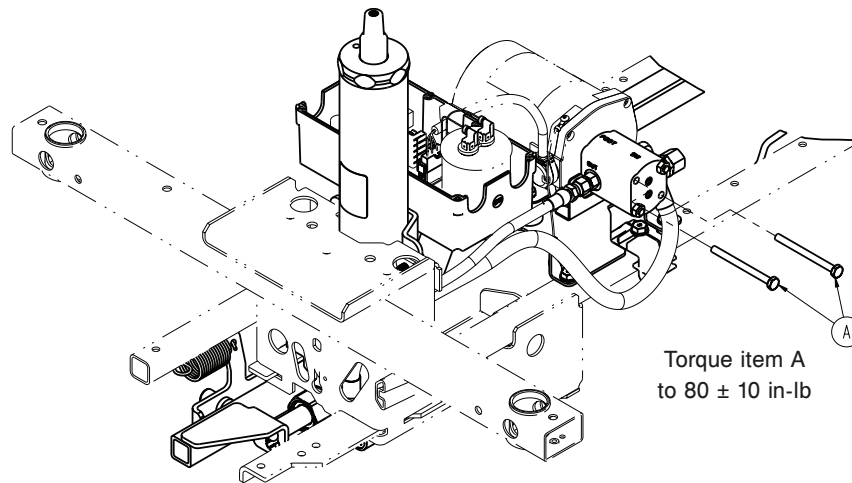

Figure 14 – Screws securing foot end pump to pump motor

4. Using a 1/2" socket with a 3/8" drive 6" extension and a 3/8" drive ratchet, remove the three hex washer head screws that secure the pump motor mounting bracket to the base frame.
5. Tip the pump and control box toward the head end.
6. Using a 1/2" socket with a 3/8" drive 6" extension and a 3/8" drive ratchet, remove the two hex washer head screws that secure the reservoir support bracket to the base frame.
7. Using a 1/2" socket with a 3/8" drive 6" extension and a 3/8" drive ratchet, remove the two hex washer head screws that secure the jack base to the base frame.
8. Using needle nose pliers, remove the rue ring cotter on the head end jack release linkage and slide the linkage off of the release pedal.
9. Remove the pump ram plug.
10. Lift up on the pump pedal connecting link and push the jack pump piston in toward the jack.
11. Lift the jack pump assembly up, tip the assembly toward the foot end, and lift the assembly out of the base frame assembly.
12. Reverse steps to install the supplied jack.
13. Verify proper operation before you return the product to service.

Remove excess air from the hydraulic system

Tools required:

- None

Procedure:

1. Raise the product to the highest height position.
2. Push down on the pump pedal several times to force the air through the system.
3. Verify proper operation before you return the product to service.

Side pump pedal replacement

Tools required:

- 1/2" socket
- 3/8" drive ratchet
- 3/8" drive extension

- 3/8" drive torque wrench (ft-lb)
- Needle nose pliers

Procedure:

1. Apply the brake. Push on the product to make sure that the brakes work.
2. Raise the hood. See *Raising the hood* (page 32).
3. Unplug the power cord from the wall outlet.
4. Using a 1/2" socket with a 3/8" drive extension and a 3/8" drive ratchet, remove the hex washer head screw (A) that secures the pump pedal link (B) to the pump pedal (Figure 15).

Note - Using a 3/8" drive torque wrench, torque the hex washer head screw to 7.5 ± 1.5 ft-lb when you reinstall.

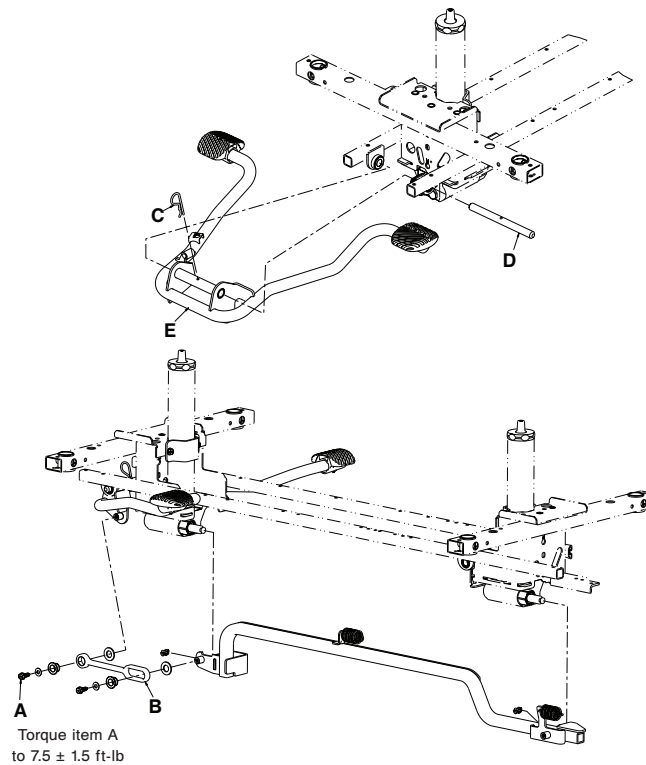

Figure 15 – Replace side the pump pedal

5. Using needle nose pliers, remove the hair pin cotter (C) from the pump pedal pivot pin (D).
6. Using needle nose pliers, remove the pump pedal return spring.
7. Remove the pump pedal pivot pin (D) from the base frame and pedal pivots.

Note - The side pump pedal assembly (E) will be loose and may fall when you remove the pump pedal pivot pin.

8. Remove and discard the side pump pedal assembly (E).
9. Reverse steps to install the supplied side pump pedal assembly.
10. Verify proper operation before you return the product to service.

Release pedal adjustment

Tools required:

- Needle nose pliers

Procedure:

1. Apply the brake. Push on the product to make sure that the brake works.
2. Raise the base hood. See *Raising the hood* (page 32).
3. Using needle nose pliers, remove the rue ring cotter (A) from the release pedal assembly (Figure 16).

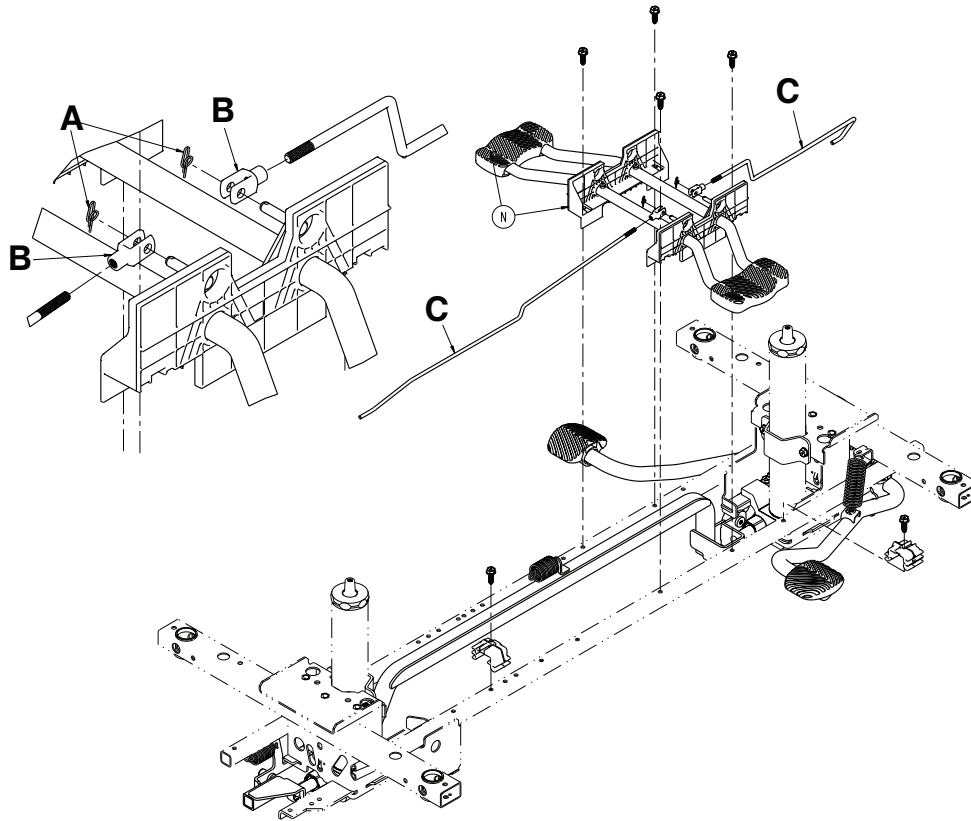

Figure 16 – Adjust the release pedal

4. Remove the clevis joint (B) from the release pedal assembly.
5. To increase the descent rate, increase the amount of the release rod thread (C) in the clevis joint (B).
6. To decrease the descent rate, decrease the amount of the release rod thread (C) in the clevis joint (B).

Note - If you thread the clevis joint too far on the release rod, it will trigger the release valve and the jack will drift.

7. Reverse steps 1-3 to reinstall.
8. Verify proper operation before you return the product to service.

Release pedal replacement, foot end, three-sided hydraulics

Tools required:

- Needle nose pliers

Procedure:

1. Apply the brake. Push on the product to make sure that the brakes work.
2. Raise the hood. See *Raising the hood* (page 32).
3. Disconnect the release pedal return springs (C) from the foot end release pedals (Figure 17).

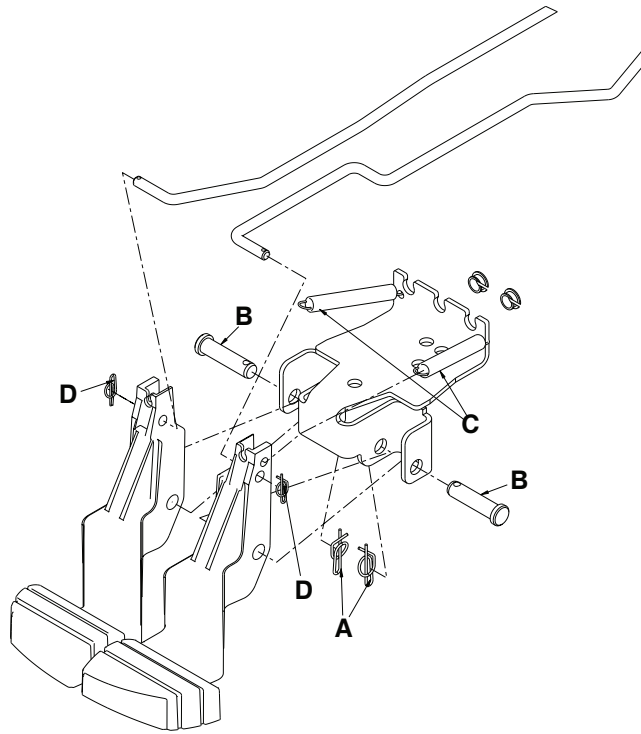

Figure 17 – Replace the release pedal

4. Using needle nose pliers, remove the ring cotter (A) and the clevis pins (B) that secure the foot end release pedals to the mounting bracket.
5. Rotate the pedals up.
6. Using needle nose pliers, remove the ring cotter pins (D) that secure the head end and foot end release rods to the foot end release pedals. Remove and discard the release pedals.
7. Reverse steps to install the supplied release pedals.
8. Verify proper operation before you return the product to service.

Release pedal rod replacement, foot end, three-sided hydraulics

Tools required:

- Needle nose pliers

Procedure:

1. Apply the brake. Push on the product to make sure that the brakes work.
2. Raise the hood. See *Raising the hood* (page 32).
3. Remove the foot end release pedal. See *Release pedal replacement, foot end, three-sided hydraulics* (page 48).
4. Using needle nose pliers, remove the snap-in Nyliners that secure the foot end pedal release rods to the pedal mounting bracket.
5. Unsnap the foot end pedal release rods from the white plastic release rod brackets (A) (Figure 18).

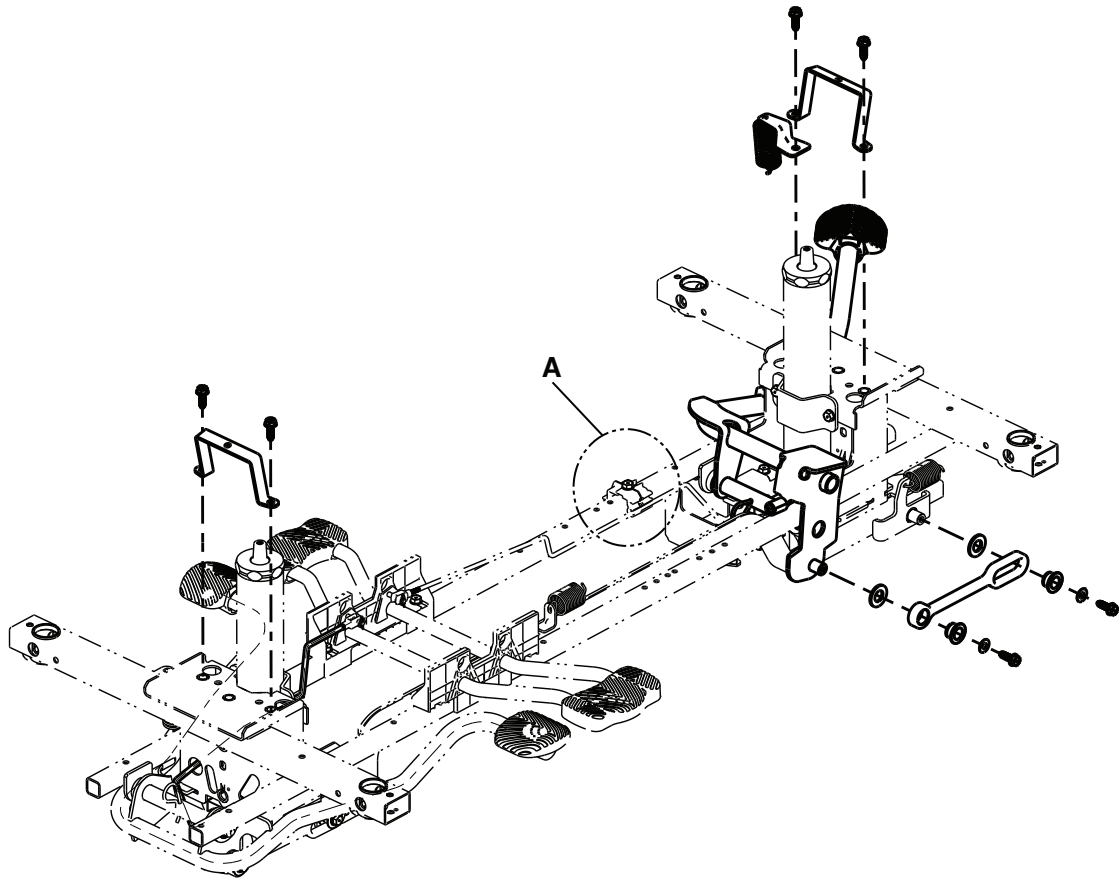

Figure 18 – Release rod brackets

6. Using needle nose pliers, remove the rue ring cotters (B) from the studs (C) on the side control release pedal weldment (Figure 19).

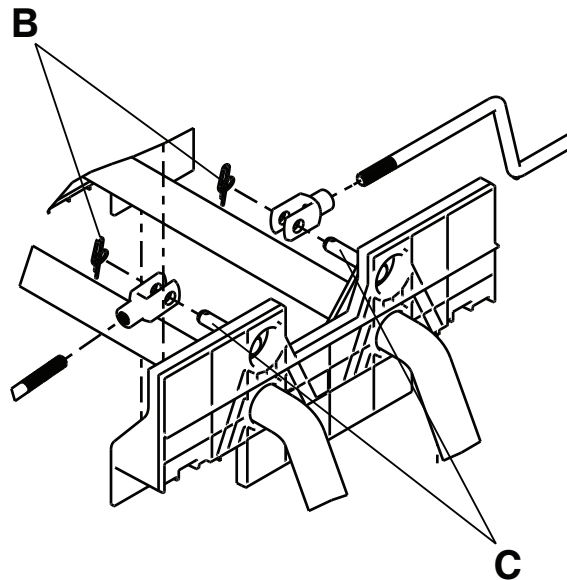

Figure 19 – Remove rue ring cotters from studs

7. Remove the foot end release pedal rods.
8. Reverse steps to install the supplied release pedal rods.

9. Verify proper operation before you return the product to service.

Power board replacement, electric lift/litter

Tools required:

- #2 Phillips screwdriver
- 3/8" drive torque wrench (in-lb)
- ESD protection

Procedure:

Note - Use ESD protection when necessary. See *Protecting against electrostatic discharge (ESD)* (page 32).

1. Apply the brake. Push on the product to make sure that the brakes work.
2. Raise the hood. See *Raising the hood* (page 32).
3. Unplug the power cord from the wall outlet.
4. Using a #2 Phillips screwdriver, remove the seven pan head tapping screws (A) that secure the power board box cover (B) (Figure 20). Remove and save the power board box cover.

Note - Using a 3/8" drive torque wrench, torque the pan head tapping screws to 14 ± 2 in-lb when you reinstall.

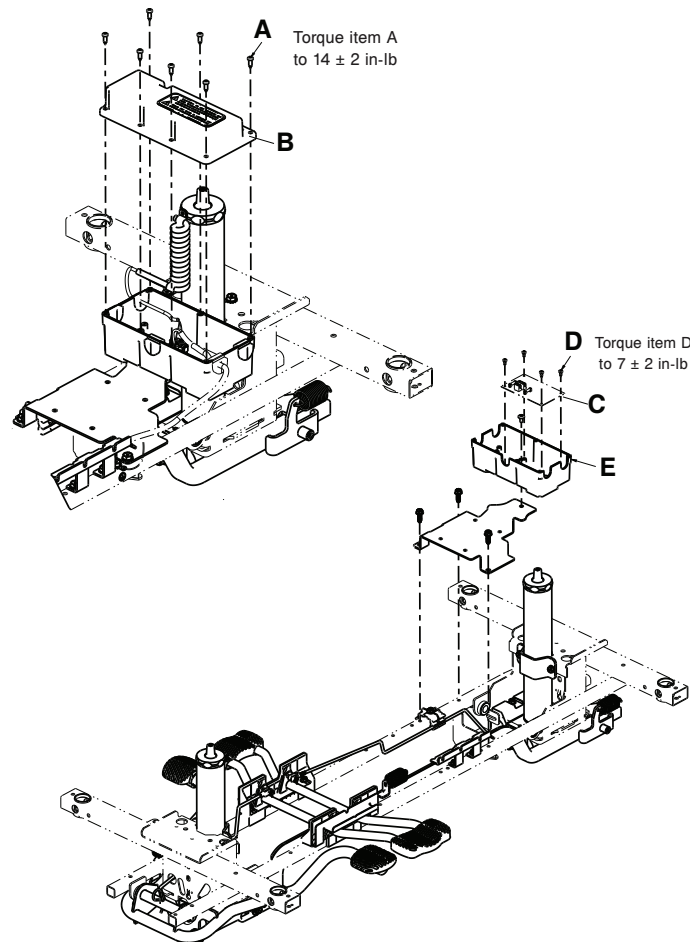

Figure 20 – Replace the power board

5. Unplug all cables connected to the power board (C).
6. Using a #2 Phillips screwdriver, remove the four pan head tapping screws (D) that secure the power board to the power board box (E). Remove and discard the power board.

Note - Using a 3/8" drive torque wrench, torque the pan head tapping screws to 7 ± 2 in-lb when you reinstall.

7. Position the supplied power board on the power board box.
8. Reverse steps to install the supplied power board.
9. Verify proper operation before you return the product to service.

Pump motor replacement, electric lift

Tools required:

- #2 Phillips screwdriver
- 3/8" drive ratchet
- 3/8" drive torque wrench (in-lb)
- 7/16" socket
- 3/8" drive extension

Procedure:

1. Raise the hood. See *Raising the hood* (page 32).
2. Unplug the power cord from the wall outlet.
3. Using a #2 Phillips screwdriver, remove the seven pan head tapping screws (A) that secure the power board box cover (B) (Figure 21). Remove and save the power board box cover.

Note - Using a 3/8" drive torque wrench, torque the pan head tapping screws to 14 ± 2 in-lb when you reinstall.

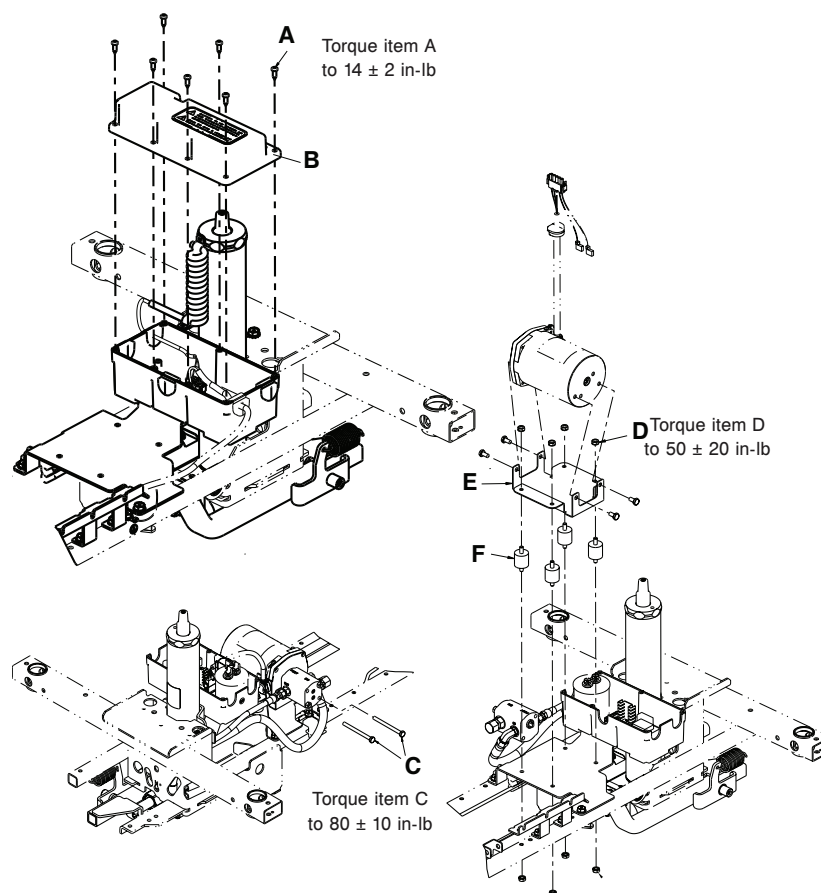

Figure 21 – Replace the pump motor

4. Unplug the cable that connects the pump motor to the power board connector.

5. Disconnect the two wires connected to the capacitor.
6. Using a #2 Phillips screwdriver, remove the ground wire from the pump motor.
7. Using a 7/16" socket with a 3/8" drive extension and a 3/8" drive ratchet, remove the two hex head cap screws (C) that secure the head end pump and foot end pump to the pump motor.
Note - Using a 3/8" drive torque wrench, torque the hex head cap screws to 80 ± 10 in-lb when you reinstall.
8. Using a 7/16" socket with a 3/8" drive extension and a 3/8" drive ratchet, remove the four hex kep nuts (D) that secure the pump motor mounting bracket (E) to the isolators (F).
Note - Using a 3/8" drive torque wrench, torque the hex kep nuts to 50 ± 20 in-lb when you reinstall.
9. Remove and discard the pump motor.
10. Reverse steps to install the supplied pump motor.
11. Verify proper operation before you return the product to service.

Litter top removal, non-electric litter

Tools required:

- 1/2" socket
- 3/8" drive extension
- 3/8" drive ratchet
- 3/8" drive torque wrench (ft-lb)
- Fine-thread 7/16"-20 bolt

Procedure:

1. Apply the brake. Push on the product to make sure that the brakes work.
2. Raise the product to the highest height position.
3. Raise the Fowler backrest to the full upright position.
4. Using a 1/2" socket with a 3/8" drive extension and a 3/8" drive ratchet, remove the two hex washer head screws (A) (from the head and the foot end) that secure the jack support tubes to the jack shafts (Figure 22).

Note - Using a 3/8" drive torque wrench, torque the hex washer head screws to 11 ± 5 ft-lb when you reinstall.

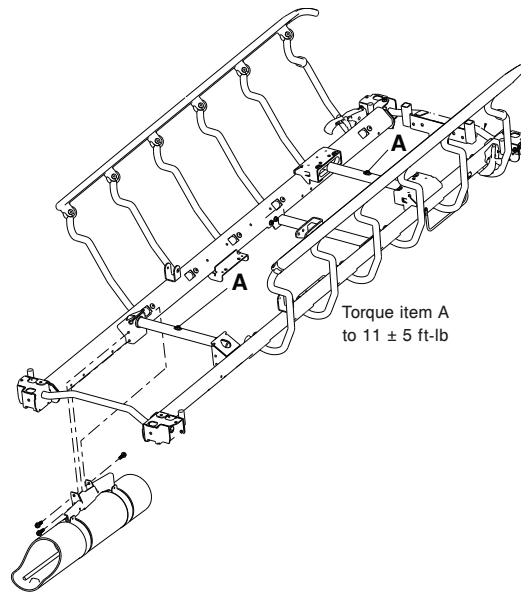

Figure 22 – Litter top removal

5. Insert a fine-thread 7/16"-20 bolt into the top of the jack supports far enough to separate the litter top from the jack shaft.
6. Lift the litter off of the jack shafts and set aside.

Note - Get assistance from another person to remove the litter top.

7. Reverse steps to reinstall.
8. Verify proper operation before you return the product to service.

Litter top removal, electric litter

Tools required:

- 1/2" socket
- 5/16" socket
- 3/8" drive extension
- 3/8" drive ratchet
- 3/8" drive torque wrench (ft-lb)
- 3/8" drive torque wrench (in-lb)
- Fine-thread 7/16"-20 bolt
- ESD protection

Procedure:

Note - Use ESD protection when necessary. See *Protecting against electrostatic discharge (ESD)* (page 32).

1. Raise the hood. See *Raising the hood* (page 32).
2. Unplug the power cord from the wall outlet.
3. Using a 1/2" socket with a 3/8" drive extension and a 3/8" drive ratchet, remove the seven pan head tapping screws (A) that secure the power box cover (B) (Figure 23). When you reinstall, use a 3/8" drive torque wrench (in-lb) to torque the screws to 14 ± 2 in-lb.

Note - Using a 3/8" drive torque wrench, torque the pan head tapping screws to 14 ± 2 in-lb when you reinstall.

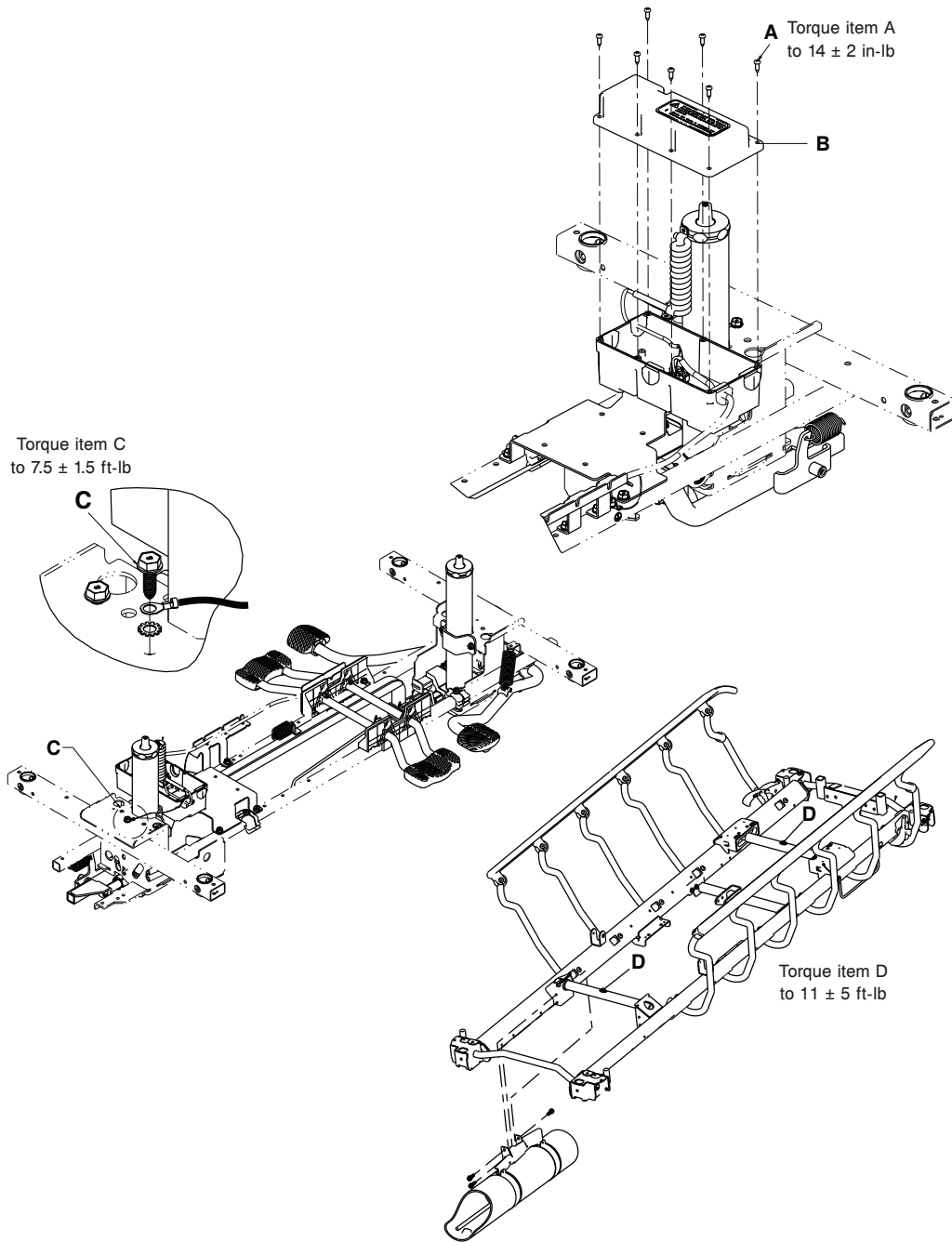

Figure 23 – Litter top removal - electric

4. Remove the cable from location B from the power board.
 5. Using a 1/2" socket with a 3/8" drive extension and a 3/8" drive ratchet, remove the screw (C) that secures the coil cord ground to the base weldment.
- Note** - Using a 3/8" drive torque wrench, torque the screw to 7.5 ± 1.5 ft-lb when you reinstall.
6. Using a 5/16" socket with a 3/8" drive extension and a 3/8" drive ratchet, remove the screw that secures the coil cord clamp.
 7. Pull the coil cord cable up through the bellows.
 8. Using a 1/2" socket with a 3/8" drive extension and a 3/8" drive ratchet, remove the two hex washer head screws (D) that secure the jack support tubes to the jack shafts.

Note - Using a 3/8" drive torque wrench, torque the hex washer head screws to 11 ± 5 ft-lb when you reinstall.

9. Insert a fine-thread 7/16"-20 bolt into the top of the jack supports to separate the litter from the jack shaft.
10. Lift the litter off of the jack shafts and set the litter aside.
Note - Get assistance from another person to remove the litter top.
11. Reverse steps to reinstall.
12. Verify proper operation before you return the product to service.

Siderail assembly removal and replacement

Tools required:

- 1/2" socket
- 3/8" socket
- 3/8" drive extension
- 3/8" drive ratchet
- 3/8" drive torque wrench (ft-lb)
- Bungee cords

Procedure:

1. Apply the brake. Push on the product to make sure that the brakes work.
2. Raise the product to the highest height position.
3. Raise the Fowler backrest to the full upright position.
4. Remove the slider board from the storage tray.
5. Pull up on the monitor/utility tray to remove from the litter frame. Save the monitor/utility tray.
6. If you are replacing the left siderail assembly, use a 1/2" socket with a 3/8" drive extension and a 3/8" drive ratchet to remove the three hex head cap screws that secure the oxygen bottle holder bracket to the litter frame. Remove the oxygen bottle holder.

Note - Using a 3/8" drive torque wrench, torque the hex head cap screws to 13 ± 3 ft-lb when you reinstall.

7. Using a 1/2" socket with a 3/8" drive extension and a 3/8" drive ratchet, remove the four hex head cap screws that secure the slider board tray to the litter frame.

Note - Using a 3/8" drive torque wrench, torque the hex head cap screws to 11.5 ± 4.5 ft-lb when you reinstall.

8. Using a 3/8" socket with a 3/8" drive extension and a 3/8" drive ratchet, remove the Fowler backrest pivot bolt that secures the Fowler backrest weldment to the siderail weldment.
9. Using a 1/2" socket with a 3/8" drive extension and a 3/8" drive ratchet, remove the two bolts that secure the frame tie weldment to the litter frame.

Note - Using a 3/8" drive torque wrench, torque the bolts to 11 ± 5 ft-lb when you reinstall.

10. Using a 1/2" socket with a 3/8" drive extension and a 3/8" drive ratchet, remove the pan head screws that secure the plastic litter corner covers and remove the covers.
11. Using a 1/2" socket with a 3/8" drive extension and a 3/8" drive ratchet, remove the two bolts that secure the Fowler backrest drop seat bracket.

Note - Using a 3/8" drive torque wrench, torque the bolts to 13 ± 2 ft-lb when you reinstall.

12. Using a 1/2" socket with a 3/8" drive extension and a 3/8" drive ratchet, remove the three bolts that secure the siderail to the foot end litter weldment.

Using a 3/8" drive torque wrench, torque the bolts to 11 ± 5 ft-lb when you reinstall.

13. Remove the siderail assembly.
14. Position the side of the stretcher with the remaining siderail next to a wall for support or support the siderail with bungee cords before you install the supplied siderail.

15. Lift the supplied siderail into position.
16. Insert the foot end jack support into the hole in the support tube bracket on the siderail.
17. Insert the head end jack support tube into the slot in the trend slide block.
18. Reverse steps 1-12 to reinstall.
19. Verify proper operation before you return the product to service.

Siderail latch replacement

Tools required:

- T40 Torx driver

Procedure:

1. Apply the brake. Push on the product to make sure that the brakes work.
2. Raise the product to the highest height position.
3. Using a T40 Torx driver, remove the two truss head machine screws (A) that secure the siderail latch (B) to the litter frame (Figure 24). Discard the truss head machine screws. Remove and discard the siderail latch.

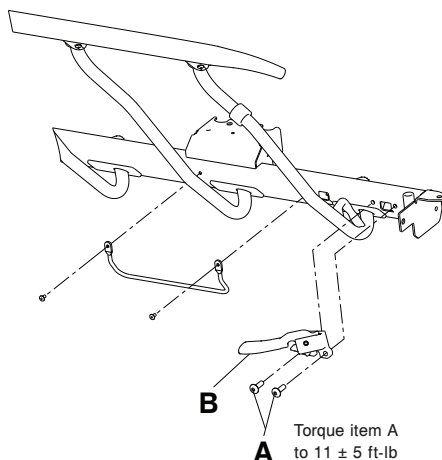

Figure 24 – Siderail latch replacement

4. Using a T40 Torx driver and the supplied siderail truss head machine screws, secure the supplied siderail latch to the litter frame. Using a T40 Torx driver, torque the truss head machine screws to 11 ± 5 ft-lb.
5. Make sure that the siderail latches and releases.
6. Verify proper operation before you return the product to service.

Gatch release handle replacement, non-electric litter

Tools required:

- Needle nose pliers

Procedure:

1. Twist off the Gatch release handle knob and discard.
2. Using needle nose pliers, remove the cotter pin that secures the Gatch release rod to the Gatch release link.
3. Pull the Gatch release rod out.
4. Reverse steps to install the supplied Gatch release handle.
5. Verify proper operation before you return the product to service.

Gatch valve body replacement, non-electric litter

Tools required:

- Needle nose pliers
- 1/2" socket
- 3/8" drive torque wrench (ft-lb)
- 3/8" drive extension
- 3/8" drive ratchet

Procedure:

1. Using needle nose pliers, remove the rue ring cotter (A) and clevis pin (B) that secure the Gatch pump ram to the pump handle (C) (Figure 25).

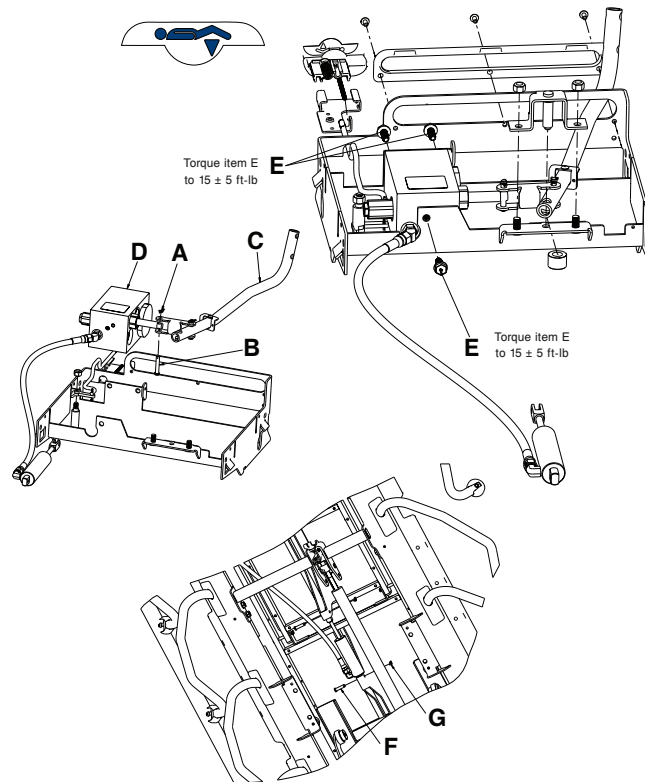

Figure 25 – Gatch valve body replacement

2. Using a 1/2" socket with a 3/8" drive extension and a 3/8" drive ratchet, remove the three hex washer head screws (E) that secure the Gatch valve body (D) to the Gatch weldment. Remove the lock nut that secures the release link, and lower the valve body out of the weldment.
Note - Using a 3/8" drive torque wrench, torque the hex washer head screws to 15 ± 5 ft-lb when you reinstall.
3. Using needle nose pliers, remove the two rue ring cotters (G) and two clevis pins (F) that secure the hydraulic cylinder to the seat section and the thigh section. Remove and discard the Gatch valve body assembly.
4. Reverse steps to install the supplied Gatch valve body assembly.
5. Verify proper operation before you return the product to service.

Fowler backrest gas cylinder replacement, non-electric litter

Tools required:

- 3/8" socket

- T40 Torx driver
- 17 mm combination wrench
- 3/8" drive extension
- 3/8" drive ratchet
- Needle nose pliers
- Diagonal pliers

Procedure:

1. Using a 3/8" drive ratchet and a T40 Torx driver, remove the four truss head machine screws (A) that secure the plastic Fowler backrest skin to the Fowler backrest frame (Figure 26).

Note

- Support the Fowler backrest gas cylinder, the gas cylinder will be loose.
- Using a T40 Torx driver, torque the truss head machine screws to 45 ± 15 in-lb when you reinstall.

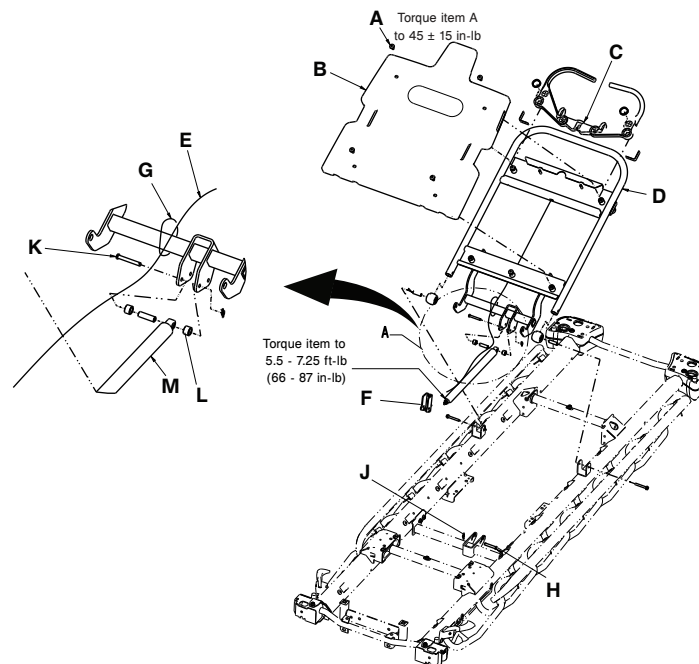

Figure 26 – Fowler gas cylinder replacement

2. Disconnect the Fowler backrest cable assembly from under the plastic Fowler backrest skin. Remove and save the Fowler backrest skin (B).
3. Remove the Fowler backrest cable assembly from the black plastic cable release pivot (C) on the Fowler backrest weldment (D). Discard the Fowler cable assembly.
4. Remove the other end of the Fowler backrest cable assembly (E) from the gas spring trip (F).
5. Using diagonal pliers, cut the cable tie (G) that secures the Fowler backrest cable assembly to the Fowler backrest support bracket.
6. Using needle nose pliers, remove the clevis pin (H) and the rue ring cotter (J) that secure the gas spring trip to the litter frame. Save the clevis pin and rue ring cotter.
7. Using a 17 mm combination wrench, loosen the jam nut from the gas spring trip. Remove the gas spring trip from the gas cylinder. Discard the gas spring clip.
8. Using a 3/8" socket with a 3/8" drive extension and a 3/8" drive ratchet, remove the hex washer head screw (K) and spacers (L) that secure the head end of the Fowler backrest gas cylinder (M) to the Fowler backrest frame. Remove and discard the Fowler backrest gas cylinder.
9. Reverse steps to reinstall the supplied Fowler backrest gas cylinder.

10. Verify proper operation before you return the product to service.

Oxygen bottle holder replacement

Tools required:

- 1/2" socket
- 3/8" drive extension
- 3/8" drive ratchet
- 3/8" drive torque wrench (ft-lb)

Procedure:

1. Raise the product to the highest height position.
2. Raise the Fowler backrest to 90 degrees.
3. Using a 1/2" socket with a 3/8" drive extension and a 3/8" drive ratchet, remove the three hex washer head screws (A) that secure the oxygen bottle holder (B) to the litter frame on the patient left side (Figure 27). Save the hex washer head screws.

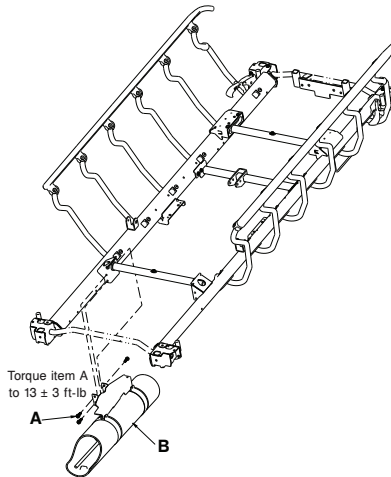

Figure 27 – Oxygen bottle holder replacement

4. Using a 1/2" socket with a 3/8" drive extension and a 3/8" drive ratchet, install the three hex washer head screws (removed in step 3) to secure the supplied oxygen bottle holder to the litter frame. Using a 3/8" drive torque wrench, torque all screws to 13 ± 3 ft-lb.
5. Verify proper operation before you return the product to service.

Fowler actuator replacement, electric litter

Tools required:

- Bungee cords
- Small slotted screwdriver
- Needle nose pliers
- Large slotted screwdriver
- 8 mm combination wrench
- Diagonal pliers

Procedure:

1. Raise the product to the highest height position.

2. Lower the Fowler backrest and the Gatch to the lowest height position.
3. Using bungee cords, secure the Fowler backrest to the litter.
4. Unplug the power cord from the wall outlet.
5. Raise the drop seat (A) and fold the seat toward the foot end of the product (Figure 28).

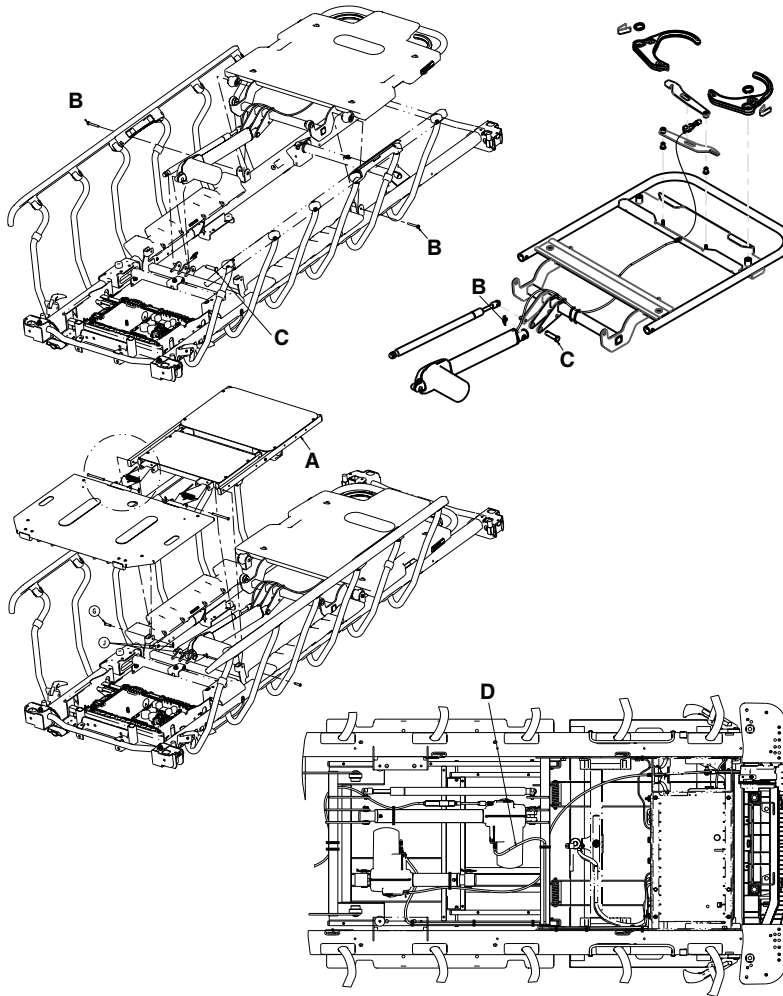

Figure 28 – Fowler backrest actuator replacement

6. Using a small slotted screwdriver, remove the actuator power cable retainer and unplug the power cable (D) from the actuator.

Note - Pay attention to the placement of the actuator power cable retainer for when you reinstall.

7. Using needle nose pliers, remove the rue ring cotter (B) from the clevis pins (C) on the head end and foot end of the actuator.
8. Support the actuator with one hand and remove the clevis pins (C) from the head end and foot end of the actuator. Set the actuator on the Fowler backrest.
9. Using a large slotted screwdriver, remove the actuator CPR cable cover. Save the actuator CPR cable cover.
10. Using needle nose pliers, pull up on the CPR cable in the actuator to remove the CPR cable from the release lever.

Note - Using needle nose pliers, place the CPR cable ball into the release lever to install the CPR cable into the supplied actuator when you reinstall.

11. Using an 8 mm combination wrench, remove the CPR cable from the actuator.

Note - Do not cross-thread the cable into the actuator case or overtighten when you reinstall.

12. Using diagonal pliers, cut the cable tie that secures the CPR cable to the actuator tube.

Note - Pay attention to the location of the cable tie for when you reinstall.

13. Remove and discard the actuator.
14. Reverse steps 1-12 to install the supplied actuator.
15. Verify proper operation before you return the product to service.

Gatch actuator replacement, electric litter

Tools required:

- Bungee cords
- Small slotted screwdriver
- Needle nose pliers
- 8 mm combination wrench
- Large slotted screwdriver
- Diagonal pliers

Procedure:

1. Raise the product to the highest height position.
2. Lower the Fowler backrest and the Gatch to the lowest height position.
3. Using bungee cords, secure the Fowler backrest to the litter.
4. Unplug the power cord from the wall outlet.
5. Using a small slotted screwdriver, remove the actuator power cable retainer and unplug the power cable (A) from the actuator (Figure 29).

Note - Pay attention to the position of the power cable retainer for when you reinstall.

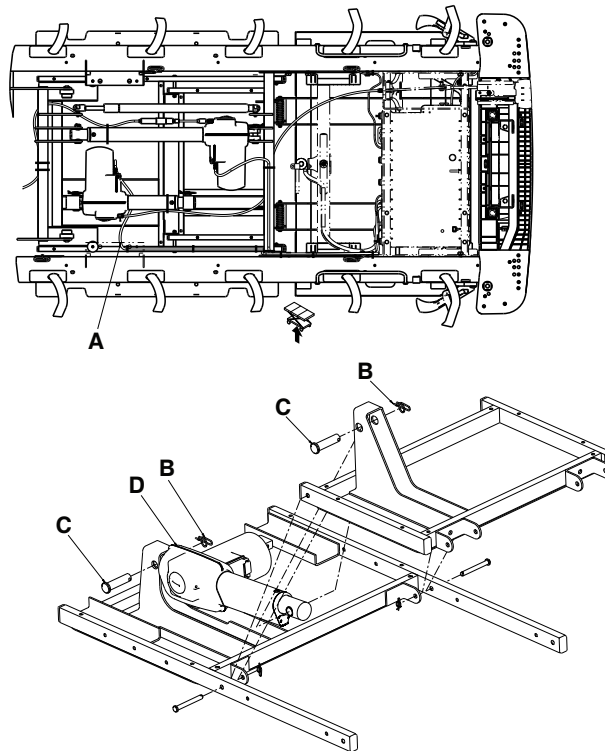

Figure 29 – Gatch actuator replacement

6. Lift up and fold the foot section toward the head end of the product.

7. Using needle nose pliers, remove the rue ring cotters (B) from the clevis pins (C) on the head end and foot end of the actuator.
8. Support the actuator (D) with one hand and remove the clevis pins (C) from the foot end of the actuator (D). Lower the actuator toward the base hood.
9. Support the actuator (D) with one hand and remove the clevis pin (C) from the head end of the actuator. Set the actuator on the control board cover.
10. Using a large slotted screwdriver, remove the actuator CPR cable cover. Save the actuator CPR cable cover.
11. Using needle nose pliers, pull the CPR release cable to the patient left side to remove the cable from the Gatch release.
12. Using needle nose pliers, pull up on the CPR cable in the actuator to remove the CPR cable from the release lever.

Note - Using needle nose pliers, place the CPR cable ball into the release lever to install the CPR cable into the supplied actuator when you reinstall.

13. Using an 8 mm combination wrench, remove the CPR cable from the actuator.

Note - Do not cross-thread the cable into the actuator case or overtighten when you reinstall.

14. Using diagonal pliers, cut the cable tie that secures the CPR cable to the actuator tube.

Note - Pay attention to the location of the cable tie for when you reinstall.

15. Remove and discard the actuator.

16. Reverse steps 1-14 to install the supplied actuator.

Note - To reconnect the CPR release cable to the foot end litter weldmen, use a slotted screwdriver to secure the CPR release cable to the Gatch release lever arm. Then install the CPR release cable to the Gatch weldment.

17. Verify proper operation before you return the product to service.

Control board replacement, electric litter

Tools required:

- #2 Phillips screwdriver
- 3/8" drive torque wrench (in-lb)
- ESD protection

Procedure:

Note - Use ESD protection when necessary. See *Protecting against electrostatic discharge (ESD)* (page 32).

1. Raise the product to the highest height position.
2. Apply the brake. Push on the product to make sure that the brake works.
3. Unplug the power cord from the wall outlet.
4. Fold the foot section toward the head end of the product.
5. Using a #2 Phillips screwdriver, remove the 10 pan head tapping screws (A) that secure the control board cover (B) to the control box bottom (Figure 30).

Note - Using a 3/8" drive torque wrench, torque the pan head tapping screws to 18 ± 2 in-lb when you reinstall.

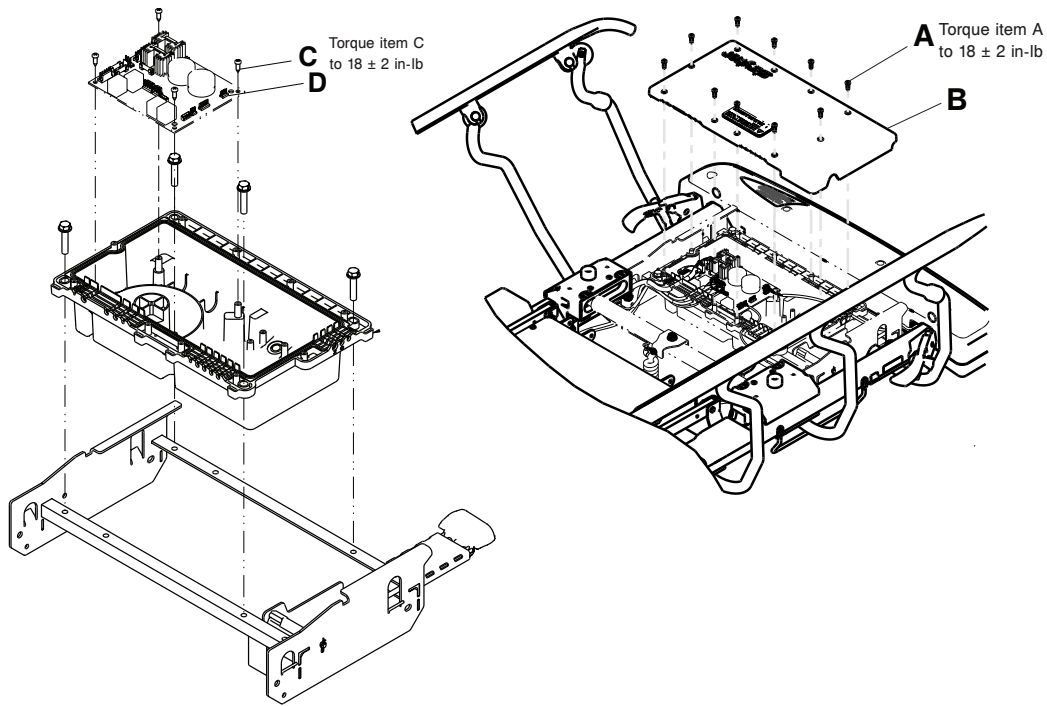

Figure 30 – Control board replacement

6. Unplug all connectors from the control board (D).
7. Using a #2 Phillips screwdriver, remove the four pan head tapping screws (C) from the control board.

Note - Using a 3/8" drive torque wrench, torque the pan head tapping screws to 18 ± 2 in-lb when you reinstall.
8. Remove and discard the control board.
9. Reverse steps to install the supplied control board.
10. Verify proper operation before you return the product to service.

Transformer replacement, electric litter

Tools required:

- #2 Phillips screwdriver
- Torque wrench (in-lb)
- ESD protection

Procedure:

Note - Use ESD protection when necessary. See *Protecting against electrostatic discharge (ESD)* (page 32).

1. Raise the product to the highest height position.
2. Apply the brake. Push on the product to make sure that the brakes work.
3. Unplug the power cord from the wall outlet.
4. Fold the foot section toward the head end.
5. Using a #2 Phillips screwdriver, remove the 10 pan head tapping screws (A) that secure the control board cover (B) to the control box bottom (Figure 31). Remove and save the control board cover.

Note - Using a torque wrench, torque the pan head tapping screws to 18 ± 2 in-lb when you reinstall.

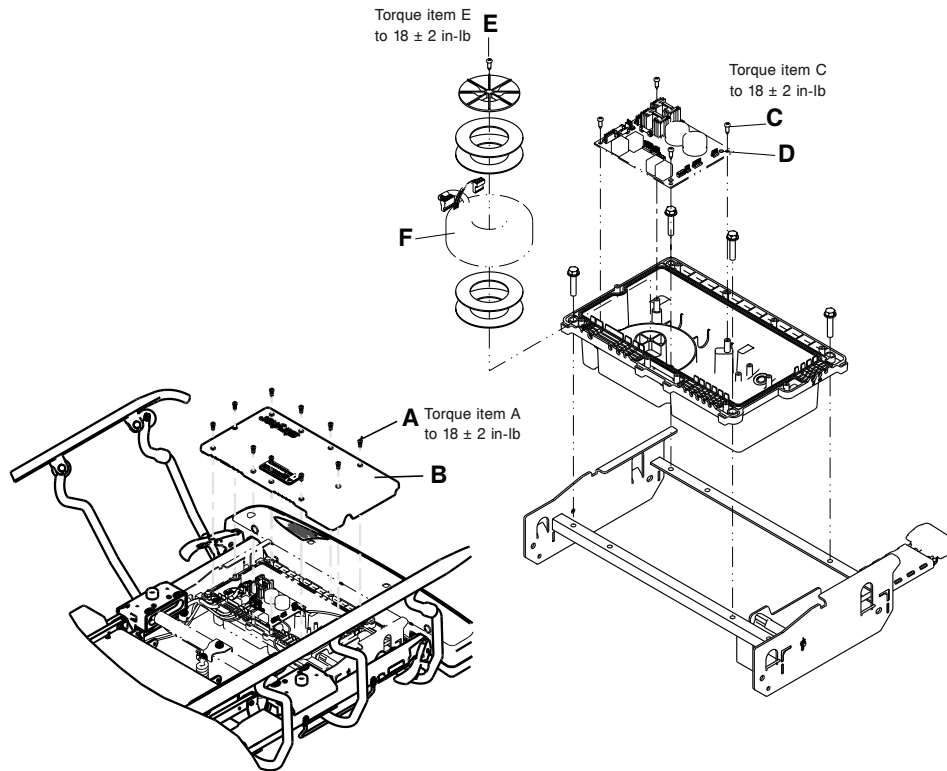

Figure 31 – Transformer replacement

6. Unplug all connectors from the control board (D).
7. Using a #2 Phillips screwdriver, remove the four pan head tapping screws (C) from the control board.

Note - Using a torque wrench, torque the pan head tapping screws to 18 ± 2 in-lb when you reinstall.
8. Remove the control board (D), and set the control board on anti-static material.
9. Using a #2 Phillips screwdriver, remove the pan head tapping screw (E) from the transformer (F).

Note - Using a torque wrench, torque the pan head tapping screws to 18 ± 2 in-lb when you reinstall.
10. Remove and discard the transformer.
11. Reverse steps to install the supplied transformer.
12. Verify proper operation before you return the product to service.

Siderail control pad replacement, electric litter

Tools required:

- #2 Phillips screwdriver
- ESD protection

Procedure:

Note - Use ESD protection when necessary. See *Protecting against electrostatic discharge (ESD)* (page 32).

1. Apply the brake. Push on the product to make sure that the brakes work.
2. Unplug the power cord from the wall outlet.
3. Using a #2 Phillips screwdriver, remove the two barrel nuts (A) that secure the control pad to the top rail (Figure 32).

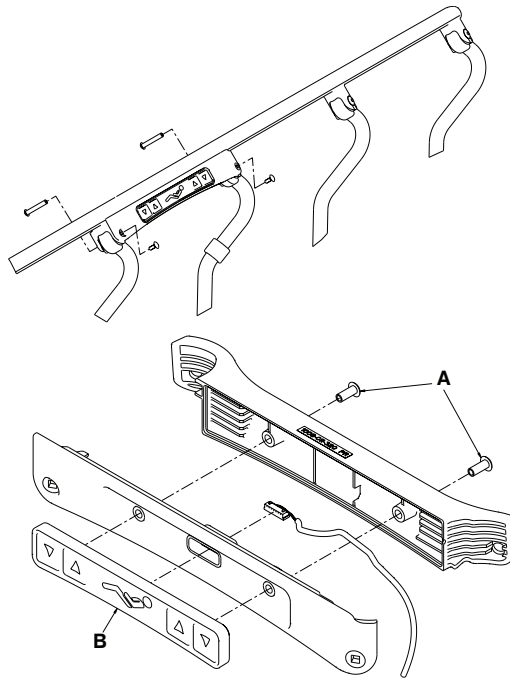

Figure 32 – Siderail control pad replacement

4. Unplug the connectors from the board.
5. Remove the control pad (B) from the top rail. Discard the control pad.
6. Reverse steps to install the supplied control pad.
7. Verify proper operation before you return the product to service.

Siderail cable replacement, electric litter

Tools required:

- #2 Phillips screwdriver
- Torque wrench (in-lb)
- Diagonal pliers
- T40 Torx driver
- Tape
- Cable ties
- ESD protection

Procedure:

Note - Use ESD protection when necessary. See *Protecting against electrostatic discharge (ESD)* (page 32).

1. Raise the product to the highest height position.
2. Apply the brake. Push on the product to make sure that the brakes work.
3. Unplug the power cord from the wall outlet.
4. Fold the foot section toward the head end of the product.
5. Using a #2 Phillips screwdriver, remove the 10 pan head tapping screws (A) that secure the control board cover to the control box bottom (Figure 33). Remove and save the control board cover.

Note - Using a torque wrench, torque the pan head tapping screws to 18 ± 2 in-lb when you reinstall.

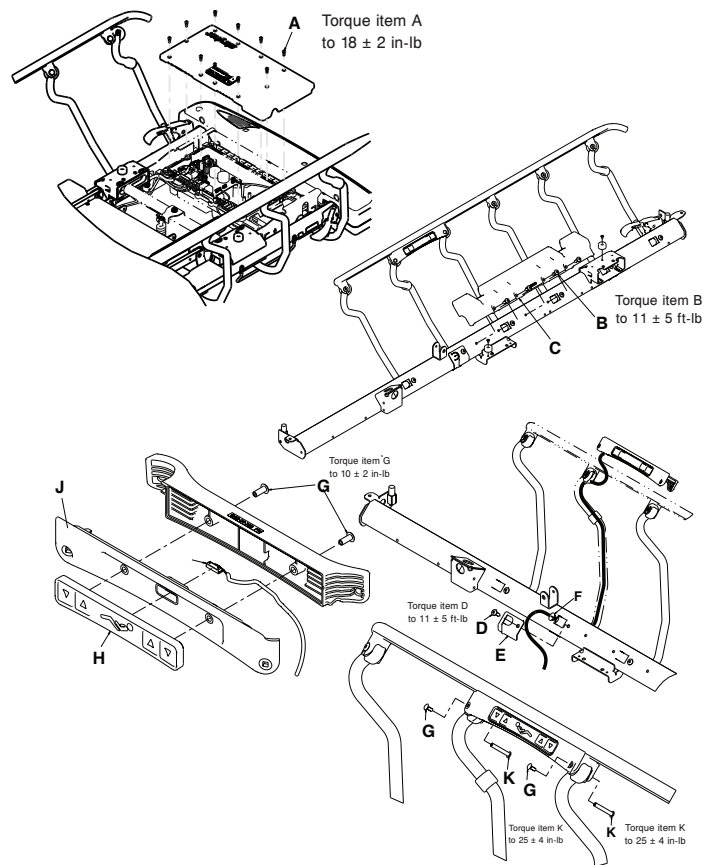

Figure 33 – Siderail cable replacement

6. Unplug the siderail cable connector G (right) or F (left) from the board.
7. Using diagonal pliers, cut the cable ties that secure the siderail cable to the litter.

Note - Pay attention to the location of the cable ties for when you reinstall.
8. Lower the foot section.
9. Fold the Gatch section toward the head end of the product.
10. Using a T40 Torx driver, remove the four truss head machine screws (B) that secure the mattress support (C) to the litter.

Note - Using a T40 Torx driver, torque the truss head machine screws to 11 ± 5 ft-lb when you reinstall.
11. Using a T40 Torx driver, remove the truss head machine screw (D) that secures the cable cover (E) to the litter.

Note - Using a T40 Torx driver, torque the truss head machine screws to 11 ± 5 ft-lb when you reinstall.
12. Remove the cable grommet (F) from the bottom of the siderail spindle.
13. Using tape, attach the supplied siderail cable to the end of the old siderail cable by folding the connector parallel with the cables.
14. Lie on the side where the siderail cable is being replaced. Pull the old siderail cable with one hand and guide the supplied siderail cable with the other hand until the supplied siderail cable is through the litter in the middle of the product.
15. Using a #2 Phillips screwdriver, remove the two barrel nuts (G) that secure the control pad to the top rail.
16. Unplug the connector from the board (H).
17. Remove the control pad from the top rail.
18. Using a #2 Phillips screwdriver, remove the two barrel nuts (K) that secure the control pad support to the top rail.

Note - Using a torque wrench, torque the barrel nuts to 25 ± 4 in-lb when you reinstall.

19. Pull up on the control pad housing (J) to remove the control pad housing.
20. Separate the spindle from the top rail.
21. Remove the spindle plug.
22. Using one hand, pull the old siderail cable through the spindle while you guide the supplied siderail cable through the bottom of the spindle with the other hand.
23. Remove the tape from the siderail cables.
24. Reverse steps to reinstall.
25. Verify proper operation before you return the product to service.

Operator control board replacement, electric litter

Tools required:

- Slotted screwdriver
- 11/32" nut driver

Procedure:

1. Apply the brake. Push on the product to make sure that the brakes work.
2. Raise the product to the highest height position.
3. Unplug the power cord from the wall outlet.
4. Using a slotted screwdriver, remove the two panel fasteners (A) (Figure 34). Save the panel fasteners.

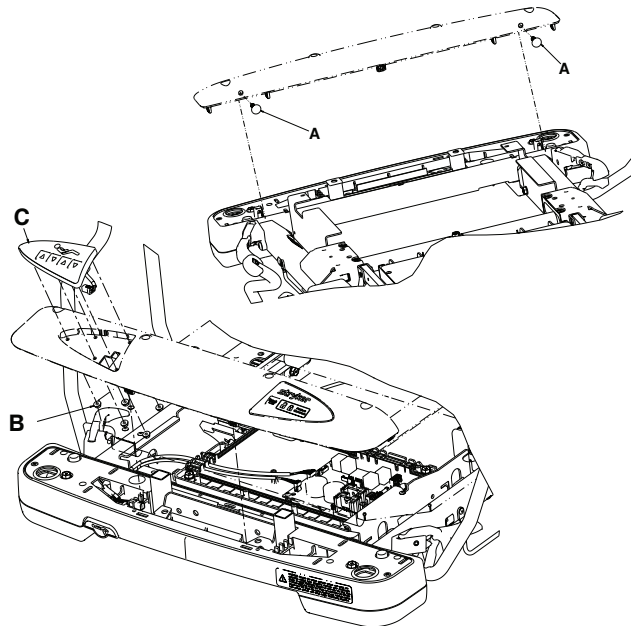

Figure 34 – Operator control board replacement

5. Using a slotted screwdriver, lift up on the nine tabs on the foot end cover to lift the cover up.
6. Unplug the operator control board cable from the quick disconnect under the foot end cover.
7. Using a 11/32" nut driver, remove the five hex flange nuts (B) that secure the operator control board (C) to the cover. Remove and discard the operator control board.
8. Reverse steps to install the supplied operator control board.
9. Verify proper operation before you return the product to service.

Operator control lockout board replacement, electric litter

Tools required:

- Slotted screwdriver
- 11/32" nut driver

Procedure:

1. Apply the brake. Push on the product to make sure that the brakes work.
2. Raise the product to the highest height position.
3. Unplug the power cord from the wall outlet.
4. Using a slotted screwdriver, remove the two panel fasteners (A) (Figure 35). Save the panel fasteners.

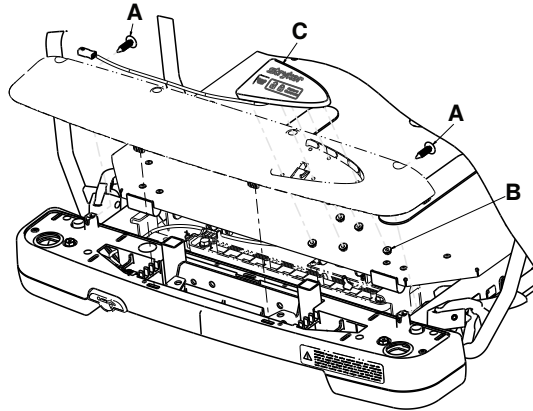

Figure 35 – Operator control lockout board replacement

5. Using a slotted screwdriver, lift up on the nine tabs on the foot end cover to lift the cover up.
6. Unplug the operator control lockout board cable from the quick disconnect under the foot end cover.
7. Using a 11/32" nut driver, remove the five hex flange nuts (B) that secure the operator control lockout board (C) to the cover. Remove and discard the operator control lockout board.
8. Reverse steps to install the supplied operator control board.
9. Verify proper operation before you return the product to service.

Scale keypad and display replacement, non-electric litter

Tools required:

- Slotted screwdriver
- 11/32" nut driver
- Needle nose pliers

Procedure:

1. Apply the brake. Push on the product to make sure that the brakes work.
2. Raise the product to the highest height position.
3. Using a slotted screwdriver and needle nose pliers, remove the two panel fasteners (A) that secure the foot end cover to the litter (Figure 36). Save the panel fasteners.

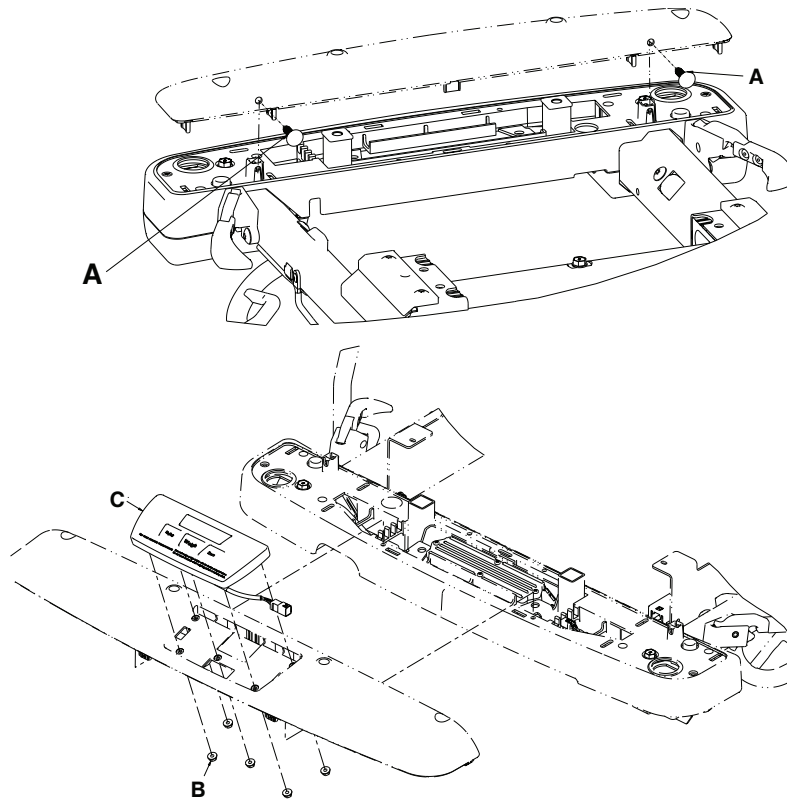

Figure 36 – Scale keypad and display replacement

4. Using a slotted screwdriver, lift up on the nine tabs on the foot end cover to lift the cover up.
5. Unplug the scale keypad cable from the quick disconnect under the foot end cover.
6. Using an 11/32" nut driver, remove the five hex flange nuts (B) that secure the scale keypad (C) to the cover.
7. Reverse steps to install the supplied scale keypad.
8. Verify proper operation before you return the product to service.

Keypad replacement, Prime Connect

Tools required:

- Bungee cord
- Plastic fastener removal tool
- Slotted screwdriver
- Pick
- 11/32" nut driver
- Torque wrench (in-lb)

Procedure:

1. Apply the brake. Push on the product to make sure that the brakes work.
2. Raise the product to the highest height position.
3. Using a bungee cord, secure the foot section in the full upright position
4. Unplug the power cord from the wall outlet.
5. Turn off the battery switch.

Note - For Model 1125, turn off the **Zoom** battery disconnect switch.

- Using a plastic fastener removal tool, remove the two panel fasteners (AT) that secure the foot end top cover to the foot end mid cover (Figure 37). Discard the panel fasteners.

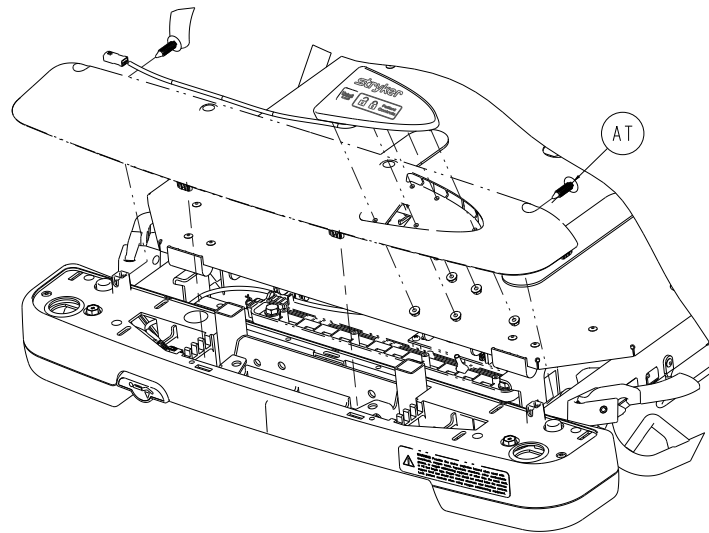

Figure 37 – Panel fasteners

- Using a slotted screwdriver and your hand, pry up and lift along the edge of the top cover assembly to detach the top cover assembly from the mid cover.

Note - Be careful when you use the slotted screwdriver to not cause damage to the top or mid cover assemblies.

- Using a pick, unplug the keypad assembly cable connections and remove the top cover assembly. Save the top cover assembly.
- Using an 11/32" nut driver, remove the five nuts (B) that secure the keypad assembly (K) to the top cover and remove the keypad assembly (Figure 38). Discard the keypad assembly and nuts. Save the top cover.

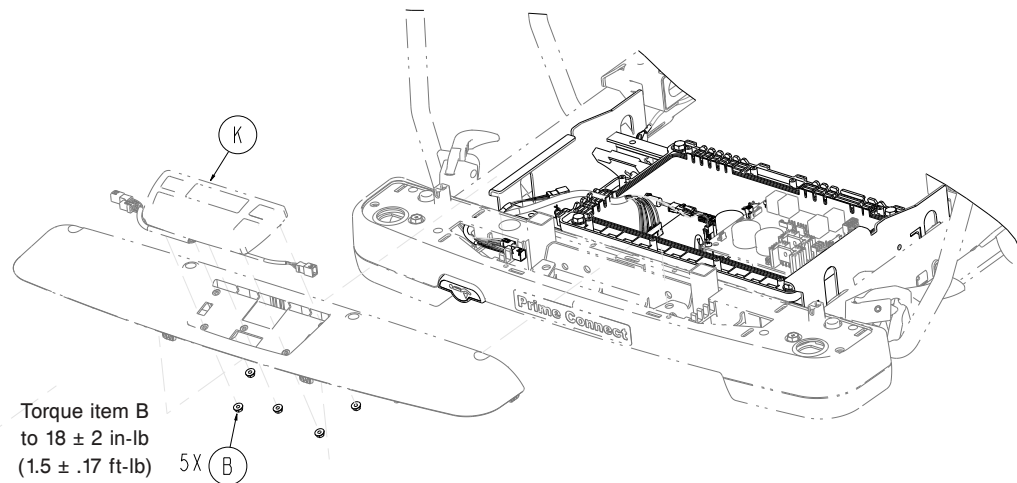

Figure 38 – Top cover assembly

- Using an 11/32" nut driver, install the five supplied hex flange nuts (0016-137-000) to secure the supplied keypad assembly (100800370800) to the top cover. Using a torque wrench, torque the hex flange nuts to 18 ± 2 in-lb ($1.5 \pm .17$ ft-lb).
- Plug the keypad assembly cable connectors into the cable connectors on the foot end and set the top cover assembly on the foot end. Insert all cable connections into the mid cover cable connector locks.

Note - Plug the gray electric litter operator control panel cable connector into the gray cable connector on the stretcher foot end.

12. Reattach the top cover assembly (removed in step 8). Align the top cover assembly with the mid cover and push down on the top cover assembly to snap into place.

Note

- Do not pinch any cables when you reattach the top cover assembly.
- Make sure there are no gaps between the top cover assembly and the mid cover after you reattach the top cover assembly.

13. Plug the power cord into a wall outlet.

14. Turn on the battery switch.

Note - For Model 1125, turn on the **Zoom** battery disconnect switch.

15. Make sure that the screen menus work on the operator keypad.

16. Install the two supplied panel fasteners (0029-027-000) (AT) to secure the top cover assembly to the mid cover (Figure 37).

17. Verify proper operation before you return the product to service.

IR/nurse call assembly replacement, Prime Connect

Tools required:

- Wire cutters
- Pick
- Ratchet
- 1/2" socket
- Torque wrench (in-lb)

Procedure:

1. Apply the brake. Push on the product to make sure that the brakes work.
2. Raise the product to the highest height position.
3. Raise the Fowler backrest to the full upright position.
4. Unplug the power cord from the wall outlet.
5. Turn off the battery switch.

Note - For Model 1125, turn off the **Zoom** battery disconnect switch.

6. For products with a monitor tray, lift up on the monitor tray to remove. Save the monitor tray.
7. Using wire cutters, cut the two cable ties (B) that secure the IR/nurse call assembly cable to the head end lift header to access the cable connector (Figure 39). Discard the cable ties.

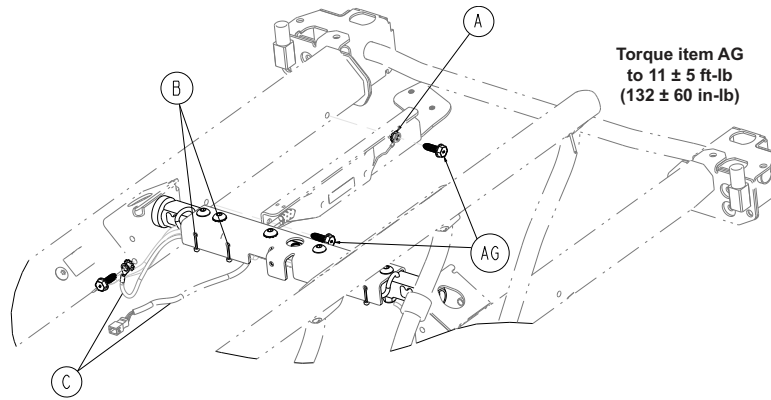

Figure 39 – IR/nurse call assembly

8. Using wire cutters, cut the cable tie (AB) that secures the IR/nurse call assembly cable to the head end lift header ground wire on the patient right side (Figure 40). Discard the cable tie.

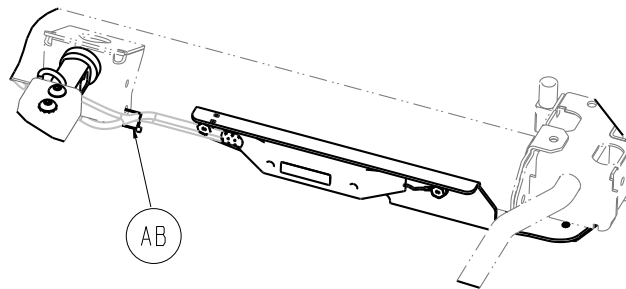

Figure 40 – Cable tie location - IR/nurse call assembly

9. Using a pick, disconnect the two cable connectors.
10. Using a ratchet and 1/2" socket, remove the two hex washer head thread rolling screws (AG) and the external tooth lock washer (A) to remove the IR/nurse call assembly (Figure 39). Save the hex washer head thread rolling screws and external tooth lock washer. Discard the IR/nurse call assembly.
11. Install the supplied IR/nurse call assembly:
 - a. At the head end of the IR/nurse call assembly, insert one of the hex washer head thread rolling screws (AG) (removed in step 10) through the ground wire eye (B), then through an external tooth lock washer (A) (Figure 41).

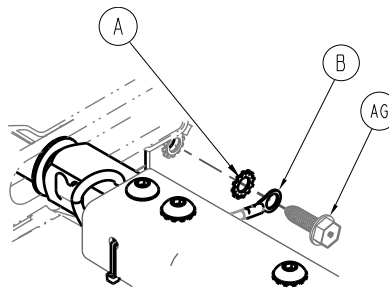

Figure 41 – Head end hex washer head thread rolling screw

- b. Using a ratchet and 1/2" socket, install the hex washer head thread rolling screw, ground wire eye, and external tooth lock washer to secure the head end of the IR/nurse call assembly.
- c. At the foot end of the IR/nurse call assembly, pull the two cables (C) down and hold the cables out of the way while you secure the foot end of the IR/nurse call assembly (Figure 39).

Note - Do not pinch or damage the two cables (C) when you secure the IR/nurse call assembly.

- d. Using a ratchet and 1/2" socket, install the remaining hex washer head thread rolling screw (AG) (removed in step 10) to secure the foot end of the IR/nurse call assembly.
 - e. Using a torque wrench, torque the hex washer head thread rolling screws to 132 ± 60 in-lb (11 ± 5 ft-lb).
12. Reconnect the cable connectors (disconnected in step 9).
 13. Using a supplied 8" cable tie (3000-300-113) (AB), secure the IR/nurse call assembly cable to the litter frame (Figure 40).
 14. Tuck the IR/nurse call assembly cable into the head end lift header.
 15. Using two supplied 8" cable ties (3000-300-113) (B), secure the IR/nurse call assembly cable to the head end lift header on the patient right side (Figure 39). Using wire cutters, cut the excess cable ties.
 16. Verify proper operation before you return the product to service.

1/4" jack cable assembly replacement, Prime Connect

Tools required:

- Wire cutters
- Pick
- T40 Torx driver
- Torque wrench (in-lb)
- Digital multimeter

Procedure:

1. Apply the brake. Push on the product to make sure that the brakes work.
2. Raise the product to the highest height position.
3. Raise the Fowler backrest to the full upright position.
4. Unplug the power cord from the wall outlet.
5. Turn off the battery switch.

Note - For Model 1125, turn off the **Zoom** battery disconnect switch.

6. Using wire cutters, cut the four cable ties (AB) that secure the 1/4" jack cable assembly and the IR/nurse call assembly cable to the head end lift header to access the cable connector (Figure 42). Discard the cable ties.

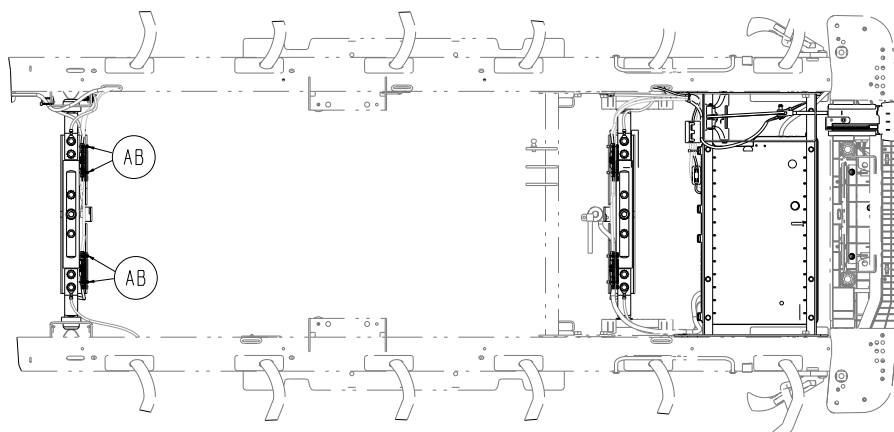

Figure 42 – Head end lift header - cable tie locations

7. Using wire cutters, cut the two fir tree mounts (AF) that secure the 1/4" jack cable assembly on the patient left side of the siderail tube (Figure 43). Discard the fir tree mounts.

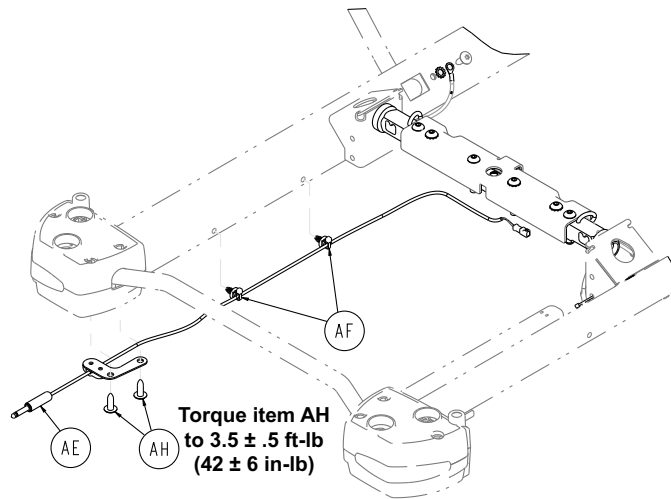

Figure 43 – 1/4" jack cable assembly

8. Using a pick, disconnect the 1/4" jack cable assembly from the IR/nurse call assembly cable.
9. Using a T40 Torx driver, remove the two truss head machine screws (AH) that secure the 1/4" jack cable assembly (AE) to the bottom of the patient left head end bumper (Figure 43). Save the truss head machine screws.

Note - Using a torque wrench, torque the truss head machine screws to 42 ± 6 in-lb ($3.5 \pm .5$ ft-lb) when you reinstall.
10. Reverse steps to install the supplied 1/4" jack cable assembly.
11. Using a digital multimeter, make sure that there is a continuity state change:
 - a. Test the tip and the base of the 1/4" jack cable assembly and record if there is continuity.
 - b. Arm bed exit.
 - c. Trigger the bed exit alarm.
 - d. Make sure that there is a continuity state change and bed exit produces visual and audible alarms.
12. Verify proper operation before you return the product to service.

Display to nurse call cable assembly replacement, Prime Connect

Tools required:

- Bungee cord
- #2 Phillips screwdriver
- Pick
- Wire cutters
- Wire fish (Klein Tools 50550)
- 1/2" pulling grip (Southwire 58281040)
- Torque screwdriver, 11-29 in-lb (Wera 7446 or equivalent)
- #2 Phillips bit

Procedure:

1. Apply the brake. Push on the product to make sure that the brakes work.
2. Raise the product to the highest height position.
3. Raise the Fowler backrest to the full upright position.
4. Using a bungee cord, secure the foot section in the full upright position.

5. Unplug the power cord from the wall outlet.
6. Turn off the battery switch.

Note - For Model 1125, turn off the **Zoom** battery disconnect switch.

7. Using a #2 Phillips screwdriver, remove the ten screws (F) that secure the litter control box cover to the litter control box assembly (Figure 44). Remove the litter control box cover and set aside. Save the screws and litter control box cover.

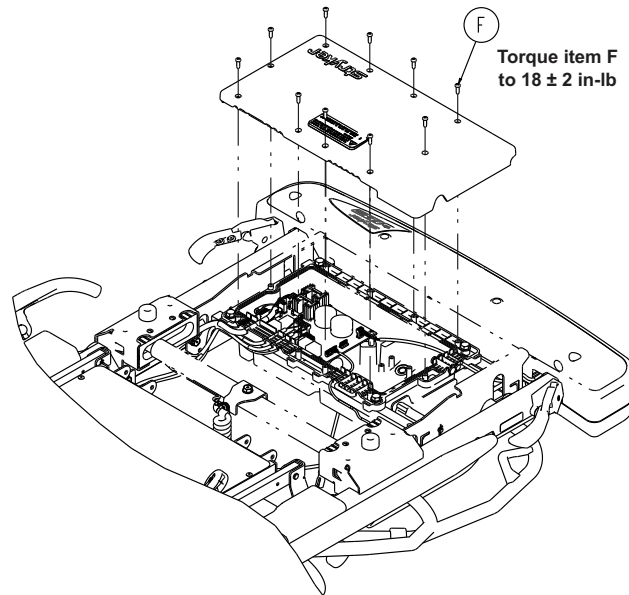

Figure 44 – Litter control box

8. Using a pick, unplug the display to nurse call extension cable assembly (AD) from the bed exit to display cable assembly (Figure 45).

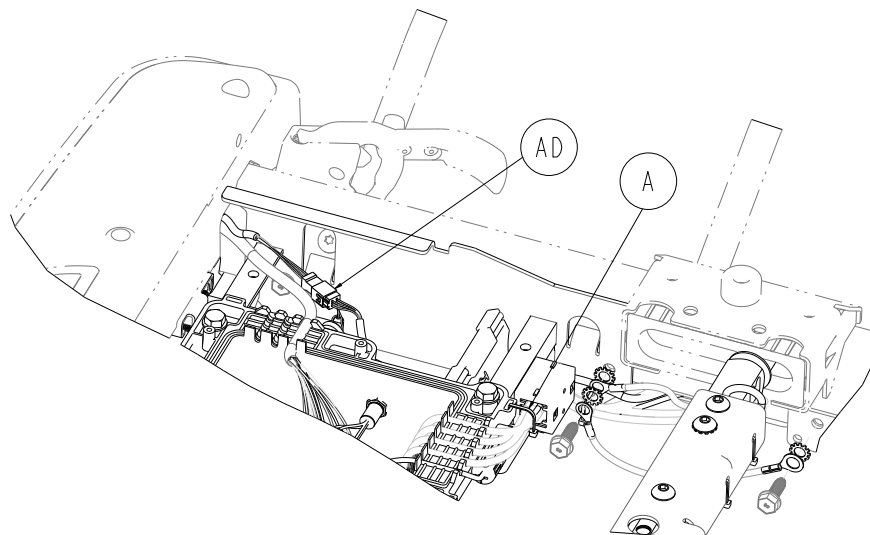

Figure 45 – Display to nurse call extension cable assembly

9. Using wire cutters, cut the cable tie (A) that secures the display to nurse call extension cable assembly to the litter control box cable tie location. Discard the cable tie.
10. Support the bottom of the uni-lower pedals to avoid lowering the litter when you remove the siderail grommets.
11. Using a pick, remove the three siderail grommets (K) from the patient right siderail tube (Figure 46). Save and hang the siderail grommets on the cables.

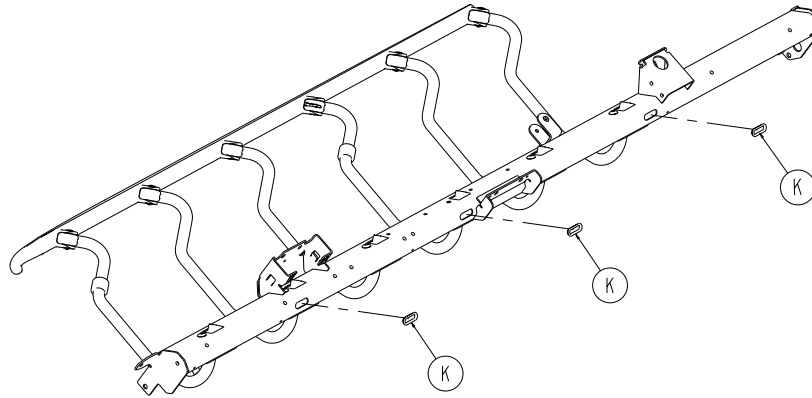

Figure 46 – Siderail grommets

12. Lift up on the monitor tray to remove. Save the monitor tray.
 13. Pull the display to nurse call extension cable assembly from the head end to access the head end cable connector.
 14. Using a pick, unplug the head end cable connector.
 15. Pull the display to nurse call extension cable assembly out from the head end. Discard the display to nurse call extension cable assembly.
 16. Using a wire fish, place the wire fish end behind the existing siderail cables in the foot end of the patient right siderail tube. Route the wire fish through the siderail tube toward the head end of the siderail tube.
 17. Using a pick, pull out the wire fish end from the head end of the patient right siderail tube.
 18. Attach a 1/2" pulling grip to the wire fish end.
 19. Attach the end of the supplied display to nurse call extension cable assembly (100800380871) to the end of the 1/2" pulling grip.
 20. Pull the wire fish and the display to nurse call extension cable assembly out from the foot end of the patient right siderail tube.
- Note** - Route both ends of the display to nurse call extension cable assembly through the siderail grommets before you plug in the display to nurse call extension cable assembly.
21. Remove the 1/2" pulling grip from the display to nurse call extension cable assembly.
 22. Plug the display to nurse call extension cable assembly into the IR/nurse call assembly.
- Note** - Gather the display to nurse call extension cable assembly slack at the foot end and push the slack into the siderail tube.
23. Using a supplied 8" cable tie (3000-300-113) (AB), secure the IR/nurse call assembly cable to the litter frame (Figure 47).

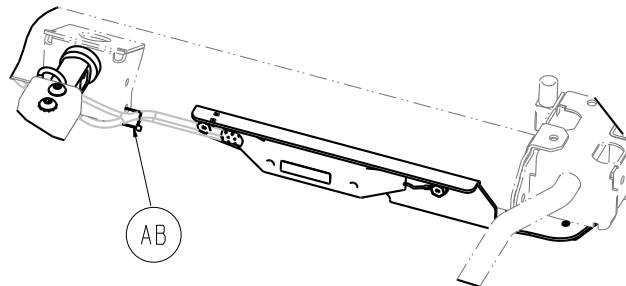

Figure 47 – Cable tie location - IR/nurse call assembly

24. Route the display to nurse call extension cable assembly (AD) and the load cell cables toward the bed exit to display cable assembly on the foot end (Figure 45). Plug the display to nurse call extension cable assembly into the bed exit to display cable assembly.

25. Reattach the monitor tray (removed in step 12).
26. Push the siderail grommets (removed in step 11) into the patient right siderail tube to protect the cables.
Note - Do not break the siderail grommets or damage the cables.
27. Using a supplied 8" cable tie (3000-300-113) (A), secure the display to nurse call extension cable assembly to the litter control box cable tie location (Figure 45). Using wire cutters, cut and discard the excess cable tie.
Note - The load cell cables are also secured to the litter control box cable tie location. Make sure that the cables do not rub on the Gatch release linkage.
28. Connect the wireless module cable and the keypad assembly cable.
29. Using an 11-29 in-lb torque screwdriver with a #2 Phillips bit, reinstall the ten screws (removed in step 7) to secure the litter control box cover to the litter control box assembly. Torque the screws to 18 ± 2 in-lb.
30. Plug the power cord into a wall outlet.
31. Turn on the battery switch.
Note - For Model 1125, turn on the **Zoom** battery disconnect switch.
32. Make sure that the screen menus work on the operator keypad.
33. Lower the Fowler backrest and foot section.
34. Verify proper operation before you return the product to service.

Wireless module replacement, Prime Connect

Tools required:

- Plastic fastener removal tool
- Slotted screwdriver
- 90-degree pick
- T25 Torx driver
- Ratchet
- 1/2" socket
- Torque wrench (in-lb)
- 3/8" combination wrench
- **iBed** wireless configuration tool (5212-503-001)

Procedure:

1. Apply the brake. Push on the product to make sure that the brakes work.
2. Raise the product to the highest height position.
3. Raise the Fowler backrest and foot section to the full upright position.
4. Unplug the power cord from the wall outlet.
5. Turn off the battery switch.

Note - For Model 1125, turn off the **Zoom** battery disconnect switch.

6. Using a plastic fastener removal tool, remove the two panel fasteners (AT) that secure the foot end top cover to the foot end mid cover (Figure 48). Discard the panel fasteners.

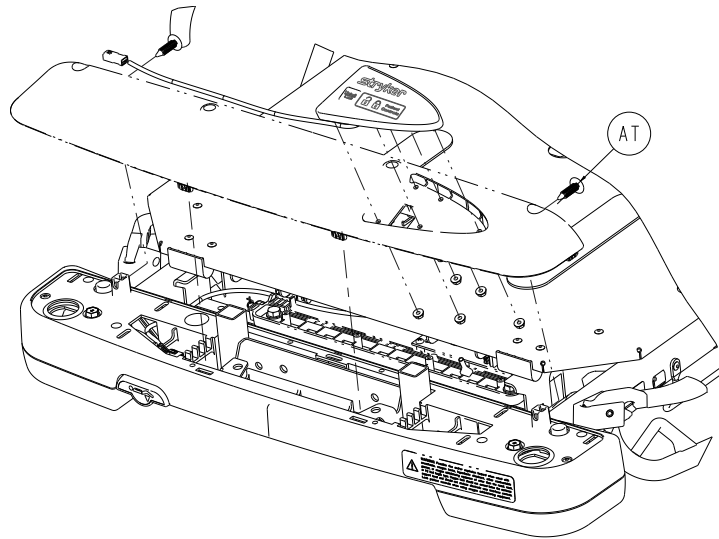

Figure 48 – Panel fasteners

- Using a slotted screwdriver and your hand, pry up and lift along the edge of the top cover assembly to detach the top cover assembly from the mid cover.

Note - Be careful when you use the slotted screwdriver to not cause damage to the top or mid cover assemblies.

- Using a 90-degree pick, unplug the wireless module cable connection from the keypad assembly.

Note - For products with a foot end IV pole option, rotate the top cover assembly to access the cable connection.

- Using a T25 Torx driver, remove the six screws (E) that secure the foot end bottom covers (P and R) to the mid cover (T) (Figure 49). Save the foot end bottom covers and screws.

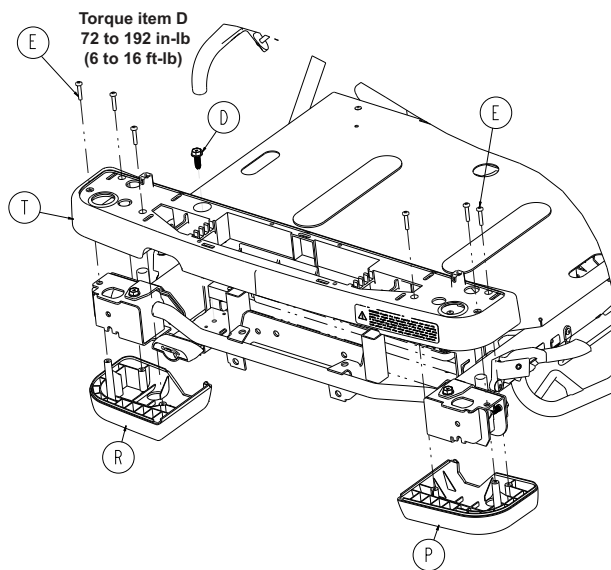

Figure 49 – Foot end covers

- Using a ratchet and 1/2" socket, remove the screw (D) that secures the Gatch release handle. Save the screw.

Note - Using a torque wrench, torque the screw to 72 to 192 in-lb (6 to 16 ft-lb) when you reinstall.

- Lift up on the mid cover (T) to remove the mid cover from the litter frame. Save the mid cover.

- For products with a pump bar option, use a ratchet and a 1/2" socket to remove the four screws (A) that secure the pump bar (B) to the litter frame (Figure 50). Save the screws and pump bar.

Note - Using a torque wrench, torque the screws to 60 to 156 in-lb (5 to 13 ft-lb) when you reinstall.

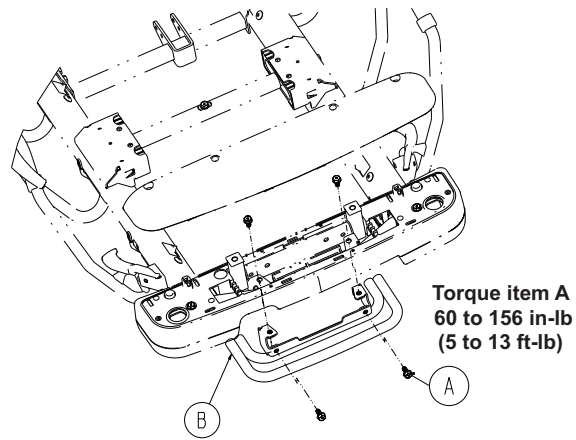

Figure 50 – Pump bar option

13. Using a 3/8" combination wrench, remove the two hex washer head machine screws (B) that secure the wireless module (A) to the litter frame (Figure 51). Discard the hex washer head machine screws.

Note

- Using a torque wrench, torque the supplied hex washer head machine screws to 36 ± 6 in-lb ($3 \pm .5$ ft-lb) when you install the supplied wireless module.
- Tuck the wireless module cable against the wireless module boss when you install the supplied wireless module. Route the cable to point up on the patient left side (Figure 52).

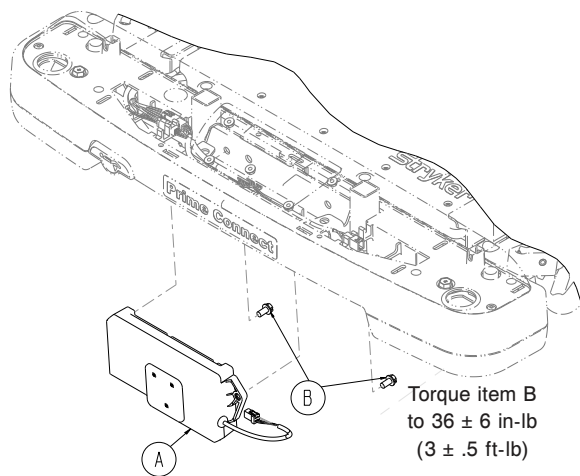

Figure 51 – Wireless module

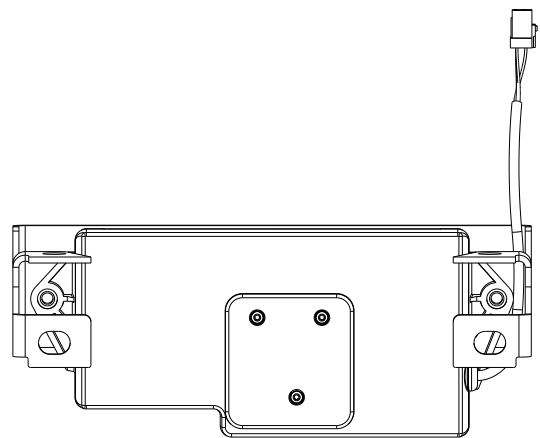

Figure 52 – Wireless module cable

14. Remove and discard the wireless module.

15. Reverse steps to install the supplied wireless module.

16. Using the iBed wireless configuration tool (5212-503-001), connect the supplied wireless module to the hospital's wireless network.

- After you connect the supplied wireless module to the hospital's wireless network, record the supplied wireless module's serial number, MAC address, and the hospital's IP address.
- Provide the recorded information to the wireless implementation team or appropriate IT personnel.

17. Record the old wireless module's serial number and MAC address. Provide the recorded information to the wireless implementation team or appropriate IT personnel.

18. Verify proper operation before you return the product to service.

Load cell replacement, scale system, non-electric litter

Tools required:

- 9/16" socket
- 7/32" hex wrench
- Wire cutters
- 3/8" drive torque wrench (ft-lb)
- ESD protection

Procedure:

Note - Use ESD protection when necessary. See *Protecting against electrostatic discharge (ESD)* (page 32).

1. Raise the product to the highest height position.
2. Raise the Fowler backrest to the full upright position.
3. Using wire cutters, cut the cable ties (A) that secure the cable to the lifthead bracket (Figure 53).

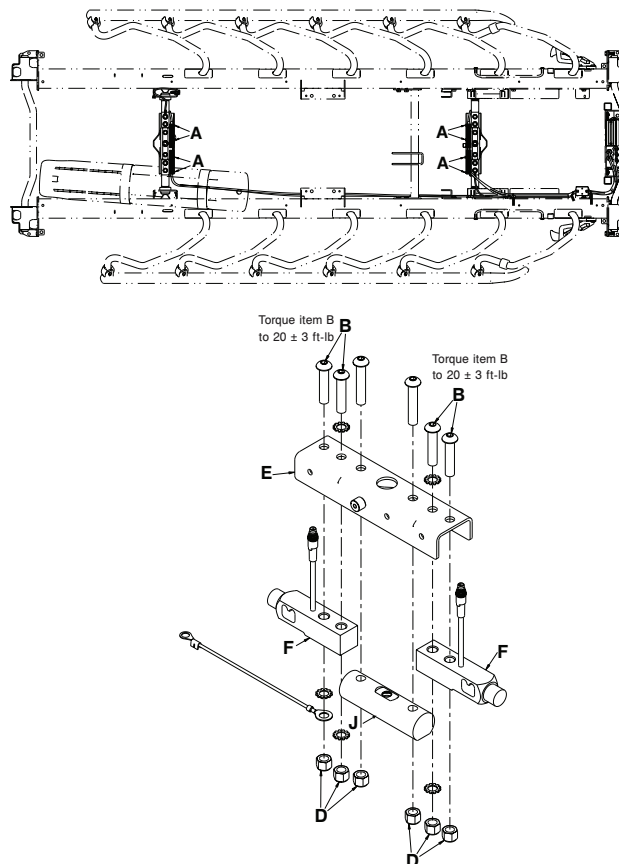

Figure 53 – Load cell replacement

4. Disconnect the cable to the defective load cell.
5. Support the end of the product so the cover does not fall when you remove the load cell.
6. Using a 7/32" hex wrench and a 9/16" socket, remove the two Nylock hex nuts (D) and button head cap screws (B) that secure the load cell (F) to the lifthead bracket (E).

Note - Using a 3/8" drive torque wrench, torque the button head caps screws to 20 ± 3 ft-lb when you reinstall.

7. If you cannot remove the load cell (F), remove the bolt from the jack cross-support tube (J) and lift the cross-support off the jack. The load cell should be easy to remove.

8. Remove the bushing from the load cell.
9. Reverse steps to install the supplied load cell.
Note - Do not compress the cable when you install the cable ties.
10. Make sure that the load cell functions.
11. Recalibrate the scale system.
12. Verify proper operation before you return the product to service.

Scale battery replacement, non-electric litter

Tools required:

- #2 Phillips screwdriver

Procedure:

Note - **Lo batt** flashes on the screen when the batteries are drained and the scale system is disabled. Replace the batteries with four new AA batteries.

1. Using a #2 Phillips screwdriver and working below the foot end of the litter, remove the two Phillips screws that secure the battery compartment cover to the display assembly. Remove and save the cover. Save the screws.
2. Replace all four AA batteries.
 - a. Install the positive and negative poles as indicated on the battery holder.
 - b. Only use alkaline type (LR6) batteries.
 - c. Do not mix old and new batteries.
 - d. Dispose of old batteries as required by local regulations.
3. Using a #2 Phillips screwdriver, replace the screws (removed in step 1) to secure the cover.
4. Verify proper operation before you return the product to service.

Scale battery replacement, electric litter

Tools required:

- #2 Phillips screwdriver
- 3/8" drive torque wrench (in-lb)
- ESD protection

Procedure:

Note - Use ESD protection when necessary. See *Protecting against electrostatic discharge (ESD)* (page 32).

1. Raise the product to the highest height position.
2. Apply the brake. Push on the product to make sure that the brakes work.
3. Unplug the power cord from the wall outlet.
4. Fold the foot section toward the head end of the stretcher.
5. Using a #2 Phillips screwdriver, remove the 10 pan head tapping screws (A) that secure the control board cover on the scale/**Chaperone** control box bottom (Figure 54).

Note - Using a 3/8" drive torque wrench, torque the pan head tapping screws to 18 ± 2 in-lb when you reinstall.

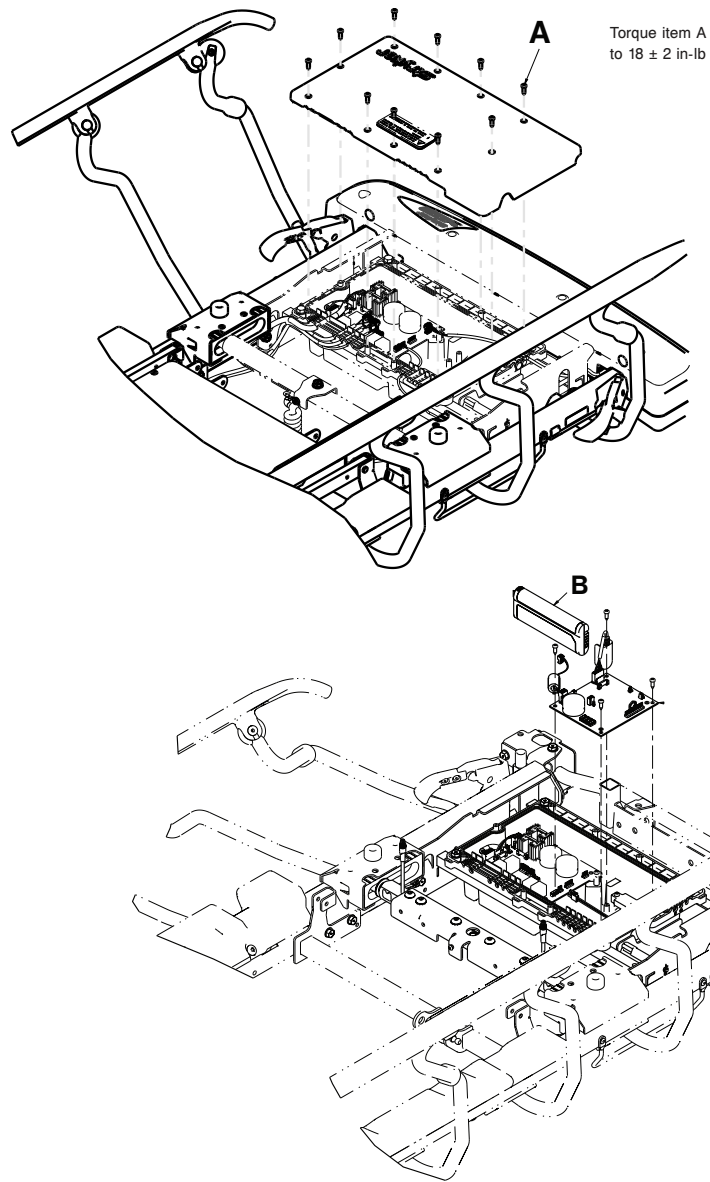

Figure 54 – Scale battery replacement - electric

6. Unplug the battery (B).
7. Remove the battery. Discard as required by local regulations.
8. Reverse steps to install the supplied battery.
9. Verify proper operation before you return the product to service.

X-ray cassette panel replacement, head end, Prime X

Tools required:

- None

Procedure:

1. Raise the product to the highest height position.
2. Raise the Fowler backrest to the full upright position.
3. Raise the siderails to the highest height position.

- Unclip the four spring clips (A) (below the litter frame) that secure the head end X-ray cassette panel to the litter frame (Figure 55).

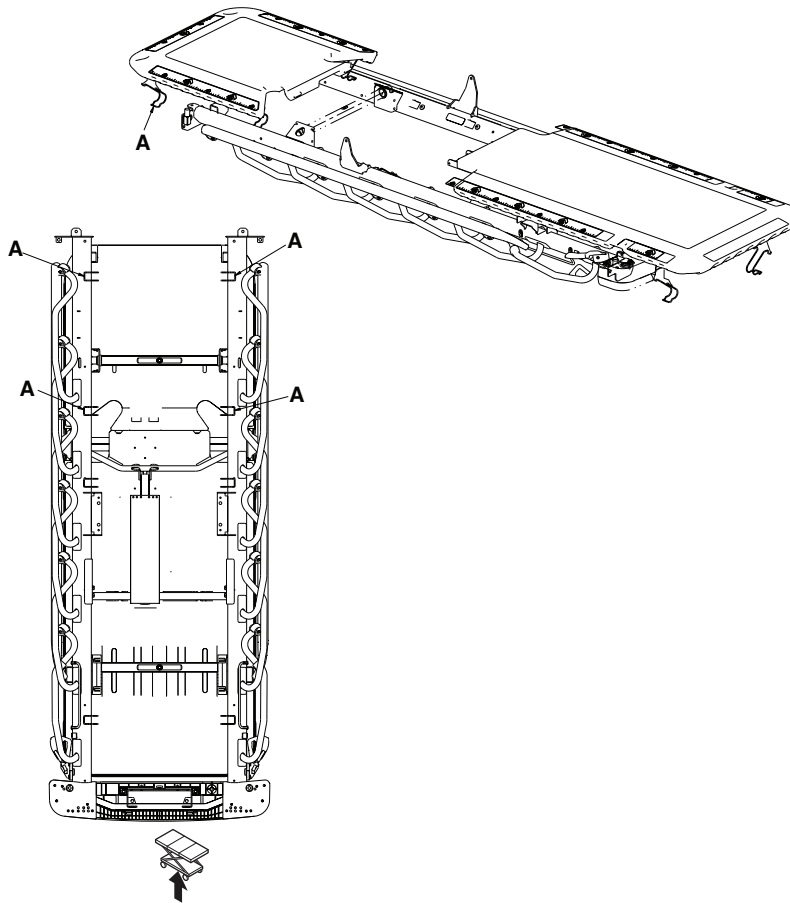

Figure 55 – X-ray panel replacement

- Remove the head end X-ray cassette panel.
Note - The head end and foot end panels are interlocked.
- Reverse steps to install the supplied X-ray cassette panel.
- Verify proper operation before you return the product to service.

X-ray cassette panel replacement, foot end, Prime X

Tools required:

- None

Procedure:

- Raise the product to the highest height position.
- Lower the Fowler backrest to the lowest height position.
- Fold the foot section toward the head end of the product until the foot section rests on the Fowler backrest.
- Raise the siderails to the highest height position.
- Unclip the four spring clips (A) (below the litter frame) that secure the foot end X-ray cassette panel to the litter frame (Figure 56).

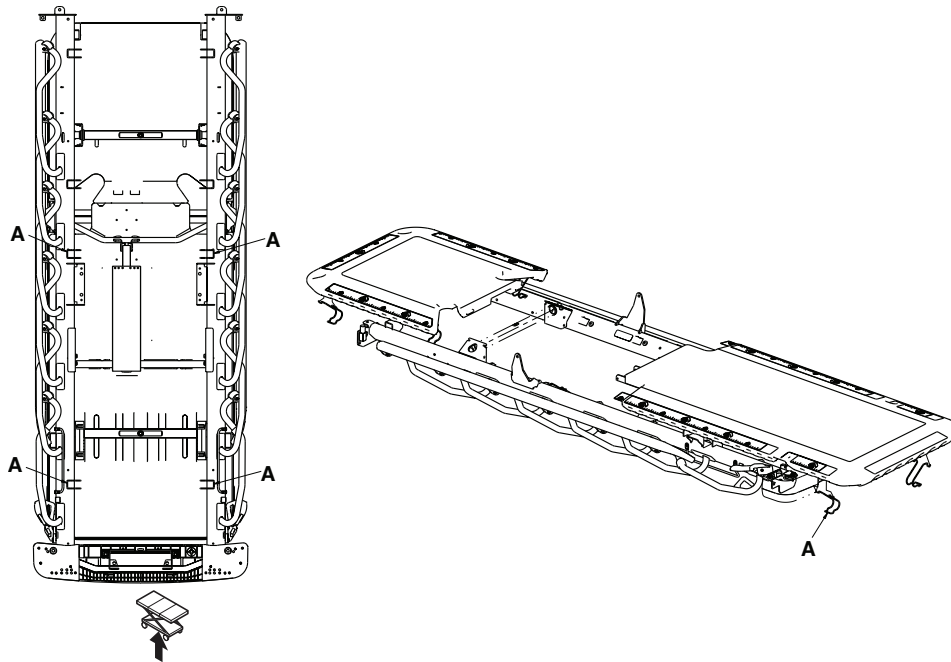

Figure 56 – X-ray panel replacement-foot end

6. Remove the foot end X-ray cassette panel.
- Note** - The head end and foot end panels are interlocked.
7. Reverse steps to install the supplied foot end X-ray cassette panel.
 8. Verify proper operation before you return the product to service.

Fowler skin replacement, Prime X

Tools required:

- #2 Phillips screwdriver
- Microfiber cleaning cloth (or equivalent)

Procedure:

1. Raise the product to the highest height position.
2. Raise the Fowler backrest to the full upright position.
3. Using a #2 Phillips screwdriver, unscrew the eight scrollok screws (A) that secure the Fowler backrest skin to the Fowler backrest frame (Figure 57).

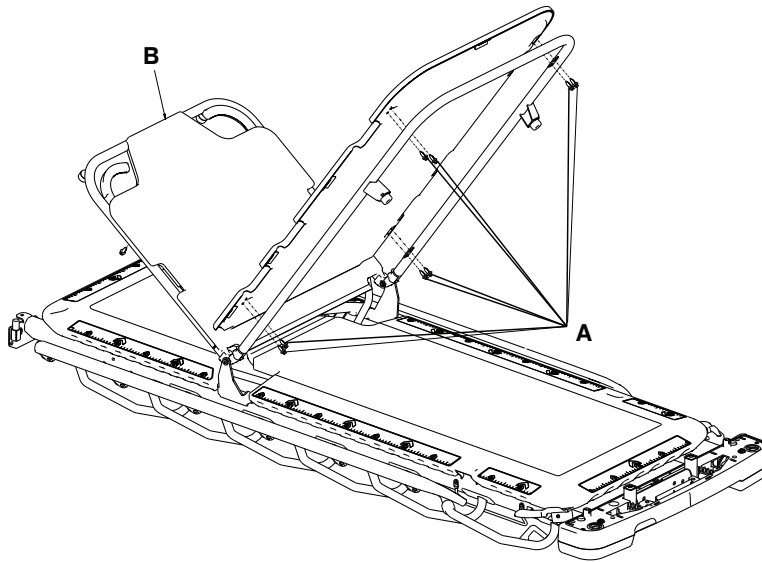

Figure 57 – Fowler skin replacement, Prime X option

4. Grasp the Fowler backrest skin (B) and pull away from the Fowler backrest frame.

Note - The eight scrulok screws will fall out when you remove the skin. Discard the screws if you replace the Fowler backrest skin.

5. Using a microfiber cleaning cloth with an isopropyl alcohol and water solution, clean the Fowler backrest frame. Install the pivot end first for accurate alignment.
6. Reverse steps to install the supplied Fowler skin.
7. Verify proper operation before you return the product to service.

Foot skin replacement, Prime X

Tools required:

- #2 Phillips screwdriver
- Microfiber cleaning cloth (or equivalent)

Procedure:

1. Raise the product to the highest height position.
2. Lower the Fowler backrest to the lowest position.
3. Fold the foot section toward the head end until the foot section rests on the Fowler backrest.
4. Using a #2 Phillips screwdriver, unscrew the eight scrulok screws (A) that secure the foot skin to the foot frame (Figure 58).

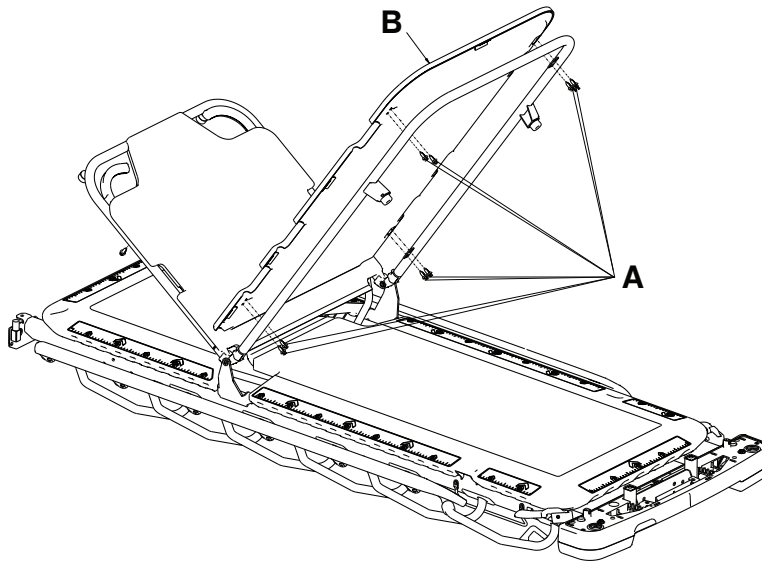

Figure 58 – Foot skin replacement, Prime X option

5. Using one hand, hold the foot section steady. Using your other hand, hit the bottom of the foot skin (B) near all four scrulok screw areas to loosen the scrulok screws.
6. Fold the foot section back toward the foot end until the foot section rests on the litter frame.
7. Grasp the foot skin and pull away from the frame.

Note - The eight scrulok screws will fall out when you remove the skin. Discard the screws if you replace the foot skin.

8. Using a microfiber cleaning cloth with an isopropyl alcohol and water solution, clean the foot end frame. Install the pivot end first for accurate alignment.
9. Reverse steps to install the supplied foot skin.
10. Verify proper operation before you return the product to service.

Fowler backrest gas cylinder replacement, Prime X

Tools required:

- Needle nose pliers
- 17 mm combination wrench
- Torque wrench (ft-lb)

Procedure:

1. Remove the mattress and set aside.
2. Raise the product to the highest height position.
3. Raise the Fowler backrest to 30 degrees.
4. Fold the foot section toward the head end until the foot section rests on the Fowler backrest.
5. Raise the siderails to the highest height position.
6. Unclip the four spring clips (A) (below the litter frame) that secure the foot skin to the foot frame (Figure 59).

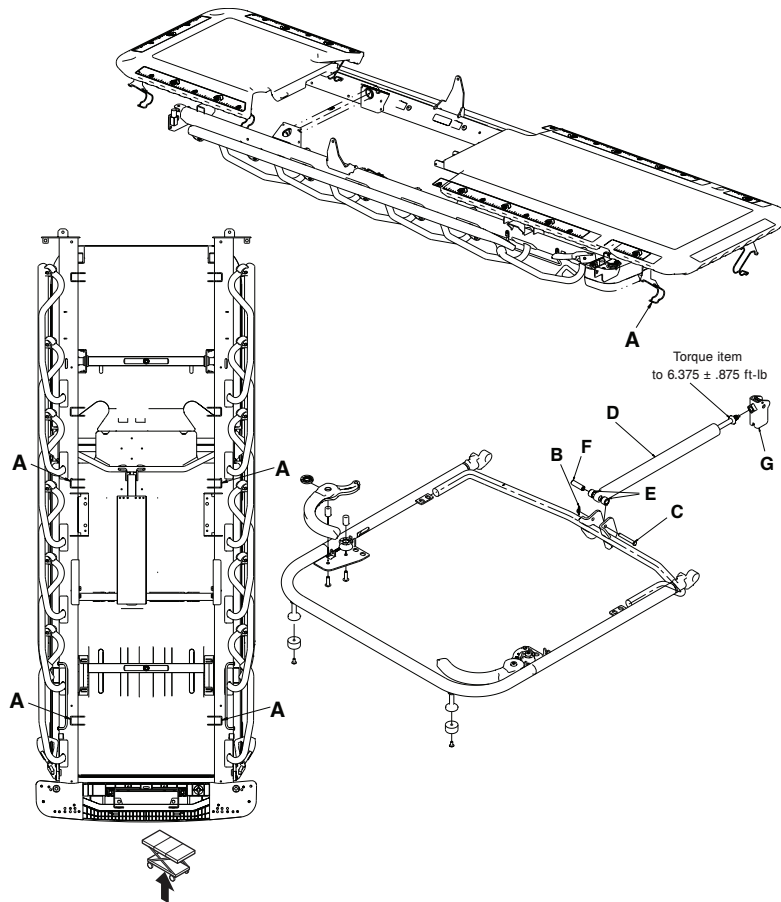

Figure 59 – Fowler gas cylinder replacement, Prime X option

7. Lower the siderails to the lowest height position.
 8. Using needle nose pliers, remove the rue ring cotter (B) and clevis pin (C) that secure the gas cylinder (D) to the Fowler backrest frame.
 9. Raise the end of the gas cylinder, and remove the spacers (E) and the sleeve (F).
 10. Using a 17 mm combination wrench, loosen the jam nut from the gas spring trip (G) and unthread the gas cylinder from the gas spring trip.
 11. Remove and discard the gas cylinder.
 12. Thread the supplied gas cylinder into the gas spring trip until the gas cylinder starts to release (extend). Turn the gas cylinder back one full turn (360 degrees).
- Note** - If the gas cylinder threads are not aligned with the gas spring trip threads, damage may occur to the gas cylinder or gas spring trip. Do not force threading together.
13. Using a 17 mm combination wrench, tighten the jam nut against the gas spring trip. Using a torque wrench, torque the jam nut to $6.375 \pm .875$ ft-lb.
- Note** - Make sure that the gas cylinder shaft does not turn when you tighten the jam nut. If the cylinder turns, repeat step 10 to readjust the gas cylinder.
14. Install the sleeve (F) and spacers (E) on the end of the gas cylinder and lower the gas cylinder into the Fowler backrest frame mounting bracket.
 15. Insert the clevis pin (C) through the Fowler backrest frame and the gas cylinder.
 16. Insert the rue ring cotter (B) through the clevis pin (C).
 17. Position the foot end X-ray cassette panel. See *X-ray cassette panel replacement, foot end, Prime X* (page 84).
 18. Interlock the foot end and head end panels.

19. Lock the four spring clips from the foot end X-ray cassette panel onto the litter frame.
20. Lower the foot section until the foot section rests on the litter frame.
21. Verify proper operation before you return the product to service.

Oxygen storage hood replacement, international - Model 1105 only

Tools required:

- 1/2" socket
- 5/8" socket
- 3/8" drive ratchet
- 3/8" drive torque wrench (ft-lb)
- #2 Phillips screwdriver
- Fine-thread 7/16"-20 bolt
- Bungee cords

Procedure:

1. Apply the brake. Push on the product to make sure that the brakes work.
2. Raise the product to the highest height position.
3. Raise the Fowler backrest to the full upright position.
4. For **Prime X**, raise the stationary foot section assembly and use bungee cords to secure the assembly in the upright position.
5. Raise the siderails to the highest height position.
6. For **Prime X**, proceed to step 8. Skip to step 12 if the product is not **Prime X**.
7. Unclip the four spring clips (A) (below the litter frame) that secure the head end X-ray cassette panel to the litter frame (Figure 60).

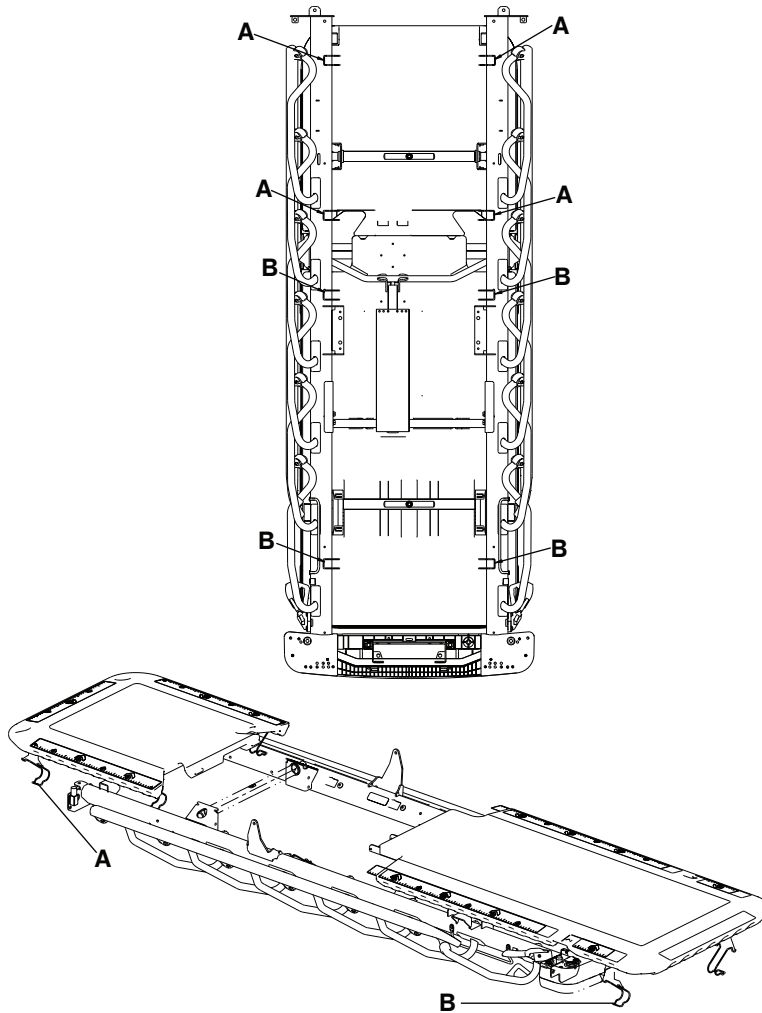

Figure 60 – Remove the head end and foot end X-ray cassette panels

8. Remove and save the head end X-ray cassette panel.
9. Unclip the four spring clips (B) (below the litter frame) that secure the foot end X-ray cassette panel to the litter frame.
10. Remove the foot end X-ray cassette panel.

Note - The head end panel and the foot end panel interlock into each other.

11. Using a 1/2" socket with a 3/8" drive ratchet, remove the hex washer head screws (C) that secure the jack support tubes to the jack shafts (Figure 61). Save the screws.

Note - Using a 3/8" drive torque wrench, torque the hex washer head screws to 11 ± 5 ft-lb when you reinstall.

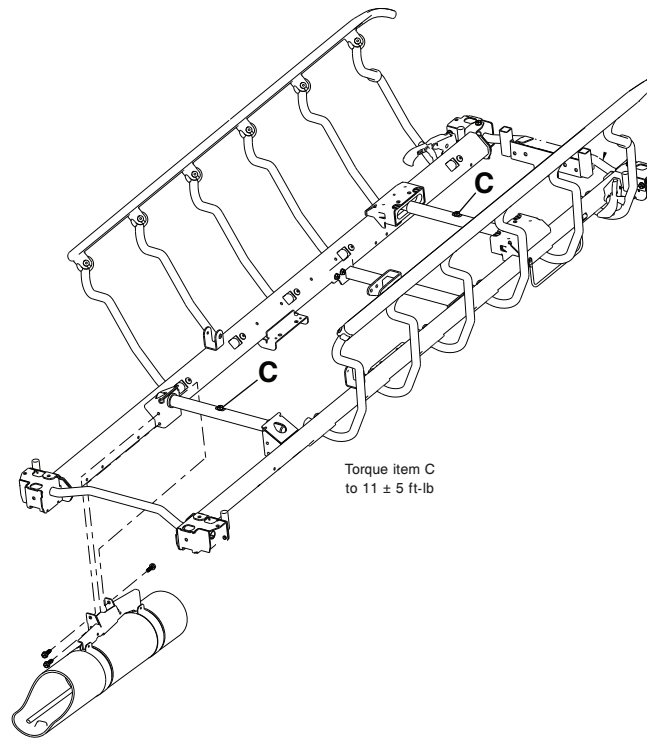

Figure 61 – Litter top removal

12. Using a 5/8" socket and a 3/8" drive ratchet, insert a fine-thread 7/16"-20 bolt into the top of the jack supports to separate the litter top from the jack shaft.

13. Lift the litter off of the jack shafts and set the litter aside.

Note - Get assistance from another person to remove the litter top.

14. Using a #2 Phillips screwdriver, remove the scrulok assemblies (E) that secure the hood to the hood retainer, if applicable (Figure 62). Save the scrulok assemblies.

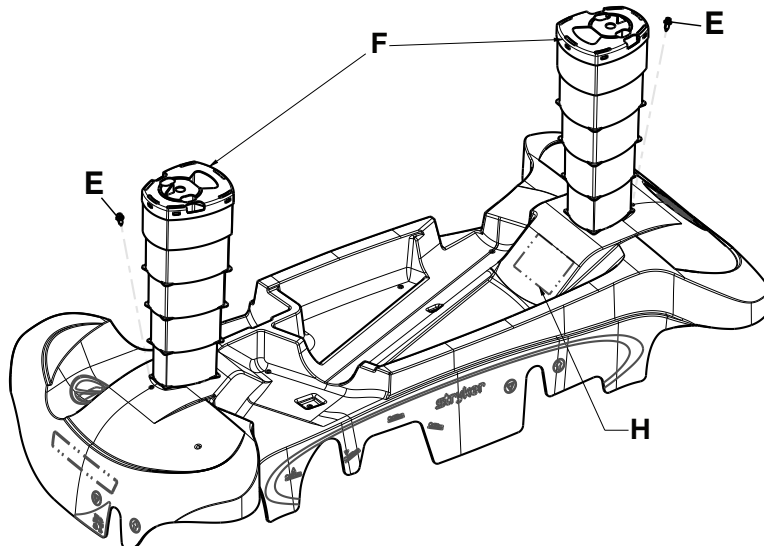

Figure 62 – Hood removal

15. Lift the base hood with the bellows (F) off of the base frame. Discard the hood. Save the bellows.

16. For **Prime X**, skip to step 18. Proceed to step 17 if the product is not **Prime X**.

17. Install a supplied trend limiter on the jack shaft at both ends of the product.

18. Remove the female side of the **Velcro®** dual lock (D) on the bottom side of the hood (Figure 63).



Figure 63 – Apply Velcro®

19. Install the supplied hood onto the base with the oxygen tank storage area toward the head end of the product.
20. Using a #2 Phillips screwdriver, install the scrulok assembly (E) (removed in step 14) that secures the hood to the hood retainer (Figure 62).
21. Affix the supplied label (H) to the base hood in the location specified.
22. Install the bellows (F) (removed in step 15) over the jack shaft on both ends of the product. Fit the bellows through the hole in the hood to secure the bellows to the base hood.
23. Reverse steps 1-13 to reinstall the litter top.
24. Verify proper operation before you return the product to service.

Siderail removal and replacement, Prime X

Tools required:

- 1/2" socket
- 3/8" socket
- 3/8" drive ratchet
- 3/8" drive extension
- 3/8" drive torque wrench (ft-lb)
- Bungee cords

Procedure:

1. Raise the Fowler backrest to the full upright position.
2. Remove the slider board from the storage tray.
3. Pull up on the monitor/utility tray to remove the monitor/utility tray from the litter frame. Save the monitor/utility tray.
4. To replace the right siderail, skip to step 6.
5. To replace the left siderail, using a 1/2" socket with a 3/8" drive extension and a 3/8" drive ratchet, remove the three hex washer head screws that secure the oxygen bottle holder bracket to the litter frame. Remove and save the oxygen bottle holder.

Note - Using a 3/8" drive torque wrench, torque the hex washer head screws to 13 ± 3 ft-lb when you reinstall.

6. Using a 1/2" socket with a 3/8" drive extension and a 3/8" drive ratchet, remove the four hex head cap screws that secure the slider board tray to the litter frame.

Note - Using a 3/8" drive torque wrench, torque the hex head cap screws to 11.5 ± 4.5 ft-lb when you reinstall.

7. Using a 3/8" socket with a 3/8" drive extension and a 3/8" drive ratchet, remove the Fowler backrest pivot bolt that secures the Fowler backrest weldment to the siderail weldment.
8. Using a 1/2" socket with a 3/8" drive extension and a 3/8" drive ratchet, remove the two bolts that secure the frame tie weldment to the litter frame.

Note - Using a 3/8" drive torque wrench, torque the bolts to 11 ± 5 ft-lb when you reinstall.

9. Using a 1/2" socket with a 3/8" drive extension and a 3/8" drive ratchet, remove the pan head tapping screws that secure the plastic litter corner covers to remove the covers.
10. Using a 1/2" socket with a 3/8" drive extension and a 3/8" drive ratchet, remove the two bolts that secure the Fowler backrest drop seat bracket.

Note - Using a 3/8" drive torque wrench, torque the bolts to 11 ± 5 ft-lb when you reinstall.

11. Using a 1/2" socket with a 3/8" drive extension and a 3/8" drive ratchet, remove the three bolts that secure the siderail to the foot end litter weldment.

Note - Using a 3/8" drive torque wrench, torque the bolts to 11 ± 5 ft-lb when you reinstall.

12. Remove and discard the siderail assembly.
13. Using bungee cords, support the remaining siderail.
14. Lift the supplied siderail into position.
15. Insert the foot end jack support into the hole in the support tube bracket on the siderail.
16. Insert the head end jack support tube into the slot in the trend slide block.
17. Reverse steps 1-11 to install the supplied siderail assembly.
18. Verify proper operation before you return the product to service.

Standard brake assembly

1105-003-205 Rev AB (Reference only)

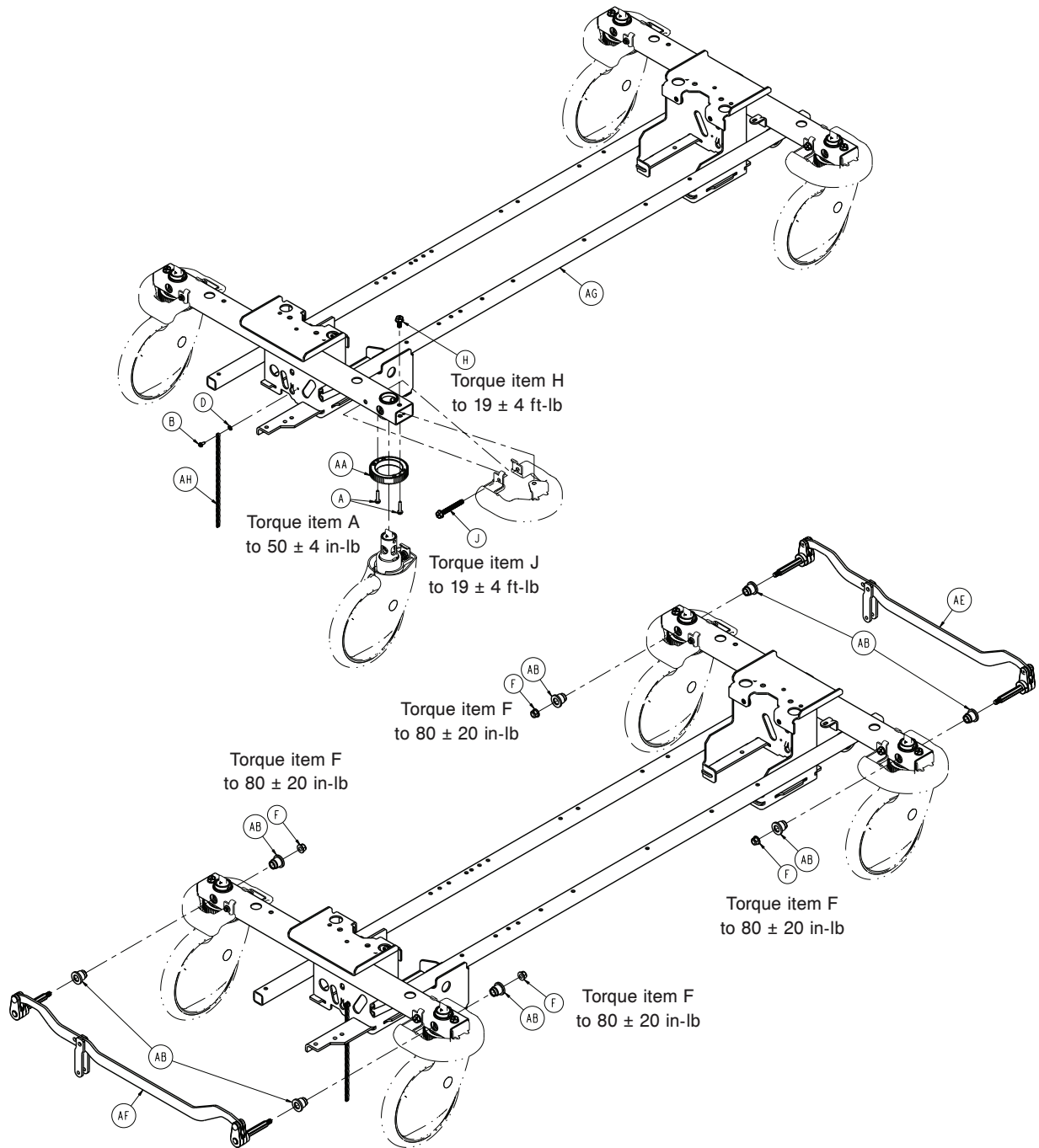

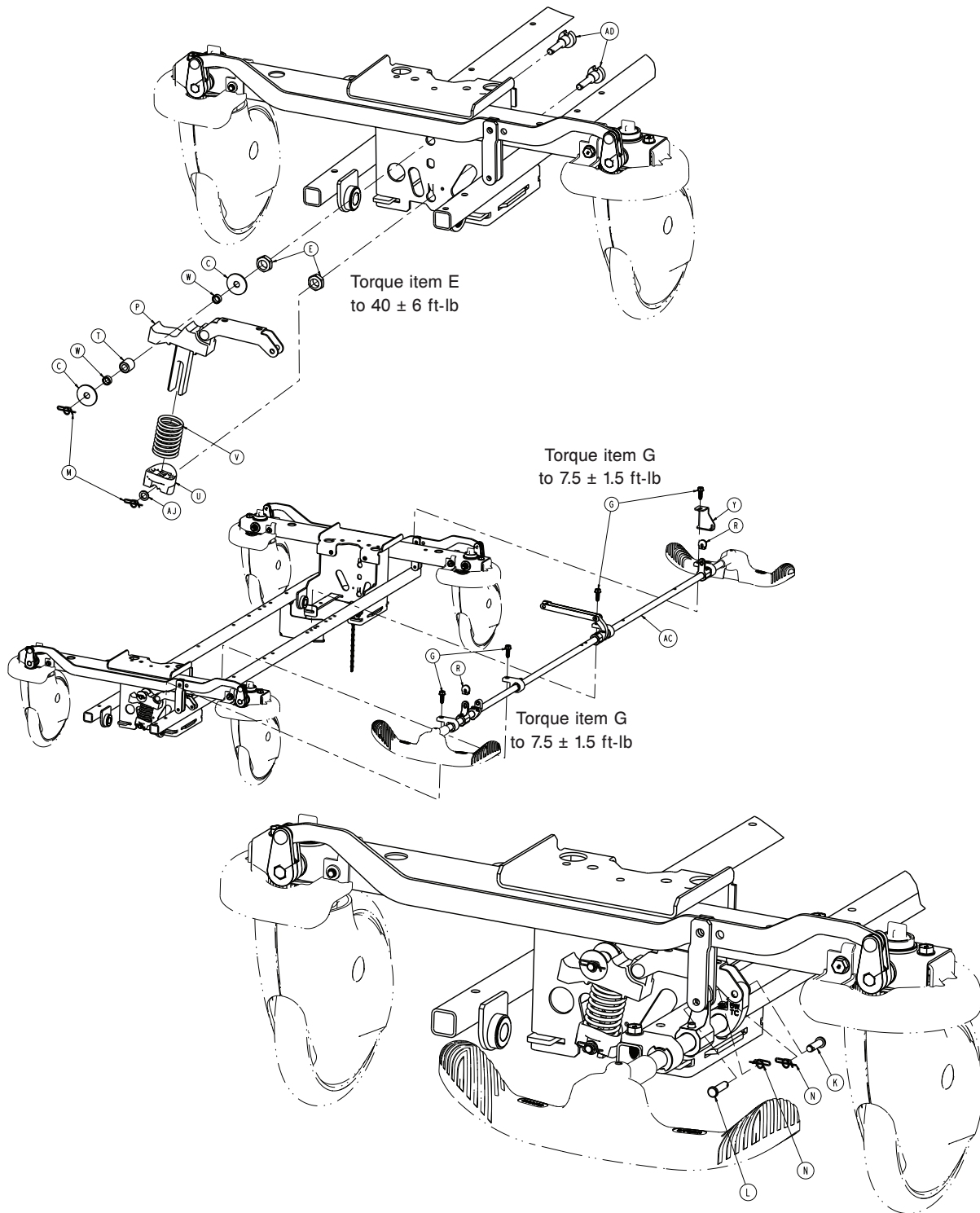

Item	Number	Name	Quantity
A	0003-147-000	Hex washer head screw	8
B	0023-071-000	Hex washer head unslotted tapping screw	1
C	0011-263-000	Washer	2
D	0013-018-000	External tooth lock washer	1
E	0016-049-000	Nylock hex nut	2

Item	Number	Name	Quantity
F	0016-135-000	Nylock flange hex nut	4
G	0023-288-000	Hex washer head screw	4
H	0023-330-000	Hex washer head screw	4
J	0023-331-000	Hex washer head screw	4
K	0026-295-000	Clevis pin	1
L	0026-393-000	Clevis pin	2
M	0027-019-000	Rue ring cotter	2
N	0027-020-000	Rue ring cotter	3
P	0853-003-035	Brake cam and link assembly	1
R	0853-003-064	Brake rod crank cap	2
T	0853-003-075	Timing cam bearing assembly	1
U	0853-003-103	Timing cam spring retainer	1
V	0853-003-104	Fifth wheel timing cam spring	1
W	0853-003-131	Timing cam spacer	2
Y	1105-005-087	Return spring hook	1
AA	0853-102-003	Caster steer lock gear	4
AB	0853-102-004	Stepped flange bearing	8
AC	0853-203-201	<i>Brake rod assembly (page 99)</i>	1
AD	0853-203-230	Bearing pivot support	2
AE	0853-303-010	Brake link assembly, head end	1
AF	0853-303-020	Brake link assembly, foot end	1
AG	0853-401-001	Base weldment	1
AH	3001-200-052	Grounding chain	1
AJ	0014-003-000	Washer	1

8" caster with full cover assembly - 0853-003-615

0853-503-020 Rev C (Reference only)

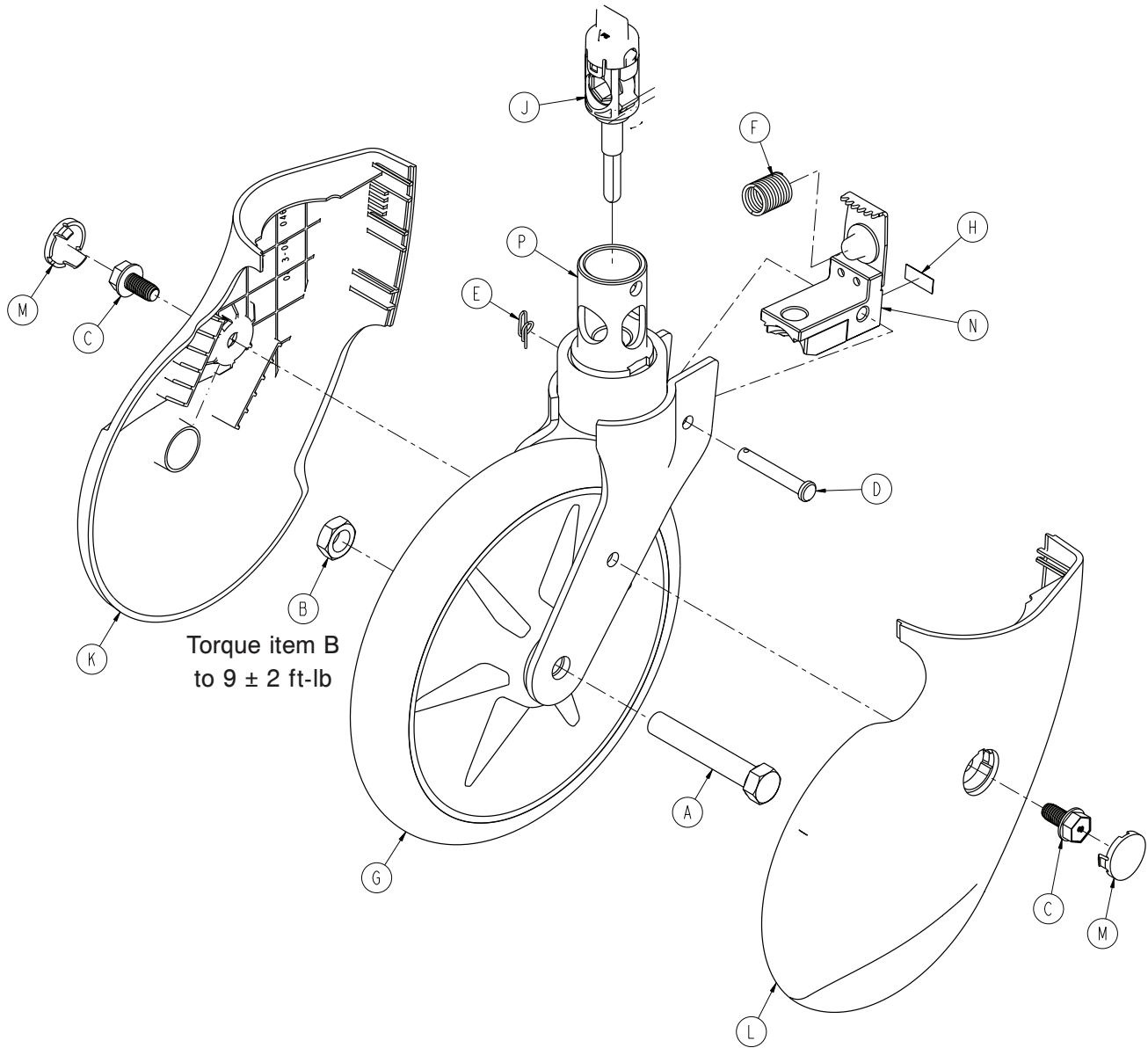

Item	Number	Name	Quantity
A	0003-099-000	Hex head cap screw	1
B	0016-060-000	Toplock hex jam nut	1
C	0023-330-000	Hex washer head screw	2
D	0026-377-000	Clevis pin	1
E	0027-020-000	Rue ring cotter	1
F	0038-596-000	Compression wire	1
G	0753-103-215	Molded wheel assembly	1
H	0853-003-032	Label, caster brake pad	1
J	0853-003-040	Cam housing assembly	1

Item	Number	Name	Quantity
K	0853-003-046	Caster cover, right	1
L	0853-003-047	Caster cover, left	1
M	0853-003-048	Caster cover plug	2
N	0853-203-030	Brake pad assembly	1
P	0853-303-021	Caster horn with bearing assembly	1

Brake rod assembly

0853-203-201 Rev AA (Reference only)

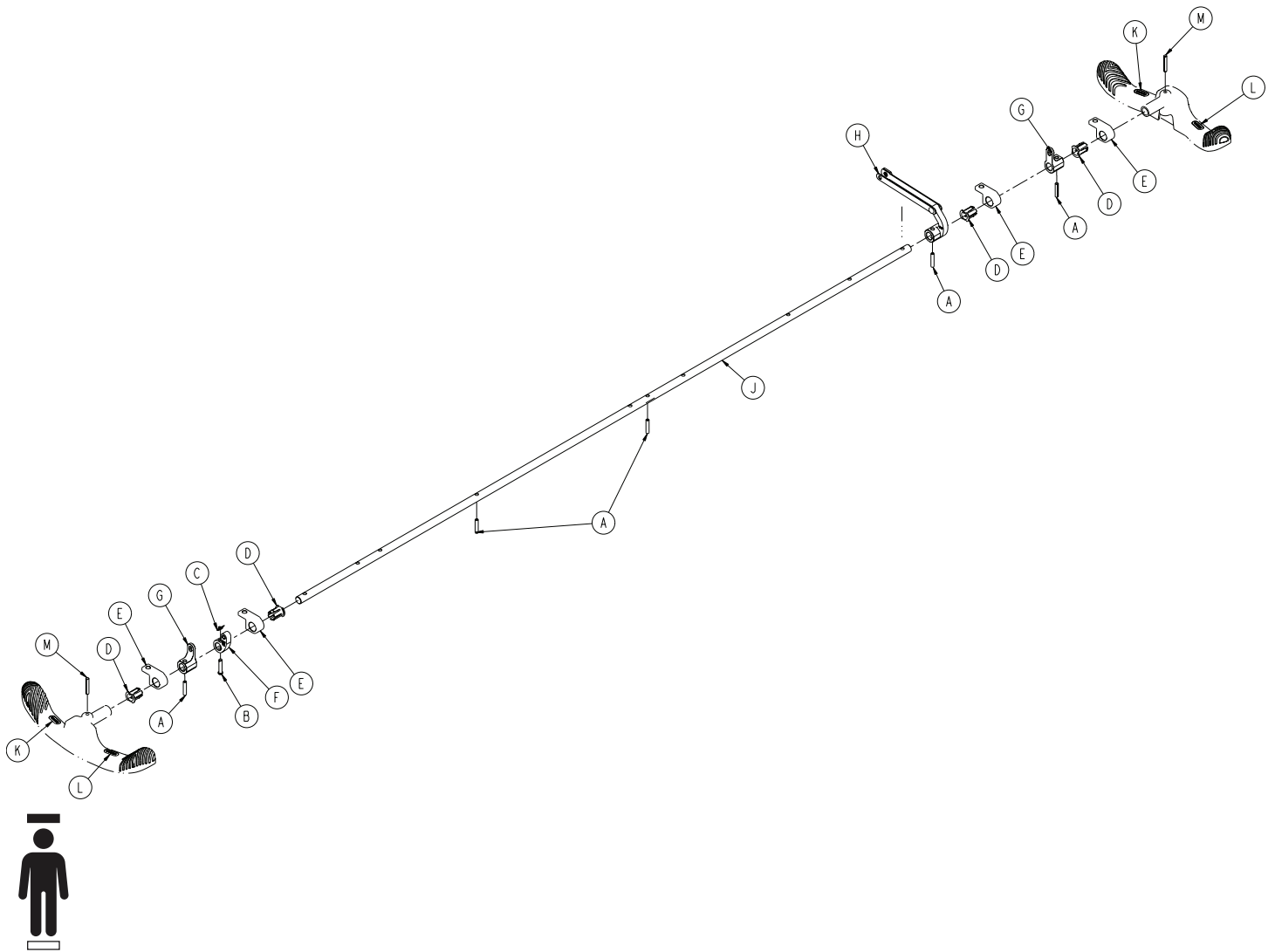

Item	Number	Name	Quantity
A	0026-014-000	Slotted spring pin	5
B	0026-251-000	Clevis pin	1
C	0027-020-000	Rue ring cotter	1
D	0753-003-015	Brake rod nyliner	4
E	0853-003-004	Brake rod support	4
F	0853-003-055	Fifth wheel timing cam crank assembly	1
G	0853-203-011	Brake activation crank	2
H	0853-206-135	Fifth wheel drive link assembly	1
J	0853-303-014	Brake rod	1
K	1105-001-335	Label, brake	2

Item	Number	Name	Quantity
L	1105-001-336	Label, steer	2
M	0026-342-000	Grooved pin	2

Standard hydraulics assembly

1105-005-600 Rev C (Reference only)

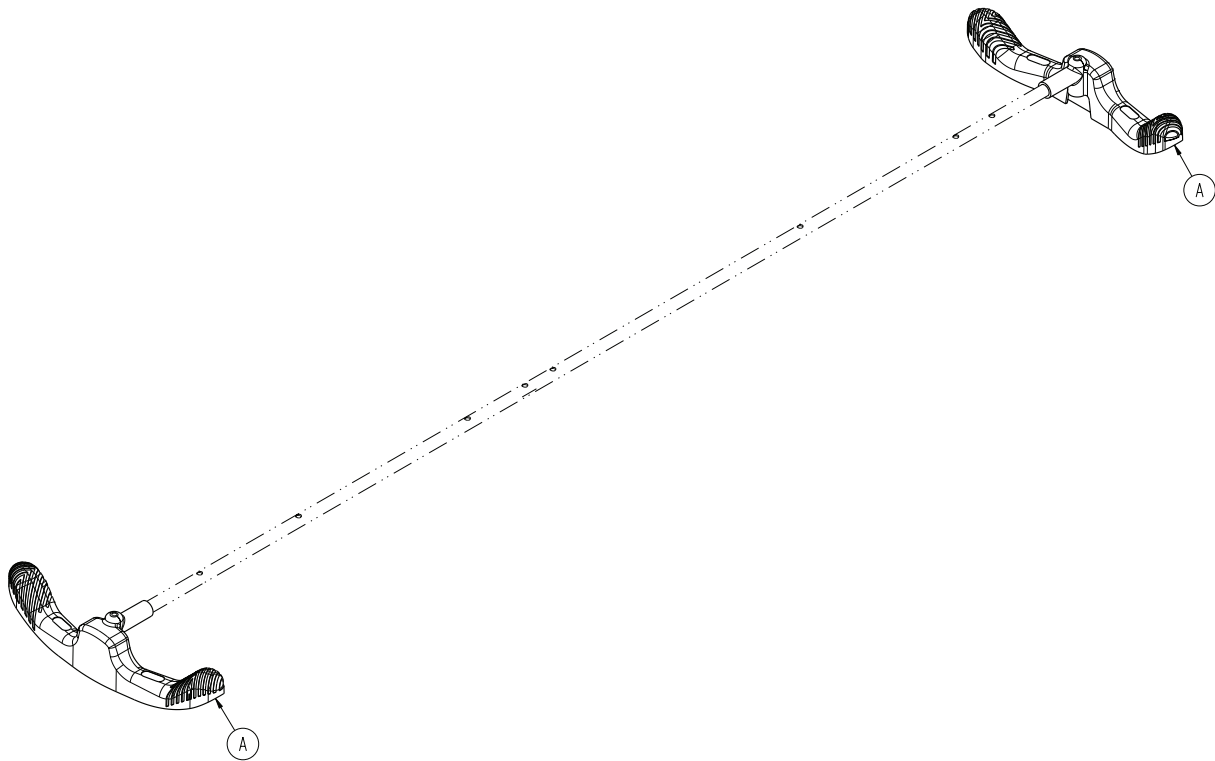

Item	Number	Name	Quantity
A	1105-005-154	Butterfly "V" pedal	2

End control hydraulics assembly

1105-005-610 Rev D (Reference only)

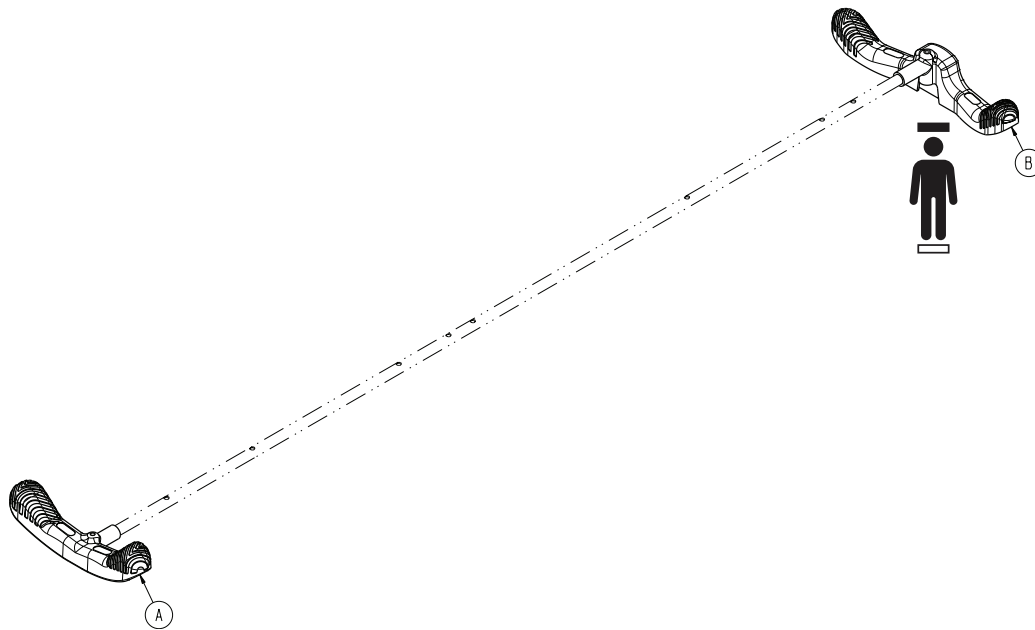

Item	Number	Name	Quantity
A	1105-003-099	Butterfly "V" pedal	1
B	1105-005-154	Butterfly "V" pedal	1

Side control brake assembly

1105-003-220 Rev AB (Reference only)

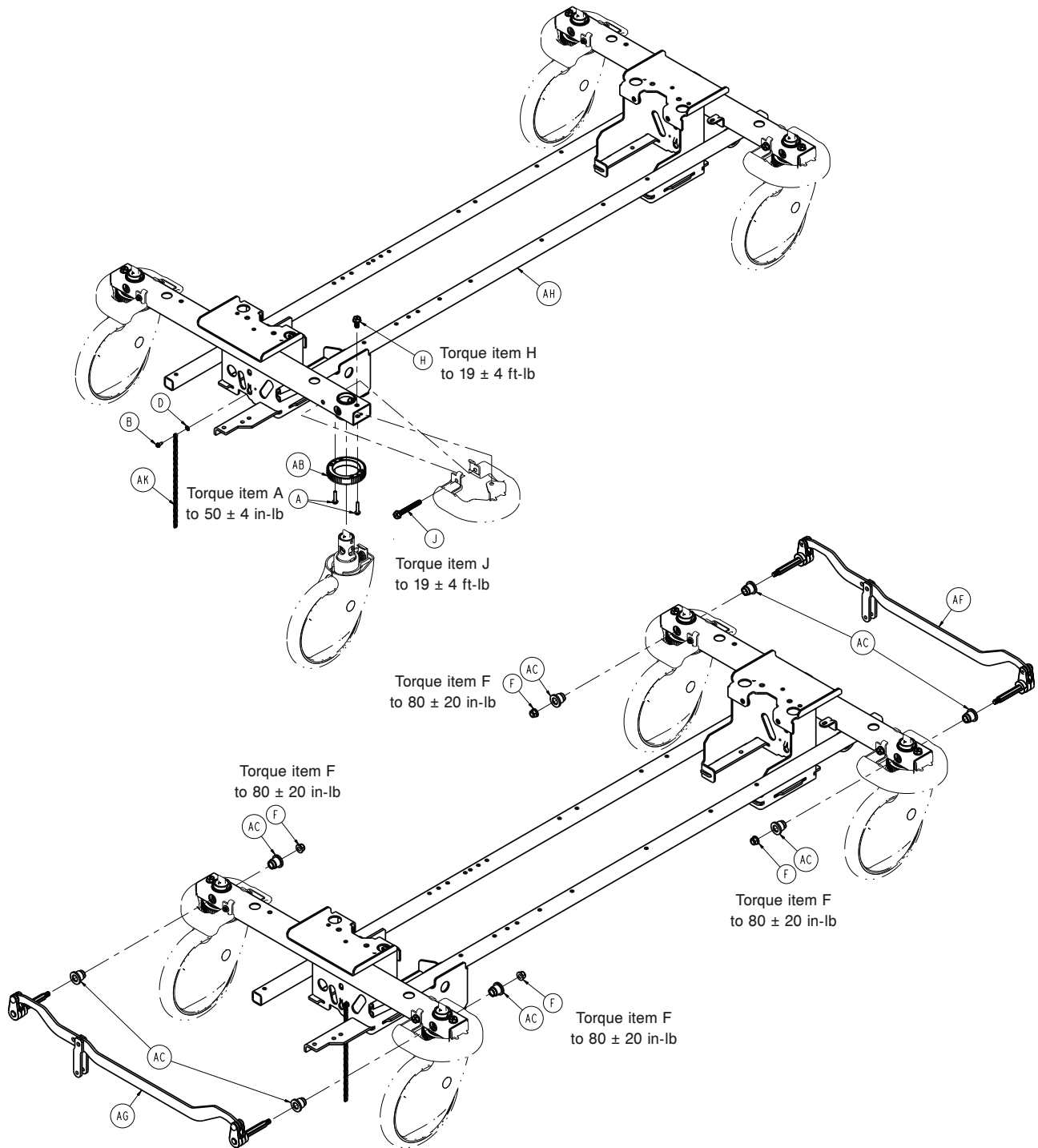

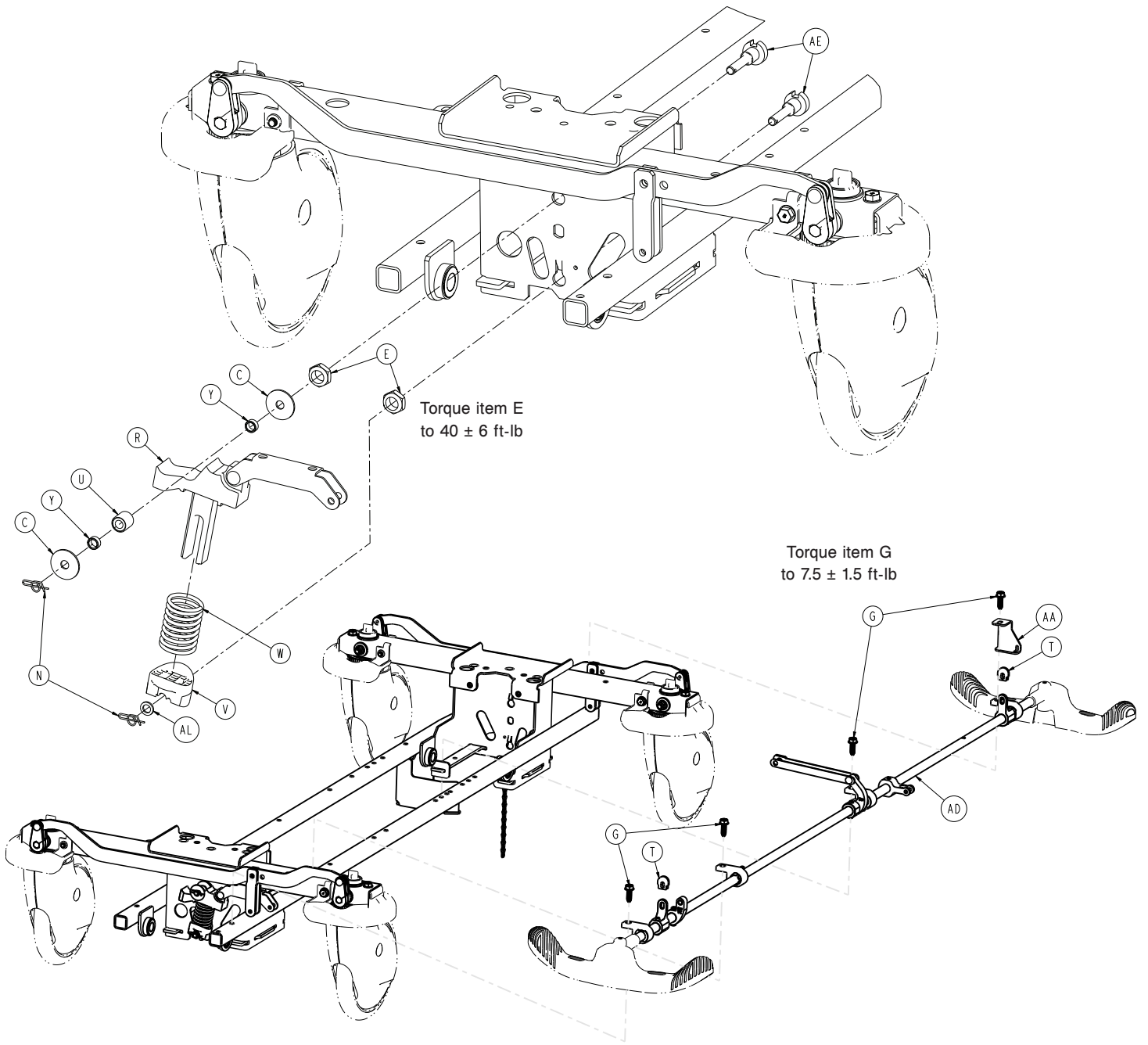

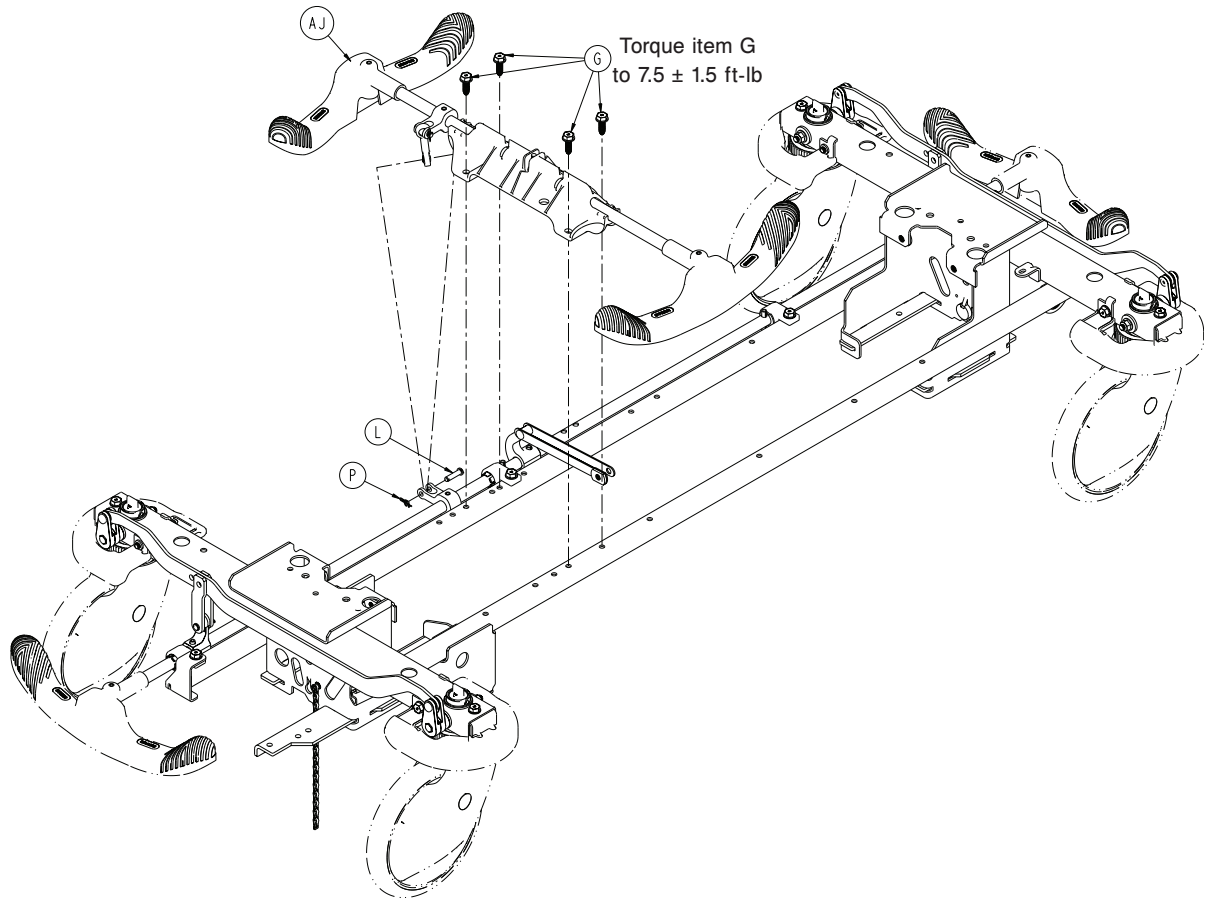
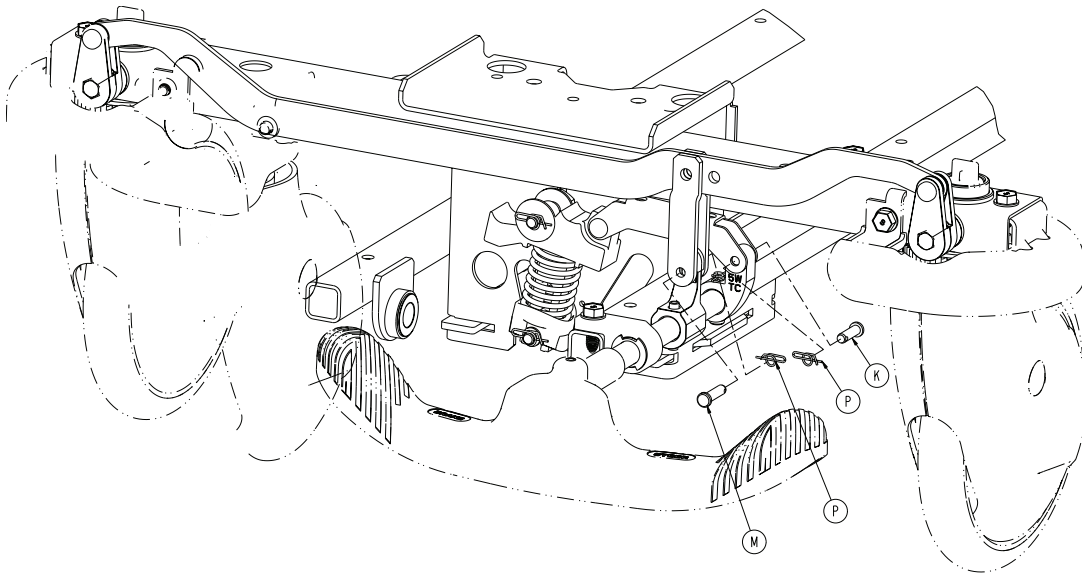

Item	Number	Name	Quantity
A	0003-147-000	Hex washer head screw	8
B	0023-071-000	Hex washer head unslotted tapping screw	1
C	0011-263-000	Washer	2
D	0013-018-000	External tooth lock washer	1
E	0016-049-000	Nylock hex nut	2

Item	Number	Name	Quantity
F	0016-135-000	Nylock flange hex nut	4
G	0023-288-000	Hex washer head screw	8
H	0023-330-000	Hex washer head screw	4
J	0023-331-000	Hex washer head screw	4
K	0026-295-000	Clevis pin	1
L	0026-340-000	Clevis pin	1
M	0026-393-000	Clevis pin	2
N	0027-019-000	Rue ring cotter	2
P	0027-020-000	Rue ring cotter	4
R	0853-003-035	Brake cam and link assembly	1
T	0853-003-064	Brake rod crank cap	2
U	0853-003-075	Timing cam bearing assembly	1
V	0853-003-103	Timing cam spring retainer	1
W	0853-003-104	Fifth wheel timing cam spring	1
Y	0853-003-131	Timing cam spacer	2
AA	1105-005-087	Return spring hook	1
AB	0853-102-003	Caster steer lock gear	4
AC	0853-102-004	Stepped flange bearing	8
AD	0853-203-225	<i>Brake rod/side control assembly (page 107)</i>	1
AE	0853-203-230	Bearing pivot support	2
AF	0853-303-010	Brake link assembly, head end	1
AG	0853-303-020	Brake link assembly, foot end	1
AH	0853-401-001	Base weldment	1
AJ	1105-003-210	<i>Side control brake assembly (page 108)</i>	1
AK	3001-200-052	Grounding chain	1
AL	0014-003-000	Washer	1

Brake rod/side control assembly

0853-203-225 Rev AA (Reference only)

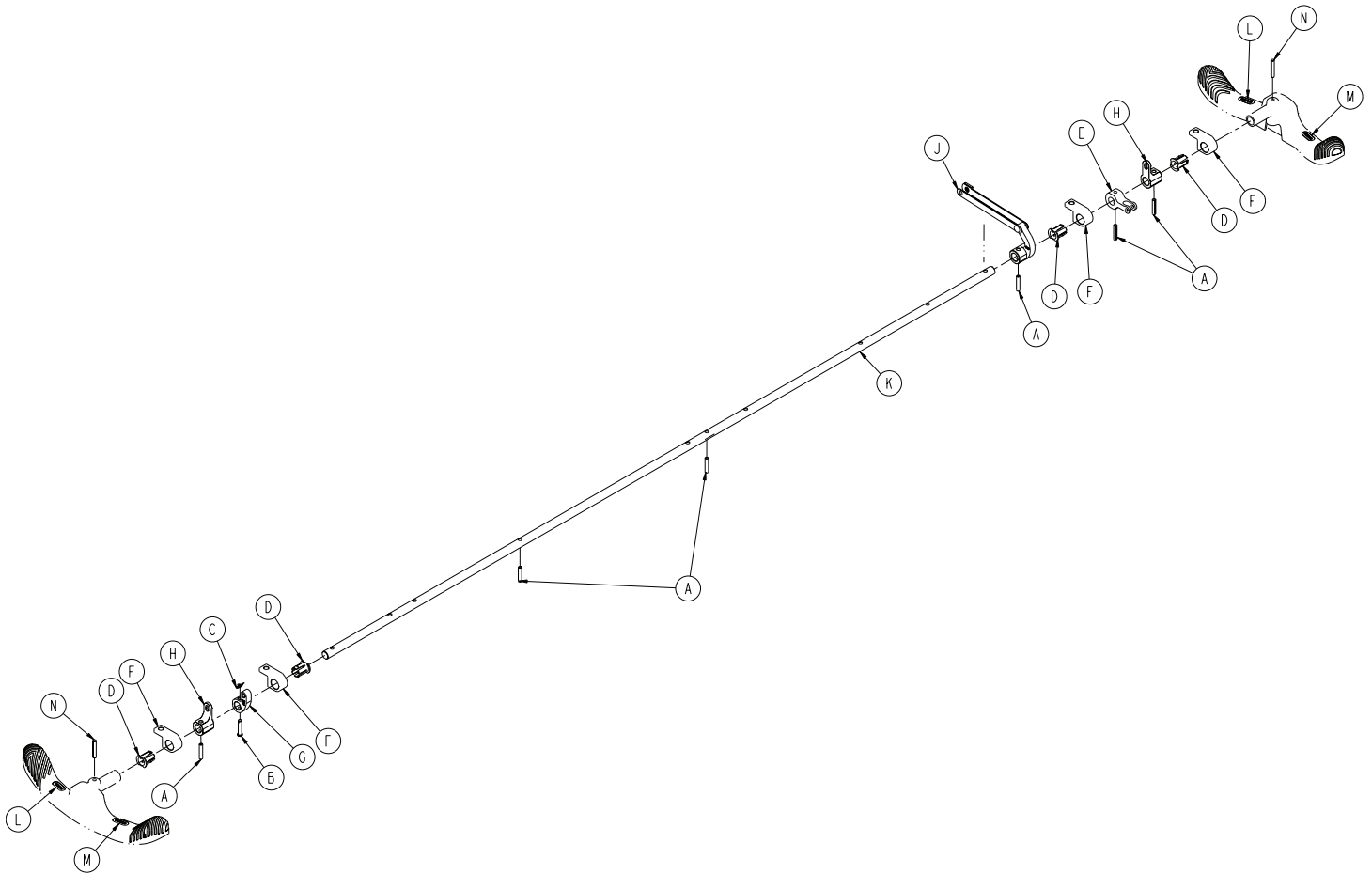

Item	Number	Name	Quantity
A	0026-014-000	Slotted spring pin	6
B	0026-251-000	Clevis pin	1
C	0027-020-000	Rue ring cotter	1
D	0753-003-015	Brake rod Nyliner	4
E	0753-003-112	Side control link	1
F	0853-003-004	Brake rod support	4
G	0853-003-055	Fifth wheel timing cam crank assembly	1
H	0853-203-011	Brake activation crank	2
J	0853-206-135	Fifth wheel drive link assembly	1
K	0853-303-014	Brake rod	1
L	1105-001-335	Label , brake	2
M	1105-001-336	Label, steer	2
N	0026-342-000	Grooved pin	2

Side control brake assembly

1105-003-210 Rev B (Reference only)

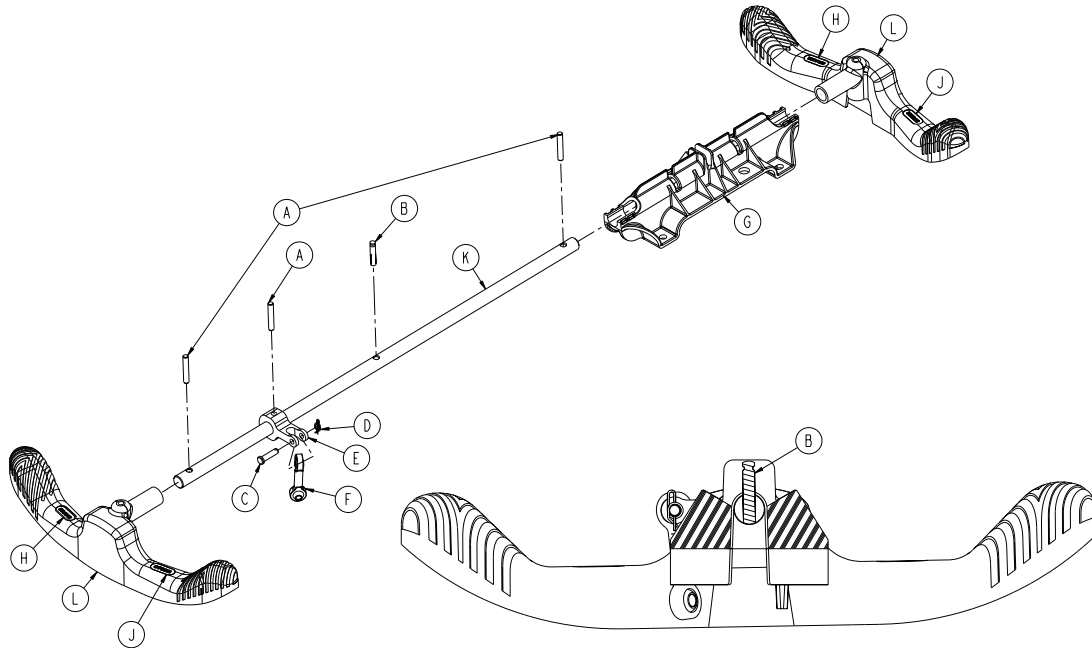

Item	Number	Name	Quantity
A	0026-342-000	Grooved pin	3
B	0026-138-000	Grooved pin	1
C	0026-340-000	Clevis pin	1
D	0027-020-000	Rue ring cotter	1
E	0753-003-112	Side control link	1
F	0753-003-117	Rod end link	1
G	0853-003-214	Side control shaft support	1
H	1105-001-335	Label, brake	2
J	1105-001-336	Label, steer	2
K	1105-003-319	Side control brake rod table	1
L	1105-005-154	Butterfly "V" pedal	2

Bumper color options

0853-003-085 Rev E (Reference only)

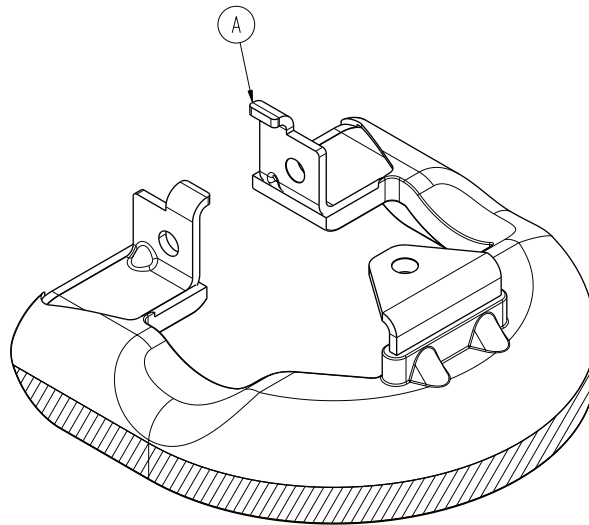

Item	Number	Name	Quantity
A	0853-003-082	Bumper	1

Color	Number (individual)	Quantity
Yellow	0853-003-551	1
Cool grey	0853-003-552	1
Powder blue	0853-003-553	1
Red	0853-003-554	1
Navy	0853-003-555	1
Dark lilac	0853-003-556	1

Color	Number (set of four)	Quantity
Yellow	1105-003-551	4
Cool grey	1105-003-552	4
Powder blue	1105-003-553	4
Red	1105-003-554	4
Navy	1105-003-555	4
Dark lilac	1105-003-556	4

Retractable fifth wheel assembly

1105-006-110 Rev AA (Reference only)

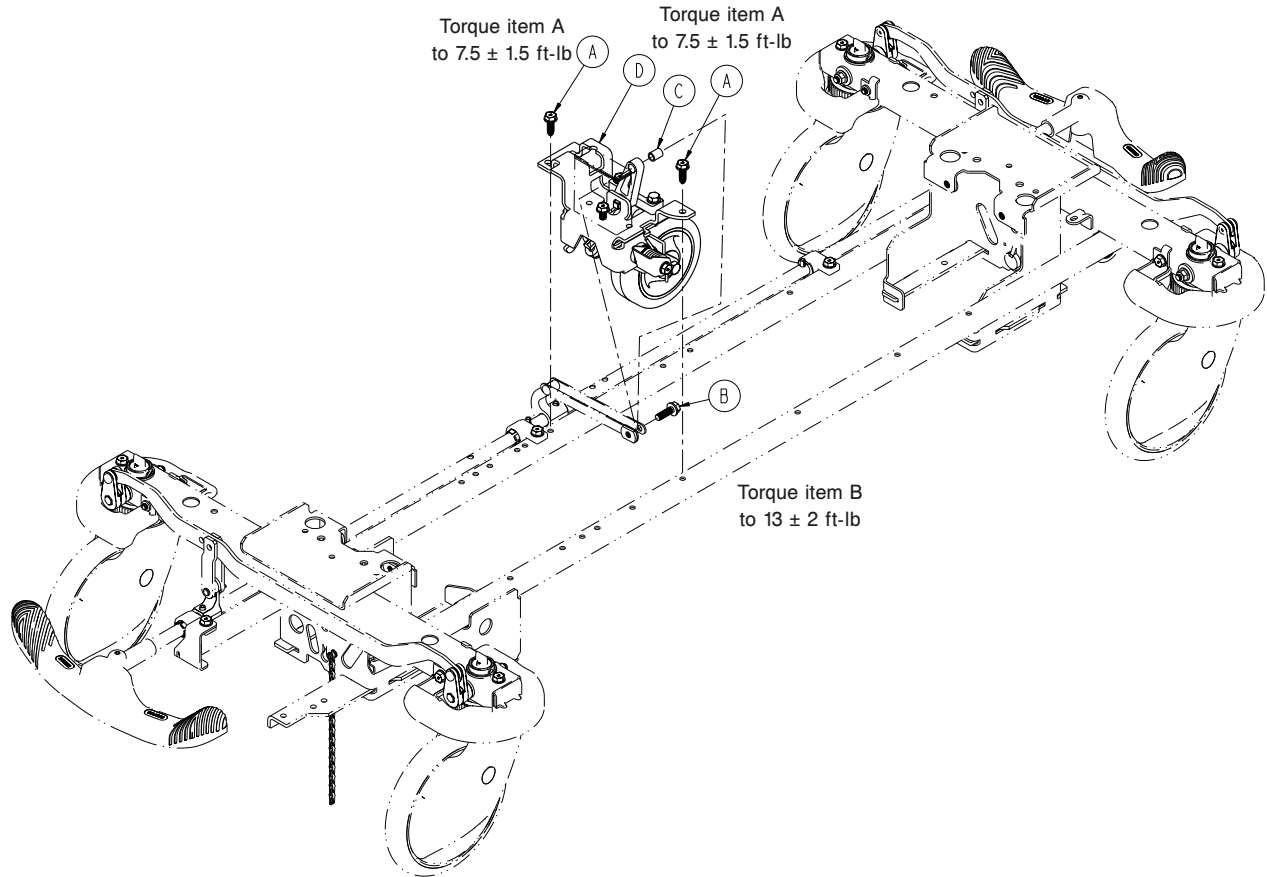

Item	Number	Name	Quantity
A	0023-288-000	Hex washer head screw	2
B	0023-305-000	Hex washer head screw	1
C	0753-006-148	Cam bearing	1
D	1105-006-130	<i>Fifth wheel assembly - 1105-006-130</i> (page 111)	1

Fifth wheel assembly - 1105-006-130

Rev E (Reference only)

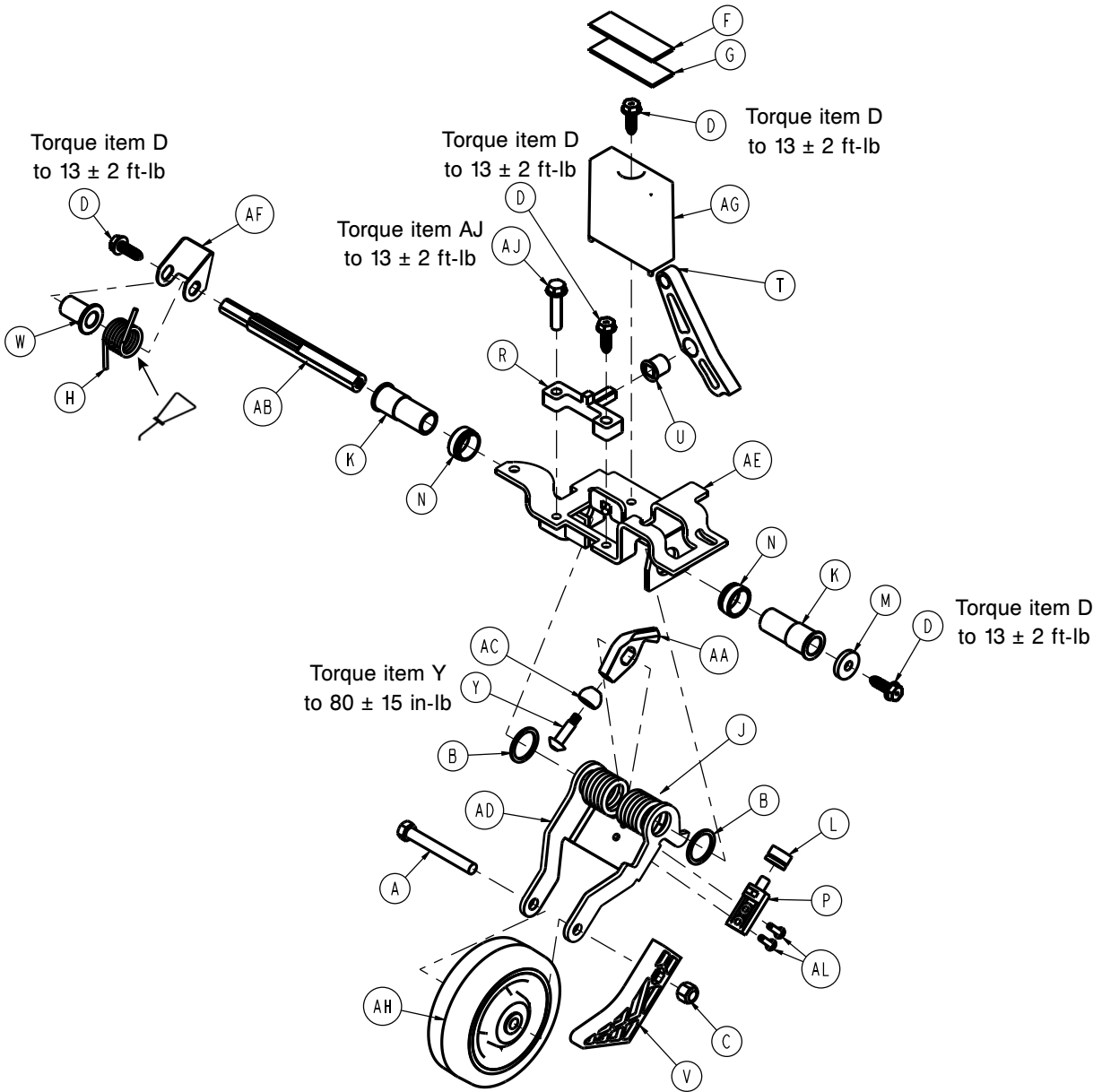

Item	Number	Name	Quantity
A	0003-083-000	Hex head cap screw	1
B	0011-360-000	Washer	2
C	0016-035-000	Nylock hex nut	1
D	0023-288-000	Hex washer head screw	4
F	0029-007-000	Dual lock	1
G	0029-009-000	Dual lock	1
H	0753-006-074	Torsion spring	1
J	0753-006-075	Torsion spring	1

Item	Number	Name	Quantity
K	0753-006-097	Drive shaft bearing	2
L	0753-006-106	Dampener	1
M	0753-006-108	Thrust washer	1
N	0753-006-115	Bearing race	2
P	0753-006-120	Bumper mounting pin	1
R	0753-006-133	Cam pivot block	1
T	0753-006-142	Fifth wheel cam	1
U	0753-006-143	Cam bearing	1
V	0753-006-149	Fifth wheel ramp	1
W	0753-006-152	Spring spacer	1
Y	0753-006-153	Roller stem	1
AA	0753-006-198	Drive pin	1
AB	0753-006-223	Drive shaft	1
AC	0753-006-277	Roller	1
AD	1105-006-126	Fifth wheel bracket	1
AE	1105-006-131	Fifth wheel weldment	1
AF	0853-006-227	Return spring hook	1
AG	0853-010-045	Hood standoff	1
AH	1210-001-147	Fifth wheel	1
AJ	0023-160-000	Hex washer head screw	1
AL	0025-270-000	Rivet	2

Dual-sided hydraulics assembly, non-electric

1105-105-500 Rev AA (Reference only)

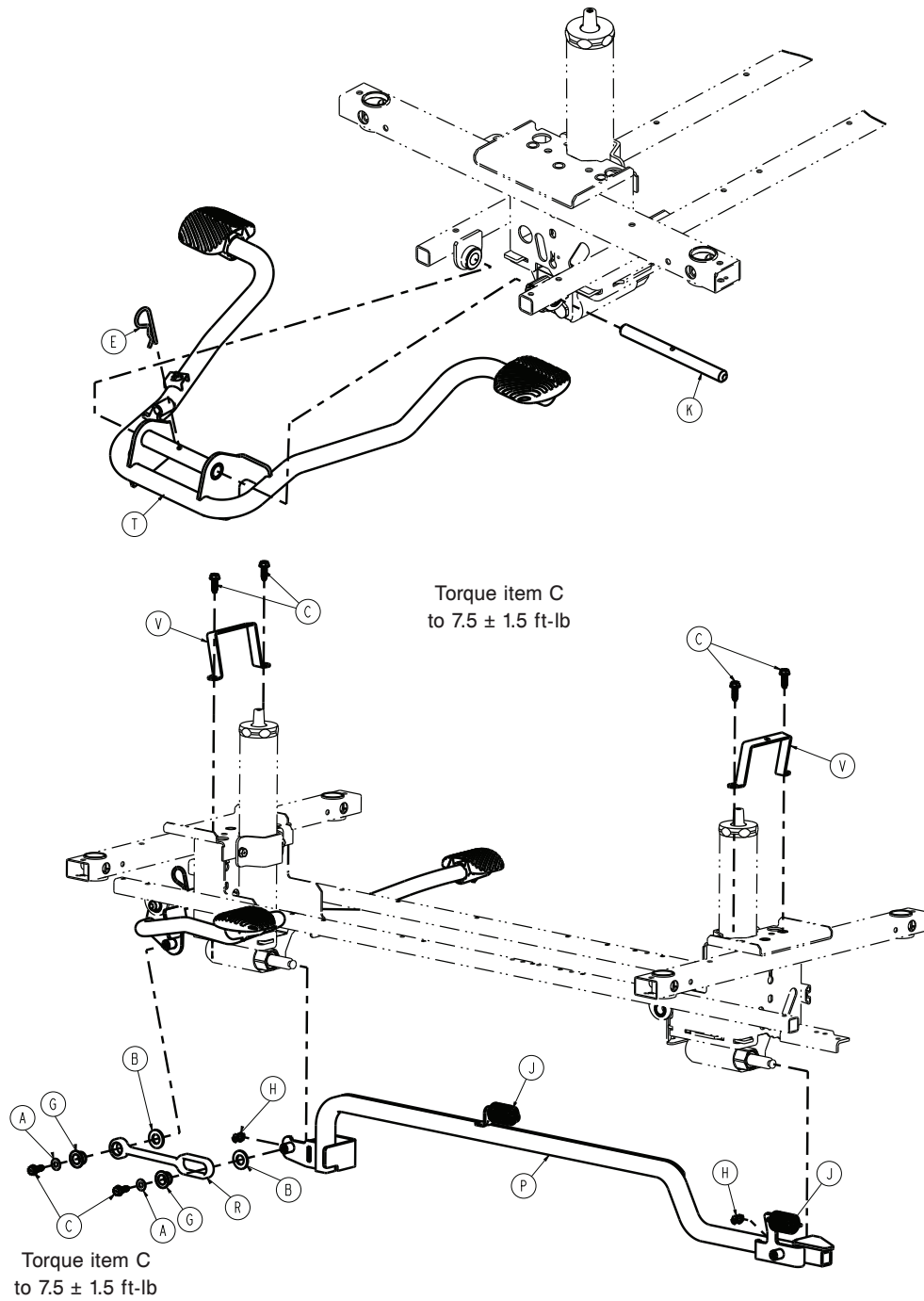

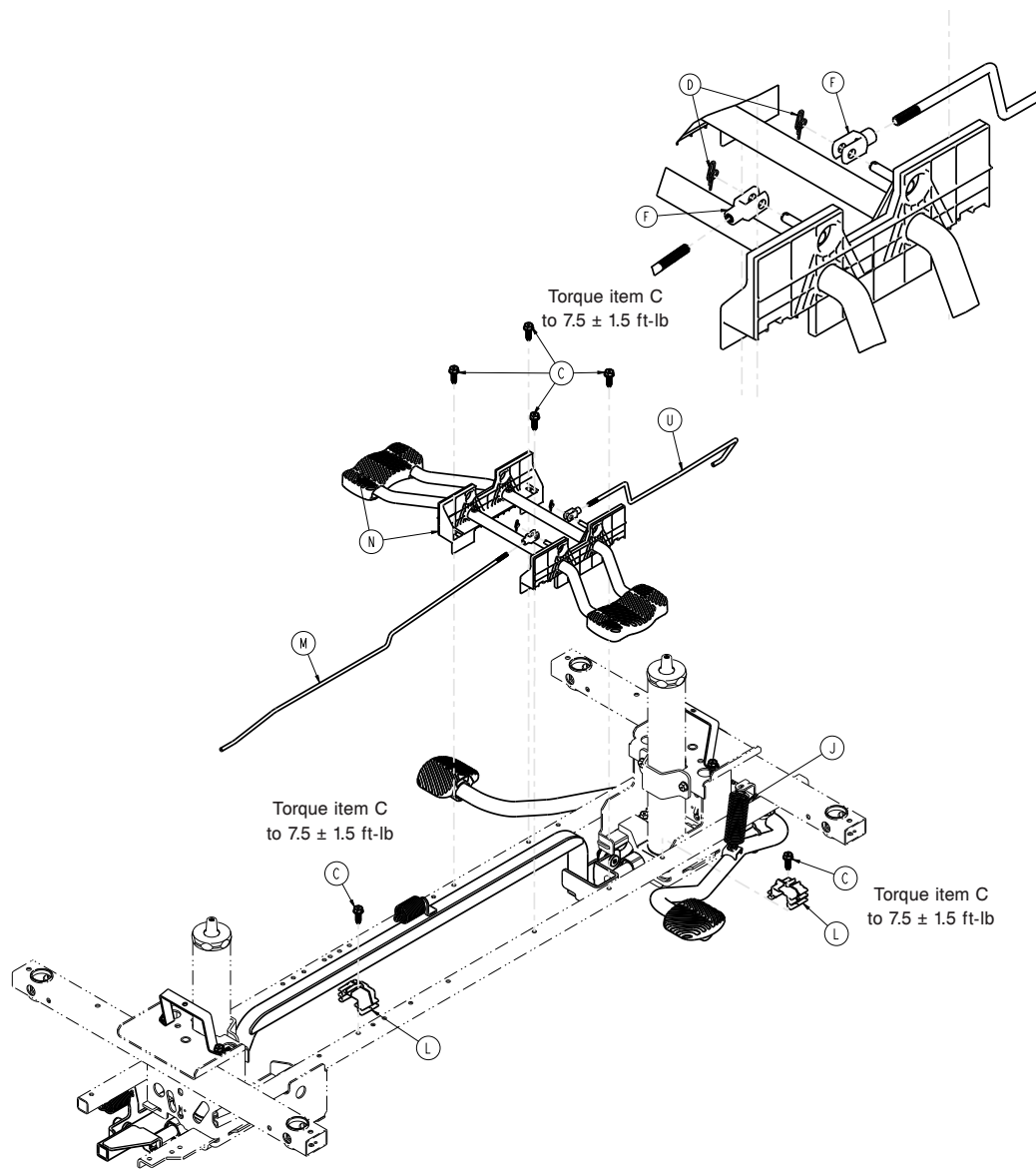

Item	Number	Name	Quantity
A	0011-023-000	Washer	2
B	0014-071-000	Washer	2
C	0023-288-000	Hex washer head screw	12
D	0027-020-000	Rue ring cotter	2
E	0027-031-000	Hair pin cotter	1
F	0052-909-000	Clevis joint	2
G	0753-005-044	Pump pedal bushing	2
H	0753-005-089	Pump ram plug	2
J	0853-005-009	Return spring	3
K	0853-005-074	Pivot pin	1
L	0853-010-215	Release rod bracket	2
M	1105-004-015	Release rod, foot end	1
N	1105-004-201	Lowering pedal assembly - 1105-004-201 (page 136)	1
P	1105-005-035	Pump connecting tube weldment	1
R	1105-005-075	Pump pedal link	1

Item	Number	Name	Quantity
T	1105-005-285	<i>Pump pedal assembly, head end - 1105-005-285 (page 137)</i>	1
U	0853-204-014	Release rod, head end	1
V	1105-001-081	Hood strap	2

Three-sided hydraulics option

1105-005-510 Rev AA (Reference only)

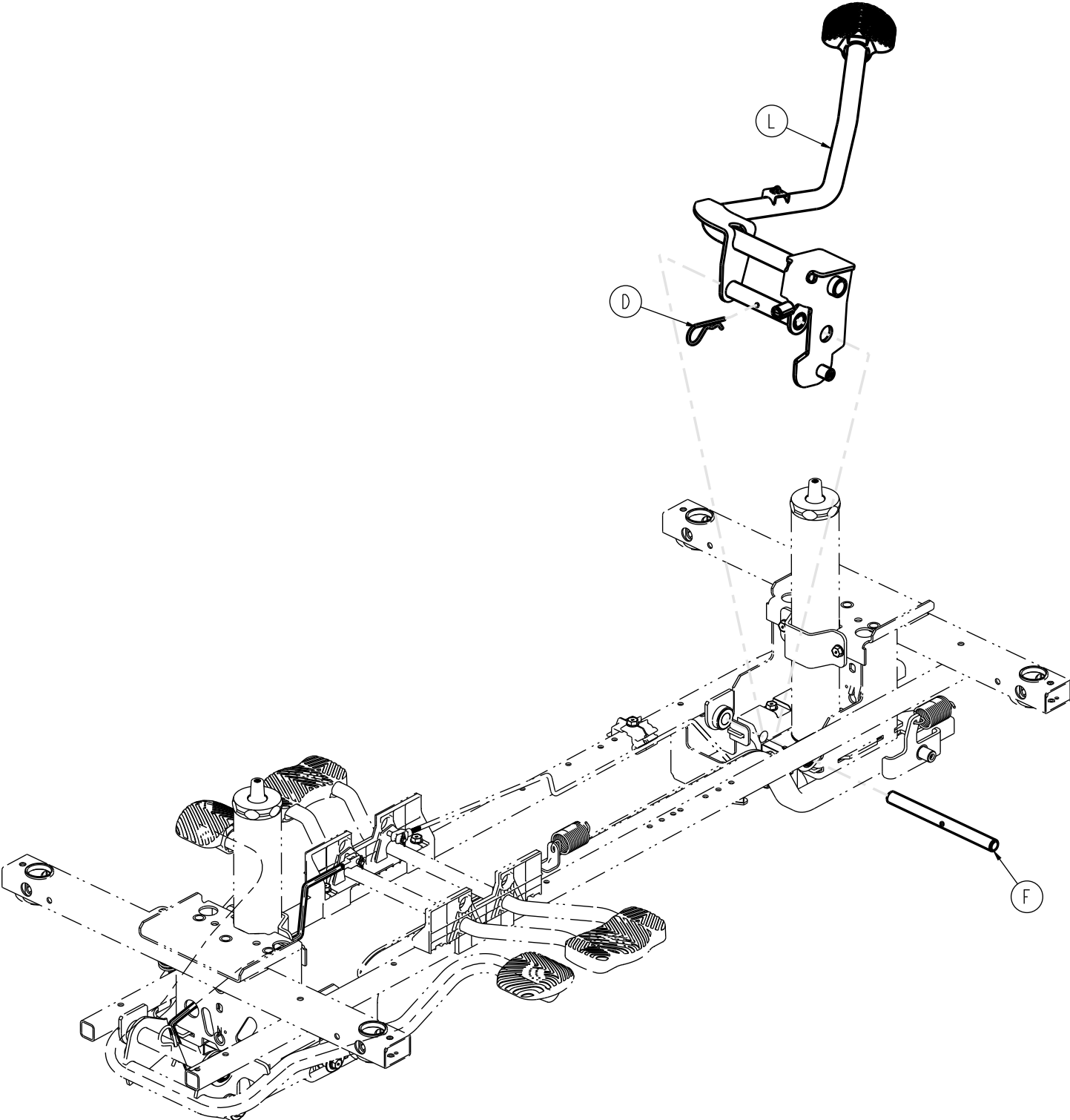

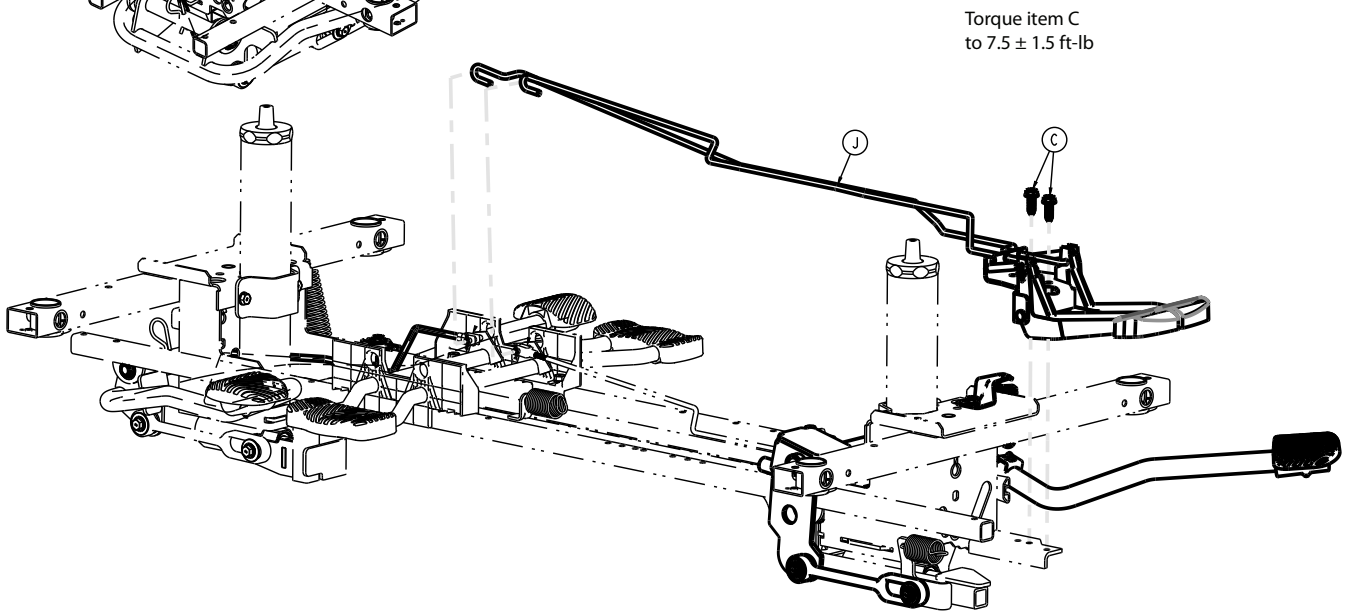
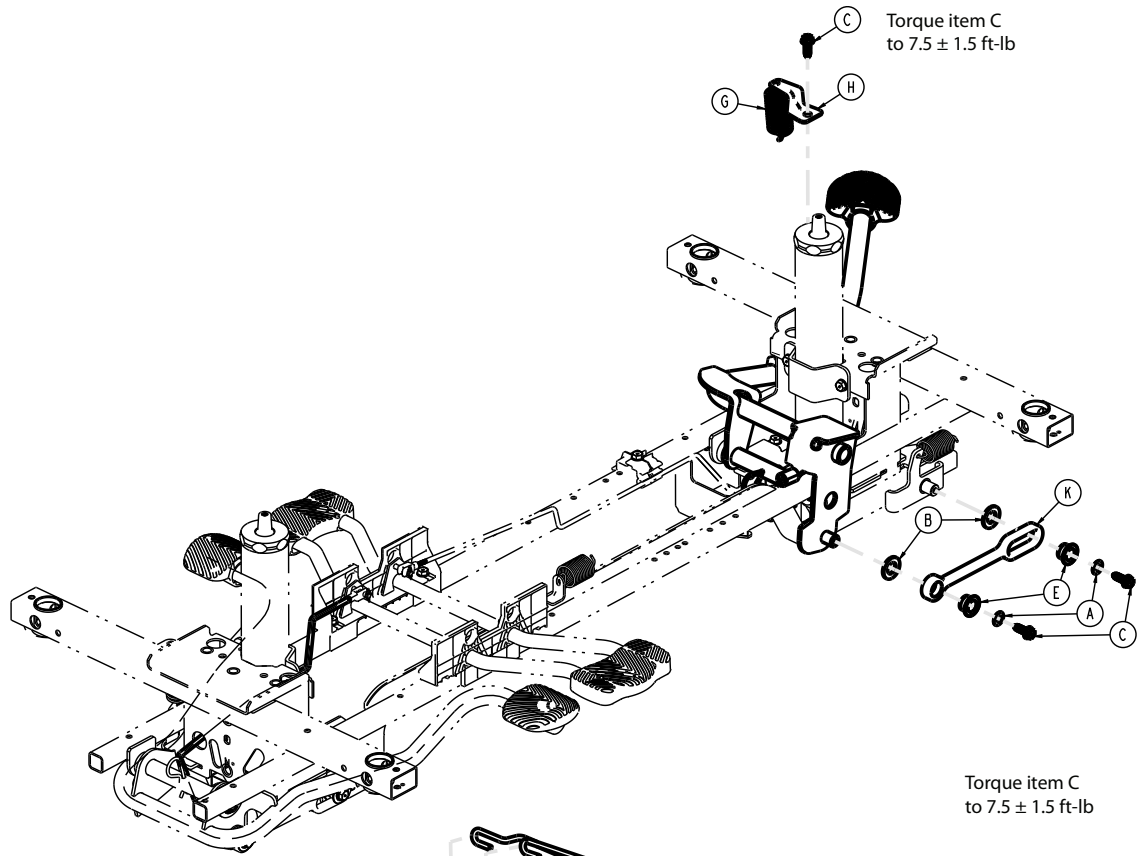

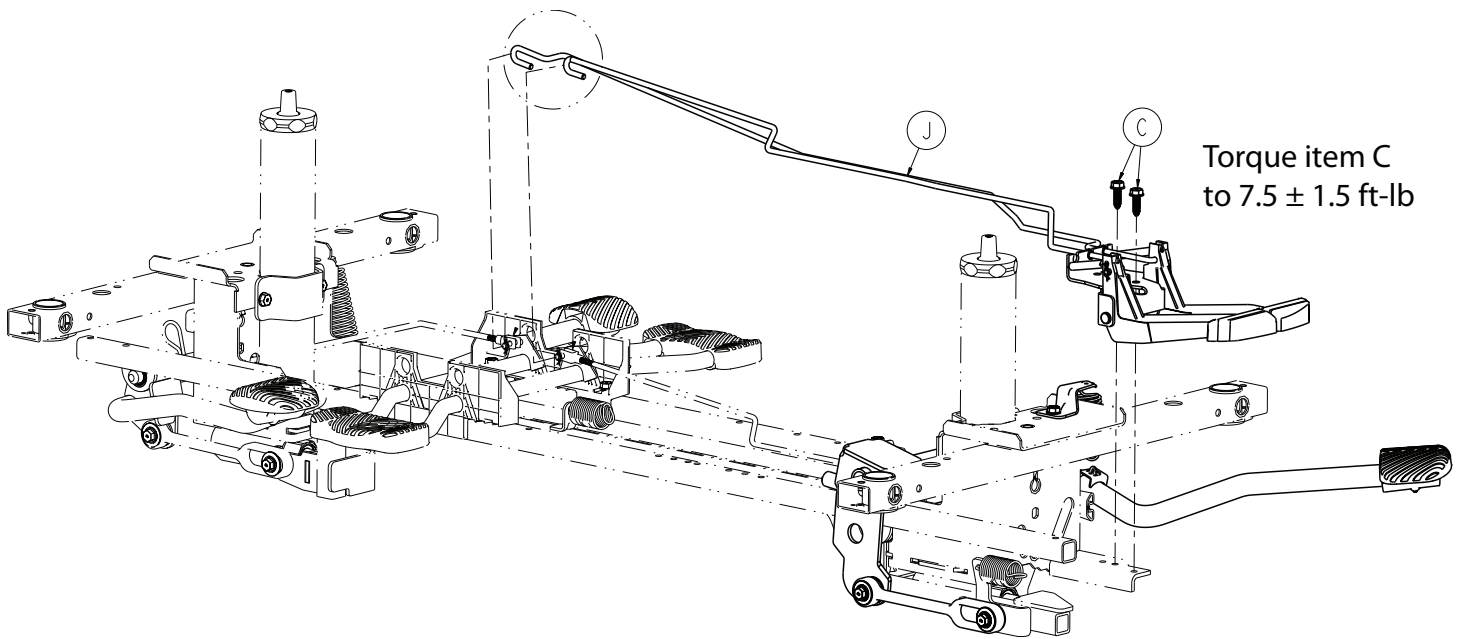

Item	Number	Name	Quantity
A	0011-023-000	Washer	2
B	0014-071-000	Washer	2
C	0023-288-000	Hex washer head screw	8
D	0027-031-000	Hair pin cotter	1
E	0753-005-044	Pump pedal bushing	2
F	0753-005-074	Pivot pin	1
G	0853-005-009	Return spring	1
H	0853-005-011	Pump pedal spring return bracket	1
J	1105-004-223	<i>Release pedal assembly, foot end (page 124)</i>	1
K	1105-005-075	Pump pedal link	1
L	1105-005-273	<i>Pump pedal assembly, foot end - 1105-005-273 (page 119)</i>	1

Pump pedal assembly, foot end - 1105-005-273

Rev A (Reference only)

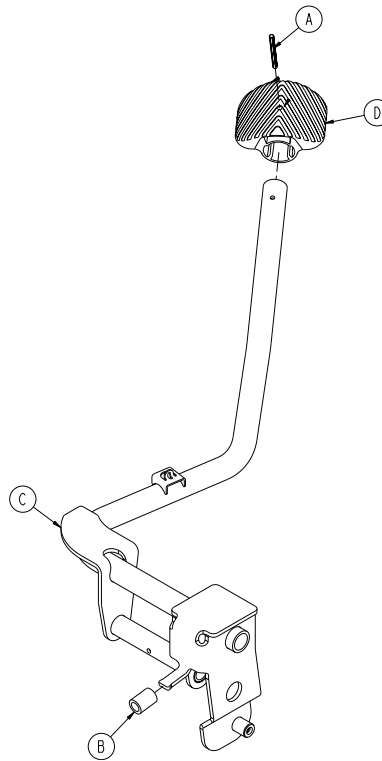

Item	Number	Name	Quantity
A	0026-343-000	Groove pin	1
B	0715-001-140	Clear vinyl tubing	1
C	1105-005-171	Pump pedal weldment, foot end	1
D	1105-201-126	Plastic pump pedal	1

Three-sided hydraulics option, head end

1105-005-710 Rev C (Reference only)

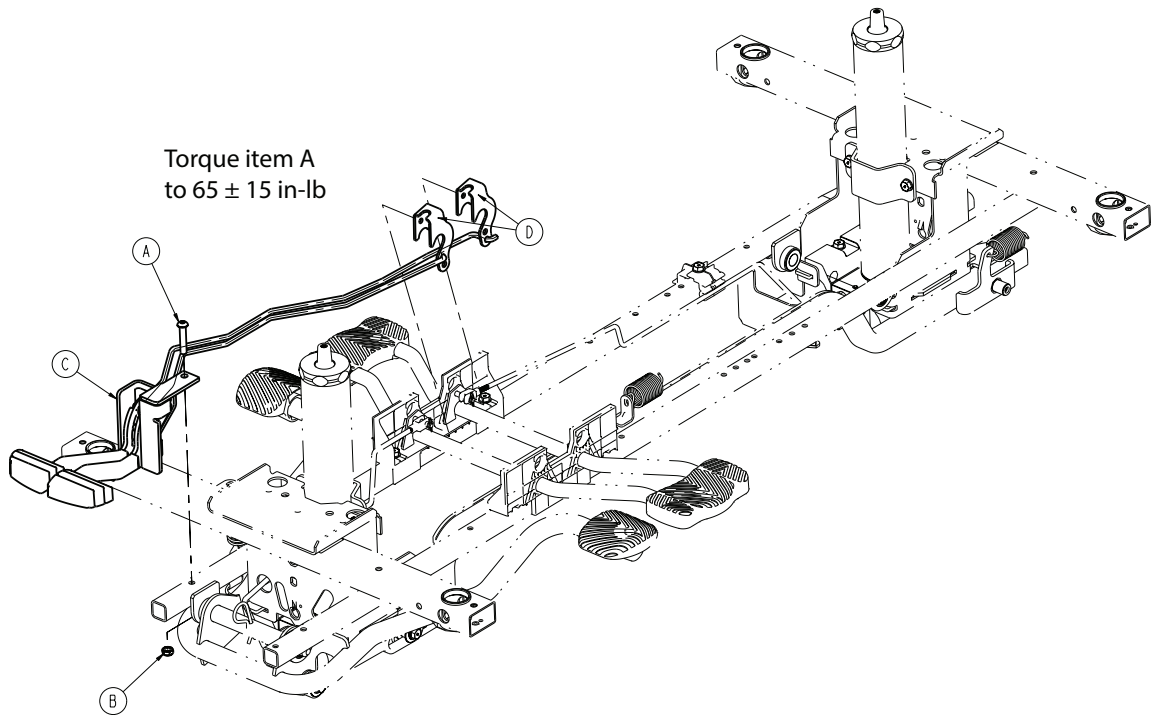

Item	Number	Name	Quantity
A	0004-452-000	Button head cap screw	1
B	0016-132-000	Nylock hex nut	1
C	1105-004-320	<i>Release pedal assembly, head end</i> (page 125)	1
D	1105-004-521	Trend release bracket	2

Four-sided hydraulics option

1105-005-810 Rev AA (Reference only)

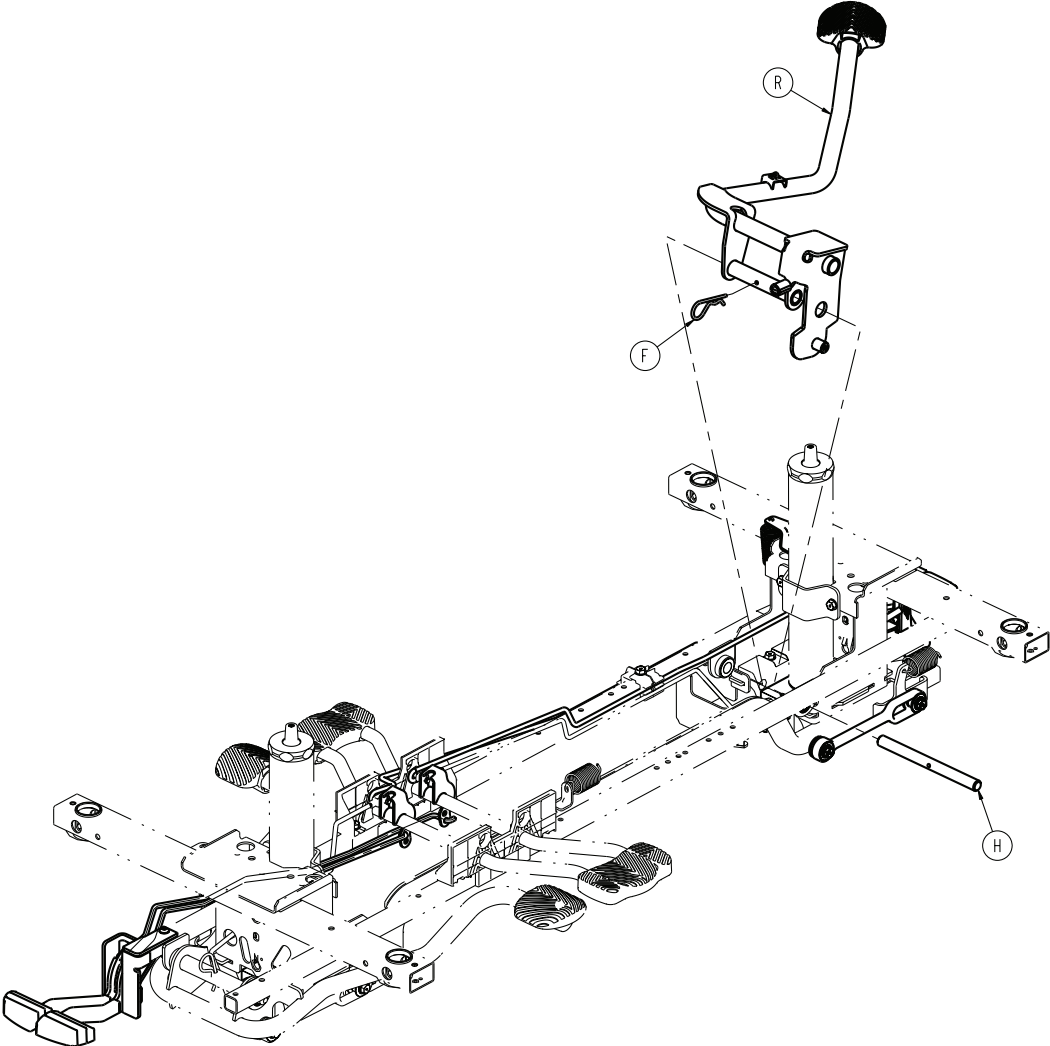

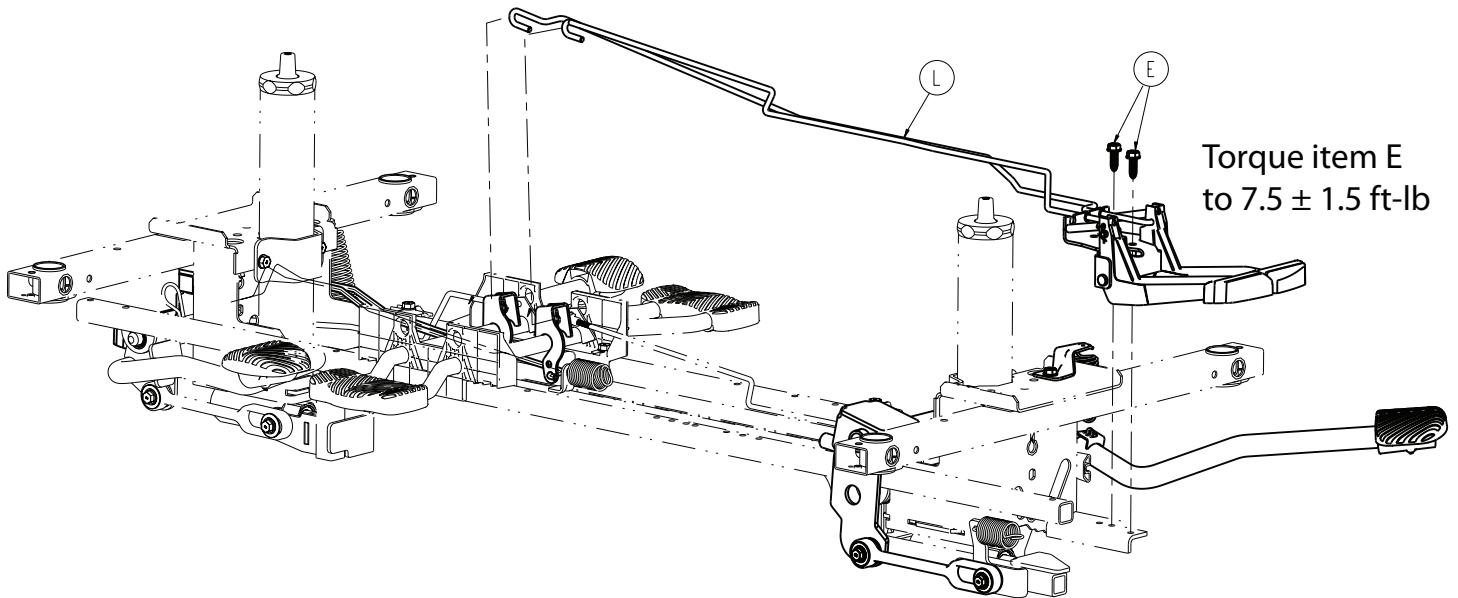
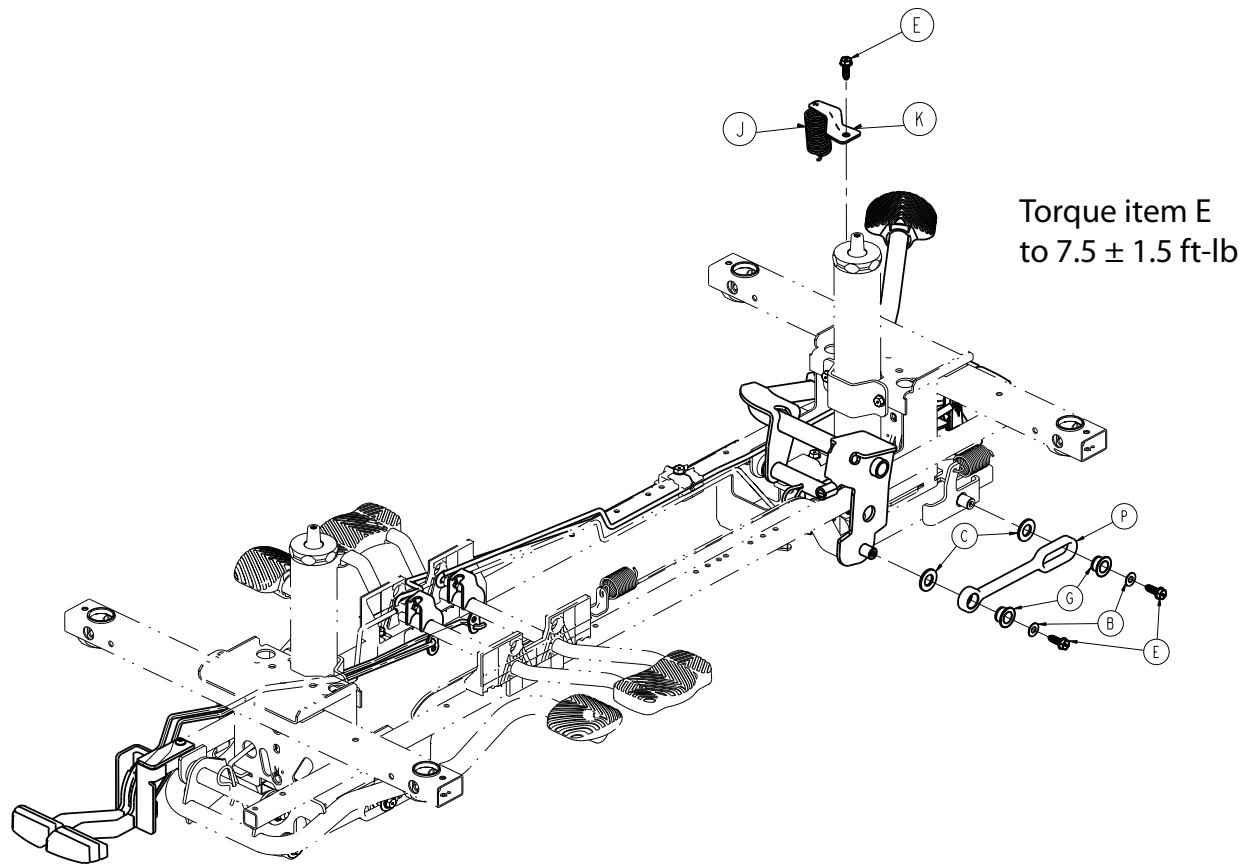

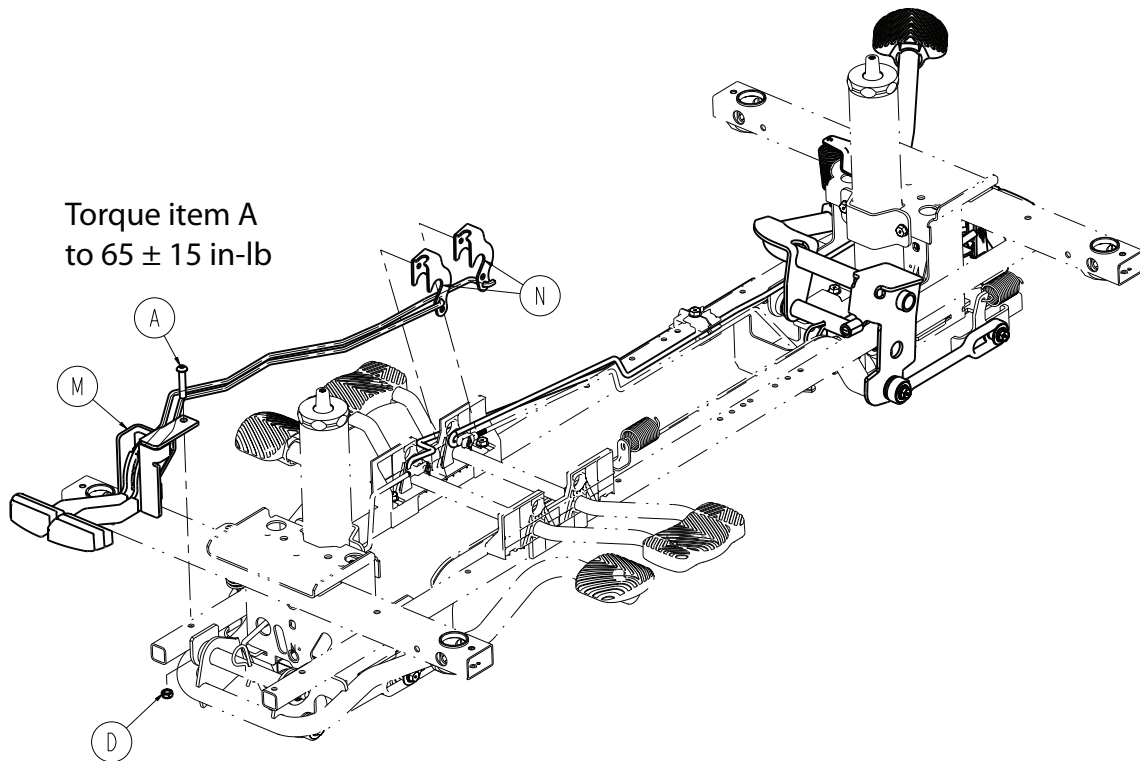

Item	Number	Name	Quantity
A	0004-452-000	Button head cap screw	1
B	0011-023-000	Washer	2
C	0014-071-000	Washer	2
D	0016-132-000	Nylock hex nut	1
E	0023-288-000	Hex washer head screw	5
F	0027-031-000	Hair pin cotter	1
G	0753-005-044	Pump pedal bushing	2
H	0753-005-074	Pivot pin	1
J	0853-005-009	Return spring	1
K	0853-005-011	Pump pedal spring return bracket	1
L	1105-004-223	<i>Release pedal assembly, foot end</i> (page 124)	1
M	1105-004-320	<i>Release pedal assembly, head end</i> (page 125)	1
N	1105-004-521	Trend release bracket	2
P	1105-005-075	Pump pedal link	1
R	1105-005-273	<i>Pump pedal assembly, foot end -</i> <i>1105-005-273</i> (page 119)	1

Release pedal assembly, foot end

1105-004-223 Rev A (Reference only)

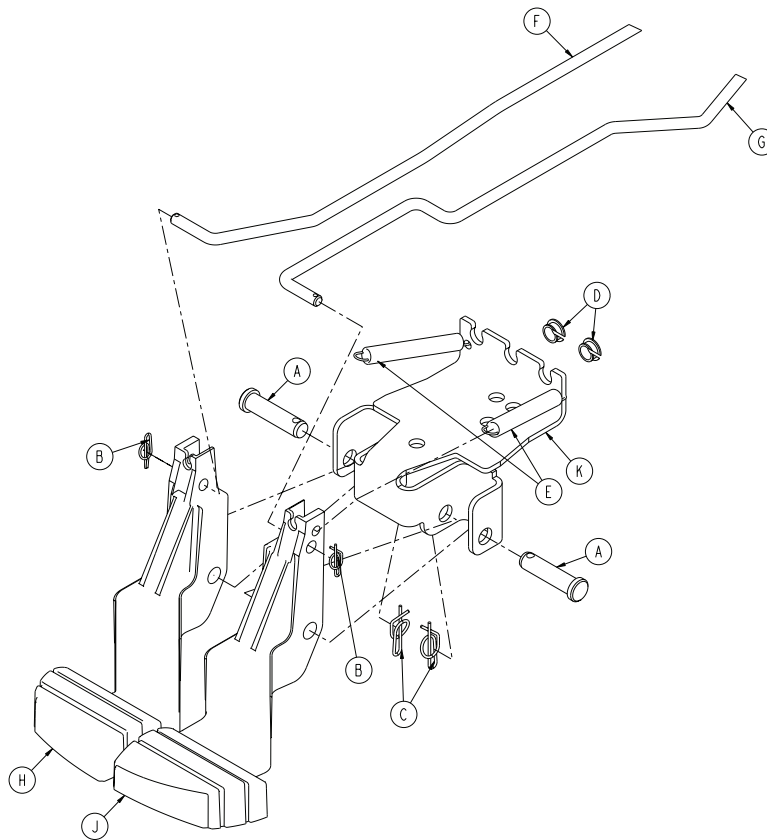

Item	Number	Name	Quantity
A	0026-132-000	Clevis pin	2
B	0027-020-000	Rue ring cotter	2
C	0027-022-000	Rue ring cotter	2
D	0052-822-000	Snap-in Nyloner	2
E	0753-004-028	Release pedal return spring, foot end	2
F	0853-004-138	Release rod, foot end	1
G	0853-004-139	Release rod, head end	1
H	1105-004-144	Release pedal, left, foot end	1
J	1105-004-145	Release pedal, right, foot end	1
K	1105-004-422	Release pedal mounting bracket, foot end	1

Release pedal assembly, head end

1105-004-320 Rev C (Reference only)

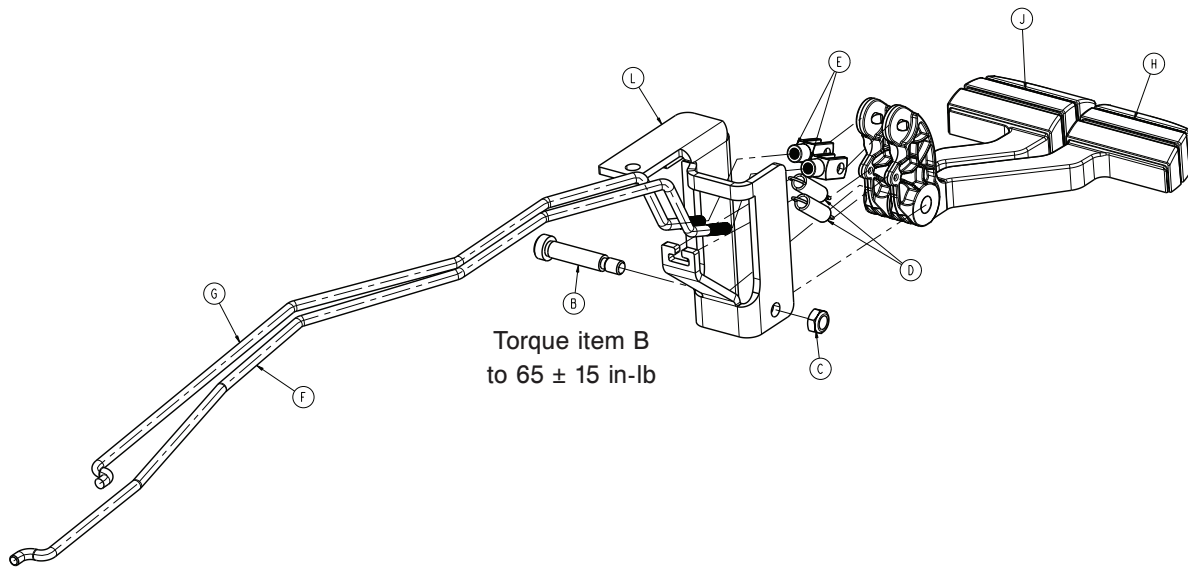

Item	Number	Name	Quantity
B	0008-012-000	Shoulder bolt	1
C	0016-132-000	Nylock hex nut	1
D	0038-355-000	Extension spring	2
E	0052-909-000	Clevis joint	2
F	0853-004-238	Foot release rod	1
G	0853-004-239	Head release rod	1
H	1105-004-244	Release pedal, left, head end	1
J	1105-004-245	Release pedal, right, head end	1
L	1105-004-522	Release pedal mounting bracket, head end	1

Constant descent jacks, non-electric

0853-102-025 Rev AA (Reference only)

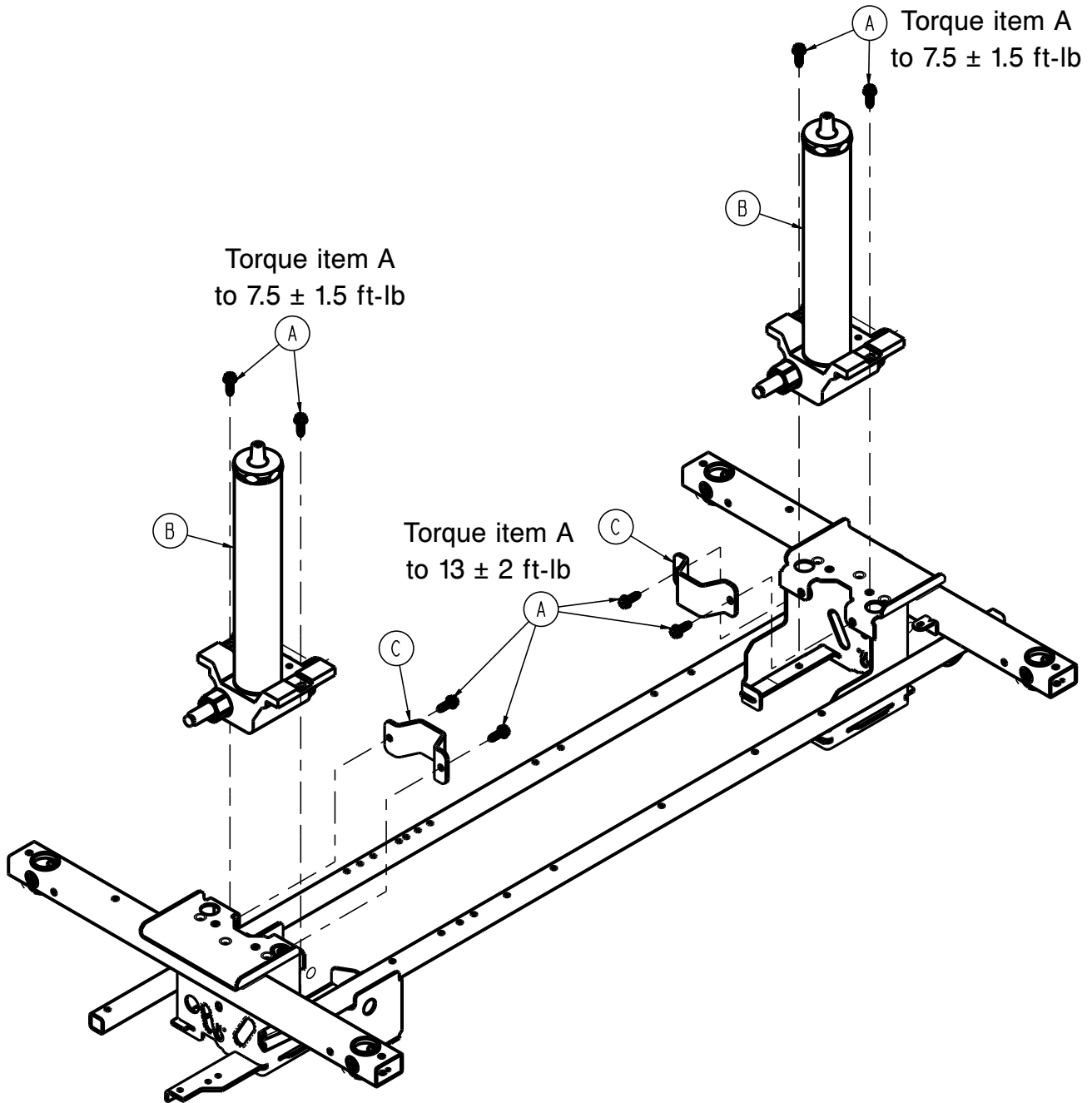

Item	Number	Name	Quantity
A	0023-288-000	Hex washer head screw	8
B	0753-002-101	Constant descent jack assembly	2
C	0853-010-007	Reservoir clamp	2

Constant descent jack assembly

0753-002-101 Rev D (Reference only)

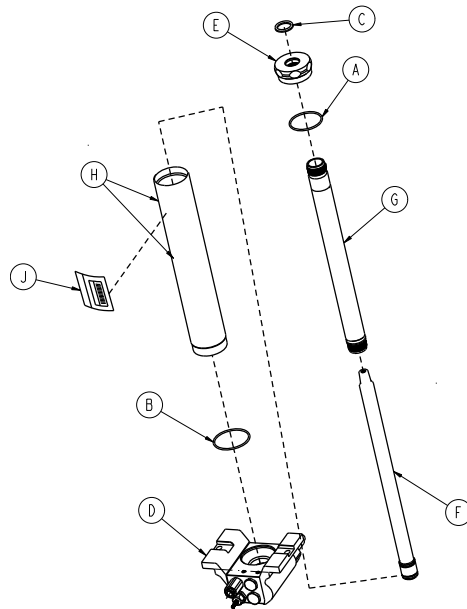

Item	Number	Name	Quantity
A	0045-273-000	O-ring	1
B	0045-274-000	O-ring	1
C	0048-190-000	Seal-u-cup	1
D	0753-002-002	Jack base assembly, non-electric (page 128)	1
E	0753-002-017	Jack cap	1
F	0753-002-104	Actuator rod assembly	1
G	0753-002-106	Actuator cylinder assembly	1
H	0753-102-129	Tube	1
J	0753-202-100	Label, jack assembly	1

Jack base assembly, non-electric

0753-002-002 Rev G (Reference only)

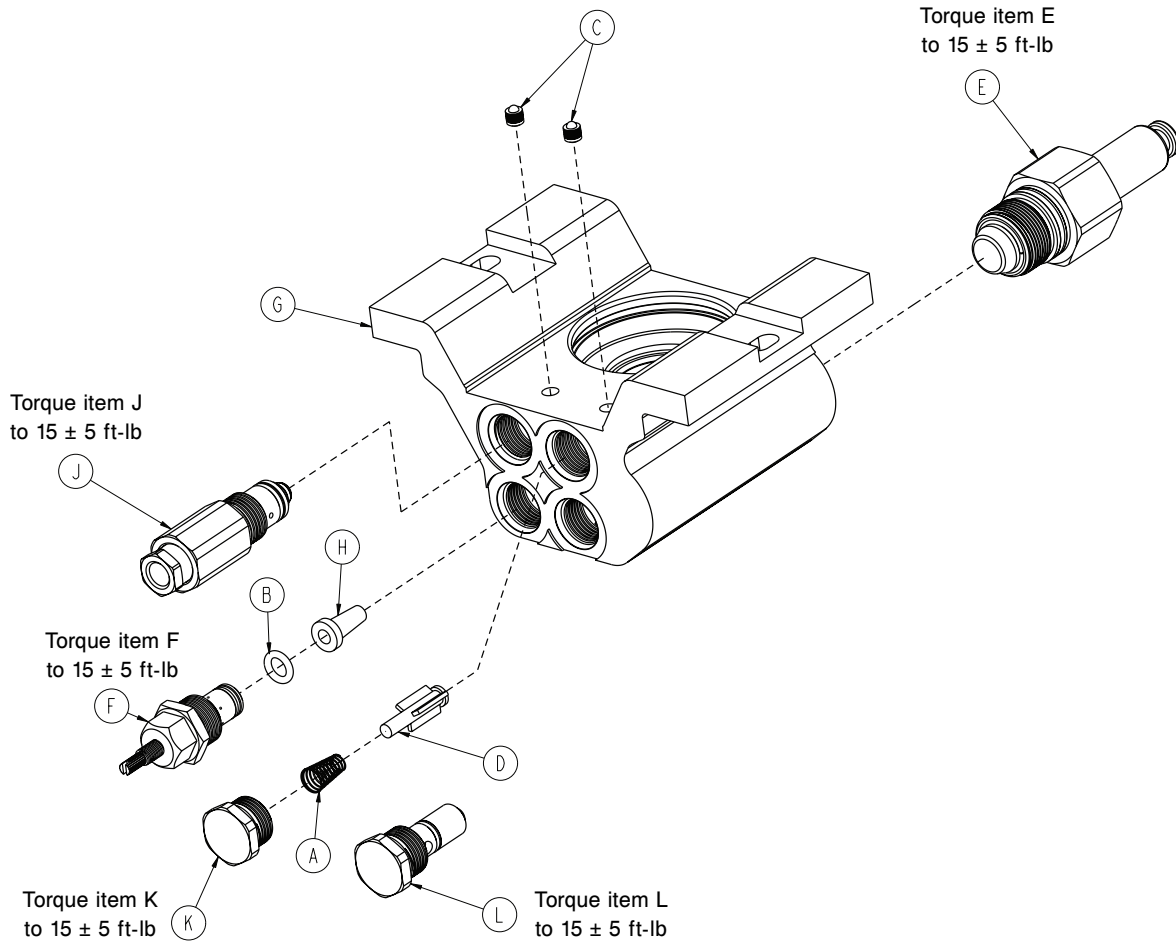

Item	Number	Name	Quantity
A	0390-002-134	Conical compression spring	1
B	0046-004-000	O-ring	1
C	0048-021-000*	CV plug	2
D	0715-001-341	Poppet	1
E	0753-002-003	Pump ram assembly	1
F	0753-002-058	Adjustable PC valve cartridge	1
G	0753-002-010*	Jack base	1
H	0753-002-019	Constant descent valve filter	1
J	0753-002-165	Release valve assembly	1
K	0753-002-051	Plug assembly	1
L	0753-002-052	Check valve assembly	1

Common non-lift base components

1008-001-130 Rev C (Reference only)

Number	Name	Quantity
1008-002-800	Non-lift control PCB assembly	1
1008-002-804	Label, base board fuses	1

Dual-sided hydraulics, non-powered

1008-005-500 Rev AA (Reference only)

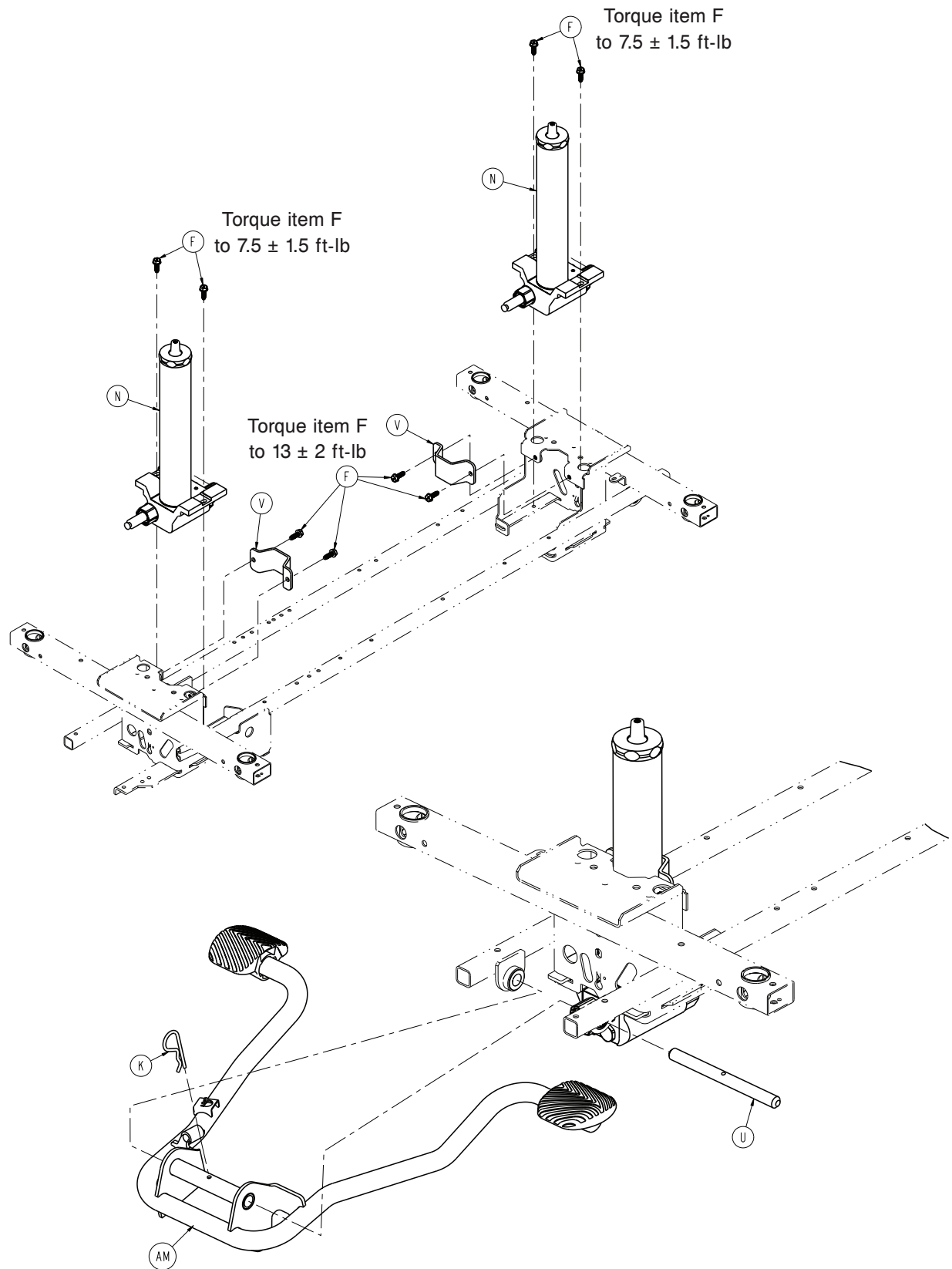

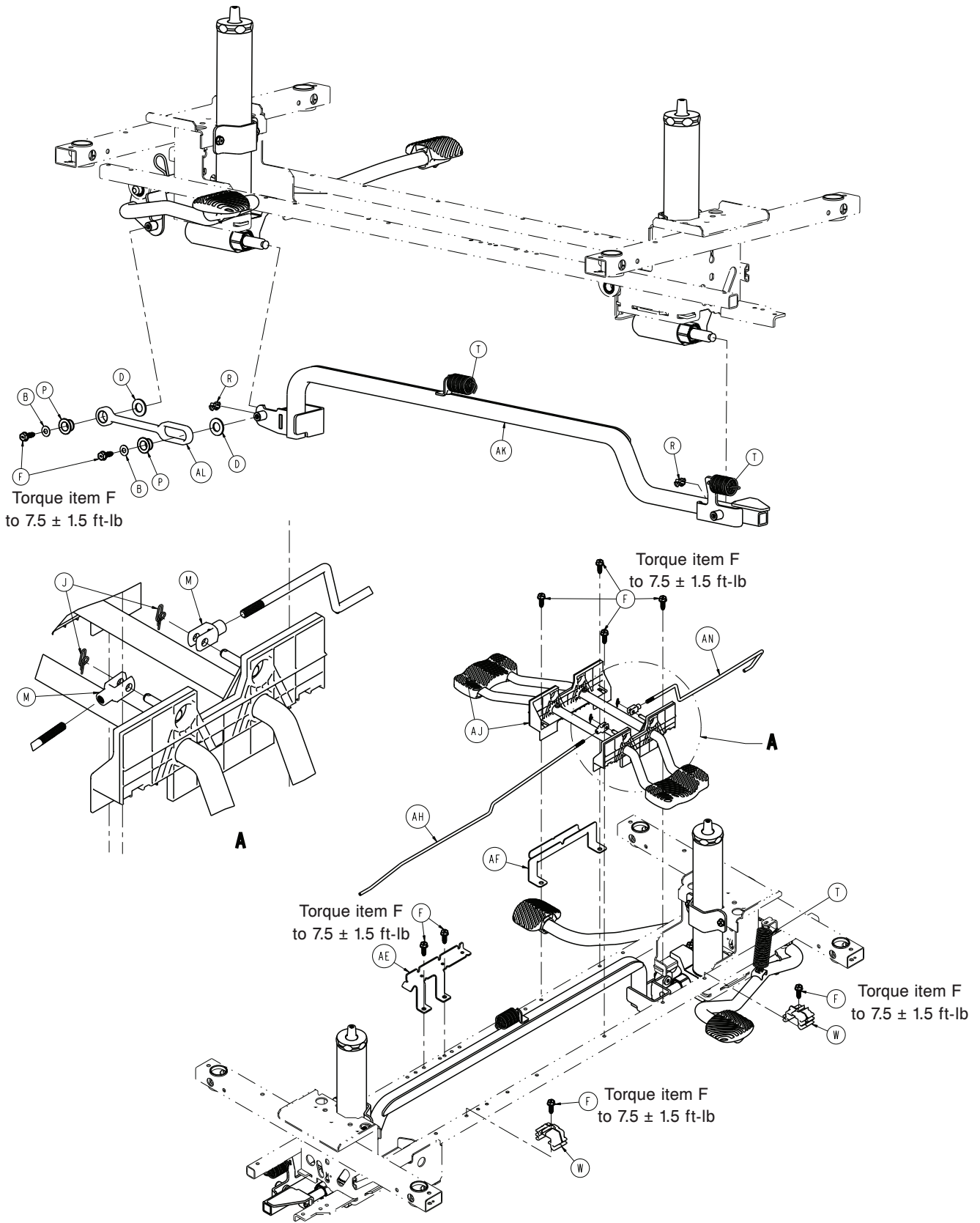

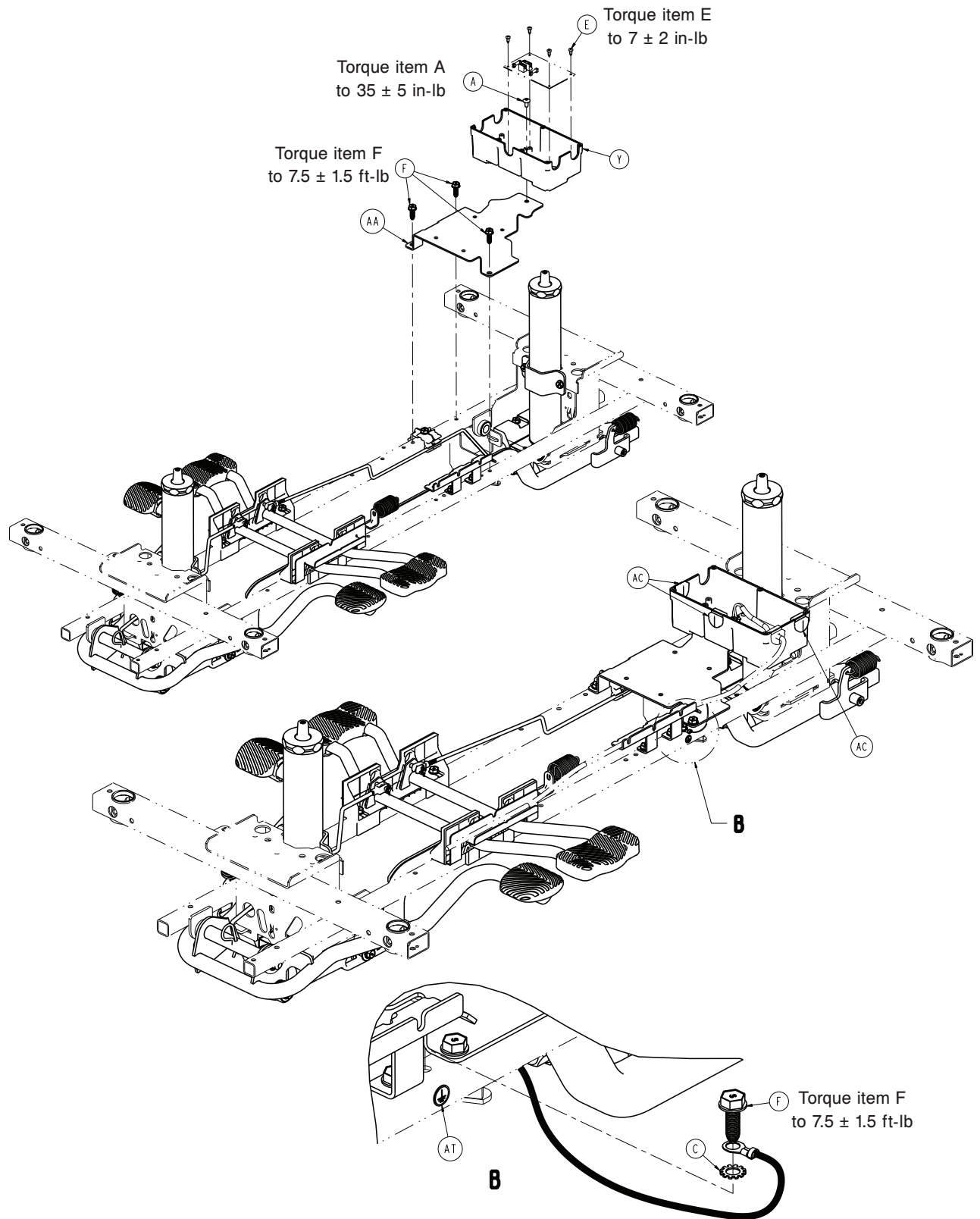

Torque item F
to 7.5 ± 1.5 ft-lb

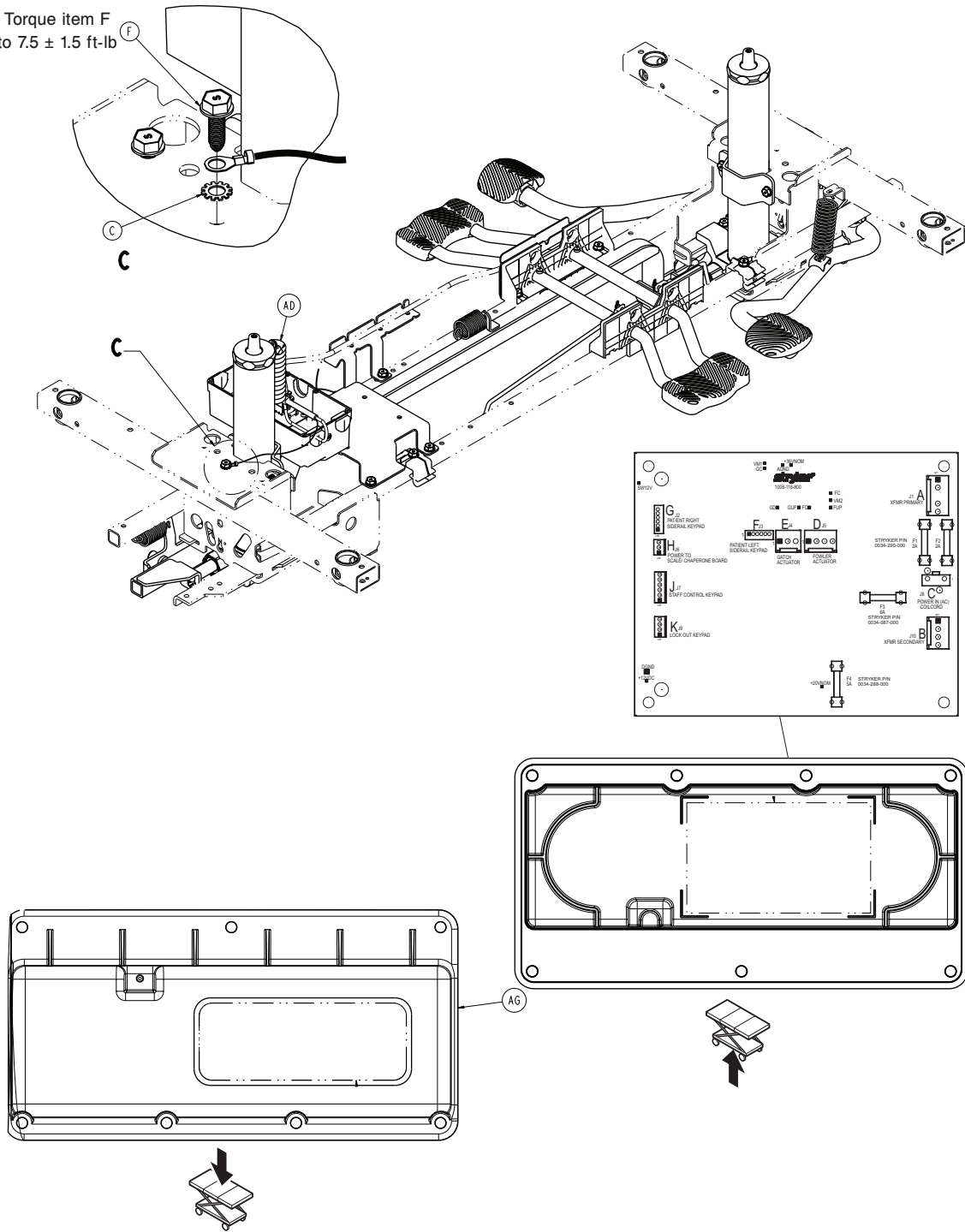

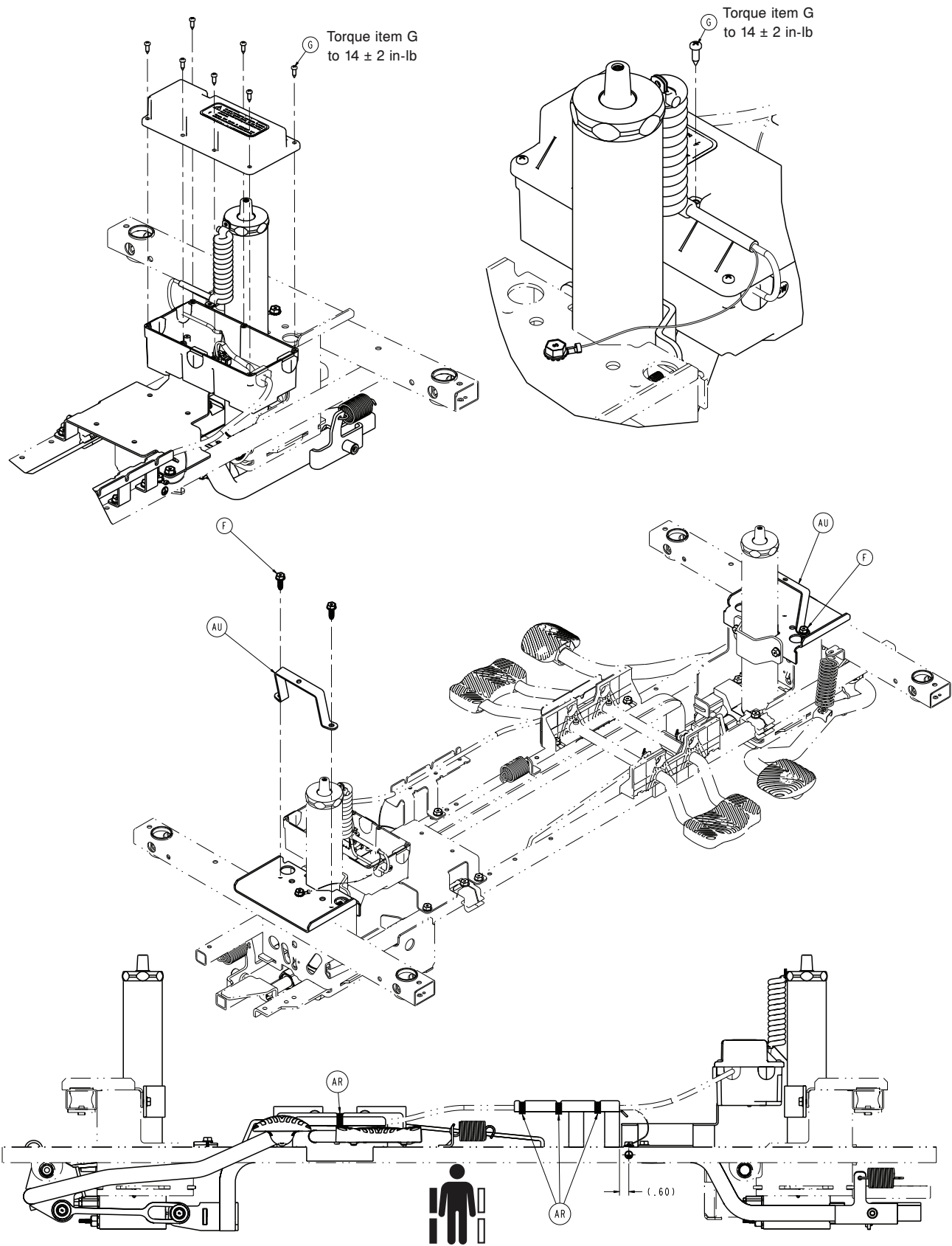

Item	Number	Name	Quantity
A	0007-052-000	Truss head Torx screw	1
B	0011-023-000	Washer	2

Item	Number	Name	Quantity
C	0013-038-000	External tooth lock washer	2
D	0014-071-000	Washer	2
E	0023-260-000	Pan head tapping screw	4
F	0023-288-000	Hex washer head screw	27
G	0023-318-000	Pan head tapping screw	8
J	0027-020-000	Rue ring cotter	2
K	0027-031-000	Hair pin cotter	1
M	0052-909-000	Clevis joint	2
N	0753-002-101	<i>Constant descent jack assembly</i> (page 127)	2
P	0753-005-044	Pump pedal bushing	2
R	0753-005-089	Pump ram plug	2
T	0853-005-009	Return spring	3
U	0853-005-074	Pivot pin	1
V	0853-010-007	Reservoir clamp	2
W	0853-010-215	Release rod bracket	2
Y	1008-002-056	Fifth wheel base control board enclosure bottom	1
AA	1008-002-501	Hydraulic pump mounting bracket	1
AC	1008-002-856	Strain relief	3
AD	1008-202-852	Controller power coil cord	1
AE	1008-004-022	Hose bracket	1
AF	1008-004-023	Release pedal hose support bracket	1
AG	1018-002-055	Base control board top enclosure assembly	1
AH	1105-004-015	Release rod, foot end	1
AJ	1105-004-201	<i>Lowering pedal assembly - 1105-004- 201</i> (page 136)	1
AK	1105-005-035	Pump connecting tube weldment	1
AL	1105-005-075	Pump pedal link	1
AM	1105-005-285	<i>Pump pedal assembly, head end - 1105-005-285</i> (page 137)	1
AN	0853-204-014	Release rod, head end	1
AR	3000-300-113	8" cable tie	4
AT	1008-002-007	Label, ground	1
AU	1105-001-081	Hood strap	2

Lowering pedal assembly - 1105-004-201

Rev A (Reference only)

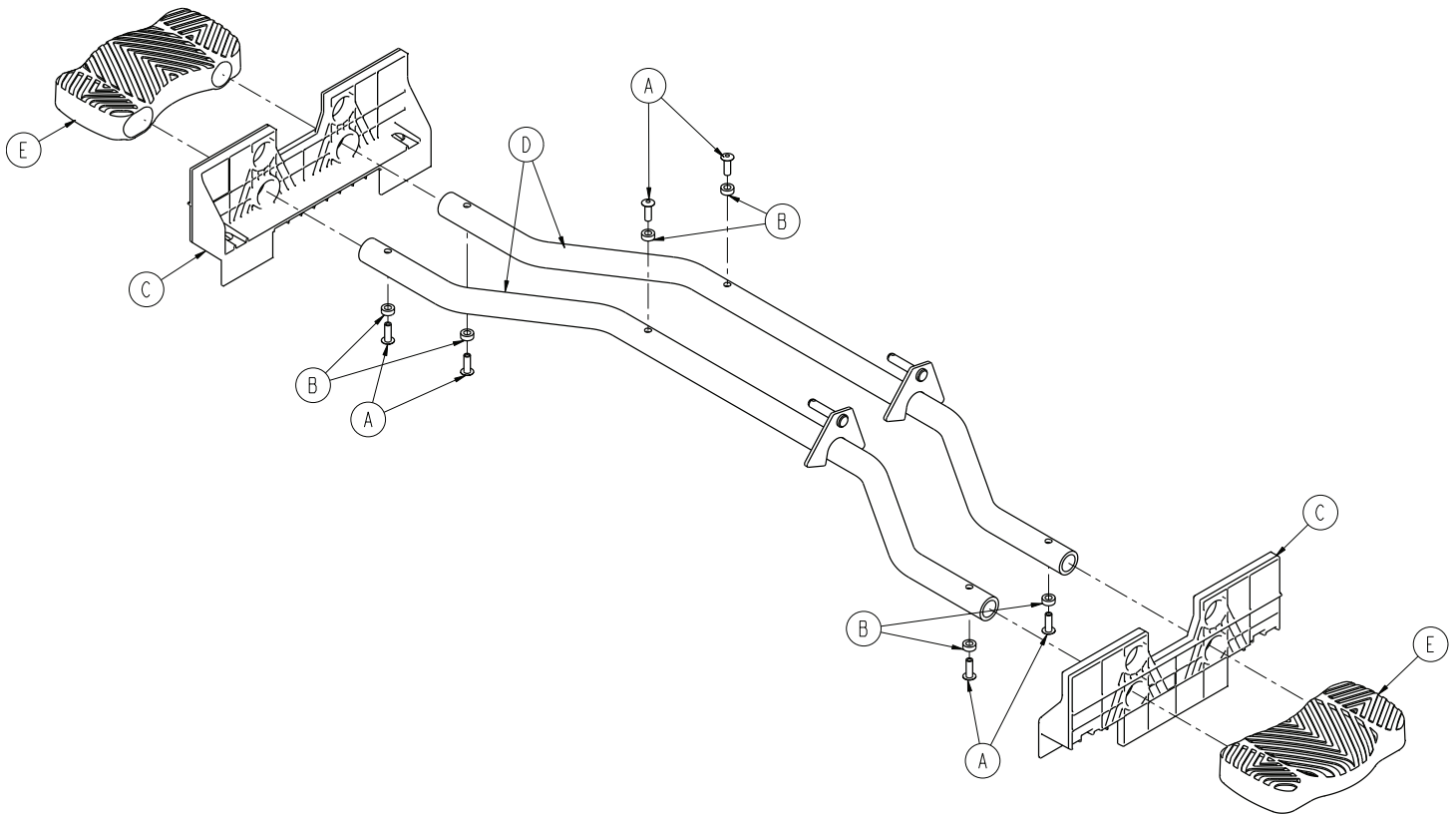

Item	Number	Name	Quantity
A	0025-133-000	Dome head rivet	6
B	0753-004-29	Release pedal standoff	6
C	0853-004-320	Release pedal support	2
D	1105-004-004	Release pedal weldment	2
E	1105-201-127	Short uni-pedal	2

Pump pedal assembly, head end - 1105-005-285

Rev B (Reference only)

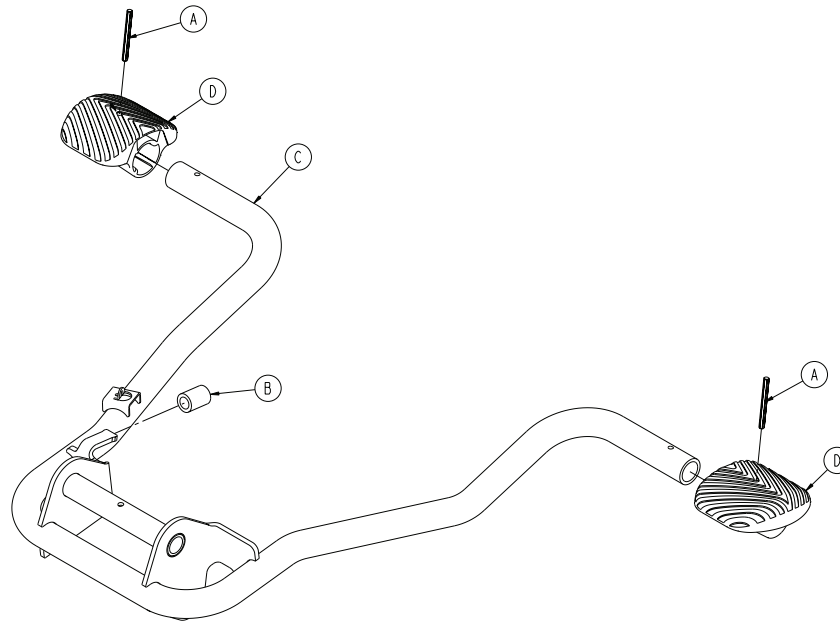

Item	Number	Name	Quantity
A	0026-343-000	Groove pin	2
B	0715-001-140	Vinyl tube	1
C	1105-105-180	Pump pedal weldment, head end	1
D	1105-201-126	Pump pedal	2

Common lift base components, 120V

1008-001-110 Rev C (Reference only)

Number	Name	Quantity
0059-087-000	Capacitor	1
1008-002-015	Pump motor	1
1008-002-810	Lift control PCB assembly	1
1008-002-804	Label, non-lift board fuses	1

Common lift base components, 230V

1008-001-120 Rev B (Reference only)

Number	Name	Quantity
0059-013-000	Capacitor	1
1008-002-013	Capacitor adaptor	1
1008-002-115	Pump motor	1
1008-002-804	Label, base board fuses	1
1008-002-830	International lift control PCB assembly	1
1008-002-006	Double-sided tape	1

Dual-sided hydraulics, powered

1008-005-560 Rev AA (Reference only)

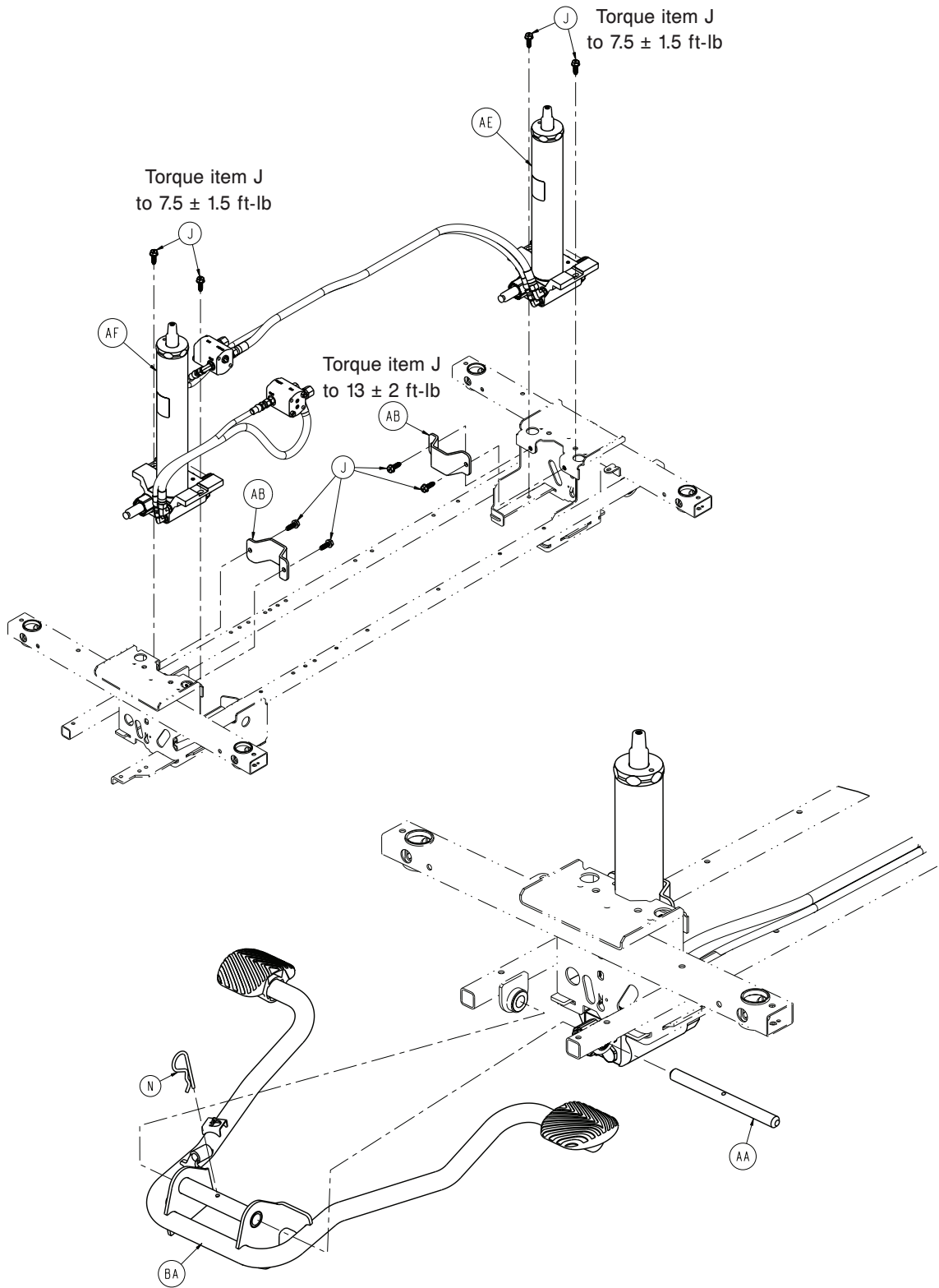

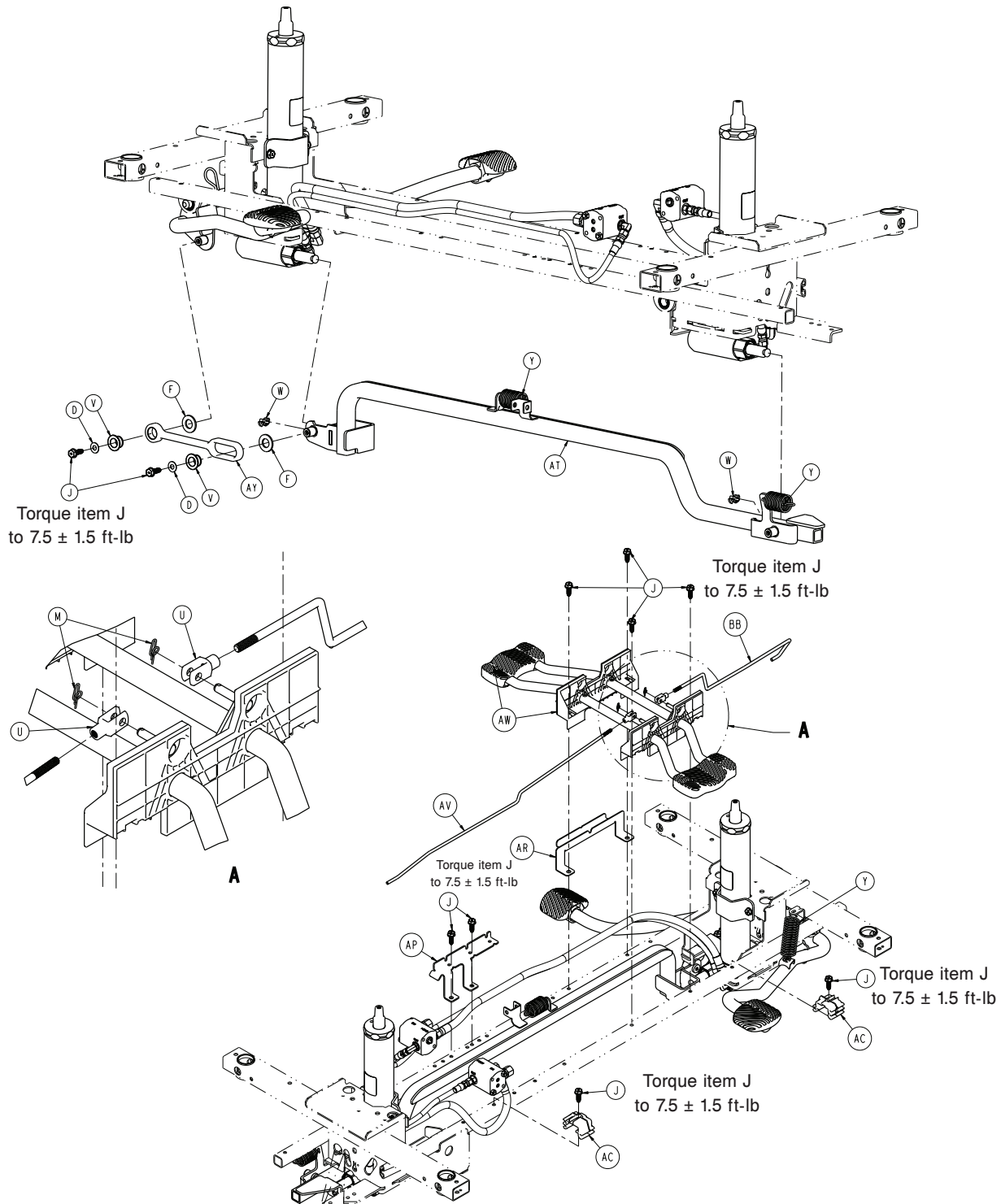

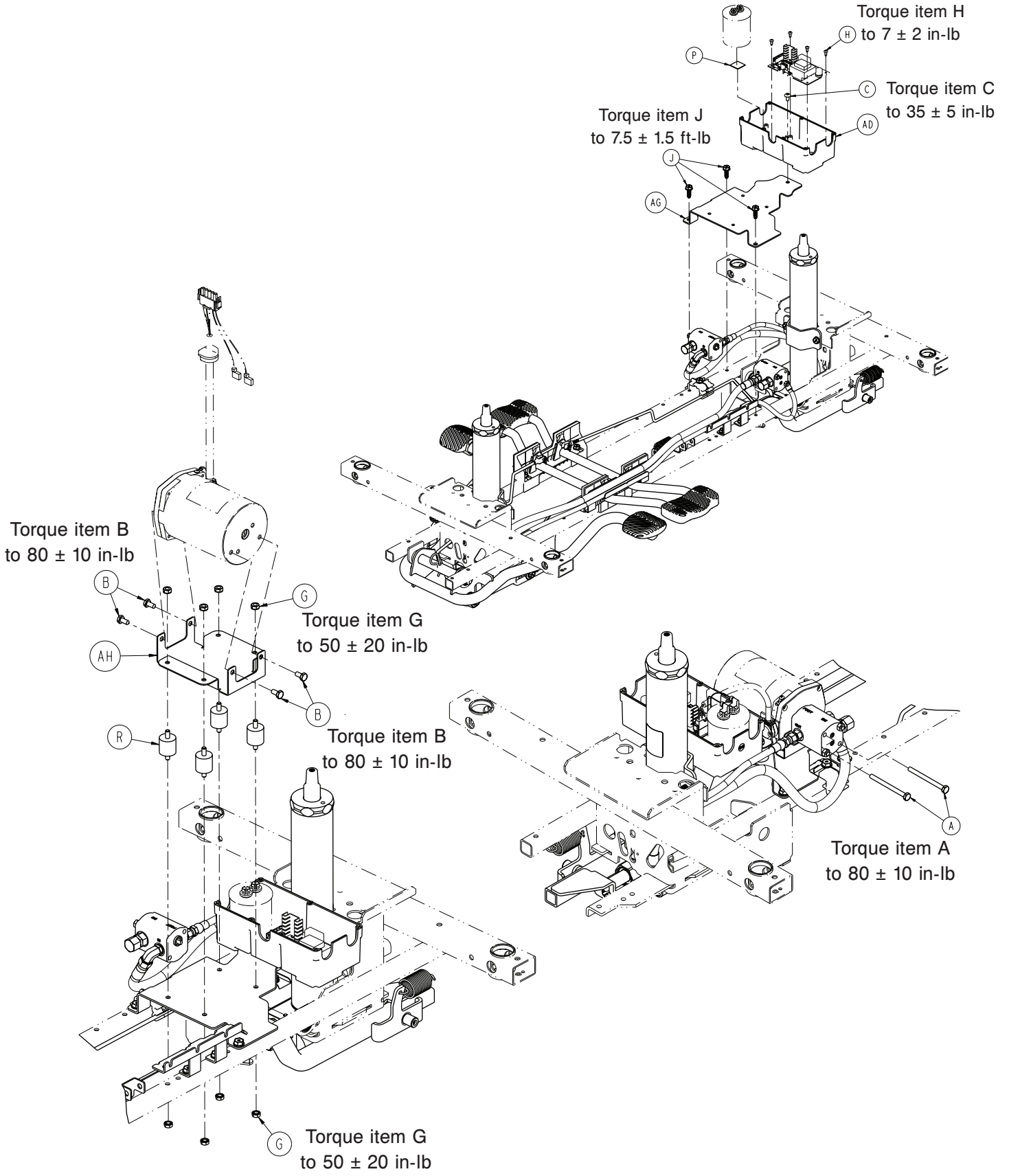

Torque item J
to 7.5 ± 1.5 ft-lb

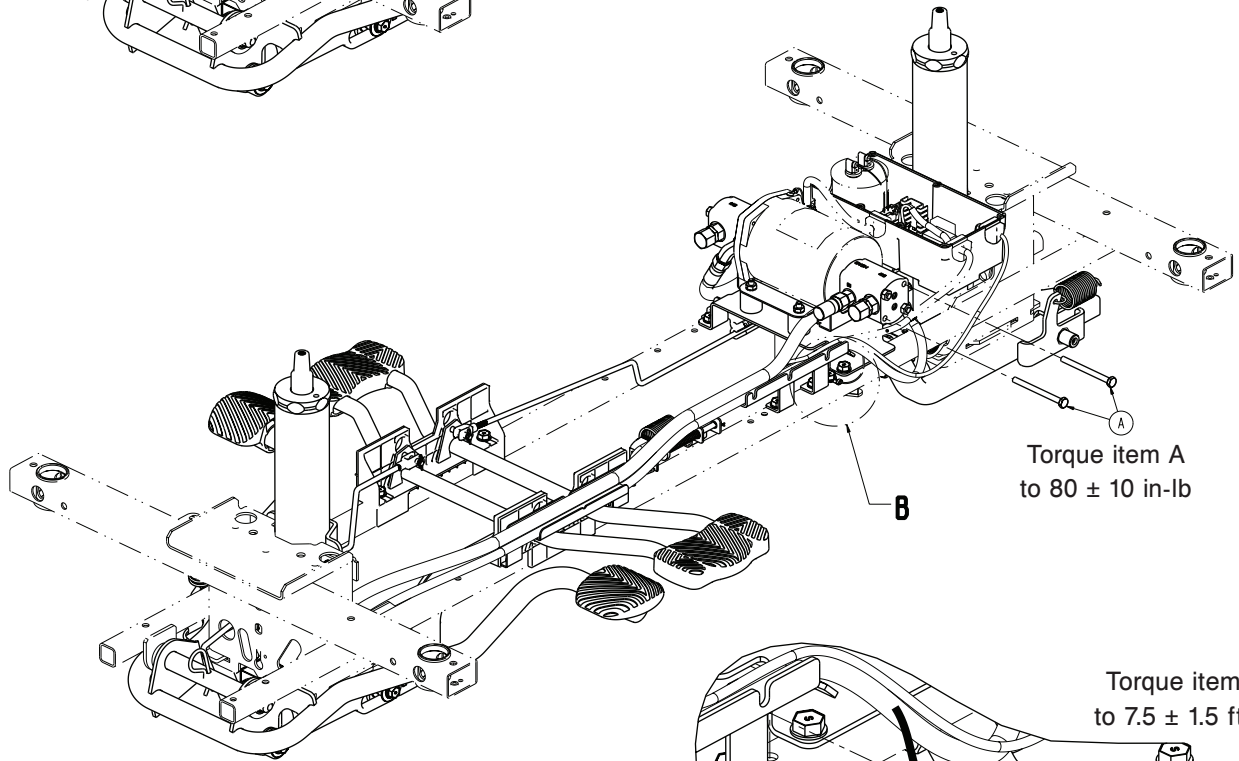
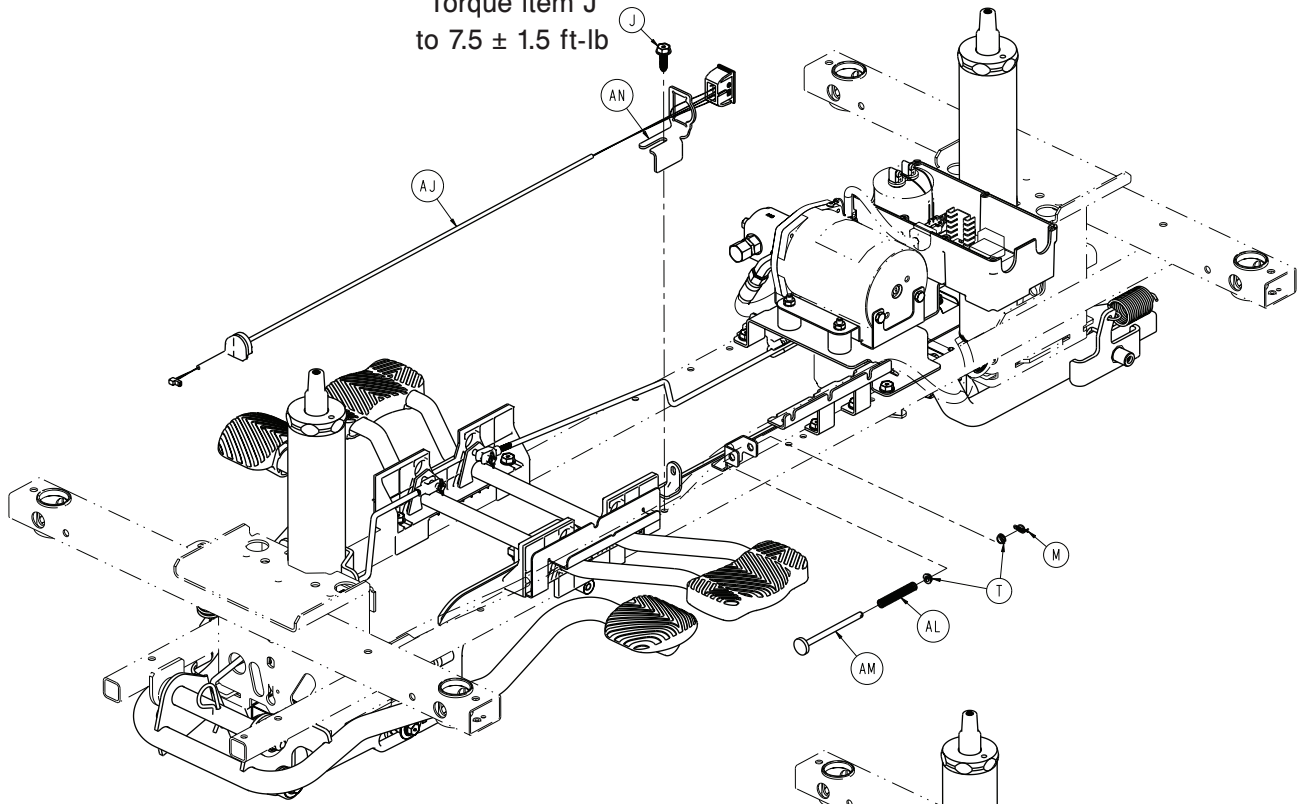

Torque item A
to 80 ± 10 in-lb

Torque item J
to 7.5 ± 1.5 ft-lb

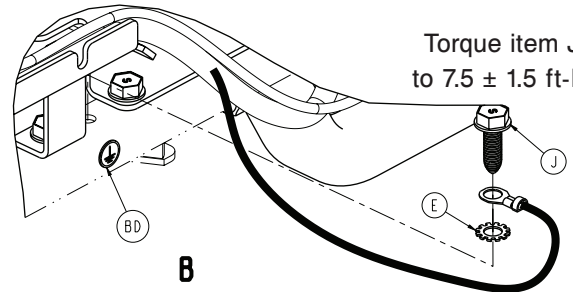

Torque item J
to 7.5 ± 1.5 ft-lb

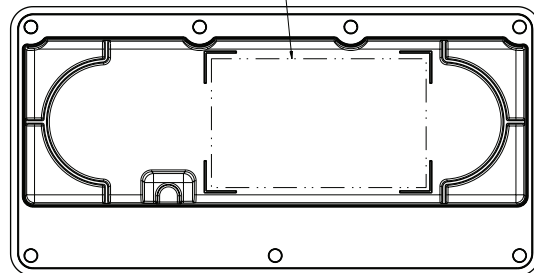
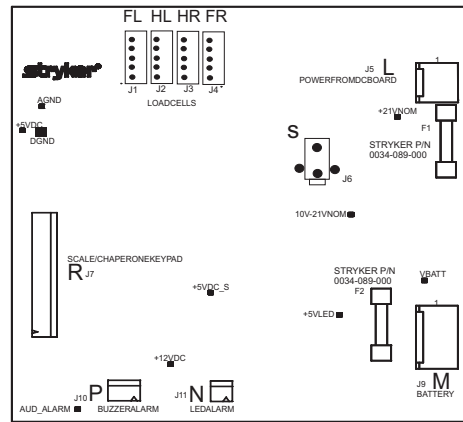
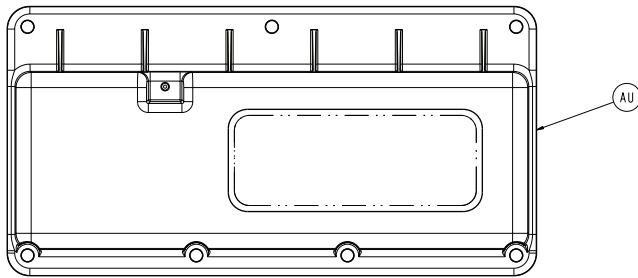
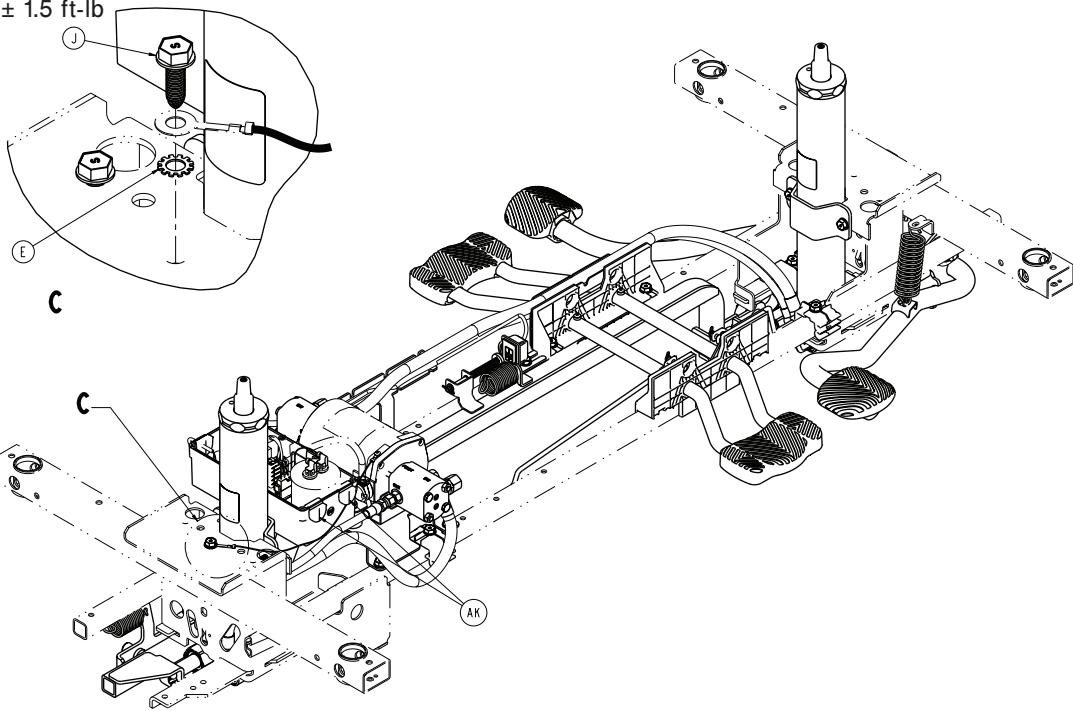

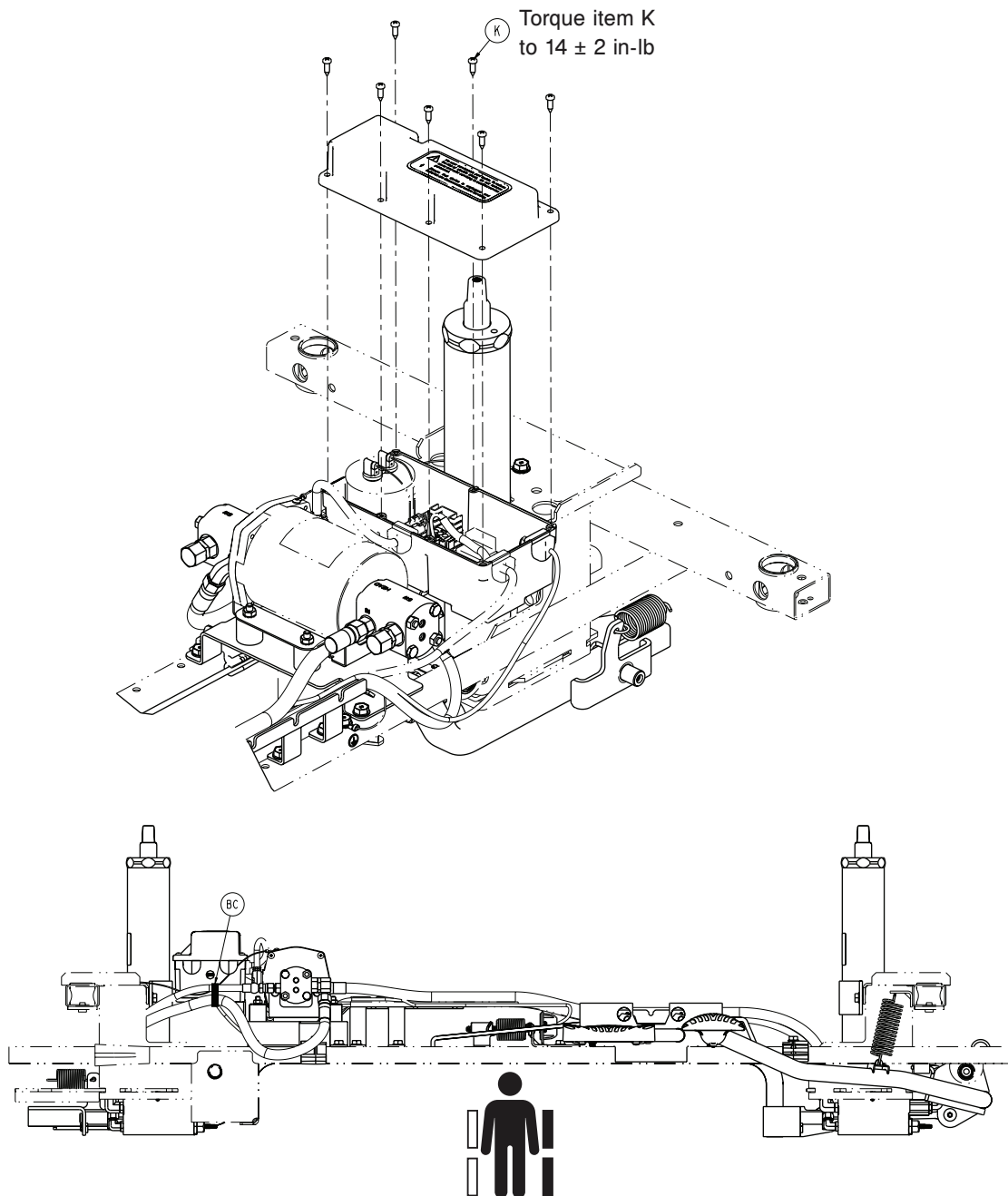

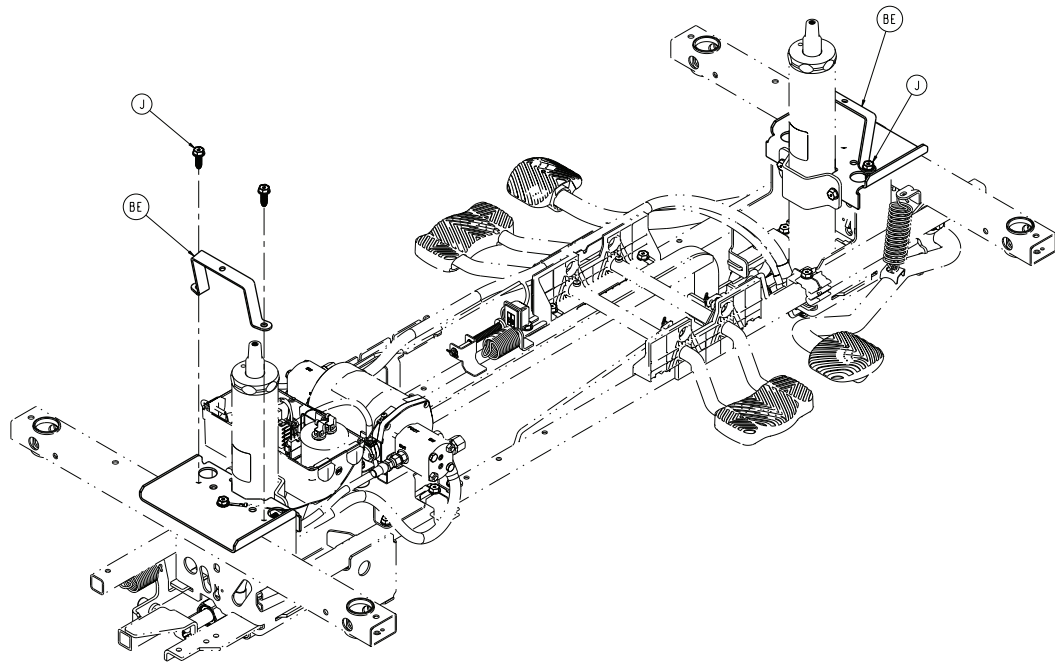
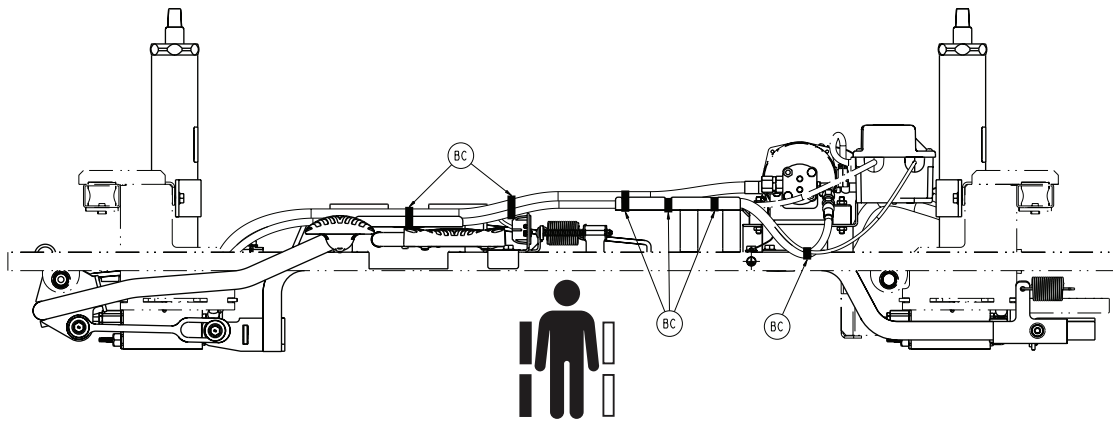

Item	Number	Name	Quantity
A	0003-397-000	Hex head cap screw	4
B	0003-207-000	Hex head cap screw	4
C	0007-052-000	Truss head Torx screw	1
D	0011-023-000	Washer	2
E	0013-038-000	External tooth lock washer	2
F	0014-071-000	Washer	2
G	0016-006-000	Hex kep nut	8
H	0023-260-000	Pan head tapping screw	4
J	0023-288-000	Hex washer head screw	28
K	0023-318-000	Pan head tapping screw	7
M	0027-020-000	Rue ring cotter	3
N	0027-031-000	Hair pin cotter	1
P	1008-002-006	Double-sided tape	1
R	0052-115-000	Sandwich mount	4
T	0052-801-000	Nyliner bearing	2
U	0052-909-000	Clevis joint	2
V	0753-005-044	Pump pedal bushing	2

Item	Number	Name	Quantity
W	0753-005-089	Pump ram plug	2
Y	0853-005-009	Return spring	3
AA	0853-005-074	Pivot pin	1
AB	0853-010-007	Reservoir clamp	2
AC	0853-010-215	Release rod bracket	2
AD	1008-002-056	Fifth wheel base control board enclosure bottom	1
AE	1008-002-101	Constant descent jack assembly, head end	1
AF	1008-002-201	Constant descent jack assembly, foot end	1
AG	1008-002-501	Hydraulic pump mounting bracket	1
AH	1008-002-502	Pump motor bracket	1
AJ	1008-002-851	Lift switch cable	1
AK	1008-002-856	Strain relief	2
AL	1008-004-018	Lift switch plunger spring	1
AM	1008-004-019	Plunger rod	1
AN	1008-004-021	Switch bracket	1
AP	1008-004-022	Hose bracket	1
AR	1008-004-023	Release pedal hose support bracket	1
AT	1008-005-135	Pump connecting tube weldment	1
AU	1018-002-055	Base control board top enclosure assembly	1
AV	1105-004-015	Release rod, foot end	1
AW	1105-004-201	<i>Lowering pedal assembly - 1105-004-201 (page 136)</i>	1
AY	1105-005-075	Pump pedal link	1
BA	1105-005-285	<i>Pump pedal assembly, head end - 1105-005-285 (page 137)</i>	1
BB	0853-204-014	Release rod, head end	1
BC	3000-300-113	8" cable tie	7
BD	1008-002-007	Label, ground	1
BE	1105-001-081	Hood strap	2

Dual-sided hydraulics, electric lift/electric litter

1008-005-510 Rev AA (Reference only)

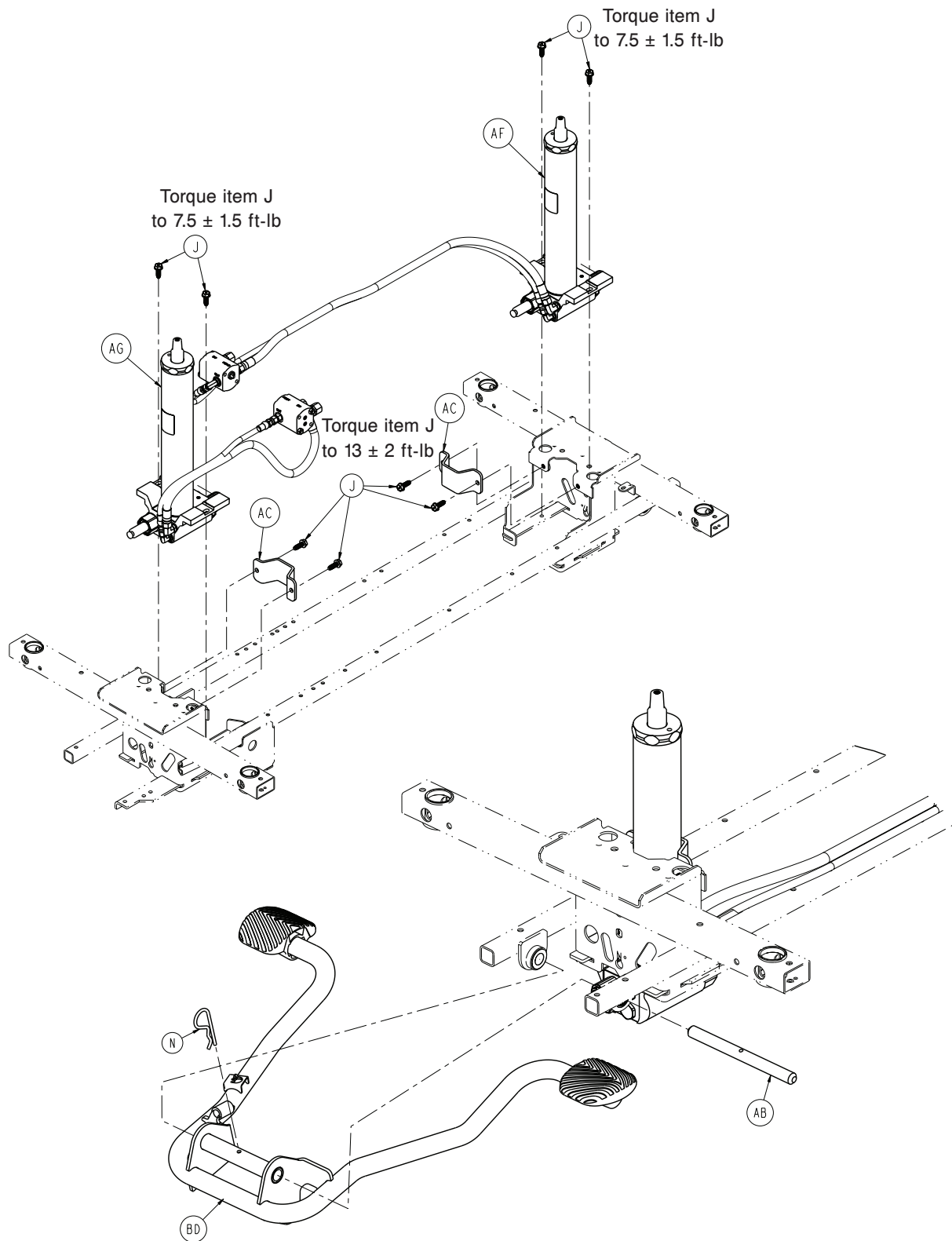

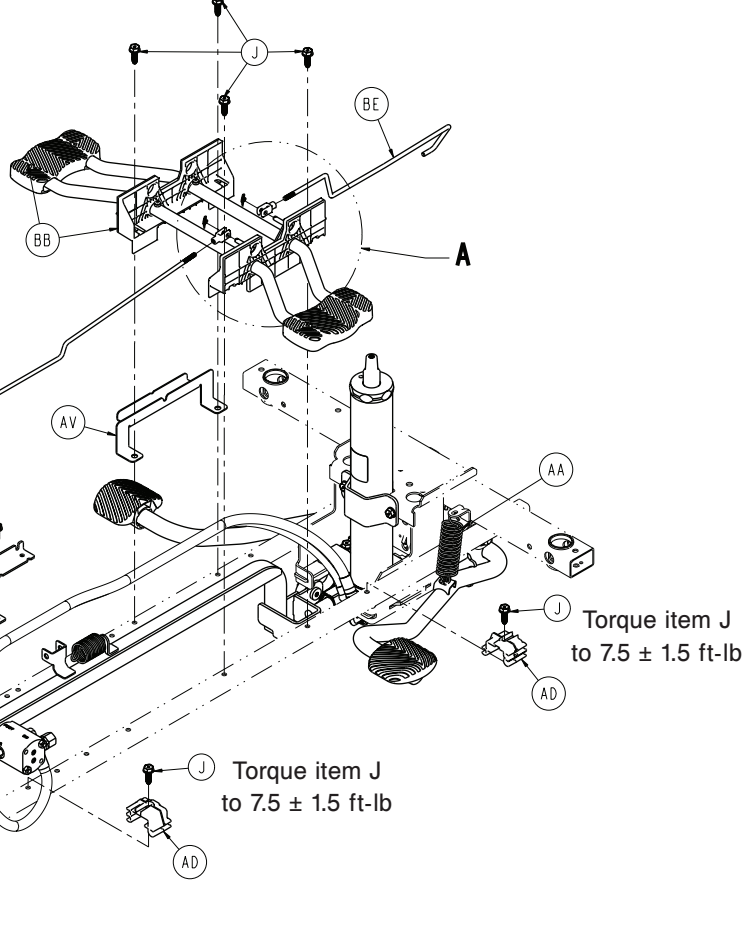
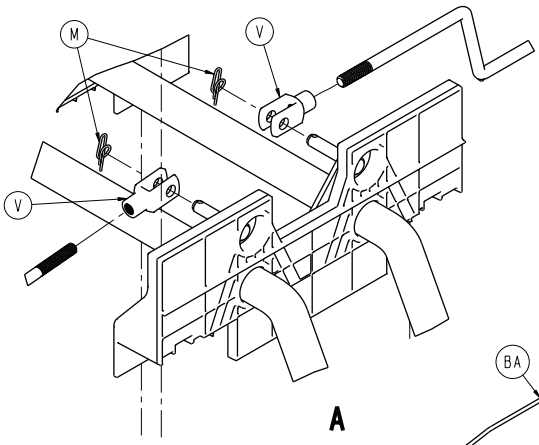
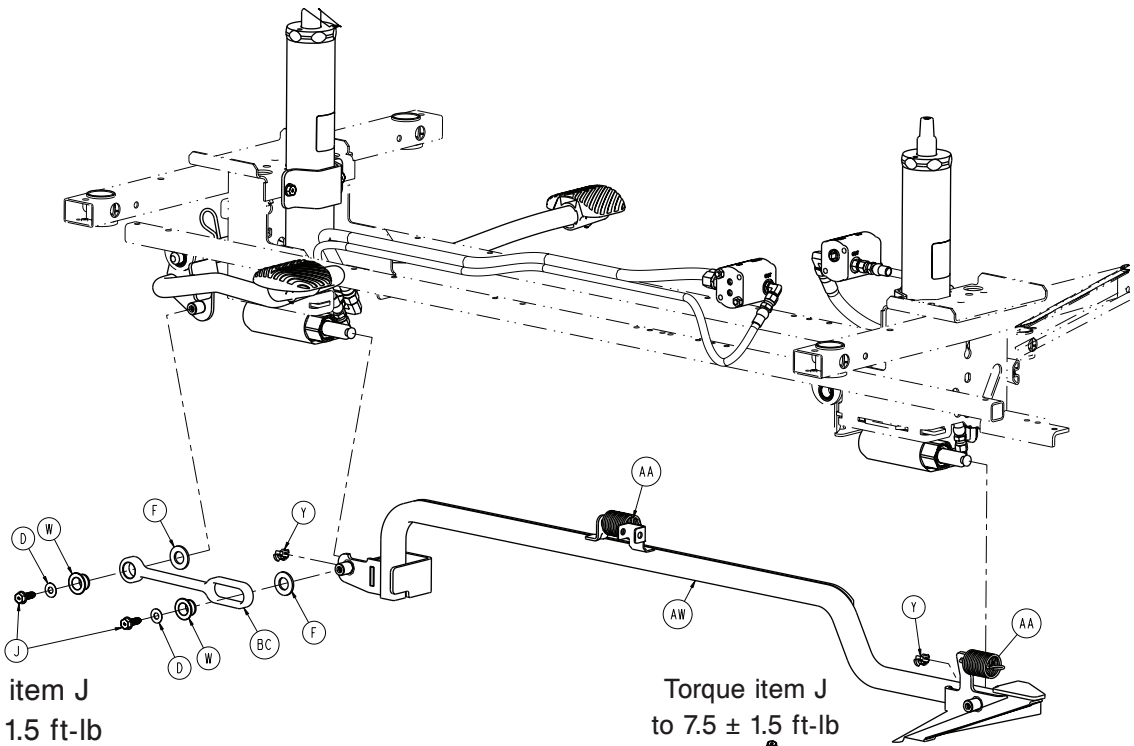

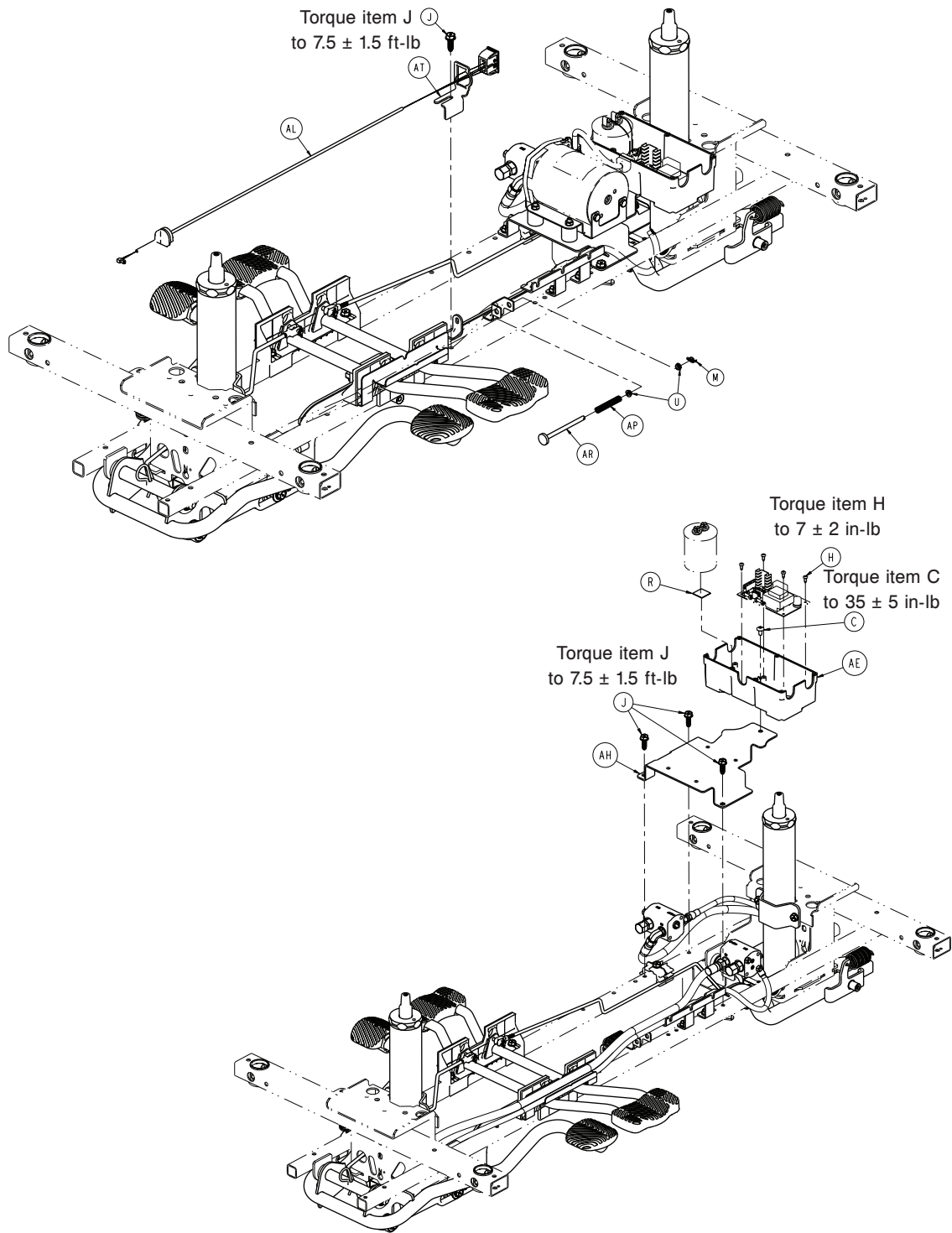

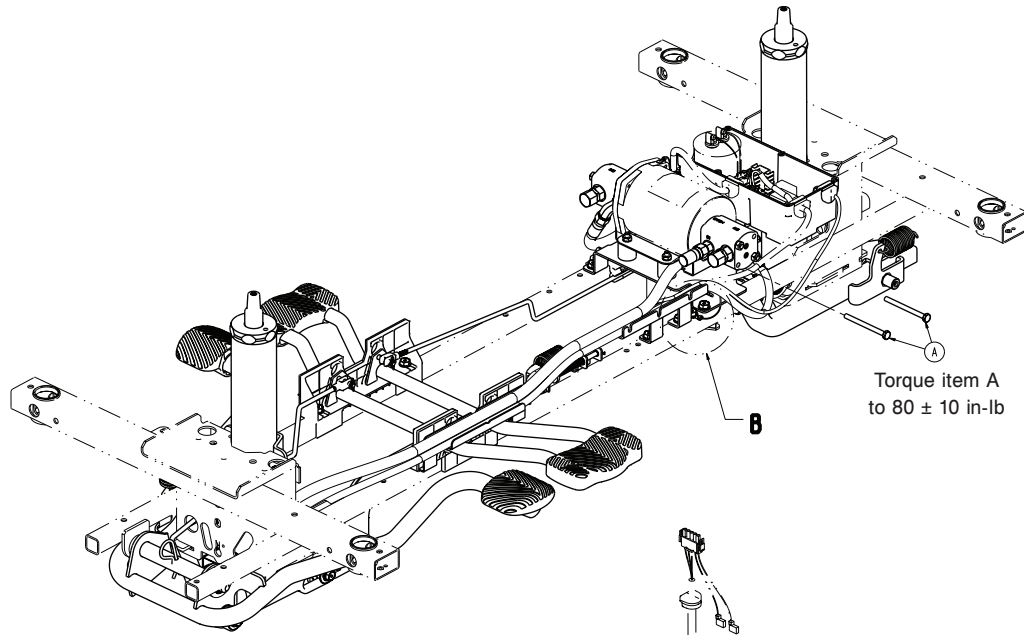

Torque item A
to 80 ± 10 in-lb

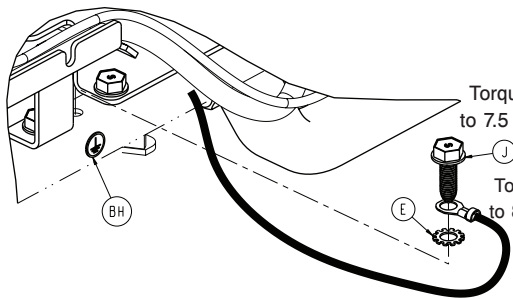

Torque item J
to 7.5 ± 1.5 ft-lb

Torque item B
to 80 ± 10 in-lb

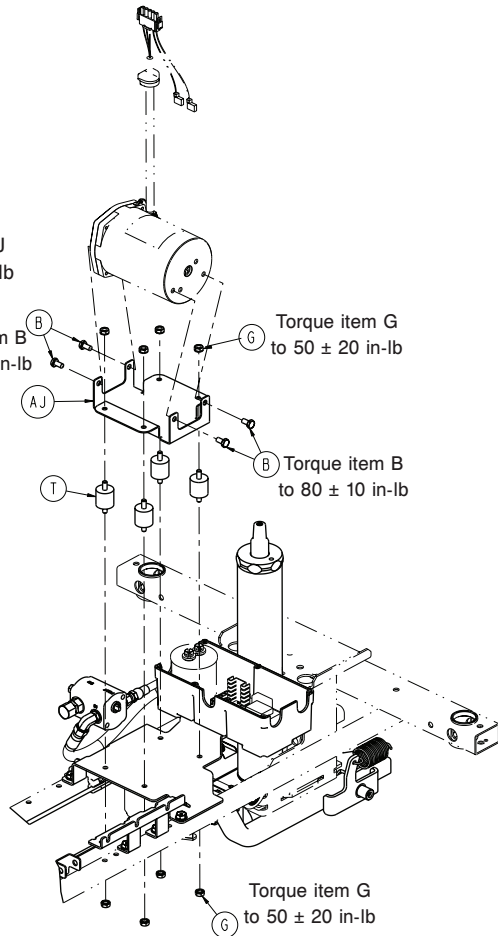

Torque item G
to 50 ± 20 in-lb

Torque item B
to 80 ± 10 in-lb

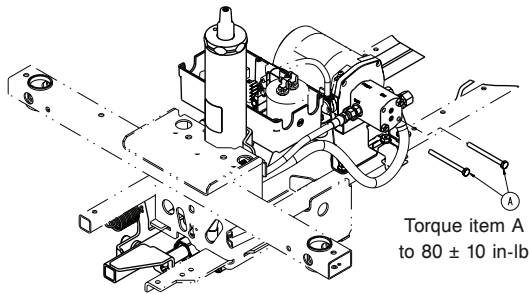

Torque item A
to 80 ± 10 in-lb

Torque item G
to 50 ± 20 in-lb

Torque item J
to 7.5 ± 1.5 ft-lb

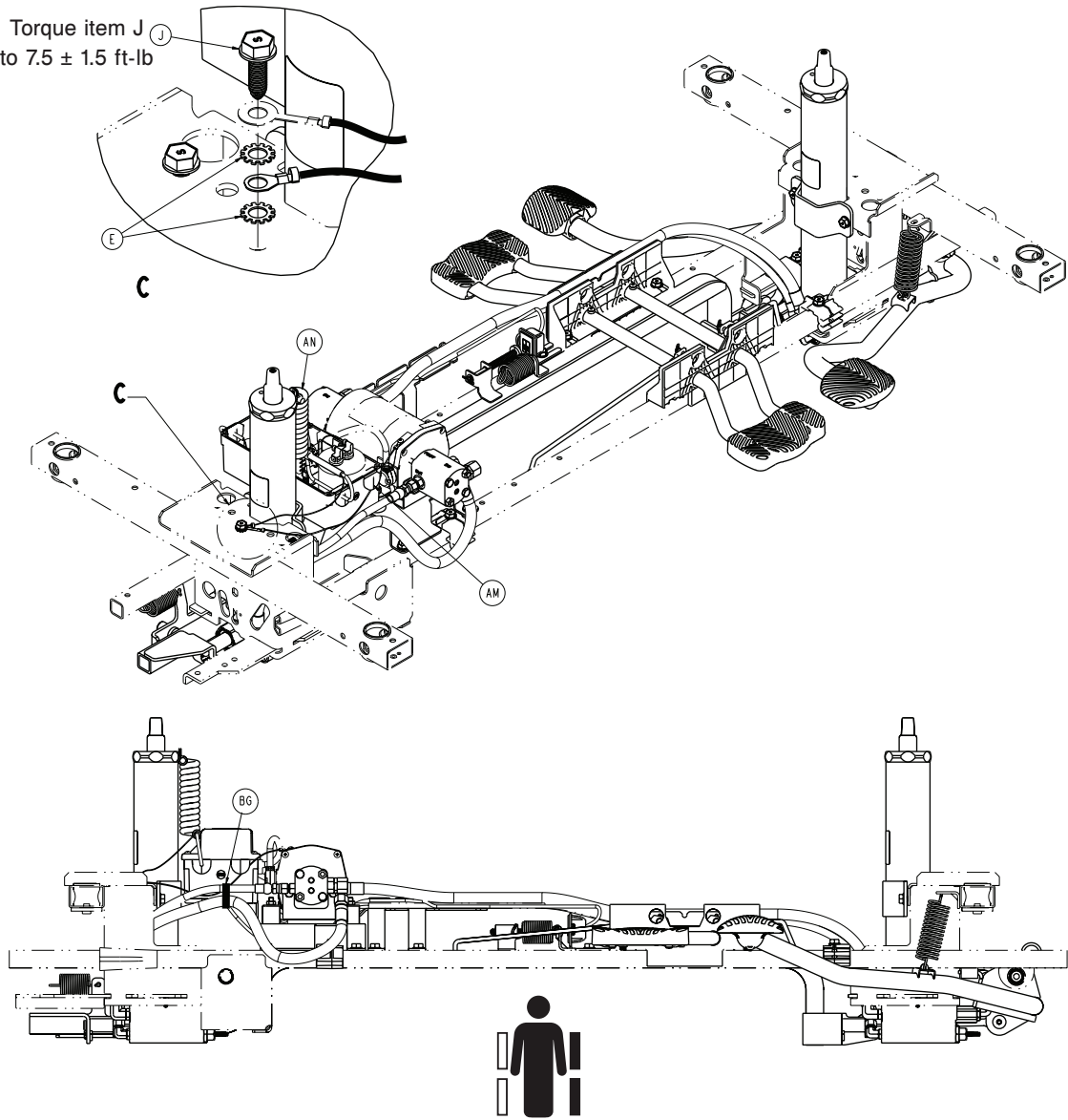

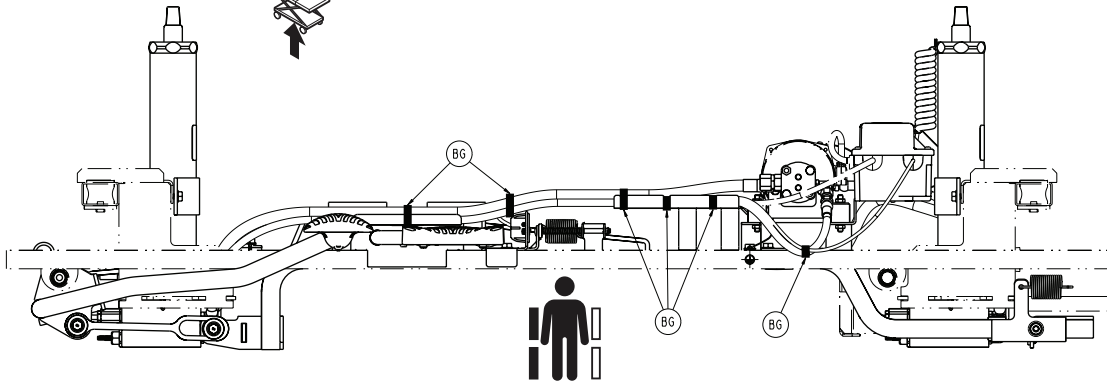
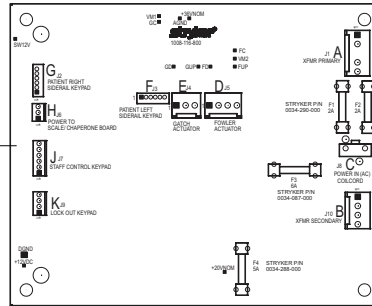
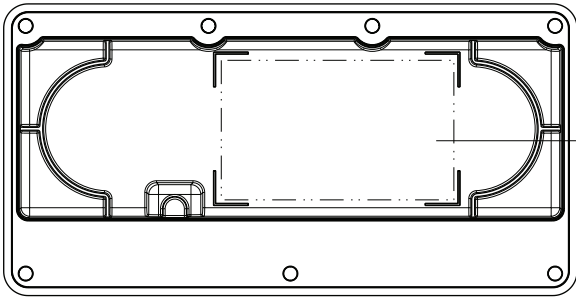
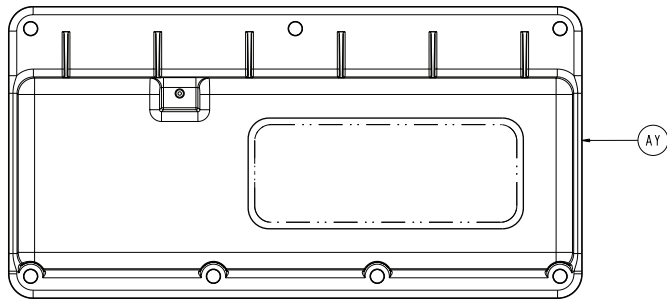

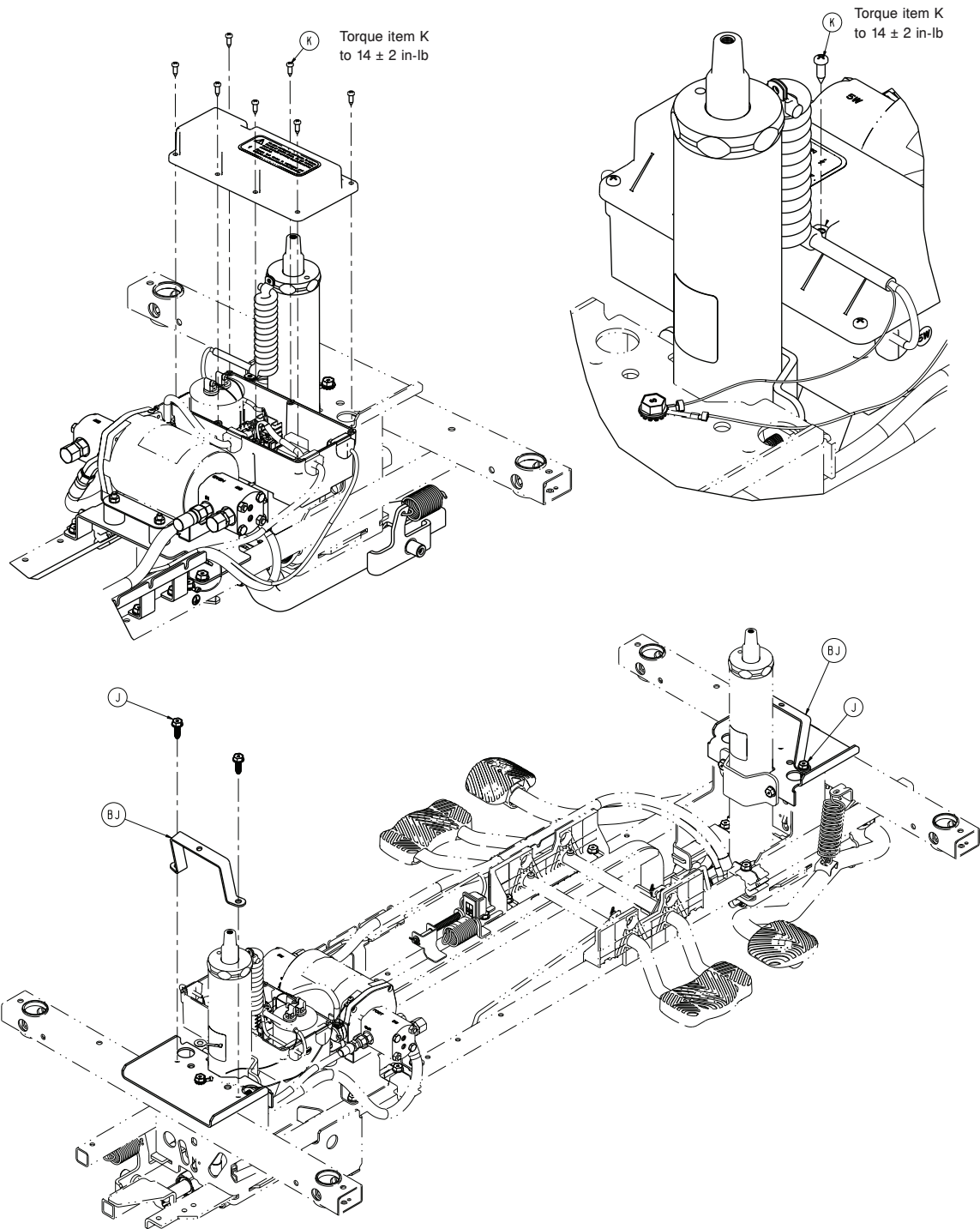

Item	Number	Name	Quantity
A	0003-397-000	Hex head cap screw	4
B	0003-207-000	Hex head cap screw	4
C	0007-052-000	Truss head Torx screw	1
D	0011-023-000	Washer	2
E	0013-038-000	External tooth lock washer	3
F	0014-071-000	Washer	2
G	0016-006-000	Hex kep nut	8

Item	Number	Name	Quantity
H	0023-260-000	Pan head tapping screw	4
J	0023-288-000	Hex washer head screw	28
K	0023-318-000	Pan head tapping screw	8
M	0027-020-000	Rue ring cotter	3
N	0027-031-000	Hair pin cotter	1
R	1008-002-006	Double-sided tape	1
T	0052-115-000	Sandwich mount	4
U	0052-801-000	Nyliner bearing	2
V	0052-909-000	Clevis joint	2
W	0753-005-044	Pump pedal bushing	2
Y	0753-005-089	Pump ram plug	2
AA	0853-005-009	Return spring	3
AB	0853-005-074	Pivot pin	1
AC	0853-010-007	Reservoir clamp	2
AD	0853-010-215	Release rod bracket	2
AE	1008-002-056	Fifth wheel base control board enclosure bottom	1
AF	1008-002-101	Constant descent jack assembly, head end	1
AG	1008-002-201	Constant descent jack assembly, foot end	1
AH	1008-002-501	Hydraulic pump mounting bracket	1
AJ	1008-002-502	Pump motor bracket	1
AL	1008-002-851	Lift switch cable	1
AM	1008-002-856	Strain relief	1
AN	1008-202-852	Controller power coil cord	1
AP	1008-004-018	Lift switch plunger spring	1
AR	1008-004-019	Plunger rod	1
AT	1008-004-021	Switch bracket	1
AU	1008-004-022	Hose bracket	1
AV	1008-004-023	Release pedal hose support bracket	1
AW	1008-005-135	Pump connecting tube weldment	1
AY	1018-002-055	Base control board top enclosure assembly	1
BA	1105-004-015	Release rod, foot end	1
BB	1105-004-201	<i>Lowering pedal assembly - 1105-004-201 (page 136)</i>	1

Item	Number	Name	Quantity
BC	1105-005-075	Pump pedal link	1
BD	1105-005-285	<i>Pump pedal assembly, head end - 1105-005-285 (page 137)</i>	1
BE	0853-204-014	Release rod, head end	1
BG	3000-300-113	8" cable tie	7
BH	1008-002-007	Label, ground	1
BJ	1105-001-081	Hood strap	2

Standard cord assembly

1008-146-060 Rev A (Reference only)

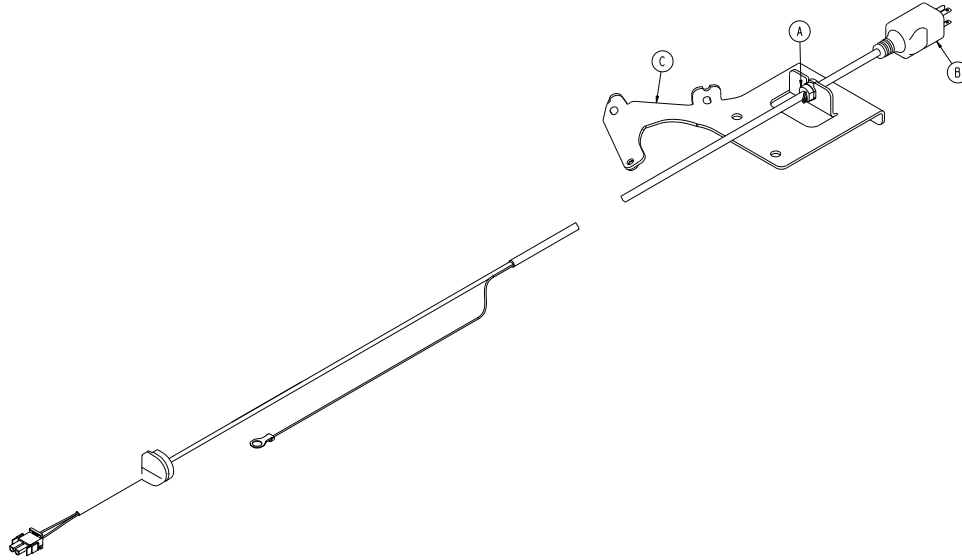

Item	Number	Name	Quantity
A	0034-406-000	Straight strain relief bushing	1
B	1008-046-061	Power cord	1
C	1008-146-033	Power cord bracket	1

Standard power cord assembly, type E

1008-146-070 Rev A (Reference only)

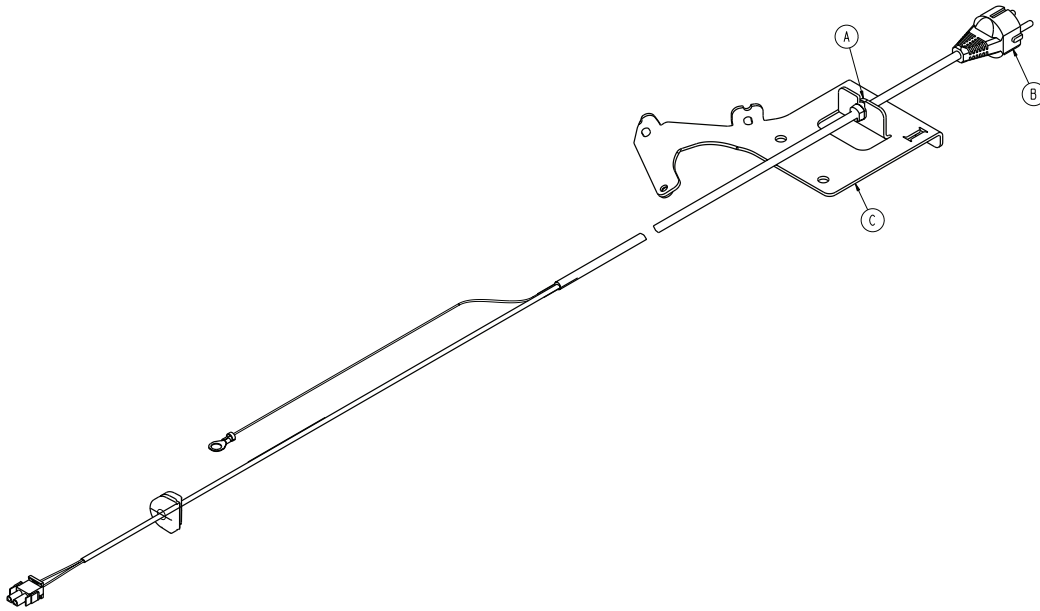

Item	Number	Name	Quantity
A	0034-447-000	Strain relief bushing	1
B	1008-046-161	Power cord, type E, international	1
C	1125-146-033	Power cord bracket	1

Standard power cord assembly, type F

1008-146-080 Rev A (Reference only)

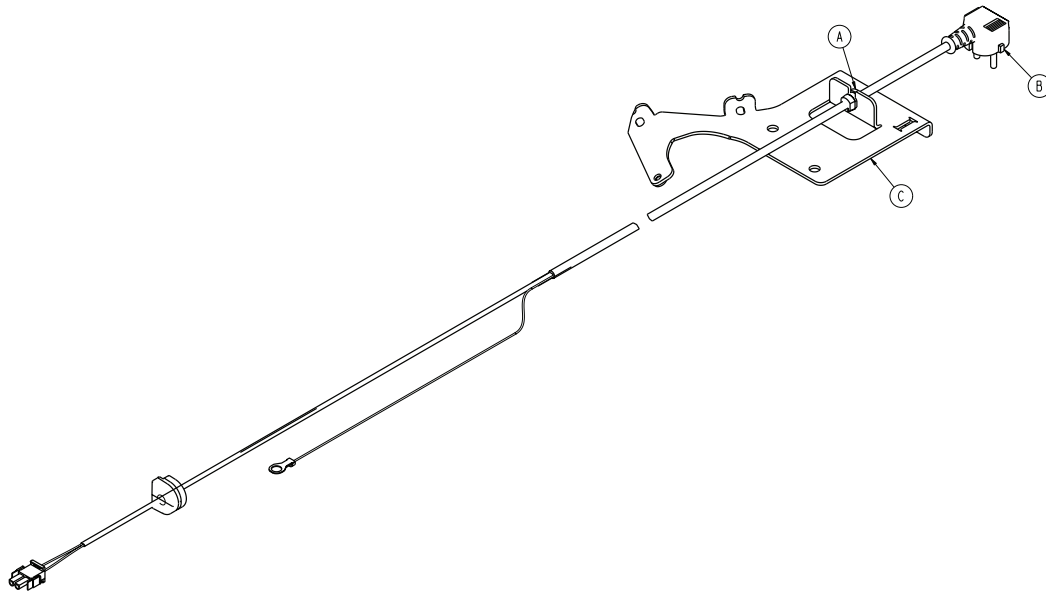

Item	Number	Name	Quantity
A	0034-447-000	Strain relief bushing	1
B	1008-046-361	Power cord, type F, international	1
C	1125-146-033	Power cord bracket	1

Standard power cord assembly, type G

1008-146-090 Rev A (Reference only)

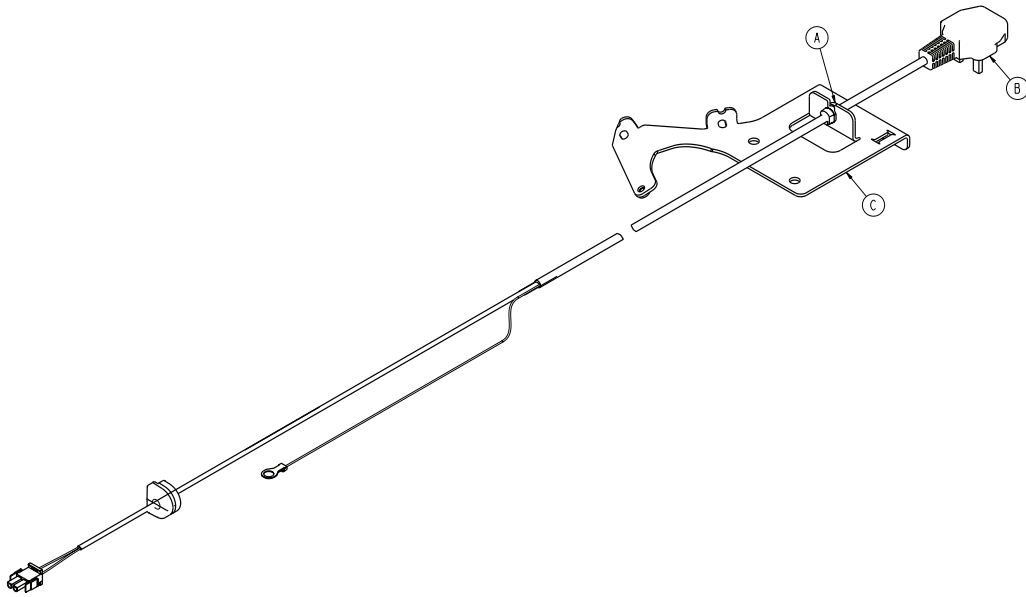

Item	Number	Name	Quantity
A	0034-447-000	Strain relief bushing	1
B	1008-046-261	Power cord, type G, international	1
C	1125-146-033	Power cord bracket	1

Standard power cord assembly, type I

1008-146-100 Rev A (Reference only)

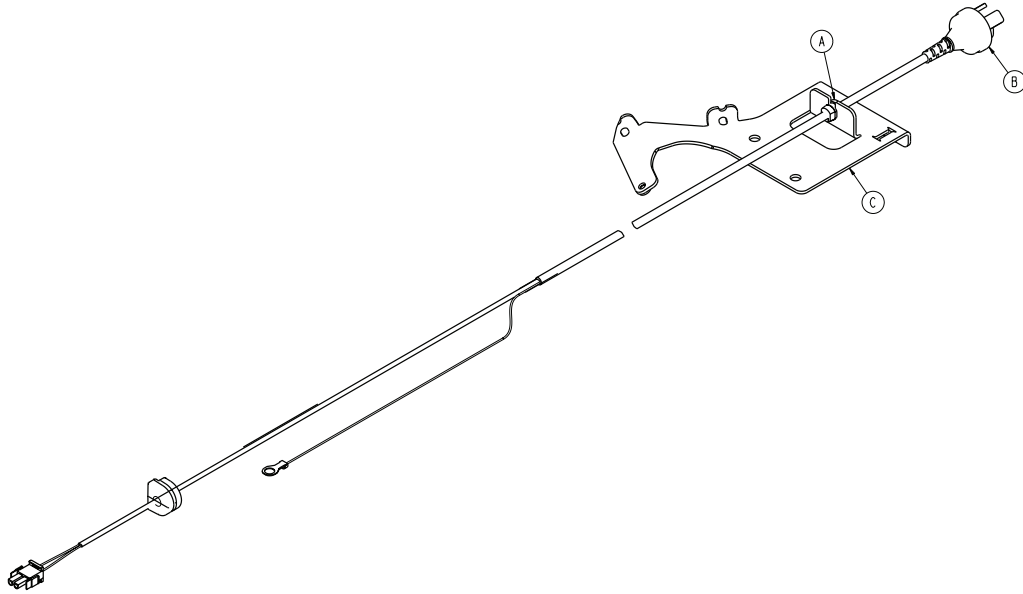

Item	Number	Name	Quantity
A	0034-447-000	Strain relief bushing	1
B	1008-046-461	Power cord, type I, international	1
C	1125-146-033	Power cord bracket	1

Cord reel assembly option

1008-146-050 Rev A (Reference only)

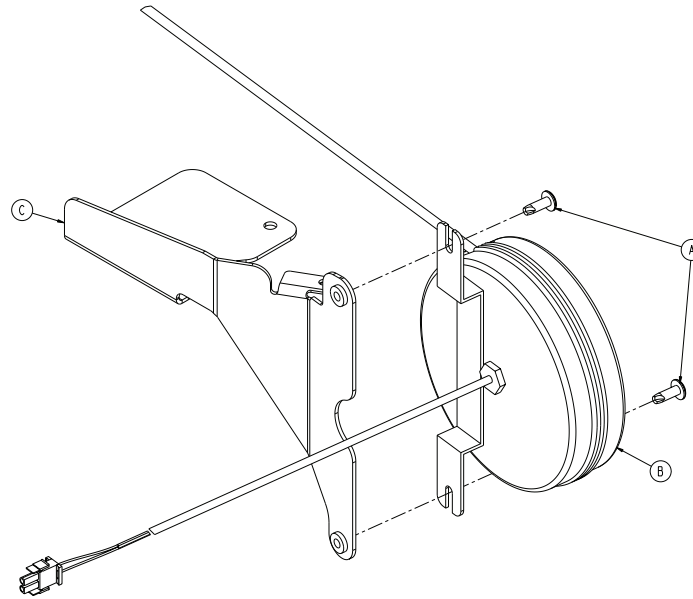

Item	Number	Name	Quantity
A	0007-065-000	Tap head screw	2
B	1008-046-051	Cord reel	1
C	1008-146-052	Cord reel bracket	1

Fifth wheel hood/bellow assembly, non-electric

1105-224-100 Rev AA (Reference only)

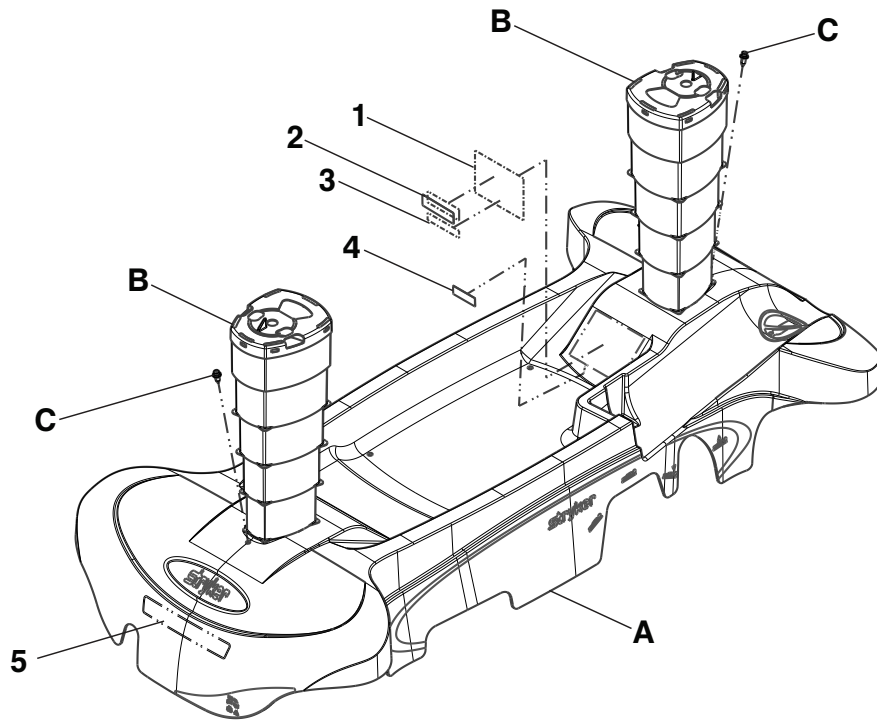

Item	Description
1	Label, specification
2	Label, DPM
3	Label, CFR
4	Label, DOM
5	Label, department

Item	Number	Name	Quantity
A	1105-101-035	Standard hood	1
B	1105-101-815	Bellows assembly	2
C	1040-010-092	Scrulok assembly	2

Fifth wheel hood/bellow assembly

1105-225-100 Rev AB (Reference only)

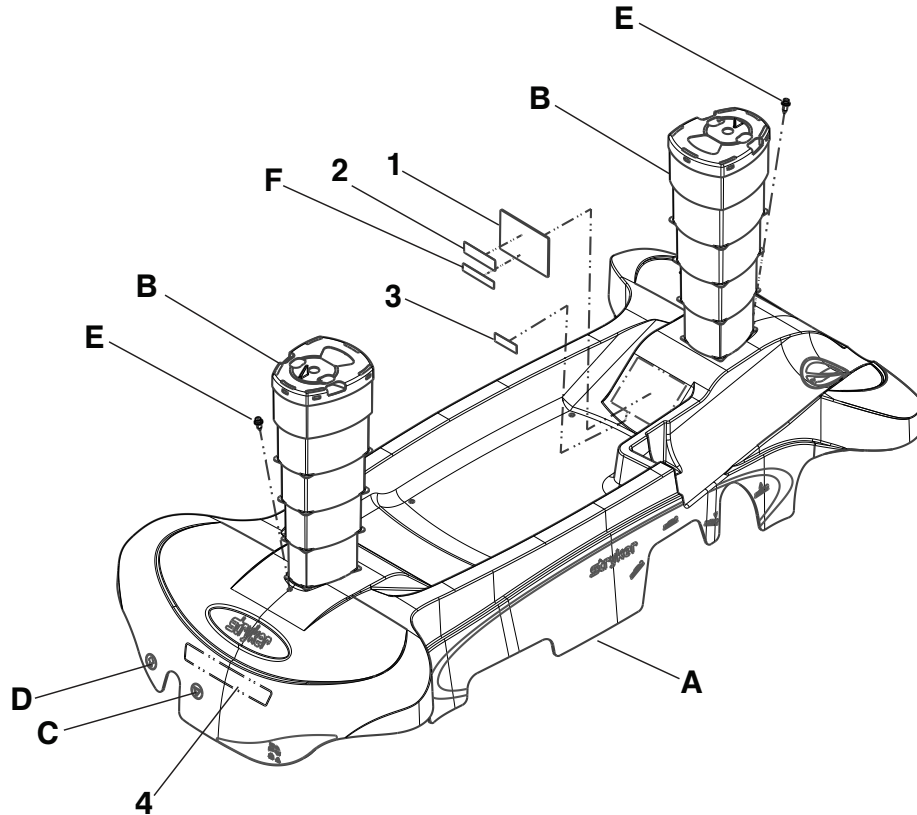

Item	Description
1	Label, specification
2	Label, DPM
3	Label, DOM
4	Label, department

Item	Number	Name	Quantity
A	1105-101-035	Standard hood	1
B	1105-101-815	Bellows assembly	2
C	1105-024-006	Label, brake symbol, international	2
D	1105-024-007	Label, steer symbol, international	2
E	1040-010-092	Scrulok assembly	2
F	108900010903	Label, EAR	1

Fifth wheel hood with three-sided hydraulics/bellow assembly, non-electric

1105-224-300 Rev AA (Reference only)

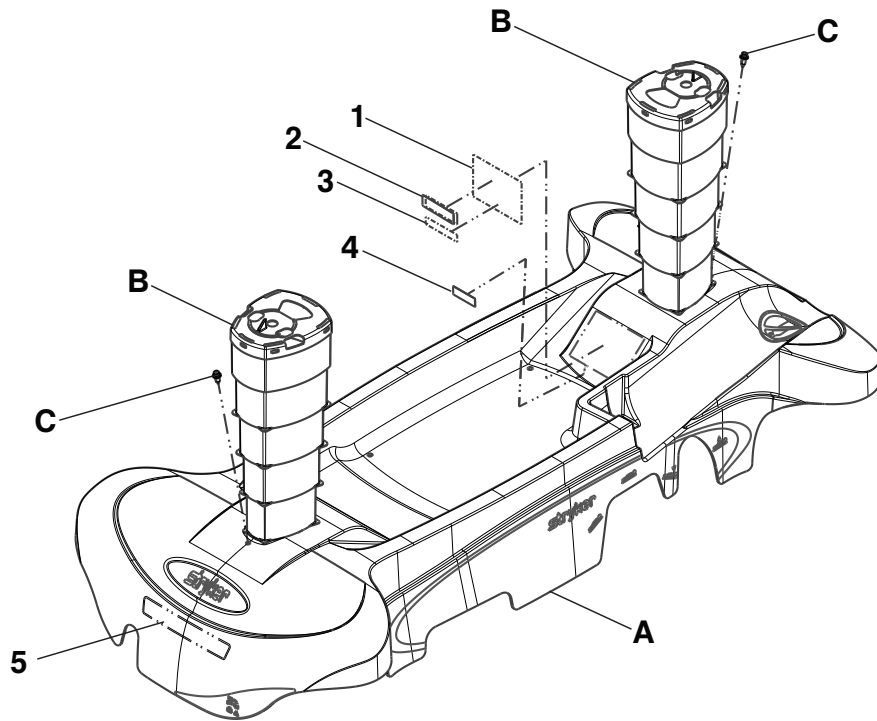

Item	Description
1	Label, specification
2	Label, DPM
3	Label, CFR
4	Label, DOM
5	Label, department

Item	Number	Name	Quantity
A	1105-101-037	Three-sided hydraulics hood	1
B	1105-101-815	Bellows assembly	2
C	1040-010-092	Scruelok assembly	2

Fifth wheel hood/bellow assembly, three-sided hydraulics

1105-225-300 Rev AB (Reference only)

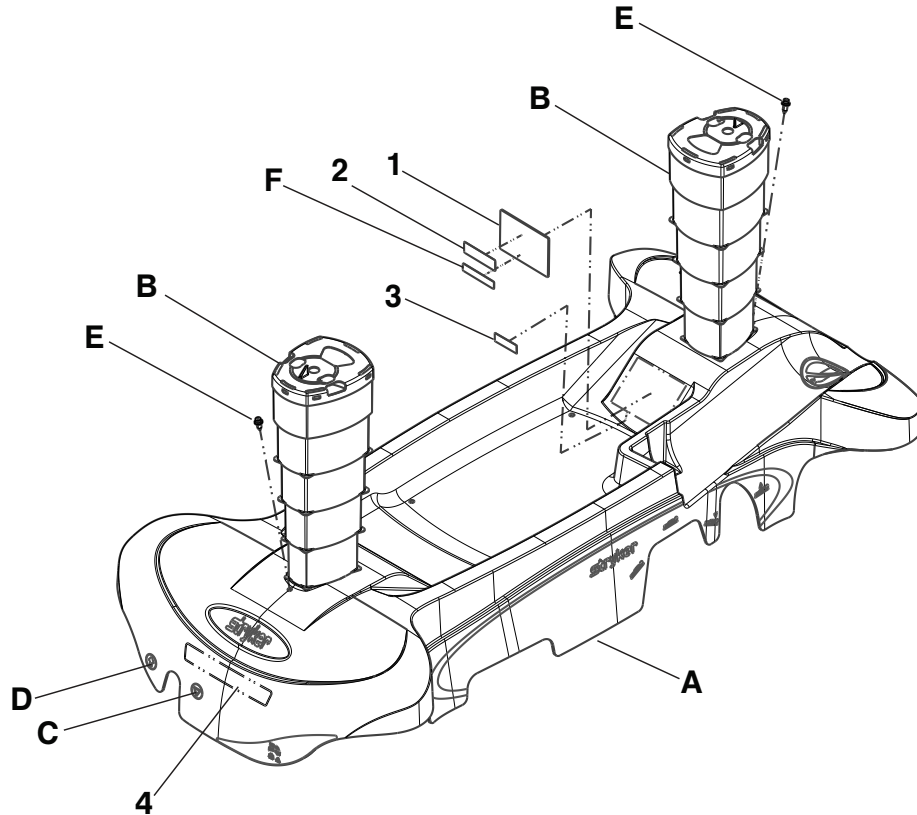

Item	Description
1	Label, specification
2	Label, DPM
3	Label, DOM
4	Label, department

Item	Number	Name	Quantity
A	1105-101-037	Hood, three-sided hydraulics	1
B	1105-101-815	Bellows assembly	2
C	1105-024-006	Label, brake symbol, international	2
D	1105-024-007	Label, steer symbol, international	2
E	1040-010-092	Scrulok assembly	2
F	108900010903	Label, EAR	1

Fifth wheel hood with four-sided brakes/bellow assembly, non-electric

1105-224-200 Rev AA (Reference only)

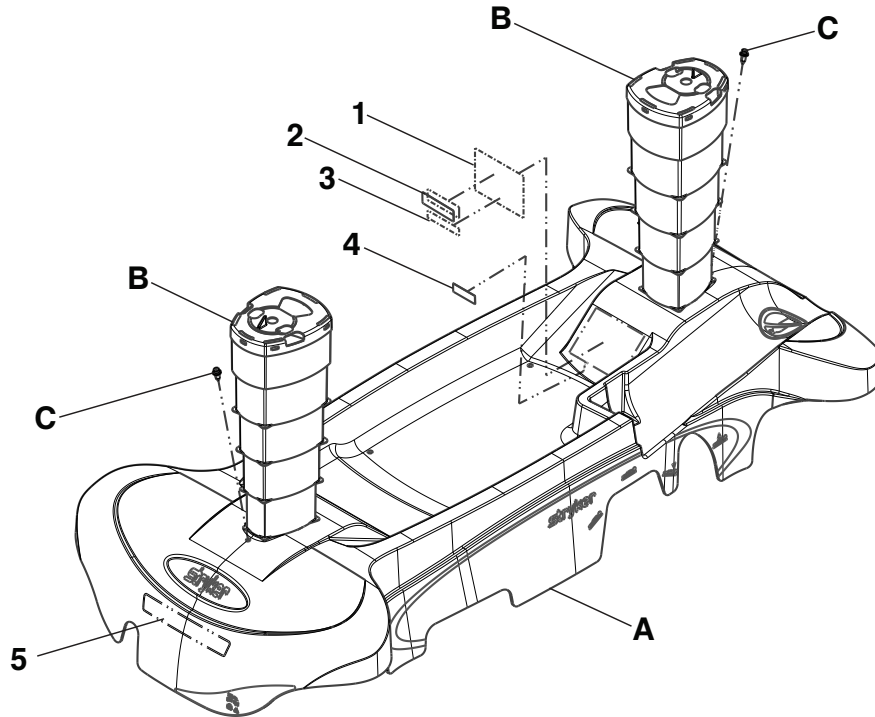

Item	Description
1	Label, specification
2	Label, DPM
3	Label, CFR
4	Label, DOM
5	Label, department

Item	Number	Name	Quantity
A	1105-101-034	Four-sided brakes hood	1
B	1105-101-815	Bellows assembly	2
C	1040-010-092	Scrulok assembly	2

Fifth wheel hood/bellow assembly, four-sided brakes

1105-225-200 Rev AB (Reference only)

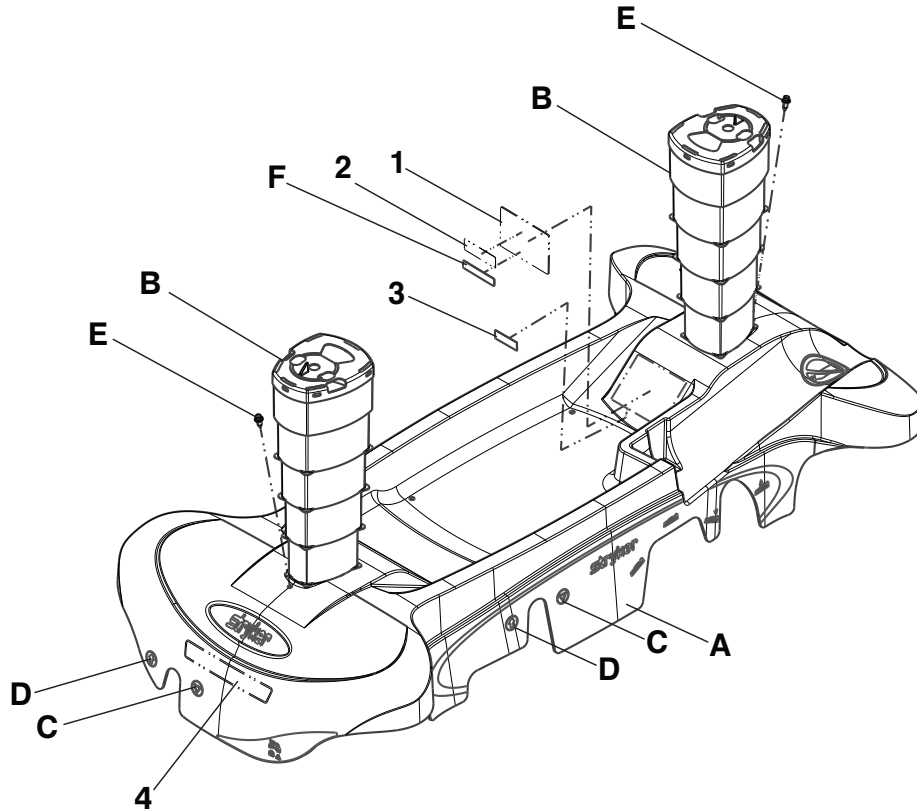

Item	Description
1	Label, specification
2	Label, DPM
3	Label, DOM
4	Label, department

Item	Number	Name	Quantity
A	1105-101-034	Hood, four-sided brakes	1
B	1105-101-815	Bellows assembly	2
C	1105-024-006	Label, brake symbol, international	4
D	1105-024-007	Label, steer symbol, international	4
E	1040-010-092	Scrulok assembly	2
F	108900010903	Label, EAR	1

Fifth wheel hood with four-sided brakes and three-sided hydraulics/ bellow assembly, non-electric

1105-224-400 Rev AA (Reference only)

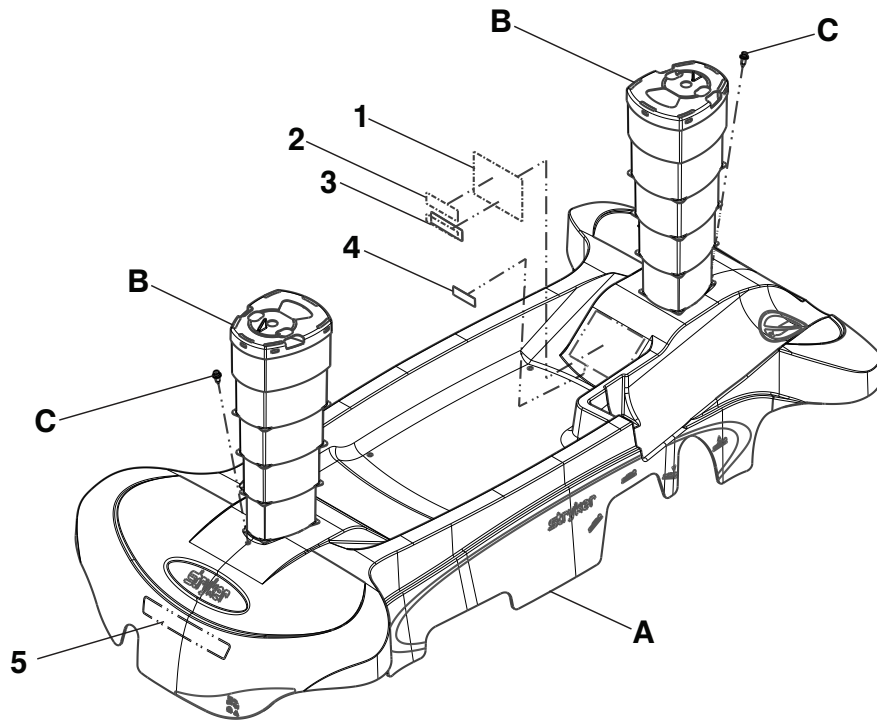

Item	Description
1	Label, specification
2	Label, DPM
3	Label, CFR
4	Label, DOM
5	Label, department

Item	Number	Name	Quantity
A	1105-101-036	Four-sided brakes and three-sided hydraulics hood	1
B	1105-101-815	Bellows assembly	2
C	1040-010-092	Scrulok assembly	2

Fifth wheel hood/bellow assembly, four-sided brakes, three-sided hydraulics

1105-225-400 Rev AB (Reference only)

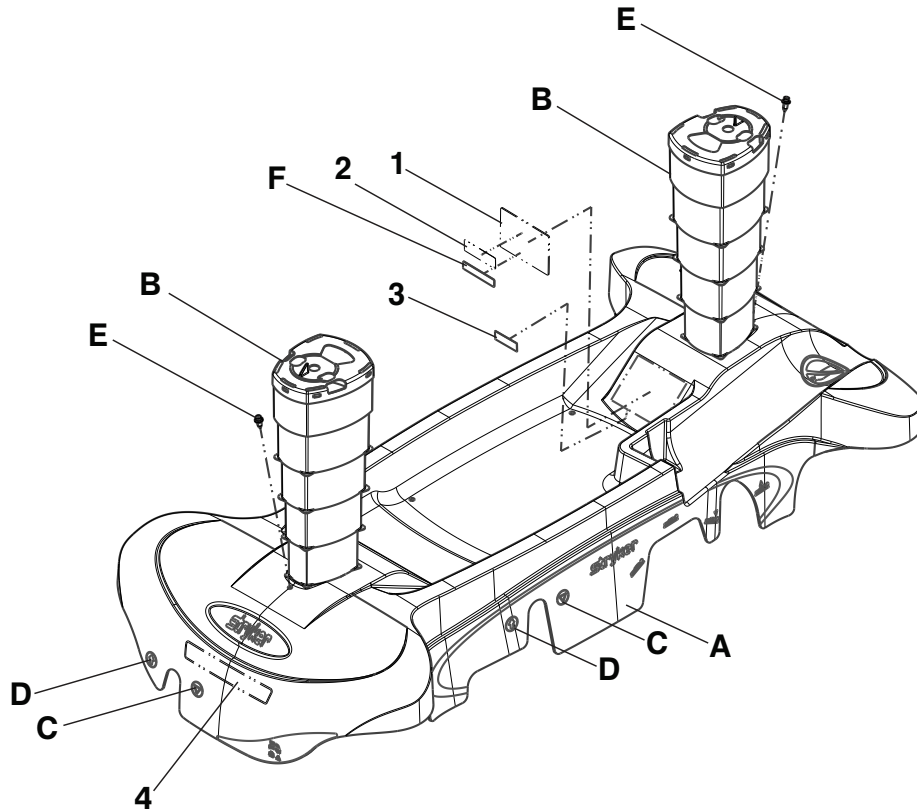

Item	Description
1	Label, specification
2	Label, DPM
3	Label, DOM
4	Label, department

Item	Number	Name	Quantity
A	1105-101-036	Hood, four-sided brakes, three-sided hydraulics	1
B	1105-101-815	Bellows assembly	2
C	1105-024-006	Label, brake symbol, international	4
D	1105-024-007	Label, steer symbol, international	4
E	1040-010-092	Scrulok assembly	2
F	108900010903	Label, EAR	1

Fifth wheel hood/bellow assembly, electric

1008-024-100 Rev AA (Reference only)

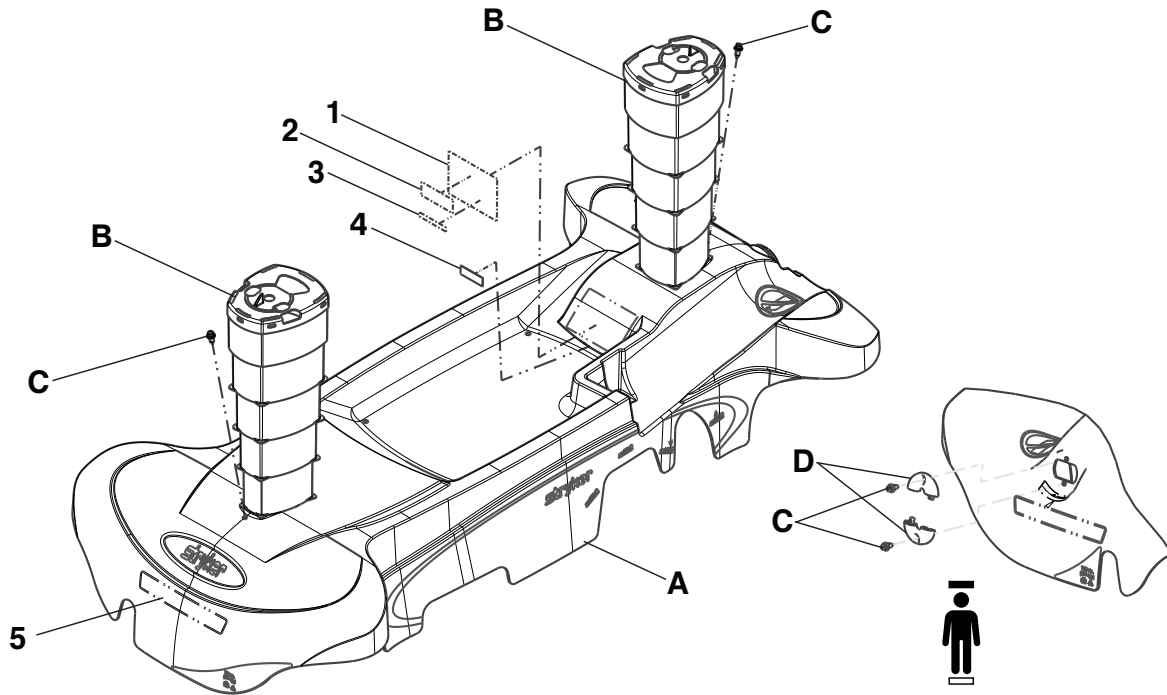

Item	Description
1	Label, specification
2	Label, DPM
3	Label, CFR
4	Label, DOM
5	Label, department

Item	Number	Name	Quantity
A	1008-101-035	Standard hood	1
B	1105-101-815	Bellows assembly	2
C	1040-010-092	Scrulok assembly	4
D	1040-010-008	Cord ring	2

Fifth wheel hood/bellow assembly

1008-025-100 Rev AB (Reference only)

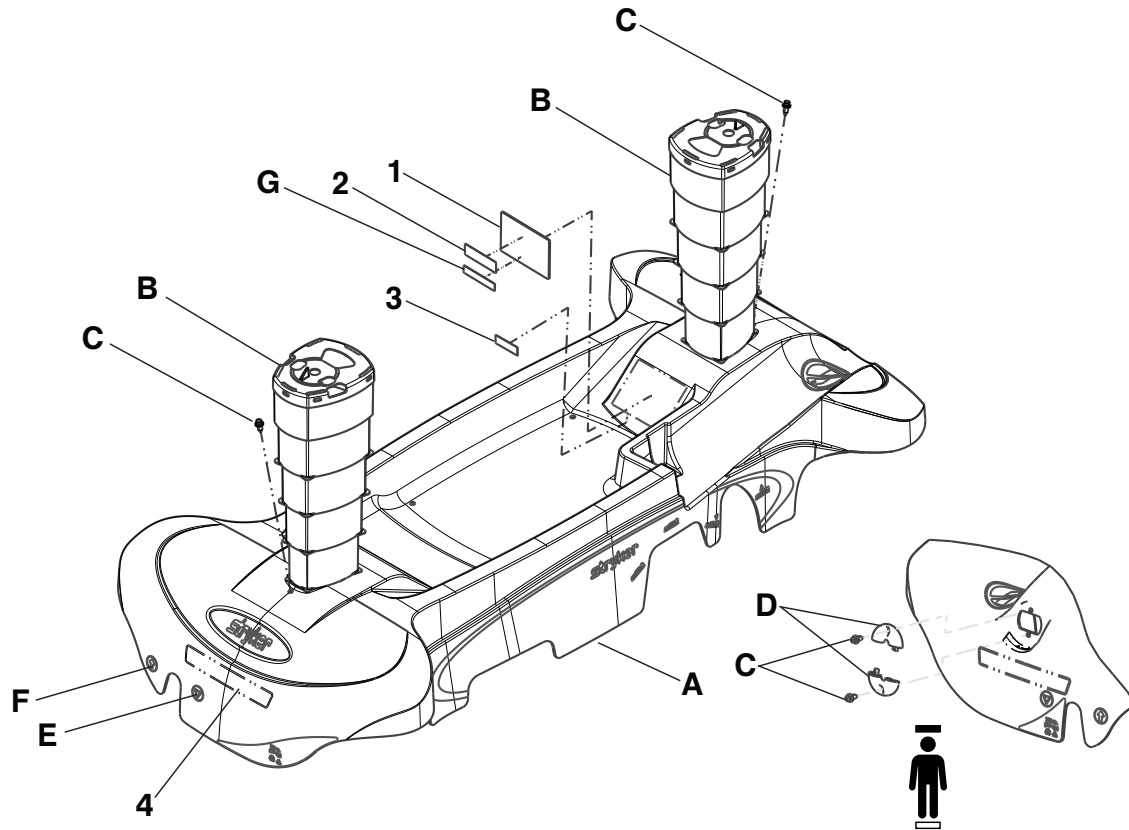

Item	Description
1	Label, specification
2	Label, DPM
3	Label, DOM
4	Label, department

Item	Number	Name	Quantity
A	1008-101-035	Standard hood	1
B	1105-101-815	Bellows assembly	2
C	1040-010-092	Scrulok assembly	4
D	1040-010-008	Cord ring	2
E	1105-024-006	Label, brake symbol, international	2
F	1105-024-007	Label, steer symbol, international	2
G	108900010903	Label, EAR	1

Fifth wheel hood with three-sided hydraulics/bellow assembly, electric

1008-024-300 Rev AA (Reference only)

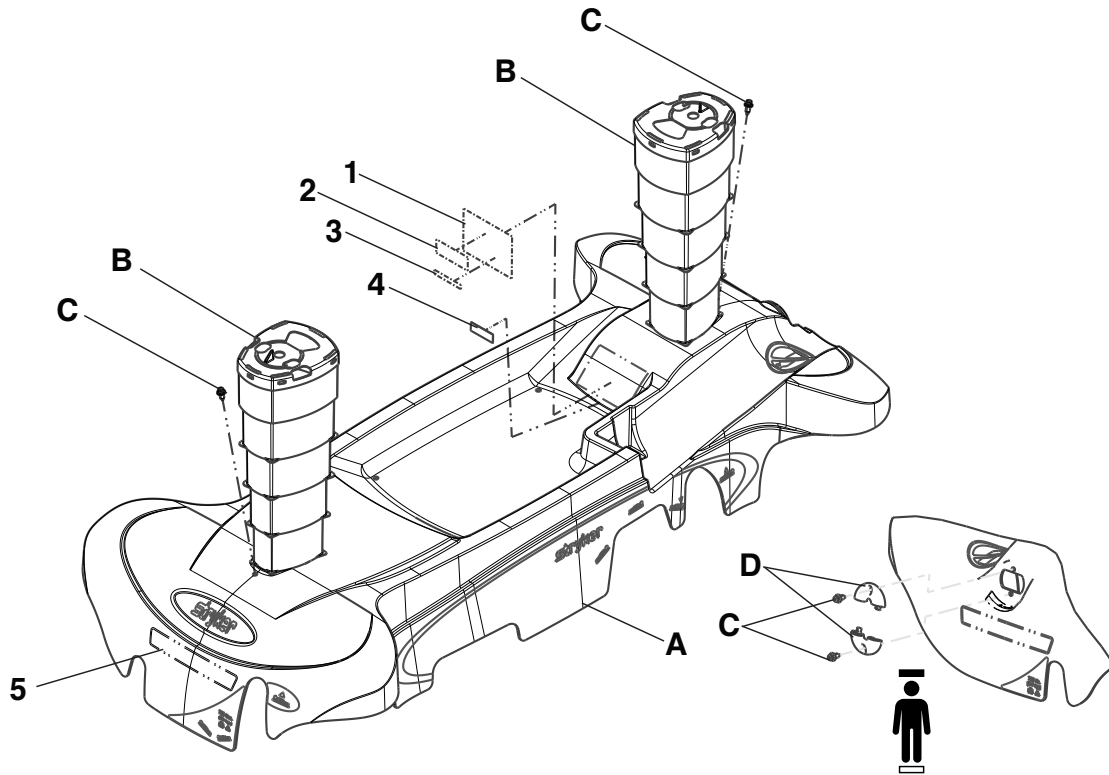

Item	Description
1	Label, specification
2	Label, DPM
3	Label, CFR
4	Label, DOM
5	Label, department

Item	Number	Name	Quantity
A	1008-101-037	Three-sided hydraulics hood	1
B	1105-101-815	Bellows assembly	2
C	1040-010-092	Scrollok assembly	4
D	1040-010-008	Cord ring	2

Fifth wheel hood/bellow assembly, three-sided hydraulics

1008-025-300 Rev AB (Reference only)

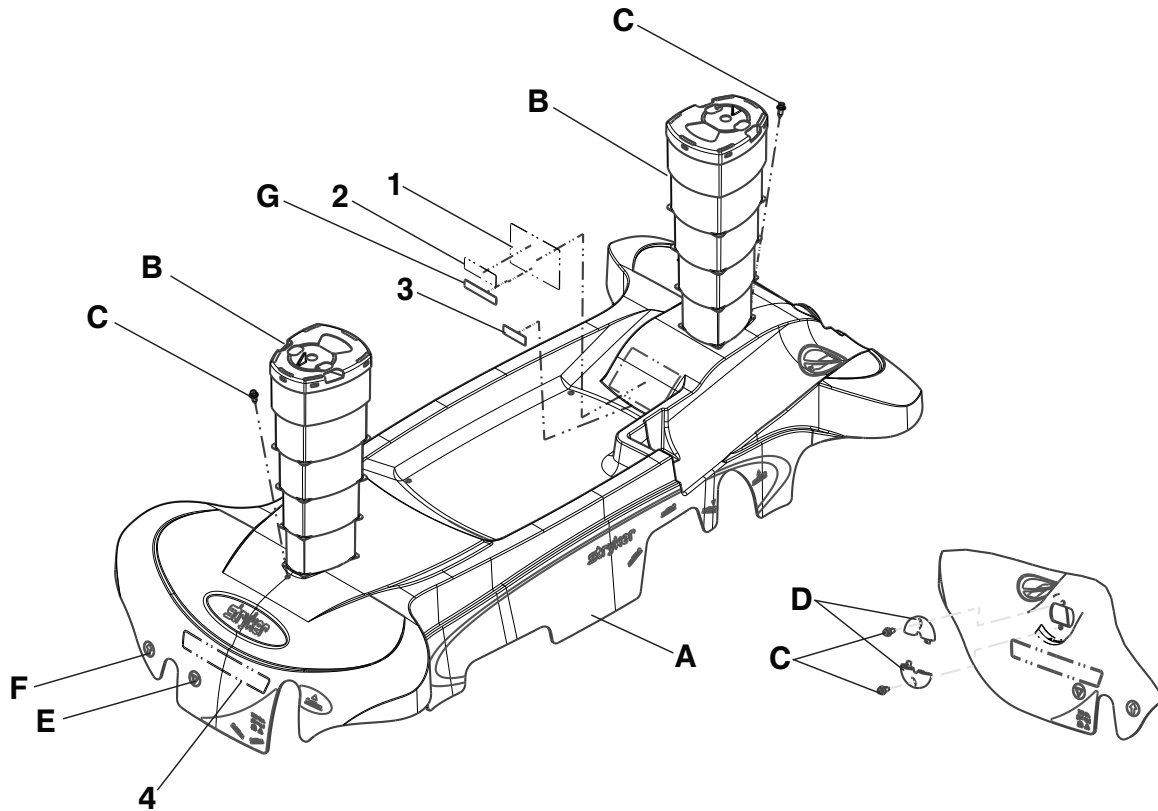

Item	Description
1	Label, specification
2	Label, DPM
3	Label, DOM
4	Label, department

Item	Number	Name	Quantity
A	1008-101-037	Hood, three-sided hydraulics	1
B	1105-101-815	Bellows assembly	2
C	1040-010-092	Scrulok assembly	4
D	1040-010-008	Cord ring	2
E	1105-024-006	Label, brake symbol, international	2
F	1105-024-007	Label, steer symbol, international	2
G	108900010903	Label, EAR	1

Fifth wheel hood with four-sided brakes/bellow assembly, electric

1008-024-200 Rev AA (Reference only)

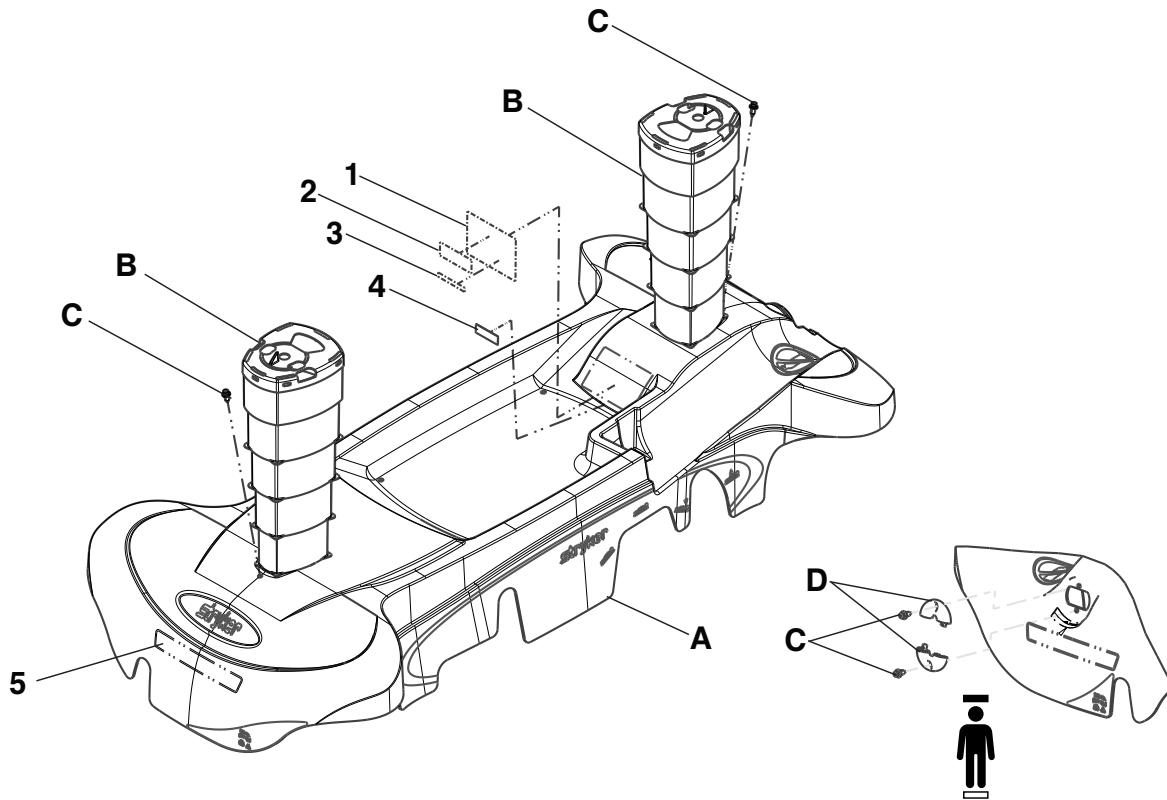

Item	Description
1	Label, specification
2	Label, DPM
3	Label, CFR
4	Label, DOM
5	Label, department

Item	Number	Name	Quantity
A	1008-101-034	Four-sided brakes hood	1
B	1105-101-815	Bellows assembly	2
C	1040-010-092	Scrulok assembly	4
D	1040-010-008	Cord ring	2

Fifth wheel hood/bellow assembly, four-sided brakes

1008-025-200 Rev AB (Reference only)

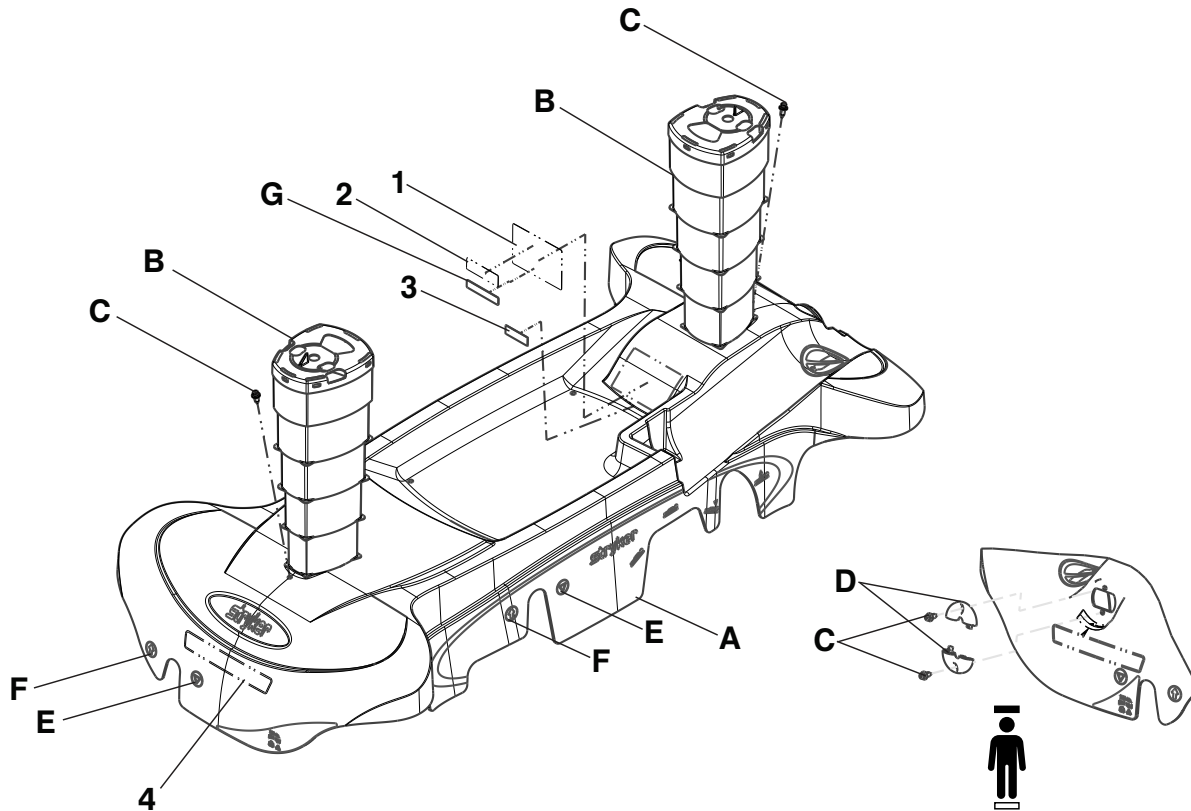

Item	Description
1	Label, specification
2	Label, DPM
3	Label, DOM
4	Label, department

Item	Number	Name	Quantity
A	1008-101-034	Hood, four-sided brakes	1
B	1105-101-815	Bellows assembly	2
C	1040-010-092	Scrollok assembly	4
D	1040-010-008	Cord ring	2
E	1105-024-006	Label, brake symbol, international	4
F	1105-024-007	Label, steer symbol, international	4
G	108900010903	Label, EAR	1

Fifth wheel hood/bellow assembly, four-sided brakes, three-sided hydraulics

1008-025-400 Rev AB (Reference only)

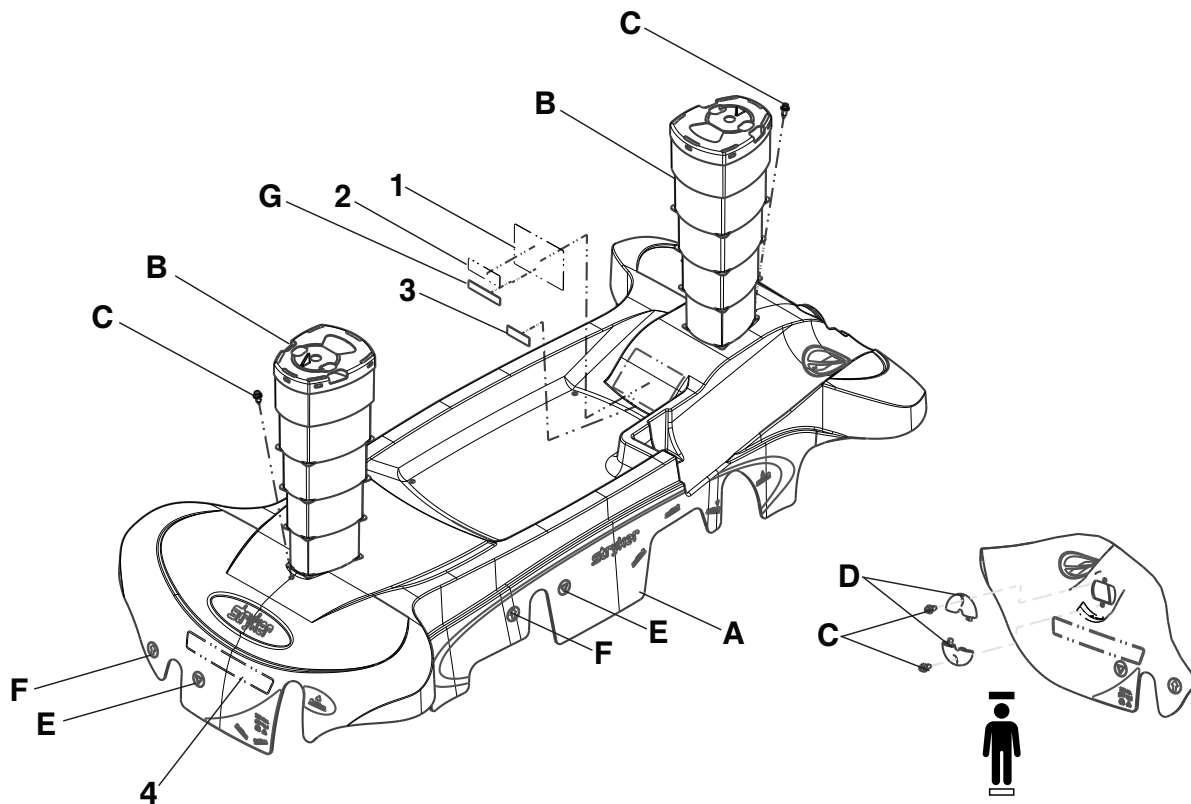

Item	Description
1	Label, specification
2	Label, DPM
3	Label, DOM
4	Label, department

Item	Number	Name	Quantity
A	1008-101-036	Hood, four-sided brakes, three-sided hydraulics	1
B	1105-101-815	Bellows assembly	2
C	1040-010-092	Scrulok assembly	4
D	1040-010-008	Cord ring	2
E	1105-024-006	Label, brake symbol, international	4
F	1105-024-007	Label, steer symbol, international	4
G	108900010903	Label, EAR	1

Fifth wheel hood with four-sided brakes and three-sided hydraulics/ bellow assembly, electric

1008-024-400 Rev AA (Reference only)

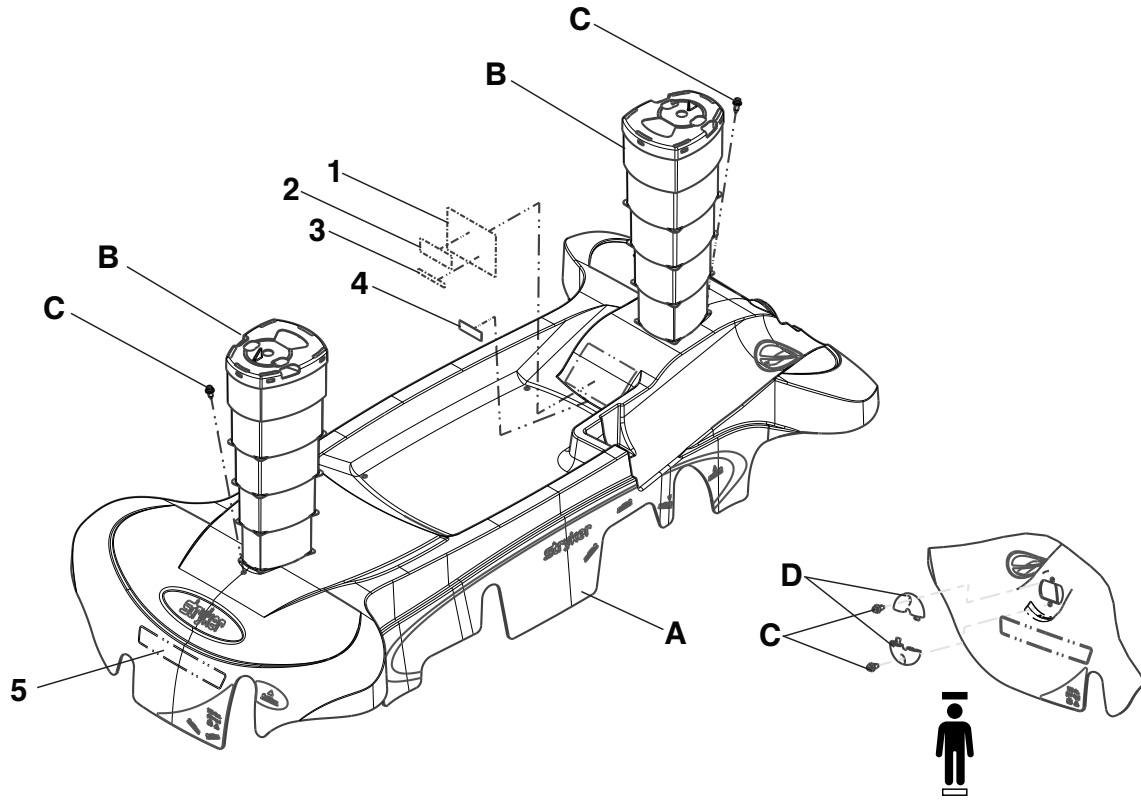

Item	Description
1	Label, specification
2	Label, DPM
3	Label, CFR
4	Label, DOM
5	Label, department

Item	Number	Name	Quantity
A	1008-101-036	Four-sided brakes and three-sided hydraulics hood	1
B	1105-101-815	Bellows assembly	2
C	1040-010-092	Scrulok assembly	4
D	1040-010-008	Cord ring	2

Fifth wheel hood/bellow assembly, four-sided brakes, three-sided hydraulics

1105-225-500 Rev AB (Reference only)

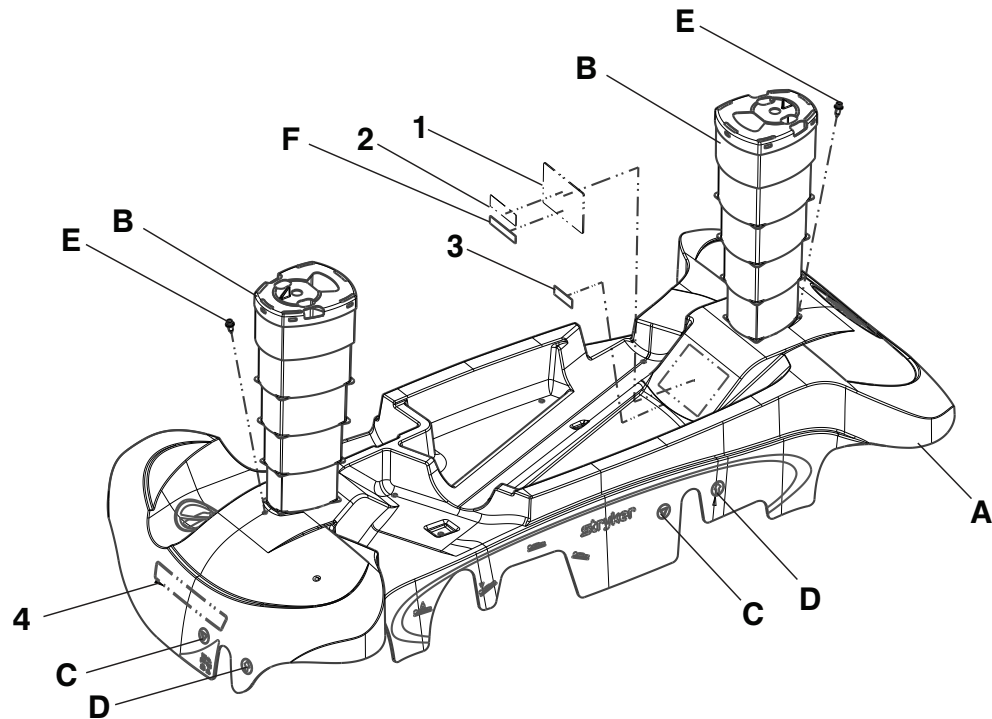

Item	Description
1	Label, specification
2	Label, DPM
4	Label, DOM
5	Label, department

Item	Number	Name	Quantity
A	1105-101-046	Hood, four-sided brakes, three-sided hydraulics	1
B	1105-101-815	Bellows assembly	2
C	1105-024-006	Label, brake symbol, international	4
D	1105-024-007	Label, steer symbol, international	4
E	1040-010-092	Scrulok assembly	2
F	108900010903	Label, EAR	1

26" common litter components

1105-016-002 Rev E (Reference only)

Number	Name	Quantity
0853-003-615	<i>8" caster with full cover assembly - 0853-003-615 (page 97)</i>	1
1105-006-110	<i>Retractable fifth wheel assembly (page 110)</i>	1
0853-102-025	<i>Constant descent jacks, non-electric (page 126)</i>	1
1105-105-500	<i>Dual-sided hydraulics assembly, non-electric (page 113)</i>	1
1105-010-607	<i>26" common litter components (page 182)</i>	1

Common components, fifth wheel, 26"

1105-016-012 Rev F (Reference only)

Number	Name	Quantity
0921-001-252	Serial number date tag	1
0853-003-615	<i>8" caster with full cover assembly - 0853-003-615 (page 97)</i>	1
1105-006-110	<i>Retractable fifth wheel assembly (page 110)</i>	1
0853-102-025	<i>Constant descent jacks, non-electric (page 126)</i>	1
1105-105-500	<i>Dual-sided hydraulics assembly, non-electric (page 113)</i>	1
1105-010-607	<i>26" common litter components (page 182)</i>	1



9501 00001
JAN 1995

9501 00001
JAN 1995

26" common litter components

1105-010-607 Rev A (Reference only)

Number	Name	Quantity
1105-009-610	<i>26" monitor tray assembly - 1105-009-610 (page 187)</i>	1
1105-030-610	<i>26" oxygen bottle assembly - 1105-030-610 (page 185)</i>	1
1105-010-250	<i>26" corner cover assembly (page 184)</i>	1
1105-010-601	<i>26" litter frame assembly (page 183)</i>	1
1105-012-602	<i>26" standard Fowler assembly (page 233)</i>	1
1210-800-008	Label, patent	1

26" litter frame assembly

1105-010-601 Rev E (Reference only)

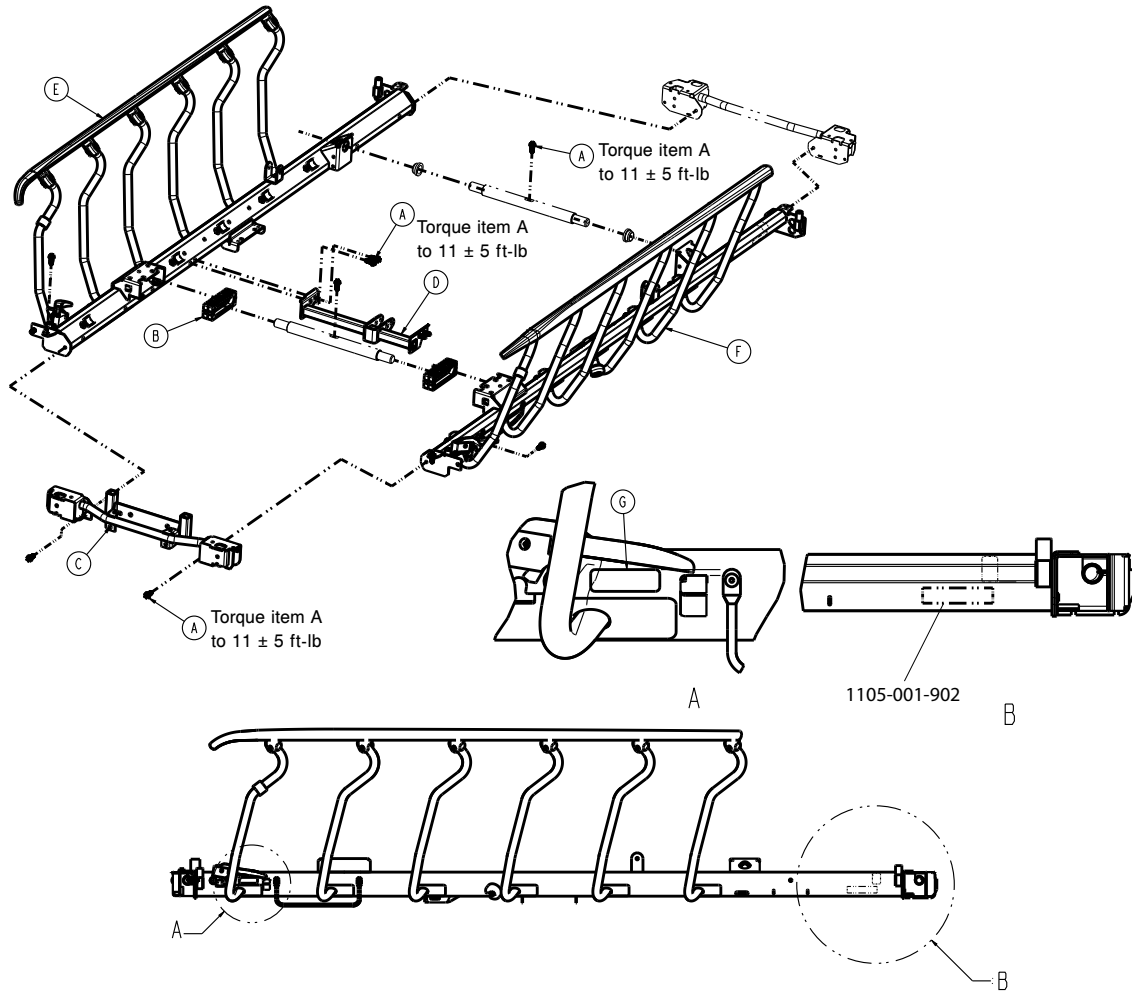

Item	Number	Name	Quantity
A	0023-288-000	Hex washer head screw	12
B	0785-010-006	Trend block slide	2
C	0785-110-620	End weldment, foot end	1
D	1105-008-610	26" frame tie weldment	1
E	1105-011-040	Siderail assembly, right - non-electric litter (page 217)	1
F	1105-011-050	Siderail assembly, left - non-electric litter (page 219)	1
G	1105-001-901	Label, applied part	2

26" corner cover assembly

1105-010-250 Rev A (Reference only)

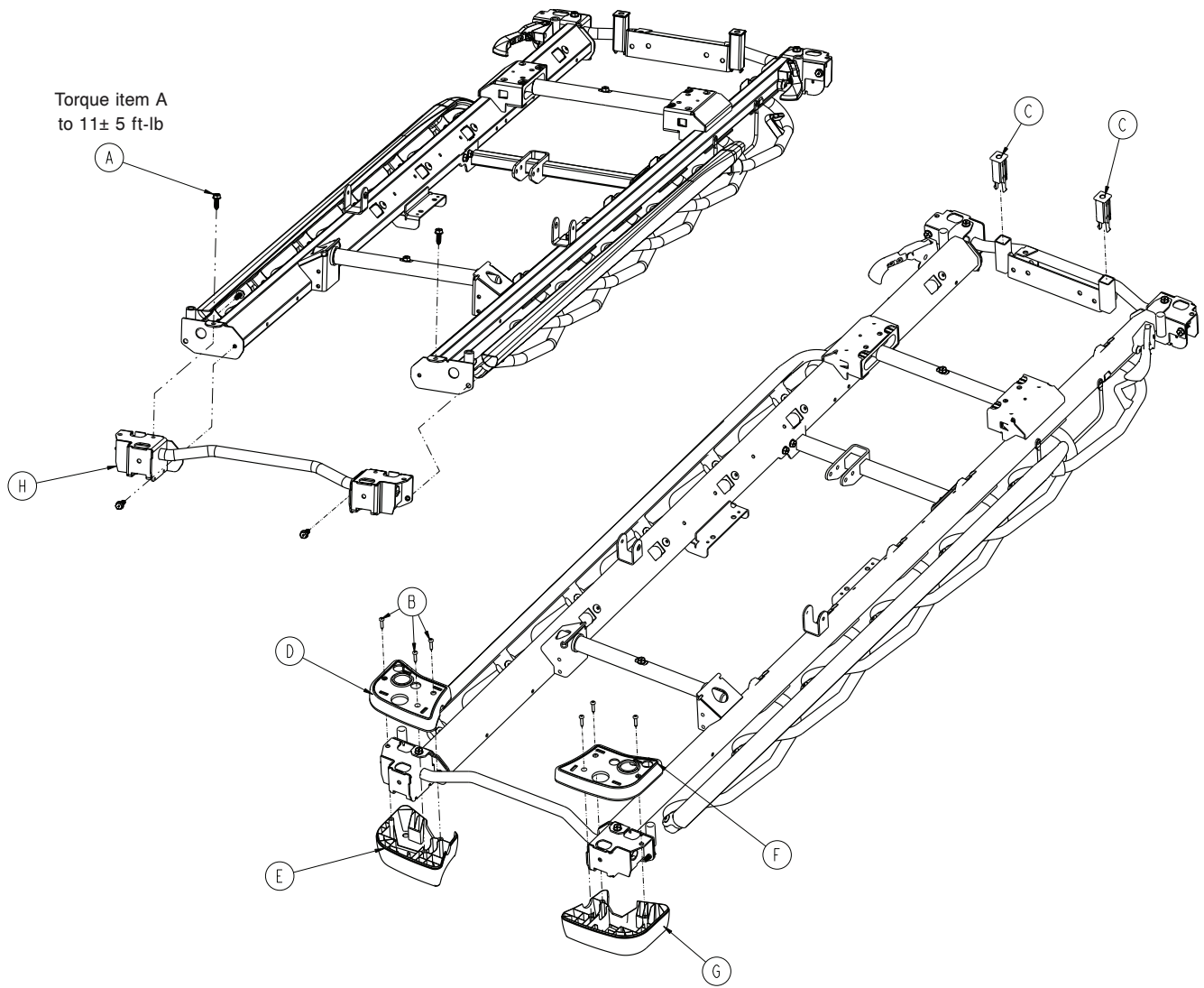

Item	Number	Name	Quantity
A	0023-288-000	Hex washer head screw	6
B	0023-310-000	Pan head tapping screw	6
C	0785-010-122	Footboard receptacle	2
D	0785-210-050	Mid cover, left, head end	1
E	0785-210-051	Bottom cover, left, head end	1
F	0785-210-055	Mid cover, right, head end	1
G	0785-210-056	Bottom cover, right, head end	1
H	1105-010-615	Weldment, head end	1

26" oxygen bottle assembly - 1105-030-610

Rev A (Reference only)

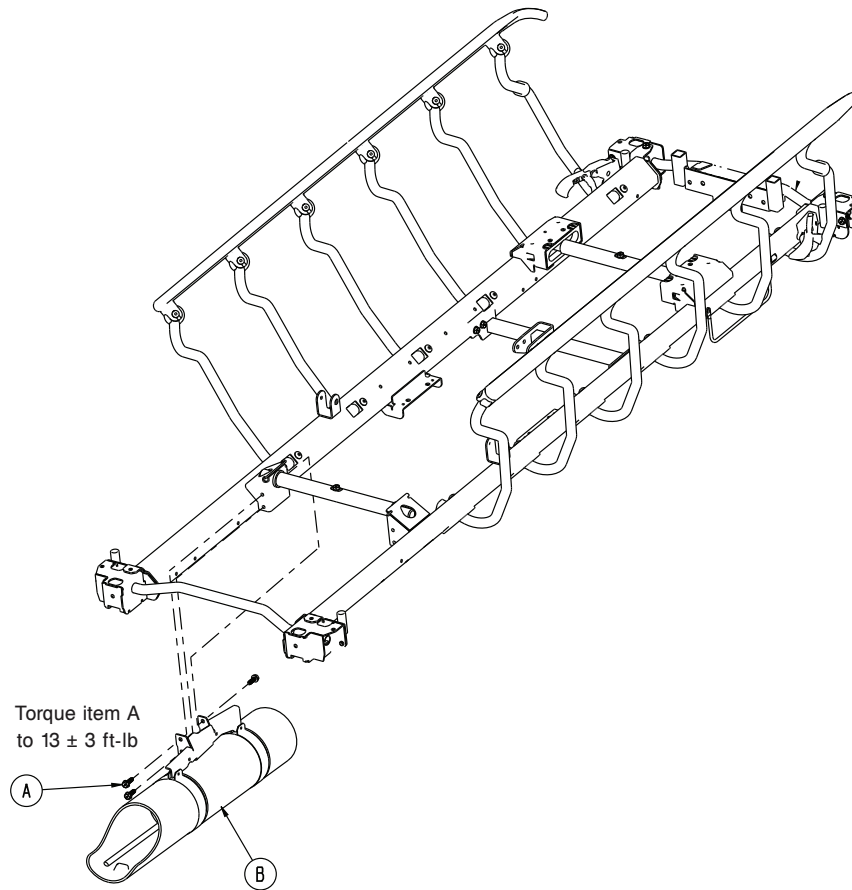

Item	Number	Name	Quantity
A	0023-288-000	Hex washer head screw	3
B	1105-030-601	26" oxygen receptacle assembly - 1105-030-601 (page 186)	1

26" oxygen receptacle assembly - 1105-030-601

Rev A (Reference only)

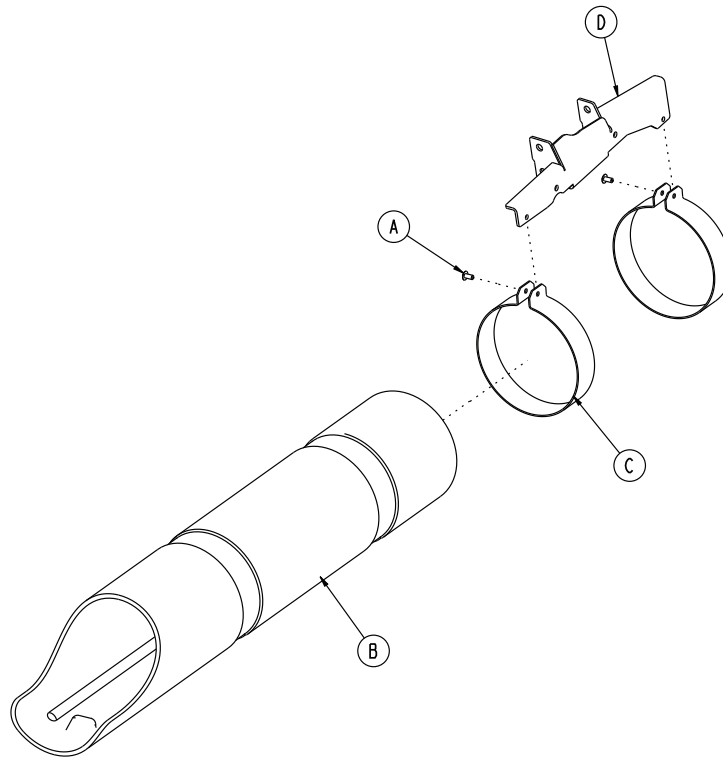

Item	Number	Name	Quantity
A	0025-079-000	Dome head rivet	2
B	1105-030-009	Oxygen tube	1
C	1105-030-021	Oxygen receptacle clamp	2
D	1105-130-608	26" oxygen bracket	1

26" monitor tray assembly - 1105-009-610

Rev B (Reference only)

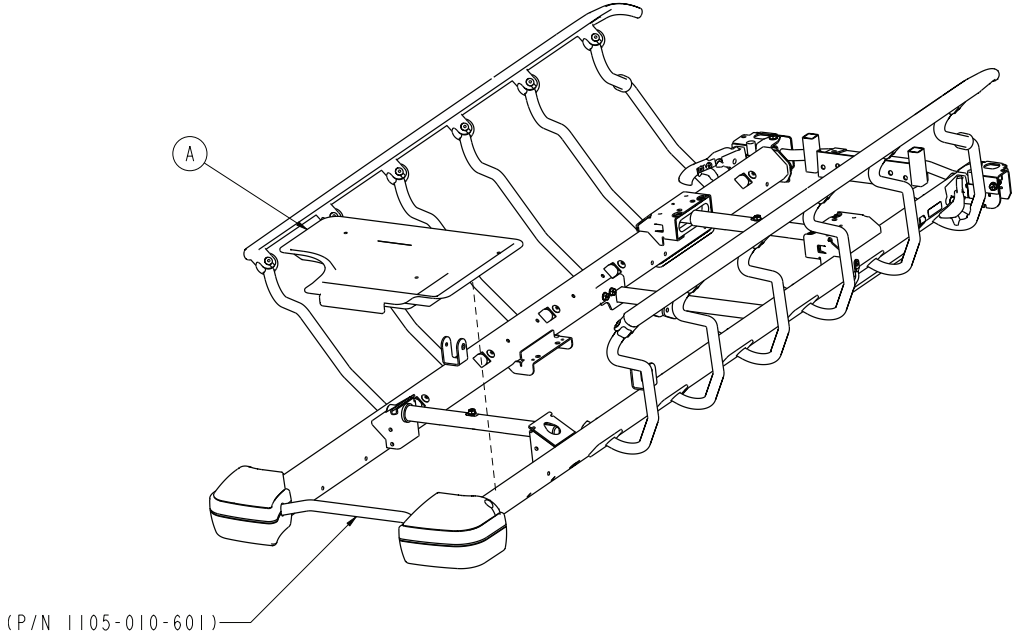

Item	Number	Name	Quantity
A	1105-145-601	26" monitor tray	1

26" standard Fowler, stationary foot - non-electric litter (scale system option)

1070-110-265 Rev E (Reference only)

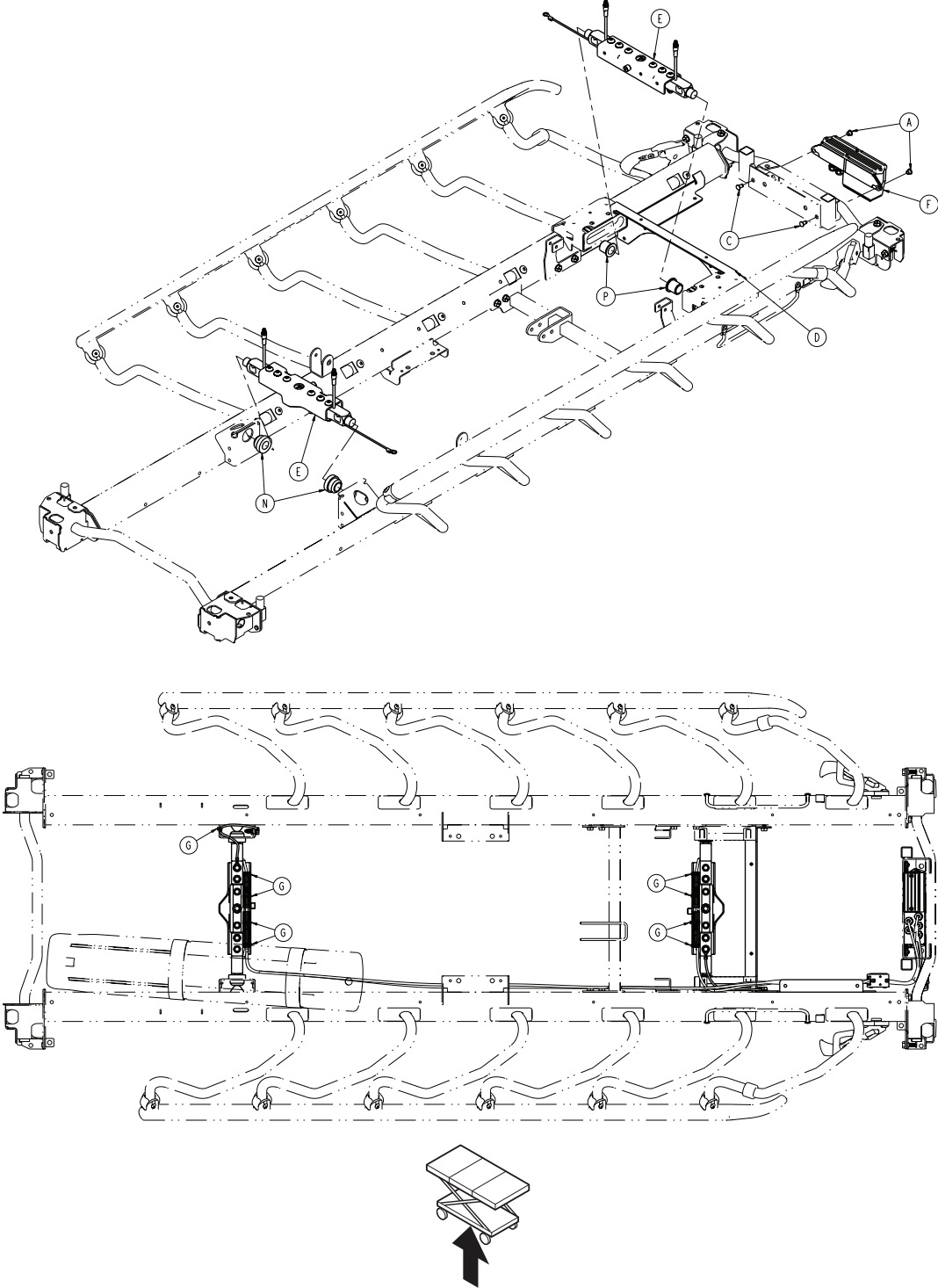

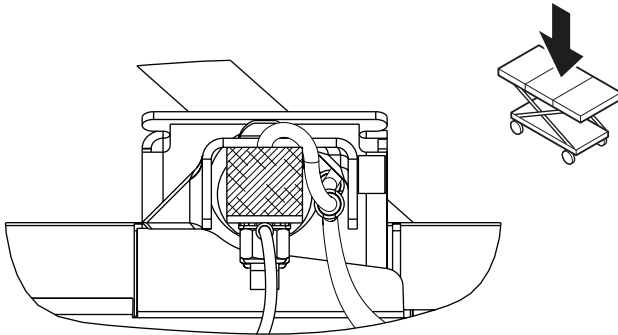
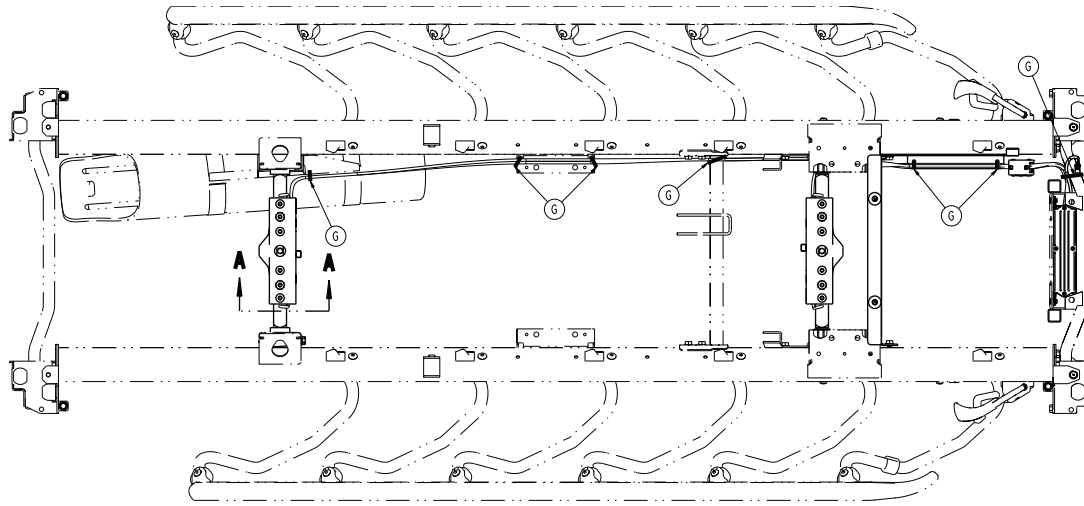

A-A

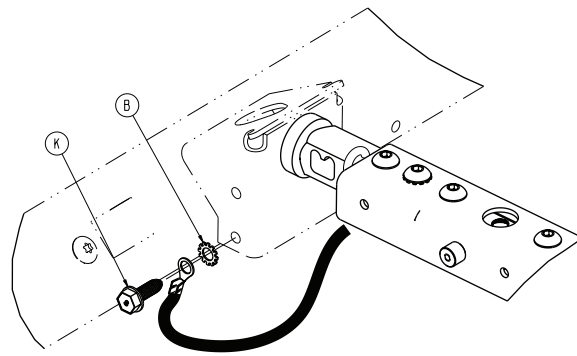
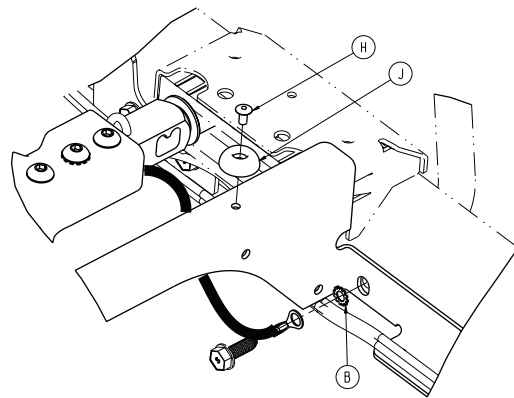
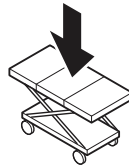

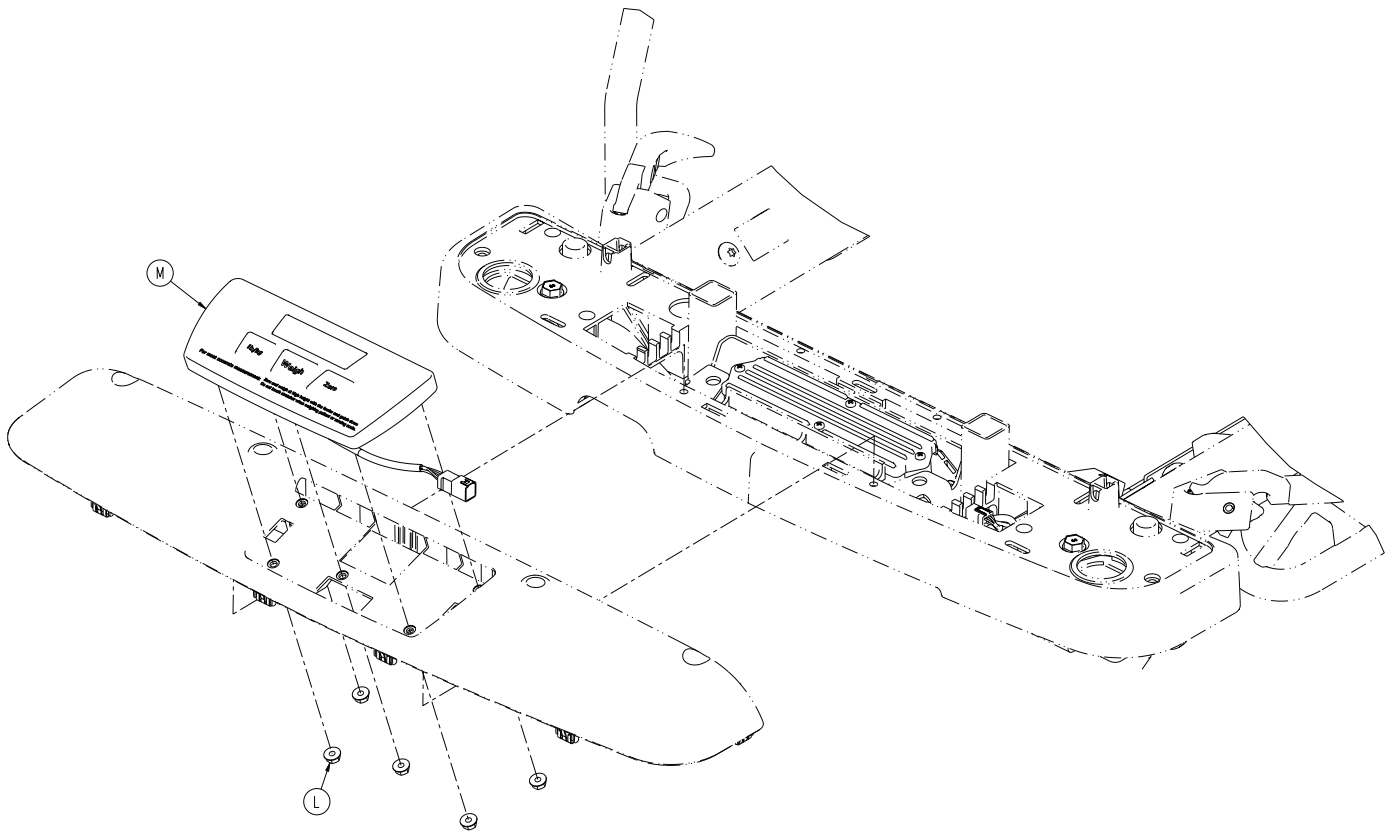

Item	Number	Name	Quantity
A	1070-137-001	Flange eyelet	2
B	0013-038-000	External tooth lock washer	2
C	0025-120-000	Dome head rivet	2
D	1105-010-641	Full foot bracket	1
E	1070-117-600	26" scale lifthead - 1070-117-600 (page 197)	2
F	1070-237-020	Scale box assembly, non-electric litter -1070-237-020 (page 216)	1
G	3000-300-113	8" cable tie	16
H	0025-079-000	Dome head rivet	2
J	0946-001-155	Bumper	2
K	0023-288-000	Hex washer head screw	1
L	0016-137-000	Hex flange nut	5
M	1008-037-820	Scale control non-backlit keypad assembly	1
N	1070-117-011	Scales bushing, head end	2
P	1070-117-012	Scales bushing, foot end	2

26" standard Fowler, Gatch - non-electric litter (scale system option)

1070-110-260 Rev E (Reference only)

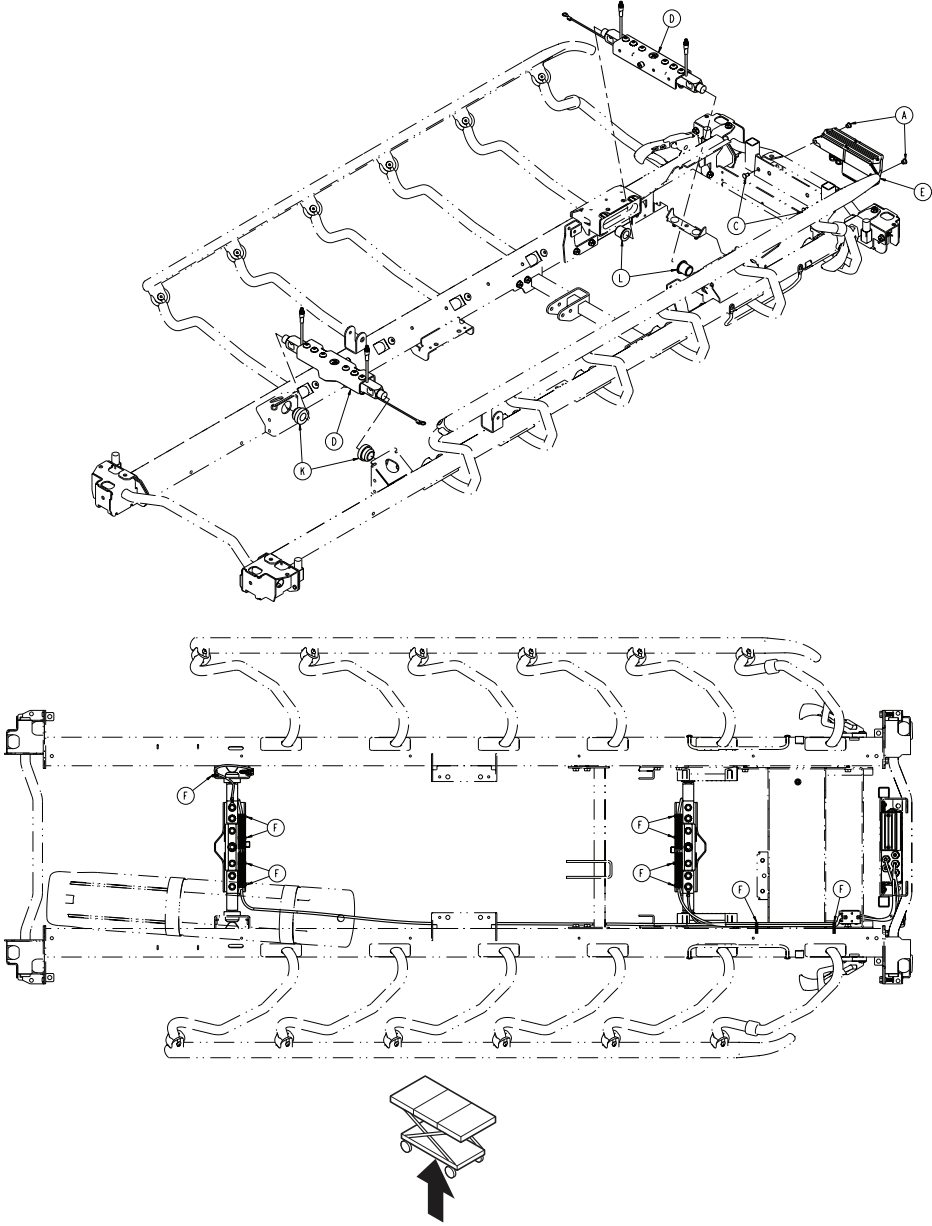

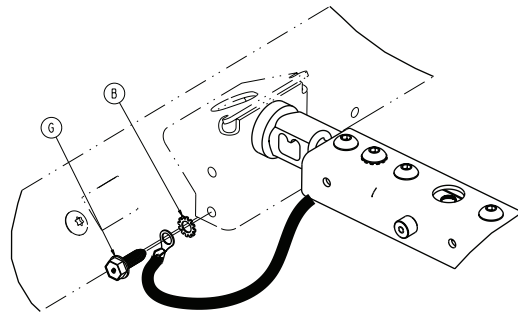
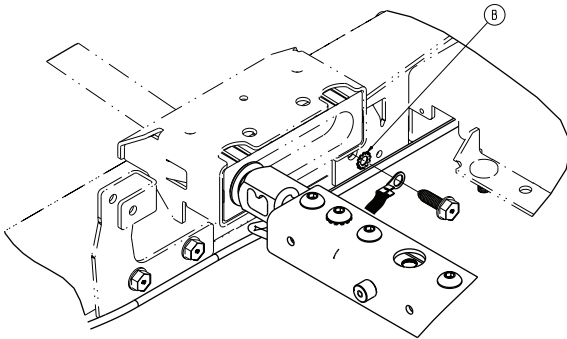
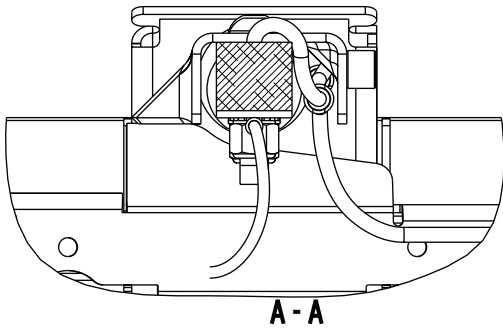
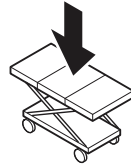
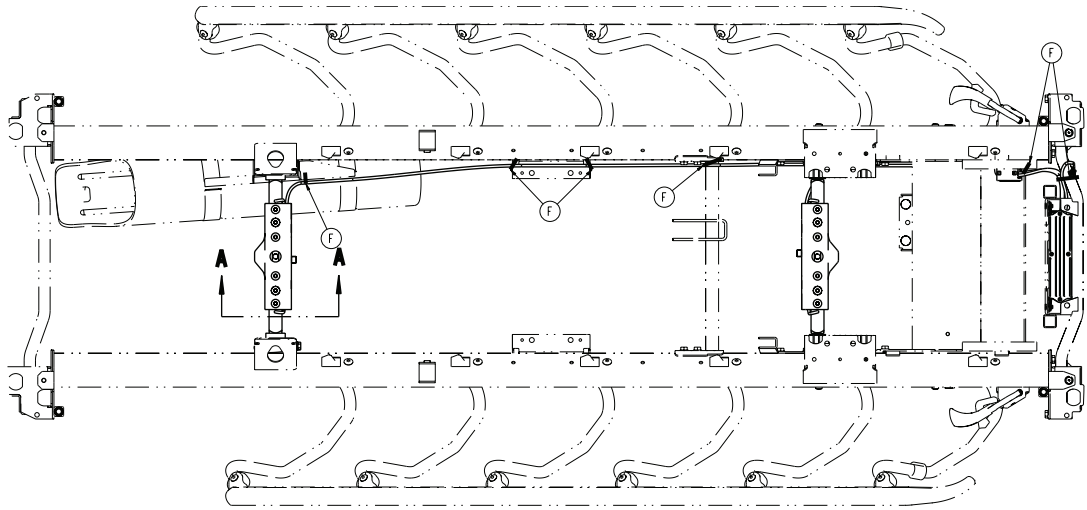

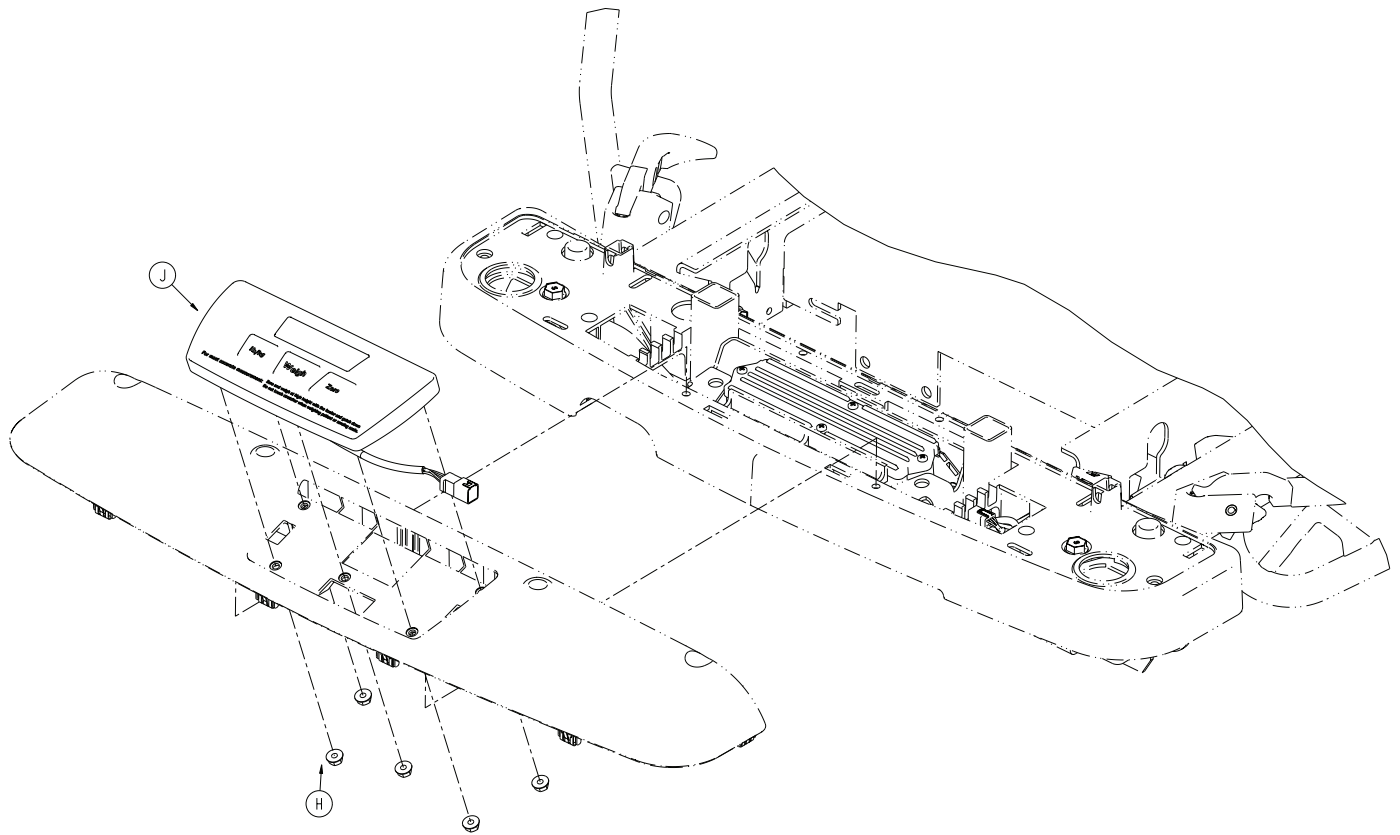

Item	Number	Name	Quantity
A	1070-137-001	Flange eyelet	2
B	0013-038-000	External tooth lock washer	2
C	0025-120-000	Dome head rivet	2
D	1070-117-600	26" scale lifthead - 1070-117-600 (page 197)	2
E	1070-237-020	Scale box assembly, non-electric litter -1070-237-020 (page 216)	1
F	3000-300-113	8" cable tie	17
G	0023-288-000	Hex washer head screw	1
H	0016-137-000	Hex flange nut	5
J	1008-037-820	Scale control non-backlit keypad assembly	1
K	1070-117-011	Scale bushing, head end	2
L	1070-117-012	Scale bushing, foot end	2

26" drop seat Fowler, stationary foot - non-electric litter (scale system option)

1070-110-270 Rev D (Reference only)

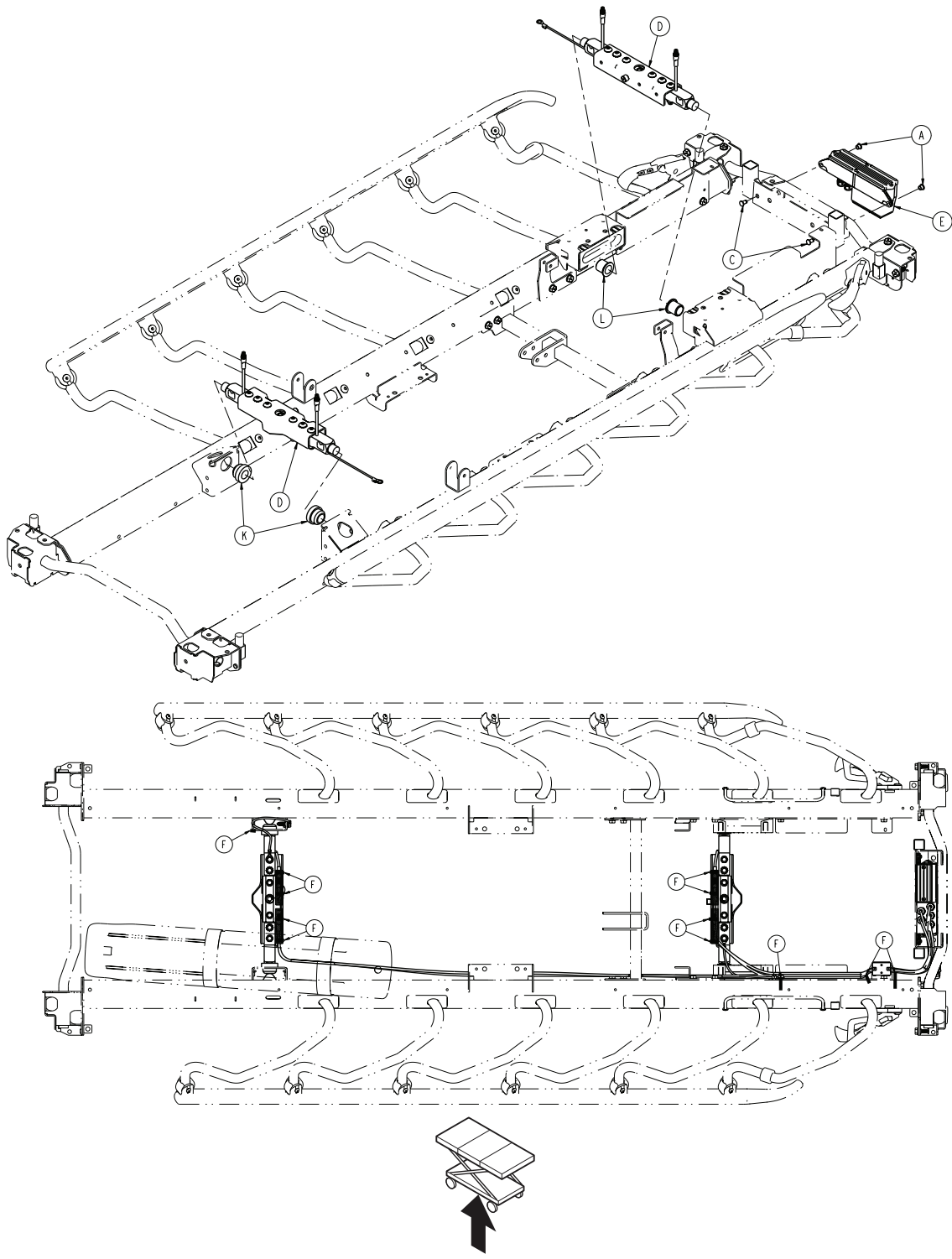

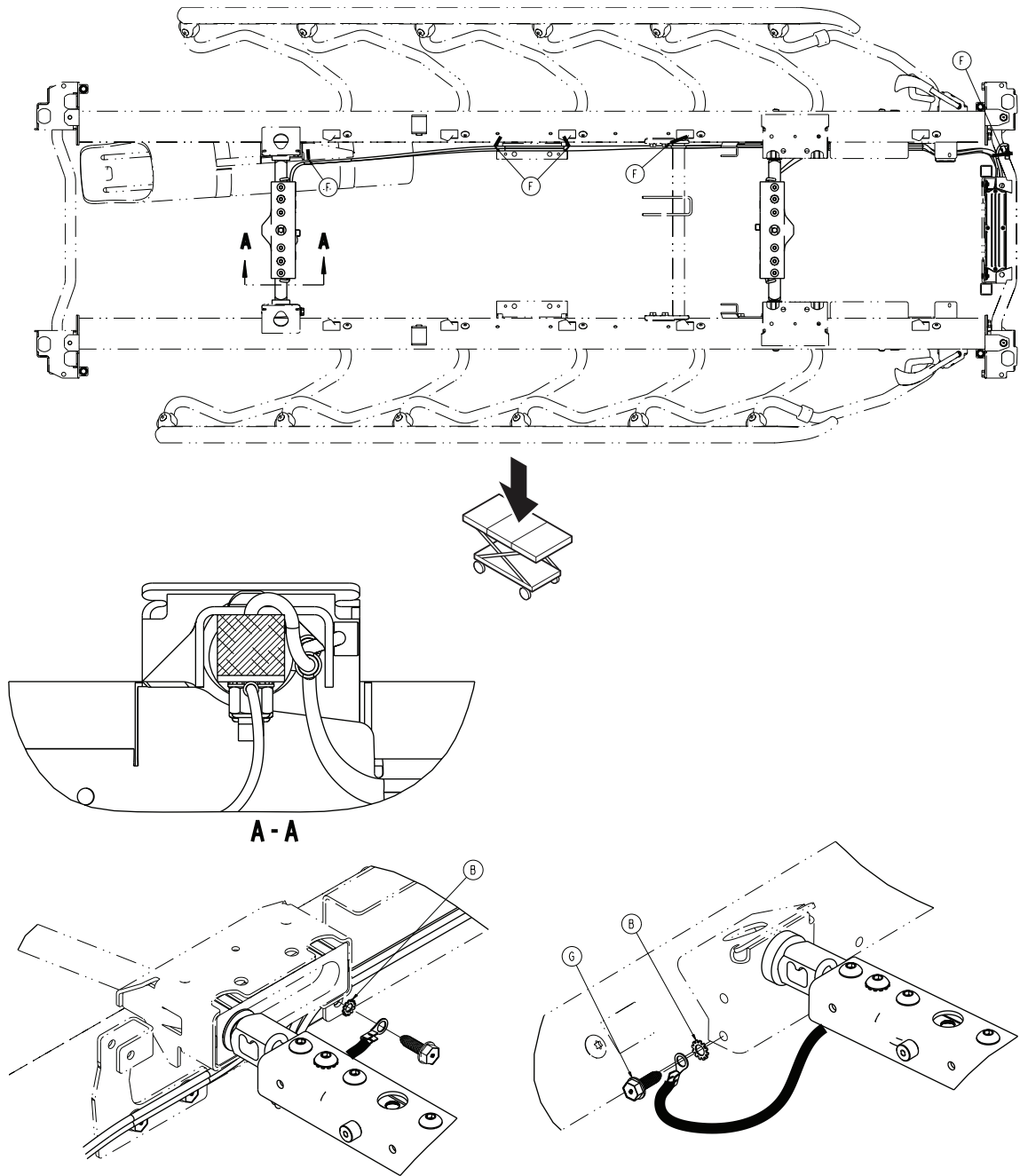

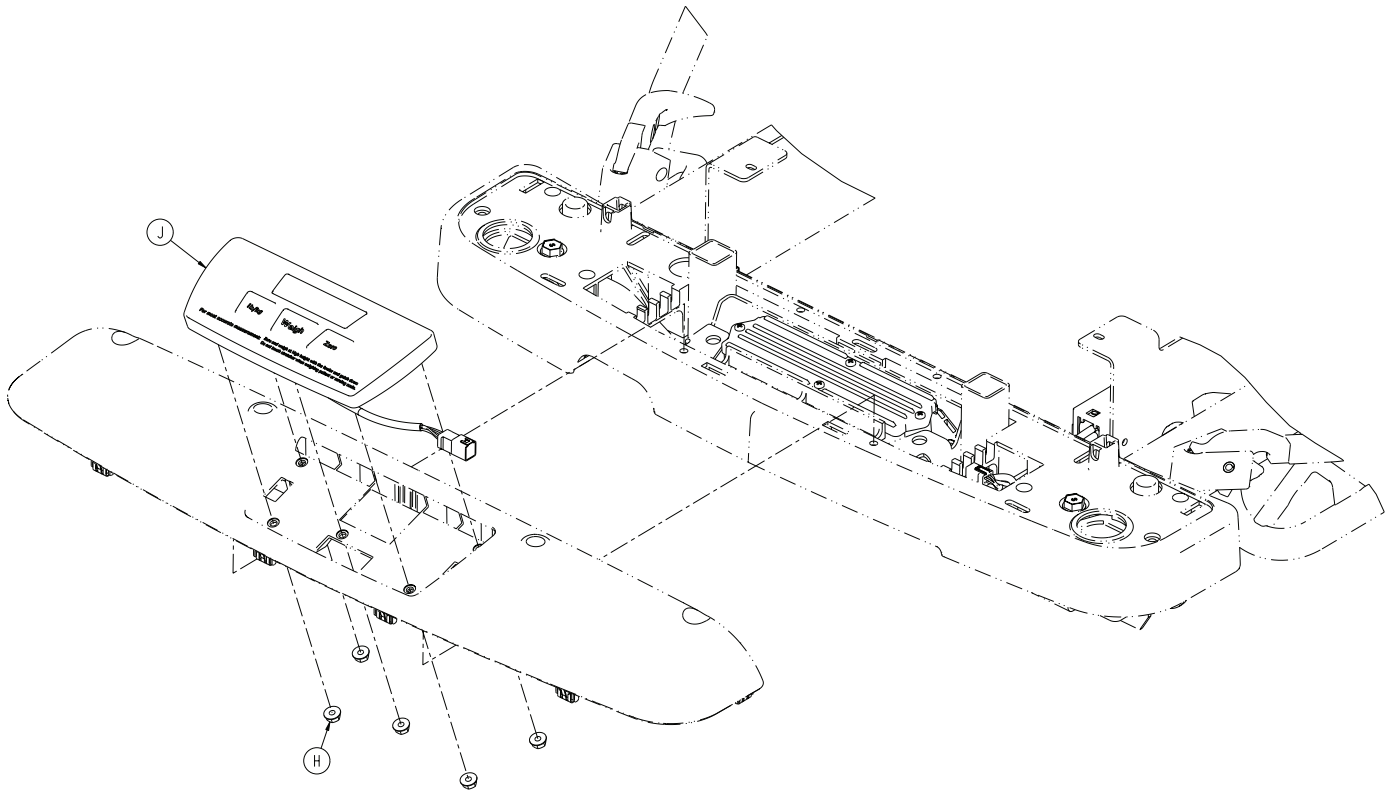

Item	Number	Name	Quantity
A	1070-137-001	Flange eyelet	2
B	0013-038-000	External tooth lock washer	2
C	0025-120-000	Dome head rivet	2
D	1070-117-600	26" scale liftheader - 1070-117-600 (page 197)	2
E	1070-237-020	Scale box assembly, non-electric litter -1070-237-020 (page 216)	1
F	3000-300-113	8" cable tie	17
G	0023-288-000	Hex washer head screw	1
H	0016-137-000	Hex flange nut	5
J	1008-037-820	Scale control non-backlit keypad assembly	1
K	1070-117-011	Scale bushing, head end	2
L	1070-117-012	Scale bushing, foot end	2

26" scale lifthead - 1070-117-600

Rev C (Reference only)

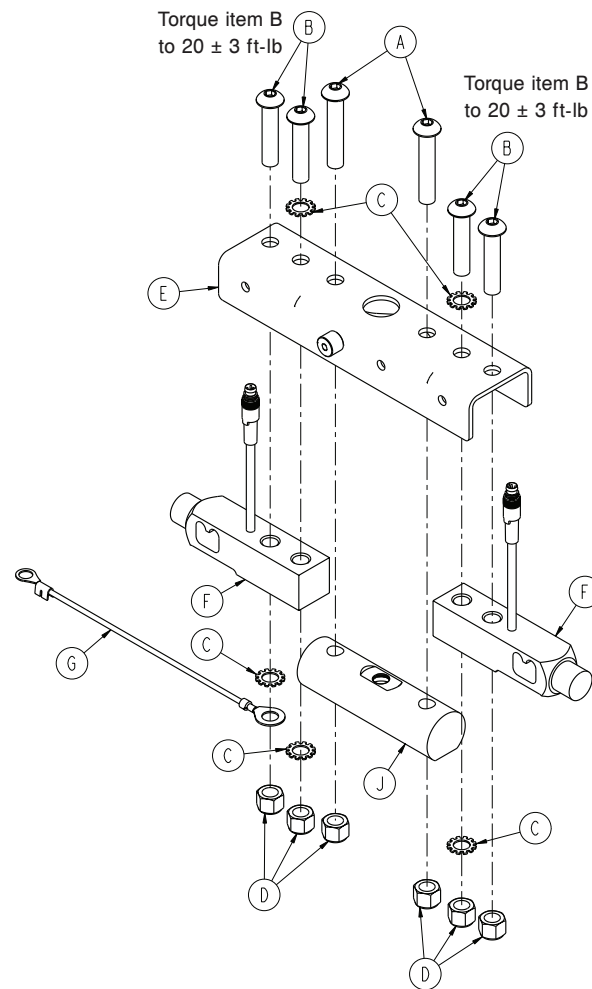

Item	Number	Name	Quantity
A	0004-368-000	Button head cap screw	2
B	0004-462-000	Button head cap screw	4
C	0013-019-000	External tooth lock washer	5
D	0016-035-000	Nylock hex nut	6
E	1008-117-651	26" lifthead bracket, foot end	1
F	1008-037-057	Load cell	2
G	1008-037-871	8" lifthead to litter ground	1
J	1070-017-662	26" lifthead support	1

30" common litter components, fifth wheel

1105-016-003 Rev E (Reference only)

Number	Name	Quantity
0853-003-615	<i>8" caster with full cover assembly - 0853-003-615 (page 97)</i>	1
1105-006-110	<i>Retractable fifth wheel assembly (page 110)</i>	1
0853-102-025	<i>Constant descent jacks, non-electric (page 126)</i>	1
1105-105-500	<i>Dual-sided hydraulics assembly, non-electric (page 113)</i>	1
1105-010-307	<i>30" common litter components (page 200)</i>	1

Common components, fifth wheel, 30"

1105-016-013 Rev F (Reference only)

Number	Name	Quantity
0921-001-252	Serial number date tag	1
0853-003-615	<i>8" caster with full cover assembly - 0853-003-615 (page 97)</i>	1
1105-006-110	<i>Retractable fifth wheel assembly (page 110)</i>	1
0853-102-025	<i>Constant descent jacks, non-electric (page 126)</i>	1
1105-105-500	<i>Dual-sided hydraulics assembly, non-electric (page 113)</i>	1
1105-010-307	<i>30" common litter components (page 200)</i>	1



9501 00001
JAN 1995

9501 00001
JAN 1995

30" common litter components

1105-010-307 Rev A (Reference only)

Number	Name	Quantity
1105-010-150	<i>30" corner cover assembly (page 202)</i>	1
1105-010-301	<i>30" litter frame assembly (page 201)</i>	1
1105-009-310	<i>30" monitor tray assembly (page 205)</i>	1
1105-012-302	<i>30" standard Fowler assembly (page 239)</i>	1
1105-030-310	<i>30" oxygen bottle assembly - 1105-030-310 (page 203)</i>	1
1210-800-008	Label, patent	1

30" litter frame assembly

1105-010-301 Rev D (Reference only)

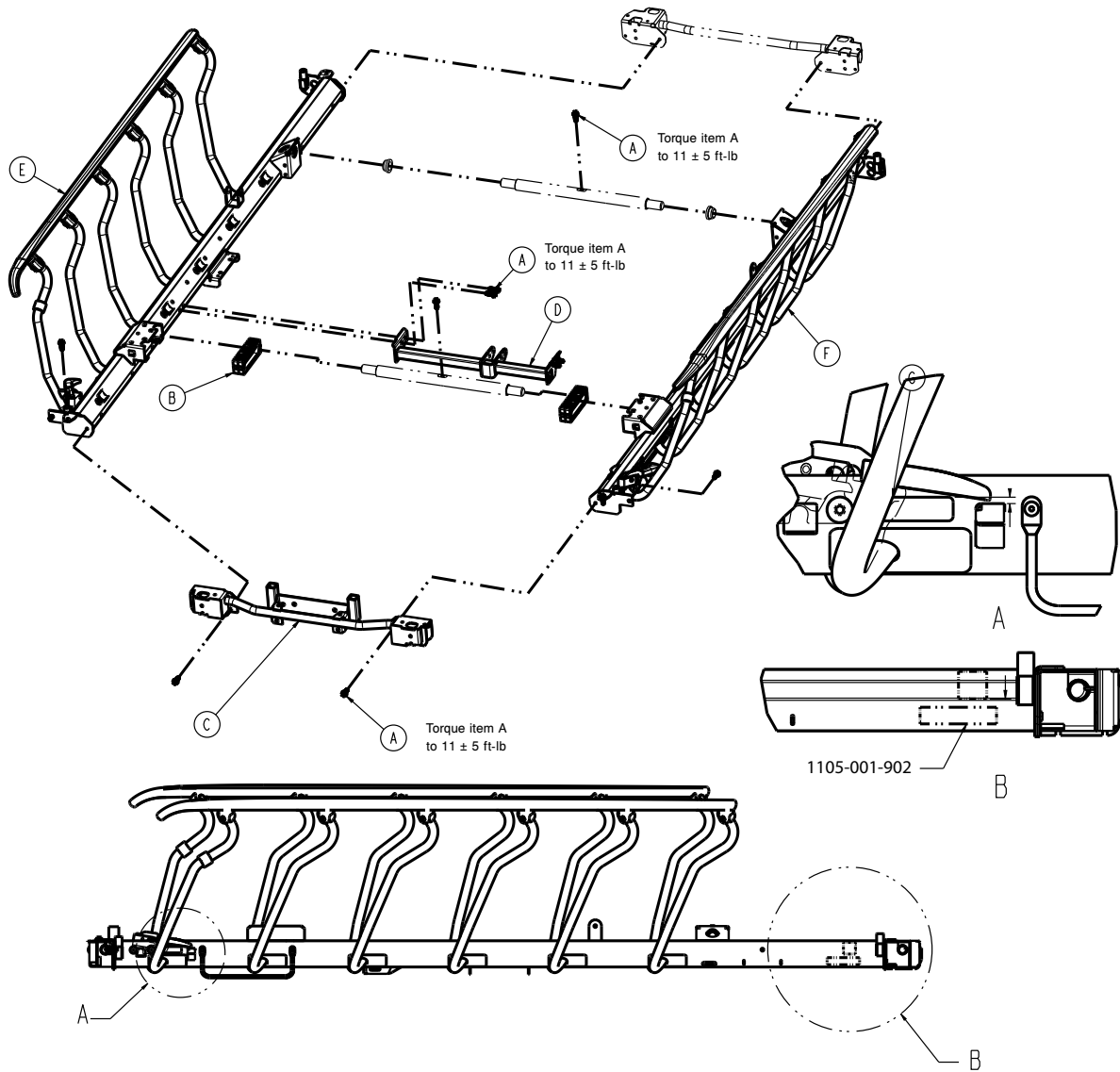

Item	Number	Name	Quantity
A	0023-288-000	Hex washer head screw	12
B	0785-010-006	Trend block slide	2
C	0785-110-320	End weldment, foot	1
D	1105-008-310	30" frame tie weldment	1
E	1105-011-040	Siderail assembly, right - non-electric litter (page 217)	1
F	1105-011-050	Siderail assembly, left - non-electric litter (page 219)	1
G	1105-001-901	Label, applied part	2

30" corner cover assembly

1105-010-150 Rev A (Reference only)

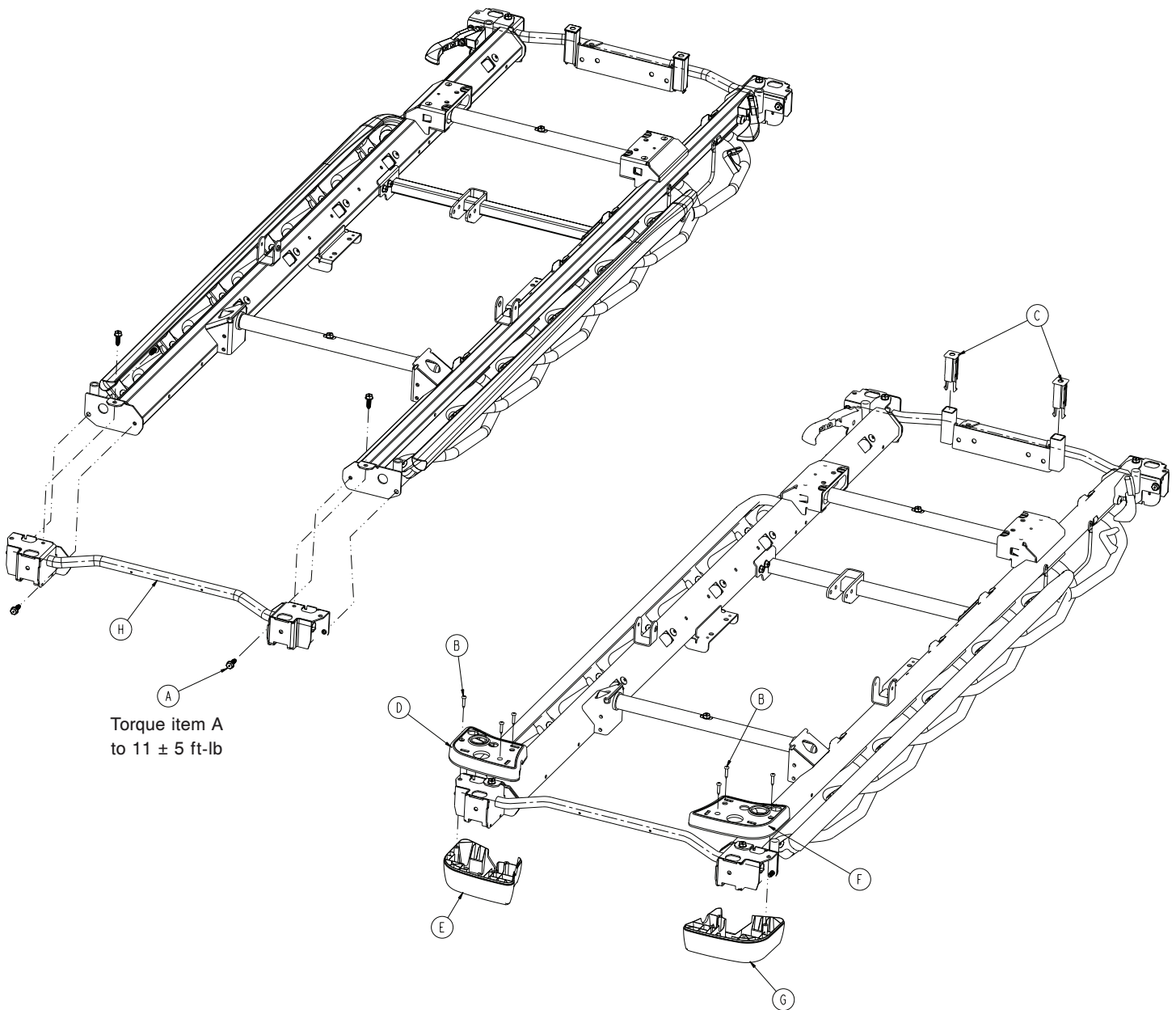

Item	Number	Name	Quantity
A	0023-288-000	Hex washer head screw	6
B	0023-310-000	Pan head tapping screw	6
C	0785-010-122	Footboard receptacle	2
D	0785-210-050	Mid cover, left, head end	1
E	0785-210-051	Bottom cover, left, head end	1
F	0785-210-055	Mid cover, right, head end	1
G	0785-210-056	Bottom cover, right, head end	1
H	1105-010-315	Weldment, head end	1

30" oxygen bottle assembly - 1105-030-310

Rev A (Reference only)

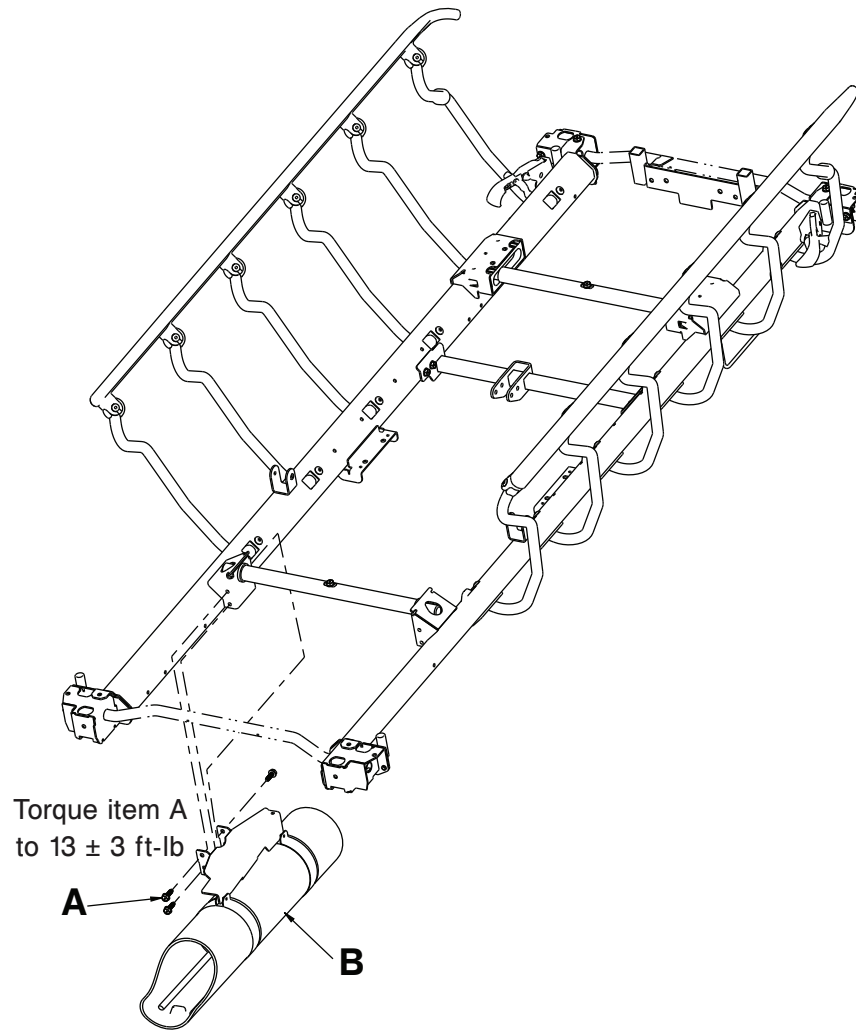

Item	Number	Name	Quantity
A	0023-288-000	Hex washer head screw	3
B	1105-030-301	30" oxygen receptacle assembly - 1105-030-301 (page 204)	1

30" oxygen receptacle assembly - 1105-030-301

Rev A (Reference only)

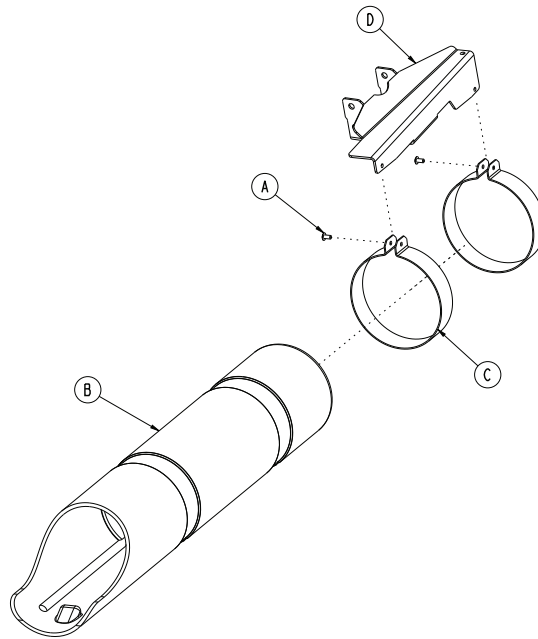

Item	Number	Name	Quantity
A	0025-079-000	Dome head rivet	2
B	1105-030-009	Oxygen tube	1
C	1105-030-021	Oxygen receptacle clamp	2
D	1105-130-308	30" oxygen bracket	1

30" monitor tray assembly

1105-009-310 Rev B (Reference only)

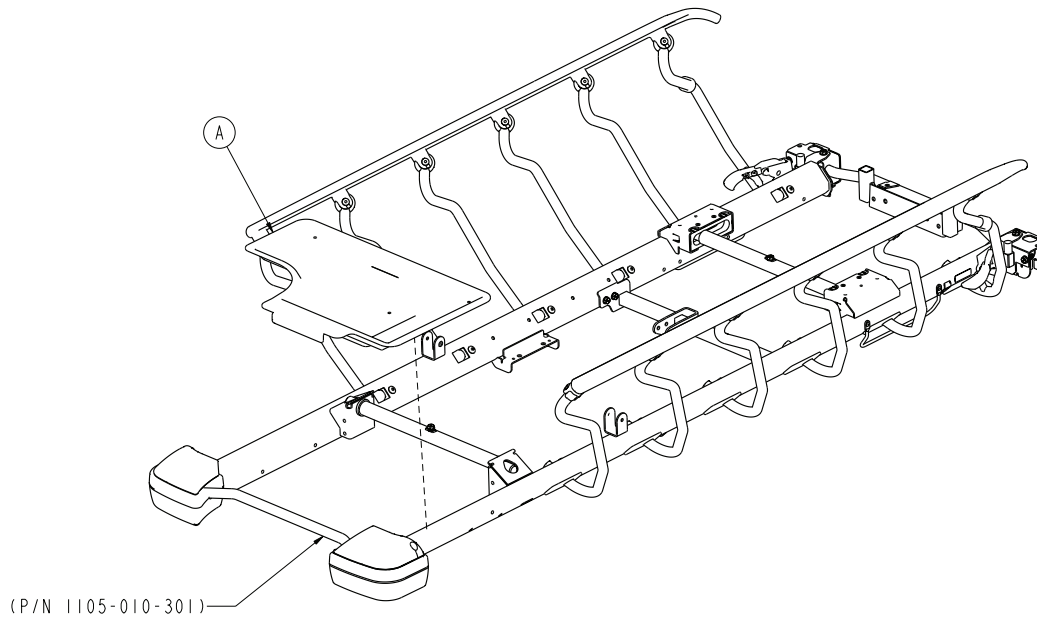

Item	Number	Name	Quantity
A	1105-145-301	30" monitor tray	1

30" standard Fowler, stationary foot - non-electric litter (scale system option)

1070-110-365 Rev D (Reference only)

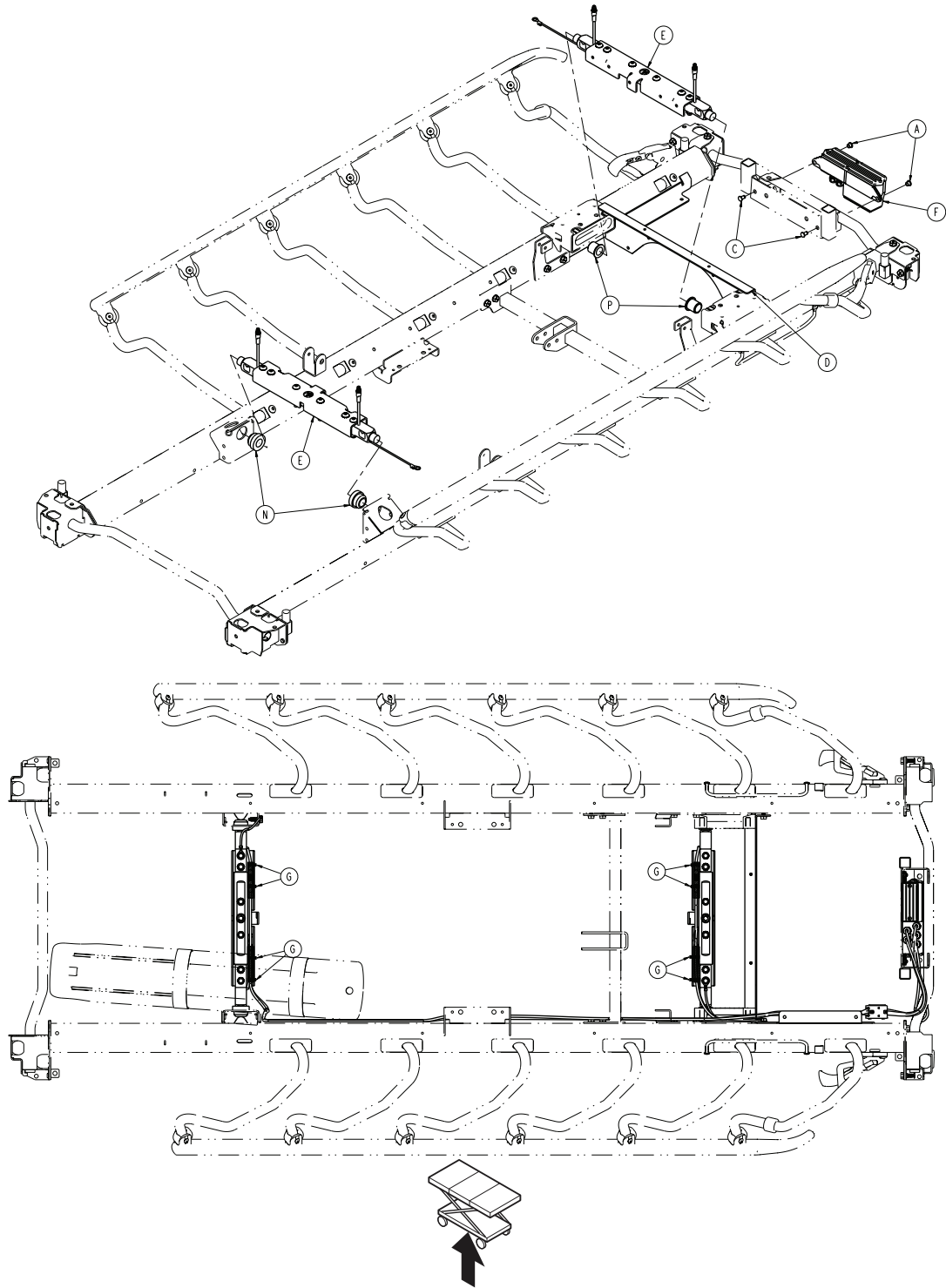

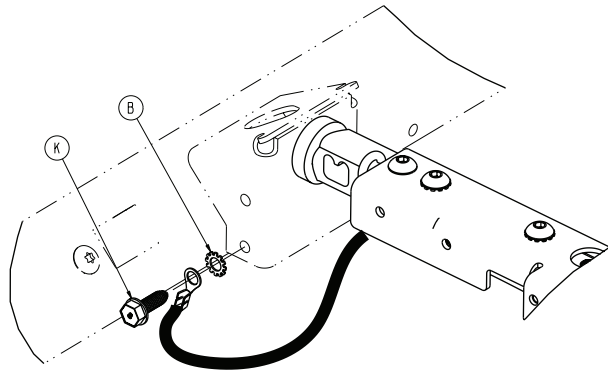
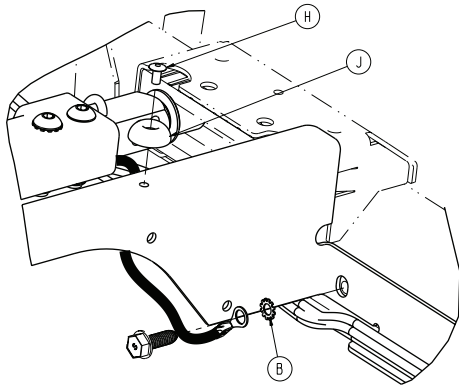
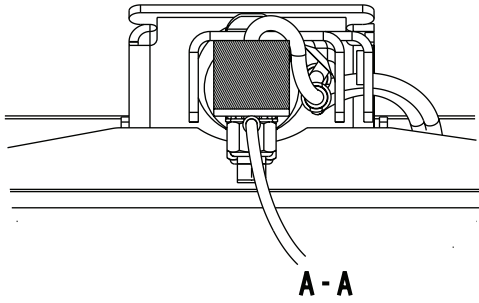
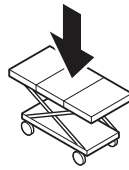
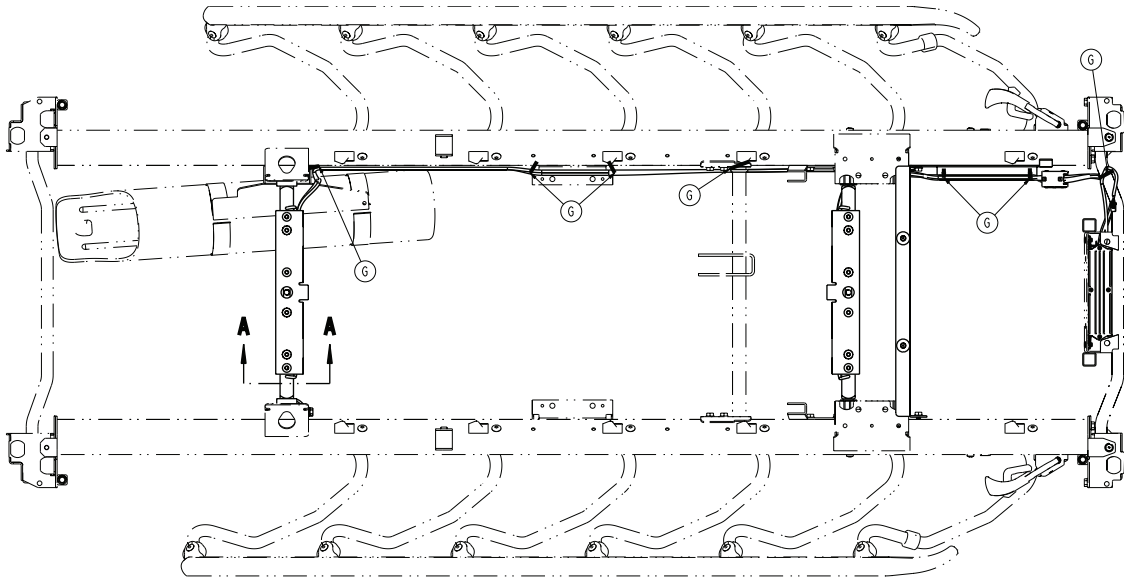

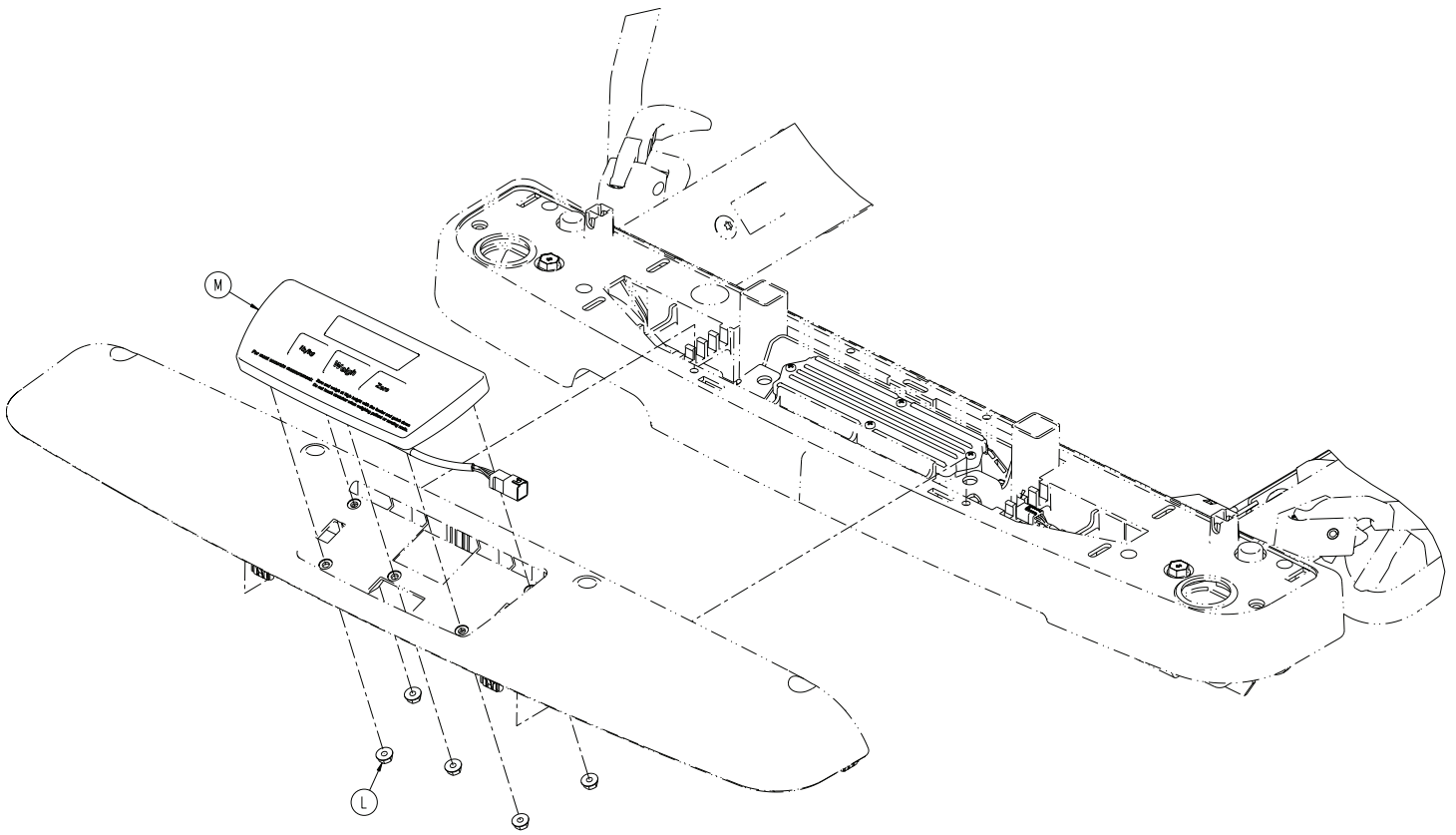

Item	Number	Name	Quantity
A	1070-137-001	Flange eyelet	2
B	0013-038-000	External tooth lock washer	2
C	0025-120-000	Dome head rivet	2
D	1105-010-341	30" full foot bracket	1
E	1070-117-300	30" scale lifthead - 1070-117-300 (page 215)	2
F	1070-237-020	Scale box assembly, non-electric litter -1070-237-020 (page 216)	1
G	3000-300-113	8" cable tie	15
H	0025-079-000	Dome head rivet	2
J	0946-001-155	Bumper	2
K	0023-288-000	Hex washer head screw	1
L	0016-137-000	Hex flange nut	5
M	1008-037-820	Scale control non-backlit keypad assembly	1
N	1070-117-011	Scale bushing, head end	2
P	1070-117-012	Scale bushing, foot end	2

30" standard Fowler, Gatch - non-electric litter (scale system option)

1070-110-360 Rev D (Reference only)

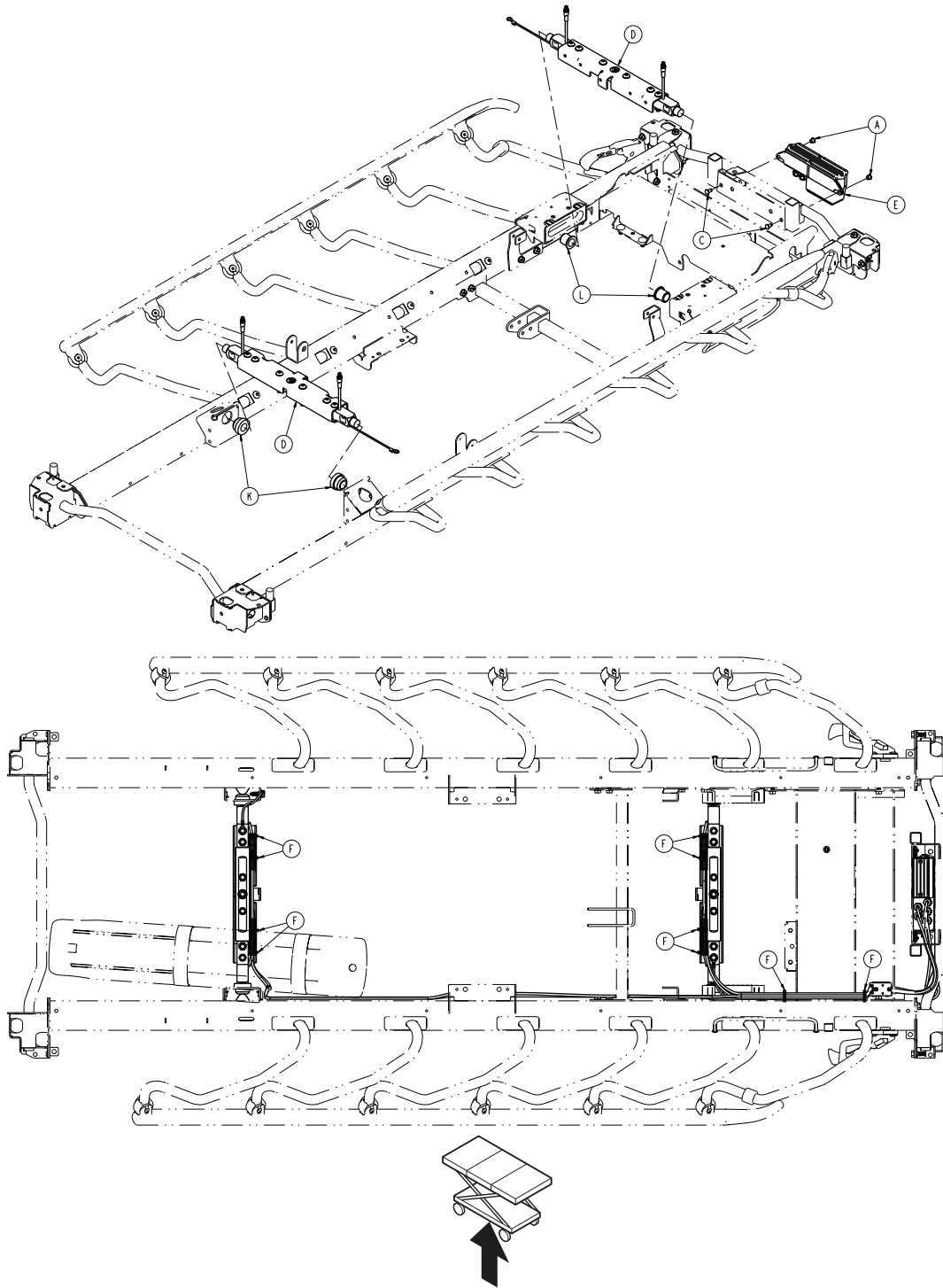

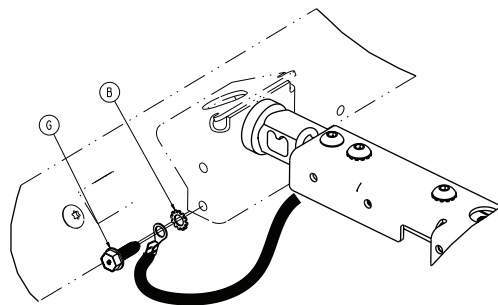
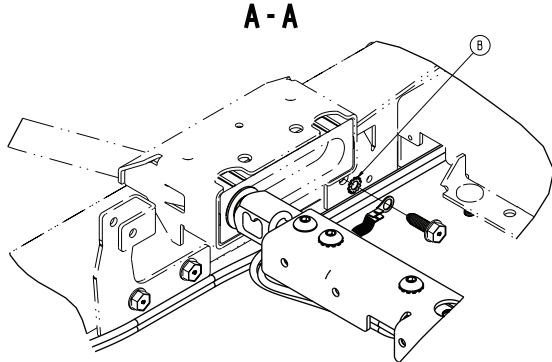
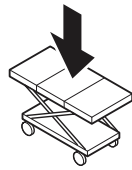
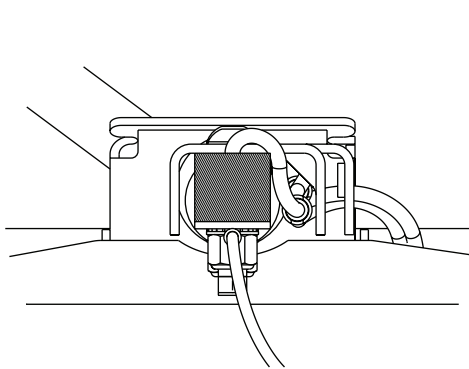
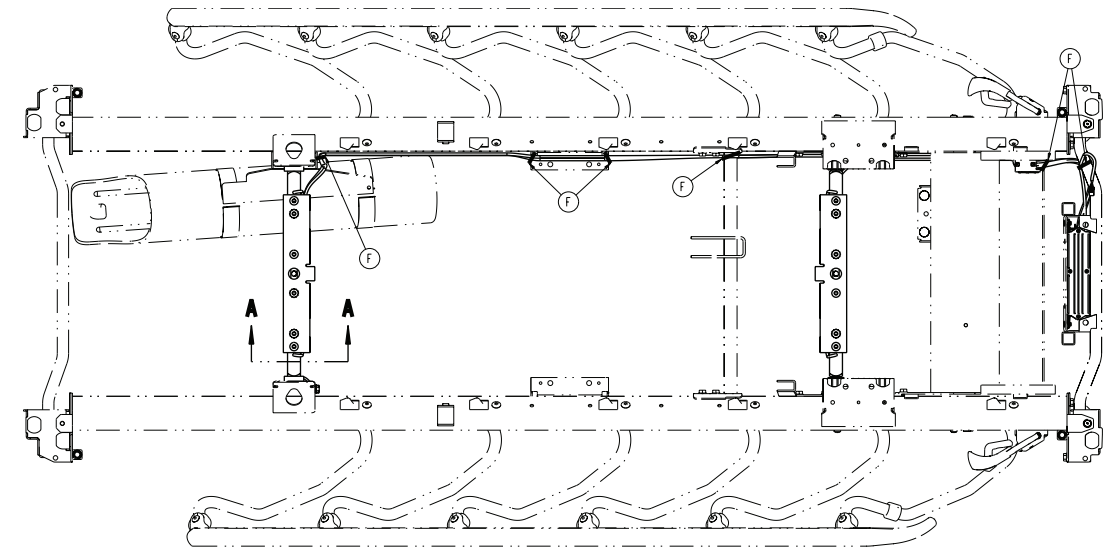

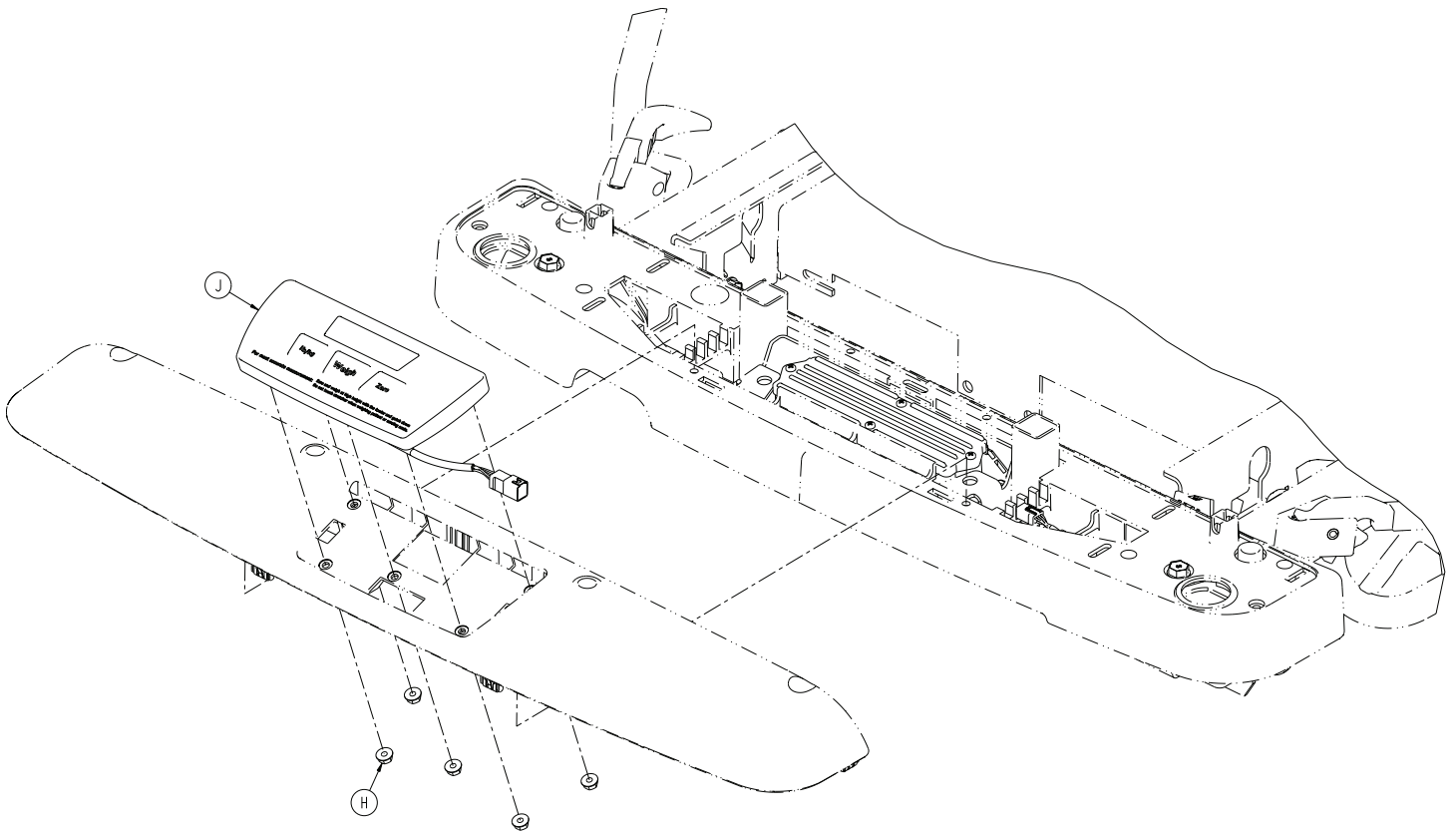

Item	Number	Name	Quantity
A	1070-137-001	Flange eyelet	2
B	0013-038-000	External tooth lock washer	2
C	0025-120-000	Dome head rivet	2
D	1070-117-300	30" scale lifthead - 1070-117-300 (page 215)	2
E	1070-237-020	Scale box assembly, non-electric litter -1070-237-020 (page 216)	1
F	3000-300-113	8" cable tie	16
G	0023-288-000	Hex washer head screw	1
H	0016-137-000	Hex flange nut	5
J	1008-037-820	Scale control non-backlit keypad assembly	1
K	1070-117-011	Scale bushing, head end	2
L	1070-117-012	Scale bushing, foot end	2

30" drop seat Fowler, stationary foot - non-electric litter (scale system option)

1070-110-370 Rev C (Reference only)

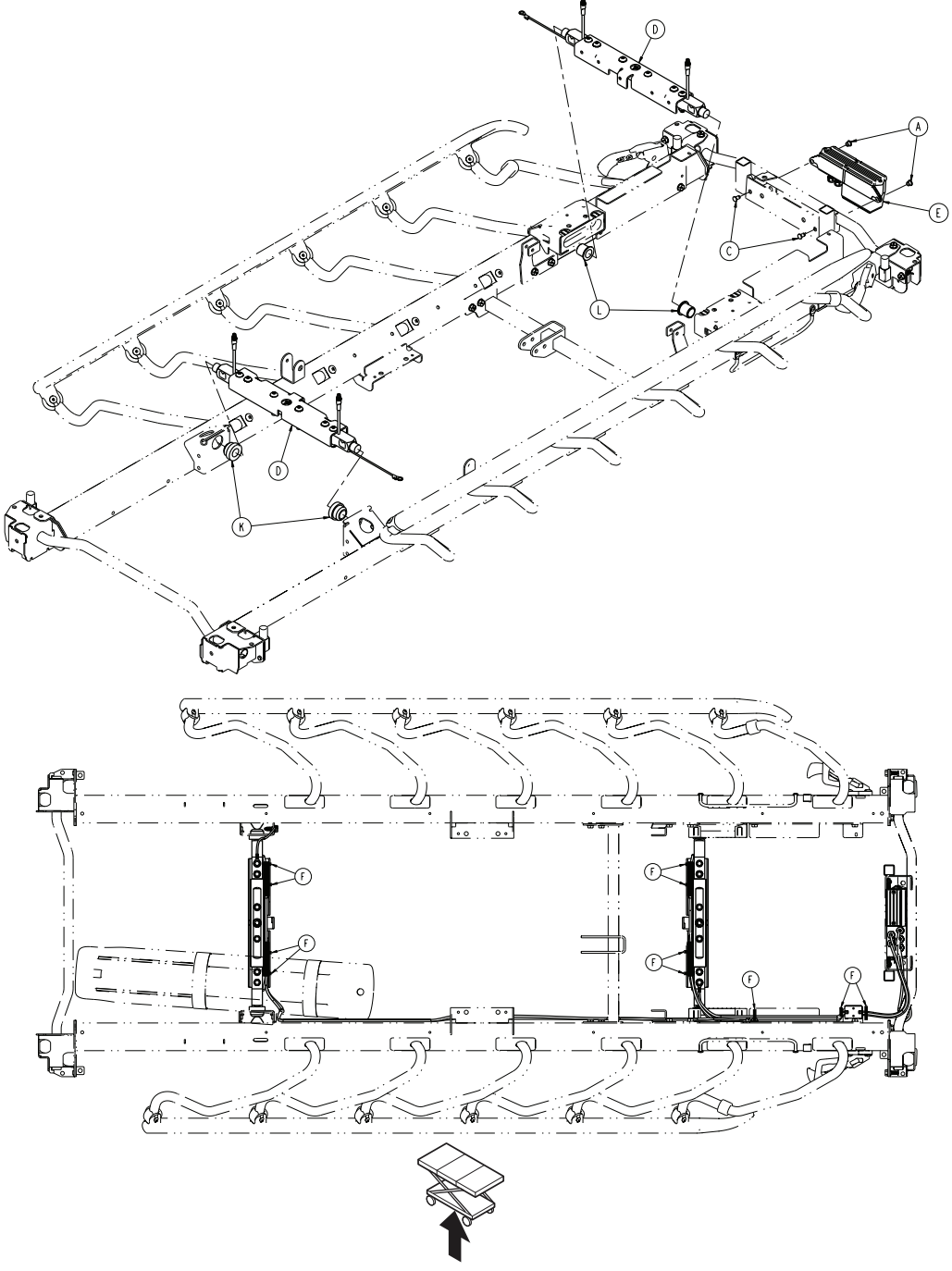

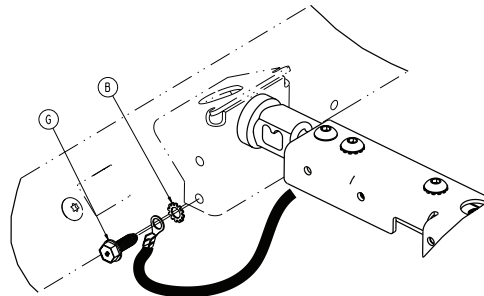
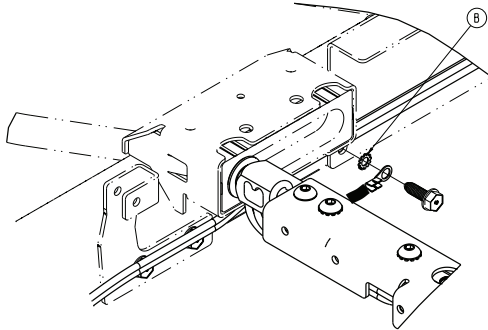
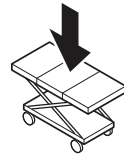
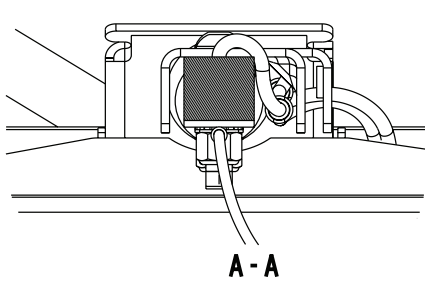
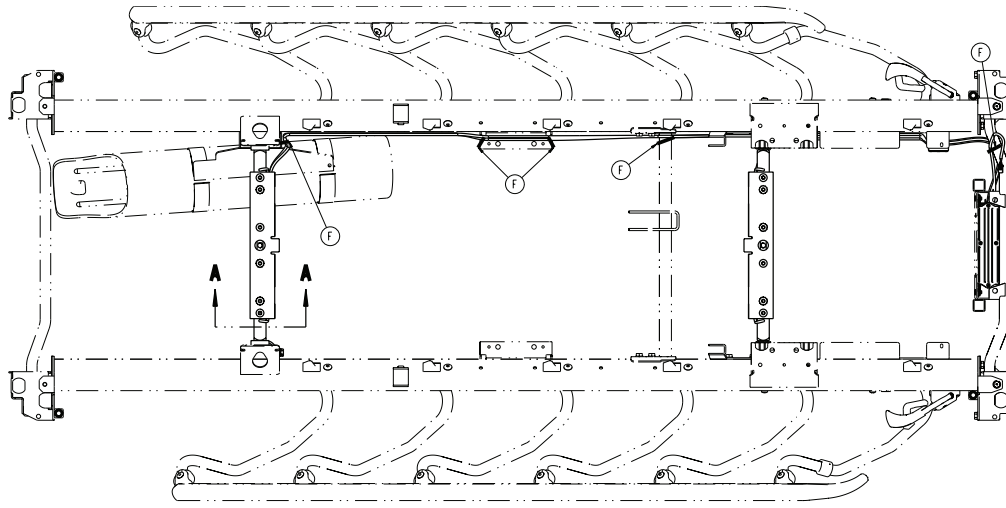

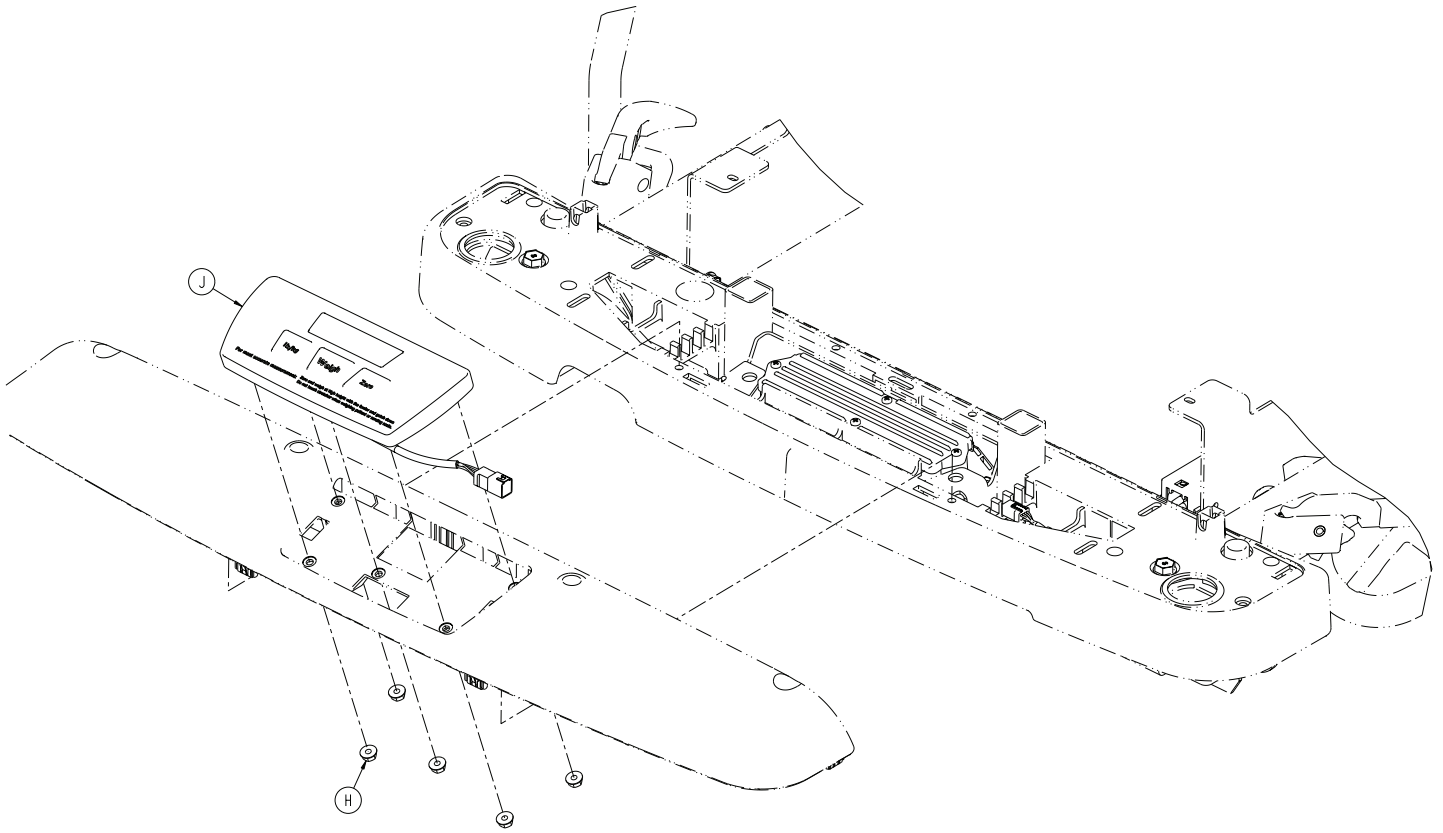

Item	Number	Name	Quantity
A	1070-137-001	Flange eyelet	2
B	0013-038-000	External tooth lock washer	2
C	0025-120-000	Dome head rivet	2
D	1070-117-300	30" scale lifthead - 1070-117-300 (page 215)	2
E	1070-237-020	Scale box assembly, non-electric litter -1070-237-020 (page 216)	1
F	3000-300-113	8" cable tie	16
G	0023-288-000	Hex washer head screw	1
H	0016-137-000	Hex flange nut	5
J	1008-037-820	Scale control non-backlit keypad assembly	1
K	1070-117-011	Scale bushing, head end	2
L	1070-117-012	Scale bushing, foot end	2

30" scale lifthead - 1070-117-300

Rev B (Reference only)

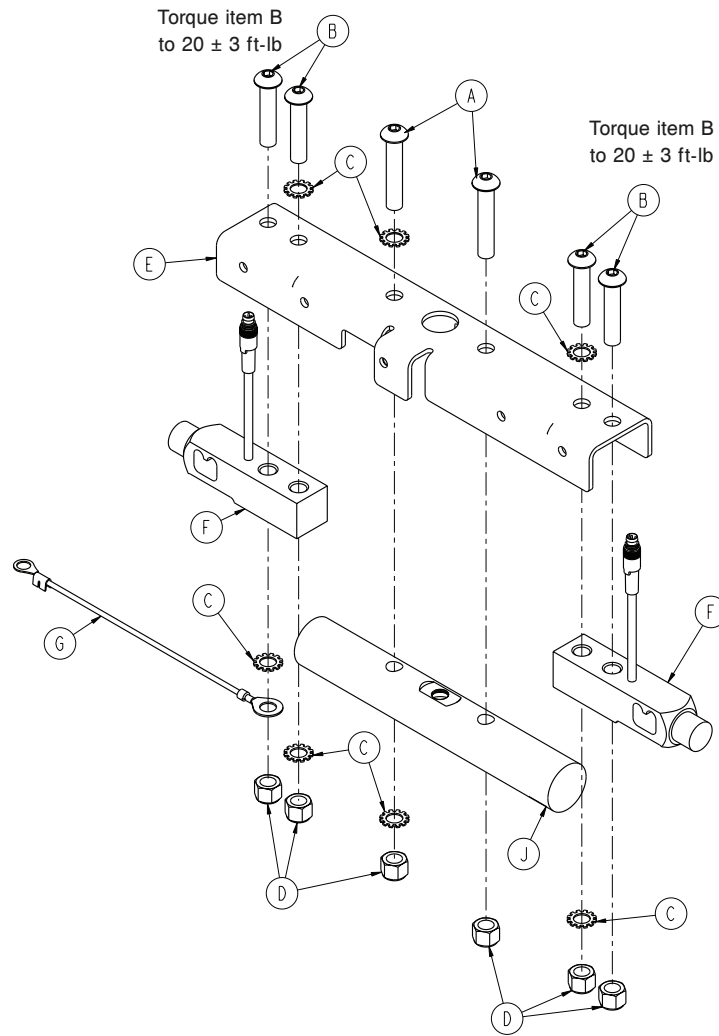

Item	Number	Name	Quantity
A	0004-368-000	Button head cap screw	2
B	0004-462-000	Button head cap screw	4
C	0013-019-000	External tooth lock washer	7
D	0016-035-000	Nylock hex nut	6
E	1008-017-351	30" lifthead bracket, head end	1
F	1008-037-057	Load cell	2
G	1008-037-871	Lifthead to litter ground 8"	1
J	1070-017-362	30" lifthead support	1

Scale box assembly, non-electric litter -1070-237-020

Rev AB (Reference only)

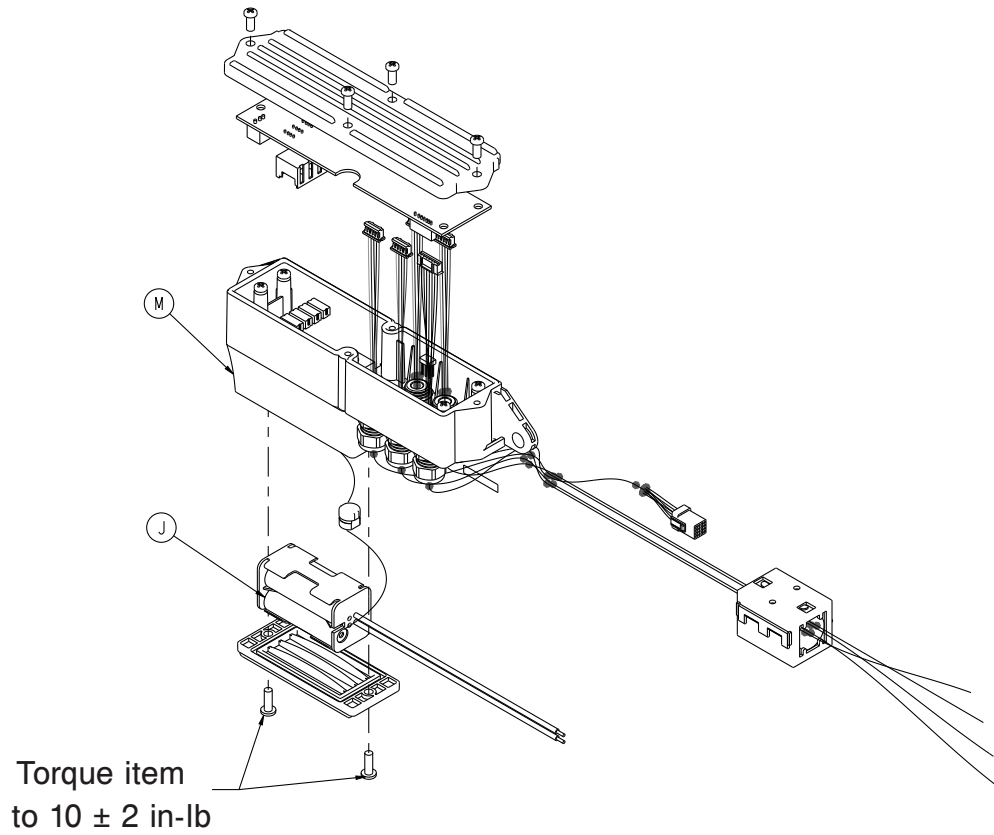

Item	Number	Name	Quantity
J	0059-782-000	Battery, AA	4
M	1070-237-030	Scale box assembly, no batteries	1

Siderail assembly, right - non-electric litter

1105-011-040 Rev C (Reference only)

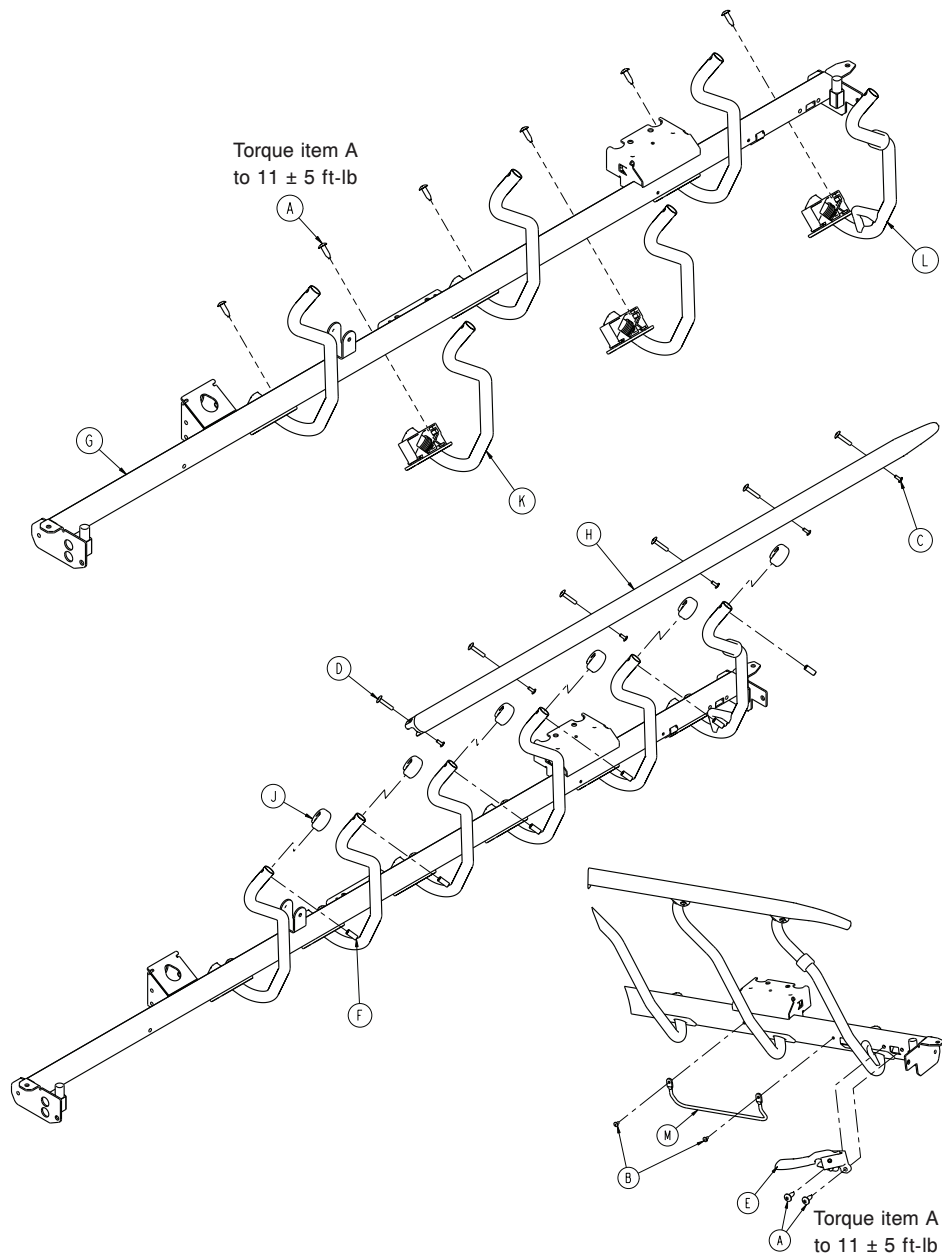

Item	Number	Name	Quantity
A	0007-074-000	Truss head machine screw	8
B	0025-079-000	Dome head rivet	2
C	0025-182-000	Blind rivet	6
D	0025-183-000	Tubular component	6
E	0785-011-020	<i>Siderail latch assembly, right (page 223)</i>	1
F	0785-011-046	Spindle bearing	6
G	1105-011-012	Siderail tube weldment, right	1
H	1105-011-037	Top rail, right	1
J	1105-011-038	Spindle plug	6

Item	Number	Name	Quantity
K	1105-011-041	<i>Spindle assembly, right - 1105-011-041 (page 221)</i>	5
L	1105-011-042	<i>Latch spindle assembly, right (page 225)</i>	1
M	1105-030-046	Foley bag rack	1

Siderail assembly, left - non-electric litter

1105-011-050 Rev C (Reference only)

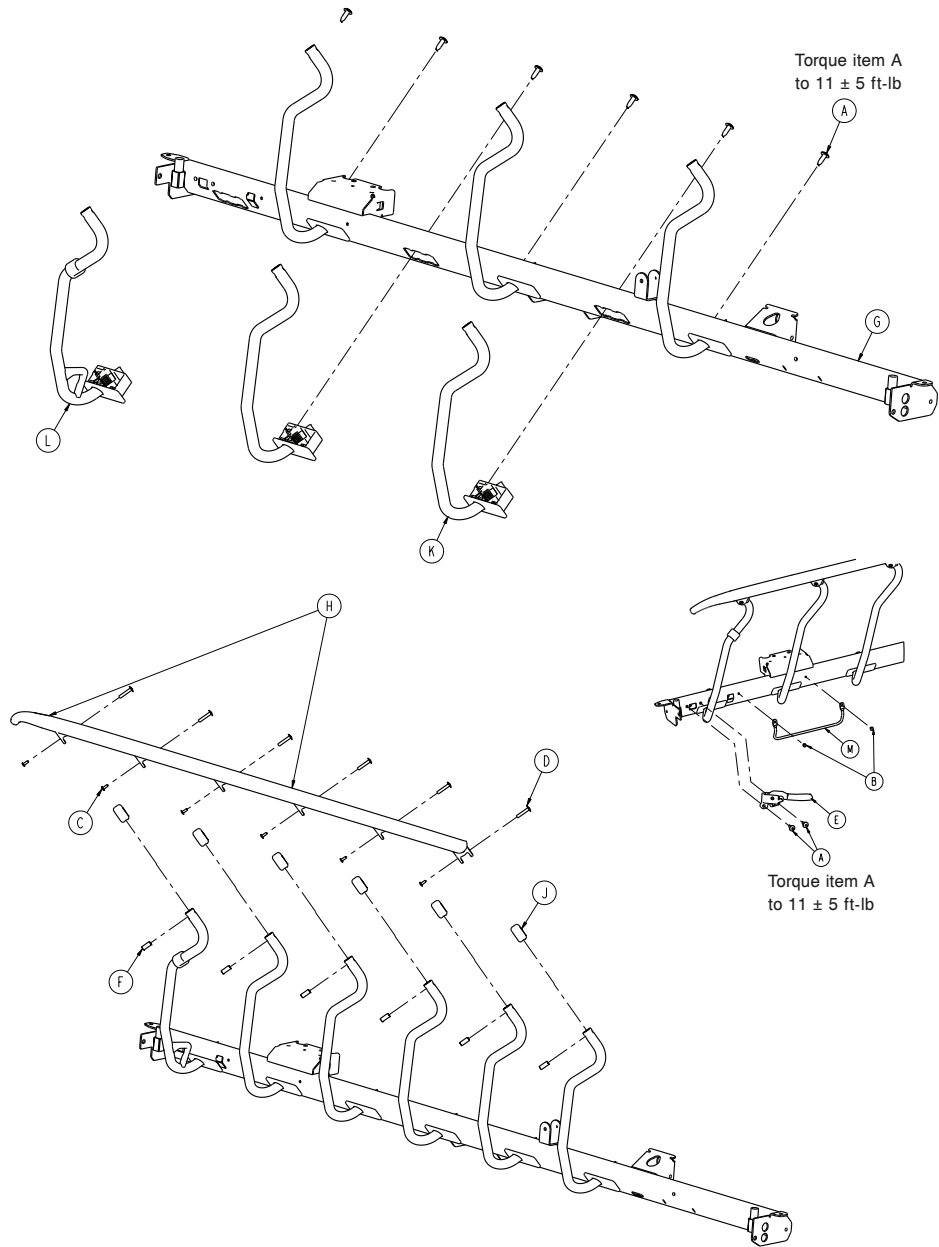

Item	Number	Name	Quantity
A	0007-074-000	Truss head machine screw	8
B	0025-079-000	Dome head rivet	2
C	0025-182-000	Blind rivet	6
D	0025-183-000	Tubular component	6
E	0785-011-021	<i>Siderail latch assembly, left (page 224)</i>	1
F	0785-011-046	Spindle bearing	6
G	1105-011-011	Siderail tube weldment, left	1
H	1105-011-036	Top rail, left, blue accent	1
J	1105-011-038	Spindle plug, blue accent	6

Item	Number	Name	Quantity
K	1105-011-051	<i>Spindle assembly, left - 1105-011-051</i> (page 222)	5
L	1105-011-052	<i>Latch spindle assembly, right</i> (page 225)	1
M	1105-030-046	Foley bag rack	1

Spindle assembly, right - 1105-011-041

Rev A (Reference only)

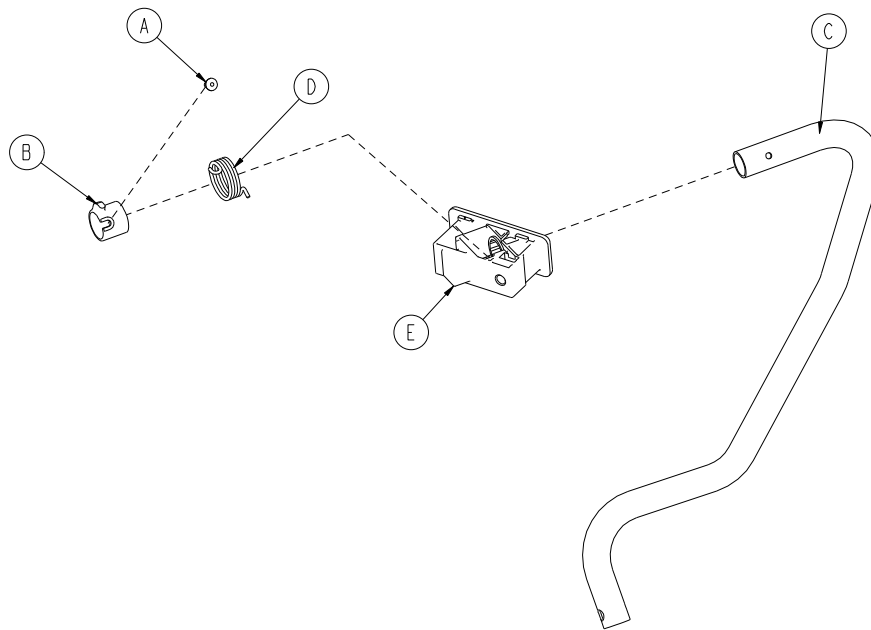

Item	Number	Name	Quantity
A	0025-079-000	Dome head rivet	1
B	0785-011-013	Spindle spacer, right	1
C	0785-011-032	Spindle, right	1
D	0785-011-047	Siderail spring, right	1
E	1105-011-197	Pivot block/nut assembly	1

Spindle assembly, left - 1105-011-051

Rev A (Reference only)

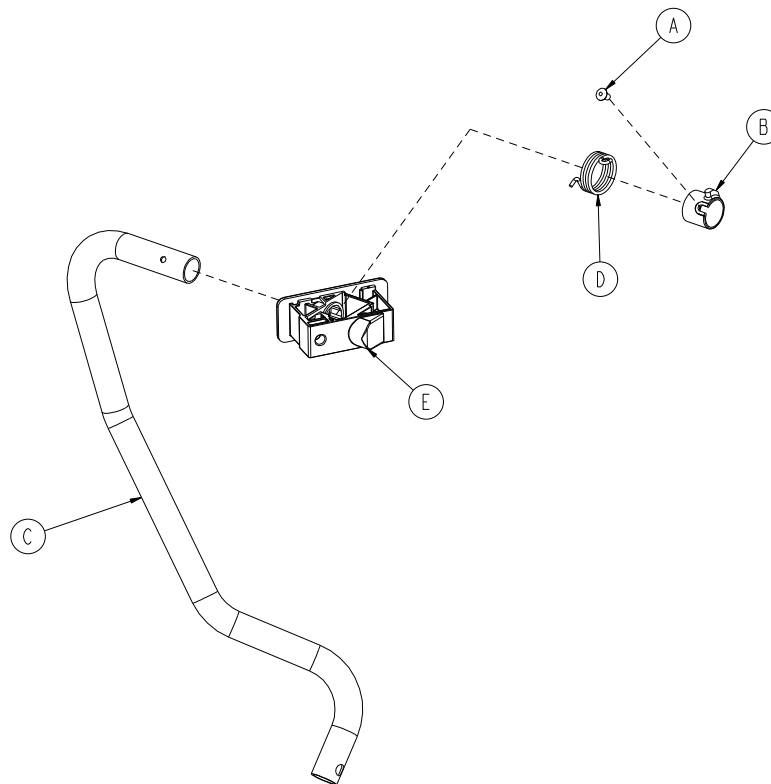

Item	Number	Name	Quantity
A	0025-079-000	Dome head rivet	1
B	0785-011-010	Spindle spacer, left	1
C	0785-011-033	Spindle, left	1
D	0785-011-048	Siderail spring, left	1
E	1105-011-197	Pivot block/nut assembly	1

Siderail latch assembly, right

0785-011-020 Rev C (Reference only)

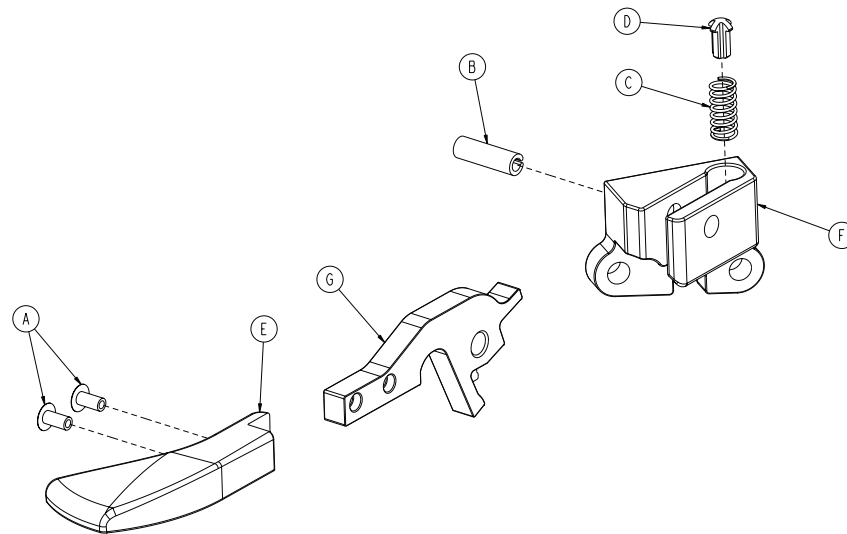

Item	Number	Name	Quantity
A	0025-079-000	Dome head rivet	2
B	0026-365-000	Slotted spring pin	1
C	0038-526-000	Compression wire	1
D	0785-011-054	Plunger	1
E	0785-011-056	Latch handle, right	1
F	0785-011-128	Latch mounting block, right	1
G	0785-011-131	Latch plate	1

Siderail latch assembly, left

0785-011-021 Rev C (Reference only)

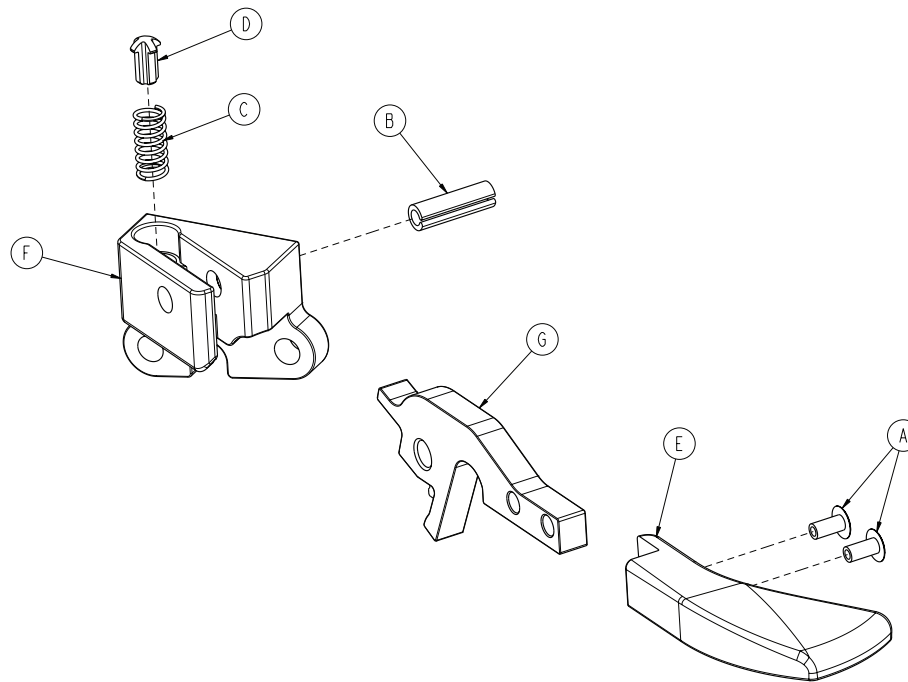

Item	Number	Name	Quantity
A	0025-079-000	Dome head rivet	2
B	0026-365-000	Slotted spring pin	1
C	0038-526-000	Compression wire	1
D	0785-011-054	Plunger	1
E	0785-011-057	Latch handle, left	1
F	0785-011-123	Latch mounting block, left	1
G	0785-011-131	Latch plate	1

Latch spindle assembly, right

1105-011-042 Rev A (Reference only)

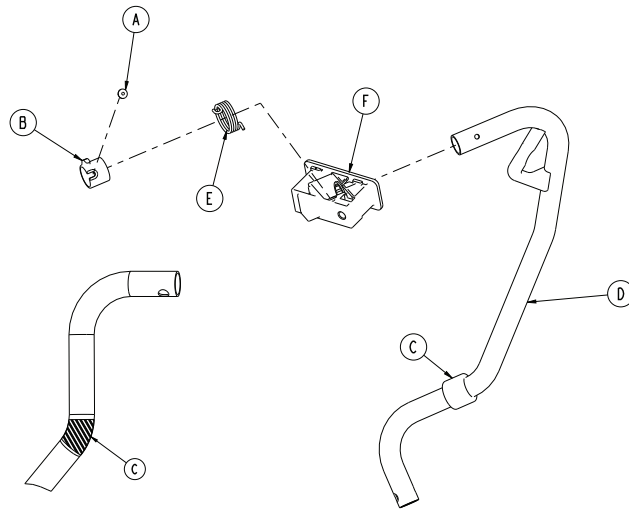

Item	Number	Name	Quantity
A	0025-079-000	Dome head rivet	1
B	0785-011-013	Spindle spacer, right	1
C	0785-011-016	Rubber stop	1
D	0785-011-043	Latch spindle, right	1
E	0785-011-047	Siderail spring, ,right	1
F	1105-011-197	Pivot block/nut assembly	1

Latch spindle assembly, left

1105-011-052 Rev A (Reference only)

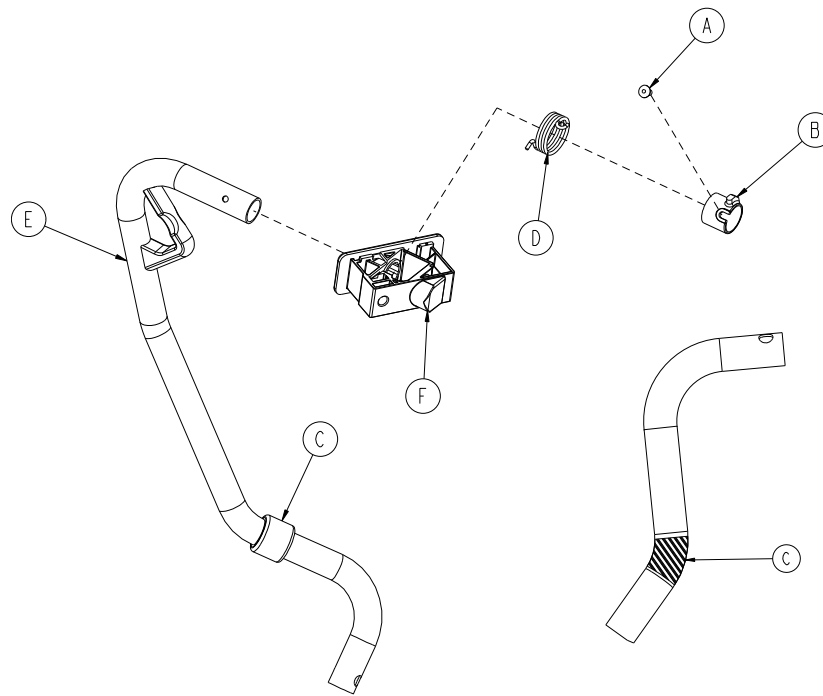

Item	Number	Name	Quantity
A	0025-079-000	Dome head rivet	1
B	0785-011-010	Spindle spacer, left	1
C	0785-011-016	Rubber stop	1
D	0785-011-048	Siderail spring, left	1
E	0785-011-053	Latch spindle, left	1
F	1105-011-197	Pivot block/nut assembly	1

Dual latch assembly option, right

1105-011-140 Rev A (Reference only)

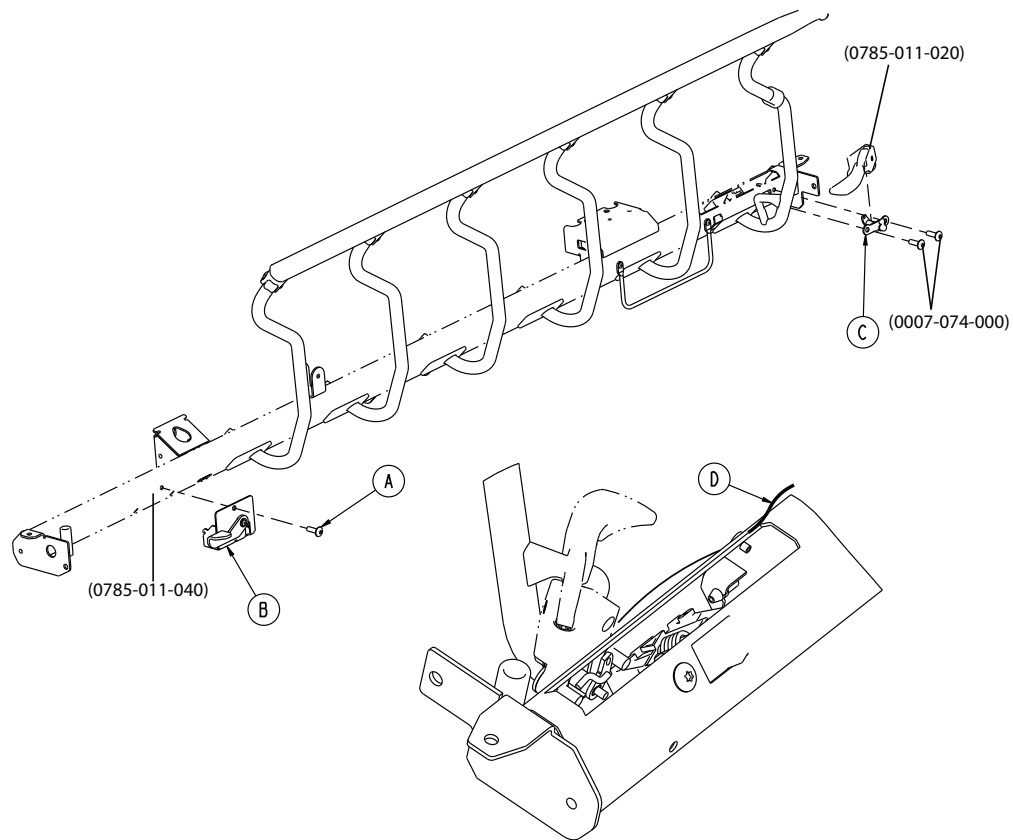

Item	Number	Name	Quantity
A	0007-074-000	Truss head machine screw	1
B	1105-011-070	Dual latch assembly option, right, head end (page 229)	1
C	0785-011-100	Dual latch assembly option, right, foot end (page 230)	1
D	0785-011-110	Dual latch cable assembly	1

Dual latch assembly option, left

1105-011-150 Rev A (Reference only)

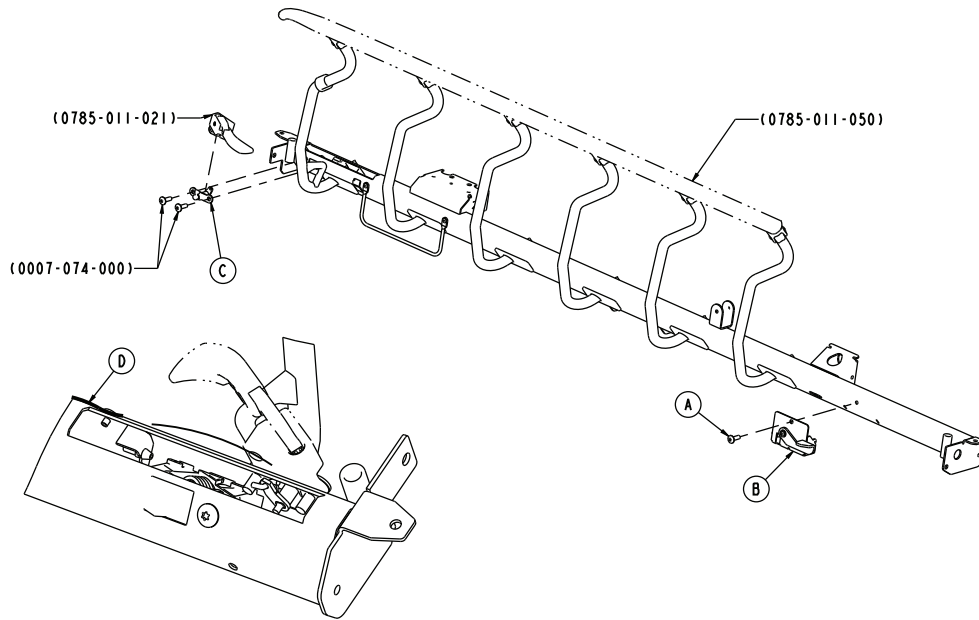

Item	Number	Name	Quantity
A	0007-074-000	Truss head machine screw	1
B	1105-011-130	Dual latch assembly option, left, head end - 1105-011-130 (page 231)	1
C	0785-011-135	Dual latch assembly option, left, foot end (page 232)	1
D	0785-011-110	Dual latch cable assembly	1

Dual latch assembly option, right, head end

1105-011-070 Rev A (Reference only)

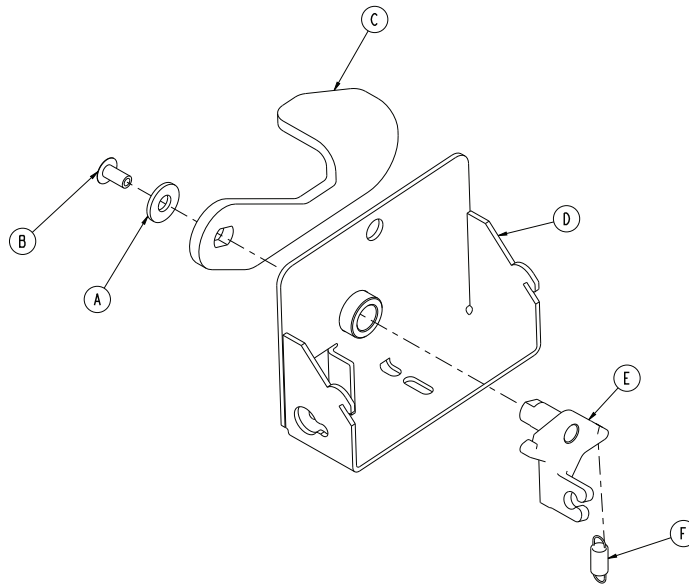

Item	Number	Name	Quantity
A	0011-063-000	Washer	1
B	0025-079-000	Dome head rivet	1
C	1105-011-074	Dual latch handle, right	1
D	1105-011-075	Mounting bracket weldment, right	1
E	0785-011-077	Dual latch cable arm	1
F	0785-011-093	Extension spring	1

Dual latch assembly option, right, foot end

0785-011-100 Rev C (Reference only)

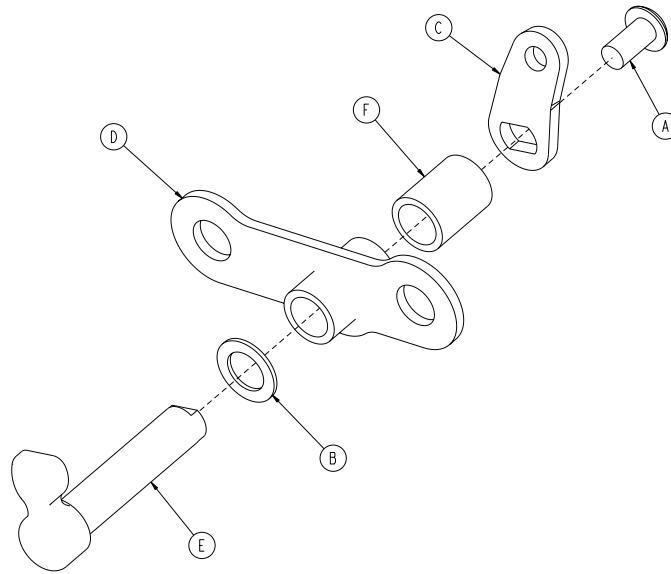

Item	Number	Name	Quantity
A	0004-136-000	Button head cap screw	1
B	0014-122-000	Washer	1
C	0785-011-086	Cable plate, right	1
D	0785-011-090	Cam pivot	1
E	0785-011-095	Dual latch cam	1
F	0785-011-096	Dual latch spacer	1

Dual latch assembly option, left, head end - 1105-011-130

Rev A (Reference only)

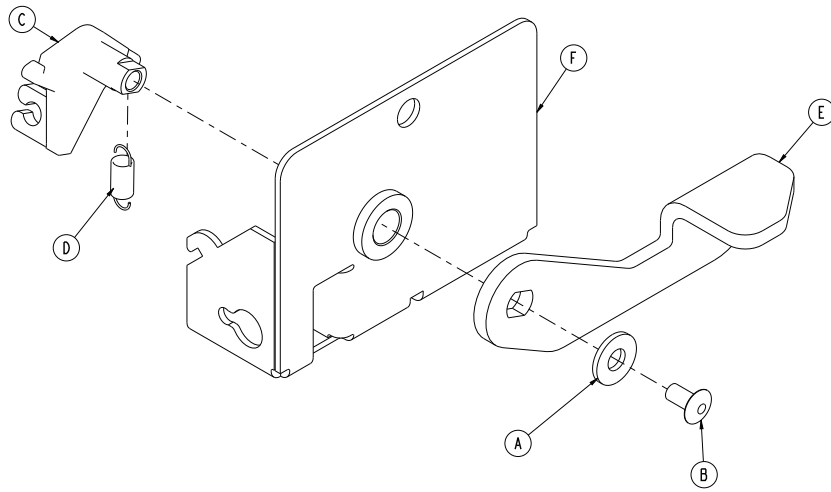

Item	Number	Name	Quantity
A	0011-063-000	Washer	1
B	0025-079-000	Dome head rivet	1
C	0785-011-077	Dual latch cable arm	1
D	0785-011-093	Extension spring	1
E	1105-011-106	Dual latch handle, left	1
F	1105-011-120	Mounting bracket weldment, left	1

Dual latch assembly option, left, foot end

0785-011-135 Rev C (Reference only)

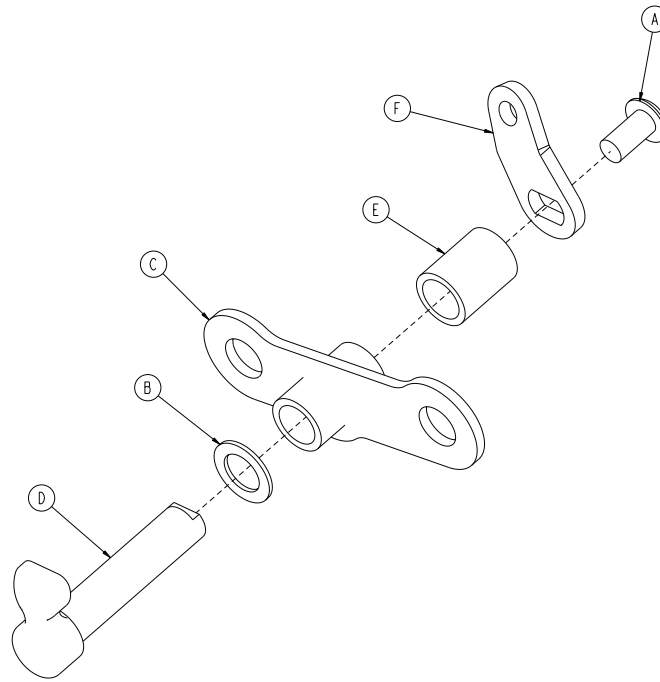

Item	Number	Name	Quantity
A	0004-136-000	Button head cap screw	1
B	0014-122-000	Washer	1
C	0785-011-090	Cam pivot	1
D	0785-011-095	Dual latch cam	1
E	0785-011-096	Dual latch spacer	1
F	0785-011-186	Cable plate, left	1

26" standard Fowler assembly

1105-012-602 Rev AB (Reference only)

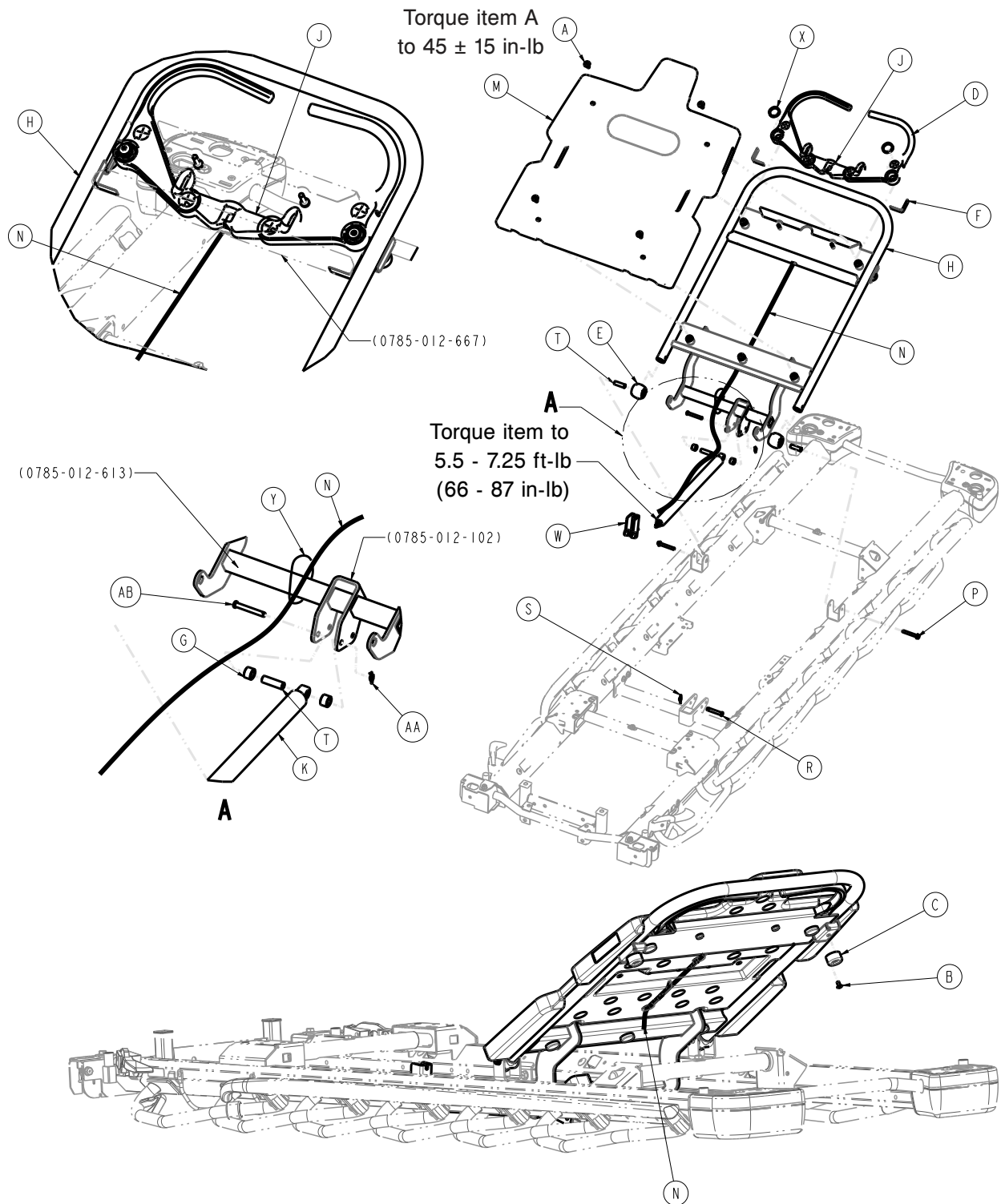

Item	Number	Name	Quantity
A	700002372142	Truss head machine screw	4
B	0025-079-000	Dome head rivet	2
C	0056-023-000	Bumper	2

Item	Number	Name	Quantity
D	0785-012-066	Fowler release handle	2
E	1105-012-076	Fowler tube plug	2
F	0785-012-086	Fowler spring	2
G	0785-012-094	Spacer	2
H	1105-012-605	26" Fowler weldment	1
J	0785-012-666	26" cable release pivot	1
K	0360-031-077	Gas cylinder	1
M	1008-012-650	26" plastic Fowler	1
N	0785-112-080	Fowler cable assembly	1
P	0003-385-000	Hex washer head screw	2
R	0026-296-000	Clevis pin	1
S	0027-019-000	Rue ring cotter	1
T	0785-012-103	Sleeve	3
W	0785-112-116	Gas spring trip	1
X	0038-557-000	Spring	2
Y	8815-029-200	Cable tie	1
AA	0027-020-000	Rue ring cotter	1
AB	0026-330-000	Clevis pin	1

26" standard Fowler, stationary foot assembly

1105-010-606 Rev B (Reference only)

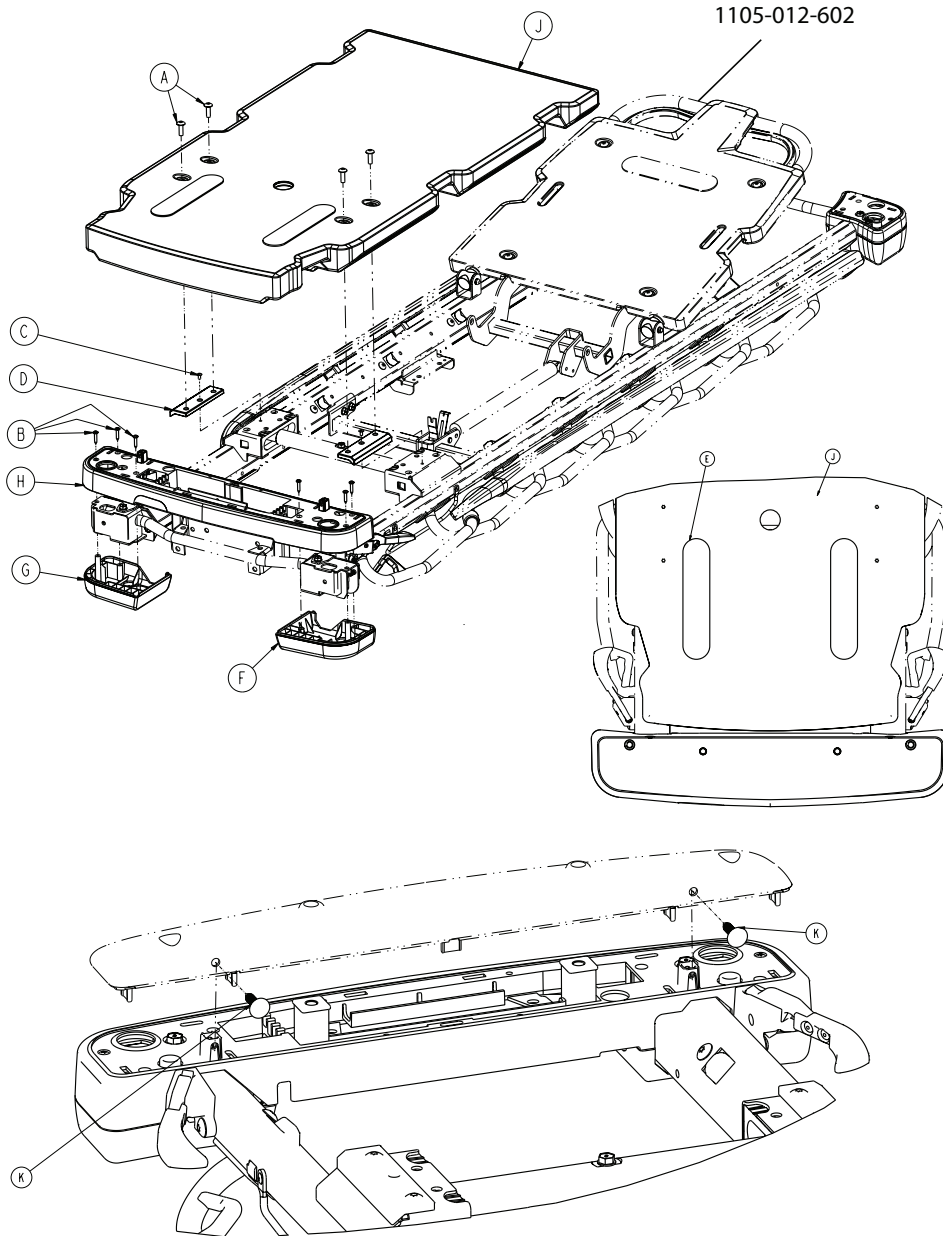

Item	Number	Name	Quantity
A	0007-074-000	Truss head machine screw	4
B	0023-310-000	Pan head tapping screw	6
C	0025-079-000	Dome head rivet	2
D	0785-012-107	Foot section skin spacer	2
E	0785-034-005	Velcro® pile	2
F	0785-210-052	Bottom cover, left, foot end	1
G	0785-210-057	Bottom cover, right, foot end	1
H	0785-210-655	26" mid cover, foot end	1
J	1105-015-650	26" stationary foot skin	1
K	0029-027-000	Panel fastener	2

26" standard Fowler with Gatch assembly

1105-010-603 Rev AA (Reference only)

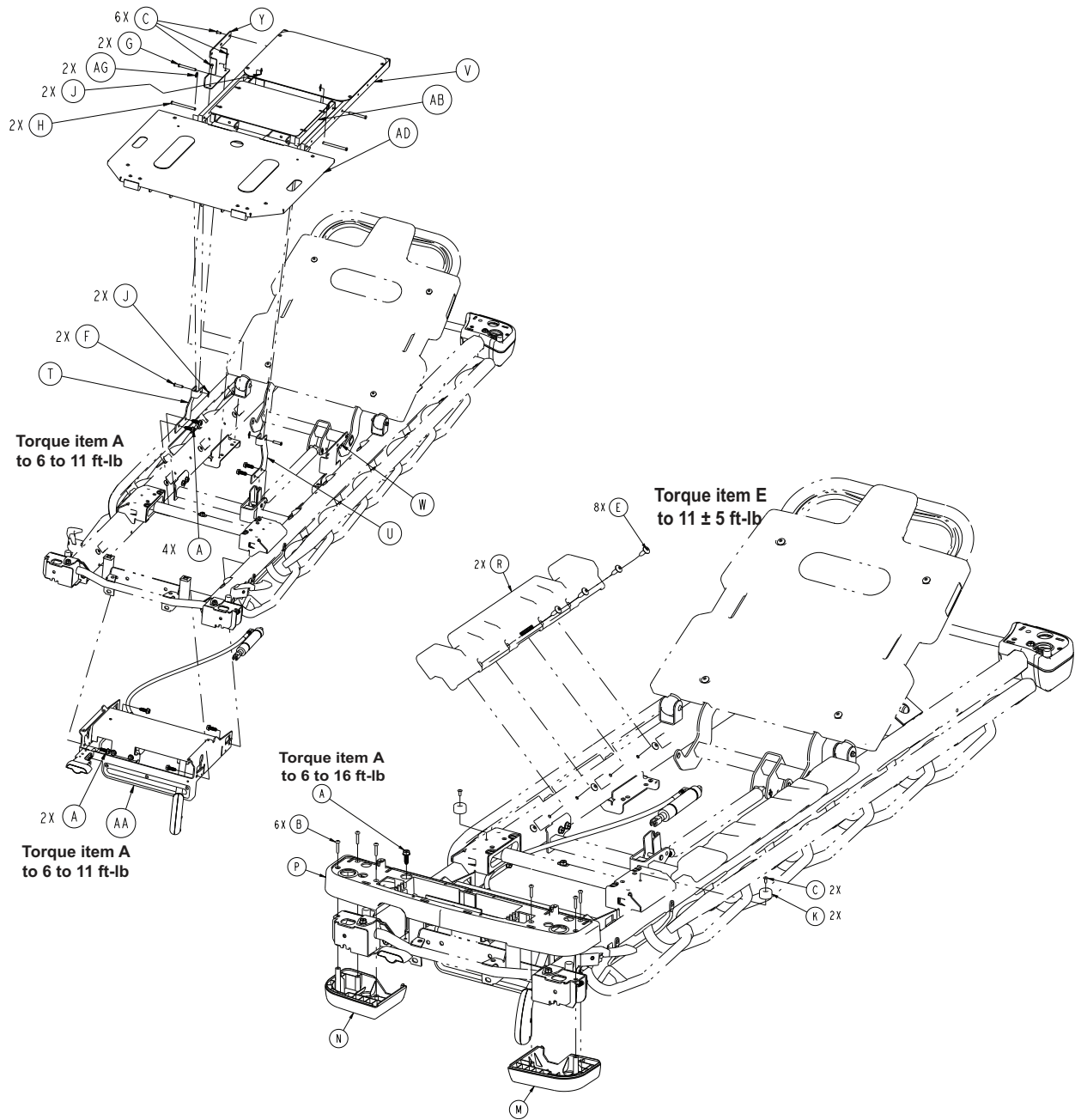

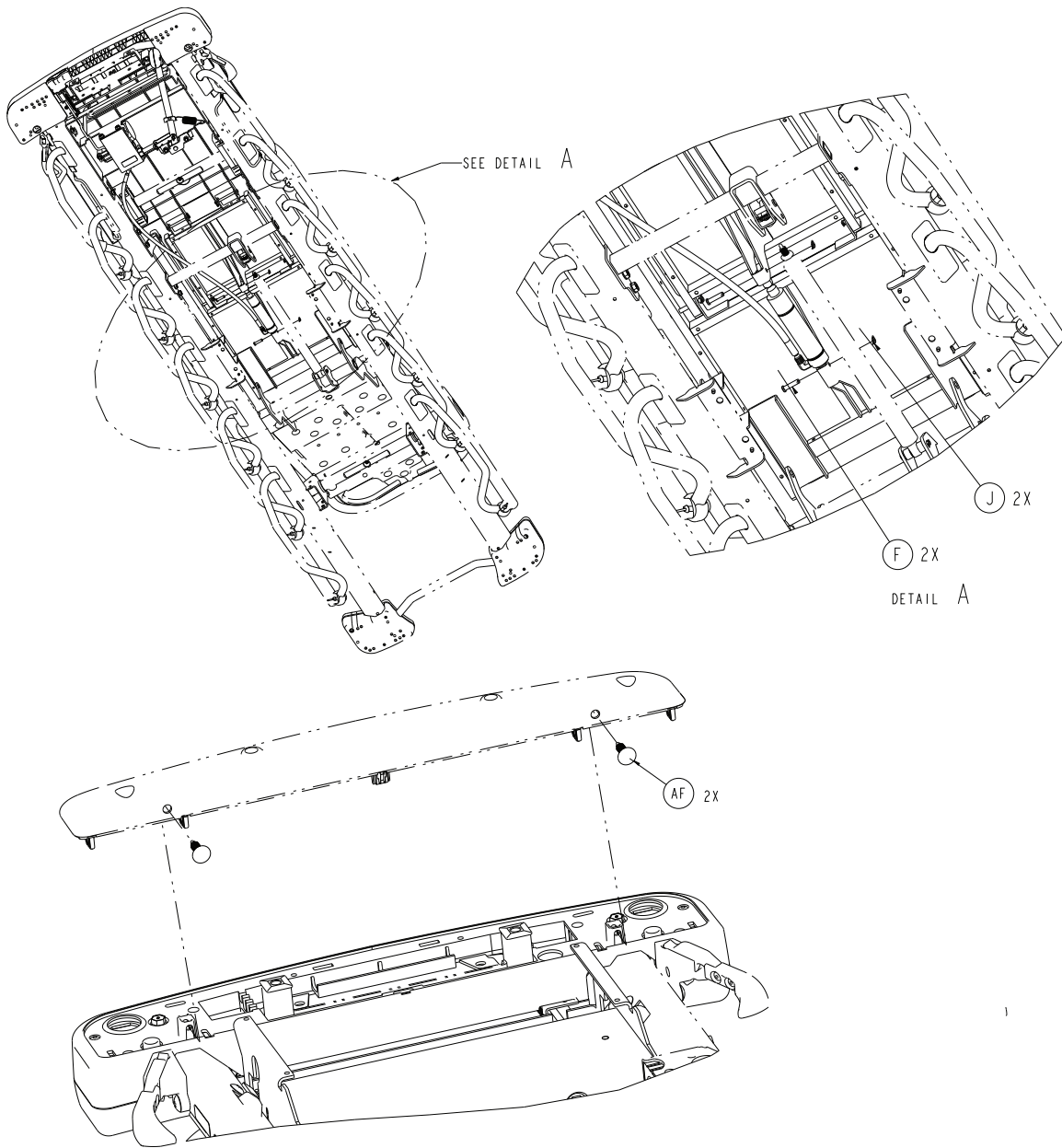

Item	Number	Name	Quantity
A	0023-288-000	Hex washer head screw	9
B	0023-310-000	Pan head tapping screw	6
C	0025-079-000	Dome head rivet	8
E	0007-074-000	Truss head machine screw	8
F	0026-316-000	Clevis pin	4
G	0026-334-000	Clevis pin	2
H	0026-364-000	Clevis pin	2
J	0027-020-000	Rue ring cotter	6
K	0056-023-000	Bumper	2
M	0785-210-052	Bottom cover, left, foot end	1

Item	Number	Name	Quantity
N	0785-210-057	Bottom cover, right, foot end	1
P	0785-210-650	Mid cover, foot end	1
R	1105-010-049	Mattress support block	2
T	1105-013-034	Drop seat pivot bracket, right	1
U	1105-013-039	Drop seat pivot bracket, left	1
V	1105-013-610	<i>26" seat section assembly - 1105-013-610 (page 254)</i>	1
W	1105-014-117	Seat support bracket, left	1
Y	1105-014-119	Seat support bracket, right	1
AA	1105-014-602	<i>26" Gatch assembly (page 257)</i>	1
AB	1105-014-610	<i>26" thigh section assembly (page 255)</i>	1
AD	1008-115-601	<i>26" foot assembly (page 256)</i>	1
AF	0029-027-000	Panel fastener	2
AG	0027-035-000	Circular cotter	2

30" standard Fowler assembly

1105-012-302 Rev AB (Reference only)

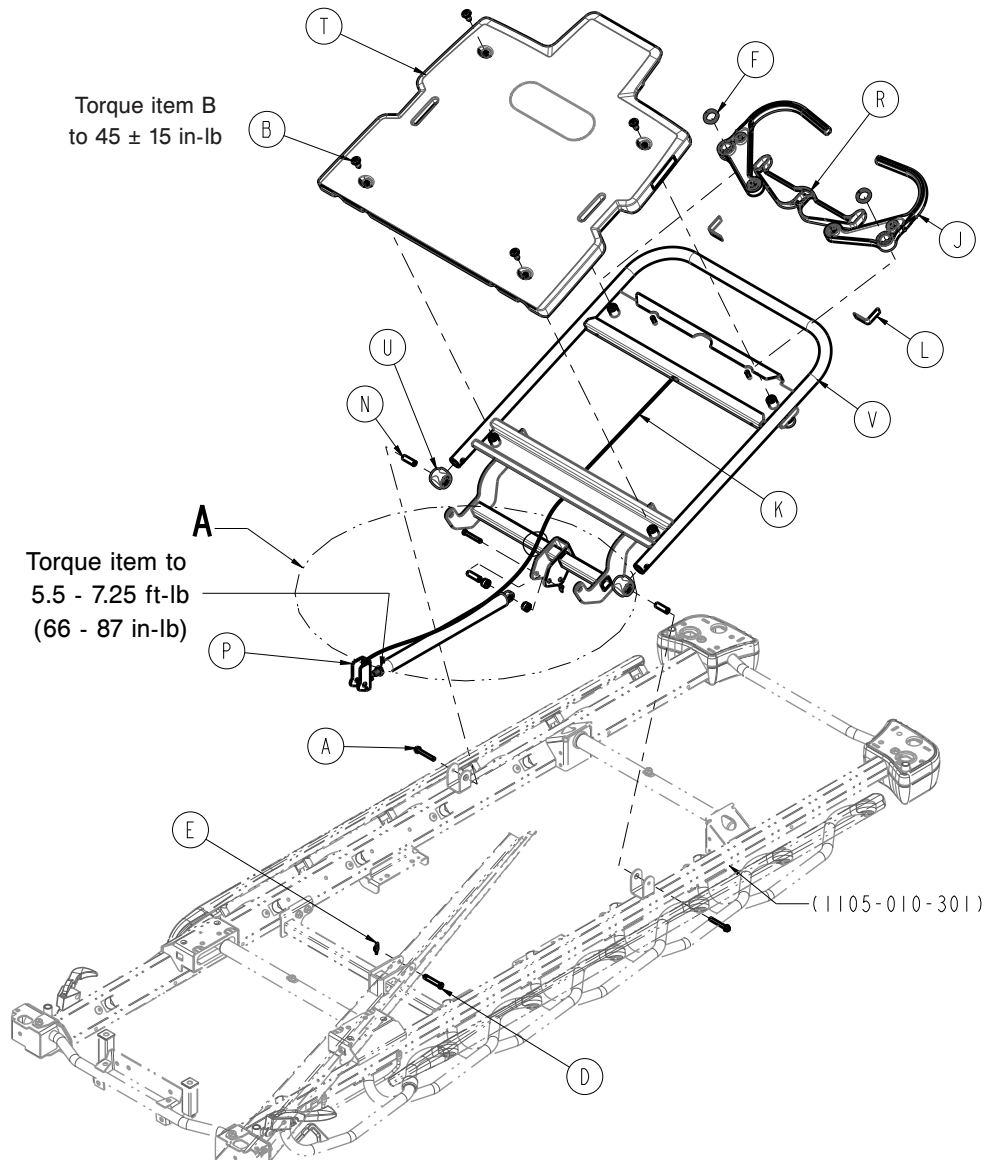

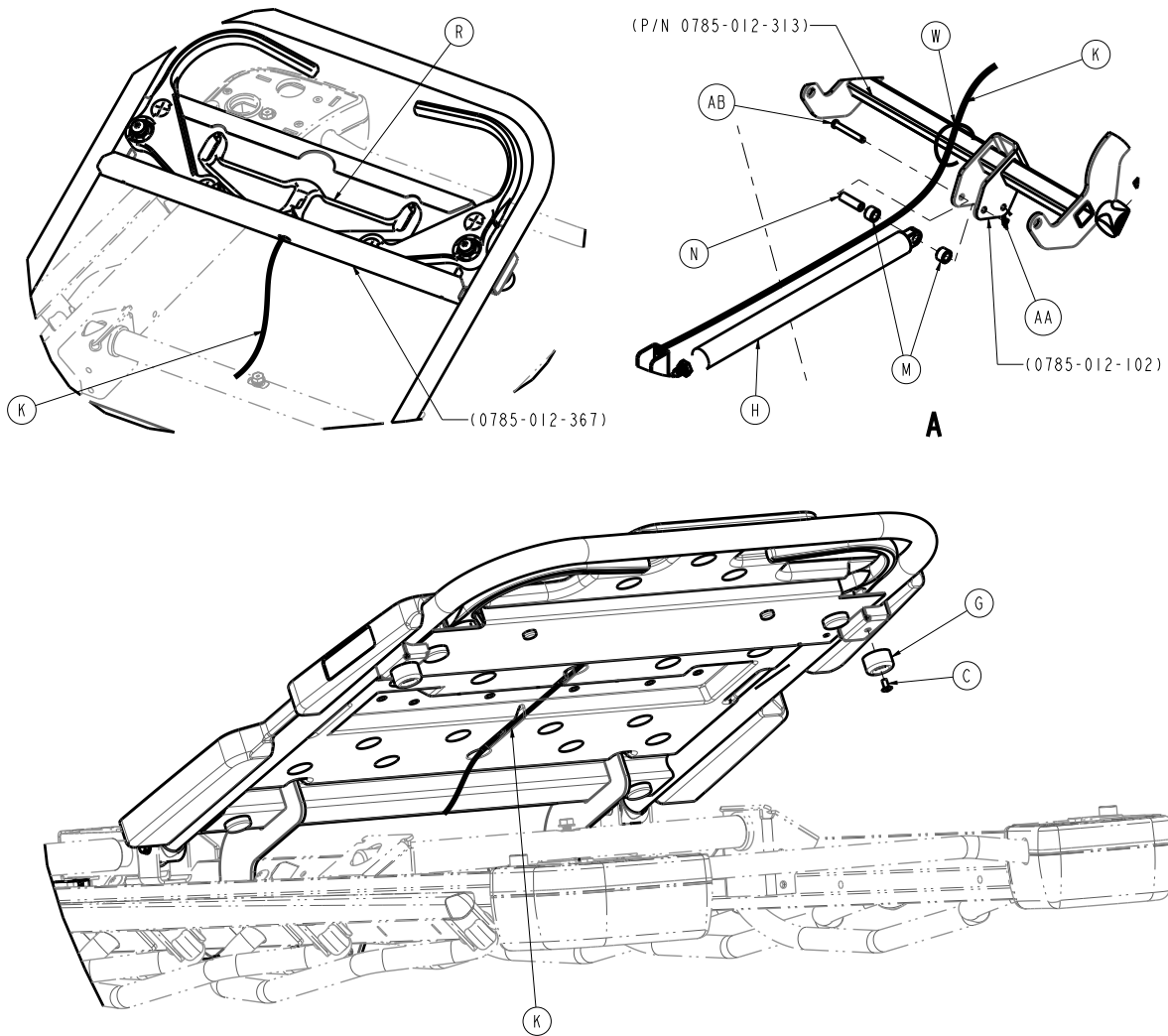

Item	Number	Name	Quantity
A	0003-385-000	Hex washer head screw	2
B	700002372142	Truss head machine screw	4
C	0025-079-000	Rivet	2
D	0026-296-000	Clevis pin	1
E	0027-019-000	Rue ring cotter	1
F	0038-557-000	Spring	2
G	0056-023-000	Bumper	2
H	0360-031-077	Gas cylinder	1
J	0785-012-066	Fowler release handle	2
K	0785-112-080	Fowler cable assembly	1
L	0785-012-086	Spring	2
M	0785-012-094	Spacer	2
N	0785-012-103	Sleeve	3
P	0785-112-116	Gas spring trip	1
R	0785-012-366	30" cable release pivot	1
T	1008-012-350	30" plastic Fowler	1
U	1105-012-076	Fowler tube plug	2
V	1105-012-305	30" Fowler weldment	1
W	8815-029-200	Cable tie	1

Item	Number	Name	Quantity
AA	0027-020-000	Rue ring cotter	1
AB	0026-330-000	Clevis pin	1

30" standard Fowler, stationary foot assembly

1105-010-306 Rev B (Reference only)

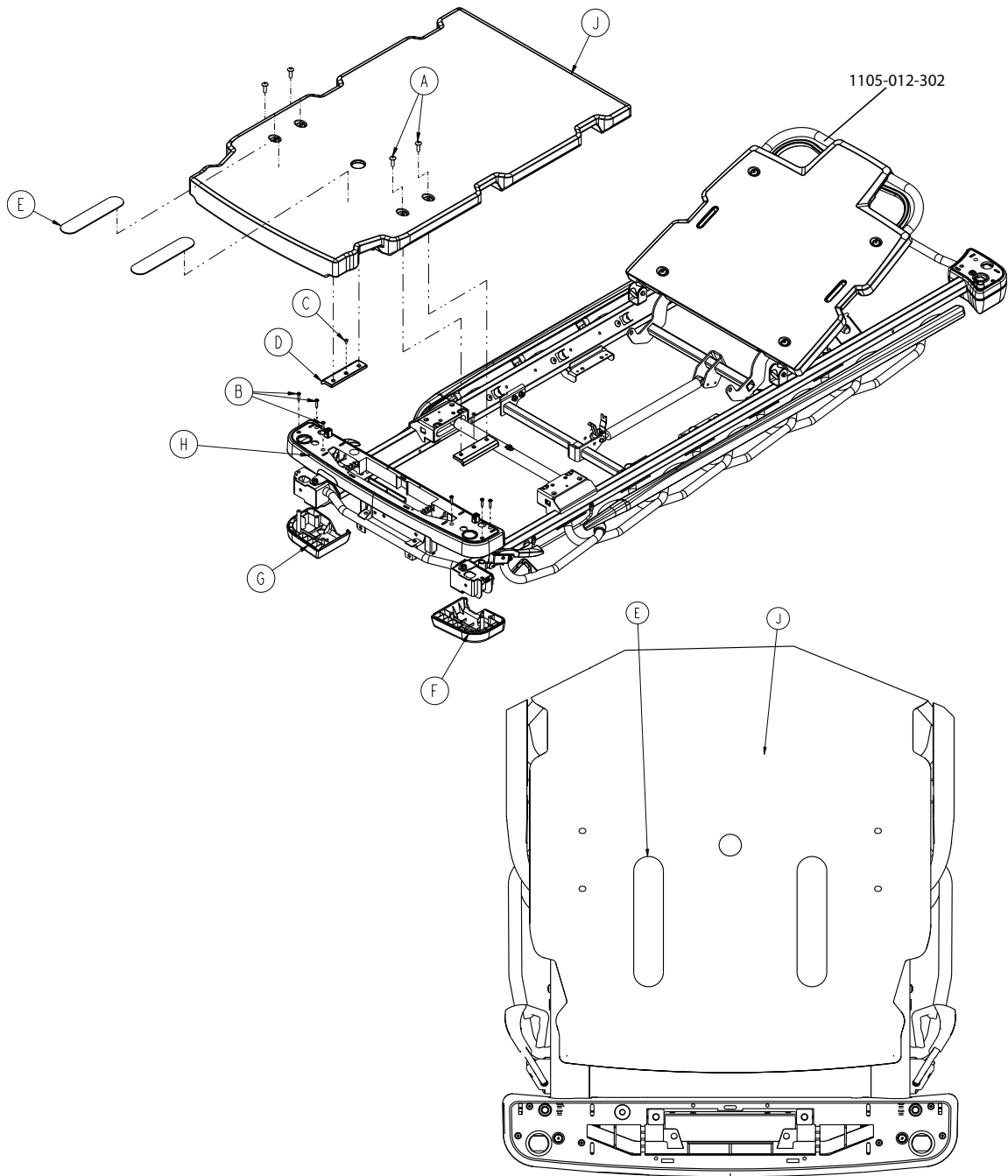

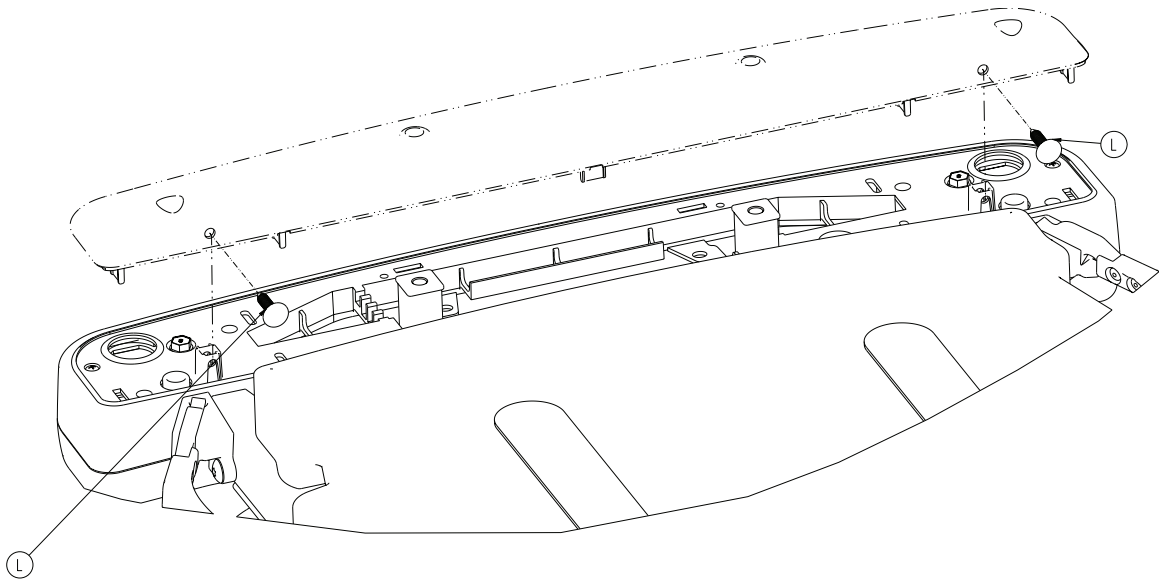

Item	Number	Name	Quantity
A	0007-074-000	Truss head machine screw	4
B	0023-310-000	Pan head tapping screw	6
C	0025-079-000	Dome head rivet	2
D	0785-012-107	Foot section skin spacer	2
E	0785-034-005	Velcro® pile	2
F	0785-210-052	Bottom cover, left, foot end	1
G	0785-210-057	Bottom cover, right, foot end	1
H	0785-210-355	Mid cover, foot end	1
J	1105-015-350	30" stationary foot skin	1
L	0029-027-000	Panel fastener	2

30" standard Fowler with Gatch assembly

1105-010-303 Rev AA (Reference only)

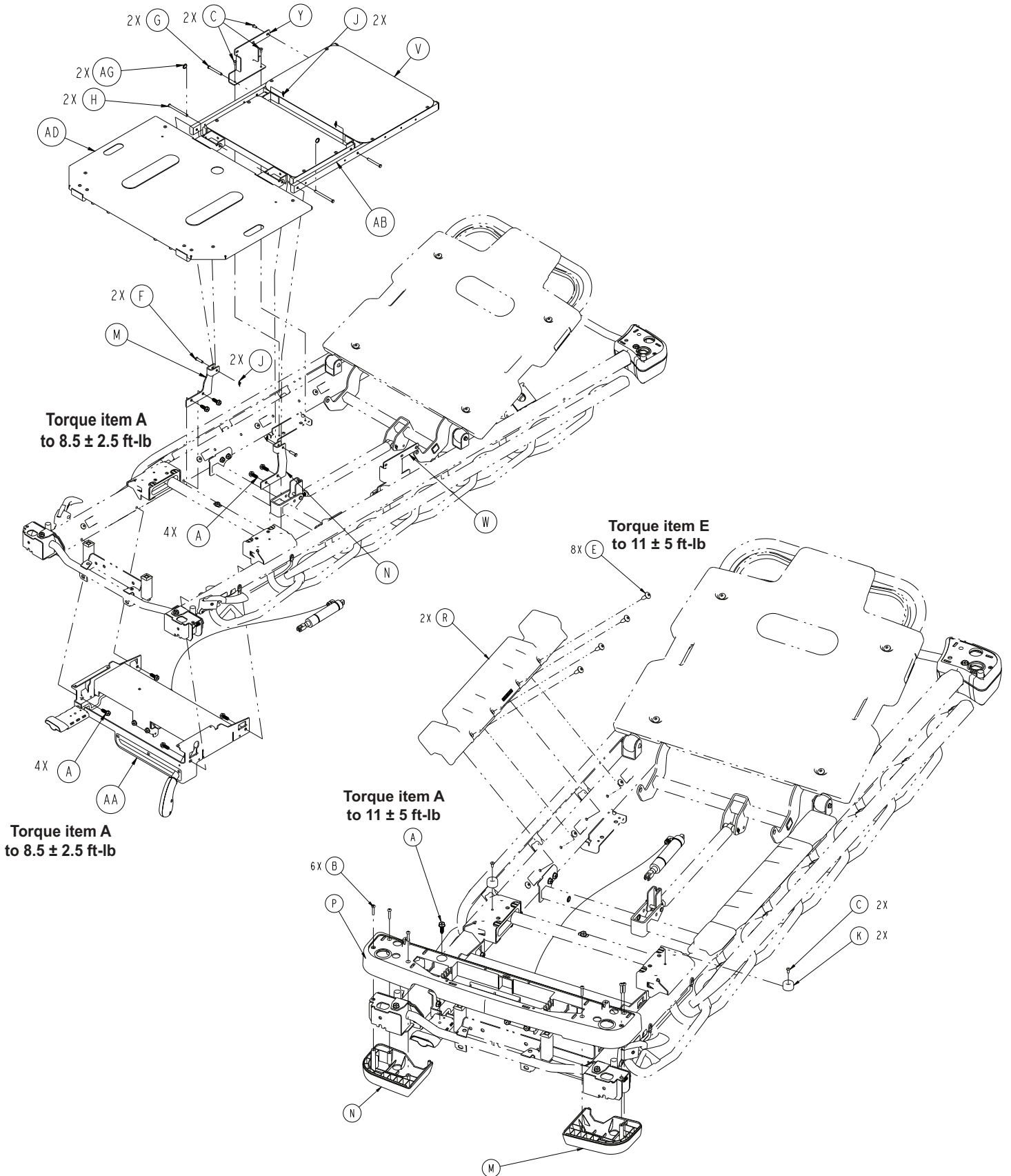

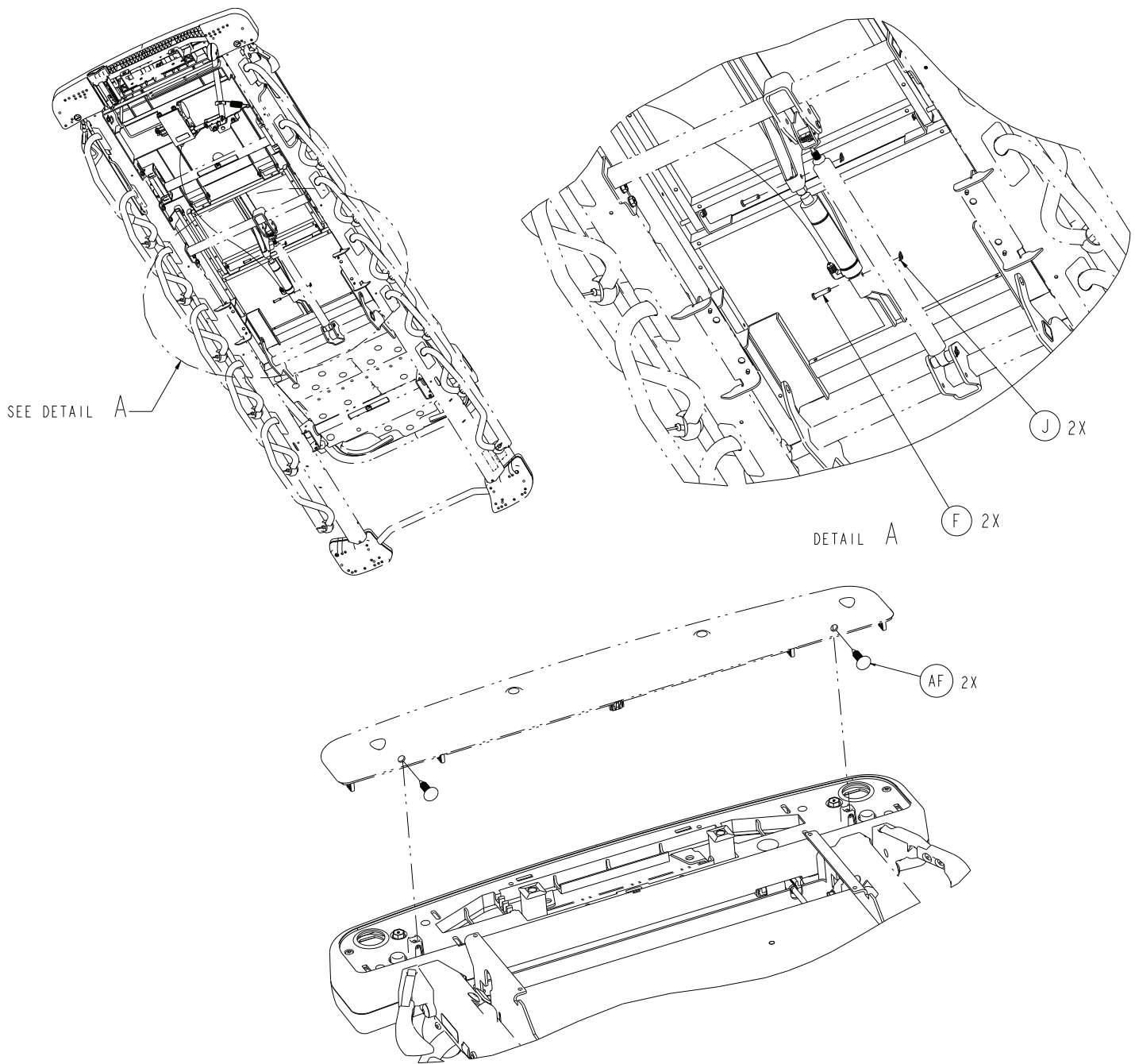

Item	Number	Name	Quantity
A	0023-288-000	Hex washer head screw	9
B	0023-310-000	Pan head tapping screw	6
C	0025-079-000	Dome head rivet	8
E	0007-074-000	Truss head machine screw	8
F	0026-316-000	Clevis pin	4
G	0026-334-000	Clevis pin	2
H	0026-364-000	Clevis pin	2
J	0027-020-000	Rue ring cotter	6
K	0056-023-000	Bumper	2
M	0785-210-052	Bottom cover, left, foot end	1
N	0785-210-057	Bottom cover, right, foot end	1

Item	Number	Name	Quantity
P	0785-210-350	Mid cover, foot end	1
R	1105-010-049	Mattress support block	2
T	1105-013-034	Drop seat pivot bracket, right	1
U	1105-013-039	Drop seat pivot bracket, left	1
V	1105-013-310	<i>30" seat section assembly (page 266)</i>	1
W	1105-014-117	Seat support bracket, left	1
Y	1105-014-119	Seat support bracket, right	1
AA	1105-014-302	<i>30" Gatch assembly (page 269)</i>	1
AB	1105-014-310	<i>30" thigh section assembly (page 267)</i>	1
AD	1008-115-301	<i>30" foot assembly (page 268)</i>	1
AF	0029-027-000	Panel fastener	2
AG	0027-035-000	Circular cotter	2

26" drop seat Fowler assembly

1105-012-601 Rev D (Reference only)

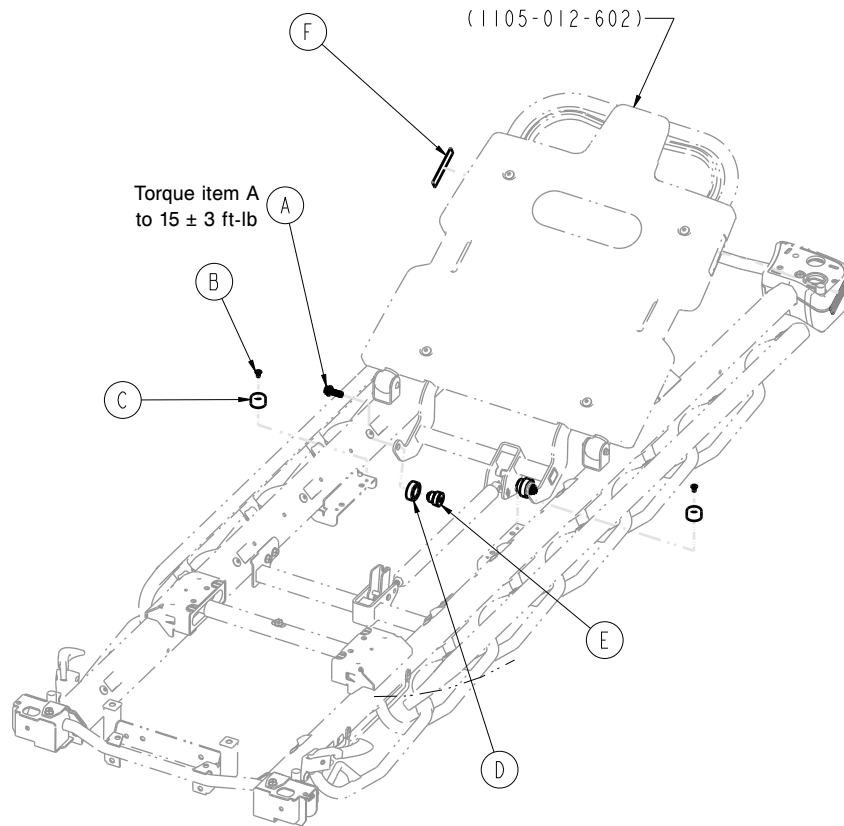

Item	Number	Name	Quantity
A	0023-305-000	Hex washer head screw	2
B	0025-079-000	Dome head rivet	2
C	0056-023-000	Bumper	2
D	0785-012-007	Fowler seat lift roller	2
E	0785-012-101	Mandrel roller	2
F	1105-010-312	Label, Backsmart	2

26" drop seat Fowler assembly, stationary foot

1105-010-604 Rev AA (Reference only)

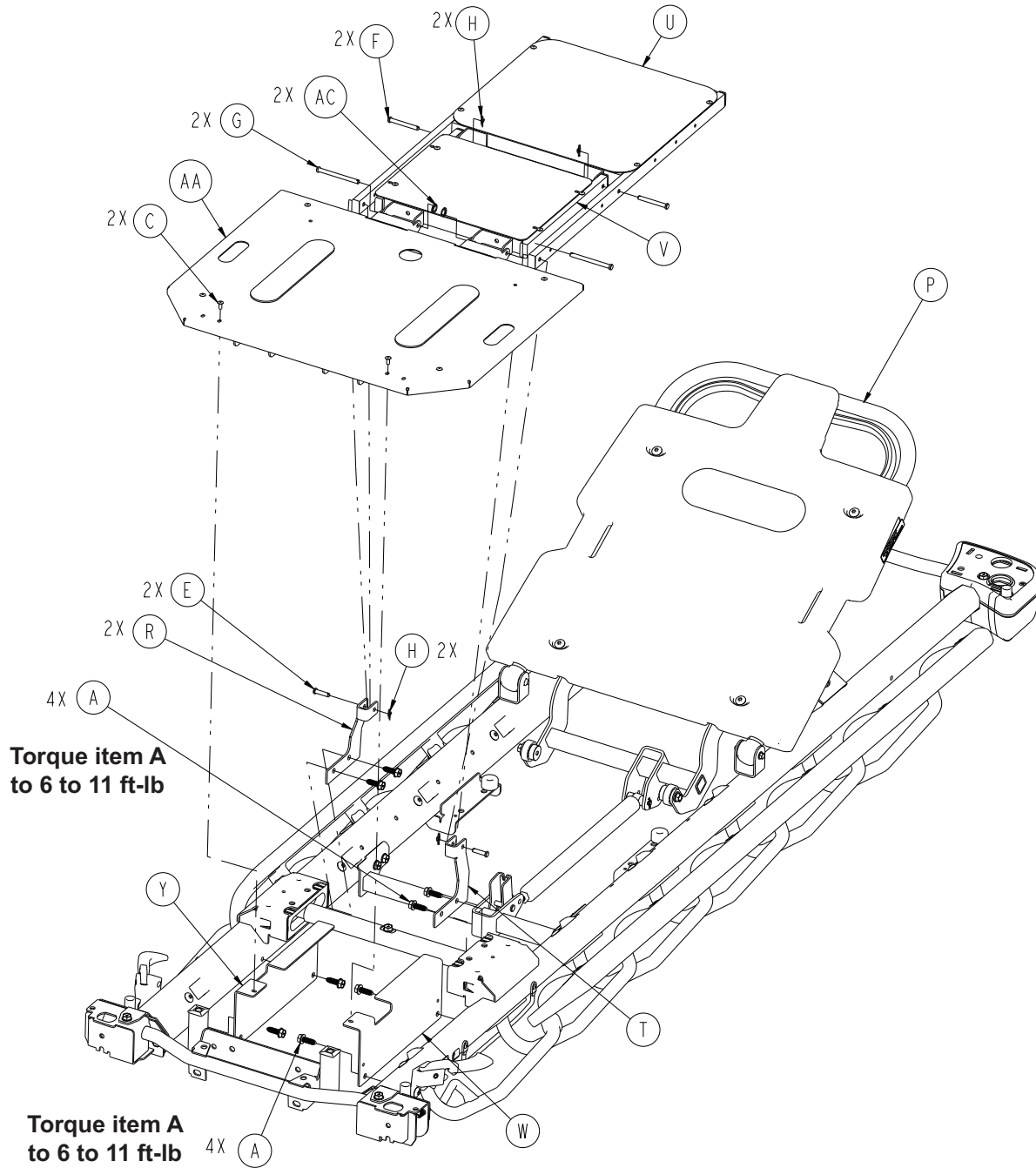

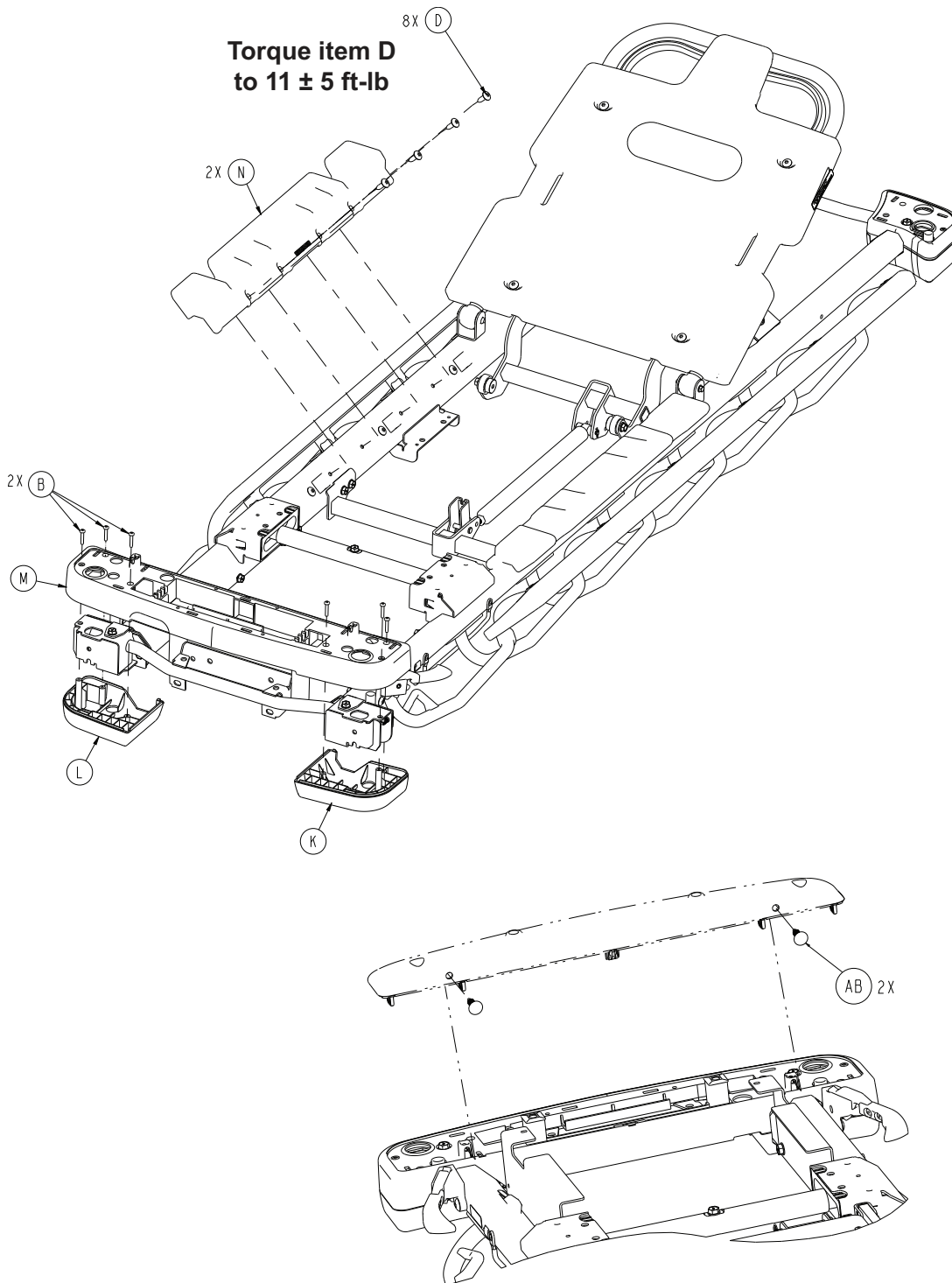

Item	Number	Name	Quantity
A	0023-288-000	Hex washer head screw	8
B	0023-310-000	Pan head tapping screw	6
C	0025-079-000	Dome head rivet	2
D	0007-074-000	Truss head machine screw	8
E	0026-316-000	Clevis pin	2
F	0026-334-000	Clevis pin	2

Item	Number	Name	Quantity
G	0026-364-000	Clevis pin	2
H	0027-020-000	Rue ring cotter	4
K	0785-210-052	Bottom cover, left, foot end	1
L	0785-210-057	Bottom cover, right, foot end	1
M	0785-210-655	Mid cover, foot end	1
N	1105-010-049	Mattress support block	2
P	1105-012-601	<i>26" drop seat Fowler assembly (page 247)</i>	1
R	1105-013-034	Drop seat pivot bracket, right	1
T	1105-013-039	Drop seat pivot bracket, left	1
U	1105-013-610	<i>26" seat section assembly - 1105-013-610 (page 254)</i>	1
V	1105-014-610	<i>26" thigh section assembly (page 255)</i>	1
W	1008-015-016	Calf support, left	1
Y	1008-015-018	Calf support, right	1
AA	1008-115-611	<i>26" foot assembly, electric litter (page 305)</i>	1
AB	0029-027-000	Panel fastener	2
AC	0027-035-000	Circular cotter	2

26" drop seat Fowler with Gatch assembly

1105-010-602 Rev AA (Reference only)

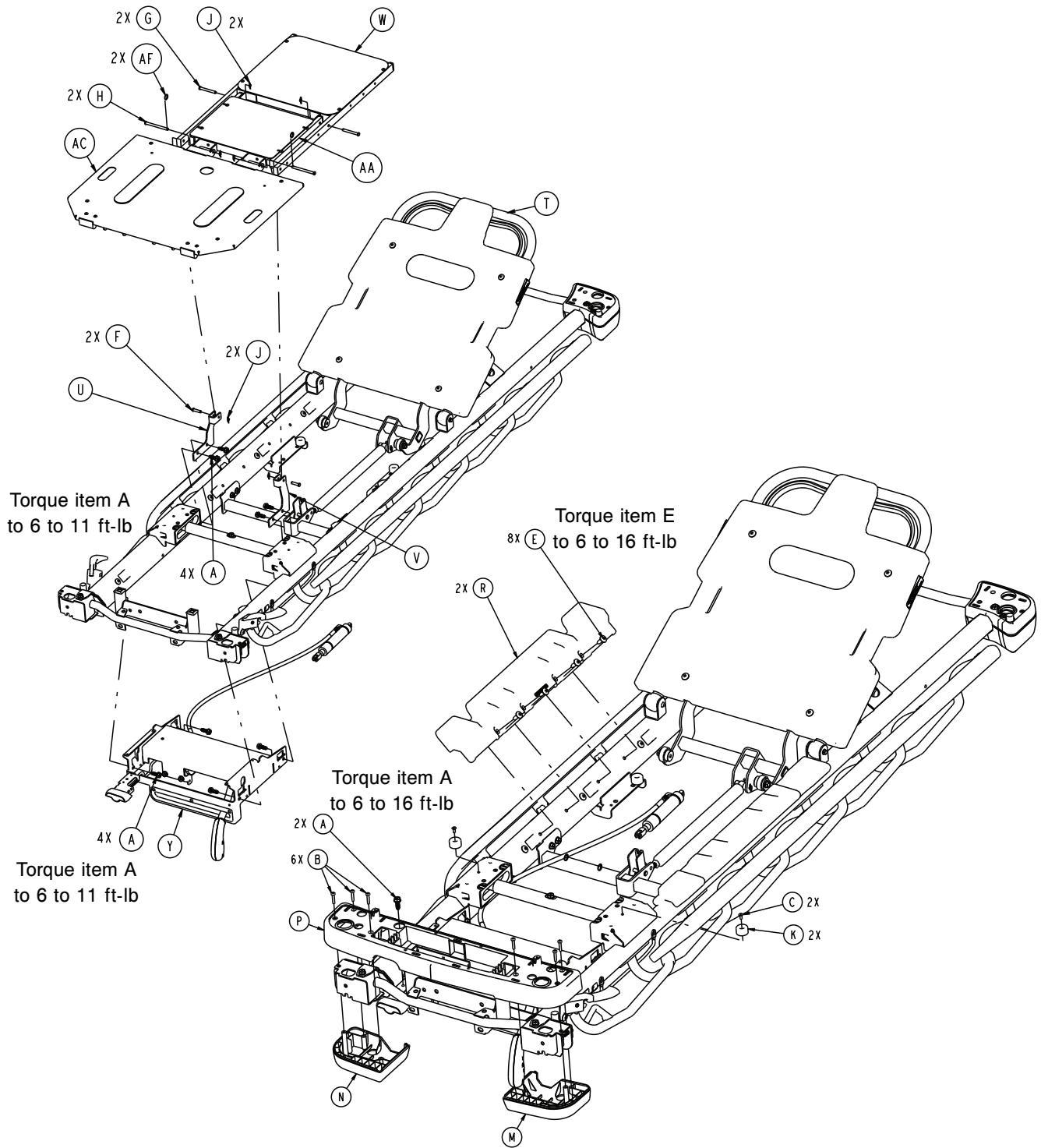

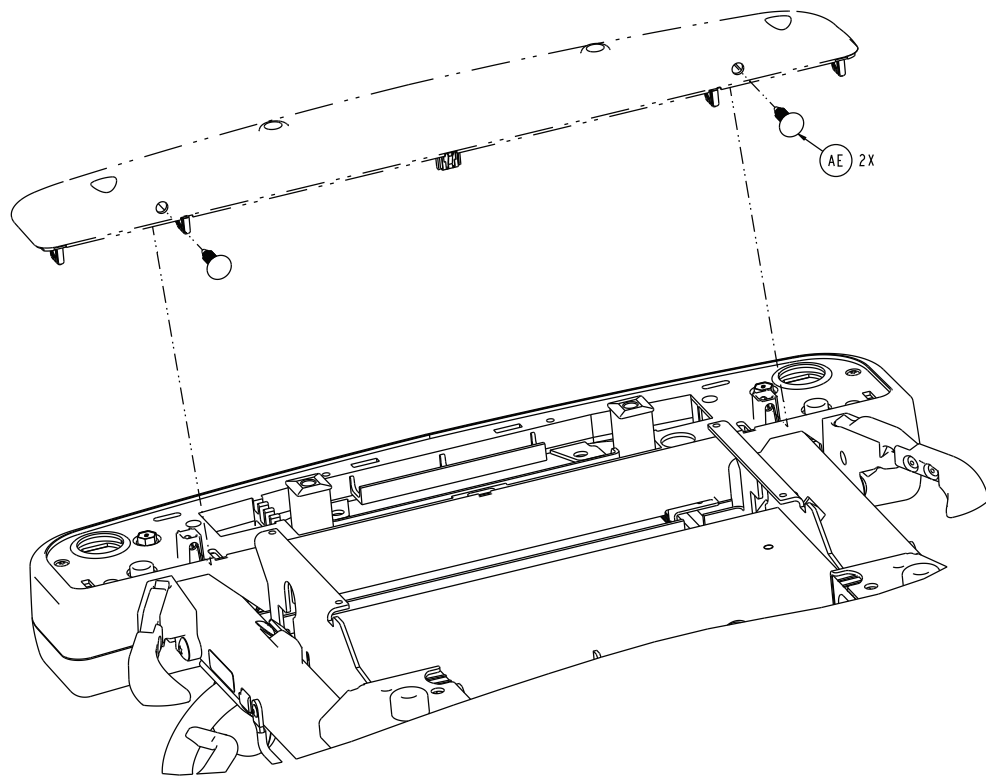
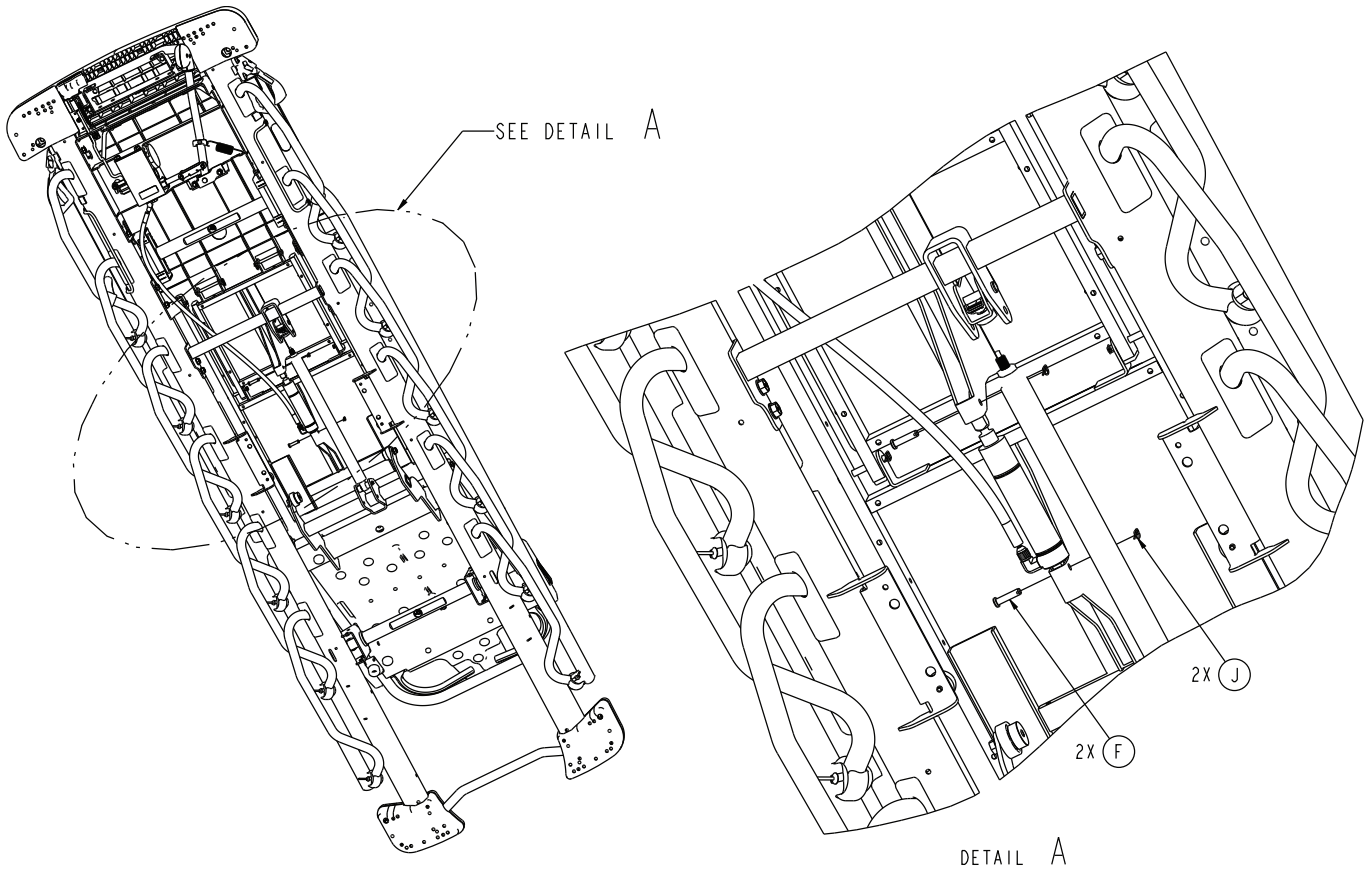

Item	Number	Name	Quantity
A	0023-288-000	Hex washer head screw	9
B	0023-310-000	Pan head tapping screw	6
C	0025-079-000	Dome head rivet	2
E	0007-074-000	Truss head machine screw	8
F	0026-316-000	Clevis pin	4
G	0026-334-000	Clevis pin	2
H	0026-364-000	Clevis pin	2
J	0027-020-000	Rue ring cotter	6
K	0056-023-000	Bumper	2
M	0785-210-052	Bottom cover, left, foot end	1
N	0785-210-057	Bottom cover, right, foot end	1
P	0785-210-650	Mid cover, foot end	1
R	1105-010-049	Mattress support block	2
T	1105-012-601	<i>26" drop seat Fowler assembly (page 247)</i>	1
U	1105-013-034	Drop seat pivot bracket, right	1
V	1105-013-039	Drop seat pivot bracket, left	1
W	1105-013-610	<i>26" seat section assembly - 1105-013-610 (page 254)</i>	1
Y	1105-014-602	<i>26" Gatch assembly (page 257)</i>	1
AA	1105-014-610	<i>26" thigh section assembly (page 255)</i>	1
AC	1008-115-601	<i>26" foot assembly (page 256)</i>	1
AE	0029-027-000	Panel fastener	2
AF	0027-035-000	Circular cotter	2

26" seat section assembly - 1105-013-610

Rev A (Reference only)

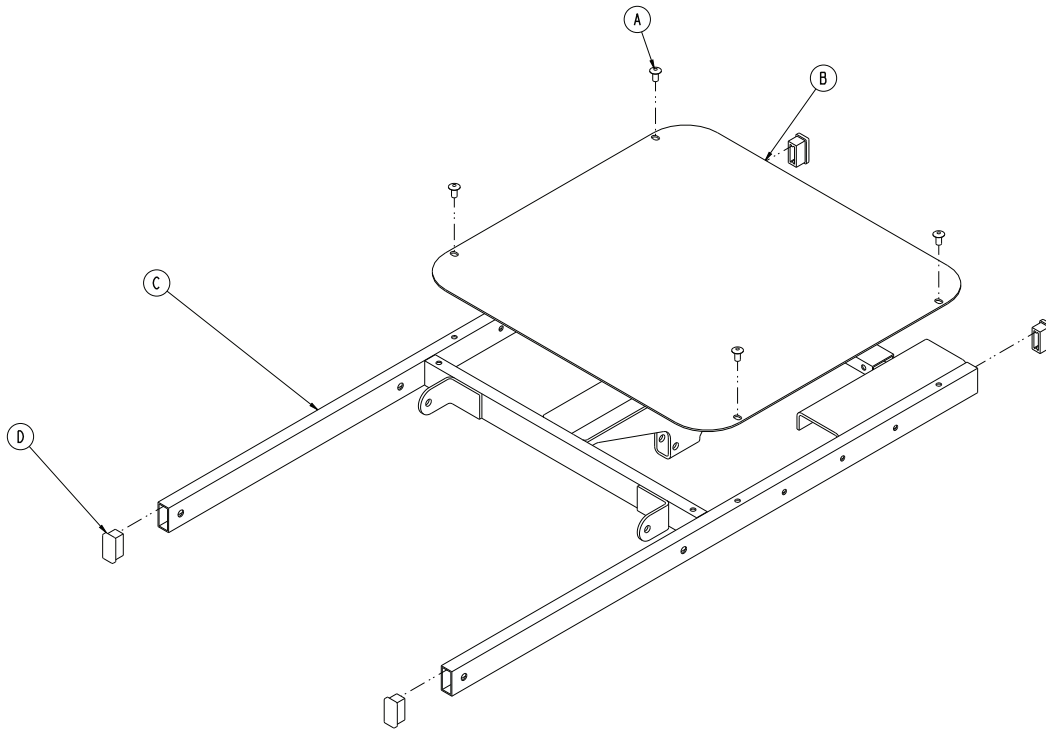

Item	Number	Name	Quantity
A	0025-079-000	Dome head rivet	4
B	1105-013-619	26" seat section skin	1
C	1105-013-625	26" seat section weldment	1
D	1010-032-066	Rectangular hole plug	4

26" thigh section assembly

1105-014-610 Rev A (Reference only)

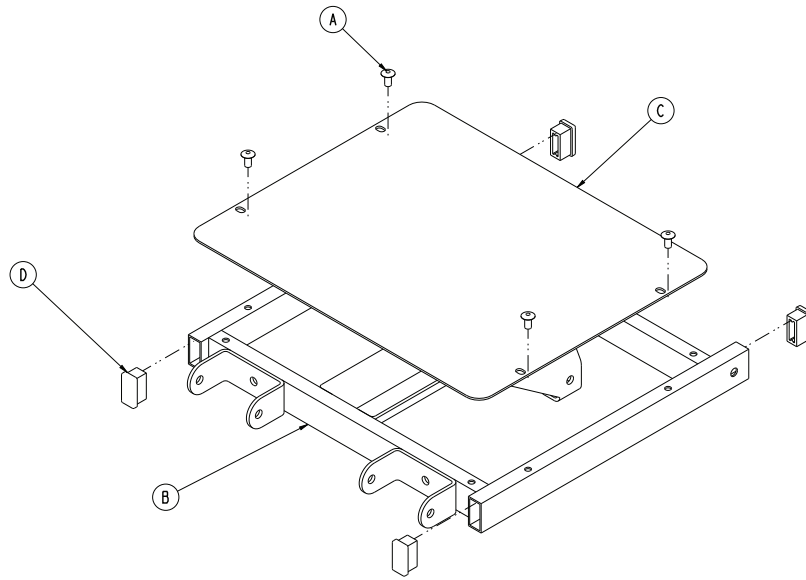

Item	Number	Name	Quantity
A	0025-079-000	Dome head rivet	4
B	1105-014-615	26" thigh section weldment	1
C	1105-014-619	26" thigh section skin	1
D	1010-032-066	Rectangular hole plug	4

26" foot assembly

1008-115-601 Rev A (Reference only)

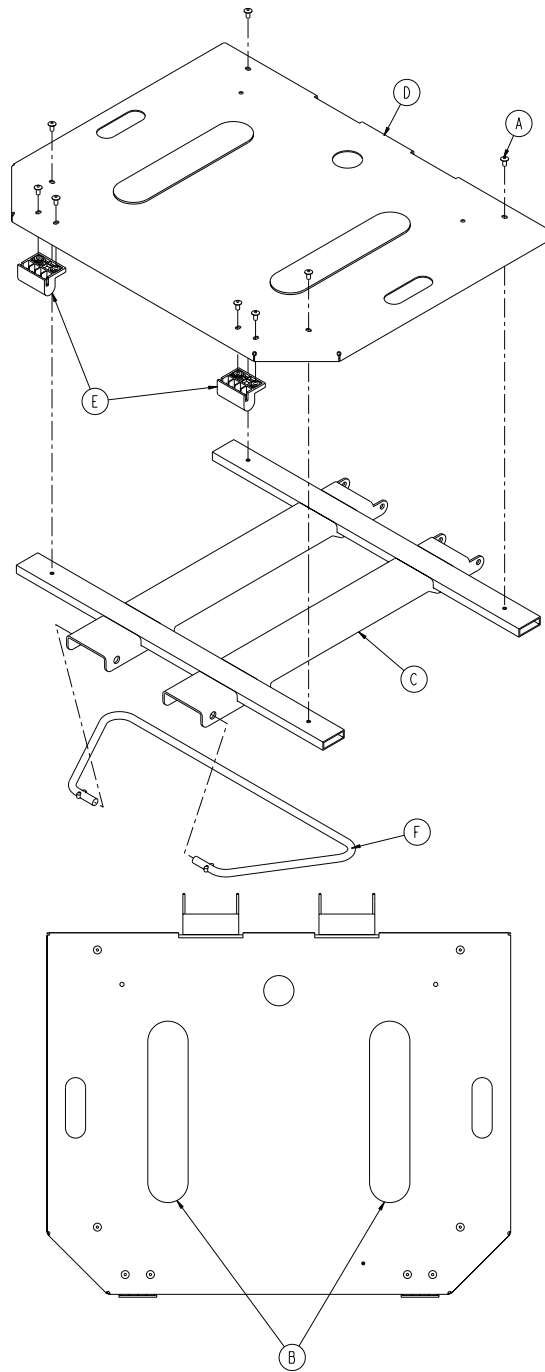

Item	Number	Name	Quantity
A	0025-079-000	Dome head rivet	8
B	0785-034-005	Velcro® pile (adhesive back)	2
C	1008-115-605	Foot weldment	1
D	1008-115-623	Foot skin	1
E	1105-015-012	Calf bumper	2
F	1008-015-609	26" prop bar	1

26" Gatch assembly

1105-014-602 Rev AA (Reference only)

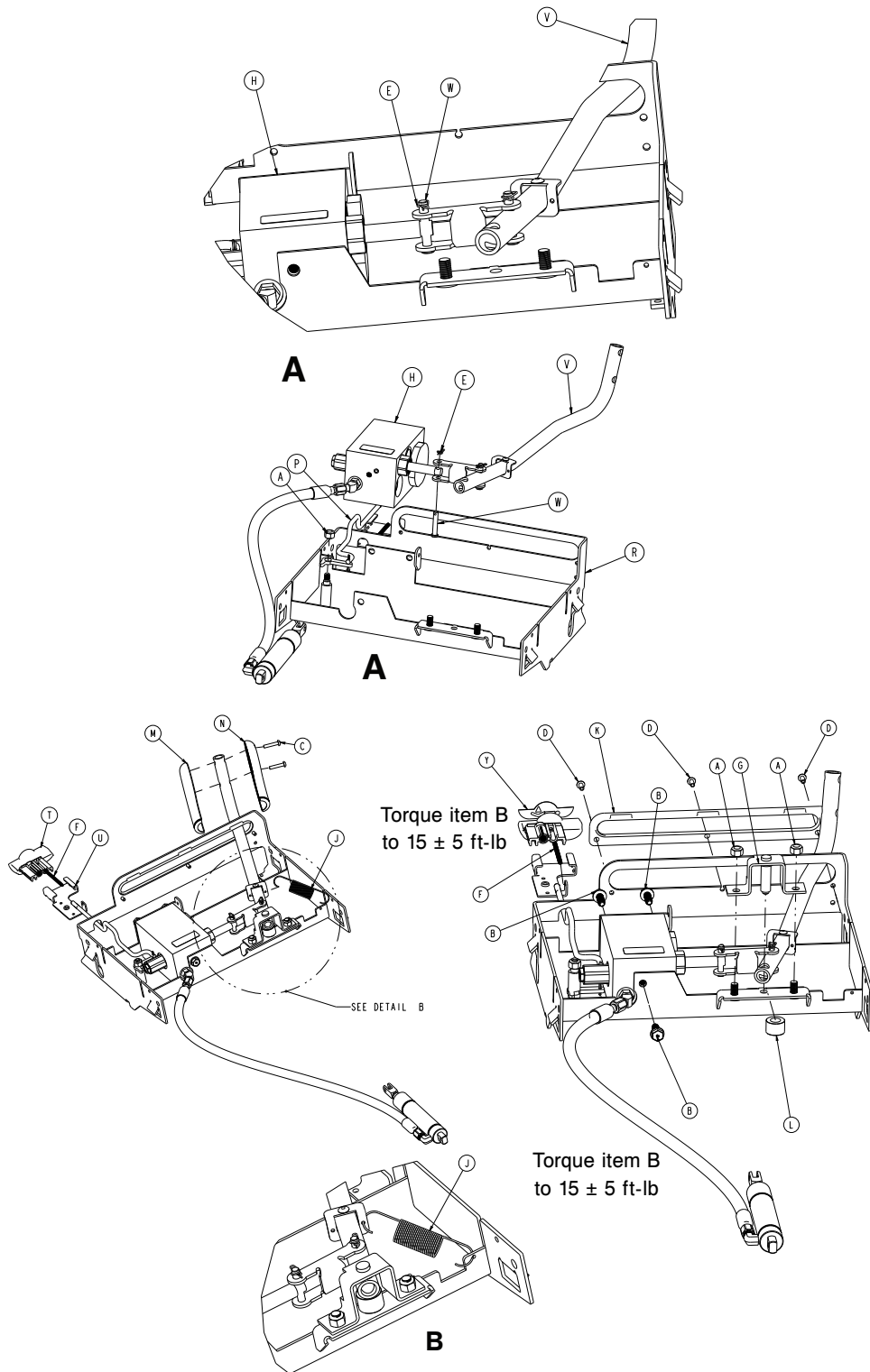

Item	Number	Name	Quantity
A	0016-036-000	Nylock hex nut	3
B	0023-288-000	Hex washer head screw	3
C	0023-310-000	Pan head tapping screw	2

Item	Number	Name	Quantity
D	0025-079-000	Dome head rivet	3
E	0027-020-000	Rue ring cotter	1
F	0038-603-000	Spring	1
G	0785-014-030	Gatch pivot weldment	1
H	0785-014-043	<i>Gatch valve body assembly - 0785-014-043 (page 272)</i>	1
J	0785-014-107	Gatch return spring	1
K	0785-014-113	Gatch pump bumper	1
L	0785-014-133	Gatch pivot spacer	1
M	0785-014-156	Gatch pump handle, left	1
N	0785-014-157	Gatch pump handle, right	1
P	0785-114-603	<i>26" Gatch release handle assembly (page 259)</i>	1
R	0785-114-625	26" Gatch weldment	1
T	0785-210-651	26" Gatch release handle	1
U	0785-210-652	26" Gatch release guide	1
V	1105-014-116	<i>Gatch pump assembly (page 273)</i>	1
W	8805-932-000	Clevis pin	1
Y	0785-210-353	Label, Gatch release	1

26" Gatch release handle assembly

0785-114-603 Rev A (Reference only)

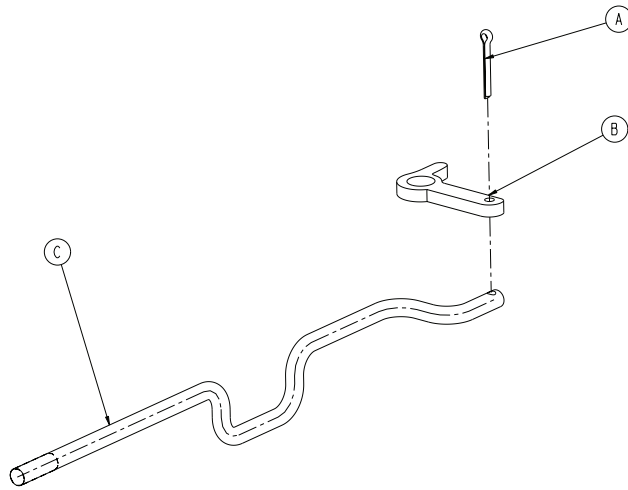

Item	Number	Name	Quantity
A	0027-015-000	Cotter pin	1
B	0785-014-038	Gatch release link	1
C	0785-114-637	26" Gatch release rod	1

30" drop seat Fowler assembly

1105-012-301 Rev D (Reference only)

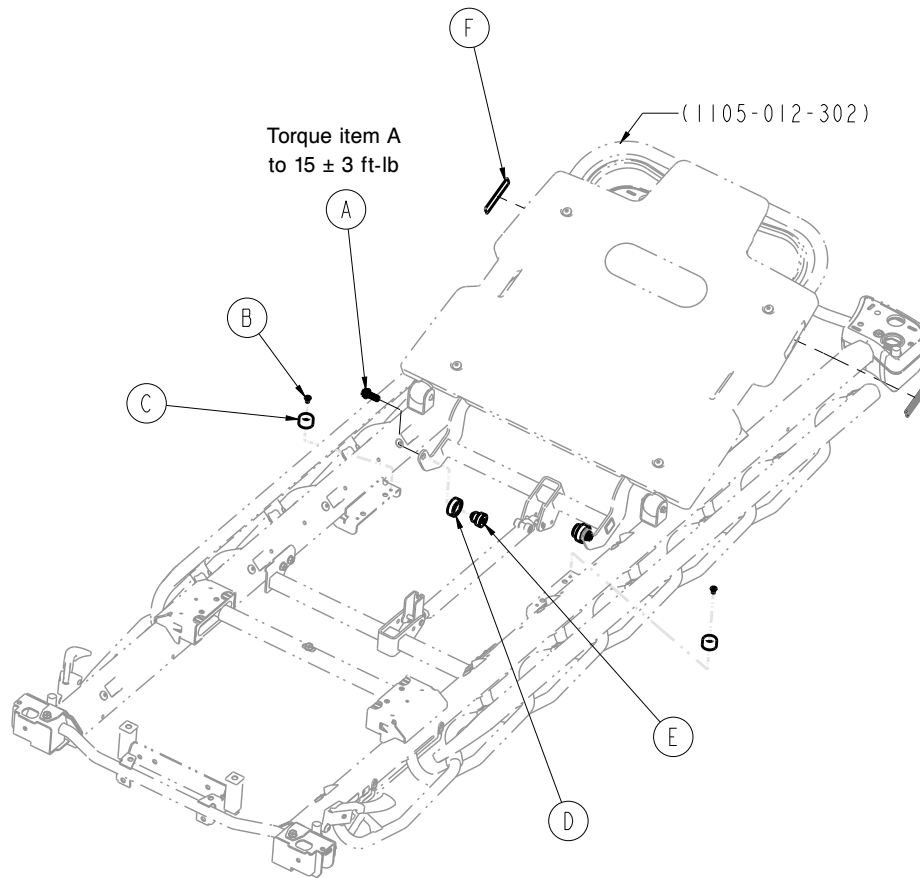

Item	Number	Name	Quantity
A	0023-012-301	Hex washer head screw	2
B	0025-079-000	Dome head rivet	2
C	0056-023-000	Bumper	2
D	0785-012-007	Fowler seat lift roller	2
E	0785-012-101	Mandrel roller	2
F	1105-010-312	Label, BackSmart	2

30" drop seat Fowler assembly, stationary foot

1105-010-304 Rev AA (Reference only)

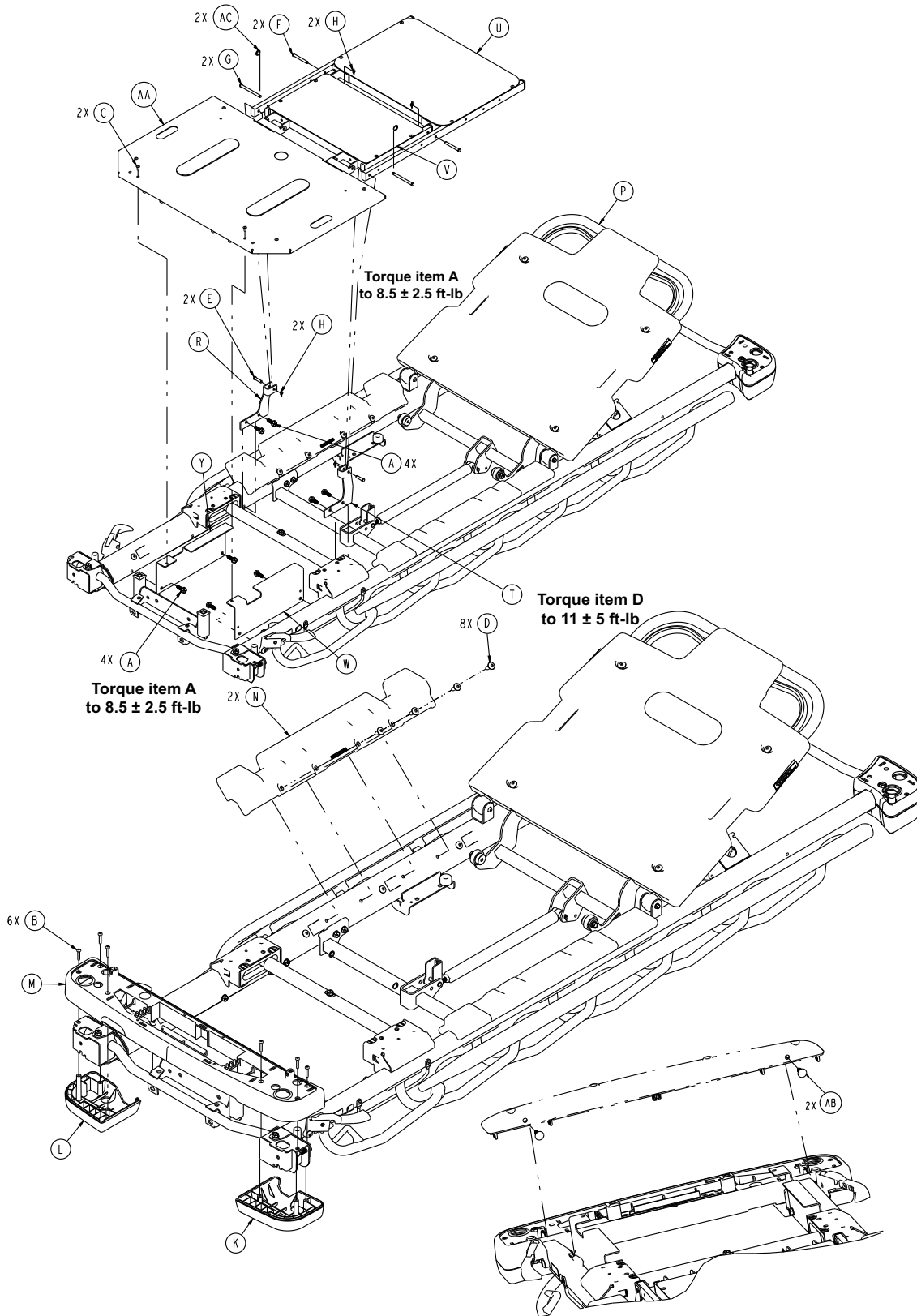

Item	Number	Name	Quantity
A	0023-288-000	Hex washer head screw	8
B	0023-310-000	Pan head tapping screw	6
C	0025-079-000	Dome head rivet	2
D	0007-074-000	Truss head machine screw	8
E	0026-316-000	Clevis pin	2
F	0026-334-000	Clevis pin	2
G	0026-364-000	Clevis pin	2
H	0027-020-000	Rue ring cotter	4
K	0785-210-052	Bottom cover, left, foot end	1
L	0785-210-057	Bottom cover, right, foot end	1
M	0785-210-355	Mid cover, foot end	1
N	1105-010-049	Mattress support block	2
P	1105-012-301	<i>30" drop seat Fowler assembly (page 260)</i>	1
R	1105-013-034	Drop seat pivot bracket, right	1
T	1105-013-039	Drop seat pivot bracket, left	1
U	1105-013-310	<i>30" seat section assembly (page 266)</i>	1
V	1105-014-310	<i>30" thigh section assembly (page 267)</i>	1
W	1008-015-016	Calf support, left	1
Y	1008-015-018	Calf support, right	1
AA	1008-115-311	<i>30" foot assembly, electric litter (page 306)</i>	1
AB	0029-027-000	Panel fastener	2
AC	0027-035-000	Circular cotter	2

30" drop seat Fowler with Gatch assembly

1105-010-302 Rev AA (Reference only)

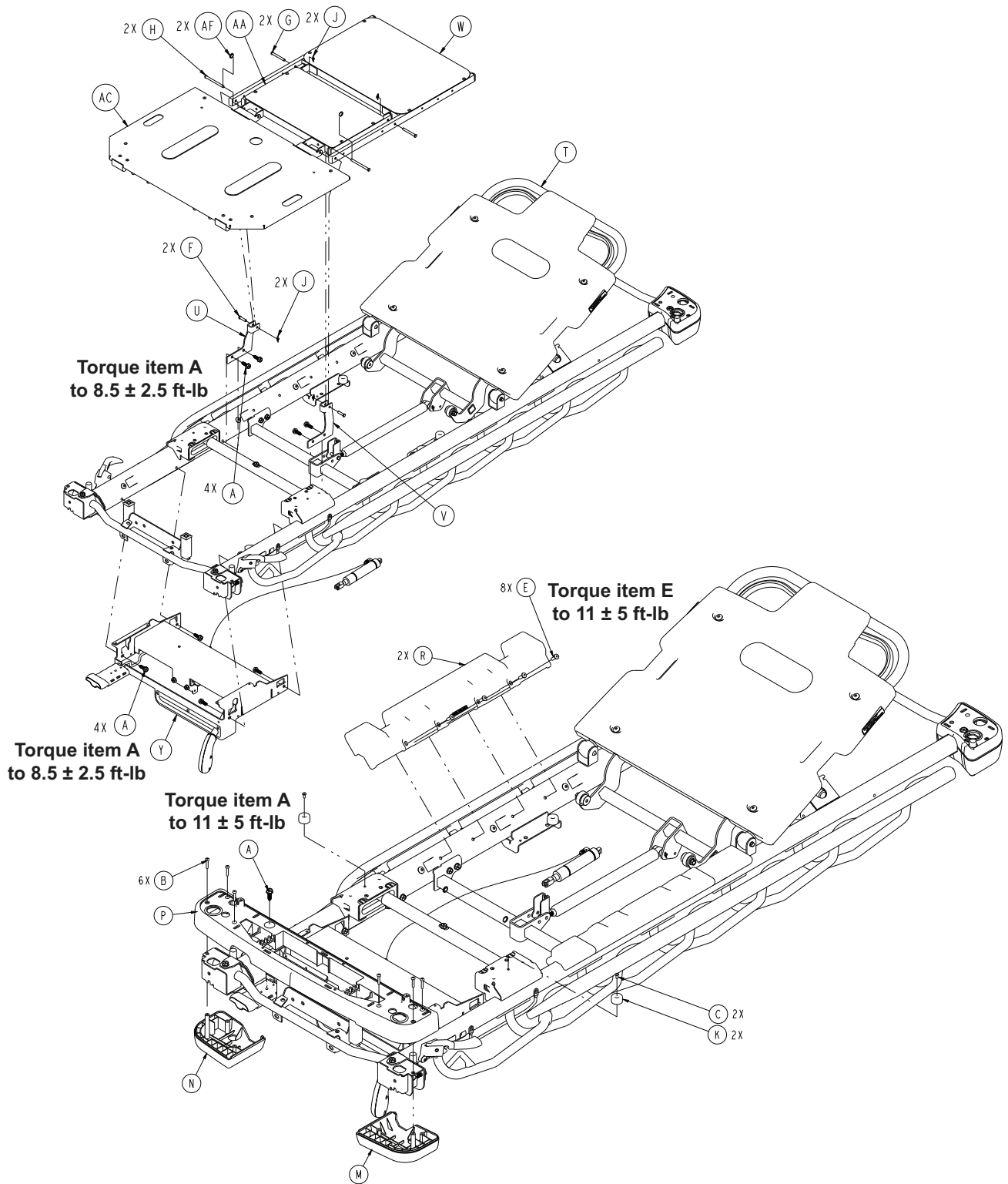

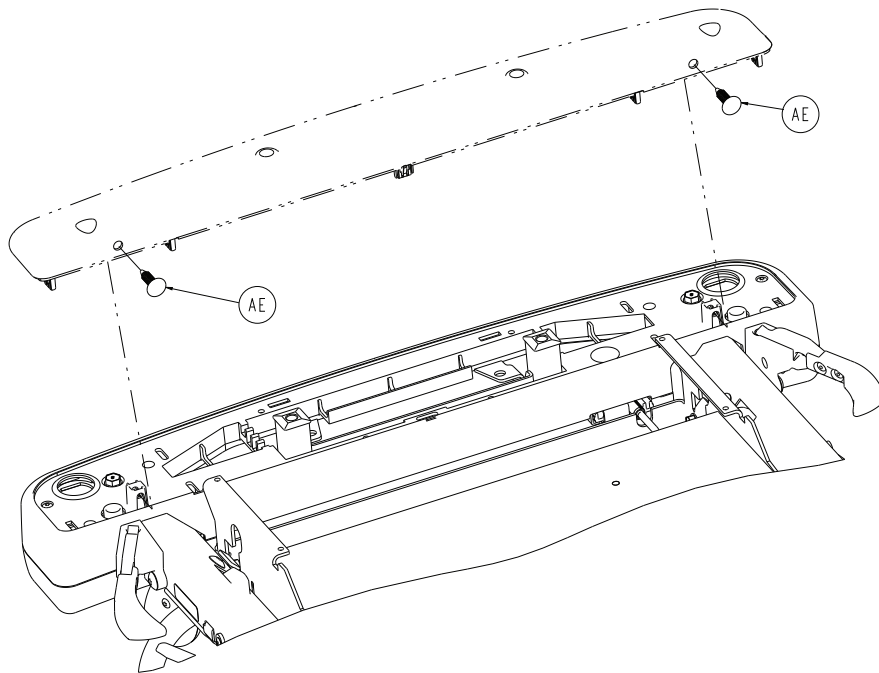
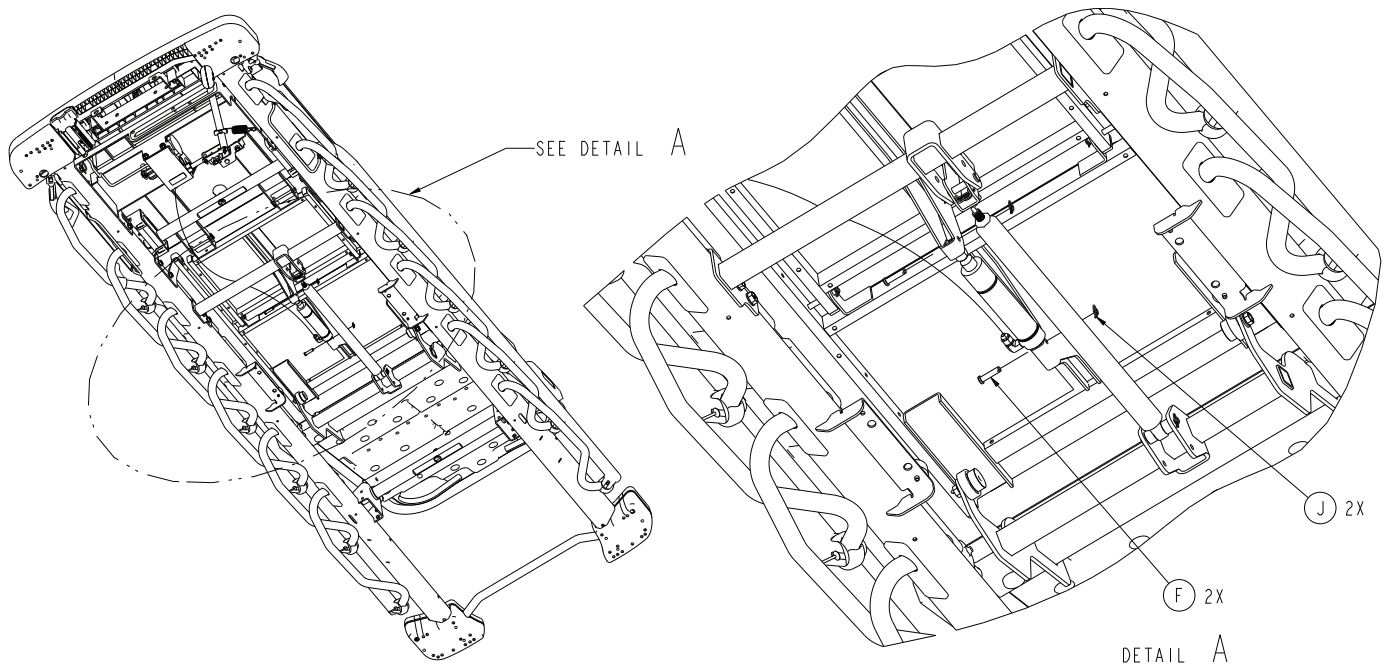

Item	Number	Name	Quantity
A	0023-288-000	Hex washer head screw	9
B	0023-310-000	Pan head tapping screw	6
C	0025-079-000	Dome head rivet	2
E	0007-074-000	Truss head machine screw	8
F	0026-316-000	Clevis pin	4
G	0026-334-000	Clevis pin	2
H	0026-364-000	Clevis pin	2
J	0027-020-000	Rue ring cotter	6
K	0056-023-000	Bumper	2
M	0785-210-052	Bottom cover, left, foot end	1

Item	Number	Name	Quantity
N	0785-210-057	Bottom cover, right, foot end	1
P	0785-210-350	Mid cover, foot end	1
R	1105-010-049	Mattress support block	2
T	1105-012-301	<i>30" drop seat Fowler assembly (page 260)</i>	1
U	1105-013-034	Drop seat pivot bracket, right	1
V	1105-013-039	Drop seat pivot bracket, left	1
W	1105-013-310	<i>30" seat section assembly (page 266)</i>	1
Y	1105-014-302	<i>30" Gatch assembly (page 269)30" Gatch assembly (page 269))</i>	1
AA	1105-014-310	<i>30" thigh section assembly (page 267)</i>	1
AC	1008-115-301	<i>30" foot assembly (page 268)</i>	1
AE	0029-027-000	Panel fastener	2
AF	0027-035-000	Circular cotter	2

30" seat section assembly

1105-013-310 Rev A (Reference only)

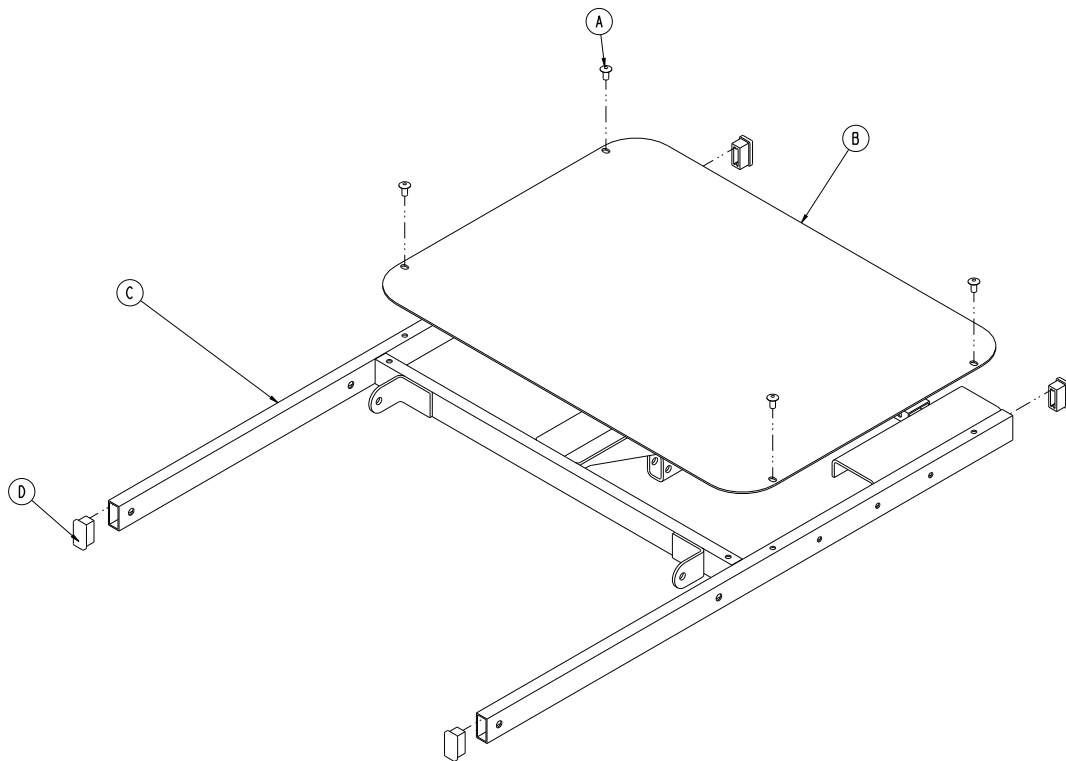

Item	Number	Name	Quantity
A	0025-079-000	Dome head rivet	4
B	1105-013-319	30" seat section skin	1
C	1105-013-325	30" seat section weldment	1
D	1010-032-066	Hole plug	4

30" thigh section assembly

1105-014-310 Rev A (Reference only)

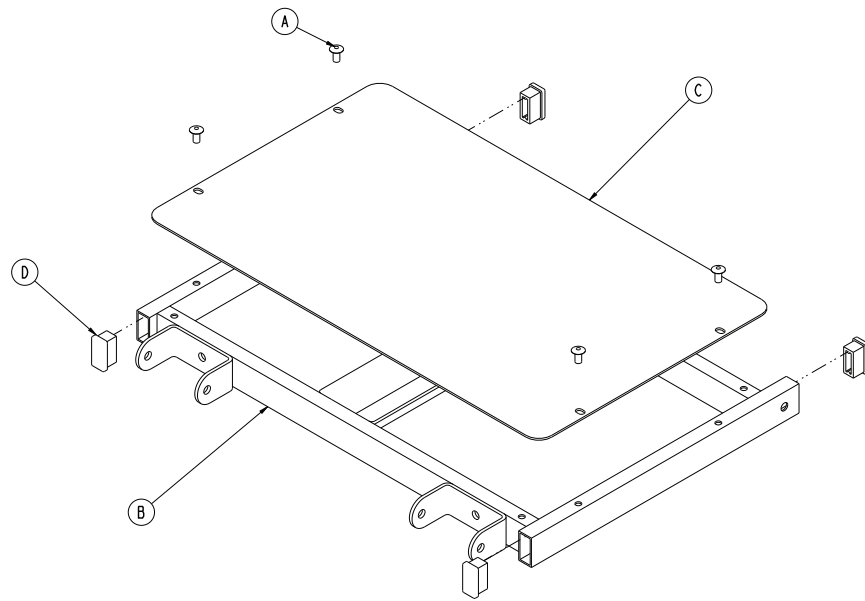

Item	Number	Name	Quantity
A	0025-079-000	Dome head rivet	4
B	1105-014-315	30" thigh section weldment	1
C	1105-014-319	30" thigh section skin	1
D	1010-032-066	Rectangular hole plug	4

30" foot assembly

1008-115-301 Rev A (Reference only)

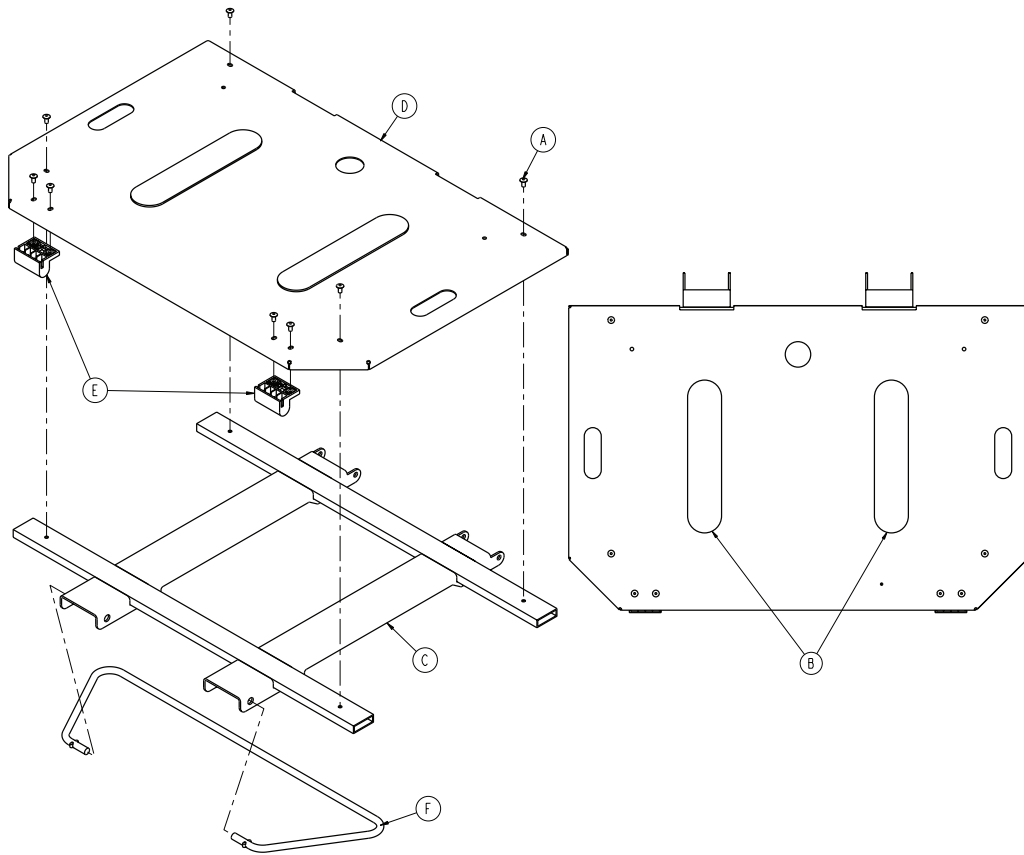

Item	Number	Name	Quantity
A	0025-079-000	Dome head rivet	8
B	0785-034-005	Velcro® pile (adhesive back)	2
C	1008-115-305	Foot weldment	1
D	1008-115-323	Foot skin	1
E	1105-015-012	Calf bumper	2
F	1008-015-309	30" prop bar	1

30" Gatch assembly

1105-014-302 Rev AA (Reference only)

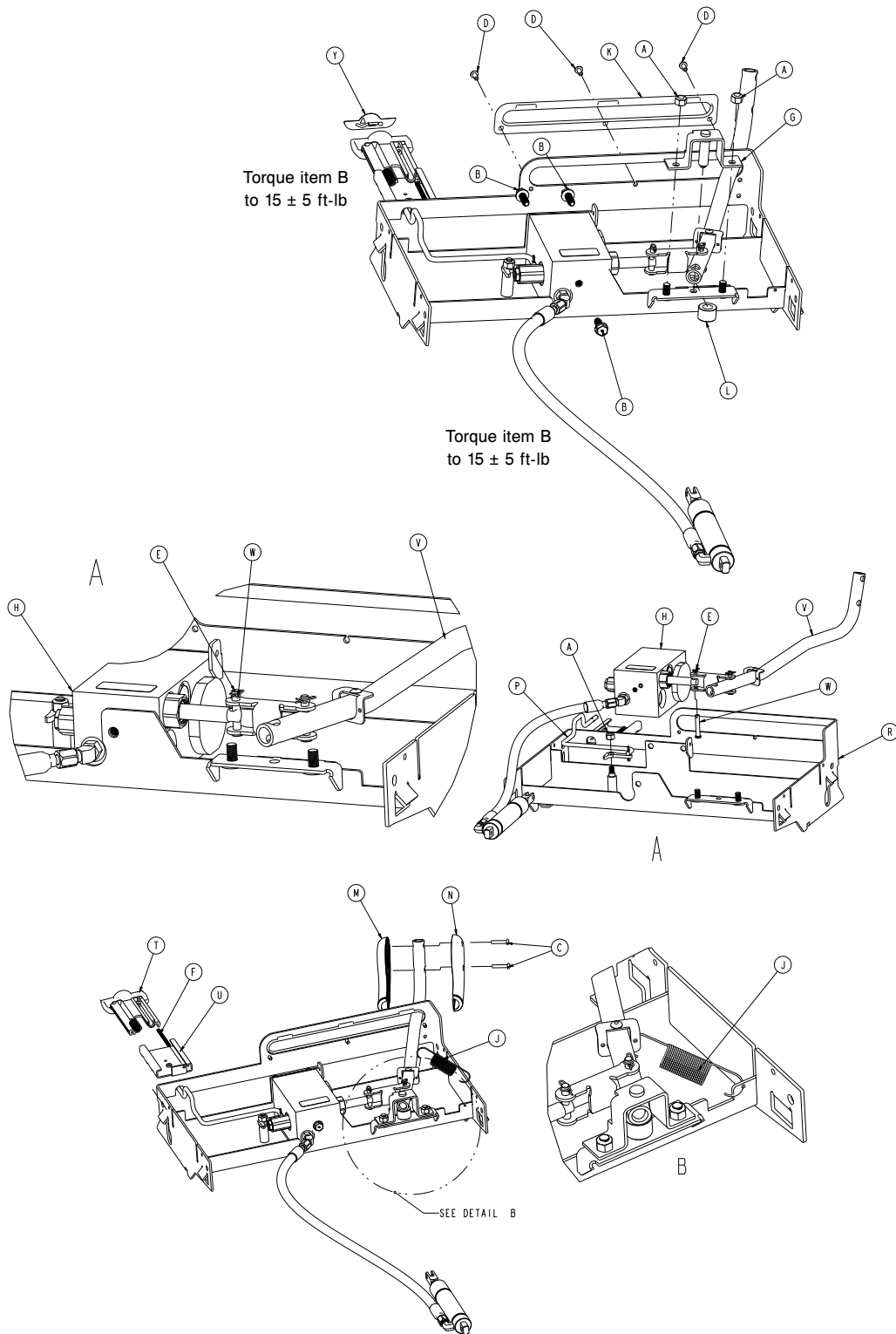

Item	Number	Name	Quantity
A	0016-036-000	Nylock hex nut	3
B	0023-288-000	Hex washer head screw	3

Item	Number	Name	Quantity
C	0023-310-000	Pan head tapping screw	2
D	0025-079-000	Dome head rivet	3
E	0027-020-000	Rue ring cotter	1
F	0038-603-000	Extension spring	1
G	0785-014-030	Gatch pivot weldment	1
H	0785-014-043	<i>Gatch valve body assembly - 0785-014-043 (page 272)</i>	1
J	0785-014-107	Gatch return spring	1
K	0785-014-113	Gatch pump bumper	1
L	0785-014-133	Gatch pivot spacer	1
M	0785-014-156	Gatch pump handle, left	1
N	0785-014-157	Gatch pump handle, right	1
P	0785-114-303	<i>30" Gatch release handle assembly (page 271)</i>	1
R	0785-114-325	30" Gatch weldment	1
T	0785-210-351	30" Gatch release handle	1
U	0785-210-352	30" Gatch release guide	1
V	1105-014-116	<i>Gatch pump assembly (page 273)</i>	1
W	8805-932-000	Clevis pin	1
Y	0785-210-353	Label, Gatch release	1

30" Gatch release handle assembly

0785-114-303 Rev A (Reference only)

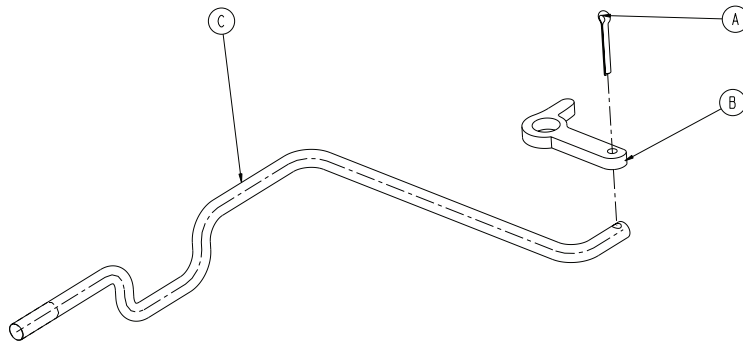

Item	Number	Name	Quantity
A	0027-015-000	Cotter pin	1
B	0785-014-038	Gatch release link	1
C	0785-114-337	30" Gatch release rod	1

Gatch valve body assembly - 0785-014-043

Rev AB (Reference only)

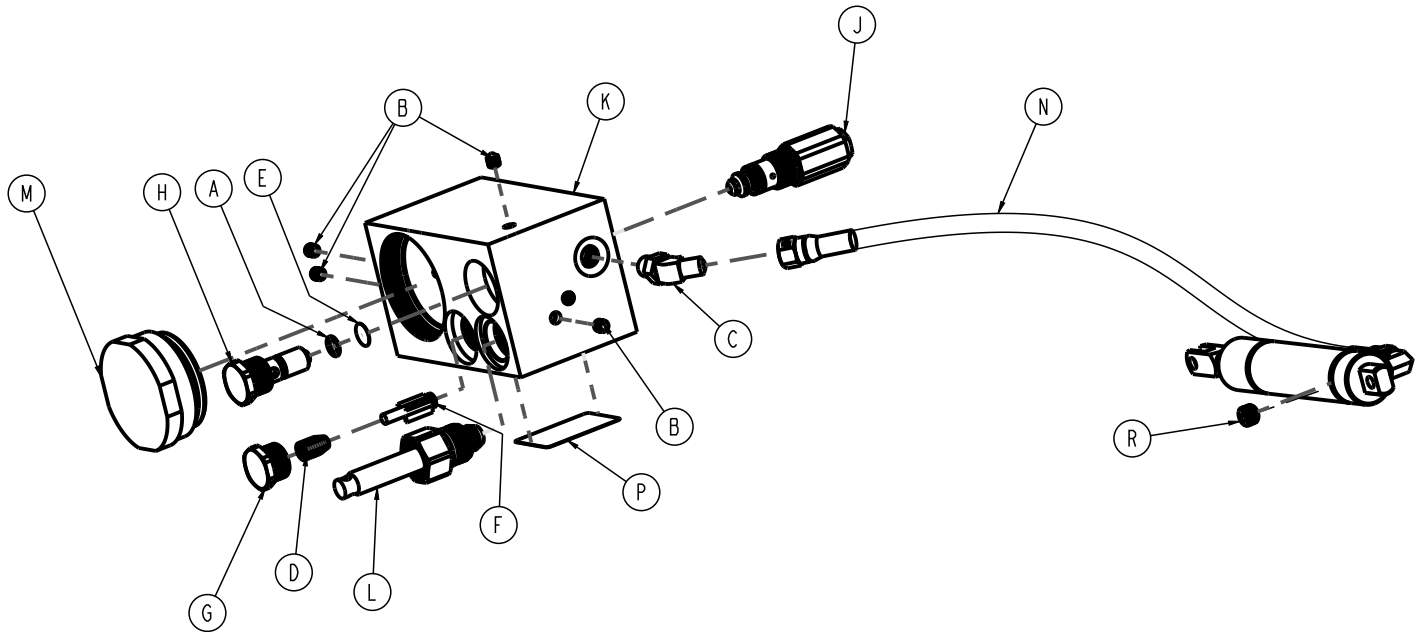

Item	Number	Name	Quantity
A	0046-004-000*	O-ring	1
B	0048-021-000*	CV plug	4
C	0048-175-000*	45° straight thread elbow	1
D	0390-002-134*	Conical compression spring	1
E	0715-001-321*	Check valve screen	1
F	0715-001-341*	Poppet	1
G	0753-002-051*	Plug assembly	1
H	0753-002-052*	Check valve assembly	1
J	0753-002-165*	Release valve assembly	1
K	0785-014-036*	Gatch valve body	1
L	0785-014-051*	Pump ram assembly	1
M	0785-014-073	Gatch assembly plug	1
N	0785-014-078*	Cylinder/hose assembly	1
P	0785-014-114*	Label, Gatch jack system	1
R	0048-000-100*	Countersunk hex head plug	1

*Shown for reference only. Individual part components are not available for sale.

Gatch pump assembly

1105-014-116 Rev A (Reference only)

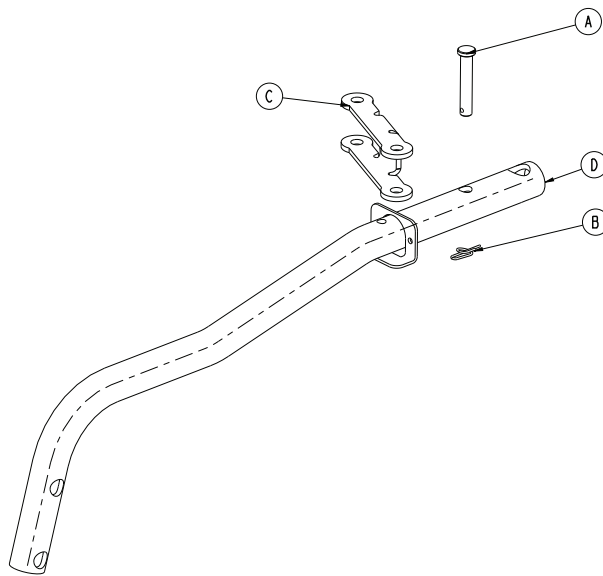

Item	Number	Name	Quantity
A	8805-932-000	Clevis pin	1
B	0027-020-000	Rue ring cotter	1
C	0785-014-024	Gatch pump link	1
D	1105-014-111	Gatch handle assembly	1

Common litter components, 120V

1008-010-010 Rev C (Reference only)

Number	Name	Quantity
1008-014-857	Transformer	1
1105-009-310	<i>30" monitor tray assembly (page 205)</i>	1
1105-010-150	<i>30" corner cover assembly (page 202)</i>	1
1105-030-310	<i>30" oxygen bottle assembly - 1105-030-310 (page 203)</i>	1
1210-800-008	Label, patent	1
1008-116-800	DC control PCB assembly	1
1008-014-804	Label, DC board schematic	1

Common litter components, 230V

1008-010-020 Rev A (Reference only)

Number	Name	Quantity
1008-014-877	Transformer, international	1
1105-009-310	<i>30" monitor tray assembly (page 205)</i>	1
1105-010-150	<i>30" corner cover assembly (page 202)</i>	1
1105-030-310	<i>30" oxygen bottle assembly - 1105-030-310 (page 203)</i>	1
1210-800-008	Label, patent	1
1008-116-800	DC control PCB assembly	1
1008-014-804	Label, DC board schematic	1

Common litter components, fifth wheel, electric

1105-016-000 Rev J (Reference only)

Number	Name	Quantity
0853-003-615	<i>8" caster with full cover assembly - 0853-003-615 (page 97)</i>	1
1105-006-110	<i>Retractable fifth wheel assembly (page 110)</i>	1
1008-010-302	<i>Drop seat Fowler assembly, electric litter (page 280)</i>	1

Common litter components, international fifth wheel, electric

1105-016-010 Rev H (Reference only)

Number	Name	Quantity
0921-001-252	Serial number date tag	1
0853-003-615	<i>8" caster with full cover assembly - 0853-003-615 (page 97)</i>	1
1105-006-110	<i>Retractable fifth wheel assembly (page 110)</i>	1
1008-010-302	<i>Drop seat Fowler assembly, electric litter (page 280)</i>	1

Non-scale litter assembly option, electric litter

1008-010-100 Rev D (Reference only)

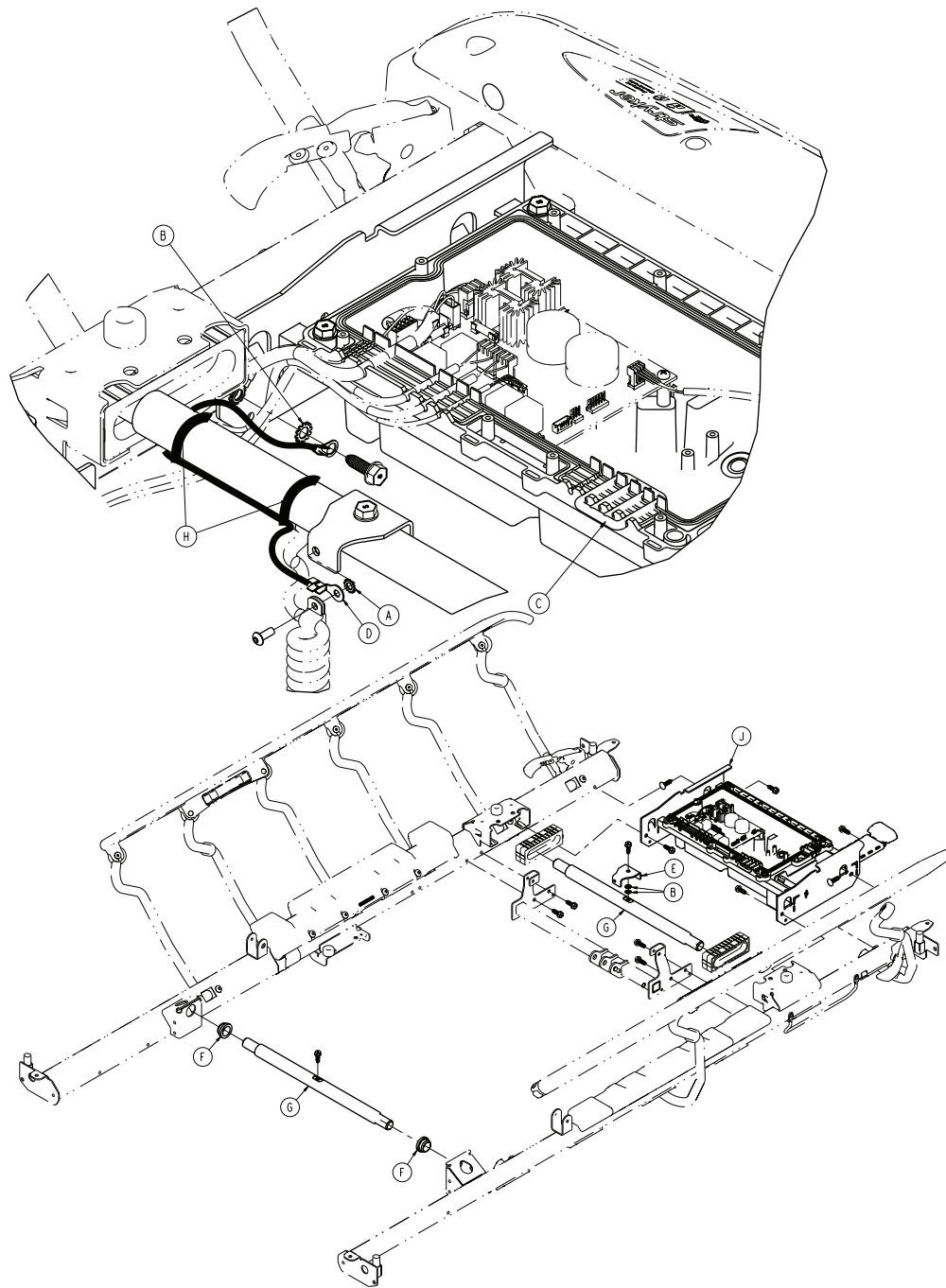

Item	Number	Name	Quantity
A	0013-018-000	External tooth lock washer	1
B	0013-038-000	External tooth lock washer	3
C	1008-010-121	Hole plug	1
D	1008-010-871	Lifthead to litter ground, 15"	1
E	1008-110-011	Support tube coil cord bracket	1
F	1105-010-008	Flange bearing	2
G	1105-010-347	30" support tube, foot end	2

Item	Number	Name	Quantity
H	3000-300-113	8" cable tie	2
J	1008-014-320	<i>Control box assembly, electric litter</i> (page 299)	1

Drop seat Fowler assembly, electric litter

1008-010-302 Rev U (Reference only)

Torque item D
to 11 ± 5 ft-lb

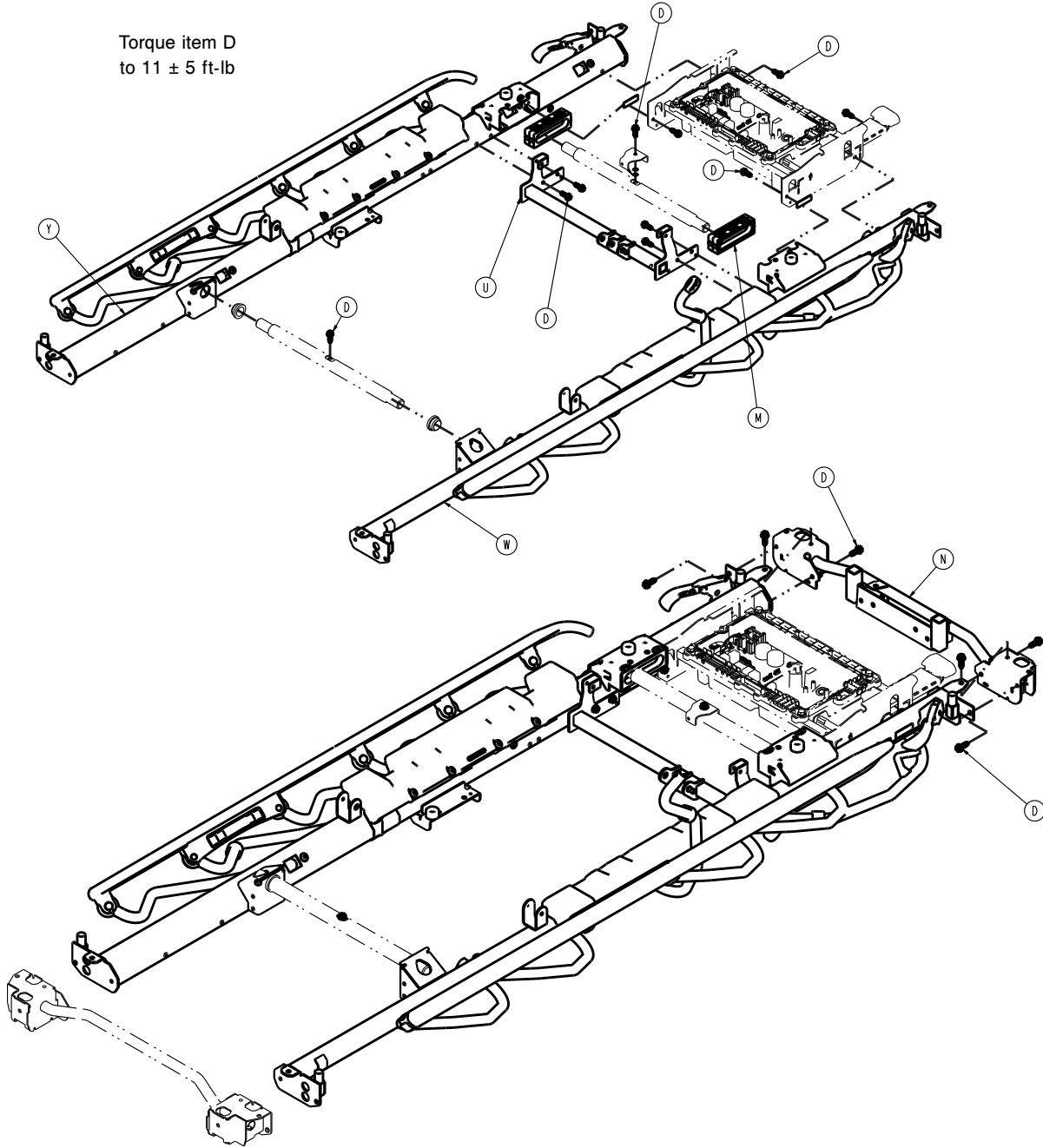

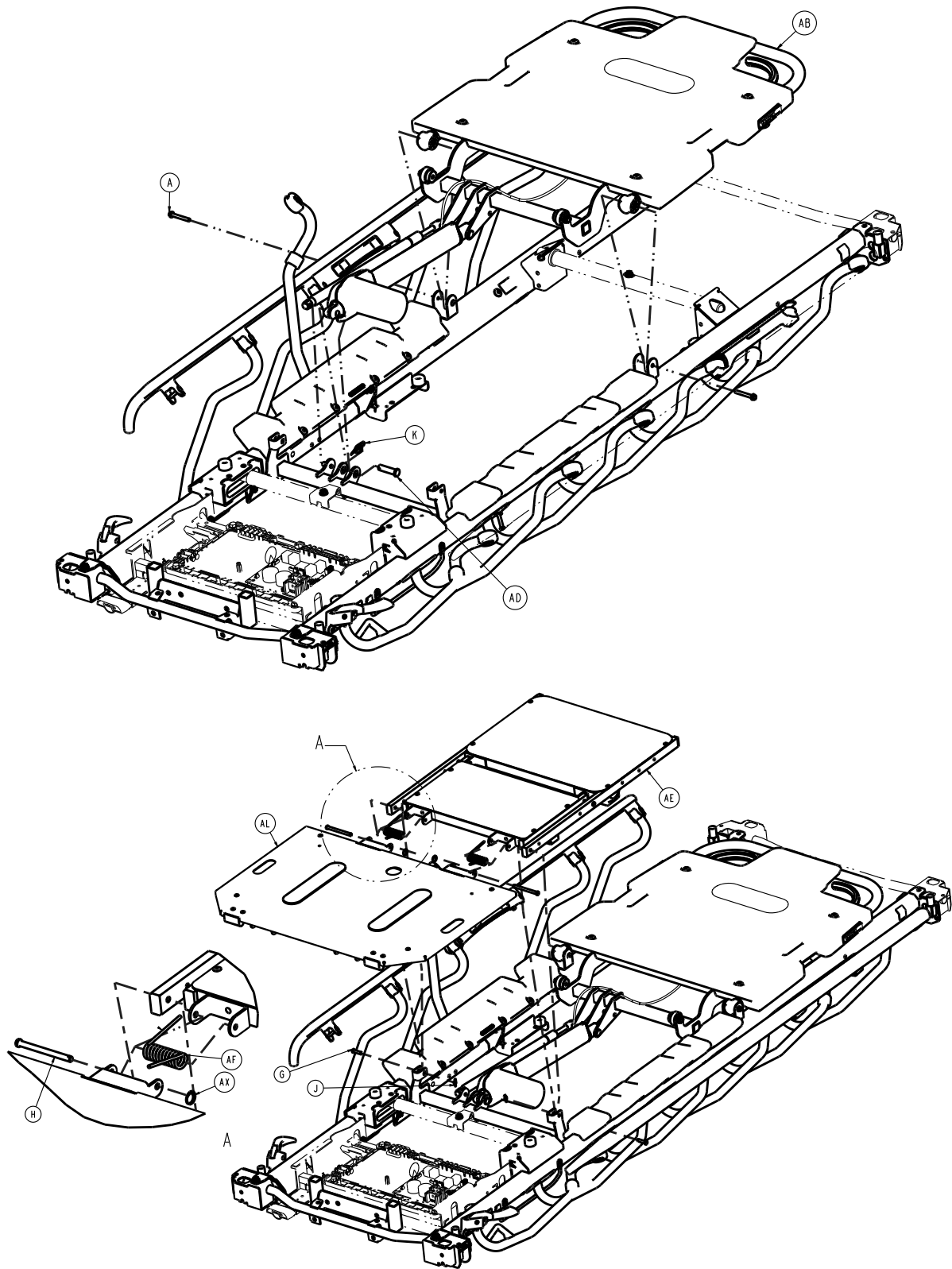

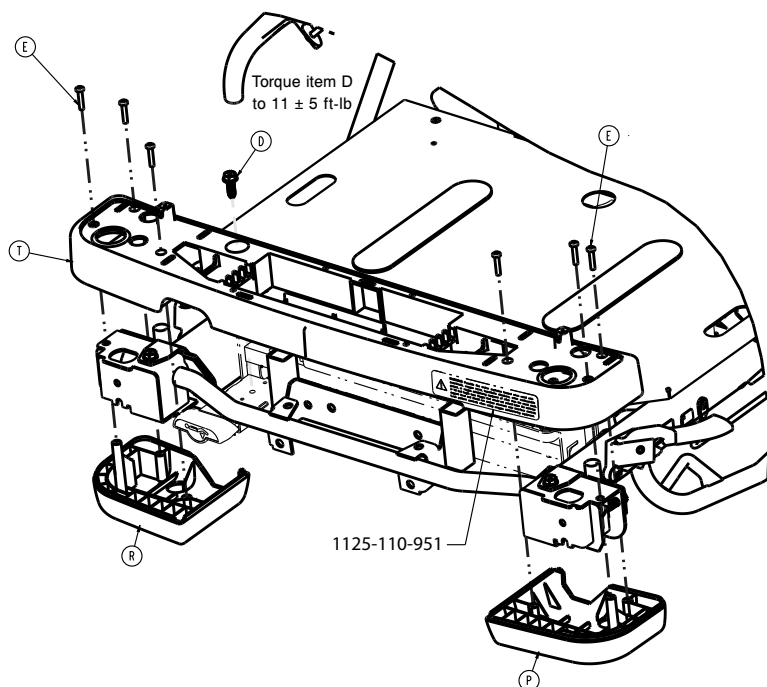
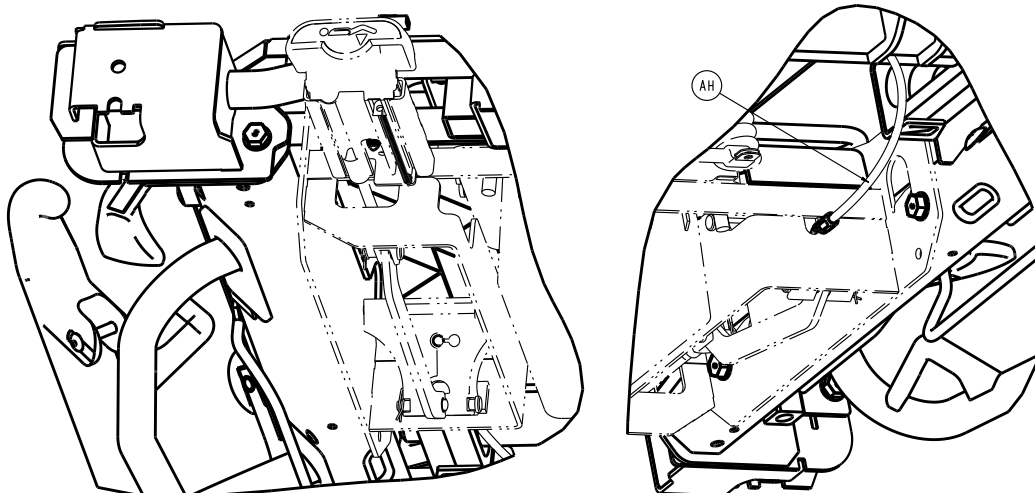

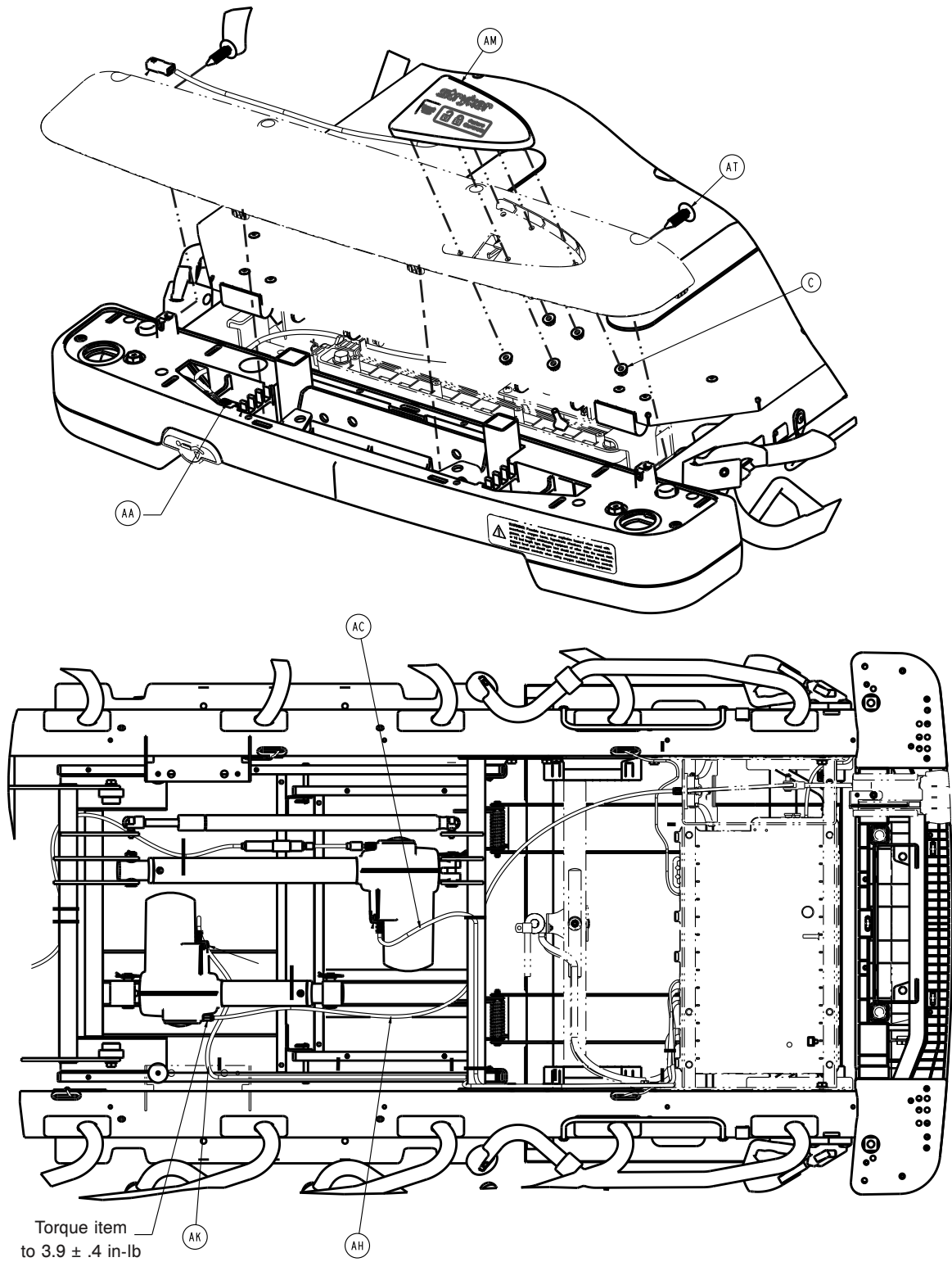

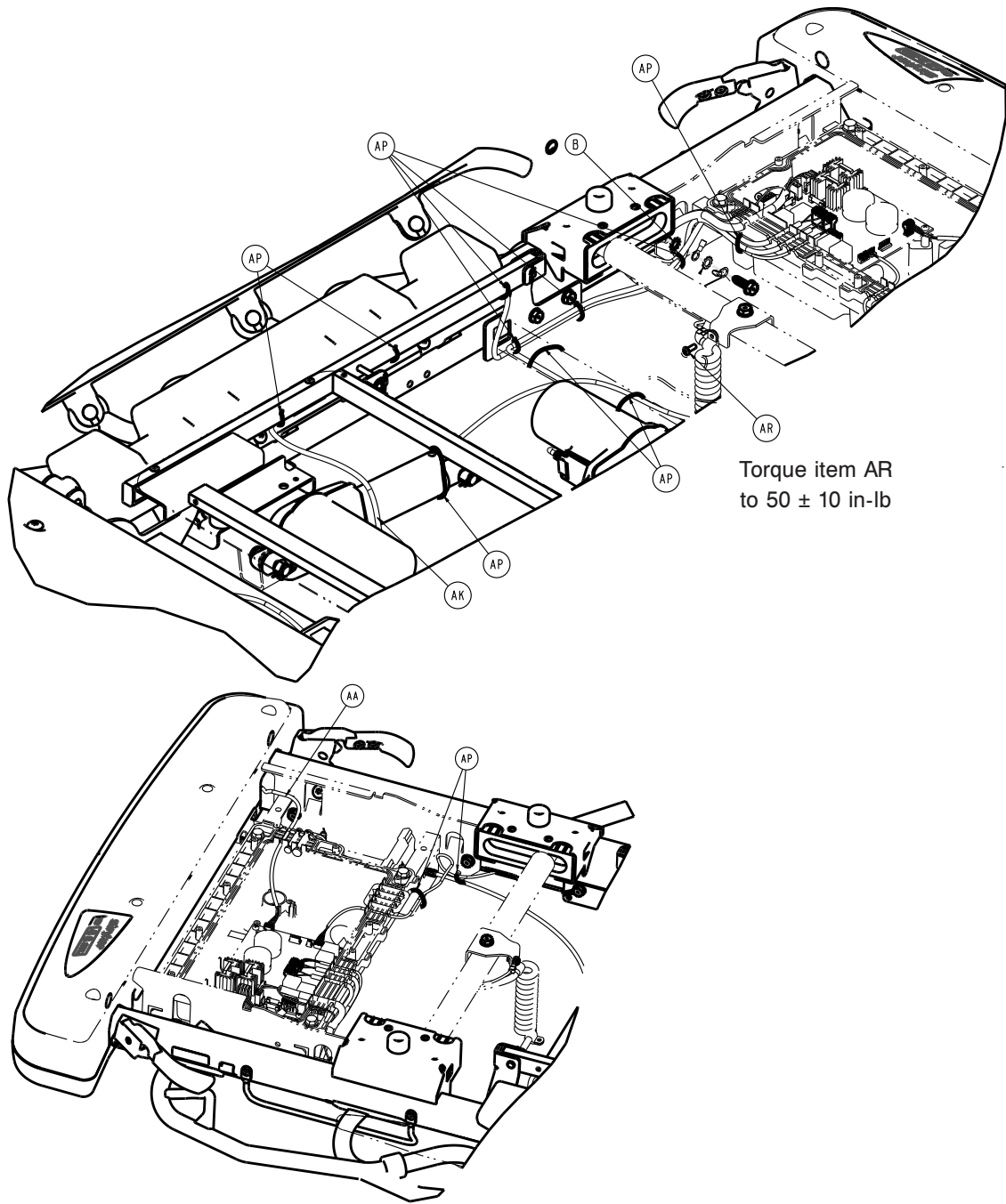

1105-124-011

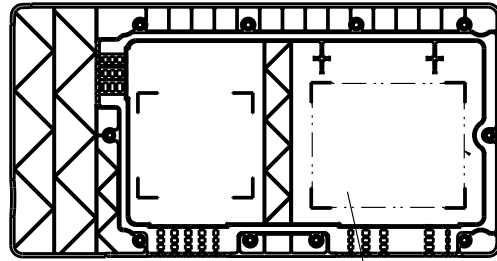
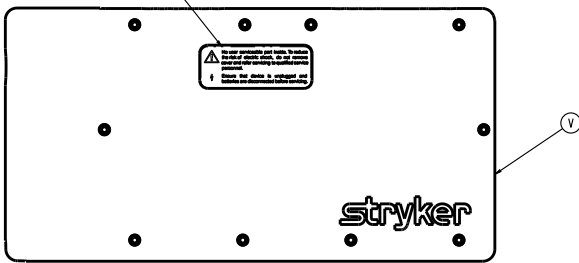

1008-014-804

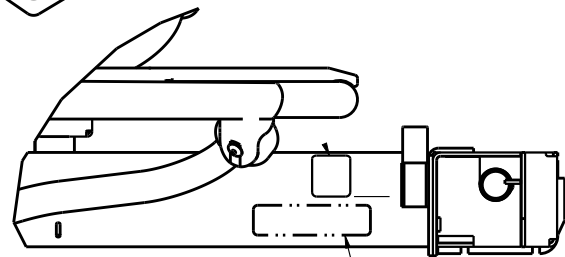
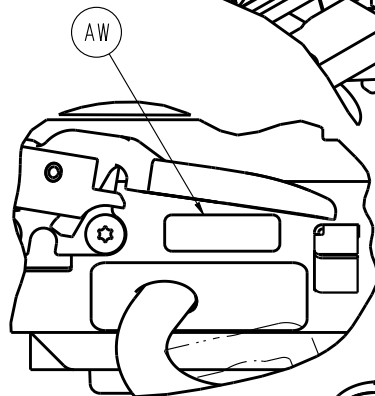
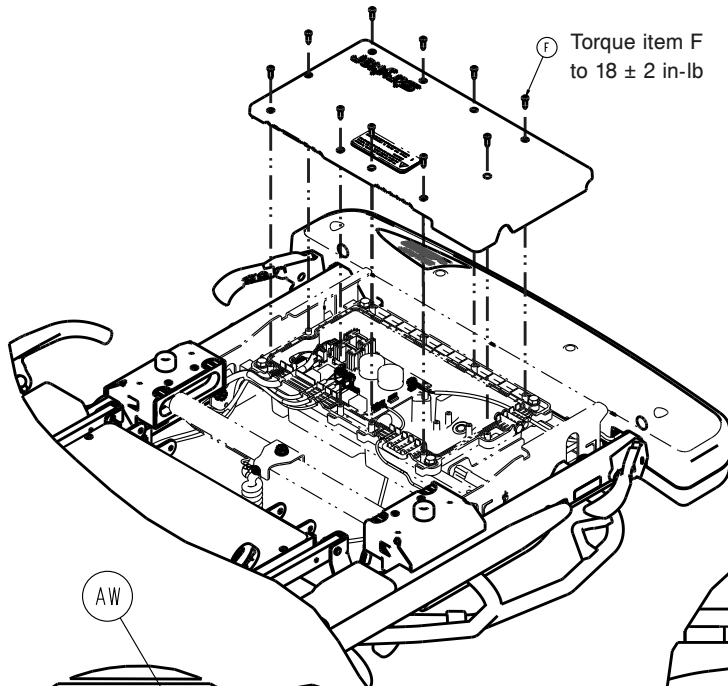

1105-001-906

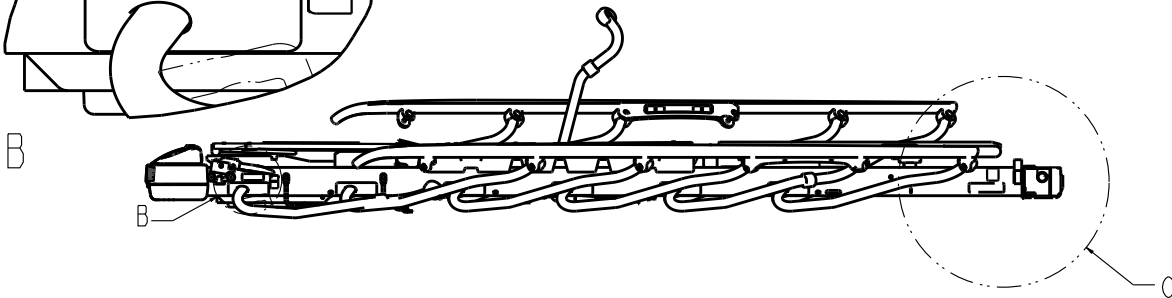

Item	Number	Name	Quantity
A	0003-385-000	Hex washer head screw	2
B	0013-038-000	External tooth lock washer	1
C	0016-137-000	Hex flange nut	5
D	0023-288-000	Hex washer head screw	17
E	0023-310-000	Pan head tapping screw	6
F	0023-318-000	Pan head tapping screw	10
G	0026-316-000	Clevis pin	2
H	0026-364-000	Clevis pin	2

Item	Number	Name	Quantity
J	0027-020-000	Rue ring cotter	2
K	0027-034-000	Rue ring cotter	1
M	0785-010-006	Trend block slide	2
N	0785-110-320	End weldment, foot end	1
P	0785-210-052	Bottom cover, foot end, left	1
R	0785-210-057	Bottom cover, foot end, right	1
T	0785-210-350	Mid cover, foot end	1
U	1008-108-310	Frame tie weldment	1
V	1008-010-115	Litter control box top assembly	1
W	1008-011-040	<i>Siderail assembly, right, electric litter</i> (page 287)	1
Y	1008-011-050	<i>Siderail assembly, left, electric litter</i> (page 291)	1
AA	1008-011-860	Lockout cable	1
AB	1008-012-302	<i>Fowler assembly, electric litter</i> (page 301)	1
AC	1008-012-821	Fowler actuator cable	1
AD	1008-013-011	Clevis pin	1
AE	1008-013-301	<i>Seat/Gatch assembly, electric litter</i> (page 304)	1
AF	1008-014-011	Gatch coil spring	2
AH	1008-014-080	Gatch release cable	1
AK	1008-014-821	Gatch actuator cable	1
AL	1008-115-301	Foot assembly	1
AM	1008-015-820	Patient lockout assembly	1
AP	3000-300-113	Cable tie	12
AR	0004-585-000	Button head cap screw	1
AT	0029-027-000	Panel fastener	2
AW	1105-001-901	Label, applied part	2
AX	0027-035-000	Circular cotter	2

Siderail assembly, right, electric litter

1008-011-040 Rev C (Reference only)

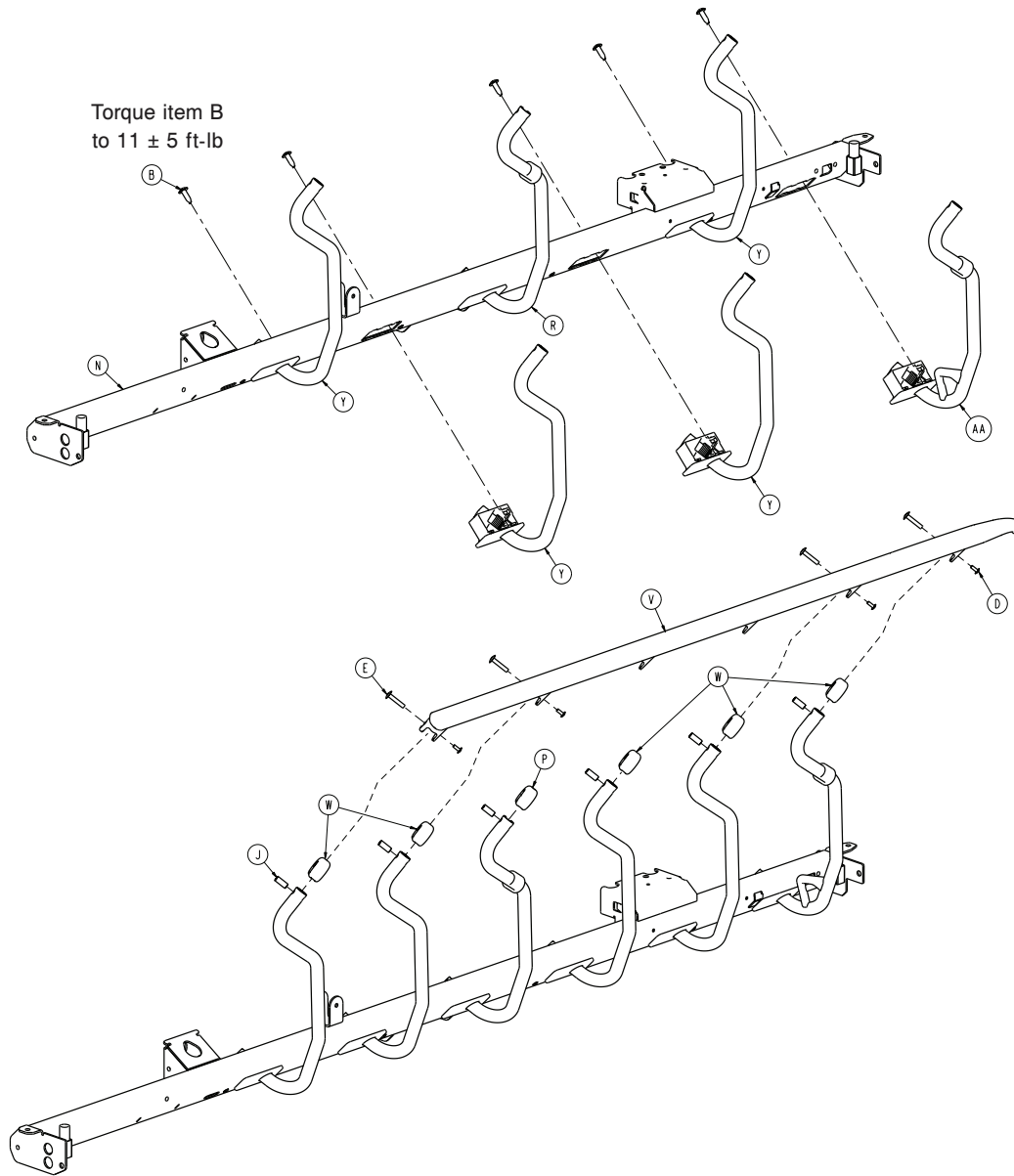

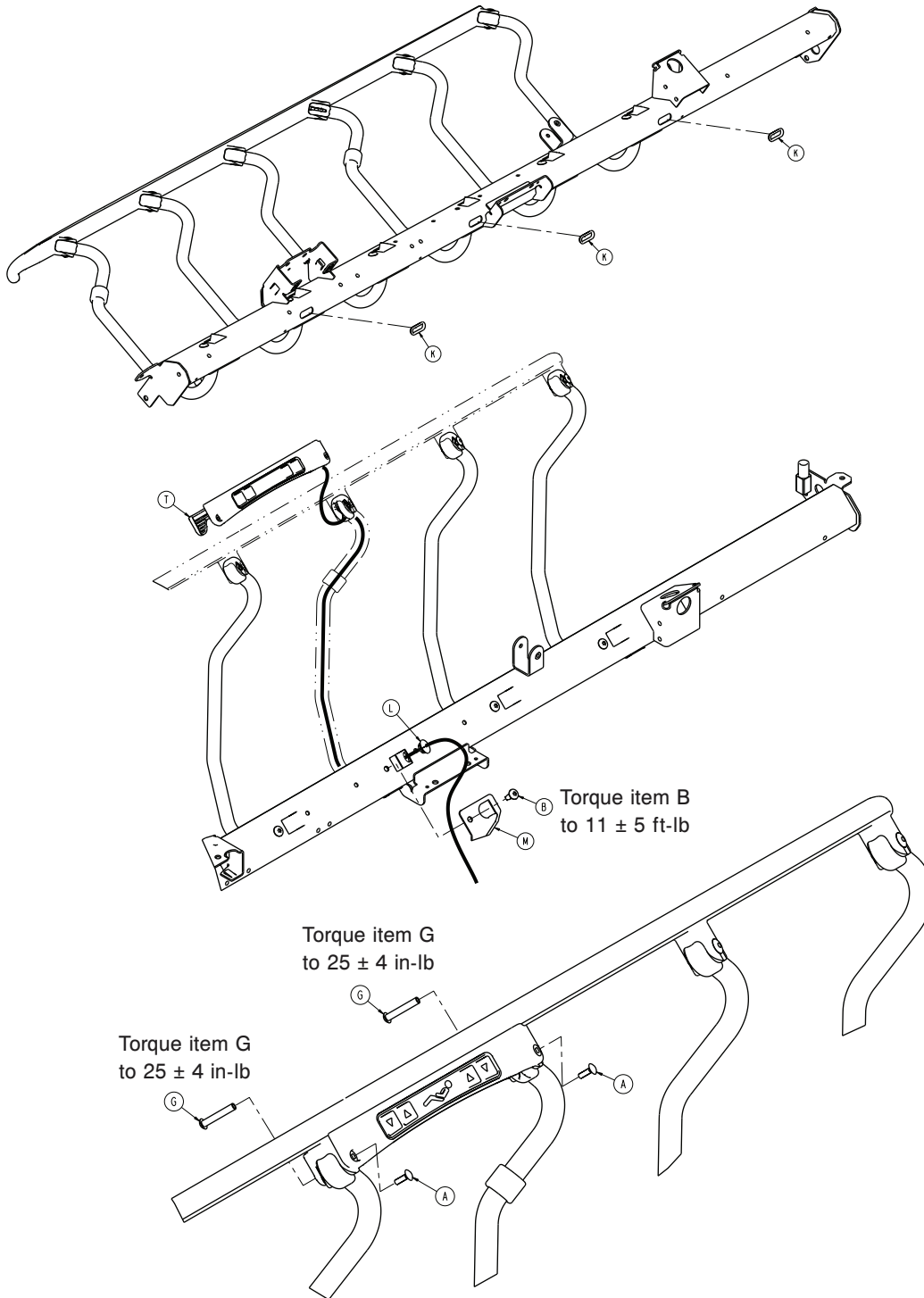

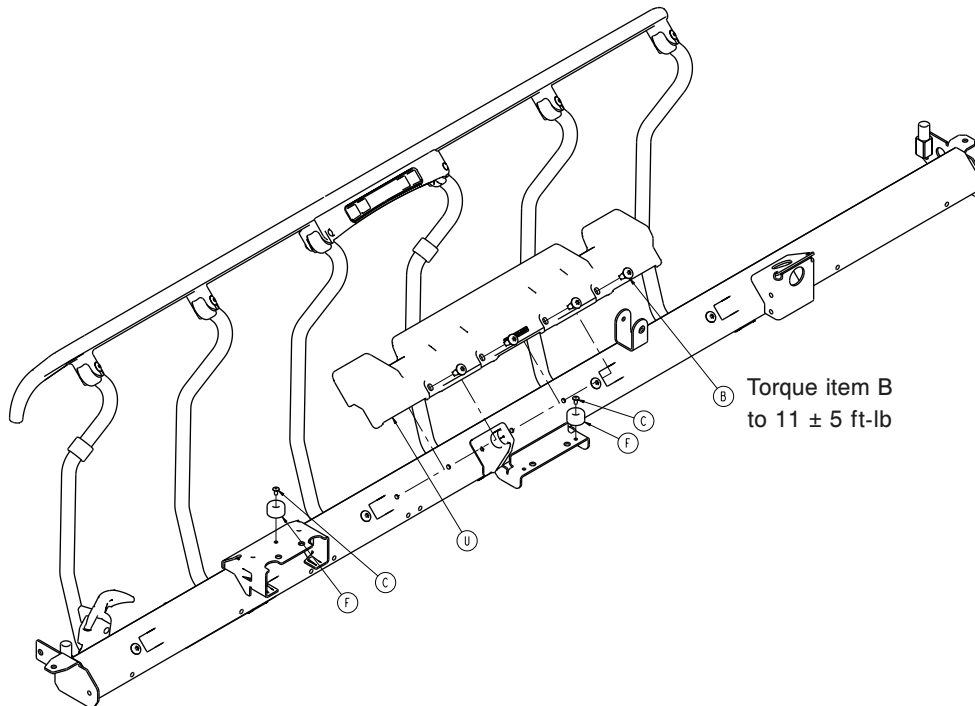
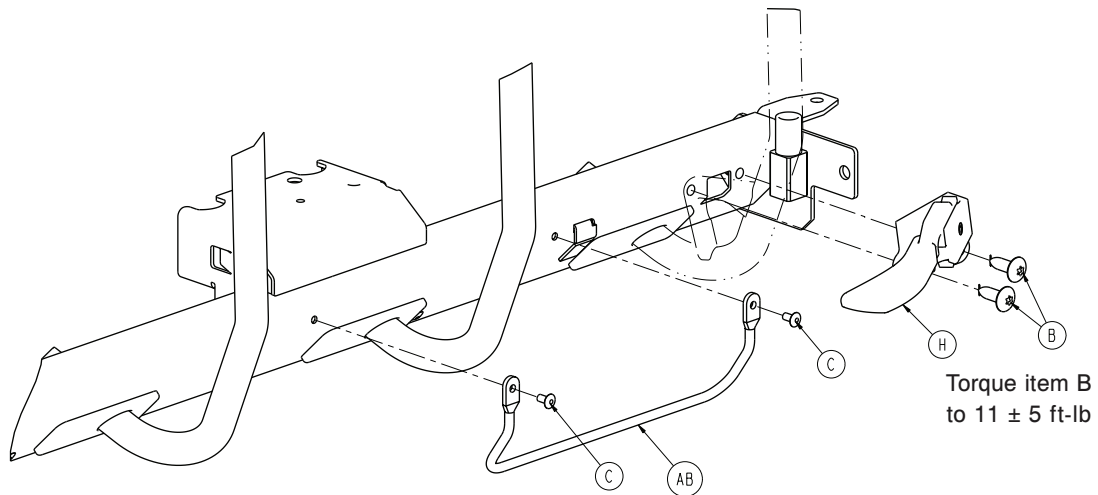

Item	Number	Name	Quantity
A	0005-047-000	Carriage bolt	2
B	0007-074-000	Truss head machine screw	12
C	0025-079-000	Dome head rivet	4
D	0025-182-000	Blind rivet	4
E	0025-183-000	Tubular component	4
F	0056-023-000	Bumper	2
G	0058-131-000	Barrel nut	2
H	0785-011-020	Siderail latch assembly, right (page 223)	1
J	0785-011-046	Spindle bearing	6
K	1008-011-008	Siderail cable channel grommet	3
L	1008-011-009	Siderail cable grommet	1
M	1008-011-013	Siderail cable shield, right	1
N	1008-011-020	Siderail tube weldment, right	1
P	1008-011-038	Spindle plug	1

Item	Number	Name	Quantity
R	1008-011-041	<i>Spindle sub assembly, right, electric litter (page 295)</i>	1
T	1008-011-320	<i>Siderail control assembly, right - 1008-011-320 (page 297)</i>	1
U	1105-010-049	Mattress support block	1
V	1105-011-037	Top rail, right	1
W	1105-011-038	Spindle plug	5
Y	1105-011-041	<i>Spindle assembly, right - 1105-011- 041 (page 221)</i>	4
AA	1105-011-042	<i>Latch spindle assembly, right (page 225)</i>	1
AB	1105-030-046	Foley bag rack	1

Siderail assembly, left, electric litter

1008-011-050 Rev C (Reference only)

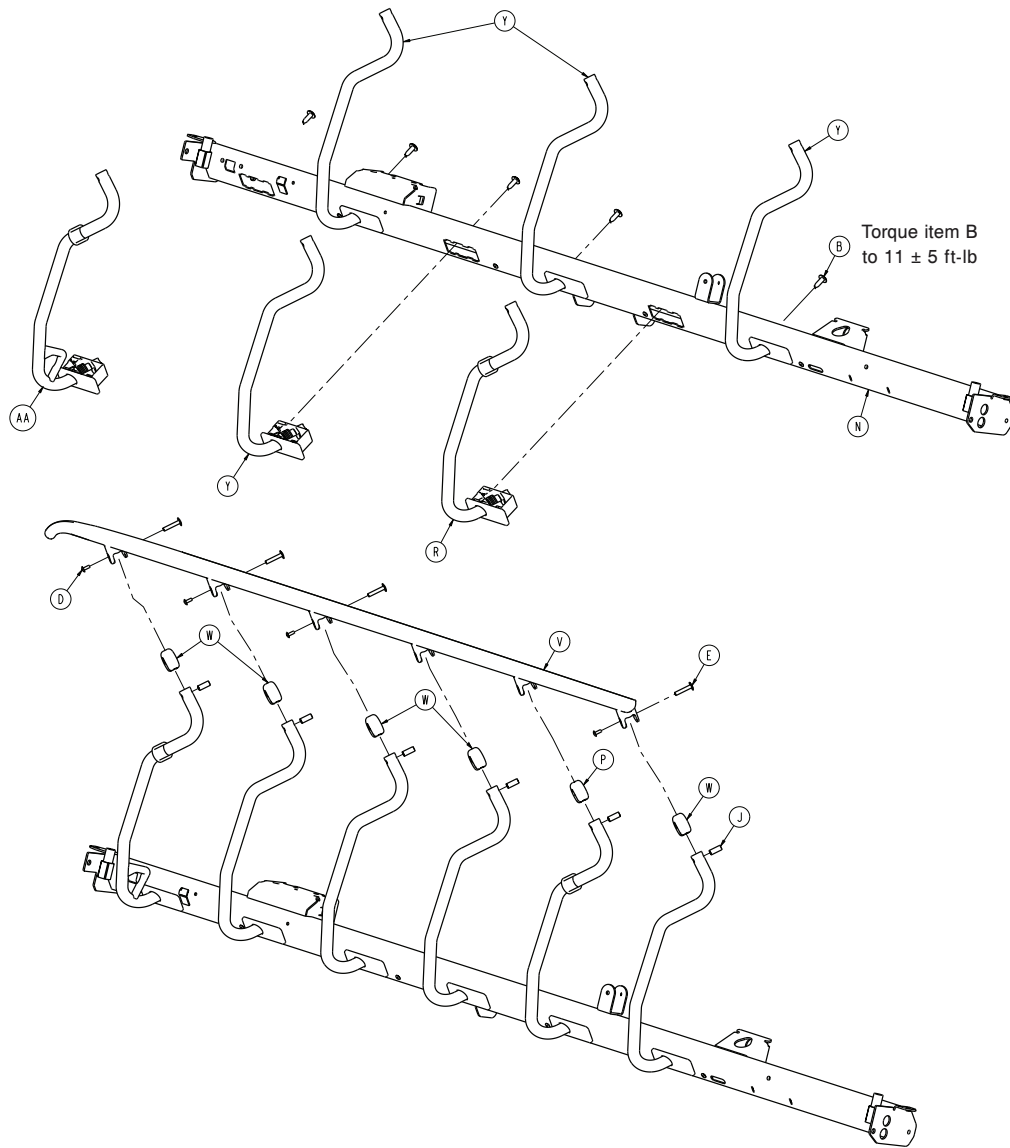

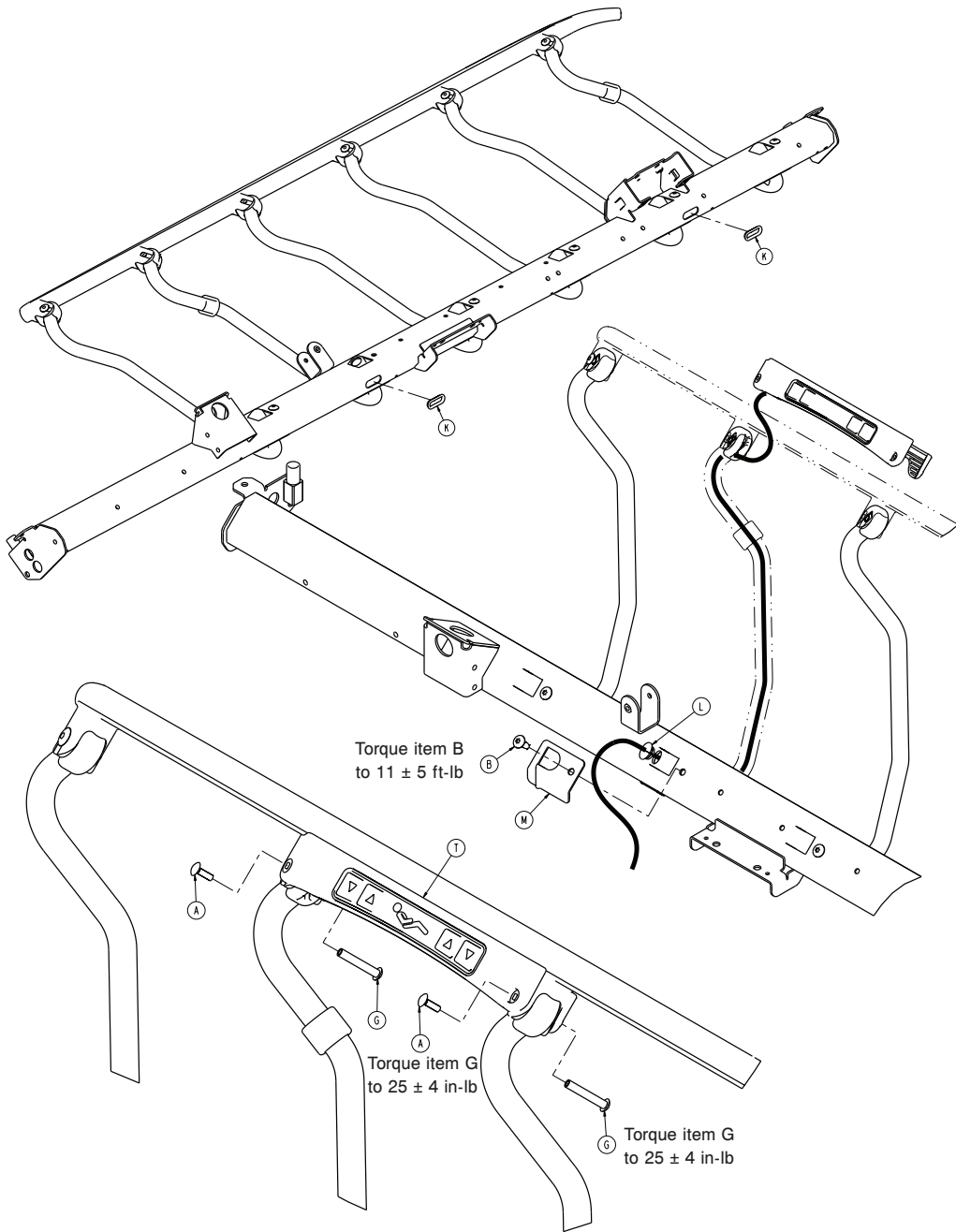

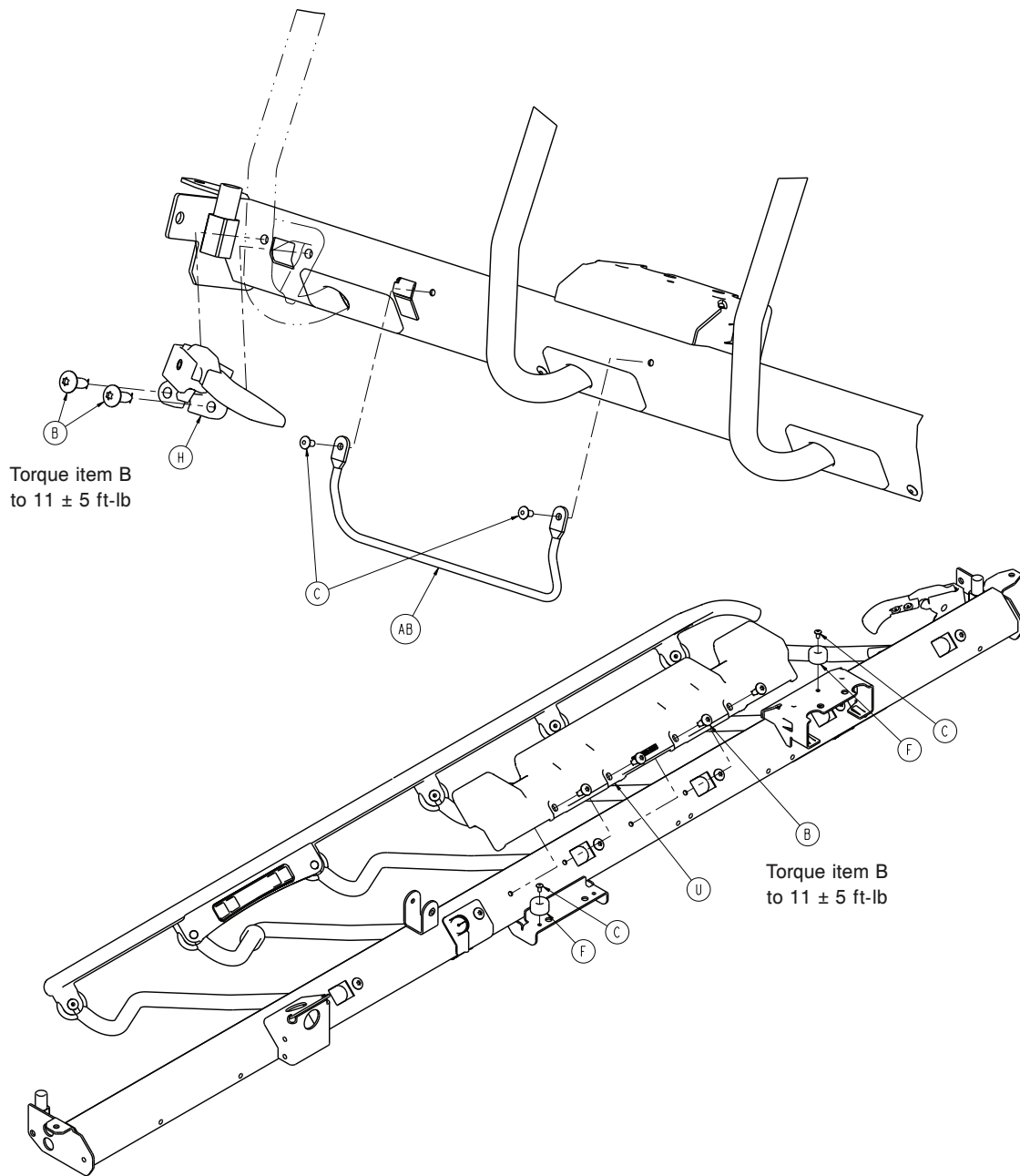

Item	Number	Name	Quantity
A	0005-047-000	Carriage bolt	2
B	0007-074-000	Truss head machine screw	12
C	0025-079-000	Dome head rivet	4
D	0025-182-000	Blind rivet	4
E	0025-183-000	Tubular component	4
F	0056-023-000	Bumper	2
G	0058-131-000	Barrel nut	2
H	0785-011-021	Siderail latch assembly, left (page 224)	1
J	0785-011-046	Spindle bearing	6
K	1008-011-008	Siderail cable channel grommet	2
L	1008-011-009	Siderail cable grommet	1
M	1008-011-014	Siderail cable shield, left	1

Item	Number	Name	Quantity
N	1008-011-030	Siderail tube weldment, left	1
P	1008-011-038	Spindle plug	1
R	1008-011-051	<i>Spindle sub assembly, left, electric litter (page 296)</i>	1
T	1008-011-330	<i>Siderail control assembly, left - 1008- 011-330 (page 298)</i>	1
U	1105-010-049	Mattress support block	1
V	1105-011-036	Top rail, left	1
W	1105-011-038	Spindle plug	5
Y	1105-011-051	<i>Spindle assembly, left - 1105-011-051 (page 222)</i>	4
AA	1105-011-052	<i>Latch spindle assembly, left (page 226)</i>	1
AB	1105-030-046	Foley bag rack	1

Spindle sub assembly, right, electric litter

1008-011-041 Rev A (Reference only)

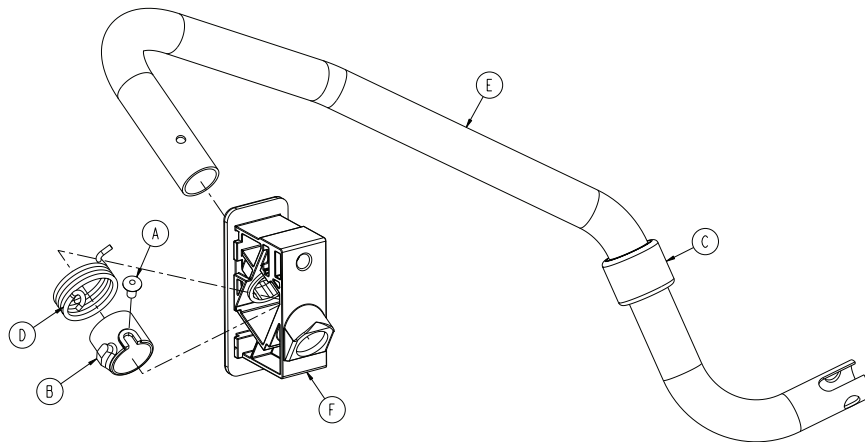

Item	Number	Name	Quantity
A	0025-079-000	Dome head rivet	1
B	0785-011-013	Spindle spacer, right	1
C	0785-011-016	Rubber stop	1
D	0785-011-047	Siderail spring, right	1
E	1008-011-032	Spindle, right	1
F	1008-011-197	Pivot block/nut assembly	1

Spindle sub assembly, left, electric litter

1008-011-051 Rev A (Reference only)

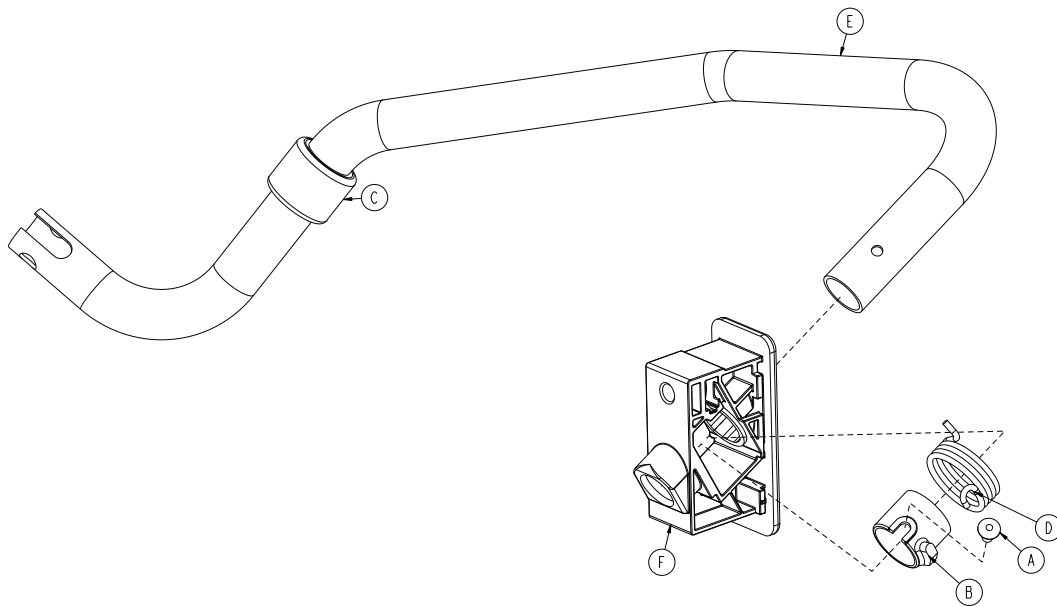

Item	Number	Name	Quantity
A	0025-079-000	Dome head rivet	1
B	0785-011-010	Spindle spacer, left	1
C	0785-011-016	Rubber stop	1
D	0785-011-048	Siderail spring, left	1
E	1008-011-033	Spindle, left	1
F	1008-011-197	Pivot block/nut assembly	1

Siderail control assembly, right - 1008-011-320

Rev AA (Reference only)

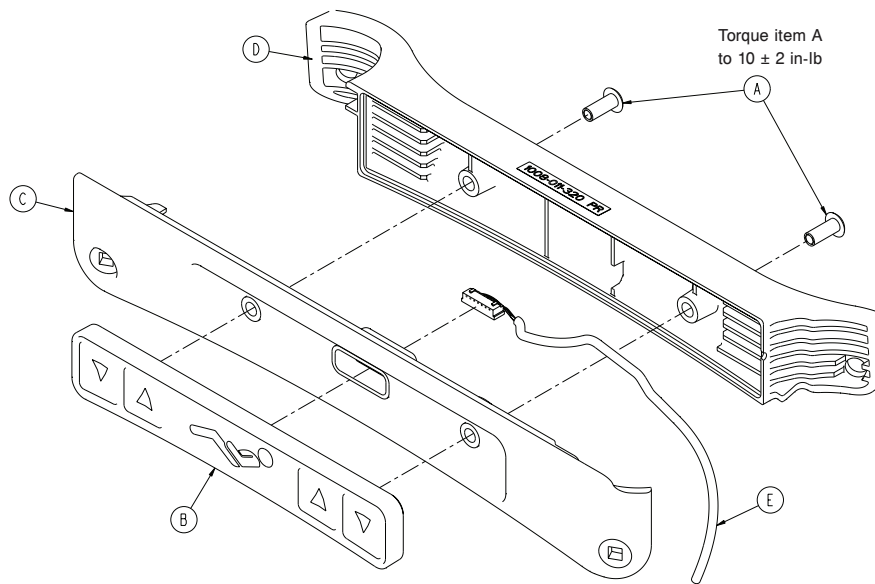

Item	Number	Name	Quantity
A	0058-130-000	Barrel nut	2
B	1008-011-016	Siderail keypad, right	1
C	1008-111-321	Siderail control top housing, right	1
D	1008-111-322	Siderail control bottom housing, right	1
E	1008-011-850	Siderail cable, right	1

Siderail control assembly, left - 1008-011-330

Rev AA (Reference only)

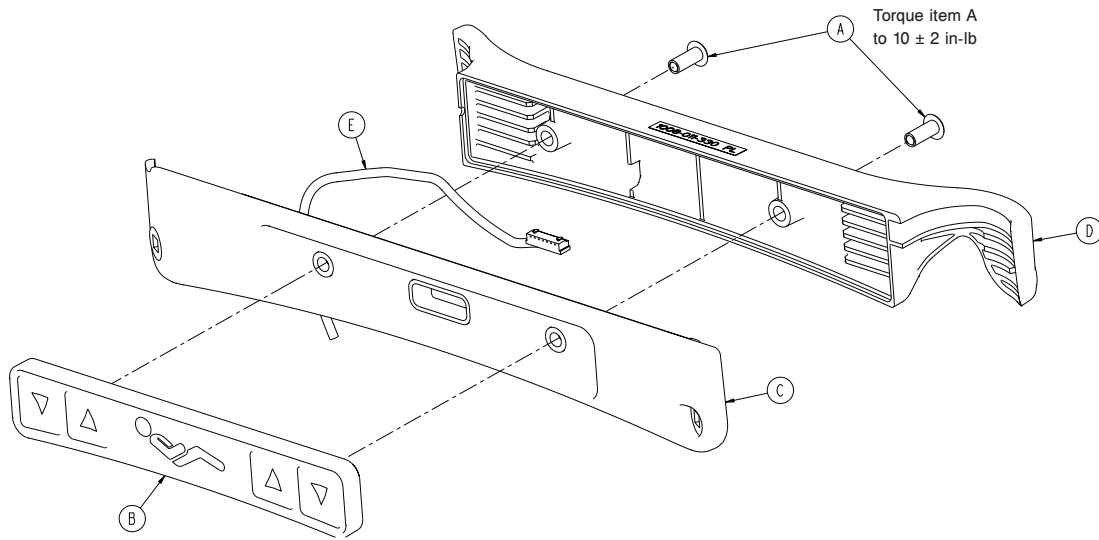

Item	Number	Name	Quantity
A	0058-130-000	Barrel nut	2
B	1008-011-017	Siderail keypad, left	1
C	1008-111-331	Siderail control top housing, left	1
D	1008-111-332	Siderail control bottom housing, left	1
E	1008-011-855	Siderail cable, left	1

Control box assembly, electric litter

1008-014-320 Rev E (Reference only)

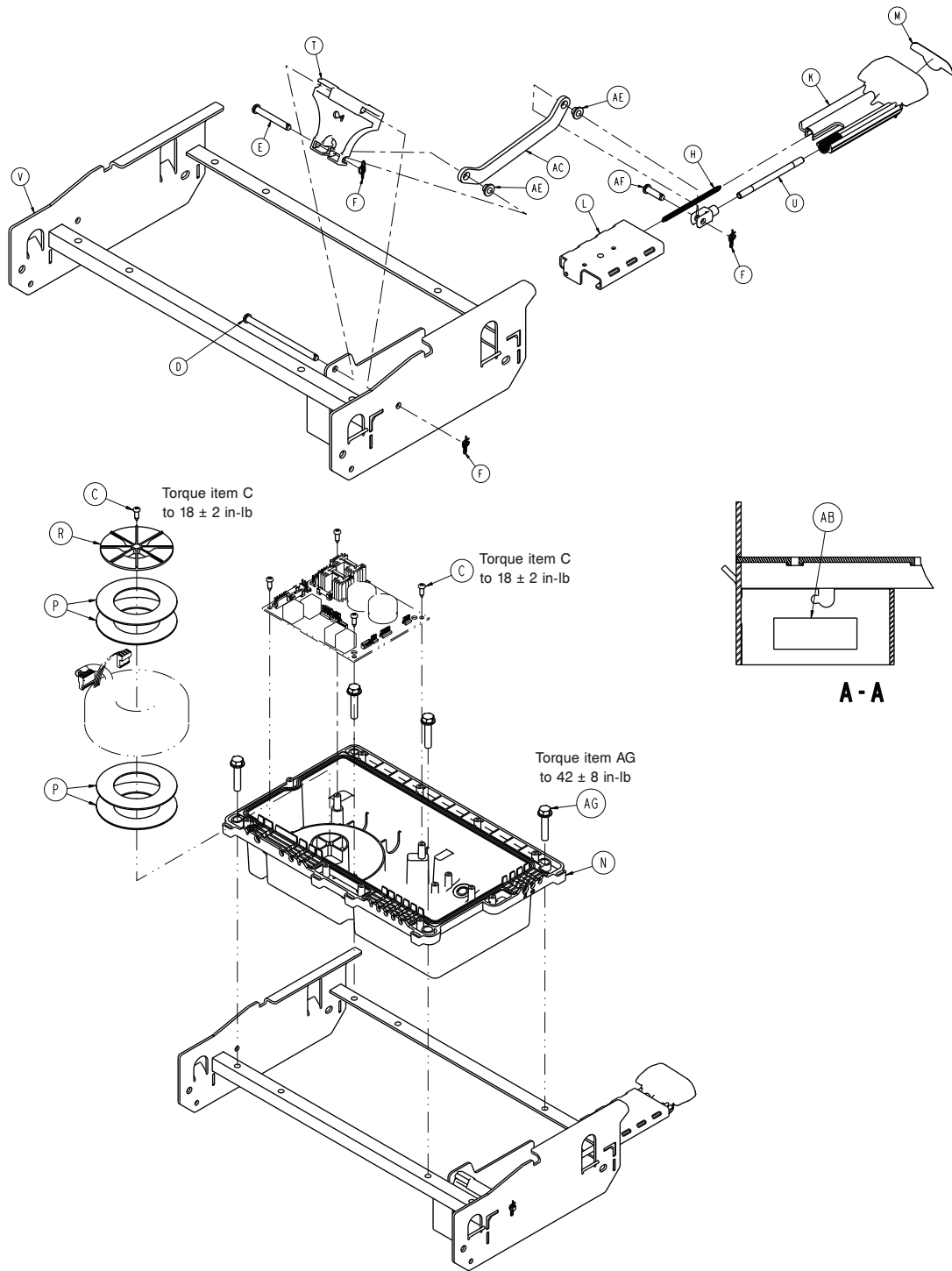

Item	Number	Name	Quantity
C	0023-318-000	Pan head tapping screw	5
D	0026-223-000	Clevis pin	1
E	0026-330-000	Clevis pin	1
F	0027-020-000	Rue ring cotter	3
H	0038-603-000	Extension spring	1

Item	Number	Name	Quantity
J	0052-909-000	Clevis joint	1
K	0785-210-351	30" Gatch release handle	1
L	0785-210-352	30" Gatch release guide	1
M	0785-210-353	Label, Gatch release	1
N	1008-010-105	Litter control box bottom assembly	1
P	1008-010-107	Torroid gasket	4
R	1008-010-108	Torroid hold down	1
T	1008-014-321	Gatch release	1
U	1008-114-322	Gatch release pull rod	1
V	1008-014-325	Control box weldment	1
AB	7900-001-291	Foam tape (2 in. length)	.17 ft
AC	1008-014-313	Flat link	1
AE	0052-718-000	Nylon insulator	2
AF	0026-295-000	Clevis pin	1
AG	0023-160-000	Hex washer head screw	4

Fowler assembly, electric litter

1008-012-302 Rev AA (Reference only)

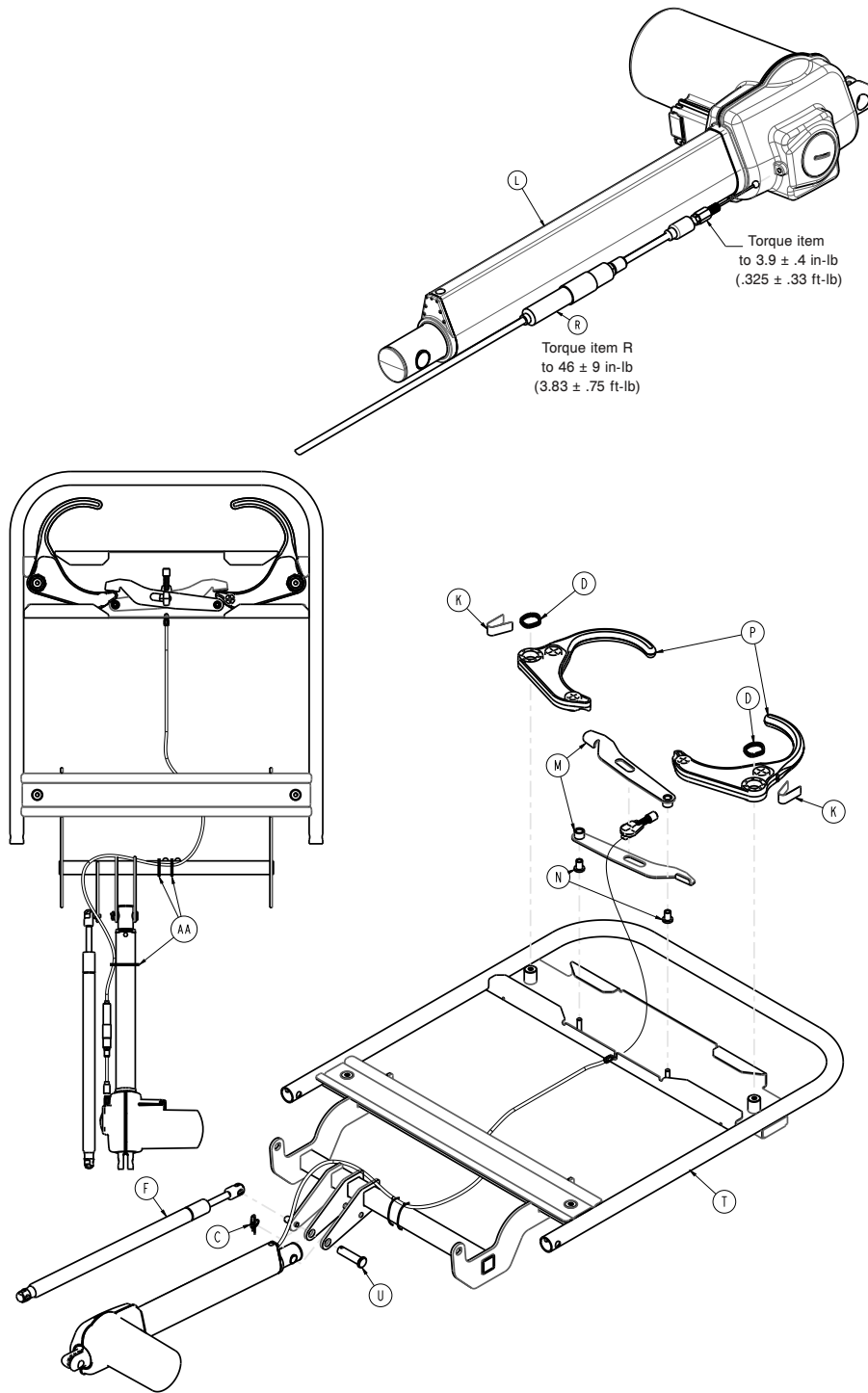

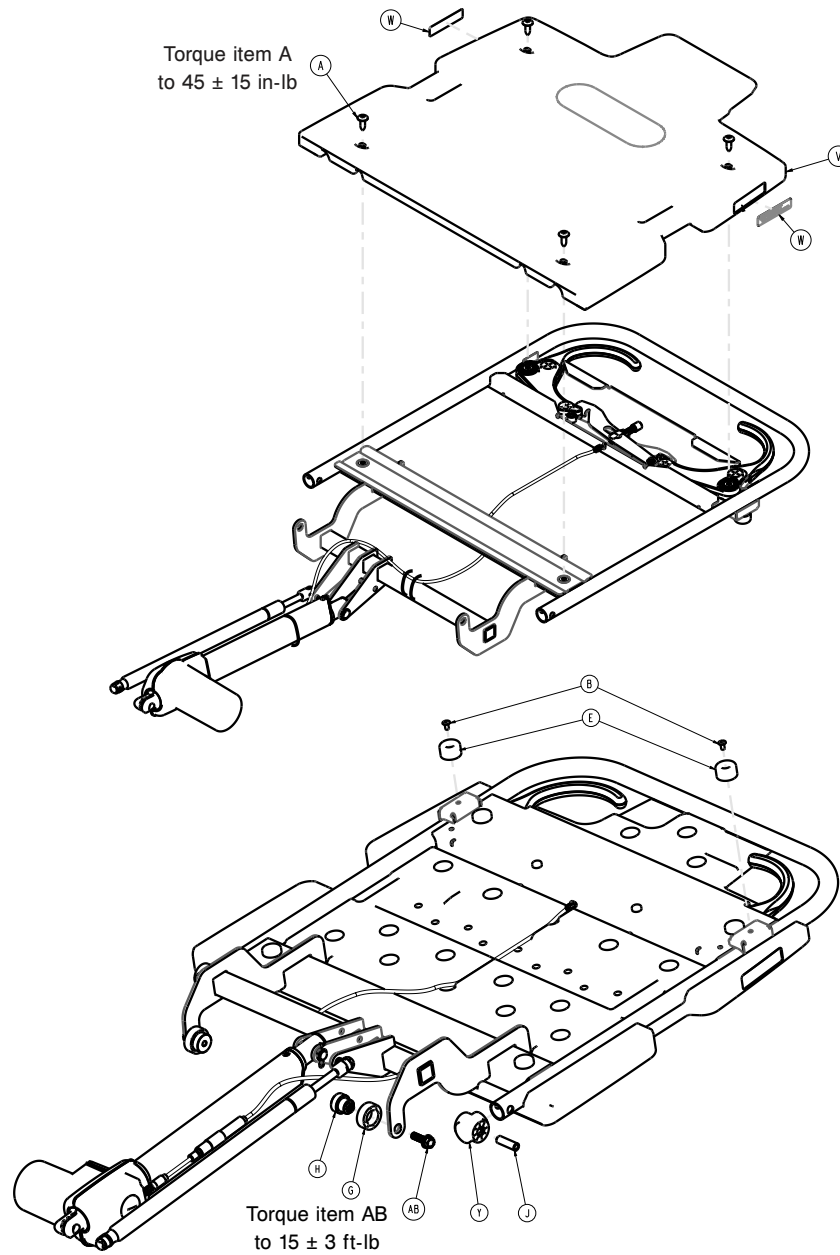

Item	Number	Name	Quantity
A	700002372142	Truss head machine screw	4
B	0025-079-000	Rivet	2
C	0027-034-000	Rue ring cotter	1
D	0038-557-000	Spring	2
E	0056-023-000	Bumper	2
F	0059-218-000	Gas spring	1
G	0785-012-007	Fowler seat lift roller	2
H	0785-012-101	Mandrel roller	2
J	0785-012-103	Sleeve	2
K	0785-012-086	Fowler spring	2
L	1008-012-020	Fowler actuator	1
M	1008-012-030	Fowler cable link weldment	2
N	1008-012-034	Fowler cable link bushing	2

Item	Number	Name	Quantity
P	1008-012-066	Fowler release handle	2
R	1008-012-080	Fowler release cable assembly	1
T	1008-012-305	Fowler weldment	1
U	1008-013-011	Clevis pin	1
V	1008-012-350	30" plastic Fowler	1
W	1105-010-312	Label, BackSmart	2
Y	1105-012-076	Fowler tube plug	2
AA	3000-300-113	8" cable tie	3
AB	0023-305-000	Hex washer head screw	2

Seat/Gatch assembly, electric litter

1008-013-301 Rev C (Reference only)

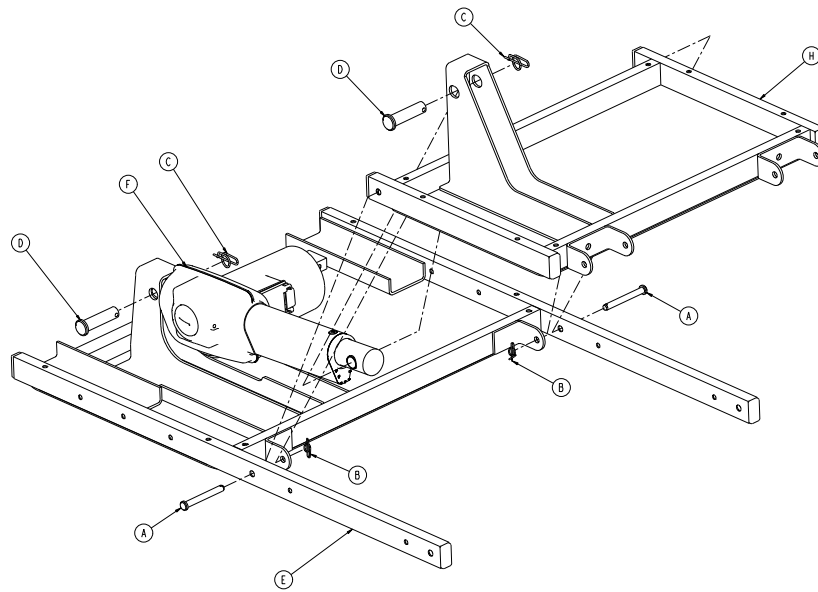

Item	Number	Name	Quantity
A	0026-334-000	Clevis pin	2
B	0027-020-000	Rue ring cotter	2
C	0027-034-000	Rue ring cotter	2
D	1008-013-011	Clevis pin	2
E	1008-013-310	Seat section assembly	1
F	1008-014-020	Gatch actuator	1
H	1008-014-310	Gatch section assembly	1

26" foot assembly, electric litter

1008-115-611 Rev A (Reference only)

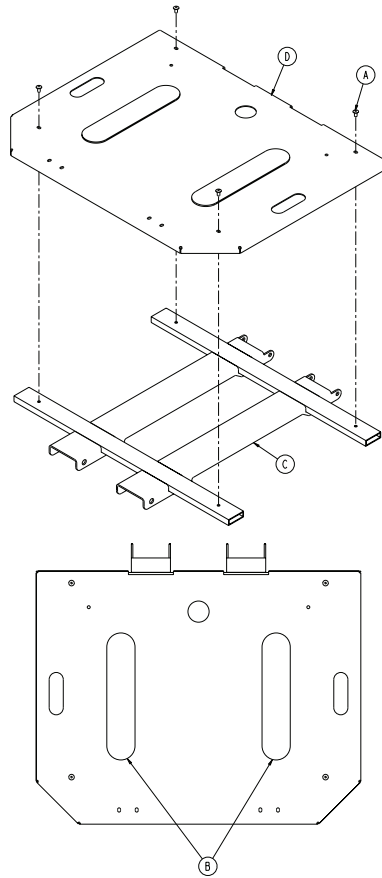

Item	Number	Name	Quantity
A	0025-079-000	Dome head rivet	4
B	0785-034-005	Velcro® pile (adhesive back)	2
C	1008-115-605	Foot weldment	1
D	1008-115-623	Foot skin	1

30" foot assembly, electric litter

1008-115-311 Rev A (Reference only)

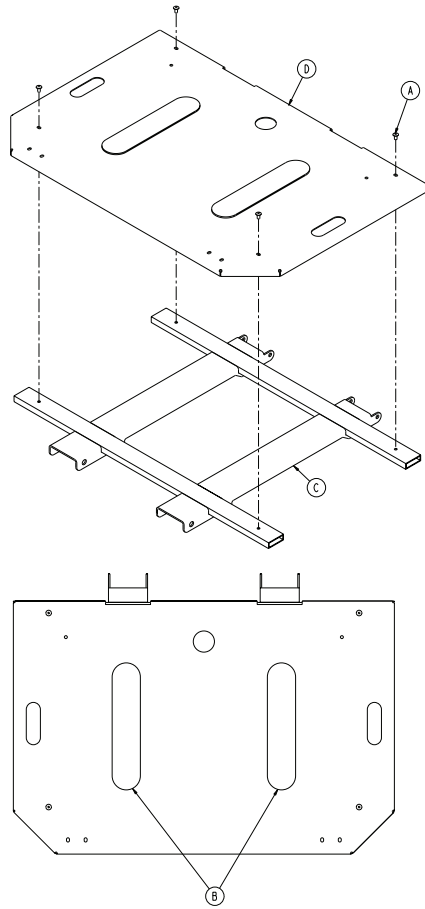

Item	Number	Name	Quantity
A	0025-079-000	Dome head rivet	4
B	0785-034-005	Velcro® pile (adhesive back)	2
C	1008-115-305	Foot weldment	1
D	1008-115-323	Foot skin	1

Operator control option, electric litter

1008-015-020 Rev B (Reference only)

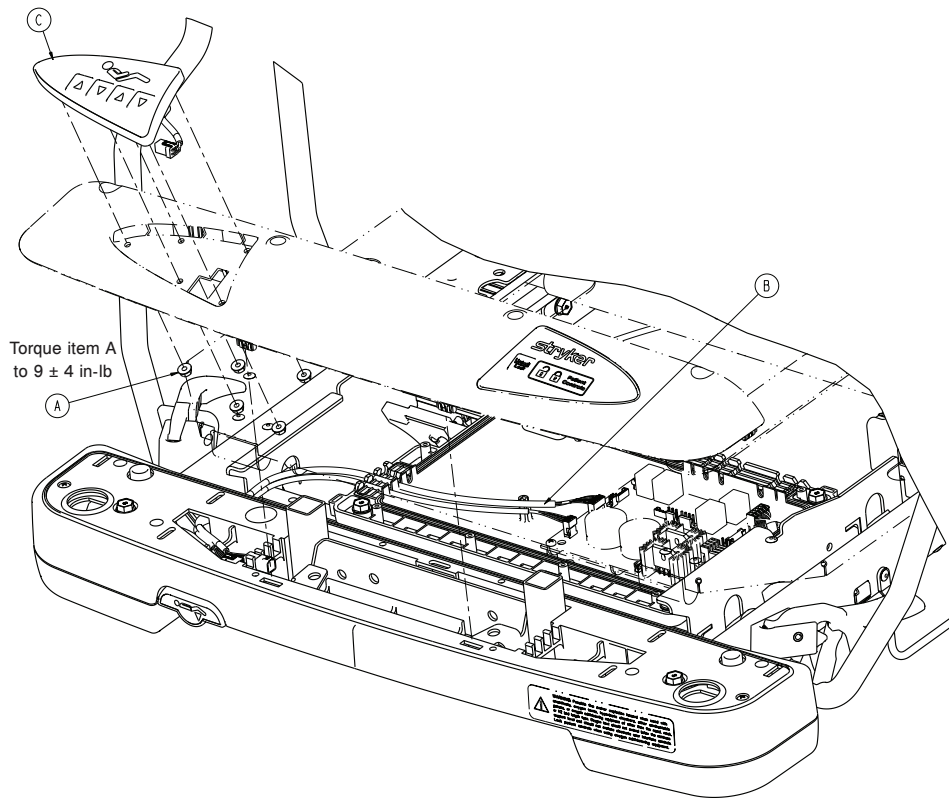

Item	Number	Name	Quantity
A	0016-137-000	Hex flange nut	5
B	1008-012-870	Staff control cable	1
C	1008-015-800	Staff control assembly	1

Scale litter assembly option, electric litter

1070-010-100 Rev J (Reference only)

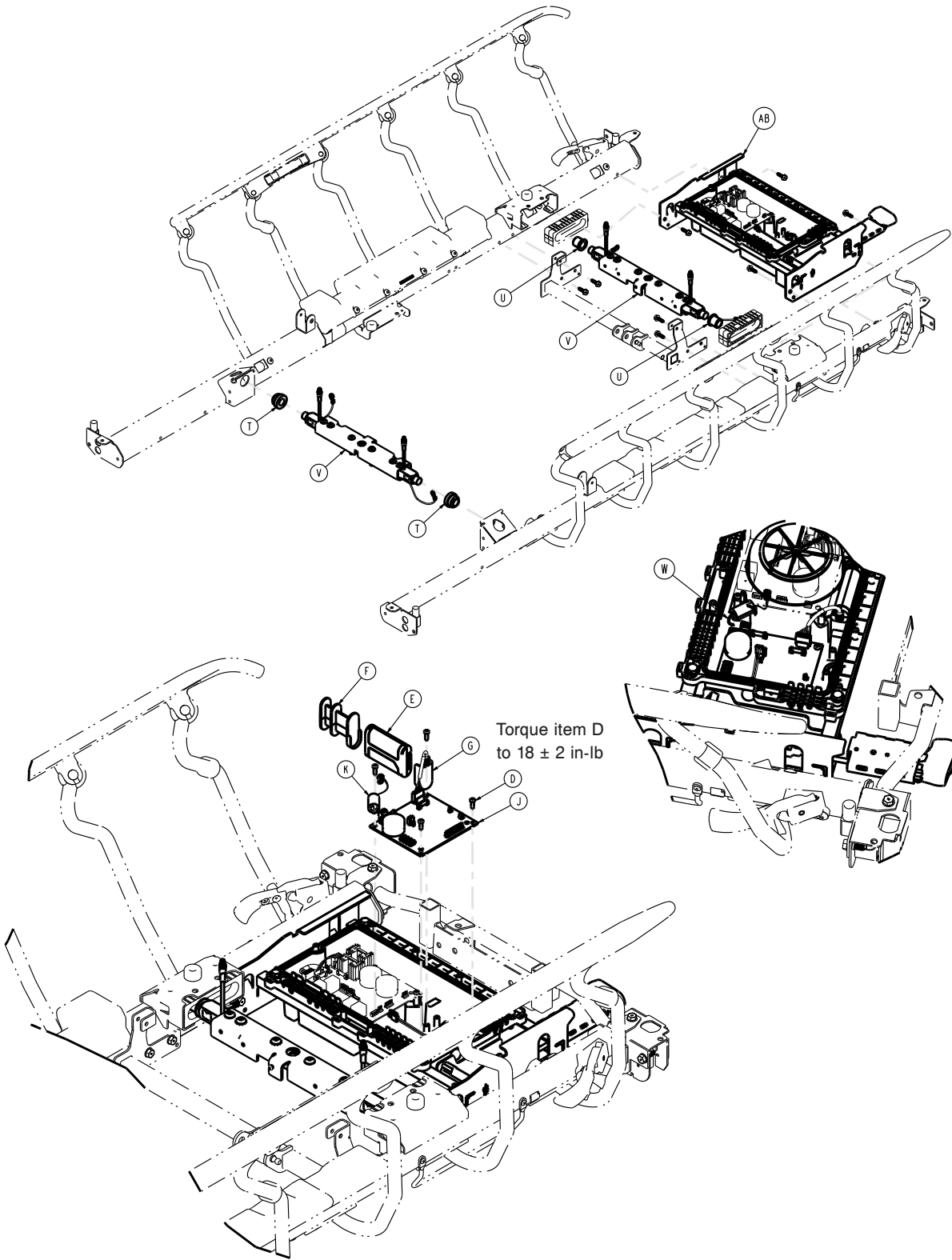

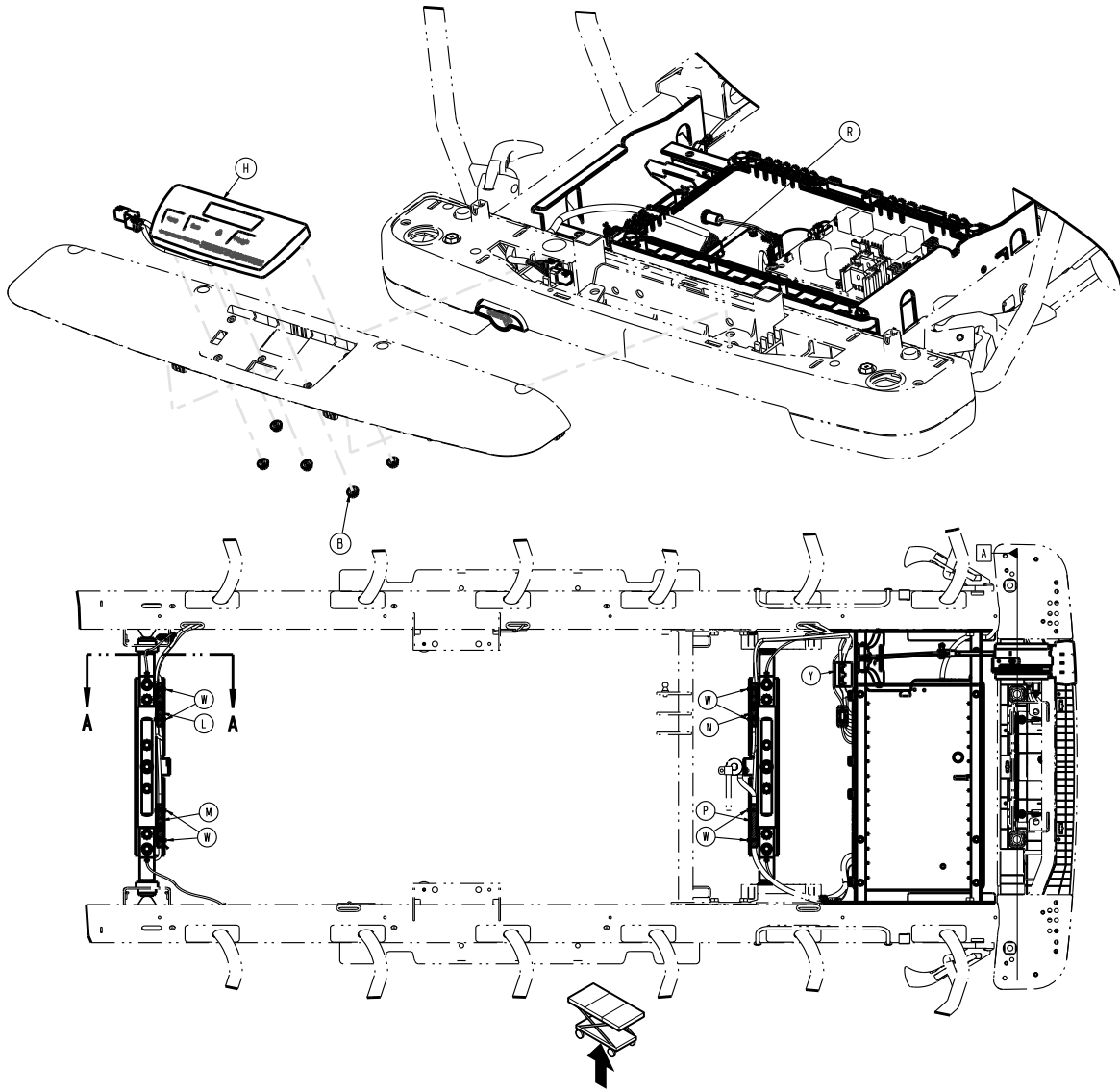

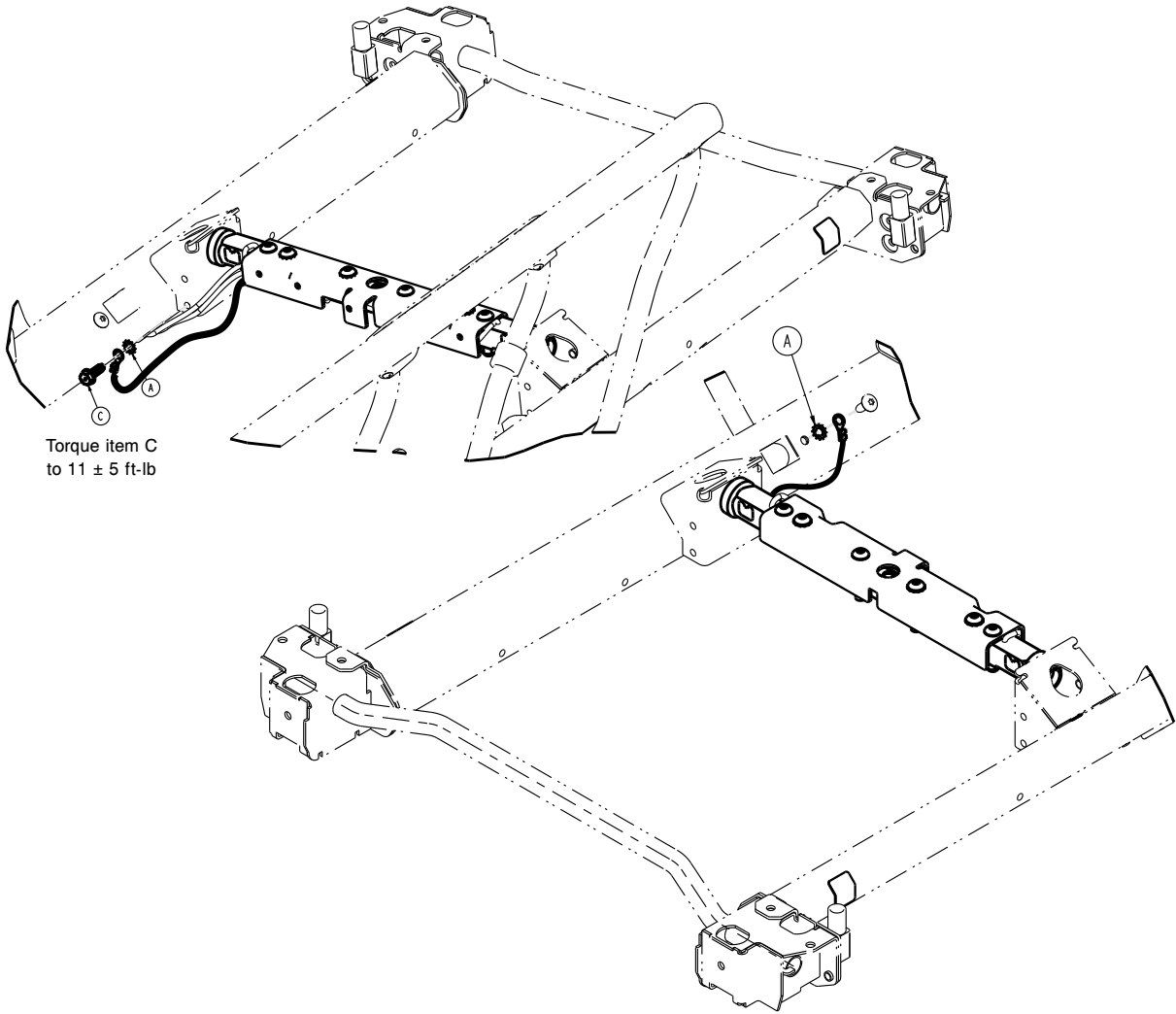

Torque item C
to 11 ± 5 ft-lb

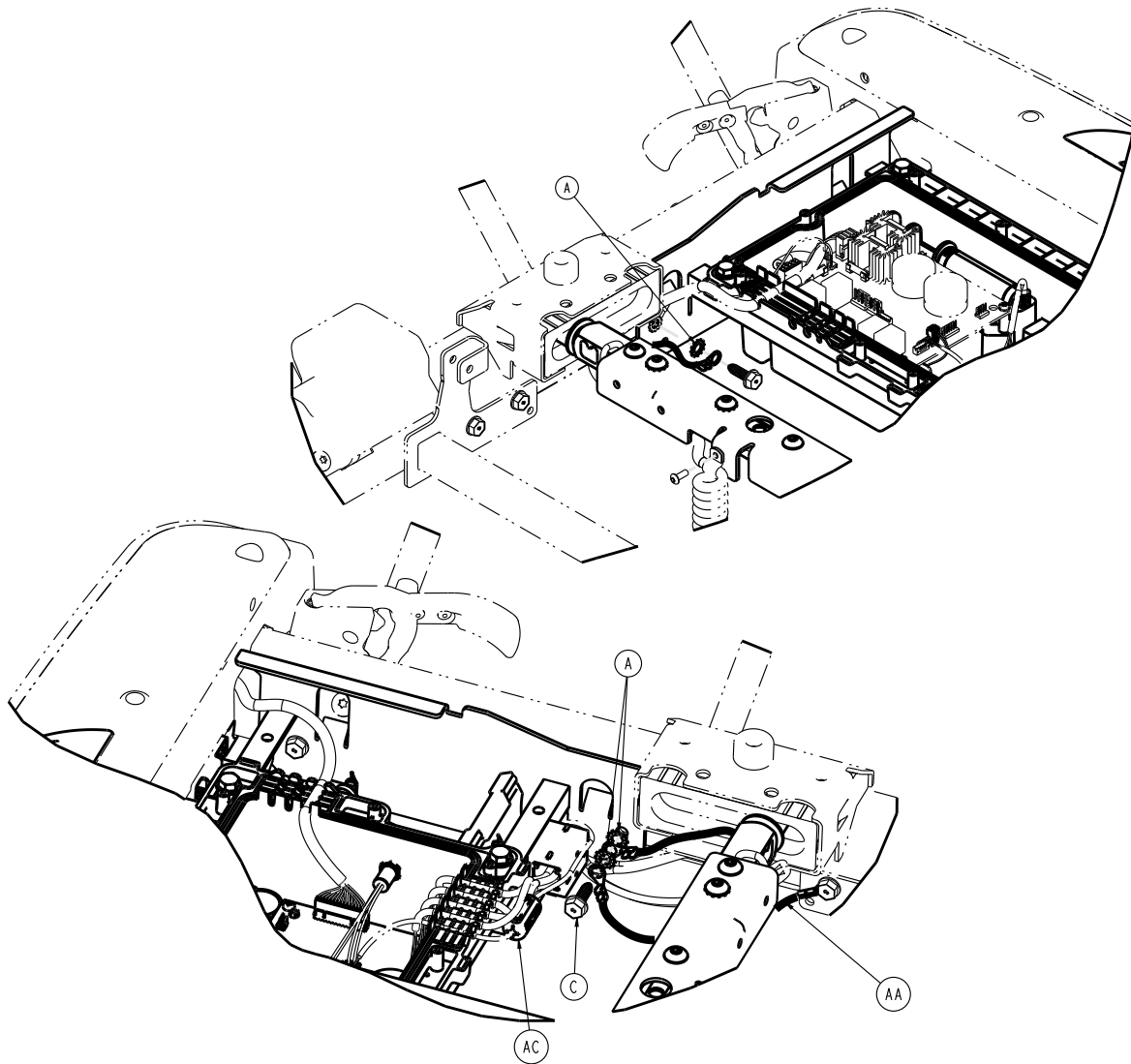

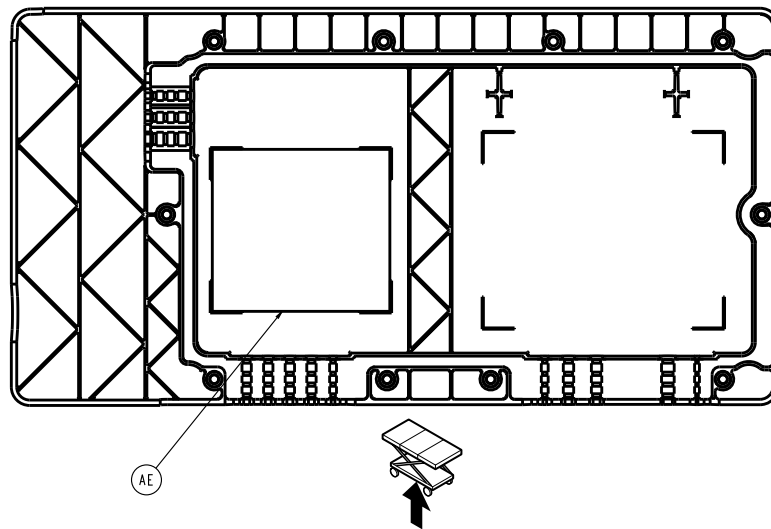
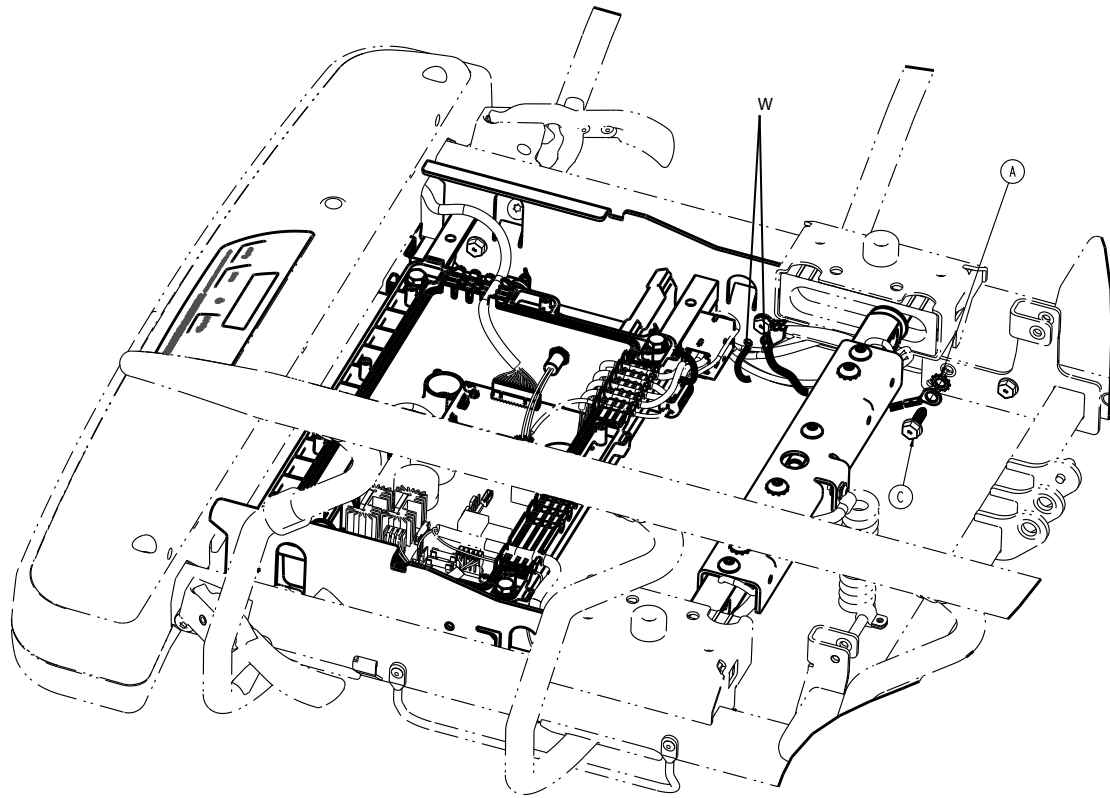

Item	Number	Name	Quantity
A	0013-038-000	External tooth lock washer	6
B	0016-137-000	Hex flange nut	5
C	0023-288-000	Hex washer head screw	1
D	0023-318-000	Pan head tapping screw	4
E	0058-135-000	Li-ion smart battery pack	1
F	1008-010-106	Battery spacer	1
G	1008-010-118	Battery cable	1
H	1008-037-810	Scale control backlit keypad assembly	1
J	1008-237-850	Scale control assembly	1
K	1008-037-806	Scale/Chaperone power cable	1

Item	Number	Name	Quantity
L	1008-137-861	Load cell extension cable, head end, right	1
M	1008-137-862	Load cell extension cable, head end, left	1
N	1008-137-863	Load cell extension cable, foot end, right	1
P	1008-137-864	Load cell extension cable, foot end, left	1
R	1008-037-870	Scale/Chaperone cable	1
T	1070-117-011	Scale bushing, head end	2
U	1070-117-012	Scale bushing, foot end	2
V	1070-037-300	30" scale lifthead (page 333)	2
W	3000-300-113	8" cable tie	9
Y	0034-317-000	Broadband split/snap-on ferrite	1
AA	1040-010-827	Load cell ground cable	1
AB	1008-014-520	Scale control box assembly (page 314)	1
AC	0034-500-000	Round cable snap-its ferrite	1
AD	1008-010-009	Label, lithium ion battery	1
AE	1008-037-844	Label, scale/Chaperone schematic	1

Scale control box assembly

1008-014-520 Rev B (Reference only)

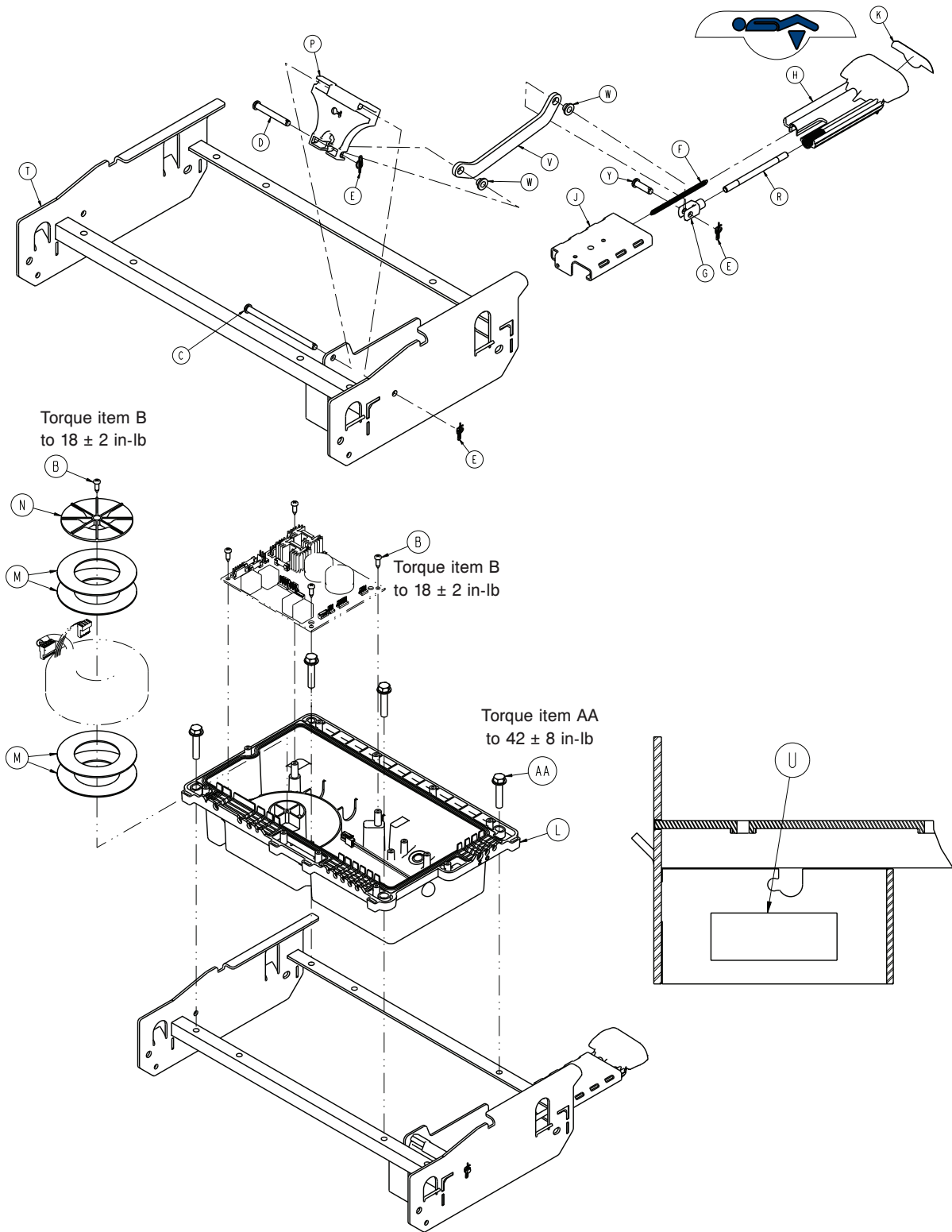

Item	Number	Name	Quantity
B	0023-318-000	Pan head tapping screw	5
C	0026-223-000	Clevis pin	1

Item	Number	Name	Quantity
D	0026-330-000	Clevis pin	1
E	0027-020-000	Rue ring cotter	3
F	0038-603-000	Extension spring	1
G	0052-909-000	Clevis joint	1
H	0785-210-351	30" Gatch release handle	1
J	0785-210-352	30" Gatch release guide	1
K	0785-210-353	Label, Gatch release	1
L	1008-014-510	Scale control box bottom assembly	1
M	1008-010-107	Torroid gasket	4
N	1008-010-108	Torroid hold down	1
P	1008-014-321	Gatch release	1
R	1008-114-322	Gatch release pull rod	1
T	1008-014-325	Control box weldment	1
U	7900-001-291	Foam tape (2 in. length)	0.17 ft
V	1008-014-313	Flat link	1
W	0052-718-000	Nylon insulator	2
Y	0026-295-000	Clevis pin	1
AA	0023-160-000	Hex washer head screw	4

Scale/Chaperone litter assembly option, electric litter

1070-010-200 Rev J (Reference only)

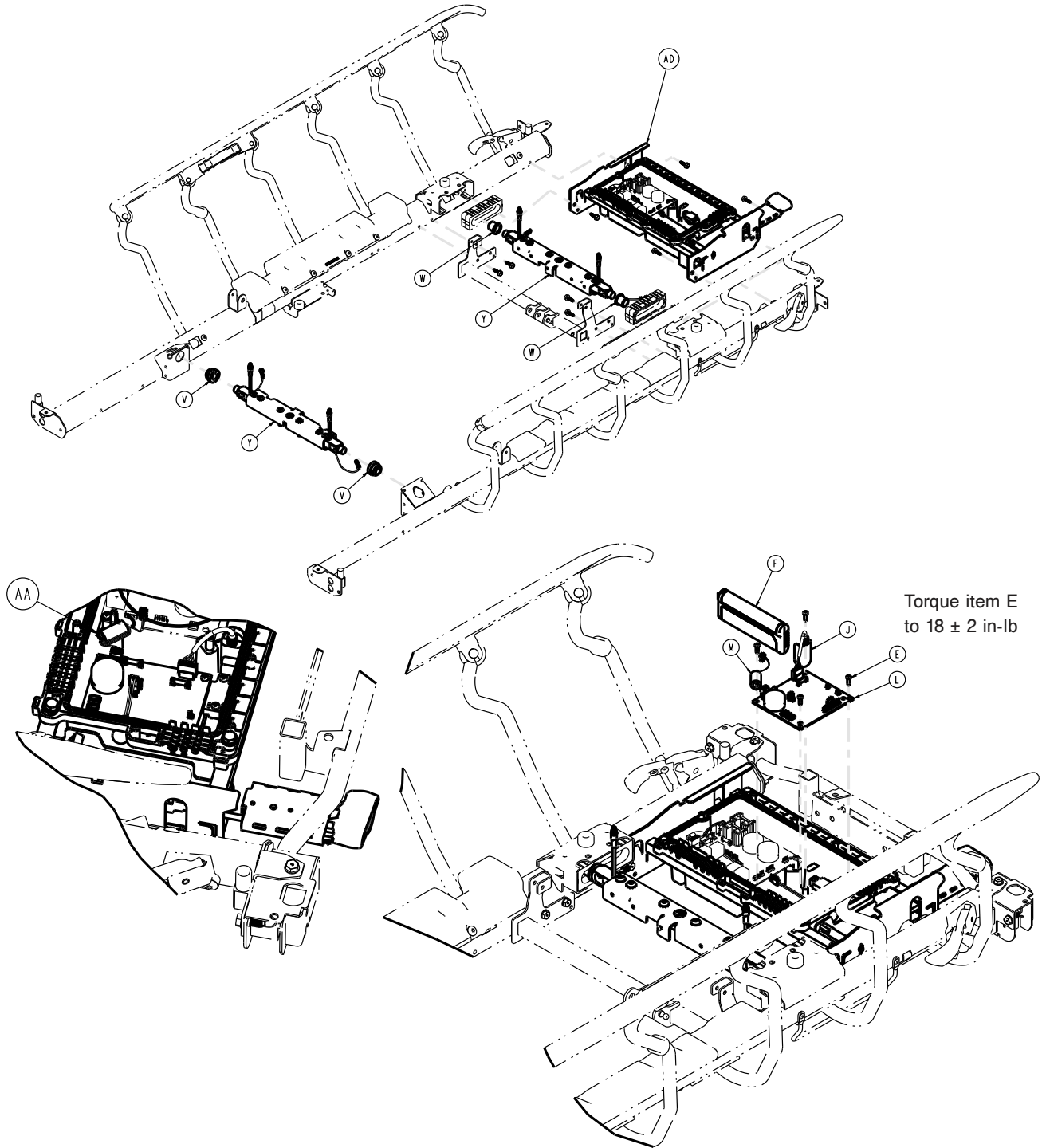

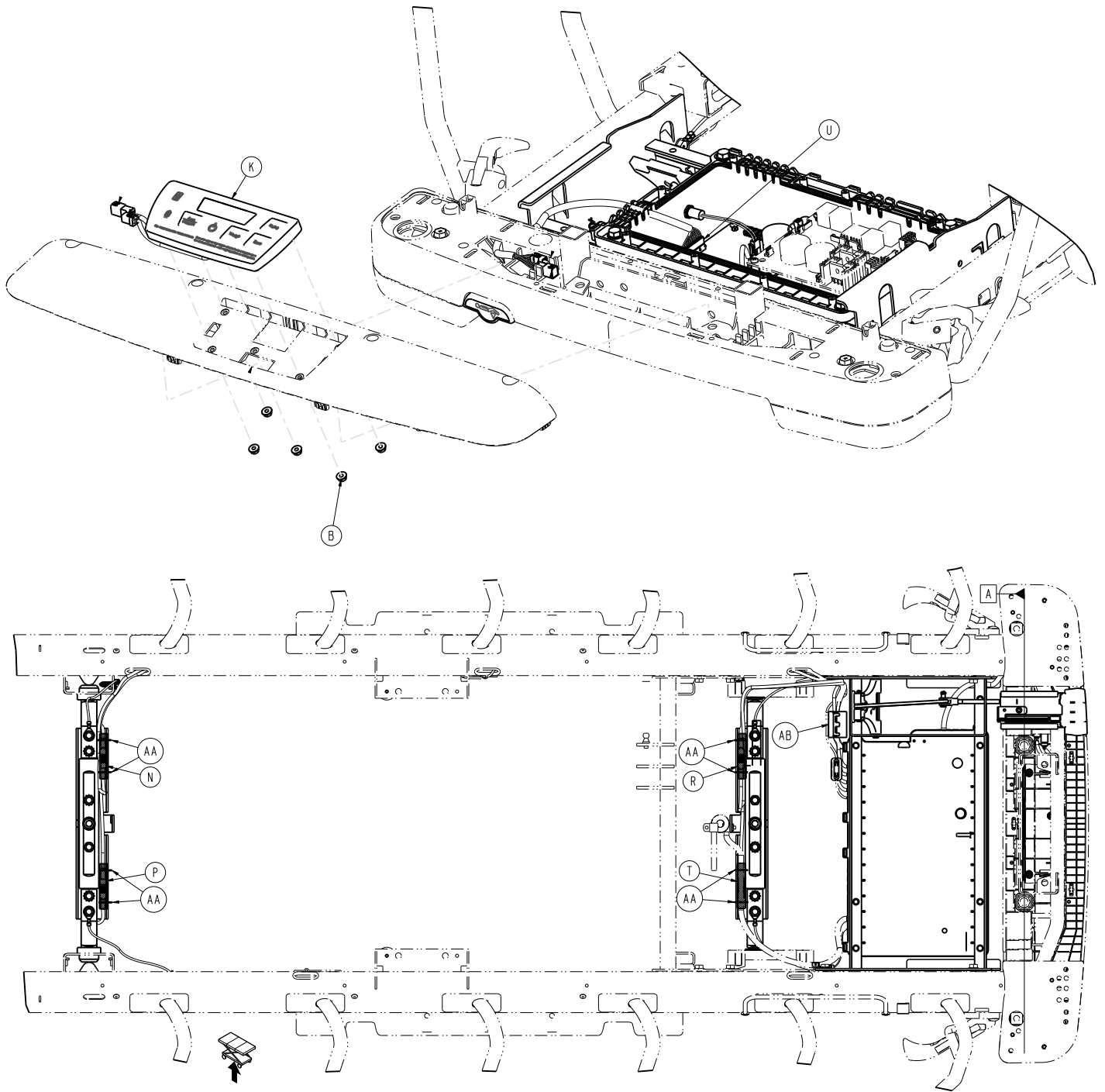

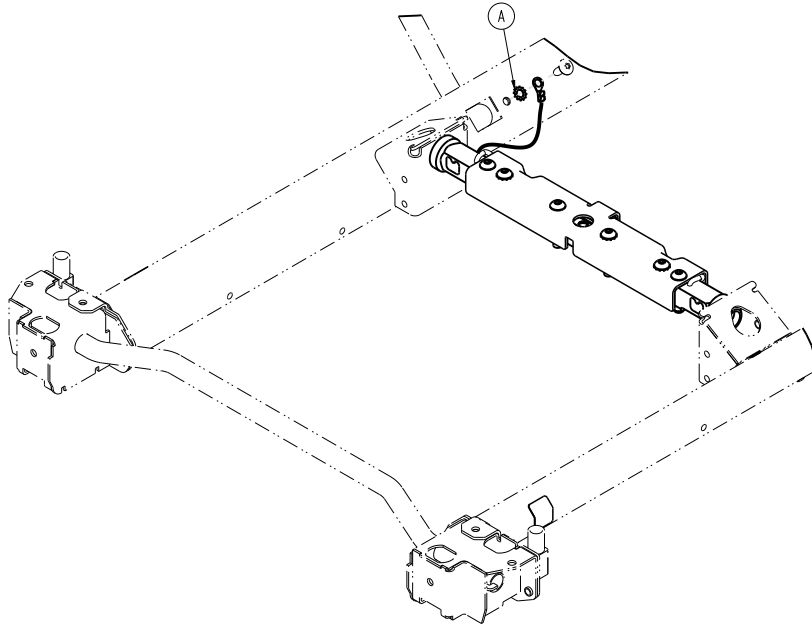
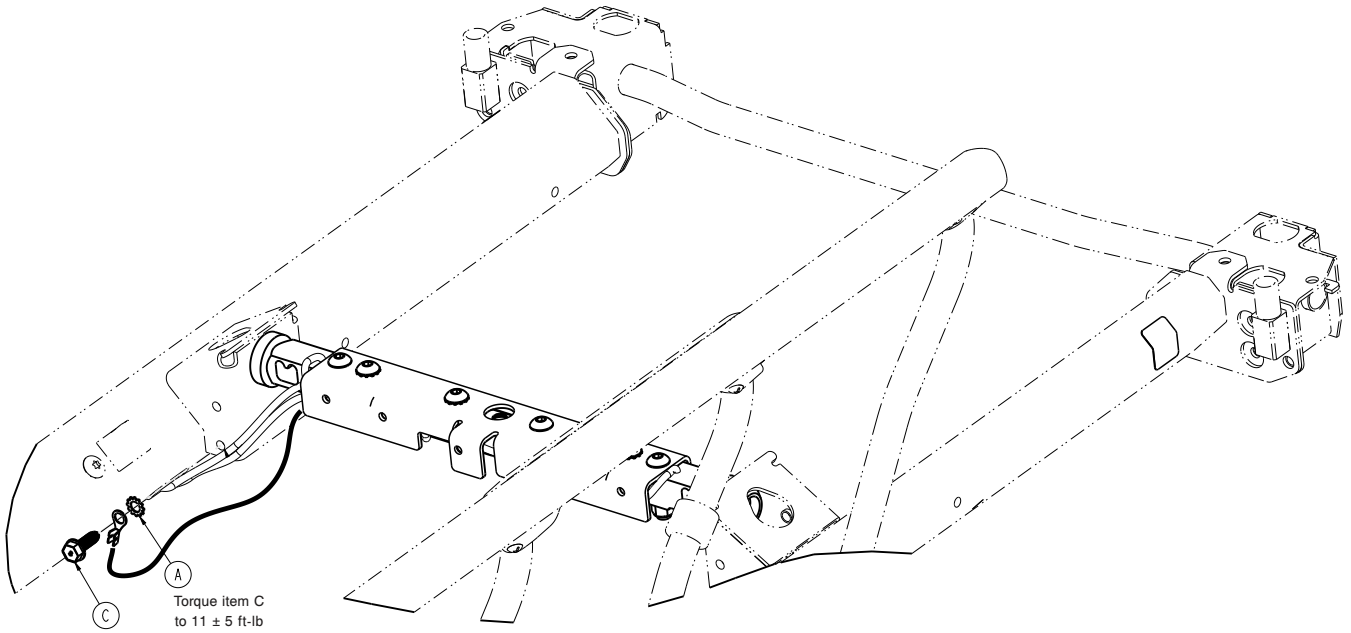

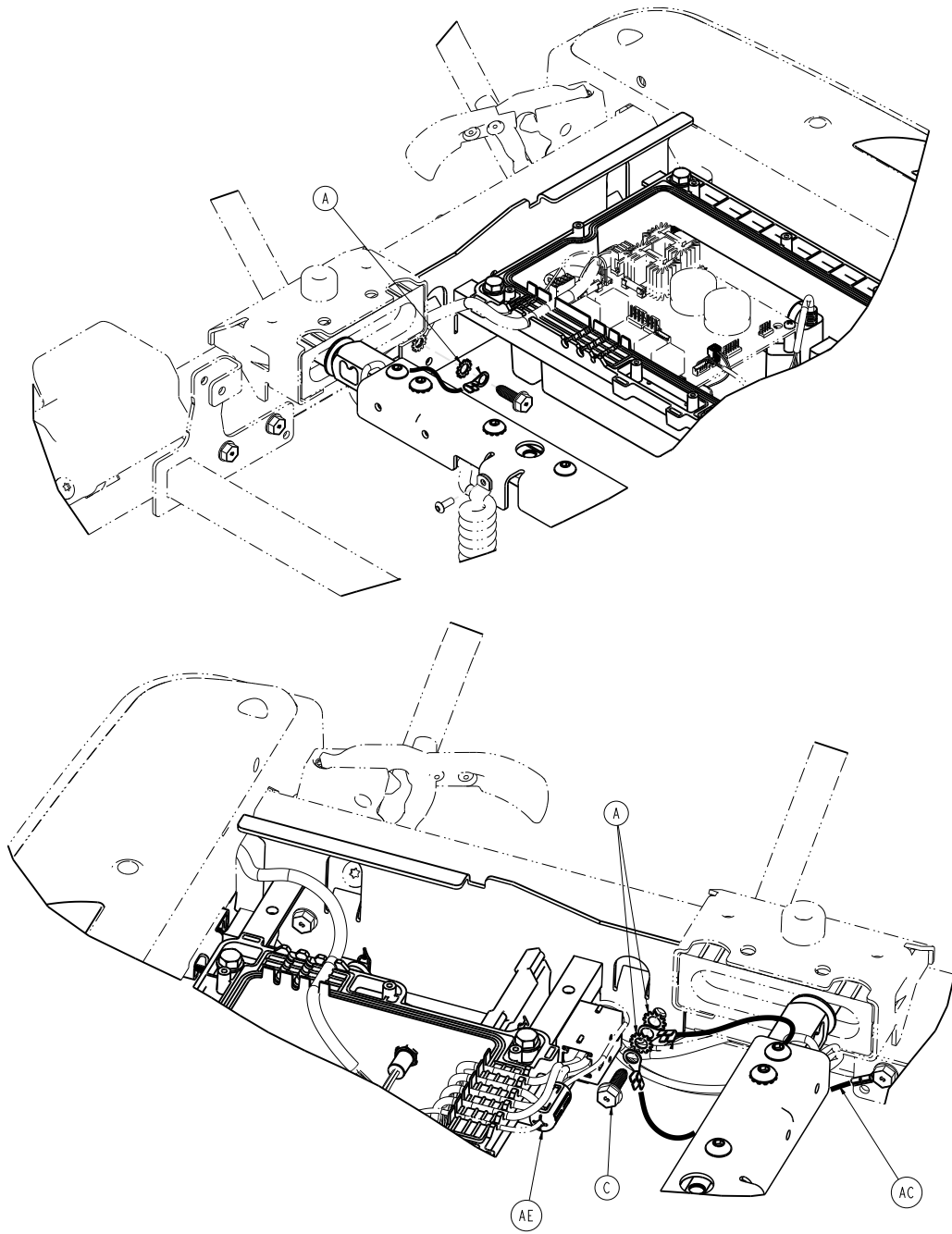

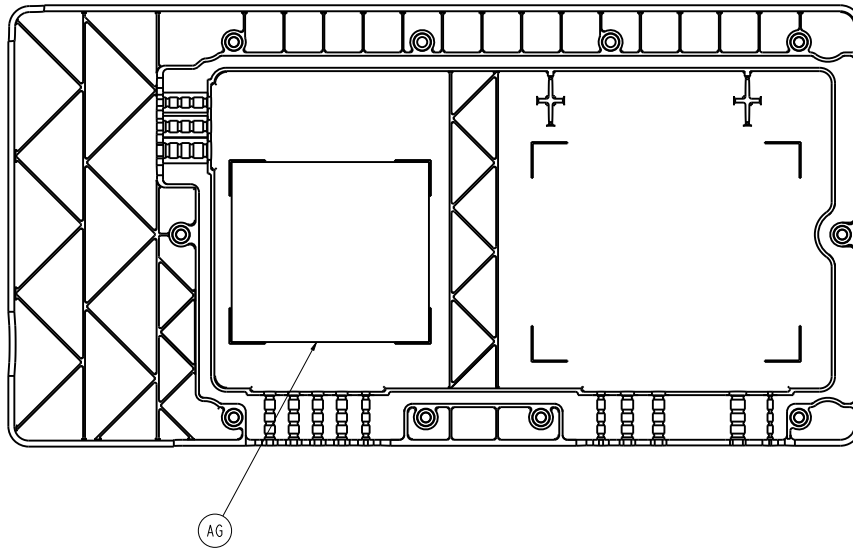
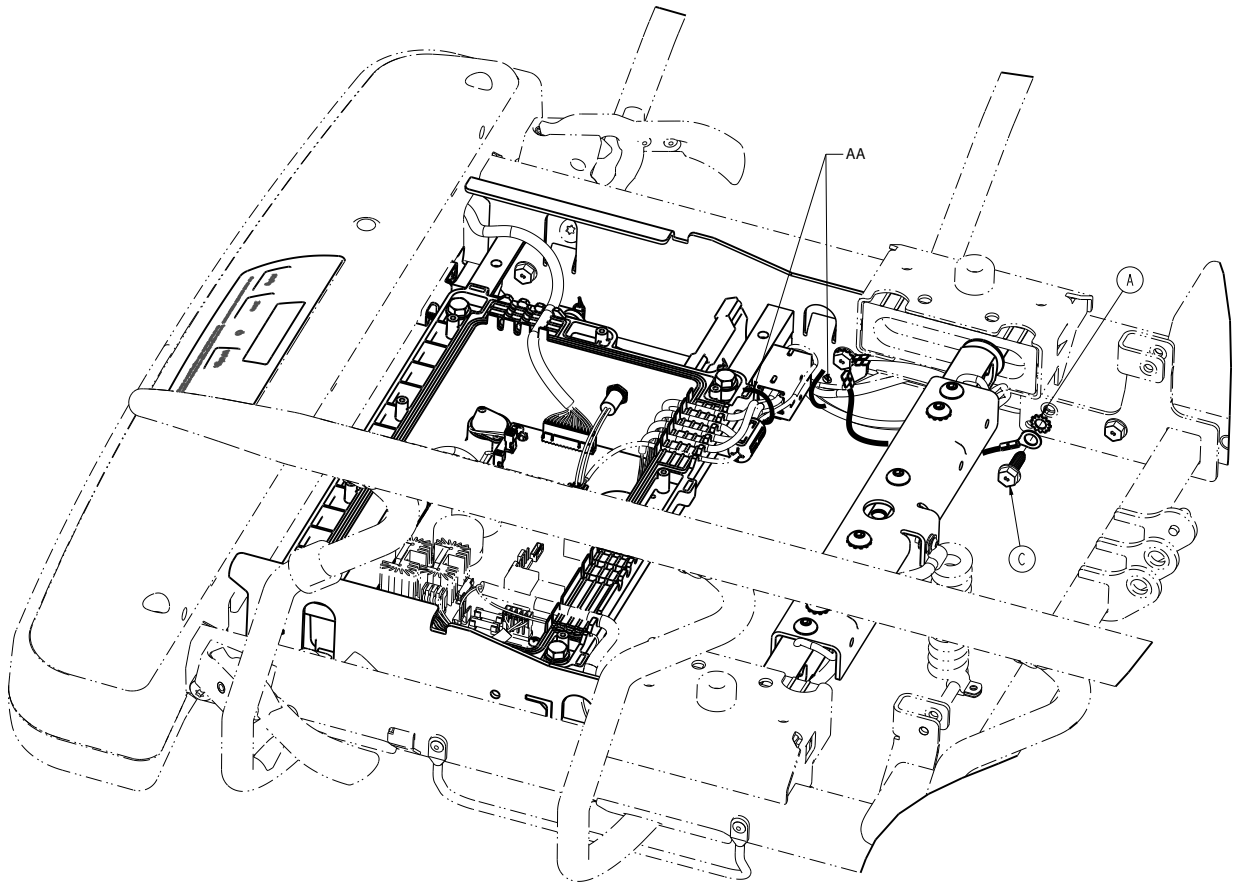

Item	Number	Name	Quantity
A	0013-038-000	External tooth lock washer	6
B	0016-137-000	Hex flange nut	5
C	0023-288-000	Hex washer head screw	1
E	0023-318-000	Pan head tapping screw	4
F	0058-134-000	Li-ion smart battery pack	1
J	1008-010-118	Battery cable	1
K	1008-037-800	Scale/Chaperone keypad assembly	1
L	1008-237-840	Scale/Chaperone control assembly	1

Item	Number	Name	Quantity
M	1008-037-806	Scale/Chaperone power cable	1
N	1008-137-861	Load cell extension cable, head end, right	1
P	1008-137-862	Load cell extension cable, head end, left	1
R	1008-137-863	Load cell extension cable, foot end, right	1
T	1008-137-864	Load cell extension cable, foot end, left	1
U	1008-037-870	Scale/Chaperone cable	1
V	1070-117-011	Scale bushing, head end	2
W	1070-117-012	Scale bushing, foot end	2
Y	1070-037-300	30" scale lifthead (page 333)	2
AA	3000-300-113	8" cable tie	9
AB	0034-317-000	Broadband split/snap-on ferrite	1
AC	1040-010-827	Load cell ground cable	1
AD	1008-014-420	Scale/Chaperone control box assembly (page 334)	1
AE	0034-500-000	Round cable snap-its ferrite	1
AF	1008-010-009	Label, lithium ion battery	1
AG	1008-037-844	Label, scale/Chaperone schematic	1

Connected litter assembly, Prime Connect

107000100300 Rev AD (Reference only)

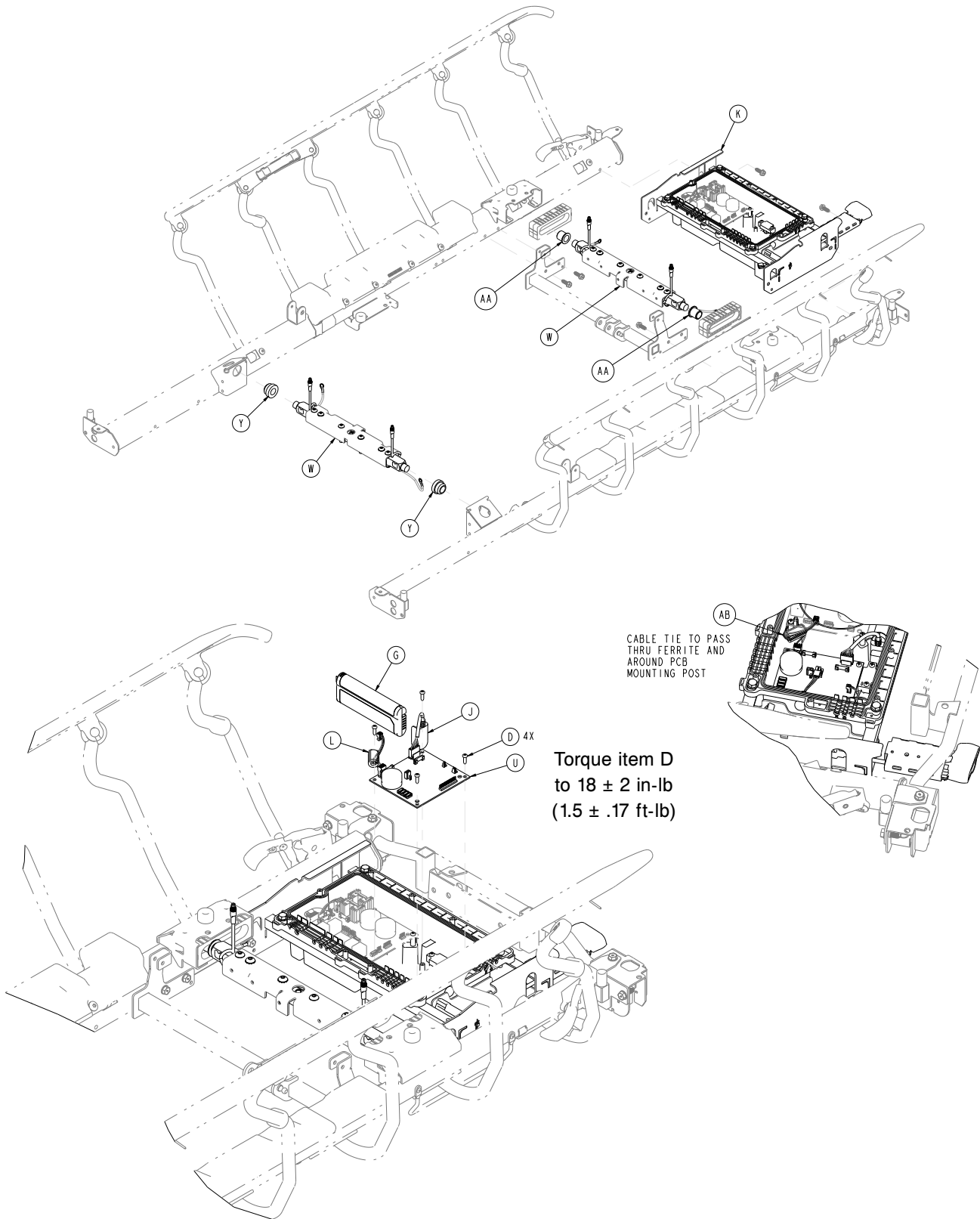

PASS CONNECTORS THRU FOOT END COVER SCALE KEYPAD CABLE ACCESS HOLE, SNAP INTO FOOT END COVER SCALE KEYPAD CONNECTOR SNAP AND PLUG SCALE CHAPERONE CABLE INTO CONNECTORS

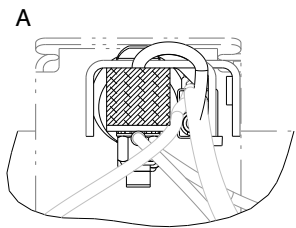
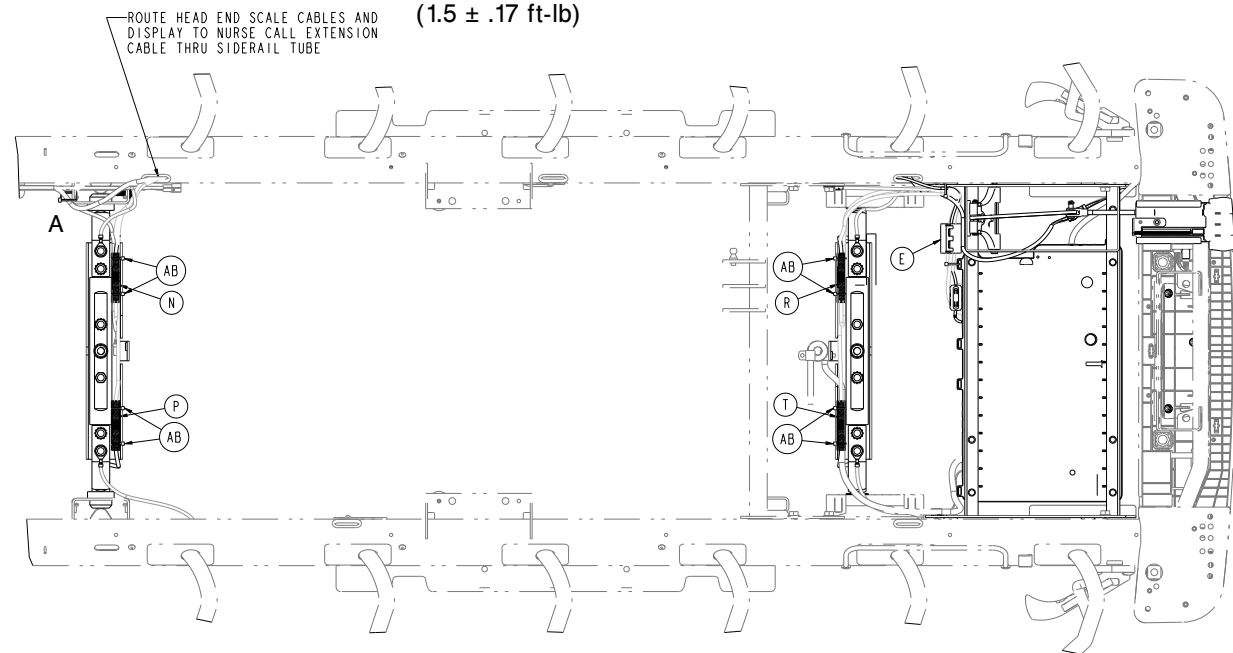
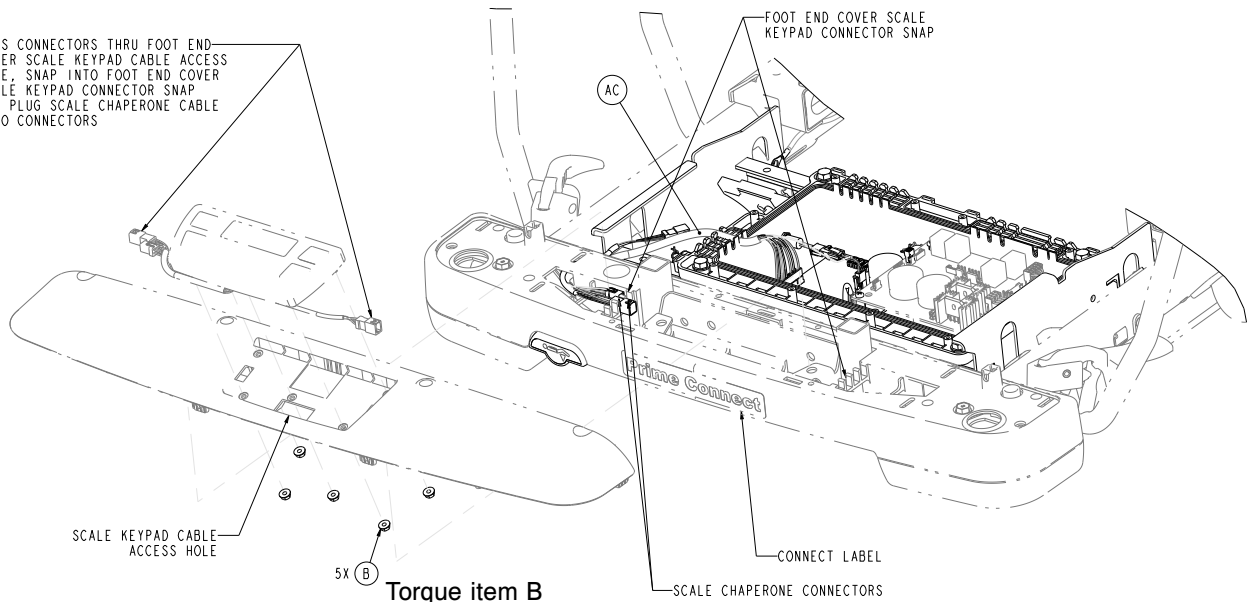

Torque item C
to 11 ± 5 ft-lb
(132 ± 60 in-lb)

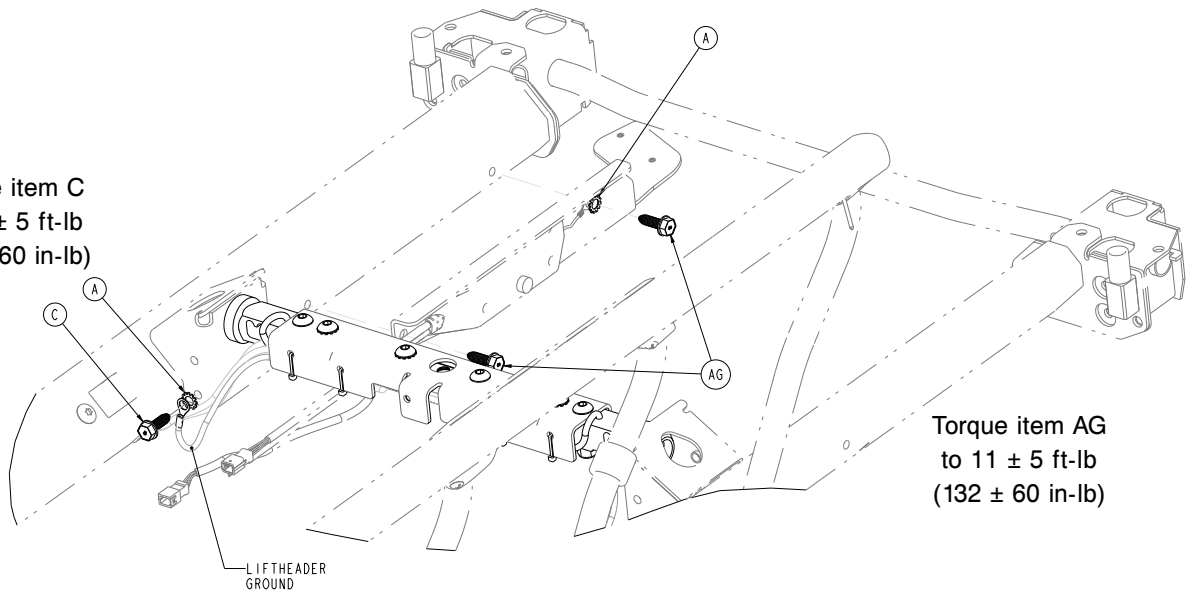

Torque item AG
to 11 ± 5 ft-lb
(132 ± 60 in-lb)

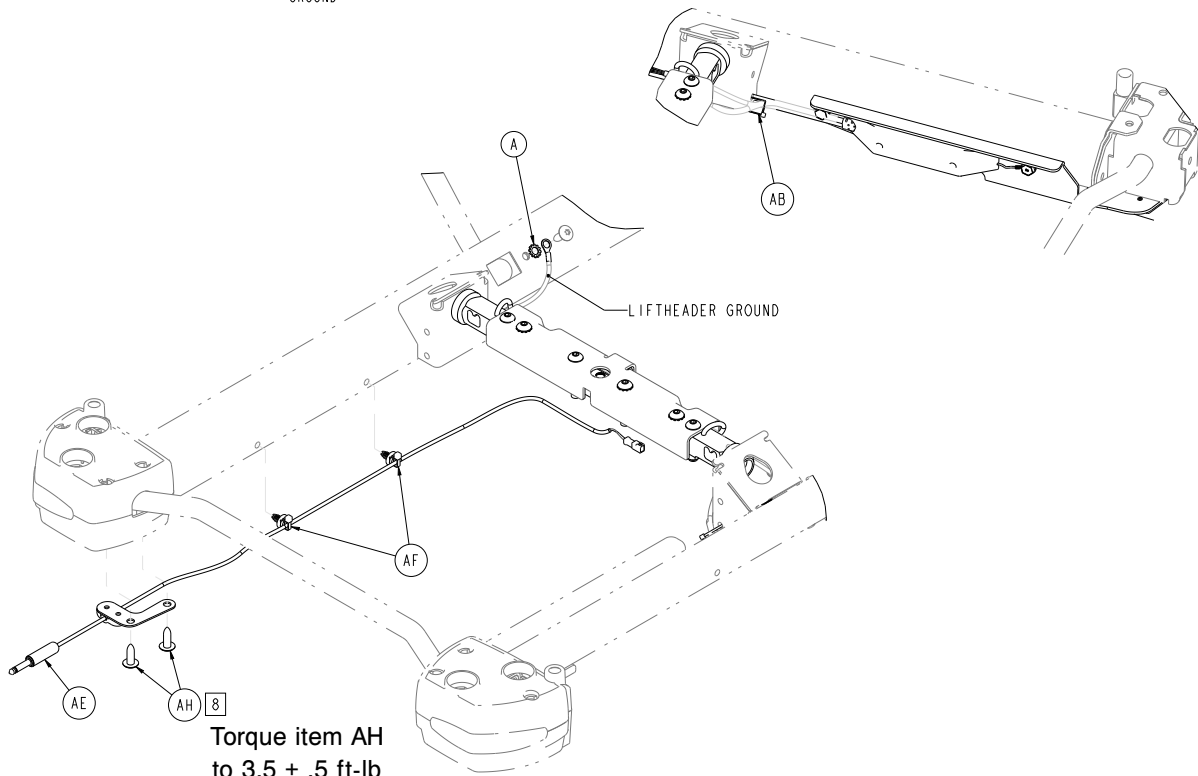

Torque item AH
to $3.5 \pm .5$ ft-lb
(42 ± 6 in-lb)

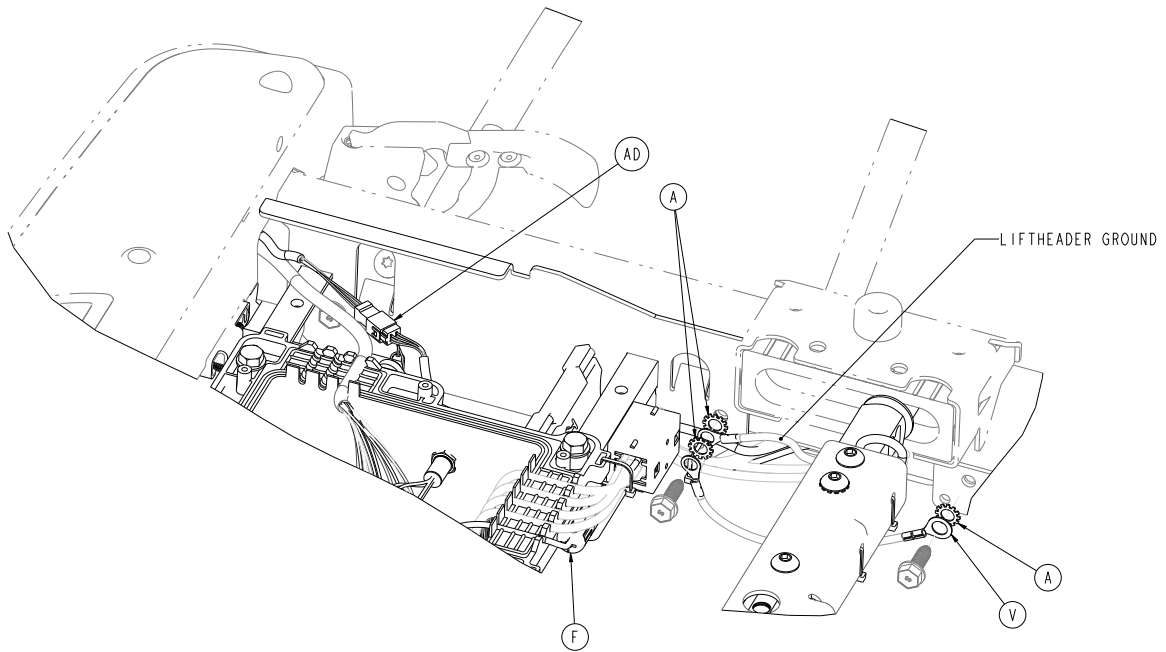
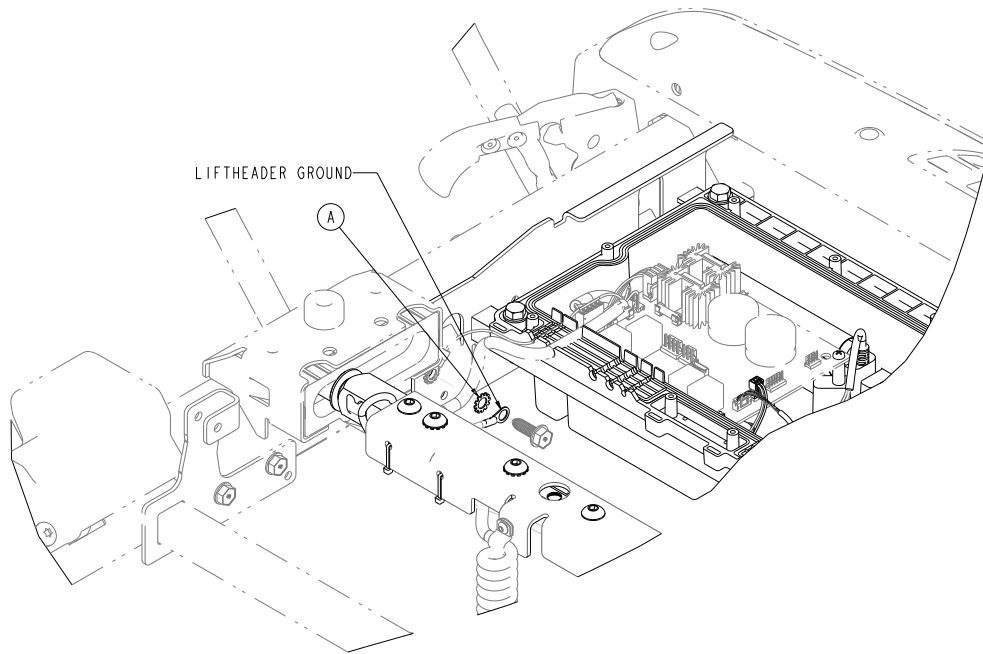

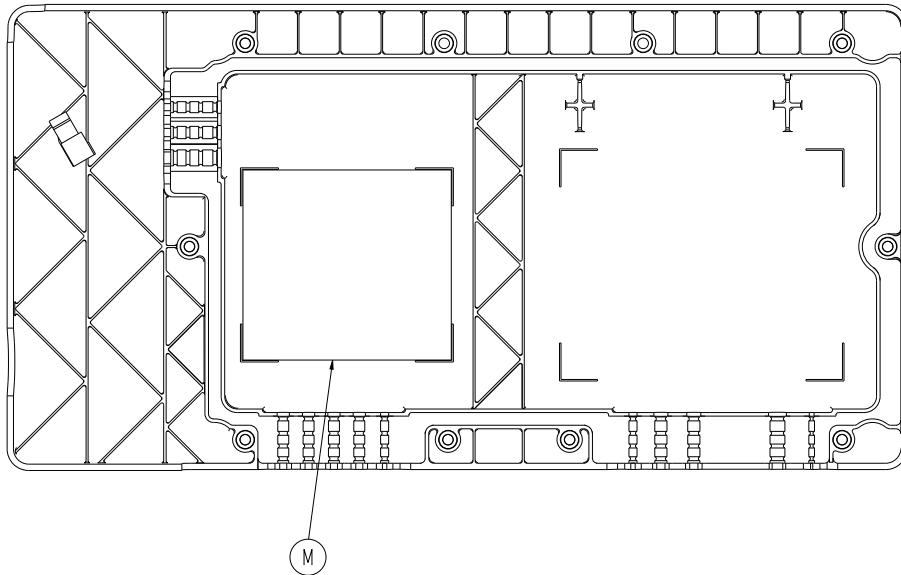
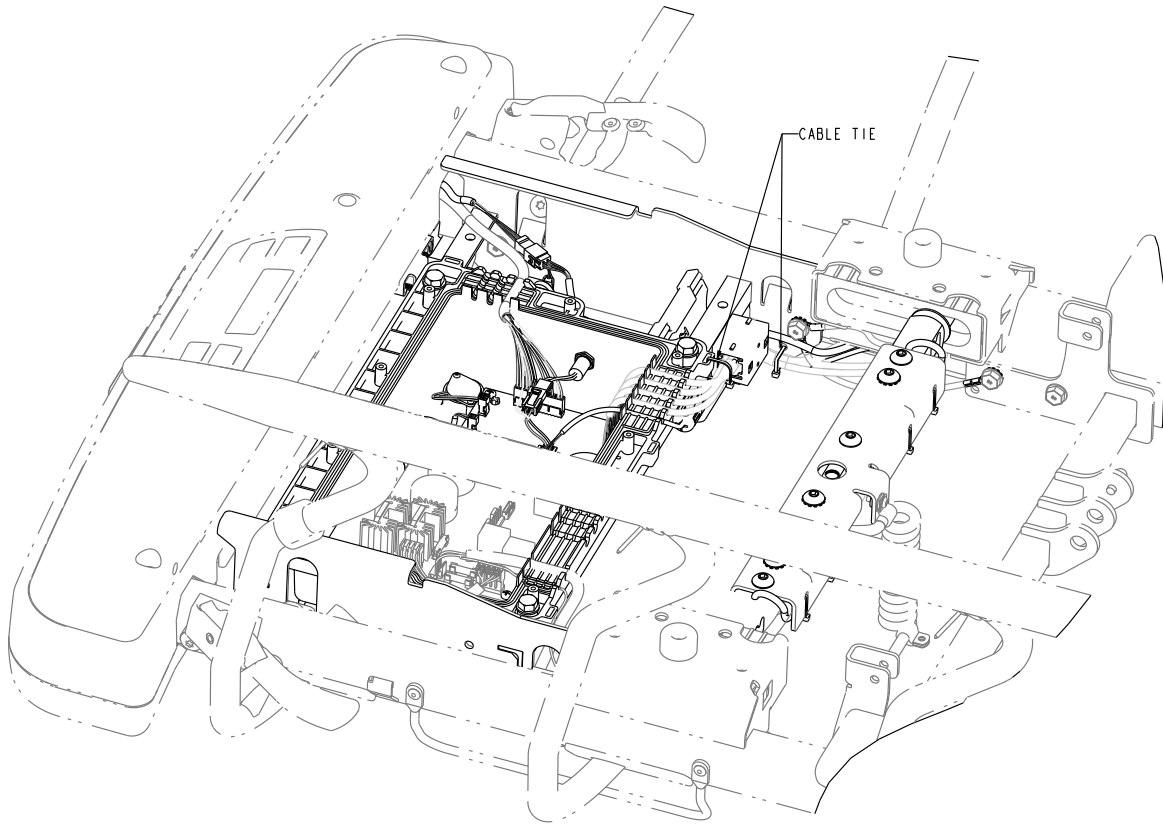

Item	Number	Name	Quantity
A	0013-038-000	External tooth lock washer	7
B	0016-137-000	Hex flange nut	5
C	0023-288-000	Hex washer head screw	1
D	0023-318-000	Pan head tapping screw	4
E	0034-317-000	Broadband split/snap-on ferrite	1
F	0034-500-000	Round cable snap-its ferrite	1
G	0058-134-000	Li-ion smart battery pack	1
H	1008-010-009	Label, lithium ion battery	1

Item	Number	Name	Quantity
J	1008-010-118	Battery cable	1
K	1008-014-420	Scale/Chaperone control box assembly	1
L	1008-037-806	Scale/Chaperone power cable	1
M	1008-037-844	Label, scale/Chaperone schematic	1
N	1008-137-861	Load cell extension cable, head end, right	1
P	1008-137-862	Load cell extension cable, head end, left	1
R	1008-137-863	Load cell extension cable, foot end, right	1
T	1008-137-864	Load cell extension cable, foot end, left	1
U	1008-237-840	Scale, Chaperone control assembly	1
V	1040-010-827	Load cell ground cable	1
W	1070-037-300	30" scale lifthead (page 333)	2
Y	1070-117-011	Scale bushing, head end	2
AA	1070-117-012	Scale bushing, foot end	2
AB	3000-300-113	8" cable tie	10
AC	100800370870	Chaperone to display cable assembly	1
AD	100800380871	Chaperone to display cable assembly	1
AE	100800380876	1/4" jack cable assembly	1
AF	700000816940	Fir tree mount	2
AG	700002647215	Hex washer head thread rolling screw	2
AH	0007-074-000	Truss head machine screw	2

Scales keypad assembly, Prime Connect - 110507000214

100800370800 AE (Reference only)

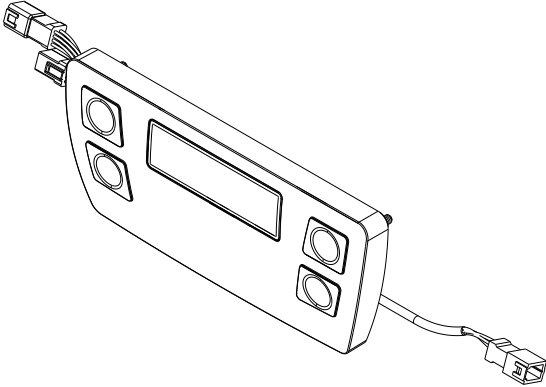

Non-scales keypad assembly, Prime Connect - 110507000215

100800370810 AE (Reference only)

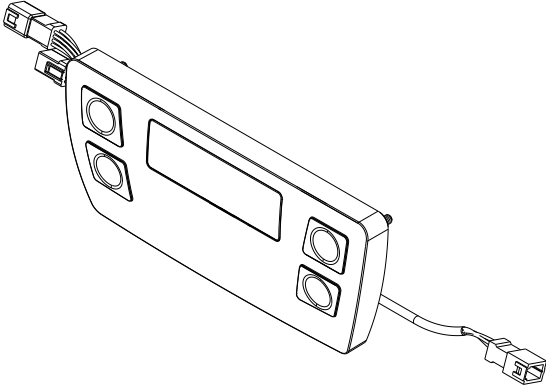

IR/nurse call assembly, NO, Prime Connect - 110507000212

100800380850 Rev AD (Reference only)

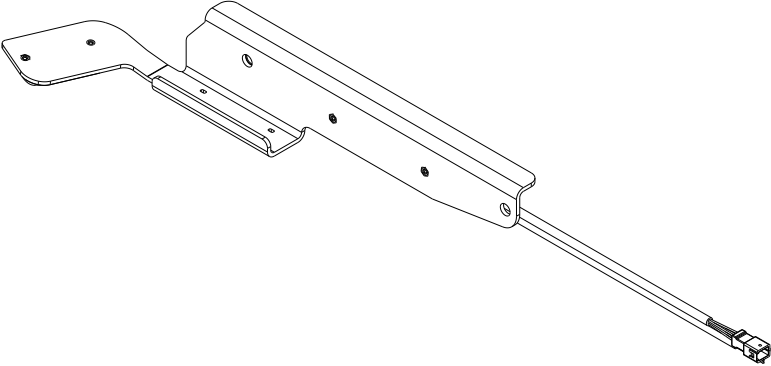

IR/nurse call assembly, NC, Prime Connect - 110507000213

100800380860 Rev AD (Reference only)

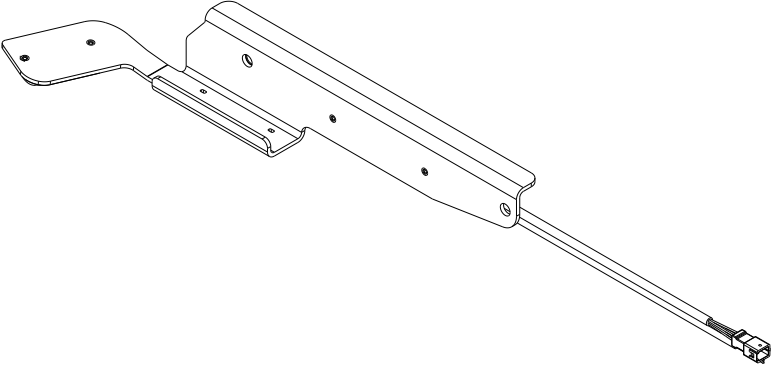

Wi-Fi option, Prime Connect - 110507000219 (US/CAN), 110507000220 (UAE/SA), 110507000221 (AUS/NZ)

100800680010 Rev AB (Reference only)

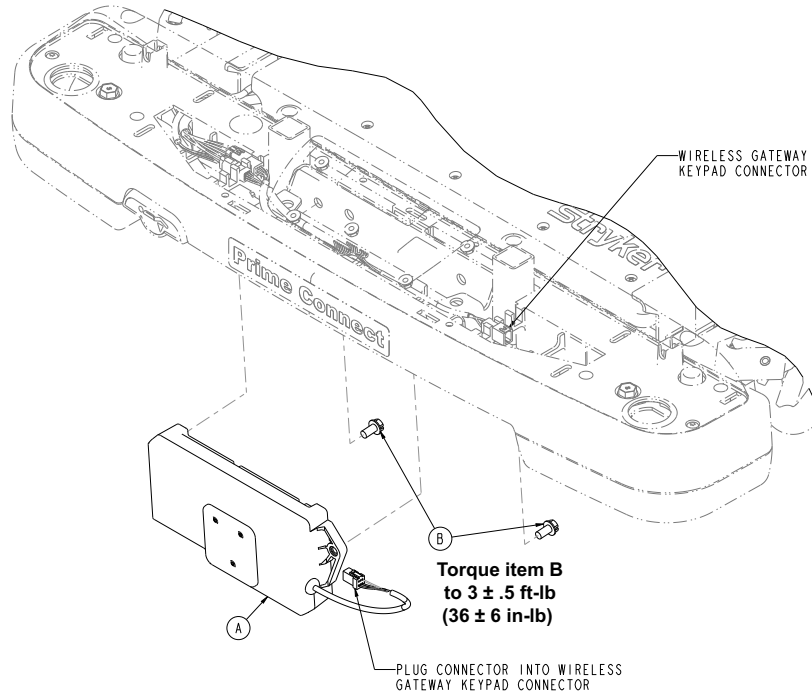

Item	Number	Name	Quantity
A	100800680910	Gateway assembly	1
B	700002459153	Hex washer head machine screw	2

30" scale lifthead

1070-037-300 Rev A (Reference only)

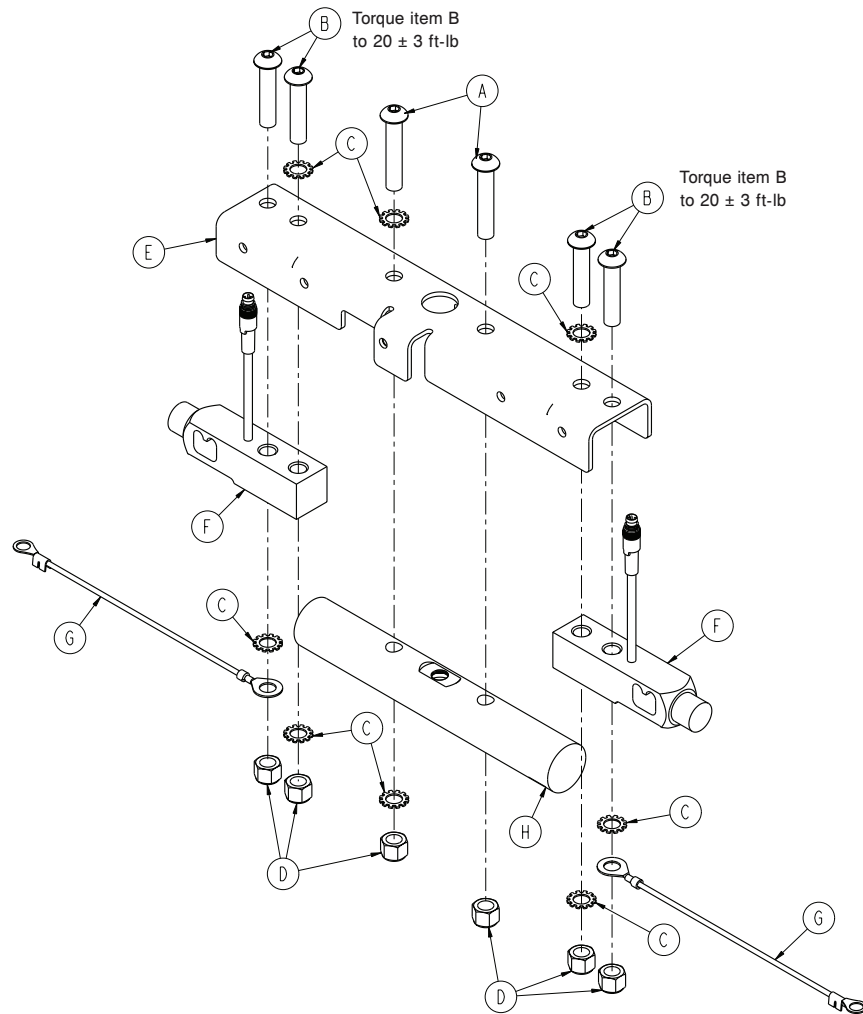

Item	Number	Name	Quantity
A	0004-368-000	Button head cap screw	2
B	0004-462-000	Button head cap screw	4
C	0013-019-000	External tooth lock washer	8
D	0016-035-000	Nylock hex nut	6
E	1008-017-351	30" lifthead bracket, foot end	1
F	1008-037-057	Load cell	2
G	1008-037-871	8" lifthead to litter ground	2
H	1070-017-362	30" lifthead support	1

Scale/Chaperone control box assembly

1008-014-420 Rev C (Reference only)

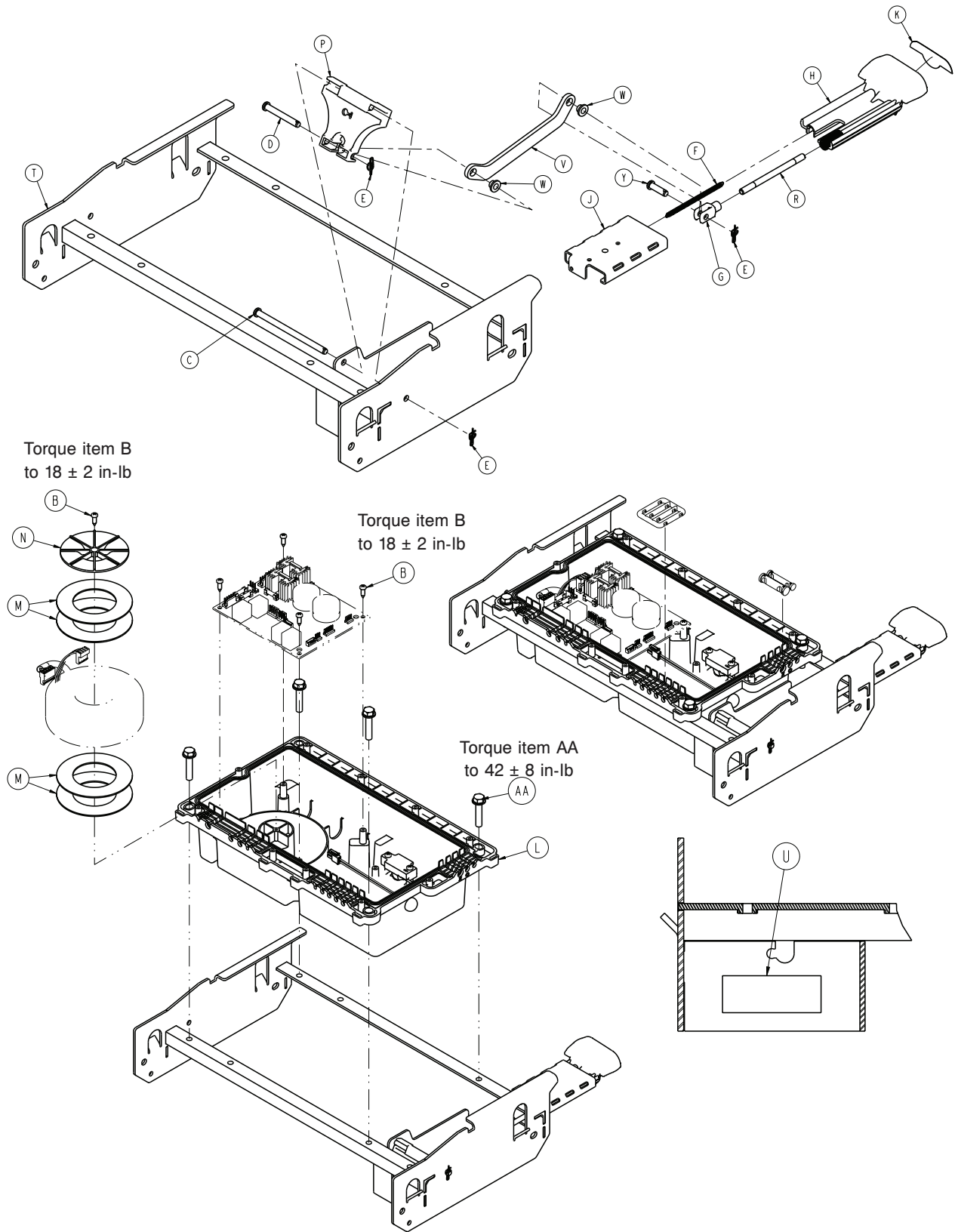

Item	Number	Name	Quantity
B	0023-318-000	Pan head tapping screw	5
C	0026-223-000	Clevis pin	1
D	0026-330-000	Clevis pin	1
E	0027-020-000	Rue ring cotter	3
F	0038-603-000	Extension spring	1
G	0052-909-000	Clevis joint	1
H	0785-210-351	30" Gatch release handle	1
J	0785-210-352	30" Gatch release guide	1
K	0785-210-353	Label, Gatch release	1
L	1008-014-410	<i>Scale/Chaperone control bottom box assembly (page 336)</i>	1
M	1008-010-107	Torroid gasket	4
N	1008-010-108	Torroid hold down	1
P	1008-014-321	Gatch release	1
R	1008-114-322	Gatch release pull rod	1
T	1008-014-325	Control box weldment	1
U	7900-001-291	Foam tape (2 in. length)	.17 ft
V	1008-014-313	Flat link	1
W	0052-718-000	Nylon insulator	2
Y	0026-295-000	Clevis pin	1
AA	0023-160-000	Hex washer head screw	4

Scale/Chaperone control bottom box assembly

1008-014-410 Rev AA (Reference only)

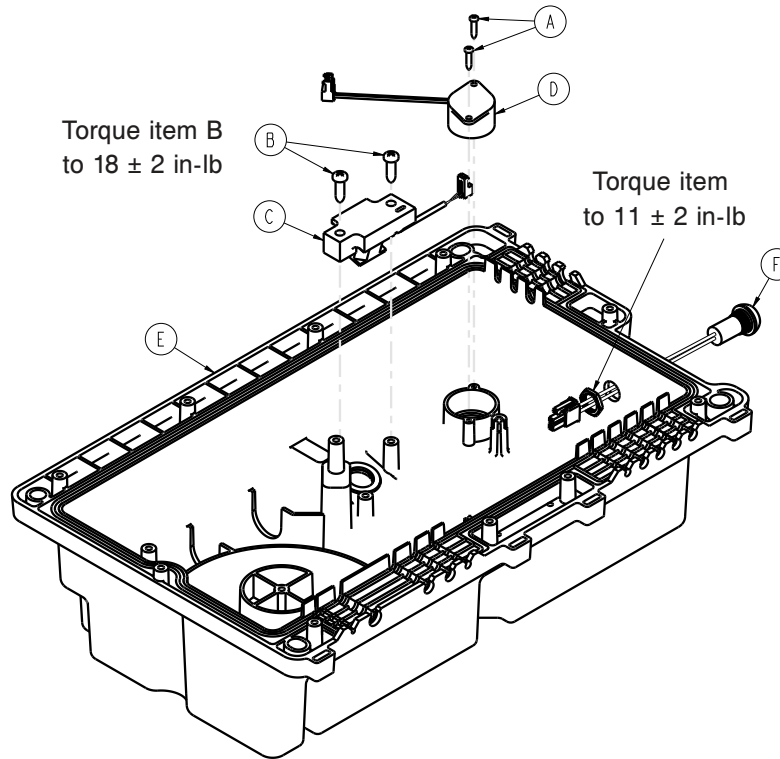

Item	Number	Name	Quantity
A	0023-127-000	Pan head tapping screw	2
B	0023-318-000	Pan head tapping screw	2
C	1008-010-111	Led cable	1
D	1008-010-116	Buzzer cable	1
E	1008-010-205	Scale/ Chaperone litter control box bottom assembly	1
F	1008-010-801	Switch cable	1

Covers assembly, no options, head end

1105-210-060 Rev A (Reference only)

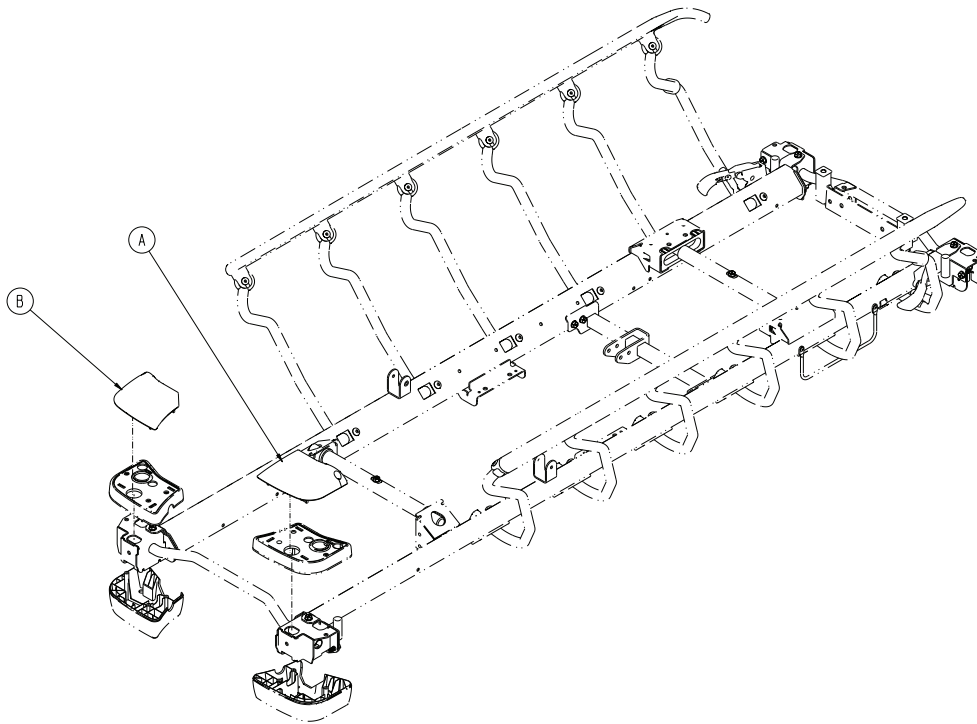

Item	Number	Name	Quantity
A	0785-210-060	Cover, right, head end	1
B	0785-210-070	Cover, left, head end	1

Covers assembly with pop-up push handles, head end - 1105-210-061

Rev A (Reference only)

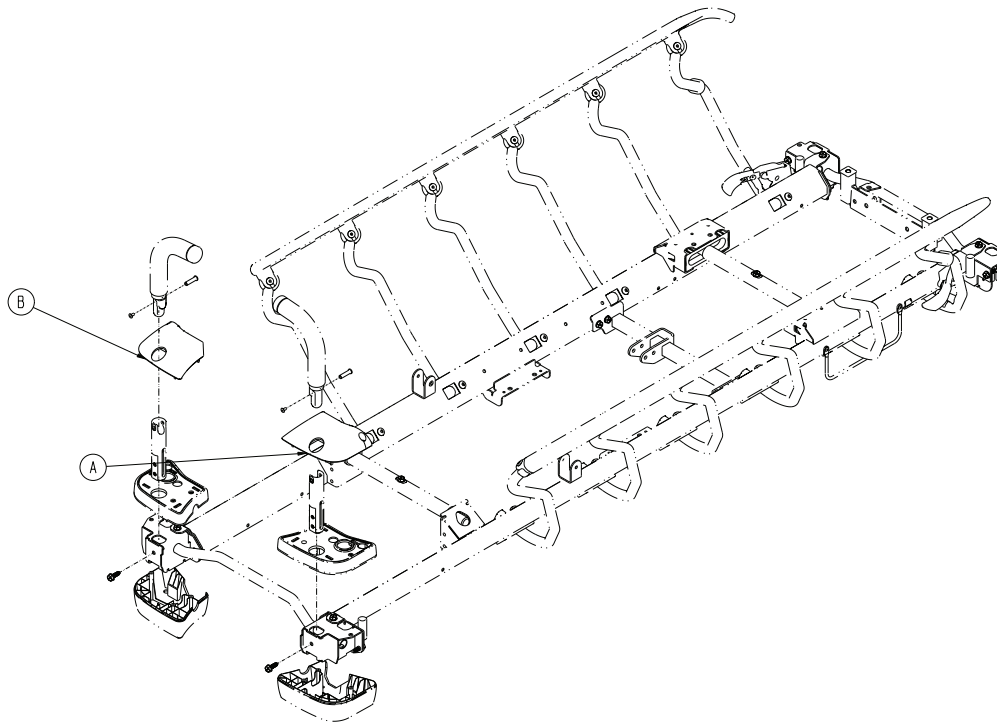

Item	Number	Name	Quantity
A	0785-210-061	Cover, right, head end	1
B	0785-210-071	Cover, left, head end	1

Covers assembly with IV pole, head end - 1105-210-062

Rev C (Reference only)

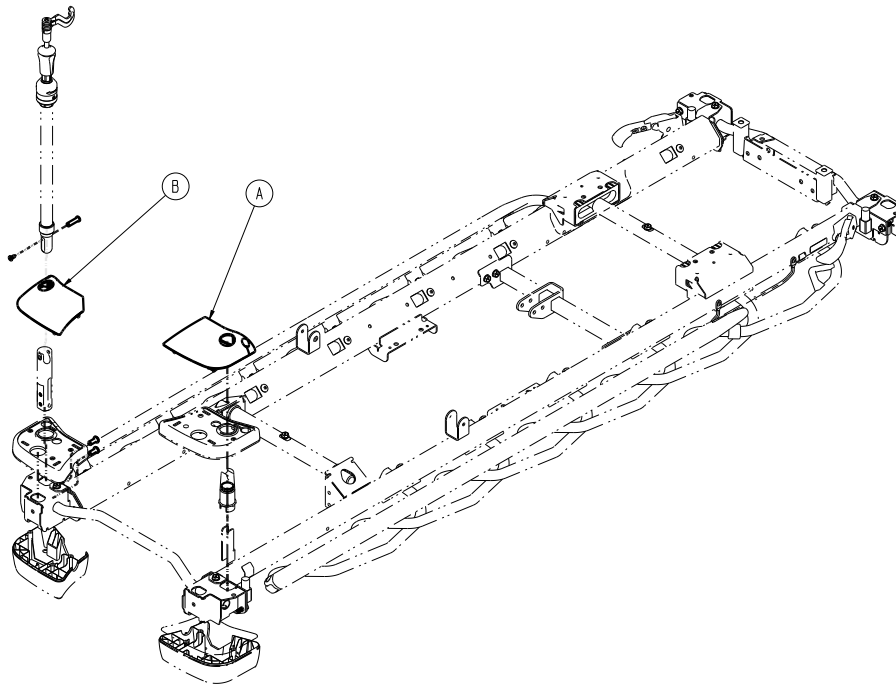

Item	Number	Name	Quantity
A	0785-210-062	Cover, right, head end	1
B	0785-210-072	Cover, left, head end	1

Covers assembly with IV pole and pop-up push handles, head end - 1105-210-063

Rev C (Reference only)

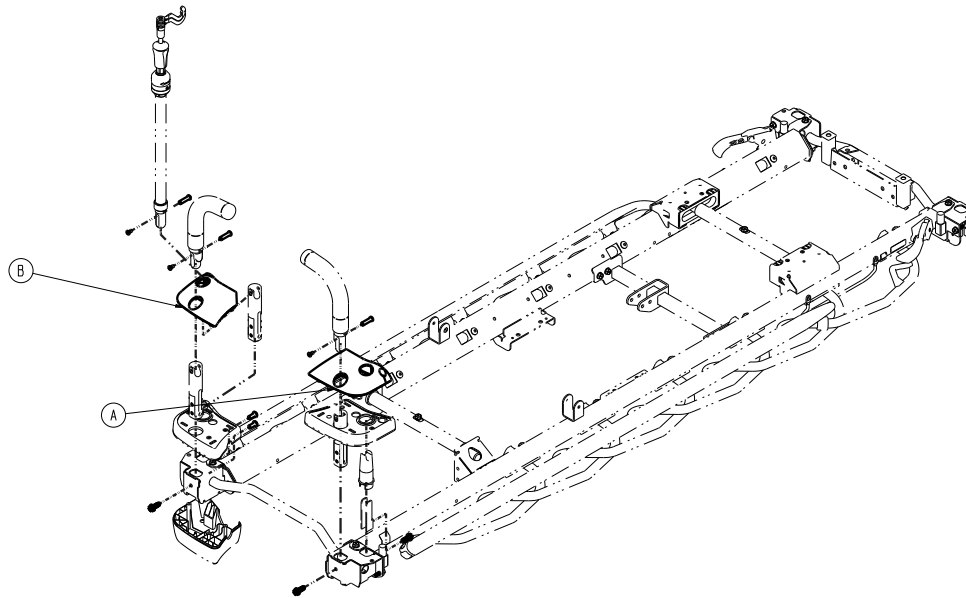

Item	Number	Name	Quantity
A	0785-210-063	Cover, right, head end	1
B	0785-210-073	Cover, left, head end	1

26" top cover assembly, no options, foot end - 1105-210-660

Rev A (Reference only)

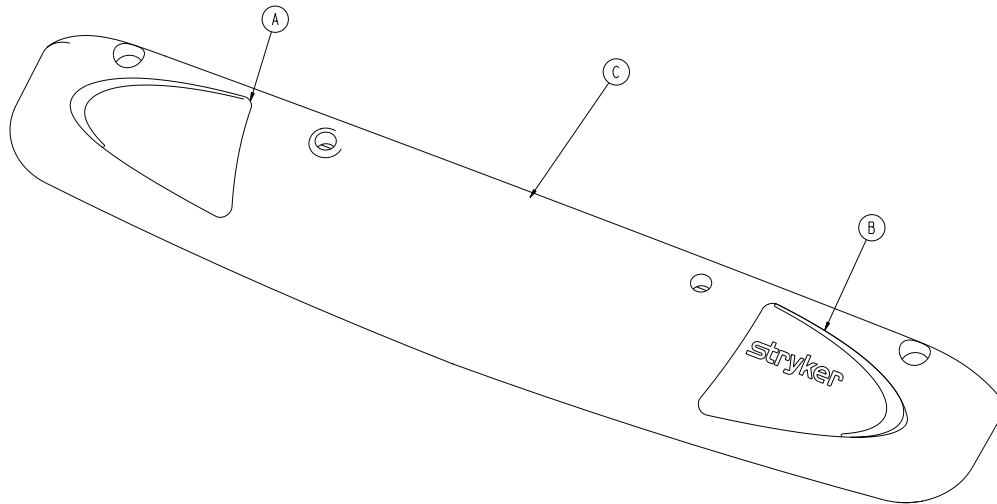

Item	Number	Name	Quantity
A	0785-210-004	Label, 26" accent, right, foot end	1
B	0785-210-005	Label, 26" accent, left, foot end	1
C	0785-210-660	26" cover, foot end	1

30" top cover assembly, no options, foot end - 1105-210-360

Rev A (Reference only)

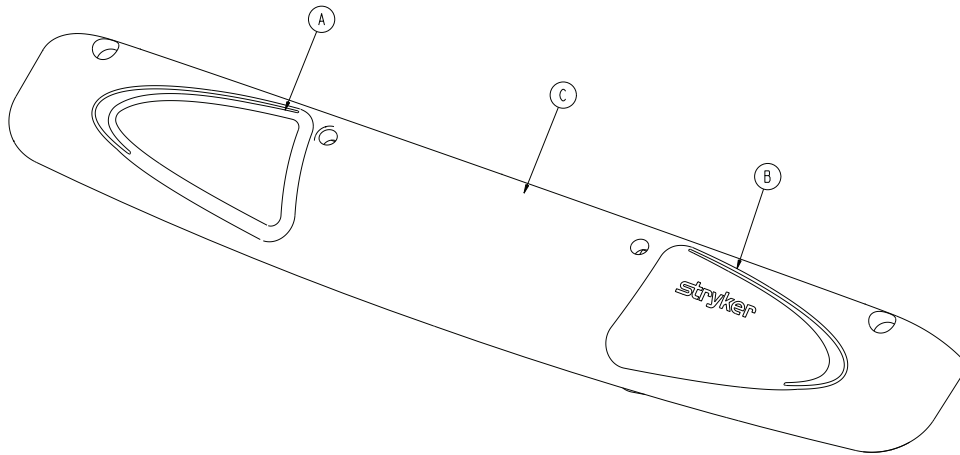

Item	Number	Name	Quantity
A	0785-210-002	Label, accent, right, foot end	1
B	0785-210-003	Label, accent, left, foot end	1
C	0785-210-360	30" top cover, foot end	1

26" top cover assembly with IV pole, without scales, foot end - 1105-210-670

Rev A (Reference only)

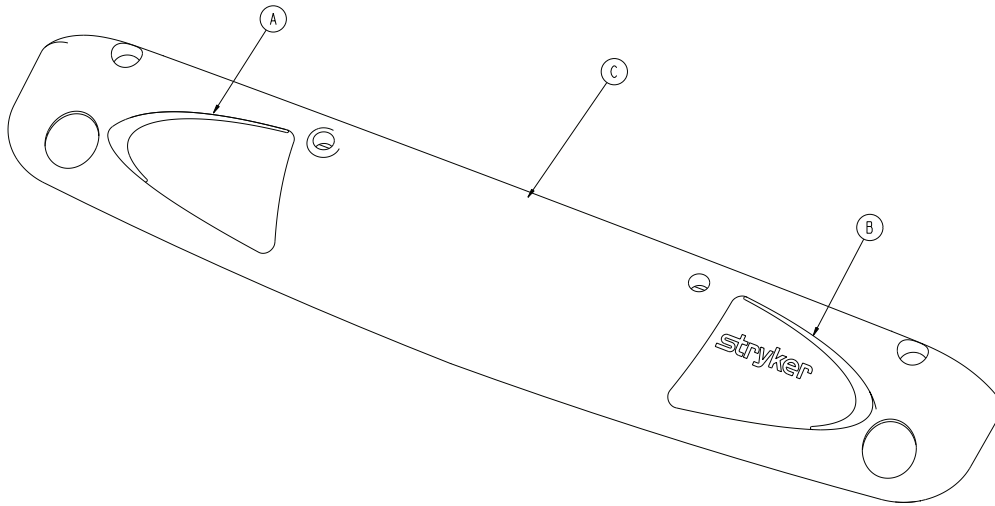

Item	Number	Name	Quantity
A	0785-210-004	Label 26", accent, right, foot end	1
B	0785-210-005	Label 26", accent, left, foot end	1
C	0785-210-670	26" top cover, foot end	1

30" top cover assembly with IV pole, without scales, foot end - 1105-210-370

Rev A (Reference only)

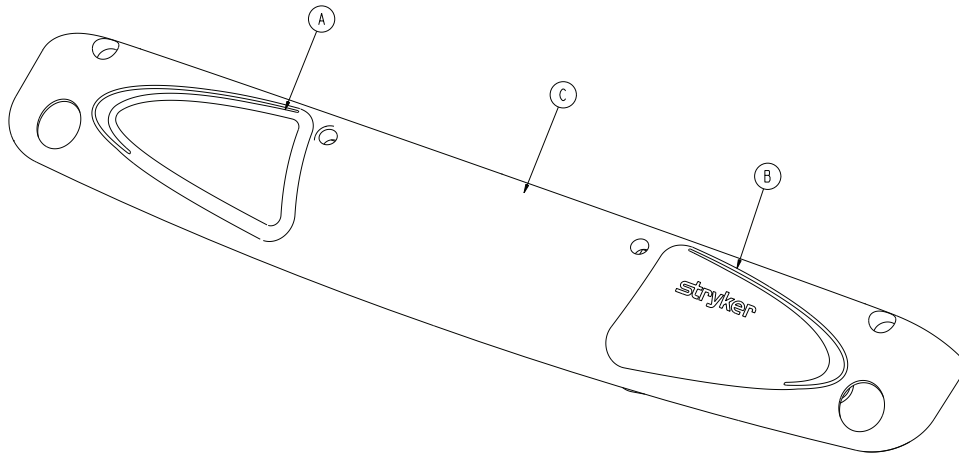

Item	Number	Name	Quantity
A	0785-210-002	Label, accent, right, foot end	1
B	0785-210-003	Label, accent/logo, left, foot end	1
C	0785-210-370	30" top cover, foot end	1

26" top cover assembly without IV pole, with scale, foot end - 1105-210-662

Rev A (Reference only)

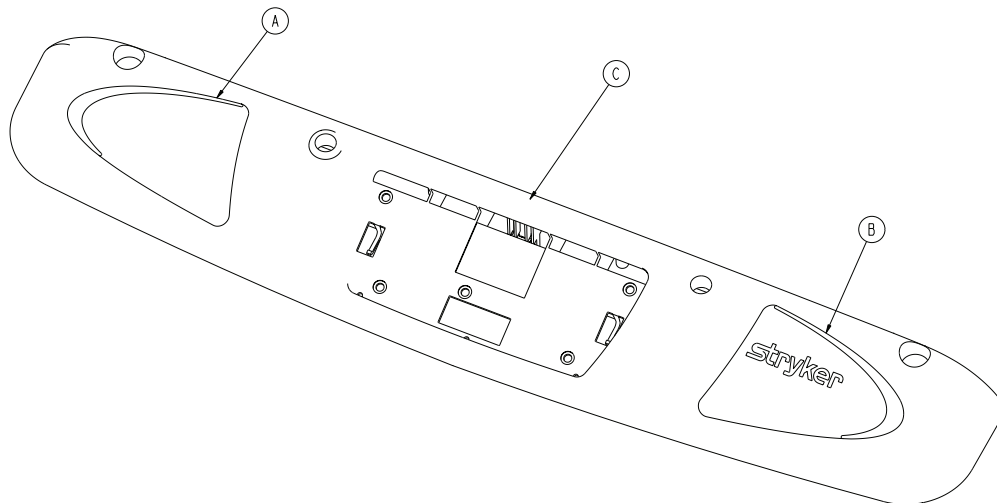

Item	Number	Name	Quantity
A	0785-210-004	Label, 26" accent, right, foot end	1
B	0785-210-005	Label, 26" accent, left, foot end	1
C	0785-210-662	26" cover, foot end	1

30" top cover assembly without IV pole, with scale, foot end - 1105-210-362

Rev A (Reference only)

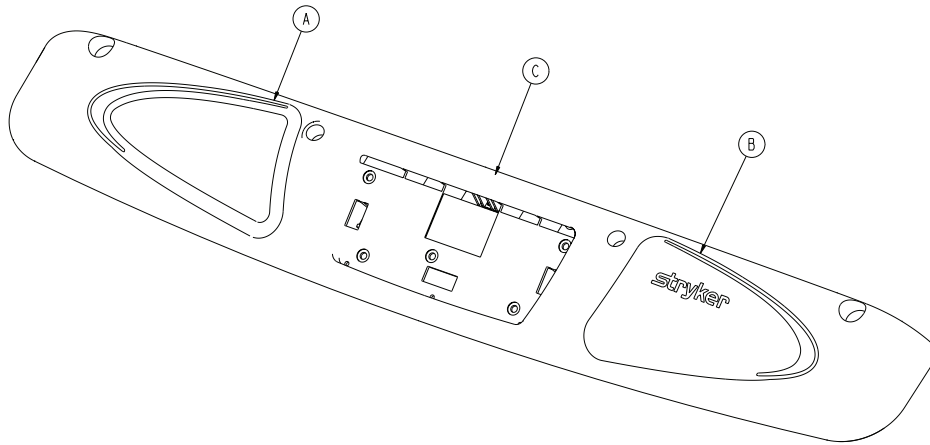

Item	Number	Name	Quantity
A	0785-210-002	Label, accent, right, foot end	1
B	0785-210-003	Label, accent/logo, left, foot end	1
C	0785-210-362	30" cover, foot end	1

26" top cover assembly, with scale and IV pole, foot end - 1105-210-672

Rev A (Reference only)

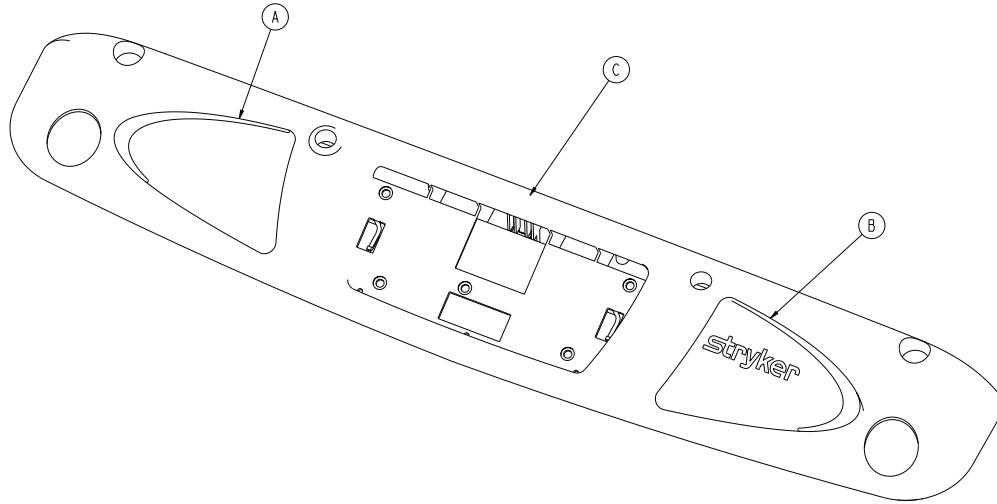

Item	Number	Name	Quantity
A	0785-210-004	Label, 26", accent, right, foot end	1
B	0785-210-005	Label, 26", accent, left, foot end	1
C	0785-210-672	26" cover, foot end	1

30" top cover assembly, with scale and IV pole, foot end - 1105-210-372

Rev A (Reference only)

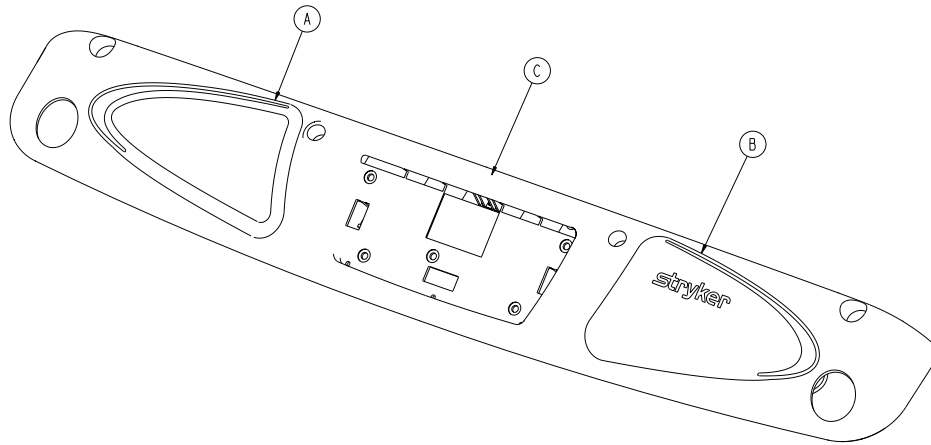

Item	Number	Name	Quantity
A	0785-210-002	Label, accent, right, foot end	1
B	0785-210-003	Label, accent/logo, left, foot end	1
C	0785-210-372	30" top cover, foot end	1

30" top cover assembly, with lockout controls, without scale or IV pole, foot end - 1105-210-361

Rev A (Reference only)

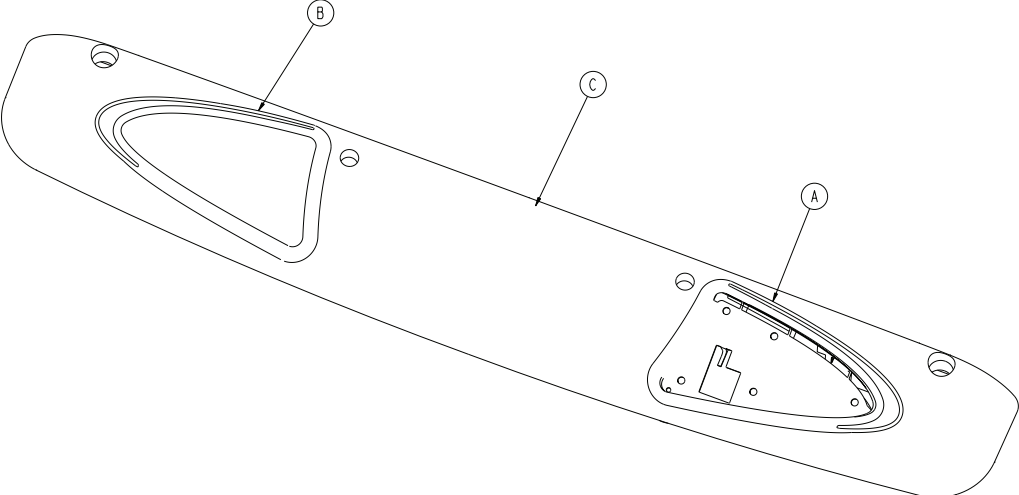

Item	Number	Name	Quantity
A	0785-210-001	Label, accent, left, foot end	1
B	0785-210-002	Label, accent, right, foot end	1
C	0785-210-361	30" cover, glide	1

30" top cover assembly, with scale and lockout controls, foot end - 1105-210-363

Rev A (Reference only)

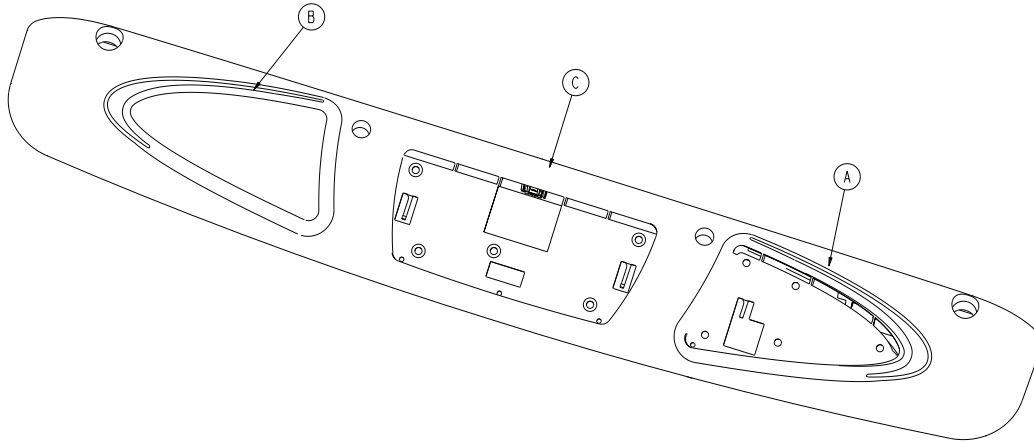

Item	Number	Name	Quantity
A	0785-210-001	Label, accent, left, foot end	1
B	0785-210-002	Label, accent, right, foot end	1
C	0785-210-363	30" top cover, foot end	1

30" top cover assembly, with nurse control and lockout controls, without scale, foot end - 1105-210-364

Rev A (Reference only)

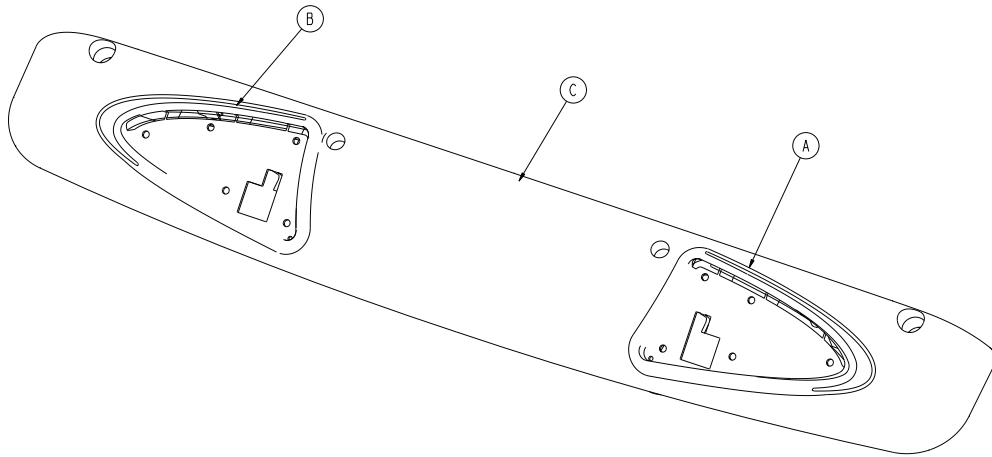

Item	Number	Name	Quantity
A	0785-210-001	Label, accent, left, foot end	1
B	0785-210-002	Label, accent, right, foot end	1
C	0785-210-364	30" top cover, foot end	1

30" top cover assembly, with scale, nurse control, lockout controls, and IV pole, foot end - 1105-210-365

Rev B (Reference only)

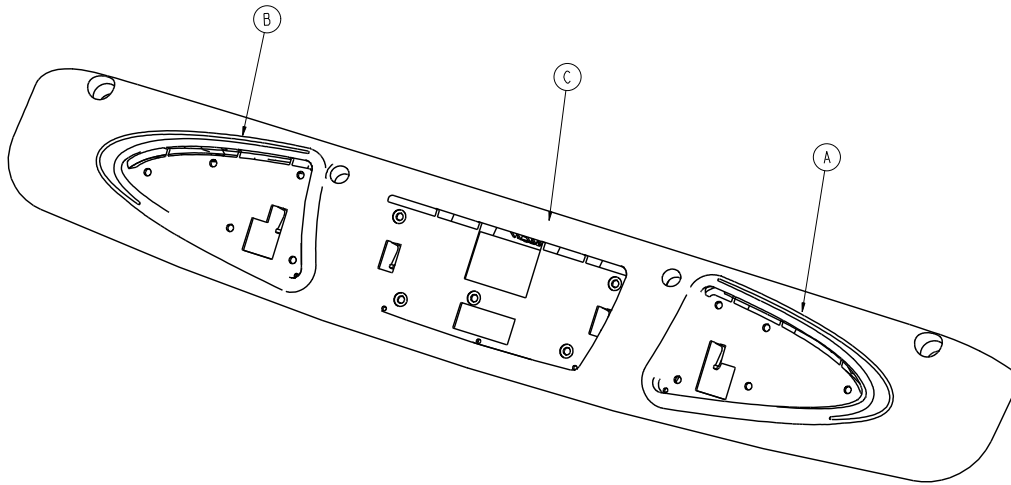

Item	Number	Name	Quantity
A	0785-210-001	Label, accent, left, foot end	1
B	0785-210-002	Label, accent, right, foot end	1
C	0785-210-365	30" top cover, staff control, patient lockout, foot end	1

30" top cover assembly, with lockout controls and IV pole, foot end - 1105-210-371

Rev A (Reference only)

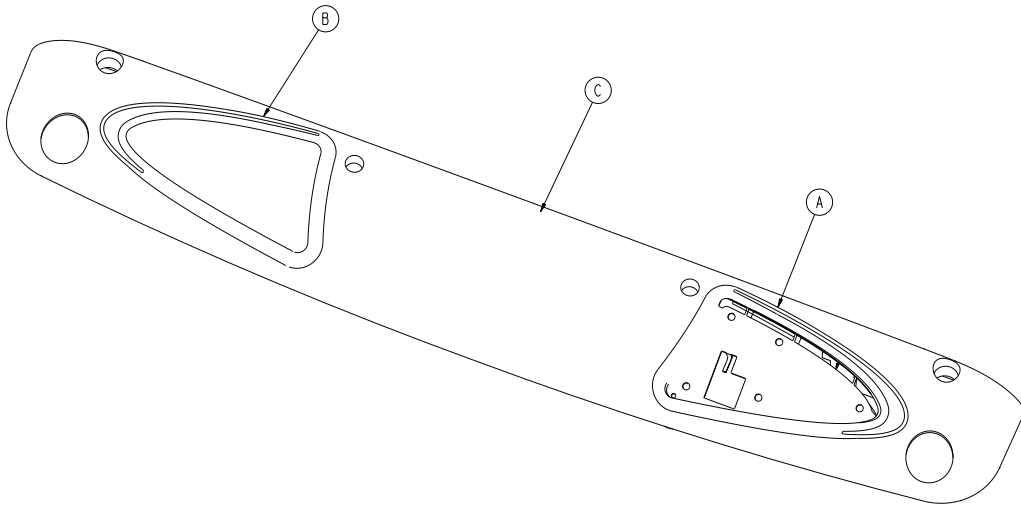

Item	Number	Name	Quantity
A	0785-210-001	Label, accent, left, foot end	1
B	0785-210-002	Label, accent, right, foot end	1
C	0785-210-371	30" top cover, foot end	1

30" top cover assembly, with scale, lockout controls, and IV pole, foot end - 1105-210-373

Rev A (Reference only)

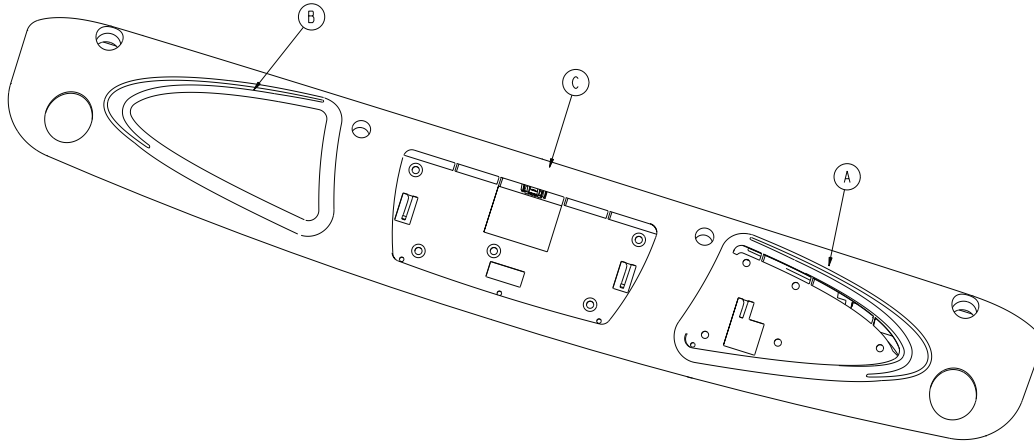

Item	Number	Name	Quantity
A	0785-210-001	Label, accent, left, foot end	1
B	0785-210-002	Label, accent, right, foot end	1
C	0785-210-373	30" top cover, foot end	1

30" top cover assembly, with nurse control, lockout controls, and IV pole, foot end - 1105-210-374

Rev A (Reference only)

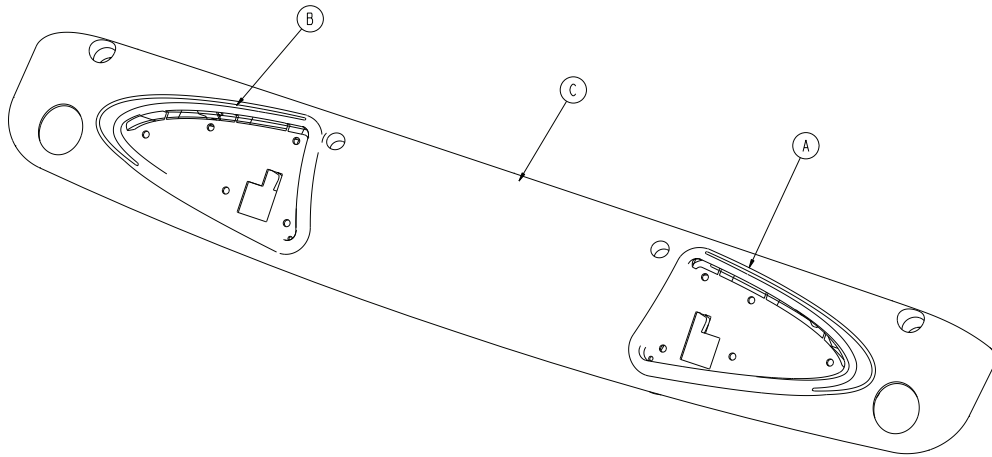

Item	Number	Name	Quantity
A	0785-210-001	Label, accent, left, foot end	1
B	0785-210-002	Label, accent, right, foot end	1
C	0785-210-374	30" top cover, foot end	1

30" top cover assembly, with scale, nurse control, lockout controls, and IV pole, foot end - 1105-210-375

Rev A (Reference only)

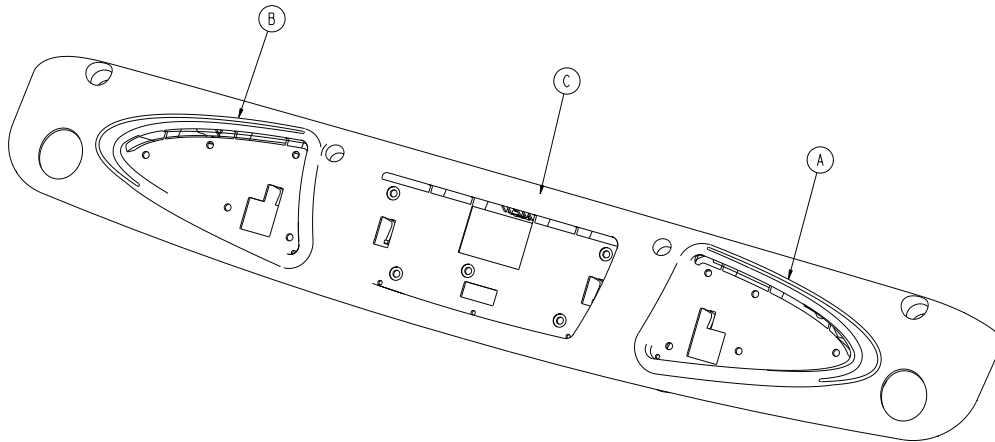

Item	Number	Name	Quantity
A	0785-210-001	Label, accent, left, foot end	1
B	0785-210-002	Label, accent, right, foot end	1
C	0785-210-375	30" top cover, foot end	1

Heel pad assembly - 1105-045-022

Rev A (Reference only)

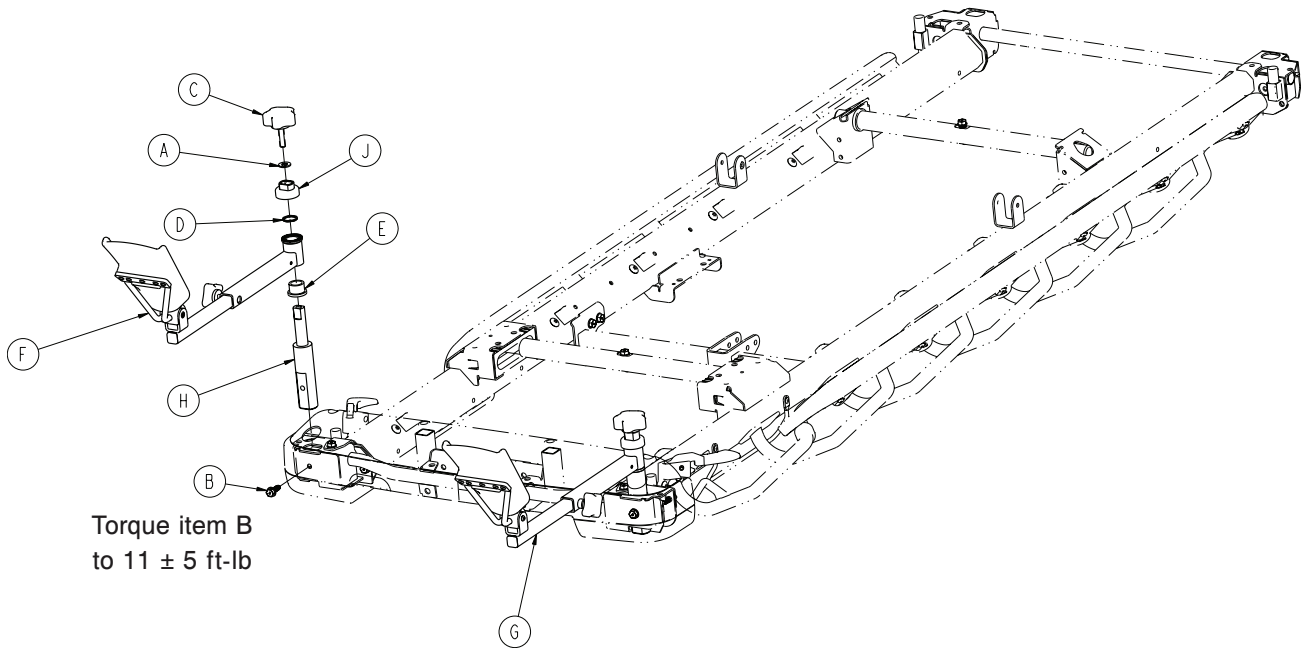

Item	Number	Name	Quantity
A	0011-004-000	Washer	2
B	0023-288-000	Hex washer head screw	2
C	0024-001-002	Knob	2
D	0038-001-013	Wave spring	2
E	0081-230-000	Flange bearing	2
F	1105-045-001	Heel pad assembly, right	1
G	1105-045-002	Heel pad assembly, left	1
H	1105-045-014	Heel pivot	2
J	1105-045-030	Gear lock assembly	2

Common components, fifth wheel, Prime X option

1105-016-060 Rev E (Reference only)

Item	Number	Name	Quantity
B	0853-003-615	<i>8" caster with full cover assembly - 0853-003-615 (page 97)</i>	1
C	1105-006-110	<i>Retractable fifth wheel assembly (page 110)</i>	1
D	0853-102-025	<i>Constant descent jacks, non-electric (page 126)</i>	1
E	1105-105-500	<i>Dual-sided hydraulics assembly, non-electric (page 113)</i>	1
F	0853-003-554	Dipped bumper	4
G	1105-030-310	<i>30" oxygen bottle assembly - 1105-030-310 (page 203)</i>	1
H	1105-060-160	<i>Litter assembly, Prime X (page 362)</i>	1
J	1105-060-161	<i>Head end assembly, Prime X option (page 367)</i>	1

International common components, fifth wheel, Prime X option

1105-016-061 Rev E (Reference only)

Number	Name	Quantity
0921-001-252	Serial number date tag	1
0853-003-615	<i>8" caster with full cover assembly - 0853-003-615 (page 97)</i>	1
1105-006-110	<i>Retractable fifth wheel assembly (page 110)</i>	1
0853-102-025	<i>Constant descent jacks, non-electric (page 126)</i>	1
1105-105-500	<i>Dual-sided hydraulics assembly, non-electric (page 113)</i>	1
0853-003-554	Dipped bumper	4
1105-030-310	<i>30" oxygen bottle assembly - 1105-030-310 (page 203)</i>	1
1105-060-160	<i>Litter assembly, Prime X (page 362)</i>	1
1105-060-161	<i>Head end assembly, Prime X option (page 367)</i>	1

Common components, fifth wheel, power lift, with Prime X option

1105-016-065 Rev E (Reference only)

Number	Name	Quantity
0853-003-615	<i>8" caster with full cover assembly - 0853-003-615 (page 97)</i>	1
1105-006-110	<i>Retractable fifth wheel assembly (page 110)</i>	1
1008-005-560	<i>Dual-sided hydraulics, powered (page 140)</i>	1
0853-003-554	Bumper	4
1105-030-310	<i>30" oxygen bottle assembly - 1105-030-310 (page 203)</i>	1
1105-060-160	<i>Litter assembly, Prime X (page 362)</i>	1
1105-060-161	<i>Head end assembly, Prime X option (page 367)</i>	1

Common components, fifth wheel, powered lift, Prime X

1105-016-066 Rev E (Revision only)

Number	Name	Quantity
0921-001-252	Serial number date tag	1
0853-003-615	<i>8" caster with full cover assembly - 0853-003-615 (page 97)</i>	1
1105-006-110	<i>Retractable fifth wheel assembly (page 110)</i>	1
1008-005-560	<i>Dual-sided hydraulics, powered (page 140)</i>	1
0853-003-554	Bumper	4
1105-030-310	<i>30" oxygen bottle assembly - 1105-030-310 (page 203)</i>	1
1105-060-160	<i>Litter assembly, Prime X (page 362)</i>	1
1105-060-161	<i>Head end assembly, Prime X option (page 367)</i>	1

Litter assembly, Prime X

1105-060-160 Rev H (Reference only)

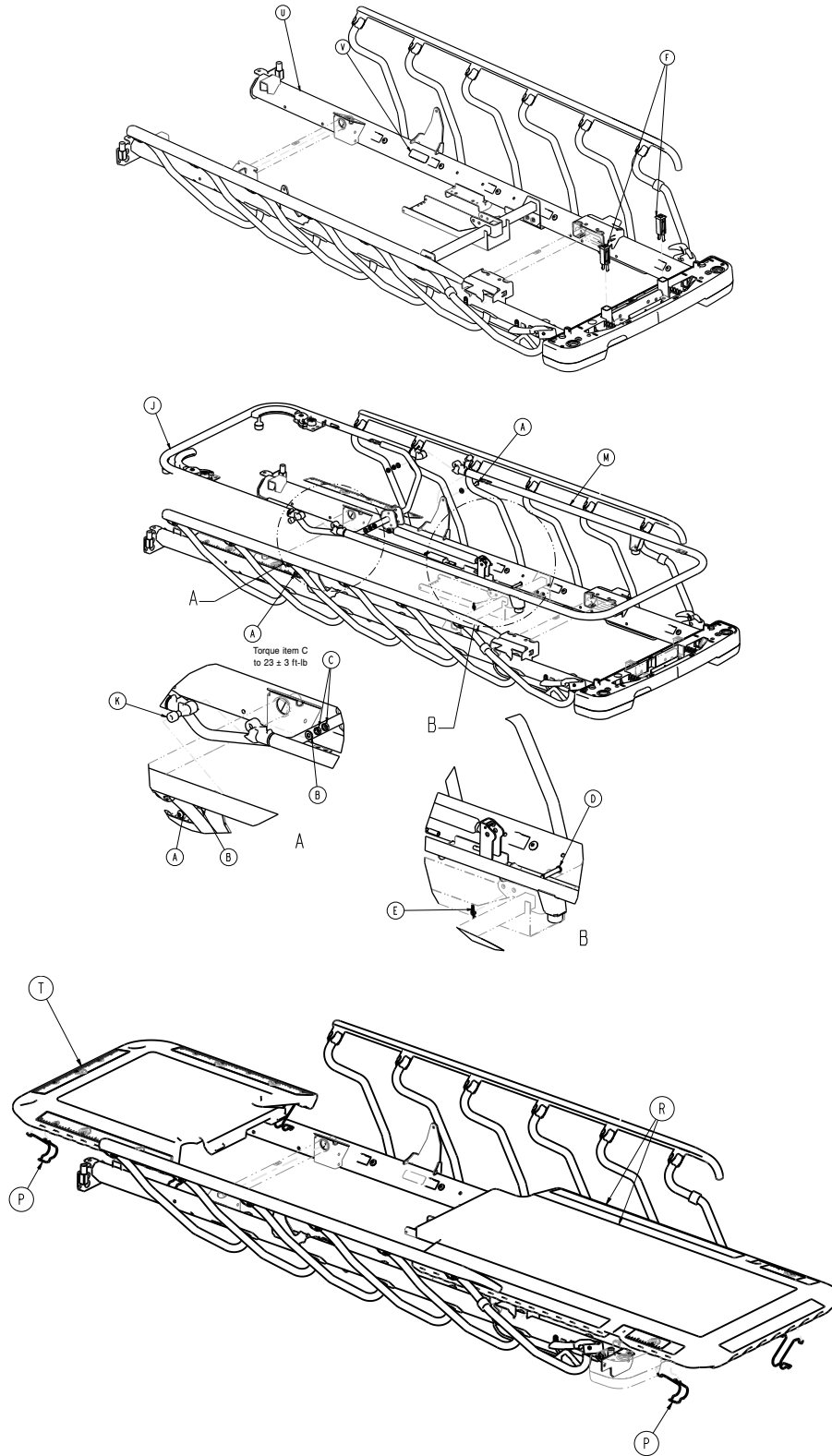

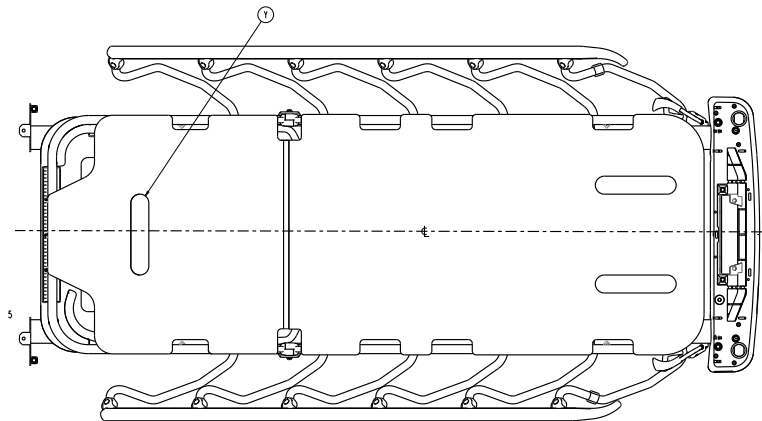
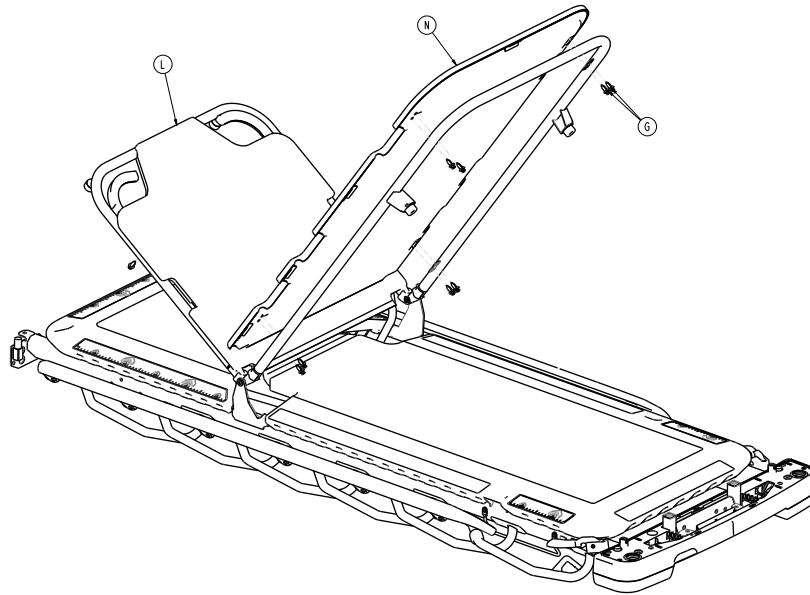
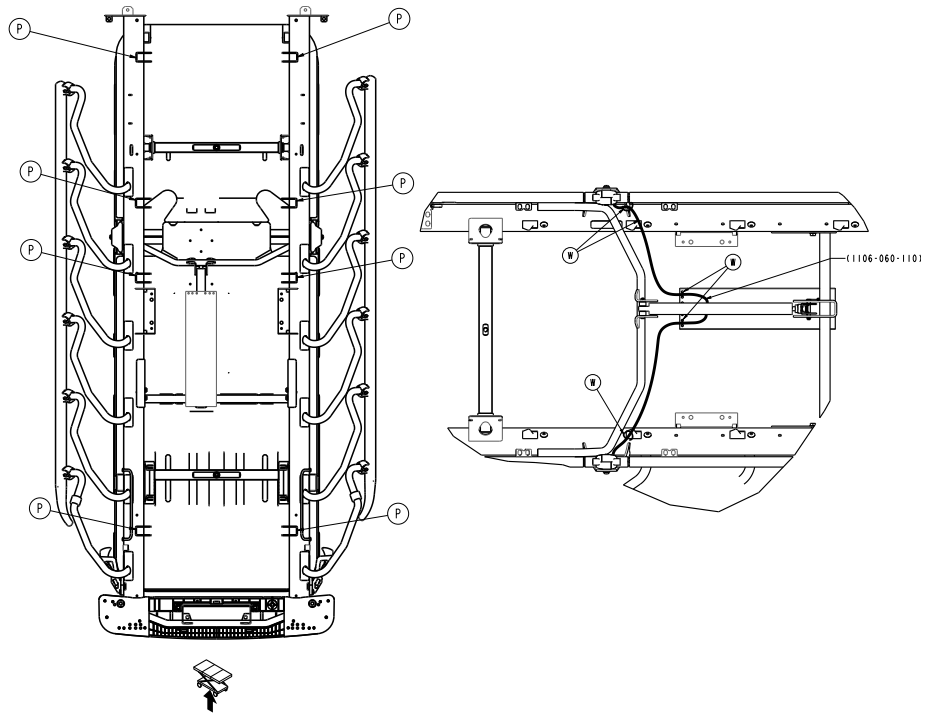

Item	Number	Name	Quantity
A	0004-054-000	Button head cap screw	2
B	0011-321-000	Washer	4
C	0016-316-000	Center lock jam nut	4
D	0026-296-000	Clevis pin	1
E	0027-019-000	Rue ring cotter	1
F	0785-010-122	Footboard receptacle	2
G	1040-010-092	Scrulok assembly	16
J	1105-060-010	Fowler assembly	1
K	1105-060-011	Pivot bushing	2
L	1105-060-019	Fowler skin	1
M	1105-060-040	Foot end assembly	1
N	1105-060-048	Foot skin	1
P	1105-060-064	Tray spring	8
R	1105-060-081	Foot end tray	1
T	1105-060-091	Fowler tray	1
U	1105-060-162	<i>30" litter frame assembly, Prime X option (page 365)</i>	1
V	1210-800-008	Label, patent	1
W	3000-300-113	8" cable tie	4
Y	0785-034-008	Velcro® pile (adhesive back)	3

30" litter frame assembly, Prime X option

1105-060-162 Rev D (Reference only)

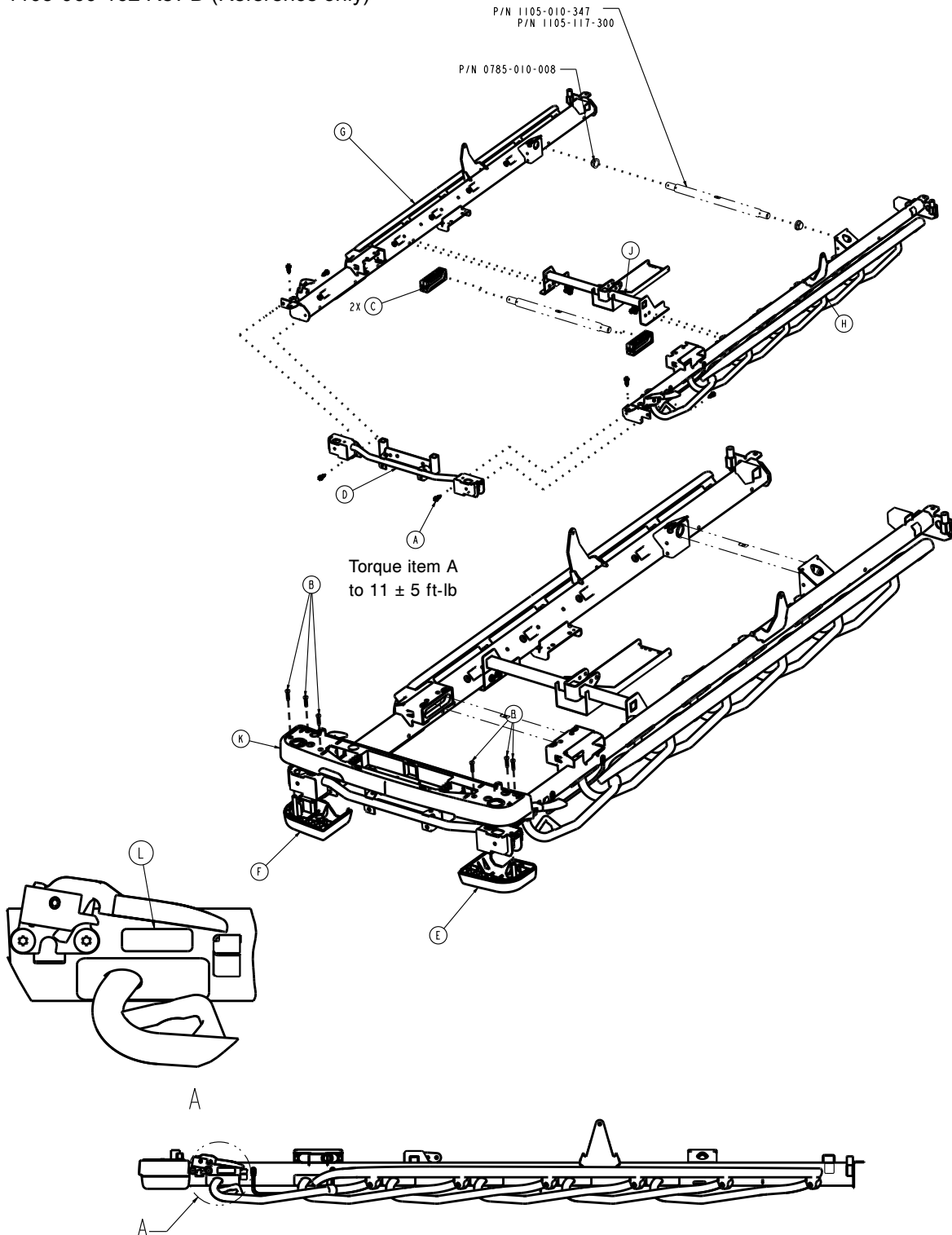

Item	Number	Name	Quantity
A	0023-288-000	Hex washer head screw	10
B	0023-310-000	Pan head tapping screw	6
C	0785-010-006	Trend block slide	2
D	0785-110-320	End weldment, foot end	1

Item	Number	Name	Quantity
E	1105-060-052	Bottom cover, foot end, left	1
F	1105-060-057	Bottom cover, foot end, right	1
G	1105-060-155	<i>Siderail assembly, right, Prime X option (page 371)</i>	1
H	1105-060-156	<i>Siderail assembly, left, Prime X option (page 372)</i>	1
J	1105-060-310	30" frame tie weldment	1
K	1105-060-355	30" mid cover, foot end	1
L	1105-001-901	Label, applied part	2

Head end assembly, Prime X option

1105-060-161 Rev B (Reference only)

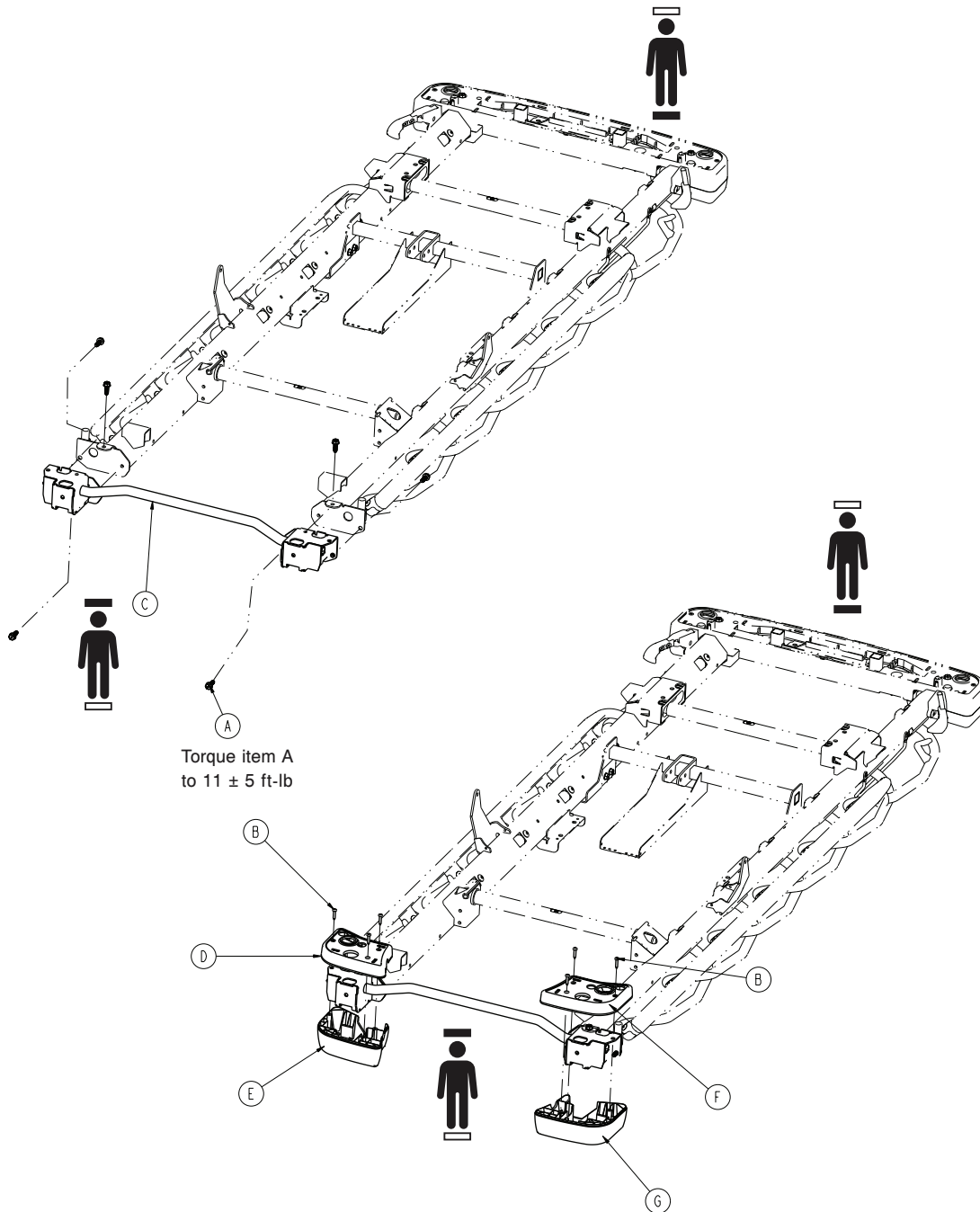

Item	Number	Name	Quantity
A	0023-288-000	Hex washer head screw	6
B	0023-310-000	Pan head tapping screw	6
C	1105-010-315	End weldment, head end	1
D	1105-060-050	Cover, mid, head end	1
E	1105-060-051	Cover, bottom, left, head end	1
F	1105-060-055	Cover, mid, right, head end	1
G	1105-060-056	Cover, bottom, right, head end	1

Scale litter assembly option, Prime X option

1070-060-360 Rev D (Reference only)

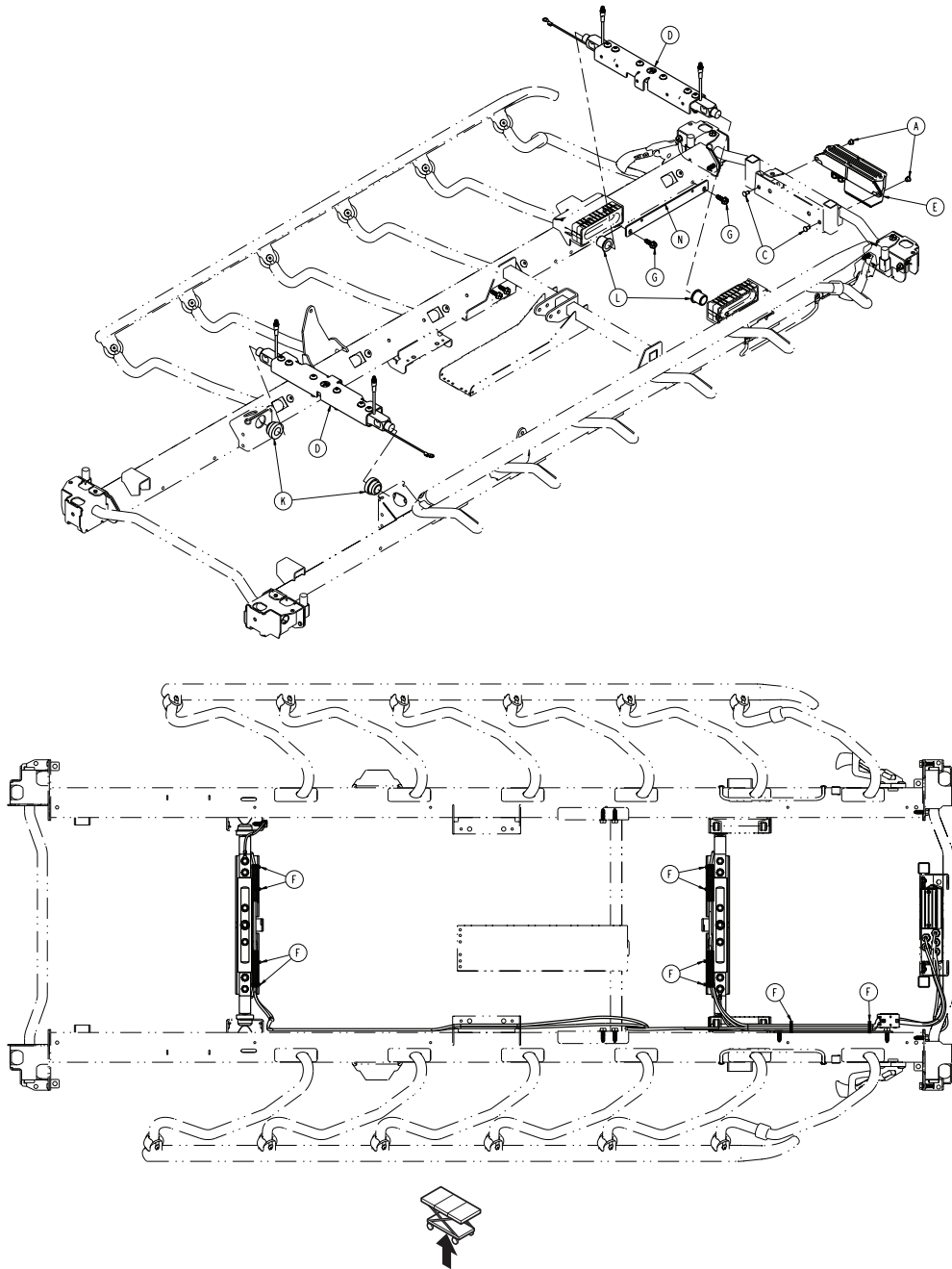

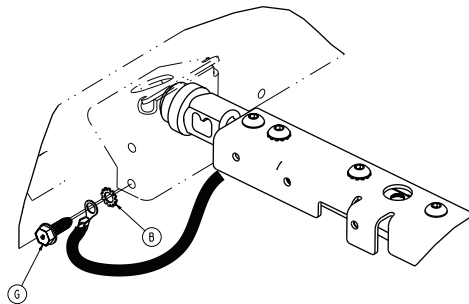
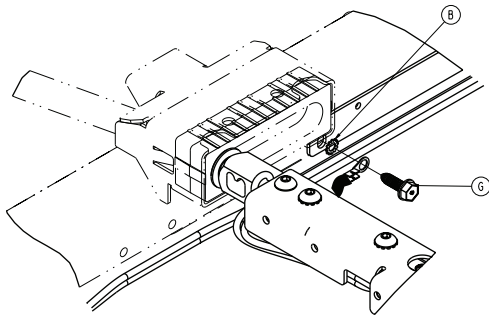
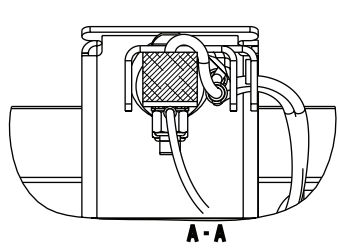
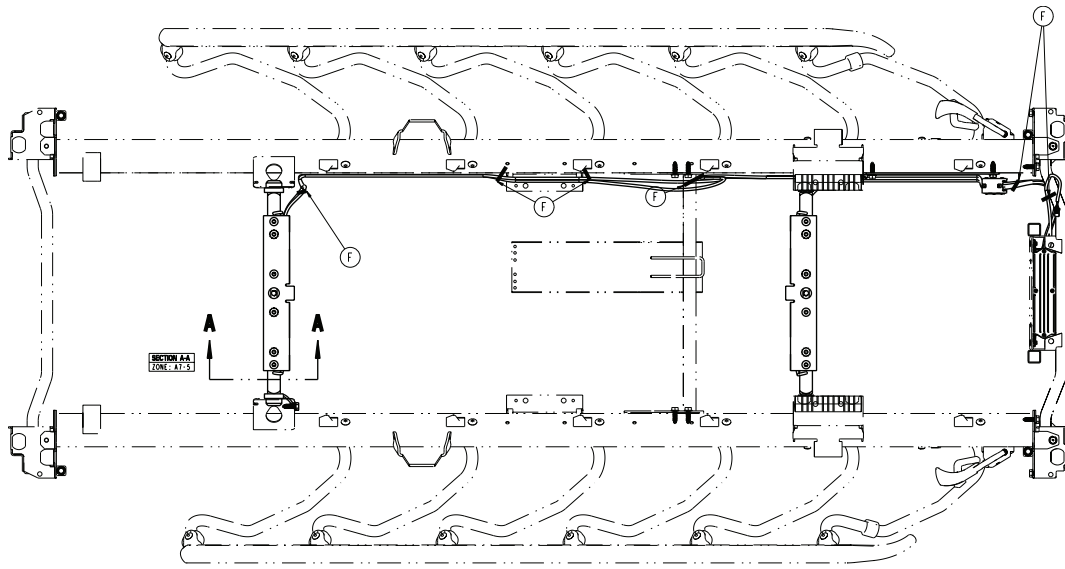

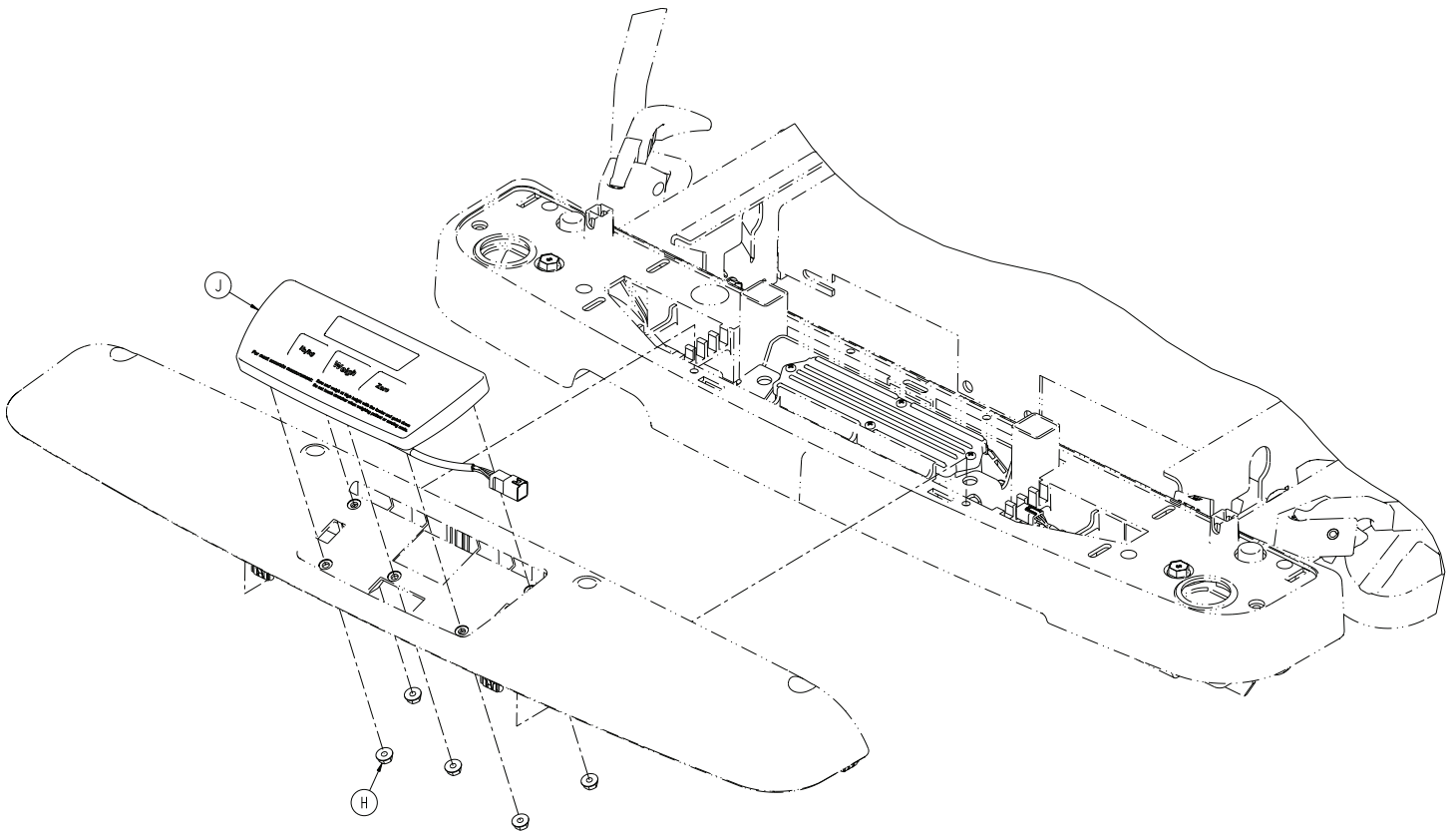

Item	Number	Name	Quantity
A	1070-137-001	Flange eyelet	2
B	0013-038-000	External tooth lock washer	2
C	0025-120-000	Dome head rivet	2
D	1070-117-300	30" scale lifthead - 1070-117-300 (page 215)	2
E	1070-237-020	Scale box assembly, non-electric litter -1070-237-020 (page 216)	1
F	3000-300-113	8" cable tie	16
G	0023-288-000	Hex washer head screw	2
H	0016-137-000	Hex flange nut	5
J	1008-037-820	Scale control non-backlit keypad assembly	1
K	1070-117-011	Scale bushing, head end	2
L	1070-117-012	Scale bushing, foot end	2
M	1008-010-127	Scale spacer (not shown)	2
N	1105-060-322	Cable hanger	1

Siderail assembly, right, Prime X option

1105-060-155 Rev C (Reference only)

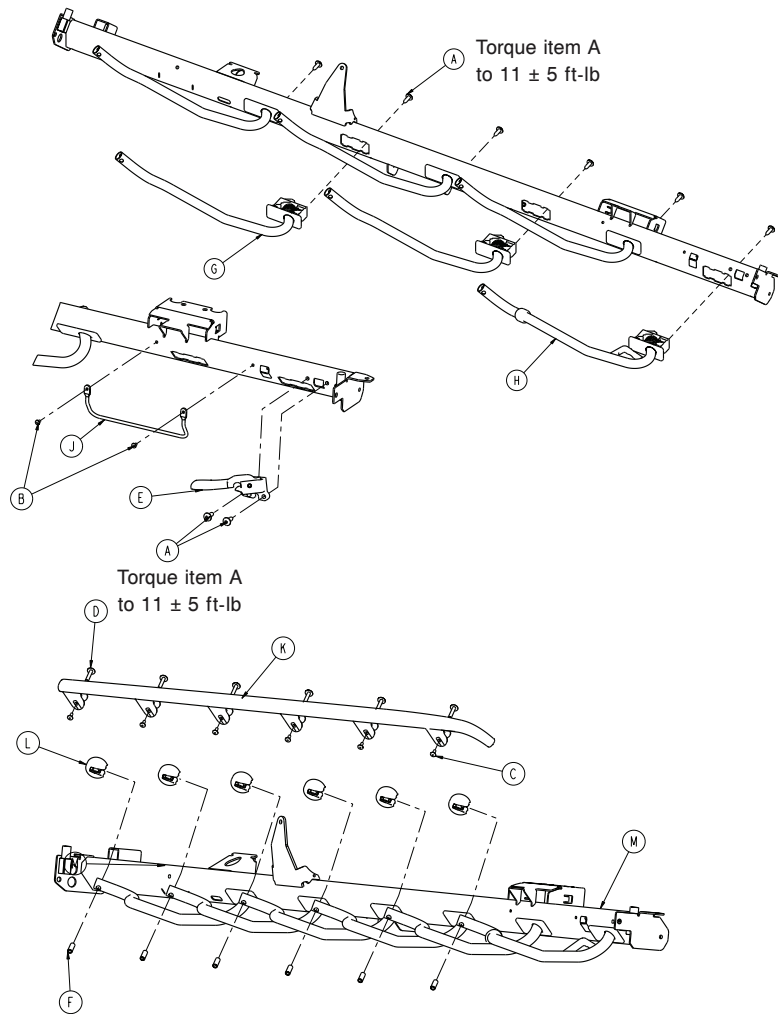

Item	Number	Name	Quantity
A	0007-074-000	Truss head machine screw	8
B	0025-079-000	Dome head rivet	2
C	0025-182-000	Rivet	6
D	0025-183-000	Tubular component	6
E	0785-011-020	<i>Siderail latch assembly, right</i> (page 223)	1
F	0785-011-046	Spindle bearing	6
G	1105-011-041	<i>Spindle assembly, right - 1105-011-041</i> (page 221)	5
H	1105-011-042	<i>Latch spindle assembly, right</i> (page 225)	1
J	1105-030-046	Foley bag rack	1
K	1105-060-037	Top rail, right	1
L	1105-060-038	Spindle plug	6
M	1105-060-154	Siderail tube weldment, right	1

Siderail assembly, left, Prime X option

1105-060-156 Rev C (Reference only)

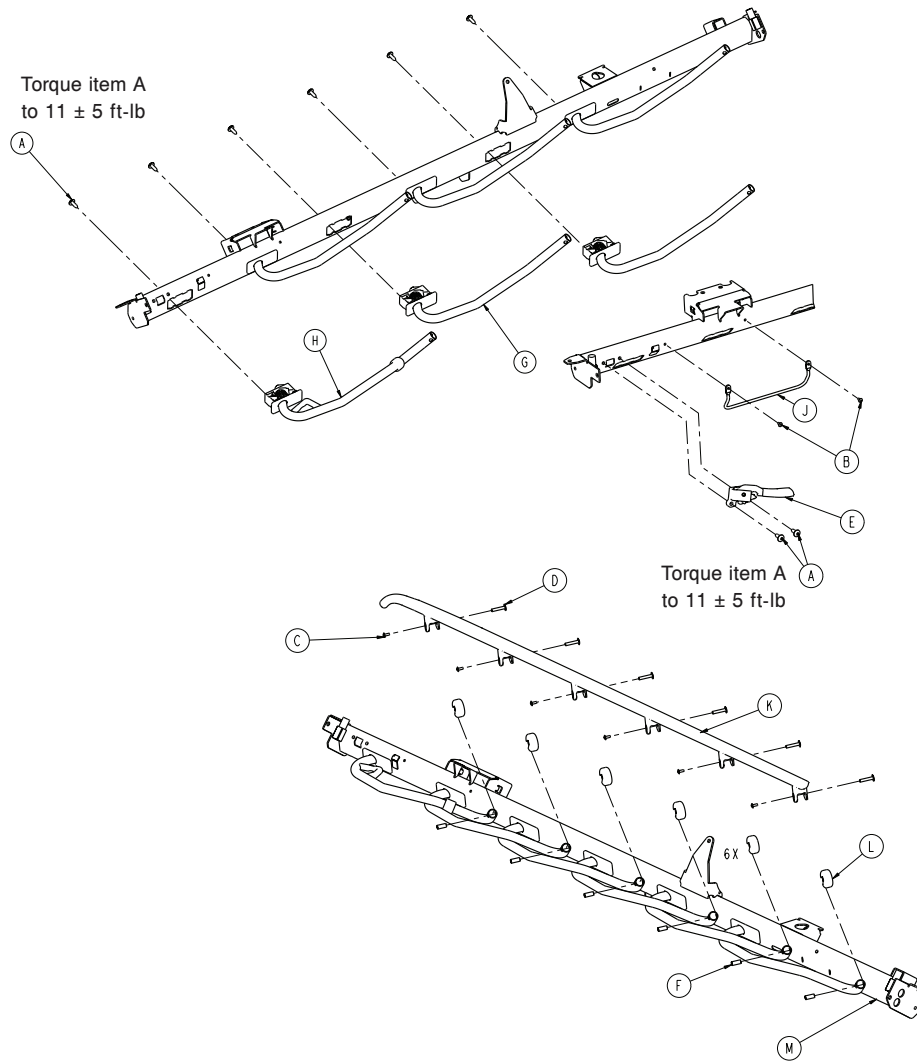

Item	Number	Name	Quantity
A	0007-074-000	Truss head machine screw	8
B	0025-079-000	Dome head rivet	2
C	0025-182-000	Rivet	6
D	0025-183-000	Tubular component	6
E	0785-011-021	Siderail latch assembly, left (page 224)	1
F	0785-011-046	Spindle bearing	6
G	1105-011-051	Spindle assembly, left - 1105-011-051 (page 222)	5
H	1105-011-052	Latch spindle assembly, left (page 226)	1
J	1105-030-046	Foley bag rack	1
K	1105-060-036	Top rail, left	1
L	1105-060-038	Spindle plug	6
M	1105-060-153	Siderail tube weldment, left	1

Fowler assembly, Prime X option

1105-060-010 Rev A (Reference only)

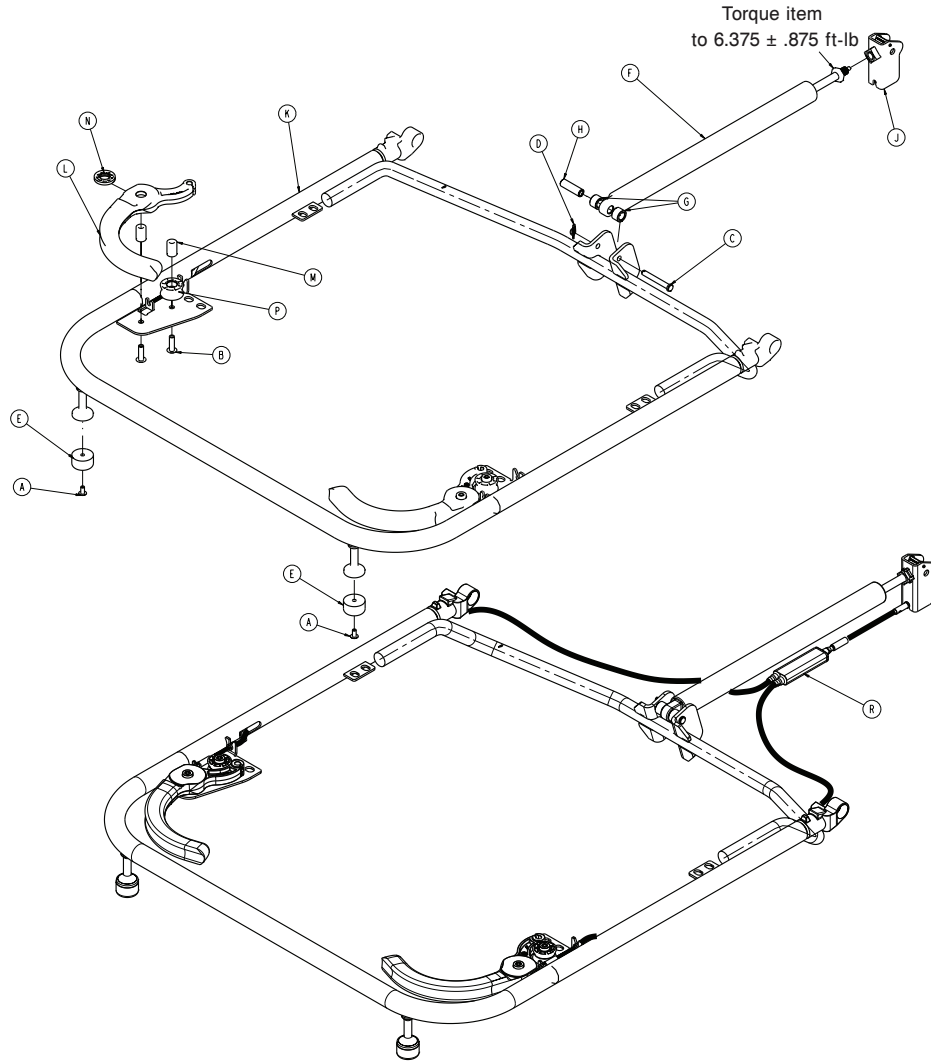

Item	Number	Name	Quantity
A	0025-079-000	Dome head rivet	2
B	0025-147-000	Pop rivet	4
C	0026-330-000	Clevis pin	1
D	0027-020-000	Rue ring cotter	1
E	0056-023-000	Recessed bumper	2
F	0360-031-077	Cylinder	1
G	0785-012-094	Spacer	2
H	0785-012-103	Sleeve	1
J	0785-112-116	Gas spring trip	1
K	1105-060-015	Fowler weldment	1
L	1105-060-101	Fowler release handle	2
M	1105-060-102	Pivot busing	4
N	1105-060-103	Inner cable roller	2
P	1105-060-104	Outer cable roller	2
R	1105-060-110	Fowler cable assembly	1

Foot end assembly, Prime X option

1105-060-040 Rev A (Reference only)

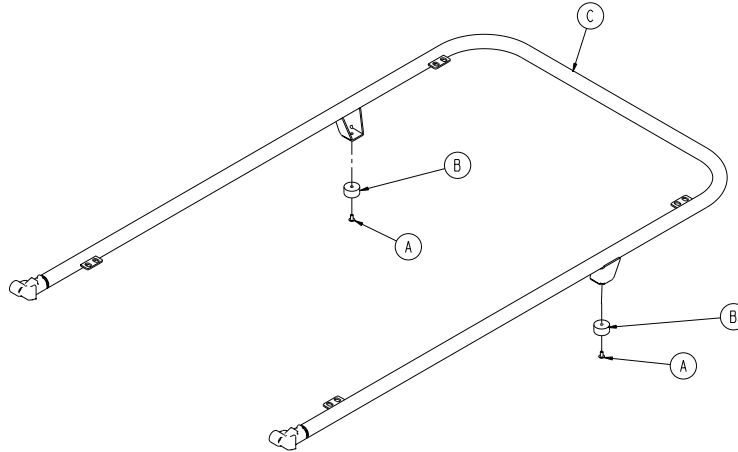

Item	Number	Name	Quantity
A	0025-079-000	Dome head rivet	2
B	0056-023-000	Bumper	2
C	1105-060-045	Foot end weldment	1

Push handles assembly, head end, Prime X option

1105-048-060 Rev B (Reference only)

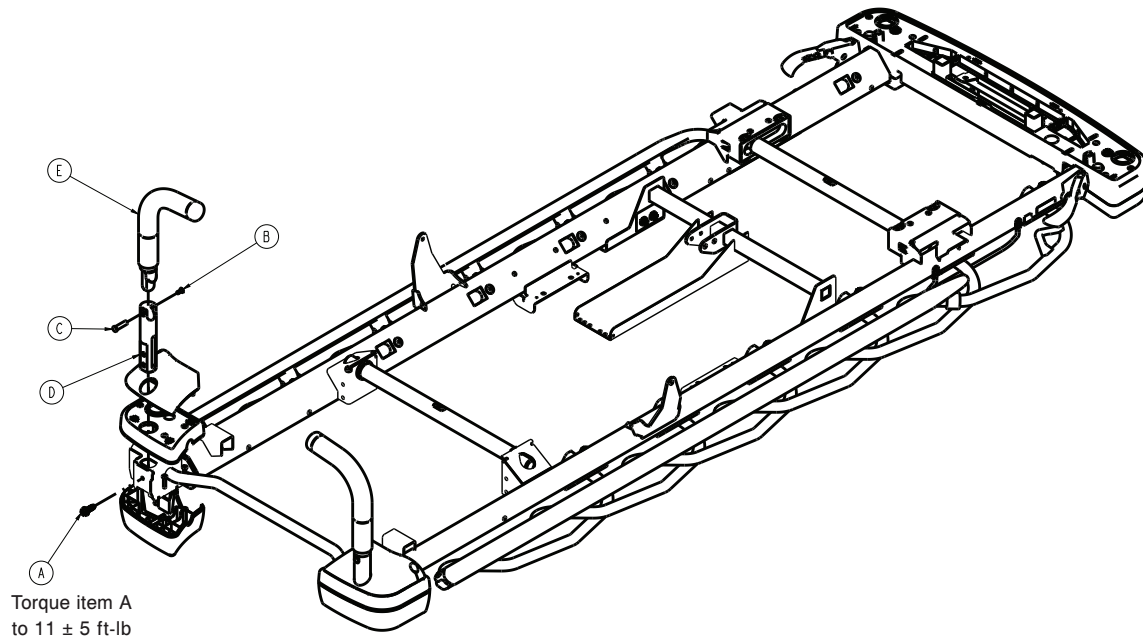

Item	Number	Name	Quantity
A	0023-288-000	Hex washer head screw	2
B	0025-079-000	Dome head rivet	2
C	0785-048-025	Handle pivot pin	2
D	0785-210-020	IV pole socket	2
E	1105-060-030	Push handle	2

Scale option

1070-010-002 Rev B (Reference only)

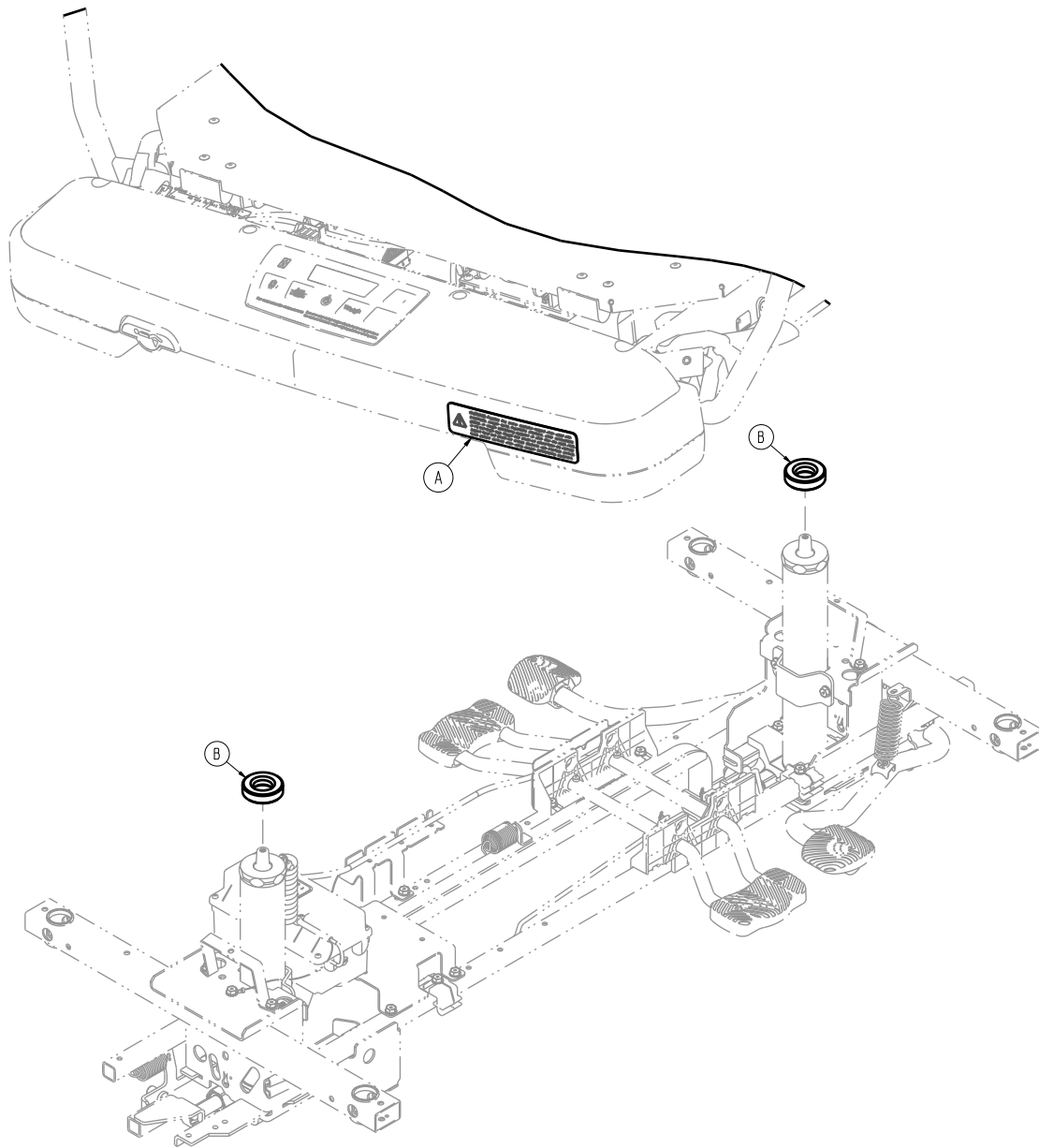

Item	Number	Name	Quantity
A	1125-110-951	Label, warning, foot end	1
B	1008-010-127	Scale spacer	2

Scale spacer

1070-017-500 Rev A (Reference only)

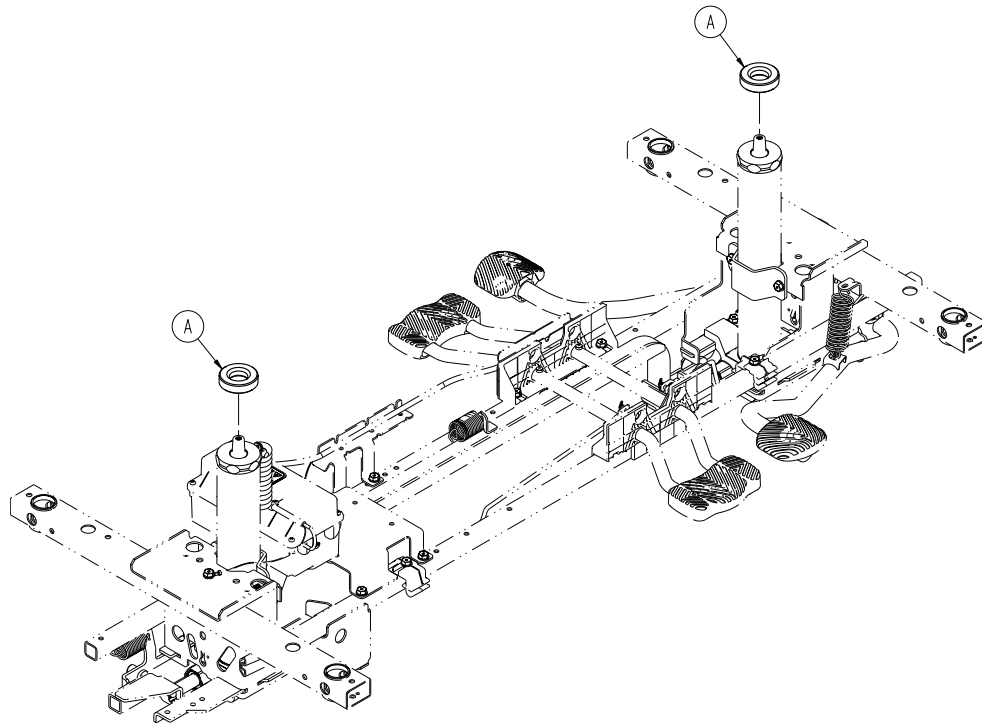

Item	Number	Name	Quantity
A	1008-010-127	Scale spacer	2

IV caddy - 0785-155-000

Rev A (Reference only)

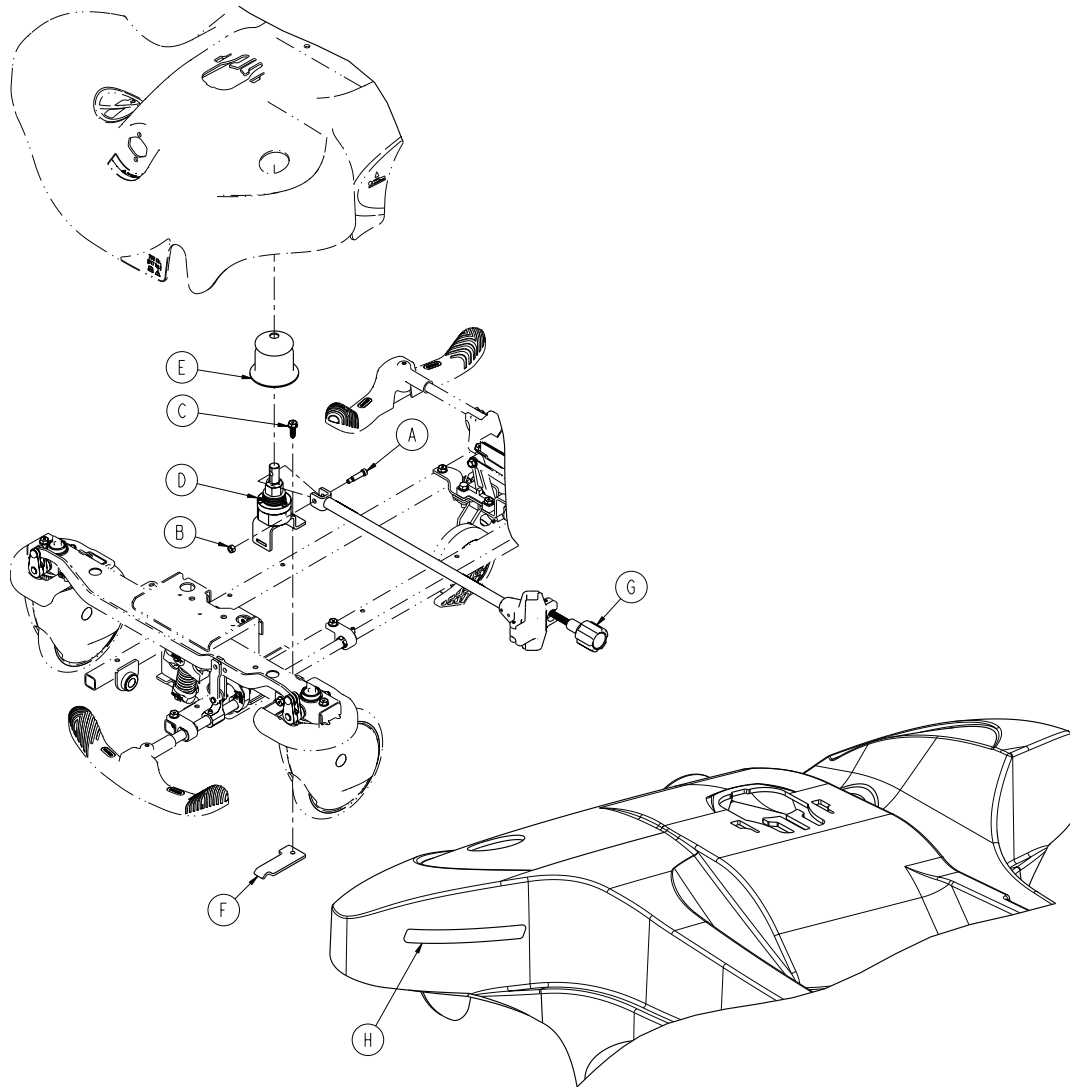

Item	Number	Name	Quantity
A	0008-006-000	Socket head shoulder screw	1
B	0016-118-000	Hex lock nut	1
C	0023-288-000	Hex washer head screw	1
D	0753-122-001	Clutch assembly	1
E	0753-122-036	Boot	1
F	0753-122-103	IV caddy plate	1
G	1050-091-044	Arm assembly	1
H	1105-024-010	Label, store properly	1

Defibrillator tray assembly - 1105-045-200

Rev B (Reference only)

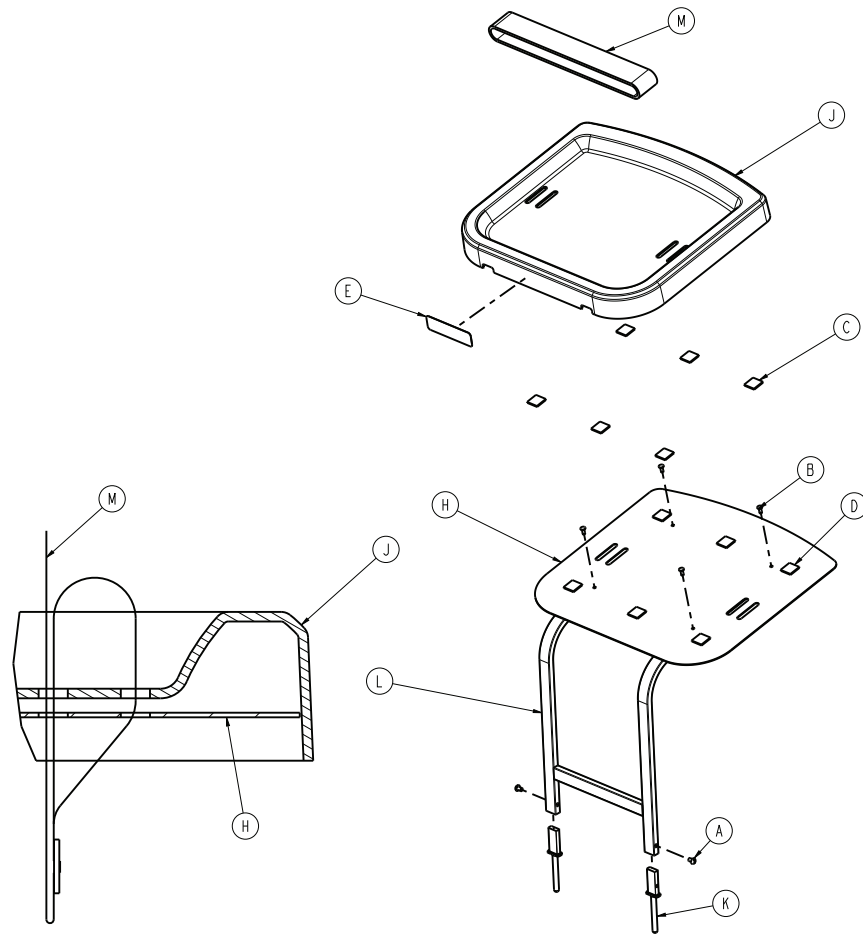

Item	Number	Name	Quantity
A	0002-044-000	Round head machine screw	2
B	0025-055-000	Blind hole rivet	4
C	0029-008-000	Dual lock	6
D	0029-010-000	Dual lock	6
E	1105-145-201	Label, defibrillator tray	1
H	1105-045-204	Tray support	1
J	1105-045-207	Tray	1
K	0785-045-208	Bayonet	2
L	1105-045-210	Defibrillator tray frame weldment	1
M	1010-050-021	Long strap	1

Defibrillator tray/foot extender/footboard - 1105-045-400

Rev B (Reference only)

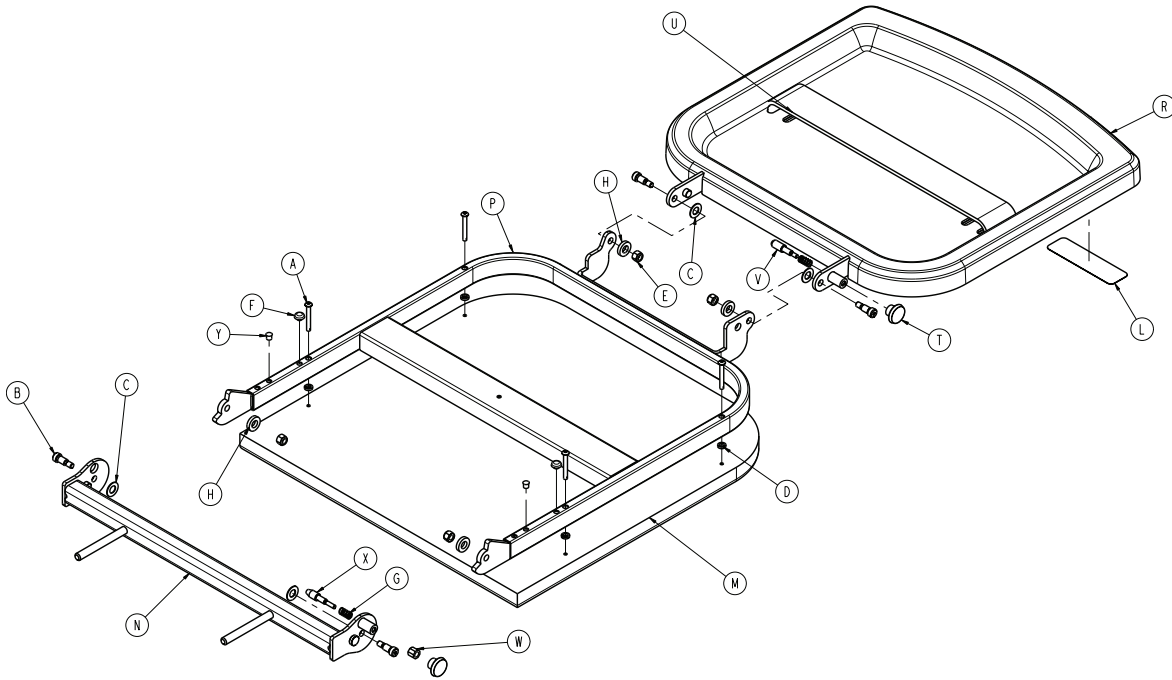

Item	Number	Name	Quantity
A	0004-215-000	Button head cap screw	4
B	0008-049-000	Socket head cap screw	4
C	0014-020-000	Washer	4
D	0014-120-000	Washer	4
E	0016-028-000	Hex nut	4
F	0037-052-000	Rubber bumper	2
G	0038-133-000	Compression spring	2
H	0052-017-000	Spacer	4
L	1105-145-401	Label, foot extender/defibrillator tray	1
M	0785-045-405	Cushion	1
N	0785-045-410	Base mounting weldment	1
P	0785-045-420	Frame pivot weldment	1
R	0747-045-430	Tray assembly	1
T	0785-045-450	Knob	2
U	1010-050-021	Long strap	1
V	1010-050-242	Pin lock	1
W	1010-050-250	Lock adjuster	1
X	1010-050-248	Lower pin lock	1
Y	0721-031-065	Hole plug	2

Footboard/chart holder - 1105-045-500

Rev AA (Reference only)

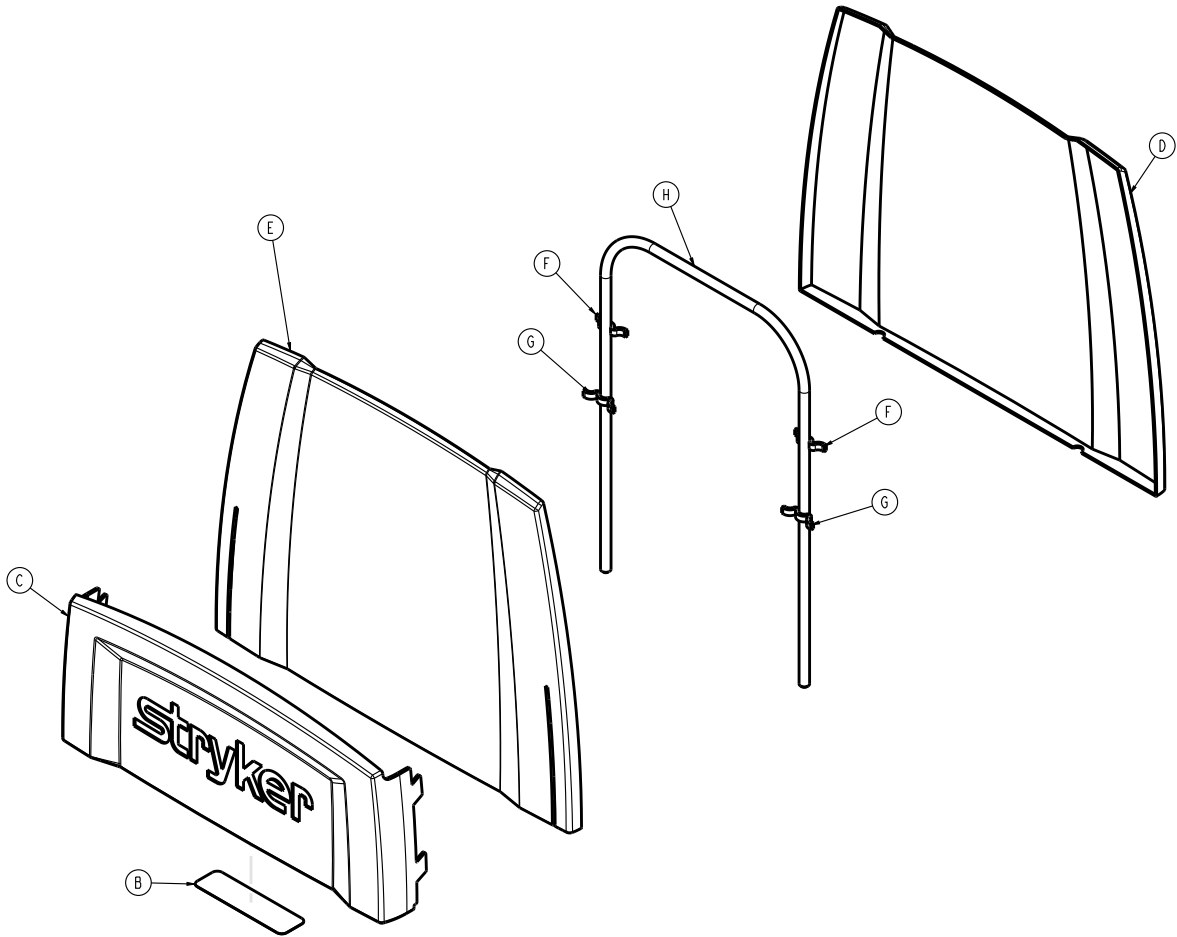

Item	Number	Name	Quantity
B	1105-045-501	Label, footboard	1
C	1105-045-511	Chart holder	1
D	1105-045-512	Footboard back	1
E	1105-045-513	Footboard front	1
F	1105-045-514	Small standoff	2
G	1105-045-515	Large standoff	2
H	0946-029-010	Support	1

Havasu IV pole, removable - 0390-025-000

Rev AA (Reference only)

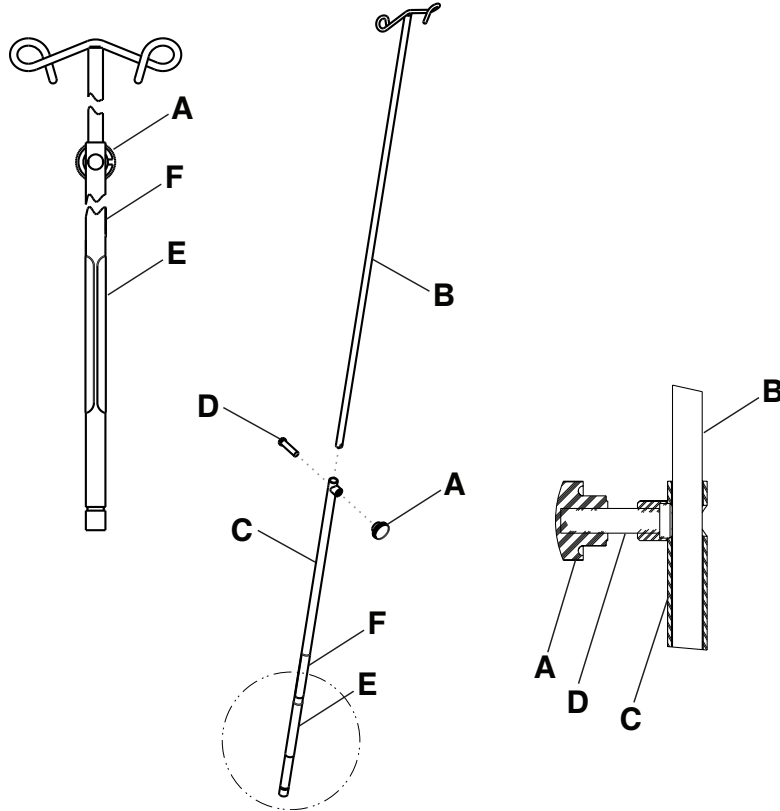

Item	Number	Name	Quantity
A	0390-003-056	Knob	1
B	0390-003-053	Double IV assembly	1
C	0393-003-043	Chrome tube assembly	1
D	0004-496-000	Socket head cap screw	1
E	0390-125-011	Label, IV pole, removable	1
F	108900350901	Label, EAR	1

26" two-stage IV pole assembly

Rev AA (Reference only)

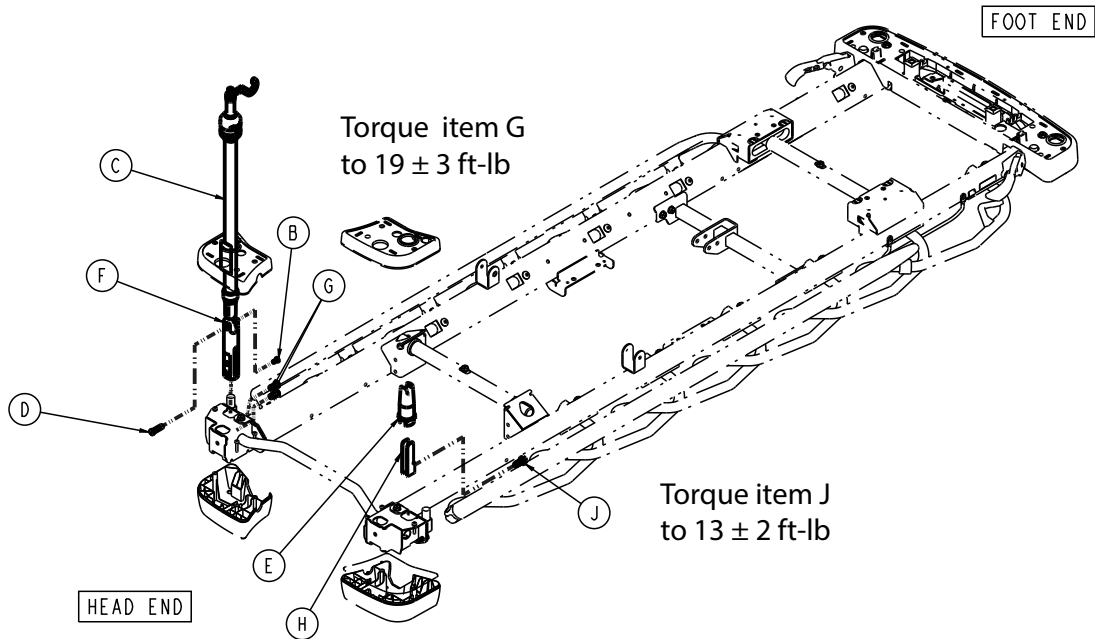

1105-035-638	Two-stage 26" IV, left, head end
1105-035-641	Two-stage 26" IV, right, head end
1105-035-640	Two-stage 26" IV, left, foot end
1105-035-643	Two-stage 26" IV, right, foot end

Item	Number	Name	Quantity
B	0025-079-000	Dome head rivet	1
C	0785-035-101	26" two-stage IV pole assembly	1
D	0785-048-025	Handle pivot pin	1
E	0785-135-020	Magnetic IV pole support assembly	1
F	0785-210-020	IV pole socket	1
G	0004-871-000	Button head cap screw	2
H	0785-135-021	Internal IV support	1
J	0023-288-000	Hex washer head screw	1

30" two-stage IV pole assembly

Rev AA (Reference only)

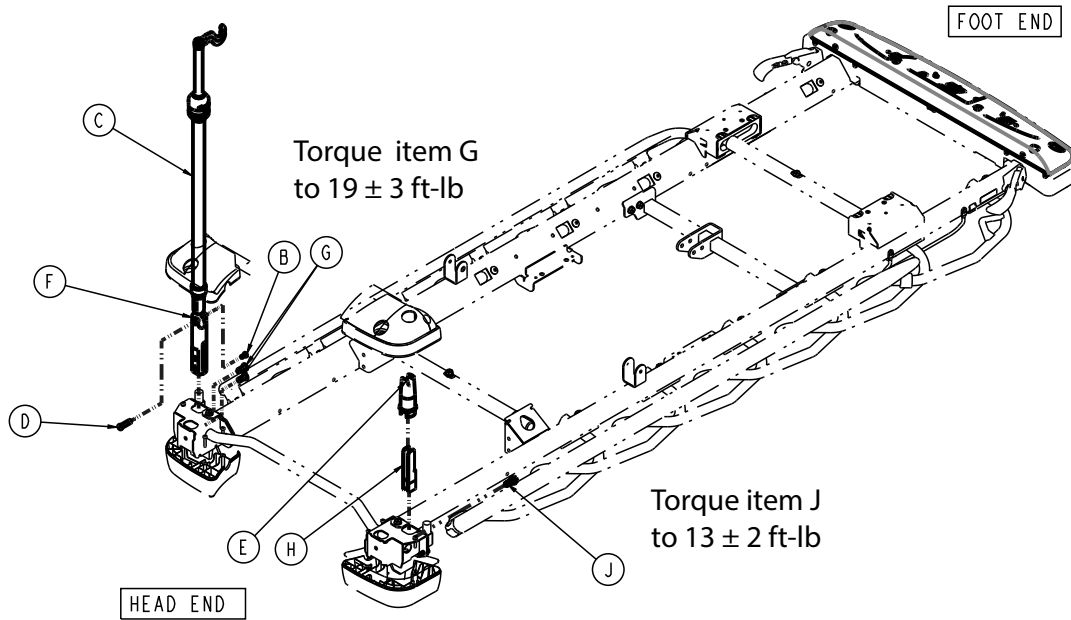

1105-035-338	Two-stage 30" IV, left, head end
1105-035-341	Two-stage 30" IV, right, head end
1105-035-340	Two-stage 30" IV, left, foot end
1105-035-343	Two-stage 30" IV, right, foot end

Item	Number	Name	Quantity
B	0025-079-000	Dome head rivet	1
C	0785-035-401	30" two-stage IV pole assembly	1
D	0785-048-025	Handle pivot pin	1
E	0785-135-020	Magnetic IV pole support assembly	1
F	0785-210-020	IV pole socket	1
G	0004-871-000	Button head cap screw	2
H	0785-135-021	Internal IV support	1
J	0023-288-000	Hex washer head screw	1

26" three-stage IV pole assembly

Rev AA (Reference only)

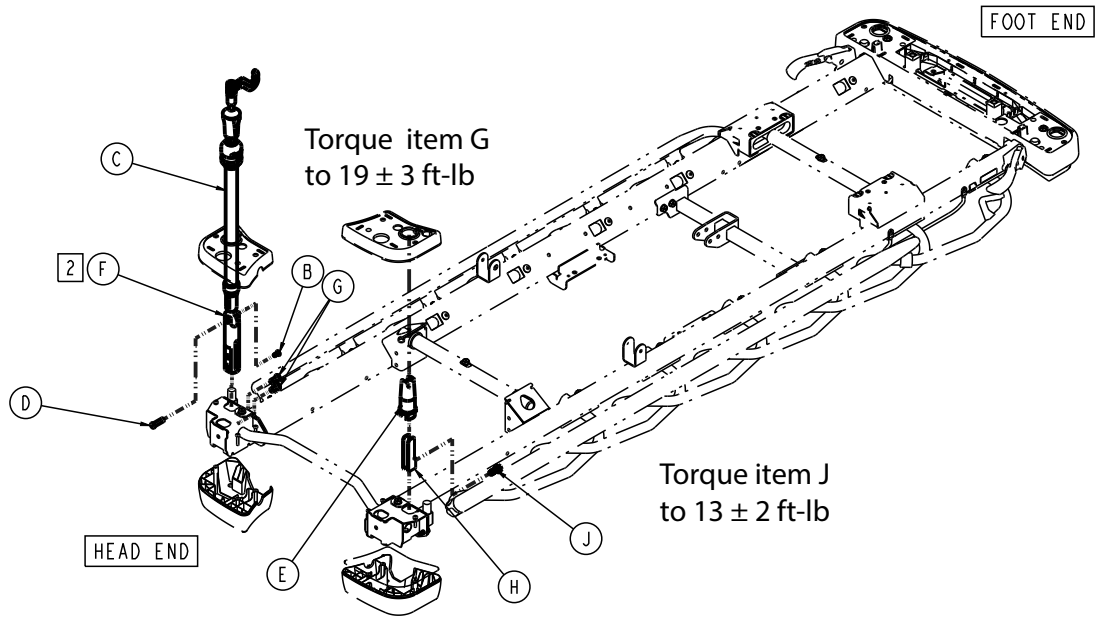

1105-035-642	Three-stage 26" IV, left, head end
1105-035-637	Three-stage 26" IV, right, head end
1105-035-644	Three-stage 26" IV, left, foot end
1105-035-639	Three-stage 26" IV, right, foot end

Item	Number	Name	Quantity
B	0025-079-000	Dome head rivet	1
C	0785-035-200	26" three-stage IV pole assembly	1
D	0785-048-025	Handle pivot pin	1
E	0785-135-020	Magnetic IV pole support assembly	1
F	0785-210-020	IV pole socket	1
G	0004-871-000	Button head cap screw	2
H	0785-135-021	Internal IV support	1
J	0023-288-000	Hex washer head screw	1

30" three-stage IV pole assembly

Rev AA (Reference only)

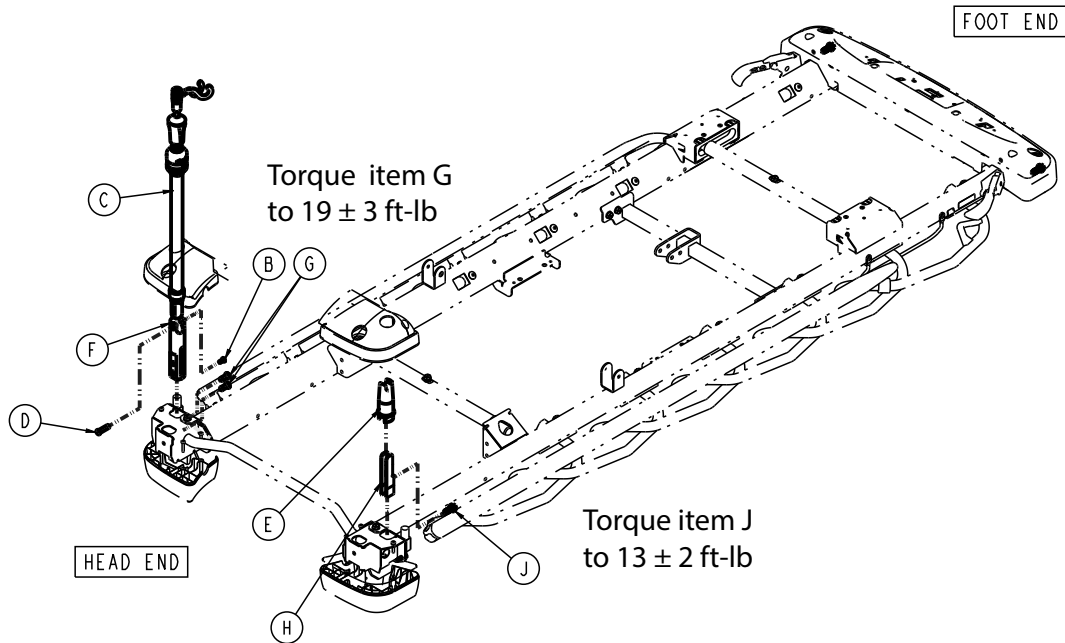

1105-035-342	Three-stage 30" IV, left, head end
1105-035-337	Three-stage 30" IV, right, head end
1105-035-344	Three-stage 30" IV, left, foot end
1105-035-339	Three-stage 30" IV, right, foot end

Item	Number	Name	Quantity
B	0025-079-000	Dome head rivet	1
C	0785-035-300	30" three-stage IV pole assembly	1
D	0785-048-025	Handle pivot pin	1
E	0785-135-020	Magnetic IV pole support assembly	1
F	0785-210-020	IV pole socket	1
G	0004-871-000	Button head cap screw	2
H	0785-135-021	Internal IV support	1
J	0023-288-000	Hex washer head screw	1

30" two-stage IV pole, Prime X option

Rev AA (Reference only)

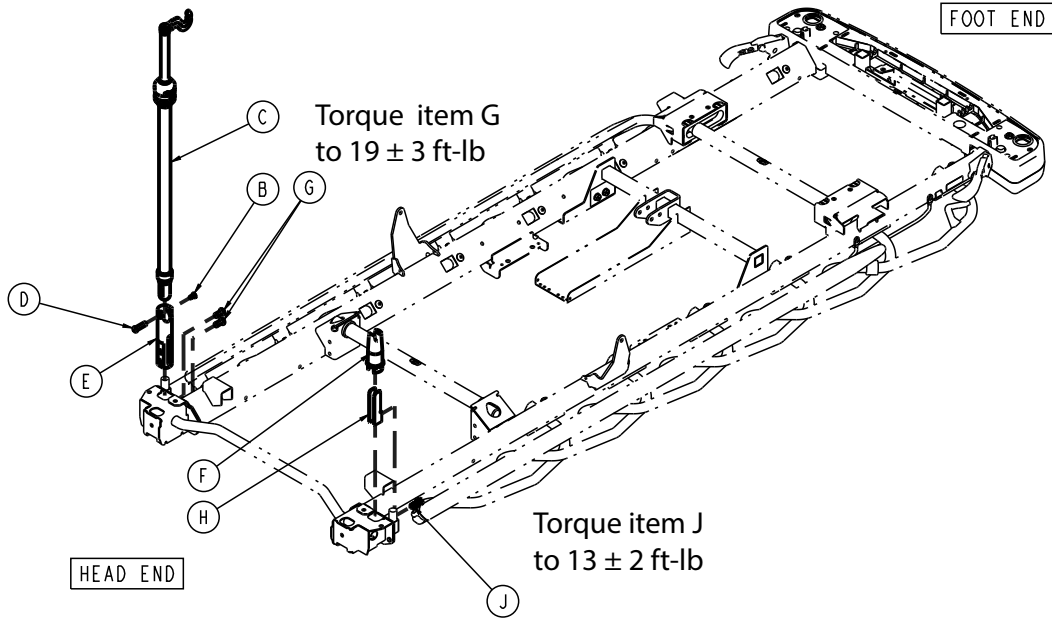

1105-035-367	Two-stage 30" IV, left, head end
1105-035-368	Two-stage 30" IV, right, head end
1105-035-362	Two-stage 30" IV, left, foot end
1105-035-363	Two-stage 30" IV, right, foot end

Item	Number	Name	Quantity
B	0025-079-000	Dome head rivet	1
C	0785-035-401	30" two-stage IV pole assembly	1
D	0785-048-025	Handle pivot pin	1
E	0785-210-020	IV pole socket	1
F	1105-060-020	Magnetic IV pole support assembly	1
G	0004-871-000	Button head cap screw	2
H	0785-135-021	Internal IV support	1
J	0023-288-000	Hex washer head screw	1

30" three-stage IV pole, Prime X option

Rev AA (Reference only)

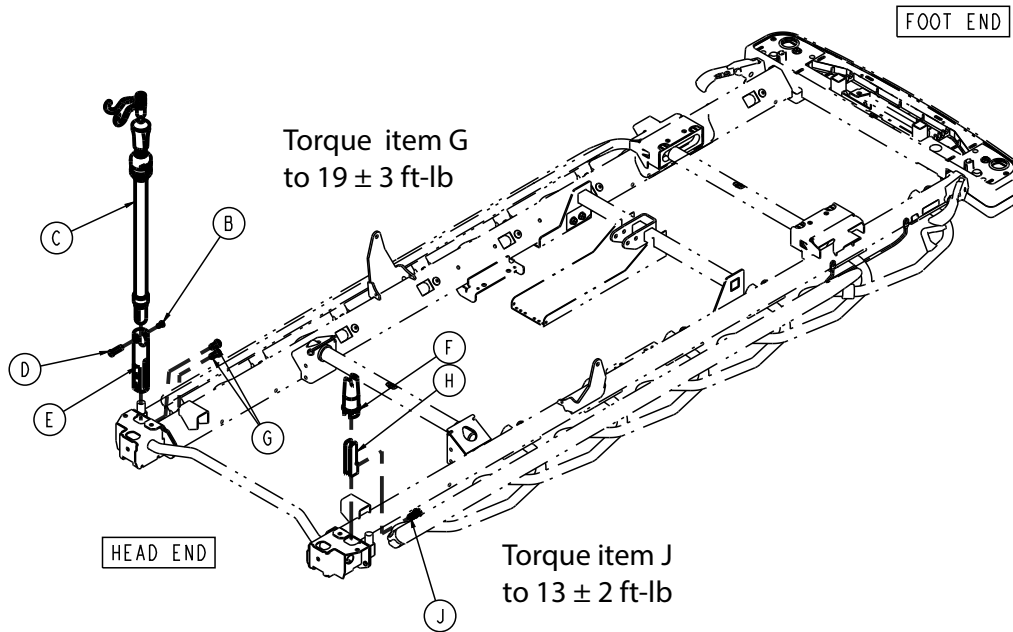

1105-035-369	Three-stage 30" IV, left, head end
1105-035-366	Three-stage 30" IV, right, head end
1105-035-364	Three-stage 30" IV, left, foot end
1105-035-361	Three-stage 30" IV, right, foot end

Item	Number	Name	Quantity
B	0025-079-000	Dome head rivet	1
C	0785-035-300	30" three-stage IV pole assembly	1
D	0785-048-025	Handle pivot pin	1
E	0785-210-020	IV pole socket	1
F	1105-060-020	Magnetic IV pole support assembly	1
G	0004-871-000	Button head cap screw	2
H	0785-135-021	Internal IV support	1
J	0023-288-000	Hex washer head screw	1

26" standard Fowler with Gatch, stretcher extender option

1105-090-603 Rev AA (Reference only)

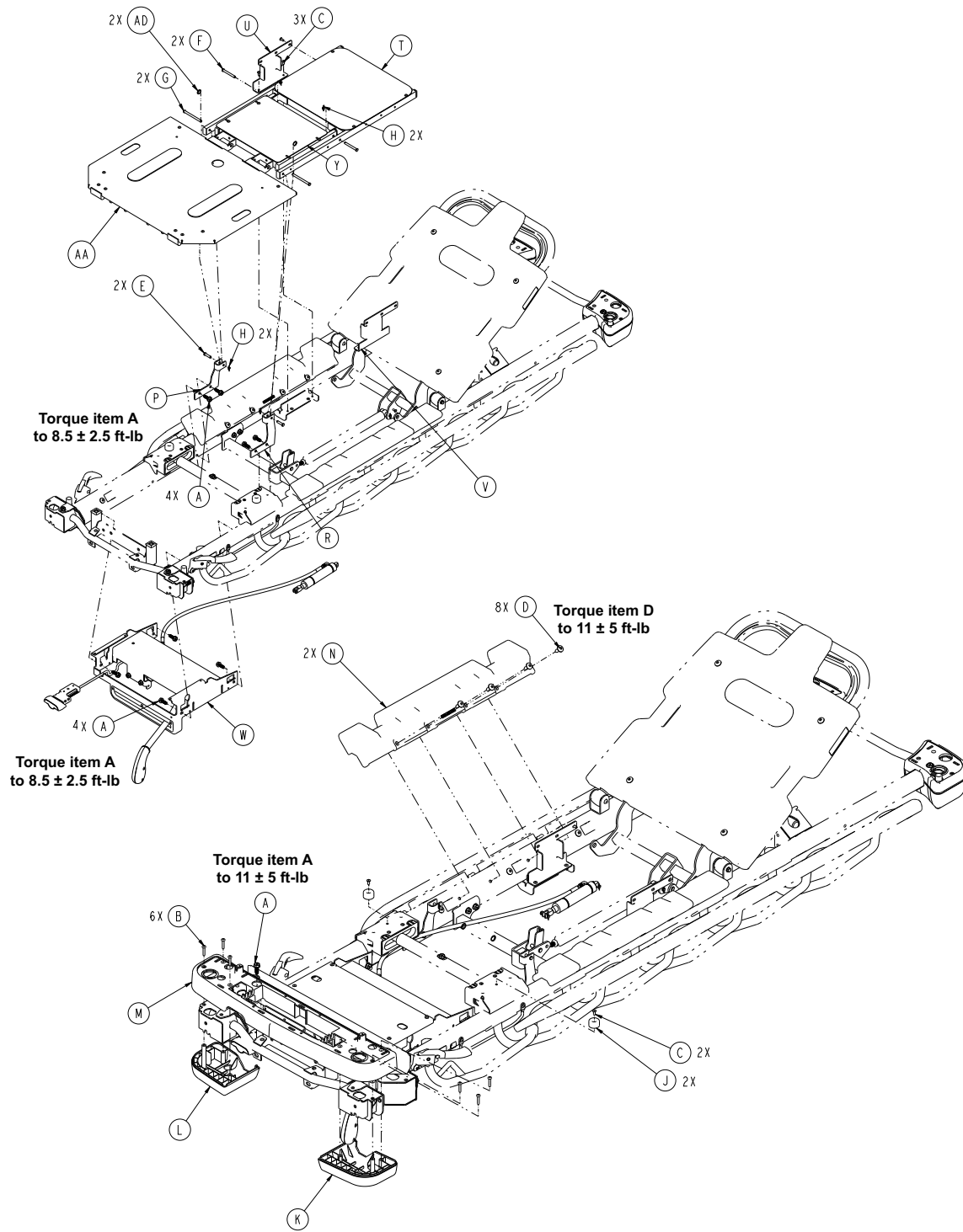

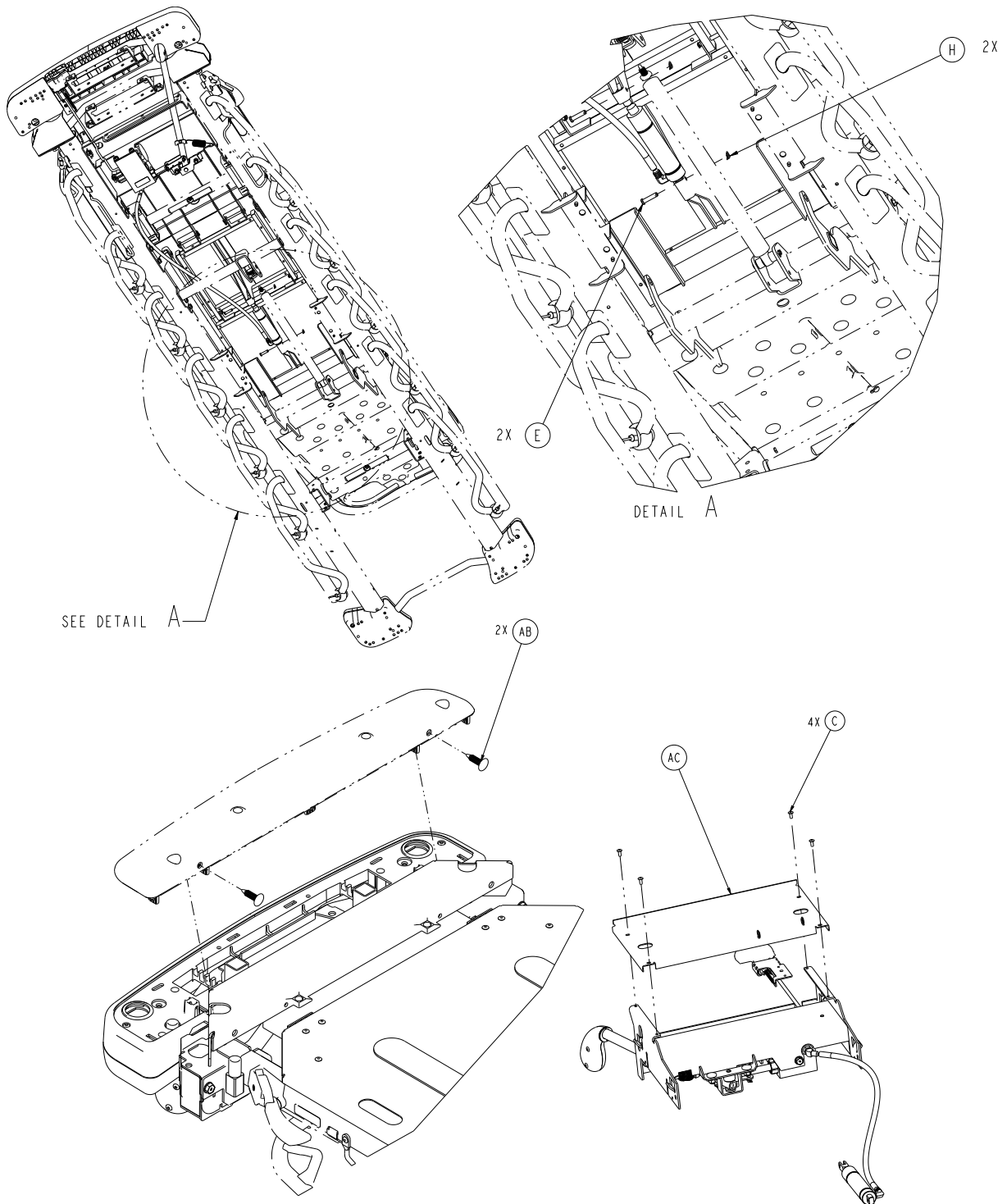

Item	Number	Number	Quantity
A	0023-288-000	Hex washer head screw	9
B	0023-310-000	Pan head tapping screw	6
C	0025-079-000	Rivet	12
D	0007-074-000	Truss head machine screw	8
E	0026-316-000	Clevis pin	4
F	0026-334-000	Clevis pin	2
G	0026-364-000	Clevis pin	2
H	0027-020-000	Rue ring cotter	6

Item	Number	Number	Quantity
J	0056-023-000	Bumper, recessed	2
K	0785-210-052	Cover, bottom, foot end, left	1
L	0785-210-057	Cover, bottom, foot end, right	1
M	0785-210-650	26" cover, mid, foot end	1
N	1105-010-049	Mattress support block	2
P	1105-013-034	Drop seat pivot bracket, right	1
R	1105-013-039	Drop seat pivot bracket, left	1
T	1105-013-610	26" seat section assembly	1
U	1105-014-117	Seat support bracket, left	1
V	1105-014-119	Seat support bracket, right	1
W	1105-014-695	26" Gatch stretcher extender assembly (page 396)	1
Y	1105-014-610	26" thigh section assembly (page 255)	1
AA	1008-115-601	26" foot assembly (page 256)	1
AB	0029-027-000	Panel fastener	2
AC	1105-014-694	26" Gatch hanger cover	1
AD	0027-035-000	Circular cotter	2

26" drop seat with Gatch, stretcher extender option

1105-090-602 Rev AA (Reference only)

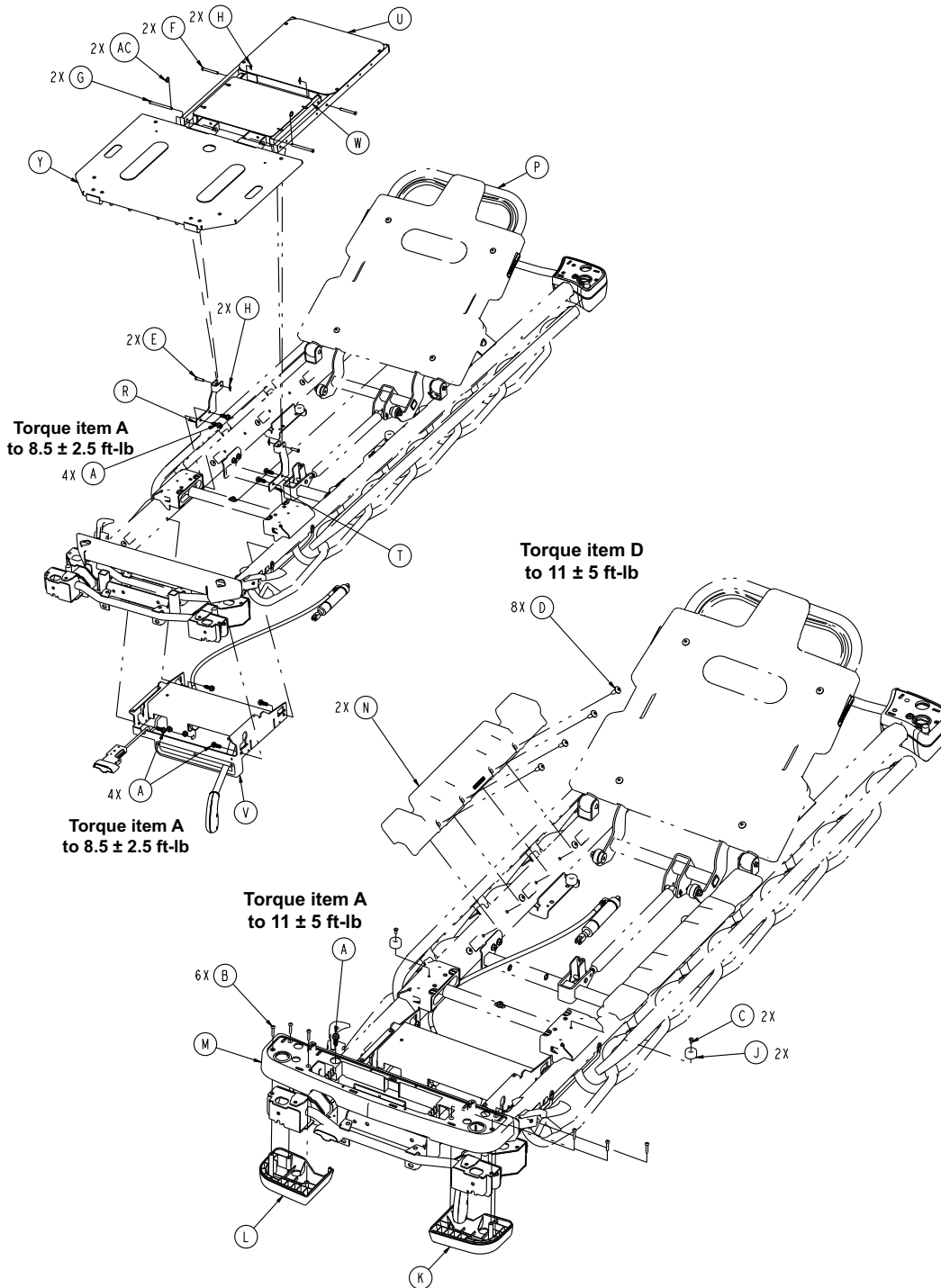

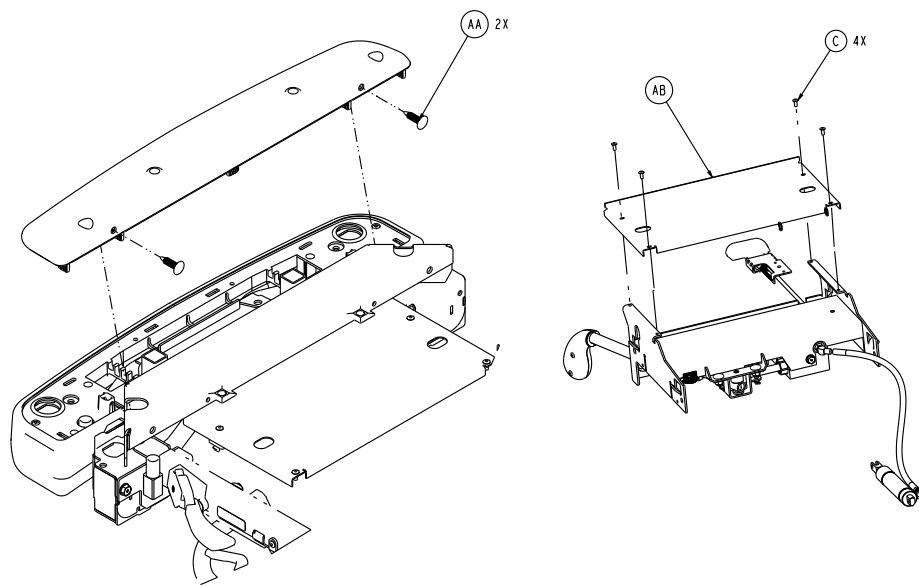
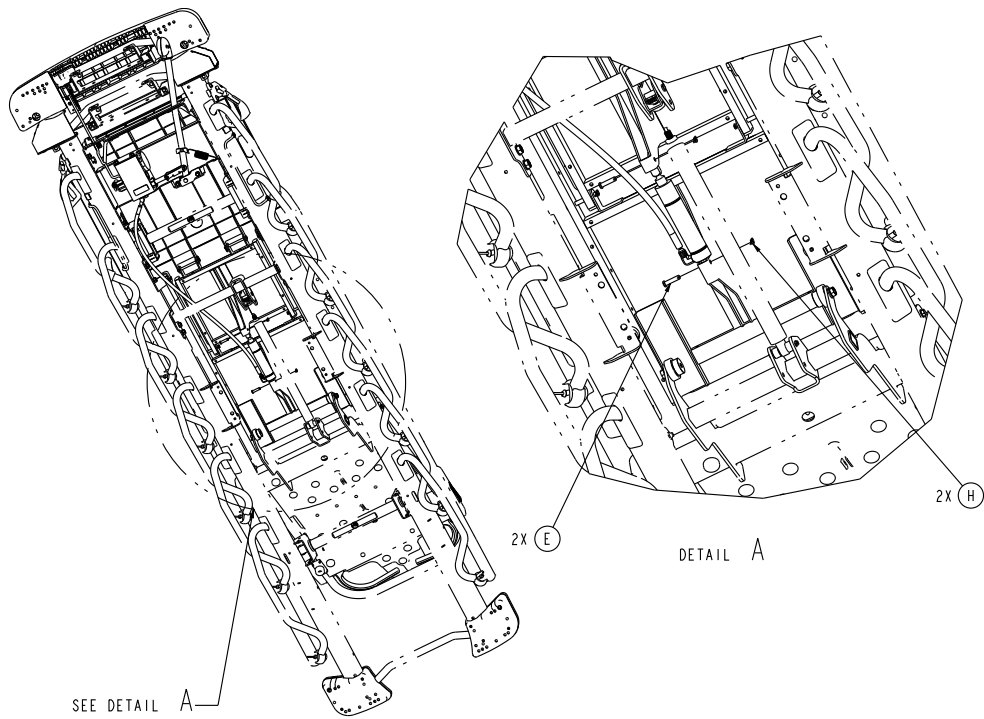

Item	Number	Name	Quantity
A	0023-288-000	Hex washer head screw	9
B	0023-310-000	Pan head tapping screw	6
C	0025-079-000	Dome head pop rivet	6
D	0007-074-000	Truss head machine screw	8
E	0026-316-000	Clevis pin	4
F	0026-334-000	Clevis pin	2
G	0026-364-000	Clevis pin	2
H	0027-020-000	Rue ring cotter	6
J	0056-023-000	Bumper	2
K	0785-210-052	Bottom cover, foot end, left	1
L	0785-210-057	Bottom cover, foot end, right	1

Item	Number	Name	Quantity
M	0785-210-650	26" mid cover, foot end	1
N	1105-010-049	Mattress support block	2
P	1105-012-601	26" drop seat Fowler assembly (page 247)	1
R	1105-013-034	Drop seat pivot bracket, right	1
T	1105-013-039	Drop seat pivot bracket, left	1
U	1105-013-610	26" seat section assembly - 1105-013-610 (page 254)	1
V	1105-014-695	26" Gatch stretcher extender assembly (page 396)	1
W	1105-014-610	26" thigh section assembly (page 255)	1
Y	1008-115-601	26" foot assembly (page 256)	1
AA	0029-027-000	Panel fastener	2
AB	1105-014-694	26" Gatch hanger cover	1
AC	0027-035-000	Circular cotter	2

26" stretcher extender option

1105-090-002 Rev A (Reference only)

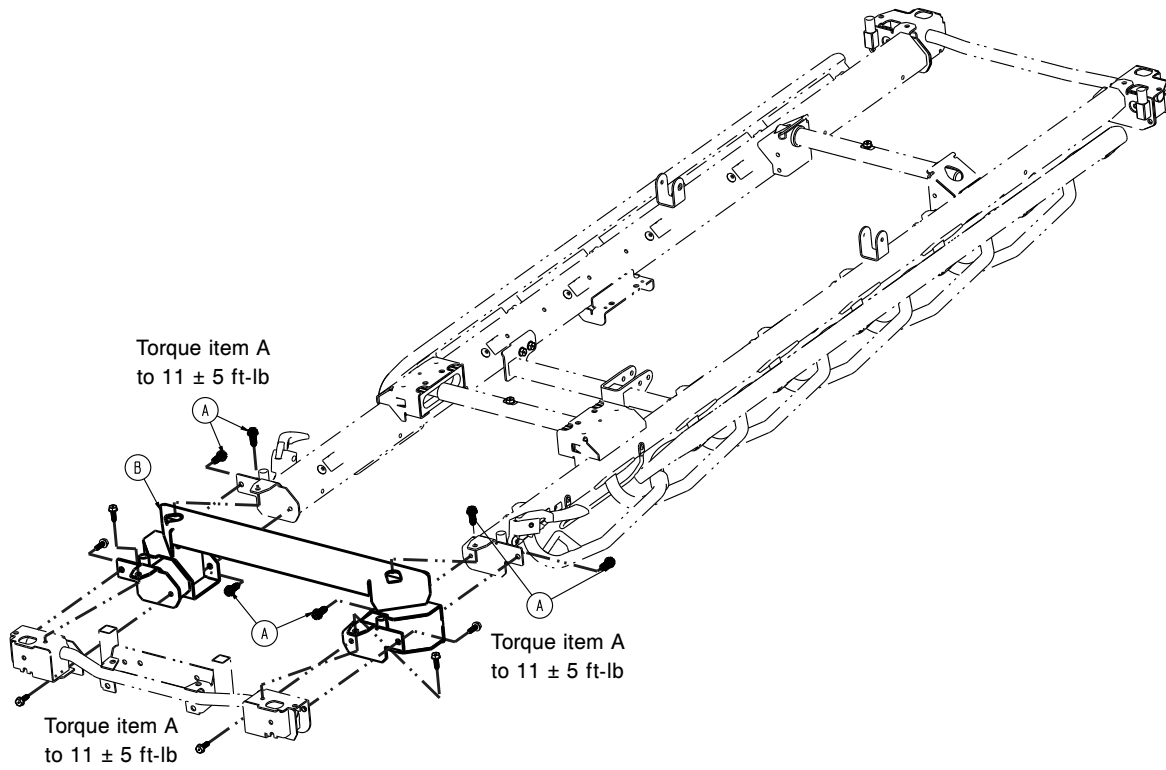

Item	Number	Name	Quantity
A	0023-288-000	Hex washer head screw	6
B	1105-090-610	26" stretcher extender weldment	1

26" Gatch stretcher extender assembly

1105-014-695 Rev A (Reference only)

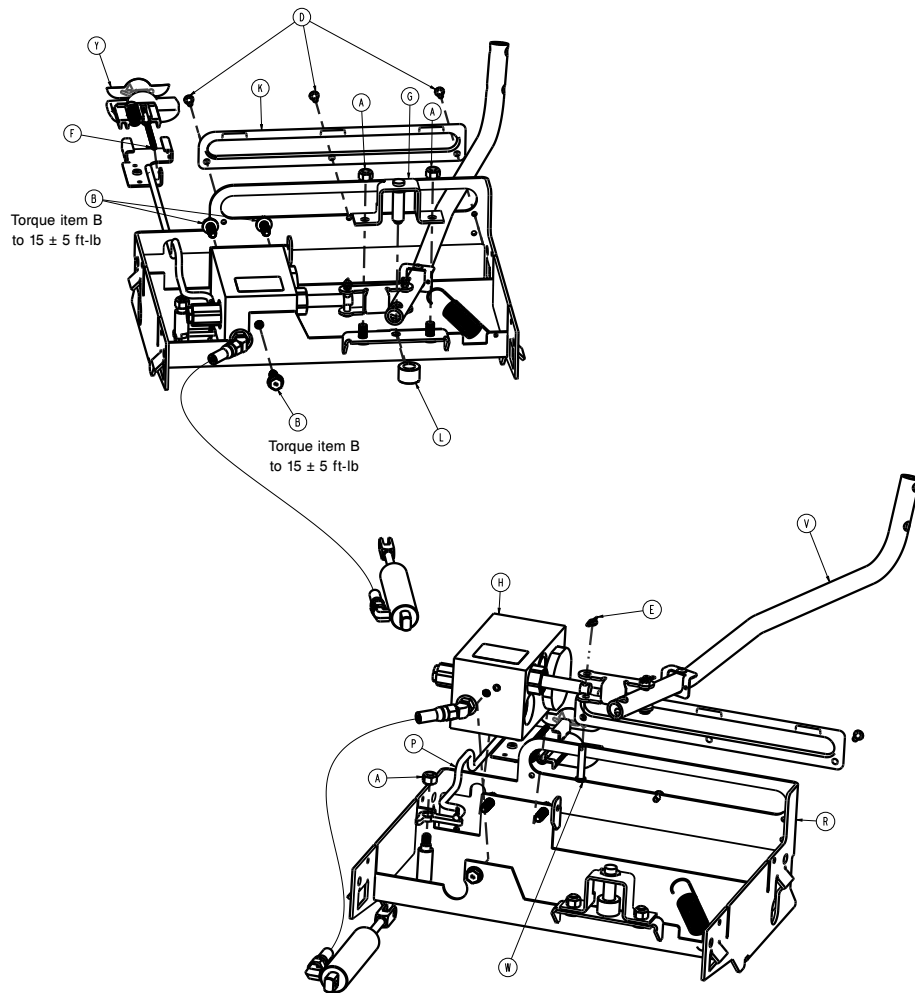

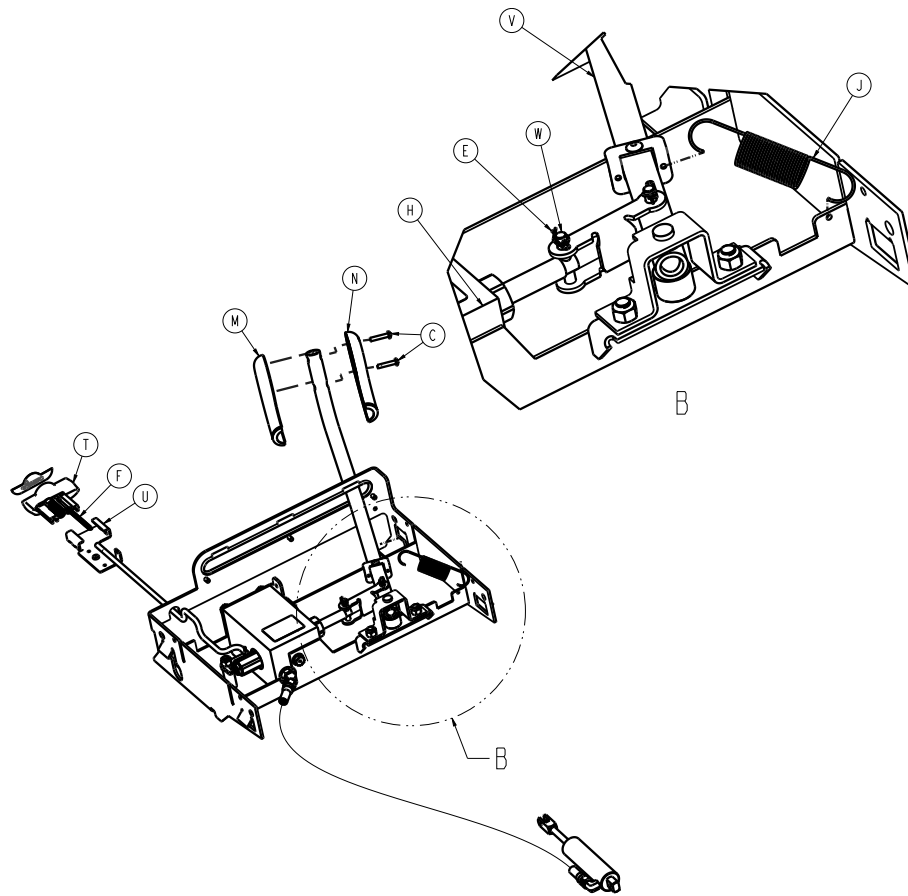

Item	Number	Name	Quantity
A	0016-036-000	Nylock hex nut	3
B	0023-288-000	Hex washer head screw	3
C	0023-310-000	Pan head tapping screw	2
D	0025-079-000	Rivet	3
E	0027-020-000	Rue ring cotter	1
F	0038-603-000	Spring	1
G	0785-014-030	Gatch pivot weldment	1
H	0785-014-043	<i>Gatch valve body assembly - 0785-014-043 (page 272)</i>	1
J	0785-014-107	Gatch return spring	1
K	0785-014-113	Gatch pump bumper	1
L	0785-014-133	Gatch pivot spacer	1
M	0785-014-156	Gatch pump handle, left	1
N	0785-014-157	Gatch pump handle, right	1
P	1105-114-693	<i>26" Gatch release handle, stretcher extender option (page 398)</i>	1
R	0785-114-625	<i>26" Gatch weldment</i>	1
T	0785-210-651	<i>26" Gatch release handle</i>	1
U	0785-210-652	<i>26" Gatch release guide</i>	1
V	1105-014-196	<i>Gatch pump assembly, stretcher extender option (page 399)</i>	1
W	8805-932-000	Clevis pin	1
Y	0785-210-353	Label, Gatch release	1

26" Gatch release handle, stretcher extender option

1105-114-693 Rev A (Reference only)

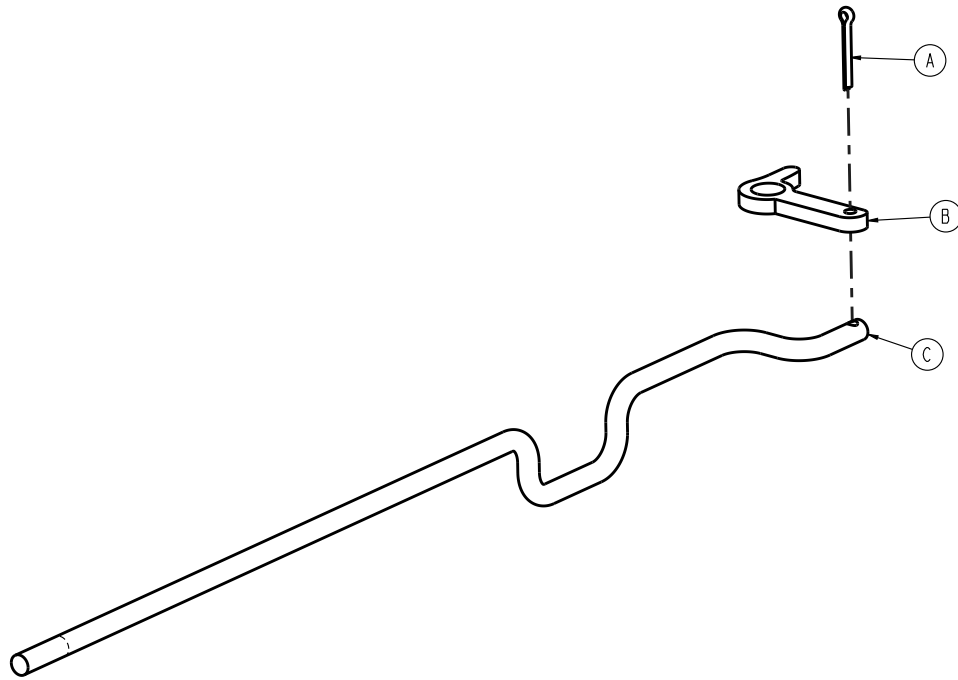

Item	Number	Name	Quantity
A	0027-015-000	Cotter pin	1
B	0785-014-038	Gatch release link	1
C	1105-014-697	26" extended Gatch release rod	1

Gatch pump assembly, stretcher extender option

1105-014-196 Rev A (Reference only)

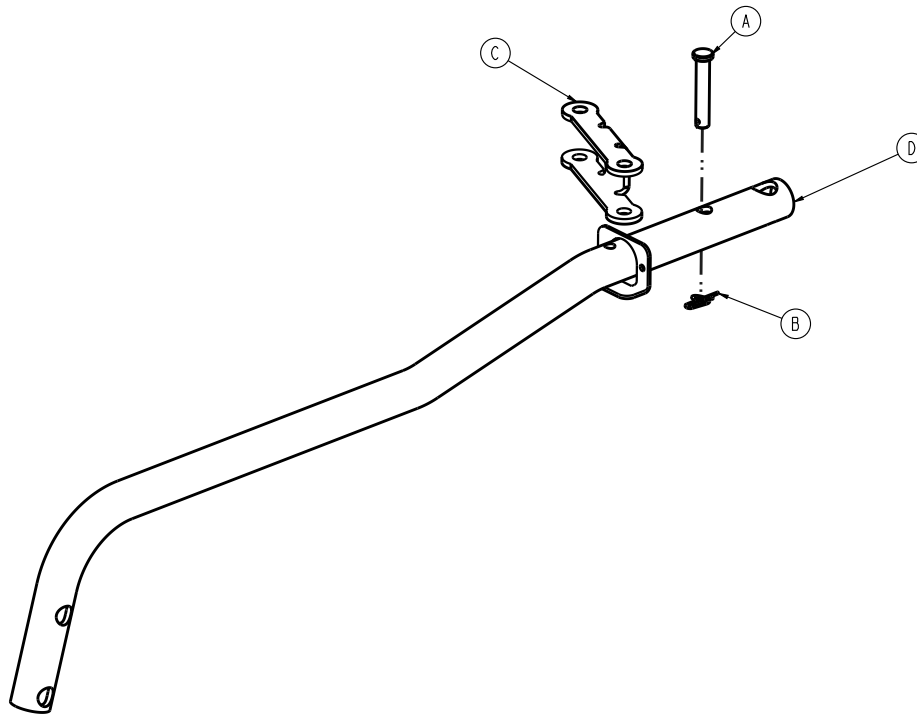

Item	Number	Name	Quantity
A	8805-932-000	Clevis pin	1
B	0027-020-000	Rue ring cotter	1
C	0785-014-024	Gatch pump link	1
D	1105-014-199	<i>Gatch handle assembly, stretcher assembly (page 400)</i>	1

Gatch handle assembly, stretcher assembly

1105-014-199 Rev A (Reference only)

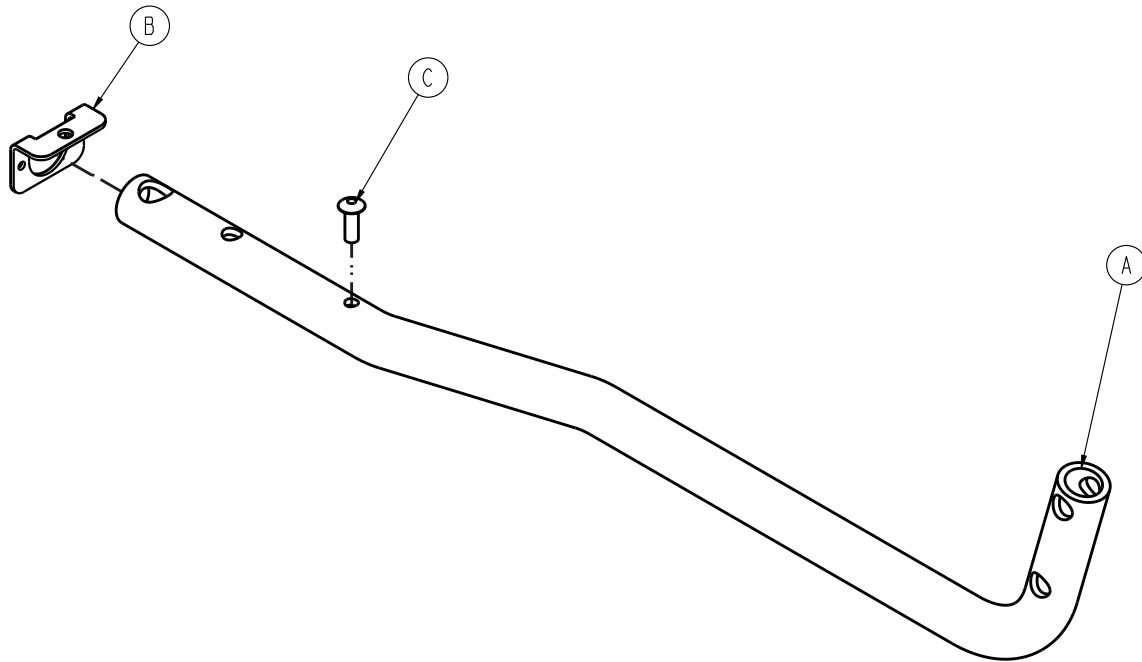

Item	Number	Name	Quantity
A	1105-014-091	Extended Gatch handle tube	1
B	1105-014-109	Gatch return spring bracket	1
C	0025-079-000	Rivet	1

30" standard Fowler with Gatch, stretcher extender option

1105-090-303 Rev AA (Reference only)

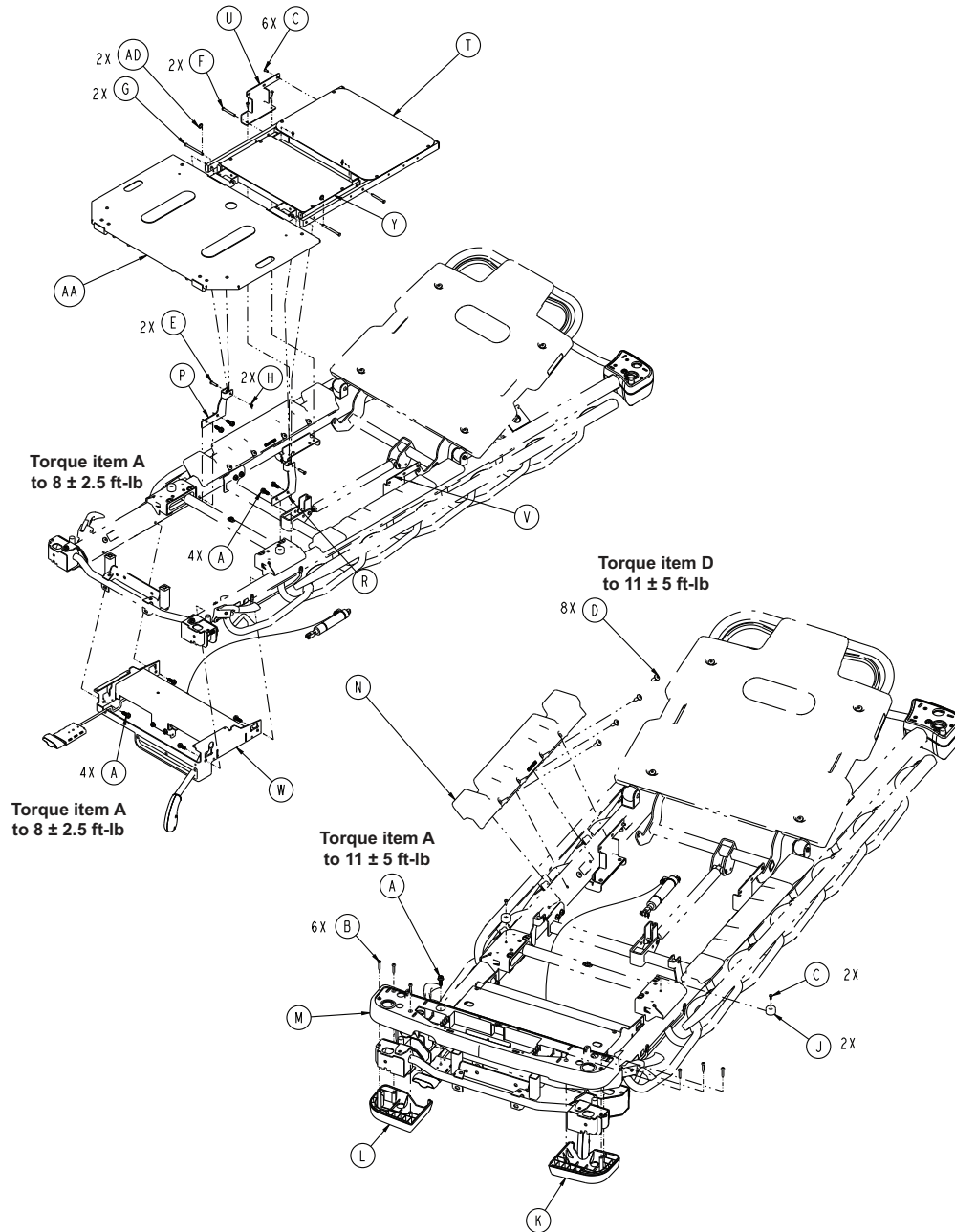

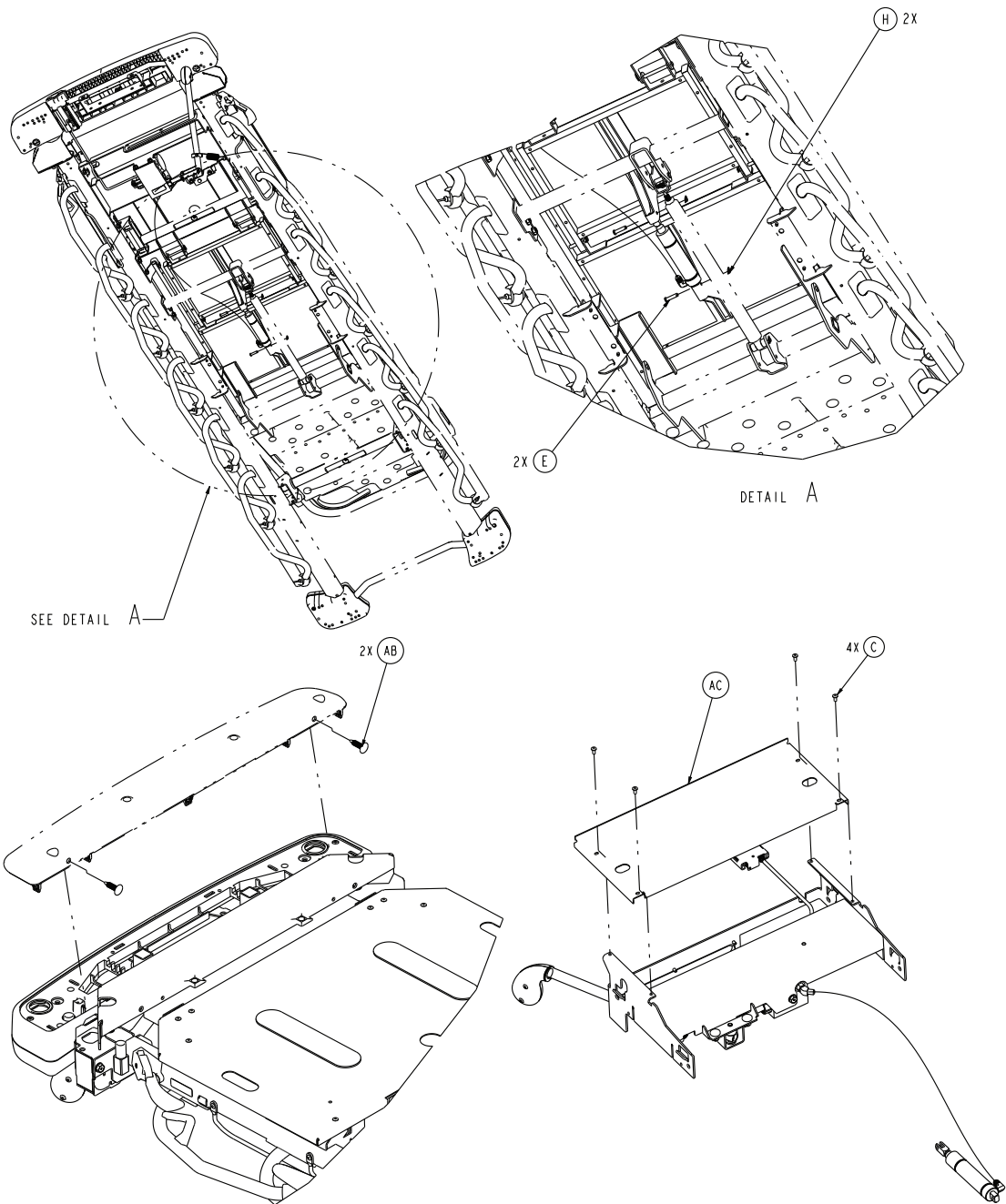

Item	Number	Name	Quantity
A	0023-288-000	Hex washer head screw	9
B	0023-310-000	Pan head tapping screw	6
C	0025-079-000	Dome head pop rivet	12
D	0007-074-000	Truss head machine screw	8
E	0026-316-000	Clevis pin	4
F	0026-334-000	Clevis pin	2
G	0026-364-000	Clevis pin	2
H	0027-020-000	Rue ring cotter	6
J	0056-023-000	Bumper	2
K	0785-210-052	Bottom cover, foot end, left	1
L	0785-210-057	Bottom cover, foot end, right	1
M	0785-210-350	30" mid cover, foot end	1

Item	Number	Name	Quantity
N	1105-010-049	Mattress support block	2
P	1105-013-034	Drop seat pivot bracket, right	1
R	1105-013-039	Drop seat pivot bracket, left	1
T	1105-013-310	<i>30" seat section assembly (page 266)</i>	1
U	1105-014-117	Seat support bracket, left	1
V	1105-014-119	Seat support bracket, right	1
W	1105-014-395	<i>30" Gatch assembly, stretcher extender option (page 408)</i>	1
Y	1105-014-310	<i>30" thigh section assembly (page 267)</i>	1
AA	1008-115-301	<i>26" foot assembly (page 256)</i>	1
AB	0029-027-000	Panel fastener	2
AC	1105-014-394	30" Gatch hanger cover	1
AD	0027-035-000	Circular cotter	2

30" drop seat with Gatch, stretcher extender option

1105-090-302 Rev AB (Reference only)

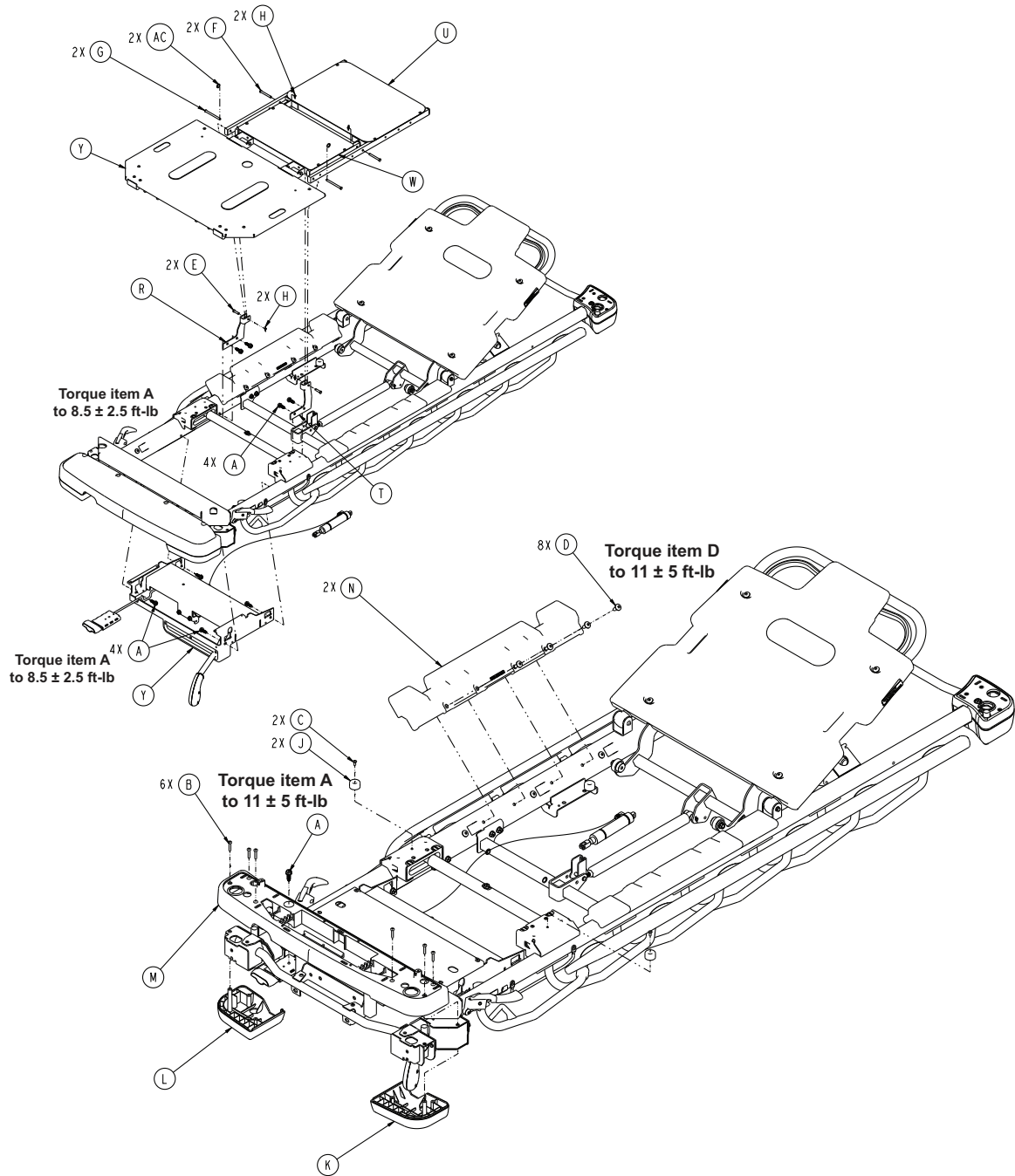

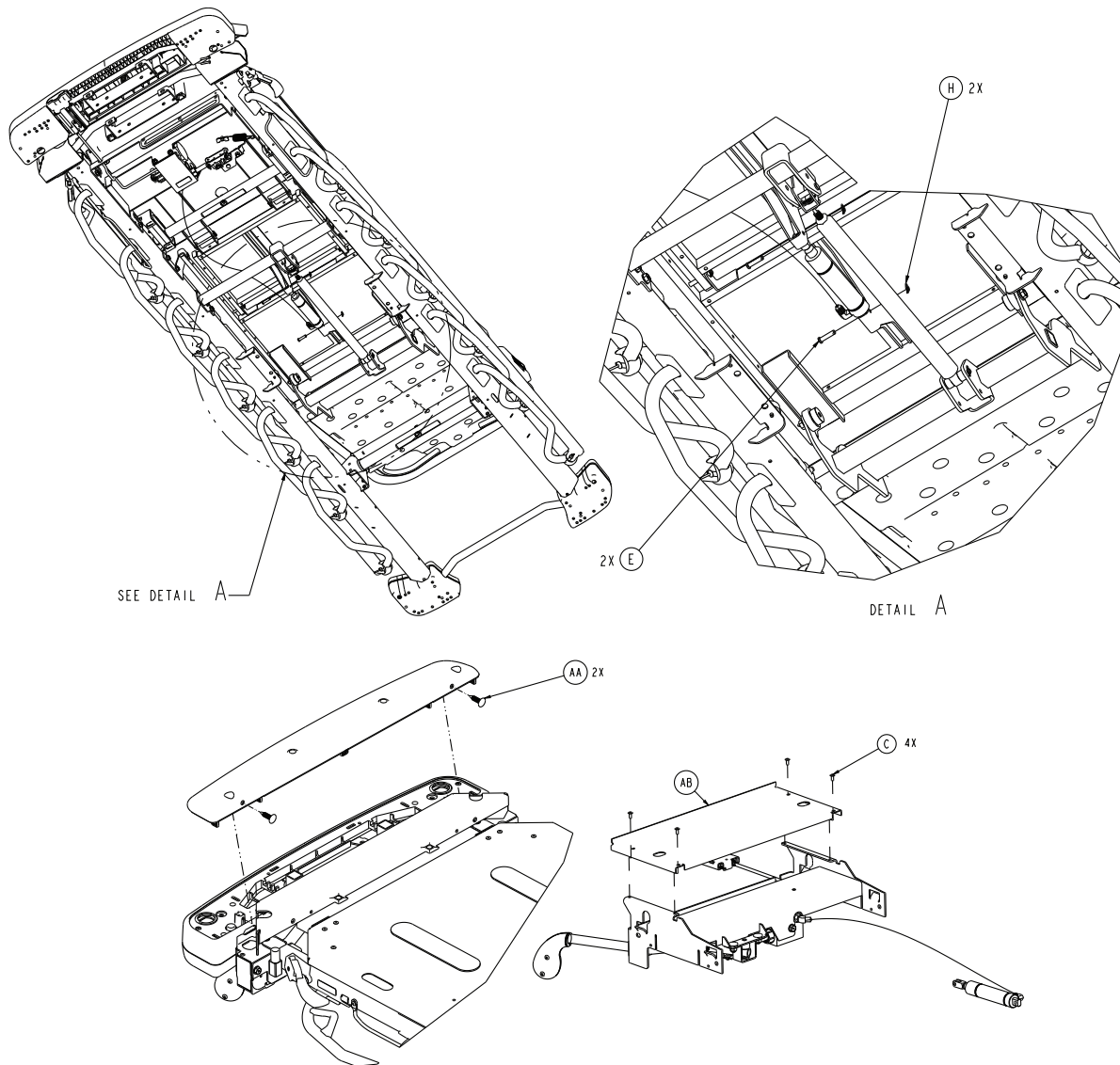

Item	Number	Name	Quantity
A	0023-288-000	Hex washer head screw	9
B	0023-310-000	Pan head tapping screw	6
C	0025-079-000	Rivet	6
D	0007-074-000	Truss head machine screw	8
E	0026-316-000	Clevis pin	4
F	0026-334-000	Clevis pin	2
G	0026-364-000	Clevis pin	2
H	0027-020-000	Rue ring cotter	6
J	0056-023-000	Bumper, recessed	2
K	0785-210-052	Cover, bottom, foot end, left	1
L	0785-210-057	Cover, bottom, foot end, right	1
M	0785-210-350	30" mid cover, foot end	1
N	1105-010-049	Mattress support block	2
P	1105-012-301	30" drop seat Fowler assembly (page 260)	1
R	1105-013-034	Drop seat pivot bracket, right	1
T	1105-013-039	Drop seat pivot bracket, left	1

Item	Number	Name	Quantity
U	1105-013-310	<i>30" seat section assembly (page 266)</i>	1
V	1105-014-395	<i>30" Gatch assembly, stretcher extender option (page 408)</i>	1
W	1105-014-310	<i>30" thigh section assembly (page 267)</i>	1
Y	1008-115-301	<i>26" foot assembly (page 256)</i>	1
AA	0029-027-000	Panel fastener	2
AB	1105-014-394	30" Gatch hanger cover	1
AC	0027-035-000	Circular cotter	2

30" stretcher extender option

1105-090-001 Rev A (Reference only)

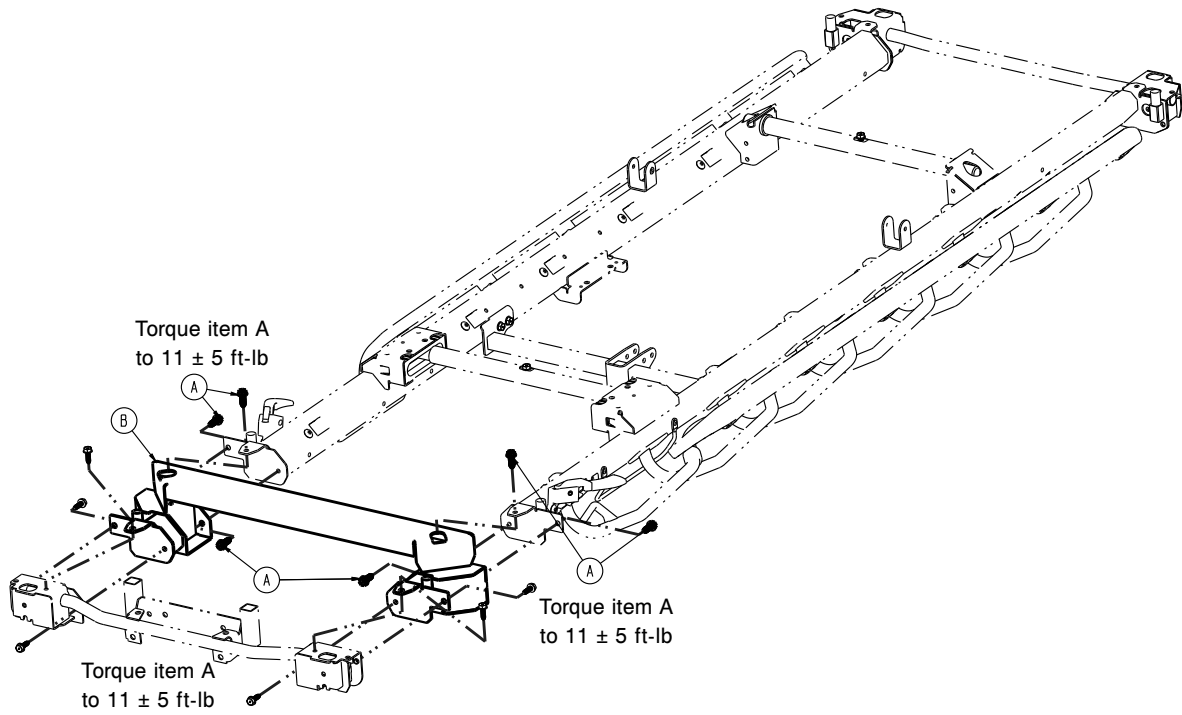

Item	Number	Name	Quantity
A	0023-288-000	Hex washer head screw	6
B	1105-090-310	30" stretcher extender weldment	1

30" Gatch assembly, stretcher extender option

1105-014-395 Rev A (Reference only)

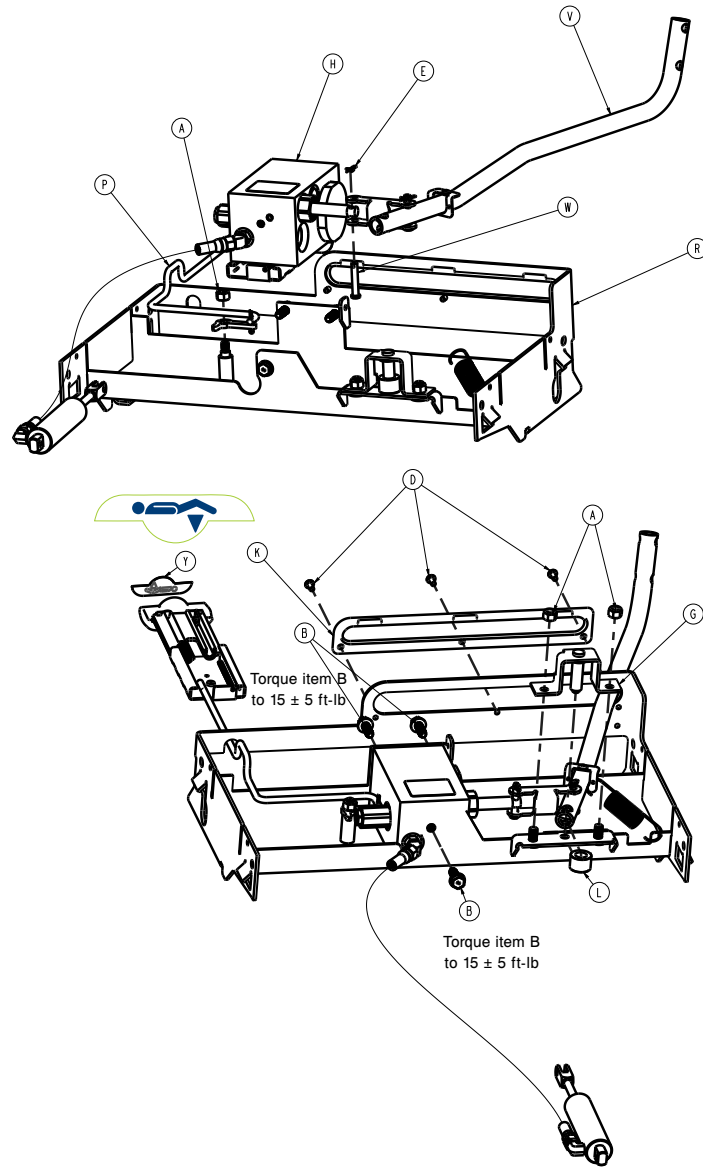

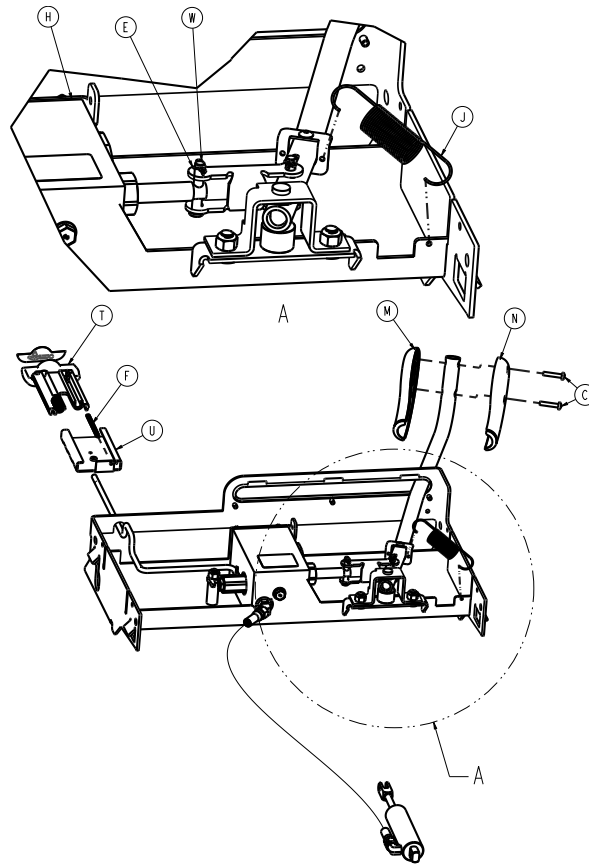

Item	Number	Name	Quantity
A	0016-036-000	Nylock hex nut	3
B	0023-288-000	Hex washer head screw	3
C	0023-310-000	Pan head tapping screw	2
D	0025-079-000	Dome head rivet	3
E	0027-020-000	Rue ring cotter	1
F	0038-603-000	Spring	1
G	0785-014-030	Gatch pivot weldment	1
H	0785-014-043	<i>Gatch valve body assembly - 0785-014-043 (page 272)</i>	1
J	0785-014-107	Gatch return spring	1
K	0785-014-113	Gatch pump bumper	1
L	0785-014-133	Gatch pivot spacer	1
M	0785-014-156	Gatch pump handle, left	1
N	0785-014-157	Gatch pump handle, right	1
P	1105-114-393	<i>30" Gatch release handle, stretcher extender option (page 410)</i>	1
R	0785-114-325	30" Gatch weldment	1
T	0785-210-351	30" Gatch release handle	1
U	0785-210-352	30" Gatch release guide	1
V	1105-014-196	<i>Gatch pump assembly, stretcher extender option (page 399)</i>	1
W	8805-932-000	Clevis pin	1
Y	0785-210-353	Gatch release label	1

30" Gatch release handle, stretcher extender option

1105-114-393 Rev A (Reference only)

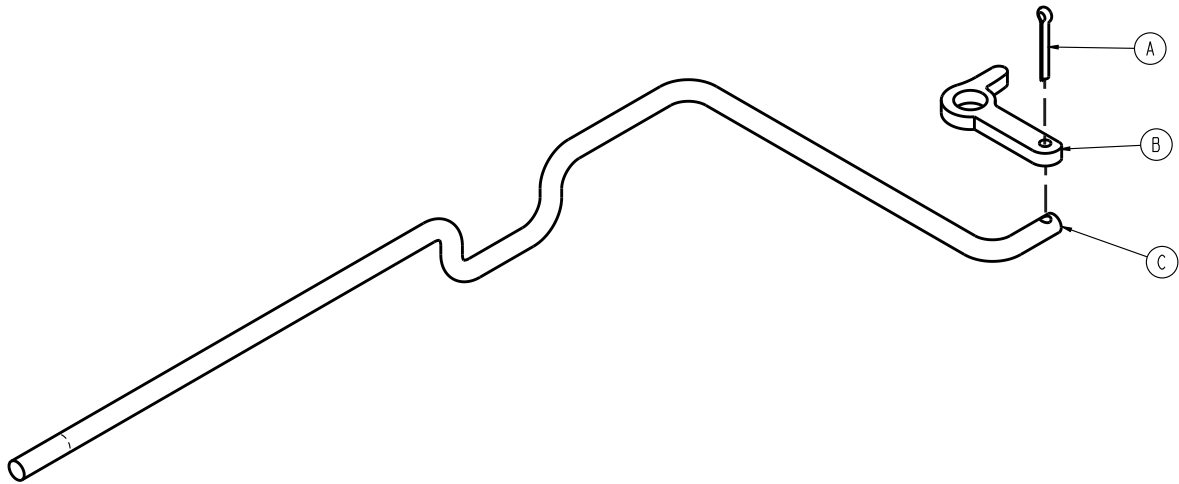

Item	Number	Name	Quantity
A	0027-015-000	Cotter pin	1
B	0785-014-038	Gatch release link	1
C	1105-014-367	30" extended Gatch release rod	1

Upright bottle holder - 1115-130-000

Rev B (Reference only)

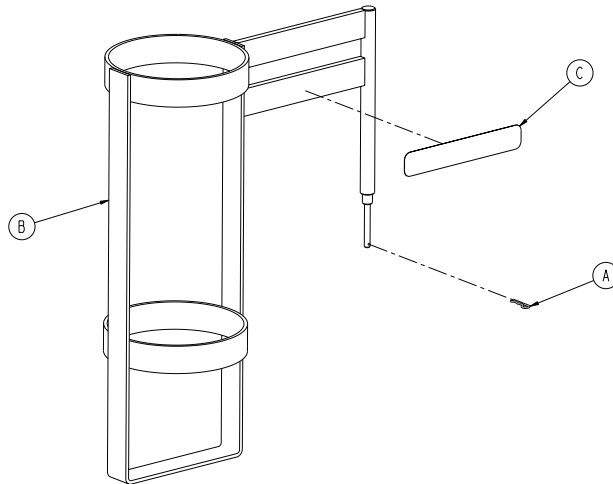

Item	Number	Name	Quantity
A	0027-030-000	Hair pin cotter	1
B	1115-030-111	Upright bottle holder	1
C	1115-130-117	Label, oxygen bottle holder	1

26" pump bar weldment - 1105-045-065

Rev B (Reference only)

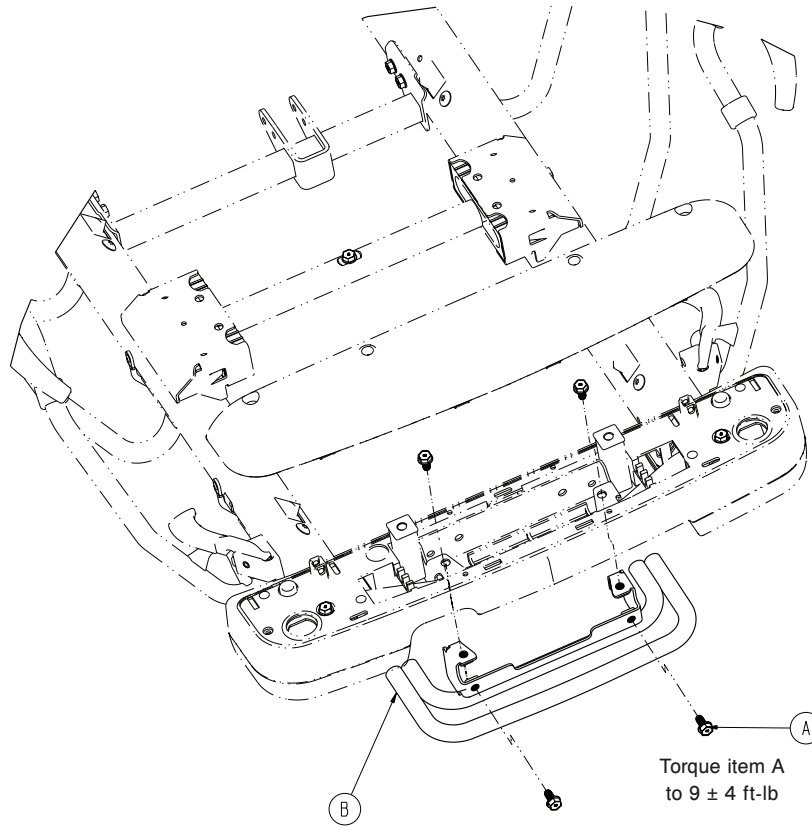

Item	Number	Name	Quantity
A	0023-330-000	Hex washer head screw	4
B	0785-045-065	26" pump bar weldment	1

30" pump bar weldment - 1105-045-035

Rev B (Reference only)

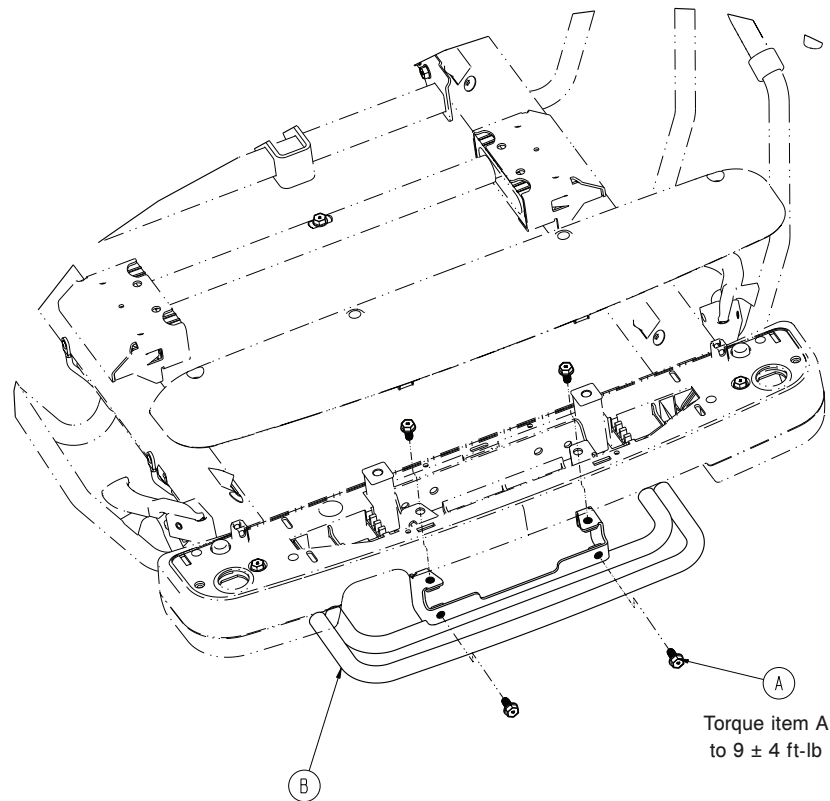

Item	Number	Name	Quantity
A	0023-330-000	Hex washer head screw	4
B	0785-045-035	30" pump bar weldment	1

26" push handle assembly - 1105-048-026

Rev A (Reference only)

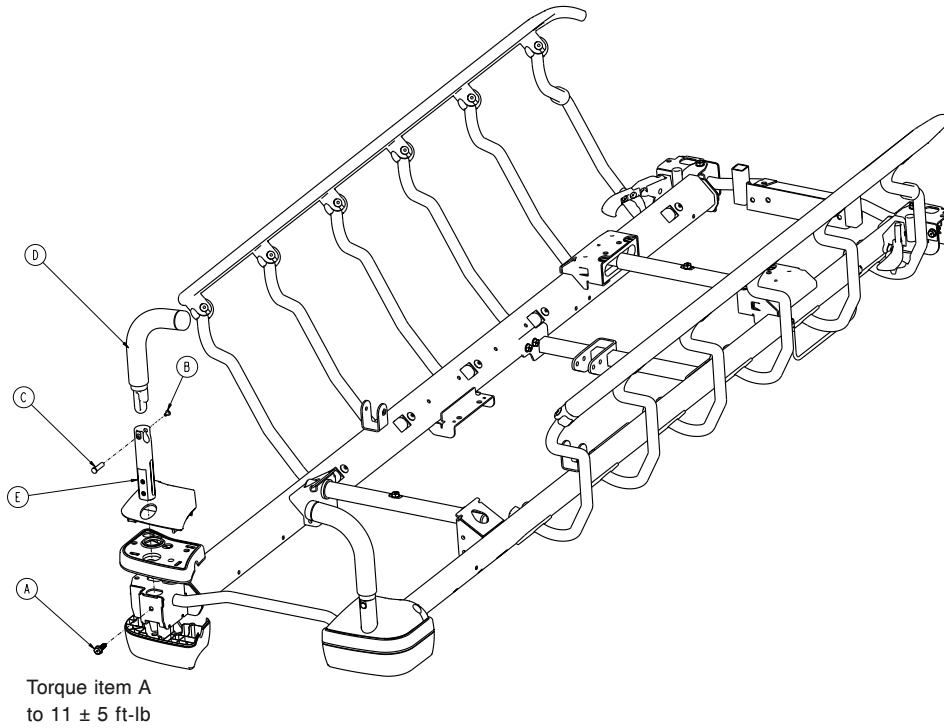

Item	Number	Name	Quantity
A	0023-288-000	Hex washer head screw	2
B	0025-079-000	Dome head rivet	2
C	0785-048-025	Handle pivot pin	2
D	0785-148-026	26" push handle	2
E	0785-210-020	IV pole socket	2

30" push handle assembly - 1105-048-030

Rev A (Reference only)

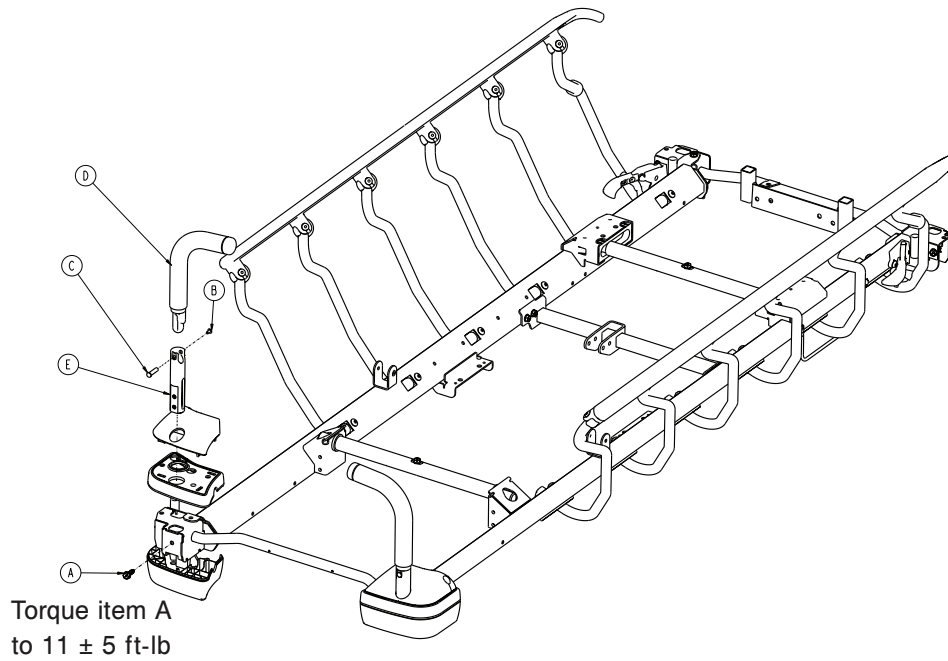

Item	Number	Name	Quantity
A	0023-288-000	Hex washer head screw	2
B	0025-079-000	Dome head rivet	2
C	0785-048-025	Handle pivot pin	2
D	0785-148-030	30" push handle	2
E	0785-210-020	IV pole socket	2

Foot end push handles assembly - 1105-048-040

Rev A (Reference only)

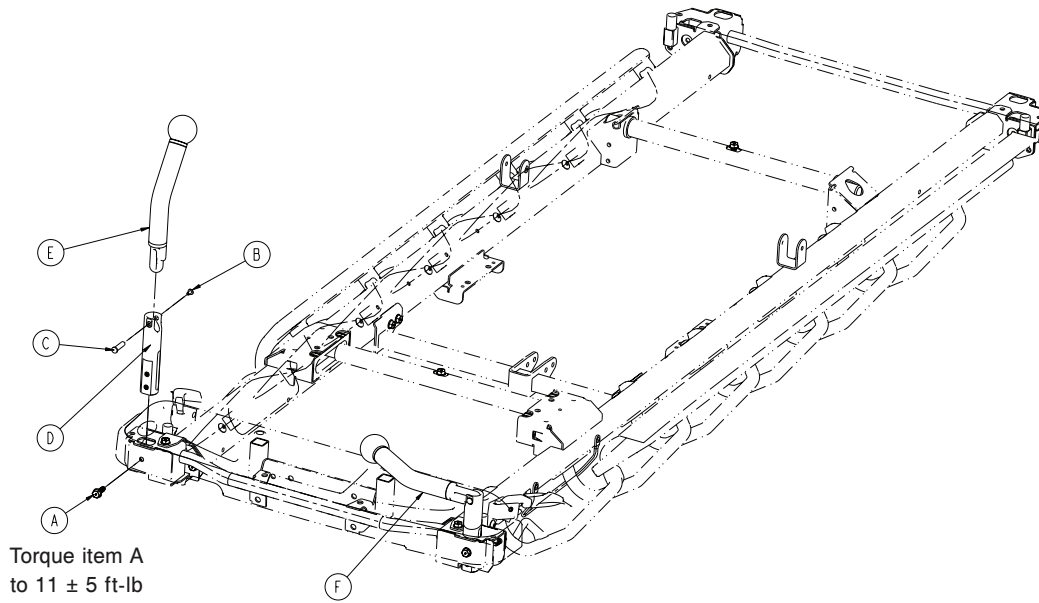

Item	Number	Name	Quantity
A	0023-288-000	Hex washer head screw	2
B	0025-079-000	Dome head pop rivet	2
C	0785-048-025	Handle pivot pin	2
D	0785-210-020	IV pole socket	2
E	1105-048-014	Foot end push handles assembly (page 417)	1
F	1105-048-024	Foot end push handles assembly (page 417)	1

Foot end push handles assembly

Right 1105-048-014 Rev A (Reference only)

Left 1105-048-024 Rev A (Reference only)

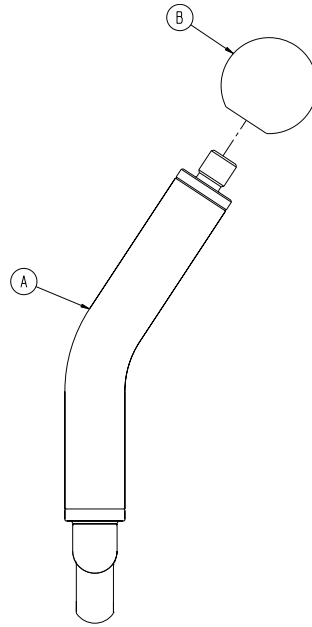

Item	Number	Name	Quantity
A	1105-048-025	Foot end push handle weldment, left	1 or
	1105-048-015	Foot end push handle weldment, right	1
B	6510-001-119	Handle ball	1

Ankle restraint strap - 0785-045-020

Rev AC (Reference only)



Chest restraint strap - 1010-058-000

Rev AC (Reference only)

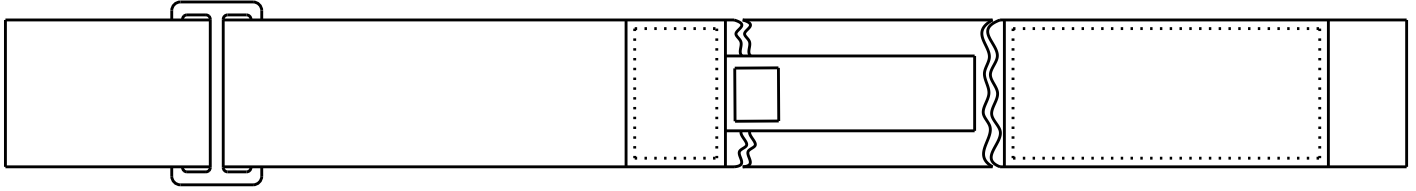

Number	Name
0390-019-001	Restraining strap, long
0390-019-002	Restraining strap, short

Wrist restraint strap - 0946-044-000

Rev C (Reference only)

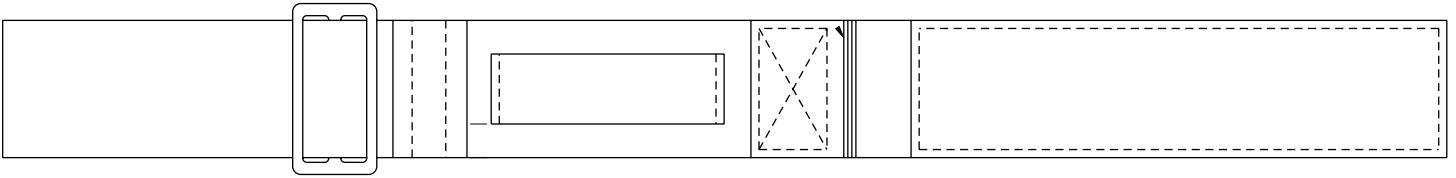

Number	Name
0946-044-001	Wrist restraining strap

Body restraint strap - 0785-045-015

Rev AC (Reference only)



Number	Name
0785-045-016	Restraining strap, long
0785-045-017	Restraining strap, short
0785-045-018	Body restraint instructions
0036-019-908	Label, packaging, JAC

Full restraint strap package - 0785-045-010

Rev E (Reference only)

Number	Name
0785-045-015	Body restraints
0785-045-020	Ankle restraints
0946-044-001	Wrist restraints

Serving tray - 1105-045-700

Rev B (Reference only)

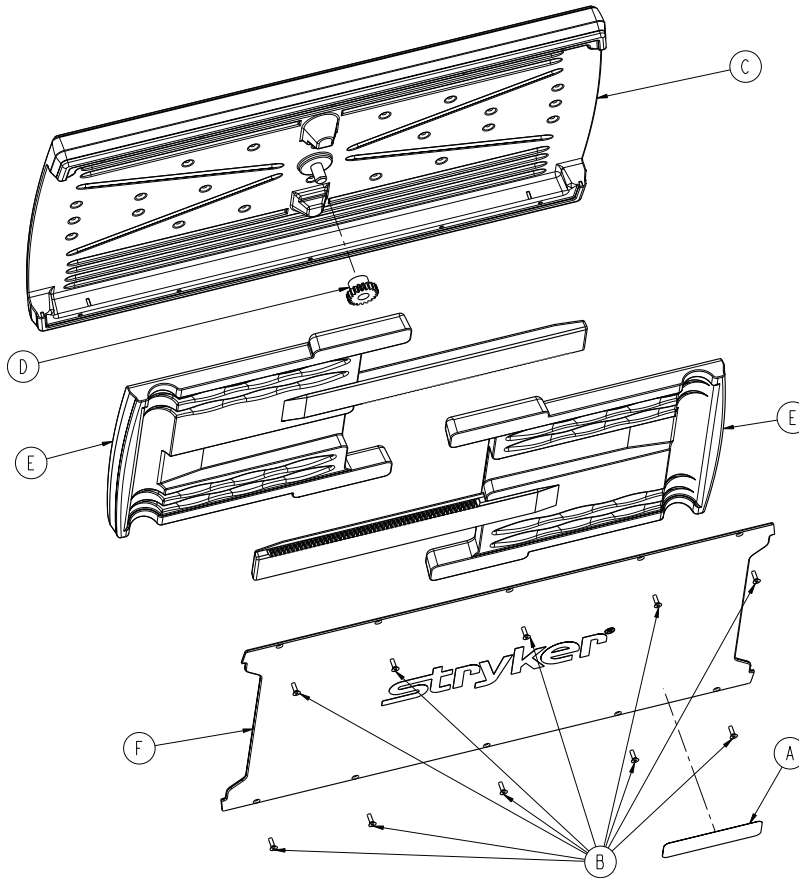

Item	Number	Name	Quantity
A	1105-145-701	Label, serving tray	1
B	0785-045-704	Flat head Torx screw	10
C	1105-045-705	Serving tray top	1
D	0785-045-706	Serving tray pinion	1
E	1105-045-710	Serving tray slider	2
F	1105-045-715	Serving tray cover	1

Footboard/serving tray holder - 1105-045-800

Rev B (Reference only)

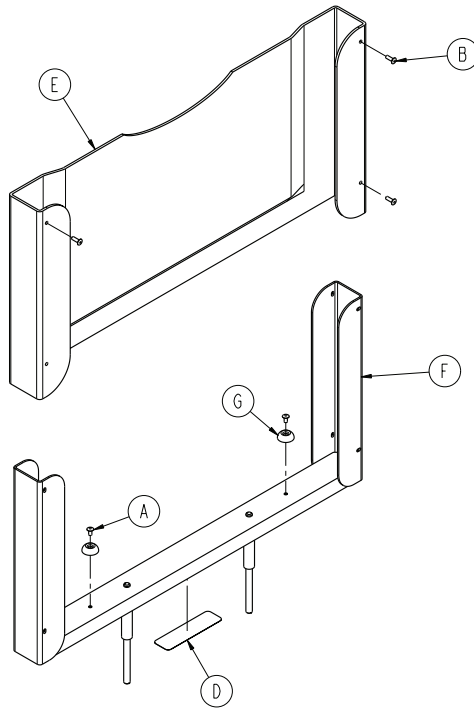

Item	Number	Name	Quantity
A	0025-079-000	Rivet	2
B	0025-133-000	Rivet	4
D	1105-145-801	Label, serving tray holder	1
E	1105-045-805	Footboard	1
F	1105-045-810	Footboard support weldment	1
G	0946-001-155	Bumper	2

26" slider board assembly - 1105-045-610

Rev A (Reference only)

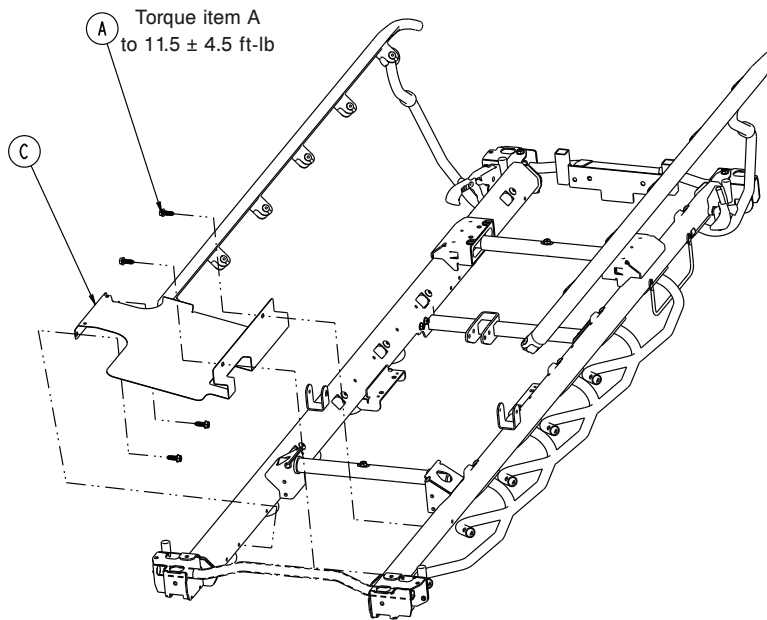

Item	Number	Name	Quantity
A	0023-288-000	Hex washer head screw	4
B	0785-018-001	Slider board - 0785-018-001 (page 427)	1
C	1105-045-611	26" slider board tray	1

30" slider board assembly - 1105-045-310

Rev A (Reference only)

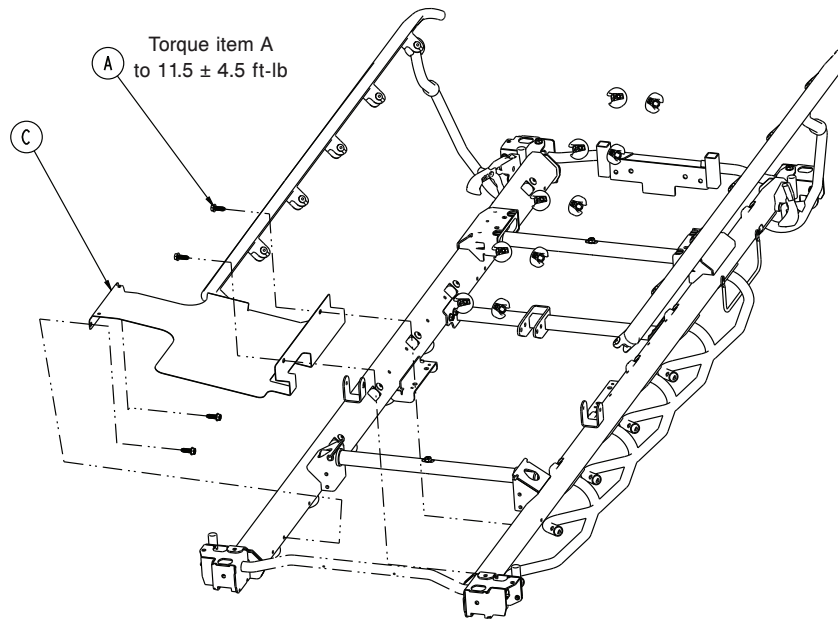

Item	Number	Name	Quantity
A	0023-288-000	Hex washer head screw	4
B	0785-018-001	Slider board - 0785-018-001 (page 427)	1
C	1105-045-311	30" slider board tray	1

Slider board - 0785-018-001

Rev E (Reference only)

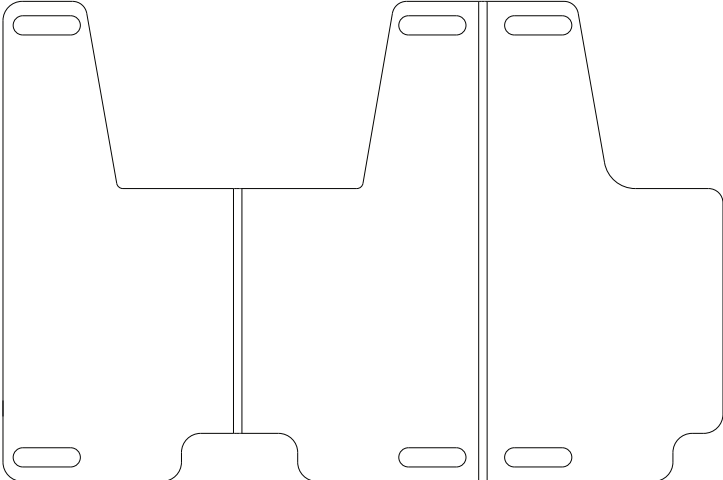

Upright assist assembly - 1105-045-300 (Prime X option only)

Rev AA (Reference only)

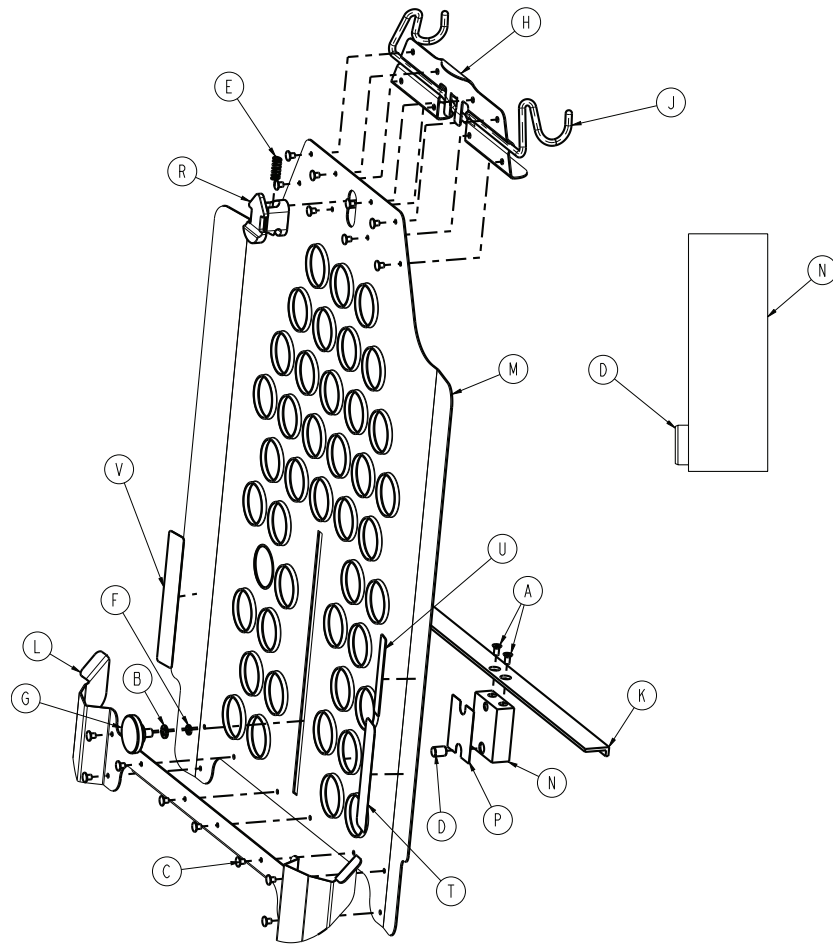

Item	Number	Name	Quantity
A	0001-020-000	Flat head machine screw	2
B	0014-003-000	Washer	1
C	0025-153-000	Rivet	16
D	0026-122-000	Dowel pin	1
E	0038-110-000	Compression spring	1
F	0926-023-071	Bushing	1
G	1020-023-021	Knob	1
H	1105-045-301	Latch hinge bracket	1
J	1105-045-302	Wire latch	1
K	1105-045-304	Cassette support rail	1
L	1105-045-305	Lower retainer guide	1
M	1105-045-306	Cassette support tray	1
N	1105-045-307	Block	1
P	1105-045-308	Pressure sensitive tape	1

Item	Number	Name	Quantity
R	1105-045-309	Slider release	1
T	1105-145-313	Label, specification, upright cassette	1
U	108900010903	Label, EAR	1
V	110500450901	Label, translation	1

Lateral cassette assembly - 1105-045-100 (Prime X option only)

Rev AA (Reference only)

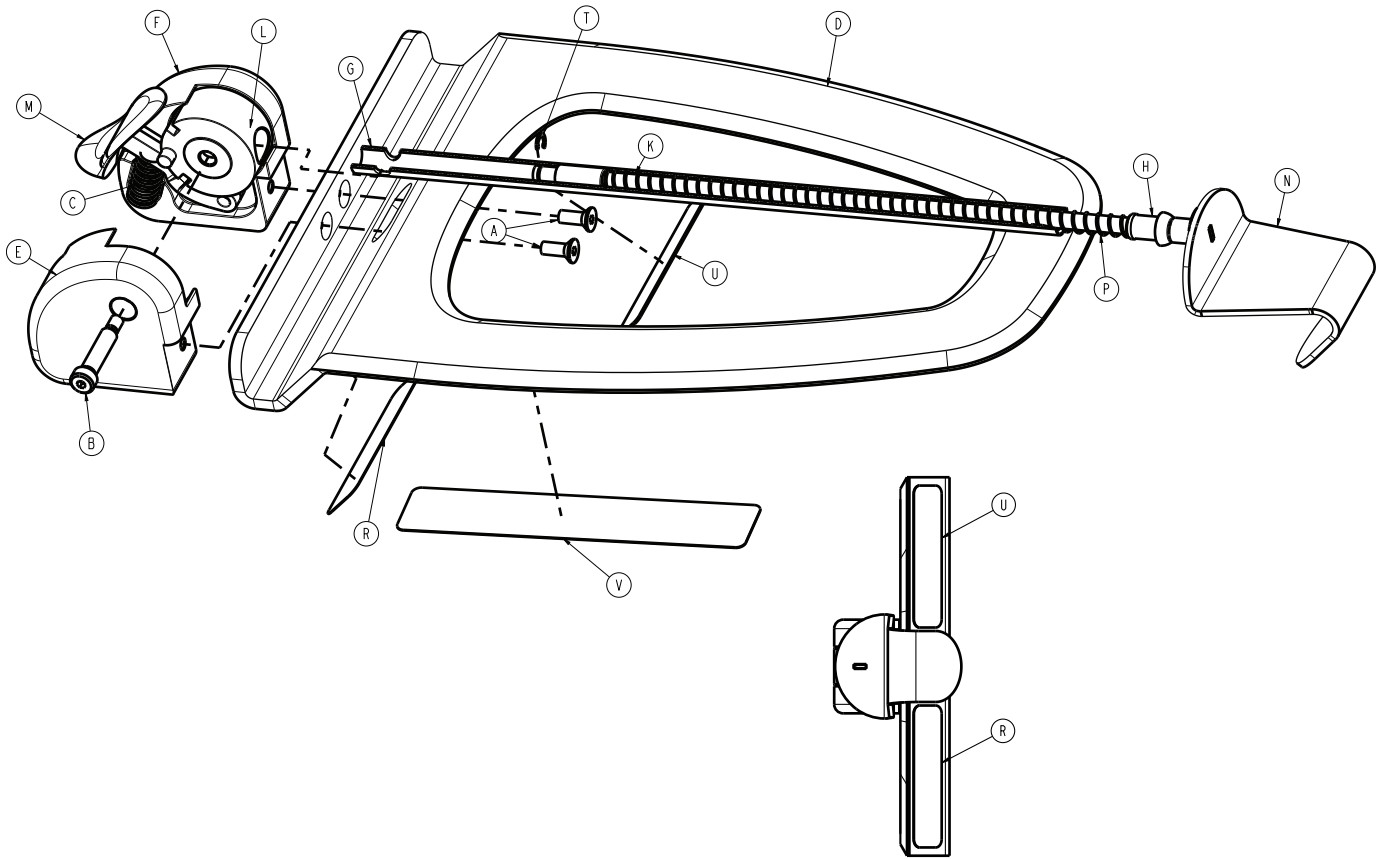

Item	Number	Name	Quantity
A	0001-011-000	Flat head cap screw	2
B	0008-030-000	Socket head shoulder bolt	1
C	0038-383-000	Compression wire	1
D	1105-045-101	Base	1
E	1105-045-102	Pivot block, right	1
F	1105-045-103	Pivot block, left	1
G	1105-045-104	Tube	1
H	1105-045-105	Upper bushing	1
K	1105-045-107	Lower bushing	1
L	1105-045-108	Pivot spacer	1
M	1105-045-109	Release button	1
N	1105-045-110	Cassette hook weldment	1
P	1105-045-112	Compression spring	1
R	1105-145-113	Label, specification, lateral cassette	1
T	0028-008-001	External retaining ring	1

Item	Number	Name	Quantity
U	108900010903	Label, EAR	1
V	110500450901	Label, translation	1

Mattresses and siderail pads

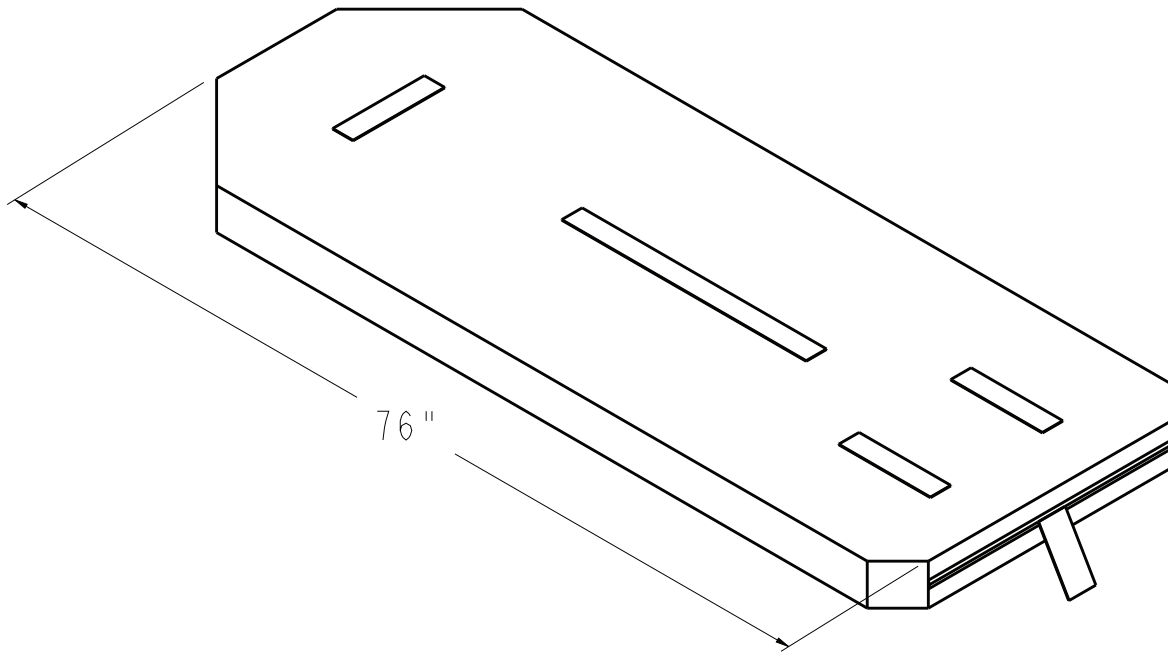

3" x 26" Enhanced Comfort , 0785-034-613	3" x 30" Enhanced Comfort , 0785-034-313	4" x 26" Enhanced Comfort , 0785-034-623	4" x 30" Enhanced Comfort , 0785-034-323
4" x 26" Ultra Comfort , 0785-034-603	4" x 30" Ultra Comfort , 0785-034-303	5" x 26" Ultra Comfort , 0785-034-633	5" x 30" Ultra Comfort , 0785-034-333
26" ComfortGel SE , without fire barrier, 1805-034-600	26" ComfortGel SE , fire barrier, 1805-034-601	30" ComfortGel SE , without fire barrier, 1805-034-300	30" ComfortGel SE , fire barrier, 1805-034-301
30" IsoFlex SE , fire barrier 1806-034-300	30" IsoFlex SE , fire barrier, international, 1806-034-301	4" x 26" Ultra Comfort stretcher extender, 1105-034-609	4" x 30" Ultra Comfort stretcher extender, 1105-034-309
3" x 26" Ultra Comfort SE , 1703-034-300	3" x 30" Ultra Comfort SE , fire barrier, 1703-034-301	4" x 26" Ultra Comfort SE , 1704-034-600	4" x 26" Ultra Comfort SE , fire barrier, international, 1704-034-601
4" x 30" Ultra Comfort SE , 1704-034-300	4" x 30" Ultra Comfort SE , fire barrier, 1704-034-301		

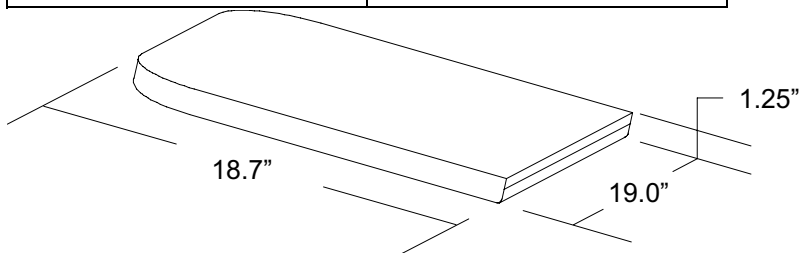

Foot extender cushion	0785-045-405
-----------------------	--------------

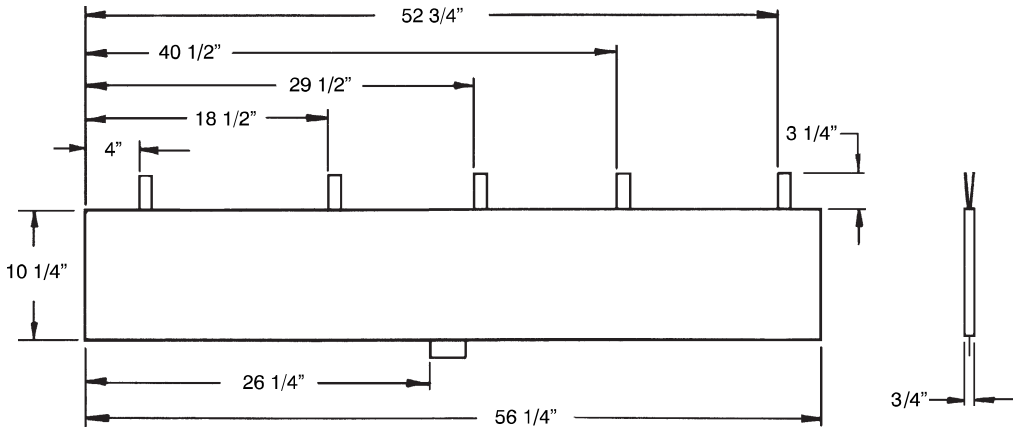

Siderail pad set	1001-052-000
------------------	--------------

EMC information

WARNING

- Portable RF communications equipment, including peripherals such as antenna cables and external antennas, should be no closer than 12 inches (30 cm) to any part of the **Prime Series** stretcher, including cables specified by the manufacturer.
- Avoid stacking or placing equipment adjacent with other equipment to prevent improper operation of the product. If such use is necessary, carefully observe stacked or adjacent equipment to make sure that they operate properly.
- The use of accessories, transducers, and cables, other than those specified or provided by the manufacturer, could result in increased electromagnetic emissions or decreased electromagnetic immunity and result in improper operation.

The **Prime Series** stretcher was evaluated using the following cables:

Cable	Length (m)
AC mains input cable	4.1
Nurse call (1/4" jack cable) Model 1105, 1115, and 1125 Prime Connect stretchers only	3.8

Guidance and manufacturer's declaration - electromagnetic emissions

The **Prime Series** stretcher is intended for use in the electromagnetic environment specified below. The customer or the user of the **Prime Series** stretcher should assure that it is used in such an environment.

Emissions test	Compliance	Electromagnetic environment
RF Emissions CISPR 11	Group 1	Note - The emissions characteristics of this equipment make it suitable for use in industrial areas and hospitals (CISPR 11 class A). If it is used in a residential environment (for which CISPR 11 class B is normally required) this equipment might not offer adequate protection to radio-frequency communication services. The user might need to take mitigation measures, such as relocating or re-orienting the equipment.
RF Emissions CISPR 11	Class A	
Harmonic Emissions IEC 61000-3-2	Class A	
Voltage Fluctuations Flicker Emissions IEC 61000-3-3	Complies	

Guidance and manufacturer's declaration - electromagnetic immunity

The **Prime Series** stretcher is suitable for use in a professional healthcare facility environment and not in environments exceeding immunity test conditions that the product was evaluated to, such as near high frequency (HF) surgical equipment and inside of the radio frequency (RF) shielded room of magnetic resonance imaging (MRI) equipment. The customer or the user of the **Prime Series** stretcher should assure that it is used in such an environment and that the electromagnetic environment guidance listed below is followed.

Immunity test	IEC 60601 test level	Compliance level	Electromagnetic environment-guidance
Electrostatic Discharge (ESD) IEC 61000-4-2	±8 kV contact ±15 kV air	±8 kV contact ±15 kV air	Floors should be wood, concrete, or ceramic tile. If floors are covered with synthetic material, the relative humidity should be at least 30%.

Guidance and manufacturer's declaration - electromagnetic immunity

Electrostatic fast transient/ burst IEC 61000-4-4	±2 kV for power supply lines ±1 kV for input/output lines	±2 kV for power supply lines ±1 kV for input/output lines	Main power quality should be that of a typical commercial or hospital environment.
Surge IEC 61000-4-5	±0.5 kV, ±1 kV lines to lines ±0.5 kV, ±1 kV, ±2 kV lines to earth	±0.5 kV, ±1 kV lines to lines ±0.5 kV, ±1 kV, ±2 kV lines to earth	Main power quality should be that of a typical commercial or hospital environment.
Voltage dips, voltage variations and short interruptions on power supply input lines IEC 61000-4-11	0%U _T for 0.5 cycle at 0°, 45°, 90°, 135°, 180°, 225°, 270°, and 315° 0%U _T for 1 cycle 70%U _T (30% dip in U _T) for 25/30 cycles 0% U _T for 250/300 cycles	0%U _T for 0.5 cycle at 0°, 45°, 90°, 135°, 180°, 225°, 270°, and 315° 0%U _T for 1 cycle 70%U _T (30% dip in U _T) for 25/30 cycles 0% U _T for 250/300 cycles	Main power quality should be that of a typical commercial or hospital environment. If the user of the Prime Series stretcher requires continued operation during power main interruptions, it is recommended that the device be powered from an uninterrupted power supply or a battery.
Power frequency (50/60 Hz) magnetic field IEC 61000-4-8	30 A/m	30 A/m	Power frequency magnetic fields should be at levels characteristic of a typical location in a typical commercial or hospital environment.

Note - U_T is the a.c. mains voltage before applications of the test level.

<p>Conducted RF IEC 61000- 4-6</p> <p>Radiated RF IEC 61000-4-3</p>	<p>3 Vrms 150 kHz to 80 MHz 3 V/m 80 MHz to 2.7 GHz</p>	<p>3 Vrms 3 V/m</p>	<p>Portable and mobile RF communications equipment should follow the guidance in the table titled “Recommended separation distances between portable and mobile RF communication equipment and the Prime Series stretcher.” If the mobile service is not listed in the table, the recommended separation distance should be calculated from the equation appropriate for the frequency of the transmitter.</p> <p>Recommended separation distance $D=(2) (\sqrt{P})$ where P is the maximum output power rating of the transmitter in watts (W) according to the transmitter manufacturer and d is the recommended separation distance in meters (m).</p> <p>Field strengths from fixed RF transmitters, as determined by an electromagnetic site survey^a, should be less than the compliance level in each frequency range^b.</p> <p>Interference may occur in the vicinity of equipment marked with the following symbol: </p>
<p>Proximity Magnetic Fields IEC 61000-4-39</p>	<p>65 A/m 134.2 kHz</p>	<p>65 A/m</p>	<p>RFID readers and similar generators of magnetic fields should not be operated closer than 50 mm from the electronics or cables of the Prime Series stretcher.</p>
<p>7.5 A/m 13.56 MHz</p>	<p>7.5 A/m</p>		
<p>Note - These guidelines may not apply in all situations. Electromagnetic propagation is affected by absorption and reflection from structures, objects and people.</p> <p>Note - The ISM (Industrial, Scientific, and Medical) bands between 0.15 MHz and 80 MHz are 6.765 MHz to 6.795 MHz; 13.553 MHz to 13.567 MHz; 26.957 MHz to 27.283 MHz; and 40.66 MHz to 40.70 MHz.</p>			

^aField strengths from fixed transmitters, such as base stations for radio (cellular/cordless) telephones and land mobile radios, amateur radio, AM and FM radio broadcast, and TV broadcast cannot be predicted theoretically with accuracy. To assess the electromagnetic environment due to fixed RF transmitters, an electromagnetic site survey should be considered. If the measured field strength in the location in which the **Prime Series** stretcher is used exceeds the applicable RF compliance level above, the **Prime Series** stretcher should be observed to verify normal operation. If abnormal performance is observed, additional measures may be necessary, such as reorienting or relocating the **Prime Series** stretcher.

^bOver the frequency range 150 kHz to 80 MHz, field strengths are less than 3 Vrms.

Recommended separation distances between portable and mobile RF communication equipment and the Prime Series stretcher

The **Prime Series** stretcher is intended for use in an electromagnetic environment in which radiated RF disturbances are controlled. The customer or the user of the **Prime Series** stretcher can help prevent electromagnetic interferences by maintaining a minimum distance between portable and mobile RF communications equipment (transmitters) and the **Prime Series** stretcher, including cables, as recommended below, according to the maximum output power of the communications equipment.

Band (MHz)	Service	Maximum power (W)	Minimum separation distance (m)
380-390	TETRA 400	1.8	0.3
430-470	GMRS 460; FRS 460	2.0	0.3
704-787	LTE Band 13, 17	0.2	0.3
800-960	GSM 800/900; TETRA 800; iDEN 820; CDMA 850; LTE Band 5	2.0	0.3
1,700-1,990	GSM 1800; CDMA 1900; GSM 1900; DECT; LTE Band 1, 3, 4, 25; UMTS	2.0	0.3
2,400-2,570	Bluetooth; WLAN; 802.11 b/g/n; RFID 2450; LTE Band 7	2.0	0.3
5,100-5,800	WLAN 802.11 a/n	0.2	0.3

For transmitters rated at a maximum output power not listed above, the recommended separation distance d in meters (m) can be estimated using the equation applicable to the frequency of the transmitter, where P is the maximum output power rating of the transmitter in watts (W) according to the transmitter manufacturer.

Note - These guidelines may not apply in all situations. Electromagnetic propagation is affected by absorption and reflection from structures, objects and people.

Recycling passport

1070-110-260/1070-110-265/1070-110-360/1070-110-365/1070-110-270/1070-110-370

Rev E/Rev E/Rev D/Rev D/Rev D/Rev C (Reference only)

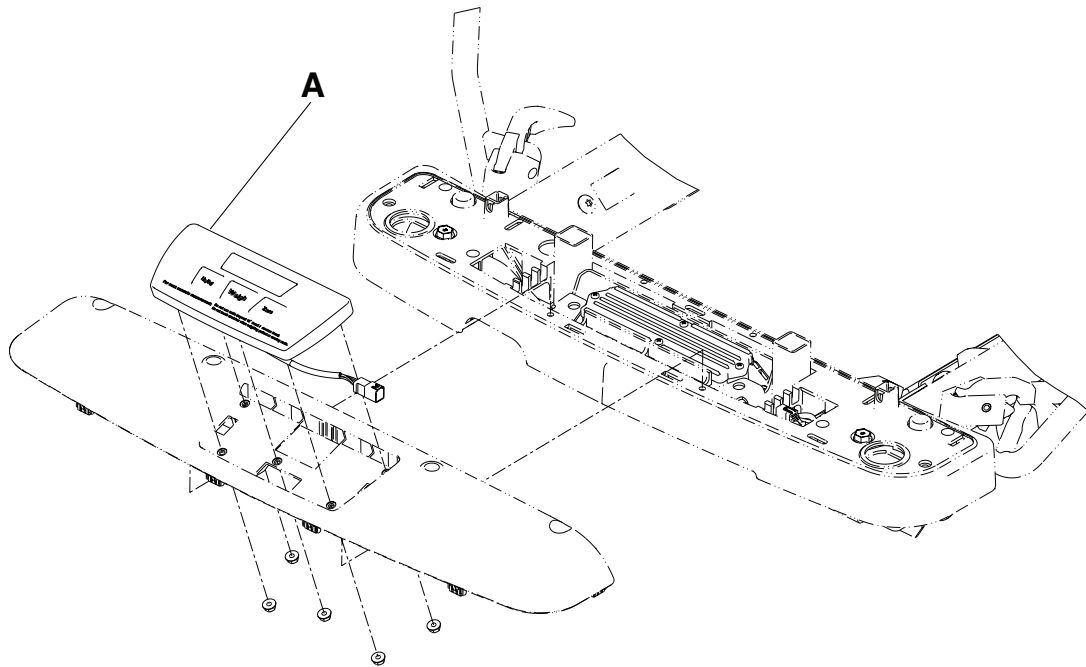

A	1008-037-820	1
---	--------------	---

1070-117-600 / 1070-117-300

Rev C / Rev B

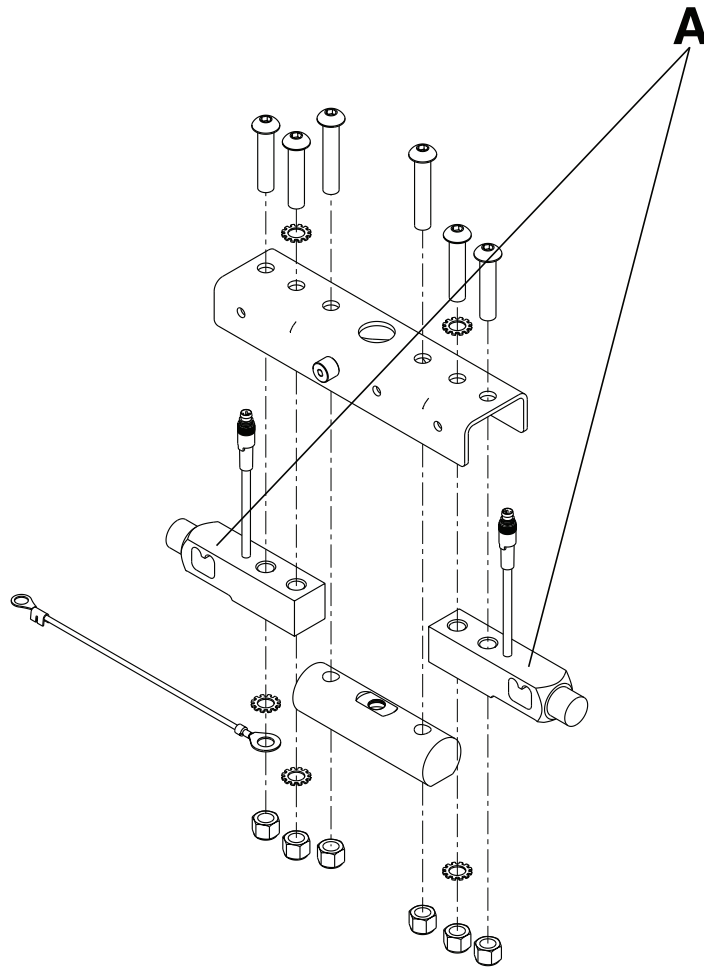

A	1008-037-057	1
---	--------------	---

1070-237-020

Rev AB (Reference only)

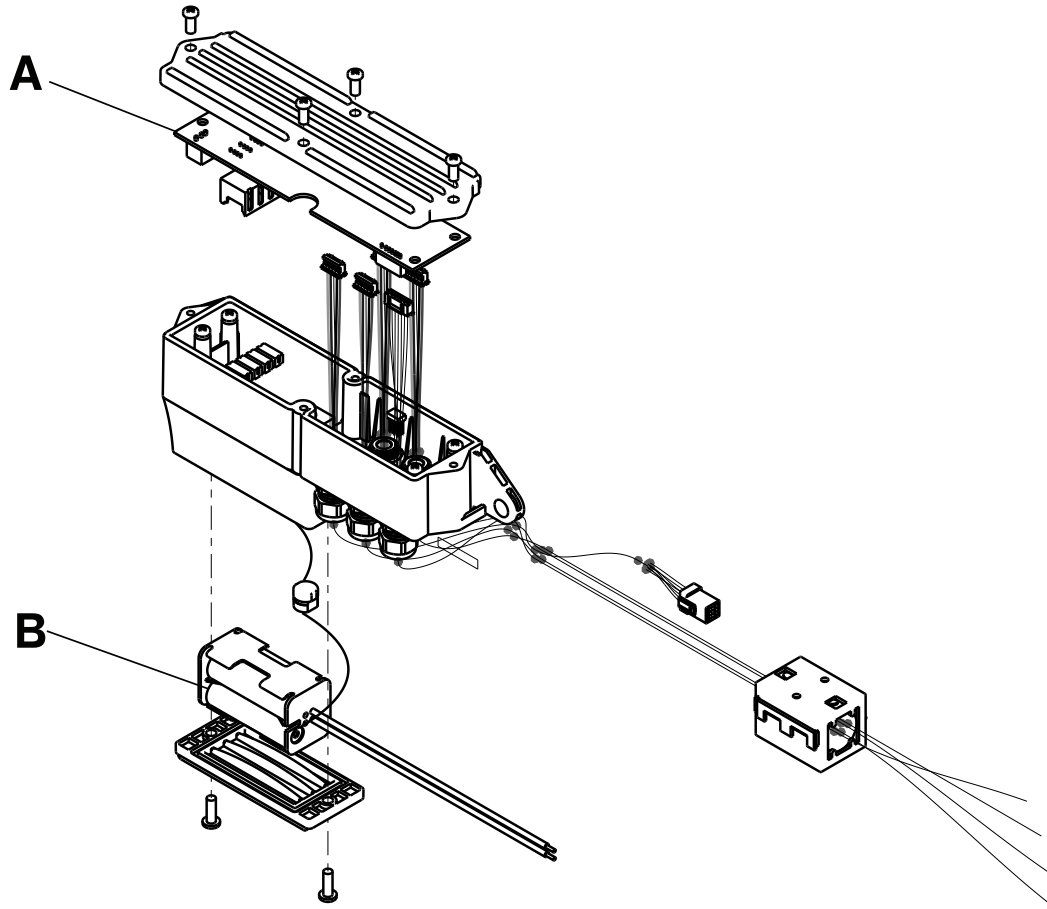

A	1008-037-830	1
B	0059-782-000	1

1008-010-302

Rev U

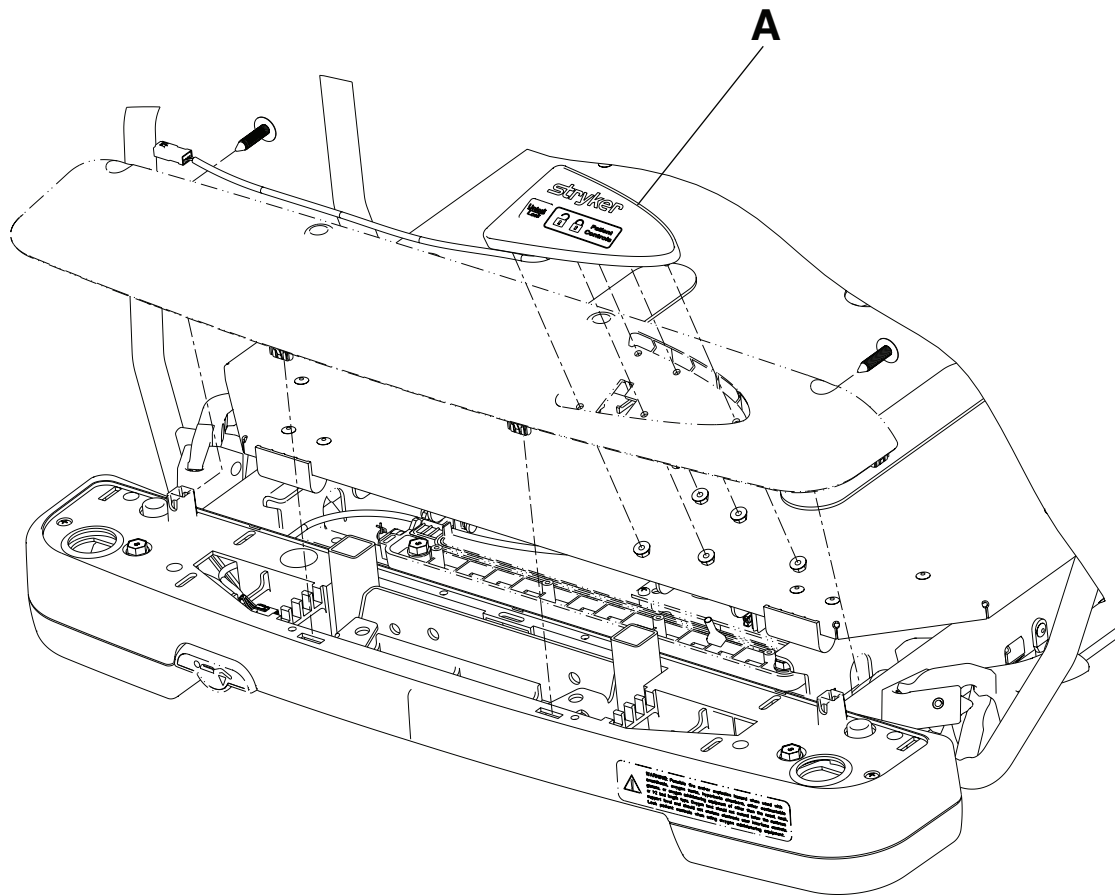

A	1008-015-820	1
---	--------------	---

1008-011-320/1008-011-330

Rev AA/Rev AA

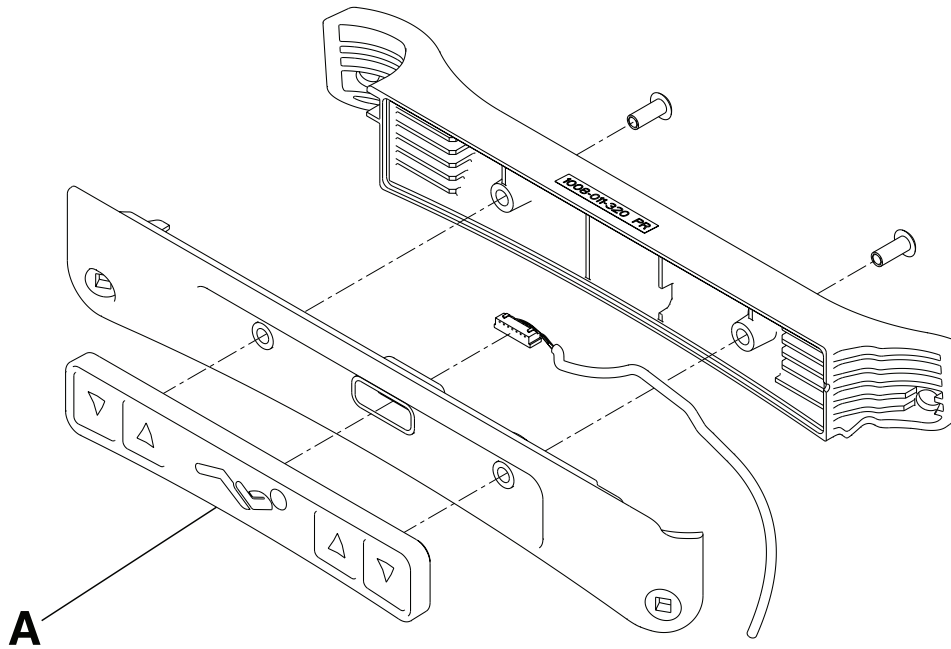

A	1008-011-016/1008-011-017	1
---	---------------------------	---

1008-015-020

Rev B

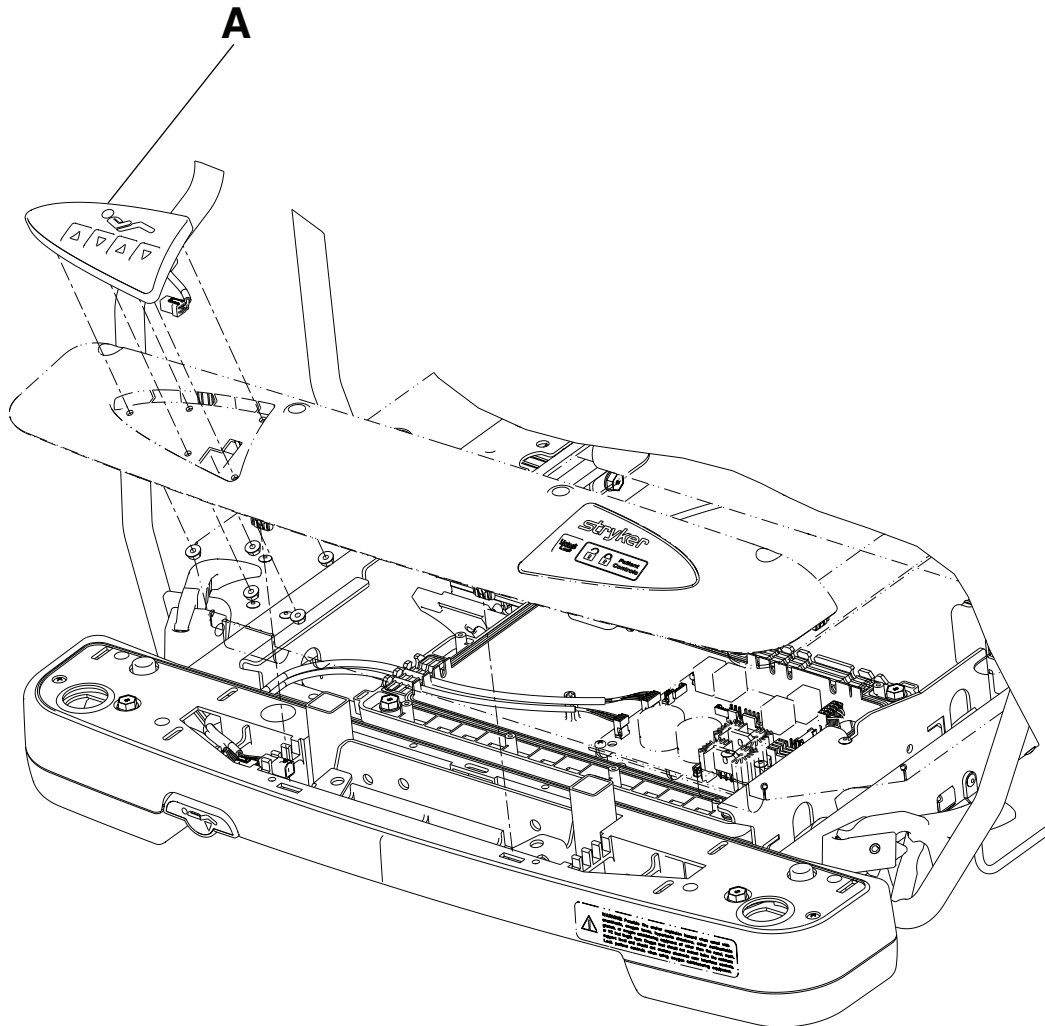

A	1008-015-800	1
---	--------------	---

1070-010-100

Rev J

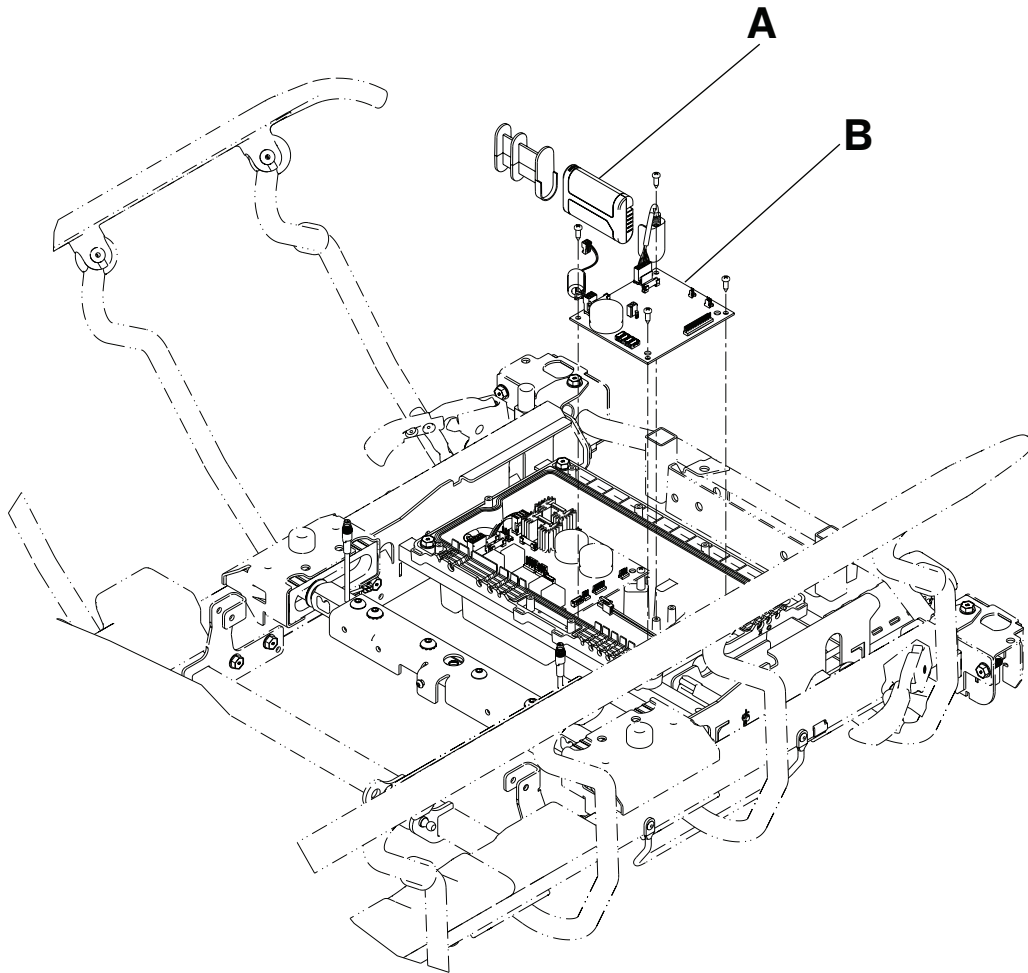

A	0058-135-000	1
B	1008-237-850	1

1070-010-100

Rev J

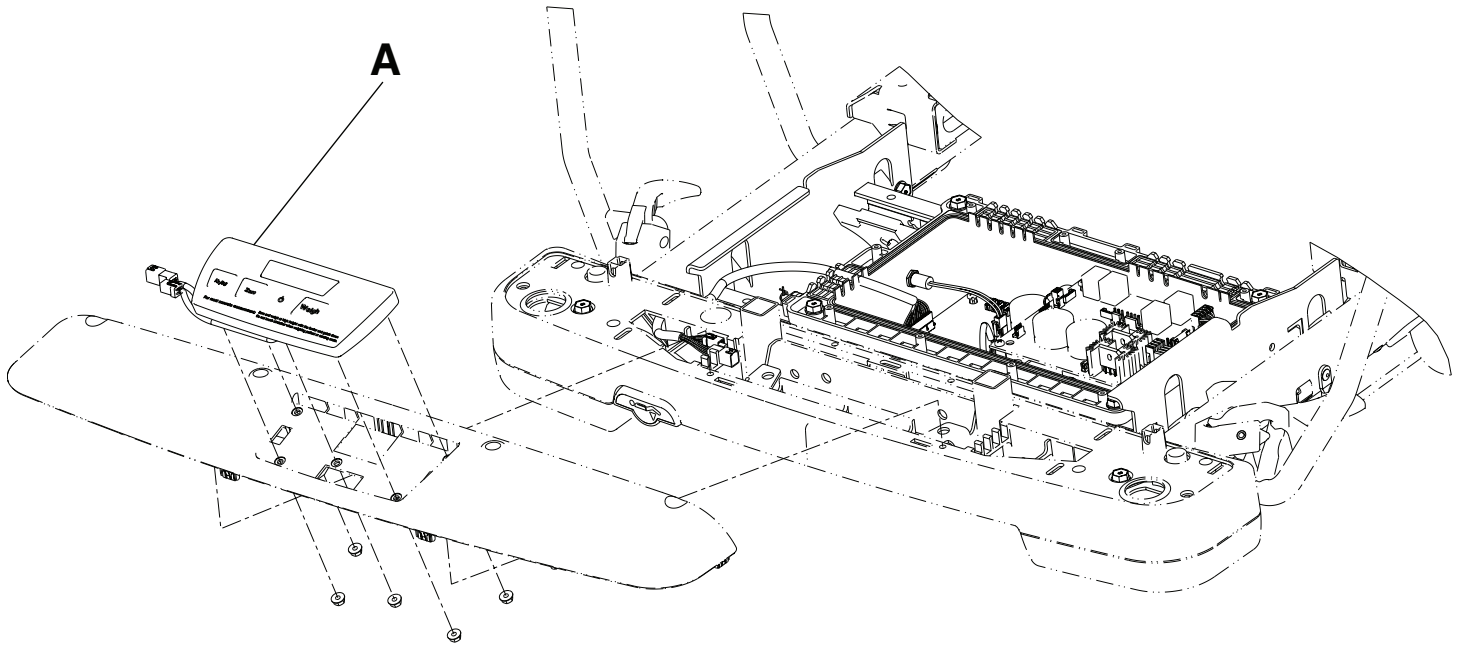

A	1008-037-810	1
---	--------------	---

1070-010-200

Rev J

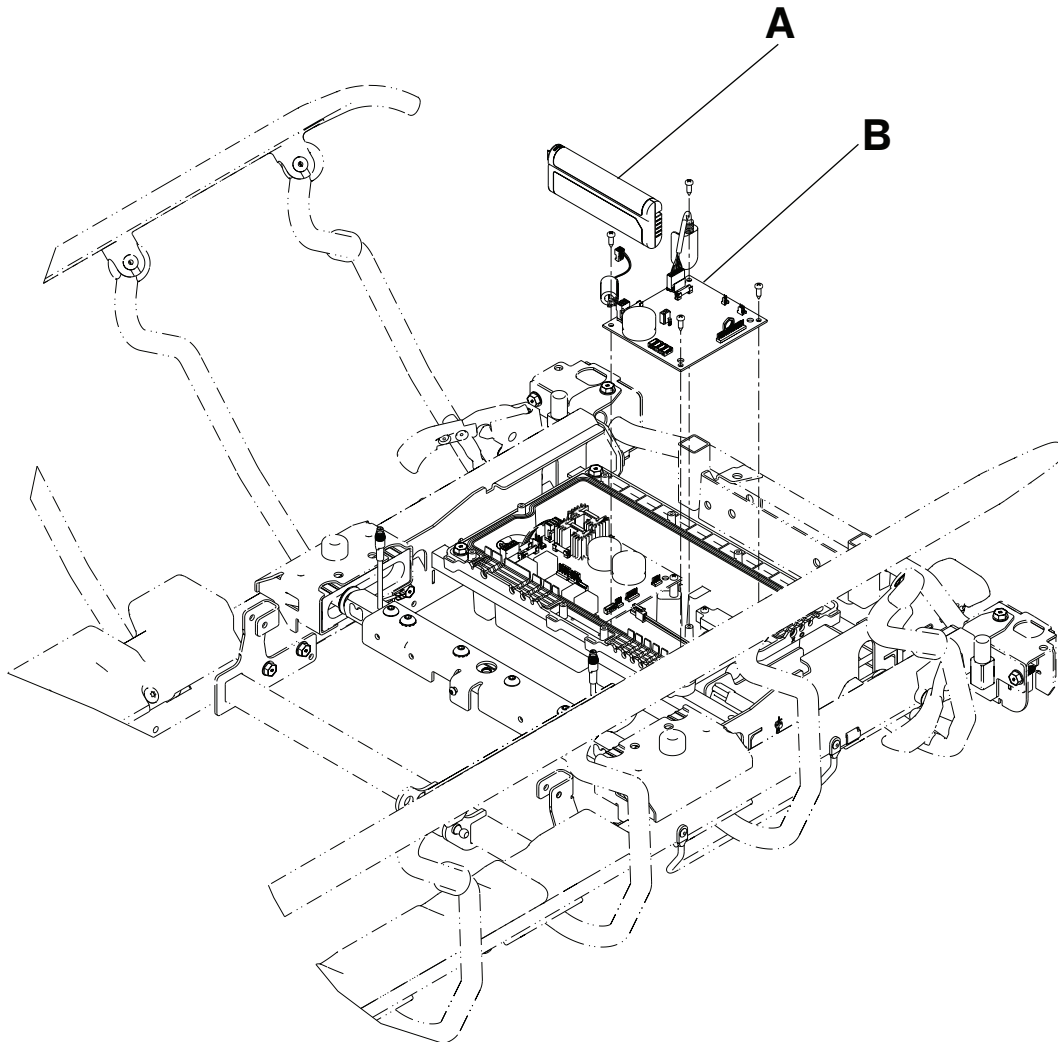

A	0058-134-000	1
B	1008-237-840	1

1070-010-200

Rev J

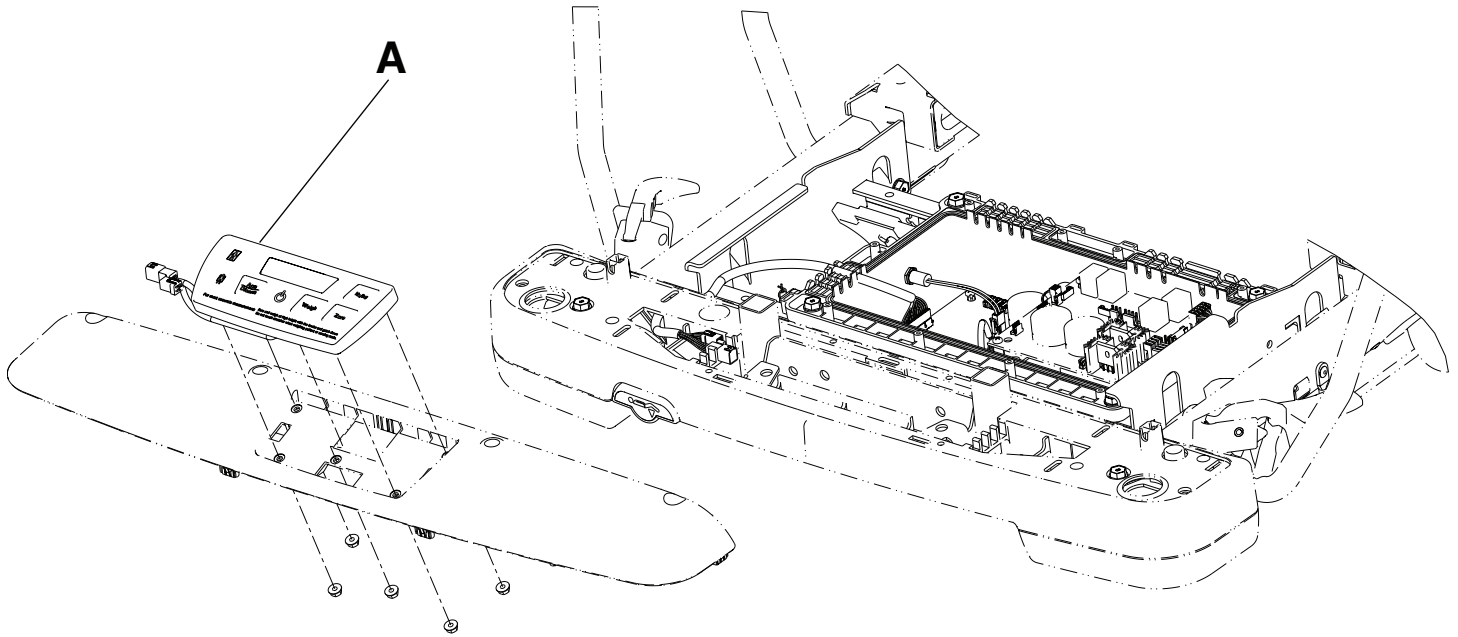

A	1008-037-800	1
---	--------------	---

1008-005-500

Rev AA

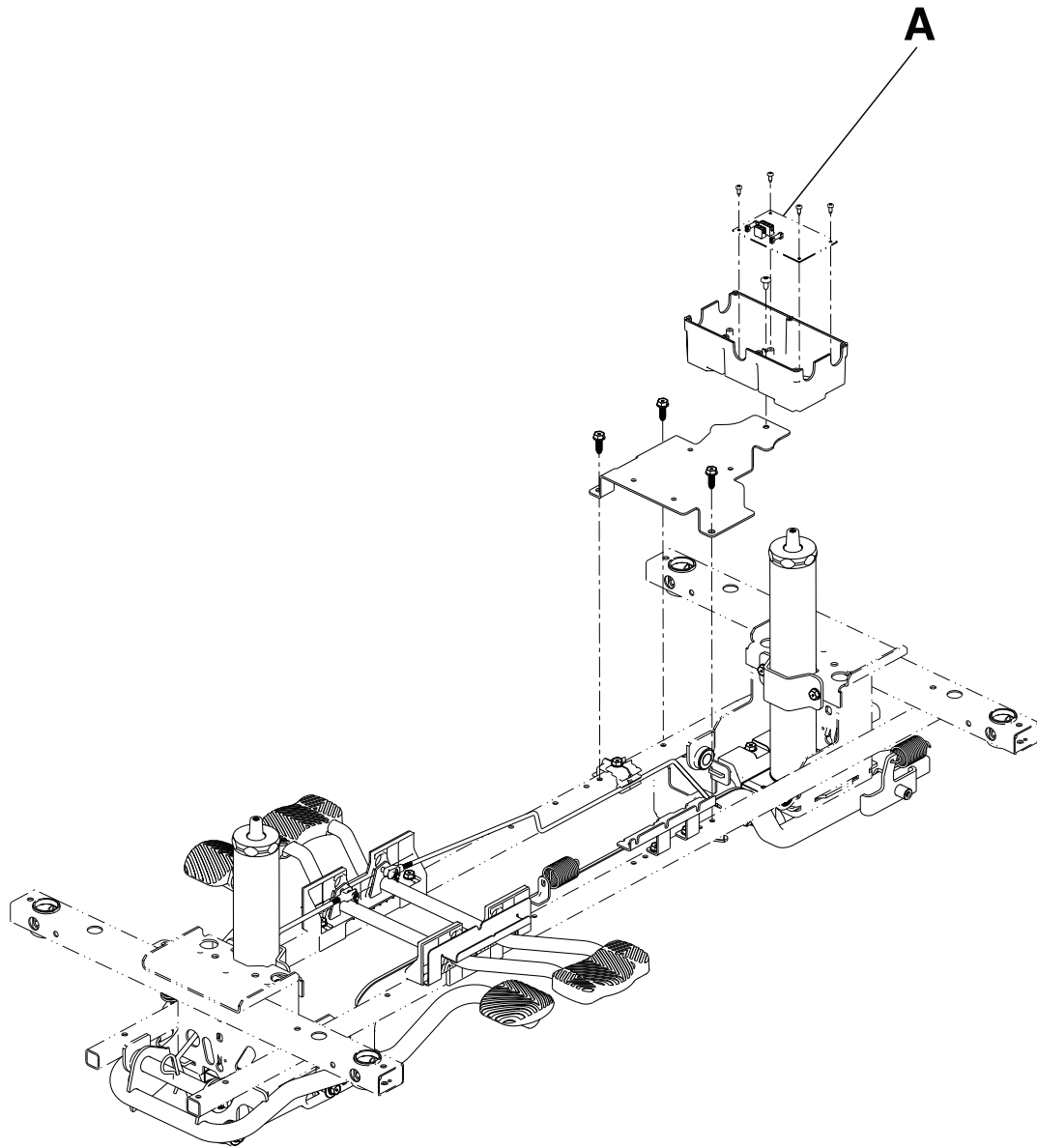

A	1008-002-800	1
---	--------------	---

1008-005-510

Rev AA

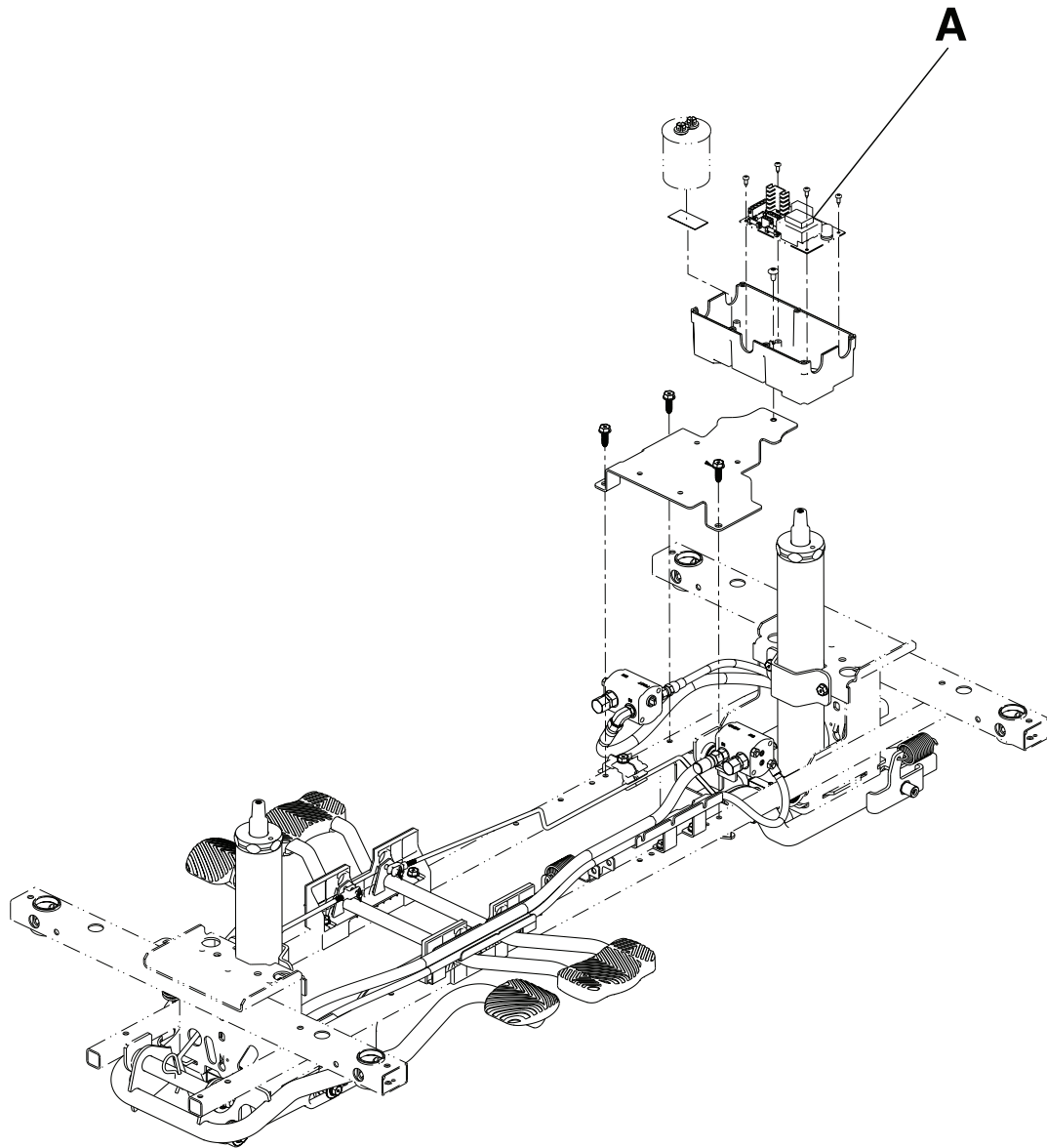

A	1008-002-810	1
---	--------------	---

100800370800

Rev AE

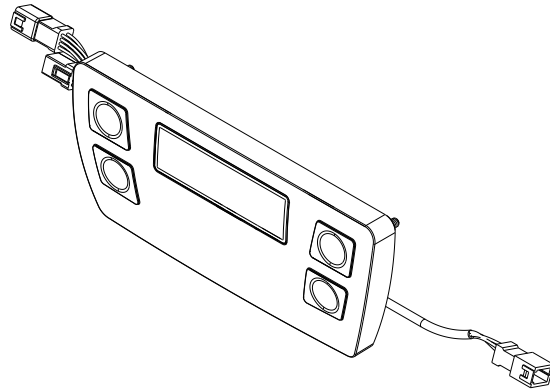

100800370810

Rev AE

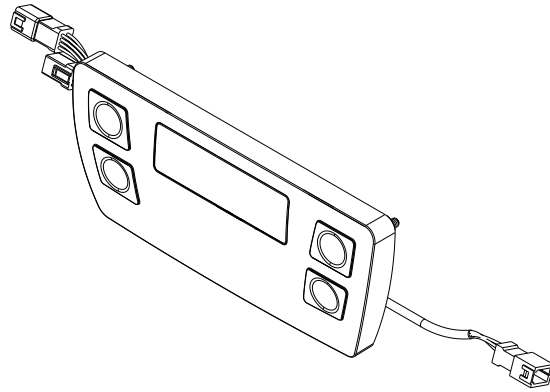

100800380850

Rev AD

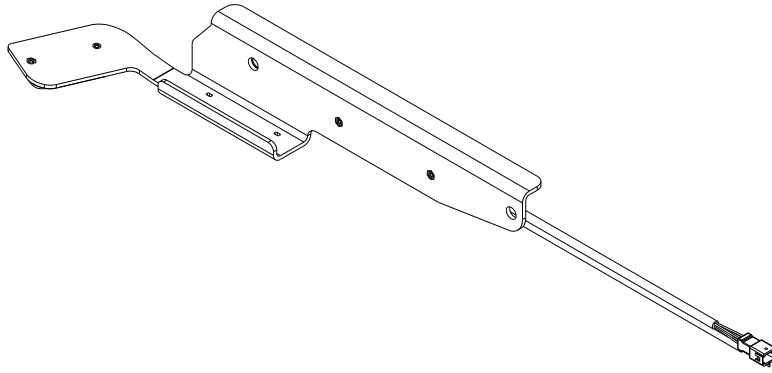

100800380860

Rev AD

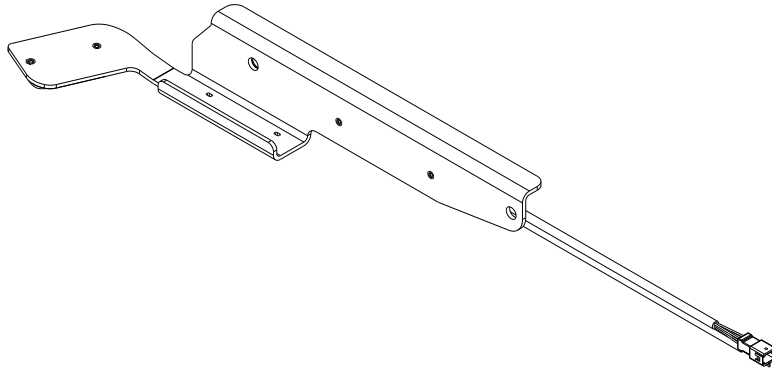

100800680910

Rev AD

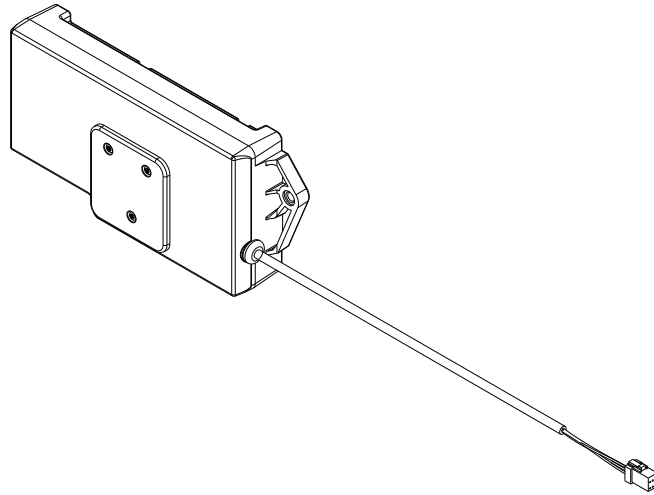



Stryker Corporation or its divisions or other corporate affiliated entities own, use or have applied for the following trademarks or service marks: **BackSmart, Chaperone, ComfortGel, Havasu, iBed, IsoFlex, Lift Assist, Prime Connect, Prime Series, Prime X, Steer-Lock, Stryker, Zoom**. All other trademarks are trademarks of their respective owners or holders.



Stryker Medical
3800 E. Centre Avenue
Portage, MI 49002
USA